



UNITED STATES
NUCLEAR REGULATORY COMMISSION

REGION IV

611 RYAN PLAZA DRIVE, SUITE 400
ARLINGTON, TEXAS 76011-6064

Docket No. 50-298
License No. DPR-46

JUL 6 1992

Nebraska Public Power District
ATTN: Guy R. Horn, Nuclear Power
Group Manager
P.O. Box 499
Columbus, NE 68602-0499

Gentlemen:

SUBJECT: GENERIC FUNDAMENTALS EXAMINATION RESULTS

This letter forwards the results of the Generic Fundamentals Examination Section (GFES) of the written operator licensing examination that was administered on June 10, 1992, to nominated employees of your facility. We are forwarding the following items:

- o the examinations, including answer keys,
- o the results for your nominated employees, and
- o copies of the individual answer sheets completed by your nominated employees

We request that your training department forward the individual answer sheets and results to the appropriate individuals. It should be noted that the examination was administered in two forms, which were identical except for the sequence of questions.

In accordance with the Commission's regulations, 10 CFR 2.790, a copy of this letter and the examination and answer key will be placed in the NRC's Public Document Room (PDR). The individual results and answer sheets are exempt from public disclosure and therefore will not be placed in the PDR.

Questions concerning this examination should be directed to Dr. George Usova at (301) 504-1064.

Sincerely,

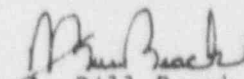
A. Bill Beach, Director
Division of Reactor Projects

Enclosures: As stated

cc: next page

9207140145 920706
PDR ADDCK 05000298
V PDR

JEH

Nebraska Public Power District - 2 -

cc w/enclosures:
Nebraska Public Power District
ATTN: J. W. Dutton, Nuclear
Training Manager
P.O. Box 98
Brownville, NE 68321

bcc w/o enclosures:

DRP Section Chief
R. Bevan, NRR Project Manager (MS: 11-D-23)
RIV File
L. Miller, TTC
J. L. Milhoan, RA
J. L. Pellet: Rdg file

bcc w/enclosures:

DMB (1E42)
L. A. Hurley: GFES file

RIV:OLS:LA
LAHurley
07/01/92

C:OLS
JLPellet
07/01/92

D:DRS
SJCollins
07/2/92

D:DRR
ABBeach
07/2/92

bcc w/o enclosures:

DRP Section Chief
R. Bevan, NRR Project Manager (MS: 11-D-23)
RIV File
L. Miller, TTC
J. L. Milhoan, RA
J. L. Pellet: Rdg file

bcc w/enclosures:

DMB (IE42)
L. A. Hurley: GFES file

RIV:OLS:LA
LAHurley *2/21*
07/01/92

Handwritten signature
C:OLS
JLPellet
07/10/92

Handwritten initials
D:DRS *PA*
SJCollins
07/2/92

Handwritten initials
D:DRB
ABBeach
07/2/92

JUNE 1992 GENERIC FUNDAMENTALS EXAM
BOILING WATER REACTOR

| FORM | | | ANS | FORM | | | ANS | FORM | | | ANS |
|------|----|---|-----|------|-----|----|-----|------|-----|----|-----|
| A | B | A | | B | A | B | | A | B | | |
| 1 | 29 | A | 26 | 54 | D | 51 | 79 | C | 76 | 4 | B |
| 2 | 30 | A | 27 | 55 | A/C | 52 | 80 | D | 77 | 5 | A |
| 3 | 31 | A | 28 | 56 | B | 53 | 81 | A | 78 | 6 | A |
| 4 | 32 | D | 29 | 57 | C | 54 | 82 | A | 79 | 7 | C |
| 5 | 33 | D | 30 | 58 | D | 55 | 83 | A | 80 | 8 | A/B |
| 6 | 34 | A | 31 | 59 | B | 56 | 84 | B | 81 | 9 | B |
| 7 | 35 | A | 32 | 60 | D | 57 | 85 | C | 82 | 10 | D |
| 8 | 36 | B | 33 | 61 | B | 58 | 86 | B | 83 | 11 | A |
| 9 | 37 | A | 34 | 62 | C | 59 | 87 | D | 84 | 12 | C |
| 10 | 38 | A | 35 | 63 | D | 60 | 88 | B | 85 | 13 | A |
| 11 | 39 | C | 36 | 64 | C | 61 | 89 | B | 86 | 14 | D |
| 12 | 40 | B | 37 | 65 | A | 62 | 90 | A | 87 | 15 | B |
| 13 | 41 | D | 38 | 66 | D | 63 | 91 | A | 88 | 16 | C |
| 14 | 42 | C | 39 | 67 | D | 64 | 92 | D | 89 | 17 | B |
| 15 | 43 | C | 40 | 68 | C | 65 | 93 | B | 90 | 18 | D |
| 16 | 44 | D | 41 | 69 | B | 66 | 94 | B | 91 | 19 | C |
| 17 | 45 | D | 42 | 70 | A | 67 | 95 | A | 92 | 20 | A |
| 18 | 46 | C | 43 | 71 | A | 68 | 96 | B | 93 | 21 | B |
| 19 | 47 | A | 44 | 72 | C | 69 | 97 | D | 94 | 22 | A |
| 20 | 48 | C | 45 | 73 | D | 70 | 98 | C | 95 | 23 | B |
| 21 | 49 | C | 46 | 74 | B | 71 | 99 | C | 96 | 24 | C |
| 22 | 50 | B | 47 | 75 | B | 72 | 100 | B | 97 | 25 | A |
| 23 | 51 | D | 48 | 76 | D | 73 | 1 | B | 98 | 26 | B |
| 24 | 52 | A | 49 | 77 | C | 74 | 2 | C | 99 | 27 | C |
| 25 | 53 | C | 50 | 78 | B | 75 | 3 | C | 100 | 28 | D |

NRC GENERIC FUNDAMENTALS EXAMINATION
CHECKLIST - BWR

- _____ 1. Verify receipt of BWR examination, form A and B.
- _____ 2. Verify each examination form has:
 - Cover sheet (page 1)
 - Rules and guidelines (page 2)
 - Equations and conversions handout (page 3)
- _____ 3. Verify each examination contains 100 questions.
 - Form A (pages 4 through 40)
 - Form B (pages 4 through 50)

UNITED STATES NUCLEAR REGULATORY COMMISSION
BOILING WATER REACTOR GENERIC FUNDAMENTALS EXAMINATION
JUNE 1992 - FORM A

Please Print:

Name: _____

Facility: _____

ID Number: _____

Start Time: _____ Stop Time: _____

INSTRUCTIONS TO CANDIDATE

Use the answer sheet provided. Each question has equal point value. A score of at least 80% is required to pass this portion of the written licensing examination. All examination papers will be collected 2.5 hours after the examination starts.

| SECTION | QUESTIONS | % OF TOTAL | SCORE |
|----------------|-----------|------------|-------|
| COMPONENTS | 1 - 44 | | |
| REACTOR THEORY | 45 - 72 | | |
| THERMODYNAMICS | 73 - 100 | | |
| TOTALS | 100 | | |

All work done on this examination is my own. I have neither given nor received aid.

Candidate's Signature

RULES AND GUIDELINES FOR THE
GENERIC FUNDAMENTALS EXAMINATION

During the administration of this examination the following rules apply:

1. Print your name in the blank provided on the cover sheet of the examination.
2. Fill in the name of your facility.
3. Fill in the ID Number you were given at registration.
4. Fill in your start and stop times at the appropriate time.
5. Two aids are provided for your use during the examination:
 - (1) An equations and conversions sheet contained within the examination copy, and
 - (2) Steam tables provided by your proctor.
6. Use only the answer sheet provided. Credit will only be given for answers properly marked on this sheet. Follow the instructions for filling out the answer sheet.
7. Scrap paper will be provided for calculations.
8. Cheating on the examination will result in the automatic forfeiture of this examination. Cheating could also result in severe penalties.
9. Restroom trips are limited. Only ONE examinee may leave the room at a time. In order to avoid the appearance or possibility of cheating, avoid all contact with anyone outside of the examination room.
10. After you have completed the examination, sign the statement on the cover sheet indicating that the work is your own and you have not received or been given any assistance in completing the examination.
11. Turn in your examination materials, answer sheet on top, followed by the examination booklet, then examination aids - steam table booklets, handouts and scrap paper used during the examination.
12. After turning in your examination materials, leave the examination area, as defined by the proctor. If after leaving you are found in the examination area while the examination is in progress, your examination may be forfeited.

GENERIC FUNDAMENTALS EXAMINATIONS SECTION
EQUATIONS AND CONVERSIONS HANDOUT SHEET

EQUATIONS

$$\dot{Q} = \dot{m}c_p\Delta T$$

$$\text{Cycle Efficiency} = \frac{\text{Net Work (out)}}{\text{Energy (in)}}$$

$$\dot{Q} = \dot{m}\Delta h$$

$$\text{SCR} = S/(1 - K_{\text{eff}})$$

$$\dot{Q} = UA\Delta T$$

$$CR_1(1 - K_{\text{eff}})_1 = CR_2(1 - K_{\text{eff}})_2$$

$$\text{SUR} = 26.06/\tau$$

$$M = 1/(1 - K_{\text{eff}}) = CR_1/CR_0$$

$$\text{SUR} = \frac{26.06(\lambda_{\text{eff}}\rho)}{(\bar{\beta} - \rho)}$$

$$H = \frac{(1 - K_{\text{eff}})_0}{(1 - K_{\text{eff}})_1}$$

$$P = P_0 10^{\text{SUR}(\tau)}$$

$$\text{SDM} = (1 - K_{\text{eff}})/K_{\text{eff}}$$

$$P = P_0 e^{(t/\tau)}$$

$$\text{Pwr} = W_f \dot{m}$$

$$\tau = (1^*/\rho) + [(\bar{\beta} - \rho)/\lambda_{\text{eff}}\rho]$$

$$\tau = 1^*/(\rho - \bar{\beta})$$

$$\rho = (K_{\text{eff}} - 1)/K_{\text{eff}}$$

$$1^* = 1 \times 10^{-5} \text{ seconds}$$

$$\rho = \Delta K_{\text{eff}}/K_{\text{eff}}$$

$$\lambda_{\text{eff}} = 0.1 \text{ seconds}^{-1}$$

$$v(P_e - P_i) + \frac{(\bar{v}_e^2 - \bar{v}_i^2)}{2} + g(z_e - z_i) = 0$$

CONVERSIONS

$$1 \text{ Curie} = 3.7 \times 10^{10} \text{ dps}$$

$$1 \text{ kg} = 2.21 \text{ lbm}$$

$$1 \text{ hp} = 2.54 \times 10^3 \text{ BTU/hr}$$

$$1 \text{ Mw} = 3.41 \times 10^6 \text{ BTU/hr}$$

$$1 \text{ BTU} = 778 \text{ ft-lbf}$$

$$^\circ\text{F} = 9/5 \text{ }^\circ\text{C} + 32$$

$$^\circ\text{C} = 5/9(^\circ\text{F} - 32)$$

USNRC GENERIC FUNDAMENTALS EXAMINATION
BWR - FORM A

QUESTION: 1

Which one of the following valves provides overpressure protection to limit the internal pressure in vessels and thus protect personnel and equipment?

- A. Safety
- B. Control
- C. Sentinel
- D. Pressure regulating

QUESTION: 2

Refer to the drawing of a hydraulically-operated valve that is shown in a throttled position (see figure on next page).

Select the position of this valve following a loss of hydraulic fluid pressure.

- A. Open
- B. Closed
- C. Remains at current position
- D. Midposition

USNRC GENERIC FUNDAMENTALS EXAMINATION
BWR - FORM A

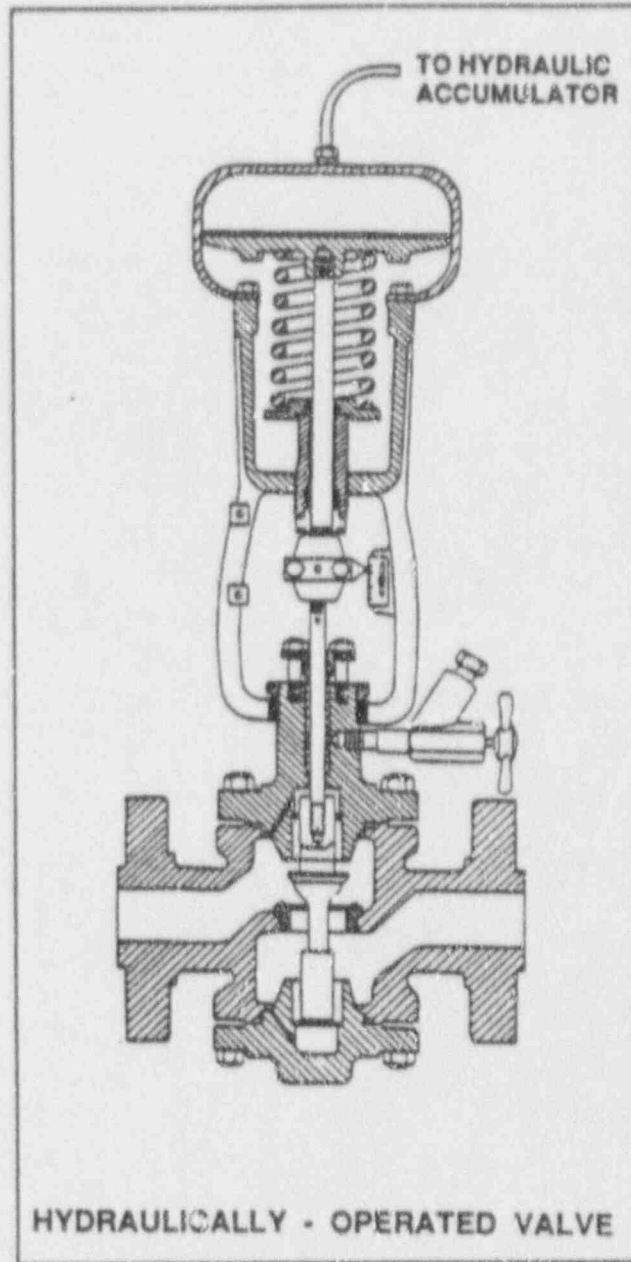

USNRC GENERIC FUNDAMENTALS EXAMINATION
LWR - FORM A

QUESTION: 3

What may be damaged if an operator attempts to manually disengage the motor on a motor-operated valve while the motor is operating?

- A. Clutch
- B. Valve seat
- C. Limit switches
- D. Torque switcher

QUESTION: 4

To verify a manual valve in an operating system is closed, the operator should operate the valve handwheel in the:

- A. open direction until the valve stem moves in the open direction, then close the valve using normal force.
- B. open direction until flow sounds are heard, then close the valve using normal force.
- C. close direction until it stops, then close it an additional one-half turn using additional force if necessary.
- D. close direction using normal force and verify there is no substantial handwheel movement.

QUESTION: 5

When comparing gate valves to globe valves, gate valves:

- A. are more effective at throttling flow.
- B. are more effective as pressure regulating valves.
- C. produce a larger pressure decrease when fully open.
- D. require more force to open against large differential pressures.

USNRC GENERIC FUNDAMENTALS EXAMINATION
BWR - FORM A

QUESTION: 6

If the density input to a density-compensated steam flow instrument rapidly falls high, the indicated flow will:

- A. increase and stabilize at a new higher value.
- B. increase temporarily, then return to its initial value.
- C. decrease and stabilize at a new lower value.
- D. decrease temporarily, then return to its initial value.

QUESTION: 7

Refer to the drawing of a venturi flow element (see figure below).

A differential pressure (D/P) detector measuring flow through the venturi will produce the highest flow indication if its high-pressure tap is connected at point _____ and its low-pressure tap is connected at point _____.

- A. A; B
- B. A; D
- C. B; C
- D. B; D

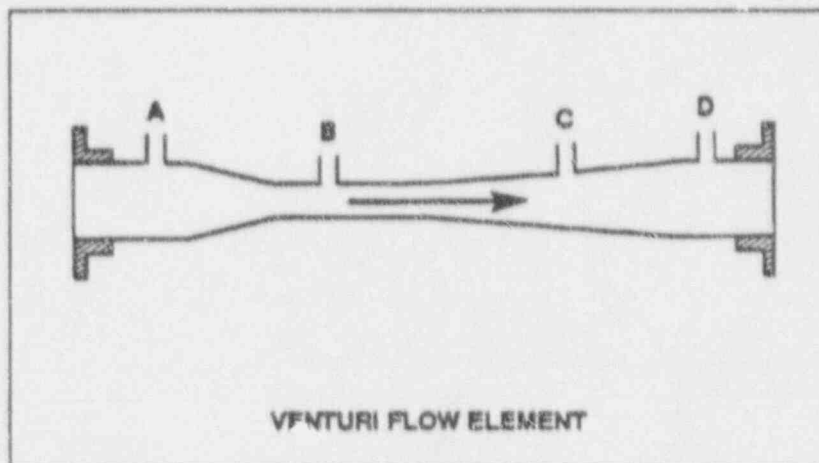

USNRC GENERIC FUNDAMENTALS EXAMINATION
BWR - FORM A

QUESTION: 8

Refer to the drawing of a pipe elbow used for flow measurement
(see figure below).

At which one of the following locations is the lowest pressure
sensed? (Assume a constant pipe diameter and zero head loss in
this section of pipe.)

- A. Point A
- B. Point B
- C. Point C
- D. Point D

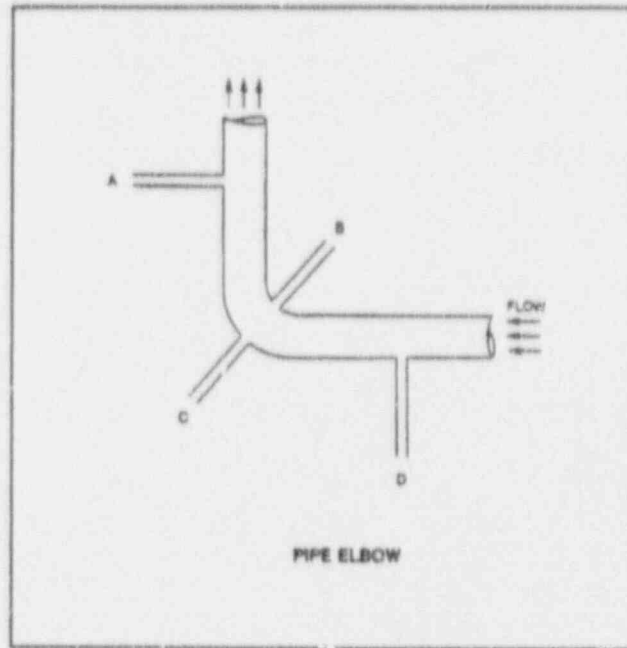

USNRC GENERIC FUNDAMENTALS EXAMINATION
BWR - FORM A

QUESTION: 9

Refer to the drawing of a tank differential pressure (D/P) level detector (see figure below).

The associated level instrument was calibrated with the water storage tank at 100°F. If mass in the tank remains constant and the water temperature increases to 120°F, the indicated level will:

- A. remain the same although actual level increases.
- B. increase but remain less than actual level.
- C. decrease in direct proportion to the temperature rise.
- D. increase in direct proportion to the temperature rise.

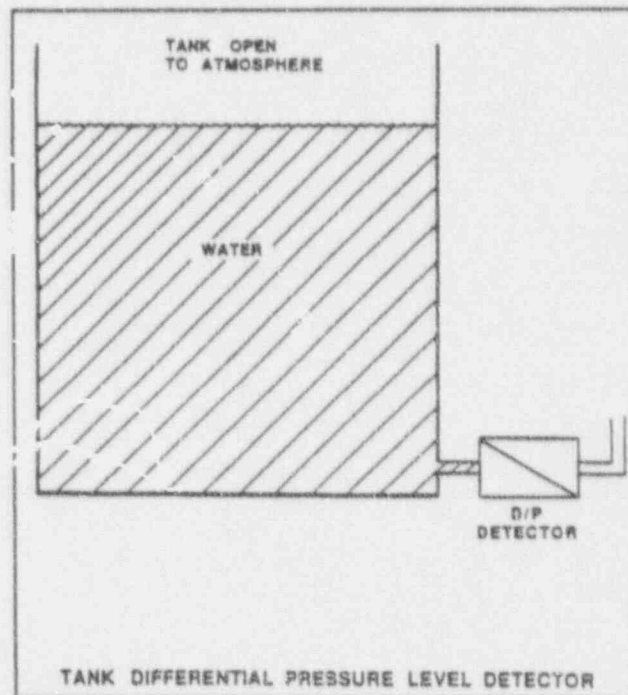

USNRC GENERIC FUNDAMENTALS EXAMINATION
BWR - FORM A

QUESTION: 10

Refer to the drawing of a tank differential pressure (D/P) level detector (see figure below).

The L/P sensed by the detector is _____ proportional to the temperature of the water in the tank if _____ is constant.

- A. directly; level
- B. inversely; level
- C. directly; mass
- D. inversely; mass

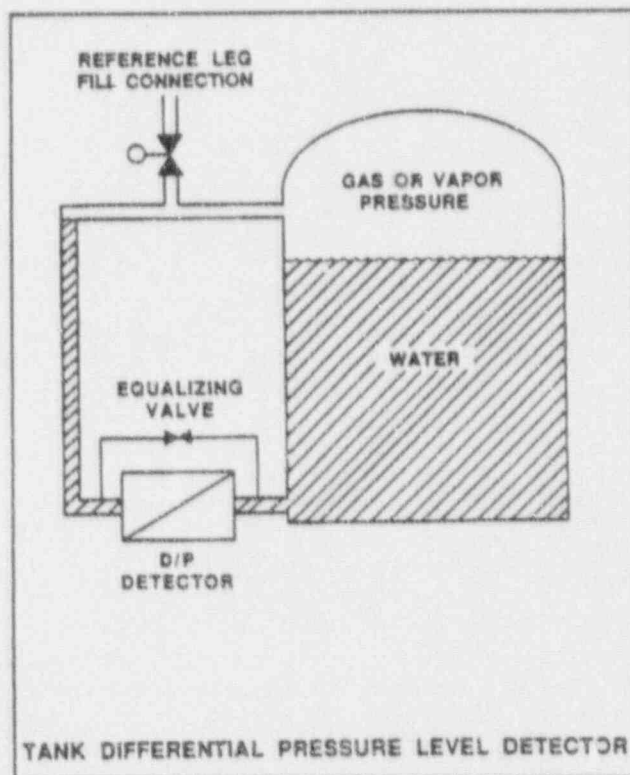

USNRC GENERIC FUNDAMENTALS EXAMINATION
BWR - FORM A

QUESTION: 11

A system has a simple bellows pressure detector with its low pressure side vented to the containment. If a main steam break raises containment pressure by 40 psig, the associated pressure indication (disregarding any temperature effect on the bellows) will:

- A. increase by 40 psig.
- B. increase by the square root of 40 psig.
- C. decrease by 40 psig.
- D. decrease by the square root of 40 psig.

QUESTION: 12

Which one of the following describes a characteristic of a thermocouple?

- A. A junction between two dissimilar metals will exhibit a change in electrical resistance proportional to temperature.
- B. A junction between two dissimilar metals will generate a voltage proportional to temperature.
- C. Thermocouples are generally more accurate than resistance temperature detectors (RTDs).
- D. Indication will fail high offscale with an open circuit.

QUESTION: 13

Which one of the following describes a characteristic of a Geiger-Mueller radiation detector?

- A. Radiation types can be identified by pulse height and duration.
- B. Specific radionuclides can be identified with the use of gamma spectrometry.
- C. Small variations in applied voltage will result in large changes in detector output.
- D. A single gamma interaction will produce the maximum useful output from the detector.

USNRC GENERIC FUNDAMENTALS EXAMINATION
BWR - FORM A

QUESTION: 14

Which one of the following describes a characteristic of a self-reading pocket dosimeter (SRPD)?

- A. The output of an SRPD is a dose rate in mr/hr.
- B. SRPDs can be used to record beta and gamma radiation.
- C. SRPD readings must be considered inaccurate when they are dropped.
- D. SRPDs hold their charge indefinitely when removed from a radiation field.

QUESTION: 15

The difference between the setpoint and the measured parameter in an automatic flow controller is called:

- A. gain.
- B. bias.
- C. error.
- D. feedback.

QUESTION: 16

An emergency diesel generator (D/G) is the only power source connected to its emergency bus. The governor of the D/G directly senses D/G _____ and adjusts D/G _____ flow to maintain a relatively constant D/G frequency.

- A. load; air
- B. load; fuel
- C. speed; air
- D. speed; fuel

USNRC GENERIC FUNDAMENTALS EXAMINATION
BWR - FORM A

QUESTION: 17

Refer to the drawing of a lube oil temperature control system (see figure below).

If the temperature transmitter fails low (low temperature output signal), the temperature controller will throttle the temperature control valve _____, causing the actual heat exchanger lube oil outlet temperature to _____.

- A. open; decrease
- B. open; increase
- C. closed; decrease
- D. closed; increase

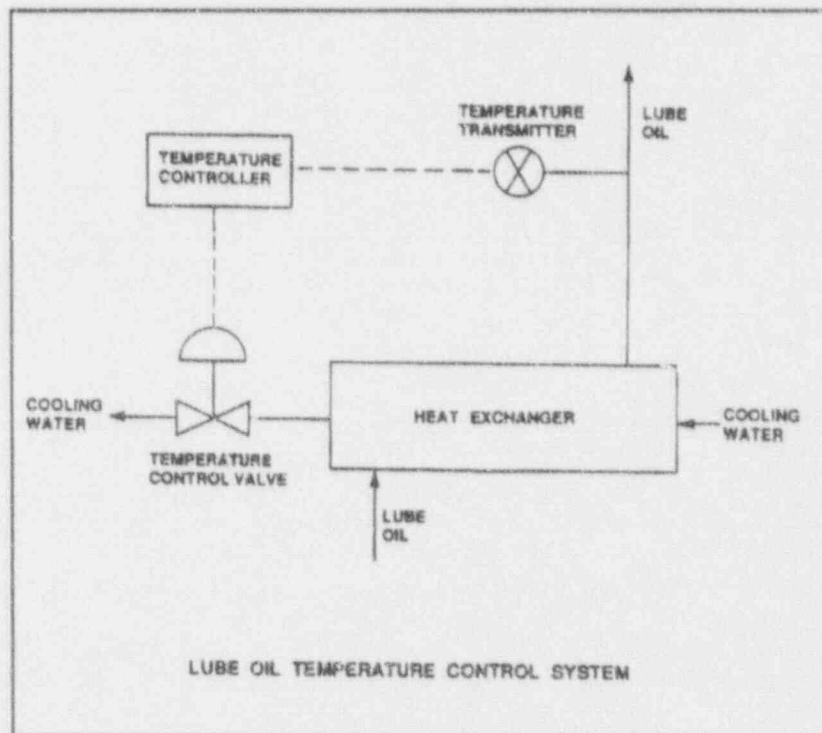

USNRC GENERIC FUNDAMENTALS EXAMINATION
BWR - FORM A

QUESTION: 18

Which one of the following is normally not a cause of gas/vapor binding of an operating centrifugal pump in a cooling water system?

- A. Increased pump inlet temperature
- B. Decreased pump suction pressure
- C. Loss of shaft seal water flow
- D. Improper venting of the pump

QUESTION: 19

A centrifugal pump with no recirculation flow path must be stopped when discharge pressure reaches pump shutoff head to prevent:

- A. overheating of the pump.
- B. overheating of the motor.
- C. bursting of the pump casing by subjecting it to excessively high pressure.
- D. water hammer in downstream lines when system pressure drops to a value where the pumps can inject water.

USNRC GENERIC FUNDAMENTALS EXAMINATION
BWR - FORM A

QUESTION: 20

A multispeed centrifugal pump is operating at 1800 rpm, providing a flow of 400 gpm at 20 psig. If the pump speed is increased to 3600 rpm, the new pump discharge pressure will be:

- A. 40 psig.
- B. 60 psig.
- C. 80 psig.
- D. 160 psig.

QUESTION: 21

Which one of the following conditions will result in a decrease in the available net positive suction head of a reactor recirculation pump?

- A. Carryunder decreases.
- B. Feedwater flow increases.
- C. Recirculation flow rate increases.
- D. Feedwater inlet subcooling increases.

USNRC GENERIC FUNDAMENTALS EXAMINATION
BWR - FORM A

QUESTION: 23

A _____ pump in a liquid system should be started with its discharge valve _____ to avoid rupturing the pump casing and/or discharge piping.

- A. centrifugal; throttled
- B. centrifugal; fully open
- C. positive displacement; throttled
- D. positive displacement; fully open

QUESTION: 24

A single-speed centrifugal fire pump takes suction on a water storage tank and discharges through a flexible fire hose. Which one of the following describes the response of the pump discharge flow rate?

- A. Decreases as the level in the storage tank decreases
- B. Increases as the height of the fire hose nozzle is increased
- C. Remains constant as the level in the storage tank decreases
- D. Remains constant as the height of the fire hose nozzle is increased

USNRC GENERIC FUNDAMENTALS EXAMINATION
BWR · FORM A

QUESTION: 25

Refer to the drawing of a centrifugal pump operating curve (see figure below).

Which one of the following determines the general shape of the curve from point D to point B?

- A. The operating characteristics of the pump
- B. The type of fluid used in the system
- C. The characteristics of the system piping and flow
- D. The combination of system and pump operating characteristics

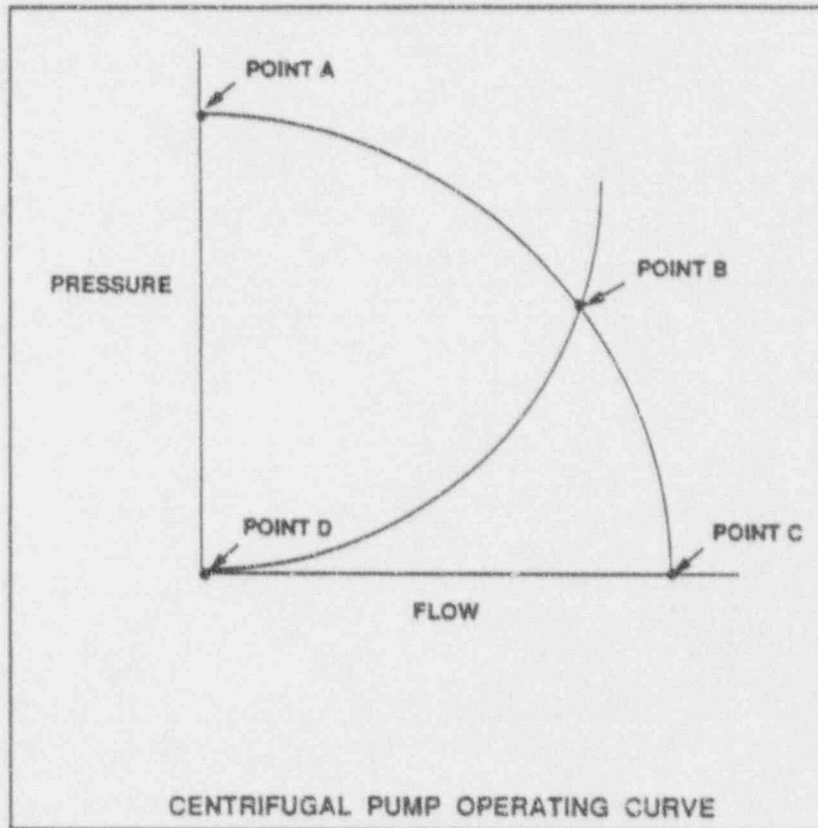

USNRC GENERIC FUNDAMENTALS EXAMINATION
BWR - FORM A

QUESTION: 26

If a locked rotor occurs on an operating motor-driven pump, motor amps will:

- A. decrease due to the decreased pump flow.
- B. decrease due to the increased mechanical load.
- C. increase due to the decreased pump flow.
- D. increase due to the increased mechanical load.

QUESTION: 27

Assuming pump flow and applied voltage remain constant, an increase in the stator temperature of an operating centrifugal pump motor will cause the motor current to:

- A. decrease because stator resistance increases.
- B. decrease because stator resistance decreases.
- C. increase because stator resistance increases.
- D. increase because stator resistance decreases.

QUESTION: 28

Motor winding temperature will be reduced by:

- A. increasing the reactive current flow in the stator windings.
- B. limiting the number of motor starts allowed in a given time period.
- C. decreasing the voltage supplied to the motor during full-load operation.
- D. decreasing the number of stator poles during the start sequence.

USNRC GENERIC FUNDAMENTALS EXAMINATION
EWR - FORM A

QUESTION: 29

What is the significance of a power factor of 0.8 when discussing output of a generator?

- A. The relationship between generator output voltage and current can be described as purely resistive.
- B. 80% of the energy input to the generator produces useful output.
- C. 80% of the generator output will be converted to useful power.
- D. This information characterizes the generator as a DC generator.

QUESTION: 30

A 125 volt DC motor is rated at 10 Kw. What is the current rating of the motor?

- A. 4.6 amps
- B. 8.0 amps
- C. 46.2 amps
- D. 80.0 amps

QUESTION: 31

As steam (shell) and liquid (tube) heat exchangers are put into service, the:

- A. water side is valved in before the steam side to ensure adequate venting.
- B. water side is valved in before the steam side to minimize thermal shock.
- C. steam side is valved in before the water side to minimize scale buildup on the heat exchanger tubes.
- D. steam side is valved in before the water side to ensure that the cooldown rate does not exceed 100°F/hr.

USNRC GENERIC FUNDAMENTALS EXAMINATION
BWR - FORM A

QUESTION: 32

Reduced heat exchanger performance will result from:

- A. tube wall thinning.
- B. turbulent flow in the tubes.
- C. increased ΔT between fluids.
- D. gas collection in the shell.

QUESTION: 33

Which one of the following changes will directly decrease subcooling of the condensate water in the main condenser hotwell?

- A. Increased circulating water flow
- B. Increased vacuum in the main condenser
- C. Decreased circulating water temperature
- D. Decreased main turbine generator Megawatt load

USNRC GENERIC FUNDAMENTALS EXAMINATION
BWR - FORM A

QUESTION: 34

Refer to the drawing of a lube oil heat exchanger (see figure below).

The heat exchanger is operating with the following parameters:

$$\begin{aligned}\dot{Q}_{\text{oil}} &= 1.0 \times 10^7 \text{ BTU/hr} \\ T_{\text{oil in}} &= 170^\circ\text{F} \\ T_{\text{oil out}} &= 134^\circ\text{F} \\ C_{p\text{-oil}} &= 1.1 \text{ BTU/lbm-}^\circ\text{F} \\ T_{\text{water in}} &= 85^\circ\text{F} \\ T_{\text{water out}} &= 112^\circ\text{F} \\ C_{p\text{-water}} &= 1.0 \text{ BTU/lbm-}^\circ\text{F}\end{aligned}$$

What is the mass flow rate of the cooling water?

- A. 1.2×10^5 lbm/hour
- B. 2.5×10^5 lbm/hour
- C. 3.7×10^5 lbm/hour
- D. 4.5×10^5 lbm/hour

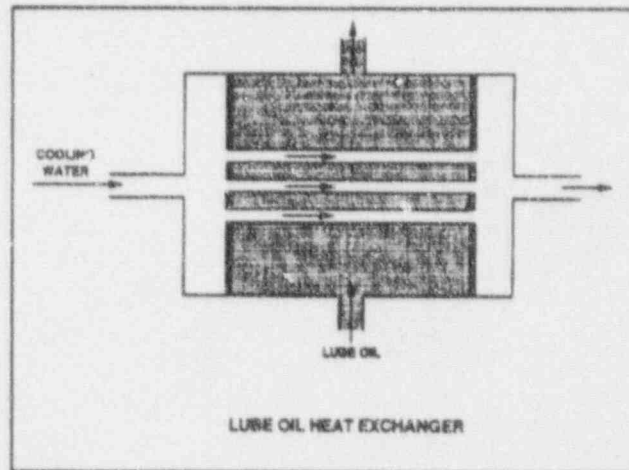

USNRC GENERIC FUNDAMENTALS EXAMINATION
BWR - FORM A

QUESTION: 35

Refer to the drawing of an operating cooling water system (see figure below).

Which one of the following effects would occur as a result of a tube failure in the heat exchanger?

- A. Level in the tank increases.
- B. HP fluid flow rate decreases.
- C. Flow in the low pressure system reverses.
- D. LP fluid heat exchanger outlet temperature increases.

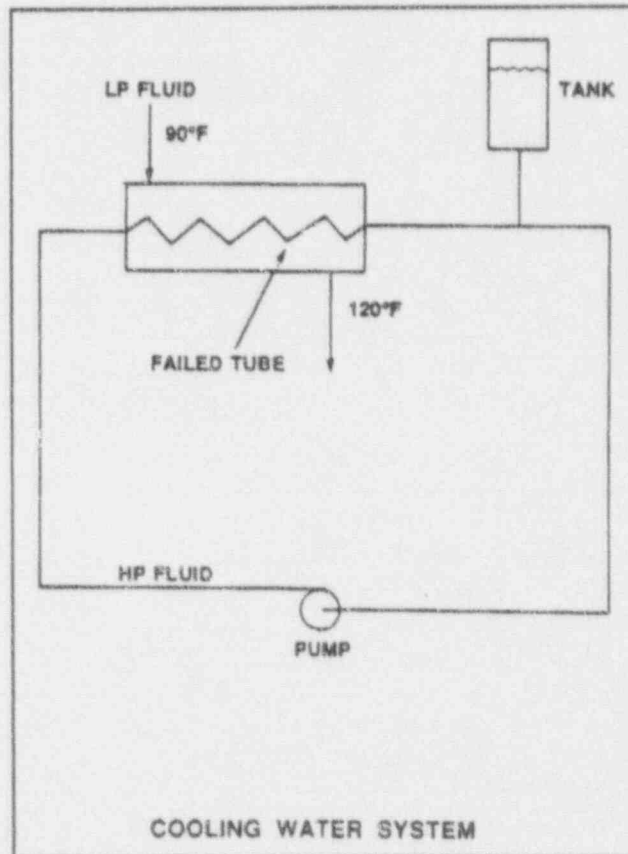

USNRC GENERIC FUNDAMENTALS EXAMINATION
BWR - FORM A

QUESTION: 36

Air entry into the main condenser will reduce the efficiency of the steam cycle because:

- A. steam flow rate through the main turbine increases.
- B. condensate subcooling in the main condenser increases.
- C. low pressure turbine exhaust steam enthalpy increases.
- D. the air mixes with the steam and enters the condensate.

QUESTION: 37

In a demineralizer, what adverse effect occurs due to channeling?

- A. Reduction in demineralizer efficiency because much of the resin is essentially bypassed.
- B. Resin dryout and cracking because much of the resin is essentially bypassed.
- C. Resin damage due to the increased velocity of fluid through the demineralizer.
- D. Loss of resin due to agitation resulting from increased fluid velocity through the demineralizer.

QUESTION: 38

The cation resin in a mixed-bed demineralizer releases _____ ions into solution while removing _____ ions from solution.

- A. negative; negative
- B. negative; positive
- C. positive; negative
- D. positive; positive

USNRC GENERIC FUNDAMENTALS EXAMINATION
BWR - FORM A

QUESTION: 39

A result of proper demineralizer operation on water with ionic impurities is that the exiting water will always have a:

- A. higher pH.
- B. lower pH.
- C. higher conductivity.
- D. lower conductivity.

QUESTION: 40

Which one of the following will cause a loss of indication from the remote breaker position indicating lights associated with a typical 480 VAC load supply breaker?

- A. Locally opening the breaker
- B. Loss of breaker line voltage
- C. Removing the breaker control power fuses
- D. Burnout of the local breaker position indicating lights

QUESTION: 41

An operator should never open or close a high voltage (greater than 750 volts) air break disconnect unless:

- A. a parallel path exists for current flow.
- B. the circuit it is in is already deenergized.
- C. the current flowing through it is approximately zero.
- D. the current flowing through it is less than its design current carrying capability.

USNRC GENERIC FUNDAMENTALS EXAMINATION
BWR - FORM A

QUESTION: 42

Refer to the drawing of a typical valve control circuit (see figure below).

Which one of the following describes the function of the #3 contact?

- A. To keep the K-3 relay energized after the initiating condition clears.
- B. To provide a method for manually energizing the K-3 relay.
- C. To increase circuit reliability as any one of the three contacts can energize the K-3 relay.
- D. To ensure the K-3 relay can always be deenergized even with the initiating condition present.

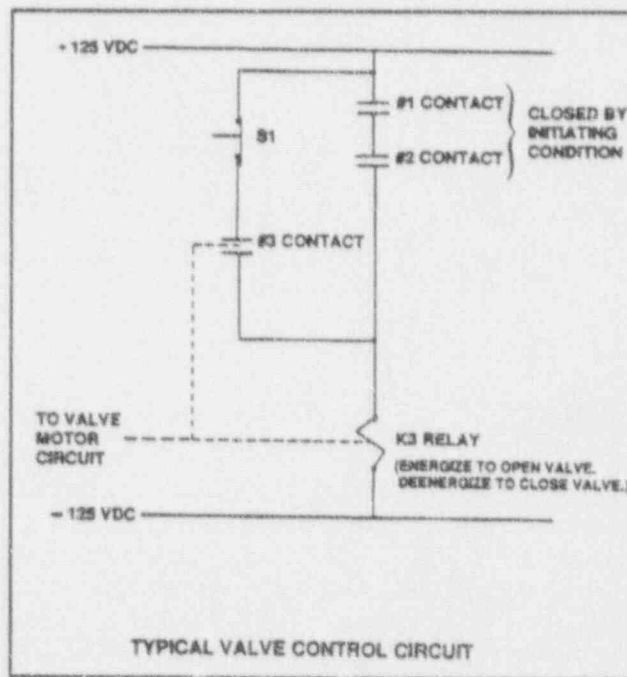

USNRC GENERIC FUNDAMENTALS EXAMINATION
BWR - FORM A

QUESTION: 43

Prior to connecting the main generator to the power grid, generator voltage should be _____ grid voltage and generator frequency should be _____ grid frequency.

- A. equal to; slightly higher than
- B. higher than; slightly higher than
- C. equal to; equal to
- D. higher than; equal to

QUESTION: 44

Which one of the following generator conditions will result in equipment damage from high current flow?

- A. Tripping the output breaker under full-load conditions
- B. Tripping the generator prime mover under full-load conditions
- C. Closing the output breaker onto a bus that has a short-circuit fault
- D. Closing the output breaker onto a bus that has an open-circuit fault

USNRC GENERIC FUNDAMENTALS EXAMINATION
BWR - FORM A

QUESTION: 45

Regarding a thermal neutron, the word "thermal" indicates that the neutron:

- A. was born greater than 10^{-14} seconds after the fission event.
- B. is a product of a thermal fission reaction.
- C. was released by the decay of fission fragments.
- D. is at the same energy level as the surrounding atoms.

QUESTION: 46

Which one of the following conditions will increase the amount of neutron moderation in a reactor operating at saturated conditions?

- A. Increasing moderator temperature
- B. Reducing feedwater inlet temperature
- C. Reducing reactor pressure vessel pressure
- D. Reducing reactor recirculation system flow

QUESTION: 47

Control rod withdrawal has increased K_{eff} from 0.998 to 1.002. The reactor currently is:

- A. subcritical.
- B. supercritical.
- C. prompt critical.
- D. exactly critical.

USNRC GENERIC FUNDAMENTALS EXAMINATION
BWR - FORM A

QUESTION: 48

Which one of the following core changes will decrease shutdown margin?

- A. Fuel depletion during reactor operation
- B. Buildup of Sm-149 after a reactor scram
- C. Increasing moderator temperature 10°F while shutdown
- D. Depletion of gadolinium during reactor operation

QUESTION: 49

Without delayed neutrons in the neutron cycle, when positive reactivity is added to a critical reactor, the reactor will:

- A. experience a prompt jump in power level followed by a decrease to the initial power level.
- B. experience a rapid but controllable power increase.
- C. begin an uncontrollable rapid power increase.
- D. not be able to attain criticality.

QUESTION: 50

A reactor is operating at 75% power with the following conditions:

| | |
|------------------------------------|------------------------|
| Total Control rod worth | = -0.0753 $\Delta K/K$ |
| Shutdown margin | = 0.0042 $\Delta K/K$ |
| Effective delayed neutron fraction | = 0.0058 |
| Effective prompt neutron fraction | = 0.9942 |

How much positive reactivity must be added to make the reactor "prompt critical"?

- A. 0.0042 $\Delta K/K$
- B. 0.0058 $\Delta K/K$
- C. 0.0753 $\Delta K/K$
- D. 0.9942 $\Delta K/K$

USNRC GENERIC FUNDAMENTALS EXAMINATION
BWR - FORM A

QUESTION: 51

During a reactor startup, the intermediate range monitor readings go from 30% to 65% on the same range in 2 minutes with no operator action. Which one of the following is the average reactor period during the power increase?

- A. 357 seconds
- B. 173 seconds
- C. 155 seconds
- D. 120 seconds

QUESTION: 52

Which one of the following pairs of isotopes is responsible for the negative reactivity associated with a fuel temperature increase near the end of core life?

- A. U-235 and Pu-239
- B. U-235 and Pu-240
- C. U-238 and Pu-239
- D. U-238 and Pu-240

QUESTION: 53

Which one of the following describes how and why the void coefficient changes as void fraction increases during a control rod withdrawal at power?

- A. Becomes more negative due to a greater fractional loss of moderator for a 1% void increase at higher void fractions.
- B. Becomes more negative due to the reduction in the fast fission contribution to the neutron population.
- C. Becomes less negative due to a greater fraction of neutrons lost to leakage from the core.
- D. Becomes less negative due to the increased absorption of neutrons by U-238.

USNRC GENERIC FUNDAMENTALS EXAMINATION
BWR - FORM A

QUESTION: 54

The reactor has been shutdown for 3 weeks with all control rods fully inserted. If a center control rod is fully withdrawn from the core, neutron population will: (Assume the reactor remains subcritical.)

- A. increase and stabilize at a new higher level.
- B. increase temporarily then return to the original value.
- C. increase exponentially until the operator inserts the control rod.
- D. remain the same.

QUESTION: 55

How is control rod density affected as control rods are inserted during a reactor shutdown?

- A. Increases continuously during rod insertion.
- B. Decreases continuously during rod insertion.
- C. Increases initially, then decreases after 50% of the rods are inserted.
- D. Decreases initially, then increases after 50% of the rods are inserted.

QUESTION: 56

Which one of the following control rods, when repositioned, will have the largest effect on axial flux shape?

- A. Deep rods at the center of the core
- B. Shallow rods at the center of the core
- C. Deep rods at the periphery of the core
- D. Shallow rods at the periphery of the core

USNRC GENERIC FUNDAMENTALS EXAMINATION
BWR - FORM A

QUESTION: 57

Neutron flux shaping within a reactor core is designed to:

- A. minimize the effects of rod shadowing.
- B. ensure that more power is generated in the lower portion of the core.
- C. ensure that local core power limits are not exceeded.
- D. minimize the effects of an ejected rod.

QUESTION: 58

Which one of the following lists the proper order of substances with the largest to the smallest microscopic cross-sections for capture of thermal neutrons?

- A. Xe-135, H₂O, U-235
- B. Xe-135, U-235, H₂O
- C. U-235, H₂O, Xe-135
- D. U-235, Xe-135, H₂O

QUESTION: 59

Which one of the following describes the primary method of Xenon-135 removal at the indicated power level?

- A. Decay of Xenon-135 to Cesium-135 at full power
- B. Decay of Xenon-135 to Iodine-135 at the point of adding heat
- C. Absorption of neutrons by Xenon-135 at the point of adding heat
- D. Absorption of neutrons by Xenon-135 at full power

USNRC GENERIC FUNDAMENTALS EXAMINATION
BWR - FORM A

QUESTION: 60

Following a 2-week shutdown, a reactor is taken critical and ramped to full power in 6 hours. How long will it take to achieve an equilibrium xenon condition after the reactor reaches full power?

- A. 70 to 80 hours
- B. 40 to 50 hours
- C. 8 to 10 hours
- D. 1 to 2 hours

QUESTION: 61

The reactor has been operating at 100% power for 2 weeks when power is reduced to 50% in 1 hour. How will the amount of core xenon change over the next 24 hours?

- A. Increase and stabilize at a new higher value
- B. Increase initially, then decrease and stabilize at a lower value.
- C. Decrease and stabilize at a new lower value
- D. Decrease initially, then increase and stabilize at a higher value.

QUESTION: 62

A reactor has been operating at full power for several weeks when a scram occurs. When the reactor is brought critical 5 hours later, Xe-135 concentration will be highest in the _____ of the core, which causes thermal neutron flux to shift toward the _____ of the core.

- A. center; periphery
- B. periphery; periphery
- C. center; center
- D. periphery; center

USNRC GENERIC FUNDAMENTALS EXAMINATION
BWR - FORM A

QUESTION: 63

Burnable poisons are placed in a reactor core to:

- A. increase the amount of fuel that can be loaded into the core.
- B. accommodate control rod depletion that occurs over core life.
- C. compensate for the buildup of Xenon-135 that occurs over core life.
- D. ensure that the reactor will always operate in an undermoderated condition.

QUESTION: 64

Sixteen hours after a reactor scram from 100% power, equilibrium xenon condition, the amount of core xenon will be:

- A. lower than 100% equilibrium xenon, and will have added a net positive reactivity since the scram.
- B. higher than 100% equilibrium xenon, and will have added a net positive reactivity since the scram.
- C. lower than 100% equilibrium xenon, and will have added a net negative reactivity since the scram.
- D. higher than 100% equilibrium xenon, and will have added a net negative reactivity since the scram.

QUESTION: 65

While withdrawing control rods during a reactor startup, the count rate doubles. If the same amount of reactivity that caused the first doubling is added again, the count rate will _____ and the reactor will be _____.

- A. more than double; subcritical
- B. more than double; critical
- C. double; subcritical
- D. double; critical

USNRC GENERIC FUNDAMENTALS EXAMINATION
BWR - FORM A

QUESTION: 66

During an initial reactor fuel load, the 1/M factor decreases from 1.0 to 0.5 after the first 100 fuel assemblies are loaded. What is the current value of K_{eff} ?

- A. 0.2
- B. 0.5
- C. 0.875
- D. 1.0

QUESTION: 67

Which one of the following describes the purpose of the neutron source in a reactor during the third fuel cycle?

- A. Ensures shutdown neutron level is large enough to be detected by nuclear instrumentation.
- B. Provides additional excess reactivity to increase the length of each fuel cycle.
- C. Increases local fission rate to flatten the neutron flux in the core.
- D. Supplies the only shutdown source of neutrons available to begin the fission process.

QUESTION: 68

After taking critical data during a reactor startup, the operator establishes a positive 26-second reactor period to increase power to the point of adding heat (POAH). How much negative reactivity must be added to stabilize power at the POAH?

Assume $\bar{\beta}_{eff} = 0.00579$

- A. 0.10% $\Delta K/K$
- B. 0.16% $\Delta K/K$
- C. 1.0% $\Delta K/K$
- D. 1.6% $\Delta K/K$

USNRC GENERIC FUNDAMENTALS EXAMINATION
BWR - FORM A

QUESTION: 69

During a normal power increase from 20% to 100%, the smallest negative reactivity addition will be caused by the change in:

- A. void content.
- B. fuel temperature.
- C. xenon concentration.
- D. moderator temperature.

QUESTION: 70

A reactor is operating at 100% power and flow. Reactor power is reduced to 90% by inserting control rods. (Recirculating pump speed remains constant.)

What is the effect on core flow?

- A. Core flow will decrease due to an increase in core voiding.
- B. Core flow will increase due to the decrease in recirculation ratio.
- C. Core flow will increase due to the decrease in two-phase flow resistance.
- D. Core flow will decrease due to an increase in two-phase flow resistance.

USNRC GENERIC FUNDAMENTALS EXAMINATION
BWR - FORM A

QUESTION: 71

The plant is operating at 85% power when a failure of the steam pressure control system opens the turbine control valves to admit 10% more steam flow to the main turbine. No operator actions occur and no protective system actuations occur.

How will reactor power respond? (Assume the valves remain in the failed position.)

- A. Increase until reactor power matches the new steam demand.
- B. Increase continuously and exceed reactor protection setpoints.
- C. Decrease and stabilize at a lower power level and cladding rate.
- D. Decrease and stabilize at a critical power level below the POAH.

QUESTION: 72

Which one of the following percentages most closely approximates the decay heat produced in the reactor at 1 second and at 1 hour, respectively, following a scram from extended operation at 100% power?

| | <u>ONE SECOND</u> | <u>ONE HOUR</u> |
|----|-------------------|-----------------|
| A. | 15.0% | 1.0% |
| B. | 7.0% | 1.0% |
| C. | 1.0% | 0.1% |
| D. | 0.5% | 0.1% |

USNRC GENERIC FUNDAMENTALS EXAMINATION
BNA - FORM A

QUESTION: 73

Refer to the drawing of four tank differential pressure level detectors (see figure below).

The tanks are identical and are being maintained at 17 psia and the same constant water level. They are surrounded by atmospheric pressure.

Which one of the level detectors will sense the greatest delta-P?

- A. No. 1
- B. No. 2
- C. No. 3
- D. No. 4

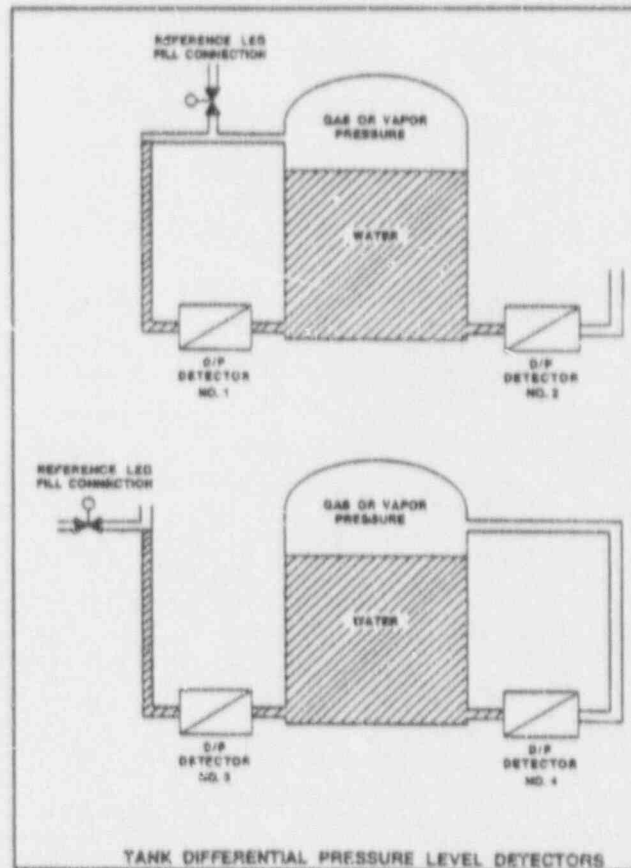

USNRC GENERIC FUNDAMENTALS EXAMINATION
BWR - FORM A

QUESTION: 74

Which one of the following sets of water parameters will result in the highest fluid quality?

- A. 500°F; 1100 BTU/lbm
- B. 320°F; 1070 BTU/lbm
- C. 200°F; 1040 BTU/lbm
- D. 160°F; 960 BTU/lbm

QUESTION: 75

Which one of the following represents the value of enthalpy (h) for steam at 235.3 psig and 500°F?

- A. $h = 1201.1$, BTU/lbm
- B. $h = 1202.2$, BTU/lbm
- C. $h = 1263.5$, BTU/lbm
- D. $h = 1286.6$, BTU/lbm

USNRC GENERIC FUNDAMENTALS EXAMINATION
BWR - FORM A

QUESTION: 79

Refer to the drawing of an operating steam-jet air ejector (see figure below).

At which of the following locations is the lowest pressure experienced?

- A. 1
- B. 2
- C. 3
- D. 4

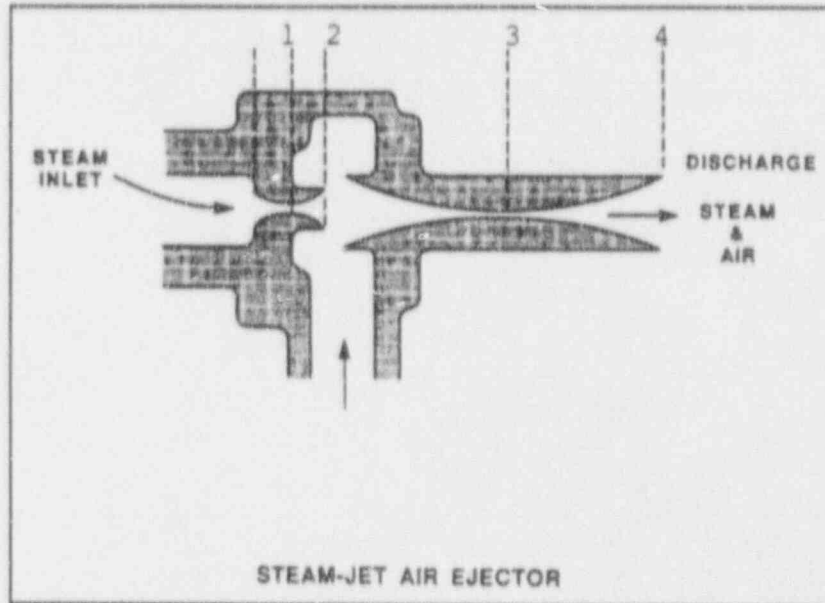

USNRC GENERIC FUNDAMENTALS EXAMINATION
BWR - FORM A

QUESTION: 77

The plant is operating at 90% of rated power. Which one of the following describes the effect of increasing circulating water flow rate through the main condenser?

- A. The heat transfer required to condense each pound-mass of turbine exhaust steam increases.
- B. The total rate of heat transfer from the turbine exhaust steam to the circulating water decreases.
- C. The circulating water temperature leaving the main condenser increases.
- D. The enthalpy of the condensate leaving the main condenser increases.

QUESTION: 78

The extraction steam to a high-pressure feedwater heater is isolated with the plant operating at 85% power. Which one of the following describes the effect on main turbine generator output (MWe)? (Assume no operator action and no reactor protection actuation.)

- A. MWe increases because the total steam flow rate through the turbine increases.
- B. MWe decreases because the total steam flow rate through the turbine decreases.
- C. MWe increases because plant efficiency increases.
- D. MWe decreases because plant efficiency decreases.

USNRC GENERIC FUNDAMENTALS EXAMINATION
BWR - FORM A

QUESTION: 79

Head loss is the:

- A. reduction in discharge pressure experienced by a real pump due to slippage.
- B. reduction in heat transfer caused by core bypass flow in the upper portions of the reactor vessel.
- C. conversion of system fluid pressure and velocity to heat energy as a result of friction.
- D. decrease in static pressure in a piping system resulting from decreases in elevation.

QUESTION: 80

A common method used in emergency cooling water systems to reduce the rate of flow through a pipe rupture, while allowing design cooling flow capability during normal operation, is the installation of:

- A. venturis.
- B. orifices.
- C. redundant pumps.
- D. pipe hangers.

QUESTION: 81

A reactor is operating at a pressure of 1025 psia. It has a temperature of 530°F in the suction of the recirculating pump and an elevation head of 25 psia.

Disregarding line losses, which one of the following values is the available net positive suction head?

- A. 177 psia
- B. 165 psia
- C. 154 psia
- D. 143 psia

USNRC GENERIC FUNDAMENTALS EXAMINATION
BWR - FORM A

QUESTION: 82

The heat-transfer mechanism using direct contact transfer of kinetic energy from molecular motion is:

- A. radiation.
- B. convection.
- C. transmission.
- D. conduction.

QUESTION: 83

The order of reactor coolant heat transfer mechanisms, from the most efficient to the least efficient, is:

- A. nucleate boiling, transition boiling, stable film boiling.
- B. stable film boiling, nucleate boiling, transition boiling.
- C. nucleate boiling, stable film boiling, transition boiling.
- D. stable film boiling, transition boiling, nucleate boiling.

QUESTION: 84

Which one of the following expressions describes core thermal power?

- A. $\dot{Q}_{core} = \dot{Q}_{feedwater} - \dot{Q}_{steam} - \dot{Q}_{CRD} - \dot{Q}_{recirc} + \dot{Q}_{Ambient} + \dot{Q}_{RWCU}$
- B. $\dot{Q}_{core} = \dot{Q}_{steam} - \dot{Q}_{feedwater} + \dot{Q}_{CRD} + \dot{Q}_{recirc} - \dot{Q}_{Ambient} - \dot{Q}_{RWCU}$
- C. $\dot{Q}_{core} = \dot{Q}_{steam} - \dot{Q}_{feedwater} - \dot{Q}_{CRD} - \dot{Q}_{recirc} + \dot{Q}_{Ambient} + \dot{Q}_{RWCU}$
- D. $\dot{Q}_{core} = \dot{Q}_{steam} - \dot{Q}_{feedwater} - \dot{Q}_{CRD} - \dot{Q}_{recirc} - \dot{Q}_{Ambient} - \dot{Q}_{RWCU}$

USNRC GENERIC FUNDAMENTALS EXAMINATION
BWR - FORM A

QUESTION: 85

Boiling improves heat transfer because:

- A. it produces agitation, which reduces the thickness of the fluid film and results in the latent heat of vaporization being removed, as the bubbles move away from the heated surface.
- B. it increases the heat transfer from the heated surface due to latent heat of condensation, as the steam bubbles collapse at the heated surface.
- C. it increases the fluid velocity past the heated surface, which offsets the reduction in fluid film thickness at the heated surface.
- D. it increases the effective thickness of the fluid film surrounding the heat transfer surface.

QUESTION: 86

Which one of the following describes convection heat transfer?

- A. The flow of heat through a body or between bodies in direct contact.
- B. The flow of heat between two different fluids not in direct contact.
- C. The flow of heat from a body by electromagnetic waves across an intervening space.
- D. The flow of heat between a fluid and surface by circulation of the fluid.

QUESTION: 87

Which one of the following describes the conditions in a fuel channel that is experiencing transition boiling?

- A. Complete steam blanketing of the fuel rod surface.
- B. Alternate wetting and drying of the fuel rod surface.
- C. Subcooled nucleate boiling.
- D. Saturated nucleate boiling.

USNRC GENERIC FUNDAMENTALS EXAMINATION
BWR - FORM A

QUESTION: 88

Refer to the drawing of a pool boiling curve (see figure below).

The point at which heat flux is increasing and the critical heat flux has been reached (point B), marks the beginning of:

- A. nucleate boiling.
- B. stable film boiling.
- C. partial film boiling.
- D. single-phase convection.

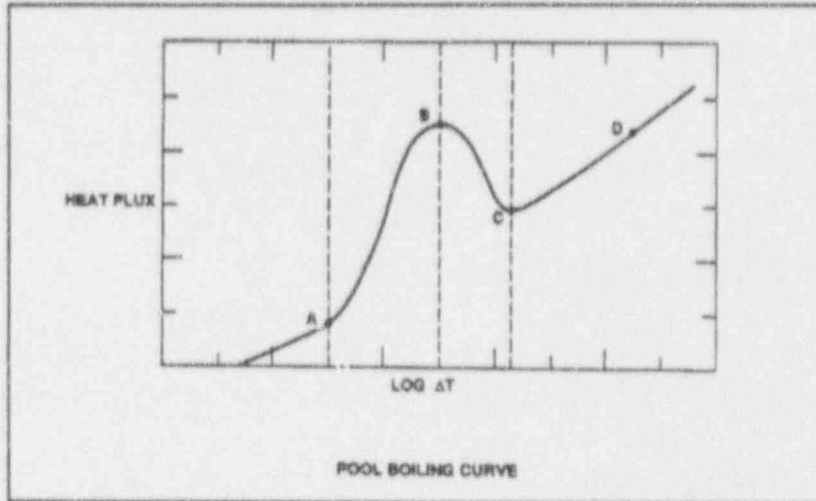

USNRC GENERIC FUNDAMENTALS EXAMINATION
BWR - FORM A

QUESTION: 89

Which one of the following will directly reduce core inlet subcooling?

- A. Raise reactor vessel downcomer level until carryover occurs.
- B. Lower reactor vessel downcomer level until carryunder occurs.
- C. Increase core recirculation flow.
- D. Isolate steam to one feedwater heater.

QUESTION: 90

Two reactors, A and B, are operating at rated power with neutron flux radially peaked in the center of each core. Reactors A and B are identical except that Reactor A has core orificing and Reactor B does not.

Compared to the center fuel bundle in Reactor B, the center fuel bundle in Reactor A will have the _____ critical power and the _____ coolant flow rate.

- A. lowest; lowest
- B. lowest; highest
- C. highest; lowest
- D. highest; highest

QUESTION: 91

With the reactor shutdown and the reactor recirculating pumps isolated, it is important to monitor reactor vessel skin temperatures because:

- A. these temperatures must be maintained constant with no flow in the core.
- B. cooldown rates are easily exceeded with the recirculation pumps isolated.
- C. these temperatures will provide one of the first indications of thermal stratification.
- D. these temperatures are the only reliable source of reactor recirculation loop temperature.

USNRC GENERIC FUNDAMENTALS EXAMINATION
BWR - FORM A

QUESTION: 92

If the linear heat generation rate (LHGR) limiting condition for operation is exceeded, the most probable type of fuel failure is cladding:

- A. cracking due to high stress.
- B. gross failure due to a lack of cooling.
- C. embrittlement due to excessive oxidation.
- D. distortion due to inadequate cooling of the clad.

QUESTION: 93

Which one of the following must be maintained within limits to ensure that peak cladding temperature will not exceed 2200°F after a design basis loss of coolant accident?

- A. Linear heat generation rate (LHGR)
- B. Average planar linear heat generation rate (APLHGR)
- C. Minimum critical power ratio (MCPR)
- D. Maximum fraction of limiting critical power ratio (MFLCPR)

QUESTION: 94

Which one of the following expressions describes the critical power ratio?

- A. Critical power/actual bundle power
- B. Actual bundle power/critical power
- C. Average bundle power/critical power
- D. Critical power/average bundle power

USNRC GENERIC FUNDAMENTALS EXAMINATION
BWR - FORM A

QUESTION: 95

During normal power operation a reactor pressure increase causes critical power to _____ because the latent heat of vaporization _____.

- A. increase; decreases
- B. decrease; decreases
- C. increase; increases
- D. decrease; increases

QUESTION: 96

The fuel thermal time constant describes the amount of time required for:

- A. the fuel to change its rate of heat generation by 63%.
- B. the fuel centerline temperature to undergo 63% of its total change resulting from a given power change.
- C. the fuel cladding temperature to undergo 63% of its total change resulting from a given change in fuel temperature.
- D. reactor power to undergo 63% of its total change resulting from a given reactivity insertion.

QUESTION: 97

The presence of embrittling isotopes is one of the initiating factors of pellet-clad-interaction (PCI). What is the source of the embrittling isotopes?

- A. Created during fission of the reactor fuel.
- B. Introduced during the manufacturing process.
- C. Migrate from reactor coolant through cladding.
- D. Produced as corrosion products inside fuel rod.

USNRC GENERIC FUNDAMENTALS EXAMINATION
BWR - FORM A

QUESTION: 98

During a rapid increase in core flow, the most limiting thermal limit is:

- A. maximum fraction of limiting power density (MFLPD).
- B. minimum critical power ratio (MCPR).
- C. average planar linear heat generation rate (APLHGR).
- D. linear heat generation rate (LHGR).

QUESTION: 99

The likelihood of brittle fracture failure of the reactor vessel is reduced by:

- A. reducing gamma flux exposure.
- B. reducing vessel temperature.
- C. reducing vessel pressure.
- D. increasing vessel age.

QUESTION: 100

Prolonged exposure of the reactor vessel to a fast neutron flux will cause the reference temperature for nil-ductility transition (RT_{NDT}) to:

- A. decrease due to the propagation of existing flaws.
- B. increase due to the propagation of existing flaws.
- C. decrease due to changes in the material properties of the vessel wall.
- D. increase due to changes in the material properties of the vessel wall.

UNITED STATES NUCLEAR REGULATORY COMMISSION
BOILING WATER REACTOR GENERIC FUNDAMENTALS EXAMINATION
JUNE 1992 - FORM B

Please Print:

Name: _____

Facility: _____

ID Number: _____

Start Time: _____ Stop Time: _____

INSTRUCTIONS TO CANDIDATE

Use the answer sheet provided. Each question has equal point value. A score of at least 80% is required to pass this portion of the written licensing examination. All examination papers will be collected 2.5 hours after the examination starts.

| SECTION | QUESTIONS | % OF TOTAL | SCORE |
|----------------|-----------|------------|-------|
| THERMODYNAMICS | 1 - 28 | | |
| COMPONENTS | 29 - 72 | | |
| REACTOR THEORY | 73 - 100 | | |
| TOTALS | 100 | | |

All work done on this examination is my own. I have neither given nor received aid.

Candidate's Signature

RULES AND GUIDELINES FOR THE
GENERIC FUNDAMENTALS EXAMINATION

During the administration of this examination the following rules apply:

1. Print your name in the blank provided on the cover sheet of the examination.
2. Fill in the name of your facility.
3. Fill in the ID Number you were given at registration.
4. Fill in your start and stop times at the appropriate time.
5. Two aids are provided for your use during the examination:
 - (1) An equations and conversions sheet contained within the examination copy, and
 - (2) Steam tables provided by your proctor.
6. Use only the answer sheet provided. Credit will only be given for answers properly marked on this sheet. Follow the instructions for filling out the answer sheet.
7. Scrap paper will be provided for calculations.
8. Cheating on the examination will result in the automatic forfeiture of this examination. Cheating could also result in severe penalties.
9. Restroom trips are limited. Only ONE examinee may leave the room at a time. In order to avoid the appearance or possibility of cheating, avoid all contact with anyone outside of the examination room.
10. After you have completed the examination, sign the statement on the cover sheet indicating that the work is your own and you have not received or been given any assistance in completing the examination.
11. Turn in your examination materials, answer sheet on top, followed by the examination booklet, then examination aids - steam table booklets, handouts and scrap paper used during the examination.
12. After turning in your examination materials, leave the examination area, as defined by the proctor. If after leaving you are found in the examination area while the examination is in progress, your examination may be forfeited.

GENERIC FUNDAMENTALS EXAMINATIONS SECTION
EQUATIONS AND CONVERSIONS HANDOUT SHEET

EQUATIONS

$$\dot{Q} = \dot{m}c_p\Delta T$$

$$\text{Cycle Efficiency} = \frac{\text{Net Work (out)}}{\text{Energy (in)}}$$

$$\dot{Q} = \dot{m}\Delta h$$

$$\text{SCR} = S/(1 - K_{\text{eff}})$$

$$\dot{Q} = UA\Delta T$$

$$CR_1(1 - K_{\text{eff}})_1 = CR_2(1 - K_{\text{eff}})_2$$

$$\text{SUR} = 26.06/\tau$$

$$M = 1/(1 - K_{\text{eff}}) = CR_1/CR_0$$

$$\text{SUR} = \frac{26.06(\lambda_{\text{eff}}\rho)}{(\bar{\beta} - \rho)}$$

$$M = \frac{(1 - K_{\text{eff}})_0}{(1 - K_{\text{eff}})_1}$$

$$P = P_0 10^{\text{SUR}(t)}$$

$$\text{SDM} = (1 - K_{\text{eff}})/K_{\text{eff}}$$

$$P = P_0 e^{(t/\tau)}$$

$$\text{Pwr} = W_f \dot{m}$$

$$\tau = (l^*/\rho) + [(\bar{\beta} - \rho)/\lambda_{\text{eff}}\rho]$$

$$\tau = l^*/(\rho - \bar{\beta})$$

$$\rho = (K_{\text{eff}} - 1)/K_{\text{eff}}$$

$$l^* = 1 \times 10^{-5} \text{ seconds}$$

$$\rho = \Delta K_{\text{eff}}/K_{\text{eff}}$$

$$\lambda_{\text{eff}} = 0.1 \text{ seconds}^{-1}$$

$$v(P_e - P_i) + \frac{(\bar{v}_e^2 - \bar{v}_i^2)}{2} + g(z_e - z_i) = 0$$

CONVERSIONS

$$1 \text{ Curie} = 3.7 \times 10^{10} \text{ dps}$$

$$1 \text{ kg} = 2.21 \text{ lbm}$$

$$1 \text{ hp} = 2.54 \times 10^3 \text{ BTU/hr}$$

$$1 \text{ Mw} = 3.41 \times 10^6 \text{ BTU/hr}$$

$$1 \text{ BTU} = 778 \text{ ft-lbf}$$

$$^{\circ}\text{F} = 9/5 ^{\circ}\text{C} + 32$$

$$^{\circ}\text{C} = 5/9(^{\circ}\text{F} - 32)$$

USNRC GENERIC FUNDAMENTALS EXAMINATION
BWR - FORM B

QUESTION: 1

Refer to the drawing of four tank differential pressure level detectors (see figure below).

The tanks are identical and are being maintained at 17 psia and the same constant water level. They are surrounded by atmospheric pressure.

Which one of the level detectors will sense the greatest delta-P?

- A. No. 1
- B. No. 2
- C. No. 3
- D. No. 4

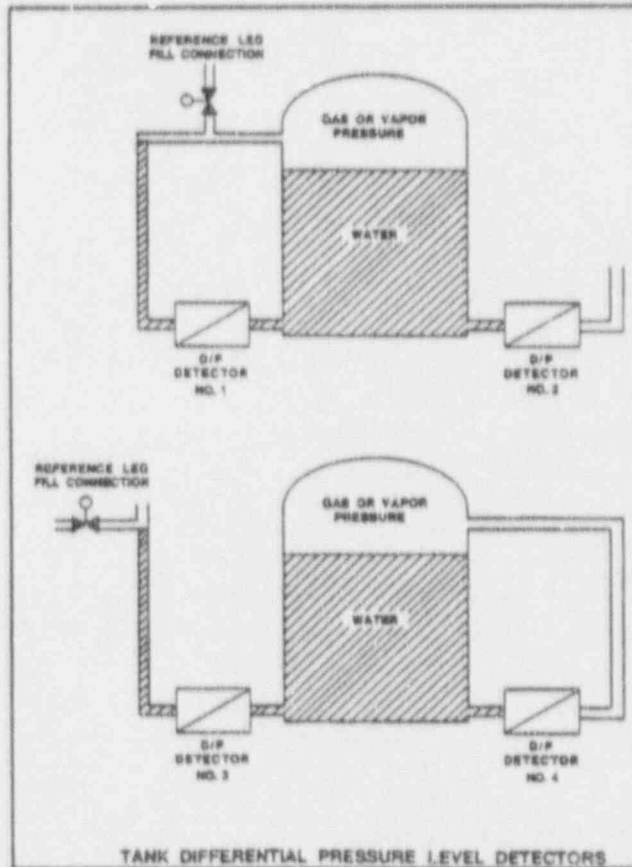

USNRC GENERIC FUNDAMENTALS EXAMINATION
BWR - FORM B

QUESTION: 2

Which one of the following sets of water parameters will result in the highest fluid quality?

- A. 500°F; 1100 BTU/lbm
- B. 320°F; 1070 BTU/lbm
- C. 200°F; 1040 BTU/lbm
- D. 160°F; 960 BTU/lbm

QUESTION: 3

Which one of the following represents the value of enthalpy (h) for steam at 235.3 psig and 500°F?

- A. $h = 1201.1$, BTU/lbm
- B. $h = 1202.2$, BTU/lbm
- C. $h = 1263.5$, BTU/lbm
- D. $h = 1286.6$, BTU/lbm

USNRC GENERIC FUNDAMENTALS EXAMINATION
BWR - FORM B

QUESTION: 4

Refer to the drawing of an operating steam-jet air ejector (see figure below).

At which of the following locations is the lowest pressure experienced?

- A. 1
- B. 2
- C. 3
- D. 4

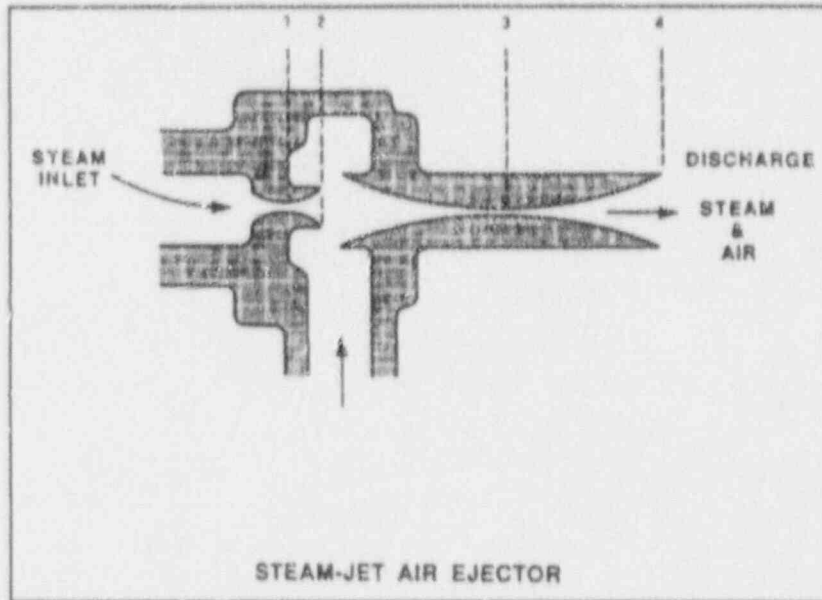

USNRC GENERIC FUNDAMENTALS EXAMINATION
BWR - FORM B

QUESTION: 5

The plant is operating at 90% of rated power. Which one of the following describes the effect of increasing circulating water flow rate through the main condenser?

- A. The heat transfer required to condense each pound-mass of turbine exhaust steam increases.
- B. The total rate of heat transfer from the turbine exhaust steam to the circulating water decreases.
- C. The circulating water temperature leaving the main condenser increases.
- D. The enthalpy of the condensate leaving the main condenser increases.

QUESTION: 6

The extraction steam to a high-pressure feedwater heater is isolated with the plant operating at 85% power. Which one of the following describes the effect on main turbine generator output (MWe)? (Assume no operator action and no reactor protection actuation.)

- A. MWe increases because the total steam flow rate through the turbine increases.
- B. MWe decreases because the total steam flow rate through the turbine decreases.
- C. MWe increases because plant efficiency increases.
- D. MWe decreases because plant efficiency decreases.

USNRC GENERIC FUNDAMENTALS EXAMINATION
BWR - FORM B

QUESTION: 7

Head loss is the:

- A. reduction in discharge pressure experienced by a real pump due to slippage.
- B. reduction in heat transfer caused by core bypass flow in the upper portions of the reactor vessel.
- C. conversion of system fluid pressure and velocity to heat energy as a result of friction.
- D. decrease in static pressure in a piping system resulting from decreases in elevation.

QUESTION: 8

A common method used in emergency cooling water systems to reduce the rate of flow through a pipe rupture, while allowing design cooling flow capability during normal operation, is the installation of:

- A. venturis.
- B. orifices.
- C. redundant pumps.
- D. pipe hangers.

QUESTION: 9

A reactor is operating at a pressure of 1025 psia. It has a temperature of 530°F in the suction of the recirculating pump and an elevation head of 25 psia.

Disregarding line losses, which one of the following values is the available net positive suction head?

- A. 177 psia
- B. 165 psia
- C. 154 psia
- D. 143 psia

USNRC GENERIC FUNDAMENTALS EXAMINATION
BWR - FORM B

QUESTION: 10

The heat-transfer mechanism using direct contact transfer of kinetic energy from molecular motion is:

- A. radiation.
- B. convection.
- C. transmission.
- D. conduction.

QUESTION: 11

The order of reactor coolant heat transfer mechanisms, from the most efficient to the least efficient, is:

- A. nucleate boiling, transition boiling, stable film boiling.
- B. stable film boiling, nucleate boiling, transition boiling.
- C. nucleate boiling, stable film boiling, transition boiling.
- D. stable film boiling, transition boiling, nucleate boiling.

QUESTION: 12

Which one of the following expressions describes core thermal power?

- A. $\dot{Q}_{\text{core}} = \dot{Q}_{\text{Feedwater}} - \dot{Q}_{\text{Steam}} - \dot{Q}_{\text{CRD}} - \dot{Q}_{\text{Recirc}} + \dot{Q}_{\text{Ambient}} + \dot{Q}_{\text{RWCU}}$
- B. $\dot{Q}_{\text{core}} = \dot{Q}_{\text{Steam}} - \dot{Q}_{\text{Feedwater}} + \dot{Q}_{\text{CRD}} + \dot{Q}_{\text{Recirc}} - \dot{Q}_{\text{Ambient}} - \dot{Q}_{\text{RWCU}}$
- C. $\dot{Q}_{\text{core}} = \dot{Q}_{\text{Steam}} - \dot{Q}_{\text{Feedwater}} - \dot{Q}_{\text{CRD}} - \dot{Q}_{\text{Recirc}} + \dot{Q}_{\text{Ambient}} + \dot{Q}_{\text{RWCU}}$
- D. $\dot{Q}_{\text{core}} = \dot{Q}_{\text{Steam}} - \dot{Q}_{\text{Feedwater}} - \dot{Q}_{\text{CRD}} - \dot{Q}_{\text{Recirc}} - \dot{Q}_{\text{Ambient}} - \dot{Q}_{\text{RWCU}}$

USNRC GENERIC FUNDAMENTALS EXAMINATION
BWR - FORM B

QUESTION: 13

Boiling improves heat transfer because:

- A. it produces agitation, which reduces the thickness of the fluid film and results in the latent heat of vaporization being removed, as the bubbles move away from the heated surface.
- B. it increases the heat transfer from the heated surface due to latent heat of condensation, as the steam bubbles collapse at the heated surface.
- C. it increases the fluid velocity past the heated surface, which offsets the reduction in fluid film thickness at the heated surface.
- D. it increases the effective thickness of the fluid film surrounding the heat transfer surface.

QUESTION: 14

Which one of the following describes convection heat transfer?

- A. The flow of heat through a body or between bodies in direct contact.
- B. The flow of heat between two different fluids not in direct contact.
- C. The flow of heat from a body by electromagnetic waves across an intervening space.
- D. The flow of heat between a fluid and surface by circulation of the fluid.

QUESTION: 15

Which one of the following describes the conditions in a fuel channel that is experiencing transition boiling?

- A. Complete steam blanketing of the fuel rod surface.
- B. Alternate wetting and drying of the fuel rod surface.
- C. Subcooled nucleate boiling.
- D. Saturated nucleate boiling.

USNRC GENERIC FUNDAMENTALS EXAMINATION
BWR - FORM B

QUESTION 16

Refer to the drawing of a pool boiling curve (see figure below).

The point at which heat flux is increasing and the critical heat flux has been reached (point B), marks the beginning of:

- A. nucleate boiling.
- B. stable film boiling.
- C. partial film boiling.
- D. single-phase convection.

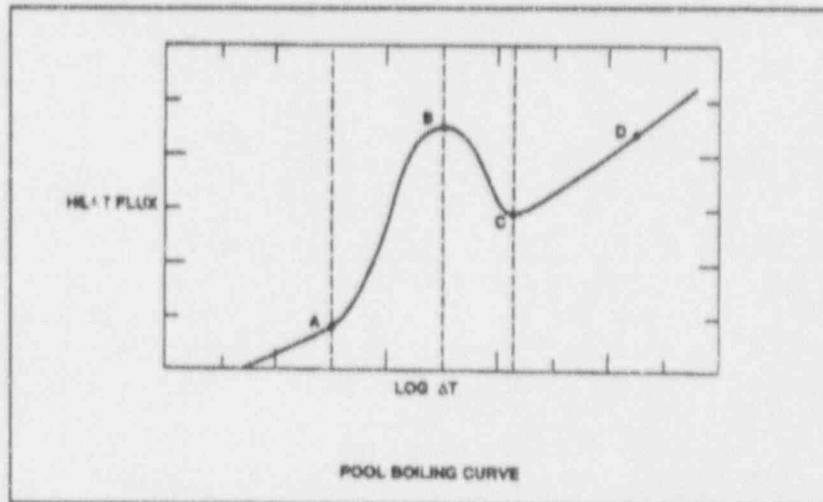

USNRC GENERIC FUNDAMENTALS EXAMINATION
BWR - FORM B

QUESTION: 17

Which one of the following will directly reduce core inlet subcooling?

- A. Raise reactor vessel downcomer level until carryover occurs.
- B. Lower reactor vessel downcomer level until carryunder occurs.
- C. Increase core recirculation flow.
- D. Isolate steam to one feedwater heater.

QUESTION: 18

Two reactors, A and B, are operating at rated power with neutron flux radially peaked in the center of each core. Reactors A and B are identical except that Reactor A has core orificing and Reactor B does not.

Compared to the center fuel bundle in Reactor B, the center fuel bundle in Reactor A will have the _____ critical power and the _____ coolant flow rate.

- A. lowest; lowest
- B. lowest; highest
- C. highest; lowest
- D. highest; highest

QUESTION: 19

With the reactor shutdown and the reactor recirculating pumps isolated, it is important to monitor reactor vessel skin temperatures because:

- A. these temperatures must be maintained constant with no flow in the core.
- B. cooldown rates are easily exceeded with the recirculation pumps isolated.
- C. these temperatures will provide one of the first indications of thermal stratification.
- D. these temperatures are the only reliable source of reactor recirculation loop temperature.

USNRC GENERIC FUNDAMENTALS EXAMINATION
BWR - FORM B

QUESTION: 20

If the linear heat generation rate (LHGR) limiting condition for operation is exceeded, the most probable type of fuel failure is cladding:

- A. cracking due to high stress.
- B. gross failure due to a lack of cooling.
- C. embrittlement due to excessive oxidation.
- D. distortion due to inadequate cooling of the clad.

QUESTION: 21

Which one of the following must be maintained within limits to ensure that peak cladding temperature will not exceed 2200°F after a design basis loss of coolant accident?

- A. Linear heat generation rate (LHGR)
- B. Average planar linear heat generation rate (APLHGR)
- C. Minimum critical power ratio (MCPR)
- D. Maximum fraction of limiting critical power ratio (MFLCPR)

QUESTION: 22

Which one of the following expressions describes the critical power ratio?

- A. Critical power/actual bundle power
- B. Actual bundle power/critical power
- C. Average bundle power/critical power
- D. Critical power/average bundle power

USNRC GENERIC FUNDAMENTALS EXAMINATION
BWR - FORM B

QUESTION: 23

During normal power operation a reactor pressure increase causes critical power to _____ because the latent heat of vaporization _____.

- A. increase; decreases
- B. decrease; decreases
- C. increase; increases
- D. decrease; increases

QUESTION: 24

The fuel thermal time constant describes the amount of time required for:

- A. the fuel to change its rate of heat generation by 63%.
- B. the fuel centerline temperature to undergo 63% of its total change resulting from a given power change.
- C. the fuel cladding temperature to undergo 63% of its total change resulting from a given change in fuel temperature.
- D. reactor power to undergo 63% of its total change resulting from a given reactivity insertion.

QUESTION: 25

The presence of embrittling isotopes is one of the initiating factors of pellet-clad-interaction (PCI). What is the source of the embrittling isotopes?

- A. Created during fission of the reactor fuel.
- B. Introduced during the manufacturing process.
- C. Migrate from reactor coolant through cladding.
- D. Produced as corrosion products inside fuel rod.

USNRC GENERIC FUNDAMENTALS EXAMINATION
BWR - FORM B

QUESTION: 26

During a rapid increase in core flow, the most limiting thermal limit is:

- A. maximum fraction of limiting power density (MFLPD).
- B. minimum critical power ratio (MCPR).
- C. average planar linear heat generation rate (APLHGR).
- D. linear heat generation rate (LHGR).

QUESTION: 27

The likelihood of brittle fracture failure of the reactor vessel is reduced by:

- A. reducing gamma flux exposure.
- B. reducing vessel temperature.
- C. reducing vessel pressure.
- D. increasing vessel age.

QUESTION: 28

Prolonged exposure of the reactor vessel to a fast neutron flux will cause the reference temperature for nil-ductility transition (RT_{NDT}) to:

- A. decrease due to the propagation of existing flaws.
- B. increase due to the propagation of existing flaws.
- C. decrease due to changes in the material properties of the vessel wall.
- D. increase due to changes in the material properties of the vessel wall.

USNRC GENERIC FUNDAMENTALS EXAMINATION
LWR - FORM B

QUESTION: 29

Which one of the following valves provides overpressure protection to limit the internal pressure in vessels and thus protect personnel and equipment?

- A. Safety
- B. Control
- C. Sentinel
- D. Pressure regulating

QUESTION: 30

Refer to the drawing of a hydraulically-operated valve that is shown in a throttled position (see figure on next page).

Select the position of this valve following a loss of hydraulic fluid pressure.

- A. Open
- B. Closed
- C. Remains at current position
- D. Midposition

USNRC GENERIC FUNDAMENTALS EXAMINATION
BWR - FORM B

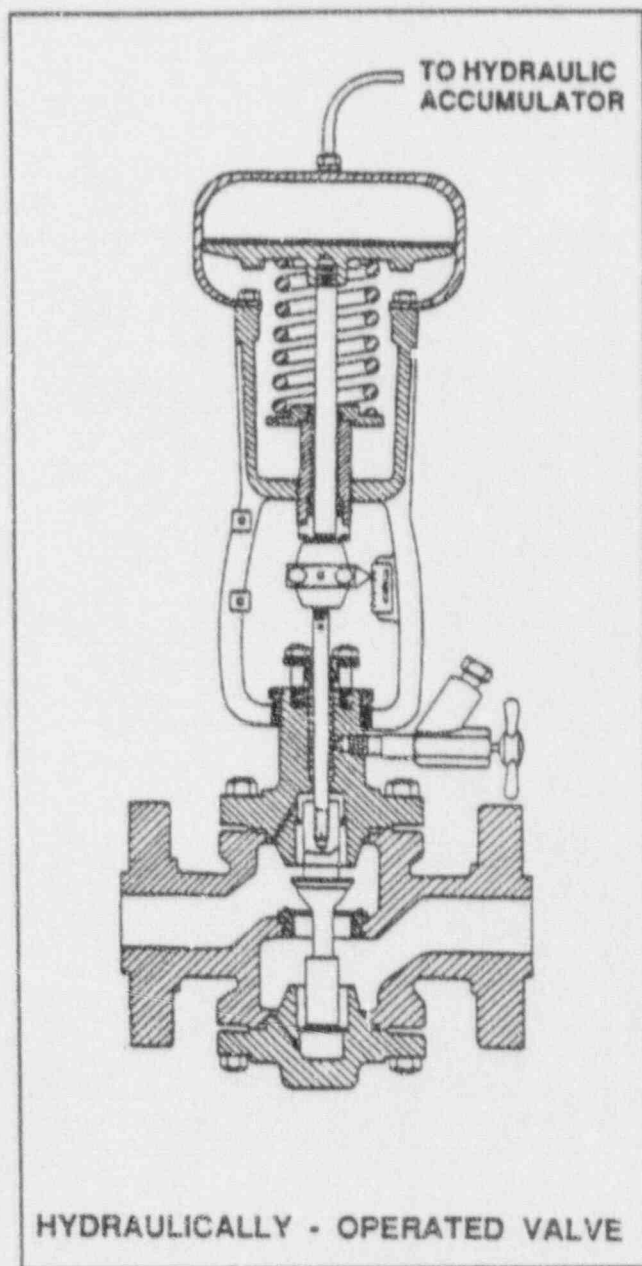

USNRC GENERIC FUNDAMENTALS EXAMINATION
BWR - FORM B

QUESTION: 31

What may be damaged if an operator attempts to manually disengage the motor on a motor-operated valve while the motor is operating?

- A. Clutch
- B. Valve seat
- C. Limit switches
- D. Torque switches

QUESTION: 32

To verify a manual valve in an operating system is closed, the operator should operate the valve handwheel in the:

- A. open direction until the valve stem moves in the open direction, then close the valve using normal force.
- B. open direction until flow sounds are heard, then close the valve using normal force.
- C. close direction until it stops, then close it an additional one-half turn using additional force if necessary.
- D. close direction using normal force and verify there is no substantial handwheel movement.

USNRC GENERIC FUNDAMENTALS EXAMINATION
BWR - FORM B

QUESTION: 33

When comparing gate valves to globe valves, gate valves:

- A. are more effective at throttling flow.
- B. are more effective as pressure regulating valves.
- C. produce a larger pressure decrease when fully open.
- D. require more force to open against large differential pressures.

QUESTION: 34

If the density input to a density-compensated steam flow instrument rapidly fails high, the indicated flow will:

- A. increase and stabilize at a new higher value.
- B. increase temporarily, then return to its initial value.
- C. decrease and stabilize at a new lower value.
- D. decrease temporarily, then return to its initial value.

USNRC GENERIC FUNDAMENTALS EXAMINATION
BPR - FORM B

QUESTION: 35

Refer to the drawing of a venturi flow element (see figure below).

A differential pressure (D/P) detector measuring flow through the venturi will produce the highest flow indication if its high-pressure tap is connected at point _____ and its low-pressure tap is connected at point _____.

- A. A; B
- B. A; D
- C. B; C
- D. B; D

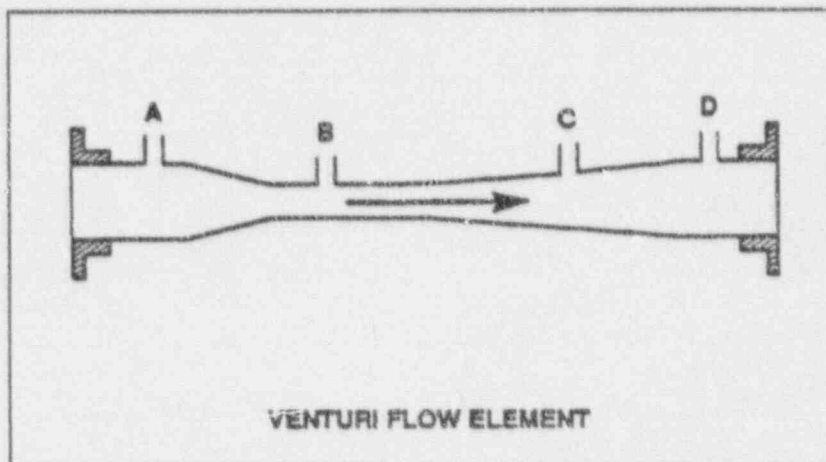

USNRC GENERIC FUNDAMENTALS EXAMINATION
BWR - FORM B

QUESTION: 36

Refer to the drawing of a pipe elbow used for flow measurement (see figure below).

At which one of the following locations is the lowest pressure sensed? (Assume a constant pipe diameter and zero head loss in this section of pipe.)

- A. Point A
- B. Point B
- C. Point C
- D. Point D

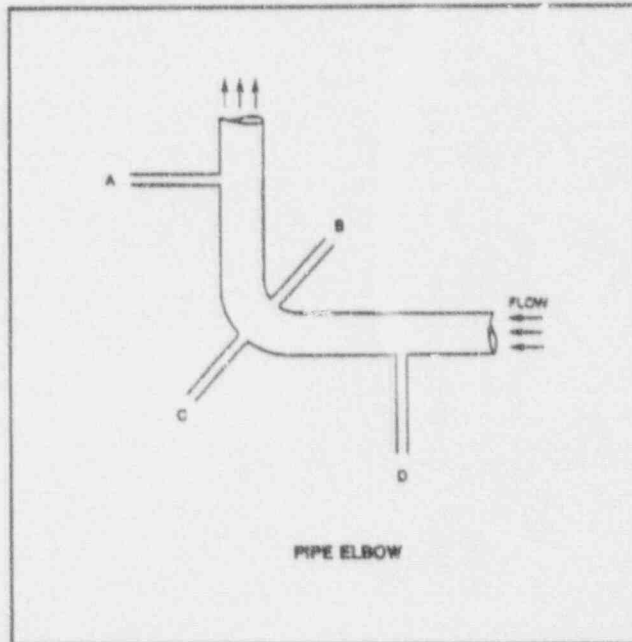

USNRC GENERIC FUNDAMENTALS EXAMINATION
BWR - FORM B

QUESTION: 37

Refer to the drawing of a tank differential pressure (D/P) level detector (see figure below).

The associated level instrument was calibrated with the water storage tank at 100°F. If mass in the tank remains constant and the water temperature increases to 120°F, the indicated level will:

- A. remain the same although actual level increases.
- B. increase but remain less than actual level.
- C. decrease in direct proportion to the temperature rise.
- D. increase in direct proportion to the temperature rise.

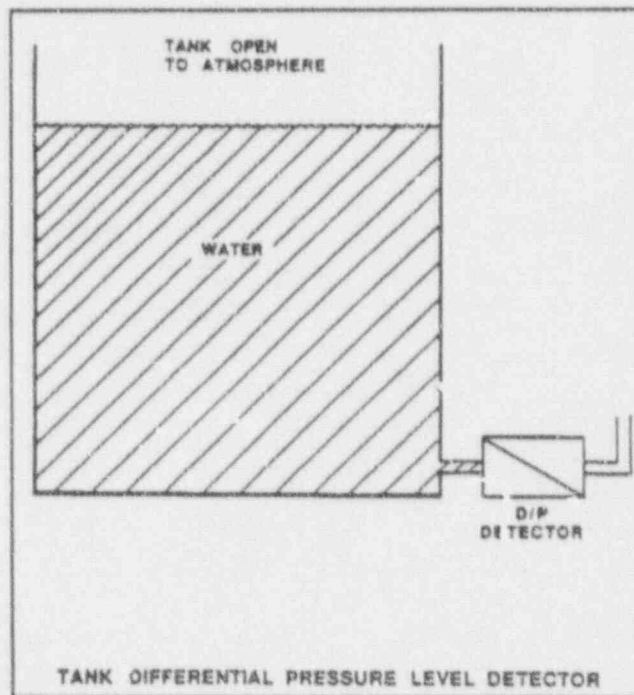

USNRC GENERIC FUNDAMENTALS EXAMINATION
BWR - FORM B

QUESTION: 38

Refer to the drawing of a tank differential pressure (D/P) level detector (see figure below).

The D/P sensed by the detector is _____ proportional to the temperature of the water in the tank if _____ is constant.

- A. directly; level
- B. inversely; level
- C. directly; mass
- D. inversely; mass

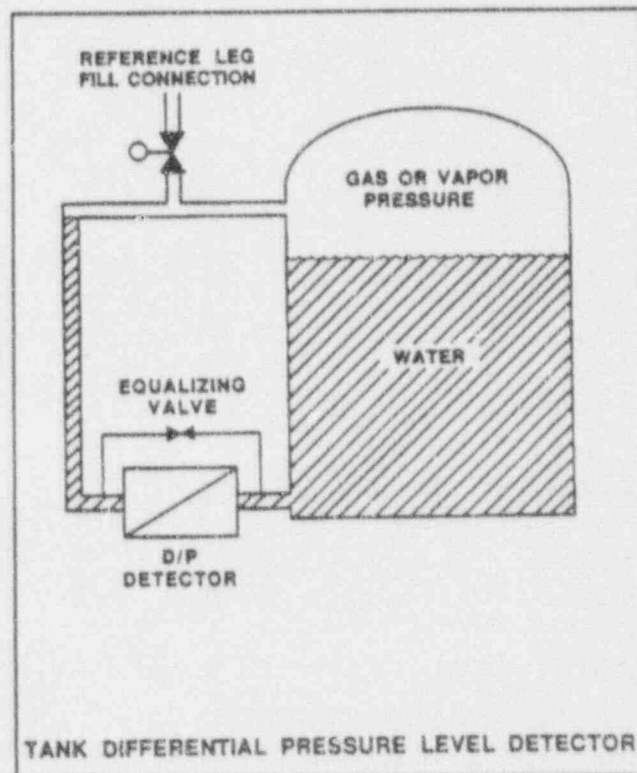

USNRC GENERIC FUNDAMENTALS EXAMINATION
BWR - FORM B

QUESTION: 39

A system has a simple bellows pressure detector with its low pressure side vented to the containment. If a main steam break raises containment pressure by 40 psig, the associated pressure indication (disregarding any temperature effect on the bellows) will:

- A. increase by 40 psig.
- B. increase by the square root of 40 psig.
- C. decrease by 40 psig.
- D. decrease by the square root of 40 psig.

QUESTION: 40

Which one of the following describes a characteristic of a thermocouple?

- A. A junction between two dissimilar metals will exhibit a change in electrical resistance proportional to temperature.
- B. A junction between two dissimilar metals will generate a voltage proportional to temperature.
- C. Thermocouples are generally more accurate than resistance temperature detectors (RTDs).
- D. Indication will fail high offscale with an open circuit.

QUESTION: 41

Which one of the following describes a characteristic of a Geiger-Mueller radiation detector?

- A. Radiation types can be identified by pulse height and duration.
- B. Specific radionuclides can be identified with the use of gamma spectrometry.
- C. Small variations in applied voltage will result in large changes in detector output.
- D. A single gamma interaction will produce the maximum useful output from the detector.

USNRC GENERIC FUNDAMENTALS EXAMINATION
BWR - FORM B

QUESTION: 42

Which one of the following describes a characteristic of a self-reading pocket dosimeter (SRPD)?

- A. The output of an SRPD is a dose rate in mr/hr.
- B. SRPDs can be used to record beta and gamma radiation.
- C. SRPD readings must be considered inaccurate when they are dropped.
- D. SRPDs hold their charge indefinitely when removed from a radiation field.

QUESTION: 43

The difference between the setpoint and the measured parameter in an automatic flow controller is called:

- A. gain.
- B. bias.
- C. error.
- D. feedback.

QUESTION: 44

An emergency diesel generator (D/G) is the only power source connected to its emergency bus. The governor of the D/G directly senses D/G _____ and adjusts D/G _____ flow to maintain a relatively constant D/G frequency.

- A. load; air
- B. load; fuel
- C. speed; air
- D. speed; fuel

USNRC GENERIC FUNDAMENTALS EXAMINATION
BWR - FOPM B

QUESTION: 45

Refer to the drawing of a lube oil temperature control system (see figure below).

If the temperature transmitter fails low (low temperature output signal), the temperature controller will throttle the temperature control valve _____, causing the actual heat exchanger lube oil outlet temperature to _____.

- A. open; decrease
- B. open; increase
- C. closed; decrease
- D. closed; increase

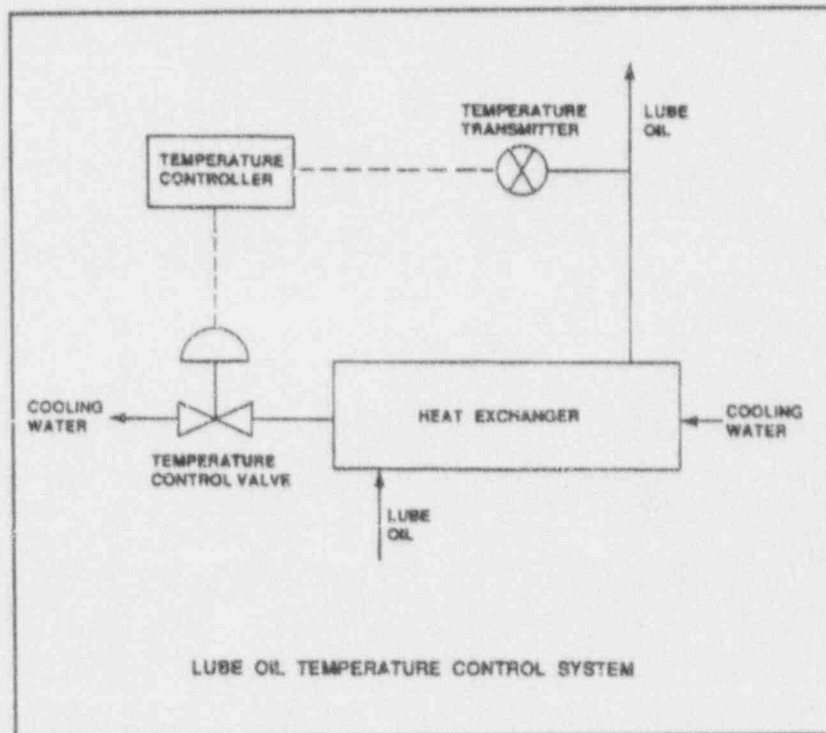

USNRC GENERIC FUNDAMENTALS EXAMINATION
BWR - FORM B

QUESTION: 46

Which one of the following is normally not a cause of gas/vapor binding of an operating centrifugal pump in a cooling water system?

- A. Increased pump inlet temperature
- B. Decreased pump suction pressure
- C. Loss of shaft seal water flow
- D. Improper venting of the pump

QUESTION: 47

A centrifugal pump with no recirculation flow path must be stopped when discharge pressure reaches pump shutoff head to prevent:

- A. overheating of the pump.
- B. overheating of the motor.
- C. bursting of the pump casing by subjecting it to excessively high pressure.
- D. water hammer in downstream lines when system pressure drops to a value where the pumps can inject water.

USNRC GENERIC FUNDAMENTALS EXAMINATION
BWR - FORM B

QUESTION: 48

A multispeed centrifugal pump is operating at 1800 rpm, providing a flow of 400 gpm at 20 psig. If the pump speed is increased to 3600 rpm, the new pump discharge pressure will be:

- A. 40 psig.
- B. 60 psig.
- C. 80 psig.
- D. 160 psig.

QUESTION: 49

Which one of the following conditions will result in a decrease in the available net positive suction head of a reactor recirculation pump?

- A. Carryunder decreases.
- B. Feedwater flow increases.
- C. Recirculation flow rate increases.
- D. Feedwater inlet subcooling increases.

USNRC GENERIC FUNDAMENTALS EXAMINATION
BWR - FORM B

QUESTION: 50

Refer to the drawing of a cooling water system (see figure below).

The centrifugal pump is circulating water at 180°F with a motor current of 100 amps. After several hours system temperature has decreased such that the water density has increased by 4%.

Which one of the following is the new pump motor current?
(Assume a constant volumetric flow rate.)

- A. 102 amps
- B. 104 amps
- C. 116 amps
- D. 164 amps

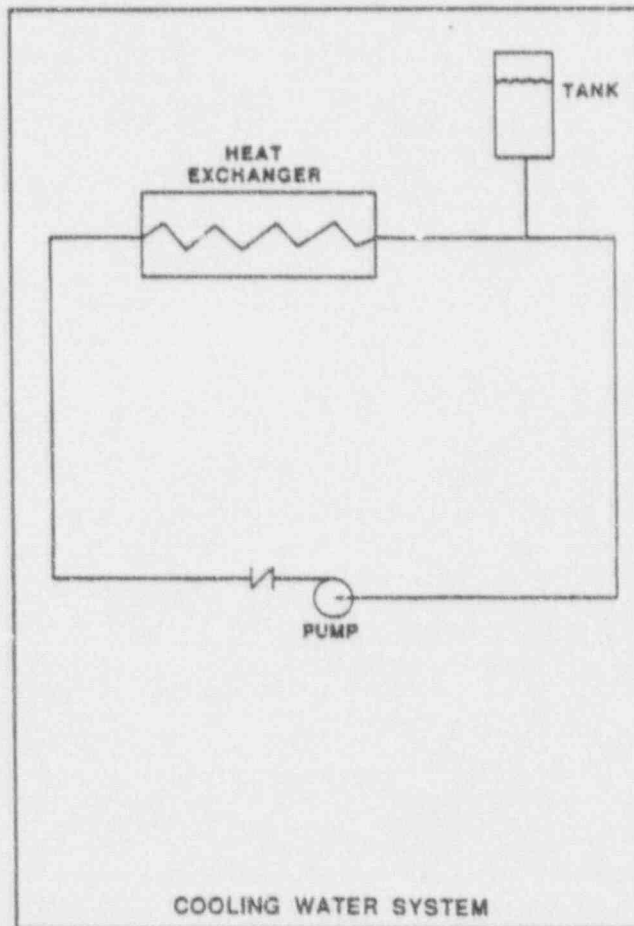

USNRC GENERIC FUNDAMENTALS EXAMINATION
BWR - FORM B

QUESTION: 51

A _____ pump in a liquid system should be started with its discharge valve _____ to avoid rupturing the pump casing and/or discharge piping.

- A. centrifugal; throttled
- B. centrifugal; fully open
- C. positive displacement; throttled
- D. positive displacement; fully open

QUESTION: 52

A single-speed centrifugal fire pump takes suction on a water storage tank and discharges through a flexible fire hose. Which one of the following describes the response of the pump discharge flow rate?

- A. Decreases as the level in the storage tank decreases
- B. Increases as the height of the fire hose nozzle is increased
- C. Remains constant as the level in the storage tank decreases
- D. Remains constant as the height of the fire hose nozzle is increased

USNRC GENERIC FUNDAMENTALS EXAMINATION
BWR - FORM B

QUESTION: 53

Refer to the drawing of a centrifugal pump operating curve (see figure below).

Which one of the following determines the general shape of the curve from point D to point B?

- A. The operating characteristics of the pump
- B. The type of fluid used in the system
- C. The characteristics of the system piping and flow
- D. The combination of system and pump operating characteristics

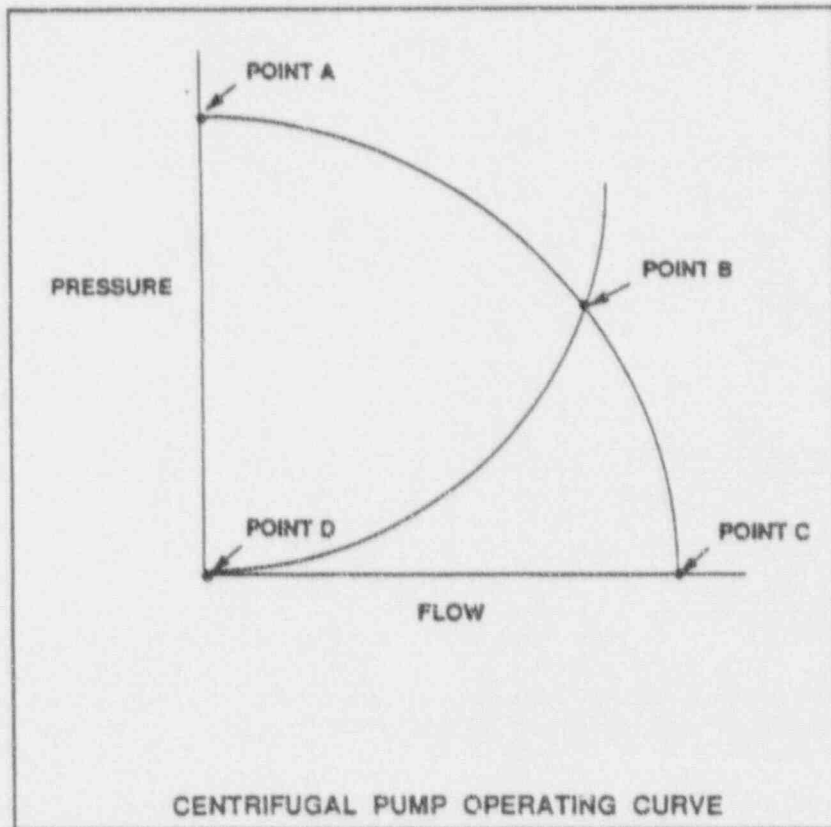

USNRC GENERIC FUNDAMENTALS EXAMINATION
BWR - FORM B

QUESTION: 54

If a locked rotor occurs on an operating motor-driven pump, motor amps will:

- A. decrease due to the decreased pump flow.
- B. decrease due to the increased mechanical load.
- C. increase due to the decreased pump flow.
- D. increase due to the increased mechanical load.

QUESTION: 55

Assuming pump flow and applied voltage remain constant, an increase in the stator temperature of an operating centrifugal pump motor will cause the motor current to:

- A. decrease because stator resistance increases.
- B. decrease because stator resistance decreases.
- C. increase because stator resistance increases.
- D. increase because stator resistance decreases.

QUESTION: 56

Motor winding temperature will be reduced by:

- A. increasing the reactive current flow in the stator windings.
- B. limiting the number of motor starts allowed in a given time period.
- C. decreasing the voltage supplied to the motor during full-load operation.
- D. decreasing the number of stator poles during the start sequence.

USNRC GENERIC FUNDAMENTALS EXAMINATION
BWR - FORM B

QUESTION: 57

What is the significance of a power factor of 0.8 when discussing output of a generator?

- A. The relationship between generator output voltage and current can be described as purely resistive.
- B. 80% of the energy input to the generator produces useful output.
- C. 80% of the generator output will be converted to useful power.
- D. This information characterizes the generator as a DC generator.

QUESTION: 58

A 125 volt DC motor is rated at 10 Kw. What is the current rating of the motor?

- A. 4.6 amps
- B. 8.0 amps
- C. 46.2 amps
- D. 80.0 amps

QUESTION: 59

As steam (shell) and liquid (tube) heat exchangers are put into service, the:

- A. water side is valved in before the steam side to ensure adequate venting.
- B. water side is valved in before the steam side to minimize thermal shock.
- C. steam side is valved in before the water side to minimize scale buildup on the heat exchanger tubes.
- D. steam side is valved in before the water side to ensure that the cooldown rate does not exceed 100°F/hr.

USNRC GENERIC FUNDAMENTALS EXAMINATION
BWR - FORM B

QUESTION: 60

Reduced heat exchanger performance will result from:

- A. tube wall thinning.
- B. turbulent flow in the tubes.
- C. increased ΔT between fluids.
- D. gas collection in the shell.

QUESTION: 61

Which one of the following changes will directly decrease subcooling of the condensate water in the main condenser hotwell?

- A. Increased circulating water flow
- B. Increased vacuum in the main condenser
- C. Decreased circulating water temperature
- D. Decreased main turbine generator Megawatt load

USNRC GENERIC FUNDAMENTALS EXAMINATION
BWR - FORM B

QUESTION: 62

Refer to the drawing of a lube oil heat exchanger (see figure below).

The heat exchanger is operating with the following parameters:

$$\begin{aligned} \dot{Q}_{\text{oil}} &= 1.0 \times 10^7 \text{ BTU/hr} \\ T_{\text{oil in}} &= 170^\circ\text{F} \\ T_{\text{oil out}} &= 134^\circ\text{F} \\ C_{p\text{-oil}} &= 1.1 \text{ BTU/lbm}\cdot^\circ\text{F} \\ T_{\text{water in}} &= 85^\circ\text{F} \\ T_{\text{water out}} &= 112^\circ\text{F} \\ C_{p\text{-water}} &= 1.0 \text{ BTU/lbm}\cdot^\circ\text{F} \end{aligned}$$

What is the mass flow rate of the cooling water?

- A. 1.2×10^5 lbm/hour
- B. 2.5×10^5 lbm/hour
- C. 3.7×10^5 lbm/hour
- D. 4.5×10^5 lbm/hour

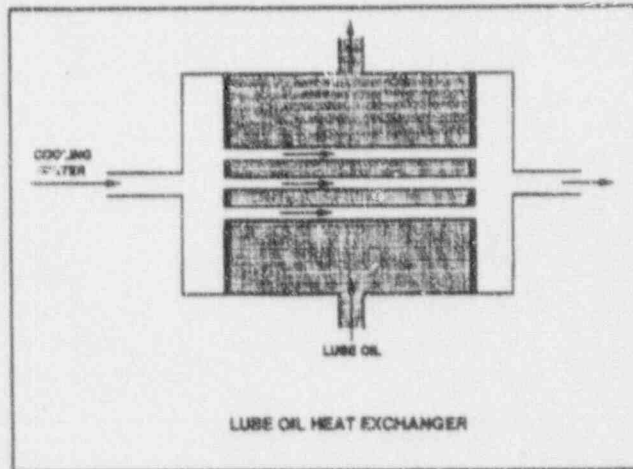

USNRC GENERIC FUNDAMENTALS EXAMINATION
BWR - FORM B

QUESTION: 63

Refer to the drawing of an operating cooling water system (see figure below).

Which one of the following effects would occur as a result of a tube failure in the heat exchanger?

- A. Level in the tank increases.
- B. HP fluid flow rate decreases.
- C. Flow in the low pressure system reverses.
- D. LP fluid heat exchanger outlet temperature increases.

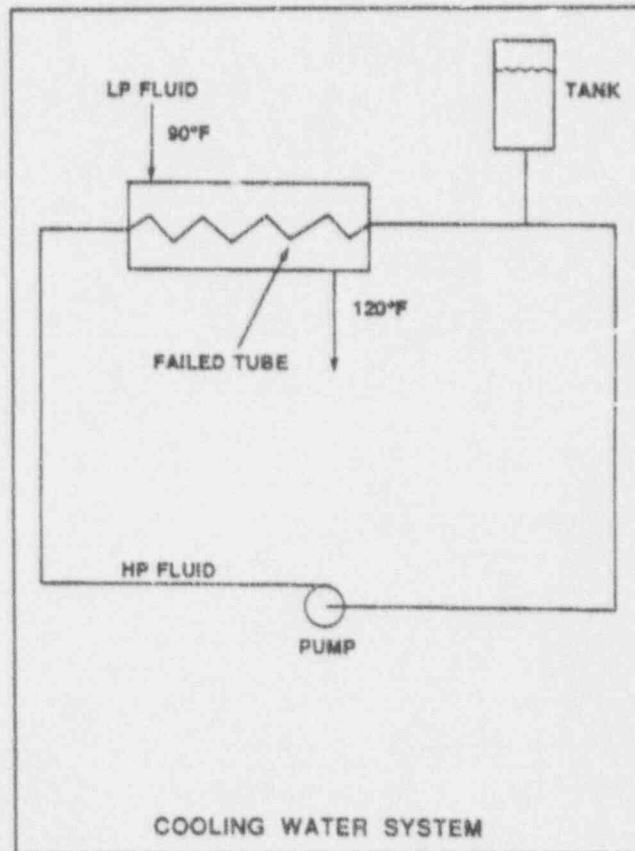

USNRC GENERIC FUNDAMENTALS EXAMINATION
BWR - FORM B

QUESTION: 64

Air entry into the main condenser will reduce the efficiency of the steam cycle because:

- A. steam flow rate through the main turbine increases.
- B. condensate subcooling in the main condenser increases.
- C. low pressure turbine exhaust steam enthalpy increases.
- D. the air mixes with the steam and enters the condensate.

QUESTION: 65

In a demineralizer, what adverse effect occurs due to channeling?

- A. Reduction in demineralizer efficiency because much of the resin is essentially bypassed.
- B. Resin dryout and cracking because much of the resin is essentially bypassed.
- C. Resin damage due to the increased velocity of fluid through the demineralizer.
- D. Loss of resin due to agitation resulting from increased fluid velocity through the demineralizer.

QUESTION: 66

The cation resin in a mixed-bed demineralizer releases _____ ions into solution while removing _____ ions from solution.

- A. negative; negative
- B. negative; positive
- C. positive; negative
- D. positive; positive

USNRC GENERIC FUNDAMENTALS EXAMINATION
BWR - FORM B

QUESTION: 67

A result of proper demineralizer operation on water with ionic impurities is that the exiting water will always have a:

- A. higher pH.
- B. lower pH.
- C. higher conductivity.
- D. lower conductivity.

QUESTION: 68

Which one of the following will cause a loss of indication from the remote breaker position indicating lights associated with a typical 480 VAC load supply breaker?

- A. Locally opening the breaker
- B. Loss of breaker line voltage
- C. Removing the breaker control power fuses
- D. Burnout of the local breaker position indicating lights

QUESTION: 69

An operator should never open or close a high voltage (greater than 750 volts) air break disconnect unless:

- A. a parallel path exists for current flow.
- B. the circuit it is in is already deenergized.
- C. the current flowing through it is approximately zero.
- D. the current flowing through it is less than its design current carrying capability.

USNRC GENERIC FUNDAMENTALS EXAMINATION
BWR - FORM B

QUESTION: 70

Refer to the drawing of a typical valve control circuit (see figure below).

Which one of the following describes the function of the #3 contact?

- A. To keep the K-3 relay energized after the initiating condition clears.
- B. To provide a method for manually energizing the K-3 relay.
- C. To increase circuit reliability as any one of the three contacts can energize the K-3 relay.
- D. To ensure the K-3 relay can always be deenergized even with the initiating condition present.

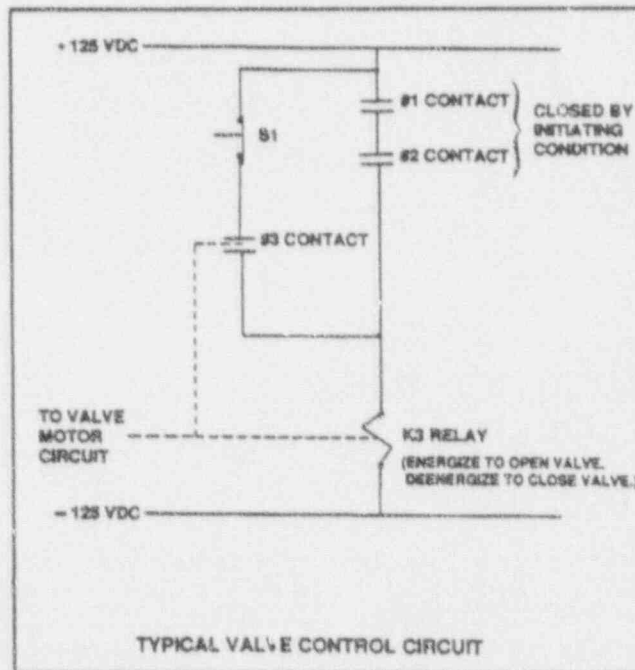

USNRC GENERIC FUNDAMENTALS EXAMINATION
BWR - FORM B

QUESTION: 71

Prior to connecting the main generator to the power grid, generator voltage should be _____ grid voltage and generator frequency should be _____ grid frequency.

- A. equal to; slightly higher than
- B. higher than; slightly higher than
- C. equal to; equal to
- D. higher than; equal to

QUESTION: 72

Which one of the following generator conditions will result in equipment damage from high current flow?

- A. Tripping the output breaker under full-load conditions
- B. Tripping the generator prime mover under full-load conditions
- C. Closing the output breaker onto a bus that has a short-circuit fault
- D. Closing the output breaker onto a bus that has an open-circuit fault

USNRC GENERIC FUNDAMENTALS EXAMINATION
BWR - FORM B

QUESTION: 73

Regarding a thermal neutron, the word "thermal" indicates that the neutron:

- A. was born greater than 10^{-14} seconds after the fission event.
- B. is a product of a thermal fission reaction.
- C. was released by the decay of fission fragments.
- D. is at the same energy level as the surrounding atoms.

QUESTION: 74

Which one of the following conditions will increase the amount of neutron moderation in a reactor operating at saturated conditions?

- A. Increasing moderator temperature
- B. Reducing feedwater inlet temperature
- C. Reducing reactor pressure vessel pressure
- D. Reducing reactor recirculation system flow

QUESTION: 75

Control rod withdrawal has increased K_{eff} from 0.998 to 1.002. The reactor currently is:

- A. subcritical.
- B. supercritical.
- C. prompt critical.
- D. exactly critical.

USNRC GENERIC FUNDAMENTALS EXAMINATION
BWR - FORM B

QUESTION: 76

Which one of the following core changes will decrease shutdown margin?

- A. Fuel depletion during reactor operation
- B. Buildup of Sm-149 after a reactor scram
- C. Increasing moderator temperature 10°F while shutdown
- D. Depletion of gadolinium during reactor operation

QUESTION: 77

Without delayed neutrons in the neutron cycle, when positive reactivity is added to a critical reactor, the reactor will:

- A. experience a prompt jump in power level followed by a decrease to the initial power level.
- B. experience a rapid but controllable power increase.
- C. begin an uncontrollable rapid power increase.
- D. not be able to attain criticality.

QUESTION: 78

A reactor is operating at 75% power with the following conditions:

| | | |
|------------------------------------|---|----------------------|
| Total Control rod worth | = | -0.0753 $\Delta K/K$ |
| Shutdown margin | = | 0.0042 $\Delta K/K$ |
| Effective delayed neutron fraction | = | 0.0058 |
| Effective prompt neutron fraction | = | 0.9942 |

How much positive reactivity must be added to make the reactor "prompt critical"?

- A. 0.0042 $\Delta K/K$
- B. 0.0058 $\Delta K/K$
- C. 0.0753 $\Delta K/K$
- D. 0.9942 $\Delta K/K$

USNRC GENERIC FUNDAMENTALS EXAMINATION
3WR - FORM B

QUESTION: 79

During a reactor startup, the intermediate range monitor readings go from 30% to 65% on the same range in 2 minutes with no operator action. Which one of the following is the average reactor period during the power increase?

- A. 357 seconds
- B. 173 seconds
- C. 155 seconds
- D. 120 seconds

QUESTION: 80

Which one of the following pairs of isotopes is responsible for the negative reactivity associated with a fuel temperature increase near the end of core life?

- A. U-235 and Pu-239
- B. U-235 and Pu-240
- C. U-238 and Pu-239
- D. U-238 and Pu-240

QUESTION: 81

Which one of the following describes how and why the void coefficient changes as void fraction increases during a control rod withdrawal at power?

- A. Becomes more negative due to a greater fractional loss of moderator for a 1% void increase at higher void fractions.
- B. Becomes more negative due to the reduction in the fast fission contribution to the neutron population.
- C. Becomes less negative due to a greater fraction of neutrons lost to leakage from the core.
- D. Becomes less negative due to the increased absorption of neutrons by U-238.

USNRC GENERIC FUNDAMENTALS EXAMINATION
BWR - FORM B

QUESTION: 82

The reactor has been shutdown for 3 weeks with all control rods fully inserted. If a center control rod is fully withdrawn from the core, neutron population will: (Assume the reactor remains subcritical.)

- A. increase and stabilize at a new higher level.
- B. increase temporarily then return to the original value.
- C. increase exponentially until the operator inserts the control rod.
- D. remain the same.

QUESTION: 83

How is control rod density affected as control rods are inserted during a reactor shutdown?

- A. Increases continuously during rod insertion.
- B. Decreases continuously during rod insertion.
- C. Increases initially, then decreases after 50% of the rods are inserted.
- D. Decreases initially, then increases after 50% of the rods are inserted.

QUESTION: 84

Which one of the following control rods, when repositioned, will have the largest effect on axial flux shape?

- A. Deep rods at the center of the core
- B. Shallow rods at the center of the core
- C. Deep rods at the periphery of the core
- D. Shallow rods at the periphery of the core

USNRC GENERIC FUNDAMENTALS EXAMINATION
BWR - FORM B

QUESTION: 85

Neutron flux shaping within a reactor core is designed to:

- A. minimize the effects of rod shadowing.
- B. ensure that more power is generated in the lower portion of the core.
- C. ensure that local core power limits are not exceeded.
- D. minimize the effects of an ejected rod.

QUESTION: 86

Which one of the following lists the proper order of substances with the largest to the smallest microscopic cross-sections for capture of thermal neutrons?

- A. Xe-135, H₂O, U-235
- B. Xe-135, U-235, H₂O
- C. U-235, H₂O, Xe-135
- D. U-235, Xe-135, H₂O

QUESTION: 87

Which one of the following describes the primary method of Xenon-135 removal at the indicated power level?

- A. Decay of Xenon-135 to Cesium-135 at full power
- B. Decay of Xenon-135 to Iodine-135 at the point of adding heat
- C. Absorption of neutrons by Xenon-135 at the point of adding heat
- D. Absorption of neutrons by Xenon-135 at full power

USNRC GENERIC FUNDAMENTALS EXAMINATION
BWR - FORM B

QUESTION: 88

Following a 2-week shutdown, a reactor is taken critical and ramped to full power in 6 hours. How long will it take to achieve an equilibrium xenon condition after the reactor reaches full power?

- A. 70 to 80 hours
- B. 40 to 50 hours
- C. 8 to 10 hours
- D. 1 to 2 hours

QUESTION: 89

The reactor has been operating at 100% power for 2 weeks when power is reduced to 50% in 1 hour. How will the amount of core xenon change over the next 24 hours?

- A. Increase and stabilize at a new higher value
- B. Increase initially, then decrease and stabilize at a lower value.
- C. Decrease and stabilize at a new lower value
- D. Decrease initially, then increase and stabilize at a higher value.

QUESTION: 90

A reactor has been operating at full power for several weeks when a scram occurs. When the reactor is brought critical 5 hours later, Xe-135 concentration will be highest in the _____ of the core, which causes thermal neutron flux to shift toward the _____ of the core.

- A. center; periphery
- B. periphery; periphery
- C. center; center
- D. periphery; center

USNRC GENERIC FUNDAMENTALS EXAMINATION
BWR - FORM B

QUESTION: 91

Burnable poisons are placed in a reactor core to:

- A. increase the amount of fuel that can be loaded into the core.
- B. accommodate control rod depletion that occurs over core life.
- C. compensate for the buildup of Xenon-135 that occurs over core life.
- D. ensure that the reactor will always operate in an undermoderated condition.

QUESTION: 92

Sixteen hours after a reactor scram from 100% power, equilibrium xenon condition, the amount of core xenon will be:

- A. lower than 100% equilibrium xenon, and will have added a net positive reactivity since the scram.
- B. higher than 100% equilibrium xenon, and will have added a net positive reactivity since the scram.
- C. lower than 100% equilibrium xenon, and will have added a net negative reactivity since the scram.
- D. higher than 100% equilibrium xenon, and will have added a net negative reactivity since the scram.

QUESTION: 93

While withdrawing control rods during a reactor startup, the count rate doubles. If the same amount of reactivity that caused the first doubling is added again, the count rate will _____ and the reactor will be _____.

- A. more than double; subcritical
- B. more than double; critical
- C. double; subcritical
- D. double; critical

USNRC GENERIC FUNDAMENTALS EXAMINATION
BWR - FORM B

QUESTION: 94

During an initial reactor fuel load, the 1/M factor decreases from 1.0 to 0.5 after the first 100 fuel assemblies are loaded. What is the current value of K_{eff} ?

- A. 0.2
- B. 0.5
- C. 0.875
- D. 1.0

QUESTION: 95

Which one of the following describes the purpose of the neutron source in a reactor during the third fuel cycle?

- A. Ensures shutdown neutron level is large enough to be detected by nuclear instrumentation.
- B. Provides additional excess reactivity to increase the length of each fuel cycle.
- C. Increases local fission rate to flatten the neutron flux in the core.
- D. Supplies the only shutdown source of neutrons available to begin the fission process.

QUESTION: 96

After taking critical data during a reactor startup, the operator establishes a positive 26-second reactor period to increase power to the point of adding heat (POAH). How much negative reactivity must be added to stabilize power at the POAH?

Assume $\bar{\beta}_{eff} = 0.00579$

- A. 0.10% $\Delta K/K$
- B. 0.16% $\Delta K/K$
- C. 1.0% $\Delta K/K$
- D. 1.6% $\Delta K/K$

USNRC GENERIC FUNDAMENTALS EXAMINATION
BWR - FORM B

QUESTION: 97

During a normal power increase from 20% to 100%, the smallest negative reactivity addition will be caused by the change in:

- A. void content.
- B. fuel temperature.
- C. xenon concentration.
- D. moderator temperature.

QUESTION: 98

A reactor is operating at 100% power and flow. Reactor power is reduced to 90% by inserting control rods. (Recirculating pump speed remains constant.)

What is the effect on core flow?

- A. Core flow will decrease due to an increase in core voiding.
- B. Core flow will increase due to the decrease in recirculation ratio.
- C. Core flow will increase due to the decrease in two-phase flow resistance.
- D. Core flow will decrease due to an increase in two-phase flow resistance.

USNRC GENERIC FUNDAMENTALS EXAMINATION
BWR - FORM B

QUESTION: 99

The plant is operating at 85% power when a failure of the steam pressure control system opens the turbine control valves to admit 10% more steam flow to the main turbine. No operator actions occur and no protective system actuations occur.

How will reactor power respond? (Assume the valves remain in the failed position.)

- A. Increase until reactor power matches the new steam demand.
- B. Increase continuously and exceed reactor protection setpoints.
- C. Decrease and stabilize at a lower power level and steaming rate.
- D. Decrease and stabilize at a critical power level below the POAH.

QUESTION: 100

Which one of the following percentages most closely approximates the decay heat produced in the reactor at 1 second and at 1 hour, respectively, following a scram from extended operation at 100% power?

| | <u>ONE SECOND</u> | <u>ONE HOUR</u> |
|----|-------------------|-----------------|
| A. | 15.0% | 1.0% |
| B. | 7.0% | 1.0% |
| C. | 1.0% | 0.1% |
| D. | 0.5% | 0.1% |