

NUREG/CR-5445
EGG-2662

Performance of Intact and Partially Degraded Concrete Barriers in Limiting Mass Transport

Prepared by
J. C. Walton

Idaho National Engineering Laboratory
EG&G Idaho, Inc.

Prepared for
U.S. Nuclear Regulatory Commission

9207060042 920630
PDR NUREG
CR-5445 R PDR

AVAILABILITY NOTICE

Availability of Reference Materials Cited in NRC Publications

Most documents cited in NRC publications will be available from one of the following sources:

1. The NRC Public Document Room, 2120 L Street, NW., Lower Level, Washington, DC 20555
2. The Superintendent of Documents, U.S. Government Printing Office, P.O. Box 37082, Washington, DC 20013-7082
3. The National Technical Information Service, Springfield, VA 22161

Although the listing that follows represents the majority of documents cited in NRC publications, it is not intended to be exhaustive.

Referenced documents available for inspection and copying for a fee from the NRC Public Document Room include NRC correspondence and internal NRC memoranda; NRC bulletins, circulars, information notices, inspection and investigation notices; licensee event reports; vendor reports and correspondence; Commission papers; and applicant and licensee documents and correspondence.

The following documents in the NUREG series are available for purchase from the GPO Sales Program: formal NRC staff and contractor reports; NRC-sponsored conference proceedings; international agreement reports; grant publications; and NRC booklets and brochures. Also available are regulatory guides, NRC regulations in the *Code of Federal Regulations*, and *Nuclear Regulatory Commission Issuances*.

Documents available from the National Technical Information Service include NUREG-series reports and technical reports prepared by other Federal agencies and reports prepared by the Atomic Energy Commission, forerunner agency to the Nuclear Regulatory Commission.

Documents available from public and special technical libraries include all open literature items, such as books, journal articles, and transactions. *Federal Register* notices, Federal and State legislation, and congressional reports can usually be obtained from these libraries.

Documents such as theses, dissertations, foreign reports and translations, and non-NRC conference proceedings are available for purchase from the organization sponsoring the publication cited.

Single copies of NRC draft reports are available free, to the extent of supply, upon written request to the Office of Administration, Distribution and Mail Services Section, U.S. Nuclear Regulatory Commission, Washington, DC 20555.

Copies of industry codes and standards used in a substantive manner in the NRC regulatory process are maintained at the NRC Library, 7120 Norfolk Avenue, Bethesda, Maryland, for use by the public. Codes and standards are usually copyrighted and may be purchased from the originating organization or, if they are American National Standards, from the American National Standards Institute, 1430 Broadway, New York, NY 10018.

DISCLAIMER NOTICE

This report was prepared as an account of work sponsored by an agency of the United States Government. Neither the United States Government nor any agency thereof, or any of their employees, makes any warranty, expressed or implied, or assumes any legal liability of responsibility for any third party's use, or the results of such use, of any information, apparatus, product or process disclosed in this report, or represents that its use by such third party would not infringe privately owned rights.

NUREG/CR-5445
EGG-2662

Performance of Intact and Partially Degraded Concrete Barriers in Limiting Mass Transport

Prepared by
J. C. Walton

Idaho National Engineering Laboratory
EG&G Idaho, Inc.

Prepared for
U.S. Nuclear Regulatory Commission

AVAILABILITY NOTICE

Availability of Reference Materials Cited in NRC Publications

Most documents cited in NRC publications will be available from one of the following sources:

1. The NRC Public Document Room, 2120 L Street, NW, Lower Level, Washington, DC 20555
2. The Superintendent of Documents, U.S. Government Printing Office, P.O. Box 37082, Washington, DC 20013-7082
3. The National Technical Information Service, Springfield, VA 22161

Although the listing that follows represents the majority of documents cited in NRC publications, it is not intended to be exhaustive.

Referenced documents available for inspection and copying for a fee from the NRC Public Document Room include NRC correspondence and internal NRC memoranda; NRC bulletins, circulars, information notices, inspection and investigation notices; licensee event reports; vendor reports and correspondence; Commission papers; and applicant and licensee documents and correspondence.

The following documents in the NUREG series are available for purchase from the GPO Sales Program: formal NRC staff and contractor reports, NRC-sponsored conference proceedings, international agreement reports, grant publications, and NRC booklets and brochures. Also available are regulatory guides, NRC regulations in the *Code of Federal Regulations*, and *Nuclear Regulatory Commission Issuances*.

Documents available from the National Technical Information Service include NUREG-series reports and technical reports prepared by other Federal agencies and reports prepared by the Atomic Energy Commission, forerunner agency to the Nuclear Regulatory Commission.

Documents available from public and special technical libraries include all open literature items, such as books, journal articles, and transactions. *Federal Register* notices, Federal and State legislation, and congressional reports can usually be obtained from these libraries.

Documents such as theses, dissertations, foreign reports and translations, and non-NRC conference proceedings are available for purchase from the organization sponsoring the publication cited.

Single copies of NRC draft reports are available free, to the extent of supply, upon written request to the Office of Administration, Distribution and Mail Services Section, U.S. Nuclear Regulatory Commission, Washington, DC 20555.

Copies of industry codes and standards used in a substantive manner in the NRC regulatory process are maintained at the NRC Library, 7920 Norfolk Avenue, Bethesda, Maryland, for use by the public. Codes and standards are usually copyrighted and may be purchased from the originating organization or, if they are American National Standards, from the American National Standards Institute, 1430 Broadway, New York, NY 10018.

DISCLAIMER NOTICE

This report was prepared as an account of work sponsored by an agency of the United States Government. Neither the United States Government nor any agency thereof, or any of their employees, makes any warranty, expressed or implied, or assumes any legal liability of responsibility for any third party's use, or the results of such use, of any information, apparatus, product or process disclosed in this report, or represents that its use by such third party would not infringe privately owned rights.

NUREG/CR-5445
EGG-2662
RW,CC,CJ,CO,CY

Performance of Intact and Partially Degraded Concrete Barriers in Limiting Mass Transport

Manuscript Completed: April 1992
Date Published: June 1992

Prepared by
J. C. Walton

Idaho National Engineering Laboratory
Managed by the U.S. Department of Energy

EG&G Idaho, Inc.
Idaho Falls, ID 83415

Prepared for
Division of Engineering
Office of Nuclear Regulatory Research
U.S. Nuclear Regulatory Commission
Washington, DC 20555
NRC FIN A6858
Under DOE Contract No. DE-AC07-76ID01570

ABSTRACT

Mass transport through concrete barriers and release rate from concrete vaults are quantitatively evaluated. The thorny issue of appropriate diffusion coefficients for use in performance assessment calculations is covered with no ultimate solution found. Release from monolithic concrete vaults composed of concrete waste forms is estimated with a semi-analytical solution. A parametric study illustrates the importance of different parameters on release. A second situation of importance is the role of a concrete shell or vault placed around typical waste forms in limiting mass transport. In both situations the primary factor controlling concrete performance is cracks. The implications of leaching behavior on likely groundwater concentrations is examined. Frequently, lower groundwater concentrations can be expected in the absence of engineered covers that reduce infiltration.

CONTENTS

ABSTRACT	iii
LIST OF FIGURES	vi
LIST OF TABLES	vii
EXECUTIVE SUMMARY	ix
ACKNOWLEDGMENTS	xi
1. INTRODUCTION	1
2. DIFFUSION IN CONCRETE	4
2.1 Basic Governing Equations	4
2.2 Leaching From Waste Forms	5
2.3 Methodology for Use of Apparent Diffusion Coefficients in Performance Assessments	7
2.4 Leaching From Concrete Waste Forms Located In The Unsaturated Zone	8
2.5 Mathematical Treatment of Unsaturated Transport	9
3. LEACHING FROM FRACTURED CONCRETE WASTE FORMS	10
3.1 Basic Governing Equations and Simplifying Assumptions	10
3.2 Dimensional Analysis and Plausible Range of Parameters for Concrete Vaults	11
3.3 Cumulative Release Calculations	12
3.4 Concentration Versus Release	14
4. MASS TRANSPORT THROUGH FRACTURED CONCRETE BARRIERS	16
4.1 Permanent Attenuation of Release	16
4.2 Smearing of Release Rate	19
5. CONCRETE VAULT PERFORMANCE OVER TIME AND IN RELATION TO CONCENTRATIONS IN GROUNDWATER	23
5.1 Overall Scenario for Concrete Vault Degradation	23
5.2 Influences on Effluent Concentration	23
5.3 Downstream Concentrations	24
5.4 Design Implications	25
6. CONCLUSIONS	27
7. REFERENCES	29

LIST OF FIGURES

1.	Effective hydraulic conductivity of a vault roof (expansion of Figure 1).	2
2.	Relationship between crack width, hydraulic conductivity of adjacent porous material, and effective hydraulic conductivity of a vault roof.	2
3.	Schematic of solubility controlled leaching.	7
4.	Leaching rate from concrete waste form in partially saturated soil.	9
5.	Dimensional analysis of equations with no radioactive decay.	12
6.	Cumulative release fraction of nitrate over 500 years as a function of crack spacing and water flux through vault.	13
7.	Cumulative release of tritium over 500 years.	13
8.	Cumulative release of chromium over 500 years.	13
9.	Cumulative release of technetium-99 over 500 years.	14
10.	Release rate of nitrate from a simulated concrete monolith with changing water percolation rate. Release rate is the logarithm to the base 10 of the fractional release rate.	14
11.	Relative concentration of nitrate in effluent for different flow rates.	14
12.	Concrete porosity as a function of water to cement ratio.	17
13.	Effective diffusion coefficient in concrete as a function of water to cement ratio.	17
14.	Influence of water to cement ratio and crack width on matrix diffusion.	18
15.	Performance of concrete barriers in attenuating carbon-14 transport.	18
16.	Performance of concrete barriers in attenuating Cesium-137 transport.	18
17.	Performance of concrete barriers in attenuating iodine-129 transport.	18
18.	Performance of concrete barriers in attenuating plutonium-239 transport.	19
19.	Performance of concrete barriers in attenuating strontium-90 transport.	19
20.	Performance of concrete barriers in attenuating technetium transport.	19
21.	Performance of concrete barriers in attenuating tritium transport.	19
22.	Influence of water to cement ratio on transport of carbon-14 through a single crack.	20
23.	Dimensionless concentration of carbon-14 as a function of Darcy flux through the vault and time.	20
24.	Dimensionless concentration of cesium-137 as a function of Darcy flux through the vault and time.	20
25.	Dimensionless concentration of plutonium-239 as a function of Darcy flux through the vault and time.	20

26.	Dimensionless concentration of iodine-129 as a function of Darcy flux through the vault and time.	21
27.	Dimensionless concentration of strontium-90 as a function of Darcy flux through the vault and time.	21
28.	Dimensionless concentration of technetium-99 as a function of Darcy flux through the vault and time.	21
29.	Dimensionless concentration of tritium as a function of Darcy flux through the vault and time.	21
30.	Concentration in groundwater near a site with concrete vaults.....	25
31.	Results from Equations (45) and (46).	25
32.	Two alternative designs for an engineered cover over a series of concrete vaults. ...	25

LIST OF TABLES

1.	Radionuclide Parameters.	16
----	-------------------------------	----

EXECUTIVE SUMMARY

Concrete vaults will be used at a number of disposal facilities for low level commercial and government radioactive wastes. The influence of the concrete over time with respect to fluid flow and radionuclide transport is an important portion of overall system performance.

This document examines mass transport of contaminants through concrete barriers and release rate of contaminants from concrete waste forms. The document has four major chapters which cover diffusion coefficients, release from concrete waste forms, mass transport through cracks, and overall performance of concrete vaults.

The document places great emphasis on the performance of concrete in the presence of cracks. Cracks are the Achilles heel of concrete barrier performance. In the absence of cracks, high quality concrete will almost always do an outstanding job of isolating waste because of its low permeability and high available surface area for sorption. In the presence of cracks, concrete only sometimes works well for waste isolation.

Since all massive concrete structures can be expected to crack, and the cracks will dominate the performance of the concrete barrier, performance of cracked concrete is an important area for research. Improved understanding of the performance of concrete barriers will lead to a) improved ability to compare the performance of waste disposal systems with regulatory standards (performance assessment) and b) improved ability to design waste disposal systems including concrete vaults and concrete waste forms.

The basic governing equations and behavior of diffusion in concrete is covered in Chapter 2. This includes treatment of the relationship between diffusion coefficients measured in the laboratory and

the diffusion coefficients used in performance assessment models. Unfortunately, measured diffusion coefficients cannot ordinarily be used directly in performance assessment models. Lack of understanding of these distinctions can (and all too frequently has) led to incorrect performance assessment calculations.

Chapter 3 covers leach rates and leachate concentration from cracked concrete vaults composed of concrete waste forms. Three performance regions are found a) pure diffusional control of release at very low flow rates, b) flow controlled release at low flow rates, and c) diffusion from matrix to crack control at higher flow rates.

Chapter 4 considers the impact of concrete barriers (e.g., the floor of a concrete vault) on radionuclide transport through cracks. In some cases the concrete barrier may significantly attenuate the release rate. In other situations the concrete may simply act to reduce spikes or peaks in release rate and in some situations, the concrete will not perform any reduction or attenuation of release.

Chapter 5 reviews some aspects of overall performance of concrete vaults including the interesting conclusion that increased water flow rate through concrete vaults and other waste disposal systems can sometimes facilitate compliance with regulatory standards.

The number of counter intuitive performance aspects of concrete vaults which appear upon more detailed consideration of performance cast serious doubt on our ability to perform conservative performance assessments. All too frequently, we are not sufficiently aware of what constitutes a conservative assumption versus assumptions which are overly optimistic.

ACKNOWLEDGMENTS

The author would like to express appreciation to Tim McCartin, the NRC technical monitor, for his support of the project. Appreciation is also due to Sally Francis for technical editing and to Roger Seitz for technical review.

PERFORMANCE OF INTACT AND PARTIALLY DEGRADED CONCRETE BARRIERS IN LIMITING MASS TRANSPORT

1. INTRODUCTION

Concrete barriers will be incorporated into low-level radioactive waste disposal facilities as structural components and barriers to fluid flow and mass transport of radionuclides. This report presents information concerning mass transport through concrete barriers such as the walls and floor of concrete vaults, release rates from concrete waste forms, and performance of monolithic concrete vaults.

Concrete is a brittle material with high compressive strength but low tensile strength. These characteristics make massive concrete structures prone to cracking. Although concrete degradation is typically modeled as loss of effective thickness of the concrete (Atkinson *et al.*, 1984, Walton *et al.*, 1984, Clifton and Knab, 1989), in fact the most widespread type of concrete degradation is extensive cracking. Examination of approximately 100 year old railroad bridges in Wisconsin and Minnesota by the author revealed that frequently the original surface of the concrete was essentially intact, while the body of the structures were riddled with cracks. The bridges were mostly earth covered and open on the bottom. Essentially all of the cracks showed evidence of water flow in the form of carbonated material on the edges of the cracks. Presumably water entering the concrete became saturated with calcium hydroxide which formed calcium carbonate when air contact at the bottom of the crack provided a source of carbon dioxide. In many cases, calcium carbonate stalactites were formed below the overpass.

New concrete structures also are prone to cracking as a result of temperature induced volume changes and shrinkage as can be observed on most massive concrete structures. Drying shrinkage is affected by many factors including unit water content, aggregate composition, and duration of initial

moist curing (USDI, 1988). Initial drying shrinkage ranges from less than 2×10^{-4} for dry, lean mixes with good quality aggregate to over 10^{-3} for rich mortars or concretes containing poor quality aggregate (USDI, 1988). Autogenous volume change related to chemical reactions and aging of the concrete may also cause shrinkage in the range of 10^{-5} to 1.5×10^{-4} (USDI, 1988).

Temperature induced volume changes occur primarily from the heat of hydration, which causes expansion during early time periods while the concrete has higher creep. When the concrete cools, it shrinks, leading to cracking. The cooling occurs after the concrete has aged and relief of stress by creep is lower. Average concrete changes about 5.5×10^{-6} per degree Fahrenheit.

Crack width and spacing are a function of total shrinkage and external restraint. In the simplest case of a flexural beam, a series of equally spaced, uniform cracks are formed. Without restraint, cracks tend to be large and widely spaced. In the presence of restraint (e.g., steel reinforcement), cracks tend to be smaller and more closely spaced. Cracks can be minimized by adding reinforcement, controlling cement mix, monitoring construction techniques, and by including joints with water stops. Over periods of several hundred years, joints and sealing treatments for early cracks are subject to degradation and may be open for water flow.

The statement is sometimes made that cracks will not influence the performance of concrete vaults located in the unsaturated zone because water held under tension will not enter the cracks. There are two major problems with this assumption. First, massive vaults tend to promote formation of perched water on the vault roof, which can migrate directly into the cracks (Walton and Seitz,

1991). Second, cracks are likely to become partially filled with porous material, allowing imbibition of water under tension into portions of the crack.

Mass transport through concrete vaults depends heavily upon water flow rates. Usually mass transport will occur out the bottom of the vault and water flow rate is controlled by the vault roof. The leakage rate through the roof is dependent upon water supply, crack spacing in the roof, and the permeability of the porous material near the roof. If a low permeability porous material such as clay is placed next to the roof, flow rates through the vault can be expected to be approximately 10^{-8} cm/s or below throughout most of the vault's lifetime. Figure 1 illustrates the results for a crack fraction of 10^{-4} . If the cracks are partially sealed with water stops, then the hydraulic conductivity will be even lower. Conversely, if higher permeability materials such as sand or gravel are placed next to the vault, then the effective hydraulic conductivity in the presence of cracks can be very high. Figure 2 gives an expanded view of Figure 1 for the domain of interest when a clay layer is placed next to the vault roof.

Cracks are the Achilles heel of concrete barrier performance. Even a single crack in a large structure can quickly dominate release calculations. Walton and Seitz (1991) examined the influence of cracking on fluid flow. This report deals extensively with mass transport through cracked concrete and attempts to define when and how cracking will be important to system performance.

Chapter 2 presents the application of measured diffusion coefficients for concrete and concrete waste forms in performance assessment calculations. In the author's experience this is a confusing area where many mistakes in performance analyses are made. Thus, although no original material is presented (soil scientists worked out the basics over 30 years ago), a thorough review and summary is appropriate. After a discussion of governing equations and the meaning of measured diffusion coefficients, the influence of location in the unsaturated zone on diffusional release from waste forms is considered. Surprisingly, diffusionally-controlled release rates from concrete waste forms are generally not lower in the unsaturated zone.

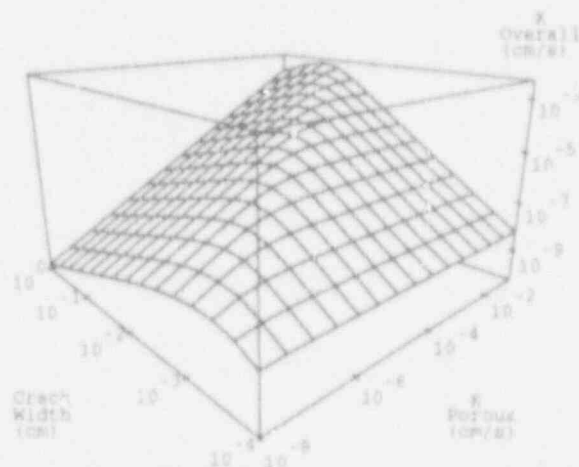

Figure 1. Relationship between crack width, hydraulic conductivity of adjacent porous material, and effective hydraulic conductivity of a vault roof.

Chapter 3 considers controls on release rates from cracked monolithic concrete vaults. Monolithic vaults are formed when a concrete vault is filled with a concrete (grout) waste form. Vaults of this type have many advantages and may be used increasingly when the output from incinerators is stabilized as concrete waste forms. Where feasible, incineration before disposal has the advantages of volume reduction, stabilization, and essentially complete destruction of organic hazardous materials in waste streams.

Chapter 4 considers radionuclide transport through the cracked floor of a concrete vault. The calculations suggest that sometimes lower quality

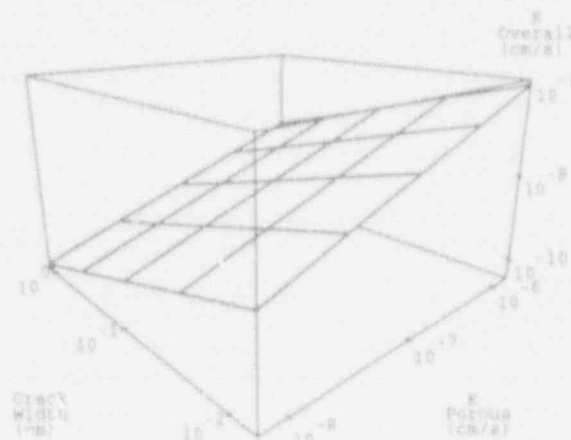

Figure 2. Effective hydraulic conductivity of a vault roof (expansion of Figure 1).

concrete can better serve at waste isolation than high quality concrete. This has some implications for the role of grout backfill inside a vault (e.g., poured around waste containers for stabilization and worker safety) that would be expected to have a high water/cement ratio. Even if these grout materials have limited structural function, they can

serve to attenuate and delay radionuclide releases by acting as a sponge for some contaminants.

Chapter 5 investigates the relationship between concrete vault performance and groundwater concentrations of contaminants — the most important performance measure for most disposal systems.

2. DIFFUSION IN CONCRETE

2.1 Basic Governing Equations

In relatively impermeable materials such as intact concrete, the rate of water flow is very low. In low flow situations, diffusional transport according to Fick's laws of diffusion will dominate mass transport. Diffusion of dissolved species can occur in either the gaseous or liquid phase. Because of the small pore sizes, concrete matrix present in belowground vaults will remain near saturation with water even when the surrounding soil materials are relatively dry. Thus, liquid diffusion is expected to be the dominant transport mode through intact concrete in subsurface concrete barriers, whether the facility is located above or below the water table.

Although diffusion is conceptually simple, estimating diffusion rates in concrete can be complicated and error prone. The major problems are the lack of standardized nomenclature and the necessity of lumping several poorly understood processes into the diffusion coefficient. When diffusion experiments are performed, the rate of flux of a particular ion is measured. This rate of flux may depend upon many factors including

- Tortuosity and constrictivity of the porous medium (i.e., concrete)
- Adsorption of the ion onto the solid phase
- Precipitation/dissolution of the ion as a solid
- Solid solution of the ion in components of the concrete
- Complex formation and speciation in solution
- Electrical potential gradients related to differential ion diffusion rates
- Physical entrapment of the ion in the concrete, and
- Radioactive decay.

Subsequent analysis of the experimental data generally results in some or all of the above processes being lumped into the resultant diffusion coefficient. Depending upon how the experiment was performed and the type of calculations used in data analysis, the reported diffusion coefficient can

mean many different things. For this reason, great care must be used when applying published diffusion coefficients for concrete in performance assessment calculations. Consistency must be maintained between the experimental methodology and subsequent use of experimentally determined diffusion coefficients.

The basic flux equation for diffusion of a contaminant at low concentration in water is

$$F = -D\nabla C \quad (1)$$

where

- F = flux of contaminant (mole/cm²-s)
- D = tracer diffusion coefficient (cm²/s)
- C = contaminant concentration in liquid (mole/cm³ of water).

In concrete and other porous materials, several physical properties of the medium interfere with the diffusion rate. The presence of the solid phase reduces the surface area available for diffusion, the ions must follow a tortuous path through the solid, and the openings or pores have alternating large areas and constrictions. The effects of tortuosity and constrictivity can be expressed as

$$\tau = \frac{\delta}{\tau_0} \quad (2)$$

where

- τ = a lumped tortuosity or geometry factor
- δ = constrictivity
- τ_0 = tortuosity.

The basic flux equation for concrete is now

$$F = -\theta\tau D\nabla C \equiv -\theta D_e \nabla C \equiv -D_a \nabla C \quad (3)$$

where

- θ = volumetric water content
- D_e = effective diffusion coefficient appropriate for use in most performance assessment codes (cm²/s)

- D_i = intrinsic diffusion coefficient (measured in steady state flux experiments (cm^2/s))
- D_a = apparent diffusion coefficient measured in leach tests (cm^2/s).

The intrinsic diffusion coefficient is measured in steady state leach tests across a small slice of concrete when concentrations are set in the aqueous phase on both sides. Apparent diffusion coefficients are measured from total mass release in leach tests. Groundwater transport codes designed for heterogeneous media must separate the effects of porosity, sorption, geometry factor, and diffusion rate in water because most of them have different effects upon contaminant transport. Most transport codes and analytical solutions will require the effective diffusion coefficient as defined in this report as input.

If linear reversible sorption is assumed, the mass balance equation for diffusion with radioactive decay for saturated and unsaturated media is

$$\theta \frac{\partial C}{\partial t} = \frac{1}{R_d} \nabla \cdot (\theta \tau D \nabla C) - \theta \lambda C - \frac{\partial \theta}{\partial t} C. \quad (4)$$

The retardation factor is given by

$$R_d = 1 + \frac{\rho_b K_d}{\theta} = 1 + \frac{(1 - \phi) \rho_s}{\theta} \quad (5)$$

where

- R_d = retardation factor
- λ = decay constant (s^{-1})
- ρ_b = bulk density of concrete ($\text{g solid}/\text{cm}^3$ total)
- K_d = distribution coefficient (mL/g)
- ϕ = porosity
- ρ_s = solid density of concrete ($\text{g solid}/\text{cm}^3$ solid).

A common methodology for dealing with diffusion in concrete waste forms is to define the diffusion coefficient based upon the total concentration of a contaminant in the porous media. Using this procedure, the flux of contaminant is

$$F = -D_a \nabla C_t \quad (6)$$

where

- D_a = apparent diffusion coefficient (cm^2/s)
- C_t = total concentration of contaminant in porous medium (mole/cm^3).

If linear partitioning of the contaminant is assumed between the solid and aqueous phase, a capacity factor for the contaminant in the porous media can be defined that relates the apparent diffusion coefficient to Equation (4) (Atkinson and Nickerson, 1988):

$$\alpha = \theta + \rho_b K_d = \theta R_d \quad (7)$$

where

- α = volumetric distribution coefficient.

The total concentration of contaminant in the porous medium is

$$C_t = \theta C + (1 - \phi) C_s = C \alpha = C \theta R_d \quad (8)$$

where

- C_s = concentration of contaminant in the solid phase (mole/cm^3 solid).

The mass balance equation written in terms of total concentration is

$$\frac{\partial C_t}{\partial t} = \nabla \cdot D_a \nabla C_t - \lambda C_t \quad (9)$$

where

$$D_a = (\theta \tau D) / \alpha = (\tau D) / R_d = D_i / R_d.$$

2.2 Leaching From Waste Forms

Much of the data concerning diffusion in concrete waste forms (and most other solid waste forms as well) is obtained from leach tests. The tests are conducted by placing the waste form in a container of water. The water is replaced periodically to maintain the contaminant concentration in the water near zero. The data available are generally the initial total concentration in the waste form (C_i) and the cumulative release of contaminant through time during the length of the experiment.

For a planar surface, integration of Equation (9) (Crank, 1975) when radioactive decay is negligible gives

$$\frac{C_i}{C_{i0}} = \text{erf} \left(\frac{x}{2 \sqrt{D_a t}} \right) \quad (10)$$

where

C_{t_0} = initial total concentration in waste
 (mole/cm³ total).

The release rate at the surface of the waste form is

$$F = (D_a \frac{\partial C_t}{\partial x})_{x=0} = \frac{D_a C_{t_0}}{\sqrt{\pi D_a t}} \quad (11)$$

Integration of the release rate over time gives

$$M_t = 2C_{t_0} \sqrt{\frac{D_a t}{\pi}} \quad (12)$$

or

$$M_t = 2C_{t_0} \sqrt{\frac{D_a}{\pi}} \sqrt{t} \quad (13)$$

where

M_t = total mass released per unit area.

these equations show there should be a linear relationship between total contaminant release and the square root of time, with the slope of the line related to the diffusion coefficient. This basic relationship, although sometimes solved in other coordinate systems, is used to determine diffusion coefficients. The conformance of the tests to the square root of time relationship is evidence that the leaching process is diffusionaly controlled. Non-linear results can be explained by considering initial surface wash off of contaminants and by kinetic controls on the release rate. The diffusion coefficient obtained in this manner is actually the apparent diffusion coefficient, which includes diffusion rate, porosity, sorption, tortuosity, and potentially other, unspecified and unknown phenomena into one empirical coefficient. Extrapolation of empirical parameters such as apparent diffusion coefficients over long time periods is a questionable practice.

As the following calculations illustrate, the conformance of the data to a square root of time relationship does not guarantee diffusional control of release. Frequently, the chemistry of cement waste forms is designed to precipitate some radionuclides as solid phases. For example, technetium can be precipitated as a sulfide in some cases.

Leach rates from waste forms with precipitated solids depend upon the solubility of the contaminant in the pore solution of the waste form. If dissolution of the contaminant solid is rapid relative to diffusion rates, then a shrinking core model can be used to estimate release rate. A schematic of the system is shown in Figure 3. The contaminant concentration is held at the solubility limit of the contaminant (solubility controlled zone) inside the unleached waste form. The portion of the waste form containing contaminant solid gradually retreats as leaching progresses. If the rate of retreat is slow, then the diffusional zone remains near steady state.

The flux of contaminant out of the system is

$$F = \frac{\theta \tau D C_{sol}}{x} \quad (14)$$

where

C_{sol} = concentration of contaminant in equilibrium with limiting solid phase
 (mole/cm³)

x = thickness of leached zone (cm).

The rate of migration of the boundary between the leached zone and the zone where the concentration remains at C_{sol} (saturated zone) is

$$\frac{dx}{dt} = \frac{F}{C_{t_0}} = \frac{\theta \tau D C_{sol}}{x C_{t_0}} \quad (15)$$

Integration of Equation (15) gives an expression for x that can be substituted back into Equation (14) to give the contaminant release rate. Integration of the expression for release rate over time gives the cumulative release

$$M_t = \sqrt{2\theta \tau D C_{sol} C_{t_0} t} \quad (16)$$

Comparing Equations (13) and (16) shows that in both cases the cumulative release of the contaminant is proportional to the square root of time. Thus, the case of solubility-controlled release may be improperly interpreted and modeled as simple diffusional control.

If a solubility-controlled system is analyzed and reported according to Equation (13) (the usual case for data reported in the literature), the appar-

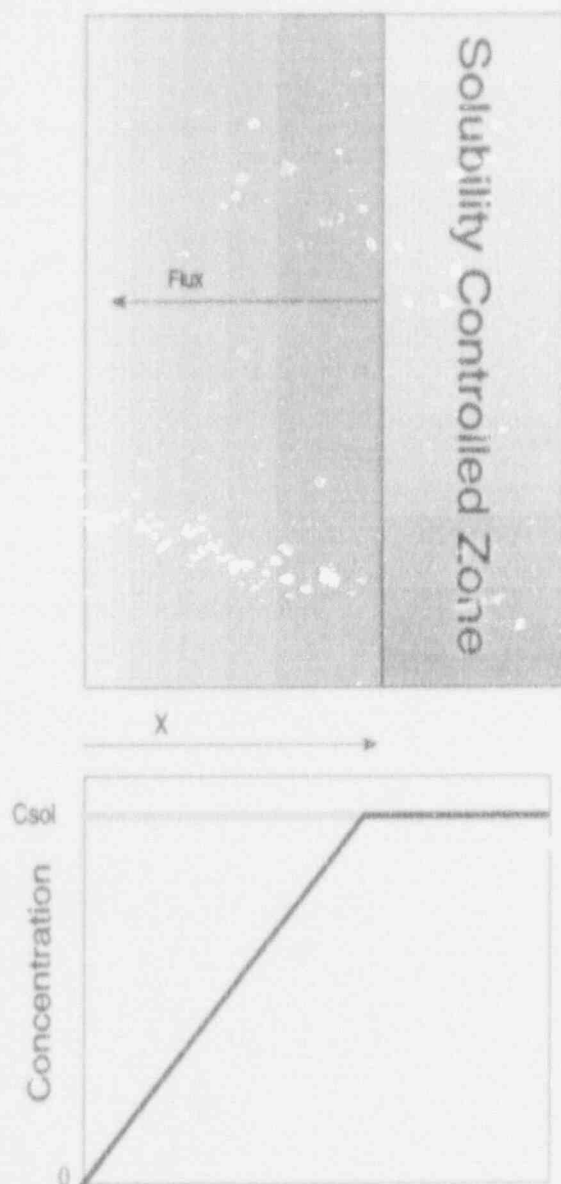

Figure 3. Schematic of solubility controlled leaching.

ent diffusion coefficient obtained should be approximately equivalent to

$$D_a = \frac{\pi\theta\tau DC_{sol}}{2C_{t_0}} \quad (17)$$

In the simplest cases of performance assessment modeling, an empirical leach rate fit to the diffusion equation may be adequate. Applying empirical leach rate data in more sophisticated codes (e.g., where advection is also considered) can lead

to conceptual errors even if consistency with experimental methods is maintained.

If radioactive decay is not important in the experiments because of time scales but is important in the performance assessment calculations, then treatment of the solubility controlled release as simple diffusion will underestimate release rate and result in a nonconservative analysis.

2.3 Methodology for Use of Apparent Diffusion Coefficients in Performance Assessments

Groundwater codes that consider transient contaminant migration in heterogeneous media define a diffusion coefficient that generally does not include sorption, porosity, entrapment of the contaminant, or solubility limits subsumed inside the diffusion coefficient. The distinction becomes critical in heterogeneous systems because the direction and rate of diffusion is actually controlled by concentration gradients in the fluid phase, not gradients in total concentration.

In the experiments used to determine apparent diffusivity, the external concentration is held at zero. As long as the external concentration is zero, it is not important to distinguish between total and aqueous concentrations. However, when significant fluid concentrations build up in media outside the waste form (e.g., in cracks in the concrete), the leach rate can no longer be described without breaking the apparent diffusion coefficient into its constituent parts. In the author's experience, confusion over diffusion coefficients and their meaning is one of the most common mistakes made in performance assessment calculations.

The best solution to this problem is to encourage two general classes of experiments to be performed with the waste form. Transient experiments where total leach rates into water are measured give values for the apparent diffusion coefficient. Experiments of steady state diffusion across small slices of the waste form give the intrinsic diffusion coefficient. The diffusion coefficient in water can be found in existing tables. When all three diffusion coefficients are known, the retardation factor and distribution coefficient can be estimated.

Another approach to breakup the apparent diffusion coefficient is to compare it with results for nonreactive ions such as nitrate and sometimes chloride. In the case of nitrate, all of the material can be assumed to be in aqueous solution, although some proportion may be in isolated pores and unavailable for transport. If all the nitrate is in aqueous solution then the capacity factor (α) is equal to the porosity which can be measured or estimated. Canceling terms shows that in this case the apparent diffusion coefficient is equivalent to the effective diffusion coefficient. The tortuosity or geometry factor can be estimated from the diffusion coefficient in water and the effective diffusion coefficient for nitrate or other non sorbing ion

$$\tau = \frac{D_e}{D} \quad (18)$$

This relationship is only valid for species that reside completely in the aqueous phase. The calculated tortuosity or geometry factor should, in principle, be applicable to all ions and, therefore, only needs to be estimated once. The retardation factor is obtained from

$$R_d = \frac{\tau D}{D_d} \quad (19)$$

where the tortuosity factor is calculated only once from Equation (18), and the retardation factor is calculated for each species from measured apparent diffusion coefficients and diffusion coefficients in water taken from the literature. The volumetric distribution coefficient can be estimated from R_d using Equation (7).

These methods have the distinct disadvantage that they require the modeler to assume reversible linear sorption and pure diffusional release in the governing equations. These assumptions are consistent with current performance assessment models; however, they are only sometimes correct.

2.4 Leaching From Concrete Waste Forms Located In The Unsaturated Zone

Leaching tests for concrete waste forms are generally performed in a water saturated system. Because most radioactive waste in the U.S. will be

placed in the unsaturated zone, the influence of water content on leach rates is of interest.

Leaching of concrete waste forms in the unsaturated zone has been investigated experimentally and documented in Oblath (1989). Oblath found that over a wide range of water contents in sand and soils typical of the Savannah River Site (South Carolina) the leach rate from a concrete waste form was independent of saturation or water content of the surrounding soil. In order to reduce the leach rate significantly below the value found in water, the Savannah River soils had to be oven dried at 100°C overnight.

The experimental result is consistent with estimates based upon physical principles. The diffusion coefficient of ions in the concrete waste form was found to be $D_e < 5 \times 10^{-9}$ cm²/s. In comparison, ions in typical water saturated soils have diffusion coefficients on the order of 10⁻⁵ to 10⁻⁶ cm²/s. Thus the leach rate of a concrete waste form immersed in soil will be controlled by the diffusion coefficient in the waste form (i.e., the rate limiting step) under saturated conditions.

When moisture tension is increased, the water content and, therefore, the diffusion coefficient in the soil decreases. Because of small pore sizes the concrete waste form remains saturated and unaffected by the reduced moisture content of the soil. Eventually, as moisture tension is further increased, the diffusion coefficient in the soil drops below the level of the diffusion coefficient in the waste form and becomes rate limiting. At this point the leach rate or apparent diffusion coefficient from the waste form in the soil begins to decline with further increases in moisture tension.

The dependence of diffusion rate on saturation in soils has been investigated and reported in Olsen and Kemper (1968). The relationship between diffusion rate and water content is given by Olsen and Kemper's Equation 57

$$D_i = Dae^{b\theta} \quad (20)$$

which is equivalent to

$$D_e = \frac{Dae^{b\theta}}{\theta} \quad (21)$$

where a and b are empirical constants. This relationship was applicable between 0.33 and 15 bars of suction, which corresponds to a volumetric water content of >0.1 . The recommended value for b is 10, and a ranges from 0.005 (sandy loam) to 0.001 (clay soils). At soil moisture tensions < 15 bar, diffusion coefficients for soil will seldom be lower than 10^{-8} cm²/s and will normally be greater than 10^{-7} cm²/s (Olsen and Kemper, 1968).

Going back to the original data in Porter *et al.*, 1960 gives a relation of the form

$$D_e = D(1.25\theta - 0.125) \quad (22)$$

which is valid down to a volumetric water content (θ) of approximately 0.12. Below this point the effective diffusion coefficient drops off at a more rapid rate and no longer obeys a linear relationship with water content.

Figure 4 compares Equation (22) with the apparent diffusion coefficients measured by Oblath (1989) for leaching of nitrate from saltstone immersed in soil (i.e., the leach rate) with variable water content and pure water. In the case of non-sorbing species such as nitrate, the apparent diffusion coefficient measured in leaching experiments is identical to the effective diffusion coefficient. The dotted extension of the constant portion of the curve represents the diffusion rate in the saltstone which should be independent of soil moisture tension. The measured rate of leaching from saltstone is independent of soil moisture content until the soil moisture content drops down to and below the level where the diffusion in soil and saltstone are approximately equivalent. At low moisture tensions, the diffusion rate in the soil becomes rate limiting and leach rates become a function of soil moisture tension. At higher soil moisture tensions, the saltstone controls the diffusion rate and leaching is not a function of soil moisture tension.

The final result is that rates of leaching of concrete waste forms in the unsaturated zone can be expected to be identical to leach rates in the saturated zone until soil moisture tensions get below the range of approximately 15 bars and moisture content of <0.1 . Clay soils will require even lower tensions to reach this moisture content. Thus, except in desiccated environments, leaching rates

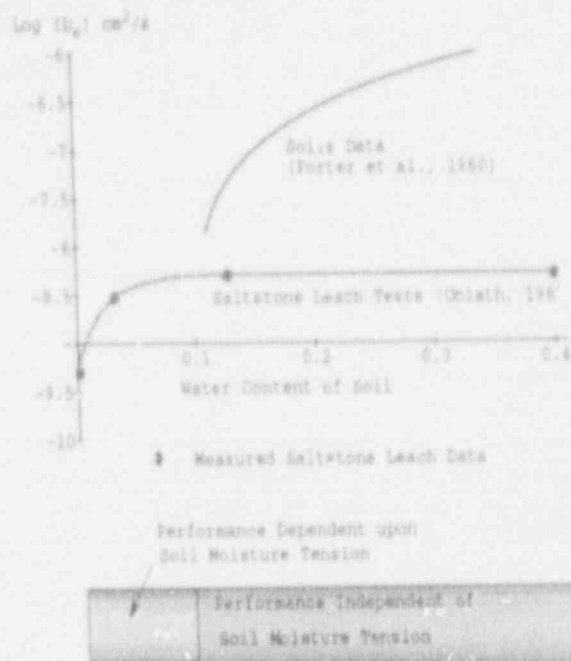

Figure 4. Leaching rate from concrete waste form in partially saturated soil.

from concrete waste forms will not be reduced by placing of waste in the unsaturated zone.

2.5 Mathematical Treatment of Unsaturated Transport

The analysis of mass transport from concrete vaults and concrete waste forms in the following chapters uses saturated flow equations to examine controls on mass transport of radionuclides from concrete vaults. The equations and analytical solutions for saturated systems are applied even though most, if not all, of the vaults currently being developed in the U.S. are intended to be built above the water table. This simplifying assumption is justified by two factors. The first is that leach rates of concrete waste forms are independent of moisture content over most of the range of interest. The other factor is that perched water is likely to form on the top of many vaults. The locally saturated conditions allow water to enter the cracks in the concrete as saturated flow. The perched water on the vault tops accelerates flow rates through the vaults to a rate faster than would be expected from a saturated zone location (Walton and Seitz, 1991).

Thus, in many respects, concrete vaults located in the unsaturated zone will not benefit from the unsaturated location.

3. LEACHING FROM FRACTURED CONCRETE WASTE FORMS

3.1 Basic Governing Equations and Simplifying Assumptions

The single greatest weakness of concrete for radioactive waste isolation is its tendency to crack. Cracks create preferential pathways in otherwise impermeable systems, leading to enhanced leaching of contaminants. The controls on mass transport through two general cases of cracked concrete are covered in this report. Chapter 3 evaluates release rates from a cracked concrete waste form. Chapter 4 evaluates transport of radionuclides through a cracked concrete vault surrounding the waste. Not surprisingly, the properties controlling release rates are not the same for both cases.

The concrete vault is envisioned as a large fractured monolith, with blocks of intact concrete separated by fractures. Waste percolates through the fractures while transport in the matrix is by diffusion.

A number of semianalytical solutions have been developed for transport through fractured porous media. Of available methods, the solution of Rasmuson and Neretnieks (1981) is perhaps most appropriate for application to release rates from massive concrete vaults. A decaying source term is assumed, which is required for leaching, and the solution is given in terms of dimensionless parameters, which can be used to interpret and generalize the results from the analysis. The published solution estimates transport from a decaying source of radionuclides into a fractured porous medium. The desired solution is the complement of the one desired for release from a fractured concrete monolith where radionuclides are leached from (rather than into) a fractured porous medium.

The parametric study is limited to the case of no dispersion in the fractures in the concrete. This is the worst or conservative case for radionuclide release rates from concrete waste forms. It should be noted that the no dispersion case is not always

conservative for modeling radionuclide transport in groundwater as is assumed by many analysts.

Fractures in concrete may channel flow. This, as well as variability in fracture spacing and location, would effectively make the concrete monolith behave as some unknown combination of the situations evaluated in this work.

The analytical solution for no dispersion is (with slight modification from Rasmuson and Neretnieks, 1981)

$$H_1(\lambda) = \lambda \left(\frac{\sinh 2\lambda + \sin 2\lambda}{\cosh 2\lambda - \cos 2\lambda} \right) - 1 \quad (23)$$

$$H_2(\lambda) = \lambda \left(\frac{\sinh 2\lambda - \sin 2\lambda}{\cosh 2\lambda - \cos 2\lambda} \right) \quad (24)$$

If $\zeta > 0$ then

$$\frac{\alpha C_f}{C_{i_0}} = (1 - \gamma) [\exp(-\beta)] \quad (25)$$

$$\gamma = \frac{1}{2} + \frac{2}{\pi} \int_0^{\infty} \exp(-\delta H_1) \sin(\zeta \lambda^2 - \delta H_2) \frac{d\lambda}{\lambda} \quad (26)$$

otherwise if $\zeta < 0$ then

$$\frac{\alpha C_f}{C_{i_0}} = \exp(-\beta) \quad (27)$$

where the solution depends upon the following dimensionless variables:

$$\zeta = (2D_a \theta) / r_0^2 = \text{dimensionless contact time}$$

$$\alpha C_f / C_{i_0} = \text{dimensionless concentration}$$

$$\beta = \lambda_d t = \text{dimensionless radioactive decay}$$

$$\delta = (\gamma z) / (mU_f) = \text{bed length parameter}$$

which are derived from the following other variables

$$\theta = t - z/U_f$$

- C_f = concentration in fractures
- α = volumetric distribution coefficient
- λ_d = decay rate = $\ln 2/t^{1/2}$
- r_o = effective radius of spherical blocks =
0.5 S for cubic blocks and 1.5 S for
slabs
- S = fracture spacing
- U_f = velocity in fractures
- D_a = apparent diffusion coefficient
- z = thickness of vault
- z_o = total distance along fracture from top
or upgradient portion of vault
- ϕ_f = fracture porosity
- ϕ_m = matrix porosity
- m = $\phi_f / (1 - \phi_f)$
- γ = $(3D_a\alpha) / r_o^2$

The analytical solution was derived for the case of a semi-infinite media, whereas, the application of concern is for a concrete vault of finite dimensions. For the no dispersion case, this is not a limitation. Considering the no dispersion case is justified by the lack of information concerning dispersion in cracks in concrete. Because crack dispersion likely results from variation in aperture, variation of assumed aperture is perhaps a better way of considering the phenomenon.

The release rate per unit area from the bottom of the fracture is

$$R = C_f V|_{z=z_o} = C_f U_f \phi_f|_{z=z_o} \quad (28)$$

where

V = average Darcy velocity through vault

Cumulative release per unit area of the bottom of the vault is

$$M_t = \int_0^t R dt. \quad (29)$$

The fractional release rate and cumulative release are given by

$$\frac{R}{M_{t_o}} = \frac{C_f V|_{z=z_o}}{M_{t_o}} = \frac{C_f U_f \phi_f|_{z=z_o}}{M_{t_o}} \quad (30)$$

and

$$\frac{M_t}{M_{t_o}} = \frac{\int_0^t R dt}{M_{t_o}} \quad (31)$$

where

$$M_{t_o} = C_{t_o} z_o.$$

The fracture flow solution assumes that the only transport in the z direction is inside the fractures (i.e., advection in the fractures is much greater than diffusion through the matrix). At very low water flow rates this assumption will not be true and transport in the z direction will be dominated by diffusion. One dimensional diffusion out of the monolith can be estimated with an error function solution as derived in the previous chapter.

$$M_t = \exp(-\lambda_d t) 2C_{t_o} \sqrt{\frac{D_a}{\pi}} \sqrt{t} \quad (32)$$

In this chapter the cumulative release of contaminants is illustrated by Equations (29) and (32). Because advective release only occurs on the downstream side of the vault while diffusional release can occur from all sides of the vault, Equation (32) could be multiplied by a correction factor to account for the greater applicable surface area. This is relatively unimportant for the parametric study in this chapter where only relative behavior is evaluated. This methodology does not take credit for other layers below or around the concrete waste form such as an outer concrete shell around the waste form. Therefore the analytical solution will over estimate the diffusion only release rate from the concrete vault.

3.2 Dimensional Analysis and Plausible Range of Parameters for Concrete Vaults

This analysis examines the performance of monolithic concrete vaults in isolating radioactive waste. Performance is measured by the effluent concentration, release rate, and cumulative release rate of contaminants. Thus the analysis focuses on the concentration at the bottom or downstream portion of the vault and z is always equal to z_o . The depth of the vault could range from approximately

1 meter for small, modular vaults to 10 meters or greater for large (e.g., football field sized) vaults. Typically, concrete will shrink approximately 10^{-4} of its initial length. Thus, ϕ_f , the proportion of the vault made up of fractures, will be around 10^{-4} and the parameter m will be essentially equal to ϕ_f .

Therefore, the bed length parameter becomes

$$\delta = \frac{\gamma z_o}{m U_f} = \frac{\gamma z_o}{V} = \frac{3D_e \alpha z_o}{V r_o^2} = \frac{3D_e z_o \phi_m}{r_o^2 V} \quad (33)$$

which can be interpreted as the average residence time of water in the entire vault ($z_o \phi_m$)/ V divided by the characteristic time for unretarded diffusion out of the blocks of matrix $r_o^2/(3D_e)$. The solution is dependent upon the total water flow rate through the vault and crack spacing but is independent of total crack gap. Crack gap or aperture only impacts the release rate when crack gap influences flow rate. The bed length parameter is dependent upon physical flow and transport properties of the system and contaminant but is not impacted by sorption phenomena.

The dimensionless contact time can be decomposed in a similar manner

$$\zeta = \frac{2D_e \theta}{r_o^2} = \frac{\theta}{\left(\frac{r_o^2}{2D_e} \right)} \quad (34)$$

and can be interpreted as the time (θ) divided by the characteristic time for diffusion out of matrix blocks when retardation is included [$r_o^2/(2D_e)$]. In this context, sorption/chemical binding of the contaminants in the matrix acts by modifying the dimensionless contact time of the simulation.

The low typical values for ϕ_f also mean that the period of time when ζ is less than zero will usually not be of great significance and will be of relatively short duration.

Figures 5 through 9 illustrate the impact of bed length and dimensionless time upon the fractional release rate of contaminants from the monolithic concrete vault. The effects of radioactive decay are

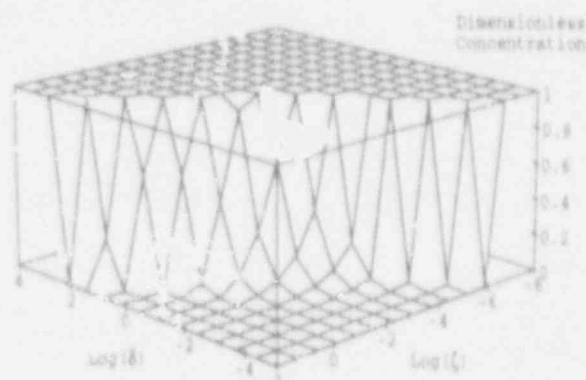

Figure 5. Dimensional analysis of equations with no radioactive decay.

obvious from inspection of the governing equations. Along any constant value for the bed length parameter (δ), increasing contact time causes the concentration to eventually decrease. As the bed length parameter increases, longer contact times are required to reduce the dimensionless concentration below unity.

3.3 Cumulative Release Calculations

One of the performance measures applicable to any waste disposal system is the cumulative release of contaminants over a fixed time period. If the linear dose-response hypothesis for exposure to radioactivity is correct, then the total health impact of the site will be approximately proportional to total release of radionuclides. Cumulative releases eliminate time as a plotting variable, allowing a wide range of parameter values to be illustrated on a single figure. The parametric calculations in this section investigate the factors that control total or cumulative release of contaminants from monolithic concrete vaults.

Four nominal contaminants are considered in the calculations: nitrate, technetium, chromium, and tritium. Nitrate is considered only because there is a substantial amount of data on nitrate leaching. Nitrate behavior is synonymous with long-lived radionuclides which have high solubility in concrete waste forms and little adsorption onto the solid phase (e.g., iodine, oxidized technetium). Technetium and chromium are subject to adsorption and solubility limitations in some mixes. Tritium is not subject to solubility limitations or adsorption and has a short half-life of 12.7 years.

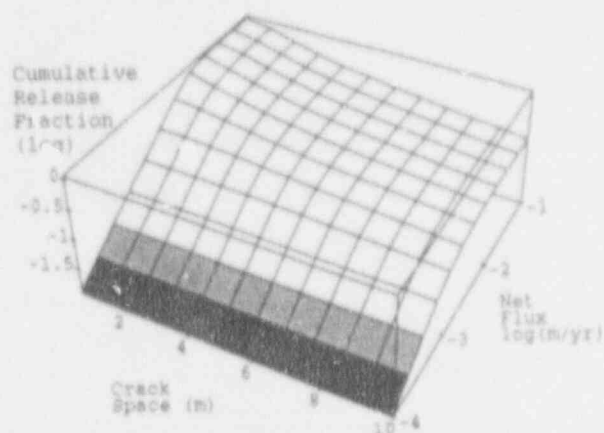

Figure 6. Cumulative release fraction of nitrate over 500 years as a function of crack spacing and water flux through vault.

Data for diffusion coefficients are taken from Serne and Wood (1990). The values used in the figures are $D_n = 5 \times 10^{-8} \text{ cm}^2/\text{s}$ for nitrate, $5 \times 10^{-8} \text{ cm}^2/\text{s}$ for tritium, $10^{-8} \text{ cm}^2/\text{s}$ for technetium, and $10^{-10} \text{ cm}^2/\text{s}$ for chromium. The retardation factor and capacity factor are estimated using the methods in Equations (18) and (19). The vault is assumed to be 10 meters thick and the waste form porosity is 0.4.

Cumulative release in Figures 6 to 9 is given as the logarithm to the base 10 of the fraction of the initial inventory that is released. A value of 0 indicates total release of the initial inventory. For non-decaying contaminants such as nitrate, eventually all of the inventory will be released in any scenario. For decaying contaminants, delays in release reduce the total release rate (i.e., greatly decays before potential release). The graphs are intended to illustrate controls on release rate and do not correspond to any actual disposal system currently being built.

The region of potential switch between the region where crack transport dominates release and where flow becomes unimportant [Equation (32)] is illustrated by shading. This transition zone to pure diffusional control is dependent upon the material placed around the vault. In most situations, a layer or shell of concrete or other materials will be placed around the concrete waste form, greatly lowering pure diffusional release rates below the values given in the shaded regions.

Three general regions are apparent in each of the graphs. The location of each region is dependent

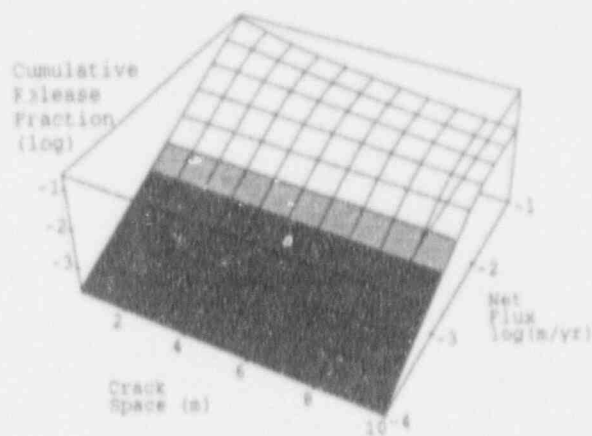

Figure 7. Cumulative release of tritium over 500 years.

upon the radionuclide of concern, the properties of the waste form, and the amount of water percolation into the vault. At higher water percolation rates, the release rate becomes independent of water flow rate, but it is highly dependent upon fracture spacing. This upper region depicts where the contaminant concentration in the fractures is essentially zero. Release rate is controlled by diffusion from the interiors of the blocks to the cracks, which is highly dependent upon crack spacing. Once the water percolation rate is rapid enough to hold the concentration in the cracks to near zero, additional water flow has little effect on release rate. The release rate shown in the second region occurs at slightly lower flow rates and is characterized by the release rate being independent of crack spacing, but it is highly dependent upon water percolation rate. In this region the contaminant concentrations in the cracks and matrix are essentially

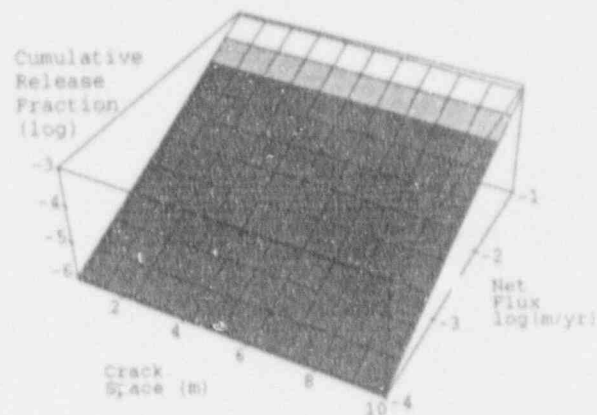

Figure 8. Cumulative release of chromium over 500 years.

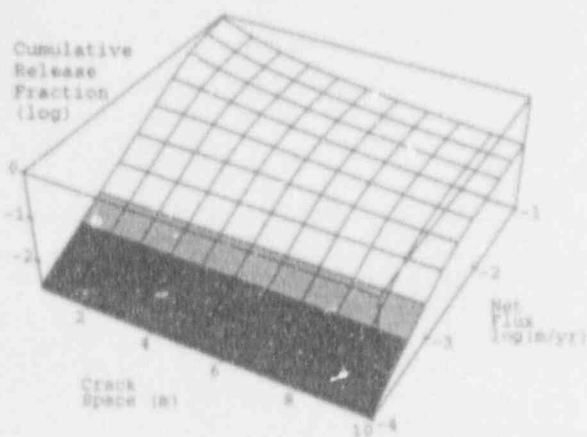

Figure 9. Cumulative release of technetium-99 over 500 years.

the same and the system behaves as an equivalent porous medium.

The third region, depicted by shading occurs at very low water percolation rates and is characterized by a constant release rate. At very low flow rates, the release rate is entirely diffusively controlled and neither flow rate nor crack spacing are important in influencing it.

The location of each performance region in the parameter space of crack spacing and water flow rate (Darcy velocity through vault) is dependent upon the apparent diffusion coefficient and radioactive decay. Contaminants that are bound to the solid, such as chromium (with low apparent diffusion coefficients), are released at much lower rates, but the release rate is sensitive to flow rate over a much broader range. When analyzing mass transport, it is not always important to be able to estimate crack spacing and flow rate in order to determine the performance of a monolithic concrete vault. In many instances, only one of the two key parameters will be important. Unfortunately, the important parameters may be different for each contaminant being leached.

3.4 Concentration Versus Release

The previous section evaluated the controls on the release rate of contaminants from a concrete vault. In general, the population exposure and, therefore, (assuming no threshold for adverse effects) total excess cancers are directly proportional to total contaminant release. In contrast, the maxi-

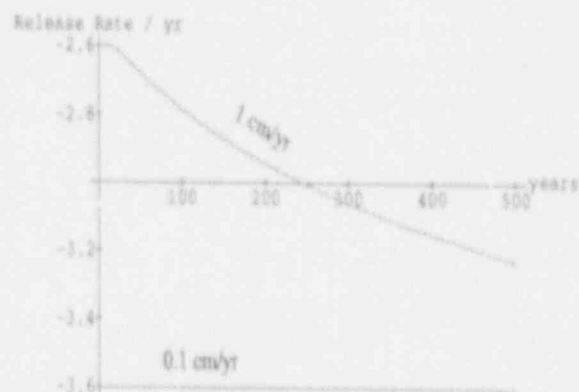

Figure 10. Release rate of nitrate from a simulated concrete monolith with changing water percolation rate. Release rate is the logarithm to the base 10 of the fractional release rate.

mum dose to an exposed individual is related to maximum concentration in groundwater. Release rate is only one of that factors influencing maximum concentrations in groundwater. Peaks in release rate may not correspond to maximum concentrations in groundwater. At low water percolation rates through the vault, the cracks maintain the same concentration as the pore water in the matrix. At more rapid flow rates, the process water passing through the cracks does not increase release but does provide dilution water.

The calculations for nitrate illustrate the phenomena. Figure 10 gives the logarithm of the fractional release rate as a function of time for water percolation rates of 1 and 0.1 cm/yr. The release rate is much greater at the higher flow rate. Figure 11 illustrates the relative concentration of the efflu-

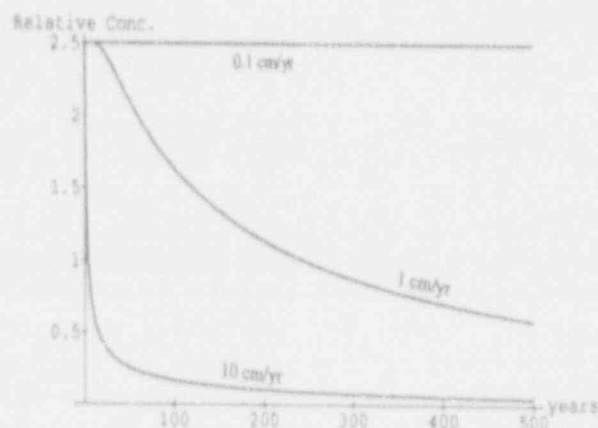

Figure 11. Relative concentration of nitrate in effluent for different flow rates.

ent for several different water flow rates. The relative concentration is the concentration in the liquid exiting the vault normalized to the total concentration initially placed in the grout waste form (i.e., solid + liquid concentration per unit total volume porous media). Because all the nitrate is in the pore fluid, the maximum relative concentration is the inverse of the porosity ($1/0.4 = 2.5$). In Figure 11, the concentration of the effluent is much higher for the low flow, low release situation.

The crossover effect between release rate and effluent concentration behavior has interesting implications for performance assessment. Because the performance standards for low level waste and most hazardous waste are based (indirectly) upon concentrations in the groundwater and not on total release rate, increasing the water flow rate through the vault (e.g., by failure of the engineered cover)

can actually facilitate compliance with regulatory standards. This is another example where a "clearly conservative" assumption for performance assessment calculation (i.e., early cover failure) can turn out to be nonconservative and lead to an underestimate of dose rates.

Although the calculations indicate that concentrations in the effluent coming out of the vault will increase at low flow rates, concentration based standards are typically enforced in the groundwater some distance from the vaults (e.g., at the site boundary). Thus, the effluent will have an opportunity to mix with groundwater, and the final concentration will be dependent upon both release rate and effluent concentration. Depending upon parameters such as dispersion and depth of the aquifer, either release rate or effluent concentration could dominate downstream well concentrations.

4. MASS TRANSPORT THROUGH FRACTURED CONCRETE BARRIERS

In many cases a variety of waste forms will be enclosed by one concrete vault. The concrete vault will be expected to limit the transport of radionuclides through the vault to the external environment. In this chapter calculations are performed of radionuclide transport through fractured concrete. The concrete is assumed to be initially free of contamination. Contaminants leach from the overlying waste and pass through the concrete layer in the floor or sides of the vault.

Two general classes of transport through the concrete barriers are possible: (1) transport through the matrix and (2) passage through cracks in the matrix. Flow and transport through concrete matrix are generally very slow. In contrast, passage through fractures in the concrete can be very rapid. Because fracture transport will generally dominate matrix transport, this report focuses on fracture transport.

The concrete barrier can have at least three functions (1) simple delay of release (2) smearing of peaks in release and (3) permanent attenuation of release. Of the three, permanent attenuation is preferable. Permanent attenuation occurs when the delay in passage through the concrete barrier is significant in relation to the half-life of the radionuclide.

This chapter includes parametric calculations that examine transport through cracked concrete barriers. The assumed parameters for each radionuclide are listed in Table 1.

4.1 Permanent Attenuation of Release

Mass transport through fractured porous media has been studied by a number of investigators, and a variety of analytical solutions for mass transport through fractured porous media have been developed. The analytical solution documented in Sudicky and Frind (1982) for transport through equally spaced parallel fractures presents a simplified case that calculates the thickness of a fractured porous media.

Table 1. Radionuclide Parameters

Nuclide	K_d (mL/g)	Half Life (yrs)
Carbon-14	5,000	5,720
Strontium-90	2	29
Technetium-99	1	2.1×10^5
Cesium-137	2	30
Iodine-129	0	1.6×10^7
Plutonium-239	5,000	2.4×10^4
Tritium	0	12.26

where the steady state concentration of the radionuclide has been reduced by a constant factor, which implies (approximately) that release has been reduced by this factor. For the parametric studies in this section, a 25% reduction in concentration is calculated. The logic is that concrete of the calculated thickness will result in a significant (25%) reduction in radionuclide concentration, which is caused by radioactive decay during transport through the concrete.

If the calculated concrete thickness for a 25% reduction is unreasonably high (greater than a few meters), then the concrete barrier will not be effective in reducing total release of the contaminant since we are unlikely to build concrete barriers more than a few meters thick. However, some smearing of release (and corresponding reduction of peak release) will occur when contaminants pass through any fractured concrete, which may assist with compliance with regulatory standards based upon peak dose.

For the nondispersive case, the steady state penetration depth in the fracture assuming a fixed concentration at the fracture mouth and an infinitely long fracture is

$$d_{(c/c_0)} = \frac{\ln(c/c_0)}{(\lambda/U_f)(1+\beta)} \quad (35)$$

$$\beta = \frac{\phi \sqrt{R_d D_e}}{\sqrt{\lambda} b} \tanh(\sigma \sqrt{\lambda}) \quad (36)$$

$$\sigma = \sqrt{\frac{R_d}{D_e}} (B - b) \quad (37)$$

where

u_{c/c_0} = distance along fracture where steady state concentration is reduced to c/c_0

$2b$ = fracture width

$2B$ = fracture spacing.

Other variables are as previously defined.

Retardation in the fracture is assumed to be zero for simplicity. For concrete systems (but not necessarily for fractured rocks) the retardation on the fracture walls should be very small in relation to the matrix. Fracture wall effects are most important when secondary minerals form on the crack walls, which are more sorptive than the host rock matrix.

The calculations require a significant amount of information about the concrete barriers including porosity, effective diffusion coefficient, and distribution coefficients for each radionuclide. The concrete is assumed to consist of 20% cement paste by volume and 80% quartz sand aggregate. The aggregate is assumed to provide no adsorption of radionuclides and does not add to the porosity. The system is assumed to consist of equally spaced parallel cracks after 0.1% shrinkage of the concrete. Thus, the total crack space is 0.001 times the width of the slab. Crack spacing is given as

$$B = \frac{b}{0.001} \quad (38)$$

Porosity as a function of water to cement ratio is estimated by (Walton *et al.*, 1990)

$$\phi = [0.61 + 0.23 \ln(wcr)] 0.20 \quad (39)$$

where the 0.20 represents the proportion of the concrete taken up by cement paste. The results of Equation (39) are illustrated in Figure 12

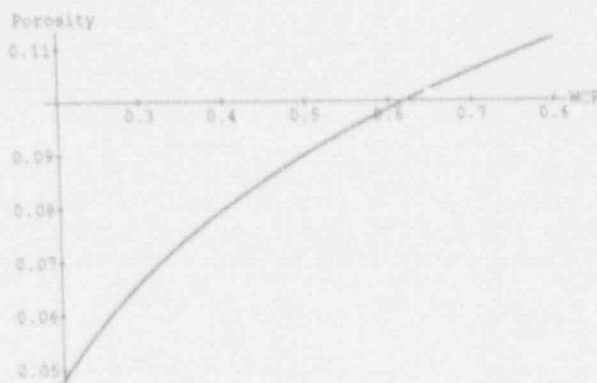

Figure 12. Concrete porosity as a function of water to cement ratio.

The effective diffusion coefficient is given by (Walton *et al.*, 1990)

$$D_e = \frac{0.20 \exp(6wcr - 9.84)}{\phi} \quad (40)$$

The effective diffusion coefficient in the concrete as a function of water to cement ratio is given in Figure 13. The graph is given in terms of the logarithm to the base 10 of the diffusion coefficient expressed in cm^2/s .

One important design controlled parameter is the water to cement ratio. Transport results for carbon-14, assuming a Darcy velocity of 10^2 cm/s (Figure 14) clearly illustrate that, in the presence of cracks, concrete with a high water to cement ratio (i.e., low quality concrete), is much more effective in isolating radionuclides. In the case of low water to cement ratios (high quality concrete) the diffusion coefficients are so low that mass transport through cracks cannot be as effectively attenuated by matrix diffusion. The figure also illustrates the

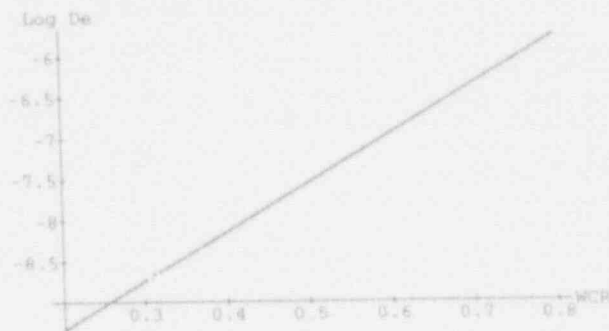

Figure 13. Effective diffusion coefficient in concrete as a function of water to cement ratio.

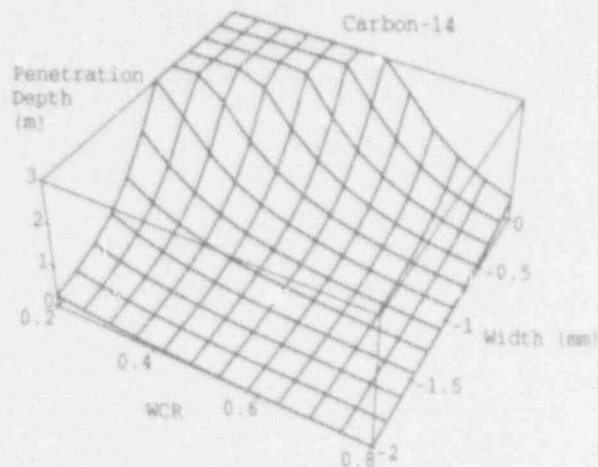

Figure 14. Influence of water to cement ratio and crack width on matrix diffusion.

influence of crack size. Small crack size represents a large number of closely spaced small cracks. Larger cracks are more widely spaced to obtain the same total crack proportion in the concrete. During construction, crack spacing can be controlled with steel reinforcement.

Because concrete vaults will generally be built with high quality concrete at low water to cement ratio, a water to cement ratio of 0.4 is used in Figures 15 to 21. These figures examine attenuation of a host of common radionuclides by concrete barriers as a function of crack width and Darcy velocity through the concrete. The flow rate in the cracks is the Darcy velocity divided by 0.001. The axes for

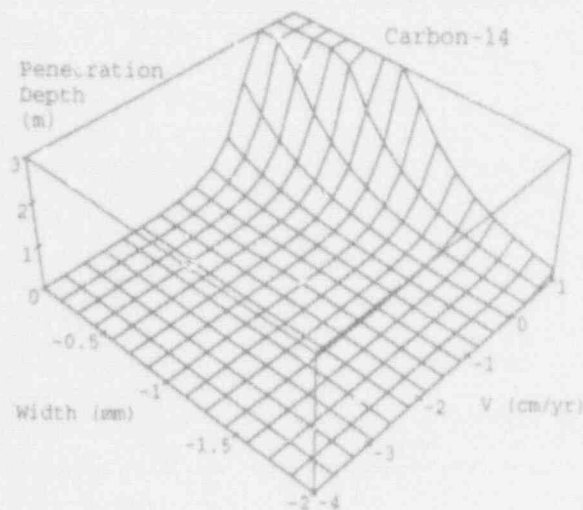

Figure 15. Performance of concrete barriers in attenuating carbon-14 transport.

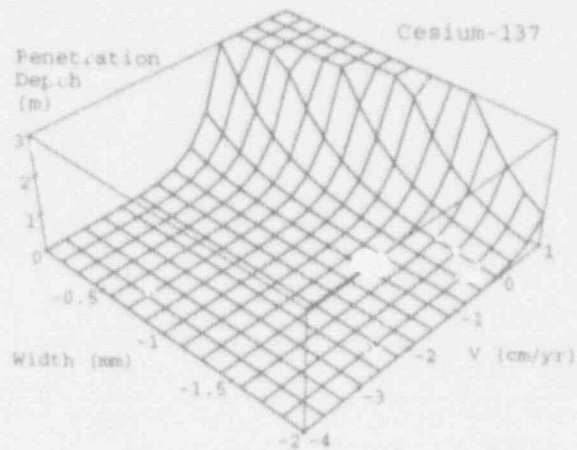

Figure 16. Performance of concrete barriers in attenuating Cesium-137 transport.

crack width are in units of logarithm to the base 10 of crack width in mm. The units on the Darcy velocity (V) are logarithm to the base 10 of velocity in cm/yr. The graphs are truncated at a penetration depth of 3 m. The upper, flat regions represent parameter space where the concrete will not be effective.

In the case of carbon-14, cesium-137, plutonium-239, and strontium-90, the concrete is fairly effective in attenuating release rates, at least at low flow rates. Tritium is also attenuated, although not as effectively. For iodine-129 and technetium, the concrete does little good unless the water flow rate is reduced to negligible levels.

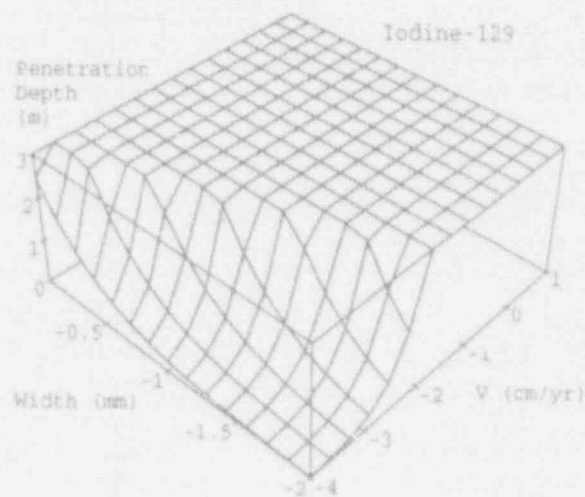

Figure 17. Performance of concrete barriers in attenuating iodine-129 transport.

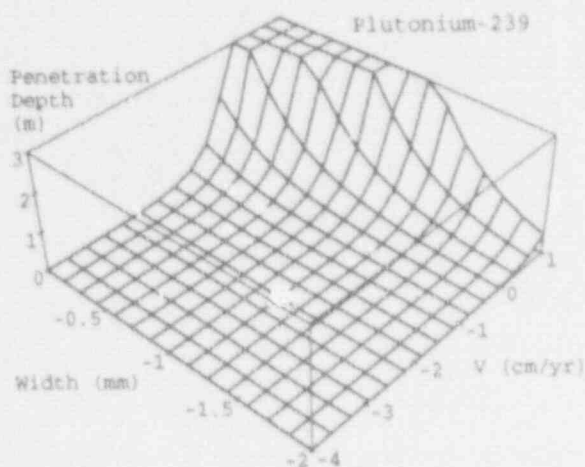

Figure 18. Performance of concrete barriers in attenuating plutonium-239 transport.

4.2 Smearing of Release Rate

Even in cases where the radionuclides will not undergo significant decay while passing through a concrete barrier, concrete may act to delay and smear releases. Spreading a release over a longer time period will not lower total population dose, but it can significantly lower dose to the maximally exposed individual.

The influence of fractured concrete on smearing of release is evaluated using the analytical solution of Tang *et al.*, (1981) and illustrated in Figures 22 through 29. The analytical solution assumes a constant concentration (C_0) at the mouth

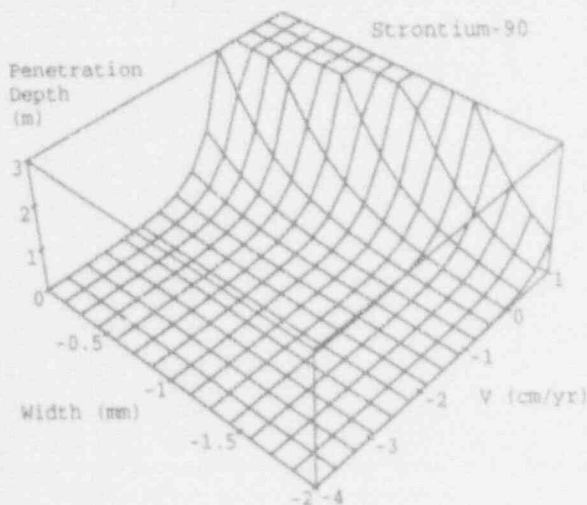

Figure 19. Performance of concrete barriers in attenuating strontium-90 transport.

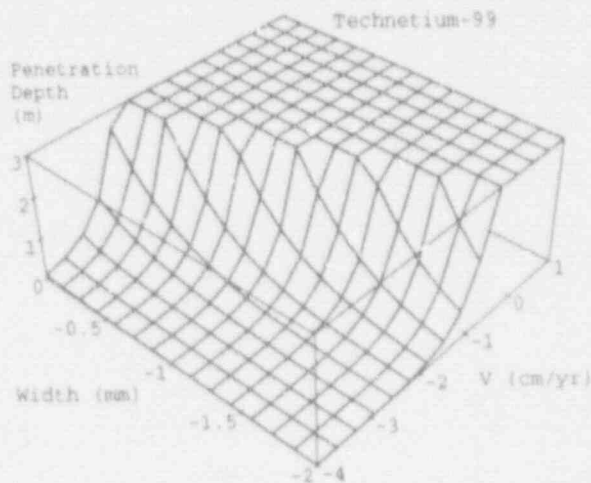

Figure 20. Performance of concrete barriers in attenuating technetium transport.

of the fracture. Only a single fracture is considered. The solution for no dispersion in the fracture is

$$\frac{C}{C_0} = 0 \quad T < 0 \quad (41)$$

$$\frac{C}{C_0} = \frac{1}{2} \exp\left(\frac{-\lambda K_a}{U_f}\right) \left[\exp\left(\frac{-\sqrt{\lambda} R_d z}{U_f A}\right) \right] \quad (42)$$

$$\operatorname{erfc}\left(\frac{z}{2U_f A T} - \sqrt{\lambda} T\right) + \exp\left(\frac{\sqrt{\lambda} R_d z}{U_f A}\right)$$

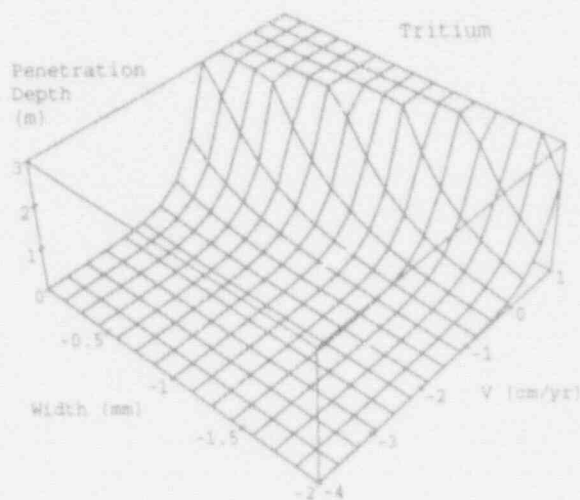

Figure 21. Performance of concrete barriers in attenuating tritium transport.

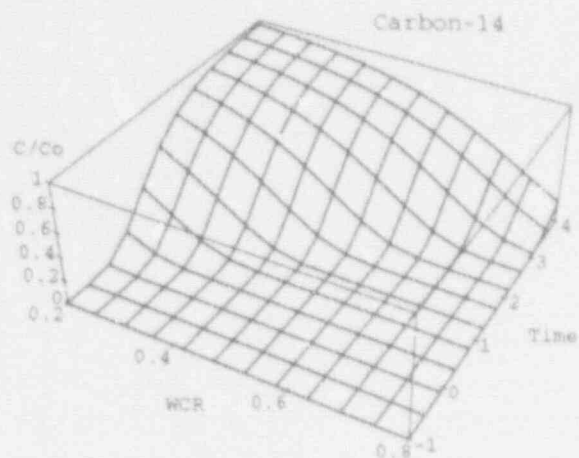

Figure 22. Influence of water to cement ratio on transport of carbon-14 through a single crack.

$$\operatorname{erfc} \left(\frac{z}{2U_f A T} - \sqrt{\lambda T} \right) \quad T > 0$$

where

$$T = \sqrt{\frac{R_d z}{U_f}} \quad (43)$$

$$A = \frac{b}{\phi \sqrt{R_d D_e}} \quad (44)$$

The importance of water to cement ratio is illustrated in Figure 22. The parametric calculations for smearing and delay time assume 100 cm of con-

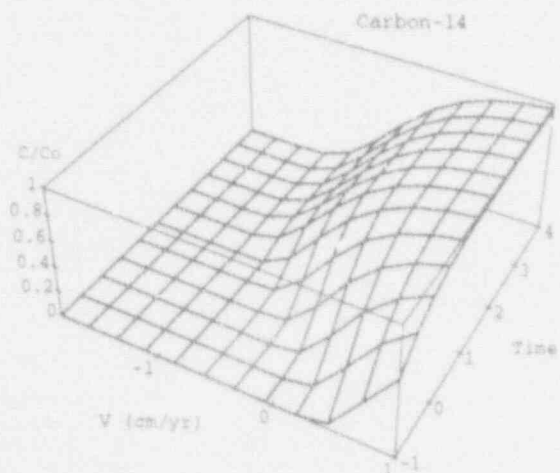

Figure 23. Dimensionless concentration of carbon-14 as a function of Darcy flux through the vault and time.

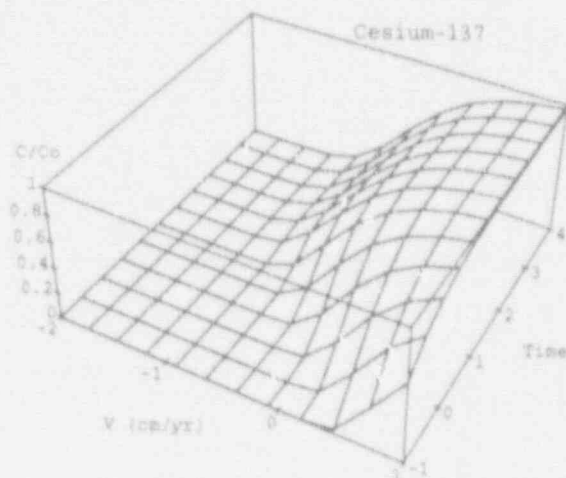

Figure 24. Dimensionless concentration of cesium-137 as a function of Darcy flux through the vault and time.

crete with 80% aggregate by volume. The fracture aperture is assumed to be 0.5 mm, and 0.1% of the concrete slab is composed of crack space. Thus the flow velocity for water in the cracks is 1,000 times the average Darcy velocity through the structure. The calculations for Figure 22 assume a Darcy velocity of 10 cm/yr. Clearly, matrix diffusion is more effective at high water to cement ratios (low quality concrete).

Figures 23 through 29 assume a water to cement ratio of 0.4. Figure 23 illustrates that peak releases of carbon-14 will be reduced significantly, even at very high flow rates. Results for cesium-

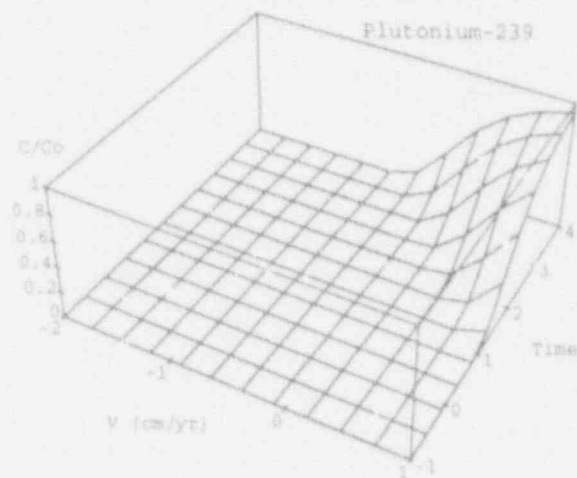

Figure 25. Dimensionless concentration of plutonium-239 as a function of Darcy flux through the vault and time.

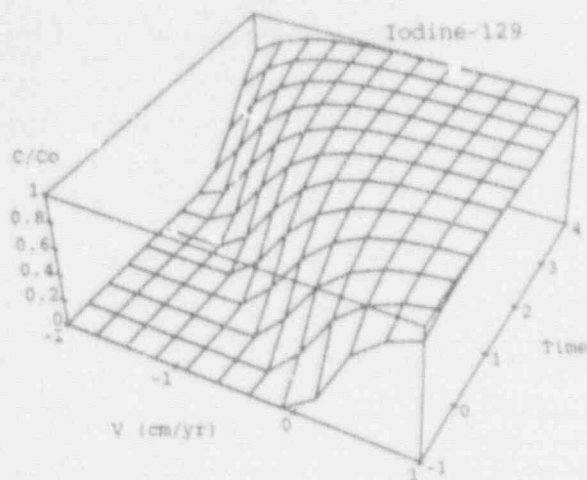

Figure 26. Dimensionless concentration of iodine-129 as a function of Darcy flux through the vault and time.

137 are illustrated in Figure 24, and results for iodine-129 are illustrated in Figure 26.

The time until the exit concentration reaches C_0 is indicative of delayed release and smearing of peaks in the release rate. If matrix diffusion were not active, then the graphs would rise from zero to one as a step function representing water travel time through the fracture. Gradually sloping graphs are indicative of significant smearing (i.e., averaging of release spikes over longer time periods) of release rate. The slopes on the figures for carbon, cesium, plutonium, strontium, and tritium are very gradual. The graphs for iodine and technetium are steeper showing less reduction or spreading of peak releases.

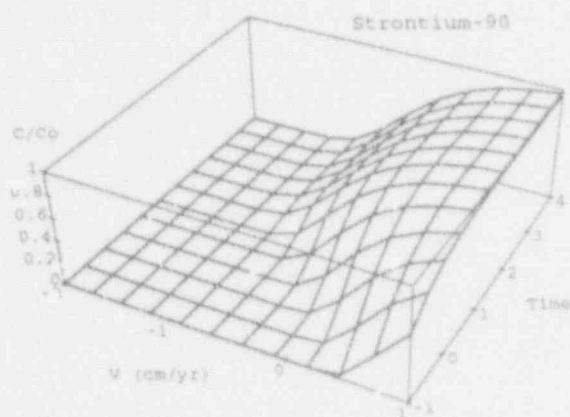

Figure 27. Dimensionless concentration of strontium-90 as a function of Darcy flux through the vault and time.

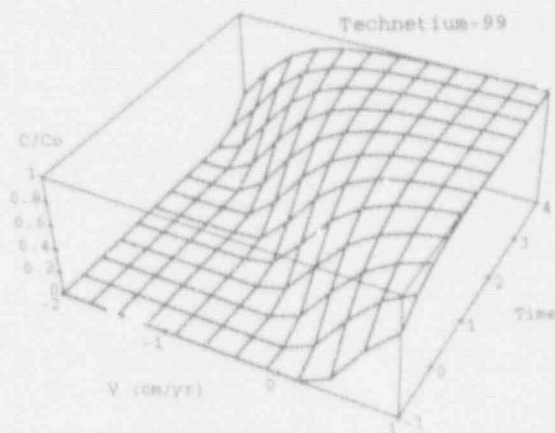

Figure 28. Dimensionless concentration of technetium-99 as a function of Darcy flux through the vault and time.

tium are steeper showing less reduction or spreading of peak releases.

The figures clearly indicate that fractured concrete barriers will generally be effective in reducing peak radionuclide releases and delaying releases, even in the absence of attenuation of total release. Attenuation of releases works best at low flow rates, for small cracks, and for high water to cement ratio concretes.

Attenuation by matrix diffusion is also important for grout backfill in concrete vaults. Although the intended function of grout is to provide physical stability and worker shielding, grout will also act as a sponge for radionuclides that can attenuate

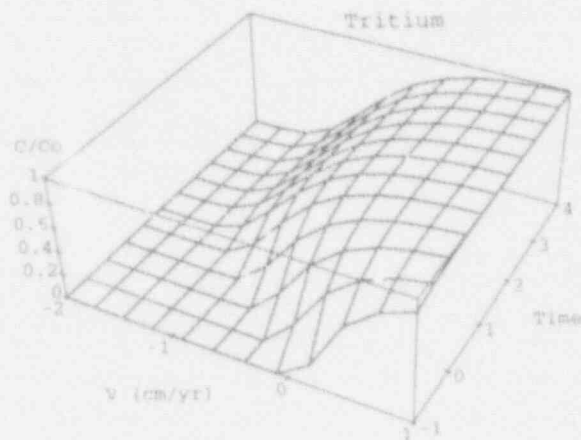

Figure 29. Dimensionless concentration of tritium as a function of Darcy flux through the vault and time.

releases. Concrete barriers without fractures will almost always provide significant retardation and attenuation of radionuclide releases.

The calculations provide little support for installing a high quality concrete vault floor. Basicel-

ly, the lower the quality of concrete on the floor of the vault, the better. This type of observation has been incorporated in the Canadian design (Philipose, 1988) where only a sorptive buffer material is placed below the vault.

5. Concrete Vault Performance Over Time and in Relation to Contaminant Concentrations in Groundwater

5.1 Overall Scenario for Concrete Vault Degradation

In practice, concrete vaults are likely to undergo a number of changes during their lifetime. Initially the vaults will have cracks related to drying shrinkage and temperature change. If quality construction practices are followed, most of this cracking can be forced to occur at control joints with built in water seals. Other cracks may be initially sealed with epoxy or other compounds. During this first period, water will move through the matrix at very slow rates and through any open cracks.

Eventually the water seals and patches will fail; at the same time the concrete will begin to degrade. Modelers conducting performance assessments must question how much performance credit to take for long-term behavior of the water seals and patches. When the seals fail, water can percolate through the initial cracks, increasing flow rates through the system. At this stage of degradation the flow rate through the cracks will likely be controlled by crack spacing and the permeability of the porous material placed next to the vault. If a gravel layer is placed next to the vault, flow into the vault can be very high.

At a later stage the degradation of the concrete by sulfate attack, reinforcement corrosion, leaching and other means, becomes more apparent. These processes cause the permeability of the matrix to gradually increase and lead to development of more cracks. These processes occur over time periods on the order of several hundred to several thousand years.

In the penultimate stage, the vault roof will collapse. This collapse will not occur for monolithic vaults with concrete waste forms, but is the eventual fate of other concrete vaults. The collapse of the roof does not necessarily lead to catastrophic releases from the vault because the roof sections will tend to channel the water through the waste. In the absence of a bathtub effect, water will be chan-

neled through only a small portion of the waste, which will leach rapidly. The remaining waste, protected by the remaining roof, will leach more slowly. The collapse of the roof creates a preferential pathway through some portions of the waste but will cover and protect other portions of the waste. Thus, a concrete vault does not completely cease to function when major structural integrity is lost.

In the final stage, the concrete turns to rubble. However even at this stage, the concrete has a residual, chemical influence on the disposal system.

During each stage of degradation the waste form is steadily being leached. The already leached waste is less sensitive to flow changes than is the original waste. Thus subsequent stages of degradation do not necessarily result in release rate peaks. Instead, each waste site will go through a natural maximum release during its lifetime.

5.2 Influences on Effluent Concentration

As shown in this report, the release rate from a monolithic concrete vault becomes independent of flow rate through the vault at high flow rates. Once the release rate becomes independent of water flow rate, additional water only provides a dilution effect.

Leachate tends to be of lower concentration at higher water flow rates in most waste disposal systems including concrete vaults with trash inside and traditional shallow land burial without engineered barriers. Water passing through nonuniform disposal systems will always follow preferential pathways. The tendency toward preferential pathways with diffusionally controlled release from stagnant zones is clear from experience at remediation sites with pump and treat systems. Higher flow rates result in lower concentrations in the effluent because of diffusional limitations on mass transport. Movement of contaminants from the slow flowing stagnant zones will be diffusionally

controlled. Releases from the stagnant zones will be less influenced by water flow rates, resulting in lower effluent concentrations at higher flow rates.

Simple models that assume complete mixing inside the vault or disposal facility (i.e., models based upon stirred tank reactor equations) are useful for rough estimates of system behavior. However, the assumption of complete mixing in the cell/vault is not strictly correct and gives an incorrect impression of the relationship between water infiltration rates and effluent concentrations.

5.3 Downstream Concentrations

In practice, compliance with regulatory standards is based upon concentrations in groundwater downstream of the disposal facility. The influence of a release on groundwater concentrations downstream from the concrete vault can be estimated with a few simple calculations. If the compliance point is not too far from the vault, dispersion in the x,y directions will have little opportunity to reduce plume centerline concentrations. This behavior is a result of typically large vaults that produce large, disperse, initial plumes (i.e., they are area sources, not point sources). Typically, the disposal site will contain a number of vaults and/or vaults in combination with trenches. If the rate of water infiltration at the site is low because of either a good cover or an arid location, the primary source of dilution for the effluent will be the groundwater flow beneath the site. At more humid sites, perhaps subsequent to cover failure, water percolating through and around the vaults/trenches will provide the primary source of dilution water.

Dilution by groundwater can be roughly estimated as follows. If a well screen is assumed to require a certain thickness of aquifer (b) then mixing in the vertical direction can be conservatively assumed to be at least b meters. If the mass of water from recharge around the vault is ignored, the groundwater concentration in the plume will be

$$\frac{R/w}{b_w V_{soil} R_d} \quad (45)$$

where

R = release rate per unit area from the concrete vault

l = length of the vault
 w = width of the vault (cancels)
 b = averaging thickness in vertical direction
 V_{soil} = Darcy velocity in groundwater below vault.

This assumes the vault is aligned parallel to the groundwater flow direction, the worst case.

If recharge around the vault is significant in relation to groundwater flow rates, then a better simplifying assumption is that the recharge around the vault and the effluent combine to form the plume. If a constant proportion of the recharge is assumed to go through rather than around the concrete vault (in a series of equally spaced vaults), then the concentration in groundwater is given by

$$C\chi \quad (46)$$

where

C = concentration of effluent coming out the bottom of the concrete vault.
 χ = the proportion of the percolation water which goes through the concrete vault

The constant proportion of water assumed to go around rather than through the vault will only be correct for a highly fractured (and therefore high permeability) vault. The simplifying assumption is required for simple quantitative prediction as illustrated in the figures; however, the qualitative trend (i.e. the groundwater concentrations pass through a maximum as infiltration increases) is not dependent upon the simplifying assumption.

The estimated concentration in groundwater is simply the minimum of the two options for dilution. For illustration, the effluent concentration from the vault is estimated assuming a monolithic concrete vault with transport properties appropriate for a nonsorbing anionic species (e.g., nitrate, iodine, oxidized technetium) and crack spacing of 3 m. The groundwater flow assumed in the simulations is 2.5 m/yr and 10 meters deep. The vault is assumed to be 100 m long.

The predicted concentrations are given in Figure 30. At low flow rates through the vaults, groundwater concentrations increase rapidly and approximately linearly with increased water percolation. This is consistent with the low flow portion

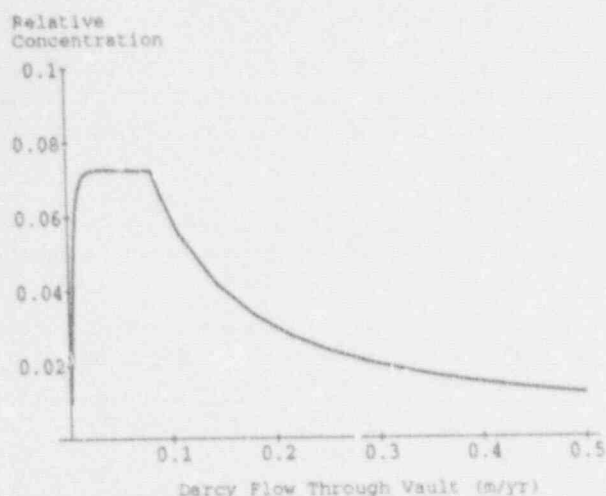

Figure 30. Concentration in groundwater near a site with concrete vaults.

of Figure 6. As water flow raises above around 0.01 m/yr (1 cm/yr) release rate becomes independent of flow rate through the vault (Figure 6) and the groundwater concentration asymptotes to a maximum. At still greater flow rates (>0.1 m/yr), infiltrating water around and through the vault swamps the background groundwater flow and leads to lower concentrations through dilution. For clarity Figure 31 gives the results from Equations (45) and (46) separately.

Clearly, this is only a screening level calculation. In particular it takes no performance credit for delay and attenuation of contaminants between the bottom of the vault and the water table, which can be substantial in many circumstances. Radioactive decay in groundwater is also ignored (i.e., the compliance point is assumed to be close to the vault). However, the simple calculation does illustrate the impact of percolation rate through the engineered cover and concrete vault on downstream concentrations for long-lived radionuclides.

5.4 Design Implications

The general behavior of groundwater concentrations has implications for vault design. Most disposal facilities for low-level radioactive waste and hazardous wastes will consist of a series of vaults or trenches. The engineered cover can either be designed to cover the entire facility or each individual vault or trench. A single cover over the entire facility will increase the proportion of water that goes into surface runoff rather than subsurface recharge.

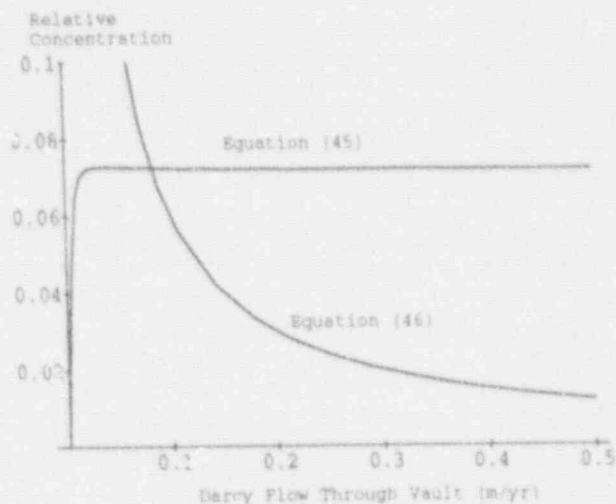

Figure 31. Results from Equations (45) and (46).

Additionally, a large cover places any recharge water away from the vaults. Multiple, smaller covers over each vault or trench (lower portion of Figure 32) will provide dilution water for the leachate without increasing the contaminant release rate from the vault.

Another design feature that will improve performance is an engineered cover design that begins at the vault rather than at the ground surface. Most covers are designed in functional layers (e.g., plant growth layer, lateral drainage, resistance, capillary break, etc.) that begin at the earth's surface. The space between the bottom of the cover and the vault is filled with available backfill soils. An alternative is to begin construction of the cover at the surface of the concrete vault. The space between the top of

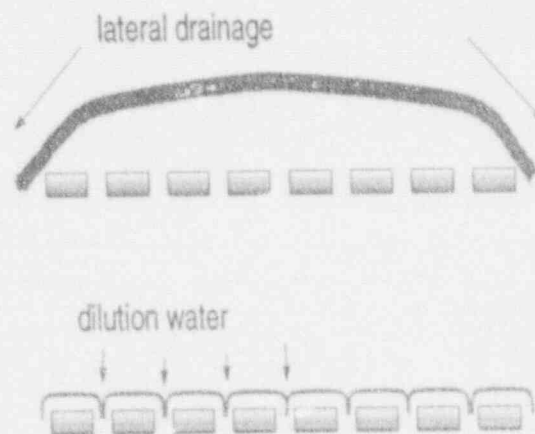

Figure 32. Two alternative designs for an engineered cover over a series of concrete vaults.

the cover and the surface grading can be filled with backfill.

The alternate design places the clay layer against the concrete vault to lower flow rates through cracks in the concrete (Walton and Seitz, 1991) and slow degradation of the concrete. Placing the layers of the cover at greater depths and against the concrete provides greater protection against cover disruption by subsidence, plant roots, burrowing animals, and erosion.

Multiple small covers are more likely to comply with regulatory standards than a single large cover. This conclusion is true not only for monolithic concrete vaults but also for traditional shal-

low trench disposal of radioactive waste. The effect of dilution water is an example of how a humid climate location may theoretically be better than an arid site (at least from the narrow viewpoint of regulatory compliance).

As with any generalized statement concerning waste isolation performance, there are exceptions. In cases where the vadose zone is very deep, a large cover over the entire disposal site will provide longer travel times to the groundwater. If the travel time is significant, relative to the radionuclide decay rate and the containment period offered by the vault, then a large cover may provide superior performance. This is potentially the case for very arid sites.

6. CONCLUSIONS

This document has covered several aspects of mass transport through and release from concrete waste forms and concrete barriers (e.g., concrete vaults). Several conclusions are made about diffusion in concrete. The most important lesson is that published experimental diffusion coefficients actually represent a lumping of several parameters of which diffusion rate is only one parameter. Unless the source of the diffusion data and the relationship between the various diffusion coefficients are clearly understood, significant errors can be made in the performance assessment calculations.

The leach tests applied to concrete and other waste forms and the apparent diffusion coefficients obtained from the leach tests are not generally sufficient to support performance assessment calculations. Performance models require separating the various physical and chemical controls on release rates. The need for more information, which is usually unavailable, means that questionable assumptions are required to estimate performance of concrete waste forms. One methodology for working around this problem is explained in the report.

The experimental work performed at the Savannah River Site (Oblath, 1989) shows that, except at very low water saturations, the release rate from concrete waste forms in unsaturated soils is independent of soil water content. Unsaturated locations, in general, do not slow leaching from concrete waste forms.

Because the leach rate from concrete waste forms is independent of moisture tension over the range of interest and because perched water can be expected to form on the top of concrete vaults, analytical solutions developed for saturated flow can be used to estimate leach rates from concrete vaults located in the unsaturated zone.

Monolithic concrete vaults have three general regions of performance. At extremely low flow rates, release is strictly diffusionally limited. In most situations, flow rates will not be low enough to ensure diffusional release.

At slightly greater flow rates (the magnitude of which is dependent upon the diffusion coefficients), release is controlled by the flow rate of water through cracks in the structure with release rate approximately proportional to Darcy flow. In this region, release is not sensitive to block size, and the vault behaves as an equivalent porous medium from a mass transport perspective.

At higher flow rates, release rate is controlled by diffusion out of intact blocks of the waste form. In this situation the release rate is very sensitive to block size (crack spacing) but independent of flow rate through the vault.

The downstream portion of the vault (i.e., the vault floor) also has performance implications. In this case, leach rates are controlled by crack spacing, flow rates, and water to cement ratio of the concrete. If crack characteristics are held constant, low quality concrete (high water to cement ratio) actually gives better performance than high quality concrete.

A concrete vault will go through several stages of degradation affecting overall concrete vault performance. These stages, with approximate corresponding time frames, are

- a) Intact with sealed cracks
- b) Water flow and mass transport through shrinkage cracks when water stops fail (ca: 30 to 200 years until roof collapse)
- c) Gradual degradation of the concrete matrix with formation of additional cracks (ca: 100 years to roof collapse)
- d) Collapse of the roof (ca: 200 to a couple thousand years)
- e) Complete loss of structural integrity.

In every case it is very difficult or impossible to make reliable and defensible estimates of the time frames involved in vault degradation. However, concrete vaults do fail in a manner that promotes a slow and gradual release of contaminants. As the vault loses integrity, the most leachable contaminants go first, while transport rates are still low. As

the vault further degrades, water percolation rates will increase, however the most leachable components of the waste will already be reduced in the inventory. Even when all structural integrity is lost, the concrete rubble still provides significant chemical influence in controlling many radionuclides (e.g., carbon-14).

Calculations presented clearly indicate that increased water flow rate around and through the vaults is not always negative to the maximum exposed individual. Greater water flow rates through concrete vaults may actually improve performance relative to regulatory standards by lowering maximum concentrations in groundwater.

The more detailed examination of concrete barrier performance in this and previous documents gives little support for the concept of making conservative performance assessment calculations.

For example it is intuitively obvious, but usually incorrect, that early failure of the engineered cover is a conservative assumption for performance assessment. Likewise, a performance analysis might assume conservatively high values for the diffusion coefficient in the floor and walls of the concrete vault, resulting in unrealistically optimistic performance estimates. Frequently we have no idea just what is conservative or overly optimistic.

A second and related problem area for performance assessment is the relationship between performance assessment and design of disposal facilities. One of the major purposes of performance assessment calculations is to provide feedback and suggestions for disposal facility designs that will better isolate waste. Given the complexity involved with the performance of current systems, we must be very careful to design facilities around actual performance features rather than modeling artifacts.

7. REFERENCES

- Atkinson, A., D.J. Goult, and J. A. Hearne, 1984, *An Assessment of the Long-Term Durability of Concrete in Radioactive Waste Repositories*, AERE-R11465, Harwell, U.K.
- Atkinson, A., and A.K. Nickerson, 1988, "Diffusion and Sorption of Cesium, Strontium, and Iodine in Water-Saturated Cement," *Nuclear Technology*, 81, pp. 100-113.
- Clifton, J. R. and L. I. Knab, 1989, *Service Life of Concrete*, NUREG/CR-5466.
- Crank, J., 1975, *The Mathematics of Diffusion*, Clarendon Press, Oxford, England.
- Oblath, S. B., 1989, "Leaching from Solidified Waste Forms under Saturated and Unsaturated Conditions," *Environ. Sci. Technol.*, 23, 9, pp. 1098-1102.
- Olsea, S. R. and W. D. Kemper, 1968, "Movement of Nutrients to Plant Roots," *Advances in Agronomy*, V. 20, pp. 91-151.
- Philipose, K. E., 1988, "500 Year Concrete for a Radioactive Waste Repository," *Waste Management '88*, University of Arizona, pp. 995-999.
- Porter L.K., W. D. Kemper, R. D. Jackson, and B. A. Stewart, 1960, "Chloride Diffusion in Soils as Influenced by Moisture Content," *Soil Science Society Proceedings*, 24 pp. 460-463.
- Rasmuson, A. and I. Neretnieks, 1981, "Migration of Radionuclides in Fissured Rock: The Influence of Micropore Diffusion and Longitudinal Dispersion," *Journal of Geophysical Research*, 36, B5, pp. 3749-3758.
- Serne, R. J. and M. I. Wood, 1990, *Hanford Waste-Form Release and Sediment Interaction, A Status Report with Rationale and Recommendations for Additional Studies*, PNL-7297, UC-512.
- Sudicky, E. A. and E. G. Frind, 1982, "Contaminant Transport in Fractured Porous Media: Analytical Solutions for a System of Parallel Fractures," *Water Resources Research*, 18, 6, pp. 1634-1642.
- Tang, D. H., E. O. Frind, E. A. Sudicky, 1981, "Contaminant Transport in Fractured Porous Media: Analytical Solution for a Single Fracture," *Water Resources Research*, 17, 3, pp. 555-564.
- USDI (United States Department of Agriculture), 1988, *Concrete Manual*, Eighth Edition, US Government Printing Office, Washington.
- Walton, J.C., and R.R. Seitz, 1991, *Performance of Intact and Partially Degraded Concrete Barriers in Limiting Fluid Flow*, NUREG/CR-5614
- Walton, J. C., L. E. Plansky, R. W. Smith, 1990, *Models for Estimation of Service Life of Concrete Barriers in Low-Level Radioactive Waste Disposal*, NUREG/CR-5542.

BIBLIOGRAPHIC DATA SHEET

(See instructions on the reverse.)

1. REPORT NUMBER
(Assigned by NRC. Add Vol., Suppl., Rev.,
and Addendum Numbers, if any.)

NUREG/CR-5445
EGG-2662

2. TITLE AND SUBTITLE

Performance of Intact and Partially Degraded Concrete Barriers
in Limiting Mass Transport

3. DATE REPORT PUBLISHED

MONTH | YEAR
June | 1992

4. FIN OR GRANT NUMBER

A6858

5. AUTHOR(S)

J. C. Walton

6. TYPE OF REPORT

Technical

7. PERIOD COVERED (include Dates)

8. PERFORMING ORGANIZATION - NAME AND ADDRESS (If NRC, provide Division, Office or Region, U.S. Nuclear Regulatory Commission, and mailing address; if contractor, provide name and mailing address.)

Idaho National Engineering Laboratory
EG&G Idaho, Inc.
Idaho Falls, ID 83415

9. SPONSORING ORGANIZATION - NAME AND ADDRESS (If NRC, type "Same as above" if contractor, provide NRC Division, Office or Region, U.S. Nuclear Regulatory Commission, and mailing address.)

Division of Engineering
Office of Nuclear Regulatory Research
U.S. Nuclear Regulatory Commission
Washington, DC 20555

10. SUPPLEMENTARY NOTES

11. ABSTRACT (200 words or less)

Mass transport through concrete barriers and release rate from concrete vaults are quantitatively evaluated. The thorny issue of appropriate diffusion coefficients for use in performance assessment calculations is covered, with no ultimate solution found. Release from monolithic concrete vaults composed of concrete waste forms is estimated with a semi-analytical solution. A parametric study illustrates the importance of different parameters on release. A second situation of importance is the role of a concrete shell or vault placed around typical waste forms in limiting mass transport. In both situations, the primary factor controlling concrete performance is cracks. The implications of leaching behavior on likely groundwater concentrations is examined. Frequently, lower groundwater concentrations can be expected in the absence of engineered covers that reduce infiltration.

12. KEY WORDS/DESCRIPTORS (List words or phrases that will assist researchers in locating the report.)

Concrete barriers
Mass transport
Leaching from waste forms
Groundwater concentrations

13. AVAILABILITY STATEMENT

Unlimited

14. SECURITY CLASSIFICATION

(This Page)

Unclassified

(This Report)

Unclassified

15. NUMBER OF PAGES

16. PRICE

UNITED STATES
NUCLEAR REGULATORY COMMISSION
WASHINGTON, D.C. 20555-0001

OFFICIAL BUSINESS
PENALTY FOR PRIVATE USE, \$300

SPECIAL FOURTH-CLASS RATE
POSTAGE AND FEES PAID
USMRC
PERMIT NO. G-87

120555139531 1 1AN1CC1CJ1C01
US MRC-04DM
DIV FCIA & PUBLICATIONS SVCS
TOP-POR-MURER
P-211
WASHINGTON DC 20555

UNITED STATES
NUCLEAR REGULATORY COMMISSION
WASHINGTON, D.C. 20555-0001

SPECIAL FOURTH-CLASS RATE
POSTAGE AND FEES PAID
USNRC
PERMIT NO. 3-B

OFFICIAL BUSINESS
PENALTY FOR PRIVATE USE, \$300

120555139531 1 1AN1CC1CJ1001
US NRC-0ADM
DIV FOIA & PUBLICATIONS SVCS
TPS-POP-NUREG
P-211
WASHINGTON DC 20555