

NUREG/CR-3521
SAND83-1715
AN
Printed August 1984

Hydrogen-Burn Survival Experiments at Fully Instrumented Test Site (FITS)

Elizabeth H. Richards, John J. Aragon

Prepared by
Sandia National Laboratories
Albuquerque, New Mexico 87185 and Livermore, California 94550
for the United States Department of Energy
under Contract DE-AC04-76DP00789

8412190375 841130
PDR NUREG
CR-3521 R PDR

Prepared for
U. S. NUCLEAR REGULATORY COMMISSION

NOTICE

This report was prepared as an account of work sponsored by an agency of the United States Government. Neither the United States Government nor any agency thereof, or any of their employees, makes any warranty, expressed or implied, or assumes any legal liability or responsibility for any third party's use, or the results of such use, of any information, apparatus product or process disclosed in this report, or represents that its use by such third party would not infringe privately owned rights.

Available from
GPO Sales Program
Division of Technical Information and Document Control
U.S. Nuclear Regulatory Commission
Washington, D.C. 20555
and
National Technical Information Service
Springfield, Virginia 22161

NUREG/CR-3521
SAND83-1715
AN

HYDROGEN-BURN SURVIVAL EXPERIMENTS
AT FULLY INSTRUMENTED TEST SITE (FITS)

Elizabeth H. Richards
John J. Aragon

Sandia National Laboratories
Albuquerque, New Mexico 87185
Operated by
Sandia Corporation
for the U. S. Department of Energy

Prepared for
Severe Accident Assessment Branch
Division of Accident Evaluation
Office of Nuclear Regulatory Research
and
Chemical Engineering Branch
Division of Engineering
Office of Nuclear Reactor Regulation
Washington, DC 20555
Under Interagency Agreement DOE 40-550-75
NRC FIN Nos. A-1270 and A-1306

ABSTRACT

A series of hydrogen-burn experiments conducted for the Hydrogen-Burn Survival Program is described. The experiments, executed at Sandia National Laboratories' Fully Instrumented Test Site (FITS) facility in Albuquerque, provided data concerning the hydrogen-burn thermal environment as it relates to equipment survivability in nuclear power plants.

The test plan, instrumentation, and results are presented, along with a brief discussion of test volume (scale) considerations. Conclusions drawn from the results concern the repeatability of the tests, the suitability of thermocouples for measuring gas temperatures, and the effects of initial hydrogen concentrations and fans on the responses of calorimeters and components. The effect of initial steam concentration on temperature response cannot be determined because of preignition pressure considerations.

CONTENTS

	<u>Page</u>
ABSTRACT	iii
LIST OF ILLUSTRATIONS	vii
LIST OF TABLES	ix
ACKNOWLEDGMENTS	x
EXECUTIVE SUMMARY	1
1. INTRODUCTION	2
2. TEST DESCRIPTION	4
2.1 Facility	4
2.2 Scale	5
2.3 HBS Instrumentation	5
2.3.1 Thermocouple Probes	7
2.3.2 Calorimeters	7
2.3.3 Heat-Flux Gages	12
2.3.4 Solenoid Valve	12
2.3.5 Additional Instrumentation	12
2.3.6 Instrumentation Location	13
2.4 Test Plan and Procedures	13
2.4.1 Test Plan	13
2.4.2 Data Acquisition	14
3. DATA ANALYSIS METHODS	16
3.1 Conversions and Adjustments	16
3.2 Treatment of Outliers	16
3.3 Smoothing of Data	16
4. RESULTS AND CONCLUSIONS	20
4.1 Gas-Temperature Measurements	20
4.1.1 Thermocouple Comparison	20
4.1.2 Peak Gas Temperatures and Initial Pressure Correction	21
4.1.3 Effects of Hydrogen Concentrations	22
4.1.4 Repeatability	23
4.1.5 Effects of Fans	24
4.2 Flat-Plate Calorimeters	24
4.2.1 Results	24

CONTENTS
(continued)

	<u>Page</u>
4.2.2 Effects of Hydrogen Concentrations and Fans	25
4.2.3 Repeatability	27
4.3 Cube Calorimeters	29
4.4 Flux Gages	31
4.5 Solenoid Valve	31
4.6 Other	32
4.6.1 Mixing Fans	32
4.6.2 Cable Samples and Terminal Blocks	33
5. SUMMARY OF FINDINGS AND CONCLUSIONS	36
REFERENCES	37
APPENDIX A	38

LIST OF ILLUSTRATIONS

<u>Figure</u>		<u>Page</u>
1	Test Vessel at FITS	4
2	Relative Volume Comparison	6
3	Schematic Drawing of Thermocouple Probe	8
4	Photograph of Thermocouple Probe	8
5	Assembly Drawing of Flat-Plate Calorimeter	9
6	Flat-Plate Calorimeter Installed in FITS Test Vessel	10
7	Location of Thermocouples on Solid and Hollow Cube Calorimeters	11
8	Cube Calorimeters Mounted in FITS Test Vessel	11
9	Solenoid Valve Mounted in FITS Test Vessel	13
10	Location of Major Instrumentation in FITS Test Vessel	14
11	Comparison of Unsmoothed Data and Data after Smoothing with Butterworth Filter	17
12	Comparison of Smoothed and Unsmoothed Data for a Gas-Temperature Peak	19
13	Thermocouple Response Comparison	20
14	Effect of Hydrogen Concentration on Peak Temperature Rise	23
15	Typical Temperature Response for Flat-Plate Calorimeter	25
16	Effect of Hydrogen Concentration on Peak Flat-Plate Calorimeter Temperature Rise	28
17	Typical Temperature Responses of Hollow and Solid Cube Calorimeters	29
18	Cube Calorimeters: Effect of Hydrogen Concentration on Peak Temperature Rise	30
19	Typical Temperature Response of Solenoid Valve	32

LIST OF ILLUSTRATIONS
(continued)

<u>Figure</u>		<u>Page</u>
20	Surface Temperature Response of Mixing Fan	34
21	Cable Samples	35

LIST OF TABLES

<u>Table</u>		<u>Page</u>
1	Test Matrix for FITS Series 1	15
2	Peak Gas-Temperature Rises (°C)	22
3	Effect of Fans on Peak Gas-Temperature Rises	24
4	Flat-Plate Calorimeters: Peak Temperature Rises (°C)	26
5	Flat-Plate Calorimeters: Peak Temperature Rises (°C) (Energy Factor Applied)	27
6	Flat-Plate Calorimeters: Effect of Fans on Peak Temperature Rises	28
7	Cube Calorimeters: Effect of Fans on Peak Temperature Rises	30
8	Temperature of Solenoid Valve 90 Seconds after Burn Initiation	33

ACKNOWLEDGMENTS

The Hydrogen-Burn Survival Program is a team effort involving several SNLA organizations. The authors gratefully acknowledge the contributions to this effort by Bill McCulloch, Lou Cropp, Ben Bader, Art Ratzel, Steve Kempka, Bob Padilla, Vince Dandini, and the staff at the FITS facility. We also thank Frank Wyant and Charles Craft for their help with computer-related tasks, and Gene Aronson for help with data reduction.

EXECUTIVE SUMMARY

As part of the Hydrogen-Burn Survival (HBS) Program, a series of hydrogen-burn experiments was conducted at the Fully Instrumented Test Site (FITS). These tests were designed to provide thermal environmental data for the combustion of hydrogen in mixtures of air and steam, to provide data concerning the thermal response of components, and to verify computational models for medium-scale volumes.

The volume of the test vessel at FITS, 5.6 m³, is orders of magnitude smaller than some of the volumes in reactor containments. Because of the widely varying surface area-to-volume ratios (and therefore different heat-transfer mechanisms), component temperature responses to burns in the FITS tank are not necessarily representative of those in a containment. For example, although a Class 1E-qualified solenoid valve survived all burns in the test series, a direct conclusion regarding its hydrogen-burn survivability in a reactor containment cannot be drawn because of the volume scaling consideration. However, the large quantity of data recorded for this medium-scale volume contributes to our overall understanding of both the hydrogen-burn environment and equipment response to that environment. It also provides medium-scale verification of computational models.

Gas and component temperature data from 21 combustion tests (burns) were recorded, reduced, and analyzed. Some findings, such as (1) increasing hydrogen concentrations increased peak temperatures and (2) thin-walled components responded faster and reached higher temperatures than thick-walled components, were expected. Some unexpected findings (e.g., smaller thermocouples did not necessarily respond better than larger ones) were also encountered. Fans appeared to promote more complete combustion. The effect of steam concentration on peak temperatures cannot be determined until the problem of different preignition pressures is resolved.

1. INTRODUCTION

A concern evolving from the accident at Three Mile Island is that considerably more hydrogen might be produced in a nuclear reactor accident than had been previously considered for design basis accidents. To prevent a severe hydrogen-oxygen reaction from threatening containment integrity, several methods of hydrogen control have been suggested. One such method calls for the intentional ignition of hydrogen before dangerously high concentrations accumulate. The pressures resulting from these low-concentration hydrogen burns may not threaten the containment building integrity; however, the survivability of safety-related equipment exposed to the burning-hydrogen environment is uncertain.

The primary near-term goal of the Hydrogen-Burn Survival (HBS) Program at Sandia National Laboratories, Albuquerque (SNLA) is to develop an analytical method for the Nuclear Regulatory Commission (NRC) to use in estimating the survivability of safety-related equipment during a hydrogen burn.[1] This method will be in the form of an algorithm that will be implemented on a desktop computer, and it will be supported by both experimental and analytical work relating to hydrogen burns. In the longer term, the HBS program is concerned with developing an understanding of the hydrogen-burn environment as it relates to component temperature response. The program seeks to develop a technological basis for determining whether consideration of the hydrogen-burn environment must be included in the procedures used for qualifying equipment for use in nuclear facilities and, if qualification is necessary, for specifying qualification test procedures.

Several series of experiments have been conducted as part of the HBS program. These include medium-scale hydrogen deflagration tests in pressure vessels and hydrogen-burn simulation tests at the Sandia Central Receiver Test Facility (CRTF). Program plans also include participation in the larger-scale hydrogen-burn experiments conducted by the Electric Power Research Institute (EPRI) at the Nevada Test Site (NTS). Described herein is a series of medium-scale (5.6 m³) hydrogen-burn tests at the Sandia Fully Instrumented Test Site (FITS). This test series is referred to as FITS Series 1.

The purpose of FITS Series 1 was twofold. First, the hydrogen-burn thermal environment needed to be characterized so that it could be simulated in further tests at the CRTF. Second, the tests provided medium-scale verification of the computational models being developed as part of the analytical portion of the HBS program. FITS Series 1 tests treated single burns only; multiple-burn phenomenology is to be examined in later tests.

This report documents the HBS instrumentation and procedures (test plan) for the FITS Series 1 tests. The analytical methods used on the HBS data are presented, along with some results and general conclusions.

2. TEST DESCRIPTION

2.1 Facility

The test vessel at the FITS facility is a 5.6 m³, above-ground, steel tank constructed to ASME boiler codes (Figure 1). The exterior of the tank is insulated with a two-inch thickness of fiberglass. The tank has 25 flanged ports, which can be used as instrumentation feedthroughs or as viewing apertures. The FITS tank contains an array of 32 12-mil thermocouples used as flame-front detectors and (typically) 5 pressure transducers. A closed-circuit television camera provides for visual observation of the burns and for monitoring the occurrence of condensation.

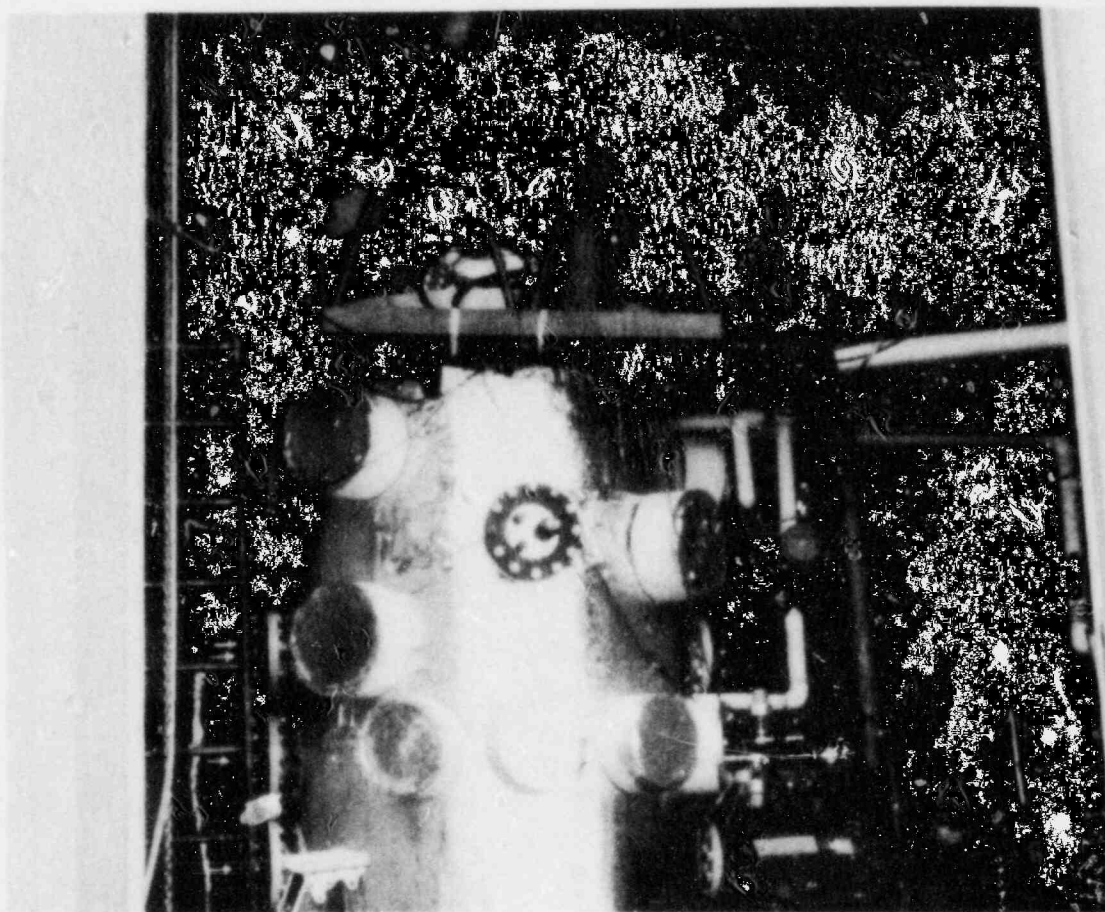

Figure 1. Test Vessel at FITS

Before each test, the tank walls and instrumentation are preheated to the desired temperature by injecting superheated steam into the tank and circulating steam through a copper coil around the outside wall of the tank for several hours. This is done to maintain wall and equipment temperatures above the saturation point, thus preventing condensation from forming on them. The tank is then purged twice with atmospheric air, each time pulling the tank pressure down to about 10 kPa (1.5 psia). Atmospheric air is then vented into the tank, and the hydrogen and steam are added to the air, using partial pressures to obtain the desired concentrations. Because of this filling method, each test has a different initial total pressure.

2.2 Scale

With a facility such as FITS it is important to consider the relative volume of the facility as compared to the volumes in an actual reactor (Figure 2). FITS is considered to be a medium-scale test facility. Figure 2a shows the relative volumes of several test facilities used in studying hydrogen burns. The large cube represents the volume of the NTS test vessel. The medium cube represents the FITS volume, and the small cube represents the volume of a laboratory-size test (such as that used in the Whiteshell tests).[2 3] A containment volume would be represented by a cube with sides of length two to four times the length of the NTS cube sides, as shown in Figure 2b.

It can be seen that widely varying volumes are used in the testing conducted as part of the hydrogen-burn/equipment-survivability effort. This is important because:

- The dominant heat-transfer mechanisms appear to be very dependent on volume
- Buoyancy effects may be much more important in a large volume than in small volumes
- The volume-to-surface ratios are much larger in large volumes. This affects the heat flux to the components

2.3 HBS Instrumentation

In addition to the existing FITS facility instrumentation, the HBS tests required 32 data-acquisition channels. These provided for 2 thermocouple probes (each containing 6 spatially arranged thermocouples for gas-temperature measurements), 12 calorimeter temperature measurements, and 3 heat-flux measurements. The remaining five channels were instrumented to measure the temperature responses of a solenoid valve and two mixing fans inside the tank.

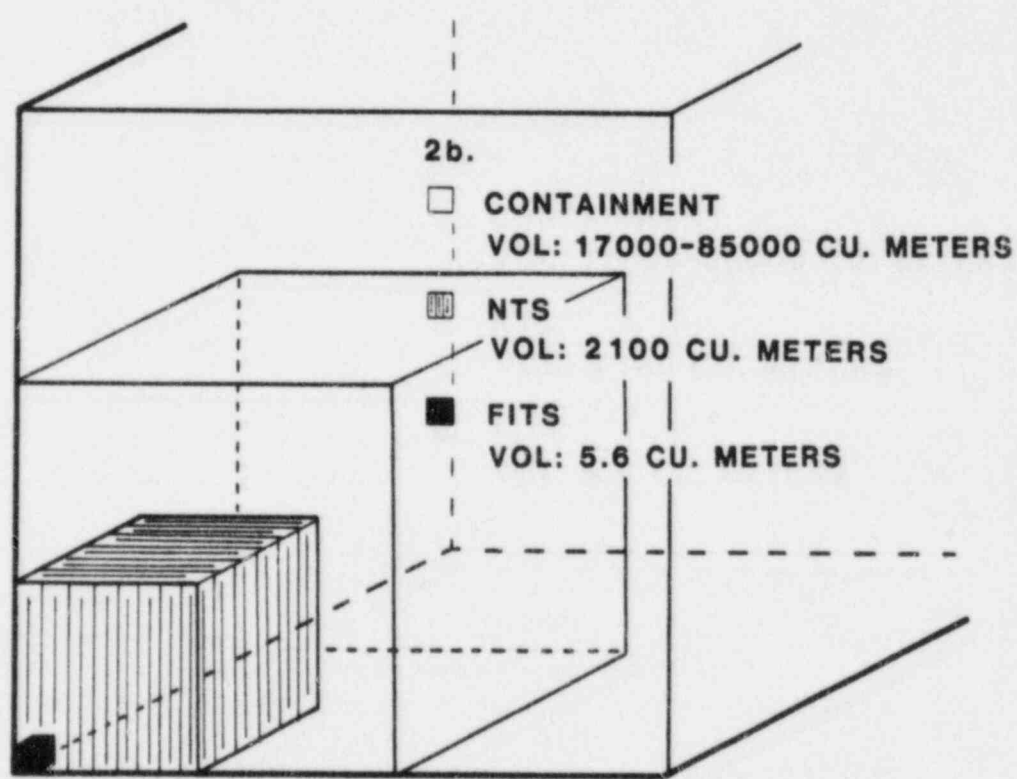
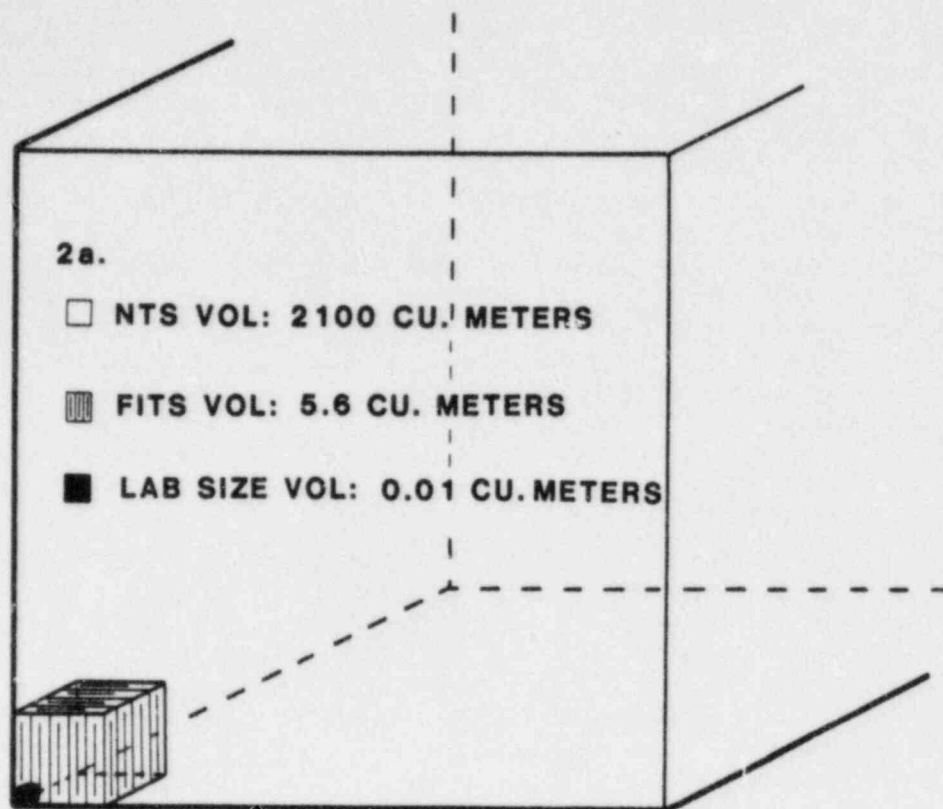

Figure 2. Relative Volume Comparison

2.3.1 Thermocouple Probes

Two thermocouple probes were designed to measure gas temperature at six locations within the FITS tank. Utilizing the flanged ports on the tank, one probe was mounted so that it was 1 m (3 ft) from the top of the tank; the second probe was mounted 3 m (10 ft) below the top of the tank. As shown in Figure 3, each probe had three pairs of Type K thermocouples affixed to it. The thermocouples were bent so that the junctions extended into the gas and were not in contact with or shielded by the probe. Each thermocouple pair consisted of a 5-mil beaded thermocouple and a 0.5-mil butt-bonded foil thermocouple. This combination was chosen so that we could compare the responses and survivabilities of the two types. Because of the fast temperature transients which occur, it was desirable to use very small (fast response) thermocouples to measure the gas temperatures. On the other hand, thermocouples that were too small may have failed (burned up) after just one or two tests. An important feature of the probes was that they were easily replaced through the instrumentation ports without necessitating removal of the tank lid. Figure 4 is a photograph of one of the thermocouple probes.

2.3.2 Calorimeters

Two types of calorimeters were used in the tests. First, flat-plate calorimeters were designed to make their heat-transfer characteristics as basic as possible so that posttest analysis would be simplified. Second, three-dimensional calorimeters were constructed to be more representative of actual reactor components.

The main component of the flat-plate calorimeters (Figure 5) was a brass plate 0.5-mm (20-mil) thick by 15-cm (6-in) square. The front surface was coated with a highly absorptive, high-temperature, flat black paint (Nextel™; $\alpha = 0.99$). The back surface of the calorimeter was insulated and sealed. Two of these calorimeters were mounted on the inside wall of the tank, one 1.2 m (4 ft) from the top and the other 2.3 m (7.5 ft) from the top, with the back insulated surface facing the wall (Figure 6).

Three thermocouples were mounted on the back side of each brass plate, one in the center and the other two 1.9 cm (0.75 in) off-center vertically. At the outset we had planned to mount a thermocouple on the front side of the flat-plate calorimeters, but heat-transfer calculations performed by Ben Blackwell of Sandia National Laboratories showed that there would be insignificant temperature differences between the front and back sides. Because of low-temperature phase changes inherent in brass, we attempted to use copper plates instead of brass to simplify heat-transfer calculations. However, we were unsuccessful at welding thermocouples to the

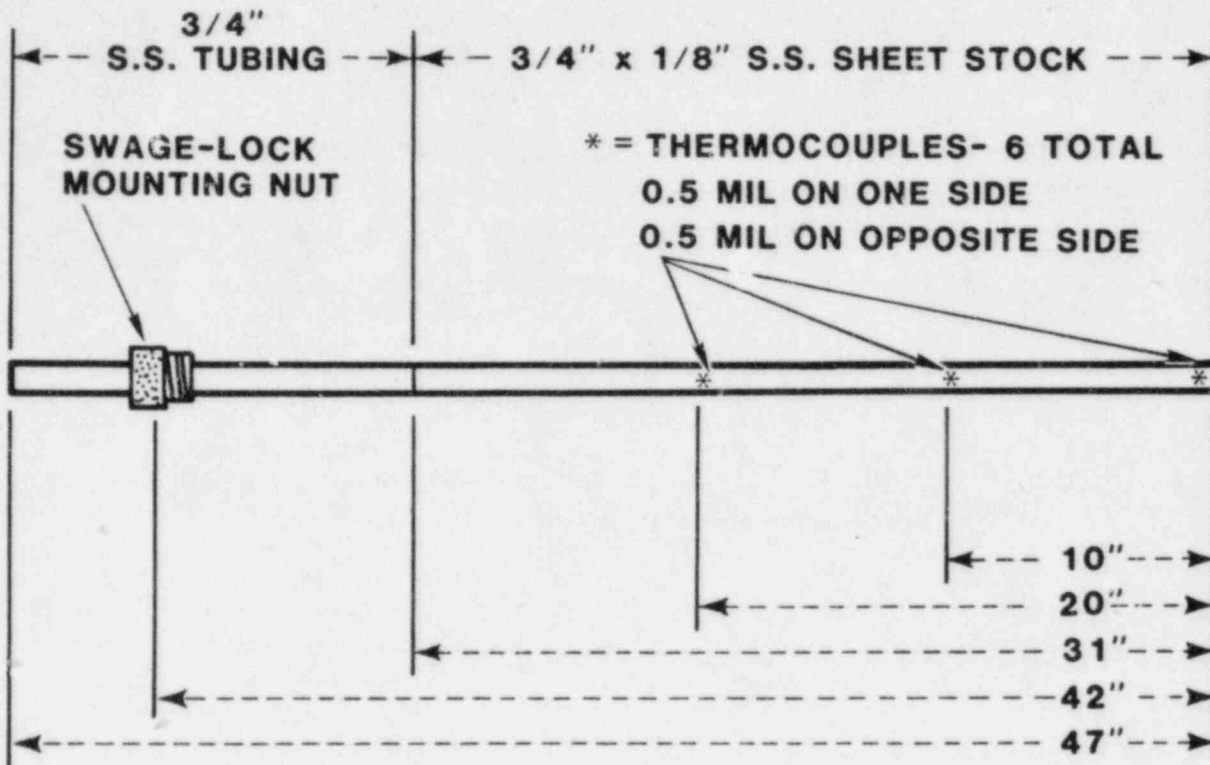

Figure 3. Schematic Drawing of Thermocouple Probe

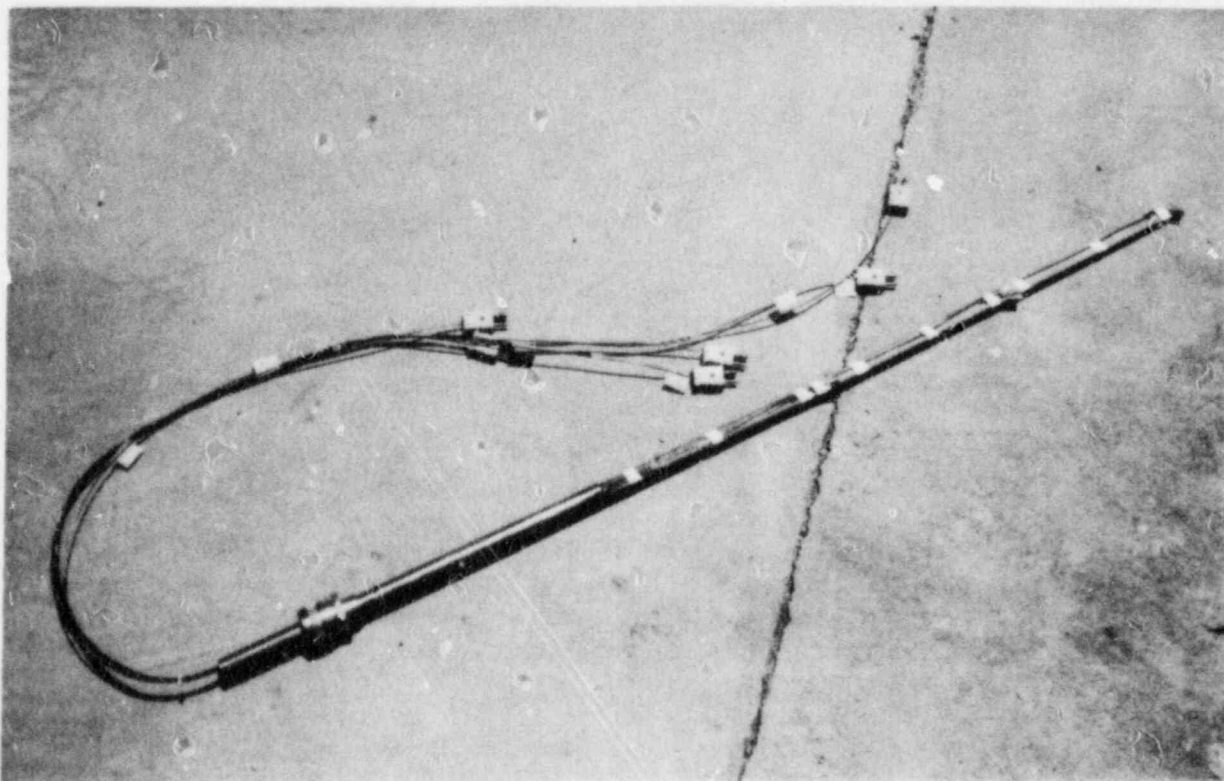

Figure 4. Photograph of Thermocouple Probe

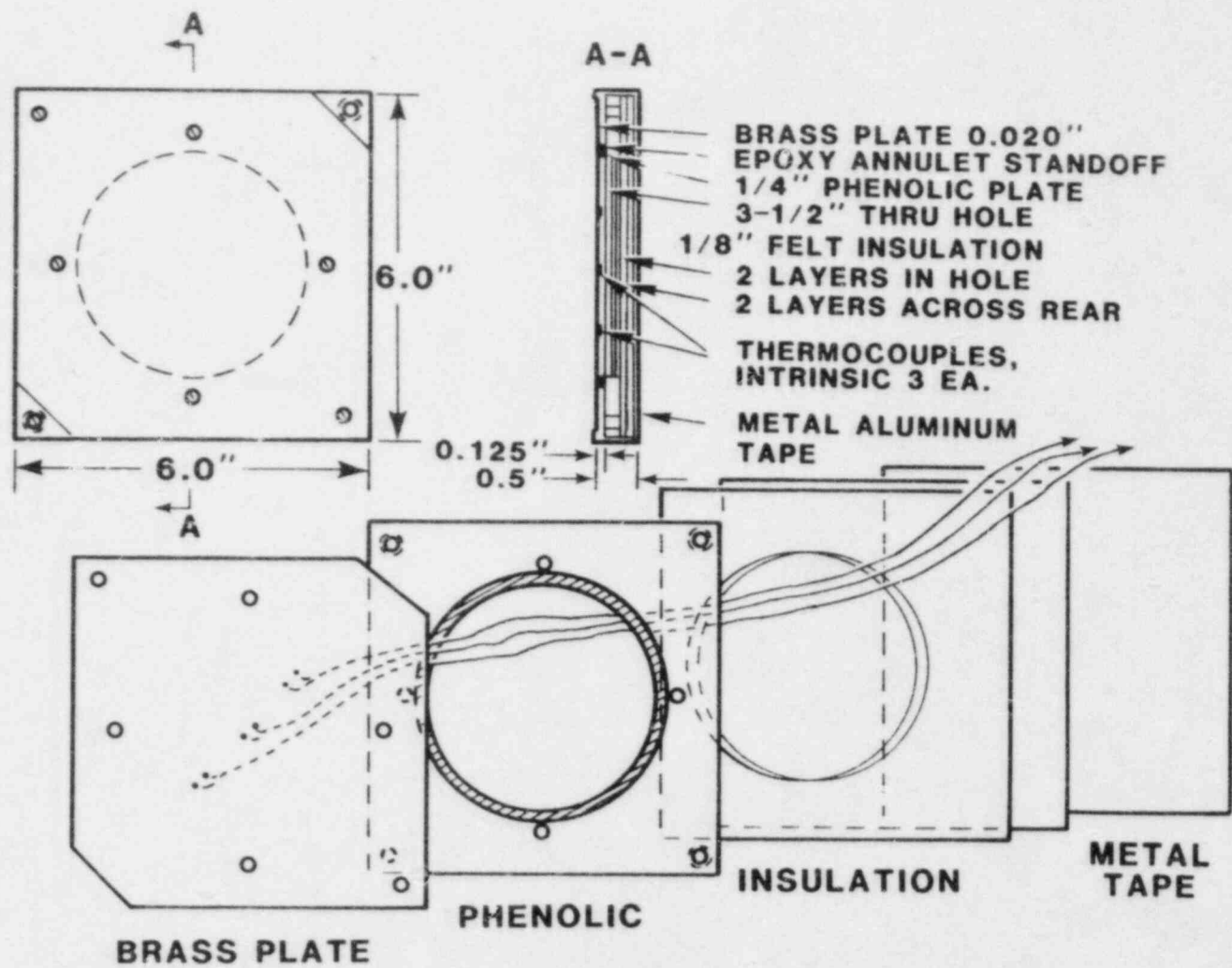

Figure 5. Assembly Drawing of Flat-Plate Calorimeter

copper plates even when the copper was nickel plated. Therefore, the use of copper plates was abandoned for FITS Series 1.

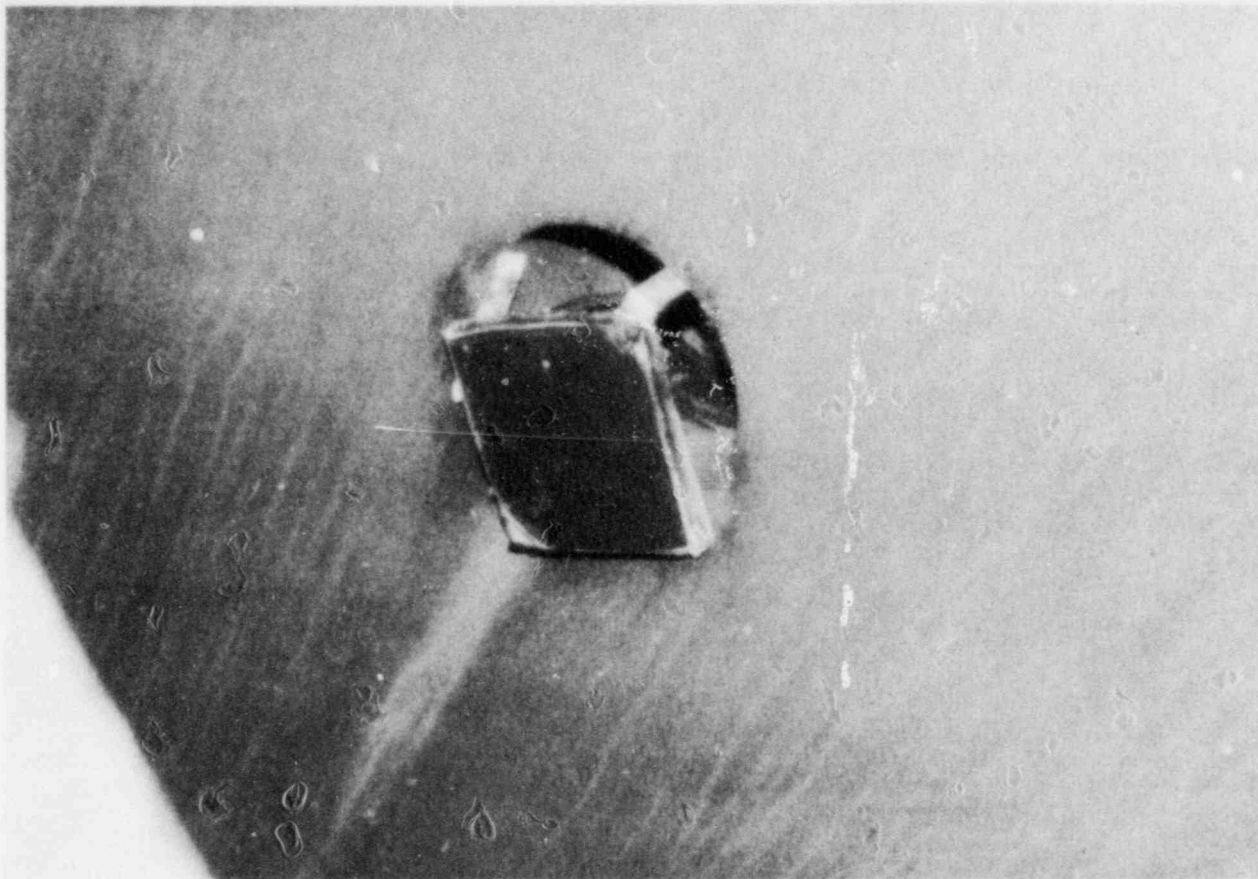

Figure 6. Flat-Plate Calorimeter Installed in FITS Test Vessel

Two three-dimensional calorimeters were constructed as 10-cm (4-in) black anodized aluminum cubes. One of the cubes was hollow, constructed from 1/8-in aluminum sheet stock. It represented components that have a low mass and therefore low heat capacity. The other cube was solid, representing massive components with high heat capacities.

Each cube was instrumented with three thermocouples. Foil thermocouples were bonded to the hollow cube at two locations on the inside surface and at one location on the outside surface. The solid cube was instrumented with beaded thermocouples. They were mounted in 0.32-cm (0.125-in)-deep holes in the same locations as the thermocouples in the hollow cube (Figure 7). The cubes were mounted about 2 m (6.6 ft) from the top of the tank and 0.6 m (2 ft) from the wall. Figure 8 shows the cubes as mounted in the FITS tank.

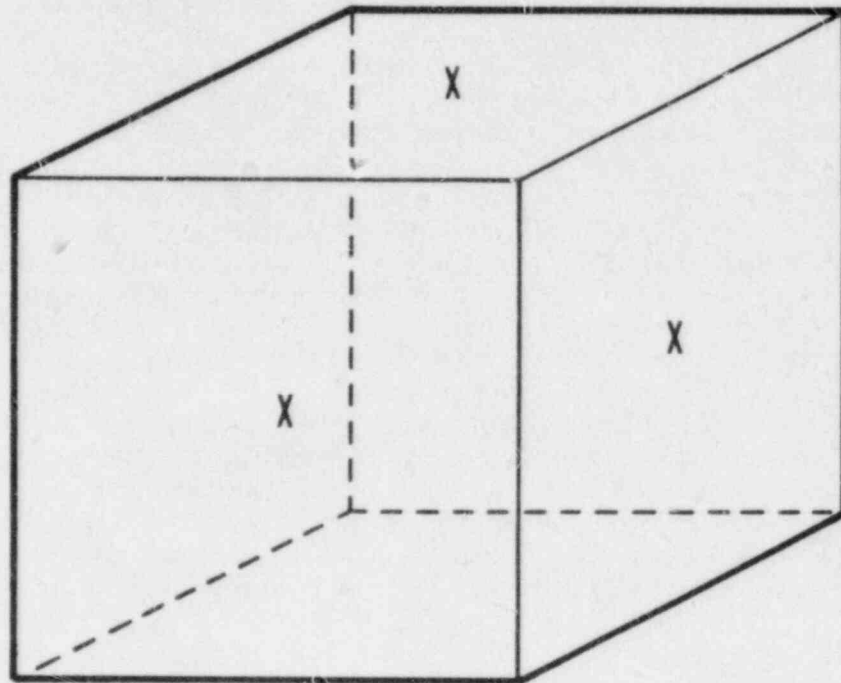

Figure 7. Location of Thermocouples on Solid and Hollow Cube Calorimeters

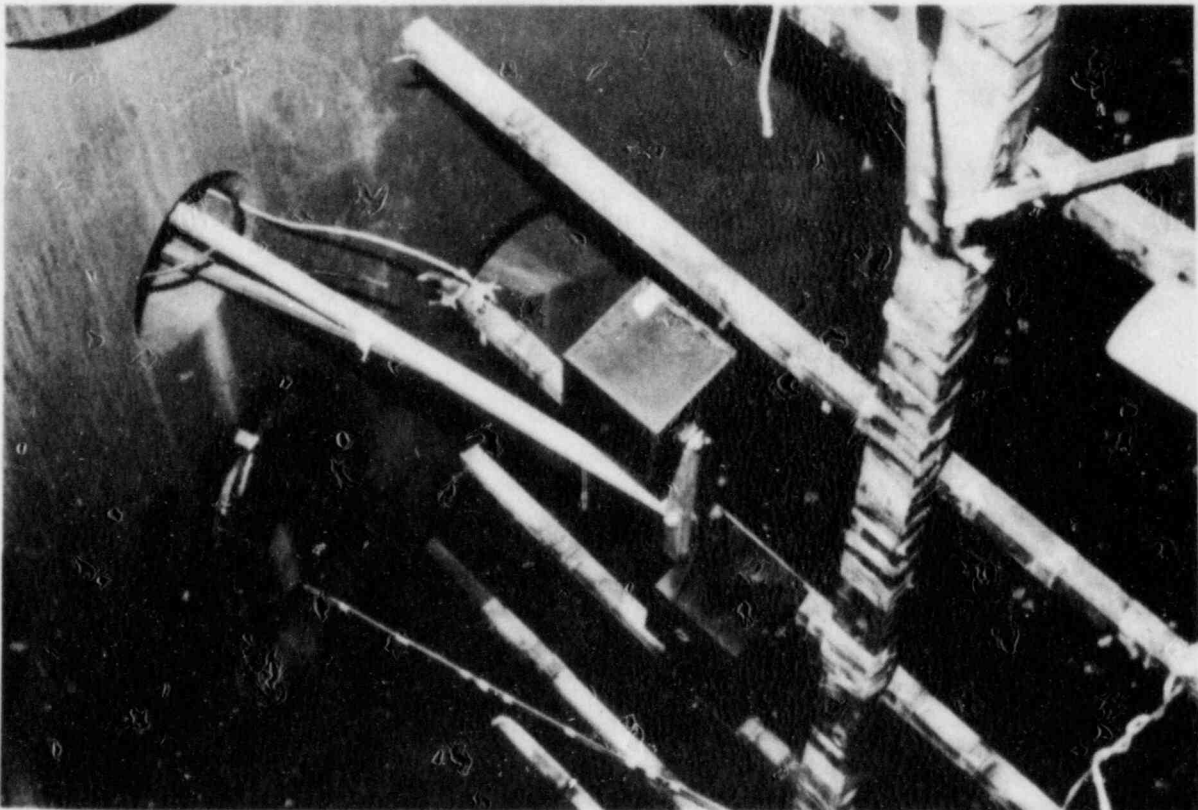

Figure 8. Cube Calorimeters Mounted in FITS Test Vessel

2.3.3 Heat-Flux Gages

Previous HBS tests and analyses indicated that the measurement of transient heat fluxes during combustion would be valuable. This data would validate analytical procedures and specify the transient radiant heat-flux criterion for the simulation tests conducted at the CRTF. To begin development of a reliable heat-flux measurement technique, some candidate heat-flux gages were utilized in FITS Series 1. One of the gages tested was designed to measure only radiative heat flux (Thermogage Model 8000-12C). To minimize convective and conductive heat transfer from the gas to the sensing element, the gage had an ellipsoidal cavity in front of the sensor and required a continuous air purge to keep the cavity surface clean and dry. The second and third gages were Gardon-type circular-foil heat-flux gages.[4 5] They had slightly different configurations and calibrations, but both measured net absorbed heat flux. Although we anticipated some problems with these gages because none were designed for use in facilities such as FITS, we felt they would provide valuable experience for future efforts in measuring heat flux.

Two of the heat-flux gages were mounted on a bracket near the tank wall 1 m (3 ft) from the top and were accessible only by removing the top of the tank. The third gage was inserted through an instrumentation port about 2 m (6.6 ft) from the top. The gages all faced the centerline of the tank.

2.3.4 Solenoid Valve

To observe the behavior of a "real" component and to gain some experience in instrumenting such components, we mounted a Class 1E-qualified solenoid valve about 1 m (3 ft) below the top of the tank. The operation of the valve was checked before and after the test series. The alternating current in the coil of the valve was monitored between burns. We mounted a thermocouple inside the cover plate of the valve's electrical enclosure and monitored that temperature during the burns. Figure 9 shows the solenoid valve as mounted in the FITS tank.

2.3.5 Additional Instrumentation

For additional information, we bonded two thermocouples to each of the two pneumatic mixing fans inside the tank to monitor their temperatures during the burns. We also placed several cable specimens, both qualified and unqualified, in the tank along with two types of terminal blocks. The cable samples and terminal blocks were included for visual inspection purposes only; mechanical (e.g., tensile) or electrical tests were not performed on the samples.

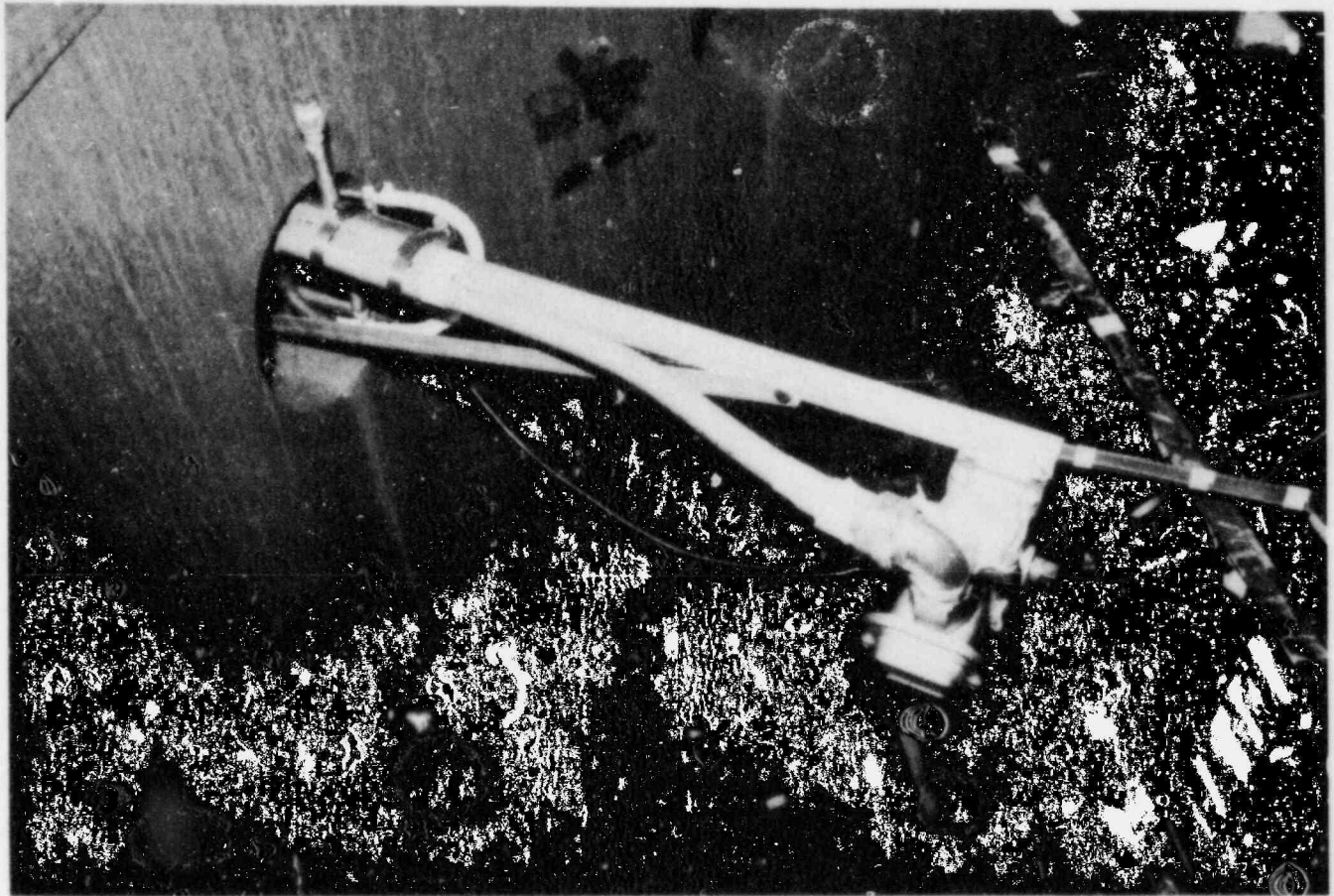

Figure 9. Solenoid Valve Mounted in FITS Test Vessel

2.3.6 Instrumentation Location

Figure 10 shows the locations of the major pieces of HBS instrumentation. The cable and terminal block samples were suspended near the center, about 1 m (3 ft) from the top. The mixing fans are part of the permanent FITS equipment. One is located 1 m (3 ft) from the top of the tank and the other about 3 m (10 ft) from the top of the tank.

2.4 Test Plan and Procedures

Detailed information concerning the general operating procedures for the FITS facility can be obtained from Reference 6 and is not repeated here. However, the test plan and procedures pertaining to the HBS program tests will be discussed.

2.4.1 Test Plan

The HBS test plan called for a series of burns to be performed that would provide information on low-hydrogen-concentration burns in atmospheres with three different steam concentrations. (Concentrations of hydrogen and steam are expressed as volume/percent [v/o] throughout this report.) Table 1 shows the matrix of burn tests that were actually performed.

These tests provided information concerning the effects of varying hydrogen and steam concentrations on the burn environment, the repeatability of the burns, and the effects of turbulence (fans on) during a burn, as well as the component responses to the specific hydrogen burns. As noted in Table 1, in one test the hydrogen could not be ignited; in seven other tests, no data were obtained because of problems with the data-acquisition system.

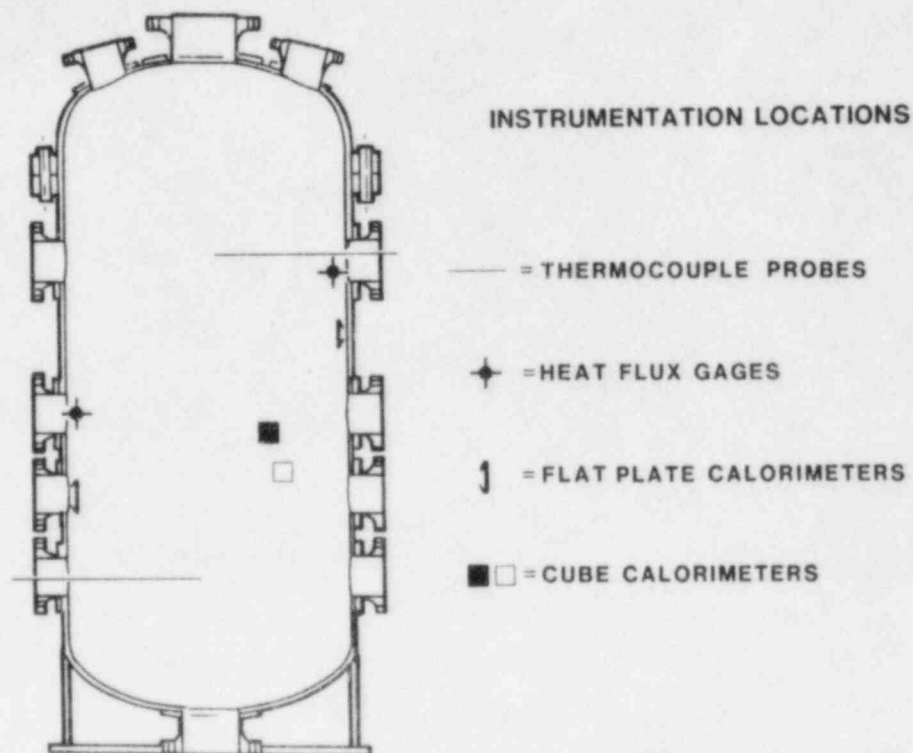

Figure 10. Location of Major Instrumentation in FITS Test Vessel

2.4.2 Data Acquisition

The data-acquisition system at the FITS facility has the capacity for storing about 2000 data points per channel. Sampling 20 times per second, the system recorded about 100 s (including 10 s of initial condition data) of data for each burn. Data sampling was initiated by the increase in pressure associated with a burn. Sufficient time elapsed between tests to output hard copy of some (but often not all) of the data so that it could be scanned for indications of system malfunctions. When malfunctions were found, corrective measures were taken before proceeding with the test sequence.

All of the raw test data from this test series were recorded on floppy discs. To facilitate analysis, the data were transferred to storage files on an SNLA VAX computer system.

Table 1
Test Matrix for FITS Series 1

Hydrogen Concentration (v/o)	Steam Concentration (v/o)		
	0	20	40
6	O O O X	X	X
7	X		
8	X	O X F F	X X N
9	O X X		
10	X	O X F	O X
11	X		
12	X	X	X
15		X	

O = No data obtained (data-acquisition system problems)
 X = Data obtained; fans not on
 F = Data obtained; fans on
 N = No ignition

3. DATA ANALYSIS METHODS

The data was recorded as output voltages read from the various pieces of instrumentation. Before they could be used, the voltages had to be converted to the corresponding temperatures, heat fluxes, or pressures. In addition, the data were treated to minimize the effects of noise in the electrical circuits.

3.1 Conversions and Adjustments

A linear equation of the form $y = mx + b + c$ was used to convert the voltages to temperatures, heat fluxes, or pressures. In this equation, y = measured quantity, m = conversion factor, x = recorded voltage, b = reference value, and c = correction value. The measured quantity was either temperature, heat flux, or pressure. The conversion factor for the temperature measurements was the appropriate value for Type K thermocouples combined with the gain on the amplifiers, while the conversion factor for the heat-flux and pressure gages was the slope of their calibration curves combined with the amplifier gains. The output voltage from each sensor was recorded by the data-acquisition system. For thermocouples, the reference value was the reference temperature (as recorded for the reference junction oven); for heat-flux gages, the reference value was zero; and for the pressure gages, the reference value was calculated from the preburn pressure for each burn. It was necessary to use a correction value on the data from some burns in which a dc offset was discovered in the amplifiers. Most of the hydrogen-burn analysis concerns temperature rises or differences rather than actual temperatures; for these cases, b and c have no effect on the interpretation of the data.

3.2 Treatment of Outliers

An outlier is a spurious data point, often caused by electrical noise in the data-acquisition system. Several outliers were discovered during a visual inspection of the data plots. All gross outliers were removed using a computer program explained in Appendix A, and more information concerning outliers can be obtained from Reference 7.

3.3 Smoothing of Data

As in most experimentally obtained data, some noise was present. Occasionally the noise was severe enough to warrant rejecting the data from certain channels. Usually, though, the noise was not very noticeable unless the scale of the data plot was greatly magnified. Figure 11 shows an example of this.

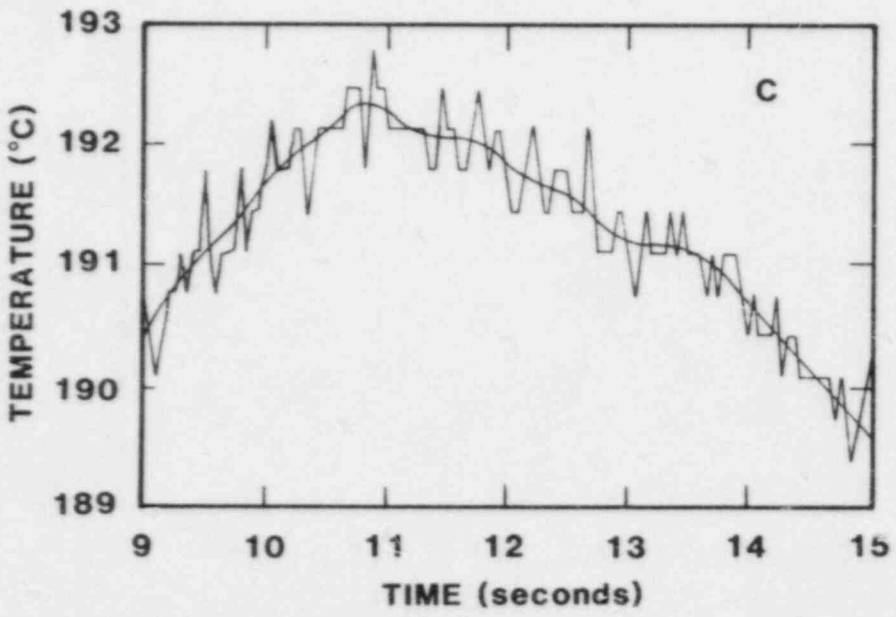
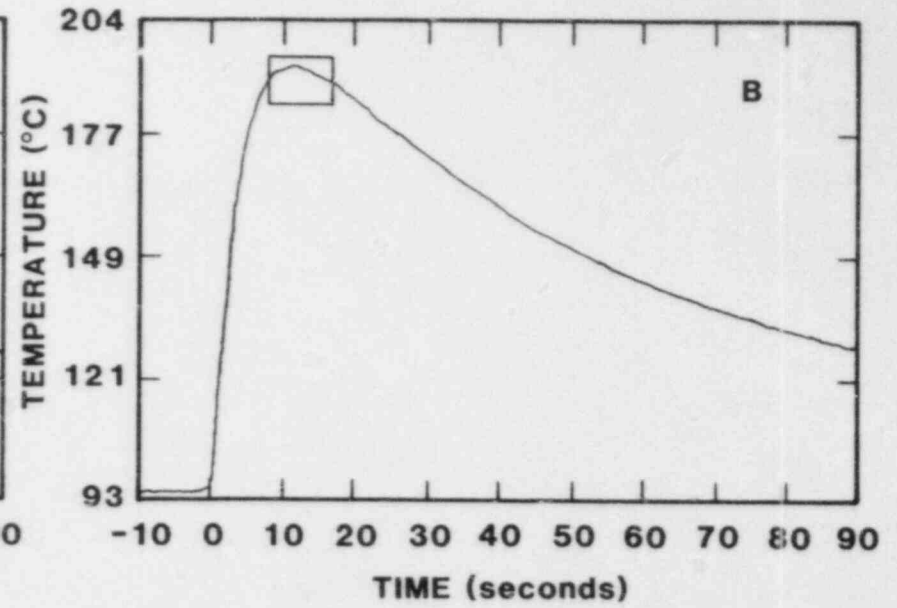
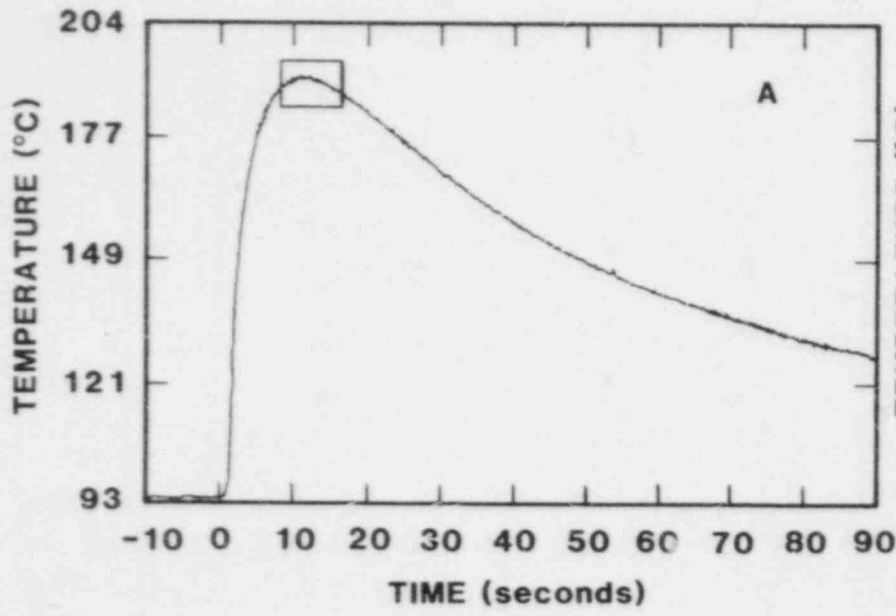

- A. ORIGINAL UNSMOOTHED DATA
- B. SMOOTHED DATA
- C. BLOW UP, COMPARING A & B

Figure 11. Comparison of Unsmoothed Data and Data after Smoothing with Butterworth Filter

Figure 11a shows the original temperature trace of a flat-plate calorimeter exposed to a 10 v/o hydrogen, 20 v/o steam burn in the FITS tank. Close examination of the trace reveals a small amount of noise present, recognizable as a slight waviness in the trace and in the thickness of the trace. Figure 11b shows the same trace after it was smoothed using a Butterworth filter technique (see Appendix A). The trace looks very much the same, except now the waviness has disappeared and the trace is much finer. Upon comparing the two traces (Figure 11c, which is an expansion of the area outlined in a and b), it can be seen that there is a substantial difference between the two traces.

This difference is important when calculating heat fluxes from temperature responses, which involves taking derivatives of the temperature profile. If the trace is jagged as in Figure 11a, the derivatives will be large and variable and unrepresentative of the physical phenomenon. The smoothed trace in 11b will produce more meaningful derivatives.

Since smoothing sometimes can distort the data, it is important to consider the effect of smoothing on the peak temperatures. Figure 12 shows a comparison of the smoothed and unsmoothed data for a gas-temperature peak. Although smoothing attenuates the peak temperature slightly, the error is small and within the experimental uncertainties.

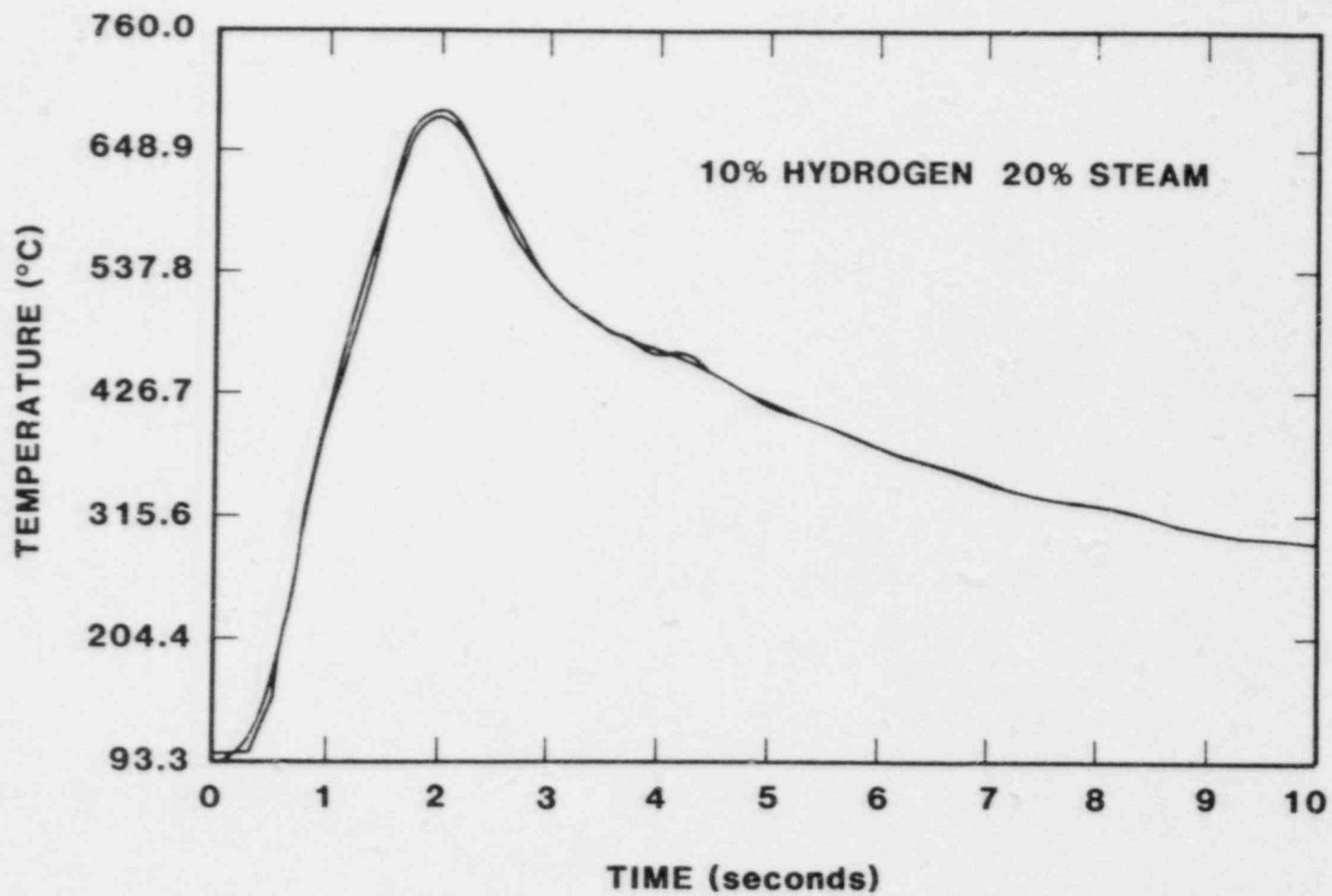

Figure 12. Comparison of Smoothed and Unsmoothed Data for a Gas-Temperature Peak

4. RESULTS AND CONCLUSIONS

4.1 Gas-Temperature Measurements

The gas-temperature data presented in this report are those measured by the HBS instrumentation. The measurements from the FITS array of 32 12-mil thermocouples were not considered in this report, because they have a much slower response and generally are used by the Hydrogen Behavior Program for indicating flame arrival.[8]

4.1.1 Thermocouple Comparison

As stated before, a comparison was made between two sizes of Type K thermocouples. The response (as indicated by peak temperature measurements) and survivability of a 0.5-mil foil thermocouple were compared to those of a 5-mil beaded thermocouple to determine whether either kind had an advantage over the other. It was expected that, because they had less mass, the 0.5-mil thermocouples would have a better response but would not survive very well compared to the 5-mil thermocouples.

However, the results did not confirm our expectations. In general, the data did not favor either size of thermocouple insofar as response was concerned, and only one thermocouple (a 0.5-mil) did not survive all the burns to which it was subjected. Figure 13 compares the responses of the two thermocouple sizes for a 12 v/o hydrogen, 40 v/o steam burn. It can be seen that neither size has a response that is consistently better than the other.

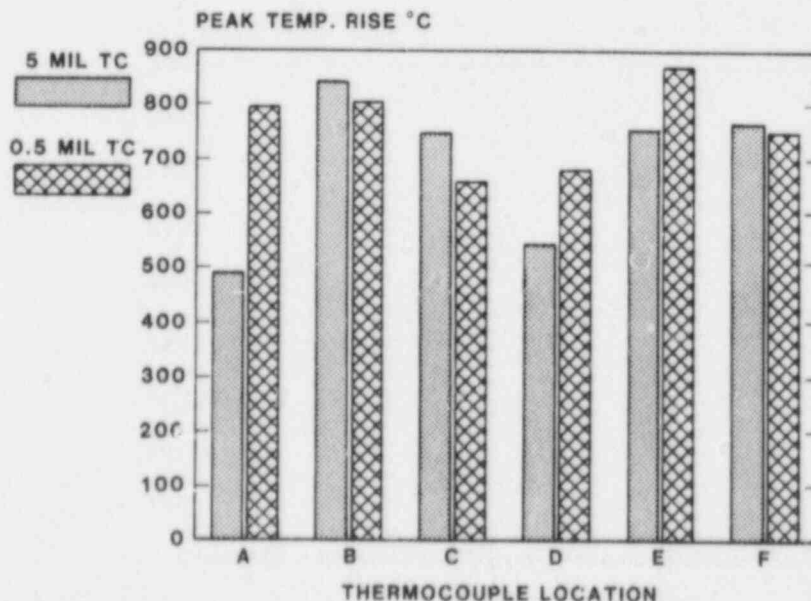

Figure 13. Thermocouple Response Comparison

This can be explained by the fact that the 0.5-mil thermocouples were not designed to measure gas temperatures. They were mounted on a thin piece of phenolic; sometimes the phenolic burned off, and sometimes it did not, leading to varying responses. The phenolic also provided some degree of protection from the burn, which the 5-mil thermocouples did not have. On a new thermocouple probe, the 5-mil thermocouples were more likely to have a better response. However, as the instrumentation was subjected to more burns, the phenolic burned off the 0.5-mil thermocouples, and their response became as good or better than that of the 5-mil thermocouples. In the future, if more HBS tests are conducted at FITS, we will pair some 2-mil beaded thermocouples with the 5-mil beaded thermocouples and repeat the comparison.

It was found that the peak gas-temperature measurements were sensitive to the location of the thermocouples with respect to the probe. Despite our efforts to ensure that all thermocouples were not in contact with or shielded by the probes, we found after removing the probes from the tank that some of the thermocouples had moved slightly and were indeed somewhat shielded from the burn, either by the probe or by the thermocouple sheathing. There is a strong correlation between the peak gas-temperature measurements from each thermocouple and the location, with respect to the probe, of each thermocouple.

4.1.2 Peak Gas Temperatures and Initial Pressure Correction

Table 2 shows the peak gas-temperature rises for each burn as measured by the gas-probe thermocouples. Note that these are not actual gas temperatures but temperature rises. The actual peak temperatures are approximately 100°C (200°F) higher because the initial temperatures were about 100°C (200°F). Several pieces of information can be obtained from Table 2.

First, however, the fact that each test had a different pre-ignition pressure should be considered. Because of the way the tank is filled, substantially different preignition pressures are obtained for cases with steam added. This results in widely varying masses of hydrogen in the tank (even if the volume percentage is the same), which in turn results in varying quantities of energy being released during combustion. To correct for this, two factors must be considered.[9] One is the amount of energy produced by the hydrogen that is burned; the other is the flame temperature (which for these lean burns is not dependent on initial pressure). The energy term can be obtained from the ideal gas law, $PV = nRT$, but this factor alone will overcorrect in most cases because it does not take rate effects into account. The flame-temperature factor, which accounts for rate effects, is not so readily obtained. Work is continuing in this area.

Table 2
Peak Gas-Temperature Rises (°C)*

Hydrogen Concentration (v/o)	Steam Concentration (v/o)		
	0	20	40
6	197	95	151
7	254		
8	542	264 719(T) 541(T)	441 384 N
9	577 768		
10	776	748 743(T)	694
11	779		
12	860	813	869
15		1088	

*Initial temperatures ~100°C
(T) = Turbulence (fans on during burn)
N = No ignition

The energy factor simply adjusts the peak gas temperatures for each burn by using a ratio of preignition pressure to a base pressure. For massive components, in which the component's temperature response is much slower than the temperature response of the gas and the rate effect is thus relatively insignificant, the energy factor alone can possibly be used to correct for the different initial pressures. For faster responding components, in which rate effects are important, the energy factor alone will overcorrect; however, the energy factor can be used as a bound. As shown in following sections, the energy factor alone can have a substantial effect.

4.1.3 Effects of Hydrogen Concentrations

Until the effect of different preignition pressures is determined, it is not feasible to draw conclusions about the effects of steam on gas or component temperatures. Since the hydrogen concentrations in FITS Series 1 are low and do not alter the initial pressures significantly, a trend can be defined for the effect of hydrogen on the peak gas-temperature

rises (Figure 14). Again, note that these are peak temperature rises; to obtain actual temperatures, the initial temperature of about 100°C (200°F) must be added. As expected, the peak temperatures increase with increasing hydrogen percentages. It also can be seen from Figure 14 that, in general, higher peaks are recorded in the upper portion of the tank than in the lower portion.

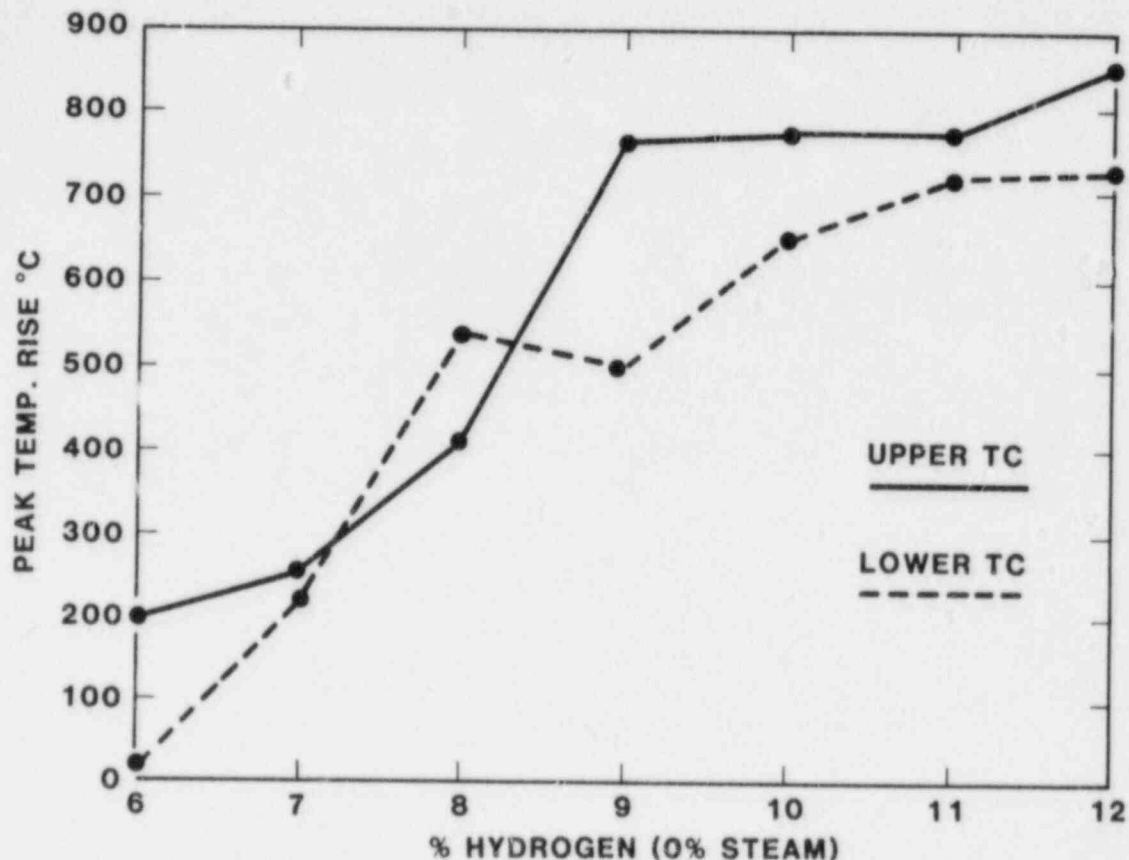

Figure 14. Effect of Hydrogen Concentration on Peak Temperature Rise

4.1.4 Repeatability

The gas temperatures in Table 2 do not show particularly good repeatability. In examining each individual thermocouple's output, it was found that the peak temperature did not occur in any one specific location and that two identical thermocouples only 25 cm (10 in) apart could have quite different responses. This leads to the conclusion that either the burns in the FITS tank had somewhat random temperature distributions, or else the gas-temperature measurements were erratic. However, the component responses were more repeatable (for hydrogen concentrations greater than 8 v/o), as will be discussed below, and the pressures also appeared to be repeatable; this suggests that while the local environments were

somewhat erratic, the net effects of the burns were fairly consistent.

4.1.5 Effects of Fans

The effect of fans on peak gas temperatures (Table 3) is uncertain, because the gas-temperature measurements themselves are somewhat uncertain. It appears that for the 8 v/o hydrogen, 20 v/o steam case, fans promote completeness of the burns, thereby raising the peak gas temperatures. However, the 10 v/o hydrogen, 20 v/o steam case apparently burns to completion without the fans; for this case the fans had substantially less effect. This is discussed further in connection with the effect of fans on calorimeter response.

Table 3
Effect of Fans on Peak Gas-Temperature Rises

Hydrogen Concentration (v/o) [†]	Thermocouple Probe	Temperature Rise (°C)*	
		Fans Off	Fans On
8	Upper	264	577
			538
8	Lower	47	719
			541
10	Upper	748	712
10	Lower	590	743

*Initial temperatures ~100°C

[†]Steam concentration 20 v/o for all burns

Another interesting point to be made about Table 3 is that, while Figure 14 shows that the maximum gas temperatures usually are recorded in the upper portion of the tank, leaving the fans on during the burn results in the peak temperatures being recorded in the lower portion of the tank. This suggests that the fans suppress the buoyancy effects that are normally present in quiescent burns.

4.2 Flat-Plate Calorimeters

4.2.1 Results

A typical temperature trace for a flat-plate calorimeter is shown in Figure 15. The mixture is ignited at time = 0 s. The temperature rises rapidly, peaks at about 10 s, and

descends gradually. Table 4 contains the peak temperature rises for the flat-plate calorimeters for FITS Series 1. Using the Sandia One-Dimensional Direct/Inverse Thermal (SODDIT) Analysis Code, heat fluxes can be calculated from the flat-plate calorimeter temperature profiles; [10] work is continuing in this area.

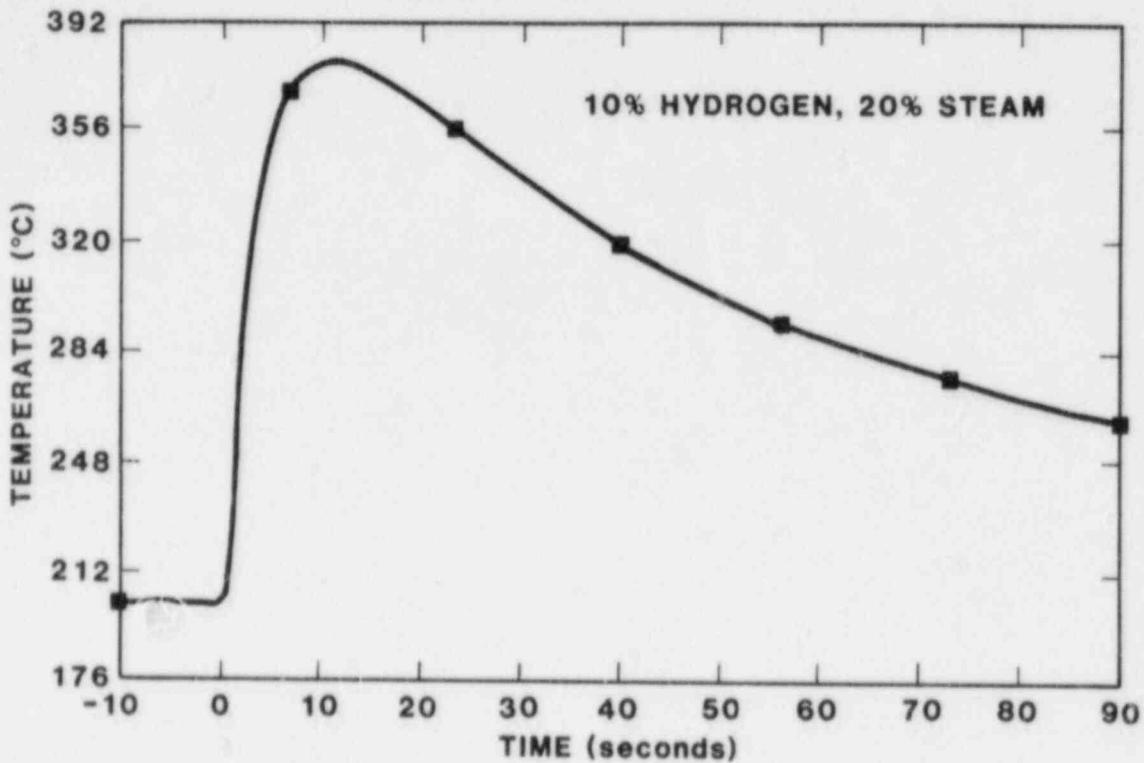

Figure 15. Typical Temperature Response for Flat-Plate Calorimeter

4.2.2 Effects of Hydrogen Concentrations and Fans

As in the results for the peak gas temperatures, the effects of steam cannot be considered until the problem of different preignition pressures is resolved. Because the flat-plate calorimeters have relatively fast response, rate effects must be accounted for; that is, the energy factor alone will over-correct the data. However the problem can be bounded by applying the energy factor alone. In Table 4, increasing steam concentrations increased the peak temperatures (for complete burns, i.e., concentrations above 8 v/o) but the energy factor (Table 5) reverses this trend. Further study concerning the rate effects is needed before the true effect of steam concentration can be properly evaluated.

Table 4

Flat-Plate Calorimeters: Peak Temperature Rises ($^{\circ}\text{C}$)*

Hydrogen Concentration (v/o)	Steam Concentration (v/o)		
	0	20	40
6	24	9	17
7	48		
8	68	49 71(T) 69(T)	98 65 N
9	70 71		
10	88	98 93(T)	124
11	74		
12	106	134	163
15		166	

*Initial temperatures $\sim 100^{\circ}\text{C}$

(T) = Turbulence (fans on during burn)

N = No ignition

The effect of hydrogen concentrations on peak temperature rises is shown in Figure 16, and the effect of fans is shown in Table 6. Again, the primary observation is that for 8 v/o hydrogen burns, the peak flat-plate calorimeter temperature is substantially higher with the fans on, while for 10 v/o hydrogen burns there is much less difference. This agrees with the observations of gas temperatures and supports the explanation that the fans make 8 v/o burns more complete but had little effect at 10 v/o because those burns were virtually complete even without fans. As mentioned above, gas temperatures measured by thermocouples indicated local variations in the combustion. Since the flat-plate calorimeters have more thermal mass, have smaller surface-area-to-volume ratios, and are strongly coupled by thermal radiation to the gas throughout the vessel, the temperatures of the flat plates are more representative of an average effect of the gas. Thus, the flat-plate data can be used to infer that the net effect of fans at 10 v/o is to increase the rate of energy transfer to the walls of the vessel during and after the burn. This

results in lower peak temperatures, both in the gas and for the flat plates. This effect is present in the 8 v/o cases also but is masked by the improved combustion completeness.

Table 5

Flat-Plate Calorimeters: Peak Temperature Rises (°C)*
(Energy Factor Applied)

Hydrogen Concentration (v/o)	Steam Concentration (v/o)		
	0	20	40
6	24	7	10
7	46		
8	66	37 53(T) 51(T)	54 37 N
9	67 67		
10	83	72 68(T)	66
11	91		
12	99	96	89
15		113	

*Initial temperatures ~100°C
(T) = Turbulence (fans on during burn)
N = No ignition

4.2.3 Repeatability

From Table 4 it can be seen that, for the more complete burns (above 8 v/o hydrogen), the peak temperature-rise data for the flat-plate calorimeters are more repeatable than the gas-temperature data. This indicates that, although the gas temperature measurements are not always repeatable, the responses of components are repeatable. Perhaps the thermocouples are responding to local variations in the gas temperatures, and the more massive component surfaces are more indicative of the average net effects. Thus it may prove more meaningful to evaluate the temperature environment by measuring the response of components (such as calorimeters or heat-flux

gages) instead of trying to measure the gas temperatures directly. (This applies only to environmental temperature measurements; the pressure measurements appear to be repeatable.)

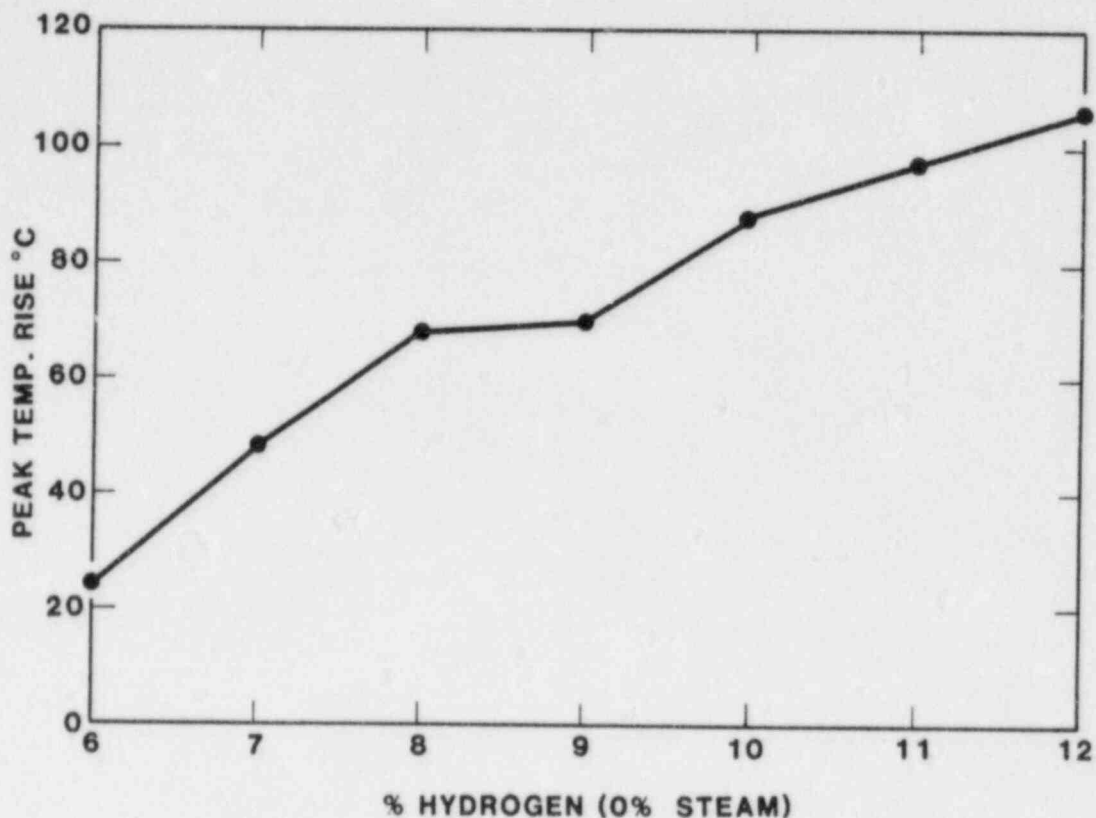

Figure 16. Effect of Hydrogen Concentration on Peak Flat-Plate Calorimeter Temperature Rise

Table 6

Flat-Plate Calorimeters: Effect of Fans on Peak Temperature Rises

Hydrogen Concentration (v/o)†	Temperature Rise (°C)*	
	Fans Off	Fans On
8	49	71
		69
10	98	93

*Initial temperatures ~100°C

†Steam concentration 20 v/o for all burns

4.3 Cube Calorimeters

The cube calorimeters provide a comparison of components having the same geometrical configurations but different thermal capacities. Figure 17 shows typical temperature traces for the hollow and solid cube calorimeters, and Figure 18 shows their peak temperature rises for varying hydrogen concentrations (0 v/o steam).

The effect of fans on peak temperature rise is shown in Table 7. Note that the cubes do not have a lower peak-temperature rise for the 10 v/o hydrogen case with fans; this is different behavior from the flat-plate calorimeters. Because the cubes are more massive and therefore slower responding, their temperature response does not follow the gas temperature. It lags behind the gas temperature and does not reach a well-defined peak but rather reaches a given temperature level slowly and remains there. Thus while the fans may cause the components to heat up more quickly, they do not have an appreciable effect on the peak temperature of the more massive components. Concerning repeatability, the discussion of the flat-plate calorimeters also applies to the cube calorimeters.

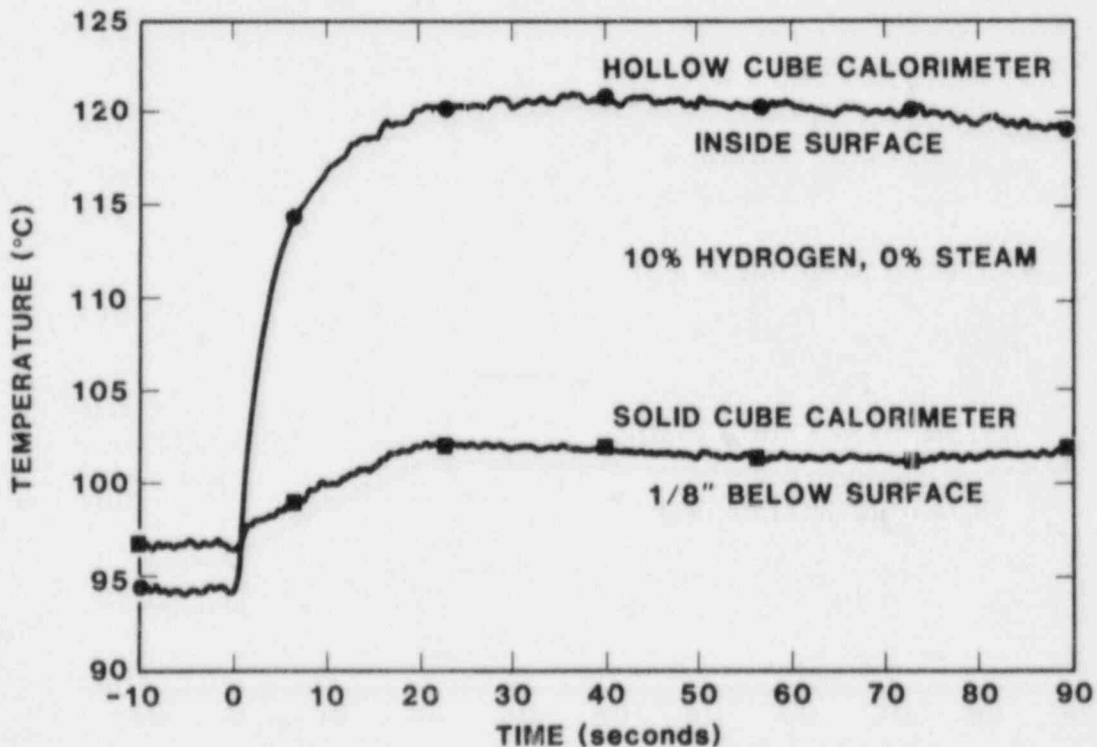

Figure 17. Typical Temperature Responses of Hollow and Solid Cube Calorimeters

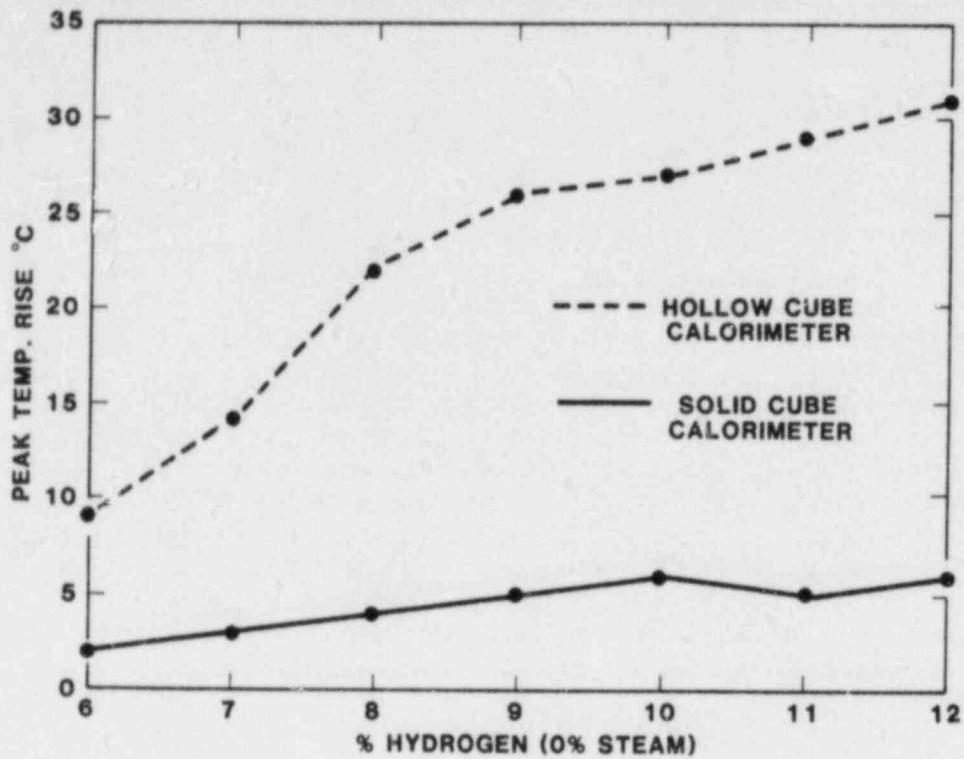

Figure 18. Cube Calorimeters: Effect of Hydrogen Concentration on Peak Temperature Rise

Table 7

Cube Calorimeters: Effect of Fans on Peak Temperature Rises

Hydrogen Concentration (v/o)†	Cube Calorimeter	Temperature Rise (°C)*	
		Fans Off	Fans On
8	Solid	3	6
			5
8	Hollow	16	33
			32
10	Solid	7	7
10	Hollow	39	41

*Initial temperatures ~100°C

†Steam concentration 20 v/o for all burns

4.4 Flux Gages

As expected, some problems were encountered with the heat-flux gages. Because of these problems, which are described below, the quantitative data from the gages will not be presented. (Flat-plate calorimeter heat-flux calculations will be presented in a future report.) However, several observations can be made by looking at the output from the gages.

The ellipsoidal gage posed difficulties in that it required a continuous air purge to keep the sensor dry; this air purge interfered with the pressure inside the tank. Also, the extra tank penetrations necessary for this air purge often leaked, causing further problems. And finally, despite the air purge, water from the steam preheat process eventually seeped into the gage, shorting it out.

The other two gages did not have air purges but posed other problems. These gages are very sensitive to any water on their sensing surface. Although an attempt was made to ensure that the tank walls and equipment were kept above the saturation temperature, this was not always achieved. Periodically, no output was produced by the gages, possibly indicating that some condensation was formed on the foil surfaces of the gages. There is a correlation between this phenomenon and the temperature of the inside wall of the tank.

In addition, these gages were somewhat fragile. It is unclear whether the combustion pressure pulses damaged the foils, but there was some degradation of the absorptive coating, which was probably a combined effect of heat and moisture. One of the gages failed (open circuit) in the last and most severe burn (15 v/o hydrogen, 20 v/o steam).

Although we do not consider the heat-flux gage data from these tests reliable enough to report, much was learned about measuring heat fluxes in the FITS tank; this experience will be useful in future attempts to measure heat flux.

4.5 Solenoid Valve

Figure 19 shows a typical temperature profile recorded for the solenoid valve. Table 8 gives the temperatures at 90 s after the burn was initiated. (The data-acquisition system was limited to recording data for 90 s after ignition.) The solenoid valve temperatures had not peaked yet but were nearly level, indicating these temperatures are probably within a few degrees of the actual peak.

The electrical operation of the valve was verified before and after the test series by connecting a 40-psi air line to the pressure port on the valve, then applying ac power several times and listening for the air release (exhaust). The valve

operated properly in all tests. This procedure could be performed only when the top of the tank was removed to provide access to the valve. During the test series there was not sufficient time to remove the top, so the operation of the valve was checked between burns by applying ac power to the valve and monitoring the current into the valve. The current before the test series was 186 mA; after the first burn it increased to 195 mA and remained at that level throughout the rest of the test series. (The current on a new, identical solenoid valve was measured at 193 mA.) This change in current did not appear to have any effect on the operation of the valve.

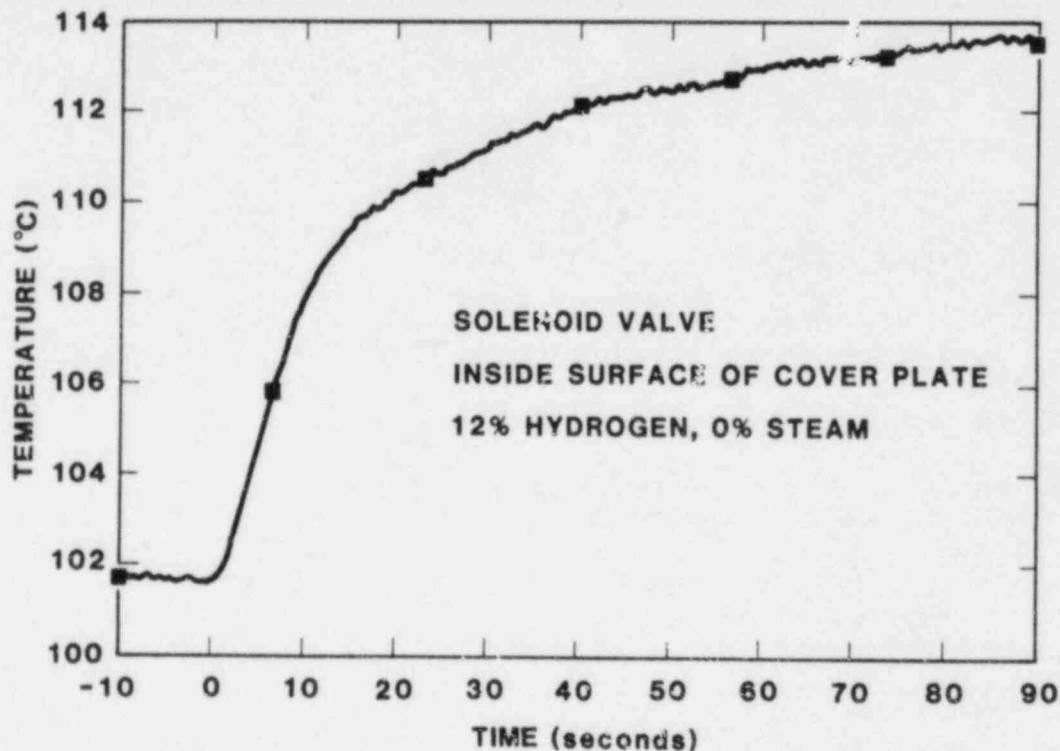

Figure 19. Typical Temperature Response of Solenoid Valve

4.6 Other

4.6.1 Mixing Fans

The mixing fans were the only "components," other than the solenoid valve, installed in the tank; in order to gain more experience in testing components in a hydrogen-burn environment, it was decided to monitor the mixing fans' temperature response. Two foil thermocouples were attached to the outer case of each fan motor, so that one thermocouple was on a surface that faced toward the centerline of the tank and the other was on a side surface perpendicular to the first surface.

Table 8

Temperature* of Solenoid Valve 90 Seconds
after Burn Initiation

Hydrogen Concentration (v/o)	Steam Concentration (v/o)		
	0	20	40
6	104	102	103
7	107		
8	109	107 111(T) 110(T)	117 110 N
9	111 112		
10	112	116 113(T)	123
11	112		
12	112	117	125
15		122	

*Temperature of inside surface of cover plate; initial temperature ~100°C

(T) = Turbulence (fans on during burn)

N = No ignition

Figure 20 shows the difference in temperature response for the two thermocouple locations. The surface facing across the tank reached a higher peak temperature but cooled rapidly until it agreed fairly well with the temperature at the perpendicular surface. This is indicative of the longer beam lengths (and greater heat transfer) seen by the surface facing across the tank and demonstrates the effect that component orientation and location have on component temperature response.

4.6.2 Cable Samples and Terminal Blocks

As stated previously, the cable samples and terminal blocks were included in the test series for visual inspection purposes only. The terminal blocks showed little deterioration after being exposed to six burns with hydrogen concentrations

less than 9 v/o. There was some corrosion and slight discoloration of the unplated metal parts (i.e., screws and rivets); this was likely caused by the wet environment.

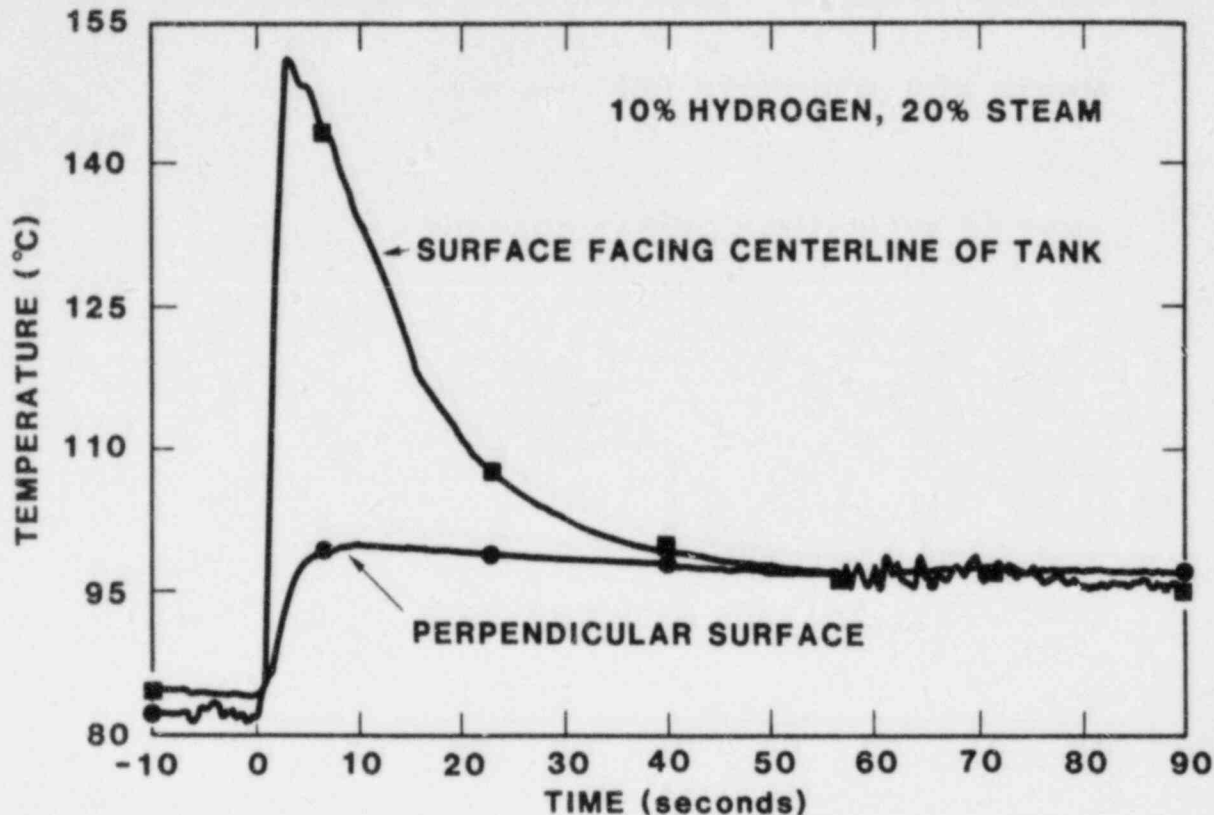

Figure 20. Surface Temperature Response of Mixing Fan

However, after being subjected to 23 burns, some with hydrogen concentrations higher than 9 v/o, the terminal blocks did show damage. Some of the smaller plastic pieces were melted, and the main block bodies were discolored. There was more severe corrosion of the smaller metal parts; again, this is likely due to extended exposure to a wet environment.

The cables tested included both Class 1E-qualified and unqualified cable samples. Although a detailed investigation of cable survival was beyond the scope of these tests, it was observed that the unqualified samples appeared to have sustained more damage than the qualified samples.

The cable samples were mounted in the test vessel such that a portion of each cable was fastened to a metal probe and the rest was suspended in space (Figure 21). The cable portions that were attached to the probe sustained significantly less damage than the portions suspended in space. This indicates

that the probe provided some degree of protection from the burns (possibly by acting as a heat sink).

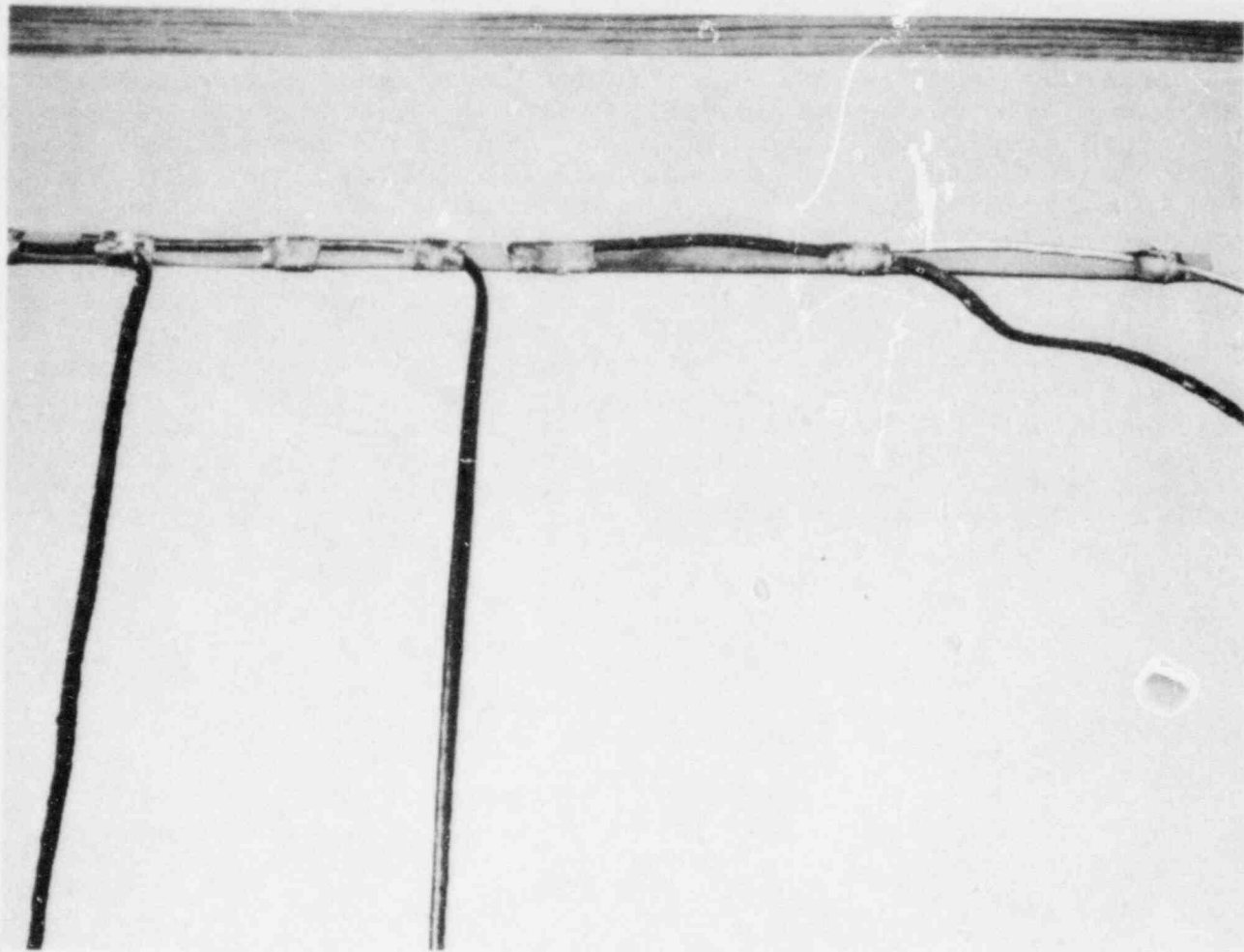

Figure 21. Cable Samples

5. SUMMARY OF FINDINGS AND CONCLUSIONS

As part of the HBS Program, a series of hydrogen-burn experiments was conducted at the FITS facility. Data from 21 combustion tests (burns) were recorded, reduced, and analyzed from instrumentation measuring both gas and component temperature responses. Some findings, such as (1) increasing hydrogen concentrations increased peak temperatures and (2) thin-walled components responded faster and reached higher temperatures than thick-walled components, were expected. Some unexpected findings (e.g., smaller thermocouples did not necessarily respond better than larger ones) were also encountered. The effect of steam concentration on temperatures cannot be determined until the problem of different preignition pressures is resolved. Fans appeared to promote more complete combustion. A Class 1E-qualified solenoid valve survived all burns in the test series; however, a direct conclusion regarding hydrogen-burn survivability in a reactor containment cannot be drawn from this data because of the volume scaling factor.

REFERENCES

1. W. H. McCulloch, A. C. Ratzel, S. N. Kempka, D. T. Furgal, and J. J. Aragon, Hydrogen Burn Survival: Preliminary Thermal Model and Test Results, SAND82-1150.
2. H. Tamm, D. D. S. Liu, W. Harrison, "The WNRE Research Program on Hydrogen Behavior in Nuclear Reactor Containments," presented at the Workshop on the Impact of Hydrogen on Water Reactor Safety, Albuquerque, NM, January 26-28, 1981.
3. D. D. S. Liu, R. MacFarlane, and L. J. Clegg, "Some Results of WNRE Experiments on Hydrogen Combustion," presented at the Workshop on the Impact of Hydrogen on Water Reactor Safety, Albuquerque, NM, January 26-28, 1981.
4. Gardon, Robert, "An Instrument for the Direct Measurement on Intense Thermal Radiation," The Review of Scientific Instruments, Vol. 24, No. 5, May 1953.
5. Brookley, Charles E., "The Circular Foil Heat Flux Gage," Thermogage, Inc., Frostburg, Maryland.
6. S. F. Roller and S. M. Falacy, "Medium Scale Combustion Tests of Hydrogen-Air-Steam Systems," SAND82-2390C, presented at the Second International Workshop on the Impact of Hydrogen on Water Reactor Safety, Albuquerque, NM, October, 1982.
7. J. B. Kennedy and A. M. Neville, Basic Statistical Methods for Engineers and Scientists, Thomas Y. Crowell Company, Inc., New York, 1976, pp 177-181.
8. M. Berman, "H₂ Research Programs," presented at the Workshop on the Impact of Hydrogen on Water Reactor Safety, Albuquerque, NM, January 26-28, 1981.
9. Conversation with Marty Sherman of Sandia Laboratories on June 3, 1983.
10. B. F. Blackwell, "User's Manual for the Sandia One-Dimensional Direct and Inverse Thermal (SODDIT) Code."

APPENDIX A

Plotting and Smoothing of HBS Data

E. A. Aronson

Reference: Sterns, S. D., Digital Signal Analysis, Hayden Book Co., Rochelle Park, New Jersey, 1974.

This appendix describes a set of programs to plot and smooth HBS data on the VAX. All coding is in FORTRAN 77. Each data file consists of a 10-character identification word, a time channel, and 32 data channels. Each channel consists of 2048 data points. A data file is read by the following code:

```
CHARACTER *10 IDENT
REAL T(2048), D(2048,32)
READ (1,'(A10)') IDENT
READ (1,'(1X,5F15.6)')(T(I),I=1,2048)
DO 10 K=1,32
READ (1,'(1X,5F15.6)')(D(I,K), I=1,2048)
```

Actually, the time channel is not needed because the data are assumed to be equispaced in time. Only the start time and time step should be required.

The input data file is specified for all programs by

```
ASSIGN datafile FOR001
```

The terminal input is assigned by

```
ASSIGN TT FOR005
```

If a new, modified, data file is created, it is written to FOR002. The file may be named as desired by inputting an ASSIGN before its creation or by RENAME after it has been generated.

Plotting is done by the WEASEL package. Once an OBJ file has been created, it is linked to WEASEL by

```
LINK code,'LINK_WSL','LINK_TK4'.
```

The TK4 is for the TEKTRONIX 4014. For other terminals or plotting devices, another code must be used. All plots are data versus time.

M P L O T

This code allows a quick look at the data. The data in each channel are grouped into 256 sets of 8 adjacent (in time) points each. For each set of 8 points, the minimum and maximum are found. The 256 minima are plotted, and the 256 maxima are overlay plotted. The result is a plot which gives a good idea of the data shape and noise in the data.

B P L O T

This program allows a blow-up of selected regions of time. For each channel, the user is queried for the time span (T_1, T_2) to be plotted. If $T_1 > T_2$, a full-scale plot of only the (T_1, T_2) region is done.

F O U T L

This code attempts to remove "outliers" from the data. The user is asked to provide two parameters, $F > 1$ and $N > 0$. For each channel, the set of 256 minima, m_i , and 256 maxima, M_i , are computed as in M P L O T. For $(N + 1) \leq i \leq (256 - N)$, a set is considered to contain a candidate outlier if

$$m_i < (m_{i-1}, m_{i+1}) \quad (1)$$

or
$$M_i > (M_{i-1}, M_{i+1}) \quad (2)$$

If Eq. 1 is satisfied, the i -th set has a candidate minimum outlier. If Eq. 2 is satisfied, it has a candidate maximum outlier. If both Eqs. 1 and 2 are satisfied, the set has a candidate minimum outlier if

$$(m_{i-1} + m_{i+1})/2 - m_i > M_i - (M_{i+1} + M_{i-1})/2. \quad (3)$$

If the sign of Eq. 3 is \leq , the set has a candidate maximum outlier. If the i -th set has an outlier candidate, then it has an outlier if

$$M_i - m_i > F \left[\sum_{j=i-N}^{i+N} (M_j - m_j) - (M_i - m_i) \right] / 2N \quad (4)$$

If Eq. 4 is satisfied and the candidate is a minimum (maximum), the outlier point itself is the minimum (maximum) of the 8 points associated with the i -th set. The outlier value is set equal to the average of its immediately adjacent 2 points (of the "original" data, not the sets of data).

This method is useful for isolated outliers but questionable if a region of adjacent points are outliers. It may be necessary to make multiple F O U T L passes on the data. Reasonable values for the parameters seem to be $F = 3$ and $N = 2$. A "corrected" data file is written to FOR002.

BUTW

This code smooths the data with a low-pass Butterworth filter--see the reference. The Butterworth filter is defined by two parameters.

FR - Relative frequency of the -3 dB power point of the filter, $0 < FR < 0.5$

NS - Number of filter stages, $1 \leq N \leq 5$

For 2048 points, the FFT (Fast Fourier Transform) will produce 1024 frequency values. The parameter FR is the "cutoff" frequency relative to these 1024 frequencies. For example, FR = 0.125 puts the cutoff at the 128th frequency.

To eliminate phase (time) shift, the data are passed through the first stage of the filter in the forward time direction and then through the first stage again in the backward time direction. This process is repeated for each of the NS stages. Thus, the -3 dB point is actually attenuated by -6 dB because of the double passes. If $\{X_i\}$ is the input data stream and $\{Y_i\}$ is the output (smoothed) data stream, then the k-th stage of the filter is implemented by

$$Y_i = A_k (X_i + 2X_{i-1} + X_{i-2}) - B_k Y_{i-1} - C_k Y_{i-2}. \quad (5)$$

The A_k , B_k , and C_k are determined by FR and NS.

If the input FR or NS is out of the bounds given above, the channel is not smoothed, but the "unsmoothed" channel is written to FOR002, nevertheless.

If the data are smoothed, they are also plotted. The user inputs the integer flag IPR and plotting time bounds. If IPR = 1, the smooth data are plotted. If IPR = 2, the unsmoothed data are overlay plotted on the smooth data. Other values of IPR are not allowed. The time bounds are the same as those given in BPLOT.

Distribution

Division of Technical Information and Document Control	6433	W. H. McCulloch
NRC Distribution Contractor	6440	D. A. Dahlgren
U.S. Nuclear Regulatory Commission	6442	W. A. von Rieseemann
15700 Crabbs Branch Way	6444	S. L. Thompson
Rockville, MD 20850	6445	J. H. Linebarger
100 Copies for AN	6445	J. J. Aragon (6)
	6445	V. J. Dandini
	6445	D. T. Furgal
	6445	D. B. King
U.S. Nuclear Regulatory Commission	6445	E. H. Richards (15)
Office of Nuclear Regulatory Research	6446	L. L. Bonzon
Division of Accident Evaluation	6447	D. L. Berry
Washington, DC 20555	6449	K. D. Bergeron
Attn: J. T. Larkins	3141	C. M. Ostrander (5)
	3151	W. L. Garner
	8424	M. A. Pound
U.S. Nuclear Regulatory Commission		
Office of Nuclear Regulatory Research		
Division of Engineering Technology		
Washington, DC 20555		
Attn: W. S. Farmer		
U.S. Nuclear Regulatory Commission		
Office of Nuclear Reactor Regulation		
Division of Engineering		
Washington, DC 20555		
Attn: K. I. Parczewski		
Duke Power Company		
Design Engineering Department		
P.O. Box 33189		
Charlotte, NC 28242		
Attn: F. G. Hudson		
Energy Incorporated		
1 Energy Drive		
Box 736		
Idaho Falls, ID 83402		
Attn: C. Moser		
1512	J. C. Cummings	
1513	S. N. Kempka	
1513	A. C. Ratzel	
2513	S. F. Roller	
2513	J. E. Shepherd	
6400	A. W. Snyder	
6411	S. E. Dingman	
6427	M. Berman	
6427	B. Marshall	

NRC FORM 335 12 841 NRCM 1102 3201, 3202		U.S. NUCLEAR REGULATORY COMMISSION		REPORT NUMBER (Assigned by TIDC add vol. No. if any)	
BIBLIOGRAPHIC DATA SHEET			NUREG/CR-3521 SAND83-1715		
SEE INSTRUCTIONS ON THE REVERSE					
2 TITLE AND SUBTITLE			3 LEAVE BLANK		
Hydrogen Burn Survival Experiments at Fully Instrumented Test Site (FITS)					
5 AUTHOR(S)			4 DATE REPORT COMPLETED		
Elizabeth Richards John J. Aragon			MONTH: December YEAR: 1983		
7 PERFORMING ORGANIZATION NAME AND MAILING ADDRESS (Include Zip Code)			6 DATE REPORT ISSUED		
Division 6445 Sandia National Laboratories P.O. Box 8500 Albuquerque, NM 87185			MONTH: June YEAR: 1984		
10 SPONSORING ORGANIZATION NAME AND MAILING ADDRESS (Include Zip Code)			8 PROJECT TASK WORK UNIT NUMBER		
Div. of Accident Evaluation, Ofc. of Nuclear Regulatory Research, and Div. of Engineering, Ofc. of Nuclear Reactor Regulation, U.S. Nuclear Regulatory Commission, Washington, DC 20555			9 FIN OR GRANT NUMBER		
			A-1270 A-1306		
12 SUPPLEMENTARY NOTES			11a TYPE OF REPORT		
			Data		
13 ABSTRACT (200 words or less)			b PERIOD COVERED (inclusive dates)		
A series of hydrogen-burn experiments conducted for the Hydrogen-Burn Survival Program is described. The experiments, executed at Sandia's Fully Instrumented Test Site (FITS) facility, provided data concerning the hydrogen-burn thermal environment as it relates to equipment survivability in nuclear power plants.			May 1982 to June 1983		
The test plan, instrumentation, and results are presented, along with a brief discussion of test volume (scale) considerations. Conclusions drawn from the results concern repeatability of the tests, the suitability of thermocouples for measuring gas temperatures, and the effects of initial hydrogen concentrations and fans on the responses of calorimeters and components. The effect of initial steam concentration on temperature response cannot be determined because of preignition pressure considerations.					
14 DOCUMENT ANALYSIS -- KEYWORDS DESCRIPTORS			15 AVAILABILITY STATEMENT		
Nuclear Safety; Hydrogen; Combustion; Containment; Equipment Survivability			Unlimited		
b IDENTIFIERS-OPEN ENDED TERMS			16 SECURITY CLASSIFICATION		
			(This page) Unclas.		
			(This report) Unclas.		
			17 NUMBER OF PAGES		
			18 PRICE		

