

TECHNICAL EVALUATION REPORT
CONCERNING THE PROPOSED RENEWAL OF
THE OPERATING LICENSE FOR THE
UNIVERSITY OF UTAH TRIGA REACTOR

DOCKET NO. 50-407

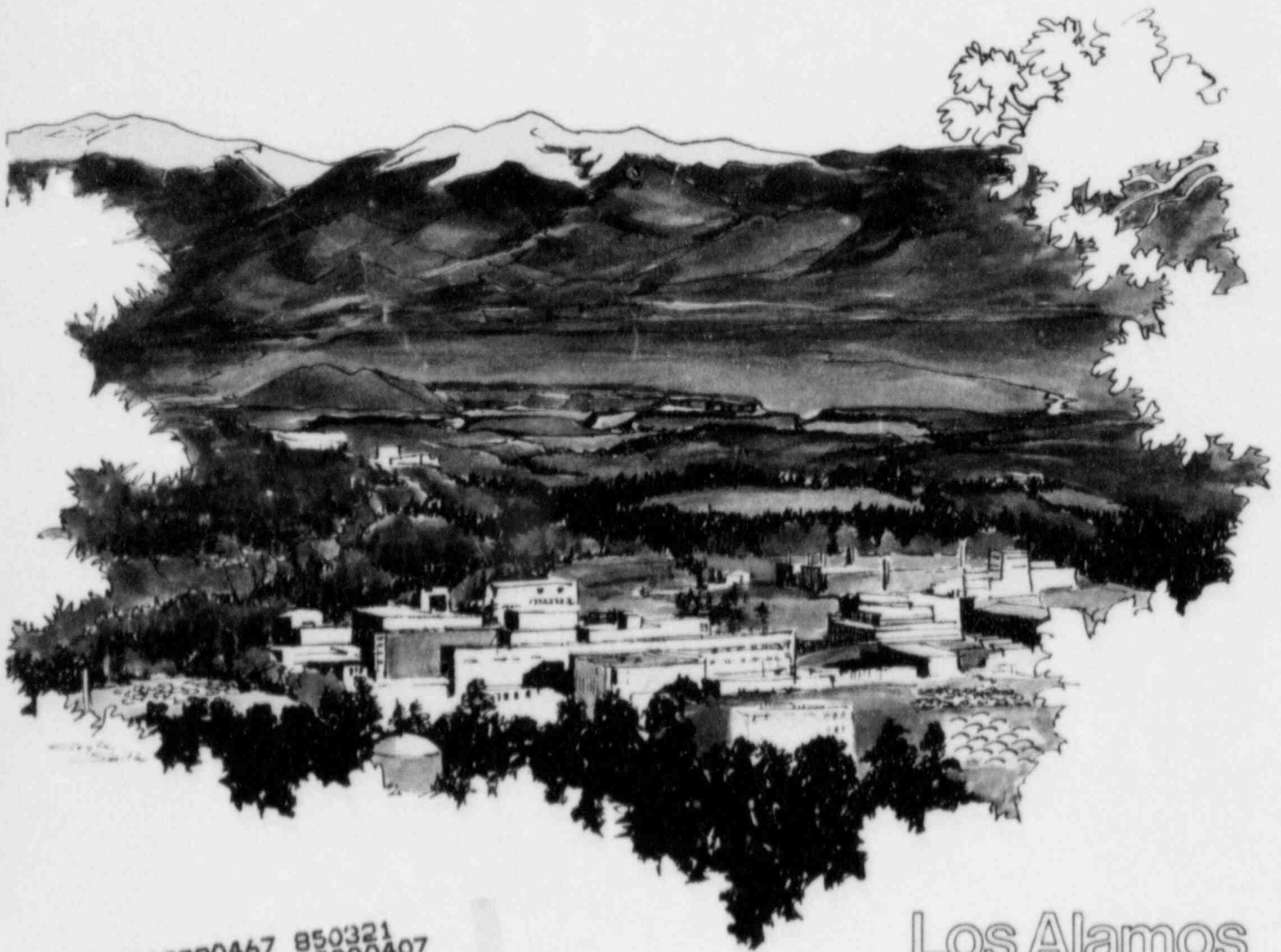

8503280467 850321
PDR ADOCK 05000407
P PDR

Los Alamos

Los Alamos National Laboratory
Los Alamos, New Mexico 87545

This report was prepared as an account of work sponsored by an agency of the United States Government. Neither the United States Government nor any agency thereof, or any of their employees, makes any warranty, expressed or implied, or assumes any legal liability or responsibility for any third party's use, or the results of such use, of any information, apparatus, product, or process disclosed in this report or represents that its use by such third party would not infringe privately owned rights.

Edited by M. C. Timmers, Group Q-6
Prepared by T. M. Glassmire and O. E. Garnica, Group Q-6

ENGINEERING EVALUATION ASSISTANCE FOR NONPOWER REACTORS

TECHNICAL EVALUATION REPORT
concerning the proposed renewal of
the operating license for the
University of Utah TRIGA Reactor

Docket No. 50-407

Completed: March 1985

Written by:

A. E. Sanchez-Pope
J. E. Hyder
K. K. S. Pillay

Reviewed by:

R. A. Haarman, Group Leader
L. H. Sullivan, Program Manager

Energy Division
Los Alamos National Laboratory
Los Alamos, NM 87545

Prepared for:

Division of Licensing
Office of Nuclear Reactor Regulation
U.S. Nuclear Regulatory Commission
Washington, DC 20555
NRC FIN A-7254

TABLE OF CONTENTS

	<u>Page</u>
ABSTRACT	vi
FORWARD	vii
PREFACE	viii
4. REACTOR	1
4.1. Reactor Facility Layout	1
4.2. Reactor Description	1
4.2.1. Reactor Core	4
4.2.2. Grid Plates and Core Support Structures	4
4.2.3. Fuel Elements	7
4.2.4. Neutron Source.	7
4.2.5. Control Rods.	9
4.2.6. Assessment	9
4.3. Reactor Tank and Biological Shield.	9
4.4. Reactor Instrumentation	10
4.5. Dynamic Design Evaluation	10
4.5.1. Excess Reactivity and Shutdown Margin	11
4.5.2. Normal Operating Conditions	11
4.5.3. Assessment	12
4.6. Functional Design of Reactivity Control Systems	13
4.6.1. Control Rod Drive Assemblies.	13
4.6.2. Scram-Logic Circuitry and Interlocks	14
4.6.3. Assessment	14
4.7. Operational Practices	15
4.8. Conclusion	15
5. REACTOR COOLANT AND ASSOCIATED SYSTEMS	16
5.1. Cooling System.	16
5.2. Primary Coolant Purification System	16
5.3. Primary Coolant Makeup System	18
5.4. Conclusion	18
6. ENGINEERED SAFETY FEATURES	19
6.1. Ventilation System	19
6.2. Conclusion	20

TABLE OF CONTENTS (CONT)

	<u>Page</u>
7. CONTROL AND INSTRUMENTATION SYSTEMS.	22
7.1. Reactor Control System.	22
7.1.1. Control Rods	22
7.1.2. Control Rod Drive Assemblies.	23
7.1.3. Rod Control Circuit	23
7.2. Scram System and Interlocks	26
7.3. Instrumentation System.	28
7.3.1. Neutron Monitoring Channels	28
7.3.2. Temperature and Water Monitor Channels.	31
7.4. Conclusion.	31
8. ELECTRICAL POWER	34
8.1. Normal Power.	34
8.2. Emergency Power	34
8.3. Conclusion	34
9. AUXILIARY SYSTEMS	35
9.1. Ventilation System.	35
9.2. Fire Protection System.	35
9.3. Compressed Air System	35
9.4. Heating and Air Conditioning System	36
9.5. Fuel Handling and Storage	36
9.6. Conclusion	36
10. EXPERIMENTAL PROGRAMS	37
10.1. Experimental Facilities	37
10.1.1. Pneumatic Transfer System	37
10.1.2. Central Irradiators	37
10.1.3. Diagonal Beam Tubes	38
10.1.4. D ₂ O-filled Reflector Tank	38
10.2. Experimental Review	40
10.3. Conclusion	40
11. RADIOACTIVE WASTE MANAGEMENT	41
11.1. ALARA Commitment.	41
11.2. Waste Generation and Handling Procedures.	41

TABLE OF CONTENTS (CONT)

	<u>Page</u>
11.2.1. Solid Waste	41
11.2.2. Liquid Waste	42
11.2.3. Airborne Waste	42
11.3. Conclusion	43
12. RADIATION PROTECTION PROGRAM	44
12.1. ALARA Commitment.	44
12.2. Health Physics Program.	44
12.2.1. Health Physics Staffing.	44
12.2.2. Procedures	45
12.2.3. Instrumentation	45
12.2.4. Training	45
12.3. Radiation Sources	46
12.3.1. Reactor.	46
12.3.2. Extraneous Sources	46
12.4. Routine Monitoring	47
12.4.1. Fixed-Position Monitors.	47
12.4.2. Experimental Support	47
12.5. Occupational Radiation Exposures.	47
12.5.1. Personnel Monitoring Program	47
12.5.2. Personnel Exposures	47
12.6. Effluent Monitoring	48
12.6.1. Airborne Effluents	48
12.6.2. Liquid Effluents	48
12.7. Environmental Monitoring.	48
12.8. Potential Dose Assessments	49
12.9. Conclusion	49
14. ACCIDENT ANALYSIS	51
14.1. Fuel Handling Accident.	51
14.1.1. Scenario	54
14.1.2. Assessment	55

TABLE OF CONTENTS (CONT)

	<u>Page</u>
14.2. Rapid Insertion of Reactivity	56
14.2.1. Scenario	56
14.2.2. Assessment	57
14.3. Loss-of-Coolant Accident.	58
14.3.1. Scenario	59
14.3.2. Assessment	60
14.4. Misplaced Experiments	61
14.5. Mechanical Rearrangement of the Fuel.	61
14.6. Effects of Fuel Aging	62
14.7. Conclusion	63
REFERENCES	65

LIST OF FIGURES

	<u>Page</u>
4.1. UUTR facility floor layout	3
4.2. Cross-section of reactor tank.	5
4.3. UUTR core configuration.	6
4.4. Aluminum-clad fuel element	8
5.1. Schematic of primary cooling and purification systems.	17
6.1. Schematic of ventilation system	21
7.1. UUTR control rod assembly	24
7.2. Control-rod drive mechanism.	25
7.3. Block diagram of nuclear instrumentation	29
7.4. Operating range of in-core detectors	32
10.1. D ₂ O-filled central irradiation facility.	39

LIST OF TABLES

4.1 UUTR Principal Design Parameters	2
7.1 Minimum Reactor Safety Channels	27
7.2 UUTR Operational Ranges of Neutron Detectors	30
14.1 Doses Resulting from Postulated Fuel-handling Accident	55

ABSTRACT

This Technical Evaluation Report (TER), which addresses the technical aspects of the application filed by the University of Utah for renewal of Operating License No. R-126 to continue to operate their reactor, has been prepared by the Safety Assessment Group, Energy Division, Los Alamos National Laboratory. The reactor facility is owned and operated by the University of Utah and is located on the University campus in Salt Lake City, Utah. Los Alamos concludes that there are no technical reasons or conditions to prevent the continued operation of the research reactor facility by the University of Utah as this review has failed to identify any significant risk to public health and safety.

FORWARD

This report is supplied as part of the Engineering Evaluation Assistance for Nonpower Reactors Program being conducted for the US Nuclear Regulatory Commission, Office of Nuclear Reactor Regulation, Division of Licensing, by Los Alamos National Laboratory.

The US Nuclear Regulatory Commission funded the work under the authorization of B&R FIN No. A-7254.

PREFACE

This report summarizes the safety review performed by the Safety Assessment Group, Energy Division, Los Alamos National Laboratory of the technical portions of the license renewal application submitted to the Nuclear Regulatory Commission (NRC) from the University of Utah for the continued operation of their research reactor. As this document is to be the basis of select sections in a formal Safety Evaluation Report (SER) to be published by the NRC before final licensing action, the section numbers in this report correspond to their appropriate positions in the final SER.

The NRC is responsible for writing the following sections of the SER.

1. Introduction
2. Site characteristics
3. Design of structure, systems, and components
13. Conduct of operations
15. Technical specifications
16. Financial qualifications
17. Other license considerations
18. Conclusions

Thus, this report consists of Secs. 4 through 12 and 14, plus the references applicable to these sections.

4. REACTOR

The University of Utah TRIGA Reactor (UUTR) is a General Atomic Mark I reactor that operates at a maximum steady-state power level of 100 kW. It uses solid uranium-zirconium-hydride fuel containing 8 and/or 8.5 weight-per cent uranium and is enriched to <20% ^{235}U . The UUTR contains a mixed core of stainless-steel-clad and aluminum-clad elements. Light water serves as the moderator and coolant. The reactor power is regulated by inserting or withdrawing neutron-absorbing control rods.

The UUTR initially attained criticality in October 1975. It is used principally as a neutron source for activation analysis studies, academic research, and the limited production of radioactive isotopes. It also is used as a training facility for the engineering program. Currently it operates an average of 10 MWh/yr. The principal design parameters for the current core configuration are listed in Table 4.1.

4.1. Reactor Facility Layout

The reactor is located on the University of Utah campus in Room 1001 of the Merrill Engineering Building. Only Rooms 1001E and 1001F are restricted areas; they form a confinement enclosure for the reactor. The reactor room is 42 ft by 23 ft by 20 ft high (12.8 m by 7.0 m by 6.1 m high) and has a structural steel frame construction with a concrete floor and ceiling. An AGN-201M 5-W nuclear reactor that is occasionally used for teaching and training purposes also is located in the reactor room. However, no neutronic interaction or hazard coupling between the TRIGA and the AGN-201M is considered credible. The UUTR facility layout is shown in Fig. 4.1.

4.2. Reactor Description

The UUTR is located in a 24-ft-deep, 8-ft-diam (7.5-m-deep, 2.4-ft-diam) reactor pool. The reactor core heat is dissipated by natural convection of the bulk pool water. The UUTR maximum reactivity loading is limited by the Technical Specifications to 1.96% $\Delta k/k$ (2.80%) excess reactivity above the cold critical condition. The UUTR has no pulsing capabilities.

TABLE 4.1

UUTR PRINCIPAL DESIGN PARAMETERS

<u>Parameter</u>	<u>Description</u>
Reactor type	TRIGA Mark I
Maximum steady-state power level	100 kW _{th}
Fuel element design	
Fuel-moderator material	U-ZrH _{1.6} and U-ZrH _{1.0}
Uranium inventory (current core configuration)	3.35 kg ²³⁵ U
Uranium content	8 and 8.5 weight-per cent (aluminum and stainless-steel clad)
Uranium enrichment	<20% ²³⁵ U
Shape	Cylindrical
Length of fuel	14 in. (35.6 cm) Al clad elements 15 in. (38.1 cm) SS clad elements
Diameter of fuel	1.47 in. (3.7 cm)
Cladding material and nominal thickness	304 stainless steel [0.02 in. (0.05 cm) thick] and aluminum [0.03 in. (0.076 cm) thick]
Weight ²³⁵ U/fuel element	~37 g (8 weight-per cent Al clad fuel) and ~39 g (8.5 weight-per cent SS clad fuel)
Number of fuel elements	72 (minimum core) or 88 (current core)
Reactivity worths	
Excess reactivity	0.83% Δk/k (1.18\$) [1.96% Δk/k (2.80\$) Tech. Spec. maximum limit with cold, clean, critical condition]
Safety-transient rod (1)	1.25% Δk/k (1.76\$)
Shim rod (1)	1.08% Δk/k (1.55\$)
Regulating rod (1)	0.32% Δk/k (0.46\$)
Total reactivity of rods	2.64% Δk/k (3.77\$)
Reactor cooling	Natural convection of pool water
Reflector	Water, D ₂ O-filled trapezoidal tanks, and cylindrical D ₂ O-filled elements
β _{effective}	0.7% Δk/k

^aFor stainless-steel-clad elements, the nominal ratio is 1.60 and the maximum value is 1.67. For aluminum-clad elements, the nominal ratio is 0.9 and the maximum value is 1.0.

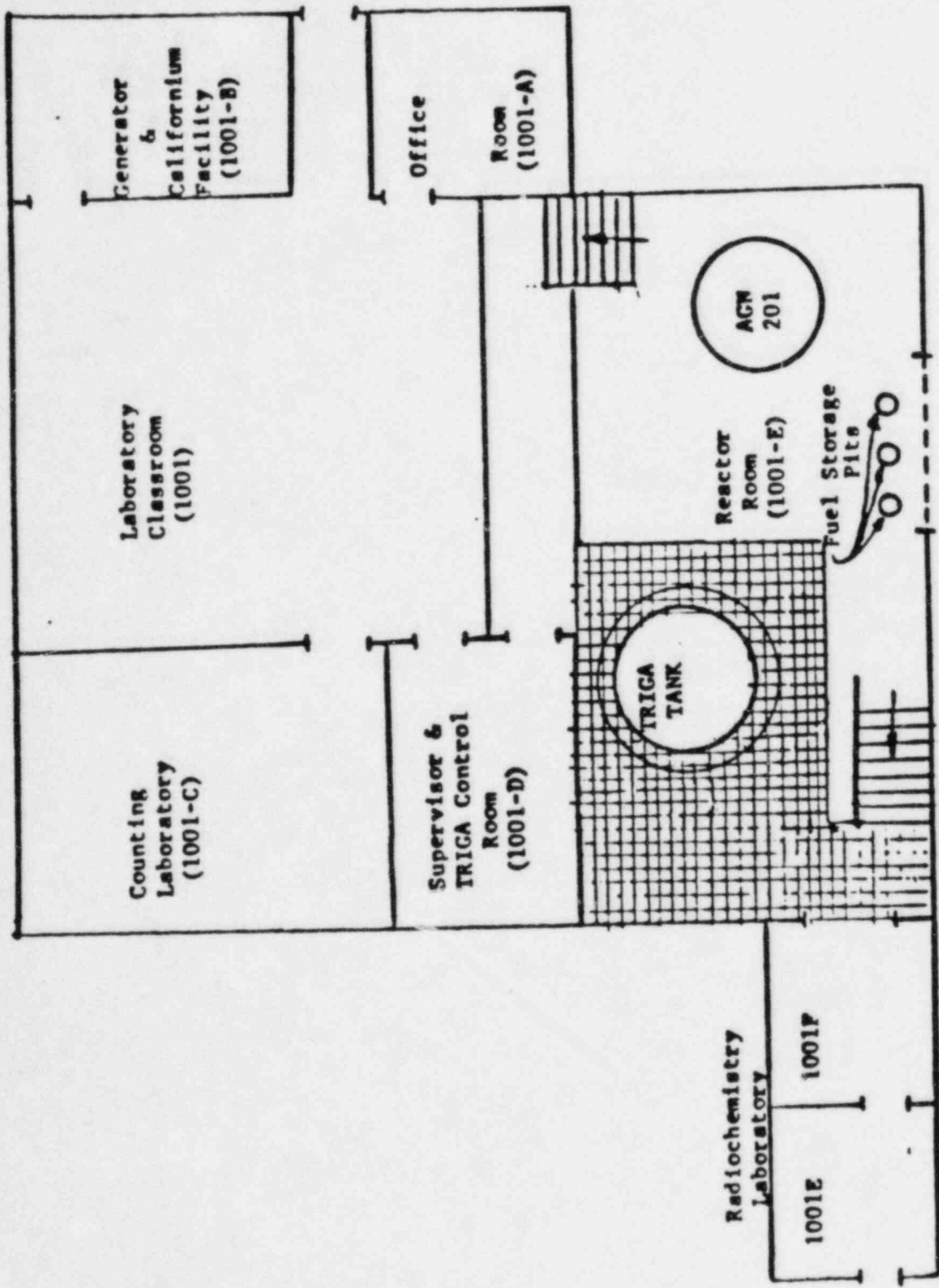

Fig. 4.1.
UUTR facility floor layout.

4.2.1. Reactor Core

The reactor core is a hexagonal configuration of cylindrical, stainless-steel and aluminum-clad <20% enriched fuel-moderator elements and D_2O -filled reflector elements surrounded by trapezoidal heavy-water (D_2O)-filled reflector tanks. Four-inch (10.2 cm) sections of graphite in the top and bottom ends of the fuel elements serve as axial reflectors for the core.

Figure 4.2 shows a cross-sectional view of the reactor tank. The reactor core assembly forms a 43-in.-diam by 23-in.-deep (1.1-m-diam by 58-cm-deep) right hexagon. The core is an arrangement of 88 cylindrical fuel elements and 3 control rods held together by the upper and lower aluminum grid plates and is surrounded by D_2O reflector tanks.

4.2.2. Grid Plates and Core Support Structures

The upper grid plate is 3/4 in. (1.9 cm) thick, is made of aluminum, and has 127 locations [each 1.5 in. (3/8 cm) in diameter] distributed in 6 hexagonal rings around a center hole. These are used to position the various core components (fuel elements, D_2O reflector elements, control rods, irradiation facilities, and other core components). A variety of experimental irradiation facilities can be inserted into the center core position by displacing the fuel elements in the B rings (Sec. 10). There are also several flux-wire insertion holes located in the interstices between the fuel element holes of the top grid plate. The current core-loading diagram is shown in Fig. 4.3.

The core and its associated components are supported by the lower grid plate, which is made of of 3/4-in. (1.9-cm)-thick aluminum. It is located ~6 in. (15.2 cm) from the base of the aluminum reactor tank and rests on six legs. The 3/16-in. (0.48-cm)-thick hexagonal aluminum core shroud plates are attached to the lower grid plate. The lower grid plate also contains 127 positioning holes for fuel elements and other core components, but each hole is 0.25 in. (0.64 cm) in diameter to accomodate the tapered element ends.

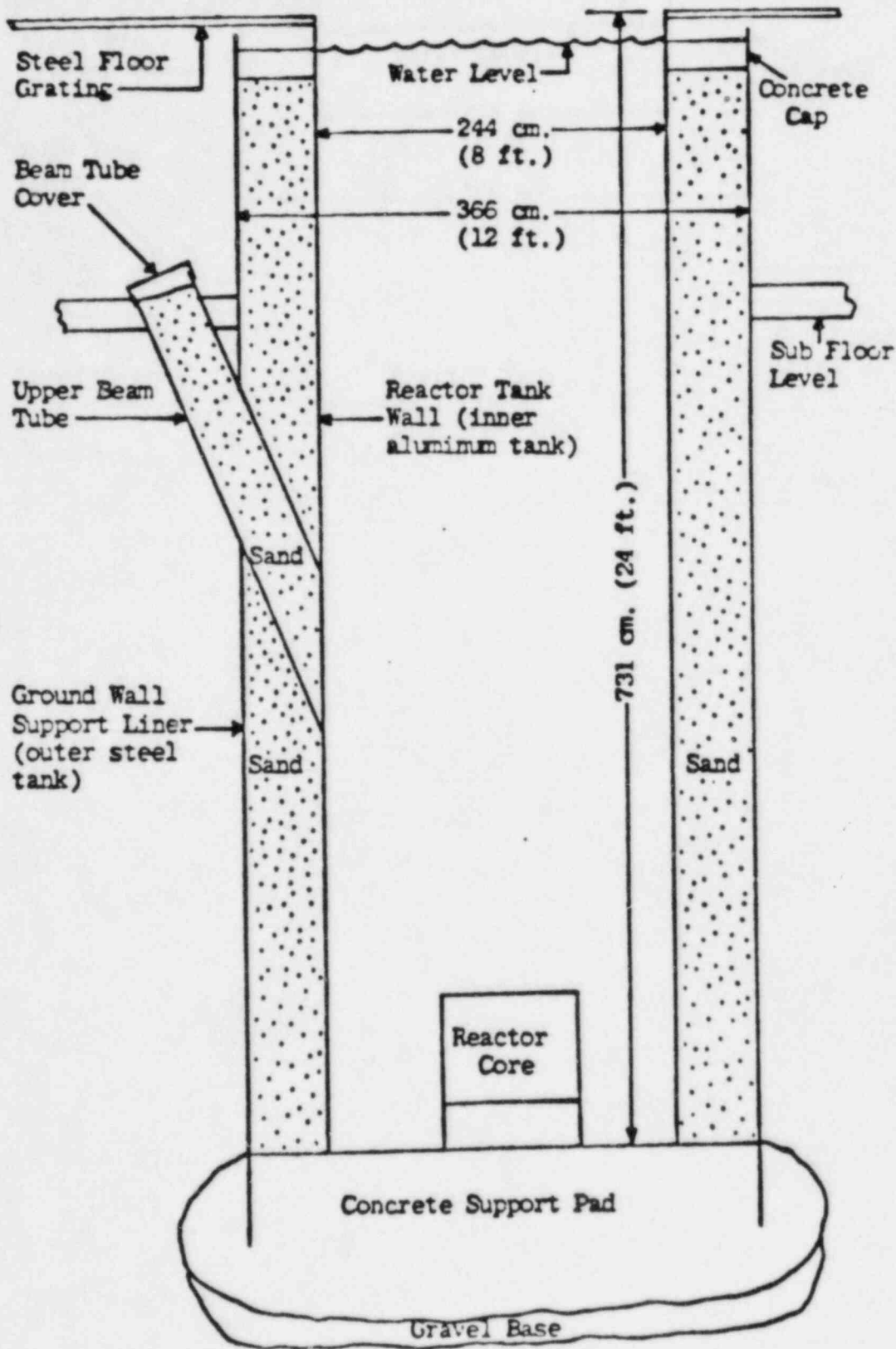

Fig. 4.2.
Cross-section of reactor tank.

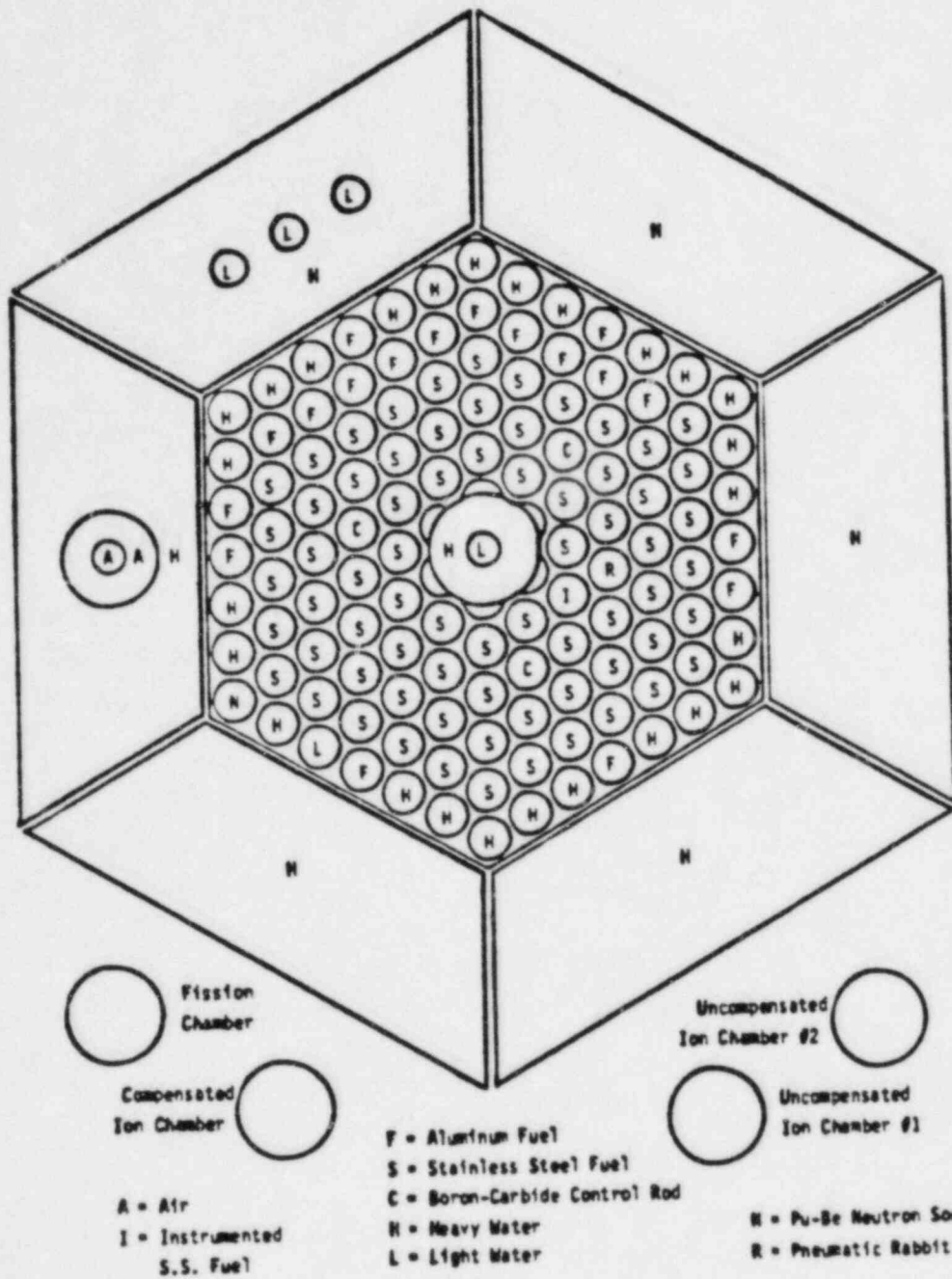

Fig. 4.3.
UUTR core configuration.

4.2.3. Fuel Elements

The UUTR uses cylindrical aluminum-clad and stainless-steel-clad fuel elements in which the fuel is a solid homogeneous mixture of uranium-zirconium-hydride alloy enriched to slightly less than 20% ^{235}U . The nominal weight of the ^{235}U in each of the aluminum-clad fuel elements is ~37 g, and the weight in each of the stainless-steel-clad fuel elements is ~39 g. Currently, there are 18 aluminum-clad fuel elements and 70 stainless-steel-clad fuel elements loaded in the UUTR core. The actual core positions of the aluminum and stainless-clad-elements are shown in Fig. 4.3. The hydrogen-to-zirconium ratio of the moderator material incorporated into the fuel is ~0.9:1 for the aluminum-clad elements and ~1.6:1 for the stainless-steel-clad elements. The actual fuel section of each cylindrical element is 14 in. (35.6 cm) long and 1.47 in. (3.7 cm) in diameter. Graphite end plugs ~4 in. (10.2 cm) long inserted in both ends of the fuel element serve as axial reflectors. The fueled section of the stainless-steel fuel elements and graphite end plugs are contained in a 0.02-in.-thick (0.05-cm-thick) stainless-steel-walled can that is welded to stainless-steel end fittings at the top and bottom. The aluminum elements and the graphite end plugs are contained in a 0.03-in.- (0.076-cm)-thick clad aluminum-walled can welded to aluminum end fittings at the top and bottom. Each element is ~28.5 in. (0.72 m) long; the aluminum-clad elements weigh ~6.5 lbs (2.9 kg), and the stainless-steel-clad elements weigh ~7.5 lbs (3.4 kg). A schematic view of a typical Mark I TRIGA aluminum-clad fuel element is shown in Fig. 4.4.

4.2.4. Neutron Source

The UUTR uses an ~5-Ci (~185 GBq) Pu-Be neutron source as a startup source. The source is located in a special reflector element source holder in the outer ring of the core. The source can be withdrawn from its in-core position manually by means of an attached steel cable that is connected to the top of the source holder cap. An indicator light coupled to the startup meter will show whether the source is in or out of the core.

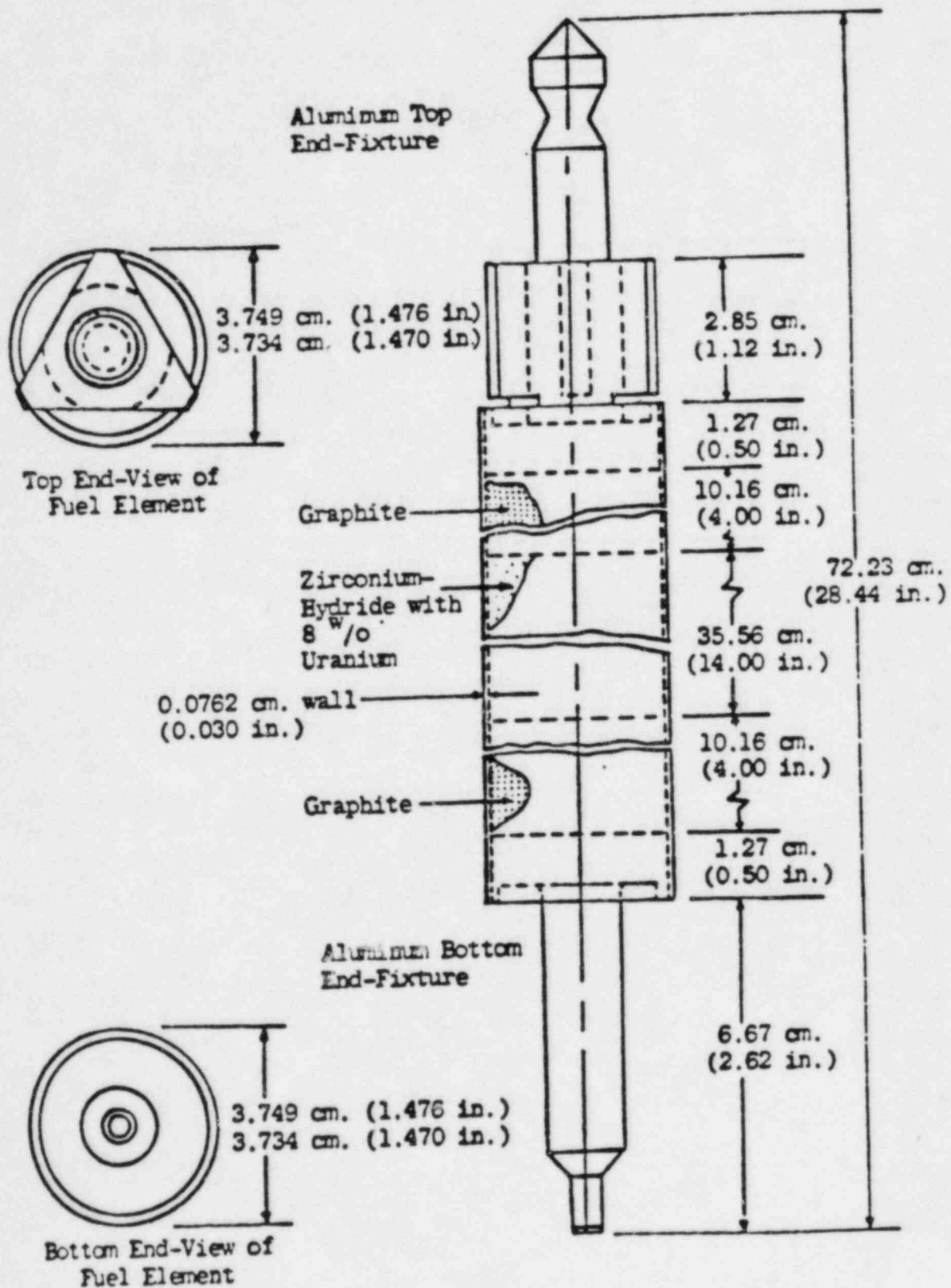

Fig. 4.4.
Aluminum-clad fuel element.

4.2.5. Control Rods

Three control rods are used to control and regulate the power levels in the UUTR: a shim rod, a regulating rod, and a safety rod. Each of the three rods operates within a perforated aluminum guide tube. The neutron poison contained in the control rods is solid boron carbide in a sealed aluminum tube. Each control rod is ~19 in. (48.3 cm) long and has a vertical travel of 15 in. (38.1 cm). The regulating rod has a 0.25-in. (0.64-cm) outside diameter, and the shim and safety rod have an 0.875-in. (2.22-cm) outside diameter. The maximum rate of withdrawal speed for the shim and safety rods is ~0.91 $\$/\text{min}$.

4.2.6. Assessment

Los Alamos has reviewed the details of the reactor core, experimental facility arrangements, and reactivity control systems and has concluded that the design features of the reactor are adequate to provide reasonable assurance that the operation of the UUTR in accord with its Technical Specifications does not pose an undue risk to the health and safety of the operating staff and the general public.

4.3. Reactor Tank and Biological Shield

The reactor core is located within two nested tanks. The outer tank is set in concrete below floor level. It is 12 ft (3.7 m) in diameter and has 1/8-in. (0.32-cm)-thick stainless-steel walls coated with a waterproof epoxy resin. The inner tank is 8 ft (2.4 m) in diameter and 24 ft (7.3 m) deep. This tank is constructed of 1/4-in. (0.64-cm)-thick welded aluminum. The 2-ft (0.6 m) intervening space between the tanks is filled with sand and concrete. A detailed cutaway view of the tank is shown in Fig. 4.2. There is at least 2 ft (0.6-m) of horizontal water shielding between the reactor core and the aluminum tank. The water level in the tank is maintained (per the Technical Specifications) at a minimum of 18 ft (5.5 m) above the top of the core to provide adequate core cooling and radiation shielding.

4.4. Reactor Instrumentation

The operation of the UUTR is monitored and controlled by safety instrumentation channels that measure

- fuel element temperature and
- reactor neutron flux.

Thermocouples in an instrumented fuel assembly provide information on fuel temperature during all operations. The readings are displayed in the control room and would initiate a reactor scram if safety settings are reached. The bulk reactor coolant temperature is measured manually with an alcohol-filled thermometer placed in the pool water. The instrumentation and control systems are discussed in Sec. 7.

4.5. Dynamic Design Evaluation

The UUTR's operation is accomplished by manipulating control rods in response to changes in parameters such as temperature, power, and neutron flux measured by the instrument channels. There are interlocks to prevent inadvertent reactivity additions and a scram system to initiate a rapid shutdown when a preset limit has been reached. In addition, the unique characteristics of the uranium-zirconium-hydride fuel-moderator material provide a large, prompt, negative temperature coefficient to reduce the reactivity in the event of a sudden insertion of reactivity. This provides additional stability and safety during any transient. The negative temperature coefficient is a result of the spectral neutron hardening properties of ZrH_x at elevated temperatures, which increases the neutron leakage from the fuel-bearing material into the water moderator material, where the neutrons are absorbed preferentially.

Because of the homogeneous mixing of the fuel and ZrH_x , the ZrH_x temperature rises simultaneously with power, and the negative temperature coefficient promptly decreases the reactivity. Additionally, the Doppler broadening of the ^{238}U resonances at higher temperatures further contributes to the prompt negative temperature effect as it increases parasitic neutron capture, thus reducing the neutrons available to induce fissions (Simnad et al., 1976;

GA-4314, 1980; GA-0471, 1958). This inherent shutdown property of U-ZrH_x fuel has been the basis for designing the TRIGA reactors with a pulsing capability as a normal mode of operation. The automatic compensation provided by the prompt negative temperature coefficient for step excess reactivity insertions is capable of terminating any resulting power excursion in the pulsing mode without using any mechanical or electrical safety systems or operator action. Because the UUTR only operates in the steady-state mode, this serves as a backup safety feature for the mitigation of accidental reactivity insertion effects (Simnad et al., 1976; GA-4314, 1980; GA-0471, 1958). (See also Sec. 14.2.)

4.5.1. Excess Reactivity and Shutdown Margin

The Technical Specifications require that the control rods provide a shutdown margin greater than 0.35% $\Delta k/k$ (0.50\$) with the highest worth control rod fully withdrawn and with the highest worth nonsecured experiment in its most reactive state under any conditions of operations.

The Technical Specifications for the UUTR limit the maximum core excess reactivity to 1.96% $\Delta k/k$ (2.80\$) above the cold, clean, critical, xenon-free condition. The Technical Specifications limit experiment reactivity worths to 1.96% $\Delta k/k$ (2.80\$) for any single experiment and 0.7% $\Delta k/k$ (1.00\$) for any single nonsecured experiment.

The current core configuration has an excess reactivity of 0.83% $\Delta k/k$ (1.18\$). The individual control rod worths are shown in Table 4.1; the total rod worth is 2.64% $\Delta k/k$ (3.77\$). The shutdown margin for the current core configuration with the highest worth rod fully withdrawn is 0.58% $\Delta k/k$ ($= 2.64 - 1.23 - 0.83$) or 0.83\$ ($= 3.77 - 1.76 - 1.18$). Therefore, the current core configuration meets the shutdown requirements. With all rods fully inserted, the current core is subcritical by 1.81% $\Delta k/k$ (2.59\$).

4.5.2. Normal Operating Conditions

The temperature in a standard TRIGA fuel element in the UUTR core is limited by the Technical Specifications to a maximum of 1832°F (1000°C) for stainless-

steel-clad high-hydride fuel elements and to 986°F (530°C) for aluminum-clad low-hydride fuel elements under any reactor operating conditions. This limit is imposed to prevent excessive stress on the cladding because of the hydrogen pressure caused by the disassociation of the zirconium-hydride fuel moderator. Based on the theoretical and experimental evidence (Simnad et al., 1976; GA-4314, 1980), the limits represent conservative values to provide confidence that the integrity of the fuel elements will be maintained and that no cladding damage will occur. The licensee's Technical Specifications provide limiting safety system settings to ensure that there is a considerable margin of safety such that the safety limits specified above are not reached. The limiting safety system temperature settings depend on the location of both the instrumental fuel element and the low-hydride-aluminum-clad fuel elements. For this reason, the licensee's Technical Specifications contain several limiting safety system temperature settings that vary with the instrumental fuel element location and core heading configuration. The maximum limiting safety temperature setting (instrumental fuel element in the B ring) for a mixed core with the low-hydride-aluminum clad elements in the F and G rings only is 1472°F (800°C). For mixed cores with low-hydride aluminum-clad elements in one of the inner rings (B through E) the maximum (B ring) limiting safety system temperature setting is 860°F (460°C). The licensee's limiting safety system temperature settings assure an adequate safety margin such that the anticipated hottest fuel element in the core (B ring element) does not approach its safety limit, regardless of the fuel element type. Currently, the UUTR is operating with a 860°F (460°C) fuel temperature scram setting. To date, the maximum measured temperature the UUTR has achieved during normal steady-state operations is ~234°F (~112°C).

4.5.3. Assessment

Los Alamos concludes that the inherent, large, prompt, negative temperature coefficient of reactivity for the U-ZrH_x fuel moderator provides a basis for the safe operation of the UUTR in the steady-state mode.

The safety limits for the UUTR are based on theoretical and experimental investigations and are consistent with those used at other TRIGA-type reactors. Also, the operating data at the maximum allowable steady-state power

indicate that the maximum fuel element temperatures will be maintained below the prescribed safety limit. TRIGA reactors using stainless-steel-clad fuel elements (>1.6 zirconium-to-hydrogen ratio) have demonstrated safe and reliable operation at steady-state power levels up to ~1.5 MW (Simnad et al., 1976; GA-4314, 1980). TRIGA reactors using aluminum-clad fuel elements with a zirconium-to-hydrogen ratio of 1.0 have demonstrated safe and reliable routine operations at steady-state power levels up to 250 kW (GA 7275, Rev. 1976).

Based on the above considerations, Los Alamos concludes that there is reasonable assurance that the UUTR can be operated safely at or below 100 kW, as limited by the current Technical Specifications.

4.6. Functional Design of Reactivity Control Systems

The power level of the UUTR is controlled by three control rods (one shim, one regulating, and one safety rod), all of which contain solid boron carbide as the neutron poison. The positions of the three rods are shown in Fig. 4.2. The rods are moved using identical winch-type electro-mechanical drives for each control rod.

Each rod drive system is energized from the control console through its own independent circuit; a manual scram at the control console is possible for each individual control rod, or they can be scrambled as a group.

4.6.1. Control Rod Drive Assemblies

The drive assemblies for the control rods are mounted below floor level on a concrete shelf alongside the reactor pit and consist of an electric motor coupled to a brake, a cable drum, a speed-reducing gear drive system, and limit switches.

If power to the electromagnet is interrupted for any reason, the connecting magnet that engages the armature on the control rod is released, and the control rod falls by gravity into the core, rapidly shutting the reactor down (scramming). Additional information on the control rod drive assemblies is in Sec. 7.1.2.

4.6.2. Scram-Logic Circuitry and Interlocks

The scram-logic circuitry and interlocks ensure that several reactor core and operational conditions are satisfied for reactor operation to occur or continue. The scram-logic circuitry uses an "open on loss of power to circuit" logic; that is, any scram signal deenergizes the electromagnets on the control rods, causing the rods to drop and shut down the reactor. In addition, a scram is initiated if power to the ion chambers is lost or the console power circuit fails. Interlocks are integrated into the control rod circuitry to provide additional safety, for example, interlocks that prevent the simultaneous withdrawal of two control rods. Also, there must be an adequate source signal available in the startup channel or rod withdrawal is prohibited. This ensures that the instrumentation is monitoring the neutron flux.

4.6.3. Assessment

The UUTR is equipped with safety and control systems, control rods, rod drives, scram-logic circuitry, and interlocks that have performed reliably and satisfactorily in the UUTR for many years.

The control systems allow for an orderly approach to criticality and for safe shutdown of the reactor during normal and abnormal conditions. There is sufficient redundancy of control rods to ensure safe reactor shutdown, even if the most reactive rod fails to insert upon receiving a scram signal. Interlocks prevent inadvertent rod withdrawal, and thus positive reactivity additions. A manual scram button allows the operator to initiate a scram independently for any condition requiring a prompt shutdown. In addition to the active electromechanical control and safety systems, the large, prompt negative temperature coefficient of reactivity inherent in the U-ZrH_x fuel-moderator provides a backup safety feature.

Additionally, the UUTR is a <20% enriched ²³⁵U reactor. Thus, 80% of the fuel is composed of ²³⁸U. Because ²³⁸U has a wide Doppler absorption

band, its resonance peaks widen as the temperature increases, thereby increasing the neutron capture and reducing the available neutrons that will continue to fission. This inherent feature enhances the prompt negative temperature coefficient.

Based on the above discussion, Los Alamos concludes that the reactivity control systems of the UUTR are designed adequately and will function to ensure adequate safety for the reactor and fuel elements.

4.7. Operational Practices

The UUTR operates under Technical Specifications that direct the review, audit, and surveillance of the reactor and provide procedural reviews for all safety-related activities. Written procedures have been established for safety-related and operational activities that include reactor startup, operation, and shutdown; maintenance; and calibration of equipment or instrumentation. In addition, the reactor is operated by trained NRC-licensed personnel in accordance with the above-mentioned procedures.

4.8. Conclusion

The Los Alamos review of the UUTR facility has included studying its specific design, controls, and safety instrumentation and selected preoperational and operational procedures. On the basis of our review of the UUTR and experiences with similar facilities, we conclude that there is reasonable assurance that the UUTR in conjunction with its Technical Specifications is capable of operating in a manner that will not pose an undue risk to the health and safety of the operating staff or to the general public.

5. REACTOR COOLANT AND ASSOCIATED SYSTEMS

The coolant in the UUTR is deionized light water. The heat generated within the fuel during reactor operation is transferred to the pool water by natural convection and by evaporative cooling into the reactor room air. The coolant is circulated using a centrifugal pump, and a portion of the circulating coolant is diverted through an ion exchange purification system.

5.1. Cooling System

The primary cooling system consists of the reactor pool, the primary coolant pump, and a fan used to blow air across the pool surface. The heat exchanger system described in the SAR has not been placed into operation. The water from the pool is withdrawn at a rate of ~50 gal/min (13.15 L/s) using a centrifugal pump and circulated through a closed loop to improve convective cooling. Figure 5.1 is a schematic of the primary cooling and purification systems.

The inlet line of the circulation loop has a 1/4-in. (0.64-cm) hole ~2 ft (~0.61 m) below the top of the reactor pool that acts as a siphon break and prevents draining of the reactor pool in case of pipe rupture. The pool water temperature normally is maintained at about 60°F (15.6°C). Administratively, pool water temperature is not allowed to rise above 95°F (35°C). The pool has a water level monitor that alarms when the pool water level falls ~2 ft (~0.61 m) below the top of the tank.

5.2. Primary Coolant Purification System

The coolant purification loop is a side-stream of the circulation loop. It consists of two particulate filters, and a mixed-bed demineralizer unit. This loop is provided with instruments to monitor the temperature and conductivity of the water inlet to the demineralizer and the conductivity of the effluent from the demineralizer. The demineralizer is a steel tank containing ~3 ft³ (~0.08 m³) of mixed bed resin. Ionized species of water soluble materials are removed by the demineralizer during the passage of water through this unit. Water from the pool is circulated through the ion exchanger at a low flow rate

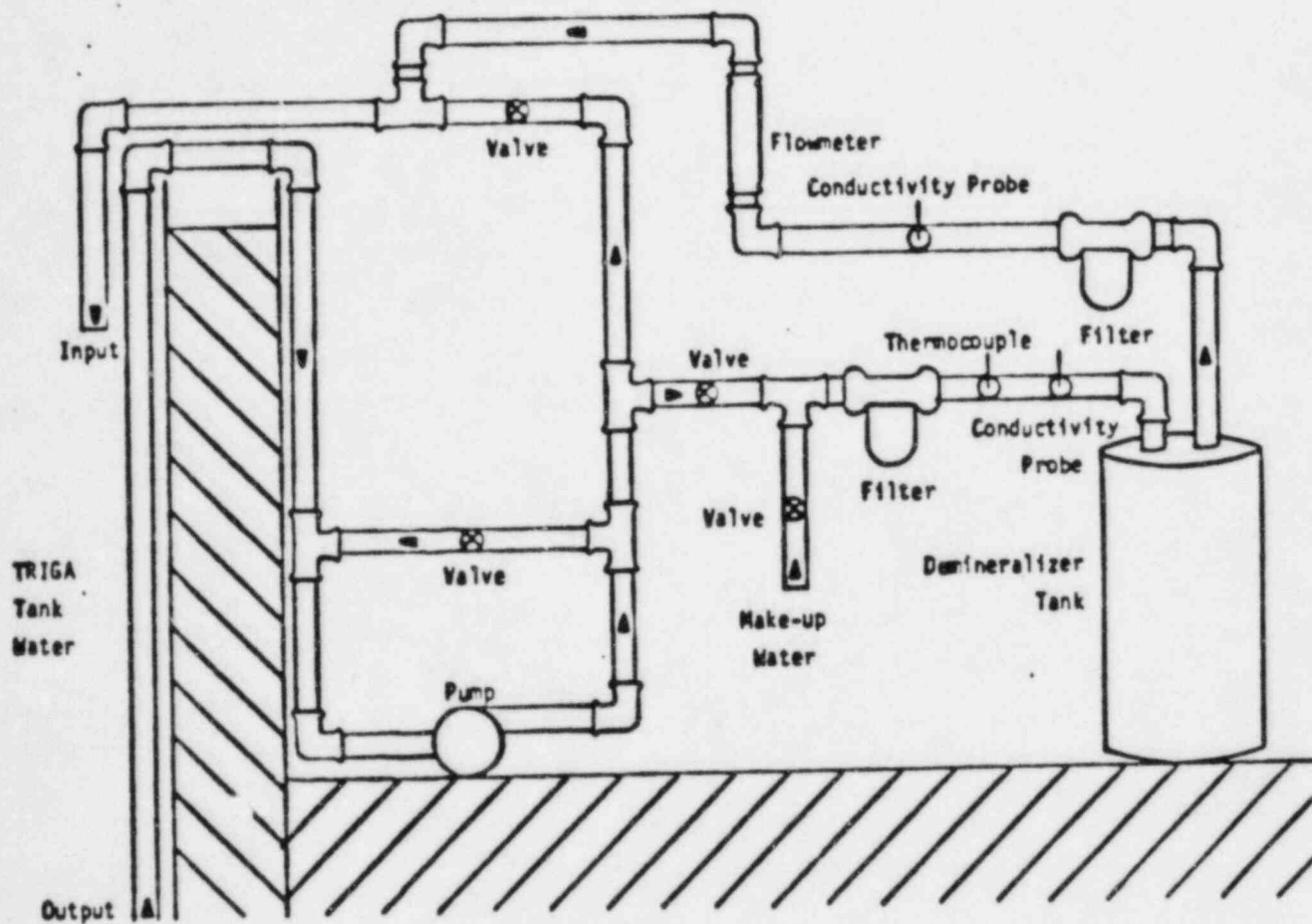

Fig. 5.1.
Schematic of primary cooling and purification systems.

[~3 to 4 gal/min (~0.2 to 0.25 L/s)] through a manually adjustable by-pass valve in the circulation loop. Conductivity probes located at the inlet and outlet of the demineralizer unit determine the effectiveness of the water purification system. A thermocouple in the inlet line of the demineralizer monitors the water temperature.

The conductivity of the primary cooling water is maintained at less than 5 μ mhos/cm. The pH of the pool water is maintained in the range of 5.0 to 8.0 in conformance with the Technical Specifications.

5.3. Primary Coolant Makeup System

The loss of coolant from the pool because of evaporation averages ~25 gal/day during reactor operation. The pool water makeup system consists of a flexible hose from the city water line that allows water to pass through the demineralizer before it enters the reactor pool; this demineralizer system is the same as the primary coolant purification system. During the addition of make-up water, the coolant purification line is closed using a set of manually operated valves.

5.4. Conclusion

Los Alamos concludes that the cooling system of UUTR, combined with the administrative controls is adequate to ensure cooling of the reactor under operating conditions specified in the UUTR operating license. There is no new or unproven technology involved in the system. On the basis of the above observations, we conclude that the reactor cooling and purification systems at UUTR are acceptable for continued safe operations.

6. ENGINEERED SAFETY FEATURES

Engineered safety features are those features or systems that mitigate the potential consequences of accidents. The only engineered safety feature associated with the UUTR facility is the ventilation system. This system is designed to minimize the release of radioactive materials during accident conditions.

6.1. Ventilation System

The ventilation system at the reactor facility is designed to mitigate the consequences of the possible release of radioactive material resulting from reactor operation. The reactor area has a ventilation system that is separate from that of the rest of the Merrill Engineering Building. The ventilation system for the reactor area is designed such that the air in this area changes at least four times per hour.

Fresh air is drawn into the building at the roof level. After appropriate processing (filtering, heating, or cooling), it is distributed throughout the building. A local thermostat in the reactor area controls the dampers to this area. Temperatures and static pressures in the main supply are maintained by automatic controls under the control of the Physical Plant Center for the University. In the reactor area, the ventilation system has additional damper and static pressure controls as well as isolation dampers. The additional damper in the ventilation system is designed to regulate the air supply to the reactor room so that a negative pressure can be maintained. The isolation damper operates in emergency status to close off the air supply to the reactor room.

Air discharge from the reactor room is accomplished through the laboratory exhaust vents in Rooms 1001F and 1001G. (See Fig. 4.1.) The duct also receives exhaust from the hoods in the radiochemistry laboratories, and the pneumatic transfer system. These exhausts operate at all times and maintain a flow rate of about 1800 ft³/min (8.5×10^5 cm³/s). The exhaust is powered by a fan located on the roof of the building, and the discharge is ~10 ft (~3 m) above the penthouse roof. The exhaust is equipped with a by-pass

HEPA filter system, which will be dampered into operation when there is a suspected release of radioactivity into the reactor area. The flow rate of air through the HEPA filter system is estimated at 148 ft³/min (7 x 10⁴ cm³/s). The emergency purge exhaust is actuated by a continuous air monitoring system in the exhaust duct or by the area monitor in the reactor room. The details of the ventilation system are shown schematically in Fig. 6.1.

6.2. Conclusion

The ventilation system at the UUTR facility is designed adequately. Isolation of the reactor area from adjacent areas of the facility and from other areas of the building can be achieved effectively. The reactor area ventilation system and equipment are adequate to control the release of airborne radioactive effluents in compliance with regulations and to minimize releases of airborne radioactivity in the event of abnormal conditions. Therefore, Los Alamos concludes that this engineered safety feature is acceptable for continued operation of the UUTR.

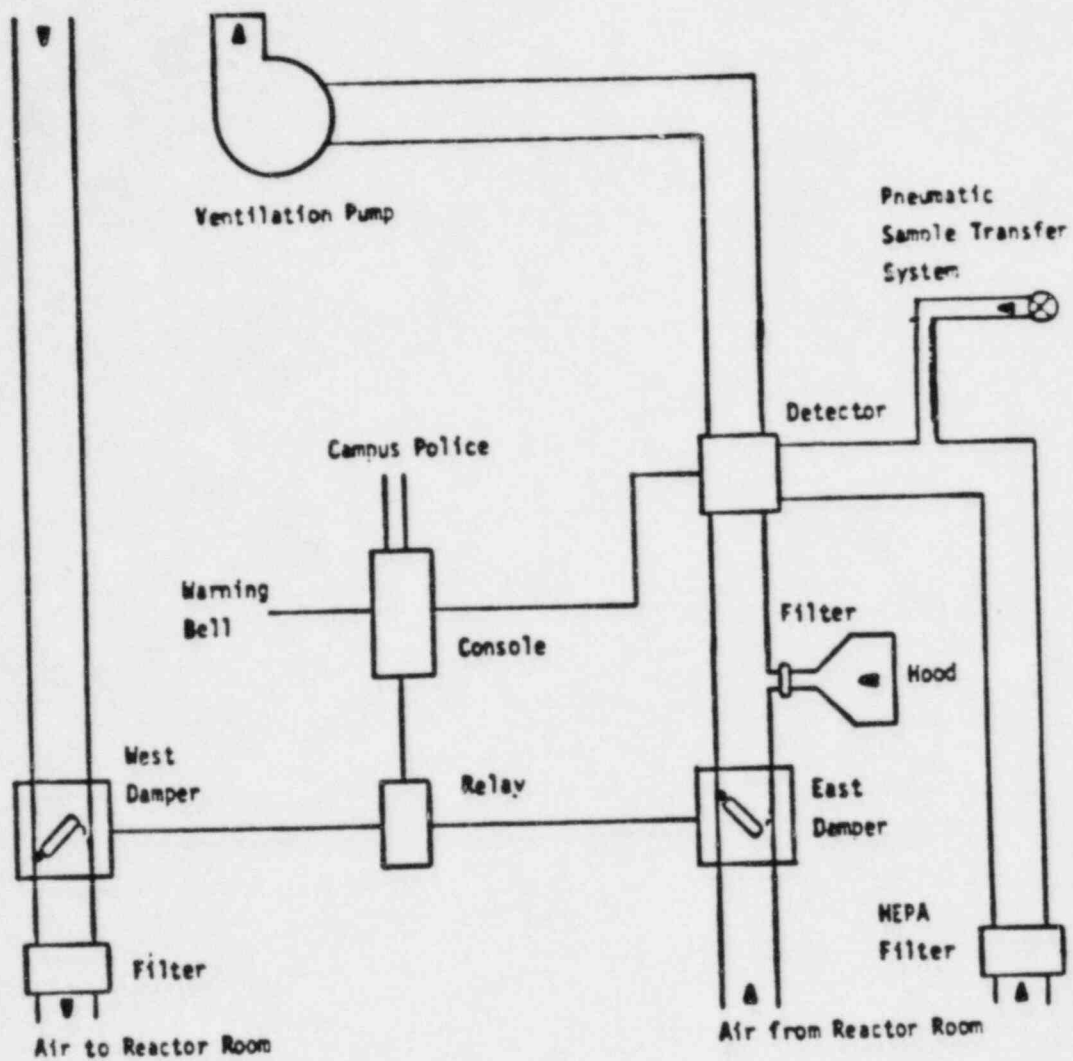

Fig. 6.1.
Schematic of ventilation system.

7. CONTROL AND INSTRUMENTATION SYSTEMS

The major components of the UUTR control and instrumentation system, including rod controls, annunciators, pen recorders, and meters, are located in the control console. Control of the nuclear fission process is achieved by using three scrammable control rods. Currently, the UUTR does not have the capability for either the automatic or pulse modes of operation and thus operates only in manual mode.

The major functions and design of the control console are to satisfy the following requirements.

1. The console instruments and the reactor area are observable by the reactor operator during reactor operation.
2. The important and necessary information for reactor operation and safety is readily available to the operator and is displayed and annunciated in such a manner that it minimizes the chances of confusing the information with other less essential information.

7.1. Reactor Control System

The control system at the UUTR facility, which consists of both nuclear and process instrumentation, provides reactor control during steady-state operations. Interlocks are provided between the instrumentation system and the scram system to provide positive control of the reactor and to minimize the chances of accident conditions.

7.1.1. Control Rods

The reactor uses three control rods: (1) a safety rod, (2) a regulating rod, and (3) a shim rod. These control rods are connected to identical electro-mechanical drive units. The vertical travel of each rod is ~15 in. (~38 cm). The descriptions, core positions, and reactivity worths of the rods are given in Sec. 4.

7.1.2. Control Rod Drive Assemblies

The electro-mechanical control rod drive assemblies for the control rods consist of a motor and reduction gear driving a winch cable. A helipot connected to the drive unit generates the rod position indication. The control rod drive assembly is connected by a stainless-steel cable to the holding magnet at the upper end of the control rod. In the event of a power failure or scram signal, the control rod magnets are deenergized, and the rods fall by gravity into the core. The rod drive motor is nonsynchronous, single-phase, and electrically reversible and will insert or withdraw the control rods at an average rate of $-0.005\% \Delta k/k/s$ ($-0.007\$/s$) for the safety and shim rods, and $0.0015\% \Delta k/k/s$ ($0.002\$/s$) for the regulating rod. The maximum reactivity insertion rate by a control rod is limited by the Technical Specifications to $<0.21\% \Delta k/k/s$ ($0.30\$/s$). Electrical, dynamic, and static breaking of the control rod drive motors provide fast stops and limit the coasting or over-travel of the rods. Figures 7.1 and 7.2 show the UUTR control rods and drive assemblies. A key-locked switch on the control console power supply prevents the unauthorized operation of the control rod drives. Limit switches mounted on the drive assembly actuate circuits that stop the rod drive motor at the top and bottom of travel and provide switching for console lights that indicate the following.

- The magnet "Up" and "Down" positions
- The magnet contact with the control rod armature

7.1.3. Rod Control Circuit

The rods are controlled manually by a series of push buttons and a selector switch located on the control panel. The following interlocks prevent the upward movement of the rods.

1. Source channel instrumentation below preset level (<2 counts/s)
2. Two "Up" switches depressed at same time
3. Magnet not in contact with armature

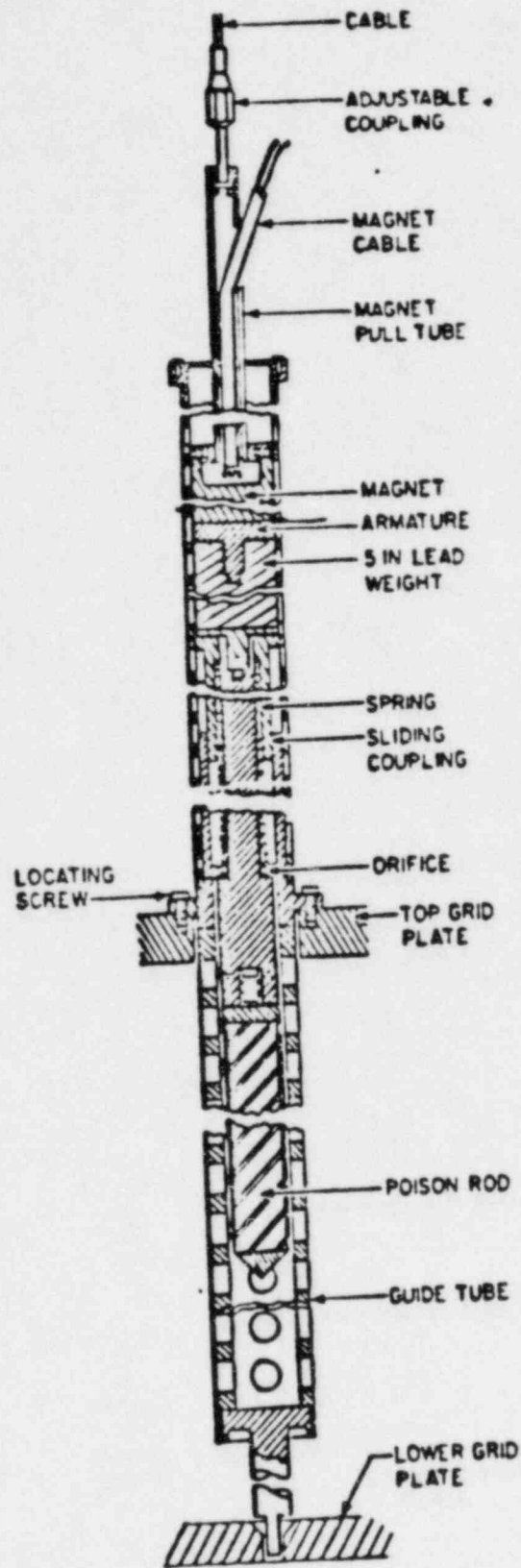

Fig. 7.1.
 UTR control rod assembly.

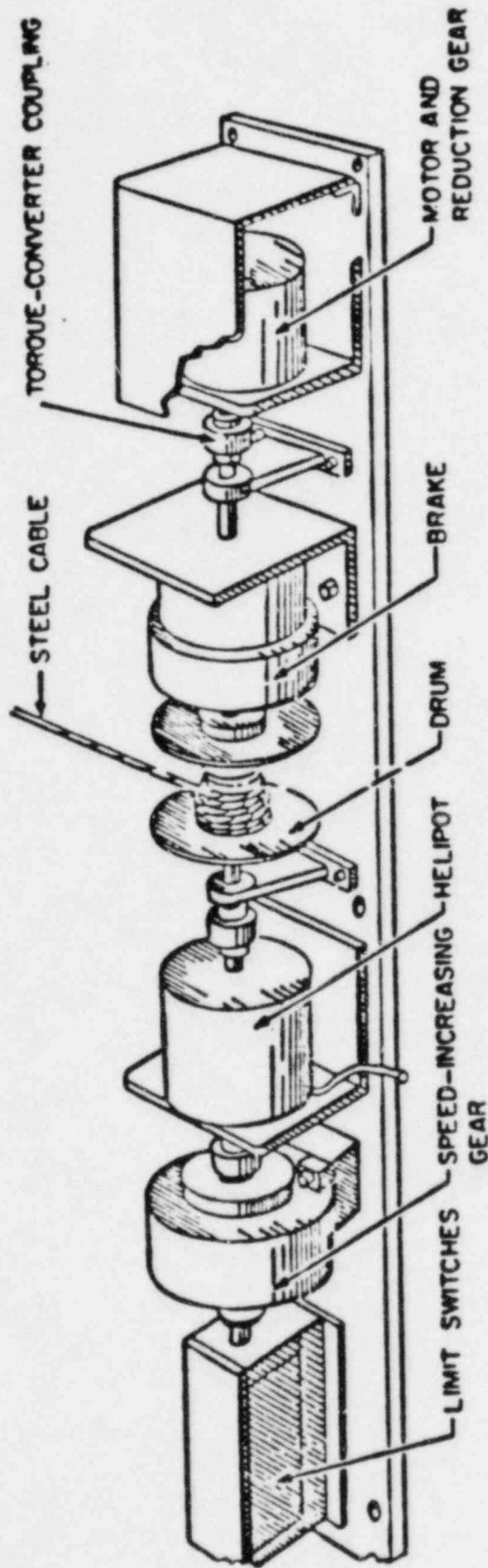

Fig. 7.2.
Control-rod drive mechanism.

Helipots connected to the rod drive units provide indication on the console of the control rod positions. Rod position indication is accurate to within $\pm 1\%$. Depressing the scram bar causes all the rods to be inserted into the reactor simultaneously.

7.2. Scram System and Interlocks

The scram system circuitry is independent of the other control system circuits. All scram conditions are indicated by the annunciators in the reactor console. The Technical Specifications for the UUTR require the operability of several safety system channel scrams during reactor operation.

The manual scram may be initiated for either individual control rods or for all control rods together. A set of bistable trip-operated relay circuits is located on the startup, fuel temperature, power level, and per cent power panels, and another set of two relay-operated annunciators is located on the control console panel. The reactor scram system is designed to interrupt the magnet current and result in the immediate insertion of the control rods under any of the following conditions (Technical Specifications and operating set points are listed in Table 7.1):

1. High neutron flux levels on safety channels
 - (a) Log N channel
 - (b) Linear power channel
 - (c) Per cent power channel
2. Power supply failure
 - (a) Ion chambers high voltage
 - (b) Console power circuit
 - (c) Fission chamber high voltage
 - (d) Power to scram relay buses
3. High fuel temperature
4. Low reactor pool water level
5. Manual initiation
6. Manual current key switch

TABLE 7.1
MINIMUM REACTOR SAFETY CHANNELS

<u>Safety Channels</u>	<u>Function</u>	<u>Technical Specification Requirement</u>	<u>Setpoint</u>
Startup channel	Prevents withdrawal of any control rod	<2 counts/s	50 counts/s
Log-W	Scram	---	150 kW
Linear power level channel	Scram	120% of full power	100% of full scale recorder (100 kW)
Per cent power level channel	Scram	120% of full power	115% of scale
Console scram button	Manual scram	Scram	---
Chamber high voltage	Scram	---	Failure of power supply
Magnet current key switch	Manual scram	Scram	Scram
Simultaneous withdrawal of two rods	Prevents withdrawal	Prevents withdrawal	---
Withdrawal of shim prior to safety rod being fully withdrawn	Prevents withdrawal	---	---
Reactor tank water level	Scram	Scram at 1 ft below normal operating level	If water level drops 2 ft below the top of the tank
Fuel temperature	Scram	Scram at or below safety system setting	460°C*
Console power	Scram	Scram on loss of electrical power	Scram on failure of power supply

*Technical Specification limits aluminum fuel in B ring to 460°C.

Several safety interlocks are incorporated into the control rod circuitry to prevent any inadvertent reactivity insertions. The interlocks prevent the simultaneous withdrawal of two control rods. An adequate neutron-induced source signal must be available in the startup channel or the control rods cannot be withdrawn.

7.3. Instrumentation System

The reactor instrumentation system is fully integrated with the control and scram systems to form a single comprehensive system. Both nuclear and non-nuclear parameters are measured and monitored by the system. The minimum reactor safety channels required by the UUTR Technical Specifications are provided in Table 7.1.

With the instrument chassis power on, the neutron detector power supply, source range count-rate circuit, water conductivity monitor, bulk water temperature monitor circuits, and reactor pool water level monitor are continuously active. The console power supply switch provides power to the remaining circuits except for control rod magnet power. Rod drive magnet power is obtained only with a key switch on the console. Key operation ensures that only authorized operation of the reactor is performed without impeding the checkout and calibration of the instrument channels. Important monitoring circuits remain continuously active, which allows rapid evaluation of reactor conditions while checkouts and calibrations are performed. The instrumentation system is designed to enable the operator to initiate various safety and control circuits for optimum system performance during operations of the reactor. Figure 7.3 shows the block diagrams of the reactor instrumentation for the UUTR.

7.3.1. Neutron Monitoring Channels

The nuclear instrumentation is designed to provide the operator with the necessary information for proper manipulation of the reactor controls. The neutron monitoring channels consist of a startup channel, a log-N and period channel, and two power-level scram channels. Table 7.2 gives the operating ranges and trip set points of these neutron detectors. All neutron-sensing

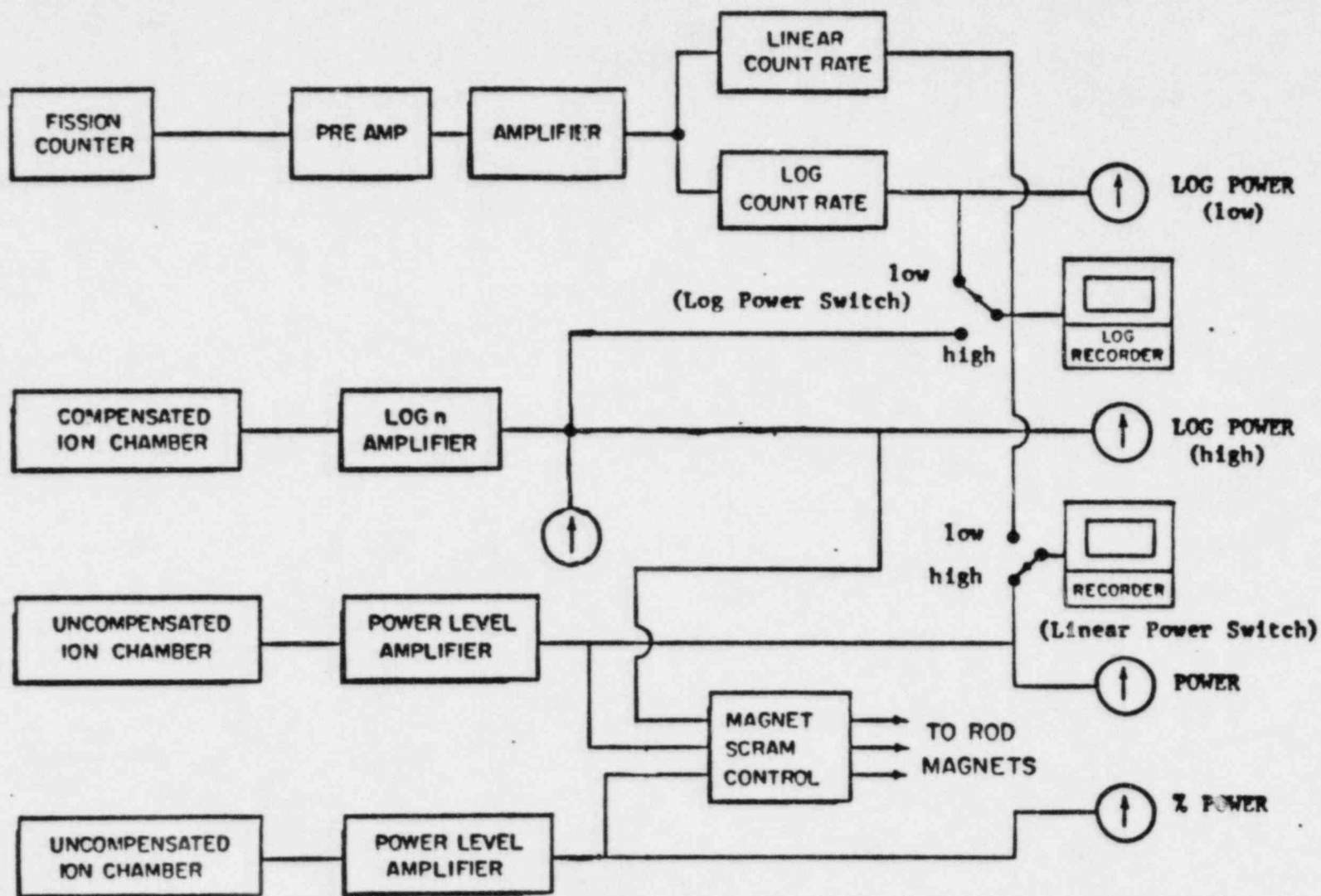

Fig. 7.3.
Block diagram of nuclear instrumentation.

TABLE 7.2

UUTR OPERATIONAL RANGES OF NEUTRON DETECTORS

<u>Channel</u>	<u>Chamber or Detector</u>	<u>Operating Ranges (Recorders)</u>	<u>Operational Alarms and Trip Setpoints</u>
Startup - Log Count Rate	Fission Chamber	10^{-3} W to 10 W (1 cps to 10 000 cps)	2 counts/s
Log-N	Compensated Ion Chamber	<1 W to >300 kW	150 kW
Linear Power Level Channel	Uncompensated Ion Chamber	<3 W to 300 kW	100% of Scale (100 kW)
Per cent Power Level Channel	Uncompensated Ion Chamber	0 - 150% Power	115% of Scale (115 kW)

chambers are sealed in aluminum cans and mounted on the outside of the reflector so that their positions are adjustable vertically to adjust sensitivity and for calibration.

The startup channel includes a fission chamber, power supply, preamplifier, linear amplifier, and linear and log-count-rate circuits. The channel provides power indication from below source level ($\sim 10^{-3}$ W) to ~ 10 W. In addition, a minimum source-count interlock prevents rod withdrawal unless the measured source level exceeds a predetermined value.

The log-N channel includes a compensated ion chamber, a power supply, a log-N amplifier, a meter, and a log-N recorder. Log-N power is indicated on one pen of the dual pen recorder and covers a range from less than 1 W to above full licensed power (>100 kW).

The per cent power level channel consists of an uncompensated ion chamber, power supply, power level scram amplifier, and per cent power recorder. Power level indication is provided from 0% to >150% (>150 kW) of full licensed power. This circuit provides for an adjustable level scram within this range (currently scrams at 115% of scale).

The linear power level channel incorporates an uncompensated ion chamber, a power supply, a microammeter with range switch amplifier, and a power level recorder or meter output (one pen of the dual-pen recorder). It provides power level indication from ~3.0 W to above full licensed power (>100 kW) and has a range switch with two ranges per decade for accurate measurements of the ion chamber current. If the power level increases to 100% of full scale on any range, a linear power level scram occurs. The output of the linear power level channel is recorded on the second pen of the dual-pen recorder.

All nuclear channels include a means of calibrating and testing their trip levels. These calibration and test circuits are built into the console as part of each channel. Figure 7.4 indicates the operating ranges of the neutron detectors.

7.3.2. Temperature and Water Monitor Channels

A fuel temperature channel with a meter readout and associated scram circuitry is mounted in the console. The channel is provided with a test switch on the front panel to allow checkout of the fuel temperature scram circuits. The reactor pool water level is monitored by a float switch. A microswitch levered to the float actuates an alarm and reactor scram if the pool water level drops to ~2 ft (0.061 m) below the top of the tank (This corresponds to ~21 ft (~6.4 m) of water above the top of the core.)

The water conductivity monitor consists of conductivity probes located in the coolant purification loop and a Wheatstone bridge circuit. The conductivity output is displayed on the lower right panel of the reactor console.

7.4. Conclusion

The control and instrumentation systems at the UUTR are designed to provide reliability and flexibility. There is adequate redundancy in the crucial nuclear and temperature monitoring circuits. In particular, nuclear power measurements are overlapped in the ranges of the log-N, linear power, and per cent power level channels. Therefore, Los Alamos concludes that the control

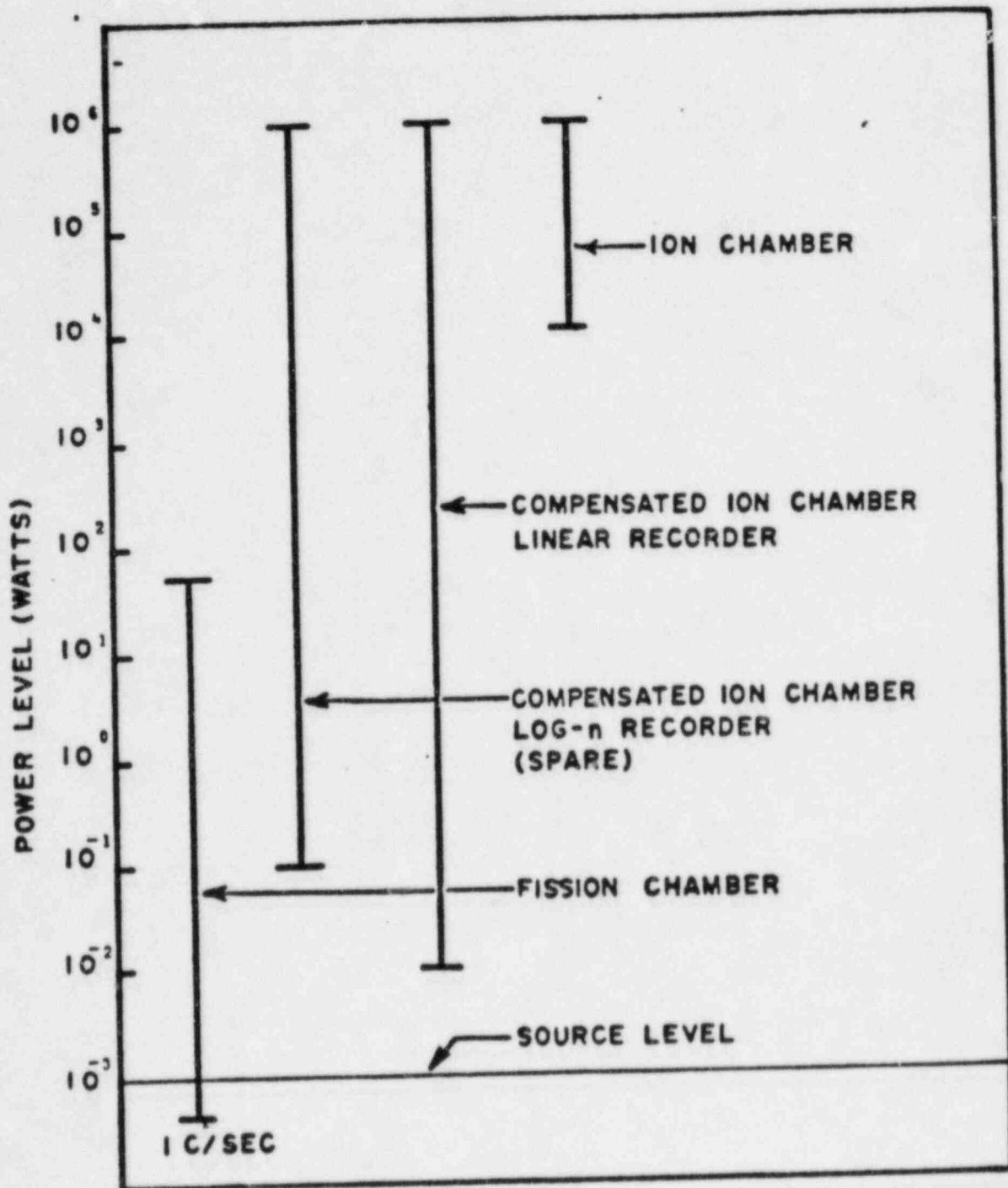

Fig. 7.4.
Operating range of incore detectors.

and instrumentation systems at the UUTR comply with the requirements and performance objectives of the Technical Specifications and will not contribute to an undue risk to the general public.

8. ELECTRICAL POWER

8.1. Normal Power

The electrical power for building lighting and reactor instrumentation is single-phase, 60 Hz, 120/240 V, which is furnished through a transformer and several control panels located throughout the building.

8.2. Emergency Power

Because the reactor control rods will scram in the case of an electrical power interruption and the decay heat generated in the core following a scram is not enough to cause fuel damage, emergency power is not required to maintain the reactor in a safe condition. Power for the radiation monitors and the facility intrusion detectors is supplied by a 12-V battery that is trickle-charged continuously. In the event of an electrical outage, this battery would supply the necessary power for these instruments for about 24 h. Battery-powered emergency lighting also is available to facilitate personnel movement during a power outage.

8.3. Conclusion

Los Alamos concludes that the design of the electrical power system and the inherent safety of the reactor design are adequate to ensure the safe operation of the UUTR.

9. AUXILIARY SYSTEMS

The auxiliary systems considered are the fuel handling and storage system, the compressed air system, the heating and air conditioning system, and the provisions for fire protection.

9.1. Ventilation System

The ventilation system is considered to be an engineered safety feature and is discussed in Sec. 6 of this report.

9.2. Fire Protection System

The fire protection system for the reactor facility has sprinklers located throughout the reactor area. In addition, there are two portable fire extinguishers available at this location. A smoke detector located in the radio-chemistry laboratory also provides fire alarms. These units are maintained by the campus Fire Marshall.

Additional fire protection to the reactor is provided by the Salt Lake City Fire Department with a fire station located on the University Campus. Both the personnel of the campus Fire Marshall and the Salt Lake City Fire Department are instructed periodically on the special needs of fire protection at the reactor facility by the staff of the Radiation Protection Department.

9.3. Compressed Air System

A 30-psig (0.2-MPa) compressed air line serves the two hoods in the radio-chemistry laboratories (Rooms 1001F and G) and the counting laboratory (Room 1001C). These lines are extensions of the compressed air system for the Merrill Engineering Building using a compressor located outside of the reactor area.

9.4. Heating and Air Conditioning System

The heating and air conditioning systems in the reactor area are integrated with the heating and air conditioning system for the Merrill Engineering Building. Air is heated using a gas-fired boiler. The reactor area is cooled using chilled air drawn through the air inlet, which also is part of the Merrill Engineering building air conditioning system.

9.5. Fuel Handling and Storage

Fuel handling at UUTR is done using special tools designed and built by GA Technologies, Inc. The fuel storage system consists of six fuel storage racks mounted inside the reactor pool. Currently, the in-pool storage facility has a maximum capacity for 91 fuel elements. Forty-six fuel elements are in storage on these racks at the present time. Two other fuel elements are stored in two separate shielded facilities on the lower level floor in the reactor bay. (See Fig. 4.1.)

9.6. Conclusion

Los Alamos feels that the auxiliary systems at UUTR are well designed and maintained and the systems are adequate for their intended purposes.

10. EXPERIMENTAL PROGRAMS

The UTR acts as a source of ionizing radiations and neutrons for various research programs. The reactor also serves educational programs in physical, biological, and medical sciences and for the training of engineering students on the campus of the University of Utah. The experimental facilities of the UTR include a pneumatic transfer system, several central irradiators, and three diagonally directed beam tubes. In addition, there are four irradiation facilities in the trapezoidal D_2O -filled reflector tanks surrounding the reactor core.

10.1. Experimental Facilities

10.1.1. Pneumatic Transfer System

A pneumatic transfer system allows small sealed samples to be rapidly transported between the laboratory located in Room 1001C and the reactor core. The in-core terminus of this system is located in one of the fuel element positions in the D-ring of the core and the receiver terminus is an unshielded location in Room 1001C. The pneumatic transfer system is driven by dry air under pressure. All the exhaust air from the system is released to the ventilation exhaust system from the radiochemistry laboratories, which is also the reactor area exhaust. The controls for the pneumatic transfer system are located in Room 1001C. The mechanical operation of this experimental facility cannot be controlled or observed from the reactor console.

10.1.2. Central Irradiators

The reactor is equipped with a central thimble for conducting experiments or irradiating small samples in the core at the point of maximum neutron flux. The central irradiator is a cylindrical aluminum insert placed in the A and B ring positions of the core. There are three variations of the central irradiators now available at UTR. Each of these is ~4.5 in. (~11 cm) in diameter and of ~6 in. (~67 cm) in height. The three designs allow various optimizations of neutron fluxes within the irradiators. One of them has an internal tube ~1 in. (~2.5 cm) in diameter, and the annulus of this

device is filled with D_2O . A second irradiator with an internal tube ~1 in. (2.5 cm) diameter has an annulus filled with air. The third irradiator has six inner tubes ~1 in. (2.5 cm) in diameter arranged in a circle as shown in Fig. 10.1. The annulus of this irradiator is filled with D_2O , and it can be rotated from the bridge using a motor at a constant speed of ~1 rpm to allow all the six sample positions to be exposed to a uniform flux. The other two irradiators are not designed to be rotated while they are in the reactor core. The actual placement of experiments or samples in the core region is limited by the Technical Specifications.

10.1.3. Diagonal Beam Tubes

The reactor system has three diagonally directed beam tubes between the reactor core and the reactor room floor. Each tube is composed of two sections aligned along a common axis. The top tube section is a 1-ft (30.5-cm)-diam tube between the reactor floor and the wall of the aluminum tank. This tube does not penetrate the aluminum reactor tank, but is sealed at the end where it butts against the reactor tank. Currently, it is filled with sand and capped at the reactor floor level with a 6-in. (15.2-cm)-thick lead plug.

10.1.4. D_2O -filled Reflector Tank

The trapezoidal D_2O -filled reflector tanks surrounding the reactor core permits the irradiation of experiments submerged in the vicinity of the core, yet inside the reflector. The decision to perform experiments in the D_2O reflector as opposed to using the pneumatic transfer system or the central thimble is dictated by the nature and size of the specimen and the desired type and intensity of radiation fields. The actual placement of experiments or samples in these irradiation locations is limited by their potential effect on reactivity, which is limited by the Technical Specifications.

There are three wet irradiation tubes in one of the trapezoidal reflector tanks and a dry irradiation tube in one of the other D_2O -filled reflectors.

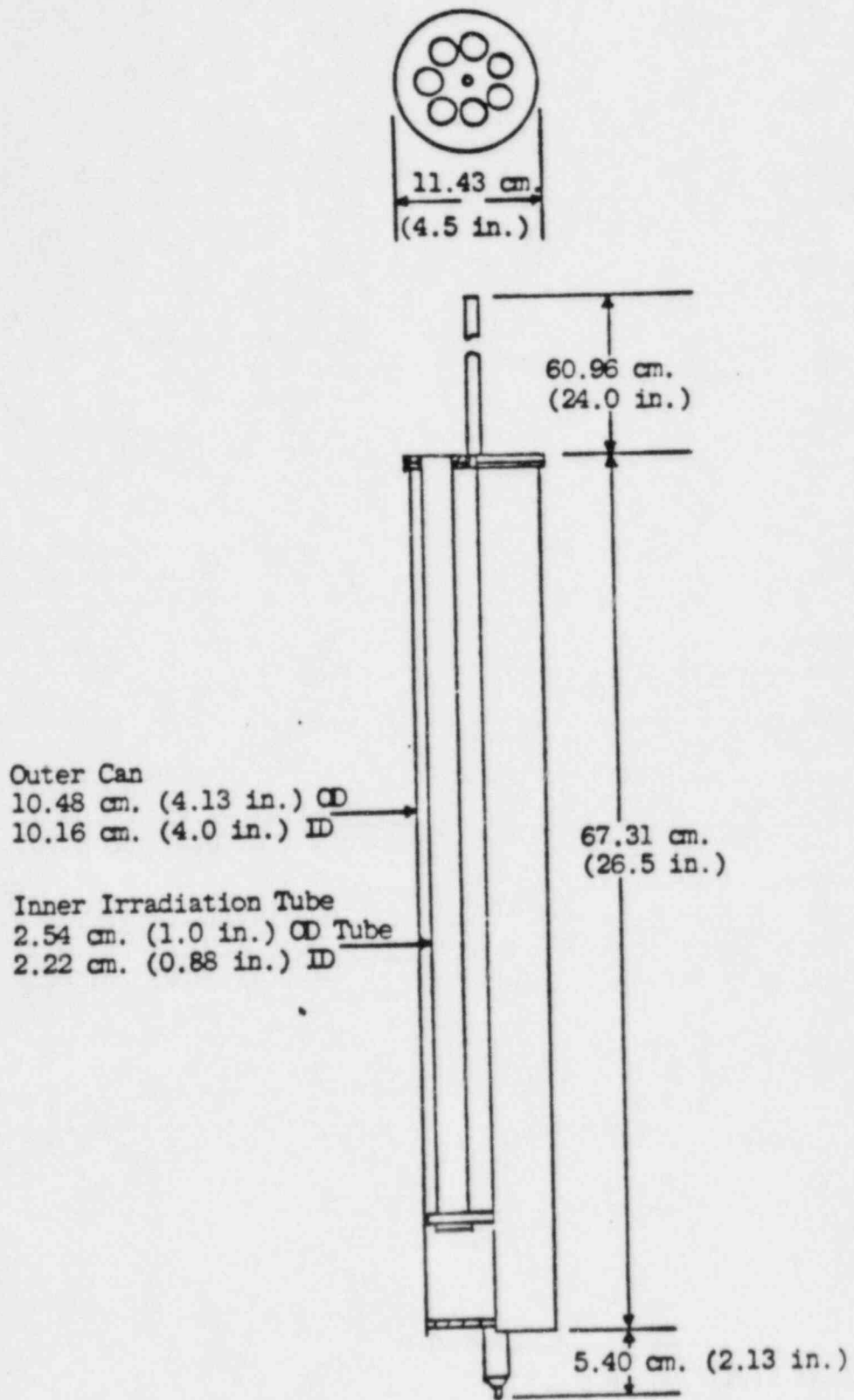

Fig. 10.1.
D₂O-filled central irradiation facility.

The internal diameters of the three wet irradiation facilities are ~2 in. (5 cm). The dimensions of the dry irradiation facility located in the D₂O tank are the same as the dimensions of the central irradiation facility discussed in Sec. 10.1.2.

10.2. Experimental Review

Before any new experiment can be conducted using the reactor or the associated experimental facilities, it is reviewed by the Reactor Operations Committee, which has five members. The membership of the Reactor Operations Committee is designed to provide a spectrum of expertise to review the experiments and their potential hazards. The University Radiation Safety Officer and the Reactor Supervisor are permanent members of this committee. The review and approval process for experiments allows personnel trained in reactor operations to consider and suggest alternative operational conditions--such as a different experimental facility, power levels, and irradiation times--that will minimize personnel exposure and/or potential release of radioactive materials to the environment.

10.3. Conclusion

Los Alamos concludes that the design of the experimental facilities, combined with the detailed review and administrative procedures applied to all research activities at the UUTR, is adequate to ensure that the experiments are (1) not likely to fail; (2) unlikely to release significant radioactivity to the environment directly; and (3) unlikely to cause damage to the reactor system or its fuel. Therefore, we feel that reasonable provisions have been made so that the experimental programs and facilities do not pose a significant risk to the facility staff and the public.

11. RADIOACTIVE WASTE MANAGEMENT

The major radioactive waste generated by reactor operations is activated gases, primarily ^{41}Ar . A limited volume of radioactive solid waste, principally spent ion exchange resins, is generated by reactor operations, and some additional solid waste is produced by associated research programs. The facility periodically regenerates the coolant purification ion exchanger resin bed using the services of an outside contractor.

11.1. ALARA Commitment

The UUTR is operated with the philosophy of limiting the release of radioactive materials to the environment to levels as low as reasonably achievable (ALARA). The University administration, through the Radiation Safety Office, instructs all operating and research personnel to develop procedures to limit the generation and subsequent release of radioactive materials.

11.2. Waste Generation and Handling Procedures

11.2.1. Solid Waste

The disposal of high-level radioactive waste in the form of spent fuel is not anticipated during the term of this license renewal. Therefore, the only solid waste generated as a result of reactor operations consists primarily of ion exchange resins and filters, and occasional small activated components. Some of the reactor-based research also results in the generation of solid low-level radioactive wastes in the form of contaminated paper, gloves, and glassware. The solid waste generated at UUTR during the past 5 yr contained mostly short-lived nuclides, and they were allowed to decay in storage containers held at the reactor facility.

The limited solid wastes, generated at the reactor facility are collected by the University's health physics staff in specially marked barrels kept at the facility. They are held temporarily before being packaged and shipped to an approved disposal site in accordance with applicable regulations.

11.2.2. Liquid Waste

Normal reactor operations produce no radioactive liquid waste other than the coolant, which has minute amounts of tritium and water-borne activation products. The coolant maintenance system is adequate to purify this coolant on a continuous basis. Some of the cleaning activities or irradiations may generate limited volumes of liquid wastes. These solutions generally are collected and, if the concentrations are initially above 10 CFR 20 limits, the liquid wastes are either stored for decay or diluted below the 10 CFR 20 levels before release to the sanitary sewer.

According to the applicant, the current concentration levels of ^3H in the reactor pool water are well below the detection levels possible by liquid scintillation counting. The major source of ^3H in the reactor is the (n, γ) reaction of D_2O in the reflector tanks, which contain a total volume of 60 gal (227 L) of D_2O . As of April 1983, the ^3H level in the D_2O was $0.12 \mu\text{Ci/mL}$ (4.44 kBq/mL), which amounts to a total inventory of 30 mCi (1.11 GBq) of ^3H in the D_2O tanks. If all the 60 gal (227 L) of D_2O were to be released to the reactor pool water, the ^3H concentration in the pool water would be $\sim 8 \times 10^{-4} \mu\text{Ci/mL}$ (29.6 Bq/mL). This concentration of ^3H is well below the release limits of ^3H according to 10 CFR 20 criteria. Therefore, the current ^3H levels of D_2O in the reflector tanks does not constitute any radiological safety hazard.

11.2.3. Airborne Waste

An activation product that can become airborne is ^{16}N produced in the coolant passing through the reactor core. Calculations by the applicant indicate the ^{16}N dose rate at the pool surface would be $\sim 0.2 \text{ mR/h}$.

Another radioactive airborne waste of concern is ^{41}Ar , which is produced principally by the neutron irradiation of air dissolved in the cooling water and the irradiation of air in the pneumatic transfer system.

The detection level of ^{41}Ar release through the ventilation system as stated by the applicant is $\sim 0.6 \times 10^{-6} \mu\text{Ci/mL}$ (22.2 m Bq/mL). Since there have

been no detectable levels of ^{41}Ar in the effluents through the ventilation system, it can be estimated that the maximum annual release of ^{41}Ar is less than 0.2 Ci (7.4 GBq), assuming an average reactor operation period of 100 h/yr. This estimate, however, does not include the releases of ^{41}Ar from the pneumatic transfer system, which may be the major source of ^{41}Ar release from the reactor facility.

11.3. Conclusion

Los Alamos concludes that the waste management activities at the UTR facility have been conducted and are expected to continue to be conducted in a manner consistent with 10 CFR 20 and the ALARA principles. Among other guidance, the Los Alamos review has followed the methods of ANSI/ANS 15.11, "Radiological Control at Research Reactor Facilities."

Because ^{41}Ar is the only significant radionuclide released by the reactor in the environment during normal operations, Los Alamos has reviewed the history and current practices of reactor operations with respect to this radionuclide. Los Alamos concludes that the radiation exposure in unrestricted areas as a result of monitored releases of ^{41}Ar has not exceeded the limits specified in 10 CFR 20 when averaged over a year.

Furthermore, our evaluation of the potential exposure beyond the limits of the reactor facilities give reasonable assurance that the exposures to the public as a result of ^{41}Ar release would not be significant even if there were major changes in the operating schedule of UTR.

12. RADIATION PROTECTION PROGRAM

The University of Utah has a structured radiation safety program with a health physics staff equipped with radiation detection instrumentation to determine, control, and document occupational radiation exposures at its reactor facility. In addition, the reactor facility monitors airborne effluents in the exhaust duct to comply with applicable guidelines.

12.1. ALARA Commitment

The University administration, through its Radiation Safety Committee, has formally established the policy that all operations are to be conducted in a manner to keep all radiation exposures ALARA. All proposed experiments and procedures at the reactor are reviewed for ways to minimize the potential exposure of personnel. All unanticipated or unusual reactor-related exposures will be investigated by both the health physics and operations staffs to develop methods to prevent recurrences.

12.2. Health Physics Program

12.2.1. Health Physics Staffing

The normal radiation safety staff at the University of Utah consists of two professional health physicists supported by three full-time technicians. This staff provides radiation safety support to the entire university complex, including a teaching hospital and many radioisotope laboratories. The routine health physics-type activities at the reactor are performed by the operations staff with additional surveys by the health physics staff. The formal health physics staff is available for consultation, and the University Radiation Safety Officer is a member of the Reactor Safety Committee. Los Alamos believes that the radiation safety support is adequate for the research efforts within this reactor facility.

12.2.2. Procedures

Detailed written procedures have been prepared that address the Radiation Safety support that is expected to be provided to the routine operation of the University's research reactor facility. These procedures identify the interactions between the operational and experimental personnel and also specify numerous administrative limits and action points, as well as appropriate responses and corrective actions if these limits or action points are reached or exceeded. Copies of these procedures are readily available to the operational and research staff and to the administrative and radiation safety personnel.

12.2.3. Instrumentation

The University of Utah has acquired a variety of detecting and measuring instruments for monitoring potentially hazardous ionizing radiation. The instrument calibration procedures and techniques ensure that any credible type of radiation and any significant intensities will be detected promptly and measured correctly. In addition, the reactor facility has several portable survey instruments supplied and calibrated by DOE/Nevada.

12.2.4. Training

All reactor-related personnel are given an indoctrination in radiation safety before they assume their work responsibilities. Additional radiation safety instructions are provided to those who will be working directly with radiation or radioactive materials. The training program is designed to identify the particulate hazards of each specific type of work to be undertaken and methods to mitigate their consequences. Retraining in radiation safety also is provided. As an example, all reactor operators are given an examination on health physics practices and procedures at least every 2 yr. The level of retraining given is determined by the examination results.

12.3. Radiation Sources

12.3.1. Reactor

Sources of radiation directly related to reactor operations include radiation from the reactor core, filters in the water cleanup systems, and radioactive gases (primarily ^{41}Ar).

The fission products are contained in the fuel's aluminum and stainless-steel cladding. Radiation exposures from the reactor core are reduced to acceptable levels by water and concrete shielding. The filters are changed routinely before high levels of radioactive materials have accumulated, thereby limiting personnel exposure.

Personnel exposure to the radiation from chemically inert ^{41}Ar is limited by dilution and prompt removal of this gas from the reactor area and its discharge to the atmosphere where it diffuses further before reaching occupied areas.

12.3.2. Extraneous Sources

Sources of radiation that may be considered as incidental to normal reactor operation but associated with reactor use include radioactive isotopes produced for research, activated components of experiments, and activated samples or specimens. An AGN-201M reactor licensed to operate at a power level of 5 W is located in the same room as the UUTR.

Personnel exposure to radiation from intentionally produced radioactive material, as well as from the required manipulation of activated experimental components, is controlled by rigidly developed and reviewed operating procedures that use the normal protective measures of time, distance, and shielding.

12.4. Routine Monitoring

12.4.1. Fixed-Position Monitors

The UUTR facility has two fixed-position radiation monitors: one on the ceiling above the reactor and another below the catwalk above the reactor. The outputs of these detectors are summed with that of the exhaust duct monitor (Sec. 12.6.1.) and read out in the control room. In the event that the sum of these detectors reaches a predetermined value, the reactor area is isolated automatically and the reactor (if operating) is scrammed.

12.4.2. Experimental Support

The health physics staff participates in experiment planning by reviewing all proposed procedures for methods of minimizing personnel exposures and limiting the generation of radioactive waste. Approved procedures specify the type and degree of radiation safety support required by each activity.

12.5. Occupational Radiation Exposures

12.5.1. Personnel Monitoring Program

The University of Utah personnel monitoring program is described in its Radiation Safety Manual. To summarize the program, personnel exposures are measured by the use of film badges assigned to individuals who might be exposed to radiation. Visitors also may be provided with film badges for monitoring purposes. In addition, instrument dose rate and time measurements are used to administratively keep occupational exposures below the applicable limits in 10 CFR 20.

12.5.2. Personnel Exposures

During the almost 9 yr since its initial criticality in 1975, personnel exposures at the UUTR have been low. The only annual exposure over 250 mrem (2.5 mSv) was in 1980 when the transfer of fuel between the storage pits and the reactor tank resulted in one individual receiving 234 mrem (2.34 mSv),

which resulted in an annual exposure of 341 mrem (3.41 mSv). A single individual received exposures of between 100 and 150 mrem (1.0 and 1.5 mSv) each year during 1977, 1978, and 1979. All other personnel exposures associated with operations and maintenance of this reactor have been less than 100 mrem/yr (1.0 m Sv/yr).

12.6. Effluent Monitoring

12.6.1. Airborne Effluents

As discussed in Sec. 11, airborne effluents from the reactor facility consist principally of low concentrations of ^{41}Ar . The small amount of ^{41}Ar released into the reactor room is diluted by the almost 20,064 ft³ (570 m³) volume of air. The reactor area exhaust is monitored in the discharge duct by an instrument designed to detect ^{41}Ar concentrations of about 2×10^{-6} $\mu\text{Ci/mL}$ (74 mBq/mL) (1/3 of 10 CFR 20 the restricted area maximum permissible concentration). The duct monitor will isolate the reactor area, scram the reactor automatically, and switch the HEPA filter into the exhaust of the ventilation system if this value is exceeded. Reactor room air is discharged at a rate of about 1700 ft/min (8×10^5 cm³/s) at a point ~39 ft (12 m) above ground level, resulting in additional dilution before reaching occupied areas at ground level.

12.6.2. Liquid Effluents

The reactor generates no radioactive liquid waste during routine operations. If small quantities of liquid waste are generated by some cleaning of decontamination equipment, it will be collected and solidified by the radiation safety office staff.

12.7. Environmental Monitoring

A DOE/EPA environmental sampling station (manned by University personnel) is located outside the engineering building. This station monitors and records external penetrating radiation levels and collects samples of airborne particulates, water vapor (tritium), and condensable gases for laboratory analysis.

In addition, the radiation safety office performs routine surveys at selected locations around the campus where materials (including radioactive materials) tend to concentrate (collect). The infrequent low positive indications cannot be correlated with reactor operations, maintenance, or potential releases.

12.8. Potential Dose Assessments

Natural background radiation levels in the central Utah area result in an exposure of about 115 mrems/yr (1.15 mSv/yr) to each individual residing there. At least an additional 7% [~ 8 mrems/yr (0.08 mSv/yr)] will be received by those living in a brick or masonry structure. Any medical diagnosis x-ray examination will add to the natural background radiation, increasing the total accumulative annual exposure.

Conservative calculations by the staff based on the amount of ^{41}Ar released during normal operations from the reactor facility stack predict a maximum annual exposure of only a fraction of 1 mrem in the unrestricted areas.

12.9. Conclusion

Los Alamos considers that radiation protection receives appropriate support from the University administration. We conclude that (1) the program is staffed and equipped properly, (2) the University health physics staff has adequate authority and lines of communication, (3) the procedures are integrated correctly into the research plans, and (4) surveys verify that operations and procedures follow ALARA principles.

Los Alamos concludes that the effluent monitoring program conducted by University personnel is adequate to identify significant releases of radioactivity promptly so that maximum exposures to individuals in the unrestricted area can be predicted. These predicted maximum levels are well within the applicable regulations and guidelines of 10 CFR Part 20.

Additionally, we find that the University of Utah radiation protection program is acceptable because we have found no instances of reactor-related exposures of personnel above applicable regulations and no unidentified significant

releases of radioactivity to the environment. Furthermore, Los Alamos considers that there is reasonable assurance that the personnel and procedures will continue to protect the health and safety of the public during routine reactor operations.

14. ACCIDENT ANALYSIS

In establishing the safety of the operation of the UUTR, the licensee analyzed potential accidents to ensure that these events would not result in potential hazards to the reactor staff or the public. In addition, the NRC has asked Los Alamos to evaluate the licensee's submitted documentation and to analyze the various types of possible accidents and their potential consequences to the public.

The following potential accidents and their consequences were considered to be sufficiently credible by the Los Alamos team for evaluation and analysis.

1. Fuel handling accident
2. Rapid insertion of reactivity (nuclear excursion)
3. Loss of coolant
4. Misplaced experiments
5. Mechanical rearrangement of the fuel
6. Effects of fuel aging

Of these potential credible accidents, the one with the potential of releasing the highest level of radioactive material to the UUTR facility and unrestricted area outside the reactor facility is the fuel handling accident, which postulates the loss of all the cladding on an irradiated fuel element and the subsequent release of fission products. Therefore, this accident will be designated the maximum hypothetical accident (MHA).

The results of the analyses of accidents with less severe consequences than the MHA are included to show the extent of the Los Alamos investigations.

14.1. Fuel Handling Accident

The fuel handling accident, which is designated as the MHA, includes various incidents to one or more irradiated fuel elements in which the fuel cladding might be breached or ruptured. The licensee has postulated the possibility that following a loss of pool water the cladding of a fuel element located in the B ring, ruptures thus releasing the noble gases and the fission products

in the fuel gap into the reactor room. The licensee assumed immersion in a finite-cloud for calculating their exposures inside the reactor room. For the outside exposures, the room air is exhausted through a filter at $\sim 150 \text{ ft}^3/\text{m}$, however, the removal of the iodines or noble gases is not assumed to occur due to the filter. They do assume a dilution factor of at least 70 due to the additional ventilation system exhausts on the Merrill Engineering Building.

To remain conservative, Los Alamos did not try to develop a detailed scenario of how the accident occurs but rather assumed that the cladding of one irradiated fuel element completely fails and that this occurs outside the reactor pool, instantly releasing all of the available volatile fission products and noble gases that have accumulated in the free volume (gap) between the fuel and the cladding. Furthermore, Los Alamos' worst-case scenario conservatively assumes that an accident occurs following an extended run at full licensed power such that the inventories of all significant radionuclides are at their maximum (saturation) values. Los Alamos assumed that the accident occurred but did not attempt to describe or evaluate all of the mechanical details of the accident or the probability of its occurrence. For purposes of this document, only the consequences of this accident were considered.

Several series of experiments at General Atomics (GA) have given data on the species and fractions of fission products released from U-ZrH_x under various conditions (Foushee, 1968; Foushee and Peters, 1971; , Simnad 1980; Simnad et al., 1976). The findings indicated that the noble gases are the principal fission product species to be released, and when the fuel specimen was irradiated at temperatures below 662°F (350°C), the fraction released could be summarized as a constant equal to 1.5×10^{-5} independent of the temperature. At temperatures greater than 662°F (350°C), the species released remained the same, but the fraction released increased significantly with increasing temperature.

GA has proposed a theory describing the release mechanisms in the two temperature regimes that appears plausible, but not all data agree in detail (Foushee, 1968; Foushee and Peters, 1971). It seems reasonable to accept the interpretation of the low-temperature results, which implies that the fraction released for a typical TRIGA fuel element will be a constant, independent of

operating history or details of operating temperatures, and will apply to fuel whose temperature is not raised above $\sim 752^{\circ}\text{F}$ ($\sim 400^{\circ}\text{C}$). This means that the 1.5×10^{-5} release fraction reasonably could be applied to TRIGA-type reactors operating at steady-state power levels up to at least 800 kW and is therefore applicable to the UUTR 100-kW steady-state reactor. The theory for the fuel temperature regime above $\sim 752^{\circ}\text{F}$ ($\sim 400^{\circ}\text{C}$) is not established as well. The proposed theory of release of the fission products incorporates a diffusion process that is a function of temperature and time. Therefore, in principle, details of the operating history and temperature distributions in fuel elements would be required to obtain actual values for release fractions at the higher temperatures. In situations where a fuel cladding failure was assumed, Los Alamos used the GA results (Simnad 1980) to estimate the fission product release fractions. Los Alamos considers these results conservative in that they represent a theoretical maximum release greater than corresponding experimental observations.

For the fuel-handling accident, Los Alamos assumed a fission product release fraction of 1.5×10^{-5} of the available noble gas and halogen inventories. Based on the GA analysis, this fraction is a conservative estimate of the expected release following a prolonged steady-state operation at 100 kW (for the UUTR) with a maximum local temperature of $\sim 234^{\circ}\text{F}$ ($\sim 112^{\circ}\text{C}$). Because the GA analysis assumes infinite operating time, it is likely that this approach gives a conservatively high release value. Also, the activity released is weighed toward the shorter half-lived nuclides.

Because the noble gases do not condense or combine chemically, it is assumed that any noble gases released from the cladding will diffuse in air until their radioactive decay. Conversely, the iodines are chemically active but are not volatile at temperatures below $\sim 356^{\circ}\text{F}$ ($\sim 180^{\circ}\text{C}$). Some of these radionuclides will be trapped by materials with which they come in contact, such as water and structures. Evidence indicates that most of the iodines either will not become or will not remain airborne under many accident scenarios that are applicable to nonpower reactors (USNRC, 1981; NRC RG 3.34, 1979). However, to be certain that the fuel-cladding failure scenario discussed leads to the upper-limit dose estimates for all events, we assumed that 100% of the iodines in the gap became airborne. This assumption will lead to computed thyroid

doses that may be much too high in many scenarios; for example, those in which the pool water is present.

14.1.1. Scenario

Los Alamos assumed that the failure occurred in air and calculated subsequent doses to an individual in both the reactor room and in the unrestricted area. The Los Alamos analysis assumed that a cladding failure occurred in a B-ring fuel element following an extended run at the authorized maximum power (100 KW). The fuel element was assumed to have a power density approximately two times greater than the core average. The calculations assumed all fission products had reached their saturated activity levels, a conservative assumption considering the typical operating history at the UUTR. Normally, a significant amount of time elapses before any fuel is removed from the reactor; however, no activity decrease was taken into account for the radioactive decay during the time between reactor shutdown and removal of the fuel element from the pool into the air. All the noble gases and halogens in the fuel cladding gap are assumed to be released from the fuel element and are distributed uniformly in the reactor room; no plate-out was assumed. Scenarios incorporating realistic estimates of the above conservative assumptions would reduce the resulting doses significantly. Using this scenario as a basis, we calculated the whole-body gamma-ray (immersion) and thyroid doses by iodine inhalation to an individual in the reactor room and in an unrestricted area immediately outside the reactor building.

For the occupational exposures, it was assumed that the ventilation system was shutdown at the time of the accident and all the airborne reactivity and fission products remained in the reactor room volume of 20 064 ft³ (570 m³). Immersion in a finite cloud was assumed for the occupational exposures. It also was assumed that the core contained 70 elements and that the failed element (B ring element) experienced a power level higher than the average element. For the outside exposure, it was assumed that the currently installed ventilation system was operating at its rated capacity of 1700 ft³/min (8×10^5 cm³/s); and, the switch to the emergency HEPA filter system was not operating. Additionally, it was assumed that the release time was equivalent to the exposure time, the dispersion factor (χ/Q) was 0.01 s/m³, and

there was no radioactive decay during the release. All exposure calculations outside the building assumed immersion in a semi-infinite cloud (a very conservative assumption that produces the highest calculated exposures) (USNRC RG 3.34, 1979; Hawley et al, 1981; AFRI, 1981).

14.1.2. Assessment

The calculated exposures for the above assumptions and locations are presented in Table 14.1. Because there is no credible way that the postulated MHA could occur without operating personnel being alerted immediately, orderly evacuation of the reactor bay would be accomplished within minutes (~10 min). As a result of the calculative and atmospheric assumptions presented above, the calculated operational and public exposures shown in Table 14.1 are higher than could occur realistically. The conservative consequences were considerably below the 10 CFR 20 limits for extended operations.

Based on the above discussions and analysis, Los Alamos concludes that even if one fuel rod from the UUTR were to release all its noble gases and halogen fission products accumulated in the fuel-cladding gap, radiation doses to both occupational personnel and to the public in unrestricted areas would be below the limits stipulated in 10 CFR 20. Accordingly, there would be no significant risk to the health and safety of the public.

TABLE 14.1

DOSES RESULTING FROM POSTULATED FUEL-HANDLING ACCIDENT

<u>Dose and Location</u>	<u>Whole-body Immersion Dose</u>	<u>Thyroid Dose</u>
10-min occupational dose in reactor bay.	0.67 mrem (6.7×10^{-3} mSv)	0.3 rem (3 mSv)
1-h public dose immediately outside the reactor building	0.04 mrem (4.0×10^{-4} mSv)	2.9 mrem (2.9×10^{-2} mSv)

14.2. Rapid Insertion of Reactivity

The U-ZrH_x fuel in the UUTR exhibits a strong, prompt, negative temperature coefficient of reactivity, as discussed in Sec. 4.5. This temperature coefficient terminates any pulse or nuclear excursion and decreases the amount of reactivity as the steady-state temperature of the fuel increases. These results have been verified at many operating TRIGA reactors. Although it may be possible theoretically to rapidly insert sufficient excess reactivity under accident conditions to create an excursion such that fuel damage would occur before the excursion could be terminated, the limits imposed by the Technical Specifications of the UUTR make such an event unlikely.

14.2.1. Scenario

The maximum power excursion transient that is postulated to occur is the event in which the total available amount of excess reactivity is inserted into the core instantaneously. The UUTR is limited by the current license to 1.96% $\Delta k/k$ (2.80\$) excess reactivity above a cold, critical condition. However, the Los Alamos review has not been able to identify a credible method for instantaneously inserting all of the available excess reactivity.

Los Alamos has considered the scenario of the reactor operating at some steady-state power level between 0 and 100 kW, at which time all the remaining excess reactivity is inserted rapidly into the core. The analysis conservatively neglected the reactivity loss as a result of the xenon (¹³⁵Xe) build-up. Los Alamos found that the worst case would be the initiation of a 1.96% $\Delta k/k$ (2.80\$) step insertion with the core at ambient temperature and essentially zero initial power. The potential significant reactivity insertion accident consequences that were considered by Los Alamos are melting of the fuel or cladding material, failure of the cladding as a result of high internal gas pressures, and/or phase changes in the fuel matrix. The major cause of fuel element cladding failure at elevated temperatures in the aluminum and stainless-steel-clad elements is a result of excessive stress buildup in the cladding that is caused by the hydrogen pressure from the dissociation of the ZrH_x.

The most limiting scenario is based on a core configuration containing aluminum elements loaded in the innermost ring. If all of the excess reactivity were inserted in one step, the fuel temperature in the innermost core position would be the maximum fuel temperature attained.

Calculations performed by General Atomic and confirmed by several experiments indicate that the fuel cladding integrity is maintained at peak fuel temperatures as high as $\sim 986^\circ\text{F}$ ($\sim 530^\circ\text{C}$) for low-hydride type (U-ZrH_{1.0}) aluminum-clad elements (Simnad, 1980), and $\sim 2147^\circ\text{F}$ (1175°C) for U-ZrH_{1.7}-type stainless-steel-clad-fuel elements (Coffer et al., 1966; Simnad et al., 1976; Simnad, 1980). Beyond these respective temperatures, substantial volume changes associated with the phase transformations occurred (West et al., 1967).

14.2.2. Assessment

Los Alamos also has reviewed the literature for large reactivity insertions into cores with aluminum-clad low hydride type elements and has found that GA has performed experiments with a 3.00\$ step reactivity transients in a Mark I type TRIGA reactor core containing ~ 90 fuel elements (aluminum/stainless-steel clad). This reactivity insertion yielded a reactor period of 4 ms, and a peak power of ~ 700 MW.

The fuel temperature in the hottest core position was measured by GA, and the fuel elements were examined after the step reactivity insertion (Hopkins et al., 1966). There was no indication of fuel or cladding melt. The maximum measured temperature associated with the 3.00\$ step insertion was found to be $\sim 475^\circ\text{C}$. This maximum temperature is below the phase transition value ($\sim 550^\circ\text{C}$) for the aluminum-clad fuel elements (Simnad, 1980).

The fuel experienced no melting effects because of the temperature increase, and the fuel element cladding integrity was maintained. Thus, a 1.96% $\Delta k/k$ (2.80\$) step reactivity insertion accident on a nonpulsing reactor such as the UUTR will not result in a loss of cladding integrity or mechanical damage to the fuel. Because the radial temperature distribution in a fuel element immediately following a step insertion of reactivity is similar to the radial

power distribution, the peak temperature immediately following a step insertion of reactivity is located at the periphery of the hottest fuel element. This temperature decreases rapidly (within seconds) as the heat flows towards the cladding and the fuel center.

Based on the above analysis, Los Alamos concludes that the rapid insertion into the UUTR core of the 1.96% $\Delta k/k$ (2.80%) available excess reactivity will not result in fuel melting nor a cladding failure due to high internal gas pressure or high temperature. Therefore, there is reasonable assurance that the fission products contained in the fuel will not be released to the environment as a result of the rapid insertion of reactivity accident.

14.3. Loss-of-Coolant Accident

The rapid loss of shielding and cooling water following reactor operation is considered to be a potential accident that would result in the increase of fuel and cladding temperatures. Because the water provides for the major moderation of the neutrons, the loss of coolant in the reactor would terminate any significant neutron chain reaction and thus terminate the power excursion. However, the residual radioactivity resulting from fission product decay would continue to deposit heat energy into the fuel.

The licensee's analysis indicates that the loss of water accident can occur as a result of a severe earthquake or major settling of the reactor building foundation that would result in the rupture of the tank and allow the water to drain, or the tank may be accidentally pumped dry. The UUTR pool outlet water line has a 1/4-in. (0.64-cm)-diam hole located ~2 ft (~0.61 m) below the top of the reactor pool that acts as a siphon break. The inlet water line terminates ~2 ft (~0.61 m) above the top of the reactor core. Thus, even if the water system is operated carelessly (for example, if it was operated when the pump discharge line was disconnected for repairs), the tank could not be pumped dry accidentally. This can be done only by deliberate action. The recirculating pump, although it has sufficient suction to drain the tank, it is installed with its suction line several feet above the core, and could not drain the shielding and cooling water below the level of the top of the core.

14.3.1. Scenario

The tank failure possibly could be caused by an earthquake; however, there are also three other barriers that would prevent the primary coolant leakage. The 2 ft (0.61 m) of sand surrounding the aluminum tank, the stainless-steel tank, and the surrounding soil would present a very high resistance to water leakage.

Even though the loss of cooling and shielding water is an exceedingly low probability, the licensee performed calculations evaluating the hazards to the fuel elements associated with this accident. It was assumed conservatively that the reactor had been operating at the licensed power of 100 kW for an extended period of time (1000 h) long enough to have achieved fission product equilibrium before losing all of its shielding/cooling water and that the reactor was shut down manually at the initiation of a cooling-water leak. It was assumed that decay heat was removed by convective water cooling until the top of the core became uncovered, after which heat removal was accomplished only by air convection. The high radiation alarm above the reactor was assumed to be operational, and the reactor is assumed to scram automatically from either a high radiation alarm or a low water level signal. The doses resulting from the loss-of-coolant accident were calculated by the licensee for two cases. Case I assumed an instantaneous loss of coolant, and Case II assumed a constant pool water level drop of 0.4 m/h.

For Case I above, the calculated dose rates at the top of the reactor pool and at the floor of the laboratory located immediately above the reactor pool were 440 rem/hr and 4.1 rem/hr respectively, 6 min after the reactor shutdown following the initiation of the accident; decaying to 80 rem/h and 0.69 rem/hr respectively after 24 h. In Case II [slow leak loss-of-coolant accident (LOCA)], the dose rates reached a maximum when the pool water level dropped to a level below the bottom of the active fuel in the core (~15 hr after reactor shutdown following the initiation of the accident). The dose rates at the top of the reactor pool and the floor of the student laboratory were 83 rem/h and 0.88 rem/hr respectively.

14.3.2. Assessment

Los Alamos performed calculations to determine the maximum temperature rise in the reactor's hottest fuel element upon the rapid loss of cooling water. The calculations indicated that the maximum fuel element temperature following an instantaneous and complete loss of coolant would be less than $\sim 302^{\circ}\text{F}$ ($\sim 150^{\circ}\text{C}$). The resulting pressure in the fuel element cladding that would be exerted by trapped air and fission product gases would result in a corresponding stress of about ~ 1000 psi (~ 6.86 MPa), which is considerably less than the $\sim 35\,000$ -psi (~ 240 -Mpa) yield stress for the stainless-steel fuel cladding and also is less than the $\sim 17\,000$ -psi (~ 117 -MPa) yield stress for the aluminum fuel cladding. Therefore, the release of hydrogen from the expansion of air and fission product gases in the fuel would not result in the rupture of the fuel element cladding and the fission products would be retained in the fuel elements.

Several investigations have evaluated such scenarios under various assumptions (West, 1970; General Atomics, 1959; Reed College, 1967; Shoptaugh, 1970) with prolonged operation and peak temperatures reaching up to $\sim 860^{\circ}\text{F}$ (460°C) and have shown that the radiative loss of the core heat would be sufficient to ensure the integrity of the fuel cladding. Furthermore, the radiation field would be highly collimated because of the reactor shield wall, thus allowing the operator to take corrective actions without excessive exposures.

The Technical Specifications require that the reactor be shut down (scrammed) if the pool water level is less than 21 ft (6.4 m) above the top grid plate of the core. The pool level alarm would alert the operating staff of a low reactor water level condition. In addition, a radiation monitor located directly above the reactor and the monitor located under the bridge across the top of the core also would alert the operating staff of a lower than normal water level condition due to elevation radiation levels.

Los Alamos has reviewed the licensee's analysis and have determined that the proper methodology was used. Additionally, we have done an independant check on selected cases, and found that the calculated consequences were in reasonable agreement with those obtained by the licensee.

Based on the above considerations, Los Alamos concludes that the possibility of the loss of coolant/shielding water is an extremely unlikely event, that the consequences from such an event would not to cause damage to the reactor and is unlikely to result in serious radiation exposure to the operating staff or occupants of the building.

14.4. Misplaced Experiments

The potential misplacement of experimental samples or devices in another experimental facility could result in an irradiation condition that could exceed the design specifications. In this situation, the sample could become overheated or develop pressures that could cause a failure of the experiment container. As discussed in Sec. 10, all experiments at UUTR are reviewed before insertion, and all experiments in the region of the core are isolated from the fuel cladding by at least two barriers such as the central thimble and an internal tube.

No fueled experiments or explosives are allowed by the Technical Specifications, therefore, Los Alamos concludes that the experimental facilities and the procedures for experimental review at the UUTR are adequate to provide reasonable assurance that failure of experiments is not likely, and even if such a failure occurred, breaching of the reactor fuel cladding would not occur. In addition, if an experiment should fail and release radioactivity within an experimental irradiation facility, there is reasonable assurance that the amount of radioactivity released to the environment would not be more than that from the accident (MHA) discussed in Sec. 14.1.

14.5. Mechanical Rearrangement of the Fuel

This type of potential accident would involve the failure of some reactor system, such as the support structure, or could involve an externally originated event that disperses the fuel and in so doing breaches the cladding of one or more fuel elements.

During the removal of irradiated fuel from the UUTR, a ~1000-lb (455-kg) steel-encased fuel handling cask is lowered into the pool by a crane. An irradiated fuel element is loaded into the cask, and the cask is removed from the pool. Los Alamos has considered the possibility of this cask being dropped into the pool during the handling process, resulting in some type of fuel cladding failure. Because of the dissolution of the halogens in the pool water, we conclude that the fission products released as a result of this accident would be considerably lower than those released from the fuel handling accident (MHA). Therefore, Los Alamos concludes that there is no credible mechanical rearrangement of fuel that would result in an accident with more severe consequences than the MHA or the rapid insertion of reactivity accident discussed in Secs. 14.1 and 14.2.

14.6. Effects of Fuel Aging

Los Alamos has included a discussion on the phenomena of fuel aging in this section for the purpose of addressing all credible effects. However, fuel aging should be considered normal with reactor operation and is, in fact, expected to occur gradually. The possibility of internal reactions is discussed below.

There is evidence that the $U-ZrH_x$ fuel tends to fragment with use, probably because of the stresses caused by high temperature gradients and the high heating rates observed during pulsing operations (West, 1970; Simnad, 1980). Possible consequences of fragmentation include (1) a decrease in thermal conductivity across cracks leading to higher central fuel temperatures during steady-state operation and (2) an increase in the amount of fission product migration into the cracks in the fuel. However, because the UUTR does not experience any pulsing, the fuel aging effects associated with the thermal stresses because of pulsing are considered not to have any effect on the fuel-cladding gap changes during the steady-state operations of the UUTR.

Two mechanisms for fission product release from TRIGA fuel meat have been proposed (Simnad, 1980; Foushee, 1968). The first mechanism is fission fragment recoil into gaps within the fuel cladding. This effect predominates up to about 752°F (400°C) and is independent of fuel temperature. According to

the licensee, the UUTR has never exceeded $\sim 234^{\circ}\text{F}$ ($\sim 112^{\circ}\text{C}$); thus, this will be the main effect. GA has postulated that in a closed system such as exists in a TRIGA fuel element, fragmentation of the fuel material within the cladding will not cause an increase in the fission product release fraction (Foushee, 1968). The reason for this is that the total free volume available for fission products remains constant within the confines of the cladding.

Under these conditions, the formation of a new gap or the widening of an existing gap must result in a corresponding narrowing of an existing gap at some other location. Such a narrowing allows more fission fragments to traverse the gap and become embedded in the fuel or cladding material on the other side. In a closed system, the average gap size, and therefore the fission product release rate, remains constant, and it is independent of the degree to which fuel material is broken up.

At temperatures greater than 752°F (400°C), the controlling mechanism for fission product release is diffusion, and the amount released depends on fuel temperature and the surface-to-volume ratio of the fuel. However, release fractions used in the accident analysis are based on a conservative calculation that assumed a degree of fuel fragmentation greater than expected in actual operation.

As the two likely effects of aging of the U-ZrH_x fuel moderator will not have a significant effect on the operating temperature of the fuel or on the assumed release of gaseous fission products from the cladding, we conclude that there is reasonable assurance that fuel aging will not significantly increase the likelihood of fuel cladding failure on the calculated consequences of an accidental release in the event of a loss of cladding integrity.

14.7. Conclusion

Los Alamos has reviewed the credible accidents for the UUTR. Based on this review, the postulated accident with the greatest potential effect on the environment is the loss of cladding integrity of one irradiated fuel element in air in the reactor room. The analysis of this accident had indicated that

even if several full rods failed simultaneously, the expected dose equivalents in unrestricted areas still would be below the 10 CFR 20 guidelines. Therefore, Los Alamos concludes that the design of the facility and the Technical Specifications provide reasonable assurance that the UUTR can be operated with no significant risk to the health and safety of the public.

REFERENCES

1. ANSI/ANS 15.11, "Radiological Control at Research Reactor Facilities."
2. Armed Forces Radiobiology Research Institute (AFRRI), "Safety Analysis Report," National Naval Medical Center (NNMC), Bethesda, Maryland (June 1981).
3. Coffey, C. O., et al., "Stability of U-ZrHx TRIGA Fuel Subjected to Large Reactivity Insertion," General Atomics report GA-6874, transmitted by letter dated July 25, 1967, docket no. 50-163 (January 1966).
4. Foushee, F. C., "Release of Rare Gas Fission Products from U-ZrHx Fuel Material," General Atomics report GA-8597 (March 1968).
5. Foushee, F. C., and R. H. Peters, "Summary of TRIGA Fuel Fission Product Release Experiments," GULF-EES-A10801 (September 1971).
6. General Atomics Company, "Technical Foundations of TRIGA," General Atomics report GA-0471 (August 1958).
7. General Atomics Company, "TRIGA Reactor," General Atomics report GA-722 (1959).
8. General Atomics Company, "Thermionic Research TRIGA Reactor Description and Analysis," General Atomics report GA-5400, Rev. C, transmitted by letter dated February 28, 1966, docket no. 50-227 (November 1, 1965).
9. General Atomics Company, "Instruction Manual for the Torrey Pines Triga Reactor," General Atomics report GA-7275 Rev. (1976).
10. Hawley, S. C., R. L. Kathren, M. A. Robkin, "Analysis of Credible Accidents for Argonaut Reactors," U.S. Nuclear Regulatory Commission report NUREG/CR-2079 PNL-3691, Washington, D.C. (April 1981).
11. G. R. Hopkins, J. C. Bokros, R. H. Stahl, T. A. Trozera, "Triga Fuel - Element Development Tests, General Atomics report GA-1966 (March 1961).
12. NRC Regulatory Guide 3.34, Rev. 11 (July 1979).
13. Reed College, "Safety Analysis Report," Portland, Oregon (1967).
14. Shoptaugh, J. F., Jr., "Simulated Loss-of-Coolant Accident for TRIGA Reactors," General Atomics report GA-6596, transmitted by letter dated September 22, 1970, docket no. 50-227 (1970).
15. Simnad, M. T., F. C. Foushee, and G. B. West, "Fuel Elements for Pulsed TRIGA Research Reactors," Nuclear Technology 28, 31 (1976).
16. Simnad, M. T., "The U-ZrHx Alloy: Its Properties and Use in TRIGA Fuel," General Atomics report GA-4314, E-117-833 (February 1980).

17. U.S. Nuclear Regulatory Commission, "Regulatory Impact of Nuclear Reactor Accident Source Term Assumptions," U.S. Nuclear Regulatory Commission report NUREG-0771 for comment (June 1981).
18. West, G. B., et al., "Kinetic Behavior of TRIGA Reactors," General Atomics report GA-7882 (March 1967).
19. West, G. B., "Safety Analysis Report for the Torrey Pines TRIGA Mark III Reactor," General Atomics report GA-9064, transmitted by letter dated January 29, 1970, docket no. 50-227 (January 5, 1970).