



Duquesne Light

Health Physics Department

RTL: A9.621A
Form: RE 1.103-1
2/93

REVISION	0	1	2	3
----------	---	---	---	---

Subject	Safety Analysis of the Common Control Room Doses from a Main Steam Line Break Outside of CNMT at U1 with Increased Primary-to-Secondary Leakage	ERS-SFL-95-008	PAGE 1 OF <u>108+</u>
---------	---	----------------	--------------------------

Reference RCM RP _____ EPP _____ T/S 3/4.4.5 EM _____ DCP _____
RIP

Review Category	<input checked="" type="checkbox"/> RSC Req'd	<input type="checkbox"/> RSC Not Req'd	<input type="checkbox"/> 10 CFR 50.59 Required	Unit 1 <input checked="" type="checkbox"/>	Unit 2 <input type="checkbox"/> 2
-----------------	---	--	--	--	-----------------------------------

Purpose

This calculation package documents an analysis of the postulated dose in the common control room following a main steam line break outside CNMT at Unit 1, with the objective of determining the maximum allowable primary to secondary leakage in the faulted steam generator. This analysis performed in support of a license amendment request for alternate tube plugging criteria (APC).

NOTE: This calculation package documents the evaluation described above. This package DOES NOT, in of itself, provide authority for any revision in a structure, system, or component; nor changes in procedures, tests, and experiments described in the plant licensing basis. The data and/or conclusions of this package shall not be extended to other purposes without explicit concurrence from Radiological Engineering.

	by	date
	chk	date
	app	date
3	by	date
	chk	date
	app	date
2	by	date
	chk	date
	app	date
1	by	date
	chk	date
	app	date

0	by	10/28/95	Checklist <input checked="" type="checkbox"/> Purpose <input checked="" type="checkbox"/> Assumptions <input checked="" type="checkbox"/> Methodology	<input checked="" type="checkbox"/> Input Data <input checked="" type="checkbox"/> Results <input checked="" type="checkbox"/> References	Attachments <input checked="" type="checkbox"/> Data Sheets <input checked="" type="checkbox"/> Illustrations <input checked="" type="checkbox"/> Printouts <input type="checkbox"/> Code Listings
	S.F. LaVie	date			
	chk	10/31/95			
	app	11/6/95	For RSC		

<input checked="" type="checkbox"/> BV RECORDS CENTER	<input type="checkbox"/> DIR, RadOps-1	<input checked="" type="checkbox"/> Author: S.F. LaVie
<input checked="" type="checkbox"/> CALCULATION FILE	<input type="checkbox"/> DIR, RadOps-2	<input checked="" type="checkbox"/> G.A. Kammerdeiner
<input type="checkbox"/> MGR, Health Physics	<input type="checkbox"/> DIR, Safety & Env Svcs	<input checked="" type="checkbox"/> R.N. Ireland
<input checked="" type="checkbox"/> DIR, RadEng & Health	<input type="checkbox"/> Trng Dept..	<input type="checkbox"/> _____

DISCUSSION

1. General

As part of the Unit 2 Licensing effort, SWEC performed calculations of the potential control room doses from DBAs at Unit 2^{1,2} and at Unit 1^{3,4}. These calculations became part of the licensing basis for BVPS-1 and -2 and have been documented in the UFSARs^{5,6}. Since 1987, there have been various re-analyses made of the control room habitability.^{7,8,9,10,11,12,13} The referenced analyses modified one or more design basis aspect(s) of the original SWEC calculations (references 1-4). There have been additional re-analyses performed as part of various incident reports. These later analyses address specific situations and are not part of the design basis.

In 1994, Westinghouse performed analyses¹⁴ to support the interim use of steam generator tube plugging limits based on voltage indications. These analyses included re-analysis of the offsite consequences of a postulated main steam line break during which a degraded tube leaks at rates higher than technical specification limits. Based on these analyses, Westinghouse postulated that a 6.6 gpm leakage could be tolerated and not exceed EAB thyroid dose of 30 rem. Based on correlation analyses it was determined that the potential 95% / 95% leakage rate associated with a 2.0 volt indication was much lower than 6.5 gpm providing reasonable margin of safety. In the licensing action, the NRC authorized use of 1 volt criterion¹⁵ for cycle 11. While offsite doses were evaluated in the Westinghouse report, control room doses were not. The reason behind this omission is beyond the scope of this calculation. In August 1995, the NRC issued Generic Letter 95-05, Voltage-Based Repair Criteria for Westinghouse Steam Generator Tubes Affected by Outside Diameter Stress Corrosion Cracking¹⁶. The generic letter specified that the accident leak rate acceptability needed to assess the offsite and control room doses. License amendment requests for these alternate plugging criteria must meet the guidance of the generic letter.

The purpose of this calculation is to analyze the postulated control room doses at the projected accident leakage rate in support of a license amendment request for cycle 12 and beyond.

2. Main Steam Line Break

The acceptability of the plant design to withstand steam generator leakage and not cause unacceptable offsite radiological consequences is assessed during plant licensing by the required analyses of a complete rupture of a single steam generator tube, i.e., the design basis Steam Generator Tube Rupture (SGTR), and by the inclusion of technical specification primary-to-secondary leakage rates (and technical specification reactor coolant radioactivity) as input parameters to other design basis accidents, such as loss of AC power auxiliaries, CRDM ejection, and, of specific interest here, main steam line breaks.

Main steam line breaks are of interest to the issue of degraded steam generator tubes because (1) the secondary depressurization event results in the most rapid differential pressure transient on the steam generator tubes thus increasing the probability of tube failure, and (2) should the tubes fail, the event would constitute a failure of two of the three fission product barriers and result in a release of radioactivity to the environment.

In typical design basis calculations, there is a single initiating event, in this case, a failure of the main steam piping outside containment. The analyses address this initiating event, and any failures that



are a direct consequence of the initiating event. Leakage of the steam generator tubes greater than technical specifications was not postulated in the original analyses of record since the steam generator tubes were assumed to have sufficient structural integrity to withstand the expected differential pressure by a very large margin. Since this analysis is being performed to support a licensing amendment allowing continued operation with steam generator tubes that have known indications of degradation, it is appropriate that the consequential tube leakage be considered.

The analyses in reference 14 determined that a postulated leakrate of 6.6 gpm was acceptable from the standpoint of offsite dose (30 rem at the site boundary). The analysis of the corresponding control room dose will initially assume a leakrate of 6.6 gpm. This value may need to be decreased, and/or other analysis inputs and assumptions modified in order to meet GDC19 dose criteria. Some of these changes in assumptions may require revision to technical specifications, e.g., reduction in steady state and transient RCS radioactivity LCOs.

METHODOLOGY

1. Overall Methodology

The analyses in this package uses version 2.0 of the TRAILS (for Transport of Radioactive mAterial In Linear Systems) code documented in ERS-SFL-89-020¹⁷. This code is comparable to the DRAGON code used by SWEC in the Reference 3 and 4 analyses, i.e., the original analyses of record. There are some differences between DRAGON and TRAILS that warrant discussion. The differences and the justification thereof are described below:

1.1 DRAGON assesses the buildup of daughter radioactivity due to the decay of a parent radionuclide. TRAILS does not assess this contribution. The decay of the iodine radioisotopes produces xenon radioisotopes. Thus, TRAILS tends to underestimate the xenon concentrations. This is not a significant concern in the current analysis in that noble gas exposure is not limiting. This is a conservative situation with regard to the onset of the radiation monitor alarm and the actuation of control room isolation, since the TRAILS gamma dose rate results will be slightly underestimated, thus delaying isolation.

1.2 The DRAGON and TRAILS codes differ in dose calculational methods:

1.2.1 The DRAGON code used in the original licensing analyses of record determined whole body-photon, whole body-beta, and thyroid dose as defined in TID14844¹⁸ and Regulatory Guides 1.4¹⁹ and 1.25²⁰.

1.2.2 Version 1.0 of the TRAILS code determined the same dose quantities as did DRAGON, using the same data sources for the thyroid dose, and the formulae of Reference 19 for the whole body doses. The energy per disintegration values used in the whole body dose formulae were taken from the BVPS Radionuclide Data Base²¹ rather than the reference stated in Reference 19 (which is no longer in print). TRAILS implements the infinite-to-finite cloud correction algorithm of Murphy and Campe²². In previous test calculations performed in Reference 23, close correlations were demonstrated with the previous DRAGON results.

1.2.3 Version 2.0 of the TRAILS code uses the same dose calculational methodology of version 1.0 and adds the capability for assessing the dose quantities: effective dose

equivalent (external) (EDE), skin dose equivalent (DE), and thyroid committed dose equivalent (CDE). In accordance with licensing positions taken in REAP-1.106, Dose Calculation Methodology in DBA Analyses²⁴, these dose quantities may be utilized in licensing procedures as substitutes for the outdated corresponding dose quantities of Reference 19 provided the initial application is reviewed by the NRC staff. The analysis herein is being performed in support of a license amendment. Thus, this stipulation will be satisfied.

1.2.4 Version 2.0 of TRAILS also assesses the committed effective dose equivalent (CEDE) and the total effective dose equivalent (TEDE). These dose quantities may not be used for showing compliance with 10 CFR Part 100.11, since that guideline specifically references the whole body and thyroid dose quantities.

1.3 The DRAGON code does not provide a direct means to handle concurrent iodine spiking. The method used by SWEC as a work-around involves averaging. The TRAILS code can isotopically model initial activity and a constant introduction rate, and, therefore can explicitly model concurrent spiking. Thus, there may be slight differences between the DRAGON and TRAILS cases and results.

2. Control Room Modeling

The modeling of the control room intake and exhaust is described in Appendix 1 to this calculation package.

Note that previous analyses of the consequences of a main steam line break accident (assuming 1 gpm primary-to-secondary leakage) on the control room habitability have shown that automatic isolation and pressurization of the control room does not occur. The control room radiation monitor reading did not exceed the monitor setpoint. Instead, previous analyses have conservatively assumed that the control room operators would manually initiate control room isolation and pressurization at T=30 minutes.

The monitor setpoint was developed by SWEC during Unit 2 licensing and was based on the dose rate at the monitor submerged in a cloud of gas having a concentration that would result in a 30-day inhalation dose less than 30 rem (thyroid dose limiting). When the analysis was performed, the small line break (outside CNMT) was the limiting accident. The intake concentration for the main steam line break did not result in a early radiation monitor alarm, but would be sufficient to result in doses exceeding GDC19. With the increased primary-to-secondary leakage assumed in this analysis, the control room radiation monitor reading may exceed its setpoint and isolation may occur prior to 30 minutes post-accident. The analysis herein will assess the timing of control room isolation actuation via the radiation monitor for differing leakrates. The dependency of the postulated dose on the timing of control room isolation, as well as the primary-to-secondary leak rate, makes it impossible to calculate a "rem per gpm" value valid for all leak rates.

3. Main Steam Line Break Modeling

The radioactivity releases from this accident are addressed in a series of cases. The results from applicable cases are summed to obtain the total postulated dose. In order to determine the timing of control room isolation, these cases may be run twice for each leakage — once for dose rate with



no isolation assumed, and once for dose, with the isolation credited. The cases are (see Attachment 1):

FRP: Release from Faulted S/G, Rupture leakage, Pre-incident RCS iodine spike activity. Release rate from steam generator equal to release rate from RCS. No hold-up or iodine decontamination credited. Eight hour release. Noble gases and iodines considered.

FRC: Release from Faulted S/G, Rupture leakage, Concurrent RCS iodine spike activity plus T/S equilibrium activity. Release rate from steam generator equal to release rate from RCS. No hold-up or iodine decontamination credited. Eight hour release. Noble gases and iodines considered.

ITN: Release from Intact S/Gs, I/S leakage, RCS Noble gas activity. Release rate from steam generator equal to release rate from RCS. No hold-up credited. Eight hour release. Noble gases considered.

ITP: Release from Intact S/G, I/S leakage, Pre-incident iodine spike RCS activity. Release rate from steam generator equal to release rate from RCS. Eight hour release. No hold-up credited. However, release rate reduced by factor of 100 to reflect iodine partitioning after one hour.

Note: Partitioning credit is appropriate whenever the steam generator level is such that the tube leak location is submerged. In this event, the level in the intact steam generators will initially drop, but is assumed to be restored within one hour. See assumption 1.9 below.

ITC: Release from Intact S/G, I/S leakage, Concurrent iodine spike plus T/S equilibrium RCS activity. Release rate from steam generator equal to release rate from RCS. Eight hour release. No hold-up credited. However, release rate reduced by factor of 100 to reflect iodine partitioning after one hour.

See note above under ITP

FLI: Release from Faulted S/G, Liquid Iodine activity initially present in S/G. Release rate based on release of 99.999999% of pre-accident activity in the liquid phase in 30 minutes.

Note: The 30 minute assumption is based on the assumption used in the original analyses. The exponential transfer lambda associated with the stated release and duration is such that 99.3% of the activity is released in the first second. Thus, the assumption will be retained as it is sufficiently conservative.

ILI: Release from Intact S/Gs, Liquid Iodine activity initially present in S/G. Release rate based on steaming rate of steam generator. Hold-up is modeled. Release rate reduced by a factor of 100 to reflect iodine partitioning.

Note: This partitioning not affected by S/G level since the activity was dispersed in the liquid prior to the event. Case ITP / ITC / ITN address leakage after the start of the event.

ASA: Release from All S/Gs, Steam space activity initially present in S/G, pre-incident S/G activity, All nuclides. Instantaneous puff release (99.999999% in 1 second.)



For the pre-incident iodine spike cases FRP and ITP, the dose equivalent iodine-131 technical specification activity of $60 \mu\text{Ci/gm}$ will be used to obtain the pre-incident activities for the five iodine nuclides. These will be added to the iodine and noble gas equilibrium concentrations associated with the $1.0 \mu\text{Ci/gm}$ dose equivalent iodine-131 technical specification.

For the co-incident iodine spike cases FRC and ITC, the iodine appearance rates equal to 500 times the iodine appearance rate that yields the $1.0 \mu\text{Ci/gm}$ dose equivalent iodine-131 technical specification concentrations will be added to the iodine and noble gas equilibrium concentrations. At four hours post accident, the co-incident spike ceases (modeled by dividing iodine appearance rates by 500).

For the ITN case, the noble gas concentrations associated with the $1.0 \mu\text{Ci/gm}$ dose equivalent iodine-131 technical specification concentration are used.

For the FLI and ILI cases, the iodine activities in the steam generator liquid phase associated with the $0.1 \mu\text{Ci/gm}$ equilibrium concentration dose equivalent iodine-131 technical specification are used. Noble gases are assumed to enter the steam phase immediately, and are addressed in ASA.

For the ASA case, the activities in the steam phase associated with the $0.1 \mu\text{Ci/gm}$ equilibrium concentration dose equivalent iodine-131 technical specification are used.

INPUT DATA AND ASSUMPTIONS

This section documents input data that are applicable to this analysis. Appendix 1 provides additional input data associated with the control room modeling.

1. Assumptions

1.1 The analysis of the main steam line break (MSLB) is based on the guidance provided in Chapter 15.1.5 of Reference 25 and Reference 16.

1.2 There is no failed fuel for the MSLB

The Unit 1 UFSAR shows that DNB is not exceeded for a MSLB. In accordance with Reference 25, no fuel damage need be assumed if DNB is not exceeded.

1.3 The MSLB occurs outside of containment releasing activity from the faulted and the intact steam generators.

1.4 The transport of radioactivity from the point of release from the CNMT or a system to the control room intake is assumed to be instantaneous.

This is a conservative assumption in that the activity intake during damper movement and diesel start-up and sequencing is maximized.

1.5 Incoming air is uniformly distributed throughout the control room volume.

This is a conservative assumption in that the radiation monitors will alarm when the dose from



the cloud of gases adjacent to the monitor exceeds the setpoint. Assuming complete mixing reduces the concentration and dose, thereby delaying the isolation actuation.

- 1.6 The control room process safety limit of 30 rem thyroid is represented by the analytical limit of 1 mR/hr on the control room area monitors.

This assumption is validated by the dose results of previous accident calculations.

- 1.7 Loss of power is assumed coincident with the control room isolation actuation.

This assumption differs from that at Unit 2, where, loss of power is assumed coincident with the accident. The Unit 1 assumption is more conservative. However, the Unit 2 assumption meets the requirements of §3.1.1.3 of the FSAR that states that a loss of offsite power is assumed if the postulated event or its effects results in a reactor or turbine trip. This requirement implies a coincident loss of power.

- 1.8 Unfiltered inleakage of 10 cfm is assumed during control room pressurization.

This assumption is consistent with Reference 25, Chapter 6.4.

- 1.9 The level in the unaffected, intact steam generators is restored to greater than 5% narrow range within one hour.

In response to the rapid pressurization of the main steam line, main steam line isolation (<500 psig) will occur and pressurizer level will drop to below the SI actuation setpoint (1845 psig). When SI occurs, all three auxiliary feedwater pumps will receive a start signal and will inject water into the steam generators. The EOPs will have the operator isolate feedwater to the faulted steam generator. However, these EOPs direct the operator to ensure that (1) the discharge MOVs for the intact generators are fully open, and (2) once level is restored, that the level is controlled between 5% and 50%. It is significant to note, that if the level is less than 5% in all intact S/Gs and feedwater flow is less than 350 gpm, a heat sink red path critical safety function terminus is declared and function restoration procedure FR-H.1 is entered. As long as the heat sink is in a red path, all operator attention is directed to restoring the heat sink. Simulator training scenarios responses indicate that the level is restored to greater than 5% within 30 minutes from completion of blowdown of the faulted generator. It is therefore reasonable to assume that partitioning be credited after one hour from the start of the event. The doubling of the expected time to cover the tubes was done to provide additional margin for this qualitative assumption.

- 1.10 The EDE result provided by TRAILS is assumed to correspond to the whole body photon guideline in SRP 6.4, the skin DE to whole body beta, and the thyroid CDE to thyroid.

See REAP 1.106 for justification.

NOTE: Assumption 1.10 is valid only in the context of a license amendment request that is to be reviewed by the NRC staff. The assumption is considered to be unreviewed safety question since the methodologies and assumptions of the original reviewed analyses are modified by this assumption. Once the license proceeding is approved by the NRC, this assumption may be considered part of the design basis for this particular postulated accident.

2. Input Data**2.1 Technical Specification Concentrations*, $\mu\text{Ci/gm}$ [26]**

**those concentrations that equate to 1.0 $\mu\text{Ci/gm}$ DE I-131 in RCS; 0.1 $\mu\text{Ci/gm}$ DE I-131 in S/G*

<u>Nuclide</u>	<u>RCS</u>	<u>S/G</u> <u>liq</u>	<u>S/G</u> <u>steam</u>
Kr-83m	1.13E-1	—	4.87E-6
Kr-85m	5.51E-1	—	2.37E-5
Kr-85	2.91E+0	—	1.25E-4
Kr-87	3.15E-1	—	1.36E-5
Kr-88	8.40E-1	—	3.62E-5
Kr-89	2.65E-2	—	1.14E-6
Xe-131m	2.83E-2	—	1.22E-6
Xe-133m	8.09E-1	—	3.49E-5
Xe-133	6.89E+0	—	2.97E-4
Xe-135m	2.86E-1	—	1.23E-5
Xe-135	8.45E-1	—	3.64E-5
Xe-137	4.29E-2	—	1.85E-6
Xe-138	1.77E-1	—	7.63E-6
I-131	6.60E-1	7.14E-2	7.14E-4
I-132	2.30E-1	1.27E-2	1.27E-4
I-133	1.03E+0	9.32E-2	9.32E-4
I-134	1.44E-1	2.23E-3	2.23E-5
I-135	5.54E-1	3.41E-2	3.41E-4

2.2 Pre-incident Iodine Spike Concentrations, $\mu\text{Ci/gm}$ [26]

<u>Nuclide</u>	<u>RCS</u>
I-131	39.8
I-132	13.9
I-133	62.2
I-134	8.7
I-135	33.4

2.3 Concurrent Iodine Spike Rate, $\mu\text{Ci/sec}$ [4]

<u>Nuclide</u>	<u>RCS</u>
I-131	1.36E+6
I-132	2.52E+6
I-133	3.08E+6
I-134	3.68E+6
I-135	2.81E+6

2.4 Concurrent Iodine Spike Duration = 4 hours [4]

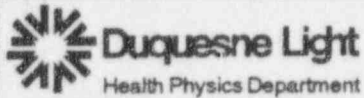

ERS-SFL-95-008

page 9

- 2.5 Technical Specification Primary-to-Secondary Leakage [27]
150 gpd any one generator, 450 gpd total
- 2.6 Primary Coolant Mass = 3.9E5 lbm, 1.77E+8 gm [4]
- 2.7 Secondary Side Mass [4]
Liquid: 97900 lbm = 4.44E+7 gm @generator
Vapor: 6460 lbm = 2.93E+6 gm @generator
- 2.8 Iodine Partition Factors [25]
Faulted S/G: 1.0
Intact S/Gs: 0.01 after one hour
- 2.9 Time to Isolate Faulted S/G = 8 hours [4]
- 2.10 Steam Release from Faulted S/G [4]
0-30 minutes: 150,000 lbm
30 min.-8 hours: 1300 lbm
- 2.11 Steam Release from Intact S/Gs [4]
0-2 hrs: 366,776 lbm
2-8 hrs: 705,393 lbm
- 2.12 Breathing Rate = 3.47E-4 m³/s [19]

CALCULATION

1. Activities

Datum 2.1 provides the technical specification concentrations, in $\mu\text{Ci}/\text{gm}$, in the RCS and in the S/Gs. For use in TRAILS, these values must be expressed in terms of activity, in μCi . The conversions are:

$$\text{RCS: } A_{\text{RCS}} = C_{\text{RCS}} \cdot \mu\text{Ci}/\text{gm} \times 1.77\text{E}8 \text{ gm}$$

$$\text{SG Liquid: } A_{\text{SG}} = C_{\text{SG}} \cdot \mu\text{Ci}/\text{gm} \times 4.44\text{E}7 \text{ gm (each S/G)}$$

$$\text{SG Vapor: } A_{\text{SG}} = C_{\text{SG}} \cdot \mu\text{Ci}/\text{gm} \times 2.93\text{E}6 \text{ gm (each S/G)}$$

Table 1
Technical Specification Equivalent Activities, μCi

<u>Nuclide</u>	<u>RCS</u>	<u>@SG</u>	
		<u>liq</u>	<u>Vapor</u>
Kr-83m	2.00E+07	0	1.43E+01
Kr-85m	9.75E+07	0	6.94E+01
Kr-85	5.15E+08	0	3.66E+02
Kr-87	5.58E+07	0	3.98E+01
Kr-88	1.49E+08	0	1.06E+02
Kr-89	4.69E+06	0	3.34E+00
Xe-131m	5.01E+06	0	3.57E+00
Xe-133m	1.43E+08	0	1.02E+02
Xe-133	1.22E+09	0	8.70E+02
Xe-135m	5.06E+07	0	3.60E+01
Xe-135	1.50E+08	0	1.07E+02
Xe-137	7.59E+06	0	5.42E+00
Xe-138	3.13E+07	0	2.24E+01
I-131	1.17E+08	3.17E+06	2.09E+03
I-132	4.07E+07	5.64E+05	3.72E+02
I-133	1.82E+08	4.14E+06	2.73E+03
I-134	2.55E+07	9.90E+04	6.53E+01
I-135	9.81E+07	1.51E+06	9.99E+02

For the pre-incident iodine spike cases, the datum 2.2 values were added to** the datum 2.1 RCS values and corrected to activity.

Table 2
RCS Pre-incident Iodine Spike

<u>Nuclide</u>	<u>μCi</u>
Kr-83m	2.00E+07
Kr-85m	9.75E+07
Kr-85	5.15E+08
Kr-87	5.58E+07
Kr-88	1.49E+08
Kr-89	4.69E+06
Xe-131m	5.01E+06
Xe-133m	1.43E+08
Xe-133	1.22E+09
Xe-135m	5.06E+07
Xe-135	1.50E+08
Xe-137	7.59E+06
Xe-138	3.13E+07
I-131	7.16E+09
I-132	2.50E+09
I-133	1.12E+10
I-134	1.56E+09
I-135	6.89E+09

<< This value should have been 6.01E+09. Affects FRP and ITP cases only. Difference is 15% high. However, I-135 represents about only 3% of the total dose. Discovered during checking. Cases were not re-run.

****NOTE:** This is conservative. The pre-incident values are based on T/S. Thus, the I-131 thru I-135 datum 2.2 values already include the equilibrium iodine values. The difference is 1-2%

2. Transfer Coefficients

Initial transfer coefficients for the model cases are determined in this section. Density based on assumption of 1.0 gm/cc:

$$8.345 \frac{\text{lb}}{\text{gal}} = \frac{\text{lb}}{453.59 \text{ gm}} \cdot \frac{3785.43 \text{ cc}}{\text{gal}}$$

2.1 FRP, FRC

Base the release rate on a primary-to-secondary leakrate = 1, 2, 3, 4, 5, 6.6 gpm.

$$1.0 \text{ gpm} = 1.6666\text{E-}2 \text{ gal/sec} = (1.6666\text{E-}2 \text{ gal/sec})(8.345 \text{ lb/gal}) / (3.9\text{E}5 \text{ lbm}) = 3.5661\text{E-}7 \text{ sec}^{-1}$$

$$2.0 \text{ gpm} = 3.5661\text{E-}7 \times 2 = 7.1322\text{E-}7 \text{ sec}^{-1}$$

$$3.0 \text{ gpm} = 3.5661\text{E-}7 \times 3 = 1.0698\text{E-}6 \text{ sec}^{-1}$$

$$4.0 \text{ gpm} = 3.5661\text{E-}7 \times 4 = 1.4264\text{E-}6 \text{ sec}^{-1}$$

$$5.0 \text{ gpm} = 3.5661\text{E-}7 \times 5 = 1.7830\text{E-}6 \text{ sec}^{-1}$$

$$6.6 \text{ gpm} = 3.5661\text{E-}7 \times 6.6 = 2.3536\text{E-}6 \text{ sec}^{-1}$$

2.2 ITN

Base the release rate on a primary to secondary leakrate = 300 gal/d (3.4722E-3 gal/sec) [2 x datum 2.5]:

$$\text{release rate} = (3.4722\text{E-}3 \text{ gal/sec})(8.345 \text{ lb/gal}) / (3.9\text{E}5 \text{ lbm}) = 7.4296\text{E-}8 \text{ sec}^{-1}$$

(Since the release rate represents two S/Gs, the Table 1 RCS activities need not be multiplied.)

2.3 ITP, ITC

Same as ITN for first hour. After the first hour, the release rate is reduced by a factor of 100 to account for partitioning:

$$\text{release rate} = 7.4296\text{E-}8 \text{ sec}^{-1} / 100 = 7.4296\text{E-}10 \text{ sec}^{-1}$$

The 0-1 hour value will be entered as the base value. The XREM multiplier after one hour is 0.01

(Since the release rate represents two S/Gs, the Table 1 RCS activities need not be multiplied.)

2.4 FLI

Release from faulted S/G of liquid activity initially in S/G. Hold-up credited.

In order to model the release of 100% of the initial activity in 30 minutes, it will be assumed that a reduction of $1.0\text{E-}6$ represents 100% of the activity. The release rate (λ) can be found:

$$0.000001 = e^{-\lambda \times 1800}$$

$$\lambda = 7.675\text{E-}3 \text{ sec}^{-1}$$

2.5 ILI

Release from intact S/Gs of liquid activity initially in S/G. Hold-up and partitioning credited.

Datum 2.11 provides a release of 366,766 lbm in 2 hours; and a release of 705,393 lbm in 6 hours. Both of these values represent the release from both intact S/Gs. Thus, in order to determine the release rate from both S/G, we divide by the mass of one generators (97,900 lbm) Partitioning applies, thus, the release rate is multiplied by 0.01.

$$\text{release rate} = (366,776 \text{ lbm} / 7200 \text{ sec}) / (97,900) \times 0.01 = 5.2034\text{E-}6 \text{ sec}^{-1}$$

$$\text{release rate} = (705,393 \text{ lbm} / 21600 \text{ sec}) / (97,900) \times 0.01 = 3.3358\text{E-}6 \text{ sec}^{-1}$$

The 0-2 hour value will be entered as the base value. The XREM multiplier after two hours is $3.3358 / 5.2034 = 0.64$. Since we assumed one S/G mass above, the Table 1 activities need not be multiplied.

2.6 ASA

Release from all S/Gs equal to release fraction of $1\text{E-}6$ in 1 second of activity initially in S/G steam space, all nuclides.

$$0.000001 = e^{-\lambda \times 1}$$

$$\lambda = 13.82 \text{ sec}^{-1}$$

3. Control Room Dose Rates

Note: Computer runs were made on the ARERAS VAX and saved to text files. These files were downloaded to Word for Windows on a PC. The files were edited on the PC to remove repetitive material in the interest of saving paper. The full printouts were available to the checker and independent reviewer.

The parameters above were entered into the input files for TRAILS and the cases were run. Run printouts for the 6.6 gpm case are provided in Attachment 2. Graphs of the control room dose versus time are provided in Attachment 3. Note that the control room photon dose rate does not exceed the process safety limit of 1.0 mR/hr for about 50 minutes. However, the control room thyroid dose exceeded the GDC19 criteria for the 150 gpd case. (Although code runs involving varying release rates for the FRP and FRC cases were made, only the 6.6 gpm case is documented herein since the timing of the radiation monitor alarm increased with decreasing release rate.) The control room monitor setpoints are set to 0.47 mR/hr. The difference between the process safety limit and the



alarm trip setpoint is due to corrections for instrument uncertainty. Even if the actual errors were to align favorably and the monitor alarmed at an actual reading of 0.47 mR/hr, the timing of the alarm for the concurrent iodine spike case would not precede the isolation initiated by operator manual action at 30 minutes.

For this reason, this analysis will assume that the control isolation occurs at t=30 minutes, that emergency pressurization fans start at 90 minutes, and that the control room is purged at t=8 hours for 30 minutes.

4. Control Room Dose

The parameter input files used for the dose rate cases were edited to reflect the control room isolation assumptions and re-ran to obtain the postulated control room dose. Attachment 4 provides excerpts from the code run printouts. Attachment 5 contains graphs of the postulated dose versus leak rate.

For the co-incident iodine spiking cases, the postulated doses were:

Postulated Control Room Dose (0-30 days)
MSLB - Co-incident Iodine Spike

	EDE mrem	Skin DE mrem	Thyroid CDE mrem
ASA	1.590E-04	1.960E-03	4.340E+00
ILI	9.490E-04	1.120E-02	2.930E+01
FLI	7.420E-02	8.560E-01	2.140E+03
ITC	1.860E-02	1.550E-01	1.580E+02
ITN	3.390E-03	1.320E-01	0
Sum non-break flow	9.730E-02	1.156E+00	2.332E+03
FRC - 4 gpm	2.380E+00	2.290E+01	2.460E+04
FRC - 5 gpm	2.960E+00	2.860E+01	3.060E+04
Sum - 4 gpm	2.477E+00	2.406E+01	2.693E+04
Sum - 5 gpm	3.057E+00	2.976E+01	3.293E+04

The results showed that the maximum allowable leak rate would be between 4 and 5 gpm. Since the graph indicates that the dose is linearly proportional to leak rate, one can ratio to obtain the maximum allowable leak rate.

Postulated Control Room Dose (0-30 days)
MSLB - Co-incident Iodine Spike - 4.5 gpm P-to-S Leak Rate

	EDE mrem	Skin DE mrem	Thyroid CDE mrem
Total	2.8E+00	2.7E+01	3.0E+04

For the pre-incident iodine spiking case assuming a 5 gpm leak rate in case FRP, the total postulated dose was determined to be 30.6 rem. This is slightly higher than the GDC criterion of 30 rem. However, the co-incident case is more limiting.

Postulated Control Room Dose (0-30 days)
MSLB - Pre-incident Iodine Spike - 5 gpm P-to-S Leak Rate

	EDE mrem	Skin DE mrem	Thyroid CDE mrem
ASA	1.590E-04	1.960E-03	4.340E+00
FLI	7.420E-02	8.560E-01	2.140E+03
ILI	9.490E-04	1.120E-02	2.930E+01
ITN	3.390E-03	1.320E-01	0
ITP	3.500E-02	3.580E-01	6.900E+02
Sum non-break flow	1.137E-01	1.359E+00	2.864E+03
FRP - 5 gpm	1.340E+00	1.640E+01	2.720E+04
Sum - 5 gpm	1.5E+00	1.8E+01	3.0E+04

CONCLUSION

The analysis documented herein has established that the maximum primary-to-secondary leak rate that could be tolerated during a main steam line break outside of CNMT is 4.5 gpm. This leak rate is less than the 6.6 gpm value established by Westinghouse as being acceptable on the basis of offsite dose.

There are two means available to increase the allowable leak rate. These are:

- Reduce the technical specification RCS activity. This change would reduce the impact of both the pre-incident and co-incident iodine spikes.
- Change the actuation signal for the control room isolation from the current CNMT isolation phase B (CIB) signal to the safety injection signal. This change would eliminate the need to assume operator action at T=30 minutes and allow the analysis to assume control room isolation near T=0. This change would provide margin not only for the MSLB, but also for the rod ejection accident, steam generator tube rupture, small break LOCA., and possibly the small line break outside of CNMT. While this modification would lower the threshold for CREBAPS isolation, the ramifications of spurious SI actuations goes beyond that of CREBAPS actuation. The setpoints for SI and CIB are summarized below:

<u>SI</u>	<u>CIB</u>
2/3 CNMT pressure instruments >1.5 psig	2/4 CNMT pressure >8 psig
2/3 pressure instruments <500 psig on 1/3 main steam lines	
2/3 PZR pressure instruments <1845 psig	

Based on the experience to date involving spurious actuations of CREBAPS by the radiation monitors, lowering the monitor alarm setpoints does not appear desirable.

REFERENCES

1. SWEC, Control Room Habitability Due to Design Basis Accident (except LOCA) at BVPS-2, 12241-UR(B)-445, 1987



2. SWEC, FSAR Section 15.6.5 - LOCA Releases and Doses - Site and Control Room. 12241-UR(B)-190, 1987
3. SWEC, Doses to the Combined Control Room due to LOCA at BVPS-1. 12241-UR(B)-450, 1987
4. SWEC, Combined BV1-BV2 Control Room Habitability Due to Design Basis Accidents (except LOCA) at BV1. 12241-UR(B)-456, 1987
5. DLC, Updated Final Safety Analysis Report Unit 1.
6. DLC, Updated Final Safety Analysis Report Unit 2.
7. DLC, Unit 2 FHA Doses at EAB, LPZ, and Common Control Room, ERS-SFL-89-019
8. DLC, Safety Analysis of the Dose Consequences of a Locked Rotor Accident at BVPS-1, ERS-SFL-89-021
9. DLC, BVPS Common CR Rad Habitability During a DBA SGTR at U2 (based on WCAP-12738), ERS-SFL-90-030
10. DLC, Assessment of the Doses in the U2 CR Due to LRA at U2 - 18% F.F., ERS-MPD-91-035
11. DLC, Safety Analysis of the Dose Consequences of a FHA at BVPS-CR, ERS-SFL-92-025
12. DLC, Combined Control Room Doses due to SGTR at Unit 1, ERS-SFL-92-033
Analysis of FHA in RBC at Unit 1, ERS-SFL-92-034
13. DLC, Combined Control Room Doses from DBAs at Unit 1. ERS-SFL-93-005, 1993
14. Westinghouse, Beaver Valley Power Station-1 Steam Generator Tube Plugging Criteria for Indications at Tube Support Plates, WCAP-14122, dtd 7/94
15. USNRC, Beaver Valley Power Station Unit No. 1 Amendment 184 to Facility Operating License 50-334, February 1995
16. USNRC, Voltage-Based Repair Criteria for Westinghouse Steam Generator Tubes Affected by Outside Diameter Stress Corrosion Cracking, Generic Letter 95-05
17. DLC, TRAILS: Transport of Radioactive Material in Linear Systems. ERS-SFL-89-020, Revision 0; 1989
18. DiNunno, J.J., et al, Calculation of Distance Factors for Power and Test Reactor Sites, USAEC TID-14844, 1962
19. USNRC, Assumptions Used for Evaluating the Potential Radiological Consequences of a Loss of Coolant Accident for Pressurized Water Reactors. Regulatory Guide 1.4, Revision 2; 1974

20. USNRC, Assumptions Used for Evaluating the Potential Radiological Consequences of a Fuel Handling Accident in the Fuel Handling and Storage Facility for Boiling and Pressurized Water Reactors. Regulatory Guide 1.25, Revision 0; 1972
21. DLC, Beaver Valley Power Station Radionuclide Database and RADFILE. ERS-SFL-84-004, Revision 0; 1984
22. Murphy, K.G. and Campe, K.W., Nuclear Power Plant Control Room Ventilation System Design for Meeting General Criterion 19, published in proceedings of 13th AEC Air Cleaning Conference
23. DLC, Combined Control Room Doses Due to DBA's at Unit 2 with Delayed Isolation. ERS-SFL-89-007, Revision 1; 1989
24. DLC, Dose Calculation Methodology in DBA Analyses, Radiological Engineering Administrative Procedure 1.106.
25. USNRC, Standard Review Plan for the Review of Safety Analysis Reports for Nuclear Power Plants. NUREG-0800, Revision 5; 1987
26. SWEC, Technical Specification and Pre-Accident Iodine spike Concentrations for BVPS-1, 12241-UR(B)-451, 1987
27. DLC, Unit 1 Technical Specifications.
28. USNRC, Assumptions Used for Evaluating a Control Rod Ejection Accident for Pressurized Water Reactors, Regulatory Guide 1.77, 1974

ATTACHMENTS

1. Main Steam Line Break Model
2. Control Room Dose Rate Printouts
3. Control Room Dose Rate vs Time
4. Control Room Dose Printouts
5. Control Room Dose Versus Leak Rate
6. Appendix 1, Control Room Model

Main Steam Line Break

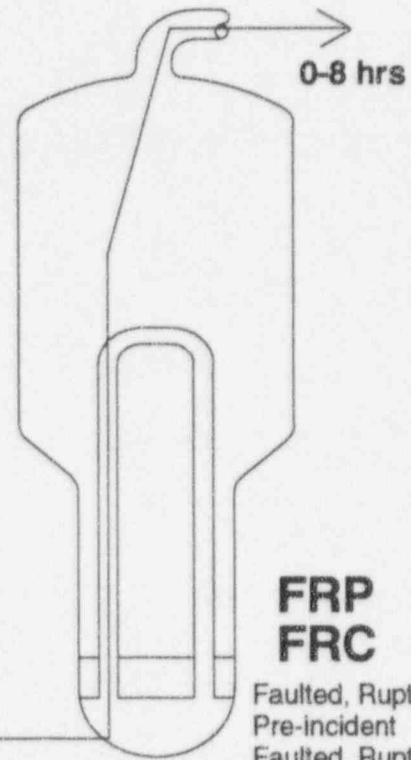
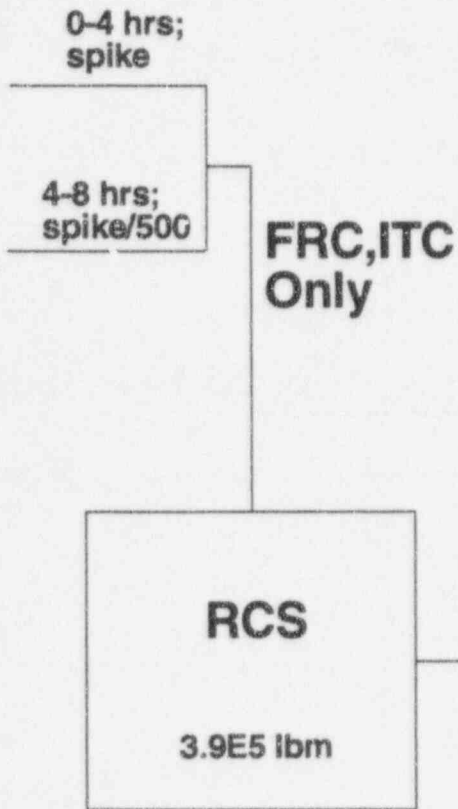

**FRP
FRC**

Faulted, Rupture Flow,
Pre-incident
Faulted, Rupture Flow, Co-
incident

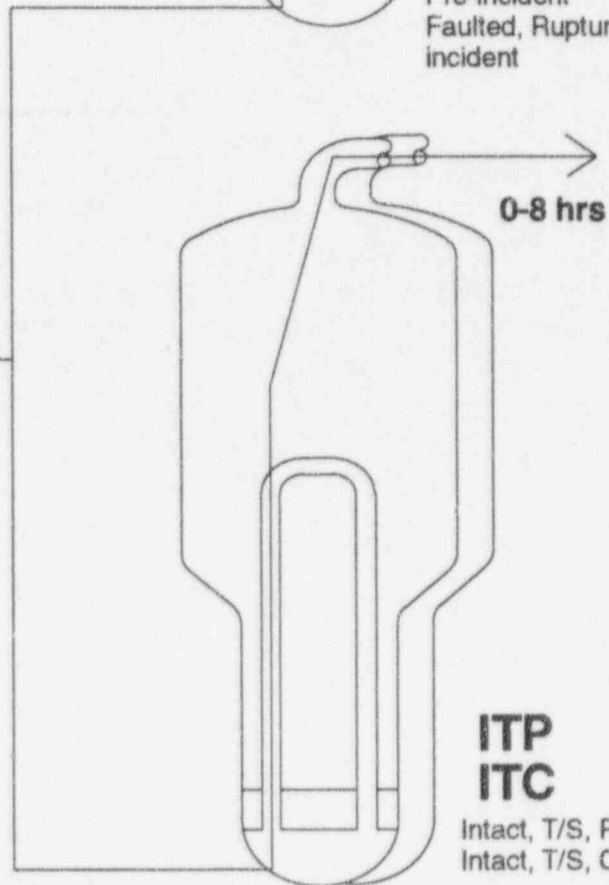

**ITP
ITC**

Intact, T/S, Pre-incident
Intact, T/S, Co-incident

Main Steam Line Break

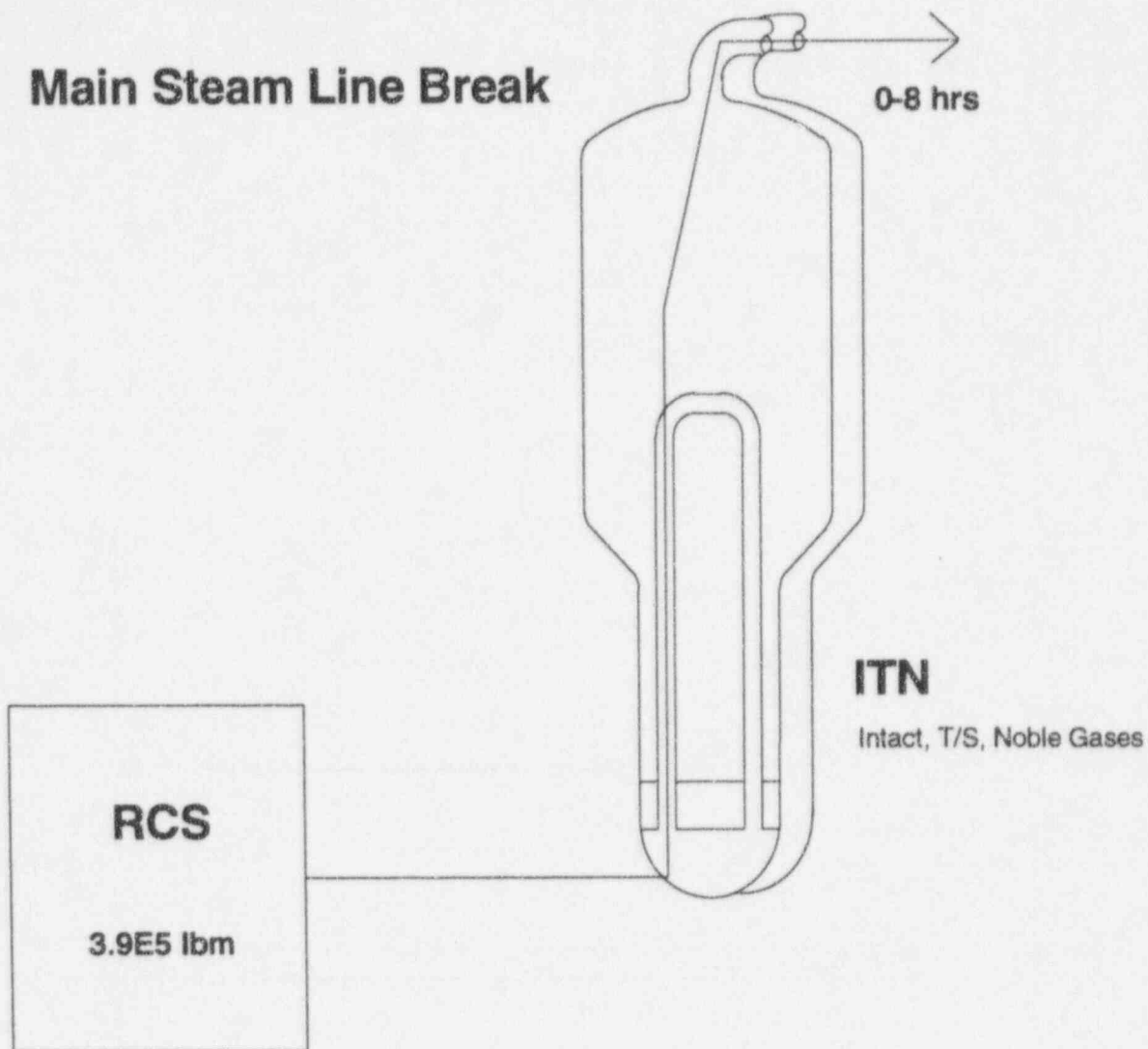

MC950802.DS4

Main Steam Line Break

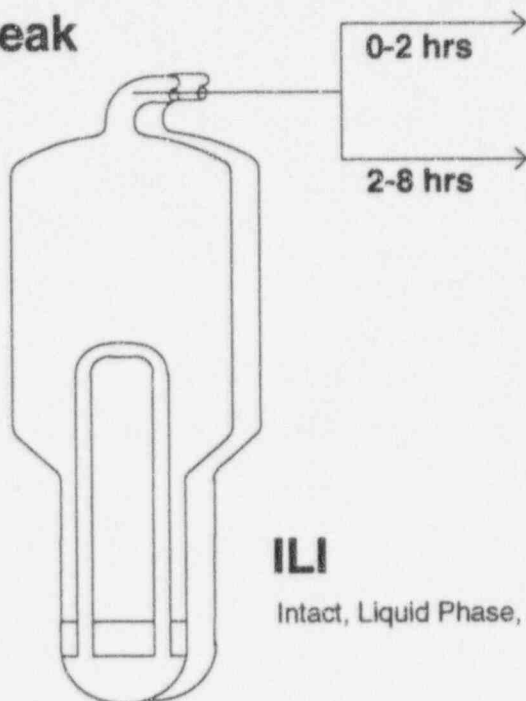

ILI

Intact, Liquid Phase, Initial

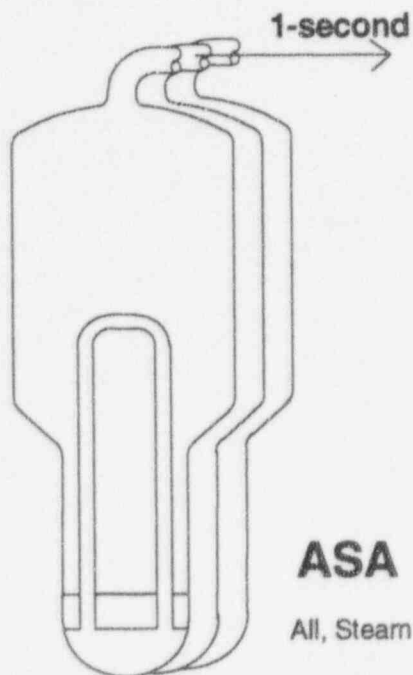

ASA

All, Steam Phase, All

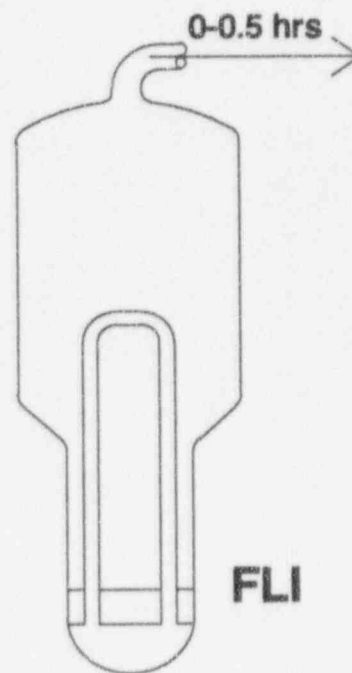

FLI

Faulted, Liquid Phase, Initial

INTENTIONALLY BLANK

TRAILS -- Transport of Radioactive Material in Linear Systems, v2.0
 FRP Case for dose rate 6.6 gpm [TC950820.DAT]

COMP: not used

COMP: faulted S/G

COMP: Control Room

VOLUME: 1.730E+05 Cu.Ft.

INITIAL:	COMP: not used	COMP: faulted S/G	COMP: Control Room
	0.000E+00 Kr-83m	2.000E+07 Kr-83m uCi	0.000E+00 Kr-83m
	0.000E+00 Kr-85m	9.750E+07 Kr-85m	0.000E+00 Kr-85m
	0.000E+00 Kr-85	5.150E+08 Kr-85	0.000E+00 Kr-85
	0.000E+00 Kr-87	5.580E+07 Kr-87	0.000E+00 Kr-87
	0.000E+00 Kr-88	1.490E+08 Kr-88	0.000E+00 Kr-88
	0.000E+00 Kr-89	4.690E+06 Kr-89	0.000E+00 Kr-89
	0.000E+00 Xe-131m	5.010E+06 Xe-131m	0.000E+00 Xe-131m
	0.000E+00 Xe-133m	1.430E+08 Xe-133m	0.000E+00 Xe-133m
	0.000E+00 Xe-133	1.220E+09 Xe-133	0.000E+00 Xe-133
	0.000E+00 Xe-135m	5.060E+07 Xe-135m	0.000E+00 Xe-135m
	0.000E+00 Xe-135	1.500E+08 Xe-135	0.000E+00 Xe-135
	0.000E+00 Xe-137	7.590E+06 Xe-137	0.000E+00 Xe-137
	0.000E+00 Xe-138	3.130E+07 Xe-138	0.000E+00 Xe-138
	0.000E+00 I-131	7.160E+09 I-131	0.000E+00 I-131
	0.000E+00 I-132	2.500E+09 I-132	0.000E+00 I-132
	0.000E+00 I-133	1.120E+10 I-133	0.000E+00 I-133
	0.000E+00 I-134	1.560E+09 I-134	0.000E+00 I-134
	0.000E+00 I-135	6.890E+09 I-135	0.000E+00 I-135
ACT MULT (to uCi):	1.000E+00	1.000E+00	1.000E+00

TRAILS -- Transport of Radioactive Material in Linear Systems, v2.0
 FRP Case for dose rate 5.6 gpm [TC950820.DAT]

REMOVAL: 1.000E+01 cfm
 INTAKE REDUCT: 0.000E+00
 INTAKE REDUCT: 0.000E+00
 INTAKE REDUCT: 0.000E+00

2.354E-06 1/sec
 0.000E+00
 0.000E+00
 0.000E+00

0.000E+00 1/sec
 0.000E+00
 0.000E+00
 0.000E+00

MULTIPLIERS====>

STEP	TIME	XPR	XREM	XRF	XPR	XREM	XRF	XPR	XREM	XRF	XPR	XREM	XRF
1	6.000E+01	0.000E+00	0.000E+00	0.000E+00	0.000E+00	1.00	0.000E+00	0.000E+00	1.00	0.000E+00	50.0	50.0	0.000E+00
2	3.000E+02	0.000E+00	0.000E+00	0.000E+00	0.000E+00	1.00	0.000E+00	0.000E+00	1.00	0.000E+00	50.0	50.0	0.000E+00
3	6.000E+02	0.000E+00	0.000E+00	0.000E+00	0.000E+00	1.00	0.000E+00	0.000E+00	1.00	0.000E+00	50.0	50.0	0.000E+00
4	9.000E+02	0.000E+00	0.000E+00	0.000E+00	0.000E+00	1.00	0.000E+00	0.000E+00	1.00	0.000E+00	50.0	50.0	0.000E+00
5	1.200E+03	0.000E+00	0.000E+00	0.000E+00	0.000E+00	1.00	0.000E+00	0.000E+00	1.00	0.000E+00	50.0	50.0	0.000E+00
6	1.800E+03	0.000E+00	0.000E+00	0.000E+00	0.000E+00	1.00	0.000E+00	0.000E+00	1.00	0.000E+00	50.0	50.0	0.000E+00
7	2.700E+03	0.000E+00	0.000E+00	0.000E+00	0.000E+00	1.00	0.000E+00	0.000E+00	1.00	0.000E+00	50.0	50.0	0.000E+00
8	3.600E+03	0.000E+00	0.000E+00	0.000E+00	0.000E+00	1.00	0.000E+00	0.000E+00	1.00	0.000E+00	50.0	50.0	0.000E+00
9	7.200E+03	0.000E+00	0.000E+00	0.000E+00	0.000E+00	1.00	0.000E+00	0.000E+00	1.00	0.000E+00	50.0	50.0	0.000E+00
10	1.440E+04	0.000E+00	0.000E+00	0.000E+00	0.000E+00	1.00	0.000E+00	0.000E+00	1.00	0.000E+00	50.0	50.0	0.000E+00
11	2.880E+04	0.000E+00	0.000E+00	0.000E+00	0.000E+00	1.00	0.000E+00	0.000E+00	1.00	0.000E+00	50.0	50.0	0.000E+00
12	8.640E+04	0.000E+00	0.000E+00	0.000E+00	0.000E+00	1.00	0.000E+00	0.000E+00	1.00	0.000E+00	50.0	50.0	0.000E+00
13	3.456E+05	0.000E+00	0.000E+00	0.000E+00	0.000E+00	1.00	0.000E+00	0.000E+00	1.00	0.000E+00	50.0	50.0	0.000E+00
14	2.592E+06	0.000E+00	0.000E+00	0.000E+00	0.000E+00	1.00	0.000E+00	0.000E+00	1.00	0.000E+00	50.0	50.0	0.000E+00

----- ENVIRONMENT -----

X/Q	Breathing
s/M3	M3/s
1.000E-03	3.470E-04
0.000E+00	3.470E-04

----- CONTROL ROOM -----

X/Q	Breathing Occupancy
s/M3	M3/s
1.000E-03	3.470E-04
1.000E+00	1.000E+00

MULTIPLIERS====>

STEP	TIME, s	X/Q	Breathing	X/Q	Breathing
		s/M3	M3/s	s/M3	M3/s
1	6.000E+01	2.43	1.00	0.000E+00	1.00
2	3.000E+02	2.43	1.00	0.000E+00	1.00
3	6.000E+02	2.43	1.00	0.000E+00	1.00
4	9.000E+02	2.43	1.00	0.000E+00	1.00
5	1.200E+03	2.43	1.00	0.000E+00	1.00
6	1.800E+03	2.43	1.00	0.000E+00	1.00
7	2.700E+03	2.43	1.00	0.000E+00	1.00
8	3.600E+03	2.43	1.00	0.000E+00	1.00
9	7.200E+03	2.43	1.00	0.000E+00	1.00
10	1.440E+04	2.43	1.00	0.000E+00	1.00
11	2.880E+04	2.43	1.00	0.000E+00	1.00
12	8.640E+04	1.22	1.00	0.000E+00	1.00
13	3.456E+05	0.890	1.00	0.000E+00	1.00
14	2.592E+06	0.626	1.00	0.000E+00	1.00

TRAILS -- Transport of Radioactive Material in Linear Systems, v2.0
 FRP Case for dose rate 6.6 gpm [TC950820.DAT]

		E N V I R O N M E N T				C O N T R O L R O O M				T H Y R O I D - I N H A L			
		P H O T O N - S U B M G		B E T A - S U B M G		T H Y R O I D - I N H A L		P H O T O N - S U B M G		B E T A - S U B M G		T H Y R O I D - I N H A L	
		DOSE	DOSE RATE	DOSE	DOSE RATE	DOSE	DOSE RATE	DOSE	DOSE RATE	DOSE	DOSE RATE	DOSE	DOSE RATE
		mrem	mrem/hr	mrem	mrem/hr	mrem	mrem/hr	mrem	mrem/hr	mrem	mrem/hr	mrem	mrem/hr
I-135		0.00E+00	0.00E+00	0.00E+00	0.00E+00	0.00E+00	0.00E+00	9.20E+00	3.93E+01	2.00E+04			
TOTALS		0.00E+00	0.00E+00	0.00E+00	0.00E+00	0.00E+00	0.00E+00	9.20E+00	3.93E+01	2.00E+04			
ALL NUCLIDES													
0.0167 h		0.00E+00	0.00E+00	0.00E+00	0.00E+00	0.00E+00	0.00E+00	1.91E-04	2.29E-02	1.28E-03	1.53E-01	2.77E+00	3.32E+02
0.0833 h		0.00E+00	0.00E+00	0.00E+00	0.00E+00	0.00E+00	0.00E+00	4.51E-03	1.12E-01	3.03E-02	7.53E-01	6.61E+01	1.65E+03
0.1667 h		0.00E+00	0.00E+00	0.00E+00	0.00E+00	0.00E+00	0.00E+00	1.38E-02	2.18E-01	9.30E-02	1.48E+00	2.05E+02	3.26E+03
0.2500 h		0.00E+00	0.00E+00	0.00E+00	0.00E+00	0.00E+00	0.00E+00	2.25E-02	3.20E-01	1.52E-01	2.17E+00	3.38E+02	4.85E+03
0.3333 h		0.00E+00	0.00E+00	0.00E+00	0.00E+00	0.00E+00	0.00E+00	3.07E-02	4.16E-01	2.09E-01	2.84E+00	4.69E+02	6.41E+03
0.5000 h		0.00E+00	0.00E+00	0.00E+00	0.00E+00	0.00E+00	0.00E+00	8.45E-02	5.96E-01	5.60E-01	4.11E+00	1.32E+03	9.44E+03
0.7500 h		0.00E+00	0.00E+00	0.00E+00	0.00E+00	0.00E+00	0.00E+00	1.80E-01	8.37E-01	1.25E+00	5.85E+00	2.91E+03	1.38E+04
1.0000 h		0.00E+00	0.00E+00	0.00E+00	0.00E+00	0.00E+00	0.00E+00	2.36E-01	1.05E+00	1.66E+00	7.43E+00	3.96E+03	1.79E+04
2.0000 h		0.00E+00	0.00E+00	0.00E+00	0.00E+00	0.00E+00	0.00E+00	1.37E+00	1.67E+00	1.00E+01	1.24E+01	2.52E+04	3.21E+04
4.0000 h		0.00E+00	0.00E+00	0.00E+00	0.00E+00	0.00E+00	0.00E+00	4.00E+00	2.29E+00	3.11E+01	1.83E+01	8.60E+04	5.26E+04
8.0000 h		0.00E+00	0.00E+00	0.00E+00	0.00E+00	0.00E+00	0.00E+00	9.60E+00	2.51E+00	8.16E+01	2.21E+01	2.56E+05	7.29E+04
24.0000 h		0.00E+00	0.00E+00	0.00E+00	0.00E+00	0.00E+00	0.00E+00	1.07E+01	7.62E-02	1.01E+02	8.18E-01	3.72E+05	3.80E+03
96.0000 h		0.00E+00	0.00E+00	0.00E+00	0.00E+00	0.00E+00	0.00E+00	2.28E-01	9.89E-08	2.50E+00	1.12E-06	1.25E+04	9.35E-03
720.0000 h		0.00E+00	0.00E+00	0.00E+00	0.00E+00	0.00E+00	0.00E+00	2.19E-07	0.00E+00	2.48E-06	0.00E+00	2.10E-02	0.00E+00
TOTALS		0.00E+00	0.00E+00	0.00E+00	0.00E+00	0.00E+00	0.00E+00	2.65E+01	2.30E+02	7.61E+05			

TRAILS -- Transport of Radioactive Material in Linear Systems, v2.0
FLI Case for dose rate [TC950803.DAT]

	COMP: not used	COMP: faulted S/G	COMP: Control Room VOLUME: 1.730E+05 Cu.Ft.
INITIAL:	0.000E+00 I-131	3.170E+06 I-131 uCi	0.000E+00 I-131
	0.000E+00 I-132	5.640E+05 I-132	0.000E+00 I-132
	0.000E+00 I-133	4.140E+06 I-133	0.000E+00 I-133
	0.000E+00 I-134	9.900E+04 I-134	0.000E+00 I-134
	0.000E+00 I-135	1.510E+06 I-135	0.000E+00 I-135
ACT MULT (to uCi):	1.000E+00	1.000E+00	1.000E+00

TRAILS -- Transport of Radioactive Material in Linear Systems, v2.0
 FLI Case for dose rate [TC950803.DAT]

REMOVAL:	0.000E+00 1/sec	7.675E-03 1/sec	1.000E+01 cfm
NUC Grp 1 REL FR:	0.000E+00	0.000E+00	INTAKE REDUCT: 0.000E+00
NUC Grp 2 REL FR:	0.000E+00	0.000E+00	INTAKE REDUCT: 0.000E+00
NUC Grp 3 REL FR:	0.000E+00	0.000E+00	INTAKE REDUCT: 0.000E+00

MULTIPLIERS====>

STEP	TIME	XPR	XREM	XRF	XPR	XREM	XRF	XPR	XREM	XRF
1	6.000E+01	0.000E+00	0.000E+00	0.000E+00	0.000E+00	1.00	0.000E+00	50.0	50.0	0.000E+00
2	3.000E+02	0.000E+00	0.000E+00	0.000E+00	0.000E+00	1.00	0.000E+00	50.0	50.0	0.000E+00
3	6.000E+02	0.000E+00	0.000E+00	0.000E+00	0.000E+00	1.00	0.000E+00	50.0	50.0	0.000E+00
4	9.000E+02	0.000E+00	0.000E+00	0.000E+00	0.000E+00	1.00	0.000E+00	50.0	50.0	0.000E+00
5	1.200E+03	0.000E+00	0.000E+00	0.000E+00	0.000E+00	1.00	0.000E+00	50.0	50.0	0.000E+00
6	1.800E+03	0.000E+00	0.000E+00	0.000E+00	0.000E+00	1.00	0.000E+00	50.0	50.0	0.000E+00
7	2.700E+03	0.000E+00	0.000E+00	0.000E+00	0.000E+00	1.00	0.000E+00	50.0	50.0	0.000E+00
8	3.600E+03	0.000E+00	0.000E+00	0.000E+00	0.000E+00	1.00	0.000E+00	50.0	50.0	0.000E+00
9	7.200E+03	0.000E+00	0.000E+00	0.000E+00	0.000E+00	1.00	0.000E+00	50.0	50.0	0.000E+00
10	1.440E+04	0.000E+00	0.000E+00	0.000E+00	0.000E+00	1.00	0.000E+00	50.0	50.0	0.000E+00
11	2.880E+04	0.000E+00	0.000E+00	0.000E+00	0.000E+00	1.00	0.000E+00	50.0	50.0	0.000E+00
12	8.640E+04	0.000E+00	0.000E+00	0.000E+00	0.000E+00	0.000E+00	0.000E+00	50.0	50.0	0.000E+00
13	3.456E+05	0.000E+00	0.000E+00	0.000E+00	0.000E+00	0.000E+00	0.000E+00	50.0	50.0	0.000E+00
14	2.592E+06	0.000E+00	0.000E+00	0.000E+00	0.000E+00	0.000E+00	0.000E+00	50.0	50.0	0.000E+00

----- CONTROL ROOM -----

X/Q	Breathing	Occupancy
s/M3	M3/s	
1.000E-03	3.470E-04	1.000E+00

---- ENVIRONMENT ----

X/Q	Breathing
s/M3	M3/s
0.000E+00	3.470E-04

MULTIPLIERS====>

STEP	TIME, s	XPR	XREM	XRF	XPR	XREM	XRF
1	6.000E+01	2.43	1.00	1.00	0.000E+00	1.00	
2	3.000E+02	2.43	1.00	1.00	0.000E+00	1.00	
3	6.000E+02	2.43	1.00	1.00	0.000E+00	1.00	
4	9.000E+02	2.43	1.00	1.00	0.000E+00	1.00	
5	1.200E+03	2.43	1.00	1.00	0.000E+00	1.00	
6	1.800E+03	2.43	1.00	1.00	0.000E+00	1.00	
7	2.700E+03	2.43	1.00	1.00	0.000E+00	1.00	
8	3.600E+03	2.43	1.00	1.00	0.000E+00	1.00	
9	7.200E+03	2.43	1.00	1.00	0.000E+00	1.00	
10	1.440E+04	2.43	1.00	1.00	0.000E+00	1.00	
11	2.880E+04	2.43	1.00	1.00	0.000E+00	1.00	
12	8.640E+04	1.22	1.00	1.00	0.000E+00	1.00	
13	3.456E+05	0.890	1.00	0.600	0.000E+00	1.00	
14	2.592E+06	0.626	1.00	0.400	0.000E+00	1.00	

	E N V I R O N M E N T						C O N T R O L R O O M					
	PHOTON-SUBMG		BETA-SUBMG		THYROID-INHAL		PHOTON-SUBMG		BETA-SUBMG		THYROID-INHAL	
	DOSE	DOSE RATE	DOSE	DOSE RATE	DOSE	DOSE RATE	DOSE	DOSE RATE	DOSE	DOSE RATE	DOSE	DOSE RATE
	mrem	mrem/hr	mrem	mrem/hr	mrem	mrem/hr	mrem	mrem/hr	mrem	mrem/hr	mrem	mrem/hr
ALL NUCLIDES												
0.0167 h	0.00E+00	0.00E+00	0.00E+00	0.00E+00	0.00E+00	0.00E+00	1.24E-04	1.49E-02	9.50E-04	1.14E-01	2.95E+00	3.54E+02
0.0833 h	0.00E+00	0.00E+00	0.00E+00	0.00E+00	0.00E+00	0.00E+00	1.69E-03	3.58E-02	1.30E-02	2.74E-01	4.04E+01	8.56E+02
0.1667 h	0.00E+00	0.00E+00	0.00E+00	0.00E+00	0.00E+00	0.00E+00	3.10E-03	3.85E-02	2.38E-02	2.96E-01	7.43E+01	9.28E+02
0.2500 h	0.00E+00	0.00E+00	0.00E+00	0.00E+00	0.00E+00	0.00E+00	3.18E-03	3.79E-02	2.45E-02	2.93E-01	7.71E+01	9.22E+02
0.3333 h	0.00E+00	0.00E+00	0.00E+00	0.00E+00	0.00E+00	0.00E+00	3.12E-03	3.71E-02	2.42E-02	2.87E-01	7.63E+01	9.08E+02
0.5000 h	0.00E+00	0.00E+00	0.00E+00	0.00E+00	0.00E+00	0.00E+00	6.03E-03	3.53E-02	4.69E-02	2.76E-01	1.49E+02	8.80E+02
0.7500 h	0.00E+00	0.00E+00	0.00E+00	0.00E+00	0.00E+00	0.00E+00	8.53E-03	3.29E-02	6.69E-02	2.59E-01	2.15E+02	8.40E+02
1.0000 h	0.00E+00	0.00E+00	0.00E+00	0.00E+00	0.00E+00	0.00E+00	7.96E-03	3.07E-02	6.30E-02	2.44E-01	2.05E+02	8.01E+02
2.0000 h	0.00E+00	0.00E+00	0.00E+00	0.00E+00	0.00E+00	0.00E+00	2.70E-02	2.35E-02	2.18E-01	1.93E-01	7.31E+02	6.64E+02
4.0000 h	0.00E+00	0.00E+00	0.00E+00	0.00E+00	0.00E+00	0.00E+00	3.69E-02	1.43E-02	3.11E-01	1.24E-01	1.11E+03	4.57E+02
8.0000 h	0.00E+00	0.00E+00	0.00E+00	0.00E+00	0.00E+00	0.00E+00	3.70E-02	5.66E-03	3.31E-01	5.25E-02	1.29E+03	2.17E+02
24.0000 h	0.00E+00	0.00E+00	0.00E+00	0.00E+00	0.00E+00	0.00E+00	2.55E-02	2.02E-04	2.46E-01	2.07E-03	1.12E+03	1.16E+01
96.0000 h	0.00E+00	0.00E+00	0.00E+00	0.00E+00	0.00E+00	0.00E+00	6.19E-04	3.01E-10	6.37E-03	2.86E-09	3.85E+01	2.94E-05
720.0000 h	0.00E+00	0.00E+00	0.00E+00	0.00E+00	0.00E+00	0.00E+00	6.70E-10	0.00E+00	6.34E-09	0.00E+00	6.63E-05	0.00E+00
TOTALS	0.00E+00		0.00E+00		0.00E+00		1.61E-01		1.38E+00		5.13E+03	

TRAILS -- Transport of Radioactive Material in Linear Systems, v2.0
ILI Case for dose rate [TC950802.DAT]

	COMP: not used	COMP: intact S/Gs	COMP: Control Room
			VOLUME: 1.730E+05 Cu.Ft.
INITIAL:	0.000E+00 I-131	3.170E+06 I-131 uCi	0.000E+00 I-131
	0.000E+00 I-132	5.640E+05 I-132	0.000E+00 I-132
	0.000E+00 I-133	4.140E+06 I-133	0.000E+00 I-133
	0.000E+00 I-134	9.900E+04 I-134	0.000E+00 I-134
	0.000E+00 I-135	1.510E+06 I-135	0.000E+00 I-135
ACT MULT (to uCi):	1.000E+00	1.000E+00	1.000E+00

TRAILS -- Transport of Radioactive Material in Linear Systems, v2.0
 ILI Case for dose rate [TC950802.DAT]

RF IOVAL: 1.000E+01 cfm
 NUC Grp 1 REL FR: 0.000E+00
 NUC Grp 2 REL FR: 0.000E+00
 NUC Grp 3 REL FR: 0.000E+00

MULTIPLIERS====>

STEP	TIME	XPR	XREM	XRF	XPR	XREM	XRF	XPR	XREM	XRF
1	6.000E+01	0.000E+00	0.000E+00	0.000E+00	0.000E+00	1.00	0.000E+00	50.0	50.0	0.000E+00
2	3.000E+02	0.000E+00	0.000E+00	0.000E+00	0.000E+00	1.00	0.000E+00	50.0	50.0	0.000E+00
3	6.000E+02	0.000E+00	0.000E+00	0.000E+00	0.000E+00	1.00	0.000E+00	50.0	50.0	0.000E+00
4	9.000E+02	0.000E+00	0.000E+00	0.000E+00	0.000E+00	1.00	0.000E+00	50.0	50.0	0.000E+00
5	1.200E+03	0.000E+00	0.000E+00	0.000E+00	0.000E+00	1.00	0.000E+00	50.0	50.0	0.000E+00
6	1.800E+03	0.000E+00	0.000E+00	0.000E+00	0.000E+00	1.00	0.000E+00	50.0	50.0	0.000E+00
7	2.700E+03	0.000E+00	0.000E+00	0.000E+00	0.000E+00	1.00	0.000E+00	50.0	50.0	0.000E+00
8	3.600E+03	0.000E+00	0.000E+00	0.000E+00	0.000E+00	1.00	0.000E+00	50.0	50.0	0.000E+00
9	7.200E+03	0.000E+00	0.000E+00	0.000E+00	0.000E+00	1.00	0.000E+00	50.0	50.0	0.000E+00
10	1.440E+04	0.000E+00	0.000E+00	0.000E+00	0.000E+00	0.640	0.000E+00	50.0	50.0	0.000E+00
11	2.880E+04	0.000E+00	0.000E+00	0.000E+00	0.000E+00	0.640	0.000E+00	50.0	50.0	0.000E+00
12	8.640E+04	0.000E+00	0.000E+00	0.000E+00	0.000E+00	0.000E+00	0.000E+00	50.0	50.0	0.000E+00
13	3.456E+05	0.000E+00	0.000E+00	0.000E+00	0.000E+00	0.000E+00	0.000E+00	50.0	50.0	0.000E+00
14	2.592E+06	0.000E+00	0.000E+00	0.000E+00	0.000E+00	0.000E+00	0.000E+00	50.0	50.0	0.000E+00

5.203E-06 1/sec
 0.000E+00 1/sec
 0.000E+00
 0.000E+00
 0.000E+00

----- ENVIRONMENT -----

STEP	TIME, s	X/Q s/M3	Breathing M3/s
1	6.000E+01	0.000E+00	1.00
2	3.000E+02	0.000E+00	1.00
3	6.000E+02	0.000E+00	1.00
4	9.000E+02	0.000E+00	1.00
5	1.200E+03	0.000E+00	1.00
6	1.800E+03	0.000E+00	1.00
7	2.700E+03	0.000E+00	1.00
8	3.600E+03	0.000E+00	1.00
9	7.200E+03	0.000E+00	1.00
10	1.440E+04	0.000E+00	1.00
11	2.880E+04	0.000E+00	1.00
12	8.640E+04	0.000E+00	1.00
13	3.456E+05	0.890	0.600
14	2.592E+06	0.626	0.400

TRAILS -- Transport of Radioactive Material in Linear Systems, v2.0
 ILI Case for dose rate [TC950802.DAT]

	ENVIRONMENT						CONTROL ROOM					
	PHOTON-SURMG		BETA-SURMG		THYROID-INHAL		PHOTON-SURMG		BETA-SURMG		THYROID-INHAL	
	DOSE mrem	DOSE RATE mrem/hr	DOSE mrem	DOSE RATE mrem/hr	DOSE mrem	DOSE RATE mrem/hr	DOSE mrem	DOSE RATE mrem/hr	DOSE mrem	DOSE RATE mrem/hr	DOSE mrem	DOSE RATE mrem/hr
ALL NUCLIDES												
0.0167 h	0.00E+00	0.00E+00	0.00E+00	0.00E+00	0.00E+00	0.00E+00	1.05E-07	1.26E-05	8.03E-07	9.63E-05	2.50E-03	2.99E-01
0.0833 h	0.00E+00	0.00E+00	0.00E+00	0.00E+00	0.00E+00	0.00E+00	2.50E-06	6.21E-05	1.91E-05	4.76E-04	5.96E-02	1.49E+00
0.1667 h	0.00E+00	0.00E+00	0.00E+00	0.00E+00	0.00E+00	0.00E+00	7.68E-06	1.22E-04	5.90E-05	9.39E-04	1.85E-01	2.94E+00
0.2500 h	0.00E+00	0.00E+00	0.00E+00	0.00E+00	0.00E+00	0.00E+00	1.26E-05	1.80E-04	9.70E-05	1.39E-03	3.05E-01	4.37E+00
0.3333 h	0.00E+00	0.00E+00	0.00E+00	0.00E+00	0.00E+00	0.00E+00	1.73E-05	2.36E-04	1.34E-04	1.83E-03	4.23E-01	5.78E+00
0.5000 h	0.00E+00	0.00E+00	0.00E+00	0.00E+00	0.00E+00	0.00E+00	4.82E-05	3.41E-04	3.74E-04	2.66E-03	1.19E+00	8.51E+00
0.7500 h	0.00E+00	0.00E+00	0.00E+00	0.00E+00	0.00E+00	0.00E+00	1.04E-04	4.87E-04	8.14E-04	3.83E-03	2.62E+00	1.24E+01
1.0000 h	0.00E+00	0.00E+00	0.00E+00	0.00E+00	0.00E+00	0.00E+00	1.38E-04	6.18E-04	1.09E-03	4.91E-03	3.57E+00	1.61E+01
2.0000 h	0.00E+00	0.00E+00	0.00E+00	0.00E+00	0.00E+00	0.00E+00	8.31E-04	1.03E-03	6.74E-03	8.44E-03	2.27E+01	2.89E+01
4.0000 h	0.00E+00	0.00E+00	0.00E+00	0.00E+00	0.00E+00	0.00E+00	2.21E-03	1.17E-03	1.87E-02	1.01E-02	6.69E+01	3.74E+01
8.0000 h	0.00E+00	0.00E+00	0.00E+00	0.00E+00	0.00E+00	0.00E+00	4.71E-03	1.19E-03	4.24E-02	1.10E-02	1.67E+02	4.54E+01
24.0000 h	0.00E+00	0.00E+00	0.00E+00	0.00E+00	0.00E+00	0.00E+00	5.35E-03	4.23E-05	5.15E-02	4.33E-04	2.34E+02	2.42E+00
96.0000 h	0.00E+00	0.00E+00	0.00E+00	0.00E+00	0.00E+00	0.00E+00	1.29E-04	6.27E-11	1.33E-03	5.96E-10	8.03E+00	6.13E-06
720.0000 h	0.00E+00	0.00E+00	0.00E+00	0.00E+00	0.00E+00	0.00E+00	1.40E-10	0.00E+00	1.32E-09	0.00E+00	1.38E-05	0.00E+00
TOTALS	0.00E+00		0.00E+00		0.00E+00		1.36E-02		1.23E-01		5.07E+02	

TRAILS -- Transport of Radioactive Material in Linear Systems, v2.0
 ITN Case for dose rate [TC950806.DAT]

	COMP: not used	COMP: intact S/G	COMP: Control Room VOLUME: 1.730E+05 Cu.Ft.
INITIAL:	0.000E+00 Kr-83m	2.000E+07 Kr-83m uCi	0.000E+00 Kr-83m
	0.000E+00 Kr-85m	9.750E+07 Kr-85m	0.000E+00 Kr-85m
	0.000E+00 Kr-85	5.150E+08 Kr-85	0.000E+00 Kr-85
	0.000E+00 Kr-87	5.580E+07 Kr-87	0.000E+00 Kr-87
	0.000E+00 Kr-88	1.490E+08 Kr-88	0.000E+00 Kr-88
	0.000E+00 Kr-89	4.690E+06 Kr-89	0.000E+00 Kr-89
	0.000E+00 Xe-131m	5.010E+06 Xe-131m	0.000E+00 Xe-131m
	0.000E+00 Xe-133m	1.430E+08 Xe-133m	0.000E+00 Xe-133m
	0.000E+00 Xe-133	1.220E+09 Xe-133	0.000E+00 Xe-133
	0.000E+00 Xe-135m	5.060E+07 Xe-135m	0.000E+00 Xe-135m
	0.000E+00 Xe-135	1.500E+08 Xe-135	0.000E+00 Xe-135
	0.000E+00 Xe-137	7.590E+06 Xe-137	0.000E+00 Xe-137
	0.000E+00 Xe-138	3.130E+07 Xe-138	0.000E+00 Xe-138
ACT MULT (to uCi):	1.000E+00	1.000E+00	1.000E+00

TRAILS -- Transport of Radioactive Material in Linear Systems, v2.0
 ITN Case for dose rate [TC950806.DAT]

REMOVAL:
 NUC GIP 1 REL FR: 0.000E+00
 NUC GIP 2 REL FR: 0.000E+00
 NUC GIP 3 REL FR: 0.000E+00

7.430E-08 1/sec
 0.000E+00
 0.000E+00
 0.000E+00

0.000E+00 1/sec
 0.000E+00
 0.000E+00
 0.000E+00

1.000E+01 cfm
 INTAKE REDUCT: 0.000E+00
 INTAKE REDUCT: 0.000E+00
 INTAKE REDUCT: 0.000E+00

MULTIPLIERS====>

STEP	TIME	XPR	XREM	XRF	XPR	XREM	XRF	XPR	XREM	XRF
1	6.000E+01	0.000E+00	0.000E+00	0.000E+00	0.000E+00	1.00	0.000E+00	50.0	50.0	0.000E+00
2	3.000E+02	0.000E+00	0.000E+00	0.000E+00	0.000E+00	1.00	0.000E+00	50.0	50.0	0.000E+00
3	6.000E+02	0.000E+00	0.000E+00	0.000E+00	0.000E+00	1.00	0.000E+00	50.0	50.0	0.000E+00
4	9.000E+02	0.000E+00	0.000E+00	0.000E+00	0.000E+00	1.00	0.000E+00	50.0	50.0	0.000E+00
5	1.200E+03	0.000E+00	0.000E+00	0.000E+00	0.000E+00	1.00	0.000E+00	50.0	50.0	0.000E+00
6	1.800E+03	0.000E+00	0.000E+00	0.000E+00	0.000E+00	1.00	0.000E+00	50.0	50.0	0.000E+00
7	2.700E+03	0.000E+00	0.000E+00	0.000E+00	0.000E+00	1.00	0.000E+00	50.0	50.0	0.000E+00
8	3.600E+03	0.000E+00	0.000E+00	0.000E+00	0.000E+00	1.00	0.000E+00	50.0	50.0	0.000E+00
9	7.200E+03	0.000E+00	0.000E+00	0.000E+00	0.000E+00	1.00	0.000E+00	50.0	50.0	0.000E+00
10	1.440E+04	0.000E+00	0.000E+00	0.000E+00	0.000E+00	1.00	0.000E+00	50.0	50.0	0.000E+00
11	2.880E+04	0.000E+00	0.000E+00	0.000E+00	0.000E+00	1.00	0.000E+00	50.0	50.0	0.000E+00
12	8.640E+04	0.000E+00	0.000E+00	0.000E+00	0.000E+00	1.00	0.000E+00	50.0	50.0	0.000E+00
13	3.456E+05	0.000E+00	0.000E+00	0.000E+00	0.000E+00	1.00	0.000E+00	50.0	50.0	0.000E+00
14	2.592E+06	0.000E+00	0.000E+00	0.000E+00	0.000E+00	1.00	0.000E+00	50.0	50.0	0.000E+00

----- CONTROL ROOM -----

X/Q Breathing Occupancy
 s/M3 M3/s
 1.000E-03 3.470E-04 1.000E+00

----- ENVIRONMENT -----

X/Q Breathing
 s/M3 M3/s
 0.000E+00 3.470E-04

MULTIPLIERS====>

STEP	TIME, s	XPR	XREM	XRF	XPR	XREM	XRF	XPR	XREM	XRF
1	6.000E+01	2.43	1.00	1.00	0.000E+00	1.00	0.000E+00	50.0	50.0	0.000E+00
2	3.000E+02	2.43	1.00	1.00	0.000E+00	1.00	0.000E+00	50.0	50.0	0.000E+00
3	6.000E+02	2.43	1.00	1.00	0.000E+00	1.00	0.000E+00	50.0	50.0	0.000E+00
4	9.000E+02	2.43	1.00	1.00	0.000E+00	1.00	0.000E+00	50.0	50.0	0.000E+00
5	1.200E+03	2.43	1.00	1.00	0.000E+00	1.00	0.000E+00	50.0	50.0	0.000E+00
6	1.800E+03	2.43	1.00	1.00	0.000E+00	1.00	0.000E+00	50.0	50.0	0.000E+00
7	2.700E+03	2.43	1.00	1.00	0.000E+00	1.00	0.000E+00	50.0	50.0	0.000E+00
8	3.600E+03	2.43	1.00	1.00	0.000E+00	1.00	0.000E+00	50.0	50.0	0.000E+00
9	7.200E+03	2.43	1.00	1.00	0.000E+00	1.00	0.000E+00	50.0	50.0	0.000E+00
10	1.440E+04	2.43	1.00	1.00	0.000E+00	1.00	0.000E+00	50.0	50.0	0.000E+00
11	2.880E+04	2.43	1.00	1.00	0.000E+00	1.00	0.000E+00	50.0	50.0	0.000E+00
12	8.640E+04	1.22	1.00	1.00	0.000E+00	1.00	0.000E+00	50.0	50.0	0.000E+00
13	3.456E+05	0.890	1.00	0.600	0.000E+00	1.00	0.000E+00	50.0	50.0	0.000E+00
14	2.592E+06	0.626	1.00	0.400	0.000E+00	1.00	0.000E+00	50.0	50.0	0.000E+00

TRAILS -- Transport of Radioactive Material in Linear Systems, v2.0
 ITN Case for dose rate [TC950806.DAT]

	E N V I R O N M E N T						C O N T R O L R O O M					
	PHOTON-SUBMG		BETA-SUBMG		THYROID-INHAL		PHOTON-SUBMG		BETA-SUBMG		THYROID-INHAL	
	DOSE mrem	DOSE RATE mrem/hr	DOSE mrem	DOSE RATE mrem/hr	DOSE mrem	DOSE RATE mrem/hr	DOSE mrem	DOSE RATE mrem/hr	DOSE mrem	DOSE RATE mrem/hr	DOSE mrem	DOSE RATE mrem/hr
ALL NUCLIDES												
0.0167 h	0.00E+00	0.00E+00	0.00E+00	0.00E+00	0.00E+00	0.00E+00	1.01E-07	1.21E-05	2.02E-06	2.42E-04	0.00E+00	0.00E+00
0.0833 h	0.00E+00	0.00E+00	0.00E+00	0.00E+00	0.00E+00	0.00E+00	2.33E-06	5.75E-05	4.72E-05	1.17E-03	0.00E+00	0.00E+00
0.1667 h	0.00E+00	0.00E+00	0.00E+00	0.00E+00	0.00E+00	0.00E+00	6.98E-06	1.10E-04	1.43E-04	2.26E-03	0.00E+00	0.00E+00
0.2500 h	0.00E+00	0.00E+00	0.00E+00	0.00E+00	0.00E+00	0.00E+00	1.11E-05	1.58E-04	2.32E-04	3.30E-03	0.00E+00	0.00E+00
0.3333 h	0.00E+00	0.00E+00	0.00E+00	0.00E+00	0.00E+00	0.00E+00	1.50E-05	2.02E-04	3.17E-04	4.31E-03	0.00E+00	0.00E+00
0.5000 h	0.00E+00	0.00E+00	0.00E+00	0.00E+00	0.00E+00	0.00E+00	4.05E-05	2.83E-04	8.78E-04	6.21E-03	0.00E+00	0.00E+00
0.7500 h	0.00E+00	0.00E+00	0.00E+00	0.00E+00	0.00E+00	0.00E+00	8.41E-05	3.88E-04	1.89E-03	8.85E-03	0.00E+00	0.00E+00
1.0000 h	0.00E+00	0.00E+00	0.00E+00	0.00E+00	0.00E+00	0.00E+00	1.08E-04	4.77E-04	2.52E-03	1.13E-02	0.00E+00	0.00E+00
2.0000 h	0.00E+00	0.00E+00	0.00E+00	0.00E+00	0.00E+00	0.00E+00	6.04E-04	7.18E-04	1.53E-02	1.92E-02	0.00E+00	0.00E+00
4.0000 h	0.00E+00	0.00E+00	0.00E+00	0.00E+00	0.00E+00	0.00E+00	1.60E-03	6.76E-04	4.93E-02	2.96E-02	0.00E+00	0.00E+00
8.0000 h	0.00E+00	0.00E+00	0.00E+00	0.00E+00	0.00E+00	0.00E+00	3.28E-03	8.03E-04	1.41E-01	3.99E-02	0.00E+00	0.00E+00
24.0000 h	0.00E+00	0.00E+00	0.00E+00	0.00E+00	0.00E+00	0.00E+00	3.17E-03	2.35E-05	2.02E-01	2.11E-03	0.00E+00	0.00E+00
96.0000 h	0.00E+00	0.00E+00	0.00E+00	0.00E+00	0.00E+00	0.00E+00	7.54E-05	5.13E-11	7.10E-03	6.19E-09	0.00E+00	0.00E+00
720.0000 h	0.00E+00	0.00E+00	0.00E+00	0.00E+00	0.00E+00	0.00E+00	1.15E-10	0.00E+00	1.41E-08	0.00E+00	0.00E+00	0.00E+00
TOTALS	0.00E+00		0.00E+00		0.00E+00		9.00E-03		4.21E-01		0.00E+00	

TRAILS -- Transport of Radioactive Material in Linear Systems, v2.0
ITP Case for dose rate [TC950805.DAT]

	COMP: not used	COMP: intact S/G	COMP: Control Room
			VOLUME: 1.730E+05 Cu.Ft.
INITIAL:	0.000E+00 I-131	7.160E+09 I-131 uCi	0.000E+00 I-131
	0.000E+00 I-132	2.500E+09 I-132	0.000E+00 I-132
	0.000E+00 I-133	1.120E+10 I-133	0.000E+00 I-133
	0.000E+00 I-134	1.560E+09 I-134	0.000E+00 I-134
	0.000E+00 I-135	6.890E+09 I-135	0.000E+00 I-135
ACT MULT (to uCi):	1.000E+00	1.000E+00	1.000E+00

TRAILS -- Transport of Radioactive Material in Linear Systems, v2.0
 ITP Case for dose rate [TC950805.DAT]

REMOVAL: 0.000E+00 1/sec 7.430E-08 1/sec 1.000E+01 cfm
 NUC GRP 1 REL FR: 0.000E+00 INTAKE REDUCT: 0.000E+00
 NUC GRP 2 REL FR: 0.000E+00 INTAKE REDUCT: 0.000E+00
 NUC GRP 3 REL FR: 0.000E+00 INTAKE REDUCT: 0.000E+00

MULTIPLIERS====>

STEP	TIME	XPR	XREM	XRF	XPR	XREM	XRF	XPR	XREM	XRF
1	6.000E+01	0.000E+00	0.000E+00	0.000E+00	0.000E+00	1.00	0.000E+00	50.0	50.0	0.000E+00
2	3.000E+02	0.000E+00	0.000E+00	0.000E+00	0.000E+00	1.00	0.000E+00	50.0	50.0	0.000E+00
3	6.000E+02	0.000E+00	0.000E+00	0.000E+00	0.000E+00	1.00	0.000E+00	50.0	50.0	0.000E+00
4	9.000E+02	0.000E+00	0.000E+00	0.000E+00	0.000E+00	1.00	0.000E+00	50.0	50.0	0.000E+00
5	1.200E+03	0.000E+00	0.000E+00	0.000E+00	0.000E+00	1.00	0.000E+00	50.0	50.0	0.000E+00
6	1.800E+03	0.000E+00	0.000E+00	0.000E+00	0.000E+00	1.00	0.000E+00	50.0	50.0	0.000E+00
7	2.700E+03	0.000E+00	0.000E+00	0.000E+00	0.000E+00	1.00	0.000E+00	50.0	50.0	0.000E+00
8	3.600E+03	0.000E+00	0.000E+00	0.000E+00	0.000E+00	1.00	0.000E+00	50.0	50.0	0.000E+00
9	7.200E+03	0.000E+00	0.000E+00	0.000E+00	0.000E+00	1.00	0.000E+00	50.0	50.0	0.000E+00
10	1.440E+04	0.000E+00	0.000E+00	0.000E+00	0.000E+00	1.000E-02	0.000E+00	50.0	50.0	0.000E+00
11	2.880E+04	0.000E+00	0.000E+00	0.000E+00	0.000E+00	1.000E-02	0.000E+00	50.0	50.0	0.000E+00
12	8.640E+04	0.000E+00	0.000E+00	0.000E+00	0.000E+00	1.000E-02	0.000E+00	50.0	50.0	0.000E+00
13	3.456E+05	0.000E+00	0.000E+00	0.000E+00	0.000E+00	0.000E+00	0.000E+00	50.0	50.0	0.000E+00
14	2.592E+06	0.000E+00	0.000E+00	0.000E+00	0.000E+00	0.000E+00	0.000E+00	50.0	50.0	0.000E+00

----- CONTROL ROOM -----
 X/Q Breathing Occupancy
 s/M3 M3/s
 1.000E-03 3.470E-04 1.000E+00

----- ENVIRONMENT -----
 X/Q Breathing
 s/M3 M3/s
 0.000E+00 3.470E-04

MULTIPLIERS====>

STEP	TIME, s	X/Q	Breathing	Occupancy	X/Q	Breathing
1	6.000E+01	2.43	1.00	1.00	0.000E+00	1.00
2	3.000E+02	2.43	1.00	1.00	0.000E+00	1.00
3	6.000E+02	2.43	1.00	1.00	0.000E+00	1.00
4	9.000E+02	2.43	1.00	1.00	0.000E+00	1.00
5	1.200E+03	2.43	1.00	1.00	0.000E+00	1.00
6	1.800E+03	2.43	1.00	1.00	0.000E+00	1.00
7	2.700E+03	2.43	1.00	1.00	0.000E+00	1.00
8	3.600E+03	2.43	1.00	1.00	0.000E+00	1.00
9	7.200E+03	2.43	1.00	1.00	0.000E+00	1.00
10	1.440E+04	2.43	1.00	1.00	0.000E+00	1.00
11	2.880E+04	2.43	1.00	1.00	0.000E+00	1.00
12	8.640E+04	1.22	1.00	1.00	0.000E+00	1.00
13	3.456E+05	0.890	1.00	0.600	0.000E+00	1.00
14	2.592E+06	0.626	1.00	0.400	0.000E+00	1.00

TRAILS -- Transport of Radioactive Material in Linear Systems, v2.0
 ITP Case for dose rate [TC950805.DAT]

- - - - - E N V I R O N M E N T - - - - -							- - - - - C O N T R O L R O O M - - - - -						
PHOTON-SUBMG		BETA-SUBMG		THYROID-INHAL		PHOTON-SUBMG		BETA-SUBMG		THYROID-INHAL			
DOSE	DOSE RATE	DOSE	DOSE RATE	DOSE	DOSE RATE	DOSE	DOSE RATE	DOSE	DOSE RATE	DOSE	DOSE RATE		
mrem	mrem/hr	mrem	mrem/hr	mrem	mrem/hr	mrem	mrem/hr	mrem	mrem/hr	mrem	mrem/hr		
ALL NUCLIDES													
0.0167 h	0.00E+00	0.00E+00	0.00E+00	0.00E+00	0.00E+00	0.00E+00	0.00E+00	5.92E-06	7.09E-04	3.83E-05	4.59E-03	8.74E-02	1.05E+01
0.0833 h	0.00E+00	0.00E+00	0.00E+00	0.00E+00	0.00E+00	0.00E+00	0.00E+00	1.40E-04	3.48E-03	9.08E-04	2.26E-02	2.09E+00	5.20E+01
0.1667 h	0.00E+00	0.00E+00	0.00E+00	0.00E+00	0.00E+00	0.00E+00	0.00E+00	4.29E-04	6.79E-03	2.79E-03	4.44E-02	6.47E+00	1.03E+02
0.2500 h	0.00E+00	0.00E+00	0.00E+00	0.00E+00	0.00E+00	0.00E+00	0.00E+00	6.98E-04	9.95E-03	4.57E-03	6.53E-02	1.07E+01	1.53E+02
0.3333 h	0.00E+00	0.00E+00	0.00E+00	0.00E+00	0.00E+00	0.00E+00	0.00E+00	9.55E-04	1.30E-02	6.29E-03	8.55E-02	1.48E+01	2.03E+02
0.5000 h	0.00E+00	0.00E+00	0.00E+00	0.00E+00	0.00E+00	0.00E+00	0.00E+00	2.63E-03	1.86E-02	1.75E-02	1.24E-01	4.18E+01	2.98E+02
0.7500 h	0.00E+00	0.00E+00	0.00E+00	0.00E+00	0.00E+00	0.00E+00	0.00E+00	5.60E-03	2.61E-02	3.76E-02	1.77E-01	9.20E+01	4.36E+02
1.0000 h	0.00E+00	0.00E+00	0.00E+00	0.00E+00	0.00E+00	0.00E+00	0.00E+00	7.37E-03	3.27E-02	5.02E-02	2.24E-01	1.25E+02	5.66E+02
2.0000 h	0.00E+00	0.00E+00	0.00E+00	0.00E+00	0.00E+00	0.00E+00	0.00E+00	2.81E-02	2.42E-02	1.97E-01	1.74E-01	5.18E+02	4.73E+02
4.0000 h	0.00E+00	0.00E+00	0.00E+00	0.00E+00	0.00E+00	0.00E+00	0.00E+00	3.73E-02	1.42E-02	2.77E-01	1.10E-01	7.97E+02	3.33E+02
8.0000 h	0.00E+00	0.00E+00	0.00E+00	0.00E+00	0.00E+00	0.00E+00	0.00E+00	3.70E-02	5.81E-03	2.98E-01	4.92E-02	9.72E+02	1.73E+02
24.0000 h	0.00E+00	0.00E+00	0.00E+00	0.00E+00	0.00E+00	0.00E+00	0.00E+00	2.49E-02	1.78E-04	2.24E-01	1.78E-03	8.83E+02	9.02E+00
96.0000 h	0.00E+00	0.00E+00	0.00E+00	0.00E+00	0.00E+00	0.00E+00	0.00E+00	5.33E-04	2.31E-10	5.41E-03	2.21E-09	2.98E+01	2.22E-05
720.0000 h	0.00E+00	0.00E+00	0.00E+00	0.00E+00	0.00E+00	0.00E+00	0.00E+00	5.13E-10	0.00E+00	4.88E-09	0.00E+00	5.00E-05	0.00E+00
TOTALS	0.00E+00		0.00E+00		0.00E+00		0.00E+00	1.46E-01		1.12E+00		3.49E+03	

TRAILS -- Transport of Radioactive Material in Linear Systems, v2.0
 ASA Case for dose rate [TC950801.DAT]

COMP: not used

COMP: all S/Gs

COMP: Control Room
 VOLUME: 1.730E+05 Cu.Ft.

INITIAL:	COMP: not used	COMP: all S/Gs	COMP: Control Room
			VOLUME: 1.730E+05 Cu.Ft.

	0.000E+00 Kr-83m	1.430E+01 Kr-83m uCi	0.000E+00 Kr-83m
	0.000E+00 Kr-85m	6.940E+01 Kr-85m	0.000E+00 Kr-85m
	0.000E+00 Kr-85	3.660E+02 Kr-85	0.000E+00 Kr-85
	0.000E+00 Kr-87	3.980E+01 Kr-87	0.000E+00 Kr-87
	0.000E+00 Kr-88	1.060E+02 Kr-88	0.000E+00 Kr-88
	0.000E+00 Kr-89	3.340E+00 Kr-89	0.000E+00 Kr-89
	0.000E+00 Xe-131m	3.570E+00 Xe-131m	0.000E+00 Xe-131m
	0.000E+00 Xe-133m	1.020E+02 Xe-133m	0.000E+00 Xe-133m
	0.000E+00 Xe-133	8.700E+02 Xe-133	0.000E+00 Xe-133
	0.000E+00 Xe-135m	3.600E+01 Xe-135m	0.000E+00 Xe-135m
	0.000E+00 Xe-135	1.070E+02 Xe-135	0.000E+00 Xe-135
	0.000E+00 Xe-137	5.420E+00 Xe-137	0.000E+00 Xe-137
	0.000E+00 Xe-138	2.240E+01 Xe-138	0.000E+00 Xe-138
	0.000E+00 I-131	2.090E+03 I-131	0.000E+00 I-131
	0.000E+00 I-132	3.720E+02 I-132	0.000E+00 I-132
	0.000E+00 I-133	2.730E+03 I-133	0.000E+00 I-133
	0.000E+00 I-134	6.530E+01 I-134	0.000E+00 I-134
	0.000E+00 I-135	9.990E+02 I-135	0.000E+00 I-135
ACT MULY (to uCi):	1.000E+00	3.000E+00	1.000E+00

```

-----
REMOVAL:                0.000E+00 1/sec                1.382E+01 1/sec                1.000E+01 cfm
NUC Grp 1 REL FR:      0.000E+00                0.000E+00                0.000E+00                INTAKE REDUCT: 0.000E+00
NUC Grp 2 REL FR:      0.000E+00                0.000E+00                0.000E+00                INTAKE REDUCT: 0.000E+00
NUC Grp 3 REL FR:      0.000E+00                0.000E+00                0.000E+00                INTAKE REDUCT: 0.000E+00
-----
  
```

MULTIPLIERS====>

STEP	TIME	XPR	XREM	XRF	XPR	XREM	XRF	XPR	XREM	XRF
1	6.000E+01	0.000E+00	0.000E+00	0.000E+00	0.000E+00	1.00	0.000E+00	50.0	50.0	0.000E+00
2	3.000E+02	0.000E+00	0.000E+00	0.000E+00	0.000E+00	0.000E+00	0.000E+00	50.0	50.0	0.000E+00
3	6.000E+02	0.000E+00	0.000E+00	0.000E+00	0.000E+00	0.000E+00	0.000E+00	50.0	50.0	0.000E+00
4	9.000E+02	0.000E+00	0.000E+00	0.000E+00	0.000E+00	0.000E+00	0.000E+00	50.0	50.0	0.000E+00
5	1.200E+03	0.000E+00	0.000E+00	0.000E+00	0.000E+00	0.000E+00	0.000E+00	50.0	50.0	0.000E+00
6	1.800E+03	0.000E+00	0.000E+00	0.000E+00	0.000E+00	0.000E+00	0.000E+00	50.0	50.0	0.000E+00
7	2.700E+03	0.000E+00	0.000E+00	0.000E+00	0.000E+00	0.000E+00	0.000E+00	50.0	50.0	0.000E+00
8	3.600E+03	0.000E+00	0.000E+00	0.000E+00	0.000E+00	0.000E+00	0.000E+00	50.0	50.0	0.000E+00
9	2.880E+04	0.000E+00	0.000E+00	0.000E+00	0.000E+00	0.000E+00	0.000E+00	50.0	50.0	0.000E+00
10	8.640E+04	0.000E+00	0.000E+00	0.000E+00	0.000E+00	0.000E+00	0.000E+00	50.0	50.0	0.000E+00
11	3.456E+05	0.000E+00	0.000E+00	0.000E+00	0.000E+00	0.000E+00	0.000E+00	50.0	50.0	0.000E+00
12	2.592E+06	0.000E+00	0.000E+00	0.000E+00	0.000E+00	0.000E+00	0.000E+00	50.0	50.0	0.000E+00

----- CONTROL ROOM -----

X/Q	Breathing	Occupancy
s/M3	M3/s	
1.000E-03	3.470E-04	1.000E+00

----- ENVIRONMENT -----

X/Q	Breathing
s/M3	M3/s
0.000E+00	3.470E-04

MULTIPLIERS====>

STEP	TIME, s	XPR	XREM	XRF	XPR	XREM	XRF
1	6.000E+01	2.43	1.00	1.00	0.000E+00	1.00	
2	3.000E+02	2.43	1.00	1.00	0.000E+00	1.00	
3	6.000E+02	2.43	1.00	1.00	0.000E+00	1.00	
4	9.000E+02	2.43	1.00	1.00	0.000E+00	1.00	
5	1.200E+03	2.43	1.00	1.00	0.000E+00	1.00	
6	1.800E+03	2.43	1.00	1.00	0.000E+00	1.00	
7	2.700E+03	2.43	1.00	1.00	0.000E+00	1.00	
8	3.600E+03	2.43	1.00	1.00	0.000E+00	1.00	
9	2.880E+04	2.43	1.00	1.00	0.000E+00	1.00	
10	8.640E+04	1.22	1.00	1.00	0.000E+00	1.00	
11	3.456E+05	0.890	1.00	0.600	0.000E+00	1.00	
12	2.592E+06	0.626	1.00	0.400	0.000E+00	1.00	

	E N V I R O N M E N T						C O N T R O L R O O M					
	PHOTON-SUBMG		BETA-SUBMG		THYROID-INHAL		PHOTON-SUBMG		BETA-SUBMG		THYROID-INHAL	
	DOSE	DOSE RATE	DOSE	DOSE RATE	DOSE	DOSE RATE	DOSE	DOSE RATE	DOSE	DOSE RATE	DOSE	DOSE RATE
	mrem	mrem/hr	mrem	mrem/hr	mrem	mrem/hr	mrem	mrem/hr	mrem	mrem/hr	mrem	mrem/hr
ALL NUCLIDES												
0.0167 h	0.00E+00	0.00E+00	0.00E+00	0.00E+00	0.00E+00	0.00E+00	7.16E-07	8.58E-05	6.07E-06	7.28E-04	1.58E-02	1.90E+00
0.0833 h	0.00E+00	0.00E+00	0.00E+00	0.00E+00	0.00E+00	0.00E+00	5.66E-06	8.40E-05	4.80E-05	7.13E-04	1.26E-01	1.87E+00
0.1667 h	0.00E+00	0.00E+00	0.00E+00	0.00E+00	0.00E+00	0.00E+00	6.91E-06	8.18E-05	5.87E-05	6.96E-04	1.55E-01	1.84E+00
0.2500 h	0.00E+00	0.00E+00	0.00E+00	0.00E+00	0.00E+00	0.00E+00	6.73E-06	7.97E-05	5.73E-05	6.80E-04	1.52E-01	1.81E+00
0.3333 h	0.00E+00	0.00E+00	0.00E+00	0.00E+00	0.00E+00	0.00E+00	6.56E-06	7.77E-05	5.61E-05	6.66E-04	1.50E-01	1.79E+00
0.5000 h	0.00E+00	0.00E+00	0.00E+00	0.00E+00	0.00E+00	0.00E+00	1.26E-05	7.39E-05	1.09E-04	6.38E-04	2.93E-01	1.73E+00
0.7500 h	0.00E+00	0.00E+00	0.00E+00	0.00E+00	0.00E+00	0.00E+00	1.78E-05	6.87E-05	1.54E-04	5.99E-04	4.23E-01	1.65E+00
1.0000 h	0.00E+00	0.00E+00	0.00E+00	0.00E+00	0.00E+00	0.00E+00	1.66E-05	6.40E-05	1.45E-04	5.63E-04	4.03E-01	1.58E+00
8.0000 h	0.00E+00	0.00E+00	0.00E+00	0.00E+00	0.00E+00	0.00E+00	2.08E-04	1.15E-05	1.98E-03	1.22E-04	6.15E+00	4.28E-01
24.0000 h	0.00E+00	0.00E+00	0.00E+00	0.00E+00	0.00E+00	0.00E+00	5.15E-05	4.08E-07	5.77E-04	5.05E-06	2.20E+00	2.28E-02
96.0000 h	0.00E+00	0.00E+00	0.00E+00	0.00E+00	0.00E+00	0.00E+00	1.25E-06	6.16E-13	1.58E-05	8.49E-12	7.57E-02	5.78E-08
720.0000 h	0.00E+00	0.00E+00	0.00E+00	0.00E+00	0.00E+00	0.00E+00	1.37E-12	0.00E+00	1.90E-11	0.00E+00	1.30E-07	0.00E+00
TOTALS	0.00E+00		0.00E+00		0.00E+00		3.34E-04		3.21E-03		1.01E+01	

	COMP: not used	COMP: intact S/G	COMP: Control Room VOLUME: 1.730E+05 Cu.Ft.
INITIAL:	0.000E+00 Kr-83m	2.000E+07 Kr-83m uCi	0.000E+00 Kr-83m
	0.000E+00 Kr-85m	9.750E+07 Kr-85m	0.000E+00 Kr-85m
	0.000E+00 Kr-85	5.150E+08 Kr-85	0.000E+00 Kr-85
	0.000E+00 Kr-87	5.580E+07 Kr-87	0.000E+00 Kr-87
	0.000E+00 Kr-88	1.490E+08 Kr-88	0.000E+00 Kr-88
	0.000E+00 Kr-89	4.690E+06 Kr-89	0.000E+00 Kr-89
	0.000E+00 Xe-131m	5.010E+06 Xe-131m	0.000E+00 Xe-131m
	0.000E+00 Xe-133m	1.430E+08 Xe-133m	0.000E+00 Xe-133m
	0.000E+00 Xe-133	1.220E+09 Xe-133	0.000E+00 Xe-133
	0.000E+00 Xe-135m	5.060E+07 Xe-135m	0.000E+00 Xe-135m
	0.000E+00 Xe-135	1.500E+08 Xe-135	0.000E+00 Xe-135
	0.000E+00 Xe-137	7.590E+06 Xe-137	0.000E+00 Xe-137
	0.000E+00 Xe-138	3.130E+07 Xe-138	0.000E+00 Xe-138
	0.000E+00 I-131	1.170E+08 I-131	0.000E+00 I-131
	0.000E+00 I-132	4.070E+07 I-132	0.000E+00 I-132
	0.000E+00 I-133	1.820E+08 I-133	0.000E+00 I-133
	0.000E+00 I-134	2.550E+07 I-134	0.000E+00 I-134
	0.000E+00 I-135	9.810E+07 I-135	0.000E+00 I-135
ACT MULT (to uCi):	1.000E+00	1.000E+00	1.000E+00
PRODUCTION, uCi/s:	0.000E+00 I-131	1.360E+06 I-131	INTAKE: 1.000E+01 CFM
	0.000E+00 I-132	2.520E+06 I-132	
	0.000E+00 I-133	3.080E+06 I-133	
	0.000E+00 I-134	3.680E+06 I-134	
	0.000E+00 I-135	2.810E+06 I-135	

TRAILS -- Transport of Radioactive Material in Linear Systems, v2.0
 FRC Case for dose rate for 6.6 gpm [TC950813.DAT]

REMOVAL: 1.000E+01 cfm
 NUC GIP 1 REL FR: 0.000E+00 INTAKE REDUCT: 0.000E+00
 NUC GIP 2 REL FR: 0.000E+00 INTAKE REDUCT: 0.000E+00
 NUC GIP 3 REL FR: 0.000E+00 INTAKE REDUCT: 0.000E+00

MULTIPLIERS====>

STEP	TIME	XPR	XREM	XRF	XPR	XREM	XRF	XPR	XREM	XRF	XPR	XREM	XRF
1	6.000E+01	0.000E+00	0.000E+00	0.000E+00	1.00	1.00	1.00	1.00	1.00	1.00	50.0	50.0	0.000E+00
2	3.000E+02	0.000E+00	0.000E+00	0.000E+00	1.00	1.00	1.00	1.00	1.00	1.00	50.0	50.0	0.000E+00
3	6.000E+02	0.000E+00	0.000E+00	0.000E+00	1.00	1.00	1.00	1.00	1.00	1.00	50.0	50.0	0.000E+00
4	9.000E+02	0.000E+00	0.000E+00	0.000E+00	1.00	1.00	1.00	1.00	1.00	1.00	50.0	50.0	0.000E+00
5	1.200E+03	0.000E+00	0.000E+00	0.000E+00	1.00	1.00	1.00	1.00	1.00	1.00	50.0	50.0	0.000E+00
6	1.800E+03	0.000E+00	0.000E+00	0.000E+00	1.00	1.00	1.00	1.00	1.00	1.00	50.0	50.0	0.000E+00
7	2.700E+03	0.000E+00	0.000E+00	0.000E+00	1.00	1.00	1.00	1.00	1.00	1.00	50.0	50.0	0.000E+00
8	3.600E+03	0.000E+00	0.000E+00	0.000E+00	1.00	1.00	1.00	1.00	1.00	1.00	50.0	50.0	0.000E+00
9	7.200E+03	0.000E+00	0.000E+00	0.000E+00	1.00	1.00	1.00	1.00	1.00	1.00	50.0	50.0	0.000E+00
10	1.440E+04	0.000E+00	0.000E+00	0.000E+00	1.00	1.00	1.00	1.00	1.00	1.00	50.0	50.0	0.000E+00
11	2.880E+04	0.000E+00	0.000E+00	0.000E+00	2.000E-03	1.00	0.000E+00	0.000E+00	0.000E+00	0.000E+00	50.0	50.0	0.000E+00
12	8.640E+04	0.000E+00	0.000E+00	0.000E+00	0.000E+00	0.000E+00	0.000E+00	0.000E+00	0.000E+00	0.000E+00	50.0	50.0	0.000E+00
13	3.456E+05	0.000E+00	0.000E+00	0.000E+00	0.000E+00	0.000E+00	0.000E+00	0.000E+00	0.000E+00	0.000E+00	50.0	50.0	0.000E+00
14	2.592E+06	0.000E+00	0.000E+00	0.000E+00	0.000E+00	0.000E+00	0.000E+00	0.000E+00	0.000E+00	0.000E+00	50.0	50.0	0.000E+00

CONTROL ROOM ----- ENVIRONMENT ----
 X/Q Breathing Occupancy X/Q Breathing
 s/M3 M3/s s/M3 M3/s

1.000E-03	3.470E-04	1.000E+00	0.000E+00	3.470E-04
2.43	1.00	1.00	0.000E+00	1.00
2.43	1.00	1.00	0.000E+00	1.00
2.43	1.00	1.00	0.000E+00	1.00
2.43	1.00	1.00	0.000E+00	1.00
2.43	1.00	1.00	0.000E+00	1.00
2.43	1.00	1.00	0.000E+00	1.00
2.43	1.00	1.00	0.000E+00	1.00
2.43	1.00	1.00	0.000E+00	1.00
2.43	1.00	1.00	0.000E+00	1.00
2.43	1.00	1.00	0.000E+00	1.00
2.43	1.00	1.00	0.000E+00	1.00
2.43	1.00	1.00	0.000E+00	1.00
2.43	1.00	1.00	0.000E+00	1.00
1.22	1.00	1.00	0.000E+00	1.00
0.890	1.00	0.600	0.000E+00	1.00
0.626	1.00	0.400	0.000E+00	1.00

TRAILS -- Transport of Radioactive Material in Linear Systems, v2.0
 FRC Case for dose rate for 6.6 gpm [TC950813.DAT]

E N V I R O N M E N T						C O N T R O L R O O M							
PHOTON-SUBMG		BETA-SUBMG		THYROID-INHAL		PHOTON-SUBMG		BETA-SUBMG		THYROID-INHAL			
DOSE	DOSE RATE	DOSE	DOSE RATE	DOSE	DOSE RATE	DOSE	DOSE RATE	DOSE	DOSE RATE	DOSE	DOSE RATE		
mrem	mrem/hr	mrem	mrem/hr	mrem	mrem/hr	mrem	mrem/hr	mrem	mrem/hr	mrem	mrem/hr		
ALL NUCLIDES													
0.0167 h	0.00E+00	0.00E+00	0.00E+00	0.00E+00	0.00E+00	0.00E+00	0.00E+00	1.02E-05	1.23E-03	1.04E-04	1.24E-02	6.45E-02	7.74E+00
0.0833 h	0.00E+00	0.00E+00	0.00E+00	0.00E+00	0.00E+00	0.00E+00	0.00E+00	5.64E-04	1.56E-02	4.04E-03	1.08E-01	3.11E+00	8.53E+01
0.1667 h	0.00E+00	0.00E+00	0.00E+00	0.00E+00	0.00E+00	0.00E+00	0.00E+00	2.90E-03	5.37E-02	1.83E-02	3.28E-01	1.55E+01	2.86E+02
0.2500 h	0.00E+00	0.00E+00	0.00E+00	0.00E+00	0.00E+00	0.00E+00	0.00E+00	6.94E-03	1.12E-01	4.09E-02	6.52E-01	3.69E+01	5.98E+02
0.3333 h	0.00E+00	0.00E+00	0.00E+00	0.00E+00	0.00E+00	0.00E+00	0.00E+00	1.26E-02	1.90E-01	7.20E-02	1.07E+00	6.75E+01	1.02E+03
0.5000 h	0.00E+00	0.00E+00	0.00E+00	0.00E+00	0.00E+00	0.00E+00	0.00E+00	4.91E-02	3.96E-01	2.72E-01	2.17E+00	2.68E+02	2.18E+03
0.7500 h	0.00E+00	0.00E+00	0.00E+00	0.00E+00	0.00E+00	0.00E+00	0.00E+00	1.52E-01	8.09E-01	8.25E-01	4.39E+00	8.62E+02	4.69E+03
1.0000 h	0.00E+00	0.00E+00	0.00E+00	0.00E+00	0.00E+00	0.00E+00	0.00E+00	2.68E-01	1.32E+00	1.45E+00	7.16E+00	1.60E+03	8.06E+03
2.0000 h	0.00E+00	0.00E+00	0.00E+00	0.00E+00	0.00E+00	0.00E+00	0.00E+00	2.73E+00	3.94E+00	1.50E+01	2.18E+01	1.88E+04	2.89E+04
4.0000 h	0.00E+00	0.00E+00	0.00E+00	0.00E+00	0.00E+00	0.00E+00	0.00E+00	1.49E+01	1.02E+01	8.57E+01	5.99E+01	1.31E+05	9.75E+04
8.0000 h	0.00E+00	0.00E+00	0.00E+00	0.00E+00	0.00E+00	0.00E+00	0.00E+00	4.77E+01	1.36E+01	3.11E+02	9.28E+01	6.32E+05	2.05E+05
24.0000 h	0.00E+00	0.00E+00	0.00E+00	0.00E+00	0.00E+00	0.00E+00	0.00E+00	4.90E+01	2.67E-01	3.78E+02	2.59E+00	1.02E+06	9.96E+03
96.0000 h	0.00E+00	0.00E+00	0.00E+00	0.00E+00	0.00E+00	0.00E+00	0.00E+00	7.58E-01	2.49E-07	7.65E+00	2.60E-06	3.24E+04	2.26E-02
720.0000 h	0.00E+00	0.00E+00	0.00E+00	0.00E+00	0.00E+00	0.00E+00	0.00E+00	5.48E-07	0.00E+00	5.70E-06	0.00E+00	5.07E-02	0.00E+00
TOTALS	0.00E+00		0.00E+00		0.00E+00		0.00E+00	1.16E+02		8.00E+02		1.84E+06	

TRAILS -- Transport of Radioactive Material in Linear Systems, v2.0
 ITC Case for dose rate [TC950804.DAT]

COMP: not used

COMP: intact S/G

COMP: Control Room
 VOLUME: 1.730E+05 Cu.Ft.

	COMP: not used	COMP: intact S/G	COMP: Control Room
INITIAL:	0.000E+00 I-131	1.170E+08 I-131 uCi	0.000E+00 I-131
	0.000E+00 I-132	4.070E+07 I-132	0.000E+00 I-132
	0.000E+00 I-133	1.820E+08 I-133	0.000E+00 I-133
	0.000E+00 I-134	2.550E+07 I-134	0.000E+00 I-134
	0.000E+00 I-135	9.810E+07 I-135	0.000E+00 I-135
ACT MULT (to uCi):	1.000E+00	1.000E+00	1.000E+00
PRODUCTION, uCi/s:	0.000E+00 I-131	1.360E+06 I-131	INTAKE: 1.000E+01 CFM
	0.000E+00 I-132	2.520E+06 I-132	
	0.000E+00 I-133	3.080E+06 I-133	
	0.000E+00 I-134	3.680E+06 I-134	
	0.000E+00 I-135	2.810E+06 I-135	

TRAILS -- Transport of Radioactive Material in Linear Systems, v2.0
 ITC Case for dose rate [TC950804.DAT]

REMOVAL: 0.000E+00 1/sec 7.430E-08 1/sec 1.000E+01 cfm
 NUC GIP 1 REL FR: 0.000E+00 INTAKE REDUCT: 0.000E+00
 NUC GIP 2 REL FR: 0.000E+00 INTAKE REDUCT: 0.000E+00
 NUC GIP 3 REL FR: 0.000E+00 INTAKE REDUCT: 0.000E+00

MULTIPLIERS====>

STEP	TIME	XPR	XREM	XRF	XPR	XREM	XRF	XPR	XREM	XRF	XPR	XREM	XRF
1	6.000E+01	0.000E+00	0.000E+00	0.000E+00	1.00	1.00	0.000E+00	50.0	50.0	0.000E+00	50.0	50.0	0.000E+00
2	3.000E+02	0.000E+00	0.000E+00	0.000E+00	1.00	1.00	0.000E+00	50.0	50.0	0.000E+00	50.0	50.0	0.000E+00
3	6.000E+02	0.000E+00	0.000E+00	0.000E+00	1.00	1.00	0.000E+00	50.0	50.0	0.000E+00	50.0	50.0	0.000E+00
4	9.000E+02	0.000E+00	0.000E+00	0.000E+00	1.00	1.00	0.000E+00	50.0	50.0	0.000E+00	50.0	50.0	0.000E+00
5	1.200E+03	0.000E+00	0.000E+00	0.000E+00	1.00	1.00	0.000E+00	50.0	50.0	0.000E+00	50.0	50.0	0.000E+00
6	1.800E+03	0.000E+00	0.000E+00	0.000E+00	1.00	1.00	0.000E+00	50.0	50.0	0.000E+00	50.0	50.0	0.000E+00
7	2.700E+03	0.000E+00	0.000E+00	0.000E+00	1.00	1.00	0.000E+00	50.0	50.0	0.000E+00	50.0	50.0	0.000E+00
8	3.600E+03	0.000E+00	0.000E+00	0.000E+00	1.00	1.00	0.000E+00	50.0	50.0	0.000E+00	50.0	50.0	0.000E+00
9	7.200E+03	0.000E+00	0.000E+00	0.000E+00	1.00	1.000E-02	0.000E+00	50.0	50.0	0.000E+00	50.0	50.0	0.000E+00
10	1.440E+04	0.000E+00	0.000E+00	0.000E+00	1.00	1.000E-02	0.000E+00	50.0	50.0	0.000E+00	50.0	50.0	0.000E+00
11	2.880E+04	0.000E+00	0.000E+00	0.000E+00	2.000E-03	1.000E-02	0.000E+00	50.0	50.0	0.000E+00	50.0	50.0	0.000E+00
12	8.640E+04	0.000E+00	0.000E+00	0.000E+00	0.000E+00	0.000E+00	0.000E+00	50.0	50.0	0.000E+00	50.0	50.0	0.000E+00
13	3.456E+05	0.000E+00	0.000E+00	0.000E+00	0.000E+00	0.000E+00	0.000E+00	50.0	50.0	0.000E+00	50.0	50.0	0.000E+00
14	2.592E+06	0.000E+00	0.000E+00	0.000E+00	0.000E+00	0.000E+00	0.000E+00	50.0	50.0	0.000E+00	50.0	50.0	0.000E+00

----- ENVIRONMENT -----

X/Q Breathing s/M3 M3/s
 1.000E-03 3.470E-04 1.000E+00 3.470E-04

----- CONTROL ROOM -----

X/Q Breathing Occupancy s/M3 M3/s
 1.000E-03 3.470E-04 1.000E+00 1.000E+00

MULTIPLIERS====>

STEP	TIME, s	XPR	XREM	XRF	XPR	XREM	XRF	XPR	XREM	XRF	XPR	XREM	XRF
1	6.000E+01	2.43	1.00	1.00	0.000E+00	1.00	0.000E+00	1.00	1.00	0.000E+00	1.00	1.00	0.000E+00
2	3.000E+02	2.43	1.00	1.00	0.000E+00	1.00	0.000E+00	1.00	1.00	0.000E+00	1.00	1.00	0.000E+00
3	6.000E+02	2.43	1.00	1.00	0.000E+00	1.00	0.000E+00	1.00	1.00	0.000E+00	1.00	1.00	0.000E+00
4	9.000E+02	2.43	1.00	1.00	0.000E+00	1.00	0.000E+00	1.00	1.00	0.000E+00	1.00	1.00	0.000E+00
5	1.200E+03	2.43	1.00	1.00	0.000E+00	1.00	0.000E+00	1.00	1.00	0.000E+00	1.00	1.00	0.000E+00
6	1.800E+03	2.43	1.00	1.00	0.000E+00	1.00	0.000E+00	1.00	1.00	0.000E+00	1.00	1.00	0.000E+00
7	2.700E+03	2.43	1.00	1.00	0.000E+00	1.00	0.000E+00	1.00	1.00	0.000E+00	1.00	1.00	0.000E+00
8	3.600E+03	2.43	1.00	1.00	0.000E+00	1.00	0.000E+00	1.00	1.00	0.000E+00	1.00	1.00	0.000E+00
9	7.200E+03	2.43	1.00	1.00	0.000E+00	1.00	0.000E+00	1.00	1.00	0.000E+00	1.00	1.00	0.000E+00
10	1.440E+04	2.43	1.00	1.00	0.000E+00	1.00	0.000E+00	1.00	1.00	0.000E+00	1.00	1.00	0.000E+00
11	2.880E+04	2.43	1.00	1.00	0.000E+00	1.00	0.000E+00	1.00	1.00	0.000E+00	1.00	1.00	0.000E+00
12	8.640E+04	1.22	1.00	1.00	0.000E+00	1.00	0.000E+00	1.00	1.00	0.000E+00	1.00	1.00	0.000E+00
13	3.456E+05	0.890	1.00	0.600	0.000E+00	1.00	0.000E+00	1.00	1.00	0.000E+00	1.00	1.00	0.000E+00
14	2.592E+06	0.626	1.00	0.400	0.000E+00	1.00	0.000E+00	1.00	1.00	0.000E+00	1.00	1.00	0.000E+00

TRAILS -- Transport of Radioactive Material in Linear Systems, v2.0
 ITC Case for dose rate [TC950804.DAT]

E N V I R O N M E N T						C O N T R O L R O O M							
PHOTON-SUBMG		BETA-SUBMG		THYROID-INHAL		PHOTON-SUBMG		BETA-SUBMG		THYROID-INHAL			
DOSE	DOSE RATE	DOSE	DOSE RATE	DOSE	DOSE RATE	DOSE	DOSE RATE	DOSE	DOSE RATE	DOSE	DOSE RATE		
mrem	mrem/hr	mrem	mrem/hr	mrem	mrem/hr	mrem	mrem/hr	mrem	mrem/hr	mrem	mrem/hr		
ALL NUCLIDES													
0.0167 h	0.00E+00	0.00E+00	0.00E+00	0.00E+00	0.00E+00	0.00E+00	0.00E+00	2.22E-07	2.67E-05	1.25E-06	1.50E-04	2.04E-03	2.44E-01
0.0833 h	0.00E+00	0.00E+00	0.00E+00	0.00E+00	0.00E+00	0.00E+00	0.00E+00	1.55E-05	4.35E-04	8.05E-05	2.25E-03	9.81E-02	2.69E+00
0.1667 h	0.00E+00	0.00E+00	0.00E+00	0.00E+00	0.00E+00	0.00E+00	0.00E+00	8.46E-05	1.59E-03	4.33E-04	8.10E-03	4.89E-01	9.02E+00
0.2500 h	0.00E+00	0.00E+00	0.00E+00	0.00E+00	0.00E+00	0.00E+00	0.00E+00	2.08E-04	3.40E-03	1.06E-03	1.73E-02	1.16E+00	1.89E+01
0.3333 h	0.00E+00	0.00E+00	0.00E+00	0.00E+00	0.00E+00	0.00E+00	0.00E+00	3.84E-04	5.81E-03	1.96E-03	2.96E-02	2.13E+00	3.23E+01
0.5000 h	0.00E+00	0.00E+00	0.00E+00	0.00E+00	0.00E+00	0.00E+00	0.00E+00	1.51E-03	1.22E-02	7.71E-03	6.25E-02	8.46E+00	6.90E+01
0.7500 h	0.00E+00	0.00E+00	0.00E+00	0.00E+00	0.00E+00	0.00E+00	0.00E+00	4.72E-03	2.52E-02	2.42E-02	1.30E-01	2.73E+01	1.48E+02
1.0000 h	0.00E+00	0.00E+00	0.00E+00	0.00E+00	0.00E+00	0.00E+00	0.00E+00	8.37E-03	4.14E-02	4.34E-02	2.16E-01	5.06E+01	2.55E+02
2.0000 h	0.00E+00	0.00E+00	0.00E+00	0.00E+00	0.00E+00	0.00E+00	0.00E+00	3.28E-02	2.59E-02	1.76E-01	1.44E-01	2.34E+02	2.14E+02
4.0000 h	0.00E+00	0.00E+00	0.00E+00	0.00E+00	0.00E+00	0.00E+00	0.00E+00	3.80E-02	1.43E-02	2.23E-01	8.31E-02	3.78E+02	1.68E+02
8.0000 h	0.00E+00	0.00E+00	0.00E+00	0.00E+00	0.00E+00	0.00E+00	0.00E+00	4.03E-02	7.68E-03	2.67E-01	5.40E-02	5.83E+02	1.29E+02
24.0000 h	0.00E+00	0.00E+00	0.00E+00	0.00E+00	0.00E+00	0.00E+00	0.00E+00	2.87E-02	1.64E-04	2.25E-01	1.57E-03	6.46E+02	6.33E+00
96.0000 h	0.00E+00	0.00E+00	0.00E+00	0.00E+00	0.00E+00	0.00E+00	0.00E+00	4.68E-04	1.58E-10	4.64E-03	1.54E-09	2.06E+01	1.45E-05
720.0000 h	0.00E+00	0.00E+00	0.00E+00	0.00E+00	0.00E+00	0.00E+00	0.00E+00	3.48E-10	0.00E+00	3.36E-09	0.00E+00	3.25E-05	0.00E+00
TOTALS	0.00E+00		0.00E+00		0.00E+00		0.00E+00	1.55E-01		9.74E-01		1.95E+03	

2002/04
Control_A Dose Rate vs Time
 MSLB-Concurrent Spike - 6.6 gpm P-to-S

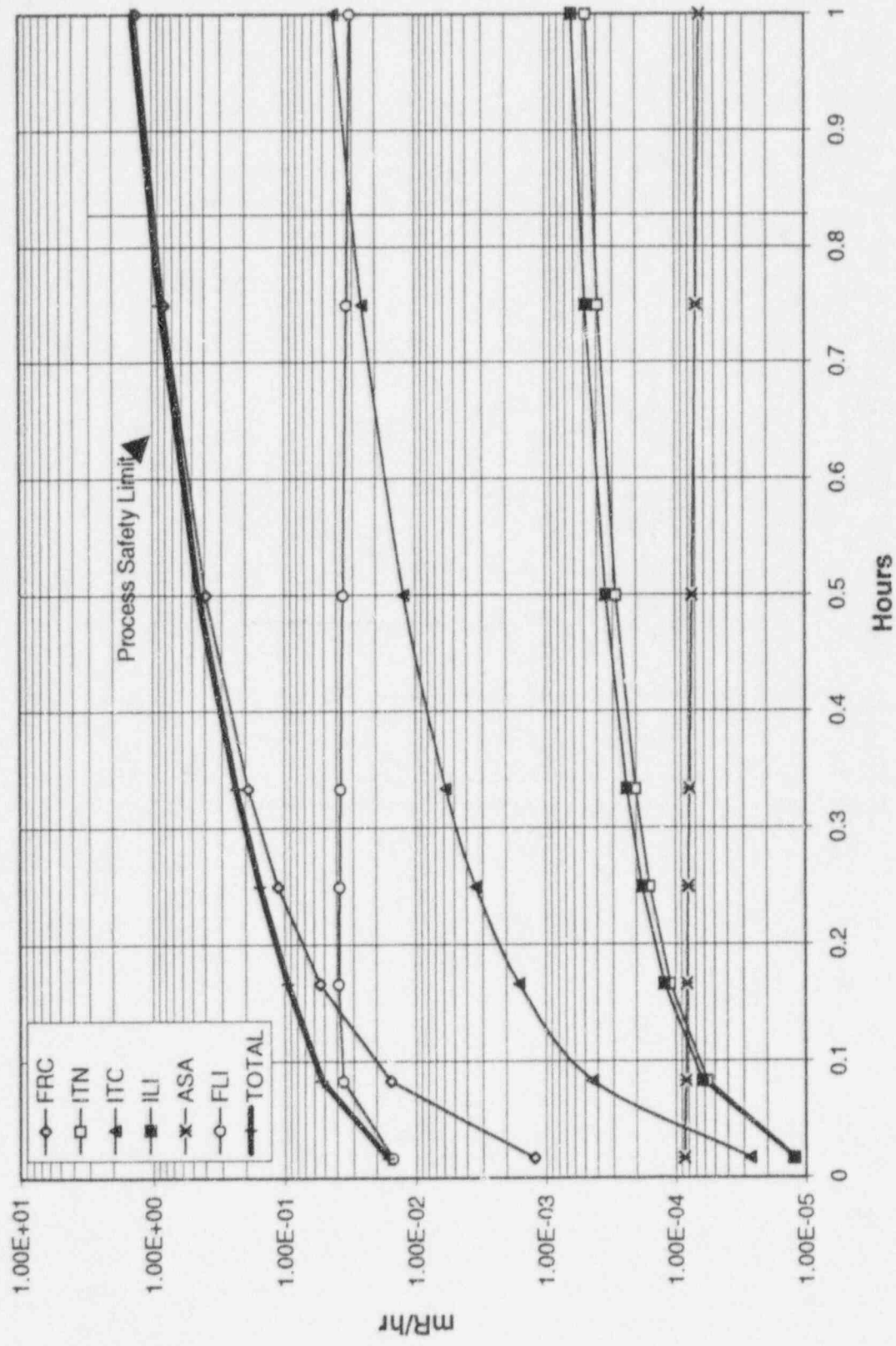

Control Room Dose Rate vs Time

MSLB - Pre-incident Spike - 6.6 gpm P-to-S

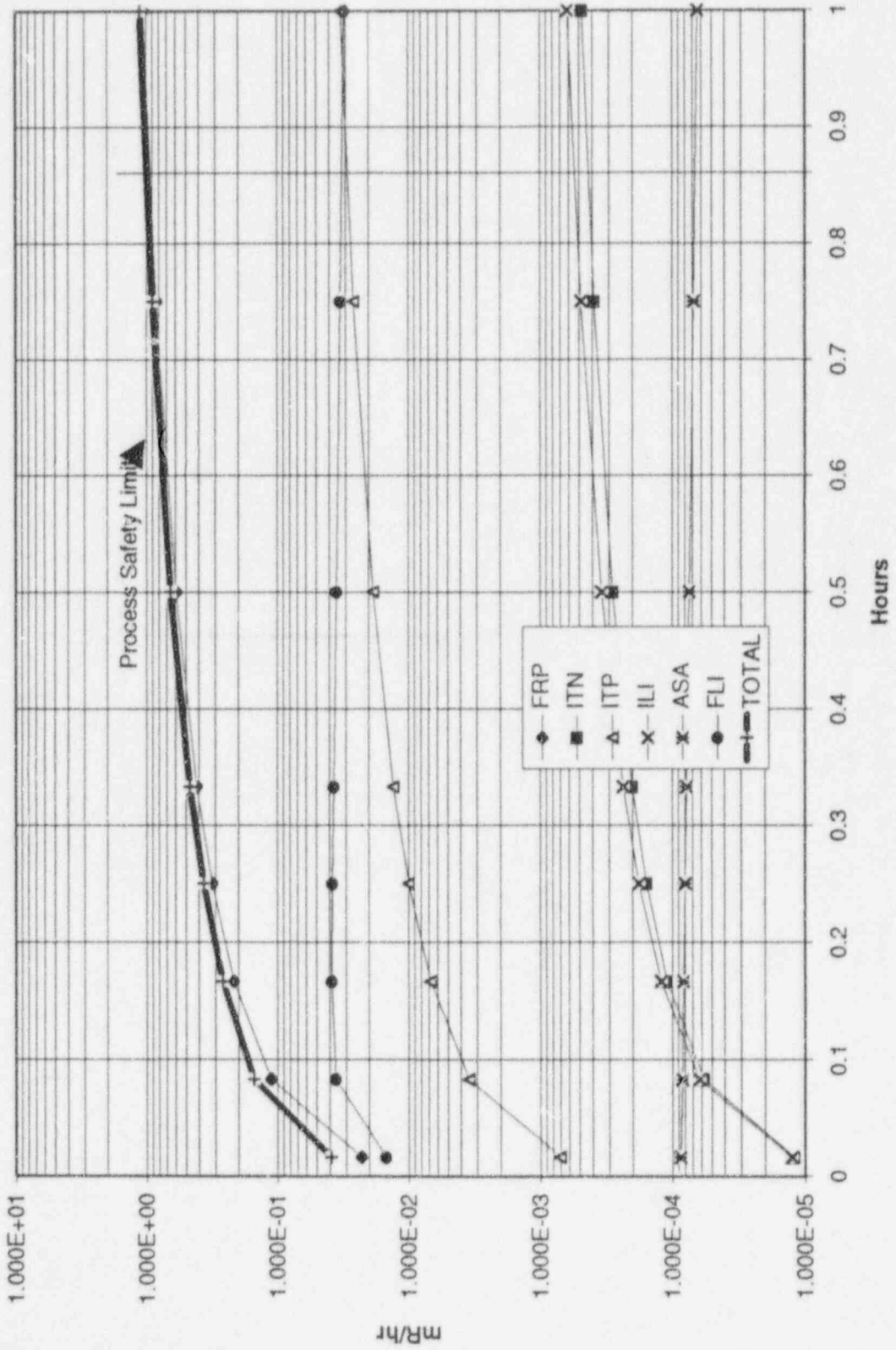

hrs	FRC	ITN	ITC	ILI	ASA	FLI	TOTAL
0.0167	1.230E-03	1.210E-05	2.670E-05	1.260E-05	8.580E-05	1.490E-02	1.627E-02
0.0833	1.560E-02	5.750E-05	4.350E-04	6.210E-05	8.400E-05	3.580E-02	5.204E-02
0.1667	5.370E-02	1.100E-04	1.590E-03	1.220E-04	8.180E-05	3.850E-02	9.410E-02
0.25	1.120E-01	1.580E-04	3.400E-03	1.800E-04	7.970E-05	3.790E-02	1.537E-01
0.3333	1.900E-01	2.020E-04	5.810E-03	2.360E-04	7.770E-05	3.710E-02	2.334E-01
0.5	3.960E-01	2.830E-04	1.220E-02	3.410E-04	7.390E-05	3.530E-02	4.442E-01
0.75	8.090E-01	3.880E-04	2.520E-02	4.870E-04	6.870E-05	3.290E-02	8.680E-01
1	1.320E+00	4.770E-04	4.140E-02	6.180E-04	6.400E-05	3.070E-02	1.393E+00
hrs	FRP	ITN	ITP	ILI	ASA	FLI	TOTAL
0.0167	2.290E-02	1.210E-05	7.090E-04	1.260E-05	8.580E-05	1.490E-02	3.862E-02
0.0833	1.120E-01	5.750E-05	3.480E-03	6.210E-05	8.400E-05	3.580E-02	1.515E-01
0.1667	2.180E-01	1.100E-04	6.790E-03	1.220E-04	8.180E-05	3.850E-02	2.636E-01
0.25	3.200E-01	1.580E-04	9.950E-03	1.800E-04	7.970E-05	3.790E-02	3.683E-01
0.3333	4.160E-01	2.020E-04	1.300E-02	2.360E-04	7.770E-05	3.710E-02	4.666E-01
0.5	5.960E-01	2.830E-04	1.860E-02	3.410E-04	7.390E-05	3.530E-02	6.506E-01
0.75	8.370E-01	3.880E-04	2.610E-02	4.870E-04	6.870E-05	3.290E-02	8.969E-01
1	1.050E+00	4.770E-04	3.270E-02	6.180E-04	6.400E-05	3.070E-02	1.115E+00

INTENTIONALLY BLANK

TRAILS -- Transport of Radioactive Material in Linear Systems, v2.0
 ASA Case for dose [TC950821.DAT]

COMP: not used

COMP: all S/Gs

COMP: Control Room
 VOLUME: 1.730E+05 Cu.Ft.

INITIAL:	0.000E+00	1.430E+01	0.000E+00
Kr-83m	Kr-83m	Kr-83m uCi	Kr-83m
Kr-85m	Kr-85m	Kr-85m	Kr-85m
Kr-85	Kr-85	Kr-85	Kr-85
Kr-87	Kr-87	Kr-87	Kr-87
Kr-88	Kr-88	Kr-88	Kr-88
Kr-89	Kr-89	Kr-89	Kr-89
Xe-131m	Xe-131m	Xe-131m	Xe-131m
Xe-133m	Xe-133m	Xe-133m	Xe-133m
Xe-133	Xe-133	Xe-133	Xe-133
Xe-135m	Xe-135m	Xe-135m	Xe-135m
Xe-135	Xe-135	Xe-135	Xe-135
Xe-137	Xe-137	Xe-137	Xe-137
Xe-138	Xe-138	Xe-138	Xe-138
I-131	I-131	I-131	I-131
I-132	I-132	I-132	I-132
I-133	I-133	I-133	I-133
I-134	I-134	I-134	I-134
I-135	I-135	I-135	I-135
ACT MULT (to uCi):	1.000E+00	3.000E+00	1.000E+00

TRAILS -- Transport of Radioactive Material in Linear Systems, v2.0
 ASA Case for dose [TC950821.DAT]

REMOVAL:	0.000E+00	1.382E+01	1.000E+01
NUC Grp 1 REL FR:	1/sec	1/sec	cfm
NUC Grp 2 REL FR:	0.000E+00	0.000E+00	INTAKE REDUCT: 0.000E+00
NUC Grp 3 REL FR:	0.000E+00	0.000E+00	INTAKE REDUCT: 9.360E-01
			INTAKE REDUCT: 0.000E+00

MULTIPLIERS====>

STEP	TIME	XPR	XREM	XRF	XPR	XREM	XRF	XPR	XREM	XRF
1	6.000E+01	0.000E+00	0.000E+00	0.000E+00	0.000E+00	1.00	0.000E+00	50.0	50.0	0.000E+00
2	1.800E+03	0.000E+00	0.000E+00	0.000E+00	0.000E+00	0.000E+00	0.000E+00	50.0	50.0	0.000E+00
3	5.400E+03	0.000E+00	0.000E+00	0.000E+00	0.000E+00	0.000E+00	0.000E+00	1.00	70.0	0.000E+00
4	7.200E+03	0.000E+00	0.000E+00	0.000E+00	0.000E+00	0.000E+00	0.000E+00	70.0	70.0	1.00
5	1.440E+04	0.000E+00	0.000E+00	0.000E+00	0.000E+00	0.000E+00	0.000E+00	70.0	70.0	1.00
6	2.880E+04	0.000E+00	0.000E+00	0.000E+00	0.000E+00	0.000E+00	0.000E+00	70.0	70.0	1.00
7	3.060E+04	0.000E+00	0.000E+00	0.000E+00	0.000E+00	0.000E+00	0.000E+00	3.350E+03	3.350E+03	0.000E+00
8	8.640E+04	0.000E+00	0.000E+00	0.000E+00	0.000E+00	0.000E+00	0.000E+00	50.0	50.0	0.000E+00
9	3.456E+05	0.000E+00	0.000E+00	0.000E+00	0.000E+00	0.000E+00	0.000E+00	50.0	50.0	0.000E+00
10	2.592E+06	0.000E+00	0.000E+00	0.000E+00	0.000E+00	0.000E+00	0.000E+00	50.0	50.0	0.000E+00

----- CONTROL ROOM -----			----- ENVIRONMENT -----		
X/Q	Breathing	Occupancy	X/Q	Breathing	
s/M3	M3/s		s/M3	M3/s	
1.000E-03	3.470E-04	1.000E+00	0.000E+00	3.470E-04	

MULTIPLIERS====>

STEP	TIME, s					
1	6.000E+01	2.43	1.00	1.00	0.000E+00	1.00
2	1.800E+03	2.43	1.00	1.00	0.000E+00	1.00
3	5.400E+03	2.43	1.00	1.00	0.000E+00	1.00
4	7.200E+03	2.43	1.00	1.00	0.000E+00	1.00
5	1.440E+04	2.43	1.00	1.00	0.000E+00	1.00
6	2.880E+04	2.43	1.00	1.00	0.000E+00	1.00
7	3.060E+04	1.22	1.00	1.00	0.000E+00	1.00
8	8.640E+04	1.22	1.00	1.00	0.000E+00	1.00
9	3.456E+05	0.890	1.00	0.600	0.000E+00	1.00
10	2.592E+06	0.626	1.00	0.400	0.000E+00	1.00

TRAILS -- Transport of Radioactive Material in Linear Systems, v2.0
 ASA Case for dose [TC950821.DAT]

	----- ENVIRONMENT -----						----- CONTROL ROOM -----					
	External EDE		SKIN-DE		THY CDE-INHAL		External EDE		SKIN-DE		THY CDE-INHAL	
	DOSE	DOSE RATE	DOSE	DOSE RATE	DOSE	DOSE RATE	DOSE	DOSE RATE	DOSE	DOSE RATE	DOSE	DOSE RATE
I-135	mrem	mrem/hr	mrem	mrem/hr	mrem	mrem/hr	mrem	mrem/hr	mrem	mrem/hr	mrem	mrem/hr
TOTALS	0.00E+00		0.00E+00		0.00E+00		4.68E-05		2.82E-04		3.83E-02	

ALL NUCLIDES

0.0167 h	0.00E+00	0.00E+00	0.00E+00	0.00E+00	0.00E+00	0.00E+00	4.69E-07	5.63E-05	5.41E-06	6.49E-04	1.02E-02	1.22E+00
0.5000 h	0.00E+00	0.00E+00	0.00E+00	0.00E+00	0.00E+00	0.00E+00	2.52E-05	4.84E-05	2.92E-04	5.65E-04	5.64E-01	1.12E+00
1.5000 h	0.00E+00	0.00E+00	0.00E+00	0.00E+00	0.00E+00	0.00E+00	4.07E-05	3.40E-05	4.82E-04	4.10E-04	9.85E-01	8.66E-01
2.0000 h	0.00E+00	0.00E+00	0.00E+00	0.00E+00	0.00E+00	0.00E+00	1.56E-05	2.87E-05	1.90E-04	3.51E-04	4.07E-01	7.63E-01
4.0000 h	0.00E+00	0.00E+00	0.00E+00	0.00E+00	0.00E+00	0.00E+00	4.20E-05	1.49E-05	5.27E-04	1.93E-04	1.20E+00	4.61E-01
8.0000 h	0.00E+00	0.00E+00	0.00E+00	0.00E+00	0.00E+00	0.00E+00	3.43E-05	4.41E-06	4.59E-04	6.17E-05	1.16E+00	1.68E-01
8.5000 h	0.00E+00	0.00E+00	0.00E+00	0.00E+00	0.00E+00	0.00E+00	3.77E-07	1.29E-08	5.27E-06	1.82E-07	1.44E-02	5.03E-04
24.0000 h	0.00E+00	0.00E+00	0.00E+00	0.00E+00	0.00E+00	0.00E+00	5.76E-08	5.06E-10	8.49E-07	7.99E-09	2.61E-03	3.05E-05
96.0000 h	0.00E+00	0.00E+00	0.00E+00	0.00E+00	0.00E+00	0.00E+00	1.55E-09	7.55E-16	2.47E-08	1.19E-14	1.02E-04	8.15E-11
720.0000 h	0.00E+00	0.00E+00	0.00E+00	0.00E+00	0.00E+00	0.00E+00	1.68E-15	0.00E+00	2.65E-14	0.00E+00	1.84E-10	0.00E+00
TOTALS	0.00E+00		0.00E+00		0.00E+00		1.59E-04		1.96E-03		4.34E+00	

TRAILS -- Transport of Radioactive Material in Linear Systems, v2.0
 ILI Case for dose [TC950822.DAT]

COMP: intact s/Gs
 COMP: Control Room
 VOLUME: 1.730E+05 Cu.Ft.

INITIAL:

0.000E+00 I-131	3.170E+06 I-131	uCi	0.000E+00 I-131
0.000E+00 I-132	5.640E+05 I-132		0.000E+00 I-132
0.000E+00 I-133	4.140E+06 I-133		0.000E+00 I-133
0.000E+00 I-134	9.900E+04 I-134		0.000E+00 I-134
0.000E+00 I-135	1.510E+06 I-135		0.000E+00 I-135
1.000E+00	1.000E+00		1.000E+00

TRAILS -- Transport of Radioactive Material in Linear Systems, v2.0
 ILI Case for dose [TC950822.DAT]

REMOVAL:

0.000E+00	0.000E+00 1/sec	5.203E-06 1/sec	1.000E+01 cfm
NUC Grp 1 REL FR:	0.000E+00		INTAKE REDUCT: 0.000E+00
NUC Grp 2 REL FR:	0.000E+00		INTAKE REDUCT: 9.360E-01
NUC Grp 3 REL FR:	0.000E+00		INTAKE REDUCT: 0.000E+00

MULTIPLIERS====>

STEP	TIME	XPR	XREM	XRF	XPR	XREM	XRF	XPR	XREM	XRF
1	1.500E+03	0.000E+00	0.000E+00	0.000E+00	0.000E+00	1.00	0.000E+00	50.0	50.0	0.000E+00
2	5.400E+03	0.000E+00	0.000E+00	0.000E+00	0.700E+00	1.00	0.000E+00	1.00	70.0	0.000E+00
3	7.200E+03	0.000E+00	0.000E+00	0.000E+00	0.000E+00	1.00	0.000E+00	70.0	70.0	1.00
4	1.440E+04	0.000E+00	0.000E+00	0.000E+00	0.000E+00	0.640	0.000E+00	70.0	70.0	1.00
5	2.880E+04	0.000E+00	0.000E+00	0.000E+00	0.000E+00	0.640	0.000E+00	70.0	70.0	1.00
6	3.060E+04	0.000E+00	0.000E+00	0.000E+00	0.000E+00	0.000E+00	0.000E+00	3.350E+03	3.350E+03	0.000E+00
7	8.640E+04	0.000E+00	0.000E+00	0.000E+00	0.000E+00	0.000E+00	0.000E+00	50.0	50.0	0.000E+00
8	3.456E+05	0.000E+00	0.000E+00	0.000E+00	0.000E+00	0.000E+00	0.000E+00	50.0	50.0	0.000E+00
9	2.592E+06	0.000E+00	0.000E+00	0.000E+00	0.000E+00	0.000E+00	0.000E+00	50.0	50.0	0.000E+00

CONTROL ROOM ----- ENVIRONMENT ---
 X/Q Breathing Occupancy X/Q Breathing
 s/M3 M3/s M3/s

1.000E-03	3.470E-04	1.000E+00	0.000E+00	3.470E-04
2.43	1.00	1.00	0.000E+00	1.00
2.43	1.00	1.00	0.000E+00	1.00
2.43	1.00	1.00	0.000E+00	1.00
2.43	1.00	1.00	0.000E+00	1.00
2.43	1.00	1.00	0.000E+00	1.00
1.22	1.00	1.00	0.000E+00	1.00
1.22	1.00	1.00	0.000E+00	1.00
0.890	1.00	0.600	0.000E+00	1.00
0.626	1.00	0.400	0.000E+00	1.00

	E N V I R O N M E N T						C O N T R O L R O O M					
	External EDE		SKIN-DE		THY CDE-INHAL		External EDE		SKIN-DE		THY CDE-INHAL	
	DOSE mrem	DOSE RATE mrem/hr	DOSE mrem	DOSE RATE mrem/hr	DOSE mrem	DOSE RATE mrem/hr	DOSE mrem	DOSE RATE mrem/hr	DOSE mrem	DOSE RATE mrem/hr	DOSE mrem	DOSE RATE mrem/hr
ALL NUCLIDES												
0.5000 h	0.00E+00	0.00E+00	0.00E+00	0.00E+00	0.00E+00	0.00E+00	5.71E-05	2.23E-04	6.22E-04	2.44E-03	1.39E+00	5.48E+00
1.5000 h	0.00E+00	0.00E+00	0.00E+00	0.00E+00	0.00E+00	0.00E+00	1.92E-04	1.65E-04	2.13E-03	1.87E-03	4.95E+00	4.46E+00
2.0000 h	0.00E+00	0.00E+00	0.00E+00	0.00E+00	0.00E+00	0.00E+00	8.03E-05	1.56E-04	9.14E-04	1.79E-03	2.21E+00	4.39E+00
4.0000 h	0.00E+00	0.00E+00	0.00E+00	0.00E+00	0.00E+00	0.00E+00	2.63E-04	1.12E-04	3.09E-03	1.35E-03	7.94E+00	3.61E+00
8.0000 h	0.00E+00	0.00E+00	0.00E+00	0.00E+00	0.00E+00	0.00E+00	3.49E-04	7.12E-05	4.34E-03	9.09E-04	1.25E+01	2.77E+00
8.5000 h	0.00E+00	0.00E+00	0.00E+00	0.00E+00	0.00E+00	0.00E+00	6.08E-06	2.08E-07	7.78E-05	2.68E-06	2.38E-01	8.28E-03
24.0000 h	0.00E+00	0.00E+00	0.00E+00	0.00E+00	0.00E+00	0.00E+00	9.32E-07	8.17E-09	1.24E-05	1.13E-07	4.29E-02	5.02E-04
96.0000 h	0.00E+00	0.00E+00	0.00E+00	0.00E+00	0.00E+00	0.00E+00	2.50E-08	1.20E-14	3.44E-07	1.37E-13	1.68E-03	1.34E-09
720.0000 h	0.00E+00	0.00E+00	0.00E+00	0.00E+00	0.00E+00	0.00E+00	2.68E-14	0.00E+00	3.01E-13	0.00E+00	3.02E-09	0.00E+00
TOTALS	0.00E+00		0.00E+00		0.00E+00		9.49E-04		1.12E-02		2.93E+01	

TRAILS -- Transport of Radioactive Material in Linear Systems, v2.0
 FLI Case for dose [TC950823.DAT]

COMP: not used
 COMP: faulted s/G
 COMP: Control Room
 VOLUME: 1.730E+05 Cu.Ft.

INITIAL:

0.000E+00	I-131	3.170E+06	I-131	uCi	0.000E+00	I-131
0.000E+00	I-132	5.640E+05	I-132		0.000E+00	I-132
0.000E+00	I-133	4.140E+06	I-133		0.000E+00	I-133
0.000E+00	I-134	9.900E+04	I-134		0.000E+00	I-134
0.000E+00	I-135	1.510E+06	I-135		0.000E+00	I-135

ACT MULT (to uCi): 1.000E+00

TRAILS -- Transport of Radioactive Material in Linear Systems, v2.0
 FLI Case for dose [TC950823.DAT]

REMOVAL:

0.000E+00	1/sec	7.675E-03	1/sec	1.000E+01	cfm
0.000E+00		0.000E+00		INTAKE REDUCT:	0.000E+00
0.000E+00		0.000E+00		INTAKE REDUCT:	9.360E-01
0.000E+00		0.000E+00		INTAKE REDUCT:	0.000E+00

MULTIPLIERS====>

STEP	TIME	XPR	XREM	XRF	XPR	Breathing	X/Q	M3/s	XPR	XRF	XPR	XRF	XPR	XRF
1	1.800E+03	0.000E+00	0.000E+00	0.000E+00	0.000E+00	1.00	0.000E+00	1.00	0.000E+00	0.000E+00	50.0	0.000E+00	50.0	0.000E+00
2	5.400E+03	0.000E+00	0.000E+00	0.000E+00	0.000E+00	1.00	0.000E+00	1.00	0.000E+00	0.000E+00	70.0	0.000E+00	70.0	0.000E+00
3	7.200E+03	0.000E+00	0.000E+00	0.000E+00	0.000E+00	1.00	0.000E+00	1.00	0.000E+00	0.000E+00	70.0	0.000E+00	70.0	1.00
4	1.440E+04	0.000E+00	0.000E+00	0.000E+00	0.000E+00	1.00	0.000E+00	1.00	0.000E+00	0.000E+00	70.0	0.000E+00	70.0	1.00
5	2.880E+04	0.000E+00	0.000E+00	0.000E+00	0.000E+00	1.00	0.000E+00	1.00	0.000E+00	0.000E+00	70.0	0.000E+00	70.0	1.00
6	3.060E+04	0.000E+00	0.000E+00	0.000E+00	0.000E+00	1.00	0.000E+00	1.00	0.000E+00	0.000E+00	3.350E+03	3.350E+03	50.0	0.000E+00
7	8.640E+04	0.000E+00	0.000E+00	0.000E+00	0.000E+00	1.00	0.000E+00	1.00	0.000E+00	0.000E+00	50.0	0.000E+00	50.0	0.000E+00
8	3.456E+05	0.000E+00	0.000E+00	0.000E+00	0.000E+00	1.00	0.000E+00	1.00	0.000E+00	0.000E+00	50.0	0.000E+00	50.0	0.000E+00
9	2.592E+06	0.000E+00	0.000E+00	0.000E+00	0.000E+00	1.00	0.000E+00	1.00	0.000E+00	0.000E+00	50.0	0.000E+00	50.0	0.000E+00

CONTROL ROOM
 Breathing Occupancy
 X/Q M3/s
 1.000E-03 3.470E-04 1.000E+00

ENVIRONMENT
 Breathing
 X/Q M3/s
 0.000E+00 3.470E-04

MULTIPLIERS====>

STEP	TIME,s	XPR	XREM	XRF	XPR	Breathing	X/Q	M3/s	XPR	XRF	XPR	XRF	XPR	XRF
1	1.800E+03	2.43	1.00	1.00	0.000E+00	1.00	0.000E+00	1.00	0.000E+00	0.000E+00	50.0	0.000E+00	50.0	0.000E+00
2	5.400E+03	2.43	1.00	1.00	0.000E+00	1.00	0.000E+00	1.00	0.000E+00	0.000E+00	70.0	0.000E+00	70.0	0.000E+00
3	7.200E+03	2.43	1.00	1.00	0.000E+00	1.00	0.000E+00	1.00	0.000E+00	0.000E+00	70.0	0.000E+00	70.0	1.00
4	1.440E+04	2.43	1.00	1.00	0.000E+00	1.00	0.000E+00	1.00	0.000E+00	0.000E+00	70.0	0.000E+00	70.0	1.00
5	2.880E+04	2.43	1.00	1.00	0.000E+00	1.00	0.000E+00	1.00	0.000E+00	0.000E+00	70.0	0.000E+00	70.0	1.00
6	3.060E+04	1.22	1.00	1.00	0.000E+00	1.00	0.000E+00	1.00	0.000E+00	0.000E+00	3.350E+03	3.350E+03	50.0	0.000E+00
7	8.640E+04	1.22	1.00	1.00	0.000E+00	1.00	0.000E+00	1.00	0.000E+00	0.000E+00	50.0	0.000E+00	50.0	0.000E+00
8	3.456E+05	0.890	1.00	0.600	0.000E+00	1.00	0.000E+00	1.00	0.000E+00	0.000E+00	50.0	0.000E+00	50.0	0.000E+00
9	2.592E+06	0.626	1.00	0.400	0.000E+00	1.00	0.000E+00	1.00	0.000E+00	0.000E+00	50.0	0.000E+00	50.0	0.000E+00

	E N V I R O N M E N T						C O N T R O L R O O M					
	External EDE		SKIN-DE		THY CDE-INHAL		External EDE		SKIN-DE		THY CDE-INH	
	DOSE mrem	DOSE RATE mrem/hr	DOSE mrem	DOSE RATE mrem/hr	DOSE mrem	DOSE RATE mrem/hr	DOSE mrem	DOSE RATE mrem/hr	DOSE mrem	DOSE RATE mrem/hr	DOSE mrem	DOSE RATE mrem/hr
ALL NUCLIDES												
0.5000 h	0.00E+00	0.00E+00	0.00E+00	0.00E+00	0.00E+00	0.00E+00	6.28E-03	2.45E-02	6.78E-02	2.66E-01	1.50E+02	5.89E+02
1.5000 h	0.00E+00	0.00E+00	0.00E+00	0.00E+00	0.00E+00	0.00E+00	2.07E-02	1.73E-02	2.28E-01	1.94E-01	5.21E+02	4.58E+02
2.0000 h	0.00E+00	0.00E+00	0.00E+00	0.00E+00	0.00E+00	0.00E+00	7.95E-03	1.46E-02	8.99E-02	1.66E-01	2.15E+02	4.03E+02
4.0000 h	0.00E+00	0.00E+00	0.00E+00	0.00E+00	0.00E+00	0.00E+00	2.15E-02	7.66E-03	2.50E-01	9.17E-02	6.34E+02	2.44E+02
8.0000 h	0.00E+00	0.00E+00	0.00E+00	0.00E+00	0.00E+00	0.00E+00	1.76E-02	2.28E-03	2.18E-01	2.92E-02	6.14E+02	8.90E+01
8.5000 h	0.00E+00	0.00E+00	0.00E+00	0.00E+00	0.00E+00	0.00E+00	1.95E-04	6.67E-06	2.49E-03	8.58E-05	7.63E+00	2.66E-01
24.0000 h	0.00E+00	0.00E+00	0.00E+00	0.00E+00	0.00E+00	0.00E+00	2.99E-05	2.62E-07	3.97E-04	3.63E-06	1.38E+00	1.61E-02
96.0000 h	0.00E+00	0.00E+00	0.00E+00	0.00E+00	0.00E+00	0.00E+00	8.02E-07	3.87E-13	1.10E-05	4.39E-12	5.39E-02	4.30E-08
720.0000 h	0.00E+00	0.00E+00	0.00E+00	0.00E+00	0.00E+00	0.00E+00	8.60E-13	0.00E+00	9.68E-12	0.00E+00	9.70E-08	0.00E+00
TOTALS	0.00E+00		0.00E+00		0.00E+00		7.42E-02		8.56E-01		2.14E+03	

TRAILS -- Transport of Radioactive Material in Linear Systems, v2.0
 ITC Case for dose [TC950824.DAT]

COMP: not used COMP: intact S/G COMP: Control Room
 VOLUME: 1.730E+05 Cu.Ft.

INITIAL:	0.000E+00 I-131	1.170E+08 I-131	uCi	0.000E+00 I-131
	0.000E+00 I-132	4.070E+07 I-132		0.000E+00 I-132
	0.000E+00 I-133	1.820E+08 I-133		0.000E+00 I-133
	0.000E+00 I-134	2.550E+07 I-134		0.000E+00 I-134
	0.000E+00 I-135	9.810E+07 I-135		0.000E+00 I-135
ACT MULT (to uCi):	1.000E+00	1.000E+00		1.000E+00
PRODUCTION, uCi/s:	0.000E+00 I-131	1.360E+06 I-131		1.000E+01 CFM
	0.000E+00 I-132	2.520E+06 I-132		
	0.000E+00 I-133	3.080E+06 I-133		
	0.000E+00 I-134	3.680E+06 I-134		
	0.000E+00 I-135	2.810E+06 I-135		

TRAILS -- Transport of Radioactive Material in Linear Systems, v2.0
 ITC Case for dose [TC950824.DAT]

REMOVAL:	0.000E+00 1/sec	7.430E-08 1/sec	1.000E+01 cfm
NUC Grp 1 REL FR:	0.000E+00	0.000E+00	INTAKE REDUCT: 0.000E+00
NUC Grp 2 REL FR:	0.000E+00	0.000E+00	INTAKE REDUCT: 9.360E-01
NUC Grp 3 REL FR:	0.000E+00	0.000E+00	INTAKE REDUCT: 0.000E+00

MULTIPLIERS====>

STEP TIME	XPR	XREM	XRF	XPR	XREM	XRF	XPR	XREM	XRF
1 1.800E+03	0.000E+00	0.000E+00	0.000E+00	1.00	1.00	0.000E+00	50.0	50.0	0.000E+00
2 3.600E+03	0.000E+00	0.000E+00	0.000E+00	1.00	1.00	0.000E+00	1.00	70.0	0.000E+00
3 5.400E+03	0.000E+00	0.000E+00	0.000E+00	1.00	1.000E-02	0.000E+00	1.00	70.0	0.000E+00
4 7.200E+03	0.000E+00	0.000E+00	0.000E+00	1.00	1.000E-02	0.000E+00	70.0	70.0	1.00
5 1.440E+04	0.000E+00	0.000E+00	0.000E+00	1.00	1.000E-02	0.000E+00	70.0	70.0	1.00
6 2.880E+04	0.000E+00	0.000E+00	0.000E+00	2.000E-03	1.000E-02	0.000E+00	70.0	70.0	1.00
7 3.060E+04	0.000E+00	0.000E+00	0.000E+00	0.000E+00	0.000E+00	0.000E+00	3.350E+03	3.350E+03	0.000E+00
8 8.640E+04	0.000E+00	0.000E+00	0.000E+00	0.000E+00	0.000E+00	0.000E+00	50.0	50.0	0.000E+00
9 3.456E+05	0.000E+00	0.000E+00	0.000E+00	0.000E+00	0.000E+00	0.000E+00	50.0	50.0	0.000E+00
10 2.592E+06	0.000E+00	0.000E+00	0.000E+00	0.000E+00	0.000E+00	0.000E+00	50.0	50.0	0.000E+00

----- CONTROL ROOM -----	---- ENVIRONMENT ---
X/Q Breathing Occupancy	X/Q Breathing
s/M3 M3/s M3/s	s/M3 M3/s
1.000E-03 3.470E-04 1.000E+00	0.000E+00 3.470E-04

MULTIPLIERS====>

STEP	TIME, s	X/Q	Breathing	Occupancy	X/Q	Breathing
		s/M3	M3/s	M3/s	s/M3	M3/s
1	1.800E+03	2.43	1.00	1.00	0.000E+00	1.00
2	3.600E+03	2.43	1.00	1.00	0.000E+00	1.00
3	5.400E+03	2.43	1.00	1.00	0.000E+00	1.00
4	7.200E+03	2.43	1.00	1.00	0.000E+00	1.00
5	1.440E+04	2.43	1.00	1.00	0.000E+00	1.00
6	2.880E+04	2.43	1.00	1.00	0.000E+00	1.00
7	3.060E+04	1.22	1.00	1.00	0.000E+00	1.00
8	8.640E+04	1.22	1.00	1.00	0.000E+00	1.00
9	3.456E+05	0.890	1.00	0.600	0.000E+00	1.00
10	2.592E+06	0.626	1.00	0.400	0.000E+00	1.00

TRAILS -- Transport of Radioactive Material in Linear Systems, v2.0
ITC Case for dose [TC950824.DAT]

----- ENVIRONMENT -----	----- CONTROL ROOM -----
External EDE SKIN-DE THY CDE-INHAL	External EDE SKIN-DE THY CDE-INHAL
DOSE DOSE RATE DOSE DOSE RATE DOSE DOSE RATE	DOSE DOSE RATE DOSE DOSE RATE DOSE DOSE RATE
mrem mrem/hr mrem mrem/hr mrem mrem/hr	mrem mrem/hr mrem mrem/hr mrem mrem/hr

ALL NUCLIDES

0.5000 h	0.00E+00	0.00E+00	0.00E+00	0.00E+00	0.00E+00	0.00E+00	2.03E-03	7.76E-03	1.53E-02	5.85E-02	9.82E+00	3.87E+01
1.0000 h	0.00E+00	0.00E+00	0.00E+00	0.00E+00	0.00E+00	0.00E+00	3.44E-03	6.10E-03	2.63E-02	4.73E-02	1.87E+01	3.61E+01
1.5000 h	0.00E+00	0.00E+00	0.00E+00	0.00E+00	0.00E+00	0.00E+00	2.65E-03	4.58E-03	2.08E-02	3.65E-02	1.69E+01	3.18E+01
2.0000 h	0.00E+00	0.00E+00	0.00E+00	0.00E+00	0.00E+00	0.00E+00	2.01E-03	3.54E-03	1.63E-02	2.90E-02	1.49E+01	2.81E+01
4.0000 h	0.00E+00	0.00E+00	0.00E+00	0.00E+00	0.00E+00	0.00E+00	4.73E-03	1.56E-03	4.06E-02	1.41E-02	4.53E+01	1.80E+01
8.0000 h	0.00E+00	0.00E+00	0.00E+00	0.00E+00	0.00E+00	0.00E+00	3.64E-03	5.42E-04	3.48E-02	5.48E-03	5.10E+01	9.01E+00
8.5000 h	0.00E+00	0.00E+00	0.00E+00	0.00E+00	0.00E+00	0.00E+00	4.60E-05	1.53E-06	4.67E-04	1.58E-05	7.72E-01	2.68E-02
24.0000 h	0.00E+00	0.00E+00	0.00E+00	0.00E+00	0.00E+00	0.00E+00	5.88E-06	3.87E-08	6.63E-05	5.17E-07	1.37E-01	1.56E-03
96.0000 h	0.00E+00	0.00E+00	0.00E+00	0.00E+00	0.00E+00	0.00E+00	1.11E-07	3.75E-14	1.51E-06	4.45E-13	5.15E-03	3.89E-09
720.0000 h	0.00E+00	0.00E+00	0.00E+00	0.00E+00	0.00E+00	0.00E+00	8.26E-14	0.00E+00	9.67E-13	0.00E+00	8.77E-09	0.00E+00
TOTALS	0.00E+00		0.00E+00		0.00E+00		1.86E-02		1.55E-01		1.58E+02	

TRAILS -- Transport of Radioactive Material in Linear Systems, v2.0
 ITP Case for dose [TC950825.DAT]

COMP: not used
 COMP: intact S/G
 COMP: Control Room
 VOLUME: 1.730E+05 Cu.Ft.

INITIAL:

NUC	REL	FR	0.000E+00	I-131	7.160E+09	I-131	uCi	0.000E+00	I-131
0.000E+00	I-132	2.500E+09	I-132	0.000E+00	I-132	0.000E+00	I-132	0.000E+00	I-132
0.000E+00	I-133	1.120E+10	I-133	0.000E+00	I-133	0.000E+00	I-133	0.000E+00	I-133
0.000E+00	I-134	1.560E+09	I-134	0.000E+00	I-134	0.000E+00	I-134	0.000E+00	I-134
0.000E+00	I-135	6.890E+09	I-135	0.000E+00	I-135	0.000E+00	I-135	0.000E+00	I-135
1.000E+00				1.000E+00				1.000E+00	

ACT MULT (to uCi): 1.000E+00

TRAILS -- Transport of Radioactive Material in Linear Systems, v2.0
 ITP Case for dose [TC950825.DAT]

REMOVAL:

NUC	REL	FR	0.000E+00	1/sec	7.430E-08	1/sec	0.000E+00	1.000E+01	cfm
NUC GIP 1	REL FR:	0.000E+00	0.000E+00	0.000E+00	0.000E+00	0.000E+00	0.000E+00	INTAKE REDUCT:	0.000E+00
NUC GIP 2	REL FR:	0.000E+00	0.000E+00	0.000E+00	0.000E+00	0.000E+00	0.000E+00	INTAKE REDUCT:	9.360E-01
NUC GIP 3	REL FR:	0.000E+00	0.000E+00	0.000E+00	0.000E+00	0.000E+00	0.000E+00	INTAKE REDUCT:	0.000E+00

MULTIPLIERS====>

STEP	TIME	XPR	XREM	XRF	XPR	XREM	XRF	XPR	XREM	XRF
1	1.800E+03	0.000E+00	0.000E+00	0.000E+00	0.000E+00	1.00	0.000E+00	50.0	50.0	0.000E+00
2	3.600E+03	0.000E+00	0.000E+00	0.000E+00	0.000E+00	1.00	0.000E+00	1.00	70.0	0.000E+00
3	5.400E+03	0.000E+00	0.000E+00	0.000E+00	0.000E+00	1.000E-02	0.000E+00	1.00	70.0	0.000E+00
4	7.200E+03	0.000E+00	0.000E+00	0.000E+00	0.000E+00	1.000E-02	0.000E+00	70.0	70.0	1.00
5	1.440E+04	0.000E+00	0.000E+00	0.000E+00	0.000E+00	1.000E-02	0.000E+00	70.0	70.0	1.00
6	2.880E+04	0.000E+00	0.000E+00	0.000E+00	0.000E+00	1.000E-02	0.000E+00	70.0	70.0	1.00
7	3.060E+04	0.000E+00	0.000E+00	0.000E+00	0.000E+00	0.000E+00	0.000E+00	3.350E+03	3.350E+03	0.000E+00
8	8.640E+04	0.000E+00	0.000E+00	0.000E+00	0.000E+00	0.000E+00	0.000E+00	50.0	50.0	0.000E+00
9	3.456E+05	0.000E+00	0.000E+00	0.000E+00	0.000E+00	0.000E+00	0.000E+00	50.0	50.0	0.000E+00
10	2.592E+06	0.000E+00	0.000E+00	0.000E+00	0.000E+00	0.000E+00	0.000E+00	50.0	50.0	0.000E+00

----- CONTROL ROOM -----

X/Q	Breathing	Occupancy
s/M3	M3/s	M3/s
1.000E-03	3.470E-04	1.000E+00

----- ENVIRONMENT -----

X/Q	Breathing
s/M3	M3/s
0.000E+00	3.470E-04

MULTIPLIERS====>

STEP	TIME, s	XPR	XREM	XRF
1	1.800E+03	2.43	1.00	1.00
2	3.600E+03	2.43	1.00	1.00
3	5.400E+03	2.43	1.00	1.00
4	7.200E+03	2.43	1.00	1.00
5	1.440E+04	2.43	1.00	1.00
6	2.880E+04	2.43	1.00	1.00
7	3.060E+04	1.22	1.00	1.00
8	8.640E+04	1.22	1.00	1.00
9	3.456E+05	0.890	1.00	0.600
10	2.592E+06	0.626	1.00	0.400

	E N V I R O N M E N T						C O N T R O L R O O M					
	External EDE		SKIN-DE		THY CDE-INHAL		External EDE		SKIN-DE		THY CDE-INHAL	
	DOSE mrem	DOSE RATE mrem/hr	DOSE mrem	DOSE RATE mrem/hr	DOSE mrem	DOSE RATE mrem/hr	DOSE mrem	DOSE RATE mrem/hr	DOSE mrem	DOSE RATE mrem/hr	DOSE mrem	DOSE RATE mrem/hr
ALL NUCLIDES												
0.5000 h	0.00E+00	0.00E+00	0.00E+00	0.00E+00	0.00E+00	0.00E+00	3.15E-03	1.22E-02	2.96E-02	1.16E-01	4.72E+01	1.86E+02
1.0000 h	0.00E+00	0.00E+00	0.00E+00	0.00E+00	0.00E+00	0.00E+00	5.58E-03	1.02E-02	5.33E-02	9.84E-02	8.82E+01	1.67E+02
1.5000 h	0.00E+00	0.00E+00	0.00E+00	0.00E+00	0.00E+00	0.00E+00	4.61E-03	8.35E-03	4.51E-02	8.26E-02	7.85E+01	1.47E+02
2.0000 h	0.00E+00	0.00E+00	0.00E+00	0.00E+00	0.00E+00	0.00E+00	3.80E-03	6.92E-03	3.80E-02	6.99E-02	6.92E+01	1.30E+02
4.0000 h	0.00E+00	0.00E+00	0.00E+00	0.00E+00	0.00E+00	0.00E+00	9.92E-03	3.46E-03	1.03E-01	3.73E-02	2.04E+02	7.87E+01
8.0000 h	0.00E+00	0.00E+00	0.00E+00	0.00E+00	0.00E+00	0.00E+00	7.81E-03	9.92E-04	8.75E-02	1.17E-02	2.00E+02	2.94E+01
8.5000 h	0.00E+00	0.00E+00	0.00E+00	0.00E+00	0.00E+00	0.00E+00	8.47E-05	2.88E-06	9.99E-04	3.43E-05	2.52E+00	8.79E-02
24.0000 h	0.00E+00	0.00E+00	0.00E+00	0.00E+00	0.00E+00	0.00E+00	1.23E-05	9.84E-08	1.54E-04	1.34E-06	4.53E-01	5.26E-03
96.0000 h	0.00E+00	0.00E+00	0.00E+00	0.00E+00	0.00E+00	0.00E+00	2.93E-07	1.26E-13	4.02E-06	1.45E-12	1.75E-02	1.38E-08
720.0000 h	0.00E+00	0.00E+00	0.00E+00	0.00E+00	0.00E+00	0.00E+00	2.80E-13	0.00E+00	3.19E-12	0.00E+00	3.11E-08	0.00E+00
TOTALS	0.00E+00		0.00E+00		0.00E+00		3.50E-02		3.58E-01		6.90E+02	

TRAILS -- Transport of Radioactive Material in Linear Systems, v2.0
 ITN Case for dose [TC950826.DAT]

COMP: not used
 COMP: intact s/g
 VOLUME: 1.730E+05 Cu.Ft.
 COMP: Control Room

INITIAL:	0.000E+00 Kr-83m	2.000E+07 Kr-83m	uCi	0.000E+00 Kr-83m
	0.000E+00 Kr-85m	9.750E+07 Kr-85m		0.000E+00 Kr-85m
	0.000E+00 Kr-85	5.150E+08 Kr-85		0.000E+00 Kr-85
	0.000E+00 Kr-87	5.580E+07 Kr-87		0.000E+00 Kr-87
	0.000E+00 Kr-88	1.490E+08 Kr-88		0.000E+00 Kr-88
	0.000E+00 Kr-89	4.690E+06 Kr-89		0.000E+00 Kr-89
	0.000E+00 Xe-131m	5.010E+06 Xe-131m		0.000E+00 Xe-131m
	0.000E+00 Xe-133m	1.430E+08 Xe-133m		0.000E+00 Xe-133m
	0.000E+00 Xe-133	1.220E+09 Xe-133		0.000E+00 Xe-133
	0.000E+00 Xe-135m	5.060E+07 Xe-135m		0.000E+00 Xe-135m
	0.000E+00 Xe-135	1.500E+08 Xe-135		0.000E+00 Xe-135
	0.000E+00 Xe-137	7.590E+06 Xe-137		0.000E+00 Xe-137
	0.000E+00 Xe-138	3.130E+07 Xe-138		0.000E+00 Xe-138
ACT MULT (to uCi):	1.000E+00	1.000E+00		1.000E+00

TRAILS -- Transport of Radioactive Material in Linear Systems, v2.0
 ITN Case for dose [TC950826.DAT]

REMOVAL:	0.000E+00 1/sec	7.430E-08 1/sec	1.000E+01 cfm
NUC GIP 1 REL FR:	0.000E+00	0.000E+00	INTAKE REDUCT: 0.000E+00
NUC GIP 2 REL FR:	0.000E+00	0.000E+00	INTAKE REDUCT: 9.360E-01
NUC GIP 3 REL FR:	0.000E+00	0.000E+00	INTAKE REDUCT: 0.000E+00

MULTIPLIERS====>

STEP	TIME	XPR	XREM	XRF	XPR	XREM	XRF	XPR	XREM	XRF
1	1.800E+03	0.000E+00	0.000E+00	0.000E+00	0.000E+00	1.00	0.000E+00	50.0	50.0	0.000E+00
2	3.600E+03	0.000E+00	0.000E+00	0.000E+00	0.000E+00	1.00	0.000E+00	1.00	70.0	0.000E+00
3	5.400E+03	0.000E+00	0.000E+00	0.000E+00	0.000E+00	1.00	0.000E+00	1.00	70.0	0.000E+00
4	7.200E+03	0.000E+00	0.000E+00	0.000E+00	0.000E+00	1.00	0.000E+00	70.0	70.0	1.00
5	1.440E+04	0.000E+00	0.000E+00	0.000E+00	0.000E+00	1.00	0.000E+00	70.0	70.0	1.00
6	2.880E+04	0.000E+00	0.000E+00	0.000E+00	0.000E+00	1.00	0.000E+00	70.0	70.0	1.00
7	3.060E+04	0.000E+00	0.000E+00	0.000E+00	0.000E+00	0.000E+00	0.000E+00	3.350E+03	3.350E+03	0.000E+00
8	8.640E+04	0.000E+00	0.000E+00	0.000E+00	0.000E+00	0.000E+00	0.000E+00	50.0	50.0	0.000E+00
9	3.456E+05	0.000E+00	0.000E+00	0.000E+00	0.000E+00	0.000E+00	0.000E+00	50.0	50.0	0.000E+00
10	2.592E+06	0.000E+00	0.000E+00	0.000E+00	0.000E+00	0.000E+00	0.000E+00	50.0	50.0	0.000E+00

----- CONTROL ROOM -----			----- ENVIRONMENT -----		
X/Q	Breathing	Occupancy	X/Q	Breathing	
s/M3	M3/s		s/M3	M3/s	
1.000E-03	3.470E-04	1.000E+00	0.000E+00	3.470E-04	

MULTIPLIERS====>

STEP	TIME, s					
1	1.800E+03	2.43	1.00	1.00	0.000E+00	1.00
2	3.600E+03	2.43	1.00	1.00	0.000E+00	1.00
3	5.400E+03	2.43	1.00	1.00	0.000E+00	1.00
4	7.200E+03	2.43	1.00	1.00	0.000E+00	1.00
5	1.440E+04	2.43	1.00	1.00	0.000E+00	1.00
6	2.880E+04	2.43	1.00	1.00	0.000E+00	1.00
7	3.060E+04	1.22	1.00	1.00	0.000E+00	1.00
8	8.640E+04	1.22	1.00	1.00	0.000E+00	1.00
9	3.456E+05	0.890	1.00	0.600	0.000E+00	1.00
10	2.592E+06	0.626	1.00	0.400	0.000E+00	1.00

TRAILS -- Transport of Radioactive Material in Linear Systems, v2.0
 ITN Case for dose [TC950826.DAT]

----- ENVIRONMENT -----						----- CONTROL ROOM -----					
External EDE		SKIN-DE		THY CDE-INHAL		External EDE		SKIN-DE		THY CDE-INHAL	
DOSE	DOSE RATE	DOSE	DOSE RATE	DOSE	DOSE RATE	DOSE	DOSE RATE	DOSE	DOSE RATE	DOSE	DOSE RATE
mrem	mrem/hr	mrem	mrem/hr	mrem	mrem/hr	mrem	mrem/hr	mrem	mrem/hr	mrem	mrem/hr

ALL NUCLIDES

0.5000 h	0.00E+00	0.00E+00	0.00E+00	0.00E+00	0.00E+00	0.00E+00	0.00E+00	5.08E-05	1.95E-04	1.16E-03	4.51E-03	0.00E+00	0.00E+00
1.0000 h	0.00E+00	0.00E+00	0.00E+00	0.00E+00	0.00E+00	0.00E+00	0.00E+00	8.64E-05	1.54E-04	2.05E-03	3.75E-03	0.00E+00	0.00E+00
1.5000 h	0.00E+00	0.00E+00	0.00E+00	0.00E+00	0.00E+00	0.00E+00	0.00E+00	6.91E-05	1.24E-04	1.73E-03	3.20E-03	0.00E+00	0.00E+00
2.0000 h	0.00E+00	0.00E+00	0.00E+00	0.00E+00	0.00E+00	0.00E+00	0.00E+00	1.04E-04	2.86E-04	2.77E-03	7.77E-03	0.00E+00	0.00E+00
4.0000 h	0.00E+00	0.00E+00	0.00E+00	0.00E+00	0.00E+00	0.00E+00	0.00E+00	8.85E-04	5.63E-04	2.78E-02	1.90E-02	0.00E+00	0.00E+00
8.0000 h	0.00E+00	0.00E+00	0.00E+00	0.00E+00	0.00E+00	0.00E+00	0.00E+00	2.14E-03	5.32E-04	9.39E-02	2.69E-02	0.00E+00	0.00E+00
8.5000 h	0.00E+00	0.00E+00	0.00E+00	0.00E+00	0.00E+00	0.00E+00	0.00E+00	4.52E-05	1.50E-06	2.30E-03	7.96E-05	0.00E+00	0.00E+00
24.0000 h	0.00E+00	0.00E+00	0.00E+00	0.00E+00	0.00E+00	0.00E+00	0.00E+00	5.64E-06	4.24E-08	3.96E-04	4.50E-06	0.00E+00	0.00E+00
96.0000 h	0.00E+00	0.00E+00	0.00E+00	0.00E+00	0.00E+00	0.00E+00	0.00E+00	1.35E-07	8.95E-14	1.51E-05	1.40E-11	0.00E+00	0.00E+00
720.0000 h	0.00E+00	0.00E+00	0.00E+00	0.00E+00	0.00E+00	0.00E+00	0.00E+00	2.00E-13	0.00E+00	3.15E-11	0.00E+00	0.00E+00	0.00E+00
TOTALS	0.00E+00		0.00E+00		0.00E+00		0.00E+00	3.39E-03		1.32E-01		0.00E+00	

COMP: not used

COMP: intact S/G

COMP: Control Room
 VOLUME: 1.730E+05 Cu.Ft.

INITIAL:	COMP: not used	COMP: intact S/G	COMP: Control Room
			VOLUME: 1.730E+05 Cu.Ft.

	0.000E+00 Kr-83m	2.000E+07 Kr-83m uCi	0.000E+00 Kr-83m
	0.000E+00 Kr-85m	9.750E+07 Kr-85m	0.000E+00 Kr-85m
	0.000E+00 Kr-85	5.150E+08 Kr-85	0.000E+00 Kr-85
	0.000E+00 Kr-87	5.580E+07 Kr-87	0.000E+00 Kr-87
	0.000E+00 Kr-88	1.490E+08 Kr-88	0.000E+00 Kr-88
	0.000E+00 Kr-89	4.690E+06 Kr-89	0.000E+00 Kr-89
	0.000E+00 Xe-131m	5.010E+06 Xe-131m	0.000E+00 Xe-131m
	0.000E+00 Xe-133m	1.430E+08 Xe-133m	0.000E+00 Xe-133m
	0.000E+00 Xe-133	1.220E+09 Xe-133	0.000E+00 Xe-133
	0.000E+00 Xe-135m	5.060E+07 Xe-135m	0.000E+00 Xe-135m
	0.000E+00 Xe-135	1.500E+08 Xe-135	0.000E+00 Xe-135
	0.000E+00 Xe-137	7.590E+06 Xe-137	0.000E+00 Xe-137
	0.000E+00 Xe-138	3.130E+07 Xe-138	0.000E+00 Xe-138
	0.000E+00 I-131	1.170E+08 I-131	0.000E+00 I-131
	0.000E+00 I-132	4.070E+07 I-132	0.000E+00 I-132
	0.000E+00 I-133	1.820E+08 I-133	0.000E+00 I-133
	0.000E+00 I-134	2.550E+07 I-134	0.000E+00 I-134
	0.000E+00 I-135	9.810E+07 I-135	0.000E+00 I-135
ACT MULT (to uCi):	1.000E+00	1.000E+00	1.000E+00

PRODUCTION,uCi/s:	0.000E+00 I-131	1.360E+06 I-131	INTAKE: 1.000E+01 CFM
	0.000E+00 I-132	2.520E+06 I-132	
	0.000E+00 I-133	3.080E+06 I-133	
	0.000E+00 I-134	3.680E+06 I-134	
	0.000E+00 I-135	2.810E+06 I-135	

TRAILS -- Transport of Radioactive Material in Linear Systems, v2.0
 ERC Case for dose for 1 gpm [TC950828.DAT]

REMOVAL: 0.000E+00 1/sec 3.566E-07 1/sec 1.000E+01 cfm
 NUC Grp 1 REL FR: 0.000E+00 INTAKE REDUCT: 0.000E+00
 NUC Grp 2 REL FR: 0.000E+00 INTAKE REDUCT: 9.360E-01
 NUC Grp 3 REL FR: 0.000E+00 INTAKE REDUCT: 0.000E+00

MULTIPLIERS====>

STEP	TIME	XFR	XREM	XRF	XPR	XREM	XRF	XPR	XREM	XRF
1	1.800E+03	0.000E+00	0.000E+00	0.000E+00	1.00	1.00	0.000E+00	50.0	50.0	0.000E+00
2	3.600E+03	0.000E+00	0.000E+00	0.000E+00	1.00	1.00	0.000E+00	1.00	70.0	0.000E+00
3	5.400E+03	0.000E+00	0.000E+00	0.000E+00	1.00	1.00	0.000E+00	1.00	70.0	0.000E+00
4	7.200E+03	0.000E+00	0.000E+00	0.000E+00	1.00	1.00	0.000E+00	70.0	70.0	1.00
5	1.440E+04	0.000E+00	0.000E+00	0.000E+00	1.00	1.00	0.000E+00	70.0	70.0	1.00
6	2.880E+04	0.000E+00	0.000E+00	0.000E+00	2.000E-03	1.00	0.000E+00	70.0	70.0	1.00
7	3.060E+04	0.000E+00	0.000E+00	0.000E+00	0.000E+00	0.000E+00	0.000E+00	3.350E+03	3.350E+03	0.000E+00
8	8.640E+04	0.000E+00	0.000E+00	0.000E+00	0.000E+00	0.000E+00	0.000E+00	50.0	50.0	0.000E+00
9	3.456E+05	0.000E+00	0.000E+00	0.000E+00	0.000E+00	0.000E+00	0.000E+00	50.0	50.0	0.000E+00
10	2.592E+06	0.000E+00	0.000E+00	0.000E+00	0.000E+00	0.000E+00	0.000E+00	50.0	50.0	0.000E+00

----- CONTROL ROOM ----- ENVIRONMENT ----
 X/Q Breathing Occupancy X/Q Breathing
 s/M3 M3/s s/M3 M3/s
 1.000E-03 3.470E-04 1.000E+00 0.000E+00 3.470E-04

MULTIPLIERS====>

STEP	TIME, s	XFR	XREM	XRF	XPR	XREM	XRF	XPR	XREM	XRF
1	1.800E+03	2.43	1.00	1.00	0.000E+00	1.00	0.000E+00	1.00	0.000E+00	1.00
2	3.600E+03	2.43	1.00	1.00	0.000E+00	1.00	0.000E+00	1.00	0.000E+00	1.00
3	5.400E+03	2.43	1.00	1.00	0.000E+00	1.00	0.000E+00	1.00	0.000E+00	1.00
4	7.200E+03	2.43	1.00	1.00	0.000E+00	1.00	0.000E+00	1.00	0.000E+00	1.00
5	1.440E+04	2.43	1.00	1.00	0.000E+00	1.00	0.000E+00	1.00	0.000E+00	1.00
6	2.880E+04	2.43	1.00	1.00	0.000E+00	1.00	0.000E+00	1.00	0.000E+00	1.00
7	3.060E+04	1.22	1.00	1.00	0.000E+00	1.00	0.000E+00	1.00	0.000E+00	1.00
8	8.640E+04	1.22	1.00	1.00	0.000E+00	1.00	0.000E+00	1.00	0.000E+00	1.00
9	3.456E+05	0.890	1.00	0.600	0.000E+00	1.00	0.000E+00	1.00	0.000E+00	1.00
10	2.592E+06	0.626	1.00	0.400	0.000E+00	1.00	0.000E+00	1.00	0.000E+00	1.00

TRAILS -- Transport of Radioactive Material in Linear Systems, v2.0
 FRC Case for dose for 1 gpm [TC950828.DAT]

STEP	TIME	not used		intact S/G		AVERAGE		-----CONTROL ROOM-----		
		CURRENT uCi	INTEGRD uCi-sec	CURRENT uCi	INTEGRD uCi-sec	RELEASED uCi	RELEASE uCi/sec	CURRENT uCi	CURRENT uCi/cc	INTEGRD uCi-sec
Kr-83m	INITIAL	0.000E+00		2.000E+07				0.000E+00		
1	0.5000 h	0.000E+00	0.000E+00	1.654E+07	3.279E+10	1.169E+04	6.496E+00	5.859E+00	1.196E-09	5.515E+03
2	1.0000 h	0.000E+00	0.000E+00	1.368E+07	2.711E+10	9.669E+03	5.371E+00	4.389E+00	8.959E-10	9.154E+03
3	1.5000 h	0.000E+00	0.000E+00	1.131E+07	2.242E+10	7.995E+03	4.442E+00	3.295E+00	6.727E-10	6.865E+03
4	2.0000 h	0.000E+00	0.000E+00	9.353E+06	1.854E+10	6.612E+03	3.673E+00	6.977E+00	1.424E-09	9.417E+03
5	4.0000 h	0.000E+00	0.000E+00	4.374E+06	4.716E+10	1.682E+04	2.336E+00	9.741E+00	1.989E-09	6.220E+04
6	8.0000 h	0.000E+00	0.000E+00	9.564E+05	3.237E+10	1.154E+04	8.016E-01	4.228E+00	8.631E-10	8.561E+04
7	8.5000 h	0.000E+00	0.000E+00	7.914E+05	1.568E+09	0.000E+00	0.000E+00	1.049E-02	2.142E-12	1.266E+03
8	24.0000 h	0.000E+00	0.000E+00	2.232E+03	7.501E+09	0.000E+00	0.000E+00	2.014E-06	4.111E-16	6.841E+01
9	96.0000 h	0.000E+00	0.000E+00	3.202E-09	2.122E+07	0.000E+00	0.000E+00	1.092E-23	2.229E-33	1.313E-02
10	720.0000 h	0.000E+00	0.000E+00	0.000E+00	3.043E-05	0.000E+00	0.000E+00	0.000E+00	0.000E+00	7.119E-20
Kr-83m	TOTALS		0.000E+00		1.895E+11	6.433E+04				1.801E+05
Kr-85m	INITIAL	0.000E+00		9.750E+07				0.000E+00		
1	0.5000 h	0.000E+00	0.000E+00	9.018E+07	1.688E+11	6.021E+04	3.345E+01	3.184E+01	6.500E-09	2.944E+04
2	1.0000 h	0.000E+00	0.000E+00	8.342E+07	1.562E+11	5.569E+04	3.094E+01	2.668E+01	5.446E-09	5.251E+04
3	1.5000 h	0.000E+00	0.000E+00	7.716E+07	1.444E+11	5.151E+04	2.862E+01	2.241E+01	4.574E-09	4.405E+04
4	2.0000 h	0.000E+00	0.000E+00	7.137E+07	1.336E+11	4.764E+04	2.647E+01	5.306E+01	1.083E-08	6.883E+04
5	4.0000 h	0.000E+00	0.000E+00	5.224E+07	4.414E+11	1.574E+05	2.186E+01	1.111E+02	2.269E-08	6.185E+05
6	8.0000 h	0.000E+00	0.000E+00	2.799E+07	5.596E+11	1.996E+05	1.386E+01	1.029E+02	2.100E-08	1.526E+06
7	8.5000 h	0.000E+00	0.000E+00	2.591E+07	4.848E+10	0.000E+00	0.000E+00	2.856E-01	5.830E-11	3.137E+04
8	24.0000 h	0.000E+00	0.000E+00	2.354E+06	5.480E+11	0.000E+00	0.000E+00	1.766E-03	3.605E-13	3.114E+03
9	96.0000 h	0.000E+00	0.000E+00	3.419E+01	5.478E+10	0.000E+00	0.000E+00	9.695E-14	1.979E-23	1.937E+01
10	720.0000 h	0.000E+00	0.000E+00	0.000E+00	7.955E+05	0.000E+00	0.000E+00	0.000E+00	0.000E+00	1.064E-09
Kr-85m	TOTALS		0.000E+00		2.255E+12	5.720E+05				2.374E+06
Kr-85	INITIAL	0.000E+00		5.150E+08				0.000E+00		
1	0.5000 h	0.000E+00	0.000E+00	5.147E+08	9.267E+11	3.305E+05	1.836E+02	1.815E+02	3.705E-08	1.657E+05
2	1.0000 h	0.000E+00	0.000E+00	5.143E+08	9.261E+11	3.303E+05	1.835E+02	1.643E+02	3.355E-08	3.109E+05
3	1.5000 h	0.000E+00	0.000E+00	5.140E+08	9.255E+11	3.300E+05	1.834E+02	1.491E+02	3.044E-08	2.818E+05
4	2.0000 h	0.000E+00	0.000E+00	5.137E+08	9.249E+11	3.298E+05	1.832E+02	3.814E+02	7.786E-08	4.817E+05
5	4.0000 h	0.000E+00	0.000E+00	5.123E+08	3.694E+12	1.317E+06	1.829E+02	1.072E+03	2.189E-07	5.434E+06
6	8.0000 h	0.000E+00	0.000E+00	5.097E+08	7.359E+12	2.624E+06	1.822E+02	1.754E+03	3.580E-07	2.113E+07
7	8.5000 h	0.000E+00	0.000E+00	5.097E+08	9.175E+11	0.000E+00	0.000E+00	5.261E+00	1.074E-09	5.418E+05
8	24.0000 h	0.000E+00	0.000E+00	5.096E+08	2.844E+13	0.000E+00	0.000E+00	3.579E-01	7.305E-11	1.018E+05
9	96.0000 h	0.000E+00	0.000E+00	5.094E+08	1.321E+14	0.000E+00	0.000E+00	1.352E-06	2.761E-16	7.429E+03
10	720.0000 h	0.000E+00	0.000E+00	5.070E+08	1.142E+15	0.000E+00	0.000E+00	0.000E+00	0.000E+00	2.807E-02
Kr-85	TOTALS		0.000E+00		1.318E+15	5.262E+06				2.846E+07

TRAILS -- Transport of Radioactive Material in Linear Systems, v2.0
 FRC Case for dose for 1 gpm [TC950828.DAT]

STEP	TIME	not used		intact S/G		AVERAGE		-----CONTROL ROOM-----		
		CURRENT uCi	INTEGRD uCi-sec	CURRENT uCi	INTEGRD uCi-sec	RELEASED uCi	RELEASE uCi/sec	CURRENT uCi	CURRENT uCi/cc	INTEGRD uCi-sec
Kr-87	INITIAL	0.000E+00		5.580E+07				0.000E+00		
1	0.5000 h	0.000E+00	0.000E+00	4.246E+07	8.789E+10	3.134E+04	1.741E+01	1.510E+01	3.082E-09	1.440E+04
2	1.0000 h	0.000E+00	0.000E+00	3.231E+07	6.688E+10	2.385E+04	1.325E+01	1.041E+01	2.125E-09	2.268E+04
3	1.5000 h	0.000E+00	0.000E+00	2.459E+07	5.089E+10	1.815E+04	1.008E+01	7.191E+00	1.468E-09	1.565E+04
4	2.0000 h	0.000E+00	0.000E+00	1.871E+07	3.873E+10	1.381E+04	7.672E+00	1.401E+01	2.861E-09	1.949E+04
5	4.0000 h	0.000E+00	0.000E+00	6.274E+06	8.194E+10	2.922E+04	4.059E+00	1.471E+01	3.002E-09	1.040E+05
6	8.0000 h	0.000E+00	0.000E+00	7.053E+05	3.669E+10	1.308E+04	9.086E-01	3.820E+00	7.797E-10	9.774E+04
7	8.5000 h	0.000E+00	0.000E+00	5.371E+05	1.111E+09	0.000E+00	0.000E+00	8.724E-03	1.781E-12	1.128E+03
8	24.0000 h	0.000E+00	0.000E+00	1.150E+02	3.546E+09	0.000E+00	0.000E+00	1.271E-07	2.595E-17	4.371E+01
9	96.0000 h	0.000E+00	0.000E+00	1.039E-15	7.597E+05	0.000E+00	0.000E+00	4.342E-30	0.000E+00	6.369E-04
10	720.0000 h	0.000E+00	0.000E+00	0.000E+00	6.864E-12	0.000E+00	0.000E+00	0.000E+00	0.000E+00	2.176E-26
Kr-87	TOTALS		0.000E+00		3.677E+11	1.295E+05				2.752E+05
Kr-88	INITIAL	0.000E+00		1.490E+08				0.000E+00		
1	0.5000 h	0.000E+00	0.000E+00	1.318E+08	2.524E+11	9.001E+04	5.001E+01	4.658E+01	9.509E-09	4.338E+04
2	1.0000 h	0.000E+00	0.000E+00	1.166E+08	2.233E+11	7.962E+04	4.423E+01	3.733E+01	7.620E-09	7.518E+04
3	1.5000 h	0.000E+00	0.000E+00	1.031E+08	1.975E+11	7.043E+04	3.913E+01	2.998E+01	6.120E-09	6.031E+04
4	2.0000 h	0.000E+00	0.000E+00	9.122E+07	1.747E+11	6.230E+04	3.461E+01	6.789E+01	1.386E-08	8.947E+04
5	4.0000 h	0.000E+00	0.000E+00	5.584E+07	5.190E+11	1.851E+05	2.571E+01	1.206E+02	2.462E-08	7.089E+05
6	8.0000 h	0.000E+00	0.000E+00	2.093E+07	5.123E+11	1.827E+05	1.269E+01	8.177E+01	1.669E-08	1.372E+06
7	8.5000 h	0.000E+00	0.000E+00	1.852E+07	3.546E+10	0.000E+00	0.000E+00	2.171E-01	4.432E-11	2.475E+04
8	24.0000 h	0.000E+00	0.000E+00	4.215E+05	2.670E+11	0.000E+00	0.000E+00	3.361E-04	6.860E-14	1.869E+03
9	96.0000 h	0.000E+00	0.000E+00	9.842E-03	6.217E+09	0.000E+00	0.000E+00	2.967E-17	6.056E-27	2.898E+00
10	720.0000 h	0.000E+00	0.000E+00	0.000E+00	1.452E+02	0.000E+00	0.000E+00	0.000E+00	0.000E+00	2.558E-13
Kr-88	TOTALS		0.000E+00		2.188E+12	6.701E+05				2.376E+06
Kr-89	INITIAL	0.000E+00		4.690E+06				0.000E+00		
1	0.5000 h	0.000E+00	0.000E+00	6.502E+03	1.281E+09	4.568E+02	2.538E-01	3.924E-02	8.010E-12	6.013E+01
2	1.0000 h	0.000E+00	0.000E+00	9.014E+00	1.776E+06	6.333E-01	3.518E-04	4.929E-05	1.006E-14	1.053E+01
3	1.5000 h	0.000E+00	0.000E+00	1.250E-02	2.462E+03	8.780E-04	4.878E-07	6.207E-08	1.267E-17	1.323E-02
4	2.0000 h	0.000E+00	0.000E+00	1.732E-05	3.413E+00	1.217E-06	6.762E-10	2.219E-10	4.529E-20	1.687E-05
5	4.0000 h	0.000E+00	0.000E+00	6.400E-17	4.738E-03	1.690E-09	2.347E-13	5.060E-14	1.033E-23	5.994E-08
6	8.0000 h	0.000E+00	0.000E+00	0.000E+00	1.750E-14	6.242E-21	4.335E-25	9.346E-26	1.908E-35	1.359E-11
7	8.5000 h	0.000E+00	0.000E+00	0.000E+00	0.000E+00	0.000E+00	0.000E+00	3.889E-31	0.000E+00	1.358E-23
8	24.0000 h	0.000E+00	0.000E+00	0.000E+00	0.000E+00	0.000E+00	0.000E+00	0.000E+00	0.000E+00	1.050E-28
9	96.0000 h	0.000E+00	0.000E+00	0.000E+00	0.000E+00	0.000E+00	0.000E+00	0.000E+00	0.000E+00	0.000E+00
10	720.0000 h	0.000E+00	0.000E+00	0.000E+00	0.000E+00	0.000E+00	0.000E+00	0.000E+00	0.000E+00	0.000E+00
Kr-89	TOTALS		0.000E+00		1.283E+09	4.574E+02				7.067E+01

TRAILS -- Transport of Radioactive Material in Linear Systems, v2.0
 FRC Case for dose for 1 gpm [TC950828.DAT]

STEP	TIME	not used		intact s/g		AVERAGE		-----CONTROL ROOM-----		
		CURRENT uCi	INTEGRD uCi-sec	CURRENT uCi	INTEGRD uCi-sec	RELEASED uCi	RELEASE uCi/sec	CURRENT uCi	CURRENT uCi/cc	INTEGRD uCi-sec
Xe-131m INITIAL		0.000E+00		5.010E+06				0.000E+00		
1	0.5000 h	0.000E+00	0.000E+00	5.001E+06	9.010E+09	3.213E+03	1.785E+00	1.764E+00	3.600E-10	1.611E+03
2	1.0000 h	0.000E+00	0.000E+00	4.991E+06	8.993E+09	3.207E+03	1.782E+00	1.595E+00	3.255E-10	3.020E+03
3	1.5000 h	0.000E+00	0.000E+00	4.982E+06	8.976E+09	3.201E+03	1.778E+00	1.445E+00	2.950E-10	2.733E+03
4	2.0000 h	0.000E+00	0.000E+00	4.973E+06	8.959E+09	3.195E+03	1.775E+00	3.692E+00	7.537E-10	4.665E+03
5	4.0000 h	0.000E+00	0.000E+00	4.936E+06	3.567E+10	1.272E+04	1.767E+00	1.033E+01	2.109E-09	5.244E+04
6	8.0000 h	0.000E+00	0.000E+00	4.863E+06	7.055E+10	2.516E+04	1.747E+00	1.674E+01	3.418E-09	2.024E+05
7	8.5000 h	0.000E+00	0.000E+00	4.857E+06	8.748E+09	0.000E+00	0.000E+00	5.017E-02	1.024E-11	5.172E+03
8	24.0000 h	0.000E+00	0.000E+00	4.677E+06	2.660E+11	0.000E+00	0.000E+00	3.286E-03	6.708E-13	9.598E+02
9	96.0000 h	0.000E+00	0.000E+00	3.924E+06	1.112E+12	0.000E+00	0.000E+00	1.042E-08	2.128E-18	6.727E+01
10	720.0000 h	0.000E+00	0.000E+00	8.563E+05	4.527E+12	0.000E+00	0.000E+00	0.000E+00	0.000E+00	2.134E-04
Xe-131m TOTALS			0.000E+00		6.055E+12	5.070E+04				2.731E+05
Xe-133m INITIAL		0.000E+00		1.430E+08				0.000E+00		
1	0.5000 h	0.000E+00	0.000E+00	1.420E+08	2.565E+11	9.146E+04	5.081E+01	5.007E+01	1.022E-08	4.577E+04
2	1.0000 h	0.000E+00	0.000E+00	1.409E+08	2.546E+11	9.080E+04	5.044E+01	4.504E+01	9.193E-09	8.550E+04
3	1.5000 h	0.000E+00	0.000E+00	1.399E+08	2.528E+11	9.015E+04	5.008E+01	4.060E+01	8.287E-09	7.698E+04
4	2.0000 h	0.000E+00	0.000E+00	1.389E+08	2.510E+11	8.950E+04	4.972E+01	1.032E+02	2.106E-08	1.306E+05
5	4.0000 h	0.000E+00	0.000E+00	1.350E+08	9.859E+11	3.516E+05	4.883E+01	2.827E+02	5.771E-08	1.444E+06
6	8.0000 h	0.000E+00	0.000E+00	1.274E+08	1.888E+12	6.734E+05	4.676E+01	4.399E+02	8.979E-08	5.392E+06
7	8.5000 h	0.000E+00	0.000E+00	1.265E+08	2.285E+11	0.000E+00	0.000E+00	1.311E+00	2.676E-10	1.357E+05
8	24.0000 h	0.000E+00	0.000E+00	1.031E+08	6.386E+12	0.000E+00	0.000E+00	7.268E-02	1.484E-11	2.389E+04
9	96.0000 h	0.000E+00	0.000E+00	3.991E+07	1.726E+13	0.000E+00	0.000E+00	1.063E-07	2.171E-17	1.402E+03
10	720.0000 h	0.000E+00	0.000E+00	1.064E+04	1.089E+13	0.000E+00	0.000E+00	0.000E+00	0.000E+00	2.051E-03
Xe-133m TOTALS			0.000E+00		3.865E+13	1.387E+06				7.336E+06
Xe-133 INITIAL		0.000E+00		1.220E+09				0.000E+00		
1	0.5000 h	0.000E+00	0.000E+00	1.216E+09	2.192E+12	7.818E+05	4.343E+02	4.288E+02	8.754E-08	3.917E+05
2	1.0000 h	0.000E+00	0.000E+00	1.212E+09	2.185E+12	7.791E+05	4.329E+02	3.872E+02	7.903E-08	7.336E+05
3	1.5000 h	0.000E+00	0.000E+00	1.208E+09	2.177E+12	7.765E+05	4.314E+02	3.503E+02	7.152E-08	6.631E+05
4	2.0000 h	0.000E+00	0.000E+00	1.204E+09	2.170E+12	7.739E+05	4.299E+02	8.937E+02	1.824E-07	1.130E+06
5	4.0000 h	0.000E+00	0.000E+00	1.187E+09	8.607E+12	3.069E+06	4.263E+02	2.486E+03	5.075E-07	1.264E+07
6	8.0000 h	0.000E+00	0.000E+00	1.155E+09	1.687E+13	6.015E+06	4.177E+02	3.982E+03	8.128E-07	4.832E+07
7	8.5000 h	0.000E+00	0.000E+00	1.152E+09	2.077E+12	0.000E+00	0.000E+00	1.191E+01	2.432E-09	1.230E+06
8	24.0000 h	0.000E+00	0.000E+00	1.058E+09	6.163E+13	0.000E+00	0.000E+00	7.440E-01	1.519E-10	2.247E+05
9	96.0000 h	0.000E+00	0.000E+00	7.117E+08	2.264E+14	0.000E+00	0.000E+00	1.892E-06	3.863E-16	1.497E+04
10	720.0000 h	0.000E+00	0.000E+00	2.291E+07	4.503E+14	0.000E+00	0.000E+00	0.000E+00	0.000E+00	3.808E-02
Xe-133 TOTALS			0.000E+00		7.746E+14	1.220E+07				6.535E+07

TRAILS -- Transport of Radioactive Material in Linear Systems, v2.0
 FRC Case for dose for 1 gpm [TC950828.DAT]

STEP	TIME	not used		intact S/G		AVERAGE		-----CONTROL ROOM-----		
		CURRENT uCi	INTEGRD uCi-sec	CURRENT uCi	INTEGRD uCi-sec	RELEASED uCi	RELEASE uCi/sec	CURRENT uCi	CURRENT uCi/cc	INTEGRD uCi-sec
Xe-135m	INITIAL	0.000E+00		5.060E+07				0.000E+00		
1	0.5000 h	0.000E+00	0.000E+00	1.306E+07	4.989E+10	1.779E+04	9.884E+00	5.405E+00	1.103E-09	5.994E+03
2	1.0000 h	0.000E+00	0.000E+00	3.371E+06	1.288E+10	4.592E+03	2.551E+00	1.264E+00	2.580E-10	5.117E+03
3	1.5000 h	0.000E+00	0.000E+00	8.699E+05	3.323E+09	1.185E+03	6.584E-01	2.962E-01	6.046E-11	1.197E+03
4	2.0000 h	0.000E+00	0.000E+00	2.245E+05	8.577E+08	3.059E+02	1.699E-01	1.961E-01	4.004E-11	4.217E+02
5	4.0000 h	0.000E+00	0.000E+00	9.962E+02	2.970E+08	1.059E+02	1.471E-02	1.491E-02	3.043E-12	3.249E+02
6	8.0000 h	0.000E+00	0.000E+00	1.961E-02	1.324E+06	4.721E-01	3.279E-05	3.223E-05	6.578E-15	1.862E+01
7	8.5000 h	0.000E+00	0.000E+00	5.065E-03	1.934E+01	0.000E+00	0.000E+00	2.497E-08	5.096E-18	8.092E-03
8	24.0000 h	0.000E+00	0.000E+00	3.008E-21	6.735E+00	0.000E+00	0.000E+00	1.008E-27	2.059E-37	3.120E-05
9	96.0000 h	0.000E+00	0.000E+00	0.000E+00	3.999E-18	0.000E+00	0.000E+00	0.000E+00	0.000E+00	1.260E-24
10	720.0000 h	0.000E+00	0.000E+00	0.000E+00	0.000E+00	0.000E+00	0.000E+00	0.000E+00	0.000E+00	0.000E+00
Xe-135m	TOTALS		0.000E+00		6.725E+10	2.398E+04				1.307E+04
Xe-135	INITIAL	0.000E+00		1.500E+08				0.000E+00		
1	0.5000 h	0.000E+00	0.000E+00	1.443E+08	2.648E+11	9.445E+04	5.247E+01	5.092E+01	1.039E-08	4.678E+04
2	1.0000 h	0.000E+00	0.000E+00	1.388E+08	2.548E+11	9.086E+04	5.048E+01	4.438E+01	9.058E-09	8.561E+04
3	1.5000 h	0.000E+00	0.000E+00	1.336E+08	2.451E+11	8.741E+04	4.856E+01	3.870E+01	7.913E-09	7.469E+04
4	2.0000 h	0.000E+00	0.000E+00	1.285E+08	2.358E+11	8.410E+04	4.672E+01	9.546E+01	1.949E-08	1.222E+05
5	4.0000 h	0.000E+00	0.000E+00	1.101E+08	8.571E+11	3.057E+05	4.245E+01	2.319E+02	4.733E-08	1.230E+06
6	8.0000 h	0.000E+00	0.000E+00	8.078E+07	1.363E+12	4.862E+05	3.376E+01	2.853E+02	5.824E-08	3.803E+06
7	8.5000 h	0.000E+00	0.000E+00	7.776E+07	1.427E+11	0.000E+00	0.000E+00	8.238E-01	1.682E-10	8.757E+04
8	24.0000 h	0.000E+00	0.000E+00	2.391E+07	2.548E+12	0.000E+00	0.000E+00	1.723E-02	3.518E-12	1.164E+04
9	96.0000 h	0.000E+00	0.000E+00	9.987E+04	1.127E+12	0.000E+00	0.000E+00	2.721E-10	5.555E-20	2.486E+02
10	720.0000 h	0.000E+00	0.000E+00	2.400E-16	4.725E+09	0.000E+00	0.000E+00	0.000E+00	0.000E+00	3.927E-06
Xe-135	TOTALS		0.000E+00		7.043E+12	1.149E+06				5.462E+06
Xe-137	INITIAL	0.000E+00		7.590E+06				0.000E+00		
1	0.5000 h	0.000E+00	0.000E+00	3.327E+04	2.505E+09	8.933E+02	4.963E-01	9.249E-02	1.888E-11	1.370E+02
2	1.0000 h	0.000E+00	0.000E+00	1.458E+02	1.098E+07	3.916E+00	2.175E-03	3.673E-04	7.499E-14	2.989E+01
3	1.5000 h	0.000E+00	0.000E+00	6.392E-01	4.813E+04	1.716E-02	9.535E-06	1.462E-06	2.985E-16	1.187E-01
4	2.0000 h	0.000E+00	0.000E+00	2.802E-03	2.109E+02	7.523E-05	4.179E-08	1.652E-08	3.372E-18	4.884E-04
5	4.0000 h	0.000E+00	0.000E+00	1.034E-12	9.287E-01	3.312E-07	4.600E-11	1.197E-11	2.444E-21	5.439E-06
6	8.0000 h	0.000E+00	0.000E+00	1.409E-31	3.428E-10	1.222E-16	8.489E-21	2.210E-21	4.511E-31	3.883E-09
7	8.5000 h	0.000E+00	0.000E+00	6.179E-34	4.650E-29	0.000E+00	0.000E+00	2.908E-26	5.935E-36	3.539E-19
8	24.0000 h	0.000E+00	0.000E+00	0.000E+00	2.049E-31	0.000E+00	0.000E+00	0.000E+00	0.000E+00	9.488E-24
9	96.0000 h	0.000E+00	0.000E+00	0.000E+00	0.000E+00	0.000E+00	0.000E+00	0.000E+00	0.000E+00	0.000E+00
10	720.0000 h	0.000E+00	0.000E+00	0.000E+00	0.000E+00	0.000E+00	0.000E+00	0.000E+00	0.000E+00	0.000E+00
Xe-137	TOTALS		0.000E+00		2.516E+09	8.972E+02				1.670E+02

TRAILS -- Transport of Radioactive Material in Linear Systems, v2.0
 FRC Case for dose for 1 gpm [TC950828.DAT]

STEP	TIME	not used		intact s/g		AVERAGE		-----CONTROL ROOM-----		
		CURRENT uCi	INTEGRD uCi-sec	CURRENT uCi	INTEGRD uCi-sec	RELEASED uCi	RELEASE uCi/sec	CURRENT uCi	CURRENT uCi/cc	INTEGRD uCi-sec
Xe-138	INITIAL	0.000E+00		3.130E+07				0.000E+00		
1	0.5000 h	0.000E+00	0.000E+00	7.180E+06	2.949E+10	1.052E+04	5.842E+00	3.055E+00	6.236E-10	3.436E+03
2	1.0000 h	0.000E+00	0.000E+00	1.647E+06	6.765E+09	2.412E+03	1.340E+00	6.349E-01	1.296E-10	2.766E+03
3	1.5000 h	0.000E+00	0.000E+00	3.779E+05	1.552E+09	5.534E+02	3.074E-01	1.323E-01	2.700E-11	5.752E+02
4	2.0000 h	0.000E+00	0.000E+00	8.668E+04	3.560E+08	1.269E+02	7.053E-02	7.786E-02	1.589E-11	1.766E+02
5	4.0000 h	0.000E+00	0.000E+00	2.400E+02	1.057E+08	3.769E+01	5.234E-03	4.873E-03	9.947E-13	1.167E+02
6	8.0000 h	0.000E+00	0.000E+00	1.841E-03	2.935E+05	1.047E-01	7.268E-06	6.607E-06	1.349E-15	5.593E+00
7	8.5000 h	0.000E+00	0.000E+00	4.226E-04	1.735E+00	0.000E+00	0.000E+00	4.549E-09	9.286E-19	1.632E-03
8	24.0000 h	0.000E+00	0.000E+00	6.501E-24	5.169E-01	0.000E+00	0.000E+00	4.761E-30	0.000E+00	5.255E-06
9	96.0000 h	0.000E+00	0.000E+00	0.000E+00	7.952E-21	0.000E+00	0.000E+00	0.000E+00	0.000E+00	5.499E-27
10	720.0000 h	0.000E+00	0.000E+00	0.000E+00	0.000E+00	0.000E+00	0.000E+00	0.000E+00	0.000E+00	0.000E+00
Xe-138	TOTALS		0.000E+00		3.827E+10	1.365E+04				7.076E+03
I-131	INITIAL	0.000E+00		1.170E+08				0.000E+00		
1	0.5000 h	0.000E+00	0.000E+00	2.562E+09	2.412E+12	8.600E+05	4.778E+02	4.720E+02	9.634E-08	4.310E+05
2	1.0000 h	0.000E+00	0.000E+00	5.001E+09	6.807E+12	2.427E+06	1.349E+03	4.435E+02	9.052E-08	8.234E+05
3	1.5000 h	0.000E+00	0.000E+00	7.433E+09	1.119E+13	3.991E+06	2.217E+03	4.351E+02	8.882E-08	7.906E+05
4	2.0000 h	0.000E+00	0.000E+00	9.360E+09	1.557E+13	5.551E+06	3.084E+03	6.530E+02	1.333E-07	9.833E+05
5	4.0000 h	0.000E+00	0.000E+00	1.951E+10	1.058E+14	3.772E+07	5.239E+03	1.929E+03	3.938E-07	9.672E+06
6	8.0000 h	0.000E+00	0.000E+00	1.917E+10	2.785E+14	9.931E+07	6.897E+03	3.965E+03	8.094E-07	4.481E+07
7	8.5000 h	0.000E+00	0.000E+00	1.914E+10	3.448E+13	0.000E+00	0.000E+00	1.187E+01	2.424E-09	1.225E+06
8	24.0000 h	0.000E+00	0.000E+00	1.810E+10	1.039E+15	0.000E+00	0.000E+00	7.639E-01	1.559E-10	2.259E+05
9	96.0000 h	0.000E+00	0.000E+00	1.398E+10	4.134E+15	0.000E+00	0.000E+00	2.230E-06	4.552E-16	1.554E+04
10	720.0000 h	0.000E+00	0.000E+00	1.486E+09	1.252E+16	0.000E+00	0.000E+00	0.000E+00	0.000E+00	4.536E-02
I-131	TOTALS		0.000E+00		1.814E+16	1.499E+08				5.898E+07
I-132	INITIAL	0.000E+00		4.070E+07				0.000E+00		
1	0.5000 h	0.000E+00	0.000E+00	4.244E+09	3.952E+12	1.409E+06	7.830E+02	7.194E+02	1.468E-07	6.730E+05
2	1.0000 h	0.000E+00	0.000E+00	7.858E+09	1.097E+13	3.913E+06	2.174E+03	5.873E+02	1.199E-07	1.171E+06
3	1.5000 h	0.000E+00	0.000E+00	1.096E+10	1.701E+13	6.066E+06	3.370E+03	5.083E+02	1.038E-07	9.829E+05
4	2.0000 h	0.000E+00	0.000E+00	1.363E+10	2.220E+13	7.916E+06	4.398E+03	7.433E+02	1.517E-07	1.136E+06
5	4.0000 h	0.000E+00	0.000E+00	2.105E+10	1.276E+14	4.549E+07	6.318E+03	1.675E+03	3.418E-07	9.301E+06
6	8.0000 h	0.000E+00	0.000E+00	6.317E+09	1.762E+14	6.282E+07	4.363E+03	1.505E+03	3.071E-07	2.248E+07
7	8.5000 h	0.000E+00	0.000E+00	5.433E+09	1.055E+13	0.000E+00	0.000E+00	3.882E+00	7.925E-10	4.533E+05
8	24.0000 h	0.000E+00	0.000E+00	5.086E+07	6.429E+13	0.000E+00	0.000E+00	2.472E-03	5.046E-13	2.942E+04
9	96.0000 h	0.000E+00	0.000E+00	1.918E-02	6.075E+11	0.000E+00	0.000E+00	3.525E-18	7.196E-28	1.875E+01
10	720.0000 h	0.000E+00	0.000E+00	0.000E+00	2.291E+02	0.000E+00	0.000E+00	0.000E+00	0.000E+00	2.673E-14
I-132	TOTALS		0.000E+00		4.333E+14	1.270E+08				3.622E+07

TRAILS -- Transport of Radioactive Material in Linear Systems, v2.0
 FRC Case for dose for 1 gpm [TC950828.DAT]

STEP	TIME	not used		intact S/G		AVERAGE		-----CONTROL ROOM-----		
		CURRENT uCi	INTEGRD uCi-sec	CURRENT uCi	INTEGRD uCi-sec	RELEASED uCi	RELEASE uCi/sec	CURRENT uCi	CURRENT uCi/cc	INTEGRD uCi-sec
I-133	INITIAL	0.000E+00		1.820E+08				0.000E+00		
1	0.5000 h	0.000E+00	0.000E+00	5.675E+09	5.286E+12	1.885E+06	1.047E+03	1.027E+03	2.096E-07	9.401E+05
2	1.0000 h	0.000E+00	0.000E+00	1.107E+10	1.509E+13	5.381E+06	2.989E+03	9.521E+02	1.944E-07	1.780E+06
3	1.5000 h	0.000E+00	0.000E+00	1.638E+10	2.472E+13	8.816E+06	4.898E+03	9.238E+02	1.886E-07	1.688E+06
4	2.0000 h	0.000E+00	0.000E+00	2.160E+10	3.419E+13	1.219E+07	6.774E+03	1.390E+03	2.837E-07	2.092E+06
5	4.0000 h	0.000E+00	0.000E+00	4.158E+10	2.283E+14	8.140E+07	1.131E+04	4.014E+03	8.193E-07	2.032E+07
6	8.0000 h	0.000E+00	0.000E+00	3.629E+10	5.597E+14	1.996E+08	1.386E+04	7.539E+03	1.539E-06	8.776E+07
7	8.5000 h	0.000E+00	0.000E+00	3.569E+10	6.477E+13	0.000E+00	0.000E+00	2.224E+01	4.540E-09	2.322E+06
8	24.0000 h	0.000E+00	0.000E+00	2.129E+10	1.555E+15	0.000E+00	0.000E+00	9.026E-01	1.842E-10	3.716E+05
9	96.0000 h	0.000E+00	0.000E+00	1.933E+09	2.091E+15	0.000E+00	0.000E+00	3.098E-07	6.324E-17	1.572E+04
10	720.0000 h	0.000E+00	0.000E+00	1.800E+00	2.088E+14	0.000E+00	0.000E+00	0.000E+00	0.000E+00	5.394E-03
I-133	TOTALS		0.000E+00		4.787E+15	3.093E+08				1.173E+08
I-134	INITIAL	0.000E+00		2.550E+07				0.000E+00		
1	0.5000 h	0.000E+00	0.000E+00	5.487E+09	5.285E+12	1.885E+06	1.047E+03	8.575E+02	1.750E-07	8.335E+05
2	1.0000 h	0.000E+00	0.000E+00	9.163E+09	1.340E+13	4.779E+06	2.655E+03	5.543E+02	1.131E-07	1.247E+06
3	1.5000 h	0.000E+00	0.000E+00	1.164E+10	1.887E+13	6.728E+06	3.738E+03	3.909E+02	7.978E-08	8.380E+05
4	2.0000 h	0.000E+00	0.000E+00	1.330E+10	2.254E+13	8.039E+06	4.466E+03	5.557E+02	1.134E-07	8.646E+05
5	4.0000 h	0.000E+00	0.000E+00	1.603E+10	1.081E+14	3.854E+07	5.352E+03	9.070E+02	1.851E-07	5.673E+06
6	8.0000 h	0.000E+00	0.000E+00	7.066E+08	7.012E+13	2.500E+07	1.736E+03	3.203E+02	6.539E-08	6.519E+06
7	8.5000 h	0.000E+00	0.000E+00	4.759E+08	1.051E+12	0.000E+00	0.000E+00	6.471E-01	1.321E-10	9.274E+04
8	24.0000 h	0.000E+00	0.000E+00	2.265E+03	2.167E+12	0.000E+00	0.000E+00	2.095E-07	4.277E-17	2.416E+03
9	96.0000 h	0.000E+00	0.000E+00	4.281E-22	1.031E+07	0.000E+00	0.000E+00	1.497E-37	0.000E+00	7.824E-04
10	720.0000 h	0.000E+00	0.000E+00	0.000E+00	1.949E-18	0.000E+00	0.000E+00	0.000E+00	0.000E+00	5.590E-34
I-134	TOTALS		0.000E+00		2.415E+14	8.497E+07				1.607E+07
I-135	INITIAL	0.000E+00		9.810E+07				0.000E+00		
1	0.5000 h	0.000E+00	0.000E+00	5.019E+09	4.645E+12	1.656E+06	9.202E+02	8.867E+02	1.810E-07	8.165E+05
2	1.0000 h	0.000E+00	0.000E+00	9.686E+09	1.327E+13	4.733E+06	2.629E+03	7.950E+02	1.623E-07	1.511E+06
3	1.5000 h	0.000E+00	0.000E+00	1.411E+10	2.145E+13	7.650E+06	4.250E+03	7.487E+02	1.528E-07	1.388E+06
4	2.0000 h	0.000E+00	0.000E+00	1.831E+10	2.921E+13	1.042E+07	5.787E+03	1.121E+03	2.287E-07	1.692E+06
5	4.0000 h	0.000E+00	0.000E+00	3.303E+10	1.867E+14	6.658E+07	9.248E+03	3.024E+03	6.174E-07	1.571E+07
6	8.0000 h	0.000E+00	0.000E+00	2.167E+10	3.881E+14	1.384E+08	9.612E+03	4.594E+03	9.377E-07	5.739E+07
7	8.5000 h	0.000E+00	0.000E+00	2.056E+10	3.800E+13	0.000E+00	0.000E+00	1.308E+01	2.669E-09	1.407E+06
8	24.0000 h	0.000E+00	0.000E+00	4.048E+09	5.670E+14	0.000E+00	0.000E+00	1.751E-01	3.574E-11	1.669E+05
9	96.0000 h	0.000E+00	0.000E+00	2.129E+06	1.389E+14	0.000E+00	0.000E+00	3.482E-10	7.108E-20	2.265E+03
10	720.0000 h	0.000E+00	0.000E+00	8.128E-23	7.309E+10	0.000E+00	0.000E+00	0.000E+00	0.000E+00	4.504E-06
I-135	TOTALS		0.000E+00		1.387E+15	2.294E+08				8.008E+07
ALL NUCLIDES		0.000E+00		2.016E+09				0.000E+00	0.000E+00	
@ STEP 10										

ENVIRONMENT							CONTROL ROOM					
External EDE		SKIN-DE		THY CDE-INHAL		External EDE		SKIN-DE		THY CDE-INHAL		
DOSE	DOSE RATE	DOSE	DOSE RATE	DOSE	DOSE RATE	DOSE	DOSE RATE	DOSE	DOSE RATE	DOSE	DOSE RATE	
mrem	mrem/hr	mrem	mrem/hr	mrem	mrem/hr	mrem	mrem/hr	mrem	mrem/hr	mrem	mrem/hr	
Kr-83m												
0.5000 h	0.00E+00	0.00E+00	0.00E+00	0.00E+00	0.00E+00	0.00E+00	8.41E-10	3.22E-09	0.00E+00	0.00E+00	0.00E+00	0.00E+00
1.0000 h	0.00E+00	0.00E+00	0.00E+00	0.00E+00	0.00E+00	0.00E+00	1.40E-09	2.41E-09	0.00E+00	0.00E+00	0.00E+00	0.00E+00
1.5000 h	0.00E+00	0.00E+00	0.00E+00	0.00E+00	0.00E+00	0.00E+00	1.05E-09	1.81E-09	0.00E+00	0.00E+00	0.00E+00	0.00E+00
2.0000 h	0.00E+00	0.00E+00	0.00E+00	0.00E+00	0.00E+00	0.00E+00	1.44E-09	3.83E-09	0.00E+00	0.00E+00	0.00E+00	0.00E+00
4.0000 h	0.00E+00	0.00E+00	0.00E+00	0.00E+00	0.00E+00	0.00E+00	9.48E-09	5.35E-09	0.00E+00	0.00E+00	0.00E+00	0.00E+00
8.0000 h	0.00E+00	0.00E+00	0.00E+00	0.00E+00	0.00E+00	0.00E+00	1.31E-08	2.32E-09	0.00E+00	0.00E+00	0.00E+00	0.00E+00
8.5000 h	0.00E+00	0.00E+00	0.00E+00	0.00E+00	0.00E+00	0.00E+00	1.93E-10	5.76E-12	0.00E+00	0.00E+00	0.00E+00	0.00E+00
24.0000 h	0.00E+00	0.00E+00	0.00E+00	0.00E+00	0.00E+00	0.00E+00	1.04E-11	1.11E-15	0.00E+00	0.00E+00	0.00E+00	0.00E+00
96.0000 h	0.00E+00	0.00E+00	0.00E+00	0.00E+00	0.00E+00	0.00E+00	1.20E-15	5.99E-33	0.00E+00	0.00E+00	0.00E+00	0.00E+00
720.0000 h	0.00E+00	0.00E+00	0.00E+00	0.00E+00	0.00E+00	0.00E+00	4.34E-33	0.00E+00	0.00E+00	0.00E+00	0.00E+00	0.00E+00
TOTALS	0.00E+00		0.00E+00		0.00E+00		2.75E-08		0.00E+00		0.00E+00	
Kr-85m												
0.5000 h	0.00E+00	0.00E+00	0.00E+00	0.00E+00	0.00E+00	0.00E+00	7.82E-06	3.04E-05	3.07E-04	1.20E-03	0.00E+00	0.00E+00
1.0000 h	0.00E+00	0.00E+00	0.00E+00	0.00E+00	0.00E+00	0.00E+00	1.39E-05	2.55E-05	5.48E-04	1.00E-03	0.00E+00	0.00E+00
1.5000 h	0.00E+00	0.00E+00	0.00E+00	0.00E+00	0.00E+00	0.00E+00	1.17E-05	2.14E-05	4.60E-04	8.42E-04	0.00E+00	0.00E+00
2.0000 h	0.00E+00	0.00E+00	0.00E+00	0.00E+00	0.00E+00	0.00E+00	1.83E-05	5.07E-05	7.18E-04	1.99E-03	0.00E+00	0.00E+00
4.0000 h	0.00E+00	0.00E+00	0.00E+00	0.00E+00	0.00E+00	0.00E+00	1.64E-04	1.06E-04	6.45E-03	4.17E-03	0.00E+00	0.00E+00
8.0000 h	0.00E+00	0.00E+00	0.00E+00	0.00E+00	0.00E+00	0.00E+00	4.05E-04	9.84E-05	1.59E-02	3.86E-03	0.00E+00	0.00E+00
8.5000 h	0.00E+00	0.00E+00	0.00E+00	0.00E+00	0.00E+00	0.00E+00	8.33E-06	2.73E-07	3.27E-04	1.07E-05	0.00E+00	0.00E+00
24.0000 h	0.00E+00	0.00E+00	0.00E+00	0.00E+00	0.00E+00	0.00E+00	8.27E-07	1.69E-09	3.25E-05	6.63E-08	0.00E+00	0.00E+00
96.0000 h	0.00E+00	0.00E+00	0.00E+00	0.00E+00	0.00E+00	0.00E+00	3.09E-09	9.27E-20	1.21E-07	3.64E-18	0.00E+00	0.00E+00
720.0000 h	0.00E+00	0.00E+00	0.00E+00	0.00E+00	0.00E+00	0.00E+00	1.13E-19	0.00E+00	4.44E-18	0.00E+00	0.00E+00	0.00E+00
TOTALS	0.00E+00		0.00E+00		0.00E+00		6.30E-04		2.48E-02		0.00E+00	
Kr-85												
0.5000 h	0.00E+00	0.00E+00	0.00E+00	0.00E+00	0.00E+00	0.00E+00	6.04E-07	2.38E-06	1.68E-03	6.63E-03	0.00E+00	0.00E+00
1.0000 h	0.00E+00	0.00E+00	0.00E+00	0.00E+00	0.00E+00	0.00E+00	1.13E-06	2.16E-06	3.16E-03	6.00E-03	0.00E+00	0.00E+00
1.5000 h	0.00E+00	0.00E+00	0.00E+00	0.00E+00	0.00E+00	0.00E+00	1.03E-06	1.96E-06	2.86E-03	5.45E-03	0.00E+00	0.00E+00
2.0000 h	0.00E+00	0.00E+00	0.00E+00	0.00E+00	0.00E+00	0.00E+00	1.76E-06	5.01E-06	4.89E-03	1.39E-02	0.00E+00	0.00E+00
4.0000 h	0.00E+00	0.00E+00	0.00E+00	0.00E+00	0.00E+00	0.00E+00	1.98E-05	1.41E-05	5.52E-02	3.92E-02	0.00E+00	0.00E+00
8.0000 h	0.00E+00	0.00E+00	0.00E+00	0.00E+00	0.00E+00	0.00E+00	7.71E-05	2.30E-05	2.14E-01	6.41E-02	0.00E+00	0.00E+00
8.5000 h	0.00E+00	0.00E+00	0.00E+00	0.00E+00	0.00E+00	0.00E+00	1.98E-06	6.91E-08	5.50E-03	1.92E-04	0.00E+00	0.00E+00
24.0000 h	0.00E+00	0.00E+00	0.00E+00	0.00E+00	0.00E+00	0.00E+00	3.71E-07	4.70E-09	1.03E-03	1.31E-05	0.00E+00	0.00E+00
96.0000 h	0.00E+00	0.00E+00	0.00E+00	0.00E+00	0.00E+00	0.00E+00	1.63E-08	1.78E-14	4.52E-05	4.94E-11	0.00E+00	0.00E+00
720.0000 h	0.00E+00	0.00E+00	0.00E+00	0.00E+00	0.00E+00	0.00E+00	4.10E-14	0.00E+00	1.14E-10	0.00E+00	0.00E+00	0.00E+00
TOTALS	0.00E+00		0.00E+00		0.00E+00		1.04E-04		2.89E-01		0.00E+00	

TRAILS -- Transport of Radioactive Material in Linear Systems, v2.0
 FRC Case for dose for 1 gpm [TC950828.DAT]

--- C O N T R O L R O O M ---											
External EDE			THY CDE-INHAL			SKIN-DE			THY CDE-INHAL		
DOSE	DOSE RATE	DOSE	DOSE RATE	DOSE	DOSE RATE	DOSE	DOSE RATE	DOSE	DOSE RATE	DOSE	DOSE RATE
mrem	mrem/hr	mrem	mrem/hr	mrem	mrem/hr	mrem	mrem/hr	mrem	mrem/hr	mrem	mrem/hr
Kr-87											
0.5000 h	0.00E+00	0.00E+00	0.00E+00	0.00E+00	7.90E-05	9.88E-04	3.73E-03	0.00E+00	0.00E+00	0.00E+00	0.00E+00
1.0000 h	0.00E+00	0.00E+00	0.00E+00	0.00E+00	3.30E-05	1.56E-03	2.57E-03	0.00E+00	0.00E+00	0.00E+00	0.00E+00
1.5000 h	0.00E+00	0.00E+00	0.00E+00	0.00E+00	2.27E-05	1.07E-03	1.78E-03	0.00E+00	0.00E+00	0.00E+00	0.00E+00
2.0000 h	0.00E+00	0.00E+00	0.00E+00	0.00E+00	2.83E-05	1.34E-03	3.46E-03	0.00E+00	0.00E+00	0.00E+00	0.00E+00
4.0000 h	0.00E+00	0.00E+00	0.00E+00	0.00E+00	1.51E-04	7.14E-03	3.63E-03	0.00E+00	0.00E+00	0.00E+00	0.00E+00
8.0000 h	0.00E+00	0.00E+00	0.00E+00	0.00E+00	1.42E-04	6.71E-03	9.43E-04	0.00E+00	0.00E+00	0.00E+00	0.00E+00
8.5000 h	0.00E+00	0.00E+00	0.00E+00	0.00E+00	1.64E-06	7.74E-05	2.15E-06	0.00E+00	0.00E+00	0.00E+00	0.00E+00
24.0000 h	0.00E+00	0.00E+00	0.00E+00	0.00E+00	6.35E-08	3.00E-06	3.14E-11	0.00E+00	0.00E+00	0.00E+00	0.00E+00
96.0000 h	0.00E+00	0.00E+00	0.00E+00	0.00E+00	5.55E-13	2.62E-11	0.00E+00	0.00E+00	0.00E+00	0.00E+00	0.00E+00
720.0000 h	0.00E+00	0.00E+00	0.00E+00	0.00E+00	1.26E-35	5.97E-34	0.00E+00	0.00E+00	0.00E+00	0.00E+00	0.00E+00
TOTALS	0.00E+00	0.00E+00	0.00E+00	0.00E+00	4.00E-04	1.89E-02	0.00E+00	0.00E+00	0.00E+00	0.00E+00	0.00E+00
Kr-88											
0.5000 h	0.00E+00	0.00E+00	0.00E+00	0.00E+00	1.59E-04	6.99E-04	2.70E-03	0.00E+00	0.00E+00	0.00E+00	0.00E+00
1.0000 h	0.00E+00	0.00E+00	0.00E+00	0.00E+00	2.76E-04	1.21E-03	2.16E-03	0.00E+00	0.00E+00	0.00E+00	0.00E+00
1.5000 h	0.00E+00	0.00E+00	0.00E+00	0.00E+00	2.22E-04	9.71E-04	1.74E-03	0.00E+00	0.00E+00	0.00E+00	0.00E+00
2.0000 h	0.00E+00	0.00E+00	0.00E+00	0.00E+00	3.29E-04	1.44E-03	3.94E-03	0.00E+00	0.00E+00	0.00E+00	0.00E+00
4.0000 h	0.00E+00	0.00E+00	0.00E+00	0.00E+00	2.61E-03	1.14E-02	6.99E-03	0.00E+00	0.00E+00	0.00E+00	0.00E+00
8.0000 h	0.00E+00	0.00E+00	0.00E+00	0.00E+00	5.04E-03	2.21E-02	4.74E-03	0.00E+00	0.00E+00	0.00E+00	0.00E+00
8.5000 h	0.00E+00	0.00E+00	0.00E+00	0.00E+00	9.10E-05	3.99E-04	1.26E-05	0.00E+00	0.00E+00	0.00E+00	0.00E+00
24.0000 h	0.00E+00	0.00E+00	0.00E+00	0.00E+00	6.87E-06	3.01E-05	1.95E-08	0.00E+00	0.00E+00	0.00E+00	0.00E+00
96.0000 h	0.00E+00	0.00E+00	0.00E+00	0.00E+00	6.39E-09	2.80E-08	1.72E-21	0.00E+00	0.00E+00	0.00E+00	0.00E+00
720.0000 h	0.00E+00	0.00E+00	0.00E+00	0.00E+00	3.76E-22	1.65E-21	0.00E+00	0.00E+00	0.00E+00	0.00E+00	0.00E+00
TOTALS	0.00E+00	0.00E+00	0.00E+00	0.00E+00	8.73E-03	3.83E-02	0.00E+00	0.00E+00	0.00E+00	0.00E+00	0.00E+00
Kr-89											
0.5000 h	0.00E+00	0.00E+00	0.00E+00	0.00E+00	1.99E-07	4.30E-06	1.01E-05	0.00E+00	0.00E+00	0.00E+00	0.00E+00
1.0000 h	0.00E+00	0.00E+00	0.00E+00	0.00E+00	3.48E-08	7.52E-07	1.27E-08	0.00E+00	0.00E+00	0.00E+00	0.00E+00
1.5000 h	0.00E+00	0.00E+00	0.00E+00	0.00E+00	4.37E-11	9.45E-10	1.60E-11	0.00E+00	0.00E+00	0.00E+00	0.00E+00
2.0000 h	0.00E+00	0.00E+00	0.00E+00	0.00E+00	5.58E-14	1.21E-12	5.71E-14	0.00E+00	0.00E+00	0.00E+00	0.00E+00
4.0000 h	0.00E+00	0.00E+00	0.00E+00	0.00E+00	1.98E-16	4.28E-15	1.30E-17	0.00E+00	0.00E+00	0.00E+00	0.00E+00
8.0000 h	0.00E+00	0.00E+00	0.00E+00	0.00E+00	4.49E-20	9.71E-19	2.40E-29	0.00E+00	0.00E+00	0.00E+00	0.00E+00
8.5000 h	0.00E+00	0.00E+00	0.00E+00	0.00E+00	4.49E-32	9.70E-31	0.00E+00	0.00E+00	0.00E+00	0.00E+00	0.00E+00
24.0000 h	0.00E+00	0.00E+00	0.00E+00	0.00E+00	3.47E-37	7.50E-36	0.00E+00	0.00E+00	0.00E+00	0.00E+00	0.00E+00
96.0000 h	0.00E+00	0.00E+00	0.00E+00	0.00E+00	0.00E+00	0.00E+00	0.00E+00	0.00E+00	0.00E+00	0.00E+00	0.00E+00
720.0000 h	0.00E+00	0.00E+00	0.00E+00	0.00E+00	0.00E+00	0.00E+00	0.00E+00	0.00E+00	0.00E+00	0.00E+00	0.00E+00
TOTALS	0.00E+00	0.00E+00	0.00E+00	0.00E+00	2.34E-07	5.05E-06	0.00E+00	0.00E+00	0.00E+00	0.00E+00	0.00E+00

ENVIRONMENT							CONTROL ROOM					
External EDE		SKIN-DE		THY CDE-INHAL		External EDE		SKIN-DE		THY CDE-INHAL		
DOSE	DOSE RATE	DOSE	DOSE RATE	DOSE	DOSE RATE	DOSE	DOSE RATE	DOSE	DOSE RATE	DOSE	DOSE RATE	
mrem	mrem/hr	mrem	mrem/hr	mrem	mrem/hr	mrem	mrem/hr	mrem	mrem/hr	mrem	mrem/hr	
Xe-131m												
0.5000 h	0.00E+00	0.00E+00	0.00E+00	0.00E+00	0.00E+00	0.00E+00	2.24E-08	8.85E-08	4.95E-06	1.95E-05	0.00E+00	0.00E+00
1.0000 h	0.00E+00	0.00E+00	0.00E+00	0.00E+00	0.00E+00	0.00E+00	4.21E-08	8.00E-08	9.28E-06	1.76E-05	0.00E+00	0.00E+00
1.5000 h	0.00E+00	0.00E+00	0.00E+00	0.00E+00	0.00E+00	0.00E+00	3.81E-08	7.25E-08	8.40E-06	1.60E-05	0.00E+00	0.00E+00
2.0000 h	0.00E+00	0.00E+00	0.00E+00	0.00E+00	0.00E+00	0.00E+00	6.50E-08	1.85E-07	1.43E-05	4.09E-05	0.00E+00	0.00E+00
4.0000 h	0.00E+00	0.00E+00	0.00E+00	0.00E+00	0.00E+00	0.00E+00	7.31E-07	5.18E-07	1.61E-04	1.14E-04	0.00E+00	0.00E+00
8.0000 h	0.00E+00	0.00E+00	0.00E+00	0.00E+00	0.00E+00	0.00E+00	2.82E-06	8.40E-07	6.22E-04	1.85E-04	0.00E+00	0.00E+00
8.5000 h	0.00E+00	0.00E+00	0.00E+00	0.00E+00	0.00E+00	0.00E+00	7.21E-08	2.52E-09	1.59E-05	5.55E-07	0.00E+00	0.00E+00
24.0000 h	0.00E+00	0.00E+00	0.00E+00	0.00E+00	0.00E+00	0.00E+00	1.34E-08	1.65E-10	2.95E-06	3.64E-08	0.00E+00	0.00E+00
96.0000 h	0.00E+00	0.00E+00	0.00E+00	0.00E+00	0.00E+00	0.00E+00	5.62E-10	5.23E-16	1.24E-07	1.15E-13	0.00E+00	0.00E+00
720.0000 h	0.00E+00	0.00E+00	0.00E+00	0.00E+00	0.00E+00	0.00E+00	1.19E-15	0.00E+00	2.62E-13	0.00E+00	0.00E+00	0.00E+00
TOTALS	0.00E+00		0.00E+00		0.00E+00		3.80E-06		8.39E-04		0.00E+00	
Xe-133m												
0.5000 h	0.00E+00	0.00E+00	0.00E+00	0.00E+00	0.00E+00	0.00E+00	2.22E-06	8.73E-06	2.93E-04	1.16E-03	0.00E+00	0.00E+00
1.0000 h	0.00E+00	0.00E+00	0.00E+00	0.00E+00	0.00E+00	0.00E+00	4.14E-06	7.85E-06	5.48E-04	1.04E-03	0.00E+00	0.00E+00
1.5000 h	0.00E+00	0.00E+00	0.00E+00	0.00E+00	0.00E+00	0.00E+00	3.73E-06	7.08E-06	4.93E-04	9.36E-04	0.00E+00	0.00E+00
2.0000 h	0.00E+00	0.00E+00	0.00E+00	0.00E+00	0.00E+00	0.00E+00	6.33E-06	1.80E-05	8.37E-04	2.38E-03	0.00E+00	0.00E+00
4.0000 h	0.00E+00	0.00E+00	0.00E+00	0.00E+00	0.00E+00	0.00E+00	7.00E-05	4.93E-05	9.25E-03	6.52E-03	0.00E+00	0.00E+00
8.0000 h	0.00E+00	0.00E+00	0.00E+00	0.00E+00	0.00E+00	0.00E+00	2.61E-04	7.67E-05	3.46E-02	1.01E-02	0.00E+00	0.00E+00
8.5000 h	0.00E+00	0.00E+00	0.00E+00	0.00E+00	0.00E+00	0.00E+00	6.58E-06	2.29E-07	8.70E-04	3.02E-05	0.00E+00	0.00E+00
24.0000 h	0.00E+00	0.00E+00	0.00E+00	0.00E+00	0.00E+00	0.00E+00	1.16E-06	1.27E-08	1.53E-04	1.68E-06	0.00E+00	0.00E+00
96.0000 h	0.00E+00	0.00E+00	0.00E+00	0.00E+00	0.00E+00	0.00E+00	4.08E-08	1.85E-14	5.39E-06	2.45E-12	0.00E+00	0.00E+00
720.0000 h	0.00E+00	0.00E+00	0.00E+00	0.00E+00	0.00E+00	0.00E+00	3.97E-14	0.00E+00	5.26E-12	0.00E+00	0.00E+00	0.00E+00
TOTALS	0.00E+00		0.00E+00		0.00E+00		3.55E-04		4.70E-02		0.00E+00	
Xe-133												
0.5000 h	0.00E+00	0.00E+00	0.00E+00	0.00E+00	0.00E+00	0.00E+00	2.24E-05	8.84E-05	8.44E-04	3.33E-03	0.00E+00	0.00E+00
1.0000 h	0.00E+00	0.00E+00	0.00E+00	0.00E+00	0.00E+00	0.00E+00	4.20E-05	7.98E-05	1.58E-03	3.00E-03	0.00E+00	0.00E+00
1.5000 h	0.00E+00	0.00E+00	0.00E+00	0.00E+00	0.00E+00	0.00E+00	3.80E-05	7.22E-05	1.43E-03	2.72E-03	0.00E+00	0.00E+00
2.0000 h	0.00E+00	0.00E+00	0.00E+00	0.00E+00	0.00E+00	0.00E+00	6.47E-05	1.84E-04	2.43E-03	6.93E-03	0.00E+00	0.00E+00
4.0000 h	0.00E+00	0.00E+00	0.00E+00	0.00E+00	0.00E+00	0.00E+00	7.24E-04	5.13E-04	2.72E-02	1.93E-02	0.00E+00	0.00E+00
8.0000 h	0.00E+00	0.00E+00	0.00E+00	0.00E+00	0.00E+00	0.00E+00	2.77E-03	8.21E-04	1.04E-01	3.09E-02	0.00E+00	0.00E+00
8.5000 h	0.00E+00	0.00E+00	0.00E+00	0.00E+00	0.00E+00	0.00E+00	7.04E-05	2.46E-06	2.65E-03	9.24E-05	0.00E+00	0.00E+00
24.0000 h	0.00E+00	0.00E+00	0.00E+00	0.00E+00	0.00E+00	0.00E+00	1.29E-05	1.53E-07	4.84E-04	5.77E-06	0.00E+00	0.00E+00
96.0000 h	0.00E+00	0.00E+00	0.00E+00	0.00E+00	0.00E+00	0.00E+00	5.14E-07	3.90E-13	1.94E-05	1.47E-11	0.00E+00	0.00E+00
720.0000 h	0.00E+00	0.00E+00	0.00E+00	0.00E+00	0.00E+00	0.00E+00	8.72E-13	0.00E+00	3.28E-11	0.00E+00	0.00E+00	0.00E+00
TOTALS	0.00E+00		0.00E+00		0.00E+00		3.74E-03		1.41E-01		0.00E+00	

TRAILS -- Transport of Radioactive Material in Linear Systems, v2.0
 FRC Case for dose for 1 gpm [TC950828.DAT]

	E N V I R O N M E N T						C O N T R O L R O O M					
	External EDE		SKIN-DE		THY CDE-INHAL		External EDE		SKIN-DE		THY CDE-INHAL	
	DOSE mrem	DOSE RATE mrem/hr	DOSE mrem	DOSE RATE mrem/hr	DOSE mrem	DOSE RATE mrem/hr	DOSE mrem	DOSE RATE mrem/hr	DOSE mrem	DOSE RATE mrem/hr	DOSE mrem	DOSE RATE mrem/hr
Xe-135m												
0.5000 h	0.00E+00	0.00E+00	0.00E+00	0.00E+00	0.00E+00	0.00E+00	4.18E-06	1.36E-05	2.65E-05	8.59E-05	0.00E+00	0.00E+00
1.0000 h	0.00E+00	0.00E+00	0.00E+00	0.00E+00	0.00E+00	0.00E+00	3.57E-06	3.18E-06	2.26E-05	2.01E-05	0.00E+00	0.00E+00
1.5000 h	0.00E+00	0.00E+00	0.00E+00	0.00E+00	0.00E+00	0.00E+00	8.36E-07	7.44E-07	5.29E-06	4.71E-06	0.00E+00	0.00E+00
2.0000 h	0.00E+00	0.00E+00	0.00E+00	0.00E+00	0.00E+00	0.00E+00	2.94E-07	4.93E-07	1.86E-06	3.12E-06	0.00E+00	0.00E+00
4.0000 h	0.00E+00	0.00E+00	0.00E+00	0.00E+00	0.00E+00	0.00E+00	2.27E-07	3.75E-08	1.44E-06	2.37E-07	0.00E+00	0.00E+00
8.0000 h	0.00E+00	0.00E+00	0.00E+00	0.00E+00	0.00E+00	0.00E+00	1.30E-08	8.10E-11	8.22E-08	5.12E-10	0.00E+00	0.00E+00
8.5000 h	0.00E+00	0.00E+00	0.00E+00	0.00E+00	0.00E+00	0.00E+00	5.65E-12	6.27E-14	3.57E-11	3.97E-13	0.00E+00	0.00E+00
24.0000 h	0.00E+00	0.00E+00	0.00E+00	0.00E+00	0.00E+00	0.00E+00	2.18E-14	2.53E-33	1.38E-13	1.60E-32	0.00E+00	0.00E+00
96.0000 h	0.00E+00	0.00E+00	0.00E+00	0.00E+00	0.00E+00	0.00E+00	5.28E-34	0.00E+00	3.34E-33	0.00E+00	0.00E+00	0.00E+00
720.0000 h	0.00E+00	0.00E+00	0.00E+00	0.00E+00	0.00E+00	0.00E+00	0.00E+00	0.00E+00	0.00E+00	0.00E+00	0.00E+00	0.00E+00
TOTALS	0.00E+00		0.00E+00		0.00E+00		9.13E-06		5.77E-05		0.00E+00	
Xe-135												
0.5000 h	0.00E+00	0.00E+00	0.00E+00	0.00E+00	0.00E+00	0.00E+00	1.91E-05	7.47E-05	6.18E-04	2.42E-03	0.00E+00	0.00E+00
1.0000 h	0.00E+00	0.00E+00	0.00E+00	0.00E+00	0.00E+00	0.00E+00	3.49E-05	6.51E-05	1.13E-03	2.11E-03	0.00E+00	0.00E+00
1.5000 h	0.00E+00	0.00E+00	0.00E+00	0.00E+00	0.00E+00	0.00E+00	3.04E-05	5.69E-05	9.87E-04	1.84E-03	0.00E+00	0.00E+00
2.0000 h	0.00E+00	0.00E+00	0.00E+00	0.00E+00	0.00E+00	0.00E+00	4.98E-05	1.40E-04	1.61E-03	4.54E-03	0.00E+00	0.00E+00
4.0000 h	0.00E+00	0.00E+00	0.00E+00	0.00E+00	0.00E+00	0.00E+00	5.01E-04	3.40E-04	1.63E-02	1.10E-02	0.00E+00	0.00E+00
8.0000 h	0.00E+00	0.00E+00	0.00E+00	0.00E+00	0.00E+00	0.00E+00	1.55E-03	4.18E-04	5.02E-02	1.36E-02	0.00E+00	0.00E+00
8.5000 h	0.00E+00	0.00E+00	0.00E+00	0.00E+00	0.00E+00	0.00E+00	3.57E-05	1.21E-06	1.16E-03	3.92E-05	0.00E+00	0.00E+00
24.0000 h	0.00E+00	0.00E+00	0.00E+00	0.00E+00	0.00E+00	0.00E+00	4.74E-06	2.53E-08	1.54E-04	8.20E-07	0.00E+00	0.00E+00
96.0000 h	0.00E+00	0.00E+00	0.00E+00	0.00E+00	0.00E+00	0.00E+00	6.08E-08	3.99E-16	1.97E-06	1.29E-14	0.00E+00	0.00E+00
720.0000 h	0.00E+00	0.00E+00	0.00E+00	0.00E+00	0.00E+00	0.00E+00	6.40E-16	0.00E+00	2.08E-14	0.00E+00	0.00E+00	0.00E+00
TOTALS	0.00E+00		0.00E+00		0.00E+00		2.23E-03		7.22E-02		0.00E+00	
Xe-137												
0.5000 h	0.00E+00	0.00E+00	0.00E+00	0.00E+00	0.00E+00	0.00E+00	4.25E-08	1.03E-07	1.28E-05	3.12E-05	0.00E+00	0.00E+00
1.0000 h	0.00E+00	0.00E+00	0.00E+00	0.00E+00	0.00E+00	0.00E+00	9.28E-09	4.11E-10	2.80E-06	1.24E-07	0.00E+00	0.00E+00
1.5000 h	0.00E+00	0.00E+00	0.00E+00	0.00E+00	0.00E+00	0.00E+00	3.69E-11	1.64E-12	1.11E-08	4.93E-10	0.00E+00	0.00E+00
2.0000 h	0.00E+00	0.00E+00	0.00E+00	0.00E+00	0.00E+00	0.00E+00	1.52E-13	1.85E-14	4.57E-11	5.56E-12	0.00E+00	0.00E+00
4.0000 h	0.00E+00	0.00E+00	0.00E+00	0.00E+00	0.00E+00	0.00E+00	1.69E-15	1.34E-17	5.09E-13	4.03E-15	0.00E+00	0.00E+00
8.0000 h	0.00E+00	0.00E+00	0.00E+00	0.00E+00	0.00E+00	0.00E+00	1.21E-18	2.47E-27	3.63E-16	7.44E-25	0.00E+00	0.00E+00
8.5000 h	0.00E+00	0.00E+00	0.00E+00	0.00E+00	0.00E+00	0.00E+00	1.10E-28	3.25E-32	3.31E-26	9.79E-30	0.00E+00	0.00E+00
24.0000 h	0.00E+00	0.00E+00	0.00E+00	0.00E+00	0.00E+00	0.00E+00	2.95E-33	0.00E+00	8.88E-31	0.00E+00	0.00E+00	0.00E+00
96.0000 h	0.00E+00	0.00E+00	0.00E+00	0.00E+00	0.00E+00	0.00E+00	0.00E+00	0.00E+00	0.00E+00	0.00E+00	0.00E+00	0.00E+00
720.0000 h	0.00E+00	0.00E+00	0.00E+00	0.00E+00	0.00E+00	0.00E+00	0.00E+00	0.00E+00	0.00E+00	0.00E+00	0.00E+00	0.00E+00
TOTALS	0.00E+00		0.00E+00		0.00E+00		5.19E-08		1.56E-05		0.00E+00	

TRAILS -- Transport of Radioactive Material in Linear Systems, v2.0
 FRC Case for dose for 1 gpm [TC950828.DAT]

--- C O N T R O L R O O M ---											
External EDE			THY CDE-INHAL			SKIN-DE			THY CDE-INHAL		
DOSE	DOSE RATE	DOSE	DOSE RATE	DOSE	DOSE RATE	DOSE	DOSE RATE	DOSE	DOSE RATE	DOSE	DOSE RATE
mrem	mrem/hr	mrem	mrem/hr	mrem	mrem/hr	mrem	mrem/hr	mrem	mrem/hr	mrem	mrem/hr
Xe-136											
0.5000 h	0.00E+00	0.00E+00	0.00E+00	0.00E+00	2.24E-05	1.04E-04	3.32E-04	0.00E+00	0.00E+00	0.00E+00	0.00E+00
1.0000 h	0.00E+00	0.00E+00	0.00E+00	0.00E+00	4.66E-06	8.34E-06	6.90E-05	0.00E+00	0.00E+00	0.00E+00	0.00E+00
1.5000 h	0.00E+00	0.00E+00	0.00E+00	0.00E+00	9.70E-07	1.74E-05	1.44E-05	0.00E+00	0.00E+00	0.00E+00	0.00E+00
2.0000 h	0.00E+00	0.00E+00	0.00E+00	0.00E+00	5.71E-07	5.33E-06	8.46E-06	0.00E+00	0.00E+00	0.00E+00	0.00E+00
4.0000 h	0.00E+00	0.00E+00	0.00E+00	0.00E+00	3.57E-06	3.52E-06	5.29E-07	0.00E+00	0.00E+00	0.00E+00	0.00E+00
8.0000 h	0.00E+00	0.00E+00	0.00E+00	0.00E+00	4.85E-11	1.69E-07	7.17E-10	0.00E+00	0.00E+00	0.00E+00	0.00E+00
8.5000 h	0.00E+00	0.00E+00	0.00E+00	0.00E+00	3.34E-14	4.92E-11	4.94E-13	0.00E+00	0.00E+00	0.00E+00	0.00E+00
24.0000 h	0.00E+00	0.00E+00	0.00E+00	0.00E+00	0.00E+00	1.59E-13	0.00E+00	0.00E+00	0.00E+00	0.00E+00	0.00E+00
96.0000 h	0.00E+00	0.00E+00	0.00E+00	0.00E+00	6.72E-36	9.95E-35	0.00E+00	0.00E+00	0.00E+00	0.00E+00	0.00E+00
720.0000 h	0.00E+00	0.00E+00	0.00E+00	0.00E+00	0.00E+00	0.00E+00	0.00E+00	0.00E+00	0.00E+00	0.00E+00	0.00E+00
TOTALS	0.00E+00	0.00E+00	0.00E+00	0.00E+00	1.44E-05	2.13E-04	0.00E+00	0.00E+00	0.00E+00	0.00E+00	0.00E+00

I-131											
0.5000 h	0.00E+00	0.00E+00	0.00E+00	0.00E+00	1.06E-03	2.81E-03	1.11E-02	3.30E+01	1.30E+02	1.30E+02	1.30E+02
1.0000 h	0.00E+00	0.00E+00	0.00E+00	0.00E+00	9.92E-04	5.37E-03	1.04E-02	6.30E+01	1.22E+02	1.22E+02	1.22E+02
1.5000 h	0.00E+00	0.00E+00	0.00E+00	0.00E+00	9.73E-04	5.16E-03	1.02E-02	6.05E+01	1.20E+02	1.20E+02	1.20E+02
2.0000 h	0.00E+00	0.00E+00	0.00E+00	0.00E+00	4.91E-04	6.41E-03	1.53E-02	7.52E+01	1.80E+02	1.80E+02	1.80E+02
4.0000 h	0.00E+00	0.00E+00	0.00E+00	0.00E+00	6.11E-04	6.31E-02	4.53E-02	7.40E+02	5.31E+02	5.31E+02	5.31E+02
8.0000 h	0.00E+00	0.00E+00	0.00E+00	0.00E+00	2.78E-02	2.92E-01	9.31E-02	3.43E+03	1.09E+03	1.09E+03	1.09E+03
8.5000 h	0.00E+00	0.00E+00	0.00E+00	0.00E+00	7.61E-04	7.99E-03	2.79E-04	9.37E+01	3.27E+00	3.27E+00	3.27E+00
24.0000 h	0.00E+00	0.00E+00	0.00E+00	0.00E+00	1.40E-04	1.47E-03	1.79E-05	1.73E+01	2.10E-01	2.10E-01	2.10E-01
96.0000 h	0.00E+00	0.00E+00	0.00E+00	0.00E+00	5.79E-06	6.08E-05	5.24E-11	7.13E-01	6.14E-07	6.14E-07	6.14E-07
720.0000 h	0.00E+00	0.00E+00	0.00E+00	0.00E+00	1.13E-11	1.18E-10	0.00E+00	1.39E-06	0.00E+00	0.00E+00	0.00E+00
TOTALS	0.00E+00	0.00E+00	0.00E+00	0.00E+00	3.66E-02	3.85E-01	0.00E+00	4.51E+03	0.00E+00	0.00E+00	0.00E+00

I-132											
0.5000 h	0.00E+00	0.00E+00	0.00E+00	0.00E+00	1.00E-02	1.53E-02	5.90E-02	3.07E-01	1.18E+00	1.18E+00	1.18E+00
1.0000 h	0.00E+00	0.00E+00	0.00E+00	0.00E+00	8.19E-03	2.67E-02	4.82E-02	5.34E-01	9.64E-01	9.64E-01	9.64E-01
1.5000 h	0.00E+00	0.00E+00	0.00E+00	0.00E+00	7.09E-03	2.24E-02	4.17E-02	4.48E-01	8.35E-01	8.35E-01	8.35E-01
2.0000 h	0.00E+00	0.00E+00	0.00E+00	0.00E+00	1.04E-02	2.59E-02	6.10E-02	5.18E-01	1.22E+00	1.22E+00	1.22E+00
4.0000 h	0.00E+00	0.00E+00	0.00E+00	0.00E+00	3.60E-02	2.12E-01	1.37E-01	4.24E+00	2.75E+00	2.75E+00	2.75E+00
8.0000 h	0.00E+00	0.00E+00	0.00E+00	0.00E+00	8.71E-02	5.12E-01	1.23E-01	1.03E+01	2.47E+00	2.47E+00	2.47E+00
8.5000 h	0.00E+00	0.00E+00	0.00E+00	0.00E+00	5.42E-05	1.03E-02	3.19E-04	2.07E-01	6.38E-03	6.38E-03	6.38E-03
24.0000 h	0.00E+00	0.00E+00	0.00E+00	0.00E+00	3.45E-08	6.71E-04	2.33E-07	1.34E-02	4.06E-06	4.06E-06	4.06E-06
96.0000 h	0.00E+00	0.00E+00	0.00E+00	0.00E+00	4.36E-08	2.56E-07	2.89E-22	5.13E-06	5.79E-21	5.79E-21	5.79E-21
720.0000 h	0.00E+00	0.00E+00	0.00E+00	0.00E+00	4.14E-23	2.44E-22	0.00E+00	4.88E-21	0.00E+00	0.00E+00	0.00E+00
TOTALS	0.00E+00	0.00E+00	0.00E+00	0.00E+00	1.40E-01	8.26E-01	0.00E+00	1.65E+01	0.00E+00	0.00E+00	0.00E+00

TRAILS -- Transport of Radioactive Material in Linear Systems, v2.0
 FRC Case for dose for 1 gpm [TC950828.DAT]

	ENVIRONMENT						CONTROL ROOM					
	External EDE		SKIN-DE		THY CDE-INHAL		External EDE		SKIN-DE		THY CDE-INHAL	
	DOSE mrem	DOSE RATE mrem/hr	DOSE mrem	DOSE RATE mrem/hr	DOSE mrem	DOSE RATE mrem/hr	DOSE mrem	DOSE RATE mrem/hr	DOSE mrem	DOSE RATE mrem/hr	DOSE mrem	DOSE RATE mrem/hr
I-133												
0.5000 h	0.00E+00	0.00E+00	0.00E+00	0.00E+00	0.00E+00	0.00E+00	9.38E-04	3.69E-03	1.73E-02	6.81E-02	1.20E+01	4.71E+01
1.0000 h	0.00E+00	0.00E+00	0.00E+00	0.00E+00	0.00E+00	0.00E+00	1.77E-03	3.42E-03	3.28E-02	6.32E-02	2.27E+01	4.37E+01
1.5000 h	0.00E+00	0.00E+00	0.00E+00	0.00E+00	0.00E+00	0.00E+00	1.68E-03	3.32E-03	3.11E-02	6.13E-02	2.15E+01	4.24E+01
2.0000 h	0.00E+00	0.00E+00	0.00E+00	0.00E+00	0.00E+00	0.00E+00	2.09E-03	4.99E-03	3.86E-02	9.22E-02	2.67E+01	6.38E+01
4.0000 h	0.00E+00	0.00E+00	0.00E+00	0.00E+00	0.00E+00	0.00E+00	2.03E-02	1.44E-02	3.74E-01	2.66E-01	2.59E+02	1.84E+02
8.0000 h	0.00E+00	0.00E+00	0.00E+00	0.00E+00	0.00E+00	0.00E+00	8.75E-02	2.71E-02	1.62E+00	5.00E-01	1.12E+03	3.46E+02
8.5000 h	0.00E+00	0.00E+00	0.00E+00	0.00E+00	0.00E+00	0.00E+00	2.32E-03	7.98E-05	4.28E-02	1.48E-03	2.96E+01	1.02E+00
24.0000 h	0.00E+00	0.00E+00	0.00E+00	0.00E+00	0.00E+00	0.00E+00	3.71E-04	3.24E-06	6.85E-03	5.99E-05	4.74E+00	4.14E-02
96.0000 h	0.00E+00	0.00E+00	0.00E+00	0.00E+00	0.00E+00	0.00E+00	9.41E-06	1.11E-12	1.74E-04	2.06E-11	1.20E-01	1.42E-08
720.0000 h	0.00E+00	0.00E+00	0.00E+00	0.00E+00	0.00E+00	0.00E+00	2.15E-12	0.00E+00	3.98E-11	0.00E+00	2.75E-08	0.00E+00
TOTALS	0.00E+00		0.00E+00		0.00E+00		1.17E-01		2.16E+00		1.50E+03	
I-134												
0.5000 h	0.00E+00	0.00E+00	0.00E+00	0.00E+00	0.00E+00	0.00E+00	3.73E-03	1.38E-02	2.44E-02	9.03E-02	6.32E-02	2.34E-01
1.0000 h	0.00E+00	0.00E+00	0.00E+00	0.00E+00	0.00E+00	0.00E+00	5.58E-03	8.93E-03	3.65E-02	5.84E-02	9.45E-02	1.51E-01
1.5000 h	0.00E+00	0.00E+00	0.00E+00	0.00E+00	0.00E+00	0.00E+00	3.75E-03	6.29E-03	2.45E-02	4.12E-02	6.35E-02	1.07E-01
2.0000 h	0.00E+00	0.00E+00	0.00E+00	0.00E+00	0.00E+00	0.00E+00	3.87E-03	8.95E-03	2.53E-02	5.85E-02	6.55E-02	1.52E-01
4.0000 h	0.00E+00	0.00E+00	0.00E+00	0.00E+00	0.00E+00	0.00E+00	2.54E-02	1.46E-02	1.66E-01	9.55E-02	4.30E-01	2.47E-01
8.0000 h	0.00E+00	0.00E+00	0.00E+00	0.00E+00	0.00E+00	0.00E+00	2.92E-02	5.16E-03	1.91E-01	3.37E-02	4.94E-01	8.74E-02
8.5000 h	0.00E+00	0.00E+00	0.00E+00	0.00E+00	0.00E+00	0.00E+00	4.15E-04	1.04E-05	2.71E-03	6.82E-05	7.03E-03	1.77E-04
24.0000 h	0.00E+00	0.00E+00	0.00E+00	0.00E+00	0.00E+00	0.00E+00	1.08E-05	3.37E-12	7.07E-05	2.21E-11	1.83E-04	5.72E-11
96.0000 h	0.00E+00	0.00E+00	0.00E+00	0.00E+00	0.00E+00	0.00E+00	2.10E-12	0.00E+00	1.37E-11	0.00E+00	3.56E-11	0.00E+00
720.0000 h	0.00E+00	0.00E+00	0.00E+00	0.00E+00	0.00E+00	0.00E+00	0.00E+00	0.00E+00	0.00E+00	0.00E+00	0.00E+00	0.00E+00
TOTALS	0.00E+00		0.00E+00		0.00E+00		7.19E-02		4.70E-01		1.22E+00	
I-135												
0.5000 h	0.00E+00	0.00E+00	0.00E+00	0.00E+00	0.00E+00	0.00E+00	2.21E-03	8.66E-03	1.33E-02	5.21E-02	1.81E+00	7.08E+00
1.0000 h	0.00E+00	0.00E+00	0.00E+00	0.00E+00	0.00E+00	0.00E+00	4.10E-03	7.76E-03	2.47E-02	4.67E-02	3.35E+00	6.35E+00
1.5000 h	0.00E+00	0.00E+00	0.00E+00	0.00E+00	0.00E+00	0.00E+00	3.77E-03	7.31E-03	2.27E-02	4.40E-02	3.08E+00	5.98E+00
2.0000 h	0.00E+00	0.00E+00	0.00E+00	0.00E+00	0.00E+00	0.00E+00	4.59E-03	1.09E-02	2.76E-02	6.59E-02	3.75E+00	8.94E+00
4.0000 h	0.00E+00	0.00E+00	0.00E+00	0.00E+00	0.00E+00	0.00E+00	4.26E-02	2.95E-02	2.57E-01	1.78E-01	3.48E+01	2.41E+01
8.0000 h	0.00E+00	0.00E+00	0.00E+00	0.00E+00	0.00E+00	0.00E+00	1.56E-01	4.49E-02	9.37E-01	2.70E-01	1.27E+02	3.67E+01
8.5000 h	0.00E+00	0.00E+00	0.00E+00	0.00E+00	0.00E+00	0.00E+00	3.82E-03	1.28E-04	2.30E-02	7.69E-04	3.12E+00	1.04E-01
24.0000 h	0.00E+00	0.00E+00	0.00E+00	0.00E+00	0.00E+00	0.00E+00	4.53E-04	1.71E-06	2.73E-03	1.03E-05	3.70E-01	1.40E-03
96.0000 h	0.00E+00	0.00E+00	0.00E+00	0.00E+00	0.00E+00	0.00E+00	3.69E-06	3.40E-15	2.22E-05	2.05E-14	3.01E-03	2.78E-12
720.0000 h	0.00E+00	0.00E+00	0.00E+00	0.00E+00	0.00E+00	0.00E+00	4.89E-15	0.00E+00	2.94E-14	0.00E+00	3.99E-12	0.00E+00
TOTALS	0.00E+00		0.00E+00		0.00E+00		2.17E-01		1.31E+00		1.78E+02	

TRAILS -- Transport of Radioactive Material in Linear Systems, v2.0
 FRC Case for dose for 1 gpm [TC950828.DAT]

	External EDE		ENVIRONMENT		THY CDE-INHAL		External EDE		CONTROL ROOM		THY CDE-INHAL	
	DOSE mrem	DOSE RATE mrem/hr	DOSE mrem	DOSE RATE mrem/hr	DOSE mrem	DOSE RATE mrem/hr	DOSE mrem	DOSE RATE mrem/hr	DOSE mrem	DOSE RATE mrem/hr	DOSE mrem	DOSE RATE mrem/hr
ALL NUCLIDES												
0.5000 h	0.00E+00	0.00E+00	0.00E+00	0.00E+00	0.00E+00	0.00E+00	1.00E-02	3.82E-02	7.88E-02	3.02E-01	4.71E+01	1.86E+02
1.0000 h	0.00E+00	0.00E+00	0.00E+00	0.00E+00	0.00E+00	0.00E+00	1.69E-02	3.00E-02	1.36E-01	2.45E-01	8.97E+01	1.73E+02
1.5000 h	0.00E+00	0.00E+00	0.00E+00	0.00E+00	0.00E+00	0.00E+00	1.38E-02	2.56E-02	1.14E-01	2.14E-01	8.56E+01	1.69E+02
2.0000 h	0.00E+00	0.00E+00	0.00E+00	0.00E+00	0.00E+00	0.00E+00	1.61E-02	3.81E-02	1.37E-01	3.30E-01	1.06E+02	2.54E+02
4.0000 h	0.00E+00	0.00E+00	0.00E+00	0.00E+00	0.00E+00	0.00E+00	1.35E-01	8.89E-02	1.21E+00	8.13E-01	1.04E+03	7.43E+02
8.0000 h	0.00E+00	0.00E+00	0.00E+00	0.00E+00	0.00E+00	0.00E+00	3.98E-01	1.09E-01	4.00E+00	1.15E+00	4.68E+03	1.48E+03
8.5000 h	0.00E+00	0.00E+00	0.00E+00	0.00E+00	0.00E+00	0.00E+00	9.28E-03	3.06E-04	9.78E-02	3.29E-03	1.27E+02	4.40E+00
24.0000 h	0.00E+00	0.00E+00	0.00E+00	0.00E+00	0.00E+00	0.00E+00	1.12E-03	6.90E-06	1.37E-02	1.10E-04	2.24E+01	2.53E-01
96.0000 h	0.00E+00	0.00E+00	0.00E+00	0.00E+00	0.00E+00	0.00E+00	1.96E-05	6.53E-12	3.29E-04	1.40E-10	8.36E-01	6.28E-07
720.0000 h	0.00E+00	0.00E+00	0.00E+00	0.00E+00	0.00E+00	0.00E+00	1.44E-11	0.00E+00	3.10E-10	0.00E+00	1.42E-06	0.00E+00
TOTALS	0.00E+00		0.00E+00		0.00E+00		5.99E-01		5.78E+00		6.20E+03	

	COMP: not used	COMP: intact S/G	COMP: Control Room VOLUME: 1.730E+05 Cu.Ft.
INITIAL:	0.000E+00 Kr-83m	2.000E+07 Kr-83m uCi	0.000E+00 Kr-83m
	0.000E+00 Kr-85m	9.750E+07 Kr-85m	0.000E+00 Kr-85m
	0.000E+00 Kr-85	5.150E+08 Kr-85	0.000E+00 Kr-85
	0.000E+00 Kr-87	5.580E+07 Kr-87	0.000E+00 Kr-87
	0.000E+00 Kr-88	1.490E+08 Kr-88	0.000E+00 Kr-88
	0.000E+00 Kr-89	4.690E+06 Kr-89	0.000E+00 Kr-89
	0.000E+00 Xe-131m	5.010E+06 Xe-131m	0.000E+00 Xe-131m
	0.000E+00 Xe-133m	1.430E+08 Xe-133m	0.000E+00 Xe-133m
	0.000E+00 Xe-133	1.220E+09 Xe-133	0.000E+00 Xe-133
	0.000E+00 Xe-135m	5.060E+07 Xe-135m	0.000E+00 Xe-135m
	0.000E+00 Xe-135	1.500E+08 Xe-135	0.000E+00 Xe-135
	0.000E+00 Xe-137	7.590E+06 Xe-137	0.000E+00 Xe-137
	0.000E+00 Xe-138	3.130E+07 Xe-138	0.000E+00 Xe-138
	0.000E+00 I-131	1.170E+08 I-131	0.000E+00 I-131
	0.000E+00 I-132	4.070E+07 I-132	0.000E+00 I-132
	0.000E+00 I-133	1.820E+08 I-133	0.000E+00 I-133
	0.000E+00 I-134	2.550E+07 I-134	0.000E+00 I-134
	0.000E+00 I-135	9.810E+07 I-135	0.000E+00 I-135
ACT MULT (to uCi):	1.000E+00	1.000E+00	1.000E+00
PRODUCTION,uCi/s:	0.000E+00 I-131	1.360E+06 I-131	INTAKE: 1.000E+01 CFM
	0.000E+00 I-132	2.520E+06 I-132	
	0.000E+00 I-133	3.080E+06 I-133	
	0.000E+00 I-134	3.680E+06 I-134	
	0.000E+00 I-135	2.810E+06 I-135	

TRAILS -- Transport of Radioactive Material in Linear Systems, v2.0
 FRC Case for dose for 2 gpm [TC950831.DAT]

REMOVAL:	0.000E+00 1/sec	7.132E-07 1/sec	1.000E+01 cfm
NUC Grp 1 REL FR:	0.000E+00	0.000E+00	INTAKE REDUCT: 0.000E+00
NUC Grp 2 REL FR:	0.000E+00	0.000E+00	INTAKE REDUCT: 9.360E-01
NUC Grp 3 REL FR:	0.000E+00	0.000E+00	INTAKE REDUCT: 0.000E+00

MULTIPLIERS====>

STEP	TIME	XPR	XREM	XRF	XPR	XREM	XRF	XPR	XREM	XRF
1	1.800E+03	0.000E+00	0.000E+00	0.000E+00	1.00	1.00	0.000E+00	50.0	50.0	0.000E+00
2	3.600E+03	0.000E+00	0.000E+00	0.000E+00	1.00	1.00	0.000E+00	1.00	70.0	0.000E+00
3	5.400E+03	0.000E+00	0.000E+00	0.000E+00	1.00	1.00	0.000E+00	1.00	70.0	0.000E+00
4	7.200E+03	0.000E+00	0.000E+00	0.000E+00	1.00	1.00	0.000E+00	70.0	70.0	1.00
5	1.440E+04	0.000E+00	0.000E+00	0.000E+00	1.00	1.00	0.000E+00	70.0	70.0	1.00
6	2.880E+04	0.000E+00	0.000E+00	0.000E+00	2.000E-03	1.00	0.000E+00	70.0	70.0	1.00
7	3.060E+04	0.000E+00	0.000E+00	0.000E+00	0.000E+00	0.000E+00	0.000E+00	3.350E+03	3.350E+03	0.000E+00
8	8.640E+04	0.000E+00	0.000E+00	0.000E+00	0.000E+00	0.000E+00	0.000E+00	50.0	50.0	0.000E+00
9	3.456E+05	0.000E+00	0.000E+00	0.000E+00	0.000E+00	0.000E+00	0.000E+00	50.0	50.0	0.000E+00
10	2.592E+06	0.000E+00	0.000E+00	0.000E+00	0.000E+00	0.000E+00	0.000E+00	50.0	50.0	0.000E+00

----- CONTROL ROOM -----

X/Q	Breathing	Occupancy
s/M3	M3/s	
1.000E-03	3.470E-04	1.000E+00

---- ENVIRONMENT ----

X/Q	Breathing
s/M3	M3/s
0.000E+00	3.470E-04

MULTIPLIERS====>

STEP	TIME, s	XPR	XREM	XRF	XPR	XREM	XRF
1	1.800E+03	2.43	1.00	1.00	0.000E+00	1.00	1.00
2	3.600E+03	2.43	1.00	1.00	0.000E+00	1.00	1.00
3	5.400E+03	2.43	1.00	1.00	0.000E+00	1.00	1.00
4	7.200E+03	2.43	1.00	1.00	0.000E+00	1.00	1.00
5	1.440E+04	2.43	1.00	1.00	0.000E+00	1.00	1.00
6	2.880E+04	2.43	1.00	1.00	0.000E+00	1.00	1.00
7	3.060E+04	1.22	1.00	1.00	0.000E+00	1.00	1.00
8	8.640E+04	1.22	1.00	1.00	0.000E+00	1.00	1.00
9	3.456E+05	0.890	1.00	0.600	0.000E+00	1.00	1.00
10	2.592E+06	0.626	1.00	0.400	0.000E+00	1.00	1.00

TRAILS -- Transport of Radioactive Material in Linear Systems, v2.0
 ERC Case for dose for 2 gpm [TC950831.DAT]

External EDE		DOSE RATE		mrem/hr		DOSE		mrem		External EDE		DOSE RATE		mrem/hr		DOSE		mrem		External EDE		DOSE RATE		mrem/hr		DOSE		mrem			
DOSE		DOSE RATE		mrem/hr		DOSE		mrem		DOSE		DOSE RATE		mrem/hr		DOSE		mrem		DOSE		DOSE RATE		mrem/hr		DOSE		mrem			
mrem		mrem/hr		mrem		mrem		mrem		mrem		mrem/hr		mrem		mrem		mrem		mrem		mrem/hr		mrem		mrem		mrem			
I-135	0.00E+00	0.00E+00	0.00E+00	0.00E+00	0.00E+00	0.00E+00	0.00E+00	0.00E+00	0.00E+00	4.33E-01	2.61E+00	3.54E+02																			
TOTALS	0.00E+00	0.00E+00	0.00E+00	0.00E+00	0.00E+00	0.00E+00	0.00E+00	0.00E+00	0.00E+00	4.33E-01	2.61E+00	3.54E+02																			
ALL NUCLIDES																															
0.5000 h	0.00E+00	0.00E+00	0.00E+00	0.00E+00	0.00E+00	0.00E+00	0.00E+00	0.00E+00	0.00E+00	2.00E-02	7.64E-02	1.58E-01	6.05E-01	9.43E+01	3.71E+02																
1.0000 h	0.00E+00	0.00E+00	0.00E+00	0.00E+00	0.00E+00	0.00E+00	0.00E+00	0.00E+00	0.00E+00	3.38E-02	6.00E-02	2.72E-01	4.90E-01	1.79E+02	3.47E+02																
1.5000 h	0.00E+00	0.00E+00	0.00E+00	0.00E+00	0.00E+00	0.00E+00	0.00E+00	0.00E+00	0.00E+00	2.77E-02	5.12E-02	2.28E-01	4.27E-01	1.71E+02	3.38E+02																
2.0000 h	0.00E+00	0.00E+00	0.00E+00	0.00E+00	0.00E+00	0.00E+00	0.00E+00	0.00E+00	0.00E+00	3.21E-02	7.61E-02	2.74E-01	6.60E-01	2.12E+02	5.08E+02																
4.0000 h	0.00E+00	0.00E+00	0.00E+00	0.00E+00	0.00E+00	0.00E+00	0.00E+00	0.00E+00	0.00E+00	2.69E-01	1.78E-01	2.41E+00	1.62E+00	2.07E+03	1.48E+03																
8.0000 h	0.00E+00	0.00E+00	0.00E+00	0.00E+00	0.00E+00	0.00E+00	0.00E+00	0.00E+00	0.00E+00	7.92E-01	2.18E-01	7.97E+00	2.29E+00	9.33E+03	2.94E+03																
8.5000 h	0.00E+00	0.00E+00	0.00E+00	0.00E+00	0.00E+00	0.00E+00	0.00E+00	0.00E+00	0.00E+00	1.85E-02	6.09E-04	1.95E-01	6.55E-03	2.52E+02	8.76E+00																
24.0000 h	0.00E+00	0.00E+00	0.00E+00	0.00E+00	0.00E+00	0.00E+00	0.00E+00	0.00E+00	0.00E+00	2.22E-03	1.37E-05	2.72E-02	2.18E-04	4.46E+01	5.04E-01																
96.0000 h	0.00E+00	0.00E+00	0.00E+00	0.00E+00	0.00E+00	0.00E+00	0.00E+00	0.00E+00	0.00E+00	3.90E-05	1.30E-11	6.55E-04	2.78E-10	1.67E+00	1.25E-06																
720.0000 h	0.00E+00	0.00E+00	0.00E+00	0.00E+00	0.00E+00	0.00E+00	0.00E+00	0.00E+00	0.00E+00	2.86E-11	0.00E+00	6.17E-10	0.00E+00	2.82E-06	0.00E+00																
TOTALS	0.00E+00	0.00E+00	0.00E+00	0.00E+00	0.00E+00	0.00E+00	0.00E+00	0.00E+00	0.00E+00	1.20E+00	1.15E+01	1.15E+01	1.15E+01	1.15E+01	1.15E+01																

TRAILS -- Transport of Radioactive Material in Linear Systems, v2.0
 FRC Case for dose for 4 gpm [TC950829.DAT]

	COMP: not used	COMP: intact S/G	COMP: Control Room VOLUME: 1.730E+05 Cu.Ft.
INITIAL:	0.000E+00 Kr-83m	2.000E+07 Kr-83m uCi	0.000E+00 Kr-83m
	0.000E+00 Kr-85m	9.750E+07 Kr-85m	0.000E+00 Kr-85m
	0.000E+00 Kr-85	5.150E+08 Kr-85	0.000E+00 Kr-85
	0.000E+00 Kr-87	5.580E+07 Kr-87	0.000E+00 Kr-87
	0.000E+00 Kr-88	1.490E+08 Kr-88	0.000E+00 Kr-88
	0.000E+00 Kr-89	4.690E+06 Kr-89	0.000E+00 Kr-89
	0.000E+00 Xe-131m	5.010E+06 Xe-131m	0.000E+00 Xe-131m
	0.000E+00 Xe-133m	1.430E+08 Xe-133m	0.000E+00 Xe-133m
	0.000E+00 Xe-133	1.220E+09 Xe-133	0.000E+00 Xe-133
	0.000E+00 Xe-135m	5.060E+07 Xe-135m	0.000E+00 Xe-135m
	0.000E+00 Xe-135	1.500E+08 Xe-135	0.000E+00 Xe-135
	0.000E+00 Xe-137	7.590E+06 Xe-137	0.000E+00 Xe-137
	0.000E+00 Xe-138	3.130E+07 Xe-138	0.000E+00 Xe-138
	0.000E+00 I-131	1.170E+08 I-131	0.000E+00 I-131
	0.000E+00 I-132	4.070E+07 I-132	0.000E+00 I-132
	0.000E+00 I-133	1.820E+08 I-133	0.000E+00 I-133
	0.000E+00 I-134	2.550E+07 I-134	0.000E+00 I-134
	0.000E+00 I-135	9.810E+07 I-135	0.000E+00 I-135
ACT MULT (to uCi):	1.000E+00	1.000E+00	1.000E+00
PRODUCTION, uCi/s:	0.000E+00 I-131	1.360E+06 I-131	INTAKE: 1.000E+01 CFM
	0.000E+00 I-132	2.520E+06 I-132	
	0.000E+00 I-133	3.080E+06 I-133	
	0.000E+00 I-134	3.680E+06 I-134	
	0.000E+00 I-135	2.810E+06 I-135	

TRAILS -- Transport of Radioactive Material in Linear Systems, v2.0
 FRC Case for dose for 4 gpm [TC950829.DAT]

REMOVAL:	0.000E+00 1/sec	1.426E-06 1/sec	1.000E+01 cfm
NUC Grp 1 REL FR:	0.000E+00	0.000E+00	INTAKE REDUCT: 0.000E+00
NUC Grp 2 REL FR:	0.000E+00	0.000E+00	INTAKE REDUCT: 9.360E-01
NUC Grp 3 REL FR:	0.000E+00	0.000E+00	INTAKE REDUCT: 0.000E+00

MULTIPLIERS====>

STEP	TIME	XPR	XREM	XRF	XPR	XREM	XRF	XPR	XREM	XRF
1	1.800E+03	0.000E+00	0.000E+00	0.000E+00	1.00	1.00	0.000E+00	50.0	50.0	0.000E+00
2	3.600E+03	0.000E+00	0.000E+00	0.000E+00	1.00	1.00	0.000E+00	1.00	70.0	0.000E+00
3	5.400E+03	0.000E+00	0.000E+00	0.000E+00	1.00	1.00	0.000E+00	1.00	70.0	0.000E+00
4	7.200E+03	0.000E+00	0.000E+00	0.000E+00	1.00	1.00	0.000E+00	70.0	70.0	1.00
5	1.440E+04	0.000E+00	0.000E+00	0.000E+00	1.00	1.00	0.000E+00	70.0	70.0	1.00
6	2.880E+04	0.000E+00	0.000E+00	0.000E+00	2.000E-03	1.00	0.000E+00	70.0	70.0	1.00
7	3.060E+04	0.000E+00	0.000E+00	0.000E+00	0.000E+00	0.000E+00	0.000E+00	3.350E+03	3.350E+03	0.000E+00
8	8.640E+04	0.000E+00	0.000E+00	0.000E+00	0.000E+00	0.000E+00	0.000E+00	50.0	50.0	0.000E+00
9	3.456E+05	0.000E+00	0.000E+00	0.000E+00	0.000E+00	0.000E+00	0.000E+00	50.0	50.0	0.000E+00
10	2.592E+06	0.000E+00	0.000E+00	0.000E+00	0.000E+00	0.000E+00	0.000E+00	50.0	50.0	0.000E+00

----- CONTROL ROOM -----

X/Q	Breathing	Occupancy
s/M3	M3/s	
1.000E-03	3.470E-04	1.000E+00

----- ENVIRONMENT -----

X/Q	Breathing
s/M3	M3/s
0.000E+00	3.470E-04

MULTIPLIERS====>

STEP	TIME, s	XPR	XREM	XRF	XPR	XREM	XRF
1	1.800E+03	2.43	1.00	1.00	0.000E+00	1.00	0.000E+00
2	3.600E+03	2.43	1.00	1.00	0.000E+00	1.00	0.000E+00
3	5.400E+03	2.43	1.00	1.00	0.000E+00	1.00	0.000E+00
4	7.200E+03	2.43	1.00	1.00	0.000E+00	1.00	0.000E+00
5	1.440E+04	2.43	1.00	1.00	0.000E+00	1.00	0.000E+00
6	2.880E+04	2.43	1.00	1.00	0.000E+00	1.00	0.000E+00
7	3.060E+04	1.22	1.00	1.00	0.000E+00	1.00	0.000E+00
8	8.640E+04	1.22	1.00	1.00	0.000E+00	1.00	0.000E+00
9	3.456E+05	0.890	1.00	0.600	0.000E+00	1.00	0.000E+00
10	2.592E+06	0.626	1.00	0.400	0.000E+00	1.00	0.000E+00

TRAILS -- Transport of Radioactive Material in Linear Systems, v2.0
 FRC Case for dose for 4 gpm [TC950829.DAT]

		ENVIRONMENT				CONTROL ROOM				THYROID-INHAL			
		External EDE		SKIN-DE		THYROID-INHAL		External EDE		SKIN-DE		THYROID-INHAL	
		DOSE	DOSE RATE	DOSE	DOSE RATE	DOSE	DOSE RATE	DOSE	DOSE RATE	DOSE	DOSE RATE	DOSE	DOSE RATE
		mrem	mrem/hr	mrem	mrem/hr	mrem	mrem/hr	mrem	mrem/hr	mrem	mrem/hr	mrem	mrem/hr
I-135		0.00E+00	0.00E+00	0.00E+00	0.00E+00	0.00E+00	0.00E+00	0.00E+00	0.00E+00	0.00E+00	0.00E+00	0.00E+00	0.00E+00
TOTALS		0.00E+00	0.00E+00	0.00E+00	0.00E+00	8.61E-01	5.19E+00	7.04E+02					
ALL NUCLIDES													
0.5000 h		0.00E+00	0.00E+00	0.00E+00	0.00E+00	4.00E-02	1.53E-01	3.15E-01	1.21E+00	1.88E+02	7.42E+02		
1.0000 h		0.00E+00	0.00E+00	0.00E+00	0.00E+00	6.76E-02	1.20E-01	5.43E-01	9.79E-01	3.58E+02	6.93E+02		
1.5000 h		0.00E+00	0.00E+00	0.00E+00	0.00E+00	5.53E-02	1.02E-01	4.56E-01	8.54E-01	3.42E+02	6.76E+02		
2.0000 h		0.00E+00	0.00E+00	0.00E+00	0.00E+00	6.41E-02	1.52E-01	5.47E-01	1.32E+00	4.24E+02	1.01E+03		
4.0000 h		0.00E+00	0.00E+00	0.00E+00	0.00E+00	5.36E-01	3.54E-01	4.80E+00	3.24E+00	4.14E+03	2.96E+03		
8.0000 h		0.00E+00	0.00E+00	0.00E+00	0.00E+00	1.57E+00	4.32E-01	1.58E+01	4.53E+00	1.85E+04	5.83E+03		
8.5000 h		0.00E+00	0.00E+00	0.00E+00	0.00E+00	3.67E-02	1.21E-03	3.86E-01	1.30E-02	5.00E+02	1.74E+01		
24.0000 h		0.00E+00	0.00E+00	0.00E+00	0.00E+00	4.40E-03	2.72E-05	5.40E-02	4.33E-04	8.84E+01	9.99E-01		
96.0000 h		0.00E+00	0.00E+00	0.00E+00	0.00E+00	7.72E-05	2.58E-11	1.30E-03	5.49E-10	3.30E+00	2.48E-06		
720.0000 h		0.00E+00	0.00E+00	0.00E+00	0.00E+00	5.67E-11	0.00E+00	1.22E-09	0.00E+00	5.59E-06	0.00E+00		
TOTALS		0.00E+00	0.00E+00	0.00E+00	0.00E+00	2.38E+00	2.29E+01						

COMP: not used

COMP: intact S/G

COMP: Control Room
 VOLUME: 1.730E+05 Cu.Ft.

	COMP: not used	COMP: intact S/G	COMP: Control Room
INITIAL:	0.000E+00 Kr-83m	2.000E+07 Kr-83m uCi	0.000E+00 Kr-83m
	0.000E+00 Kr-85m	9.750E+07 Kr-85m	0.000E+00 Kr-85m
	0.000E+00 Kr-85	5.150E+08 Kr-85	0.000E+00 Kr-85
	0.000E+00 Kr-87	5.580E+07 Kr-87	0.000E+00 Kr-87
	0.000E+00 Kr-88	1.490E+08 Kr-88	0.000E+00 Kr-88
	0.000E+00 Kr-89	4.690E+06 Kr-89	0.000E+00 Kr-89
	0.000E+00 Xe-131m	5.010E+06 Xe-131m	0.000E+00 Xe-131m
	0.000E+00 Xe-133m	1.430E+08 Xe-133m	0.000E+00 Xe-133m
	0.000E+00 Xe-133	1.220E+09 Xe-133	0.000E+00 Xe-133
	0.000E+00 Xe-135m	5.060E+07 Xe-135m	0.000E+00 Xe-135m
	0.000E+00 Xe-135	1.500E+08 Xe-135	0.000E+00 Xe-135
	0.000E+00 Xe-137	7.590E+06 Xe-137	0.000E+00 Xe-137
	0.000E+00 Xe-138	3.130E+07 Xe-138	0.000E+00 Xe-138
	0.000E+00 I-131	1.170E+08 I-131	0.000E+00 I-131
	0.000E+00 I-132	4.070E+07 I-132	0.000E+00 I-132
	0.000E+00 I-133	1.820E+08 I-133	0.000E+00 I-133
	0.000E+00 I-134	2.550E+07 I-134	0.000E+00 I-134
	0.000E+00 I-135	9.810E+07 I-135	0.000E+00 I-135
ACT MULT (to uCi):	1.000E+00	1.000E+00	1.000E+00
PRODUCTION, uCi/s:	0.000E+00 I-131	1.360E+06 I-131	INTAKE: 1.000E+01 CFM
	0.000E+00 I-132	2.520E+06 I-132	
	0.000E+00 I-133	3.080E+06 I-133	
	0.000E+00 I-134	3.680E+06 I-134	
	0.000E+00 I-135	2.810E+06 I-135	

REMOVAL:	0.000E+00 1/sec	1.783E-06 1/sec	1.000E+01 cfm
NUC Grp 1 REL FR:	0.000E+00	0.000E+00	INTAKE REDUCT: 0.000E+00
NUC Grp 2 REL FR:	0.000E+00	0.000E+00	INTAKE REDUCT: 9.360E-01
NUC Grp 3 REL FR:	0.000E+00	0.000E+00	INTAKE REDUCT: 0.000E+00

MULTIPLIERS====>

STEP	TIME	XPR	XREM	XRF	XPR	XREM	XRF	XPR	XREM	XRF
1	1.800E+03	0.000E+00	0.000E+00	0.000E+00	1.00	1.00	0.000E+00	50.0	50.0	0.000E+00
2	3.600E+03	0.000E+00	0.000E+00	0.000E+00	1.00	1.00	0.000E+00	1.00	70.0	0.000E+00
3	5.400E+03	0.000E+00	0.000E+00	0.000E+00	1.00	1.00	0.000E+00	1.00	70.0	0.000E+00
4	7.200E+03	0.000E+00	0.000E+00	0.000E+00	1.00	1.00	0.000E+00	70.0	70.0	1.00
5	1.440E+04	0.000E+00	0.000E+00	0.000E+00	1.00	1.00	0.000E+00	70.0	70.0	1.00
6	2.880E+04	0.000E+00	0.000E+00	0.000E+00	2.000E-03	1.00	0.000E+00	70.0	70.0	1.00
7	3.060E+04	0.000E+00	0.000E+00	0.000E+00	0.000E+00	0.000E+00	0.000E+00	3.350E+03	3.350E+03	0.000E+00
8	8.640E+04	0.000E+00	0.000E+00	0.000E+00	0.000E+00	0.000E+00	0.000E+00	50.0	50.0	0.000E+00
9	3.456E+05	0.000E+00	0.000E+00	0.000E+00	0.000E+00	0.000E+00	0.000E+00	50.0	50.0	0.000E+00
10	2.592E+06	0.000E+00	0.000E+00	0.000E+00	0.000E+00	0.000E+00	0.000E+00	50.0	50.0	0.000E+00

----- CONTROL ROOM -----

X/Q	Breathing	Occupancy
s/M3	M3/s	
1.000E-03	3.470E-04	1.000E+00

----- ENVIRONMENT -----

X/Q	Breathing
s/M3	M3/s
0.000E+00	3.470E-04

MULTIPLIERS====>

STEP	TIME, s	XPR	XREM	XRF	XPR	XREM	XRF
1	1.800E+03	2.43	1.00	1.00	0.000E+00	1.00	
2	3.600E+03	2.43	1.00	1.00	0.000E+00	1.00	
3	5.400E+03	2.43	1.00	1.00	0.000E+00	1.00	
4	7.200E+03	2.43	1.00	1.00	0.000E+00	1.00	
5	1.440E+04	2.43	1.00	1.00	0.000E+00	1.00	
6	2.880E+04	2.43	1.00	1.00	0.000E+00	1.00	
7	3.060E+04	1.22	1.00	1.00	0.000E+00	1.00	
8	8.640E+04	1.22	1.00	1.00	0.000E+00	1.00	
9	3.456E+05	0.890	1.00	0.600	0.000E+00	1.00	
10	2.592E+06	0.626	1.00	0.400	0.000E+00	1.00	

TRAILS -- Transport of Radioactive Material in Linear Systems, v2.0
 FRC Case for dose for 5 gpm [TC950830.DAT]

External EDE		ENVIRONMENT		THY CDE-INHAL		External EDE		CONTROL ROOM		THY CDE-INHAL	
DOSE	DOSE RATE	DOSE	DOSE RATE	DOSE	DOSE RATE	DOSE	DOSE RATE	DOSE	DOSE RATE	DOSE	DOSE RATE
mrem	mrem/hr	mrem	mrem/hr	mrem	mrem/hr	mrem	mrem/hr	mrem	mrem/hr	mrem	mrem/hr
0.00E+00	0.00E+00	0.00E+00	0.00E+00	0.00E+00	0.00E+00	1.07E+00	6.46E+00	8.78E+02			
ALL NUCLIDES											
0.5000 h	0.00E+00	0.00E+00	0.00E+00	0.00E+00	0.00E+00	5.00E-02	1.91E-01	3.94E-01	1.51E+00	2.35E+02	9.27E+02
1.0000 h	0.00E+00	0.00E+00	0.00E+00	0.00E+00	0.00E+00	8.45E-02	1.50E-01	6.79E-01	1.22E+00	4.48E+02	8.66E+02
1.5000 h	0.00E+00	0.00E+00	0.00E+00	0.00E+00	0.00E+00	6.91E-02	1.28E-01	5.70E-01	1.07E+00	4.27E+02	8.45E+02
2.0000 h	0.00E+00	0.00E+00	0.00E+00	0.00E+00	0.00E+00	8.01E-02	1.90E-01	6.84E-01	1.65E+00	5.30E+02	1.27E+03
4.0000 h	0.00E+00	0.00E+00	0.00E+00	0.00E+00	0.00E+00	6.69E-01	4.42E-01	5.99E+00	4.04E+00	5.16E+03	3.69E+03
8.0000 h	0.00E+00	0.00E+00	0.00E+00	0.00E+00	0.00E+00	1.96E+00	5.38E-01	1.97E+01	5.64E+00	2.31E+04	7.26E+03
8.5000 h	0.00E+00	0.00E+00	0.00E+00	0.00E+00	0.00E+00	4.56E-02	1.50E-03	4.80E-01	1.62E-02	6.22E+02	2.16E+01
24.0000 h	0.00E+00	0.00E+00	0.00E+00	0.00E+00	0.00E+00	5.48E-03	3.39E-05	6.71E-02	5.38E-04	1.10E+02	1.24E+00
96.0000 h	0.00E+00	0.00E+00	0.00E+00	0.00E+00	0.00E+00	9.61E-05	3.21E-11	1.61E-03	6.83E-10	4.11E+00	3.09E-06
720.0000 h	0.00E+00	0.00E+00	0.00E+00	0.00E+00	0.00E+00	7.06E-11	0.00E+00	1.52E-09	0.00E+00	6.95E-06	0.00E+00
TOTALS	0.00E+00	0.00E+00	0.00E+00	0.00E+00	0.00E+00	2.96E+00		2.86E+01		3.06E+04	

TRAILS -- Transport of Radioactive Material in Linear Systems, v2.0
 FRP Case for dose 1 gpm [TC950835.DAT]

COMP: not used

COMP: faulted S/G

COMP: Control Room
 VOLUME: 1.730E+05 Cu.Ft.

INITIAL:	COMP: not used	COMP: faulted S/G	COMP: Control Room
	0.000E+00 Kr-83m	2.000E+07 Kr-83m uCi	0.000E+00 Kr-83m
	0.000E+00 Kr-85m	9.750E+07 Kr-85m	0.000E+00 Kr-85m
	0.000E+00 Kr-85	5.150E+08 Kr-85	0.000E+00 Kr-85
	0.000E+00 Kr-87	5.580E+07 Kr-87	0.000E+00 Kr-87
	0.000E+00 Kr-88	1.490E+08 Kr-88	0.000E+00 Kr-88
	0.000E+00 Kr-89	4.690E+06 Kr-89	0.000E+00 Kr-89
	0.000E+00 Xe-131m	5.010E+06 Xe-131m	0.000E+00 Xe-131m
	0.000E+00 Xe-133m	1.430E+08 Xe-133m	0.000E+00 Xe-133m
	0.000E+00 Xe-133	1.220E+09 Xe-133	0.000E+00 Xe-133
	0.000E+00 Xe-135m	5.060E+07 Xe-135m	0.000E+00 Xe-135m
	0.000E+00 Xe-135	1.500E+08 Xe-135	0.000E+00 Xe-135
	0.000E+00 Xe-137	7.590E+06 Xe-137	0.000E+00 Xe-137
	0.000E+00 Xe-138	3.130E+07 Xe-138	0.000E+00 Xe-138
	0.000E+00 I-131	7.160E+09 I-131	0.000E+00 I-131
	0.000E+00 I-132	2.500E+09 I-132	0.000E+00 I-132
	0.000E+00 I-133	1.120E+10 I-133	0.000E+00 I-133
	0.000E+00 I-134	1.560E+09 I-134	0.000E+00 I-134
	0.000E+00 I-135	6.890E+09 I-135	0.000E+00 I-135
ACT MULT (to uCi):	1.000E+00	1.000E+00	1.000E+00

TRAILS -- Transport of Radioactive Material in Linear Systems, v2.0
 FRP Case for dose 1 gpm [TC950835.DAT]

REMOVAL:
 NUC GIP 1 REL FR: 0.000E+00 1/sec
 NUC GIP 2 REL FR: 0.000E+00
 NUC GIP 3 REL FR: 0.000E+00

3.566E-07 1/sec
 INTAKE REDUCT: 0.000E+00
 INTAKE REDUCT: 9.360E-01
 INTAKE REDUCT: 0.000E+00

0.000E+00 1/sec
 INTAKE REDUCT: 0.000E+00
 INTAKE REDUCT: 9.360E-01
 INTAKE REDUCT: 0.000E+00

1.000E+01 cfm
 INTAKE REDUCT: 0.000E+00
 INTAKE REDUCT: 9.360E-01
 INTAKE REDUCT: 0.000E+00

MULTIPLIERS====>

STEP	TIME	XPR	XREM	XRF	XPR	XREM	XRF	XPR	XREM	XRF
1	1.800E+03	0.000E+00	0.000E+00	0.000E+00	0.000E+00	1.00	0.000E+00	50.0	50.0	0.000E+00
2	3.600E+03	0.000E+00	0.000E+00	0.000E+00	0.000E+00	1.00	0.000E+00	1.00	70.0	0.000E+00
3	5.400E+03	0.000E+00	0.000E+00	0.000E+00	0.000E+00	1.00	0.000E+00	1.00	70.0	0.000E+00
4	7.200E+03	0.000E+00	0.000E+00	0.000E+00	0.000E+00	1.00	0.000E+00	70.0	70.0	1.00
5	1.440E+04	0.000E+00	0.000E+00	0.000E+00	0.000E+00	1.00	0.000E+00	70.0	70.0	1.00
6	2.880E+04	0.000E+00	0.000E+00	0.000E+00	0.000E+00	1.00	0.000E+00	70.0	70.0	1.00
7	3.060E+04	0.000E+00	0.000E+00	0.000E+00	0.000E+00	0.000E+00	0.000E+00	3.350E+03	3.350E+03	0.000E+00
8	8.640E+04	0.000E+00	0.000E+00	0.000E+00	0.000E+00	0.000E+00	0.000E+00	50.0	50.0	0.000E+00
9	3.456E+05	0.000E+00	0.000E+00	0.000E+00	0.000E+00	0.000E+00	0.000E+00	50.0	50.0	0.000E+00
10	2.592E+06	0.000E+00	0.000E+00	0.000E+00	0.000E+00	0.000E+00	0.000E+00	50.0	50.0	0.000E+00

----- CONTROL ROOM -----

X/Q	Breathing	Occupancy
s/M3	M3/s	M3/s
1.000E-03	3.470E-04	1.000E+00

----- ENVIRONMENT -----

X/Q	Breathing
s/M3	M3/s
0.000E+00	3.470E-04

MULTIPLIERS====>

STEP	TIME, s	XPR	XREM	XRF	XPR	XREM	XRF	XPR	XREM	XRF
1	1.800E+03	2.43	1.00	1.00	0.000E+00	1.00	0.000E+00	50.0	50.0	0.000E+00
2	3.600E+03	2.43	1.00	1.00	0.000E+00	1.00	0.000E+00	1.00	70.0	0.000E+00
3	5.400E+03	2.43	1.00	1.00	0.000E+00	1.00	0.000E+00	1.00	70.0	0.000E+00
4	7.200E+03	2.43	1.00	1.00	0.000E+00	1.00	0.000E+00	70.0	70.0	1.00
5	1.440E+04	2.43	1.00	1.00	0.000E+00	1.00	0.000E+00	70.0	70.0	1.00
6	2.880E+04	2.43	1.00	1.00	0.000E+00	1.00	0.000E+00	70.0	70.0	1.00
7	3.060E+04	1.22	1.00	1.00	0.000E+00	0.000E+00	0.000E+00	3.350E+03	3.350E+03	0.000E+00
8	8.640E+04	1.22	1.00	1.00	0.000E+00	0.000E+00	0.000E+00	50.0	50.0	0.000E+00
9	3.456E+05	0.890	1.00	0.600	0.000E+00	0.000E+00	0.000E+00	50.0	50.0	0.000E+00
10	2.592E+06	0.626	1.00	0.400	0.000E+00	0.000E+00	0.000E+00	50.0	50.0	0.000E+00

TRAILS -- Transport of Radioactive Material in Linear Systems, v2.0
 FRP Case for dose 1 gpm [TC950835.DAT]

STEP	TIME	not used		faulted S/G		AVERAGE		-----CONTROL ROOM-----		
		CURRENT uCi	INTEGRD uCi-sec	CURRENT uCi	INTEGRD uCi-sec	RELEASED uCi	RELEASE uCi/sec	CURRENT uCi	CURRENT uCi/cc	INTEGRD uCi-sec
Kr-83m	INITIAL	0.000E+00		2.000E+07				0.000E+00		
1	0.5000 h	0.000E+00	0.000E+00	1.654E+07	3.279E+10	1.169E+04	6.496E+00	5.859E+00	1.196E-09	5.515E+03
2	1.0000 h	0.000E+00	0.000E+00	1.368E+07	2.711E+10	9.669E+03	5.371E+00	4.389E+00	8.959E-10	9.154E+03
3	1.5000 h	0.000E+00	0.000E+00	1.131E+07	2.242E+10	7.995E+03	4.442E+00	3.295E+00	6.727E-10	6.865E+03
4	2.0000 h	0.000E+00	0.000E+00	9.353E+06	1.854E+10	6.612E+03	3.673E+00	6.977E+00	1.424E-09	9.417E+03
5	4.0000 h	0.000E+00	0.000E+00	4.374E+06	4.716E+10	1.682E+04	2.336E+00	9.741E+00	1.989E-09	6.220E+04
6	8.0000 h	0.000E+00	0.000E+00	9.564E+05	3.237E+10	1.154E+04	8.016E-01	4.228E+00	8.631E-10	8.561E+04
7	8.5000 h	0.000E+00	0.000E+00	7.914E+05	1.568E+09	0.000E+00	0.000E+00	1.049E-02	2.142E-12	1.266E+03
8	24.0000 h	0.000E+00	0.000E+00	2.232E+03	7.501E+09	0.000E+00	0.000E+00	2.014E-06	4.111E-16	6.841E+01
9	96.0000 h	0.000E+00	0.000E+00	3.202E-09	2.122E+07	0.000E+00	0.000E+00	1.092E-23	2.229E-33	1.313E-02
10	720.0000 h	0.000E+00	0.000E+00	0.000E+00	3.043E-05	0.000E+00	0.000E+00	0.000E+00	0.000E+00	7.119E-20
Kr-83m	TOTALS		0.000E+00		1.895E+11	6.433E+04				1.801E+05
Kr-85m	INITIAL	0.000E+00		9.750E+07				0.000E+00		
1	0.5000 h	0.000E+00	0.000E+00	9.018E+07	1.688E+11	6.021E+04	3.345E+01	3.184E+01	6.500E-09	2.944E+04
2	1.0000 h	0.000E+00	0.000E+00	8.342E+07	1.562E+11	5.569E+04	3.094E+01	2.668E+01	5.446E-09	5.251E+04
3	1.5000 h	0.000E+00	0.000E+00	7.716E+07	1.444E+11	5.151E+04	2.862E+01	2.241E+01	4.574E-09	4.405E+04
4	2.0000 h	0.000E+00	0.000E+00	7.137E+07	1.336E+11	4.764E+04	2.647E+01	5.306E+01	1.083E-08	6.883E+04
5	4.0000 h	0.000E+00	0.000E+00	5.224E+07	4.414E+11	1.574E+05	2.186E+01	1.111E+02	2.269E-08	6.185E+05
6	8.0000 h	0.000E+00	0.000E+00	2.799E+07	5.596E+11	1.996E+05	1.386E+01	1.029E+02	2.100E-08	1.526E+06
7	8.5000 h	0.000E+00	0.000E+00	2.591E+07	4.848E+10	0.000E+00	0.000E+00	2.856E-01	5.830E-11	3.137E+04
8	24.0000 h	0.000E+00	0.000E+00	2.354E+06	5.480E+11	0.000E+00	0.000E+00	1.766E-03	3.605E-13	3.114E+03
9	96.0000 h	0.000E+00	0.000E+00	3.419E+01	5.478E+10	0.000E+00	0.000E+00	9.695E-14	1.979E-23	1.937E+01
10	720.0000 h	0.000E+00	0.000E+00	0.000E+00	7.955E+05	0.000E+00	0.000E+00	0.000E+00	0.000E+00	1.064E-09
Kr-85m	TOTALS		0.000E+00		2.255E+12	5.720E+05				2.374E+06
Kr-85	INITIAL	0.000E+00		5.150E+08				0.000E+00		
1	0.5000 h	0.000E+00	0.000E+00	5.147E+08	9.267E+11	3.305E+05	1.836E+02	1.815E+02	3.705E-08	1.657E+05
2	1.0000 h	0.000E+00	0.000E+00	5.143E+08	9.261E+11	3.303E+05	1.835E+02	1.643E+02	3.355E-08	3.109E+05
3	1.5000 h	0.000E+00	0.000E+00	5.140E+08	9.255E+11	3.300E+05	1.834E+02	1.491E+02	3.044E-08	2.818E+05
4	2.0000 h	0.000E+00	0.000E+00	5.137E+08	9.249E+11	3.298E+05	1.832E+02	3.814E+02	7.786E-08	4.817E+05
5	4.0000 h	0.000E+00	0.000E+00	5.123E+08	3.694E+12	1.317E+06	1.829E+02	1.072E+03	2.189E-07	5.434E+06
6	8.0000 h	0.000E+00	0.000E+00	5.097E+08	7.359E+12	2.624E+06	1.822E+02	1.754E+03	3.580E-07	2.113E+07
7	8.5000 h	0.000E+00	0.000E+00	5.097E+08	9.175E+11	0.000E+00	0.000E+00	5.261E+00	1.074E-09	5.418E+05
8	24.0000 h	0.000E+00	0.000E+00	5.096E+08	2.844E+13	0.000E+00	0.000E+00	3.579E-01	7.305E-11	1.018E+05
9	96.0000 h	0.000E+00	0.000E+00	5.094E+08	1.321E+14	0.000E+00	0.000E+00	1.352E-06	2.761E-16	7.429E+03
10	720.0000 h	0.000E+00	0.000E+00	5.070E+08	1.142E+15	0.000E+00	0.000E+00	0.000E+00	0.000E+00	2.807E-02
Kr-85	TOTALS		0.000E+00		1.318E+15	5.262E+06				2.846E+07

TRAILS -- Transport of Radioactive Material in Linear Systems, v2.0
 FRP Case for dose 1 gpm [TC950835.DAT]

STEP	TIME	not used		faulted S/G		AVERAGE		-----CONTROL ROOM-----		
		CURRENT uCi	INTEGRD uCi-sec	CURRENT uCi	INTEGRD uCi-sec	RELEASED uCi	RELEASE uCi/sec	CURRENT uCi	CURRENT uCi/cc	INTEGRD uCi-sec
Kr-87	INITIAL	0.000E+00		5.580E+07				0.000E+00		
1	0.5000 h	0.000E+00	0.000E+00	4.246E+07	8.789E+10	3.134E+04	1.741E+01	1.510E+01	3.082E-09	1.440E+04
2	1.0000 h	0.000E+00	0.000E+00	3.231E+07	6.688E+10	2.385E+04	1.325E+01	1.041E+01	2.125E-09	2.268E+04
3	1.5000 h	0.000E+00	0.000E+00	2.459E+07	5.089E+10	1.815E+04	1.008E+01	7.191E+00	1.468E-09	1.565E+04
4	2.0000 h	0.000E+00	0.000E+00	1.871E+07	3.873E+10	1.381E+04	7.672E+00	1.401E+01	2.861E-09	1.949E+04
5	4.0000 h	0.000E+00	0.000E+00	6.274E+06	8.194E+10	2.922E+04	4.059E+00	1.471E+01	3.002E-09	1.040E+05
6	8.0000 h	0.000E+00	0.000E+00	7.053E+05	3.669E+10	1.308E+04	9.086E-01	3.820E+00	7.797E-10	9.774E+04
7	8.5000 h	0.000E+00	0.000E+00	5.371E+05	1.111E+09	0.000E+00	0.000E+00	8.724E-03	1.781E-12	1.128E+03
8	24.0000 h	0.000E+00	0.000E+00	1.150E+02	3.546E+09	0.000E+00	0.000E+00	1.271E-07	2.595E-17	4.371E+01
9	96.0000 h	0.000E+00	0.000E+00	1.039E-15	7.597E+05	0.000E+00	0.000E+00	4.342E-30	0.000E+00	6.369E-04
10	720.0000 h	0.000E+00	0.000E+00	0.000E+00	6.864E-12	0.000E+00	0.000E+00	0.000E+00	0.000E+00	2.176E-26
Kr-87	TOTALS		0.000E+00		3.677E+11	1.295E+05				2.752E+05
Kr-88	INITIAL	0.000E+00		1.490E+08				0.000E+00		
1	0.5000 h	0.000E+00	0.000E+00	1.318E+08	2.524E+11	9.001E+04	5.001E+01	4.658E+01	9.509E-09	4.338E+04
2	1.0000 h	0.000E+00	0.000E+00	1.166E+08	2.233E+11	7.962E+04	4.423E+01	3.733E+01	7.620E-09	7.518E+04
3	1.5000 h	0.000E+00	0.000E+00	1.031E+08	1.975E+11	7.043E+04	3.913E+01	2.998E+01	6.120E-09	6.031E+04
4	2.0000 h	0.000E+00	0.000E+00	9.122E+07	1.747E+11	6.230E+04	3.461E+01	6.789E+01	1.386E-08	8.947E+04
5	4.0000 h	0.000E+00	0.000E+00	5.584E+07	5.190E+11	1.851E+05	2.571E+01	1.206E+02	2.462E-08	7.089E+05
6	8.0000 h	0.000E+00	0.000E+00	2.093E+07	5.123E+11	1.827E+05	1.269E+01	8.177E+01	1.669E-08	1.372E+06
7	8.5000 h	0.000E+00	0.000E+00	1.852E+07	3.546E+10	0.000E+00	0.000E+00	2.171E-01	4.432E-11	2.475E+04
8	24.0000 h	0.000E+00	0.000E+00	4.215E+05	2.670E+11	0.000E+00	0.000E+00	3.361E-04	6.860E-14	1.869E+03
9	96.0000 h	0.000E+00	0.000E+00	9.842E-03	6.217E+09	0.000E+00	0.000E+00	2.967E-17	6.056E-27	2.898E+00
10	720.0000 h	0.000E+00	0.000E+00	0.000E+00	1.452E+02	0.000E+00	0.000E+00	0.000E+00	0.000E+00	2.558E-13
Kr-88	TOTALS		0.000E+00		2.188E+12	6.701E+05				2.376E+06
Kr-89	INITIAL	0.000E+00		4.690E+06				0.000E+00		
1	0.5000 h	0.000E+00	0.000E+00	6.502E+03	1.281E+09	4.568E+02	2.538E-01	3.924E-02	8.010E-12	6.013E+01
2	1.0000 h	0.000E+00	0.000E+00	9.014E+00	1.776E+06	6.333E-01	3.518E-04	4.929E-05	1.006E-14	1.053E+01
3	1.5000 h	0.000E+00	0.000E+00	1.250E-02	2.462E+03	8.780E-04	4.878E-07	6.207E-08	1.267E-17	1.323E-02
4	2.0000 h	0.000E+00	0.000E+00	1.732E-05	3.413E+00	1.217E-06	6.762E-10	2.219E-10	4.529E-20	1.687E-05
5	4.0000 h	0.000E+00	0.000E+00	6.400E-17	4.738E-03	1.690E-09	2.347E-13	5.060E-14	1.033E-23	5.994E-08
6	8.0000 h	0.000E+00	0.000E+00	0.000E+00	1.750E-14	6.242E-21	4.335E-25	9.346E-26	1.908E-35	1.359E-11
7	8.5000 h	0.000E+00	0.000E+00	0.000E+00	0.000E+00	0.000E+00	0.000E+00	3.889E-31	0.000E+00	1.358E-23
8	24.0000 h	0.000E+00	0.000E+00	0.000E+00	0.000E+00	0.000E+00	0.000E+00	0.000E+00	0.000E+00	1.050E-28
9	96.0000 h	0.000E+00	0.000E+00	0.000E+00	0.000E+00	0.000E+00	0.000E+00	0.000E+00	0.000E+00	0.000E+00
10	720.0000 h	0.000E+00	0.000E+00	0.000E+00	0.000E+00	0.000E+00	0.000E+00	0.000E+00	0.000E+00	0.000E+00
Kr-89	TOTALS		0.000E+00		1.283E+09	4.574E+02				7.067E+01

TRAILS -- Transport of Radioactive Material in Linear Systems, v2.0
 FRP Case for dose 1 gpm [TC950835.DAT]

STEP	TIME	not used		faulted S/G		AVERAGE		-----CONTROL ROOM-----		
		CURRENT uCi	INTEGRD uCi-sec	CURRENT uCi	INTEGRD uCi-sec	RELEASED uCi	RELEASE uCi/sec	CURRENT uCi	CURRENT uCi/cc	INTEGRD uCi-sec
Xe-131m INITIAL		0.000E+00		5.010E+06				0.000E+00		
1	0.5000 h	0.000E+00	0.000E+00	5.001E+06	9.010E+09	3.213E+03	1.785E+00	1.764E+00	3.600E-10	1.611E+03
2	1.0000 h	0.000E+00	0.000E+00	4.991E+06	8.993E+09	3.207E+03	1.782E+00	1.595E+00	3.255E-10	3.020E+03
3	1.5000 h	0.000E+00	0.000E+00	4.982E+06	8.976E+09	3.201E+03	1.778E+00	1.445E+00	2.950E-10	2.733E+03
4	2.0000 h	0.000E+00	0.000E+00	4.973E+06	8.959E+09	3.195E+03	1.775E+00	3.692E+00	7.537E-10	4.665E+03
5	4.0000 h	0.000E+00	0.000E+00	4.936E+06	3.567E+10	1.272E+04	1.767E+00	1.033E+01	2.109E-09	5.244E+04
6	8.0000 h	0.000E+00	0.000E+00	4.863E+06	7.055E+10	2.516E+04	1.747E+00	1.674E+01	3.418E-09	2.024E+05
7	8.5000 h	0.000E+00	0.000E+00	4.857E+06	8.748E+09	0.000E+00	0.000E+00	5.017E-02	1.024E-11	5.172E+03
8	24.0000 h	0.000E+00	0.000E+00	4.677E+06	2.660E+11	0.000E+00	0.000E+00	3.286E-03	6.708E-13	9.598E+02
9	96.0000 h	0.000E+00	0.000E+00	3.924E+06	1.112E+12	0.000E+00	0.000E+00	1.042E-08	2.128E-18	6.727E+01
10	720.0000 h	0.000E+00	0.000E+00	8.563E+05	4.527E+12	0.000E+00	0.000E+00	0.000E+00	0.000E+00	2.134E-04
Xe-131m TOTALS			0.000E+00		6.055E+12	5.070E+04				2.731E+05
Xe-133m INITIAL		0.000E+00		1.430E+08				0.000E+00		
1	0.5000 h	0.000E+00	0.000E+00	1.420E+08	2.565E+11	9.146E+04	5.081E+01	5.007E+01	1.022E-08	4.577E+04
2	1.0000 h	0.000E+00	0.000E+00	1.409E+08	2.546E+11	9.080E+04	5.044E+01	4.504E+01	9.193E-09	6.550E+04
3	1.5000 h	0.000E+00	0.000E+00	1.399E+08	2.528E+11	9.015E+04	5.008E+01	4.060E+01	8.287E-09	7.698E+04
4	2.0000 h	0.000E+00	0.000E+00	1.389E+08	2.510E+11	8.950E+04	4.972E+01	1.032E+02	2.106E-08	1.306E+05
5	4.0000 h	0.000E+00	0.000E+00	1.350E+08	9.859E+11	3.516E+05	4.883E+01	2.827E+02	5.771E-08	1.444E+06
6	8.0000 h	0.000E+00	0.000E+00	1.274E+08	1.888E+12	6.734E+05	4.676E+01	4.399E+02	8.979E-08	5.392E+06
7	8.5000 h	0.000E+00	0.000E+00	1.265E+08	2.285E+11	0.000E+00	0.000E+00	1.311E+00	2.676E-10	1.357E+05
8	24.0000 h	0.000E+00	0.000E+00	1.031E+08	6.386E+12	0.000E+00	0.000E+00	7.268E-02	1.484E-11	2.389E+04
9	96.0000 h	0.000E+00	0.000E+00	3.991E+07	1.726E+13	0.000E+00	0.000E+00	1.063E-07	2.171E-17	1.402E+03
10	720.0000 h	0.000E+00	0.000E+00	1.064E+04	1.089E+13	0.000E+00	0.000E+00	0.000E+00	0.000E+00	2.051E-03
Xe-133m TOTALS			0.000E+00		3.865E+13	1.387E+06				7.336E+06
Xe-133 INITIAL		0.000E+00		1.220E+09				0.000E+00		
1	0.5000 h	0.000E+00	0.000E+00	1.216E+09	2.192E+12	7.818E+05	4.343E+02	4.288E+02	8.754E-08	3.917E+05
2	1.0000 h	0.000E+00	0.000E+00	1.212E+09	2.185E+12	7.791E+05	4.329E+02	3.872E+02	7.903E-08	7.336E+05
3	1.5000 h	0.000E+00	0.000E+00	1.208E+09	2.177E+12	7.765E+05	4.314E+02	3.503E+02	7.152E-08	6.631E+05
4	2.0000 h	0.000E+00	0.000E+00	1.204E+09	2.170E+12	7.739E+05	4.299E+02	8.937E+02	1.824E-07	1.130E+06
5	4.0000 h	0.000E+00	0.000E+00	1.187E+09	8.607E+12	3.069E+06	4.263E+02	2.486E+03	5.075E-07	1.264E+07
6	8.0000 h	0.000E+00	0.000E+00	1.155E+09	1.687E+13	6.015E+06	4.177E+02	3.982E+03	8.128E-07	4.832E+07
7	8.5000 h	0.000E+00	0.000E+00	1.152E+09	2.077E+12	0.000E+00	0.000E+00	1.191E+01	2.432E-09	1.230E+06
8	24.0000 h	0.000E+00	0.000E+00	1.058E+09	6.163E+13	0.000E+00	0.000E+00	7.440E-01	1.519E-10	2.247E+05
9	96.0000 h	0.000E+00	0.000E+00	7.117E+08	2.264E+14	0.000E+00	0.000E+00	1.892E-06	3.863E-16	1.497E+04
10	720.0000 h	0.000E+00	0.000E+00	2.291E+07	4.503E+14	0.000E+00	0.000E+00	0.000E+00	0.000E+00	3.808E-02
Xe-133 TOTALS			0.000E+00		7.746E+14	1.220E+07				6.535E+07

TRAILS -- Transport of Radioactive Material in Linear Systems, v2.0
 FRP Case for dose 1 gpm [TC950835.DAT]

STEP	TIME	not used		faulted S/G		AVERAGE		-----CONTROL ROOM-----		
		CURRENT uCi	INTEGRD uCi-sec	CURRENT uCi	INTEGRD uCi-sec	RELEASED uCi	RELEASE uCi/sec	CURRENT uCi	CURRENT uCi/cc	INTEGRD uCi-sec
Xe-135m INITIAL		0.000E+00		5.060E+07				0.000E+00		
1	0.5000 h	0.000E+00	0.000E+00	1.306E+07	4.989E+10	1.779E+04	9.884E+00	5.405E+00	1.103E-09	5.994E+03
2	1.0000 h	0.000E+00	0.000E+00	3.371E+06	1.288E+10	4.592E+03	2.551E+00	1.264E+00	2.580E-10	5.117E+03
3	1.5000 h	0.000E+00	0.000E+00	8.699E+05	3.323E+09	1.185E+03	6.584E-01	2.962E-01	6.046E-11	1.197E+03
4	2.0000 h	0.000E+00	0.000E+00	2.245E+05	8.577E+08	3.059E+02	1.699E-01	1.961E-01	4.004E-11	4.217E+02
5	4.0000 h	0.000E+00	0.000E+00	9.962E+02	2.970E+08	1.059E+02	1.471E-02	1.491E-02	3.043E-12	3.249E+02
6	8.0000 h	0.000E+00	0.000E+00	1.961E-02	1.324E+06	4.721E-01	3.279E-05	3.223E-05	6.578E-15	1.862E+01
7	8.5000 h	0.000E+00	0.000E+00	5.065E-03	1.934E+01	0.000E+00	0.000E+00	2.497E-08	5.096E-18	8.092E-03
8	24.0000 h	0.000E+00	0.000E+00	3.008E-21	6.735E+00	0.000E+00	0.000E+00	1.008E-27	2.059E-37	3.120E-05
9	96.0000 h	0.000E+00	0.000E+00	0.000E+00	3.999E-18	0.000E+00	0.000E+00	0.000E+00	0.000E+00	1.260E-24
10	720.0000 h	0.000E+00	0.000E+00	0.000E+00	0.000E+00	0.000E+00	0.000E+00	0.000E+00	0.000E+00	0.000E+00
Xe-135m TOTALS			0.000E+00		6.725E+10	2.398E+04				1.307E+04
Xe-135 INITIAL		0.000E+00		1.500E+08				0.000E+00		
1	0.5000 h	0.000E+00	0.000E+00	1.443E+08	2.648E+11	9.445E+04	5.247E+01	5.092E+01	1.039E-08	4.678E+04
2	1.0000 h	0.000E+00	0.000E+00	1.388E+08	2.548E+11	9.086E+04	5.048E+01	4.438E+01	9.058E-09	8.561E+04
3	1.5000 h	0.000E+00	0.000E+00	1.336E+08	2.451E+11	8.741E+04	4.856E+01	3.876E+01	7.913E-09	7.469E+04
4	2.0000 h	0.000E+00	0.000E+00	1.285E+08	2.358E+11	8.410E+04	4.672E+01	9.546E+01	1.949E-08	1.222E+05
5	4.0000 h	0.000E+00	0.000E+00	1.101E+08	8.571E+11	3.057E+05	4.245E+01	2.319E+02	4.733E-08	1.230E+06
6	8.0000 h	0.000E+00	0.000E+00	8.078E+07	1.363E+12	4.862E+05	3.376E+01	2.853E+02	5.824E-08	3.803E+06
7	8.5000 h	0.000E+00	0.000E+00	7.776E+07	1.427E+11	0.000E+00	0.000E+00	8.238E-01	1.682E-10	8.757E+04
8	24.0000 h	0.000E+00	0.000E+00	2.391E+07	2.548E+12	0.000E+00	0.000E+00	1.723E-02	3.518E-12	1.164E+04
9	96.0000 h	0.000E+00	0.000E+00	9.987E+04	1.127E+12	0.000E+00	0.000E+00	2.721E-10	5.555E-20	2.486E+02
10	720.0000 h	0.000E+00	0.000E+00	2.400E-16	4.725E+09	0.000E+00	0.000E+00	0.000E+00	0.000E+00	3.927E-06
Xe-135 TOTALS			0.000E+00		7.043E+12	1.149E+06				5.462E+06
Xe-137 INITIAL		0.000E+00		7.590E+06				0.000E+00		
1	0.5000 h	0.000E+00	0.000E+00	3.327E+04	2.505E+09	8.933E+02	4.963E-01	9.249E-02	1.888E-11	1.370E+02
2	1.0000 h	0.000E+00	0.000E+00	1.458E+02	1.098E+07	3.916E+00	2.175E-03	3.673E-04	7.499E-14	2.989E+01
3	1.5000 h	0.000E+00	0.000E+00	6.392E-01	4.813E+04	1.716E-02	9.535E-06	1.462E-06	2.985E-16	1.187E-01
4	2.0000 h	0.000E+00	0.000E+00	2.802E-03	2.109E+02	7.523E-05	4.179E-08	1.652E-08	3.372E-18	4.884E-04
5	4.0000 h	0.000E+00	0.000E+00	1.034E-12	9.287E-01	3.312E-07	4.600E-11	1.197E-11	2.444E-21	5.439E-06
6	8.0000 h	0.000E+00	0.000E+00	1.409E-31	5.428E-10	1.222E-16	8.489E-21	2.210E-21	4.511E-31	3.883E-09
7	8.5000 h	0.000E+00	0.000E+00	6.179E-34	4.650E-29	0.000E+00	0.000E+00	2.908E-26	5.935E-36	3.539E-19
8	24.0000 h	0.000E+00	0.000E+00	0.000E+00	2.049E-31	0.000E+00	0.000E+00	0.000E+00	0.000E+00	9.488E-24
9	96.0000 h	0.000E+00	0.000E+00	0.000E+00	0.000E+00	0.000E+00	0.000E+00	0.000E+00	0.000E+00	0.000E+00
10	720.0000 h	0.000E+00	0.000E+00	0.000E+00	0.000E+00	0.000E+00	0.000E+00	0.000E+00	0.000E+00	0.000E+00
Xe-137 TOTALS			0.000E+00		2.516E+09	8.972E+02				1.670E+02

TRAILS -- Transport of Radioactive Material in Linear Systems, v2.0
 FRP Case for dose 1 gpm [TC950835.DAT]

STEP	TIME	not used		faulted S/G		AVERAGE		-----CONTROL ROOM-----		
		CURRENT uCi	INTEGRD uCi-sec	CURRENT uCi	INTEGRD uCi-sec	RELEASED uCi	RELEASE uCi/sec	CURRENT uCi	CURRENT uCi/cc	INTEGRD uCi-sec
Xe-138	INITIAL	0.000E+00		3.130E+07				0.000E+00		
1	0.5000 h	0.000E+00	0.000E+00	7.180E+06	2.949E+10	1.052E+04	5.842E+00	3.055E+00	6.236E-10	3.436E+03
2	1.0000 h	0.000E+00	0.000E+00	1.647E+06	6.765E+09	2.412E+03	1.340E+00	6.349E-01	1.296E-10	2.766E+03
3	1.5000 h	0.000E+00	0.000E+00	3.779E+05	1.552E+09	5.534E+02	3.074E-01	1.323E-01	2.700E-11	5.752E+02
4	2.0000 h	0.000E+00	0.000E+00	8.668E+04	3.560E+08	1.269E+02	7.053E-02	7.786E-02	1.589E-11	1.766E+02
5	4.0000 h	0.000E+00	0.000E+00	2.400E+02	1.057E+08	3.769E+01	5.234E-03	4.873E-03	9.947E-13	1.167E+02
6	8.0000 h	0.000E+00	0.000E+00	1.841E-03	2.935E+05	1.047E-01	7.268E-06	6.607E-06	1.349E-15	5.593E+00
7	8.5000 h	0.000E+00	0.000E+00	4.226E-04	1.735E+00	0.000E+00	0.000E+00	4.549E-09	9.286E-19	1.632E-03
8	24.0000 h	0.000E+00	0.000E+00	6.501E-24	5.169E-01	0.000E+00	0.000E+00	4.761E-30	0.000E+00	5.255E-06
9	96.0000 h	0.000E+00	0.000E+00	0.000E+00	7.952E-21	0.000E+00	0.000E+00	0.000E+00	0.000E+00	5.499E-27
10	720.0000 h	0.000E+00	0.000E+00	0.000E+00	0.000E+00	0.000E+00	0.000E+00	0.000E+00	0.000E+00	0.000E+00
Xe-138	TOTALS		0.000E+00		3.827E+10	1.365E+04				7.076E+03
I-131	INITIAL	0.000E+00		7.160E+09				0.000E+00		
1	0.5000 h	0.000E+00	0.000E+00	7.143E+09	1.287E+13	4.590E+06	2.550E+03	2.519E+03	5.142E-07	2.301E+06
2	1.0000 h	0.000E+00	0.000E+00	7.125E+09	1.284E+13	4.579E+06	2.544E+03	2.277E+03	4.647E-07	4.312E+06
3	1.5000 h	0.000E+00	0.000E+00	7.108E+09	1.281E+13	4.568E+06	2.538E+03	2.062E+03	4.209E-07	3.901E+06
4	2.0000 h	0.000E+00	0.000E+00	7.091E+09	1.278E+13	4.557E+06	2.532E+03	2.043E+03	4.171E-07	3.694E+06
5	4.0000 h	0.000E+00	0.000E+00	7.022E+09	5.080E+13	1.812E+07	2.516E+03	1.983E+03	4.049E-07	1.448E+07
6	8.0000 h	0.000E+00	0.000E+00	6.886E+09	1.001E+14	3.771E+07	2.480E+03	1.907E+03	3.893E-07	2.792E+07
7	8.5000 h	0.000E+00	0.000E+00	6.874E+09	1.238E+13	0.000E+00	0.000E+00	5.710E+00	1.166E-09	5.890E+05
8	24.0000 h	0.000E+00	0.000E+00	6.501E+09	3.731E+14	0.000E+00	0.000E+00	3.674E-01	7.500E-11	1.087E+05
9	96.0000 h	0.000E+00	0.000E+00	5.020E+09	1.485E+15	0.000E+00	0.000E+00	1.073E-06	2.189E-16	7.473E+03
10	720.0000 h	0.000E+00	0.000E+00	5.336E+08	4.496E+15	0.000E+00	0.000E+00	0.000E+00	0.000E+00	2.181E-02
I-131	TOTALS		0.000E+00		6.569E+15	7.212E+07				5.731E+07
I-132	INITIAL	0.000E+00		2.500E+09				0.000E+00		
1	0.5000 h	0.000E+00	0.000E+00	2.149E+09	4.176E+12	1.489E+06	8.273E+02	7.602E+02	1.552E-07	7.112E+05
2	1.0000 h	0.000E+00	0.000E+00	1.847E+09	3.590E+12	1.280E+06	7.112E+02	5.919E+02	1.208E-07	1.210E+06
3	1.5000 h	0.000E+00	0.000E+00	1.588E+09	3.086E+12	1.100E+06	6.113E+02	4.620E+02	9.431E-08	9.432E+05
4	2.0000 h	0.000E+00	0.000E+00	1.365E+09	2.652E+12	9.458E+05	5.254E+02	3.945E+02	8.053E-08	7.681E+05
5	4.0000 h	0.000E+00	0.000E+00	7.450E+08	7.372E+12	2.629E+06	3.651E+02	2.152E+02	4.392E-08	2.080E+06
6	8.0000 h	0.000E+00	0.000E+00	2.220E+08	6.221E+12	2.219E+06	1.541E+02	7.084E+01	1.446E-08	1.709E+06
7	8.5000 h	0.000E+00	0.000E+00	1.910E+08	3.710E+11	0.000E+00	0.000E+00	1.828E-01	3.731E-11	2.134E+04
8	24.0000 h	0.000E+00	0.000E+00	1.788E+06	2.260E+12	0.000E+00	0.000E+00	1.164E-04	2.376E-14	1.385E+03
9	96.0000 h	0.000E+00	0.000E+00	6.742E-04	2.136E+10	0.000E+00	0.000E+00	1.660E-19	3.388E-29	8.825E-01
10	720.0000 h	0.000E+00	0.000E+00	0.000E+00	8.054E+00	0.000E+00	0.000E+00	0.000E+00	0.000E+00	1.258E-15
I-132	TOTALS		0.000E+00		2.975E+13	9.663E+06				7.444E+06

TRAILS -- Transport of Radioactive Material in Linear Systems, v2.0
 FRP Case for dose 1 gpm [TC950835.DAT]

STEP	TIME	not used		faulted S/G		AVERAGE		-----CONTROL ROOM-----		
		CURRENT uCi	INTEGRD uCi-sec	CURRENT uCi	INTEGRD uCi-sec	RELEASED uCi	RELEASE uCi/sec	CURRENT uCi	CURRENT uCi/cc	INTEGRD uCi-sec
I-133	INITIAL	0.000E+00		1.120E+10				0.000E+00		
1	0.5000 h	0.000E+00	0.000E+00	1.101E+10	1.999E+13	7.127E+06	3.960E+03	3.883E+03	7.926E-07	3.555E+06
2	1.0000 h	0.000E+00	0.000E+00	1.082E+10	1.964E+13	7.005E+06	3.892E+03	3.457E+03	7.057E-07	6.597E+06
3	1.5000 h	0.000E+00	0.000E+00	1.063E+10	1.931E+13	6.885E+06	3.825E+03	3.085E+03	6.298E-07	5.880E+06
4	2.0000 h	0.000E+00	0.000E+00	1.045E+10	1.898E+13	6.767E+06	3.759E+03	3.012E+03	6.149E-07	5.486E+06
5	4.0000 h	0.000E+00	0.000E+00	9.752E+09	7.270E+13	2.593E+07	3.601E+03	2.758E+03	5.629E-07	2.069E+07
6	8.0000 h	0.000E+00	0.000E+00	8.491E+09	1.311E+14	4.677E+07	3.248E+03	2.369E+03	4.835E-07	3.640E+07
7	8.5000 h	0.000E+00	0.000E+00	8.351E+09	1.516E+13	0.000E+00	0.000E+00	6.987E+00	1.426E-09	7.296E+05
8	24.0000 h	0.000E+00	0.000E+00	4.982E+09	3.639E+14	0.000E+00	0.000E+00	2.836E-01	5.789E-11	1.167E+05
9	96.0000 h	0.000E+00	0.000E+00	4.523E+08	4.894E+14	0.000E+00	0.000E+00	9.733E-08	1.987E-17	4.938E+03
10	720.0000 h	0.000E+00	0.000E+00	4.212E-01	4.886E+13	0.000E+00	0.000E+00	0.000E+00	0.000E+00	1.695E-03
I-133	TOTALS		0.000E+00		1.199E+15	1.005E+08				7.946E+07
I-134	INITIAL	0.000E+00		1.560E+09				0.000E+00		
1	0.5000 h	0.000E+00	0.000E+00	1.050E+09	2.319E+12	8.269E+05	4.594E+02	3.762E+02	7.680E-08	3.657E+05
2	1.0000 h	0.000E+00	0.000E+00	7.066E+08	1.561E+12	5.565E+05	3.092E+02	2.294E+02	4.682E-08	5.337E+05
3	1.5000 h	0.000E+00	0.000E+00	4.756E+08	1.050E+12	3.745E+05	2.081E+02	1.402E+02	2.861E-08	3.257E+05
4	2.0000 h	0.000E+00	0.000E+00	3.201E+08	7.069E+11	2.521E+05	1.400E+02	9.373E+01	1.913E-08	2.069E+05
5	4.0000 h	0.000E+00	0.000E+00	6.567E+07	1.156E+12	4.124E+05	5.728E+01	2.082E+01	4.249E-09	3.278E+05
6	8.0000 h	0.000E+00	0.000E+00	2.764E+06	2.859E+11	1.020E+05	7.081E+00	1.581E+00	3.227E-10	8.526E+04
7	8.5000 h	0.000E+00	0.000E+00	1.862E+06	4.110E+09	0.000E+00	0.000E+00	3.193E-03	6.518E-13	4.576E+02
8	24.0000 h	0.000E+00	0.000E+00	8.861E+00	8.477E+09	0.000E+00	0.000E+00	1.034E-09	2.110E-19	1.192E+01
9	96.0000 h	0.000E+00	0.000E+00	1.675E-24	4.034E+04	0.000E+00	0.000E+00	0.000E+00	0.000E+00	3.861E-06
10	720.0000 h	0.000E+00	0.000E+00	0.000E+00	7.625E-21	0.000E+00	0.000E+00	0.000E+00	0.000E+00	0.000E+00
I-134	TOTALS		0.000E+00		7.091E+12	2.524E+06				1.846E+06
I-135	INITIAL	0.000E+00		6.890E+09				0.000E+00		
1	0.5000 h	0.000E+00	0.000E+00	6.534E+09	1.208E+13	4.307E+06	2.393E+03	2.306E+03	4.707E-07	2.123E+06
2	1.0000 h	0.000E+00	0.000E+00	6.196E+09	1.145E+13	4.085E+06	2.269E+03	1.981E+03	4.044E-07	3.850E+06
3	1.5000 h	0.000E+00	0.000E+00	5.876E+09	1.086E+13	3.874E+06	2.152E+03	1.706E+03	3.482E-07	3.311E+06
4	2.0000 h	0.000E+00	0.000E+00	5.572E+09	1.030E+13	3.673E+06	2.041E+03	1.607E+03	3.280E-07	2.979E+06
5	4.0000 h	0.000E+00	0.000E+00	4.506E+09	3.615E+13	1.289E+07	1.790E+03	1.279E+03	2.611E-07	1.025E+07
6	8.0000 h	0.000E+00	0.000E+00	2.947E+09	5.287E+13	1.886E+07	1.309E+03	8.416E+02	1.718E-07	1.456E+07
7	8.5000 h	0.000E+00	0.000E+00	2.797E+09	5.168E+12	0.000E+00	0.000E+00	2.396E+00	4.890E-10	2.577E+05
8	24.0000 h	0.000E+00	0.000E+00	5.505E+08	7.711E+13	0.000E+00	0.000E+00	3.208E-02	6.548E-12	3.058E+04
9	96.0000 h	0.000E+00	0.000E+00	2.896E+05	1.889E+13	0.000E+00	0.000E+00	6.379E-11	1.302E-20	4.150E+02
10	720.0000 h	0.000E+00	0.000E+00	1.105E-23	9.940E+09	0.000E+00	0.000E+00	0.000E+00	0.000E+00	8.253E-07
I-135	TOTALS		0.000E+00		2.349E+14	4.768E+07				3.736E+07
ALL NUCLIDES		0.000E+00		1.064E+09				0.000E+00	0.000E+00	
@ STEP 10										

TRAILS -- Transport of Radioactive Material in Linear Systems, v2.0
 FRP Case for dose 1 gpm [TC950835.DAT]

	ENVIRONMENT						CONTROL ROOM					
	External EDE		SKIN-DE		THY CDE-INHAL		External EDE		SKIN-DE		THY CDE-INHAL	
	DOSE mrem	DOSE RATE mrem/hr	DOSE mrem	DOSE RATE mrem/hr	DOSE mrem	DOSE RATE mrem/hr	DOSE mrem	DOSE RATE mrem/hr	DOSE mrem	DOSE RATE mrem/hr	DOSE mrem	DOSE RATE mrem/hr
Kr-83m												
0.5000 h	0.00E+00	0.00E+00	0.00E+00	0.00E+00	0.00E+00	0.00E+00	8.41E-10	3.22E-09	0.00E+00	0.00E+00	0.00E+00	0.00E+00
1.0000 h	0.00E+00	0.00E+00	0.00E+00	0.00E+00	0.00E+00	0.00E+00	1.40E-09	2.41E-09	0.00E+00	0.00E+00	0.00E+00	0.00E+00
1.5000 h	0.00E+00	0.00E+00	0.00E+00	0.00E+00	0.00E+00	0.00E+00	1.05E-09	1.81E-09	0.00E+00	0.00E+00	0.00E+00	0.00E+00
2.0000 h	0.00E+00	0.00E+00	0.00E+00	0.00E+00	0.00E+00	0.00E+00	1.44E-09	3.83E-09	0.00E+00	0.00E+00	0.00E+00	0.00E+00
4.0000 h	0.00E+00	0.00E+00	0.00E+00	0.00E+00	0.00E+00	0.00E+00	9.48E-09	5.35E-09	0.00E+00	0.00E+00	0.00E+00	0.00E+00
8.0000 h	0.00E+00	0.00E+00	0.00E+00	0.00E+00	0.00E+00	0.00E+00	1.31E-08	2.32E-09	0.00E+00	0.00E+00	0.00E+00	0.00E+00
8.5000 h	0.00E+00	0.00E+00	0.00E+00	0.00E+00	0.00E+00	0.00E+00	1.93E-10	5.76E-12	0.00E+00	0.00E+00	0.00E+00	0.00E+00
24.0000 h	0.00E+00	0.00E+00	0.00E+00	0.00E+00	0.00E+00	0.00E+00	1.04E-11	1.11E-15	0.00E+00	0.00E+00	0.00E+00	0.00E+00
96.0000 h	0.00E+00	0.00E+00	0.00E+00	0.00E+00	0.00E+00	0.00E+00	1.20E-15	5.99E-33	0.00E+00	0.00E+00	0.00E+00	0.00E+00
720.0000 h	0.00E+00	0.00E+00	0.00E+00	0.00E+00	0.00E+00	0.00E+00	4.34E-33	0.00E+00	0.00E+00	0.00E+00	0.00E+00	0.00E+00
TOTALS	0.00E+00		0.00E+00		0.00E+00		2.75E-08		0.00E+00		0.00E+00	
Kr-85m												
0.5000 h	0.00E+00	0.00E+00	0.00E+00	0.00E+00	0.00E+00	0.00E+00	7.82E-06	3.04E-05	3.07E-04	1.20E-03	0.00E+00	0.00E+00
1.0000 h	0.00E+00	0.00E+00	0.00E+00	0.00E+00	0.00E+00	0.00E+00	1.39E-05	2.55E-05	5.48E-04	1.00E-03	0.00E+00	0.00E+00
1.5000 h	0.00E+00	0.00E+00	0.00E+00	0.00E+00	0.00E+00	0.00E+00	1.17E-05	2.14E-05	4.60E-04	8.42E-04	0.00E+00	0.00E+00
2.0000 h	0.00E+00	0.00E+00	0.00E+00	0.00E+00	0.00E+00	0.00E+00	1.83E-05	5.07E-05	7.18E-04	1.99E-03	0.00E+00	0.00E+00
4.0000 h	0.00E+00	0.00E+00	0.00E+00	0.00E+00	0.00E+00	0.00E+00	1.64E-04	1.00E-04	6.45E-03	4.17E-03	0.00E+00	0.00E+00
8.0000 h	0.00E+00	0.00E+00	0.00E+00	0.00E+00	0.00E+00	0.00E+00	4.05E-04	9.64E-05	1.59E-02	3.86E-03	0.00E+00	0.00E+00
8.5000 h	0.00E+00	0.00E+00	0.00E+00	0.00E+00	0.00E+00	0.00E+00	8.33E-06	2.73E-07	3.27E-04	1.07E-05	0.00E+00	0.00E+00
24.0000 h	0.00E+00	0.00E+00	0.00E+00	0.00E+00	0.00E+00	0.00E+00	8.27E-07	1.69E-09	3.25E-05	6.63E-08	0.00E+00	0.00E+00
96.0000 h	0.00E+00	0.00E+00	0.00E+00	0.00E+00	0.00E+00	0.00E+00	3.09E-09	9.27E-20	1.21E-07	3.64E-18	0.00E+00	0.00E+00
720.0000 h	0.00E+00	0.00E+00	0.00E+00	0.00E+00	0.00E+00	0.00E+00	1.13E-19	0.00E+00	4.44E-18	0.00E+00	0.00E+00	0.00E+00
TOTALS	0.00E+00		0.00E+00		0.00E+00		6.30E-04		2.48E-02		0.00E+00	
Kr-85												
0.5000 h	0.00E+00	0.00E+00	0.00E+00	0.00E+00	0.00E+00	0.00E+00	6.04E-07	2.38E-06	1.68E-03	6.63E-03	0.00E+00	0.00E+00
1.0000 h	0.00E+00	0.00E+00	0.00E+00	0.00E+00	0.00E+00	0.00E+00	1.13E-06	2.16E-06	3.16E-03	6.00E-03	0.00E+00	0.00E+00
1.5000 h	0.00E+00	0.00E+00	0.00E+00	0.00E+00	0.00E+00	0.00E+00	1.03E-06	1.96E-06	2.86E-03	5.45E-03	0.00E+00	0.00E+00
2.0000 h	0.00E+00	0.00E+00	0.00E+00	0.00E+00	0.00E+00	0.00E+00	1.76E-06	5.01E-06	4.89E-03	1.39E-02	0.00E+00	0.00E+00
4.0000 h	0.00E+00	0.00E+00	0.00E+00	0.00E+00	0.00E+00	0.00E+00	1.98E-05	1.41E-05	5.52E-02	3.92E-02	0.00E+00	0.00E+00
8.0000 h	0.00E+00	0.00E+00	0.00E+00	0.00E+00	0.00E+00	0.00E+00	7.71E-05	2.30E-05	2.14E-01	6.41E-02	0.00E+00	0.00E+00
8.5000 h	0.00E+00	0.00E+00	0.00E+00	0.00E+00	0.00E+00	0.00E+00	1.98E-06	6.91E-08	5.50E-03	1.92E-04	0.00E+00	0.00E+00
24.0000 h	0.00E+00	0.00E+00	0.00E+00	0.00E+00	0.00E+00	0.00E+00	3.71E-07	4.70E-09	1.03E-03	1.31E-05	0.00E+00	0.00E+00
96.0000 h	0.00E+00	0.00E+00	0.00E+00	0.00E+00	0.00E+00	0.00E+00	1.63E-08	1.78E-14	4.52E-05	4.94E-11	0.00E+00	0.00E+00
720.0000 h	0.00E+00	0.00E+00	0.00E+00	0.00E+00	0.00E+00	0.00E+00	4.10E-14	0.00E+00	1.14E-10	0.00E+00	0.00E+00	0.00E+00
TOTALS	0.00E+00		0.00E+00		0.00E+00		1.04E-04		2.89E-01		0.00E+00	

TRAILS -- Transport of Radioactive Material in Linear Systems, v2.0
 FRP Case for dose 1 gpm [TC950835.DAT]

ENVIRONMENT							CONTROL ROOM						
External EDE		SKIN-DE		THY CDE-INHAL		External EDE		SKIN-DE		THY CDE-INHAL			
DOSE	DOSE RATE	DOSE	DOSE RATE	DOSE	DOSE RATE	DOSE	DOSE RATE	DOSE	DOSE RATE	DOSE	DOSE RATE		
mrem	mrem/hr	mrem	mrem/hr	mrem	mrem/hr	mrem	mrem/hr	mrem	mrem/hr	mrem	mrem/hr		
Kr-87													
0.5000 h	0.00E+00	0.00E+00	0.00E+00	0.00E+00	0.00E+00	0.00E+00	0.00E+00	2.09E-05	7.90E-05	9.88E-04	3.73E-03	0.00E+00	0.00E+00
1.0000 h	0.00E+00	0.00E+00	0.00E+00	0.00E+00	0.00E+00	0.00E+00	0.00E+00	3.30E-05	5.45E-05	1.56E-03	2.57E-03	0.00E+00	0.00E+00
1.5000 h	0.00E+00	0.00E+00	0.00E+00	0.00E+00	0.00E+00	0.00E+00	0.00E+00	2.27E-05	3.76E-05	1.07E-03	1.78E-03	0.00E+00	0.00E+00
2.0000 h	0.00E+00	0.00E+00	0.00E+00	0.00E+00	0.00E+00	0.00E+00	0.00E+00	2.83E-05	7.33E-05	1.34E-03	3.46E-03	0.00E+00	0.00E+00
4.0000 h	0.00E+00	0.00E+00	0.00E+00	0.00E+00	0.00E+00	0.00E+00	0.00E+00	1.51E-04	7.69E-05	7.14E-03	3.63E-03	0.00E+00	0.00E+00
8.0000 h	0.00E+00	0.00E+00	0.00E+00	0.00E+00	0.00E+00	0.00E+00	0.00E+00	1.42E-04	2.00E-05	6.71E-03	9.43E-04	0.00E+00	0.00E+00
8.5000 h	0.00E+00	0.00E+00	0.00E+00	0.00E+00	0.00E+00	0.00E+00	0.00E+00	1.64E-06	4.56E-08	7.74E-05	2.15E-06	0.00E+00	0.00E+00
24.0000 h	0.00E+00	0.00E+00	0.00E+00	0.00E+00	0.00E+00	0.00E+00	0.00E+00	6.35E-08	6.65E-13	3.00E-06	3.14E-11	0.00E+00	0.00E+00
96.0000 h	0.00E+00	0.00E+00	0.00E+00	0.00E+00	0.00E+00	0.00E+00	0.00E+00	5.55E-13	0.00E+00	2.62E-11	0.00E+00	0.00E+00	0.00E+00
720.0000 h	0.00E+00	0.00E+00	0.00E+00	0.00E+00	0.00E+00	0.00E+00	0.00E+00	1.26E-35	0.00E+00	5.97E-34	0.00E+00	0.00E+00	0.00E+00
TOTALS	0.00E+00		0.00E+00		0.00E+00		0.00E+00	4.00E-04		1.89E-02		0.00E+00	
Kr-88													
0.5000 h	0.00E+00	0.00E+00	0.00E+00	0.00E+00	0.00E+00	0.00E+00	0.00E+00	1.59E-04	6.16E-04	6.99E-04	2.70E-03	0.00E+00	0.00E+00
1.0000 h	0.00E+00	0.00E+00	0.00E+00	0.00E+00	0.00E+00	0.00E+00	0.00E+00	2.76E-04	4.94E-04	1.21E-03	2.16E-03	0.00E+00	0.00E+00
1.5000 h	0.00E+00	0.00E+00	0.00E+00	0.00E+00	0.00E+00	0.00E+00	0.00E+00	2.22E-04	3.97E-04	9.71E-04	1.74E-03	0.00E+00	0.00E+00
2.0000 h	0.00E+00	0.00E+00	0.00E+00	0.00E+00	0.00E+00	0.00E+00	0.00E+00	3.29E-04	8.98E-04	1.44E-03	3.94E-03	0.00E+00	0.00E+00
4.0000 h	0.00E+00	0.00E+00	0.00E+00	0.00E+00	0.00E+00	0.00E+00	0.00E+00	2.61E-03	1.60E-03	1.14E-02	6.99E-03	0.00E+00	0.00E+00
8.0000 h	0.00E+00	0.00E+00	0.00E+00	0.00E+00	0.00E+00	0.00E+00	0.00E+00	5.04E-03	1.08E-03	2.21E-02	4.74E-03	0.00E+00	0.00E+00
8.5000 h	0.00E+00	0.00E+00	0.00E+00	0.00E+00	0.00E+00	0.00E+00	0.00E+00	9.10E-05	2.87E-06	3.99E-04	1.26E-05	0.00E+00	0.00E+00
24.0000 h	0.00E+00	0.00E+00	0.00E+00	0.00E+00	0.00E+00	0.00E+00	0.00E+00	6.87E-06	4.45E-09	3.01E-05	1.95E-08	0.00E+00	0.00E+00
96.0000 h	0.00E+00	0.00E+00	0.00E+00	0.00E+00	0.00E+00	0.00E+00	0.00E+00	6.39E-09	3.93E-22	2.80E-08	1.72E-21	0.00E+00	0.00E+00
720.0000 h	0.00E+00	0.00E+00	0.00E+00	0.00E+00	0.00E+00	0.00E+00	0.00E+00	3.76E-22	0.00E+00	1.65E-21	0.00E+00	0.00E+00	0.00E+00
TOTALS	0.00E+00		0.00E+00		0.00E+00		0.00E+00	8.73E-03		3.83E-02		0.00E+00	
Kr-89													
0.5000 h	0.00E+00	0.00E+00	0.00E+00	0.00E+00	0.00E+00	0.00E+00	0.00E+00	1.99E-07	4.67E-07	4.30E-06	1.01E-05	0.00E+00	0.00E+00
1.0000 h	0.00E+00	0.00E+00	0.00E+00	0.00E+00	0.00E+00	0.00E+00	0.00E+00	3.48E-08	5.87E-10	7.52E-07	1.27E-08	0.00E+00	0.00E+00
1.5000 h	0.00E+00	0.00E+00	0.00E+00	0.00E+00	0.00E+00	0.00E+00	0.00E+00	4.37E-11	7.39E-13	9.45E-10	1.60E-11	0.00E+00	0.00E+00
2.0000 h	0.00E+00	0.00E+00	0.00E+00	0.00E+00	0.00E+00	0.00E+00	0.00E+00	5.58E-14	2.64E-15	1.21E-12	5.71E-14	0.00E+00	0.00E+00
4.0000 h	0.00E+00	0.00E+00	0.00E+00	0.00E+00	0.00E+00	0.00E+00	0.00E+00	1.98E-16	6.02E-19	4.28E-15	1.30E-17	0.00E+00	0.00E+00
8.0000 h	0.00E+00	0.00E+00	0.00E+00	0.00E+00	0.00E+00	0.00E+00	0.00E+00	4.49E-20	1.11E-30	9.71E-19	2.40E-29	0.00E+00	0.00E+00
8.5000 h	0.00E+00	0.00E+00	0.00E+00	0.00E+00	0.00E+00	0.00E+00	0.00E+00	4.49E-32	0.00E+00	9.70E-31	0.00E+00	0.00E+00	0.00E+00
24.0000 h	0.00E+00	0.00E+00	0.00E+00	0.00E+00	0.00E+00	0.00E+00	0.00E+00	3.47E-37	0.00E+00	7.50E-36	0.00E+00	0.00E+00	0.00E+00
96.0000 h	0.00E+00	0.00E+00	0.00E+00	0.00E+00	0.00E+00	0.00E+00	0.00E+00	0.00E+00	0.00E+00	0.00E+00	0.00E+00	0.00E+00	0.00E+00
720.0000 h	0.00E+00	0.00E+00	0.00E+00	0.00E+00	0.00E+00	0.00E+00	0.00E+00	0.00E+00	0.00E+00	0.00E+00	0.00E+00	0.00E+00	0.00E+00
TOTALS	0.00E+00		0.00E+00		0.00E+00		0.00E+00	2.34E-07		5.05E-06		0.00E+00	

E N V I R O N M E N T							C O N T R O L R O O M					
External EDE		SKIN-DE		THY CDE-INHAL		External EDE		SKIN-DE		THY CDE-INHAL		
DOSE	DOSE RATE	DOSE	DOSE RATE	DOSE	DOSE RATE	DOSE	DOSE RATE	DOSE	DOSE RATE	DOSE	DOSE RATE	
mrem	mrem/hr	mrem	mrem/hr	mrem	mrem/hr	mrem	mrem/hr	mrem	mrem/hr	mrem	mrem/hr	
Xe-131m												
0.5000 h	0.00E+00	0.00E+00	0.00E+00	0.00E+00	0.00E+00	0.00E+00	2.24E-08	8.85E-08	4.95E-06	1.95E-05	0.00E+00	0.00E+00
1.0000 h	0.00E+00	0.00E+00	0.00E+00	0.00E+00	0.00E+00	0.00E+00	4.21E-08	8.00E-08	9.28E-06	1.76E-05	0.00E+00	0.00E+00
1.5000 h	0.00E+00	0.00E+00	0.00E+00	0.00E+00	0.00E+00	0.00E+00	3.81E-08	7.25E-08	8.40E-06	1.60E-05	0.00E+00	0.00E+00
2.0000 h	0.00E+00	0.00E+00	0.00E+00	0.00E+00	0.00E+00	0.00E+00	6.50E-08	1.85E-07	1.43E-05	4.09E-05	0.00E+00	0.00E+00
4.0000 h	0.00E+00	0.00E+00	0.00E+00	0.00E+00	0.00E+00	0.00E+00	7.31E-07	5.18E-07	1.61E-04	1.14E-04	0.00E+00	0.00E+00
8.0000 h	0.00E+00	0.00E+00	0.00E+00	0.00E+00	0.00E+00	0.00E+00	2.82E-06	8.40E-07	6.22E-04	1.85E-04	0.00E+00	0.00E+00
8.5000 h	0.00E+00	0.00E+00	0.00E+00	0.00E+00	0.00E+00	0.00E+00	7.21E-08	2.52E-09	1.59E-05	5.55E-07	0.00E+00	0.00E+00
24.0000 h	0.00E+00	0.00E+00	0.00E+00	0.00E+00	0.00E+00	0.00E+00	1.34E-08	1.65E-10	2.95E-06	3.64E-08	0.00E+00	0.00E+00
96.0000 h	0.00E+00	0.00E+00	0.00E+00	0.00E+00	0.00E+00	0.00E+00	5.62E-10	5.23E-16	1.24E-07	1.15E-13	0.00E+00	0.00E+00
720.0000 h	0.00E+00	0.00E+00	0.00E+00	0.00E+00	0.00E+00	0.00E+00	1.19E-15	0.00E+00	2.62E-13	0.00E+00	0.00E+00	0.00E+00
TOTALS	0.00E+00		0.00E+00		0.00E+00		3.80E-06		8.39E-04		0.00E+00	
Xe-133m												
0.5000 h	0.00E+00	0.00E+00	0.00E+00	0.00E+00	0.00E+00	0.00E+00	2.22E-06	8.73E-06	2.93E-04	1.16E-03	0.00E+00	0.00E+00
1.0000 h	0.00E+00	0.00E+00	0.00E+00	0.00E+00	0.00E+00	0.00E+00	4.14E-06	7.85E-06	5.48E-04	1.04E-03	0.00E+00	0.00E+00
1.5000 h	0.00E+00	0.00E+00	0.00E+00	0.00E+00	0.00E+00	0.00E+00	3.73E-06	7.08E-06	4.93E-04	9.36E-04	0.00E+00	0.00E+00
2.0000 h	0.00E+00	0.00E+00	0.00E+00	0.00E+00	0.00E+00	0.00E+00	6.33E-06	1.80E-05	8.37E-04	2.38E-03	0.00E+00	0.00E+00
4.0000 h	0.00E+00	0.00E+00	0.00E+00	0.00E+00	0.00E+00	0.00E+00	7.00E-05	4.93E-05	9.25E-03	6.52E-03	0.00E+00	0.00E+00
8.0000 h	0.00E+00	0.00E+00	0.00E+00	0.00E+00	0.00E+00	0.00E+00	2.61E-04	7.67E-05	3.46E-02	1.01E-02	0.00E+00	0.00E+00
8.5000 h	0.00E+00	0.00E+00	0.00E+00	0.00E+00	0.00E+00	0.00E+00	6.58E-06	2.29E-07	8.70E-04	3.02E-05	0.00E+00	0.00E+00
24.0000 h	0.00E+00	0.00E+00	0.00E+00	0.00E+00	0.00E+00	0.00E+00	1.16E-06	1.27E-08	1.53E-04	1.68E-06	0.00E+00	0.00E+00
96.0000 h	0.00E+00	0.00E+00	0.00E+00	0.00E+00	0.00E+00	0.00E+00	4.08E-08	1.85E-14	5.39E-06	2.45E-12	0.00E+00	0.00E+00
720.0000 h	0.00E+00	0.00E+00	0.00E+00	0.00E+00	0.00E+00	0.00E+00	3.97E-14	0.00E+00	5.26E-12	0.00E+00	0.00E+00	0.00E+00
TOTALS	0.00E+00		0.00E+00		0.00E+00		3.55E-04		4.70E-02		0.00E+00	
Xe-133												
0.5000 h	0.00E+00	0.00E+00	0.00E+00	0.00E+00	0.00E+00	0.00E+00	2.24E-05	8.84E-05	8.44E-04	3.33E-03	0.00E+00	0.00E+00
1.0000 h	0.00E+00	0.00E+00	0.00E+00	0.00E+00	0.00E+00	0.00E+00	4.20E-05	7.98E-05	1.58E-03	3.00E-03	0.00E+00	0.00E+00
1.5000 h	0.00E+00	0.00E+00	0.00E+00	0.00E+00	0.00E+00	0.00E+00	3.80E-05	7.22E-05	1.43E-03	2.72E-03	0.00E+00	0.00E+00
2.0000 h	0.00E+00	0.00E+00	0.00E+00	0.00E+00	0.00E+00	0.00E+00	6.47E-05	1.84E-04	2.43E-03	6.93E-03	0.00E+00	0.00E+00
4.0000 h	0.00E+00	0.00E+00	0.00E+00	0.00E+00	0.00E+00	0.00E+00	7.24E-04	5.13E-04	2.72E-02	1.93E-02	0.00E+00	0.00E+00
8.0000 h	0.00E+00	0.00E+00	0.00E+00	0.00E+00	0.00E+00	0.00E+00	2.77E-03	8.21E-04	1.04E-01	3.09E-02	0.00E+00	0.00E+00
8.5000 h	0.00E+00	0.00E+00	0.00E+00	0.00E+00	0.00E+00	0.00E+00	7.04E-05	2.46E-06	2.65E-03	9.24E-05	0.00E+00	0.00E+00
24.0000 h	0.00E+00	0.00E+00	0.00E+00	0.00E+00	0.00E+00	0.00E+00	1.29E-05	1.53E-07	4.84E-04	5.77E-06	0.00E+00	0.00E+00
96.0000 h	0.00E+00	0.00E+00	0.00E+00	0.00E+00	0.00E+00	0.00E+00	5.14E-07	3.90E-13	1.94E-05	1.47E-11	0.00E+00	0.00E+00
720.0000 h	0.00E+00	0.00E+00	0.00E+00	0.00E+00	0.00E+00	0.00E+00	8.72E-13	0.00E+00	3.28E-11	0.00E+00	0.00E+00	0.00E+00
TOTALS	0.00E+00		0.00E+00		0.00E+00		3.74E-03		1.41E-01		0.00E+00	

TRAILS -- Transport of Radioactive Material in Linear Systems, v2.0
 FRP Case for dose 1 gpm [TC950835.DAT]

	E N V I R O N M E N T						C O N T R O L R O O M					
	External EDE		SKIN-DE		THY CDE-INHAL		External EDE		SKIN-DE		THY CDE-INHAL	
	DOSE mrem	DOSE RATE mrem/hr	DOSE mrem	DOSE RATE mrem/hr	DOSE mrem	DOSE RATE mrem/hr	DOSE mrem	DOSE RATE mrem/hr	DOSE mrem	DOSE RATE mrem/hr	DOSE mrem	DOSE RATE mrem/hr
Xe-135m												
0.5000 h	0.00E+00	0.00E+00	0.00E+00	0.00E+00	0.00E+00	0.00E+00	4.18E-06	1.36E-05	2.65E-05	8.59E-05	0.00E+00	0.00E+00
1.0000 h	0.00E+00	0.00E+00	0.00E+00	0.00E+00	0.00E+00	0.00E+00	3.57E-06	3.18E-06	2.26E-05	2.01E-05	0.00E+00	0.00E+00
1.5000 h	0.00E+00	0.00E+00	0.00E+00	0.00E+00	0.00E+00	0.00E+00	8.36E-07	7.44E-07	5.29E-06	4.71E-06	0.00E+00	0.00E+00
2.0000 h	0.00E+00	0.00E+00	0.00E+00	0.00E+00	0.00E+00	0.00E+00	2.94E-07	4.93E-07	1.86E-06	3.12E-06	0.00E+00	0.00E+00
4.0000 h	0.00E+00	0.00E+00	0.00E+00	0.00E+00	0.00E+00	0.00E+00	2.27E-07	3.75E-08	1.44E-06	2.37E-07	0.00E+00	0.00E+00
8.0000 h	0.00E+00	0.00E+00	0.00E+00	0.00E+00	0.00E+00	0.00E+00	1.30E-08	8.10E-11	8.22E-08	5.12E-10	0.00E+00	0.00E+00
8.5000 h	0.00E+00	0.00E+00	0.00E+00	0.00E+00	0.00E+00	0.00E+00	5.65E-12	6.27E-14	3.57E-11	3.97E-13	0.00E+00	0.00E+00
24.0000 h	0.00E+00	0.00E+00	0.00E+00	0.00E+00	0.00E+00	0.00E+00	2.18E-14	2.53E-33	1.38E-13	1.60E-32	0.00E+00	0.00E+00
96.0000 h	0.00E+00	0.00E+00	0.00E+00	0.00E+00	0.00E+00	0.00E+00	5.28E-34	0.00E+00	3.34E-33	0.00E+00	0.00E+00	0.00E+00
720.0000 h	0.00E+00	0.00E+00	0.00E+00	0.00E+00	0.00E+00	0.00E+00	0.00E+00	0.00E+00	0.00E+00	0.00E+00	0.00E+00	0.00E+00
TOTALS	0.00E+00		0.00E+00		0.00E+00		9.13E-06		5.77E-05		0.00E+00	
Xe-135												
0.5000 h	0.00E+00	0.00E+00	0.00E+00	0.00E+00	0.00E+00	0.00E+00	1.91E-05	7.47E-05	6.18E-04	2.42E-03	0.00E+00	0.00E+00
1.0000 h	0.00E+00	0.00E+00	0.00E+00	0.00E+00	0.00E+00	0.00E+00	3.49E-05	6.51E-05	1.13E-03	2.11E-03	0.00E+00	0.00E+00
1.5000 h	0.00E+00	0.00E+00	0.00E+00	0.00E+00	0.00E+00	0.00E+00	3.04E-05	5.69E-05	9.87E-04	1.84E-03	0.00E+00	0.00E+00
2.0000 h	0.00E+00	0.00E+00	0.00E+00	0.00E+00	0.00E+00	0.00E+00	4.98E-05	1.40E-04	1.61E-03	4.54E-03	0.00E+00	0.00E+00
4.0000 h	0.00E+00	0.00E+00	0.00E+00	0.00E+00	0.00E+00	0.00E+00	5.01E-04	3.40E-04	1.63E-02	1.10E-02	0.00E+00	0.00E+00
8.0000 h	0.00E+00	0.00E+00	0.00E+00	0.00E+00	0.00E+00	0.00E+00	1.55E-03	4.18E-04	5.02E-02	1.36E-02	0.00E+00	0.00E+00
8.5000 h	0.00E+00	0.00E+00	0.00E+00	0.00E+00	0.00E+00	0.00E+00	3.57E-05	1.21E-06	1.16E-03	3.92E-05	0.00E+00	0.00E+00
24.0000 h	0.00E+00	0.00E+00	0.00E+00	0.00E+00	0.00E+00	0.00E+00	4.74E-06	2.53E-08	1.54E-04	8.20E-07	0.00E+00	0.00E+00
96.0000 h	0.00E+00	0.00E+00	0.00E+00	0.00E+00	0.00E+00	0.00E+00	6.08E-08	3.99E-16	1.97E-06	1.29E-14	0.00E+00	0.00E+00
720.0000 h	0.00E+00	0.00E+00	0.00E+00	0.00E+00	0.00E+00	0.00E+00	6.40E-16	0.00E+00	2.08E-14	0.00E+00	0.00E+00	0.00E+00
TOTALS	0.00E+00		0.00E+00		0.00E+00		2.23E-03		7.22E-02		0.00E+00	
Xe-137												
0.5000 h	0.00E+00	0.00E+00	0.00E+00	0.00E+00	0.00E+00	0.00E+00	4.25E-08	1.03E-07	1.28E-05	3.12E-05	0.00E+00	0.00E+00
1.0000 h	0.00E+00	0.00E+00	0.00E+00	0.00E+00	0.00E+00	0.00E+00	9.28E-09	4.11E-10	2.80E-06	1.24E-07	0.00E+00	0.00E+00
1.5000 h	0.00E+00	0.00E+00	0.00E+00	0.00E+00	0.00E+00	0.00E+00	3.69E-11	1.64E-12	1.11E-08	4.93E-10	0.00E+00	0.00E+00
2.0000 h	0.00E+00	0.00E+00	0.00E+00	0.00E+00	0.00E+00	0.00E+00	1.52E-13	1.85E-14	4.57E-11	5.56E-12	0.00E+00	0.00E+00
4.0000 h	0.00E+00	0.00E+00	0.00E+00	0.00E+00	0.00E+00	0.00E+00	1.69E-15	1.34E-17	5.09E-13	4.03E-15	0.00E+00	0.00E+00
8.0000 h	0.00E+00	0.00E+00	0.00E+00	0.00E+00	0.00E+00	0.00E+00	1.21E-18	2.47E-27	3.63E-16	7.44E-25	0.00E+00	0.00E+00
8.5000 h	0.00E+00	0.00E+00	0.00E+00	0.00E+00	0.00E+00	0.00E+00	1.10E-28	3.25E-32	3.31E-26	9.79E-30	0.00E+00	0.00E+00
24.0000 h	0.00E+00	0.00E+00	0.00E+00	0.00E+00	0.00E+00	0.00E+00	2.95E-33	0.00E+00	8.88E-31	0.00E+00	0.00E+00	0.00E+00
96.0000 h	0.00E+00	0.00E+00	0.00E+00	0.00E+00	0.00E+00	0.00E+00	0.00E+00	0.00E+00	0.00E+00	0.00E+00	0.00E+00	0.00E+00
720.0000 h	0.00E+00	0.00E+00	0.00E+00	0.00E+00	0.00E+00	0.00E+00	0.00E+00	0.00E+00	0.00E+00	0.00E+00	0.00E+00	0.00E+00
TOTALS	0.00E+00		0.00E+00		0.00E+00		5.19E-08		1.56E-05		0.00E+00	

TRAILS -- Transport of Radioactive Material in Linear Systems, v2.0
 FRP Case for dose 1 gpm [TC950835.DAT]

	E N V I R O N M E N T						C O N T R O L R O O M					
	External EDE		SKIN-DE		THY CDE-INHAL		External EDE		SKIN-DE		THY CDE-INHAL	
	DOSE mrem	DOSE RATE mrem/hr	DOSE mrem	DOSE RATE mrem/hr	DOSE mrem	DOSE RATE mrem/hr	DOSE mrem	DOSE RATE mrem/hr	DOSE mrem	DOSE RATE mrem/hr	DOSE mrem	DOSE RATE mrem/hr
Xe-138												
0.5000 h	0.00E+00	0.00E+00	0.00E+00	0.00E+00	0.00E+00	0.00E+00	7.00E-06	2.24E-05	1.04E-04	3.32E-04	0.00E+00	0.00E+00
1.0000 h	0.00E+00	0.00E+00	0.00E+00	0.00E+00	0.00E+00	0.00E+00	5.63E-06	4.66E-06	8.34E-05	6.90E-05	0.00E+00	0.00E+00
1.5000 h	0.00E+00	0.00E+00	0.00E+00	0.00E+00	0.00E+00	0.00E+00	1.17E-06	9.70E-07	1.74E-05	1.44E-05	0.00E+00	0.00E+00
2.0000 h	0.00E+00	0.00E+00	0.00E+00	0.00E+00	0.00E+00	0.00E+00	3.60E-07	5.71E-07	5.33E-06	8.46E-06	0.00E+00	0.00E+00
4.0000 h	0.00E+00	0.00E+00	0.00E+00	0.00E+00	0.00E+00	0.00E+00	2.38E-07	3.57E-08	3.52E-06	5.29E-07	0.00E+00	0.00E+00
8.0000 h	0.00E+00	0.00E+00	0.00E+00	0.00E+00	0.00E+00	0.00E+00	1.14E-08	4.85E-11	1.69E-07	7.17E-10	0.00E+00	0.00E+00
8.5000 h	0.00E+00	0.00E+00	0.00E+00	0.00E+00	0.00E+00	0.00E+00	3.33E-12	3.34E-14	4.52E-11	4.94E-13	0.00E+00	0.00E+00
24.0000 h	0.00E+00	0.00E+00	0.00E+00	0.00E+00	0.00E+00	0.00E+00	1.07E-14	0.00E+00	1.59E-13	0.00E+00	0.00E+00	0.00E+00
96.0000 h	0.00E+00	0.00E+00	0.00E+00	0.00E+00	0.00E+00	0.00E+00	6.72E-36	0.00E+00	9.95E-35	0.00E+00	0.00E+00	0.00E+00
720.0000 h	0.00E+00	0.00E+00	0.00E+00	0.00E+00	0.00E+00	0.00E+00	0.00E+00	0.00E+00	0.00E+00	0.00E+00	0.00E+00	0.00E+00
TOTALS	0.00E+00		0.00E+00		0.00E+00		1.44E-05		2.13E-04		0.00E+00	
I-131												
0.5000 h	0.00E+00	0.00E+00	0.00E+00	0.00E+00	0.00E+00	0.00E+00	1.43E-03	5.63E-03	1.50E-02	5.91E-02	1.76E+02	6.94E+02
1.0000 h	0.00E+00	0.00E+00	0.00E+00	0.00E+00	0.00E+00	0.00E+00	2.68E-03	5.09E-03	2.81E-02	5.34E-02	3.30E+02	6.27E+02
1.5000 h	0.00E+00	0.00E+00	0.00E+00	0.00E+00	0.00E+00	0.00E+00	2.42E-03	4.61E-03	2.54E-02	4.84E-02	2.98E+02	5.68E+02
2.0000 h	0.00E+00	0.00E+00	0.00E+00	0.00E+00	0.00E+00	0.00E+00	2.29E-03	4.57E-03	2.41E-02	4.80E-02	2.83E+02	5.63E+02
4.0000 h	0.00E+00	0.00E+00	0.00E+00	0.00E+00	0.00E+00	0.00E+00	8.99E-03	4.44E-03	9.44E-02	4.66E-02	1.11E+03	5.46E+02
8.0000 h	0.00E+00	0.00E+00	0.00E+00	0.00E+00	0.00E+00	0.00E+00	1.73E-02	4.26E-03	1.82E-01	4.48E-02	2.14E+03	5.25E+02
8.5000 h	0.00E+00	0.00E+00	0.00E+00	0.00E+00	0.00E+00	0.00E+00	3.66E-04	1.28E-05	3.84E-03	1.34E-04	4.51E+01	1.57E+00
24.0000 h	0.00E+00	0.00E+00	0.00E+00	0.00E+00	0.00E+00	0.00E+00	6.75E-05	8.22E-07	7.09E-04	8.63E-06	8.31E+00	1.01E-01
96.0000 h	0.00E+00	0.00E+00	0.00E+00	0.00E+00	0.00E+00	0.00E+00	2.79E-06	2.40E-12	2.92E-05	2.52E-11	3.43E-01	2.95E-07
720.0000 h	0.00E+00	0.00E+00	0.00E+00	0.00E+00	0.00E+00	0.00E+00	5.42E-12	0.00E+00	5.69E-11	0.00E+00	6.68E-07	0.00E+00
TOTALS	0.00E+00		0.00E+00		0.00E+00		3.56E-02		3.74E-01		4.38E+03	
I-132												
0.5000 h	0.00E+00	0.00E+00	0.00E+00	0.00E+00	0.00E+00	0.00E+00	2.76E-03	1.06E-02	1.62E-02	6.24E-02	3.24E-01	1.25E+00
1.0000 h	0.00E+00	0.00E+00	0.00E+00	0.00E+00	0.00E+00	0.00E+00	4.69E-03	8.26E-03	2.76E-02	4.86E-02	5.52E-01	9.72E-01
1.5000 h	0.00E+00	0.00E+00	0.00E+00	0.00E+00	0.00E+00	0.00E+00	3.66E-03	6.45E-03	2.15E-02	3.79E-02	4.30E-01	7.59E-01
2.0000 h	0.00E+00	0.00E+00	0.00E+00	0.00E+00	0.00E+00	0.00E+00	2.98E-03	5.50E-03	1.75E-02	3.24E-02	3.50E-01	6.48E-01
4.0000 h	0.00E+00	0.00E+00	0.00E+00	0.00E+00	0.00E+00	0.00E+00	2.98E-03	5.50E-03	1.75E-02	3.24E-02	3.50E-01	6.48E-01
8.0000 h	0.00E+00	0.00E+00	0.00E+00	0.00E+00	0.00E+00	0.00E+00	8.06E-03	3.00E-03	4.74E-02	1.77E-02	9.49E-01	3.53E-01
8.5000 h	0.00E+00	0.00E+00	0.00E+00	0.00E+00	0.00E+00	0.00E+00	6.62E-03	9.88E-04	3.90E-02	5.81E-03	7.80E-01	1.16E-01
24.0000 h	0.00E+00	0.00E+00	0.00E+00	0.00E+00	0.00E+00	0.00E+00	8.27E-05	2.55E-06	4.86E-04	1.50E-05	9.73E-03	3.00E-04
96.0000 h	0.00E+00	0.00E+00	0.00E+00	0.00E+00	0.00E+00	0.00E+00	5.37E-06	1.62E-09	3.16E-05	9.55E-09	6.32E-04	1.91E-07
720.0000 h	0.00E+00	0.00E+00	0.00E+00	0.00E+00	0.00E+00	0.00E+00	2.05E-09	2.32E-24	1.21E-08	1.36E-23	2.42E-07	2.73E-22
TOTALS	0.00E+00		0.00E+00		0.00E+00		2.88E-02		1.70E-01		3.40E+00	

TRAILS -- Transport of Radioactive Material in Linear Systems, v2.0
 FRP Case for dose 1 gpm [TC950835.DAT]

ENVIRONMENT							CONTROL ROOM						
External EDE		SKIN-DE		THY CDE-INHAL		External EDE		SKIN-DE		THY CDE-INHAL			
DOSE	DOSE RATE	DOSE	DOSE RATE	DOSE	DOSE RATE	DOSE	DOSE RATE	DOSE	DOSE RATE	DOSE	DOSE RATE		
mrem	mrem/hr	mrem	mrem/hr	mrem	mrem/hr	mrem	mrem/hr	mrem	mrem/hr	mrem	mrem/hr		
I-133													
0.5000 h	0.00E+00	0.00E+00	0.00E+00	0.00E+00	0.00E+00	0.00E+00	0.00E+00	3.55E-03	1.39E-02	6.55E-02	2.58E-01	4.53E+01	1.78E+02
1.0000 h	0.00E+00	0.00E+00	0.00E+00	0.00E+00	0.00E+00	0.00E+00	0.00E+00	6.58E-03	1.24E-02	1.22E-01	2.29E-01	8.41E+01	1.59E+02
1.5000 h	0.00E+00	0.00E+00	0.00E+00	0.00E+00	0.00E+00	0.00E+00	0.00E+00	5.86E-03	1.11E-02	1.08E-01	2.05E-01	7.50E+01	1.42E+02
2.0000 h	0.00E+00	0.00E+00	0.00E+00	0.00E+00	0.00E+00	0.00E+00	0.00E+00	5.47E-03	1.08E-02	1.01E-01	2.00E-01	6.99E+01	1.38E+02
4.0000 h	0.00E+00	0.00E+00	0.00E+00	0.00E+00	0.00E+00	0.00E+00	0.00E+00	2.06E-02	9.90E-03	3.81E-01	1.83E-01	2.64E+02	1.27E+02
8.0000 h	0.00E+00	0.00E+00	0.00E+00	0.00E+00	0.00E+00	0.00E+00	0.00E+00	3.63E-02	8.50E-03	6.71E-01	1.57E-01	4.64E+02	1.09E+02
8.5000 h	0.00E+00	0.00E+00	0.00E+00	0.00E+00	0.00E+00	0.00E+00	0.00E+00	7.28E-04	2.51E-05	1.34E-02	4.64E-04	9.30E+00	3.21E-01
24.0000 h	0.00E+00	0.00E+00	0.00E+00	0.00E+00	0.00E+00	0.00E+00	0.00E+00	1.16E-04	1.02E-06	2.15E-03	1.88E-05	1.49E+00	1.30E-02
96.0000 h	0.00E+00	0.00E+00	0.00E+00	0.00E+00	0.00E+00	0.00E+00	0.00E+00	2.95E-06	3.49E-13	5.46E-05	6.46E-12	3.78E-02	4.47E-09
720.0000 h	0.00E+00	0.00E+00	0.00E+00	0.00E+00	0.00E+00	0.00E+00	0.00E+00	6.76E-13	0.00E+00	1.25E-11	0.00E+00	8.64E-09	0.00E+00
TOTALS	0.00E+00		0.00E+00		0.00E+00		0.00E+00	7.92E-02		1.46E+00		1.01E+03	
I-134													
0.5000 h	0.00E+00	0.00E+00	0.00E+00	0.00E+00	0.00E+00	0.00E+00	0.00E+00	1.64E-03	6.06E-03	1.07E-02	3.96E-02	2.77E-02	1.03E-01
1.0000 h	0.00E+00	0.00E+00	0.00E+00	0.00E+00	0.00E+00	0.00E+00	0.00E+00	2.39E-03	3.69E-03	1.56E-02	2.42E-02	4.05E-02	6.26E-02
1.5000 h	0.00E+00	0.00E+00	0.00E+00	0.00E+00	0.00E+00	0.00E+00	0.00E+00	1.46E-03	2.26E-03	9.53E-03	1.48E-02	2.47E-02	3.82E-02
2.0000 h	0.00E+00	0.00E+00	0.00E+00	0.00E+00	0.00E+00	0.00E+00	0.00E+00	9.26E-04	1.51E-03	6.05E-03	9.87E-03	1.57E-02	2.56E-02
4.0000 h	0.00E+00	0.00E+00	0.00E+00	0.00E+00	0.00E+00	0.00E+00	0.00E+00	1.47E-03	3.35E-04	9.59E-03	2.19E-03	2.48E-02	5.68E-03
8.0000 h	0.00E+00	0.00E+00	0.00E+00	0.00E+00	0.00E+00	0.00E+00	0.00E+00	3.81E-04	2.55E-05	2.49E-03	1.66E-04	6.46E-03	4.31E-04
8.5000 h	0.00E+00	0.00E+00	0.00E+00	0.00E+00	0.00E+00	0.00E+00	0.00E+00	2.05E-06	5.14E-08	1.34E-05	3.36E-07	3.47E-05	8.71E-07
24.0000 h	0.00E+00	0.00E+00	0.00E+00	0.00E+00	0.00E+00	0.00E+00	0.00E+00	5.33E-08	1.67E-14	3.49E-07	1.09E-13	9.04E-07	2.82E-13
96.0000 h	0.00E+00	0.00E+00	0.00E+00	0.00E+00	0.00E+00	0.00E+00	0.00E+00	1.04E-14	0.00E+00	6.78E-14	0.00E+00	1.76E-13	0.00E+00
720.0000 h	0.00E+00	0.00E+00	0.00E+00	0.00E+00	0.00E+00	0.00E+00	0.00E+00	0.00E+00	0.00E+00	0.00E+00	0.00E+00	0.00E+00	0.00E+00
TOTALS	0.00E+00		0.00E+00		0.00E+00		0.00E+00	8.26E-03		5.40E-02		1.40E-01	
I-135													
0.5000 h	0.00E+00	0.00E+00	0.00E+00	0.00E+00	0.00E+00	0.00E+00	0.00E+00	5.76E-03	2.25E-02	3.47E-02	1.36E-01	4.71E+00	1.84E+01
1.0000 h	0.00E+00	0.00E+00	0.00E+00	0.00E+00	0.00E+00	0.00E+00	0.00E+00	1.04E-02	1.93E-02	6.29E-02	1.16E-01	8.53E+00	1.58E+01
1.5000 h	0.00E+00	0.00E+00	0.00E+00	0.00E+00	0.00E+00	0.00E+00	0.00E+00	8.98E-03	1.67E-02	5.41E-02	1.00E-01	7.34E+00	1.36E+01
2.0000 h	0.00E+00	0.00E+00	0.00E+00	0.00E+00	0.00E+00	0.00E+00	0.00E+00	8.08E-03	1.57E-02	4.86E-02	9.45E-02	6.60E+00	1.28E+01
4.0000 h	0.00E+00	0.00E+00	0.00E+00	0.00E+00	0.00E+00	0.00E+00	0.00E+00	2.78E-02	1.25E-02	1.67E-01	7.52E-02	2.27E+01	1.02E+01
8.0000 h	0.00E+00	0.00E+00	0.00E+00	0.00E+00	0.00E+00	0.00E+00	0.00E+00	3.95E-02	8.22E-03	2.38E-01	4.95E-02	3.23E+01	6.72E+00
8.5000 h	0.00E+00	0.00E+00	0.00E+00	0.00E+00	0.00E+00	0.00E+00	0.00E+00	6.99E-04	2.34E-05	4.21E-03	1.41E-04	5.71E-01	1.91E-02
24.0000 h	0.00E+00	0.00E+00	0.00E+00	0.00E+00	0.00E+00	0.00E+00	0.00E+00	8.29E-05	3.13E-07	4.99E-04	1.89E-06	6.78E-02	2.56E-04
96.0000 h	0.00E+00	0.00E+00	0.00E+00	0.00E+00	0.00E+00	0.00E+00	0.00E+00	6.75E-07	6.23E-16	4.07E-06	3.75E-15	5.52E-04	5.09E-13
720.0000 h	0.00E+00	0.00E+00	0.00E+00	0.00E+00	0.00E+00	0.00E+00	0.00E+00	8.95E-16	0.00E+00	5.39E-15	0.00E+00	7.32E-13	0.00E+00
TOTALS	0.00E+00		0.00E+00		0.00E+00		0.00E+00	1.01E-01		6.10E-01		8.28E+01	

	E N V I R O N M E N T						C O N T R O L R O O M					
	External EDE		SKIN-DE		THY CDE-INHAL		External EDE		SKIN-DE		THY CDE-INHAL	
	DOSE mrem	DOSE RATE mrem/hr	DOSE mrem	DOSE RATE mrem/hr	DOSE mrem	DOSE RATE mrem/hr	DOSE mrem	DOSE RATE mrem/hr	DOSE mrem	DOSE RATE mrem/hr	DOSE mrem	DOSE RATE mrem/hr
ALL NUCLIDES												
0.5000 h	0.00E+00	0.00E+00	0.00E+00	0.00E+00	0.00E+00	0.00E+00	1.54E-02	5.97E-02	1.48E-01	5.76E-01	2.26E+02	8.92E+02
1.0000 h	0.00E+00	0.00E+00	0.00E+00	0.00E+00	0.00E+00	0.00E+00	2.72E-02	4.95E-02	2.66E-01	4.90E-01	4.23E+02	8.02E+02
1.5000 h	0.00E+00	0.00E+00	0.00E+00	0.00E+00	0.00E+00	0.00E+00	2.27E-02	4.16E-02	2.27E-01	4.21E-01	3.81E+02	7.24E+02
2.0000 h	0.00E+00	0.00E+00	0.00E+00	0.00E+00	0.00E+00	0.00E+00	2.02E-02	3.95E-02	2.11E-01	4.22E-01	3.60E+02	7.14E+02
4.0000 h	0.00E+00	0.00E+00	0.00E+00	0.00E+00	0.00E+00	0.00E+00	7.12E-02	3.29E-02	8.33E-01	4.15E-01	1.40E+03	6.83E+02
8.0000 h	0.00E+00	0.00E+00	0.00E+00	0.00E+00	0.00E+00	0.00E+00	1.10E-01	2.45E-02	1.58E+00	3.86E-01	2.63E+03	6.41E+02
8.5000 h	0.00E+00	0.00E+00	0.00E+00	0.00E+00	0.00E+00	0.00E+00	2.09E-03	7.10E-05	3.30E-02	1.13E-03	5.49E+01	1.91E+00
24.0000 h	0.00E+00	0.00E+00	0.00E+00	0.00E+00	0.00E+00	0.00E+00	2.99E-04	2.36E-06	5.28E-03	5.08E-05	9.87E+00	1.14E-01
96.0000 h	0.00E+00	0.00E+00	0.00E+00	0.00E+00	0.00E+00	0.00E+00	7.06E-06	3.18E-12	1.60E-04	9.83E-11	3.81E-01	3.00E-07
720.0000 h	0.00E+00	0.00E+00	0.00E+00	0.00E+00	0.00E+00	0.00E+00	7.05E-12	0.00E+00	2.22E-10	0.00E+00	6.76E-07	0.00E+00
TOTALS	0.00E+00		0.00E+00		0.00E+00		2.70E-01		3.30E+00		5.48E+03	

TRAILS -- Transport of Radioactive Material in Linear Systems, v2.0
 FRP Case for dose 2 gpm [TC950836.DAT]

	COMP: not used	COMP: faulted S/G	COMP: Control Room
	VOLUME: 1.730E+05 Cu.Ft.		
INITIAL:	0.000E+00 Kr-83m	2.000E+07 Kr-83m uCi	0.000E+00 Kr-83m
	0.000E+00 Kr-85m	9.750E+07 Kr-85m	0.000E+00 Kr-85m
	0.000E+00 Kr-85	5.150E+08 Kr-85	0.000E+00 Kr-85
	0.000E+00 Kr-87	5.580E+07 Kr-87	0.000E+00 Kr-87
	0.000E+00 Kr-88	1.490E+08 Kr-88	0.000E+00 Kr-88
	0.000E+00 Kr-89	4.690E+06 Kr-89	0.000E+00 Kr-89
	0.000E+00 Xe-131m	5.010E+06 Xe-131m	0.000E+00 Xe-131m
	0.000E+00 Xe-133m	1.430E+08 Xe-133m	0.000E+00 Xe-133m
	0.000E+00 Xe-133	1.220E+09 Xe-133	0.000E+00 Xe-133
	0.000E+00 Xe-135m	5.060E+07 Xe-135m	0.000E+00 Xe-135m
	0.000E+00 Xe-135	1.500E+08 Xe-135	0.000E+00 Xe-135
	0.000E+00 Xe-137	7.590E+06 Xe-137	0.000E+00 Xe-137
	0.000E+00 Xe-138	3.130E+07 Xe-138	0.000E+00 Xe-138
	0.000E+00 I-131	7.160E+09 I-131	0.000E+00 I-131
	0.000E+00 I-132	2.500E+09 I-132	0.000E+00 I-132
	0.000E+00 I-133	1.120E+10 I-133	0.000E+00 I-133
	0.000E+00 I-134	1.560E+09 I-134	0.000E+00 I-134
	0.000E+00 I-135	6.890E+09 I-135	0.000E+00 I-135
ACT MULT (to uCi):	1.000E+00	1.000E+00	1.000E+00

TRAILS -- Transport of Radioactive Material in Linear Systems, v2.0
 FRP Case for dose 2 gpm [TC950836.DAT]

REMOVAL:	0.000E+00 1/sec	7.132E-07 1/sec	1.000E+01 cfm
NUC Grp 1 REL FR:	0.000E+00	0.000E+00	INTAKE REDUCT: 0.000E+00
NUC Grp 2 REL FR:	0.000E+00	0.000E+00	INTAKE REDUCT: 9.360E-01
NUC Grp 3 REL FR:	0.000E+00	0.000E+00	INTAKE REDUCT: 0.000E+00

MULTIPLIERS====>

STEP	TIME	XPR	XREM	XRF	XPR	XREM	XRF	XPR	XREM	XRF
1	1.800E+03	0.000E+00	0.000E+00	0.000E+00	0.000E+00	1.00	0.000E+00	50.0	50.0	0.000E+00
2	3.600E+03	0.000E+00	0.000E+00	0.000E+00	0.000E+00	1.00	0.000E+00	1.00	70.0	0.000E+00
3	5.400E+03	0.000E+00	0.000E+00	0.000E+00	0.000E+00	1.00	0.000E+00	1.00	70.0	0.000E+00
4	7.200E+03	0.000E+00	0.000E+00	0.000E+00	0.000E+00	1.00	0.000E+00	70.0	70.0	1.00
5	1.440E+04	0.000E+00	0.000E+00	0.000E+00	0.000E+00	1.00	0.000E+00	70.0	70.0	1.00
6	2.880E+04	0.000E+00	0.000E+00	0.000E+00	0.000E+00	1.00	0.000E+00	70.0	70.0	1.00
7	3.060E+04	0.000E+00	0.000E+00	0.000E+00	0.000E+00	0.000E+00	0.000E+00	3.350E+03	3.350E+03	0.000E+00
8	8.640E+04	0.000E+00	0.000E+00	0.000E+00	0.000E+00	0.000E+00	0.000E+00	50.0	50.0	0.000E+00
9	3.456E+05	0.000E+00	0.000E+00	0.000E+00	0.000E+00	0.000E+00	0.000E+00	50.0	50.0	0.000E+00
10	2.592E+06	0.000E+00	0.000E+00	0.000E+00	0.000E+00	0.000E+00	0.000E+00	50.0	50.0	0.000E+00

----- CONTROL ROOM -----
 X/Q Breathing Occupancy
 s/M3 M3/s
 1.000E-03 3.470E-04 1.000E+00

----- ENVIRONMENT -----
 X/Q Breathing
 s/M3 M3/s
 0.000E+00 3.470E-04

MULTIPLIERS====>

STEP	TIME, s	X/Q	Breathing	Occupancy	X/Q	Breathing
		s/M3	M3/s		s/M3	M3/s
1	1.800E+03	2.43	1.00	1.00	0.000E+00	1.00
2	3.600E+03	2.43	1.00	1.00	0.000E+00	1.00
3	5.400E+03	2.43	1.00	1.00	0.000E+00	1.00
4	7.200E+03	2.43	1.00	1.00	0.000E+00	1.00
5	1.440E+04	2.43	1.00	1.00	0.000E+00	1.00
6	2.880E+04	2.43	1.00	1.00	0.000E+00	1.00
7	3.060E+04	1.22	1.00	1.00	0.000E+00	1.00
8	8.640E+04	1.22	1.00	1.00	0.000E+00	1.00
9	3.456E+05	0.890	1.00	0.600	0.000E+00	1.00
10	2.592E+06	0.626	1.00	0.400	0.000E+00	1.00

TRAILS -- Transport of Radioactive Material in Linear Systems, v2.0
 FRP Case for dose 2 gpm [TC950836.DAT]

	----- ENVIRONMENT -----						----- CONTROL ROOM -----					
	External EDE		SKIN-DE		THY CDE-INHAL		External EDE		SKIN-DE		THY CDE-INHAL	
	DOSE	DOSE RATE	DOSE	DOSE RATE	DOSE	DOSE RATE	DOSE	DOSE RATE	DOSE	DOSE RATE	DOSE	DOSE RATE
	mrem	mrem/hr	mrem	mrem/hr	mrem	mrem/hr	mrem	mrem/hr	mrem	mrem/hr	mrem	mrem/hr
I-135												
TOTALS	0.00E+00		0.00E+00		0.00E+00		2.02E-01		1.22E+00		1.65E+02	

ALL NUCLIDES

0.5000 h	0.00E+00	0.00E+00	0.00E+00	0.00E+00	0.00E+00	0.00E+00	3.07E-02	1.19E-01	2.95E-01	1.15E+00	4.53E+02	1.78E+03
1.0000 h	0.00E+00	0.00E+00	0.00E+00	0.00E+00	0.00E+00	0.00E+00	5.44E-02	9.90E-02	5.31E-01	9.80E-01	8.46E+02	1.60E+03
1.5000 h	0.00E+00	0.00E+00	0.00E+00	0.00E+00	0.00E+00	0.00E+00	4.54E-02	8.33E-02	4.54E-01	8.42E-01	7.62E+02	1.45E+03
2.0000 h	0.00E+00	0.00E+00	0.00E+00	0.00E+00	0.00E+00	0.00E+00	4.05E-02	7.89E-02	4.21E-01	8.43E-01	7.19E+02	1.43E+03
4.0000 h	0.00E+00	0.00E+00	0.00E+00	0.00E+00	0.00E+00	0.00E+00	1.42E-01	6.56E-02	1.66E+00	8.29E-01	2.79E+03	1.36E+03
8.0000 h	0.00E+00	0.00E+00	0.00E+00	0.00E+00	0.00E+00	0.00E+00	2.20E-01	4.88E-02	3.15E+00	7.67E-01	5.25E+03	1.27E+03
8.5000 h	0.00E+00	0.00E+00	0.00E+00	0.00E+00	0.00E+00	0.00E+00	4.16E-03	1.41E-04	6.56E-02	2.25E-03	1.09E+02	3.80E+00
24.0000 h	0.00E+00	0.00E+00	0.00E+00	0.00E+00	0.00E+00	0.00E+00	5.95E-04	4.69E-06	1.05E-02	1.01E-04	1.96E+01	2.28E-01
96.0000 h	0.00E+00	0.00E+00	0.00E+00	0.00E+00	0.00E+00	0.00E+00	1.40E-05	6.32E-12	3.18E-04	1.95E-10	7.59E-01	5.96E-07
720.0000 h	0.00E+00	0.00E+00	0.00E+00	0.00E+00	0.00E+00	0.00E+00	1.40E-11	0.00E+00	4.41E-10	0.00E+00	1.35E-06	0.00E+00
TOTALS	0.00E+00		0.00E+00		0.00E+00		5.38E-01		6.59E+00		1.09E+04	

TRAILS -- Transport of Radioactive Material in Linear Systems, v2.0

FRP Case for dose 4 gpm [TC950837.DAT]

	COMP: not used	COMP: faulted S/G	COMP: Control Room
			VOLUME: 1.730E+05 Cu.Ft.
INITIAL:	0.000E+00 Kr-83m	2.000E+07 Kr-83m uCi	0.000E+00 Kr-83m
	0.000E+00 Kr-85m	9.750E+07 Kr-85m	0.000E+00 Kr-85m
	0.000E+00 Kr-85	5.150E+08 Kr-85	0.000E+00 Kr-85
	0.000E+00 Kr-87	5.580E+07 Kr-87	0.000E+00 Kr-87
	0.000E+00 Kr-88	1.490E+08 Kr-88	0.000E+00 Kr-88
	0.000E+00 Kr-89	4.690E+06 Kr-89	0.000E+00 Kr-89
	0.000E+00 Xe-131m	5.010E+06 Xe-131m	0.000E+00 Xe-131m
	0.000E+00 Xe-133m	1.430E+08 Xe-133m	0.000E+00 Xe-133m
	0.000E+00 Xe-133	1.220E+09 Xe-133	0.000E+00 Xe-133
	0.000E+00 Xe-135m	5.060E+07 Xe-135m	0.000E+00 Xe-135m
	0.000E+00 Xe-135	1.500E+08 Xe-135	0.000E+00 Xe-135
	0.000E+00 Xe-137	7.590E+06 Xe-137	0.000E+00 Xe-137
	0.000E+00 Xe-138	3.130E+07 Xe-138	0.000E+00 Xe-138
	0.000E+00 I-131	7.160E+09 I-131	0.000E+00 I-131
	0.000E+00 I-132	2.500E+09 I-132	0.000E+00 I-132
	0.000E+00 I-133	1.120E+10 I-133	0.000E+00 I-133
	0.000E+00 I-134	1.560E+09 I-134	0.000E+00 I-134
	0.000E+00 I-135	6.890E+09 I-135	0.000E+00 I-135
ACT MULT (to uCi):	1.000E+00	1.000E+00	1.000E+00

TRAILS -- Transport of Radioactive Material in Linear Systems, v2.0

FRP Case for dose 4 gpm [TC950837.DAT]

REMOVAL:	0.000E+00 1/sec	1.426E-06 1/sec	1.000E+01 cfm
NUC Grp 1 REL FR:	0.000E+00	0.000E+00	INTAKE REDUCT: 0.000E+00
NUC Grp 2 REL FR:	0.000E+00	0.000E+00	INTAKE REDUCT: 9.360E-01
NUC Grp 3 REL FR:	0.000E+00	0.000E+00	INTAKE REDUCT: 0.000E+00

MULTIPLIERS====>

STEP	TIME	XPR	XREM	XRF	XPR	XREM	XRF	XPR	XREM	XRF
1	1.800E+03	0.000E+00	0.000E+00	0.000E+00	0.000E+00	1.00	0.000E+00	50.0	50.0	0.000E+00
2	3.600E+03	0.000E+00	0.000E+00	0.000E+00	0.000E+00	1.00	0.000E+00	1.00	70.0	0.000E+00
3	5.400E+03	0.000E+00	0.000E+00	0.000E+00	0.000E+00	1.00	0.000E+00	1.00	70.0	0.000E+00
4	7.200E+03	0.000E+00	0.000E+00	0.000E+00	0.000E+00	1.00	0.000E+00	70.0	70.0	1.00
5	1.440E+04	0.000E+00	0.000E+00	0.000E+00	0.000E+00	1.00	0.000E+00	70.0	70.0	1.00
6	2.880E+04	0.000E+00	0.000E+00	0.000E+00	0.000E+00	1.00	0.000E+00	70.0	70.0	1.00
7	3.060E+04	0.000E+00	0.000E+00	0.000E+00	0.000E+00	0.000E+00	0.000E+00	3.350E+03	3.350E+03	0.000E+00
8	8.640E+04	0.000E+00	0.000E+00	0.000E+00	0.000E+00	0.000E+00	0.000E+00	50.0	50.0	0.000E+00
9	3.456E+05	0.000E+00	0.000E+00	0.000E+00	0.000E+00	0.000E+00	0.000E+00	50.0	50.0	0.000E+00
10	2.592E+06	0.000E+00	0.000E+00	0.000E+00	0.000E+00	0.000E+00	0.000E+00	50.0	50.0	0.000E+00

----- CONTROL ROOM -----			----- ENVIRONMENT -----		
X/Q	Breathing	Occupancy	X/Q	Breathing	
s/M3	M3/s		s/M3	M3/s	
1.000E-03	3.470E-04	1.000E+00	0.000E+00	3.470E-04	

MULTIPLIERS====>

STEP	TIME, s					
1	1.800E+03	2.43	1.00	1.00	0.000E+00	1.00
2	3.600E+03	2.43	1.00	1.00	0.000E+00	1.00
3	5.400E+03	2.43	1.00	1.00	0.000E+00	1.00
4	7.200E+03	2.43	1.00	1.00	0.000E+00	1.00
5	1.440E+04	2.43	1.00	1.00	0.000E+00	1.00
6	2.880E+04	2.43	1.00	1.00	0.000E+00	1.00
7	3.060E+04	1.22	1.00	1.00	0.000E+00	1.00
8	8.640E+04	1.22	1.00	1.00	0.000E+00	1.00
9	3.456E+05	0.890	1.00	0.600	0.000E+00	1.00
10	2.592E+06	0.626	1.00	0.400	0.000E+00	1.00

TRAILS -- Transport of Radioactive Material in Linear Systems, v2.0
FRP Case for dose 4 gpm [TC950837.DAT]

	----- ENVIRONMENT -----						----- CONTROL ROOM -----					
	External EDE		SKIN-DE		THY CDE-INHAL		External EDE		SKIN-DE		THY CDE-INHAL	
	DOSE	DOSE RATE	DOSE	DOSE RATE	DOSE	DOSE RATE	DOSE	DOSE RATE	DOSE	DOSE RATE	DOSE	DOSE RATE
I-135	mrem	mrem/hr	mrem	mrem/hr	mrem	mrem/hr	mrem	mrem/hr	mrem	mrem/hr	mrem	mrem/hr
TOTALS	0.00E+00		0.00E+00		0.00E+00		4.03E-01		2.43E+00		3.29E+02	

ALL NUCLIDES

0.5000 h	0.00E+00	0.00E+00	0.00E+00	0.00E+00	0.00E+00	0.00E+00	6.14E-02	2.39E-01	5.90E-01	2.30E+00	9.05E+02	3.56E+03
1.0000 h	0.00E+00	0.00E+00	0.00E+00	0.00E+00	0.00E+00	0.00E+00	1.09E-01	1.98E-01	1.06E+00	1.96E+00	1.69E+03	3.21E+03
1.5000 h	0.00E+00	0.00E+00	0.00E+00	0.00E+00	0.00E+00	0.00E+00	9.08E-02	1.66E-01	9.08E-01	1.68E+00	1.52E+03	2.89E+03
2.0000 h	0.00E+00	0.00E+00	0.00E+00	0.00E+00	0.00E+00	0.00E+00	8.09E-02	1.58E-01	8.41E-01	1.68E+00	1.44E+03	2.85E+03
4.0000 h	0.00E+00	0.00E+00	0.00E+00	0.00E+00	0.00E+00	0.00E+00	2.84E-01	1.31E-01	3.32E+00	1.65E+00	5.56E+03	2.72E+03
8.0000 h	0.00E+00	0.00E+00	0.00E+00	0.00E+00	0.00E+00	0.00E+00	4.37E-01	9.66E-02	6.24E+00	1.52E+00	1.04E+04	2.52E+03
8.5000 h	0.00E+00	0.00E+00	0.00E+00	0.00E+00	0.00E+00	0.00E+00	8.24E-03	2.79E-04	1.30E-01	4.46E-03	2.16E+02	7.53E+00
24.0000 h	0.00E+00	0.00E+00	0.00E+00	0.00E+00	0.00E+00	0.00E+00	1.18E-03	9.27E-06	2.08E-02	2.00E-04	3.88E+01	4.50E-01
96.0000 h	0.00E+00	0.00E+00	0.00E+00	0.00E+00	0.00E+00	0.00E+00	2.78E-05	1.25E-11	6.29E-04	3.86E-10	1.50E+00	1.18E-06
720.0000 h	0.00E+00	0.00E+00	0.00E+00	0.00E+00	0.00E+00	0.00E+00	2.77E-11	0.00E+00	8.70E-10	0.00E+00	2.66E-06	0.00E+00
TOTALS	0.00E+00		0.00E+00		0.00E+00		1.07E+00		1.31E+01		2.18E+04	

TRAILS -- Transport of Radioactive Material in Linear Systems, v2.0
 FRP Case for dose 5 gpm [TC950838.DAT]

COMP: not used

COMP: faulted S/G

COMP: Control Room
 VOLUME: 1.730E+05 Cu.Ft.

INITIAL:	COMP: not used	COMP: faulted S/G	COMP: Control Room
0.000E+00 Kr-83m	2.000E+07 Kr-83m uCi	0.000E+00 Kr-83m	0.000E+00 Kr-83m
0.000E+00 Kr-85m	9.750E+07 Kr-85m	0.000E+00 Kr-85m	0.000E+00 Kr-85m
0.000E+00 Kr-85	5.150E+08 Kr-85	0.000E+00 Kr-85	0.000E+00 Kr-85
0.000E+00 Kr-87	5.580E+07 Kr-87	0.000E+00 Kr-87	0.000E+00 Kr-87
0.000E+00 Kr-88	1.490E+08 Kr-88	0.000E+00 Kr-88	0.000E+00 Kr-88
0.000E+00 Kr-89	4.690E+06 Kr-89	0.000E+00 Kr-89	0.000E+00 Kr-89
0.000E+00 Xe-131m	5.010E+06 Xe-131m	0.000E+00 Xe-131m	0.000E+00 Xe-131m
0.000E+00 Xe-133m	1.430E+08 Xe-133m	0.000E+00 Xe-133m	0.000E+00 Xe-133m
0.000E+00 Xe-133	1.220E+09 Xe-133	0.000E+00 Xe-133	0.000E+00 Xe-133
0.000E+00 Xe-135m	5.060E+07 Xe-135m	0.000E+00 Xe-135m	0.000E+00 Xe-135m
0.000E+00 Xe-135	1.500E+08 Xe-135	0.000E+00 Xe-135	0.000E+00 Xe-135
0.000E+00 Xe-137	7.590E+06 Xe-137	0.000E+00 Xe-137	0.000E+00 Xe-137
0.000E+00 Xe-138	3.130E+07 Xe-138	0.000E+00 Xe-138	0.000E+00 Xe-138
0.000E+00 I-131	7.160E+09 I-131	0.000E+00 I-131	0.000E+00 I-131
0.000E+00 I-132	2.500E+09 I-132	0.000E+00 I-132	0.000E+00 I-132
0.000E+00 I-133	1.120E+10 I-133	0.000E+00 I-133	0.000E+00 I-133
0.000E+00 I-134	1.560E+09 I-134	0.000E+00 I-134	0.000E+00 I-134
0.000E+00 I-135	6.890E+09 I-135	0.000E+00 I-135	0.000E+00 I-135
ACT MULT (to uCi):	1.000E+00	1.000E+00	1.000E+00

TRAILS -- Transport of Radioactive Material in Linear Systems, v2.0
 FRP Case for dose 5 gpm [TC950838.DAT]

REMOVAL:	0.000E+00 1/sec	1.783E-06 1/sec	1.000E+01 cfm
NUC Grp 1 REL FR:	0.000E+00	0.000E+00	INTAKE REDUCT: 0.000E+00
NUC Grp 2 REL FR:	0.000E+00	0.000E+00	INTAKE REDUCT: 9.360E-01
NUC Grp 3 REL FR:	0.000E+00	0.000E+00	INTAKE REDUCT: 0.000E+00

MULTIPLIERS====>

STEP	TIME	XPR	XREM	XRF	XPR	XREM	XRF	XPR	XREM	XRF
1	1.800E+03	0.000E+00	0.000E+00	0.000E+00	0.000E+00	1.00	0.000E+00	50.0	50.0	0.000E+00
2	3.600E+03	0.000E+00	0.000E+00	0.000E+00	0.000E+00	1.00	0.000E+00	1.00	70.0	0.000E+00
3	5.400E+03	0.000E+00	0.000E+00	0.000E+00	0.000E+00	1.00	0.000E+00	1.00	70.0	0.000E+00
4	7.200E+03	0.000E+00	0.000E+00	0.000E+00	0.000E+00	1.00	0.000E+00	70.0	70.0	1.00
5	1.440E+04	0.000E+00	0.000E+00	0.000E+00	0.000E+00	1.00	0.000E+00	70.0	70.0	1.00
6	2.880E+04	0.000E+00	0.000E+00	0.000E+00	0.000E+00	1.00	0.000E+00	70.0	70.0	1.00
7	3.060E+04	0.000E+00	0.000E+00	0.000E+00	0.000E+00	0.000E+00	0.000E+00	3.350E+03	3.350E+03	0.000E+00
8	8.640E+04	0.000E+00	0.000E+00	0.000E+00	0.000E+00	0.000E+00	0.000E+00	50.0	50.0	0.000E+00
9	3.456E+05	0.000E+00	0.000E+00	0.000E+00	0.000E+00	0.000E+00	0.000E+00	50.0	50.0	0.000E+00
10	2.592E+06	0.000E+00	0.000E+00	0.000E+00	0.000E+00	0.000E+00	0.000E+00	50.0	50.0	0.000E+00

```

----- CONTROL ROOM -----
X/Q      Breathing Occupancy
s/M3     M3/s      1.000E+00
1.000E-03 3.470E-04 1.000E+00

----- ENVIRONMENT ----
X/Q      Breathing
s/M3     M3/s
0.000E+00 3.470E-04

```

MULTIPLIERS====>

STEP	TIME, s	X/Q s/M3	Breathing M3/s	Occupancy	X/Q s/M3	Breathing M3/s
1	1.800E+03	2.43	1.00	1.00	0.000E+00	1.00
2	3.600E+03	2.43	1.00	1.00	0.000E+00	1.00
3	5.400E+03	2.43	1.00	1.00	0.000E+00	1.00
4	7.200E+03	2.43	1.00	1.00	0.000E+00	1.00
5	1.440E+04	2.43	1.00	1.00	0.000E+00	1.00
6	2.880E+04	2.43	1.00	1.00	0.000E+00	1.00
7	3.060E+04	1.22	1.00	1.00	0.000E+00	1.00
8	8.640E+04	1.22	1.00	1.00	0.000E+00	1.00
9	3.456E+05	0.890	1.00	0.600	0.000E+00	1.00
10	2.592E+06	0.626	1.00	0.400	0.000E+00	1.00

TRAILS -- Transport of Radioactive Material in Linear Systems, v2.0
FRP Case for dose 5 gpm [TC950838.DAT]

```

----- ENVIRONMENT -----
External EDE      SKIN-DE      THY CDE-INHAL
DOSE      DOSE RATE      DOSE      DOSE RATE      DOSE      DOSE RATE
mrem      mrem/hr      mrem      mrem/hr      mrem      mrem/hr

----- CONTROL ROOM -----
External EDE      SKIN-DE      THY CDE-INHAL
DOSE      DOSE RATE      DOSE      DOSE RATE      DOSE      DOSE RATE
mrem      mrem/hr      mrem      mrem/hr      mrem      mrem/hr

I-135
TOTALS      0.00E+00      0.00E+00      0.00E+00      0.00E+00      5.03E-01      3.03E+00      4.11E+02

```

ALL NUCLIDES

Time	External EDE DOSE	External EDE DOSE RATE	SKIN-DE DOSE	SKIN-DE DOSE RATE	THY CDE-INHAL DOSE	THY CDE-INHAL DOSE RATE	External EDE DOSE	External EDE DOSE RATE	SKIN-DE DOSE	SKIN-DE DOSE RATE	THY CDE-INHAL DOSE	THY CDE-INHAL DOSE RATE
0.5000 h	0.00E+00	0.00E+00	0.00E+00	0.00E+00	0.00E+00	0.00E+00	7.68E-02	2.98E-01	7.37E-01	2.88E+00	1.13E+03	4.45E+03
1.0000 h	0.00E+00	0.00E+00	0.00E+00	0.00E+00	0.00E+00	0.00E+00	1.36E-01	2.47E-01	1.33E+00	2.45E+00	2.11E+03	4.01E+03
1.5000 h	0.00E+00	0.00E+00	0.00E+00	0.00E+00	0.00E+00	0.00E+00	1.13E-01	2.08E-01	1.13E+00	2.10E+00	1.90E+03	3.61E+03
2.0000 h	0.00E+00	0.00E+00	0.00E+00	0.00E+00	0.00E+00	0.00E+00	1.01E-01	1.97E-01	1.05E+00	2.10E+00	1.79E+03	3.56E+03
4.0000 h	0.00E+00	0.00E+00	0.00E+00	0.00E+00	0.00E+00	0.00E+00	3.54E-01	1.63E-01	4.14E+00	2.06E+00	6.94E+03	3.39E+03
8.0000 h	0.00E+00	0.00E+00	0.00E+00	0.00E+00	0.00E+00	0.00E+00	5.44E-01	1.20E-01	7.77E+00	1.88E+00	1.30E+04	3.14E+03
8.5000 h	0.00E+00	0.00E+00	0.00E+00	0.00E+00	0.00E+00	0.00E+00	1.02E-02	3.47E-04	1.61E-01	5.54E-03	2.69E+02	9.36E+00
24.0000 h	0.00E+00	0.00E+00	0.00E+00	0.00E+00	0.00E+00	0.00E+00	1.46E-03	1.15E-05	2.58E-02	2.48E-04	4.83E+01	5.60E-01
96.0000 h	0.00E+00	0.00E+00	0.00E+00	0.00E+00	0.00E+00	0.00E+00	3.45E-05	1.55E-11	7.82E-04	4.79E-10	1.87E+00	1.47E-06
720.0000 h	0.00E+00	0.00E+00	0.00E+00	0.00E+00	0.00E+00	0.00E+00	3.45E-11	0.00E+00	1.08E-09	0.00E+00	3.31E-06	0.00E+00
TOTALS	0.00E+00		0.00E+00		0.00E+00		1.34E+00		1.64E+01		2.72E+04	

INTENTIONALLY BLANK

107

Control Room Dose vs Leak Rate MSLB - Co-incident Spike

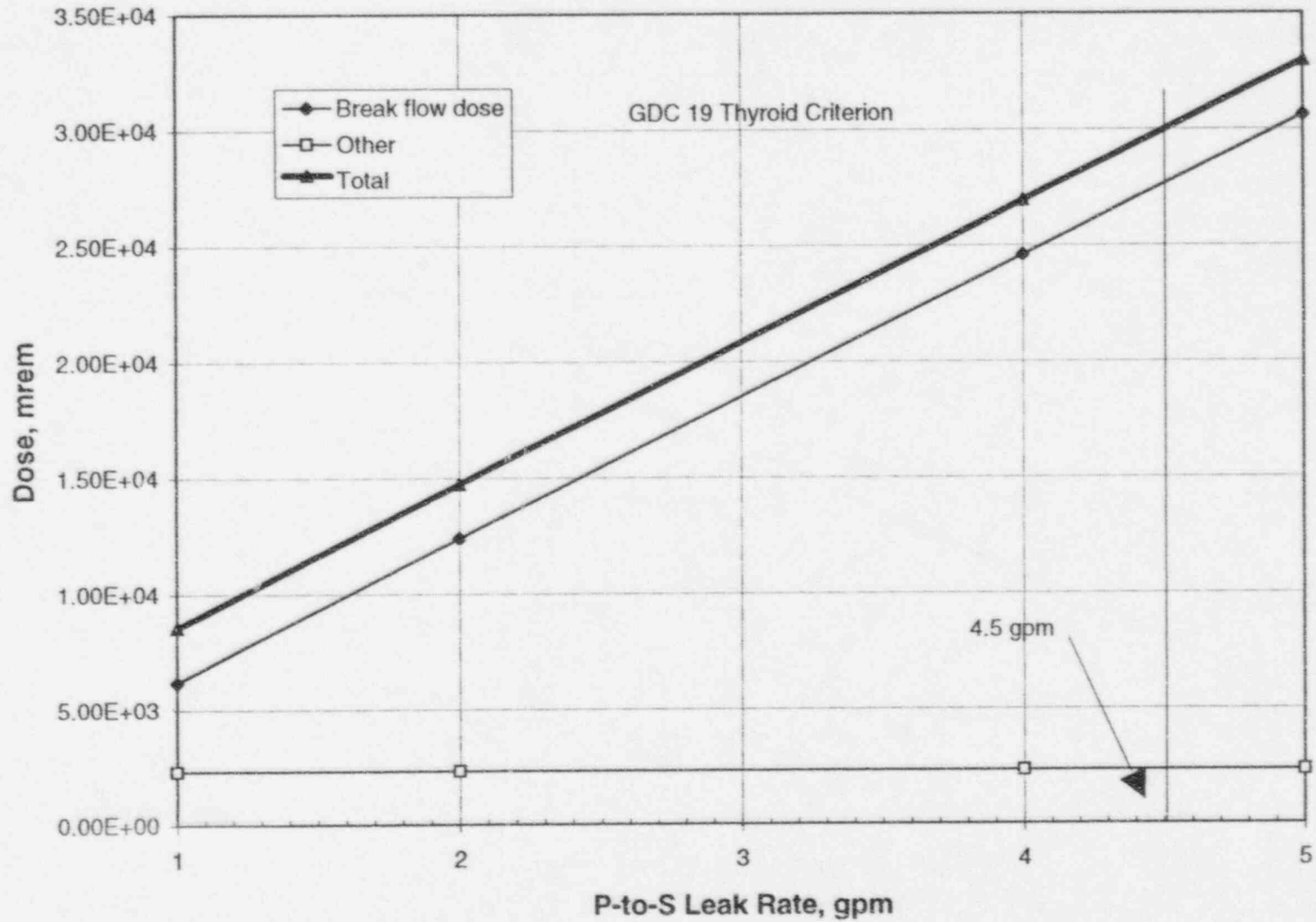

Control Room Dose vs Leak Rate MSLB - Pre-incident Spike

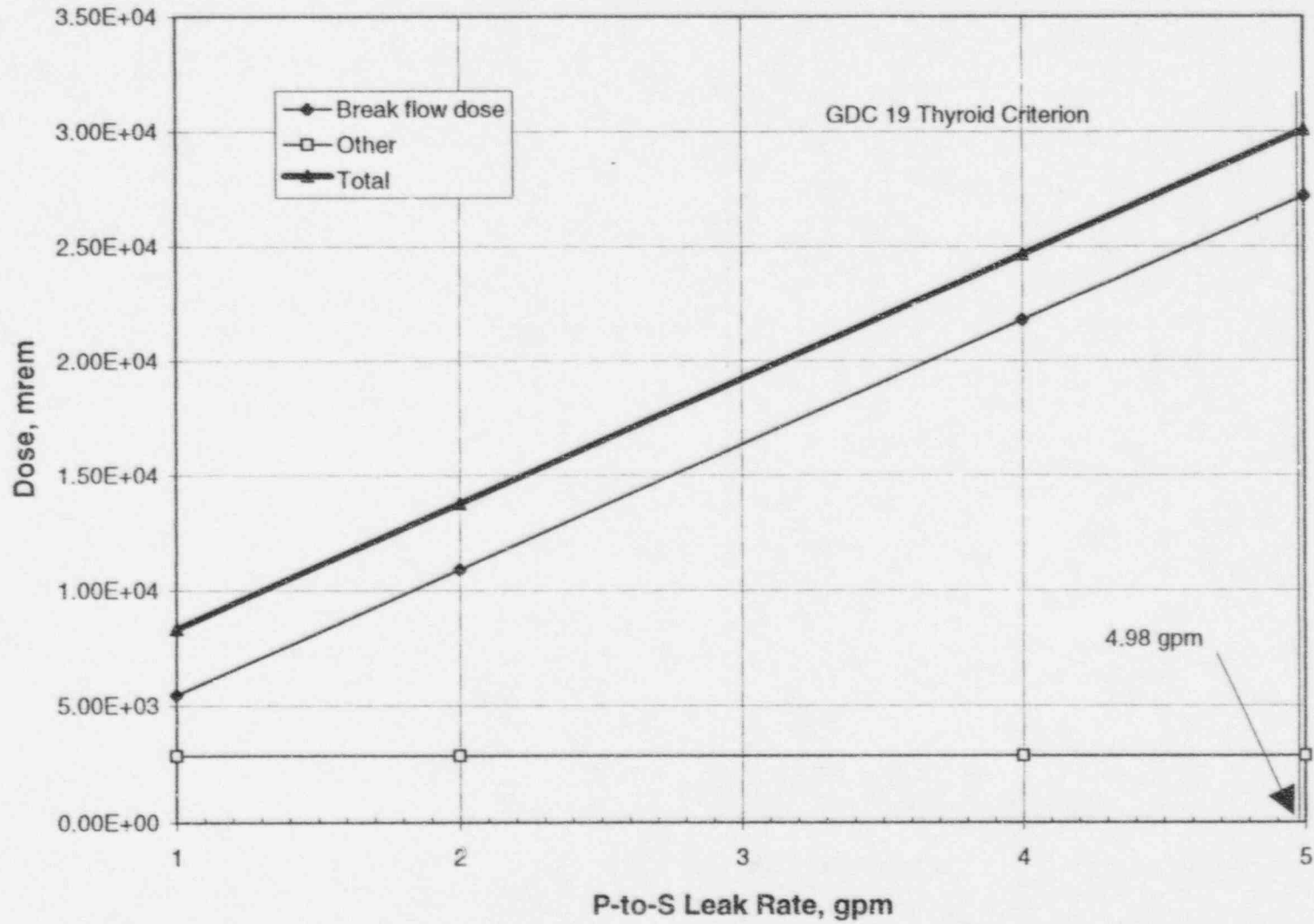

Note: This appendix was reviewed and approved as part of ERS-SFL-95-008 revision 0. This appendix is intended to standardize the modeling assumptions and to eliminate the need to re-review these input parameters and assumptions with each new application. If a specific deviation from the information herein is necessary to meet the needs of a particular analysis, it should be described and justified in the main text of the package.

Generic Control Room Modeling

1. General

This appendix describes the generic modeling of the Unit 1 / Unit 2 common control room. This modeling is essentially generic to all accidents. The values of the input parameters may vary from accident-to-accident and from case-to-case within an accident. Additionally, not all phases may be applicable to all cases. For example, radiation monitor initiated isolation might not occur, or may not be credited in the interest of simplifying the analysis (a conservative situation). The calculation package to which this appendix is attached will explain and justify any deviations. Figure 3 illustrates the generic modeling of the phases of alignment during an accident situation. Figure 4 is a representation of the CREBAPS actuation circuitry.

2. Control Room Ventilation System^{1,2,3,4}

Figures 1 and 2 illustrate the normal system alignment of the U1 and U2 control room ventilation systems. The systems in both sides of the control room operate independently, but are interlocked through the Control Room Emergency Breathing Air Pressurization System (CREBAPS). The following actuate CREBAPS:

- A Containment Isolation Signal, Phase B (CIB) at either unit.
- A high-high alarm on 1RM-RM-218A or B (Unit 1) or a high alarm on 2RMC*RQ201 or 202.
- Chlorine detection alarms at either unit

Note: There is no automatic transfer to emergency filtered intake for an isolation actuated by a chlorine alarm.

- Manual operator action.

The normal system alignment is to have the control room envelope ventilation on recirculation at both units, with a small amount of make-up air via throttled intake bypass dampers. The intake flow at each unit is drawn through two in series motor operated dampers (NSA open). The four dampers (two at each unit) receive close signals from CREBAPS. The maximum intake flow is 33,500 cfm at Unit 1 and 18,000 cfm at Unit 2. However, this path at each unit is isolated by a motor operated damper (NSA shut). Bypass lines with a throttled damper and a motor operated damper are balanced to provide an unfiltered intake flow of 300 cfm from Unit 1 and 200 cfm from Unit 2.

There are two motor operated exhaust dampers at each unit, (NSA open at Unit 1, NSA shut at Unit 2). These four dampers receive close signals from CREBAPS. At Unit 1, a motor operated damper upstream of the two exhaust dampers (NSA shut) isolates the exhaust during recirculation. The 500 cfm intake is dissipated by exfiltration through doorways and other penetrations.

A bottled air pressurization system, comprised of ten air bottles arranged in five sets of two with redundant actuation valves and circuitry, serves both units. Each set of bottles is sized to deliver 200 cfm for one hour in order to maintain control pressure slightly positive with relation to the outside environment.

At Unit 1, there is a single filtered emergency intake train comprised of motor operated dampers (NSA shut), two 1000 cfm fans (NSA off), and one HEPA / charcoal filter train. A manual damper downstream of the filter is NSA shut as the NSA is to have Unit 2 supply the emergency filtered intake. At Unit 2, there are

two trains of motor operated dampers (NSA shut), fans (NSA off), and HEPA / charcoal filters. At both units, this filtered intake train bypasses the intake dampers.

On a CREBAPS actuation, all four intake dampers and all four exhaust dampers receive a close signal. This isolates the normal intake. The air bottles start to release air to maintain a slight positive pressure. If the actuation was due to CIB or a radiation monitor alarm, a one hour timer is started. No timer is started on a chlorine actuation. When the one hour timer elapses, the air bleed is halted and the Unit 2 emergency filtered intake dampers open, and an emergency intake fan starts to maintain the control room slightly positive. The intake is dissipated by exfiltration through doorways and other penetrations.

The ventilation systems can be operated to purge the control room envelope, by opening the exhaust dampers, opening the full flow intake dampers, and closing the recirculation dampers. The air handlers draw in outside air and exhaust to the environment (33,500 cfm at Unit 1, 18,000 cfm at Unit 2).

The control room ventilation intake (4) and exhaust (4) dampers, air handlers (4), and emergency filtered intake fans are powered from emergency AC buses.

2. Specific Ventilation Alignment During Accidents^{3,4}

- 2.1 Prior to the start of the incident (T_0 , $T < 0$), the control room ventilation system is drawing in 500 cfm of unfiltered outside air. 300 cfm of this intake is via Unit 1 intakes, and 200 cfm is via Unit 2 intakes. The intake is being removed via exfiltration through control room penetrations, seals, and doors. Although the motor operated exhaust dampers are open, upstream isolation dampers are shut.
- 2.2 The accident starts at T_0 . The onset of the radioactive release is typically assumed to occur at T_0 . Note that some of the accidents have multiple release paths and that the releases from these paths may start and terminate at different times. Regardless of the pathway or the timing of the release, activity transport in the buildings and environment is conservatively assumed to be instantaneous.
- 2.3 For the control room habitability, the process safety limit is set to 1 mR/hr. It was previously established by SWEC that the GDC 19 criteria⁵ could be met if the ambient dose rate was kept less than 1 mR/hr⁶. The point in time that this dose rate is reached is designated T_s . For cases involving manual operator action, T_s = the time of the first indication that manual isolation is necessary.
- 2.4 As noted above, the ambient dose rate reaches 1 mR/hr at T_s . The monitor reading, however, does not necessarily ramp up at the same rate as the ambient dose rate builds up at. The monitor lag time will be a function of the rate of activity introduction. Once the alarm trip setpoint is reached, there will be delay in the damper movement. The total delay time is identified as T_0 . The isolation time, T_i , equals $T_s + T_0$. For the DBA LOCA case, T_s , T_0 , T_i are assumed to be 0. For the manual isolation case, T_i is assumed to be the time that the manual isolation is complete.
 - 2.4.1 For Unit 1, the ARM does not lose power. Therefore a loss of power during the monitor reading ramp-up will not cause a delay in the monitor reaching the trip setpoint. Reference 7 indicates that the time to reach 1 mR/hr is 97 seconds. If the power is lost at that time, the dampers will not close for 77 seconds (i.e., diesel start, sequencing, damper movement). Thus, the maximum delay was shown to be 97 + 77 seconds or slightly less than 3 minutes. SWEC assumed T_0 = 3 minutes in all Unit 1 calculations⁷.
 - 2.4.2 For Unit 2, Reference 6 notes that the ARM ramps up in about 107 seconds to 1 mR/hr. The maximum ramp time was shown to be 128 seconds, which SWEC assumed to be the time used. The damper closure time is 10 seconds, with a signal processing time of 2 seconds. This yields a delay of 140 seconds or, T_0 = 2.33 minutes. The SWEC analysis notes that although the Unit 2 ARM does lose power, doing so just prior to reaching the trip setpoint does not add significantly to the monitor ramp time.



- 2.4.3 The assumption in the original record of analysis⁷ for Unit 1 is that non-vital AC power is lost just prior to the damper movement. For Unit 2, SWEC assumed that the loss of non-vital power occurred concurrent with the accident initiation⁸. Although these two bases are different, it must be remembered that the assumption regarding instantaneous transport of the radioactivity to the control room provides margin to compensate for the difference.
- 2.4.4 In 1993, DLC was notified by Limitorque⁹ that under certain seismic events, the valve operators may malfunction and not close upon receipt of the shut signal. This malfunction ceases once the seismic event has abated, and the valve operator goes shut at that time. A maximum delay time of 15 seconds was established, consistent with the design basis assumption of a 15 second seismic envelope. As a result, the isolation delay times in ¶2.4.2 are increased: $T_o = 2.33 \text{ min} + 15 \text{ seconds} = 2.58 \text{ minutes}$ Unit 1; $T_o = 3 \text{ min} + 15 \text{ seconds} = 3.25 \text{ minutes}$ Unit 2^{9,10,11}.
- 2.4.5 For the DBA LOCA, control room isolation is actuated by a CIB signal. No time delay is modeled for diesel loading and damper movement in the licensing basis calculations. In Reference 12, SWEC postulated an environmental transport time of 121 seconds between the Unit 1 release point and the control room intake. For Unit 2, Reference 13 provided a transport time of 142 seconds. Both of these transport times are in excess of the damper closure delay times under CIB conditions.
- 2.5 At T_i , CREBAPS has shut the normal intake dampers, and has shut the exhaust dampers. An air bleed from the air bottles is commenced. Also at this time, a 60 minute timer is started. During the time between T_o and T_i , it is conservatively assumed that the control room intake continues at 500 cfm. After T_i , the intake drops to zero and an infiltration rate of 10 cfm is assumed¹⁴.
- Note: Although the dampers may not be able to close due to loss of AC power until the diesel generator loads, it is important to note that the fan motors also lose power. The flow rate would coast down once the fan motor was de-energized. In accordance with Reference 14 it would be acceptable to assume the intake flow rate to be 50% of the measured exfiltration rate, or 350 cfm. This is generally not modeled as the difference is generally insignificant to the overall results.*
- 2.6 The pressurization system will bleed air at a rate sufficient to maintain the requisite pressure. Based on earlier testing, reported in References 6 and 7, 690 cfm would be needed to maintain the specified pressure differential. In order to account for the specified infiltration rate, the exfiltration rate is set to $690 + 10$ or 700 cfm.
- 2.7 At one hour beyond CREBAPS actuation (assumed to be equal to $T_i + 3600\text{s}$), the air bleed is automatically terminated and outside air is drawn through filters via the emergency pressurization intake dampers and fans. Since the exfiltration rate was assumed to be 700 cfm, the fans are assumed to draw in outside air at a rate of 700 cfm. The emergency intake fans are rated at 1000 cfm, however, the actual intake flow is limited by the available exfiltration flow rate. Note that only 690 cfm of the intake is filtered. The 10 cfm infiltration rate is not filtered. The filter efficiency is reduced to:
- $$PF = \frac{(0.95)(690) + (0.0)(10)}{690 + 10} = 0.936$$
- 2.7.1 Technical specification 3/4.7.7¹⁵ addresses control room habitability systems. Operability requirements require testing for less than 1% leakage and a methyl iodine removal efficiency greater than 99%. In accordance with Regulatory Guide 1.52¹⁶, assigned efficiencies are 95% for elemental and organic iodines.

- 2.8 The ventilation system remains in this alignment through the remainder of the event for many accident sequences. For the remaining sequences, the control room is purged for 30 minutes commencing at T=8 hours. The purge and exhaust are unfiltered and have flow rates of 33,500 cfm at Unit 1, and 18,000 cfm at Unit 2.
- 2.9 At the completion of the purge and continuing through to the end of the assessment period (i.e., 720 hours), the flow rates return to their original value of 500 cfm.

3. Control Room Model Parameters

- 3.1 Control Room Volume = 1.73E+5 ft³ [4 - Tbl 6.4-1]
- 3.2 Normal ventilation intake: BV1 = 300 cfm; BV2 = 200 cfm [4 - Tbl 6.4-1]
- 3.3 Filter efficiency = 93.6% [¶2.7 above]
- 3.4 Purge Flow Rate: BV1 = 33,500 cfm; BV2 = 18,000 cfm [3 - §9.13.4, 4 - Tbl 9.4-3]

Note: the licensing basis calculations assumed a purge flow of 20,000 cfm. The flow thru the ACUs was subsequently determined to be 18,000 which is reflected on U2 UFSAR Figure 9.4-1 and Table 9.4-3. These values conflict with the value in Table 6.4-1, which appears to be outdated. Purging was not a significant factor in the analyses.

- 3.5 Air pressurization flow rate for first hour: 690 cfm [3,4,6,7]
- 3.6 Filtered air intake flow rate: 700 cfm [See below]

The design capacity of the fan is 1000 cfm. However, by testing the amount of air bottle flow needed to maintain the requisite pressure differential, the exfiltration rate has been deemed to be 690 cfm + 10 cfm unfiltered inleakage. Thus, the intake will be constrained by the exfiltration capability. Thus, the analysis assumes an fan intake flow rate of 700 cfm.

3.7 Isolation delays based on radiation monitor actuation

AC Power Loss	@damper [7] movement	@T=0 [6]	
Diesel Start	n/a (1)	n/a (2)	
Diesel Sequence	n/a (1)	n/a (2)	
Damper Movement	n/a (1)	12 sec	[6]
Sum	77 sec	12 sec	[6]
RMS Response	97 sec [7]	128 sec	[6]
Seismic Delay	15 sec [10,11]	15 sec	[10,11]
Total	195 sec (3)	155 sec	

(1) U1 T/S ESF actuation timing Table 3.3-5 specifies a control room isolation response of 22 seconds without diesel starting and sequencing and 77 seconds with diesel starting and sequencing included based on CIB. The 22 second period would include damper movement, CNMT pressure sensor response time, and circuitry delays. (The actual breakdown is unknown). Per OST^{17,18}, the diesel start and sequencing delay to the step at which the dampers are powered is 10 + 40 ± 4 seconds.

(2) The RMS response delay includes the diesel start and sequencing delays.

(3) SWEC rounded the original sum of 174 to 180.

3.8 Isolation delays based on CIB actuation

AC Power Loss	@damper [7] movement	@T=0 [6]
Diesel Start	n/a (1)	10 sec [18]
Diesel Sequence	n/a (1)	40 ± 4 sec [18]
Damper Movement	n/a (1)	12 sec [6]
Sum	77 sec	12 sec [6]
Seismic Delay	15 sec [10,11]	15 sec [10,11]
Total	92 sec	81 sec

(1) See note 1 for datum 3.7.

3.9 Control Room χ/Q , sec/m³ — Unit 1

[3 - Tbl 2.2-12, 19]

Release Point	0-8 hrs	8-24 hrs	1-4 days	4-30 days
CNMT edge	4.33E-4	2.04E-4	1.46E-4	8.84E-5
CNMT top (SLCRS)	2.73E-4	1.28E-4	9.17E-5	5.57E-5
PAB	4.30E-3	2.01E-3	1.49E-3	9.25E-4
MSVA	7.60E-4	3.51E-4	2.59E-4	1.58E-4
Service Bldg	6.25E-4	3.04E-4	2.36E-4	1.57E-4
Turbine Bldg	2.43E-3	1.22E-3	8.90E-4	6.26E-4
Waste Gas Vault	5.11E-4	2.15E-4	1.65E-4	1.14E-4

3.10 Control Room χ/Q , sec/m³ — Unit 2

[4 - Tbl 15.0-14, 19]

Release Point	0-8 hrs	8-24 hrs	1-4 days	4-30 days
CNMT edge	1.88E-4	9.32E-5	7.06E-5	4.18E-5
CNMT top (SLCRS)	1.20E-4	5.91E-5	4.45E-5	2.64E-5
PAB	1.04E-3	5.15E-4	4.04E-4	2.46E-4
MSVA	1.59E-4	7.86E-5	5.96E-5	3.76E-5
Service Bldg	2.21E-4	1.11E-4	8.51E-5	5.17E-5
Turbine Bldg	2.72E-4	1.43E-4	1.10E-4	6.30E-5
Waste Gas Vault	1.74E-3	9.36E-4	7.69E-4	5.55E-4

3.11 Occupancy Factors

[20]

0-24 hrs	1.0
1-4 days	0.6
>4 days	0.4

REFERENCES

1. DLC, BVPS-1 Operating Manual, Chapter 44C
2. DLC, BVPS-2 Operating Manual, Chapter 44C
3. DLC, Updated Final Safety Analysis Report Unit 1.
4. DLC, Updated Final Safety Analysis Report Unit 2.
5. USNRC, Criterion 19. Title 10 Code of Federal Regulations Part 50, Appendix A
6. SWEC, Control Room Habitability Due to Design Basis Accidents (except LOCA) at BV2. 12241-UR(B)-445, Revision 0; 1987
7. SWEC, Combined BV1-BV2 Control Room Habitability Due to Design Basis Accidents (except LOCA) at BV1. 12241-UR(B)-456, Revision 0, 1987
8. Limitorque, Potentially Reportable 10 CFR Part 21 Condition, ltr dtd 12/7/92
9. DLC, 10 CFR Part 21 Notice: Limitorque Declutching Mechanism, EM104392 dtd 12/21/92
10. DLC, Safety Analysis of Consequences of Control Room Damper Response Delay (Limitorque 10 CFR 21) — Unit 1 Accidents. ERS-SFL-93-005, Revision 0; 1993
11. DLC, Safety Analysis of Consequences of Control Room Damper Response Delay (Limitorque 10 CFR 21) — Unit 2 Accidents. ERS-SFL-93-004, Revision 0; 1993
12. SWEC, Doses to the Combined Control Room due to a LOCA at BVPS-1. 12241-UR(B)-450, Revision 1
13. SWEC, FSAR Sec 15.6.5 Loss of Coolant Accident Analysis: Releases and Doses - Site and Control Room. 12241-UR(B)-190, Revision 7; 1987
14. USNRC, Standard Review Plan for the Review of Safety Analysis Reports for Nuclear Power Plants. NUREG-0800, Revision 5; 1987 (§6.4.3)
15. DLC, Technical Specification 3/4.7.7 (U1 and U2)
16. USNRC, Design, Testing, and Maintenance Criteria for Postaccident Engineered Safety Feature Atmosphere Cleanup System Air Filtration and Adsorption Units of Light Water Cooled Nuclear Power Plants. Regulatory Guide 1.52, Revision 2; 1978
17. DLC, BVPS-1 Operating Manual OST 1.36.3 (4)
18. DLC, BVPS-2 Operating Manual OST 2.36.3
19. DLC, Control Room X/Q Values for the Beaver Valley Power Station (NUS Report EPC-91-1025). ERS-NUS-92-020, Revision 0; 1992
20. Murphy, K.G. and Campe, K.W., Nuclear Power Plant Control Room Ventilation System Design for Meeting General Criterion 19, published in proceedings of 13th AEC Air Cleaning Conference

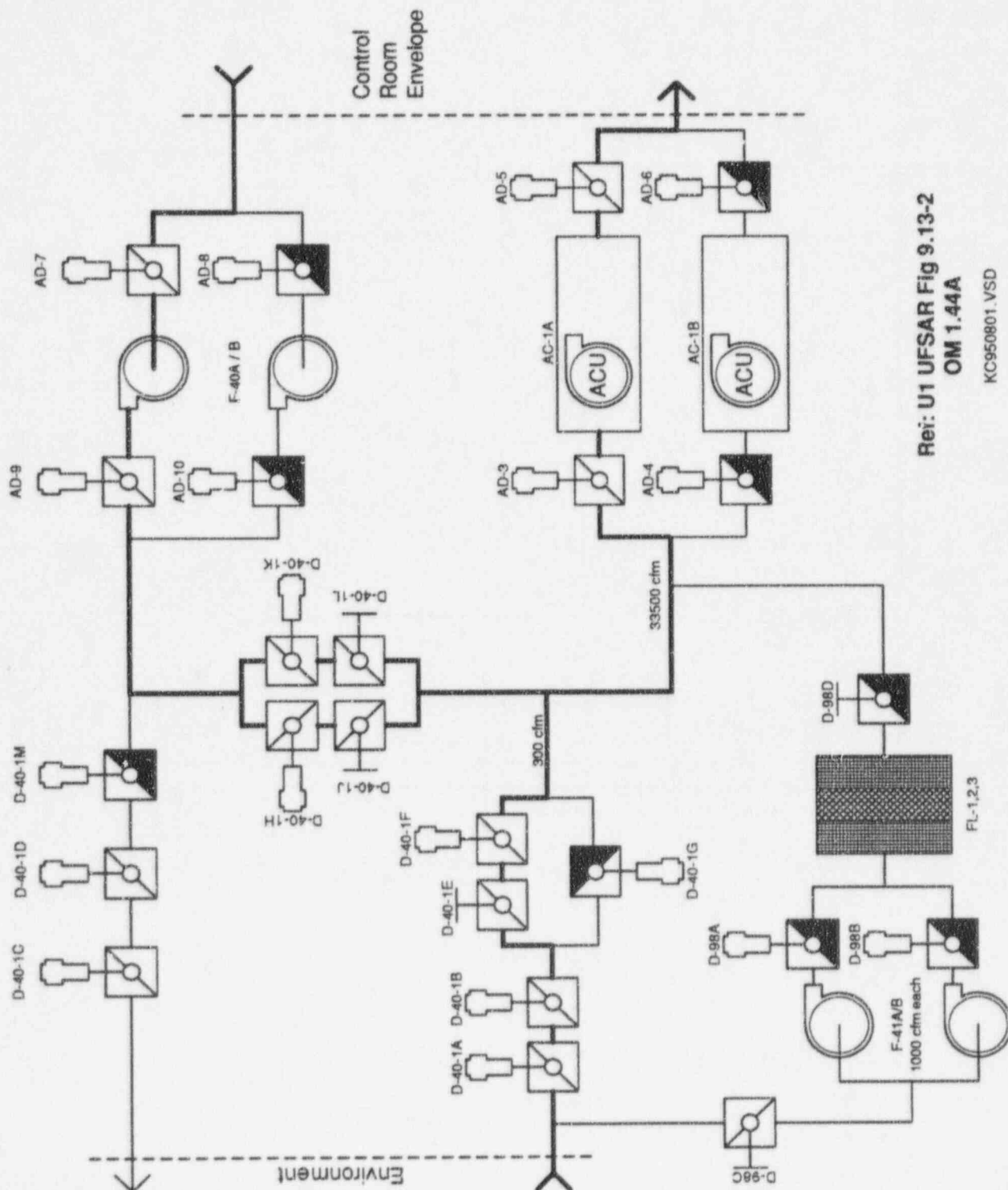

Rei: U1 UFSAR Fig 9.13-2
OM 1.44A

KC950801.VSD

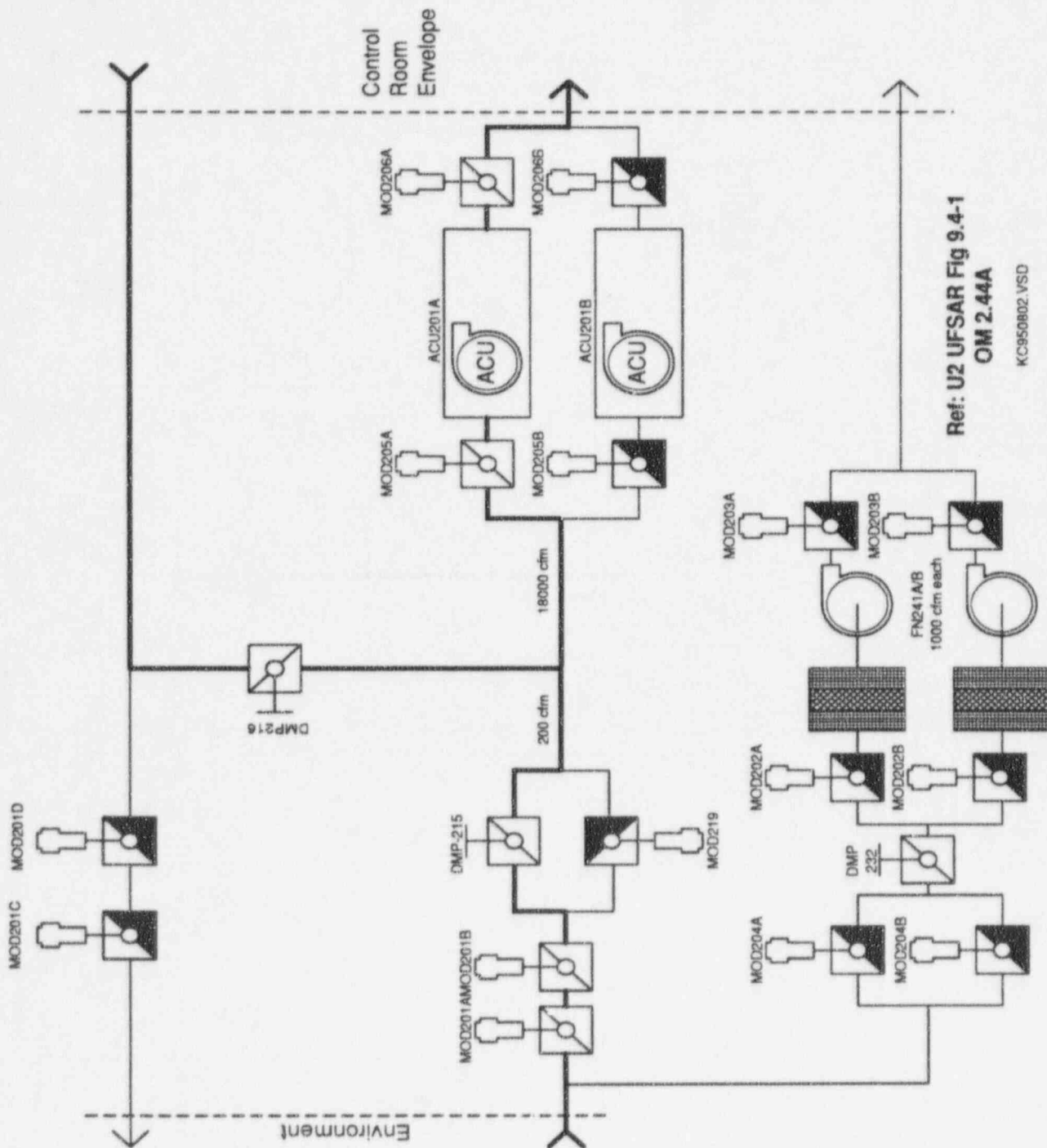

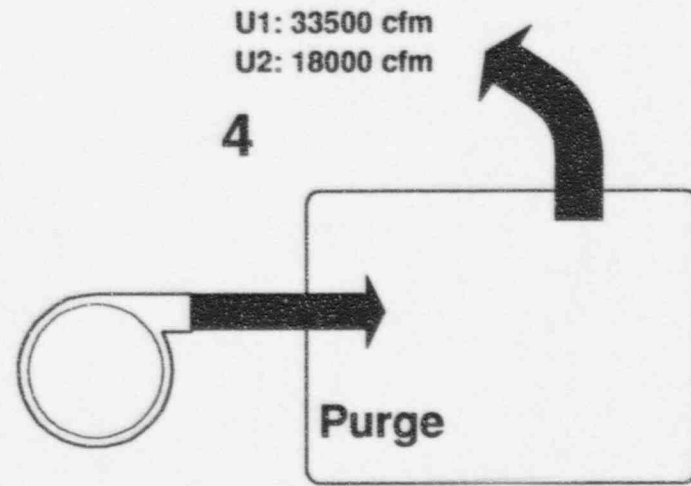
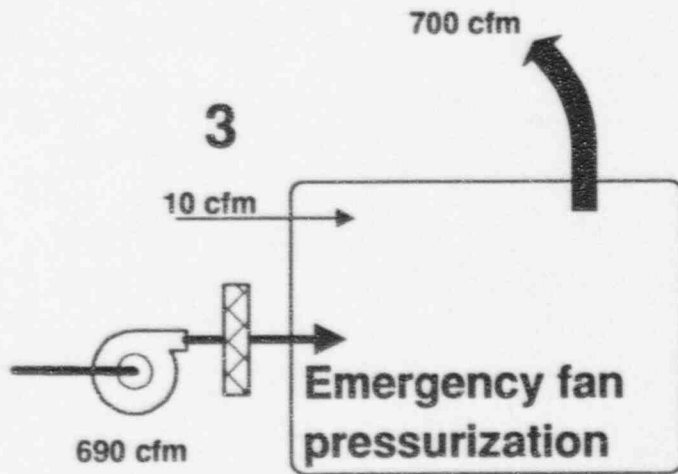
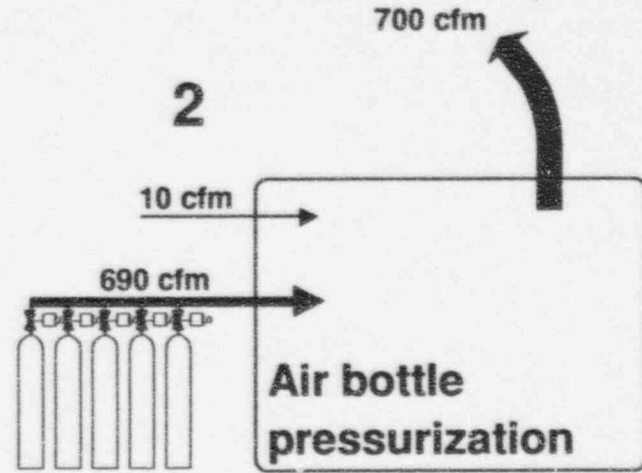
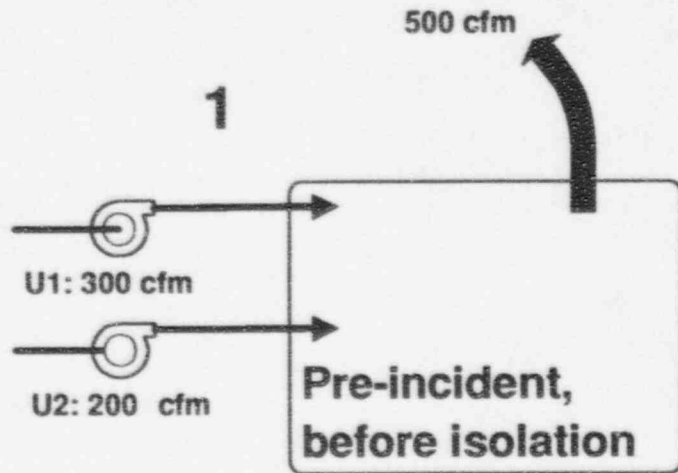

KC950803.VSD

Control Room Modeling

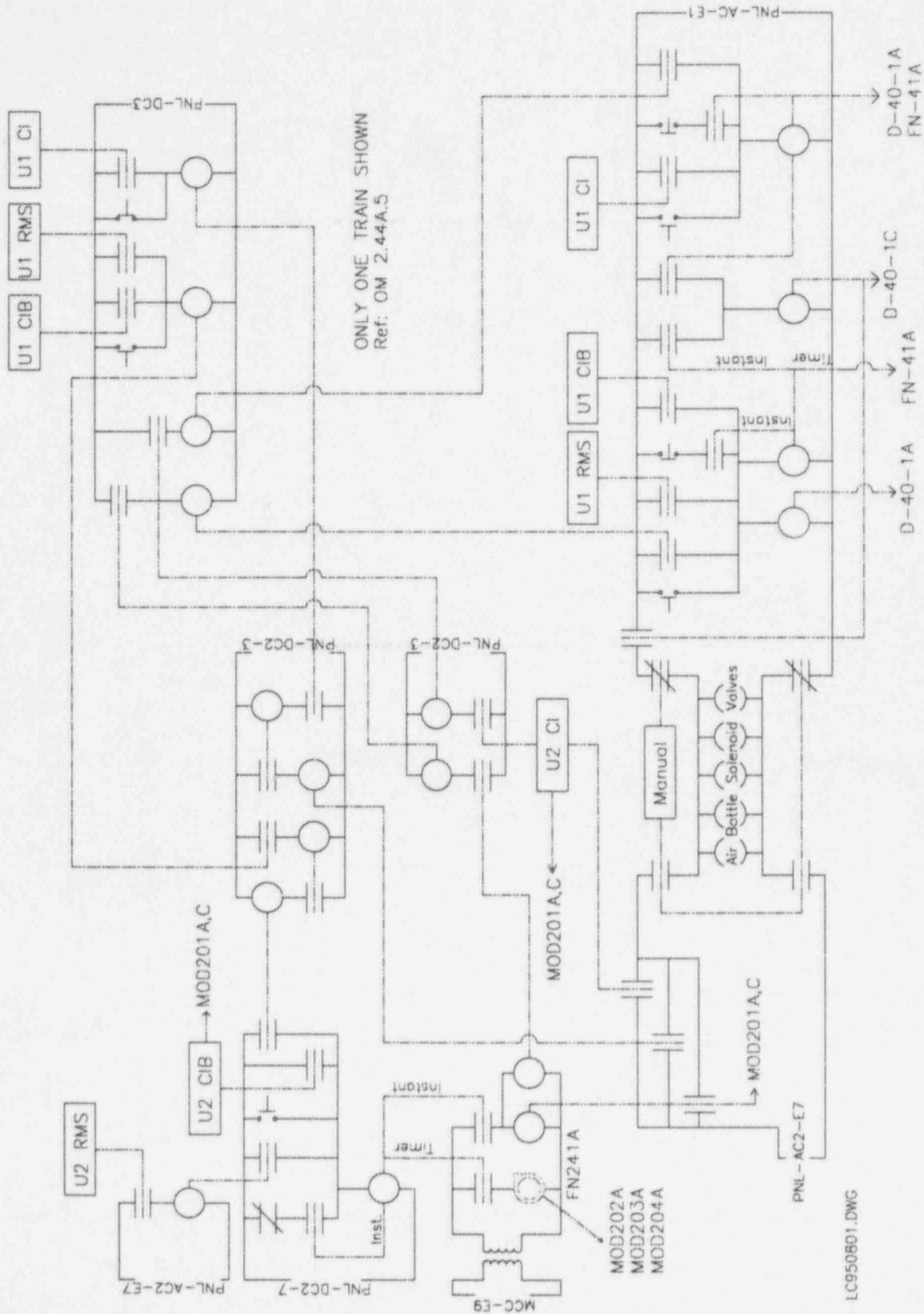

LC950801.DWG

INTENTIONALLY BLANK

INTENTIONALLY BLANK