



**Public Service Company of Colorado**

16805 WCR 19 1/2, Platteville, Colorado 80651

50-267

July 20, 1984  
Fort St. Vrain  
Unit #1  
P-84225

Mr. E. H. Johnson, Chief  
Reactor Project Branch 1  
Region IV  
Nuclear Regulatory Commission  
611 Ryan Plaza Drive, Suite 1000  
Arlington, TX 76011

SUBJECT: Re-submittal of FOSAVEX-84  
Scenario Package

- REFERENCE: 1) Letter, Johnson to Lee,  
dated July 9, 1984  
(G-84235)
- 2) Letter, Warembourg to  
Johnson, dated June 11,  
1984 (P-84170)

Dear Mr. Johnson:

This letter confirms the scheduling change for the 1984 Fort St. Vrain Radiological Emergency Exercise (FOSAVEX-84) that was discussed during telephone conversations of July 16, 17, and 18, 1984.

The exercise has been postponed from July 25, 1984 until the mutually agreeable date of August 15, 1984. The reason for this postponement is to take advantage of the Federal Register Notice, 49 CFR 27733, which clarifies FEMA and NRC regulations concerning the participation of state agencies in licensee exercises. Our understanding of this notice is that, effective August 6, 1984, licensees will no longer be required to request an exemption for state participation if FEMA has already granted such an exemption to the state. As you know, FEMA has granted an exemption to the State of Colorado from participation in FOSAVEX-84.

As indicated by Mr. Phil Wagner of your staff, the review of the overall status of emergency preparedness at Fort St. Vrain will not be affected due to the postponement of the exercise date, and the requirement to conduct an annual exercise, as set forth in 10 CFR 50, Appendix E, will be satisfied, even though the exercise will be held fourteen months after the previous FOSAVEX.

8408290181 840720  
PDR ADOCK 05000267  
F PDR

H005  
11

In response to your letter of July 9, 1984, requesting escalation to a General Emergency classification during the exercise, provided are revised attachments comprising a complete package for FOSAVEX-84. While an incident resulting in offsite doses of the magnitude represented in the scenario would be virtually impossible, we have endeavored to elevate the release rates in order to simulate the occurrence of a General Emergency.

The attachments provided herein are as follows:

Scope and Objectives	Attachment A
Narrative Summary and Sequence of Events	Attachment B
Conduct of the Exercise	Attachment C
Observer/Prompter Packages	Attachment D

Please note that Public Service Company of Colorado fully intends to include activation of the Early Warning Alert System as part of the drill to demonstrate its effectiveness as a warning device in the event of an emergency at Fort St. Vrain. Public Service Company personnel will simulate notifications required to activate the system during the normal course of the event, however, activation will occur during mid-morning instead of at the onset of the exercise, which will be at approximately 4:00 AM. We feel that there is no additional benefit of activation at such an early hour, rather, it could be detrimental to what we feel is a good rapport with the residents living in the vicinity of the plant.

If you have any comments or questions regarding this submittal, please contact Mr. Chuck Fuller of my staff at (303) 785-2223 as soon as possible.

Very truly yours,

  
Don W. Warembourg  
Manager, Nuclear Production

Attachments

cc: Pat Byrnes, DODES  
Rick Holtz, DODES  
Lea Ekman, Weld County  
Jim Montgomery, Region IV

DWW/dkh



Attachment A

SCOPE AND OBJECTIVES

FORT ST. VRAIN

FOSAVEX-84

PURPOSE:

The purpose of FOSAVEX-84 is to test the Radiological Emergency Response Plan and Implementing Procedures as tools for use by personnel when responding to a radiological emergency at Fort St. Vrain.

DATE:

FOSAVEX-84 has been scheduled as a one-day exercise to be held on August 15, 1984.

SCOPE:

1. The exercise will be an unannounced off-hours emergency exercise, with participation by the licensee only.
2. The scenario begins as an initiating event which increases in severity to a "GENERAL EMERGENCY". Actual meteorological conditions will be used for simulated radiological assessment during the exercise.
3. All Emergency Response Facilities actively participated in by the licensee will be activated. State and local authorities will activate communications links and will participate in a limited manner from the Weld County and the State Emergency Operations Center.
4. Personnel not participating in the exercise shall report to normal work locations and shall perform normal duties.

OBJECTIVES:

1. Demonstrate that response center personnel can be alerted and notified during non-working hours to man the emergency response centers.
2. Demonstrate that the emergency response facilities can be manned and operational in a timely fashion.
3. Demonstrate that accountability printouts from the Security computer system are used to aid in accurately determining personnel accountability of those personnel on-site at the onset of the exercise.
4. Demonstrate that the incident assessment staff can perform the assigned tasks related to assessment and that timely decisions and appropriate response can be made concerning the incident category.
5. Demonstrate that the telecommunications system can be manned and operated in a timely manner and that the system is adequate to handle anticipated traffic during site emergency conditions.
6. Demonstrate that emergency monitoring teams and damage control teams, if needed, can be assembled and dispatched from the Personnel Control Center in a timely manner and can adequately perform assigned functions at their appointed destinations. Demonstrate also that the teams are adequately briefed of applicable plant conditions and required protective clothing, dosimetry and respiratory protection prior to being dispatched from the Personnel Control Center.
7. Demonstrate that plant operations and support personnel respond to the emergency situation utilizing emergency procedures to mitigate the consequences of the incident.
8. Demonstrate the capability of emergency personnel to follow and use emergency procedures, checklists, and data sheets.

Attachment B

NARRATIVE SUMMARY

and

SEQUENCE OF EVENTS

FOSAVEX-84 Narrative Summary

(NOTE: Numbers in parentheses refer to points on schematic.)

The initiating event is a leak in the A Train Helium Purification Cooler (E-2301) (1). The leaking primary coolant enters the cooling water system where it rises to the cooling water system surge tank (T-4701) (2). High pressure in the tank is not alarmed, however, as the pressure indicator and alarm are cleared out for calibration (3).

The cooling water loop remains functional, however, as the pressure in the line remains below 92 psig (precluding automatic isolation) and the pump (4) does not show sign of cavitation.

The valve stem on the valve bypassing the surge tank is broken, keeping the valve in the open position (5), allowing the surge tank to vent to the gas waste system. The loop seal (6) is lost, and primary coolant enters the gas waste vacuum tank (T-6301) (7).

The gas waste vacuum tank pressure rises rapidly to its alarm setpoint of 12 psia. The corresponding alarm in the Control Room is the first indication to the operators that there is a problem. Since there are no indications of problems in the cooling water system, it is not evident what pressurization of the tank is due to, and more obvious possibilities will probably be investigated.

The standby gas waste compressor starts in addition to the one normally running to attempt to alleviate the pressure rise in the vacuum tank. The tank pressure continues to rise and the rupture disk blows and the safety valve lifts (8), releasing the gas waste vacuum tank contents to the exhaust ventilation filters (9), exhaust fans (10), past the radiation monitors (11), and out the plant stack (12). The pressure in the vacuum tank is high enough that, should rupture disks be swapped, the other will also rupture.

Radioactive release rates are such that a GENERAL EMERGENCY is declared.

The source of in-leakage to the gas waste system is eventually diagnosed to be the leak in the Helium Purification cooler. The leak is not isolable, however, as the helium inlet valve to the cooler, (HV-2301), is not able to be closed. Cooling water loops may not be swapped due to a faulty breaker, and B Purification Train may not be used due to regeneration and a frozen low temperature adsorber.

The release continues until the PCRV is depressurized, either due to the leak or due to depressurization through the A Train.

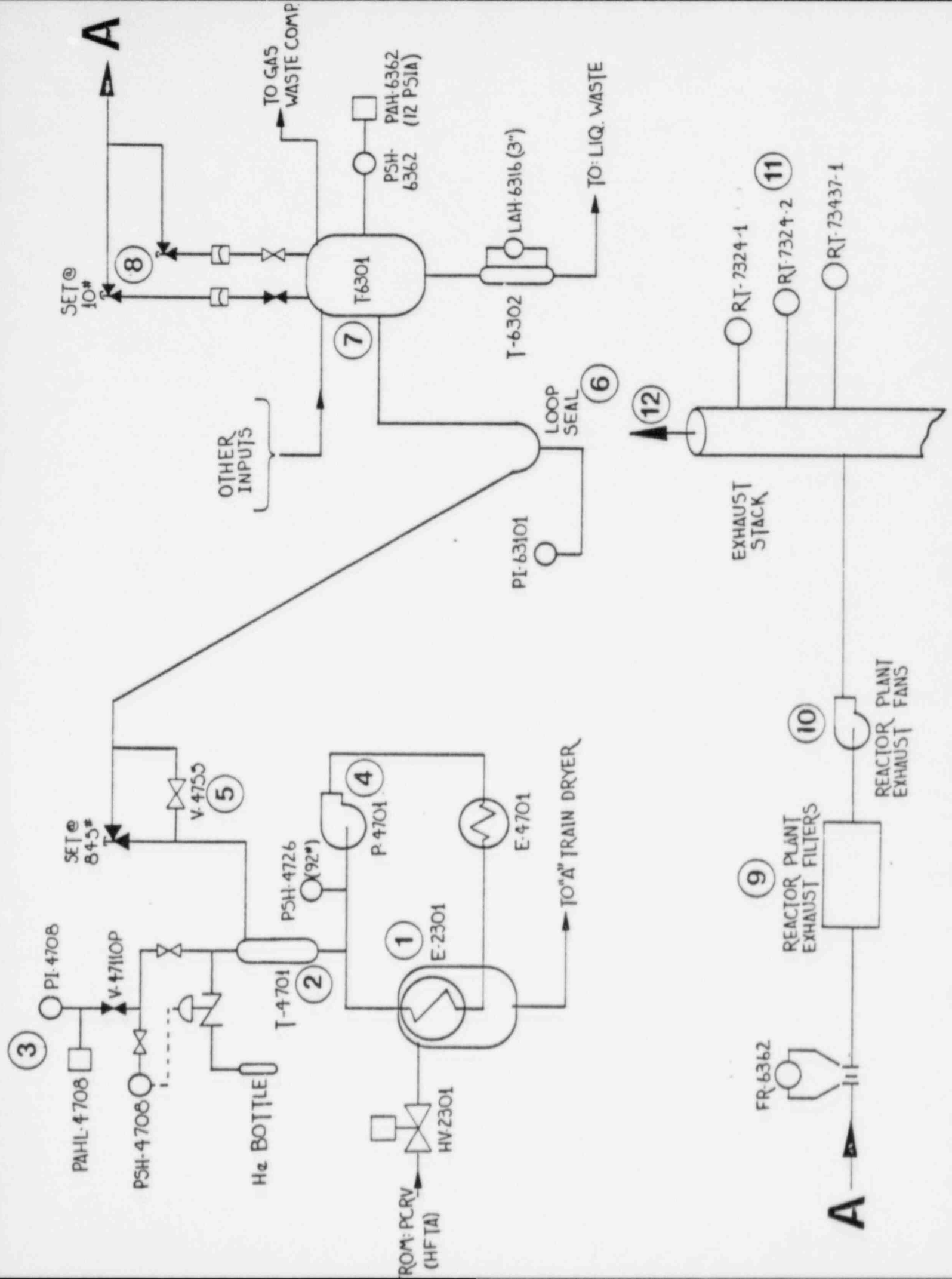

FOSAVEX-84 - PLANNED SEQUENCE OF EVENTS

<u>Approximate Time (minutes)</u>	<u>Event</u>
T=-10	<p>Control Room operators are informed of plant conditions at the start of the drill. Those pertinent to the scenario include:</p> <ul style="list-style-type: none"><li>• Reactor power steady at 70%</li><li>• A Helium Purification Train in service</li><li>• B Helium Purification Train regenerating Helium Dryer (LTA assumed frozen)</li><li>• Loop I System 47 in service</li><li>• Gas Waste release of "A" surge tank in progress since 0300 hours; Gas Waste "B" surge tank pressure is 150#</li><li>• PI-4708 (Pressure Indicator Loop I System 47 surge tank) out-of-service on PTR. V-47110P is main clearance point.</li></ul>
T=0	<p>A leak occurs in E-2301, the Helium Purification Cooler on A Train. Control Room operators are alerted to high gas waste vacuum tank pressure. Both gas waste compressors will be running, and recurring spikes in the stack flow will be indicated on Control Room flow recorder, FR-6352.</p>
T=30	<p>Stack radiation indications begin increasing.</p>
T=5	<p>High stack radiation alarms RT-7324-1 and 7324-2 alarm in the Control Room. The gas waste release automatically terminates, and effluents that normally vent directly to the exhaust filters automatically transfer to the gas waste vacuum tank.</p>
T=0 to 15	<p>Stack radiation monitor readings continue to increase. (See Table 1 for monitor readings.)</p>

PLANNED SEQUENCE OF EVENTS (cont.)

<u>Approximate Time (minutes)</u>	<u>Event</u>
T=0 to 45	Operators attempt to locate source of in-leakage to gas waste vacuum tank. Anticipated operator actions and results of these actions are given in the CR prompter package.
T=15 to 30	Due to high stack monitor readings, a GENERAL EMERGENCY should be declared.
T=30	Low Reactor Pressure Alarm sounds at 20 psi below normal pressure. If the reactor is not manually scrammed at this point, an automatic scram will occur at 50 psi below normal (at T=60 min).
T=15 to 45	Release rates remain relatively constant until the reactor is scrammed. After the reactor is scrammed, release rates decrease until T=360.
T=60	Automatic reactor scram on low reactor pressure, if manual scram has not already been performed.
T=45 to 90	The source of the leak into the gas waste vacuum tank is determined to be a non-isolable leak in the A Train Helium Purification Cooler. Operators may begin depressurization of the PCRV.
T=90 to 360	Release rates continue to decrease.
T=360	Radiation levels are decreasing, with release rates at the EAB being approximately background. Transition to a recovery phase is performed, and the exercise is terminated.



Table 1  
Radiation Monitor Readings  
 (before Reactor Scram)

<u>Time (min)</u>	<u>7324-1 (CPM)</u>	<u>7324-2 (CPM)</u>	<u>73437-1 (CPM)</u>	<u>Classification &amp; EAB Dose Rate (mrem/hr)</u>	
T = 0	26	42	7	N/A	Bkgd
T = + 30 sec.	300	42	"	UNUSUAL EVENT (if class- ification made)	Bkgd
T = + 1 min.	890	60	"	"	"
T = + 2 min.	8,900	500	"	"	"
T = + 3 min.	26,000	1,600	"	"	"
T = + 4 min.	130,000	8,000	"	"	"
T = + 5 min.	360,000	21,300	"	"	"
T = + 6 min.	800,000	49,000	"	ALERT	"
T = + 7 min.	1,500,000	89,000	"	"	"
T = + 8 min.	2,600,000	160,000	20	SITE AREA EMERGENCY	"
T = + 9 min.	4,400,000	270,000	100	"	"
T = + 10 min.	6,200,000	400,000	200	"	"
T = + 11 min.	8,000,000	480,000	300	"	0.3
T = + 12 min.	10,700,000	650,000	400	GENERAL EMERGENCY	0.9
T = + 13 min.	12,000,000	730,000	500	"	2.6
T = + 14 min.	13,300,000	800,000	600	"	13
T = + 15 min.	16,000,000	980,000	700	"	35
T = + 16 min.	"	"	"	"	78

Table 1  
Radiation Monitor Readings  
 (before Reactor Scram)

<u>Time</u> <u>(min)</u>	<u>7324-1</u> <u>(CPM)</u>	<u>7324-2</u> <u>(CPM)</u>	<u>73437-1</u> <u>(CPM)</u>	<u>Classification &amp;</u> <u>EAB Dose Rate</u> <u>(mrem/hr)</u>	
T = + 17 min.	16,000,000	980,000	700	GENERAL EMERGENCY	150
T = + 18 min.	"	"	"	"	255
T = + 19 min.	"	"	"	"	440
T = + 20 min.	"	"	"	"	640
T = + 21 min.	"	"	"	"	780
T = + 22 min.	"	"	"	"	1040
T = + 23 min.	"	"	"	"	1170
T = + 24 min.	"	"	"	"	1290
T = + 25 min.	"	"	"	"	1562
T = + 26 min.	"	"	"	"	"
T = + 27 min.	"	"	"	"	"
T = + 28 min.	"	"	"	"	"
T = + 29 min.	"	"	"	"	"
T = + 30 min. until Reactor scram	"	"	"	"	"

Table 1  
Radiation Monitor Readings  
 (after Reactor Scram)

<u>Time (min)</u>	<u>7324-1 (CPM)</u>	<u>7324-2 (CPM)</u>	<u>73437-1* (CPM)</u>	<u>Classification &amp; EAB Dose Rate (mrem/hr)</u>
Rx Scram	16,000,000	980,000	700	GENERAL EMERGENCY (N/G only) 1,562
Scram + 15	10,200,000	620,000	800	" 990
Scram + 30	6,400,000	390,000	900	SITE AREA EMERGENCY 620
Scram + 45	4,050,000	250,000	980	" 520
Scram + 60	2,550,000	150,000	1,500	" 390
Scram + 75	1,600,000	97,000	1,100	" 260
Scram + 90	1,000,000	60,000	1,120	" 190
Scram + 105	645,000	40,000	"	ALERT 130
Scram + 120	400,000	25,000	"	" 100
Scram + 150	160,000	10,000	"	" 65
Scram + 180	63,000	4,000	"	UNUSUAL EVENT 50
Scram + 210	25,000	1,500	"	" 33
Scram + 240	10,000	600	"	" 15
Scram + 270	4,000	250	"	" 8
Scram + 300	1,600	100	"	" 4
Scram + 330	620	40	"	" 2
Scram + 360	250	15	"	" Bkgd

\* If cartridge is changed out, RT-73437-1 reading returns to background and remains at background for the remainder of the exercise.

Attachment C

CONDUCT OF THE EXERCISE

CONDUCT OF THE EXERCISE

1. Activity released and doses received are designed to be significant enough to escalate the event to a General Emergency. The release is not intended to be realistic in terms of actual available inventory.
2. Actual meteorological conditions will be utilized.
  - a. Field monitoring teams will be provided with pre-determined field measurement data (via prompter cards). The field monitoring teams will be dispatched to track the plume. In the event that the meteorological stability category would preclude a plume from being detected (from a radiological standpoint), the field monitoring teams will continue to use the pre-determined data to demonstrate plume tracking capability.
  - b. Depending upon the meteorological conditions during the exercise, the Personnel Control Center may have to be relocated. If this becomes necessary, in the judgement of the Technical Support Center Director, the Personnel Control Center will be moved only once to the other onsite location, for purposes of demonstrating the capability.
3. An extra crew of shift operating personnel will be used as the operating crew for the exercise. The regularly scheduled operating crew will perform their normal functions for the plant conditions at the time.
4. Since this will be an off-hours exercise, it will be well underway prior to normal work arrival of personnel. In this respect there will be no effort made to involve personnel arriving for normal work schedule. These personnel will be processed routinely through the Search & ID facility.
5. Deliveries and routine visitation to the plant will be allowed during the exercise so as to minimize impact on operations and schedules of non-company personnel.
6. The Visitor's Center will likewise be operating routinely with no involvement in the exercise.
7. There will not be a great deal of interface with the Executive Command Post (ECP). Therefore the Director of the ECP may, at his discretion, reduce the normal compliment of the ECP after personnel accountability and initial establishment of the Command Post and communication system.

8. Likewise, without State participation, activities at the State EOC will be very limited. PSC involvement at the State EOC may be terminated after initial manning and communication checks.
9. As in last year's exercise, the new meteorological/dose assessment model will be utilized.
10. Certain operator actions may have to be pre-empted in order to prevent the premature termination of the exercise.
11. The Early Warning Alert (EWA) system will be exercised during the drill by activation in mid-morning.

Attachment D

OBSERVER/PROMPTER PACKAGES

Control Room Packet

## Control Room Observer/Prompter Instructions:

- Supply cards at specified times. Be aware of "T=Scram"; cards may need to be supplied out of given sequence.
- A plot is supplied to give the following plant parameters if requested:

Reactor Pressure  
Core inlet temperature  
Average region outlet temperature  
Total Feedwater Flow  
Total Helium Flow

- The following are operator actions that are anticipated and the prompter responses for each:

Operator Action: Verify that FV-6351 has closed upon automatic termination of gas waste release on high activity.

Response: FR-6351 still shows 20 acfm.

Operator Action: Change rupture disk on GWVT.

Response: Pressure in tank is sufficient to blow other rupture disk.

Operator Action: Scram reactor manually before T=15 minutes.

Response: Elevate radioactive release to maximum values.

Operator Action: Isolate Core Support Floor leakage by isolating V-111063.

Response: PAH-1194 (I-13C 3-2) will reset.

Operator Action: Isolate MM penetration vents.

Response: Vents isolate as expected.



Control Room Packet

- Operator Action: Put HS-2301 to close.
- Response: Red light on HS remains on (valve still open).
- Operator Action: Attempt to swap system 47 loops.
- Response: Faulty breaker on P-4702 prevents pump from being started (disagreement light on I-01 at handswitch).
- Operator Action: Replace faulty breaker.
- Response: For purposes of the drill, the breaker may not be replaced. This action would normally enable P-4702 to be started, and would provide a mechanism to terminate the release.

1000000000

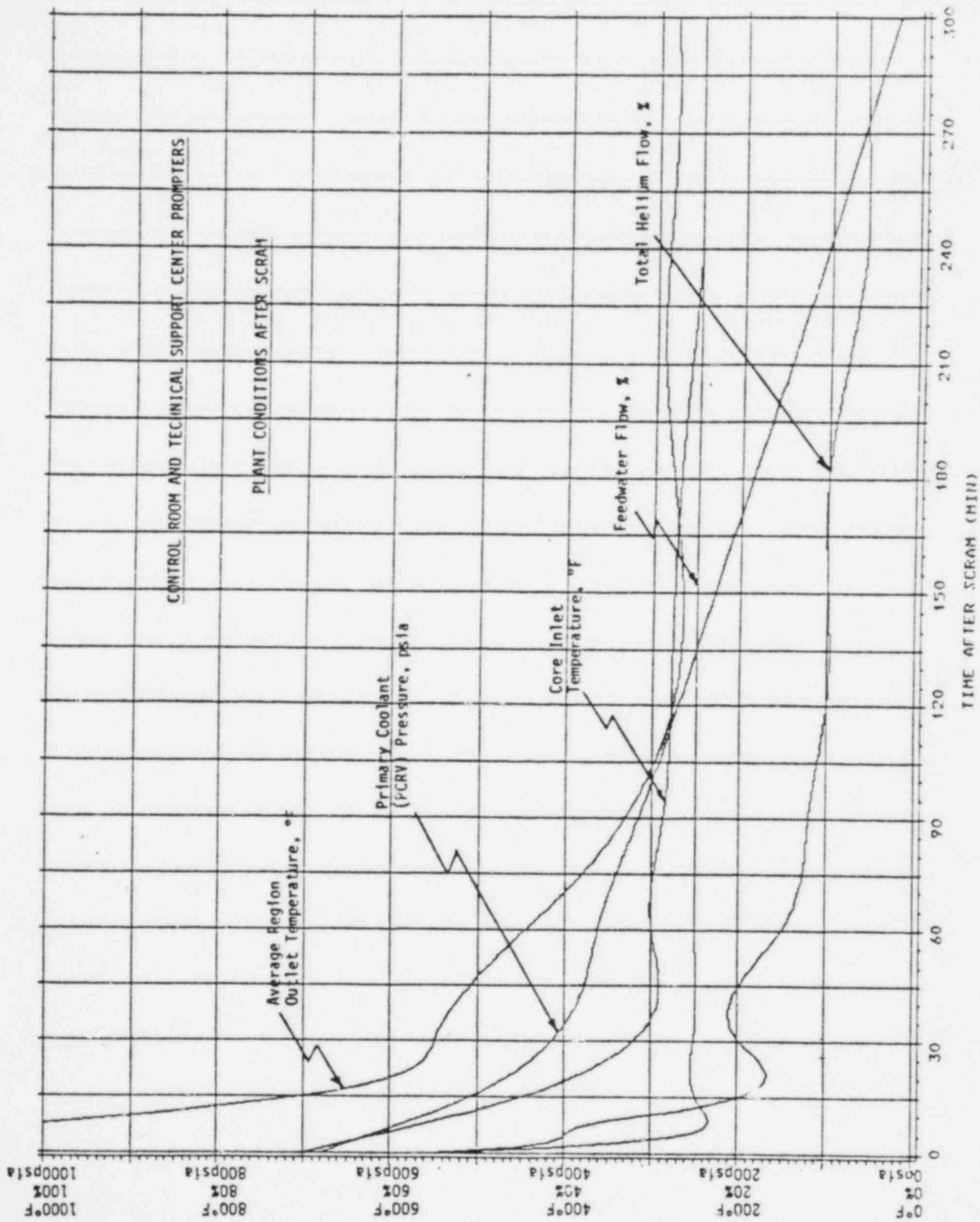

043000

Control Room Packet

<u>Time</u>	<u>CR Card No.</u>	<u>Description</u>	<u>Recipient</u>
T = -10	1	Initial Conditions	SS/WRO/ERO*
T = Throughout Exercise	2	RT-7312 readings	Post on I-14
T = 0	3	I-01 Alarm (Gas Waste Vacuum Tank)	WRO
T = 0	4	Flow Recorder Indication	WRO
T = 30 sec. - 4 min.	5	Optional (if requested) - Stack Radiation Monitor Readings	WRO
T = 5	6	Alarms-Stack Radiation	WRO
T = 6	7	Stack Monitor Readings	Post on I-14
.	.	.	.
.	.	.	.
.	.	.	.
T = 15	16	Stack Monitor Readings	Post on I-14
T = 30	17	Alarm-Low Reactor Pressure	WRO
T = 60	18	Reactor Plant Exhaust Filters Monitor Readings	Post on I-14
T = 60	19	Automatic Low Reactor Pressure Scram	WRO

\* SS = Shift Supervisor  
WRO = West Reactor Operator  
ERO = East Reactor Operator

Control Room Packet

<u>Time</u>	<u>CR Card No.</u>	<u>Description</u>	<u>Recipient</u>
T = Scram	20	Stack Monitor Readings	Post on I-14
•	•	•	•
•	•	•	•
•	•	•	•
T = Scram + 360	36	Stack Monitor Readings	Post on I-14

SHIFT SUPERVISOR AND REACTOR OPERATOR'SINITIAL CONDITIONS

CR Card 1

T=-10 Minutes

1. Reactor power steady at 70% for entire month.
2. All controls in remote auto.
3. All three boiler feed pumps in service.
4. B Purification Train regenerating (dryer being purged).
5. Gas Waste release of "A"-Surge Tank started at 0300 hours; "B" Surge Tank pressure is 150 psi.
6. The following equipment is out of service:
  - a. Bearing water pump 1D (P-2102S) - motor removed for repairs.
  - b. Hydraulic pump 1C (P-9102X) - low discharge pressure.
  - c. Turbine water removal pump 1A (P-2103) - impeller replacement.
  - d. Loop 2 backup bearing water - tagged out at V-21458 to repair leak on PV-2192.
  - e. Buffer helium recirculator 1C (C-2106) cleared out.
  - f. The following instrumentation is cleared out:
    - PI-4708 cleared out for calibration at V-47110P
    - PIC-6364 out of service
    - FT-6375 transmitter cleared out
7. Stack monitors have the following indications:

RT-7324-1	30 CPM
RT-7324-2	30 CPM
RT-73437-1	10 CPM
8. Annunciator alarms are up per attached.

LIST OF ALARMS AT T=-10 MINUTES

I-01A

3-1 Liquid Waste Receiver 1A Level High

I-01B

5-1 Regeneration Knockout Drum Water Level High-Low

I-01C

2-8 HP Helium Supply Tank Prssure High-Low

I-02A

None

I-02B

5-6 Turbine Water Drain Tank Level High-Low

I-03A and I-03B

None

I-05A

None

I-05B

4-3 Loop 1 Hydraulic Oil/Gas Differential Pressure Low

I-05C

3-5 Water Turbine Pressurizing Nitrogen Header Pressure Low

I-05D

5-5 Circulator Pelton Drain Cavity Level High

I-06A

5-7 "B" Hydraulic Reservoir Oil Level 100 Gallons

LIST OF ALARMS AT T=-10 MINUTES

I-06B

None

I-06C

None

I-06D

4-11 "B" Hydraulic Reservoir Oil Level 75 Gallons

I-06E

None

I-06F

None

I-06G

1-4 Main Cooling Tower Fan 1A Vibration High

I-06H

None

I-06I

None

I-09

4-4 Chemical Building

I-13A

None

I-13B

None

LIST OF ALARMS AT T=-10 MINUTES

I-13C

3-2 Core Support Floor Columns Vent Pressure High

5-6 Reactor Building Sump Level High



CR Card 2

T=Throughout Exercise

Post on I-14

RT-7312 reads background on all 5 sampling points

CR Card 3

West RO

T=0 (0400)

The following alarm has sounded:

"Hi Vacuum Tank Pressure" I-01A 1-3



CR Prompter  
CR Card 4 (optional)

T=0 (0400)

FR-6352 is showing recurring spikes

CR Prompter

T=30sec-4min

CR Card 5 (optional)

(0400-0404)

<u>T(min)</u>	<u>7324-1(cpm)</u>	<u>7324-2(cpm)</u>
30 sec	15	background
1	890	200
2	8,900	500
3	26,000	1,600
4	130,000	8,000

RT-73437-1 indicates background



CR Card 6

West R0

T=5 (0405)

The following alarms have sounded:

"Vent Exhaust Gas Activity 1 High" I-01C 1-1

"Vent Exhaust Gas Activity 2 High" I-03A 1-7

Readings: RT-7324-1: 360,000 cpm

RT-7324-2: 21,300 cpm

RT-73437-1: background

CR Card 7

Post on I-14

T=6 (0406)

RT-7324-1: 800,000 cpm

RT-7324-2: 49,000 cpm

RT-73437-1: background



CR Card 8

Post on I-14

T=7 (0407)

RT-7324-1: 1,500,000 cpm

RT-7324-2: 89,000 cpm

RT-73437-1: background

CR Card 9

Post on I-14

T=8 (0408)

RT-7324-1: 2,600,000 cpm

RT-7324-2: 160,000 cpm

RT-73437-1: 20 cpm



CR Card 10

Post on I-14

T=9 min

RT-7324-1: 4,400,000 cpm

RT-7324-2: 270,000 cpm

RT-73437-1: 100 cpm

CR Card 11

Post on I-14

T=10 min

RT-7324-1: 6,200,000 cpm

RT-7324-2: 400,000 cpm

RT-73437-1: 200 cpm



CR Card 12

Post on I-14

T=11 min

RT-7324-1: 8,000,000 cpm

RT-7324-2: 480,000 cpm

RT-73437-1: 300 cpm

CR Card 13

Post on I-14

T=12 min

RT-7324-1: 10,700,000 cpm

RT-7324-2: 650,000 cpm

RT-73437-1: 400 cpm



CR Card 14

Post on I-14

T=13 min

RT-7324-1: 12,000,000 cpm

RT-7324-2: 730,000 cpm

RT-73437-1: 500 cpm

CR Card 15

Post on I-14

T=14 min

RT-7324-1: 13,300,000 cpm

RT-7324-2: 800,000 cpm

RT-73437-1: 600 cpm



CR Card 16

Post on I-14

T=15 min to  
Reactor Scram

RT-7324-1: 16,000,000 cpm

RT-7324-2: 980,000 cpm

RT-73437-1: 700 cpm

CR Card 17

West RO

T=30 (0430)

The following alarm has sounded:

"Reactor Pressure Low" I-03A 2-5



Cr Card 18

Post on I-14

T=60 (0500)

RT-93251-1 (reactor plant exhaust filters)  
reads 20 mR/hr from T=60 throughout the  
remainder of the exercise

CR Card 19

West RO

T=60 (0500)

(If scram not already manually performed)

Low Pressure Reactor Scram Occurs



CR Card 20

Post on I-14

T=Scram

RT-7324-1: 16,000,000 cpm

RT-7324-2: 980,000 cpm

RT-73437-1: 700 cpm

CR Card 21

Post on I-14

T=Scram +15

RT-7324-1: 10,200,000 cpm

RT-7324-2: 620,000 cpm

RT-73437-1: 800 cpm



CR Card 22

Post on I-14

T=Scram +30

RT-7324-1: 6,400,000 cpm

RT-7324-2: 390,000 cpm

RT-73437-1: 900 cpm

CR Card 23

Post on I-14

T=Scram +45

RT-7324-1: 4,050,000 cpm

RT-7324-2: 250,000 cpm

RT-73437-1: 980 cpm



CR Card 24

Post on I-14

T=Scram +60

RT-7324-1: 2,550,000 cpm

RT-7324-2: 150,000 cpm

RT-73437-1: 1,050 cpm

CR Card 25

Post on I-14

T=Scram +75

RT-7324-1: 1,600,000 cpm

RT-7324-2: 97,000 cpm

RT-73437-1: 1,100 cpm



CR Card 26

Post on I-14

T=Scram +90

RT-7324-1: 1,000,000 cpm

RT-7324-2: 60,000 cpm

RT-73437-1: 1,120 cpm

CR Card 27

Post on I-14

T=Scram +105

RT-7324-1: 645,000 cpm

RT-7324-2: 40,000 cpm

RT-73437-1: 1,120 cpm



CR Card 28

Post on I-14

T=Scram +120

RT-7324-1: 400,000 cpm

RT-7324-2: 25,000 cpm

RT-73437-1: 1,120 cpm

CR Card 29

Post on I-14

T=Scram +150

RT-7324-1: 160,000 cpm

RT-7324-2: 10,000 cpm

RT-73437-1: 1,120 cpm



CR Card 30

Post on I-14

T=Scram +180

RT-7324-1: 63,000 cpm

RT-7324-2: 4,000 cpm

RT-73437-1: 1,120 cpm

CR Card 31

Post on I-14

T=Scram +210

RT-7324-1: 25,000 cpm

RT-7324-2: 1,500 cpm

RT-73437-1: 1,120 cpm



CR Card 32

Post on I-14

T=Scram +240

RT-7324-1: 10,000 cpm

RT-7324-2: 600 cpm

RT-73437-1: 1,120 cpm

CR Card 33

Post on I-14

T=Scram +270

RT-7324-1: 4,000 cpm

RT-7324-2: 250 cpm

RT-73437-1: 1,120 cpm



CR Card 34

Post on I-14

T=Scram +300

RT-7324-1: 1,600 cpm

RT-7324-2: 100 cpm

RT-73437-1: 1,120 cpm

CR Card 35

Post on I-14

T=Scram +330

RT-7324-1: 620 cpm

RT-7324-2: 40 cpm

RT-73437-1: 1,120 cpm



CR Card 36

Post on I-14

T=Scram +360

RT-7324-1: 250 cpm

RT-7324-2: 15 cpm

RT-73437-1: 1,120 cpm

PCC PROMPTER

TIME	CARD NO.	DESCRIPTION	RECIPIENT
Upon Establishing PCC	1	PCC Radiation Readings	HP Technician at PCC
After PCC Established	2	PCC Habitability	Person Performing Habitability

PCC Card 1

HP Tech  
Performing  
Habitability

T=upon  
establishing  
PCC

Radiation readings at PCC are background

PCC Card 2

HP Technician  
Performing  
Habitability

T= After PCC is  
Established

After the PCC is established, and if the PCC is in the plume, the person performing habitability shall be informed of the dose rate in the PCC per the attached graph. Note that, for T=15 to the time of reactor scram, the maximum value shown (1220 mR/hr) should be used.

If the PCC is not in the plume, readings are background and the PCC is habitable.



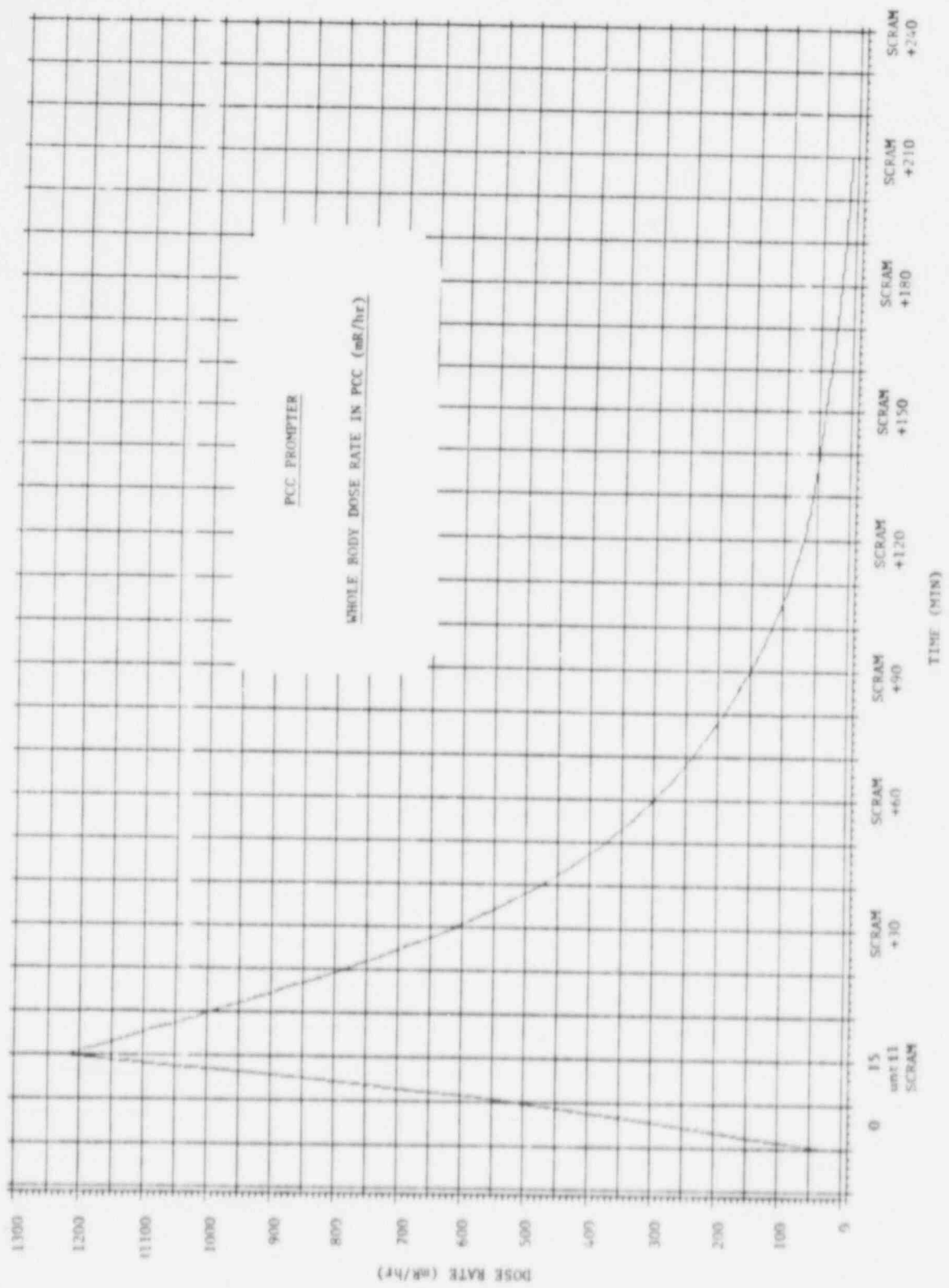

TSC PROMPTER

1. Information from the attached "Effluent Monitoring Cards" is to be provided to the Radiological Assessment Individual at the times indicated.
2. When requested by the Technical Services Engineering Supervisor/Senior Plant Engineer, the PCRV pressure, average region outlet temperature, core inlet temperature, primary coolant flow, and secondary coolant flow, are to be provided per the attached graph. For any other information that is requested, refer the Engineer to the Technical Advisor in the Control Room.

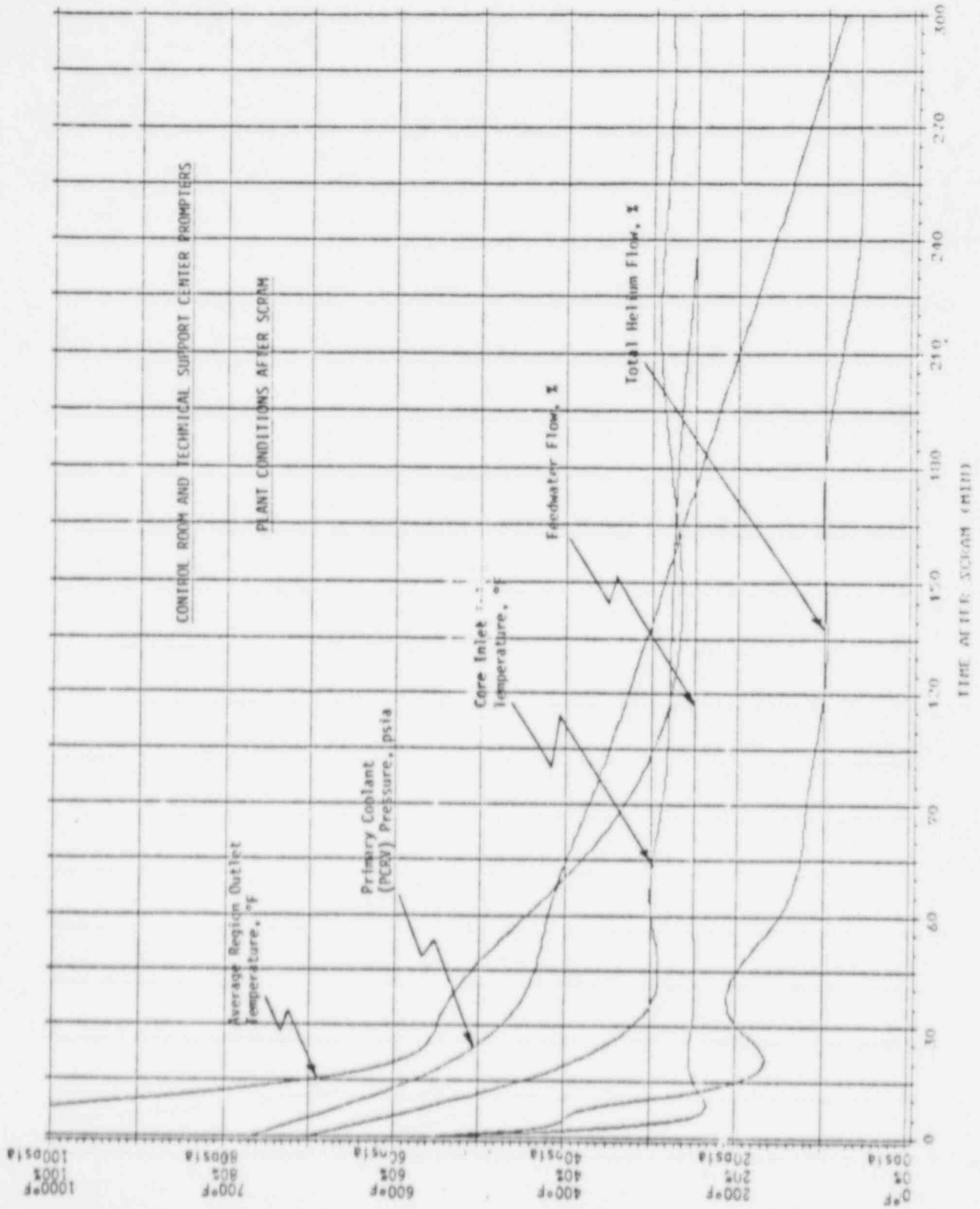



Effluent Monitoring Card 1

T=10 (0410)

RT-7324-1: 6,200,000 cpm

RT-7324-2: 400,000 cpm

RT-73437-1: 200 cpm

Effluent Monitoring Card 2

T=15 (0415) to  
Reactor Scram

RT-7324-1: 16,000,000 cpm

RT-7324-2: 980,000 cpm

RT-73437-1: 700 cpm



Effluent Monitoring Card 3

T=Scram +15

RT-7324-1:	10,200,000	cpm
RT-7324-2:	620,000	cpm
RT-73437-1:	800	cpm



Effluent Monitoring Card 4

T=Scram +30

RT-7324-1: 6,400,000 cpm

RT-7324-2: 390,000 cpm

RT-73437-1: 900 cpm

Effluent Monitoring Card 5

T=Scram +45

RT-7324-1: 4,050,000 cpm

RT-7324-2: 250,000 cpm

RT-73437-1: 980 cpm



Effluent Monitoring Card 6

T=Scram +60

RT-7324-1: 2,550,000 cpm

RT-7324-2: 150,000 cpm

RT-73437-1: 1,050 cpm



Effluent Monitoring Card 7

T=Scram +75

RT-7324-1: 1,600,000 cpm

RT-7324-2: 97,000 cpm

RT-73437-1: 1,100 cpm

Effluent Monitoring Card 8

T=Scram +90

RT-7324-1: 1,000,000 cpm

RT-7324-2: 60,000 cpm

RT-73437-1: 1,120 cpm



Effluent Monitoring Card 9

T=Scram +105

RT-7324-1: 645,000 cpm

RT-7324-2: 40,000 cpm

RT-73437-1: 1,120 cpm



Effluent Monitoring Card 10

T=Scram +120

RT-7324-1: 400,000 cpm

RT-7324-2: 25,000 cpm

RT-73437-1: 1,120 cpm

Effluent Monitoring Card 11

T=Scram +150

RT-7324-1: 160,000 cpm

RT-7324-2: 10,000 cpm

RT-73437-1: 1,120 cpm



Effluent Monitoring Card 12

T=Scram +180

RT-7324-1: 63,000 cpm

RT-7324-2: 4,000 cpm

RT-73437-1: 1,120 cpm



Effluent Monitoring Card 13

T=Scram +210

RT-7324-1: 25,000 cpm

RT-7324-2: 1,500 cpm

RT-73437-1: 1,120 cpm

Effluent Monitoring Card 14

T=Scram +240

RT-7324-1: 10,000 cpm

RT-7324-2: 600 cpm

RT-73437-1: 1,120 cpm



Effluent Monitoring Card 15

T=Scram +270

RT-7324-1: 4,000 cpm

RT-7324-2: 250 cpm

RT-73437-1: 1,120 cpm



Effluent Monitoring Card 16

T=Scram +300

RT-7324-1: 1,600 cpm

RT-7324-2: 100 cpm

RT-73437-1: 1,120 cpm

Effluent Monitoring Card 17

T=Scram +330

RT-7324-1: 620 cpm

RT-7324-2: 40 cpm

RT-73437-1: 1,120 cpm



Effluent Monitoring Card 18

T=Scram +360

RT-7324-1: 250 cpm

RT-7324-2: 15 cpm

RT-73437-1: 1,120 cpm



EAB TEAM PROMPTER

- On all attached EAB Team cards, "Centerline" refers to locations that  
- are directly downwind of the predominant wind direction at the time  
- of the survey.

"Off-Centerline" values should be provided at approximately 1/4 mile  
from the centerline sampling location. At 1/2 mile or more from  
centerline, the whole body dose rate is <1 mR/hour.

EAB Team Card 1

T=30 (0430)

Whole Body: .

Centerline: 1562 mR/hr

Off-Center: 400 mR/hr

SAM-2: Background



EAB Team Card 2

T=45 (0445)

Whole Body:

Centerline: 990 mR/hr

Off-Center: 200 mR/hr

SAM-2: Background



EAB Team Card 3

T=60 (0500)

Whole Body:

Centerline: 620 mR/hr

Off-Center: 150 mR/hr

SAM-2: Background



EAB Team Card 4

T=75 (0515)

Whole Body:

Centerline: 520 mR/hr

Off-Center: 125 mR/hr

SAM-2: Background



EAB Team Card 5

T=90 (0530)

Whole Body:

Centerline: 390 mR/hr

Off-Center: 100 mR/hr

SAM-2: Background



EAB Team Card 6

T=105 (0545)

Whole Body:

Centerline: 260 mR/hr

Off-Center: 65 mR/hr

SAM-2: Background



EAB Team Card 7

T=120 (0600)

Whole Body:

Centerline: 190 mR/hr

Off-Center: 50 mR/hr

SAM-2: Background

EAB Team Card 8

T=135(0615)

Whole Body:

Centerline: 130 mR/hr

Off-Center: 35 mR/hr

SAM-2: < MDA



EAB Team Card 9

T=150 (0630)

Whole Body:

Centerline: 100 mR/hr

Off-Center: 25 mR/hr

SAM-2: Background

EAB Team Card 10

T=165 (0645)

Whole Body:

Centerline: 80 mR/hr

Off-Center: 20 mR/hr

SAM-2: Background



EAB Team Card 11

T=180 (0700)

Whole Body:

Centerline: 65 mR/hr

Off-Center: 15 mR/hr

SAM-2: Background



EAB Team Card 12

T-195 (0715)

Whole Body:

Centerline: 57 mR/hr

Off-Center: 14 mR/hr

SAM-2: Background

EAB Team Card 13

T=210 (0730)

Whole Body:

Centerline: 50 mR/hr

Off-Center: 12 mR/hr

SAM-2: Background



EAB Team Card 14

T=225 (0745)

Whole Body:

Centerline: 40 mR/hr

Off-Center: 10 mR/hr

SAM-2: Background



EAB Team Card 15

T=240 (0800)

Whole Body:

Centerline: 33 mR/hr

Off-Center: 8 mR/hr

SAM-2: Background

EAB Team Card 16

T=255 (0815)

Whole Body:

Centerline: 24 mR/hr

Off-Center: 6 mR/hr

SAM-2: Background



EAB Team Card 17

T=270 (0830)

Whole Body:

Centerline: 15 mR/hr

Off-Center: 4 mR/hr

SAM-2: Background



EAB Team Card 18

T=285 (0845)

Whole Body:

Centerline: 11 mR/hr

Off-Center: 3 mR/hr

SAM-2: Background



EAB Team Card 19

T=300 (0900)

Whole Body:

Centerline: 8 mR/hr

Off-Center: 2 mR/hr

SAM-2: Background



EAB Team Card 20

T=315 (0915)

Whole Body:

Centerline: 6 mR/hr

Off-Center: 1.5 mR/hr

SAM-2: Background

EAB Team Card 21

T=330 (0930)

Whole Body:

Centerline: 4 mR/hr

Off-Center: 1 mR/hr

SAM-2: Background



EAB Team Card 22

T=345 (0945)

Whole Body:

Centerline: 3 mR/hr

Off-Center: 0.5 mR/hr

SAM-2: Background

EPZ TEAM PROMPTER

- On all attached EPZ Team Cards, "Centerline" refers to locations that are directly downwind of the predominant wind direction at the time of the survey. All readings are given at a distance of a 5 mile radius from the plant.

"Off-Centerline" values should be provided at approximately 1/4 mile from the centerline sampling location. At 1/2 mile or more from centerline, the whole body dose rate is  $<1 \text{ mR/hour}$ .



EPZ Team Card 1

T=30 (0430)

Whole Body:

Centerline: 72 mR/hr

Off-Center: 20 mR/hr

SAM-2: Background

EPZ Team Card 2

T=45 (0445)

Whole Body:

Centerline: 46 mR/hr

Off-Center: 10 mR/hr

SAM-2: Background



EPZ Team Card 3

T=60 (0500)

Whole Body:

Centerline: 29 mR/hr

Off-Center: 8 mR/hr

SAM-2: Background

EPZ Team Card 4

T=75 (0515)

Whole Body:

Centerline: 24 mR/hr

Off-Center: 6 mR/hr

SAM-2: Background



EPZ Team Card 5

T=90 (0530)

Whole Body:

Centerline: 18 mR/hr

Off-Center: 3 mR/hr

SAM-2: Background

EPZ Team Card 6

T=105 (0545)

Whole Body:

Centerline: 12 mR/hr

Off-Center: 3 mR/hr

SAM-2: Background



EPZ Team Card 7

T=120 (0600)

Whole Body:

Centerline: 9 mR/hr

Off-Center: 2 mR/hr

SAM-2: Background

EPZ Team Card 8

T=135 (0615)

Whole Body:

Centerline: 6 mR/hr

Off-Center: 1.5 mR/hr

SAM-2: Background



EPZ Team Card 9

T=150 (0630)

Whole Body:

Centerline: 4.6 mR/hr

Off-Center: 1.2 mR/hr

SAM-2: Background

EPZ Team Card 10

T=165 (0645)

Whole Body:

Centerline: 3.8 mR/hr

Off-Center: 1.0 mR/hr

SAM-2: Background



EPZ Team Card 11

T=180 (0700)

Whole Body:

Centerline: 3 mR/hr

Off-Center: 0.8 mR/hr

SAM-2: Background

EPZ Team Card 12

T=195 (0715)

Whole Body:

Centerline: 2.7 mR/hr

Off-Center: 0.7 mR/hr

SAM-2: Background



EPZ Team Card 13

T=210 (0730)

Whole Body:

Centerline: 2.3 mR/hr

Off-Center: 0.6 mR/hr

SAM-2: Background

EPZ Team Card 14

T=225 (0745)

Whole Body:

Centerline: 1.9 mR/hr

Off-Center: 0.5 mR/hr

SAM-2: Background



EPZ Team Card 15

T=240 (0800)

Whole Body:

Centerline: 1.5 mR/hr

Off-Center: 0.4 mR/hr

SAM-2: Background

EPZ Team Card 16

T=255 (0815)

Whole Body:

Centerline: 1.1 mR/hr

Off-Center: 0.3 mR/hr

SAM-2: Background



EPZ Team Card 17

T=270 (0830)

Whole Body:

Centerline: 0.7 mR/hr

Off-Center: 0.2 mR/hr

SAM-2: Background

EPZ Team Card 18

T=285 (0845)

Whole Body:

Centerline: 0.5 mR/hr

Off-Center: 0.15 mR/hr

SAM-2: Background



EPZ Team Card 19

T=300 (0900)

Whole Body:

Centerline: 0.4 mR/hr

Off-Center: 0.1 mR/hr

SAM-2: Background

EPZ Team Card 20

T=315 (0915)

Whole Body:

Centerline: 0.3 mR/hr

Off-Center: 0.07 mR/hr

SAM-2: Background



EPZ Team Card 21

T=330 (0930)

Whole Body:

Centerline: 0.2 mR/hr

Off-Center: Background

SAM-2: Background

EPZ Team Card 22

T=345 (0945)

Whole Body:

Centerline: Background

Off-Center: Background

SAM-2: Background



HP ACCESS AREA PROMPTER

The information on the following cards is to be given to the HP Technician taking samples or checking monitor readings in the reactor building, as required.

HP Access Area Prompter 1

T=Throughout Exercise

\* \* INFORMATION CARD \* \*

If air samples are taken in the reactor building and counted in the HP Access Area, particulate filter reads 14,000 cpm net; silver zeolite reads background (this corresponds to  $\sim 3.8E-8$   $\mu$ ci/cc). Half life, if performed, is 28 minutes.

\* \* DO NOT VOLUNTEER THIS INFORMATION \* \*



HP Access Area Prompter 2      T=Throughout Exercise

All reactor building and turbine building area monitors  
remain at background through out exercise except

RT-93251-1 (reactor plant exhaust filters)  
which reads 20 mR/hr from T=60 to end

HP Access Area  
Prompter 3

T=10(0410) Throughout Exercise

Beta Monitor - Reactor Level 11

500 cpm/min, "ALERT" lit

Level remains constant until scram +60, then decreases gradually to background. "ALERT" clears.at

T=Scram + 90.



HP Access Area  
Prompter 4

T=10(0410) Throughout Exercise

CAM - Reactor Level 7

Noble Gas - background

Iodine - background

Particulate - 500 cpm/minute

Levels remain constant until T=120 and then decrease  
gradually to background.

HP Access Area T=10(0410) Throughout Exercise  
Prompter 5  
CAM - Reactor Level 9

Noble Gas - background

Iodine - background

Particulate - 50 cpm/minute above background

Levels remain constant until T=120 and then all  
gradually decrease to background.



PLANT EQUIPMENT CARDS

The attached cards are to be hung on plant equipment for purposes of the drill. This information contained on the cards would only be obtained by equipment operators and would not be indicated by instrumentation in the Control Room.

Plant Card 1

V-4755

\*\* THIS IS A DRILL \*\*

This valve is in the open position.

The stem is broken off and the valve may not be manipulated.

\*\* THIS IS A DRILL \*\*



Plant Card 2

PI-63101  
(on Loop seal)

\*\* THIS IS A DRILL \*\*

This pressure indicator reads 2 psig.

\*\* THIS IS A DRILL \*\*

Plant Card 3

HV-2301

\* \* THIS IS A DRILL \* \*

This valve is broken in the open position.

\* \* THIS IS A DRILL \* \*

[