

S-39
50-348/364-CIVP
2/19/92

50442-2

LOCKETED
USNRC

Staff Exh. 39

'92 MAR 13 12:10

WYLE LABORATORIES

SCIENTIFIC SERVICES AND SYSTEMS GROUP
WESTERN OPERATIONS, NORCO FACILITY
1841 HILLSIDE AVENUE, NORCO, CALIF. 91760

OFFICE OF SECRETARY
DOCKETING & SERVICE
BRANCH

Environmental Qualification Test Report
of
Raychem Nuclear Cable Breakout and End Sealing Kits
for
Raychem Corporation
Menlo Park, California

Received from
Raychem Virginia.
no letter.
DuBaton



FOR INFORMATION ONLY

RECORD COPY

test REPORT

005499

7597-03-E91-14-1

9204060314 920217
PDR ADOCK 05000348
G PDR

NUCLEAR REGULATORY COMMISSION

Docket No. 50-34834-1 Official Ex. No. 39

In the matter of Alabama Power Company

Staff IDENTIFIED 12:19 p.m. 2/1/92

Applicant _____ RECEIVED 12:23 p.m. 2/1/92

Intervenor _____ REJECTED _____

Contractor _____ DATE 2/1/92

Other _____ WITNESS _____

Reporter L. Estep

BECHTEL EASTERN POWER COMPANY

JOB NO. 7597-20	ACCESSION NO.
UNIT <u>2</u>	U- <u>406385</u>
TITLE ENVIRONMENTAL QUALIFICATION TEST REPORT OF RAYCHEM NUCLEAR CABLE BREAKOUT AND END SEALING KITS	
JOB: JOSEPH M. FARLEY NUCLEAR PLANT ALABAMA POWER CO.	
Supplier: RAYCHEM CORPORATION (071508)	F.O. APCO Req. APCO PCN No. (If Applic.) <u>B-87-0-4475</u>

SUPPLIER DOCUMENT REVIEW STATUS	
<u>STATUS NO.</u>	
1.	<input type="checkbox"/> REVISE AND RESUBMIT. WORK MAY NOT PROCEED.
2.	<input type="checkbox"/> REVISE AND RESUBMIT. WORK MAY PROCEED SUBJECT TO INCORPORATION OF CHANGES INDICATED.
3.	<input type="checkbox"/> WORK MAY PROCEED.
7.	<input type="checkbox"/> VOID OR SUPERSEDED.
8.	<input checked="" type="checkbox"/> REVIEW NOT REQUIRED. WORK MAY PROCEED.
<p>Permission to proceed does not constitute acceptance or approval of design details, calculations, analyses, test methods or materials developed or selected by the supplier and does not relieve supplier from full compliance with contractual obligations.</p>	
By <u>D. B. Burton</u>	DATE <u>9/15/87</u>

A Unit of Bechtel Power Corporation

BEPC-13000-V Rev. 8/87

RECORD COPY

7597-20-E-91-17-1

005500

WYLE LABORATORIES

SCIENTIFIC SERVICES AND SYSTEMS GROUP
WESTERN OPERATIONS, NORCO FACILITY
1841 HILLSIDE AVENUE, NORCO, CALIF. 91760

Environmental Qualification Test Report
of
Raychem Nuclear Cable Breakout and End Sealing Kits
for
Raychem Corporation
Menlo Park, California

*Received from
Raychem Virginia
No letter
D. Subramani*

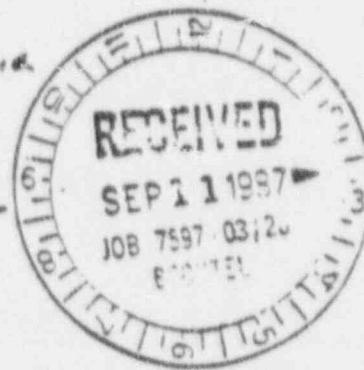

RECORD COPY

FOR INFORMATION ONLY

test REPORT

7597-20-E91-17-1

005501

TEST REPORT

WYLE LABORATORIES

SCIENTIFIC SERVICES & SYSTEMS GROUP
WESTERN OPERATIONS, NORCO FACILITY

REPORT NO. 58442-2
OUR JOB NO. NDO 58442
CONTRACT ---
YOUR P. O. NO. A01183

Raychem Corporation
300 Constitution Drive
Menlo Park, California 94025

DATE 3 April 1981

ENVIRONMENTAL QUALIFICATION TEST REPORT
OF
RAYCHEM NUCLEAR CABLE BREAKOUT AND END SEALING KITS
FOR
RAYCHEM CORPORATION
MENLO PARK, CALIFORNIA

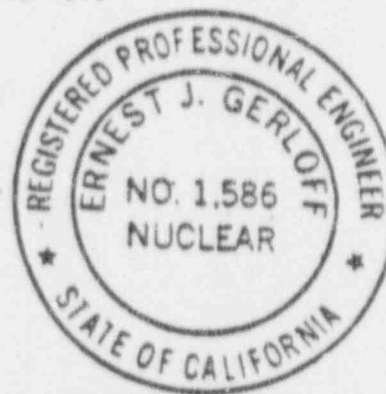

STATE OF CALIFORNIA }
COUNTY OF RIVERSIDE }

Ray C. Myrick, being duly sworn,

deposes and says: That the information contained in this report is the result of complete and carefully conducted tests and is to the best of his knowledge true and correct in all respects.

Ray C. Myrick

SUBSCRIBED and sworn to before me this 7th day of April, 19 81

Catherine C. Kelly
Notary Public in and for the County of Riverside, State of California

My Commission expires 14 July, 19 83

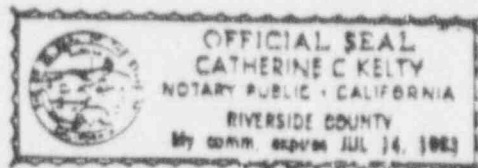

W-867A

DEPARTMENT DYNAMICS

DEPT. MGR. J. J. Anderson
J. J. Anderson

TEST ENGINEER Walter Franz
WALTER FRANZ

Registered Professional Engineer [Signature]

DCAS-QAR VERIFICATION

QUALITY CONTROL A. Heesema
A. Heesema 005502

CONTENTS

<u>Section</u>	<u>Title</u>	<u>Page</u>
1.0	SUMMARY	1
2.0	TEST SPECIMENS	1
3.0	TEST PROGRAM	5
	3.1 Pretest Inspection	5
	3.2 Thermal Aging	5
	3.3 Radiation Exposure	8
	3.4 Loss of Coolant Accident and Main Steamline Break (LOCA/MSLB) Environmental Exposure	8
4.0	CONCLUSIONS	14
	TABLES	16
	APPENDICES	

FIGURES

<u>Title</u>	<u>Page</u>
Figure 1 - Sample Construction	2
Figure 2 - Detail of Sample Construction	3
Figure 3 - Mandrel and Samples	6
Figure 4 - Mandrel and Samples Immersed in Water	7
Figure 5 - LOCA/MSLB Test Profile	8
Figure 6 - LOCA/MSLB Pressure Vessel	10
Figure 7 - Test Schematic	10
Figure 8 - Test Chamber and Samples	12
Figure 9 - Mandrel after Removal from Vessel	12

TABLES

Table 1 - I.R. Values	16
Table 2 - Current Monitoring of Specimens During Simulated LOCA/MSLB Environment	18
Table 3 - Post LOCA/MSLB Investigation Summary	19

APPENDICES

Appendix A - Certificate of Radiation Dose
Appendix B - Data Acquisition Instruments

005504

C

1.0 SUMMARY

Six Raychem test specimens, each consisting of four cable break-out and four end cap assemblies, were subjected to a test program based on the guidelines of IEEE Standards 323-1974(1) and 383-1974(2) to determine their suitability for service within the containment of a nuclear generating station.

The test program consisted of:

1. Thermal aging (0, 1000, 1500 hours @ 150°C)
2. Radiation exposure (200 - 290 Mrads)
3. Simulated loss of coolant accident combined with main steam-line break (LOCA/MSLB) conditions while the specimens were energized at rated current and voltage. (20A rms, 1000V rms)

The electrical integrity of the specimens was evaluated by:

1. Insulation resistance measurements at 500V d-c.
2. Voltage withstand tests at 3600V rms for 5 minutes.
3. The ability to maintain electrical loading at rated voltage and current during the simulated LOCA/MSLB.

The cable breakout and end cap assemblies demonstrated satisfactory functional performance in this test program. All specimens had a high insulation resistance (>10Mohms) and, with the exception of end cap sample 2-1W1, passed a voltage withstand test at the conclusion of the test program.

The test program was conducted by Wyle Laboratories, Norco, California during the period of August, 1979 to February, 1980.

2.0 TEST SPECIMENS

005505

Each test specimen was comprised of four cable breakouts and four end caps forming a loop as shown in Figure 1. The cable breakouts were tested as part of a transition splice assembly

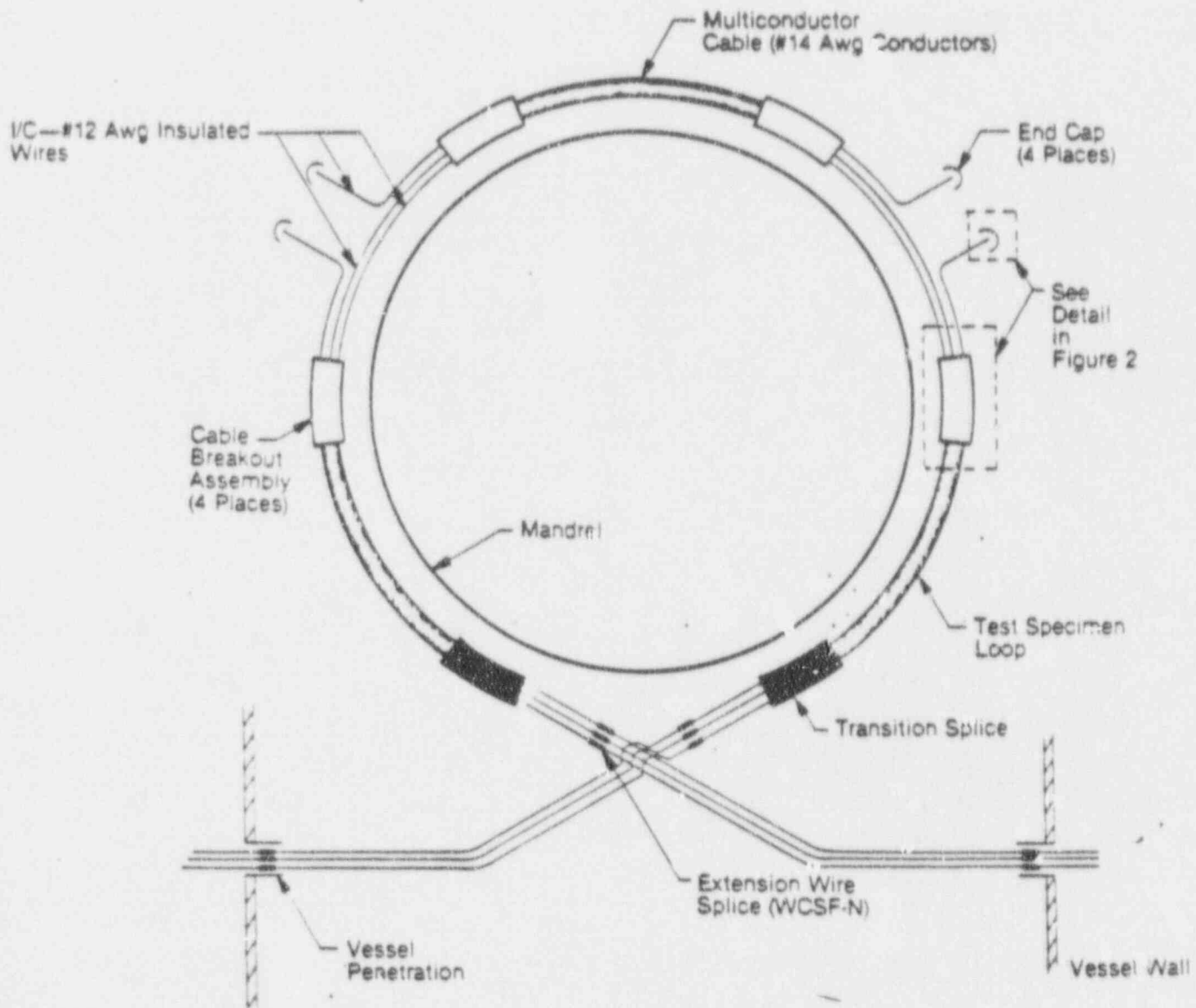
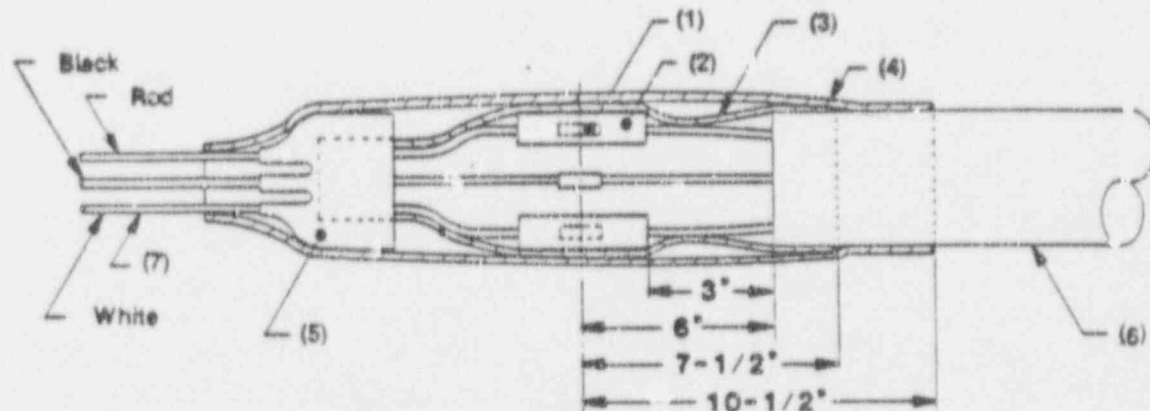
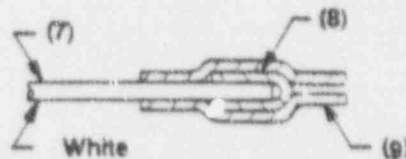

Figure 1 SAMPLE CONSTRUCTION

005506



- (1) Raychem Crimp Connector, D609-1
- (2) Raychem WCSF-N, Insulating Sleeve, Size 115, 6 inches, S-1119 Adhesive
- (3) Raychem WCSF-N, Insulating Sleeve, Size 300, 15 inches, S-1119 Adhesive
- (4) Raychem WCSF-N, Insulating Sleeve, Size 300, 21 inches, uncoated
- (5) Raychem 403A112-52, Cable Breakout S-1119 Adhesive
- (6) Rockbestos Firewall III Insulated Cable, 5/C, 14 Awg, XLPE Insulation and Jacket
- (7) Rockbestos Firewall III Insulated Wire, 1/C, 12 Awg, .030 inch XLPE Insulation



- (8) Raychem 101A021-52, End Cap, S-1119 Adhesive
- (9) Raychem WCSF-U, Insulating Sleeve, Size 115, 3 inches, uncoated

005507

Figure 2 DETAIL OF SAMPLE CONSTRUCTION

connecting three No. 14 AWG wires from a multiconductor cable to three No. 12 AWG single conductor wires. Details of the cable breakout and end cap samples tested are shown in Figure 2. The materials used to make the connections are also listed. A total of 24 cable breakouts and 24 end caps were used for the test program.

Because of availability, a five-conductor cable (5/C No. 14) was used for each test specimen loop. Only three of the five conductors were actually used to avoid an excessive number of test vessel penetrations and energizing circuits. The two unused conductors were cut back with the cable jacket inside the splice assembly.

The wire insulations in the test specimen loops were color coded for ease of identification during the test. The red and black wires were continuous throughout the test loops and had voltage and current applied. The white wire was terminated in end caps at four places as shown in Figure 1 and therefore could not have current applied. Voltage was applied to the white wire from each end of the test loop. The white wire in the two cable breakout assemblies and end caps in the middle of the test loop was isolated and could not be energized.

To evaluate the sealing effectiveness of the cable breakout assembly, the crimp splice joining the black insulated wire in each cable breakout assembly was left uninsulated. In this way, any water leakage into the assembly would be detected. In all cases the red and white wire crimp slices were covered with WCSF-N heat shrinkable tubing.

A length of uncoated WCSF (without adhesive lining) was recovered over each cable breakout assembly and end cap.

005508

The ends of the specimen loop were spliced to single conductor No. 12 extension wires using a transition splice assembly similar to the samples tested except that all internal crimp splices

were covered with WCSF-N. The extension wires connected the specimen loops to the test vessel penetrations.

3.0 TEST PROGRAM

3.1 Pretest Inspection

The specimens were visually inspected upon receipt at Wyle Laboratories. There was no evidence of damage due to shipping.

3.1.1 Functional Test (Baseline Data)

Each specimen was immersed in water and given a voltage withstand test of 3.6kV a-c for five minutes. All cable breakouts and end caps were immersed during this test. Specimen 2-2 failed the baseline voltage withstand test. The wire insulation was found to be damaged. Specimen 2-6 was used to replace 2-2 to allow the thermal aging to proceed. A replacement for specimen 2-2 was provided by Raychem. All other specimens passed the baseline test.

While still immersed for the above test, the insulation resistance (IR) of each specimen was measured at 500V d-c. These results are given in Table 1 on page 14.

The measurements were made on both the black and red insulated wire in each specimen loop and on the white wire at each end of the loop since the white wire was not continuous throughout the loop. Therefore, four measurements of both IR & voltage withstand were recorded on each specimen.

The continuity of the red and black insulated wires in each specimen loop was also verified with a low voltage ohmmeter.

005509

3.2 Thermal Aging

Two of the six specimen loops were wrapped onto a 20-inch diameter stainless steel mandrel and tied in place. The mandrel and

specimens were placed in an air-circulating oven operating at 150°C (302°F) for 500 hours. At that time, two additional specimen loops were added to the mandrel, and the oven aging continued for another 1000 hours. After removal from the oven, the two remaining specimen loops were then added to the mandrel.

<u>Specimen No.</u>	<u>Thermal Aging (Hours at 150°C)¹</u>
2-1	1500
2-6	1500
2-2	1000
2-3	1000
2-4	0
2-5	0

The mandrel, with the specimens in place, is shown in Figure 3.

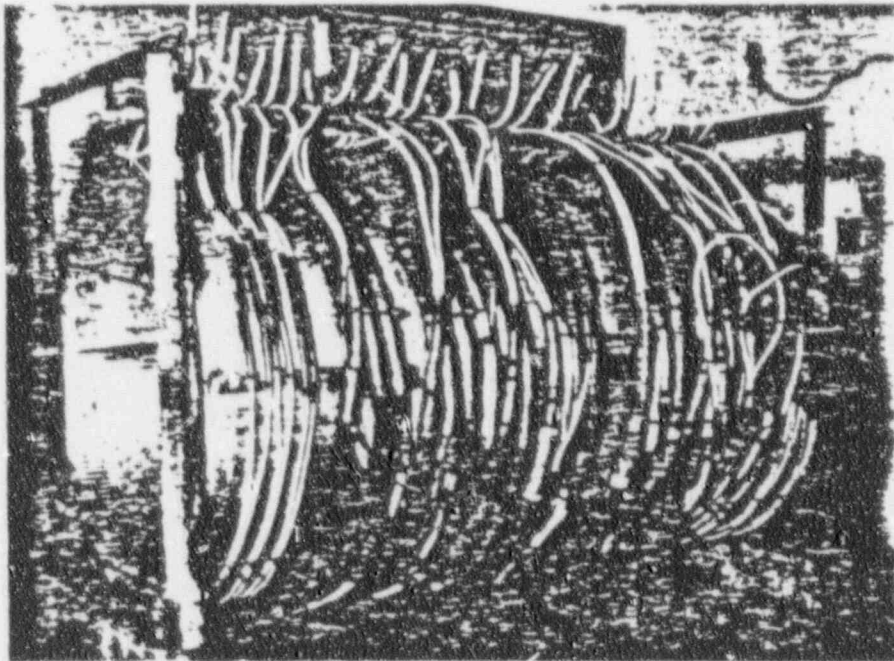

FIGURE 3. Mandrel and Samples

(Specimens 2-1 through 2-6 are located **005510**
in the center section of the mandrel.)

¹ Both 1000 and 1500 hours at 150°C exceed the required aging time to simulate 40 year life at 90°C for the cable.

Note Several other types of specimens were also tested in this program and are shown on the mandrel. This report covers only the cable breakout and end cap assemblies. The other specimens are the subject of separate reports.

3.2.1 Functional Tests

The mandrel with the specimens in place was immersed in water for functional tests as described in 3.1.1. This was accomplished by splicing long extension leads to each end of the test loops. The splices between the specimens and the extension leads were covered with WCSF-N heat shrinkable tubing. The mandrel in the water is shown in Figure 4.

All specimens again passed the 3.6kV a-c voltage withstand test for five minutes. The insulation resistance values are given in Table 1 on page 14.

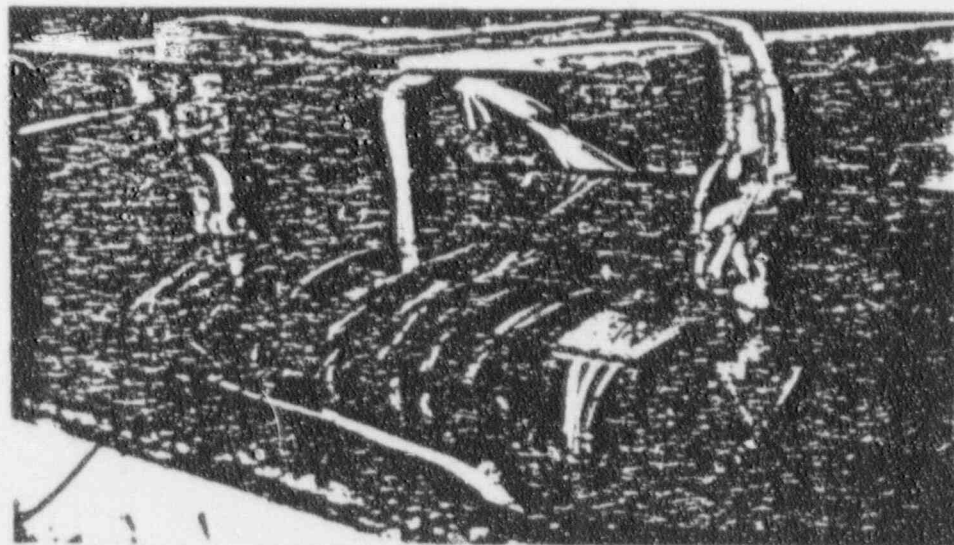

FIGURE 4. Mandrel and Samples Immersed in Water

005511

3.3 Radiation Exposure

All the specimens, while still on the mandrel, were subjected to gamma radiation from a Cobalt-60 source. The total air equivalent dose given the specimens ranged from 2.0×10^8 to 2.9×10^8 rads. The dose rate was between 0.32 and 0.47×10^6 rads per hour. The certificate of radiation dose is shown in Appendix A.

3.3.1 Functional Tests

The functional tests were again performed as described in 3.1.1. All specimens passed the voltage withstand test. The insulation resistance values are given in Table 1.

3.4 Loss of Coolant Accident and Main Steamline Break (LOCA/MSLB) Environmental Exposure

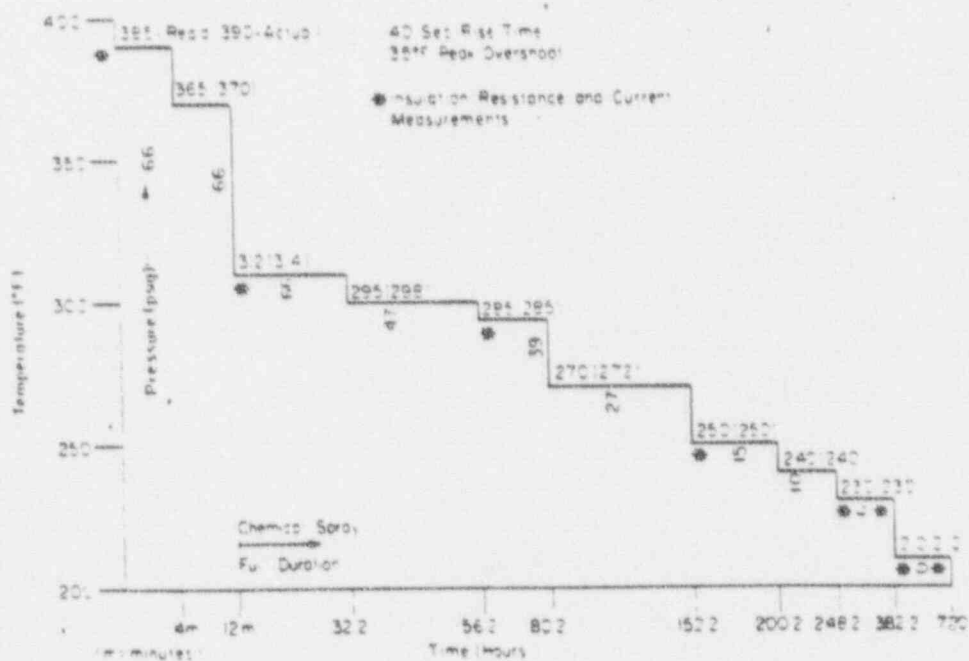

Figure 5. Temperature/Pressure Profile for Simulation of LOCA/MSLB Environment

005512

3.4 Loss of Coolant Accident and Main Steamline
Break (LOCA/MSLB) Environmental Exposure (continued)

The specimens on the mandrel were placed in a test chamber capable of exposing the specimens to the steam and chemical spray environment shown in Figure 5.

The extension leads were brought out through penetrations in the vessel to allow the specimens to be energized during the exposure. The specimens were energized at 1.0kV a-c to ground and carried a current of 20 amperes at 25°C ambient at the start of the simulated accident. The current was allowed to drop as the resistance in the conductors increased at elevated temperatures. Current values during the test are recorded in Table 2 on page 15.

Fuses were installed in the voltage circuit for each specimen so that during the exposure a breakdown in the insulation of one specimen would not affect the voltage applied to the others. Schematics of the test chamber and energizing circuit are given in Figures 6 and 7 respectively. All data acquisition instruments used in the test program are listed in Appendix B.

The chemical spray consisted of 6200 ppm of boron, 50 ppm of hydrazine buffered to a pH of 10.5 with trisodium phosphate. The spray was applied at the top of the vessel through a horizontal spray header at a rate in excess of 0.15 gpm/ft² (actual flow varied from .26 to .81 gpm/ft²).

005513

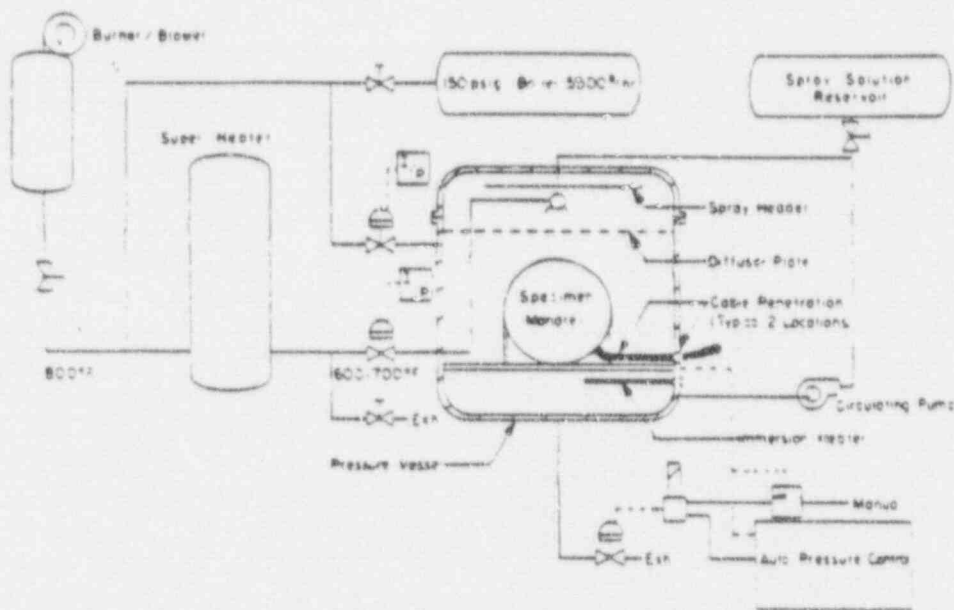

FIGURE 6. LOCA/MSLB Pressure Vessel and Auxiliary Equipment

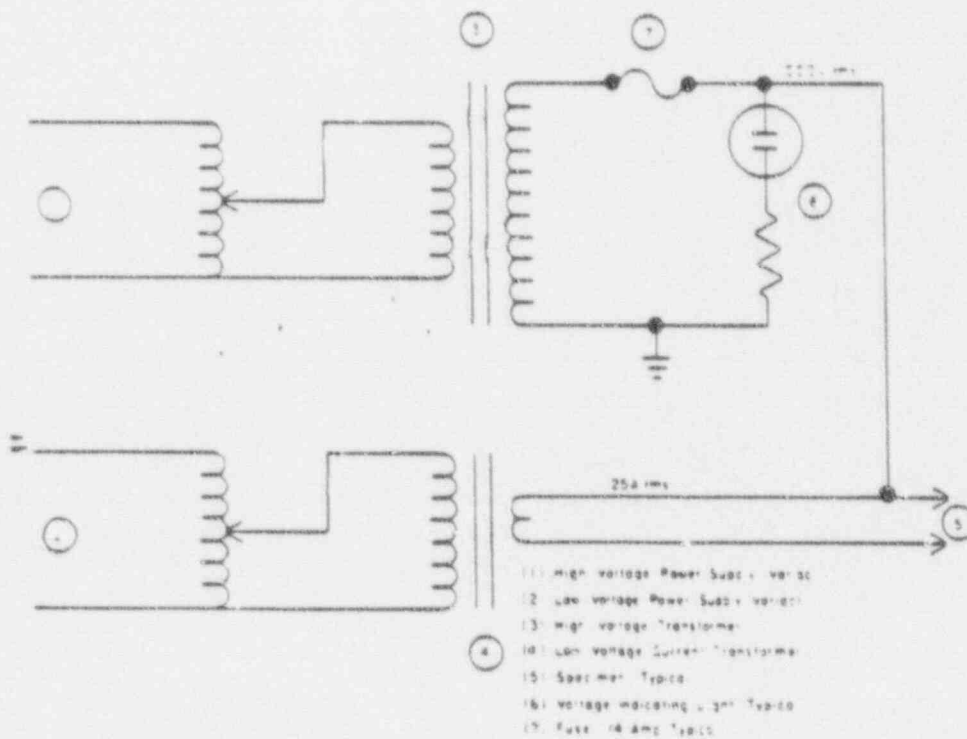

FIGURE 7. Test Schematic for Energizing Specimens

005514

3.4.1 Test Results

During the course of the LOCA/MSLB environment exposure, all energized specimens held the rated current. The capability to supply voltage continuously throughout the test was impaired on some specimens due to insulation failures in the test loop other than at the test samples themselves. The 1.0kV a-c was necessarily terminated on these specimens when the fuse opened. A complete discussion of the anomalies associated with the loss of voltage is given in section 3.4.2.

Insulation resistance values measured at selected times during the LOCA/MSLB exposure are given in Table 1 on page 14.

3.4.2 Post LOCA/MSLB Inspection

At the conclusion of the test profile (Figure 5), the test vessel was flooded with tap water. The specimens were then given a voltage withstand test, and the insulation resistances measured. The results of the insulation resistance tests are given in Table 1. The vessel was then opened and the cause for some of the specimens being unable to hold rated voltage investigated. The test vessel with the specimens in place is shown in Figure 8. Figure 9 shows the test specimens after removal from the test vessel.

The extension wires were cut inside the vessel so that the mandrel could be removed. This also allowed the test vessel penetrations to be inspected. It was found that some of the wires in the penetration had a low insulation resistance and would not pass the 3.6kV a-c voltage withstand test. The specimens associated with the penetration wires having a low insulation resistance were retested immersed in water (see Figure 4). The retest of specimens 2-1R, 2-2B, and 2-5W2 showed high values of insulation resistance and all specimens passed the voltage withstand test. The low values previously measured on these specimens can therefore be attributed to the test vessel penetrations and not the specimens.

005515

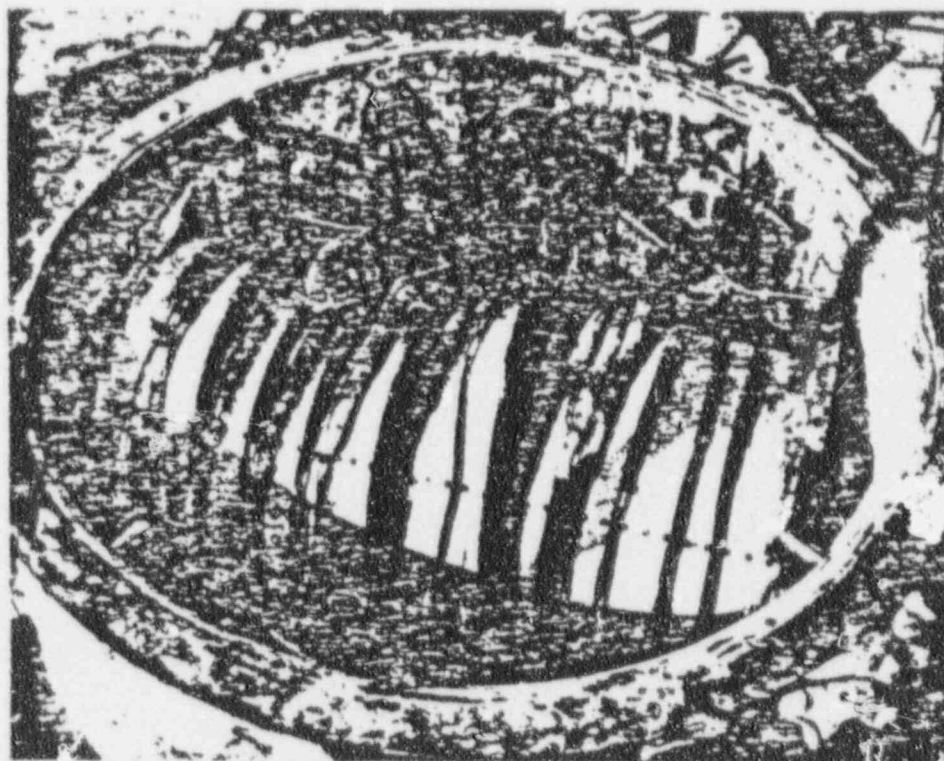

FIGURE 8. Test Chamber and Samples

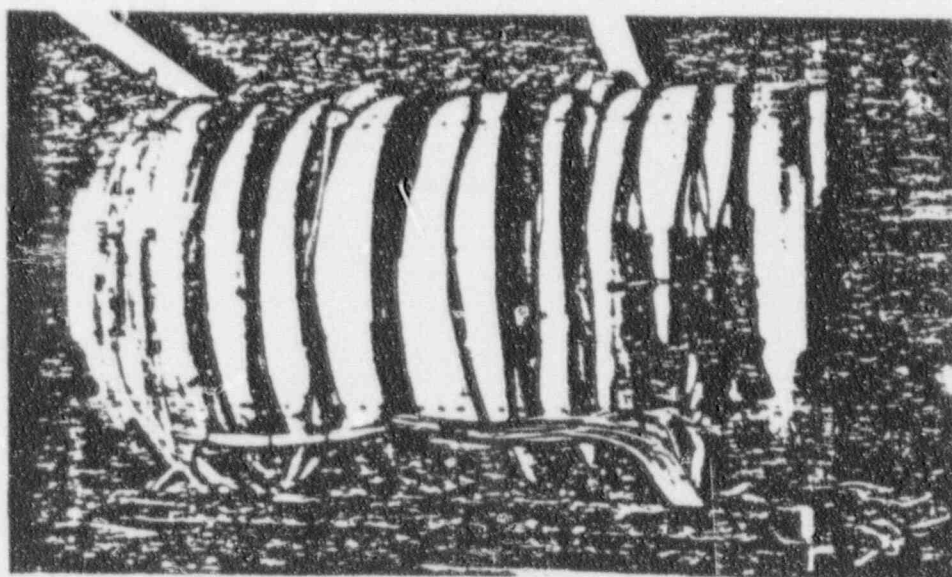

FIGURE 9. Mandrel After Removal from Vessel

005316

3.4.2 Post LOCA/MSLB Inspection (continued)

Some specimens had high values of insulation resistance throughout the simulated LOCA/MSLB test but dropped in insulation resistance or did not pass the voltage withstand test when the vessel was flooded with water. It was found that the low values were caused by cracks in the extension wire insulation away from the mandrel area. The samples again had high insulation resistance values and passed the voltage withstand test when the mandrel was removed from the vessel, the extension wires repaired, and the mandrel re-immersed in water. The insulation values are given in Table 1.

The remaining specimens had cracked wire insulation on the test loops around the mandrel. In these cases, the specimens were removed from the mandrel and individually immersed in water for test. In this way, the cracked wire could be isolated. The remaining specimens, except 2-5B, gave high insulation resistance values and passed the voltage withstand tests when tested with the cracked wire insulation out of the water. This could not be done with specimen 2-5B since the crack in the wire insulation was too close to the end of the cable breakout. An insulation resistance value could not be obtained on this specimen because the surface leakage gave an erroneous value. This specimen did, however, pass the voltage withstand test using an aluminum foil ground plane.

End cap assembly 2-1W1 had a dielectric failure through the end of the cap after repeated over-voltage testing (up to 6kV a-c) used to locate the cracked wire insulation during the post-test investigation. The failure occurred at the end of the cap where the cut strands of the No. 12 wire contacted the end cap.

None of the low insulation resistances recorded during the test were attributable to the Raychem test samples themselves.

005517

3.4.2 Post LOCA/MSLB Inspection (continued)

Visual examination of the sleeves used over the cable breakouts and end caps showed surface degradation and some superficial crazing. This was most apparent on specimens 2-4 and 2-5.

A summary of the findings during the post LOCA/MSLB investigation is given in Table 3 on page 16.

4.0 CONCLUSIONS

Six test specimen loops, each containing four cable breakout assemblies and four end cap assemblies, were subjected to an extensive test program including thermal aging, radiation exposure, and simulated LOCA/MSLB environmental exposure. During the LOCA/MSLB exposure, the specimens were energized at rated current and voltage.

All specimens demonstrated satisfactory electrical performance at the conclusion of the test program. Wire insulation cracks and low resistance of some wires in the test vessel penetrations caused apparent low values in some of the specimens, but subsequent testing substantiates the functional ability of these assemblies. All specimens had high insulation resistance values and (except for one end cap assembly) passed the voltage withstand test at the conclusion of the program.

The results of this comprehensive test program confirm, by type testing, the adequacy and suitability of the Raychem cable breakout and end cap assemblies for use on Class IE systems within the containment of a nuclear power generating station.

005518

REFERENCES

- (1) IEEE Standard 323-1974, "IEEE Standard for Qualifying IE Equipment for Nuclear Power Generating Stations."
- (2) IEEE Standard 383-1974, "IEEE Standard for Type Test of Class IE Electric Cables, Field Splices, and Connections for Nuclear Power Generation Stations."

OC 519

TABLE I
INSULATION RESISTANCE (OHMS)

TEST CONDITIONS	TEMPERATURE (°C)	PRESSURE (psig)	SPECIMEN NUMBER															
			R	W1	W2	R	W1	W2	R	W1	W2	R	W1	W2				
Initial (Baseline) (1)	Ambient	0	4×10^{10}	$>5 \times 10^{10}$	$>5 \times 10^{10}$	$>5 \times 10^{10}$	$>5 \times 10^{10}$	$>5 \times 10^{10}$	$>5 \times 10^{10}$	$>5 \times 10^{10}$	$>5 \times 10^{10}$	$>5 \times 10^{10}$	$>5 \times 10^{10}$	$>5 \times 10^{10}$	$>5 \times 10^{10}$	$>5 \times 10^{10}$	$>5 \times 10^{10}$	$>5 \times 10^{10}$
After Aging (2)	Ambient	0	$>1 \times 10^8$	$>1 \times 10^8$	$>1 \times 10^8$	$>1 \times 10^8$	$>1 \times 10^8$	$>1 \times 10^8$	$>1 \times 10^8$	$>1 \times 10^8$	$>1 \times 10^8$	$>1 \times 10^8$	$>1 \times 10^8$	$>1 \times 10^8$	$>1 \times 10^8$	$>1 \times 10^8$	$>1 \times 10^8$	$>1 \times 10^8$
After Irradiation (1)	Ambient	0	$>5 \times 10^{10}$	$>5 \times 10^{10}$	$>5 \times 10^{10}$	$>5 \times 10^{10}$	$>5 \times 10^{10}$	$>5 \times 10^{10}$	$>5 \times 10^{10}$	$>5 \times 10^{10}$	$>5 \times 10^{10}$	$>5 \times 10^{10}$	$>5 \times 10^{10}$	$>5 \times 10^{10}$	$>5 \times 10^{10}$	$>5 \times 10^{10}$	$>5 \times 10^{10}$	$>5 \times 10^{10}$
In Test Vessel (1)	Ambient	0	$>5 \times 10^{10}$	$>5 \times 10^{10}$	$>5 \times 10^{10}$	$>5 \times 10^{10}$	$>5 \times 10^{10}$	$>5 \times 10^{10}$	$>5 \times 10^{10}$	$>5 \times 10^{10}$	$>5 \times 10^{10}$	$>5 \times 10^{10}$	$>5 \times 10^{10}$	$>5 \times 10^{10}$	$>5 \times 10^{10}$	$>5 \times 10^{10}$	$>5 \times 10^{10}$	$>5 \times 10^{10}$
During Simulated LOCA/MSLB Test (See Figure 5)																		
After 12 minutes	314	66	3.0×10^6	7.0×10^6	16.0×10^6	3.0×10^6	17.0×10^6	19.0×10^6	3.3×10^6	17.0×10^6	19.0×10^6	3.3×10^6	17.0×10^6	19.0×10^6	3.3×10^6	17.0×10^6	19.0×10^6	3.3×10^6
After 56.2 hours	285	39	4.0×10^6	1.8×10^7	1.4×10^7	9.0×10^5	8.0×10^5	8.0×10^5	5.0×10^6	8.0×10^5	8.0×10^5	5.0×10^6	8.0×10^5	8.0×10^5	5.0×10^6	8.0×10^5	8.0×10^5	5.0×10^6
After 152.2 hours	250	15	(3)	12.5×10^7	12.9×10^7	(3)	(4)	(4)	19.5×10^7	14.0×10^7	12.2×10^7	2.0×10^7	2.0×10^7	2.0×10^7	2.0×10^7	2.0×10^7	2.0×10^7	2.0×10^7
After 240.2 hours	230	6		15.2×10^7	16.0×10^7				3.5×10^8	8.5×10^7	12.4×10^7	2.4×10^7	2.4×10^7	2.4×10^7	2.4×10^7	2.4×10^7	2.4×10^7	2.4×10^7
After 361 hours	230	6		15.5×10^7	16.0×10^7				16.2×10^5	1.1×10^8	13.2×10^7	3.7×10^7	3.7×10^7	3.7×10^7	3.7×10^7	3.7×10^7	3.7×10^7	3.7×10^7
After 383 hours	210	0		11.6×10^8	11.6×10^8				(3)	3.0×10^8	15.0×10^7	7.0×10^7	7.0×10^7	7.0×10^7	7.0×10^7	7.0×10^7	7.0×10^7	7.0×10^7
After 720 hours	210	0		11.2×10^8	11.2×10^8					12.6×10^8	19.0×10^5	5.0×10^7	5.0×10^7	5.0×10^7	5.0×10^7	5.0×10^7	5.0×10^7	5.0×10^7
Test Vessel Filled with Water	---	---			12.5×10^{10}													
Mandrel Removed from Vessel and Immersed in Water	---	---																
Specimens Removed from Mandrel and Tested in Water	---	---																

005520

- (1) 5.0×10^{10} is the maximum insulation resistance readable at 500V d-c with the specific test equipment.
- (2) 1.0×10^8 is the maximum insulation resistance readable at 500V d-c with the specific test equipment.
- (3) Subsequent test showed low value due to cracks in the wire insulation.
- (4) Subsequent test showed low value due to the electrical penetration in the test vessel.
- (5) No insulation resistance value could be obtained since crack in wire insulation was too close to specimen. (Specimen passed VMT.)

NOTE: All specimens (except 2-1W1; ref. p. 11) passed a voltage withstand test at 3.6kV a-c for 5 minutes at each test point excluding post aging and during the simulated event.

TABLE I (Cont.)
INSUR A-100N RESISTANCE (OHMS)

TEST CONDITIONS	TEMPERATURE (°C)		PRESSURE (psig)	7.4		7.5		7.6	
	B	W ²		B	W ²	B	W ²	B	W ²
Initial (Baseline) (1)	>5x10 ¹⁰	>5x10 ¹⁰	0	>5x10 ¹⁰	>5x10 ¹⁰	>5x10 ¹⁰	>5x10 ¹⁰	>5x10 ¹⁰	>5x10 ¹⁰
After Aging (2)	>1x10 ⁸	>1x10 ⁸	0	>1x10 ⁸	>1x10 ⁸	>1x10 ⁸	>1x10 ⁸	>1x10 ⁸	>1x10 ⁸
After Irradiation (1)	>5x10 ¹⁰	>5x10 ¹⁰	0	>5x10 ¹⁰	>5x10 ¹⁰	>5x10 ¹⁰	>5x10 ¹⁰	>5x10 ¹⁰	>5x10 ¹⁰
In Test Vessel (1)	>5x10 ¹⁰	>5x10 ¹⁰	0	>5x10 ¹⁰	>5x10 ¹⁰	>5x10 ¹⁰	>5x10 ¹⁰	>5x10 ¹⁰	>5x10 ¹⁰
During Simulated LOCA/MSLB Test (See Figure 5)									
After 12 minutes	12.0x10 ⁷	12.2x10 ⁷	66	12.1x10 ⁷	12.7x10 ⁷	12.7x10 ⁷	12.7x10 ⁷	12.9x10 ⁶	3.0x10 ⁶ 16.0x10 ⁶
After 56.2 hours	11.9x10 ⁷	13.1x10 ⁷	39	12.2x10 ⁷	13.3x10 ⁷	12.8x10 ⁷	13.3x10 ⁷	3.5x10 ⁶	3.0x10 ⁶ 11.3x10 ⁶
After 152.2 hours	12.7x10 ⁷	11.0x10 ⁸	15	14.6x10 ⁷	11.1x10 ⁸	18.5x10 ⁷	11.1x10 ⁸	11.9x10 ⁷	11.5x10 ⁷ 12.4x10 ⁷
After 248.2 hours	14.5x10 ⁷	11.3x10 ⁸	6	17.5x10 ⁷	11.1x10 ⁸	11.1x10 ⁸	2.4x10 ⁵	12.0x10 ⁷	12.0x10 ⁷ 14.3x10 ⁷
After 361 hours	11.3x10 ⁸	11.3x10 ⁸	6	17.0x10 ⁷	11.2x10 ⁸	11.2x10 ⁸	(4)	3.0x10 ⁷	12.4x10 ⁷ 16.0x10 ⁷
After 303 hours	12.3x10 ⁸	11.6x10 ⁸	0	13.1x10 ⁸	14.3x10 ⁷	13.1x10 ⁸	14.3x10 ⁷	3.3x10 ⁷	11.8x10 ⁸ 11.4x10 ⁸
After 220 hours	11.5x10 ⁸	13.0x10 ⁷	0	12.2x10 ⁸	(3)	12.2x10 ⁸	(3)	12.5x10 ⁷	11.0x10 ⁸ 11.1x10 ⁸
Test Vessel Filled with Water	12.6x10 ⁸		---	10.0x10 ⁹		10.0x10 ⁹		12.4x10 ¹⁰	11.4x10 ⁹ 11.6x10 ¹⁰
Mandrel Removed from Vessel and Immersed in Water	>5x10 ¹⁰		---	12.5x10 ⁹		13.0x10 ⁹			
Specimens Removed from Mandrel and Tested in Water	14.2x10 ⁷		---	(15)					

005521

TABLE 2
CURRENT MONITORING OF SPECIMENS
DURING SIMULATED LUCA/MSLB ENVIRONMENT

TEST CONDITIONS	TEMPERATURE (°F) (°C)	PRESSURE (psig)	CURRENT (AMPERES)											
			2-1	2-2	2-3	2-4	2-5	2-6	2-7	2-8	2-9	2-10	2-11	2-12
Before Start of Test	Ambient		20.0	20.2	20.5	20.9	20.0	21.4	21.0	21.3	20.4	20.6	20.1	18.2
During Test (See Figure 5)														
12 minutes	314 157	66	16.4	16.6	17.0	17.2	17.3	17.6	17.1	17.4	16.9	17.0	16.6	16.3
56.2 hours	205 141	39	17.1	17.1	17.7	17.9	17.9	18.2	17.6	17.9	17.4	17.4	17.0	16.7
152.2 hours	250 121	15	16.9	17.7	18.4	18.6	18.5	19.0	18.4	18.7	18.2	18.3	17.9	16.9
248.2 hours	230 110	6	18.3	18.0	18.7	18.9	18.9	19.4	19.0	19.3	18.6	18.6	18.2	17.3
381 hours	230 110	6	17.9	18.1	18.6	18.7	18.7	19.1	18.6	18.9	18.2	18.5	18.0	17.0
383 hours	210 99	0	18.5	18.6	18.7	18.9	18.9	19.4	19.0	19.4	18.6	18.8	18.3	17.3
720 hours	210 99	0	18.4	18.4	18.6	18.8	18.8	19.3	18.9	19.2	18.6	18.6	18.3	16.7

005522

TABLE 3
POST LOCA/MSLB INVESTIGATION SUMMARY

<u>Specimen No.</u>	<u>Aging Time at 150°C</u>	<u>Time voltage Was Applied</u>	<u>Results</u>
2-1R	1500 Hours	12 Minutes	Penetration failure. Passed subsequent VWT.
2-1B	1500 Hours	7 Days	Cracks in wire insulation. Passed subsequent VWT.
2-1W1	1500 Hours	31 Days	Completed test at rated voltage with good IR's. Dielectric failure of end cap during repeated VWT's.
2-1W2	1500 Hours	31 Days	Completed test.
2-2R	1000 Hours	1 Day	Cracks in wire insulation. Passed subsequent VWT.
2-2B	1000 Hours	12 Minutes	Penetration failure. Passed subsequent VWT.
2-2W1	1000 Hours	3 Days	Cracks in wire insulation. Passed subsequent VWT.
2-2W2	1000 Hours	31 Days	Completed test.
2-3R	1000 Hours	31 Days	Post test failure in wire insulation. Passed subsequent VWT.
2-3B	1000 Hours	31 Days	Post test failure in wire insulation. Passed subsequent VWT.
2-3W1	1000 Hours	31 Days	Completed test.
2-3W2	1000 Hours	31 Days	Completed test.

005523

TABLE 3 (CONT.)
POST LOCA/MSLB INVESTIGATION SUMMARY

<u>Specimen No.</u>	<u>Aging Time at 150°C</u>	<u>Time Voltage Was Applied</u>	<u>Results</u>
2-4R	Unaged	15 Days	Cracks in wire insulation. Passed subsequent VWT.
2-4B	Unaged	1 Day	Crack in cable jacket and wire insulation. Passed subsequent VWT.
2-4W1	Unaged	31 Days	Completed test.
2-4W2	Unaged	1 Day	Cracks in wire insulation. Passed subsequent VWT.
2-5R	Unaged	31 Days	Penetration failure. Passed subsequent VWT.
2-5B	Unaged	4 Days	Cracks in wire insulation. Passed subsequent VWT.
2-5W1	Unaged	31 Days	Completed test.
2-5W2	Unaged	18 Days	Penetration failure. Passed subsequent VWT.
2-6R	1500 Hours	30 Days	Post test failure in wire insu- lation. Passed subsequent VWT.
2-6B	1500 Hours	31 Days	Completed test.
2-6W1	1500 Hours	31 Days	Completed test.
2-6W2	1500 Hours	31 Days	Completed test.

005524

APPENDIX A

CERTIFICATION OF RADIATION DOSE

005525

Atomics International Division
8900 De Soto Avenue
Canoga Park, California 91304
(213) 341-1000



Rockwell
International

CERTIFICATE OF GAMMA RADIATION DOSE

CUSTOMER Wyle Laboratories

PURCHASE ORDER NO. 8057

Wyle Job No. NDQ 58442

DATE IN October 26, 1979

TIME IN 11:00 AM

DATE OUT November 21, 1979

TIME OUT 8:00 AM

MINIMUM DOSE 2.0×10^8 RADS

MAXIMUM DOSE 2.9×10^8 RADS

Signature RK Paschall

005526

APPENDIX B

LIST OF DATA ACQUISITION INSTRUMENTS

005527

KOB NO 58442-2
DATE 1/3/80
TEST BY M. Schmitz
WITNESS

SPECIMEN SPLICES
CUSTOMER RAYCHEM CORPORATION
PART NO SEE RECEIVING INSP.
S/N SEE RECEIVING INSP.

ACCIDENT SIMULATION

WVLR LABORATORY

EQUIPMENT	MANUFACTURER	MODEL NO	RANGE	WYLE NO	CALIBRATION		ACCY
					LAST	DUE	
Electrostatic Voltmeter	Electrical Instrum. Ser. Superior	University	0-1000 Volt 0-28 Amp 0-280 VAC	8416	11-30-79	03-20-80	±1.0%
Powerstat	Elect. Co.	1258C	240/480 VAC	N/A	SYSTEM CALIBRATION		
Transformer	Messinghouse	6C98-071	12KVA 12KVOut	N/A	SYSTEM CALIBRATION		
Digital Multimeter	Fluke	8010A	0-200 mA 0-2000 VAC	8188	11-12-79	11-12-80	±0.5%
Amp Probe	Fluke	N/A	1000:1 Ratio	7691	06-25-79	06-29-80	±3.0%
Shunt	Weston	0041218	50Amp/50mV	8183	01-15-79	01-20-80	±0.5%
Shunt	Weston	0041218	50Amp/50mV	8184	01-15-79	01-20-80	±0.5%
Shunt	Weston	0041218	50Amp/50mV	8185	01-15-79	01-20-80	±0.5%
Powerstat (Typ. 3)	Superior Elect. Co.	1258C	0-280 VAC	N/A	SYSTEM CALIBRATION		
Transformer (Typ. 3)	UMK.	N/A	1000:6 Ratio	N/A	SYSTEM CALIBRATION		
Venturi	Barco	553	1-300 gpm	8166	12-16-79	12-16-80	±1%
Pressure Transducer	Validyne	DP15	0-100 psi	7660	SYSTEM CALIBRATION		±.25%
Recorder	H.P.	7132A	0-500 mV	7613	SYSTEM CALIBRATION		±0.2%
Recorder	H.P.	7132A	0-500 mV	7612	SYSTEM CALIBRATION		±0.2%
Delta Press. Gauge	Barton	04-49053-1	0-80 in M.C.	7784	09-03-79	01-03-80	±.25%
Dig. Thermometer	Fluke	2160A	-328 to +750°F	8290	09-04-79	09-07-80	±2°F
Dig. Thermometer	Fluke	2160A	-328 to +750°F	8401	10-12-79	10-12-80	±2°F
Dig. Thermometer	Fluke	2160A	-328 to +750°F	8032	06-13-79	08-17-80	±2°F

005531