

GENERAL PUBLIC UTILITIES
OYSTER CREEK NUCLEAR GENERATING STATION
EMERGENCY PREPAREDNESS DRILL SCENARIO

SCENARIO NO. 42
(REVISION 0)

NOVEMBER 1, 1995

DF01
0/1

130060

9511150143 951101
PDR ADOCK 05000219
F PLR

GENERAL PUBLIC UTILITIES
OYSTER CREEK NUCLEAR GENERATING STATION

TABLE OF CONTENTS

COVER PAGE

TABLE OF CONTENTS

I. Administrative

I.A. Summary

I.A.1. Purpose

I.A.2. Narrative Summary

I.A.3. Objectives

I.A.4. Performance Guidelines

I.A.5. Radiological Assumptions

I.A.6. Schedule of Events

I.B. Time Line

I.C Exercise Control

I.C.1 Pre-Exercise Briefings

I.C.1.a. POD Meeting Briefing

I.C.1.b. On-Shift Crew Briefing

I.C.1.c. Participants Briefing

I.C.2 Cont/Observer Assignments

I.C.3 Communications

I.C.3.a. Drill Controller Phone List

I.C.3.b. Emergency Response Center Phone List

I.C.4 Forms

I.C.4.a. Chronology of Events and Minor Comments Form

I.C.4.b. Observer Comments/Deficiencies Form

I.C.4.c. Player Participants Evaluation Form

I.C.4.d. Attendance Form

II. Operational Data

II.A. Plant Parameter Trends

II.B. Backup Plant Parameter

II.C. Backup Annunciator Data

III. Onsite Radiological Data

III.A. Process and Area Radiation Monitors

III.B. Area Dose Rates

III.C. On-Site and ERF Dose Rates

III.D. Building Air Activity

III.E. Plant Sample Activity

IV. Off-Site Radiological Data

IV.A. Dose Projection

IV.B. Plume Data

IV.B.1. Plume Map

IV.B.2. Closed Window Dose Rate

IV.B.3. Open Window Dose Rate

IV.B.4. Particulate Filter Data

IV.B.5. Silver Zeolite Data

IV.B.6 Environmental Sample Data

IV.C. Meteorological Data

IV.D. CREST Data

V. Message Cards

VI. Mini-Scenarios

VI.A. DG Fuel Oil Tank Fire

VI.B. Off-site Fire Support

VI.C. EDG Alternate Fuel Oil Lineup

VI.D. Isolation Condenser Valves

VI.E. "B" CRD Pump Breaker

VI.F. Public Information Activities

VI.G. Field Monitoring Team Sampling

VI.H. Liquid Poison

VI.I. Alternate Poison Injection

VI.J. SCRAM Discharge Volume

VI.K. Venting Overpiston Area

SECTION I ADMINISTRATIVE

I.A. SUMMARY

I.B. TIME LINE

I.C. EXERCISE CONTROL

SECTION I.A. SUMMARY

- I.A.1. Purpose
- I.A.2. Narrative Summary
- I.A.3. Objectives
- I.A.4. Performance Guidelines
- I.A.5. Radiological Assumptions
- I.A.6. Schedule of Events

I.A. SUMMARY

I.A.1. PURPOSE

This scenario will be used as the 1995 Annual Exercise at Oyster Creek Nuclear Generating Station on November 1, 1995. The OCNGS Replica Simulator will be used to implement this scenario.

The scenario has been developed to meet the Objectives outlined in Section I.A.3 "Objectives." The scenario will involve the declaration of an **UNUSUAL EVENT, ALERT, SITE AREA EMERGENCY** and **GENERAL EMERGENCY**. There will be a radiological release sufficient to exercise the Off-site Dose Assessment, Field Monitoring Teams and Protective Action Recommendation processes.

The scenario will involve a fire in the Diesel Generator Fuel Oil Storage Tank Room and off-site fire fighting support will be demonstrated using the Forked River Fire Department.

All times indicated in this scenario are clock times based on a start time of 16:00 on November 1, 1995. Start time may be delayed due to plant or simulator conditions. If this is the case, clock times may have to be adjusted. Controllers have been briefed on this possibility. Plant Computer System (PCS) time is used in this scenario.

The scenario is organized as follows:

- Section I - Administrative & Logistical information
- Section I.B - Detailed Scenario Time Line
- Section II - Ops data
- Sections III & IV - Radiological Data
- Section V - Message Cards
- Section VI - Mini Scenarios for each key activity outside the Control Room.

I.A. SUMMARY

I.A.3. OBJECTIVES

The 1995 Oyster Creek Nuclear Generating Station Annual Exercise Objectives are as follows:

1. Demonstrate the ability of on-shift and Initial Response Organization personnel to detect and assess accident conditions.
2. Demonstrate the ability of on-shift and ERO personnel to properly declare emergency classifications based on plant accident conditions.
- 3a. Demonstrate the timely notification of offsite response organizations.
- 3b. Demonstrate the timely mobilization of the GPU Emergency Response Organization.
- 3c. Demonstrate the proper notification of non-essential personnel on site or in the owner controlled area.
4. Demonstrate adequate communications between ERF's and with onsite and offsite GPU emergency teams.
- 5a. Demonstrate adequate radiological controls for exposure during emergencies.
- 5b. Demonstrate adequate radiological controls for contamination of personnel and equipment.
6. Demonstrate that appropriate Protective Action Recommendations can be provided to New Jersey authorities.
7. Demonstrate that the on-shift Emergency Response Organization can adequately respond to the initial stages of an emergency.
- 8a. Demonstrate that the Initial Response and Emergency Support Organizations can supplement and support the on-shift emergency organization.
- 8b. Demonstrate adequate transition of authority between emergency organizations.
9. Demonstrate the ability to assign qualified individuals to the Emergency Response Organization for shift operation.
10. Demonstrate the ability to properly conduct a critique with participants and to identify major strengths and weaknesses.

The optional Objectives covered by this drill are as follows:

1. Demonstrate Joint Information Center (Media Center).
2. Demonstrate the capability of the Fire Brigade and local fire department to respond to emergency conditions.
3. Demonstrate the ability of First Aid and/or rescue teams to respond in a timely manner.
4. Demonstrate the ability of offsite medical personnel to respond to onsite injured personnel.
5. Demonstrate the ability of security personnel to provide prompt access for offsite emergency equipment and personnel.
6. Demonstrate adequate rumor control.
7. Demonstrate the ability to perform field monitoring including soil, vegetation and water sampling.
8. Demonstrate the ability to perform dose estimates for the affected population.
9. Demonstrate the ability to consider the use of KI and to administer it if necessary.
10. Demonstrate the ability to perform accountability for all personnel onsite.
11. Demonstrate the ability to respond to an off-site release in excess of two hours that will exceed Protective Action Guidelines (PAG's).

NOTE

Optional Objectives Three (3) and Four (4) will be conducted separately as an MS-1 Drill.

I.A. SUMMARY

I.A.4. PERFORMANCE GUIDELINES

The following performance guidelines have been developed to define the "extent of play" by the exercise participants in meeting the exercise objectives.

- a. The 1995 Annual Exercise will be conducted on November 1, 1995. Exercise participants will possess prior knowledge of the approximate start time. However, all personnel should follow their normal routines for that day except those prestaged in accordance with items below.
- b. All times indicated in this scenario are clock times based on a start time 16:00, as displayed by the Plant Computer System. Start times may be delayed due to the fact that Oyster Creek will be operating during the Exercise. If conditions of the plant or simulator require a delay in exercise initiation, clock times may have to be adjusted.
- c. Control Room activities will be performed in the replica simulator Control Room.
- d. Plant parameters are generated on the simulator and will be displayed on the normal PCS in the TSC, OCS, PTFC, and EOF. ERDS will be available through NRC Headquarters.
- e. Plant data is generated by the replica simulator for the operational transients. This data will be affected by simulator operator actions, pre-planned component failures, and simulator controls applied as necessary to maintain events within the overall exercise time line. This scenario was developed and tested on the simulator. We believe that operator actions and engineering solutions (from the TSC) have been anticipated. However, should additional actions or solutions be identified, they will be recognized as positive but, may not be allowed by exercise controllers. This level of control is necessary to avoid a simulator model crash as the scenario greatly exceeds the design basis accidents, that the simulator was designed to replicate. Should a simulator crash occur, the exercise will be placed on hold, as best as it can be, and the simulator rebooted. This process would take at least 15 minutes.
- f. All radiological and chemistry data is generated based on simulator indications and preplanned personnel actions. Off-site radiological data is based on GPU Nuclear's RAC dose projection program results.

- g. All site personnel will participate in the Exercise with the exceptions of those necessary for continued plant operation and critical work activities.
- h. Mini-scenarios have been developed to support plant efforts for events that require more detail than can be included in the time line.
- i. Drill players will perform, as appropriate, radiological monitoring and dose assessment activities to the extent appropriate to the scenario. This will include actual sampling on-site and off-site.
- j. Two (2) Offsite Radiological Field Monitoring Teams and one (1) Onsite Radiological Field Monitoring Team will be dispatched for the purpose of testing response time, communications, and monitoring and sampling procedures. The field teams will gather sample material and route those samples for analysis.

Each Radiological Monitoring Field Team will be accompanied by an Observer throughout the drill. Each field team will rendezvous with its Observer at the location at which it obtains its emergency kits.
- k. All emergency response facilities will be manned and will perform their prescribed functions as appropriate to the drill scenario.
- l. The Prompt Notification System will not be activated.
- m. The Emergency Broadcast System will not be activated.
- n. Where possible, actual samples will be obtained and analyzed. It must be realized this is dependent on plant status and management priorities. RAGEMS is a routine effluent monitoring system. It cannot be aligned to its post emergency sampling configuration for the drill.
- o. The scenario will require the assembly and accounting for site personnel.
- p. Exemptions for accountability may be allowed if the work is critical to plant operations. All such exemptions will be approved in advance by plant management.

- q. Participation by GPUNC onsite personnel directly involved in responding to an emergency shall be carried out to the fullest extent practical, including the deployment of the radiological monitoring teams, emergency repair teams, and other emergency workers. However, drill participation shall not be carried to the extent of manipulating plant equipment or deviation from Rad Con, Safety, Security, or other plant procedures. This requirement may at times delay scenario play while actions are taken to ensure procedural compliance. This delay shall not be construed as detracting from team response.
- r. Initial conditions are given in the simulated Control Room. Initial conditions that would normally be known by plant staff regarding current plant conditions may be communicated by drill Controllers in other locations at a convenient time before or during the drill. Examples of this would be identification of on-going maintenance and out-of-service systems; simulated "Plan of the Day" meeting minutes; "Drill" log entries; and other such items.
- s. A site evacuation may be called for if a General Emergency is declared. An evacuation will not be announced or performed.

I.A. SUMMARY

I.A.5. RADIOLOGICAL ASSUMPTIONS

a. Source Terms

Fuel damage occurs during the Turbine Trip with partial failure to SCRAM, and the subsequent core power oscillations incidents resulting in 11% clad damage.

Activities for plant systems are based on the reactor coolant, resulting from the above conditions, Torus gas and water, Drywell Gas and Main Steam activities.

b. In-Plant Radiation Doses

Turbine Building Operating Floor is elevated due to the increase NG shine from the turbine due to degraded fuel.

During the SCRAM, Rx Bldg 75' and 95' elevation dose rates increase when the Iso Condenser initiates and increases as clad damage increases.

When the Iso Condenser Steam Leak occurs, the Reactor Building dose rates and airborne activity increase dramatically due to the postulated 4000 - 5000 gpm leak occurring for 10-20 minutes as Reactor pressure decreases. Reactor Building dose rates increase dramatically, and this, in conjunction to the steam environment, will make the building inaccessible. Dose rates in the vicinity of the Reactor Building will be elevated due to shine effects.

c. Onsite Data

On-site dose rates will increase due to plume effect, shine from the Stack pad and shine from the Reactor Building airborne activity. A ground level release due to the Reactor Building positive pressure affects radiological conditions within the Protected Area and on-site in the downwind plume direction.

d. Offsite Data

An elevated release through SBT results from the Iso Condenser Steam Leak. SBT System efficiency is degraded to less than 20% efficiency to increase the offsite dose, especially the thyroid dose.

d. Offsite Data continued

Off-site data is based on the elevated release, wind speed of 2.2 mph, Class "F" meteorological conditions, and a main stack flow rate of 1.35E5 CFM. SBGT System auto-initiates after two minutes. Dose projection based on a stack RAGEMS sample source term is a peak TEDE of 4050 mr at 4.0 miles, and a Thyroid CDE of 796 mr at 10.0 miles. The associated PAR is evacuate 360 degrees out to 2 miles and 10 miles downwind.

The dose projection of a TEDE of 3860 mr, and a Thyroid CDE of 572 mr at 5 miles meets the FEMA criteria established September 1, 1994.

I.A. SUMMARY

I.A.6. SCHEDULE OF EVENTS

Observer Pre-Briefings

Date and Time: Week of October 23, 1995
Location: EP Conference Rm/OCAB 2nd fl.

NRC GET

Date and Time: November 1, 1995 8:00 a.m.
Location: Processing Center, Bld. 14

NRC Entrance Meeting

Date and Time: November 1, 1995 11:00 a.m.
Location: Video Conf. Rm./OCAB 3rd fl.

Observer Briefing

Date and Time: October 31, 1995 2:00 p.m.
Location: Cafeteria/OCAB 1st fl.

Exercise Period

Date and Time: November 1, 1995 16:00 p.m.

Observer Debrief

Date and Time: November 2, 1995 9:00 a.m.
Location: Cafeteria/OCAB 1st fl.

Exercise Critique

Date and Time: November 2, 1995 1:30 p.m.
Location: Cafeteria/OCAB 1st fl.

NRC Exit Meeting

Date and Time: November 2, 1995 3:00 p.m.
Location: Cafeteria/OCAB 1st fl.

SECTION I.B. TIME LINE

SECTION I.C. EXERCISE CONTROL

I.C.1. PRE-EXERCISE BRIEFINGS

I.C.2. CONT/OBSERVER ASSIGNMENTS

I.C.3. COMMUNICATIONS

I.C.4. FORMS

SECTION I.C.1. PRE-EXERCISE BRIEFINGS

- I.C.1.a. POD Meeting Briefing
- I.C.1.b. On-Shift Crew Briefing
- I.C.1.c. Participants Briefing

I.C. EXERCISE CONTROL

I.C.1. Pre-Exercise Briefings

a. **POD Meeting Briefing**

A member of the drill development and/or drill control group should attend the Oyster Creek Plan of the Day (POD) meeting, the morning of the drill. This person will brief station management on the simulated conditions leading up to the start of the drill, using the attached POD and STA Report.

The following scenario control items should also be included in this briefing:

- Drill start time is 16:00.
- If a General Emergency is declared, a site evacuation will not be announced or performed.

THIS IS A DRILL... THIS IS A DRILL

Plan of the Day --- Morning Briefing, November 1, 1995

Plant has been operating at 100% power for 300 days.

- CRD Pump "A" (P-15-001A) is OOS for replacement of a shorted motor winding. Tech Spec 3.4.D.2 LCO (7 day) was entered October 30th, at 10:00 a.m.. A new motor is to be delivered tomorrow.
- RWCU Recirc. Pump "B" (P-16-001B) is OOS for breaker repairs.
- Service Air Compressor 1-3 is OOS for replacement of the high temperature switch.

THIS IS A DRILL... THIS IS A DRILL

SHIFT TECHNICAL ADVISOR PLANT STATUS SHEET
OYSTER CREEK NUCLEAR GENERATING STATION

STA : Shift STA
DATE: 11/01/95
TIME: 02:30

MODE SWITCH: RUN
REACTOR POWER: 1929 MWTH 100.0% (LICENSE)
GENERATOR: 658 MWE (GROSS)
641 MWE (NET) 103.6 % NET
ACT-PRED: -3.3

MS RAD LEVELS (MR/HR):
A- 252 B- 250 C- 241 D- 241

MAIN STEAM FLOW: 7.19 MLB/HR
STEAM CHEST PRESS: 930 PSIG

AOG: IN SERVICE
OFF-GAS ACTIVITY (MR/HR): 141 / 147
CONV. FACT.: 25 / 30 DATE: 05/13/95
STACK GAS ACTIVITY (CPS): 7.0 / 7.0

RX LEVEL: 159" TAP (YARWAY)
RX PRESS: 1022 PSIG (WR)

FEED PUMPS: ALL ON
FEED FLOW: 7.17 MLB/HR
FEED TEMP. (FINAL): 310.0 F
COND. DEMIN DP: 31 PSID

THERMAL LIMITS (% of Limit/Location)
(TIME: 02:02)

MCPR	94.2	35	26
MLHGR	72.6	29	24 32
MAPLHGR	91.6	35	26 06
PCI (KW/PT)	1.4	29	24 30

CONDENSER VAC: 28.4 / 28.7 / 28.5
LP HOOD TEMP (F): 114 / 115 / 116
BAROMETER: 29.96 "HG
INTAKE TEMP: 62.0 F BRIDGE TEMP: 74.2 F
DISCHARGE TEMP: 81.5 F

RECIRC PUMPS: ALL ON
FLOW: 15.35 E4 GPM
CORE DP: 17.0 PSID

RX CHEMISTRY: DATE 05/16/95
TIME: 09:40 POWER: 1927 MWth
PH: 6.07 @ 26.0 C
COND: 0.062 uS/CM, CL: < 0.4 uG/ml
I-131: 6.5E-5 uC/ML
HWC: 11.0 SCFM, ECPMS: -0.293 V

RX CONTAINMENT:
D PRESS: 1.23 PSIG, TEMP: 120.6 F (BULK)
T PRESS: 1.10 PSIG, TEMP: 74.2 F
TORUS LEVEL: 149 IN.

CHLORINATION STATUS
CIRC WATER: IS
SERVICE WATER: IS
NRW / AOG: IS

TRUNNION ROOM TEMP: 132 F
RBCCW TEMP: 74 F
TBCCW TEMP: 83 F

LEAKAGE: (GPM) Based on 24 HOUR AVG
UNIDENTIFIED: 0 IDENTIFIED: 0

CONTINUOUS DAYS ON LINE: 300

LOAD LIMITED BY: LICENSE LIMIT (1930 MWth)
MAJOR EQUIPMENT OUT OF SERVICE / TECH SPEC ITEMS:

- * CRD Pump "A" (P-15-001A) is OOS for replacement of a shorted motor winding. Tech Spec 3.4.D.2 LCO (7 day) was entered October 30th, at 10:00 a.m.. A new motor is to be delivered tomorrow.
- * RWCU Recirc. Pump "B" (P-16-001B) is OOS for breaker repairs.
- * Service Air Compressor 1-3 is OOS for replacement of the high temperature switch.

THIS IS A DRILL... THIS IS A DRILL

b. ON-SHIFT CREW BRIEFING

After ensuring that only the Exempt Operations and STA personnel are present conducting a briefing, covering as a minimum the following:

- The basic time line of the drill including major events and expected plant simulations.
- Review the details of the EP phone switching function. Simulator Communications Interface (SCI) switch controls and details located in EPIP - OC-.03 (Emergency Notification) body.
- GSS controls SCI switch and continued performance of any drill activities. GSS has authority to secure from any drill if a plant event warrants. GSS should make a plant page announcement stating that the drill is terminated and what the conditions are that required termination. As soon as possible the GSS should contact the Lead Controller in the TSC to discuss the termination.
- The ON-SHIFT CREW of SROs, STAs, CROs, and EOs not participating in the drill shall wear yellow "Exempt" arm badges.
- Minimize normal plant pages and activities during the drill. This will prevent confusion for drill participants and non-drill participants.
- Minimize plant evolutions during the drill to prevent overall confusion.
- Drill controllers can be reached at:
 - Lead Controller, TSC (609 457-2094)
 - Plant Data Controller (609 457-2451)
- Utilize "This is not a drill" for any event in the plant requiring real plant actions.
- If people come or call the Control Room who are drill players, inform them to call the Simulator Control Room at Extension 5666 or Extension 5959.
- Discuss PCS switching function from Operator Menu. Remind the Control Room that they should log in the Lead CRO's Logbook when the Simulator Communications Interface Switch and the PCS is shifted to the drill mode and again when they are returned to the normal operational mode.

c. **Participants Briefing**

Gather the GSS, GOS, STA, CROs, EOs and any other Operations personnel that are to participate in the drill (such as a refueling crew) and conduct a drill briefing to include the following as a minimum:

- Once the drill crew takes the shift in the simulator they will coordinate with the ON-SHIFT CREW to swap communications and the PCS to the simulator. When the drill is terminated they will coordinate with the ON-SHIFT CREW to return both systems to normal.
- During the drill all conditions in the simulator should be treated as they would in the plant. Any condition that can not be done should be brought to the attention of a controller in the Simulator Control Room.
- All actions in the field shall be simulated in such a manner as to not affect plant operations but by procedure and in as much detail as possible. There will be one or more Observer/Controller at each important location. Controllers will provide information and clarification on which actions are to be simulated or are outside the scope of this exercise in order to keep the exercise progressing in accordance with the scenario. Observer/Controllers will also observe all aspects of the exercise to prepare an in-house evaluation of plans, procedures, and training.
- All communications should start and end with "THIS IS A DRILL - THIS IS A DRILL". All phone notifications should be made unless an observer tells you to only simulate the call but notification forms must still be filled out for simulated calls.
- Exercise events will be initiated by the simulator indications and alarms, drill controllers issuing message cards, and/or drill controller verbal instructions as appropriate.
- Controllers will provide appropriate information at the location where that information would normally be available (e.g., dose rate readings with field teams, etc.). Only selected parameters and readings outside the Simulator Control Room will be provided. The selected information will be sufficient to make decision in accordance with Oyster Creek plans and procedures.
- Drill logs will be made available for the GSS and Lead CRO and should be maintained as up-to-date as conditions will allow. These logs, along with all check lists and forms, will be collected at the end of the drill.

- Comment sheet will be made available for the crew to document drill related problems and any suggestions for making the drills better.
- The purpose of the exercise is to test Emergency Plan Implementing Procedures and implementation of the major aspects of the Emergency Plan. **DO NOT BECOME OVERLY CONCERNED WITH THE MECHANICS OF THE REACTOR OR THE CAUSE OF THE ACCIDENT. THIS EXERCISE IS DESIGNED TO TEST OYSTER CREEK PLANS AND PROCEDURES AND IS NOT CONCERNED WITH ESTABLISHING THE PROBABILITY, FEASIBILITY, OR DETAILED MECHANICS OF THE SIMULATED ACCIDENT.**
- When appropriate think out loud, so the observers understand your thought process. If you are involved in a drill related discussion or briefing, be sure to speak up so the observers can hear you without intruding.
- There may be times when the crew decides on actions not taken into account in the drill scenario and will not be allowed in order to preserve the scenario structure. If such an action is taken before the drill controller can prevent it, then the simulator will be backtracked and restarted just prior to that action taking place.
- At the completion of the drill, a short debriefing will be conducted in the simulator.

SECTION I.C.2 CONT/OBSERVER ASSIGNMENTS

I.C. EXERCISE CONTROL

I.C.2. CONTROLLER/OBSERVER ASSIGNMENTS

ECC/SIMULATOR

Plant Data Controller	P. Hays
Radiological Data Controller	J. Bontempo
Simulator Console Operator	T. Genna
Operations Observer	S. Ames
Roving Operations Observer	J. Frank
ECC Communications Observer	

TSC

TSC Controller	T. Blount
TSC Controller	G. Busch
Radiological Assessment Controller	R. Heffner
TSC Observer-Eng.	P. Cervenka
TSC Observer-Comm.	J. Nichols
TSC Observer-EOP	H. Tritt

OSC

OSC Controller	D. VanNortwick
OSC Lead Observer	K. Bass
OSC Observer	R. Skelskey
OSC Observer	R. Schubring
OSC Observer	A. Krukowski
OSC Observer	D. Janda
OSC Observer	D. Ratz
OSC Observer	P. Fischler
OSC Observer	R. Newberry
OSC Observer	E. Gregory
OSC Observer	G. True
OSC Observer-EAA	G. Saronsen
OSC Observer	T. Trettle
OSC Observer	T. Prosser
Chemistry Observer	F. Jordan
Radiological Observer	**
Radiological Observer	**
Radiological Observer	**
Radiological Observer	R. Beck
Radiological Observer	TBD
On-site Monitoring Observer	TBD
Radwaste Operator Observer	R. Matysik

SECURITY

Security Observer
Security Observer-Fire

G. Shannon
G. Applegate

JIC

Media Controller
Media Observer
Media Observer

S. Molello
J. Kowalski
J. May

EOF

EOF Controller
Ldr. RE & C Observer
EOF T.F. Observer
EOF Observer
EOF Observer
EOF Observer

J. Hildebrand
K. Wolf
C. Lefler
J. Perry
A. Recchion
A. Smith

EACC

EACC Controller
Off-site Monitoring Observer
Off-site Monitoring Observer

D. Weigle
T. McShane
M. Button

PTFC

PTFC Observer

S. Parsons

AEOF

AEOF Observer

M. Chanda

FORKED RIVER FIRE DEPARTMENT

Local Government Observer

TBD

** To be assigned by K. Wolf

SECTION I.C.3. COMMUNICATIONS

I.C.3.a. Drill Controller Phone List

I.C.3.b. Emergency Response Center Phone List

SECTION I.C.4. FORMS

- I.C.4.a. Chronology of Events and Minor Comments Form
- I.C.4.b. Observer Comments/Deficiencies Form
- I.C.4.c. Player Participants Evaluation Form
- I.C.4.d. Attendance Form

I.C. EXERCISE CONTROL

I.C.4. FORMS

The following forms are included in this section:

- a. Chronology of Events and Minor Comments Form. This form is used by the Observer to document, in chronological order, the major events that have been observed.
- b. Observer Comments/Deficiencies Form
This form is used by the Observer to document observation including, but not limited to:
 - Superior performance
 - Sub-standard performance
 - Facility/Equipment deficiencies
 - Procedure deficiencies
 - Scenario and Scenario control comments

Be sure to include any recommendations you have for improving performance or correcting deficiencies. Please make your comment descriptive, yet concise.

c. Player Participant's Evaluation Form

The center's Controller/Observers are responsible for duplicating and handing out these forms. They are used to record the drill participants comments; suggestions and/or any deficiencies encountered during the drill. The participant may turn the form in during the center's debriefing (immediately following the drill) or forward it directly to the Emergency Preparedness Office.

d. Training Attendance Form

Used to record the drill participation of players, observers and controllers. Center controllers and observers are responsible for circulating the attendance forms(s) within their centers and returning them to the EP department. They should be signed in pencil or **BLACK** ink.

Player Participant's Evaluation Form

DATE: November 1, 1995

Your Emergency Position Title: _____

Summary of Comments/Deficiencies/Suggestions:

Facility/Equipment Problems: _____

Procedure Problems: _____

Scenario Problems: _____

Other Problems/Comments/Concerns/Suggestions: _____

Submitted By: _____ Ext.: _____

(CONTINUE ON BACK, IF NEEDED)

NOTE: PLEASE FORWARD ALL COMMENTS TO EP DEPARTMENT.

Player Participant's Evaluation Form

DATE: November 1, 1995

Your Emergency Position Title: _____

Summary of Comments/Deficiencies/Suggestions:

Facility/Equipment Problems: _____

Procedure Problems: _____

Scenario Problems: _____

Other Problems/Comments/Concerns/Suggestions: _____

Submitted By: _____ Ext.: _____

(CONTINUE ON BACK, IF NEEDED)

NOTE: PLEASE FORWARD ALL COMMENTS TO EP DEPARTMENT.

Player Participant's Evaluation Form

DATE: November 1, 1995

Your Emergency Position Title: _____

Summary of Comments/Deficiencies/Suggestions:

Facility/Equipment Problems: _____

Procedure Problems: _____

Scenario Problems: _____

Other Problems/Comments/Concerns/Suggestions: _____

Submitted By: _____ Ext.: _____

(CONTINUE ON BACK, IF NEEDED)

NOTE: PLEASE FORWARD ALL COMMENTS TO EP DEPARTMENT.

Player Participant's Evaluation Form

DATE: November 1, 1995

Your Emergency Position Title: _____

Summary of Comments/Deficiencies/Suggestions:

Facility/Equipment Problems: _____

Procedure Problems: _____

Scenario Problems: _____

Other Problems/Comments/Concerns/Suggestions: _____

Submitted By: _____ Ext.: _____

(CONTINUE ON BACK, IF NEEDED)

NOTE: PLEASE FORWARD ALL COMMENTS TO EP DEPARTMENT.

SECTION II OPERATIONAL DATA

- II.A. Plant Parameter Trends
- II.B. Backup Plant Parameters
- II.C. Backup Annunciator Data

SECTION II.A.

PLANT PARAMETER TRENDS

Time	HIGH	CORE	AVE	MCPR	MLHGR	RECIRC	RECIRC	RPV NR	RPV WR	MSIV	EMRV					ISO COND A				ISO COND B				SLC	SLC
	APRM	PWR	APRM			TEMP	FLOW	PRESS	PRESS		A	B	C	D	E	30	31	34	36	32	33	35	37	FLOW	LEV
	%	%	%	%LMT	%LMT	DEG F	GPM	PSIG	PSIG	POS	POSITION					POSITION				POSITION					
16:00	INITIAL CONDITIONS																								
16:00	101.5	99.7	100.2	39.0	72.6	521.0	1.53E+05	1019.7	1005.8	O	C	C	C	C	C	O	O	C	O	O	O	C	O	NO	2017
16:08	DIESEL STORAGE TANK FIRE																								
16:31	101.5	99.7	100.2	39.0	72.6	521.0	1.53E+05	1019.7	1005.8	O	C	C	C	C	C	O	O	C	O	O	O	C	O	NO	2017
16:35	REACTOR SHUTDOWN COMMENCED																								
16:40	101.5	99.7	100.2	39.0	72.6	521.0	1.53E+05	1019.8	1005.8	O	C	C	C	C	C	O	O	C	O	O	O	C	O	NO	2017
16:45	98.2	98.3	97.0	39.0	72.6	520.6	1.47E+05	1016.6	1003.5	O	C	C	C	C	C	O	O	C	O	O	O	C	O	NO	2017
16:50	93.9	96.1	92.4	39.0	72.6	519.9	1.39E+05	1009.8	997.5	O	C	C	C	C	C	O	O	C	O	O	O	C	O	NO	2017
16:55	89.2	92.3	87.3	39.0	72.6	518.4	1.29E+05	1002.8	991.7	O	C	C	C	C	C	O	O	C	O	O	O	C	O	NO	2017
17:00	90.2	87.5	88.3	39.0	72.6	518.4	1.26E+05	1016.2	1006.1	O	C	C	C	C	C	O	O	C	O	O	O	C	O	NO	2017
17:05	90.4	88.4	88.7	39.0	72.6	518.4	1.27E+05	1016.3	1006.1	O	C	C	C	C	C	O	O	C	O	O	O	C	O	NO	2017
17:10	90.0	87.4	88.2	39.0	72.6	518.7	1.26E+05	1018.8	1008.2	O	C	C	C	C	C	O	O	C	O	O	O	C	O	NO	2017
17:15	90.2	88.1	88.4	39.0	72.6	518.7	1.26E+05	1018.8	1008.2	O	C	C	C	C	C	O	O	C	O	O	O	C	O	NO	2017
17:20	90.5	88.6	88.7	39.0	72.6	518.7	1.27E+05	1019.0	1008.2	O	C	C	C	C	C	O	O	C	O	O	O	C	O	NO	2017
17:20	CONDENSER VACUUM STARTS TO DECREASE																								
17:21	78.6	86.7	76.2	39.0	72.6	514.3	1.01E+05	1002.8	994.4	O	C	C	C	C	C	O	O	C	O	O	O	C	O	NO	2017
17:22	74.4	73.9	71.9	39.0	72.6	513.8	9.36E+04	998.7	990.9	O	C	C	C	C	C	O	O	C	O	O	O	C	O	NO	2017
17:22	REACTOR FAILS TO SCRAM DUE TO HYDRAULIC LOCK																								
17:22	TURBINE TRIP ON LOW VACUUM																								
17:22	POWER OSCILLATIONS OCCUR UNTIL LEVEL REACHS 0"TA																								
17:23	32.9	49.6	30.6	39.0	72.6	510.5	3.98E+04	< 970.0	952.6	O	C	C	C	C	C	O	O	C	O	O	O	O	O	YES	2017
17:24	38.0	11.4	35.0	39.0	72.6	514.0	3.44E+04	< 970.0	963.6	O	C	C	C	C	C	O	O	C	O	O	O	O	O	YES	2017
17:25	23.2	2.6	21.6	39.0	72.6	528.9	2.73E+04	< 970.0	951.6	O	C	C	C	C	C	O	O	C	O	O	O	O	O	YES	1991
17:26	15.6	2.6	14.4	39.0	72.6	527.4	1.75E+04	< 970.0	947.1	O	C	C	C	C	C	O	O	C	O	O	O	O	O	YES	1965
17:27	TORUS COOLING USING CONT. SPRAY																								
17:27	12.0	2.3	11.1	39.0	72.6	503.5	0.00E+00	< 970.0	945.5	O	C	C	C	C	C	O	O	C	O	O	O	O	O	YES	1934
17:28	9.7	2.3	8.5	39.0	72.6	500.3	0.00E+00	< 970.0	944.2	O	C	C	C	C	C	O	O	C	O	O	O	O	O	YES	1903
17:29	7.6	2.3	6.2	39.0	72.6	503.0	0.00E+00	< 970.0	899.8	O	O	C	C	C	C	O	O	C	O	O	O	O	O	YES	1878
17:30	6.2	4.1	4.7	39.0	72.6	502.3	6.50E+03	< 970.0	797.7	O	C	C	C	C	C	O	O	C	O	O	O	O	O	YES	1847
17:31	BYPASS VALVES CLOSE ON LOW PRESSURE																								
17:32	7.2	4.9	5.5	39.0	72.6	494.6	0.00E+00	< 970.0	857.7	O	C	C	C	C	C	O	O	C	O	O	O	O	O	YES	1790
17:33	5.4	4.4	5.0	39.0	72.6	494.3	0.00E+00	< 970.0	894.6	O	C	C	C	C	C	O	O	C	O	O	O	O	O	YES	1759
17:34	6.5	4.9	4.3	39.0	72.6	494.6	0.00E+00	< 970.0	888.2	O	C	C	C	C	C	O	O	C	O	O	O	O	O	YES	1733
17:35	7.0	5.5	4.5	39.0	72.6	496.6	0.00E+00	< 970.0	910.9	O	C	C	C	C	C	O	O	C	O	O	O	C	O	YES	1733
17:40	8.0	4.4	5.2	39.0	72.6	499.0	0.00E+00	991.5	990.6	O	C	C	C	C	C	O	O	C	O	O	O	C	O	YES	1553

Time	HIGH	CORE	AVE	MCPR	MLHGR	RECIRC	RECIRC	RPV NR	RPV WR	MSIV	EMRV					ISO COND A				ISO COND B				SLC	SLC
	APRM	PWR	APRM			TEMP	FLOW	PRESS	PRESS		A	B	C	D	E	30	31	34	36	32	33	35	37	FLOW	LEV
	%	%	%	%LMT	%LMT	DEG F	GPM	PSIG	PSIG	POS	POSITION					'POSITION				POSITION					
17:45	4.6	3.1	3.1	39.0	72.6	498.6	0.00E+00	< 970.0	942.4	O	C	C	C	C	C	O	O	C	O	O	O	O	O	YES	1403
17:50	6.6	3.1	4.3	39.0	72.6	500.7	0.00E+00	< 970.0	878.4	O	C	C	C	C	C	O	O	C	O	O	O	C	O	YES	1255
17:55	7.4	3.3	4.8	39.0	72.6	500.4	0.00E+00	975.9	975.8	O	C	C	C	C	C	O	O	C	O	O	O	C	O	YES	1105
18:00	3.8	2.9	2.4	39.0	72.6	501.3	0.00E+00	994.3	993.2	O	C	C	C	C	C	O	O	C	O	O	O	O	O	YES	955
18:10	4.3	2.8	2.8	39.0	72.6	502.0	0.00E+00	< 970.0	899.3	O	C	C	C	C	C	O	O	C	O	O	O	C	O	YES	655
18:20	5.9	3.0	3.8	39.0	72.6	503.1	0.00E+00	< 970.0	938.3	O	C	C	C	C	C	O	O	C	O	O	O	C	O	NO	655
18:30	6.8	2.8	4.4	39.0	72.6	503.4	0.00E+00	1011.2	1010.1	O	C	C	C	C	C	O	O	C	O	O	O	O	O	NO	655
18:40	3.4	3.0	2.3	39.0	72.6	504.1	0.00E+00	< 970.0	873.4	O	C	C	C	C	C	O	O	C	O	O	O	O	O	NO	655
18:50	6.0	4.7	3.9	39.0	72.6	504.1	0.00E+00	< 970.0	879.7	O	C	C	C	C	C	O	O	C	O	O	O	O	O	NO	655
19:00	3.1	3.6	2.0	39.0	72.6	495.9	0.00E+00	< 970.0	777.0	O	C	C	C	C	C	O	O	C	O	O	O	C	O	NO	655
19:10	ISOLATION CONDENSER STEAM LINE BREAK INTO THE REACTOR BUILDING																								
19:11	<2	0.0	<2	39.0	72.6	484.4	3.56E+04	< 970.0	568.5	O	C	C	C	C	C	O	O	C	O	O	O	C	C	NO	655
19:12	START EMERGENCY DEPRESSURIZATION																								
19:13	<2	0.0	<2	39.0	72.6	451.8	6.66E+04	< 970.0	411.8	O	O	O	O	O	O	O	O	C	O	O	O	C	C	NO	655
19:14	<2	0.0	<2	39.0	72.6	408.0	6.11E+04	< 970.0	252.5	O	O	O	O	O	O	O	O	C	O	O	O	C	C	NO	655
19:15	<2	0.0	<2	39.0	72.6	376.3	5.62E+04	< 970.0	169.5	O	O	O	O	O	O	O	O	C	O	O	O	C	C	NO	655
19:16	<2	0.0	<2	39.0	72.6	349.8	6.10E+04	< 970.0	117.1	O	O	O	O	O	O	O	O	C	O	O	O	C	C	NO	655
19:17	<2	0.0	<2	39.0	72.6	331.7	4.58E+04	< 970.0	90.4	O	O	O	O	O	O	O	O	C	O	O	O	C	C	NO	655
19:18	<2	0.0	<2	39.0	72.6	318.2	4.56E+04	< 970.0	72.2	O	O	O	O	O	O	O	O	C	O	O	O	C	C	NO	655
19:19	<2	0.0	<2	39.0	72.6	302.2	3.94E+04	< 970.0	56.1	O	O	O	O	O	O	O	O	C	O	O	O	C	C	NO	655
19:20	<2	0.0	<2	39.0	72.6	273.1	0.00E+00	< 970.0	39.0	O	O	O	O	O	O	O	O	C	O	O	O	C	C	NO	655
10:21	<2	0.0	<2	39.0	72.6	263.2	0.00E+00	< 970.0	34.9	O	O	O	O	O	O	O	O	C	O	O	O	C	C	NO	655
19:22	<2	0.0	<2	39.0	72.6	255.1	0.00E+00	< 970.0	30.8	O	O	O	O	O	O	O	O	C	O	O	O	C	C	NO	655
19:23	<2	0.0	<2	39.0	72.6	244.2	0.00E+00	< 970.0	28.8	O	O	O	O	O	O	O	O	C	O	O	O	C	C	NO	655
19:24	<2	0.0	<2	39.0	72.6	235.6	0.00E+00	< 970.0	26.8	O	O	O	O	O	O	O	O	C	O	O	O	C	C	NO	655
19:25	<2	0.0	<2	39.0	72.6	225.0	0.00E+00	< 970.0	28.1	O	O	O	O	O	O	O	O	C	O	O	O	C	C	NO	655
19:30	ALL RODS FULLY INSERTED																								
19:31	<2	0.0	<2	39.0	72.6	218.6	0.00E+00	< 970.0	28.1	O	O	O	O	O	O	O	O	C	O	O	O	C	C	NO	655
19:32	<2	0.0	<2	39.0	72.6	211.0	0.00E+00	< 970.0	27.1	O	O	O	O	O	O	O	O	C	O	O	O	C	C	NO	655
19:33	<2	0.0	<2	39.0	72.6	211.0	0.00E+00	< 970.0	24.0	O	O	O	O	O	O	O	O	C	O	O	O	C	C	NO	655
19:34	<2	0.0	<2	39.0	72.6	322.5	4.51E+04	< 970.0	75.3	O	O	O	O	O	O	O	O	C	O	O	O	C	C	NO	655
19:35	<2	0.0	<2	39.0	72.6	308.1	7.26E+04	< 970.0	58.8	O	O	O	O	O	O	O	O	C	O	O	O	C	C	NO	655
19:36	<2	0.0	<2	39.0	72.6	300.7	7.05E+04	< 970.0	51.5	O	O	O	O	O	O	O	O	C	O	O	O	C	C	NO	655
19:37	<2	0.0	<2	39.0	72.6	296.0	5.79E+04	< 970.0	47.4	O	O	O	O	O	O	O	O	C	O	O	O	C	C	NO	655
19:38	<2	0.0	<2	39.0	72.6	292.9	4.86E+04	< 970.0	45.3	O	O	O	O	O	O	O	O	C	O	O	O	C	C	NO	655

Time	HIGH	CORE	AVE	MCPR	MLHGR	RECIRC	RECIRC	RPV NR	RPV WR	MSIV	EMRV					ISO COND A				'ISO COND B				SLC	SLC
	APRM	PWR	APRM			TEMP	FLOW	PRESS	PRESS		A	B	C	D	E	30	31	34	36	32	33	35	37	FLOW	LEV
	%	%	%	%LMT	%LMT	DEG F	GPM	PSIG	PSIG	POS	POSITION					'POSITION				POSITION	655				
19:39	<2	0.0	<2	39.0	72.6	290.6	4.80E+04	< 970.0	42.3	O	O	O	O	O	O	O	O	C	O	O	O	C	C	NO	655
19:40	ISOLATION CONDENSER B ISOLATED																								
19:40	<2	0.0	<2	39.0	72.6	249.1	2.23E+04	< 970.0	35.2	O	O	O	O	O	O	O	O	C	O	C	C	C	C	NO	655
19:41	<2	0.0	<2	39.0	72.6	204.7	0.00E+00	< 970.0	28.8	O	O	O	O	O	O	O	O	C	O	C	C	C	C	NO	655
19:42	<2	0.0	<2	39.0	72.6	212.1	0.00E+00	< 970.0	26.8	O	O	O	O	O	O	O	O	C	O	C	C	C	C	NO	655
19:43	<2	0.0	<2	39.0	72.6	214.1	0.00E+00	< 970.0	27.8	O	O	O	O	O	O	O	O	C	O	C	C	C	C	NO	655
19:44	<2	0.0	<2	39.0	72.6	215.3	0.00E+00	< 970.0	27.8	O	O	O	O	O	O	O	O	C	O	C	C	C	C	NO	655
19:45	<2	0.0	<2	39.0	72.6	216.9	0.00E+00	< 970.0	27.8	O	O	O	O	O	O	O	O	C	O	C	C	C	C	NO	655
19:50	<2	0.0	<2	39.0	72.6	202.6	0.00E+00	< 970.0	27.8	O	O	O	O	O	O	O	O	C	O	C	C	C	C	NO	655
19:55	<2	0.0	<2	39.0	72.6	204.7	0.00E+00	< 970.0	27.8	O	O	O	O	O	O	O	O	C	O	C	C	C	C	NO	655
20:00	<2	0.0	<2	39.0	72.6	212.1	0.00E+00	< 970.0	27.8	O	O	O	O	O	O	O	O	C	O	C	C	C	C	NO	655
20:10	<2	0.0	<2	39.0	72.6	214.1	0.00E+00	< 970.0	27.8	O	O	O	O	O	O	O	O	C	O	C	C	C	C	NO	655
20:15	<2	0.0	<2	39.0	72.6	215.3	0.00E+00	< 970.0	27.8	O	O	O	O	O	O	O	O	C	O	C	C	C	C	NO	655
20:20	<2	0.0	<2	39.0	72.6	216.9	0.00E+00	< 970.0	27.8	O	O	O	O	O	O	O	O	C	O	C	C	C	C	NO	655
20:25	<2	0.0	<2	39.0	72.6	202.6	0.00E+00	< 970.0	27.8	O	O	O	O	O	O	O	O	C	O	C	C	C	C	NO	655
20:30	<2	0.0	<2	39.0	72.6	200.9	0.00E+00	< 970.0	27.8	O	O	O	O	O	O	O	O	C	O	C	C	C	C	NO	655
20:30	EXERCISE IS COMPLETED																								

Time	RPV FZ	RPV FZ	GEMAC	YARWAY	GEMAC	FEED	FEED	STEAM	CORE SPRAY	
	LEV A	LEV B	NR A	LEV A	WR	TEMP	FLOW	FLOW	I	II
	IN TAF	IN TAF	IN TAF	IN TAF	IN TAF	DEG F	MLB/H	MLB/H	GPM	GPM
16:00	INITIAL CONDITIONS									
16:00	OFF	OFF	160.5	159.8	138.4	311.5	7.17	7.19	0	0
16:08	DIESEL STORAGE TANK FIRE									
16:31	OFF	OFF	160.5	159.8	138.4	311.5	7.17	7.19	0	0
16:35	REACTO SHUTDOWN COMMENCED									
16:40	OFF	OFF	160.5	159.8	138.4	311.5	7.17	7.19	0	0
16:45	OFF	OFF	160.9	160.1	138.4	311.5	7.06	7.02	0	0
16:50	OFF	OFF	161.3	160.7	138.9	310.2	6.89	6.78	0	0
16:55	OFF	OFF	161.7	161.2	139.4	309.0	6.61	6.39	0	0
17:00	OFF	OFF	160.7	159.9	138.5	305.3	6.23	6.32	0	0
17:05	OFF	OFF	160.4	159.6	138.5	305.3	6.30	6.32	0	0
17:10	OFF	OFF	161.4	160.5	138.8	306.9	6.24	6.31	0	0
17:15	OFF	OFF	160.6	160.0	138.8	306.1	6.29	6.32	0	0
17:20	OFF	OFF	160.4	159.6	138.4	305.3	6.32	6.33	0	0
17:20	CONDENSER VACUUM STARTS TO DECREASE									
17:21	OFF	OFF	161.2	160.7	139.3	304.9	6.17	5.31	0	0
17:22	OFF	OFF	161.3	160.4	138.8	301.1	5.23	5.12	0	0
17:22	REACTOR FAILS TO SCRAM DUE TO HYDRAULIC LOCK									
17:22	TURBINE TRIP ON LOW VACUUM									
17:22	POWER OSCILLATIONS OCCUR UNTIL LEVEL REACHS 0" TAF									
17:23	98.8	94.9	150.7	148.8	129.6	279.2	3.37	2.76	0	0
17:24	86.4	90.8	119.1	118.6	107.5	400.0	0.81	1.66	0	0
17:25	56.6	73.0	< 90	86.3	85.8	400.0	0.11	1.51	0	0
17:26	23.9	53.1	< 90	< 85	76.1	400.0	0.11	1.32	0	0
17:27	TORUS COOLING USING CONT. SPRAY									
17:27	-5.4	34.6	< 90	< 85	74.7	400.0	0.11	0.78	0	0
17:28	-22.7	15.6	< 90	< 85	73.8	400.0	0.11	0.51	0	0
17:29	-32.8	-5.4	< 90	< 85	73.4	388.2	0.11	0.40	0	0
17:30	-35.6	-22.9	< 90	< 85	72.5	392.7	0.21	0.12	0	0
17:31	BYPASS VALVES CLOSE ON LOW PRESSURE									
17:32	-32.8	-9.4	< 90	< 85	72.5	349.4	0.30	-0.00	0	0
17:33	-26.9	-5.7	< 90	< 85	72.5	218.9	0.25	-0.00	0	0
17:34	-21.0	-1.1	< 90	< 85	72.5	153.5	0.22	-0.00	0	0
17:35	-18.6	5.4	< 90	< 85	72.5	121.6	0.25	-0.00	0	0
17:40	-14.3	12.7	< 90	< 85	72.9	105.2	0.23	-0.00	0	0

Time	RPV FZ	RPV FZ	GEMAC	YARWAY	GEMAC	FEED	FEED	STEAM	CORE SPR	
	LEV A	LEV B	NR A	LEV A	WR	TEMP	FLOW	FLOW	I	II
	IN TAF	IN TAF	IN TAF	IN TAF	IN TAF	DEG F	MLB/H	MLB/H	GPM	GPM
17:45	-9.0	-2.1	< 90	< 85	73.4	96.9	0.15	0.41	0	0
17:50	-21.7	-0.8	< 90	< 85	72.5	92.3	0.15	-0.00	0	0
17:55	-18.5	6.8	< 90	< 85	72.9	89.8	0.16	-0.00	0	0
18:00	-15.7	-5.5	< 90	< 85	73.4	88.1	0.14	-0.00	0	0
18:10	-20.0	-14.0	< 90	< 85	72.9	86.9	0.13	0.39	0	0
18:20	-25.1	-6.7	< 90	< 85	72.9	86.1	0.14	-0.00	0	0
18:30	-22.1	-3.1	< 90	< 85	72.9	85.3	0.13	-0.00	0	0
18:40	-24.6	-23.0	< 90	< 85	72.5	84.4	0.14	0.38	0	0
18:50	-25.9	-8.2	< 90	< 85	72.0	83.6	0.24	-0.00	0	0
19:00	-60.5	-69.5	< 90	< 85	71.1	82.4	0.17	-0.00	0	0
19:10	ISOLATION CONDENSER STEAM LINE BREAK INTO THE REACTOR BUILDING									
19:11	20.9	3.9	< 90	< 85	71.6	82.0	0.30	-0.00	0	0
19:12	START EMERGENCY DEPRESSURIZATION									
19:13	73.4	-0.9	< 90	< 85	73.7	81.6	0.11	0.20	0	0
19:14	44.5	-18.8	< 90	< 85	71.9	87.0	0.02	0.11	0	0
19:15	22.7	-26.5	< 90	< 85	71.4	90.9	0.10	0.07	0	0
19:16	38.6	-31.0	< 90	< 85	71.4	87.9	0.59	0.04	0	0
19:17	6.2	-34.4	< 90	< 85	71.0	86.7	0.48	0.02	0	0
19:18	15.8	-32.4	< 90	< 85	71.0	83.8	0.51	0.02	0	0
19:19	15.9	-35.0	< 90	< 85	71.0	81.6	0.74	0.02	0	0
19:20	-45.9	-47.2	< 90	< 85	70.0	78.7	1.07	-0.00	0	0
19:21	-45.2	-42.7	< 90	< 85	70.0	77.5	1.14	-0.00	0	0
19:22	-43.4	-41.5	< 90	< 85	70.0	76.7	1.21	-0.00	0	0
19:23	-38.2	-36.7	< 90	< 85	70.0	75.9	1.36	-0.00	0	0
19:24	-30.5	-30.2	< 90	< 85	70.0	75.1	1.38	-0.00	0	0
19:25	-26.4	-22.8	< 90	< 85	70.0	74.7	1.38	-0.00	0	0
19:30	ALL RODS FULLY INSERTED									
19:31	-5.6	2.5	< 90	< 85	70.0	74.3	1.38	-0.00	0	0
19:32	19.3	18.6	< 90	< 85	70.5	73.9	1.38	-0.00	0	0
19:33	42.9	40.7	< 90	< 85	71.4	73.4	1.38	-0.00	0	0
19:34	81.2	65.0	98.0	93.7	97.2	70.6	0.22	0.02	0	0
19:35	127.3	50.3	140.3	139.7	134.3	70.6	0.20	0.02	0	0
19:36	120.2	45.0	139.2	139.8	132.1	70.6	0.03	0.06	0	0
19:37	108.0	61.3	115.4	113.3	112.5	70.6	0.03	0.02	0	0
19:38	93.1	64.8	100.1	97.4	98.5	70.6	0.03	-0.00	0	0

Time	RPV FZ	RPV FZ	GEMAC	YARWAY	GEMAC	FEED	FEED	STEAM	CORE SPR	
	LEV A	LEV B	NR A	LEV A	WR	TEMP	FLOW	FLOW	I	II
	IN TAF	IN TAF	IN TAF	IN TAF	IN TAF	DEG F	MLB/H	MLB/H	GPM	GPM
19:39	92.5	64.1	98.8	96.1	97.6	70.6	0.03	-0.00	0	0
19:40	ISOLATION CONDENSER B ISOLATED									
19:40	112.5	78.6	113.2	110.7	112.5	69.0	3.02	-0.00	0	0
19:41	175.2	142.5	152.4	151.2	148.2	68.6	3.03	-0.00	0	0
19:42	143.0	156.7	140.6	139.7	136.8	68.2	0.29	-0.00	0	0
19:43	152.3	177.3	148.4	147.9	143.5	67.8	0.31	-0.00	0	0
19:44	157.0	178.7	153.0	152.7	147.8	67.0	0.30	-0.00	0	0
19:45	162.5	169.0	160.5	160.4	154.7	66.6	0.30	-0.00	0	0
19:50	162.5	169.0	160.5	160.4	154.7	66.6	0.30	-0.00	0	0
19:55	162.5	169.0	160.5	160.4	154.7	66.6	0.30	-0.00	0	0
20:00	162.5	169.0	160.5	160.4	154.7	66.6	0.30	-0.00	0	0
20:10	162.5	169.0	160.5	160.4	154.7	66.6	0.30	-0.00	0	0
20:15	162.5	169.0	160.5	160.4	154.7	66.6	0.30	-0.00	0	0
20:20	162.5	169.0	160.5	160.4	154.7	66.6	0.30	-0.00	0	0
20:25	162.5	169.0	160.5	160.4	154.7	66.6	0.30	-0.00	0	0
20:30	162.5	169.0	160.5	160.4	154.7	66.6	0.30	-0.00	0	0
20:30	EXERCISE IS COMPLETED									

Time	SEC CONT	MAIN	EDG	EDG	S1A	S1B	1A	1B	1C	1D	BATT	BATT	BATT	MAIN COND VAC		
	SBGT	GEN	1	2							A	B	C	INCHES HG		
	ON/OFF	MW	KW	KW	POS	POS	POS	POS	POS	POS	VDC	VDC	VDC	A	B	C
16:00	INITIAL CONDITIONS															
16:00	OFF	661	0	0	O	O	C	C	C	C	131	132	131	28.4	28.4	28.4
16:08	DIESEL STORAGE TANK FIRE															
16:31	OFF	661	0	0	O	O	C	C	C	C	131	132	131	28.4	28.4	28.4
16:35	REACTOR SHUTDOWN COMMENCED															
16:40	OFF	661	0	0	O	O	C	C	C	C	131	132	131	28.4	28.4	28.4
16:45	OFF	647	0	0	O	O	C	C	C	C	131	132	131	28.4	28.4	28.4
16:50	OFF	625	0	0	O	O	C	C	C	C	131	132	131	28.5	28.4	28.4
16:55	OFF	590	0	0	O	O	C	C	C	C	131	132	131	28.5	28.5	28.5
17:00	OFF	563	0	0	O	O	C	C	C	C	131	132	131	28.6	28.6	28.5
17:05	OFF	583	0	0	O	O	C	C	C	C	131	132	131	28.6	28.6	28.5
17:10	OFF	582	0	0	O	O	C	C	C	C	131	132	131	28.5	28.6	28.6
17:15	OFF	583	0	0	O	O	C	C	C	C	131	132	131	28.5	28.6	28.5
17:20	OFF	580	0	0	O	O	C	C	C	C	131	132	131	28.4	28.4	28.4
17:20	CONDENSER VACUUM STARTS TO DECREASE															
17:21	OFF	443	0	0	O	O	C	C	C	C	131	132	131	25.8	25.8	25.8
17:22	OFF	365	0	0	O	O	C	C	C	C	131	132	131	23.0	22.9	22.9
17:22	REACTOR FAILS TO SCRAM DUE TO HYDRAULIC LOCK															
17:22	TURBINE TRIP ON LOW VACUUM															
17:22	POWER OSCILLATIONS OCCUR UNTIL LEVEL REACHS 0"TA															
17:23	OFF	0	0	0	C	C	O	O	C	C	131	132	131	20.2	20.2	20.2
17:24	OFF	0	0	0	C	C	O	O	C	C	131	132	131	17.0	17.0	17.0
17:25	ON	0	0	0	C	C	O	O	C	C	131	132	131	14.0	14.0	14.0
17:26	ON	0	0	0	C	C	O	O	C	C	131	132	131	13.0	13.0	13.0
17:27	TORUS COOLING USING CONT. SPRAY															
17:27	ON	0	0	0	C	C	O	O	C	C	131	132	131	12.0	12.0	12.0
17:28	ON	0	0	0	C	C	O	O	C	C	131	132	131	12.0	12.0	12.0
17:29	ON	0	0	0	C	C	O	O	C	C	131	132	131	11.0	11.0	11.0
17:30	ON	0	0	0	C	C	O	O	C	C	131	132	131	10.0	10.0	10.0
17:31	BYPASS VALVES CLOSE ON LOW PRESSURE															
17:32	ON	0	0	0	C	C	O	O	C	C	131	132	131	10.0	10.0	10.0
17:33	ON	0	0	0	C	C	O	O	C	C	131	132	131	8.0	8.0	8.0
17:34	ON	0	0	0	C	C	O	O	C	C	131	132	131	6.0	6.0	6.0
17:35	ON	0	0	0	C	C	O	O	C	C	131	132	131	4.0	4.0	4.0
17:40	ON	0	0	0	C	C	O	O	C	C	131	132	131	2.0	2.0	2.0

Time	SEC CONT	MAIN	EDG	EDG	S1A	S1B	1A	1B	1C	1D	BATT	BATT	BATT	MAIN	COND	VAC
	SBGT	GEN	1	2							A	B	C	INCHES HG		
	ON/OFF	MW	KW	KW	POS	POS	POS	POS	POS	POS	VDC	VDC	VDC	A	B	C
17:45	ON	0	0	0	C	C	O	O	C	C	131	132	131	0.0	0.0	0.0
17:50	ON	0	0	0	C	C	O	O	C	C	131	132	131	0.0	0.0	0.0
17:55	ON	0	0	0	C	C	O	O	C	C	131	132	131	0.0	0.0	0.0
18:00	ON	0	0	0	C	C	O	O	C	C	131	132	131	0.0	0.0	0.0
18:10	ON	0	0	0	C	C	O	O	C	C	131	132	131	0.0	0.0	0.0
18:20	ON	0	0	0	C	C	O	O	C	C	131	132	131	0.0	0.0	0.0
18:30	ON	0	0	0	C	C	O	O	C	C	131	132	131	0.0	0.0	0.0
18:40	ON	0	0	0	C	C	O	O	C	C	131	132	131	0.0	0.0	0.0
18:50	ON	0	0	0	C	C	O	O	C	C	131	132	131	0.0	0.0	0.0
19:00	ON	0	0	0	C	C	O	O	C	C	131	132	131	0.0	0.0	0.0
19:10	ISOLATION CONDENSER STEAM LINE BREAK INTO THE REACTOR BUILDING															
19:11	ON	0	0	0	C	C	O	O	C	C	131	132	131	0.0	0.0	0.0
19:12	START EMERGENCY DEPRESSURIZATION															
19:13	ON	0	0	0	C	C	O	O	C	C	131	132	131	0.0	0.0	0.0
19:14	ON	0	0	0	C	C	O	O	C	C	131	132	131	0.0	0.0	0.0
19:15	ON	0	0	0	C	C	O	O	C	C	131	132	131	0.0	0.0	0.0
19:16	ON	0	0	0	C	C	O	O	C	C	131	132	131	0.0	0.0	0.0
19:17	ON	0	0	0	C	C	O	O	C	C	131	132	131	0.0	0.0	0.0
19:18	ON	0	0	0	C	C	O	O	C	C	131	132	131	0.0	0.0	0.0
19:19	ON	0	0	0	C	C	O	O	C	C	131	132	131	0.0	0.0	0.0
19:20	ON	0	0	0	C	C	O	O	C	C	131	132	131	0.0	0.0	0.0
10:21	ON	0	0	0	C	C	O	O	C	C	131	132	131	0.0	0.0	0.0
19:22	ON	0	0	0	C	C	O	O	C	C	131	132	131	0.0	0.0	0.0
19:23	ON	0	0	0	C	C	O	O	C	C	131	132	131	0.0	0.0	0.0
19:24	ON	0	0	0	C	C	O	O	C	C	131	132	131	0.0	0.0	0.0
19:25	ON	0	0	0	C	C	O	O	C	C	131	132	131	0.0	0.0	0.0
19:30	ALL RODS FULLY INSERTED															
19:31	ON	0	0	0	C	C	O	O	C	C	131	132	131	0.0	0.0	0.0
19:32	ON	0	0	0	C	C	O	O	C	C	131	132	131	0.0	0.0	0.0
19:33	ON	0	0	0	C	C	O	O	C	C	131	132	131	0.0	0.0	0.0
19:34	ON	0	0	0	C	C	O	O	C	C	131	132	131	0.0	0.0	0.0
19:35	ON	0	0	0	C	C	O	O	C	C	131	132	131	0.0	0.0	0.0
19:36	ON	0	0	0	C	C	O	O	C	C	131	132	131	0.0	0.0	0.0
19:37	ON	0	0	0	C	C	O	O	C	C	131	132	131	0.0	0.0	0.0
19:38	ON	0	0	0	C	C	O	O	C	C	131	132	131	0.0	0.0	0.0

Time	SEC CONT	MAIN	EDG	EDG	S1A	S1B	1A	1B	1C	1D	BATT	BATT	BATT	MAIN COND VAC		
	SBGT	GEN	1	2							A	B	C	INCHES HG		
	ON/OFF	MW	KW	KW	POS	POS	POS	POS	POS	POS	VDC	VDC	VDC	A	B	C
19:39	ON	0	0	0	C	C	O	O	C	C	131	132	131	0.0	0.0	0.0
19:40	ISOLATION CONDENSER B ISOLATED															
19:40	ON	0	0	0	C	C	O	O	C	C	131	132	131	0.0	0.0	0.0
19:41	ON	0	0	0	C	C	O	O	C	C	131	132	131	0.0	0.0	0.0
19:42	ON	0	0	0	C	C	O	O	C	C	131	132	131	0.0	0.0	0.0
19:43	ON	0	0	0	C	C	O	O	C	C	131	132	131	0.0	0.0	0.0
19:44	ON	0	0	0	C	C	O	O	C	C	131	132	131	0.0	0.0	0.0
19:45	ON	0	0	0	C	C	O	O	C	C	131	132	131	0.0	0.0	0.0
19:50	ON	0	0	0	C	C	O	O	C	C	131	132	131	0.0	0.0	0.0
19:55	ON	0	0	0	C	C	O	O	C	C	131	132	131	0.0	0.0	0.0
20:00	ON	0	0	0	C	C	O	O	C	C	131	132	131	0.0	0.0	0.0
20:10	ON	0	0	0	C	C	O	O	C	C	131	132	131	0.0	0.0	0.0
20:15	ON	0	0	0	C	C	O	O	C	C	131	132	131	0.0	0.0	0.0
20:20	ON	0	0	0	C	C	O	O	C	C	131	132	131	0.0	0.0	0.0
20:25	ON	0	0	0	C	C	O	O	C	C	131	132	131	0.0	0.0	0.0
20:30	ON	0	0	0	C	C	O	O	C	C	131	132	131	0.0	0.0	0.0
20:30	EXERCISE IS COMPLETED															

Time	CONT SPRAY		DW WR	DW NR	DW	DW	TOR	TORUS	TORUS	TOR	DW	DW UNID	DW	CONT	CONT
	I	II	PRESS	PRESS	O2	H2	LEV	TEMP	PRESS	O2	O2	LK RATE	TEMP	RAD	RAD
	GPM	GPM	PSIG	PSIG	%	%	INCH	DEG F	PSIG	%	%	GPM	DEG F	R/HR	R/HR
16:00	INITIAL CONDITIONS														
16:00	0	0	1.25	1.25	0.0	0.0	150	74.2	1.0	2.3	2.6	0.00	121	4	4
16:08	DIESEL STORAGE TANK FIRE														
16:31	0	0	1.25	1.25	0.0	0.0	150	74.2	1.0	2.3	2.6	0.00	121	4	4
16:35	REACTOR SHUTDOWN COMMENCED														
16:40	0	0	1.25	1.25	0.0	0.0	150	74.2	1.0	2.3	2.6	0.00	121	4	4
16:45	0	0	1.25	1.25	0.0	0.0	150	74.2	1.0	2.3	2.6	0.00	121	4	4
16:50	0	0	1.25	1.25	0.0	0.0	150	74.2	1.0	2.3	2.6	0.00	121	4	4
16:55	0	0	1.25	1.23	0.0	0.0	150	74.2	1.0	2.3	2.6	0.00	120	3	4
17:00	0	0	1.25	1.19	0.0	0.0	150	74.2	1.0	2.3	2.6	0.00	119	3	4
17:05	0	0	1.18	1.18	0.0	0.0	150	74.2	1.0	2.3	2.6	0.00	119	3	4
17:10	0	0	1.25	1.22	0.0	0.0	150	74.2	1.0	2.3	2.6	0.00	120	3	4
17:15	0	0	1.25	1.20	0.0	0.0	150	74.2	1.0	2.3	2.6	0.00	119	3	4
17:20	0	0	1.18	1.16	0.0	0.0	150	74.2	1.0	2.3	2.6	0.00	118	3	4
17:20	CONDENSER VACUUM STARTS TO DECREASE														
17:21	0	0	1.18	1.15	0.0	0.0	150	74.2	1.0	2.3	2.6	0.00	118	3	3
17:22	0	0	1.18	1.12	0.0	0.0	150	74.2	1.0	2.3	2.6	0.00	117	3	3
17:22	REACTOR FAILS TO SCRAM DUE TO HYDRAULIC LOCK														
17:22	TURBINE TRIP ON LOW VACUUM														
17:22	POWER OSCILLATIONS OCCUR UNTIL LEVEL REACHS 0" TAF														
17:23	0	0	1.18	1.11	0.0	0.0	150	76.2	1.0	2.3	2.6	0.00	116	2	2
17:24	0	0	1.10	1.06	0.0	0.0	150	76.1	1.0	2.3	2.6	0.00	115	2	2
17:25	0	0	1.03	1.03	0.0	0.0	150	76.1	1.0	2.1	2.2	0.00	114	2	2
17:26	0	0	1.03	0.96	0.0	0.0	150	76.1	1.0	2.1	2.1	0.00	111	1	1
17:27	TORUS COOLING USING CONT. SPRAY														
17:27	5965	5978	0.95	0.91	0.0	0.0	150	76.1	1.0	2.1	2.1	0.00	109	1	1
17:28	5965	5978	0.95	0.89	0.0	0.0	150	76.0	1.0	2.1	2.1	0.00	109	1	1
17:29	5965	5978	0.95	0.88	0.0	0.0	150	77.7	1.0	2.1	2.1	0.00	108	1	1
17:30	5962	5978	0.88	0.87	0.0	0.0	151	79.2	1.0	2.1	2.1	0.00	108	1	1
17:31	BYPASS VALVES CLOSE ON LOW PRESSURE														
17:32	5962	5978	0.88	0.86	0.0	0.0	151	79.0	1.0	2.1	2.1	0.00	107	1	1
17:33	5962	5978	0.88	0.86	0.0	0.0	151	78.9	1.0	2.1	2.1	0.00	107	1	1
17:34	5962	5978	0.88	0.85	0.0	0.0	151	78.8	1.1	2.1	2.1	0.00	107	1	1
17:35	5962	5978	0.88	0.85	0.0	0.0	151	78.7	1.1	2.1	2.1	0.00	107	1	1
17:40	5962	5978	0.88	0.85	0.0	0.0	151	78.6	1.1	2.1	2.1	0.00	107	1	1

Time	CONT SPR		DW WR	DW NR	DW	DW	TOR	TORUS	TORUS	TOR	DW	DW UNID	DW	CONT	CONT
	I	II	PRESS	PRESS	O2	H2	LEV	TEMP	PRESS	O2	O2	LK RATE	TEMP	RAD	RAD
	GPM	GPM	PSIG	PSIG	%	%	INCH	DEG F	PSIG	%	%	GPM	DEG F	R/HR	R/HR
17:45	5962	5978	0.88	0.86	0.0	0.0	151	79.7	1.1	2.1	2.1	0.00	107	1	2
17:50	5962	5978	0.88	0.85	0.0	0.0	151	80.3	1.1	2.1	2.1	0.00	107	1	2
17:55	5962	5978	0.88	0.84	0.0	0.0	151	80.2	1.1	2.1	2.1	0.00	107	88	86
18:00	5962	5978	0.88	0.86	0.0	0.0	151	81.2	1.1	2.1	2.1	0.00	107	88	86
18:10	5962	5978	0.88	0.86	0.0	0.0	151	82.3	1.2	2.1	2.1	0.00	107	88	86
18:20	5962	5978	0.88	0.85	0.0	0.0	151	82.1	1.2	2.1	2.1	0.00	107	88	86
18:30	5962	5978	0.88	0.84	0.0	0.0	151	82.0	1.2	2.1	2.1	0.00	106	88	86
18:40	5962	5978	0.88	0.84	0.0	0.0	151	81.9	1.2	2.1	2.1	0.00	106	88	86
18:50	5962	5978	0.88	0.83	0.0	0.0	151	81.7	1.2	2.1	2.1	0.00	106	88	86
19:00	5962	5978	0.80	0.78	0.0	0.0	151	81.4	1.2	2.1	2.1	0.00	104	84	82
19:10	ISOLATION CONDENSER STEAM LINE BREAK INTO THE REACTOR BUILDING														
19:11	5962	5978	0.80	0.75	0.0	0.0	151	81.0	1.2	2.1	2.1	0.00	103	76	76
19:12	START EMERGENCY DEPRESSURIZATION														
19:13	5962	5978	0.80	0.76	0.0	0.0	152	84.4	1.2	2.1	2.1	0.00	102	69	68
19:14	5962	5978	0.80	0.76	0.0	0.0	152	87.5	1.2	2.1	2.1	0.00	102	62	60
19:15	5964	5978	0.80	0.76	0.0	0.0	152	89.3	1.2	2.1	2.1	0.00	101	53	53
19:16	5964	5978	0.80	0.76	0.0	0.0	152	90.4	1.2	2.1	2.1	0.00	100	46	46
19:17	5964	5978	0.80	0.76	0.0	0.0	152	91.3	1.2	2.1	2.1	0.00	99	39	39
19:18	5964	5978	0.80	0.76	0.0	0.0	152	91.9	1.2	2.1	2.1	0.00	98	31	31
19:19	5964	5978	0.80	0.76	0.0	0.0	152	92.5	1.2	2.1	2.1	0.00	97	23	24
19:20	5964	5978	0.80	0.76	0.0	0.0	153	92.8	1.2	2.1	2.1	0.00	96	21	22
10:21	5964	5978	0.80	0.76	0.0	0.0	153	92.6	1.2	2.1	2.1	0.00	96	21	22
19:22	5964	5978	0.80	0.76	0.0	0.0	153	92.5	1.2	2.1	2.1	0.00	95	21	22
19:23	5964	5978	0.80	0.76	0.0	0.0	153	92.3	1.2	2.1	2.1	0.00	95	21	22
19:24	5964	5978	0.80	0.77	0.0	0.0	153	92.1	1.2	2.1	2.1	0.00	95	21	22
19:25	5964	5978	0.80	0.77	0.0	0.0	153	92.0	1.2	2.1	2.1	0.00	95	21	22
19:30	ALL RODS FULLY INSERTED														
19:31	5964	5978	0.80	0.78	0.0	0.0	153	91.8	1.2	2.1	2.1	0.00	94	21	22
19:32	5964	5978	0.80	0.78	0.0	0.0	153	91.6	1.2	2.1	2.1	0.00	94	21	22
19:33	5964	5978	0.80	0.78	0.0	0.0	153	91.5	1.2	2.1	2.1	0.00	94	21	22
19:34	5964	5978	0.80	0.84	0.0	0.0	153	91.4	1.3	2.1	2.1	0.00	94	21	22
19:35	5964	5978	0.80	0.85	0.0	0.0	153	91.3	1.4	2.1	2.1	0.00	94	21	22
19:36	5964	5978	0.80	0.86	0.0	0.0	153	91.2	1.4	2.1	2.1	0.00	93	21	22
19:37	5964	5978	0.80	0.86	0.0	0.0	153	91.1	1.4	2.1	2.1	0.00	93	21	22
19:38	5964	5978	0.80	0.86	0.0	0.0	153	91.0	1.4	2.1	2.1	0.00	93	21	22

Time	CONT SPR		DW WR	DW NR	DW	DW	TOR	TORUS	TORUS	TOR	DW	DW UNID	DW	CONT	CONT
	I	II	PRESS	PRESS	O2	H2	LEV	TEMP	PRESS	O2	O2	LK RATE	TEMP	RAD	RAD
	GPM	GPM	PSIG	PSIG	%	%	INCH	DEG F	PSIG	%	%	GPM	DEG F	R/HR	R/HR
19:39	5964	5978	0.80	0.86	0.0	0.0	153	90.9	1.4	2.1	2.1	0.00	93	21	22
19:40	ISOLATION CONDENSER B ISOLATED														
19:40	5964	5978	0.80	0.87	0.0	0.0	153	90.9	1.4	2.1	2.1	0.00	93	21	22
19:41	5964	5978	0.80	0.87	0.0	0.0	153	90.8	1.4	2.1	2.1	0.00	92	21	22
19:42	5964	5978	0.80	0.87	0.0	0.0	153	90.8	1.4	2.1	2.1	0.00	92	21	22
19:43	5964	5978	0.80	0.87	0.0	0.0	153	90.7	1.4	2.1	2.1	0.00	92	21	22
19:44	5964	5978	0.80	0.87	0.0	0.0	153	90.6	1.4	2.1	2.1	0.00	91	21	22
19:45	5964	5978	0.80	0.87	0.0	0.0	153	90.6	1.4	2.1	2.1	0.00	91	21	22
19:50	5964	5978	0.80	0.87	0.0	0.0	153	90.4	1.4	2.1	2.1	0.00	91	21	22
19:55	5964	5978	0.80	0.87	0.0	0.0	153	90.1	1.4	2.1	2.1	0.00	90	21	22
20:00	5964	5978	0.80	0.87	0.0	0.0	153	89.9	1.4	2.1	2.1	0.00	90	21	22
20:10	5964	5978	0.80	0.87	0.0	0.0	153	89.5	1.4	2.1	2.1	0.00	90	21	22
20:15	5964	5978	0.80	0.87	0.0	0.0	153	89.0	1.4	2.1	2.1	0.00	90	21	22
20:20	5964	5978	0.80	0.87	0.0	0.0	153	88.8	1.4	2.1	2.1	0.00	89	21	22
20:25	5964	5978	0.80	0.87	0.0	0.0	153	88.4	1.4	2.1	2.1	0.00	89	21	22
20:30	5964	5978	0.80	0.87	0.0	0.0	153	88.1	1.4	2.1	2.1	0.00	89	21	22
20:30	EXERCISE IS COMPLETED														

SECTION II.B.

BACKUP PLANT PARAMETERS

REACTOR PARAMETERS

AVERAGE ALL APRM's	RECIRC FLOW	SLC STATUS	SLC TANK LEVEL	REACTOR PRESSURE	STEAM FLCW
100.2%	15.3 E4 GPM	OFF	2017 GAL	1019 PSIG	7.19 MLM/H

FUEL ZONE LEVEL	YARWAY LEVEL	FEEDWATER FLOW	CRD FLOW	CORE SPRAY SYSTEM I	CORE SPRAY SYSTEM II	
OFF "TAF"	159.8"TAF	7.17 MLM/H	60 GPM	0 GPM	0 GPM	

ISOLATION CONDENSER A				ISOLATION CONDENSER B			
V-14-30	V-14-31	V-14-34	V-14-36	V-14-32	V-14-33	V-14-35	V-14-37
OPEN	OPEN	CLOSE	OPEN	OPEN	OPEN	CLOSE	OPEN

EMRV A	EMRV B	EMRV C	EMRV D	EMRV E
CLOSE	CLOSE	CLOSE	CLOSE	CLOSE

CONTAINMENT PARAMETERS

DRYWELL TEMP	DRYWELL PRESSURE	DRYWELL HYDROGEN	DRYWELL OXYGEN	CONT SPRAY SYSTEM I	CONT SPRAY SYSTEM II
121°F	1.25 PSIG	0 %	2.6%	GPM	GPM
				OFF	OFF

TORUS PRESSURE	TORUS TEMP	TORUS LEVEL	TORUS HYDROGEN	TORUS OXYGEN
1.0 PSIG	74.2°F	150 INCHES	0%	2.3%

DW UNIDENT LEAKRATE	DW IDENT LEAKRATE	CHRRMS SYS I	CHRRMS SYS II
0 GPM	0 GPM	4 REM	4 REM

TIME 16:00

BALANCE OF PLANT

VENTILATION

RX BLDG FAN EF 1-5	RX/TURB BLDG FAN EF 1-8	TURB BLDG FAN EF 1-7	TURB BLDG FAN EF 1-1	TURB BLDG FAN EF 1-4	TURB BLDG FAN EF 1-33	SBGT FAN EF 1-8	SBGT FAN EF 1-9
ON	OFF	ON	ON	ON	ON	OFF	OFF

ELECTRIC PLANT

MAIN GEN	EDG #1	EDG #2	BKR 1A	BKR 1B	BKR S1A	BKR S1B	BKR 1C	BKR 1D	BATT A	BATT B	BATT C
661 MWe	0 KW	0 KW	C	C	0	0	C	C	131	132	131

TURBINE/AUXILIARIES

MAIN TURB	BYPASS VALVES	TURNING GEAR	VACUUM COND A	VACUUM COND B	VACUUM COND C
ON-LINE	CONTROLLING	OFF	28.4	28.4	28.4

COOLING WATER

RBCCW PUMP 1	RBCCW PUMP 2	TBCCW PUMP 1	TBCCW PUMP 2	TBCCW PUMP 3	SERV WTR PUMP 1	SERV WTR PUMP 2
ON	OFF	ON	ON	STDBY	ON	OFF

TIME 16:00

REACTOR PARAMETERS

AVERAGE ALL APRM's
100.2%

RECIRC FLOW
15.3 E4 GPM

SLC STATUS
OFF

SLC TANK LEVEL
2017 GAL

REACTOR PRESSURE
1019 PSIG

STEAM FLOW
7.19 MLM/H

FUEL ZONE LEVEL
OFF "TAF

YARWAY LEVEL
159.8" TAF

FEEDWATER FLOW
7.17 MLM/H

CRD FLOW
60 GPM

CORE SPRAY SYSTEM I
0 GPM

CORE SPRAY SYSTEM II
0 GPM

ISOLATION CONDENSER A			
V-14-30	V-14-31	V-14-34	V-14-36
OPEN	OPEN	CLOSE	OPEN

ISOLATION CONDENSER B			
V-14-32	V-14-33	V-14-35	V-14-37
OPEN	OPEN	CLOSE	OPEN

EMRV A
CLOSE

EMRV B
CLOSE

EMRV C
CLOSE

EMRV D
CLOSE

EMRV E
CLOSE

CONTAINMENT PARAMETERS

DRYWELL TEMP
121°F

DRYWELL PRESSURE
1.25 PSIG

DRYWELL HYDROGEN
0 %

DRYWELL OXYGEN
2.6%

CONT SPRAY SYSTEM I
GPM
OFF

CONT SPRAY SYSTEM II
GPM
OFF

TORUS PRESSURE
1.0 PSIG

TORUS TEMP
74.2°F

TORUS LEVEL
150 INCHES

TORUS HYDROGEN
0%

TORUS OXYGEN
2.3%

DW UNIDENT LEAKRATE
0 GPM

DW IDENT LEAKRATE
0 GPM

CHRRMS SYS I
4 REM

CHRRMS SYS II
4 REM

TIME

16:31

BALANCE OF PLANT

VENTILATION

RX BLDG FAN EF 1-5	RX/TURB BLDG FAN EF 1-6	TURB BLDG FAN EF 1-7	TURB BLDG FAN EF 1-1	TURB BLDG FAN EF 1-4	TURB BLDG FAN EF 1-33	SBGT FAN EF 1-8	SBGT FAN EF 1-9
ON	OFF	ON	ON	ON	ON	OFF	OFF

ELECTRIC PLANT

MAIN GEN	EDG #1	EDG #2	BKR 1A	BKR 1B	BKR S1A	BKR S1B	BKR 1C	BKR 1D	BATT A	BATT B	BATT C
661 MWe	0 KW	0 KW	C	C	O	C	C	C	131	132	131

TURBINE/AUXILIARIES

MAIN TURB	BYPASS VALVES	TURNING GEAR	VACUUM COND A	VACUUM COND B	VACUUM COND C
ON-LINE	CONTROLLING	OFF	28.4	28.4	28.4

COOLING WATER

RBCCW PUMP 1	RBCCW PUMP 2	TBCCW PUMP 1	TBCCW PUMP 2	TBCCW PUMP 3	SERV WTR PUMP 1	SERV WTR PUMP 2
ON	OFF	ON	ON	STDBY	ON	OFF

TIME

16:31

REACTOR PARAMETERS

AVERAGE ALL APRM's	RECIRC FLOW	SLC STATUS	SLC TANK LEVEL	REACTOR PRESSURE	STEAM FLOW		
100.2%	15.3 E4 GPM	OFF	2017 GAL	1019 PSIG	7.19 MLM/H		
FUEL ZONE LEVEL	YARWAY LEVEL	FEEDWATER FLOW	CRD FLOW	CORE SPRAY SYSTEM I	CORE SPRAY SYSTEM II		
OFF "TAF	159.8" TAF	7.17 MLM/H	60 GPM	0 GPM	0 GPM		
ISOLATION CONDENSER A				ISOLATION CONDENSER B			
V-14-30	V-14-31	V-14-34	V-14-36	V-14-32	V-14-33	V-14-35	V-14-37
OPEN	OPEN	CLOSE	OPEN	OPEN	OPEN	CLOSE	OPEN
EMRV A	EMRV B	EMRV C	EMRV D	EMRV E			
CLOSE	CLOSE	CLOSE	CLOSE	CLOSE			

CONTAINMENT PARAMETERS

DRYWELL TEMP	DRYWELL PRESSURE	DRYWELL HYDROGEN	DRYWELL OXYGEN	CONT SPRAY SYSTEM I	CONT SPRAY SYSTEM II	
121°F	1.25 PSIG	0 %	2.6%	GPM OFF	GPM OFF	
TORUS PRESSURE	TORUS TEMP	TORUS LEVEL	TORUS HYDROGEN	TORUS OXYGEN		
1.0 PSIG	74.2°F	150 INCHES	0%	2.3%		
DW UNIDENT LEAKRATE	DW IDENT LEAKRATE	CHRRMS SYS I	CHRRMS SYS II			
0 GPM	0 GPM	4 REM	4 REM			
TIME		16:40				

BALANCE OF PLANT

VENTILATION

RX BLDG FAN EF 1-5	RX/TURB BLDG FAN EF 1-6	TURB BLDG FAN EF 1-7	TURB BLDG FAN EF 1-1	TURB BLDG FAN EF 1-4	TURB BLDG FAN EF 1-33	SBGT FAN EF 1-8	SBGT FAN EF 1-9
ON	OFF	ON	ON	ON	ON	OFF	OFF

ELECTRIC PLANT

MAIN GEN	EDG #1	EDG #2	BKR 1A	BKR 1B	BKR S1A	BKR S1B	BKR 1C	BKR 1D	BATT A	BATT B	BATT C
66 ¹ MWe	0 KW	0 KW	C	C	O	O	C	C	131	132	131

TURBINE/AUXILIARIES

MAIN TURB	BYPASS VALVES	TURNING GEAR	VACUUM COND A	VACUUM COND B	VACUUM COND C
ON-LINE	CONTROLLING	OFF	28.4	28.4	28.4

COOLING WATER

RBCCW PUMP 1	RBCCW PUMP 2	TBCCW PUMP 1	TBCCW PUMP 2	TBCCW PUMP 3	SERV WTR PUMP 1	SERV WTR PUMP 2
ON	OFF	ON	ON	STDBY	ON	OFF

TIME

16:40

REACTOR PARAMETERS

AVERAGE ALL APRM's
97.0%

RECIRC FLOW
14.7 E4 GPM

SLC STATUS
OFF

SLC TANK LEVEL
2017 GAL

REACTOR PRESSURE
1016 PSIG

STEAM FLOW
7.02 MLM/H

FUEL ZONE LEVEL
OFF "TAF

YARWAY LEVEL
160.1" TAF

FEEDWATER FLOW
7.06 MLM/H

CRD FLOW
60 GPM

CORE SPRAY SYSTEM I
0 GPM

CORE SPRAY SYSTEM II
0 GPM

ISOLATION CONDENSER A			
V-14-30	V-14-31	V-14-34	V-14-36
OPEN	OPEN	CLOSE	OPEN

ISOLATION CONDENSER B			
V-14-32	V-14-33	V-14-35	V-14-37
OPEN	OPEN	CLOSE	OPEN

EMRV A
CLOSE

EMRV B
CLOSE

EMRV C
CLOSE

EMRV D
CLOSE

EMRV E
CLOSE

CONTAINMENT PARAMETERS

DRYWELL TEMP
121°F

DRYWELL PRESSURE
1.25 PSIG

DRYWELL HYDROGEN
0 %

DRYWELL OXYGEN
2.6%

CONT SPRAY SYSTEM I
GPM
OFF

CONT SPRAY SYSTEM II
GPM
OFF

TORUS PRESSURE
1.0 PSIG

TORUS TEMP
74.2°F

TORUS LEVEL
150 INCHES

TORUS HYDROGEN
0%

TORUS OXYGEN
2.3%

DW UNIDENT LEAKRATE
0 GPM

DW IDENT LEAKRATE
0 GPM

CHRRMS SYS I
4 REM

CHRRMS SYS II
4 REM

TIME

16:45

BALANCE OF PLANT

VENTILATION

RX BLDG FAN EF 1-5	RX/TURB BLDG FAN EF 1-6	TURB BLDG FAN EF 1-7	TURB BLDG FAN EF 1-1	TURB BLDG FAN EF 1-4	TURB BLDG FAN EF 1-33	SBGT FAN EF 1-8	SBGT FAN EF 1-9
ON	OFF	ON	ON	ON	ON	OFF	OFF

ELECTRIC PLANT

MAIN GEN	EDG #1	EDG #2	BKR 1A	BKR 1B	BKR S1A	BKR S1B	BKR 1C	BKR 1D	BATT A	BATT B	BATT C
647 MWe	0 KW	0 KW	C	C	O	O	C	C	131	132	131

TURBINE/AUXILIARIES

MAIN TURB	BYPASS VALVES	TURNING GEAR	VACUUM COND A	VACUUM COND B	VACUUM COND C
ON-LINE	CONTROLLING	OFF	28.4	28.4	28.4

COOLING WATER

RBCCW PUMP 1	RBCCW PUMP 2	TBCCW PUMP 1	TBCCW PUMP 2	TBCCW PUMP 3	SERV WTR PUMP 1	SERV WTR PUMP 2
ON	OFF	ON	ON	STDBY	ON	OFF

TIME

16:45

REACTOR PARAMETERS

AVERAGE ALL APRM's	RECIRC FLOW	SLC STATUS	SLC TANK LEVEL	REACTOR PRESSURE	STEAM FLOW
92.4%	13.9 E4 GPM	OFF	2017 GAL	1009 PSIG	6.78 MLM/H

FUEL ZONE LEVEL	YARWAY LEVEL	FEEDWATER FLOW	CRD FLOW	CORE SPRAY SYSTEM I	CORE SPRAY SYSTEM II	
OFF "TAF"	160.7" TAF	6.89 MLM/H	60 GPM	0 GPM	0 GPM	

ISOLATION CONDENSER A				ISOLATION CONDENSER B			
V-14-30	V-14-31	V-14-34	V-14-36	V-14-32	V-14-33	V-14-35	V-14-37
OPEN	OPEN	CLOSE	OPEN	OPEN	OPEN	CLOSE	OPEN

EMRV A	EMRV B	EMRV C	EMRV D	EMRV E
CLOSE	CLOSE	CLOSE	CLOSE	CLOSE

CONTAINMENT PARAMETERS

DRYWELL TEMP	DRYWELL PRESSURE	DRYWELL HYDROGEN	DRYWELL OXYGEN	CONT SPRAY SYSTEM I	CONT SPRAY SYSTEM II
121°F	1.25 PSIG	0 %	2.6%	GPM OFF	GPM OFF

TORUS PRESSURE	TORUS TEMP	TORUS LEVEL	TORUS HYDROGEN	TORUS OXYGEN
1.0 PSIG	74.2°F	150 INCHES	0%	2.3%

DW UNIDENT LEAKRATE	DW IDENT LEAKRATE	CHRRMS SYS I	CHRRMS SYS II
0 GPM	0 GPM	4 REM	4 REM

TIME 16:50

BALANCE OF PLANT

VENTILATION

RX BLDG FAN EF 1-5	RX/TURB BLDG FAN EF 1-6	TURB BLDG FAN EF 1-7	TURB BLDG FAN EF 1-1	TURB BLDG FAN EF 1-4	TURB BLDG FAN EF 1-33	SBGT FAN EF 1-8	SBGT FAN EF 1-9
ON	OFF	ON	ON	ON	ON	OFF	OFF

ELECTRIC PLANT

MAIN GEN	EDG #1	EDG #2	BKR A	BKR B	BKR S1A	BKR S1B	BKR 1C	BKR 1D	BATT A	BATT B	BATT C
625 MWe	0 KW	0 KW	C	C	O	O	C	C	131	132	131

TURBINE/AUXILIARIES

MAIN TURB	BYPASS VALVES	TURNING GEAR	VACUUM COND A	VACUUM COND B	VACUUM COND C
ON-LINE	CONTROLLING	OFF	28.5	28.4	28.4

COOLING WATER

RBCCW PUMP 1	RBCCW PUMP 2	TBCCW PUMP 1	TBCCW PUMP 2	TBCCW PUMP 3	SERV WTR PUMP 1	SERV WTR PUMP 2
ON	OFF	ON	ON	STDBY	ON	OFF

TIME

16:50

REACTOR PARAMETERS

AVERAGE ALL
APRM's
87.3%

RECIRC
FLOW
12.9 E4 GPM

SLC STATUS
OFF

SLC TANK
LEVEL
2017 GAL

REACTOR
PRESSURE
1002 PSIG

STEAM FLOW
6.39 MLM/H

FUEL ZONE
LEVEL
OFF "TAF

YARWAY
LEVEL
161.2" TAF

FEEDWATER
FLOW
6.61 MLM/H

CRD
FLOW
60 GPM

CORE SPRAY
SYSTEM I
0 GPM

CORE SPRAY
SYSTEM II
0 GPM

ISOLATION CONDENSER A			
V-14-30	V-14-31	V-14-34	V-14-36
OPEN	OPEN	CLOSE	OPEN

ISOLATION CONDENSER B			
V-14-32	V-14-33	V-14-35	V-14-37
OPEN	OPEN	CLOSE	OPEN

EMRV A
CLOSE

EMRV B
CLOSE

EMRV C
CLOSE

EMRV D
CLOSE

EMRV E
CLOSE

CONTAINMENT PARAMETERS

DRYWELL
TEMP
120°F

DRYWELL
PRESSURE
1.23 PSIG

DRYWELL
HYDROGEN
0 %

DRYWELL
OXYGEN
2.6%

CONT SPRAY
SYSTEM I
GPM
OFF

CONT SPRAY
SYSTEM II
GPM
OFF

TORUS
PRESSURE
1.0 PSIG

TORUS TEMP
74.2°F

TORUS
LEVEL
150 INCHES

TORUS
HYDROGEN
0%

TORUS
OXYGEN
2.3%

DW UNIDENT
LEAKRATE
0 GPM

DW IDENT
LEAKRATE
0 GPM

CHRRMS
SYS I
3 REM

CHRRMS
SYS II
4 REM

TIME

16:55

BALANCE OF PLANT

VENTILATION

RX BLDG FAN EF 1-5	RX/TURB BLDG FAN EF 1-6	TURB BLDG FAN EF 1-7	TURB BLDG FAN EF 1-1	TURB BLDG FAN EF 1-4	TURB BLDG FAN EF 1-33	SBGT FAN EF 1-8	SBGT FAN EF 1-9
ON	OFF	ON	ON	ON	ON	OFF	OFF

ELECTRIC PLANT

MAIN GEN	EDG #1	EDG #2	BKR 1A	BKR 1B	BKR S1A	BKR S1B	BKR 1C	BKR 1D	BATT A	BATT B	BATT C
590 MWe	0 KW	0 KW	C	C	O	O	C	C	131	132	131

TURBINE/AUXILIARIES

MAIN TURB	BYPASS VALVES	TURNING GEAR	VACUUM COND A	VACUUM COND B	VACUUM COND C
ON-LINE	CONTROLLING	OFF	28.5	28.5	28.5

COOLING WATER

RBCCW PUMP 1	RBCCW PUMP 2	TBCCW PUMP 1	TBCCW PUMP 2	TBCCW PUMP 3	SERV WTR PUMP 1	SERV WTR PUMP 2
ON	OFF	ON	ON	STDBY	ON	OFF

TIME

16:55

REACTOR PARAMETERS

AVERAGE ALL
APRM's
88.3%

RECIRC
FLOW
12.6 E4 GPM

SLC STATUS
OFF

SLC TANK
LEVEL
2017 GAL

REACTOR
PRESSURE
1016 PSIG

STEAM FLOW
6.32 MLM/H

FUEL ZONE
LEVEL
OFF "TAF

YARWAY
LEVEL
159.9"TAF

FEEDWATER
FLOW
6.23 MLM/H

CRD
FLOW
60 GPM

CORE SPRAY
SYSTEM I
0 GPM

CORE SPRAY
SYSTEM II
0 GPM

ISOLATION CONDENSER A			
V-14-30	V-14-31	V-14-34	V-14-36
OPEN	OPEN	CLOSE	OPEN

ISOLATION CONDENSER B			
V-14-32	V-14-33	V-14-35	V-14-37
OPEN	OPEN	CLOSE	OPEN

EMRV A
CLOSE

EMRV B
CLOSE

EMRV C
CLOSE

EMRV D
CLOSE

EMRV E
CLOSE

CONTAINMENT PARAMETERS

DRYWELL
TEMP
119°F

DRYWELL
PRESSURE
1.19 PSIG

DRYWELL
HYDROGEN
0 %

DRYWELL
OXYGEN
2.6%

CONT SPRAY
SYSTEM I
GPM
OFF

CONT SPRAY
SYSTEM II
GPM
OFF

TORUS
PRESSURE
1.0 PSIG

TORUS TEMP
74.2°F

TORUS
LEVEL
150 INCHES

TORUS
HYDROGEN
0%

TORUS
OXYGEN
2.3%

DW UNIDENT
LEAKRATE
0 GPM

DW IDENT
LEAKRATE
0 GPM

CHRRMS
SYS I
3 REM

CHRRMS
SYS II
4 REM

TIME

17:00

BALANCE OF PLANT

VENTILATION

RX BLDG FAN EF 1-5	RX/TURB BLDG FAN EF 1-8	TURB BLDG FAN EF 1-7	TURB BLDG FAN EF 1-1	TURB BLDG FAN EF 1-4	TURB BLDG FAN EF 1-33	SBGT FAN EF 1-8	SBGT FAN EF 1-9
ON	OFF	ON	ON	ON	ON	OFF	OFF

ELECTRIC PLANT

MAIN GEN	EDG #1	EDG #2	BKR 1A	BKR 1B	BKR S1A	BKR S1B	BKR 1C	BKR 1D	BATT A	BATT B	BATT C
583 MWe	0 KW	0 KW	C	C	O	O	C	C	131	132	131

TURBINE/AUXILIARIES

MAIN TURB	BYPASS VALVES	TURNING GEAR	VACUUM COND A	VACUUM COND B	VACUUM COND C
ON-LINE	CONTROLLING	OFF	28.6	28.6	28.5

COOLING WATER

RBCCW PUMP 1	RBCCW PUMP 2	TBCCW PUMP 1	TBCCW PUMP 2	TBCCW PUMP 3	SERV WTR PUMP 1	SERV WTR PUMP 2
ON	OFF	ON	ON	STDBY	ON	OFF

TIME

17:00

REACTOR PARAMETERS

AVERAGE ALL
APRM's
88.7%

RECIRC
FLOW
12.7 E4 GPM

SLC STATUS
OFF

SLC TANK
LEVEL
2017 GAL

REACTOR
PRESSURE
1016 PSIG

STEAM FLOW
6.32 MLM/H

FUEL ZONE
LEVEL
OFF "TAF"

YARWAY
LEVEL
159.6" TAF

FEEDWATER
FLOW
6.30 MLM/H

CRD
FLOW
60 GPM

CORE SPRAY
SYSTEM I
0 GPM

CORE SPRAY
SYSTEM II
0 GPM

ISOLATION CONDENSER A			
V-14-30	V-14-31	V-14-34	V-14-36
OPEN	OPEN	CLOSE	OPEN

ISOLATION CONDENSER B			
V-14-32	V-14-33	V-14-35	V-14-37
OPEN	OPEN	CLOSE	OPEN

EMRV A
CLOSE

EMRV B
CLOSE

EMRV C
CLOSE

EMRV D
CLOSE

EMRV E
CLOSE

CONTAINMENT PARAMETERS

DRYWELL
TEMP
119°F

DRYWELL
PRESSURE
1.18 PSIG

DRYWELL
HYDROGEN
0 %

DRYWELL
OXYGEN
2.6%

CONT SPRAY
SYSTEM I
GPM
OFF

CONT SPRAY
SYSTEM II
GPM
OFF

TORUS
PRESSURE
1.0 PSIG

TORUS TEMP
74.2°F

TORUS
LEVEL
150 INCHES

TORUS
HYDROGEN
0%

TORUS
OXYGEN
2.3%

DW UNIDENT
LEAKRATE
0 GPM

DW IDENT
LEAKRATE
0 GPM

CHRRMS
SYS I
3 REM

CHRRMS
SYS II
4 REM

TIME

17:05

BALANCE OF PLANT

VENTILATION

RX BLDG FAN EF 1-5	RX/TURB BLDG FAN EF 1-6	TURB BLDG FAN EF 1-7	TURB BLDG FAN EF 1-1	TURB BLDG FAN EF 1-4	TURB BLDG FAN EF 1-33	SBGT FAN EF 1-8	SBGT FAN EF 1-9
ON	OFF	ON	ON	ON	ON	OFF	OFF

ELECTRIC PLANT

MAIN GEN	EDG #1	EDG #2	BKR 1A	BKR 1B	BKR S1A	BKR S1B	BKR 1C	BKR 1D	BATT A	BATT B	BATT C
582 MWe	0 KW	0 KW	C	C	O	O	C	C	131	132	131

TURBINE/AUXILIARIES

MAIN TURB	BYPASS VALVES	TURNING GEAR	VACUUM COND A	VACUUM COND B	VACUUM COND C
ON-LINE	CONTROLLING	OFF	28.6	28.6	28.5

COOLING WATER

RBCCW PUMP 1	RBCCW PUMP 2	TBCCW PUMP 1	TBCCW PUMP 2	TBCCW PUMP 3	SERV WTR PUMP 1	SERV WTR PUMP 2
ON	OFF	ON	ON	STDBY	ON	OFF

TIME

17:05

REACTOR PARAMETERS

AVERAGE ALL
APRM's
88.2%

RECIRC
FLOW
12.6 E4 GPM

SLC STATUS
OFF

SLC TANK
LEVEL
2017 GAL

REACTOR
PRESSURE
1018 PSIG

STEAM FLOW
6.31 MLM/H

FUEL ZONE
LEVEL
OFF "TAF

YARWAY
LEVEL
160.5" TAF

FEEDWATER
FLOW
6.24 MLM/H

CRD
FLOW
60 GPM

CORE SPRAY
SYSTEM I
0 GPM

CORE SPRAY
SYSTEM II
0 GPM

ISOLATION CONDENSER A			
V-14-30	V-14-31	V-14-34	V-14-36
OPEN	OPEN	CLOSE	OPEN

ISOLATION CONDENSER B			
V-14-32	V-14-33	V-14-35	V-14-37
OPEN	OPEN	CLOSE	OPEN

EMRV A
CLOSE

EMRV B
CLOSE

EMRV C
CLOSE

EMRV D
CLOSE

EMRV E
CLOSE

CONTAINMENT PARAMETERS

DRYWELL
TEMP
120 °F

DRYWELL
PRESSURE
1.22 PSIG

DRYWELL
HYDROGEN
0 %

DRYWELL
OXYGEN
2.6%

CONT SPRAY
SYSTEM I
GPM
OFF

CONT SPRAY
SYSTEM II
GPM
OFF

TORUS
PRESSURE
1.0 PSIG

TORUS TEMP
74.2 °F

TORUS
LEVEL
150 INCHES

TORUS
HYDROGEN
0%

TORUS
OXYGEN
2.3%

DW UNIDENT
LEAKRATE
0 GPM

DW IDENT
LEAKRATE
0 GPM

CHRRMS
SYS I
3 REM

CHRRMS
SYS II
4 REM

TIME

17:10

BALANCE OF PLANT

VENTILATION

RX BLDG FAN EF 1-5	RX/TURB BLDG FAN EF 1-6	TURB BLDG FAN EF 1-7	TURB BLDG FAN EF 1-1	TURB BLDG FAN EF 1-4	TURB BLDG FAN EF 1-33	SBGT FAN EF 1-8	SBGT FAN EF 1-9
ON	OFF	ON	ON	ON	ON	OFF	OFF

ELECTRIC PLANT

MAIN GEN	EDG #1	EDG #2	BKR 1A	BKR 1B	BKR S1A	BKR S1B	BKR 1C	BKR 1D	BATT A	BATT B	BATT C
582 MWe	0 KW	0 KW	C	C	O	O	C	C	131	132	131

TURBINE/AUXILIARIES

MAIN TURB	BYPASS VALVES	TURNING GEAR	VACUUM COND A	VACUUM COND B	VACUUM COND C
ON-LINE	CONTROLLING	OFF	28.5	28.6	28.6

COOLING WATER

RBCCW PUMP 1	RBCCW PUMP 2	TBCCW PUMP 1	TBCCW PUMP 2	TBCCW PUMP 3	SERV WTR PUMP 1	SERV WTR PUMP 2
ON	OFF	ON	ON	STDBY	ON	OFF

TIME

17:10

REACTOR PARAMETERS

AVERAGE ALL
APRM's
88.4%

RECIRC
FLOW
12.6 E4 GPM

SLC STATUS
OFF

SLC TANK
LEVEL
2017 GAL

REACTOR
PRESSURE
1018 PSIG

STEAM FLOW
6.32 MLM/H

FUEL ZONE
LEVEL
OFF "TAF

YARWAY
LEVEL
160.0"TAF

FEEDWATER
FLOW
6.29 MLM/H

CRD
FLOW
60 GPM

CORE SPRAY
SYSTEM I
0 GPM

CORE SPRAY
SYSTEM II
0 GPM

ISOLATION CONDENSER A			
V-14-30	V-14-31	V-14-34	V-14-36
OPEN	OPEN	CLOSE	OPEN

ISOLATION CONDENSER B			
V-14-32	V-14-33	V-14-35	V-14-37
OPEN	OPEN	CLOSE	OPEN

EMRV A
CLOSE

EMRV B
CLOSE

EMRV C
CLOSE

EMRV D
CLOSE

EMRV E
CLOSE

CONTAINMENT PARAMETERS

DRYWELL
TEMP
119 °F

DRYWELL
PRESSURE
1.20 PSIG

DRYWELL
HYDROGEN
0 %

DRYWELL
OXYGEN
2.6%

CONT SPRAY
SYSTEM I
GPM
OFF

CONT SPRAY
SYSTEM II
GPM
OFF

TORUS
PRESSURE
1.0 PSIG

TORUS TEMP
74.2 °F

TORUS
LEVEL
150 INCHES

TORUS
HYDROGEN
0%

TORUS
OXYGEN
2.3%

DW UNIDENT
LEAKRATE
0 GPM

DW IDENT
LEAKRATE
0 GPM

CHRRMS
SYS I
3 REM

CHRRMS
SYS II
4 REM

TIME

17:15

BALANCE OF PLANT

VENTILATION

RX BLDG FAN EF 1-5	RX/TURB BLDG FAN EF 1-6	TURB BLDG FAN EF 1-7	TURB BLDG FAN EF 1-1	TURB BLDG FAN EF 1-4	TURB BLDG FAN EF 1-33	SBGT FAN EF 1-8	SBGT FAN EF 1-9
ON	OFF	ON	ON	ON	ON	OFF	OFF

ELECTRIC PLANT

MAIN GEN	EDG #1	EDG #2	BKR 1A	BKR 1B	BKR S1A	BKR S1B	BKR 1C	BKR 1D	BATT A	BATT B	BATT C
583 MWe	0 KW	0 KW	C	C	O	O	C	C	131	132	131

TURBINE/AUXILIARIES

MAIN TURB	BYPASS VALVES	TURNING GEAR	VACUUM COND A	VACUUM COND B	VACUUM COND C
ON-LINE	CONTROLLING	OFF	28.5	28.6	28.5

COOLING WATER

RBCCW PUMP 1	RBCCW PUMP 2	TBCCW PUMP 1	TBCCW PUMP 2	TBCCW PUMP 3	SERV WTR PUMP 1	SERV WTR PUMP 2
ON	OFF	ON	ON	STDBY	ON	OFF

TIME

17:15

REACTOR PARAMETERS

AVERAGE ALL APRM's
88.7%

RECIRC FLOW
12.7 E4 GPM

SLC STATUS
OFF

SLC TANK LEVEL
2017 GAL

REACTOR PRESSURE
1019 PSIG

STEAM FLOW
6.33 MLM/H

FUEL ZONE LEVEL
OFF "TAF

YARWAY LEVEL
159.6"TAF

FEEDWATER FLOW
6.32 MLM/H

CRD FLOW
60 GPM

CORE SPRAY SYSTEM I
0 GPM

CORE SPRAY SYSTEM II
0 GPM

ISOLATION CONDENSER A			
V-14-30	V-14-31	V-14-34	V-14-36
OPEN	OPEN	CLOSE	OPEN

ISOLATION CONDENSER B			
V-14-32	V-14-33	V-14-35	V-14-37
OPEN	OPEN	CLOSE	OPEN

EMRV A
CLOSE

EMRV B
CLOSE

EMRV C
CLOSE

EMRV D
CLOSE

EMRV E
CLOSE

CONTAINMENT PARAMETERS

DRYWELL TEMP
118 °F

DRYWELL PRESSURE
1.16 PSIG

DRYWELL HYDROGEN
0 %

DRYWELL OXYGEN
2.6%

CONT SPRAY SYSTEM I
GPM
OFF

CONT SPRAY SYSTEM II
GPM
OFF

TORUS PRESSURE
1.0 PSIG

TORUS TEMP
74.2 °F

TORUS LEVEL
150 INCHES

TORUS HYDROGEN
0%

TORUS OXYGEN
2.3%

DW UNIDENT LEAKRATE
0 GPM

DW IDENT LEAKRATE
0 GPM

CHRRMS SYS I
3 REM

CHRRMS SYS II
4 REM

TIME

17:20

BALANCE OF PLANT

VENTILATION

RX BLDG FAN EF 1-5	HX/TURB BLDG FAN EF 1-6	TURB BLDG FAN EF 1-7	TURB BLDG FAN EF 1-1	TURB BLDG FAN EF 1-4	TURB BLDG FAN EF 1-33	SBGT FAN EF 1-8	SBGT FAN EF 1-9
ON	OFF	ON	ON	ON	ON	OFF	OFF

ELECTRIC PLANT

MAIN GEN	EDG #1	EDG #2	BKR 1A	BKR 1B	BKR S1A	BKR S1B	BKR 1C	BKR 1D	BATT A	BATT B	BATT C
580 MWe	0 KW	0 KW	C	C	O	O	C	C	131	132	131

TURBINE/AUXILIARIES

MAIN TURB	BYPASS VALVES	TURNING GEAR	VACUUM COND A	VACUUM COND B	VACUUM COND C
ON-LINE	CONTROLLING	OFF	28.4	28.4	28.4

COOLING WATER

RBCCW PUMP 1	RBCCW PUMP 2	TBCCW PUMP 1	TBCCW PUMP 2	TBCCW PUMP 3	SERV WTR PUMP 1	SERV WTR PUMP 2
ON	OFF	ON	ON	STDBY	ON	OFF

TIME

17:20

REACTOR PARAMETERS

AVERAGE ALL
APRM's
76.2%

RECIRC
FLOW
10.1 E4 GPM

SLC STATUS
OFF

SLC TANK
LEVEL
2017 GAL

REACTOR
PRESSURE
1002 PSIG

STEAM FLOW
5.31 MLM/H

FUEL ZONE
LEVEL
OFF "TAF

YARWAY
LEVEL
160.7" TAF

FEEDWATER
FLOW
6.17 MLM/H

CRD
FLOW
60 GPM

CORE SPRAY
SYSTEM I
0 GPM

CORE SPRAY
SYSTEM II
0 GPM

ISOLATION CONDENSER A			
V-14-30	V-14-31	V-14-34	V-14-36
OPEN	OPEN	CLOSE	OPEN

ISOLATION CONDENSER B			
V-14-32	V-14-33	V-14-35	V-14-37
OPEN	OPEN	CLOSE	OPEN

EMRV A
CLOSE

EMRV B
CLOSE

EMRV C
CLOSE

EMRV D
CLOSE

EMRV E
CLOSE

CONTAINMENT PARAMETERS

DRYWELL
TEMP
118 °F

DRYWELL
PRESSURE
1.15 PSIG

DRYWELL
HYDROGEN
0 %

DRYWELL
OXYGEN
2.6%

CONT SPRAY
SYSTEM I
GPM
OFF

CONT SPRAY
SYSTEM II
GPM
OFF

TORUS
PRESSURE
1.0 PSIG

TORUS
TEMP
74.2 °F

TORUS
LEVEL
150 INCHES

TORUS
HYDROGEN
0%

TORUS
OXYGEN
2.3%

DW UNIDENT
LEAKRATE
0 GPM

DW IDENT
LEAKRATE
0 GPM

CHRRMS
SYS I
3 REM

CHRRMS
SYS II
3 REM

TIME

17:21

BALANCE OF PLANT

VENTILATION

RX BLDG FAN EF 1-5	RX/TURB BLDG FAN EF 1-6	TURB BLDG FAN EF 1-7	TURB BLDG FAN EF 1-1	TURB BLDG FAN EF 1-4	TURB BLDG FAN EF 1-33	SBGT FAN EF 1-8	SBGT FAN EF 1-9
ON	OFF	ON	ON	ON	ON	OFF	OFF

ELECTRIC PLANT

MAIN GEN	EDG #1	EDG #2	BKR 1A	BKR 1B	BKR S1A	BKR S1B	BKR 1C	BKR 1D	BATT A	BATT B	BATT C
443 MWe	0 KW	0 KW	C	C	O	O	C	C	131	132	131

TURBINE/AUXILIARIES

MAIN TURB	BYPASS VALVES	TURNING GEAR	VACUUM COND A	VACUUM COND B	VACUUM COND C
ON-LINE	CONTROLLING	OFF	25.8	25.8	25.8

COOLING WATER

RBCCW PUMP 1	RBCCW PUMP 2	TBCCW PUMP 1	TBCCW PUMP 2	TBCCW PUMP 3	SERV WTR PUMP 1	SERV WTR PUMP 2
ON	OFF	ON	ON	STDBY	ON	OFF

TIME

17:21

REACTOR PARAMETERS

AVERAGE ALL APRM's	RECIRC FLOW	SLC STATUS	SLC TANK LEVEL	REACTOR PRESSURE	STEAM FLOW
71.9%	9.3 E4 GPM	OFF	2017 GAL	998 PSIG	5.12 MLM/H

FUEL ZONE LEVEL	YARWAY LEVEL	FEEDWATER FLOW	CRD FLOW	CORE SPRAY SYSTEM I	CORE SPRAY SYSTEM II	
OFF "TAF"	160.4"TAF	5.23 MLM/H	60 GPM	0 GPM	0 GPM	

ISOLATION CONDENSER A				ISOLATION CONDENSER B			
V-14-30	V-14-31	V-14-34	V-14-36	V-14-32	V-14-33	V-14-35	V-14-37
OPEN	OPEN	CLOSE	OPEN	OPEN	OPEN	CLOSE	OPEN

EMRV A	EMRV B	EMRV C	EMRV D	EMRV E
CLOSE	CLOSE	CLOSE	CLOSE	CLOSE

CONTAINMENT PARAMETERS

DRYWELL TEMP	DRYWELL PRESSURE	DRYWELL HYDROGEN	DRYWELL OXYGEN	CONT SPRAY SYSTEM I	CONT SPRAY SYSTEM II
117 °F	1.12 PSIG	0 %	2.6%	GPM	GPM
				OFF	OFF

TORUS PRESSURE	TORUS TEMP	TORUS LEVEL	TORUS HYDROGEN	TORUS OXYGEN
1.0 PSIG	74.2 °F	150 INCHES	0%	2.3%

DW UNIDENT LEAKRATE	DW IDENT LEAKRATE	CHRRMS SYS I	CHRRMS SYS II
0 GPM	0 GPM	3 REM	3 REM

TIME 17:22

BALANCE OF PLANT

VENTILATION

RX BLDG FAN EF 1-5	RX/TURB BLDG FAN EF 1-6	TURB BLDG FAN EF 1-7	TURB BLDG FAN EF 1-1	TURB BLDG FAN EF 1-4	TURB BLDG FAN EF 1-33	SBGT FAN EF 1-8	SBGT FAN EF 1-9
ON	OFF	ON	ON	ON	ON	OFF	OFF

ELECTRIC PLANT

MAIN GEN	EDG #1	EDG #2	BKR 1A	BKR 1B	BKR S1A	BKR S1B	BKR 1C	BKR 1D	BATT A	BATT B	BATT C
365 MWe	0 KW	0 KW	C	C	O	O	C	C	131	132	131

TURBINE/AUXILIARIES

MAIN TURB	BYPASS VALVES	TURNING GEAR	VACUUM COND A	VACUUM COND B	VACUUM COND C
ON-LINE	CONTROLLING	OFF	23.0	22.9	22.9

COOLING WATER

RBCCW PUMP 1	RBCCW PUMP 2	TBCCW PUMP 1	TBCCW PUMP 2	TBCCW PUMP 3	SERV WTR PUMP 1	SERV WTR PUMP 2
ON	OFF	ON	ON	STDBY	ON	OFF

TIME

17:22

REACTOR PARAMETERS

AVERAGE ALL
APRM's
30.6%

RECIRC
FLOW
3.9 E4 GPM

SLC STATUS
OFF

SLC TANK
LEVEL
2017 GAL

REACTOR
PRESSURE
998 PSIG

STEAM FLOW
2.76 MLM/H

FUEL ZONE
LEVEL
OFF TAF

YARWAY
LEVEL
148.8 TAF

FEEDWATER
FLOW
3.37 MLM/H

CRD
FLOW
100 GPM

CORE SPRAY
SYSTEM I
0 GPM

CORE SPRAY
SYSTEM II
0 GPM

ISOLATION CONDENSER A			
V-14-30	V-14-31	V-14-34	V-14-36
OPEN	OPEN	OPEN	OPEN

ISOLATION CONDENSER B			
V-14-32	V-14-33	V-14-35	V-14-37
OPEN	OPEN	OPEN	OPEN

EMRV A
CLOSE

EMRV B
CLOSE

EMRV C
CLOSE

EMRV D
CLOSE

EMRV E
CLOSE

CONTAINMENT PARAMETERS

DRYWELL
TEMP
116 °F

DRYWELL
PRESSURE
1.11 PSIG

DRYWELL
HYDROGEN
0 %

DRYWELL
OXYGEN
2.6%

CONT SPRAY
SYSTEM I
GPM
OFF

CONT SPRAY
SYSTEM II
GPM
OFF

TORUS
PRESSURE
1.0 PSIG

TORUS TEMP
76.2 °F

TORUS
LEVEL
150 INCHES

TORUS
HYDROGEN
0%

TORUS
OXYGEN
2.3%

DW UNIDENT
LEAKRATE
0 GPM

DW IDENT
LEAKRATE
0 GPM

CHRRMS
SYS I
2 REM

CHRRMS
SYS II
2 REM

TIME

17:23

BALANCE OF PLANT

VENTILATION

RX BLDG FAN EF 1-5	RX/TURB BLDG FAN EF 1-6	TURB BLDG FAN EF 1-7	TURB BLDG FAN EF 1-1	TURB BLDG FAN EF 1-4	TURB BLDG FAN EF 1-33	SBGT FAN EF 1-8	SBGT FAN EF 1-9
ON	OFF	ON	ON	ON	ON	OFF	OFF

ELECTRIC PLANT

MAIN GEN	EDG #1	EDG #2	BKR 1A	BKR 1B	BKR S1A	BKR S1B	BKR 1C	BKR 1D	BATT A	BATT B	BATT C
0 MWe	0 KW	0 KW	O	O	C	C	C	C	131	132	131

TURBINE/AUXILIARIES

MAIN TURB	BYPASS VALVES	TURNING GEAR	VACUUM COND A	VACUUM COND B	VACUUM COND C
TRIPPED	CONTROLLING	OFF	20.2	20.2	20.2

COOLING WATER

RBCCW PUMP 1	RBCCW PUMP 2	TBCCW PUMP 1	TBCCW PUMP 2	TBCCW PUMP 3	SERV WTR PUMP 1	SERV WTR PUMP 2
ON	OFF	ON	ON	STDBY	ON	OFF

TIME 17:23

REACTOR PARAMETERS

AVERAGE ALL
APRM's
35.0%

RECIRC
FLOW
3.4 E4 GPM

SLC STATUS
OFF

SLC TANK
LEVEL
2017 GAL

REACTOR
PRESSURE
963 PSIG

STEAM FLOW
1.66 MLM/H

FUEL ZONE
LEVEL
OFF "TAF"

YARWAY
LEVEL
118.6"TAF

FEEDWATER
FLOW
0.81 MLM/H

CRD
FLOW
100 GPM

CORE SPRAY
SYSTEM I
0 GPM

CORE SPRAY
SYSTEM II
0 GPM

ISOLATION CONDENSER A			
V-14-30	V-14-31	V-14-34	V-14-36
OPEN	OPEN	OPEN	OPEN

ISOLATION CONDENSER B			
V-14-32	V-14-33	V-14-35	V-14-37
OPEN	OPEN	OPEN	OPEN

EMRV A
CLOSE

EMRV B
CLOSE

EMRV C
CLOSE

EMRV D
CLOSE

EMRV E
CLOSE

CONTAINMENT PARAMETERS

DRYWELL
TEMP
115 °F

DRYWELL
PRESSURE
1.03 PSIG

DRYWELL
HYDROGEN
0 %

DRYWELL
OXYGEN
2.6%

CONT SPRAY
SYSTEM I
GPM
OFF

CONT SPRAY
SYSTEM II
GPM
OFF

TORUS
PRESSURE
1.0 PSIG

TORUS TEMP
76.1 °F

TORUS
LEVEL
150 INCHES

TORUS
HYDROGEN
0%

TORUS
OXYGEN
2.3%

DW UNIDENT
LEAKRATE
0 GPM

DW IDENT
LEAKRATE
0 GPM

CHRRMS
SYS I
2 REM

CHRRMS
SYS II
2 REM

TIME

17:24

BALANCE OF PLANT

VENTILATION

RX BLDG FAN EF 1-5	RX/TURB BLDG FAN EF 1-6	TURB BLDG FAN EF 1-7	TURB BLDG FAN EF 1-1	TURB BLDG FAN EF 1-4	TURB BLDG FAN EF 1-33	SBGT FAN EF 1-8	SBGT FAN EF 1-9
ON	OFF	ON	ON	ON	ON	OFF	OFF

ELECTRIC PLANT

MAIN GEN	EDG #1	EDG #2	BKR 1A	BKR 1B	BKR S1A	BKR S1B	BKR 1C	BKR 1D	BATT A	BATT B	BATT C
0 MWe	0 KW	0 KW	O	O	C	C	C	C	131	132	131

TURBINE/AUXILIARIES

MAIN TURB	BYPASS VALVES	TURNING GEAR	VACUUM COND A	VACUUM COND B	VACUUM COND C
TRIPPED	CONTROLLING	OFF	17.0	17.0	17.0

COOLING WATER

RBCCW PUMP 1	RBCCW PUMP 2	TBCCW PUMP 1	TBCCW PUMP 2	TBCCW PUMP 3	SERV WTR PUMP 1	SERV WTR PUMP 2
ON	OFF	ON	ON	STDBY	ON	OFF

TIME

17:24

REACTOR PARAMETERS

AVERAGE ALL
APRM's
21.6%

RECIRC
FLOW
2.7 E4 GPM

SLC STATUS
SYS 1 - ON

SLC TANK
LEVEL
1991 GAL

REACTOR
PRESSURE
951 PSIG

STEAM FLOW
1.51 MLM/H

FUEL ZONE
LEVEL
73 "TAF

YARWAY
LEVEL
86.3" TAF

FEEDWATER
FLOW
0.11 MLM/H

CRD
FLOW
100 GPM

CORE SPRAY
SYSTEM I
0 GPM

CORE SPRAY
SYSTEM II
0 GPM

ISOLATION CONDENSER A			
V-14-30	V-14-31	V-14-34	V-14-36
OPEN	OPEN	OPEN	OPEN

ISOLATION CONDENSER B			
V-14-32	V-14-33	V-14-35	V-14-37
OPEN	OPEN	OPEN	OPEN

EMRV A
CLOSE

EMRV B
CLOSE

EMRV C
CLOSE

EMRV D
CLOSE

EMRV E
CLOSE

CONTAINMENT PARAMETERS

DRYWELL
TEMP
114 °F

DRYWELL
PRESSURE
1.03 PSIG

DRYWELL
HYDROGEN
0 %

DRYWELL
OXYGEN
2.2%

CONT SPRAY
SYSTEM I
GPM
OFF

CONT SPRAY
SYSTEM II
GPM
OFF

TORUS
PRESSURE
1.0 PSIG

TORUS TEMP
76.1 °F

TORUS
LEVEL
150 INCHES

TORUS
HYDROGEN
0%

TORUS
OXYGEN
2.1%

DW UNIDENT
LEAKRATE
0 GPM

DW IDENT
LEAKRATE
0 GPM

CHRRMS
SYS I
2 REM

CHRRMS
SYS II
2 REM

TIME

17:25

BALANCE OF PLANT

VENTILATION

RX BLDG FAN EF 1-5	RX/TURB BLDG FAN EF 1-6	TURB BLDG FAN EF 1-7	TURB BLDG FAN EF 1-1	TURB BLDG FAN EF 1-4	TURB BLDG FAN EF 1-33	SBGT FAN EF 1-8	SBGT FAN EF 1-9
OFF	OFF	ON	ON	ON	ON	ON	ON

ELECTRIC PLANT

MAIN GEN	EDG #1	EDG #2	BKR 1A	BKR 1B	BKR S1A	BKR S1B	BKR 1C	BKR 1D	BATT A	BATT B	BATT C
0 MWe	0 KW	0 KW	0	0	C	C	C	C	131	132	131

TURBINE/AUXILIARIES

MAIN TURB	BYPASS VALVES	TURNING GEAR	VACUUM COND A	VACUUM COND B	VACUUM COND C
TRIPPED	CONTROLLING	OFF	14.0	14.0	14.0

COOLING WATER

RBCCW PUMP 1	RBCCW PUMP 2	TBCCW PUMP 1	TBCCW PUMP 2	TBCCW PUMP 3	SERV WTR PUMP 1	SERV WTR PUMP 2
ON	OFF	ON	ON	STDBY	ON	OFF

TIME

17:25

REACTOR PARAMETERS

AVERAGE ALL
APRM's
14.4%

RECIRC
FLOW
1.7 E4 GPM

SLC STATUS
SYS 1 - ON

SLC TANK
LEVEL
1965 GAL

REACTOR
PRESSURE
947 PSIG

STEAM FLOW
1.32 MLM/H

FUEL ZONE
LEVEL
53 "TAF

YARWAY
LEVEL
<85"TAF

FEEDWATER
FLOW
0.11 MLM/H

CRD
FLOW
100 GPM

CORE SPRAY
SYSTEM I
0 GPM

CORE SPRAY
SYSTEM II
0 GPM

ISOLATION CONDENSER A			
V-14-30	V-14-31	V-14-34	V-14-36
OPEN	OPEN	OPEN	OPEN

ISOLATION CONDENSER B			
V-14-32	V-14-33	V-14-35	V-14-37
OPEN	OPEN	OPEN	OPEN

EMRV A
CLOSE

EMRV B
CLOSE

EMRV C
CLOSE

EMRV D
CLOSE

EMRV E
CLOSE

CONTAINMENT PARAMETERS

DRYWELL
TEMP
111 °F

DRYWELL
PRESSURE
0.96 PSIG

DRYWELL
HYDROGEN
0 %

DRYWELL
OXYGEN
2.1%

CONT SPRAY
SYSTEM I
GPM
OFF

CONT SPRAY
SYSTEM II
GPM
OFF

TORUS
PRESSURE
1.0 PSIG

TORUS TEMP
76.1 °F

TORUS
LEVEL
150 INCHES

TORUS
HYDROGEN
0%

TORUS
OXYGEN
2.1%

DW UNIDENT
LEAKRATE
0 GPM

DW IDENT
LEAKRATE
0 GPM

CHRRMS
SYS I
1 REM

CHRRMS
SYS II
1 REM

TIME

17:26

BALANCE OF PLANT

VENTILATION

RX BLDG FAN EF 1-5	RX/TURB BLDG FAN EF 1-6	TURB BLDG FAN EF 1-7	TURB BLDG FAN EF 1-1	TURB BLDG FAN EF 1-4	TURB BLDG FAN EF 1-33	SBGT FAN EF 1-8	SBGT FAN EF 1-9
OFF	OFF	ON	ON	ON	ON	ON	ON

ELECTRIC PLANT

MAIN GEN	EDG #1	EDG #2	BKR 1A	BKR 1B	BKR S1A	BKR S1B	BKR 1C	BKR 1D	BATT A	BATT B	BATT C
0 MWe	0 KW	0 KW	O	O	C	C	C	C	131	132	131

TURBINE/AUXILIARIES

MAIN TURB	BYPASS VALVES	TURNING GEAR	VACUUM COND A	VACUUM COND B	VACUUM COND C
TRIPPED	CONTROLLING	OFF	13.0	13.0	13.0

COOLING WATER

RBCCW PUMP 1	RBCCW PUMP 2	TBCCW PUMP 1	TBCCW PUMP 2	TBCCW PUMP 3	SERV WTR PUMP 1	SERV WTR PUMP 2
ON	OFF	ON	ON	STDBY	ON	OFF

TIME

17:26

REACTOR PARAMETERS

AVERAGE ALL APRM's
11.1%

RECIRC FLOW
0.0 E0 GPM

SLC STATUS
SYS 1 - ON

SLC TANK LEVEL
1934 GAL

REACTOR PRESSURE
945 PSIG

STEAM FLOW
0.78 MLM/H

FUEL ZONE LEVEL
34 "TAF

YARWAY LEVEL
<85" TAF

FEEDWATER FLOW
0.11 MLM/H

CRD FLOW
100 GPM

CORE SPRAY SYSTEM I
0 GPM

CORE SPRAY SYSTEM II
0 GPM

ISOLATION CONDENSER A			
V-14-30	V-14-31	V-14-34	V-14-36
OPEN	OPEN	CLOSE	OPEN

ISOLATION CONDENSER B			
V-14-32	V-14-33	V-14-35	V-14-37
OPEN	OPEN	OPEN	OPEN

EMRV A
CLOSE

EMRV B
CLOSE

EMRV C
CLOSE

EMRV D
CLOSE

EMRV E
CLOSE

CONTAINMENT PARAMETERS

DRYWELL TEMP
109 °F

DRYWELL PRESSURE
0.91 PSIG

DRYWELL HYDROGEN
0 %

DRYWELL OXYGEN
2.1%

CONT SPRAY SYSTEM I
5965 GPM
TORUS

CONT SPRAY SYSTEM II
GPM
OFF

TORUS PRESSURE
1.0 PSIG

TORUS TEMP
76.1 °F

TORUS LEVEL
150 INCHES

TORUS HYDROGEN
0%

TORUS OXYGEN
2.1%

DW UNIDENT LEAKRATE
0 GPM

DW IDENT LEAKRATE
0 GPM

CHRRMS SYS I
1 REM

CHRRMS SYS II
1 REM

TIME

17:27

BALANCE OF PLANT

VENTILATION

RX BLDG FAN EF 1-5	RX/TURB BLDG FAN EF 1-6	TURB BLDG FAN EF 1-7	TURB BLDG FAN EF 1-1	TURB BLDG FAN EF 1-4	TURB BLDG FAN EF 1-33	SBGT FAN EF 1-8	SBGT FAN EF 1-9
OFF	OFF	ON	ON	ON	ON	ON	ON

ELECTRIC PLANT

MAIN GEN	EDG #1	EDG #2	BKR 1A	BKR 1B	BKR S1A	BKR S1B	BKR 1C	BKR 1D	BATT A	BATT B	BATT C
0 MWe	0 KW	0 KW	O	O	C	C	C	C	131	132	131

TURBINE/AUXILIARIES

MAIN TURB	BYPASS VALVES	TURNING GEAR	VACUUM COND A	VACUUM COND B	VACUUM COND C
TRIPPED	CONTROLLING	OFF	12.0	12.0	12.0

COOLING WATER

RBCCW PUMP 1	RBCCW PUMP 2	TBCCW PUMP 1	TBCCW PUMP 2	TBCCW PUMP 3	SERV WTR PUMP 1	SERV WTR PUMP 2
ON	OFF	ON	ON	STDBY	ON	OFF

TIME

17:27

REACTOR PARAMETERS

AVERAGE ALL APRM's	RECIRC FLOW	SLC STATUS	SLC TANK LEVEL	REACTOR PRESSURE	STEAM FLOW
8.5%	0.0 E0 GPM	SYS 1 - ON	1903 GAL	944 PSIG	0.51 MLM/H

FUEL ZONE LEVEL	YARWAY LEVEL	FEEDWATER FLOW	CRD FLOW	CORE SPRAY SYSTEM I	CORE SPRAY SYSTEM II	
15 "TAF	<85"TAF	0.11 MLM/H	100 GPM	0 GPM	0 GPM	

ISOLATION CONDENSER A				ISOLATION CONDENSER B			
V-14-30	V-14-31	V-14-34	V-14-36	V-14-32	V-14-33	V-14-35	V-14-37
OPEN	OPEN	CLOSE	OPEN	OPEN	OPEN	OPEN	OPEN

EMRV A	EMRV B	EMRV C	EMRV D	EMRV E
CLOSE	CLOSE	CLOSE	CLOSE	CLOSE

CONTAINMENT PARAMETERS

DRYWELL TEMP	DRYWELL PRESSURE	DRYWELL HYDROGEN	DRYWELL OXYGEN	CONT SPRAY SYSTEM I	CONT SPRAY SYSTEM II
109 °F	0.89 PSIG	0 %	2.1%	5965 GPM TORUS	GPM OFF

TORUS PRESSURE	TORUS TEMP	TORUS LEVEL	TORUS HYDROGEN	TORUS OXYGEN
1.0 PSIG	76.0 °F	150 INCHES	0%	2.1%

DW UNIDENT LEAKRATE	DW IDENT LEAKRATE	CHRRMS SYS I	CHRRMS SYS II
0 GPM	0 GPM	1 REM	1 REM

TIME 17:28

BALANCE OF PLANT

VENTILATION

RX BLDG FAN EF 1-5	RX/TURB BLDG FAN EF 1-5	TURB BLDG FAN EF 1-7	TURB BLDG FAN EF 1-1	TURB BLDG FAN EF 1-4	TURB BLDG FAN EF 1-33	SBGT FAN EF 1-8	SBGT FAN EF 1-9
OFF	OFF	ON	ON	ON	ON	ON	ON

ELECTRIC PLANT

MAIN GEN	EDG #1	EDG #2	BKR 1A	BKR 1B	BKR S1A	BKR S1B	BKR 1C	BKR 1D	BATT A	BATT B	BATT C
0 MWe	0 KW	0 KW	0	0	C	C	C	C	131	132	131

TURBINE/AUXILIARIES

MAIN TURB	BYPASS VALVES	TURNING GEAR	VACUUM COND A	VACUUM COND B	VACUUM COND C
TRIPPED	CONTROLLING	OFF	12.0	12.0	12.0

COOLING WATER

RBCCW PUMP 1	RBCCW PUMP 2	TBCCW PUMP 1	TBCCW PUMP 2	TBCCW PUMP 3	SERV WTR PUMP 1	SERV WTR PUMP 2
ON	OFF	ON	ON	STDBY	ON	OFF

TIME

17:28

REACTOR PARAMETERS

AVERAGE ALL
APRM's
6.2%

RECIRC
FLOW
0.0 E0 GPM

SLC STATUS
SYS 1 - ON

SLC TANK
LEVEL
1878 GAL

REACTOR
PRESSURE
899 PSIG

STEAM FLOW
0.40 MLM/H

FUEL ZONE
LEVEL
-5" TAF

YARWAY
LEVEL
<85" TAF

FEEDWATER
FLOW
0.11 MLM/H

CRD
FLOW
100 GPM

CORE SPRAY
SYSTEM I
0 GPM

CORE SPRAY
SYSTEM II
0 GPM

ISOLATION CONDENSER A			
V-14-30	V-14-31	V-14-34	V-14-36
OPEN	OPEN	CLOSE	OPEN

ISOLATION CONDENSER B			
V-14-32	V-14-33	V-14-35	V-14-37
OPEN	OPEN	OPEN	OPEN

EMRV A
OPEN

EMRV B
CLOSE

EMRV C
CLOSE

EMRV D
CLOSE

EMRV E
CLOSE

CONTAINMENT PARAMETERS

DRYWELL
TEMP
108 °F

DRYWELL
PRESSURE
0.88 PSIG

DRYWELL
HYDROGEN
0 %

DRYWELL
OXYGEN
2.1%

CONT SPRAY
SYSTEM I
5965 GPM
TORUS

CONT SPRAY
SYSTEM II
GPM
OFF

TORUS
PRESSURE
1.0 PSIG

TORUS TEMP
77.7 °F

TORUS
LEVEL
150 INCHES

TORUS
HYDROGEN
0%

TORUS
OXYGEN
2.1%

DW UNIDENT
LEAKRATE
0 GPM

DW IDENT
LEAKRATE
0 GPM

CHRRMS
SYS I
1 REM

CHRRMS
SYS II
1 REM

TIME

17:29

BALANCE OF PLANT

VENTILATION

RX BLDG FAN EF 1-5	RX/TURB BLDG FAN EF 1-6	TURB BLDG FAN EF 1-7	TURB BLDG FAN EF 1-1	TURB BLDG FAN EF 1-4	TURB BLDG FAN EF 1-33	SBGT FAN EF 1-8	SBGT FAN EF 1-9
OFF	OFF	ON	ON	ON	ON	ON	ON

ELECTRIC PLANT

MAIN GEN	EDG #1	EDG #2	BKR 1A	BKR 1B	BKR S1A	BKR S1B	BKR 1C	BKR 1D	BATT A	BATT B	BATT C
0 MWe	0 KW	0 KW	0	0	C	C	C	C	131	132	131

TURBINE/AUXILIARIES

MAIN TURB	BYPASS VALVES	TURNING GEAR	VACUUM COND A	VACUUM COND B	VACUUM COND C
TRIPPED	CONTROLLING	OFF	11.0	11.0	11.0

COOLING WATER

RBCCW PUMP 1	RBCCW PUMP 2	TBCCW PUMP 1	TBCCW PUMP 2	TBCCW PUMP 3	SERV WTR PUMP 1	SERV WTR PUMP 2
ON	OFF	ON	ON	STDBY	ON	OFF

TIME

17:29

REACTOR PARAMETERS

AVERAGE ALL
APRM's
4.7%

RECIRC
FLOW
6.5 E3 GPM

SLC STATUS
SYS 1 - ON

SLC TANK
LEVEL
1847 GAL

REACTOR
PRESSURE
797 PSIG

STEAM FLOW
0.12 MLM/H

FUEL ZONE
LEVEL
-22" TAF

YARWAY
LEVEL
<85" TAF

FEEDWATER
FLOW
0.21 MLM/H

CRD
FLOW
100 GPM

CORE SPRAY
SYSTEM I
0 GPM

CORE SPRAY
SYSTEM II
0 GPM

ISOLATION CONDENSER A			
V-14-30	V-14-31	V-14-34	V-14-36
OPEN	OPEN	CLOSE	OPEN

ISOLATION CONDENSER B			
V-14-32	V-14-33	V-14-35	V-14-37
OPEN	OPEN	OPEN	OPEN

EMRV A
CLOSE

EMRV B
CLOSE

EMRV C
CLOSE

EMRV D
CLOSE

EMRV E
CLOSE

CONTAINMENT PARAMETERS

DRYWELL
TEMP
108 °F

DRYWELL
PRESSURE
0.87 PSIG

DRYWELL
HYDROGEN
0 %

DRYWELL
OXYGEN
2.1%

CONT SPRAY
SYSTEM I
5965 GPM
TORUS

CONT SPRAY
SYSTEM II
GPM
OFF

TORUS
PRESSURE
1.0 PSIG

TORUS TEMP
79.2 °F

TORUS
LEVEL
151 INCHES

TORUS
HYDROGEN
0%

TORUS
OXYGEN
2.1%

DW UNIDENT
LEAKRATE
0 GPM

DW IDENT
LEAKRATE
0 GPM

CHRRMS
SYS I
1 REM

CHRRMS
SYS II
1 REM

TIME

17:30

BALANCE OF PLANT

VENTILATION

RX BLDG FAN EF 1-5	RX/TURB BLDG FAN EF 1-8	TURB BLDG FAN EF 1-7	TURB BLDG FAN EF 1-1	TURB BLDG FAN EF 1-4	TURB BLDG FAN EF 1-33	SBGT FAN EF 1-8	SBGT FAN EF 1-9
OFF	OFF	ON	ON	ON	ON	ON	ON

ELECTRIC PLANT

MAIN GEN	EDG #1	EDG #2	BKR 1A	BKR 1B	BKR S1A	BKR S1B	BKR 1C	BKR 1D	BATT A	BATT B	BATT C
0 MWe	0 KW	0 KW	0	0	C	C	C	C	131	132	131

TURBINE/AUXILIARIES

MAIN TURB	BYPASS VALVES	TURNING GEAR	VACUUM COND A	VACUUM COND B	VACUUM COND C
TRIPPED	CONTROLLING	OFF	10.0	10.0	10.0

COOLING WATER

RBCCW PUMP 1	RBCCW PUMP 2	TBCCW PUMP 1	TBCCW PUMP 2	TBCCW PUMP 3	SERV WTR PUMP 1	SERV WTR PUMP 2
ON	OFF	ON	ON	STDBY	ON	OFF

TIME

17:30

REACTOR PARAMETERS

AVERAGE ALL
APRM's
5.5%

RECIRC
FLOW
0.0 E0 GPM

SLC STATUS
SYS 1 - ON

SLC TANK
LEVEL
1790 GAL

REACTOR
PRESSURE
857 PSIG

STEAM FLOW
0.0 MLM/H

FUEL ZONE
LEVEL
-9" TAF

YARWAY
LEVEL
<85" TAF

FEEDWATER
FLOW
0.30 MLM/H

CRD
FLOW
100 GPM

CORE SPRAY
SYSTEM I
0 GPM

CORE SPRAY
SYSTEM II
0 GPM

ISOLATION CONDENSER A			
V-14-30	V-14-31	V-14-34	V-14-36
OPEN	OPEN	CLOSE	OPEN

ISOLATION CONDENSER B			
V-14-32	V-14-33	V-14-35	V-14-37
OPEN	OPEN	OPEN	OPEN

EMRV A
CLOSE

EMRV B
CLOSE

EMRV C
CLOSE

EMRV D
CLOSE

EMRV E
CLOSE

CONTAINMENT PARAMETERS

DRYWELL
TEMP
107 °F

DRYWELL
PRESSURE
0.86 PSIG

DRYWELL
HYDROGEN
0 %

DRYWELL
OXYGEN
2.1%

CONT SPRAY
SYSTEM I
5965 GPM
TORUS

CONT SPRAY
SYSTEM II
GPM
OFF

TORUS
PRESSURE
1.0 PSIG

TORUS TEMP
79.0 °F

TORUS
LEVEL
151 INCHES

TORUS
HYDROGEN
0%

TORUS
OXYGEN
2.1%

DW UNIDENT
LEAKRATE
0 GPM

DW IDENT
LEAKRATE
0 GPM

CHRRMS
SYS I
1 REM

CHRRMS
SYS II
1 REM

TIME

17:32

BALANCE OF PLANT

VENTILATION

RX BLDG FAN EF 1-5	RX/TURB BLDG FAN EF 1-6	TURB BLDG FAN EF 1-7	TURB BLDG FAN EF 1-1	TURB BLDG FAN EF 1-4	TURB BLDG FAN EF 1-33	SBGT FAN EF 1-8	SBGT FAN EF 1-9
OFF	OFF	ON	ON	ON	ON	ON	OFF

ELECTRIC PLANT

MAIN GEN	EDG #1	EDG #2	BKR 1A	BKR 1B	BKR S1A	BKR S1B	BKR 1C	BKR 1D	BATT A	BATT B	BATT C
0 MWe	0 KW	0 KW	0	0	C	C	C	C	131	132	131

TURBINE/AUXILIARIES

MAIN TURB	BYPASS VALVES	TURNING GEAR	VACUUM COND A	VACUUM COND B	VACUUM COND C
TRIPPED	TRIPPED	ON	10.0	10.0	10.0

COOLING WATER

RBCCW PUMP 1	RBCCW PUMP 2	TBCCW PUMP 1	TBCCW PUMP 2	TBCCW PUMP 3	SERV WTR PUMP 1	SERV WTR PUMP 2
ON	OFF	ON	ON	STDBY	ON	OFF

TIME

17:32

REACTOR PARAMETERS

AVERAGE ALL
APRM's
5.0%

RECIRC
FLOW
0.0 E0 GPM

SLC STATUS
SYS 1 - ON

SLC TANK
LEVEL
1759 GAL

REACTOR
PRESSURE
894 PSIG

STEAM FLOW
0.0 MLM/H

FUEL ZONE
LEVEL
-5" TAF

YARWAY
LEVEL
<85" TAF

FEEDWATER
FLOW
0.25 MLM/H

CRD
FLOW
100 GPM

CORE SPRAY
SYSTEM I
0 GPM

CORE SPRAY
SYSTEM II
0 GPM

ISOLATION CONDENSER A			
V-14-30	V-14-31	V-14-34	V-14-36
OPEN	OPEN	CLOSE	OPEN

ISOLATION CONDENSER B			
V-14-32	V-14-33	V-14-35	V-14-37
OPEN	OPEN	OPEN	OPEN

EMRV A
CLOSE

EMRV B
CLOSE

EMRV C
CLOSE

EMRV D
CLOSE

EMRV E
CLOSE

CONTAINMENT PARAMETERS

DRYWELL
TEMP
107 °F

DRYWELL
PRESSURE
0.86 PSIG

DRYWELL
HYDROGEN
0 %

DRYWELL
OXYGEN
2.1%

CONT SPRAY
SYSTEM I
5965 GPM
TORUS

CONT SPRAY
SYSTEM II
GPM
OFF

TORUS
PRESSURE
1.0 PSIG

TORUS TEMP
78.9 °F

TORUS
LEVEL
151 INCHES

TORUS
HYDROGEN
0%

TORUS
OXYGEN
2.1%

DW UNIDENT
LEAKRATE
0 GPM

DW IDENT
LEAKRATE
0 GPM

CHRRMS
SYS I
1 REM

CHRRMS
SYS II
1 REM

TIME

17:33

BALANCE OF PLANT

VENTILATION

RX BLDG FAN EF 1-5	RX/TURB BLDG FAN EF 1-8	TURB BLDG FAN EF 1-7	TURB BLDG FAN EF 1-1	TURB BLDG FAN EF 1-4	TURB BLDG FAN EF 1-33	SBGT FAN EF 1-8	SBGT FAN EF 1-9
OFF	OFF	ON	ON	ON	ON	ON	OFF

ELECTRIC PLANT

MAIN GEN	EDG #1	EDG #2	BKR 1A	BKR 1B	BKR S1A	BKR S1B	BKR 1C	BKR 1D	BATT A	BATT B	BATT C
0 MWe	0 KW	0 KW	O	O	C	C	C	C	131	132	131

TURBINE/AUXILIARIES

MAIN TURB	BYPASS VALVES	TURNING GEAR	VACUUM COND A	VACUUM COND B	VACUUM COND C
TRIPPED	TRIPPED	ON	8.0	8.0	8.0

COOLING WATER

RBCCW PUMP 1	RBCCW PUMP 2	TBCCW PUMP 1	TBCCW PUMP 2	TBCCW PUMP 3	SERV WTR PUMP 1	SERV WTR PUMP 2
ON	OFF	ON	ON	STDBY	ON	OFF

TIME

17:33

REACTOR PARAMETERS

AVERAGE ALL APRM's	RECIRC FLOW	SLC STATUS	SLC TANK LEVEL	REACTOR PRESSURE	STEAM FLOW
4.3%	0.0 E0 GPM	SYS 1 - ON	1733 GAL	888 PSIG	0.0 MLM/H

FUEL ZONE LEVEL	YARWAY LEVEL	FEEDWATER FLOW	CRD FLOW	CORE SPRAY SYSTEM I	CORE SPRAY SYSTEM II	
-1.1" TAF	<85" TAF	0.22 MLM/H	0 GPM	0 GPM	0 GPM	

ISOLATION CONDENSER A				ISOLATION CONDENSER B			
V-14-30	V-14-31	V-14-34	V-14-36	V-14-32	V-14-33	V-14-35	V-14-37
OPEN	OPEN	CLOSE	OPEN	OPEN	OPEN	OPEN	OPEN

EMRV A	EMRV B	EMRV C	EMRV D	EMRV E
CLOSE	CLOSE	CLOSE	CLOSE	CLOSE

CONTAINMENT PARAMETERS

DRYWELL TEMP	DRYWELL PRESSURE	DRYWELL HYDROGEN	DRYWELL OXYGEN	CONT SPRAY SYSTEM I	CONT SPRAY SYSTEM II
107 °F	0.85 PSIG	0 %	2.1%	595 GPM	GPM
				DRUS	OFF

TORUS PRESSURE	TORUS TEMP	TORUS LEVEL	TORUS HYDROGEN	TORUS OXYGEN
1.1 PSIG	78.8 °F	151 INCHES	0%	2.1%

DW UNIDENT LEAKRATE	DW IDENT LEAKRATE	CHRRMS SYS I	CHRRMS SYS II
0 GPM	0 GPM	1 REM	1 REM

TIME 17:34

BALANCE OF PLANT

VENTILATION

RX BLDG FAN EF 1-5	RX/TURB BLDG FAN EF 1-6	TURB BLDG FAN EF 1-7	TURB BLDG FAN EF 1-1	TURB BLDG FAN EF 1-4	TURB BLDG FAN EF 1-33	SBGT FAN EF 1-8	SBGT FAN EF 1-9
OFF	OFF	ON	ON	ON	ON	ON	OFF

ELECTRIC PLANT

MAIN GEN	EDG #1	EDG #2	BKR 1A	BKR 1B	BKR S1A	BKR S1B	BKR 1C	BKR 1D	BATT A	BATT B	BATT C
0 MWe	0 KW	0 KW	O	O	C	C	C	C	131	132	131

TURBINE/AUXILIARIES

MAIN TURB	BYPASS VALVES	TURNING GEAR	VACUUM COND A	VACUUM COND B	VACUUM COND C
TRIPPED	TRIPPED	ON	6.0	6.0	6.0

COOLING WATER

RBCCW PUMP 1	RBCCW PUMP 2	TBCCW PUMP 1	TBCCW PUMP 2	TBCCW PUMP 3	SERV WTR PUMP 1	SERV WTR PUMP 2
ON	OFF	ON	ON	STDBY	ON	OFF

TIME

17:34

REACTOR PARAMETERS

AVERAGE ALL APRM's
4.5%

RECIRC FLOW
0.0 E0 GPM

SLC STATUS
SYS 1 - ON

SLC TANK LEVEL
1703 GAL

REACTOR PRESSURE
910 PSIG

STEAM FLOW
0.0 MLM/H

FUEL ZONE LEVEL
5.4" TAF

YARWAY LEVEL
<85" TAF

FEEDWATER FLOW
0.25 MLM/H

CRD FLOW
0 GPM

CORE SPRAY SYSTEM I
0 GPM

CORE SPRAY SYSTEM II
0 GPM

ISOLATION CONDENSER A			
V-14-30	V-14-31	V-14-34	V-14-36
OPEN	OPEN	CLOSE	OPEN

ISOLATION CONDENSER B			
V-14-32	V-14-33	V-14-35	V-14-37
OPEN	OPEN	CLOSE	OPEN

EMRV A
CLOSE

EMRV B
CLOSE

EMRV C
CLOSE

EMRV D
CLOSE

EMRV E
CLOSE

CONTAINMENT PARAMETERS

DRYWELL TEMP
107 °F

DRYWELL PRESSURE
0.85 PSIG

DRYWELL HYDROGEN
0 %

DRYWELL OXYGEN
2.1%

CONT SPRAY SYSTEM I
5965 GPM
TORUS

CONT SPRAY SYSTEM II
GPM
OFF

TORUS PRESSURE
1.1 PSIG

TORUS TEMP
78.7 °F

TORUS LEVEL
151 INCHES

TORUS HYDROGEN
0%

TORUS OXYGEN
2.1%

DW UNIDENT LEAKRATE
0 GPM

DW IDENT LEAKRATE
0 GPM

CHRRMS SYS I
1 REM

CHRRMS SYS II
1 REM

TIME

17:35

BALANCE OF PLANT

VENTILATION

RX BLDG FAN EF 1-5	RX/TURB BLDG FAN EF 1-6	TURB BLDG FAN EF 1-7	TURB BLDG FAN EF 1-1	TURB BLDG FAN EF 1-4	TURB BLDG FAN EF 1-33	SBGT FAN EF 1-8	SBGT FAN EF 1-9
OFF	OFF	ON	ON	ON	ON	ON	OFF

ELECTRIC PLANT

MAIN GEN	EDG #1	EDG #2	BKR 1A	BKR 1B	BKR S1A	BKR S1B	BKR 1C	BKR 1D	BATT A	BATT B	BATT C
0 MWe	0 KW	0 KW	O	O	C	C	C	C	131	132	131

TURBINE/AUXILIARIES

MAIN TURB	BYPASS VALVES	TURNING GEAR	VACUUM COND A	VACUUM COND B	VACUUM COND C
TRIPPED	TRIPPED	ON	4.0	4.0	4.0

COOLING WATER

RBCCW PUMP 1	RBCCW PUMP 2	TBCCW PUMP 1	TBCCW PUMP 2	TBCCW PUMP 3	SERV WTR PUMP 1	SERV WTR PUMP 2
ON	OFF	ON	ON	STDBY	ON	OFF

TIME 17:35

REACTOR PARAMETERS

AVERAGE ALL APRM's
5.2%

RECIRC FLOW
0.0 E0 GPM

SLC STATUS
SYS 1 - ON

SLC TANK LEVEL
1553 GAL

REACTOR PRESSURE
990 PSIG

STEAM FLOW
0.0 MLM/H

FUEL ZONE LEVEL
12.7" TAF

YARWAY LEVEL
<85" TAF

FEEDWATER FLOW
0.23 MLM/H

CRD FLOW
0 GPM

CORE SPRAY SYSTEM I
0 GPM

CORE SPRAY SYSTEM II
0 GPM

ISOLATION CONDENSER A			
V-14-30	V-14-31	V-14-34	V-14-36
OPEN	OPEN	CLOSE	OPEN

ISOLATION CONDENSER B			
V-14-32	V-14-33	V-14-35	V-14-37
OPEN	OPEN	CLOSE	OPEN

EMRV A
CLOSE

EMRV B
CLOSE

EMRV C
CLOSE

EMRV D
CLOSE

EMRV E
CLOSE

CONTAINMENT PARAMETERS

DRYWELL TEMP
107 °F

DRYWELL PRESSURE
0.85 PSIG

DRYWELL HYDROGEN
0 %

DRYWELL OXYGEN
2.1%

CONT SPRAY SYSTEM I
5965 GPM
TORUS

CONT SPRAY SYSTEM II
GPM
OFF

TORUS PRESSURE
1.1 PSIG

TORUS TEMP
78.6 °F

TORUS LEVEL
151 INCHES

TORUS HYDROGEN
0%

TORUS OXYGEN
2.1%

DW UNIDENT LEAKRATE
0 GPM

DW IDENT LEAKRATE
0 GPM

CHRRMS SYS I
1 REM

CHRRMS SYS II
1 REM

TIME

17:40

BALANCE OF PLANT

VENTILATION

RX BLDG FAN EF 1-5	RX/TURB BLDG FAN EF 1-6	TURB BLDG FAN EF 1-7	TURB BLDG FAN EF 1-1	TURB BLDG FAN EF 1-4	TURB BLDG FAN EF 1-33	SBGT FAN EF 1-6	SBGT FAN EF 1-9
OFF	OFF	ON	ON	ON	ON	ON	OFF

ELECTRIC PLANT

MAIN GEN	EDG #1	EDG #2	BKR 1A	BKR 1B	BKR S1A	BKR S1B	BKR 1C	BKR 1D	BATT A	BATT B	BATT C
0 MWe	0 KW	0 KW	O	O	C	C	C	C	131	132	131

TURBINE/AUXILIARIES

MAIN TURB	BYPASS VALVES	TURNING GEAR	VACUUM COND A	VACUUM COND B	VACUUM COND C
TRIPPED	TRIPPED	ON	2.0	2.0	2.0

COOLING WATER

RBCCW PUMP 1	RBCCW PUMP 2	TBCCW PUMP 1	TBCCW PUMP 2	TBCCW PUMP 3	SERV WTR PUMP 1	SERV WTR PUMP 2
ON	OFF	ON	ON	STDBY	ON	OFF

TIME

17:40

REACTOR PARAMETERS

AVERAGE ALL APRM's
3.1%

RECIRC FLOW
0.0 E0 GPM

SLC STATUS
SYS 1 - ON

SLC TANK LEVEL
1403 GAL

REACTOR PRESSURE
942 PSIG

STEAM FLOW
0.41 MLM/H

FUEL ZONE LEVEL
-2.1" TAF

YARWAY LEVEL
<85" TAF

FEEDWATER FLOW
0.15 MLM/H

CRD FLOW
0 GPM

CORE SPRAY SYSTEM I
0 GPM

CORE SPRAY SYSTEM II
0 GPM

ISOLATION CONDENSER A			
V-14-30	V-14-31	V-14-34	V-14-36
OPEN	OPEN	CLOSE	OPEN

ISOLATION CONDENSER B			
V-14-32	V-14-33	V-14-35	V-14-37
OPEN	OPEN	OPEN	OPEN

EMRV A
CLOSE

EMRV B
CLOSE

EMRV C
CLOSE

EMRV D
CLOSE

EMRV E
CLOSE

CONTAINMENT PARAMETERS

DRYWELL TEMP
107 °F

DRYWELL PRESSURE
0.86 PSIG

DRYWELL HYDROGEN
0 %

DRYWELL OXYGEN
2.1%

CONT SPRAY SYSTEM I
5965 GPM
TORUS

CONT SPRAY SYSTEM II
GPM
OFF

TORUS PRESSURE
1.1 PSIG

TORUS TEMP
79.7 °F

TORUS LEVEL
151 INCHES

TORUS HYDROGEN
0%

TORUS OXYGEN
2.1%

DW UNIDENT LEAKRATE
0 GPM

DW IDENT LEAKRATE
0 GPM

CHRRM'S SYS I
1 REM

CHRRM'S SYS II
2 REM

TIME

17:45

BALANCE OF PLANT

VENTILATION

RX BLDG FAN EF 1-5	RX/TURB BLDG FAN EF 1-6	TURB BLDG FAN EF 1-7	TURB BLDG FAN EF 1-1	TURB BLDG FAN EF 1-4	TURB BLDG FAN EF 1-33	SBGT FAN EF 1-6	SBGT FAN EF 1-5
OFF	OFF	ON	ON	ON	ON	ON	OFF

ELECTRIC PLANT

MAIN GEN	EDG #1	EDG #2	BKR 1A	BKR 1B	BKR S1A	BKR S1B	BKR 1C	BKR 1D	BATT A	BATT B	BATT C
0 MWe	0 KW	0 KW	0	0	C	C	C	C	131	132	131

TURBINE/AUXILIARIES

MAIN TURB	BYPASS VALVES	TURNING GEAR	VACUUM COND A	VACUUM COND B	VACUUM COND C
TRIPPED	TRIPPED	ON	0	0	0

COOLING WATER

RBCCW PUMP 1	RBCCW PUMP 2	TBCCW PUMP 1	TBCCW PUMP 2	TBCCW PUMP 3	SERV WTR PUMP 1	SERV WTR PUMP 2
ON	OFF	ON	ON	STDBY	ON	OFF

TIME

17:45

REACTOR PARAMETERS

AVERAGE ALL
APRM's
4.3%

RECIRC
FLOW
0.0 E0 GPM

SLC STATUS
SYS 1 - ON

SLC TANK
LEVEL
1255 GAL

REACTOR
PRESSURE
878 PSIG

STEAM FLOW
0.00 MLM/H

FUEL ZONE
LEVEL
-0.8" TAF

YARWAY
LEVEL
<85" TAF

FEEDWATER
FLOW
0.15 MLM/H

CRD
FLOW
0 GPM

CORE SPRAY
SYSTEM I
0 GPM

CORE SPRAY
SYSTEM II
0 GPM

ISOLATION CONDENSER A			
V-14-30	V-14-31	V-14-34	V-14-36
OPEN	OPEN	CLOSE	OPEN

ISOLATION CONDENSER B			
V-14-32	V-14-33	V-14-35	V-14-37
OPEN	OPEN	CLOSE	OPEN

EMRV A
CLOSE

EMRV B
CLOSE

EMRV C
CLOSE

EMRV D
CLOSE

EMRV E
CLOSE

CONTAINMENT PARAMETERS

DRYWELL
TEMP
107 °F

DRYWELL
PRESSURE
0.85 PSIG

DRYWELL
HYDROGEN
0 %

DRYWELL
OXYGEN
2.1%

CONT SPRAY
SYSTEM I
5965 GPM
TORUS

CONT SPRAY
SYSTEM II
GPM
OFF

TORUS
PRESSURE
1.1 PSIG

TORUS TEMP
80.3 °F

TORUS
LEVEL
151 INCHES

TORUS
HYDROGEN
0%

TORUS
OXYGEN
2.1%

DW UNIDENT
LEAKRATE
0 GPM

DW IDENT
LEAKRATE
0 GPM

CHRRMS
SYS I
1 REM

CHRRMS
SYS II
2 REM

TIME

17:50

BALANCE OF PLANT

VENTILATION

RX BLDG FAN EF 1-5	RX/TURB BLDG FAN EF 1-6	TURB BLDG FAN EF 1-7	TURB BLDG FAN EF 1-1	TURB BLDG FAN EF 1-4	TURB BLDG FAN EF 1-33	SBGT FAN EF 1-8	SBGT FAN EF 1-9
OFF	OFF	ON	ON	ON	ON	ON	OFF

ELECTRIC PLANT

MAIN GEN	EDG #1	EDG #2	BKR 1A	BKR 1B	BKR S1A	BKR S1B	BKR 1C	BKR 1D	BATT A	BATT B	BATT C
0 MWe	0 KW	0 KW	0	0	C	C	C	C	131	132	131

TURBINE/AUXILIARIES

MAIN TURB	BYPASS VALVES	TURNING GEAR	VACUUM COND A	VACUUM COND B	VACUUM COND C
TRIPPED	TRIPPED	ON	0	0	0

COOLING WATER

RBCCW PUMP 1	RBCCW PUMP 2	TBCCW PUMP 1	TBCCW PUMP 2	TBCCW PUMP 3	SERV WTR PUMP 1	SERV WTR PUMP 2
ON	OFF	ON	ON	STDBY	ON	OFF

TIME

17:50

REACTOR PARAMETERS

AVERAGE ALL
APRM's
4.8%

RECIRC
FLOW
0.0 E0 GPM

SLC STATUS
SYS 1 - ON

SLC TANK
LEVEL
1105 GAL

REACTOR
PRESSURE
975 PSIG

STEAM FLOW
0.00 MLM/H

FUEL ZONE
LEVEL
6.8" TAF

YARWAY
LEVEL
<85" TAF

FEEDWATER
FLOW
0.16 MLM/H

CRD
FLOW
0 GPM

CORE SPRAY
SYSTEM I
0 GPM

CORE SPRAY
SYSTEM II
0 GPM

ISOLATION CONDENSER A			
V-14-30	V-14-31	V-14-34	V-14-36
OPEN	OPEN	CLOSE	OPEN

ISOLATION CONDENSER B			
V-14-32	V-14-33	V-14-35	V-14-37
OPEN	OPEN	CLOSE	OPEN

EMRV A
CLOSE

EMRV B
CLOSE

EMRV C
CLOSE

EMRV D
CLOSE

EMRV E
CLOSE

CONTAINMENT PARAMETERS

DRYWELL
TEMP
107 °F

DRYWELL
PRESSURE
0.84 PSIG

DRYWELL
HYDROGEN
0 %

DRYWELL
OXYGEN
2.1%

CONT SPRAY
SYSTEM I
5965 GPM
TORUS

CONT SPRAY
SYSTEM II
GPM
OFF

TORUS
PRESSURE
1.1 PSIG

TORUS TEMP
80.2 °F

TORUS
LEVEL
151 INCHES

TORUS
HYDROGEN
0%

TORUS
OXYGEN
2.1%

DW UNIDENT
LEAKRATE
0 GPM

DW IDENT
LEAKRATE
0 GPM

CHRRMS
SYS I
88 REM

CHRRMS
SYS II
2 REM

TIME

17:55

BALANCE OF PLANT

VENTILATION

RX BLDG FAN EF 1-5	RX/TURB BLDG FAN EF 1-6	TURB BLDG FAN EF 1-7	TURB BLDG FAN EF 1-1	TURB BLDG FAN EF 1-4	TURB BLDG FAN EF 1-33	SBGT FAN EF 1-8	SBGT FAN EF 1-9
OFF	OFF	ON	ON	ON	ON	ON	OFF

ELECTRIC PLANT

MAIN GEN	EDG #1	EDG #2	BKR 1A	BKR 1B	BKR S1A	BKR S1B	BKR 1C	BKR 1D	BATT A	BATT B	BATT C
0 MWe	0 KW	0 KW	0	0	C	C	C	C	131	132	131

TURBINE/AUXILIARIES

MAIN TURB	BYPASS VALVES	TURNING GEAR	VACUUM COND A	VACUUM COND B	VACUUM COND C
TRIPPED	TRIPPED	ON	0	0	0

COOLING WATER

RBCCW PUMP 1	RBCCW PUMP 2	TBCCW PUMP 1	TBCCW PUMP 2	TBCCW PUMP 3	SERV WTR PUMP 1	SERV WTR PUMP 2
ON	OFF	ON	ON	STDBY	ON	OFF

TIME

17:55

REACTOR PARAMETERS

AVERAGE ALL APRM's	RECIRC FLOW	SLC STATUS	SLC TANK LEVEL	REACTOR PRESSURE	STEAM FLOW
2.4%	0.0 E0 GPM	SYS 1 - ON	955 GAL	993 PSIG	0.00 MLM/H

FUEL ZONE LEVEL	YARWAY LEVEL	FEEDWATER FLCW	CRD FLOW	CORE SPRAY SYSTEM I	CORE SPRAY SYSTEM II	
-5.5" TAF	<85" TAF	0.14 MLM/H	0 GPM	0 GPM	0 GPM	

ISOLATION CONDENSER A				ISOLATION CONDENSER B			
V-14-30	V-14-31	V-14-34	V-14-36	V-14-32	V-14-33	V-14-35	V-14-37
OPEN	OPEN	CLOSE	OPEN	OPEN	OPEN	OPEN	OPEN

EMRV A	EMRV B	EMRV C	EMRV D	EMRV E
CLOSE	CLOSE	CLOSE	CLOSE	CLOSE

CONTAINMENT PARAMETERS

DRYWELL TEMP	DRYWELL PRESSURE	DRYWELL HYDROGEN	DRYWELL OXYGEN	CONT SPRAY SYSTEM I	CONT SPRAY SYSTEM II
107 °F	0.86 PSIG	0 %	2.1%	5965 GPM TORUS	GPM OFF

TORUS PRESSURE	TORUS TEMP	TORUS LEVEL	TORUS HYDROGEN	TORUS OXYGEN
1.1 PSIG	81.2 °F	151 INCHES	0%	2.1%

DW UNIDENT LEAKRATE	DW IDENT LEAKRATE	CHRRMS SYS I	CHRRMS SYS II
0 GPM	0 GPM	88 REM	86 REM

TIME 18:00

BALANCE OF PLANT

VENTILATION

RX BLDG FAN EF 1-5	RX/TURB BLDG FAN EF 1-6	TURB BLDG FAN EF 1-7	TURB BLDG FAN EF 1-1	TURB BLDG FAN EF 1-4	TURB BLDG FAN EF 1-33	SBGT FAN EF 1-8	SBGT FAN EF 1-9
OFF	OFF	ON	ON	ON	ON	ON	OFF

ELECTRIC PLANT

MAIN GEN	EDG #1	EDG #2	BKR 1A	BKR 1B	BKR S1A	BKR S1B	BKR 1C	BKR 1D	BATT A	BATT B	BATT C
0 MWe	0 KW	0 KW	0	0	C	C	C	C	131	132	131

TURBINE/AUXILLARIES

MAIN TURB	BYPASS VALVES	TURNING GEAR	VACUUM COND A	VACUUM COND B	VACUUM COND C
TRIPPED	TRIPPED	ON	0	0	0

COOLING WATER

RBCCW PUMP 1	RBCCW PUMP 2	TBCCW PUMP 1	TBCCW PUMP 2	TBCCW PUMP 3	SERV WTR PUMP 1	SERV WTR PUMP 2
ON	OFF	ON	ON	STDBY	ON	OFF

TIME 18:00

REACTOR PARAMETERS

AVERAGE ALL APRM's
2.8%

RECIRC FLOW
0.0 E0 GPM

SLC STATUS
SYS 1 - ON

SLC TANK LEVEL
655 GAL

REACTOR PRESSURE
899 PSIG

STEAM FLOW
0.39 MLM/H

FUEL ZONE LEVEL
-14.0" TAF

YARWAY LEVEL
<85" TAF

FEEDWATER FLOW
0.13 MLM/H

CRD FLOW
0 GPM

CORE SPRAY SYSTEM I
0 GPM

CORE SPRAY SYSTEM II
0 GPM

ISOLATION CONDENSER A			
V-14-30	V-14-31	V-14-34	V-14-36
OPEN	OPEN	CLOSE	OPEN

ISOLATION CONDENSER B			
V-14-32	V-14-33	V-14-35	V-14-37
OPEN	OPEN	CLOSE	OPEN

EMRV A
CLOSE

EMRV B
CLOSE

EMRV C
CLOSE

EMRV D
CLOSE

EMRV E
CLOSE

CONTAINMENT PARAMETERS

DRYWELL TEMP
107 °F

DRYWELL PRESSURE
0.86 PSIG

DRYWELL HYDROGEN
0 %

DRYWELL OXYGEN
2.1%

CONT SPRAY SYSTEM I
5965 GPM
TORUS

CONT SPRAY SYSTEM II
GPM
OFF

TORUS PRESSURE
1.2 PSIG

TORUS TEMP
82.3 °F

TORUS LEVEL
151 INCHES

TORUS HYDROGEN
0%

TORUS OXYGEN
2.1%

DW UNIDENT LEAKRATE
0 GPM

DW IDENT LEAKRATE
0 GPM

CHRRMS SYS I
88 REM

CHRRMS SYS II
86 REM

TIME

18:10

BALANCE OF PLANT

VENTILATION

RX BLDG FAN EF 1-5	RX/TURB BLDG FAN EF 1-6	TURB BLDG FAN EF 1-7	TURB BLDG FAN EF 1-1	TURB BLDG FAN EF 1-4	TURB BLDG FAN EF 1-33	SBGT FAN EF 1-B	SBGT FAN EF 1-9
OFF	OFF	ON	ON	ON	ON	ON	OFF

ELECTRIC PLANT

MAIN GEN	EDG #1	EDG #2	BKR 1A	BKR 1B	BKR S1A	BKR S1B	BKR 1C	BKR 1D	BATT A	BATT B	BATT C
0 MWe	0 KW	0 KW	0	0	C	C	C	C	131	132	131

TURBINE/AUXILIARIES

MAIN TURB	BYPASS VALVES	TURNING GEAR	VACUUM COND A	VACUUM COND B	VACUUM COND C
TRIPPED	TRIPPED	ON	0	0	0

COOLING WATER

RBCCW PUMP 1	RBCCW PUMP 2	TBCCW PUMP 1	TBCCW PUMP 2	TBCCW PUMP 3	SERV WTR PUMP 1	SERV WTR PUMP 2
ON	OFF	ON	ON	STDBY	ON	OFF

TIME

18:10

REACTOR PARAMETERS

AVERAGE ALL APRM's	RECIRC FLOW	SLC STATUS	SLC TANK LEVEL	REACTOR PRESSURE	STEAM FLOW
3.8%	0.0 E0 GPM	SYS 1 - OFF	655 GAL	938 PSIG	0.00 MLM/H

FUEL ZONE LEVEL	YARWAY LEVEL	FEEDWATER FLOW	CRD FLOW	CORE SPRAY SYSTEM I	CORE SPRAY SYSTEM II	
-6.7" TAF	<85" TAF	0.14 MLM/H	0 GPM	0 GPM	0 GPM	

ISOLATION CONDENSER A				ISOLATION CONDENSER B			
V-14-30	V-14-31	V-14-34	V-14-36	V-14-32	V-14-33	V-14-35	V-14-37
OPEN	OPEN	CLOSE	OPEN	OPEN	OPEN	CLOSE	OPEN

EMRV A	EMRV B	EMRV C	EMRV D	EMRV E
CLOSE	CLOSE	CLOSE	CLOSE	CLOSE

CONTAINMENT PARAMETERS

DRYWELL TEMP	DRYWELL PRESSURE	DRYWELL HYDROGEN	DRYWELL OXYGEN	CONT SPRAY SYSTEM I	CONT SPRAY SYSTEM II
107 °F	0.85 PSIG	0 %	2.1%	5965 GPM TORUS	GPM OFF

TORUS PRESSURE	TORUS TEMP	TORUS LEVEL	TORUS HYDROGEN	TORUS OXYGEN
1.2 PSIG	82.1 °F	151 INCHES	0%	2.1%

DW UNIDENT LEAKRATE	DW IDENT LEAKRATE	CHRRMS SYS I	CHRRMS SYS II
0 GPM	0 GPM	88 REM	86 REM

TIME 18:20

BALANCE OF PLANT

VENTILATION

RX BLDG FAN EF 1-5	RX/TURB BLDG FAN EF 1-6	TURB BLDG FAN EF 1-7	TURB BLDG FAN EF 1-1	TURB BLDG FAN EF 1-4	TURB BLDG FAN EF 1-33	SBGT FAN EF 1-8	SBGT FAN EF 1-9
OFF	OFF	ON	ON	ON	ON	ON	OFF

ELECTRIC PLANT

MAIN GEN	EDG #1	EDG #2	BKR 1A	BKR 1B	BKR S1A	BKR S1B	BKR 1C	BKR 1D	BATT A	BATT B	BATT C
0 MWe	0 KW	0 KW	0	0	C	C	C	C	131	132	131

TURBINE/AUXILIARIES

MAIN TURB	BYPASS VALVES	TURNING GEAR	VACUUM COND A	VACUUM COND B	VACUUM COND C
TRIPPED	TRIPPED	ON	0	0	0

COOLING WATER

RBCCW PUMP 1	RBCCW PUMP 2	TBCCW PUMP 1	TBCCW PUMP 2	TBCCW PUMP 3	SERV WTR PUMP 1	SERV WTR PUMP 2
ON	OFF	ON	ON	STDBY	ON	OFF

TIME

18:20

REACTOR PARAMETERS

AVERAGE ALL APRM's
4.4%

RECIRC FLOW
0.0 E0 GPM

SLC STATUS
SYS 1 - OFF

SLC TANK LEVEL
655 GAL

REACTOR PRESSURE
1010 PSIG

STEAM FLOW
0.00 MLM/H

FUEL ZONE LEVEL
-3.3" TAF

YARWAY LEVEL
<85" TAF

FEEDWATER FLOW
0.13 MLM/H

CRD FLOW
0 GPM

CORE SPRAY SYSTEM I
0 GPM

CORE SPRAY SYSTEM II
0 GPM

ISOLATION CONDENSER A			
V-14-30	V-14-31	V-14-34	V-14-36
OPEN	OPEN	CLOSE	OPEN

ISOLATION CONDENSER B			
V-14-32	V-14-33	V-14-35	V-14-37
OPEN	OPEN	OPEN	OPEN

EMRV A
CLOSE

EMRV B
CLOSE

EMRV C
CLOSE

EMRV D
CLOSE

EMRV E
CLOSE

CONTAINMENT PARAMETERS

DRYWELL TEMP
106 °F

DRYWELL PRESSURE
0.84 PSIG

DRYWELL HYDROGEN
0 %

DRYWELL OXYGEN
2.1%

CONT SPRAY SYSTEM I
5965 GPM
TORUS

CONT SPRAY SYSTEM II
GPM
OFF

TORUS PRESSURE
1.2 PSIG

TORUS TEMP
82.0 °F

TORUS LEVEL
151 INCHES

TORUS HYDROGEN
0%

TORUS OXYGEN
2.1%

DW UNIDENT LEAKRATE
0 GPM

DW IDENT LEAKRATE
0 GPM

CHRRMS SYS I
88 REM

CHRRMS SYS II
86 REM

TIME

18:30

BALANCE OF PLANT

VENTILATION

RX BLDG FAN EF 1-5	RX/TURB BLDG FAN EF 1-6	TURB BLDG FAN EF 1-7	TURB BLDG FAN EF 1-1	TURB BLDG FAN EF 1-4	TURB BLDG FAN EF 1-33	SBGT FAN EF 1-8	SBGT FAN EF 1-9
OFF	OFF	ON	ON	ON	ON	ON	OFF

ELECTRIC PLANT

MAIN GEN	EDG #1	EDG #2	BKR 1A	BKR 1B	BKR S1A	BKR S1B	BKR 1C	BKR 1D	BATT A	BATT B	BATT C
0 MWe	0 KW	0 KW	0	0	C	C	C	C	131	132	131

TURBINE/AUXILIARIES

MAIN TURB	BYPASS VALVES	TURNING GEAR	VACUUM COND A	VACUUM COND B	VACUUM COND C
TRIPPED	TRIPPED	ON	0	0	0

COOLING WATER

RBCCW PUMP 1	RBCCW PUMP 2	TBCCW PUMP 1	TBCCW PUMP 2	TBCCW PUMP 3	SERV WTR PUMP 1	SERV WTR PUMP 2
ON	OFF	ON	ON	STDBY	ON	OFF

TIME

18:30

REACTOR PARAMETERS

AVERAGE ALL
APRM's
2.3%

RECIRC
FLOW
0.0 E0 GPM

SLC STATUS
SYS 1 - OFF

SLC TANK
LEVEL
655 GAL

REACTOR
PRESSURE
873 PSIG

STEAM FLOW
0.38 MLM/H

FUEL ZONE
LEVEL
-23.0" TAF

YARWAY
LEVEL
<85" TAF

FEEDWATER
FLOW
0.14 MLM/H

CRD
FLOW
0 GPM

CORE SPRAY
SYSTEM I
0 GPM

CORE SPRAY
SYSTEM II
0 GPM

ISOLATION CONDENSER A			
V-14-30	V-14-31	V-14-34	V-14-36
OPEN	OPEN	CLOSE	OPEN

ISOLATION CONDENSER B			
V-14-32	V-14-33	V-14-35	V-14-37
OPEN	OPEN	OPEN	OPEN

EMRV A
CLOSE

EMRV B
CLOSE

EMRV C
CLOSE

EMRV D
CLOSE

EMRV E
CLOSE

CONTAINMENT PARAMETERS

DRYWELL
TEMP
106 °F

DRYWELL
PRESSURE
0.84 PSIG

DRYWELL
HYDROGEN
0 %

DRYWELL
OXYGEN
2.1%

CONT SPRAY
SYSTEM I
5965 GPM
TORUS

CONT SPRAY
SYSTEM II
GPM
OFF

TORUS
PRESSURE
1.2 PSIG

TORUS TEMP
81.9 °F

TORUS
LEVEL
151 INCHES

TORUS
HYDROGEN
0%

TORUS
OXYGEN
2.1%

DW UNIDENT
LEAKRATE
0 GPM

DW IDENT
LEAKRATE
0 GPM

CHRRMS
SYS I
88 REM

CHRRMS
SYS II
86 REM

TIME

18:40

BALANCE OF PLANT

VENTILATION

RX BLDG FAN EF 1-5	RX/TURB BLDG FAN EF 1-6	TURB BLDG FAN EF 1-7	TURB BLDG FAN EF 1-1	TURB BLDG FAN EF 1-4	TURB BLDG FAN EF 1-33	SBGT FAN EF 1-5	SBGT FAN EF 1-9
OFF	OFF	ON	ON	ON	ON	ON	OFF

ELECTRIC PLANT

MAIN GEN	EDG #1	EDG #2	BKR 1A	BKR 1B	BKR S1A	BKR S1B	BKR 1C	BKR 1D	BATT A	BATT B	BATT C
0 MWe	0 KW	0 KW	O	O	C	C	C	C	131	132	131

TURBINE/AUXILIARIES

MAIN TURB	BYPASS VALVES	TURNING GEAR	VACUUM COND A	VACUUM COND B	VACUUM COND C
TRIPPED	TRIPPED	ON	0	0	0

COOLING WATER

RBCCW PUMP 1	RBCCW PUMP 2	TBCCW PUMP 1	TBCCW PUMP 2	TBCCW PUMP 3	SERV WTR PUMP 1	SERV WTR PUMP 2
ON	OFF	ON	ON	STDBY	ON	OFF

TIME

18:40

REACTOR PARAMETERS

AVERAGE ALL
APRM's
3.9%

RECIRC
FLOW
0.0 E0 GPM

SLC STATUS
SYS 1 - OFF

SLC TANK
LEVEL
655 GAL

REACTOR
PRESSURE
879 PSIG

STEAM FLOW
0.00 MLM/H

FUEL ZONE
LEVEL
-8.2" TAF

YARWAY
LEVEL
<85" TAF

FEEDWATER
FLOW
0.24 MLM/H

CRD
FLOW
0 GPM

CORE SPRAY
SYSTEM I
0 GPM

CORE SPRAY
SYSTEM II
0 GPM

ISOLATION CONDENSER A			
V-14-30	V-14-31	V-14-34	V-14-36
OPEN	OPEN	CLOSE	OPEN

ISOLATION CONDENSER B			
V-14-32	V-14-33	V-14-35	V-14-37
OPEN	OPEN	OPEN	OPEN

EMRV A
CLOSE

EMRV B
CLOSE

EMRV C
CLOSE

EMRV D
CLOSE

EMRV E
CLOSE

CONTAINMENT PARAMETERS

DRYWELL
TEMP
106 °F

DRYWELL
PRESSURE
0.83 PSIG

DRYWELL
HYDROGEN
0 %

DRYWELL
OXYGEN
2.1%

CONT SPRAY
SYSTEM I
5965 GPM
TORUS

CONT SPRAY
SYSTEM II
GPM
OFF

TORUS
PRESSURE
1.2 PSIG

TORUS TEMP
81.7 °F

TORUS
LEVEL
151 INCHES

TORUS
HYDROGEN
0%

TORUS
OXYGEN
2.1%

DW UNIDENT
LEAKRATE
0 GPM

DW IDENT
LEAKRATE
0 GPM

CHRRMS
SYS I
88 REM

CHRRMS
SYS II
86 REM

TIME

18:50

BALANCE OF PLANT

VENTILATION

RX BLDG FAN EF 1-5	RX/TURB BLDG FAN EF 1-8	TURB BLDG FAN EF 1-7	TURB BLDG FAN EF 1-1	TURB BLDG FAN EF 1-4	TURB BLDG FAN EF 1-33	SBGT FAN EF 1-8	SBGT FAN EF 1-9
OFF	OFF	ON	ON	ON	ON	ON	OFF

ELECTRIC PLANT

MAIN GEN	EDG #1	EDG #2	BKR 1A	BKR 1B	BKR S1A	BKR S1B	BKR 1C	BKR 1D	BATT A	BATT B	BATT C
0 MWe	0 KW	0 KW	0	0	C	C	C	C	131	132	131

TURBINE/AUXILIARIES

MAIN TURB	BYPASS VALVES	TURNING GEAR	VACUUM COND A	VACUUM COND B	VACUUM COND C
TRIPPED	TRIPPED	ON	0	0	0

COOLING WATER

RBCCW PUMP 1	RBCCW PUMP 2	TBCCW PUMP 1	TBCCW PUMP 2	TBCCW PUMP 3	SERV WTR PUMP 1	SERV WTR PUMP 2
ON	OFF	ON	ON	STDBY	ON	OFF

TIME

18:50

REACTOR PARAMETERS

AVERAGE ALL APRM's
2.0%

RECIRC FLOW
0.0 E0 GPM

SLC STATUS
SYS 1 - OFF

SLC TANK LEVEL
655 GAL

REACTOR PRESSURE
850 PSIG

STEAM FLOW
0.00 MLM/H

FUEL ZONE LEVEL
-6.9" TAF

YARWAY LEVEL
<85" TAF

FEEDWATER FLOW
0.17 MLM/H

CRD FLOW
60 GPM

CORE SPRAY SYSTEM I
0 GPM

CORE SPRAY SYSTEM II
0 GPM

ISOLATION CONDENSER A			
V-14-30	V-14-31	V-14-34	V-14-36
OPEN	OPEN	CLOSE	OPEN

ISOLATION CONDENSER B			
V-14-32	V-14-33	V-14-35	V-14-37
OPEN	OPEN	CLOSE	OPEN

EMRV A
CLOSE

EMRV B
CLOSE

EMRV C
CLOSE

EMRV D
CLOSE

EMRV E
CLOSE

CONTAINMENT PARAMETERS

DRYWELL TEMP
104 °F

DRYWELL PRESSURE
0.78 PSIG

DRYWELL HYDROGEN
0 %

DRYWELL OXYGEN
2.1%

CONT SPRAY SYSTEM I
5965 GPM
TORUS

CONT SPRAY SYSTEM II
GPM
OFF

TORUS PRESSURE
1.2 PSIG

TORUS TEMP
81.4 °F

TORUS LEVEL
151 INCHES

TORUS HYDROGEN
0%

TORUS OXYGEN
2.1%

DW UNIDENT LEAKRATE
0 GPM

DW IDENT LEAKRATE
0 GPM

CHRRMS SYS I
84 REM

CHRRMS SYS II
82 REM

TIME

19:00

BALANCE OF PLANT

VENTILATION

RX BLDG FAN EF 1-5	RX/TURB BLDG FAN EF 1-6	TURB BLDG FAN EF 1-7	TURB BLDG FAN EF 1-1	TURB BLDG FAN EF 1-4	TURB BLDG FAN EF 1-33	SBGT FAN EF 1-8	SBGT FAN EF 1-9
OFF	OFF	ON	ON	ON	ON	ON	OFF

ELECTRIC PLANT

MAIN GEN	EDG #1	EDG #2	BKR 1A	BKR 1B	BKR S1A	BKR S1B	BKR 1C	BKR 1D	BATT A	BATT B	BATT C
0 MWe	0 KW	0 KW	0	0	C	C	C	C	131	132	131

TURBINE/AUXILIARIES

MAIN TURB	BYPASS VALVES	TURNING GEAR	VACUUM COND A	VACUUM COND B	VACUUM COND C
TRIPPED	TRIPPED	ON	0	0	0

COOLING WATER

RBCCW PUMP 1	RBCCW PUMP 2	TBCCW PUMP 1	TBCCW PUMP 2	TBCCW PUMP 3	SERV WTR PUMP 1	SERV WTR PUMP 2
ON	OFF	ON	ON	STDBY	ON	OFF

TIME

19:00

REACTOR PARAMETERS

AVERAGE ALL APRM's
 <2.0%

RECIRC FLOW
 3.5 E4 GPM

SLC STATUS
 SYS 1 - OFF

SLC TANK LEVEL
 655 GAL

REACTOR PRESSURE
 568 PSIG

STEAM FLOW
 0.00 MLM/H

FUEL ZONE LEVEL
 3.9" TAF

YARWAY LEVEL
 <85" TAF

FEEDWATER FLOW
 0.30 MLM/H

CRD FLOW
 60 GPM

CORE SPRAY SYSTEM I
 0 GPM

CORE SPRAY SYSTEM II
 0 GPM

ISOLATION CONDENSER A			
V-14-30	V-14-31	V-14-34	V-14-36
OPEN	OPEN	CLOSE	OPEN

ISOLATION CONDENSER B			
V-14-32	V-14-33	V-14-35	V-14-37
OPEN	OPEN	CLOSE	CLOSE

EMRV A
 CLOSE

EMRV B
 CLOSE

EMRV C
 CLOSE

EMRV D
 CLOSE

EMRV E
 CLOSE

CONTAINMENT PARAMETERS

DRYWELL TEMP
 103 °F

DRYWELL PRESSURE
 0.75 PSIG

DRYWELL HYDROGEN
 0 %

DRYWELL OXYGEN
 2.1%

CONT SPRAY SYSTEM I
 5965 GPM
 TORUS

CONT SPRAY SYSTEM II
 GPM
 OFF

TORUS PRESSURE
 1.2 PSIG

TORUS TEMP
 81.0 °F

TORUS LEVEL
 151 INCHES

TORUS HYDROGEN
 0%

TORUS OXYGEN
 2.1%

DW UNIDENT LEAKRATE
 0 GPM

DW IDENT LEAKRATE
 0 GPM

CHRRMS SYS I
 76 REM

CHRRMS SYS II
 76 REM

TIME 19:11

BALANCE OF PLANT

VENTILATION

RX BLDG FAN EF 1-5	RX/TURB BLDG FAN EF 1-6	TURB BLDG FAN EF 1-7	TURB BLDG FAN EF 1-1	TURB BLDG FAN EF 1-4	TURB BLDG FAN EF 1-33	SBGT FAN EF 1-8	SBGT FAN EF 1-9
OFF	OFF	ON	ON	ON	ON	ON	OFF

ELECTRIC PLANT

MAIN GEN	EDG #1	EDG #2	BKR 1A	BKR 1B	BKR S1A	BKR S1B	BKR 1C	BKR 1D	BATT A	BATT B	BATT C
0 MWe	0 KW	0 KW	0	0	C	C	C	C	131	132	131

TURBINE/AUXILIARIES

MAIN TURB	BYPASS VALVES	TURNING GEAR	VACUUM COND A	VACUUM COND B	VACUUM COND C
TRIPPED	TRIPPED	ON	0	0	0

COOLING WATER

RBCCW PUMP 1	RBCCW PUMP 2	TBCCW PUMP 1	TBCCW PUMP 2	TBCCW PUMP 3	SERV WTR PUMP 1	SERV WTR PUMP 2
ON	OFF	ON	ON	STDBY	ON	OFF

TIME 19:11

REACTOR PARAMETERS

AVERAGE ALL APRM's
 <2.0%

RECIRC FLOW
 6.6 E4 GPM

SLC STATUS
 SYS 1 - OFF

SLC TANK LEVEL
 655 GAL

REACTOR PRESSURE
 411 PSIG

STEAM FLOW
 0.20 MLM/H

FUEL ZONE LEVEL
 0.0" TAF

YARWAY LEVEL
 <85" TAF

FEEDWATER FLOW
 0.11 MLM/H

CRD FLOW
 60 GPM

CORE SPRAY SYSTEM I
 0 GPM

CORE SPRAY SYSTEM II
 0 GPM

ISOLATION CONDENSER A			
V-14-30	V-14-31	V-14-34	V-14-36
OPEN	OPEN	CLOSE	OPEN

ISOLATION CONDENSER B			
V-14-32	V-14-33	V-14-35	V-14-37
OPEN	OPEN	CLOSE	CLOSE

EMRV A
 OPEN

EMRV B
 OPEN

EMRV C
 OPEN

EMRV D
 OPEN

EMRV E
 OPEN

CONTAINMENT PARAMETERS

DRYWELL TEMP
 102 °F

DRYWELL PRESSURE
 0.76 PSIG

DRYWELL HYDROGEN
 0 %

DRYWELL OXYGEN
 2.1%

CONT SPRAY SYSTEM I
 5965 GPM
 TORUS

CONT SPRAY SYSTEM II
 5978 GPM
 TORUS

TORUS PRESSURE
 1.2 PSIG

TORUS TEMP
 84.4 °F

TORUS LEVEL
 152 INCHES

TORUS HYDROGEN
 0%

TORUS OXYGEN
 2.1%

DW UNIDENT LEAKRATE
 0 GPM

DW IDENT LEAKRATE
 0 GPM

CHRRMS SYS I
 69 REM

CHRRMS SYS II
 68 REM

TIME

19:13

BALANCE OF PLANT

VENTILATION

RX BLDG FAN EF 1-5	RX/TURB BLDG FAN EF 1-6	TURB BLDG FAN EF 1-7	TURB BLDG FAN EF 1-1	TURB BLDG FAN EF 1-4	TURB BLDG FAN EF 1-33	SBGT FAN EF 1-6	SBGT FAN EF 1-9
OFF	OFF	ON	ON	ON	ON	ON	OFF

ELECTRIC PLANT

MAIN GEN	EDG #1	EDG #2	BKR 1A	BKR 1B	BKR S1A	BKR S1B	BKR 1C	BKR 1D	BATT A	BATT B	BATT C
0 MWe	0 KW	0 KW	0	0	C	C	C	C	131	132	131

TURBINE/AUXILIARIES

MAIN TURB	BYPASS VALVES	TURNING GEAR	VACUUM COND A	VACUUM COND B	VACUUM COND C
TRIPPED	TRIPPED	ON	0	0	0

COOLING WATER

RBCCW PUMP 1	RBCCW PUMP 2	TBCCW PUMP 1	TBCCW PUMP 2	TBCCW PUMP 3	SERV WTR PUMP 1	SERV WTR PUMP 2
ON	OFF	ON	ON	STDBY	ON	OFF

TIME

19:13

REACTOR PARAMETERS

AVERAGE ALL
APRM's
<2.0%

RECIRC
FLOW
6.1 E4 GPM

SLC STATUS
SYS 1 - OFF

SLC TANK
LEVEL
655 GAL

REACTOR
PRESSURE
252 PSIG

STEAM FLOW
0.11 MLM/H

FUEL ZONE
LEVEL
-18.8" TAF

YARWAY
LEVEL
<85" TAF

FEEDWATER
FLOW
0.02 MLM/H

CRD
FLOW
60 GPM

CORE SPRAY
SYSTEM I
0 GPM

CORE SPRAY
SYSTEM II
0 GPM

ISOLATION CONDENSER A			
V-14-30	V-14-31	V-14-34	V-14-36
OPEN	OPEN	CLOSE	OPEN

ISOLATION CONDENSER B			
V-14-32	V-14-33	V-14-35	V-14-37
OPEN	OPEN	CLOSE	CLOSE

EMRV A
OPEN

EMRV B
OPEN

EMRV C
OPEN

EMRV D
OPEN

EMRV E
OPEN

CONTAINMENT PARAMETERS

DRYWELL
TEMP
102 °F

DRYWELL
PRESSURE
0.76 PSIG

DRYWELL
HYDROGEN
0 %

DRYWELL
OXYGEN
2.1%

CONT SPRAY
SYSTEM I
5965 GPM
TORUS

CONT SPRAY
SYSTEM II
5978 GPM
TORUS

TORUS
PRESSURE
1.2 PSIG

TORUS TEMP
87.5 °F

TORUS
LEVEL
152 INCHES

TORUS
HYDROGEN
0%

TORUS
OXYGEN
2.1%

DW UNIDENT
LEAKRATE
0 GPM

DW IDENT
LEAKRATE
0 GPM

CHRRMS
SYS I
62 REM

CHRRMS
SYS II
60 REM

TIME

19:14

BALANCE OF PLANT

VENTILATION

RX BLDG FAN EF 1-5	RX/TURB BLDG FAN EF 1-6	TURB BLDG FAN EF 1-7	TURB BLDG FAN EF 1-1	TURB BLDG FAN EF 1-4	TURB BLDG FAN EF 1-33	SBGT FAN EF 1-8	SBGT FAN EF 1-9
OFF	OFF	ON	ON	ON	ON	ON	OFF

ELECTRIC PLANT

MAIN GEN	EDG #1	EDG #2	BKR 1A	BKR 1B	BKR S1A	BKR S1B	BKR iC	BKR 1D	BATT A	BATT B	BATT C
0 MWe	0 KW	0 KW	0	0	C	C	C	C	131	132	131

TURBINE/AUXILIARIES

MAIN TURB	BYPASS VALVES	TURNING GEAR	VACUUM COND A	VACUUM COND B	VACUUM COND C
TRIPPED	TRIPPED	ON	0	0	0

COOLING WATER

RBCCW PUMP 1	RBCCW PUMP 2	TBCCW PUMP 1	TBCCW PUMP 2	TBCCW PUMP 3	SERV WTR PUMP 1	SERV WTR PUMP 2
ON	OFF	ON	ON	STDBY	ON	OFF

TIME

19:14

REACTOR PARAMETERS

AVERAGE ALL
APRM's
<2.0%

RECIRC
FLOW
5.6 E4 GPM

SLC STATUS
SYS 1 - OFF

SLC TANK
LEVEL
655 GAL

REACTOR
PRESSURE
169 PSIG

STEAM FLOW
0.07 MLM/H

FUEL ZONE
LEVEL
-26.5" TAF

YARWAY
LEVEL
<85" TAF

FEEDWATER
FLOW
0.10 MLM/H

CRD
FLOW
60 GPM

CORE SPRAY
SYSTEM I
0 GPM

CORE SPRAY
SYSTEM II
0 GPM

ISOLATION CONDENSER - A			
V-14-30	V-14-31	V-14-34	V-14-36
OPEN	OPEN	CLOSE	OPEN

ISOLATION CONDENSER - B			
V-14-32	V-14-33	V-14-35	V-14-37
OPEN	OPEN	CLOSE	CLOSE

EMRV A
OPEN

EMRV B
OPEN

EMRV C
OPEN

EMRV D
OPEN

EMRV E
OPEN

CONTAINMENT PARAMETERS

DRYWELL
TEMP
101 °F

DRYWELL
PRESSURE
0.76 PSIG

DRYWELL
HYDROGEN
0 %

DRYWELL
OXYGEN
2.1%

CONT SPRAY
SYSTEM I
5965 GPM
TORUS

CONT SPRAY
SYSTEM II
5978 GPM
TORUS

TORUS
PRESSURE
1.2 PSIG

TORUS TEMP
89.3 °F

TORUS
LEVEL
152 INCHES

TORUS
HYDROGEN
0%

TORUS
OXYGEN
2.1%

DW UNIDENT
LEAKRATE
0 GPM

DW IDENT
LEAKRATE
0 GPM

CHRRMS
SYS I
53 REM

CHRRMS
SYS II
53 REM

TIME

19:15

BALANCE OF PLANT

VENTILATION

RX BLDG FAN EF 1-5	RX/TURB BLDG FAN EF 1-8	TURB BLDG FAN EF 1-7	TURB BLDG FAN EF 1-1	TURB BLDG FAN EF 1-4	TURB BLDG FAN EF 1-33	SBGT FAN EF 1-8	SBGT FAN EF 1-9
OFF	OFF	ON	ON	ON	ON	ON	OFF

ELECTRIC PLANT

MAIN GEN	EDG #1	EDG #2	BKR 1A	BKR 1B	BKR S1A	BKR S1B	BKR 1C	BKR 1D	BATT A	BATT B	BATT C
0 MWe	0 KW	0 KW	0	0	C	C	C	C	131	132	131

TURBINE/AUXILIARIES

MAIN TURB	BYPASS VALVES	TURNING GEAR	VACUUM COND A	VACUUM COND B	VACUUM COND C
TRIPPED	TRIPPED	ON	0	0	0

COOLING WATER

RBCCW PUMP 1	RBCCW PUMP 2	TBCCW PUMP 1	TBCCW PUMP 2	TBCCW PUMP 3	SERV WTR PUMP 1	SERV WTR PUMP 2
ON	OFF	ON	ON	STDBY	ON	OFF

TIME

19:15

REACTOR PARAMETERS

AVERAGE ALL APRM's
 <2.0%

RECIRC FLOW
 6.1 E4 GPM

SLC STATUS
 SYS 1 - OFF

SLC TANK LEVEL
 655 GAL

REACTOR PRESSURE
 117 PSIG

STEAM FLOW
 0.04 MLM/H

FUEL ZONE LEVEL
 -31.0" TAF

YARWAY LEVEL
 <85" TAF

FEEDWATER FLOW
 0.59 MLM/H

CRD FLOW
 60 GPM

CORE SPRAY SYSTEM I
 0 GPM

CORE SPRAY SYSTEM II
 0 GPM

ISOLATION CONDENSER A			
V-14-30	V-14-31	V-14-34	V-14-36
OPEN	OPEN	CLOSE	OPEN

ISOLATION CONDENSER B			
V-14-32	V-14-33	V-14-35	V-14-37
OPEN	OPEN	CLOSE	CLOSE

EMRV A
 OPEN

EMRV B
 OPEN

EMRV C
 OPEN

EMRV D
 OPEN

EMRV E
 OPEN

CONTAINMENT PARAMETERS

DRYWELL TEMP
 100 °F

DRYWELL PRESSURE
 0.76 PSIG

DRYWELL HYDROGEN
 0 %

DRYWELL OXYGEN
 2.1%

CONT SPRAY SYSTEM I
 5965 GPM
 TORUS

CONT SPRAY SYSTEM II
 5978 GPM
 TORUS

TORUS PRESSURE
 1.2 PSIG

TORUS TEMP
 90.4 °F

TORUS LEVEL
 152 INCHES

TORUS HYDROGEN
 0%

TORUS OXYGEN
 2.1%

DW UNIDENT LEAKRATE
 0 GPM

DW IDENT LEAKRATE
 0 GPM

CHRRMS SYS I
 46 REM

CHRRMS SYS II
 46 REM

TIME

19:16

BALANCE OF PLANT

VENTILATION

RX BLDG FAN EF 1-5	RX/TURB BLDG FAN EF 1-6	TURB BLDG FAN EF 1-7	TURB BLDG FAN EF 1-1	TURB BLDG FAN EF 1-4	TURB BLDG FAN EF 1-33	SBGT FAN EF 1-8	SBGT FAN EF 1-9
OFF	OFF	ON	ON	ON	ON	ON	OFF

ELECTRIC PLANT

MAIN GEN	EDG #1	EDG #2	BKR 1A	BKR 1B	BKR S1A	BKR S1B	BKR 1C	BKR 1D	BATT A	BATT B	BATT C
0 MWe	0 KW	0 KW	0	0	C	C	C	C	131	132	131

TURBINE/AUXILIARIES

MAIN TURB	BYPASS VALVES	TURNING GEAR	VACUUM COND A	VACUUM COND B	VACUUM COND C
TRIPPED	TRIPPED	ON	0	0	0

COOLING WATER

RBCCW PUMP 1	RBCCW PUMP 2	TBCCW PUMP 1	TBCCW PUMP 2	TBCCW PUMP 3	SERV WTR PUMP 1	SERV WTR PUMP 2
ON	OFF	ON	ON	STDBY	ON	OFF

TIME 19:16

REACTOR PARAMETERS

AVERAGE ALL APRM's
 <2.0%

RECIRC FLOW
 4.5 E4 GPM

SLC STATUS
 SYS 1 - OFF

SLC TANK LEVEL
 655 GAL

REACTOR PRESSURE
 90 PSIG

STEAM FLOW
 0.02 MLM/H

FUEL ZONE LEVEL
 -34.4" TAF

YARWAY LEVEL
 <85" TAF

FEEDWATER FLOW
 0.48 MLM/H

CRD FLOW
 60 GPM

CORE SPRAY SYSTEM I
 0 GPM

CORE SPRAY SYSTEM II
 0 GPM

ISOLATION CONDENSER A			
V-14-30	V-14-31	V-14-34	V-14-36
OPEN	OPEN	CLOSE	OPEN

ISOLATION CONDENSER B			
V-14-32	V-14-33	V-14-35	V-14-37
OPEN	OPEN	CLOSE	CLOSE

EMRV A
 OPEN

EMRV B
 OPEN

EMRV C
 OPEN

EMRV D
 OPEN

EMRV E
 OPEN

CONTAINMENT PARAMETERS

DRYWELL TEMP
 99 °F

DRYWELL PRESSURE
 0.76 PSIG

DRYWELL HYDROGEN
 0 %

DRYWELL OXYGEN
 2.1%

CONT SPRAY SYSTEM I
 5965 GPM
 TORUS

CONT SPRAY SYSTEM II
 5978 GPM
 TORUS

TORUS PRESSURE
 1.2 PSIG

TORUS TEMP
 91.3 °F

TORUS LEVEL
 152 INCHES

TORUS HYDROGEN
 0%

TORUS OXYGEN
 2.1%

DW UNIDENT LEAKRATE
 0 GPM

DW IDENT LEAKRATE
 0 GPM

CHRRMS SYS I
 39 REM

CHRRMS SYS II
 39 REM

TIME

19:17

BALANCE OF PLANT

VENTILATION

RX BLDG FAN EF 1-3	RX/TURB BLDG FAN EF 1-6	TURB BLDG FAN EF 1-7	TURB BLDG FAN EF 1-1	TURB BLDG FAN EF 1-4	TURB BLDG FAN EF 1-33	SBGT FAN EF 1-8	SBGT FAN EF 1-9
OFF	OFF	ON	ON	ON	ON	ON	OFF

ELECTRIC PLANT

MAIN GEN	EDG #1	EDG #2	BKR 1A	BKR 1B	BKR S1A	BKR S1B	BKR 1C	BKR 1D	BATT A	BATT B	BATT C
0 MWe	0 KW	0 KW	0	0	C	C	C	C	131	132	131

TURBINE/AUXILIARIES

MAIN TURB	BYPASS VALVES	TURNING GEAR	VACUUM COND A	VACUUM COND B	VACUUM COND C
TRIPPED	TRIPPED	ON	0	0	0

COOLING WATER

RBCCW PUMP 1	RBCCW PUMP 2	TBCCW PUMP 1	TBCCW PUMP 2	TBCCW PUMP 3	SERV WTR PUMP 1	SERV WTR PUMP 2
ON	OFF	ON	ON	STDBY	ON	OFF

TIME

19:17



REACTOR PARAMETERS

AVERAGE ALL APRM's	RECIRC FLOW	SLC STATUS	SLC TANK LEVEL	REACTOR PRESSURE	STEAM FLOW
<2.0%	4.5 E4 GPM	SYS 1 - OFF	655 GAL	72 PSIG	0.02 MLM/H

FUEL ZONE LEVEL	YARWAY LEVEL	FEEDWATER FLOW	CRD FLOW	CORE SPRAY SYSTEM I	CORE SPRAY SYSTEM II	
-32.4" TAF	<85" TAF	0.51 MLM/H	60 GPM	0 GPM	0 GPM	

ISOLATION CONDENSER A				ISOLATION CONDENSER B			
V-14-30	V-14-31	V-14-34	V-14-36	V-14-32	V-14-33	V-14-35	V-14-37
OPEN	OPEN	CLOSE	OPEN	OPEN	OPEN	CLOSE	CLOSE

EMRV A	EMRV B	EMRV C	EMRV D	EMRV E
OPEN	OPEN	OPEN	OPEN	OPEN

CONTAINMENT PARAMETERS

DRYWELL TEMP	DRYWELL PRESSURE	DRYWELL HYDROGEN	DRYWELL OXYGEN	CONT SPRAY SYSTEM I	CONT SPRAY SYSTEM II
98 °F	0.76 PSIG	0 %	2.1%	5965 GPM TORUS	5978 GPM TORUS

TORUS PRESSURE	TORUS TEMP	TORUS LEVEL	TORUS HYDROGEN	TORUS OXYGEN
1.2 PSIG	91.9 °F	152 INCHES	0%	2.1%

DW UNIDENT LEAKRATE	DW IDENT LEAKRATE	CHRRMS SYS I	CHRRMS SYS II
0 GPM	0 GPM	31 REM	31 REM

TIME 19:18

BALANCE OF PLANT

VENTILATION

RX BLDG FAN EF 1-5	RX/TURB BLDG FAN EF 1-6	TURB BLDG FAN EF 1-7	TURB BLDG FAN EF 1-1	TURB BLDG FAN EF 1-4	TURB BLDG FAN EF 1-33	SBGT FAN EF 1-8	SBGT FAN EF 1-9
OFF	OFF	ON	ON	ON	ON	ON	OFF

ELECTRIC PLANT

MAIN GEN	EDG #1	EDG #2	BKR 1A	BKR 1B	BKR S1A	BKR S1B	BKR 1C	BKR 1D	BATT A	BATT B	BATT C
0 MWe	0 KW	0 KW	0	0	C	C	C	C	131	132	131

TURBINE/AUXILIARIES

MAIN TURB	BYPASS VALVES	TURNING GEAR	VACUUM COND A	VACUUM COND B	VACUUM COND C
TRIPPED	TRIPPED	ON	0	0	0

COOLING WATER

RBCCW PUMP 1	RBCCW PUMP 2	TBCCW PUMP 1	TBCCW PUMP 2	TBCCW PUMP 3	SERV WTR PUMP 1	SERV WTR PUMP 2
ON	OFF	ON	ON	STDBY	ON	OFF

TIME

19:18

REACTOR PARAMETERS

AVERAGE ALL APRM's
 <2.0%

RECIRC FLOW
 3.9 E4 GPM

SLC STATUS
 SYS 1 - OFF

SLC TANK LEVEL
 655 GAL

REACTOR PRESSURE
 56 PSIG

STEAM FLOW
 0.02 MLM/H

FUEL ZONE LEVEL
 -35.0" TAF

YARWAY LEVEL
 <85" TAF

FEEDWATER FLOW
 0.74 MLM/H

CRD FLOW
 60 GPM

CORE SPRAY SYSTEM I
 0 GPM

CORE SPRAY SYSTEM II
 0 GPM

ISOLATION CONDENSER A			
V-14-30	V-14-31	V-14-34	V-14-36
OPEN	OPEN	CLOSE	OPEN

ISOLATION CONDENSER B			
V-14-32	V-14-33	V-14-35	V-14-37
OPEN	OPEN	CLOSE	CLOSE

EMRV A
 OPEN

EMRV B
 OPEN

EMRV C
 OPEN

EMRV D
 OPEN

EMRV E
 OPEN

CONTAINMENT PARAMETERS

DRYWELL TEMP
 97 °F

DRYWELL PRESSURE
 0.76 PSIG

DRYWELL HYDROGEN
 0 %

DRYWELL OXYGEN
 2.1%

CONT SPRAY SYSTEM I
 5965 GPM
 TORUS

CONT SPRAY SYSTEM II
 5978 GPM
 TORUS

TORUS PRESSURE
 1.2 PSIG

TORUS TEMP
 92.5 °F

TORUS LEVEL
 152 INCHES

TORUS HYDROGEN
 0%

TORUS OXYGEN
 2.1%

DW UNIDENT LEAKRATE
 0 GPM

DW IDENT LEAKRATE
 0 GPM

CHRRMS SYS I
 23 REM

CHRRMS SYS II
 24 REM

TIME

19:19

BALANCE OF PLANT

VENTILATION

RX BLDG FAN EF 1-5	RX/TURB BLDG FAN EF 1-6	TURB BLDG FAN EF 1-7	TURB BLDG FAN EF 1-1	TURB BLDG FAN EF 1-4	TURB BLDG FAN EF 1-33	SBGT FAN EF 1-8	SBGT FAN EF 1-9
OFF	OFF	ON	ON	ON	ON	ON	OFF

ELECTRIC PLANT

MAIN GEN	EDG #1	EDG #2	BKR 1A	BKR 1B	BKR S1A	BKR S1B	BKR 1C	BKR 1D	BATT A	BATT B	BATT C
0 MWe	0 KW	0 KW	O	O	C	C	C	C	131	132	131

TURBINE/AUXILIARIES

MAIN TURB	BYPASS VALVES	TURNING GEAR	VACUUM COND A	VACUUM COND B	VACUUM COND C
TRIPPED	TRIPPED	ON	0	0	0

COOLING WATER

RBCCW PUMP 1	RBCCW PUMP 2	TBCCW PUMP 1	TBCCW PUMP 2	TBCCW PUMP 3	SERV WTR PUMP 1	SERV WTR PUMP 2
ON	OFF	ON	ON	STDBY	ON	OFF

TIME

19:19

REACTOR PARAMETERS

AVERAGE ALL
APRM's
<2.0%

RECIRC
FLOW
0.0 E0 GPM

SLC STATUS
SYS 1 - OFF

SLC TANK
LEVEL
655 GAL

REACTOR
PRESSURE
39 PSIG

STEAM FLOW
0.00 MLM/H

FUEL ZONE
LEVEL
-47.2" TAF

YARWAY
LEVEL
<85" TAF

FEEDWATER
FLOW
1.07 MLM/H

CRD
FLOW
60 GPM

CORE SPRAY
SYSTEM I
0 GPM

CORE SPRAY
SYSTEM II
0 GPM

ISOLATION CONDENSER A			
V-14-30	V-14-31	V-14-34	V-14-36
OPEN	OPEN	CLOSE	OPEN

ISOLATION CONDENSER B			
V-14-32	V-14-33	V-14-35	V-14-37
OPEN	OPEN	CLOSE	CLOSE

EMRV A
OPEN

EMRV B
OPEN

EMRV C
OPEN

EMRV D
OPEN

EMRV E
OPEN

CONTAINMENT PARAMETERS

DRYWELL
TEMP
96 °F

DRYWELL
PRESSURE
0.76 PSIG

DRYWELL
HYDROGEN
0 %

DRYWELL
OXYGEN
2.1%

CONT SPRAY
SYSTEM I
5965 GPM
TORUS

CONT SPRAY
SYSTEM II
5978 GPM
TORUS

TORUS
PRESSURE
1.2 PSIG

TORUS TEMP
92.8 °F

TORUS
LEVEL
153 INCHES

TORUS
HYDROGEN
0%

TORUS
OXYGEN
2.1%

DW UNIDENT
LEAKRATE
0 GPM

DW IDENT
LEAKRATE
0 GPM

CHRRMS
SYS I
21 REM

CHRRMS
SYS II
22 REM

TIME

19:20

BALANCE OF PLANT

VENTILATION

RX BLDG FAN EF 1-5	RX/TURB BLDG FAN EF 1-6	TURB BLDG FAN EF 1-7	TURB BLDG FAN EF 1-1	TURB BLDG FAN EF 1-4	TURB BLDG FAN EF 1-33	SBGT FAN EF 1-8	SBGT FAN EF 1-9
OFF	OFF	ON	ON	ON	ON	ON	OFF

ELECTRIC PLANT

MAIN GEN	EDG #1	EDG #2	BKR 1A	BKR 1B	BKR S1A	BKR S1B	BKR 1C	BKR 1D	BATT A	BATT B	BATT C
0 MWe	0 KW	0 KW	0	0	C	C	C	C	131	132	131

TURBINE/AUXILIARIES

MAIN TURB	BYPASS VALVES	TURNING GEAR	VACUUM COND A	VACUUM COND B	VACUUM COND C
TRIPPED	TRIPPED	ON	0	0	0

COOLING WATER

RBCCW PUMP 1	RBCCW PUMP 2	TBCCW PUMP 1	TBCCW PUMP 2	TBCCW PUMP 3	SERV WTR PUMP 1	SERV WTR PUMP 2
ON	OFF	ON	ON	STDBY	ON	OFF

TIME

19:20

REACTOR PARAMETERS

AVERAGE ALL APRM's	RECIRC FLOW	SLC STATUS	SLC TANK LEVEL	REACTOR PRESSURE	STEAM FLOW
<2.0%	0.0 E0 GPM	SYS 1 - OFF	655 GAL	34 PSIG	0.00 MLM/H

FUEL ZONE LEVEL	YARWAY LEVEL	FEEDWATER FLOW	CRD FLOW	CORE SPRAY SYSTEM I	CORE SPRAY SYSTEM II	
-42.7" TAF	<85" TAF	1.14 MLM/H	60 GPM	0 GPM	0 GPM	

ISOLATION CONDENSER A				ISOLATION CONDENSER B			
V-14-30	V-14-31	V-14-34	V-14-36	V-14-32	V-14-33	V-14-35	V-14-37
OPEN	OPEN	CLOSE	OPEN	OPEN	OPEN	CLOSE	CLOSE

EMRV A	EMRV B	EMRV C	EMRV D	EMRV E
OPEN	OPEN	OPEN	OPEN	OPEN

CONTAINMENT PARAMETERS

DRYWELL TEMP	DRYWELL PRESSURE	DRYWELL HYDROGEN	DRYWELL OXYGEN	CONT SPRAY SYSTEM I	CONT SPRAY SYSTEM II
96 °F	0.76 PSIG	0 %	2.1%	5965 GPM TORUS	5978 GPM TORUS

TORUS PRESSURE	TORUS TEMP	TORUS LEVEL	TORUS HYDROGEN	TORUS OXYGEN
1.2 PSIG	92.6 °F	153 INCHES	0%	2.1%

DW UNIDENT LEAKRATE	DW IDENT LEAKRATE	CHRRMS SYS I	CHRRMS SYS II
0 GPM	0 GPM	21 REM	22 REM

TIME 19:21

BALANCE OF PLANT

VENTILATION

RX BLDG FAN EF 1-5	RX/TURB BLDG FAN EF 1-6	TURB BLDG FAN EF 1-7	TURB BLDG FAN EF 1-1	TURB BLDG FAN EF 1-4	TURB BLDG FAN EF 1-33	SBGT FAN EF 1-8	SBGT FAN EF 1-9
OFF	OFF	ON	ON	ON	ON	ON	OFF

ELECTRIC PLANT

MAIN GEN	EDG #1	EDG #2	BKR 1A	BKR 1B	BKR S1A	BKR S1B	BKR 1C	BKR 1D	BATT A	BATT B	BATT C
0 MWe	0 KW	0 KW	0	0	C	C	C	C	131	132	131

TURBINE/AUXILIARIES

MAIN TURB	BYPASS VALVES	TURNING GEAR	VACUUM COND A	VACUUM COND B	VACUUM COND C
TRIPPED	TRIPPED	ON	0	0	0

COOLING WATER

RBCCW PUMP 1	RBCCW PUMP 2	TBCCW PUMP 1	TBCCW PUMP 2	TBCCW PUMP 3	SERV WTR PUMP 1	SERV WTR PUMP 2
ON	OFF	ON	ON	STDBY	ON	OFF

TIME

19:21

REACTOR PARAMETERS

AVERAGE ALL APRM's
 <2.0%

RECIRC FLOW
 0.0 E0 GPM

SLC STATUS
 SYS 1 - OFF

SLC TANK LEVEL
 655 GAL

REACTOR PRESSURE
 30 PSIG

STEAM FLOW
 0.00 MLM/H

FUEL ZONE LEVEL
 -41.5" TAF

YARWAY LEVEL
 <85" TAF

FEEDWATER FLOW
 1.21 MLM/H

CRD FLOW
 60 GPM

CORE SPRAY SYSTEM I
 0 GPM

CORE SPRAY SYSTEM II
 0 GPM

ISOLATION CONDENSER A			
V-14-30	V-14-31	V-14-34	V-14-36
OPEN	OPEN	CLOSE	OPEN

ISOLATION CONDENSER B			
V-14-32	V-14-33	V-14-35	V-14-37
OPEN	OPEN	CLOSE	CLOSE

EMRV A
 OPEN

EMRV B
 OPEN

EMRV C
 OPEN

EMRV D
 OPEN

EMRV E
 OPEN

CONTAINMENT PARAMETERS

DRYWELL TEMP
 95 °F

DRYWELL PRESSURE
 0.76 PSIG

DRYWELL HYDROGEN
 0 %

DRYWELL OXYGEN
 2.1%

CONT SPRAY SYSTEM I
 5965 GPM
 TORUS

CONT SPRAY SYSTEM II
 5978 GPM
 TORUS

TORUS PRESSURE
 1.2 PSIG

TORUS TEMP
 92.5 °F

TORUS LEVEL
 153 INCHES

TORUS HYDROGEN
 0%

TORUS OXYGEN
 2.1%

DW UNIDENT LEAKRATE
 0 GPM

DW IDENT LEAKRATE
 0 GPM

CHRRMS SYS I
 21 REM

CHRRMS SYS II
 22 REM

TIME

19:22

BALANCE OF PLANT

VENTILATION

RX BLDG FAN EF 1-5	RX/TURB BLDG FAN EF 1-6	TURB BLDG FAN EF 1-7	TURB BLDG FAN EF 1-1	TURB BLDG FAN EF 1-4	TURB BLDG FAN EF 1-33	SBGT FAN EF 1-8	SBGT FAN EF 1-9
OFF	OFF	ON	ON	ON	ON	ON	OFF

ELECTRIC PLANT

MAIN GEN	EDG #1	EDG #2	BKR 1A	BKR 1B	BKR S1A	BKR S1B	BKR 1C	BKR 1D	BATT A	BATT B	BATT C
0 MWe	0 KW	0 KW	0	0	C	C	C	C	131	132	131

TURBINE/AUXILIARIES

MAIN TURB	BYPASS VALVES	TURNING GEAR	VACUUM COND A	VACUUM COND B	VACUUM COND C
TRIPPED	TRIPPED	ON	0	0	0

COOLING WATER

RBCCW PUMP 1	RBCCW PUMP 2	TBCCW PUMP 1	TBCCW PUMP 2	TBCCW PUMP 3	SERV WTR PUMP 1	SERV WTR PUMP 2
ON	OFF	ON	ON	STDBY	ON	OFF

TIME

19:22

REACTOR PARAMETERS

AVERAGE ALL APRM's
 <2.0%

RECIRC FLOW
 0.0 E0 GPM

SLC STATUS
 SYS 1 - OFF

SLC TANK LEVEL
 655 GAL

REACTOR PRESSURE
 28 PSIG

STEAM FLOW
 0.00 MLM/H

FUEL ZONE LEVEL
 -36.7" TAF

YARWAY LEVEL
 <85" TAF

FEEDWATER FLOW
 1.36 MLM/H

CRD FLOW
 60 GPM

CORE SPRAY SYSTEM I
 0 GPM

CORE SPRAY SYSTEM II
 0 GPM

ISOLATION CONDENSER A
 V-14-30 V-14-31 V-14-34 V-14-36
 OPEN OPEN CLOSE OPEN

ISOLATION CONDENSER B
 V-14-32 V-14-33 V-14-35 V-14-37
 OPEN OPEN CLOSE CLOSE

EMRV A
 OPEN

EMRV B
 OPEN

EMRV C
 OPEN

EMRV D
 OPEN

EMRV E
 OPEN

CONTAINMENT PARAMETERS

DRYWELL TEMP
 95 °F

DRYWELL PRESSURE
 0.76 PSIG

DRYWELL HYDROGEN
 0 %

DRYWELL OXYGEN
 2.1%

CONT SPRAY SYSTEM I
 5965 GPM

CONT SPRAY SYSTEM II
 5978 GPM

TORUS PRESSURE
 1.2 PSIG

TORUS TEMP
 92.3 °F

TORUS LEVEL
 153 INCHES

TORUS HYDROGEN
 0%

TORUS OXYGEN
 2.1%

DW UNIDENT LEAKRATE
 0 GPM

DW IDENT LEAKRATE
 0 GPM

CHRRMS SYS I
 21 REM

CHRRMS SYS II
 22 REM

TIME 19:23

BALANCE OF PLANT

VENTILATION

RX BLDG FAN EF 1-5	RX/TURB BLDG FAN EF 1-6	TURB BLDG FAN EF 1-7	TURB BLDG FAN EF 1-1	TURB BLDG FAN EF 1-4	TURB BLDG FAN EF 1-33	SBGT FAN EF 1-8	SBGT FAN EF 1-9
OFF	OFF	ON	ON	ON	ON	ON	OFF

ELECTRIC PLANT

MAIN GEN	EDG #1	EDG #2	BKR 1A	BKR 1B	BKR S1A	BKR S1B	BKR 1C	BKR 1D	BATT A	BATT B	BATT C
0 MWe	0 KW	0 KW	0	0	C	C	C	C	131	132	131

TURBINE/AUXILIARIES

MAIN TURB	BYPASS VALVES	TURNING GEAR	VACUUM COND A	VACUUM COND B	VACUUM COND C
TRIPPED	TRIPPED	ON	0	0	0

COOLING WATER

RBCCW PUMP 1	RBCCW PUMP 2	TBCCW PUMP 1	TBCCW PUMP 2	TBCCW PUMP 3	SERV WTR PUMP 1	SERV WTR PUMP 2
ON	OFF	ON	ON	STDBY	ON	OFF

TIME

19:23

REACTOR PARAMETERS

AVERAGE ALL
APRM's
<2.0%

RECIRC
FLOW
0.0 E0 GPM

SLC STATUS
SYS 1 - OFF

SLC TANK
LEVEL
655 GAL

REACTOR
PRESSURE
26 PSIG

STEAM FLOW
0.00 MLM/H

FUEL ZONE
LEVEL
-30.2" TAF

YARWAY
LEVEL
<85" TAF

FEEDWATER
FLOW
1.38 MLM/H

CRD
FLOW
60 GPM

CORE SPRAY
SYSTEM I
0 GPM

CORE SPRAY
SYSTEM II
0 GPM

ISOLATION CONDENSER A			
V-14-30	V-14-31	V-14-34	V-14-36
OPEN	OPEN	CLOSE	OPEN

ISOLATION CONDENSER B			
V-14-32	V-14-33	V-14-35	V-14-37
OPEN	OPEN	CLOSE	CLOSE

EMRV A
OPEN

EMRV B
OPEN

EMRV C
OPEN

EMRV D
OPEN

EMRV E
OPEN

CONTAINMENT PARAMETERS

DRYWELL
TEMP
95 °F

DRYWELL
PRESSURE
0.77 PSIG

DRYWELL
HYDROGEN
0 %

DRYWELL
OXYGEN
2.1%

CONT SPRAY
SYSTEM I
5965 GPM
TORUS

CONT SPRAY
SYSTEM II
5978 GPM
TORUS

TORUS
PRESSURE
1.2 PSIG

TORUS TEMP
92.1 °F

TORUS
LEVEL
153 INCHES

TORUS
HYDROGEN
0%

TORUS
OXYGEN
2.1%

DW UNIDENT
LEAKRATE
0 GPM

DW IDENT
LEAKRATE
0 GPM

CHRRMS
SYS I
21 REM

CHRRMS
SYS II
22 REM

TIME

19:24

BALANCE OF PLANT

VENTILATION

RX BLDG FAN EF 1-5	RX/TURB BLDG FAN EF 1-6	TURB BLDG FAN EF 1-7	TURB BLDG FAN EF 1-1	TURB BLDG FAN EF 1-4	TURB BLDG FAN EF 1-33	SBGT FAN EF 1-8	SBGT FAN EF 1-9
OFF	OFF	ON	ON	ON	ON	ON	OFF

ELECTRIC PLANT

MAIN GEN	EDG #1	EDG #2	BKR 1A	BKR 1B	BKR S1A	BKR S1B	BKR 1C	BKR 1D	BATT A	BATT B	BATT C
0 MWe	0 KW	0 KW	0	0	C	C	C	C	131	132	131

TURBINE/AUXILIARIES

MAIN TURB	BYPASS VALVES	TURNING GEAR	VACUUM COND A	VACUUM COND B	VACUUM COND C
TRIPPED	TRIPPED	ON	0	0	0

COOLING WATER

RBCCW PUMP 1	RBCCW PUMP 2	TBCCW PUMP 1	TBCCW PUMP 2	TBCCW PUMP 3	SERV WTR PUMP 1	SERV WTR PUMP 2
ON	OFF	ON	ON	STDBY	ON	OFF

TIME

19:24

REACTOR PARAMETERS

AVERAGE ALL APRM's <2.0%
 RECIRC FLOW 0.0 E0 GPM
 SLC STATUS SYS 1 - OFF
 SLC TANK LEVEL 655 GAL
 REACTOR PRESSURE 28 PSIG
 STEAM FLOW 0.00 MLM/H

FUEL ZONE LEVEL -22.8" TAF
 YARWAY LEVEL <85" TAF
 FEEDWATER FLOW 1.38 MLM/H
 CRD FLOW 60 GPM
 CORE SPRAY SYSTEM I 0 GPM
 CORE SPRAY SYSTEM II 0 GPM

ISOLATION CONDENSER A
 V-14-30 V-14-31 V-14-34 V-14-36
 OPEN OPEN CLOSE OPEN
 ISOLATION CONDENSER B
 V-14-32 V-14-33 V-14-35 V-14-37
 OPEN OPEN CLOSE CLOSE

EMRV A OPEN
 EMRV B OPEN
 EMRV C OPEN
 EMRV D OPEN
 EMRV E OPEN

CONTAINMENT PARAMETERS

DRYWELL TEMP 95 °F
 DRYWELL PRESSURE 0.77 PSIG
 DRYWELL HYDROGEN 0 %
 DRYWELL OXYGEN 2.1 %
 CONT SPRAY SYSTEM I 5965 GPM
 CONT SPRAY SYSTEM II 5978 GPM
 TORUS TORUS

TORUS PRESSURE 1.2 PSIG
 TORUS TEMP 92.0 °F
 TORUS LEVEL 153 INCHES
 TORUS HYDROGEN 0 %
 TORUS OXYGEN 2.1 %
 DW UNIDENT LEAKRATE 0 GPM
 DW IDENT LEAKRATE 0 GPM
 CHRRMS SYS I 21 REM
 CHRRMS SYS II 22 REM

TIME 19:25

BALANCE OF PLANT

VENTILATION

RX BLDG FAN EF 1-5	RX/TURB BLDG FAN EF 1-6	TURB BLDG FAN EF 1-7	TURB BLDG FAN EF 1-1	TURB BLDG FAN EF 1-4	TURB BLDG FAN EF 1-3	SBGT FAN EF 1-8	SBGT FAN EF 1-9
OFF	OFF	ON	ON	ON	ON	ON	OFF

ELECTRIC PLANT

MAIN GEN	EDG #1	EDG #2	BKR 1A	BKR 1B	BKR S1A	BKR S1B	BKR 1C	BKR 1D	BATT A	BATT B	BATT C
0 MWe	0 KW	0 KW	0	0	C	C	C	C	131	132	131

TURBINE/AUXILIARIES

MAIN TURB	BYPASS VALVES	TURNING GEAR	VACUUM COND A	VACUUM COND B	VACUUM COND C
TRIPPED	TRIPPED	ON	0	0	0

COOLING WATER

RBCCW PUMP 1	RBCCW PUMP 2	TBCCW PUMP 1	TBCCW PUMP 2	TBCCW PUMP 3	SERV WTR PUMP 1	SERV WTR PUMP 2
ON	OFF	ON	ON	STDBY	ON	OFF

TIME

19:25

REACTOR PARAMETERS

AVERAGE ALL APRM's
 <2.0%

RECIRC FLOW
 0 50 GPM

SLC STATUS
 SYS 1 - OFF

SLC TANK LEVEL
 655 GAL

REACTOR PRESSURE
 28 PSIG

STEAM FLOW
 0.00 MLM/H

FUEL ZONE LEVEL
 2.5" TAF

YARWAY LEVEL
 <85" TAF

FEEDWATER FLOW
 1.38 MLM/H

CRD FLOW
 60 GPM

CORE SPRAY SYSTEM I
 0 GPM

CORE SPRAY SYSTEM II
 0 GPM

ISOLATION CONDENSER A			
V-14-30	V-14-31	V-14-34	V-14-36
OPEN	OPEN	CLOSE	OPEN

ISOLATION CONDENSER B			
V-14-32	V-14-33	V-14-35	V-14-37
OPEN	OPEN	CLOSE	CLOSE

EMRV A
 OPEN

EMRV B
 OPEN

EMRV C
 OPEN

EMRV D
 OPEN

EMRV E
 OPEN

CONTAINMENT PARAMETERS

DRYWELL TEMP
 94 °F

DRYWELL PRESSURE
 0.78 PSIG

DRYWELL HYDROGEN
 0 %

DRYWELL OXYGEN
 2.1%

CONT SPRAY SYSTEM I
 5965 GPM
 TORUS

CONT SPRAY SYSTEM II
 5978 GPM
 TORUS

TORUS PRESSURE
 1.2 PSIG

TORUS TEMP
 91.8 °F

TORUS LEVEL
 153 INCHES

TORUS HYDROGEN
 0%

TORUS OXYGEN
 2.1%

DW UNIDENT LEAKRATE
 0 GPM

DW IDENT LEAKRATE
 0 GPM

CHRRMS SYS I
 21 REM

CHRRMS SYS II
 22 REM

TIME

19:31

BALANCE OF PLANT

VENTILATION

RX BLDG FAN EF 1-5	RX/TURB BLDG FAN EF 1-6	TURB BLDG FAN EF 1-7	TURB BLDG FAN EF 1-1	TURB BLDG FAN EF 1-4	TURB BLDG FAN EF 1-33	SBGT FAN EF 1-8	SBGT FAN EF 1-9
OFF	OFF	ON	ON	ON	ON	ON	OFF

ELECTRIC PLANT

MAIN GEN	EDG #1	EDG #2	BKR 1A	BKR 1B	BKR S1A	BKR S1B	BKR 1C	BKR 1D	BATT A	BATT B	BATT C
0 MWe	0 KW	0 KW	0	0	C	C	C	C	131	132	131

TURBINE/AUXILLARIES

MAIN TURB	BYPASS VALVES	TURNING GEAR	VACUUM COND A	VACUUM COND B	VACUUM COND C
TRIPPED	TRIPPED	ON	0	0	0

COOLING WATER

RBCCW PUMP 1	RBCCW PUMP 2	TBCCW PUMP 1	TBCCW PUMP 2	TBCCW PUMP 3	SERV WTR PUMP 1	SERV WTR PUMP 2
ON	OFF	ON	ON	STDBY	ON	OFF

TIME 19:31

REACTOR PARAMETERS

AVERAGE ALL
APRM's
<2.0%

RECIRC
FLOW
0.0 E0 GPM

SLC STATUS
SYS 1 - OFF

SLC TANK
LEVEL
655 GAL

REACTOR
PRESSURE
27 PSIG

STEAM FLOW
0.00 MLM/H

FUEL ZONE
LEVEL
18.6" TAF

YARWAY
LEVEL
<85" TAF

FEEDWATER
FLOW
1.38 MLM/H

CRD
FLOW
60 GPM

CORE SPRAY
SYSTEM I
0 GPM

CORE SPRAY
SYSTEM II
0 GPM

ISOLATION CONDENSER A			
V-14-30	V-14-31	V-14-34	V-14-36
OPEN	OPEN	CLOSE	OPEN

ISOLATION CONDENSER B			
V-14-32	V-14-33	V-14-35	V-14-37
OPEN	OPEN	CLOSE	CLOSE

EMRV A
OPEN

EMRV B
OPEN

EMRV C
OPEN

EMRV D
OPEN

EMRV E
OPEN

CONTAINMENT PARAMETERS

DRYWELL
TEMP
94 °F

DRYWELL
PRESSURE
0.78 PSIG

DRYWELL
HYDROGEN
0 %

DRYWELL
OXYGEN
2.1%

CONT SPRAY
SYSTEM I
5965 GPM
TORUS

CONT SPRAY
SYSTEM II
5978 GPM
TORUS

TORUS
PRESSURE
1.2 PSIG

TORUS TEMP
91.6 °F

TORUS
LEVEL
153 INCHES

TORUS
HYDROGEN
0%

TORUS
OXYGEN
2.1%

DW UNIDENT
LEAKRATE
0 GPM

DW IDENT
LEAKRATE
0 GPM

CHRRMS
SYS I
21 REM

CHRRMS
SYS II
22 REM

TIME

19:32

BALANCE OF PLANT

VENTILATION

RX BLDG FAN EF 1-5	RX/TURB BLDG FAN EF 1-6	TURB BLDG FAN EF 1-7	TURB BLDG FAN EF 1-1	TURB BLDG FAN EF 1-4	TURB BLDG FAN EF 1-33	SBGT FAN EF 1-8	SBGT FAN EF 1-9
OFF	OFF	ON	ON	ON	ON	ON	OFF

ELECTRIC PLANT

MAIN GEN	EDG #1	EDG #2	BKR 1A	BKR 1B	BKR S1A	BKR S1B	BKR 1C	BKR 1D	BATT A	BATT B	BATT C
0 MWe	0 KW	0 KW	0	0	C	C	C	C	131	132	131

TURBINE/AUXILIARIES

MAIN TURB	BYPASS VALVES	TURNING GEAR	VACUUM COND A	VACUUM COND B	VACUUM COND C
TRIPPED	TRIPPED	ON	0	0	0

COOLING WATER

RBCCW PUMP 1	RBCCW PUMP 2	TBCCW PUMP 1	TBCCW PUMP 2	TBCCW PUMP 3	SERV WTR PUMP 1	SERV WTR PUMP 2
ON	OFF	ON	ON	STDBY	ON	OFF

TIME

19:32

REACTOR PARAMETERS

AVERAGE ALL
APRM's
<2.0%

RECIRC
FLOW
0.0 E0 GPM

SLC STATUS
SYS 1 - OFF

SLC TANK
LEVEL
655 GAL

REACTOR
PRESSURE
24 PSIG

STEAM FLOW
0.00 MLM/H

FUEL ZONE
LEVEL
40.7" TAF

YARWAY
LEVEL
<85" TAF

FEEDWATER
FLOW
1.38 MLM/H

CRD
FLOW
60 GPM

CORE SPRAY
SYSTEM I
0 GPM

CORE SPRAY
SYSTEM II
0 GPM

ISOLATION CONDENSER A			
V-14-30	V-14-31	V-14-34	V-14-36
OPEN	OPEN	CLOSE	OPEN

ISOLATION CONDENSER B			
V-14-32	V-14-33	V-14-35	V-14-37
OPEN	OPEN	CLOSE	CLOSE

EMRV A
OPEN

EMRV B
OPEN

EMRV C
OPEN

EMRV D
OPEN

EMRV E
OPEN

CONTAINMENT PARAMETERS

DRYWELL
TEMP
94 °F

DRYWELL
PRESSURE
0.78 PSIG

DRYWELL
HYDROGEN
0 %

DRYWELL
OXYGEN
2.1%

CONT SPRAY
SYSTEM I
5965 GPM
TORUS

CONT SPRAY
SYSTEM II
5978 GPM
TORUS

TORUS
PRESSURE
1.2 PSIG

TORUS TEMP
91.5 °F

TORUS
LEVEL
153 INCHES

TORUS
HYDROGEN
0%

TORUS
OXYGEN
2.1%

DW UNIDENT
LEAKRATE
0 GPM

DW IDENT
LEAKRATE
0 GPM

CHRRMS
SYS I
21 REM

CHRRMS
SYS II
22 REM

TIME

19:33

BALANCE OF PLANT

VENTILATION

RX BLDG FAN EF 1-5	RX/TURB BLDG FAN EF 1-6	TURB BLDG FAN EF 1-7	TURB BLDG FAN EF 1-1	TURB BLDG FAN EF 1-4	TURB BLDG FAN EF 1-33	SBGT FAN EF 1-5	SBGT FAN EF 1-9
OFF	OFF	ON	ON	ON	ON	ON	OFF

ELECTRIC PLANT

MAIN GEN	EDG #1	EDG #2	BKR 1A	BKR 1B	BKR S1A	BKR S1B	BKR 1C	BKR 1D	BATT A	BATT B	BATT C
0 MWe	0 KW	0 KW	0	0	C	C	C	C	131	132	131

TURBINE/AUXILIARIES

MAIN TURB	BYPASS VALVES	TURNING GEAR	VACUUM COND A	VACUUM COND B	VACUUM COND C
TRIPPED	TRIPPED	ON	0	0	0

COOLING WATER

RBCCW PUMP 1	RBCCW PUMP 2	TBCCW PUMP 1	TBCCW PUMP 2	TBCCW PUMP 3	SERV WTR PUMP 1	SERV WTR PUMP 2
ON	OFF	ON	ON	STDBY	ON	OFF

TIME

19:33

REACTOR PARAMETERS

AVERAGE ALL APRM's
 <2.0%

RECIRC FLOW
 4.5 E4 GPM

SLC STATUS
 SYS 1 - OFF

SLC TANK LEVEL
 655 GAL

REACTOR PRESSURE
 75 PSIG

STEAM FLOW
 0.02 MLM/H

FUEL ZONE LEVEL
 65.0" TAF

YARWAY LEVEL
 93.7AF

FEEDWATER FLOW
 0.22 MLM/H

CRD FLOW
 60 GPM

CORE SPRAY SYSTEM I
 0 GPM

CORE SPRAY SYSTEM II
 0 GPM

ISOLATION CONDENSER A			
V-14-30	V-14-31	V-14-34	V-14-36
OPEN	OPEN	CLOSE	OPEN

ISOLATION CONDENSER B			
V-14-32	V-14-33	V-14-35	V-14-37
OPEN	OPEN	CLOSE	CLOSE

EMRV A
 OPEN

EMRV B
 OPEN

EMRV C
 OPEN

EMRV D
 OPEN

EMRV E
 OPEN

CONTAINMENT PARAMETERS

DRYWELL TEMP
 94 °F

DRYWELL PRESSURE
 0.84 PSIG

DRYWELL HYDROGEN
 0 %

DRYWELL OXYGEN
 2.1%

CONT SPRAY SYSTEM I
 5965 GPM
 TORUS

CONT SPRAY SYSTEM II
 5978 GPM
 TORUS

TORUS PRESSURE
 1.3 PSIG

TORUS TEMP
 91.4 °F

TORUS LEVEL
 153 INCHES

TORUS HYDROGEN
 0%

TORUS OXYGEN
 2.1%

DW UNIDENT LEAKRATE
 0 GPM

DW IDENT LEAKRATE
 0 GPM

CHRRMS SYS I
 21 REM

CHRRMS SYS II
 22 REM

TIME

19:34

BALANCE OF PLANT

VENTILATION

RX BLDG FAN EF 1-5	RX/TURB BLDG FAN EF 1-8	TURB BLDG FAN EF 1-7	TURB BLDG FAN EF 1-1	TURB BLDG FAN EF 1-4	TURB BLDG FAN EF 1-33	SBGT FAN EF 1-8	SBGT FAN EF 1-9
OFF	OFF	ON	ON	ON	ON	ON	OFF

ELECTRIC PLANT

MAIN GEN	EDG #1	EDG #2	BKR 1A	BKR 1B	BKR S1A	BKR S1B	BKR 1C	BKR 1D	BATT A	BATT B	BATT C
0 MWe	0 KW	0 KW	0	0	C	C	C	C	131	132	131

TURBINE/AUXILIARIES

MAIN TURB	BYPASS VALVES	TURNING GEAR	VACUUM COND A	VACUUM COND B	VACUUM COND C
TRIPPED	TRIPPED	ON	0	0	0

COOLING WATER

RBCCW PUMP 1	RBCCW PUMP 2	TBCCW PUMP 1	TBCCW PUMP 2	TECCW PUMP 3	SERV WTR PUMP 1	SERV WTR PUMP 2
ON	OFF	ON	ON	STDBY	ON	OFF

TIME

19:34

REACTOR PARAMETERS

AVERAGE ALL APRM's
 <2.0%

RECIRC FLOW
 7.2 E4 GPM

SLC STATUS
 SYS 1 - OFF

SLC TANK LEVEL
 655 GAL

REACTOR PRESSURE
 58 PSIG

STEAM FLOW
 0.02 MLM/H

FUEL ZONE LEVEL
 50.3" TAF

YARWAY LEVEL
 139.7" TAF

FEEDWATER FLOW
 0.20 MLM/H

CRD FLOW
 60 GPM

CORE SPRAY SYSTEM I
 0 GPM

CORE SPRAY SYSTEM II
 0 GPM

ISOLATION CONDENSER A			
V-14-30	V-14-31	V-14-34	V-14-36
OPEN	OPEN	CLOSE	OPEN

ISOLATION CONDENSER B			
V-14-32	V-14-33	V-14-35	V-14-37
OPEN	OPEN	CLOSE	CLOSE

EMRV A
 OPEN

EMRV B
 OPEN

EMRV C
 OPEN

EMRV D
 OPEN

EMRV E
 OPEN

CONTAINMENT PARAMETERS

DRYWELL TEMP
 94 °F

DRYWELL PRESSURE
 0.85 PSIG

DRYWELL HYDROGEN
 0 %

DRYWELL OXYGEN
 2.1%

CONT SPRAY SYSTEM I
 5965 GPM
 TORUS

CONT SPRAY SYSTEM II
 5978 GPM
 TORUS

TORUS PRESSURE
 1.4 PSIG

TORUS TEMP
 91.3 °F

TORUS LEVEL
 153 INCHES

TORUS HYDROGEN
 0%

TORUS OXYGEN
 2.1%

DW UNIDENT LEAKRATE
 0 GPM

DW IDENT LEAKRATE
 0 GPM

CHRRMS SYS I
 21 REM

CHRRMS SYS II
 22 REM

TIME

19:35

BALANCE OF PLANT

VENTILATION

RX BLDG FAN EF 1-5	RX/TURB BLDG FAN EF 1-6	TURB BLDG FAN EF 1-7	TURB BLDG FAN EF 1-1	TURB BLDG FAN EF 1-4	TURB BLDG FAN EF 1-33	SBGT FAN EF 1-8	SBGT FAN EF 1-9
OFF	OFF	ON	ON	ON	ON	ON	OFF

ELECTRIC PLANT

MAIN GEN	EDG #1	EDG #2	BKR 1A	BKR 1B	BKR S1A	BKR S1B	BKR 1C	BKR 1D	BATT A	BATT B	BATT C
0 MWe	0 KW	0 KW	0	0	C	C	C	C	131	132	131

TURBINE/AUXILIARIES

MAIN TURB	BYPASS VALVES	TURNING GEAR	VACUUM COND A	VACUUM COND B	VACUUM COND C
TRIPPED	TRIPPED	ON	0	0	0

COOLING WATER

RBCCW PUMP 1	RBCCW PUMP 2	TBCCW PUMP 1	TBCCW PUMP 2	TBCCW PUMP 3	SERV WTR PUMP 1	SERV WTR PUMP 2
ON	OFF	ON	ON	STDBY	ON	OFF

TIME

19:35

REACTOR PARAMETERS

AVERAGE ALL APRM's
 <2.0%

RECIRC FLOW
 7.0 E4 GPM

SLC STATUS
 SYS 1 - OFF

SLC TANK LEVEL
 655 GAL

REACTOR PRESSURE
 51 PSIG

STEAM FLOW
 0.06 MLM/H

FUEL ZONE LEVEL
 45.0" TAF

YARWAY LEVEL
 139.8" TAF

FEEDWATER FLOW
 0.03 MLM/H

CRD FLOW
 60 GPM

CORE SPRAY SYSTEM I
 0 GPM

CORE SPRAY SYSTEM II
 0 GPM

ISOLATION CONDENSER A			
V-14-30	V-14-31	V-14-34	V-14-36
OPEN	OPEN	CLOSE	OPEN

ISOLATION CONDENSER B			
V-14-32	V-14-33	V-14-35	V-14-37
OPEN	OPEN	CLOSE	CLOSE

EMRV A
 OPEN

EMRV B
 OPEN

EMRV C
 OPEN

EMRV D
 OPEN

EMRV E
 OPEN

CONTAINMENT PARAMETERS

DRYWELL TEMP
 93 °F

DRYWELL PRESSURE
 0.86 PSIG

DRYWELL HYDROGEN
 0 %

DRYWELL OXYGEN
 2.1%

CONT SPRAY SYSTEM I
 5965 GPM
 TORUS

CONT SPRAY SYSTEM II
 5978 GPM
 TORUS

TORUS PRESSURE
 1.4 PSIG

TORUS TEMP
 91.2 °F

TORUS LEVEL
 153 INCHES

TORUS HYDROGEN
 0%

TORUS OXYGEN
 2.1%

DW UNIDENT LEAKRATE
 0 GPM

DW IDENT LEAKRATE
 0 GPM

CHRRMS SYS I
 21 REM

CHRRMS SYS II
 22 REM

TIME

19:36

BALANCE OF PLANT

VENTILATION

RX BLDG FAN EF 1-5	RX/TURB BLDG FAN EF 1-6	TURB BLDG FAN EF 1-7	TURB BLDG FAN EF 1-1	TURB BLDG FAN EF 1-4	TURB BLDG FAN EF 1-33	SBGT FAN EF 1-8	SBGT FAN EF 1-9
OFF	OFF	ON	ON	ON	ON	ON	OFF

ELECTRIC PLANT

MAIN GEN	EDG #1	EDG #2	BKR 1A	BKR 1B	BKR S1A	BKR S1B	BKR 1C	BKR 1D	BATT A	BATT B	BATT C
0 MWe	0 KW	0 KW	0	0	C	C	C	C	131	132	131

TURBINE/AUXILIARIES

MAIN TURB	BYPASS VALVES	TURNING GEAR	VACUUM COND A	VACUUM COND B	VACUUM COND C
TRIPPED	TRIPPED	ON	0	0	0

COOLING WATER

RBCCW PUMP 1	RBCCW PUMP 2	TBCCW PUMP 1	TBCCW PUMP 2	TBCCW PUMP 3	SERV WTR PUMP 1	SERV WTR PUMP 2
ON	OFF	ON	ON	STDBY	ON	OFF

TIME

19:36

REACTOR PARAMETERS

AVERAGE ALL APRM's
 <2.0%

RECIRC FLOW
 5.7 E4 GPM

SLC STATUS
 SYS 1 - OFF

SLC TANK LEVEL
 655 GAL

REACTOR PRESSURE
 47 PSIG

STEAM FLOW
 0.02 MLM/H

FUEL ZONE LEVEL
 61.3" TAF

YARWAY LEVEL
 113.3" TAF

FEEDWATER FLOW
 0.03 MLM/H

CRD FLOW
 60 GPM

CORE SPRAY SYSTEM I
 0 GPM

CORE SPRAY SYSTEM II
 0 GPM

ISOLATION CONDENSER A			
V-14-30	V-14-31	V-14-34	V-14-36
OPEN	OPEN	CLOSE	OPEN

ISOLATION CONDENSER B			
V-14-32	V-14-33	V-14-35	V-14-37
OPEN	OPEN	CLOSE	CLOSE

EMRV A
 OPEN

EMRV B
 OPEN

EMRV C
 OPEN

EMRV D
 OPEN

EMRV E
 OPEN

CONTAINMENT PARAMETERS

DRYWELL TEMP
 93 °F

DRYWELL PRESSURE
 0.86 PSIG

DRYWELL HYDROGEN
 0 %

DRYWELL OXYGEN
 2.1%

CONT SPRAY SYSTEM I
 5965 GPM
 TORUS

CONT SPRAY SYSTEM II
 5978 GPM
 TORUS

TORUS PRESSURE
 1.4 PSIG

TORUS TEMP
 91.1 °F

TORUS LEVEL
 153 INCHES

TORUS HYDROGEN
 0%

TORUS OXYGEN
 2.1%

DW UNIDENT LEAKRATE
 0 GPM

DW IDENT LEAKRATE
 0 GPM

CHRRMS SYS I
 21 REM

CHRRMS SYS II
 22 REM

TIME 19:37

BALANCE OF PLANT

VENTILATION

RX BLDG FAN EF 1-5	RX/TURB BLDG FAN EF 1-6	TURB BLDG FAN EF 1-7	TURB BLDG FAN EF 1-1	TURB BLDG FAN EF 1-4	TURB BLDG FAN EF 1-33	SBGT FAN EF 1-8	SBGT FAN EF 1-9
OFF	OFF	ON	ON	ON	ON	ON	OFF

ELECTRIC PLANT

MAIN GEN	EDG #1	EDG #2	BKR 1A	BKR 1B	BKR S1A	BKR S1B	BKR 1C	BKR 1D	BATT A	BATT B	BATT C
0 MWe	0 KW	0 KW	0	0	C	C	C	C	131	132	131

TURBINE/AUXILIARIES

MAIN TURB	BYPASS VALVES	TURNING GEAR	VACUUM COND A	VACUUM COND B	VACUUM COND C
TRIPPED	TRIPPED	ON	0	0	0

COOLING WATER

RBCCW PUMP 1	RBCCW PUMP 2	TBCCW PUMP 1	TBCCW PUMP 2	TBCCW PUMP 3	SERV WTR PUMP 1	SERV WTR PUMP 2
ON	OFF	ON	ON	STDBY	ON	OFF

TIME

19:37

REACTOR PARAMETERS

AVERAGE ALL
APRM's
<2.0%

RECIRC
FLOW
4.8 E4 GPM

SLC STATUS
SYS 1 - OFF

SLC TANK
LEVEL
655 GAL

REACTOR
PRESSURE
45 PSIG

STEAM FLOW
0.00 MLM/H

FUEL ZONE
LEVEL
64.8" TAF

YARWAY
LEVEL
97.4" TAF

FEEDWATER
FLOW
0.03 MLM/H

CRD
FLOW
60 GPM

CORE SPRAY
SYSTEM I
0 GPM

CORE SPRAY
SYSTEM II
0 GPM

ISOLATION CONDENSER A			
V-14-30	V-14-31	V-14-34	V-14-36
OPEN	OPEN	CLOSE	OPEN

ISOLATION CONDENSER B			
V-14-32	V-14-33	V-14-35	V-14-37
OPEN	OPEN	CLOSE	CLOSE

EMRV A
OPEN

EMRV B
OPEN

EMRV C
OPEN

EMRV D
OPEN

EMRV E
OPEN

CONTAINMENT PARAMETERS

DRYWELL
TEMP
93 °F

DRYWELL
PRESSURE
0.86 PSIG

DRYWELL
HYDROGEN
0 %

DRYWELL
OXYGEN
2.1%

CONT SPRAY
SYSTEM I
5965 GPM
TORUS

CONT SPRAY
SYSTEM II
5978 GPM
TORUS

TORUS
PRESSURE
1.4 PSIG

TORUS TEMP
91.0 °F

TORUS
LEVEL
153 INCHES

TORUS
HYDROGEN
0%

TORUS
OXYGEN
2.1%

DW UNIDENT
LEAKRATE
0 GPM

DW IDENT
LEAKRATE
0 GPM

CHRRMS
SYS I
21 REM

CHRRMS
SYS II
22 REM

TIME

19:38

BALANCE OF PLANT

VENTILATION

RX BLDG FAN EF 1-5	RX/TURB BLDG FAN EF 1-6	TURB BLDG FAN EF 1-7	TURB BLDG FAN EF 1-1	TURB BLDG FAN EF 1-4	TURB BLDG FAN EF 1-33	SBGT FAN EF 1-8	SBGT FAN EF 1-9
OFF	OFF	ON	ON	ON	ON	ON	OFF

ELECTRIC PLANT

MAIN GEN	EDG #1	EDG #2	BKR 1A	BKR 1B	BKR S1A	BKR S1B	BKR 1C	BKR 1D	BATT A	BATT B	BATT C
0 MWe	0 KW	0 KW	0	0	C	C	C	C	131	132	131

TURBINE/AUXILIARIES

MAIN TURB	BYPASS VALVES	TURNING GEAR	VACUUM COND A	VACUUM COND B	VACUUM COND C
TRIPPED	TRIPPED	ON	0	0	0

COOLING WATER

RBCCW PUMP 1	RBCCW PUMP 2	TBCCW PUMP 1	TBCCW PUMP 2	TBCCW PUMP 3	SERV WTR PUMP 1	SERV WTR PUMP 2
ON	OFF	ON	ON	STDBY	ON	OFF

TIME

19:38

REACTOR PARAMETERS

AVERAGE ALL APRM's
 <2.0%

RECIRC FLOW
 4.8 E4 GPM

SLC STATUS
 SYS 1 - OFF

SLC TANK LEVEL
 655 GAL

REACTOR PRESSURE
 42 PSIG

STEAM FLOW
 0.00 MLM/H

FUEL ZONE LEVEL
 64.1" TAF

YARWAY LEVEL
 96.1" TAF

FEEDWATER FLOW
 0.03 MLM/H

CRD FLOW
 60 GPM

CORE SPRAY SYSTEM I
 0 GPM

CORE SPRAY SYSTEM II
 0 GPM

ISOLATION CONDENSER A			
V-14-3C	V-14-31	V-14-34	V-14-36
OPEN	OPEN	CLOSE	OPEN

ISOLATION CONDENSER B			
V-14-32	V-14-33	V-14-35	V-14-37
OPEN	OPEN	CLOSE	CLOSE

EMRV A
 OPEN

EMRV B
 OPEN

EMRV C
 OPEN

EMRV D
 OPEN

EMRV E
 OPEN

CONTAINMENT PARAMETERS

DRYWELL TEMP
 93 °F

DRYWELL PRESSURE
 0.86 PSIG

DRYWELL HYDROGEN
 0 %

DRYWELL OXYGEN
 2.1%

CONT SPRAY SYSTEM I
 5965 GPM
 TORUS

CONT SPRAY SYSTEM II
 5978 GPM
 TORUS

TORUS PRESSURE
 1.4 PSIG

TORUS TEMP
 90.9 °F

TORUS LEVEL
 153 INCHES

TORUS HYDROGEN
 0%

TORUS OXYGEN
 2.1%

DW UNIDENT LEAKRATE
 0 GPM

DW IDENT LEAKRATE
 0 GPM

CHRRMS SYS I
 21 REM

CHRRMS SYS II
 22 REM

TIME

19:39

BALANCE OF PLANT

VENTILATION

RX BLDG FAN EF 1-5	RX/TURB BLDG FAN EF 1-6	TURB BLDG FAN EF 1-7	TURB BLDG FAN EF 1-1	TURB BLDG FAN EF 1-4	TURB BLDG FAN EF 1-33	SBGT FAN EF 1-8	SBGT FAN EF 1-9
OFF	OFF	ON	ON	ON	ON	ON	OFF

ELECTRIC PLANT

MAIN GEN	EDG #1	EDG #2	BKR 1A	BKR 1B	BKR S1A	BKR S1B	BKR 1C	BKR 1D	BATT A	BATT B	BATT C
0 MWe	0 KW	0 KW	O	O	C	C	C	C	131	132	131

TURBINE/AUXILIARIES

MAIN TURB	BYPASS VALVES	TURNING GEAR	VACUUM COND A	VACUUM COND B	VACUUM COND C
TRIPPED	TRIPPED	ON	0	0	0

COOLING WATER

RBCCW PUMP 1	RBCCW PUMP 2	TBCCW PUMP 1	TBCCW PUMP 2	TBCCW PUMP 3	SERV WTR PUMP 1	SERV WTR PUMP 2
ON	OFF	ON	ON	STDBY	ON	OFF

TIME 19:39

REACTOR PARAMETERS

AVERAGE ALL
APRM's
<2.0%

RECIRC
FLOW
2.2 E4 GPM

SLC STATUS
SYS 1 - OFF

SLC TANK
LEVEL
655 GAL

REACTOR
PRESSURE
35 PSIG

STEAM FLOW
0.00 MLM/H

FUEL ZONE
LEVEL
78.6" TAF

YARWAY
LEVEL
110.7" TAF

FEEDWATER
FLOW
3.02 MLM/H

CRD
FLOW
60 GPM

CORE SPRAY
SYSTEM I
0 GPM

CORE SPRAY
SYSTEM II
0 GPM

ISOLATION CONDENSER - A			
V-14-30	V-14-31	V-14-34	V-14-36
OPEN	OPEN	CLOSE	OPEN

ISOLATION CONDENSER - B			
V-14-32	V-14-33	V-14-35	V-14-37
CLOSE	CLOSE	CLOSE	CLOSE

EMRV A
OPEN

EMRV B
OPEN

EMRV C
OPEN

EMRV D
OPEN

EMRV E
OPEN

CONTAINMENT PARAMETERS

DRYWELL
TEMP
93 °F

DRYWELL
PRESSURE
0.87 PSIG

DRYWELL
HYDROGEN
0 %

DRYWELL
OXYGEN
2.1%

CONT SPRAY
SYSTEM I
5965 GPM
TORUS

CONT SPRAY
SYSTEM II
5978 GPM
TORUS

TORUS
PRESSURE
1.4 PSIG

TORUS TEMP
90.9 °F

TORUS
LEVEL
153 INCHES

TORUS
HYDROGEN
0%

TORUS
OXYGEN
2.1%

DW UNIDENT
LEAKRATE
0 GPM

DW IDENT
LEAKRATE
0 GPM

CHRRMS
SYS I
21 REM

CHRRMS
SYS II
22 REM

TIME

19:40

BALANCE OF PLANT

VENTILATION

RX BLDG FAN EF 1-5	RX/TURB BLDG FAN EF 1-6	TURB BLDG FAN EF 1-7	TURB BLDG FAN EF 1-1	TURB BLDG FAN EF 1-4	TURB BLDG FAN EF 1-33	SBGT FAN EF 1-8	SBGT FAN EF 1-9
OFF	OFF	ON	ON	ON	ON	ON	OFF

ELECTRIC PLANT

MAIN GEN	EDG #1	EDG #2	BKR 1A	BKR 1B	BKR S1A	BKR S1B	BKR 1C	BKR 1D	BATT A	BATT B	BATT C
0 MWe	0 KW	0 KW	0	0	C	C	C	C	131	132	131

TURBINE/AUXILIARIES

MAIN TURB	BYPASS VALVES	TURNING GEAR	VACUUM COND A	VACUUM COND B	VACUUM COND C
TRIPPED	TRIPPED	ON	0	0	0

COOLING WATER

RBCCW PUMP 1	RBCCW PUMP 2	TBCCW PUMP 1	TBCCW PUMP 2	TBCCW PUMP 3	SERV WTR PUMP 1	SERV WTR PUMP 2
ON	OFF	ON	ON	STDBY	ON	OFF

TIME

19:40

REACTOR PARAMETERS

AVERAGE ALL
APRM's
<2.0%

RECIRC
FLOW
0.0 E0 GPM

SLC STATUS
SYS 1 - OFF

SLC TANK
LEVEL
655 GAL

REACTOR
PRESSURE
28 PSIG

STEAM FLOW
0.00 MLM/H

FUEL ZONE
LEVEL
142.5" TAF

YARWAY
LEVEL
151.2" TAF

FEEDWATER
FLOW
3.03 MLM/H

CRD
FLOW
60 GPM

CORE SPRAY
SYSTEM I
0 GPM

CORE SPRAY
SYSTEM II
0 GPM

ISOLATION CONDENSER A			
V-14-30	V-14-31	V-14-34	V-14-36
OPEN	OPEN	CLOSE	OPEN

ISOLATION CONDENSER B			
V-14-32	V-14-33	V-14-35	V-14-37
CLOSE	CLOSE	CLOSE	CLOSE

EMRV A
OPEN

EMRV B
OPEN

EMRV C
OPEN

EMRV D
OPEN

EMRV E
OPEN

CONTAINMENT PARAMETERS

DRYWELL
TEMP
92 °F

DRYWELL
PRESSURE
0.87 PSIG

DRYWELL
HYDROGEN
0 %

DRYWELL
OXYGEN
2.1%

CONT SPRAY
SYSTEM I
5965 GPM
TORUS

CONT SPRAY
SYSTEM II
5978 GPM
TORUS

TORUS
PRESSURE
1.4 PSIG

TORUS TEMP
90.8 °F

TORUS
LEVEL
153 INCHES

TORUS
HYDROGEN
0%

TORUS
OXYGEN
2.1%

DW UNIDENT
LEAKRATE
0 GPM

DW IDENT
LEAKRATE
0 GPM

CHRRMS
SYS I
21 REM

CHRRMS
SYS II
22 REM

TIME

19:41

BALANCE OF PLANT

VENTILATION

RX BLDG FAN EF 1-5	RX/TURB BLDG FAN EF 1-6	TURB BLDG FAN EF 1-7	TURB BLDG FAN EF 1-1	TURB BLDG FAN EF 1-4	TURB BLDG FAN EF 1-33	SBGT FAN EF 1-8	SBGT FAN EF 1-9
OFF	OFF	ON	ON	ON	ON	ON	OFF

ELECTRIC PLANT

MAIN GEN	EDG #1	EDG #2	BKR 1A	BKR 1B	BKR S1A	BKR S1B	BKR 1C	BKR 1D	BATT A	BATT B	BATT C
0 MWe	0 KW	0 KW	0	0	C	C	C	C	131	132	131

TURBINE/AUXILIARIES

MAIN TURB	BYPASS VALVES	TURNING GEAR	VACUUM COND A	VACUUM COND B	VACUUM COND C
TRIPPED	TRIPPED	ON	0	0	0

COOLING WATER

RBCCW PUMP 1	RBCCW PUMP 2	TBCCW PUMP 1	TBCCW PUMP 2	TBCCW PUMP 3	SERV WTR PUMP 1	SERV WTR PUMP 2
ON	OFF	ON	ON	STDBY	ON	OFF

TIME

19:41

REACTOR PARAMETERS

AVERAGE ALL APRM's
 <2.0%

RECIRC FLOW
 0.0 E0 GPM

SLC STATUS
 SYS 1 - OFF

SLC TANK LEVEL
 655 GAL

REACTOR PRESSURE
 26 PSIG

STEAM FLOW
 0.00 MLM/H

FUEL ZONE LEVEL
 156.7" TAF

YARWAY LEVEL
 139.7" TAF

FEEDWATER FLOW
 0.29 MLM/H

CRD FLOW
 60 GPM

CORE SPRAY SYSTEM I
 0 GPM

CORE SPRAY SYSTEM II
 0 GPM

ISOLATION CONDENSER A			
V-14-30	V-14-31	V-14-34	V-14-36
OPEN	OPEN	CLOSE	OPEN

ISOLATION CONDENSER B			
V-14-32	V-14-33	V-14-35	V-14-37
CLOSE	CLOSE	CLOSE	CLOSE

EMRV A
 OPEN

EMRV B
 OPEN

EMRV C
 OPEN

EMRV D
 OPEN

EMRV E
 OPEN

CONTAINMENT PARAMETERS

DRYWELL TEMP
 92 °F

DRYWELL PRESSURE
 0.87 PSIG

DRYWELL HYDROGEN
 0 %

DRYWELL OXYGEN
 2.1%

CONT SPRAY SYSTEM I
 5965 GPM
 TORUS

CONT SPRAY SYSTEM II
 5978 GPM
 TORUS

TORUS PRESSURE
 1.4 PSIG

TORUS TEMP
 90.8 °F

TORUS LEVEL
 153 INCHES

TORUS HYDROGEN
 0%

TORUS OXYGEN
 2.1%

DW UNIDENT LEAKRATE
 0 GPM

DW IDENT LEAKRATE
 0 GPM

CHRRMS SYS I
 21 REM

CHRRMS SYS II
 22 REM

TIME

19:42

BALANCE OF PLANT

VENTILATION

RX BLDG FAN EF 1-5	RX/TURB BLDG FAN EF 1-6	TURB BLDG FAN EF 1-7	TURB BLDG FAN EF 1-1	TURB BLDG FAN EF 1-4	TURB BLDG FAN EF 1-33	SBGT FAN EF 1-8	SBGT FAN EF 1-9
OFF	OFF	ON	ON	ON	ON	ON	OFF

ELECTRIC PLANT

MAIN GEN	EDG #1	EDG #2	BKR 1A	BKR 1B	BKR S1A	BKR S1B	BKR 1C	BKR 1D	BATT A	BATT B	BATT C
0 MWe	0 KW	0 KW	0	0	C	C	C	C	131	132	131

TURBINE/AUXILIARIES

MAIN TURB	BYPASS VALVES	TURNING GEAR	VACUUM COND A	VACUUM COND B	VACUUM COND C
TRIPPED	TRIPPED	ON	0	0	0

COOLING WATER

RBCCW PUMP 1	RBCCW PUMP 2	TBCCW PUMP 1	TBCCW PUMP 2	TBCCW PUMP 3	SERV WTR PUMP 1	SERV WTR PUMP 2
ON	OFF	ON	ON	STDBY	ON	OFF

TIME

19:42

REACTOR PARAMETERS

AVERAGE ALL
APRM's
<2.0%

RECIRC
FLOW
0.0 E0 GPM

SLC STATUS
SYS 1 - OFF

SLC TANK
LEVEL
655 GAL

REACTOR
PRESSURE
27 PSIG

STEAM FLOW
0.00 MLM/H

FUEL ZONE
LEVEL
177.3" TAF

YARWAY
LEVEL
147.9" TAF

FEEDWATER
FLOW
0.31 MLM/H

CRD
FLOW
60 GPM

CORE SPRAY
SYSTEM I
0 GPM

CORE SPRAY
SYSTEM II
0 GPM

ISOLATION CONDENSER A			
V-14-30	V-14-31	V-14-34	V-14-36
OPEN	OPEN	CLOSE	OPEN

ISOLATION CONDENSER B			
V-14-32	V-14-33	V-14-35	V-14-37
CLOSE	CLOSE	CLOSE	CLOSE

EMRV A
OPEN

EMRV B
OPEN

EMRV C
OPEN

EMRV D
OPEN

EMRV E
OPEN

CONTAINMENT PARAMETERS

DRYWELL
TEMP
92 °F

DRYWELL
PRESSURE
0.87 PSIG

DRYWELL
HYDROGEN
0 %

DRYWELL
OXYGEN
2.1%

CONT SPRAY
SYSTEM I
5965 GPM
TORUS

CONT SPRAY
SYSTEM II
5978 GPM
TORUS

TORUS
PRESSURE
1.4 PSIG

TORUS TEMP
90.7 °F

TORUS
LEVEL
153 INCHES

TORUS
HYDROGEN
0%

TORUS
OXYGEN
2.1%

DW UNIDENT
LEAKRATE
0 GPM

DW IDENT
LEAKRATE
0 GPM

CHRRMS
SYS I
21 REM

CHRRMS
SYS II
22 REM

TIME

19:43

BALANCE OF PLANT

VENTILATION

RX BLDG FAN EF 1-5	RX/TURB BLDG FAN EF 1-6	TURB BLDG FAN EF 1-7	TURB BLDG FAN EF 1-1	TURB BLDG FAN EF 1-4	TURB BLDG FAN EF 1-33	SBGT FAN EF 1-8	SBGT FAN EF 1-9
OFF	OFF	ON	ON	ON	ON	ON	OFF

ELECTRIC PLANT

MAIN GEN	EDG #1	EDG #2	BKR 1A	BKR 1B	BKR S1A	BKR S1B	BKR 1C	BKR 1D	BATT A	BATT B	BATT C
0 MWe	0 KW	0 KW	0	0	C	C	C	C	131	132	131

TURBINE/AUXILIARIES

MAIN TURB	BYPASS VALVES	TURNING GEAR	VACUUM COND A	VACUUM COND B	VACUUM COND C
TRIPPED	TRIPPED	ON	0	0	0

COOLING WATER

RBCCW PUMP 1	RBCCW PUMP 2	TBCCW PUMP 1	TBCCW PUMP 2	TBCCW PUMP 3	SERV WTR PUMP 1	SERV WTR PUMP 2
ON	OFF	ON	ON	STDBY	ON	OFF

TIME

19:43

REACTOR PARAMETERS

AVERAGE ALL
APRM's
<2.0%

RECIRC
FLOW
0.0 E0 GPM

SLC STATUS
SYS 1 - OFF

SLC TANK
LEVEL
655 GAL

REACTOR
PRESSURE
27 PSIG

STEAM FLOW
0.00 MLM/H

FUEL ZONE
LEVEL
178.7" TAF

YARWAY
LEVEL
152.7" TAF

FEEDWATER
FLOW
0.30 MLM/H

CRD
FLOW
60 GPM

CORE SPRAY
SYSTEM I
0 GPM

CORE SPRAY
SYSTEM II
0 GPM

ISOLATION CONDENSER A			
V-14-30	V-14-31	V-14-34	V-14-36
OPEN	OPEN	CLOSE	OPEN

ISOLATION CONDENSER B			
V-14-32	V-14-33	V-14-35	V-14-37
CLOSE	CLOSE	CLOSE	CLOSE

EMRV A
OPEN

EMRV B
OPEN

EMRV C
OPEN

EMRV D
OPEN

EMRV E
OPEN

CONTAINMENT PARAMETERS

DRYWELL
TEMP
91 °F

DRYWELL
PRESSURE
0.87 PSIG

DRYWELL
HYDROGEN
0 %

DRYWELL
OXYGEN
2.1%

CONT SPRAY
SYSTEM I
5965 GPM
TORUS

CONT SPRAY
SYSTEM II
5978 GPM
TORUS

TORUS
PRESSURE
1.4 PSIG

TORUS TEMP
90.6 °F

TORUS
LEVEL
153 INCHES

TORUS
HYDROGEN
0%

TORUS
OXYGEN
2.1%

DW UNIDENT
LEAKRATE
0 GPM

DW IDENT
LEAKRATE
0 GPM

CHRRMS
SYS I
21 REM

CHRRMS
SYS II
22 REM

TIME

19:44

BALANCE OF PLANT

VENTILATION

RX BLDG FAN EF 1-5	RX/TURB BLDG FAN EF 1-8	TURB BLDG FAN EF 1-7	TURB BLDG FAN EF 1-1	TURB BLDG FAN EF 1-4	TURB BLDG FAN EF 1-33	SBGT FAN EF 1-8	SBGT FAN EF 1-9
OFF	OFF	ON	ON	ON	ON	ON	OFF

ELECTRIC PLANT

MAIN GEN	EDG #1	EDG #2	BKR 1A	BKR 1B	BKR S1A	BKR S1B	BKR 1C	BKR 1D	BATT A	BATT B	BATT C
0 MWe	0 KW	0 KW	0	0	C	C	C	C	131	132	131

TURBINE/AUXILIARIES

MAIN TURB	BYPASS VALVES	TURNING GEAR	VACUUM COND A	VACUUM COND B	VACUUM COND C
TRIPPED	TRIPPED	ON	0	0	0

COOLING WATER

RBCCW PUMP 1	RBCCW PUMP 2	TBCCW PUMP 1	TBCCW PUMP 2	TBCCW PUMP 3	SERV WTR PUMP 1	SERV WTR PUMP 2
ON	OFF	ON	ON	STDBY	ON	OFF

TIME

19:44

REACTOR PARAMETERS

AVERAGE ALL
APRM's
<2.0%

RECIRC
FLOW
0.0 E0 GPM

SLC STATUS
SYS 1 - OFF

SLC TANK
LEVEL
655 GAL

REACTOR
PRESSURE
27 PSIG

STEAM FLOW
0.00 MLM/H

FUEL ZONE
LEVEL
169.0" TAF

YARWAY
LEVEL
160.4" TAF

FEEDWATER
FLOW
0.30 MLM/H

CRD
FLOW
60 GPM

CORE SPRAY
SYSTEM I
0 GPM

CORE SPRAY
SYSTEM II
0 GPM

ISOLATION CONDENSER A			
V-14-30	V-14-31	V-14-34	V-14-36
OPEN	OPEN	CLOSE	OPEN

ISOLATION CONDENSER B			
V-14-32	V-14-33	V-14-35	V-14-37
CLOSE	CLOSE	CLOSE	CLOSE

EMRV A
OPEN

EMRV B
OPEN

EMRV C
OPEN

EMRV D
OPEN

EMRV E
OPEN

CONTAINMENT PARAMETERS

DRYWELL
TEMP
91 °F

DRYWELL
PRESSURE
0.87 PSIG

DRYWELL
HYDROGEN
0 %

DRYWELL
OXYGEN
2.1%

CONT SPRAY
SYSTEM I
5965 GPM
TORUS

CONT SPRAY
SYSTEM II
5978 GPM
TORUS

TORUS
PRESSURE
1.4 PSIG

TORUS TEMP
90.6 °F

TORUS
LEVEL
153 INCHES

TORUS
HYDROGEN
0%

TORUS
OXYGEN
2.1%

DW UNIDENT
LEAKRATE
0 GPM

DW IDENT
LEAKRATE
0 GPM

CHRRMS
SYS I
21 REM

CHRRMS
SYS II
22 REM

TIME

19:45

BALANCE OF PLANT

VENTILATION

RX BLDG FAN EF 1-5	RX/TURB BLDG FAN EF 1-6	TURB BLDG FAN EF 1-7	TURB BLDG FAN EF 1-1	TURB BLDG FAN EF 1-4	TURB BLDG FAN EF 1-33	SBGT FAN EF 1-8	SBGT FAN EF 1-9
OFF	OFF	ON	ON	ON	ON	ON	OFF

ELECTRIC PLANT

MAIN GEN	EDG #1	EDG #2	BKR 1A	BKR 1B	BKR S1A	BKR S1B	BKR 1C	BKR 1D	BATT A	BATT B	BATT C
0 MWe	0 KW	0 KW	0	0	C	C	C	C	131	132	131

TURBINE/AUXILIARIES

MAIN TURB	BYPASS VALVES	TURNING GEAR	VACUUM COND A	VACUUM COND B	VACUUM COND C
TRIPPED	TRIPPED	ON	0	0	0

COOLING WATER

RBCCW PUMP 1	RBCCW PUMP 2	TBCCW PUMP 1	TBCCW PUMP 2	TBCCW PUMP 3	SERV WTR PUMP 1	SERV WTR PUMP 2
ON	OFF	ON	ON	STDBY	ON	OFF

TIME 19:45

REACTOR PARAMETERS

AVERAGE ALL APRM's	RECIRC FLOW	SLC STATUS	SLC TANK LEVEL	REACTOR PRESSURE	STEAM FLOW
<2.0%	0.0 E0 GPM	SYS 1 - OFF	655 GAL	27 PSIG	0.00 MLM/H

FUEL ZONE LEVEL	YARWAY LEVEL	FEEDWATER FLOW	CRD FLOW	CORE SPRAY SYSTEM I	CORE SPRAY SYSTEM II	
169.0" TAF	160.4" TAF	0.30 MLM/H	60 GPM	0 GPM	0 GPM	

ISOLATION CONDENSER A				ISOLATION CONDENSER B			
V-14-30	V-14-31	V-14-34	V-14-36	V-14-32	V-14-33	V-14-35	V-14-37
OPEN	OPEN	CLOSE	OPEN	CLOSE	CLOSE	CLOSE	CLOSE

EMRV A	EMRV B	EMRV C	EMRV D	EMRV E
OPEN	OPEN	OPEN	OPEN	OPEN

CONTAINMENT PARAMETERS

DRYWELL TEMP	DRYWELL PRESSURE	DRYWELL HYDROGEN	DRYWELL OXYGEN	CONT SPRAY SYSTEM I	CONT SPRAY SYSTEM II
91 °F	0.87 PSIG	0 %	2.1%	5965 GPM TORUS	5978 GPM TORUS

TORUS PRESSURE	TORUS TEMP	TORUS LEVEL	TORUS HYDROGEN	TORUS OXYGEN
1.4 PSIG	90.4 °F	153 INCHES	0%	2.1%

DW UNIDENT LEAKRATE	DW IDENT LEAKRATE	CHRRMS SYS I	CHRRMS SYS II
0 GPM	0 GPM	21 REM	22 REM

TIME 19:50

BALANCE OF PLANT

VENTILATION

RX BLDG FAN EF 1-5	RX/TURB BLDG FAN EF 1-6	TURB BLDG FAN EF 1-7	TURB BLDG FAN EF 1-1	TURB BLDG FAN EF 1-4	TURB BLDG FAN EF 1-33	SBGT FAN EF 1-8	SBGT FAN EF 1-9
OFF	OFF	ON	ON	ON	ON	ON	OFF

ELECTRIC PLANT

MAIN GEN	EDG #1	EDG #2	BKR 1A	BKR 1B	BKR S1A	BKR S1B	BKR 1C	BKR 1D	BATT A	BATT B	BATT C
0 MWe	0 KW	0 KW	0	0	C	C	C	C	131	132	131

TURBINE/AUXILIARIES

MAIN TURB	BYPASS VALVES	TURNING GEAR	VACUUM COND A	VACUUM COND B	VACUUM COND C
TRIPPED	TRIPPED	ON	0	0	0

COOLING WATER

RBCCW PUMP 1	RBCCW PUMP 2	TBCCW PUMP 1	TBCCW PUMP 2	TBCCW PUMP 3	SERV WTR PUMP 1	SERV WTR PUMP 2
ON	OFF	ON	ON	STDBY	ON	OFF

TIME

19:50

REACTOR PARAMETERS

AVERAGE ALL
APRM's
<2.0%

RECIRC
FLOW
0.0 E0 GPM

SLC STATUS
SYS 1 - OFF

SLC TANK
LEVEL
655 GAL

REACTOR
PRESSURE
27 PSIG

STEAM FLOW
0.00 MLM/H

FUEL ZONE
LEVEL
169.0" TAF

YARWAY
LEVEL
160.4" TAF

FEEDWATER
FLOW
0.30 MLM/H

CRD
FLOW
60 GPM

CORE SPRAY
SYSTEM I
0 GPM

CORE SPRAY
SYSTEM II
0 GPM

ISOLATION CONDENSER A			
V-14-30	V-14-31	V-14-34	V-14-36
OPEN	OPEN	CLOSE	OPEN

ISOLATION CONDENSER B			
V-14-32	V-14-33	V-14-35	V-14-37
CLOSE	CLOSE	CLOSE	CLOSE

EMRV A
OPEN

EMRV B
OPEN

EMRV C
OPEN

EMRV D
OPEN

EMRV E
OPEN

CONTAINMENT PARAMETERS

DRYWELL
TEMP
90 °F

DRYWELL
PRESSURE
0.87 PSIG

DRYWELL
HYDROGEN
0 %

DRYWELL
OXYGEN
2.1%

CONT SPRAY
SYSTEM I
5965 GPM
TORUS

CONT SPRAY
SYSTEM II
5978 GPM
TORUS

TORUS
PRESSURE
1.4 PSIG

TORUS TEMP
90.1 °F

TORUS
LEVEL
153 INCHES

TORUS
HYDROGEN
0%

TORUS
OXYGEN
2.1%

DW UNIDENT
LEAKRATE
0 GPM

DW IDENT
LEAKRATE
0 GPM

CHRRMS
SYS I
21 REM

CHRRMS
SYS II
22 REM

TIME

19:55

BALANCE OF PLANT

VENTILATION

RX BLDG FAN EF 1-5	RX/TURB BLDG FAN EF 1-6	TURB BLDG FAN EF 1-7	TURB BLDG FAN EF 1-1	TURB BLDG FAN EF 1-4	TURB BLDG FAN EF 1-33	SBGT FAN EF 1-8	SBGT FAN EF 1-9
OFF	OFF	ON	ON	ON	ON	ON	OFF

ELECTRIC PLANT

MAIN GEN	EDG #1	EDG #2	BKR 1A	BKR 1B	BKR S1A	BKR S1B	BKR 1C	BKR 1D	BATT A	BATT B	BATT C
0 MWe	0 KW	0 KW	0	0	C	C	C	C	131	132	131

TURBINE/AUXILIARIES

MAIN TURB	BYPASS VALVES	TURNING GEAR	VACUUM COND A	VACUUM COND B	VACUUM COND C
TRIPPED	TRIPPED	ON	0	0	0

COOLING WATER

RBCCW PUMP 1	RBCCW PUMP 2	TBCCW PUMP 1	TBCCW PUMP 2	TBCCW PUMP 3	SERV WTR PUMP 1	SERV WTR PUMP 2
ON	OFF	ON	ON	STDBY	ON	OFF

TIME

19:55

REACTOR PARAMETERS

AVERAGE ALL APRM's <2.0%	RECIRC FLOW 0.0 E0 GPM	SLC STATUS SYS 1 - OFF	SLC TANK LEVEL 655 GAL	REACTOR PRESSURE 27 PSIG	STEAM FLOW 0.00 MLM/H
FUEL ZONE LEVEL 169.0" TAF	YARWAY LEVEL 160.4" TAF	FEEDWATER FLOW 0.30 MLM/H	CRD FLOW 60 GPM	CORE SPRAY SYSTEM I 0 GPM	CORE SPRAY SYSTEM II 0 GPM
ISOLATION CONDENSER A				ISOLATION CONDENSER B	
V-14-30 OPEN	V-14-31 OPEN	V-14-34 CLOSE	V-14-36 OPEN	V-14-32 CLOSE	V-14-33 CLOSE
		V-14-35 CLOSE	V-14-37 CLOSE		
EMRV A OPEN	EMRV B OPEN	EMRV C OPEN	EMRV D OPEN	EMRV E OPEN	

CONTAINMENT PARAMETERS

DRYWELL TEMP 90 °F	DRYWELL PRESSURE 0.87 PSIG	DRYWELL HYDROGEN 0 %	DRYWELL OXYGEN 2.1%	CONT SPRAY SYSTEM I 5965 GPM TORUS	CONT SPRAY SYSTEM II 5978 GPM TORUS
TORUS PRESSURE 1.4 PSIG	TORUS TEMP 89.9 °F	TORUS LEVEL 153 INCHES	TORUS HYDROGEN 0%	TORUS OXYGEN 2.1%	
	DW UNIDENT LEAKRATE 0 GPM	DW IDENT LEAKRATE 0 GPM	CHRRMS SYS I 21 REM	CHRRMS SYS II 22 REM	
TIME		20:00			

BALANCE OF PLANT

VENTILATION

HX BLDG FAN EF 1-5	RX/TURB BLDG FAN EF 1-6	TURB BLDG FAN EF 1-7	TURB BLDG FAN EF 1-1	TURB BLDG FAN EF 1-4	TURB BLDG FAN EF 1-33	SBGT FAN EF 1-8	SBGT FAN EF 1-9
OFF	OFF	ON	ON	ON	ON	ON	OFF

ELECTRIC PLANT

MAIN GEN	EDG #1	EDG #2	BKR 1A	BKR 1B	BKR S1A	BKR S1B	BKR 1C	BKR 1D	BATT A	BATT B	BATT C
0 MWe	0 KW	0 KW	0	0	C	C	C	C	131	132	131

TURBINE/AUXILIARIES

MAIN TURB	BYPASS VALVES	TURNING GEAR	VACUUM COND A	VACUUM COND B	VACUUM COND C
TRIPPED	TRIPPED	ON	0	0	0

COOLING WATER

RBCCW PUMP 1	RBCCW PUMP 2	TBCCW PUMP 1	TBCCW PUMP 2	TBCCW PUMP 3	SERV WTR PUMP 1	SERV WTR PUMP 2
ON	OFF	ON	ON	STDBY	ON	OFF

TIME

20:00

REACTOR PARAMETERS

AVERAGE ALL APRM's
<2.0%

RECIRC FLOW
0.0 E0 GPM

SLC STATUS
SYS 1 - OFF

SLC TANK LEVEL
655 GAL

REACTOR PRESSURE
27 PSIG

STEAM FLOW
0.00 MLM/H

FUEL ZONE LEVEL
169.0" TAF

YARWAY LEVEL
160.4" TAF

FEEDWATER FLOW
0.30 MLM/H

CRD FLOW
60 GPM

CORE SPRAY SYSTEM I
0 GPM

CORE SPRAY SYSTEM II
0 GPM

ISOLATION CONDENSER A			
V-14-30	V-14-31	V-14-34	V-14-36
OPEN	OPEN	CLOSE	OPEN

ISOLATION CONDENSER B			
V-14-32	V-14-33	V-14-35	V-14-37
CLOSE	CLOSE	CLOSE	CLOSE

EMRV A
OPEN

EMRV B
OPEN

EMRV C
OPEN

EMRV D
OPEN

EMRV E
OPEN

CONTAINMENT PARAMETERS

DRYWELL TEMP
90 °F

DRYWELL PRESSURE
0.87 PSIG

DRYWELL HYDROGEN
0 %

DRYWELL OXYGEN
2.1%

CONT SPRAY SYSTEM I
5965 GPM
TORUS

CONT SPRAY SYSTEM II
5978 GPM
TORUS

TORUS PRESSURE
1.4 PSIG

TORUS TEMP
89.5 °F

TORUS LEVEL
153 INCHES

TORUS HYDROGEN
0%

TORUS OXYGEN
2.1%

DW UNIDENT LEAKRATE
0 GPM

DW IDENT LEAKRATE
0 GPM

CHRRMS SYS I
21 REM

CHRRMS SYS II
22 REM

TIME
20:10

20:10

BALANCE OF PLANT

VENTILATION

RX BLDG FAN EF 1-5	RX/TURB BLDG FAN EF 1-6	TURB PLDG FAN EF 1-7	TURB BLDG FAN EF 1-1	TURB BLDG FAN EF 1-4	TURB BLDG FAN EF 1-33	SBGT FAN EF 1-8	SBGT FAN EF 1-9
OFF	OFF	ON	ON	ON	ON	ON	OFF

ELECTRIC PLANT

MAIN GEN	EDG #1	EDG #2	BKR 1A	BKR 1B	BKR S1A	BKR S1B	BKR 1C	BKR 1D	BATT A	BATT B	BATT C
0 MWe	0 KW	0 KW	0	0	C	C	C	C	131	132	131

TURBINE/AUXILIARIES

MAIN TURB	BYPASS VALVES	TURNING GEAR	VACUUM COND A	VACUUM COND B	VACUUM COND C
TRIPPED	TRIPPED	ON	0	0	0

COOLING WATER

RBCCW PUMP 1	RBCCW PUMP 2	TBCCW PUMP 1	TBCCW PUMP 2	TBCCW PUMP 3	SERV WTR PUMP 1	SERV WTR PUMP 2
ON	OFF	ON	ON	STDBY	ON	OFF

TIME

20:10

REACTOR PARAMETERS

AVERAGE ALL APRM's
 <2.0%

RECIRC FLOW
 0.0 E0 GPM

SLC STATUS
 SYS 1 - OFF

SLC TANK LEVEL
 655 GAL

REACTOR PRESSURE
 27 PSIG

STEAM FLOW
 0.00 MLM/H

FUEL ZONE LEVEL
 169.0" TAF

YARWAY LEVEL
 160.4" TAF

FEEDWATER FLOW
 0.30 MLM/H

CRD FLOW
 60 GPM

CORE SPRAY SYSTEM I
 0 GPM

CORE SPRAY SYSTEM II
 0 GPM

ISOLATION CONDENSER A			
V-14-30	V-14-31	V-14-34	V-14-36
OPEN	OPEN	CLOSE	OPEN

ISOLATION CONDENSER B			
V-14-32	V-14-33	V-14-35	V-14-37
CLOSE	CLOSE	CLOSE	CLOSE

EMRV A
 OPEN

EMRV B
 OPEN

EMRV C
 OPEN

EMRV D
 OPEN

EMRV E
 OPEN

CONTAINMENT PARAMETERS

DRYWELL TEMP
 90 °F

DRYWELL PRESSURE
 0.87 PSIG

DRYWELL HYDROGEN
 0 %

DRYWELL OXYGEN
 2.1%

CONT SPRAY SYSTEM I
 5965 GPM
 TORUS

CONT SPRAY SYSTEM II
 5978 GPM
 TORUS

TORUS PRESSURE
 1.4 PSIG

TORUS TEMP
 89.0 °F

TORUS LEVEL
 153 INCHES

TORUS HYDROGEN
 0%

TORUS OXYGEN
 2.1%

DW UNIDENT LEAKRATE
 0 GPM

DW IDENT LEAKRATE
 0 GPM

CHRRMS SYS I
 21 REM

CHRRMS SYS II
 22 REM

TIME

20:15

BALANCE OF PLANT

VENTILATION

RX BLDG FAN EF 1-5	RX/TURB BLDG FAN EF 1-6	TURB BLDG FAN EF 1-7	TURB BLDG FAN EF 1-1	TURB BLDG FAN EF 1-4	TURB BLDG FAN EF 1-33	SBGT FAN EF 1-8	SBGT FAN EF 1-9
OFF	OFF	ON	ON	ON	ON	ON	OFF

ELECTRIC PLANT

MAIN GEN	EDG #1	EDG #2	BKR 1A	BKR 1B	BKR S1A	BKR S1B	BKR 1C	BKR 1D	BATT A	BATT B	BATT C
0 MWe	0 KW	0 KW	0	0	C	C	C	C	131	132	131

TURBINE/AUXILIARIES

MAIN TURB	BYPASS VALVES	TURNING GEAR	VACUUM COND A	VACUUM COND B	VACUUM COND C
TRIPPED	TRIPPED	ON	0	0	0

COOLING WATER

RBCCW PUMP 1	RBCCW PUMP 2	TBCCW PUMP 1	TBCCW PUMP 2	TBCCW PUMP 3	SERV WTR PUMP 1	SERV WTR PUMP 2
ON	OFF	ON	ON	STDBY	ON	OFF

TIME

20:15

REACTOR PARAMETERS

AVERAGE ALL APRM's <2.0%	RECIRC FLOW 0.0 E0 GPM	SLC STATUS SYS 1 - OFF	SLC TANK LEVEL 655 GAL	REACTOR PRESSURE 27 PSIG	STEAM FLOW 0.00 MLM/H		
FUEL ZONE LEVEL 169.0" TAF	YARWAY LEVEL 160.4" TAF	FEEDWATER FLOW 0.30 MLM/H	CRD FLOW 60 GPM	CORE SPRAY SYSTEM I 0 GPM	CORE SPRAY SYSTEM II 0 GPM		
ISOLATION CONDENSER A				ISOLATION CONDENSER B			
V-14-30	V-14-31	V-14-34	V-14-36	V-14-32	V-14-33	V-14-35	V-14-37
OPEN	OPEN	CLOSE	OPEN	CLOSE	CLOSE	CLOSE	CLOSE
EMRV A OPEN	EMRV B OPEN	EMRV C OPEN	EMRV D OPEN	EMRV E OPEN			

CONTAINMENT PARAMETERS

DRYWELL TEMP 89 °F	DRYWELL PRESSURE 0.87 PSIG	DRYWELL HYDROGEN 0 %	DRYWELL OXYGEN 2.1%	CONT SPRAY SYSTEM I 5965 GPM TORUS	CONT SPRAY SYSTEM II 5978 GPM TORUS
TORUS PRESSURE 1.4 PSIG	TORUS TEMP 88.8 °F	TORUS LEVEL 153 INCHES	TORUS HYDROGEN 0%	TORUS OXYGEN 2.1%	
DW UNIDENT LEAKRATE 0 GPM	DW IDENT LEAKRATE 0 GPM	CHRRMS SYS I 21 REM	CHRRMS SYS II 22 REM		

TIME

20:20

BALANCE OF PLANT

VENTILATION

RX BLDG FAN EF 1-5	RX/TURB BLDG FAN EF 1-8	TURB BLDG FAN EF 1-7	TURB BLDG FAN EF 1-1	TURB BLDG FAN EF 1-4	TURB BLDG FAN EF 1-33	SBGT FAN EF 1-8	SBGT FAN EF 1-9
OFF	OFF	ON	ON	ON	ON	ON	OFF

ELECTRIC PLANT

MAIN GEN	EDG #1	EDG #2	BKR 1A	BKR 1B	BKR S1A	BKR S1B	BKR 1C	BKR 1D	BATT A	BATT B	BATT C
0 MWe	0 KW	0 KW	O	O	C	C	C	C	131	132	131

TURBINE/AUXILIARIES

MAIN TURB	BYPASS VALVES	TURNING GEAR	VACUUM COND A	VACUUM COND B	VACUUM COND C
TRIPPED	TRIPPED	ON	0	0	0

COOLING WATER

RBCCW PUMP 1	RBCCW PUMP 2	TBCCW PUMP 1	TBCCW PUMP 2	TBCCW PUMP 3	SERV WTR PUMP 1	SERV WTR PUMP 2
ON	OFF	ON	ON	STDBY	ON	OFF

TIME 20:20

REACTOR PARAMETERS

AVERAGE ALL APRM's <2.0%	RECIRC FLOW 0.0 E0 GPM	SLC STATUS SYS 1 - OFF	SLC TANK LEVEL 655 GAL	REACTOR PRESSURE 27 PSIG	STEAM FLOW 0.00 MLM/H		
FUEL ZONE LEVEL 169.0" TAF	YARWAY LEVEL 160.4" TAF	FEEDWATER FLOW 0.30 MLM/H	CRD FLOW 60 GPM	CORE SPRAY SYSTEM I 0 GPM	CORE SPRAY SYSTEM II 0 GPM		
ISOLATION CONDENSER A				ISOLATION CONDENSER B			
V-14-30	V-14-31	V-14-34	V-14-35	V-14-32	V-14-33	V-14-35	V-14-37
OPEN	OPEN	CLOSE	OPEN	CLOSE	CLOSE	CLOSE	CLOSE
EMRV A OPEN	EMRV B OPEN	EMRV C OPEN	EMRV D OPEN	EMRV E OPEN			

CONTAINMENT PARAMETERS

DRYWELL TEMP 89 °F	DRYWELL PRESSURE 0.87 PSIG	DRYWELL HYDROGEN 0 %	DRYWELL OXYGEN 2.1%	CONT SPRAY SYSTEM I 5965 GPM TORUS	CONT SPRAY SYSTEM II 5978 GPM TORUS
TORUS PRESSURE 1.4 PSIG	TORUS TEMP 88.4 °F	TORUS LEVEL 153 INCHES	TORUS HYDROGEN 0%	TORUS OXYGEN 2.1%	
DW UNIDENT LEAKRATE 0 GPM	DW IDENT LEAKRATE 0 GPM	CHRRMS SYS I 21 REM	CHRRMS SYS II 22 REM		
TIME		20:25			

BALANCE OF PLANT

VENTILATION

RX BLDG FAN EF 1-5	RX/TURB BLDG FAN EF 1-6	TURB BLDG FAN EF 1-7	TURB BLDG FAN EF 1-1	TURB BLDG FAN EF 1-4	TURB BLDG FAN EF 1-33	SBGT FAN EF 1-8	SBGT FAN EF 1-9
OFF	OFF	ON	ON	ON	ON	ON	OFF

ELECTRIC PLANT

MAIN GEN	EDG #1	EDG #2	BKR 1A	BKR 1B	BKR S1A	BKR S1B	BKR 1C	BKR 1D	BATT A	BATT B	BATT C
0 MWe	0 KW	0 KW	0	0	C	C	C	C	131	132	131

TURBINE/AUXILIARIES

MAIN TURB	BYPASS VALVES	TURNING GEAR	VACUUM COND A	VACUUM COND B	VACUUM COND C
TRIPPED	TRIPPED	ON	0	0	0

COOLING WATER

RBCCW PUMP 1	RBCCW PUMP 2	TBCCW PUMP 1	TBCCW PUMP 2	TBCCW PUMP 3	SERV WTR PUMP 1	SERV WTR PUMP 2
ON	OFF	ON	ON	STDBY	ON	OFF

TIME

20:25

REACTOR PARAMETERS

AVERAGE ALL APRM's
 <2.0%

RECIRC FLOW
 0.0 E0 GPM

SLC STATUS
 SYS 1 - OFF

SLC TANK LEVEL
 655 GAL

REACTOR PRESSURE
 27 PSIG

STEAM FLOW
 0.00 MLM/H

FUEL ZONE LEVEL
 169.0" TAF

YARWAY LEVEL
 160.4" TAF

FEEDWATER FLOW
 0.30 MLM/H

CRD FLOW
 60 GPM

CORE SPRAY SYSTEM I
 0 GPM

CORE SPRAY SYSTEM II
 0 GPM

ISOLATION CONDENSER A			
V-14-30	V-14-31	V-14-34	V-14-36
OPEN	OPEN	CLOSE	OPEN

ISOLATION CONDENSER B			
V-14-32	V-14-33	V-14-35	V-14-37
CLOSE	CLOSE	CLOSE	CLOSE

EMRV A
 OPEN

EMRV B
 OPEN

EMRV C
 OPEN

EMRV D
 OPEN

EMRV E
 OPEN

CONTAINMENT PARAMETERS

DRYWELL TEMP
 89 °F

DRYWELL PRESSURE
 0.87 PSIG

DRYWELL HYDROGEN
 0 %

DRYWELL OXYGEN
 2.1%

CONT SPRAY SYSTEM I
 5965 GPM
 TORUS

CONT SPRAY SYSTEM II
 5978 GPM
 TORUS

TORUS PRESSURE
 1.4 PSIG

TORUS TEMP
 88.1 °F

TORUS LEVEL
 153 INCHES

TORUS HYDROGEN
 0%

TORUS OXYGEN
 2.1%

DW UNIDENT LEAKRATE
 0 GPM

DW IDENT LEAKRATE
 0 GPM

CHRRMS SYS I
 21 REM

CHRRMS SYS II
 22 REM

TIME

20:30

BALANCE OF PLANT

VENTILATION

RX BLDG FAN EF 1-5	RX/TURB BLDG FAN EF 1-8	TURB BLDG FAN EF 1-7	TURB BLDG FAN EF 1-1	TURB BLDG FAN EF 1-4	TURB BLDG FAN EF 1-33	SBGT FAN EF 1-8	SBGT FAN EF 1-9
OFF	OFF	ON	ON	ON	ON	ON	OFF

ELECTRIC PLANT

MAIN GEN	EDG #1	EDG #2	BKR 1A	BKR 1B	BKR S1A	BKR S1B	BKR 1C	BKR 1D	BATT A	BATT B	BATT C
0 MWe	0 KW	0 KW	0	0	C	C	C	C	131	132	131

TURBINE/AUXILIARIES

MAIN TURB	BYPASS VALVES	TURNING GEAR	VACUUM COND A	VACUUM COND B	VACUUM COND C
TRIPPED	TRIPPED	ON	0	0	0

COOLING WATER

RBCCW PUMP 1	RBCCW PUMP 2	TBCCW PUMP 1	TBCCW PUMP 2	TBCCW PUMP 3	SERV WTR PUMP 1	SERV WTR PUMP 2
ON	OFF	ON	ON	STDBY	ON	OFF

TIME

20:30

SECTION III ONSITE RADIOLOGICAL DATA

- III.A. PROCESS AND AREA RADIATION MONITORS
- III.B. AREA DOSE RATES
- III.C. ON-SITE AND ERF DOSE RATES
- III.D. BUILDING AIR ACTIVITY
- III.E. PLANT SAMPLE ACTIVITY

SECTION III. A

PROCESS AND AREA RADIATION MONITORS

SECTION III A
Area Radiation Monitors

NOTE: 'OSH' = Offscale High

T-TIME		00:00	01:00	01:30	01:40	01:50	02:00	03:00	03:10	03:20	03:30	03:40	03:50	04:00	04:10	04:20
CLOCK TIME		16:00	17:00	17:30	17:40	17:50	18:00	19:00	19:10	19:20	19:30	19:40	19:50	20:00	20:10	20:20
Admin Bldg Entry-Turb Bldg	A-1	0.12	0.12	0.12	0.12	0.12	0.12	0.12	0.12	0.12	0.12	0.12	0.12	0.12	0.12	0.12
Access to Control Room	A-2	0.02	0.02	0.02	0.02	0.02	0.02	0.02	0.02	30.	35.	30.	30.	30.	30.	30.
Reactor Contro Room	A-3	0.07	0.07	0.07	0.07	0.07	0.07	0.07	0.07	0.07	0.07	0.07	0.07	0.07	0.07	0.07
Turbine Oper Floor Entry	A-4	3.0	3.0	1.5	260.	288.	255.	250.	245.	240.	240.	237.	235.	234.	232.	230.
Blank	A-5	BLANK	BLANK	BLANK	BLANK	BLANK	BLANK	BLANK	BLANK	BLANK	BLANK	BLANK	BLANK	BLANK	BLANK	BLANK
Turb Lube Oil Equip Area	A-6	0.40	0.40	0.40	0.40	0.40	0.40	0.40	0.40	0.40	0.40	0.40	0.40	0.40	0.40	0.40
Feed Pump Area	A-7	2.40	2.40	2.40	2.40	10.	85.	160.	235.	310.	310.	310.	310.	310.	295.	285.
Condensate Pump Area	A-8	4.50	4.50	4.50	4.50	15.	85.	160.	235.	310.	310.	310.	310.	310.	295.	285.
Cond Demin Valve Area	A-9	3.70	3.70	3.70	3.70	3.70	3.70	3.70	3.70	3.70	3.70	3.70	3.70	3.70	3.70	3.70
Regeneration Area	A-10	50.0	50.0	50.0	50.0	50.	50.	50.	50.	50.	50.	50.	50.	50.	50.	50.
Makeup Demin Area	B-1	0.12	0.12	0.12	0.12	0.12	0.12	0.12	0.12	0.12	0.12	0.12	0.12	0.12	0.12	0.12
Air Compressor Area	B-2	0.35	0.35	0.35	0.35	0.35	0.35	0.35	0.35	0.35	0.35	0.35	0.35	0.35	0.35	0.35
Radwaste Pump Room	B-3	70.	70.	70.	70.	70.	70.	70.	70.	70.	70.	70.	70.	70.	70.	70.
Radwaste Control Room	B-4	2.1	2.1	2.1	2.1	2.1	2.1	2.1	2.1	2.1	2.1	2.1	2.1	2.1	2.1	2.1
Radwaste Conveyor Aisle	B-5	2.1	2.1	2.1	2.1	2.1	2.1	2.1	2.1	2.1	2.1	2.1	2.1	2.1	2.1	2.1
Radwaste Store and Ship	B-6	0.18	0.18	0.18	0.18	0.18	0.18	0.18	0.18	0.18	0.18	0.18	0.18	0.18	0.18	0.18
TIP Valve Room	B-7	3.10	3.10	3.10	3.10	3.10	3.10	3.10	3.10	OSH	OSH	OSH	OSH	OSH	OSH	OSH
Personnel Air Lock	B-8	4.60	4.60	4.60	600.	820.	860.	900.	940.	OSH	OSH	OSH	OSH	OSH	OSH	OSH
Reactor Oper Floor Area	B-9	0.80	0.80	0.80	23.	25.	27.	28.	30.	OSH	OSH	OSH	OSH	OSH	OSH	OSH
Reactor Equip Drain Tank	B-10	19.5	19.5	19.5	25.	30.	33.	37.	40.	OSH	OSH	OSH	OSH	OSH	OSH	OSH
STACK RAGEMS HIGH RANGE	amps	1.0E-13	1.0E-13	1.0E-13	1.0E-13	1.0E-13	1.0E-13	1.0E-13	1.0E-13	7.0E-13	7.3E-10	7.0E-10	6.8E-10	6.5E-10	6.2E-10	6.0E-10
STACK RAGEMS HIGH RANGE	uCi/cc	.006	.006	.006	.006	.006	.006	.006	.006	1.74	1.82	1.76	1.69	1.63	1.56	1.51
STACK RAGEMS LOW RANGE	cps	10.	10.	10.	10.	10.	195.	45.	35.	0.	0.	0.	0.	0.	0.	0.
TB RAGEMS HIGH RANGE	uCi/cc	.006	.006	.006	.006	.006	.006	.006	.006	.006	.006	.006	.006	.006	.006	.006
TB RAGEMS LOW RANGE	cpm	0.5	0.5	0.5	12.	18.	17.	15.	15.	15.	15.	15.	15.	15.	15.	15.
OFFGAS AIR EJECTOR	mR/hr	142.	142.	142.	6300.	4700.	3500.	2100.	40.	40.	40.	40.	40.	40.	40.	40.
Main Steam Line	mR/hr	239.	140.	55.	350.	250.	30.	30.	30.	30.	30.	30.	30.	30.	30.	30.
				TURB TRIP FUEL DAMAGE					LOCA RELEASE							

SECTION III A
Area Radiation Monitors

NOTE: 'OSH' = Offscale High

T-TIME		00:00	01:00	01:30	01:40	01:50	02:00	03:00	03:10	03:20	03:30	03:40	03:50	04:00	04:10	04:20
CLOCK TIME		16:00	17:00	17:30	17:40	17:50	18:00	19:00	19:10	19:20	19:30	19:40	19:50	20:00	20:10	20:20
Cleanup System Pump Area	C-1	2.5	2.5	2.5	190.	184.	180.	180.	OSH	OSH	OSH	OSH	OSH	OSH	OSH	OSH
Fuel Pool Filters (ORW)	C-2	31.	31.	31.	31.	31.	31.	31.	31.	31.	31.	31.	31.	31.	31.	31.
Emergency Condenser Area	C-3	6.0	6.0	OSH	OSH	OSH	OSH	OSH	OSH	OSH	OSH	OSH	OSH	OSH	OSH	OSH
Shutdown Heat Exchanger	C-4	28.	28.	28.	28.	28.	28.	28.	OSH	OSH	OSH	OSH	OSH	OSH	OSH	OSH
Spent Fuel Pool Area	C-5	2.5	2.5	2.5	2.5	2.5	2.5	2.5	OSH	OSH	OSH	OSH	OSH	OSH	OSH	OSH
Liquid Poison System Area	C-6	1.31	1.31	1.31	1.31	1.31	1.31	1.31	OSH	OSH	OSH	OSH	OSH	OSH	OSH	OSH
Control Rod Drive Module	C-7	1.7	1.7	1.7	2.1	66.	65.	65.	OSH	OSH	OSH	OSH	OSH	OSH	OSH	OSH
Air Ejectors Area	C-8	11.2	7.0	4.0	60.	70.	70.	70.	67.	66.	66.	65.	65.	64.	62.	62.
Fuel Pool (Low Range)	C-9	2.0	2.0	2.0	2.0	2.0	2.0	2.0	OSH	OSH	OSH	OSH	OSH	OSH	OSH	OSH
Fuel Pool (High Range)	C-10	31.	31.	31.	31.	31.	31.	31.	OSH	OSH	OSH	OSH	OSH	OSH	OSH	OSH
Containment Spray HX A Eff	P-1	0.6	0.6	0.6	0.6	7.0	7.0	65.	OSH	OSH	OSH	OSH	OSH	OSH	OSH	OSH
Containment Spray HX B Eff	P-2	0.6	0.6	0.6	0.6	7.0	7.0	65.	OSH	OSH	OSH	OSH	OSH	OSH	OSH	OSH
Containment Spray HX C Eff	P-3	13.	13.	13.	13.	19.	19.	70.	OSH	OSH	OSH	OSH	OSH	OSH	OSH	OSH
Containment Spray HX D Eff	P-4	8.97	8.97	8.97	8.97	15.	15.	70.	OSH	OSH	OSH	OSH	OSH	OSH	OSH	OSH
Vent Manifold Rad Mon Ch 1	P-5	1.1	1.1	1.1	1.1	1.1	1.1	1.1	12.	18.	18.	18.	18.	18.	18.	18.
Vent Manifold Rad Mon Ch 2	P-6	1.4	1.4	1.4	1.4	1.4	1.4	1.4	18.	18.	18.	18.	18.	18.	18.	18.
Cond Vent 1 Rad Mon Ch 1	P-7	0.91	0.91	0.91	4.	OSH	OSH	OSH	OSH	OSH	OSH	OSH	OSH	OSH	OSH	OSH
Cond Vent 1 Rad Mon Ch 2	P-8	0.60	0.60	0.60	4.	OSH	OSH	OSH	OSH	OSH	OSH	OSH	OSH	OSH	OSH	OSH
Cond Vent 2 Rad Mon Ch 1	P-9	0.55	0.55	0.55	4.	OSH	OSH	OSH	OSH	OSH	OSH	OSH	OSH	OSH	OSH	OSH
Cond Vent 2 Rad Mon Ch 2	P-10	0.80	0.80	0.80	4.	OSH	OSH	OSH	OSH	OSH	OSH	OSH	OSH	OSH	OSH	OSH
Service Water Discharge	P-11	89.5	89.5	89.5	89.5	89.5	89.5	89.5	89.5	89.5	89.5	89.5	89.5	89.5	89.5	89.5
RBCCW Discharge	P-12	914.	914.	914.	914.	914.	914.	914.	OSH	OSH	OSH	OSH	OSH	OSH	OSH	OSH
CHRRMS NUMBER 1	R/hr	4.	3.	2.	89.	89.	89.	88.	87.	63.	21.	21.	21.	21.	21.	21.
CHRRMS NUMBER 2	R/hr	4.	3.	2.	1.0	1.0	1.0	87.	86.	62.	22.	22.	22.	22.	22.	22.
				TURB TRIP FUEL DAMAGE					LOCA RELEASE							

SECTION III A
Area Radiation Monitors

NOTE: 'OSH' = Offscale High

T-TIME		04:30	05:00	06:00	07:00	08:00	TIME	16:00	16:30	17:00	17:30	18:00	18:30	19:00	19:30	20:00
CLOCK TIME		20:30	21:00	22:00	23:00	24:00	WARP	08:00	08:30	09:00	09:30	10:00	10:30	11:00	11:30	12:00
Cleanup System Pump Area	C-1	OSH	OSH	OSH	OSH	OSH		OSH	OSH	OSH	OSH	OSH	OSH	OSH	OSH	OSH
Fuel Pool Filters (ORW)	C-2	OSH	OSH	OSH	OSH	OSH		OSH	OSH	OSH	OSH	OSH	OSH	OSH	OSH	OSH
Emergency Condenser Area	C-3	OSH	OSH	OSH	OSH	OSH		OSH	OSH	OSH	OSH	OSH	OSH	OSH	OSH	OSH
Shutdown Heat Exchanger	C-4	OSH	OSH	OSH	OSH	OSH		OSH	OSH	OSH	OSH	OSH	OSH	OSH	OSH	OSH
Spent Fuel Pool Area	C-5	OSH	OSH	OSH	OSH	OSH		OSH	OSH	OSH	OSH	OSH	OSH	OSH	OSH	OSH
Liquid Poison System Area	C-6	OSH	OSH	OSH	OSH	OSH		OSH	OSH	OSH	OSH	OSH	OSH	OSH	OSH	OSH
Control Rod Drive Module	C-7	OSH	OSH	OSH	OSH	OSH		OSH	OSH	OSH	OSH	OSH	OSH	OSH	OSH	OSH
Air Ejectors Area	C-8	61.	61.	60.	59.	58.		3.	3.	3.	3.	3.	3.	3.	3.	3.
Fuel Pool (Low Range)	C-9	OSH	OSH	OSH	OSH	OSH		OSH	OSH	OSH	OSH	OSH	OSH	OSH	OSH	OSH
Fuel Pool (High Range)	C-10	OSH	OSH	OSH	OSH	OSH		245000	189600	146770	113600	87930	68000	52700	40800	31500
Containment Spray HX A Eff	P-1	OSH	OSH	OSH	OSH	OSH		OSH	OSH	OSH	OSH	OSH	OSH	OSH	OSH	OSH
Containment Spray HX B Eff	P-2	OSH	OSH	OSH	OSH	OSH		OSH	OSH	OSH	OSH	OSH	OSH	OSH	OSH	OSH
Containment Spray HX C Eff	P-3	OSH	OSH	OSH	OSH	OSH		OSH	OSH	OSH	OSH	OSH	OSH	OSH	OSH	OSH
Containment Spray HX D Eff	P-4	OSH	OSH	OSH	OSH	OSH		OSH	OSH	OSH	OSH	OSH	OSH	OSH	OSH	OSH
Vent Manifold Rad Mon Ch 1	P-5	18.	15.	13.	11.	8.		0.4	0.4	0.4	0.4	0.4	0.4	0.4	0.4	0.4
Vent Manifold Rad Mon Ch 2	P-6	18.	15.	13.	11.	8.		0.4	0.4	0.4	0.4	0.4	0.4	0.4	0.4	0.4
Cond Vent 1 Rad Mon Ch 1	P-7	OSH	OSH	OSH	OSH	OSH		OSH	OSH	OSH	OSH	OSH	OSH	OSH	OSH	OSH
Cond Vent 1 Rad Mon Ch 2	P-8	OSH	OSH	OSH	OSH	OSH		OSH	OSH	OSH	OSH	OSH	OSH	OSH	OSH	OSH
Cond Vent 2 Rad Mon Ch 1	P-9	OSH	OSH	OSH	OSH	OSH		OSH	OSH	OSH	OSH	OSH	OSH	OSH	OSH	OSH
Cond Vent 2 Rad Mon Ch 2	P-10	OSH	OSH	OSH	OSH	OSH		OSH	OSH	OSH	OSH	OSH	OSH	OSH	OSH	OSH
Service Water Discharge	P-11	89.5	89.5	89.5	89.5	89.5		89.5	89.5	89.5	89.5	89.5	89.5	89.5	89.5	89.5
RBCCW Discharge	P-12	OSH	OSH	OSH	OSH	OSH		OSH	OSH	OSH	OSH	OSH	OSH	OSH	OSH	OSH
CHRRMS NUMBER 1	R/hr	21.	21.	21.	21.	21.		20.	19.	18.	17.	16.	16.	15.	15.	14.
CHRRMS NUMBER 2	R/hr	22.	22.	22.	22.	22.		21.	20.	19.	18.	17.	17.	16.	16.	15.

SECTION III B

AREA DOSE RATES

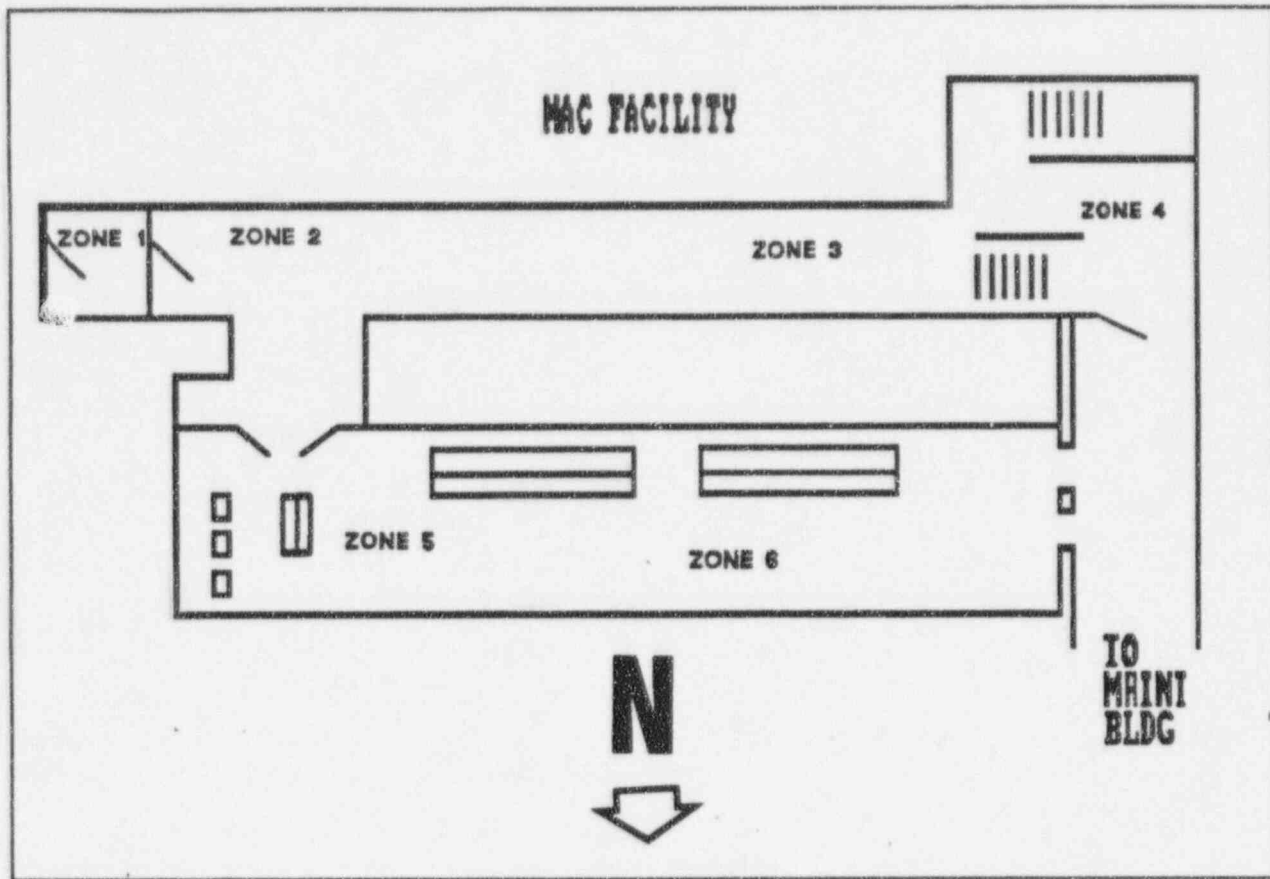

AREA DOSE RATES

TIME	ZONE 1		ZONE 2		ZONE 3		ZONE 4		ZONE 5		ZONE 6	
	mR/hr		mR/hr		mR/hr		mR/hr		mR/hr		mR/hr	
	CW	OW	CW	OW	CW	OW	CW	OW	CW	OW	CW	OW
16:00	< 2.0	< 2.0	< 2.0	< 2.0	< 2.0	< 2.0	< 2.0	< 2.0	< 2.0	< 2.0	< 2.0	< 2.0
17:00	< 2.0	< 2.0	< 2.0	< 2.0	< 2.0	< 2.0	< 2.0	< 2.0	< 2.0	< 2.0	< 2.0	< 2.0
17:30	< 2.0	< 2.0	< 2.0	< 2.0	< 2.0	< 2.0	< 2.0	< 2.0	< 2.0	< 2.0	< 2.0	< 2.0
17:45	< 2.0	< 2.0	< 2.0	< 2.0	< 2.0	< 2.0	< 2.0	< 2.0	< 2.0	< 2.0	< 2.0	< 2.0
18:00	< 2.0	< 2.0	< 2.0	< 2.0	< 2.0	< 2.0	< 2.0	< 2.0	< 2.0	< 2.0	< 2.0	< 2.0
19:00	< 2.0	< 2.0	< 2.0	< 2.0	< 2.0	< 2.0	< 2.0	< 2.0	< 2.0	< 2.0	< 2.0	< 2.0
19:10	< 2.0	< 2.0	< 2.0	< 2.0	< 2.0	< 2.0	< 2.0	< 2.0	< 2.0	< 2.0	< 2.0	< 2.0
19:20	544,000	544,000	54,000	54,000	2,160	2,160	10	10	240	240	25	25
19:30	572,000	572,000	57,200	57,200	2,300	2,300	15	15	250	250	25	25
19:40	552,000	552,000	55,200	55,200	2,200	2,200	15	15	245	245	25	25
19:50	532,000	532,000	53,200	53,200	2,100	2,100	15	15	235	235	25	25
20:00	512,000	512,000	51,200	51,200	2,000	2,000	15	15	225	225	20	20
20:10	492,000	492,000	49,200	49,200	1,950	1,950	15	15	220	220	20	20
20:20	476,000	476,000	47,600	47,600	1,900	1,900	15	15	210	210	20	20
20:30	460,000	460,000	46,000	46,000	1,800	1,800	15	15	200	200	20	20

MAC FACILITY
AREA AIRBORNE & CONTAMINATION DATA

Time	10 Minute 60 lpm sample		Particulate Contact Dose Rate		Charcoal Contact Dose Rate	
	Net cpm		mR/hr		mR/hr	
	Part	Char	CW	OW	CW	OW
	16:00	< 100	< 100	< 2.0	< 2.0	< 2.0
17:00	< 100	< 100	< 2.0	< 2.0	< 2.0	< 2.0
17:30	< 100	< 100	< 2.0	< 2.0	< 2.0	< 2.0
17:45	< 100	< 100	< 2.0	< 2.0	< 2.0	< 2.0
18:00	< 100	< 100	< 2.0	< 2.0	< 2.0	< 2.0
19:00	< 100	< 100	< 2.0	< 2.0	< 2.0	< 2.0
19:10	< 100	< 100	< 2.0	< 2.0	< 2.0	< 2.0
19:20	< 100	< 100	< 2.0	< 2.0	< 2.0	< 2.0
19:30	< 100	< 100	< 2.0	< 2.0	< 2.0	< 2.0
19:40	< 100	< 100	< 2.0	< 2.0	< 2.0	< 2.0
19:50	< 100	< 100	< 2.0	< 2.0	< 2.0	< 2.0
20:00	< 100	< 100	< 2.0	< 2.0	< 2.0	< 2.0
20:10	< 100	< 100	< 2.0	< 2.0	< 2.0	< 2.0
20:20	< 100	< 100	< 2.0	< 2.0	< 2.0	< 2.0
20:30	< 100	< 100	< 2.0	< 2.0	< 2.0	< 2.0

Time	Floor Contamination			Personnel Contamination		
	Netcpm	CW mR/hr	OW mR/hr	Netcpm	CW mR/hr	OW mR/hr
16:00	< 100	< 2.0	< 2.0	< 100	< 2.0	< 2.0
17:00	< 100	< 2.0	< 2.0	< 100	< 2.0	< 2.0
17:30	< 100	< 2.0	< 2.0	< 100	< 2.0	< 2.0
17:45	< 100	< 2.0	< 2.0	< 100	< 2.0	< 2.0
18:00	< 100	< 2.0	< 2.0	< 100	< 2.0	< 2.0
19:00	< 100	< 2.0	< 2.0	< 100	< 2.0	< 2.0
19:10	< 100	< 2.0	< 2.0	< 100	< 2.0	< 2.0
19:20	< 100	< 2.0	< 2.0	< 100	< 2.0	< 2.0
19:30	< 100	< 2.0	< 2.0	< 100	< 2.0	< 2.0
19:40	< 100	< 2.0	< 2.0	< 100	< 2.0	< 2.0
19:50	< 100	< 2.0	< 2.0	< 100	< 2.0	< 2.0
20:00	< 100	< 2.0	< 2.0	< 100	< 2.0	< 2.0
20:10	< 100	< 2.0	< 2.0	< 100	< 2.0	< 2.0
20:20	< 100	< 2.0	< 2.0	< 100	< 2.0	< 2.0
20:30	< 100	< 2.0	< 2.0	< 100	< 2.0	< 2.0

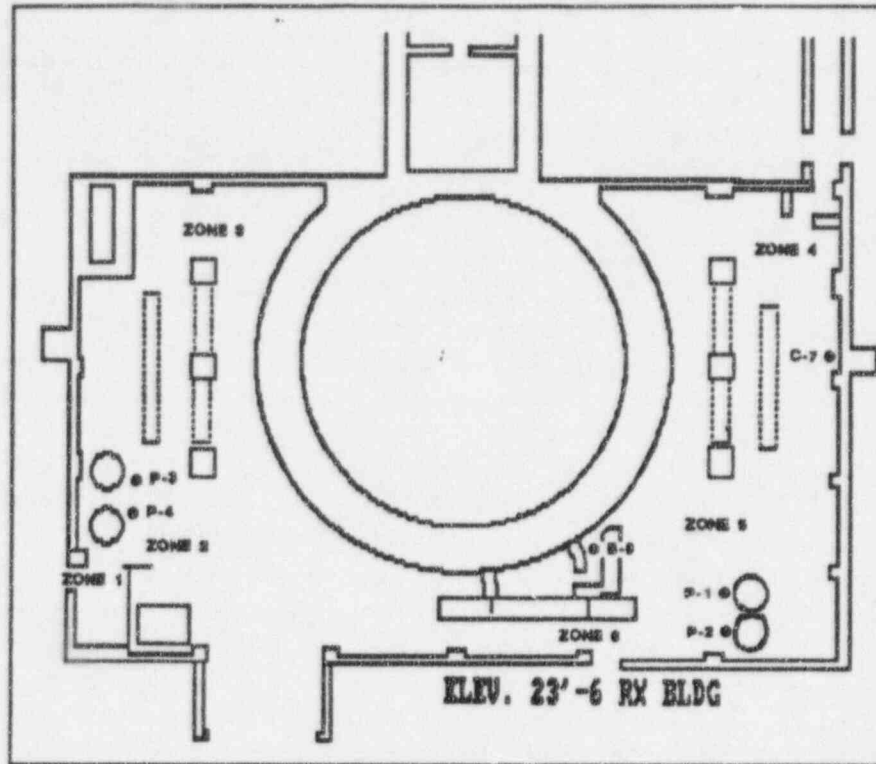

AREA DOSE RATES

TIME	ZONE 1		ZONE 2		ZONE 3		ZONE 4		ZONE 5		ZONE 6	
	mR/hr		mR/hr		mR/hr		mR/hr		mR/hr		mR/hr	
	CW	OW	CW	OW	CW	OW	CW	OW	CW	OW	CW	OW
16:00	< 2.0	< 2.0	< 2.0	< 2.0	< 2.0	< 2.0	< 2.0	< 2.0	< 2.0	< 2.0	< 2.0	< 2.0
17:00	< 2.0	< 2.0	< 2.0	< 2.0	< 2.0	< 2.0	< 2.0	< 2.0	< 2.0	< 2.0	< 2.0	< 2.0
17:30	< 2.0	< 2.0	< 2.0	< 2.0	< 2.0	< 2.0	< 2.0	< 2.0	< 2.0	< 2.0	< 2.0	< 2.0
17:45	5.	5.	20.	20.	< 2.0	< 2.0	50.	50.	7.	7.	7.	7.
18:00	5.	5.	20.	20.	< 2.0	< 2.0	60.	60.	7.	7.	7.	7.
19:00	10.	10.	70.	70.	< 2.0	< 2.0	60.	60.	65.	65.	65.	65.
19:10	10.	10.	70.	70.	< 2.0	< 2.0	60.	60.	65.	65.	65.	65.
19:20	544,000	544,000	5,440,000	7,020,000	5,440,000	7,020,000	5,440,000	7,020,000	5,440,000	7,020,000	5,440,000	7,020,000
19:30	572,000	572,000	5,720,000	7,150,000	5,720,000	7,150,000	5,720,000	7,150,000	5,720,000	7,150,000	5,720,000	7,150,000
19:40	552,000	552,000	5,520,000	6,900,000	5,520,000	6,900,000	5,520,000	6,900,000	5,520,000	6,900,000	5,520,000	6,900,000
19:50	532,000	532,000	5,320,000	6,650,000	5,320,000	6,650,000	5,320,000	6,650,000	5,320,000	6,650,000	5,320,000	6,650,000
20:00	512,000	512,000	5,120,000	6,400,000	5,120,000	6,400,000	5,120,000	6,400,000	5,120,000	6,400,000	5,120,000	6,400,000
20:10	492,000	492,000	4,920,000	6,150,000	4,920,000	6,150,000	4,920,000	6,150,000	4,920,000	6,150,000	4,920,000	6,150,000
20:20	476,000	476,000	4,760,000	5,950,000	4,760,000	5,950,000	4,760,000	5,950,000	4,760,000	5,950,000	4,760,000	5,950,000
20:30	460,000	460,000	4,600,000	5,750,000	4,600,000	5,750,000	4,600,000	5,750,000	4,600,000	5,750,000	4,600,000	5,750,000

RXB 23' ELEVATION
AREA AIRBORNE & CONTAMINATION DATA

Time	10 Minute 60 lpm sample		Particulate Contact Dose Rate		Charcoal Contact Dose Rate	
	Net cpm		mR/hr		mR/hr	
	Part	Char	CW	OW	CW	OW
	16:00	< 100	< 100	< 2.0	< 2.0	< 2.0
17:00	< 100	< 100	< 2.0	< 2.0	< 2.0	< 2.0
17:30	< 100	< 100	< 2.0	< 2.0	< 2.0	< 2.0
17:45	< 100	< 100	< 2.0	< 2.0	< 2.0	< 2.0
18:00	< 100	< 100	< 2.0	< 2.0	< 2.0	< 2.0
19:00	< 100	< 100	< 2.0	< 2.0	< 2.0	< 2.0
19:10	< 100	< 100	< 2.0	< 2.0	< 2.0	< 2.0
19:20	> 50,000	> 50,000	216,000,000	270,000,000	198,000	248,000
19:30	> 50,000	> 50,000	502,000,000	628,000,000	213,000	266,000
19:40	> 50,000	> 50,000	288,000,000	285,000,000	209,000	261,000
19:50	> 50,000	> 50,000	223,000,000	279,000,000	203,000	254,000
20:00	> 50,000	> 50,000	218,000,000	272,000,000	198,000	248,000
20:10	> 50,000	> 50,000	213,000,000	266,000,000	192,000	240,000
20:20	> 50,000	> 50,000	207,000,000	259,000,000	187,000	234,000
20:30	> 50,000	> 50,000	203,000,000	254,000,000	182,000	228,000

Time	Floor Contamination			Personnel Contamination		
	Netcpm	CW mR/hr	OW mR/hr	Netcpm	CW mR/hr	OW mR/hr
16:00	< 100	< 2.0	< 2.0	< 100	< 2.0	< 2.0
17:00	< 100	< 2.0	< 2.0	< 100	< 2.0	< 2.0
17:30	< 100	< 2.0	< 2.0	< 100	< 2.0	< 2.0
17:45	< 100	< 2.0	< 2.0	< 100	< 2.0	< 2.0
18:00	< 100	< 2.0	< 2.0	< 100	< 2.0	< 2.0
19:00	< 100	< 2.0	< 2.0	< 100	< 2.0	< 2.0
19:10	< 100	< 2.0	< 2.0	< 100	< 2.0	< 2.0
19:20	> 50,000	> 500,000	> 500,000	> 50,000	1,040,000	1,304,000
19:30	> 50,000	> 500,000	> 500,000	> 50,000	1,103,000	1,379,000
19:40	> 50,000	> 500,000	> 500,000	> 50,000	1,071,000	1,339,000
19:50	> 50,000	> 500,000	> 500,000	> 50,000	1,034,000	1,293,000
20:00	> 50,000	> 500,000	> 500,000	> 50,000	1,000,000	1,250,000
20:10	> 50,000	> 500,000	> 500,000	> 50,000	966,000	1,210,000
20:20	> 50,000	> 500,000	> 500,000	> 50,000	930,000	1,163,000
20:30	> 50,000	> 500,000	> 500,000	> 50,000	900,000	1,125,000

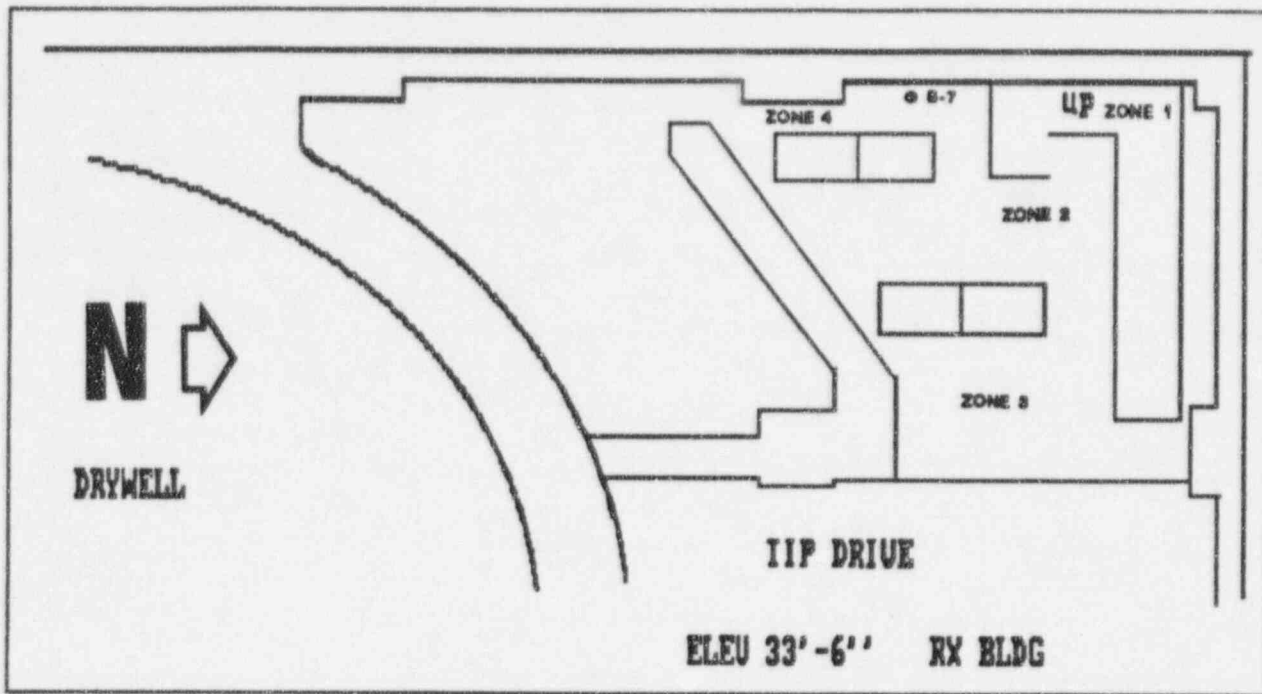

AREA DOSE RATES

TIME	ZONE 1		ZONE 2		ZONE 3		ZONE 4	
	mR/hr		mR/hr		mR/hr		mR/hr	
	CW	OW	CW	OW	CW	OW	CW	OW
16:00	< 2.0	< 2.0	< 2.0	< 2.0	< 2.0	< 2.0	< 2.0	< 2.0
17:00	< 2.0	< 2.0	< 2.0	< 2.0	< 2.0	< 2.0	< 2.0	< 2.0
17:30	< 2.0	< 2.0	< 2.0	< 2.0	< 2.0	< 2.0	< 2.0	< 2.0
17:45	< 2.0	< 2.0	< 2.0	< 2.0	< 2.0	< 2.0	< 2.0	< 2.0
18:00	< 2.0	< 2.0	< 2.0	< 2.0	< 2.0	< 2.0	< 2.0	< 2.0
19:00	< 2.0	< 2.0	< 2.0	< 2.0	< 2.0	< 2.0	< 2.0	< 2.0
19:10	< 2.0	< 2.0	< 2.0	< 2.0	< 2.0	< 2.0	< 2.0	< 2.0
19:20	5,440,000	7,020,000	5,440,000	7,020,000	5,440,000	7,020,000	5,440,000	7,020,000
19:30	5,720,000	7,150,000	5,720,000	7,150,000	5,720,000	7,150,000	5,720,000	7,150,000
19:40	5,520,000	6,900,000	5,520,000	6,900,000	5,520,000	6,900,000	5,520,000	6,900,000
19:50	5,320,000	6,650,000	5,320,000	6,650,000	5,320,000	6,650,000	5,320,000	6,650,000
20:00	5,120,000	6,400,000	5,120,000	6,400,000	5,120,000	6,400,000	5,120,000	6,400,000
20:10	4,920,000	6,150,000	4,920,000	6,150,000	4,920,000	6,150,000	4,920,000	6,150,000
20:20	4,760,000	5,950,000	4,760,000	5,950,000	4,760,000	5,950,000	4,760,000	5,950,000
20:30	4,600,000	5,750,000	4,600,000	5,750,000	4,600,000	5,750,000	4,600,000	5,750,000

RXB 33' ELEVATION
AREA AIRBORNE & CONTAMINATION DATA

Time	10 Minute 60 lpm sample		Particulate Contact Dose Rate		Charcoal Contact Dose Rate	
	Net cpm		mR/hr		mR/hr	
	Part	Char	CW	OW	CW	OW
16:00	< 100	< 100	< 2.0	< 2.0	< 2.0	< 2.0
17:00	< 100	< 100	< 2.0	< 2.0	< 2.0	< 2.0
17:30	< 100	< 100	< 2.0	< 2.0	< 2.0	< 2.0
17:45	< 100	< 100	< 2.0	< 2.0	< 2.0	< 2.0
18:00	< 100	< 100	< 2.0	< 2.0	< 2.0	< 2.0
19:00	< 100	< 100	< 2.0	< 2.0	< 2.0	< 2.0
19:10	< 100	< 100	< 2.0	< 2.0	< 2.0	< 2.0
19:20	> 50,000	> 50,000	216,000,000	270,000,000	198,000	248,000
19:30	> 50,000	> 50,000	502,000,000	628,000,000	213,000	266,000
19:40	> 50,000	> 50,000	288,000,000	285,000,000	209,000	261,000
19:50	> 50,000	> 50,000	223,000,000	279,000,000	203,000	254,000
20:00	> 50,000	> 50,000	218,000,000	272,000,000	198,000	248,000
20:10	> 50,000	> 50,000	213,000,000	266,000,000	192,000	240,000
20:20	> 50,000	> 50,000	207,000,000	259,000,000	187,000	234,000
20:30	> 50,000	> 50,000	203,000,000	254,000,000	182,000	228,000

Time	Floor Contamination			Personnel Contamination		
	Netcpm	CW mR/hr	OW mR/hr	Netcpm	CW mR/hr	OW mR/hr
16:00	< 100	< 2.0	< 2.0	< 100	< 2.0	< 2.0
17:00	< 100	< 2.0	< 2.0	< 100	< 2.0	< 2.0
17:30	< 100	< 2.0	< 2.0	< 100	< 2.0	< 2.0
17:45	< 100	< 2.0	< 2.0	< 100	< 2.0	< 2.0
18:00	< 100	< 2.0	< 2.0	< 100	< 2.0	< 2.0
19:00	< 100	< 2.0	< 2.0	< 100	< 2.0	< 2.0
19:10	< 100	< 2.0	< 2.0	< 100	< 2.0	< 2.0
19:20	> 50,000	> 500,000	> 500,000	> 50,000	1,040,000	1,304,000
19:30	> 50,000	> 500,000	> 500,000	> 50,000	1,103,000	1,379,000
19:40	> 50,000	> 500,000	> 500,000	> 50,000	1,071,000	1,339,000
19:50	> 50,000	> 500,000	> 500,000	> 50,000	1,034,000	1,293,000
20:00	> 50,000	> 500,000	> 500,000	> 50,000	1,000,000	1,250,000
20:10	> 50,000	> 500,000	> 500,000	> 50,000	966,000	1,210,000
20:20	> 50,000	> 500,000	> 500,000	> 50,000	930,000	1,163,000
20:30	> 50,000	> 500,000	> 500,000	> 50,000	900,000	1,125,000

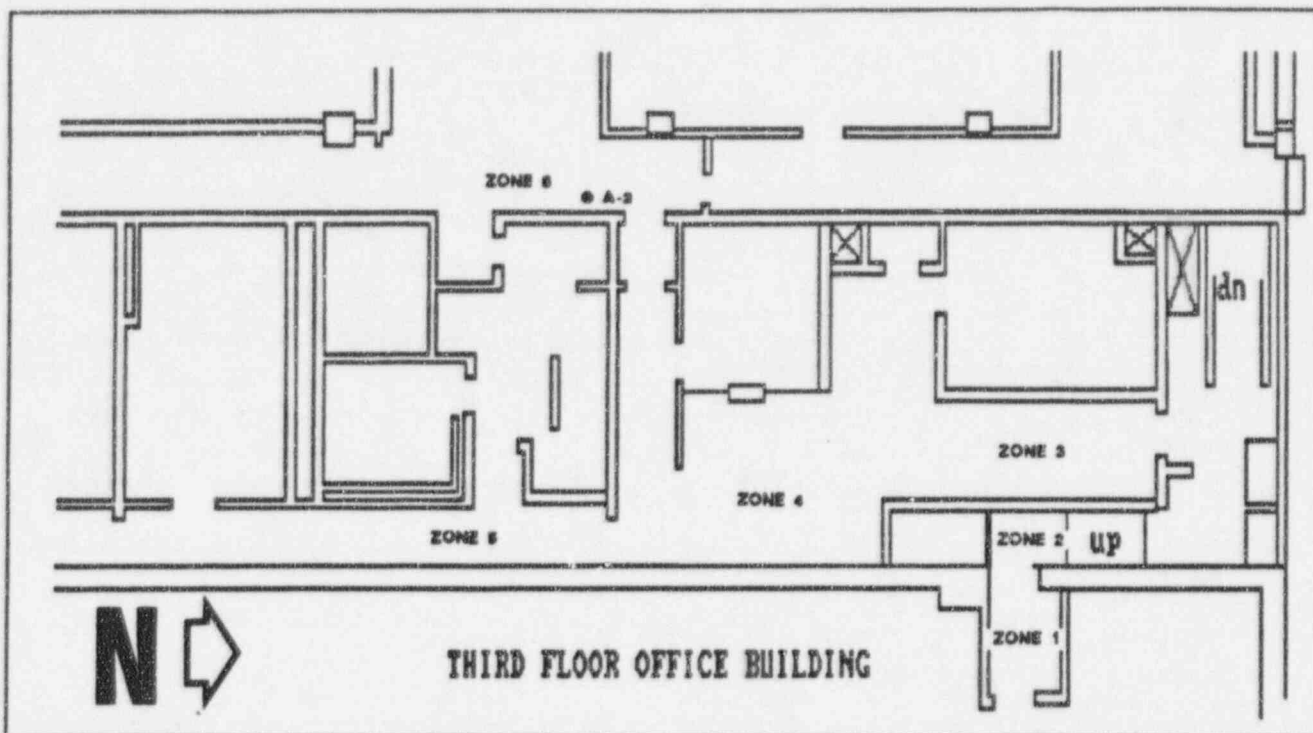

AREA DOSE RATES

TIME	ZONE 1		ZONE 2		ZONE 3		ZONE 4		ZONE 5		ZONE 6	
	mR/hr		mR/hr		mR/hr		mR/hr		mR/hr		mR/hr	
	CW	OW	CW	OW	CW	OW	CW	OW	CW	OW	CW	OW
16:00	< 2.0	< 2.0	< 2.0	< 2.0	< 2.0	< 2.0	< 2.0	< 2.0	< 2.0	< 2.0	< 2.0	< 2.0
17:00	< 2.0	< 2.0	< 2.0	< 2.0	< 2.0	< 2.0	< 2.0	< 2.0	< 2.0	< 2.0	< 2.0	< 2.0
17:30	< 2.0	< 2.0	< 2.0	< 2.0	< 2.0	< 2.0	< 2.0	< 2.0	< 2.0	< 2.0	< 2.0	< 2.0
17:45	< 2.0	< 2.0	< 2.0	< 2.0	< 2.0	< 2.0	< 2.0	< 2.0	< 2.0	< 2.0	< 2.0	< 2.0
18:00	< 2.0	< 2.0	< 2.0	< 2.0	< 2.0	< 2.0	< 2.0	< 2.0	< 2.0	< 2.0	< 2.0	< 2.0
19:00	< 2.0	< 2.0	< 2.0	< 2.0	< 2.0	< 2.0	< 2.0	< 2.0	< 2.0	< 2.0	< 2.0	< 2.0
19:10	< 2.0	< 2.0	< 2.0	< 2.0	< 2.0	< 2.0	< 2.0	< 2.0	< 2.0	< 2.0	< 2.0	< 2.0
19:20	544,000	544,000	54,000	54,000	5,400	5,400	250	250	250	250	30	30
19:30	572,000	572,000	57,200	57,200	5,700	5,700	275	275	275	275	35	35
19:40	552,000	552,000	55,200	55,200	5,520	5,520	265	265	265	265	30	30
19:50	532,000	532,000	53,200	53,200	5,320	5,320	255	255	255	255	30	30
20:00	512,000	512,000	51,200	51,200	5,120	5,120	245	245	245	245	30	30
20:10	492,000	492,000	49,200	49,200	4,920	4,920	235	235	235	235	30	30
20:20	476,000	476,000	47,600	47,600	4,760	4,760	230	230	230	230	30	30
20:30	460,000	460,000	46,000	46,000	4,600	4,600	220	220	220	220	20	20

THIRD FLOOR OFFICE BUILDING
AREA AIRBORNE & CONTAMINATION DATA

Time	10 Minute 60 lpm sample		Particulate Contact Dose Rate		Charcoal Contact Dose Rate	
	Net cpm		mR/hr		mR/hr	
	Part	Char	CW	OW	CW	OW
16:00	< 100	< 100	< 2.0	< 2.0	< 2.0	< 2.0
17:00	< 100	< 100	< 2.0	< 2.0	< 2.0	< 2.0
17:30	< 100	< 100	< 2.0	< 2.0	< 2.0	< 2.0
17:45	< 100	< 100	< 2.0	< 2.0	< 2.0	< 2.0
18:00	< 100	< 100	< 2.0	< 2.0	< 2.0	< 2.0
19:00	< 100	< 100	< 2.0	< 2.0	< 2.0	< 2.0
19:10	< 100	< 100	< 2.0	< 2.0	< 2.0	< 2.0
19:20	< 100	< 100	< 2.0	< 2.0	< 2.0	< 2.0
19:30	< 100	< 100	< 2.0	< 2.0	< 2.0	< 2.0
19:40	< 100	< 100	< 2.0	< 2.0	< 2.0	< 2.0
19:50	< 100	< 100	< 2.0	< 2.0	< 2.0	< 2.0
20:00	< 100	< 100	< 2.0	< 2.0	< 2.0	< 2.0
20:10	< 100	< 100	< 2.0	< 2.0	< 2.0	< 2.0
20:20	< 100	< 100	< 2.0	< 2.0	< 2.0	< 2.0
20:30	< 100	< 100	< 2.0	< 2.0	< 2.0	< 2.0

Time	Floor Contamination			Personnel Contamination		
	Netcpm	CW mR/hr	OW mR/hr	Netcpm	CW mR/hr	OW mR/hr
16:00	< 100	< 2.0	< 2.0	< 100	< 2.0	< 2.0
17:00	< 100	< 2.0	< 2.0	< 100	< 2.0	< 2.0
17:30	< 100	< 2.0	< 2.0	< 100	< 2.0	< 2.0
17:45	< 100	< 2.0	< 2.0	< 100	< 2.0	< 2.0
18:00	< 100	< 2.0	< 2.0	< 100	< 2.0	< 2.0
19:00	< 100	< 2.0	< 2.0	< 100	< 2.0	< 2.0
19:10	< 100	< 2.0	< 2.0	< 100	< 2.0	< 2.0
19:20	< 100	< 2.0	< 2.0	< 100	< 2.0	< 2.0
19:30	< 100	< 2.0	< 2.0	< 100	< 2.0	< 2.0
19:40	< 100	< 2.0	< 2.0	< 100	< 2.0	< 2.0
19:50	< 100	< 2.0	< 2.0	< 100	< 2.0	< 2.0
20:00	< 100	< 2.0	< 2.0	< 100	< 2.0	< 2.0
20:10	< 100	< 2.0	< 2.0	< 100	< 2.0	< 2.0
20:20	< 100	< 2.0	< 2.0	< 100	< 2.0	< 2.0
20:30	< 100	< 2.0	< 2.0	< 100	< 2.0	< 2.0

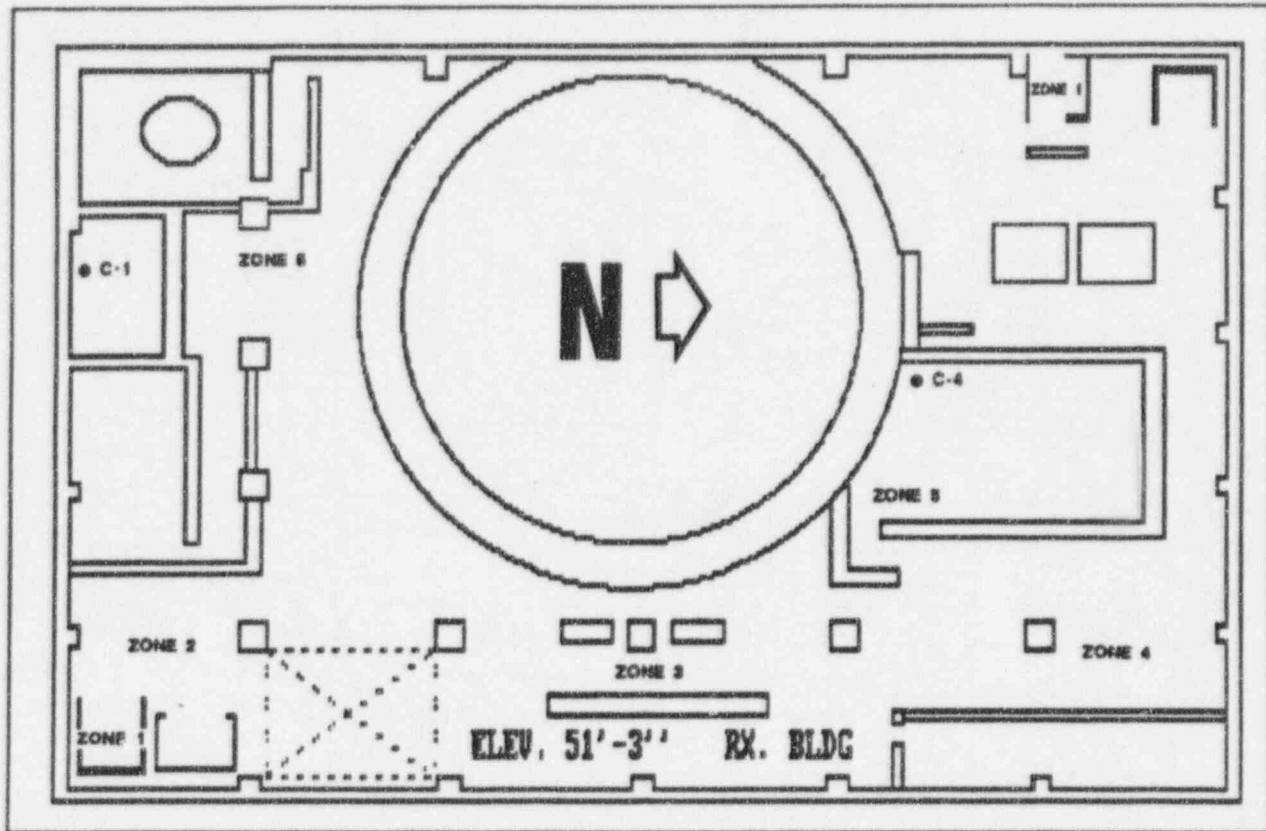

AREA DOSE RATES

TIME	ZONE 1		ZONE 2		ZONE 3		ZONE 4		ZONE 5		ZONE 6	
	mR/hr		mR/hr		mR/hr		mR/hr		mR/hr		mR/hr	
	CW	OW	CW	OW	CW	OW	CW	OW	CW	OW	CW	OW
16:00	< 2.0	< 2.0	< 2.0	< 2.0	< 2.0	< 2.0	< 2.0	< 2.0	< 2.0	< 2.0	< 2.0	< 2.0
17:00	< 2.0	< 2.0	< 2.0	< 2.0	< 2.0	< 2.0	< 2.0	< 2.0	< 2.0	< 2.0	< 2.0	< 2.0
17:30	2.0	2.0	10	10	80	80	10	10	500	500	5	5
17:45	3.0	3.0	15	15	100	100	20	20	2000	2000	10	10
18:00	4.0	4.0	20	20	200	200	40	40	2800	2800	20	20
19:00	5.0	5.0	25	25	300	300	60	60	2600	2600	30	30
19:10	6.0	6.0	30	30	400	400	80	80	2200	2200	40	40
19:20	544,000	544,000	5,440,000	7,020,000	5,440,000	7,020,000	5,440,000	7,020,000	5,440,000	7,020,000	5,440,000	7,020,000
19:30	572,000	572,000	5,720,000	7,150,000	5,720,000	7,150,000	5,720,000	7,150,000	5,720,000	7,150,000	5,720,000	7,150,000
19:40	552,000	552,000	5,520,000	6,900,000	5,520,000	6,900,000	5,520,000	6,900,000	5,520,000	6,900,000	5,520,000	6,900,000
19:50	532,000	532,000	5,320,000	6,650,000	5,320,000	6,650,000	5,320,000	6,650,000	5,320,000	6,650,000	5,320,000	6,650,000
20:00	512,000	512,000	5,120,000	6,400,000	5,120,000	6,400,000	5,120,000	6,400,000	5,120,000	6,400,000	5,120,000	6,400,000
20:10	492,000	492,000	4,920,000	6,150,000	4,920,000	6,150,000	4,920,000	6,150,000	4,920,000	6,150,000	4,920,000	6,150,000
20:20	476,000	476,000	4,760,000	5,950,000	4,760,000	5,950,000	4,760,000	5,950,000	4,760,000	5,950,000	4,760,000	5,950,000
20:30	460,000	460,000	4,600,000	5,750,000	4,600,000	5,750,000	4,600,000	5,750,000	4,600,000	5,750,000	4,600,000	5,750,000

RXB 51' ELEVATION
AREA AIRBORNE & CONTAMINATION DATA

Time	10 Minute 60 lpm sample		Particulate Contact Dose Rate		Charcoal Contact Dose Rate	
	Net cpm		mR/hr		mR/hr	
	Part	Char	CW	OW	CW	OW
	16:00	< 100	< 100	< 2.0	< 2.0	< 2.0
17:00	< 100	< 100	< 2.0	< 2.0	< 2.0	< 2.0
17:30	< 100	< 100	< 2.0	< 2.0	< 2.0	< 2.0
17:45	< 100	< 100	< 2.0	< 2.0	< 2.0	< 2.0
18:00	< 100	< 100	< 2.0	< 2.0	< 2.0	< 2.0
19:00	< 100	< 100	< 2.0	< 2.0	< 2.0	< 2.0
19:10	< 100	< 100	< 2.0	< 2.0	< 2.0	< 2.0
19:20	> 50,000	> 50,000	216,000,000	270,000,000	198,000	248,000
19:30	> 50,000	> 50,000	502,000,000	628,000,000	213,000	266,000
19:40	> 50,000	> 50,000	288,000,000	285,000,000	209,000	261,000
19:50	> 50,000	> 50,000	223,000,000	279,000,000	203,000	254,000
20:00	> 50,000	> 50,000	218,000,000	272,000,000	198,000	248,000
20:10	> 50,000	> 50,000	213,000,000	266,000,000	192,000	240,000
20:20	> 50,000	> 50,000	207,000,000	259,000,000	187,000	234,000
20:30	> 50,000	> 50,000	203,000,000	254,000,000	182,000	228,000

Time	Floor Contamination			Personnel Contamination		
	Netcpm	CW mR/hr	OW mR/hr	Netcpm	CW mR/hr	OW mR/hr
16:00	< 100	< 2.0	< 2.0	< 100	< 2.0	< 2.0
17:00	< 100	< 2.0	< 2.0	< 100	< 2.0	< 2.0
17:30	< 100	< 2.0	< 2.0	< 100	< 2.0	< 2.0
17:45	< 100	< 2.0	< 2.0	< 100	< 2.0	< 2.0
18:00	< 100	< 2.0	< 2.0	< 100	< 2.0	< 2.0
19:00	< 100	< 2.0	< 2.0	< 100	< 2.0	< 2.0
19:10	< 100	< 2.0	< 2.0	< 100	< 2.0	< 2.0
19:20	> 50,000	> 500,000	> 500,000	> 50,000	1,040,000	1,304,000
19:30	> 50,000	> 500,000	> 500,000	> 50,000	1,103,000	1,379,000
19:40	> 50,000	> 500,000	> 500,000	> 50,000	1,071,000	1,339,000
19:50	> 50,000	> 500,000	> 500,000	> 50,000	1,034,000	1,293,000
20:00	> 50,000	> 500,000	> 500,000	> 50,000	1,000,000	1,250,000
20:10	> 50,000	> 500,000	> 500,000	> 50,000	966,000	1,210,000
20:20	> 50,000	> 500,000	> 500,000	> 50,000	930,000	1,163,000
20:30	> 50,000	> 500,000	> 500,000	> 50,000	900,000	1,125,000

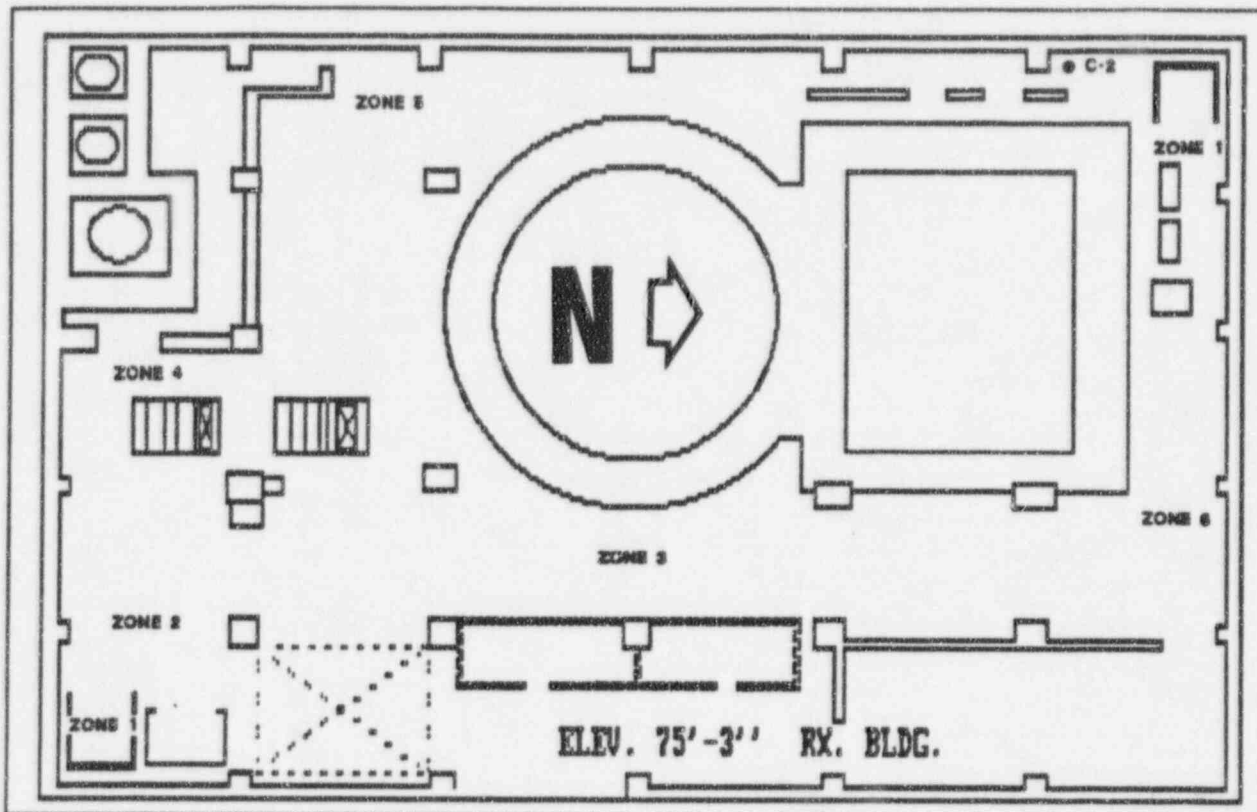

AREA DOSE RATES

TIME	ZONE 1		ZONE 2		ZONE 3		ZONE 4		ZONE 5		ZONE 6	
	mR/hr		mR/hr		mR/hr		mR/hr		mR/hr		mR/hr	
	CW	OW	CW	OW	CW	OW	CW	OW	CW	OW	CW	OW
16:00	< 2.0	< 2.0	< 2.0	< 2.0	< 2.0	< 2.0	< 2.0	< 2.0	< 2.0	< 2.0	< 2.0	< 2.0
17:00	< 2.0	< 2.0	< 2.0	< 2.0	< 2.0	< 2.0	< 2.0	< 2.0	< 2.0	< 2.0	< 2.0	< 2.0
17:30	50	50	200	200	1600	1600	100	100	20	20	100	100
17:45	55	55	225	225	1800	1800	110	110	25	25	110	110
18:00	60	60	250	250	2000	2000	125	125	30	30	125	125
19:00	65	65	280	280	2300	2300	150	150	35	35	150	150
19:10	70	70	320	320	2500	2500	160	160	40	40	160	160
19:20	544,000	544,000	5,440,000	7,020,000	5,440,000	7,020,000	5,440,000	7,020,000	5,440,000	7,020,000	5,440,000	7,020,000
19:30	572,000	572,000	5,720,000	7,150,000	5,720,000	7,150,000	5,720,000	7,150,000	5,720,000	7,150,000	5,720,000	7,150,000
19:40	552,000	552,000	5,520,000	6,900,000	5,520,000	6,900,000	5,520,000	6,900,000	5,520,000	6,900,000	5,520,000	6,900,000
19:50	532,000	532,000	5,320,000	6,650,000	5,320,000	6,650,000	5,320,000	6,650,000	5,320,000	6,650,000	5,320,000	6,650,000
20:00	512,000	512,000	5,120,000	6,400,000	5,120,000	6,400,000	5,120,000	6,400,000	5,120,000	6,400,000	5,120,000	6,400,000
20:10	492,000	492,000	4,920,000	6,150,000	4,920,000	6,150,000	4,920,000	6,150,000	4,920,000	6,150,000	4,920,000	6,150,000
20:20	476,000	476,000	4,760,000	5,950,000	4,760,000	5,950,000	4,760,000	5,950,000	4,760,000	5,950,000	4,760,000	5,950,000
20:30	460,000	460,000	4,600,000	5,750,000	4,600,000	5,750,000	4,600,000	5,750,000	4,600,000	5,750,000	4,600,000	5,750,000

RXB 75' ELEVATION
AREA AIRBORNE & CONTAMINATION DATA

Time	10 Minute 60 lpm sample		Particulate Contact Dose Rate		Charcoal Contact Dose Rate	
	Net cpm		mR/hr		mR/hr	
	Part	Char	CW	OW	CW	OW
	16:00	< 100	< 100	< 2.0	< 2.0	< 2.0
17:00	< 100	< 100	< 2.0	< 2.0	< 2.0	< 2.0
17:30	< 100	< 100	< 2.0	< 2.0	< 2.0	< 2.0
17:45	< 100	< 100	< 2.0	< 2.0	< 2.0	< 2.0
18:00	< 100	< 100	< 2.0	< 2.0	< 2.0	< 2.0
19:00	< 100	< 100	< 2.0	< 2.0	< 2.0	< 2.0
19:10	< 100	< 100	< 2.0	< 2.0	< 2.0	< 2.0
19:20	> 50,000	> 50,000	216,000,000	270,000,000	198,000	248,000
19:30	> 50,000	> 50,000	502,000,000	628,000,000	213,000	266,000
19:40	> 50,000	> 50,000	288,000,000	285,000,000	209,000	261,000
19:50	> 50,000	> 50,000	223,000,000	279,000,000	203,000	254,000
20:00	> 50,000	> 50,000	218,000,000	272,000,000	198,000	248,000
20:10	> 50,000	> 50,000	213,000,000	266,000,000	192,000	240,000
20:20	> 50,000	> 50,000	207,000,000	259,000,000	187,000	234,000
20:30	> 50,000	> 50,000	203,000,000	254,000,000	182,000	228,000

Time	Floor Contamination			Personnel Contamination		
	Netcpm	CW mR/hr	OW mR/hr	Netcpm	CW mR/hr	OW mR/hr
16:00	< 100	< 2.0	< 2.0	< 100	< 2.0	< 2.0
17:00	< 100	< 2.0	< 2.0	< 100	< 2.0	< 2.0
17:30	< 100	< 2.0	< 2.0	< 100	< 2.0	< 2.0
17:45	< 100	< 2.0	< 2.0	< 100	< 2.0	< 2.0
18:00	< 100	< 2.0	< 2.0	< 100	< 2.0	< 2.0
19:00	< 100	< 2.0	< 2.0	< 100	< 2.0	< 2.0
19:10	< 100	< 2.0	< 2.0	< 100	< 2.0	< 2.0
19:20	> 50,000	> 500,000	> 500,000	> 50,000	1,040,000	1,304,000
19:30	> 50,000	> 500,000	> 500,000	> 50,000	1,103,000	1,379,000
19:40	> 50,000	> 500,000	> 500,000	> 50,000	1,071,000	1,339,000
19:50	> 50,000	> 500,000	> 500,000	> 50,000	1,034,000	1,293,000
20:00	> 50,000	> 500,000	> 500,000	> 50,000	1,000,000	1,250,000
20:10	> 50,000	> 500,000	> 500,000	> 50,000	966,000	1,210,000
20:20	> 50,000	> 500,000	> 500,000	> 50,000	930,000	1,163,000
20:30	> 50,000	> 500,000	> 500,000	> 50,000	900,000	1,125,000

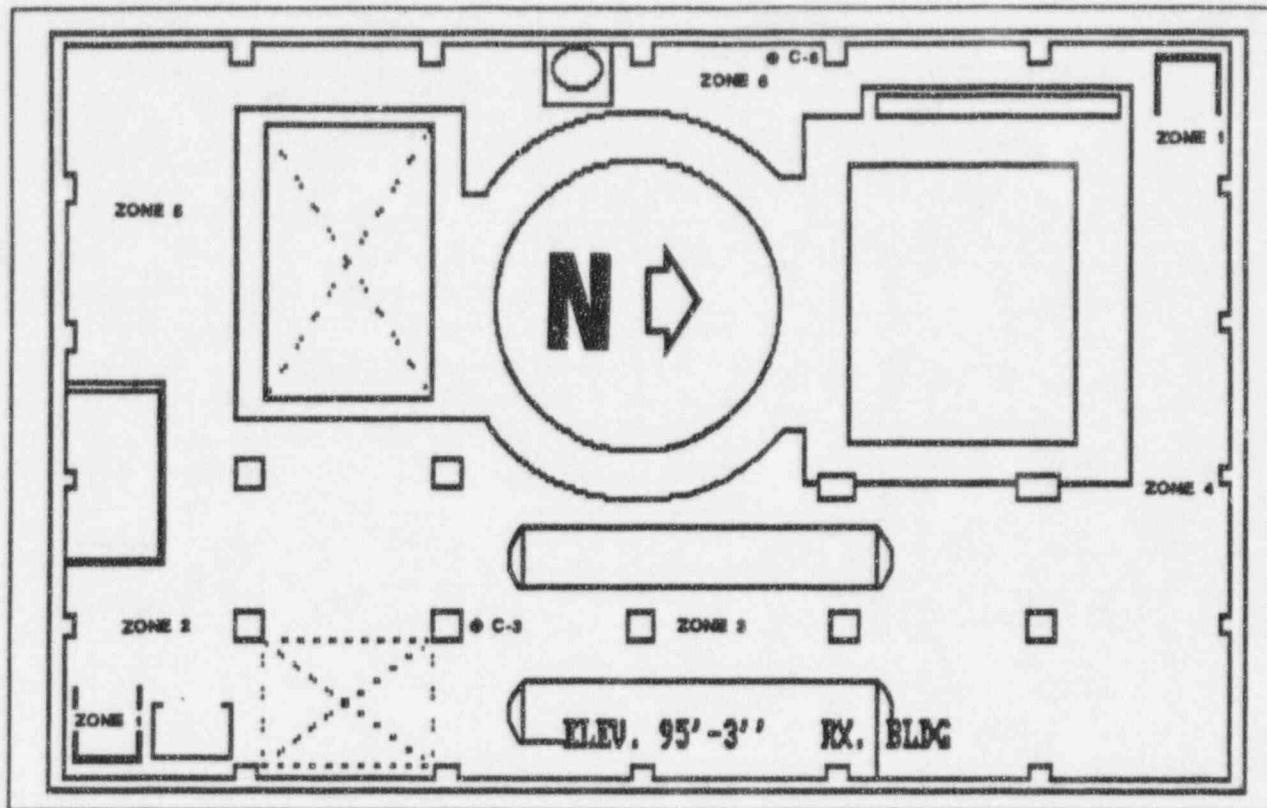

AREA DOSE RATES

TIME	ZONE 1		ZONE 2		ZONE 3		ZONE 4		ZONE 5		ZONE 6	
	mR/hr		mR/hr		mR/hr		mR/hr		mR/hr		mR/hr	
	CW	OW	CW	OW	CW	OW	CW	OW	CW	OW	CW	OW
16:00	< 2.0	< 2.0	< 2.0	< 2.0	< 2.0	< 2.0	< 2.0	< 2.0	< 2.0	< 2.0	< 2.0	< 2.0
17:00	< 2.0	< 2.0	< 2.0	< 2.0	< 2.0	< 2.0	< 2.0	< 2.0	< 2.0	< 2.0	< 2.0	< 2.0
17:30	10	10	50	50	800	800	50	50	10	10	5	5
17:45	55	55	225	225	2000	2000	110	110	25	25	5	5
18:00	60	60	250	250	2200	2200	125	125	30	30	5	5
19:00	65	65	280	280	2500	2500	150	150	35	35	5	5
19:10	70	75	320	320	2700	2700	160	160	40	40	5	5
19:20	544,000	544,000	5,440,000	7,020,000	5,440,000	7,020,000	5,440,000	7,020,000	5,440,000	7,020,000	5,440,000	7,020,000
19:30	572,000	572,000	5,720,000	7,150,000	5,720,000	7,150,000	5,720,000	7,150,000	5,720,000	7,150,000	5,720,000	7,150,000
19:40	552,000	552,000	5,520,000	6,900,000	5,520,000	6,900,000	5,520,000	6,900,000	5,520,000	6,900,000	5,520,000	6,900,000
19:50	532,000	532,000	5,320,000	6,650,000	5,320,000	6,650,000	5,320,000	6,650,000	5,320,000	6,650,000	5,320,000	6,650,000
20:00	512,000	512,000	5,120,000	6,400,000	5,120,000	6,400,000	5,120,000	6,400,000	5,120,000	6,400,000	5,120,000	6,400,000
20:10	492,000	492,000	4,920,000	6,150,000	4,920,000	6,150,000	4,920,000	6,150,000	4,920,000	6,150,000	4,920,000	6,150,000
20:20	476,000	476,000	4,760,000	5,950,000	4,760,000	5,950,000	4,760,000	5,950,000	4,760,000	5,950,000	4,760,000	5,950,000
20:30	460,000	460,000	4,600,000	5,750,000	4,600,000	5,750,000	4,600,000	5,750,000	4,600,000	5,750,000	4,600,000	5,750,000

RXB 95' ELEVATION
AREA AIRBORNE & CONTAMINATION DATA

Time	10 Minute 60 lpm sample		Particulate Contact Dose Rate		Charcoal Contact Dose Rate	
	Net cpm		mR/hr		mR/hr	
	Part	Char	CW	OW	CW	OW
16:00	< 100	< 100	< 2.0	< 2.0	< 2.0	< 2.0
17:00	< 100	< 100	< 2.0	< 2.0	< 2.0	< 2.0
17:30	< 100	< 100	< 2.0	< 2.0	< 2.0	< 2.0
17:45	< 100	< 100	< 2.0	< 2.0	< 2.0	< 2.0
18:00	< 100	< 100	< 2.0	< 2.0	< 2.0	< 2.0
19:00	< 100	< 100	< 2.0	< 2.0	< 2.0	< 2.0
19:10	< 100	< 100	< 2.0	< 2.0	< 2.0	< 2.0
19:20	> 50,000	> 50,000	216,000,000	270,000,000	198,000	248,000
19:30	> 50,000	> 50,000	502,000,000	628,000,000	213,000	266,000
19:40	> 50,000	> 50,000	288,000,000	285,000,000	209,000	261,000
19:50	> 50,000	> 50,000	223,000,000	279,000,000	203,000	254,000
20:00	> 50,000	> 50,000	218,000,000	272,000,000	198,000	248,000
20:10	> 50,000	> 50,000	213,000,000	266,000,000	192,000	240,000
20:20	> 50,000	> 50,000	207,000,000	259,000,000	187,000	234,000
20:30	> 50,000	> 50,000	203,000,000	254,000,000	182,000	228,000

Time	Floor Contamination			Personnel Contamination		
	Netcpm	CW mR/hr	OW mR/hr	Netcpm	CW mR/hr	OW mR/hr
16:00	< 100	< 2.0	< 2.0	< 100	< 2.0	< 2.0
17:00	< 100	< 2.0	< 2.0	< 100	< 2.0	< 2.0
17:30	< 100	< 2.0	< 2.0	< 100	< 2.0	< 2.0
17:45	< 100	< 2.0	< 2.0	< 100	< 2.0	< 2.0
18:00	< 100	< 2.0	< 2.0	< 100	< 2.0	< 2.0
19:00	< 100	< 2.0	< 2.0	< 100	< 2.0	< 2.0
19:10	< 100	< 2.0	< 2.0	< 100	< 2.0	< 2.0
19:20	> 50,000	> 500,000	> 500,000	> 50,000	1,040,000	1,304,000
19:30	> 50,000	> 500,000	> 500,000	> 50,000	1,103,000	1,379,000
19:40	> 50,000	> 500,000	> 500,000	> 50,000	1,071,000	1,339,000
19:50	> 50,000	> 500,000	> 500,000	> 50,000	1,034,000	1,293,000
20:00	> 50,000	> 500,000	> 500,000	> 50,000	1,000,000	1,250,000
20:10	> 50,000	> 500,000	> 500,000	> 50,000	966,000	1,210,000
20:20	> 50,000	> 500,000	> 500,000	> 50,000	930,000	1,163,000
20:30	> 50,000	> 500,000	> 500,000	> 50,000	900,000	1,125,000

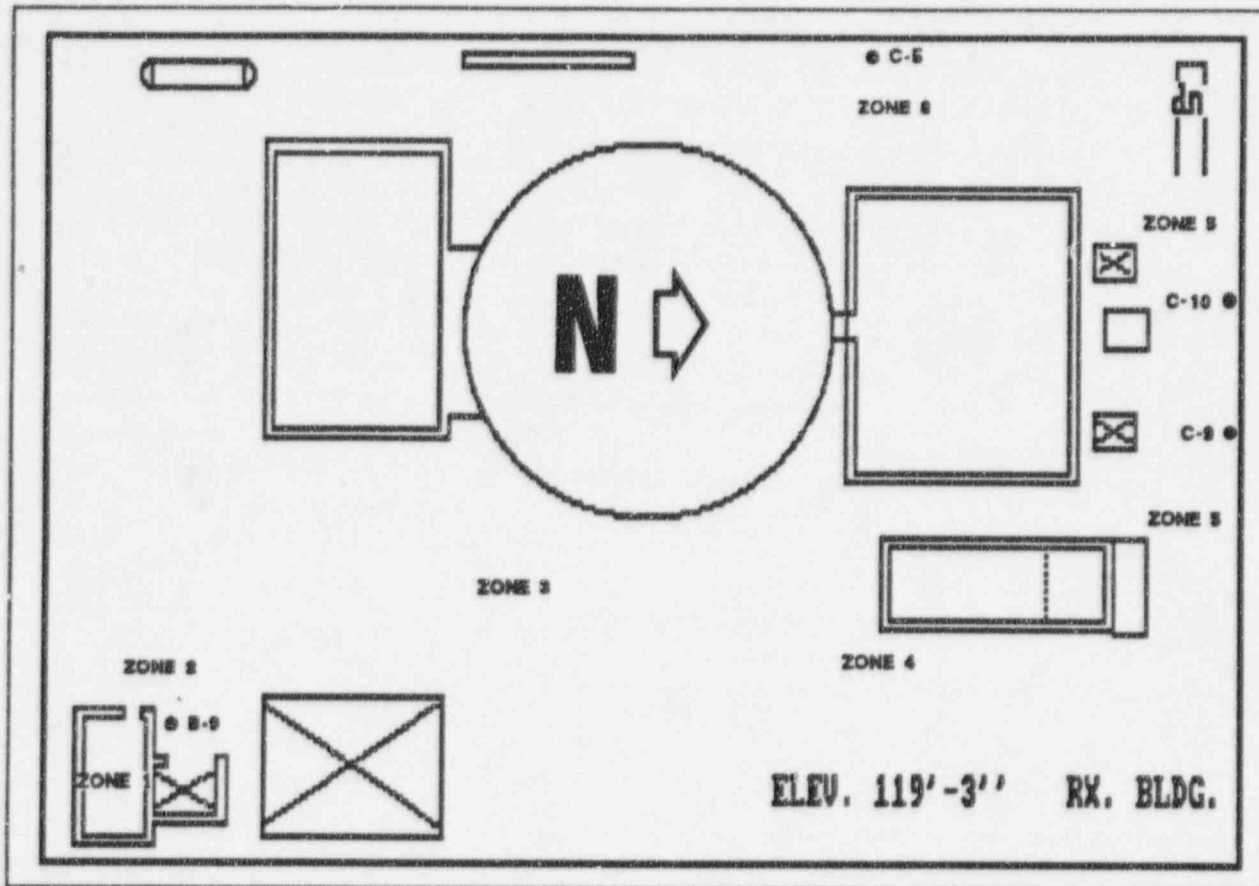

AREA DOSE RATES

TIME	ZONE 1		ZONE 2		ZONE 3		ZONE 4		ZONE 5		ZONE 6	
	mR/hr		mR/hr		mR/hr		mR/hr		mR/hr		mR/hr	
	CW	OW	CW	OW	CW	OW	CW	OW	CW	OW	CW	OW
16:00	< 2.0	< 2.0	< 2.0	< 2.0	< 2.0	< 2.0	< 2.0	< 2.0	< 2.0	< 2.0	< 2.0	< 2.0
17:00	< 2.0	< 2.0	< 2.0	< 2.0	< 2.0	< 2.0	< 2.0	< 2.0	< 2.0	< 2.0	< 2.0	< 2.0
17:30	< 2.0	< 2.0	5	5	2.5	2.5	< 2.0	< 2.0	< 2.0	< 2.0	< 2.0	< 2.0
17:45	5	5	25	25	10	10	< 2.0	< 2.0	< 2.0	< 2.0	< 2.0	< 2.0
18:00	5	5	25	25	10	10	< 2.0	< 2.0	< 2.0	< 2.0	< 2.0	< 2.0
19:00	5	5	30	30	15	15	< 2.0	< 2.0	< 2.0	< 2.0	< 2.0	< 2.0
19:10	5	5	30	30	15	15	< 2.0	< 2.0	< 2.0	< 2.0	< 2.0	< 2.0
19:20	544,000	544,000	5,440,000	7,020,000	5,440,000	7,020,000	5,440,000	7,020,000	5,440,000	7,020,000	5,440,000	7,020,000
19:30	572,000	572,000	5,720,000	7,150,000	5,720,000	7,150,000	5,720,000	7,150,000	5,720,000	7,150,000	5,720,000	7,150,000
19:40	552,000	552,000	5,520,000	6,900,000	5,520,000	6,900,000	5,520,000	6,900,000	5,520,000	6,900,000	5,520,000	6,900,000
19:50	532,000	532,000	5,320,000	6,650,000	5,320,000	6,650,000	5,320,000	6,650,000	5,320,000	6,650,000	5,320,000	6,650,000
20:00	512,000	512,000	5,120,000	6,400,000	5,120,000	6,400,000	5,120,000	6,400,000	5,120,000	6,400,000	5,120,000	6,400,000
20:10	492,000	492,000	4,920,000	6,150,000	4,920,000	6,150,000	4,920,000	6,150,000	4,920,000	6,150,000	4,920,000	6,150,000
20:20	476,000	476,000	4,760,000	5,950,000	4,760,000	5,950,000	4,760,000	5,950,000	4,760,000	5,950,000	4,760,000	5,950,000
20:30	460,000	460,000	4,600,000	5,750,000	4,600,000	5,750,000	4,600,000	5,750,000	4,600,000	5,750,000	4,600,000	5,750,000

RXB 119' ELEVATION
AREA AIRBORNE & CONTAMINATION DATA

Time	10 Minute 60 lpm sample		Particulate Contact Dose Rate		Charcoal Contact Dose Rate	
	Net cpm		mR/hr		mR/hr	
	Part	Char	CW	OW	CW	OW
16:00	< 100	< 100	< 2.0	< 2.0	< 2.0	< 2.0
17:00	< 100	< 100	< 2.0	< 2.0	< 2.0	< 2.0
17:30	< 100	< 100	< 2.0	< 2.0	< 2.0	< 2.0
17:45	< 100	< 100	< 2.0	< 2.0	< 2.0	< 2.0
18:00	< 100	< 100	< 2.0	< 2.0	< 2.0	< 2.0
19:00	< 100	< 100	< 2.0	< 2.0	< 2.0	< 2.0
19:10	< 100	< 100	< 2.0	< 2.0	< 2.0	< 2.0
19:20	> 50,000	> 50,000	216,000,000	270,000,000	190,000	248,000
19:30	> 50,000	> 50,000	502,000,000	628,000,000	213,000	266,000
19:40	> 50,000	> 50,000	288,000,000	285,000,000	209,000	261,000
19:50	> 50,000	> 50,000	223,000,000	279,000,000	203,000	254,000
20:00	> 50,000	> 50,000	218,000,000	272,000,000	198,000	248,000
20:10	> 50,000	> 50,000	213,000,000	266,000,000	192,000	240,000
20:20	> 50,000	> 50,000	207,000,000	259,000,000	187,000	234,000
20:30	> 50,000	> 50,000	203,000,000	254,000,000	182,000	228,000

Time	Floor Contamination			Personnel Contamination		
	Netcpm	CW mR/hr	OW mR/hr	Netcpm	CW mR/hr	OW mR/hr
16:00	< 100	< 2.0	< 2.0	< 100	< 2.0	< 2.0
17:00	< 100	< 2.0	< 2.0	< 100	< 2.0	< 2.0
17:30	< 100	< 2.0	< 2.0	< 100	< 2.0	< 2.0
17:45	< 100	< 2.0	< 2.0	< 100	< 2.0	< 2.0
18:00	< 100	< 2.0	< 2.0	< 100	< 2.0	< 2.0
19:00	< 100	< 2.0	< 2.0	< 100	< 2.0	< 2.0
19:10	< 100	< 2.0	< 2.0	< 100	< 2.0	< 2.0
19:20	> 50,000	> 500,000	> 500,000	> 50,000	1,040,000	1,304,000
19:30	> 50,000	> 500,000	> 500,000	> 50,000	1,103,000	1,379,000
19:40	> 50,000	> 500,000	> 500,000	> 50,000	1,071,000	1,339,000
19:50	> 50,000	> 500,000	> 500,000	> 50,000	1,034,000	1,293,000
20:00	> 50,000	> 500,000	> 500,000	> 50,000	1,000,000	1,250,000
20:10	> 50,000	> 500,000	> 500,000	> 50,000	966,000	1,210,000
20:20	> 50,000	> 500,000	> 500,000	> 50,000	930,000	1,163,000
20:30	> 50,000	> 500,000	> 500,000	> 50,000	900,000	1,125,000

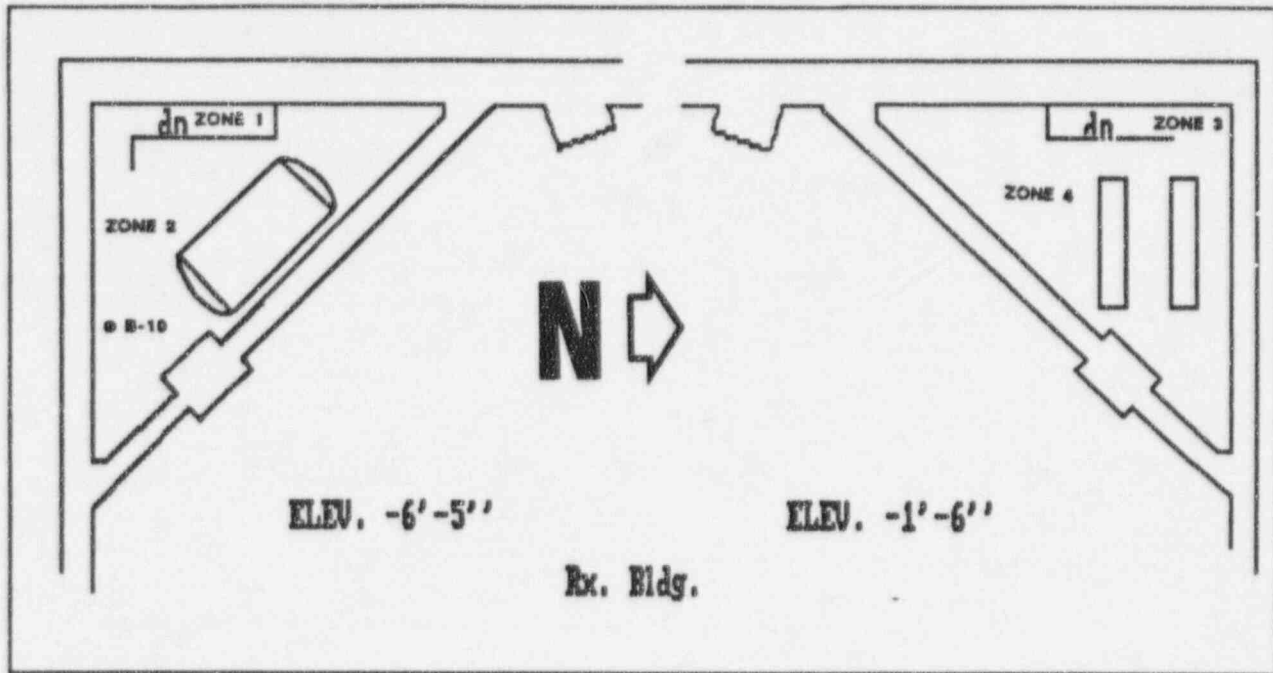

AREA DOSE RATES

TIME	ZONE 1		ZONE 2		ZONE 3		ZONE 4	
	mR/hr		mR/hr		mR/hr		mR/hr	
	CW	OW	CW	OW	CW	OW	CW	OW
16:00	< 2.0	< 2.0	30.	30.	< 2.0	< 2.0	30.	30.
17:00	< 2.0	< 2.0	30.	30.	< 2.0	< 2.0	30.	30.
17:30	< 2.0	< 2.0	30.	30.	< 2.0	< 2.0	30.	30.
17:45	< 2.0	< 2.0	30.	30.	< 2.0	< 2.0	30.	30.
18:00	< 2.0	< 2.0	30.	30.	< 2.0	< 2.0	30.	30.
19:00	< 2.0	< 2.0	30.	30.	< 2.0	< 2.0	30.	30.
19:10	< 2.0	< 2.0	30.	30.	< 2.0	< 2.0	30.	30.
19:20	5,440,000	7,020,000	5,440,000	7,020,000	5,440,000	7,020,000	5,440,000	7,020,000
19:30	5,720,000	7,150,000	5,720,000	7,150,000	5,720,000	7,150,000	5,720,000	7,150,000
19:40	5,520,000	6,900,000	5,520,000	6,900,000	5,520,000	6,900,000	5,520,000	6,900,000
19:50	5,320,000	6,650,000	5,320,000	6,650,000	5,320,000	6,650,000	5,320,000	6,650,000
20:00	5,120,000	6,400,000	5,120,000	6,400,000	5,120,000	6,400,000	5,120,000	6,400,000
20:10	4,920,000	6,150,000	4,920,000	6,150,000	4,920,000	6,150,000	4,920,000	6,150,000
20:20	4,760,000	5,950,000	4,760,000	5,950,000	4,760,000	5,950,000	4,760,000	5,950,000
20:30	4,600,000	5,750,000	4,600,000	5,750,000	4,600,000	5,750,000	4,600,000	5,750,000

RXB -6' ELEVATION
AREA AIRBORNE & CONTAMINATION DATA

Time	10 Minute 60 lpm sample		Particulate Contact Dose Rate		Charcoal Contact Dose Rate	
	Net cpm		mR/hr		mR/hr	
	Part	Char	CW	OW	CW	OW
16:00	< 100	< 100	< 2.0	< 2.0	< 2.0	< 2.0
17:00	< 100	< 100	< 2.0	< 2.0	< 2.0	< 2.0
17:30	< 100	< 100	< 2.0	< 2.0	< 2.0	< 2.0
17:45	< 100	< 100	< 2.0	< 2.0	< 2.0	< 2.0
18:00	< 100	< 100	< 2.0	< 2.0	< 2.0	< 2.0
19:00	< 100	< 100	< 2.0	< 2.0	< 2.0	< 2.0
19:10	< 100	< 100	< 2.0	< 2.0	< 2.0	< 2.0
19:20	> 50,000	> 50,000	216,000,000	270,000,000	198,000	248,000
19:30	> 50,000	> 50,000	502,000,000	628,000,000	213,000	266,000
19:40	> 50,000	> 50,000	288,000,000	285,000,000	209,000	261,000
19:50	> 50,000	> 50,000	223,000,000	279,000,000	203,000	254,000
20:00	> 50,000	> 50,000	218,000,000	272,000,000	198,000	248,000
20:10	> 50,000	> 50,000	213,000,000	266,000,000	192,000	240,000
20:20	> 50,000	> 50,000	207,000,000	259,000,000	187,000	234,000
20:30	> 50,000	> 50,000	203,000,000	254,000,000	182,000	228,000

Time	Floor Contamination			Personnel Contamination		
	Netcpm	CW mR/hr	OW mR/hr	Netcpm	CW mR/hr	OW mR/hr
16:00	< 100	< 2.0	< 2.0	< 100	< 2.0	< 2.0
17:00	< 100	< 2.0	< 2.0	< 100	< 2.0	< 2.0
17:30	< 100	< 2.0	< 2.0	< 100	< 2.0	< 2.0
17:45	< 100	< 2.0	< 2.0	< 100	< 2.0	< 2.0
18:00	< 100	< 2.0	< 2.0	< 100	< 2.0	< 2.0
19:00	< 100	< 2.0	< 2.0	< 100	< 2.0	< 2.0
19:10	< 100	< 2.0	< 2.0	< 100	< 2.0	< 2.0
19:20	> 50,000	> 500,000	> 500,000	> 50,000	1,040,000	1,304,000
19:30	> 50,000	> 500,000	> 500,000	> 50,000	1,103,000	1,379,000
19:40	> 50,000	> 500,000	> 500,000	> 50,000	1,071,000	1,339,000
19:50	> 50,000	> 500,000	> 500,000	> 50,000	1,034,000	1,293,000
20:00	> 50,000	> 500,000	> 500,000	> 50,000	1,000,000	1,250,000
20:10	> 50,000	> 500,000	> 500,000	> 50,000	966,000	1,210,000
20:20	> 50,000	> 500,000	> 500,000	> 50,000	930,000	1,163,000
20:30	> 50,000	> 500,000	> 500,000	> 50,000	900,000	1,125,000

RXB -19' ELEVATION
AREA AIRBORNE & CONTAMINATION DATA

Time	10 Minute 60 lpm sample		Particulate Contact Dose Rate		Charcoal Contact Dose Rate	
	Net cpm		mR/hr		mR/hr	
	Part	Char	CW	OW	CW	OW
	16:00	< 100	< 100	< 2.0	< 2.0	< 2.0
17:00	< 100	< 100	< 2.0	< 2.0	< 2.0	< 2.0
17:30	< 100	< 100	< 2.0	< 2.0	< 2.0	< 2.0
17:45	< 100	< 100	< 2.0	< 2.0	< 2.0	< 2.0
18:00	< 100	< 100	< 2.0	< 2.0	< 2.0	< 2.0
19:00	< 100	< 100	< 2.0	< 2.0	< 2.0	< 2.0
19:10	< 100	< 100	< 2.0	< 2.0	< 2.0	< 2.0
19:20	> 50,000	> 50,000	216,000,000	270,000,000	198,000	248,000
19:30	> 50,000	> 50,000	502,000,000	628,000,000	213,000	266,000
19:40	> 50,000	> 50,000	288,000,000	285,000,000	209,000	261,000
19:50	> 50,000	> 50,000	223,000,000	279,000,000	203,000	254,000
20:00	> 50,000	> 50,000	218,000,000	272,000,000	198,000	248,000
20:10	> 50,000	> 50,000	213,000,000	266,000,000	192,000	240,000
20:20	> 50,000	> 50,000	207,000,000	259,000,000	187,000	234,000
20:30	> 50,000	> 50,000	203,000,000	254,000,000	182,000	228,000

Time	Floor Contamination			Personnel Contamination		
	Netcpm	CW mR/hr	OW mR/hr	Netcpm	CW mR/hr	OW mR/hr
16:00	< 100	< 2.0	< 2.0	< 100	< 2.0	< 2.0
17:00	< 100	< 2.0	< 2.0	< 100	< 2.0	< 2.0
17:30	< 100	< 2.0	< 2.0	< 100	< 2.0	< 2.0
17:45	< 100	< 2.0	< 2.0	< 100	< 2.0	< 2.0
18:00	< 100	< 2.0	< 2.0	< 100	< 2.0	< 2.0
19:00	< 100	< 2.0	< 2.0	< 100	< 2.0	< 2.0
19:10	< 100	< 2.0	< 2.0	< 100	< 2.0	< 2.0
19:20	> 50,000	> 500,000	> 500,000	> 50,000	1,040,000	1,304,000
19:30	> 50,000	> 500,000	> 500,000	> 50,000	1,103,000	1,379,000
19:40	> 50,000	> 500,000	> 500,000	> 50,000	1,071,000	1,339,000
19:50	> 50,000	> 500,000	> 500,000	> 50,000	1,034,000	1,293,000
20:00	> 50,000	> 500,000	> 500,000	> 50,000	1,000,000	1,250,000
20:10	> 50,000	> 500,000	> 500,000	> 50,000	966,000	1,210,000
20:20	> 50,000	> 500,000	> 500,000	> 50,000	930,000	1,163,000
20:30	> 50,000	> 500,000	> 500,000	> 50,000	900,000	1,125,000

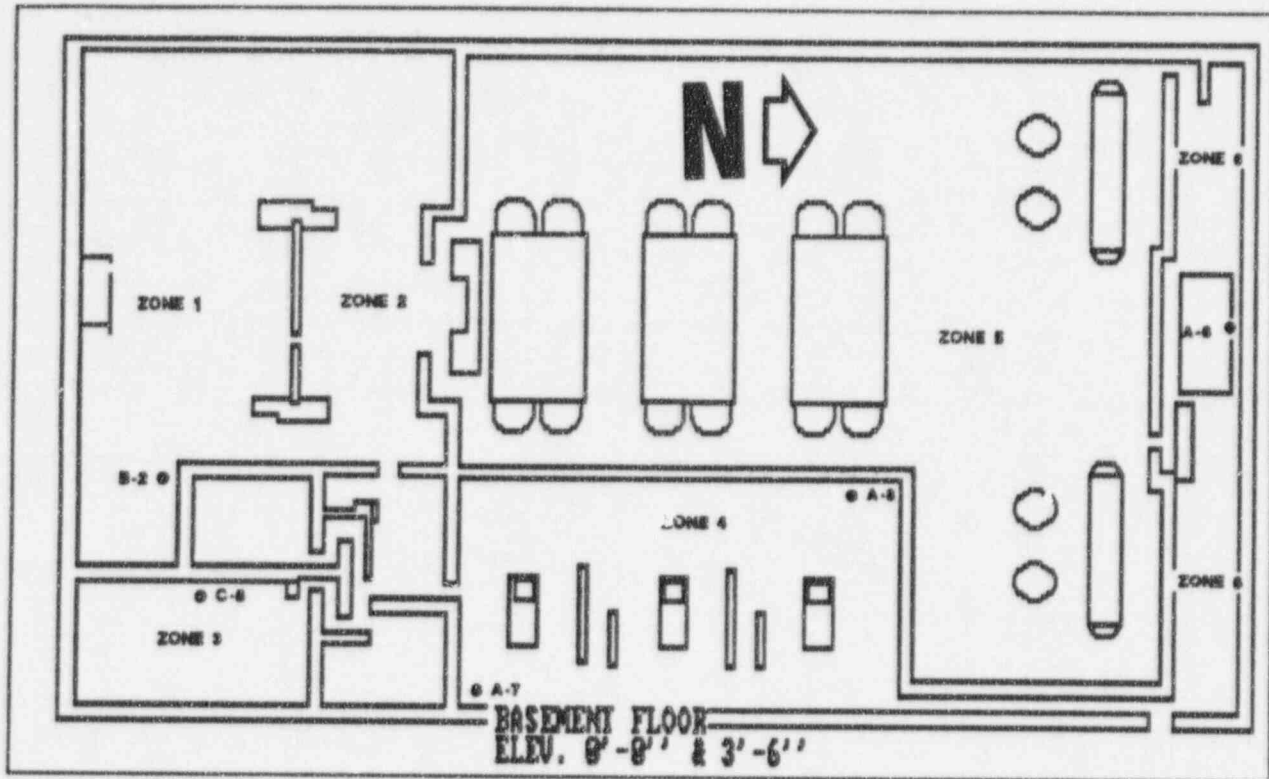

AREA DOSE RATES

TIME	ZONE 1		ZONE 2		ZONE 3		ZONE 4		ZONE 5		ZONE 6	
	mR/hr		mR/hr		mR/hr		mR/hr		mR/hr		mR/hr	
	CW	OW	CW	OW	CW	OW	CW	OW	CW	OW	CW	OW
16:00	< 2.0	< 2.0	< 2.0	< 2.0	< 2.0	< 2.0	3.	3.	240.	240.	< 2.0	< 2.0
17:00	< 2.0	< 2.0	< 2.0	< 2.0	< 2.0	< 2.0	3.	3.	240.	240.	< 2.0	< 2.0
17:30	< 2.0	< 2.0	< 2.0	< 2.0	< 2.0	< 2.0	3.	3.	240.	240.	< 2.0	< 2.0
17:45	< 2.0	< 2.0	< 2.0	< 2.0	< 2.0	< 2.0	3.	3.	240.	240.	< 2.0	< 2.0
18:00	< 2.0	< 2.0	< 2.0	< 2.0	< 2.0	< 2.0	85.	85.	1240.	1240.	< 2.0	< 2.0
19:00	< 2.0	< 2.0	< 2.0	< 2.0	< 2.0	< 2.0	160.	160.	1240.	1240.	< 2.0	< 2.0
19:10	< 2.0	< 2.0	< 2.0	< 2.0	< 2.0	< 2.0	235.	235.	1240.	1240.	< 2.0	< 2.0
19:20	< 2.0	< 2.0	< 2.0	< 2.0	< 2.0	< 2.0	310.	310.	1240.	1240.	< 2.0	< 2.0
19:30	< 2.0	< 2.0	< 2.0	< 2.0	< 2.0	< 2.0	310.	310.	1240.	1240.	< 2.0	< 2.0
19:40	< 2.0	< 2.0	< 2.0	< 2.0	< 2.0	< 2.0	310.	310.	1240.	1240.	< 2.0	< 2.0
19:50	< 2.0	< 2.0	< 2.0	< 2.0	< 2.0	< 2.0	310.	310.	1240.	1240.	< 2.0	< 2.0
20:00	< 2.0	< 2.0	< 2.0	< 2.0	< 2.0	< 2.0	310.	310.	1240.	1240.	< 2.0	< 2.0
20:10	< 2.0	< 2.0	< 2.0	< 2.0	< 2.0	< 2.0	295.	295.	1240.	1240.	< 2.0	< 2.0
20:20	< 2.0	< 2.0	< 2.0	< 2.0	< 2.0	< 2.0	285.	285.	1240.	1240.	< 2.0	< 2.0
20:30	< 2.0	< 2.0	< 2.0	< 2.0	< 2.0	< 2.0	270.	270.	1240.	1240.	< 2.0	< 2.0

TB BASEMENT ELEVATION
AREA AIRBORNE & CONTAMINATION DATA

Time	10 Minute 60 lpm sample		Particulate Contact Dose Rate		Charcoal Contact Dose Rate	
	Net cpm		mR/hr		mR/hr	
	Part	Char	CW	OW	CW	OW
16:00	< 100	< 100	< 2.0	< 2.0	< 2.0	< 2.0
17:00	< 100	< 100	< 2.0	< 2.0	< 2.0	< 2.0
17:30	< 100	< 100	< 2.0	< 2.0	< 2.0	< 2.0
17:45	< 100	< 100	< 2.0	< 2.0	< 2.0	< 2.0
18:00	< 100	< 100	< 2.0	< 2.0	< 2.0	< 2.0
19:00	< 100	< 100	< 2.0	< 2.0	< 2.0	< 2.0
19:10	< 100	< 100	< 2.0	< 2.0	< 2.0	< 2.0
19:20	< 100	< 100	< 2.0	< 2.0	< 2.0	< 2.0
19:30	< 100	< 100	< 2.0	< 2.0	< 2.0	< 2.0
19:40	< 100	< 100	< 2.0	< 2.0	< 2.0	< 2.0
19:50	< 100	< 100	< 2.0	< 2.0	< 2.0	< 2.0
20:00	< 100	< 100	< 2.0	< 2.0	< 2.0	< 2.0
20:10	< 100	< 100	< 2.0	< 2.0	< 2.0	< 2.0
20:20	< 100	< 100	< 2.0	< 2.0	< 2.0	< 2.0
20:30	< 100	< 100	< 2.0	< 2.0	< 2.0	< 2.0

Time	Floor Contamination			Personnel Contamination		
	Netcpm	CW mR/hr	OW mR/hr	Netcpm	CW mR/hr	OW mR/hr
16:00	< 100	< 2.0	< 2.0	< 100	< 2.0	< 2.0
17:00	< 100	< 2.0	< 2.0	< 100	< 2.0	< 2.0
17:30	< 100	< 2.0	< 2.0	< 100	< 2.0	< 2.0
17:45	< 100	< 2.0	< 2.0	< 100	< 2.0	< 2.0
18:00	< 100	< 2.0	< 2.0	< 100	< 2.0	< 2.0
19:00	< 100	< 2.0	< 2.0	< 100	< 2.0	< 2.0
19:10	< 100	< 2.0	< 2.0	< 100	< 2.0	< 2.0
19:20	< 100	< 2.0	< 2.0	< 100	< 2.0	< 2.0
19:30	< 100	< 2.0	< 2.0	< 100	< 2.0	< 2.0
19:40	< 100	< 2.0	< 2.0	< 100	< 2.0	< 2.0
19:50	< 100	< 2.0	< 2.0	< 100	< 2.0	< 2.0
20:00	< 100	< 2.0	< 2.0	< 100	< 2.0	< 2.0
20:10	< 100	< 2.0	< 2.0	< 100	< 2.0	< 2.0
20:20	< 100	< 2.0	< 2.0	< 100	< 2.0	< 2.0
20:30	< 100	< 2.0	< 2.0	< 100	< 2.0	< 2.0

TB MEZZANINE ELEVATION
AREA AIRBORNE & CONTAMINATION DATA

Time	10 Minute 60 lpm sample		Particulate Contact Dose Rate		Charcoal Contact Dose Rate	
	Net cpm		mR/hr		mR/hr	
	Part	Char	CW	OW	CW	OW
16:00	< 100	< 100	< 2.0	< 2.0	< 2.0	< 2.0
17:00	< 100	< 100	< 2.0	< 2.0	< 2.0	< 2.0
17:30	< 100	< 100	< 2.0	< 2.0	< 2.0	< 2.0
17:45	< 100	< 100	< 2.0	< 2.0	< 2.0	< 2.0
18:00	< 100	< 100	< 2.0	< 2.0	< 2.0	< 2.0
19:00	< 100	< 100	< 2.0	< 2.0	< 2.0	< 2.0
19:10	< 100	< 100	< 2.0	< 2.0	< 2.0	< 2.0
19:20	< 100	< 100	< 2.0	< 2.0	< 2.0	< 2.0
19:30	< 100	< 100	< 2.0	< 2.0	< 2.0	< 2.0
19:40	< 100	< 100	< 2.0	< 2.0	< 2.0	< 2.0
19:50	< 100	< 100	< 2.0	< 2.0	< 2.0	< 2.0
20:00	< 100	< 100	< 2.0	< 2.0	< 2.0	< 2.0
20:10	< 100	< 100	< 2.0	< 2.0	< 2.0	< 2.0
20:20	< 100	< 100	< 2.0	< 2.0	< 2.0	< 2.0
20:30	< 100	< 100	< 2.0	< 2.0	< 2.0	< 2.0

Time	Floor Contamination			Personnel Contamination		
	Netcpm	CW mR/hr	OW mR/hr	Netcpm	CW mR/hr	OW mR/hr
16:00	< 100	< 2.0	< 2.0	< 100	< 2.0	< 2.0
17:00	< 100	< 2.0	< 2.0	< 100	< 2.0	< 2.0
17:30	< 100	< 2.0	< 2.0	< 100	< 2.0	< 2.0
17:45	< 100	< 2.0	< 2.0	< 100	< 2.0	< 2.0
18:00	< 100	< 2.0	< 2.0	< 100	< 2.0	< 2.0
19:00	< 100	< 2.0	< 2.0	< 100	< 2.0	< 2.0
19:10	< 100	< 2.0	< 2.0	< 100	< 2.0	< 2.0
19:20	< 100	< 2.0	< 2.0	< 100	< 2.0	< 2.0
19:30	< 100	< 2.0	< 2.0	< 100	< 2.0	< 2.0
19:40	< 100	< 2.0	< 2.0	< 100	< 2.0	< 2.0
19:50	< 100	< 2.0	< 2.0	< 100	< 2.0	< 2.0
20:00	< 100	< 2.0	< 2.0	< 100	< 2.0	< 2.0
20:10	< 100	< 2.0	< 2.0	< 100	< 2.0	< 2.0
20:20	< 100	< 2.0	< 2.0	< 100	< 2.0	< 2.0
20:30	< 100	< 2.0	< 2.0	< 100	< 2.0	< 2.0

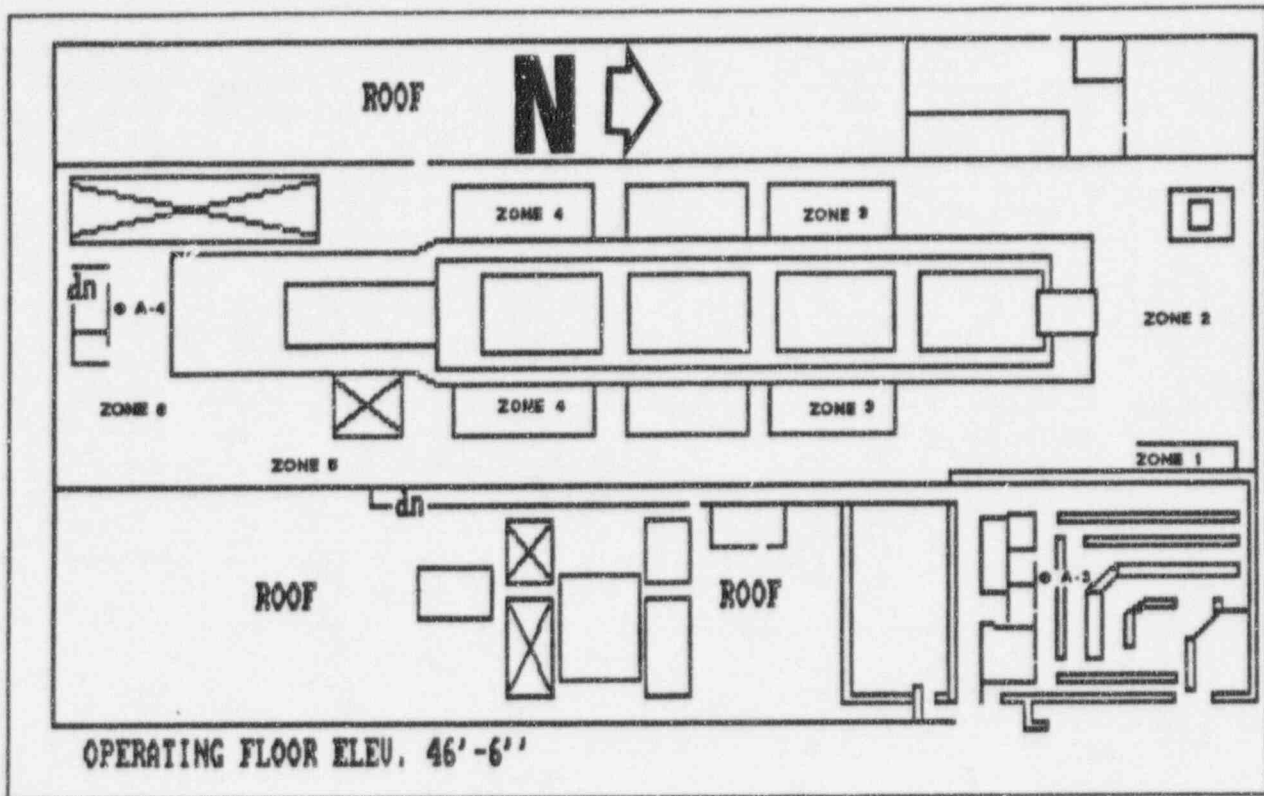

AREA DOSE RATES

TIME	ZONE 1		ZONE 2		ZONE 3		ZONE 4		ZONE 5		ZONE 6	
	mR/hr		mR/hr		mR/hr		mR/hr		mR/hr		mR/hr	
	CW	OW	CW	OW	CW	OW	CW	OW	CW	OW	CW	OW
16:00	< 2.0	< 2.0	10.	10.	30.	30.	30.	30.	10.	10.	< 2.0	< 2.0
17:00	< 2.0	< 2.0	10.	10.	30.	30.	30.	30.	10.	10.	< 2.0	< 2.0
17:30	< 2.0	< 2.0	10.	10.	30.	30.	30.	30.	10.	10.	< 2.0	< 2.0
17:45	60.	60.	250.	250.	350.	350.	350.	350.	300.	300.	270.	270.
18:00	60.	60.	230.	230.	330.	330.	330.	330.	280.	280.	250.	250.
19:00	60.	50.	230.	230.	330.	330.	330.	330.	280.	280.	250.	250.
19:10	50.	50.	220.	220.	300.	300.	300.	300.	270.	270.	240.	240.
19:20	50.	50.	220.	220.	300.	300.	300.	300.	270.	270.	240.	240.
19:30	50.	50.	220.	220.	300.	300.	300.	300.	270.	270.	240.	240.
19:40	50.	50.	215.	215.	290.	290.	290.	290.	260.	260.	235.	235.
19:50	50.	50.	215.	215.	290.	290.	290.	290.	260.	260.	235.	235.
20:00	50.	50.	215.	215.	290.	290.	290.	290.	260.	260.	235.	235.
20:10	50.	50.	210.	210.	290.	290.	290.	290.	260.	260.	230.	230.
20:20	50.	50.	210.	210.	290.	290.	290.	290.	260.	260.	230.	230.
20:30	50.	50.	210.	210.	290.	290.	290.	290.	260.	260.	230.	230.

**TB OPERATING FLOOR ELEVATION
AREA AIRBORNE & CONTAMINATION DATA**

Time	10 Minute 60 lpm sample		Particulate Contact Dose Rate		Charcoal Contact Dose Rate	
	Net cpm		mR/hr		mR/hr	
	Part	Char	CW	OW	CW	OW
16:00	< 100	< 100	< 2.0	< 2.0	< 2.0	< 2.0
17:00	< 100	< 100	< 2.0	< 2.0	< 2.0	< 2.0
17:30	< 100	< 100	< 2.0	< 2.0	< 2.0	< 2.0
17:45	< 100	< 100	< 2.0	< 2.0	< 2.0	< 2.0
18:00	< 100	< 100	< 2.0	< 2.0	< 2.0	< 2.0
19:00	< 100	< 100	< 2.0	< 2.0	< 2.0	< 2.0
19:10	< 100	< 100	< 2.0	< 2.0	< 2.0	< 2.0
19:20	< 100	< 100	< 2.0	< 2.0	< 2.0	< 2.0
19:30	< 100	< 100	< 2.0	< 2.0	< 2.0	< 2.0
19:40	< 100	< 100	< 2.0	< 2.0	< 2.0	< 2.0
19:50	< 100	< 100	< 2.0	< 2.0	< 2.0	< 2.0
20:00	< 100	< 100	< 2.0	< 2.0	< 2.0	< 2.0
20:10	< 100	< 100	< 2.0	< 2.0	< 2.0	< 2.0
20:20	< 100	< 100	< 2.0	< 2.0	< 2.0	< 2.0
20:30	< 100	< 100	< 2.0	< 2.0	< 2.0	< 2.0

Time	Floor Contamination			Personnel Contamination		
	Netcpm	CW mR/hr	OW mR/hr	Netcpm	CW mR/hr	OW mR/hr
16:00	< 100	< 2.0	< 2.0	< 100	< 2.0	< 2.0
17:00	< 100	< 2.0	< 2.0	< 100	< 2.0	< 2.0
17:30	< 100	< 2.0	< 2.0	< 100	< 2.0	< 2.0
17:45	< 100	< 2.0	< 2.0	< 100	< 2.0	< 2.0
18:00	< 100	< 2.0	< 2.0	< 100	< 2.0	< 2.0
19:00	< 100	< 2.0	< 2.0	< 100	< 2.0	< 2.0
19:10	< 100	< 2.0	< 2.0	< 100	< 2.0	< 2.0
19:20	< 100	< 2.0	< 2.0	< 100	< 2.0	< 2.0
19:30	< 100	< 2.0	< 2.0	< 100	< 2.0	< 2.0
19:40	< 100	< 2.0	< 2.0	< 100	< 2.0	< 2.0
19:50	< 100	< 2.0	< 2.0	< 100	< 2.0	< 2.0
20:00	< 100	< 2.0	< 2.0	< 100	< 2.0	< 2.0
20:10	< 100	< 2.0	< 2.0	< 100	< 2.0	< 2.0
20:20	< 100	< 2.0	< 2.0	< 100	< 2.0	< 2.0
20:30	< 100	< 2.0	< 2.0	< 100	< 2.0	< 2.0

SECTION III C

ON-SITE AND ERF DOSE RATES

SECTION III C
Emergency Center Dose Rates

(T = 00:00) (CT = 16:00)

Emergency CENTER	PARTICULATE AIR SAMPLE					SILVER ZEOLITE AIR SAMPLE				SMEAR SURVEY	
	CLOSED WINDOW	OPEN WINDOW	COUNT RATE	DOSE RATE		COUNT RATE	DOSE RATE		DOSE RATE		
	(mR/hr)	(mR/hr)	(cpm per 10 min)	OPEN WINDOW (mR/hr)	CLOSED WINDOW (mR/hr)	(cpm per 10 min)	OPEN WINDOW (mR/hr)	CLOSED WINDOW (mR/hr)	(cpm per 100 cm2)	OPEN WINDOW (mR/hr)	CLOSED WINDOW (mR/hr)
ECC	< 2.	< 2.	< 100.	< 2.0	< 2.0	< 100.	< 2.0	< 2.0	< 100.	< 2.0	< 2.0
OSC	< 2.	< 2.	< 100.	< 2.0	< 2.0	< 100.	< 2.0	< 2.0	< 100.	< 2.0	< 2.0
TSC	< 2.	< 2.	< 100.	< 2.0	< 2.0	< 100.	< 2.0	< 2.0	< 100.	< 2.0	< 2.0
EAA	< 2.	< 2.	< 100.	< 2.0	< 2.0	< 100.	< 2.0	< 2.0	< 100.	< 2.0	< 2.0
Main Gate	< 2.	< 2.	< 100.	< 2.0	< 2.0	< 100.	< 2.0	< 2.0	< 100.	< 2.0	< 2.0
Building 14	< 2.	< 2.	< 100.	< 2.0	< 2.0	< 100.	< 2.0	< 2.0	< 100.	< 2.0	< 2.0
New Office Bldg	< 2.	< 2.	< 100.	< 2.0	< 2.0	< 100.	< 2.0	< 2.0	< 100.	< 2.0	< 2.0

ONSITE MONITORING LOCATIONS

Emergency CENTER	PARTICULATE AIR SAMPLE					SILVER ZEOLITE AIR SAMPLE				SMEAR SURVEY	
	CLOSED WINDOW	OPEN WINDOW	COUNT RATE	DOSE RATE		COUNT RATE	DOSE RATE		DOSE RATE		
	(mR/hr)	(mR/hr)	(cpm per 10 min)	OPEN WINDOW (mR/hr)	CLOSED WINDOW (mR/hr)	(cpm per 10 min)	OPEN WINDOW (mR/hr)	CLOSED WINDOW (mR/hr)	(cpm per 100 cm2)	OPEN WINDOW (mR/hr)	CLOSED WINDOW (mR/hr)
N	< 2.	< 2.	< 100.	< 2.0	< 2.0	< 100.	< 2.0	< 2.0	< 100.	< 2.0	< 2.0
NNE	< 2.	< 2.	< 100.	< 2.0	< 2.0	< 100.	< 2.0	< 2.0	< 100.	< 2.0	< 2.0
NE	< 2.	< 2.	< 100.	< 2.0	< 2.0	< 100.	< 2.0	< 2.0	< 100.	< 2.0	< 2.0
ENE	< 2.	< 2.	< 100.	< 2.0	< 2.0	< 100.	< 2.0	< 2.0	< 100.	< 2.0	< 2.0
E	< 2.	< 2.	< 100.	< 2.0	< 2.0	< 100.	< 2.0	< 2.0	< 100.	< 2.0	< 2.0
ESE	< 2.	< 2.	< 100.	< 2.0	< 2.0	< 100.	< 2.0	< 2.0	< 100.	< 2.0	< 2.0
SE	< 2.	< 2.	< 100.	< 2.0	< 2.0	< 100.	< 2.0	< 2.0	< 100.	< 2.0	< 2.0
SSE	< 2.	< 2.	< 100.	< 2.0	< 2.0	< 100.	< 2.0	< 2.0	< 100.	< 2.0	< 2.0
S	< 2.	< 2.	< 100.	< 2.0	< 2.0	< 100.	< 2.0	< 2.0	< 100.	< 2.0	< 2.0
SSW	< 2.	< 2.	< 100.	< 2.0	< 2.0	< 100.	< 2.0	< 2.0	< 100.	< 2.0	< 2.0
SW	< 2.	< 2.	< 100.	< 2.0	< 2.0	< 100.	< 2.0	< 2.0	< 100.	< 2.0	< 2.0
WSW	< 2.	< 2.	< 100.	< 2.0	< 2.0	< 100.	< 2.0	< 2.0	< 100.	< 2.0	< 2.0
W	< 2.	< 2.	< 100.	< 2.0	< 2.0	< 100.	< 2.0	< 2.0	< 100.	< 2.0	< 2.0
WNW	< 2.	< 2.	< 100.	< 2.0	< 2.0	< 100.	< 2.0	< 2.0	< 100.	< 2.0	< 2.0
NW	< 2.	< 2.	< 100.	< 2.0	< 2.0	< 100.	< 2.0	< 2.0	< 100.	< 2.0	< 2.0
NNW	< 2.	< 2.	< 100.	< 2.0	< 2.0	< 100.	< 2.0	< 2.0	< 100.	< 2.0	< 2.0

SECTION III C
Emergency Center Dose Rates

(T = 01:00) (CT = 17:00)

Emergency CENTER	PARTICULATE AIR SAMPLE		DOSE RATE		SILVER ZEOLITE AIR SAMPLE		DOSE RATE		COUNT RATE (cpm per 100 cm2)	SMEAR SURVEY	
	CLOSED WINDOW	OPEN WINDOW	COUNT RATE	DOSE RATE	COUNT RATE	DOSE RATE	COUNT RATE	DOSE RATE		OPEN WINDOW	CLOSED WINDOW
	(mR/hr)	(mR/hr)	(cpm per 10 min)	OPEN WINDOW mR/hr	CLOSED WINDOW mR/hr	(cpm per 10 min)	OPEN WINDOW mR/hr	CLOSED WINDOW mR/hr		(cpm per 100 cm2)	mR/hr
ECC	< 2.	< 2.	< 100.	< 2.0	< 2.0	< 100.	< 2.0	< 2.0	< 100.	< 2.0	< 2.0
OSC	< 2.	< 2.	< 100.	< 2.0	< 2.0	< 100.	< 2.0	< 2.0	< 100.	< 2.0	< 2.0
TSC	< 2.	< 2.	< 100.	< 2.0	< 2.0	< 100.	< 2.0	< 2.0	< 100.	< 2.0	< 2.0
EAA	< 2.	< 2.	< 100.	< 2.0	< 2.0	< 100.	< 2.0	< 2.0	< 100.	< 2.0	< 2.0
Main Gate	< 2.	< 2.	< 100.	< 2.0	< 2.0	< 100.	< 2.0	< 2.0	< 100.	< 2.0	< 2.0
Building 14	< 2.	< 2.	< 100.	< 2.0	< 2.0	< 100.	< 2.0	< 2.0	< 100.	< 2.0	< 2.0
New Office Bldg	< 2.	< 2.	< 100.	< 2.0	< 2.0	< 100.	< 2.0	< 2.0	< 100.	< 2.0	< 2.0

ONSITE MONITORING LOCATIONS

Emergency CENTER	PARTICULATE AIR SAMPLE		DOSE RATE		SILVER ZEOLITE AIR SAMPLE		DOSE RATE		COUNT RATE (cpm per 100 cm2)	SMEAR SURVEY	
	CLOSED WINDOW	OPEN WINDOW	COUNT RATE	DOSE RATE	COUNT RATE	DOSE RATE	COUNT RATE	DOSE RATE		OPEN WINDOW	CLOSED WINDOW
	(mR/hr)	(mR/hr)	(cpm per 10 min)	OPEN WINDOW mR/hr	CLOSED WINDOW mR/hr	(cpm per 10 min)	OPEN WINDOW mR/hr	CLOSED WINDOW mR/hr		(cpm per 100 cm2)	mR/hr
N	< 2.	< 2.	< 100.	< 2.0	< 2.0	< 100.	< 2.0	< 2.0	< 100.	< 2.0	< 2.0
NNE	< 2.	< 2.	< 100.	< 2.0	< 2.0	< 100.	< 2.0	< 2.0	< 100.	< 2.0	< 2.0
NE	< 2.	< 2.	< 100.	< 2.0	< 2.0	< 100.	< 2.0	< 2.0	< 100.	< 2.0	< 2.0
ENE	< 2.	< 2.	< 100.	< 2.0	< 2.0	< 100.	< 2.0	< 2.0	< 100.	< 2.0	< 2.0
E	< 2.	< 2.	< 100.	< 2.0	< 2.0	< 100.	< 2.0	< 2.0	< 100.	< 2.0	< 2.0
ESE	< 2.	< 2.	< 100.	< 2.0	< 2.0	< 100.	< 2.0	< 2.0	< 100.	< 2.0	< 2.0
SE	< 2.	< 2.	< 100.	< 2.0	< 2.0	< 100.	< 2.0	< 2.0	< 100.	< 2.0	< 2.0
SSE	< 2.	< 2.	< 100.	< 2.0	< 2.0	< 100.	< 2.0	< 2.0	< 100.	< 2.0	< 2.0
S	< 2.	< 2.	< 100.	< 2.0	< 2.0	< 100.	< 2.0	< 2.0	< 100.	< 2.0	< 2.0
SSW	< 2.	< 2.	< 100.	< 2.0	< 2.0	< 100.	< 2.0	< 2.0	< 100.	< 2.0	< 2.0
SW	< 2.	< 2.	< 100.	< 2.0	< 2.0	< 100.	< 2.0	< 2.0	< 100.	< 2.0	< 2.0
WSW	< 2.	< 2.	< 100.	< 2.0	< 2.0	< 100.	< 2.0	< 2.0	< 100.	< 2.0	< 2.0
W	< 2.	< 2.	< 100.	< 2.0	< 2.0	< 100.	< 2.0	< 2.0	< 100.	< 2.0	< 2.0
WNW	< 2.	< 2.	< 100.	< 2.0	< 2.0	< 100.	< 2.0	< 2.0	< 100.	< 2.0	< 2.0
NW	< 2.	< 2.	< 100.	< 2.0	< 2.0	< 100.	< 2.0	< 2.0	< 100.	< 2.0	< 2.0
NNW	< 2.	< 2.	< 100.	< 2.0	< 2.0	< 100.	< 2.0	< 2.0	< 100.	< 2.0	< 2.0

SECTION III C
Emergency Center Dose Rates

(T = 02:00) (CT = 18:00)

Emergency CENTER	PARTICULATE AIR SAMPLE			SILVER ZEOLITE AIR SAMPLE			SHEAR SURVEY		
	COUNT RATE (cpm per 10 min)	DOSE RATE OPEN WINDOW (mR/hr)	DOSE RATE CLOSED WINDOW (mR/hr)	COUNT RATE (cpm per 10 min)	DOSE RATE OPEN WINDOW (mR/hr)	DOSE RATE CLOSED WINDOW (mR/hr)	DOSE RATE OPEN WINDOW (mR/hr)	DOSE RATE CLOSED WINDOW (mR/hr)	COUNT RATE (cpm per 100 cm ²)
Emergency CENTER	< 100.	< 2.0	< 2.0	< 100.	< 2.0	< 2.0	< 2.0	< 2.0	< 100.
ECC	< 100.	< 2.0	< 2.0	< 100.	< 2.0	< 2.0	< 2.0	< 2.0	< 100.
OSC	< 100.	< 2.0	< 2.0	< 100.	< 2.0	< 2.0	< 2.0	< 2.0	< 100.
TSC	< 100.	< 2.0	< 2.0	< 100.	< 2.0	< 2.0	< 2.0	< 2.0	< 100.
EAA	< 100.	< 2.0	< 2.0	< 100.	< 2.0	< 2.0	< 2.0	< 2.0	< 100.
Main Gate	< 100.	< 2.0	< 2.0	< 100.	< 2.0	< 2.0	< 2.0	< 2.0	< 100.
Building 14	< 100.	< 2.0	< 2.0	< 100.	< 2.0	< 2.0	< 2.0	< 2.0	< 100.
New Office Bldg	< 100.	< 2.0	< 2.0	< 100.	< 2.0	< 2.0	< 2.0	< 2.0	< 100.

ONSITE MONITORING LOCATIONS

Emergency CENTER	PARTICULATE AIR SAMPLE			SILVER ZEOLITE AIR SAMPLE			SHEAR SURVEY		
	COUNT RATE (cpm per 10 min)	DOSE RATE OPEN WINDOW (mR/hr)	DOSE RATE CLOSED WINDOW (mR/hr)	COUNT RATE (cpm per 10 min)	DOSE RATE OPEN WINDOW (mR/hr)	DOSE RATE CLOSED WINDOW (mR/hr)	DOSE RATE OPEN WINDOW (mR/hr)	DOSE RATE CLOSED WINDOW (mR/hr)	COUNT RATE (cpm per 100 cm ²)
N	< 100.	< 2.0	< 2.0	< 100.	< 2.0	< 2.0	< 2.0	< 2.0	< 100.
NNE	< 100.	< 2.0	< 2.0	< 100.	< 2.0	< 2.0	< 2.0	< 2.0	< 100.
NE	< 100.	< 2.0	< 2.0	< 100.	< 2.0	< 2.0	< 2.0	< 2.0	< 100.
ENE	< 100.	< 2.0	< 2.0	< 100.	< 2.0	< 2.0	< 2.0	< 2.0	< 100.
E	< 100.	< 2.0	< 2.0	< 100.	< 2.0	< 2.0	< 2.0	< 2.0	< 100.
ESE	< 100.	< 2.0	< 2.0	< 100.	< 2.0	< 2.0	< 2.0	< 2.0	< 100.
SE	< 100.	< 2.0	< 2.0	< 100.	< 2.0	< 2.0	< 2.0	< 2.0	< 100.
SSE	< 100.	< 2.0	< 2.0	< 100.	< 2.0	< 2.0	< 2.0	< 2.0	< 100.
S	< 100.	< 2.0	< 2.0	< 100.	< 2.0	< 2.0	< 2.0	< 2.0	< 100.
SSW	< 100.	< 2.0	< 2.0	< 100.	< 2.0	< 2.0	< 2.0	< 2.0	< 100.
SW	< 100.	< 2.0	< 2.0	< 100.	< 2.0	< 2.0	< 2.0	< 2.0	< 100.
WSW	< 100.	< 2.0	< 2.0	< 100.	< 2.0	< 2.0	< 2.0	< 2.0	< 100.
W	< 100.	< 2.0	< 2.0	< 100.	< 2.0	< 2.0	< 2.0	< 2.0	< 100.
WNW	< 100.	< 2.0	< 2.0	< 100.	< 2.0	< 2.0	< 2.0	< 2.0	< 100.
NW	< 100.	< 2.0	< 2.0	< 100.	< 2.0	< 2.0	< 2.0	< 2.0	< 100.
NNW	< 100.	< 2.0	< 2.0	< 100.	< 2.0	< 2.0	< 2.0	< 2.0	< 100.

SECTION III C
Emergency Center Dose Rates

(T = 03:00) (CT = 19:00)

Emergency CENTER	PARTICULATE AIR SAMPLE			SILVER ZEOLITE AIR SAMPLE			SMEAR SURVEY		
	CLOSED WINDOW (mR/hr)	OPEN WINDOW (mR/hr)	COUNT RATE (cpm per 10 min)	CLOSED WINDOW (mR/hr)	OPEN WINDOW (mR/hr)	COUNT RATE (cpm per 10 min)	CLOSED WINDOW (mR/hr)	OPEN WINDOW (mR/hr)	DOSE RATE (mR/hr)
ECC	< 2.	< 2.	< 100.	< 2.0	< 2.0	< 100.	< 2.0	< 2.0	< 2.0
OSC	< 2.	< 2.	< 100.	< 2.0	< 2.0	< 100.	< 2.0	< 2.0	< 2.0
TSC	< 2.	< 2.	< 100.	< 2.0	< 2.0	< 100.	< 2.0	< 2.0	< 2.0
EAA	< 2.	< 2.	< 100.	< 2.0	< 2.0	< 100.	< 2.0	< 2.0	< 2.0
Main Gate	< 2.	< 2.	< 100.	< 2.0	< 2.0	< 100.	< 2.0	< 2.0	< 2.0
Building 14	< 2.	< 2.	< 100.	< 2.0	< 2.0	< 100.	< 2.0	< 2.0	< 2.0
New Office Bldg	< 2.	< 2.	< 100.	< 2.0	< 2.0	< 100.	< 2.0	< 2.0	< 2.0

ONSITE MONITORING LOCATIONS

Emergency CENTER	PARTICULATE AIR SAMPLE			SILVER ZEOLITE AIR SAMPLE			SMEAR SURVEY		
	CLOSED WINDOW (mR/hr)	OPEN WINDOW (mR/hr)	COUNT RATE (cpm per 10 min)	CLOSED WINDOW (mR/hr)	OPEN WINDOW (mR/hr)	COUNT RATE (cpm per 10 min)	CLOSED WINDOW (mR/hr)	OPEN WINDOW (mR/hr)	DOSE RATE (mR/hr)
N	< 2.	< 2.	< 100.	< 2.0	< 2.0	< 100.	< 2.0	< 2.0	< 2.0
NNE	< 2.	< 2.	< 100.	< 2.0	< 2.0	< 100.	< 2.0	< 2.0	< 2.0
NE	< 2.	< 2.	< 100.	< 2.0	< 2.0	< 100.	< 2.0	< 2.0	< 2.0
ENE	< 2.	< 2.	< 100.	< 2.0	< 2.0	< 100.	< 2.0	< 2.0	< 2.0
E	< 2.	< 2.	< 100.	< 2.0	< 2.0	< 100.	< 2.0	< 2.0	< 2.0
ESE	< 2.	< 2.	< 100.	< 2.0	< 2.0	< 100.	< 2.0	< 2.0	< 2.0
SE	< 2.	< 2.	< 100.	< 2.0	< 2.0	< 100.	< 2.0	< 2.0	< 2.0
SSE	< 2.	< 2.	< 100.	< 2.0	< 2.0	< 100.	< 2.0	< 2.0	< 2.0
S	< 2.	< 2.	< 100.	< 2.0	< 2.0	< 100.	< 2.0	< 2.0	< 2.0
SSW	< 2.	< 2.	< 100.	< 2.0	< 2.0	< 100.	< 2.0	< 2.0	< 2.0
SW	< 2.	< 2.	< 100.	< 2.0	< 2.0	< 100.	< 2.0	< 2.0	< 2.0
WSW	< 2.	< 2.	< 100.	< 2.0	< 2.0	< 100.	< 2.0	< 2.0	< 2.0
W	< 2.	< 2.	< 100.	< 2.0	< 2.0	< 100.	< 2.0	< 2.0	< 2.0
WNW	< 2.	< 2.	< 100.	< 2.0	< 2.0	< 100.	< 2.0	< 2.0	< 2.0
NW	< 2.	< 2.	< 100.	< 2.0	< 2.0	< 100.	< 2.0	< 2.0	< 2.0
NNW	< 2.	< 2.	< 100.	< 2.0	< 2.0	< 100.	< 2.0	< 2.0	< 2.0

SECTION III C
Emergency Center Dose Rates

(T = 03:10) (CT = 19:10)

Emergency CENTER	PARTICULATE AIR SAMPLE					SILVER ZEOLITE AIR SAMPLE				SMEAR SURVEY	
	CLOSED WINDOW (mR/hr)	OPEN WINDOW (mR/hr)	COUNT RATE (cpm per 10 min)	DOSE RATE		COUNT RATE (cpm per 10 min)	DOSE RATE		COUNT RATE (cpm per 100 cm2)	DOSE RATE	
				OPEN WINDOW mR/hr	CLOSED WINDOW mR/hr		OPEN WINDOW mR/hr	CLOSED WINDOW mR/hr		OPEN WINDOW mR/hr	CLOSED WINDOW mR/hr
ECC	< 2.	< 2.	< 100.	< 2.0	< 2.0	< 100.	< 2.0	< 2.0	< 100.	< 2.0	< 2.0
OSC	< 2.	< 2.	< 100.	< 2.0	< 2.0	< 100.	< 2.0	< 2.0	< 100.	< 2.0	< 2.0
TSC	< 2.	< 2.	< 100.	< 2.0	< 2.0	< 100.	< 2.0	< 2.0	< 100.	< 2.0	< 2.0
EAA	< 2.	< 2.	< 100.	< 2.0	< 2.0	< 100.	< 2.0	< 2.0	< 100.	< 2.0	< 2.0
Main Gate	< 2.	< 2.	< 100.	< 2.0	< 2.0	< 100.	< 2.0	< 2.0	< 100.	< 2.0	< 2.0
Building 14	< 2.	< 2.	< 100.	< 2.0	< 2.0	< 100.	< 2.0	< 2.0	< 100.	< 2.0	< 2.0
New Office Bldg	< 2.	< 2.	< 100.	< 2.0	< 2.0	< 100.	< 2.0	< 2.0	< 100.	< 2.0	< 2.0

ONSITE MONITORING LOCATIONS

Emergency CENTER	PARTICULATE AIR SAMPLE					SILVER ZEOLITE AIR SAMPLE				SMEAR SURVEY	
	CLOSED WINDOW (mR/hr)	OPEN WINDOW (mR/hr)	COUNT RATE (cpm per 10 min)	DOSE RATE		COUNT RATE (cpm per 10 min)	DOSE RATE		COUNT RATE (cpm per 100 cm2)	DOSE RATE	
				OPEN WINDOW mR/hr	CLOSED WINDOW mR/hr		OPEN WINDOW mR/hr	CLOSED WINDOW mR/hr		OPEN WINDOW mR/hr	CLOSED WINDOW mR/hr
N	< 2.	< 2.	< 100.	< 2.0	< 2.0	< 100.	< 2.0	< 2.0	< 100.	< 2.0	< 2.0
NNE	< 2.	< 2.	< 100.	< 2.0	< 2.0	< 100.	< 2.0	< 2.0	< 100.	< 2.0	< 2.0
NE	< 2.	< 2.	< 100.	< 2.0	< 2.0	< 100.	< 2.0	< 2.0	< 100.	< 2.0	< 2.0
ENE	< 2.	< 2.	< 100.	< 2.0	< 2.0	< 100.	< 2.0	< 2.0	< 100.	< 2.0	< 2.0
E	< 2.	< 2.	< 100.	< 2.0	< 2.0	< 100.	< 2.0	< 2.0	< 100.	< 2.0	< 2.0
ESE	< 2.	< 2.	< 100.	< 2.0	< 2.0	< 100.	< 2.0	< 2.0	< 100.	< 2.0	< 2.0
SE	< 2.	< 2.	< 100.	< 2.0	< 2.0	< 100.	< 2.0	< 2.0	< 100.	< 2.0	< 2.0
SSE	< 2.	< 2.	< 100.	< 2.0	< 2.0	< 100.	< 2.0	< 2.0	< 100.	< 2.0	< 2.0
S	< 2.	< 2.	< 100.	< 2.0	< 2.0	< 100.	< 2.0	< 2.0	< 100.	< 2.0	< 2.0
SSW	< 2.	< 2.	< 100.	< 2.0	< 2.0	< 100.	< 2.0	< 2.0	< 100.	< 2.0	< 2.0
SW	< 2.	< 2.	< 100.	< 2.0	< 2.0	< 100.	< 2.0	< 2.0	< 100.	< 2.0	< 2.0
WSW	< 2.	< 2.	< 100.	< 2.0	< 2.0	< 100.	< 2.0	< 2.0	< 100.	< 2.0	< 2.0
W	< 2.	< 2.	< 100.	< 2.0	< 2.0	< 100.	< 2.0	< 2.0	< 100.	< 2.0	< 2.0
WNW	< 2.	< 2.	< 100.	< 2.0	< 2.0	< 100.	< 2.0	< 2.0	< 100.	< 2.0	< 2.0
NW	< 2.	< 2.	< 100.	< 2.0	< 2.0	< 100.	< 2.0	< 2.0	< 100.	< 2.0	< 2.0
NNW	< 2.	< 2.	< 100.	< 2.0	< 2.0	< 100.	< 2.0	< 2.0	< 100.	< 2.0	< 2.0

SECTION III C
Emergency Center Dose Rates

(T = 03:15) (CT = 19:15)

Emergency CENTER	PARTICULATE AIR SAMPLE					SILVER ZEOLITE AIR SAMPLE				SMEAR SURVEY	
	CLOSED WINDOW (mR/hr)	OPEN WINDOW (mR/hr)	COUNT RATE (cpm per 10 min)	DOSE RATE		COUNT RATE (cpm per 10 min)	DOSE RATE		COUNT RATE (cpm per 100 cm ²)	DOSE RATE	
				OPEN WINDOW mR/hr	CLOSED WINDOW mR/hr		OPEN WINDOW mR/hr	CLOSED WINDOW mR/hr		OPEN WINDOW mR/hr	CLOSED WINDOW mR/hr
ECC	< 2.	< 2.	< 100.	< 2.0	< 2.0	< 100.	< 2.0	< 2.0	< 100.	< 2.0	< 2.0
OSC	10.	10.	< 100.	< 2.0	< 2.0	< 100.	< 2.0	< 2.0	< 100.	< 2.0	< 2.0
TSC	< 2.	< 2.	< 100.	< 2.0	< 2.0	< 100.	< 2.0	< 2.0	< 100.	< 2.0	< 2.0
EAA	5.	5.	< 100.	< 2.0	< 2.0	< 100.	< 2.0	< 2.0	< 100.	< 2.0	< 2.0
Main Gate	20.	20.	< 100.	< 2.0	< 2.0	< 100.	< 2.0	< 2.0	< 100.	< 2.0	< 2.0
Building 14	< 2.	< 2.	< 100.	< 2.0	< 2.0	< 100.	< 2.0	< 2.0	< 100.	< 2.0	< 2.0
New Office Bldg	20.	20.	< 100.	< 2.0	< 2.0	< 100.	< 2.0	< 2.0	< 100.	< 2.0	< 2.0

ONSITE MONITORING LOCATIONS

Emergency CENTER	PARTICULATE AIR SAMPLE					SILVER ZEOLITE AIR SAMPLE				SMEAR SURVEY	
	CLOSED WINDOW (mR/hr)	OPEN WINDOW (mR/hr)	COUNT RATE (cpm per 10 min)	DOSE RATE		COUNT RATE (cpm per 10 min)	DOSE RATE		COUNT RATE (cpm per 100 cm ²)	DOSE RATE	
				OPEN WINDOW mR/hr	CLOSED WINDOW mR/hr		OPEN WINDOW mR/hr	CLOSED WINDOW mR/hr		OPEN WINDOW mR/hr	CLOSED WINDOW mR/hr
N	95.	100.	37600	10.7	12.8	3760	< 2.0	< 2.0	3380	< 2.0	< 2.0
NNE	95.	100.	37600	10.7	12.8	3760	< 2.0	< 2.0	3380	< 2.0	< 2.0
NE	95.	100.	37600	10.7	12.8	3760	< 2.0	< 2.0	3380	< 2.0	< 2.0
ENE	95.	100.	37600	10.7	12.8	3760	< 2.0	< 2.0	3380	< 2.0	< 2.0
E	95	100.	37600	10.7	12.5	3760	< 2.0	< 2.0	3380	< 2.0	< 2.0
ESE	95	100.	37600	10.7	12.8	3760	< 2.0	< 2.0	3380	< 2.0	< 2.0
SE	95	100.	37600	10.7	12.8	3760	< 2.0	< 2.0	3380	< 2.0	< 2.0
SSE	210	215.	37600	10.7	12.8	3760	< 2.0	< 2.0	3380	< 2.0	< 2.0
S	405	410.	37600	10.7	12.8	3760	< 2.0	< 2.0	3380	< 2.0	< 2.0
SSW	1500	1505.	37600	10.7	12.8	3760	< 2.0	< 2.0	3380	< 2.0	< 2.0
SW	1980	1985.	37600	10.7	12.5	3760	< 2.0	< 2.0	3380	< 2.0	< 2.0
WSW	1500	1505.	37600	10.7	12.8	3760	< 2.0	< 2.0	3380	< 2.0	< 2.0
W	405	405.	37600	10.0	12.8	3760	< 2.0	< 2.0	3380	< 2.0	< 2.0
WNW	210	210.	37600	10.7	12.8	3760	< 2.0	< 2.0	3380	< 2.0	< 2.0
NW	95	100.	37600	10.7	12.8	3760	< 2.0	< 2.0	3380	< 2.0	< 2.0
NNW	95	100.	37600	10.7	12.8	3760	< 2.0	< 2.0	3380	< 2.0	< 2.0

SECTION III C
Emergency Center Dose Rates

(T = 03:20) (CT = 19:20)

Emergency CENTER	PARTICULATE AIR SAMPLE					SILVER ZEOLITE AIR SAMPLE				SMEAR SURVEY	
	CLOSED WINDOW (mR/hr)	OPEN WINDOW (mR/hr)	COUNT RATE (cpm per 10 min)	DOSE RATE		COUNT RATE (cpm per 10 min)	DOSE RATE		COUNT RATE (cpm per 100 cm2)	DOSE RATE	
				OPEN WINDOW mR/hr	CLOSED WINDOW mR/hr		OPEN WINDOW mR/hr	CLOSED WINDOW mR/hr		OPEN WINDOW mR/hr	CLOSED WINDOW mR/hr
ECC	< 2.	< 2.	< 100.	< 2.0	< 2.0	< 100.	< 2.0	< 2.0	< 100.	< 2.0	< 2.0
OSC	10.	10.	< 100.	< 2.0	< 2.0	< 100.	< 2.0	< 2.0	< 100.	< 2.0	< 2.0
TSC	< 2.	< 2.	< 100.	< 2.0	< 2.0	< 100.	< 2.0	< 2.0	< 100.	< 2.0	< 2.0
EAA	5.	5.	< 100.	< 2.0	< 2.0	< 100.	< 2.0	< 2.0	< 100.	< 2.0	< 2.0
Main Gate	20.	20.	< 100.	< 2.0	< 2.0	< 100.	< 2.0	< 2.0	< 100.	< 2.0	< 2.0
Building 14	< 2.	< 2.	< 100.	< 2.0	< 2.0	< 100.	< 2.0	< 2.0	< 100.	< 2.0	< 2.0
New Office Bldg	20.	20.	< 100.	< 2.0	< 2.0	< 100.	< 2.0	< 2.0	< 100.	< 2.0	< 2.0

ONSITE MONITORING LOCATIONS

Emergency CENTER	PARTICULATE AIR SAMPLE					SILVER ZEOLITE AIR SAMPLE				SMEAR SURVEY	
	CLOSED WINDOW (mR/hr)	OPEN WINDOW (mR/hr)	COUNT RATE (cpm per 10 min)	DOSE RATE		COUNT RATE (cpm per 10 min)	DOSE RATE		COUNT RATE (cpm per 100 cm2)	DOSE RATE	
				OPEN WINDOW mR/hr	CLOSED WINDOW mR/hr		OPEN WINDOW mR/hr	CLOSED WINDOW mR/hr		OPEN WINDOW mR/hr	CLOSED WINDOW mR/hr
N	100.	105.	40000	10.0	12.5	4000	< 2.0	< 2.0	3600	< 2.0	< 2.0
NNE	100.	105.	40000	10.0	12.5	4000	< 2.0	< 2.0	3600	< 2.0	< 2.0
NE	100.	105.	40000	10.0	12.5	4000	< 2.0	< 2.0	3600	< 2.0	< 2.0
ENE	100.	105.	40000	10.0	12.5	4000	< 2.0	< 2.0	3600	< 2.0	< 2.0
E	100	105.	40000	10.0	12.5	4000	< 2.0	< 2.0	3600	< 2.0	< 2.0
ESE	100	105.	40000	10.0	12.5	4000	< 2.0	< 2.0	3600	< 2.0	< 2.0
SE	100	105.	40000	10.0	12.5	4000	< 2.0	< 2.0	3600	< 2.0	< 2.0
SSE	220	225.	40000	10.0	12.5	4000	< 2.0	< 2.0	3600	< 2.0	< 2.0
S	430	435.	40000	10.0	12.5	4000	< 2.0	< 2.0	3600	< 2.0	< 2.0
SSW	1610	1615.	40000	10.0	12.5	4000	< 2.0	< 2.0	3600	< 2.0	< 2.0
SW	2110	2115.	40000	10.0	12.5	4000	< 2.0	< 2.0	3600	< 2.0	< 2.0
WSW	1610	1615.	40000	10.0	12.5	4000	< 2.0	< 2.0	3600	< 2.0	< 2.0
W	430	435.	40000	10.0	12.5	4000	< 2.0	< 2.0	3600	< 2.0	< 2.0
WNW	220	225.	40000	10.0	12.5	4000	< 2.0	< 2.0	3600	< 2.0	< 2.0
NW	100	105.	40000	10.0	12.5	4000	< 2.0	< 2.0	3600	< 2.0	< 2.0
NHW	100	105.	40000	10.0	12.5	4000	< 2.0	< 2.0	3600	< 2.0	< 2.0

SECTION III C
Emergency Center Dose Rates

(T = 03:30) (CT = 19:30)

Emergency CENTER	PARTICULATE AIR SAMPLE					SILVER ZEOLITE AIR SAMPLE				SMEAR SURVEY	
	CLOSED	OPEN	COUNT	DOSE RATE		COUNT RATE	DOSE RATE		COUNT RATE	DOSE RATE	
	WINDOW (mR/hr)	WINDOW (mR/hr)	RATE (cpm per 10 min)	OPEN WINDOW mR/hr	CLOSED WINDOW mR/hr	(cpm per 10 min)	OPEN WINDOW mR/hr	CLOSED WINDOW mR/hr	(cpm per 100 cm2)	OPEN WINDOW mR/hr	CLOSED WINDOW mR/hr
ECC	< 2.	< 2.	< 100.	< 2.0	< 2.0	< 100.	< 2.0	< 2.0	< 100.	< 2.0	< 2.0
OSC	15.	15.	< 100.	< 2.0	< 2.0	< 100.	< 2.0	< 2.0	< 100.	< 2.0	< 2.0
TSC	< 2.	< 2.	< 100.	< 2.0	< 2.0	< 100.	< 2.0	< 2.0	< 100.	< 2.0	< 2.0
EAA	7.	7.	< 100.	< 2.0	< 2.0	< 100.	< 2.0	< 2.0	< 100.	< 2.0	< 2.0
Main Gate	25.	25.	< 100.	< 2.0	< 2.0	< 100.	< 2.0	< 2.0	< 100.	< 2.0	< 2.0
Building 14	< 2.	< 2.	< 100.	< 2.0	< 2.0	< 100.	< 2.0	< 2.0	< 100.	< 2.0	< 2.0
New Office Bldg	25.	25.	< 100.	< 2.0	< 2.0	< 100.	< 2.0	< 2.0	< 100.	< 2.0	< 2.0

ONSITE MONITORING LOCATIONS

Emergency CENTER	PARTICULATE AIR SAMPLE					SILVER ZEOLITE AIR SAMPLE				SMEAR SURVEY	
	CLOSED	OPEN	COUNT	DOSE RATE		COUNT RATE	DOSE RATE		COUNT RATE	DOSE RATE	
	WINDOW (mR/hr)	WINDOW (mR/hr)	RATE (cpm per 10 min)	OPEN WINDOW mR/hr	CLOSED WINDOW mR/hr	(cpm per 10 min)	OPEN WINDOW mR/hr	CLOSED WINDOW mR/hr	(cpm per 100 cm2)	OPEN WINDOW mR/hr	CLOSED WINDOW mR/hr
N	110.	115.	44000	11.0	13.5	4400	< 2.0	< 2.0	3600	< 2.0	< 2.0
NNE	110.	115.	44000	11.0	13.5	4400	< 2.0	< 2.0	3600	< 2.0	< 2.0
NE	110.	115.	44000	11.0	13.5	4400	< 2.0	< 2.0	3600	< 2.0	< 2.0
ENE	110.	115.	44000	11.0	13.5	4400	< 2.0	< 2.0	3600	< 2.0	< 2.0
E	110	115.	44000	11.0	13.5	4400	< 2.0	< 2.0	3600	< 2.0	< 2.0
ESE	110	115.	44000	11.0	13.5	4400	< 2.0	< 2.0	3600	< 2.0	< 2.0
SE	110	115.	44000	11.0	13.5	4400	< 2.0	< 2.0	3600	< 2.0	< 2.0
SSE	230	235.	44000	11.0	13.5	4400	< 2.0	< 2.0	3600	< 2.0	< 2.0
S	440	445.	44000	11.0	13.5	4400	< 2.0	< 2.0	3600	< 2.0	< 2.0
SSW	1620	1625.	44000	11.0	13.5	4400	< 2.0	< 2.0	3600	< 2.0	< 2.0
SW	2120	2125.	44000	11.0	13.5	4400	< 2.0	< 2.0	3600	< 2.0	< 2.0
WSW	1620	1625.	44000	11.0	13.5	4400	< 2.0	< 2.0	3600	< 2.0	< 2.0
W	440	445.	44000	11.0	13.5	4400	< 2.0	< 2.0	3600	< 2.0	< 2.0
WNW	230	245.	44000	11.0	13.5	4400	< 2.0	< 2.0	3600	< 2.0	< 2.0
NW	110	115.	44000	11.0	13.5	4400	< 2.0	< 2.0	3600	< 2.0	< 2.0
NNW	110	115.	44000	11.0	13.5	4400	< 2.0	< 2.0	3600	< 2.0	< 2.0

SECTION III C
Emergency Center Dose Rates

(T = 03:40) (CT = 19:40)

Emergency CENTER	PARTICULATE AIR SAMPLE					SILVER ZEOLITE AIR SAMPLE				SMEAR SURVEY	
	CLOSED	OPEN	COUNT	DOSE RATE		COUNT RATE	DOSE RATE		COUNT RATE	DOSE RATE	
	WINDOW (mR/hr)	WINDOW (mR/hr)	RATE (cpm per 10 min)	OPEN WINDOW mR/hr	CLOSED WINDOW mR/hr	(cpm per 10 min)	OPEN WINDOW mR/hr	CLOSED WINDOW mR/hr	(cpm per 100 cm2)	OPEN WINDOW mR/hr	CLOSED WINDOW mR/hr
ECC	< 2.	< 2.	< 100.	< 2.0	< 2.0	< 100.	< 2.0	< 2.0	< 100.	< 2.0	< 2.0
OSC	10.	10.	< 100.	< 2.0	< 2.0	< 100.	< 2.0	< 2.0	< 100.	< 2.0	< 2.0
TSC	< 2.	< 2.	< 100.	< 2.0	< 2.0	< 100.	< 2.0	< 2.0	< 100.	< 2.0	< 2.0
EAA	5.	5.	< 100.	< 2.0	< 2.0	< 100.	< 2.0	< 2.0	< 100.	< 2.0	< 2.0
Main Gate	20.	20.	< 100.	< 2.0	< 2.0	< 100.	< 2.0	< 2.0	< 100.	< 2.0	< 2.0
Building 14	< 2.	< 2.	< 100.	< 2.0	< 2.0	< 100.	< 2.0	< 2.0	< 100.	< 2.0	< 2.0
New Office Bldg	20.	20.	< 100.	< 2.0	< 2.0	< 100.	< 2.0	< 2.0	< 100.	< 2.0	< 2.0

ONSITE MONITORING LOCATIONS

Emergency CENTER	PARTICULATE AIR SAMPLE					SILVER ZEOLITE AIR SAMPLE				SMEAR SURVEY	
	CLOSED	OPEN	COUNT	DOSE RATE		COUNT RATE	DOSE RATE		COUNT RATE	DOSE RATE	
	WINDOW (mR/hr)	WINDOW (mR/hr)	RATE (cpm per 10 min)	OPEN WINDOW mR/hr	CLOSED WINDOW mR/hr	(cpm per 10 min)	OPEN WINDOW mR/hr	CLOSED WINDOW mR/hr	(cpm per 100 cm2)	OPEN WINDOW mR/hr	CLOSED WINDOW mR/hr
N	100.	105.	40000	11.4	13.4	4000	< 2.0	< 2.0	3600	< 2.0	< 2.0
NNE	100.	105.	40000	11.4	13.4	4000	< 2.0	< 2.0	3600	< 2.0	< 2.0
NE	100.	105.	40000	11.4	13.4	4000	< 2.0	< 2.0	3600	< 2.0	< 2.0
ENE	100.	105.	40000	11.4	13.4	4000	< 2.0	< 2.0	3600	< 2.0	< 2.0
E	100	105.	40000	11.4	13.4	4000	< 2.0	< 2.0	3600	< 2.0	< 2.0
ESE	100	105.	40000	11.4	13.4	4000	< 2.0	< 2.0	3600	< 2.0	< 2.0
SE	100	105.	40000	11.4	13.4	4000	< 2.0	< 2.0	3600	< 2.0	< 2.0
SSE	220	225.	40000	11.4	13.4	4000	< 2.0	< 2.0	3600	< 2.0	< 2.0
S	430	435.	40000	11.4	13.4	4000	< 2.0	< 2.0	3600	< 2.0	< 2.0
SSW	1610	1615.	40000	11.4	13.4	4000	< 2.0	< 2.0	3600	< 2.0	< 2.0
SW	2110	2115.	40000	11.4	13.4	4000	< 2.0	< 2.0	3600	< 2.0	< 2.0
WSW	1610	1615.	40000	11.4	13.4	4000	< 2.0	< 2.0	3600	< 2.0	< 2.0
W	430	435.	40000	11.4	13.4	4000	< 2.0	< 2.0	3600	< 2.0	< 2.0
WNW	220	225.	40000	11.4	13.4	4000	< 2.0	< 2.0	3600	< 2.0	< 2.0
NW	100	105.	40000	11.4	13.4	4000	< 2.0	< 2.0	3600	< 2.0	< 2.0
NNW	100	105.	40000	11.4	13.4	4000	< 2.0	< 2.0	3600	< 2.0	< 2.0

SECTION III C
Emergency Center Dose Rates

(T = 03:50) (CT = 19:50)

Emergency CENTER	PARTICULATE AIR SAMPLE					SILVER ZEOLITE AIR SAMPLE				SMEAR SURVEY	
	CLOSED WINDOW (mR/hr)	OPEN WINDOW (mR/hr)	COUNT RATE	DOSE RATE		COUNT RATE (cpm per 10 min)	DOSE RATE		COUNT RATE (cpm per 100 cm2)	DOSE RATE	
			(cpm per 10 min)	OPEN WINDOW (mR/hr)	CLOSED WINDOW (mR/hr)		OPEN WINDOW (mR/hr)	CLOSED WINDOW (mR/hr)		OPEN WINDOW (mR/hr)	CLOSED WINDOW (mR/hr)
ECC	< 2.	< 2.	< 100.	< 2.0	< 2.0	< 100.	< 2.0	< 2.0	< 100.	< 2.0	< 2.0
OSC	10.	10.	< 100.	< 2.0	< 2.0	< 100.	< 2.0	< 2.0	< 100.	< 2.0	< 2.0
TSC	< 2.	< 2.	< 100.	< 2.0	< 2.0	< 100.	< 2.0	< 2.0	< 100.	< 2.0	< 2.0
EAA	5.	5.	< 100.	< 2.0	< 2.0	< 100.	< 2.0	< 2.0	< 100.	< 2.0	< 2.0
Main Gate	20.	20.	< 100.	< 2.0	< 2.0	< 100.	< 2.0	< 2.0	< 100.	< 2.0	< 2.0
Building 14	< 2.	< 2.	< 100.	< 2.0	< 2.0	< 100.	< 2.0	< 2.0	< 100.	< 2.0	< 2.0
New Office Bldg	20.	20.	< 100.	< 2.0	< 2.0	< 100.	< 2.0	< 2.0	< 100.	< 2.0	< 2.0

ONSITE MONITORING LOCATIONS

Emergency CENTER	PARTICULATE AIR SAMPLE					SILVER ZEOLITE AIR SAMPLE				SMEAR SURVEY	
	CLOSED WINDOW (mR/hr)	OPEN WINDOW (mR/hr)	COUNT RATE	DOSE RATE		COUNT RATE (cpm per 10 min)	DOSE RATE		COUNT RATE (cpm per 100 cm2)	DOSE RATE	
			(cpm per 10 min)	OPEN WINDOW (mR/hr)	CLOSED WINDOW (mR/hr)		OPEN WINDOW (mR/hr)	CLOSED WINDOW (mR/hr)		OPEN WINDOW (mR/hr)	CLOSED WINDOW (mR/hr)
N	100.	105.	37600	10.7	12.8	3760	< 2.0	< 2.0	3600	< 2.0	< 2.0
NNE	100.	105.	37600	10.7	12.8	3760	< 2.0	< 2.0	3600	< 2.0	< 2.0
NE	100.	105.	37600	10.7	12.8	3760	< 2.0	< 2.0	3600	< 2.0	< 2.0
ENE	100.	105.	37600	10.7	12.8	3760	< 2.0	< 2.0	3600	< 2.0	< 2.0
E	100	105.	37600	10.7	12.8	3760	< 2.0	< 2.0	3600	< 2.0	< 2.0
ESE	100	105.	37600	10.7	12.8	3760	< 2.0	< 2.0	3600	< 2.0	< 2.0
SE	100	105.	37600	10.7	12.8	3760	< 2.0	< 2.0	3600	< 2.0	< 2.0
SSE	220	225.	37600	10.7	12.8	3760	< 2.0	< 2.0	3600	< 2.0	< 2.0
S	430	435.	37600	10.7	12.8	3760	< 2.0	< 2.0	3600	< 2.0	< 2.0
SSW	1610	1615.	37600	10.7	12.8	3760	< 2.0	< 2.0	3600	< 2.0	< 2.0
SW	2110	2115.	37600	10.7	12.8	3760	< 2.0	< 2.0	3600	< 2.0	< 2.0
WSW	1610	1615.	37600	10.7	12.8	3760	< 2.0	< 2.0	3600	< 2.0	< 2.0
W	430	435.	37600	10.7	12.8	3760	< 2.0	< 2.0	3600	< 2.0	< 2.0
WNW	220	225.	37600	10.7	12.8	3760	< 2.0	< 2.0	3600	< 2.0	< 2.0
NW	100	105.	37600	10.7	12.8	3760	< 2.0	< 2.0	3600	< 2.0	< 2.0
NNW	100	105.	37600	10.7	12.8	3760	< 2.0	< 2.0	3600	< 2.0	< 2.0

SECTION III C
Emergency Center Dose Rates

(T = 04:00) (CT = 20:00)

Emergency CENTER	PARTICULATE AIR SAMPLE					SILVER ZEOLITE AIR SAMPLE				SMEAR SURVEY	
	CLOSED WINDOW (mR/hr)	OPEN WINDOW (mR/hr)	COUNT RATE (cpm per 10 min)	DOSE RATE		COUNT RATE (cpm per 10 min)	DOSE RATE		COUNT RATE (cpm per 100 cm2)	DOSE RATE	
				OPEN WINDOW mR/hr	CLOSED WINDOW mR/hr		OPEN WINDOW mR/hr	CLOSED WINDOW mR/hr		OPEN WINDOW mR/hr	CLOSED WINDOW mR/hr
ECC	< 2.	< 2.	< 100.	< 2.0	< 2.0	< 100.	< 2.0	< 2.0	< 100.	< 2.0	< 2.0
OSC	10.	10.	< 100.	< 2.0	< 2.0	< 100.	< 2.0	< 2.0	< 100.	< 2.0	< 2.0
TSC	< 2.	< 2.	< 100.	< 2.0	< 2.0	< 100.	< 2.0	< 2.0	< 100.	< 2.0	< 2.0
EAA	5.	5.	< 100.	< 2.0	< 2.0	< 100.	< 2.0	< 2.0	< 100.	< 2.0	< 2.0
Main Gate	20.	20.	< 100.	< 2.0	< 2.0	< 100.	< 2.0	< 2.0	< 100.	< 2.0	< 2.0
Building 14	< 2.	< 2.	< 100.	< 2.0	< 2.0	< 100.	< 2.0	< 2.0	< 100.	< 2.0	< 2.0
New Office Bldg	20.	20.	< 100.	< 2.0	< 2.0	< 100.	< 2.0	< 2.0	< 100.	< 2.0	< 2.0

ONSITE MONITORING LOCATIONS

Emergency CENTER	PARTICULATE AIR SAMPLE					SILVER ZEOLITE AIR SAMPLE				SMEAR SURVEY	
	CLOSED WINDOW (mR/hr)	OPEN WINDOW (mR/hr)	COUNT RATE (cpm per 10 min)	DOSE RATE		COUNT RATE (cpm per 10 min)	DOSE RATE		COUNT RATE (cpm per 100 cm2)	DOSE RATE	
				OPEN WINDOW mR/hr	CLOSED WINDOW mR/hr		OPEN WINDOW mR/hr	CLOSED WINDOW mR/hr		OPEN WINDOW mR/hr	CLOSED WINDOW mR/hr
N	100.	105.	35350	10.1	12.0	3535	< 2.0	< 2.0	3600	< 2.0	< 2.0
NNE	100.	105.	35350	10.1	12.0	3535	< 2.0	< 2.0	3600	< 2.0	< 2.0
NE	100.	105.	35350	10.1	12.0	3535	< 2.0	< 2.0	3600	< 2.0	< 2.0
ENE	100.	105.	35350	10.1	12.0	3535	< 2.0	< 2.0	3600	< 2.0	< 2.0
E	100	105.	35350	10.1	12.0	3535	< 2.0	< 2.0	3600	< 2.0	< 2.0
ESE	100	105.	35350	10.1	12.0	3535	< 2.0	< 2.0	3600	< 2.0	< 2.0
SE	100	105.	35350	10.1	12.0	3535	< 2.0	< 2.0	3600	< 2.0	< 2.0
SSE	220	225.	35350	10.1	12.0	3535	< 2.0	< 2.0	3600	< 2.0	< 2.0
S	430	435.	35350	10.1	12.0	3535	< 2.0	< 2.0	3600	< 2.0	< 2.0
SSW	1610	1615.	35350	10.1	12.0	3535	< 2.0	< 2.0	3600	< 2.0	< 2.0
SW	2110	2115.	35350	10.1	12.0	3535	< 2.0	< 2.0	3600	< 2.0	< 2.0
WSW	1610	1615.	35350	10.1	12.0	3535	< 2.0	< 2.0	3600	< 2.0	< 2.0
W	430	435.	35350	10.1	12.0	3535	< 2.0	< 2.0	3600	< 2.0	< 2.0
WNW	220	225.	35350	10.1	12.0	3535	< 2.0	< 2.0	3600	< 2.0	< 2.0
NW	100	105.	35350	10.1	12.0	3535	< 2.0	< 2.0	3600	< 2.0	< 2.0
NNW	100	105.	35350	10.1	12.0	3535	< 2.0	< 2.0	3600	< 2.0	< 2.0

SECTION III C
Emergency Center Dose Rates

(T = 04:10) (CT = 20:10)

Emergency CENTER	PARTICULATE AIR SAMPLE					SILVER ZEOLITE AIR SAMPLE				SMEAR SURVEY	
	CLOSED WINDOW (mR/hr)	OPEN WINDOW (mR/hr)	COUNT RATE (cpm per 10 min)	DOSE RATE		COUNT RATE (cpm per 10 min)	DOSE RATE		COUNT RATE (cpm per 100 cm ²)	DOSE RATE	
				OPEN WINDOW mR/hr	CLOSED WINDOW mR/hr		OPEN WINDOW mR/hr	CLOSED WINDOW mR/hr		OPEN WINDOW mR/hr	CLOSED WINDOW mR/hr
ECC	< 2.	< 2.	< 100.	< 2.0	< 2.0	< 100.	< 2.0	< 2.0	< 100.	< 2.0	< 2.0
OSC	10.	10.	< 100.	< 2.0	< 2.0	< 100.	< 2.0	< 2.0	< 100.	< 2.0	< 2.0
TSC	< 2.	< 2.	< 100.	< 2.0	< 2.0	< 100.	< 2.0	< 2.0	< 100.	< 2.0	< 2.0
EAA	5.	5.	< 100.	< 2.0	< 2.0	< 100.	< 2.0	< 2.0	< 100.	< 2.0	< 2.0
Main Gate	20.	20.	< 100.	< 2.0	< 2.0	< 100.	< 2.0	< 2.0	< 100.	< 2.0	< 2.0
Building 14	< 2.	< 2.	< 100.	< 2.0	< 2.0	< 100.	< 2.0	< 2.0	< 100.	< 2.0	< 2.0
New Office Bldg	20.	20.	< 100.	< 2.0	< 2.0	< 100.	< 2.0	< 2.0	< 100.	< 2.0	< 2.0

ONSITE MONITORING LOCATIONS

Emergency CENTER	PARTICULATE AIR SAMPLE					SILVER ZEOLITE AIR SAMPLE				SMEAR SURVEY	
	CLOSED WINDOW (mR/hr)	OPEN WINDOW (mR/hr)	COUNT RATE (cpm per 10 min)	DOSE RATE		COUNT RATE (cpm per 10 min)	DOSE RATE		COUNT RATE (cpm per 100 cm ²)	DOSE RATE	
				OPEN WINDOW mR/hr	CLOSED WINDOW mR/hr		OPEN WINDOW mR/hr	CLOSED WINDOW mR/hr		OPEN WINDOW mR/hr	CLOSED WINDOW mR/hr
N	100.	105.	33200	9.5	11.4	3320	< 2.0	< 2.0	3600	< 2.0	< 2.0
NNE	100.	105.	33200	9.5	11.4	3320	< 2.0	< 2.0	3600	< 2.0	< 2.0
NE	100.	105.	33200	9.5	11.4	3320	< 2.0	< 2.0	3600	< 2.0	< 2.0
ENE	100.	105.	33200	9.5	11.4	3320	< 2.0	< 2.0	3600	< 2.0	< 2.0
E	100	105.	33200	9.5	11.4	3320	< 2.0	< 2.0	3600	< 2.0	< 2.0
ESE	100	105.	33200	9.5	11.4	3320	< 2.0	< 2.0	3600	< 2.0	< 2.0
SE	100	105.	33200	9.5	11.4	3320	< 2.0	< 2.0	3600	< 2.0	< 2.0
SSE	220	225.	33200	9.5	11.4	3320	< 2.0	< 2.0	3600	< 2.0	< 2.0
S	430	435.	33200	9.5	11.4	3320	< 2.0	< 2.0	3600	< 2.0	< 2.0
SSW	1610	1615.	33200	9.5	11.4	3320	< 2.0	< 2.0	3600	< 2.0	< 2.0
SW	2110	2115.	33200	9.5	11.4	3320	< 2.0	< 2.0	3600	< 2.0	< 2.0
WSW	1610	1615.	33200	9.5	11.4	3320	< 2.0	< 2.0	3600	< 2.0	< 2.0
W	430	435.	33200	9.5	11.4	3320	< 2.0	< 2.0	3600	< 2.0	< 2.0
WNW	220	225.	33200	9.5	11.4	3320	< 2.0	< 2.0	3600	< 2.0	< 2.0
NW	100	105.	33200	9.5	11.4	3320	< 2.0	< 2.0	3600	< 2.0	< 2.0
NNW	100	105.	33200	9.5	11.4	3320	< 2.0	< 2.0	3600	< 2.0	< 2.0

SECTION III C
Emergency Center Dose Rates

(T = 04:20) (CT = 20:20)

Emergency CENTER	PARTICULATE AIR SAMPLE					SILVER ZEOLITE AIR SAMPLE				SMEAR SURVEY	
	CLOSED WINDOW (mR/hr)	OPEN WINDOW (mR/hr)	COUNT RATE	DOSE RATE		COUNT RATE (cpm per 100 cm ²)	DOSE RATE		DOSE RATE		
			(cpm per 10 min)	OPEN WINDOW (mR/hr)	CLOSED WINDOW (mR/hr)		OPEN WINDOW (mR/hr)	CLOSED WINDOW (mR/hr)			
ECC	< 2.	< 2.	< 100.	< 2.0	< 2.0	< 100.	< 2.0	< 2.0	< 100.	< 2.0	< 2.0
OSC	10.	10.	< 100.	< 2.0	< 2.0	< 100.	< 2.0	< 2.0	< 100.	< 2.0	< 2.0
TSC	< 2.	< 2.	< 100.	< 2.0	< 2.0	< 100.	< 2.0	< 2.0	< 100.	< 2.0	< 2.0
EAA	5.	5.	< 100.	< 2.0	< 2.0	< 100.	< 2.0	< 2.0	< 100.	< 2.0	< 2.0
Main Gate	20.	20.	< 100.	< 2.0	< 2.0	< 100.	< 2.0	< 2.0	< 100.	< 2.0	< 2.0
Building 14	< 2.	< 2.	< 100.	< 2.0	< 2.0	< 100.	< 2.0	< 2.0	< 100.	< 2.0	< 2.0
New Office Bldg	20.	20.	< 100.	< 2.0	< 2.0	< 100.	< 2.0	< 2.0	< 100.	< 2.0	< 2.0

ONSITE MONITORING LOCATIONS

Emergency CENTER	PARTICULATE AIR SAMPLE					SILVER ZEOLITE AIR SAMPLE				SMEAR SURVEY	
	CLOSED WINDOW (mR/hr)	OPEN WINDOW (mR/hr)	COUNT RATE	DOSE RATE		COUNT RATE (cpm per 100 cm ²)	DOSE RATE		DOSE RATE		
			(cpm per 10 min)	OPEN WINDOW (mR/hr)	CLOSED WINDOW (mR/hr)		OPEN WINDOW (mR/hr)	CLOSED WINDOW (mR/hr)			
N	100.	105.	31200	8.9	10.8	3120	< 2.0	< 2.0	3600	< 2.0	< 2.0
NNE	100.	105.	31200	8.9	10.8	3120	< 2.0	< 2.0	3600	< 2.0	< 2.0
NE	100.	105.	31200	8.9	10.8	3120	< 2.0	< 2.0	3600	< 2.0	< 2.0
ENE	100.	105.	31200	8.9	10.8	3120	< 2.0	< 2.0	3600	< 2.0	< 2.0
E	100.	105.	31200	8.9	10.8	3120	< 2.0	< 2.0	3600	< 2.0	< 2.0
ESE	100.	105.	31200	8.9	10.8	3120	< 2.0	< 2.0	3600	< 2.0	< 2.0
SE	100.	105.	31200	8.9	10.8	3120	< 2.0	< 2.0	3600	< 2.0	< 2.0
SSE	220	225.	31200	8.9	10.8	3120	< 2.0	< 2.0	3600	< 2.0	< 2.0
S	430	435.	31200	8.9	10.8	3120	< 2.0	< 2.0	3600	< 2.0	< 2.0
SSW	1610	1615.	31200	8.9	10.8	3120	< 2.0	< 2.0	3600	< 2.0	< 2.0
SW	2110	2115.	31200	8.9	10.8	3120	< 2.0	< 2.0	3600	< 2.0	< 2.0
WSW	1610	1615.	31200	8.9	10.8	3120	< 2.0	< 2.0	3600	< 2.0	< 2.0
W	430	435.	31200	8.9	10.8	3120	< 2.0	< 2.0	3600	< 2.0	< 2.0
WNW	220	225.	31200	8.9	10.8	3120	< 2.0	< 2.0	3600	< 2.0	< 2.0
NW	100	105.	31200	8.9	10.8	3120	< 2.0	< 2.0	3600	< 2.0	< 2.0
NNW	100	105.	31200	8.9	10.8	3120	< 2.0	< 2.0	3600	< 2.0	< 2.0

SECTION III C
Emergency Center Dose Rates

(T = 04:30) (CT = 20:30)

Emergency CENTER	PARTICULATE AIR SAMPLE					SILVER ZEOLITE AIR SAMPLE				SMEAR SURVEY	
	CLOSED WINDOW (mR/hr)	OPEN WINDOW (mR/hr)	COUNT	DOSE RATE		COUNT RATE (cpm per 10 min)	DOSE RATE		COUNT RATE (cpm per 100 cm2)	DOSE RATE	
			RATE (cpm per 10 min)	OPEN WINDOW mR/hr	CLOSED WINDOW mR/hr		OPEN WINDOW mR/hr	CLOSED WINDOW mR/hr		OPEN WINDOW mR/hr	CLOSED WINDOW mR/hr
ECC	< 2.	< 2.	< 100.	< 2.0	< 2.0	< 100.	< 2.0	< 2.0	< 100.	< 2.0	< 2.0
OSC	10.	10.	< 100.	< 2.0	< 2.0	< 100.	< 2.0	< 2.0	< 100.	< 2.0	< 2.0
TSC	< 2.	< 2.	< 100.	< 2.0	< 2.0	< 100.	< 2.0	< 2.0	< 100.	< 2.0	< 2.0
EAA	5.	5.	< 100.	< 2.0	< 2.0	< 100.	< 2.0	< 2.0	< 100.	< 2.0	< 2.0
Main Gate	20.	20.	< 100.	< 2.0	< 2.0	< 100.	< 2.0	< 2.0	< 100.	< 2.0	< 2.0
Building 14	< 2.	< 2.	< 100.	< 2.0	< 2.0	< 100.	< 2.0	< 2.0	< 100.	< 2.0	< 2.0
New Office Bldg	20.	20.	< 100.	< 2.0	< 2.0	< 100.	< 2.0	< 2.0	< 100.	< 2.0	< 2.0

ONSITE MONITORING LOCATIONS

Emergency CENTER	PARTICULATE AIR SAMPLE					SILVER ZEOLITE AIR SAMPLE				SMEAR SURVEY	
	CLOSED WINDOW (mR/hr)	OPEN WINDOW (mR/hr)	COUNT	DOSE RATE		COUNT RATE (cpm per 10 min)	DOSE RATE		COUNT RATE (cpm per 100 cm2)	DOSE RATE	
			RATE (cpm per 10 min)	OPEN WINDOW mR/hr	CLOSED WINDOW mR/hr		OPEN WINDOW mR/hr	CLOSED WINDOW mR/hr		OPEN WINDOW mR/hr	CLOSED WINDOW mR/hr
N	100.	105.	29400	8.4	10.3	2940	< 2.0	< 2.0	3600	< 2.0	< 2.0
NNE	100.	105.	29400	8.4	10.3	2940	< 2.0	< 2.0	3600	< 2.0	< 2.0
NE	100.	105.	29400	8.4	10.3	2940	< 2.0	< 2.0	3600	< 2.0	< 2.0
ENE	100.	105.	29400	8.4	10.3	2940	< 2.0	< 2.0	3600	< 2.0	< 2.0
E	100	105.	29400	8.4	10.3	2940	< 2.0	< 2.0	3600	< 2.0	< 2.0
ESE	100	105.	29400	8.4	10.3	2940	< 2.0	< 2.0	3600	< 2.0	< 2.0
SE	100	105.	29400	8.4	10.3	2940	< 2.0	< 2.0	3600	< 2.0	< 2.0
SSE	220	225.	29400	8.4	10.3	2940	< 2.0	< 2.0	3600	< 2.0	< 2.0
S	430	435.	29400	8.4	10.3	2940	< 2.0	< 2.0	3600	< 2.0	< 2.0
SSW	1610	1615.	29400	8.4	10.3	2940	< 2.0	< 2.0	3600	< 2.0	< 2.0
SW	2110	2115.	29400	8.4	10.3	2940	< 2.0	< 2.0	3600	< 2.0	< 2.0
WSW	1610	1615.	29400	8.4	10.3	2940	< 2.0	< 2.0	3600	< 2.0	< 2.0
W	430	435.	29400	8.4	10.3	2940	< 2.0	< 2.0	3600	< 2.0	< 2.0
WNW	220	225.	29400	8.4	10.3	2940	< 2.0	< 2.0	3600	< 2.0	< 2.0
NW	100	105.	29400	8.4	10.3	2940	< 2.0	< 2.0	3600	< 2.0	< 2.0
NNW	100	105.	29400	8.4	10.3	2940	< 2.0	< 2.0	3600	< 2.0	< 2.0

SECTION III D

BUILDING AIR ACTIVITY

SECTION III D
BUILDING AIR ACTIVITY
(T=00:00) (CLOCK=16:00)

	RX BLDG AIR Concentration uCi/cc	TURB BLDG AIR Concentration uCi/cc
Kr-85	2.2E-11	3.1E-12
Kr-85m	6.9E-09	9.6E-10
Kr-87	6.0E-09	1.2E-09
Kr-88	1.3E-08	2.1E-09
Xe131m.....	1.6E-08	1.8E-09
Xe-133.....	9.0E-09	1.0E-09
Xe133m	3.1E-10	3.4E-11
Xe-135	2.0E-08	2.3E-09
Xe-138	1.7E-10	5.0E-11
Total Gas Sample ..	7.3E-08	8.5E-09
I-131	1.9E-11	2.1E-12
I-132	9.5E-11	1.2E-11
I-133	1.2E-10	1.4E-11
I-134	6.7E-11	9.7E-12
I-135	1.5E-10	1.7E-11
DEI-131	5.7E-11	6.4E-12
Sr-89	4.3E-12	5.9E-13
Sr-90	3.4E-13	4.6E-14
Sr-91	8.5E-11	1.2E-11
Y-91	5.8E-12	8.0E-13
Mo-99	3.1E-11	4.3E-12
Ru-103	2.8E-14	3.9E-15
Ru-106	3.7E-15	5.1E-16
Te-129m	5.6E-14	7.8E-15
Te-131m	1.6E-12	2.2E-13
Te-132	6.8E-11	9.5E-12
Sb-127	8.1E-12	1.1E-13
Sb-129	5.9E-12	8.8E-13
Cs-134	2.2E-13	3.1E-14
Cs-136	1.5E-13	2.1E-14
Cs-137	2.6E-13	3.7E-14
Ba-140	1.3E-11	1.8E-12
La-140	8.0E-12	1.1E-12
Ce-144	5.0E-14	7.0E-15
Np-239	1.3E-09	1.8E-10
Total Filter	1.5E-09	2.1E-10
Hydrogen conc	0.0 %	0.0 %
Oxygen conc	0.0 %	0.0 %

Dose Rate at 1 foot

Pass Sample (1225 cc)	< 2.0E+00 mR/hr	< 2.0E+00 mR/hr
Airborne Beta Dose Rate	< 2.0E+00 mR/hr	< 2.0E+00 mR/hr
Air Sample Count Rate per 1000 cc	< 100 cpm	< 100 cpm
Air Sample Dose Rate per 1000 cc	< 2.0E+00 mR/hr	< 2.0E+00 mR/hr
Floor Contamination Rate	< 100 cpm/100 cm2	< 100 cpm/100 cm2
Wall & Equip Contamination Rate	< 100 cpm/100 cm2	< 100 cpm/100 cm2
Personnel Cont per minute in area	< 100 cpm/100 cm2	< 100 cpm/100 cm2

SECTION III D
BUILDING AIR ACTIVITY
(T=01:00) (CLOCK=17:00)

	RX BLDG AIR Concentration uCi/cc	TURB BLDG AIR Concentration uCi/cc
Kr-85	2.2E-11	3.1E-12
Kr-85m	6.9E-09	9.6E-10
Kr-87	6.8E-09	1.2E-09
Kr-88	1.3E-08	2.1E-09
Xe131m.....	1.6E-08	1.8E-09
Xe-133.....	9.0E-09	1.0E-09
Xe133m	3.1E-10	3.4E-11
Xe-135	2.0E-08	2.3E-09
Xe-138	1.7E-10	5.0E-11
Total Gas Sample ..	7.3E-08	8.5E-09
I-131	1.9E-11	2.1E-12
I-132	9.5E-11	1.2E-11
I-133	1.2E-10	1.4E-11
I-134	6.7E-11	9.7E-12
I-135	1.5E-10	1.7E-11
DEI-131	5.7E-11	6.4E-12
Sr-89	4.3E-12	5.9E-13
Sr-90	3.4E-13	4.6E-14
Sr-91	8.5E-11	1.2E-11
Y-91	5.8E-12	8.0E-13
Mo-99	3.1E-11	4.3E-12
Ru-103	2.8E-14	3.9E-15
Ru-106	3.7E-15	5.1E-16
Te-129m	5.6E-14	7.8E-15
Te-131m	1.6E-12	2.2E-13
Te-132	6.8E-11	9.5E-12
Sb-127	8.1E-12	1.1E-13
Sb-129	5.9E-12	8.8E-13
Cs-134	2.2E-13	3.1E-14
Cs-136	1.5E-13	2.1E-14
Cs-137	2.6E-13	3.7E-14
Ba-140	1.3E-11	1.8E-12
La-140	8.0E-12	1.1E-12
Ce-144	5.0E-14	7.0E-15
Np-239	1.3E-09	1.8E-10
Total Filter	1.5E-09	2.1E-10
Hydrogen conc	0.0 %	0.0 %
Oxygen conc	0.0 %	0.0 %

Dose Rate at 1 foot

Pass Sample (1225 cc)	< 2.0E+00 mR/hr	< 2.0E+00 mR/hr
Airborne Beta Dose Rate	< 2.0E+00 mR/hr	< 2.0E+00 mR/hr
Air Sample Count Rate per 1000 cc	< 100 cpm	< 100 cpm
Air Sample Dose Rate per 1000 cc	< 2.0E+00 mR/hr	< 2.0E+00 mR/hr
Floor Contamination Rate	< 100 cpm/100 cm2	< 100 cpm/100 cm2
Wall & Equip Contamination Rate	< 100 cpm/100 cm2	< 100 cpm/100 cm2
Personnel Cont per minute in area	< 100 cpm/100 cm2	< 100 cpm/100 cm2

SECTION III D
BUILDING AIR ACTIVITY
(T=02:00) (CLOCK=18:00)

	RX BLDG AIR Concentration uCi/cc	TURB BLDG AIR Concentration uCi/cc
Kr-85	2.2E-11	3.1E-12
Kr-85m	6.9E-09	9.6E-10
Kr-87	6.8E-09	1.2E-09
Kr-88	1.3E-08	2.1E-09
Xe131m.....	1.6E-08	1.8E-09
Xe-133.....	9.0E-09	1.0E-09
Xe133m	3.1E-10	3.4E-11
Xe-135	2.0E-08	2.3E-09
Xe-138	1.7E-10	5.0E-11
Total Gas Sample ..	7.3E-08	8.5E-09
I-131	1.9E-11	2.1E-12
I-132	9.5E-11	1.2E-11
I-133	1.2E-10	1.4E-11
I-134	6.7E-11	9.7E-12
I-135	1.5E-10	1.7E-11
DEI-131	5.7E-11	6.4E-12
Sr-89	4.3E-12	5.9E-13
Sr-90	3.4E-13	4.6E-14
Sr-91	8.5E-11	1.2E-11
Y-91	5.8E-12	8.0E-13
Mo-99	3.1E-11	4.3E-12
Ru-103	2.8E-14	3.9E-15
Ru-106	3.7E-15	5.1E-16
Te-129m	5.6E-14	7.8E-15
Te-131m	1.6E-12	2.2E-13
Te-132	6.8E-11	9.5E-12
Sb-127	8.1E-12	1.1E-13
Sb-129	5.9E-12	8.8E-13
Cs-134	2.2E-13	3.1E-14
Cs-136	1.5E-13	2.1E-14
Cs-137	2.6E-13	3.7E-14
Ba-140	1.3E-11	1.8E-12
La-140	8.0E-12	1.1E-12
Ce-144	5.0E-14	7.0E-15
Np-239	1.3E-09	1.8E-10
Total Filter	1.5E-09	2.1E-10
Hydrogen conc	0.0 %	0.0 %
Oxygen conc	0.0 %	0.0 %

Dose Rate at 1 foot

Pass Sample (1225 cc)	< 2.0E+00 mR/hr	< 2.0E+00 mR/hr
Airborne Beta Dose Rate	< 2.0E+00 mR/hr	< 2.0E+00 mR/hr
Air Sample Count Rate per 1000 cc	< 100 cpm	< 100 cpm
Air Sample Dose Rate per 1000 cc	< 2.0E+00 mR/hr	< 2.0E+00 mR/hr
Floor Contamination Rate	< 100 cpm/100 cm2	< 100 cpm/100 cm2
Wall & Equip Contamination Rate	< 100 cpm/100 cm2	< 100 cpm/100 cm2
Personnel Cont per minute in area	< 100 cpm/100 cm2	< 100 cpm/100 cm2

SECTION III D
BUILDING AIR ACTIVITY
(T=03:00) (CLOCK=19:00)

	RX BLDG AIR Concentration uCi/cc	TURB BLDG AIR Concentration uCi/cc
Kr-85	2.2E-11	1.6E-12
Kr-85m	6.9E-09	5.0E-10
Kr-87	6.8E-09	4.9E-10
Kr-88	1.3E-08	9.5E-10
Xe131m.....	1.6E-08	1.2E-09
Xe-133.....	9.0E-09	6.5E-10
Xe133m	3.1E-10	2.2E-11
Xe-135	2.0E-08	1.5E-09
Xe-138	1.7E-10	1.2E-11
Total Gas Sample ..	7.3E-08	5.3E-09
I-131	1.9E-11	1.4E-12
I-132	9.5E-11	6.8E-12
I-133	1.2E-10	8.9E-12
I-134	6.7E-11	4.8E-12
I-135	1.5E-10	1.1E-11
DEI-131	5.7E-11	4.1E-12
Sr-89	4.3E-12	3.1E-13
Sr-90	3.4E-13	2.4E-14
Sr-91	8.5E-11	6.1E-12
Y-91	5.8E-12	4.2E-13
Mo-99	3.1E-11	2.2E-12
Ru-103	2.8E-14	2.0E-15
Ru-106	3.7E-15	2.7E-16
Te-129m	5.6E-14	4.1E-15
Te-131m	1.6E-12	1.1E-13
Te-132	6.8E-11	4.9E-12
Sb-127	8.1E-12	5.9E-13
Sb-129	5.9E-12	4.2E-13
Cs-134	2.2E-13	1.6E-14
Cs-136	1.5E-13	1.1E-14
Cs-137	2.6E-13	1.9E-14
Ba-140	1.3E-11	9.5E-13
La-140	8.0E-12	5.7E-13
Ce-144	5.0E-14	3.6E-15
Np-239	1.3E-09	9.3E-11
Total Filter	1.5E-09	1.1E-10
Hydrogen conc	0.0 %	0.0 %
Oxygen conc	0.0 %	0.0 %

Dose Rate at 1 foot

Pass Sample (1225 cc) < 2.0E+00 mR/hr < 2.0E+00 mR/hr

Airborne Beta Dose Rate < 2.0E+00 mR/hr < 2.0E+00 mR/hr

Air Sample Count Rate per 1000 cc < 100 cpm < 100 cpm

Air Sample Dose Rate per 1000 cc < 2.0E+00 mR/hr < 2.0E+00 mR/hr

Floor Contamination Rate < 100 cpm/100 cm2 < 100 cpm/100 cm2

Wall & Equip Contamination Rate < 100 cpm/100 cm2 < 100 cpm/100 cm2

Personnel Cont per minute in area < 100 cpm/100 cm2 < 100 cpm/100 cm2

SECTION III D
BUILDING AIR ACTIVITY
(T=03:10) (CLOCK=19:10)

	RX BLDG AIR Concentration uCi/cc	TURB BLDG AIR Concentration uCi/cc
Kr-85	7.2E-11	1.3E-12
Kr-85m	6.8E-09	4.0E-10
Kr-87	6.9E-09	3.6E-10
Kr-88	1.2E-08	7.3E-10
Xe131m.....	1.6E-08	9.5E-10
Xe-133.....	1.9E-08	5.2E-10
Xe133m	6.4E-10	1.8E-11
Xe-135	4.2E-08	1.2E-09
Xe-138	1.1E-10	6.0E-12
Total Gas Sample ..	1.0E-07	4.2E-09
I-131	2.5E-11	1.1E-12
I-132	9.1E-11	5.2E-12
I-133	1.2E-10	7.1E-12
I-134	5.9E-11	3.4E-12
I-135	1.5E-10	8.6E-12
DEI-131	6.2E-11	3.3E-12
Sr-89	4.2E-12	2.5E-13
Sr-90	3.3E-13	2.0E-14
Sr-91	8.7E-11	4.9E-12
Y-91	5.8E-12	3.4E-13
Mo-99	3.0E-11	1.8E-12
Ru-103	1.8E-13	1.6E-15
Ru-106	3.9E-15	2.2E-16
Te-129m	5.5E-14	3.3E-15
Te-131m	1.5E-12	9.1E-14
Te-132	6.6E-11	4.0E-12
Sb-127	7.9E-12	4.7E-13
Sb-129	5.6E-12	3.3E-13
Cs-134	2.3E-13	1.3E-14
Cs-136	1.6E-13	8.6E-15
Cs-137	2.6E-13	1.5E-14
Ba-140	1.3E-11	7.6E-13
La-140	7.8E-12	4.6E-13
Ce-144	5.3E-11	2.9E-15
Np-239	1.3E-09	7.5E-11
Total Filter	1.5E-09	8.8E-11
Hydrogen conc	0.0 %	0.0 %
Oxygen conc	0.0 %	0.0 %

Dose Rate at 1 foot

Pass Sample (1225 cc)	< 2.0E+00 mR/hr	< 2.0E+00 mR/hr
Airborne Beta Dose Rate	< 2.0E+00 mR/hr	< 2.0E+00 mR/hr
Air Sample Count Rate per 1000 cc	< 100 cpm	< 100 cpm
Air Sample Dose Rate per 1000 cc	< 2.0E+00 mR/hr	< 2.0E+00 mR/hr
Floor Contamination Rate	< 100 cpm/100 cm2	< 100 cpm/100 cm2
Wall & Equip Contamination Rate	< 100 cpm/100 cm2	< 100 cpm/100 cm2
Personnel Cont per minute in area	< 100 cpm/100 cm2	< 100 cpm/100 cm2

SECTION III D
BUILDING AIR ACTIVITY
(T=03:20) (CLOCK=19:20)

	RX BLDG AIR Concentration uCi/cc	TURB BLDG AIR Concentration uCi/cc
Kr-85	2.5E-01	1.3E-12
Kr-85m	8.6E+00	4.0E-10
Kr-87	1.0E+01	3.6E-10
Kr-88	2.2E+01	7.3E-10
Xe131m.....	4.4E-01	9.5E-10
Xe-133.....	7.5E+01	5.2E-10
Xe133m	2.6E+00	1.8E-11
Xe-135	1.4E+01	1.2E-09
Xe-138	1.6E+00	6.0E-12
Total Gas Sample ..	1.3E+02	4.2E-09
I-131	2.5E-02	1.1E-12
I-132	2.4E-02	5.2E-12
I-133	4.8E-02	7.1E-12
I-134	2.0E-02	3.4E-12
I-135	3.9E-02	8.6E-12
DEI-131	3.9E-02	3.3E-12
Sr-89	4.1E-12	2.5E-13
Sr-90	3.2E-13	2.0E-14
Sr-91	7.9E-11	4.9E-12
Y-91	6.0E-12	3.4E-13
Mo-99	3.0E-11	1.8E-12
Ru-103	4.1E-13	1.6E-15
Ru-106	4.3E-15	2.2E-16
Te-129m	1.9E-03	3.3E-15
Te-131m	4.6E-02	9.1E-14
Te-132	4.4E-03	4.0E-12
Sb-127	2.2E-03	4.7E-13
Sb-129	9.8E-03	3.3E-13
Cs-134	1.4E+00	1.3E-14
Cs-136	5.5E-01	8.6E-15
Cs-137	8.6E-01	1.5E-14
Ba-140	1.3E-11	7.6E-13
La-140	7.6E-12	4.6E-13
Ce-144	5.7E-11	2.9E-15
Np-239	1.2E-09	7.5E-11
Total Filter	2.9E+00	8.8E-11
Hydrogen conc	0.0 %	0.0 %
Oxygen conc	0.0 %	0.0 %

Dose Rate at 1 foot

Pass Sample (1225 cc)	800 mR/hr	< 2.0E+00 mR/hr
Airborne Beta Dose Rate	10300 R/hr	< 2.0E+00 mR/hr
Air Sample Count Rate per 1000 cc	> 50000 cpm	< 100 cpm
Air Sample Dose Rate per 1000 cc	9500000 R/hr	< 2.0E+00 mR/hr
Floor Contamination Rate	> 50000 cpm/100 cm2	< 100 cpm/100 cm2
Wall & Equip Contamination Rate	> 50000 cpm/100 cm2	< 100 cpm/100 cm2
Personnel Cont per minute in area	> 50000 cpm/100 cm2	< 100 cpm/100 cm2

SECTION III D
BUILDING AIR ACTIVITY
(T=03:30) (CLOCK=19:30)

	RX BLDG AIR Concentration uCi/cc	TURB BLDG AIR Concentration uCi/cc
Kr-85	2.7E-01	1.3E-12
Kr-85m	9.0E+00	4.0E-10
Kr-87	9.9E+00	3.6E-10
Kr-88	2.3E+01	7.3E-10
Xe131m.....	4.7E-01	9.5E-10
Xe-133.....	8.0E+01	5.2E-10
Xe133m	2.8E+00	1.8E-11
Xe-135	1.4E+01	1.2E-09
Xe-138	1.1E+00	6.0E-12
Total Gas Sample ..	1.4E+02	4.2E-09
I-131	2.7E-02	1.1E-12
I-132	2.4E-02	5.2E-12
I-133	5.1E-02	7.1E-12
I-134	1.8E-02	3.4E-12
I-135	4.1E-02	8.6E-12
DEI-131	4.1E-02	3.3E-12
Sr-89	4.1E-12	2.5E-13
Sr-90	3.2E-13	2.0E-14
Sr-91	7.9E-11	4.9E-12
Y-91	6.0E-12	3.4E-13
Mo-99	3.0E-11	1.8E-12
Ru-103	4.1E-13	1.6E-15
Ru-106	4.3E-15	2.2E-16
Te-129m	2.1E-03	3.3E-15
Te-131m	5.0E-03	9.1E-14
Te-132	4.7E-02	4.0E-12
Sb-127	2.4E-03	4.7E-13
Sb-129	1.0E-02	3.3E-13
Cs-134	1.5E+00	1.3E-14
Cs-136	6.0E-01	8.6E-15
Cs-137	9.3E+00	1.5E-14
Ba-140	1.3E-11	7.6E-13
La-140	7.6E-12	4.6E-13
Ce-144	5.7E-11	2.9E-15
Np-239	1.2E-09	7.5E-11
Total Filter	3.1E+00	8.8E-11
Hydrogen conc	0.0 %	0.0 %
Oxygen conc	0.0 %	0.0 %

Dose Rate at 1 foot

Pass Sample (1225 cc)	1000 mR/hr	< 2.0E+00 mR/hr
Airborne Beta Dose Rate	6320 R/hr	< 2.0E+00 mR/hr
Air Sample Count Rate per 1000 cc	> 50000 cpm	< 100 cpm
Air Sample Dose Rate per 1000 cc	6200 R/hr	< 2.0E+00 mR/hr

Floor Contamination Rate	> 50000 cpm/100 cm2	< 100 cpm/100 cm2
Wall & Equip Contamination Rate	> 50000 cpm/100 cm2	< 100 cpm/100 cm2
Personnel Cont per minute in area	> 50000 cpm/100 cm2	< 100 cpm/100 cm2

SECTION III D
BUILDING AIR ACTIVITY
(T=03:40) (CLOCK=19:40)

	RX BLDG AIR Concentration uCi/cc	TURB BLDG AIR Concentration uCi/cc
Kr-85	2.6E-01	1.3E-12
Kr-85m	8.7E+00	4.0E-10
Kr-87	8.9E+00	3.6E-10
Kr-88	2.1E+01	7.3E-10
Xe131m.....	4.7E-01	9.5E-10
Xe-133.....	7.9E+01	5.2E-10
Xe133m	2.8E+00	1.8E-11
Xe-135	1.4E+01	1.2E-09
Xe-138	6.4E-01	6.0E-12
Total Gas Sample ..	1.4E+02	4.2E-09
I-131	2.6E-02	1.1E-12
I-132	2.3E-02	5.2E-12
I-133	5.0E-02	7.1E-12
I-134	1.6E-02	3.4E-12
I-135	3.9E-02	8.6E-12
DEI-131	4.1E-02	3.3E-12
Sr-89	4.1E-12	2.5E-13
Sr-90	3.2E-13	2.0E-14
Sr-91	7.9E-11	4.9E-12
Y-91	6.0E-12	3.4E-13
Mo-99	3.0E-11	1.8E-12
Ru-103	4.1E-13	1.6E-15
Ru-106	4.3E-15	2.2E-16
Te-129m	2.1E-03	3.3E-15
Te-131m	4.9E-02	9.1E-14
Te-132	4.6E-02	4.0E-12
Sb-127	2.4E-03	4.7E-13
Sb-129	9.9E-03	3.3E-13
Cs-134	1.5E+00	1.3E-14
Cs-136	5.9E-01	8.6E-15
Cs-137	9.2E-01	1.5E-14
Ba-140	1.3E-11	7.6E-13
La-140	7.6E-12	4.6E-13
Ce-144	5.7E-11	2.9E-15
Np-239	1.2E-09	7.5E-11
Total Filter	3.0E+00	8.8E-11
Hydrogen conc	0.0 %	0.0 %
Oxygen conc	0.0 %	0.0 %

Dose Rate at 1 foot

Pass Sample (1225 cc)	1000 mR/hr	< 2.0E+00 mR/hr
Airborne Beta Dose Rate	6120 R/hr	< 2.0E+00 mR/hr
Air Sample Count Rate per 1000 cc	> 50000 cpm	< 100 cpm
Air Sample Dose Rate per 1000 cc	6100 R/hr	< 2.0E+00 mR/hr

Floor Contamination Rate	> 50000 cpm/100 cm2	< 100 cpm/100 cm2
Wall & Equip Contamination Rate	> 50000 cpm/100 cm2	< 100 cpm/100 cm2
Personnel Cont per minute in area	> 50000 cpm/100 cm2	< 100 cpm/100 cm2

SECTION III D
BUILDING AIR ACTIVITY
(T=03:50) (CLOCK=19:50)

	RX BLDG AIR Concentration uCi/cc	TURB BLDG AIR Concentration uCi/cc
Kr-85	2.6E-01	1.3E-12
Kr-85m	8.3E+00	4.0E-10
Kr-87	7.9E+00	3.6E-10
Kr-88	2.0E+01	7.3E-10
Xe131m.....	4.6E-01	9.5E-10
Xe-133.....	7.7E+01	5.2E-10
Xe133m	2.7E+00	1.8E-11
Xe-135	1.4E+01	1.2E-09
Xe-138	3.8E-01	6.0E-12
Total Gas Sample ..	1.3E+02	4.2E-09
I-131	2.6E-02	1.1E-12
I-132	2.1E-02	5.2E-12
I-133	4.9E-02	7.1E-12
I-134	1.4E-02	3.4E-12
I-135	3.8E-02	8.6E-12
DEI-131	4.0E-02	3.3E-12
Sr-89	4.1E-12	2.5E-13
Sr-90	3.2E-13	2.0E-14
Sr-91	7.9E-11	4.9E-12
Y-91	6.0E-12	3.4E-13
Mo-99	3.0E-11	1.8E-12
Ru-103	4.1E-13	1.6E-15
Ru-106	4.3E-15	2.2E-16
Te-129m	2.0E-03	3.3E-15
Te-131m	4.8E-03	9.1E-14
Te-132	4.5E-02	4.0E-12
Sb-127	2.3E-03	4.7E-13
Sb-129	9.4E-03	3.3E-13
Cs-134	1.4E+00	1.3E-14
Cs-136	5.7E-01	8.6E-15
Cs-137	9.0E-01	1.5E-14
Ba-140	1.3E-11	7.6E-13
La-140	7.6E-12	4.6E-13
Ce-144	5.7E-11	2.9E-15
Np-239	1.2E-09	7.5E-11
Total Filter	3.0E+00	8.8E-11
Hydrogen conc	0.0 %	0.0 %
Oxygen conc	0.0 %	0.0 %

Dose Rate at 1 foot

Pass Sample (1225 cc)	960 mR/hr	< 2.0E+00 mR/hr
Airborne Beta Dose Rate	5850 R/hr	< 2.0E+00 mR/hr
Air Sample Count Rate per 1000 cc	> 50000 cpm	< 100 cpm
Air Sample Dose Rate per 1000 cc	6000 R/hr	< 2.0E+00 mR/hr
Floor Contamination Rate	> 50000 cpm/100 cm2	< 100 cpm/100 cm2
Wall & Equip Contamination Rate	> 50000 cpm/100 cm2	< 100 cpm/100 cm2
Personnel Cont per minute in area	> 50000 cpm/100 cm2	< 100 cpm/100 cm2

SECTION III D
BUILDING AIR ACTIVITY
(T=04:00) (CLOCK=20:00)

	RX BLDG AIR Concentration uCi/cc	TURB BLDG AIR Concentration uCi/cc
Kr-85	2.5E-01	1.3E-12
Kr-85m	7.9E+00	4.0E-10
Kr-87	7.1E+00	3.6E-10
Kr-88	1.9E+01	7.3E-10
Xe131m.....	4.4E-01	9.5E-10
Xe-133.....	7.5E+01	5.2E-10
Xe133m	2.6E+00	1.8E-11
Xe-135	1.3E+01	1.2E-09
Xe-138	2.3E-01	6.0E-12
Total Gas Sample ..	1.3E+02	4.2E-09
I-131	2.5E-02	1.1E-12
I-132	2.0E-02	5.2E-12
I-133	4.8E-02	7.1E-12
I-134	1.2E-02	3.4E-12
I-135	3.6E-02	8.6E-12
DEI-131	3.9E-02	3.3E-12
Sr-89	4.1E-12	2.5E-13
Sr-90	3.2E-13	2.0E-14
Sr-91	7.9E-11	4.9E-12
Y-91	6.0E-12	3.4E-13
Mo-99	3.0E-11	1.8E-12
Ru-103	4.1E-13	1.6E-15
Ru-106	4.3E-15	2.2E-16
Te-129m	2.0E-03	3.3E-15
Te-131m	4.6E-03	9.1E-14
Te-132	4.4E-02	4.0E-12
Sb-127	2.2E-03	4.7E-13
Sb-129	9.0E-03	3.3E-13
Cs-134	1.4E+00	1.3E-14
Cs-136	5.6E-01	8.6E-15
Cs-137	8.7E-01	1.5E-14
Ba-140	1.3E-11	7.6E-13
La-140	7.6E-12	4.6E-13
Ce-144	5.7E-11	2.9E-15
Np-239	1.2E-09	7.5E-11
Total Filter	2.9E+00	8.8E-11
Hydrogen conc	0.0 %	0.0 %
Oxygen conc	0.0 %	0.0 %

Dose Rate at 1 foot

Pass Sample (1225 cc)	920 mR/hr	< 2.0E+00 mR/hr
Airborne Beta Dose Rate	5600 R/hr	< 2.0E+00 mR/hr
Air Sample Count Rate per 1000 cc	> 50000 cpm	< 100 cpm
Air Sample Dose Rate per 1000 cc	5860 R/hr	< 2.0E+00 mR/hr
Floor Contamination Rate	> 50000 cpm/100 cm2	< 100 cpm/100 cm2
Wall & Equip Contamination Rate	> 50000 cpm/100 cm2	< 100 cpm/100 cm2
Personnel Cont per minute in area	> 50000 cpm/100 cm2	< 100 cpm/100 cm2

SECTION III D
BUILDING AIR ACTIVITY
(T=04:10) (CLOCK=20:10)

	RX BLDG AIR Concentration uCi/cc	TURB BLDG AIR Concentration uCi/cc
Kr-85	2.5E-01	1.3E-12
Kr-85m	7.5E+00	4.0E-10
Kr-87	6.3E+00	3.6E-10
Kr-88	1.8E+01	7.3E-10
Xe131m.....	4.3E-01	9.5E-10
Xe-133.....	7.3E+01	5.2E-10
Xe133m	2.6E+00	1.8E-11
Xe-135	1.3E+01	1.2E-09
Xe-138	1.4E-01	6.0E-12
Total Gas Sample ..	1.2E+02	4.2E-09
I-131	2.5E-02	1.1E-12
I-132	1.8E-02	5.2E-12
I-133	4.6E-02	7.1E-12
I-134	1.6E-02	3.4E-12
I-135	3.5E-02	8.6E-12
DEI-131	3.7E-02	3.3E-12
Sr-89	4.1E-12	2.5E-13
Sr-90	3.2E-13	2.0E-14
Sr-91	7.9E-11	4.9E-12
Y-91	6.0E-12	3.4E-13
Mo-99	3.0E-11	1.8E-12
Ru-103	4.1E-13	1.6E-15
Ru-106	4.3E-15	2.2E-16
Te-129m	1.9E-03	3.3E-15
Te-131m	4.5E-02	9.1E-14
Te-132	4.3E-02	4.0E-12
Sb-127	2.2E-03	4.7E-13
Sb-129	8.5E-03	3.3E-13
Cs-134	1.4E+00	1.3E-14
Cs-136	5.5E-01	8.6E-15
Cs-137	8.5E-01	1.5E-14
Ba-140	1.3E-11	7.6E-13
La-140	7.6E-12	4.6E-13
Ce-144	5.7E-11	2.9E-15
Np-239	1.2E-09	7.5E-11
Total Filter	2.8E+00	8.8E-11
Hydrogen conc	0.0 %	0.0 %
Oxygen conc	0.0 %	0.0 %

Dose Rate at 1 foot

Pass Sample (1225 cc)	890 mR/hr	< 2.0E+00 mR/hr
Airborne Beta Dose Rate	5400 R/hr	< 2.0E+00 mR/hr
Air Sample Count Rate per 1000 cc	> 50000 cpm	< 100 cpm
Air Sample Dose Rate per 1000 cc	5720 R/hr	< 2.0E+00 mR/hr
Floor Contamination Rate	> 50000 cpm/100 cm2	< 100 cpm/100 cm2
Wall & Equip Contamination Rate	> 50000 cpm/100 cm2	< 100 cpm/100 cm2
Personnel Cont per minute in area	> 50000 cpm/100 cm2	< 100 cpm/100 cm2

SECTION III D
BUILDING AIR ACTIVITY
(T=04:20) (CLOCK=20:20)

	RX BLDG AIR Concentration uCi/cc	TURB BLDG AIR Concentration uCi/cc
Kr-85	2.4E-01	1.3E-12
Kr-85m	7.1E+00	4.0E-10
Kr-87	5.6E+00	3.6E-10
Kr-88	1.6E+01	7.3E-10
Xe131m.....	4.2E-01	9.5E-10
Xe-133.....	7.2E+01	5.2E-10
Xe133m	2.5E+00	1.8E-11
Xe-135	1.2E+01	1.2E-09
Xe-138	8.2E-02	6.0E-12
Total Gas Sample ..	1.2E+02	4.2E-09
I-131	2.4E-02	1.1E-12
I-132	1.7E-02	5.2E-12
I-133	4.5E-02	7.1E-12
I-134	8.6E-03	3.4E-12
I-135	3.3E-02	8.6E-12
DEI-131	3.6E-02	3.3E-12
Sr-89	4.1E-12	2.5E-13
Sr-90	3.2E-13	2.0E-14
Sr-91	7.9E-11	4.9E-12
Y-91	6.0E-12	3.4E-13
Mo-99	3.0E-11	1.8E-12
Ru-103	4.1E-13	1.6E-15
Ru-106	4.3E-15	2.2E-16
Te-129m	1.9E-03	3.3E-15
Te-131m	4.4E-03	9.1E-14
Te-132	4.2E-02	4.0E-12
Sb-127	2.1E-03	4.7E-13
Sb-129	8.1E-02	3.3E-13
Cs-134	1.3E+00	1.3E-14
Cs-136	5.3E-01	8.6E-15
Cs-137	8.3E-01	1.5E-14
Ba-140	1.3E-11	7.6E-13
La-140	7.6E-12	4.6E-13
Ce-144	5.7E-11	2.9E-15
Np-239	1.2E-09	7.5E-11
Total Filter	2.8E+00	8.8E-11
Hydrogen conc	0.0 %	0.0 %
Oxygen conc	0.0 %	0.0 %

Dose Rate at 1 foot

Pass Sample (1225 cc)	850 mR/hr	< 2.0E+00 mR/hr
Airborne Beta Dose Rate	5400 R/hr	< 2.0E+00 mR/hr
Air Sample Count Rate per 1000 cc	> 50000 cpm	< 100 cpm
Air Sample Dose Rate per 1000 cc	5580 R/hr	< 2.0E+00 mR/hr
Floor Contamination Rate	> 50000 cpm/100 cm2	< 100 cpm/100 cm2
All & Equip Contamination Rate	> 50000 cpm/100 cm2	< 100 cpm/100 cm2
Personnel Cont per minute in area	> 50000 cpm/100 cm2	< 100 cpm/100 cm2

SECTION III D
BUILDING AIR ACTIVITY
(T=04:30) (CLOCK=20:30)

	RX BLDG AIR Concentration uCi/cc	TURB BLDG AIR Concentration uCi/cc
Kr-85	2.3E-01	1.3E-12
Kr-85m	6.8E+00	4.0E-10
Kr-87	5.0E+00	3.6E-10
Kr-88	1.5E+01	7.3E-10
Xe131m.....	4.1E-01	9.5E-10
Xe-133.....	7.0E+01	5.2E-10
Xe133m	2.4E+00	1.8E-11
Xe-135	1.2E+01	1.2E-09
Xe-138	4.9E-02	6.0E-12
Total Gas Sample ..	1.1E+02	4.2E-09
I-131	2.3E-02	1.1E-12
I-132	1.6E-02	5.2E-12
I-133	4.4E-02	7.1E-12
I-134	7.4E-03	3.4E-12
I-135	3.2E-02	8.6E-12
DEI-131	3.6E-02	3.3E-12
Sr-89	4.1E-12	2.5E-13
Sr-90	3.2E-13	2.0E-14
Sr-91	7.9E-11	4.9E-12
Y-91	6.0E-12	3.4E-13
Mo-99	3.0E-11	1.8E-12
Ru-103	4.1E-13	1.6E-15
Ru-106	4.3E-15	2.2E-16
Te-129m	1.8E-03	3.3E-15
Te-131m	4.3E-03	9.1E-14
Te-132	4.1E-02	4.0E-12
Sb-127	2.1E-03	4.7E-13
Sb-129	7.7E-03	3.3E-13
Cs-134	1.3E+00	1.3E-14
Cs-136	5.2E-01	8.6E-15
Cs-137	8.1E-01	1.5E-14
Ba-140	1.3E-11	7.6E-13
La-140	7.6E-12	4.6E-13
Ce-144	5.7E-11	2.9E-15
Np-239	1.2E-09	7.5E-11
Total Filter	2.7E+00	8.8E-11
Hydrogen conc	0.0 %	0.0 %
Oxygen conc	0.0 %	0.0 %

Dose Rate at 1 foot

Pass Sample (1225 cc) 820 mR/hr < 2.0E+00 mR/hr

Airborne Beta Dose Rate 5040 R/hr < 2.0E+00 mR/hr

Air Sample Count Rate per 1000 cc > 50000 cpm < 100 cpm

Air Sample Dose Rate per 1000 cc 5450 R/hr < 2.0E+00 mR/hr

Floor Contamination Rate > 50000 cpm/100 cm2 < 100 cpm/100 cm2

Wall & Equip Contamination Rate > 50000 cpm/100 cm2 < 100 cpm/100 cm2

Personnel Cont per minute in area > 50000 cpm/100 cm2 < 100 cpm/100 cm2

SECTION III E

PLANT SAMPLE ACTIVITY

TABLE III E-1
PLANT CHEMISTRY ACTIVITY
(T=00:00) (CLOCK=16:00)

Nuclide	RX WATER	TORUS WATER	DRYWELL GAS	TORUS GAS	STACK RAGEMS	TB RAGEMS
	Conc uCi/cc	Conc uCi/cc	Conc uCi/cc	Conc uCi/cc	Conc uCi/cc	Conc uCi/cc
Kr-85	2.5E-04	1.0E-09	6.5E-08	6.5E-08	2.7E-10	3.1E-12
Kr-85m	2.4E-07	1.0E-09	1.3E-06	1.3E-06	8.4E-08	9.6E-10
Kr-87	6.0E-07	1.0E-09	2.6E-06	2.6E-06	2.7E-07	1.2E-09
Kr-88	8.5E-07	1.0E-09	4.1E-06	4.1E-06	2.7E-07	2.1E-09
Xe131m	9.1E-05	1.0E-09	1.4E-05	1.4E-05	2.0E-07	1.8E-09
Xe-133	4.9E-02	1.0E-09	9.2E-07	9.2E-07	1.1E-07	1.0E-09
Xe133m	1.7E-03	1.0E-09	9.2E-07	9.2E-07	3.8E-09	3.4E-11
Xe-135	1.3E-01	1.0E-09	1.1E-05	1.1E-05	2.9E-07	2.3E-09
Xe-138	5.5E-02	1.0E-09	2.9E-06	2.9E-06	1.2E-06	5.0E-11
Total Gas Sample	6.8E-01	9.0E-09	9.8E-05	9.8E-05	2.4E-06	8.5E-09
I-131	4.9E-04	1.0E-08	3.6E-12	3.6E-12	2.3E-10	2.1E-12
I-132	4.9E-04	1.0E-07	2.4E-13	2.4E-13	2.2E-09	1.2E-11
I-133	3.3E-04	1.0E-07	1.1E-11	1.1E-11	1.6E-09	1.4E-11
I-134	9.5E-04	1.0E-07	2.4E-13	2.4E-13	4.5E-09	9.7E-12
I-135	4.9E-04	1.0E-07	2.4E-13	2.4E-13	2.3E-09	1.7E-11
DEI 131	6.0E-04	4.0E-08	6.2E-12	6.2E-12	7.6E-10	6.4E-12
Sr-89	2.0E-09	1.0E-11	1.0E-11	1.0E-11	5.2E-11	5.9E-13
Sr-90	2.0E-09	1.0E-11	1.0E-11	1.0E-11	4.1E-12	4.6E-14
Sr-91	2.0E-05	1.0E-11	1.0E-11	1.0E-11	1.2E-09	1.2E-11
Y-91	1.4E-05	1.0E-11	1.0E-11	1.0E-11	7.0E-11	8.0E-13
Mo-99	1.4E-05	1.0E-11	1.0E-11	1.0E-11	3.8E-10	4.3E-12
Ru-103	1.2E-05	1.0E-11	1.0E-11	1.0E-11	3.4E-13	3.9E-15
Rh-106	2.0E-08	1.0E-11	1.0E-11	1.0E-11	4.5E-14	5.1E-16
Te-129m	2.0E-09	1.0E-11	1.0E-11	1.0E-11	6.8E-13	7.8E-15
Te-131m	2.0E-09	1.0E-11	1.0E-11	1.0E-11	1.1E-11	2.2E-13
Te-132	2.2E-07	1.0E-11	1.0E-11	1.0E-11	8.4E-10	9.5E-12
Sb-127	2.0E-09	1.0E-11	1.0E-11	1.0E-11	5.3E-11	1.1E-13
Sb-129	2.0E-09	1.0E-11	1.0E-11	1.0E-11	5.3E-11	8.8E-13
Cs-134	1.2E-06	6.4E-06	1.0E-11	1.0E-11	2.7E-12	3.1E-14
Cs-136	1.1E-06	1.0E-11	1.0E-11	1.0E-11	1.8E-12	2.1E-14
Cs-137	1.4E-08	1.0E-11	1.0E-11	1.0E-11	3.2E-12	3.7E-14
Ba-140	4.0E-06	1.0E-11	1.0E-11	1.0E-11	1.6E-10	1.8E-12
La-140	1.1E-06	1.0E-11	1.0E-11	1.0E-11	5.3E-11	1.1E-12
Ce-144	2.7E-07	1.0E-11	1.0E-11	1.0E-11	6.1E-13	7.0E-15
Mp-239	2.0E-06	1.0E-11	1.0E-11	1.0E-11	1.6E-08	1.8E-10
Total Filter	4.8E-05	6.4E-06	1.9E-10	1.9E-10	1.9E-08	2.1E-10
Hydrogen conc	0.0 %	0.0 %	0.0 %	0.0 %	0.0 %	0.0 %
Oxygen conc	0.0 %	0.0 %	0.0 %	0.0 %	0.0 %	0.0 %

Dose Rate at 1 foot

Normal Pass Sample (10 ml)	< 2.0	< 2.0				
Diluted Sample (0.1 ml)	< 2.0	< 2.0				
Normal Pass Sample (15 ml)			< 2.0	< 2.0		
Diluted Gas Sample (1225 cc)					< 2.0	< 2.0

TABLE III E-1
PLANT CHEMISTRY ACTIVITY
(T=01:00) (CLOCK=17:00)

Nuclide	RX WATER	TORUS WATER	DRYWELL GAS	TORUS GAS	STACK RAGEMS	TB RAGEMS
	Conc uCi/cc	Conc uCi/cc	Conc uCi/cc	Conc uCi/cc	Conc uCi/cc	Conc uCi/cc
Kr-85	2.5E-04	1.0E-09	6.5E-08	6.5E-08	1.5E-10	3.1E-09
Kr-85m	2.4E-07	1.0E-09	1.3E-06	1.3E-06	4.5E-08	9.6E-10
Kr-87	6.0E-07	1.0E-09	2.6E-06	2.6E-06	1.5E-07	1.2E-09
Kr-88	8.5E-07	1.0E-09	4.1E-06	4.1E-06	1.5E-07	2.1E-09
Xe131m	9.1E-05	1.0E-09	1.4E-05	1.4E-05	1.1E-08	1.8E-09
Xe-133	4.9E-02	1.0E-09	9.2E-07	9.2E-07	6.0E-08	1.0E-09
Xe133m	1.7E-03	1.0E-09	9.2E-07	9.2E-07	2.1E-09	3.4E-11
Xe-135	1.3E-01	1.0E-09	1.1E-05	1.1E-05	1.6E-07	2.3E-09
Xe-138	5.5E-02	1.0E-09	2.9E-06	2.9E-06	6.5E-07	5.0E-11
Total Gas Sample	6.8E-01	9.0E-09	9.8E-05	9.8E-05	1.3E-06	8.5E-09
I-131	4.9E-04	1.0E-08	3.6E-12	3.6E-12	1.2E-10	2.1E-12
I-132	4.9E-04	1.0E-07	2.4E-13	2.4E-13	1.2E-09	1.2E-11
I-133	3.3E-04	1.0E-07	1.1E-11	1.1E-11	8.7E-10	1.4E-11
I-134	9.5E-04	1.0E-07	2.4E-13	2.4E-13	2.4E-09	9.7E-12
I-135	4.9E-04	1.0E-07	2.4E-13	2.4E-13	1.2E-09	1.7E-11
DEI 131	6.0E-04	4.0E-08	6.2E-12	6.2E-12	4.1E-10	6.4E-12
Sr-89	2.0E-09	1.0E-11	1.0E-11	1.0E-11	2.8E-11	5.9E-13
Sr-90	2.0E-09	1.0E-11	1.0E-11	1.0E-11	2.2E-12	4.6E-14
Sr-91	2.0E-05	1.0E-11	1.0E-11	1.0E-11	6.5E-10	1.2E-11
Y-91	1.4E-05	1.0E-11	1.0E-11	1.0E-11	3.7E-11	8.0E-13
Mo-99	1.4E-05	1.0E-11	1.0E-11	1.0E-11	2.1E-10	4.3E-12
Ru-103	1.2E-05	1.0E-11	1.0E-11	1.0E-11	1.8E-13	3.9E-15
Ru-106	2.0E-08	1.0E-11	1.0E-11	1.0E-11	2.4E-14	5.1E-16
Te-129m	2.0E-09	1.0E-11	1.0E-11	1.0E-11	3.7E-13	7.8E-15
Te-131m	2.0E-09	1.0E-11	1.0E-11	1.0E-11	1.1E-11	2.2E-13
Te-132	2.2E-07	1.0E-11	1.0E-11	1.0E-11	4.5E-11	9.5E-12
Sb-127	2.0E-09	1.0E-11	1.0E-11	1.0E-11	5.4E-11	1.1E-13
Sb-129	2.0E-09	1.0E-11	1.0E-11	1.0E-11	5.4E-11	8.8E-13
Cs-134	1.2E-06	6.4E-06	1.0E-11	1.0E-11	1.5E-12	3.1E-14
Cs-136	1.1E-06	1.0E-11	1.0E-11	1.0E-11	9.7E-13	2.1E-14
Cs-137	1.4E-08	1.0E-11	1.0E-11	1.0E-11	1.7E-12	3.7E-14
Ba-140	4.0E-06	1.0E-11	1.0E-11	1.0E-11	8.7E-11	1.8E-12
La-140	1.1E-06	1.0E-11	1.0E-11	1.0E-11	5.4E-11	1.1E-12
Ce-144	2.7E-07	1.0E-11	1.0E-11	1.0E-11	3.3E-13	7.0E-15
Np-239	2.0E-06	1.0E-11	1.0E-11	1.0E-11	8.7E-09	1.8E-10
Total Filter	4.8E-05	6.4E-06	1.9E-10	1.9E-10	1.0E-08	2.1E-10
Hydrogen conc	0.0 %	0.0 %	0.0 %	0.0 %	0.0 %	0.0 %
Oxygen conc	0.0 %	0.0 %	0.0 %	0.0 %	0.0 %	0.0 %

Dose Rate at 1 foot

Normal Pass Sample (10 ml)	< 2.0	< 2.0				
Diluted Sample (0.1 ml)	< 2.0	< 2.0				
Normal Pass Sample (15 ml)			< 2.0	< 2.0		
Diluted Gas Sample (1225 cc)					< 2.0	< 2.0

TABLE III E-1
PLANT CHEMISTRY ACTIVITY
(T=01:30) (CLOCK=17:30)

Nuclide	RX WATER	TORUS WATER	DRYWELL GAS	TORUS GAS	STACK RAGEMS	TB RAGEMS
	Conc uCi/cc	Conc uCi/cc	Conc uCi/cc	Conc uCi/cc	Conc uCi/cc	Conc uCi/cc
Kr-85	8.3E+02	1.0E-09	6.5E-08	6.5E-08	1.5E-10	3.1E-12
Kr-85m	3.5E+04	1.0E-09	1.3E-06	1.3E-06	4.5E-08	9.6E-10
Kr-87	6.3E+04	1.0E-09	2.6E-06	2.6E-06	1.5E-07	1.2E-09
Kr-88	9.7E+04	1.0E-09	4.1E-06	4.1E-06	1.5E-07	2.1E-09
Xe131m	1.5E+03	1.0E-09	1.4E-05	1.4E-05	1.1E-08	1.8E-09
Xe-133	2.5E+05	1.0E-09	9.2E-07	9.2E-07	6.0E-08	1.0E-09
Xe133m	8.9E+03	1.0E-09	9.2E-07	9.2E-07	2.1E-09	3.4E-11
Xe-135	5.0E+04	1.0E-09	1.1E-05	1.1E-05	1.6E-07	2.3E-09
Xe-138	1.5E+05	1.0E-09	2.9E-06	2.9E-06	6.5E-07	5.0E-11
Total Gas Sample	6.6E+05	9.0E-09	9.8E-05	9.8E-05	1.3E-06	8.5E-09
I-131	8.4E+04	1.0E-08	3.6E-12	3.6E-12	1.2E-10	2.1E-12
I-132	1.1E+05	1.0E-07	2.4E-13	2.4E-13	1.2E-09	1.2E-11
I-133	1.7E+05	1.0E-07	1.1E-11	1.1E-11	8.7E-10	1.4E-11
I-134	1.6E+05	1.0E-07	2.4E-13	2.4E-13	2.4E-09	9.7E-12
I-135	1.5E+05	1.0E-07	2.4E-13	2.4E-13	1.2E-09	1.7E-11
DEI 131	1.3E+05	4.0E-08	6.2E-12	6.2E-12	4.1E-10	6.4E-12
Sr-89	2.0E-09	1.0E-11	1.0E-11	1.0E-11	2.8E-11	5.9E-13
Sr-90	2.0E-09	1.0E-11	1.0E-11	1.0E-11	2.2E-12	4.6E-14
Sr-91	2.0E-05	1.0E-11	1.0E-11	1.0E-11	6.5E-10	1.2E-11
Y-91	1.4E-05	1.0E-11	1.0E-11	1.0E-11	3.7E-11	8.0E-13
Mo-99	1.4E-05	1.0E-11	1.0E-11	1.0E-11	2.1E-10	4.3E-12
Ru-103	1.2E-05	1.0E-11	1.0E-11	1.0E-11	1.8E-13	3.9E-15
Ru-106	2.0E-08	1.0E-11	1.0E-11	1.0E-11	2.4E-14	5.1E-16
Te-129m	2.6E+01	1.0E-11	1.0E-11	1.0E-11	3.7E-13	7.8E-15
Te-131m	6.4E+01	1.0E-11	1.0E-11	1.0E-11	1.1E-11	2.2E-13
Te-132	5.9E+02	1.0E-11	1.0E-11	1.0E-11	4.5E-11	9.5E-12
Sb-127	3.0E+01	1.0E-11	1.0E-11	1.0E-11	5.4E-11	1.1E-13
Sb-129	1.6E+02	1.0E-11	1.0E-11	1.0E-11	5.4E-11	8.8E-13
Cs-134	1.8E+04	6.4E-06	1.0E-11	1.0E-11	1.5E-12	3.1E-14
Cs-136	7.4E+04	1.0E-11	1.0E-11	1.0E-11	9.7E-13	2.1E-14
Cs-137	1.2E+04	1.0E-11	1.0E-11	1.0E-11	1.7E-12	3.7E-14
Ba-140	4.0E-06	1.0E-11	1.0E-11	1.0E-11	8.7E-11	1.8E-12
La-140	1.1E-06	1.0E-11	1.0E-11	1.0E-11	5.4E-11	1.1E-12
Ce-144	2.7E-07	1.0E-11	1.0E-11	1.0E-11	3.3E-13	7.0E-15
Np-239	2.0E-06	1.0E-11	1.0E-11	1.0E-11	8.7E-09	1.8E-10
Total Filter	3.8E+04	6.4E-06	1.9E-10	1.9E-10	1.0E-08	2.1E-10
Hydrogen conc	0.0 %	0.0 %	0.0 %	0.0 %	0.0 %	0.0 %
Oxygen conc	0.0 %	0.0 %	0.0 %	0.0 %	0.0 %	0.0 %

Dose Rate at 1 foot

Normal Pass Sample (10 ml)	40,000	< 2.0
Diluted Sample (0.1 ml)	400	< 2.0
Normal Pass Sample (15 ml)		< 2.0
Diluted Gas Sample (1225 cc)		< 2.0

TABLE III E-1
PLANT CHEMISTRY ACTIVITY
(T=01:45) (CLOCK=17:45)

Nuclide	RX WATER	TORUS WATER	DRYWELL GAS	TORUS GAS	STACK RAGEMS	TB RAGEMS
	Conc uCi/cc	Conc uCi/cc	Conc uCi/cc	Conc uCi/cc	Conc uCi/cc	Conc uCi/cc
Kr-85	1.7E+03	1.6E-04	1.6E-03	1.6E-02	1.5E-10	3.1E-12
Kr-85m	7.1E+04	6.9E-03	6.9E-02	6.9E-01	4.5E-08	9.6E-10
Kr-87	1.2E+05	1.1E-02	1.1E-01	1.6E+00	1.5E-07	1.2E-09
Kr-88	1.9E+05	1.8E-02	1.8E-01	1.8E+00	1.5E-07	2.1E-09
Xe-131m	3.0E+03	2.9E-04	2.9E-03	2.9E-02	1.1E-08	1.8E-09
Xe-133	5.0E+05	4.9E-02	4.9E-01	4.9E+00	6.0E-08	1.0E-09
Xe-133m	1.8E+04	1.7E-03	1.7E-02	1.7E-01	2.1E-09	3.4E-11
Xe-135	9.8E+04	9.6E-03	9.6E-02	9.6E-01	1.6E-07	2.3E-09
Xe-138	2.5E+05	1.8E-02	1.8E-01	1.8E+00	6.5E-07	5.0E-11
Total Gas Sample	1.3E+06	1.2E-01	1.2E+00	1.2E+01	1.3E-06	8.5E-09
I-131	1.7E+05	1.6E-05	1.6E-04	1.6E-03	1.2E-10	2.1E-12
I-132	2.2E+05	2.1E-05	2.1E-04	2.1E-03	1.2E-09	1.2E-11
I-133	3.3E+05	3.2E-05	3.2E-04	3.2E-03	8.7E-10	1.4E-11
I-134	3.1E+05	2.8E-05	2.8E-04	2.8E-03	2.4E-09	9.7E-12
I-135	2.9E+05	2.8E-05	2.8E-04	2.8E-03	1.2E-09	1.7E-11
DEI 131	2.6E+05	2.6E-05	2.6E-04	2.6E-03	4.1E-10	6.4E-12
Sr-89	2.0E-09	1.0E-11	1.0E-11	1.0E-11	2.8E-11	5.9E-13
Sr-90	2.0E-09	1.0E-11	1.0E-11	1.0E-11	2.2E-12	4.6E-14
Sr-91	2.0E-05	1.0E-11	1.0E-11	1.0E-11	6.5E-10	1.2E-11
Y-91	1.4E-05	1.0E-11	1.0E-11	1.0E-11	3.7E-11	8.0E-13
Mo-99	1.4E-05	1.0E-11	1.0E-11	1.0E-11	2.1E-10	4.3E-12
Ru-103	1.2E-05	1.0E-11	1.0E-11	1.0E-11	1.8E-13	3.9E-15
Ru-106	2.0E-08	1.0E-11	1.0E-11	1.0E-11	2.4E-14	5.1E-16
Te-129m	5.2E+01	1.3E-04	1.3E-05	1.3E-06	3.7E-13	7.8E-15
Te-131m	1.3E+02	3.1E-04	3.1E-05	3.1E-06	1.1E-11	2.2E-13
Te-132	1.2E+03	2.9E-03	2.9E-04	2.9E-05	4.5E-11	9.5E-12
Sb-127	6.0E+01	1.5E-04	1.5E-05	1.5E-06	5.4E-11	1.1E-13
Sb-129	3.1E+02	7.5E-04	7.5E-05	7.5E-06	5.4E-11	8.8E-13
Cs-134	3.7E+04	9.0E-02	9.0E-03	9.0E-04	1.5E-12	3.1E-14
Cs-136	1.5E+04	3.6E-02	3.6E-03	3.6E-04	9.7E-13	2.1E-14
Cs-137	2.3E+04	5.6E-02	5.6E-03	5.6E-04	1.7E-12	3.7E-14
Ba-140	4.0E-06	1.0E-11	1.0E-11	1.0E-11	8.7E-11	1.8E-12
La-140	1.1E-06	1.0E-11	1.0E-11	1.0E-11	5.4E-11	1.1E-12
Ce-144	2.7E-07	1.0E-11	1.0E-11	1.0E-11	3.3E-13	7.0E-15
Np-239	2.0E-06	1.0E-11	1.0E-11	1.0E-11	8.7E-09	1.8E-10
Total Filter	7.6E+04	1.8E+01	1.8E+00	1.8E-01	1.0E-08	2.1E-10
Hydrogen conc	0.0 %	0.0 %	0.0 %	0.0 %	0.0 %	0.0 %
Oxygen conc	0.0 %	0.0 %	0.0 %	0.0 %	0.0 %	0.0 %

Dose Rate at 1 foot

Normal Pass Sample (10 ml)	75,000	< 2.0
Diluted Sample (0.1 ml)	750	< 2.0
Normal Pass Sample (15 ml)		< 2.0
Diluted Gas Sample (1225 cc)		< 2.0

TABLE III E-1
PLANT CHEMISTRY ACTIVITY
(T=02:00) (CLOCK=18:00)

Nuclide	RX WATER	TORUS WATER	DRYWELL GAS	TORUS GAS	STACK	TB
	Conc uCi/cc	Conc uCi/cc	Conc uCi/cc	Conc uCi/cc	RAGEMS Conc uCi/cc	RAGEMS Conc uCi/cc
Kr-85	2.5E+03	1.7E-04	1.7E-03	1.7E-02	1.5E-10	3.1E-12
Kr-85m	1.1E+05	7.1E-03	7.1E-02	7.1E-01	4.5E-08	9.6E-10
Kr-87	1.7E+05	1.1E-02	1.1E-01	1.1E+00	1.5E-07	1.2E-09
Kr-88	2.8E+05	1.8E-02	1.8E-01	1.8E+00	1.5E-07	2.1E-09
Xe131m	4.4E+03	3.0E-04	3.0E-03	3.0E-02	1.1E-08	1.8E-09
Xe-133	7.5E+05	5.0E-02	5.0E-01	5.0E+00	6.0E-08	1.0E-09
Xe133m	2.7E+04	1.8E-03	1.8E-02	1.8E-01	2.1E-09	3.4E-11
Xe-135	1.5E+05	9.6E-03	9.6E-02	9.6E-01	1.6E-07	2.3E-09
Xe-138	3.1E+05	1.2E-02	1.1E-01	1.1E+00	6.5E-07	5.0E-11
Total Gas Sample	1.8E+06	1.1E-01	1.1E+00	1.1E+01	1.3E-06	8.5E-09
I-131	2.5E+05	1.7E-05	1.7E-04	1.7E-03	1.2E-10	2.1E-12
I-132	3.2E+05	2.0E-05	2.4E-04	2.4E-03	1.2E-09	1.2E-11
I-133	5.0E+05	3.3E-05	3.3E-04	3.3E-03	8.7E-10	1.4E-11
I-134	4.3E+05	2.5E-05	2.4E-04	2.4E-03	2.4E-09	9.7E-12
I-135	4.3E+05	2.8E-05	2.4E-04	2.4E-03	1.2E-09	1.7E-11
DEI 131	3.9E+05	2.6E-05	2.6E-04	2.6E-03	4.1E-10	6.4E-12
Sr-89	2.0E-09	1.0E-11	1.0E-11	1.0E-11	2.8E-11	5.9E-13
Sr-90	2.0E-09	1.0E-11	1.0E-11	1.0E-11	2.2E-12	4.6E-14
Sr-91	2.0E-05	1.0E-11	1.0E-11	1.0E-11	6.5E-10	1.2E-11
Y-91	1.4E-05	1.0E-11	1.0E-11	1.0E-11	3.7E-11	8.0E-13
Mo-99	1.4E-05	1.0E-11	1.0E-11	1.0E-11	2.1E-10	4.3E-12
Ru-103	1.2E-05	1.0E-11	1.0E-11	1.0E-11	1.8E-13	3.9E-15
Ru-106	2.0E-08	1.0E-11	1.0E-11	1.0E-11	2.4E-14	5.1E-16
Te-129m	7.8E+01	1.3E-04	1.3E-05	1.3E-06	3.7E-13	7.8E-15
Te-131m	1.9E+02	3.1E-04	3.1E-05	3.1E-06	1.1E-11	2.2E-13
Te-132	1.8E+03	2.9E-03	2.9E-04	2.9E-05	4.5E-11	9.5E-12
Sb-127	9.0E+01	1.5E-04	1.5E-05	1.5E-06	5.4E-11	1.1E-13
Sb-129	4.6E+02	7.5E-04	7.5E-05	7.5E-06	5.4E-11	8.8E-13
Cs-134	5.5E+04	6.4E-06	9.0E-02	9.0E-03	9.0E-04	3.1E-14
Cs-136	2.2E+04	1.0E-11	3.6E-02	3.6E-03	3.6E-04	2.1E-14
Cs-137	3.5E+04	1.0E-11	5.6E-02	5.6E-03	5.6E-04	3.7E-14
Ba-140	4.0E-06	1.0E-11	1.0E-11	1.0E-11	8.7E-11	1.8E-12
La-140	1.1E-06	1.0E-11	1.0E-11	1.0E-11	5.4E-11	1.1E-12
Ce-144	2.7E-07	1.0E-11	1.0E-11	1.0E-11	3.3E-13	7.0E-15
Np-239	2.0E-06	1.0E-11	1.0E-11	1.0E-11	8.7E-09	1.8E-10
Total Filter	1.2E+05	6.4E-06	1.9E-01	1.9E-02	1.9E-03	2.1E-10
Hydrogen conc	0.0 %	0.0 %	0.0 %	0.0 %	0.0 %	0.0 %
Oxygen conc	0.0 %	0.0 %	0.0 %	0.0 %	0.0 %	0.0 %

Dose Rate at 1 foot

Normal Pass Sample (10 ml) 110,000	< 2.0
Diluted Sample (0.1 ml) 1,100	< 2.0
Normal Pass Sample (15 ml)	< 2.0
Diluted Gas Sample (1225 cc)	< 2.0

TABLE III E-1
PLANT CHEMISTRY ACTIVITY
(T=02:15) (CLOCK=18:15)

Nuclide	RX WATER	TORUS WATER	DRYWELL GAS	TORUS GAS	STACK	TB
	Conc uCi/cc	Conc uCi/cc	Conc uCi/cc	Conc uCi/cc	RAGEMS Conc uCi/cc	RAGEMS Conc uCi/cc
Kr-85	2.5E+03	1.7E-04	1.7E-03	1.7E-02	1.5E-10	3.1E-12
Kr-85m	1.1E+05	7.1E-03	7.1E-02	7.1E-01	4.5E-08	9.6E-10
Kr-87	1.6E+05	9.7E-03	9.7E-02	9.7E-01	1.5E-07	1.2E-09
Kr-88	2.7E+05	1.7E-02	1.7E-01	1.7E+00	1.5E-07	2.1E-09
Xe131m	4.4E+03	2.9E-04	2.9E-03	2.9E-02	1.1E-08	1.8E-09
Xe-133	7.5E+05	5.0E-02	5.2E-01	5.2E+00	6.0E-08	1.0E-09
Xe133m	2.6E+04	1.8E-03	1.8E-02	1.8E-01	2.1E-09	3.4E-11
Xe-135	1.5E+05	9.5E-03	9.5E-02	9.5E-01	1.6E-07	2.3E-09
Xe-138	1.9E+05	7.1E-03	7.1E-02	7.1E-01	6.5E-07	5.0E-11
Total Gas Sample	1.7E+06	1.0E-01	1.0E+00	9.8E+00	1.3E-06	8.5E-09
I-131	2.5E+05	1.7E-05	1.7E-04	1.6E-03	1.2E-10	2.1E-12
I-132	3.1E+05	1.9E-05	1.9E-04	1.9E-03	1.2E-09	1.2E-11
I-133	4.9E+05	3.3E-05	3.3E-04	3.3E-03	8.7E-10	1.4E-11
I-134	3.8E+05	2.2E-05	2.4E-04	2.4E-03	2.4E-09	9.7E-12
I-135	4.2E+05	2.8E-05	2.4E-04	2.4E-03	1.2E-09	1.7E-11
DEI 131	3.9E+05	2.6E-05	2.6E-04	2.6E-03	4.1E-10	6.4E-12
Sr-89	2.0E-09	1.0E-11	1.0E-11	1.0E-11	2.8E-11	5.9E-13
Sr-90	2.0E-09	1.0E-11	1.0E-11	1.0E-11	2.2E-12	4.6E-14
Sr-91	2.0E-05	1.0E-11	1.0E-11	1.0E-11	6.5E-10	1.2E-11
Y-91	1.4E-05	1.0E-11	1.0E-11	1.0E-11	3.7E-11	8.0E-13
Mo-99	1.4E-05	1.0E-11	1.0E-11	1.0E-11	2.1E-10	4.3E-12
Ru-103	1.2E-05	1.0E-11	1.0E-11	1.0E-11	1.8E-13	3.9E-15
Ru-106	2.0E-08	1.0E-11	1.0E-11	1.0E-11	2.4E-14	5.1E-16
Te-129m	7.8E+01	1.0E-11	1.3E-04	1.3E-05	1.3E-06	7.8E-15
Te-131m	1.9E+02	1.0E-11	3.1E-04	3.1E-05	3.1E-06	2.2E-13
Te-132	1.8E+03	1.0E-11	2.9E-03	2.9E-04	2.9E-05	9.5E-12
Sb-127	9.0E+01	1.0E-11	1.5E-04	1.5E-05	1.5E-06	1.1E-13
Sb-129	4.5E+02	1.0E-11	7.3E-04	7.3E-05	7.3E-06	8.8E-13
Cs-134	5.50+04	6.4E-06	9.2E-02	9.2E-03	9.2E-04	3.1E-14
Cs-136	2.2E+04	1.0E-11	3.7E-02	3.7E-03	3.7E-04	2.1E-14
Cs-137	3.5E+04	1.0E-11	5.8E-02	5.8E-03	5.8E-04	3.7E-14
Ba-140	4.0E-06	1.0E-11	1.0E-11	1.0E-11	8.7E-11	1.8E-12
La-140	1.1E-06	1.0E-11	1.0E-11	1.0E-11	5.4E-11	1.1E-12
Ce-144	2.7E-07	1.0E-11	1.0E-11	1.0E-11	3.3E-13	7.0E-54
Np-239	2.0E-06	1.0E-11	1.0E-11	1.0E-11	8.7E-09	1.8E-10
Total Filter	1.2E+05	6.4E-06	9.2E-01	9.2E-02	9.0E-03	2.1E-10
Hydrogen conc	0.0 %	0.0 %	0.0 %	0.0 %	0.0 %	0.0 %
Oxygen conc	0.0 %	0.0 %	0.0 %	0.0 %	0.0 %	0.0 %

Dose Rate at 1 foot

Normal Pass Sample (10 ml)	99,000	< 2.0
Diluted Sample (0.1 ml)	990	< 2.0
Normal Pass Sample (15 ml)		< 2.0
Diluted Gas Sample (1225 cc)		< 2.0

TABLE III E-1
PLANT CHEMISTRY ACTIVITY
(T=02:30) (CLOCK=18:30)

Nuclide	RX WATER	TORUS WATER	DRYWELL GAS	TORUS GAS	STACK	TB
	Conc uCi/cc	Conc uCi/cc	Conc uCi/cc	Conc uCi/cc	RAGEMS Conc uCi/cc	RAGEMS Conc uCi/cc
Kr-85	2.5E+03	1.7E-04	1.7E-03	1.7E-02	1.5E-10	3.1E-12
Kr-85m	1.1E+05	7.1E-03	7.1E-02	7.1E-01	4.5E-08	9.6E-10
Kr-87	1.5E+05	8.8E-03	8.8E-02	8.8E-01	1.5E-07	1.2E-09
Kr-88	2.6E+05	1.6E-02	1.6E-01	1.6E+00	1.5E-07	2.1E-09
Xe131m	4.4E+03	2.9E-04	2.9E-03	2.9E-02	1.1E-08	1.8E-09
Xe-133	7.5E+05	5.0E-02	5.0E-01	5.0E+00	6.0E-08	1.0E-09
Xe133m	2.6E+04	1.7E-03	1.7E-02	1.7E-01	2.1E-09	3.4E-11
Xe-135	1.4E+05	9.4E-03	9.4E-02	9.4E-01	1.6E-07	2.3E-09
Xe-138	1.1E+05	4.4E-03	4.4E-02	4.4E-01	6.5E-07	5.0E-11
Total Gas Sample	1.6E+06	9.8E-02	9.8E-01	9.8E+00	1.3E-06	8.5E-09
I-131	2.5E+05	1.7E-05	1.7E-04	1.7E-03	1.2E-10	2.1E-12
I-132	2.9E+05	1.8E-05	1.8E-04	1.8E-03	1.2E-09	1.2E-11
I-133	4.9E+05	3.3E-05	3.3E-04	3.3E-03	8.7E-10	1.4E-11
I-134	3.3E+05	1.9E-05	1.9E-04	1.9E-03	2.4E-09	9.7E-12
I-135	4.1E+05	2.7E-05	2.7E-04	2.7E-03	1.2E-09	1.7E-11
DEI 131	3.9E+05	2.6E-05	2.6E-04	2.6E-03	4.1E-10	6.4E-12
Sr-89	2.0E-09	1.0E-11	1.0E-11	1.0E-11	2.8E-11	5.9E-13
Sr-90	2.0E-09	1.0E-11	1.0E-11	1.0E-11	2.2E-12	4.6E-14
Sr-91	2.0E-05	1.0E-11	1.0E-11	1.0E-11	6.5E-10	1.2E-11
Y-91	1.4E-05	1.0E-11	1.0E-11	1.0E-11	3.7E-11	8.0E-13
Mo-99	1.4E-05	1.0E-11	1.0E-11	1.0E-11	2.1E-10	4.3E-12
Ru-103	1.2E-05	1.0E-11	1.0E-11	1.0E-11	1.8E-13	3.9E-15
Ru-106	2.0E-08	1.0E-11	1.0E-11	1.0E-11	2.4E-14	5.1E-16
Te-129m	7.8E+01	1.3E-04	1.3E-05	1.3E-06	3.7E-13	7.8E-15
Te-131m	1.9E+02	3.1E-04	3.1E-05	3.1E-06	1.1E-11	2.2E-13
Te-132	1.8E+03	2.9E-03	2.9E-04	2.9E-05	4.5E-11	9.5E-12
Sb-127	9.0E+01	1.5E-03	1.5E-04	1.5E-06	5.4E-11	1.1E-13
Sb-129	4.4E+02	7.1E-04	7.1E-05	7.1E-06	5.4E-11	8.8E-13
Cs-134	5.5E+04	9.2E-02	9.2E-03	9.2E-04	1.5E-12	3.1E-14
Cs-136	2.2E+04	3.7E-02	3.7E-03	3.7E-04	9.7E-13	2.1E-14
Cs-137	3.5E+04	5.8E-02	5.8E-03	5.8E-04	1.7E-12	3.7E-14
Ba-140	4.0E-06	1.0E-11	1.0E-11	1.0E-11	8.7E-11	1.8E-12
La-140	1.1E-06	1.0E-11	1.0E-11	1.0E-11	5.4E-11	1.1E-12
Ce-144	2.7E-07	1.0E-11	1.0E-11	1.0E-11	3.3E-13	7.0E-15
Np-239	2.0E-06	1.0E-11	1.0E-11	1.0E-11	8.7E-09	1.8E-10
Total Filter	1.1E+05	8.8E-01	8.8E-02	8.8E-03	1.0E-08	2.1E-10
Hydrogen conc	0.0 %	0.0 %	0.0 %	0.0 %	0.0 %	0.0 %
Oxygen conc	0.0 %	0.0 %	0.0 %	0.0 %	0.0 %	0.0 %

Dose Rate at 1 foot

Normal Pass Sample (10 ml) 93,000	< 2.0
Diluted Sample (0.1 ml) 930	< 2.0
Normal Pass Sample (15 ml)	< 2.0
Diluted Gas Sample (1225 cc)	< 2.0

TABLE III E-1
PLANT CHEMISTRY ACTIVITY
(T=02:45) (CLOCK=18:45)

Nuclide	RX WATER	TORUS WATER	DRYWELL GAS	TORUS GAS	STACK RAGEMS	TB RAGEMS
	Conc uCi/cc	Conc uCi/cc	Conc uCi/cc	Conc uCi/cc	Conc uCi/cc	Conc uCi/cc
Kr-85	2.5E+03	1.7E-04	1.7E-03	1.7E-02	1.5E-10	3.1E-12
Kr-85m	1.1E+05	7.3E-03	7.1E-02	7.1E-01	4.5E-08	9.6E-10
Kr-87	1.3E+05	8.3E-03	8.6E-02	8.3E-01	1.5E-07	1.2E-09
Kr-88	2.5E+05	1.6E-02	1.6E-01	1.6E+00	1.5E-07	2.1E-09
Xe-131m	4.4E+03	3.0E-04	3.0E-03	3.0E-02	1.1E-08	1.8E-09
Xe-133	7.5E+05	5.1E-02	5.1E-01	5.2E+00	6.0E-08	1.0E-09
Xe-133m	2.6E+04	1.8E-03	1.8E-02	1.8E-01	2.1E-09	3.4E-11
Xe-135	1.4E+05	9.6E-03	9.6E-02	9.6E-01	1.6E-07	2.3E-09
Xe-138	7.0E+04	2.8E-03	2.9E-02	2.9E-01	6.5E-07	5.0E-11
Total Gas Sample	1.5E+06	9.8E-02	9.8E-01	9.8E+00	1.3E-06	8.5E-09
I-131	2.5E+05	1.7E-05	1.7E-04	1.7E-03	1.2E-10	2.1E-12
I-132	2.8E+05	1.8E-05	1.8E-04	1.8E-03	1.2E-09	1.2E-11
I-133	4.9E+05	3.3E-05	3.3E-04	3.3E-03	8.7E-10	1.4E-11
I-134	2.9E+05	1.8E-05	1.8E-04	1.8E-03	2.4E-09	9.7E-12
I-135	4.1E+05	2.7E-05	2.4E-04	2.4E-03	1.2E-09	1.7E-11
DEI 131	3.9E+05	2.7E-05	2.7E-04	2.7E-03	4.1E-10	6.4E-12
Sr-89	2.0E-09	1.0E-11	1.0E-11	1.0E-11	2.8E-11	5.9E-13
Sr-90	2.0E-09	1.0E-11	1.0E-11	1.0E-11	2.2E-12	4.6E-14
Sr-91	2.0E-05	1.0E-11	1.0E-11	1.0E-11	6.5E-10	1.2E-11
Y-91	1.4E-05	1.0E-11	1.0E-11	1.0E-11	3.7E-11	8.0E-13
Mo-99	1.4E-05	1.0E-11	1.0E-11	1.0E-11	2.1E-10	4.3E-12
Ru-103	1.2E-05	1.0E-11	1.0E-11	1.0E-11	1.8E-13	3.9E-15
Ru-106	2.0E-08	1.0E-11	1.0E-11	1.0E-11	2.4E-14	5.1E-16
Te-129m	7.8E+01	1.3E-04	1.3E-05	1.3E-06	3.7E-13	7.8E-15
Te-131m	1.9E+02	3.2E-04	3.2E-05	3.2E-06	1.1E-11	2.2E-13
Te-132	1.8E+03	3.0E-03	3.0E-04	3.0E-05	4.5E-11	9.5E-12
Sb-127	8.9E+01	1.5E-04	1.5E-05	1.5E-06	5.4E-11	1.1E-13
Sb-129	4.3E+02	7.1E-04	7.1E-05	7.1E-06	5.4E-11	8.8E-13
Cs-134	5.5E+04	9.5E-02	9.5E-03	9.5E-04	1.5E-12	3.1E-14
Cs-136	2.2E+04	3.8E-02	3.8E-03	3.8E-04	9.7E-13	2.1E-14
Cs-137	3.5E+04	5.9E-02	5.9E-03	5.9E-04	1.7E-12	3.7E-14
Ba-140	4.0E-06	3.0E-11	1.0E-11	1.0E-11	8.7E-11	1.8E-12
La-140	1.1E-06	1.0E-11	1.0E-11	1.0E-11	5.4E-11	1.1E-12
Ce-144	2.7E-07	1.0E-11	1.0E-11	1.0E-11	3.3E-13	7.0E-15
Np-239	2.0E-06	1.0E-11	1.0E-11	1.0E-11	8.7E-09	1.8E-10
Total Filter	1.1E+05	8.8E-01	8.8E-02	8.9E-03	1.0E-08	2.1E-10
Hydrogen conc	0.0 %	0.0 %	0.0 %	0.0 %	0.0 %	0.0 %
Oxygen conc	0.0 %	0.0 %	0.0 %	0.0 %	0.0 %	0.0 %

Dose Rate at 1 foot

Normal Pass Sample (10 ml)	89,000	< 2.0				
Diluted Sample (0.1 ml)	890	< 2.0				
Normal Pass Sample (15 ml)			< 2.0	< 2.0		
Diluted Gas Sample (1225 cc)					< 2.0	< 2.0

TABLE III E-1
PLANT CHEMISTRY ACTIVITY
(T=03:00) (CLOCK=19:00)

Nuclide	RX WATER	TORUS WATER	DRYWELL GAS	TORUS GAS	STACK RAGEMS	TB RAGEMS
	Conc uCi/cc	Conc uCi/cc	Conc uCi/cc	Conc uCi/cc	Conc uCi/cc	Conc uCi/cc
Kr-85	2.5E+03	1.7E-04	1.7E-03	1.7E-02	1.5E-10	1.6E-12
Kr-85m	1.1E+05	7.3E-03	7.3E-02	7.1E-01	4.5E-08	5.0E-10
Kr-87	1.2E+05	7.6E-03	7.6E-02	7.6E-01	1.5E-07	4.9E-10
Kr-88	2.4E+05	1.6E-02	1.6E-01	1.6E+00	1.5E-07	9.5E-10
Xe-131m	4.4E+03	3.0E-04	3.0E-03	3.0E-02	1.1E-08	1.2E-09
Xe-133	7.5E+05	5.0E-02	5.2E-01	5.2E+00	6.0E-08	6.5E-10
Xe-133m	2.6E+04	1.8E-03	1.8E-02	1.8E-01	2.1E-09	2.2E-11
Xe-135	1.4E+05	9.4E-03	9.4E-02	9.4E-01	1.6E-07	1.5E-09
Xe-138	4.3E+04	1.7E-03	1.7E-02	1.7E-01	6.5E-07	1.2E-11
Total Gas Sample	1.4E+06	9.5E-02	9.5E-01	9.8E+00	1.3E-06	5.3E-09
I-131	2.5E+05	1.7E-05	1.6E-04	1.6E-03	1.2E-10	1.4E-12
I-132	2.6E+05	1.7E-05	1.4E-04	1.4E-03	1.2E-09	6.8E-12
I-133	4.9E+05	3.3E-05	3.1E-04	3.1E-03	8.7E-10	8.9E-12
I-134	2.6E+05	1.5E-05	1.4E-04	1.4E-03	2.4E-09	4.8E-12
I-135	4.0E+05	2.7E-05	2.4E-04	2.4E-03	1.2E-09	1.1E-11
DEI 131	3.9E+05	2.7E-05	2.2E-04	2.2E-03	4.1E-10	4.1E-12
Sr-89	2.0E-09	1.0E-11	1.0E-11	1.0E-11	2.8E-11	3.1E-13
Sr-90	2.0E-09	1.0E-11	1.0E-11	1.0E-11	2.2E-12	2.4E-14
Sr-91	2.0E-05	1.0E-11	1.0E-11	1.0E-11	6.5E-10	6.1E-12
Y-91	1.4E-05	1.0E-11	1.0E-11	1.0E-11	3.7E-11	4.2E-13
Mo-99	1.4E-05	1.0E-11	1.0E-11	1.0E-11	2.1E-10	2.2E-12
Ru-103	1.2E-05	1.0E-11	1.0E-11	1.0E-11	1.8E-13	2.0E-15
Ru-106	2.0E-08	1.0E-11	1.0E-11	1.0E-11	2.4E-14	2.7E-16
Te-129m	7.8E+01	1.3E-04	1.3E-05	1.3E-06	3.7E-13	4.1E-15
Te-131m	1.9E+02	3.2E-04	3.2E-05	3.2E-06	1.1E-11	1.1E-13
Te-132	1.8E+03	3.0E-03	3.0E-04	4.0E-05	4.5E-11	4.9E-12
Sb-127	8.9E+01	1.5E-04	1.5E-05	1.5E-06	5.4E-11	5.9E-13
Sb-129	4.2E+02	7.0E-04	7.0E-05	7.0E-06	5.4E-11	4.2E-13
Cs-134	5.5E+04	9.4E-02	1.0E-02	1.0E-03	1.5E-12	1.6E-14
Cs-136	2.2E+04	3.8E-02	3.8E-03	3.8E-04	9.7E-13	1.1E-14
Cs-137	3.5E+04	5.9E-02	5.9E-03	5.9E-04	1.7E-12	1.9E-14
Ba-140	4.0E-06	1.0E-11	1.0E-11	1.0E-11	8.7E-11	9.5E-13
La-140	1.1E-06	1.0E-11	1.0E-11	1.0E-11	5.4E-11	5.7E-13
Ce-144	2.7E-07	1.0E-11	1.0E-11	1.0E-11	3.3E-13	3.6E-15
Np-239	2.0E-06	1.0E-11	1.0E-11	1.0E-11	8.7E-09	9.3E-11
Total Filter	1.1E+05	8.6E-01	8.9E-02	8.9E-03	1.0E-08	1.1E-10
Hydrogen conc	0.0 %	0.0 %	0.0 %	0.0 %	0.0 %	0.0 %
Oxygen conc	0.0 %	0.0 %	0.0 %	0.0 %	0.0 %	0.0 %
Dose Rate at 1 foot						
Normal Pass Sample (10 ml)	86,000	< 2.0				
Diluted Sample (0.1 ml)	860	< 2.0				
Normal Pass Sample (15 ml)		< 2.0	< 2.0			
Filtered Gas Sample (1225 cc)				< 2.0	< 2.0	

TABLE III E-1
PLANT CHEMISTRY ACTIVITY
(T=03:10) (CLOCK=19:10)

Nuclide	RX WATER	TORUS WATER	DRYWELL GAS	TORUS GAS	STACK RAGEMS	TB RAGEMS
	Conc uCi/cc	Conc uCi/cc	Conc uCi/cc	Conc uCi/cc	Conc uCi/cc	Conc uCi/cc
Kr-85	2.5E+03	1.7E-04	1.5E-03	1.5E-02	1.5E-10	1.3E-12
Kr-85m	1.1E+05	7.3E-03	7.3E-02	7.3E-01	4.5E-08	4.0E-10
Kr-87	1.1E+05	6.9E-03	6.9E-02	6.6E-01	1.5E-07	3.6E-10
Kr-88	2.3E+05	1.5E-02	1.5E-01	1.5E+00	1.5E-07	7.3E-10
Xe131m	4.4E+03	3.0E-04	3.4E-03	3.4E-02	1.1E-08	9.5E-10
Xe-133	7.5E+05	5.1E-02	5.2E-01	5.2E+00	6.0E-08	5.2E-10
Xe133m	2.6E+04	1.8E-03	1.8E-02	1.8E-01	2.1E-09	1.8E-11
Xe-135	1.4E+05	9.3E-03	9.3E-02	9.1E-01	1.6E-07	1.2E-09
Xe-138	2.6E+04	1.1E-03	1.1E-02	1.1E-01	6.5E-07	6.0E-12
Total Gas Sample	1.4E+06	9.0E-02	9.1E-01	9.1E+00	1.3E-06	4.2E-09
I-131	2.5E+05	1.7E-05	1.6E-04	1.6E-03	1.2E-10	1.1E-12
I-132	2.5E+05	1.6E-05	1.4E-04	1.4E-03	1.2E-09	5.2E-12
I-133	4.8E+05	3.3E-05	3.1E-04	3.1E-03	8.7E-10	7.1E-12
I-134	2.2E+05	1.4E-05	1.4E-04	1.4E-03	2.4E-09	3.4E-12
I-135	3.9E+05	2.6E-05	2.4E-04	2.4E-03	1.2E-09	8.6E-12
DEI 131	3.9E+05	2.7E-05	2.7E-04	2.7E-03	4.1E-10	3.3E-12
Sr-89	2.0E-09	1.0E-11	1.0E-11	1.0E-11	2.8E-11	2.5E-13
Sr-90	2.0E-09	1.0E-11	1.0E-11	1.0E-11	2.2E-12	2.0E-14
Sr-91	2.0E-05	1.0E-11	1.0E-11	1.0E-11	6.5E-10	4.9E-12
Y-91	1.4E-05	1.0E-11	1.0E-11	1.0E-11	3.7E-11	3.4E-13
Mo-99	1.4E-05	1.0E-11	1.0E-11	1.0E-11	2.1E-10	1.8E-12
Ru-103	1.2E-05	1.0E-11	1.0E-11	1.0E-11	1.8E-13	1.6E-15
Ru-106	2.0E-08	1.0E-11	1.0E-11	1.0E-11	2.4E-14	2.2E-16
Te-129m	7.8E+01	1.3E-04	1.3E-05	1.3E-06	3.7E-13	3.3E-15
Te-131m	1.9E+02	3.2E-04	3.2E-05	3.2E-06	1.1E-11	9.1E-14
Te-132	1.8E+03	3.0E-03	3.0E-04	3.0E-05	4.5E-11	4.0E-12
Sb-127	8.9E+01	1.5E-04	1.5E-05	1.5E-06	5.4E-11	4.7E-13
Sb-129	4.1E+02	6.8E-04	6.8E-05	6.8E-06	5.4E-11	3.3E-13
Cs-134	5.5E+04	9.5E-02	9.5E-03	9.5E-04	1.5E-12	1.3E-14
Cs-136	2.2E+04	3.8E-02	3.8E-03	3.8E-04	9.7E-13	8.6E-15
Cs-137	3.5E+04	5.9E-02	5.9E-03	5.9E-04	1.7E-12	1.5E-14
Be-140	4.0E-06	1.0E-11	1.0E-11	1.0E-11	8.7E-11	7.6E-13
La-140	1.1E-06	1.0E-11	1.0E-11	1.0E-11	5.4E-11	4.6E-13
Ce-144	2.7E-07	1.0E-11	1.0E-11	1.0E-11	3.3E-13	2.9E-15
Np-239	2.0E-06	1.0E-11	1.0E-11	1.0E-11	8.7E-09	7.5E-11
Total Filter	1.1E+05	8.4E-01	8.9E-02	8.9E-03	1.0E-08	8.8E-11
Hydrogen conc	0.0 %	0.0 %	0.0 %	0.0 %	0.0 %	0.0 %
Oxygen conc	0.0 %	0.0 %	0.0 %	0.0 %	0.0 %	0.0 %

Dose Rate at 1 foot

Normal Pass Sample (10 ml)	83,000	< 2.0				
Diluted Sample (0.1 ml)	830	< 2.0				
Normal Pass Sample (15 ml)			< 2.0	< 2.0		
Diluted Gas Sample (1225 cc)					< 2.0	< 2.0

TABLE III E-1
PLANT CHEMISTRY ACTIVITY
(T=03:20) (CLOCK=19:20)

Nuclide	RX WATER	TORUS WATER	DRYWELL GAS	TORUS GAS	STACK RAGEMS	TB RAGEMS
	Conc	Conc	Conc	Conc	Conc	Conc
	uCi/cc	uCi/cc	uCi/cc	uCi/cc	uCi/cc	uCi/cc
Kr-85	2.4E+03	1.7E-04	1.7E-03	1.5E-02	3.2E-03	1.3E-12
Kr-85m	1.0E+05	7.3E-03	7.3E-02	7.3E-01	1.1E-01	4.0E-10
Kr-87	9.9E+04	6.3E-03	6.6E-02	6.6E-01	1.3E-01	3.6E-10
Kr-88	2.1E+05	1.4E-02	1.4E-01	1.4E+00	2.8E-01	7.3E-10
Xe131m	4.3E+03	3.0E-04	3.1E-03	3.1E-02	5.7E-03	9.5E-10
Xe-133	7.3E+05	5.1E-02	5.2E-01	5.2E+00	9.7E-01	5.2E-10
Xe133m	2.6E+04	1.8E-03	1.8E-02	1.8E-01	3.4E-02	1.8E-11
Xe-135	1.3E+05	9.2E-03	9.1E-02	9.1E-01	1.8E-01	1.2E-09
Xe-138	1.6E+04	6.4E-04	6.4E-03	6.4E-02	2.1E-02	6.0E-12
Total Gas Sample	1.3E+06	9.0E-02	9.0E-01	9.1E+00	1.7E+00	4.2E-09
I-131	2.5E+05	1.7E-05	1.6E-04	1.6E-03	2.6E-04	1.1E-12
I-132	2.4E+05	1.6E-05	1.4E-04	1.4E-03	2.5E-04	5.2E-12
I-133	4.8E+05	3.3E-05	3.3E-04	3.3E-03	5.0E-04	7.1E-12
I-134	2.0E+05	1.2E-05	1.2E-04	1.2E-03	2.0E-04	3.4E-12
I-135	3.9E+05	2.6E-05	2.6E-04	2.4E-03	4.0E-04	8.6E-12
DEI 131	3.9E+05	2.6E-05	2.6E-04	2.6E-03	4.0E-04	3.3E-12
Sr-89	2.0E-09	1.3E-11	1.3E-11	1.3E-11	2.8E-11	2.5E-13
Sr-90	2.0E-09	3.2E-11	3.2E-11	3.2E-11	2.2E-12	2.0E-14
Sr-91	2.0E-05	3.0E-11	3.0E-11	3.0E-11	6.5E-10	4.9E-12
Y-91	1.4E-05	1.5E-11	1.5E-11	1.5E-11	3.7E-11	3.4E-13
Mo-99	1.4E-05	6.6E-11	6.6E-11	6.6E-11	2.1E-10	1.8E-12
Ru-103	1.2E-05	9.5E-11	9.5E-11	9.5E-11	1.8E-13	1.6E-15
Ru-106	2.0E-08	1.0E-11	1.0E-11	1.0E-11	2.4E-14	2.2E-16
Te-129m	7.7E+01	1.3E-04	1.3E-05	1.3E-06	2.0E-05	3.3E-15
Te-131m	1.9E+03	3.2E-04	3.2E-05	3.2E-06	4.8E-05	9.1E-14
Te-132	1.7E+03	3.0E-05	3.0E-06	3.0E-07	4.5E-04	4.0E-12
Sb-127	8.9E+01	1.5E-04	1.5E-05	1.5E-06	2.3E-05	4.7E-13
Sb-129	4.0E+02	6.6E-04	6.6E-05	6.6E-06	1.0E-04	3.3E-13
Cs-134	5.5E+04	9.5E-02	9.5E-03	9.5E-04	1.4E-02	1.3E-14
Cs-136	2.2E+04	3.8E-02	3.8E-03	3.8E-04	5.8E-03	8.6E-15
Cs-137	3.4E+04	5.9E-02	5.9E-03	5.9E-04	8.9E-03	1.5E-14
Ba-140	4.0E-06	1.0E-11	1.0E-11	1.0E-11	8.7E-11	7.6E-13
La-140	1.1E-06	1.0E-11	1.0E-11	1.0E-11	5.4E-11	4.6E-13
Ce-144	2.7E-07	1.0E-11	1.0E-11	1.0E-11	3.3E-13	2.9E-15
Np-239	2.0E-06	1.0E-11	1.0E-11	1.0E-11	8.7E-09	7.5E-11
Total Filter	1.1E+05	2.0E-01	2.0E-02	2.0E-03	3.0E-02	8.8E-11
Hydrogen conc	0.0 %	0.0 %	0.0 %	0.0 %	0.0 %	0.0 %
Oxygen conc	0.0 %	0.0 %	0.0 %	0.0 %	0.0 %	0.0 %

Dose Rate at 1 foot

Normal Pass Sample (10 ml)	80,000	< 2.0
Diluted Sample (0.1 ml)	800	< 2.0
Normal Pass Sample (15 ml)		< 2.0
Diluted Gas Sample (1225 cc)		13.0 < 2.0

TABLE III E-1
PLANT CHEMISTRY ACTIVITY
(T=03:30) (CLOCK=19:30)

Nuclide	RX WATER	TORUS WATER	DRYWELL GAS	TORUS GAS	STACK RAGEMS	TB RAGEMS
	Conc uCi/cc	Conc uCi/cc	Conc uCi/cc	Conc uCi/cc	Conc uCi/cc	Conc uCi/cc
Kr-85	2.4E+03	6.5E-04	6.5E-03	6.5E-02	3.5E-03	1.3E-12
Kr-85m	1.0E+05	2.8E-02	2.8E-01	2.8E+00	1.2E-01	4.0E-10
Kr-87	8.9E+04	2.4E-02	2.6E-01	2.6E+00	1.3E-01	3.6E-10
Kr-88	2.0E+05	5.4E-02	5.1E-01	5.1E+00	2.9E-01	7.3E-10
Xe131m	4.3E+03	1.2E-03	1.4E-02	1.4E-01	6.2E-03	9.5E-10
Xe-133	7.2E+05	2.0E-01	2.1E+00	2.1E+01	1.0E+00	5.2E-10
Xe133m	2.5E+04	6.8E-03	6.8E-02	6.8E-01	3.6E-02	1.8E-11
Xe-135	1.3E+05	3.5E-02	3.5E-01	3.5E+00	1.9E-01	1.2E-09
Xe-138	9.5E+03	2.3E-03	2.3E-02	2.3E-01	1.4E-02	6.0E-12
Total Gas Sample	1.3E+06	3.5E-01	3.5E+00	3.5E+01	1.8E+00	4.2E-09
I-131	2.5E+05	6.6E-05	6.6E-04	6.6E-03	2.8E-04	1.1E-12
I-132	2.3E+05	5.9E-05	5.9E-04	5.9E-03	2.5E-04	5.2E-12
I-133	4.8E+05	1.3E-04	1.3E-03	1.3E-02	5.3E-04	7.1E-12
I-134	1.7E+05	4.4E-05	4.4E-04	4.4E-03	1.9E-04	3.4E-12
I-135	3.8E+05	1.0E-04	1.0E-03	1.0E-02	4.2E-04	8.6E-12
DEI 131	3.8E+05	1.0E-04	1.0E-03	1.0E-02	4.3E-04	3.3E-12
Sr-89	2.0E-09	1.0E-11	1.0E-11	1.0E-11	2.8E-11	2.5E-13
Sr-90	2.0E-09	1.0E-11	1.0E-11	1.0E-11	2.2E-12	2.0E-14
Sr-91	2.0E-05	1.0E-11	1.0E-11	1.0E-11	6.5E-10	4.9E-12
Y-91	1.4E-05	1.0E-11	1.0E-11	1.0E-11	3.7E-11	3.4E-13
Mo-99	1.4E-05	1.0E-11	1.0E-11	1.0E-11	2.1E-10	1.8E-12
Ru-103	1.2E-05	1.0E-11	1.0E-11	1.0E-11	1.8E-13	1.6E-15
Ru-106	2.0E-08	1.0E-11	1.0E-11	1.0E-11	2.4E-14	2.2E-16
Te-129m	7.7E+01	5.2E-04	5.2E-05	5.2E-06	2.2E-05	3.3E-15
Te-131m	1.8E+02	1.2E-03	1.2E-04	1.2E-05	5.2E-05	9.1E-14
Te-132	1.7E+03	1.2E-02	1.2E-03	1.2E-04	4.9E-04	4.0E-12
Sb-127	8.8E+01	5.9E-04	5.9E-05	5.9E-05	2.5E-05	4.7E-13
Sb-129	3.8E+02	2.5E-03	2.5E-03	2.5E-04	1.1E-04	3.3E-13
Cs-134	5.5E+04	3.6E-01	3.6E-02	3.6E-02	1.5E-02	1.3E-14
Cs-136	2.2E+04	1.5E-01	1.5E-02	1.5E-03	6.2E-03	8.6E-15
Cs-137	3.4E+04	2.3E-01	2.3E-02	2.3E-03	9.7E-03	1.5E-14
Ba-140	4.0E-06	1.0E-11	1.0E-11	1.0E-11	8.7E-11	7.6E-13
La-140	1.1E-06	1.0E-11	1.0E-11	1.0E-11	5.4E-11	4.6E-13
Ce-144	2.7E-07	1.0E-11	1.0E-11	1.0E-11	3.3E-13	2.9E-15
Np-239	2.0E-06	1.0E-11	1.0E-11	1.0E-11	8.7E-09	7.5E-11
Total Filter	1.1E+05	7.8E-01	7.8E-02	7.6E-03	3.2E-02	8.8E-11
Hydrogen conc	0.0 %	0.0 %	0.0 %	0.0 %	0.0 %	0.0 %
Oxygen conc	0.0 %	0.0 %	0.0 %	0.0 %	0.0 %	0.0 %

Dose Rate at 1 foot

Normal Pass Sample (10 ml)	77,000	< 2.0			
Diluted Sample (0.1 ml)	770	< 2.0			
Normal Pass Sample (15 ml)			< 2.0	3.1	
Diluted Gas Sample (1225 cc)					13.0 < 2.0

TABLE III E-1
PLANT CHEMISTRY ACTIVITY
(T=03:40) (CLOCK=19:40)

Nuclide	RX WATER	TORUS WATER	DRYWELL GAS	TORUS GAS	STACK	TB
	Conc uCi/cc	Conc uCi/cc	Conc uCi/cc	Conc uCi/cc	RAGEMS Conc uCi/cc	RAGEMS Conc uCi/cc
Kr-85	2.4E+03	1.1E-03	1.1E-02	1.1E-01	3.4E-03	1.3E-12
Kr-85m.....	1.0E+05	4.8E-02	4.8E-01	4.8E+00	1.1E-01	4.0E-10
Kr-87	8.0E+04	3.7E-02	3.7E-01	3.7E+00	1.2E-01	3.6E-10
Kr-88	1.9E+05	9.0E-02	9.0E-01	9.0E+00	2.8E-01	7.3E-10
Xe131m.....	4.2E+03	2.0E-03	2.0E-02	2.0E-01	6.1E-03	9.5E-10
Xe-133	7.1E+05	3.4E-01	3.4E+00	3.4E+01	1.0E+00	5.2E-10
Xe133m.....	2.5E+04	1.2E-02	1.2E-01	1.2E+00	3.6E-02	1.8E-11
Xe-135	1.3E+05	6.0E-02	6.0E-01	6.0E+00	1.8E-01	1.2E-09
Xe-138	5.7E+03	2.6E-03	2.6E-02	2.6E-01	8.3E-03	6.0E-12
Total Gas Sample	1.2E+06	5.9E-01	5.9E+00	5.9E+01	1.8E+00	4.2E-09
I-131	2.5E+05	1.2E-04	1.2E-03	1.2E-02	2.8E-04	1.1E-12
I-132	2.2E+05	9.8E-05	9.8E-04	9.8E-03	2.4E-04	5.2E-12
I-133	4.7E+05	2.2E-04	2.2E-03	2.2E-02	5.2E-04	7.1E-12
I-134	1.5E+05	6.8E-05	6.8E-04	6.8E-03	1.7E-04	3.4E-12
I-135	3.7E+05	1.7E-04	1.7E-03	1.7E-02	4.1E-04	8.6E-12
DEI 131	3.8E+05	1.8E-04	1.8E-03	6.2E-02	4.2E-04	3.3E-12
Sr-89	2.0E-09	1.0E-11	1.0E-11	1.0E-11	2.8E-11	2.5E-13
Sr-90	2.0E-09	1.0E-11	1.0E-11	1.0E-11	2.2E-12	2.0E-14
Sr-91	2.0E-05	1.0E-11	1.0E-11	1.0E-11	6.5E-10	4.9E-12
Y-91	1.4E-05	1.0E-11	1.0E-11	1.0E-11	3.7E-11	3.4E-13
Mo-99	1.4E-05	1.0E-11	1.0E-11	1.0E-11	2.1E-10	1.8E-12
Ru-103	1.2E-05	1.0E-11	1.0E-11	1.0E-11	1.8E-13	1.6E-15
Ru-106	2.0E-08	1.0E-11	1.0E-11	1.0E-11	2.4E-14	2.2E-16
Te-129m.....	7.7E+01	8.9E-04	8.9E-05	8.9E-06	2.2E-05	3.3E-15
Te-131m.....	1.8E+02	2.1E-03	2.1E-04	2.1E-05	5.1E-05	9.1E-14
Te-132	1.7E+03	2.0E-02	2.0E-03	2.0E-04	4.8E-04	4.0E-12
Sb-127	8.8E+01	1.0E-03	1.0E-04	1.0E-05	2.5E-05	4.7E-13
Sb-129	3.7E+02	4.3E-03	4.3E-04	4.3E-05	1.0E-04	3.3E-13
Cs-134	5.5E+04	6.3E-01	6.3E-02	6.3E-03	1.5E-02	1.3E-14
Cs-136	2.2E+04	2.5E-01	2.5E-02	2.5E-03	6.1E-03	8.6E-15
Cs-137	3.4E+04	4.0E-01	4.0E-02	4.0E-03	9.5E-03	1.5E-14
Ba-140	4.0E-06	1.0E-11	1.0E-11	1.0E-11	8.7E-11	7.6E-13
La-140	1.1E-06	1.0E-11	1.0E-11	1.0E-11	5.4E-11	4.6E-13
Ce-144	2.7E-07	1.0E-11	1.0E-11	1.0E-11	3.3E-13	2.9E-15
Np-239	2.0E-06	1.0E-11	1.0E-11	1.0E-11	8.7E-09	7.5E-11
Total Filter	1.1E+05	1.3E+00	1.3E-01	1.3E-02	3.2E-02	8.8E-11
Hydrogen conc	0.0 %	0.0 %	0.0 %	0.0 %	0.0 %	0.0 %
Oxygen conc	0.0 %	0.0 %	0.0 %	0.0 %	0.0 %	0.0 %

Dose Rate at 1 foot

Normal Pass Sample (10 ml)	75,000	< 2.0		
Diluted Sample (0.1 ml)	750	< 2.0		
Normal Pass Sample (15 ml)		< 2.0	5.3	
Unfiltered Gas Sample (1225 cc)			13.0	< 2.0

TABLE III E-1
PLANT CHEMISTRY ACTIVITY
(T=03:50) (CLOCK=19:50)

Nuclide	RX WATER	TORUS WATER	DRYWELL GAS	TORUS GAS	STACK RAGEMS	TB RAGEMS
	Conc uCi/cc	Conc uCi/cc	Conc uCi/cc	Conc uCi/cc	Conc uCi/cc	Conc uCi/cc
Kr-85	2.3E+03	1.1E-03	1.1E-02	1.1E-01	3.3E-03	1.3E-12
Kr-85m	1.0E+05	4.8E-02	4.8E-01	4.8E+00	1.1E-01	4.0E-10
Kr-87	7.2E+04	3.4E-02	3.4E-01	3.4E+00	1.0E-01	3.6E-10
Kr-88	1.8E+05	8.7E-02	8.7E-01	8.7E+00	2.6E-01	7.3E-10
Xe131m	4.2E+03	2.0E-03	2.0E-02	2.0E-01	5.9E-03	9.5E-10
Xe-133	7.0E+05	3.4E-01	3.4E+00	3.4E+01	1.0E+00	5.2E-10
Xe133m	2.5E+04	1.2E-02	1.2E-01	1.2E+00	3.5E-02	1.8E-11
Xe-135	1.2E+05	5.9E-02	5.9E-01	5.9E+00	1.8E-01	1.2E-09
Xe-138	3.4E+03	1.6E-03	1.6E-02	1.6E-16	5.0E-03	6.0E-12
Total Gas Sample	1.2E+06	5.8E-01	5.8E+00	5.8E+01	1.7E+00	4.2E-09
I-131	2.5E+05	1.2E-04	1.2E-03	1.2E-02	2.7E-04	1.1E-12
I-132	2.0E+05	9.4E-05	9.4E-04	9.4E-03	2.2E-04	5.2E-12
I-133	4.7E+05	2.2E-04	2.2E-03	2.2E-02	5.1E-04	7.1E-12
I-134	1.3E+05	6.0E-05	6.0E-04	6.0E-03	1.4E-04	3.4E-12
I-135	3.7E+05	1.7E-04	1.7E-03	1.7E-02	3.9E-04	8.6E-12
DEI 131	3.8E+05	1.8E-04	1.8E-03	1.8E-02	4.1E-04	3.3E-12
Sr-89	2.0E-09	1.0E-11	1.0E-11	1.0E-11	2.8E-11	2.5E-13
Sr-90	2.0E-09	1.0E-11	1.0E-11	1.0E-11	2.2E-12	2.0E-14
Sr-91	2.0E-05	1.0E-11	1.0E-11	1.0E-11	6.5E-10	4.9E-12
Y-91	1.4E-05	1.0E-11	1.0E-11	1.0E-11	3.7E-11	3.4E-13
Mo-99	1.4E-05	1.0E-11	1.0E-11	1.0E-11	2.1E-10	1.8E-12
Ru-103	1.2E-05	1.0E-11	1.0E-11	1.0E-11	1.8E-13	1.6E-15
Ru-106	2.0E-08	1.0E-11	1.0E-11	1.0E-11	2.4E-14	2.2E-16
Te-129m	7.7E+01	9.0E-04	9.0E-05	9.0E-06	2.1E-05	3.3E-15
Te-131m	1.8E+02	2.1E-03	2.1E-04	2.1E-05	4.9E-05	9.1E-14
Te-132	1.7E+03	2.0E-02	2.0E-03	2.0E-04	4.7E-04	4.0E-12
Sb-127	8.8E+01	1.0E-03	1.0E-04	1.0E-05	2.4E-05	4.7E-13
Sb-129	3.6E+02	4.2E-03	4.2E-04	4.2E-05	9.8E-05	3.3E-13
Cs-134	5.4E+04	6.4E-01	6.4E-02	6.4E-03	1.5E-02	1.3E-14
Cs-136	2.2E+04	2.6E-01	2.6E-02	2.6E-03	6.0E-03	8.6E-15
Cs-137	3.4E+04	4.0E-01	4.0E-02	4.0E-03	9.3E-03	1.5E-14
Ba-140	4.0E-06	1.0E-11	1.0E-11	1.0E-11	8.7E-11	7.6E-13
La-140	1.1E-06	1.0E-11	1.0E-11	1.0E-11	5.4E-11	4.6E-13
Ce-144	2.7E-07	1.0E-11	1.0E-11	1.0E-11	3.3E-13	2.9E-15
Np-239	2.0E-06	1.0E-11	1.0E-11	1.0E-11	8.7E-09	7.5E-11
Total Filter	1.1E+05	1.3E+00	1.3E-01	1.3E-02	3.1E-02	8.8E-11
Hydrogen conc	0.0 %	0.0 %	0.0 %	0.0 %	0.0 %	0.0 %
Oxygen conc	0.0 %	0.0 %	0.0 %	0.0 %	0.0 %	0.0 %
Dose Rate at 1 foot						
Normal Pass Sample (10 ml)	73,000	< 2.0				
Diluted Sample (0.1 ml)	730	< 2.0				
Normal Pass Sample (15 ml)			< 2.0	5.2		
Diluted Gas Sample (1225 cc)					13.0	< 2.0

TABLE III E-1
PLANT CHEMISTRY ACTIVITY
(T=04:00) (CLOCK=20:00)

Nuclide	RX WATER	TORUS WATER	DRYWELL GAS	TORUS GAS	STACK	TB
	Conc uCi/cc	Conc uCi/cc	Conc uCi/cc	Conc uCi/cc	RAGEMS Conc uCi/cc	RAGEMS Conc uCi/cc
Kr-85	2.3E+03	1.6E-03	1.6E-02	1.6E-01	3.3E-03	1.3E-12
Kr-85m	1.0E+05	6.8E-02	6.8E-01	6.8E+00	1.0E-01	4.0E-10
Kr-87	6.6E+04	4.4E-02	4.4E-01	4.4E+00	9.2E-02	3.6E-10
Kr-88	1.7E+05	1.2E-01	1.2E+00	1.2E+01	2.4E-01	7.3E-10
Xe131m	4.2E+03	2.8E-03	2.8E-02	2.8E-01	5.8E-03	9.5E-10
Xe-133	7.0E+05	4.7E-01	4.7E+00	4.7E+01	9.8E-01	5.2E-10
Xe133m	2.4E+04	1.7E-02	1.7E-01	1.7E+00	3.4E-02	1.8E-11
Xe-135	1.2E+05	8.2E-02	8.2E-01	8.2E+00	1.7E-01	1.2E-09
Xe-138	2.1E+03	1.4E-03	1.4E-02	1.4E-01	3.0E-03	6.0E-12
Total Gas Sample	1.2E+06	8.1E-01	8.1E+00	8.1E+01	1.6E+00	4.2E-09
I-131	2.5E+05	1.6E-04	1.6E-03	1.6E-02	2.6E-04	1.1E-12
I-132	1.9E+05	1.3E-04	1.3E-03	1.3E-02	2.0E-04	5.2E-12
I-133	4.7E+05	3.1E-04	3.1E-03	3.1E-02	4.9E-04	7.1E-12
I-134	1.2E+05	7.6E-04	7.6E-03	7.6E-02	1.2E-04	3.4E-12
I-135	3.6E+05	2.4E-04	2.4E-03	2.4E-02	3.8E-04	8.6E-12
DEI 131	3.8E+05	2.5E-04	2.5E-03	2.5E-02	4.0E-04	3.3E-12
Sr-89	2.0E-09	1.0E-11	1.0E-11	1.0E-11	2.8E-11	2.5E-13
Sr-90	2.0E-09	1.0E-11	1.0E-11	1.0E-11	2.2E-12	2.0E-14
Sr-91	2.0E-05	1.0E-11	1.0E-11	1.0E-11	6.5E-10	4.9E-12
Y-91	1.4E-05	1.0E-11	1.0E-11	1.0E-11	3.7E-11	3.4E-13
Mo-99	1.4E-05	1.0E-11	1.0E-11	1.0E-11	2.1E-10	1.8E-12
Ru-103	1.2E-05	1.0E-11	1.0E-11	1.0E-11	1.8E-13	1.6E-15
Ru-106	2.0E-08	1.0E-11	1.0E-11	1.0E-11	2.4E-14	2.2E-16
Te-129m	7.7E+01	1.3E-03	1.3E-04	1.3E-05	2.1E-05	3.3E-15
Te-131m	1.8E+02	3.0E-03	3.0E-04	3.0E-05	4.8E-05	9.1E-14
Te-132	1.7E+03	2.8E-02	2.8E-03	2.8E-04	4.6E-04	4.0E-12
Sb-127	8.7E+01	1.5E-03	1.5E-04	1.5E-05	2.3E-05	4.7E-13
Sb-129	3.5E+02	5.8E-03	5.8E-04	5.8E-05	9.3E-05	3.3E-13
Cs-134	5.4E+04	9.4E-01	9.4E-02	9.4E-03	1.5E-02	1.3E-14
Cs-136	2.2E+04	3.6E-01	3.6E-02	3.6E-03	5.8E-03	8.6E-15
Cs-137	3.4E+04	5.6E-01	5.6E-02	5.6E-03	9.1E-03	1.5E-14
Ba-140	4.0E-06	1.0E-11	1.0E-11	1.0E-11	8.7E-11	7.6E-13
La-140	1.1E-06	1.0E-11	1.0E-11	1.0E-11	5.4E-11	4.6E-13
Ce-144	2.7E-07	1.0E-11	1.0E-11	1.0E-11	3.3E-13	2.9E-15
Np-239	2.0E-06	1.0E-11	1.0E-11	1.0E-11	8.7E-09	7.5E-11
Total Filter	1.1E+05	1.9E+00	1.9E-01	1.9E-02	3.0E-02	8.8E-11
Hydrogen conc	0.0 %	0.0 %	0.0 %	0.0 %	0.0 %	0.0 %
Oxygen conc	0.0 %	0.0 %	0.0 %	0.0 %	0.0 %	0.0 %

Dose Rate at 1 foot

Normal Pass Sample (10 ml)	72,000	< 2.0		
Diluted Sample (0.1 ml)	720	< 2.0		
Normal Pass Sample (15 ml)			< 2.0	7.3
Diluted Gas Sample (1225 cc)				12.0 < 2.0

TABLE III E-1
PLANT CHEMISTRY ACTIVITY
(T=04:10) (CLOCK=20:10)

Nuclide	RX WATER		TORUS WATER		DRYWELL GAS		TORUS GAS		STACK	TB
	Conc	Conc	Conc	Conc	Conc	Conc	Conc	Conc	RAGEMS	RAGEMS
	uCi/cc	uCi/cc	uCi/cc	uCi/cc	uCi/cc	uCi/cc	uCi/cc	uCi/cc	uCi/cc	uCi/cc
Kr-85	2.3E+03	1.6E-03	1.6E-02	1.6E-01	3.2E-03	1.3E-12				
Kr-85m	1.0E+05	6.8E-02	6.8E-01	6.8E+00	9.7E-02	4.0E-10				
Kr-87	6.0E+04	4.1E-02	4.1E-01	4.1E+00	8.2E-02	3.6E-10				
Kr-88	1.7E+05	1.1E-01	1.1E+00	1.1E+01	2.3E-01	7.3E-10				
Xe131m	4.1E+03	2.8E-03	2.8E-02	2.8E-01	5.6E-03	9.5E-10				
Xe-133	7.0E+05	4.8E-01	4.8E+00	4.8E+01	9.5E-01	5.2E-10				
Xe133m	2.4E+04	1.7E-02	1.7E-01	1.7E+00	3.3E-02	1.8E-09				
Xe-135	1.2E+05	8.1E-02	8.1E-01	8.1E+00	1.6E-01	1.2E-12				
Xe-138	1.3E+03	8.5E-04	8.5E-03	8.5E-02	1.8E-03	6.0E-09				
Total Gas Sample	1.2E+06	8.0E-01	8.0E+00	8.0E+01	1.6E+00	4.2E-09				
I-131	2.5E+05	1.6E-04	1.6E-03	1.6E-02	2.6E-04	1.1E-12				
I-132	1.9E+05	1.2E-04	1.2E-03	1.2E-02	1.9E-04	5.2E-12				
I-133	4.7E+05	3.1E-04	3.1E-03	3.1E-02	4.8E-04	7.1E-12				
I-134	1.0E+05	6.6E-05	6.6E-04	6.6E-03	1.0E-04	3.4E-12				
I-135	3.5E+05	2.3E-04	2.3E-03	2.3E-02	3.6E-04	8.6E-12				
DEI 131	3.8E+05	2.5E-04	2.5E-03	2.5E-02	3.9E-04	3.3E-12				
Sr-89	2.0E-09	1.0E-11	1.0E-11	1.0E-11	2.8E-11	2.5E-13				
Sr-90	2.0E-09	1.0E-11	1.0E-11	1.0E-11	2.2E-12	2.0E-14				
Sr-91	2.0E-05	1.0E-11	1.0E-11	1.0E-11	6.5E-10	4.9E-12				
Y-91	1.4E-05	1.0E-11	1.0E-11	1.0E-11	3.7E-11	3.4E-13				
No-99	1.4E-05	1.0E-11	1.0E-11	1.0E-11	2.1E-10	1.8E-12				
Ru-103	1.2E-05	1.0E-11	1.0E-11	1.0E-11	1.8E-13	1.6E-15				
Ru-106	2.0E-08	1.0E-11	1.0E-11	1.0E-11	2.4E-14	2.2E-16				
Te-129m	7.7E+01	1.3E-03	1.3E-04	1.3E-05	1.0E-05	3.3E-15				
Te-131m	1.8E+02	3.0E-03	3.0E-04	3.0E-05	4.7E-05	9.1E-14				
Te-132	1.7E+03	2.8E-02	2.8E-03	2.8E-04	4.5E-04	4.0E-12				
Sb-127	8.7E+01	1.5E-03	1.5E-04	1.5E-05	2.3E-05	4.7E-13				
Sb-129	3.4E+02	5.7E-03	5.7E-04	5.7E-05	8.9E-05	3.3E-13				
Cs-134	5.4E+04	9.1E-01	9.1E-02	9.1E-03	1.4E-02	1.3E-14				
Cs-136	2.2E+04	3.6E-01	3.6E-02	3.6E-03	5.7E-03	8.6E-15				
Cs-137	3.4E+04	5.7E-01	5.7E-02	5.7E-03	8.9E-03	1.5E-14				
Ba-140	4.0E-06	1.0E-11	1.0E-11	1.0E-11	8.7E-11	7.6E-13				
La-140	1.1E-06	1.0E-11	1.0E-11	1.0E-11	5.4E-11	4.6E-13				
Ce-144	2.7E-07	1.0E-11	1.0E-11	1.0E-11	3.3E-13	2.9E-15				
Np-239	2.0E-06	1.0E-11	1.0E-11	1.0E-11	8.7E-09	7.5E-11				
Total Filter	1.1E+05	1.8E+00	1.8E-01	1.8E-02	2.9E-02	8.8E-11				
Hydrogen conc	0.0 %	0.0 %	0.0 %	0.0 %	0.0 %	0.0 %				
Oxygen conc	0.0 %	0.0 %	0.0 %	0.0 %	0.0 %	0.0 %				

Dose Rate at 1 foot

Normal Pass Sample (10 ml)	71,000	< 2.0	
Diluted Sample (0.1 ml)	710	< 2.0	
Normal Pass Sample (15 ml)		< 2.0	7.2
Diluted Gas Sample (1225 cc)			10.0 < 2.0

TABLE III E-1
PLANT CHEMISTRY ACTIVITY
(T=04:20) (CLOCK=20:20)

Nuclide	RX WATER	TORUS WATER	DRYWELL GAS	TORUS GAS	STACK RAGEMS	TB RAGEMS
	Conc uCi/cc	Conc uCi/cc	Conc uCi/cc	Conc uCi/cc	Conc uCi/cc	Conc uCi/cc
Kr-85	2.3E+03	3.9E-03	3.9E-02	3.9E-01	3.1E-03	1.3E-12
Kr-85m	1.0E+05	1.7E-03	1.7E-02	1.7E-01	9.2E-02	4.0E-10
Kr-87	5.5E+04	9.1E-02	9.1E-01	9.1E+00	7.3E-02	3.6E-10
Kr-88	1.6E+05	2.7E-01	2.7E+00	2.7E+01	2.1E-01	7.3E-10
Xe131m	4.1E+03	6.9E-03	6.9E-02	6.9E-01	5.5E-03	9.5E-10
Xe-133	7.0E+05	1.2E+00	1.2E+01	1.2E+02	9.3E-01	5.2E-10
Xe133m	2.4E+04	4.0E-02	4.0E-01	4.0E+00	3.2E-02	1.8E-11
Xe-135	1.2E+05	2.0E-01	2.0E+00	2.0E+01	1.6E-01	1.2E-09
Xe-138	8.0E+02	1.3E-03	1.3E-02	1.3E-01	1.1E-03	6.0E-11
Total Gas Sample	1.2E+06	1.9E+00	1.9E+01	1.9E+02	1.5E+00	4.2E-09
I-131	2.5E+05	4.1E-04	4.1E-03	4.1E-02	2.5E-04	1.1E-12
I-132	1.8E+05	2.9E-04	2.9E-03	2.9E-02	1.8E-04	5.2E-12
I-133	4.6E+05	7.6E-04	7.6E-03	7.6E-02	4.7E-04	7.1E-12
I-134	8.9E+04	1.5E-04	1.5E-03	1.5E-02	8.9E-05	3.4E-12
I-135	3.5E+05	5.7E-04	5.7E-03	5.7E-03	3.5E-04	8.6E-12
DEI 131	3.8E+05	6.2E-04	6.2E-03	6.2E-02	3.8E-04	3.3E-12
Sr-89	2.0E-09	1.0E-11	1.0E-11	1.0E-11	2.8E-11	2.5E-13
Sr-90	2.0E-09	1.0E-11	1.0E-11	1.0E-11	2.2E-12	2.0E-14
Sr-91	2.0E-05	1.0E-11	1.0E-11	1.0E-11	6.5E-10	4.9E-12
Y-91	1.4E-05	1.0E-11	1.0E-11	1.0E-11	3.7E-11	3.4E-13
Mo-99	1.4E-05	1.0E-11	1.0E-11	1.0E-11	2.1E-10	1.8E-12
Ru-103	1.2E-05	1.0E-11	1.0E-11	1.0E-11	1.8E-13	1.6E-15
Ru-106	2.0E-08	1.0E-11	1.0E-11	1.0E-11	2.4E-14	2.2E-16
Te-129m	7.7E+01	3.2E-03	3.2E-04	3.2E-05	2.0E-05	3.3E-15
Te-131m	1.8E+02	7.4E-03	7.4E-04	7.4E-05	4.6E-05	9.1E-14
Te-132	1.7E+03	7.0E-02	7.0E-03	7.0E-04	4.3E-04	4.0E-12
Sb-127	8.7E+01	3.6E-03	3.6E-04	3.6E-05	2.2E-05	4.7E-13
Sb-129	3.3E+02	1.4E-02	1.4E-03	1.4E-04	8.4E-05	3.3E-13
Cs-134	5.4E+04	2.2E+00	2.2E-01	2.2E-02	1.4E-02	1.3E-14
Cs-136	2.2E+04	9.0E-01	9.0E-02	9.0E-03	5.5E-03	8.6E-15
Cs-137	3.4E+04	1.4E+00	1.4E-01	1.4E-02	8.7E-03	1.5E-14
Ba-140	4.0E-06	1.0E-11	1.0E-11	1.0E-11	8.7E-11	7.6E-13
La-140	1.1E-06	1.0E-11	1.0E-11	1.0E-11	5.4E-11	4.6E-13
Ce-144	2.7E-07	1.0E-11	1.0E-11	1.0E-11	3.3E-13	2.9E-15
Np-239	2.0E-06	1.0E-11	1.0E-11	1.0E-11	8.7E-09	7.5E-11
Total Filter	1.1E+05	4.6E+00	4.6E-01	4.6E-02	2.9E-02	8.8E-11
Hydrogen conc	0.0 %	0.0 %	0.0 %	0.0 %	0.0 %	0.0 %
Oxygen conc	0.0 %	0.0 %	0.0 %	0.0 %	0.0 %	0.0 %

Dose Rate at 1 foot

Normal Pass Sample (10 ml)	70,000	< 2.0		
Diluted Sample (0.1 ml)	700	< 2.0		
Normal Pass Sample (15 ml)			< 2.0	17.0
Diluted Gas Sample (1225 cc)				10.0 < 2.0

TABLE III E-1
PLANT CHEMISTRY ACTIVITY
(T=04:30) (CLOCK=20:30)

Nuclide	PX WATER	TORUS WATER	DRYWELL GAS	TORUS GAS	STACK	TB
	Conc uCi/cc	Conc uCi/cc	Conc uCi/cc	Conc uCi/cc	RAGEMS Conc uCi/cc	RAGEMS Conc uCi/cc
Kr-85	2.3E+03	3.9E-03	3.9E-02	3.9E-01	3.0E-03	1.3E-12
Kr-85m	1.0E+05	1.7E-01	1.7E+00	1.7E+01	8.8E-02	4.0E-10
Kr-87	5.0E+04	8.3E-02	8.3E-01	8.3E+00	6.5E-02	3.6E-10
Kr-88	1.5E+05	2.6E-01	2.6E+00	2.6E+01	2.0E-01	7.3E-10
Xe131m	4.1E+03	6.9E-03	6.9E-02	6.9E-01	5.4E-03	9.5E-10
Xe-133	7.0E+05	1.2E+00	1.2E+01	1.2E+02	9.1E-01	5.2E-10
Xe133m	2.4E+04	4.0E-02	4.0E-01	4.0E+00	3.1E-02	1.8E-11
Xe-135	1.2E+05	1.9E-01	1.9E+00	1.9E+01	1.5E-01	1.2E-09
Xe-138	4.9E+02	8.0E-04	8.0E-03	8.0E-02	6.3E-04	6.0E-12
Total Gas Sample	1.2E+06	1.9E+00	1.9E+01	1.9E+02	1.5E+00	4.2E-09
I-131	2.5E+05	4.1E-04	4.1E-03	4.1E-02	2.4E-04	1.1E-12
I-132	1.7E+05	2.7E-04	2.7E-03	2.7E-02	1.6E-04	5.2E-12
I-133	4.6E+05	7.6E-04	7.6E-03	7.6E-02	4.5E-04	7.1E-12
I-134	7.8E+04	1.3E-04	1.3E-03	1.3E-02	7.7E-05	3.4E-12
I-135	3.4E+05	5.6E-04	5.6E-03	5.6E-02	3.3E-04	8.6E-12
DEI 131	3.8E+05	6.2E-04	6.2E-03	6.2E-02	3.7E-04	3.3E-12
Sr-89	2.0E-09	1.0E-11	1.0E-11	1.0E-11	2.8E-11	2.5E-13
Sr-90	2.0E-09	1.0E-11	1.0E-11	1.0E-11	2.2E-12	2.0E-14
Sr-91	2.0E-05	1.0E-11	1.0E-11	1.0E-11	6.5E-10	4.9E-12
Y-91	1.4E-05	1.0E-11	1.0E-11	1.0E-11	3.7E-11	3.4E-13
Mo-99	1.4E-05	1.0E-11	1.0E-11	1.0E-11	2.1E-10	1.8E-12
Ru-103	1.2E-05	1.0E-11	1.0E-11	1.0E-11	1.8E-13	1.6E-15
Ru-106	2.0E-08	1.0E-11	1.0E-11	1.0E-11	2.4E-14	2.2E-16
Te-129m	7.7E+01	3.2E-03	3.2E-04	3.2E-05	1.9E-05	3.3E-15
Te-131m	1.8E+02	7.3E-03	7.3E-04	7.3E-05	4.4E-05	9.1E-14
Te-132	1.7E+03	7.0E-02	7.0E-03	7.0E-04	4.2E-04	4.0E-12
Sb-127	8.7E+01	3.6E-03	3.6E-04	3.6E-05	2.2E-05	4.7E-13
Sb-129	3.2E+02	1.3E-02	1.3E-03	1.3E-04	8.0E-05	3.3E-13
Cs-134	5.4E+04	2.2E+00	2.2E-01	2.2E-02	1.4E-02	1.3E-14
Cs-136	2.2E+04	9.0E-01	9.0E-02	9.0E-03	5.4E-03	8.6E-15
Cs-137	3.4E+04	1.4E+00	1.4E-01	1.4E-02	8.4E-03	1.5E-14
Ba-140	4.0E-06	1.0E-11	1.0E-11	1.0E-11	8.7E-11	7.6E-13
La-140	1.1E-06	1.0E-11	1.0E-11	1.0E-11	5.4E-11	4.6E-13
Ce-144	2.7E-07	1.0E-11	1.0E-11	1.0E-11	3.3E-13	2.9E-15
Np-239	2.0E-06	1.0E-11	1.0E-11	1.0E-11	8.7E-09	7.5E-11
Total Filter	1.1E+05	4.6E+00	4.6E-01	4.6E-02	2.8E-02	8.8E-11
Hydrogen conc	0.0 %	0.0 %	0.0 %	0.0 %	0.0 %	0.0 %
Oxygen conc	0.0 %	0.0 %	0.0 %	0.0 %	0.0 %	0.0 %
Dose Rate at 1 foot						
Normal Pass Sample (10 ml)	69,000	< 2.0				
Diluted Sample (0.1 ml)	690	< 2.0				
Normal Pass Sample (15 ml)			< 2.0	17.0		
Diluted Gas Sample (1225 cc)					10.0	< 2.0

SECTION IV OFF-SITE RADIOLOGICAL DATA

- IV.A. DOSE PROJECTION
- IV.B. PLUME DATA
- IV.C. METEOROLOGICAL DATA
- IV.D. CREST DATA

SECTION IV.A. DOSE PROJECTION

TIME 19:22

TOTAL EFFECTIVE DOSE EQUIVALENT				THYROID COMMITTED DOSE EQUIVALENT				
Dis. Miles	Dose mRem	Dose Rate mRem/Hr	Hours to PAG	Dis. Miles	Chi/Q Sec/M ³	Dose mRem	Dose Rate mRem/Hr	Hours to PAG
SB	2.15E+03	3.08E+02	3.2	SB	4.55E-21	BKG	BKG	>99
2.0	2.55E+03	3.64E+02	2.7	2.0	4.93E-09	1.29E+00	1.84E-01	>99
5.0	3.86E+03	5.52E+02	1.8	5.0	2.22E-06	5.72E+02	8.17E+01	61.2
10.0	3.04E+03	4.35E+02	2.3	10.0	3.18E-06	7.96E+02	1.14E+02	44.0
Max. Dose				Max. Dose				
4.0	4.05E+03	5.79E+02	1.7	10.0	3.18E-06	7.96E+02	1.14E+02	44.0

MET DATA

Ground Wind Speed	2.2 mph	Elevated Wind Speed	2.2 mph
Ground Wind Dir (from)	45 degrees	Elevated Wind Dir (from)	45 degrees
Ground Stability Class	F	Elevated Stability Class	F

FIELD READINGS

Time	Location	WB Dose Rate	Th Dose Rate
		mRem/hr	mRem/hr
		mRem/hr	mRem/hr
		mRem/hr	mRem/hr
		mRem/hr	mRem/hr

F1 Update All F2 Source Term F3 Met Data F4 Update Dose F5 PAR F9 Quit

EMERGENCY CLASSIFICATION

GENERAL EMERGENCY based on Total Effective Dose Equivalent

ASSUMPTIONS / INPUTS USED

Time = 19:22 Date = 11/1/1995
 Stack release calculation
 Stack RAGEMs sample used
 Release duration = 7.00 hours
 Assumed gross elevated release rates:
 1.12E+08 uCi/s Noble Gas, 1.98E+06 uCi/s Iodine
 Assumed gross ground release rates:
 0.00E+00 uCi/s Noble Gas, 0.00E+00 uCi/s Iodine

Time: 19:21:46

Date: 11/01/1995

ELEVATED RELEASE CONCENTRATIONS

Kr 85	3.2E-03	uCi/cc	Y 91	6.0E-12	uCi/cc
Kr 85m	1.4E-01	uCi/cc	Mo 99	2.8E-11	uCi/cc
Kr 87	1.3E-01	uCi/cc	Ru 103	3.1E-12	uCi/cc
Kr 88	2.8E-01	uCi/cc	Ru 106	8.1E-15	uCi/cc
Xe 131m	5.7E-03	uCi/cc	Te 129m	2.0E-05	uCi/cc
Xe 133	9.7E-01	uCi/cc	Te 131m	4.8E-05	uCi/cc
Xe 133m	3.4E-02	uCi/cc	Te 132	4.5E-04	uCi/cc
Xe 135	1.8E-01	uCi/cc	Sb 127	2.3E-05	uCi/cc
Xe 138	2.1E-02	uCi/cc	Sb 129	1.0E-04	uCi/cc
I 131	2.6E-04	uCi/cc	Cs 134	1.4E-02	uCi/cc
I 132	2.5E-04	uCi/cc	Cs 136	5.8E-03	uCi/cc
I 133	5.0E-04	uCi/cc	Cs 137	9.0E-03	uCi/cc
I 134	2.0E-04	uCi/cc	Ba 140	1.1E-11	uCi/cc
I 135	4.0E-04	uCi/cc	La 140	3.7E-12	uCi/cc
Sr 89	8.8E-12	uCi/cc	Ce 144	1.1E-13	uCi/cc
Sr 90	2.7E-13	uCi/cc	Np 239	1.0E-09	uCi/cc
Sr 91	8.2E-11	uCi/cc			

Flow rate = 1.4E+05 cfm

Time: 19:22:06

Date: 11/01/1995

	A Sensor	B Sensor	USE	Units
33 Ft Wind Speed	MISSING	MISSING	2.2	Mph
150 Ft Wind Speed	MISSING	MISSING		Mph
380 Ft Wind Speed	MISSING	MISSING	2.2	Mph
33 Ft Wind Direction	MISSING	MISSING	45	Degrees
150 Ft Wind Direction	MISSING	MISSING		Degrees
380 Ft Wind Direction	MISSING	MISSING	45	Degrees
150 Ft - 33 Ft Delta T	MISSING	MISSING	1.0	Degrees F
380 Ft - 33 Ft Delta T	MISSING	MISSING	3.0	Degrees F

Elevated Sector Affected SW

Ground Sector Affected SW

GENERAL EMERGENCY IS DECLARED



CAN A PAR BE MADE WITHIN APPROXIMATELY 15 MINUTES?



IF NO OTHER PAR IS WARRANTED, THEN A MINIMUM RECOMMEND SHELTERING FOR 2 MILE RADIUS AND 5 MILES DOWNWIND AND CONTINUE ASSESSMENT



IS THERE A RELEASE IN PROGRESS WITH A SUFFICIENT DURATION TO EXCEED EPA LOWER LIMIT PAG'S? (1 REM TEDE OR 5 REM THYROID CDE)



IS THERE ACTUAL OR EXPECTED SUBSTANTIAL CORE DAMAGE?



IS THERE A LARGE FISSION PRODUCT INVENTORY OUTSIDE OF THE REACTOR COOLANT SYSTEM SUFFICIENT TO EXCEED EPA LOWER LIMIT PAG IF RELEASED?



RECOMMEND SHELTERING 2 MILE RADIUS AND 10 MILES DOWNWIND



IS CONTAINMENT INTEGRITY BREACHED, BYPASSED, OR SERIOUSLY CHALLENGED?



RECOMMEND EVACUATION AND SHELTERING AS INDICATED BY PAR ANALYSIS

PROTECTIVE ACTION RECOMMENDATION ANALYSIS

A DISTANCE (miles)	B PROJECTED DOSE RATE (mR/hr)	C WIND SPEED (mph)	D E.T.E. (hrs)	E TIME TILL RELEASE (hrs)	F RELEASE DURATION (hrs)	G NO ACTION (mR)	H SHELTER (mR)	I EVACUATE (mR)
S.B. 0 miles	364.5	2.2	2.00	0.00	7.00	2551	1939	729 *
2.0	578.8 MAX	2.2	2.08	0.00	7.00	4052	2316	678 *
5.0	551.5	2.2	2.25	0.00	7.00	3861	3417	0 *

Both TEDE and Thyroid CDE doses considered

Computer Recommendations:

Sectors

Affected EPA's

Evacuate 2 mile radius

SSW, SW, WSW

1, 2

Evacuate 10 miles downwind

3, 4, 5

7, 8, 11

TOTAL EFFECTIVE DOSE EQUIVALENT				TIME 19:30	THYROID COMMITTED DOSE EQUIVALENT			
Dis. Miles	Dose mRem	Dose Rate mRem/Hr	Hours to PAG	Dis. Miles	Chi/Q Sec/M ³	Dose mRem	Dose Rate mRem/Hr	Hours to PAG
SB	2.20E+03	3.15E+02	3.2	SB	4.55E-21	BKG	BKG	>99
2.0	2.62E+03	3.75E+02	2.7	2.0	4.93E-09	1.39E+00	1.98E-01	>99
5.0	4.04E+03	5.77E+02	1.7	5.0	2.22E-06	6.16E+02	8.79E+01	56.9
10.0	3.22E+03	4.60E+02	2.2	10.0	3.18E-06	8.57E+02	1.22E+02	40.9
Max. Dose				Max. Dose				
4.0	4.22E+03	6.03E+02	1.7	10.0	3.18E-06	8.57E+02	1.22E+02	40.9

MET DATA			
Ground Wind Speed	2.2 mph	Elevated Wind Speed	2.2 mph
Ground Wind Dir (from)	45 degrees	Elevated Wind Dir (from)	45 degrees
Ground Stability Class	F	Elevated Stability Class	F

FIELD READINGS			
Time	Location	WB Dose Rate	Th Dose Rate
		mRem/hr	mRem/hr
		mRem/hr	mRem/hr
		mRem/hr	mRem/hr
		mRem/hr	mRem/hr

F1 Update All F2 Source Term F3 Met Data F4 Update Dose F5 PAR F9 Quit

EMERGENCY CLASSIFICATION

GENERAL EMERGENCY based on Total Effective Dose Equivalent

ASSUMPTIONS / INPUTS USED

Time = 19:30 Date = 11/1/1995
 Stack release calculation
 Stack RAGEMS sample used
 Release duration = 7.00 hours
 Assumed gross elevated release rates:
 1.14E+08 uCi/s Noble Gas, 2.12E+06 uCi/s Iodine
 Assumed gross ground release rates:
 0.00E+00 uCi/s Noble Gas, 0.00E+00 uCi/s Iodine

Time: 19:30

Date: 11/1/1995

ELEVATED RELEASE CONCENTRATIONS

Kr 85	3.5E-03	uCi/cc	Y 91	6.3E-12	uCi/cc
Kr 85m	1.2E-01	uCi/cc	Mo 99	2.8E-11	uCi/cc
Kr 87	1.3E-01	uCi/cc	Ru 103	3.4E-12	uCi/cc
Kr 88	2.9E-01	uCi/cc	Ru 106	8.5E-15	uCi/cc
Xe 131m	6.2E-03	uCi/cc	Te 129m	2.2E-05	uCi/cc
Xe 133	1.0E+00	uCi/cc	Te 131m	5.2E-05	uCi/cc
Xe 133m	3.6E-02	uCi/cc	Te 132	4.9E-04	uCi/cc
Xe 135	1.9E-01	uCi/cc	Sb 127	2.5E-05	uCi/cc
Xe 138	1.4E-02	uCi/cc	Sb 129	1.1E-04	uCi/cc
I 131	2.8E-04	uCi/cc	Cs 134	1.5E-02	uCi/cc
I 132	2.5E-04	uCi/cc	Cs 136	6.2E-03	uCi/cc
I 133	5.3E-04	uCi/cc	Cs 137	9.7E-03	uCi/cc
I 134	1.9E-04	uCi/cc	Ba 140	1.2E-11	uCi/cc
I 135	4.2E-04	uCi/cc	La 140	3.7E-12	uCi/cc
Sr 89	8.8E-12	uCi/cc	Ce 144	1.2E-13	uCi/cc
Sr 90	2.7E-13	uCi/cc	Np 239	1.0E-09	uCi/cc
Sr 91	8.3E-11	uCi/cc			

Flow rate = 1.4E+05 cfm

Time: 19:30

Date: 11/1/1995

	A Sensor	B Sensor	USE	Units
33 Ft Wind Speed	MISSING	MISSING	2.2	Mph
150 Ft Wind Speed	MISSING	MISSING		Mph
380 Ft Wind Speed	MISSING	MISSING	2.2	Mph
33 Ft Wind Direction	MISSING	MISSING	45	Degrees
150 Ft Wind Direction	MISSING	MISSING		Degrees
380 Ft Wind Direction	MISSING	MISSING	45	Degrees
150 Ft - 33 Ft Delta T	MISSING	MISSING	1.0	Degrees F
380 Ft - 33 Ft Delta T	MISSING	MISSING	3.0	Degrees F

Elevated Sector Affected SW

Ground Sector Affected SW

TOTAL EFFECTIVE DOSE EQUIVALENT				TIME 19:40	THYROID COMMITTED DOSE EQUIVALENT			
Dis. Miles	Dose mRem	Dose Rate mRem/Hr	Hours to PAG	Dis. Miles	Chi/Q Sec/M ³	Dose mRem	Dose Rate mRem/Hr	Hours to PAG
SB	2.12E+03	3.03E+02	3.3	SB	4.55E-21	BKG	BKG	>99
2.0	2.55E+03	3.64E+02	2.7	2.0	4.93E-09	1.38E+00	1.97E-01	>99
5.0	3.97E+03	5.67E+02	1.8	5.0	2.22E-06	6.10E+02	8.72E+01	57.3
10.0	3.18E+03	4.55E+02	2.2	10.0	3.18E-06	8.50E+02	1.21E+02	41.2
Max. Dose				Max. Dose				
4.0	4.14E+03	5.91E+02	1.7	10.0	3.18E-06	8.50E+02	1.21E+02	41.2

MET DATA			
Ground Wind Speed	2.2 mph	Elevated Wind Speed	2.2 mph
Ground Wind Dir (from)	45 degrees	Elevated Wind Dir (from)	45 degrees
Ground Stability Class	F	Elevated Stability Class	F

FIELD READINGS			
Time	Location	WB Dose Rate	Th Dose Rate
		mRem/hr	mRem/hr
		mRem/hr	mRem/hr
		mRem/hr	mRem/hr
		mRem/hr	mRem/hr

F1 Update All F2 Source Term F3 Met Data F4 Update Dose F5 PAR F9 Quit

EMERGENCY CLASSIFICATION

GENERAL EMERGENCY based on Total Effective Dose Equivalent

ASSUMPTIONS / INPUTS USED

Time = 19:40 Date = 11/1/1995
 Stack release calculation
 Stack RAGEMS sample used
 Release duration = 7.00 hours
 Assumed gross elevated release rates:
 1.14E+08 uCi/s Noble Gas, 2.10E+06 uCi/s Iodine
 Assumed gross ground release rates:
 0.00E+00 uCi/s Noble Gas, 0.00E+00 uCi/s Iodine

Time: 19:40

Date: 11/01/1995

ELEVATED RELEASE CONCENTRATIONS

Kr 85	3.4E-03	uCi/cc	Y 91	6.3E-12	uCi/cc
Kr 85m	1.5E-01	uCi/cc	Mo 99	2.8E-11	uCi/cc
Kr 87	1.2E-01	uCi/cc	Ru 103	3.3E-12	uCi/cc
Kr 88	2.8E-01	uCi/cc	Ru 106	8.4E-15	uCi/cc
Xe 131m	6.1E-03	uCi/cc	Te 129m	2.2E-05	uCi/cc
Xe 133	1.0E+00	uCi/cc	Te 131m	5.1E-05	uCi/cc
Xe 133m	3.6E-02	uCi/cc	Te 132	4.8E-04	uCi/cc
Xe 135	1.8E-01	uCi/cc	Sb 127	2.5E-05	uCi/cc
Xe 138	8.3E-03	uCi/cc	Sb 129	1.0E- 4	uCi/cc
I 131	2.8E-04	uCi/cc	Cs 134	1.5E-02	uCi/cc
I 132	2.4E-04	uCi/cc	Cs 136	6.1E-03	uCi/cc
I 133	5.2E-04	uCi/cc	Cs 137	9.5E-03	uCi/cc
I 134	1.7E-04	uCi/cc	Ba 140	1.1E-11	uCi/cc
I 135	4.1E-04	uCi/cc	La 140	3.7E-12	uCi/cc
Sr 89	8.8E-12	uCi/cc	Ce 144	1.1E-13	uCi/cc
Sr 90	2.7E-13	uCi/cc	Np 239	1.0E-09	uCi/cc
Sr 91	8.2E-11	uCi/cc			

Flow rate = 1.4E+05 cfm

Time: 19:40

Date: 11/01/1995

	A Sensor	B Sensor	USE	Units
33 Ft Wind Speed	MISSING	MISSING	2.2	Mph
150 Ft Wind Speed	MISSING	MISSING		Mph
380 Ft Wind Speed	MISSING	MISSING	2.2	Mph
33 Ft Wind Direction	MISSING	MISSING	45	Degrees
150 Ft Wind Direction	MISSING	MISSING		Degrees
380 Ft Wind Direction	MISSING	MISSING	45	Degrees
150 Ft - 33 Ft Delta T	MISSING	MISSING	1.0	Degrees F
380 Ft - 33 Ft Delta T	MISSING	MISSING	3.0	Degrees F

Elevated Sector Affected SW

Ground Sector Affected SW

TIME 19:50

TOTAL EFFECTIVE DOSE EQUIVALENT				THYROID COMMITTED DOSE EQUIVALENT				
Distances	Dose mRem	Dose Rate mRem/Hr	Hours to PAG	Dis. Miles	Chi/Q Sec/M ³	Dose mRem	Dose Rate mRem/Hr	Hours to PAG
SB	1.90E+03	2.71E+02	3.7	SB	4.35E-21	BKG	BKG	>99
2.0	2.32E+03	3.31E+02	3.0	2.0	5.03E-09	1.37E+00	1.95E-01	>99
5.0	3.73E+03	5.33E+02	1.9	5.0	2.18E-06	5.80E+02	8.29E+01	60.3
10.0	3.04E+03	4.34E+02	2.3	10.0	3.08E-06	8.00E+02	1.14E+02	43.7
Max. Dose				Max. Dose				
4.0	3.86E+03	5.52E+02	1.8	10.0	3.08E-06	8.00E+02	1.14E+02	43.7

MET DATA

Ground Wind Speed	2.3 mph	Elevated Wind Speed	2.3 mph
Ground Wind Dir (from)	45 degrees	Elevated Wind Dir (from)	45 degrees
Ground Stability Class	F	Elevated Stability Class	F

FIELD READINGS

Time	Location	WB Dose Rate	Th Dose Rate
		mRem/hr	mRem/hr
		mRem/hr	mRem/hr
		mRem/hr	mRem/hr
		mRem/hr	mRem/hr

F1 Update All F2 Source Term F3 Met Data F4 Update Dose F5 PAR F9 Quit

EMERGENCY CLASSIFICATION

GENERAL EMERGENCY based on Total Effective Dose Equivalent

ASSUMPTIONS / INPUTS USED

Time = 19:50 Date = 11/1/1995
 Stack release calculation
 Stack RAGEMS sample used
 Release duration = 7.00 hours
 Assumed gross elevated release rates:
 1.10E+08 uCi/s Noble Gas, 2.07E+06 uCi/s Iodine
 Assumed gross ground release rates:
 0.00E+00 uCi/s Noble Gas, 0.00E+00 uCi/s Iodine

Time: 19:50

Date: 11/01/1995

ELEVATED RELEASE CONCENTRATIONS

Kr 85	3.3E-03	uCi/cc	Y 91	6.2E-12	uCi/cc
Kr 85m	1.4E-01	uCi/cc	Mo 99	2.8E-11	uCi/cc
Kr 87	1.0E-01	uCi/cc	Ru 103	3.3E-12	uCi/cc
Kr 88	2.6E-01	uCi/cc	Ru 106	8.3E-15	uCi/cc
Xe 131m	5.9E-03	uCi/cc	Te 129m	2.1E-05	uCi/cc
Xe 133	1.0E+00	uCi/cc	Te 131m	4.9E-05	uCi/cc
Xe 133m	3.5E-02	uCi/cc	Te 132	4.7E-04	uCi/cc
Xe 135	1.8E-01	uCi/cc	Sb 127	2.4E-05	uCi/cc
Xe 138	5.0E-03	uCi/cc	Sb 129	9.8E-05	uCi/cc
I 131	2.7E-04	uCi/cc	Cs 134	1.5E-02	uCi/cc
I 132	2.2E-04	uCi/cc	Cs 136	6.0E-03	uCi/cc
I 133	5.1E-04	uCi/cc	Cs 137	9.3E-03	uCi/cc
I 134	1.4E-04	uCi/cc	Ba 140	1.1E-11	uCi/cc
I 135	3.9E-04	uCi/cc	La 140	3.7E-12	uCi/cc
Sr 89	8.8E-12	uCi/cc	Ce 144	1.1E-13	uCi/cc
Sr 90	2.7E-13	uCi/cc	Np 239	1.0E-09	uCi/cc
Sr 91	8.2E-11	uCi/cc			

Flow rate = 1.4E+05 cfm

Time: 19:50

Date: 11/01/1995

	A Sensor	B Sensor	USE	Units
33 Ft Wind Speed	MISSING	MISSING	2.3	Mph
150 Ft Wind Speed	MISSING	MISSING		Mph
380 Ft Wind Speed	MISSING	MISSING	2.3	Mph
33 Ft Wind Direction	MISSING	MISSING	45	Degrees
150 Ft Wind Direction	MISSING	MISSING		Degrees
380 Ft Wind Direction	MISSING	MISSING	45	Degrees
150 Ft - 33 Ft Delta T	MISSING	MISSING	1.0	Degrees F
380 Ft - 33 Ft Delta T	MISSING	MISSING	3.0	Degrees F

Elevated Sector Affected SW

Ground Sector Affected SW

TOTAL EFFECTIVE DOSE EQUIVALENT				TIME 20:00	THYROID COMMITTED DOSE EQUIVALENT			
Dis. Miles	Dose mRem	Dose Rate mRem/Hr	Hours to PAG	Dis. Miles	Chi/Q Sec/M ³	Dose mRem	Dose Rate mRem/Hr	Hours to PAG
SB	1.82E+03	2.59E+02	3.9	SB	4.55E-21	BKG	BKG	>99
2.0	2.21E+03	3.15E+02	3.2	2.0	4.93E-09	1.29E+00	1.84E-01	>99
5.0	3.64E+03	5.20E+02	1.9	5.0	2.22E-06	5.72E+02	8.17E+01	61.2
10.0	3.03E+03	4.33E+02	2.3	10.0	3.18E-06	7.97E+02	1.14E+02	43.9
Max. Dose				Max. Dose				
4.0	3.74E+03	5.35E+02	1.9	10.0	3.18E-06	7.97E+02	1.14E+02	43.9

MET DATA			
Ground Wind Speed	2.2 mph	Elevated Wind Speed	2.2 mph
Ground Wind Dir (from)	45 degrees	Elevated Wind Dir (from)	45 degrees
Ground Stability Class	F	Elevated Stability Class	F

FIELD READINGS			
Time	Location	WB Dose Rate	Th Dose Rate
		mRem/hr	mRem/hr
		mRem/hr	mRem/hr
		mRem/hr	mRem/hr
		mRem/hr	mRem/hr

F1 Update All F2 Source Term F3 Met Data F4 Update Dose F5 PAR F9 Quit

EMERGENCY CLASSIFICATION

GENERAL EMERGENCY based on Total Effective Dose Equivalent

ASSUMPTIONS / INPUTS USED

Time = 20:00 Date = 11/1/1995
 Stack release calculation
 Stack RAGEMS sample used
 Release duration = 7.00 hours
 Assumed gross elevated release rates:
 1.04E+08 uCi/s Noble Gas, 2.04E+06 uCi/s Iodine
 Assumed gross ground release rates:
 0.00E+00 uCi/s Noble Gas, 0.00E+00 uCi/s Iodine

Time: 20:00

Date: 11/1/1995

ELEVATED RELEASE CONCENTRATIONS

Kr 85	3.3E-03	uCi/cc	Y 91	6.1E-12	uCi/cc
Kr 85m	1.0E-01	uCi/cc	Mo 99	2.8E-11	uCi/cc
Kr 87	9.2E-02	uCi/cc	Ru 103	3.2E-12	uCi/cc
Kr 88	2.4E-01	uCi/cc	Ru 106	8.2E-15	uCi/cc
Xe 131m	5.8E-03	uCi/cc	Te 129m	2.1E-05	uCi/cc
Xe 133	9.8E-01	uCi/cc	Te 131m	4.8E-05	uCi/cc
Xe 133m	3.4E-02	uCi/cc	Te 132	4.6E-04	uCi/cc
Xe 135	1.7E-01	uCi/cc	Sb 127	2.3E-05	uCi/cc
Xe 138	3.0E-03	uCi/cc	Sb 129	9.3E-05	uCi/cc
I 131	2.6E-04	uCi/cc	Cs 134	1.5E-02	uCi/cc
I 132	2.0E-04	uCi/cc	Cs 136	5.8E-03	uCi/cc
I 133	4.9E-04	uCi/cc	Cs 137	9.1E-03	uCi/cc
I 134	1.2E-04	uCi/cc	Ba 140	1.1E-11	uCi/cc
I 135	3.8E-04	uCi/cc	La 140	3.7E-12	uCi/cc
Sr 89	8.8E-12	uCi/cc	Ce 144	1.1E-13	uCi/cc
Sr 90	2.7E-13	uCi/cc	Np 239	1.0E-09	uCi/cc
Sr 91	8.2E-11	uCi/cc			

Flow rate = 1.4E+05 cfm

Time: 20:00

Date: 11/1/1995

	A Sensor	B Sensor	USE	Units
33 Ft Wind Speed	MISSING	MISSING	2.2	Mph
150 Ft Wind Speed	MISSING	MISSING		Mph
380 Ft Wind Speed	MISSING	MISSING	2.2	Mph
33 Ft Wind Direction	MISSING	MISSING	45	Degrees
150 Ft Wind Direction	MISSING	MISSING		Degrees
380 Ft Wind Direction	MISSING	MISSING	45	Degrees
150 Ft - 33 Ft Delta T	MISSING	MISSING	1.0	Degrees F
380 Ft - 33 Ft Delta T	MISSING	MISSING	3.0	Degrees F

Elevated Sector Affected SW

Ground Sector Affected SW

TIME 20:10

TOTAL EFFECTIVE DOSE EQUIVALENT				THYROID COMMITTED DOSE EQUIVALENT				
Dis. Miles	Dose mRem	Dose Rate mRem/Hr	Hours to PAG	Dis. Miles	Chi/Q Sec/M ³	Dose mRem	Dose Rate mRem/Hr	Hours to PAG
SB	1.81E+03	2.58E+02	3.9	SB	4.77E-21	BKG	BKG	>99
2.0	2.20E+03	3.14E+02	3.2	2.0	4.81E-09	1.25E+00	1.78E-01	>99
5.0	3.59E+03	5.12E+02	2.0	5.0	2.27E-06	5.79E+02	8.27E+01	60.5
10.0	2.98E+03	4.26E+02	2.3	10.0	3.29E-06	8.14E+02	1.16E+02	43.0
Max. Dose				Max. Dose				
4.0	3.70E+03	5.28E+02	1.9	10.0	3.29E-06	8.14E+02	1.16E+02	43.0

MET DATA

Ground Wind Speed	2.1 mph	Elevated Wind Speed	2.1 mph
Ground Wind Dir (from)	45 degrees	Elevated Wind Dir (from)	45 degrees
Ground Stability Class	F	Elevated Stability Class	F

FIELD READINGS

Time	Location	WB Dose Rate	Th Dose Rate
		mRem/hr	mRem/hr
		mRem/hr	mRem/hr
		mRem/hr	mRem/hr
		mRem/hr	mRem/hr

F1 Update All F2 Source Term F3 Met Data F4 Update Dose F5 PAR F9 Quit

EMERGENCY CLASSIFICATION

GENERAL EMERGENCY based on Total Effective Dose Equivalent

ASSUMPTIONS / INPUTS USED

Time = 20:10 Date = 11/1/1995
 Stack release calculation
 Stack RAGEMS sample used
 Release duration = 7.00 hours
 Assumed gross elevated release rates:
 1.02E+08 uCi/s Noble Gas, 1.95E+06 uCi/s Iodine
 Assumed gross ground release rates:
 0.00E+00 uCi/s Noble Gas, 0.00E+00 uCi/s Iodine

Time: 20:10

Date: 11/01/1995

ELEVATED RELEASE CONCENTRATIONS

Kr 85	3.2E-03	uCi/cc	Y 91	6.0E-12	uCi/cc
Kr 85m	1.4E-01	uCi/cc	Mo 99	2.8E-11	uCi/cc
Kr 87	8.2E-02	uCi/cc	Ru 103	3.1E-12	uCi/cc
Kr 88	2.3E-01	uCi/cc	Ru 106	8.0E-15	uCi/cc
Xe 131m	5.6E-03	uCi/cc	Te 129m	2.0E-05	uCi/cc
Xe 133	9.5E-01	uCi/cc	Te 131m	4.7E-05	uCi/cc
Xe 133m	3.3E-02	uCi/cc	Te 132	4.5E-04	uCi/cc
Xe 135	1.6E-01	uCi/cc	Sb 127	2.3E-05	uCi/cc
Xe 138	1.8E-03	uCi/cc	Sb 129	8.9E-05	uCi/cc
I 131	2.6E-04	uCi/cc	Cs 134	1.4E-02	uCi/cc
I 132	1.9E-04	uCi/cc	Cs 136	5.7E-03	uCi/cc
I 133	4.8E-04	uCi/cc	Cs 137	8.9E-03	uCi/cc
I 134	1.0E-04	uCi/cc	Ba 140	1.1E-11	uCi/cc
I 135	3.6E-04	uCi/cc	La 140	3.7E-12	uCi/cc
Sr 89	8.8E-12	uCi/cc	Ce 144	1.1E-13	uCi/cc
Sr 90	2.7E-13	uCi/cc	Np 239	1.0E-09	uCi/cc
Sr 91	8.2E-11	uCi/cc			

Flow rate = 1.4E+05 cfm

Time: 20:10

Date: 11/01/1995

	A Sensor	B Sensor	USE	Units
33 Ft Wind Speed	MISSING	MISSING	2.1	Mph
150 Ft Wind Speed	MISSING	MISSING		Mph
380 Ft Wind Speed	MISSING	MISSING	2.1	Mph
33 Ft Wind Direction	MISSING	MISSING	45	Degrees
150 Ft Wind Direction	MISSING	MISSING		Degrees
380 Ft Wind Direction	MISSING	MISSING	45	Degrees
150 Ft - 33 Ft Delta T	MISSING	MISSING	1.0	Degrees F
380 Ft - 33 Ft Delta T	MISSING	MISSING	3.0	Degrees F

Elevated Sector Affected SW

Ground Sector Affected SW

TOTAL EFFECTIVE DOSE EQUIVALENT				TIME 20:20	THYROID COMMITTED DOSE EQUIVALENT			
Dis. Miles	Dose mRem	Dose Rate mRem/Hr	Hours to PAG	Dis. Miles	Chi/Q Sec/M ³	Dose mRem	Dose Rate mRem/Hr	Hours to PAG
SB	1.55E+03	2.22E+02	4.5	SB	4.35E-21	BKG	BKG	>99
2.0	1.93E+03	2.75E+02	3.6	2.0	5.03E-09	1.26E+00	1.80E-01	>99
5.0	3.28E+03	4.68E+02	2.1	5.0	2.18E-06	5.35E+02	7.64E+01	65.4
10.0	2.76E+03	3.94E+02	2.5	10.0	3.08E-06	7.38E+02	1.05E+02	47.4
Max. Dose				Max. Dose				
4.0	3.35E+03	4.78E+02	2.1	10.0	3.08E-06	7.38E+02	1.05E+02	47.4

MET DATA			
Ground Wind Speed	2.3 mph	Elevated Wind Speed	2.3 mph
Ground Wind Dir (from)	45 degrees	Elevated Wind Dir (from)	45 degrees
Ground Stability Class	F	Elevated Stability Class	F

FIELD READINGS			
Time	Location	WB Dose Rate	Th Dose Rate
		mRem/hr	mRem/hr
		mRem/hr	mRem/hr
		mRem/hr	mRem/hr
		mRem/hr	mRem/hr

F1 Update All F2 Source Term F3 Met Data F4 Update Dose F5 PAR F9 Quit

EMERGENCY CLASSIFICATION

GENERAL EMERGENCY based on Total Effective Dose Equivalent

ASSUMPTIONS / INPUTS USED

Time = 20:20 Date = 11/1/1995
 Stack release calculation
 Stack RAGEMS sample used
 Release duration = 7.00 hours
 Assumed gross elevated release rates:
 9.84E+07 uCi/s Noble Gas, 1.92E+06 uCi/s Iodine
 Assumed gross ground release rates:
 0.00E+00 uCi/s Noble Gas, 0.00E+00 uCi/s Iodine

Time: 20:20

Date: 11/01/1995

ELEVATED RELEASE CONCENTRATIONS

Kr 85	3.1E-03	uCi/cc	Y 91	5.9E-12	uCi/cc
Kr 85m	1.3E-01	uCi/cc	Mo 99	2.8E-11	uCi/cc
Kr 87	7.3E-02	uCi/cc	Ru 103	3.0E-12	uCi/cc
Kr 88	2.1E-01	uCi/cc	Ru 106	7.9E-15	uCi/cc
Xe 131m	5.5E-03	uCi/cc	Te 129m	2.0E-05	uCi/cc
Xe 133	9.3E-01	uCi/cc	Te 131m	4.6E-05	uCi/cc
Xe 133m	3.2E-02	uCi/cc	Te 132	4.3E-04	uCi/cc
Xe 135	1.6E-01	uCi/cc	Sb 127	2.2E-05	uCi/cc
Xe 138	1.1E-03	uCi/cc	Sb 129	8.4E-05	uCi/cc
I 131	2.5E-04	uCi/cc	Cs 134	1.4E-02	uCi/cc
I 132	1.8E-04	uCi/cc	Cs 136	5.5E-03	uCi/cc
I 133	4.7E-04	uCi/cc	Cs 137	8.7E-03	uCi/cc
I 134	8.9E-05	uCi/cc	Ba 140	1.1E-11	uCi/cc
I 135	3.5E-04	uCi/cc	La 140	3.7E-12	uCi/cc
Sr 89	8.8E-12	uCi/cc	Ce 144	1.1E-13	uCi/cc
Sr 90	2.7E-13	uCi/cc	Np 239	1.0E-09	uCi/cc
Sr 91	8.2E-11	uCi/cc			

Flow rate = 1.4E+05 cfm

Time: 20:20

Date: 11/01/1995

	A Sensor	B Sensor	USE	Units
33 Ft Wind Speed	MISSING	MISSING	2.3	Mph
150 Ft Wind Speed	MISSING	MISSING		Mph
380 Ft Wind Speed	MISSING	MISSING	2.3	Mph
33 Ft Wind Direction	MISSING	MISSING	45	Degrees
150 Ft Wind Direction	MISSING	MISSING		Degrees
380 Ft Wind Direction	MISSING	MISSING	45	Degrees
150 Ft - 33 Ft Delta T	MISSING	MISSING	1.0	Degrees F
380 Ft - 33 Ft Delta T	MISSING	MISSING	3.0	Degrees F

Elevated Sector Affected SW

Ground Sector Affected SW

TIME 20:30

TOTAL EFFECTIVE DOSE EQUIVALENT				THYROID COMMITTED DOSE EQUIVALENT				
Dis. es	Dose mRem	Dose Rate mRem/Hr	Hours to PAG	Dis. Miles	Chi/Q Sec/M ³	Dose mRem	Dose Rate mRem/Hr	Hours to PAG
SB	1.46E+03	2.08E+02	4.8	SB	4.35E-21	BKG	BKG	>99
2.0	1.81E+03	2.59E+02	3.9	2.0	5.03E-09	1.21E+00	1.73E-01	>99
5.0	3.15E+03	4.50E+02	2.2	5.0	2.18E-06	5.15E+02	7.36E+01	67.9
10.0	2.69E+03	3.84E+02	2.6	10.0	3.08E-06	7.11E+02	1.02E+02	49.2
Max. Dose				Max. Dose				
4.4	3.20E+03	4.58E+02	2.2	10.0	3.08E-06	7.11E+02	1.02E+02	49.2

MET DATA

Ground Wind Speed	2.3 mph	Elevated Wind Speed	2.3 mph
Ground Wind Dir (from)	46 degrees	Elevated Wind Dir (from)	46 degrees
Ground Stability Class	F	Elevated Stability Class	F

FIELD READINGS

Time	Location	WB Dose Rate	Th Dose Rate
		mRem/hr	mRem/hr
		mRem/hr	mRem/hr
		mRem/hr	mRem/hr
		mRem/hr	mRem/hr

F1 Update All F2 Source Term F3 Met Data F4 Update Dose F5 PAR F9 Quit

EMERGENCY CLASSIFICATION

GENERAL EMERGENCY based on Total Effective Dose Equivalent

ASSUMPTIONS / INPUTS USED

Time = 20:30 Date = 11/1/1995
 Stack release calculation
 Stack RAGEMS sample used
 Release duration = 7.00 hours
 Assumed gross elevated release rates:
 9.26E+07 uCi/s Noble Gas, 1.89E+05 uCi/s Iodine
 Assumed gross ground release rates:
 0.00E+00 uCi/s Noble Gas, 0.00E+00 uCi/s Iodine

Time: 20:30

Date: 11/1/1995

ELEVATED RELEASE CONCENTRATIONS

Kr 85	3.0E-03	uCi/cc	Y 91	5.8E-12	uCi/cc
Kr 85m	8.8E-02	uCi/cc	Mo 99	2.8E-11	uCi/cc
Kr 87	6.5E-02	uCi/cc	Ru 103	3.0E-12	uCi/cc
Kr 88	2.0E-01	uCi/cc	Ru 106	7.8E-15	uCi/cc
Xe 131m	5.4E-03	uCi/cc	Te 129m	1.9E-05	uCi/cc
Xe 133	9.1E-01	uCi/cc	Te 131m	4.4E-05	uCi/cc
Xe 133m	3.1E-02	uCi/cc	Te 132	4.2E-04	uCi/cc
Xe 135	1.5E-01	uCi/cc	Sb 127	2.2E-05	uCi/cc
Xe 138	6.3E-04	uCi/cc	Sb 129	8.0E-05	uCi/cc
I 131	2.4E-04	uCi/cc	Cs 134	1.4E-02	uCi/cc
I 132	1.6E-04	uCi/cc	Cs 136	5.4E-03	uCi/cc
I 133	4.5E-04	uCi/cc	Cs 137	8.4E-03	uCi/cc
I 134	7.7E-05	uCi/cc	Ba 140	1.1E-11	uCi/cc
I 135	3.3E-04	uCi/cc	La 140	3.7E-12	uCi/cc
Sr 89	8.8E-12	uCi/cc	Ce 144	1.1E-13	uCi/cc
Sr 90	2.7E-13	uCi/cc	Np 239	1.0E-09	uCi/cc
Sr 91	8.2E-11	uCi/cc			

Flow rate = 1.4E+05 cfm

Time: 20:30

Date: 11/1/1995

	A Sensor	B Sensor	USE	Units
33 Ft Wind Speed	MISSING	MISSING	2.3	Mph
150 Ft Wind Speed	MISSING	MISSING		Mph
380 Ft Wind Speed	MISSING	MISSING	2.3	Mph
33 Ft Wind Direction	MISSING	MISSING	46	Degrees
150 Ft Wind Direction	MISSING	MISSING		Degrees
380 Ft Wind Direction	MISSING	MISSING	46	Degrees
150 Ft - 33 Ft Delta T	MISSING	MISSING	1.0	Degrees F
380 Ft - 33 Ft Delta T	MISSING	MISSING	3.0	Degrees F

Elevated Sector Affected SW

Ground Sector Affected SW

SECTION IV.B. PLUME DATA

- IV.B.1. Plume Map
- IV.B.2. Closed Window Dose Rate
- IV.B.3. Open Window Dose Rate
- IV.B.4. Particulate Filter Data
- IV.B.5. Silver Zeolite Data
- IV.B.6. Environmental Sample Data

Section IV B.2

CLOSED WINDOW DOSE RATES (MR/HR)

TIME	SB	DOWNWIND DISTANCE (MILES)																		
		1	1.5	2	2.5	3	3.5	4	4.5	5	5.5	6	6.5	7	7.5	8	8.5	9	9.5	10
1930	310																			
1940	310																			
1950	310	330																		
2000	310	330	330																	
2010	300	315	315																	
2020	285	300	300	360																
2030	275	290	290	360	380															
2040	260	280	280	345	380															
2050	250	265	265	330	365	400														
2100	240	255	255	315	350	400	410													
2110	230	245	245	300	335	385	410	430												
2120	220	235	235	290	320	365	395	410												
2130	210	225	225	280	305	350	375	395	400											
2140	200	215	215	265	295	335	360	380	400	360										
2150	190	205	205	255	280	325	345	365	385	360	340									
2200	185	195	195	245	270	310	335	355	365	345	340									
2210	175	190	190	235	260	295	320	340	350	335	325	320								
2220	170	180	180	225	245	285	305	325	335	320	310	320	300							
2230	165	175	175	215	235	270	295	315	325	305	300	305	300	280						
2240	155	165	165	205	225	260	280	300	310	295	285	295	285	280						
2250	150	160	160	195	220	250	270	290	295	280	275	280	275	270	260					
2300	145	150	150	190	210	240	260	280	285	270	265	270	265	255	260	240				
2310	135	145	145	180	200	230	250	270	270	260	250	260	250	245	250	240	220			
2320	130	140	140	175	190	220	240	260	260	250	240	245	240	235	240	230	220			
2330	125	135	135	165	185	210	230	250	250	240	230	235	230	225	230	220	210	200		
2340	120	130	130	160	175	200	220	240	240	230	220	225	220	215	220	210	200	200	180	
2350	115	125	125	155	170	195	200	220	230	220	210	215	210	205	210	200	195	190	180	
2400	110	120	120	145	160	185	195	215	220	200	200	210	205	200	200	195	185	185	175	160

@ FOR MEASUREMENTS TAKEN OFF-CENTERLINE, INTERPOLATE BETWEEN THE CENTERLINE AND THE EDGE OF THE PLUME. ASSUME VALUE AT PLUME EDGE EQUALS 1% OF CENTERLINE

@ BACKGROUND LEVELS (LESS THAN .001 MR/HR) ARE INDICATED BY *

Section IV B.3
OPEN WINDOW DOSE RATE (MR/HR)

TIME	SB	DOWNWIND DISTANCE (MILES)																		
		1	1.5	2	2.5	3	3.5	4	4.5	5	5.5	6	6.5	7	7.5	8	8.5	9	9.5	10
1930	1200																			
1940	1200																			
1950	1200	1220																		
2000	1200	1220	1220																	
2010	1150	1170	1220																	
2020	1100	1120	1170	1300																
2030	1055	1075	1120	1300	1400															
2040	1010	1025	1075	1245	1400															
2050	970	985	1025	1195	1340	1500														
2100	925	945	985	1145	1285	1500	1600													
2110	890	900	945	1095	1230	1435	1600	1700												
2120	850	865	900	1050	1180	1375	1530	1700												
2130	820	830	865	1000	1130	1320	1470	1630	1500											
2140	780	795	830	965	1085	1265	1405	1560	1500	1400										
2150	750	760	795	925	1035	1210	1350	1495	1435	1400	1400									
2200	720	730	760	885	995	1160	1290	1430	1375	1340	1400									
2210	690	700	730	845	950	1110	1235	1370	1320	1285	1340	1300								
2220	660	670	700	810	910	1065	1185	1315	1265	1180	1285	1300	1200							
2230	630	640	670	775	875	1020	1135	1260	1210	1130	1180	1245	1200	1100						
2240	605	615	640	745	835	975	1090	1205	1160	1085	1130	1195	1150	1100						
2250	580	590	615	715	800	935	1040	1155	1110	1035	1085	1140	1100	1055	1000					
2300	555	560	590	685	770	900	1000	1105	1065	995	1035	1095	1055	1000	1000	960				
2310	530	540	560	655	735	860	955	1060	1020	950	995	1050	1010	970	960	960	880			
2320	510	515	540	625	705	825	915	1015	975	910	950	1000	970	925	920	890	880			
2330	490	495	515	600	675	790	890	975	935	875	915	965	925	890	880	855	845	800		
2340	470	475	495	575	645	755	840	930	895	835	875	920	890	850	840	820	810	800	720	
2350	450	455	475	550	620	725	805	895	860	800	835	885	850	815	805	785	775	765	720	
2400	430	435	455	530	595	690	770	855	820	770	800	845	815	780	775	750	740	735	690	640

⊗ FOR MEASUREMENTS TAKEN OFF-CENTERLINE, INTERPOLATE BETWEEN THE CENTERLINE AND THE EDGE OF THE PLUME. ASSUME VALUE AT PLUME EDGE EQUALS 1% OF CENTERLINE

⊗ BACKGROUND LEVELS (LESS THAN .001 MR/HR) ARE INDICATED BY *

Section IV B.4
BUREAU OF NUCLEAR ENGINEERING
Particulate Filter DATA IN cpm

DOWNWIND DISTANCE (MILES)

TIME	SB	1	1.5	2	2.5	3	3.5	4	4.5	5	5.5	6	6.5	7	7.5	8	8.5	9	9.5	10
1930	17800																			
1940	17800																			
1950	17800	18800																		
2000	17800	18800	18800																	
2010	17050	18000	18600																	
2020	16335	17250	18800	21700																
2030	15650	16530	17250	21700	22700															
2040	15000	15850	16530	20800	22700															
2050	14365	15200	15850	19920	21750	23700														
2100	13760	14500	15200	19020	21750	23700	23700													
2110	13200	13900	14500	18280	20820	22700	23700	24700												
2120	12630	13350	13900	17500	19920	21750	22700	24700												
2130	12100	12800	13350	16775	18280	20800	21750	23660	22700											
2140	11600	12250	12800	16070	17500	19920	20800	22700	22700	20700										
2150	11100	11700	12250	15400	16775	19020	19920	21700	21750	20700	19800									
2200	10650	11200	11700	14750	16070	18280	19020	20800	20800	19800	19800									
2210	10200	10750	11200	14130	15450	17500	18280	19920	19920	19000	19000	18800								
2220	9760	10300	10750	13500	14750	16775	17500	19000	19000	18200	18200	18800	17800							
2230	9350	9900	10300	13000	14130	16070	16775	18200	18200	17400	17400	18000	17800	16800						
2240	8950	9450	9900	12400	13500	15400	16070	17500	17500	16700	16700	17250	17000	16800						
2250	8580	9050	9450	11900	13000	14750	15400	16770	16700	16000	16000	16500	16300	16100	15800					
2300	8220	8700	9050	11400	12400	14130	14750	16070	16070	15300	15800	15800	15600	15400	15800	14800				
2310	7875	8300	8700	10900	11900	13500	14130	15400	15400	14700	14800	15200	15000	14800	15100	14800	13800			
2320	7550	7950	8300	10450	11400	13000	13500	14750	14700	14070	14100	14500	14400	14200	14500	14200	13800			
2330	7225	7635	7950	10000	10900	12400	13000	14100	14100	13500	13600	13900	13800	13550	13900	13600	13200	12900		
2340	6925	7320	7635	9600	10450	11900	12400	13500	13500	12900	12800	13300	13200	13000	13300	13000	12700	12900	11900	
2350	6635	7000	7320	9200	10000	11400	11900	13000	13000	12400	12800	12800	12700	12500	12750	12500	12100	12400	11900	
2400	6350	6720	7000	8800	9600	10900	11400	12400	12400	11850	11800	12250	12100	12000	12200	11900	11600	11800	11400	10900

Ⓜ ALL VALUES ARE CALCULATED AT PLUME CENTERLINE

Ⓜ FOR MEASUREMENTS TAKEN OFF-CENTERLINE, INTERPOLATE BETWEEN THE CENTERLINE AND THE EDGE OF THE PLUME. ASSUME VALUE AT PLUME EDGE EQUALS 1% OF CENTERLINE

Ⓜ READINGS THAT ARE NOT DETECTABLE ABOVE BACKGROUND ARE REPRESENTED BY *

Ⓜ ALL VALUES ARE NET COUNTS

Section IV B.5
BUREAU OF NUCLEAR ENGINEERING
Silver Zeolite DATA IN cpm

DOWNWIND DISTANCE (MILES)

TIME	SB	1	1.5	2	2.5	3	3.5	4	4.5	5	5.5	6	6.5	7	7.5	8	8.5	9	9.5	10
1930	90																			
1940	90																			
1950	90	95																		
2000	90	95	95																	
2010	85	95	95																	
2020	85	95	95	110																
2030	80	90	90	110	115															
2040	75	90	90	105	115															
2050	75	85	85	100	110	120														
2100	70	80	80	95	105	120	120													
2110	65	75	75	90	100	115	120	125												
2120	65	75	75	90	95	110	115	125												
2130	60	70	70	85	90	105	110	120	115											
2140	60	65	65	80	90	100	105	115	115	105										
2150	55	65	65	75	85	95	100	110	110	105	100									
2200	55	60	60	75	80	90	95	105	105	105	100									
2210	50	60	60	70	75	85	90	100	100	105	95	95								
2220	50	55	55	65	75	80	85	95	95	95	90	95	90							
2230	50	55	55	65	70	75	80	90	90	90	85	90	90	85						
2240	45	50	50	60	65	75	75	85	85	85	80	85	85	85						
2250	45	50	50	60	65	70	75	80	80	80	75	80	80	80	80					
2300	40	50	50	55	60	65	70	75	75	75	75	75	75	75	80	75				
2310	40	45	45	55	60	65	65	75	75	75	70	75	75	75	75	75	70			
2320	40	45	45	50	55	60	65	70	70	70	65	70	65	70	75	70	70			
2330	35	40	40	50	55	60	60	65	65	65	65	65	65	65	70	65	65	65		
2340	35	40	40	50	50	55	60	65	65	65	60	65	60	65	65	65	65	65	60	
2350	35	40	40	45	50	55	55	60	60	60	60	60	60	60	65	60	60	60	60	
2400	30	35	35	45	50	50	55	60	60	60	55	960	55	60	60	60	60	60	60	55

⊗ ALL VALUES ARE CALCULATED AT PLUME CENTERLINE

⊗ FOR MEASUREMENTS TAKEN OFF-CENTERLINE, INTERPOLATE BETWEEN THE CENTERLINE AND THE EDGE OF THE PLUME. ASSUME VALUE AT PLUME EDGE EQUALS 1% OF CENTERLINE

⊗ READINGS THAT ARE NOT DETECTABLE ABOVE BACKGROUND ARE REPRESENTED BY *

⊗ ALL VALUES ARE NET COUNTS

Section IV B.6a
Environmental Sample Data

(Clock Time= 16:00)

Field Monitor Point	Closed Window Ground Level (mR/hr)	Open Window Ground Level (mR/hr)	Closed Window One Meter Level (mR/hr)	Open Window One Meter Level (mR/hr)	Cartridge Reading (net cpm)	Filter Reading (net cpm)	Change In SRD (mR/min)
ALL	0	0	0	0	0	0	0

*For Controller/Observer Use Only
(Not to be Provided to Players):

Section IV B.6a
Environmental Sample Data

(Clock Time= 19:20)

Field Monitor Point	Closed Window Ground Level (mR/hr)	Open Window Ground Level (mR/hr)	Closed Window One Meter Level (mR/hr)	Open Window One Meter Level (mR/hr)	Cartridge Reading (net cpm)	Filter Reading (net cpm)	Change In SRD (mR/min)
ALL	0	0	0	0	0	0	0

*For Controller/Observer Use Only
(Not to be Provided to Players):

OCNGS
ANNUAL EXERCISE

SCENARIO 42
REV NO 0

Section IV B.6b
Environmental Sample Data

(Clock Time= 19:30)

Field Monitor Point	Closed Window Ground Level (mR/hr)	Open Window Ground Level (mR/hr)	Closed Window One Meter Level (mR/hr)	Open Window One Meter Level (mR/hr)	Cartridge Reading (net cpm)	Filter Reading (net cpm)	Change In SRD (mR/min)
WSW1	310	1200	310	1200	90	17800	5
OTHERS	0	0	0	0	0	0	0

*For Controller/Observer Use Only
(Not to be Provided to Players):

Section IV B.6b
Environmental Sample Data

(Clock Time= 19:40)

Field Monitor Point	Closed Window Ground Level (mR/hr)	Open Window Ground Level (mR/hr)	Closed Window One Meter Level (mR/hr)	Open Window One Meter Level (mR/hr)	Cartridge Reading (net cpm)	Filter Reading (net cpm)	Change In SRD (mR/min)
WSW1	310	1200	310	1200	90	17800	5
OTHERS	0	0	0	0	0	0	0

*For Controller/Observer Use Only
(Not to be Provided to Players):

Section IV B.6b
Environmental Sample Data

(Clock Time= 19:50)

Field Monitor Point	Closed Window Ground Level (mR/hr)	Open Window Ground Level (mR/hr)	Closed Window One Meter Level (mR/hr)	Open Window One Meter Level (mR/hr)	Cartridge Reading (net cpm)	Filter Reading (net cpm)	Change In SRD (mR/min)
WSW1	310	1200	310	1200	90	17800	5
OTHERS	0	0	0	0	0	0	0

*For Controller/Observer Use Only
(Not to be Provided to Players):

Section IV B.6b
Environmental Sample Data

(Clock Time= 20:00)

Field Monitor Point	Closed Window Ground Level (mR/hr)	Open Window Ground Level (mR/hr)	Closed Window One Meter Level (mR/hr)	Open Window One Meter Level (mR/hr)	Cartridge Reading (net cpm)	Filter Reading (net cpm)	Change In SRD (mR/min)
WSW1	310	1200	310	1200	90	17800	5
OTHERS	0	0	0	0	0	0	0

*For Controller/Observer Use Only
(Not to be Provided to Players):

Section IV B.6b
Environmental Sample Data

(Clock Time= 20:10)

Field Monitor Point	Closed Window Ground Level (mR/hr)	Open Window Ground Level (mR/hr)	Closed Window One Meter Level (mR/hr)	Open Window One Meter Level (mR/hr)	Cartridge Reading (net cpm)	Filter Reading (net cpm)	Change In SRD (mR/min)
WSW1	300	1150	300	1150	85	17050	5
OTHERS	0	0	0	0	0	0	0

*For Controller/Observer Use Only
(Not to be Provided to Players):

Section IV B.6b
Environmental Sample Data

(Clock Time= 20:20)

Field Monitor Point	Closed Window Ground Level (mR/hr)	Open Window Ground Level (mR/hr)	Closed Window One Meter Level (mR/hr)	Open Window One Meter Level (mR/hr)	Cartridge Reading (net cpm)	Filter Reading (net cpm)	Change In SRD (mR/min)
SW2	175	630	175	630	55	10300	3
WSW1	285	1100	285	1100	80	16340	5
OTHERS	0	0	0	0	0	0	0

*For Controller/Observer Use Only
(Not to be Provided to Players):

Section IV B.6b
Environmental Sample Data

(Clock Time= 20:30)

Field Monitor Point	Closed Window Ground Level (mR/hr)	Open Window Ground Level (mR/hr)	Closed Window One Meter Level (mR/hr)	Open Window One Meter Level (mR/hr)	Cartridge Reading (net cpm)	Filter Reading (net cpm)	Change In SRD (mR/min)
SW2	170	605	170	605	50	9870	3
WSW1	275	1055	275	1055	80	15660	4
WSW3	0	1	0	1	0	23	0
OTHERS	0	0	0	0	0	0	0

*For Controller/Observer Use Only
(Not to be Provided to Players):

Section IV B.6b
Environmental Sample Data

(Clock Time= 20:40)

Field Monitor Point	Closed Window Ground Level (mR/hr)	Open Window Ground Level (mR/hr)	Closed Window One Meter Level (mR/hr)	Open Window One Meter Level (mR/hr)	Cartridge Reading (net cpm)	Filter Reading (net cpm)	Change In SRD (mR/min)
SW2	160	580	160	580	50	9450	3
WSW1	265	1010	265	1010	75	15000	4
WSW3	0	1	0	1	0	25	0
OTHERS	0	0	0	0	0	0	0

*For Controller/Observer Use Only
(Not to be Provided to Players):

Section IV B.6b
Environmental Sample Data

(Clock Time= 20:50)

Field Monitor Point	Closed Window Ground Level (mR/hr)	Open Window Ground Level (mR/hr)	Closed Window One Meter Level (mR/hr)	Open Window One Meter Level (mR/hr)	Cartridge Reading (net cpm)	Filter Reading (net cpm)	Change In SRD (mR/min)
SW2	155	555	155	555	50	9050	3
WSW1	250	970	250	970	70	14400	4
WSW3	0	1	0	1	0	20	0
OTHERS	0	0	0	0	0	0	0

*For Controller/Observer Use Only
(Not to be Provided to Players):

Section IV B.6b
Environmental Sample Data

(Clock Time= 21:00)

Field Monitor Point	Closed Window Ground Level (mR/hr)	Open Window Ground Level (mR/hr)	Closed Window One Meter Level (mR/hr)	Open Window One Meter Level (mR/hr)	Cartridge Reading (net cpm)	Filter Reading (net cpm)	Change In SRD (mR/min)
SW2	150	530	150	530	45	8675	2
SW4	3	15	3	15	1	185	0
WSW1	240	930	240	930	70	13780	4
WSW3	0	1	0	1	0	20	0
OTHERS	0	0	0	0	0	0	0

*For Controller/Observer Use Only
(Not to be Provided to Players):

Section IV B.6b
Environmental Sample Data

(Clock Time= 21:10)

Field Monitor Point	Closed Window Ground Level (mR/hr)	Open Window Ground Level (mR/hr)	Closed Window One Meter Level (mR/hr)	Open Window One Meter Level (mR/hr)	Cartridge Reading (net cpm)	Filter Reading (net cpm)	Change In SRD (mR/min)
SW2	145	505	145	505	45	8310	3
SW4	3	3	3	15	1	175	0
WSW1	230	890	230	890	65	13200	4
WSW3	0	1	0	1	0	20	0
OTHERS	0	0	0	0	0	0	0

*For Controller/Observer Use Only
(Not to be Provided to Players):

Section IV B.6b
Environmental Sample Data

(Clock Time= 21:20)

Field Monitor Point	Closed Window Ground Level (mR/hr)	Open Window Ground Level (mR/hr)	Closed Window One Meter Level (mR/hr)	Open Window One Meter Level (mR/hr)	Cartridge Reading (net cpm)	Filter Reading (net cpm)	Change In SRD (mR/min)
SW2	140	485	140	485	40	7960	2
SW4	3	15	3	15	1	170	0
WSW1	220	855	220	855	65	12650	4
WSW3	0	1	0	1	0	20	0
OTHERS	0	0	0	0	0	0	0

*For Controller/Observer Use Only
(Not to be Provided to Players):

Section IV B.6b
Environmental Sample Data

(Clock Time= 21:30)

Field Monitor Point	Closed Window Ground Level (mR/hr)	Open Window Ground Level (mR/hr)	Closed Window One Meter Level (mR/hr)	Open Window One Meter Level (mR/hr)	Cartridge Reading (net cpm)	Filter Reading (net cpm)	Change In SRD (mR/min)
SW2	130	465	130	465	40	7630	2
SW4	3	15	3	15	1	160	0
SW5	2	10	2	10	1	115	0
WSW1	210	820	210	820	60	12115	4
WSW3	0	1	0	1	0	10	0
OTHERS	0	0	0	0	0	0	0

*For Controller/Observer Use Only
(Not to be Provided to Players):

Section IV B.6b
Environmental Sample Data

(Clock Time= 21:40)

Field Monitor Point	Closed Window Ground Level (mR/hr)	Open Window Ground Level (mR/hr)	Closed Window One Meter Level (mR/hr)	Open Window One Meter Level (mR/hr)	Cartridge Reading (net cpm)	Filter Reading (net cpm)	Change In SRD (mR/min)
SW2	125	445	125	445	40	7300	2
SW4	3	15	3	15	1	155	0
SW5	2	10	2	10	1	110	0
WSW1	200	785	200	785	60	11605	4
WSW3	0	1	0	1	0	15	0
OTHERS	0	0	0	0	0	0	0

*For Controller/Observer Use Only
(Not to be Provided to Players):

Section IV B.6b
Environmental Sample Data

(Clock Time= 21:50)

Field Monitor Point	Closed Window Ground Level (mR/hr)	Open Window Ground Level (mR/hr)	Closed Window One Meter Level (mR/hr)	Open Window One Meter Level (mR/hr)	Cartridge Reading (net cpm)	Filter Reading (net cpm)	Change In SRD (mR/min)
SW2	120	425	120	425	35	7000	2
SW4	2	10	2	10	1	150	0
SW5	2	10	2	10	1	105	0
WSW1	195	750	195	750	55	11200	3
WSW3	0	1	0	1	0	15	0
OTHERS	0	0	0	0	0	0	0

*For Controller/Observer Use Only
(Not to be Provided to Players):

Section IV B.6b
Environmental Sample Data

(Clock Time= 22:00)

Field Monitor Point	Closed Window Ground Level (mR/hr)	Open Window Ground Level (mR/hr)	Closed Window One Meter Level (mR/hr)	Open Window One Meter Level (mR/hr)	Cartridge Reading (net cpm)	Filter Reading (net cpm)	Change In SRD (mR/min)
SW2	115	410	115	410	35	6770	2
SW4	2	10	2	10	1	145	0
SW5	1	10	1	10	1	100	0
WSW1	185	720	185	720	55	10650	3
WSW3	0	1	0	1	0	15	0
OTHERS	0	0	0	0	0	0	0

*For Controller/Observer Use Only
(Not to be Provided to Players):

Section IV B.6b
Environmental Sample Data

(Clock Time= 22:10)

Field Monitor Point	Closed Window Ground Level (mR/hr)	Open Window Ground Level (mR/hr)	Closed Window One Meter Level (mR/hr)	Open Window One Meter Level (mR/hr)	Cartridge Reading (net cpm)	Filter Reading (net cpm)	Change In SRD (mR/min)
SW2	110	390	110	390	35	6425	2
SW4	2	10	2	10	1	135	0
SW5	2	10	2	10	1	95	0
WSW1	180	690	180	690	50	10205	5
WSW3	0	1	0	1	0	15	0
OTHERS	0	0	0	0	0	0	0

*For Controller/Observer Use Only
(Not to be Provided to Players):

Section IV B.6b
Environmental Sample Data

(Clock Time= 22:20)

Field Monitor Point	Closed Window Ground Level (mR/hr)	Open Window Ground Level (mR/hr)	Closed Window One Meter Level (mR/hr)	Open Window One Meter Level (mR/hr)	Cartridge Reading (net cpm)	Filter Reading (net cpm)	Change In SRD (mR/min)
SW2	105	375	105	375	30	6150	2
SW4	2	10	2	10	1	130	0
SW5	2	10	2	10	1	90	0
WSW1	170	660	170	660	50	9775	5
WSW3	0	1	0	1	0	15	0
OTHERS	0	0	0	0	0	0	0

*For Controller/Observer Use Only
(Not to be Provided to Players):

Section IV B.6b
Environmental Sample Data

(Clock Time= 22:30)

Field Monitor Point	Closed Window Ground Level (mR/hr)	Open Window Ground Level (mR/hr)	Closed Window One Meter Level (mR/hr)	Open Window One Meter Level (mR/hr)	Cartridge Reading (net cpm)	Filter Reading (net cpm)	Change In SRD (mR/min)
SW2	100	360	100	360	30	5900	2
SW4	2	10	2	10	1	125	0
SW5	2	10	2	10	1	90	0
SW7	210	875	210	875	60	12600	4
WSW1	165	630	165	635	50	9365	3
WSW3	0	1	0	1	0	15	0
OTHERS	0	0	0	0	0	0	0

*For Controller/Observer Use Only
(Not to be Provided to Players):

Section IV B.6b
Environmental Sample Data

(Clock Time= 22:40)

Field Monitor Point	Closed Window Ground Level (mR/hr)	Open Window Ground Level (mR/hr)	Closed Window One Meter Level (mR/hr)	Open Window One Meter Level (mR/hr)	Cartridge Reading (net cpm)	Filter Reading (net cpm)	Change In SRD (mR/min)
SW2	95	345	95	345	30	5650	2
SW4	2	10	2	10	1	120	0
SW5	2	5	2	5	1	85	0
SW7	200	840	200	840	60	12070	4
WSW1	155	605	155	605	45	8970	3
WSW3	0	1	0	1	0	15	0
OTHERS	0	0	0	0	0	0	0

*For Controller/Observer Use Only
(Not to be Provided to Players):

Section IV B.6b
Environmental Sample Data

(Clock Time= 22:50)

Field Monitor Point	Closed Window Ground Level (mR/hr)	Open Window Ground Level (mR/hr)	Closed Window One Meter Level (mR/hr)	Open Window One Meter Level (mR/hr)	Cartridge Reading (net cpm)	Filter Reading (net cpm)	Change In SRD (mR/min)
SW2	95	330	95	330	30	5410	2
SW4	2	10	2	10	1	115	0
SW5	2	5	2	5	1	80	0
SW7	190	805	190	805	55	11565	4
WSW1	150	580	150	580	45	8595	3
WSW3	0	1	0	1	0	10	0
OTHERS	0	0	0	0	0	0	0

*For Controller/Observer Use Only
(Not to be Provided to Players):

Section IV B.6b
Environmental Sample Data

(Clock Time= 23:00)

Field Monitor Point	Closed Window Ground Level (mR/hr)	Open Window Ground Level (mR/hr)	Closed Window One Meter Level (mR/hr)	Open Window One Meter Level (mR/hr)	Cartridge Reading (net cpm)	Filter Reading (net cpm)	Change In SRD (mR/min)
SW2	90	315	90	315	25	5185	2
SW4	2	10	2	10	0	110	0
SW5	2	5	2	5	0	70	0
SW7	180	770	180	770	55	11080	2
WSW1	145	555	145	555	40	8235	2
WSW3	0	1	0	1	0	10	0
OTHERS	0	0	0	0	0	0	0

*For Controller/Observer Use Only
(Not to be Provided to Players):

Section IV B.6b
Environmental Sample Data

(Clock Time= 24:00)

Field Monitor Point	Closed Window Ground Level (mR/hr)	Open Window Ground Level (mR/hr)	Closed Window One Meter Level (mR/hr)	Open Window One Meter Level (mR/hr)	Cartridge Reading (net cpm)	Filter Reading (net cpm)	Change In SRD (mR/min)
SW2	70	70	245	70	20	4015	1
SW4	2	2	4	2	0	85	0
SW5	2	2	5	2	0	60	0
SW7	185	140	595	140	45	8575	2
WSW1	145	110	430	110	30	6375	2
WSW3	0	1	2	0	0	7	0
OTHERS	0	0	0	0	0	0	0

*For Controller/Observer Use Only
(Not to be Provided to Players):

Section IV B.6b
Environmental Sample Data

(Clock Time= 01:00)

Field Monitor Point	Closed Window Ground Level (mR/hr)	Open Window Ground Level (mR/hr)	Closed Window One Meter Level (mR/hr)	Open Window One Meter Level (mR/hr)	Cartridge Reading (net cpm)	Filter Reading (net cpm)	Change In SRD (mR/min)
SW2	55	190	55	190	15	3105	1
SW4	2	3	0	3	0	65	0
SW5	2	5	0	5	0	45	0
SW7	110	460	110	460	30	6640	2
WSW1	85	330	85	330	25	4935	1
WSW3	0	1	0	0	0	6	0
OTHERS	0	0	0	0	0	0	0

*For Controller/Observer Use Only
(Not to be Provided to Players):

Section IV B.6b
Environmental Sample Data

(Clock Time= 02:00)

Field Monitor Point	Closed Window Ground Level (mR/hr)	Open Window Ground Level (mR/hr)	Closed Window One Meter Level (mR/hr)	Open Window One Meter Level (mR/hr)	Cartridge Reading (net cpm)	Filter Reading (net cpm)	Change In SRD (mR/min)
SW2	40	145	40	145	10	2400	1
SW4	2	2	0	2	0	50	0
SW5	1	5	0	5	0	35	0
SW7	85	360	85	360	25	5140	1
WSW1	65	260	65	260	20	3820	1
WSW3	0	0	0	0	0	4	0
OTHERS	0	0	0	0	0	0	0

*For Controller/Observer Use Only
(Not to be Provided to Players):

Section IV B.6b
Environmental Sample Data

(Clock Time= 03:00)

Field Monitor Point	Closed Window Ground Level (mR/hr)	Open Window Ground Level (mR/hr)	Closed Window One Meter Level (mR/hr)	Open Window One Meter Level (mR/hr)	Cartridge Reading (net cpm)	Filter Reading (net cpm)	Change In SRD (mR/min)
SW2	30	115	30	115	9	1860	0
SW4	2	2	0	2	0	40	0
SW5	1	5	0	5	0	25	0
SW7	65	275	65	275	20	3975	1
WSW1	50	200	50	200	15	2955	1
WSW3	0	1	0	0	0	3	0
OTHERS	0	0	0	0	0	0	0

*For Controller/Observer Use Only
(Not to be Provided to Players):

Section IV B.6b
Environmental Sample Data

(Clock Time= 04:00)

Field Monitor Point	Closed Window Ground Level (mR/hr)	Open Window Ground Level (mR/hr)	Closed Window One Meter Level (mR/hr)	Open Window One Meter Level (mR/hr)	Cartridge Reading (net cpm)	Filter Reading (net cpm)	Change In SRD (mR/min)
SW2	25	90	25	90	7	1440	0
SW4	2	2	0	2	0	30	0
SW5	0	5	0	5	0	20	0
SW7	50	215	55	215	15	3080	1
WSW1	40	155	40	155	10	2290	1
WSW3	0	1	0	0	0	3	0
OTHERS	0	0	0	0	0	0	0

*For Controller/Observer Use Only
(Not to be Provided to Players):

Section IV B.6b
Environmental Sample Data

(Clock Time= 05:00)

Field Monitor Point	Closed Window Ground Level (mR/hr)	Open Window Ground Level (mR/hr)	Closed Window One Meter Level (mR/hr)	Open Window One Meter Level (mR/hr)	Cartridge Reading (net cpm)	Filter Reading (net cpm)	Change In SRD (mR/min)
SW2	20	70	20	70	5	115	0
SW4	2	3	0	1	0	25	0
SW5	0	1	0	5	0	15	0
SW7	40	165	40	165	10	2380	1
WSW1	30	120	30	120	9	1770	2
WSW3	0	0	0	0	0	2	0
OTHERS	0	0	0	0	0	0	0

*For Controller/Observer Use Only
(Not to be Provided to Players):

Section IV B.6b
Environmental Sample Data

(Clock Time= 06:00)

Field Monitor Point	Closed Window Ground Level (mR/hr)	Open Window Ground Level (mR/hr)	Closed Window One Meter Level (mR/hr)	Open Window One Meter Level (mR/hr)	Cartridge Reading (net cpm)	Filter Reading (net cpm)	Change In SRD (mR/min)
SW2	15	55	15	55	4	860	0
SW4	2	3	0	0	0	20	0
SW5	0	1	0	5	0	15	0
SW7	30	130	30	130	9	1845	0
WSW1	25	90	25	90	7	1370	0
WSW3	0	0	0	0	0	2	0
OTHERS	0	0	0	0	0	0	0

*For Controller/Observer Use Only
(Not to be Provided to Players):

Section IV B.6b
Environmental Sample Data

(Clock Time= 07:00)

Field Monitor Point	Closed Window Ground Level (mR/hr)	Open Window Ground Level (mR/hr)	Closed Window One Meter Level (mR/hr)	Open Window One Meter Level (mR/hr)	Cartridge Reading (net cpm)	Filter Reading (net cpm)	Change In SRD (mR/min)
SW2	10	40	10	40	3	670	0
SW4	2	3	0	0	0	15	0
SW5	0	1	0	0	0	10	0
SW7	25	100	25	100	7	1425	0
WSW1	20	70	20	75	5	1060	0
WSW3	0	0	0	0	0	1	0
OTHERS	0	0	0	0	0	0	0

*For Controller/Observer Use Only
(Not to be Provided to Players):

Section IV B.6b
Environmental Sample Data

(Clock Time= 08:00)

Field Monitor Point	Closed Window Ground Level (mR/hr)	Open Window Ground Level (mR/hr)	Closed Window One Meter Level (mR/hr)	Open Window One Meter Level (mR/hr)	Cartridge Reading (net cpm)	Filter Reading (net cpm)	Change In SRD (mR/min)
SW2	10	30	10	30	2	515	0
SW4	2	3	0	0	0	10	0
SW5	0	1	0	1	0	7	0
SW7	20	75	20	75	5	1100	0
WSW1	15	55	15	55	4	820	0
WSW3	0	0	0	0	0	1	0
OTHERS	0	0	0	0	0	0	0

*For Controller/Observer Use Only
(Not to be Provided to Players):

Section IV B.6b
Environmental Sample Data

(Clock Time= 09:00)

Field Monitor Point	Closed Window Ground Level (mR/hr)	Open Window Ground Level (mR/hr)	Closed Window One Meter Level (mR/hr)	Open Window One Meter Level (mR/hr)	Cartridge Reading (net cpm)	Filter Reading (net cpm)	Change In SRD (mR/min)
SW2	5	25	5	25	2	400	0
SW4	2	3	0	0	0	8	0
SW5	0	1	0	1	0	6	0
SW7	15	770	15	60	4	855	0
WSW1	10	555	10	45	3	635	0
WSW3	0	0	0	0	0	1	0
OTHERS	0	0	0	0	0	0	0

*For Controller/Observer Use Only
(Not to be Provided to Players):

Section IV B.6b
Environmental Sample Data

(Clock Time= 10:00)

Field Monitor Point	Closed Window Ground Level (mR/hr)	Open Window Ground Level (mR/hr)	Closed Window One Meter Level (mR/hr)	Open Window One Meter Level (mR/hr)	Cartridge Reading (net cpm)	Filter Reading (net cpm)	Change In SRD (mR/min)
SW2	5	20	5	20	1	310	0
SW4	2	3	0	0	0	7	0
SW5	0	1	0	1	0	5	0
SW7	10	45	10	45	3	660	0
WSW1	8	35	8	35	2	490	0
WSW3	0	1	0	0	0	1	0
OTHERS	0	0	0	0	0	0	0

*For Controller/Observer Use Only
(Not to be Provided to Players):

Section IV B.6b
Environmental Sample Data

(Clock Time= 11:00)

Field Monitor Point	Closed Window Ground Level (mR/hr)	Open Window Ground Level (mR/hr)	Closed Window One Meter Level (mR/hr)	Open Window One Meter Level (mR/hr)	Cartridge Reading (net cpm)	Filter Reading (net cpm)	Change In SRD (mR/min)
SW2	5	15	5	15	1	240	0
SW4	2	3	0	0	0	5	0
SW5	0	1	0	1	0	4	0
SW7	8	35	8	35	3	510	0
WSW1	7	25	7	25	2	380	0
WSW3	0	1	0	0	0	0	0
OTHERS	0	0	0	0	0	0	0

*For Controller/Observer Use Only
(Not to be Provided to Players):

Section IV B.6b
Environmental Sample Data

(Clock Time= 12:00)

Field Monitor Point	Closed Window Ground Level (mR/hr)	Open Window Ground Level (mR/hr)	Closed Window One Meter Level (mR/hr)	Open Window One Meter Level (mR/hr)	Cartridge Reading (net cpm)	Filter Reading (net cpm)	Change In SRD (mR/min)
SW2	5	10	5	15	1	185	0
SW4	2	3	0	0	0	4	0
SW5	0	1	0	1	0	3	0
SW7	6	30	6	30	2	400	0
WSW1	5	25	5	20	1	295	0
WSW3	0	0	0	0	0	0	0
OTHERS	0	0	0	0	0	0	0

*For Controller/Observer Use Only
(Not to be Provided to Players):

SECTION IV.C. METEOROLOGICAL DATA

SECTION IV C
METEOROLOGICAL DATA

Met data file for Drill Version of RAC Program
1995 ANNUAL EXERCISE NOVEMBER 01, 1995
Note: A blank data range is interpreted as "MISSING"

Date Time					Wind Speed			Wind Direction			Delta T	
*YY	MM	DD	HH	mm	033Ft	150Ft	380Ft	033Ft	150Ft	380Ft	150-33Ft	380-33Ft
95	11	01	00	01	4.7	4.9	5.3	166	167	168	-1.00	-3.0
95	11	01	16	00	4.8	5.0	5.4	146	148	150	-1.05	-3.0
95	11	01	16	15	4.7	5.0	5.4	136	139	142	-1.02	-2.9
95	11	01	16	30	4.7	5.0	5.5	136	137	138	-1.00	-3.1
95	11	01	16	45	4.9	5.1	5.6	137	136	139	-1.05	-3.0
95	11	01	17	00	5.5	5.7	6.2	135	137	139	-1.10	-3.5
95	11	01	17	15	6.1	6.3	6.8	126	129	132	-1.10	-3.4
95	11	01	17	30	6.7	6.9	7.4	135	136	134	-1.20	-3.5
95	11	01	17	45	7.3	7.5	8.0	107	104	102	-1.10	-3.2
95	11	01	18	00	7.0	7.1	7.0	090	091	092	-1.10	-3.2
95	11	01	18	15	6.1	6.3	6.2	085	087	089	-1.00	-2.0
95	11	01	18	30	4.9	5.0	5.5	070	072	072	-0.65	-1.1
95	11	01	18	45	2.2	2.2	2.2	046	047	046	-0.20	-0.5
95	11	01	19	00	2.2	2.2	2.2	045	045	045	-0.30	-0.4
95	11	01	19	15	2.2	2.2	2.2	044	045	045	-0.25	-0.3
95	11	01	19	30	2.2	2.2	2.2	045	045	045	-0.25	-0.4
95	11	01	19	45	2.3	2.3	2.3	044	045	045	-0.24	-0.3
95	11	01	20	00	2.2	2.2	2.2	045	045	045	-0.21	-0.4
95	11	01	20	15	2.1	2.1	2.1	045	045	045	-0.23	-0.5
95	11	01	20	30	2.3	2.3	2.3	045	045	045	-0.21	-0.4
95	11	01	20	45	2.2	2.2	2.2	046	046	046	-0.28	-0.3
95	11	01	21	00	2.2	2.2	2.2	043	046	053	-0.26	-0.4
95	11	01	21	15	2.3	2.3	2.3	046	050	054	-0.22	-0.5
95	11	01	21	30	2.5	2.4	2.5	047	049	051	-0.21	-0.6
95	11	01	21	45	2.5	2.5	2.5	040	042	044	-0.21	-0.7
95	11	01	22	00	2.7	2.7	2.7	048	050	053	-0.20	-0.8
95	11	01	22	15	4.9	5.0	5.5	046	050	054	-0.30	-0.8
95	11	01	22	30	5.7	5.8	6.3	047	049	051	-0.30	-0.9
95	11	01	22	45	6.5	6.6	7.1	040	042	044	-0.61	-1.5
95	11	01	23	00	7.4	7.5	8.0	048	050	053	-0.90	-2.5
95	11	02	00	01	8.6	8.7	9.2	048	046	051	-0.00	-3.1

SECTION IV.D.CREST DATA



STATE OF NEW JERSEY
BUREAU OF NUCLEAR ENGINEERING
CREST LOCATIONS

CREST data file for Drill Version of RAC Program

1995 ANNUAL EXERCISE NOV 01, 1995

* Note: when file is accessed, the current date-time is compared to the met file date-time. When the current date-time is less than or equal to the a file's date-time the file's met data is used. Thus if the drill goes on for days past it's intended end the last value in the file. Conversely if the computer date-time is less than the first date-time in this file then the first set of met data values will be used

* Note: A blank data range is interpreted as "MISSING"

variable start col length

Month	2	2
Day	5	2
Hour	8	2
Minute	11	2
Second	14	2

Date Time	CREST SITES															
MM DD HH mm ss	1	2	3	4	5	6	7	8	9	10	11	12	13	14	15	16
11 01 00 15 15	0.0059	0.0054	0.0056	0.0061	0.0058	0.0052	0.0059	0.0048	0.0045	0.0046	0.0053	0.0055	0.0044	0.0056	0.0048	0.0067
11 01 16 00 15	0.0049	0.0059	0.0051	0.0057	0.0051	0.0057	0.0051	0.0058	0.0048	0.0056	0.0048	0.0059	0.0054	0.0051	0.0054	0.0061
11 01 16 15 15	0.0050	0.0051	0.0052	0.0051	0.0052	0.0055	0.0056	0.0052	0.0057	0.0049	0.0048	0.0054	0.0046	0.0051	0.0055	0.0058
11 01 16 30 15	0.0051	0.0049	0.0056	0.0053	0.0051	0.0051	0.0056	0.0052	0.0051	0.0059	0.0053	0.0051	0.0056	0.0047	0.0045	0.0058
11 01 16 45 15	0.0053	0.0052	0.0051	0.0055	0.0054	0.0053	0.0051	0.0050	0.0052	0.0051	0.0052	0.0055	0.0051	0.0052	0.0057	0.0049
11 01 17 00 15	0.0055	0.0054	0.0053	0.0052	0.0052	0.0052	0.0056	0.0052	0.0057	0.0049	0.0049	0.0054	0.0046	0.0051	0.0055	0.0058
11 01 17 30 15	0.0054	0.0053	0.0052	0.0054	0.0051	0.0056	0.0052	0.0051	0.0053	0.0050	0.0058	0.0051	0.0048	0.0052	0.0053	0.0052
11 01 18 00 15	0.0056	0.0052	0.0051	0.0052	0.0049	0.0051	0.0053	0.0053	0.0052	0.0053	0.0053	0.0054	0.0051	0.0054	0.0051	0.0051
11 01 18 15 15	0.0052	0.0050	0.0052	0.0053	0.0050	0.0055	0.0056	0.0057	0.0054	0.0052	0.0055	0.0053	0.0052	0.0055	0.0055	0.0053
11 01 18 30 15	0.0050	0.0051	0.0049	0.0051	0.0053	0.0053	0.0055	0.0062	0.0057	0.0055	0.0051	0.0055	0.0049	0.0052	0.0052	0.0054
11 01 18 45 45	0.0056	0.0059	0.0058	0.0058	0.0059	0.0058	0.0051	0.0052	0.0054	0.0049	0.0056	0.0049	0.0059	0.0062	0.0052	0.0064
11 01 19 00 15	0.0051	0.0050	0.0052	0.0052	0.0052	0.0055	0.0056	0.0062	0.0057	0.0054	0.0059	0.0051	0.0051	0.0054	0.0053	0.0053
11 01 19 10 15	0.0056	0.0053	0.0056	0.0056	0.0053	0.0057	0.0049	0.0058	0.0051	0.0059	0.0052	0.0054	0.0041	0.0047	0.0054	0.0052
11 01 19 12 10	0.0051	0.0050	0.0052	0.0051	0.0051	0.0055	0.0056	0.0052	0.0057	0.0051	0.0058	0.0059	0.0051	0.0051	0.0051	0.0053
11 01 19 12 15	0.0053	0.0059	0.0049	0.0059	0.4052	0.4055	0.2856	0.0057	0.2057	0.0058	0.0052	0.0054	0.0047	0.1854	0.0054	0.4053
11 01 19 13 15	0.0050	0.0048	0.0055	0.0055	0.3925	0.4007	0.2851	0.0054	99.9999	0.0056	0.0054	0.0055	0.0054	0.1855	0.0043	0.4056

11 01 19 15 15	0.0057	0.0045	0.0057	0.0051	0.3955	0.3957	0.2883	0.0051	99.9999	0.0052	0.0051	0.0053	0.0052	0.1845	0.0053	0.4006
11 01 19 20 15	0.0050	0.0043	0.0055	0.0058	0.3955	0.3997	0.2853	0.0054	99.9999	0.0056	0.0054	0.0055	0.0056	0.1855	0.0061	0.3956
11 01 19 30 15	0.0054	0.0049	0.0056	0.0055	0.4155	0.4156	0.2873	0.0058	99.9999	0.0052	0.0056	0.0059	0.0053	0.1885	0.0052	0.3996
11 01 19 45 00	0.0057	0.0045	0.0052	0.0052	0.4155	0.4156	0.2853	0.0052	99.9999	0.0044	0.0051	0.0056	0.0052	0.1805	0.0052	0.4156
11 01 19 45 15	0.0054	0.0047	0.0058	0.0055	0.4055	0.4056	0.2823	0.0059	99.9999	0.0052	0.0053	0.0054	0.0051	0.1755	0.0053	0.4138
11 01 19 57 10	0.0059	0.0045	0.0056	0.0057	0.4055	0.4096	0.2893	0.0054	99.9999	0.0041	0.0056	0.0056	0.0054	0.1825	0.0052	0.4108
11 01 19 57 15	0.0054	0.0041	0.0051	0.0055	0.4055	0.4056	0.2853	0.2054	99.9999	0.0052	0.0057	0.0059	0.0051	0.1755	0.0072	0.3858
11 01 19 58 15	0.0056	0.0043	0.0057	0.0050	0.4056	0.4057	0.2823	99.9999	99.9999	0.0048	0.0052	0.0053	0.0047	0.1650	0.0393	0.3756
11 01 20 00 15	0.0054	0.0048	0.0054	0.0056	0.4056	0.4017	0.2853	99.9999	99.9999	0.0058	0.0042	0.0043	0.0051	0.1710	0.0353	0.3656
11 01 20 03 00	0.0104	0.0043	0.0052	0.0050	0.3956	0.3957	0.2813	99.9999	99.9999	0.0048	0.0052	0.0053	0.0047	0.1550	0.0373	0.3456
11 01 20 03 15	0.0251	0.0050	0.0058	0.0051	0.4052	0.4055	0.2846	99.9999	99.9999	0.0059	0.0041	0.0047	0.0046	0.1451	0.0355	0.3258
11 01 20 15 15	1.9351	0.0057	0.0059	0.0057	0.3952	0.3955	0.2856	99.9999	99.9999	0.0049	0.0048	0.0054	0.0056	0.1351	0.0335	0.3058
11 01 20 18 15	3.8051	0.0050	0.0052	0.0051	0.4052	0.4055	0.2876	99.9999	99.9999	0.0053	0.0048	0.0047	0.0046	0.1311	0.0315	0.2858
11 01 20 30 15	3.7651	0.0053	0.0057	0.0050	0.4053	0.4059	0.2850	99.9999	99.9999	0.0050	0.0043	0.0054	0.0050	0.1249	0.0298	0.2649
11 01 20 45 15	3.5351	0.0057	0.0051	0.0053	0.3953	0.3959	0.2850	99.9999	99.9999	0.0059	0.0053	0.0057	0.0054	0.1148	0.0278	0.2449
11 01 21 00 15	3.3148	0.0050	0.0054	0.0059	0.4058	0.4056	0.2853	99.9999	99.9999	0.0050	0.0046	0.0053	0.0050	0.1054	0.0252	0.2356
11 01 21 15 15	3.1151	0.0053	0.0057	0.0052	0.3853	0.3859	0.2750	99.9999	99.9999	0.0045	0.0053	0.0044	0.0059	0.1048	0.0248	0.2149
11 01 21 30 15	2.9151	0.0048	0.0052	0.0056	0.3654	0.3655	0.2555	99.9999	99.9999	0.0051	0.0051	0.0054	0.0051	0.0946	0.0221	0.2054
11 01 21 45 15	2.7353	0.0049	0.0051	0.0052	0.3356	0.3353	0.2453	99.9999	99.9999	0.0048	0.0053	0.0043	0.0053	0.0948	0.0211	0.1953
11 01 22 00 15	2.5652	0.0053	0.0052	0.0053	0.3152	0.3154	0.2252	99.9999	99.9999	0.0052	0.0041	0.0053	0.0054	0.0951	0.0192	0.1851
11 01 22 15 15	2.4052	0.0059	0.0057	0.0058	0.2952	0.2954	0.2152	99.9999	99.9999	0.0052	0.0047	0.0047	0.0046	0.0851	0.0182	0.1651
11 01 22 29 15	2.2652	0.0053	0.0052	0.0053	0.2852	0.2854	0.1952	99.9999	99.9999	0.0058	0.0047	0.0053	0.0054	0.0851	0.0172	0.1551
11 01 22 30 15	2.1253	0.0049	0.0054	0.0052	0.2656	0.2653	0.1853	99.9999	99.3999	0.0048	0.0053	0.0042	0.0053	0.0748	0.0161	0.1453
11 01 22 30 30	0.0973	0.0043	0.0051	0.0051	0.0126	0.0123	0.0113	6.8267	5.1253	0.0041	0.0047	0.0053	0.0059	0.0048	0.0051	0.0067
11 01 22 45 15	0.0809	0.0049	0.0059	0.0057	0.0102	0.0102	0.0094	5.6734	4.2593	0.0048	0.0053	0.0048	0.0053	0.0048	0.0051	0.0063
11 01 23 00 15	0.0672	0.0046	0.0054	0.0059	0.0086	0.0085	0.0078	4.7149	3.5393	0.0045	0.0045	0.0053	0.0047	0.0048	0.0051	0.0063
11 01 23 15 15	0.0553	0.0049	0.0053	0.0052	0.0076	0.0071	0.0065	3.9188	2.9453	0.0048	0.0053	0.0043	0.0053	0.0048	0.0051	0.0063
11 01 23 30 15	0.0463	0.0045	0.0054	0.0056	0.0058	0.0059	0.0054	3.2558	2.4443	0.0058	0.0043	0.0053	0.0046	0.0048	0.0051	0.0059
11 01 23 45 15	0.0383	0.0049	0.0059	0.0052	0.0057	0.0058	0.0053	2.7058	2.0353	0.0048	0.0053	0.0041	0.0053	0.0048	0.0051	0.0058
11 01 24 00 15	0.0323	0.0044	0.0054	0.0058	0.0056	0.0057	0.0052	2.2498	1.6883	0.0054	0.0049	0.0053	0.0048	0.0048	0.0051	0.0057
11 02 00 15 15	0.0263	0.0049	0.0051	0.0052	0.0055	0.0056	0.0051	1.8598	1.4053	0.0048	0.0053	0.0049	0.0053	0.0048	0.0051	0.0056
11 02 00 30 15	0.0223	0.0047	0.0054	0.0057	0.0054	0.0055	0.0050	1.5558	1.1663	0.0058	0.0045	0.0053	0.0041	0.0048	0.0051	0.0055
11 02 00 45 15	0.0183	0.0049	0.0059	0.0052	0.0056	0.0054	0.0053	1.2958	0.9693	0.0048	0.0053	0.0042	0.0053	0.0048	0.0051	0.0054
11 02 01 00 15	0.0153	0.0043	0.0054	0.0055	0.0054	0.0053	0.0052	1.0758	0.8053	0.0053	0.0048	0.0053	0.0043	0.0048	0.0051	0.0053
11 02 01 15 15	0.0133	0.0049	0.0052	0.0052	0.0052	0.0052	0.0055	0.8958	0.6693	0.0048	0.0053	0.0046	0.0053	0.0048	0.0051	0.0052
11 02 01 30 15	0.0103	0.0046	0.0054	0.0059	0.0051	0.0051	0.0053	0.7458	0.5563	0.0041	0.0044	0.0053	0.0059	0.0048	0.0051	0.0051
11 02 01 45 15	0.0083	0.0049	0.0056	0.0052	0.0058	0.0050	0.0052	0.6158	0.4623	0.0048	0.0053	0.0043	0.0053	0.0048	0.0051	0.0053
11 02 02 00 15	0.0063	0.0043	0.0054	0.0057	0.0053	0.0053	0.0053	0.5118	0.3843	0.0054	0.0043	0.0052	0.0047	0.0048	0.0051	0.0053
11 02 02 15 15	0.0057	0.0049	0.0052	0.0052	0.0056	0.0054	0.0055	0.4258	0.2653	0.0048	0.0053	0.0043	0.0053	0.0048	0.0051	0.0053
11 02 02 30 15	0.0053	0.0046	0.0054	0.0054	0.0052	0.0052	0.0052	0.3538	0.2203	0.0058	0.0049	0.0057	0.0041	0.0048	0.0051	0.0053
11 02 02 45 15	0.0055	0.0049	0.0054	0.0052	0.0054	0.0056	0.0051	0.2938	0.1833	0.0048	0.0053	0.0043	0.0053	0.0048	0.0051	0.0053
11 02 03 00 15	0.0053	0.0042	0.0057	0.0058	0.0057	0.0053	0.0053	0.2448	0.1523	0.0051	0.0046	0.0053	0.0049	0.0048	0.0051	0.0053

SECTION V MESSAGE CARDS

MESSAGE NO.: PL-1	CLOCK TIME: 15:00 +/- 30 min.
FROM: Plant Data Controller	TO: Simulator Control Room
CONTROLLER INFORMATION: Provide initial conditions as presented in Section I.C.1.c. of the Scenario to the Simulator Control Room Staff.	
MESSAGE: <p style="text-align: center;"><u>THIS IS A DRILL</u></p> <p style="text-align: center;"><u>DO NOT</u> initiate actions affecting normal plant operations.</p> <p style="text-align: center;">"See Section I.C.1.c. of the Scenario"</p> <p style="text-align: center;"><u>THIS IS A DRILL</u></p>	

MESSAGE NO.: PD-2	CLOCK TIME: 16:00 or earlier
FROM: Plant Data Controller	TO: Simulator Control Room Operators
CONTROLLER INFORMATION: Have a Control Room Operator transfer PCS control to the Simulator. Verify both "Simulator Communications Interface" switches (one in Control Room and one in Simulator) are in the ON position. Then make the Page Announcement at 16:00.	
MESSAGE: <p style="text-align: center;"><u>THIS IS A DRILL</u></p> <p style="text-align: center;"><u>DO NOT</u> initiate actions affecting normal plant operations.</p> <ol style="list-style-type: none">1. Coordinate with the On-Shift Lead Control Room Operator and transfer PCS control to the Simulator.2. Coordinate with the On-Shift Lead Control Room Operator to transfer both "Simulator Communications Interface" switches to the "ON" position.3. Make the following Page: "Attention All Personnel, Attention All Personnel, the Annual Exercise has commenced, Drill time is now _____." <p style="text-align: center;">"PCS time"</p> <p style="text-align: center;"><u>THIS IS A DRILL</u></p>	

MESSAGE NO.: A-1	CLOCK TIME: 16:08
FROM: Observer	TO: Passerby or Workers
CONTROLLER INFORMATION: A passerby or worker in the area of the Diesel Generator Building notices thick black smoke coming from the building. The person reports a fire to the Control Room. NOTE: If no one is in the area, then the Controller will call the Control Room and report the fire as if he/she were a worker.	
MESSAGE: <p style="text-align: center;"><u>THIS IS A DRILL</u></p> <p style="text-align: center;"><u>DO NOT</u> initiate actions affecting normal plant operations.</p> <p>You see thick black smoke coming from the Diesel Generator Building Fuel Oil Tank Room.</p> <p style="text-align: center;"><u>THIS IS A DRILL</u></p>	

MESSAGE NO.: A-2	CLOCK TIME: 16:20 +/- 10 min.
FROM: Observer	TO: First Fire Brigade member or Brigade Leader
CONTROLLER INFORMATION: This message is to define the condition at the fire scene. Provide the following information only if earned.	
MESSAGE: <p style="text-align: center;"><u>THIS IS A DRILL</u></p> <p style="text-align: center;"><u>DO NOT</u> initiate actions affecting normal plant operations.</p> <p><u>IF</u> observed from a distance: "Thick black smoke is coming from the Diesel Generator Building's Fuel Oil Tank Room."</p> <p><u>IF</u> approached without a fire hose for cooling: "Intense heat and thick smoke prevent you from reaching the alcove outside the DG Fuel Oil Tank Room's door."</p> <p><u>IF</u> approached with a fire hose for cooling: "The thick black smoke is difficult to see through, but it appears that there is intense flames surrounding the tank. Intense heat prevents entering the alcove outside the DG Fuel Oil Tank Room's door."</p> <p style="text-align: center;"><u>THIS IS A DRILL</u></p>	

MESSAGE NO.: A-3	CLOCK TIME: 16:25 +/- 10 min.
FROM: Observer	TO: Fire Brigade Leader
CONTROLLER INFORMATION: This message is intended to get the Fire Brigade Leader to call for off-site assistance if not already done.	
MESSAGE: <p style="text-align: center;"><u>THIS IS A DRILL</u></p> <p style="text-align: center;"><u>DO NOT</u> initiate actions affecting normal plant operations.</p> <p>"The heat from the DG FO Tank Room doorway is too intense to approach even with a fire hose in the cooling mode. Flames have penetrated the room's roof."</p> <p style="text-align: center;"><u>THIS IS A DRILL</u></p>	

MESSAGE NO.: A-4	CLOCK TIME: 17:15 or before
FROM: Observer	TO: Fire Brigade Leader
CONTROLLER INFORMATION: This message is to provide the information necessary to conclude the fire mini-scenario in an orderly manner.	
MESSAGE: <p style="text-align: center;"><u>THIS IS A DRILL</u></p> <p style="text-align: center;"><u>DO NOT</u> initiate actions affecting normal plant operations.</p> <p>Once the Forked River Fire Department has commenced fire fighting support, such that it would impact the fire's intensity, inform the Fire Brigade Leader:</p> <p>"The fire is out."</p> <p>Once the Fire Brigade Leader has established the proper controls for the post-fire condition, inform the participants:</p> <p>"This mini-scenario has concluded, return to your appropriate stations."</p> <p style="text-align: center;"><u>THIS IS A DRILL</u></p>	

MESSAGE NO.: E-1	CLOCK TIME: 17:45 or later
FROM: OSC Observer	TO: Repair Team
CONTROLLER INFORMATION: Offer information to CRD Pump "B" Repair Team when they arrive at 480V Switchgear Room.	
MESSAGE: <p style="text-align: center;"><u>THIS IS A DRILL</u></p> <p style="text-align: center;"><u>DO NOT</u> initiate actions affecting normal plant operations.</p> <p><u>IF</u> Team asks about breaker status.</p> <p><u>THEN</u> Refer to note below.</p> <p style="text-align: center;"><u>NOTE:</u></p> <p>There will be a mock-up of a MVT located by CRD Pump "B" Breaker. Team should demonstrate and utilize this for drill purposes.</p> <p><u>IF</u> Team asks about "A" Breaker.</p> <p><u>THEN</u> Tell them it just needs to be trip checked and could be utilized.</p> <p><u>IF</u> Team meggers and bridge checks motor,</p> <p><u>THEN</u> Tell them the following: meggar = \geq 100 megohms bridge = \leq .06 ohms A-B, B-C, A-C</p> <p style="text-align: center;"><u>THIS IS A DRILL</u></p>	

MESSAGE NO.: E-2	CLOCK TIME: 17:45 or later
FROM: OSC Observer	TO: Repair Team
CONTROLLER INFORMATION: CRD Pump "B" Breaker cannot be repaired or returned to service until 19:10 hours. If repairs are moving too quickly, use the following to maintain the timeline:	
MESSAGE: <p style="text-align: center;"><u>THIS IS A DRILL</u></p> <p style="text-align: center;"><u>DO NOT</u> initiate actions affecting normal plant operations.</p> Repair team goes to Warehouse to obtain MVT unit. New units have just arrived and must be "receipt inspected" prior to use. Observer can control how long or short it takes to meet time line. <p style="text-align: center;"><u>THIS IS A DRILL</u></p>	

MESSAGE NO.: H-1	CLOCK TIME: 18:00 +/- 15 min.
FROM: Observer	TO: OSC Team
CONTROLLER INFORMATION: Provide this information only when the team arrives at the area indicated such that the problem could be seen.	
MESSAGE: <p style="text-align: center;"><u>THIS IS A DRILL</u></p> <p style="text-align: center;"><u>DO NOT</u> initiate actions affecting normal plant operations.</p> <p>IF the team investigating the Liquid Poison System arrives at the pumps on the 95' elevation of the Reactor Building,</p> <p>THEN supply the following information:</p> <p>"Liquid poison is spraying out of the pumps discharge pipe between the squib valve and the Drywell. There is a large pool of poison inside the moat."</p> <p>IF the team investigates the problem by going to the 75' elevation of the Reactor Building in the area of the Poison Collection drum,</p> <p>THEN provide the following information:</p> <p>"The Liquid Poison is overflowing the drum and running into the nearest floor drain."</p> <p style="text-align: center;"><u>THIS IS A DRILL</u></p>	

MESSAGE NO.: G-1	CLOCK TIME: 18:30 or Later
FROM: FMT Observer	TO: FMT Member
CONTROLLER INFORMATION: Provide these directions at a time when the FMT is not performing specific tasks directed by the EACC, if the FMT collects environmental samples (soil & vegetation) in accordance with EPIP-OC-.11, Exh. 8 and 9. <u>NOTE:</u> <u>Sample collection does not take precedence over direction from the RAC or EACC.</u>	
MESSAGE: <u>THIS IS A DRILL</u> <u>DO NOT</u> initiate actions affecting normal plant operations. Conduct sample collection in accordance with EPIP-OC-.11, Exh. 8 and 9, for a minimum of one sample each. <u>THIS IS A DRILL</u>	

MESSAGE NO.: K-1	CLOCK TIME: 19:05 +/- 5 min.
FROM: Observer	TO: OSC Team
CONTROLLER INFORMATION: A copy of Support Procedure 21 and a CRD System flow diagram is included with the mini-scenario for the Observer's use <u>only</u> . The task <u>cannot</u> be completed prior to 19:00.	
MESSAGE: <p style="text-align: center;"><u>THIS IS A DRILL</u></p> <p style="text-align: center;"><u>DO NOT</u> initiate actions affecting normal plant operations.</p> <p>When the OSC team attempts to close the cooling water PCV isolation valve v-15-24, inform the team that: "V-15-24 turns but only with great exertion." Then after 4 or 5 minutes or effort, inform them that: "V-15-24 is closed."</p> <p>When the OSC team attempts to close the Exhaust Header root valve V-15-25, inform the team that: "The handwheel for V-15-25 is missing."</p> <p>When the OSC team attempts to close the Stabilizer Unit outlet valve V-15-40, inform the team that: "V-15-40 does not move." If excessive force is applied to the valve, then inform the team that: "The valve stem for V-15-40 has broken off just below the valve handwheel."</p> <p style="text-align: center;"><u>NOTE</u></p> <p>This should cause them to isolate this path by closing valves V-15-39 and V-15-37.</p> <p>When the OSC team attempts to open the drain valve V-15-74, inform the team that: "The handwheel turns with little or not resistance."</p> <p style="text-align: center;"><u>NOTE</u></p> <p>This is meant to simulate that the stem and disk have separated and, although the stem is moving the valve, disk remains on the closed seats.</p> <p>If the OSC team asks about conditions that would indicate flow in the drain line, inform the OSC team of a negative response such as: "There is no sound of flow in the drain line." "The drain line is not getting warmer to the touch." "No water or steam is visible where the drain line enters the hub drain."</p> <p style="text-align: center;"><u>THIS IS A DRILL</u></p>	

MESSAGE NO.: PD-3	CLOCK TIME: 19:20 or later
FROM: Controller	TO: ED/Communicators
CONTROLLER INFORMATION: This message is intended to drive the site to replace the evacuation at the "GE" with a Site Accountability exercise if not already performed. In either case, site evacuation will not be performed. Provide this message to those who are discussing or communicating the evacuation of site personnel. Insure that they understand that this is a drill artificiality.	
MESSAGE: <p style="text-align: center;"><u>THIS IS A DRILL</u></p> <p style="text-align: center;"><u>DO NOT</u> initiate actions affecting normal plant operations.</p> <p><u>IF</u> Site Accountability has not been previously conducted, <u>THEN</u> provide the following information: Do not conduct/announce a Site Evacuation, instead, conduct/announce a site accountability using the attached form.</p> <p><u>IF</u> Site Accountability has been conducted, <u>THEN</u> provide the following information: Do not conduct/announce a site evacuation.</p> <p style="text-align: center;"><u>THIS IS A DRILL</u></p>	

MESSAGE NO.: PD-4	CLOCK TIME: 19:20 or later
FROM: Observers/Controller	TO: ED/Warehouse personnel
CONTROLLER INFORMATION: This message is intended to prevent a site evacuation when the "GE" is declared. This message will only be used if Accountability has previously been conducted. If a Site Accountability has not been conducted use PD-3 message.	
MESSAGE: <p style="text-align: center;"><u>THIS IS A DRILL</u></p> <p style="text-align: center;"><u>DO NOT</u> initiate actions affecting normal plant operations.</p> <p>Do Not conduct a Site Evacuation, instead continue controlling site personnel in accordance with the Site Accountability process.</p> <p style="text-align: center;"><u>THIS IS A DRILL</u></p>	

MESSAGE NO.: D-1	CLOCK TIME: 19:40 +/- 15 min.
FROM: OSC Observer	TO: DC-2 Repair Team
CONTROLLER INFORMATION: Offer the following information to Team responding to repair of V-14-33. (Team cannot enter Reactor Building, should go to 4160 Room - DC "C").	
MESSAGE: <p style="text-align: center;"><u>THIS IS A DRILL</u></p> <p style="text-align: center;"><u>DO NOT</u> initiate actions affecting normal plant operations.</p> <p>"For drill purposes, breaker 13 is to be used to simulate Breaker #3". See note below.</p> <p>When team closes breaker 13, tell them "Breaker closed and held. Power restored to DC-2".</p> <p style="text-align: center;"><u>NOTE:</u></p> <p>Breaker #13 on C1 Dist. Panel will be utilized for drill purposes. It will be marked "in trip free position". Breaker #13 is a spare and may be operated.</p> <p style="text-align: center;"><u>THIS IS A DRILL</u></p>	

MESSAGE NO.: PD-5	CLOCK TIME: 20:30 or later
FROM: Controllers	TO: Players
CONTROLLER INFORMATION: The purpose of this message is to end the scenario. The Lead Controller will notify the appropriate ERF Controllers as to when this message should be passed.	
MESSAGE: <p style="text-align: center;"><u>THIS IS A DRILL</u></p> <p style="text-align: center;"><u>DO NOT</u> initiate actions affecting normal plant operations.</p> <p>The time is now 8:00 a.m. Thursday, November 2nd. The Reactor is in cold shutdown with decay heat being removed by using Core Spray to circulate torus water through the reactor and back to the torus via the EMRV's.</p> <p>Radiation levels in all inplant areas are decreasing.</p> <p>Radiological Releases to the environment are within Tech. Spec. Limits.</p> <p style="text-align: center;"><u>THIS IS A DRILL</u></p>	

SECTION VI MINI-SCENARIOS

- VI.A. DG FUEL OIL TANK FIRE
- VI.B. OFF-SITE FIRE SUPPORT
- VI.C. EDG ALTERNATE FUEL OIL LINEUP
- VI.D. ISOLATION CONDENSER VALVES
- VI.E. "B" CRD PUMP BREAKER
- VI.F. PUBLIC INFORMATION ACTIVITIES
- VI.G. FIELD MONITORING TEAM SAMPLING
- VI.H. LIQUID POISON
- VI.I. ALTERNATE POISON INJECTION
- VI.J. SCRAM DISCHARGE VOLUME

SECTION VI

MINI-SCENARIO A

DG FUEL OIL TANK FIRE

MINI-SCENARIO A - DG Fuel Oil Tank Fire

1. Summary

This mini-scenario provides additional guidance and information to the Controller/Observer in support of the Fire Brigade/Emergency Response personnel covering the Diesel Generator Building Oil Tank fire.

A seam weld on the Diesel Bldg. Oil Tank fails. This failure develops into a leak that gives off a heavy mist of oil. The resulting oil cloud reaches a heater that is in operation due to cool weather and auto ignites. This auto ignition results in a fire that rapidly grows due to the oil leak. Heavy black smoke is visible and flames are impinging on the side of the tank.

2. Event Time Line (All Times Approximate)

<u>TIME</u>	<u>ACTIVITY/RESPONSE</u>
T = 16:08	DG FO Tank Room Fire. Seam weld on the oil storage tank in the DG FO fails. The resulting leak is ignited by a heater. A fire with heavy black smoke and large flames develops. THIS FIRE IS REPORTED BY WORKERS IN THE AREA. (Message Card A-1)
T = 16:10 +/- 2 min.	Fire Brigade Call Out. Control Room receives report of the fire in the DG FO tank room. Fire Brigade is called out and told to report to the designated dress out area.
T = 16:20 +/- 10 min.	Fire Brigade Arrival. Fire Brigade leader arrives at the scene of the fire and is informed of the situation. (Message Card A-2)
T = 16:20 +/- 10 min.	Fire Brigade Leader calls for outside Fire Department help.
T = 16:25 +/- 10 min.	Fire Intensifies. Due to the amount of oil now leaking, the fire grows and becomes too large for the brigade. (Message Card A-3)
T = 16:30 +/- 10 min.	Control Room calls Lacey Police for Forked River Fire Company help.
T = 16:50 +/- 10 min.	Forked River Department arrival.
T = 17:15 or before	Fire is extinguished. (Message Card A-4)

3. Controller/Observer Information

NOTE:

For this exercise, fire hoses will be connected to the hydrants but will not be charged.

and

Fire extinguishers will not be discharged (i.e. safety pins should remain in place wherever possible).

This mini-scenario is intended to demonstrate the Fire Brigades ability to respond to a large oil fire in the DG FO Tank Room and upon determining that the fire is beyond the capabilities of the Fire Brigade alone, make the appropriate request for off-site support.

The Observer should evaluate the Fire Brigades choice of equipment and strategies to fight the fire. Communication with on-site and off-site personnel should also be evaluated. Coordination between the on-site and off-site teams should be included in the evaluation.

As soon as the Fire Brigade and the Fire Department have demonstrated their ability to coordinate their efforts and address the fire, the fire can be declared out. A lengthy fire fighting demonstration is not required.

SECTION VI

MINI-SCENARIO B

OFFSITE FIRE SUPPORT

MINI-SCENARIO B - Offsite Fire Support

1. Summary

This mini-scenario is to provide additional guidance and data to the Controller/Observer organization in support of the Offsite Fire Support responding to the DG FO Tank Room fire. The responding personnel are expected to be the Forked River Fire Co. #1.

The intent of this mini-scenario is to demonstrate the ability of the site Security and the off-site support to gain access to the Protected Area in accordance with emergency procedures.

2. Event Time Line (All Times Approximate)

<u>TIME</u>	<u>ACTIVITY/RESPONSE</u>
T = 16:08	DG FO Tank Room fire starts.
T = 16:30 +/- 10 min.	Control Room calls out offsite fire support.
T = 16:50 +/- 10 min.	Forked River Fire Co. #1 arrives at Main Gate.
T = 16:52 +/- 2 min.	Site Security begins processing personnel and equipment into Protected Area.
T = 17:00 +/- 2 min.	Fire Co. being escorted on its way to DG FO Tank Room fire.
T = 17:15 +/- 5 min.	Fire is out.
T = 17:50 +/- 10 min.	Forked River Fire Department exits Protected Area.

3. Controller/Observer Information

This mini-scenario is intended to exercise the implementation of the Emergency Plan in conjunction with the Security Plan. The Security Observer should require Security participants to actually perform as required by the plan, except those areas/tasks that would require the call out of large numbers of personnel. These will be simulated to the fullest extent possible. The offsite Fire Dept's access to the Protected Area will be executed in the same manner as a real emergency.

SECTION VI

MINI-SCENARIO C

EDG ALTERNATE FUEL OIL LINEUP

MINI-SCENARIO C - EDG Alternate Fuel Oil Lineup

1. Summary

This mini-scenario provides additional guidance and data to the Controller/Observer covering personnel responding to the "Alternate Fuel Oil Supply" operation of the EDG. This is intended to allow operation of the EDG, this does not make the EDG "Tech Spec" operable.

2. Event Time Line (All Times Approximate)

<u>TIME</u>	<u>ACTIVITY/RESPONSE</u>
T = 16:08	DG FO Tank Room fire has been initiated, rendering the FO tank unavailable to supply DG fuel oil.
T = 16:30 +/- 10 min.	Fire Brigade has responded to the scene and off-site support has been requested (Forked River Fire Dept.)
T = 16:35 +/- 15 min.	GSS/ED determines the DGs are inoperable due to the loss of the fuel storage tank. It is <u>expected</u> that the GSS will direct that the "Alternate fuel oil lineup" be initiated to supply fuel oil to the DG.
T = 17:15 or before	Operations personnel implement the steps in procedure 341, necessary to provide fuel oil to the DG.

NOTE:

Portions of the Alternate Fuel Oil Lineup may be delayed until after the fire is out, due to their proximity to the fire.

T = 17:25 +/- 20 min. Gravity feed lineup complete, team reports status to Control Room and returns to previous duties.

3. Controller/Observer Information

This mini-scenario is intended to test the response of the Players to the loss of normal fuel oil supply for the DG. A fully successful response would include:

- * Recognition of the appropriate procedure - 341.
- * Implementation of the correct procedure steps while simulating component manipulation.
- * Demonstrating concern for impact to existing damaged equipment.

Title Emergency Diesel Generator Operation	Revision No. 46
Applicability/Scope Applies to work at Oyster Creek	Responsible Office Plant Operations 2110
This document is within QA plan scope <u>X</u> Yes ___ No Safety Reviews Required <u>X</u> Yes ___ No	Effective Date (05/30/95) 06/09/95

Prior Revision 45 incorporated the following Temporary Changes:

This Revision 46 incorporates the following Temporary Changes:

TC-12/23/94-1

N/A

List of Effective Pages

Page	Revision	Page	Revision	Page	Revision	Page	Revision
1.0	46	19.0	43	37.0	46	E5-1	39
2.0	42	20.0	43	38.0	46	E5-2	39
3.0	39	21.0	43	39.0	46	E6-1	39
4.0	40	22.0	43	40.0	46	E6-2	39
5.0	40	23.0	43	E1-1	39	E7-1	39
6.0	40	24.0	43	E1-2	42	E7-2	39
7.0	42	25.0	43	E1-3	42	E8-1	40
8.0	45	26.0	43	E2-1	39	E8-2	40
9.0	42	27.0	43	E2-2	39	E8-3	40
10.0	42	28.0	43	E2-3	39	E8-4	40
11.0	42	29.0	43	E2-4	39	E9-1	39
12.0	42	30.0	43	E2-5	45	E10-1	39
13.0	42	31.0	43	E2-6	39	E11-1	42
14.0	42	32.0	43	E2-7	44		
15.0	43	33.0	43	E2-8	44		
16.0	43	34.0	43	E2-9	44		
17.0	43	35.0	46	E3-1	41		
18.0	43	36.0	46	E4-1	41		

	Signature	Concurring Organization Element	Date
Originator		Plant Operations	5/19/95
Concurred By		Manager Plant Operations	5-22-95
		OYSTER CREEK CONTROLLED DISTRIBUTION DOCUMENT SERIAL NUMBER <u>81</u>	
		IRMC	
Approved By		Director, Ops./Mtce. - O.C.	5/26/95

Title
Emergency Diesel Generator OperationRevision No.
42**1.0 PURPOSE**

To provide detailed instructions for the operation of the Emergency Diesel Generators. The operations included are as follows:

<u>Section</u>	<u>Operation</u>
3.0	Alignment of Emergency Diesel Generators for Automatic Start
4.0	Emergency Diesel Generator Automatic Start and Loading Sequences
5.0	Normal Operation from the Control Room
6.0	Emergency Start from the Control Room
7.0	Manual Starting and Synchronizing for Peaking Operation From The Diesel Generator Switchgear Cubicle
8.0	Manual Control For Deadload Pickup From The Diesel Generator Switchgear Cubicle
9.0	EDG Performance Monitoring During Operation
10.0	Restoring 4160V Bus to Normal Service From Automatic Deadload Pickup
11.0	Manual Stop Sequence From the Diesel Generator Cubicle
12.0	Emergency Stop Sequence From Outside the Diesel Generator Cubicle
13.0	Fuel Oil Day Tank Draining During Outages

2.0 REFERENCES

- 2.1 Procedure 636.4.003, Diesel Generator Load Test.
- 2.2 Technical Specifications Section 3.7.C, Standby Diesel Generators.
- 2.3 NRC IE Information Notice 84-69 and Supplement No.1. (Describes cases of diesel failure when tied to unstable grids.)
- 2.4 NRC "Power Reactor Events" May 4, 1984 Item 1.2, (unstable power grids).
- 2.5 Vendor Manual VM-OC-0095, Operating Manual - MU20E Power Plant.

Title
Emergency Diesel Generator OperationRevision No.
39**3.0 ALIGNMENT OF EMERGENCY DIESEL GENERATORS FOR AUTOMATIC START****3.1 Prerequisites**

None

3.2 Precautions and Limitations

3.2.1 Oil shall be added through the strainer housing using the fill connection on the square cap. Removal of the round oil fill caps when the engine is running or shutdown is not permitted because hot oil under pressure will come from the openings and could possibly cause personal injury. It is not desired nor required to tag out the Diesel Generator for lube oil addition.

3.2.2 If the cooling system of a hot engine has been drained, do not refill the system until the engine has cooled down to ambient (8 to 12 hours). A sudden change in temperature could cause damage to the engine. If a substantial volume of coolant is lost (not visible in sight glass), immersion heaters and all auxiliary oil pumps (circ. oil, AC and DC turbo oil pumps) shall be secured.

3.2.3 All control panels and enclosure doors shall be secured to prevent relay vibration except as required for maintenance and testing.

3.2.4 For the Diesel Generator to be considered operable the associated fuel oil transfer, cooling water and auxiliary lube oil systems shall be operable.

SECTION VI

MINI-SCENARIO D

ISOLATION CONDENSER VALVES

MINI SCENARIO D - Isolation Condenser Valves

1. Summary

This mini-scenario provides additional guidance and data to the Observer and personnel responding to the loss of power supplying motor control center DC-2, located on RB 75' el.

Isolation Condenser steam line leak causes dose to increase within Reactor Building and site wide. It is necessary to repair and close V-14-33 to terminate this release.

Isolation Condenser inlet isolation valves V-14-32 (AC powered) experienced a seized shaft that left the valves in the opened position. When the leak begins, V-14-33 starts to close, but a high current draw causes the main feed breaker for DC-2 (on DC C) to trip. It will be necessary to close DC operated valve V-14-33 to secure reactor steam leak. A team will be dispatched from OSC to investigate and repair.

2. Event Time Line (All Times Approximate)

<u>Time</u>	<u>Activity/Response</u>
T = 19:10	Isolation Condenser Leak. V-14-32 and V-14-33 fail to automatically close on "high flow" sensor.
T = 19:20 +/- 10 min.	Operations attempts to close V-14-33 but can not. Request OSC to dispatch repair team.
T = 19:40 +/- 15 min.	OSC team finds and repairs fault of MCC DC-2 feeder (on DC C). Operations closes V-14-33 securing steam leak.

3. Controller/Observer Information

This mini-scenario is intended to exercise the OSC in assembling and dispatching a team, and their ability to investigate and repair components.

The team is not expected to be sent into the Reactor Building due to high radiation levels.

The inability to close V-14-33 is due to a momentary high current spike caused by initiating the closure sequence. That, and the weakening of the MCC DC-2 breaker trip springs, (caused by heat and age) permitted breaker to trip.

It is intended that the repair crew will attempt to reset this breaker and due to being exercised, it will hold.

The main feeder breaker for DC-2 is located in the 4160V Switchgear Room on 125vdc "C" Distribution Center breaker #3.

The Observer should not permit access to any energized equipment, but that effective simulation is demonstrated for repair.

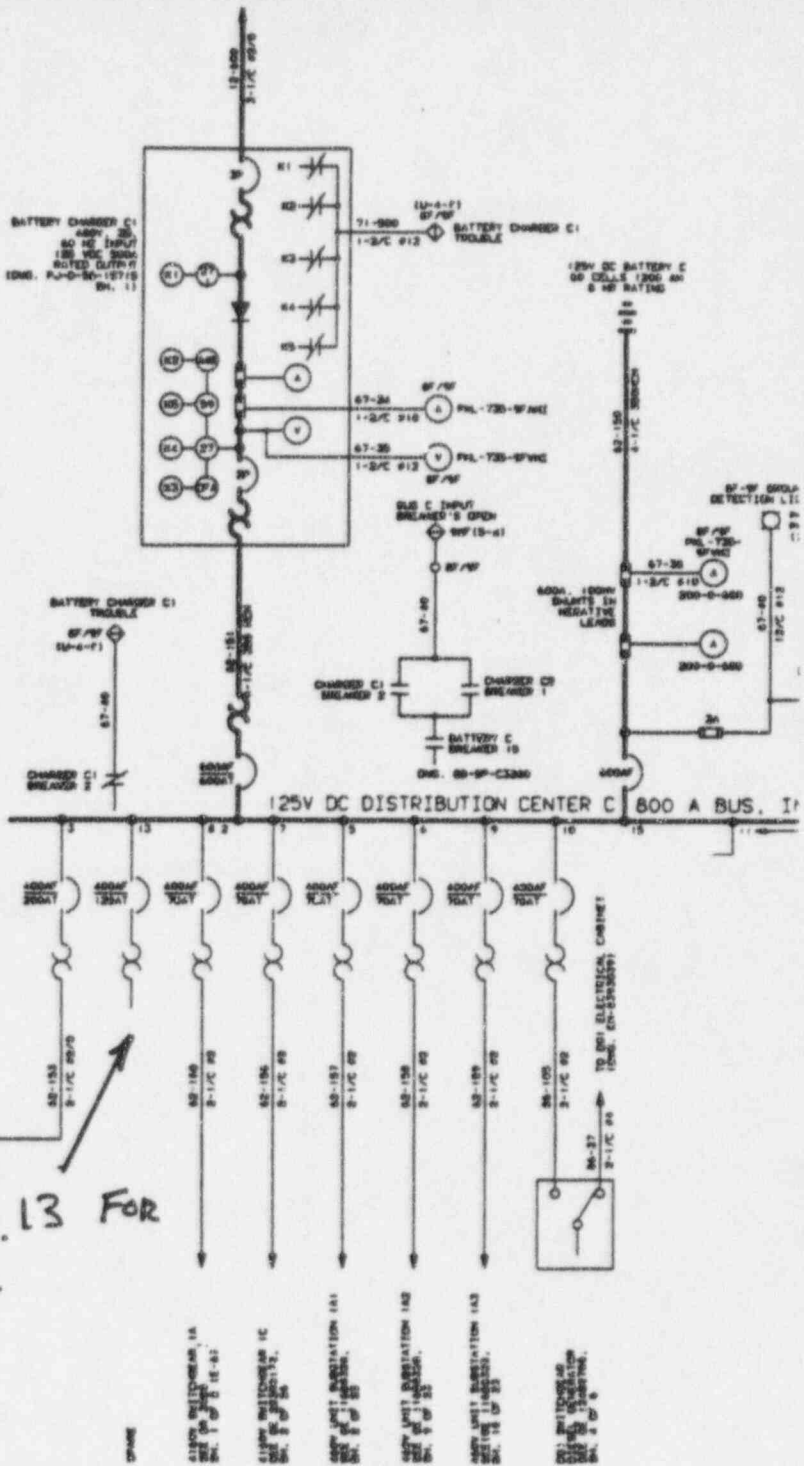
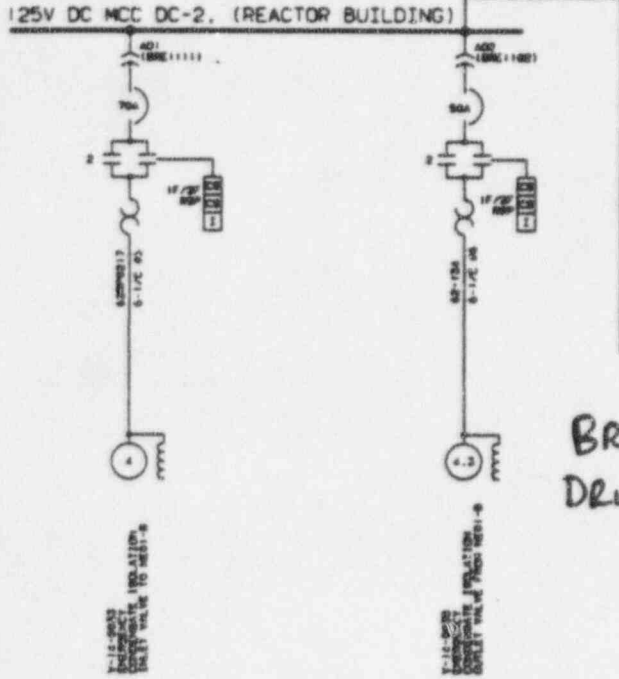

MCC DC-2

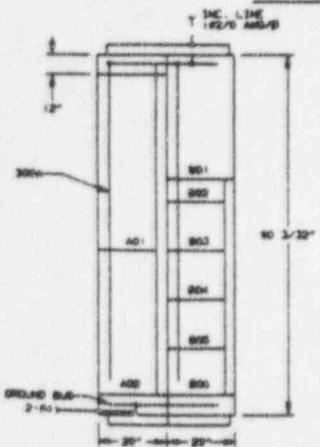

LINE LOCATION	WATER FILL LOAD APPEARS	OVERLOAD RELAY HEATER	CIRCUIT BREAKER TYPE	REFERENCE DRAWINGS	
				ELEMENTARY DRAWING SHEET	CONNECTION DRAWING SHEET
AD1				SP E1111	SP E1211
AD2				SP E1100	
AD3					
AD4					
AD5					
AD6					

SECTION VI

MINI-SCENARIO E

CRD PUMP #2 BREAKER REPAIR

MINI-SCENARIO E - CRD Pump #2 Breaker Repair

1. Summary

This mini-scenario provides additional guidance and data to the Observer and personnel responding to the repair of #2 Control Rod Drive (CRD) Pump Breaker. #1 CRD pump is OOS due to faulted motor windings and can not be repaired until a new motor is acquired. Additionally, #1 CRD pump breaker is in the Electric Shop receiving annual "PM".

This mini-scenario initiates when #2 CRD pump breaker trips and will not close. After repeated attempts with no success, a team will be sent to investigate and repair.

2. Event Time Line (All Times Approximate)

<u>Time</u>	<u>Activity/Response</u>
T = 17:30 +/- 5 min.	CRD pump #2 breaker trips and will not close after repeated attempts from the Control Room. A team is requested and dispatched.
T = 17:45 or later	Team arrives at CRD breaker. (Message E-1 and E-2).
T = 19:10	CRD pump #2 breaker is restored and pump is started. +/- 15 min.

3. Controller/Observer Information

This mini-scenario is intended to exercise the ability to troubleshoot and repair equipment.

The failure of #2 CRD breaker is a fault of the Micro Versa trip unit (MVT). The MVT shorted and burned causing a permanent "trip" on the breaker (Message E-1).

The Observer should note that the team recognizes the faulty MVT, a knockup will be taped on the breaker door and a trip signal is indicated. It is expected that motor will be meggered and bridged. By performing these steps and obtaining and setting a new MVT, the prescribed time line should be met (Message E-2).

The condition of the #1 CRD breaker is that it is in the Electrical Shop being "PMd". The remaining work is that it just needs to be trip checked and, if successful, may be installed in the #2 cube.

CRD Pump "B" Breaker is located in the 480V Switchgear room, 1B2 Unit Substation, cube 043c.

If necessary, the Observer should create steps to maintain the activities to the time. He/she should look for proper testing techniques and insure that proper tools and test equipment are carried into the field.

SECTION VI

MINI-SCENARIO F

PUBLIC INFORMATION

MINI-SCENARIO F - Public Information

1. Summary

This mini-scenario provides additional guidance and information to the Controller/Observer responding to this event. The responding organizations are expected to be the OCNGS Communications, Public Information, and Rumor Control organizations.

2. Event Time (All Times Approximate)

Upon declaration of Alert, personnel will man the GPUNC Joint Information Center in Brick, New Jersey. News releases will be distributed from the JIC and Communications Office in the Admin. Building at the Oyster Creek site.

At strategic times throughout the course of the exercise, telephone calls simulating calls from concerned GPUNC personnel, local citizens, the media and industry-related organizations, e.g., INPO, will be made to various locations onsite and the OCNGS Emergency Response Facilities.

Additionally, throughout the course of the exercise, telephone calls simulating calls from the general public, media, industry-related organizations, and plant personnel will be made to the rumor controls organization at the JIC.

Periodic news conferences, i.e., media briefings, should be conducted at the JIC beginning after activation and until termination of the exercise.

3. Controller/Observer Information

This mini-scenario is intended to exercise the response and interface of the GPUNC Communications Department at OCNGS, including public and media relations, information gathering and press releases, facility activation, rumor control, and press briefings.

The Observer/Controller and associated personnel, e.g., telephone callers, will be provided sufficient data to support these activities. Observers/Controllers are expected to perform the following:

- ° Evaluate timely activation of the JIC and response of Communications Department personnel.
- ° Evaluate press releases in regards to timely dissemination, accuracy, content, and proper approvals.

- ° Evaluate the 3PUNC Emergency Response Organization in regards to channeling of telephone inquiries to the appropriate organizations.
- ° Evaluate media briefings in regards to presentation, timeliness, and informational content, accuracy and personnel relations.
- ° Evaluate information gathering activities by communication personnel in regards to information content, accuracy, and timeliness of all information disseminated to the media and the public.
- ° Evaluate communication personnel in regard to compliance with 8000-IMP-1720.01, "Emergency Public Information Implementing Procedure".
- ° Upon termination of the exercise, conduct a critique with participants identifying strengths and weaknesses of their performance.
- ° Upon termination of the exercise, gather copies of press releases and attendance forms and other material, as appropriate, and submit it to the OCNGS Emergency Preparedness Department.

PRESS RELEASE EVALUATION CRITERIA

The following guidance has been developed for the timely issuance of the press releases during emergencies.

The following categories of information should be included in press releases:

1. Level of Emergency

This is simply identifying which one of the four emergency levels was declared.

2. Basis for Emergency Declaration

This should be a simplified description of the plant condition which produced the Emergency Action Level (e.g., a leak of radioactive water within the plant building).

3. Operational Status of Plant

A simple description of the plant status at the time of the emergency declaration (e.g., OCNGS was operating at 100% power when the leak was discovered, however, the plant is currently reducing power).

4. Company/Government Interface

This is intended to inform the public that GPUNC has notified and is working closely with government officials so that public confidence and company credibility can be increased.

5. Corrective Action

This should be a non-technical description of that plant personnel are doing to correct the problem. It may include such language as "attempts are being made to stop the leak" or "plant personnel are investigating the cause of the leak".

6. Offsite Impact

A statement which simply assesses what impact this event may have on the environment. This is intended to provide factual information on offsite radiological conditions (e.g., a radioactive release is in progress, however, environmental monitoring teams have not detected any radiation levels offsite in excess of natural background).

The initial press release should include all, or part, of the above information since time is of the essence. However, at the very least, it should contain items 1-5 above.

In addition to the previous information, the following guidance will be used in issuing press releases:

- Speculation, dose projections, and Protective Action Recommendations should not be included in press releases.
- All press releases (written) require approval of the ES/ESD after operational and/or radiological review. However, announcements of a change in the emergency classification (emergency action level) can be made verbally, without prior review, and should be made as promptly as possible.
- Press releases will be reviewed expeditiously in order to support timely issuance.
- Press releases should avoid technical terms (e.g., plant system names) and jargon (e.g., trip) and should be written as simply as possible. For example, Diesel Generators could be referred to as a backup power source.

The above guidance should be the basic minimum elements of a press release. This guidance should significantly help those providing information as well as press release authors, reviewers, and approvers in performing this very important function in a consistent, timely, and accurate manner.

PUBLIC INFORMATION INQUIRIES TO EMERGENCY RESPONSE FACILITIES.
PREFACE AND END ALL MESSAGES WITH "THIS IS A DRILL"

1. SIMULATOR CONTROL ROOM (971-5666)

THIS IS DRILL, THIS IS A DRILL. I heard that there was a fire in the Nuclear Reactor at the Plant. I live on Lacey Road in Forked River. Should I evacuate my family?
THIS IS A DRILL, THIS IS A DRILL.

NAME OF PERSON ANSWERING PHONE:
TIME:
RESPONSE PERSON GAVE:

2. OPERATOR (971-4000)

THIS IS A DRILL, THIS IS A DRILL. My name is Diane Pointer from Congressman Green's office. The Congressman wants to know soon you will be evacuating children and pregnant women from the areas immediately around the plant. What can you tell me?
THIS IS A DRILL, THIS IS A DRILL.

NAME OF PERSON ANSWERING PHONE:
TIME:
RESPONSE PERSON GAVE:

3. SIMULATOR CONTROL ROOM (971-5666)

THIS IS A DRILL, THIS IS A DRILL. My name is Marie Stricker from WLOQ TV in Philadelphia. I understand your generators for producing electricity are on fire, can you give me the details on how the fire started?
THIS IS A DRILL, THIS IS A DRILL.

NAME OF PERSON ANSWERING PHONE:
TIME:
RESPONSE PERSON GAVE:

PUBLIC INFORMATION INQUIRIES, CONTINUED:

4. JIC 908 (920-3338)

THIS IS A DRILL, THIS IS A DRILL. This is Carla Frazier from WXOB radio in Camden. We are sending our mobile unit to your Plant and would like to set it up next to the Reactor Building. Who in Security can I talk to get permission?
THIS IS A DRILL, THIS IS A DRILL.

NAME OF PERSON ANSWERING PHONE:
TIME:
RESPONSE PERSON GAVE:

5. COMMUNICATIONS (971-4020)

THIS IS A DRILL, THIS IS A DRILL. This is Rache! Bally calling from FEMA office. We want to know if you need our help. Who should I speak with?
THIS IS A DRILL, THIS IS A DRILL.

NAME OF PERSON ANSWERING PHONE:
TIME:
RESPONSE PERSON GAVE:

6. EOF (908-367-8805)

THIS IS A DRILL, THIS IS A DRILL. I live over in Barnegat and I smell a strong odor of fuel oil and see black smoke in the vicinity of your plant. Is there danger of a radiation release?
THIS IS A DRILL, THIS IS A DRILL.

NAME OF PERSON ANSWERING PHONE:
TIME:
RESPONSE PERSON GAVE:

7. JIC (908-920-6191)

THIS IS A DRILL, THIS IS A DRILL. This is Dana Lunswald calling from the Vineland Bugle newspaper. I need some background information on your plant; size, age, number of employees and so on, can you help me?
THIS IS A DRILL, THIS IS A DRILL.

NAME OF PERSON ANSWERING PHONE:
TIME:
RESPONSE PERSON GAVE:

8. JIC (908-920-6191)

THIS IS A DRILL, THIS IS A DRILL. This is Erica Langford calling. I'm the superintendent of schools for all of Central NJ. When will you begin evacuating the students?
THIS IS A DRILL, THIS IS A DRILL.

NAME OF PERSON ANSWERING PHONE:
TIME:
RESPONSE PERSON GAVE:

9. COMMUNICATIONS (971-4020)

THIS IS A DRILL, THIS IS A DRILL. My family and I live in Toms River and I'm pregnant. I understand there may be a radiation release. What can I do to protect myself?
THIS IS A DRILL, THIS IS A DRILL.

NAME OF PERSON ANSWERING PHONE:
TIME:
RESPONSE PERSON GAVE:

10. SIMULATOR CONTROL ROOM (971-5666)

THIS IS A DRILL, THIS IS A DRILL. This is agent Jackson from the FBI Terrorist Response Unit. Please connect me to the Chief of Security immediately.
THIS IS A DRILL, THIS IS A DRILL.

NAME OF PERSON ANSWERING PHONE:
TIME:
RESPONSE PERSON GAVE:

11. EOF (908-367-8805)

THIS IS A DRILL, THIS IS A DRILL. I live in Forked River and I want someone to come down my block and test for radiation, I heard there was a leak down there.
THIS IS A DRILL, THIS IS A DRILL.

NAME OF PERSON ANSWERING PHONE:
TIME:
RESPONSE PERSON GAVE:

12. EOF (908-367-8812)

THIS IS A DRILL, THIS IS A DRILL. This is Ellen Immaculata calling from WAXD TV in Trenton. Our mobile unit is on its way and will need access to the fire site. Please be ready to admit us.
THIS IS A DRILL, THIS IS A DRILL.

NAME OF PERSON ANSWERING PHONE:
TIME:
RESPONSE PERSON GAVE:

13. SECURITY (971-4954)

THIS IS A DRILL, THIS IS A DRILL. This is Donna Morley calling from Senator Krieger's office. The Senator wants details on the cancer and disease risks from the radiation your plant is leaking? What can you tell me?

THIS IS A DRILL, THIS IS A DRILL.

NAME OF PERSON ANSWERING PHONE:
TIME:
RESPONSE PERSON GAVE:

14. JIC (908-477-3935)

THIS IS A DRILL, THIS IS A DRILL. My son works at the plant. How can I find out if he is OK? THIS IS A DRILL, THIS IS A DRILL.

NAME OF PERSON ANSWERING PHONE:
TIME:
RESPONSE PERSON GAVE:

PUBLIC INFORMATION OBSERVER SHEET

Observer's Name: _____ Date: _____

Observer's Location: _____

YES - NO - N/A

- _____ 1. Was JIC activated in a timely manner? Clock time when center was manned and declared operational: _____
- _____ 2. Did all press releases contain Items 1 through 5 (as a minimum) as shown on Press Release Evaluation Criteria?
- _____ 3. Did press releases meet the following requirements?
 - ° Timely dissemination
 - ° Accurate
 - ° Proper approvals
- _____ 4. Did GPUNC media team appropriately channel telephone inquiries?
- _____ 5. Were media briefings adequate regarding the following:
 - ° Timeliness
 - ° Informational Content
 - ° Accuracy
 - ° Presentation
 - ° Personnel relations
- _____ 6. Was media information gathering by Communications personnel accurate and complete.
- _____ 7. Were Communication personnel actions in compliance with the Public Information Emergency Plan.
- _____ 8. Upon termination, were all copies of press releases, attendance forms and other materials, as appropriate, gathered? (Attach to this sheet and submit to OCNGS Emergency Preparedness Department).
- _____ 9. Upon termination, was a facility critique conducted by Observer identifying strengths and weaknesses of players performances?
- _____ 10. Upon termination, was Media Center returned to pre-drill conditions.
- _____ 11. Were all necessary supplies and equipment available in center?
- _____ 12. Were all checklists, including Exhibit 9 to EPIP-25, completed and collected?

SECTION VI

MINI-SCENARIO G

FIELD MONITORING TEAM SAMPLING

MINI-SCENARIO G - Field Monitoring Team Sampling

1. Summary

This mini-scenario provides additional guidance and data to the Controller/Observer and Emergency Response personnel responding with the Field Monitoring Teams.

2. Event Time (All Time Approximate)

<u>Time</u>	<u>Activity/Response</u>
T = 17:35 +/- 10 min.	ALERT Declared, pagers activated, Field Monitoring Team (FMT) members respond to Building 12 and initiate Procedure EPIP-OC-.11.
T = 18:05	Team members complete activation and prepare for dispatch.
T = 19:10	Rx Bldg. LOCA occurs. EACC deploys FMTs to verify release condition.
T = 19:20 +/- 10 min.	GENERAL EMERGENCY declared, "Loss of 2 of 3 Fission Product Barriers". Offsite radiological conditions increasing.
T = 19:20	EACC deploys FMTs for plume search.
T = 19:25 or later	EACC directs team to perform air sampling and environmental sampling. Observer ensures actual environmental samples taken. (Message G-1)
T = 20:30	Drill terminated.

3. Controller/Observer Information

This mini-scenario is intended to ensure at least one of each type of environmental sample is collected in accordance with EPIP-OC-.11, by each Field Monitoring Team.

SECTION VI

MINI-SCENARIO H

LIQUID POISON LEAK

MINI-SCENARIO H - Liquid Poison Leak

1. Summary

This mini-scenario provides guidance and information to the Controller/Observer evaluating persons responding to a request to investigate the possible malfunction of the Liquid Poison System.

With the failure to scram due to a hydraulic lock on the scram discharge volume, the loss of the operable CRD Pump and core oscillation occurring, the Control Room crew will attempt to inject liquid poison. A line rupture between the squib valve and the drywell wall is simulated such that the pump runs and tank level decreases but no poison is injected into the reactor. It is expected that it will take around a half an hour for anyone to notice that the expected effects on core power are not being seen.

At this point preparation to inject liquid poison via the Cleanup and/or Feed and Condensate Systems. Cleanup may not be utilized because of elevated radiation levels in the reactor building due to core damage. Alternate Poison Injection is covered in Mini-scenario "I".

2. Event Time (All Time Approximate)

<u>Time</u>	<u>Activity/Response</u>
T = 17:22	Failure to scram.
T = 17:24 +/- 2 min.	Power Oscillations commence and Liquid Poison System is started.
T = 17:50 +/- 15 min.	OSC Team is requested to investigate possible malfunction of the Liquid Poison System.
T = 18:00 +/- 15 min.	OSC Team is requested to send a team out to inject liquid poison by an Alternate Method.
T = 18:00 +/- 15 min.	OSC Team arrives at Liquid Poison area and finds leak. (Message Card H-1)
T = 19:10	Isolation Condenser steam line rupture in Reactor Building stops any efforts to investigate or repair the Liquid poison System.
T = 19:10 +/- 15 min.	"B" CRD pump is returned to service.
T = 19:40 +/- 15 min.	All control rods are fully inserted and Alternate Poison Injection is secured.

3. Controller/Observer Information

This mini-scenario is intended to provide the Observer with the information necessary to evaluate the OSC Team's investigation of problems with the Liquid Poison System. taken.

The team should be required to demonstrate the ability to locate the appropriate all valves, switches, panels and tools require for the any repair efforts that may be undertaken.

SECTION VI

MINI-SCENARIO I

ALTERNATE POISON INJECTION

MINI-SCENARIO 1 - Alternate Poison Injection

1. SUMMARY

This mini-scenario provides guidance and information to the Controller/Observer evaluating persons responding to a request to make preparations for Alternate Boron Injection with the Cleanup and/or with the Feed and Condensate System.

With the failure to scram due to a hydraulic lock on the scram discharge volume, the loss of the operable CRD Pump and core oscillation occurring, the Control Room crew will attempt to inject liquid poison. A line rupture between the squib valve and the drywell wall is simulated such that the pump runs and tank level decreases but no poison is injected into the reactor. It is expected that it will take around a half an hour for anyone to notice that the expected effects on core power are not being seen.

At this point preparation to inject liquid poison via the Cleanup and/or Feed and Condensate Systems will be initiated. Cleanup may not be utilized because of elevated radiation levels in the reactor building due to core damage.

If Feed and Condensate System is used, this labor intensive task involves moving 20 or more drums of Boric Acid and Borax to the Heater Bay roof where it is added to the Cation tank. The poison is then mixed with water and transferred to an empty demineralizer. The demineralizer is then lined up so that feedwater carries the poison into the core. It would take at least three additions to add the required amount of poison.

If the Cleanup system is used the 20 drums of poison must be moved to the 75' elevation of the Reactor Building. The poison is then mixed with water in the Cleanup System Pre-coat Tank and pumped into the cleanup filters. The Cleanup System is then lined up to the reactor and the poison is flushed into the core. It will require at least three additions to inject the required amount of poison.

It is expected that this evolution will be secured when CRD is returned to service and the control rods are inserted.

2. Event Time Line (All times approximately)

<u>TIME</u>	<u>EVENT DESCRIPTION</u>
T = 17:22	Failure to scram.
T = 17:24 +/- 2 min.	Power Oscillations commence and Liquid Poison System is started.
T = 17:30 +/- 5 min.	"B" CRD pump trips.

2. Event Time Line (continued)

<u>TIME</u>	<u>EVENT DESCRIPTION</u>
T = 18:00 +/- 15 min.	OSC is requested to send a team out to inject liquid poison by an Alternate Method.
T = 19:10	Isolation Condenser steam line rupture in Reactor Building stops any efforts to use Cleanup System for Alternate Poison Injection.
T = 19:10 +/- 15 min.	"B" CRD pump is returned to service.
T = 19:40 +/- 15 min.	All control rods are fully inserted and Alternate Poison Injection is secured.

3. Controller/Observer Information

This mini-scenario is intended to provide the Observer with the information necessary to evaluate the OSC Team's ability to add Poison via either alternate injection method. The Observer should use the attached EOP Support Procedure 23 or 24 as a guide and record the actions taken.

It should be noted that as soon as CRD capabilities are returned, halting the alternate injection will be discussed and the process will be secured when the control rods are all fully inserted, if not before.

The team should be required to demonstrate the ability to locate the appropriate materials in the warehouse and an adequate method of moving these materials to the appropriate point.

The responders should also demonstrate the proper procedure use and locations of all valves, switches, panels and tools require for the selected methods.

SUPPORT PROCEDURE 23

ALTERNATE BORON INJECTION WITH THE CLEANUP SYSTEM

1.0 PREREQUISITES

Injection of Boron via the Cleanup System has been directed by the Emergency Operating Procedures.

2.0 PREPARATION

NOTE

After completing the steps in this section, Cleanup System Valves V-16-1, V-16-2, V-16-14 and V-16-61 will only operate from the control switches in the Control Room. All automatic operation will be removed.

2.1 Open the EOP BYPASS PLUGS panel in the rear of Panel 3F.

2.1.1 Remove the bypass plug from position BP2 and insert into position BP1.

2.1.2 Remove the bypass plug from position BP4 and insert into position BP3.

2.1.3 Remove the bypass plug from position BP6 and insert into position BP5.

2.1.4 Remove the bypass plug from position BP8 and insert into position BP7.

2.2 Obtain a flat head screwdriver from the EOP Tool Room in the Control Room.

2.3 Open the front panel of Auxiliary Relay Panel ER-215-087 (A/B Battery Room).

2.3.1 Remove bypass plug 1 (upper left hand corner).

2.3.2 Remove bypass plug 2 (upper left hand corner).

3.0 Procedure

When directed by the GSS/GOS, perform the following:

- 3.1 IF no recirculation pump is running,
THEN
1. Confirm at least one recirculation loop suction and discharge valves open other than B loop.
 2. Close the B recirc loop discharge and discharge bypass valves.
- 3.2 Bypass and isolate the cleanup filters:
- 3.2.1 Open V-16-83, Filter Bypass Valve (RB 75).
 - 3.2.2 Confirm close ND28A and ND28B, Filter Outlet Valve (RB 75).

3.3

NOTE

The remote valve operators to valves V-16-102, V-16-113, and V-16-114 have been disconnected.

Bypass and isolate the Cleanup Demineralizer:

- 3.3.1 Open V-16-113, Demineralizer Bypass Valve (RB 75 SW).
 - 3.3.2 Close V-16-102, Demineralizer Inlet Valve (RB 75 SW).
 - 3.3.3 Close V-16-114, Demineralizer Outlet Valve (RB 75 SW).
- 3.4 IF Cleanup System is not in service,
THEN Place the system in service in accordance with Procedure 303, Reactor Cleanup Demineralizer System.
- 3.5 Use a backwashed/empty Cleanup Filter, or backwash a Cleanup Filter as follows:
- 3.5.1 Confirm Cleanup Filter Backwash Tank full.
(Pressure Gauge on RB 119' El. under tank should indicate -11.6 psig).

- 3.5.2 *****
* CAUTION *
* *
* If Sludge Receiver Tank level is over nine (9) feet, *
* the backwashing sequence can cause contamination of *
* the plant ventilation system via six inch vent. *

Verify Sludge Receiver Tank has sufficient volume to accommodate backwashing a filter. Approximately a 2.5 feet level increase will occur per backwash.

3.5.3

NOTE

Only one set of Filter Recycle Valves are capable of being open at any one time.

Place cleanup filter in recycle as follows:

1. Open ND-31 A(B) Precoat/Recycle Outlet Valve.
2. Start Precoat Pump to selected filter A(B).
3. Open ND-30 A(B) Precoat/Recycle Inlet Valve.

3.5.4 Press ND-35 A(B) Backwash Programmer Control START button, until the A(B) programmer seals in. It is sealed in when the green START and red UNIT IN BACKWASH lights stay on after the button is released.

3.5.5 Place PRECOAT PUMP CONTROL switch in OFF.

3.5.6 The following automatic sequence will occur:

1. ND-27A(B), Filter Inlet Valve, closes.
2. ND-23A(B), Air Inlet Valve, opens.
3. ND-25A(B), 1" Vent Valve (to RBEDT), opens.
4. ND-25A(B) closes.
5. ND-30A(B), Precoat (Recycle) Inlet Valve, and ND-31A(B), Back to Precoat Valve, close.
6. ND-26A(B), Filter Sludge Tank Inlet Valve opens.
7. ND-23A(B), Air Inlet Valve, closes.
8. ND-24A(B), Vent/Overflow Valve, opens.
9. ND-29A(B), Backwash Inlet Valve, opens.
10. ND-29A(B), Backwash Inlet Valve, closes.
11. ND-24A(B) closes.
12. ND-26A(B) closes.

- 3.6 IF the Filter Aid Precoat Tank is being used to mix and add powdered Boric Acid and Borax,
THEN continue in this procedure at Step 3.22.
- 3.7 IF the contents of the SLC Storage Tank is being injected using the Cleanup System,
THEN continue in this procedure at Step 3.8.
- 3.8 Drain the Filter Aid Precoat Tank by opening V-16-117, Filter Aid Precoat Tank Drain Valve. Close V-16-117 when the tank is drained.
- 3.9 Transfer the contents of the SLC Storage Tank to the Filter Aid Precoat Tank by performing Steps 3.9.1 through 3.9.4.
- 3.9.1 Connect a hose downstream of V-19-29, SLC Storage Tank Drain Valve, and route the free end to the Filter Aid Precoat Tank. Insert it through the hinged lid at the top and secure.
- 3.9.2 Unlock V-19-29 SLC Storage Tank Drain Valve.
- 3.9.3 Open V-19-29 and fill the Filter Aid Precoat Tank to 90% full by gravity draining the SLC Storage Tank.
- 3.9.4 Close V-19-29.
- 3.10 Close V-16-108, Filter Recycle Valve.
- 3.11 Verify V-16-109, Cleanup Filter Return to Precoat Tank, is closed.
- 3.12 Open ND-30A(B), Precoat/Recycle Inlet Valve.
- 3.13 Open V-16-107, Precoat Pump Suction Valve.
- 3.14 Place ND32, Precoat Pump Discharge Valve, control switch in the HOLD position.
- 3.15 Start the Precoat Pump in HAND position.
- 3.16 Open ND25A(B), 1" Vent Valve (to RBEDT).
- 3.17 WHEN a steady stream of water is observed in the sightglass downstream of Valve ND-25A(B)
OR the Cleanup Filter Precoat Tank low level alarm annunciates,
THEN
1. Stop the Precoat Pump.
 2. Close Valves ND-25A(B), V-16-107, and ND-30A(B).

3.18 IF the Cleanup Filter Precoat Tank has reached the low level limit,

THEN repeat Steps 3.9.3 through 3.17.

3.19

NOTE

During valving operations allow sufficient time for the (Red, Green) valve indication lights to completely change over.

Inject boron in accordance with Steps 3.19.1 through 3.19.4.

3.19.1 Open the ND27A(B), Filter Inlet Valve, by placing its selector switch to the OPEN position.

3.19.2

NOTE

When Valve ND28A(B) is placed in AUTO, if the valve does not open or if it opens and then closes, a Cleanup Filter Isolation signal was actuated while the filter was in hold, and the programmer needs to be reset. Instructions for resetting the programmer are contained in Procedure 303, Reactor Cleanup Demineralizer System.

Open ND28A(B), Filter Outlet Valve, by placing its selector switch to the AUTO position.

3.19.3 Close V-16-83, Cleanup Filter Bypass Valve. Allow approximately one (1) minute to ensure that the Filter Outlet Valve (ND28A(B)) remains open.

3.19.4 Operate the Cleanup System in this mode for five (5) minutes.

3.20 Bypass and isolate the Cleanup Filters.

3.20.1 Open V-16-83

3.20.2 Close ND27A(B)

3.20.3 Close ND28A(B)

3.21 Repeat Steps 3.9 through 3.20 until the contents of the SLC Storage Tank are injected into the reactor.

3.22

NOTE

As required by Section 3.22, Boric Acid and Borax come in approximately 300 lb. barrels and are stored in the warehouse under Stock Numbers 001-512-1800-1 (Bin 2-Q068-E,J) and 001-512-2000-1 (Bin 2-Q064-E) respectively. Although only six (6) barrels each are necessary to achieve a cold Boron shutdown weight of 273 lbs., plus a 25 percent conservatism, all available barrels (normally 10 each) should be transported to the Reactor Building 75 ft. elevation.

NOTE

Steps 3.22 through 3.37 are used to mix and inject powdered boron using the Cleanup System and the Precoat Tank.

Verify that the Precoat Tank is 80% full and if not, fill with condensate transfer to a level of 80%.

- 3.23 Start the Precoat Tank Agitator and Precoat Tank Evacuator.
- 3.24 Add four barrels of Boric Acid and four barrels of Borax to the Filter Aid Precoat Tank and mix thoroughly.
- 3.25 Close V-16-108, Filter/Recycle Valve.
- 3.26 Verify V-16-109, Cleanup Filter Return to Precoat Tank Valve, is closed.
- 3.27 Open ND-30A(B), Precoat/Recycle Inlet Valve.
- 3.28 Open V-16-107, Precoat Pump Suction Valve.
- 3.29 Place ND32, Precoat Pump Discharge Valve, control switch in the HOLD position.
- 3.30 Start the Precoat Pump in HAND position.
- 3.31 Open ND-25A(B), 1" Vent Valve (to RBEDT).
- 3.32 WHEN a steady stream of water is observed in the sightglass downstream of valve ND-25A(B),
- OR the Cleanup Filter Precoat Tank low level alarm annunciates,
- THEN
1. Place the Precoat Pump control switch to OFF.
 2. Close valves ND-25A(B), V-16-107 and ND-30A(B).

- 3.33 IF the Filter Aid Precoat Tank has reached the low level limit
- THEN
1. Fill the Filter Aid Precoat Tank with condensate to a level of 80%.
 2. Repeat Steps 3.27 through 3.32.

3.34 Stop the Precoat Tank Agitator and Dust Evacuator.

3.35

NOTE

During valving operations, allow sufficient time for the (Red, Green) valve indication lights to completely change over.

Inject boron in accordance with Steps 3.35.1 through 3.35.4.

3.35.1 Open ND-27A(B), Filter Inlet Valve, by placing its selector switch to the OPEN position.

3.25.2

NOTE

When Valve ND28A(B) is placed in AUTO, if the valve does not open or if it opens and then closes, a Cleanup Filter Isolation signal was actuated while the filter was in hold, and the programmer needs to be reset. To reset programmer refer to Procedure 303, Reactor Cleanup Demineralizer System.

Open ND28A(B), Filter Outlet Valve, by placing its selector switch to the AUTO position.

3.25.3 Close V-16-83, Cleanup System Filter Bypass Valve. Allow approximately one (1) minute to ensure that the Filter Outlet Valve ND28A(B) remains open.

3.25.4 Operate the Cleanup System in this mode for five (5) minutes.

3.36 Bypass and isolate the Cleanup Filters by opening V-16-83 and closing ND27A(B) and ND28A(B).

3.37 Return to Step 3.5 as required to add additional boron.

SUPPORT PROCEDURE 24

ALTERNATE BORON INJECTION WITH THE FEED AND CONDENSATE SYSTEM

1.0 PREREQUISITES

Injection of Boron via the Feed and Condensate System has been directed by the Emergency Operating Procedures.

2.0 PREPARATION

NOTE

The required Boric Acid and Borax come in approximately 300 lb. barrels and are stored in the warehouse under Stock Numbers 001-512-1800-1 (Bin 2-Q068-E,J) and 001-512-2000-1 (Bin 2-Q064-E) respectively. Although only six (6) barrels each are necessary to achieve a cold shutdown Boron weight of 273 lbs. plus a 25 percent conservatism, all available barrels (normally 10 each) should be transported to the Turbine Operating Floor.

- 2.1 Transport all available barrels of Boric Acid and Borax from the warehouse to the Turbine Operating Floor.
- 2.2 Select a Condensate Demineralizer and transfer its resin to the Final Rinse & Storage Tank in accordance with Procedure 319, Condensate Demineralizer Resin Regeneration and Transfer System.
- 2.3 Confirm open Condensate Transfer Supply Valve V-11-14. (Con Demin Area)
- 2.4 Confirm open FR & ST Bypass Valve V-2-788. (Regen Room)
- 2.5 Confirm closed Resin Transfer Piping Cross-Connect Valve V-2-786 and FR & ST Inlet Valve V-2-787. (Regen Room)
- 2.6 Confirm the HI/LO select switch on the Condensate Demineralizer Control Panel in the HI position.
- 2.7 Check closed pressure breaker valves V-2-S-7 and V-2-S-9, by observing closed (green) indicating lights.

3.0 PROCEDURE

When directed by the GSS/GOS, perform the following:

3.1 Addition of Borax and Boric Acid into the Cation Tank

NOTE

Unless otherwise noted, all valve manipulations refer to selecting and operating a valve on the J.O. Backwash MANUAL OPERATION screen.

- 3.1.1 On the J.O. Backwash Main Menu, select the MANUAL OPERATION function.
- 3.1.2 Vent and drain the cation tank as follows:
- 3.1.2.1 Open vent valve V-2-C-4.
- 3.1.2.2 Open rinse outlet valve V-2-C-2.
- 3.1.3 WHEN the cation tank is vented and drained,
THEN close rinse outlet valve V-2-C-2.
- 3.1.4 Open rinse inlet valve V-2-C-8 until the tank is approximately 30% full, then close V-2-C-8.
- 3.1.5 On the heater bay roof, perform the following:
- 3.1.5.1 Manually open pressure gauge isolation valve V-2-743 and verify that the cation tank is depressurized, then close V-2-743.
- 3.1.5.2 Confirm closed cation tank resin fill valve V-2-742.
- 3.1.5.3 Remove the flange above V-2-742. Insert the funnel and hook up the water hose. The funnel and hose are located on the east wall of the Turbine Building, directly in-line with the fill valve.

3.1.5.4 Open cation tank resin fill valve V-2-742. _____

3.1.5.5

NOTE

Three drums of Borax and three drums of Boric Acid shall be added to the cation tank. The time assumption for the addition of the six drums is approximately 45 minutes.

Open Domestic Water Valve V-10-562 and add three drums of Boric Acid and three drums of Borax to the cation tank. Alternate scoops of boric acid and borax when filling cation tank. _____

3.1.5.6 WHEN all six drums have been added

or

cation tank is 75% full,

THEN close Domestic Water Valve V-10-562 and resin fill valve V-2-742. _____

3.1.6 IF cation tank level is not approximately 75% full,
THEN open rinse inlet valve V-2-C-8 until cation tank level indicates approximately 75% full, then close V-2-C-8. _____

3.1.7 Open air inlet valve V-2-C-3, and air mix cation tank contents for 5-10 minutes, then close V-2-C-3. _____

3.1.8 Close vent valve V-2-C-4, and confirm closed vent valve V-2-C-14. _____

3.2 Transferring Borated Water from the Cation Tank to the
Condensate Demineralizer Unit.

NOTE

This instruction and subsequent valve management will apply to
condensate demineralizer unit 1-1. This same procedure is
typical for the remaining demineralizer units.

3.2.1 Ensure the demineralizer to be used is isolated and
drained by performing the following:

3.2.1.1 Verify the following valves are closed:

- Condensate Inlet V-2-D-11
- Condensate Outlet V-2-D-12
- Mixed Resin Inlet V-2-D-13
- Mixed Resin Outlet V-2-D-14
- Recycle Outlet V-2-D-15
- Vent V-2-D-16.

3.2.1.2 Drain the unit by manually
performing the following:

- Confirm closed vent valve
V-2-D-100.
- Open header vent valve
V-2-D-99.
- Open recycle drain valves
V-2-D-3 and V-2-D-8.
- Slowly open demineralizer vent
valve V-2-D-16 and recycle
outlet valve V-2-D-15.

3.2.2 WHEN the demineralizer is drained,
THEN manually close the following valves:

- recycle drains V-2-D-3 and
V-2-D-8
- recycle outlet V-2-D-15

- 3.2.3 Prepare to transfer borated water by opening the following valves:
 - 3.2.3.1 Manually open demineralizer resin inlet valve V-2-D-13. _____
 - 3.2.3.2 Open transfer valves V-2-T-2 and V-2-T-3. _____
- 3.2.4 Pressurize the cation tank by opening cation tank air inlet valve V-2-C-3. _____
- 3.2.5 Open cation tank resin outlet valve V-2-C-10 and transfer the borated water to the demineralizer unit. _____
- 3.2.6 After all borated water has been transferred to the demineralizer, as indicated by J.O. Backwash Panel or local sightglass, close the following valves:
 - 3.2.6.1 Cation tank air inlet V-2-C-3. _____
 - 3.2.6.2 Cation tank resin outlet V-2-C-10. _____
 - 3.2.6.3 Transfer valves V-2-T-2 and V-2-T-3. _____
 - 3.2.6.4 Demineralizer resin inlet V-2-D-13 (manually). _____
 - 3.2.6.5 Demineralizer vent V-2-D-16 (manually). _____
 - 3.2.6.6 Vent header isolation V-2-D-99 (manually). _____

3.3

* **CAUTION** *
* The amount of time condensate flow is allowed to drop below *
* 2400 gpm should be minimized to ensure adequate cooling flow *
* is maintained to condensate system components. *

To prevent loss of boron, isolate the following flow paths using Steps 3.3.1 through 3.3.5.

NOTE

A KA10 Key is required for entry into the Condensate Transfer Building.

3.3.1 Isolate the demineralizer discharge to the Condensate Storage Tank by closing the following valves located in the Condensate Transfer Building.

- V-2-42, Cond. Reject to CST Isolation Valve
- V-2-14, Cond. Reject FRV Bypass Valve
- V-2-88, Cond. Reject FRV Bypass Valve

3.3.2 Isolate the demineralizer discharge to the CRD WATER QUALITY LINE BY SHUTTING V-2-122, Flow Control Valve (V-2-124) Inlet Isolation Valve, in the Condenser Bay.

3.3.3 Isolate any reactor feedwater strings not required to maintain adequate core cooling by closing their Heater String Outlet Isolation Valves (V-2-10, V-2-11, V-2-12).

NOTE

An MB-1 Key is required to complete Step 3.3.4

3.3.4 Isolate the reactor feed pump minimum flow lines by unlocking and closing V-2-230 (A), 231 (B) and 232 (C), Minimum Flow Isolation Valves, to prevent boron loss.

3.3.5 Isolate Turbine Exhaust Hood Spray by shutting V-2-83, Condenser Hood Spray Isolation Valve. (Turbine Bldg Mezzanine)

3.4

NOTE

All valve manipulations in this section must be done manually, as these valves are not operated on the J.O. Backwash MANUAL OPERATION screen.

Place the demineralizer with Borated Water in service in accordance with the following:

- 3.4.1 Confirm at least one feed string is lined up for injection into RPV with its Condensate Pump running, feed pump running and heater string outlet valve open. _____
- 3.4.2 Confirm demineralizer inlet valve is cracked open. _____
- 3.4.3 Vent the demineralizer as follows:
 - 1. Check closed auxiliary vent valve V-2-D-100 and open header vent valve V-2-D-99. _____
 - 2. Insure drain valve V-2-D-3, V-2-D-8 and other demineralizer units recycle valve are closed. _____

3.4.4

NOTE

Minimize venting of Borated Water from the demineralizer.

*
* **CAUTION** *
* All air must be vented from the demineralizer before *
* placing unit in service. *
*

Verify proper fill and venting of the demineralizer by cracking open the unit vent valve V-2-D-16 until water runs through the vent sight glass.

- 3.4.5 Close the unit's vent valve V-2-D-16 and V-2-D-99 when the demineralizer is filled and vented. _____
- 3.4.6 Open outlet valve V-2-D-12 to put Condensate Demineralizer in service. _____

- 3.5 IF additional Boron is required,
THEN repeat Steps 3.1 through 3.4
- 3.6 If directed by the GSS, return system to normal per
Procedure 319.
- 3.7 Return to the J.O. Backwash Main Menu by pressing
the HOME key.
-

SECTION VI

MINI-SCENARIO J

SCRAM DISCHARGE VOLUME

MINI-SCENARIO J - SCRAM Discharge Volume

1. SUMMARY

This mini-scenario provides additional guidance and data for the Observer/personnel responding to investigate/repair the failure of Control Rods to fully insert. The responding disciplines are expected to be Maintenance and Operations.

This mini-scenario initiates when repeated attempts to scram the Reactor fail. An OSC repair team is dispatched to investigate and repair.

2. Event Time Line (All times approximate)

T = 17:45 or later	Reactor fails to "scram". Repeated attempts by Operations to insert control rods fail. OSC is requested to dispatch team to investigate and repair.
T = 18:00 or later	Team arrives at scram discharge header and attempts to vent the header to eliminate hydraulic block.
T = 19:10 or later	"B" Isolation Condenser ruptures, filling the Reactor building with steam. If team has not been successful in venting header, they are expected to leave the building at this time. If they have been successful, venting is complete and will allow control rods to insert.

3. Controller/Observer Information

This mini-scenario is intended to test the ability of the OSC to dispatch a team in a timely manner to investigate and repair the hydraulic blockage of the Scram Discharge Volume (SDV) system.

The intended problem with the SDV is that over time, minor valve leakage has allowed water to seep into the headers of Scram Discharge Instrument Volume (SDIV) panels (see drawing 197E871 attached for specific details). This water has caused a hydraulic block in the system which is not allowing control rod drives (CRDs) to bleed off, permitting rods to insert.

It is expected the responding team will attempt to open/vent the system by opening valves V-305-223 through V-305-234. These are drain valves (see attached drawing), which will allow the system to vent when selectively opened.

THE SYSTEM CANNOT BE RETURNED TO SERVICE PRIOR TO 19:10 HOURS. IT IS INTENDED THAT AT 19:10, "B" ISOLATION CONDENSER RUPTURES, FILLING THE REACTOR BUILDING WITH STEAM.

It is necessary to maintain that time so that sufficient pressure is maintained in the reactor to drive the intended off-site release. If the repair team realizes the problem and attempts to repair it too quickly, the Observer should take steps to slow down the process to maintain the time line (Message J-1). The Observers may, at his/her discretion, not allow the team to succeed prior to 19:10, thus forcing them to leave the Reactor building at the time of the rupture (Message J-2).

The Observer should note that the responding team brings appropriate tools and test equipment to evaluate and repair the problem.

DO NOT PERMIT ANY VALVES OR EQUIPMENT TO BE MANIPULATED DURING THIS SCENARIO!!! SIMULATE ALL ACTIVITIES!

If team is successful and rods are inserted (AFTER 19:10 hrs), ensure the Control Room/Simulator is notified so that appropriate response can be modeled.

MESSAGE NO.: J-1	CLOCK TIME: 18:00 or later
FROM: Observer	TO: SDV Repair Team
CONTROLLER INFORMATION: Provide this information <u>only</u> if repair team appears to be returning SDV prior to time line - 19:10 hours or later.	
MESSAGE: <p style="text-align: center;"><u>THIS IS A DRILL</u></p> <p style="text-align: center;"><u>DO NOT</u> initiate actions affecting normal plant operations.</p> <ol style="list-style-type: none">1. "Valve operating hand wheels are removed and none are staged in area."2. "Selected pipe caps will not loosen, have rusted in place over time." (Intended crew will need to obtain much larger pipe wrench)3. <u>IF</u> the team realizes that there will be approx. 1000 lbs. water pressure at the vent valves, <u>THEN</u> inform them they are expected to contain/re-direct water, i.e. hose, barrel, etc. <p style="text-align: center;"><u>THIS IS A DRILL</u></p>	

H
G
F
E
D
C
B

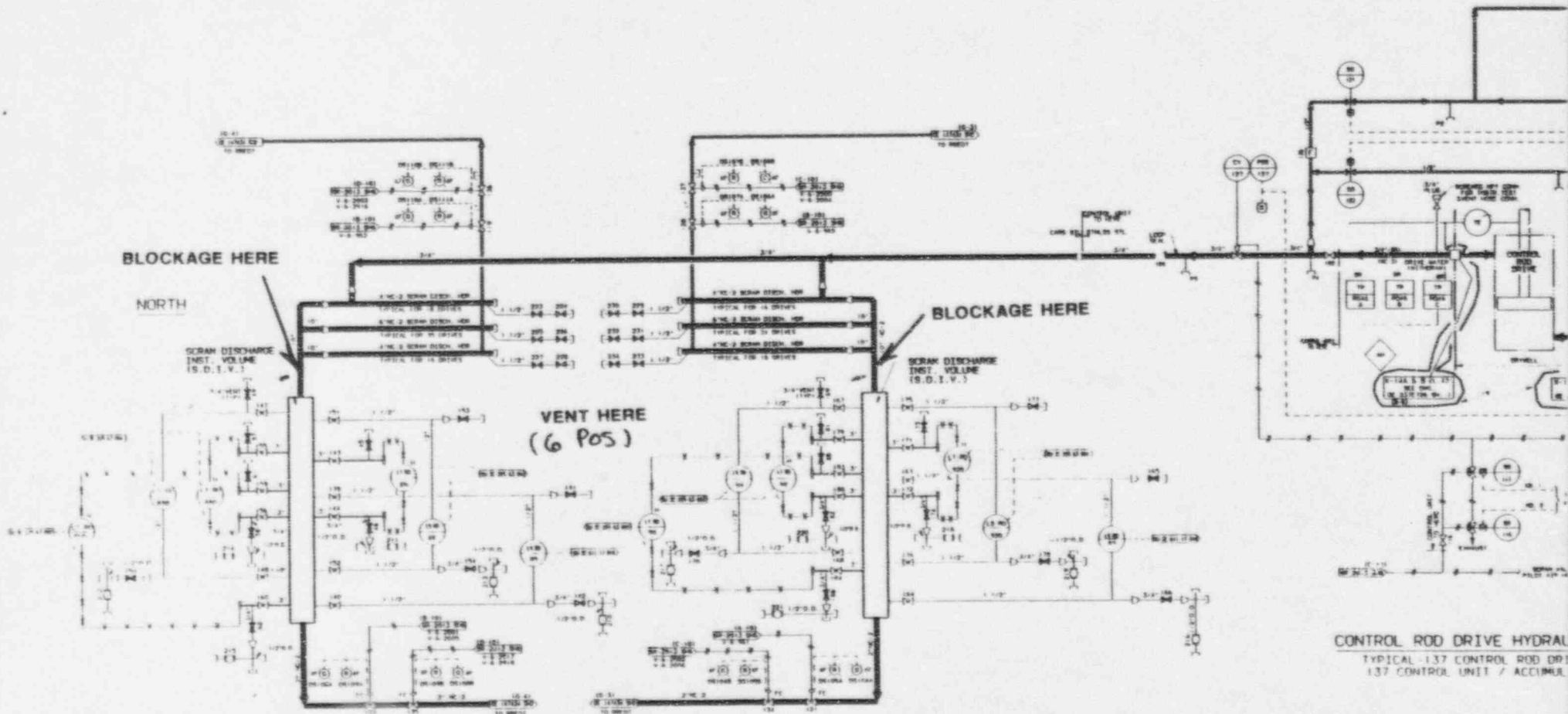

SCRAM DISCHARGE VOLUME SYSTEM

CONTROL ROD DRIVE HYDRAL
TYPICAL 137 CONTROL ROD DR
137 CONTROL UNIT / ACCUMUL

LABELLING NOTES:

1. ALL VALVES AND INSTRUMENTS ON CONTROL ROD SYSTEM ARE PREFIXED BY "305" UNLESS OTHER
2. ALL VALVES AND INSTRUMENTS ON SCRAM DISCH SYSTEM ARE PREFIXED BY "157" UNLESS OTHER

MESSAGE NO.: J-2	CLOCK TIME: 19:10 or later
FROM: Observer	TO: SDV Repair Team
CONTROLLER INFORMATION: Provide this information <u>only</u> if at 19:10 hours or later, the crew/team has not yet determined/repared SDV.	
MESSAGE: <p style="text-align: center;"><u>THIS IS A DRILL</u></p> <p style="text-align: center;"><u>DO NOT</u> initiate actions affecting normal plant operations.</p> <p>"You have just heard a loud rupture and extreme hissing noise. The building is filling with steam."</p> <p style="text-align: center;"><u>THIS IS A DRILL</u></p>	

SECTION VI

MINI-SCENARIO K

VENTING OVERPISTON AREA

MINI-SCENARIO K - Venting Overpiston Area

1. **SUMMARY**

This mini-scenario provides additional guidance and data for the Observer/Controller and personnel attempting to insert control rods by venting the overpiston area to the Rx Building atmosphere.

Once the failure to SCRAM is recognized to be due to a hydraulic lock and the operable CRD pump has tripped, the GSS/ED and/or the IREO ED is expected to direct the OSC to send a team to vent the overpiston area to enable Rx pressure to insert the rods rapidly.

This team "cannot" be allowed to succeed because power and pressure must be maintained until 19:10 to ensue a driving force for the leak.

A series of problems/malfunctions will be used to prevent the success of this operation until they are forced to leave the Rx Building due to the Isolation Condenser leak.

2. **Event Time Line (All times approximate)**

- | | |
|--------------------------|---|
| T = 17:22 | Failure to scram - commence inserting control rods using CRD pressure. |
| T = 17:30
+/- 5 min. | CRD Pump "B" trips. |
| T = 17:40
+/- 10 min. | OSC is requested to send a team into the Rx Building to vent the CRD overpiston area. |
| T = 17:55
+/- 15 min. | OSC Team arrives at the CRD valve area on Rx Building ele. 23'.
(Message Card K-1) |
| T = 19:05
+/- 5 min. | Earliest that lineup can be successfully completed. |
| T = 19:10 | Iso. Condenser line ruptures filling the Rx Building with highly radioactive steam. OSC team must evacuate. |

3. Controller/Observer Information

This mini-scenario is designed to prevent shutting down the reactor prior to the Isolation Condenser. This is necessary to ensure the leak's driving force.

The OSC team will be following EOP Support Procedure 21 "Alternate Insertion of Control Rods", Section 3.7. (attached). A copy of the piping arrangement has also been attached to the message card K-1. This message is intended to provide problems to delay the completion until just before the team is forced to leave the Rx Building due to the Iso. Condenser leak.

NOTE

Allowing completion of this lineup prior to 19:00 will cause significant deviation from the scenario and an unsuccessful performance by the exercise participants.

Insure that any information is provided only if it is earned. The Observer should all use all steps of the procedure and any troubleshooting and repair activities are fully simulated.

If necessary, the Observer should create steps beyond message K-1 to maintain the activities to the time line.

1. 1/2" DIA. (1/4" DIA. FOR 1/2" DIA. VALVES)
 2. 1/4" DIA. (1/8" DIA. FOR 1/4" DIA. VALVES)
 3. 1/8" DIA. (1/16" DIA. FOR 1/8" DIA. VALVES)
 4. 1/16" DIA. (1/32" DIA. FOR 1/16" DIA. VALVES)
 5. 1/32" DIA. (1/64" DIA. FOR 1/32" DIA. VALVES)

LEGEND
 A. MOTOR OPERATED
 B. SELECTOR SWITCH
 C. VALVE POSITION

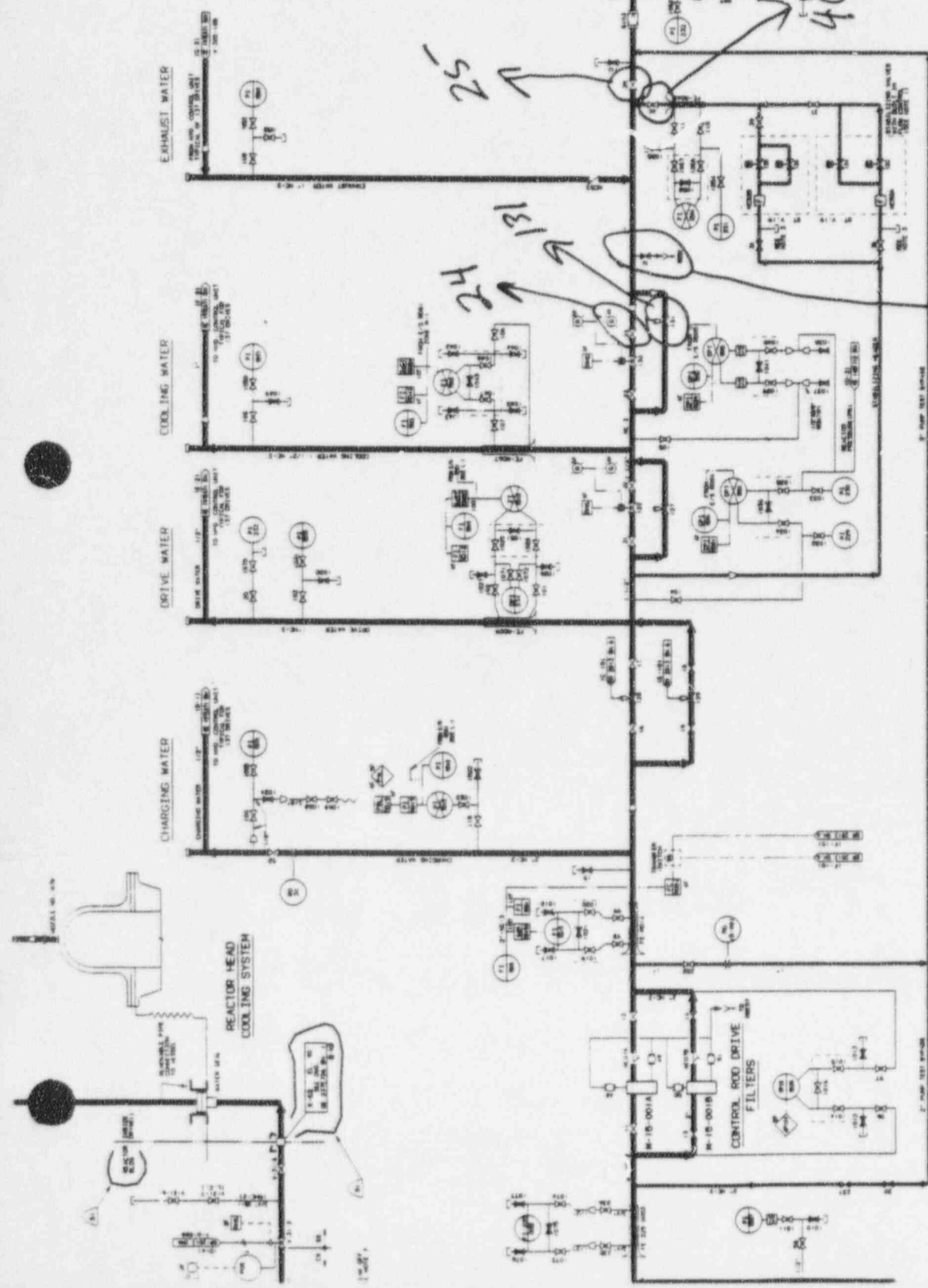

GENERAL NOTES:

1. ALL VALVES ARE PREFRIGED V-15 UNLESS OTHERWISE NOTED.
2. ALL VALVES ARE PREFRIGED V-15 UNLESS OTHERWISE NOTED.
3. ALL VALVES ARE PREFRIGED V-15 UNLESS OTHERWISE NOTED.
4. ALL VALVES ARE PREFRIGED V-15 UNLESS OTHERWISE NOTED.
5. ALL VALVES ARE PREFRIGED V-15 UNLESS OTHERWISE NOTED.
6. ALL VALVES ARE PREFRIGED V-15 UNLESS OTHERWISE NOTED.
7. ALL VALVES ARE PREFRIGED V-15 UNLESS OTHERWISE NOTED.

LABELLING NOTE:

1. ALL VALVES ARE PREFRIGED V-15 UNLESS OTHERWISE NOTED.

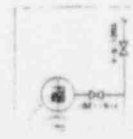

1. 1/2" DIA. (1/4" DIA. FOR 1/2" DIA. VALVES)
 2. 1/4" DIA. (1/8" DIA. FOR 1/4" DIA. VALVES)
 3. 1/8" DIA. (1/16" DIA. FOR 1/8" DIA. VALVES)
 4. 1/16" DIA. (1/32" DIA. FOR 1/16" DIA. VALVES)
 5. 1/32" DIA. (1/64" DIA. FOR 1/32" DIA. VALVES)

CONTROL ROD DRIVE SYSTEM
 FLOW DIAGRAM
 237E487
 1. 1/2" DIA. (1/4" DIA. FOR 1/2" DIA. VALVES)
 2. 1/4" DIA. (1/8" DIA. FOR 1/4" DIA. VALVES)
 3. 1/8" DIA. (1/16" DIA. FOR 1/8" DIA. VALVES)
 4. 1/16" DIA. (1/32" DIA. FOR 1/16" DIA. VALVES)
 5. 1/32" DIA. (1/64" DIA. FOR 1/32" DIA. VALVES)

NO.	DATE	DESCRIPTION	TITLE
1	10/15/54	REVISION	CONTROL ROD DRIVE SYSTEM FLOW DIAGRAM
2	11/15/54	REVISION	CONTROL ROD DRIVE SYSTEM FLOW DIAGRAM
3	12/15/54	REVISION	CONTROL ROD DRIVE SYSTEM FLOW DIAGRAM
4	1/15/55	REVISION	CONTROL ROD DRIVE SYSTEM FLOW DIAGRAM
5	2/15/55	REVISION	CONTROL ROD DRIVE SYSTEM FLOW DIAGRAM
6	3/15/55	REVISION	CONTROL ROD DRIVE SYSTEM FLOW DIAGRAM
7	4/15/55	REVISION	CONTROL ROD DRIVE SYSTEM FLOW DIAGRAM
8	5/15/55	REVISION	CONTROL ROD DRIVE SYSTEM FLOW DIAGRAM
9	6/15/55	REVISION	CONTROL ROD DRIVE SYSTEM FLOW DIAGRAM
10	7/15/55	REVISION	CONTROL ROD DRIVE SYSTEM FLOW DIAGRAM
11	8/15/55	REVISION	CONTROL ROD DRIVE SYSTEM FLOW DIAGRAM
12	9/15/55	REVISION	CONTROL ROD DRIVE SYSTEM FLOW DIAGRAM
13	10/15/55	REVISION	CONTROL ROD DRIVE SYSTEM FLOW DIAGRAM
14	11/15/55	REVISION	CONTROL ROD DRIVE SYSTEM FLOW DIAGRAM
15	12/15/55	REVISION	CONTROL ROD DRIVE SYSTEM FLOW DIAGRAM

1. 1/2" DIA. (1/4" DIA. FOR 1/2" DIA. VALVES)
 2. 1/4" DIA. (1/8" DIA. FOR 1/4" DIA. VALVES)
 3. 1/8" DIA. (1/16" DIA. FOR 1/8" DIA. VALVES)
 4. 1/16" DIA. (1/32" DIA. FOR 1/16" DIA. VALVES)
 5. 1/32" DIA. (1/64" DIA. FOR 1/32" DIA. VALVES)

SUPPORT PROCEDURE 21

ALTERNATE INSERTION OF CONTROL RODS

1.0 PREREQUISITES

Insertion of Control Rods utilizing alternate methods has been directed by the Emergency Operating Procedures.

2.0 PREPARATION

None.

3.0 PROCEDURE

NOTE

Alternate methods of control rod insertion may be performed in any order or concurrently as applicable.

When directed by the GSS/GOS, perform the following:

3.1 Driving Control Rods

- 3.1.1 Start available CRD Pumps (Panel 4F). _____
- 3.1.2 Place Reactor Mode Switch in REFUEL (Panel 4F). _____
- 3.1.3 Place the ROD WORTH MININIZER keylock in BYPASS
(Panel 4F). _____
- 3.1.4 Maximize CRD drive water differential pressure by
closing CRD DRIVE WATER PRESS CONTROL Valve (NC18)
(Panel 4F). _____
- 3.1.5 Close Charging Header Supply Valve V-15-52
(RB 23 SE). _____
- 3.1.6 Throttle closed bypass valve V-15-30 as
required (RB 23 SE). _____
- 3.1.7 Rapidly insert control rods manually
(Panel 4F). _____

3.2 Deenergize Scram Solenoids

3.2.1 IF MSIVs are closed,
THEN place both 100-amp Main RPS Breakers
in OFF (Panel 6R/7R). _____
WHEN the control rods are no longer moving in,
THEN confirm the 100 amp Main RPS Breakers in ON. _____

3.2.2 IF MSIVs are open,
THEN place RPS Channel I and II Subchannel Test
Keylocks IA, IB, IIA and IIB in TRIP
position (Panel 6R/7R). _____
WHEN the control rods are no longer moving in,
THEN confirm the RPS Channel I and II Subchannel
Test Keylocks in NORMAL position
(Panel 6R/7R). _____

3.3 Venting the Scram Air Header

3.3.1 Close Scram Air Header Isolation Valve
V-6-175 (RB23SE). _____
3.3.2 Open Scram Air Header Drain Valve V-6-409 (RB23SE). _____
3.3.3 WHEN control rods are no longer moving in,
THEN 1. Close Scram Air Header Drain Valve V-6-409. _____
2. Open Scram Air Header Isolation Valve V-6-175. _____

3.4 Manual Scram

3.4.1 Place the ARI Normal/Bypass Switch in BYPASS position
(Rear of Panel 8R). _____

3.4.2 Depress the ARI Manual Reset pushbutton (Panel 4F). _____

3.4.3 IF Defeating RPS logic trips is necessary prior
to resetting the scram,

THEN perform the following:

3.4.3.1 Obtain four (4) bypass plugs from the EOP
Tool Box in the Control Room.

3.4.3.2 Open the EOP BYPASS PLUGS panel in
the rear of Panel 6R.

1. Insert a bypass plug into BP5. _____

2. Insert a bypass plug into BP6. _____

3.4.3.3 Open the EOP BYPASS PLUGS panel in
the rear of Panel 7R.

1. Insert a bypass plug into BP5. _____

2. Insert a bypass plug into BP6. _____

3.4.4 Confirm operating all available CRD Pumps (Panel 4F). _____

3.4.5 Reset the scram by depressing the Scram Reset
Buttons (Panel 4F). _____

3.4.6 Confirm open SDV vent and drain valves (Panel 4F). _____

3.4.7 When the SDV LEVEL HI-HI alarms (H-1-b and
H-2-b) clear

then manually scram the reactor by depressing the
scram buttons (Panel 4F). _____

3.5 Opening Individual Scram Test Switches

3.5.1 Place the ARI Normal/Bypass Switch in Bypass position
(Rear of Panel 6R). _____

3.5.2 Depress the ARI Manual Reset pushbutton (Panel 4F). _____

3.5.3 IF Defeating RPS Logic trips is necessary
prior to resetting the scram,
THEN perform the following:

3.5.3.1 Obtain four (4) bypass plugs from the EOP Tool Box
in the Control Room.

3.5.3.2 Open the EOP BYPASS PLUGS panel in
the rear of Panel 6R.

1. Insert a bypass plug into BP5. _____

2. Insert a bypass plug into BP6. _____

3.5.3.3 Open the EOP BYPASS PLUGS panel in
the rear of Panel 7R.

1. Insert a bypass plug into BP5. _____

2. Insert a bypass plug into BP6. _____

3.5.4 Confirm operating all available CRD Pumps (Panel 4F). _____

3.5.5 Reset the scram by depressing the Scram Reset
Buttons (Panel 4F). _____

3.5.6 Confirm open SDV vent and drain valves (Panel 4F). _____

3.5.7 *****
*
* CAUTION *
*
* While performing this procedure, potentially *
* radioactive steam may be released and Reactor *
* Building airborne contamination levels may *
* increase. *

Individually open the scram test switch on

Panel 6XR for a control rod not inserted. _____

3.5.8 Close the scram test switch when the control
rod stops moving. _____

3.5.9 Repeat Steps 3.5.7 and 3.5.8 as required.

3.6 Increasing CRD Cooling Water Differential Pressure

3.6.1 Start available CRD Pumps (Panel 4F). _____

3.6.2 Close Charging Header Supply Valve V-15-52
(RB 23 SE). _____

3.6.3 Increase CRD cooling water differential
pressure. _____

3.6.4 Throttle closed bypass valve V-15-30
as required (RB 23 SE). _____

NOTE

This method is to be used ONLY if all other insertion methods fail.

3.7 Venting Control Rod Drive Over Piston Volume

NOTE

If no CRD Pumps are available, this method may still be used provided Reactor pressure is greater than 600 psig.

* CAUTION *
* *
* While performing this procedure, potentially radioactive steam *
* may be released from the drain line effluent and Reactor *
* Building airborne contamination levels may increase. *

- 3.7.1 Start available CRD pumps (Panel 4F). _____
- 3.7.2 Close Cooling Water PCV isolation V-15-24 (RB23SE). _____
- 3.7.3 Close Exhaust Header root valve V-15-25 (RB23SE). _____
- 3.7.4 Close Stabilizer Unit Outlet valve V-15-40 (RB23SE). _____

- 3.7.5 Confirm closed Cooling Water PCV bypass valve
V-15-131 (RB 23 SE). _____
- 3.7.6 Open drain valve V-15-74 (RB 23 SE). _____
- 3.7.7 Place Reactor Mode Switch in REFUEL (Panel 4F). _____
- 3.7.8 Insert control rods manually from Panel 4F. _____
- 3.7.9 Monitor Reactor Building airborne radiation
levels. _____

- 3.7.10 WHEN control rods are no longer moving in
THEN 1. Close V-15-74 (RB 23 SE). _____
2. Open the following valves (RB 23 SE):
 - V-15-40 _____
 - V-15-25 _____
 - V-15-24 _____

Title
Emergency Diesel Generator OperationRevision No.
40

3.2.5 For the Diesel Generators to be considered operable per Technical Specifications, there shall be a minimum of 14,000 gallons of diesel fuel in the Diesel Generator Fuel Tank.

3.2.6

NOTE 1

The Alternate Fuel Oil Supply is not required for meeting the Technical Specification requirements for declaring the Diesel Generators operable; nor can it take the place of the Diesel Fuel Oil Storage Tank when meeting operability requirements.

NOTE 2

A minimum level of 8 feet in the 75,000 gallon fuel oil tank is required to ensure adequate suction pressure at the EDG skid mounted fuel oil pump during alternate fuel oil transfer. This will ensure that sufficient fuel is available to one diesel generator for 24 hours of operation at the maximum capacity KW load.

The Alternate Fuel Oil Supply shall be considered available when there is a minimum of 8 feet of fuel oil in the 75,000 gallon fuel oil tank.

3.2.7 In the event of an oil spill in the Diesel Generator Building which could cause oil to reach the floor drains, drain plugs shall be inserted in the drains to prevent oil discharging to the canal. The drain plugs are located in the tool storage box for this purpose. The GSS shall be notified when the drain plugs are installed.

Title
Emergency Diesel Generator Operation

Revision No.
40

3.2.8 Maintain the following battery voltages at the battery charger:

- 1. Float voltage setting = 127.5 volts
- 2. Equalizing voltage setting = 129.0 volts
(When batteries are connected to DC controls)
- 3. Equalizing voltage setting = 132.7 volts
(When batteries are not connected to controls)

3.3 Instructions for Alignment of the Emergency Diesel Generators for Automatic Start

NOTE

If a Diesel Generator is taken out of the auto-start mode due to maintenance, Attachment 341-1 must be completed before the Diesel Generator is operated to be returned to an operable status.

- 3.3.1 Complete Equipment Check-List, Attachment 341-1.
- 3.3.2 Complete Valve Check-off List, Attachment 341-2, for normal operation, with the Diesel Generator Fuel Tank in service.

- 3.3.3 *****
*
* CAUTION *
*
* Use of the alternate fuel oil supply requires isolating *
* the diesel fuel oil storage tank thereby rendering the *
* Emergency Diesel Generator inoperable per Technical *
* Specifications. This line-up should only be used in an *
* extreme emergency and only with the approval of the *
* Manager of Plant Operations, if available or the GSS *
* during plant emergencies. Only one EDG can be supplied *
* at a time with the alternate fuel oil supply. *
*
*

Title
Emergency Diesel Generator OperationRevision No.
40

IF the Diesel Oil Storage Tank is out of service,

AND

the approval of the Manager Plant Operations, or designee,
or the GSS during a plant emergency, has been obtained,

THEN complete Attachment 341-3 to supply fuel oil to #1
Emergency Diesel Generator

OR

Attachment 341-4 to supply fuel oil to #2 Emergency Diesel
Generator.

4.0 EMERGENCY DIESEL GENERATOR AUTOMATIC START AND LOADING SEQUENCES

4.1 Prerequisites

4.1.1 The Diesel Generators are lined up for automatic operation in
accordance with Section 3.0.

4.2 Precautions and Limitations

4.2.1 Diesel generator loading shall be restricted as follows:

4.2.1.1 In automatic peaking mode operation parallel with
the system (automatic or manual operation),
load shall be limited to the peaking rating
of 2750 KW, 3440 KVA.

4.2.1.2 With automatic parallel operation, load may be
permitted up to 2850 KW for a maximum period of two
hours during any one diesel load cycle.

4.2.1.3 During emergency operation of Diesel Generators
(for actual loss of power to plant buses), load

Title
Emergency Diesel Generator Operation

Revision No.
41

ATTACHMENT 341-3

EMERGENCY DIESEL GENERATOR NO. 1

VALVE LINEUP LIST FOR ALTERNATE FUEL OIL SUPPLY

<u>Valve Number</u>	<u>Type Oper</u>	<u>Function</u>	<u>Control Location</u>	<u>Position</u>	<u>Initial/Verify</u>
V-36-46	M	Alternate Supply to #1 & #2 DG Isolation	Outside EDG Bldg.	O	_____ / _____
V-36-94	M	FI-442-8 Bypass	Outside EDG Bldg.	O	_____ / _____
V-36-95	M	FI-442-8 Inlet	Outside EDG Bldg.	C	_____ / _____
V-36-96	M	FI-442-8 Outlet	Outside EDG Bldg.	C	_____ / _____
V-36-18	M	DG Fuel Oil Tank and Alternate Supply Transfer Isolation	Outside EDG Bldg.	O	_____ / _____
V-39-107	M	#2 EDG Normal Supply Isolation	West Wall EDG-2 Room	C	_____ / _____
V-36-47	M	Alternate Supply to #1 DG Isolation	West Wall EDG-1 Room	O	_____ / _____
V-39-106	M	#1 EDG Normal Supply Isolation	West Wall EDG-1 Room	C	_____ / _____
V-36-90	M	Fuel Oil Transfer Line Outlet	Outside Wall of Boiler Hse.	C	_____ / _____
V-36-51	M	Alternate Fuel Oil Line Supply	Boiler Hse.	O	_____ / _____
V-36-53	M	Fuel Oil Transfer Pump 1-1 Suction	Boiler Hse.	C	_____ / _____
V-36-13	M	Fuel Oil Transfer Pump 1-1 Supply	Boiler Hse.	O	_____ / _____
V-36-7	M	#1 Boiler Fuel Oil Pumps 1A/1B Suction Strainers Isolation	Boiler Hse.	C	_____ / _____

Checked By: _____
Signature Date Time

Verified By: _____
Signature Date Time

Reviewed and Approved By: _____
GSS Signature Date Time

Title
Emergency Diesel Generator Operation

Revision No.
41

ATTACHMENT 341-4

EMERGENCY DIESEL GENERATOR NO. 2

VALVE LINEUP LIST FOR ALTERNATE FUEL OIL SUPPLY

<u>Valve Number</u>	<u>Type Oper</u>	<u>Function</u>	<u>Control Location</u>	<u>Position</u>	<u>Initial/Verify</u>
V-36-46	M	Alternate Supply to #1 & #2 DG Isolation	Outside EDG Bldg.	O	_____ / _____
V-36-94	M	FI-442-8 Bypass	Outside EDG Bldg.	O	_____ / _____
V-36-95	M	FI-442-8 Inlet	Outside EDG Bldg.	C	_____ / _____
V-36-96	M	FI-442-8 Outlet	Outside EDG Bldg.	C	_____ / _____
V-36-18	M	DG Fuel Oil Tank and Alternate Supply Transfer Isolation	Outside EDG Bldg.	O	_____ / _____
V-39-10	M	#1 EDG Normal Supply Isolation	West Wall EDG-1 Room	C	_____ / _____
V-36-48	M	Alternate Supply to #2 DG Isolation	West Wall EDG-2 Room	O	_____ / _____
V-39-107	M	#2 EDG Normal Supply Isolation	West Wall EDG-2 Room	C	_____ / _____
V-36-90	M	Fuel Oil Transfer Line Outlet Pump to Diesel Generator Fuel Oil Tank	Outside Wall of Boiler Hse.	C	_____ / _____
V-36-51	M	Alternate Fuel Oil Line Supply	Boiler Hse.	O	_____ / _____
V-36-53	M	Fuel Oil Transfer Pump 1-1 Suction	Boiler Hse.	C	_____ / _____
V-36-13	M	Fuel Oil Transfer Pump 1-1 Supply	Boiler Hse.	O	_____ / _____
V-36-7	M	#1 Boiler Fuel Oil Pumps 1A/1B Suction Strainers Isolation	Boiler Hse.	C	_____ / _____

Checked By: _____
Signature Date Time

Verified By: _____
Signature Date Time

Reviewed and Approved By: _____
GSS Signature Date Time