

Georgia Power Company
333 Piedmont Avenue
Atlanta, Georgia 30308
Telephone 404 526-6526

Mailing Address:
Post Office Box 4545
Atlanta, Georgia 30302

L. T. Gucwa
Manager Nuclear Engineering
and Chief Nuclear Engineer

August 7, 1984

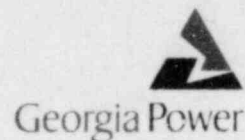

the southern electric system

NED-84-397

Director of Nuclear Reactor Regulation
Attention: Mr. John F. Stolz, Chief
Operating Reactors Branch No. 4
Division of Licensing
U. S. Nuclear Regulatory Commission
Washington, D. C. 20555

NRC DOCKETS 50-321, 50-366
OPERATING LICENSES DPR-57, NPF-5
EDWIN I. HATCH NUCLEAR PLANT UNITS 1, 2
SUPPLEMENT TO SUBMITTAL OF SPDS INFORMATION

Gentlemen:

This letter is in response to a telephone request on July 17, 1984, from Prasad Kadambi and Joe Joyce of the NRC to Mr. Paul Springer of my staff. The following is a supplement to our letter of June 7, 1984, as requested during that telecon.

The following requests for information were noted during the telecon:

Question: The letter of June 7 states that the maximum voltage in cable trays used by SPDS is 50 volts. What about electrical cabinets, etc., that cables are routed through?

Response: Electrical cabinets have 120 VAC power supply for electronic equipment, etc. The location of the power cables makes it unlikely that they will contact any instrument cables.

Question: Where are Paragraphs 6.4.2.1, 2 and 3 of Attachment 1 to the GPC letter of June 7? They are referenced in the letter, but missing in the Attachment.

Response: There was a typographical error in the letter of June 7. The correct reference is to paragraphs 5.4.2.1, 2 and 3.

8408130379 840807
PDR ADCK 05000321
F PDR

A047
1/1

Director of Nuclear Reactor Regulation
Attention: Mr. John F. Stolz, Chief
Operating Reactors Branch No. 4
August 7, 1984
Page 2

Question: What is the pass/fail acceptance criteria for tests on the SPDS isolation devices? This information was requested in question 2.3.d of the NRC request for information dated April 23, 1984.

Response: Pass/fail acceptance criteria and results of qualification testing of the SPDS isolation devices are contained in Foxboro documents QOAAA04 (Attachment 1), and QOAB44 (Attachment 2). We have obtained permission from Foxboro to transmit these documents to the NRC for the purpose of licensing the SPDS/ERF information system.

Acceptance criteria for qualification testing are listed on page 4 of test report QOAAA04. There are no explicit acceptance criteria provided for performance of the isolation devices in response to faults applied to the outputs. However, the isolation devices were determined to be adequate for isolating Class 1E instrument loops based on the following:

Results of testing in which faults were applied to the outputs of the isolation device are contained in Foxboro test report QOAB44. Refer to page 14, Figure 1 for the test configuration. Applied faults and the corresponding equipment responses are listed on pages 11 and 12. Test results show no significant disturbance at the input in response to grounding of both outputs (reference Figure 2), and no significant disturbance at the input in response to application of 600 VAC across the outputs of the isolation device (reference Figure 4). Noise equivalent to 8% of full scale was observed on one channel when 600 VAC was applied from ground to both outputs of the isolation device (reference Figure 3). Note from the test configuration that the noise was measured at the output of the device's current-to-voltage converter, a circuit which also functions as an isolation device. The converter would prevent noise from propagating into the class 1E instrument loop. Based on these test results, and the fact that the worst credible fault in the SPDS results in 50 volts at the output of the isolation device, we conclude that Class 1E instrument loops are adequately isolated from the SPDS.

Question: What is the Military Specification (Mil Spec) for EMI emissions from the SPDS equipment?

Response: The standards for EMI characteristics of the SPDS equipment are MIL-STDs 461A and 461B (computers and monitors, respectively), "Electromagnetic Interference Characteristics Requirements for Equipment."

Georgia Power 

Director of Nuclear Reactor Regulation
Attention: Mr. John F. Stolz, Chief
Operating Reactors Branch No. 4
August 7, 1984
Page 3

Please contact this office if you have any questions or comments.

Very truly yours,



L. T. Gicwa

PLS/
Attachments: as noted

xc (w/o attachment):

H. C. Nix, Jr.
J. P. O'Reilly (NRC- Region II)
Senior Resident Inspector

Q0AAA04 PART-1
SEISMIC VIBRATION TEST PROCEDURE
for
N-2ES STYLE B RACK
and
CURRENT PRODUCTION MODEL RACK MOUNTED MODULES
for
CLASS 1E QUALIFICATION
PER IEEE 344-1975
REV D

16 JAN 78

L. W. Hewey
L. HEWEY
SUPERVISOR
QUALITY ASSURANCE LABORATORIES

J. C. Childs
J. CHILDS
STAFF ENGINEER
NUCLEAR POWER PRODUCTS
AND STANDARDS

This document, the specifications, procedures, and descriptions contained herein, are the property of The Foxboro Company, and shall not be reproduced in whole or in part, nor transmitted to others, without written permission of The Foxboro Company. This document is a working paper for review purposes only and as such does not represent any contractual intent by Foxborc. Foxboro reserves the right to revise this document without prior notice.

EXPLANATION OF LATEST REVISIONS

REV_A: First Issue

REV_B

Deleted Section 2.2 - Naturally-aged Units; will be included in QOAAA04, Part II. Specified Required Response Spectra for Class 1E Qualification of Modules, Figures 1A, 1B, 2A & 2B. Revised Sections 3.3 and 3.4 per user comments; included acceptance criteria. Added items 31 and 32 to Section 2.1. Added additional Notes to Figures 5 thru 30, where applicable, to clarify instrument testing during seismic.

REV_C

Revised Figures 1A, 1B, 1D, 2A, 2B, and 2D based on results of tests per QOAAA19. Correction second paragraph, Section 3.2.; item 11, page 1; and Figure 3, page 15.

REV_D

Clarified Section 2.1 by correcting quantity of item 6, 20 and 36; removed 2ANU-M (was Item 7) and 2AT+SBU (was Item 40); renumbered Items 7 - 37; added clarification to Section 3.2 to refer to QOAAA19; added notes to Figures 3 and 4 to clarify; revised 4th paragraph of Section 3.2 to clarify rack orientations during test. Added N-2ES Rack in second paragraph, Section 1. Added vertical RRS's to Figures 1A, 1B, 2A, 2B.

REVISION STATUS OF PAGES

<u>PAGE NO.</u>	<u>REV</u>
Title	D
i - ii	D
1 - 43	D

REVISION HISTORY

<u>REV</u>	<u>DATE</u>	<u>WRITTEN/REVISED BY</u>	<u>REVIEWED BY</u>
a	19 DEC 77	L. HEWEY	J. CHILDS
C	16 JAN 78	J. CHILDS	L. HEWEY
D	MAR 80	L. HEWEY	J. CHILDS

07450092

TABLE OF CONTENTS

<u>SECTION</u>	<u>DESCRIPTION</u>	<u>PAGE</u>
1.	Test Objective	1
2.	Test Items	1
3.	Test Procedure	2
4.	Test Documentation	4
5.	Raw Data	4

07453 0093

LIST OF ILLUSTRATIONS

<u>FIGURE</u>	<u>DESCRIPTION</u>	<u>PAGE</u>
1	Generic Required Response Spectra at OBE Level	5
1A	Generic Required Response Spectra for Class 1E (Front to Back, Back to Front, and Vertical) - OBE	6
1B	Generic Required Response Spectra for Class 1E (Side to Side and Vertical) - OBE	7
1C	Estimated Table Response Levels (Front to Back, Back to Front, and Vertical) - OBE	8
1D	Estimated Table Response Levels (Side to Side and Vertical) - OBE	9
2	Generic Required Response Spectra at SSE Level	10
2A	Generic Required Response Spectra for Class 1E (Front to Back, Back to Front, and Vertical) - SSE	11
2B	Generic Required Response Spectra for Class 1E (Side to Side and Vertical) - SSE	12
2C	Estimated Table Response Levels (Front to Back, Back to Front, and Vertical) - SSE	13
2D	Estimated Table Response Levels (Side to Side and Vertical) - SSE	14
3	Nest Loading Configurations	15
4	N-2ES Rack Configurations	16
5-30	Instrument Seismic Test Setup	17-42
31	N-2ES Rack-Accelerometer Placement	43

074560094

1. TEST OBJECTIVE

Demonstrate that the instruments listed under Section 2. Test Items will perform their required Class 1E functions, as mounted in the N-2ES Style B Rack, under generic OBE and SSE seismic environments specified herein.

To establish the structural integrity of the N-2ES Style B Rack and rack-mounted modules under generic OBE and SSE seismic environments specified herein.

2. TEST ITEMS2.1 Units of current Production Design

ITEM	QTY	MODEL	CS_CODE	STYLE	TYPE
1	1	2AI-C2L	CS-N/SRC	A	Contact Input Isolator
2	1	2AI-T2V+E	CS-N/SRC	B	EMP to Voltage Converter
3	1	2AI-I2V	CS-N/SRC	B	Current to Voltage Converter
4	1	2AI-I3V	CS-N/SRC	A	Current to Voltage Converter
5	1	2AI-I2V*	CS-N/SRC	B	Current to Voltage Converter
6	3	2ANU-D	CS-N/SRC	A	Nests
7	1	2ANU-P	CS-N/SRD	A	Nest
8	1	2AO-IPD-R++	CS-N/SRD	A	Integrator Power Driver
9	1	2AO-L2C-R	CS-N/SRC	A	Contact Output Isolator
10	1	2AO-L2C-R**	CS-N/SRC	A	Contact Output Isolator
11	1	2AO-V2C	CS-N/SRC	A	Voltage-to-Contact Converter
12	1	2AO-VAI	CS-N/SRC	A	Voltage-to-Current Converter
13	1	2AO-V3I	CS-N/SRC	A	Voltage-to-Current Converter
14	1	2ARPS-A6+BB2	CS-N/SRC	D	Multi-nest Power Supply with Battery Backup
15	1	2AT-SBU++	CS-N/SRC	A	Standby Unit
16	1	2AC-M2+AM	CS-N/SRC	B	Auto Manual Balance Card
17	1	2AP+ALM-AR	CS-N/SRC	B	Alarm (Relay Output)
18	1	2AP+ALM-AS	CS-N/SRC	B	Alarm (Solid State Output)
19	1	2AC-D+A5+RM	CS-N/SRC	C	Controller and Removable Manual Cards
20	2	2AX+DP10	CS-N/SRC	C	Power Distribution Module
21	1	2AX+DS1	CS-N/SRC	A	Signal Distribution Module
22	1	2AX+DSR	CS-N/SRC	B	Relay Logic Card
23	1	2AX+DSS	CS-N/SRC	A	Solid State Logic Card
24	1	2AC+DYC	CS-N/SRC	A	Dynamic Compensation
25	1	2AP+INT-S	CS-N/SRC	A	Square Root Integrator
26	1	2AC+MO	CS-N/SRC	A	Manual Output Card
27	1	2AX+P	CS-N/SRC	A	By Pass Module
28	1	2AX+PS9A	CS-N/SRC	B	Single Nest Power Supply
29	1	2AX+DSC	CS-N/SRC	C	Distribution Module
30	1	2AX+DSP	CS-N/SRC	D	Distribution Module

*Unit modified per ECEP 9531- becomes a 48 V dc power supply

**Unit modified per ECEP 10273 - changes output relays to DPDT

++Units to be qualified for Class II (structural integrity) and therefore are not operational during seismic tests.

07453 0095

ITEM	QTY	MODEL	CS_CODE	STYLE	TYPE
31	1	2AP+SGC	CS-N/SRC	A	Signal Characterizer
32	1	2AP+TIM	CS-N/SRC	A	Timer
33	1	2AP+MUL	CS-N/SRC	A	Multiplier/Divider
34	1	2AP+MSL	CS-N/SRC	A	Median Selector
35	1	2AX+LS	CS-N/SRC	A	Blind Set Plug
36	2	N-2ES	CS-N/SRC	B	Rack
37	1	2AO-VAI+++	CS-N/SRC	A	Voltage-to-Current Converter

+++Unit modified per ECEP 9206- places a 500 ohm resistor across the output.

3. TEST PROCEDURE

3.1 Test Mounting

The instrument modules will be mounted in one 2ANU-P and three 2ANU-D nests which in turn will be mounted at the top level (one on each side) of two N-2ES racks. (Refer to Figure 4.) Each rack will be tested separately. The arrangement of the modules to be qualified within the nests in which they are to be tested will be as illustrated in Figure 3 of this test procedure.

3.2 Random Test

The Required Response Spectra (RRS) at the OBE and SSE level to which the modules are to be qualified are Foxboro Generic curves (Figure 1A, 1B, 2A and 2B) which envelope normalized test response spectra (TRS's) obtained at nest mounting locations during Class II (structural integrity) testing of the N-2ES rack and were later refined based upon additional response data obtained per Test QOAAA19. The control accelerometer for the test will be at the top nest location to assure that the TRS's will envelope the Foxboro Generic Curves. TRS's at nest mounting locations were obtained in testing of fully - loaded balanced and unbalanced loading configurations of the N-2ES Style B Rack, and then were normalized to the Foxboro Generic Required (Floor) Response Spectra, Figure 2. The TRS's were normalized at each frequency by the factor by which the table TRS exceeded the generic Required (Floor) Response Spectra during the Class II tests. In addition the Required Response Spectra (RRS) for Class 1E qualification of the modules incorporates response peaks which have been broadened towards higher frequencies than obtained in testing of the fully-loaded racks to account for the higher resonant frequencies (of the primary response mode of the rack) to be obtained with lighter rack loadings.

To achieve the required response at the equipment mounting locations will require table response accelerations well in excess of the Foxboro Required (Floor) Response Spectra, particularly in the range of 10 to 20 Hz. The required table TRS's at the OBE and SSE levels have been estimated to be as shown in Figures 1C (OBE - Front-to-Back) and 1D (OBE - Side-to-Side) and 2C (SSE - Front-to-Back) and 2D (SSE - Side-to-Side).

009-5
007455

Triaxial accelerometer arrays will be mounted at functional equipment mounting locations (i.e., the top nest level and top Power Supply). TRS's produced from these accelerometer outputs will be used to assure that the RRS levels for qualification have been achieved or exceeded. Placement of accelerometers is as shown on Figure 31.

The table input will be band-limited white noise (random). At each test level the excitation will be simultaneous biaxial, achieved by driving the test table at a 45 degree angle. The racks will be tested in each of four orientations, such that the input is applied in the horizontal left-to-right and vertical axes, the horizontal front-to-back and vertical axes, the horizontal right-to-left and vertical axes, and the horizontal back-to-front and vertical axes. The test will be performed five times in each of the above orientations with the horizontal in-axis TRS's enveloping the 1% damping RRS of Figures 1A and 1B for rack-mounted modules. The amplitude will be controlled in one-third octave bandwidths. One SSE will be performed in each of the four orientations with the horizontal in-axis TRS's enveloping the full level of the 1% damping RRS of Figures 2A and 2B for rack-mounted modules.

In order to achieve the specified module horizontal response levels of Figures 1A, 1B, 2A, and 2B, it is expected that the table TRS's, both horizontal and vertical, will exceed the floor-level RRS's of Figures 1 and 2 by 30% or more in the frequency range above 2.5 Hz (Refer to Figures 1C, 1D, 2C, and 2D). Since vertical amplification factors at module locations of the N-2ES rack are expected to be within the range of 0.9 to 1.2, the resultant vertical TRS's obtained in testing the functioning nests are expected to envelope vertical response spectra obtained in operation of the N-2ES rack at the generic floor-level RRS's of Figures 1 and 2.

Horizontal in-axis, horizontal cross-axis, and vertical TRS's will be generated and plotted for 1%, 2 1/2% and 5% damping at one-third octave intervals during one of each series of OBE's and each SSE test for all accelerometers during both rack tests. The test duration of each OBE and SSE will be 30 seconds.

3.3 Test Monitoring

The functional nests and power supplies to be qualified will be energized and the functioning modules will be monitored during the test, as required to demonstrate satisfactory performance of Class 1E functions during the specified generic OBE and SSE seismic events.

The test setups and input and output signal levels for each individual instrument will be as diagrammed in Figures 5 thru 30. Where electromechanical relay-type outputs are to be monitored for spurious openings or closures, and where logic functions are to be operated during the test, such operation is also indicated on these Figures.

07455 0097

All nests will be energized and de-energized 45 times through the 2ABPS Power Supply before seismic tests.

Target Acceptance criteria during seismic are as follows:

- Output shifts of analog outputs will not exceed published accuracy specification.
- Spurious outputs of alarm modules of duration greater than 100 microseconds will not occur with set points and input values set within 5% of each other.
- Logic functions will be demonstrated to be operable.
- Isolation devices will be tested for isolation capability.

4. TEST DOCUMENTATION

The test shall be documented in the following manner:

List of devices tested including model number.

Description of installation details with any resultant limitations on equipment installation.

Weight and center of gravity of modules tested.

Test facility identification and location.

Identification of test equipment with reference to calibration status.

Test data on all devices as taken before, during and after testing will be compared with Target Acceptance Criteria. Refer to Section 3.3.

Analysis of test results and conclusions.

An independent report by the independent test laboratory at which the seismic test was conducted documenting equipment tested, test procedures, acceleration levels, and observations by test laboratory personnel.

5. RAW DATA

All raw data obtained in the form of tabulated data and chart records will be made available for review at The Foxboro Company, Foxboro, Massachusetts, upon request.

07456 0093

Figure 1
Generic Required Response Spectra (RRS)
at OBE Level for Qualification of
Floor-mounted Control Room Equipment

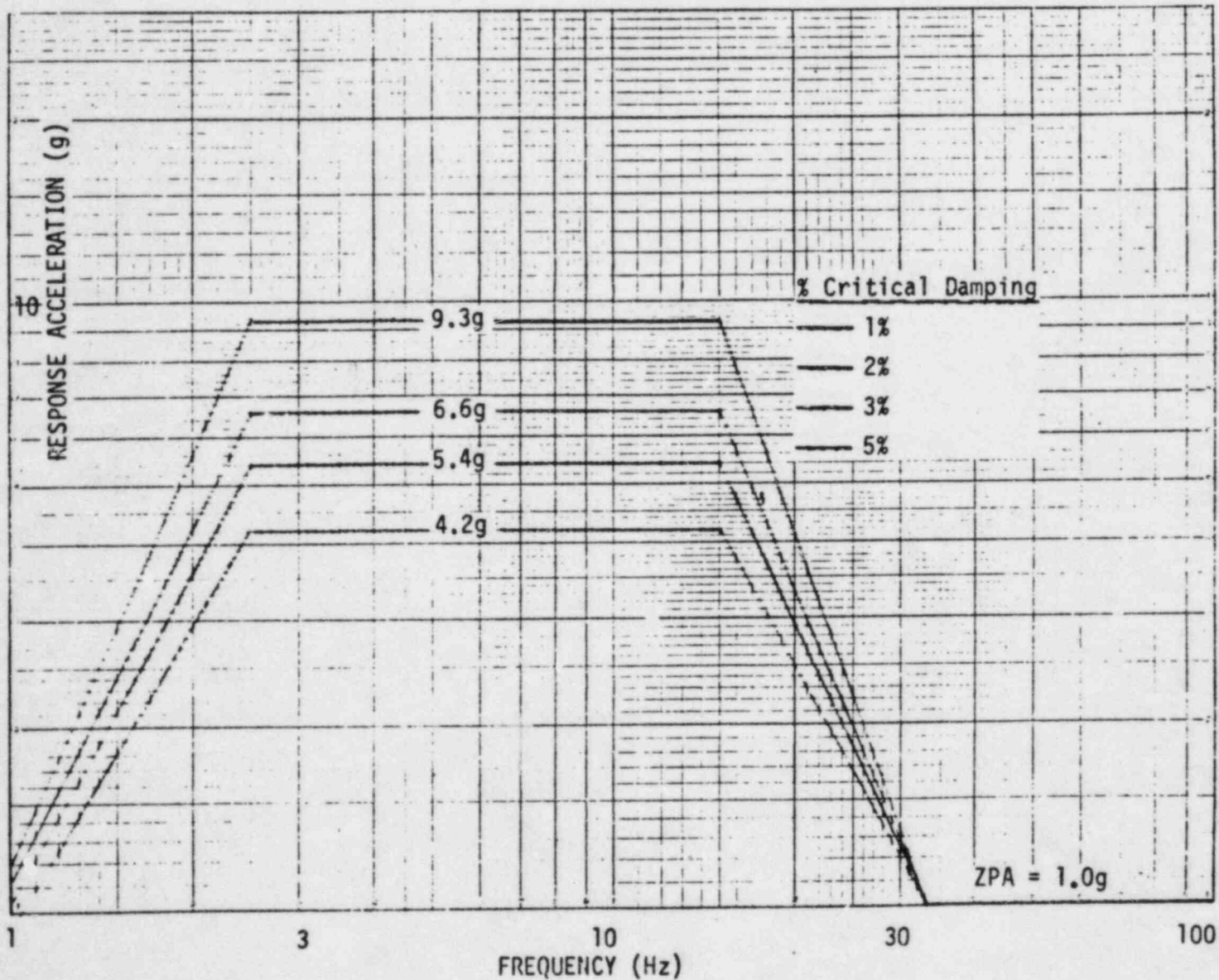
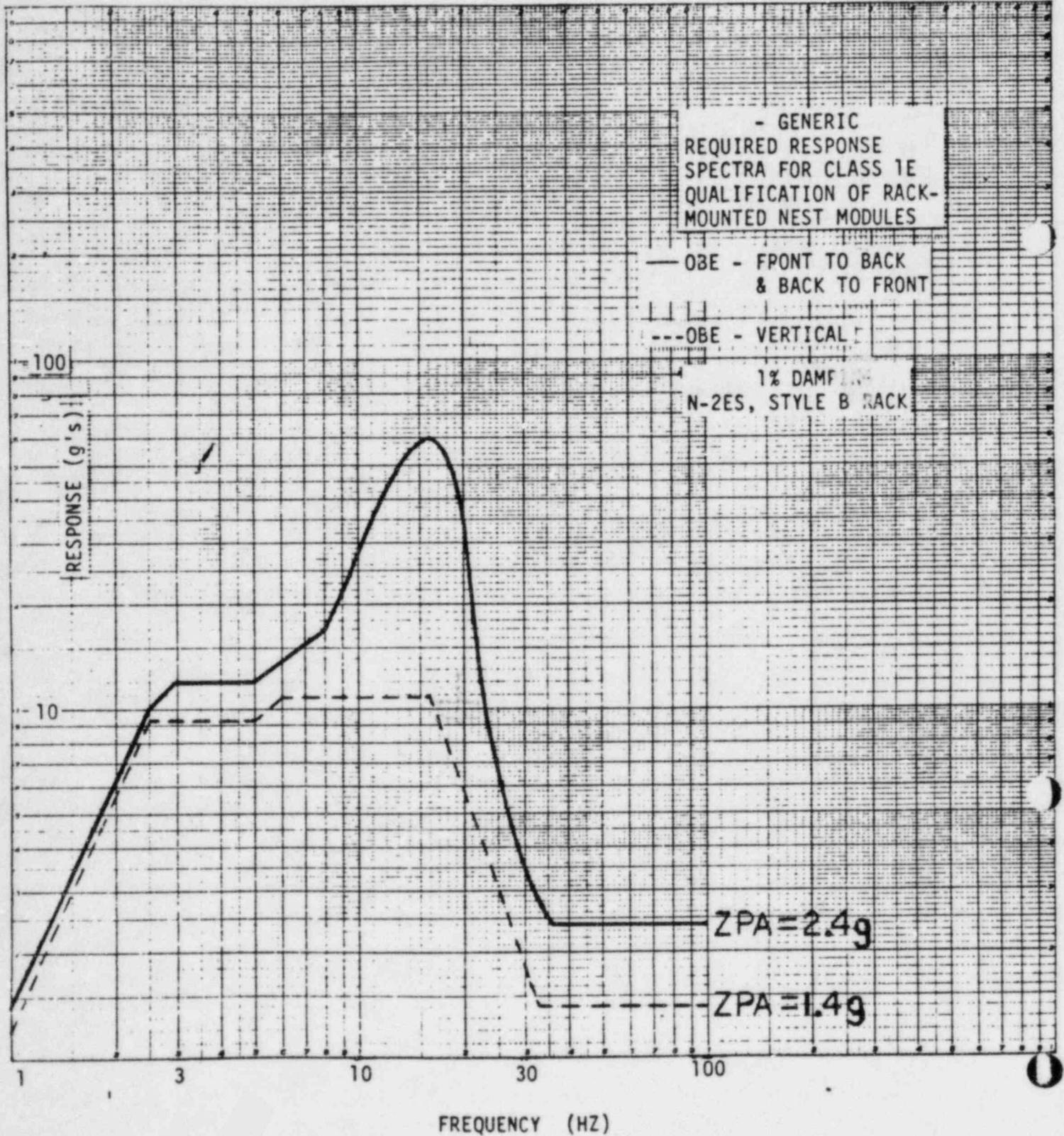

Figure 1A



J.C.CHILDS
16 JAN 78 (REVISED)
29 JAN 80 (ADD VERT CURVE)

Figure 1C

0 7 4 5 6
0 0 1 3

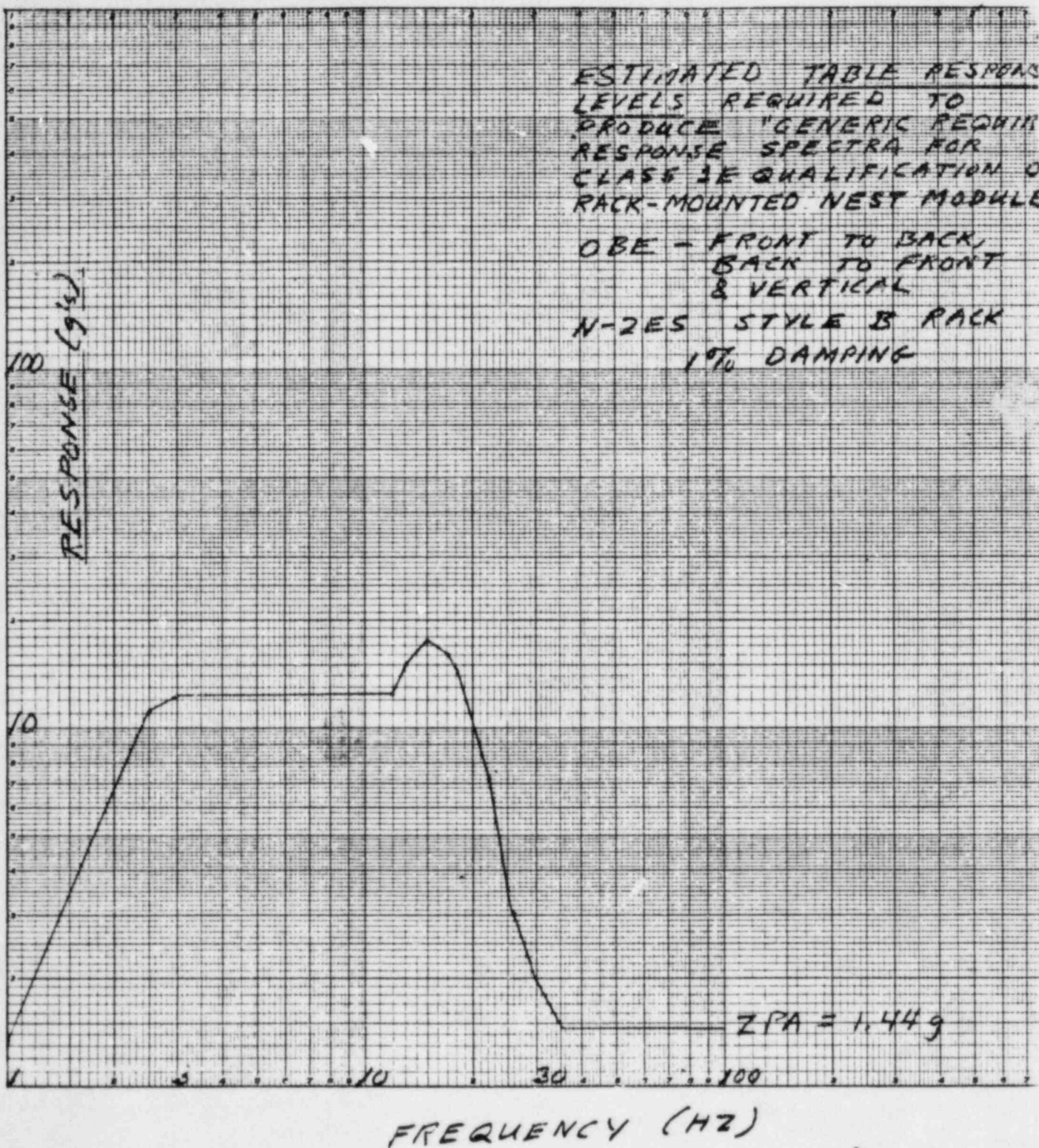

J.C. Childs
12/16/77

Figure 1D

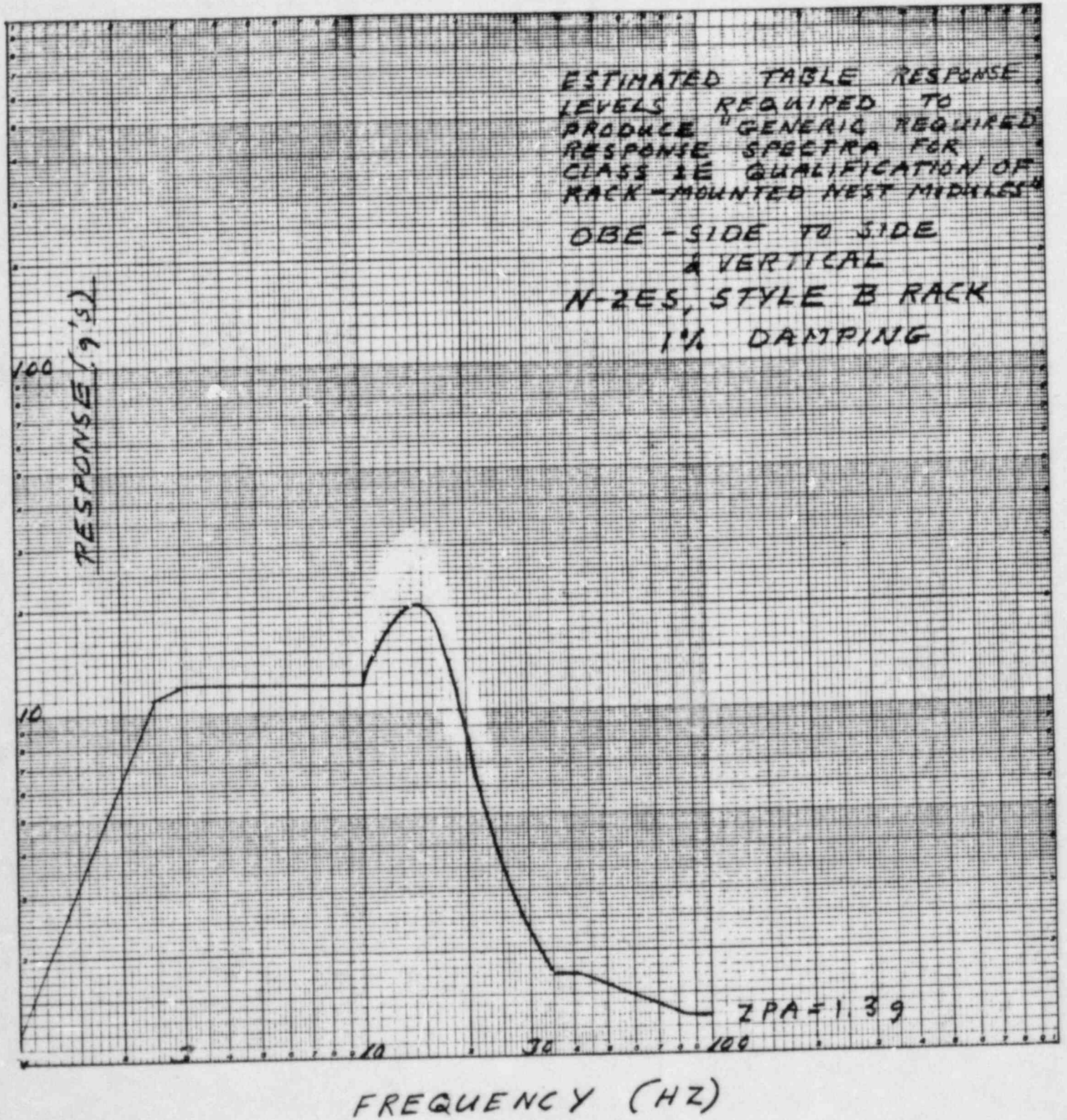

gocwids
1/16/78 (Revised)

Figure 2
Generic Required Response Spectra (RRS)
at SSE Level for Qualification of
Floor-mounted Control Room Equipment

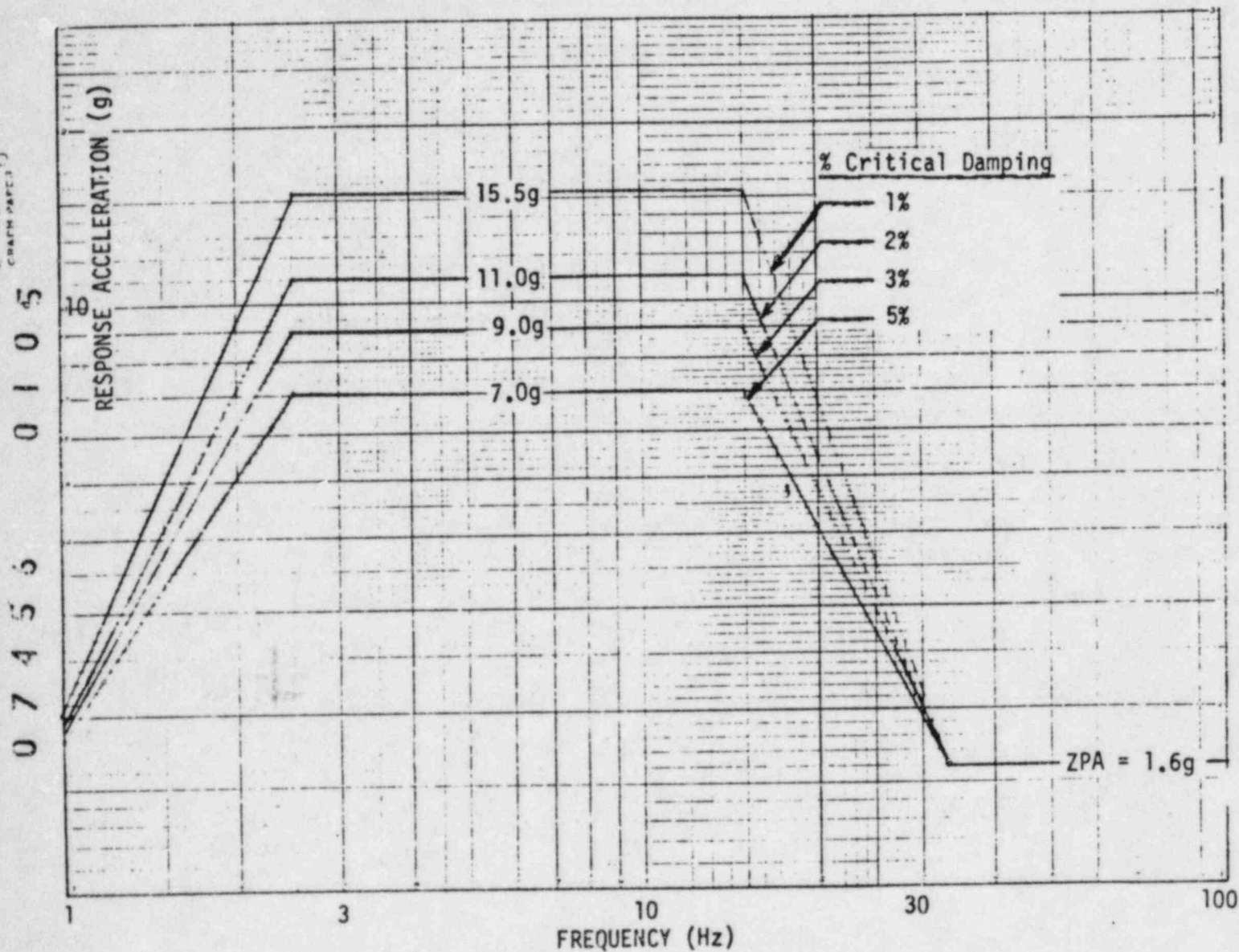
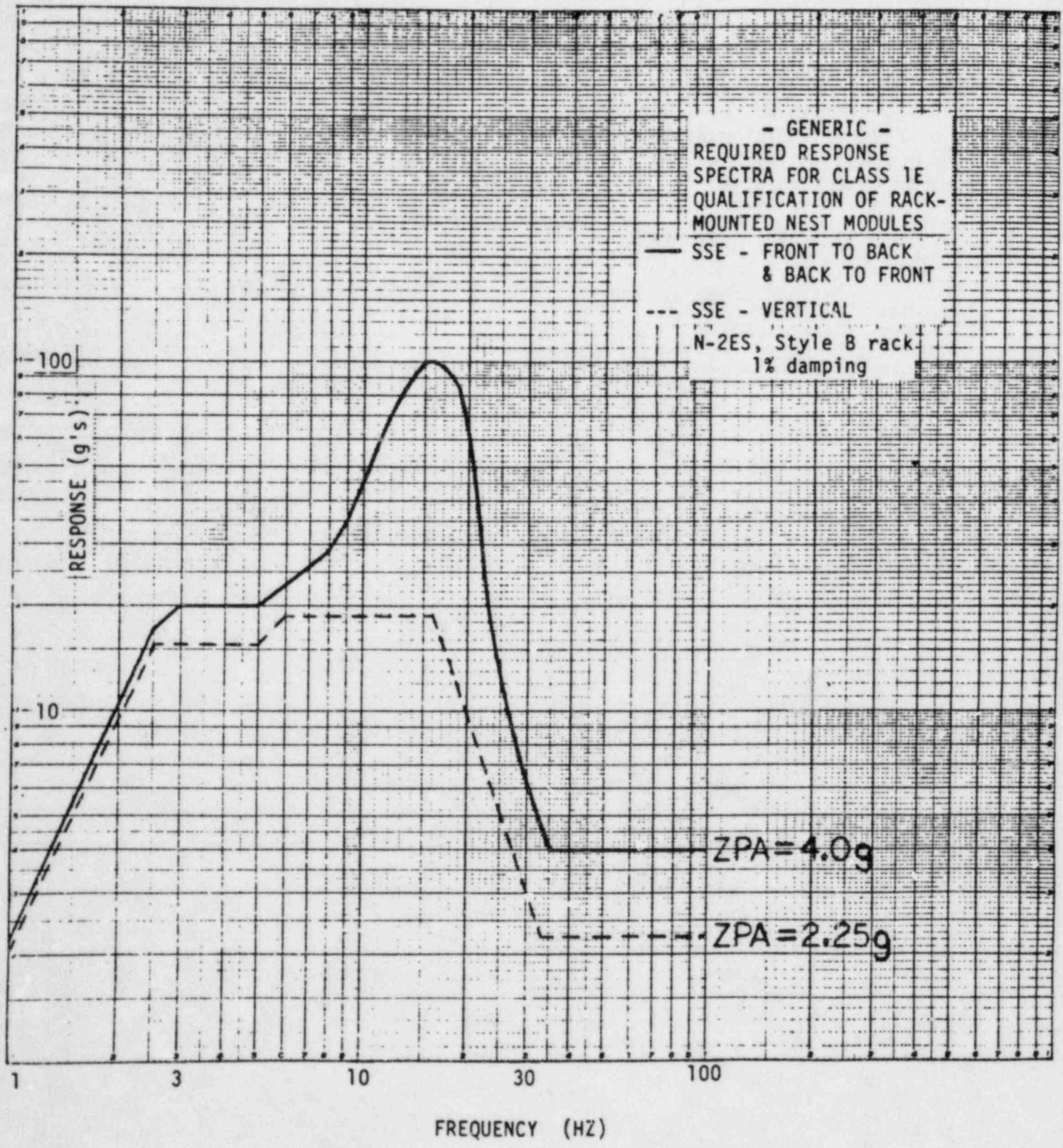

Figure 2A



J.C. CHILDS
16 JAN 78 (REVISED)
29 JAN 80 (ADD VERT. CURVE)

07456 016
EARTH & RIVIER COMPANY, INC. NURWOOD, MASSACHUSETTS PRINTED IN U.S.A.
NO 31295R - 3 - 1/81/1/81

Figure 2B

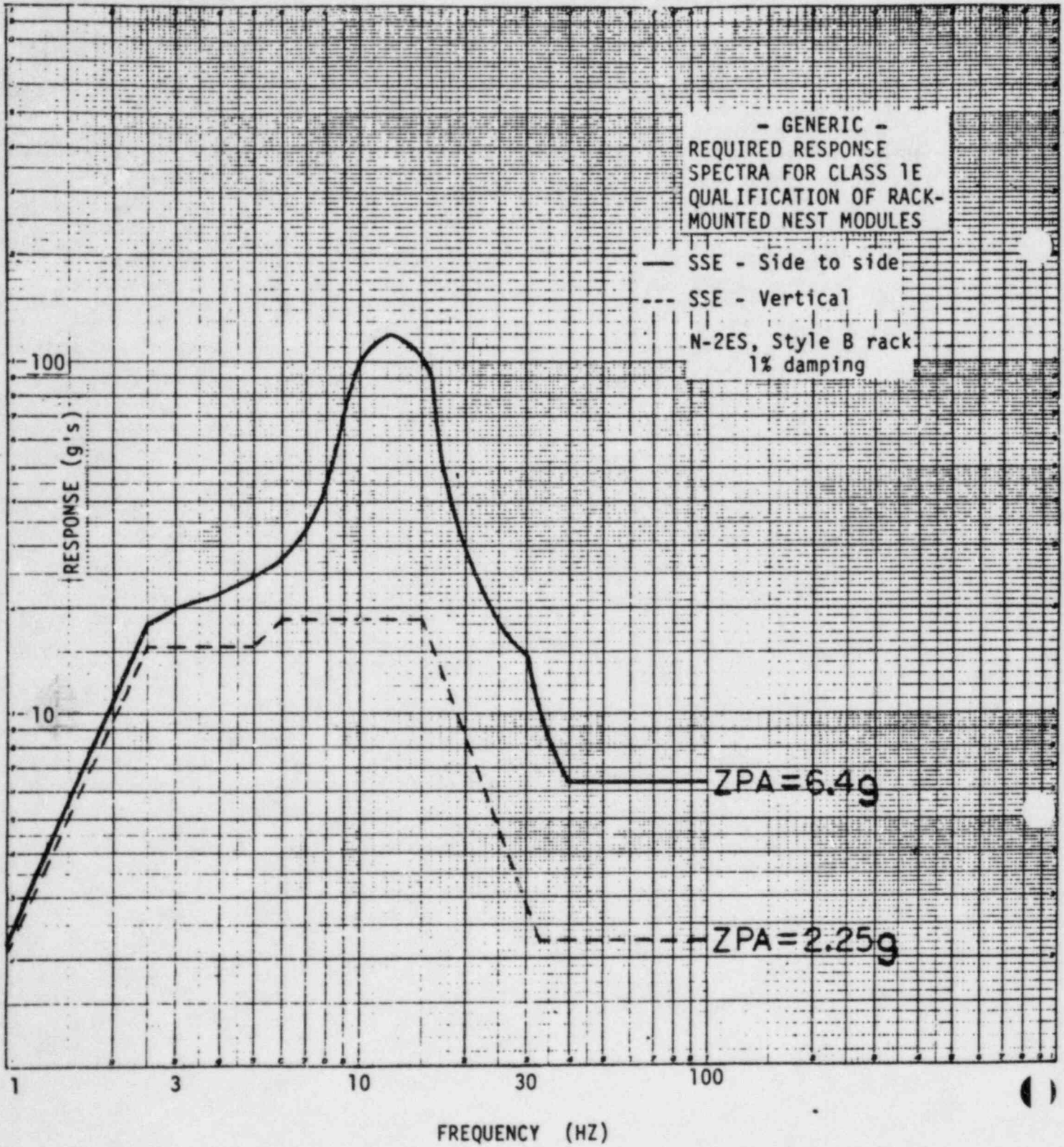

J.C. CHILDS
16 JAN 78 (REVISED)
29 JAN 80 (ADD VERT CURVE)

07456 0107
NO 31 295 R 30-UNISSYMI THREE BY THREE 2 1/2 IN. H. LINES BASE SHORT WAY
THE ROK COMPANY INC. NORWOOD, MASSACHUSETTS PRINTED IN U.S.A.

07156 • 013

FREQUENCY (HZ)

RESPONSE (g's)

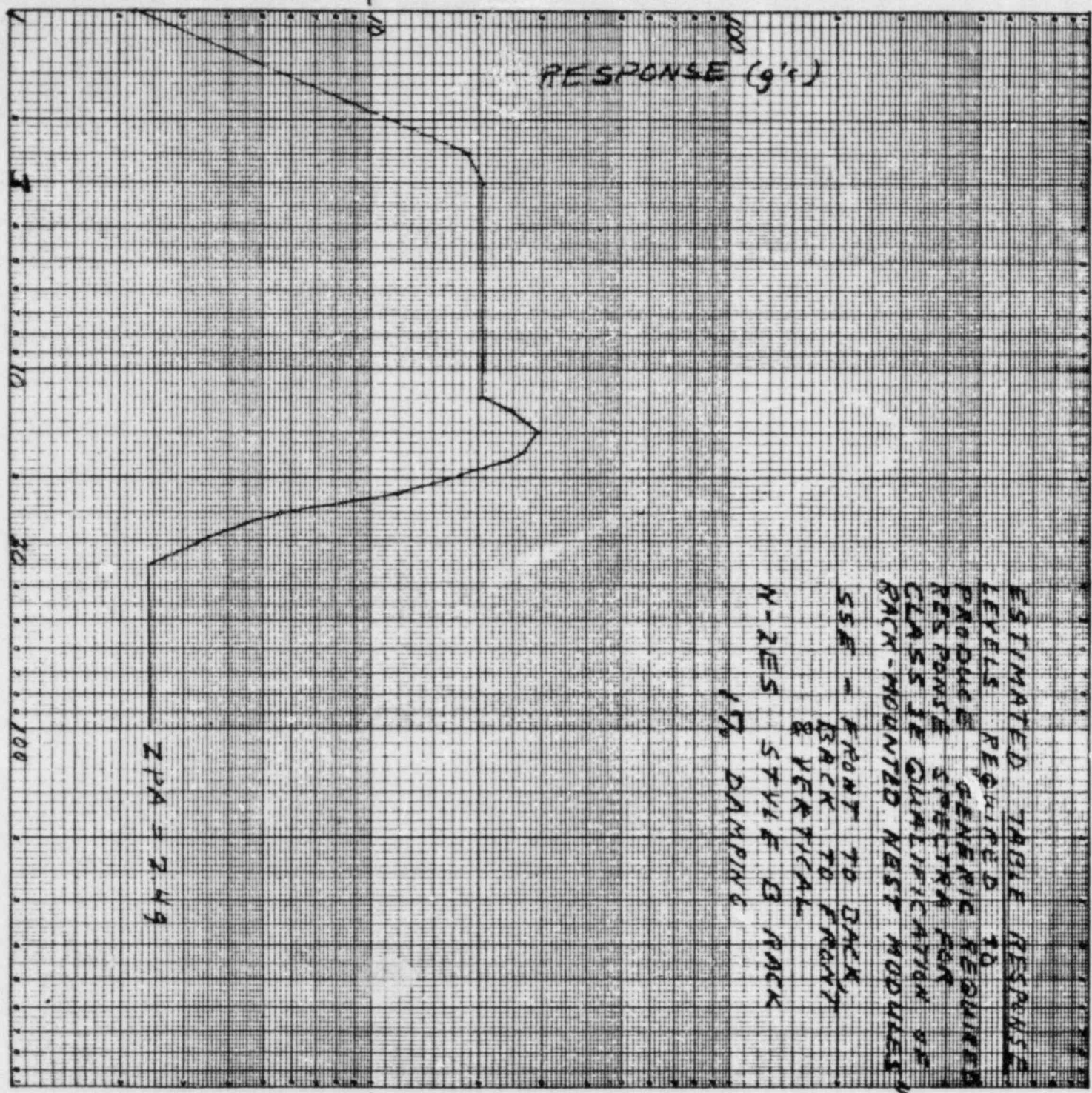

ESTIMATED TABLE RESPONSE LEVELS REQUIRED TO PRODUCE GENERIC REQUIRED RESPONSE SPECTRA FOR CLASS II QUALIFICATION OF RACK-MOUNTED NEST MODULES

55% - FRONT TO BACK & VERTICAL
 17% DAMPING
 N-2ES STYLE B RACK

ZPA = 2.49

g (stable)
12/16/77

Figure 2c

Figure 2D

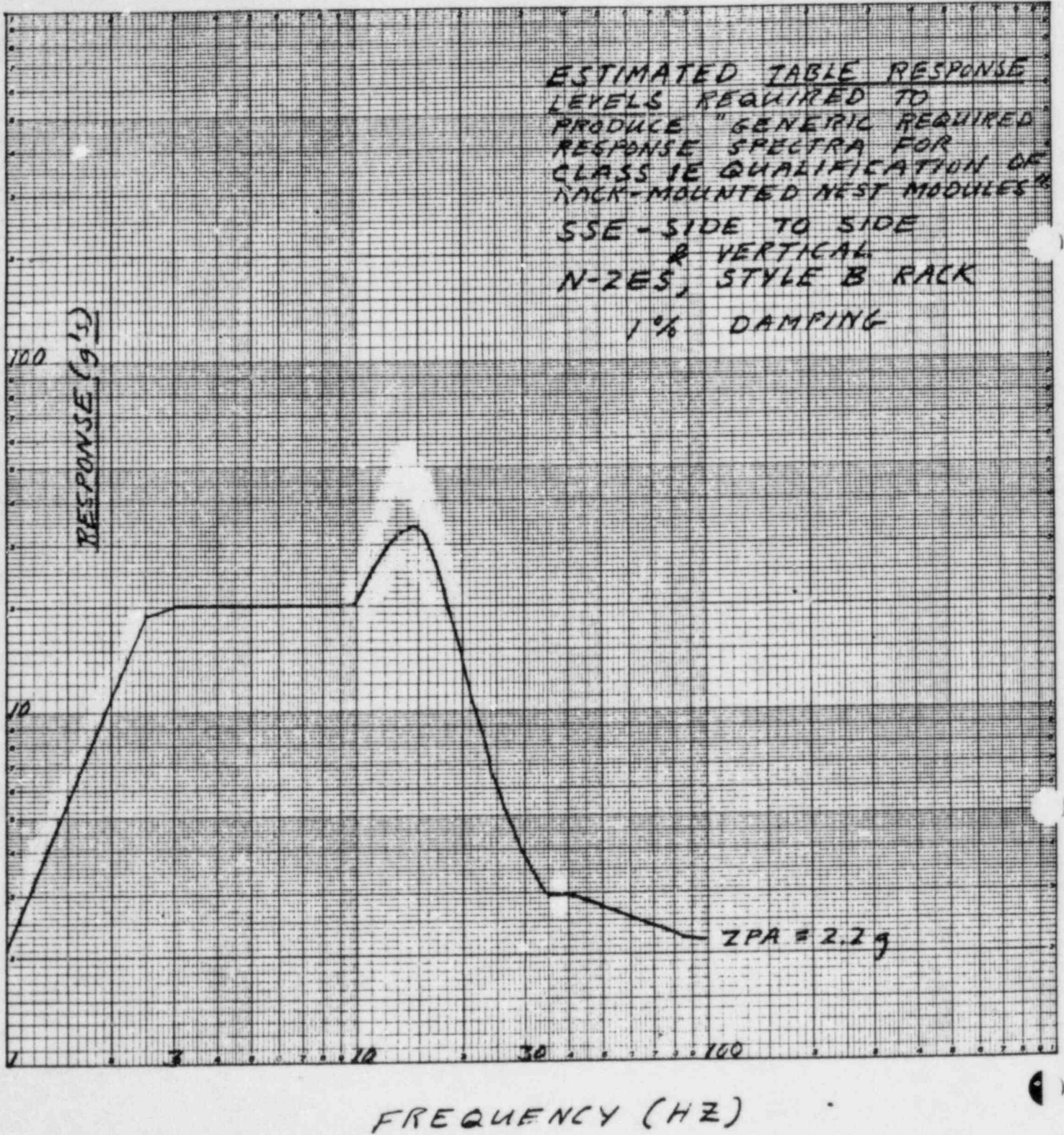

LOUISA BOOK COMPANY, INC. NORWOOD, MASSACHUSETTS, PRINTED IN U.S.A.

07456009

NO. 31-295-R. LOGARITHMIC THREE BY THREE 2.2 INCH CYCLES (BASE SHORT WAY)

gocchido
1/16/78 (Revised)

Figure 3
Nests Loading for Modules of
Current Production Design

2AO-L2C-R
ECEP 10273
2AI-I2V
2AP+ALM-AR
2AP+ALM-AS
2AO-L2C-R

STYLE A
2AO-IPD-R
2AI-T2V+E
2AI-I3V
2AX+DP10

NEST NO. 1

2AI-C2L
2AI-I2V**
2AX+DSS
2AX+DSR
2AT+SBU
2AX+DS1
2AC+H0
2AC+A5*+LS
2AC-M2+AM

2AC+DYC

NEST NO. 2***

2AO-V2C
2AO-VAI+P
2AO-V3I
2AC-D+A5
+RM
2AP-SGC
2AP+MUL
2AP+MSL
2AP+TIM
2AP+INT-S
2AX+DP10

NEST NO. 3

2AO-VAI
ECEP 9206
2AI-I2V*
2AX+DP10

2AX+DSC

2AX+DSP
2AX+PS9A

NEST NO. 4

*Instrument used as a piece of test equipment and is not part of the qualification program.

**ECEP 9531

***Power to Nest No. 2 was hand-wired to Nest Buss (f.e.; no 2AX+DP10 Power Distribution Module was used).

Figure 4
N-2ES Rack Configurations
Two Racks will be Tested in this Configuration

Nest *	Nest*
Nest	Nest
Nest	Nest
Nest	Nest
Nest	Nest
Power** Supply	Power Supply
Power Supply	Power Supply

*Functional Nests

**Power Supply was tested for performance functions during seismic in one rack only.

07456 0112

Figure 5
Seismic Test Setup
2AI-C2L Contact Input Isolator

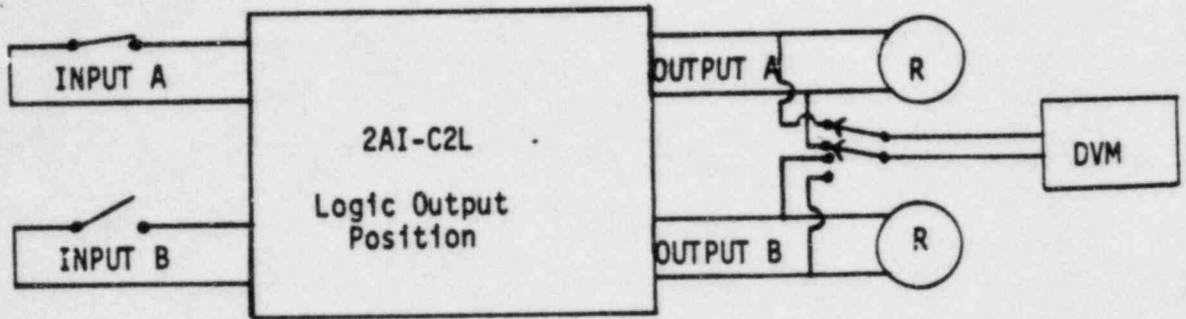

Test Conditions:

Input Switches, A = Closed, B = Open;
both A and B inputs will be switched
during one OBE and SSE test; recorders
calibrated for full scale traverse of
0 to 15 V dc.

07456 0113

Figure 6
Seismic Test Setup
2AI-12V ECEP 9531 48 V dc Power Supply

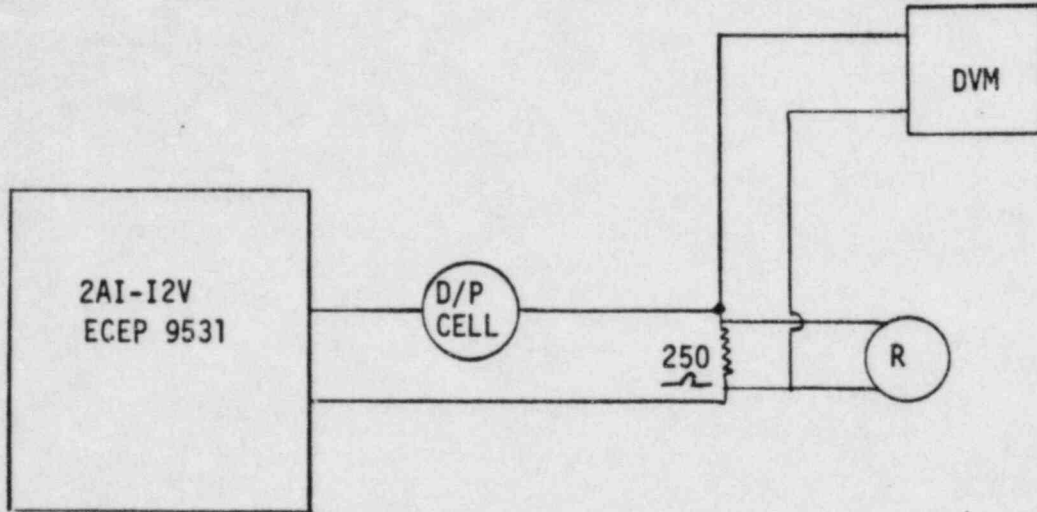

07456 0114

Test Conditions:

D/P Cell zeroed to 12 mA; Recorder calibrated for full scale traverse of 12 ± 0.8 mA or $50 \pm 5\%$ of span.

Figure 7
Seismic Test Setup
2AX+DSS Solid State Logic Card
and 2 AX+DS1 Signal Distribution Module

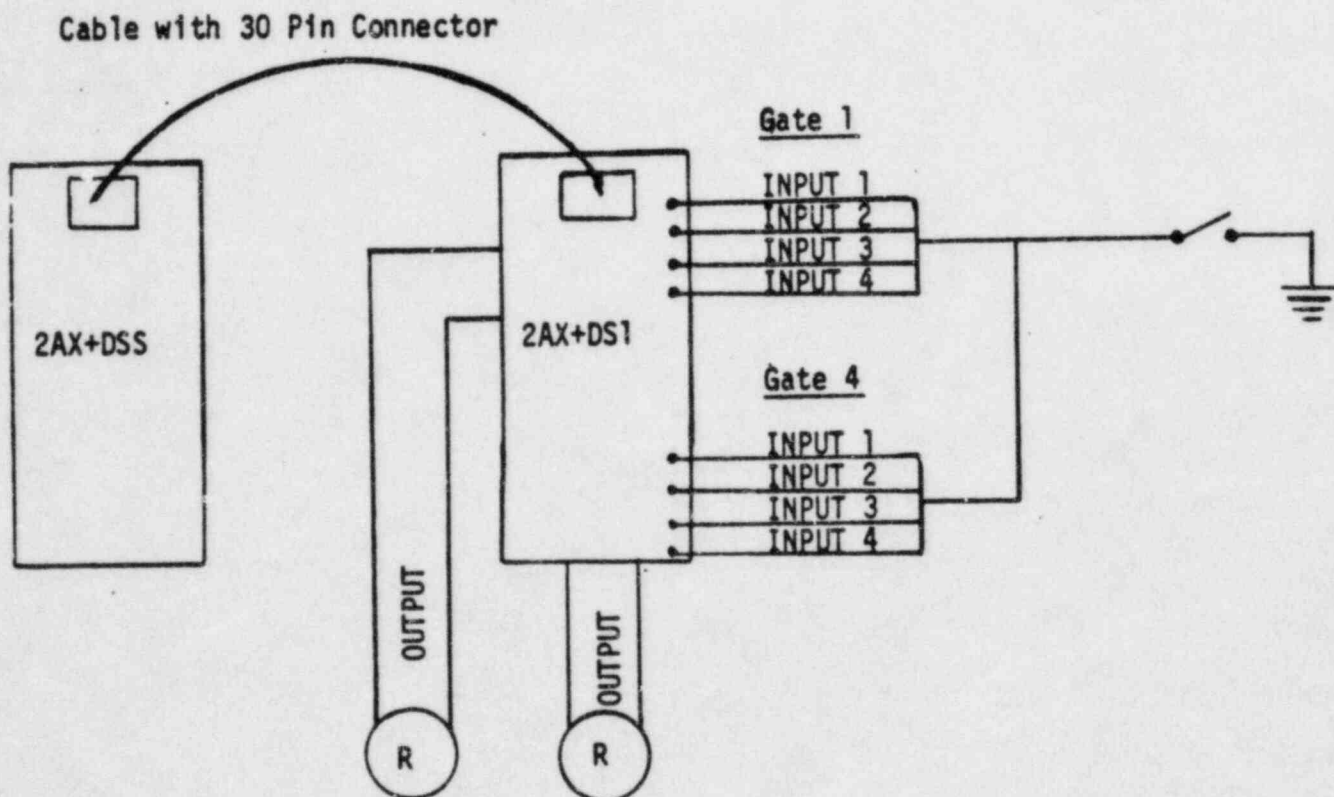

Test Conditions:

Gate 1 setup for OB configuration, Gate 4 for AND configuration; Gates 1 and 4 will be switched during one OBE and SSE test; output recorders calibrated for full scale traverse of 0 to 15 V dc.

07455 0115

Figure 8
Seismic Test Setup
2AC+MO Manual Output Card

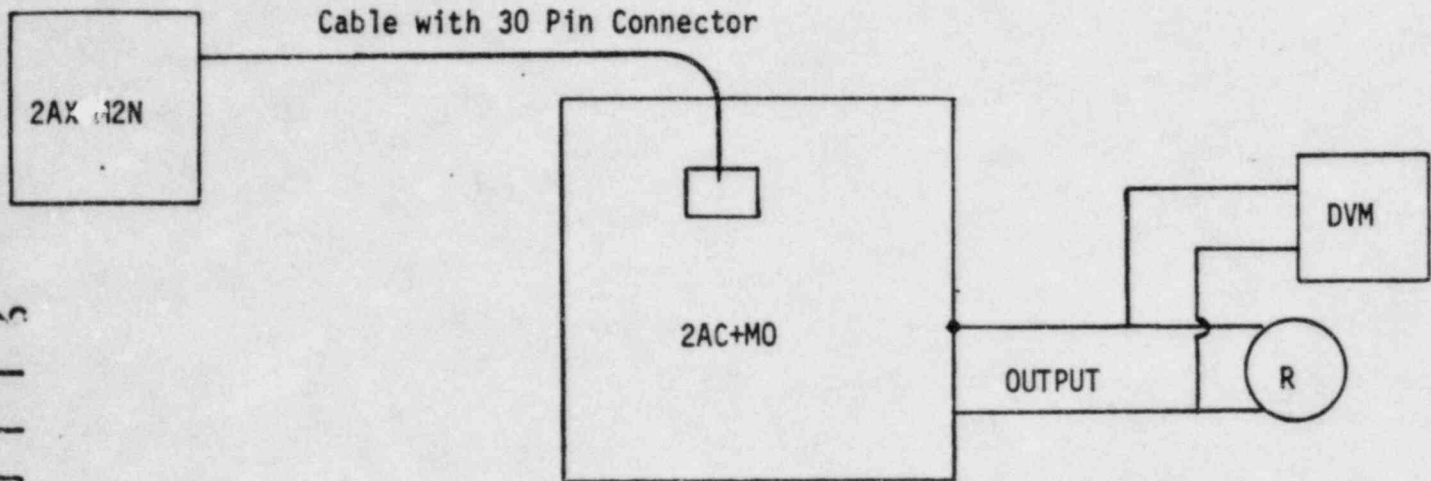

0 7 1 5 6 0 1 1 5

Test Conditions:

The 2AX+M2N is used to functionally check the 2AX+MO before and after each test; output set to 5 V dc and recorder calibrated for a full scale traverse of 5 V dc $\pm 5\%$

Figure 9
Seismic Test Setup
2AC-M2+AM
Auto/Manual Balance Unit

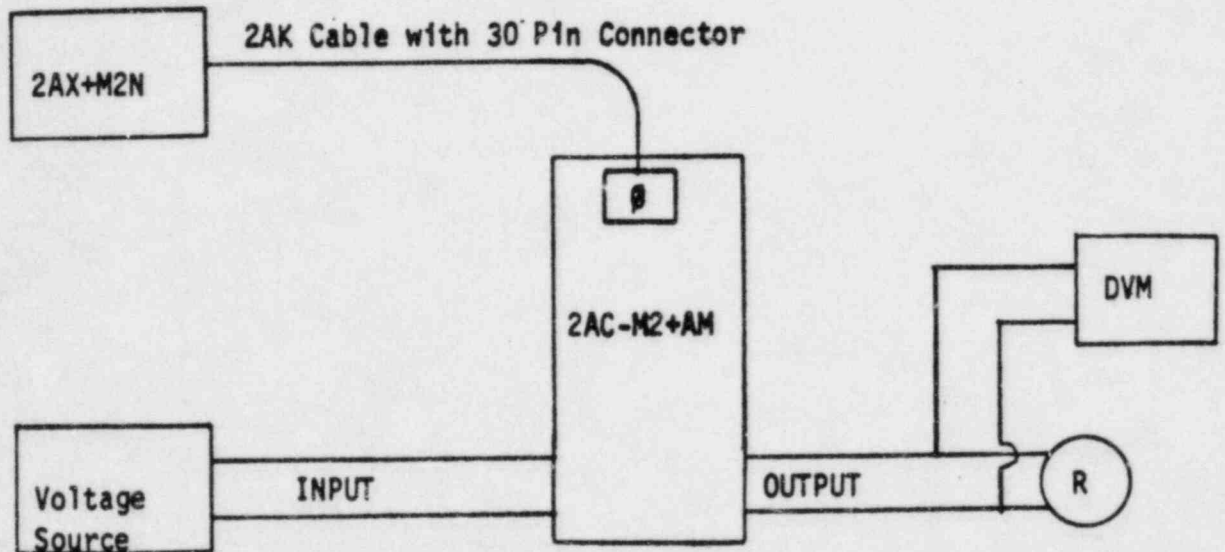

Test Conditions:

2AC+AM AUTO/MANUAL card to be tested in
the auto position with 5 V dc input;
output recorder calibrated for full scale
traverse of 5 V dc $\pm 5\%$

0 7 4 5 6 0 1 1 7

Figure 10
Seismic Test Setup
2AC+DYC Dynamic Compensator

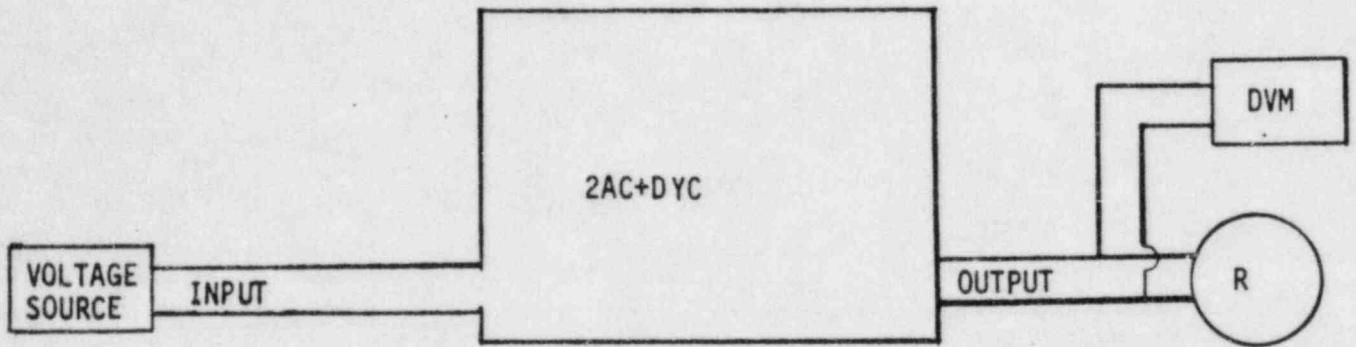

Test Conditions:

Input at 5 V dc; output recorder
calibrated for full scale traverse
of 5 V dc $\pm 5\%$

07456 0113

Figure 11
Seismic Test Setup
2A0-V2C Voltage-to-Contact Converter

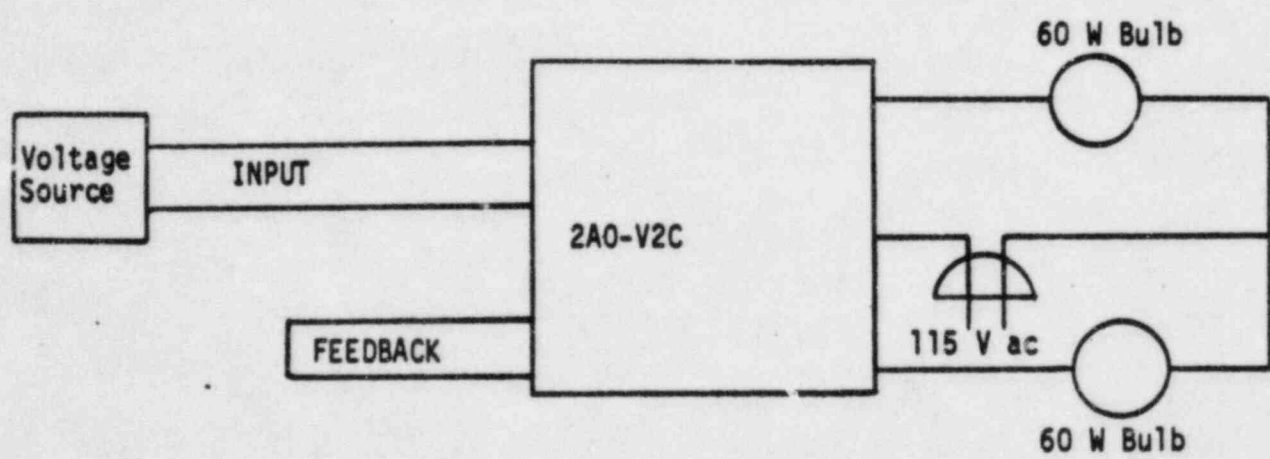

07456 0119

Test Conditions:

Input at 0 V dc; lockup at 1%
Gap at 1% and feedback jumper in
the feedback position

Figure 12
Seismic Test Setup
2A0-VAI Voltage-to-Current Converter

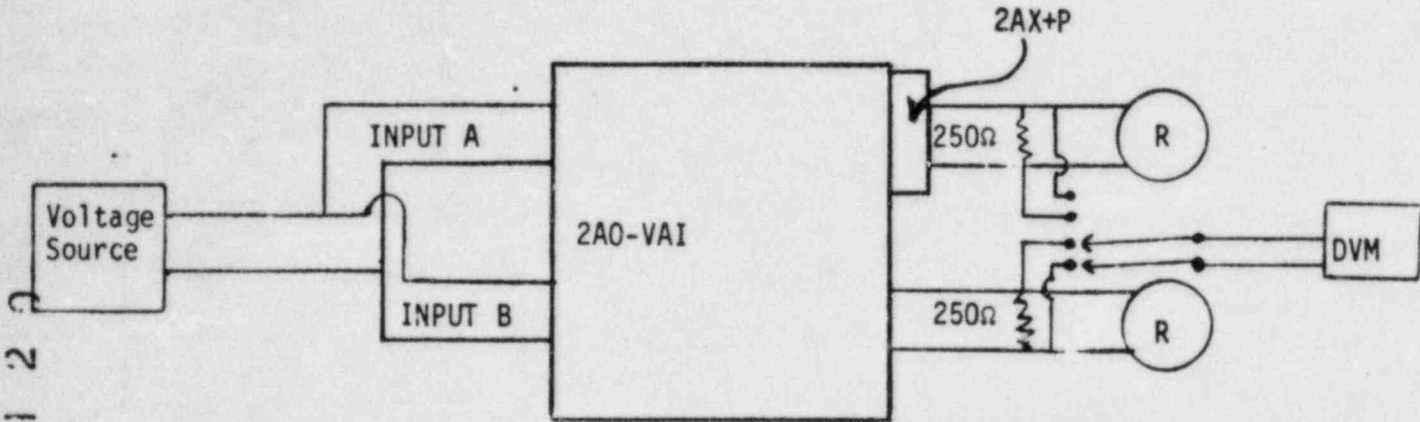

0
1
2
3
4
5
6

Test Conditions:

Input at 5 V dc; output recorders
calibrated for full scale traverse
of 12 mA ±5%

Figure 13
Seismic Test Setup
2A0-V3I Voltage-to-Current Converter

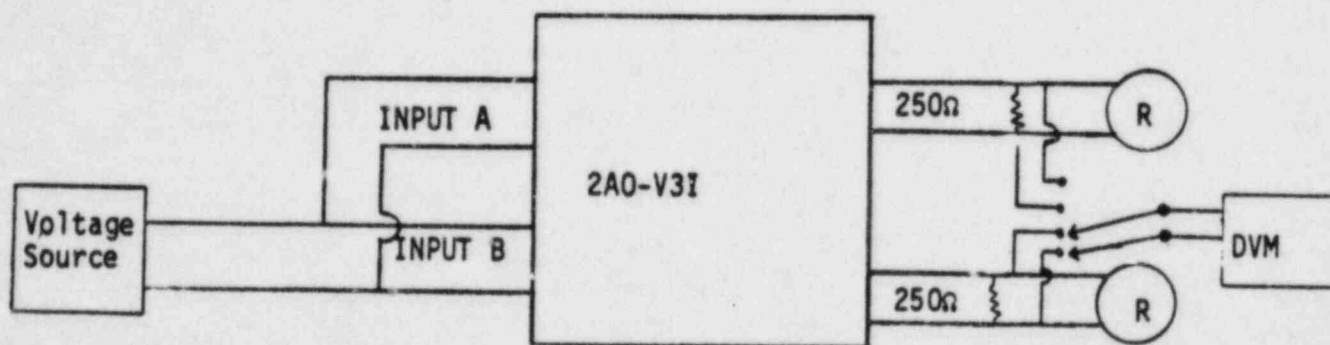

Test Conditions:

Input at 5 V dc; output recorders
calibrated for full scale traverse
of 12 mA $\pm 5\%$

07453 0121

Figure 14
Seismic Test Setup
2AC-D+A5+RM
Controller and Removable Manual Cards

07456
0122

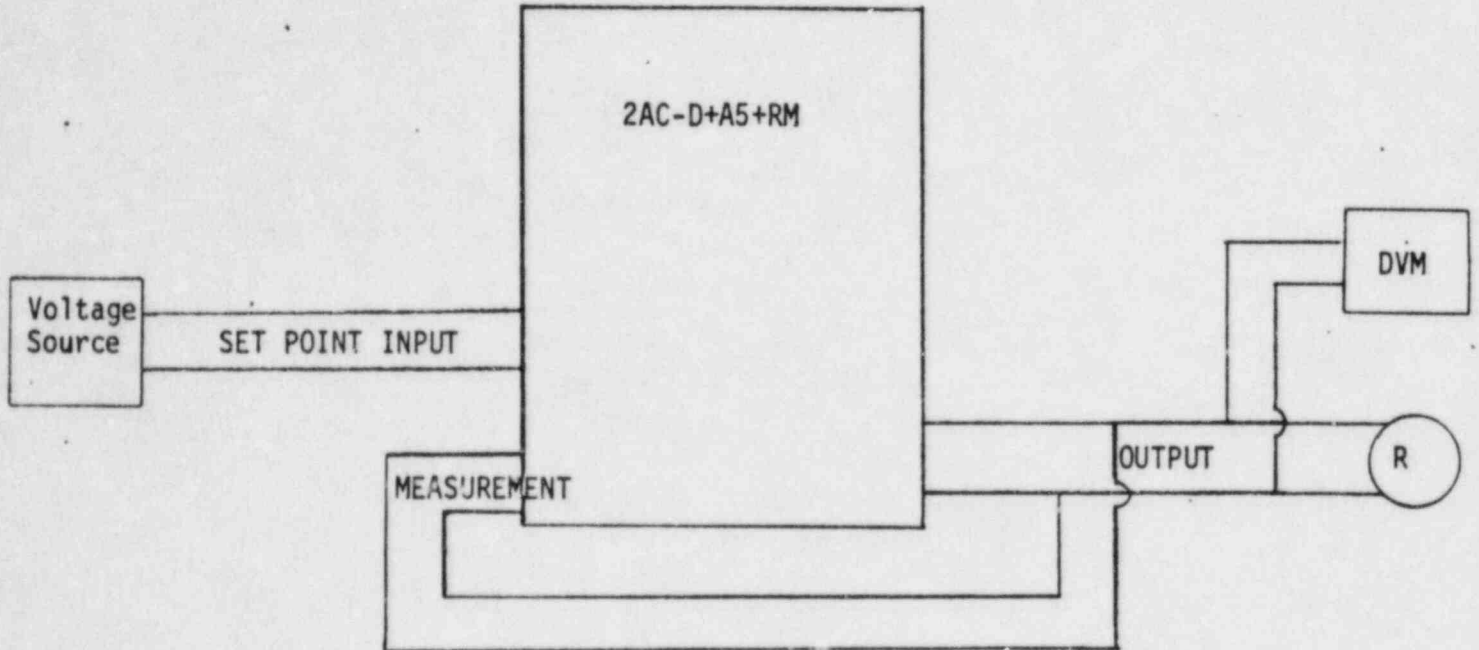

Test Conditions:

Set point at 5 V dc; Controller closed loop, output recorders calibrated for full scale traverse of 5 V dc $\pm 5\%$

Figure 15
Seismic Test Setup
2AP+SGC Signal Characterizer

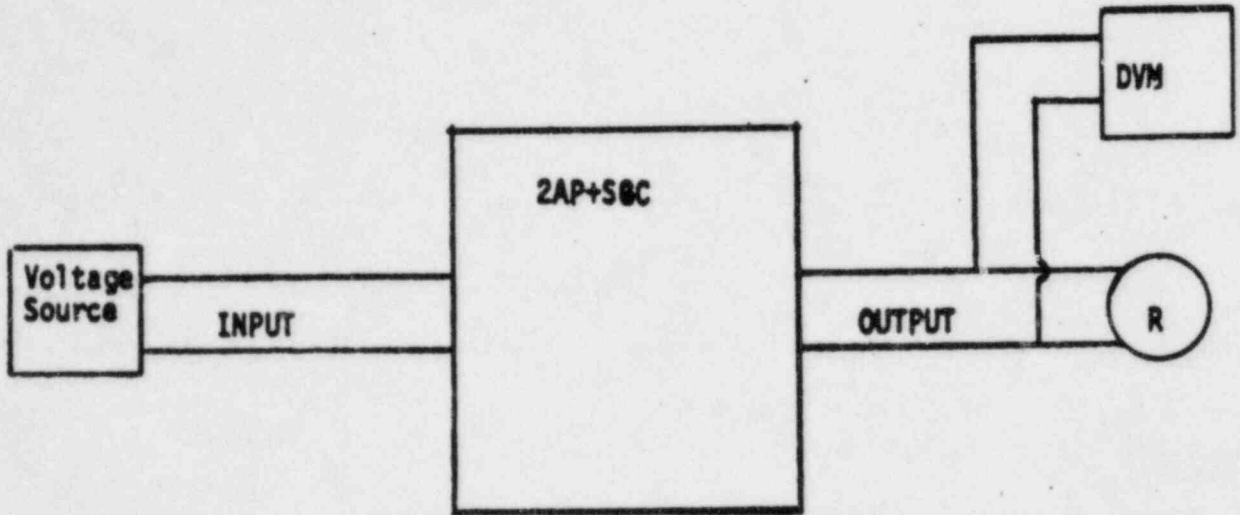

Test Conditions:

Input at 5 v dc; output recorder
calibrated for full scale traverse
of 7.07 v dc $\pm 5\%$; 2AP+SGC calibrated
for square root function; i.e.,
output (%) = 10 $\sqrt{\text{input (\%)}}$

07456 0123

Figure 16
Seismic Test Setup
2AP+MUL Multiplier/Divider

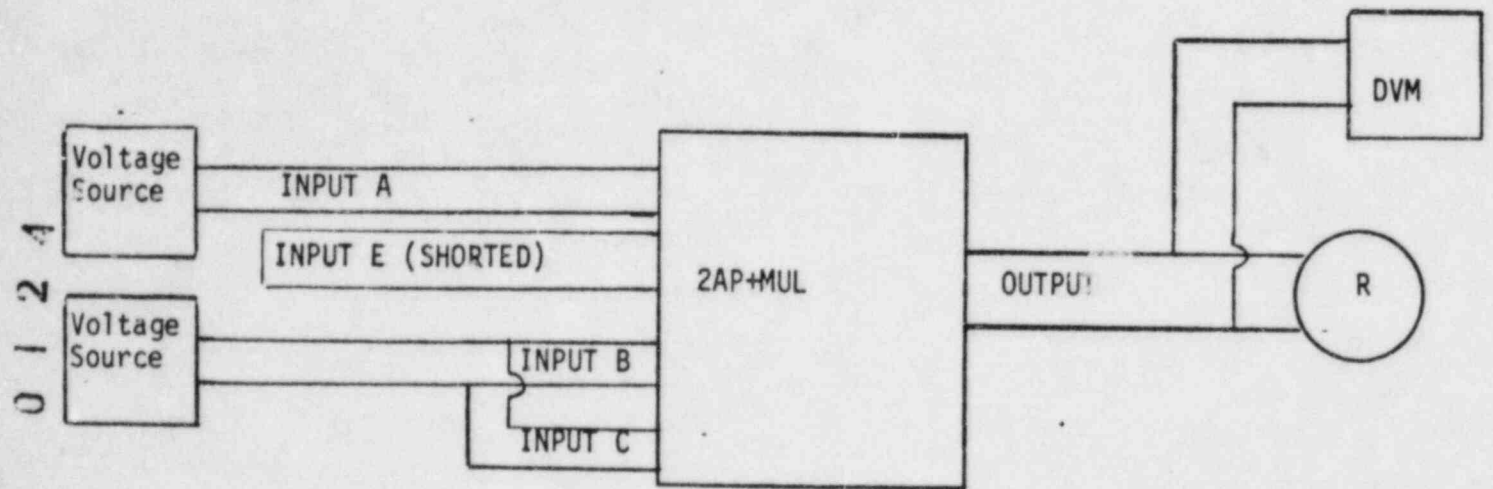

Test Conditions:

Input A at 5 V dc, input B & C
at 10 V dc; output recorder
calibrated for full scale traverse
of 5 V dc $\pm 5\%$; INPUT/OUTPUT Relationship
equals $\frac{A \times B}{C} = D$

Figure 17
Seismic Test Setup
2AP+MSL Median Selector

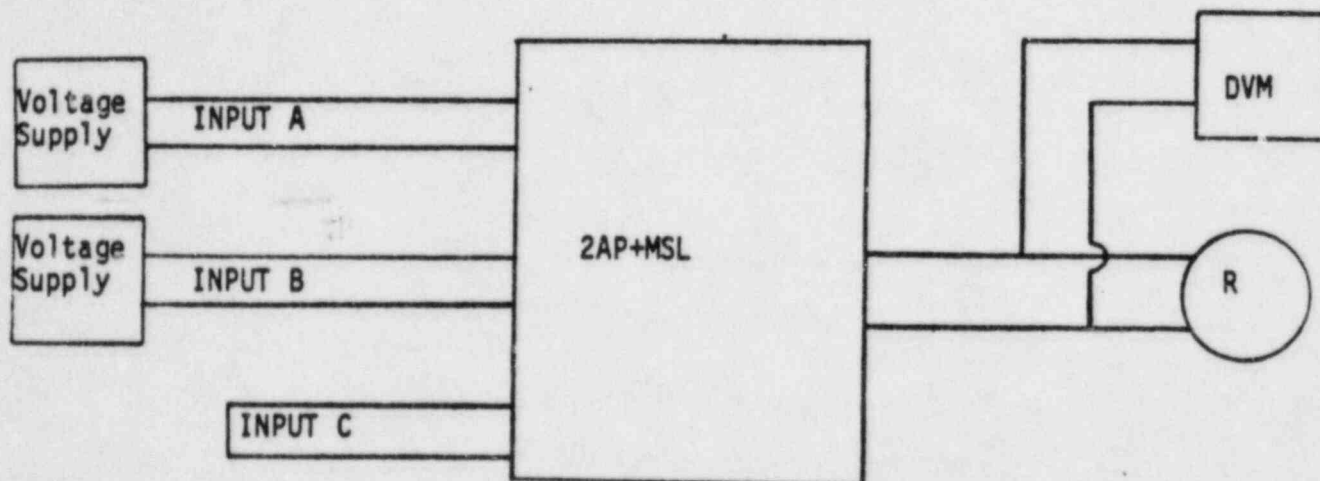

Test Conditions:

Input A at 10 V dc; input B at 5 V dc;
input C shorted (0 V dc); output
recorder calibrated for 5 V dc $\pm 5\%$

0 1 2 5
0 7 4 5 6

Figure 18
Seismic Test Setup
2AP+TIM Timer

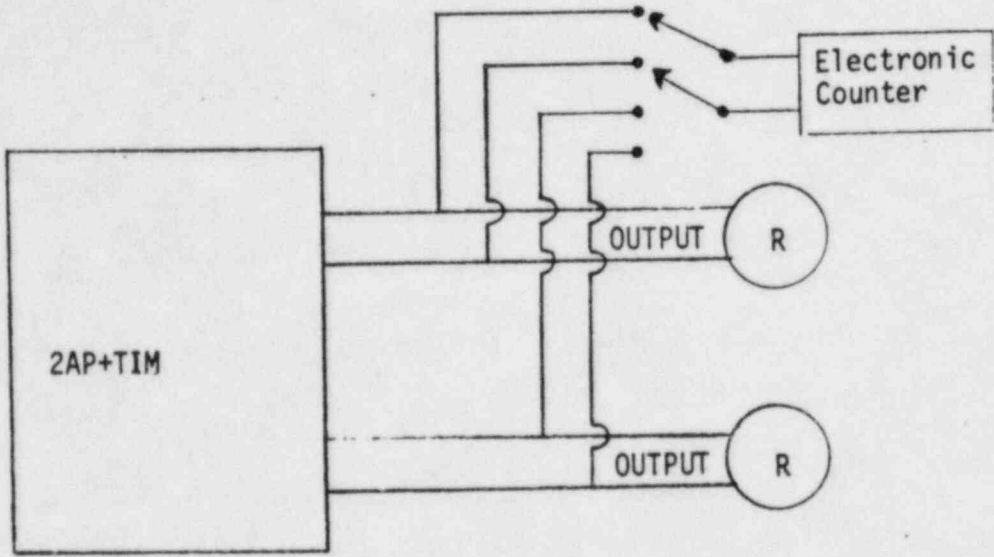

0 7 4 5 6 0 1 2 5

Test Conditions:
Timer's in clock position

Figure 19
Seismic Test Setup
2AP+INT-S Square Root Integrator

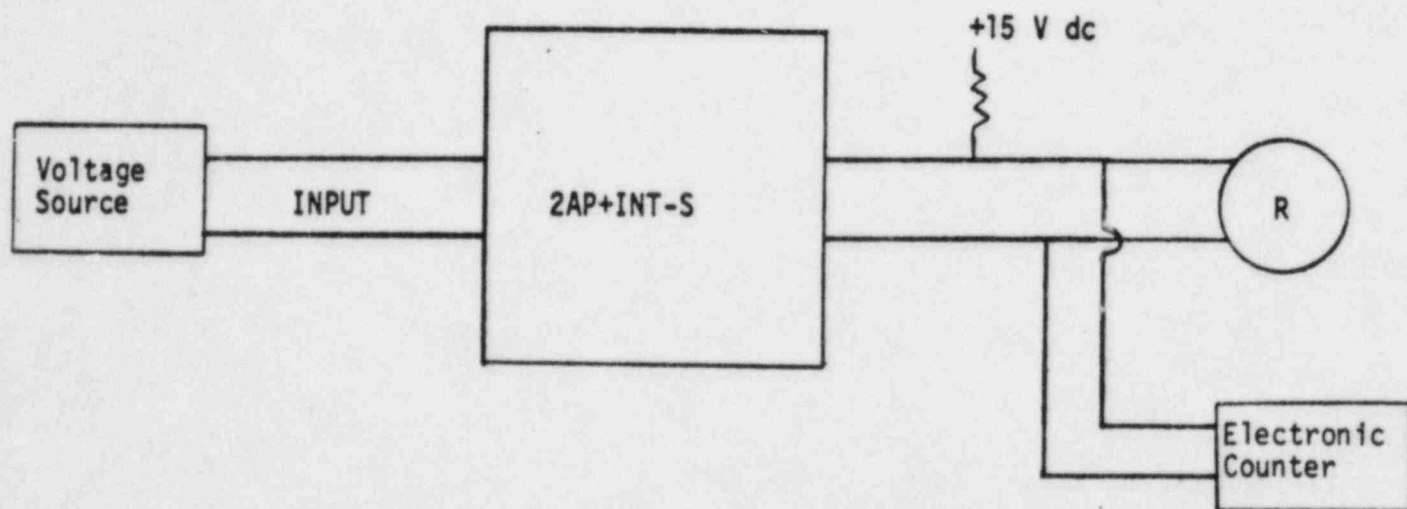

Test Conditions:

Input at 5 V dc; output monitored
on a recorder calibrated for full
scale traverse of 0 to 15 V dc

07456 0127

Figure 20
Seismic Test Setup
2AP+DP10 Power Distribution Module

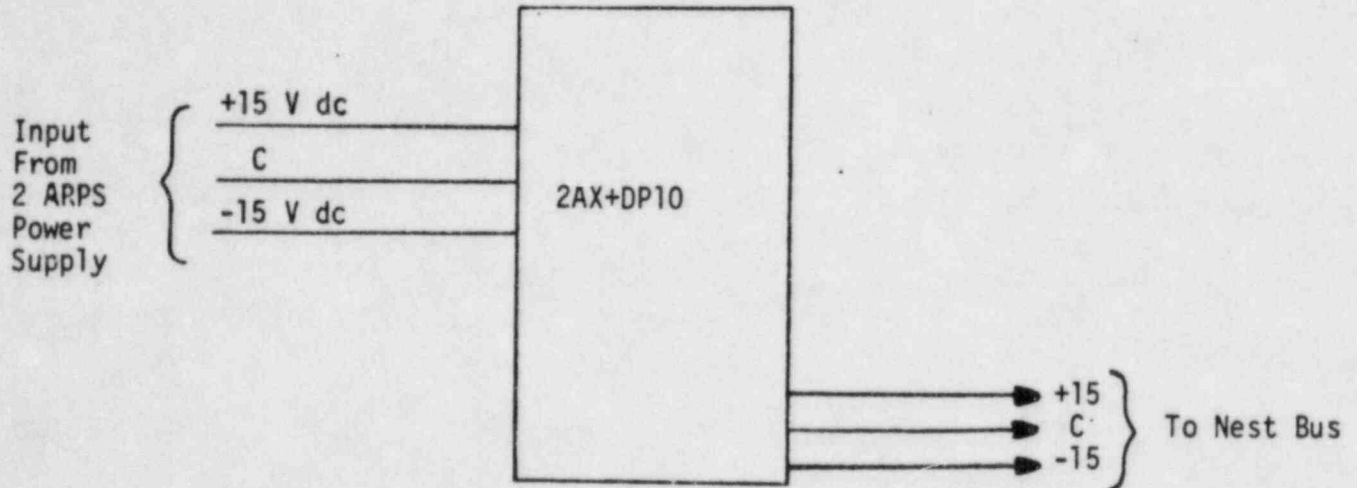

Test Conditions:

The 2AX+DP10 will not be monitored during test. Since it is the supply to the other nest instruments, any failure will be reflected in the performance of the other modules within that nest.

0 7 4 5 6 0 1 2 3

Figure 21
Seismic Test Setup
2AI-T2V EMF Converter

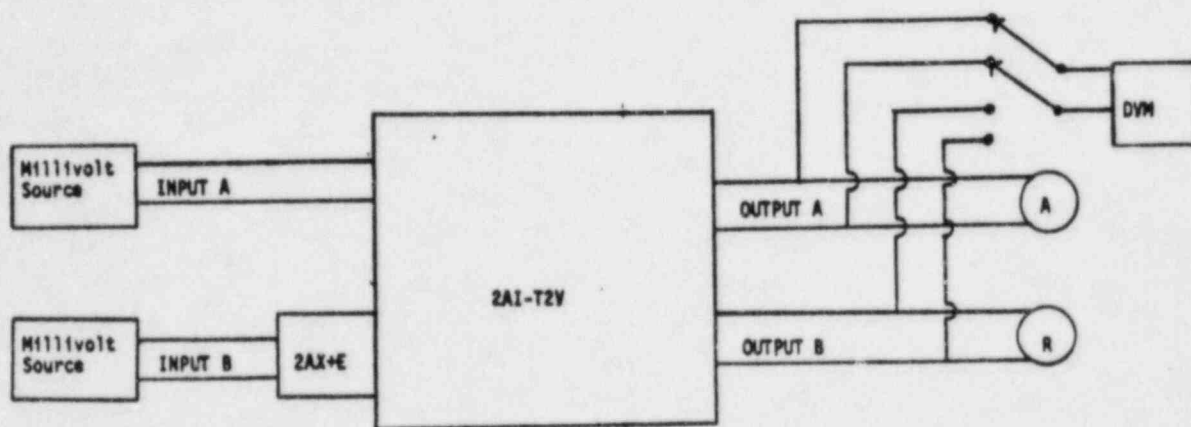

Test Conditions:

Both channels of the 2AI-T2V are calibrated for 0 to 5 mV dc;
input A & B set at 2.5 mV; output recorder calibrated for a full
scale traverse of 5 V dc $\pm 5\%$

07456 0129

Figure 22
Seismic Test Setup
2AI-13V Current-to-Voltage Converter

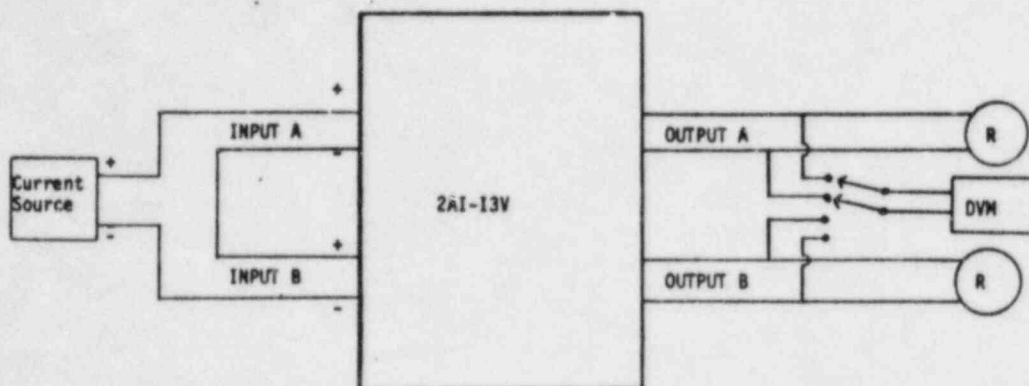

07456 0130

Test Conditions:

Input set at 12 mA; output recorder
calibrated for full scale traverse
of 5 V dc $\pm 5\%$

Figure 23
Seismic Test Setup
2AI-I2V Current-to-Voltage Converter

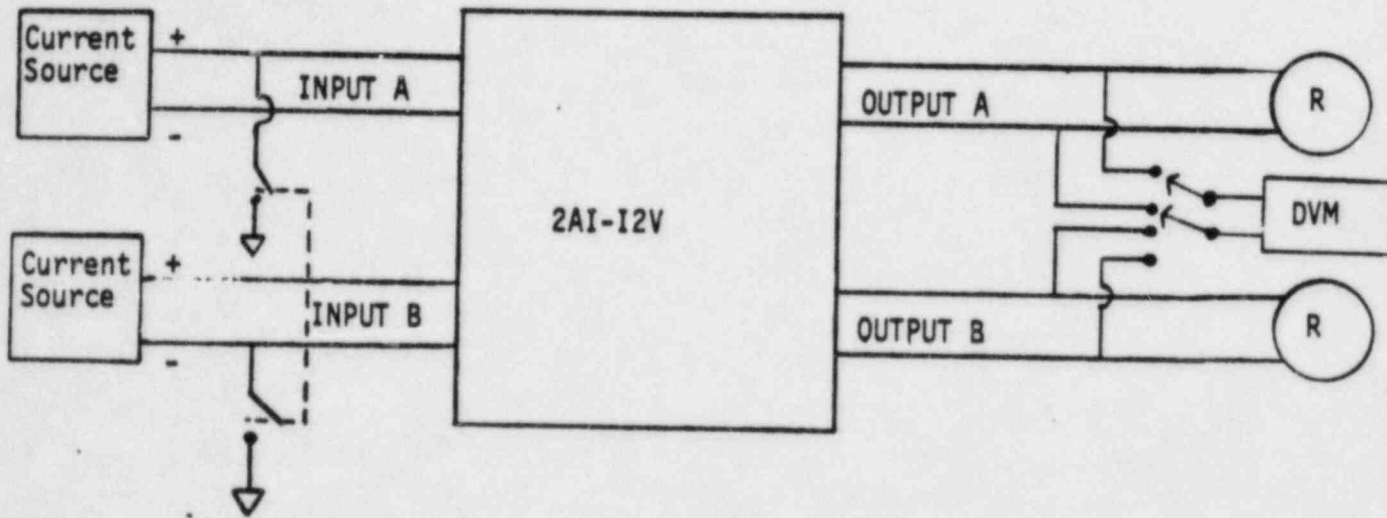

Test Conditions:

Input A & B at 12 mA; output recorders calibrated for full scale traverse of 5 V dc $\pm 5\%$; switches used for isolation test - to be closed 10 seconds during one SSE.

07456 0131

Figure 24
Seismic Test Setup
2AP+ALM-2B Alarm

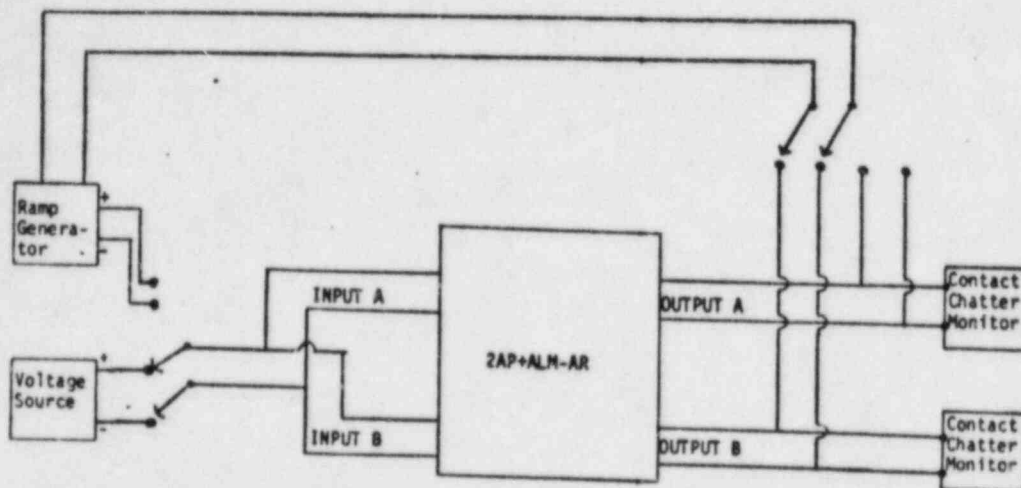

Test Conditions:

Alarm A programmed as a HI alarm and B as a LO alarm; setpoint A at 51% and B at 49%, input at 50% or 5 V dc: outputs are monitored with contact chatter monitor capable of detecting 100 us opening or closure; the input will be stepped during one OBE and SSE test to ensure output operability during such tests; the ramp generator is used for calibration runs before and after OBE and SSE tests.

07456 0132

Figure 25
Seismic Test Setup
2AP+ALM-AS Alarm

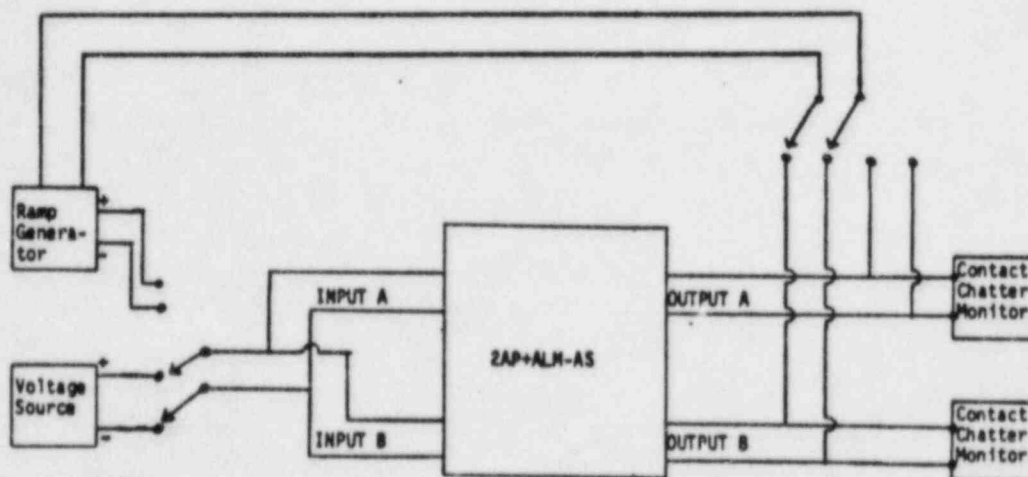

Test Conditions:

Alarm A programmed as a HI alarm and Alarm B as a LO alarm; setpoint A set for 51% and B set for 49% input at 50% or 5 V dc: outputs are monitored with contact chatter monitor capable of detecting 100 us opening or closure; the input will be stepped during one OBE and SSE test to ensure output operability during such test; the ramp generator is used for calibration runs before and after OBE and SSE tests; logic output.

07456 0133

Figure 26
Seismic Test Setup
2A0-L2C-R Contact Output Isolator

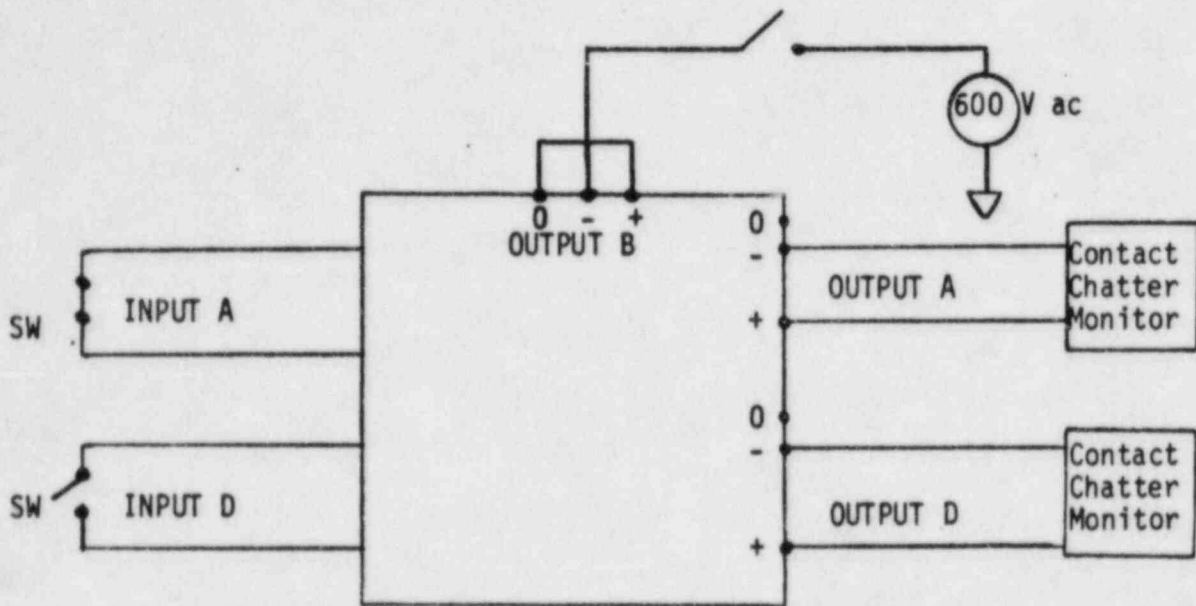

Test Conditions:

Input A shorted; input D open; outputs A & D monitored with contact chatter monitors capable of detecting 100 us opening or closure; both A&D outputs switched during OBE and SSP test; 600 V ac applied to output B for 10 seconds during one SSP test

07456 0134

Figure 27
Seismic Test Setup
2AO-VAI ECEP 9206 Voltage-to-Current Converter

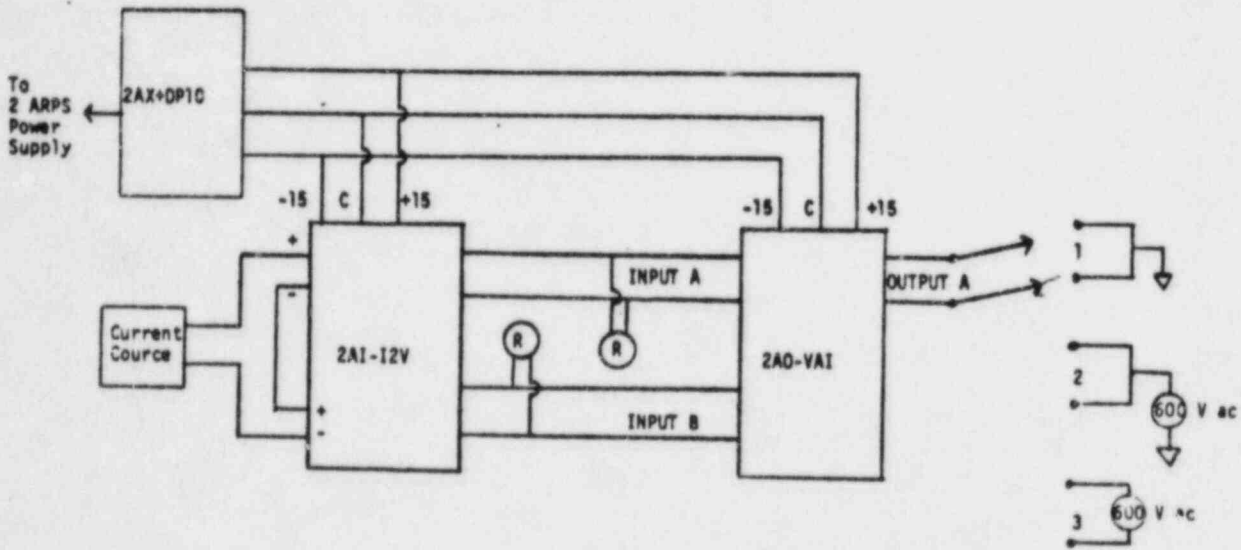

0135
07456

Test Condition:

Three tests are to be performed: 1) Ground both outputs of Channel A for 10 seconds during 1 SSE. 2) Apply 600 V ac between both output leads tied together and ground for 10 seconds during another SSE. 3) Apply 600 V ac across the output leads during a third SSE for 10 seconds; current source input at 12 mA, recorders calibrated for full scale traverse of 5 V dc $\pm 5\%$.

Figure 28
Seismic Test Setup
2AX+PS9A Power Supply

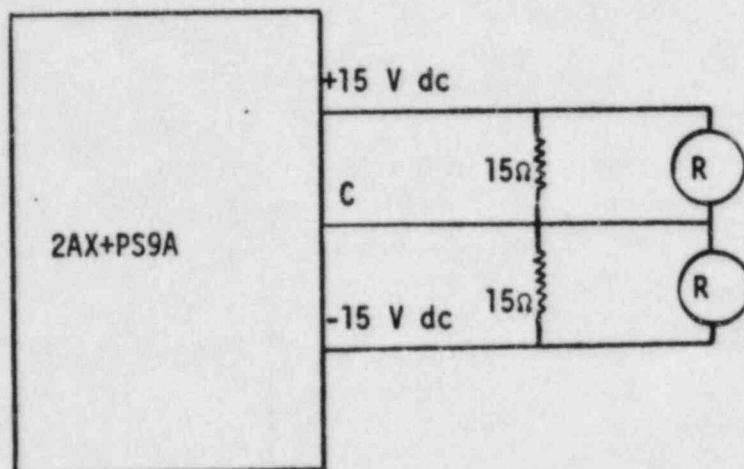

0 7 4 5 6 0 1 3 5

Test Conditions:

Recorders calibrated for full scale
traverse of 15 V dc $\pm 5\%$

Figure 29
Seismic Test Setup
2ARPS+BB2
Multi Nest Power Supply with Battery Backup

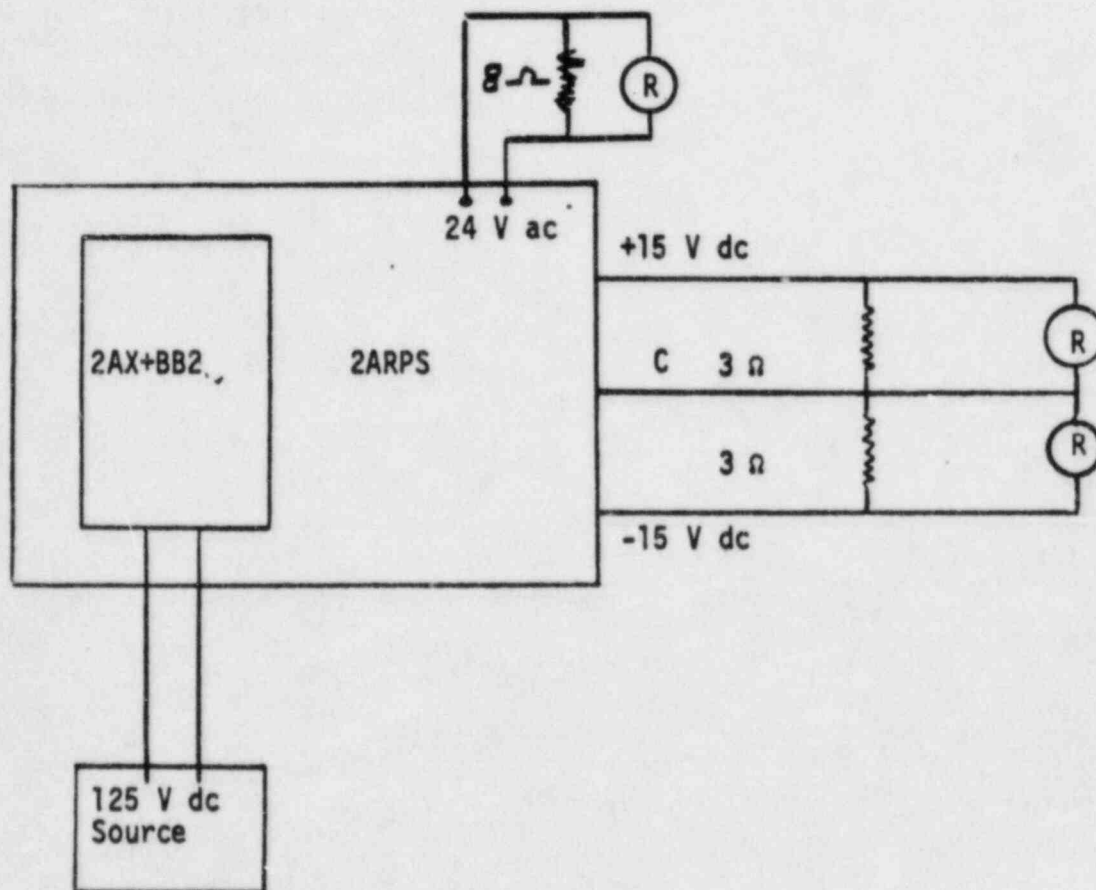

0 7 4 5 6 0 1 3 7

Test Conditions:

The Recorders monitoring the dc output are calibrated for full scale traverse of 15 V dc +5%; the operation of 2AX+BB2 will be checked during one SSE. The 24 V ac Recorder is calibrated for a full scale traverse of 24 V ac.

Figure 30
Seismic Test Setup
2AX+LS Bypass Module

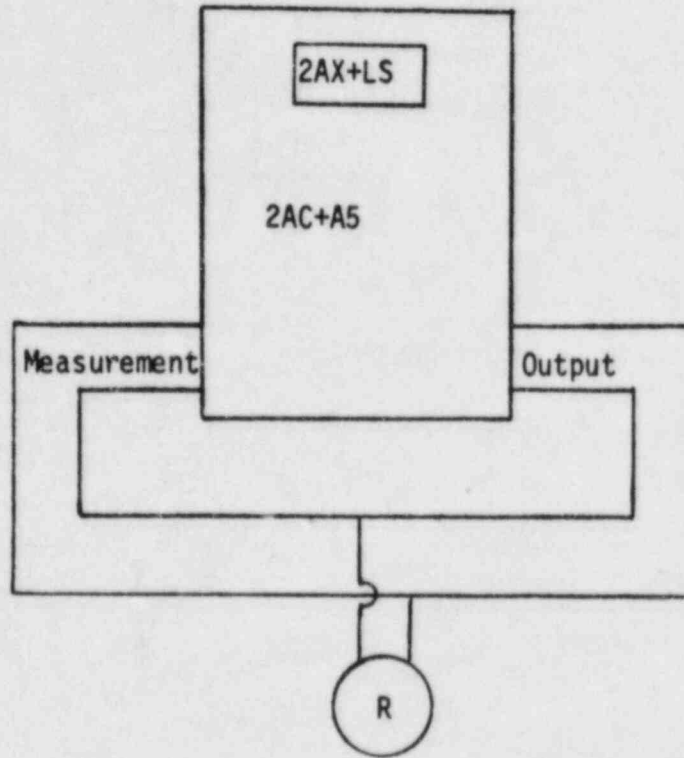

0 7 1 5 6
0 1 3 3

Test Conditions:

Output recorder calibrated for 5 V dc $\pm 5\%$

Figure 31.
Balanced Rack
(Equipment - Front and Rear)
Right Side View of N-2ES Style B Rack
Location of Triaxial Accelerometers

NOTE: The placement of Accelerometers in the same location on the Balanced and Unbalanced Racks.

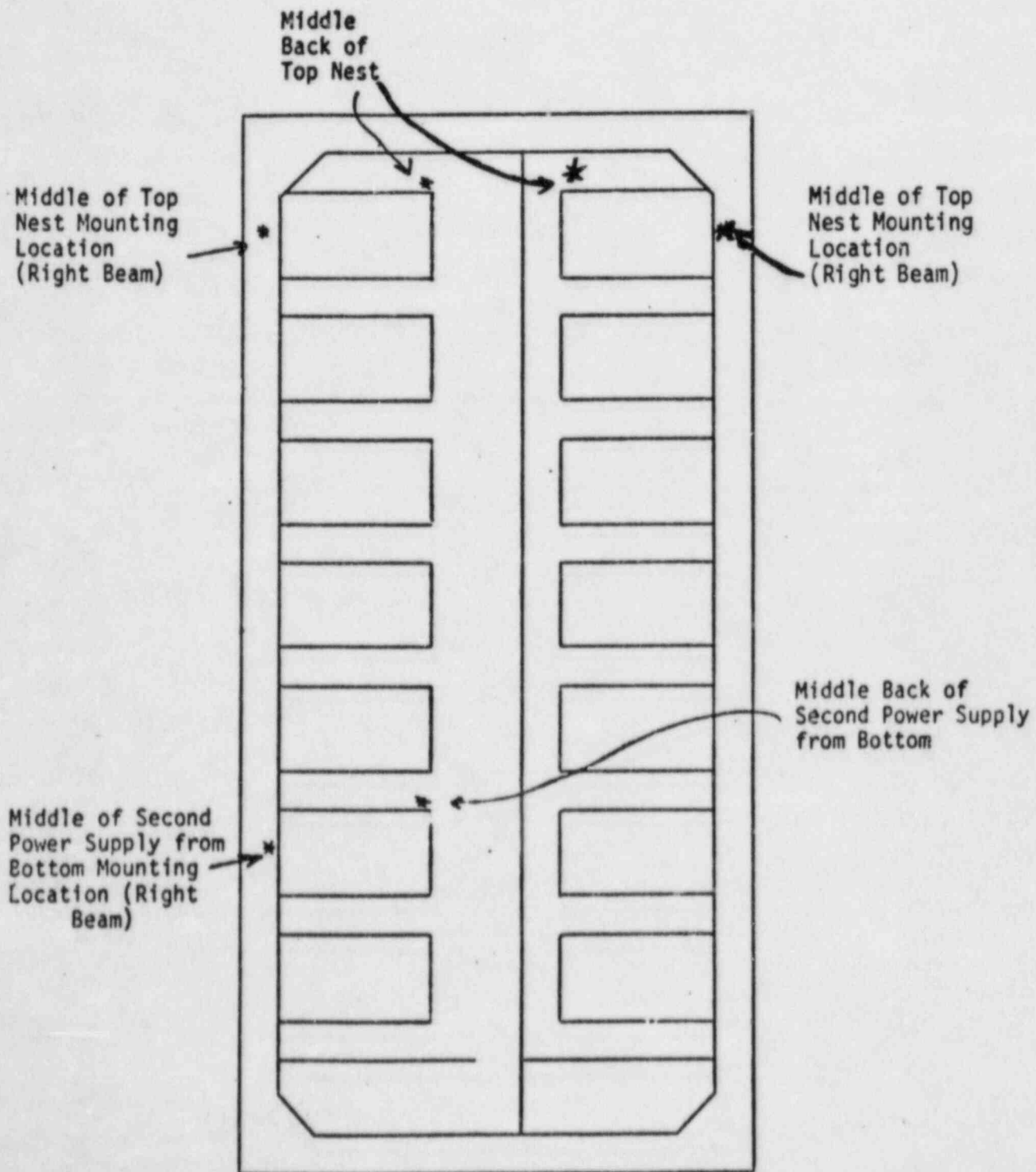

07455 0139

The Foxboro Company
Corporate Quality Assurance Laboratory
Type Test Report

Q0AAB44
REV A

2AO-VAI CUSTOM (ECEP 9206)
STYLE A CS-N/SRC
VOLTAGE-TO-CURRENT CONVERTERS

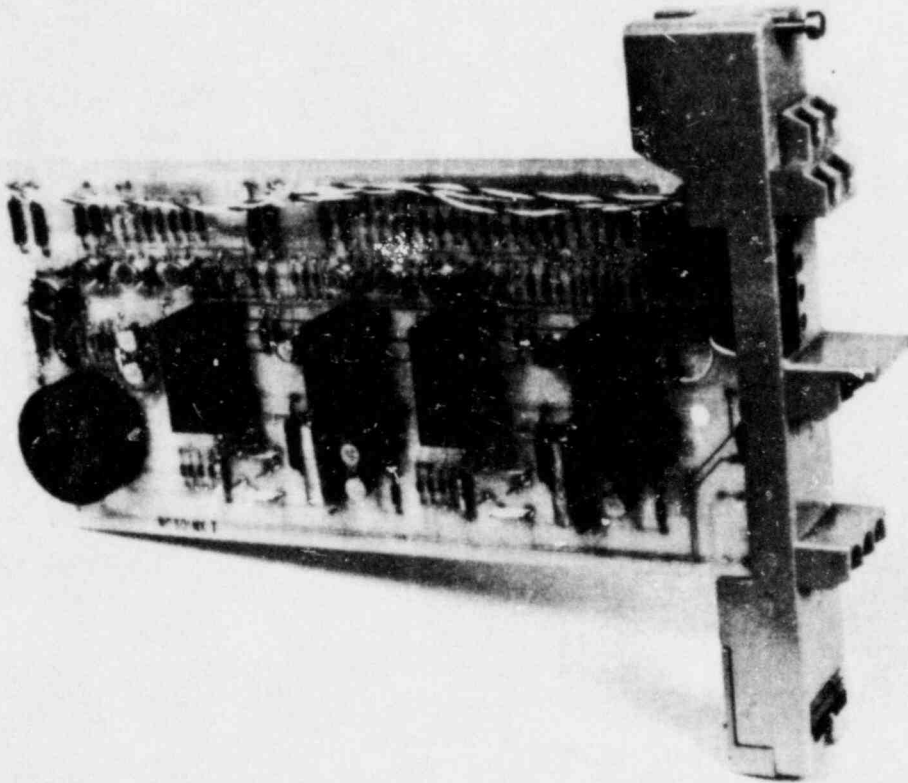

This report, the procedures, data and conclusions contained herein are the property of The Foxboro Company and shall not be loaned or otherwise transferred to a third party or reproduced, copied or used for any purpose, without written consent of The Foxboro Company.

Pre-Seismic

Seismic

DATE OF TEST:

SEP 77

JAN 76

TEST ENG./TECH.:

G.M. Karol

R.L. Andrews

E.D. Wardyga, Jr.

R.L. Andrews

APPROVED:

L.W. Hewey Date: 3/14/79
L.W. Hewey, Supervisor, Corp. Qual. Assurance Lab.

Q0AAB44
PAGE 0
REV A

THE FOXBORO COMPANY
CORPORATE QUALITY ASSURANCE LABORATORY
TYPE TEST REPORT

EXPLANATION OF LATEST REVISION

First Issue

REVISION STATUS OF PAGES

<u>PAGE NO.</u>	<u>REV</u>
Title	A
1 - 17	A

PRODUCT TESTED

<u>MODEL</u>	<u>DATE OF MANUFACTURE</u>	<u>STYLE</u>
2AO-VAI (ECEP 9206)	Week 34, 1977	A

PRODUCT QUALIFIED

<u>MODEL</u>	<u>STYLE</u>	<u>CERTIFICATION CODE</u>
2AO-VAI (ECEP 9206)	A	CS-N/SRC CS-N/SRD

REFERENCE DOCUMENTS

1. Q0AAB01, Demonstration/Analysis of Qualified Life
2. Q0AAA20, Part 1, Seismic Test Report
3. IEEE¹ 323-1974 and IEEE 344-1975
4. ISA²-S51.1-1976, Process Instrumentation Terminology
5. Q0AAA02, Performance Tests and Operating Influence Tests for Rack-Mounted Modules

REVISION HISTORY

<u>REV</u>	<u>DATE</u>
A	14 MAR 79

¹Institute of Electrical and Electronic Engineers, Incorporated
²Instrument Society of America

I. TEST OBJECTIVE

To determine the isolation characteristics on this custom 2AO-VAI Voltage-to-Current Converter during seismic tests. Also, to verify the performance characteristics and the operating influences before seismic tests.

II. SUMMARY AND CONCLUSIONS

This module, when tested in a 2ANU-D nest, was found to be within specification during pre-seismic tests.

The module also maintained its isolation capabilities (Refer to Section III.F.6.) and its structural integrity during all seismic tests.

For demonstration and analysis of estimated Qualified Life, refer to Document Q0AAB01.

III. SUMMARY OF TEST RESULTS

Measurement equipment accuracy during pre-seismic tests was 0.05%, therefore, all data is reported to that tolerance.

A. Calibration Characteristics

Reference Conditions: Temperature 23 ±2°C
Relative Humidity 40 ±10%
Supply Voltage +15, -15 V dc ±0.1%

Specification: Accuracy ±0.5%

	<u>Pre-Seismic</u>	
	<u>Channel A</u>	<u>Channel E</u>
Measured Accuracy, %)	{ +0.25	+0.35
	-0.30	-0.15
Zero Error, %	-0.30	-0.15
Span Error, %	+0.20	+0.15
Repeatability, %	<0.05	<0.05
Hysteresis, %	<0.05	<0.05
Linearity (Independent), %	±0.25	±0.25

III. SUMMARY OF TEST RESULTS (Continued)

B. Supply Voltage Effects

Reference Conditions: Temperature 23 ±2°C
 Relative Humidity 40 ±10%
 Supply Voltage +15, -15 V dc ±0.1%

Specification: The output will shift less than ±0.5% for a ±5% change in the +15, -15 V dc supply.

<u>Supply Voltage</u> <u>(V dc)</u>		<u>Output Shift (% of Span)</u> <u>Pre-Seismic</u>			
<u>+</u>	<u>-</u>	<u>Channel A</u>		<u>Channel B</u>	
		<u>0%</u>	<u>100%</u>	<u>0%</u>	<u>100%</u>
15.00	15.00	Ref.	Ref.	Ref.	Ref.
15.75	15.75	-0.05	-0.05	-0.05	-0.05
14.25	14.25	+0.10	+0.10	+0.10	+0.10
15.75	14.25	<0.05	+0.10	<0.05	<0.05
14.25	15.75	<0.05	<0.05	<0.05	<0.05

C. Ambient Temperature Effects

Reference Conditions: Temperature 27 ±2°C
 Relative Humidity 40 ±10%
 Supply Voltage +15, -15 V dc ±0.1%

Specification: The maximum error for a change in ambient temperature of 28°C within the normal operating limits of 5 and 50°C will not exceed ±0.5%.

<u>Ambient</u> <u>Temperature (°C)</u>	<u>Output Shift (% of Span)</u> <u>Pre-Seismic</u>			
	<u>Channel A</u>		<u>Channel B</u>	
	<u>0%</u>	<u>100%</u>	<u>0%</u>	<u>100%</u>
27	Ref.	Ref.	Ref.	Ref.
4	+0.10	+0.10	+0.05	+0.10
27	<0.05	<0.05	<0.05	<0.05
50	-0.10	+0.10	<0.05	+0.10
60	-0.15	+0.15	<0.05	+0.20
27	<0.05	+0.05	<0.05	<0.05

III. SUMMARY OF TEST RESULTS (Continued)

D. Relative Humidity Effects

Reference Conditions: Temperature 31 ±2°C
 Relative Humidity 50 ±5%
 Supply Voltage +15, -15 V dc ±0.1%

Specification: The output shift due to an exposure to 95% relative humidity at 30°C wet bulb, will be no greater than ±0.5%.

Relative Humidity (%)	<u>Output Shift (% of Span)</u>			
	<u>Pre-Seismic</u>			
	<u>Channel A</u>		<u>Channel B</u>	
	<u>0%</u>	<u>100%</u>	<u>0%</u>	<u>100%</u>
50	Ref.	Ref.	Ref.	Ref.
95	<0.05	<0.05	<0.05	<0.05
50	<0.05	<0.05	<0.05	<0.05

E. Response Time

Reference Conditions: Temperature 23 ±2°C
 Relative Humidity 40 ±10%
 Supply Voltage +15, -15 V dc ±0.1%

Specification: When excited by an 80% input step (10 to 90% change), the maximum time required for the output to reach 90% of the final steady-state value is 160 milliseconds.

90% Response Time For an 80% input step (10 to 90%), ms	<u>Pre-Seismic</u>			
	<u>Channel A</u>		<u>Channel B</u>	
	<u>Step Up</u>	<u>Step Down</u>	<u>Step Up</u>	<u>Step Down</u>
	90	85	90	85

III. SUMMARY OF TEST RESULTS (Continued)

F. Seismic Vibration Effects

1. Test Facility

Acton Environmental Testing Laboratory, Acton, MA

2. Test Objective

To demonstrate that the module maintains its isolation capabilities when mounted in an N-2ES Rack which is loaded in accordance with established rack-loading guidelines and is subjected to floor-level inputs of magnitude equal to or exceeded by those defined by the Foxboro³ Generic Response Spectra for Floor-Mounted Equipment, shown in the following.

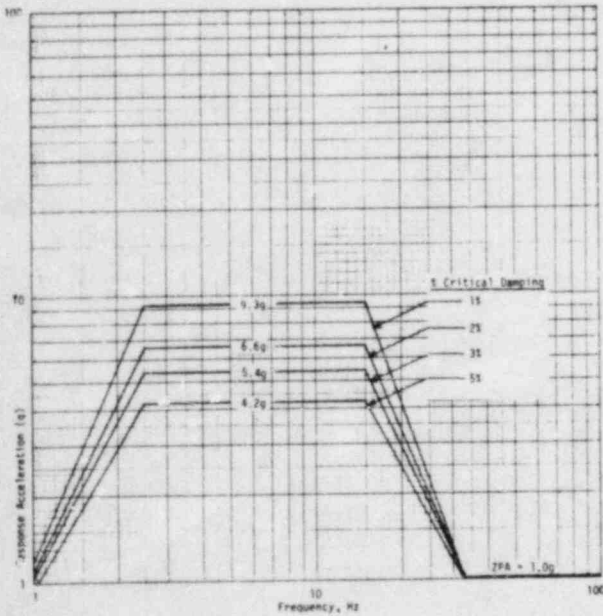

OPERATING BASIS EARTHQUAKE (OBE)

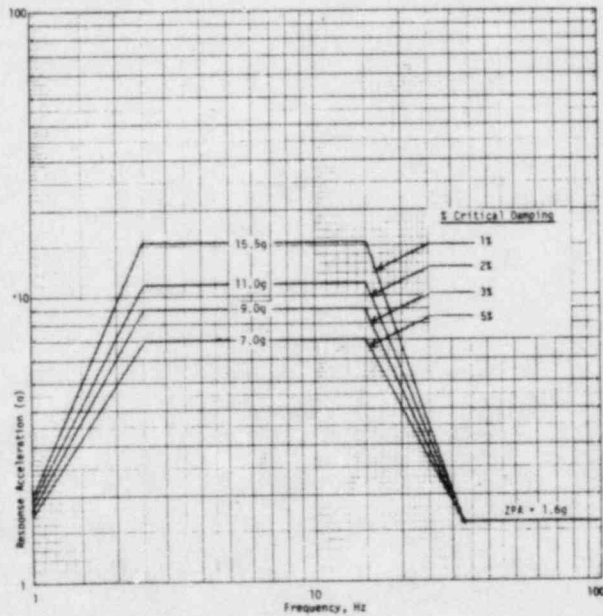

SAFE SHUTDOWN EARTHQUAKE (SSE)

GENERIC REQUIRED RESPONSE SPECTRA (RRS) FOR
 QUALIFICATION OF FLOOR-MOUNTED CONTROL ROOM
 EQUIPMENT - HORIZONTAL AND VERTICAL

III. SUMMARY OF TEST RESULTS (Continued)
F. Seismic Vibration Effects (Continued)

3. Test Procedure

The module was mounted in a 2ANU-D nest at Level 1 (top level) of an N-2ES Rack. The nest was subjected to a series of tests with band-limited white noise (random) inputs applied at the base of the rack for a duration of 30 seconds. Inputs as determined by the Test Response Spectra (TRS) of the test table exceeded the OBE and SSE levels for floor mounted equipment defined in Section III.F.2., with the objective of producing TRS's at the module mounting location which enveloped the target GENERIC REQUIRED RESPONSE SPECTRA FOR QUALIFICATION OF BACK-MOUNTED MODULES. Five tests at the OBE level and one at the SSE level were performed in each of four planes, front-to-back and vertical, back-to-front and vertical, left-to-right and vertical, and right-to-left and vertical with horizontal and vertical inputs applied simultaneously and in phase.

TRS's were generated from accelerometers on the table and at the module mounting location for 1, 2.5, and 5% damping during OBE and SSE tests. The module was energized and functioning during all tests, and its primary performance functions were monitored during and immediately after each SSE and each series of OBE tests.

III. SUMMARY OF TEST RESULTS (Continued)
F. Seismic Vibration Effects (Continued)

4. Seismic, Summary and Conclusions

The 2A0-VAI Custom Module was tested in Nest No. 4*.

The one-third octave response points achieved in testing generally enveloped the target REQUIRED RESPONSE SPECTRA FOR QUALIFICATION OF RACK MOUNTED NEST MODULES (Refer to response plots, Section III.F.5.).

Relative to the target RRS's, undertesting occurred at several points in the frequency range of 1.25 to 6.3 Hz due primarily to test table velocity limitations. At the most significant response frequencies of the target RRS's, those which define the response peaks in the horizontal axes, the one-third octave response points of the TRS's enveloped the RRS's in every case.

Some undertesting occurred immediately above and below the response peaks of the horizontal RRS's, at 10 and 20 Hz. However, these response points were only marginally low (Refer to TRS - Front-to-Back and Vertical, and TRS - Back-to-Front and Vertical). A single point of undertesting occurred in the vertical response at 16 Hz (TRS - Front-to-Back and Vertical) and at 10 Hz (TRS - Back-to-Front and Vertical). Peak response levels of the vertical RRS's are considerably lower than those of the horizontal RRS's, and are regarded to be of much less significance relative to module performance under seismic testing.

Overall, the TRS's achieved are considered to provide the required basis for demonstrating the successful performance of the 2A0-VAI Custom Module at the response levels of the target RRS's.

*Reference Q0AAB20, Parts 1 and 2, Seismic Test Reports

III. SUMMARY OF TEST RESULTS (Continued)
P. Seismic Vibration Effects (Continued)

5. Test Results (Seismic Response)

1% damped Test Response Spectra are plotted below at one-third octave intervals for each of the four SSE tests, as obtained at the module mounting location (see dots). Target GENERIC REQUIRED RESPONSE SPECTRA FOR QUALIFICATION OF BACK-MOUNTED MODULES are also shown on the same plots (solid line) to permit a direct comparison of the two plots.

TBS - Front-to-Back/Vertical Plane

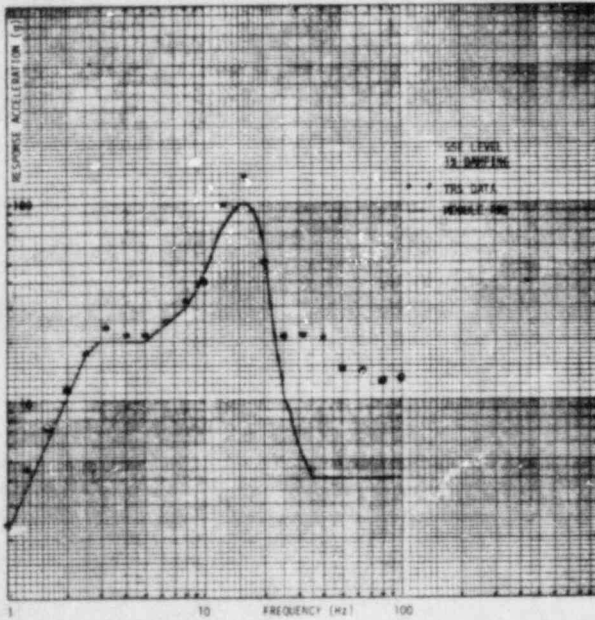

Front-to-Back Response

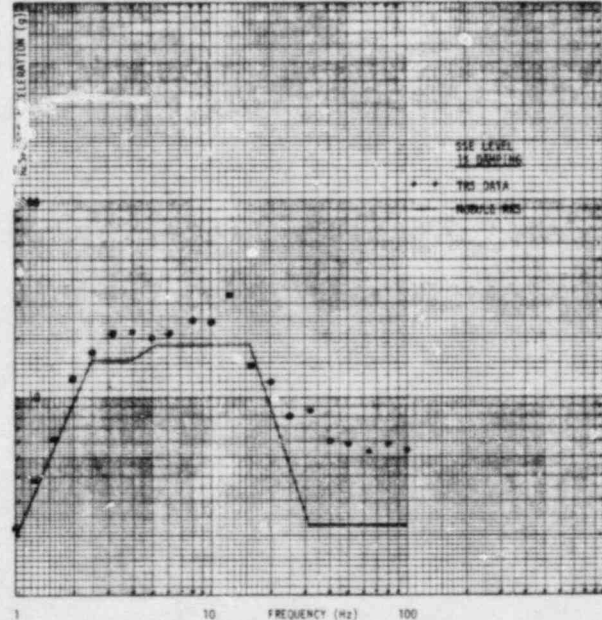

Vertical Response

III. SUMMARY OF TEST RESULTS (Continued)
F. Seismic Vibration Effects (Continued)
5. Test Results (Seismic Response) (Continued)

TRS - Back-to-Front/Vertical Plane

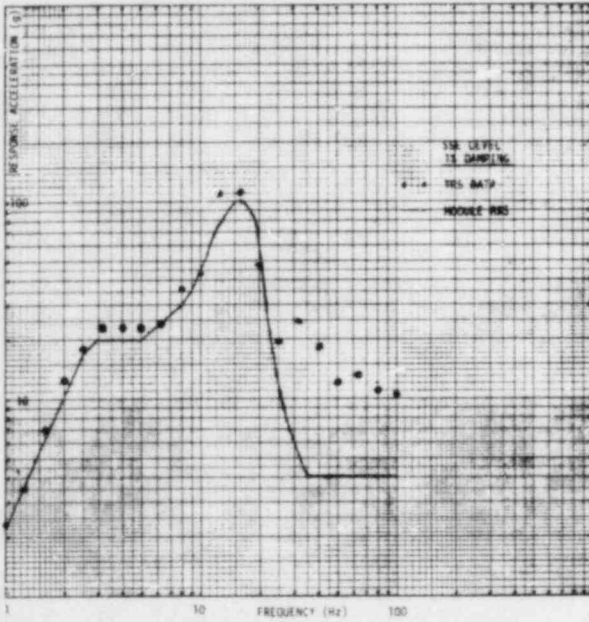

Back-to-Front Response

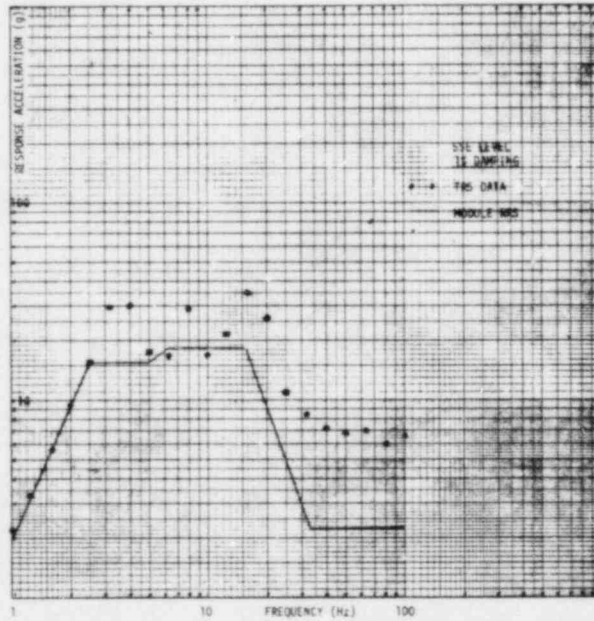

Vertical Response

III. SUMMARY OF TEST RESULTS (Continued)

F. Seismic Vibration Effects (Continued)

5. Test Results (Seismic Response) (Continued)

TRS - Right-to-Left/Vertical Plane⁵

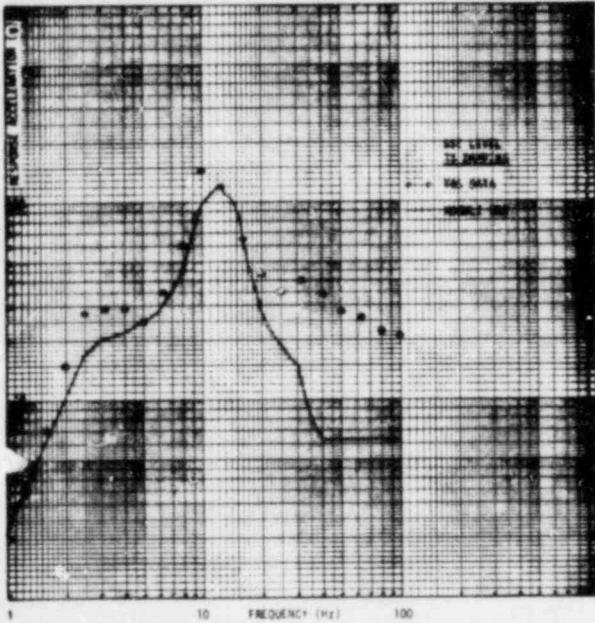

Right-to-Left Response

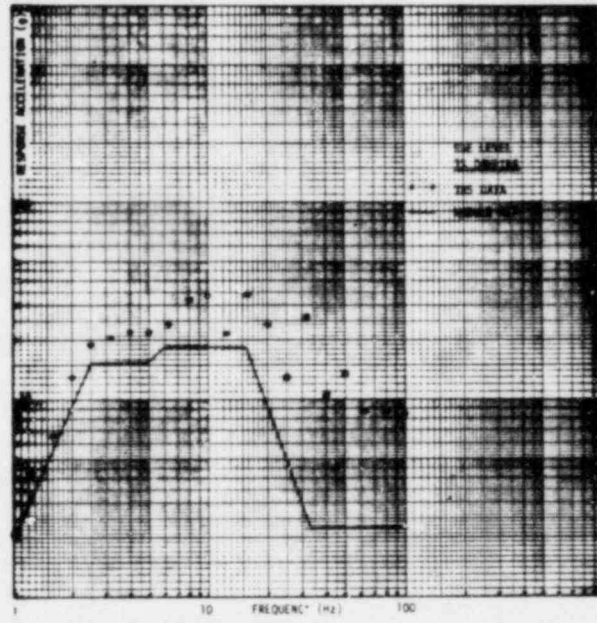

Vertical Response

⁵TRS data on Nest No. 4 not obtained during SSE level test in Right-to-Left and Vertical plane because accelerometers fell off during test. Data can be inferred from TRS's shown, taken at same rack level (Level 1) at rear of rack, since rack itself is symmetrical, front and rear, and rack loading during test was also symmetrical.

III. SUMMARY OF TEST RESULTS (Continued)
P. Seismic Vibration Effects (Continued)
5. Test Results (Seismic Response) (Continued)

TRS - Left-to-Right/Vertical Plane

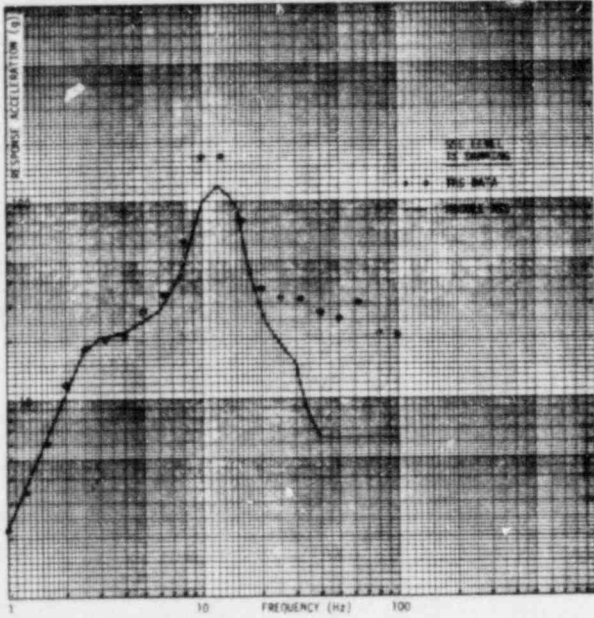

Left-to-Right Response

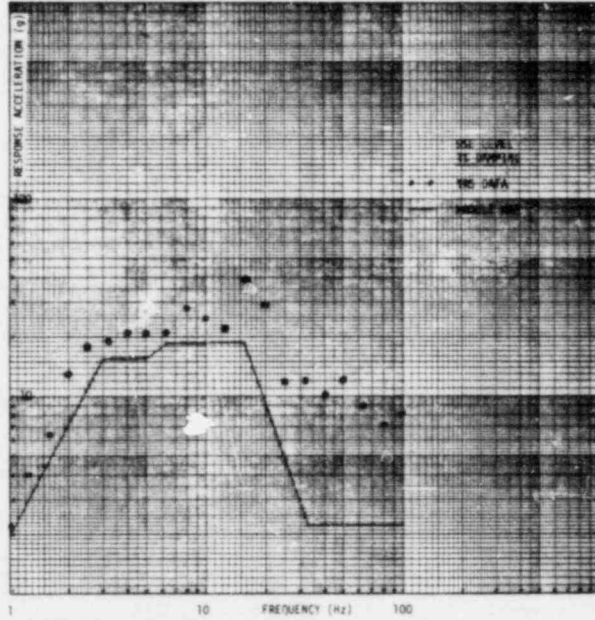

Vertical Response

III. SUMMARY OF TEST RESULTS (Continued)
P. Seismic Vibration Effects (Continued)

6. Test Results (Module Performance)

Three isolation tests were performed on the output of this custom 2AO-VAI Voltage-to-Current Converter. All three tests were performed to ensure proper isolation during a seismic event. The three tests and results were as follows (also refer to Figure No. 1):

- a. Ground both outputs of Channel A for 10 seconds during 1 SSE.

RESULTS: Neither channel of the 2AI-I2V Current-to-Voltage Converter which fed the 2AO-VAI Voltage-to-Current Converter shifted more than 0.5% when one channel of the 2AO-VAI's output was grounded. Also, both channels of the 2AO-VAI functioned properly after the test was completed. Refer to Figure 2 for oscillograph recording of 2AI-I2V outputs.

- b. Apply 600 V ac between both output leads tied together and earth (ground) for 10 seconds during another SSE.

RESULTS: Both the 2AO-VAI and 2AO-V2I remained operational during this test. There was some ac feedthrough to the 2AI-I2V. Refer to Figure 3 for recordings of outputs.

III. SUMMARY OF TEST RESULTS (Continued)
F. Seismic Vibration Effects (Continued)
6. Test Results (Continued)

- c. Apply 600 V ac across the output leads during a third SSE for 10 seconds.

RESULTS: The application of 600 V ac across the output terminals of Section A of this custom 2A0-VAI produced the following damage to the unit:

- Circuit foil from the (+) output lead connection to J9 opened.
- Circuit foil from the (-) output lead connection to J14 opened.
- Resistor Resistor R32 (402 Ω , $\pm 3\%$, 6 W) opened.
- Capacitor C17 (6.8 uF tantalum) opened.
- Capacitor C11 (4.0 uF polycarbonate) shorted.
- Diodes CR19, 20, 21, and 22 (Type IN4447) opened.

Reference Drawings: 10102FY and 10201NZ

No damage occurred to Section B or to the 2AI-I2V Voltage-to-Current Converter due to the application of the test voltage to Section A. Refer to Figure 4 for the 2AI-I2V output recordings.

7. Module Mass and Center of Gravity

<u>Model</u>	<u>Mass</u>		<u>Height</u>		<u>Width</u>		<u>Depth</u>	
	<u>lb</u>	<u>g</u>	<u>in.</u>	<u>cm</u>	<u>in.</u>	<u>cm</u>	<u>in.</u>	<u>cm</u>
2A0-VAI	1.27	578	4.4	11.0	0.8	2.0	2.6	6.5

Note: Reference for height, width, and depth measurements was the lower left rear of the front plate.

III. SUMMARY OF TEST RESULTS (Continued)

G. Test Equipment

1. Pre-Seismic

<u>Instrument</u>	<u>Manufacturer</u>	<u>Model</u>	<u>Serial</u>	<u>Calibration Information</u>	
				<u>Last Date</u>	<u>Date Due</u>
DVM	SD ⁶	7000A	1122	5/77	11/77
Power Supply	H-P ⁷	60155C	1135A01589	3/77	9/78
Power Supply	H-P	6227-B	1146A00880	8/77	2/78
Voltage Source Storage	EDC ⁸	MV100N	3637	5/77	11/77
Oscilloscope	H-P	184A	1316A00705	1/77	10/77
Environmental Chamber	Tenney ⁹	TTUPR- 40240	4709	2/77	11/77
Environmental Chamber	Tenney	TR-40- 100250	7397	5/77	2/78

2. Seismic

<u>Instrument</u>	<u>Manufacturer</u>	<u>Model</u>	<u>Serial</u>	<u>Calibration Information</u>	
				<u>Last Date</u>	<u>Date Due</u>
Power Supply	H-P	60155C	1135A01391	11/77	5/79
Voltage Source	EDC	MV100N	1890	12/77	6/78
Recorder	H-P	7414A	1244A00839	12/77	9/78
Current-to-Voltage Converter	Foxboro ¹⁰	2AI-I2V	N/A	N/A	N/A

⁶Syston Donner (Formerly Fairchild Camera and Instrument Corporation)

⁷Hewlett-Packard Company

⁸Electronic Development Corporation

⁹Tenney Engineering, Incorporated

¹⁰The Foxboro Company

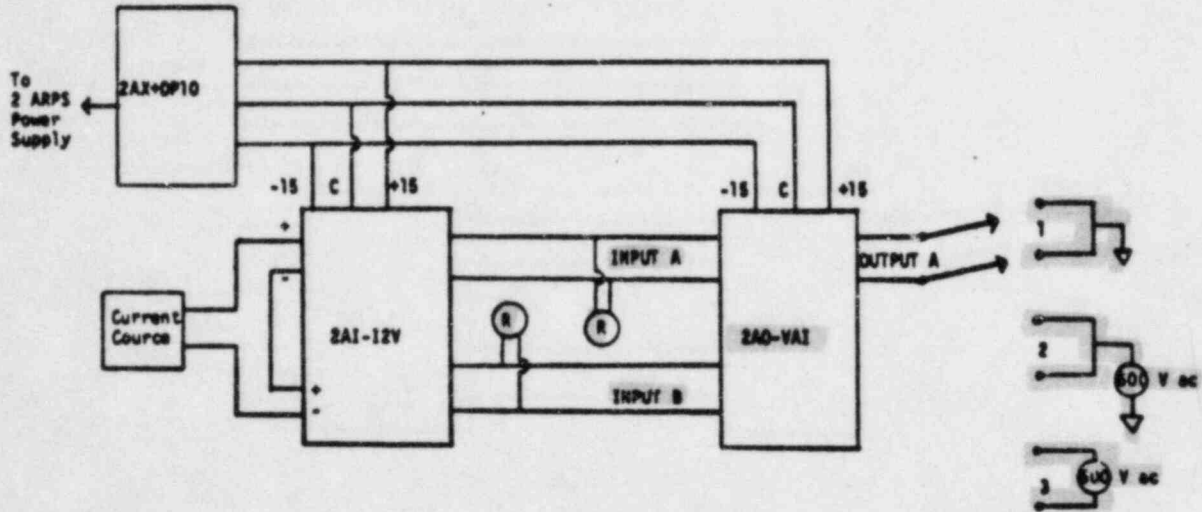

Figure 1

Seismic Test Setup

2AO-VAI Custom ECEP 9206 Voltage-to-Current Converter

2AI-12V
High Voltage Test 1

January 1978

F-B SSi

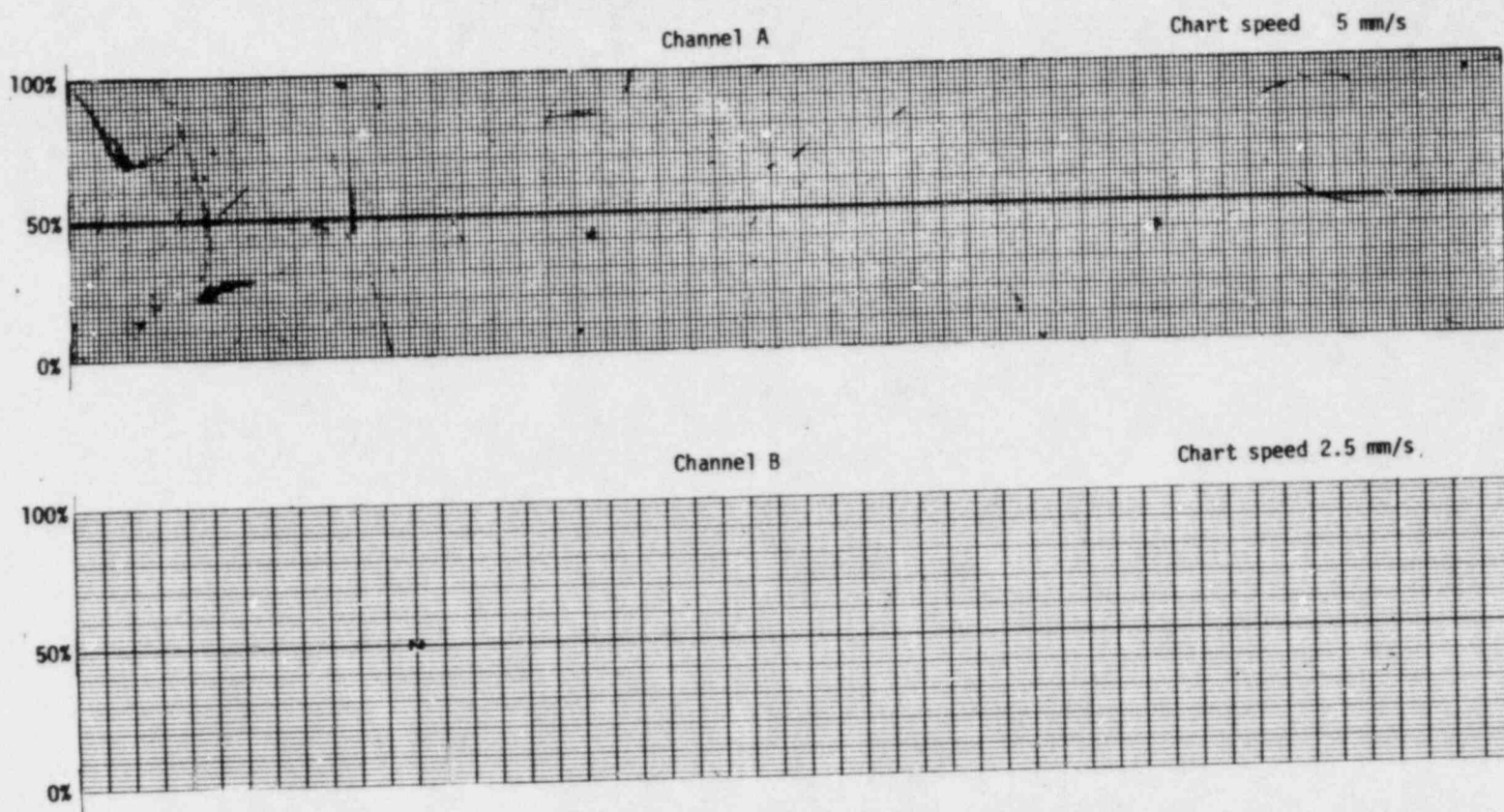

Figure 2
Graphs of High Voltage Test No. 1

2A1-I2V
High Voltage Test 2

January 1978

L-R SSE

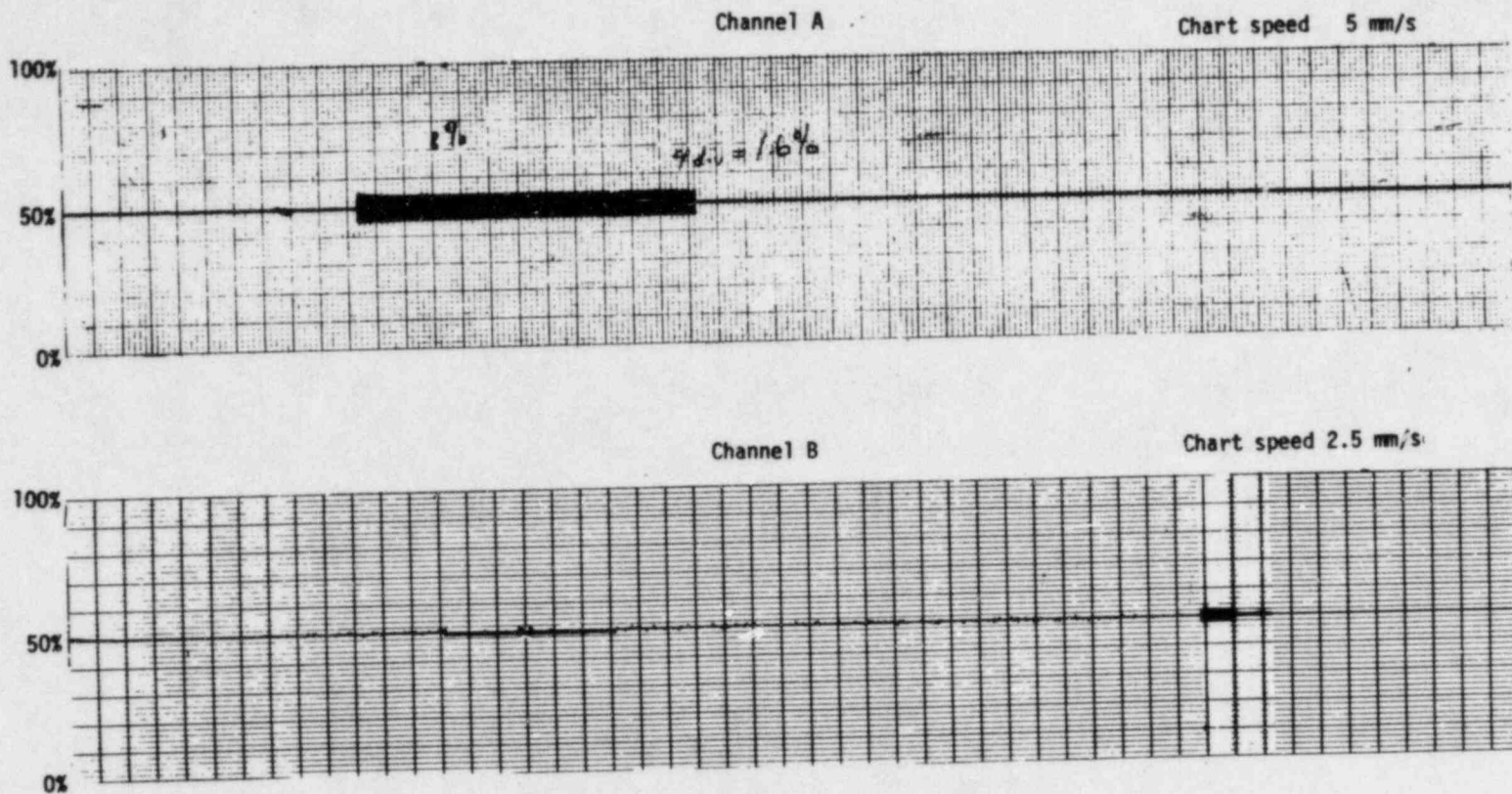

Figure 3
Graphs of High Voltage Test No. 2

Figure 4
Graphs of High Voltage Test No. 3

2AI-12V
High Voltage Test 3

January 1978

R-L SSE

