

ATTACHMENT

SEP Topic No. VII-1A Isolation of Reactor  
Protection System From Nonsafety Systems,  
Including Qualifications of Isolation  
Devices.

Failure Mode and Effects Analysis

Oyster Creek Nuclear Generating Station  
Docket No. 50-219.

TABLE OF CONTENTS

1.0 Introduction

2.0 Method

3.0 Results

4.0 Conclusion

5.0 Recommendation

Fig. 1 - APRM/IRII Interface with Recorders

Fig. 2 - Recorder Input Buffer Circuit

Fig. 3 - RPS Logic

Fig. 4 - Nuclear Monitoring System Interface with RPS  
Channel 1

Fig. 5 - Nuclear Monitoring System Interface with RPS  
Channel 2

## 1.0 INTRODUCTION

The integrated Plant Safety Assessment - Systematic Evaluation Program (SEP) was initiated by US Nuclear Regulatory Commission (NRC) to review the designs of older operating nuclear reactors to reconfirm and document their safety. The results of SEP for Oyster Creek Nuclear Generating Station (OCNGS) are published by NRC in NUREG-0822 in January 1983.

Item 4.27, Topic VII - 1-A in NUREG 0822 - "Isolation of Reactor Protection System From Nonsafety Systems, Including Qualification of Isolation Devices" identifies that there are no isolation devices between the Nuclear flux monitoring system IRMs and APRMs and their process recorders.

GPUN has agreed to perform a Failure Mode and Effects Analysis to evaluate the need for isolation devices between these systems and their recorders. This TDR documents the FMEA and its results.

## 2.0 METHODS

The analysis considers the worst case failure of the Recorders and the consequences of the failures to the APRMs and IRM trip functions which trip the Reactor Protection System.

The consequences of the Recorder failure are considered to be

1. Open circuit at the Recorder input terminals
2. Short circuit at the Recorder input terminals
3. Recorder Power Supply voltage (115 VAC) applied to recorder input terminals.

The APRM/IRM interface with their process recorders is shown in figure 1.

### 2.1 References

Following General Electric documents show the Elementary Drawings of the system and its component parts.

- 2.1.1 GE237E645 Average Power Range Monitor (Dual)
- 2.1.2 GE237E650 Wide Range Monitor (Mean Square Voltage)
- 2.1.3 GE107C4818 Direct Current Amplifier
- 2.1.3 GE 706E812 Neutron Monitoring System

## 2.2 Analysis

The high impedance buffer circuit between IRM/APRM recorders and the associated DC amplifiers is shown in Figure 2.

The DC amplifier circuit is given in reference 2.1.3.

The outputs from DC amplifiers is 0-10 VDC. This 0-10 VDC output is fed to IRM/APRM trip units that provide Reactor Protection System scram under Hi Flux conditions. The same output through a high impedance potential divider circuit is stepped down to 0-1 Vdc signal, and is used to record the reactor core flux level on the IRM/APRM process recorders.

The effects of the various failure model of the IRM/APRM recorders on the RPS trip functions are analyzed below.

### 2.2.1 Open Circuit At the Recorder Input Terminals

In this failure mode, recorder signal input circuit is assumed to be opened due to recorder failure.

This open circuit will not degrade the 0-10Vdc signal that drives the Scram Trip Unit, therefore, the integrity of the RPS system will not be compromised.

### 2.2.2 Short Circuit at the Recorder Input Terminals

In this failure mode, a short circuit across 0-1 Vdc signal resistor (R18 in fig. 2), is assumed.

The short circuit across resistor R18 will not be able to degrade the Scram Trip Unit signal. The 9K resistor (R17) provides isolation to 0-10Vdc Scram Trip Unit signal against such faults. Therefore, this type of fault will not compromise RPS integrity.

### 2.2.3 Recorder Power Supply Voltage (115 AC) Applied to Recorder Input Signal Terminals

This type of failure mode can be further divided into two types. One where 115 VAC is applied to one of the input signal terminals and the other where 115 VAC is applied across the recorder input signal terminals (or across resistor R18, Fig. 2).

#### 2.2.3.1 The reference point of the DC amplifier is floating, therefore, applying 115 VAC to one of the recorder input signal terminals will just change the reference and the

input signal to Scram Trip Unit (with respect to reference) will still remain 0-10 Vdc. Therefore, in this type of failure mode the input to Scram Trip Unit will not be degraded and the integrity of the RPS will not be compromised.

#### 2.2.3.2

The Reactor Protection System (RPS) logic is wired in one-out-of-two-twice logic, as shown in Figure 3. The RPS consists of two logic channels and each logic channel has two subchannels. At least one subchannel in each of the logic channels must trip to provide reactor scram.

Figures 4 and 5 show the IRM/APRM interface with the RPS logic channels 1 and 2, respectively. The RPS circuit is normally energized, i.e., the logic subchannels deenergize relays 1K1, 1K2, 2K1 and 2K2, by opening trip contacts, to provide reactor scram. Each RPS subchannel can be tripped by two IRMs or two APRMs under abnormal core flux conditions. Therefore, to fail one RPS subchannel its associated IRM/APRM scram trips have to fail. But due to nature of the RPS logic failure of one subchannel cannot prevent reactor trip when the safety limits are exceeded. The RPS will fail to scram the reactor, under unsafe flux conditions, only if one entire RPS channel fails (i.e., both the subchannels in one channel fail). With respect to Nuclear Monitoring system interface with RPS, the above condition will occur when channels 1, 2, 3, and 4 of APRM system (11, 12, 13 and 14 of IRM system in start up mode) fail simultaneously or channels 5, 6, 7, and 8 of APRM system (15, 16, 17, and 18 of IRM system in startup mode) fail simultaneously. Furthermore considering the allowable by-pass conditions of the APRM/IRM, three of these four APRM/IRMs have to fail simultaneously to defeat the safety functions.

The probability of the second type of recorder failure (described in this section) degrading the scram trip signals in the above combinations of the APRMs or IRMs is very low (almost negligible).

### 3.0 RESULTS

The above analysis shows that the failure of IRM/APRM process recorders, in any mode, will not compromise the integrity of the RPS system and would, therefore, not create a safety concern.

4.0 CONCLUSION

The APRM/IRMs will not fail to initiate a scram signal in the event of any credible failure in their process recorders. Therefore, in the existing configuration, the RPS integrity will not be compromised due to any failures in the APRM/IRM process recorders. Therefore, isolation devices between APRM/IRM electronics and their process recorders are not required.

5.0 RECOMMENDATION

The analysis indicates that the isolation devices between the IRM/APRMs and their process recorders are not required.

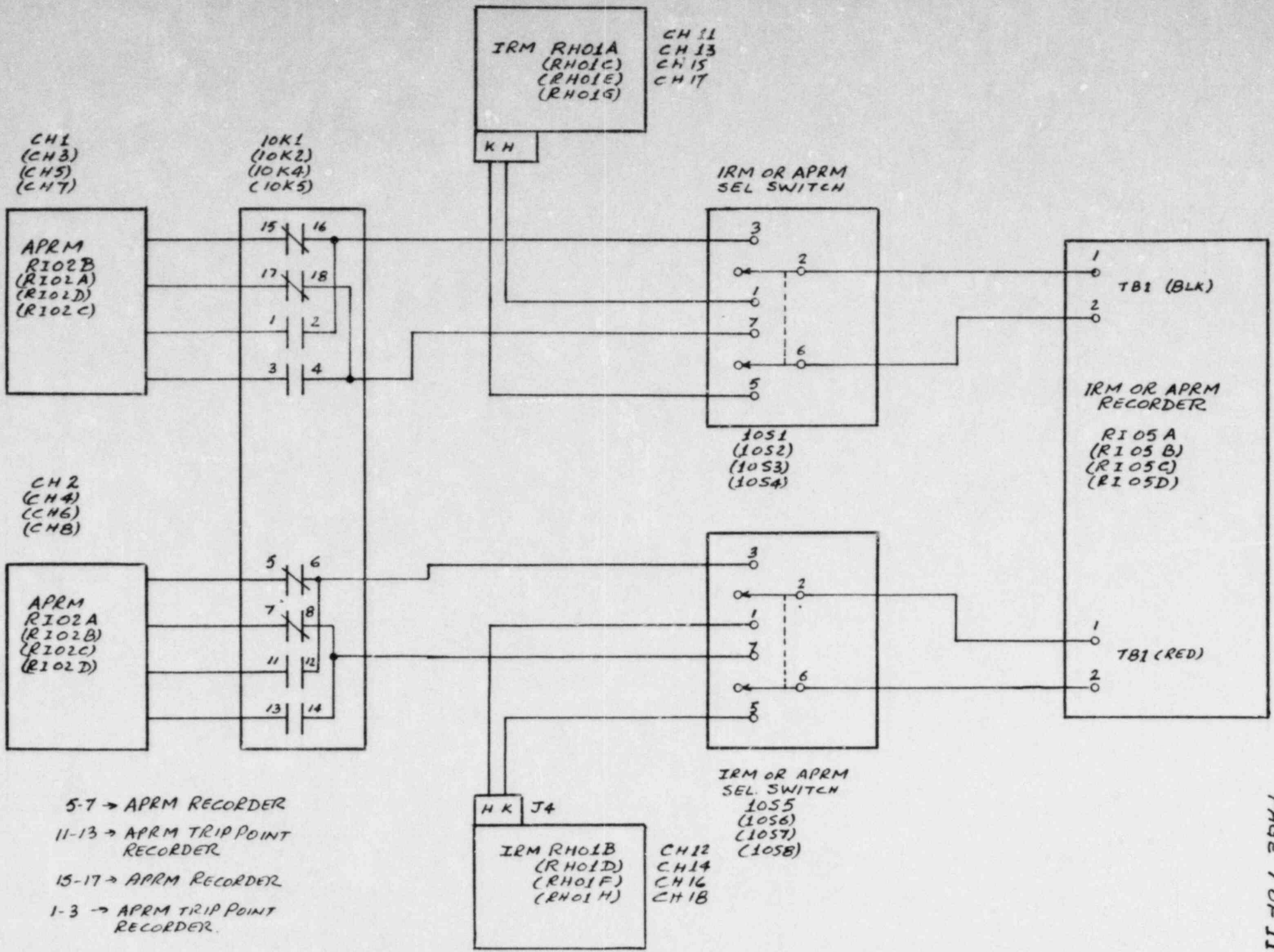

FIGURE 1: APRM/IRM INTER FACE WITH RECORDERS.

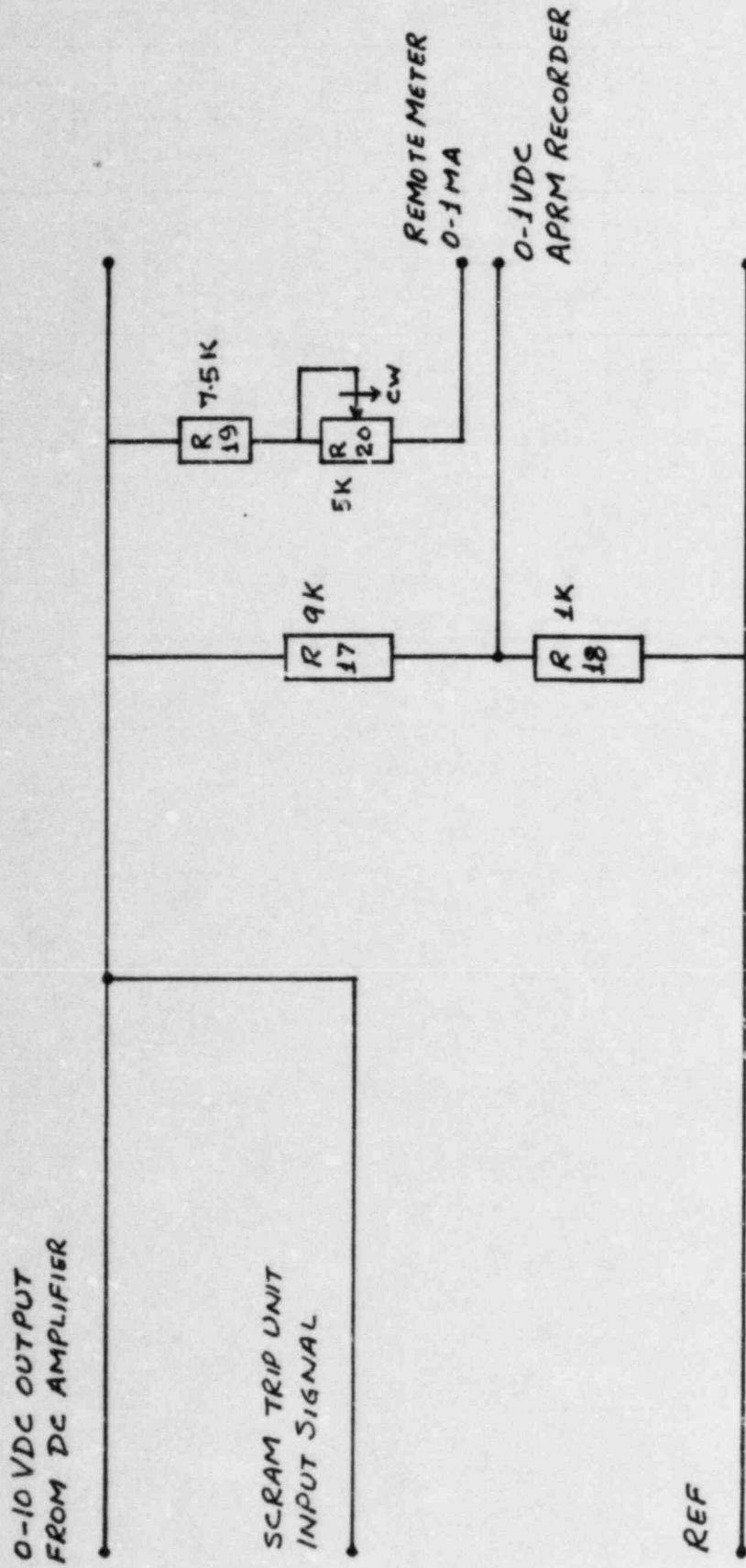

FIGURE 2: RECORDER INPUT BUFFER CIRCUIT



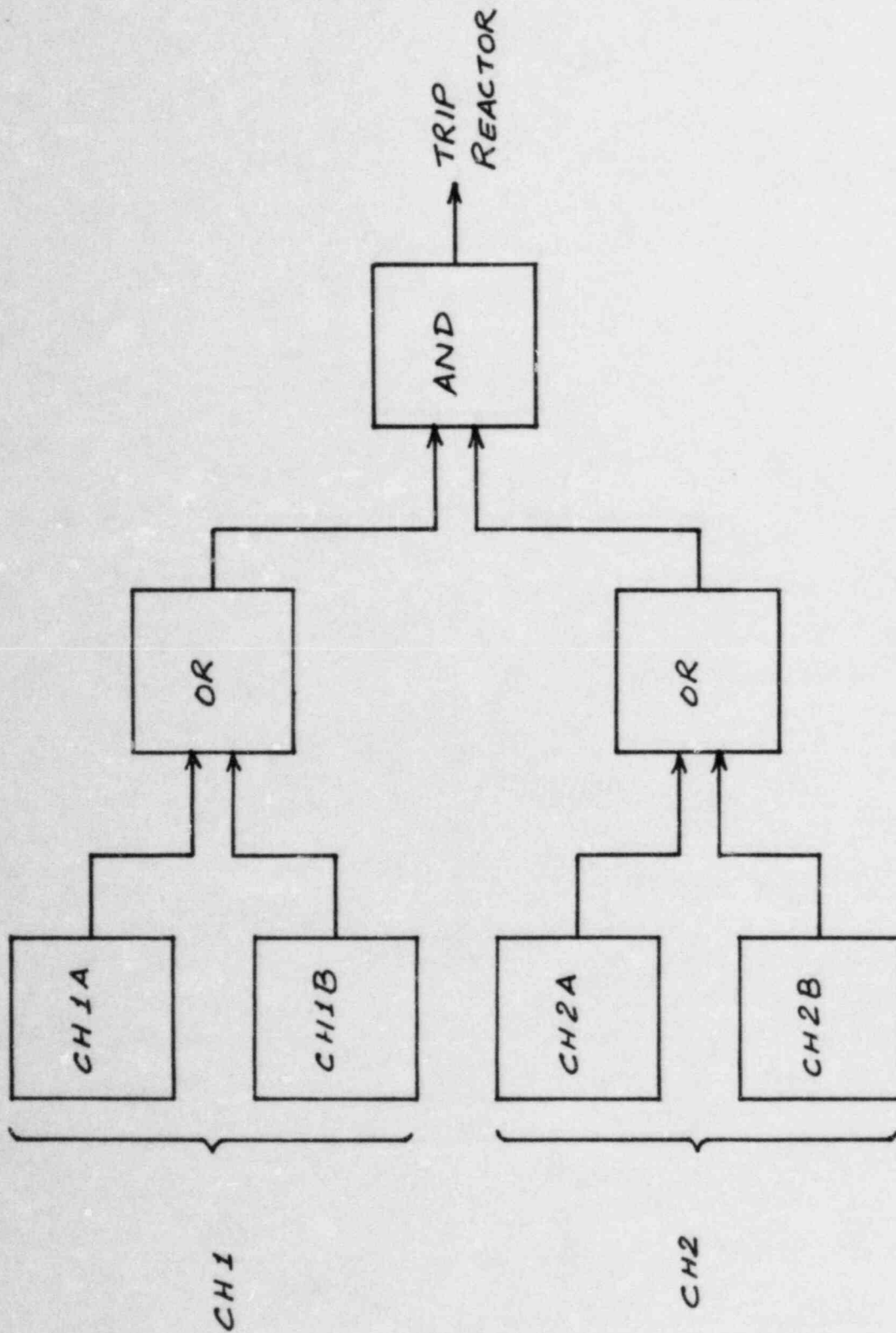

FIGURE 3: RPS LOGIC

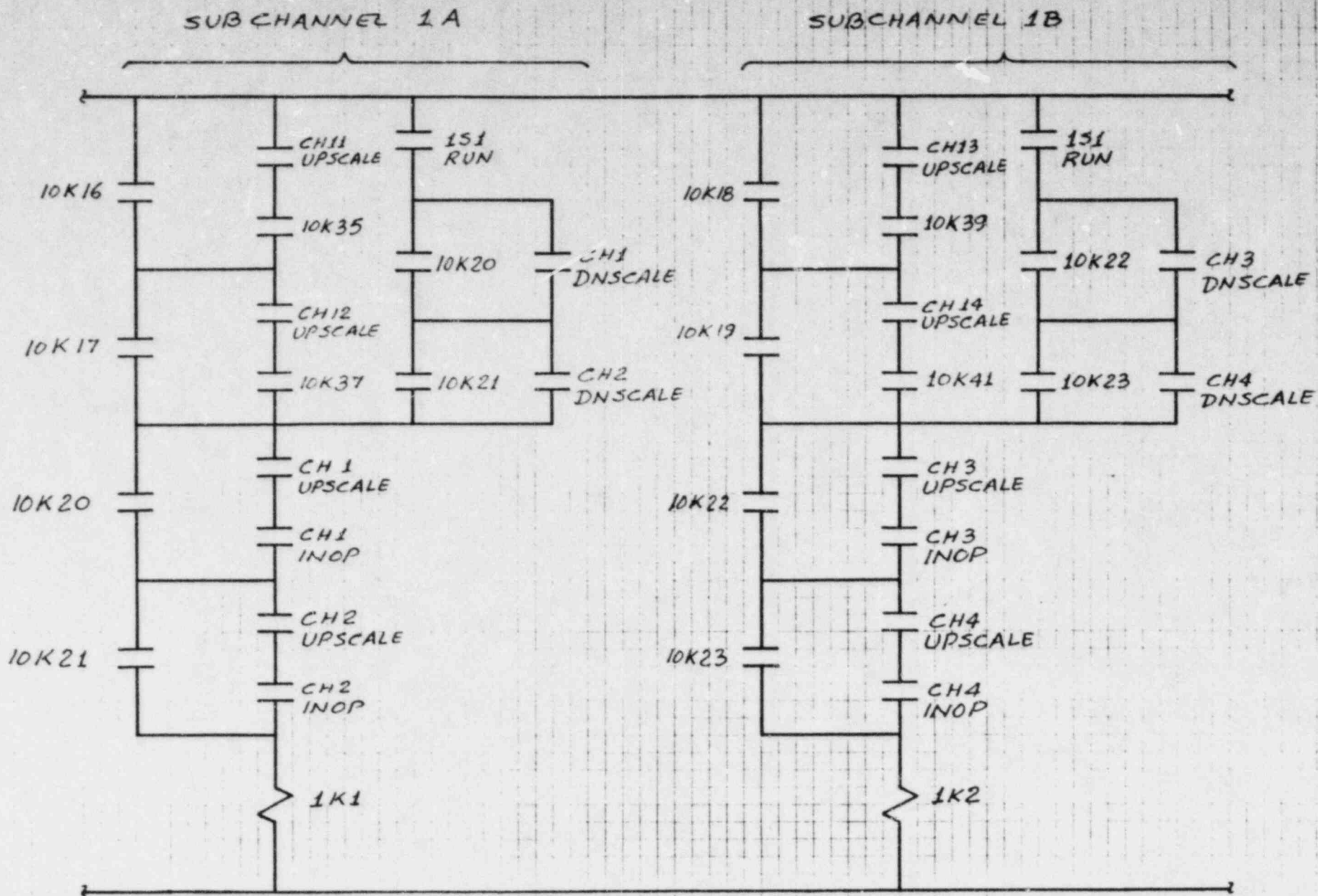

FIG 4: NUCLEAR MONITORING SYSTEM INTERFACE WITH RPS CHANNEL 1

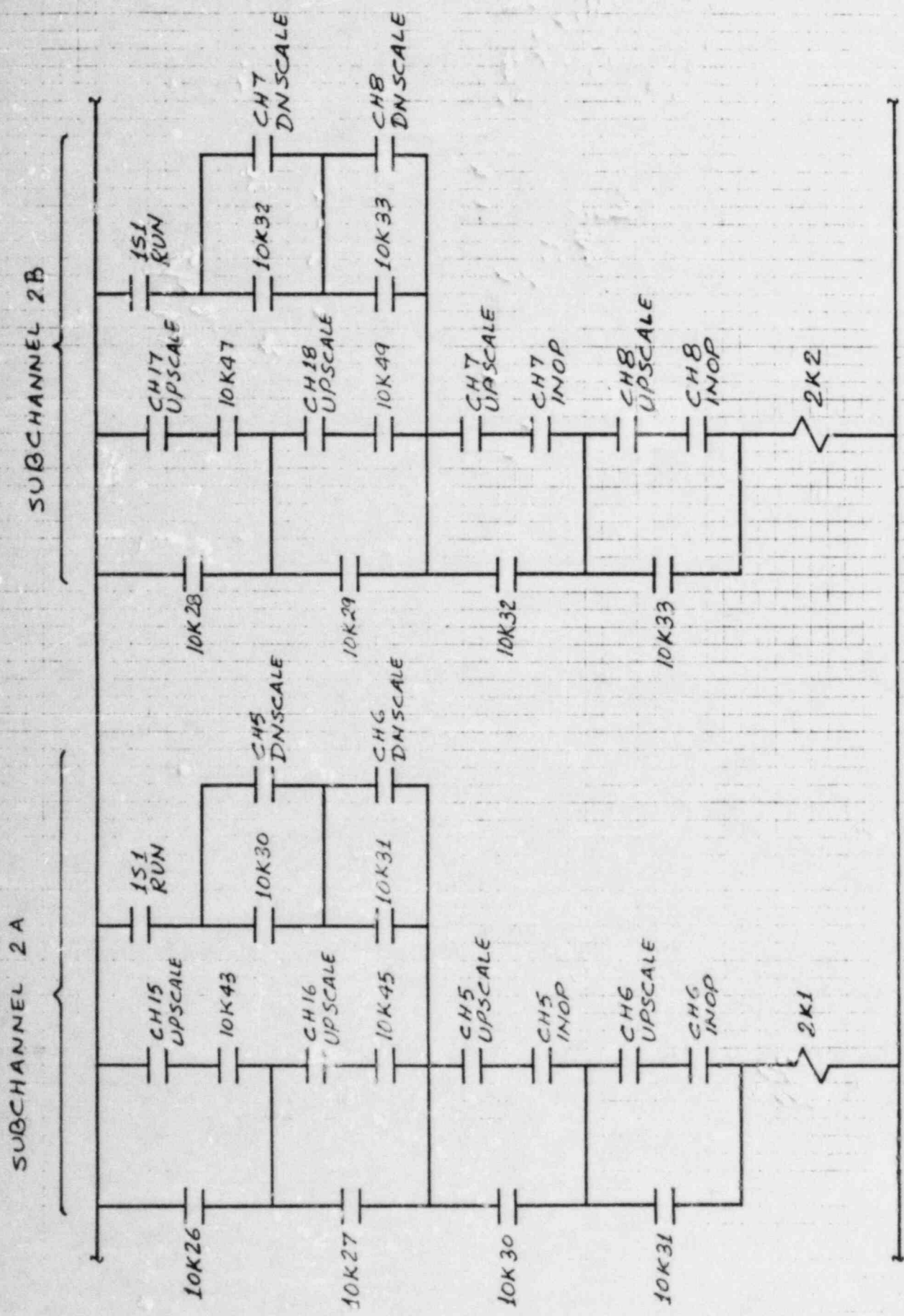

FIG 5 : NUCLEAR MONITORING SYSTEM INTERFACE WITH RPS  
CHANNEL 2