

October 31, 1995

Attached are the recent revisions to the ComEd Offsite Dose Calculation Manual (ODCM) Chapters 10, 11, 12 and Appendix F for **LaSalle Station**. This revision was approved on October 18, 1995. Please complete the following manual update:

Remove	Insert
LaSalle Station Chapter 10 Entire Contents	LaSalle Station Chapter 10 Revision 1.7 Entire Contents
LaSalle Station Chapter 11 Entire Contents	LaSalle Station Chapter 11 Revision 1.7 Entire Contents
LaSalle Station Chapter 12 Entire Contents	LaSalle Station Chapter 12 Revision 1.7 Entire Contents
LaSalle Station Appendix F Entire Contents	LaSalle Station Appendix F Revision 1.7 Entire Contents

Please sign and date this control sheet. Return to:

COMMONWEALTH EDISON COMPANY
c/o Document Control - EP
1400 Opus Place - 5th Floor
Downers Grove, IL 60515
(708)663-7324 or (708)663-6496

Your signature indicates you have verified that your control number is correct and you have updated your manual.

Signature _____

Date _____

X244
NRC C/O DOC CTRL DSK, C. PATEL
DIRECTOR OF NUC. REACTOR REGULATION
U. S. NUC. REGULATORY COMMISSION
MAIL STATION P1-137

EPUEPIP/docctrl4/5

9511060309 950930
PDR ADDCK 05000373
P PDR

WASHINGTON
20555

DC

ADD 9/21

LASALLE ANNEX INDEX**CHAPTER 10**

<u>PAGE</u>	<u>REVISION</u>
10-i	1.7
10-ii	1.7
10-iii	1.7
10-iv	1.7
10-v	1.7
10-1	1.7
10-2	1.7
10-3	1.7
10-4	1.7
10-5	1.7
10-6	1.7
10-7	1.7
10-8	1.7
10-9	1.7
10-10	1.7
10-11	1.7
10-12	1.7
10-13	1.7
10-14	1.7
10-15	1.7
10-16	1.7

CHAPTER 10**RADIOACTIVE EFFLUENT TREATMENT AND MONITORING****Table of Contents**

<u>NUMBER</u>		<u>PAGE</u>
10.1	AIRBORNE RELEASES	1
1.	System Description	1
1.	Condenser Offgas Treatment System	1
2.	Ventilation Exhaust Treatment System	2
2.	Radiation Monitors	2
1.	Station Vent Stack Effluent Monitor	2
2.	Standby Gas Treatment System Effluent Monitor	2
3.	Reactor Building Ventilation Monitors	3
4.	Condenser Air Ejector Monitors	3
5.	Turbine Building	3
3.	Alarm and Trip Setpoints	3
1.	Setpoint Calculations	3
1.	Reactor Building Vent Effluent Monitor	3
2.	Condenser Air Ejector Monitors	3
3.	Station Vent Stack Effluent Monitor	5
4.	Standby Gas Treatment Stack Monitor	5
2.	Release Limits	5
3.	Release Mixture	6
4.	Conversion Factors	6
5.	HVAC Flow Rates	7
4.	Allocation of Effluents from Common Release Points	7
5.	Dose Projections	7
10.2	LIQUID RELEASES	7
1.	System Description	7
1.	Radwaste Discharge Tanks	7
2.	Radiation Monitors	7
1.	Liquid Radwaste Effluent Monitor	7
2.	Service Water Effluent Monitors	7
3.	RHR Heat Exchanger Cooling Water Effluent Monitors	8

CHAPTER 10

RADIOACTIVE EFFLUENT TREATMENT AND MONITORING

Table of Contents (Cont'd)

<u>NUMBER</u>		<u>PAGE</u>
3.	Alarm and Trip Setpoints	8
1.	Setpoint Calculations	8
1.	Liquid Radwaste Effluent Monitor	8
2.	Service Water Effluent Monitors	9
3.	RHR Heat Exchanger Cooling Water Monitors	9
2.	Discharge Flow Rates	9
1.	Release Tank Discharge Flow Rate	9
3.	Release Limits	10
4.	Release Mixture	10
5.	Conversion Factors	10
6.	Liquid Dilution Flow Rates	10
4.	Allocation of Effluents from Common Release Points	10
5.	Projected Concentrations for Releases	10
10.3	SOLIDIFICATION OF WASTE/PROCESS CONTROL PROGRAM	10

CHAPTER 10
LIST OF TABLES

<u>NUMBER</u>		<u>PAGE</u>
10-1	Assumed Composition of the LaSalle Station Noble Gas Effluent	10-11

CHAPTER 10**LIST OF FIGURES**

<u>NUMBER</u>		<u>PAGE</u>
10-1	Simplified Gaseous Radwaste and Gaseous Effluent Flow Diagram	10-12
10-2	Simplified Liquid Radwaste Processing Diagram	10-14
10-3	Simplified Liquid Effluent Flow Diagram	10-15
10-4	Simplified Solid Radwaste Processing Diagram	10-16

CHAPTER 10**RADIOACTIVE EFFLUENT TREATMENT AND MONITORING****10.1 AIRBORNE RELEASES****10.1.1 System Description**

A simplified gaseous radwaste and gaseous effluent flow diagram are provided in Figure 10-1.

The airborne release point for radioactive effluents is the ventilation stack which is classified as a stack in accordance with the definitions in Section 4.1.4 and the results in Table A-1 of Appendix A.

In addition, the standby gas treatment system effluent is released through a separate stack inside the ventilation stack. This release point has the same location and classification as the ventilation stack.

Exfiltration to the environment from the Turbine Building has been identified at times of positive pressure in the Turbine Building. Continuous air sampling is in place in the south Turbine Building trackway to monitor releases through this pathway. The releases through the trackway door and other potential release paths contain insignificant levels of contamination when compared to the Station Vent Stack which has a 1,000,000 cfm typical stack flow compared to the Trackway flow rate of 40,000 scfm and conservatively estimated as a total of 80,000 scfm to account for pathways other than the trackway. In addition, typical releases from LaSalle Station have not exceeded 0.02% of the 10CFR50 Appendix I dose limits. This pathway is a ground level release and should be considered in dose calculations. See Figure 10-1 for further information.

Waste oil processing via incineration is planned at LaSalle Station. Upon implementation, evaluations will be made which focus on the radiological characteristics of the oil. The identified radiological characteristics may warrant inclusion into the radiological effluent report and inclusion in calculations to determine member of the public dose.

10.1.1.1 Condenser Offgas Treatment System

The condenser offgas treatment system is designed and installed to reduce radioactive gaseous effluents by collecting non-condensable off-gases from the condenser and providing for holdup to reduce the total radioactivity by radiodecay prior to release to the environment. The daughter products are retained by charcoal and HEPA filters. The system is described in Section 11.3.2.1 of the LaSalle UFSAR.

10.1.1.2 Ventilation Exhaust Treatment System

Ventilation exhaust treatment systems are designed and installed to reduce gaseous radioiodine or radioactive material in particulate form in selected effluent streams by passing ventilation or vent exhaust gases through charcoal adsorbers and/or HEPA filters prior to release to the environment. Such a system is not considered to have any effect on noble gas effluents. The ventilation exhaust treatment systems are shown in Figure 10-1.

Engineered safety features atmospheric cleanup systems are not considered to be ventilation exhaust treatment system components.

10.1.2 Radiation Monitors

10.1.2.1 Station Vent Stack Effluent Monitor

Monitor OPLD5J (Wide Range Noble Gas Monitor) continuously monitors the final effluent from the station vent stack.

The monitor system has isokinetic sampling, gaseous grab sampling, iodine and particulate sampling, tritium sampling, and postaccident sampling capability.

In normal operation the low-range noble gas channel is on line and active. The mid-range channel replaces the low-range channel at a concentration of 0.1 $\mu\text{Ci}/\text{cc}$ and the high-range channel replaces the mid-range channel at a concentration of 100 $\mu\text{Ci}/\text{cc}$.

The low-range and mid/high-range iodine and particulate samplers operate in a similar manner. In normal operation the low-range samplers are on line. At a concentration of 0.05 $\mu\text{Ci}/\text{cc}$ the mid/high-range samplers are brought on line, and at a concentration of 10 $\mu\text{Ci}/\text{cc}$ the low-range sample pump is turned off.

No automatic isolation or control functions are performed by this monitor. Pertinent information on this monitor is provided in the LaSalle UFSAR Section 11.5.2.2.1.

10.1.2.2 Standby Gas Treatment System Effluent Monitor

Monitor OPLD2J (Wide Range Noble Gas Monitor) continuously monitors the final effluent from the standby gas treatment system (SGTS) stack.

The SGTS stack monitor has isokinetic sampling, gaseous grab sampling, particulate and iodine sampling, and post accident sampling capability.

In normal operation the low range noble gas channel is on line and active. The mid-range channel replaces the low-range channel at a concentration of 0.1 $\mu\text{Ci}/\text{cc}$ and the high-range channel replaces the mid-range channel at a concentration of 100 $\mu\text{Ci}/\text{cc}$.

The low-range and mid/high-range iodine and particulate samples operate in a similar manner. In normal operation, the low-range samples are on-line. At a concentration of 0.05 $\mu\text{Ci}/\text{cc}$ the mid/high-range samplers are brought on-line, and at a concentration of 10 $\mu\text{Ci}/\text{cc}$ the low-range sample pump is turned off.

No automatic isolation or control functions are performed by this monitor.

Pertinent information on this monitor is provided in the LaSalle UFSAR Section 11.5.2.2.2.

10.1.2.3 Reactor Building Ventilation Monitors

Monitors 1(2)D18-N009 continuously monitor the effluent from the Unit 1(2) reactor building. On high alarm, the monitors automatically initiate the following actions:

- A. Shutdown and isolation of the reactor building vent system
- B. Startup of the standby gas treatment system
- C. Isolation of primary containment purge and vent lines

Pertinent information on these monitors is provided in LaSalle UFSAR Section 11.5.2.1.1.

10.1.2.4 Condenser Air Ejector Monitors

Monitors 1(2)D18-N002/N012 (pre-treatment) and 1(2)D18-N903A/B (post-treatment) continuously monitor gross gamma activity downstream of the steam jet air ejector and prior to release to the main stack.

On "high-high-high" alarm monitor 1(2)D18-N903A/B automatically initiates closure of valve 1(2)N62-F057 thus terminating the release.

Pertinent information on these monitors is found in LaSalle UFSAR Sections 11.5.2.1.2 and 11.5.2.1.3.

10.1.2.5 Turbine Building Trackway

In order to quantify releases via the Turbine Building trackway, at times of positive pressure in the Turbine Building, airborne sampling should be continuously collected using an air sampler located within the trackway. The samples collected should be counted on a weekly basis. Air sampling to identify noble gas, iodine and particulate monitoring (either as a grab sample or continuous sampling) is designed to ensure evaluation of releases emanating from the Turbine Building.

10.1.3 Alarm and Trip Setpoints

10.1.3.1 Setpoint Calculations

10.1.3.1.1 Reactor Building Vent Effluent Monitor

The setpoint for the reactor building vent effluent monitor is established at 10 mR/hr.

10.1.3.1.2

Condenser Air Ejector Monitors

Pre-Treatment Monitor

The high-high trip setpoint is conservatively set at or below one-half the release limit obtained from the post-treatment monitor "high-high-high" trip setpoint.

$$P \leq K \times 0.5 \times Q_{cs} \times \sum f_i \times e^{\lambda t} \quad (10-1)$$

P Off-gas Pretreatment high-high alarm setpoint

K Conversion constant [(mr/hr) per (μ Ci/sec)]

The value is determined using noble gas radionuclides identified in a representative sample, and the off-gas release rate and monitor response at the time the sample is taken.

0.5 Factor for conservatism

Q_{cs} Release Rate [μ Ci/sec]

The release rate of all noble gas radionuclides released as stack releases based on post treatment monitor "high-high-high" trip setpoint. This is less than the solutions obtained from Equations 10-3 and 10-4.

f_i Predetermined fraction of total release attributed to nuclide i.

The fractions, f_i , are obtained from the mixture of radionuclides calculated to be present in the steam as it exits the vessel.

$e^{\lambda t}$ Term to correct for 30 minute transit time.

The high trip setpoint is established at $\leq 100 \mu$ Ci/sec per MW-th $\approx 3.4E5 \mu$ Ci/sec per Technical Specification 3.11.2.2.

Post-Treatment Monitor

The off gas isolation setpoint is conservatively set at or below one-half the release limit calculated using equations 10-3 and 10-4 below.

The off-gas isolation setpoint is converted into the monitor units of counts per second (cps) as follows:

$$P \leq 0.5 \times Q_{cs} \times E / (472 \times F) \quad (10-2)$$

P Off-gas Post-treatment Monitor Isolation Setpoint [cps]

The off-gas post-treatment monitor setpoint which initiates isolation

of flow of off-gas to the station vent stack.

Q_{ts} Total Allowed Release Rate, Stack Release [μCi/sec]

The total allowed release rate of all noble gas radionuclides released as stack releases. This is the smaller of the solutions obtained from Equations 10-3 and 10-4.

E Efficiency of the Off-Gas Posttreatment Monitor [cps per (μCi/cc)]

The response of the off-gas post-treatment monitor to a reference source.

472 Conversion Constant [(cc/sec)/cfm]

Converts cubic feet per minute to cubic centimeters per second.

F Maximum Off-Gas Flow Rate [cfm]

10.1.3.1.3 Station Vent Stack Effluent Monitor

The setpoint for the station vent stack effluent monitor is conservatively set at or below one-half the calculated release limit calculated using equations 10-3 and 10-4 below.

10.1.3.1.4 Standby Gas Treatment Stack Monitor

The setpoint for the standby gas treatment system effluent monitor is conservatively set at or below one-half the release limit calculated using equations 10-3 and 10-4 below.

10.1.3.2 Release Limits

Alarm and trip setpoints of gaseous effluent monitors are established to ensure that the release rate limits of RETS are not exceeded. The release limit Q_{ts} is found by solving Equations 10-3 and 10-4.

$$(1.11) Q_{ts} \sum (f_i S_i) < 500\text{mrem/yr} \tag{10-3}$$

$$Q_{ts} \sum \left[(L_i F_i (X/Q)) \exp(-\lambda_i R/3600u_s) + (1.11) (f_i) S_i \right] < 3000\text{mrem/yr} \tag{10-4}$$

The summations are over noble gas radionuclides i.

f_i Fractional Radionuclide Composition

The release rate of noble gas radionuclide i divided by the total release rate of all noble gas radionuclides.

Q_{ts} Total Allowed Release Rate, Stack Release [μCi/sec]

The total allowed release rate of all noble gas radionuclides released as stack releases.

$\exp(-\lambda_t R/3600 U_d)$ is conservatively set equal to 1.0 for purposes of determining setpoints.

The remaining parameters in Equation 10-3 have the same definitions as in Equation A-8 of Appendix A. The remaining parameters in Equation 10-4 have the same definition as in Equation A-9 of Appendix A.

Equation 10-3 is based on Equation A-8 of Appendix A and the RETS restriction on whole body dose rate (500 mrem/yr) due to noble gases released in gaseous effluents (see Section A.1.3.1 of Appendix A). Equation 10-4 is based on Equation A-9 of Appendix A and the RETS restriction on skin dose rate (3000 mrem/yr) due to noble gases released in gaseous effluents (see Section A.1.3.2 of Appendix A).

Since the solution to Equation 10-3 is more conservative than the solution to Equation 10-4, the value of Equation 10-3, $1.22 \times 10^6 \mu\text{Ci}/\text{sec}$, is used as the limiting noble gas release rate.

Calibration methods and surveillance frequency for the monitors will be conducted as specified in the RETS.

10.1.3.3 Release Mixture

In the determination of alarm and trip set points, the radioactivity mixture in the exhaust air is assumed to have the radionuclide composition in Table 10-1.

10.1.3.4 Conversion Factors

The conversion factors used to establish gaseous effluent monitor setpoints are obtained as follows.

Station vent stack effluent monitor.

Calibrations compare the response of station detectors to that of a reference detector using NIST traceable sources (Cs-137 and Co-60).

Condenser air ejector monitor.

Pretreatment Monitor

The value is determined using noble gas radionuclides identified in a representative sample, and the offgas release rate and monitor response at the time the sample is taken.

Post-treatment Monitor

The value is determined using noble gas radionuclides identified in a representative sample, and the offgas concentration and monitor response at the time the sample is taken.

Standby gas treatment system monitor.

Calibrations compare the response of station detectors to that of a reference detector using NIST traceable sources (Cs-137 and Co-60).

10.1.3.5 HVAC Flow Rates

The main stack flow rate is obtained from either the process computer or Monitor RM-23.

The SGTS flow rate is obtained from either the process computer or chart recorders in the main control room.

10.1.4 Allocation of Effluents from Common Release Points

Radioactive gaseous effluents released from the main chimney are comprised of contributions from both units. Under normal operating conditions, it is difficult to allocate the radioactivity between units due to fuel performance, in-plant leakage, power history, and other variables. Consequently, no allocation is normally made between the units. Instead, the entire release is treated as a single source.

10.1.5 Dose Projections

Because the gaseous releases are continuous, the doses are routinely calculated in accordance with the RETS.

10.2 LIQUID RELEASES

10.2.1 System Description

A simplified liquid radwaste and liquid effluent flow diagram are provided in Figures 10-2 and 10-3.

The liquid radwaste treatment system is designed and installed to reduce radioactive liquid effluents by collecting the liquids, providing for retention or holdup, and providing for treatment by filter, demineralizer, or evaporator for the purpose of reducing the total radioactivity prior to release to the environment. The system is described in Section 11.2.2 of the LaSalle UFSAR.

10.2.1.1 Radwaste Discharge Tanks

There are two discharge tanks (1(2)WF05T, 25,000 gallons each) which receive water for discharge to the Illinois River via the cooling lake blowdown.

10.2.2 Radiation Monitors

10.2.2.1 Liquid Radwaste Effluent Monitor

Monitor 0D018-N907 monitors all releases from the release tanks. On high alarm the monitor automatically initiates closure of valves 0WL067 and trips the radwaste discharge pump to terminate the release.

Pertinent information on the monitor and associated control devices is provided in LaSalle UFSAR Section 11.5.2.3.3.

10.2.2.2 Service Water Effluent Monitors

Monitors 1/(2)D18-N912 continuously monitor the service water effluent. On high alarm service water discharge may be terminated manually. No control device is initiated by these monitors.

Pertinent information on these monitors is provided in LaSalle UFSAR 11.5.2.3.2.

10.2.2.3 RHR Heat Exchanger Cooling Water Effluent Monitors

Instrument channels 1/(2)D18-N906/8 continuously monitor the RHR heat exchanger cooling water effluent. On high alarm the operating loop may be terminated manually and the redundant loop brought on line. No control device is initiated by these monitors.

Pertinent information on these monitors is provided in LaSalle UFSAR Section 11.5.2.3.4.

10.2.3 Alarm and Trip Setpoints

10.2.3.1 Setpoint Calculations

Alarm and trip setpoints of liquid effluent monitors at the principal release points are established to ensure that the limits of RETS are not exceeded in the unrestricted area.

10.2.3.1.1 Liquid Radwaste Effluent Monitor

The monitor setpoint is found by solving equation 10-5 for the total isotopic activity.

$$P \leq K \times \left(\sum C_i^r / \sum (C_i^r / 10 \times DWC_i) \right) \times \left((F^r + F_{max}^r) / F_{max}^r \right) \quad (10-5)$$

P Release Setpoint [cpm]

K $\left(\sum (K_i \times C_i \times W_i) / \sum C_i^r \right)$ [cpm/ μ Ci/m³]

K_i Counting efficiency for radionuclide i [cpm/ μ Ci/m³]

W_i Weighting Factor

C_i^r Concentration of radionuclide i in the release tank. [μ Ci/m³]

F_{max}^r Maximum Release Tank Discharge Flow Rate [gpm]
The maximum flow rate is 45 gpm.

DWC_i Derived Water Concentration [μ Ci/m³]
of radionuclide i

The concentration of radionuclide i given in Appendix B, Table 2, Column 2 to 10CFR20.1001-2402.

10 Multiplier

F^d Dilution Flow

[gpm]

10.2.3.1.2 Service Water Effluent Monitors

The monitor setpoint is established at two times the background count rate (not to exceed 10000 cpm).

10.2.3.1.3 RHR Heat Exchanger Cooling Water Monitors

The monitor setpoint is established at two times the background count rate (not to exceed 10000 cpm).

10.2.3.2 Discharge Flow Rates

10.2.3.2.1 Release Tank Discharge Flow Rate

Prior to each batch release, a grab sample is obtained.

The results of the analysis of the sample determine the discharge rate of each batch as follows:

$$F_{max}^r = 0.1 \times \left(F^d / \sum (C_i / 10 \times DWC_i) \right) \times MF \quad (10-6)$$

The summation is over radionuclides i.

0.1 Reduction factor for conservatism.

F_{max}^r Maximum Permitted Discharge Flow Rate [gpm]

The maximum permitted flow rate from the radwaste discharge tank.

F^d Dilution Flow [gpm]

C_i Concentration of Radionuclide i in the Release Tank [μCi/mL]

The concentration of radioactivity in the radwaste discharge tank based on measurements of a sample drawn from the tank.

DWC_i Maximum Permissible Concentration of Radionuclide i [μCi/mL]

The concentration of radionuclide i given in Appendix B, Table 2, Column 2 to 10CFR20.1001-2402.

10 Multiplier

MF Multiplication Factor

$$F_{max} < 0.5; MF = 3$$

$$0.5 < F_{max} \leq 5; MF = 5$$

$$5 < F_{max}; MF = 7.5$$

10.2.3.3 Release Limits

Release limits are determined from RETS. Calculated maximum permissible discharge rates are divided by 10 for conservatism and to ensure that release concentrations are well below applicable derived water concentrations (DWC).

10.2.3.4 Release Mixture

For the liquid radwaste effluent monitor the release mixture used for the setpoint determination is the radionuclide mix identified in the grab sample isotopic analysis plus four additional radionuclides. The additional radionuclides are H-3, Fe-59, Sr-89, and Sr-90. The quantities to be added are obtained from the most current analysis for these four radionuclides.

For all other liquid effluent monitors no release mixture is used because the setpoint is established at "two times background."

10.2.3.5 Conversion Factors

The readout for the liquid radwaste effluent monitor is in CPM. The calibration constant is based on the detector sensitivity to Cs-137/Ba-137.

10.2.3.6 Liquid Dilution Flow Rates

A conservative maximum blowdown flowrate of 20,000 gpm is used for all radwaste discharge calculations unless actual blowdown flow is determined to be less.

10.2.4 Allocation of Effluents from Common Release Points

Radioactive liquid effluents released from the Unit 1 release tank are allocated to Unit 1, and effluents released from the Unit 2 tank are allocated to Unit 2. Other potential pathways (i.e., RHR) are allocated to their respective unit.

10.2.5 Projected Doses for Releases

Doses are not calculated prior to release. Dose contributions from liquid effluents are determined in accordance with the RETS and station procedures.

10.3 SOLIDIFICATION OF WASTE/PROCESS CONTROL PROGRAM

The process control program (PCP) contains the sampling, analysis, and formulation determination by which solidification of radioactive wastes from liquid systems is ensured.

Figure 10-4 is a simplified diagram of solid radwaste processing.

TABLE 10-1

Assumed Composition of the LaSalle Station Noble Gas Effluent

<u>Isotope</u>	<u>Percent of Total Annual Release</u>
Kr-83m	4.5E-3
Kr-85m	8.0E-3
Kr-85	2.6E-5
Kr-87	2.6E-2
Kr-88	2.6E-2
Kr-89	1.7E-1
Kr-90	3.7E-1
Xe-131m	2.0E-5
Xe-133m	3.8E-4
Xe-133	1.1E-2
Xe-135m	3.4E-2
Xe-135	2.9E-2
Xe-137	2.0E-1
Xe-138	1.2E-1

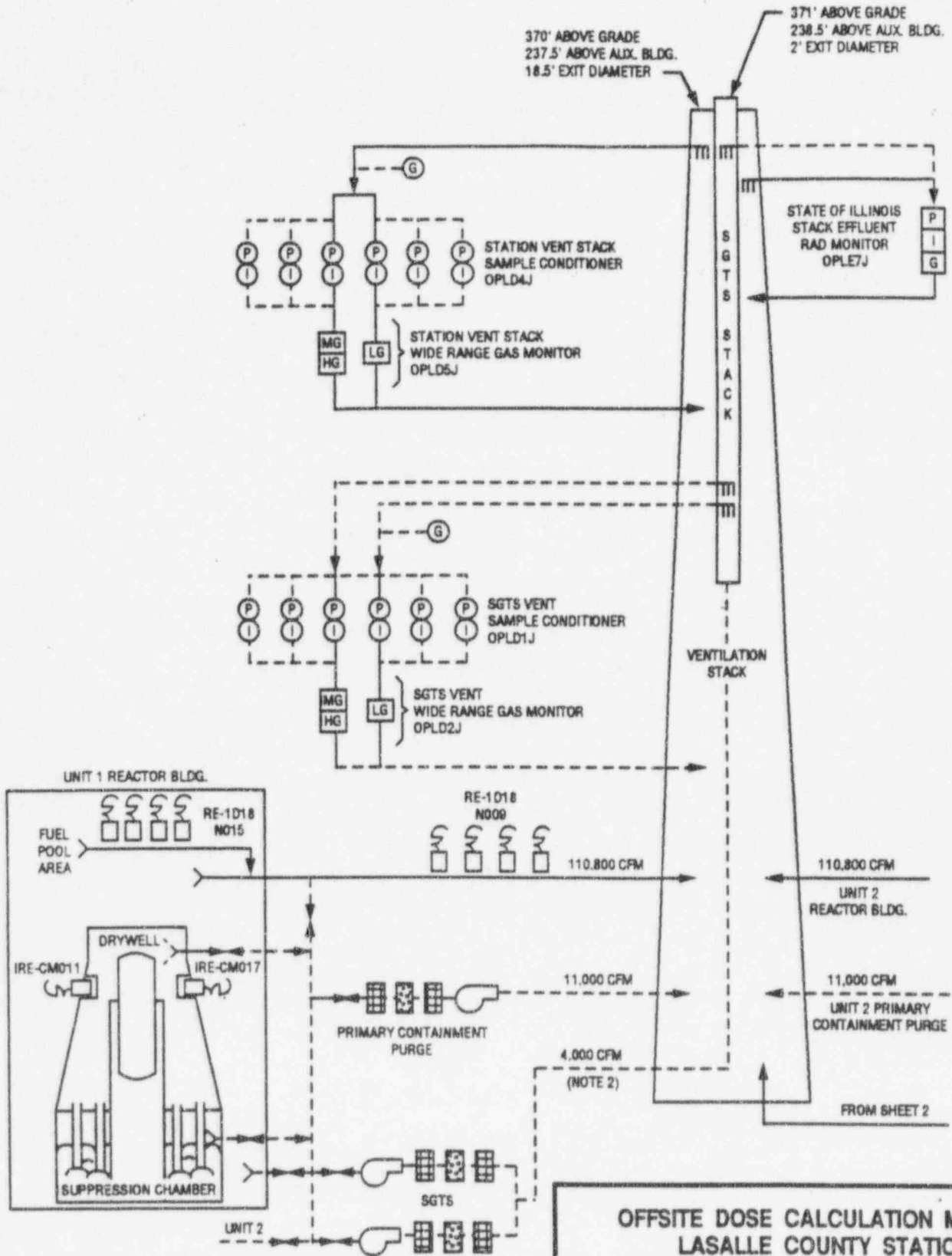
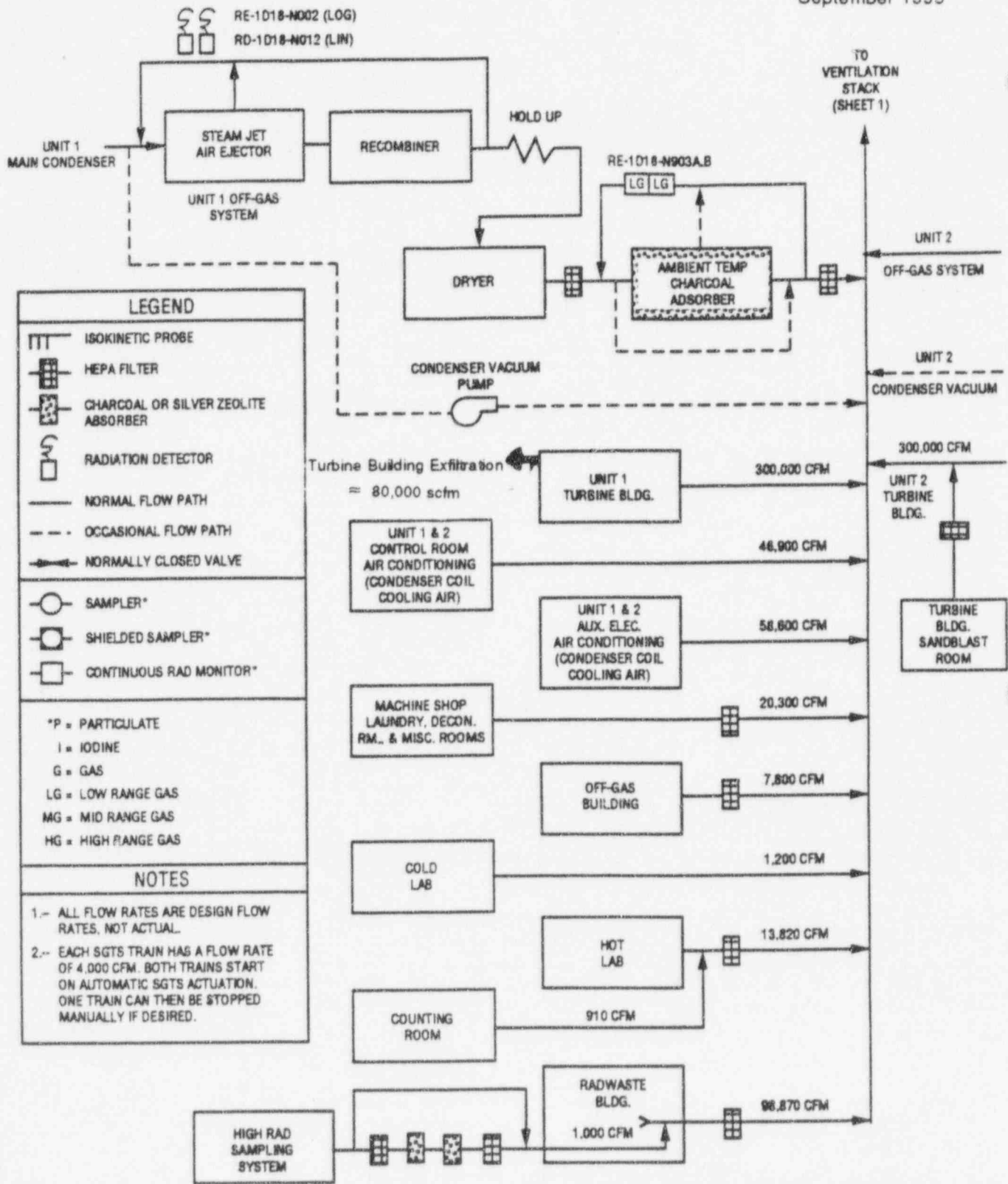

FIGURE 10-1

SIMPLIFIED GASEOUS RADWASTE AND
GASEOUS EFFLUENT FLOW DIAGRAM
(SHEET 1 OF 2)



LEGEND

- ISOKINETIC PROBE
- HEPA FILTER
- CHARCOAL OR SILVER ZEOLITE ABSORBER
- RADIATION DETECTOR
- NORMAL FLOW PATH
- OCCASIONAL FLOW PATH
- NORMALLY CLOSED VALVE
- SAMPLER*
- SHIELDED SAMPLER*
- CONTINUOUS RAD MONITOR*

*P = PARTICULATE
I = IODINE
G = GAS
LG = LOW RANGE GAS
MG = MID RANGE GAS
HG = HIGH RANGE GAS

NOTES

- 1.- ALL FLOW RATES ARE DESIGN FLOW RATES, NOT ACTUAL.
- 2.- EACH SGTS TRAIN HAS A FLOW RATE OF 4,000 CFM. BOTH TRAINS START ON AUTOMATIC SGTS ACTUATION. ONE TRAIN CAN THEN BE STOPPED MANUALLY IF DESIRED.

**OFFSITE DOSE CALCULATION MANUAL
LASALLE COUNTY STATION**

FIGURE 10-1

**SIMPLIFIED GASEOUS RADWASTE AND
GASEOUS EFFLUENT FLOW DIAGRAM
(SHEET 2 OF 2)**

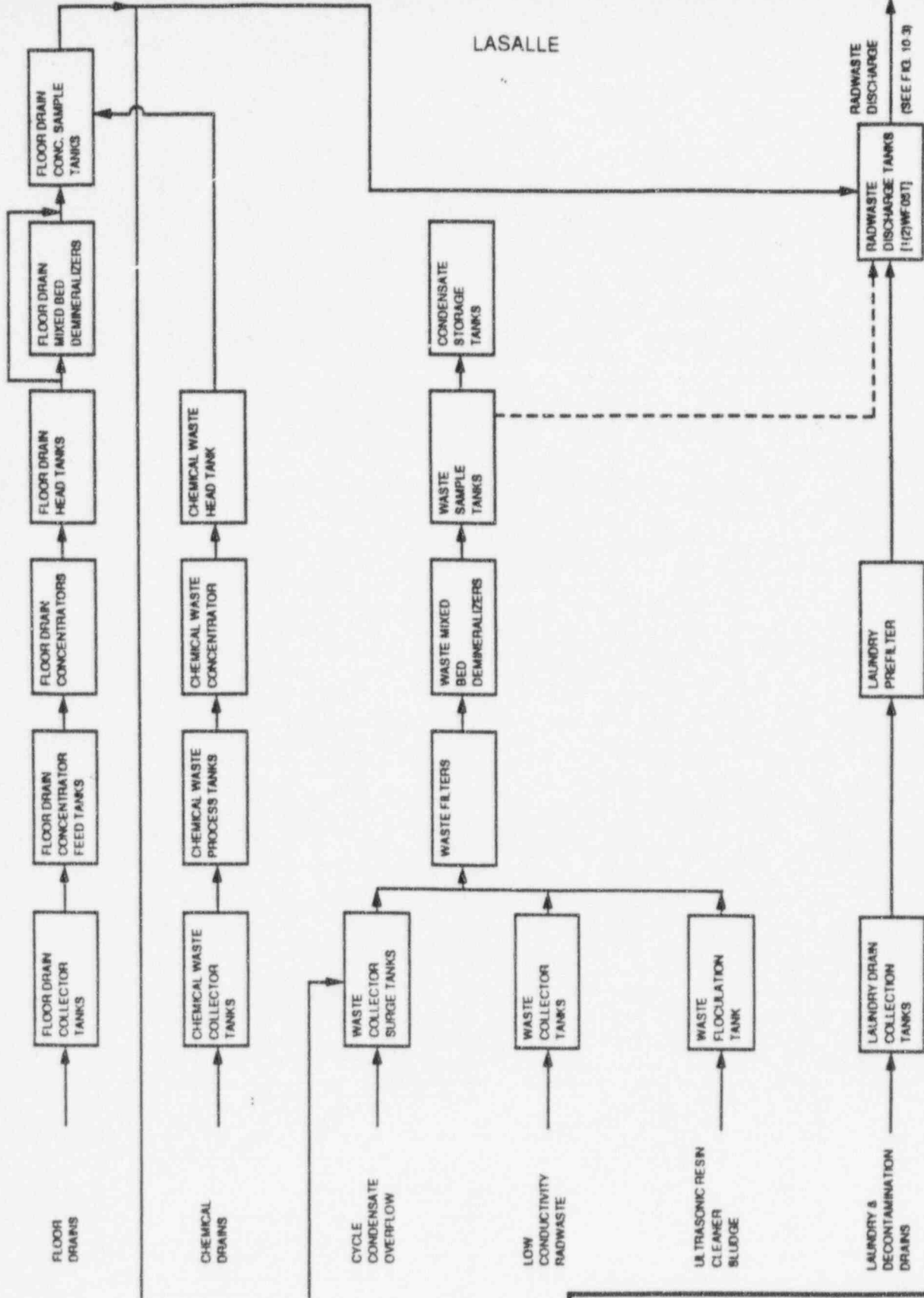

— PREFERRED FLOW PATH
 - - - ALTERNATE FLOW PATH

OFFSITE DOSE CALCULATION MANUAL
 LASALLE COUNTY STATION

FIGURE 10-2

SIMPLIFIED LIQUID RADWASTE
 PROCESSING DIAGRAM

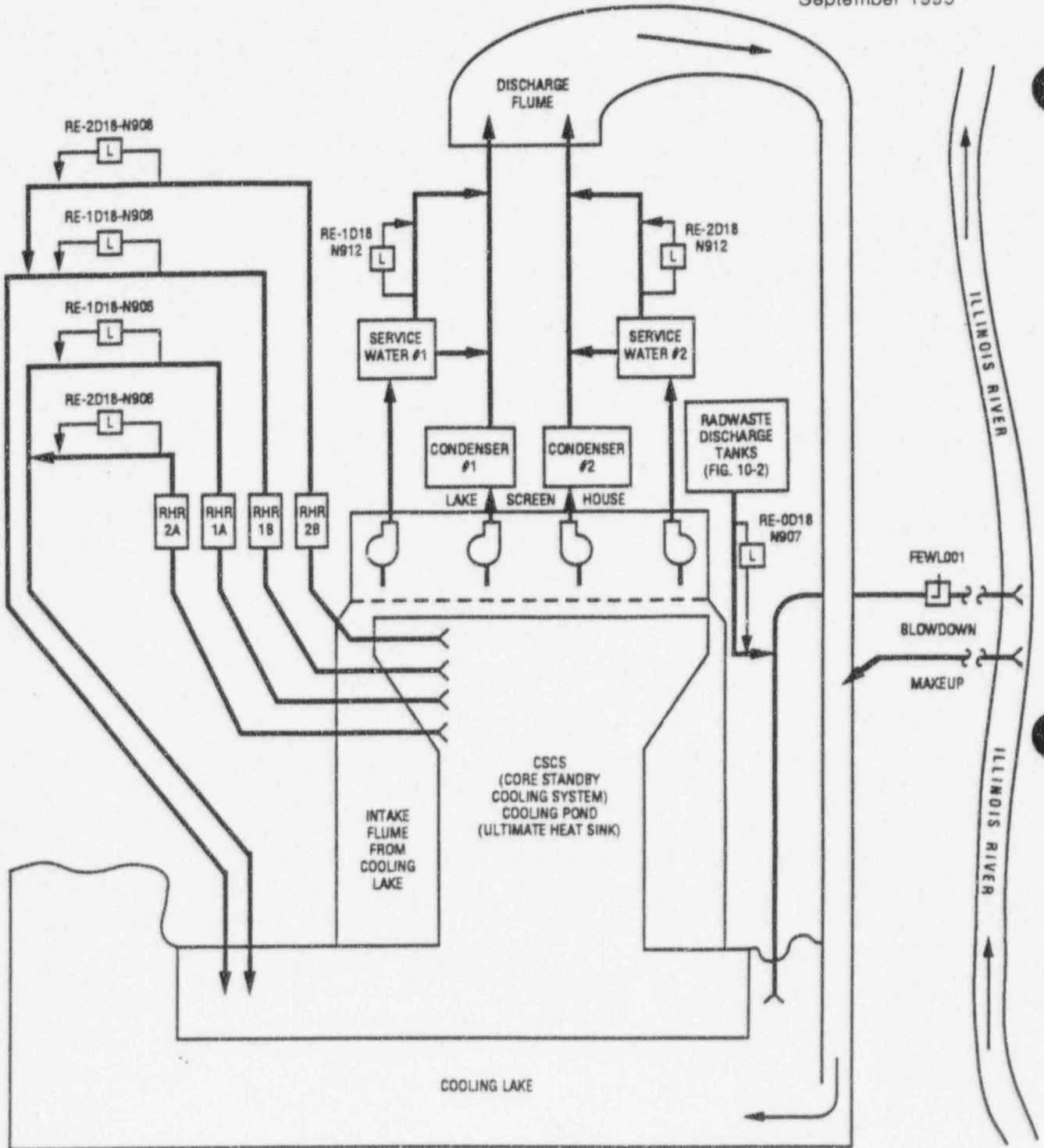

LEGEND AND NOTES	
	LIQUID RADIATION MONITOR
	FLOW ELEMENT

**OFFSITE DOSE CALCULATION MANUAL
LASALLE COUNTY STATION**

FIGURE 10-3
SIMPLIFIED LIQUID EFFLUENT
FLOW DIAGRAM

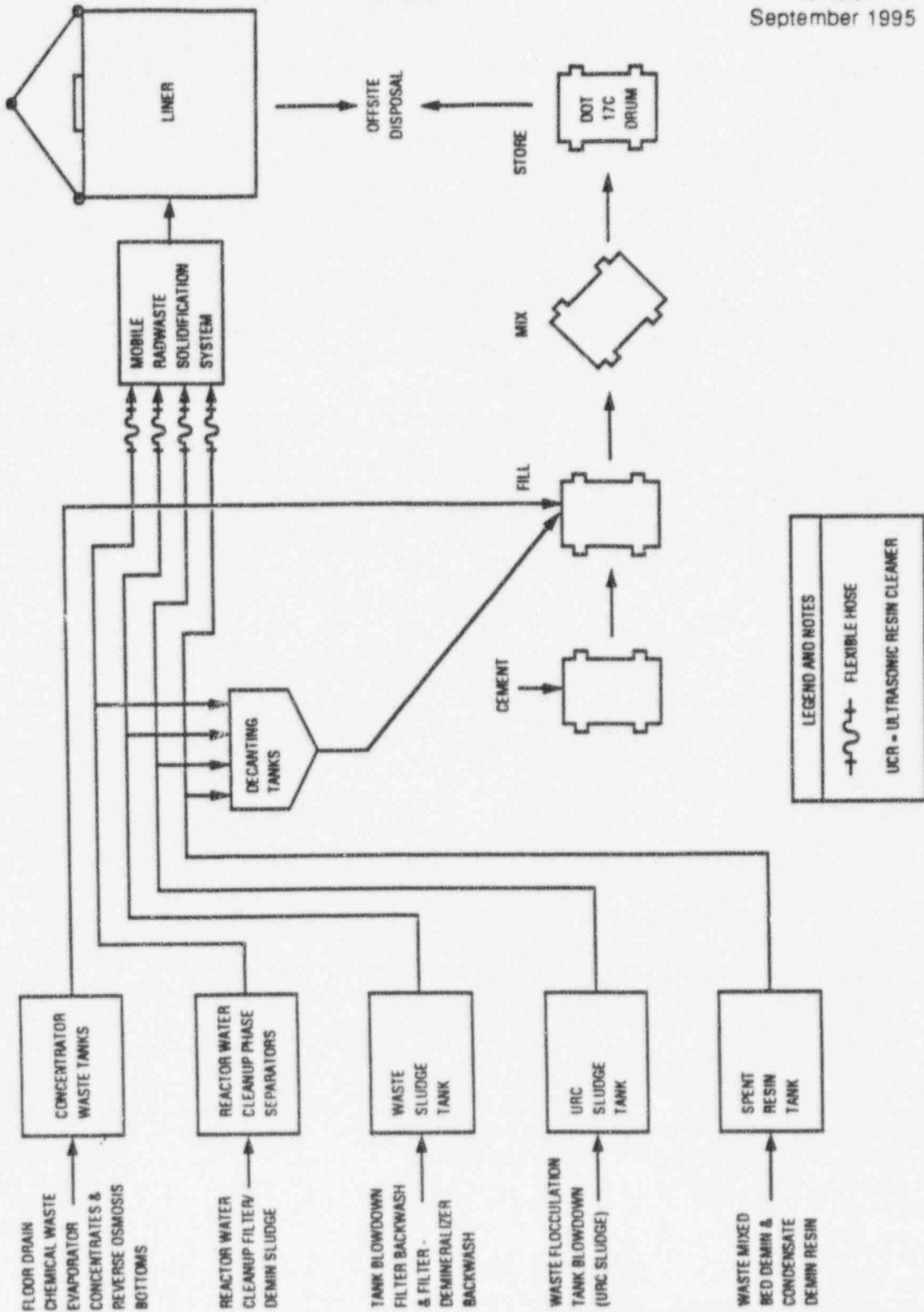

OFFSITE DOSE CALCULATION MANUAL
LASALLE COUNTY STATION

FIGURE 10-4
SIMPLIFIED SOLID RADWASTE
PROCESSING DIAGRAM

CHAPTER 11***LaSalle Annex Index***

<u>Page</u>	<u>Revision</u>
11-i	1.7
11-ii	1.7
11-iii	1.7
11-iv	1.7
11-1	1.7
11-2	1.7
11-3	1.7
11-4	1.7
11-5	1.7
11-6	1.7
11-7	1.7
11-8	1.7
11-9	1.7
11-10	1.7
11-11	1.7

CHAPTER 11
RADIOLOGICAL ENVIRONMENTAL MONITORING PROGRAM
TABLE OF CONTENTS

<u>CHAPTER</u>	<u>TITLE</u>	<u>PAGE</u>
11	Radiological Environmental Monitoring Program	11-1

LIST OF TABLES

<u>NUMBER</u>	<u>TITLE</u>	<u>PAGE</u>
11-1	Radiological Environmental Monitoring Program	11-2

LIST OF FIGURES

<u>NUMBER</u>	<u>TITLE</u>	<u>PAGE</u>
11-1	Fixed Air Sampling Sites and Outer Ring TLD Locations	11-9
11-2	Inner Ring TLD Locations	11-10
11-3	Ingestion and Waterborne Exposure Pathway Sample Locations	11-11

CHAPTER 11
RADIOLOGICAL ENVIRONMENTAL MONITORING PROGRAM

LaSalle Station follows the Uniform Radiological Environmental monitoring Program which is described in Chapter 9. This chapter identifies the site specific REMP for LaSalle Station.

Supplemental tables describing reporting levels and LLDs/MDCs are included within Chapter 9 and figures generally denoting LaSalle Station sample locations are contained herein.

Table 11-1
Radiological Environmental Monitoring Program

Exposure Pathway and/or Sample	Sample or Monitoring Location	Sampling or Collection Frequency	Type and Frequency of Analysis
<p>1. <u>Airborne</u></p> <p><u>Radioiodine and Particulates</u></p>	<p>a. <u>Indicators-Near Field</u></p> <p>L-01, Nearsite No. 1, 0.5 mi NNW (0.8 km R) L-03, Onsite No. 3, 0.2 mi ENE (0.3 km D) L-05, Onsite No. 5, 0.3 mi ESE (0.5 km F) L-06, Nearsite No. 6, 0.4 mi WSW (0.6 km M)</p> <p>b. <u>Indicators-Far Field</u></p> <p>L-07, Seneca, 5.2 mi NNE (8.4 km B) L-08, Marseilles, 6.3 mi NNW (10.1 km R) L-11, Ransom, 6.0 mi S (9.7 km J) L-12, Kernan, 5.0 mi SSW (8.0 km K)</p> <p>c. <u>Controls</u></p> <p>L-10, Streator, 13.5 mi SW (21.7 km L)</p>	<p>Continuous sampler operation with sample collection weekly, or more frequently if required by dust loading.</p>	<p><u>Radioiodine Canisters:</u></p> <p>I-131 analysis weekly on near field and control samples¹.</p> <p><u>Particulate Sampler:</u></p> <p>Gross beta analysis following weekly filter change² and gamma isotopic analysis³ quarterly on composite filters by location on near field and control samples.</p>

Table 11-1 (Cont'd)
Radiological Environmental Monitoring Program

Exposure Pathway and/or Sample	Sample or Monitoring Location	Sampling or Collection Frequency	Type and Frequency of Analysis
2. <u>Direct Radiation</u>	a. <u>Indicators</u> Inner Ring L-101-1, 0.5 mi N (0.8 km A) L-101-2, 0.5 mi N (0.8 km A) L-102-1, 0.6 mi NNE (1.0 km B) L-102-2, 0.6 mi NNE (1.0 km B) L-103-1, 0.7 mi NE (1.1 km C) L-103-2, 0.7 mi NE (1.1 km C) L-104-1, 0.8 mi ENE (1.3 km D) L-104-2, 0.8 mi ENE (1.3 km D) L-105-1, 0.7 mi E (1.1 km E) L-105-2, 0.7 mi E (1.1 km E) L-106-1, 1.4 mi ESE (2.2 km F) L-106-2, 1.4 mi ESE (2.2 km F) L-107-1, 0.8 mi SE (1.3 km G) L-107-2, 0.8 mi SE (1.3 km G) L-108-1, 0.5 mi SSE (0.8 km H) L-108-2, 0.5 mi SSE (0.8 km H) L-109-1, 0.6 mi S (1.0 km J) L-109-2, 0.6 mi S (1.0 km J) L-110-1, 0.6 mi SSW (1.0 km K) L-110-2, 0.6 mi SSW (1.0 km K) L-111b-1, 0.8 mi SW (1.3 km L) L-111b-2, 0.8 mi SW (1.3 km L) L-112-1, 0.9 mi WSW (1.4 km M) L-112-2, 0.9 mi WSW (1.4 km M) L-113a-1, 0.8 mi W (1.3 km N) L-113a-2, 0.8 mi W (1.3 km N) L-114-1, 0.9 mi WNW (1.4 km P) L-114-2, 0.9 mi WNW (1.4 km P) L-115-1, 0.7 mi NW (1.1 km Q) L-115-2, 0.7 mi NW (1.1 km Q) L-116-1, 0.6 mi NNW (1.0 km R) L-116-2, 0.6 mi NNW (1.0 km R)	Quarterly	Gamma dose quarterl

Table 11-1 (Cont'd)
Radiological Environmental Monitoring Program

Exposure Pathway and/or Sample	Sample or Monitoring Location	Sampling or Collection Frequency	Type and Frequency of Analysis
2. Direct Radiation (Cont'd)	b. <u>Indicators</u> -Outer Ring L-201-3, 4.0 mi N (6.4 km A) L-201-4, 4.0 mi N (6.4 km A) L-202-3, 3.6 mi NNE (5.8 km B) L-202-4, 3.6 mi NNE (5.8 km B) L-203-1, 4.0 mi NE (6.4 km C) L-203-2, 4.0 mi NE (6.4 km C) L-204-1, 3.5 mi ENE (5.6 km D) L-204-2, 3.5 mi ENE (5.6 km D) L-205-1, 3.2 mi ESE (5.2 km F) L-205-2, 3.2 mi ESE (5.2 km F) L-205-3, 5.1 mi E (8.2 km E) L-205-4, 5.1 mi E (8.2 km E) L-206-1, 4.3 mi SE (6.9 km G) L-206-2, 4.3 mi SE (6.9 km G) L-207-1, 4.5 mi SSE (7.2 km H) L-207-2, 4.5 mi SSE (7.2 km H) L-208-1, 4.5 mi S (7.2 km J) L-208-2, 4.5 mi S (7.2 km J) L-209-1, 4.0 mi SSW (6.4 km K) L-209-2, 4.0 mi SSW (6.4 km K) L-210-1, 3.3 mi SW (5.3 km L) L-210-2, 3.3 mi SW (5.3 km L) L-211-1, 4.5 mi WSW (7.2 km M)* L-211-2, 4.5 mi WSW (7.2 km M)* L-212-1, 4.0 mi WSW (6.4 km M) L-212-2, 4.0 mi WSW (6.4 km M) L-213-3, 4.9 mi W (7.9 km N) L-213-4, 4.9 mi W (7.9 km N) L-214-3, 5.1 mi WNW (8.2 km P) L-214-4, 5.1 mi WNW (8.2 km P) L-215-3, 5.0 mi NW (8.0 km Q) L-215-4, 5.0 mi NW (8.0 km Q) L-216-3, 5.0 mi NNW (8.0 km R) L-216-4, 5.0 mi NNW (8.0 km R)		
* TLD placement scheduled during 4th quarter 1995			

Table 11-1 (Cont'd)
Radiological Environmental Monitoring Program

Exposure Pathway and/or Sample	Sample or Monitoring Location	Sampling or Collection Frequency	Type and Frequency of Analysis
2. Direct Radiation (Cont'd)	c. <u>Other</u> indicators		
	One at each of the airborne location given in part 1.a and 1.b.		
	d. <u>Controls</u>		
	One at each airborne control location given in part 1.c.		

Table 11-1 (Cont'd)
Radiological Environmental Monitoring Program

Exposure Pathway and/or Sample	Sample or Monitoring Location	Sampling or Collection Frequency	Type and Frequency of Analysis
<p>3. <u>Waterborne</u></p> <p>a. <u>Ground/Well</u></p> <p>b. <u>Drinking Water</u></p> <p>c. <u>Surface Water</u></p> <p>d. <u>Control</u></p> <p>e. <u>Sediments</u></p>	<p>a. Indicators</p> <p>L-27, LSCS Onsite Well at Station L-28, Marseilles Well, 7.0 mi NW (11.3 km Q)</p> <p>There is no drinking water pathway within 6.2 km downstream of station.</p> <p>a. <u>Indicator</u></p> <p>L-40, Illinois River downstream, 5.2 mi NNW (8.4 km R)</p> <p>a. <u>Control</u></p> <p>L-21, Illinois River at Seneca, 4.0 mi NE (6.4 km C)</p> <p>a. Indicators</p> <p>L-40, Illinois River downstream, 5.2 mi NNW (8.4 km R)</p>	<p>Quarterly</p> <p>Weekly grab sample</p> <p>Weekly grab sample</p> <p>Weekly grab sample</p> <p>Semiannually</p>	<p>Gamma isotopic³ and tritium analysis quarterly.</p> <p>Gross beta and gamma isotopic analysis³ on monthly composite; tritium analysis on quarterly composite.</p> <p>Gross beta and gamma isotopic analysis³ on monthly composite tritium and analysis on quarterly composite.</p> <p>Gross beta and gamma isotopic analysis³ on monthly composite tritium and analysis on quarterly composite.</p> <p>Gamma isotopic analysis³ semiannually.</p>

Table 11-1 (Cont'd)
Radiological Environmental Monitoring Program

Exposure Pathway and/or Sample	Sample or Monitoring Location	Sampling or Collection Frequency	Type and Frequency of Analysis
<p>4. <u>Ingestion</u></p> <p>a. <u>Milk</u></p> <p>b. <u>Fish</u></p> <p>c. <u>Food Products</u></p>	<p>a. <u>Indicators</u></p> <p>At the time of this revision, there are no dairies within 6.2 miles which consistently produce milk.</p> <p>b. <u>Controls</u></p> <p>L-16, Lowery Dairy, 7.2 mi ESE (11.6 km F) L-41, Burton Farm, 7.5 mi N (12 km A)</p> <p>a. <u>Indicator</u></p> <p>L-35, Marseilles Pool of Illinois River, 6.5 mi NW (10.5 km Q)</p> <p>b. <u>Control</u></p> <p>L-36, Illinois River upstream of discharge, 4.3 mi NNE (6.9 km B)</p> <p>a. <u>Indicators</u></p> <p>Two sample locations within 6.2 mi.</p> <p>Sample locations for food products may vary based on availability and therefore are not required to be identified here but shall be taken.</p> <p>b. <u>Controls</u></p> <p>Two samples within 9.3 to 18.6 mi.</p>	<p>Biweekly: May through October or monthly: November through April</p> <p>Two times annually</p> <p>Three times annually.</p>	<p>Gamma isotopic³ and I-131 analysis⁴ biweekly May through October, monthly November through April.</p> <p>Gamma isotopic analysis³ on edible portions of each</p> <p>Gamma isotopic analysis on edible portions.</p>

Table 11-1 (Cont'd)
Radiological Environmental Monitoring Program

- 1 Far field samples are analyzed when near field results are inconsistent with previous measurements and radioactivity is confirmed as having its origin in airborne effluents released from the station, or at the discretion of the Emergency Preparedness Director.
- 2 Airborne particulate sample filters shall be analyzed for gross beta radioactivity 24 hours or more after sampling to allow for radon and thoron daughter decay. If gross-beta activity in air particulate samples is greater than 10 times the yearly mean of control samples, gamma isotopic analysis shall be performed on the individual samples.
- 3 Gamma isotopic analysis means the identification and quantification of gamma emitting radionuclides that may be attributable to the effluents from the station.
- 4 I-131 analysis means the analytical separation and counting procedure are specific for this radionuclide.

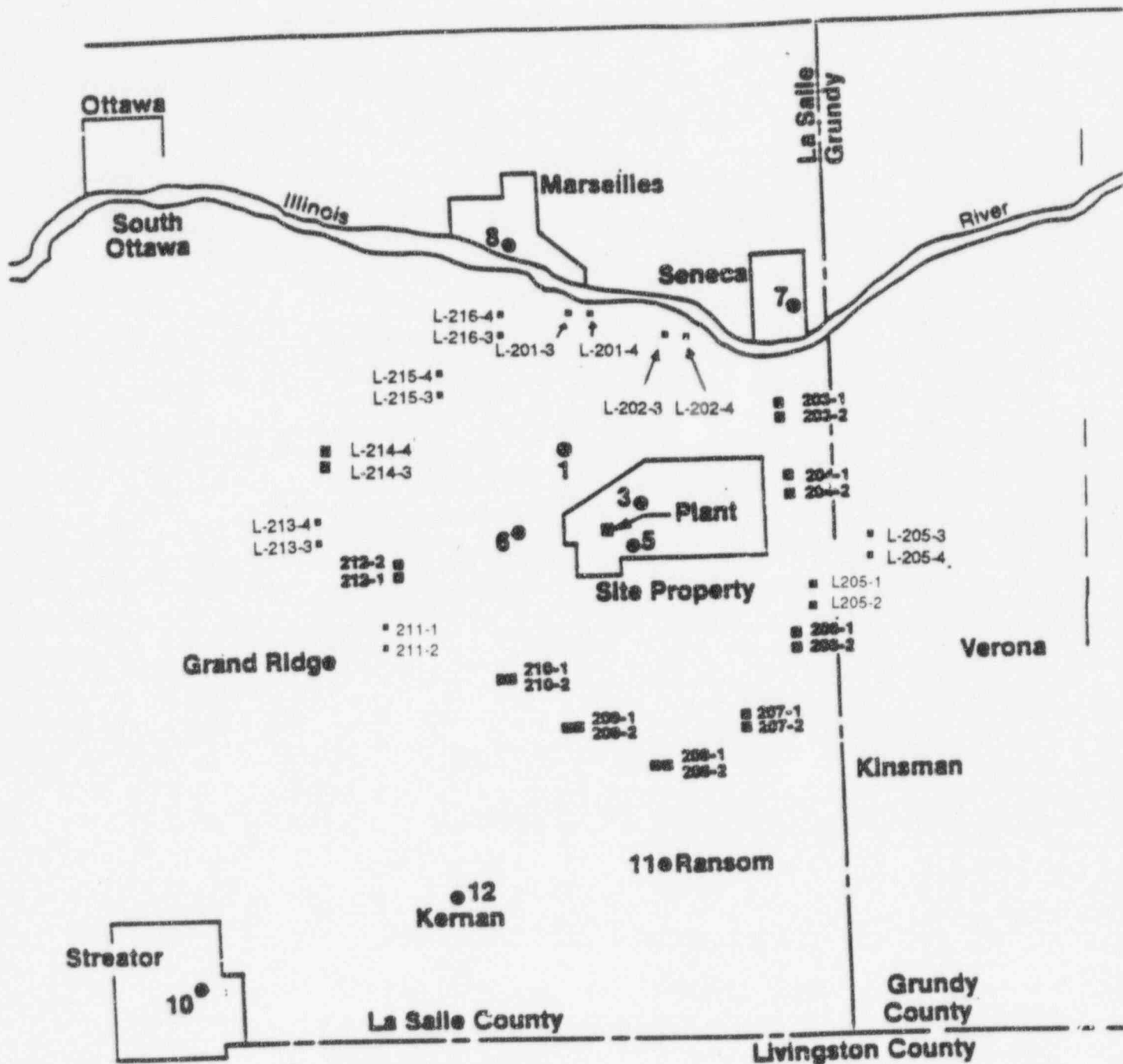

- Air Sampling Location
- TLD Location
- ▣ LaSalle Station

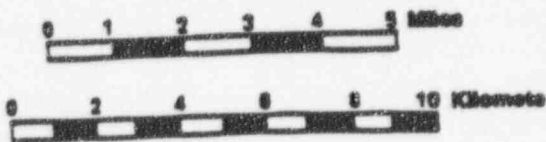

**OFFSITE DOSE CALCULATION MANUAL
LA SALLE COUNTY STATION**

FIGURE 11-1

**FIXED AIR SAMPLING SITES AND
OUTER RING TLD LOCATIONS**

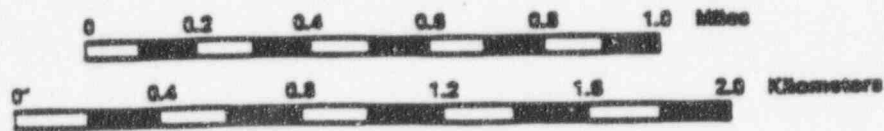
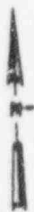
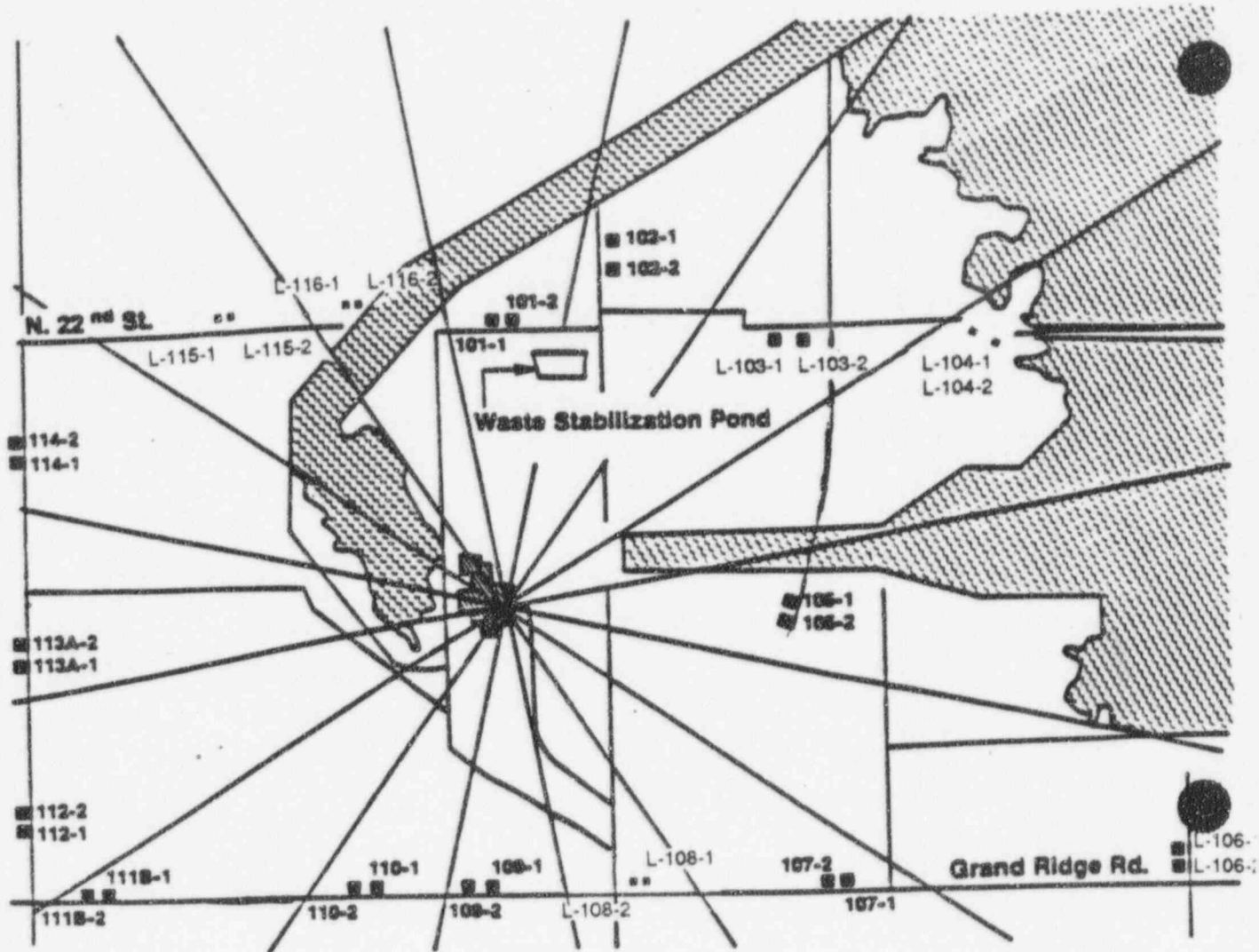

■ TLD Location

**OFFSITE DOSE CALCULATION MANUAL
LA SALLE COUNTY STATION**

FIGURE 11-2

INNER RING TLD LOCATIONS

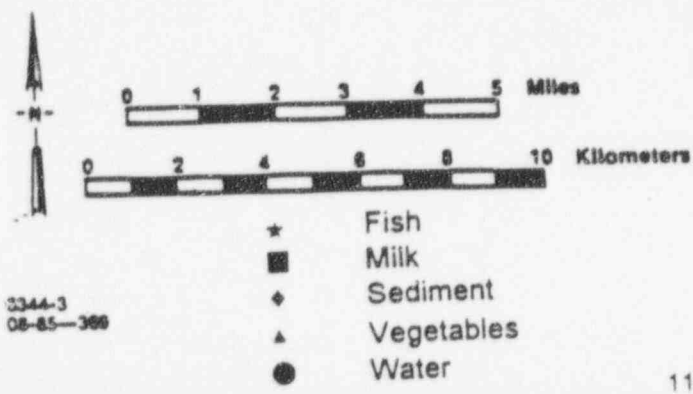
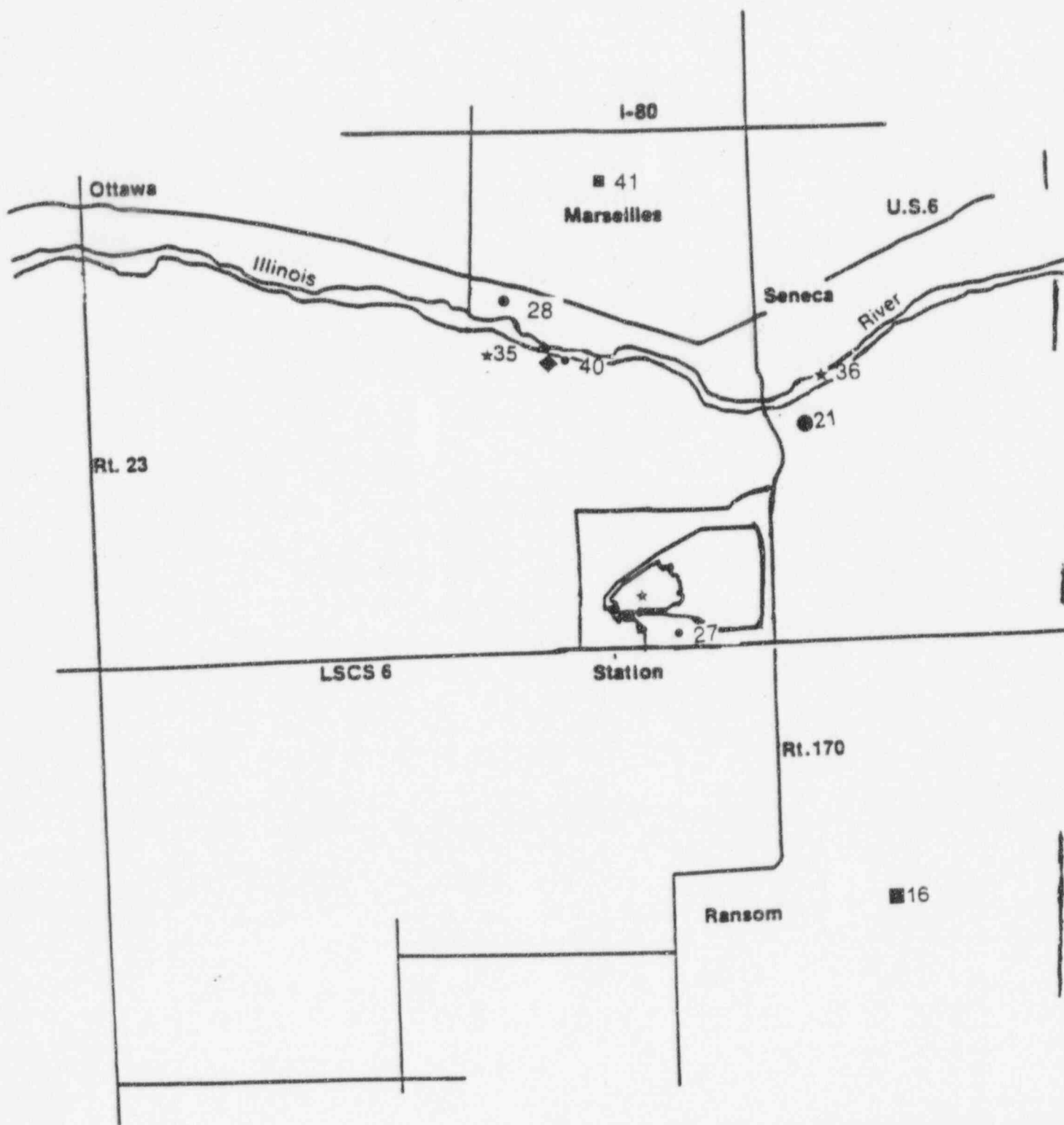

3344-3
08-85-389

**OFFSITE DOSE CALCULATION MANUAL
LA SALLE COUNTY STATION**

FIGURE 11-3

**INGESTION AND WATERBORNE EXPOSURE
PATHWAY SAMPLE LOCATIONS**

CHAPTER 12

SPECIAL NOTE

The transfer of the Radiological Effluent Technical Specifications (RETS) to the ODCM has been approved by the Nuclear Regulatory Commission in Amendments 85/69.

LASALLE ANNEX INDEX**CHAPTER 12**

<u>PAGE</u>	<u>REVISION</u>	<u>PAGE</u>	<u>REVISION</u>
12 - i	1.7	12 - 43	1.7
12 - ii	1.7	12 - 44	1.7
12 - iii	1.7	12 - 45	1.7
12 - iv	1.7	12 - 46	1.7
12 - 1	1.7	12 - 47	1.7
12 - 2	1.7		
12 - 3	1.7		
12 - 4	1.7		
12 - 5	1.7		
12 - 6	1.7		
12 - 7	1.7		
12 - 8	1.7		
12 - 9	1.7		
12 - 10	1.7		
12 - 11	1.7		
12 - 12	1.7		
12 - 13	1.7		
12 - 14	1.7		
12 - 15	1.7		
12 - 16	1.7		
12 - 17	1.7		
12 - 18	1.7		
12 - 19	1.7		
12 - 20	1.7		
12 - 21	1.7		
12 - 22	1.7		
12 - 23	1.7		
12 - 24	1.7		
12 - 25	1.7		
12 - 26	1.7		
12 - 27	1.7		
12 - 28	1.7		
12 - 29	1.7		
12 - 30	1.7		
12 - 31	1.7		
12 - 32	1.7		
12 - 33	1.7		
12 - 34	1.7		
12 - 35	1.7		
12 - 36	1.7		
12 - 37	1.7		
12 - 38	1.7		
12 - 39	1.7		
12 - 40	1.7		
12 - 41	1.7		
12 - 42	1.7		

CHAPTER 12

**RADIOACTIVE EFFLUENT TECHNICAL STANDARDS
(RETS)
TABLE OF CONTENTS**

		<u>PAGE</u>
12.0	RADIOLOGICAL EFFLUENT TECHNICAL STANDARDS	12-1
12.1	DEFINITIONS	12-4
12.2	INSTRUMENTATION	12-8
	1. Radioactive Liquid Effluent Monitoring Instrumentation	12-8
	2. Radioactive Gaseous Effluent Monitoring Instrumentation	12-13
12.3	LIQUID EFFLUENTS	12-19
	1. Concentration	12-19
	2. Dose	12-24
	3. Liquid Waste Treatment System	12-26
12.4	GASEOUS EFFLUENTS	12-27
	1. Dose Rate	12-27
	2. Dose - Noble Gases	12-31
	3. Dose - Iodine-131, Iodine-133, Tritium, and Radionuclides in Particulate Form	12-32
	4. Gaseous Radwaste Treatment System	12-34
	5. Ventilation Exhaust Treatment System	12-35
	6. Venting or Purging	12-36
	7. Total Dose	12-37
	8. Main Condenser	12-39
	9. Dose Limits for Members of the Public	12-40
12.5	RADIOLOGICAL ENVIRONMENTAL MONITORING PROGRAM	12-41
	1. Radiological Environmental Monitoring Program	12-41
	2. Land Use Census	12-42
	3. Interlaboratory Comparison Program	12-43
12.6	REPORTING REQUIREMENTS	12-44
	1. Annual Radiological Environmental Operating Report	12-44
	2. Radioactive Effluent Release Report	12-45
	3. Offsite Dose Calculation Manual (ODCM)	12-46
	4. Major Changes to Radioactive Waste Treatment Systems	12-47

CHAPTER 12**RADIOACTIVE EFFLUENT TECHNICAL STANDARDS
(RETS)
LIST OF TABLES**

	<u>PAGE</u>
12.0-1 Effluent Compliance Matrix	12-2
12.0-2 REMP Compliance Matrix	12-3
12.1-1 Frequency Notation	12-7
12.2.1-1 Radioactive Liquid Effluent Monitoring Instrumentation	12-9
12.2.1-2 Radioactive Liquid Effluent Monitoring Instrumentation Surveillance Requirements	12-11
12.2.2-1 Radioactive Gaseous Effluent Monitoring Instrumentation	12-14
12.2.2-2 Radioactive Gaseous Effluent Monitoring Instrumentation Surveillance Requirements	12-16
12.3.1-1 Allowable Concentration of Dissolved or Entrained Noble Gases Release from the Site to Unrestricted Areas in Liquid Waste	12-20
12.3.1-2 Radioactive Liquid Waste Sampling and Analysis Program	12-21
12.4.1-1 Radioactive Gaseous Waste Sampling and Analysis Program	12-28

12.0 RADIOLOGICAL EFFLUENT TECHNICAL STANDARDS

Chapter 12 of the LaSalle Station ODCM is a compilation of the various regulatory requirements, surveillances and bases, commitments and/or components of the radiological effluent and environmental monitoring programs for LaSalle Station. To assist in the understanding of the relationship between effluent regulations, ODCM equations, RETS (Chapter 12 section) and related Technical Specification requirements, Table 12.0-1 is a matrix which relates these various components. The Radiological Environmental Monitoring Program fundamental requirements are contained within this chapter and are explained programmatically in Chapter 9 with LaSalle specific information in Chapter 11 and with a supplemental matrix in Table 12.0-2.

TABLE 12.0-1

EFFLUENT COMPLIANCE MATRIX

Regulation	Dose to be compared to limit	ODCM Equation	RETS	Technical Specification
10CFR50 Appendix I	1. gamma air dose and beta air dose due to airborne radioactivity in effluent plume.	A-1 A-2	12.4.2	6.2.F.4.h
	1.a whole body and skin dose due to airborne radioactivity in effluent plume are reported only if certain gamma and beta air dose criteria are exceeded.	A-6 A-7	N/A	N/A
	2. CDE for all organs and all four age groups due to iodines and particulates in effluent plume. All pathways are considered.	A-13	12.4.3	6.2.F.4.i
	3. CDE for all organs and all four age groups due to radioactivity in liquid effluents.	A-29	12.3.2	6.2.F.4.d
10CFR20	1. TEDE, totaling all deep dose equivalent components (direct, ground and plume shine) and committed effective dose equivalents (all pathways, both airborne and liquid-borne). CDE evaluation is made for adult only using FGR 11 data base.	A-38	12.4.9	6.2.F.4.c
40CFR190 (now by reference, also part of 10CFR20)	1. Whole body dose (DDE) due to direct dose, ground and plume shine from all sources at a station.	A-35	12.4.7	6.2.F.4.k
	2. Organ doses (CDE) to an adult due to all pathways.	A-13		
Technical Specifications	1. "Instantaneous" whole body (DDE), thyroid (CDE) and skin (SDE), dose rates to an adult due to radioactivity in airborne effluents. For the thyroid dose, only inhalation is considered.	A-8 A-9 A-28	12.4.1	6.2.F.4.g
	2. "Instantaneous" concentration limits for liquid effluents.	A-32	12.3.1	6.2.F.4.b
Technical Specifications	1. Radiological Effluent Release Report	NA	12.6.2	6.6.A.4

Table 12.0-2

REMP Compliance Matrix

Regulation	Component	RETS	Technical Specification
10CFR50 Appendix I Section IV.B.2	Implement environmental monitoring program.	12.5.1	6.2.F.5
Technical Specifications	Land Use Census	12.5.2	6.2.F.5.b
Technical Specifications	Interlaboratory Comparison Program	12.5.3	6.2.F.5.c

12.1 DEFINITIONS

- 12.1.1 ACTION - ACTION shall be that part of a requirement which prescribes remedial measures required under designated conditions.
- 12.1.2 CHANNEL CALIBRATION - A CHANNEL CALIBRATION shall be the adjustment, as necessary, of the channel output such that it responds with the necessary range and accuracy to known values of the parameter which the channel monitors. The CHANNEL CALIBRATION shall encompass the entire channel including the alarm and/or trip functions, and shall include the CHANNEL FUNCTIONAL TEST. The CHANNEL CALIBRATION may be performed by any series of sequential, overlapping or total channel steps such that the entire channel is calibrated.
- 12.1.3 CHANNEL CHECK - A CHANNEL CHECK shall be the qualitative assessment of channel behavior during operation by observation. This determination shall include, where possible, comparison of the channel indication and/or status with other indications and/or status derived from independent instrument channels measuring the same parameter.
- 12.1.4 CHANNEL FUNCTIONAL TEST - A CHANNEL FUNCTIONAL TEST shall be:
- Analog channels - the injection of a simulated signal into the channel as close to the sensor as practical to verify OPERABILITY including alarm and/or trip functions and channel failure trips.
 - Bistable channels - the injection of a simulated signal into the sensor to verify OPERABILITY including alarm and/or trip functions.
- The CHANNEL FUNCTIONAL TEST may be performed by any series of sequential, overlapping, or total channel steps such that the entire channel is tested.
- 12.1.5 DOSE EQUIVALENT I-131 - DOSE EQUIVALENT I-131 shall be that concentration of I-131, microcuries/gram, which alone would produce the same thyroid dose as the quantity and isotopic mixture of I-131, I-132, I-133, I-134 and I-135 actually present. The thyroid dose conversion factors used for this calculation shall be those listed in Table III of TID-14844, "Calculation of Distance Factors for Power and Test Reactor Sites."
- 12.1.6 FREQUENCY - Table 12.1-1 provides the definitions of various frequencies for which surveillances, sampling, etc. are performed unless defined otherwise. The 25% variance shall not be applied to Operability Action statements. The bases to Technical Specification 4.0.2 provide clarifications to this requirement.
- 12.1.7 GASEOUS RADWASTE TREATMENT SYSTEM - A GASEOUS RADWASTE TREATMENT SYSTEM shall be any system designed and installed to reduce radioactive gaseous effluents by collecting primary coolant system offgases from the primary system and providing for delay or holdup for the purpose of reducing total radioactivity prior to release to the environment.
- 12.1.8 MEMBER(S) OF THE PUBLIC - means an individual except when that individual is receiving and occupational dose.
- 12.1.9 OCCUPATIONAL DOSE - means the dose received by an individual in the course of employment in which the individual's assigned duties involve exposure to radiation and/or to radioactive material from licensed and unlicensed sources of radiation, whether in the possession of the licensee or other person. Occupational dose does not include dose from background radiation as a patient from medical practices, from voluntary participation in

- 12.1.10 OPERABLE - OPERABILITY - A system, subsystem, train, component or device shall be OPERABLE or have OPERABILITY when it is capable of performing its specified function(s), and when all necessary attendant instrumentation, controls, cooling or seal water, lubrication or other auxiliary equipment that are required for the system, subsystem, train, component or device to perform its function(s) are also capable of performing their related support function(s).
- 12.1.11 PROCESS CONTROL PROGRAM - The PROCESS CONTROL PROGRAM (PCP) shall contain the current formulas, sampling, analyses, test, and determinations to be made to ensure that processing and packaging of solid radioactive wastes based on demonstrated processing of actual or simulated wet solid wastes shall be accomplished in such a way as to assure compliance with 10 CFR Parts 20, 61, and 71, State regulations, burial ground requirements, and other requirements governing the disposal of solid radioactive waste.
- 12.1.12 PURGE - PURGING - PURGE or PURGING shall be the controlled process of discharging air or gas from a confinement to maintain temperature, pressure, humidity, concentration or other operating condition, in such a manner that replacement air or gas is required to purify the confinement.
- 12.1.13 RATED THERMAL POWER - RATED THERMAL POWER shall be a total reactor core heat transfer rate to the reactor coolant of 3323 MWt.
- 12.1.14 SITE BOUNDARY - The SITE BOUNDARY shall be that line beyond which the land is neither owned, nor leased, nor otherwise controlled by the licensee.
- 12.1.15 SOLIDIFICATION - SOLIDIFICATION shall be the conversion of radioactive wastes from liquid systems to a homogeneous (uniformly distributed), monolithic, immobilized solid with definite volume and shape, bounded by a stable surface of distinct outline on all sides (free-standing).
- 12.1.16 SOURCE CHECK - A SOURCE CHECK shall be the qualitative assessment of channel response when the channel sensor is exposed to a radioactive source.
- 12.1.17 THERMAL POWER - THERMAL POWER shall be the total reactor core heat transfer rate to the reactor coolant.
- 12.1.18 UNRESTRICTED AREA BOUNDARY - means an area, access to which is neither limited nor controlled by the licensee.
- 12.1.19 VENTILATION EXHAUST TREATMENT SYSTEM - A VENTILATION EXHAUST TREATMENT SYSTEM shall be any system designed and installed to reduce gaseous radioiodine or radioactive material in particulate form in effluents by passing ventilation or vent exhaust gases through charcoal adsorbers and/or HEPA filters for the purpose of removing iodines or particulates from the gaseous exhaust system prior to the release to the environment (such a system is not considered to have any effect on noble gas effluents). Engineered Safety Feature (ESF) atmospheric cleanup systems are not considered to be VENTILATION EXHAUST TREATMENT SYSTEM components.
- 12.1.20 VENTING - VENTING shall be the controlled process of discharging air or gas from a confinement to maintain temperature, pressure, humidity, concentration or other operating condition, in such a manner that replacement air or gas is not provided or required during VENTING. Vent, used in system names, does not imply a VENTING process.

12.1.21 Definitions Peculiar to Estimating Dose to Members of the Public Using the ODCM Computer Program.

- a. ACTUAL - ACTUAL refers to using known release data to project the dose to members of the public for the previous time period. This data is stored in the database and used to demonstrate compliance with the reporting requirements of Chapter 12.6.
- b. PROJECTED - PROJECTED refers to using known release data from the previous time period or estimated release data to forecast a future dose to members of the public. This data is not incorporated into the database.

TABLE 12.1-1FREQUENCY NOTATION*

<u>NOTATION</u>	<u>FREQUENCY</u>
S - Shiftly	At least once per 12 hours.
D - Daily	At least once per 24 hours.
W - Weekly	At least once per 7 days.
M - Monthly	At least once per 31 days.
Q - Quarterly	At least once per 92 days.
SA - Semiannually	At least once per 184 days.
A - Annually	At least once per 366 days.
R - Refueling cycle	At least once per 18 months (550 days).
S/U - Startup	Prior to each reactor startup.
P - Prior	Prior to each radioactive release.
N.A.	Not applicable.

* Each frequency requirement shall be performed within the specified time interval with the maximum allowable extension not to exceed 25% of the frequency interval. The 25% variance shall not be applied to Operability Action statements. The bases to Technical Specification 4.0.2 provide clarifications to this requirement.

12.2 INSTRUMENTATION12.2.1 Radioactive Liquid Effluent Monitoring InstrumentationOperability Requirements

12.2.1.A The radioactive liquid effluent monitoring instrumentation channels shown in Table 12.2.1-1 shall be OPERABLE with their alarm/trip setpoints set to ensure that the limits of Section 12.3.1.A are not exceeded. The alarm trip setpoints of these channels shall be determined in accordance with the ODCM Chapter 10.

Applicability: At all times.

Action:

- a. With a radioactive liquid effluent monitoring instrumentation channel alarm/trip setpoint less conservative than required, immediately suspend the release of radioactive liquid effluents monitored by the affected channel or declare the channel inoperable.
- b. With less than the minimum number of radioactive liquid effluent monitoring instrumentation channels OPERABLE, take the ACTION shown in Table 12.2.1-1. Restore the inoperable instrumentation to OPERABLE status within the time specified in the ACTION or, explain in the next Radioactive Effluent Release Report why this inoperability was not corrected within the time specified.

Surveillance Requirements

12.2.1.B Each radioactive liquid effluent monitoring instrumentation channel shall be demonstrated OPERABLE by performance of the CHANNEL CHECK, SOURCE CHECK, CHANNEL FUNCTIONAL TEST and CHANNEL CALIBRATION operations at the frequencies shown in Table 12.2.1-2.

Bases

12.2.1.C The radioactive liquid effluent monitoring instrumentation is provided to monitor and control, as applicable, the releases of radioactive materials in liquid effluents during actual or potential releases of liquid effluents. The alarm/trip setpoints for these instruments shall be calculated in accordance with the procedures in the ODCM to ensure that the alarm/trip will occur prior to exceeding the limits of RETS. The OPERABILITY and use of this instrumentation is consistent with the requirements of General Design Criteria 60, 63, and 64 of Appendix A to 10 CFR Part 50.

TABLE 12.2.1-1RADIOACTIVE LIQUID EFFLUENT MONITORING INSTRUMENTATION

<u>INSTRUMENT</u>	<u>MINIMUM CHANNELS OPERABLE</u>	<u>ACTION</u>
1. GAMMA SCINTILLATION MONITOR PROVIDING ALARM AND AUTOMATIC TERMINATION OF RELEASE		
a. Liquid Radwaste Effluent Line	1	100
2. GAMMA SCINTILLATION MONITORS PROVIDING ALARM BUT NOT PROVIDING AUTOMATIC TERMINATION OF RELEASE		
a. Service Water System Effluent Line (Unit 1)	1	101
b. RHR Service Water (Line A) Effluent Line	1	101
c. RHR Service Water (Line B) Effluent Line	1	101
d. Service Water System Effluent Line (Unit 2)	1	101
3. FLOW RATE MEASUREMENT DEVICES		
a. Liquid Radwaste Effluent Line	1	102
b. River Discharge - Blowdown Pipe	1	102

RADIOACTIVE LIQUID EFFLUENT MONITORING INSTRUMENTATIONTABLE 12.2.1-1 (Continued)TABLE NOTATION

- ACTION 100 - With the number of OPERABLE channels less than required by the Minimum Channels OPERABLE requirement, effluent releases may continue for up to 14 days provided that prior to initiating a release:
- a. At least two independent samples are analyzed in accordance with Section 12.3.1.B.3, and
 - b. At least two technically qualified members of the Facility Staff independently verify the release rate calculations and discharge line valving;
- Otherwise, suspend release of radioactive effluents via this pathway.
- ACTION 101 - With the number of channels OPERABLE less than required by the Minimum Channels OPERABLE requirement, effluent releases via this pathway may continue for up to 30 days provided that, at least once per 8 hours, grab samples are collected and analyzed at a limit of detection as specified in Table 12.3-2.
- ACTION 102 - With the number of channels OPERABLE less than required by the Minimum Channels OPERABLE requirement, actual radioactive releases in progress via this pathway may continue provided the flow rate is estimated at least once per 4 hours. Pump curves for Instrument 3a, or for known valve positions for Instrument 3b, may be used to estimate flow. Actual releases of radioactive effluent will not be initiated without an OPERABLE channel.

TABLE 12.2.1-2

RADIOACTIVE LIQUID EFFLUENT MONITORING INSTRUMENTATION SURVEILLANCE REQUIREMENTS

<u>INSTRUMENT</u>	<u>CHANNEL CHECK</u>	<u>SOURCE CHECK</u>	<u>CHANNEL FUNCTIONAL TEST</u>	<u>CHANNEL CALIBRATION</u>
1. GAMMA SCINTILLATION MONITOR PROVIDING ALARM AND AUTOMATIC TERMINATION OF RELEASE				
a. Liquid Radwaste Effluents Line	D	P	Q(1)	R(3)
2. GAMMA SCINTILLATION MONITORS PROVIDING ALARM BUT NOT PROVIDING AUTOMATIC TERMINATION OF RELEASE				
a. Service Water System Effluent Line (Unit 1)	D	M	Q(2)	R(3)
b. RHR Service Water (Line A) Effluent Line	D	M	Q(2)	R(3)
c. RHR Service Water (Line B) Effluent Line	D	M	Q(2)	R(3)
d. Service Water System Effluent Line (Unit 2)	D	M	Q(2)	R(3)
3. FLOW RATE MEASUREMENT DEVICES				
a. Liquid Radwaste Effluent Line	D(4)	N.A.	P	R
b. River Discharge - Blowdown Pipe	D(4)	N.A.	Q	R

RADIOACTIVE LIQUID EFFLUENT MONITORING INSTRUMENTATIONTABLE 12.2.1-2 (Continued)TABLE NOTATION

- (1) The CHANNEL FUNCTIONAL TEST shall also demonstrate that automatic isolation of this pathway and control alarm annunciation occurs if any of the following conditions exist:
 1. Instrument indicates measured levels above the alarm/trip setpoint.
 2. Loss of power.
 3. Instrument alarms on downscale failure.
 4. Instrument controls not set in Operate or High Voltage mode.
- (2) The CHANNEL FUNCTIONAL TEST shall also demonstrate that control room alarm annunciation occurs if any of the following conditions exist:
 1. Instrument indicates measured levels above the alarm setpoint.
 2. Loss of power.
 3. Instrument alarms on downscale failure.
 4. Instrument controls not set in Operate or High Voltage mode.
- (3) The initial CHANNEL CALIBRATION shall be performed using one or more of the reference radioactive standards certified by the National Institute of Standards and Technology (NIST) or using standards that have been obtained from suppliers that participate in measurement assurance activities with NIST. These standards shall permit calibrating the system over its intended range of energy and measurement range. For subsequent CHANNEL CALIBRATION, the initial reference radioactive standards or radioactive sources that have been related to the initial calibration shall be used.
- (4) CHANNEL CHECK shall consist of verifying indication of flow during periods of release. CHANNEL CHECK shall be made at least once per 24 hours on days in which continuous, periodic, or batch releases are made.

12.2 INSTRUMENTATION

12.2.2 Radioactive Gaseous Effluent Monitoring Instrumentation

Operability Requirements

- 12.2.2.A The radioactive gaseous effluent monitoring instrumentation channels shown in Table 12.2.2-1 shall be OPERABLE with their alarm/trip setpoints set to ensure that the limits of Section 12.4.1.A are not exceeded. The alarm/trip setpoints of these channels shall be determined in accordance with the ODCM.

Applicability: As shown in Table 12.2.2-1.

Action:

- a. With a radioactive gaseous effluent monitoring instrumentation channel alarm/trip setpoint less conservative than required, immediately suspend the release of radioactive gaseous effluents monitored by the affected channel or declare the channel inoperable.
- b. With less than the minimum number of radioactive gaseous effluent monitoring instrumentation channels OPERABLE, take the ACTION shown in Table 12.2.2-1.

Surveillance Requirements

- 12.2.2.B Each radioactive gaseous effluent monitoring instrumentation channel shall be demonstrated OPERABLE by performance of the CHANNEL CHECK, SOURCE CHECK, CHANNEL FUNCTIONAL TEST and CHANNEL CALIBRATION operations at the frequencies shown in Table 12.2.2-2.

Bases

- 12.2.2.C The radioactive gaseous effluent monitoring instrumentation is provided to monitor and control, as applicable, the releases of radioactive materials in gaseous effluents during actual or potential releases of gaseous effluents. The alarm/trip setpoints for these instruments shall be calculated in accordance with the procedures in the ODCM to ensure that the alarm/trip will occur prior to exceeding the limits of RETS.

TABLE 12.2.1-1
RADIOACTIVE GASEOUS EFFLUENT MONITORING INSTRUMENTATION

<u>INSTRUMENT¹</u>	<u>MINIMUM CHANNELS OPERABLE</u>	<u>APPLICABILITY</u>	<u>ACTION</u>
1. MAIN CONDENSER OFFGAS TREATMENT SYSTEM EFFLUENT MONITORING SYSTEM			
a. Noble Gas Activity Monitor - Providing Alarm and Automatic Termination of Release (1(2) D18-N903A, K901A, K601A, R601) and/or (1(2) D18-N903B, K901B, K601B, R601)	1	*	110
2. MAIN STACK MONITORING SYSTEM			
a. Noble Gas Activity Monitor (0D18-N514, R517, R518 Low Range WRGM) or (0D18-N515, R517, R518 Mid Range WRGM)	1	*	110
b. Iodine Sampler (Grab Sampler)	1	*	111
c. Particulate Sampler (Grab Sampler)	1	*	111
d. Effluent System Flow Rate Monitor (0FT-VR019, 0FY-VR019 and 19A, 0FR-VR019, 0D18-K510)	1	*	112
e. Sampler Flow Rate Monitor (Low: 0D18-N527, 0D18-N528, 0D18-R518; Mid/Hi: 0D18-N530, 0D18-531, 0D18-R518)	1	*	112
3. CONDENSER AIR EJECTOR RADIOACTIVITY MONITOR (Prior to Input to Holdup System)			
a. Noble Gas Activity Monitor (1(2) D18-N002, K613, R604) (1(2) D18-N012, K600, R605)	1	#	113
4. SBGTS MONITORING SYSTEM			
a. Noble Gas Activity Monitor (0D18-N511, R515, R516 Low Range WRGM) or (0D18-N512, R515, R516 Mid Range WRGM)	1	##	110
b. Iodine Sampler (Grab Sampler)	1	##	111
c. Particulate Sampler (Grab Sampler)	1	##	111
d. Effluent System Flow Rate Monitor (1(2)FT-VG009, 1(2)FY-VG009, 1(2)FR-VG009)	1	##	112
e. Sampler Flow Rate Monitor (0D18-N520 WRGM; Low: 0D18-N521, Mid/Hi: 0D18-N524)	1	##	112

¹ Equipment Part Number (EPN) numbers or monitor types are provided in parentheses "()".

RADIOACTIVE GASEOUS EFFLUENT MONITORING INSTRUMENTATIONTABLE 12.2.2-1 (Continued)TABLE NOTATION

- * At all times.
- ** During main condenser offgas treatment system operation.
- # During operation of the main condenser air ejector.
- ## During operation of the SBGTS.

ACTION 110 - For the Main Condenser Offgas Treatment System Effluent Monitoring System and low/mid range of WRGMs:

With the number of channels OPERABLE less than required by the Minimum Channels OPERABLE requirement, effluent releases via this pathway may continue for up to 30 days provided grab samples are taken at least once per 8 hours and these samples are analyzed for noble gas gamma emitters within 24 hours.

ACTION 111 - With the number of channels OPERABLE less than required by the Minimum Channels OPERABLE requirement, effluent releases via this pathway may continue for up to 30 days provided that within 4 hours after the channel has been declared inoperable, samples are continuously collected with auxiliary sampling equipment as required in Table 12.4.1-1.

ACTION 112 - With the number of channels OPERABLE less than required by the Minimum Channels OPERABLE requirement, effluent releases via this pathway may continue for up to 30 days provided the flow rate is estimated at least once per 4 hours.

ACTION 113 - With the number of channels OPERABLE less than required by the Minimum Channels OPERABLE requirement, the output from the charcoal adsorber vessels may be released to the environment for up to 72 hours provided:

- a. The offgas treatment system is not bypassed, and
- b. The offgas treatment delay system noble gas activity effluent downstream monitor is OPERABLE;

Otherwise, be in at least STARTUP with the main steam isolation valves closed within 12 hours.

NOTE: Clarification: Even though only 1 channel is required by Tech Specs, in order to provide automatic termination of release (i.e. to auto close 1(2)N62-F057), 1 out of 3 twice logic is required (i.e. 2 channels). One channel uses the 1(2)A Post Treatment PRM Hi³, Downscale, Trips while the other channel uses the 1(2)B Post Treatment PRM Hi³, Downscale, Inop Trips. Therefore, if one of the Post Treatment PRM's is inop, then that inop PRM must be placed in the Trip Condition (i.e. taken out of operate), otherwise the Associated Action Statement must be followed (i.e. Sample 1/8 hrs. for up to 30 days). (See Technical Specification clarification 02/88 signed by Station Manager 3/31/88.)

TABLE 12.2.2-2

RADIOACTIVE GASEOUS EFFLUENT MONITORING INSTRUMENTATION SURVEILLANCE REQUIREMENTS

<u>INSTRUMENT</u>	<u>CHANNEL CHECK</u>	<u>SOURCE CHECK</u>	<u>CHANNEL FUNCTIONAL TEST</u>	<u>CHANNEL CALIBRATION</u>	<u>OPERATIONAL CONDITIONS FOR WHICH SURVEILLANCE REQUIRED</u>
1. MAIN CONDENSER OFFGAS TREATMENT SYSTEM EFFLUENT MONITORING SYSTEM					
a. Noble Gas Activity Monitor - Providing Alarm and Automatic Termination of Release	D	D	Q(1)	R(3)	*
2. MAIN STACK MONITORING SYSTEM					
a. Noble Gas Activity Monitor	D	M	Q(4)	R(3)	*
b. Iodine Sampler	W	N.A.	N.A.	N.A.	*
c. Particulate Sampler	W	N.A.	N.A.	N.A.	*
d. Effluent System Flow Rate Monitor	D	N.A.	Q	R	*
e. Sampler Flow Rate Monitor	D	N.A.	Q	R	*
3. CONDENSER AIR EJECTOR RADIOACTIVITY MONITOR					
a. Noble Gas Activity Monitor	D	M	Q(2)	R(3)	#
4. SBGTS MONITORING SYSTEM					
a. Noble Gas Activity Monitor	D	M	Q(4)	R(3)	##
b. Iodine Sampler	W	N.A.	N.A.	N.A.	##
c. Particulate Sampler	W	N.A.	N.A.	N.A.	##
d. Effluent System Flow Rate Monitor	D	N.A.	Q	R	##
e. Sampler Flow Rate Monitor	D	N.A.	Q	R	##

RADIOACTIVE GASEOUS EFFLUENT MONITORING INSTRUMENTATION SURVEILLANCE
REQUIREMENTSTABLE 12.2.2-2 (Continued)TABLE NOTATION

- * At all times.
- # During operation of the main condenser air ejector.
- ## During operation of the SBGTS.
- (1) The CHANNEL FUNCTIONAL TEST shall also demonstrate the automatic isolation capability of this pathway for the following conditions:
 - 1. Upscale.
 - 2. Inoperative.
 - 3. Downscale.
- (2) The CHANNEL FUNCTIONAL TEST for the log scale monitor shall also demonstrate that control room alarm annunciation occurs for the following conditions:
 - 1. Upscale.
 - 2. Inoperative.
 - 3. Downscale.
- (3) The initial CHANNEL CALIBRATION shall be performed using one or more of the reference radioactive standards certified by the National Institute of Standards and Technology (NIST) or using standards that have been obtained from suppliers that participate in measurement assurance activities with NIST. These standards shall permit calibrating the system over its intended range of energy and measurement range. For subsequent CHANNEL CALIBRATION, the initial reference radioactive standards or radioactive sources that have been related to the initial calibration shall be used.

RADIOACTIVE GASEOUS EFFLUENT MONITORING INSTRUMENTATION SURVEILLANCE
REQUIREMENTSTABLE 12.2.2-2 (Continued)TABLE NOTATION

- (4) The CHANNEL FUNCTIONAL TEST shall also demonstrate that control room alarm annunciation occurs if any of the following conditions exists:
1. Instrument indicates measured levels above the alarm setpoint.
 2. Loss of Counts

12.3 LIQUID EFFLUENTS

12.3.1 Concentration

Operability Requirements

- 12.3.1.A The concentration of radioactive material released from the site shall be limited to ten (10) times the concentration value in Appendix B, Table 2, Column 2 to 10CFR20.1001-20.2402 for radionuclides other than dissolved or entrained noble gases. For dissolved or entrained noble gases, the concentration shall be limited to the concentrations specified in Table 12.3.1-1.

Applicability: At all times.

Action:

With the concentration of radioactive material released from the site exceeding the above limits, immediately restore the concentration to within the above limits.

Surveillance Requirements

- 12.3.1.B.1 The radioactivity content of each batch of radioactive liquid waste shall be determined prior to release by sampling and analysis in accordance with Table 12.3.1-2. The results of pre-release analyses shall be used with the calculational methods in the ODCM to assure that the concentration at the point of release is maintained within the limits of Section 12.3.1.A.
- 12.3.1.B.2 Post-release analyses of samples composited from batch releases shall be performed in accordance with Table 12.3.1-2. The results of the previous post-release analyses shall be used with the calculational methods in the ODCM to assure that the concentrations at the point of release were maintained within the limits of Section 12.3.1.A.
- 12.3.1.B.3 The radioactivity concentration of liquids discharged from continuous release points shall be determined by collection and analysis of samples in accordance with Table 12.3.1-2. The results of the analyses shall be used with the calculational methods in the ODCM to assure that the concentrations at the point of release are maintained within the limits of Section 12.3.1.A.
- 12.3.1.B.4 Identify outside temporary liquid holdup tanks within the site and restrict the quantity of radioactive material contained in specified tanks to provide assurance that in the event of an uncontrolled release of the tanks contents, the resulting concentrations would be less than the limits of Section 12.3.1.A. Refer to LaSalle Technical Specification 3/4.11.1.

Bases

- 12.3.1.C This requirement is provided to ensure that the concentration of radioactive materials released in liquid waste effluents from the site will be less than ten (10) times the concentration levels specified in Appendix B, Table 2, Column 2 to 10CFR20.1001-2402. This limitation provides additional assurance that the levels of radioactive materials in bodies of water outside the site will result in exposure within (1) the Section II.A design objectives of Appendix I, 10 CFR 50, to an individual, and (2) the limits of 10 CFR 20.1301 to the population. In addition, this limit is associated with 40 CFR 141 which states concentration limits at the nearest downstream potable water supply.

TABLE 12.3.1-1

ALLOWABLE CONCENTRATION (AC) OF
DISSOLVED OR ENTRAINED NOBLE GASES
RELEASED FROM THE SITE TO UNRESTRICTED AREAS
IN LIQUID WASTE

<u>NUCLIDE</u>	<u>AC(μCi/ml)*</u>
Kr 85 m	2E-4
85	5E-4
87	4E-5
88	9E-5
Ar 41	7E-5
Xe 131 m	7E-4
133 m	5E-4
133	6E-4
135 m	2E-4
135	2E-4

* Computed from Equation 20 of ICRP Publication 2 (1959), adjusted for infinite cloud submersion in water, and $R = 0.01$ rem/week, $p_w = 1.0$ gm/cm³, and $P_w/P_i = 1.0$.

TABLE 12.3.1-2

RADIOACTIVE LIQUID WASTE SAMPLING AND ANALYSIS PROGRAM

LIQUID RELEASE TYPE	SAMPLING FREQUENCY	MINIMUM ANALYSIS FREQUENCY	TYPE OF ACTIVITY ANALYSIS	LOWER LIMIT OF DETECTION (LLD) ($\mu\text{Ci/ml}$) ^a
A. Batch Waste Release Tanks ^d	P Each Batch	P Each Batch	Principal Gamma Emitters ^f	5×10^{-7}
			I-131	1×10^{-6}
	P One Batch/M	M	Dissolved and Entrained Gases (Gamma Emitters)	1×10^{-5}
	P Each Batch	M Composite ^b	H-3	1×10^{-5}
			Gross Alpha	1×10^{-7}
	P Each Batch	Q Composite ^b	Sr-89, Sr-90	5×10^{-6}
			Fe-55	1×10^{-5}
2. Continuous Releases ^a	Continuous ^c	Composite ^c	Principal Gamma Emitters ^f	5×10^{-7}
			I-131	1×10^{-6}
	M Grab Sample	M	Dissolved and Entrained Gases (Gamma Emitters)	1×10^{-5}
	Continuous ^c	M Composite ^c	H-3	1×10^{-5}
			Gross Alpha	1×10^{-7}
	Continuous ^c	Q Composite ^c	Sr-89, Sr-90	5×10^{-6}
			Fe-55	1×10^{-6}

RADIOACTIVE LIQUID WASTE SAMPLING AND ANALYSIS PROGRAMTABLE 12.3.1-2 (Continued)TABLE NOTATION

- a. The LLD is the smallest concentration of radioactive material in a sample that will be detected with 95% probability with 5% probability of falsely concluding that a blank observation represents a "real" signal.

For a particular measurement system (which may include radiochemical separation):

$$\text{LLD} = \frac{4.66 s_b}{E \cdot V \cdot 2.22 \times 10^6 \cdot Y \cdot \exp(-\lambda \Delta t)}$$

Where:

LLD is the "a priori" lower limit of detection as defined above (as microcurie per unit mass or volume),

s_b is the standard deviation of the background counting rate or of the counting rate of a blank sample as appropriate (as counts per minute),

E is the counting efficiency (as counts per transformation),

V is the sample size (in units of mass or volume),

2.22×10^6 is the number of transformations per minute per microcurie,

Y is the fractional radiochemical yield (when applicable),

λ is the radioactive decay constant for the particular radionuclide and for composite samples, and

Δt is the elapsed time between midpoint of sample collection and time of counting (for plant effluents, not environmental samples). For batch samples taken and analyzed prior to release, Δt is taken to be zero.

The value of s_b used in the calculation of the LLD for a detection system shall be based on the actual observed variance of the background counting rate or of the counting rate of the blank samples (as appropriate) rather than on an unverified theoretically predicted variance. Typical values of E, V, Y, and Δt shall be used in the calculation.

- b. A composite sample is one in which the quantity of liquid sampled is proportional to the quantity of liquid waste discharged and in which the method of sample employed results in a specimen which is representative of the liquids released.

RADIOACTIVE LIQUID WASTE SAMPLING AND ANALYSIS PROGRAMTABLE 12.3.1-2 (Continued)TABLE NOTATION

- c. To be representative of the quantities and concentrations of radioactive materials in liquid effluents, samples shall be collected continuously in proportion to the rate of flow of the effluent stream. Prior to analyses, all samples taken for the composite shall be thoroughly mixed in order for the composite sample to be representative of the effluent release.
- d. A batch release is the discharge of liquid waste of a discrete volume. Prior to sampling for analyses, each batch shall be isolated, and then thoroughly mixed, by a method described in the ODCM, to assure representative sampling.
- e. A continuous release is the discharge of liquid wastes of a nondiscrete volume; e.g., from a volume of system that has an input flow during the continuous release.
- f. The principal gamma emitters for which the LLD specification applies exclusively are the following radionuclides: Mn-54, Fe-59, Co-58, Co-60, Zn-65, Mo-99, Cs-134, Cs-137, Ce-141, and Ce-144. This list does not mean that only these nuclides are to be detected and reported. Other peaks which are measurable and identifiable, at the 95% confidence level, together with the above nuclides, shall also be identified and reported.

| 12.3 LIQUID EFFLUENTS

| 12.3.2 Dose

Operability Requirements

- 12.3.2.A The dose or dose commitment to an individual from radioactive materials in liquid effluents released, from each reactor unit, from the site shall be limited:
- a. During any calendar quarter to less than or equal to 1.5 mrem to the total body and to less than or equal to 5 mrem to any organ, and
 - b. During any calendar year to less than to equal to 3 mrem to the total body and to less than or equal to 10 mrem to any organ.

APPLICABILITY: At all times.

ACTION:

- a. With the calculated dose from the release of radioactive materials in liquid effluents exceeding any of the above limits, in lieu of any other report required by LaSalle Technical Specification 6.6.A, prepare and submit to the Commission within 30 days, pursuant to LaSalle Technical Specification 6.6.C, a Special Report which identifies the cause(s) for exceeding the limit(s) and defines the corrective actions to be taken to reduce the releases of radioactive materials in liquid effluents during the remainder of the current calendar quarter and during the subsequent three calendar quarters, so that the cumulative dose or dose commitment to an individual from these releases is within 3 mrem to the total body and 10 mrem to any organ. This Special Report shall also include the radiological impact on finished drinking water supplies at the nearest downstream drinking water source.

Surveillance Requirements

- 12.3.2.B Dose Calculations- Cumulative dose contributions from liquid effluents shall be determined in accordance with the ODCM at least once per 31 days, when liquid discharges are performed.

Bases

- 12.3.2.C This requirement is provided to implement the requirements of Sections II.A, III.A and IV.A of Appendix I, 10 CFR Part 50. The Limiting Condition for Operation implements to guides set forth in Section II.A of Appendix I. The ACTION statements provide the required operating flexibility and at the same time implement the guides set forth in Section IV.A of Appendix I to assure that the releases of radioactive material in liquid effluents will be kept "as low as is reasonably achievable." Also, for fresh water sites with drinking water supplies which can be potentially affected by plant operations, there is reasonable assurance that the operation of the facility will not result in radionuclide concentrations in the finished drinking water that are in excess of the requirements of 40 CFR 141. The dose calculations in the ODCM implement the requirements in Section III.A of Appendix I that conformance with the guides of Appendix I be shown by calculational procedures based on models and data, such that the actual exposure of an individual through appropriate pathways is unlikely to be substantially underestimated. The equations specified in the ODCM

for calculating the doses due to the actual release rates of radioactive materials in liquid effluents are consistent with the methodology provided in Regulatory Guide 1.109, "Calculation of Annual Doses to Man from Routine Releases of Reactor Effluents for the Purpose of Evaluating Compliance with 10 CFR Part 50, Appendix I," Revision 1, October 1977 and Regulatory Guide 1.113, "Estimating Aquatic Dispersion of Effluents from Accidental and Routine Reactor Releases for the Purpose of Implementing Appendix I," April 1977.

This requirement applies to the release of radioactive materials in liquid effluents from each reactor at the site. For units with shared radwaste treatment systems, the liquid effluents from the shared are proportioned among the units sharing that system.

12.3 LIQUID EFFLUENTS

12.3.3 Liquid Waste Treatment System

Operability Requirements

12.3.3.A The liquid radwaste treatment system shall be OPERABLE. The appropriate portions of the system shall be used to reduce the radioactive materials in liquid wastes prior to their discharge when the projected doses due to the liquid effluent from each reactor unit, from the site, when averaged over 31 days, would exceed 0.06 mrem to the total body or 0.2 mrem to any organ.

Applicability: At all times.

Action:

- a. With the liquid radwaste treatment system inoperable for more than 31 days or with radioactive liquid waste being discharged without treatment and in excess of the above limits, in lieu of any other report required by LaSalle Technical Specification 6.6.A, prepare and submit to the Commission within 30 days pursuant to LaSalle Technical Specification 6.6.C, a Special Report which includes the following information:
1. Identification of the inoperable equipment or subsystems and the reason for inoperability,
 2. Action(s) taken to restore the inoperable equipment to OPERABLE status, and
 3. Summary description of action(s) taken to prevent a recurrence.

Surveillance Requirements

12.3.3.B.1 Doses due to liquid releases shall be projected at least once per 31 days or when releases are to be performed, in accordance with the methods in the ODCM.

12.3.3.B.2 The liquid radwaste treatment system shall be demonstrated OPERABLE by operating the liquid radwaste treatment system equipment for at least 30 minutes at least once per 92 days unless the liquid radwaste system has been utilized to process radioactive liquid effluents during the previous 92 days.

Bases

12.3.3.C The OPERABILITY of the liquid radwaste treatment system ensures that this system will be available for use whenever liquid effluents require treatment prior to release to the environment. The requirement that the appropriate portions of this system be used when specified provides assurance that the releases of radioactive materials in liquid effluents will be kept "as low as is reasonably achievable." During extended shutdown or low power operation, i.e., > 92 days, when steam is not available to the concentrators, Surveillance Requirement 12.3.3.B.2 may be extended to 180 days. This specification implements the requirements of 10 CFR Part 50.36a, General Design Criterion 50 of Appendix A to 10 CFR Part 50 and the design objective given in Section II.0 of Appendix I to 10 CFR Part 50. The specified limits governing the use of appropriate portions of the liquid radwaste treatment system were specified as a suitable fraction of the dose design objectives set forth in Section II.A of Appendix I, 10 CFR Part 50, for liquid effluents.

12.4 GASEOUS EFFLUENTS

12.4.1 Dose Rate

Operability Requirements

- 12.4.1.A The dose rate due to radioactive materials released in gaseous effluents from the site to areas at and beyond the SITE BOUNDARY, shall be limited to the following:
- For noble gases: Less than or equal to a dose rate of 500 mrem/yr to the total body and less than or equal to a dose rate of 3000 mrem/yr to the skin, and
 - For iodine-131, for iodine-133, for tritium, and for α radionuclides in particulate form with half lives greater than 8 days less than or equal to a dose rate of 1500 mrems/yr to any organ via the inhalation pathway.

Applicability: At all times.

Action:

With the dose rate(s) exceeding the above limits, immediately decrease the release rate to within the above limit(s).

Surveillance Requirements

- 12.4.1.B.1 The dose rate due to noble gases in gaseous effluents shall be determined to be within the above limits in accordance with the methods and procedures of the ODCM.
- 12.4.1.B.2 The dose rate due to iodine-131, iodine-133, tritium, and all radionuclides in particulate form with half lives greater than eight days, in accordance with the methodology and parameters of the ODCM by obtaining representative samples and performing analyses in accordance with sampling and analysis program specified in Table 12.4.1-1.

Bases

- 12.4.1.C This specification is provided to ensure that the dose at any time at the site boundary from gaseous effluents from all units on the site will be within the annual dose limits of RETS for unrestricted areas. These limits provide reasonable assurance that radioactive material discharged in gaseous effluents will not result in the exposure of an individual in an unrestricted area, either within or outside the site boundary exceeding the limits specified in 10CFR20.1301. For individuals who may at times be within the site boundary, the occupancy of the individual will be sufficiently low to compensate for any increase in the atmospheric diffusion factor above that for the site boundary. The specified release rate limits restrict, at all times, the corresponding gamma and beta dose rates above background to an individual at or beyond the site boundary to less than or equal to a dose rate of 500 mrem/year to the total body or to less than or equal to a dose rate of 3000 mrem/year to the skin. These release rate limits also restrict, at all times, the corresponding thyroid dose rate above background via the inhalation pathway to less than or equal to a dose rate of 1500 mrem/year.

This specification applies to the release of radioactive effluents in gaseous effluents from all reactors at the site. For units within shared radwaste treatment systems, the gaseous effluents from the shared system are proportioned among the units sharing that system.

TABLE 12.4.1-1
RADIOACTIVE GASEOUS WASTE SAMPLING AND ANALYSIS PROGRAM

GASEOUS RELEASE TYPE	SAMPLING FREQUENCY	MINIMUM ANALYSIS FREQUENCY	TYPE OF ACTIVITY ANALYSIS	LOWER LIMIT OF DETECTION (LLD) ($\mu\text{Ci/ml}$) ^a
A. Containment Vent and Purge System ^h	P Each Purge ^b Grab Sample	P Each Purge ^b	Principal Gamma Emitters ^g	1×10^{-4}
			H-3	1×10^{-6}
B. Main Vent Stack	M ^{b,*} Grab Sample	M ^b	Principal Gamma Emitters ^g	1×10^{-4}
			H-3	1×10^{-6}
				1×10^{-7}
C. Standby Gas Treatment System	D ^c Grab Sample	W ^c	Principal Gamma Emitters ^g	1×10^{-4}
D. All Release Types as listed in A and B above, at the Vent Stack, and as listed in C above, at the SBGTS whenever there is flow.	Continuous ^f	W ^d Charcoal Sample	I-131	1×10^{-12}
			I-131	1×10^{-10}
	Continuous ^f	W ^d Particulate Sample	Principal Gamma Emitters ^g (I-131, Others)	1×10^{-11}
	Continuous ^f	M Composite Particulate Sample	Gross Alpha	1×10^{-11}
	Continuous ^f	Q Composite Particulate Sample	Sr-89, Sr-90	1×10^{-11}
Continuous ^f	Noble Gas Monitor	Noble Gases Gross Beta & Gamma	1×10^{-6} (Xe-133 equivalent)	

TABLE 12.4.1-1 (Continued)

RADIOACTIVE GASEOUS WASTE SAMPLING AND ANALYSIS PROGRAMTABLE NOTATION

- a. The LLD is the smallest concentration of radioactive material in a sample that will be detected with 95% probability with 5% probability of falsely concluding that a blank observation represents a "real" signal.

For a particular measurement system (which may include radiochemical separation):

$$4.66 s_b$$

$$\text{LLD} = \frac{4.66 s_b}{E \cdot V \cdot 2.22 \times 10^6 \cdot Y \cdot \exp(-\lambda \Delta t)}$$

Where:

LLD is the "a priori" lower limit of detection as defined above (as microcurie per unit mass or volume),

s_b is the standard deviation of the background counting rate or of the counting rate of a blank sample as appropriate (as counts per minute),

E is the counting efficiency (as counts per transformation),

V is the sample size (in units of mass or volume),

2.22×10^6 is the number of transformations per minute per microcurie,

Y is the fractional radiochemical yield (when applicable),

λ is the radioactive decay constant for the particular radionuclide, and

Δt is the elapsed time between midpoint of sample collection and time of counting (for plant effluents, not environmental samples).

The value of s_b used in the calculation of the LLD for a detection system shall be based on the actual observed variance of the background counting rate or of the counting rate of the blank samples (as appropriate) rather than on an unverified theoretically predicted variance. Typical values of E, V, Y, and Δt shall be used in the calculation.

- b. Analyses shall also be performed following shutdown, startup, or a THERMAL POWER change exceeding 15% of the RATED THERMAL POWER within a 1 hour period.

If there are several power transients that exceed 15%, the off gas sample may be delayed until after the last transient provided it is within 24 hours of the first transient (See Technical Specification clarification 01/87 (p. 17) signed by Station Manager 3/23/87.)

- c. Whenever there is flow through the SBGTS. (If SBGTS is run more than 10 minutes in a 24 hour period then it must be run a minimum of 5 hours. The 5 hour run is required to meet the sample requirements for iodine and particulates.)

TABLE 12.4.1-1 (Continued)

RADIOACTIVE GASEOUS WASTE SAMPLING AND ANALYSIS PROGRAMTABLE NOTATION

- d. Samples shall be changed at least once per 7 days and analyses shall be completed within 48 hours after changing or after removal from sampler. Sampling shall also be performed at least once per 24 hours for at least 7 days following each shutdown, startup or THERMAL POWER change exceeding 15 percent of RATED THERMAL POWER in 1 hour and analyses completed within 48 hours of changing. When samples collected for 24 hours are analyzed, the corresponding LLD's may be increased by a factor of 10.

This requirement does not apply if (1) analysis shows that the DOSE EQUIVALENT I-131 concentration in the primary coolant has not increased more than a factor of 3; (2) the noble gas monitor shows that effluent activity has not increased more than a factor of 3.

- e. Tritium grab samples shall be taken at least once per 7 days from the plant vent to determine tritium releases in the ventilation exhaust from the spent fuel pool area whenever spent fuel is in the spent fuel pool.
- f. The ratio of the sample flow rate to the sampled stream flow rate shall be known for the time period covered by each dose or dose rate calculation made in accordance with Sections 12.4.1.A, 12.4.2.A and 12.4.3.A.
- g. The principal gamma emitters for which the LLD specification applies include the following radionuclides: Kr-87, Kr-88, Xe-133, Xe-133m, Xe-135, and Xe-138 for gaseous emissions and Mn-54, Fe-59, Co-58, Co-60, Zn-65, Mo-99, Cs-134, Cs-137, Ce-141 and Ce-144 for particulate emissions. This list does not mean that only these nuclides are to be detected and reported. Other peaks which are measurable and identifiable, at the 95% confidence level, together with the above nuclides, shall also be identified and reported.
- h. The drywell tritium and noble gas sample results are valid for 30 hours from sample time if 1) the drywell radioactivity monitors have not indicated an increase in airborne or gaseous radioactivity, and 2) the drywell equipment and floor drain sump pumps run times have not indicated an increase in leakage in the drywell since the sample was taken.

If there is any reason to suspect that gaseous radioactivity levels have changed in the drywell since the last sample (30 hours), a new sample and analyses should be requested prior to starting a drywell purge to meet the intent of providing current analyses to reflect actual activity released to the environment.

If the drywell is purged in accordance with Technical Specification definitions, both noble gas and tritium analyses must be completed before the purge begins. If the drywell is simply vented in accordance with Technical Specification definitions, no sample is required before venting. When SBT equipment is started and shut down, ensure noble gas iodine and particulate samples are taken. (This is from Technical Specification Clarification 01/87 p.34 signed 3-23-87 by Station Manager)

12.4 GASEOUS EFFLUENTS

12.4.2 Dose - Noble Gases

Operability Requirements

12.4.2.A The air dose due to noble gases released in gaseous effluents, from each reactor unit, from the site shall be limited to the following:

- a. During any calendar quarter: Less than or equal to 5 mrad for gamma radiation and less than or equal to 10 mrad for beta radiation, and
- b. During any calendar year: Less than or equal to 10 mrad for gamma radiation and less than or equal to 20 mrad for beta radiation.

Applicability: At all times.

Action:

- a. With the calculated air dose from radioactive noble gases in gaseous effluents exceeding any of the above limits, in lieu of any other report required by LaSalle Technical Specification 6.6.A, prepare and submit to the Commission within 30 days, pursuant to LaSalle Technical Specification 6.6.C, a Special Report which identifies the cause(s) for exceeding the limit(s) and defines the corrective actions to be taken to reduce the releases and the proposed corrective actions to be taken to assure that subsequent releases will be in compliance with the above limits.

Surveillance Requirements

12.4.2.B Dose Calculations - Cumulative dose contributions for the current calendar quarter and current calendar year shall be determined in accordance with the ODCM at least once per 31 days.

Bases

12.4.2.C This specification is provided to implement the requirements of Sections II.B, III.A and IV.A of Appendix I, 10 CFR Part 50. The Operability Requirements are the guides set forth in Section II.B of Appendix I. The ACTION statements provide the required operating flexibility and at the same time implement the guides set forth in Section IV.A of Appendix I to assure that the releases of radioactive material in gaseous effluents will be kept "as low as is reasonably achievable." The Surveillance Requirements implement the requirements in Section III.A of Appendix I that conformance with the guides of Appendix I be shown by calculational procedures based on models and data such that the actual exposure of an individual through appropriate pathways is unlikely to be substantially underestimated. The dose calculations established in the ODCM for calculating the doses due to the actual release rates of radioactive noble gases in gaseous effluents are consistent with the methodology provided in Regulatory Guide 1.109, "Calculation of Annual Doses to Man from Routine Releases of Reactor Effluents for the Purpose of Evaluating Compliance with 10 CFR Part 50, Appendix I, "Revision 1, October 1977 and Regulatory Guide 1.111, "Methods for Estimating Atmospheric Transport and Dispersion of Gaseous Effluents in Routine Releases from Light-Water Cooled Reactors," Revision 1, July 1977. The ODCM equations provided for determining the air doses at the site boundary are based upon the historical average atmospheric conditions.

12.4 GASEOUS EFFLUENTS

12.4.3 Dose - Iodine-131, Iodine-133, Tritium, and Radionuclides in Particulate Form

Operability Requirements

12.4.3.A The dose to a MEMBER OF THE PUBLIC from iodine-131, iodine-133, tritium, and all radionuclides in particulate form with half-lives greater than 8 days in gaseous effluents released, from each reactor unit, to areas at and beyond the SITE BOUNDARY shall be limited to the following:

- a. During any calendar quarter: Less than or equal to 7.5 mrems to any organ and,
- b. During any calendar year: Less than or equal to 15 mrems to any organ.

Applicability: At all times.

Action:

- a. With the calculated dose from the release of iodine-131, iodine-133, tritium, and radionuclides in particulate form with half lives greater than 8 days, in gaseous effluents exceeding any of the above limits, in lieu of any other report required by Technical Specification 6.6.A, prepare and submit to the Commission within 30 days, pursuant to LaSalle Technical Specification 6.6.C, a Special Report that identifies the cause(s) for exceeding the limit and defines the corrective actions that have been taken to reduce the releases and the proposed correction actions to be taken to assure that subsequent releases will be in compliance with the above limits.

Surveillance Requirements

12.4.3.B Cumulative dose contributions for the current calendar quarter and current calendar year for iodine-131, iodine-133, tritium, and radionuclides in particulate form with half lives greater than 8 days shall be determined in accordance with the methodology and parameters in the ODCM at least once per 31 days.

Bases

12.4.3.C The specification is provided to implement the requirements of Sections II.C, III.A and IV.A of Appendix I, 10 CFR Part 50. The Operability Requirements are the guides set forth in Section II.C of Appendix I. The ACTION statements provide the required operating flexibility and at the same time implement the guides set forth in Section IV.A of Appendix I to assure that the releases of radioactive materials in gaseous effluents will be kept "as low as is reasonably achievable." The ODCM calculational methods specified in the Surveillance Requirements implement the requirements in Section III.A of Appendix I that conformance with the guides of Appendix I be shown by calculational procedures based on models and data, such that the actual exposure of an individual through appropriate pathways is unlikely to be substantially underestimated. The ODCM calculational methods for calculating the doses due to the actual release rates of the subject materials are consistent with the methodology provided in Regulatory Guide 1.109, "Calculation of Annual Doses

to Man from Routine Releases of Reactor Effluents for the Purpose of Evaluating Compliance with 10 CFR Part 50, Appendix I, "Revision 1, October 1977 and Regulatory Guide 1.111, "Methods for Estimating Atmospheric Transport and Dispersion of Gaseous Effluents in Routine Releases from Light-Water-Cooled Reactors," Revision 1, July 1977. These equations also provide for determining the actual doses based upon the historical average atmospheric conditions. The release rate specifications for radioiodines, radioactive materials in particulate form and radionuclides other than noble gases are dependent on the existing radionuclide pathways to man, in the unrestricted area. The pathways which were examined in the development of these calculations were: 1) individual inhalation of airborne radionuclides, 2) deposition of radionuclides onto green leafy vegetation with subsequent consumption by man, 3) deposition onto grassy areas where milk animals and meat producing animals graze with consumption of the milk and meat by man, and 4) deposition on the ground with subsequent exposure of man.

| 12.4 GASEOUS EFFLUENTS

| 12.4.4 Gaseous Radwaste Treatment System

Operability Requirements

12.4.4.A The GASEOUS RADWASTE (OFF-GAS) TREATMENT SYSTEM shall be in operation.

Applicability: Whenever the main condenser air ejector system is in operation.

Action:

- a. With the GASEOUS RADWASTE (OFF-GAS) TREATMENT SYSTEM inoperable for more than 7 days, in lieu of any other report required by LaSalle Technical Specification 6.6.A, prepare and submit to the Commission within 30 days, pursuant to LaSalle Technical Specification 6.6.C, a Special Report which includes the following information:
1. Identification of the inoperable equipment or subsystems and the reason for inoperability.
 2. Action(s) taken to restore the inoperable equipment to OPERABLE status, and
 3. Summary description of action(s) taken to prevent a recurrence.

Surveillance Requirements

12.4.4.B The GASEOUS RADWASTE TREATMENT SYSTEM shall be verified to be in operation at least once per 7 days.

Bases

12.4.4.C The OPERABILITY of the GASEOUS RADWASTE TREATMENT SYSTEM and the VENTILATION EXHAUST TREATMENT SYSTEM ensures that the system will be available for use whenever gaseous effluents require treatment prior to release to the environment. The requirement that the appropriate portions of these systems be used, when specified, provides reasonable assurance that the releases of radioactive materials in gaseous effluents will be kept "as low as is reasonably achievable". This specification implements the requirements of 10 CFR Part 50.36a, General Design Criterion 60 of Appendix A to 10 CFR Part 50, and the design objectives given in Section II.0 of Appendix I to 10 CFR Part 50. The specified limits governing the use of appropriate portions of the systems were specified as a suitable fraction of the dose design objectives set forth in Sections II.3 and II.0 of Appendix I, 10 CFR Part 50, for gaseous effluents.

12.4 GASEOUS EFFLUENTS

12.4.5 Ventilation Exhaust Treatment System

Operability Requirements

12.4.5.A The appropriate portions of the VENTILATION EXHAUST TREATMENT SYSTEM shall be OPERABLE and be used to reduce radioactive materials in gaseous waste prior to their discharge when the projected doses due to gaseous effluent releases from each reactor unit, from the site, when averaged over 31 days, would exceed 0.3 mrem to any organ.

Applicability: At all times.

Action:

With the VENTILATION EXHAUST TREATMENT SYSTEM inoperable for more than 31 days, and with gaseous waste being discharged without treatment and in excess of the above limits, in lieu of any other report required by LaSalle Technical Specification 6.6.A, prepare and submit to the Commission within 30 days, pursuant to LaSalle Technical Specification 6.6.C, a Special Report which includes the following information:

1. Identification of the inoperable equipment or subsystems and the reason for inoperability,
2. Action(s) taken to restore the inoperable equipment to OPERABLE status, and
3. Summary description of action(s) taken to prevent a recurrence.

Surveillance Requirements

12.4.5.B.1 Doses due to gaseous releases from the site shall be projected at least once per 31 days in accordance with the ODCM.

12.4.5.B.2 The VENTILATION EXHAUST TREATMENT SYSTEM shall be demonstrated OPERABLE by operating the VENTILATION EXHAUST TREATMENT SYSTEM equipment for at least 30 minutes, at least once per 92 days unless the appropriate system has been utilized to process radioactive gaseous effluents during the previous 92 days.

Bases

12.4.5.C The OPERABILITY of the GASEOUS RADWASTE TREATMENT SYSTEM and the VENTILATION EXHAUST TREATMENT SYSTEM ensures that the system will be available for use whenever gaseous effluents require treatment prior to release to the environment. The requirement that the appropriate portions of these systems be used, when specified, provides reasonable assurance that the releases of radioactive materials in gaseous effluents will be kept "as low as is reasonably achievable". This specification implements the requirements of 10 CFR Part 50.36a, General Design Criterion 60 of Appendix A to 10 CFR Part 50, and the design objectives given in Section II.0 of Appendix I to 10 CFR Part 50. The specified limits governing the use of appropriate portions of the systems were specified as a suitable fraction of the dose design objectives set forth in Sections II.3 and II.0 of Appendix I, 10 CFR Part 50, for gaseous effluents.

| 12.4 GASEOUS EFFLUENTS

| 12.4.6 Venting or Purging

Operability Requirements

12.4.6.A VENTING or PURGING of the containment drywell shall be through the Primary Containment Vent and Purge System or the Standby Gas Treatment System.

Applicability: Whenever the drywell is vented or purged.

Action:

- a. With the requirements of the above specification not satisfied, suspend all VENTING and PURGING of the drywell.

Surveillance Requirements

12.4.6.B.1 The containment drywell shall be determined to be aligned for VENTING or PURGING through the Primary Containment Vent and Purge System or the Standby Gas Treatment System within 4 hours prior to start of and at least once per 12 hours during VENTING or PURGING of the drywell.

12.4.6.B.2 Prior to use of the Purge System through the Standby Gas Treatment System in OPERATIONAL CONDITION 1, 2 or 3 assure that:

- a. Both Standby Gas Treatment System trains are OPERABLE, and
- b. Only one of the Standby Gas Treatment System trains is used for PURGING.

Bases

12.4.6.C This specification provides reasonable assurance that releases from drywell purging operations will not exceed the annual dose limits of 10CFR20 for unrestricted areas.

| 12.4 GASEOUS EFFLUENTS

| 12.4.7 Total Dose

Operability Requirements

12.4.7.A The dose or dose commitment to any member of the public, due to releases of radioactivity and radiation, from uranium fuel cycle sources shall be limited to less than or equal to 25 mrem to the total body or any organ (except the thyroid, which shall be limited to less or equal to 75 mrem) over 12 consecutive months.

Applicability: At all times.

Action:

With the calculated doses from the release of radioactive materials in liquid or gaseous effluents exceeding twice the limits of Sections 12.3.2.A.a, 12.3.2.A.b, 12.4.2.A.a, 12.4.2.A.b, 12.4.3.A.a or 12.4.3.A.b, in lieu of any other report required by LaSalle Technical Specification 6.6.A, prepare and submit, pursuant to LaSalle Technical Specification 6.6.C, a Special Report to the Director, Nuclear Reactor Regulation, U.S. Nuclear Regulatory Commission, Washington, D.C. 20555, within 30 days, which defines the corrective action to be taken to reduce subsequent releases to prevent recurrence of exceeding the limits of Section 12.4.7.A. This Special Report shall include an analysis which estimates the radiation exposure (dose) to a member of the public from uranium fuel cycle sources (including all effluents pathways and direct radiation) for a 12 consecutive month period that includes the release(s) covered by this report. If the estimated dose(s) exceeds the limits of Section 12.4.7.A, and if the release condition resulting in violation of 40 CFR 190 has not already been corrected, the Special Report shall include a request for a variance in accordance with the provisions of 40 CFR 190 and including the specified information of 40 CFR 190.11. Submittal of the report is considered a timely request, and a variance is granted until staff action on the request is complete. The variance only relates to the limits of 40 CFR 190, and does not apply in any way to the requirements for dose limitation of 10 CFR Part 20, as addressed in other sections of this technical specification.

Surveillance Requirements

12.4.7.B Dose Calculations - Cumulative dose contributions from liquid and gaseous effluents shall be determined in accordance with Sections 12.3.2.B, 12.4.2.B and 12.4.3.B, and in accordance with the ODCM.

Bases

12.4.7.C This specification is provided to meet the dose limitations of 40 CFR 190. The specification requires the preparation and submittal of a Special Report whenever the calculated doses from plant radioactive effluents exceed twice the design objective doses of Appendix I. For sites containing up to 4 reactors, it is highly unlikely that the resultant dose to a member of the public will exceed the dose limits of 40 CFR 190 if the individual reactors remain within the reporting requirement level. The Special Report will describe a course of action which should result in the limitation of dose to a member of the public for 12

consecutive months to within the 40 CFR 190 limits. For the purpose of the Special Report, it may be assumed that the dose commitment to the member of the public from other uranium fuel cycle sources is negligible, with the exception that dose contributions from other nuclear fuel cycle facilities at the same site or within a radius of 5 miles must be considered. If the dose to any member of the public is estimated to exceed the requirements of 40 CFR 190, the Special Report with a request for a variance (provided the release conditions resulting in violation of 40 CFR 190 have not already been corrected), in accordance with the provisions of 40 CFR 190.11, is considered to be a timely request and fulfills the requirements of 40 CFR 190 until NRC staff action is completed. An individual is not considered a member of the public during any period in which he/she is engaged in carrying out any operation which is part of the nuclear fuel cycle.

12.4 GASEOUS EFFLUENTS

12.4.8 Main Condenser

Operability Requirements

- 12.4.8.A The release rate of the sum of the activities from the noble gases measured prior to the holdup line shall be limited to less than or equal to 3.4×10^5 microcuries/second.

Applicability: Operational Conditions 1, 2 and 3.

Action:

With the release rate of the sum of the activities from the noble gases prior to the holdup line exceeding 3.4×10^5 microcuries/second, restore the release rate to within its limit within 72 hours or be in at least STARTUP with the main steam isolation valves closed within the next 6 hours.

Surveillance Requirements

- 12.4.8.B.1 The radioactivity rate of noble gases prior to the holdup line shall be continuously monitored in accordance with the ODCM and Table 12.2.2-2.
- 12.4.8.B.2 The release rate of the sum of the activities from noble gases prior to the holdup line shall be determined to be within the limits of specification 12.4.8.A at the following frequencies by performing an isotopic analysis of a representative sample of gases taken prior to the holdup line.
- a. At least once per 31 days.
 - b. Within 4 hours following an increase, as indicated by the off gas pre-treatment Noble Gas Activity Monitor, of greater than 50%, after factoring out increases due to changes in THERMAL POWER level, in the nominal steady state fission gas release from the primary coolant.

Bases

- 12.4.8.C In accordance with surveillance requirements contained within ODCM Chapter 12 item number 12.4.8.B.1 and 2, this specification provides reasonable assurance that the releases from the main condenser will not exceed the requirements of the LaSalle Technical Specifications 3/4.11.2.2. In addition, a sample is required within 4 hours if the increase is not due to thermal power changes. If the cause is known and not fuel related and less than 1 hour in duration, then no sample is required. [This is based on interpretation letter from W. R. Huntington to Operating Engineers, Shift Engineers and F.R. Lawless, dated May 24, 1984.]

12.4.9 Dose Limits for Members of the PublicOperability Requirements

12.4.9.A The licensee shall conduct operations such that the TEDE to individual MEMBERS OF THE PUBLIC does not exceed 100 mrem in a year. In addition, the dose in any unrestricted area from external sources does not exceed 2 mrem in any one hour. The Effluents Program shall implement monitoring, sampling, and analysis of radioactive liquid and gaseous effluents in accordance with 10CFR20.1302 and with the methodology and parameters in the ODCM.

Applicability: At all times.

Action:

1. If the calculated dose from the release or exposure of radiation meets or exceeds the 100 mrem/year limit for the MEMBER OF THE PUBLIC, prepare and submit a report to the Commission in accordance with 10CFR20.2203.
2. If the dose in any unrestricted area from external sources of radiation meets or exceeds the 2 mrem in any one hour limit for the MEMBER OF THE PUBLIC, prepare and submit a report to the Commission in accordance with 10CFR20.2203.

Surveillance Requirements

12.4.9.B Calculate the TEDE to individual MEMBERS OF THE PUBLIC annually to determine compliance with the 100 mrem/year limit in accordance with the ODCM. In addition, evaluate and/or determine if direct radiation exposures exceed 2 mrem in any hour in unrestricted areas.

Bases

12.4.9.C This section applies to direct exposure of radioactive materials as well as radioactive materials released in gaseous and liquid effluents. 10CFR20.1301 sets forth the 100 mrem/year dose limit to members of the public; 2 mrem in any one hour limit in the unrestricted area; and reiterates that the licensee is also required to meet the 40CFR190 standards. 10CFR20.1302 provides options to determine compliance to 10CFR20.1301. Compliance to the above operability requirement is based on 10CFR20, 40CFR190 and LaSalle Station Technical Specifications.

12.5 RADIOLOGICAL ENVIRONMENTAL MONITORING PROGRAM

12.5.1 Radiological Environmental Monitoring Program

Operability Requirements

12.5.1.A The radiological environmental monitoring program shall be conducted as specified in Table 9.1-1 of Chapter 9.

Applicability: At all times

Action:

- a. With the radiological environmental monitoring program not being conducted as specified in Table 9.1-1 of Chapter 9 and Chapter 11, see Chapter 9 for required actions.

Surveillance Requirements

12.5.1.B The radiological environmental monitoring program samples shall be collected pursuant to Table 9.1-1 of Chapter 9 and Chapter 11, see Chapter 9 for detailed surveillance requirements.

Bases

12.5.1.C The radiological environmental monitoring program required by this specification provides measurements of radiation and of radioactive materials in those exposure pathways and for those radionuclides which lead to the highest potential radiation exposures of MEMBERS OF THE PUBLIC resulting from the station operation. See Chapter 9 for further information. In addition, this requirement is stated in Technical Specification 6.2.F.5.

| 12.5 RADIOLOGICAL ENVIRONMENTAL MONITORING PROGRAM

| 12.5.2 Land Use Census

Operability Requirements

| 12.5.2.A A land use census shall be conducted to ensure changes in the use of areas at
| and beyond the SITE BOUNDARY are identified and that modifications to the
| monitoring program are made if required by the results of this census.

Applicability: At all times

Action:

| a. See Section of 9.2 of Chapter 9 for required actions.

Surveillance Requirements

| 12.5.2.B The land use census shall be conducted at least once per 12 months between the
| dates of (June 1 and October 1) using that information which will provide the best
| results, such as by a door-to-door survey, aerial survey, or by consulting local
| agriculture authorities. See Section of 9.2 of Chapter 9 for required surveillances.

Bases

| 12.5.2.C See Section of 9.2 of Chapter 9 for required surveillances and Technical
| Specification Section 6.2.F.5.b for more bases details.

12.5 RADIOLOGICAL ENVIRONMENTAL MONITORING PROGRAM

12.5.3 Interlaboratory Comparison Program

Operability Requirements

12.5.3.A Participation in an Interlaboratory Comparison Program to ensure that independent checks on the precision and accuracy of the measurements of radioactive materials in environmental sample matrices are performed as part of the quality assurance program for environmental monitoring.

Applicability: At all times

Action:

1. With analyses not being performed as required above, report the corrective actions taken to prevent a recurrence to the Commission in the Annual Radiological Environmental Operating Report.
2. See Section 9.2 of Chapter 9 for required actions.

Surveillance Requirements

12.5.3.B 1. See Section 9.2 of Chapter 9 for surveillance requirements.

Bases

12.5.3.C See Section 9.2 of Chapter 9 for more information. In addition, this requirement is stated in Technical Specification Section 6.2.F.c.

12.6 REPORTING REQUIREMENTS12.6.1 Annual Radiological Environmental Operating Report³Operability Requirements

- 12.6.1.A Routine environmental radiological operating report covering the operation of the units during the previous calendar year shall be submitted prior to May 1 of each year.

Applicability: At all times

Action:

1. See Section 9.2 of Chapter 9 for required actions.

Surveillance Requirements

- 12.6.1.B 1. See Section 9.2 of Chapter 9 for surveillance requirements.

Bases

- 12.6.3.C See Section 9.2 of Chapter 9 for more information. In addition, this requirement is stated in Technical Specification Section 6.6.A.3.

³ A single submittal may be made for a multiple unit station. The submittal should combine those sections that are common to all units at the station; however, for units with separate radwaste systems, the submittal shall specify the releases of radioactive material from each unit.

12.6 REPORTING REQUIREMENTS12.6.2 Radioactive Effluent Release Report⁴

- a. Routine radioactive effluent release reports covering the operation of the unit during the previous calendar year of operation shall be submitted according to the Technical Specifications. The period of the first report shall begin with the date of initial criticality.
- b. The radioactive effluent release reports shall include a summary of the quantities of radioactive liquid and gaseous effluents and solid waste released from the unit as outlined in Regulatory Guide 1.21, "Measuring, Evaluating and Reporting Radioactivity in Solid Wastes and Releases of Radioactive Materials in Liquid and Gaseous Effluents from Light-Water-Cooled Nuclear Power Plants," Revision 1, June 1974, with data summarized on a quarterly basis following the format of Appendix B thereof.
- c. The radioactive effluent release report shall include the following information for each type of solid waste shipped offsite during the report period:
 1. Container volume,
 2. Total curie quantity (specify whether determined by measurement or estimate).
 3. Principal radionuclides (specify whether determined by measurement or estimate),
 4. Type of waste (e.g., spent resin, compacted dry waste, evaporator bottoms),
 5. Type of container (e.g., LSA, Type A, Type B, Large Quantity), and
 6. Solidification agent (e.g., cement, urea formaldehyde).

The radioactive effluent release reports shall include unplanned releases from the site to unrestricted areas of radioactive materials in gaseous and liquid effluents on a quarterly basis.

The radioactive effluent release reports shall include any changes to the PROCESS CONTROL PROGRAM (PCP) made during the reporting period.

⁴A single submittal may be made for a multiple unit station. The submittal should combine those sections that are common to all units at the station; however, for units with separate radwaste systems, the submittal shall specify the releases of radioactive material from each unit. Semiannual Radioactive Effluent Release Reports are required until the frequency change to annual is approved by the NRC in the LaSalle Technical Specifications.

12.6 REPORTING REQUIREMENTS12.6.3 Offsite Dose Calculation Manual (ODCM)*

12.6.3.1 The ODCM shall be approved by the Commission prior to implementation.

12.6.3.2 Licensee-initiated changes to the ODCM:

- a. Shall be documented and records of reviews performed shall be retained as required by Specification 6.5.B. This documentation shall contain:
 1. Sufficient information to support the change together with the appropriate analyses or evaluations justifying the changes(s); and
 2. A determination that the change will maintain the level of radioactive effluent control required by 10 CFR 20.1302, 106, 40 CFR Part 190, 10 CFR 50.36a, and Appendix I to 10 CFR Part 50 and not adversely impact the accuracy or reliability of effluent, dose, or setpoint calculations.
 - a. Shall become effective after review and acceptance by the Onsite Review and Investigative Function and the approval of the Plant Manager on the date specified by the Onsite Review and Investigative Function.
 - b. Shall be submitted to the Commission in the form of a complete, legible copy of the entire ODCM as a part of or concurrent with the Radioactive Effluent Release Report for the period of the report in which any change to the ODCM was made effective. Each change shall be identified by markings in the margin of the affected pages, clearly indicating the area of the page that was changed, and shall indicate the date (e.g., month/year) the change was implemented.

*The OFFSITE DOSE CALCULATION MANUAL (ODCM) is common to LaSalle Unit 1 and LaSalle Unit 2.

12.6 REPORTING REQUIREMENTS12.6.4 Major Changes to Radioactive Waste Treatment Systems

- 12.6.4.1 License initiated major changes to the radioactive waste treatment systems (liquid and gaseous):
- a. Shall be reported to the Commission in the Monthly Operating Report for the period in which the evaluation was reviewed by the Onsite Review and Investigative Function. The discussion of each change shall contain:
1. A summary of the evaluation that led to the determination that the change could be made in accordance with 10 CFR 50.59;
 2. Sufficient detailed information to totally support the reason for the change without benefit or additional or supplemental information;
 3. A detailed description of the equipment, components and processes involved and the interfaces with other plant systems;
 4. An evaluation of the change which shows the predicted releases of radioactive materials in liquid and gaseous effluents waste that differ from those previously predicted in the license application and amendments thereto;
 5. An evaluation of the change which shows the expected maximum exposures to individual in the unrestricted area and to the general population that differ from those previously estimated in the license application and amendments thereto;
 6. A comparison of the predicted releases of radioactive materials, in liquid and gaseous effluents, to the actual releases for the period to when the changes are to be made;
 7. An estimate of the exposure to plant operating personnel as a result of the change; and
 8. Documentation of the fact that the change was reviewed and found acceptable by the Onsite Review and Investigative Function.
- b: Shall become effective upon review and acceptance by the Onsite Review and Investigative Function.

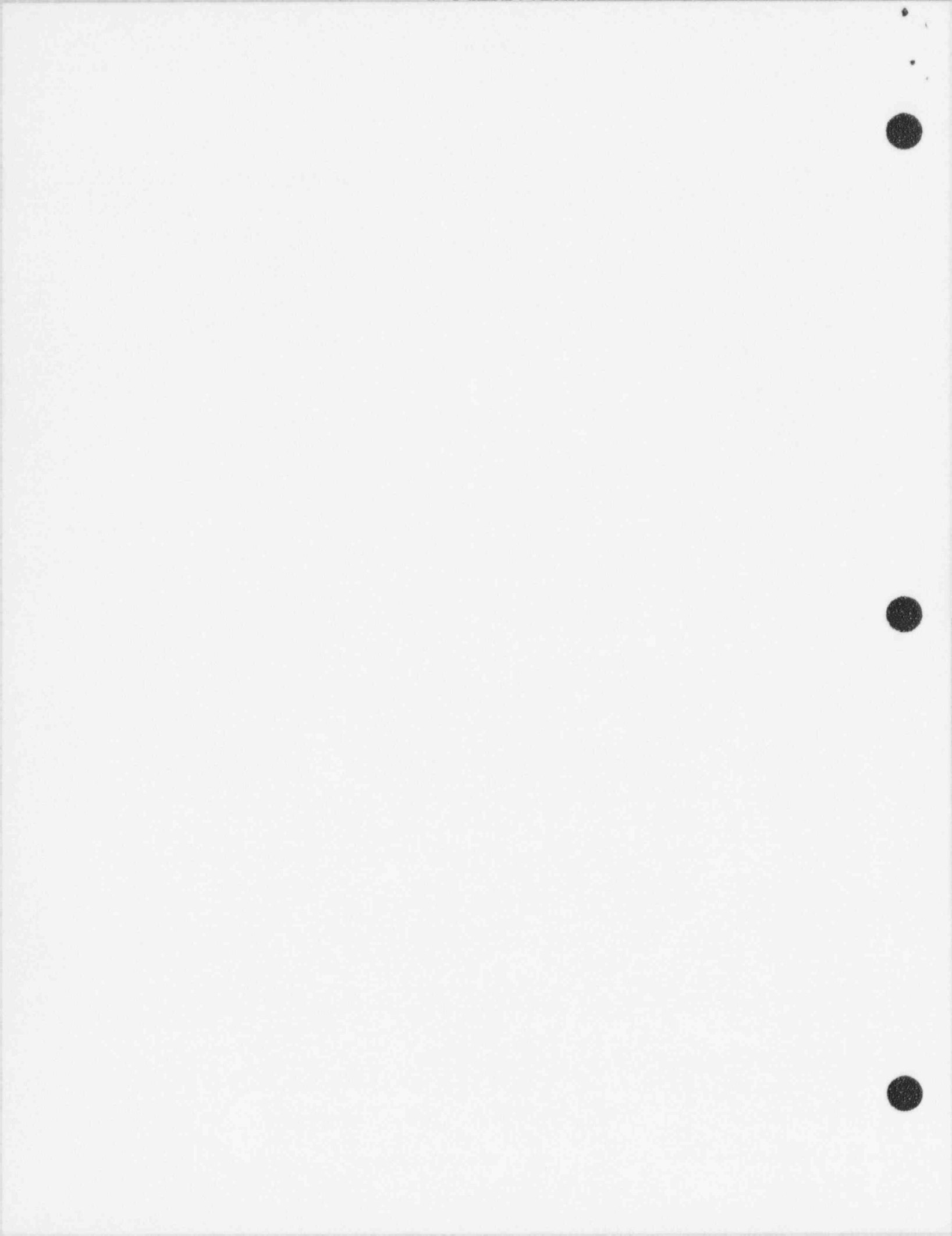

APPENDIX F**LASALLE ANNEX INDEX**

<u>PAGE</u>	<u>REVISION</u>	<u>PAGE</u>	<u>REVISION</u>
F-i	1.7	F-43	1.7
F-ii	1.7	F-44	1.7
F-iii	1.7	F-45	1.7
F-iv	1.7	F-46	1.7
F-1	1.7	F-47	1.7
F-2	1.7		
F-3	1.7		
F-4	1.7		
F-5	1.7		
F-6	1.7		
F-7	1.7		
F-8	1.7		
F-9	1.7		
F-10	1.7		
F-11	1.7		
F-12	1.7		
F-13	1.7		
F-14	1.7		
F-15	1.7		
F-16	1.7		
F-17	1.7		
F-18	1.7		
F-19	1.7		
F-20	1.7		
F-21	1.7		
F-22	1.7		
F-23	1.7		
F-24	1.7		
F-25	1.7		
F-26	1.7		
F-27	1.7		
F-28	1.7		
F-29	1.7		
F-30	1.7		
F-31	1.7		
F-32	1.7		
F-33	1.7		
F-34	1.7		
F-35	1.7		
F-36	1.7		
F-37	1.7		
F-38	1.7		
F-39	1.7		
F-40	1.7		
F-41	1.7		
F-42	1.7		

APPENDIX F
STATION-SPECIFIC DATA FOR LASALLE
UNITS 1 AND 2

Table of Contents

	<u>PAGE</u>
F.1 INTRODUCTION	F-1
F.2 REFERENCES	F-1

APPENDIX F
LIST OF TABLES

<u>NUMBER</u>	<u>TITLE</u>	<u>PAGE</u>
F-1	Aquatic Environment Dose Parameters	F-2
F-2	Station Characteristics	F-3
F-3	Critical Ranges	F-4
F-4	Average Wind Speeds	F-5
F-5	X/Q and D/Q Maxima At or Beyond the Unrestricted Area Boundary	F-6
F-5a	X/Q and D/Q Maxima At or Beyond the Restricted Area Boundary	F-7
F-6	D/Q at the Nearest Milk Cow and Meat Animal Locations Within 5 Miles	F-8
F-7	Maximum Offsite Finite Plume Gamma Dose Factors Based on 1 cm Depth at the Unrestricted Area Boundary for Selected Nuclides	F-9
F-7a	Maximum Offsite Finite Plume Gamma Dose Factors Based on 1 cm Depth at the Restricted Area Boundary for Selected Nuclides	F-24
F-8	Parameters for Calculation of N-16 Skyshine Radiation from LaSalle	F-39
Supplemental Tables		
A	Elevated Level Joint Frequency Distribution Table Summary - 375 Foot Elevation Data	F-40
	-Summary Table of Percent by Direction and Class -Summary Table of Percent by Direction and Speed -Summary Table of Percent by Speed and Class	
B	Mid Elevation Joint Frequency Distribution Table Summary - 200 Foot Elevation Data	F-42
	-Summary Table of Percent by Direction and Class -Summary Table of Percent by Direction and Speed -Summary Table of Percent by Speed and Class	
C	Ground Level Joint Frequency Distribution Table Summary - 33 Foot Elevation Data	F-44
	-Summary Table of Percent by Direction and Class -Summary Table of Percent by Direction and Speed -Summary Table of Percent by Speed and Class	

APPENDIX F
LIST OF FIGURES

<u>NUMBER</u>	<u>TITLE</u>	<u>PAGE</u>
F-1	Unrestricted Area Boundary	F-46
F-2	Restricted Area Boundary	F-47

APPENDIX F
STATION-SPECIFIC DATA FOR LASALLE
UNITS 1 AND 2

F.1 INTRODUCTION

This appendix contains data relevant to the LaSalle site. Included is a figure showing the unrestricted area boundary, restricted area boundary, and values of parameters used in offsite dose assessment.

F.2 REFERENCES

1. Sargent & Lundy, Analysis and Technology Division, LaSalle Calculation No. ATD-0164, Revisions 0, 1, 2 and 3.
2. Sargent & Lundy, Nuclear Safeguards and Licensing Division, LaSalle Calculation No. ATD-0139, "N-16 Skyshine Ground Level Doses from LaSalle Turbine System & Piping, Revision 0.
3. Verification of Environmental Parameter used for Commonwealth Edison Company's Offsite Dose Calculations, "NUS Corporation, 1988.

Table F-1
Aquatic Environment Dose Parameters

General Information^a

The station liquid discharge flows into the Illinois River then into the Mississippi River.

Recreation includes one or more of the following: boating, waterskiing, swimming, and sport fishing.

Two downstream dams are on the Illinois River, Marseilles and Starved Rock. This information is based on Section 2.4.1.1 and Figures 2.4-2 and 2.4-6 of the LaSalle Environmental Report.

Water and Fish Ingestion Parameters

<u>Parameter^b</u>	<u>Value</u>
I/M ^w , I/M ^f	1.0
F ^w , cfs	1.85E4
F ^f , cfs	1.31E4
t ^f , hr ^c	24.0
t ^w , hr ^d	97.0

Limits on Radioactivity in Unprotected Outdoor Tanks^e

Outside Temporary Tank $\leq 10 \text{ Ci}^f$

(per Technical Specification 3.11)

^a This is based on information in LaSalle Environmental Report, Figure 3.3-1 and Section 2.1.4.2.1.

^b The parameters are defined in Sections A.2.1 of Appendix A.

^c t^f (hr) = 24 hr (all stations) for the fish ingestion pathway

^d t^w (hr) = 97 hr (distance to nearest public potable water intake, Peoria, is 97 miles; flow rate of 1 mph is assumed.)

^e See Section A.2.4 of Appendix A.

^f Tritium and dissolved or entrained noble gases are excluded from this limit.

Table F-2

Station Characteristics

STATION: LaSalle

LOCATION: 6 miles south of Marseilles, Illinois - LaSalle County

CHARACTERISTICS OF ELEVATED RELEASE POINT

- | | |
|---|---|
| 1) Release Height = <u>112.8</u> m ^a | 2) Diameter = <u>5.64</u> m |
| 2) Exit Speed = <u>14.7</u> ms ^{-1a} | 4) Heat Content = <u>0</u> KCals ^{-1a} |

CHARACTERISTICS OF VENT STACK RELEASE POINT: Not Applicable (NA)

- | | |
|--|-----------------------|
| 1) Release Height = _____ m | 2) Diameter = _____ m |
| 3) Exit Speed = _____ ms ⁻¹ | |

CHARACTERISTICS OF GROUND LEVEL RELEASE

- | |
|---|
| 1) Release Height = 0 m |
| 2) Building Factor (D) = <u>56.4</u> m ^a |

METEOROLOGICAL DATA

A 400 ft Tower is Located 300 m SSW of elevated release point

Tower Data Used in Calculations

Release Point	Wind Speed and Direction	Differential Temperature
Elevated	375 ft	375-33 ft
Vent	(NA)	(NA)
Ground	33 ft	200-33 ft

^aUsed in calculating the meteorological and dose factors in Tables F-5, F-6, and F-7. See Sections B.3 through B.6 of Appendix B.

Table F-3
Critical Ranges

<u>Direction</u>	<u>Unrestricted Area Boundary^a (m)</u>	<u>Restricted Area Boundary (m)</u>	<u>Nearest Resident^b (m)</u>	<u>Nearest Dairy Farm Within 5 Miles^c (m)</u>
N	1036	1036	6300	None
NNE	1378	1378	2800	None
NE	2408	1609	3400	None
ENE	4450	1079	5300	None
E	1996	833	5200	None
ESE	1465	845	2300	None
SE	969	969	2700	None
SSE	858	698	2900	None
S	829	820	2400	None
SSW	835	835	1100	None
SW	628	628	1600	None
WSW	533	533	2400	None
W	524	524	1300	None
WNW	643	643	1400	None
NW	762	762	2900	None
NNW	890	890	2700	7400

^a Used in calculating the meteorological dose factors in Tables F-5 and F-7. See Sections B.3 through B.6 of Appendix B.

^b 1994 annual survey by Teledyne Isotopes Midwest Laboratories. The distances are rounded to the nearest conservative 100 meters.

^c 1994 annual milch animal census, by Teledyne Isotopes Midwest Laboratories. Used in calculating the D/Q values in Table F-6. The distances are rounded to the nearest conservative 100 meters. A default value of 8000 meters is used when there are no dairies within 5 miles.

Table F-4
Average Wind Speeds

<u>Downwind Direction</u>	<u>Average Wind Speed (m/sec)^a</u>		
	<u>Elevated</u>	<u>Vent^b</u>	<u>Ground Level</u>
N	9.7	7.7	4.9
NNE	10.1	8.0	5.1
NE	9.2	7.4	4.9
ENE	9.0	7.2	4.8
E	9.5	7.8	5.2
ESE	9.7	8.4	5.9
SE	8.1	7.4	5.9
SSE	7.4	6.7	5.0
S	6.7	5.9	4.3
SSW	5.6	3.7	2.9
SW	5.5	4.1	3.1
WSW	6.9	5.4	3.9
W	7.6	6.5	4.5
WNW	7.5	6.3	4.3
NW	7.5	6.2	3.9
NNW	8.3	6.7	4.3

^aBased on LaSalle site meteorological data, January 1978 through December 1987. Calculated in Reference 1 of Section F.2, using formulas in Section B.1.3 of Appendix B.

Table F-5

X/Q and D/Q Maxima at or Beyond the Unrestricted Area Boundary

Downwind Direction	Elevated(Stack) Release				Mixed Mode(Vent) Release			Ground Level Release		
	Radius (meters)	X/Q (sec/m**3)	Radius (meters)	D/Q (1/m**2)	Radius (meters)	X/Q (sec/m**3)	D/Q (1/m**2)	Radius (meters)	X/Q (sec/m**3)	D/Q (1/m**2)
N	5633.	6.123E-09	1036.	7.203E-10	6000.	6.289E-09	8.311E-10	1036.	1.524E-06	1.019E-08
NNE	1378.	7.045E-09	1378.	9.831E-10	5633.	7.102E-09	9.659E-10	1378.	9.737E-07	7.095E-09
NE	4400.	5.535E-09	2408.	4.245E-10	2408.	5.600E-09	4.836E-10	2408.	3.907E-07	2.377E-09
ENE	5200.	5.086E-09	4450.	2.021E-10	4450.	4.909E-09	2.024E-10	4450.	1.496E-07	6.784E-10
E	5200.	5.865E-09	1996.	5.415E-10	1996.	6.198E-09	6.396E-10	1996.	4.870E-07	2.980E-09
ESE	5200.	8.000E-09	1500.	8.896E-10	1465.	8.290E-09	1.229E-09	1465.	7.223E-07	5.880E-09
SE	5633.	7.116E-09	1500.	7.505E-10	969.	1.087E-08	1.709E-09	969.	1.137E-06	1.123E-08
SSE	5200.	6.717E-09	1500.	7.176E-10	838.	1.313E-08	2.124E-09	838.	1.124E-06	1.064E-08
S	5633.	5.910E-09	1500.	6.136E-10	829.	8.402E-09	1.303E-09	829.	1.112E-06	1.039E-08
SSW	6000.	5.269E-09	835.	5.793E-10	835.	7.322E-09	9.999E-10	835.	7.940E-07	5.359E-09
SW	6000.	6.767E-09	628.	8.545E-10	628.	2.224E-08	2.154E-09	628.	1.864E-06	1.407E-08
WSW	6000.	6.065E-09	533.	6.527E-10	540.	2.105E-08	2.079E-09	533.	2.101E-06	1.970E-08
W	6437.	5.354E-09	1500.	4.811E-10	540.	1.344E-08	1.629E-09	524.	2.830E-06	2.453E-08
WNW	7242.	3.916E-09	1500.	3.175E-10	643.	5.963E-09	9.071E-10	643.	2.429E-06	1.508E-08
NW	7242.	3.766E-09	1500.	3.118E-10	5633.	4.127E-09	6.660E-10	762.	1.984E-06	1.055E-08
NNW	6437.	4.240E-09	1500.	3.806E-10	6437.	4.095E-09	5.574E-10	890.	1.605E-06	8.840E-09

LASALLE SITE METEOROLOGICAL DATA 1/78 - 12/87

Note: Based on Reference 2 of Section F.2 and the formulas in Sections B.3 and B.4 of Appendix B.
Used for beta air, beta skin, and inhalation dose pathways. See sections A.1.2, A.1.3 and A.1.4.2 of Appendix A.
Used for produce and leafy vegetable pathways. See A.1.4 of Appendix A.

Table F-5a

X/Q and D/Q Maxima at or Beyond the Restricted Area Boundary

Downwind Direction	Elevated(Stack) Release				Mixed Mode(Vent) Release			Ground Level Release		
	Radius (meters)	X/Q (sec/m**3)	Radius (meters)	D/Q (1/m**2)	Radius (meters)	X/Q (sec/m**3)	D/Q (1/m**2)	Radius (meters)	X/Q (sec/m**3)	D/Q (1/m**2)
N	5633.	6.123E-09	1036.	7.203E-10	6000.	6.289E-09	8.311E-10	1036.	1.524E-06	1.019E-08
NNE	1378.	7.045E-09	1378.	9.831E-10	5633.	7.102E-09	9.659E-10	1378.	9.737E-07	7.095E-09
NE	4400.	5.535E-09	1609.	6.556E-10	1609.	6.052E-09	7.953E-10	1609.	7.003E-07	4.747E-09
ENE	5200.	5.086E-09	1079.	6.376E-10	1079.	6.579E-09	9.861E-10	1079.	1.128E-06	7.788E-09
E	5200.	5.865E-09	1500.	6.659E-10	1055.	7.712E-09	1.160E-09	1055.	1.278E-06	8.779E-09
ESE	5200.	8.000E-09	1500.	8.896E-10	1055.	9.981E-09	1.546E-09	1055.	1.192E-06	1.021E-08
SE	5633.	7.116E-09	1500.	7.505E-10	969.	1.087E-08	1.709E-09	969.	1.137E-06	1.123E-08
SSE	5200.	6.717E-09	698.	7.210E-10	698.	1.444E-08	2.403E-09	698.	1.492E-06	1.428E-08
S	5633.	5.910E-09	1500.	6.136E-10	820.	8.455E-09	1.312E-09	820.	1.130E-06	1.058E-08
SSW	6000.	5.269E-09	835.	5.793E-10	835.	7.322E-09	9.999E-10	835.	7.940E-07	5.359E-09
SW	6000.	6.767E-09	628.	8.545E-10	628.	2.224E-08	2.154E-09	628.	1.864E-06	1.407E-08
WSW	6000.	6.065E-09	533.	6.527E-10	540.	2.105E-08	2.079E-09	533.	2.101E-06	1.970E-08
W	6437.	5.354E-09	1500.	4.811E-10	540.	1.344E-08	1.629E-09	524.	2.830E-06	2.453E-08
WNW	7242.	3.916E-09	1500.	3.175E-10	643.	5.963E-09	9.071E-10	643.	2.429E-06	1.508E-08
NW	7242.	3.766E-09	1500.	3.118E-10	5633.	4.127E-09	6.660E-10	762.	1.984E-06	1.055E-08
NHW	6437.	4.240E-09	1500.	3.806E-10	6437.	4.095E-09	5.574E-10	890.	1.605E-06	8.840E-09

LASALLE SITE METEOROLOGICAL DATA 1/78 - 12/87

Table F-6

D/Q at the Nearest Milk Cow and Meat Animal Locations within 5 miles

Downwind Direction	Nearest Milk Cow D/Q(1/m**2)				Nearest Meat Animal D/Q(1/m**2)			
	Radius (meters)	Elevated Release	Mixed Release	Ground Release	Radius (meters)	Elevated Release	Mixed Release	Ground Release
N	8000.	9.711E-11	1.006E-10	2.915E-10	6400.	1.387E-10	1.436E-10	4.352E-10
NNE	8000.	1.151E-10	1.178E-10	3.273E-10	3100.	4.257E-10	4.320E-10	1.760E-09
NE	8000.	8.839E-11	9.468E-11	2.851E-10	5600.	1.538E-10	1.649E-10	5.403E-10
ENE	8000.	8.559E-11	8.420E-11	2.381E-10	5000.	1.739E-10	1.725E-10	5.519E-10
E	8000.	1.056E-10	9.772E-11	2.587E-10	8000.	1.056E-10	9.772E-11	2.587E-10
ESE	8000.	1.450E-10	1.356E-10	3.010E-10	8000.	1.450E-10	1.356E-10	3.010E-10
SE	8000.	1.242E-10	1.322E-10	2.881E-10	7600.	1.354E-10	1.437E-10	3.160E-10
SSE	8000.	1.174E-10	1.278E-10	2.152E-10	7600.	1.279E-10	1.389E-10	2.360E-10
S	8000.	9.947E-11	9.895E-11	2.065E-10	8000.	9.947E-11	9.895E-11	2.065E-10
SSW	8000.	8.647E-11	9.097E-11	1.077E-10	8000.	8.647E-11	9.097E-11	1.077E-10
SW	8000.	1.096E-10	1.210E-10	1.793E-10	8000.	1.096E-10	1.210E-10	1.793E-10
WSW	8000.	1.017E-10	1.083E-10	1.940E-10	8000.	1.017E-10	1.083E-10	1.940E-10
W	8000.	8.494E-11	1.094E-10	2.354E-10	4800.	1.808E-10	2.362E-10	5.866E-10
WNW	8000.	5.824E-11	6.886E-11	1.994E-10	5200.	1.117E-10	1.331E-10	4.312E-10
NW	8000.	5.436E-11	6.319E-11	1.828E-10	6400.	7.773E-11	9.022E-11	2.730E-10
NNW	7400.	7.317E-11	7.264E-11	2.269E-10	7600.	7.002E-11	6.954E-11	2.163E-10

LaSalle Site Meteorological Data 1/78 - 12/87

Note: Based on Reference 2 of Section F.2 and the formulas in Section B.4 of Appendix B.

Table F-7

Maximum Offsite Finite Plume Gamma Dose Factors Based on 1 cm Depth at the Unrestricted Area Boundary for Kr-83m

Direction	Unrestricted Area Bound		Elevated(Stack) Release		Mixed Mode(Vent) Release			Ground Level Release		
	Radius (meters)	Radius (meters)	S (mrad/yr)/(uCi/sec)	SBAR (mrad/yr)/(uCi/sec)	Radius (meters)	V (mrad/yr)/(uCi/sec)	VBAR (mrad/yr)/(uCi/sec)	Radius (meters)	G (mrad/yr)/(uCi/sec)	GBAR (mrad/yr)/(uCi/sec)
N	1036.	1036.	4.787E-07	3.609E-07	1036.	5.281E-07	3.982E-07	1036.	1.785E-04	1.346E-04
NNE	1378.	1378.	8.751E-07	6.599E-07	1378.	6.905E-07	5.206E-07	1378.	1.139E-04	8.586E-05
NE	2408.	2408.	6.471E-07	4.879E-07	2408.	6.697E-07	5.049E-07	2408.	4.355E-05	3.284E-05
ENE	4450.	4450.	5.700E-07	4.298E-07	4450.	5.653E-07	4.262E-07	4450.	1.466E-05	1.105E-05
E	1996.	1996.	4.687E-07	3.534E-07	1996.	7.559E-07	5.700E-07	1996.	5.491E-05	4.140E-05
ESE	1465.	1465.	5.252E-07	3.960E-07	1465.	1.002E-06	7.559E-07	1465.	8.270E-05	6.236E-05
SE	969.	969.	3.545E-07	2.673E-07	969.	1.267E-06	9.554E-07	969.	1.333E-04	1.005E-04
SSE	838.	838.	3.051E-07	2.301E-07	838.	1.512E-06	1.140E-06	838.	1.323E-04	9.978E-05
S	829.	829.	2.840E-07	2.141E-07	829.	1.040E-06	7.842E-07	829.	1.330E-04	1.003E-04
SSW	835.	835.	3.185E-07	2.401E-07	835.	1.071E-06	8.076E-07	835.	9.326E-05	7.032E-05
SW	628.	628.	3.177E-07	2.395E-07	628.	2.826E-06	2.131E-06	628.	2.305E-04	1.738E-04
WSW	533.	533.	2.617E-07	1.973E-07	533.	2.674E-06	2.017E-06	533.	2.568E-04	1.936E-04
W	524.	524.	2.327E-07	1.754E-07	524.	1.658E-06	1.250E-06	524.	3.352E-04	2.527E-04
WNW	643.	643.	1.714E-07	1.292E-07	643.	7.235E-07	5.455E-07	643.	2.728E-04	2.057E-04
NW	762.	762.	1.744E-07	1.315E-07	762.	4.391E-07	3.311E-07	762.	2.219E-04	1.673E-04
NNW	890.	890.	2.397E-07	1.807E-07	890.	3.334E-07	2.514E-07	890.	1.823E-04	1.374E-04

LASALLE SITE METEOROLOGICAL DATA 1/78 - 12/87

Note: Based on Reference 1 of Section F.2 and the formulas in Sections B.5 and B.6 of Appendix B.

Table F-7 (Continued)

Maximum Offsite Finite Plume Gamma Dose Factors Based on 1 cm Depth at the Unrestricted Area Boundary for Kr-85m

Downwind Direction	Unrestricted Area Bound Radius (meters)	Elevated(Stack) Release		Mixed Mode(Vent) Release		Ground Level Release				
		Radius (meters)	S (mrad/yr)/(uCi/sec)	SBAR (mrad/yr)/(uCi/sec)	Radius (meters)	V (mrad/yr)/(uCi/sec)	VBAR (mrad/yr)/(uCi/sec)	Radius (meters)	G (mrad/yr)/(uCi/sec)	GBAR (mrad/yr)/(uCi/sec)
N	1036.	1036.	5.747E-05	5.560E-05	1036.	6.602E-05	6.388E-05	1036.	9.660E-04	9.252E-04
NNE	1378.	1378.	5.063E-05	4.896E-05	1378.	5.514E-05	5.334E-05	1378.	6.776E-04	6.496E-04
NE	2408.	2408.	2.592E-05	2.506E-05	2408.	2.727E-05	2.636E-05	2408.	2.969E-04	2.849E-04
ENE	4450.	4450.	1.351E-05	1.304E-05	4450.	1.332E-05	1.286E-05	4450.	1.156E-04	1.111E-04
E	1996.	1996.	2.705E-05	2.616E-05	1996.	2.863E-05	2.767E-05	1996.	3.557E-04	3.412E-04
ESE	1465.	1465.	4.351E-05	4.209E-05	1465.	4.624E-05	4.470E-05	1465.	5.201E-04	4.989E-04
SE	969.	969.	5.596E-05	5.415E-05	969.	6.610E-05	6.391E-05	969.	7.793E-04	7.470E-04
SSE	838.	838.	5.518E-05	5.339E-05	838.	6.630E-05	6.410E-05	838.	7.683E-04	7.364E-04
S	829.	829.	4.712E-05	4.560E-05	829.	5.330E-05	5.154E-05	829.	7.986E-04	7.657E-04
SSW	835.	835.	4.422E-05	4.279E-05	835.	5.351E-05	5.174E-05	835.	5.684E-04	5.450E-04
SW	628.	628.	7.281E-05	7.046E-05	628.	9.952E-05	9.618E-05	628.	1.285E-03	1.231E-03
WSW	533.	533.	7.757E-05	7.507E-05	533.	9.714E-05	9.388E-05	533.	1.389E-03	1.331E-03
W	524.	524.	7.601E-05	7.356E-05	524.	9.705E-05	9.385E-05	524.	1.687E-03	1.614E-03
WNW	643.	643.	5.286E-05	5.116E-05	643.	6.615E-05	6.399E-05	643.	1.327E-03	1.270E-03
NW	762.	762.	4.668E-05	4.518E-05	762.	5.688E-05	5.503E-05	762.	1.094E-03	1.047E-03
NNW	890.	890.	4.683E-05	4.532E-05	890.	5.142E-05	4.976E-05	890.	9.282E-04	8.885E-04

LASALLE SITE METEOROLOGICAL DATA 1/78 - 12/87

Table F-7 (Continued)

Maximum Offsite Finite Plume Gamma Dose Factors Based on 1 cm Depth at the Unrestricted Area Boundary for Kr-85

Direction	Unrestricted Area Bound Radius (meters)	Elevated(Stack) Release		Mixed Mode(Vent) Release			Ground Level Release			
		Radius (meters)	S (mrad/yr)/(uCi/sec)	SBAR (mrad/yr)/(uCi/sec)	Radius (meters)	V (mrad/yr)/(uCi/sec)	VBAR (mrad/yr)/(uCi/sec)	Radius (meters)	G (mrad/yr)/(uCi/sec)	GBAR (mrad/yr)/(uCi/sec)
N	1036.	1036.	8.547E-07	8.265E-07	1036.	9.889E-07	9.563E-07	1036.	1.056E-05	1.021E-05
NNE	1378.	1378.	7.309E-07	7.068E-07	1378.	8.077E-07	7.811E-07	1378.	7.474E-06	7.227E-06
NE	2408.	2408.	3.651E-07	3.530E-07	2408.	3.909E-07	3.780E-07	2408.	3.363E-06	3.252E-06
ENE	4450.	4450.	1.885E-07	1.823E-07	4450.	1.856E-07	1.795E-07	4450.	1.377E-06	1.332E-06
E	1996.	1996.	3.912E-07	3.782E-07	1996.	4.096E-07	3.961E-07	1996.	4.008E-06	3.876E-06
ESE	1465.	1465.	6.359E-07	6.149E-07	1465.	6.632E-07	6.413E-07	1465.	5.783E-06	5.593E-06
SE	969.	969.	8.386E-07	8.110E-07	969.	9.583E-07	9.267E-07	969.	8.555E-06	8.273E-06
SSE	838.	838.	8.350E-07	8.075E-07	838.	9.612E-07	9.294E-07	838.	8.432E-06	8.154E-06
S	829.	829.	7.262E-07	7.023E-07	829.	8.067E-07	7.801E-07	829.	8.741E-06	8.453E-06
SSW	835.	835.	6.857E-07	6.630E-07	835.	8.402E-07	8.124E-07	835.	6.270E-06	6.063E-06
SW	628.	628.	1.142E-06	1.104E-06	628.	1.494E-06	1.444E-06	628.	1.401E-05	1.355E-05
WSW	533.	533.	1.211E-06	1.171E-06	533.	1.433E-06	1.386E-06	533.	1.510E-05	1.460E-05
W	524.	524.	1.172E-06	1.134E-06	524.	1.443E-06	1.395E-06	524.	1.824E-05	1.763E-05
WNW	643.	643.	8.185E-07	7.915E-07	643.	1.000E-06	9.670E-07	643.	1.436E-05	1.389E-05
NW	762.	762.	7.192E-07	6.954E-07	762.	8.694E-07	8.407E-07	762.	1.188E-05	1.148E-05
NNW	890.	890.	7.128E-07	6.893E-07	890.	7.849E-07	7.590E-07	890.	1.011E-05	9.778E-06

LASALLE SITE METEOROLOGICAL DATA 1/78 - 12/87

Table F-7 (Continued)

Maximum Offsite Finite Plume Gamma Dose Factors Based on 1 cm Depth at the Unrestricted Area Boundary for Kr-87

Downwind Direction	Unrestricted Area Bound (meters)	Elevated(Stack) Release		Mixed Mode(Vent) Release			Ground Level Release			
		Radius (meters)	S (mrad/yr)/(uCi/sec)	SBAR (mrad/yr)/(uCi/sec)	Radius (meters)	V (mrad/yr)/(uCi/sec)	VBAR (mrad/yr)/(uCi/sec)	Radius (meters)	G (mrad/yr)/(uCi/sec)	GBAR (mrad/yr)/(uCi/sec)
N	1036.	1036.	3.226E-04	3.135E-04	1036.	3.758E-04	3.652E-04	1036.	2.879E-03	2.795E-03
NNE	1378.	1378.	2.672E-04	2.597E-04	1378.	3.005E-04	2.920E-04	1378.	2.019E-03	1.960E-03
NE	2408.	2408.	1.283E-04	1.246E-04	2408.	1.359E-04	1.320E-04	2408.	8.605E-04	8.355E-04
ENE	4450.	4450.	5.904E-05	5.737E-05	4450.	5.859E-05	5.692E-05	4450.	3.133E-04	3.042E-04
E	1996.	1996.	1.412E-04	1.372E-04	1996.	1.458E-04	1.417E-04	1996.	1.030E-03	9.998E-04
ESE	1465.	1465.	2.351E-04	2.284E-04	1465.	2.426E-04	2.357E-04	1465.	1.545E-03	1.500E-03
SE	969.	969.	3.211E-04	3.120E-04	969.	3.612E-04	3.510E-04	969.	2.355E-03	2.287E-03
SSE	838.	838.	3.254E-04	3.162E-04	838.	3.655E-04	3.552E-04	838.	2.329E-03	2.262E-03
S	829.	829.	2.850E-04	2.770E-04	829.	3.081E-04	2.994E-04	829.	2.431E-03	2.361E-03
SSW	835.	835.	2.742E-04	2.665E-04	835.	3.400E-04	3.305E-04	835.	1.706E-03	1.657E-03
SW	628.	628.	4.614E-04	4.484E-04	628.	5.936E-04	5.769E-04	628.	3.903E-03	3.790E-03
WSW	533.	533.	4.880E-04	4.743E-04	533.	5.683E-04	5.523E-04	533.	4.251E-03	4.128E-03
W	524.	524.	4.675E-04	4.543E-04	524.	5.708E-04	5.547E-04	524.	5.136E-03	4.986E-03
WNW	643.	643.	3.224E-04	3.133E-04	643.	3.914E-04	3.804E-04	643.	4.001E-03	3.884E-03
NW	762.	762.	2.823E-04	2.743E-04	762.	3.397E-04	3.301E-04	762.	3.276E-03	3.180E-03
NNW	890.	890.	2.747E-04	2.669E-04	890.	3.031E-04	2.945E-04	890.	2.763E-03	2.683E-03

LASALLE SITE METEOROLOGICAL DATA 1/78 - 12/87

Table F-7 (Continued)

Maximum Offsite Finite Plume Gamma Dose Factors Based on 1 cm Depth at the Unrestricted Area Boundary for Kr-88

Direction	Unrestricted Area Bound (meters)	Elevated(Stack) Release		Mixed Mode(Vent) Release			Ground Level Release			
		Radius (meters)	S (mrad/yr)/(uCi/sec)	SBAR (mrad/yr)/(uCi/sec)	Radius (meters)	V (mrad/yr)/(uCi/sec)	VBAR (mrad/yr)/(uCi/sec)	Radius (meters)	G (mrad/yr)/(uCi/sec)	GBAR (mrad/yr)/(uCi/sec)
N	1036.	1036.	8.602E-04	8.374E-04	1036.	1.003E-03	9.769E-04	1036.	6.988E-03	6.787E-03
NNE	1378.	1378.	7.111E-04	6.922E-04	1378.	7.989E-04	7.777E-04	1378.	4.940E-03	4.798E-03
NE	2408.	2408.	3.435E-04	3.344E-04	2408.	3.694E-04	3.596E-04	2408.	2.182E-03	2.120E-03
ENE	4450.	4450.	1.648E-04	1.604E-04	4450.	1.646E-04	1.602E-04	4450.	8.502E-04	8.263E-04
E	1996.	1996.	3.781E-04	3.680E-04	1996.	3.928E-04	3.824E-04	1996.	2.599E-03	2.525E-03
ESE	1465.	1465.	6.235E-04	6.070E-04	1465.	6.445E-04	6.273E-04	1465.	3.816E-03	3.707E-03
SE	969.	969.	8.537E-04	8.311E-04	969.	9.571E-04	9.317E-04	969.	5.712E-03	5.549E-03
SSE	838.	838.	8.671E-04	8.442E-04	838.	9.702E-04	9.445E-04	838.	5.645E-03	5.483E-03
S	829.	829.	7.696E-04	7.492E-04	829.	8.417E-04	8.194E-04	829.	5.862E-03	5.695E-03
SSW	835.	835.	7.427E-04	7.231E-04	835.	9.375E-04	9.127E-04	835.	4.167E-03	4.048E-03
SW	628.	628.	1.246E-03	1.213E-03	628.	1.601E-03	1.559E-03	628.	9.396E-03	9.126E-03
WSW	533.	533.	1.314E-03	1.279E-03	533.	1.525E-03	1.485E-03	533.	1.017E-02	9.882E-03
W	524.	524.	1.249E-03	1.216E-03	524.	1.520E-03	1.480E-03	524.	1.225E-02	1.190E-02
WNW	643.	643.	8.669E-04	8.440E-04	643.	1.045E-03	1.017E-03	643.	9.595E-03	9.317E-03
NW	762.	762.	7.580E-04	7.379E-04	762.	9.125E-04	8.884E-04	762.	7.895E-03	7.666E-03
NNW	890.	890.	7.369E-04	7.174E-04	890.	8.161E-04	7.945E-04	890.	6.693E-03	6.500E-03

LASALLE SITE METEOROLOGICAL DATA 1/78 - 12/87

Table F-7 (Continued)

Maximum Offsite Finite Plume Gamma Dose Factors Based on 1 cm Depth at the Unrestricted Area Boundary for Kr-89

Downwind Unrestricted Direction Area Bound	Elevated(Stack) Release Radius (meters)	S		Mixed Mode(Vent) Release			Ground Level Release			
		(meters)	(mrad/yr)/(uCi/sec)	Radius (meters)	V (mrad/yr)/(uCi/sec)	VBAR (meters)	Radius (meters)	G (mrad/yr)/(uCi/sec)	GBAR (meters)	
N	1036.	1036.	3.904E-04	3.794E-04	1036.	4.258E-04	4.139E-04	1036.	2.051E-03	1.992E-03
NNE	1378.	1378.	2.820E-04	2.741E-04	1378.	2.988E-04	2.904E-04	1378.	1.151E-03	1.118E-03
NE	2408.	2408.	8.306E-05	8.072E-05	2408.	7.403E-05	7.195E-05	2408.	2.060E-04	2.001E-04
ENE	4450.	4450.	1.570E-05	1.526E-05	4450.	1.153E-05	1.121E-05	4450.	1.701E-05	1.653E-05
E	1996.	1996.	1.052E-04	1.023E-04	1996.	9.299E-05	9.037E-05	1996.	3.031E-04	2.944E-04
ESE	1465.	1465.	2.365E-04	2.299E-04	1465.	2.240E-04	2.177E-04	1465.	7.762E-04	7.540E-04
SE	969.	969.	3.891E-04	3.782E-04	969.	4.188E-04	4.070E-04	969.	1.846E-03	1.793E-03
SSE	838.	838.	4.108E-04	3.993E-04	838.	4.365E-04	4.243E-04	838.	1.831E-03	1.778E-03
S	829.	829.	3.408E-04	3.312E-04	829.	3.253E-04	3.162E-04	829.	2.034E-03	1.976E-03
SSW	835.	835.	2.921E-04	2.839E-04	835.	2.779E-04	2.702E-04	835.	1.021E-03	9.916E-04
SW	628.	628.	5.830E-04	5.667E-04	628.	6.600E-04	6.415E-04	628.	3.274E-03	3.180E-03
WSW	533.	533.	6.913E-04	6.720E-04	533.	7.525E-04	7.314E-04	533.	4.592E-03	4.460E-03
W	524.	524.	6.961E-04	6.766E-04	524.	8.259E-04	8.028E-04	524.	5.967E-03	5.796E-03
WNW	643.	643.	4.295E-04	4.174E-04	643.	5.147E-04	5.003E-04	643.	3.746E-03	3.638E-03
NW	762.	762.	3.500E-04	3.402E-04	762.	4.035E-04	3.922E-04	762.	2.561E-03	2.488E-03
NNW	890.	890.	3.301E-04	3.208E-04	890.	3.415E-04	3.319E-04	890.	1.966E-03	1.909E-03

LASALLE SITE METEOROLOGICAL DATA 1/78 - 12/87

Table F-7 (Continued)

Maximum Offsite Finite Plume Gamma Dose Factors Based on 1 cm Depth at the Unrestricted Area Boundary for Kr-90

Downwind Unrestricted Direction Area Bound	Radius (meters)	Elevated(Stack) Release		Mixed Mode(Vent) Release			Ground Level Release			
		Radius (meters)	S (mrad/yr)/(uCi/sec)	SBAR (mrad/yr)/(uCi/sec)	Radius (meters)	V (mrad/yr)/(uCi/sec)	VBAR (mrad/yr)/(uCi/sec)	Radius (meters)	G (mrad/yr)/(uCi/sec)	GBAR (mrad/yr)/(uCi/sec)
N	1036.	1036.	6.785E-05	6.586E-05	1036.	5.199E-05	5.047E-05	1036.	8.203E-05	7.954E-05
NNE	1378.	1378.	3.195E-05	3.102E-05	1378.	2.161E-05	2.098E-05	1378.	2.265E-05	2.196E-05
NE	2408.	2408.	2.160E-06	2.097E-06	2408.	9.136E-07	8.868E-07	2408.	5.870E-07	5.693E-07
ENE	4450.	4450.	1.109E-07	1.076E-07	4450.	3.907E-08	3.792E-08	4450.	1.814E-08	1.759E-08
E	1996.	1996.	4.713E-06	4.575E-06	1996.	2.562E-06	2.486E-06	1996.	2.865E-06	2.779E-06
ESE	1465.	1465.	2.134E-05	2.072E-05	1465.	1.551E-05	1.506E-05	1465.	2.503E-05	2.427E-05
SE	969.	969.	5.843E-05	5.673E-05	969.	5.324E-05	5.168E-05	969.	1.365E-04	1.324E-04
SSE	838.	838.	6.863E-05	6.663E-05	838.	6.174E-05	5.993E-05	838.	1.227E-04	1.190E-04
S	829.	829.	5.057E-05	4.909E-05	829.	3.745E-05	3.635E-05	829.	1.055E-04	1.023E-04
SSW	835.	835.	3.062E-05	2.972E-05	835.	1.274E-05	1.237E-05	835.	1.835E-05	1.779E-05
SW	628.	628.	9.754E-05	9.470E-05	628.	6.538E-05	6.347E-05	628.	1.410E-04	1.368E-04
WSW	533.	533.	1.892E-04	1.836E-04	533.	1.525E-04	1.480E-04	533.	4.861E-04	4.713E-04
W	524.	524.	2.165E-04	2.101E-04	524.	2.185E-04	2.121E-04	524.	8.427E-04	8.170E-04
WNW	643.	643.	1.018E-04	9.883E-05	643.	1.008E-04	9.787E-05	643.	3.141E-04	3.045E-04
NW	762.	762.	6.634E-05	6.440E-05	762.	5.815E-05	5.645E-05	762.	1.306E-04	1.267E-04
NNW	890.	890.	5.725E-05	5.558E-05	890.	4.336E-05	4.209E-05	890.	8.819E-05	8.551E-05

LASALLE SITE METEOROLOGICAL DATA 1/78 - 12/87

Table F-7 (Continued)

Maximum Offsite Finite Plume Gamma Dose Factors Based on 1 cm Depth at the Unrestricted Area Boundary for Xe-131m

Downwind Unrestricted Direction Area Bound (meters)	Elevated(Stack) Release Radius (meters)	Elevated(Stack) Release		Mixed Mode(Vent) Release Radius (meters)	Mixed Mode(Vent) Release		Ground Level Release Radius (meters)	Ground Level Release		
		S (mrad/yr)/(uCi/sec)	SBAR (uCi/sec)		V (mrad/yr)/(uCi/sec)	VBAR (uCi/sec)		G (mrad/yr)/(uCi/sec)	GBAR (uCi/sec)	
N	1036.	1036.	1.606E-06	1.473E-06	1036.	1.827E-06	1.679E-06	1036.	1.645E-04	1.283E-04
NNE	1378.	1378.	1.778E-06	1.572E-06	1378.	1.726E-06	1.553E-06	1378.	1.072E-04	8.384E-05
NE	2408.	2408.	1.086E-06	9.376E-07	2408.	1.136E-06	9.826E-07	2408.	4.347E-05	3.412E-05
ENE	4450.	4450.	7.931E-07	6.617E-07	4450.	7.858E-07	6.550E-07	4450.	1.623E-05	1.279E-05
E	1996.	1996.	9.572E-07	8.457E-07	1996.	1.230E-06	1.058E-06	1996.	5.428E-05	4.253E-05
ESE	1465.	1465.	1.347E-06	1.215E-06	1465.	1.789E-06	1.560E-06	1465.	7.935E-05	6.215E-05
SE	969.	969.	1.472E-06	1.365E-06	969.	2.406E-06	2.115E-06	969.	1.240E-04	9.696E-05
SSE	838.	838.	1.415E-06	1.318E-06	838.	2.598E-06	2.260E-06	838.	1.228E-04	9.597E-05
S	829.	829.	1.231E-06	1.144E-06	829.	1.966E-06	1.727E-06	829.	1.232E-04	9.639E-05
SSW	835.	835.	1.196E-06	1.103E-06	835.	2.003E-06	1.755E-06	835.	8.798E-05	6.885E-05
SW	628.	628.	1.802E-06	1.691E-06	628.	4.345E-06	3.728E-06	628.	2.109E-04	1.646E-04
WSW	533.	533.	1.859E-06	1.755E-06	533.	4.161E-06	3.577E-06	533.	2.324E-04	1.813E-04
W	524.	524.	1.800E-06	1.703E-06	524.	3.359E-06	2.972E-06	524.	3.000E-04	2.335E-04
WNN	643.	643.	1.263E-06	1.194E-06	643.	1.976E-06	1.791E-06	643.	2.446E-04	1.902E-04
NW	762.	762.	1.135E-06	1.069E-06	762.	1.561E-06	1.437E-06	762.	2.005E-04	1.560E-04
NNW	890.	890.	1.191E-06	1.112E-06	890.	1.363E-06	1.263E-06	890.	1.664E-04	1.295E-04

LASALLE SITE METEOROLOGICAL DATA 1/78 - 12/87

Table F-7 (Continued)

Maximum Offsite Finite Plume Gamma Dose Factors Based on 1 cm Depth at the Unrestricted Area Boundary for Xe-133m

Direction	Downwind Unrestricted Area Bound (meters)	Elevated(Stack) Release		Mixed Mode(Vent) Release		Ground Level Release				
		Radius (meters)	S (mrad/yr)/(uCi/sec)	SBAR (mrad/yr)/(uCi/sec)	Radius (meters)	V (mrad/yr)/(uCi/sec)	VBAR (mrad/yr)/(uCi/sec)	Radius (meters)	G (mrad/yr)/(uCi/sec)	GBAR (mrad/yr)/(uCi/sec)
N	1036.	1036.	8.557E-06	8.199E-06	1036.	9.814E-06	9.407E-06	1036.	2.822E-04	2.410E-04
NNE	1378.	1378.	7.917E-06	7.509E-06	1378.	8.400E-06	8.009E-06	1378.	1.901E-04	1.633E-04
NE	2408.	2408.	4.246E-06	3.993E-06	2408.	4.482E-06	4.217E-06	2408.	8.032E-05	6.950E-05
ENE	4450.	4450.	2.488E-06	2.298E-06	4450.	2.450E-06	2.262E-06	4450.	3.108E-05	2.706E-05
E	1996.	1996.	4.247E-06	4.028E-06	1996.	4.721E-06	4.433E-06	1996.	9.835E-05	8.482E-05
ESE	1465.	1465.	6.614E-06	6.309E-06	1465.	7.393E-06	6.978E-06	1465.	1.432E-04	1.234E-04
SE	969.	969.	8.229E-06	7.903E-06	969.	1.039E-05	9.834E-06	969.	2.189E-04	1.879E-04
SSE	838.	838.	8.070E-06	7.758E-06	838.	1.060E-05	9.998E-06	838.	2.163E-04	1.856E-04
S	829.	829.	6.932E-06	6.660E-06	829.	8.449E-06	7.995E-06	829.	2.201E-04	1.893E-04
SSW	835.	835.	6.541E-06	6.276E-06	835.	8.500E-06	8.036E-06	835.	1.574E-04	1.354E-04
SW	628.	628.	1.059E-05	1.020E-05	628.	1.637E-05	1.535E-05	628.	3.668E-04	3.140E-04
WSW	533.	533.	1.121E-05	1.081E-05	533.	1.588E-05	1.490E-05	533.	4.005E-04	3.423E-04
W	524.	524.	1.096E-05	1.056E-05	524.	1.504E-05	1.427E-05	524.	5.039E-04	4.287E-04
WNW	643.	643.	7.648E-06	7.374E-06	643.	9.956E-06	9.510E-06	643.	4.055E-04	3.441E-04
NW	762.	762.	6.774E-06	6.526E-06	762.	8.435E-06	8.088E-06	762.	3.334E-04	2.831E-04
NNW	890.	890.	6.855E-06	6.594E-06	890.	7.588E-06	7.286E-06	890.	2.794E-04	2.377E-04

LASALLE SITE METEOROLOGICAL DATA 1/78 - 12/87

Table F-7 (Continued)

Maximum Offsite Finite Plume Gamma Dose Factors Based on 1 cm Depth at the Unrestricted Area Boundary for Xe-133

Downwind Unrestricted Direction Area Bound	Radius (meters)	Elevated(Stack) Release		Mixed Mode(Vent) Release			Ground Level Release			
		Radius (meters)	S (mrad/yr)/(uCi/sec)	SBAR (mrad/yr)/(uCi/sec)	Radius (meters)	V (mrad/yr)/(uCi/sec)	VBAR (mrad/yr)/(uCi/sec)	Radius (meters)	G (mrad/yr)/(uCi/sec)	GBAR (mrad/yr)/(uCi/sec)
N	1036.	1036.	7.010E-06	6.757E-06	1036.	7.933E-06	7.649E-06	1036.	3.136E-04	2.785E-04
NNE	1378.	1378.	6.939E-06	6.629E-06	1378.	7.149E-06	6.860E-06	1378.	2.132E-04	1.903E-04
NE	2408.	2408.	3.969E-06	3.767E-06	2408.	4.106E-06	3.897E-06	2408.	9.094E-05	8.164E-05
ENE	4450.	4450.	2.442E-06	2.286E-06	4450.	2.384E-06	2.229E-06	4450.	3.540E-05	3.193E-05
E	1996.	1996.	3.841E-06	3.671E-06	1996.	4.310E-06	4.083E-06	1996.	1.109E-04	9.929E-05
ESE	1465.	1465.	5.762E-06	5.534E-06	1465.	6.599E-06	6.277E-06	1465.	1.612E-04	1.443E-04
SE	969.	969.	6.641E-06	6.416E-06	969.	8.978E-06	8.558E-06	969.	2.450E-04	2.185E-04
SSE	838.	838.	6.364E-06	6.153E-06	838.	9.231E-06	8.769E-06	838.	2.418E-04	2.156E-04
S	829.	829.	5.333E-06	5.152E-06	829.	6.962E-06	6.627E-06	829.	2.476E-04	2.212E-04
SSW	835.	835.	4.969E-06	4.793E-06	835.	6.598E-06	6.266E-06	835.	1.770E-04	1.582E-04
SW	628.	628.	7.798E-06	7.549E-06	628.	1.362E-05	1.285E-05	628.	4.090E-04	3.640E-04
WSW	533.	533.	8.245E-06	7.992E-06	533.	1.326E-05	1.252E-05	533.	4.447E-04	3.951E-04
W	524.	524.	8.166E-06	7.919E-06	524.	1.220E-05	1.164E-05	524.	5.551E-04	4.911E-04
WNW	643.	643.	5.715E-06	5.541E-06	643.	7.885E-06	7.574E-06	643.	4.444E-04	3.922E-04
NW	762.	762.	5.117E-06	4.958E-06	762.	6.538E-06	6.303E-06	762.	3.661E-04	3.233E-04
NNW	890.	890.	5.340E-06	5.165E-06	890.	5.911E-06	5.708E-06	890.	3.080E-04	2.725E-04

LASALLE SITE METEOROLOGICAL DATA 1/78 - 12/87

Table F-7 (Continued)

Maximum Offsite Finite Plume Gamma Dose Factors Based on 1 cm Depth at the Unrestricted Area Boundary for Xe-135m

Downwind Unrestricted Direction Area Bound	Elevated(Stack) Release Radius S	SBAR	Mixed Mode(Vent) Release			Ground Level Release				
			Radius	V	VBAR	Radius	G	GBAR		
(meters)	(meters)	(mrad/yr)/(uCi/sec)	(meters)	(mrad/yr)/(uCi/sec)	(meters)	(mrad/yr)/(uCi/sec)	(meters)	(mrad/yr)/(uCi/sec)		
N	1036.	1036.	1.396E-04	1.349E-04	1036.	1.598E-04	1.545E-04	1036.	1.531E-03	1.475E-03
NNE	1378.	1378.	1.151E-04	1.113E-04	1378.	1.274E-04	1.232E-04	1378.	1.019E-03	9.821E-04
NE	2408.	2408.	5.077E-05	4.907E-05	2408.	5.129E-05	4.958E-05	2408.	3.516E-04	3.390E-04
ENE	4450.	4450.	1.919E-05	1.854E-05	4450.	1.778E-05	1.718E-05	4450.	8.758E-05	8.445E-05
E	1996.	1996.	5.672E-05	5.483E-05	1996.	5.675E-05	5.486E-05	1996.	4.329E-04	4.172E-04
ESE	1465.	1465.	1.005E-04	9.716E-05	1465.	1.024E-04	9.902E-05	1465.	7.369E-04	7.103E-04
SE	969.	969.	1.389E-04	1.343E-04	969.	1.575E-04	1.522E-04	969.	1.262E-03	1.216E-03
SSE	838.	838.	1.402E-04	1.356E-04	838.	1.591E-04	1.538E-04	838.	1.254E-03	1.209E-03
S	829.	829.	1.183E-04	1.144E-04	829.	1.235E-04	1.194E-04	829.	1.341E-03	1.292E-03
SSW	835.	835.	1.104E-04	1.068E-04	835.	1.260E-04	1.218E-04	835.	8.762E-04	8.444E-04
SW	628.	628.	1.904E-04	1.841E-04	628.	2.444E-04	2.363E-04	628.	2.173E-03	2.094E-03
WSW	533.	533.	2.063E-04	1.995E-04	533.	2.427E-04	2.345E-04	533.	2.479E-03	2.388E-03
W	524.	524.	2.033E-04	1.966E-04	524.	2.511E-04	2.427E-04	524.	3.050E-03	2.937E-03
WNW	643.	643.	1.363E-04	1.318E-04	643.	1.687E-04	1.631E-04	643.	2.286E-03	2.201E-03
NW	762.	762.	1.187E-04	1.148E-04	762.	1.423E-04	1.376E-04	762.	1.806E-03	1.739E-03
NNW	890.	890.	1.161E-04	1.122E-04	890.	1.259E-04	1.217E-04	890.	1.482E-03	1.427E-03

LASALLE SITE METEOROLOGICAL DATA 1/78 - 12/87

Table F-7 (Continued)

Maximum Offsite Finite Plume Gamma Dose Factors Based on 1 cm Depth at the Unrestricted Area Boundary for Xe-135

Downwind Unrestricted Direction Area Bound (meters)	Elevated(Stack) Release Radius (meters)	S SBAR (mrad/yr)/(uCi/sec)		Mixed Mode(Vent) Release Radius (meters)	V VBAR (mrad/yr)/(uCi/sec)		Ground Level Release Radius (meters)			G GBAR (mrad/yr)/(uCi/sec)	
N	1036.	1036.	8.165E-05	7.902E-05	1036.	9.387E-05	9.085E-05	1036.	1.302E-03	1.257E-03	
NNE	1378.	1378.	7.171E-05	6.940E-05	1378.	7.821E-05	7.569E-05	1378.	9.178E-04	8.866E-04	
NE	2408.	2408.	3.669E-05	3.550E-05	2408.	3.876E-05	3.751E-05	2408.	4.075E-04	3.937E-04	
ENE	4450.	4450.	1.928E-05	1.866E-05	4450.	1.899E-05	1.837E-05	4450.	1.625E-04	1.570E-04	
E	1996.	1996.	3.838E-05	3.714E-05	1996.	4.056E-05	3.925E-05	1996.	4.869E-04	4.704E-04	
ESE	1465.	1465.	6.171E-05	5.972E-05	1465.	6.539E-05	6.328E-05	1465.	7.073E-04	6.833E-04	
SE	969.	969.	7.953E-05	7.697E-05	969.	9.346E-05	9.044E-05	969.	1.052E-03	1.017E-03	
SSE	838.	838.	7.845E-05	7.593E-05	838.	9.367E-05	9.064E-05	838.	1.037E-03	1.002E-03	
S	829.	829.	6.719E-05	6.503E-05	829.	7.587E-05	7.342E-05	829.	1.078E-03	1.041E-03	
SSW	835.	835.	6.306E-05	6.103E-05	835.	7.636E-05	7.389E-05	835.	7.699E-04	7.438E-04	
SW	628.	628.	1.039E-04	1.006E-04	628.	1.409E-04	1.363E-04	628.	1.729E-03	1.670E-03	
WSW	533.	533.	1.106E-04	1.071E-04	533.	1.372E-04	1.328E-04	533.	1.864E-03	1.801E-03	
W	524.	524.	1.082E-04	1.048E-04	524.	1.374E-04	1.329E-04	524.	2.256E-03	2.179E-03	
WNW	643.	643.	7.538E-05	7.296E-05	643.	9.395E-05	9.092E-05	643.	1.775E-03	1.713E-03	
NW	762.	762.	6.654E-05	6.440E-05	762.	8.098E-05	7.838E-05	762.	1.466E-03	1.415E-03	
NNW	890.	890.	6.671E-05	6.456E-05	890.	7.327E-05	7.092E-05	890.	1.247E-03	1.204E-03	

LASALLE SITE METEOROLOGICAL DATA 1/78 - 12/87

Table F-7 (Continued)

Maximum Offsite Finite Plume Gamma Dose Factors Based on 1 cm Depth at the Unrestricted Area Boundary for Xe-137

Downwind Unrestricted Direction Area Bound	Radius (meters)	Elevated(Stack) Release		Mixed Mode(Vent) Release		Ground Level Release				
		S (mrad/yr)/(uCi/sec)	SBAR (mrad/yr)/(uCi/sec)	V (mrad/yr)/(uCi/sec)	VBAR (mrad/yr)/(uCi/sec)	G (mrad/yr)/(uCi/sec)	GBAR (mrad/yr)/(uCi/sec)			
N	1036.	1036.	4.780E-05	4.627E-05	1036.	5.242E-05	5.074E-05	1036.	3.409E-04	3.298E-04
NNE	1378.	1378.	3.585E-05	3.471E-05	1378.	3.814E-05	3.692E-05	1378.	1.975E-04	1.911E-04
NE	2408.	2408.	1.153E-05	1.116E-05	2408.	1.052E-05	1.018E-05	2408.	3.979E-05	3.850E-05
ENE	4450.	4450.	2.512E-06	2.432E-06	4450.	1.933E-06	1.871E-06	4450.	3.949E-06	3.821E-06
E	1996.	1996.	1.420E-05	1.374E-05	1996.	1.285E-05	1.244E-05	1996.	5.599E-05	5.418E-05
ESE	1465.	1465.	3.033E-05	2.936E-05	1465.	2.918E-05	2.825E-05	1465.	1.327E-04	1.284E-04
SE	969.	969.	4.743E-05	4.591E-05	969.	5.188E-05	5.023E-05	969.	2.989E-04	2.892E-04
SSE	838.	838.	4.926E-05	4.769E-05	838.	5.357E-05	5.186E-05	838.	2.970E-04	2.874E-04
S	829.	829.	4.072E-05	3.942E-05	829.	3.975E-05	3.849E-05	829.	3.298E-04	3.191E-04
SSW	835.	835.	3.521E-05	3.408E-05	835.	3.424E-05	3.315E-05	835.	1.748E-04	1.691E-04
SW	628.	628.	6.779E-05	6.563E-05	628.	7.938E-05	7.685E-05	628.	5.333E-04	5.161E-04
WSW	533.	533.	7.919E-05	7.667E-05	533.	8.829E-05	8.548E-05	533.	7.164E-04	6.932E-04
W	524.	524.	7.990E-05	7.736E-05	524.	9.608E-05	9.302E-05	524.	9.223E-04	8.924E-04
WNW	643.	643.	5.023E-05	4.863E-05	643.	6.090E-05	5.896E-05	643.	6.002E-04	5.808E-04
NW	762.	762.	4.160E-05	4.028E-05	762.	4.841E-05	4.687E-05	762.	4.228E-04	4.090E-04
NNW	890.	890.	3.985E-05	3.858E-05	890.	4.152E-05	4.020E-05	890.	3.279E-04	3.172E-04

LASALLE SITE METEOROLOGICAL DATA 1/78 - 12/87

Table F-7 (Continued)

Maximum Offsite Finite Plume Gamma Dose Factors Based on 1 cm Depth at the Unrestricted Area Boundary for Xe-138

Direction	Unrestricted Area Bound Radius (meters)	Elevated(Stack) Release		Mixed Mode(Vent) Release			Ground Level Release			
		Radius (meters)	S (mrad/yr)/(uCi/sec)	SBAR (mrad/yr)/(uCi/sec)	Radius (meters)	V (mrad/yr)/(uCi/sec)	VBAR (mrad/yr)/(uCi/sec)	Radius (meters)	G (mrad/yr)/(uCi/sec)	GBAR (mrad/yr)/(uCi/sec)
N	1036.	1036.	3.926E-04	3.816E-04	1036.	4.523E-04	4.396E-04	1036.	3.178E-03	3.084E-03
NNE	1378.	1378.	3.160E-04	3.071E-04	1378.	3.536E-04	3.437E-04	1378.	2.117E-03	2.055E-03
NE	2408.	2408.	1.356E-04	1.318E-04	2408.	1.379E-04	1.340E-04	2408.	7.244E-04	7.032E-04
ENE	4450.	4450.	4.939E-05	4.799E-05	4450.	4.572E-05	4.443E-05	4450.	1.769E-04	1.718E-04
E	1996.	1996.	1.540E-04	1.497E-04	1996.	1.535E-04	1.492E-04	1996.	8.921E-04	8.659E-04
ESE	1465.	1465.	2.766E-04	2.689E-04	1465.	2.804E-04	2.725E-04	1465.	1.532E-03	1.487E-03
SE	969.	969.	3.938E-04	3.828E-04	969.	4.408E-04	4.285E-04	969.	2.641E-03	2.564E-03
SSE	838.	838.	4.037E-04	3.924E-04	838.	4.484E-04	4.358E-04	838.	2.628E-03	2.551E-03
S	829.	829.	3.457E-04	3.360E-04	829.	3.560E-04	3.460E-04	829.	2.809E-03	2.727E-03
SSW	835.	835.	3.277E-04	3.186E-04	835.	3.832E-04	3.724E-04	835.	1.828E-03	1.774E-03
SW	628.	628.	5.698E-04	5.538E-04	628.	7.209E-04	7.007E-04	628.	4.546E-03	4.412E-03
WSW	533.	533.	6.144E-04	5.973E-04	533.	7.121E-04	6.921E-04	533.	5.206E-03	5.053E-03
W	524.	524.	5.976E-04	5.809E-04	524.	7.318E-04	7.113E-04	524.	6.383E-03	6.195E-03
WNW	643.	643.	3.986E-04	3.875E-04	643.	4.887E-04	4.750E-04	643.	4.757E-03	4.616E-03
NW	762.	762.	3.457E-04	3.360E-04	762.	4.131E-04	4.016E-04	762.	3.746E-03	3.635E-03
NNW	890.	890.	3.330E-04	3.236E-04	890.	3.626E-04	3.525E-04	890.	3.069E-03	2.978E-03

LASALLE SITE METEOROLOGICAL DATA 1/78 - 12/87

Table F-7 (Continued)

Maximum Offsite Finite Plume Gamma Dose Factors Based on 1 cm Depth at the Unrestricted Area Boundary for Ar-41

Downwind Direction	Unrestricted Area Bound (meters)	Elevated(Stack) Release Radius (meters)	Release S SBAR (mrad/yr)/(uCi/sec)		Mixed Mode(Vent) Release Radius (meters)	Release V VBAR (mrad/yr)/(uCi/sec)		Ground Level Release Radius (meters)	Release G GBAR (mrad/yr)/(uCi/sec)	
N	1036.	1036.	4.746E-04	4.594E-04	1036.	5.528E-04	5.351E-04	1036.	4.557E-03	4.411E-03
NNE	1378.	1378.	3.954E-04	3.828E-04	1378.	4.439E-04	4.297E-04	1378.	3.203E-03	3.101E-03
NE	2408.	2408.	1.925E-04	1.863E-04	2408.	2.045E-04	1.980E-04	2408.	1.387E-03	1.343E-03
ENE	4450.	4450.	9.141E-05	8.848E-05	4450.	9.061E-05	8.772E-05	4450.	5.219E-04	5.052E-04
E	1996.	1996.	2.110E-04	2.043E-04	1996.	2.180E-04	2.110E-04	1996.	1.658E-03	1.605E-03
ESE	1465.	1465.	3.480E-04	3.368E-04	1465.	3.593E-04	3.478E-04	1465.	2.459E-03	2.381E-03
SE	969.	969.	4.711E-04	4.560E-04	969.	5.320E-04	5.149E-04	969.	3.715E-03	3.597E-03
SSE	838.	838.	4.761E-04	4.608E-04	838.	5.378E-04	5.206E-04	838.	3.671E-03	3.554E-03
S	829.	829.	4.168E-04	4.035E-04	829.	4.533E-04	4.388E-04	829.	3.823E-03	3.701E-03
SSW	835.	835.	3.994E-04	3.866E-04	835.	4.930E-04	4.772E-04	835.	2.700E-03	2.614E-03
SW	628.	628.	6.711E-04	6.496E-04	628.	8.591E-04	8.316E-04	628.	6.139E-03	5.943E-03
WSW	533.	533.	7.089E-04	6.862E-04	533.	8.229E-04	7.966E-04	533.	6.667E-03	6.453E-03
W	524.	524.	6.802E-04	6.584E-04	524.	8.291E-04	8.026E-04	524.	8.057E-03	7.799E-03
WNW	643.	643.	4.708E-04	4.558E-04	643.	5.716E-04	5.533E-04	643.	6.300E-03	6.099E-03
NW	762.	762.	4.123E-04	3.991E-04	762.	4.970E-04	4.811E-04	762.	5.173E-03	5.008E-03
NNW	890.	890.	4.025E-04	3.896E-04	890.	4.447E-04	4.305E-04	890.	4.374E-03	4.234E-03

LASALLE SITE METEOROLOGICAL DATA 1/78 - 12/87

Table F-7a

Maximum Offsite Finite Plume Gamma Dose Factors Based on 1 cm Depth at the Restricted Area Boundary for Kr-83m

Downwind Direction	Restricted Area Bound (meters)	Elevated(Stack) Release		Mixed Mode(Vent) Release			Ground Level Release			
		Radius (meters)	S (mrad/yr)/(uCi/sec)	SBAR	Radius (meters)	V (mrad/yr)/(uCi/sec)	VBAR	Radius (meters)	G (mrad/yr)/(uCi/sec)	GBAR
N	1036.	1036.	4.787E-07	3.609E-07	1036.	5.281E-07	3.982E-07	1036.	1.785E-04	1.346E-04
NNE	1378.	1378.	8.751E-07	6.599E-07	1378.	6.905E-07	5.206E-07	1378.	1.139E-04	8.586E-05
NE	1609.	1609.	6.873E-07	5.182E-07	1609.	7.291E-07	5.497E-07	1609.	8.106E-05	6.112E-05
ENE	1079.	1079.	4.160E-07	3.137E-07	1079.	8.010E-07	6.039E-07	1079.	1.322E-04	9.967E-05
E	1055.	1055.	3.476E-07	2.621E-07	1055.	9.181E-07	6.923E-07	1055.	1.483E-04	1.118E-04
ESE	1055.	1055.	4.371E-07	3.296E-07	1055.	1.175E-06	8.856E-07	1055.	1.394E-04	1.051E-04
SE	969.	969.	3.545E-07	2.673E-07	969.	1.267E-06	9.554E-07	969.	1.333E-04	1.005E-04
SSE	698.	698.	2.415E-07	1.821E-07	698.	1.646E-06	1.241E-06	698.	1.773E-04	1.337E-04
S	820.	820.	2.803E-07	2.114E-07	820.	1.047E-06	7.895E-07	820.	1.354E-04	1.021E-04
SSW	835.	835.	3.185E-07	2.401E-07	835.	1.071E-06	8.076E-07	835.	9.326E-05	7.032E-05
SW	628.	628.	3.177E-07	2.395E-07	628.	2.826E-06	2.131E-06	628.	2.305E-04	1.738E-04
WSW	533.	533.	2.617E-07	1.973E-07	533.	2.674E-06	2.017E-06	533.	2.568E-04	1.936E-04
W	524.	524.	2.327E-07	1.754E-07	524.	1.658E-06	1.250E-06	524.	3.352E-04	2.527E-04
WNW	643.	643.	1.714E-07	1.292E-07	643.	7.235E-07	5.455E-07	643.	2.728E-04	2.057E-04
NW	762.	762.	1.744E-07	1.315E-07	762.	4.391E-07	3.311E-07	762.	2.219E-04	1.673E-04
NNW	890.	890.	2.397E-07	1.807E-07	890.	3.334E-07	2.514E-07	890.	1.823E-04	1.374E-04

LASALLE SITE METEOROLOGICAL DATA 1/78 - 12/87

* = The restricted area boundary (RAB) was redefined in sectors E and ESE to 833 and 848 from 1055 and 1055 meters, respectively. As a result of this change of range, the dose factors were re-evaluated using the following equation. Here, F_R is the resulting dose factor at the new range (i.e. 833). F_{R_0} is the value provided in the above ODCM tables (i.e. S, SBAR, V, VBAR, G, GBAR). R_0 is the former RAB distance (i.e. 1055), and R is the RAB distance (i.e. 833).

$$F_R = F_{R_0} \left[\frac{R_0}{R} \right]^{1.5}$$

This analysis indicates that the change in range would increase the dose factor error by approximately 40%. Since this difference is well within the expected error of the current factors, no further adjustment in the above factors is considered necessary.

Note: Based on Reference 1 of Section F.2 and the formulas in Sections B.5 and B.6 of Appendix B.

Table F-7a (Continued)

Maximum Offsite Finite Plume Gamma Dose Factors Based on 1 cm Depth at the Restricted Area Boundary for Kr-85m

Downwind Direction	Restricted Area Bound (meters)	Elevated(Stack) Release		Mixed Mode(Vent) Release			Ground Level Release			
		Radius (meters)	S (mrad/yr)/(uCi/sec)	SBAR (mrad/yr)/(uCi/sec)	Radius (meters)	V (mrad/yr)/(uCi/sec)	VBAR (mrad/yr)/(uCi/sec)	Radius (meters)	G (mrad/yr)/(uCi/sec)	GBAR (mrad/yr)/(uCi/sec)
N	1036.	1036.	5.747E-05	5.560E-05	1036.	6.602E-05	6.388E-05	1036.	9.660E-04	9.252E-04
NNE	1378.	1378.	5.063E-05	4.896E-05	1378.	5.514E-05	5.334E-05	1378.	6.776E-04	6.496E-04
NE	1609.	1609.	3.632E-05	3.512E-05	1609.	3.847E-05	3.720E-05	1609.	5.003E-04	4.798E-04
ENE	1079.	1079.	4.315E-05	4.174E-05	1079.	4.569E-05	4.419E-05	1079.	7.345E-04	7.037E-04
E	1055.	1055.	4.572E-05	4.424E-05	1055.	5.053E-05	4.886E-05	1055.	8.134E-04	7.792E-04
ESE	1055.	1055.	5.730E-05	5.544E-05	1055.	6.298E-05	6.090E-05	1055.	8.020E-04	7.687E-04
SE	969.	969.	5.596E-05	5.415E-05	969.	6.610E-05	6.391E-05	969.	7.793E-04	7.470E-04
SSE	698.	698.	6.471E-05	6.263E-05	698.	7.905E-05	7.643E-05	698.	9.815E-04	9.404E-04
S	820.	820.	4.756E-05	4.603E-05	820.	5.386E-05	5.208E-05	820.	8.103E-04	7.769E-04
SSW	835.	835.	4.422E-05	4.279E-05	835.	5.351E-05	5.174E-05	835.	5.684E-04	5.450E-04
SW	628.	628.	7.281E-05	7.046E-05	628.	9.952E-05	9.618E-05	628.	1.285E-03	1.231E-03
WSW	533.	533.	7.757E-05	7.507E-05	533.	9.714E-05	9.388E-05	533.	1.389E-03	1.331E-03
W	524.	524.	7.601E-05	7.356E-05	524.	9.705E-05	9.385E-05	524.	1.687E-03	1.614E-03
WNW	643.	643.	5.286E-05	5.116E-05	643.	6.615E-05	6.399E-05	643.	1.327E-03	1.270E-03
NW	762.	762.	4.668E-05	4.518E-05	762.	5.688E-05	5.503E-05	762.	1.094E-03	1.047E-03
NNW	890.	890.	4.683E-05	4.532E-05	890.	5.142E-05	4.976E-05	890.	9.282E-04	8.885E-04

LASALLE SITE METEOROLOGICAL DATA 1/78 - 12/87

The restricted area boundary (RAB) was redefined in sectors E and ESE to 833 and 848 from 1055 and 1055 meters, respectively. As a result of this change of range, the dose factors were re-evaluated using the following equation. Here, F_R is the resulting dose factor at the new range (i.e. 833). F_{R_0} is the value provided in the above ODCM tables (i.e. S, SBAR, V, VBAR, G, GBAR). R_0 is the former RAB distance (i.e. 1055) and R is the RAB distance (i.e. 833).

$$F_R \approx F_{R_0} \left[\frac{R_0}{R} \right]^{1.5}$$

This analysis indicates that the change in range would increase the dose factor error by approximately 40%. Since this difference is well within the expected error of the current factors, no further adjustment in the above factors is considered necessary.

Table F-7a (Continued)

Maximum Offsite Finite Plume Gamma Dose Factors Based on 1 cm Depth at the Restricted Area Boundary for Kr-85

Downwind Direction	Restricted Area Bound (meters)	Elevated(Stack) Release		Mixed Mode(Vent) Release			Ground Level Release			
		Radius (meters)	S (mrad/yr)/(uCi/sec)	SBAR (mrad/yr)/(uCi/sec)	Radius (meters)	V (mrad/yr)/(uCi/sec)	VBAR (mrad/yr)/(uCi/sec)	Radius (meters)	G (mrad/yr)/(uCi/sec)	GBAR (mrad/yr)/(uCi/sec)
N	1036.	1036.	8.547E-07	8.265E-07	1036.	9.889E-07	9.563E-07	1036.	1.056E-05	1.021E-05
NNE	1378.	1378.	7.309E-07	7.068E-07	1378.	8.077E-07	7.811E-07	1378.	7.474E-06	7.227E-06
NE	1609.	1609.	5.225E-07	5.052E-07	1609.	5.615E-07	5.430E-07	1609.	5.559E-06	5.375E-06
ENE	1079.	1079.	6.463E-07	6.249E-07	1079.	6.707E-07	6.486E-07	1079.	8.057E-06	7.791E-06
E	1055.	1055.	6.819E-07	6.594E-07	1055.	7.385E-07	7.142E-07	1055.	8.923E-06	8.628E-06
ESE	1055.	1055.	8.484E-07	8.204E-07	1055.	9.108E-07	8.808E-07	1055.	8.808E-06	8.517E-06
SE	969.	969.	8.386E-07	8.110E-07	969.	9.583E-07	9.267E-07	969.	8.555E-06	8.273E-06
SSE	698.	698.	9.869E-07	9.543E-07	698.	1.153E-06	1.115E-06	698.	1.072E-05	1.036E-05
S	820.	820.	7.333E-07	7.091E-07	820.	8.154E-07	7.885E-07	820.	8.866E-06	8.574E-06
SSW	835.	835.	6.857E-07	6.630E-07	835.	8.402E-07	8.124E-07	835.	6.270E-06	6.063E-06
SW	628.	628.	1.142E-06	1.104E-06	628.	1.494E-06	1.444E-06	628.	1.401E-05	1.355E-05
WSW	533.	533.	1.211E-06	1.171E-06	533.	1.433E-06	1.386E-06	533.	1.510E-05	1.460E-05
W	524.	524.	1.172E-06	1.134E-06	524.	1.443E-06	1.395E-06	524.	1.824E-05	1.763E-05
WNW	643.	643.	8.185E-07	7.915E-07	643.	1.000E-06	9.670E-07	643.	1.436E-05	1.389E-05
NW	762.	762.	7.192E-07	6.954E-07	762.	8.694E-07	8.407E-07	762.	1.188E-05	1.148E-05
NNW	890.	890.	7.128E-07	6.893E-07	890.	7.849E-07	7.590E-07	890.	1.011E-05	9.778E-06

LASALLE SITE METEOROLOGICAL DATA 1/78 - 12/87

* = The restricted area boundary (RAB) was redefined in sectors E and ESE to 833 and 848 from 1055 and 1055 meters, respectively. As a result of this change of range, the dose factors were re-evaluated using the following equation. Here, F_R is the resulting dose factor at the new range (i.e. 833). F_{R_0} is the value provided in the above ODCM tables (i.e. S, SBAR, V, VBAR, G, GBAR). R_0 is the former RAB distance (i.e. 1055) and R is the RAB distance (i.e. 833).

$$F_R = F_{R_0} \left[\frac{R_0}{R} \right]^{1.5}$$

This analysis indicates that the change in range would increase the dose factor error by approximately 40%. Since this difference is well within the expected error of the current factors, no further adjustment in the above factors is considered necessary.

Table F-7a (Continued)

Maximum Offsite Finite Plume Gamma Dose Factors Based on 1 cm Depth at the Restricted Area Boundary for Kr-87

Downwind Direction	Restricted Area Bound (meters)	Elevated(Stack) Release		Mixed Mode(Vent) Release		Ground Level Release				
		Radius (meters)	S (mrad/yr)/(uCi/sec)	SBAR (mrad/yr)/(uCi/sec)	Radius (meters)	V (mrad/yr)/(uCi/sec)	VBAR (mrad/yr)/(uCi/sec)	Radius (meters)	G (mrad/yr)/(uCi/sec)	GBAR (mrad/yr)/(uCi/sec)
N	1036.	1036.	3.226E-04	3.135E-04	1036.	3.758E-04	3.652E-04	1036.	2.879E-03	2.795E-03
NNE	1378.	1378.	2.672E-04	2.597E-04	1378.	3.005E-04	2.920E-04	1378.	2.019E-03	1.960E-03
NE	1609.	1609.	1.908E-04	1.853E-04	1609.	2.038E-04	1.981E-04	1609.	1.480E-03	1.437E-03
ENE	1079.	1079.	2.430E-04	2.361E-04	1079.	2.534E-04	2.462E-04	1079.	2.192E-03	2.129E-03
E	1055.	1055.	2.601E-04	2.528E-04	1055.	2.785E-04	2.706E-04	1055.	2.423E-03	2.353E-03
ESE	1055.	1055.	3.217E-04	3.125E-04	1055.	3.412E-04	3.315E-04	1055.	2.407E-03	2.337E-03
SE	969.	969.	3.211E-04	3.120E-04	969.	3.612E-04	3.510E-04	969.	2.355E-03	2.287E-03
SSE	698.	698.	3.885E-04	3.776E-04	698.	4.423E-04	4.298E-04	698.	2.985E-03	2.898E-03
S	820.	820.	2.881E-04	2.800E-04	820.	3.117E-04	3.029E-04	820.	2.467E-03	2.396E-03
SSW	835.	835.	2.742E-04	2.665E-04	835.	3.400E-04	3.305E-04	835.	1.706E-03	1.657E-03
SW	628.	628.	4.614E-04	4.484E-04	628.	5.936E-04	5.769E-04	628.	3.903E-03	3.790E-03
WSW	533.	533.	4.880E-04	4.743E-04	533.	5.683E-04	5.523E-04	533.	4.251E-03	4.128E-03
W	524.	524.	4.675E-04	4.543E-04	524.	5.708E-04	5.547E-04	524.	5.136E-03	4.986E-03
WNW	643.	643.	3.224E-04	3.133E-04	643.	3.914E-04	3.804E-04	643.	4.001E-03	3.884E-03
NW	762.	762.	2.823E-04	2.743E-04	762.	3.397E-04	3.301E-04	762.	3.276E-03	3.180E-03
NNW	890.	890.	2.747E-04	2.669E-04	890.	3.031E-04	2.945E-04	890.	2.763E-03	2.683E-03

LASALLE SITE METEOROLOGICAL DATA 1/78 - 12/87

* = The restricted area boundary (RAB) was redefined in sectors E and ESE to 833 and 848 from 1055 and 1055 meters, respectively. As a result of this change of range, the dose factors were re-evaluated using the following equation. Here, F_R is the resulting dose factor at the new range (i.e. 833). F_{R_0} is the value provided in the above ODCM tables (i.e. S, SBAR, V, VBAR, G, GBAR). R_0 is the former RAB distance (i.e. 1055) and R is the RAB distance (i.e. 833).

$$F_R = F_{R_0} \left[\frac{R_0}{R} \right]^{1.5}$$

This analysis indicates that the change in range would increase the dose factor error by approximately 40%. Since this difference is well within the expected error of the current factors, no further adjustment in the above factors is considered necessary.

Table F-7a (Continued)

Maximum Offsite Finite Plume Gamma Dose Factors Based on 1 cm Depth at the Restricted Area Boundary for Kr-88

Downwind Direction	Restricted Area Bound (meters)	Elevated(Stack) Release		Mixed Mode(Vent) Release		Ground Level Release				
		Radius (meters)	S (mrad/yr)/(uCi/sec)	SBAR (meters)	V (mrad/yr)/(uCi/sec)	VBAR (meters)	G (mrad/yr)/(uCi/sec)	GBAR (meters)		
N	1036.	1036.	8.602E-04	8.374E-04	1036.	1.003E-03	9.769E-04	1036.	6.988E-03	6.787E-03
NNE	1378.	1378.	7.111E-04	6.922E-04	1378.	7.989E-04	7.777E-04	1378.	4.940E-03	4.798E-03
NE	1609.	1609.	5.067E-04	4.932E-04	1609.	5.485E-04	5.340E-04	1609.	3.656E-03	3.552E-03
ENE	1079.	1079.	6.528E-04	6.355E-04	1079.	6.769E-04	6.589E-04	1079.	5.337E-03	5.184E-03
E	1055.	1055.	6.915E-04	6.732E-04	1055.	7.419E-04	7.222E-04	1055.	5.907E-03	5.737E-03
ESE	1055.	1055.	8.514E-04	8.288E-04	1055.	9.030E-04	8.790E-04	1055.	5.857E-03	5.689E-03
SE	969.	969.	8.537E-04	8.311E-04	969.	9.571E-04	9.317E-04	969.	5.712E-03	5.549E-03
SSE	698.	698.	1.034E-03	1.007E-03	698.	1.172E-03	1.141E-03	698.	7.193E-03	6.986E-03
S	820.	820.	7.777E-04	7.571E-04	820.	8.513E-04	8.287E-04	820.	5.947E-03	5.777E-03
SSW	835.	835.	7.427E-04	7.231E-04	835.	9.375E-04	9.127E-04	835.	4.167E-03	4.048E-03
SW	628.	628.	1.246E-03	1.213E-03	628.	1.601E-03	1.559E-03	628.	9.396E-03	9.126E-03
WSW	533.	533.	1.314E-03	1.279E-03	533.	1.525E-03	1.485E-03	533.	1.017E-02	9.882E-03
W	524.	524.	1.249E-03	1.216E-03	524.	1.520E-03	1.480E-03	524.	1.225E-02	1.190E-02
WNW	643.	643.	8.669E-04	8.440E-04	643.	1.045E-03	1.017E-03	643.	9.595E-03	9.317E-03
NW	762.	762.	7.580E-04	7.379E-04	762.	9.125E-04	8.84E-04	762.	7.895E-03	7.666E-03
NNW	890.	890.	7.369E-04	7.174E-04	890.	8.161E-04	7.945E-04	890.	6.693E-03	6.500E-03

LASALLE SITE METEOROLOGICAL DATA 1/78 - 12/87

The restricted area boundary (RAB) was redefined in sectors E and ESE to 833 and 848 from 1055 and 1055 meters, respectively. As a result of this change of range, the dose factors were re-evaluated using the following equation. Here, F_R is the resulting dose factor at the new range (i.e. 833). F_{R_0} is the value provided in the above ODCM tables (i.e. S, SBAR, V, VBAR, G, GBAR). R_0 is the former RAB distance (i.e. 1055) and R is the RAB distance (i.e. 833).

$$F_R = F_{R_0} \left[\frac{R_0}{R} \right]^{1.5}$$

This analysis indicates that the change in range would increase the dose factor error by approximately 40%. Since this difference is well within the expected error of the current factors, no further adjustment in the above factors is considered necessary.

Table F-7a (Continued)

Maximum Offsite Finite Plume Gamma Dose Factors Based on 1 cm Depth at the Restricted Area Boundary for Kr-89

Downwind Direction	Restricted Area Bound (meters)	Elevated(Stack) Release		Mixed Mode(Vent) Release		Ground Level Release				
		Radius (meters)	S (mrad/yr)/(uCi/sec)	SBAR (mrad/yr)/(uCi/sec)	Radius (meters)	V (mrad/yr)/(uCi/sec)	VBAR (mrad/yr)/(uCi/sec)	Radius (meters)	G (mrad/yr)/(uCi/sec)	GBAR (mrad/yr)/(uCi/sec)
N	1036.	1036.	3.904E-04	3.794E-04	1036.	4.258E-04	4.139E-04	1036.	2.051E-03	1.992E-03
NNE	1378.	1378.	2.820E-04	2.741E-04	1378.	2.988E-04	2.904E-04	1378.	1.151E-03	1.118E-03
NE	1609.	1609.	1.750E-04	1.701E-04	1609.	1.654E-04	1.607E-04	1609.	6.564E-04	6.375E-04
ENE	1079.	1079.	2.703E-04	2.628E-04	1079.	2.619E-04	2.545E-04	1079.	1.450E-03	1.409E-03
E	1055.	1055.	3.041E-04	2.956E-04	1055.	2.972E-04	2.888E-04	1055.	1.569E-03	1.524E-03
ESE	1055.	1055.	3.931E-04	3.821E-04	1055.	3.909E-04	3.800E-04	1055.	1.682E-03	1.633E-03
SE	969.	969.	3.891E-04	3.782E-04	969.	4.188E-04	4.070E-04	969.	1.846E-03	1.793E-03
SSE	698.	698.	5.333E-04	5.184E-04	698.	5.797E-04	5.634E-04	698.	2.722E-03	2.643E-03
S	820.	820.	3.464E-04	3.367E-04	820.	3.312E-04	3.219E-04	820.	2.083E-03	2.023E-03
SSW	835.	835.	2.921E-04	2.839E-04	835.	2.779E-04	2.702E-04	835.	1.021E-03	9.916E-04
SW	628.	628.	5.830E-04	5.667E-04	628.	6.600E-04	6.415E-04	628.	3.274E-03	3.180E-03
WSW	533.	533.	6.913E-04	6.720E-04	533.	7.525E-04	7.314E-04	533.	4.592E-03	4.460E-03
W	524.	524.	6.961E-04	6.766E-04	524.	8.259E-04	8.028E-04	524.	5.967E-03	5.796E-03
WNW	643.	643.	4.295E-04	4.174E-04	643.	5.147E-04	5.003E-04	643.	3.746E-03	3.638E-03
NW	762.	762.	3.500E-04	3.402E-04	762.	4.035E-04	3.922E-04	762.	2.561E-03	2.488E-03
NNW	890.	890.	3.301E-04	3.208E-04	890.	3.415E-04	3.319E-04	890.	1.966E-03	1.909E-03

LASALLE SITE METEOROLOGICAL DATA 1/78 - 12/87

The restricted area boundary (RAB) was redefined in sectors E and ESE to 833 and 848 from 1055 and 1055 meters, respectively. As a result of this change of range, the dose factors were re-evaluated using the following equation. Here, F_R is the resulting dose factor at the new range (i.e. 833). F_{R_0} is the value provided in the above ODCM tables (i.e. S, SBAR, V, VBAR, G, GBAR). R_0 is the former RAB distance (i.e. 1055) and R is the RAB distance (i.e. 833).

$$F_R = F_{R_0} \left[\frac{R_0}{R} \right]^{1.5}$$

This analysis indicates that the change in range would increase the dose factor error by approximately 40%. Since this difference is well within the expected error of the current factors, no further adjustment in the above factors is considered necessary.

Table F-7a (Continued)

Maximum Offsite Finite Plume Gamma Dose Factors Based on 1 cm Depth at the Restricted Area Boundary for Kr-90

Downwind Direction	Restricted Area Bound (meters)	Elevated(Stack) Release		Mixed Mode(Vent) Release			Ground Level Release			
		Radius (meters)	S (mrad/yr)/(uCi/sec)	SBAR (mrad/yr)/(uCi/sec)	Radius (meters)	V (mrad/yr)/(uCi/sec)	VBAR (mrad/yr)/(uCi/sec)	Radius (meters)	G (mrad/yr)/(uCi/sec)	GBAR (mrad/yr)/(uCi/sec)
N	1036.	1036.	6.785E-05	6.586E-05	1036.	5.199E-05	5.047E-05	1036.	8.203E-05	7.954E-05
NNE	1378.	1378.	3.195E-05	3.102E-05	1378.	2.161E-05	2.098E-05	1378.	2.265E-05	2.196E-05
NE	1609.	1609.	1.240E-05	1.203E-05	1609.	6.949E-06	6.745E-06	1609.	7.357E-06	7.134E-06
ENE	1079.	1079.	3.718E-05	3.610E-05	1079.	2.538E-05	2.464E-05	1079.	4.577E-05	4.438E-05
E	1055.	1055.	4.582E-05	4.448E-05	1055.	3.257E-05	3.162E-05	1055.	6.817E-05	6.610E-05
ESE	1055.	1055.	6.315E-05	6.130E-05	1055.	5.071E-05	4.922E-05	1055.	1.078E-04	1.046E-04
SE	969.	969.	5.843E-05	5.673E-05	969.	5.324E-05	5.168E-05	969.	1.365E-04	1.324E-04
SSE	698.	698.	1.170E-04	1.136E-04	698.	1.103E-04	1.070E-04	698.	2.578E-04	2.500E-04
S	820.	820.	5.233E-05	5.081E-05	820.	3.888E-05	3.775E-05	820.	1.108E-04	1.075E-04
SSW	835.	835.	3.062E-05	2.972E-05	835.	1.274E-05	1.237E-05	835.	1.835E-05	1.779E-05
SW	628.	628.	9.754E-05	9.470E-05	628.	6.538E-05	6.347E-05	628.	1.410E-04	1.368E-04
WSW	533.	533.	1.892E-04	1.836E-04	533.	1.525E-04	1.480E-04	533.	4.861E-04	4.713E-04
W	524.	524.	2.165E-04	2.101E-04	524.	2.185E-04	2.121E-04	524.	8.427E-04	8.170E-04
WNW	643.	643.	1.018E-04	9.883E-05	643.	1.008E-04	9.787E-05	643.	3.141E-04	3.045E-04
NW	762.	762.	6.634E-05	6.440E-05	762.	5.815E-05	5.645E-05	762.	1.306E-04	1.267E-04
NNW	890.	890.	5.725E-05	5.558E-05	890.	4.336E-05	4.209E-05	890.	8.819E-05	8.551E-05

LASALLE SITE METEOROLOGICAL DATA 1/78 - 12/87

* = The restricted area boundary (RAB) was redefined in sectors E and ESE to 833 and 848 from 1055 and 1055 meters, respectively. As a result of this change of range, the dose factors were re-evaluated using the following equation. Here, F_R is the resulting dose factor at the new range (i.e. 833). F_{R_0} is the value provided in the above ODCM tables (i.e. S, SBAR, V, VBAR, G, GBAR). R_0 is the former RAB distance (i.e. 1055) and R is the RAB distance (i.e. 833).

$$F_R = F_{R_0} \left[\frac{R_0}{R} \right]^{1.5}$$

This analysis indicates that the change in range would increase the dose factor error by approximately 40%. Since this difference is well within the expected error of the current factors, no further adjustment in the above factors is considered necessary.

Table F-7a (Continued)

Maximum Offsite Finite Plume Gamma Dose Factors Based on 1 cm Depth at the Restricted Area Boundary for Xe-131m

Downwind Direction	Restricted Area Bound (meters)	Elevated(Stack) Release		Mixed Mode(Vent) Release		Ground Level Release				
		Radius (meters)	S (mrad/yr)/(uCi/sec)	SBAR (mrad/yr)/(uCi/sec)	Radius (meters)	V (mrad/yr)/(uCi/sec)	VBAR (mrad/yr)/(uCi/sec)	Radius (meters)	G (mrad/yr)/(uCi/sec)	GBAR (mrad/yr)/(uCi/sec)
N	1036.	1036.	1.606E-06	1.473E-06	1036.	1.827E-06	1.679E-06	1036.	1.645E-04	1.283E-04
NNE	1378.	1378.	1.778E-06	1.572E-06	1378.	1.726E-06	1.553E-06	1378.	1.072E-04	8.384E-05
NE	1609.	1609.	1.327E-06	1.167E-06	1609.	1.409E-06	1.239E-06	1609.	7.747E-05	6.064E-05
ENE	1079.	1079.	1.254E-06	1.143E-06	1079.	1.612E-06	1.423E-06	1079.	1.225E-04	9.563E-05
E	1055.	1055.	1.249E-06	1.150E-06	1055.	1.806E-06	1.592E-06	1055.	1.376E-04	1.073E-04
ESE	1055.	1055.	1.566E-06	1.442E-06	1055.	2.270E-06	1.998E-06	1055.	1.298E-04	1.014E-04
SE	969.	969.	1.472E-06	1.365E-06	969.	2.406E-06	2.115E-06	969.	1.240E-04	9.696E-05
SSE	698.	698.	1.566E-06	1.476E-06	698.	2.969E-06	2.597E-06	698.	1.624E-04	1.267E-04
S	820.	820.	1.238E-06	1.151E-06	820.	1.983E-06	1.742E-06	820.	1.253E-04	9.802E-05
SSW	835.	835.	1.196E-06	1.103E-06	835.	2.003E-06	1.755E-06	835.	8.798E-05	6.885E-05
SW	628.	628.	1.802E-06	1.691E-06	628.	4.345E-06	3.728E-06	628.	2.109E-04	1.646E-04
WSW	533.	533.	1.859E-06	1.755E-06	533.	4.161E-06	3.577E-06	533.	2.324E-04	1.813E-04
W	524.	524.	1.800E-06	1.703E-06	524.	3.359E-06	2.972E-06	524.	3.000E-04	2.335E-04
WNW	643.	643.	1.263E-06	1.194E-06	643.	1.976E-06	1.791E-06	643.	2.446E-04	1.902E-04
NW	762.	762.	1.135E-06	1.069E-06	762.	1.561E-06	1.437E-06	762.	2.005E-04	1.560E-04
NNW	890.	890.	1.191E-06	1.112E-06	890.	1.363E-06	1.263E-06	890.	1.664E-04	1.295E-04

LASALLE SITE METEOROLOGICAL DATA 1/78 - 12/87

The restricted area boundary (RAB) was redefined in sectors E and ESE to 833 and 848 from 1055 and 1055 meters, respectively. As a result of this change of range, the dose factors were re-evaluated using the following equation. Here, F_R is the resulting dose factor at the new range (i.e. 833). F_{R_0} is the value provided in the above ODCM tables (i.e. S, SBAR, V, VBAR, G, GBAR). R_0 is the former RAB distance (i.e. 1055) and R is the RAB distance (i.e. 833).

$$F_R = F_{R_0} \left[\frac{R_0}{R} \right]^{1.5}$$

This analysis indicates that the change in range would increase the dose factor error by approximately 40%. Since this difference is well within the expected error of the current factors, no further adjustment in the above factors is considered necessary.

Table F-7a (Continued)

Maximum Offsite Finite Plume Gamma Dose Factors Based on 1 cm Depth at the Restricted Area Boundary for Xe-133m

Downwind Direction	Restricted Area Bound (meters)	Elevated(Stack) Release		Mixed Mode(Vent) Release			Ground Level Release			
		Radius (meters)	S (mrad/yr)/(uCi/sec)	SBAR	Radius (meters)	V (mrad/yr)/(uCi/sec)	VBAR	Radius (meters)	G (mrad/yr)/(uCi/sec)	GBAR
N	1036.	1036.	8.557E-06	8.199E-06	1036.	9.814E-06	9.407E-06	1036.	2.822E-04	2.410E-04
NNE	1378.	1378.	7.917E-06	7.509E-06	1378.	8.400E-06	8.009E-06	1378.	1.901E-04	1.633E-04
NE	1609.	1609.	5.729E-06	5.423E-06	1609.	6.093E-06	5.768E-06	1609.	1.389E-04	1.195E-04
ENE	1079.	1079.	6.486E-06	6.205E-06	1079.	7.141E-06	6.771E-06	1079.	2.121E-04	1.815E-04
E	1055.	1055.	6.770E-06	6.492E-06	1055.	7.917E-06	7.501E-06	1055.	2.368E-04	2.024E-04
ESE	1055.	1055.	8.481E-06	8.132E-06	1055.	9.879E-06	9.355E-06	1055.	2.276E-04	1.951E-04
SE	969.	969.	8.229E-06	7.903E-06	969.	1.039E-05	9.834E-06	969.	2.189E-04	1.879E-04
SSE	698.	698.	9.363E-06	9.021E-06	698.	1.250E-05	1.181E-05	698.	2.815E-04	2.409E-04
S	820.	820.	6.991E-06	6.718E-06	820.	8.532E-06	8.075E-06	820.	2.236E-04	1.923E-04
SSW	835.	835.	6.541E-06	6.276E-06	835.	8.500E-06	8.036E-06	835.	1.574E-04	1.354E-04
SW	628.	628.	1.059E-05	1.020E-05	628.	1.637E-05	1.535E-05	628.	3.668E-04	3.140E-04
WSW	533.	533.	1.121E-05	1.081E-05	533.	1.588E-05	1.490E-05	533.	4.005E-04	3.423E-04
W	524.	524.	1.096E-05	1.056E-05	524.	1.504E-05	1.427E-05	524.	5.039E-04	4.287E-04
WNW	643.	643.	7.648E-06	7.374E-06	643.	9.956E-06	9.510E-06	643.	4.055E-04	3.441E-04
NW	762.	762.	6.774E-06	6.526E-06	762.	8.435E-06	8.088E-06	762.	3.334E-04	2.831E-04
NNW	890.	890.	6.855E-06	6.594E-06	890.	7.588E-06	7.286E-06	890.	2.794E-04	2.377E-04

LASALLE SITE METEOROLOGICAL DATA 1/78 - 12/87

The restricted area boundary (RAB) was redefined in sectors E and ESE to 833 and 848 from 1055 and 1055 meters, respectively. As a result of this change of range, the dose factors were re-evaluated using the following equation. Here, F_R is the resulting dose factor at the new range (i.e. 833). F_{R_0} is the value provided in the above ODCM tables (i.e. S, SBAR, V, VBAR, G, GBAR). R_0 is the former RAB distance (i.e. 1055) and R is the RAB distance (i.e. 833).

$$F_R = F_{R_0} \left[\frac{R_0}{R} \right]^{1.5}$$

This analysis indicates that the change in range would increase the dose factor error by approximately 40%. Since this difference is well within the expected error of the current factors, no further adjustment in the above factors is considered necessary.

Table F-7a (Continued)

Maximum Offsite Finite Plume Gamma Dose Factors Based on 1 cm Depth at the Restricted Area Boundary for Xe-133

Downwind Direction	Restricted Area Bound Radius (meters)	Elevated(Stack) Release		Mixed Mode(Vent) Release			Ground Level Release			
		Radius (meters)	S (mrad/yr)/(uCi/sec)	SBAR (meters)	V (mrad/yr)/(uCi/sec)	VBAR (meters)	Radius (meters)	G (mrad/yr)/(uCi/sec)	GBAR (meters)	
N	1036.	1036.	7.010E-06	6.757E-06	1036.	7.933E-06	7.649E-06	1036.	3.136E-04	2.785E-04
NNE	1378.	1378.	6.939E-06	6.629E-06	1378.	7.149E-06	6.860E-06	1378.	2.132E-04	1.903E-04
NE	1609.	1609.	5.088E-06	4.853E-06	1609.	5.323E-06	5.076E-06	1609.	1.562E-04	1.397E-04
ENE	1079.	1079.	5.306E-06	5.106E-06	1079.	6.045E-06	5.769E-06	1079.	2.362E-04	2.101E-04
E	1055.	1055.	5.535E-06	5.340E-06	1055.	6.764E-06	6.452E-06	1055.	2.632E-04	2.338E-04
ESE	1055.	1055.	7.016E-06	6.769E-06	1055.	8.566E-06	8.169E-06	1055.	2.543E-04	2.266E-04
SE	969.	969.	6.641E-06	6.416E-06	969.	8.978E-06	8.558E-06	969.	2.450E-04	2.185E-04
SSE	698.	698.	7.217E-06	6.994E-06	698.	1.073E-05	1.021E-05	698.	3.132E-04	2.785E-04
S	820.	820.	5.369E-06	5.188E-06	820.	7.024E-06	6.687E-06	820.	2.515E-04	2.246E-04
SSW	835.	835.	4.969E-06	4.793E-06	835.	6.598E-06	6.266E-06	835.	1.770E-04	1.582E-04
SW	628.	628.	7.798E-06	7.549E-06	628.	1.362E-05	1.285E-05	628.	4.090E-04	3.640E-04
WSW	533.	533.	8.245E-06	7.992E-06	533.	1.326E-05	1.252E-05	533.	4.447E-04	3.951E-04
W	524.	524.	8.166E-06	7.919E-06	524.	1.220E-05	1.164E-05	524.	5.551E-04	4.911E-04
WNW	643.	643.	5.715E-06	5.541E-06	643.	7.885E-06	7.574E-06	643.	4.444E-04	3.922E-04
NW	762.	762.	5.117E-06	4.958E-06	762.	6.538E-06	6.303E-06	762.	3.661E-04	3.233E-04
NNW	890.	890.	5.340E-06	5.165E-06	890.	5.911E-06	5.708E-06	890.	3.060E-04	2.725E-04

LASALLE SITE METEOROLOGICAL DATA 1/78 - 12/87

* = The restricted area boundary (RAB) was redefined in sectors E and ESE to 833 and 848 from 1055 and 1055 meters, respectively. As a result of this change of range, the dose factors were re-evaluated using the following equation. Here, F_R is the resulting dose factor at the new range (i.e. 833). F_{R_0} is the value provided in the above ODCM tables (i.e. S, SBAR, V, VBAR, G, GBAR). R_0 is the former RAB distance (i.e. 1055) and R is the RAB distance (i.e. 833).

$$F_R = F_{R_0} \left[\frac{R_0}{R} \right]^{1.5}$$

This analysis indicates that the change in range would increase the dose factor error by approximately 40%. Since this difference is well within the expected error of the current factors, no further adjustment in the above factors is considered necessary.

Table F-7a (Continued)

Maximum Offsite Finite Plume Gamma Dose Factors Based on 1 cm Depth at the Restricted Area Boundary for Xe-135m

Downwind Direction	Restricted Area Bound (meters)	Elevated(Stack) Release		Mixed Mode(Vent) Release			Ground Level Release			
		Radius (meters)	S (mrad/yr)/(uCi/sec)	SBAR (mrad/yr)/(uCi/sec)	Radius (meters)	V (mrad/yr)/(uCi/sec)	VBAR (mrad/yr)/(uCi/sec)	Radius (meters)	G (mrad/yr)/(uCi/sec)	GBAR (mrad/yr)/(uCi/sec)
N	1036.	1036.	1.396E-04	1.349E-04	1036.	1.598E-04	1.545E-04	1036.	1.531E-03	1.475E-03
NNE	1378.	1378.	1.151E-04	1.113E-04	1378.	1.274E-04	1.232E-04	1378.	1.019E-03	9.821E-04
NE	1609.	1609.	8.046E-05	7.779E-05	1609.	8.260E-05	7.985E-05	1609.	7.033E-04	6.778E-04
ENE	1079.	1079.	1.024E-04	9.898E-05	1079.	1.064E-04	1.028E-04	1079.	1.147E-03	1.105E-03
E	1055.	1055.	1.121E-04	1.084E-04	1055.	1.183E-04	1.144E-04	1055.	1.253E-03	1.207E-03
ESE	1055.	1055.	1.411E-04	1.365E-04	1055.	1.490E-04	1.441E-04	1055.	1.256E-03	1.211E-03
SE	969.	969.	1.389E-04	1.343E-04	969.	1.575E-04	1.522E-04	969.	1.262E-03	1.216E-03
SSE	698.	698.	1.692E-04	1.636E-04	698.	1.955E-04	1.890E-04	698.	1.667E-03	1.606E-03
S	820.	820.	1.196E-04	1.157E-04	820.	1.251E-04	1.209E-04	820.	1.363E-03	1.314E-03
SSW	835.	835.	1.104E-04	1.068E-04	835.	1.260E-04	1.218E-04	835.	8.762E-04	8.444E-04
SW	628.	628.	1.904E-04	1.841E-04	628.	2.444E-04	2.363E-04	628.	2.173E-03	2.094E-03
WSW	533.	533.	2.063E-04	1.995E-04	533.	2.427E-04	2.345E-04	533.	2.479E-03	2.388E-03
W	524.	524.	2.033E-04	1.966E-04	524.	2.511E-04	2.427E-04	524.	3.050E-03	2.937E-03
WNW	643.	643.	1.363E-04	1.318E-04	643.	1.687E-04	1.631E-04	643.	2.286E-03	2.201E-03
NW	762.	762.	1.187E-04	1.148E-04	762.	1.423E-04	1.376E-04	762.	1.806E-03	1.739E-03
NNW	890.	890.	1.161E-04	1.122E-04	890.	1.259E-04	1.217E-04	890.	1.482E-03	1.427E-03

LASALLE SITE METEOROLOGICAL DATA 1/78 - 12/87

The restricted area boundary (RAB) was redefined in sectors E and ESE to 833 and 848 from 1055 and 1055 meters, respectively. As a result of this change of range, the dose factors were re-evaluated using the following equation. Here, F_R is the resulting dose factor at the new range (i.e. 833). F_{R_0} is the value provided in the above ODCM tables (i.e. S, SBAR, V, VBAR, G, GBAR). R_0 is the former RAB distance (i.e. 1055) and R is the RAB distance (i.e. 833).

$$F_R = F_{R_0} \left[\frac{R_0}{R} \right]^{1.5}$$

This analysis indicates that the change in range would increase the dose factor error by approximately 40%. Since this difference is well within the expected error of the current factors, no further adjustment in the above factors is considered necessary.

Table F-7a (Continued)

Maximum Offsite Finite Plume Gamma Dose Factors Based on 1 cm Depth at the Restricted Area Boundary for Xe-135

Downwind Direction	Restricted Area Bound (meters)	Elevated(Stack) Release		Mixed Mode(Vent) Release			Ground Level Release			
		Radius (meters)	S (mrad/yr)/(uCi/sec)	SBAR (mrad/yr)/(uCi/sec)	Radius (meters)	V (mrad/yr)/(uCi/sec)	VBAR (mrad/yr)/(uCi/sec)	Radius (meters)	G (mrad/yr)/(uCi/sec)	GBAR (mrad/yr)/(uCi/sec)
N	1036.	1036.	8.165E-05	7.902E-05	1036.	9.387E-05	9.085E-05	1036.	1.302E-03	1.257E-03
NNE	1378.	1378.	7.171E-05	6.940E-05	1378.	7.821E-05	7.569E-05	1378.	9.178E-04	8.866E-04
NE	1609.	1609.	5.140E-05	4.974E-05	1609.	5.463E-05	5.286E-05	1609.	6.801E-04	6.570E-04
ENE	1079.	1079.	6.139E-05	5.942E-05	1079.	6.476E-05	6.267E-05	1079.	9.912E-04	9.573E-04
E	1055.	1055.	6.493E-05	6.284E-05	1055.	7.155E-05	6.924E-05	1055.	1.097E-03	1.060E-03
ESE	1055.	1055.	8.130E-05	7.869E-05	1055.	8.905E-05	8.617E-05	1055.	1.083E-03	1.046E-03
SE	969.	969.	7.953E-05	7.697E-05	969.	9.346E-05	9.044E-05	969.	1.052E-03	1.017E-03
SSE	698.	698.	9.205E-05	8.910E-05	698.	1.117E-04	1.081E-04	698.	1.321E-03	1.276E-03
S	820.	820.	6.782E-05	6.564E-05	820.	7.666E-05	7.419E-05	820.	1.093E-03	1.056E-03
SSW	835.	835.	6.306E-05	6.103E-05	835.	7.636E-05	7.389E-05	835.	7.699E-04	7.438E-04
SW	628.	628.	1.039E-04	1.006E-04	628.	1.409E-04	1.363E-04	628.	1.729E-03	1.670E-03
WSW	533.	533.	1.106E-04	1.071E-04	533.	1.372E-04	1.328E-04	533.	1.864E-03	1.801E-03
W	524.	524.	1.082E-04	1.048E-04	524.	1.374E-04	1.329E-04	524.	2.256E-03	2.179E-03
WNW	643.	643.	7.538E-05	7.296E-05	643.	9.395E-05	9.092E-05	643.	1.775E-03	1.713E-03
NW	762.	762.	6.654E-05	6.440E-05	762.	8.098E-05	7.838E-05	762.	1.466E-03	1.415E-03
NNW	890.	890.	6.671E-05	6.456E-05	890.	7.327E-05	7.092E-05	890.	1.247E-03	1.204E-03

LASALLE SITE METEOROLOGICAL DATA 1/78 - 12/87

* = The restricted area boundary (RAB) was redefined in sectors E and ESE to 833 and 848 from 1055 and 1055 meters, respectively. As a result of this change of range, the dose factors were re-evaluated using the following equation. Here, F_R is the resulting dose factor at the new range (i.e. 833). F_{R_0} is the value provided in the above ODCM tables (i.e. S, SBAR, V, VBAR, G, GBAR). R_0 is the former RAB distance (i.e. 1055) and R is the RAB distance (i.e. 833).

$$F_R = F_{R_0} \left[\frac{R_0}{R} \right]^{1.5}$$

This analysis indicates that the change in range would increase the dose factor error by approximately 40%. Since this difference is well within the expected error of the current factors, no further adjustment in the above factors is considered necessary.

Table F-7a (Continued)

Maximum Offsite Finite Plume Gamma Dose Factors Based on 1 cm Depth at the Restricted Area Boundary for Xe-137

Downwind Direction	Restricted Area Bound (meters)	Elevated(Stack) Release		Mixed Mode(Vent) Release			Ground Level Release		
		Radius (meters)	S SBAR (mrad/yr)/(uCi/sec)	Radius (meters)	V VBAR (mrad/yr)/(uCi/sec)	Radius (meters)	G GBAR (mrad/yr)/(uCi/sec)		
N	1036.	1036.	4.780E-05 4.627E-05	1036.	5.242E-05 5.074E-05	1036.	3.409E-04 3.298E-04		
NNE	1378.	1378.	3.585E-05 3.471E-05	1378.	3.814E-05 3.692E-05	1378.	1.975E-04 1.911E-04		
NE	1609.	1609.	2.282E-05 2.209E-05	1609.	2.185E-05 2.115E-05	1609.	1.166E-04 1.128E-04		
ENE	1079.	1079.	3.342E-05 3.236E-05	1079.	3.282E-05 3.177E-05	1079.	2.437E-04 2.358E-04		
E	1055.	1055.	3.741E-05 3.622E-05	1055.	3.716E-05 3.597E-05	1055.	2.625E-04 2.540E-04		
ESE	1055.	1055.	4.827E-05 4.673E-05	1055.	4.871E-05 4.715E-05	1055.	2.765E-04 2.676E-04		
SE	969.	969.	4.743E-05 4.591E-05	969.	5.188E-05 5.023E-05	969.	2.489E-04 2.892E-04		
SSE	698.	698.	6.273E-05 6.073E-05	698.	6.983E-05 6.760E-05	698.	4.329E-04 4.189E-04		
S	820.	820.	4.133E-05 4.002E-05	820.	4.042E-05 3.913E-05	820.	3.373E-04 3.264E-04		
SSW	835.	835.	3.521E-05 3.408E-05	835.	3.424E-05 3.315E-05	835.	1.748E-04 1.691E-04		
SW	628.	628.	6.779E-05 6.563E-05	628.	7.938E-05 7.685E-05	628.	5.333E-04 5.161E-04		
WSW	533.	533.	7.919E-05 7.667E-05	533.	8.829E-05 8.548E-05	533.	7.164E-04 6.932E-04		
W	524.	524.	7.990E-05 7.736E-05	524.	9.608E-05 9.302E-05	524.	9.223E-04 8.924E-04		
WNW	643.	643.	5.023E-05 4.863E-05	643.	6.090E-05 5.896E-05	643.	6.002E-04 5.808E-04		
NW	762.	762.	4.160E-05 4.028E-05	762.	4.841E-05 4.687E-05	762.	4.228E-04 4.090E-04		
NNW	890.	890.	3.985E-05 3.858E-05	890.	4.152E-05 4.020E-05	890.	3.279E-04 3.172E-04		

LASALLE SITE METEOROLOGICAL DATA 1/78 - 12/87

* = The restricted area boundary (RAB) was redefined in sectors E and ESE to 833 and 848 from 1055 and 1055 meters, respectively. As a result of this change of range, the dose factors were re-evaluated using the following equation. Here, F_R is the resulting dose factor at the new range (i.e. 833). F_{R_0} is the value provided in the above ODCM tables (i.e. S, SBAR, V, VBAR, G, GBAR). R_0 is the former RAB distance (i.e. 1055) and R is the RAB distance (i.e. 833).

$$F_R = F_{R_0} \left[\frac{R_0}{R} \right]^{1.5}$$

This analysis indicates that the change in range would increase the dose factor error by approximately 40%. Since this difference is well within the expected error of the current factors, no further adjustment in the above factors is considered necessary.

Table F-7a (Continued)

Maximum Offsite Finite Plume Gamma Dose Factors Based on 1 cm Depth at the Restricted Area Boundary for Xe-138

Downwind Direction	Restricted Area Bound (meters)	Elevated(Stack) Release		Mixed Mode(Vent) Release		Ground Level Release				
		Radius (meters)	S (mrad/yr)/(uCi/sec)	SBAR	Radius (meters)	V (mrad/yr)/(uCi/sec)	VBAR	Radius (meters)	G (mrad/yr)/(uCi/sec)	GBAR
N	1036.	1036.	3.926E-04	3.816E-04	1036.	4.523E-04	4.396E-04	1036.	3.178E-03	3.084E-03
NNE	1378.	1378.	3.160E-04	3.071E-04	1378.	3.536E-04	3.437E-04	1378.	2.117E-03	2.055E-03
NE	1609.	1609.	2.198E-04	2.136E-04	1609.	2.272E-04	2.208E-04	1609.	1.457E-03	1.414E-03
ENE	1079.	1079.	2.887E-04	2.806E-04	1079.	2.996E-04	2.912E-04	1079.	2.383E-03	2.313E-03
E	1055.	1055.	3.167E-04	3.079E-04	1055.	3.323E-04	3.230E-04	1055.	2.600E-03	2.524E-03
ESE	1055.	1055.	3.961E-04	3.850E-04	1055.	4.149E-04	4.032E-04	1055.	2.618E-03	2.541E-03
SE	969.	969.	3.938E-04	3.828E-04	969.	4.408E-04	4.285E-04	969.	2.641E-03	2.564E-03
SSE	698.	698.	4.911E-04	4.773E-04	698.	5.540E-04	5.384E-04	698.	3.494E-03	3.391E-03
S	820.	820.	3.498E-04	3.400E-04	820.	3.606E-04	3.505E-04	820.	2.857E-03	2.773E-03
SSW	835.	835.	3.277E-04	3.186E-04	835.	3.832E-04	3.724E-04	835.	1.828E-03	1.774E-03
SW	628.	628.	5.698E-04	5.538E-04	628.	7.209E-04	7.007E-04	628.	4.546E-03	4.412E-03
WSW	533.	533.	6.144E-04	5.973E-04	533.	7.121E-04	6.921E-04	533.	5.206E-03	5.053E-03
W	524.	524.	5.976E-04	5.809E-04	524.	7.318E-04	7.113E-04	524.	6.383E-03	6.195E-03
WNW	643.	643.	3.986E-04	3.875E-04	643.	4.887E-04	4.750E-04	643.	4.757E-03	4.616E-03
NW	762.	762.	3.457E-04	3.360E-04	762.	4.131E-04	4.016E-04	762.	3.746E-03	3.635E-03
NNW	890.	890.	3.330E-04	3.236E-04	890.	3.626E-04	3.525E-04	890.	3.069E-03	2.978E-03

LASALLE SITE METEOROLOGICAL DATA 1/78 - 12/87

* = The restricted area boundary (RAB) was redefined in sectors E and ESE to 833 and 848 from 1055 and 1055 meters, respectively. As a result of this change of range, the dose factors were re-evaluated using the following equation. Here, F_R is the resulting dose factor at the new range (i.e. 833). F_{R_0} is the value provided in the above ODCM tables (i.e. S, SBAR, V, VBAR, G, GBAR). R_0 is the former RAB distance (i.e. 1055) and R is the RAB distance (i.e. 833).

$$F_R = F_{R_0} \left[\frac{R_0}{R} \right] \exp 1.5$$

This analysis indicates that the change in range would increase the dose factor error by approximately 40%. Since this difference is well within the expected error of the current factors, no further adjustment in the above factors is considered necessary.

Table F-7a (Continued)

Maximum Offsite Finite Plume Gamma Dose Factors Based on 1 cm Depth at the Restricted Area Boundary for Ar-41

Downwind Direction	Restricted Area Bound (meters)	Elevated(Stack) Release		Mixed Mode(Vent) Release			Ground Level Release			
		Radius (meters)	S (mrad/yr)/(uCi/sec)	SBAR (mrad/yr)/(uCi/sec)	Radius (meters)	V (mrad/yr)/(uCi/sec)	VBAR (mrad/yr)/(uCi/sec)	Radius (meters)	G (mrad/yr)/(uCi/sec)	GBAR (mrad/yr)/(uCi/sec)
N	1036.	1036.	4.746E-04	4.594E-04	1036.	5.528E-04	5.351E-04	1036.	4.557E-03	4.411E-03
NNE	1378.	1378.	3.954E-04	3.828E-04	1378.	4.439E-04	4.297E-04	1378.	3.203E-03	3.101E-03
NE	1609.	1609.	2.825E-04	2.734E-04	1609.	3.029E-04	2.932E-04	1609.	2.358E-03	2.283E-03
ENE	1079.	1079.	3.582E-04	3.468E-04	1079.	3.729E-04	3.610E-04	1079.	3.472E-03	3.361E-03
E	1055.	1055.	3.818E-04	3.696E-04	1055.	4.100E-04	3.969E-04	1055.	3.841E-03	3.718E-03
ESE	1055.	1055.	4.725E-04	4.574E-04	1055.	5.025E-04	4.864E-04	1055.	3.807E-03	3.685E-03
SE	969.	969.	4.711E-04	4.560E-04	969.	5.320E-04	5.149E-04	969.	3.715E-03	3.597E-03
SSE	698.	698.	5.672E-04	5.490E-04	698.	6.491E-04	6.284E-04	698.	4.695E-03	4.545E-03
S	820.	820.	4.212E-04	4.077E-04	820.	4.585E-04	4.438E-04	820.	3.879E-03	3.755E-03
SSW	835.	835.	3.994E-04	3.866E-04	835.	4.930E-04	4.772E-04	835.	2.700E-03	2.614E-03
SW	628.	628.	6.711E-04	6.496E-04	628.	8.591E-04	8.316E-04	628.	6.139E-03	5.943E-03
WSW	533.	533.	7.089E-04	6.862E-04	533.	8.229E-04	7.966E-04	533.	6.667E-03	6.453E-03
W	524.	524.	6.802E-04	6.584E-04	524.	8.291E-04	8.026E-04	524.	8.057E-03	7.799E-03
WNW	643.	643.	4.708E-04	4.558E-04	643.	5.716E-04	5.533E-04	643.	6.300E-03	6.099E-03
NW	762.	762.	4.123E-04	3.991E-04	762.	4.970E-04	4.811E-04	762.	5.173E-03	5.008E-03
NNW	890.	890.	4.025E-04	3.896E-04	890.	4.447E-04	4.305E-04	890.	4.374E-03	4.234E-03

LASALLE SITE METEOROLOGICAL DATA 1/78 - 12/87

* = The restricted area boundary (RAB) was redefined in sectors E and ESE to 833 and 848 from 1055 and 1055 meters, respectively. As a result of this change of range, the dose factors were re-evaluated using the following equation. Here, F_R is the resulting dose factor at the new range (i.e. 833). F_{R_0} is the value provided in the above ODCM tables (i.e. S, SBAR, V, VBAR, G, GBAR). R_0 is the former RAB distance (i.e. 1055) and R is the RAB distance (i.e. 833).

$$F_R = F_{R_0} \left[\frac{R_0}{R} \right]^{1.5}$$

This analysis indicates that the change in range would increase the dose factor error by approximately 40%. Since this difference is well within the expected error of the current factors, no further adjustment in the above factors is considered necessary.

Table F-8
Parameters for Calculations of N-16 Skyshine Radiation
From LaSalle

Location Number k	Activity	Occupancy Hours OH_k	Occupancy Factor ^a OF_k	Shielding Factor SF_k	Distance R_k (m)
1	Living at home (nearest resident)	8360	0.95	0.7	1100 ^b
2	Fishing	400	0.05	1.0	2100
3	Living at the National Guard Facility	2500		0.7	2400

$$M_h = 5$$

$$K = 2.28E-05 \text{ mrem/(MWe-hr)}$$

These parameters are used to obtain an initial estimate of skyshine dose to the maximally exposed member of the public using Equation A-34 in Appendix A. If desired, more realistic parameters could be used in place of these to refine the estimate. For example, one could determine whether the nearest resident really fishes the specified number of hours at the specified location.

- a The amount of time in a year that a maximally exposed fisherman would spend fishing near the site is estimated as 12 hours per week for 8 months per year. This yields an estimate of:

$$[12 \text{ hours/week}] [(8 \text{ months/yr}) / (12 \text{ months/yr})] \times [52 \text{ weeks/yr}] = 416 \text{ hours/yr}$$

The remaining time is assumed to be spent at the nearest residence.

- b Distance to nearest residence (See Table F-3).
- c The OF_k is the quotient of the number of hours a location is occupied and the number of hours in a year. Thus $OH_k / 8760 \text{ hours} = OF_k$ rounded to the 0.01 digit.

In determining the maximally exposed individual, the following possibilities were considered: the nearest resident, fishermen, and persons at the National Guard facility north of the site. The annual exposure time and location of a maximally exposed fisherman were estimated on the basis of discussion with a member of the station staff. The nearest resident was found to have the greatest exposure to skyshine. For details, see Reference 2 of Section F.2.

Supplemental Table A

Elevated Level Joint Frequency Distribution Table Summary

375 Foot Elevation Data

Summary Table of Percent by Direction and Class

Class	N	NNE	NE	ENE	E	ESE	SE	SSE	S	SSW	SW	WSW	W	WNW	NW	NNW	Total
A	.024	.032	.067	.057	.062	.040	.030	.060	.058	.189	.087	.051	.058	.064	.063	.024	.943
B	.149	.175	.227	.149	.080	.047	.056	.070	.233	.463	.330	.189	.145	.192	.153	.183	2.843
C	.300	.262	.351	.255	.138	.069	.104	.130	.375	.579	.454	.361	.344	.420	.329	.332	4.805
D	3.100	2.634	3.282	3.192	2.780	1.945	1.767	2.053	2.810	2.875	2.270	2.460	3.248	4.533	3.922	3.681	46.551
E	1.018	.913	1.162	1.431	1.823	1.495	1.460	1.752	2.867	2.978	2.124	1.531	1.575	2.065	1.670	1.196	27.061
F	.320	.182	.248	.260	.469	.707	.905	.995	1.459	1.735	1.861	1.041	1.012	1.099	.894	.553	13.438
G	.055	.039	.022	.012	.041	.081	.278	.507	.674	.658	.660	.460	.309	.242	.217	.103	4.358
Total	4.965	4.237	5.359	5.356	5.394	4.385	4.601	5.567	8.474	9.457	7.487	6.093	6.688	8.615	7.248	6.073	100.000

Summary Table of Percent by Direction and Speed

Speed	N	NNE	NE	ENE	E	ESE	SE	SSE	S	SSW	SW	WSW	W	WNW	NW	NNW	Total
.45	.018	.017	.015	.010	.006	.010	.013	.008	.018	.010	.000	.013	.000	.000	.001	.000	.137
1.05	.016	.033	.030	.027	.021	.023	.032	.027	.027	.017	.017	.028	.021	.024	.034	.027	.402
2.05	.162	.260	.276	.215	.147	.149	.159	.171	.165	.168	.155	.135	.147	.115	.136	.160	2.721
3.05	.381	.479	.551	.477	.369	.287	.311	.278	.323	.317	.272	.302	.321	.317	.302	.311	5.599
4.05	.508	.647	.785	.547	.494	.428	.437	.404	.453	.455	.428	.400	.387	.482	.487	.455	7.798
5.05	.489	.598	.792	.515	.451	.403	.420	.505	.477	.489	.492	.472	.493	.540	.542	.533	8.213
6.05	.577	.599	.861	.596	.506	.419	.479	.483	.556	.584	.523	.487	.556	.598	.668	.656	9.150
8.05	1.297	.918	1.353	1.289	1.207	.872	.969	1.062	1.415	1.500	1.371	1.164	1.207	1.622	1.669	1.623	20.637
10.05	.912	.421	.487	.845	.998	.751	.736	.947	1.385	1.552	1.325	1.088	1.240	1.671	1.557	1.270	17.188
13.05	.482	.210	.183	.594	.858	.692	.749	1.187	2.107	2.440	1.822	1.338	1.432	1.962	1.428	.800	16.286
18.00	.120	.055	.026	.231	.326	.240	.283	.459	1.476	1.815	1.043	.581	.746	1.137	.404	.222	9.163
99.00	.002	.000	.000	.011	.011	.011	.013	.035	.072	.109	.038	.085	.137	.147	.019	.015	.706
Total	4.965	4.237	5.359	5.356	5.394	4.385	4.601	5.567	8.474	9.457	7.487	6.093	6.688	8.615	7.248	6.073	100.000

NOTE: Wind directions in tables are presented in "wind from" and not "wind to" direction.

Supplemental Table A -Continued

Elevated Level Joint Frequency Distribution Table Summary

375 Foot Elevation Data

Summary Table of Percent by Speed and Class

Class Speed	A	B	C	D	E	F	G
.45	.000	.000	.000	.052	.058	.023	.004
1.05	.001	.004	.004	.176	.153	.060	.005
2.05	.017	.041	.109	1.540	.656	.307	.050
3.05	.046	.159	.290	3.269	1.193	.547	.096
4.05	.102	.249	.499	4.364	1.629	.788	.166
5.05	.102	.335	.547	4.159	1.945	.916	.210
6.05	.106	.341	.565	4.563	2.320	.986	.268
8.05	.225	.701	1.116	10.191	5.190	2.460	.755
10.05	.141	.429	.785	7.441	4.924	2.591	.878
13.05	.134	.404	.598	6.977	5.670	3.208	1.296
18.00	.068	.163	.256	3.424	3.126	1.511	.615
99.00	.001	.017	.036	.396	.198	.043	.015

Supplemental Table B

Mid Elevation Joint Frequency Distribution Table Summaries

Summary Table of Percent by Direction and Class

200 Foot Elevation Data

Class	N	NNE	NE	ENE	E	ESE	SE	SSE	S	SSW	SW	WSW	W	WNW	NW	NNW	Total
A	.381	.248	.801	.790	.531	.256	.142	.119	.231	.357	.441	.370	.453	.653	.579	.678	7.030
B	.313	.249	.377	.343	.290	.175	.110	.104	.207	.288	.327	.292	.350	.496	.530	.612	5.062
C	.531	.420	.566	.434	.390	.299	.321	.282	.370	.498	.479	.470	.506	.573	.710	.785	7.534
D	2.274	2.315	2.517	2.248	2.669	1.715	1.677	1.775	2.781	3.045	2.096	1.839	2.140	3.069	2.841	2.408	37.410
E	.777	.734	1.088	1.105	1.486	1.323	1.243	1.436	2.678	2.910	1.697	1.176	1.226	1.712	1.429	1.015	23.034
F	.233	.155	.177	.205	.433	.809	.802	.801	1.210	1.383	1.183	.852	.854	1.017	.848	.446	11.419
G	.065	.060	.021	.013	.059	.265	.635	.896	1.244	1.239	.997	.689	.740	.776	.562	.150	8.411
Total	4.575	4.182	5.547	5.138	5.857	4.841	4.930	5.413	8.722	9.721	7.219	5.698	6.268	8.297	7.498	6.094	100.000

Summary Table of Percent by Direction and Speed

Speed	N	NNE	NE	ENE	E	ESE	SE	SSE	S	SSW	SW	WSW	W	WNW	NW	NNW	Total
.45	.043	.003	.000	.020	.015	.003	.005	.009	.005	.000	.008	.000	.000	.000	.000	.000	.113
1.05	.046	.072	.063	.042	.033	.025	.040	.034	.037	.021	.026	.038	.031	.026	.034	.046	.612
2.05	.219	.575	.500	.323	.233	.197	.202	.201	.232	.193	.201	.189	.183	.151	.153	.163	3.815
3.05	.442	1.132	1.140	.691	.497	.350	.399	.363	.366	.344	.339	.353	.413	.374	.366	.374	7.946
4.05	.536	.970	1.375	.729	.617	.528	.545	.532	.599	.583	.557	.466	.481	.553	.630	.618	10.319
5.05	.681	.584	1.041	.800	.639	.553	.635	.558	.621	.610	.579	.560	.590	.686	.737	.720	10.593
6.05	.729	.383	.670	.802	.777	.728	.708	.681	.843	.887	.696	.687	.695	.815	.940	.916	11.959
8.05	1.088	.339	.576	1.004	1.557	1.351	1.333	1.426	2.234	2.473	1.925	1.484	1.604	1.933	1.903	1.559	23.790
10.05	.472	.106	.153	.475	.801	.691	.690	1.015	2.122	2.439	1.707	1.106	1.106	1.586	1.315	.910	16.693
13.05	.202	.016	.029	.214	.509	.348	.296	.476	1.342	1.778	1.012	.626	.790	1.414	1.096	.580	10.728
18.00	.111	.001	.001	.034	.177	.067	.076	.113	.310	.383	.154	.159	.300	.683	.312	.203	3.086
99.00	.007	.000	.000	.004	.001	.000	.000	.005	.010	.009	.014	.030	.074	.074	.013	.004	.247
Total	4.575	4.182	5.547	5.138	5.857	4.841	4.930	5.413	8.722	9.721	7.219	5.698	6.268	8.297	7.498	6.094	100.000

NOTE: Wind directions in tables are presented in "wind from" and not "wind to" direction.

Supplemental Table B - Continued

Mid Elevation Joint Frequency Distribution Table Summaries

200 Foot Elevation Data

Summary Table of Percent by Speed and Class

Class Speed	A	B	C	D	E	F	G
.45	.000	.000	.001	.046	.037	.021	.009
1.05	.013	.004	.022	.219	.175	.116	.063
2.05	.172	.130	.281	1.946	.732	.437	.207
3.05	.600	.453	.809	3.533	1.531	.642	.378
4.05	.776	.588	.970	4.134	2.329	.930	.591
5.05	.828	.588	.966	3.915	2.455	1.150	.690
6.05	.835	.533	.921	4.389	2.742	1.461	1.079
8.05	1.542	1.208	1.671	8.019	5.377	3.357	2.616
10.05	1.030	.780	.979	5.271	4.154	2.319	2.160
13.05	.874	.558	.754	4.155	2.854	.935	.597
18.00	.331	.207	1.231	1.621	.630	.046	.020
99.00	.029	.012	1.018	.162	.020	.005	.001

Supplemental Table C

Ground Level Joint Frequency Distribution Table Summary

33 Foot Elevation Data

Summary Table of Percent by Direction and Class

Class	N	NNE	NE	ENE	E	ESE	SE	SSE	S	SSW	SW	WSW	W	WNW	NW	NNW	Total
A	.411	.318	.688	.887	.594	.308	.133	.135	.212	.407	.478	.447	.532	.665	.844	.904	7.962
B	.314	.150	.278	.310	.276	.177	.108	.071	.172	.239	.268	.222	.293	.405	.505	.501	4.288
C	.380	.233	.330	.328	.262	.270	.189	.172	.285	.385	.424	.343	.380	.507	.638	.501	5.626
D	3.149	1.449	2.178	2.504	2.687	1.735	1.577	1.540	2.195	2.673	2.178	1.925	2.243	3.240	3.269	2.509	37.051
E	1.131	.661	1.168	1.021	1.758	1.434	1.303	1.561	2.558	2.795	1.968	1.480	1.557	1.945	1.692	.917	24.947
F	.166	.087	.177	.160	.646	.840	.750	.817	1.259	1.280	1.376	1.039	1.048	.867	.609	.378	11.499
G	.019	.008	.017	.025	.127	.615	.873	1.023	1.183	1.050	.998	.966	.925	.490	.214	.093	8.827
Total	5.570	2.906	4.836	5.235	6.349	5.379	4.932	5.319	7.862	8.829	7.690	6.422	6.979	8.118	7.771	5.803	100.000

Summary Table of Percent by Direction and Speed

Speed	N	NNE	NE	ENE	E	ESE	SE	SSE	S	SSW	SW	WSW	W	WNW	NW	NNW	Total
.45	.000	.004	.000	.002	.002	.000	.000	.002	.006	.002	.002	.004	.002	.000	.002	.002	.029
1.05	.052	.048	.073	.046	.056	.056	.052	.073	.081	.075	.079	.067	.102	.093	.066	.066	1.085
2.05	.378	.609	.813	.517	.424	.601	.686	.582	.532	.441	.457	.466	.613	.626	.497	.488	8.731
3.05	1.124	1.183	1.802	1.268	1.191	1.270	1.276	1.222	1.149	1.156	1.112	1.031	1.035	1.079	.931	1.043	18.932
4.05	1.326	.621	1.122	1.230	1.420	1.116	1.058	1.079	1.731	1.719	1.648	1.550	1.274	1.023	1.000	.896	19.813
5.05	1.129	.247	.617	1.106	1.189	.694	.642	.738	1.276	1.509	1.305	1.129	1.029	1.104	1.014	.777	15.505
6.05	.667	.091	.297	.597	.879	.551	.509	.588	1.047	1.434	1.112	.808	.894	.914	.966	.813	12.163
8.05	.628	.102	.106	.422	.817	.767	.480	.642	1.262	1.638	1.291	.827	1.072	1.478	1.644	1.014	14.189
10.05	.145	.002	.006	.042	.303	.227	.172	.289	.561	.588	.532	.358	.480	.942	.933	.457	6.036
13.05	.114	.000	.000	.002	.057	.093	.056	.094	.202	.256	.119	.121	.254	.634	.563	.220	2.797
18.00	.008	.000	.000	.002	.000	.004	.002	.012	.015	.012	.031	.046	.145	.212	.154	.029	.871
99.00	.000	.000	.000	.000	.000	.000	.000	.000	.000	.000	.002	.013	.019	.012	.002	.000	.048
Total	5.570	2.906	4.836	5.235	6.349	5.379	4.932	5.319	7.862	8.829	7.690	6.422	6.979	8.118	7.771	5.803	100.000

NOTE: Wind directions in tables are presented in "wind from" and not "wind to" direction.

Supplemental Table C - Continued

Ground Level Joint Frequency Distribution Table Summary

33 Foot Elevation Data

Summary Table of Percent by Speed and Class

Class Speed	A	B	C	D	E	F	G
.45	.000	.000	.004	.002	.008	.010	.008
1.05	.021	.008	.012	.197	.355	.299	.195
2.05	.326	.202	.272	2.282	2.334	1.764	1.552
3.05	.998	.578	.798	5.133	5.350	3.267	2.808
4.05	1.247	.686	.862	6.435	4.793	3.064	2.725
5.05	1.203	.646	.852	6.115	3.880	1.773	1.037
6.05	1.201	.570	.804	5.472	3.049	.817	.251
8.05	1.629	.900	1.208	6.605	3.334	.463	.050
10.05	.775	.422	.518	2.955	1.334	.031	.002
13.05	.428	.212	.245	1.469	.438	.004	.002
18.00	.112	.052	.052	.382	.069	.004	.000
99.00	.023	.012	.000	.006	.004	.004	.000

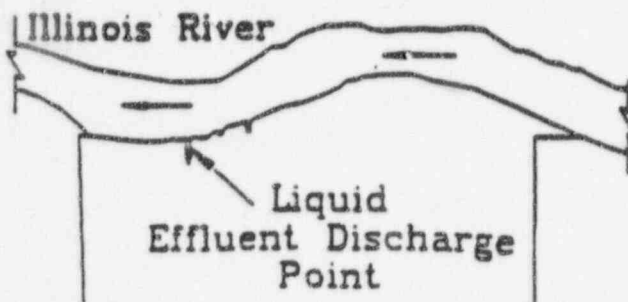

OFFSITE DOSE CALCULATION MANUAL
LASALLE COUNTY STATION
FIGURE F-1
UNRESTRICTED AREA BOUNDARY

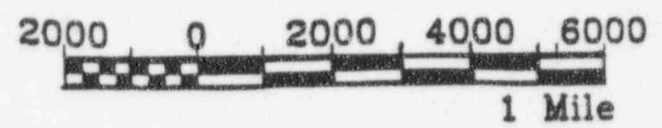

Scale in Feet

UNRESTRICTED AREA BOUNDARY
(Property Line)

Waste
Stabilization
Pond

Exclusion
Area

LaSalle Lake

Meteorological Tower

Gaseous Effluent Release Point

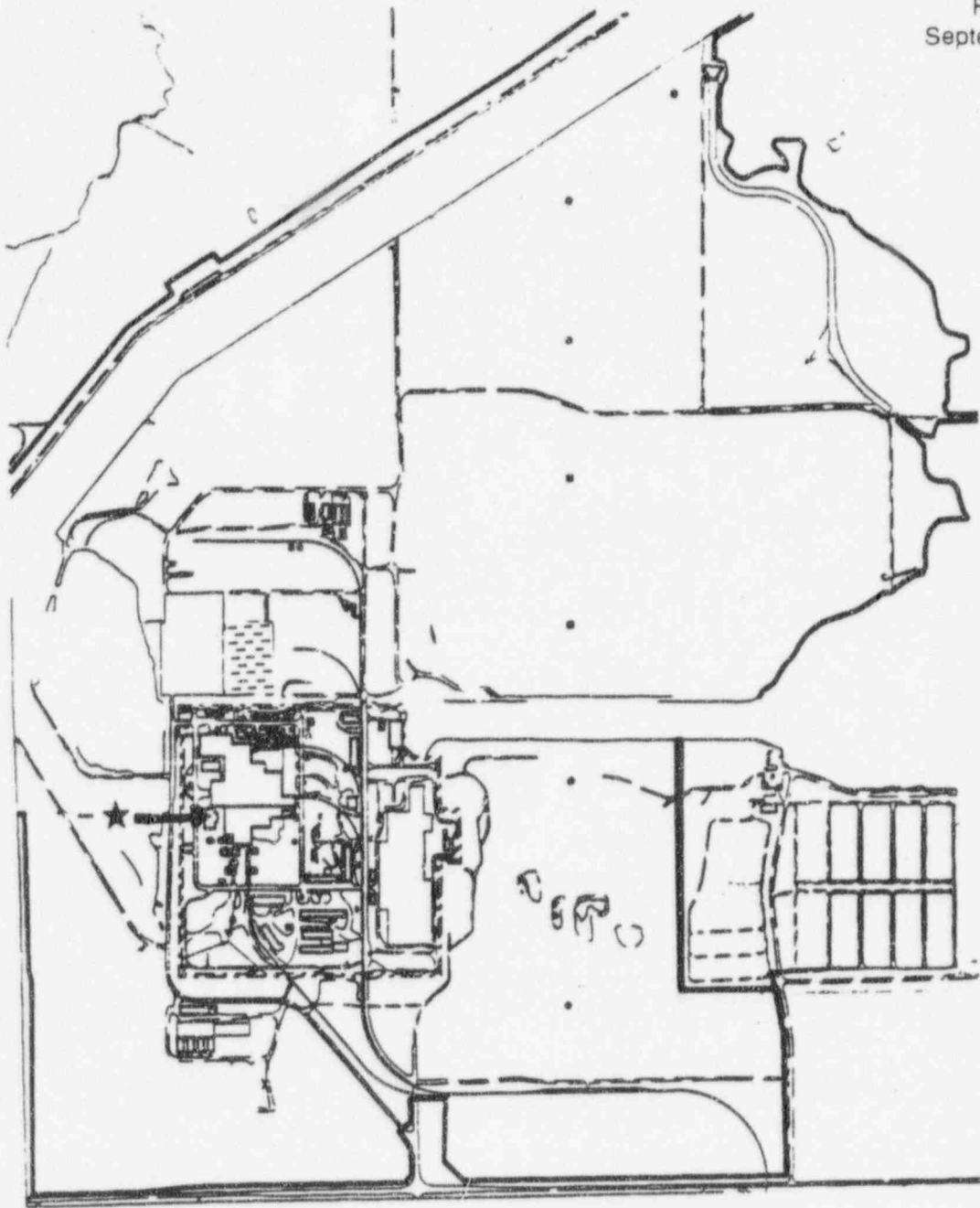

- ★ Interim Radwaste Storage Facility
- Restricted Area Boundary
- ▨ Radwaste Storage Area (When Operational, this area may include 48-packs, DAW, and other types of storage)

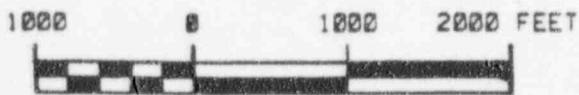

GRAPHIC SCALE

OFFSITE DOSE CALCULATION MANUAL
LA SALLE COUNTY STATION

FIGURE F-2
RESTRICTED AREA BOUNDARY