



GE Nuclear Energy

23A6999	SH NO. 1
REV. 5	

REVISION STATUS SHEET

DOC TITLE ISOLATION CONDENSER & PASSIVE CONTAINMENT CONDENSER TEST

LEGEND OR DESCRIPTION OF GROUPS

TYPE: TEST SPECIFICATION

FMF: SBWR

MPL NO: B32-3030/T15-3030

REVISION				C
A	PRELIMINARY ISSUE DMH5018 11/12/91	4	A. FORTIN 4/28/95	
1	F.E. WILHELMI 9/29/92 RJA DMH5738 CHK BY: F.E. WILHELMI G.W.	5	CN02463 GENERAL DOCUMENT CHANGE	
2	A. FORTIN 8/23/94 RJA CN01588 CHK BY: A. FORTIN		A. FORTIN OCT 23 1995 RJA CN03265 GENERAL DOCUMENT CHANGE	
3	A. FORTIN 1/9/95 RJA CN01911 CHK BY: A. FORTIN			
PRINTS TO				
MADE BY	APPROVALS	GENERAL ELECTRIC COMPANY		
F.E. WILHELMI	G.W. FITZSIMMONS	175 CURTNER AVENUE		
CHK BY	ISSUED	SAN JOSE, CALIFORNIA 95125		
F.E. WILHELMI	G.A. BAYLIS	CONT ON SHEET 2		



TABLE OF CONTENTS

	SHEET NO.
1. SCOPE	4
2. APPLICABLE DOCUMENTS	4
2.1 GE-Nuclear Energy Documents	4
2.2 Ansaldo Documents	4
2.3 Other Documents	5
3. DESCRIPTION AND GENERAL TEST REQUIREMENTS	5
3.1 Introduction	5
3.2 Test Objectives - Passive Containment Condenser	5
3.3 Test Objectives - Isolation Condenser Tests	5
3.4 General Strategy and Description of Tests	6
3.5 Deleted	7
3.6 Test Plan and Procedures	7
3.7 Quality Assurance Requirements	7
3.8 Data Transmittal and Reporting Requirements	8
4. TEST FACILITY REQUIREMENTS	8
4.1 Facility Requirements for the PCC	8
4.2 Facility Requirements for the IC	20
4.3 Data Recording Requirements (PCC and IC Tests)	31
5. PASSIVE CONTAINMENT CONDENSER TESTS	31
5.1 General Test Procedures	31
5.2 PCC Test Strategy	32
5.3 Data Processing/Analysis General Requirements	40
6. ISOLATION CONDENSER TESTS	41
6.1 General Test Procedures	41
6.2 Required Test Conditions	43
6.3 Data Processing/Analysis General Requirements	45
APPENDICES:	
A. REFERENCE MATRIX OF PCC TEST CONDITIONS	48
B. REFERENCE MATRIX OF IC TEST CONDITIONS	52



LIST OF FIGURES

	SHEET NO.
4-1 SCHEMATIC OF PCC TEST FACILITY	13
4-2 REQUIRED DIMENSIONS FOR PCC TEST POOL	14
4-3 LOCATION OF PCC WALL TEMPERATURE MEASUREMENTS	15
4-4 PCC STRUCTURAL INSTRUMENTATION	16
4-5 SCHEMATIC OF IC TEST FACILITY	25
4-6 REQUIRED DIMENSIONS FOR IC TEST POOL	26
4-7 IC STRUCTURAL INSTRUMENTATION	27
6-1 BASIC STRUCTURAL IC TEST CYCLES	46
6-2 REQUIRED IC INLET PRESSURE FOR TEST CONDITION NO. 1	47

LIST OF TABLES

4-1 Required Thermal-Hydraulic Measurements—PCC Test	17
4-2 Required Structural Measurements—PCC Test	18
4-3 Required Thermal-Hydraulic Measurements—IC Test	28
4-4 Required Structural Measurements—IC Test	29
4-5 Water Quality Requirements	30



TEST SPECIFICATION FOR IC & PCC TESTS

1. SCOPE

This document specifies the requirements for tests of full-scale prototypes of the isolation condenser (IC) and passive containment cooling (PCC) condenser designed for use in the Simplified Boiling Water Reactor (SBWR). The purpose of the tests is to confirm the thermal hydraulic and structural adequacy of the Ansaldo designed hardware for use in the SBWR.

2. APPLICABLE DOCUMENTS

2.1 GE-Nuclear Energy Documents

- a. Isolation Condenser System Piping and Instrumentation Diagram, Drawing Number 107E5154.
- b. Isolation Condenser System Design Specification, Document Number 25A5013.
- c. Isolation Condenser System Interlock Block Diagram, Drawing Number 137C9292.
- d. Isolation Condenser System Process Flow Diagram, Drawing Number 107E6073.
- e. Passive Containment Cooling System Piping and Instrumentation Diagram, Drawing Number 107E5160.
- f. Passive Containment Cooling System Design Specification, Document Number 25A5020.
- g. Passive Containment Cooling System Process Flow Diagram, Drawing Number 107E6072.
- h. SBWR Composite Design Specification, Document Number 25A6723.
- i. Containment Configuration Data Book, Document Number 25A5044.

2.2 Ansaldo Documents

- a. IC H.X. Equipment Requirements Specification. Document Number SBW 5280 TN1XN014000.
- b. PCC Equipment Requirements Specification. Document Number SBW 5280 TN1XN015000.
- c. Passive Containment Cooling and Isolation Condenser Prototype Structural Instrumentation, Document Number SBW 5280-TNIX-1115000.
- d. IC Pool Compartment Arrangement. Drawing Number SBW5280DMNX1103.



- e. IC Prototype General Arrangement. Drawing Number SBW5280DMNX1106.
- f. PCC Pool Compartment Arrangement. Drawing Number SBW5280DMNX1102.
- g. PCC Prototype General Arrangement. Drawing Number SBW5280DMNX1105.

2.3 Other Documents

- a. "SBWR Design and Certification Program, Quality Assurance Plan", Report NEDG-31831, May 1990.
- b. "Fluid Meters, Their Theory and Application", ASME, Sixth Edition, 1971.

3. DESCRIPTION AND GENERAL TEST REQUIREMENTS

3.1 Introduction. The tests specified in this document are part of the program to design and certify the SBWR. The IC system and the PCC system perform vital roles in removing heat from the reactor vessel and the containment during certain postulated operating and accident conditions. Full-scale, prototypical condensers for these systems are to be tested at full pressure, temperature and flow conditions. The test facilities specified for this program are not representative of the SBWR systems of which these condensers will be a part. The specified tests are component "Design Qualification Tests" tests and therefore the test system performance is not intended nor expected to be representative of the SBWR system performance.

3.2 Test Objectives - Passive Containment Condenser. The general objectives of the full-scale PCC test are as stated in the following paragraphs. The specific objectives described in Paragraph 5.1.1 provide additional details to the general objectives.

3.2.1 Thermal-Hydraulic. Confirm that the Ansaldo designed PCC meets the thermal-hydraulic performance requirements for use in the SBWR. Performance requirements are specified in Reference f. of Paragraph 2.1.

3.2.2 Structural. Confirm that the mechanical design of the Ansaldo PCC is adequate to assure the structural integrity of the unit for the expected SBWR lifetime process service conditions.

3.3 Test Objectives - Isolation Condenser Tests. The general objectives of the full-scale IC test are as stated in the following paragraphs. The specific objectives of Paragraph 6.1.1 provide additional details to the general objectives.

3.3.1 Thermal-Hydraulic. Confirm that the Ansaldo designed IC meets the thermal-hydraulic performance requirements for use in the SBWR. Performance requirements are specified in Reference b. of Paragraph 2.1.



3.3.2 Structural. Confirm that the mechanical design of the Ansaldo IC is adequate to assure the structural integrity of the condenser for the SBWR lifetime process service conditions expected between In Service Inspections.

3.3.3 In Service Inspection. Confirm the adequacy of proposed In Service Inspection (ISI) procedures and methods by performing NDE tests prior to testing and after thermal-hydraulic testing has been completed. (Test Requestor will provide NDE testing of IC.)

3.3.4 Leak Detection Methods. Record reference data for use in evaluation of proposed methods for IC system leak/break detection. (See Paragraph 6.1.1.4)

3.4 General Strategy and Description of Tests

3.4.1 Definitions. This specification uses the following definitions in referring to the various responsibilities related to the PCC and IC tests:

Test Requestor – The organization requesting the tests and specifying the requirements, i.e. the SBWR Design Team (GE lead).

Test Performer – The organization responsible for the test facility and performance of the tests, i.e. SIET.

Responsible Test Engineer – The engineer, representing the Test Requestor, responsible for supervising the preparations for testing and the test performance. For the PCC and IC tests this is an ENEA engineer.

3.4.2 PCC Tests. A full-scale unit (two modules) of the Ansaldo designed PCC as described by the documents referenced in 2.2.b and 2.2.g will be tested to accomplish the objectives stated in Section 3.1. Most of the testing will be done at near-steady-state conditions covering the range of the process variables required for SBWR. The condenser pool temperature for most tests will be the equilibrium (steady-state) value and the water level in the pool will be maintained at the normal level (full). The inlet (drywell) pressure, the steam flow rate and the flow rate of noncondensable gases in the inlet steam will be systematically varied. The tests will include sufficient pressure/temperature cycles (five times the number of cycles used for design) to confirm the structural integrity.

3.4.3 IC Tests. One-half (single module) of a full-scale unit of the Ansaldo designed IC as described by the documents referenced in 2.2.a and 2.2.e will be tested to accomplish the objectives stated in Section 3.2. The tests will be both steady-state performance tests and slow transients simulating the thermal cycles defined in the IC design specification. At the conclusion of the testing the condenser will be inspected, using the normal ISI procedures, to confirm that there is no excessive deformation, crack initiation or excessive crack growth rate.



Tests of steady-state operation at various conditions will be used to confirm the adequate capacity of the condenser and verify the expected thermal hydraulic characteristics.

3.5 DELETED

3.6 Test Plan and Procedures. The tests shall be performed in accordance with a Test Plan and Procedures (TP&P) document to be prepared and issued by the Test Performer and approved by the Responsible Test Engineer. The TP&P shall be a traceable and retrievable document of test requirements consisting of the following parts:

- a. Section 1 - Test Plan. Describe how the test is to be set up and performed to meet the quality assurance requirements, any special or unique safety or chemical hazard conditions associated with the test, and the test requirements specified in this document.
- b. Section 2 - Quality Assurance (QA) Plan. Determine the quality assurance requirements and describe how they are met, including instrumentation (calibration and accuracy), confirmation of test item identification, test record information (date, performer, results, corrective actions, etc.), certification of test personnel, satisfying of environmental conditions, and establishment of test equipment conditions, data logging, data acquisition systems, and others needed to satisfy test requirements.
- c. Section 3 - Test Procedures. Describe the specific procedures required to perform the test in accordance with test and quality assurance requirements.

3.6.1 Test Hold/Decision Points. The following hold/decision points shall be established for this program:

- a. The Responsible Test Engineer will review and approve the Test Plan and Procedures before test initiation.
- b. The Responsible Test Engineer (or his appointed representative) will review and approve the test setup, configuration, and planned test conditions prior to each test run.

3.7 Quality Assurance Requirements

3.7.1 General Requirements. The organization performing the testing (also referred to herein as the Test Performer) shall have a quality assurance program that is in compliance with the documents referenced in Paragraph 2. The Test Performer shall provide copies of their quality assurance documents upon request of the Test Requestor for review and approval. All discrepancies shall be resolved prior to program start.

3.7.2 Audit Requirements. The Test Requestor reserves the right to perform an audit to verify that the Test Performer's quality assurance program is in place and being followed.



3.7.3 Notification. The Test Performer has the responsibility to notify the Responsible Test Engineer with documentation of; (a) any changes in the test procedure, (b) any failure of the test device to meet performance requirements, (c) any revisions or modifications of the test device, and (d) the dates when tests are expected to be performed. Notification shall be provided at least five working days in advance, whenever possible.

3.7.4 Test Data/Records/Reports. The Test Performer's quality assurance personnel shall review all test data, records, and reports. All test records, analyses and verification records shall be organized by the Test Performer into a Design Record File (DRF).

3.8 Data Transmittal and Reporting Requirements

3.8.1 Data Transmittal. The Test Performer shall provide the Test Requestor with a copy of all test data, in a format approved by the Responsible Test Engineer.

3.8.2 Reports. A brief Apparent Test Results (ATR) report will be prepared for each test, as defined by the Test Number in Appendices A and B, within one week following performance of the test. A Final Test Report (FTR) will contain the data, analysis and results of all tests and shall be transmitted to the Test Requestor within two months of the completion of testing.

3.8.3 Design Record File. The Test Performer shall submit the test DRF, or a copy, to the Test Requestor within 1 month after completion of the Final Test Report.

3.8.4 Disposition of Test Articles. The Test Performer shall remove the Prototype Condensers from the test facility following the conclusion of the Test Program and return this equipment to the Test Requestor.

4. TEST FACILITY REQUIREMENTS

4.1 Facility Requirements for the PCC

4.1.1 Principal Functions and Components. The test facility must have a tank simulating the PCC pool in SBWR. A full-size PCC unit will be provided by the Test Requestor to be mounted inside this tank. The facility must be able to supply steam, water and noncondensable gases in quantities and at conditions which are representative of those anticipated for the SBWR PCC. Thermal hydraulic and structural instrumentation will be installed for measuring the parameters of interest. The rate of heat transfer from the inlet gas (steam and noncondensibles) to the PCC pool will be determined. The heat losses from the inlet gas supply lines to the surroundings shall be minimized and shall not exceed 1 MWth.



Figure 4-1 gives an approximate schematic of the PCC test facility. The principal components of this facility shall be:

- A supply of saturated steam.
- A supply of noncondensable gases (air or nitrogen and helium).
- Condensate drain tank.
- Noncondensable vent tank.
- PCC pool tank.
- Piping and valves.

4.1.2 Test Variables. The independent test variables shall be:

- PCC inlet pressure.
- Inlet steam flow rate.
- Inlet noncondensable flow rate.

The following variables need to be controlled:

- Temperature of the inlet steam or steam/gas mixture.
- PCC pool level (supply makeup to maintain constant level).
- PCC pool temperature (maintain constant).
- Condensate tank pressure (maintain equal to PCC inlet pressure).
- Condensate tank level (control tank drain flow).
- Vent tank level (control tank drain flow).

Dependent variables:

- Vent tank pressure or PCC differential pressure.
- Condensate flow rate (heat transfer rate).

4.1.3 Component Requirements.

4.1.3.1 Steam and Noncondensable Gas Supplies. Saturated steam with quality greater than 99.8% shall be supplied to the PCC at a controllable flow rate for PCC inlet pressure in the range 69 to 689 kPa gage (10 to 100 psig). Available continuous steam flow rate shall be at least 6.5 kg/s (14.3 lb/s) at 689 kPa (100 psig). It is desirable to have available a continuous steam flow rate of 9.75 kg/s (21.5 lb/s) at 689 kPa gage (100 psig) (based on 20 MWth).

Noncondensable gases (air or nitrogen and helium) shall be supplied to the PCC at a controllable flow rate for PCC inlet pressure in the range of 69 to 689 kPa gage (10 to 100 psig). Steam/gas mixtures in the range of 0 to 50 noncondensable mass percent are required. Noncondensable mass percent is defined as 100 multiplied by the ratio of the noncondensable mass to the total mass.



The noncondensable gas supplies shall be sized such that the following flow rates can be provided to the PCC:

- Air (or nitrogen) 2700 Nm³/h at 69 to 689 kPa gage (1678 SCFM at 10 to 100 psig)
- Helium Sufficient to fill the PCC with helium at 689 kPa gage (100 psig) in 15 minutes.

The flow rates of steam and noncondensable gas shall be controlled using critical flow devices so the flow rates are independent of the PCC inlet pressure. The flow rates can be controlled either by variation of the stagnation pressure or the critical flow area or a combination. Provision shall be made to control the temperature of the steam or steam/gas mixture at the PCC inlet. For steam tests, the inlet steam shall be saturated, or with a specified superheat. For tests with a steam/gas mixture, the temperature shall be controllable between saturated and 44°C (80°F) superheated.

4.1.3.2 PCC Pool Tank. The PCC pool tank shall be a rectangular elevated tank, open to the atmosphere for the purpose of containing the PCC and the water which cools it. The tank shall be covered, and shall have an opening of 2 m² (21.5 ft²) in the wall, 250 mm (9.8 in) above the pool normal water level, for boil-off. The tank shall be large enough and have provisions for internally attaching, with prototypical mounting hardware, a complete full-scale two-module PCC unit, and prototypical inlet, vent and condensate drain piping. The pool depth shall be sufficient to submerge the PCC to a prototypical water level. The required dimensions of the pool are shown in Figure 4-2.

Systems shall be provided to fill the pool with highly purified water prior to a test, to control the tank level and replace boil-off during a test, and to drain the pool for maintenance or modifications to the PCC. The makeup water system shall be sufficient to maintain a constant pool level at the maximum condensation rate for a period of at least 4 hours. Pool boil-off (no moisture carryover) with 15 MWth heat transfer was calculated to be approximately 6.9x10⁻³ m³/s (110 gpm). The makeup water shall be the same quality as the pool water. It shall be distributed in the pool such that nonprototypical flow patterns and temperature distributions are avoided.

The water quality requirements for the PCC pool tank are shown in Table 4-5.

4.1.3.3 Condensate Drain Tank. A tank shall be provided for collecting the water condensed and drained from the PCC. The condensate drain tank shall be a closed tank, normally pressurized above atmospheric and partially filled with water. The elevation between the PCC pool tank bottom and the condensate drain tank water level shall be adjustable between 2.0m (6.6ft) and 3.5m (11.5ft). The condensate from the PCC shall discharge to the drain tank beneath the water level. A line shall be provided to drain water from the tank during a test to maintain the water level at a controlled position. The tank and drain shall be sized such that flooding of the tank is prevented and good control of water level can be maintained during testing with the greatest



expected condensate flow rate. The condensate flow rate for 15 MWth heat transfer at 689 kPa gage (100 psig) steam inlet pressure was calculated to be $8.2 \times 10^{-3} \text{ m}^3/\text{s}$ (130 gpm).

The condensate drain tank shall be provided with systems to fill the tank to a predetermined level, and to control that level during a test at a constant value by adjusting the rate of tank drain. The tank gas-space during testing shall be maintained at the same pressure as the PCC inlet flow. The method of equalizing pressure with the PCC inlet shall not divert flow from the PCC inlet line. Figure 4-1 shows one method of controlling condensate tank pressure by injecting high pressure air into the tank and using a pressure control valve on the gas outlet line.

Venting of the gas space in the tank may be necessary for pressure control or if noncondensable gas is carried into the PCC drain.

4.1.3.4 Noncondensible Vent Tank. Noncondensible gases, separated in the PCC shall be vented to a closed tank. The elevation of the highest expected water level in the vent tank should be lower than the lowest expected water level in the condensate drain tank. At some conditions the flow into the vent tank may include uncondensed steam, noncondensable gases and liquid condensate carried over from the PCC lower plenum. The vent line from the PCC shall terminate in the vent tank. The vent line discharge in the tank shall be arranged such that testing may be performed with discharge either submerged, as in SBWR or unsubmerged. Provision shall be made to drain water from the bottom of the vent tank and to condense steam which may pass through the PCC vent without condensing.

The vent tank shall be provided with systems to fill the tank to a predetermined level, and to maintain that level during a test. Provision shall be made to measure water flow rate from the vent tank drain, in the event that condensate from the PCC is carried over in the vent line.

The vent tank gas discharge pipe shall be provided with a system to control the tank pressure by throttling vent tank exhaust. During tests with no noncondensable inlet flow to the PCC it may be necessary to pressurize the vent tank by some means such as injecting air directly into the vent tank as suggested by Figure 4-1. Although the system is shown to control vent tank pressure, the variable used for setting up the desired test conditions will be PCC inlet pressure.

4.1.3.5 Piping. The piping for the inlet gases, condensate drain and venting shall be as prototypical as is practical with respect to inside diameter, irreversible hydraulic losses and elevation differences. The piping external to the PCC pool shall be thermally insulated as necessary to:

1. Minimize the heat losses to the surroundings
2. Ensure an accurate measure of the condensing capacity of the PCC.

Routing shall avoid nonprototypical opportunities for steam pocketing. The vent line shall include a gate valve or flanges for a blind orifice to provide capability to physically prevent venting of the PCC.



4.1.4 Instrument Requirements (PCC)

4.1.4.1 General Requirements. All test instrumentation shall be provided by the Test Performer and shall be calibrated against standards traceable to the U. S. National Institute of Standards and Technology or equivalent.

4.1.4.2 Thermal-Hydraulic. The required thermal-hydraulic measurements, the required accuracy and the proposed digital sampling frequency for the PCC are listed in Table 4-1. The required accuracy in Table 4-1, is given as the "two standard deviation" level of a normally distributed error, i.e. there is a 95% probability that the error does not exceed the specified value.

Inside and outside tube wall temperature measurements are required on four tubes at nine axial positions on each tube. The preferred tubes for these measurements are 1A, 4A, 5Q and 8Q. The location of these tubes in the tube bundle is illustrated in Figure 4-3. The axial locations of the measurements are shown below:

Location Number	1	2	3	4	5	6	7	8	9
Distance Above Tube Centerline (cm)	750	650	550	450	250	50	-150	-450	-750

Thermocouples and lead wires shall be installed such that flow disturbances are minimized.

4.1.4.3 Structural. The required structural measurements for the PCC are listed in Table 4-2 and the numbered instrument positions identified in Figure 4-4. The positions are only indicative: the exact locations will be defined by Ansaldo after the stress analysis. See Reference 2.2.c. The two PCC condenser modules are referred to as "A" and "B". Module B is instrumented in only a few positions for comparison with Module A and for confirmation of symmetrical performance. The types of structural measurement required for the PCC are acceleration, displacement, strain, permanent strain and surface temperature.

Acceleration measurements will be made primarily for the purpose of evaluating vibration characteristics and detection of possible condensation/water hammer loads. Piezoelectric accelerometers are recommended for these measurements. The required temperature range is 10 to 177°C (50 to 350°F). The unfiltered signals shall be recorded in analog form with a recorder having a bandwidth of 1 - 500 Hz.

Linear displacement measurements are required at points specified in Table 4-2 with an accuracy of ±0.2 mm (0.008 in).

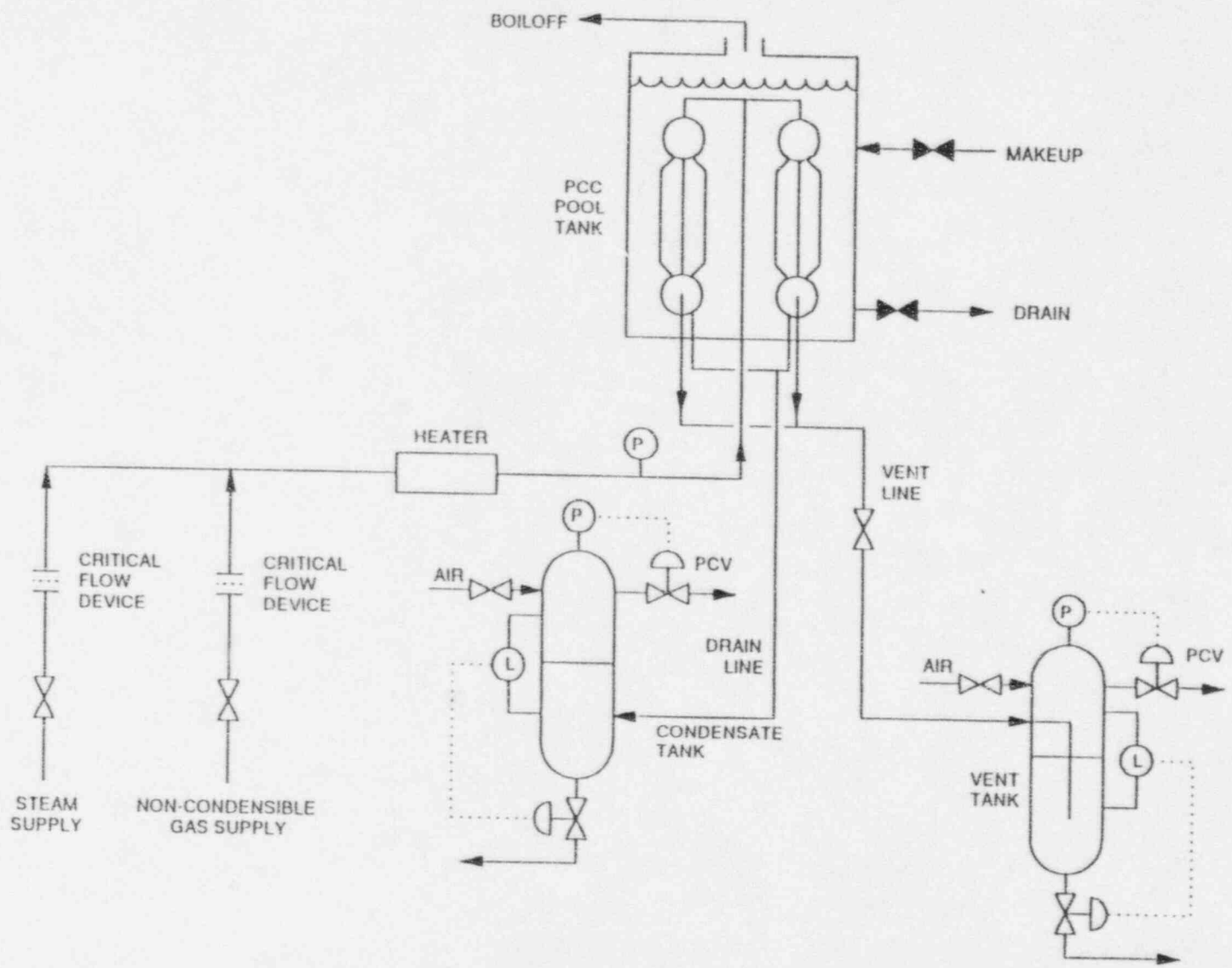

FIGURE 4-1. SCHEMATIC OF PCC TEST FACILITY

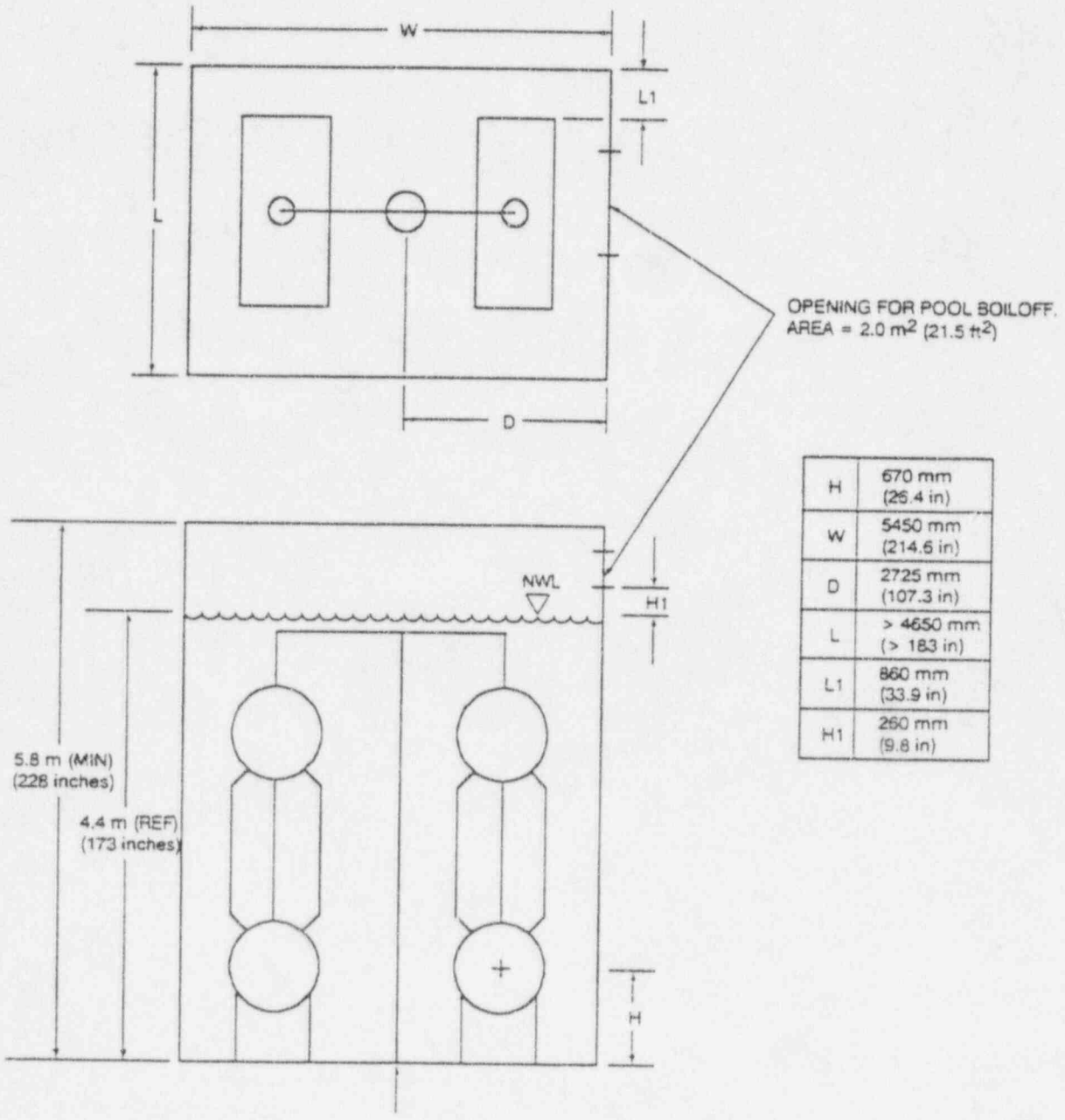

FIGURE 4-2. REQUIRED DIMENSIONS FOR PCC TEST POOL

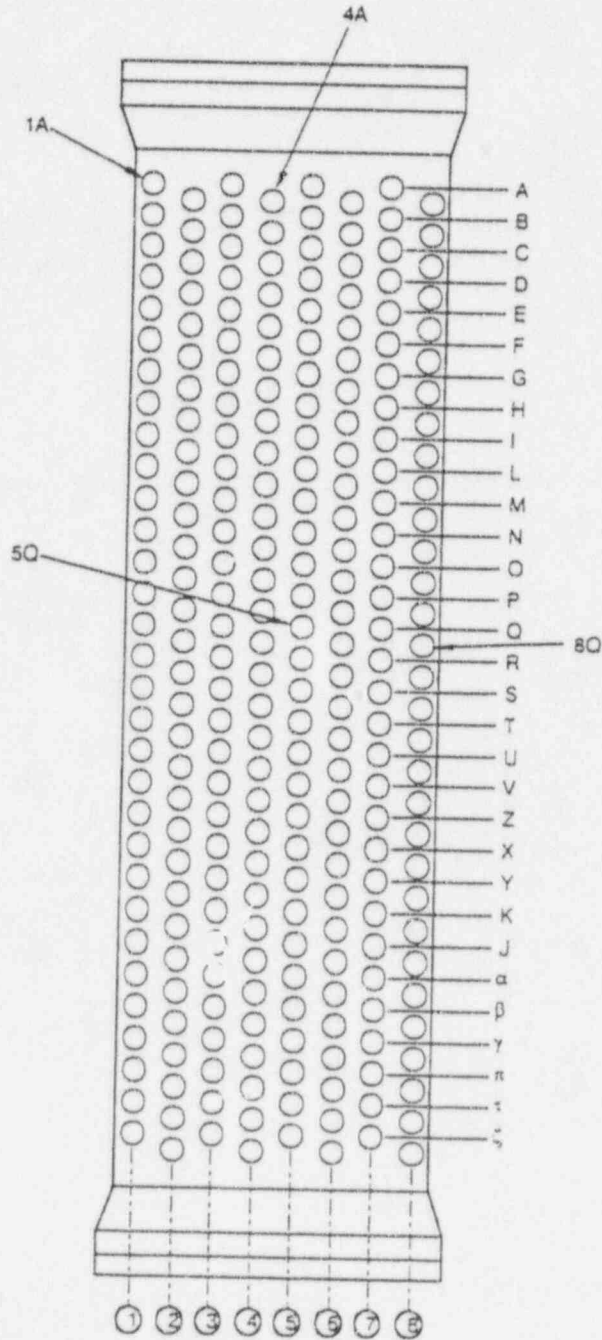
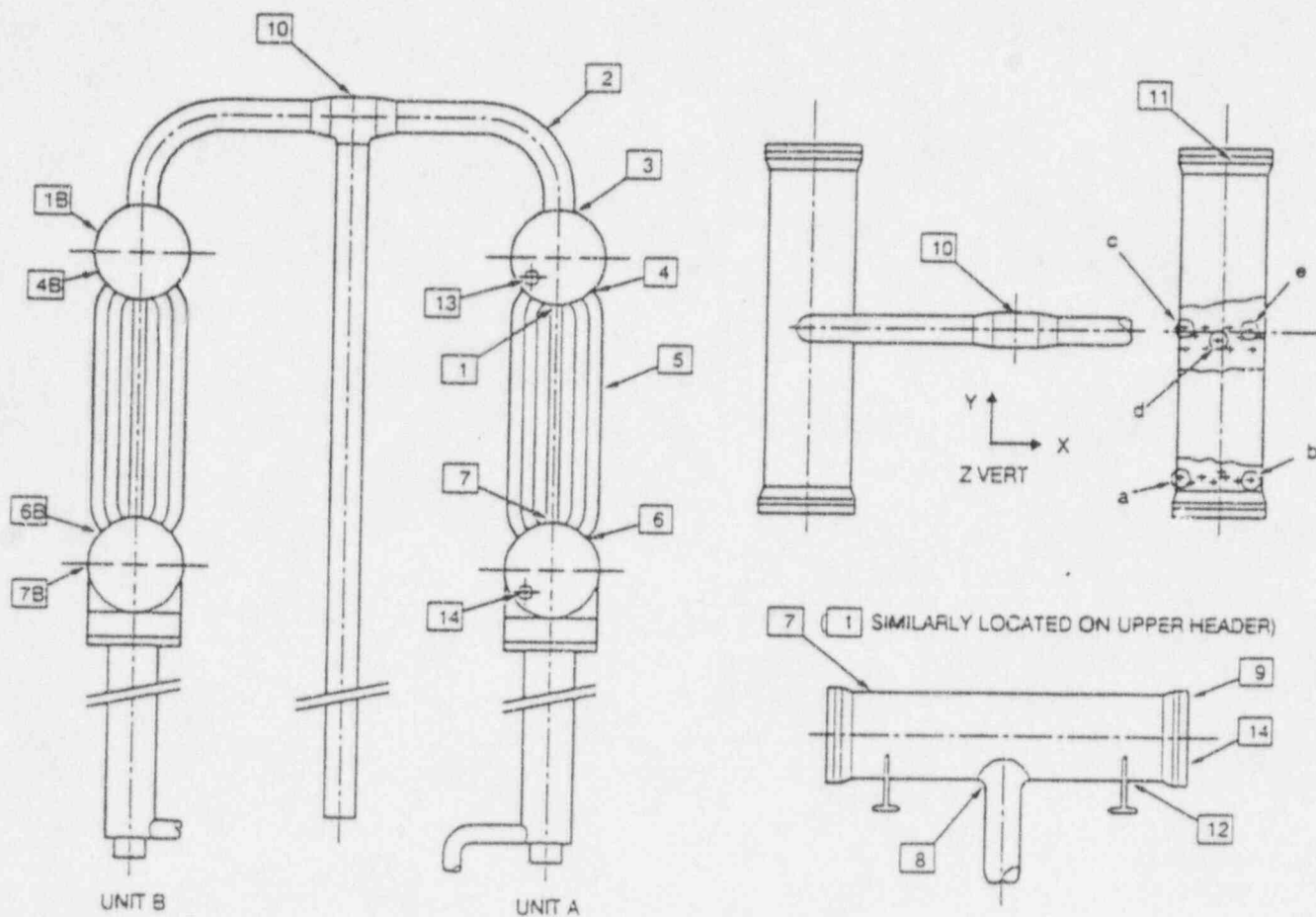

FIGURE 4-3. LOCATION OF PCC WALL TEMPERATURE MEASUREMENT



NOTE: NUMBERS REFER TO INSTRUMENTS LISTED IN TABLE 4-2

FIGURE 44. PCC STRUCTURAL INSTRUMENTATION



Table 4-1. REQUIRED THERMAL HYDRAULIC MEASUREMENTS—PCC TEST

Measurement	Units	Expected Range	Accuracy (2 Std. Dev.)	Frequency (samples per sec)
Pressures:				
noncondensible gas inlet,	kPa gage (psig)	0 - 760 (0 - 110)	2 % *	0.1
steam inlet,	kPa gage (psig)	0 - 760 (0 - 110)	2 %	0.1
PCC inlet,	kPa gage (psig)	30 - 690 (5 - 100)	2 %	0.1
condensate tank gas space,	kPa gage (psig)	30 - 690 (5 - 100)	2 %	0.1
PCC upper plenum,	kPa gage (psig)	30 - 690 (5 - 100)	2 %	0.1
vent tank gas space,	kPa gage (psig)	30 - 690 (5 - 100)	2 %	0.1
Differential pressures:				
condensate tank/vent tank,	kPa (psi)	0 - 30 (0 - 5)	2 %	0.1
upper plenum/lower plenum,	kPa (psi)	0 - 30 (0 - 5)	2 %	1
condensate tank/upper plenum,	kPa (psi)	0 - 30 (0 - 5)	2 %	1
Flow rates:				
steam inlet,	kg/s (lb/s)	0 - 12 (0 - 25)	2 %	0.1
noncondensible inlet,	kg/s (lb/s)	0 - 3 (0 - 5)	2 %	0.1
condensate,	kg/s (lb/s)	0 - 12 (0 - 25)	2 %	0.1
vent line gas,	kg/s (lb/s)	0 - 3 (0 - 5)	2 %	0.1
pool makeup,	l/s (gpm)	0 - 13 (0 - 200)	2 %	0.1
Temperatures:				
steam inlet,	deg C (deg F)	100 - 177 (212 - 350)	3 (5)	0.1
noncondensible gas inlet,	deg C (deg F)	100 - 177 (212 - 350)	3 (5)	0.1
upper plenum,	deg C (deg F)	100 - 171 (212 - 340)	3 (5)	0.1
PCC inlet dry bulb,	deg C (deg F)	100 - 171 (212 - 340)	3 (5)	0.1
lower plenum,	deg C (deg F)	10 - 171 (50 - 340)	3 (5)	0.1
drain line,	deg C (deg F)	10 - 171 (50 - 340)	3 (5)	0.1
drain tank,	deg C (deg F)	10 - 171 (50 - 340)	3 (5)	0.1
vent line dry bulb,	deg C (deg F)	10 - 171 (50 - 340)	3 (5)	0.1
vent tank,	deg C (deg F)	10 - 171 (50 - 340)	3 (5)	0.1
PCC pool (6 places),	deg C (deg F)	10 - 100 (50 - 212)	3 (5)	0.1
tube wall (inside & outside)	deg C (deg F)	82 - 171 (180 - 340)	3 (5)	0.1
pool makeup water,	deg C (deg F)	10 - 100 (50 - 212)	3 (5)	0.1
Water levels (collapsed):				
PCC pool,	m (ft)	3.5 - 5.0 (11.5 - 16.4)	0.03 (0.1)	0.1
drain tank,	m (ft)	0 - 6.5 (0 - 21.2)	0.03 (0.1)	0.1
drain line	m (ft)	0 - 6.0 (0 - 19.7)	0.03 (0.1)	0.1
vent tank,	m (ft)	0 - 6.5 (0 - 21.3)	0.03 (0.1)	0.1
lower plenum	m (ft)	0 - 3.0 (0 - 9.8)	0.03 (0.1)	0.1
Other (indirect):				
heat rejection rate,	MWth	0 - 15	0.3	0.02
system heat losses,	MWth	0 - 0.5	0.05	0.02

* - % means percent of full-scale



Table 4-2. REQUIRED STRUCTURAL MEASUREMENTS—PCC TEST

Module A

Measurement/Location	Position Number	No. of Positions	Quantity at each Position	Total Meas.	Direct	Notes
Acceleration:						
steam distributor	10	1	3	3	X,Y,Z	
mid-length of tube	5	5	2	10	X, Y	
upper header cover	11	1	3	3	X,Y,Z	
Displacement:						
inlet/header junction	3	1	2	2	X,Z	note 1
steam distributor	10	1	1	1	Z	note 1
lower header support	12	2	1	2	Y	
Total Strain:						
inlet elbow	2	1	2	2	axial	note 8
inlet/header junction	3	1	2	2	Z	note 1
upper header/tube junction	4	5	1 or 2	7	Z	notes 1, 4
tube/lower header junction	6	3	1	3	Z	notes 1, 3
lower header	7	2	2	4	X, Y	note 1
lower header cover	9	1	2	2	Z, X	note 1
upper header	1	2	4	8	X, Z	notes 1, 5
upper header cover	11	1	4	4	X, Z	notes 1, 5
upper header cover bolts	13	3	1 or 2	5	Y	notes 1, 6
lower header cover bolts	14	3	1 or 2	5	Y	notes 1, 6
drain/lower header junction	8	1	2	2	X, Z	note 1
lower header supports	12	1	2	2	Z	note 1
Permanent strain:						
inlet/header junction	3	1	1	1	Z	
upper header/tube junction	5	3	1	3	Z	note 3
lower header/drain junction	8	1	2	2	Z	
Temperature:						
steam line	2	1	1	1		notes 1,2

Instrument positions are illustrated on Figure 4-4.

Notes:

1. The sampling interval shall be 15 sec. during steady-state.
2. Instrument elevation shall correspond to the normal water level of the pool.
3. Tubes c, e, f
4. Tubes/quantity: a/1, b/2, c/2, e/1, f/1
5. Two instrument inside, two outside
6. Three bolts at 120 .2 with two instruments, 1 with one instrument.
7. One instrument inside, one outside.
8. If it's not practical to locate the strain gage at a junction, locate the strain gage near the junction.



Table 4-2. REQUIRED STRUCTURAL MEASUREMENTS—PCC TEST (Continued)

Module A (Continued)

Measurement/Location	Position Number	No. of Positions	Quantity at each Position	Total Meas.	Direct	Notes
Temperature:						
inlet/header junction	3	1	1	1		note 1
upper header/tube junction	4	3	1	3		notes 1, 3
tube/lower header junction	6	3	1	3		notes 1, 3
lower header	7	2	1	2		note 1
lower header cover	9	1	1	1		note 1
upper header	1	2	2	4		notes 1, 7
upper header cover	11	1	2	2		notes 1, 7
drain/lower header junction	8	1	1	1		note 1

Instrument positions are illustrated on Figure 4-4.

Notes:

1. The sampling interval shall be 15 sec. during steady-state.
2. Instrument elevation shall correspond to the normal water level of the pool.
3. Tubes c, e, f
4. Tubes/quantity: a/1, b/2, c/2, e/1, f/1
5. Two instrument inside, two outside
6. Three bolts at 120, 2 with two instruments, 1 with one instrument.
7. One instrument inside, one outside.

Module B

Measurement/Location	Position Number	No. of Positions	Quantity at each Position	Total Meas.	Direct	Notes
Temperature:						
upper header/tube junction	4B	3	1	3		notes 1,3
tube/lower header junction	6B	3	1	3		notes 1,3
lower header	7B	2	1	2		note 1
upper header	1B	2	1	2		

Instrument positions are illustrated on Figure 4-4.

Notes:

1. The sampling interval shall be 15 sec. during steady-state.
2. Module B is used for dual module PCC tests only. Position numbers correspond to Module A positions with the same number without the letter suffix.
3. Tubes c, e and f.



Total strain on the surface shall be determined at the locations and directions specified in Table 4-2. In general, monodirectional strain gages should be used to determine the total strain. At some positions referred to in Table 4-2, multiple measurements are specified at the same position. All strain gages shall be compensated for temperature variations in the range of 10 to 177°C (50 to 350°F) and shall be waterproof.

Permanent strain shall be measured at the locations and directions specified in Table 4-2, by surface scribe marks. The distance between scribe marks will be measured prior of testing, once during the test and at the end of the tests, to determine if there has been any permanent strain.

PCC external surface temperatures shall be measured at the locations shown in Table 4-2 and Figure 4-4 with an accuracy (2 std. dev.) of 3°C (5°F) or better. The temperature range is 10 to 177°C (50 to 350°F).

4.2 Facility Requirements for the IC

4.2.1 Principal Functions and Components. A schematic diagram illustrating the essential features of the facility required for testing the IC is shown in Figure 4-5. The principal components of the test facility shall be:

- Simulated reactor pressure vessel (RPV).
- Steam supply.
- Supply of high pressure noncondensable gas(es).
- IC pool tank.
- Piping and valves.

The test facility must supply steam, water and noncondensable gases in quantities and at conditions which are representative of those anticipated for the SBWR IC.

4.2.2 Test Variables. The independent test variables are:

- Drain valve position (open or closed).
- IC inlet steam pressure.
- Noncondensable gas inlet flow rate.
- Composition of noncondensable gas.

The following variables shall be controlled:

- IC pool tank level (supply makeup to maintain constant level).
- IC pool tank temperature.
- IC pool water quality.
- Steam supply vessel water level.



4.2.3 Component Requirements

4.2.3.1 Steam and Noncondensable Gases. Saturated dry steam (quality greater than 99.8%) shall be supplied to the IC at a controllable pressure in the range 0.48 to 9.48 MPa gage (70 to 1375 psig). Available continuous steam flow rate shall be at least 14.3 kg/s (31.6 lb/s) at 8.618 MPa gage (1250 psig) (based on 20 MWth).

Provision shall be made for injection of noncondensable gases (nitrogen or air and helium) into the IC steam supply at a controlled and measured rate. The noncondensable gases will be injected at steam pressures in the range 0.48 to 8.618 MPa gage (70 to 1250 psig). The gas supplies shall be sized such that the Isolation Condenser can be filled with the gas at 8.618 MPa gage (1250 psig) in one test period.

The possible need to provide the capability to heat the noncondensable gases or the gas/steam mixture shall be considered.

4.2.3.2 IC Pool Tank. The IC pool tank shall be a rectangular elevated tank, open to the atmosphere, for the purpose of containing the IC and the water which cools it. The tank shall be large enough and have provision for internally attaching, with prototypical mounting hardware, a full-scale, single-module IC test unit (one-half of a full unit), and prototypical inlet, vent and condensate drain piping. The upper steam header and upper steam pipe transition fitting shall be fixed so as to prevent sliding in the horizontal direction to simulate worst case support conditions.

The pool depth shall be sufficient to submerge the IC to a prototypical water level. The required dimensions for the IC test pool are shown on Figure 4-6. The pool shall be covered, and shall have an open area for venting pool boiloff. The open area of the vent shall be at least 1 m² (10.8 ft²) and not more than 5 m² (54 ft²).

The IC Pool Tank shall be provided with systems to fill the pool with highly purified water prior to a test, to replace boiloff and maintain constant water level and temperature during a test. Systems shall be provided to cool the pool inventory between tests and to drain the pool for maintenance or modifications to the IC. The water quality requirements for the IC pool are shown in Table 4-5.

The makeup water system shall be sufficient to replace pool boiloff and water entrained with the steam and to maintain a constant pool level at the maximum condensation rate for a period of at least 4 hours. Pool boiloff (no carryover) with 20 MWth heat transfer was calculated to be approximately 9.3×10^{-3} m³/s (147 gpm). The makeup water shall be the same quality as the pool water. It shall be distributed in the pool such that non-prototypical flow patterns and temperature distributions are avoided.

The pool cooling system shall provide for control of pool heatup and cooldown rates typical of SBWR to adequately simulate the design thermal cycles.



4.2.3.3 Simulated RPV. A pressure vessel shall be provided to simulate the reactor pressure vessel (RPV) and supply saturated steam to the IC. The vessel shall be partially filled with saturated water and the steam supply to the IC shall be taken from above the water level and the condensate from the IC shall be returned to the vessel below the water level. The vessel shall be heated with a source sufficient to maintain vessel pressure with maximum heat rejection by the IC.

4.2.3.4 Piping and Valves. The piping for the IC inlet steam, condensate drain and venting shall be as prototypical as is practical with respect to inside diameter, irreversible hydraulic losses and elevation differences. The piping shall be thermally insulated and routing shall avoid nonprototypical opportunities for steam pocketing.

The condensate drain line shall have a valve for startup of the IC. The valve shall meet the leakage (through the valve) and opening time requirements of SBWR IC valve (see document reference in Paragraph 2.1 h.) A valve size as small as 102mm (4-inch) may be used provided the total IC loop irreversible hydraulic losses (piping, elbows, valves and condenser) do not exceed 6.3 psi at the maximum flow rate (Reference document 2.1 a, note 5). The valve and operator shall be supplied by SIET. The condensate drain line shall include a loop seal of at least 0.5 m (20 inches) elevation at the return to the simulated RPV.

The condensate drain line shall have a bypass line around the drain valve. The bypass line shall include a small valve (approximately 20mm [3/4-inch]) for simulating drain valve leakage.

The steam supply pipe and the condensate return pipe shall be designed to produce a stress in bending which corresponds to the maximum allowable pipe bending stress of 1.5 Sm which is caused by combined mechanical, seismic, and thermal expansion loads at 8.618 MPa gage (1250°psig), 302°C (575°F). Direction of deflection shall be selected to maximize the resultant stress on the piping and nozzles between the transition fittings and headers.

As an alternative, guides or lugs may be provided at the lower end of these pipes, at locations to be defined by Ansaldo. If this alternative is selected, the Test Performer shall define the load and moment on the steam supply and condensate drain pipe connections that results from the test facility piping arrangement.

4.2.3.5 Vent Lines. Vent lines shall be provided on the IC from both the upper and lower plenum. Each line shall be manually controlled by a normally-closed, fail-closed solenoid valve and shall have a 12.7 mm (1/2-inch) flow restricting orifice to limit the venting rate as in SBWR. Provision shall be made for measuring the volume of gas vented from the IC.

It is expected that noncondensable gases injected into the inlet steam will separate in the IC and eventually fill the upper and/or lower IC plenum, and reduce the heat removal capability. The vent lines shall be used, as described in Paragraph 6.2.1, during tests to remove the noncondensable gases from the IC and restore capacity. The vent lines shall be actuated by



manual opening of the solenoid valves. It is desired to manually simulate the automatic venting scheme of the SBWR IC system during some tests (See Reference document 2.1.c.).

4.2.3.6 Elbow Flow Meters. One horizontal elbow in both the steam supply line and the condensate drain line shall be equipped for use as elbow flow meters. These devices represent the elbow meters used in the SBWR IC system and are not intended to be used for flow measurement in the IC tests. For the SBWR IC system, the elbow flow meters will provide a signal to indicate the occurrence of a break in the IC inlet or condensate drain lines. Their purpose in the SIET test is to provide a measurement of the "IC startup transient" operating signal and noise levels.

The elbow on each of the two lines shall be the same pipe diameter as used in the SBWR IC. Ninety-degree, long radius ($R/d = 1.5$), elbows shall be used and the pressure taps shall be in the outer and inner circumferences of the elbow midplane, 45 degrees from the inlet end. The pressure tap holes shall be 6 mm (0.236 in) in diameter. There must be no burrs, wire edges or other irregularities on the inside of the pipe at the nipple connection or along the edge of the hole through the pipe wall. The diameter of the hole should not decrease within a distance of 12 mm (0.472 in) from the inner surface of the pipe but may be increased within a lesser distance.

Where the pressure hole breaks through the inner surface of the pipe there must be no roughness, burrs nor wire edge. The edge of the hole may be left truly square or may be dulled (rounded) very slightly.

Connections to the pressure holes should be made by nipples, couplings, or adapters welded to the outside of the pipe. It is important that no part of any such fitting projects beyond the inner surface of the pipe.

It is desirable that the velocity profile of the fluid stream entering the elbow be fairly uniform and free of swirls. The recommendations of the document referenced in Paragraph 2.3.b regarding straight lengths of pipe upstream and downstream of the elbows shall be followed as much as possible. Condensation pots shall be used on the pressure tap lines if necessary to keep the line full of water.

4.2.4 Instrumentation Requirements (IC)

4.2.4.1 General Requirements. All test instrumentation shall be provided by the Test Performer and shall be calibrated against standards traceable to the U. S. National Institute of Standards and Technology or equivalent.

4.2.4.2 Thermal-Hydraulic. The required thermal hydraulic measurements, the required accuracy and the proposed digital sampling frequency for the IC are listed in Table 4-3. The required accuracy in Table 4-3, is given as the "two standard deviation" level of "normally" distributed error, i.e. there is a 95% probability that the error does not exceed the specified value.



Temperature, steam flow, condensate flow and pressure instruments shall be provided to monitor the heatup and cooldown rates of the coolant and the heat transfer from the condenser during the thermal cycle conditions to be tested.

Temperature measurements shall be made on the vertical section of steam pipe which connects to the steam header below pool water level. The purpose of this measurement is to detect condensate return valve or IC unit leakage when the IC is in the hot standby (fully pressurized) non-operating mode with the condensate return valves closed. Six temperature elements shall be located on the outside of the steam pipe spaced at 0.1m (3.9-inch). The upper element shall be at the pool normal water level elevation.

4.2.4.3 Structural. The required structural measurements for the IC are listed in Table 4-4 and the numbered instrument positions identified in Figure 4-7. The positions are only indicative: the exact locations will be defined by Ansaldo after the stress analysis of the IC. See reference 2.2.c. The types of structural measurement required for the IC are acceleration, displacement, strain, surface temperature and surface scribe marks for measurement of permanent strain.

Acceleration measurements will be made primarily for the purpose of evaluating vibration characteristics and detection of possible condensation/water hammer loads. Piezoelectric accelerometers are recommended for these measurements. The required temperature range is 10 to 314°C (50 to 598°F).

Linear displacement measurement is required at points specified in Table 4-4 with an accuracy of +0.2 mm (0.008 in).

Total strain on the surface shall be determined at the locations and directions specified in Table 4-4. In general, monodirectional strain gage should be used to determine the total strain. At some positions referred to in Table 4-4, multiple measurements are specified at the same position. All strain gages shall be compensated for temperature variations in the range of 10 to 314°C (50 to 598°F) and shall be waterproof.

IC external surface temperatures shall be measured at the locations shown in Table 4-4 and Figure 4-7 with an accuracy (2 std. dev.) of 3°C (5°F) or better. The temperature range is 10 to 314°C (50 to 598°F).

Permanent strain shall be measured at the locations and directions specified in Table 4-4, by surface scribe marks. The distance between scribe marks will be measured prior of testing, once during the test and at the end of the tests, to determine if there has been any permanent strain.

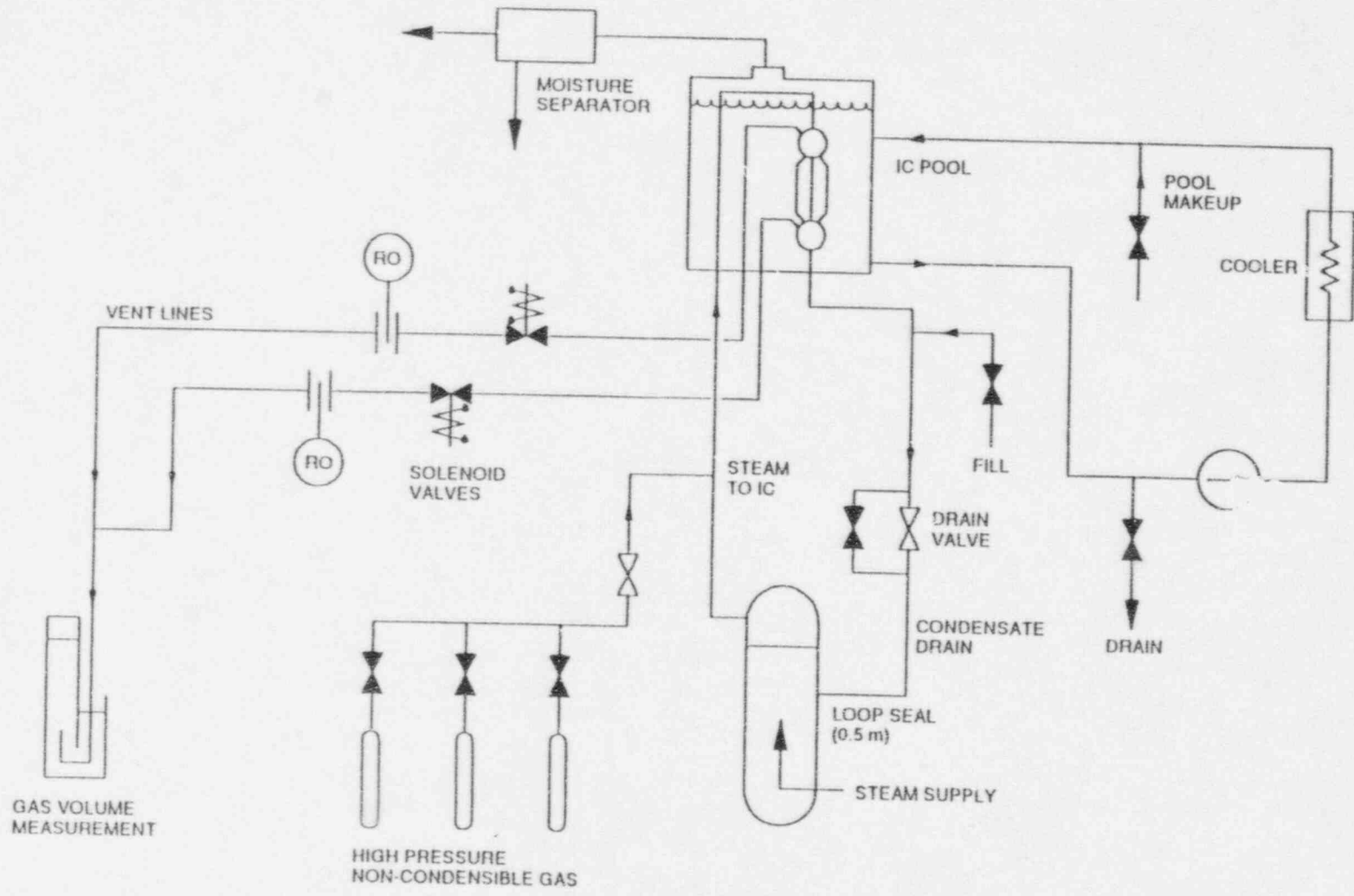

FIGURE 4-5. SCHEMATIC OF IC TEST FACILITY

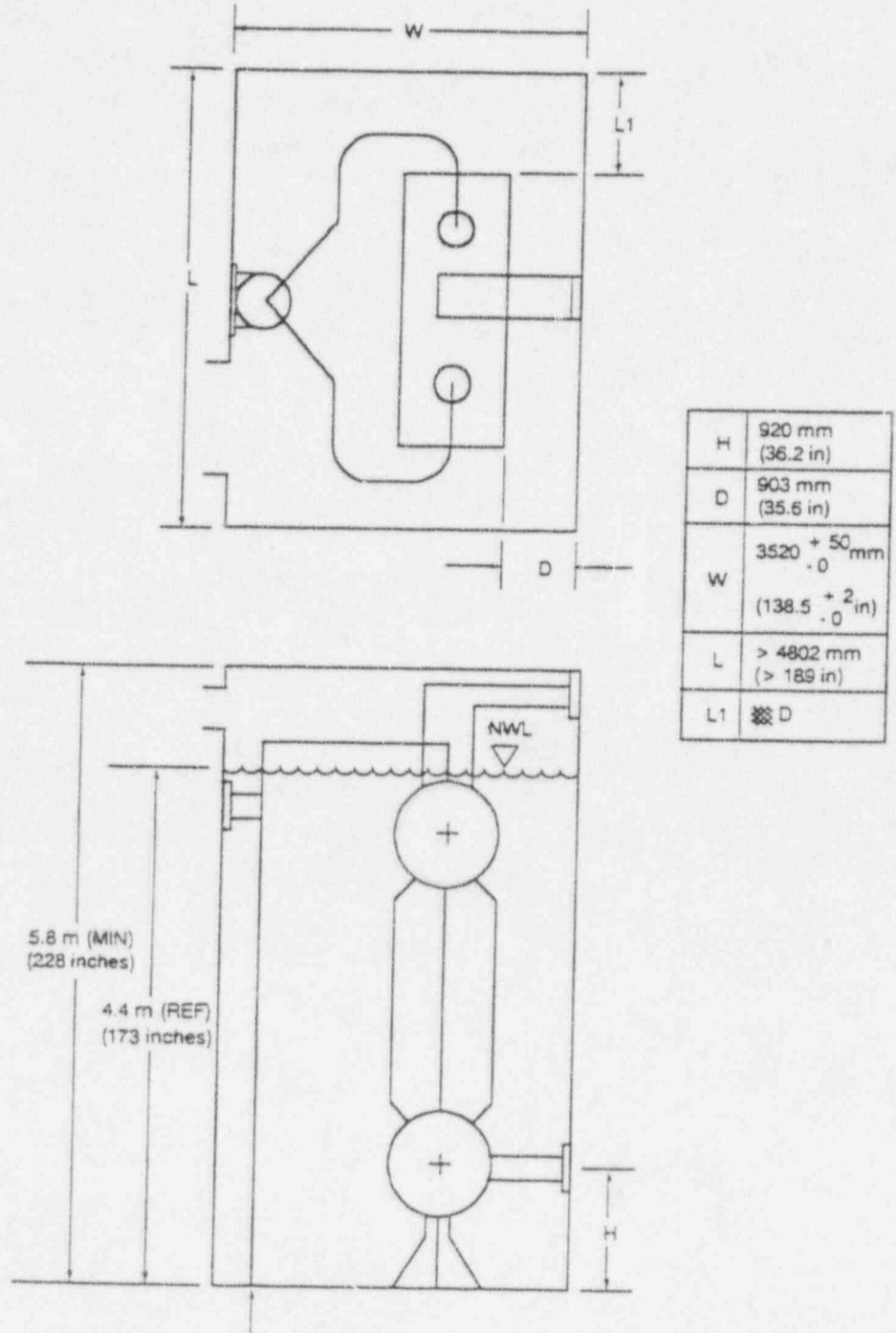

FIGURE 4-6. REQUIRED DIMENSIONS FOR IC TEST POOL

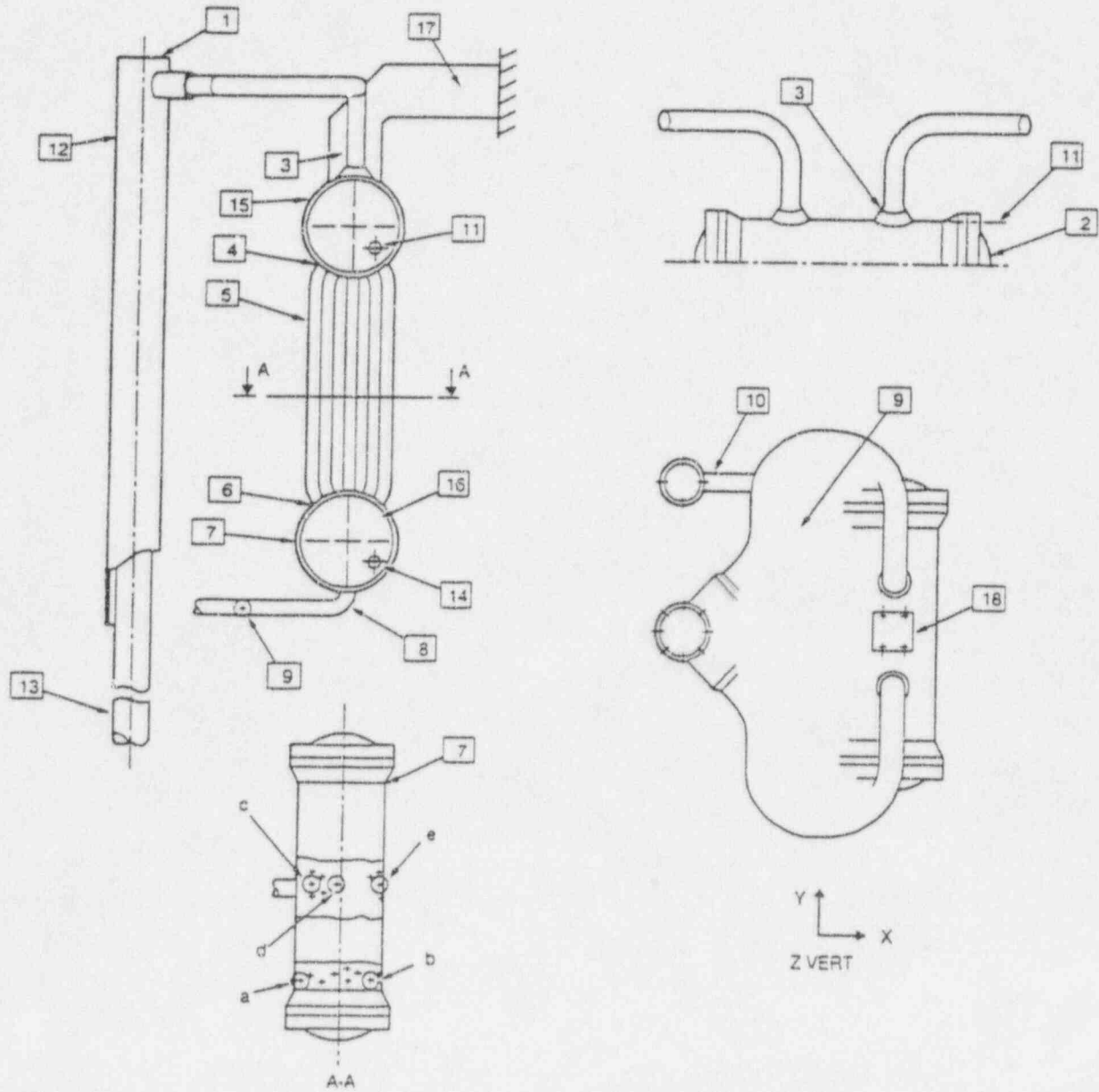

FIGURE 4-7. IC STRUCTURAL INSTRUMENTATION



Table 4-3. REQUIRED THERMAL HYDRAULIC MEASUREMENTS—IC TEST

Measurement	Units	Expected Range	Accuracy (2 Std. Dev.)	Frequency (samples per sec)
Pressures:				
steam vessel,	MPa gage (psig)	0.4 - 10.34 (70 - 1500)	2 % *	0.1
IC inlet,	MPa gage (psig)	0.4 - 10.34 (70 - 1500)	2 %	0.1
IC upper plenum,	MPa gage (psig)	0.4 - 10.34 (70 - 1500)	2 %	0.1
Differential pressures:				
IC inlet/IC vent line,	kPa (psi)	0 - 69 (0 - 10)	2 %	0.1
IC inlet/IC drain line,	kPa (psi)	0 - 69 (0 - 10)	2 %	0.1
upper plenum/lower plenum,	kPa (psi)	0 - 69 (0 - 10)	2 %	0.1
elbow meter taps (2),	kPa (psi)	0 - ** (0 - **)	2 %	0.1
Flow rates:				
steam inlet,	kg/s (lb/s)	0 - 16 (0 - 35)	2 %	0.1
noncondensible inlet,	kg/s (lb/s)	0 - 0.3 (0 - 0.5)	2 %	0.1
IC pool makeup,	l/s (gpm)	0 - 11.4 (0 - 180)	5 %	0.1
Temperatures:				
IC inlet steam,	deg C (deg F)	157 - 314 (315 - 598)	3 (5)	0.1
IC inlet pipe (6), (leak det.) drain line,	deg C (deg F)	100 - 314 (212 - 598)	3 (5)	0.1
vent lines (2),	deg C (deg F)	10 - 314 (50 - 598)	3 (5)	0.1
steam vessel,	deg C (deg F)	10 - 314 (50 - 598)	3 (5)	0.1
IC pool (12 places),	deg C (deg F)	65 - 314 (150 - 598)	3 (5)	0.1
pool makeup water,	deg C (deg F)	10 - 104 (50 - 220)	3 (5)	0.1
pool outlet temperature,	deg C (deg F)	10 - 104 (50 - 220)	3 (5)	0.1
tubes (3 @ 5 axial locations),	deg C (deg F)	10 - 104 (50 - 220)	3 (5)	0.1
Water levels (collapsed):				
IC pool,	m (ft)	3.5 - 5.5 (11.5 - 18.0)	0.03 (0.1)	0.1
simulated RPV,	m (ft)	later (later)	0.03 (0.1)	0.1
drain line,	m (ft)	later (later)	0.03 (0.1)	0.1
vent lines (2),	m (ft)	later (later)	0.03 (0.1)	0.1
Other (indirect):				
IC heat rejection rate,	MWth	0 - 20	0.1	0.02
system heat loss,	MWth	0 - 1	0.1	0.02

* - % means percent of full-scale

** - The elbow meter tap expected differential pressure range will be derived by the tester and will depend on both the nature of the fluid (steam or condensate) and the characteristics of the elbow. The range must cover the available steam flow requirement for both the steam and condensate taps.



Table 44. REQUIRED STRUCTURAL MEASUREMENTS—IC TEST

Measurement/Location	Position Number	No. of Positions	Quantity at each Position	Total Meas.	Dir.	Notes
Acceleration:						
mid-length of tube	5	5	2	10	X,Y	note 2
drain line curve	9	1	3	3	X,Y,Z	
lower header cover	16	1	1	1	Z	
upper header cover	2	1	3	3	X,Y,Z	
Displacement:						
Steam distributor	1	1	1	1	Z	note 1
drain/lower header junction	8	1	1	1	Z	note 1
steam pipe lower zone	13	1	1	1	Z	note 1
Total Strain:						
inlet/upper header junction	3	1	6	6	X,Y,Z	note 11
upper header/tube junction	4	5	1 or 2	7	Z	notes 1, 3
mid-length of tube	5	3	1	3	circ.	notes 1, 2, 8
tube/lower header junction	6	3	1	3	Z	notes 1, 4
lower header	7	2	2	4	X,Y	notes 1, 4
lower header cover	16	1	2	2	X,Z	note 1
upper header	15	2	4	8	X,Y	notes 1, 5
upper header cover	2	1	4	4	X,Z	notes 1, 5
drain/lower header junction	8	1	4	4	X,Z	note 1
drain line curve	9	1	2	2	Y	note 1
drain line/drain tube	10	1	4	4	X	note 1
upper header cover bolts	11	3	2 or 1	5	Y	notes 1, 6
lower header cover bolts	14	3	2 or 1	5	Y	notes 1, 6
guard pipe/distributor	12	1	3	3	X,Z	notes 1, 7
support	17	1	2	2	X,45°	note 1
upper header near support	18	1	4	4	X,Y	notes 1, 5

Instrument positions are illustrated on Figure 4-7.

Notes:

1. The sampling interval shall be 1 sec. during transients, 1 minute during steady-state.
2. Tubes a, b, c, e, f.
3. Three instruments above normal water level, three below.
4. Tubes c, e, f.
5. Two instruments inside, two outside.
6. Three bolts at 120°/2 with two instruments, 1 with one.
7. Two in Z direction, one in X.
8. Two instruments on tubes b and c, one on tubes a, e, f.
9. Near level of pool water.
10. One instrument inside, one outside..
11. If it's not practical to locate the strain gage at a junction, locate the strain gage near the junction.



Table 4-4. REQUIRED STRUCTURAL MEASUREMENTS—IC TEST (Continued)

Measurement/Location	Position Number	No. of Positions	Quantity at each Position	Total Meas.	Dir.	Notes
Permanent Strain:						
inlet/upper header junction	3	1	3	3	Y,Z,45°	note 9
condensing tube bend	4	3	1	3	Z	note 4
drain/lower header junction	8	1	1	1	Z	
Temperature:						
guard pipe/distributor	12	1	1	1		note 1
inlet pipe/upper header	3	2	2	4		notes 1, 5
upper header/tube junction	4	3	1	3		notes 1, 2
tube/lower header junction	6	3	1	3		notes 1, 4
lower header	7	2	1	2		note 1
upper header	15	2	2	4		notes 1, 2
drain line bend	9	1	1	1		note 1
upper header cover	2	1	2	2		notes 1, 10
lower header cover	16	1	1	1		note 1

Instrument positions are illustrated on Figure 4-7.

Table 4-5. WATER QUALITY REQUIREMENTS

Water Quality Parameter	Requirement
Chloride (ppb)	< 20.0
Sulfate (ppb)	< 20.0
Silica (ppb as SiO ₂)	< 1000
Conductivity at 25°C (77°F), (micro S/cm)	< 1.2
pH at 25°C (77°F) min -	5.6
max -	8.6
Corrosion Product Metals (ppb)	
Fe Insoluble	< 20.0
Soluble	
Cu Total	< 1.0
All Other Metals	< 9.0
Sum	< 30.0



4.3 Data Recording Requirements (PCC and IC Tests)

4.3.1 Data Acquisition. A digital data acquisition system, of adequate capacity to monitor and record all specified measurements, shall be supplied by the Test Performer. The measurements shall be recorded, in digital format, on magnetic tape or disk for later calculation and analysis of test results. Sampling frequency for each measurement shall be adjustable. Preliminary sampling frequency requirements are shown on Tables 4-1 through 4-4, but values may be changed prior to testing.

The unfiltered accelerometer signals shall be recorded in analog form with a recorder having a bandwidth of 1 - 500 Hz.

Physical measurements such as scribe mark distances and other NDE measurements not recordable in magnetic format will be recorded in writing on data sheets to be prepared by the Test Performer as part of the Test Plan and Procedures document.

4.3.2 Test Observations. Qualitative observations of test conditions such as leakage of steam or water, discoloration of materials, erosion or corrosion of parts, etc. shall be noted for each test. These observations shall be recorded in a log book. The entries will be reviewed for appropriate action by the Responsible Test Engineer.

5. PASSIVE CONTAINMENT CONDENSER TESTS

5.1 General Test Procedures

5.1.1 Specific Test Objectives. The general objectives of the PCC test (Paragraph 3.2) can be accomplished by means of the following specific objectives.

5.1.1.1 Thermal-Hydraulic

- a. Measure the steady-state heat removal capability over the expected range of SBWR conditions:
 - inlet pressure
 - concentration of noncondensable gases
 - PCC differential pressure
 - pool-side bulk average water temperature
 - pool-side water level
- b. Confirm that when a mixture of steam and noncondensable gases flows into the PCC, the uncondensed gases will be discharged from the vent line and the condensate will be discharged from the drain line.
- c. Confirm that heat transfer and flow rates are stable and without large fluctuations.



- d. Confirm that there is no condensation water hammer during the expected startup, shutdown and operating modes of the PCC.
- e. Measure the inside and outside wall temperatures at "typical" tube locations to:
 - i. Provide diagnostic information for the investigation of unexpected condenser performance.
 - ii. Confirm the understanding of tubeside performance gained from other test programs.
 - iii. Provide a fundamental data base for confirmation of TRACG simulation of poolside performance.

5.1.1.2 Structural

- a. Confirm that the stress levels at critical locations on the PCC do not exceed design values for the following conditions:
 - i. Standby operation at normal containment pressure, temperature, gas content and relative humidity.
 - ii. Pneumatic leak testing.
 - iii. Transition from: operation at normal containment conditions to LOCA and severe accident conditions.
- b. Confirm that cyclic loads at critical locations on the PCC, resulting from flow and/or condensation induced vibration, do not exceed design values during expected periods of PCC operation.
- c. Demonstrate, by performing 5 times the expected number of pressure and thermal cycles that the PCC will successfully survive 60 years of SBWR service.

5.2 PCC Test Strategy. The PCC tests will be a series of steady-state tests at specified steam flow rate, noncondensable flow rate, inlet gas temperature and inlet pressure (equivalent to drywell). The condensate tank pressure will be equal to the inlet pressure and the vent tank pressure will be adjusted to obtain the specified PCC inlet pressure. The PCC pool will be maintained at a constant level (full) and equilibrium bulk average temperature during most tests. The PCC will be brought to the specified conditions and allowed to stabilize, i.e. reach a condition of steady-state heat transfer and allowed to operate for approximately 15 minutes at these conditions. Data will be recorded during pool heatup and for the period of steady operation.



The types of PCC tests which are considered to be necessary to achieve the objectives in Paragraph 5.1.1 are listed in Paragraph 5.2.1. Each of these test types is described in more detail in Paragraphs 5.2.2 through 5.2.9. It should be noted that the procedures described in the paragraphs are proposals and not requirements. The Test Performer may elect to use alternative or modified procedures which accomplish the same objective. The actual test procedures will be part of the Test Plan and Procedures document described in Paragraph 3.6.

A matrix of the test conditions required for the PCC is provided in Appendix A.

5.2.1 Types of Tests Required for the PCC. The types of tests to be performed with the PCC have been defined as follows:

- A.1.1. Steady state performance - saturated steam/air mixtures.
- A.1.2. Steady state performance - superheated steam/air mixtures
- A.1.3. Steady state performance - steam only
- A.2.1. Effect of pool water level - saturated steam
- A.2.2. Effect of pool water level - saturated steam/air mixtures
- A.3.1. Additional Structural Tests - simulated LOCA pressurization
- A.3.2. Additional Structural Tests - simulated leak testing
- B.1. Deleted
- B.2. Effect of low density noncondensibles

5.2.2 Description of Test Type A.1.1

Definition: Two Modules, Steady State - Saturated Steam/Air

General Test Procedure:

Set up selected constant values of air and steam flow rates (m_a and m_s respectively) according to procedures determined during shakedown testing. Adjust PCC inlet pressure to maximum value, P_i (max) using vent tank discharge valve. Adjust inlet mixture temperature to saturated condition. Allow PCC pool water to heat up to steady state bulk average temperature. Trim valve settings to adjust inlet temperature and pressure to prescribed values.

Record data at approximately 5 inlet pressure values between P_i (max) and P_i (min) or until a specified PCC ΔP limit is reached. The ΔP limit will be approximately 14 kPa (2 psi), but will be specified by the Responsible Test Engineer prior to the test. Repeat for each selected value of m_a and m_s . (See sketch below.)

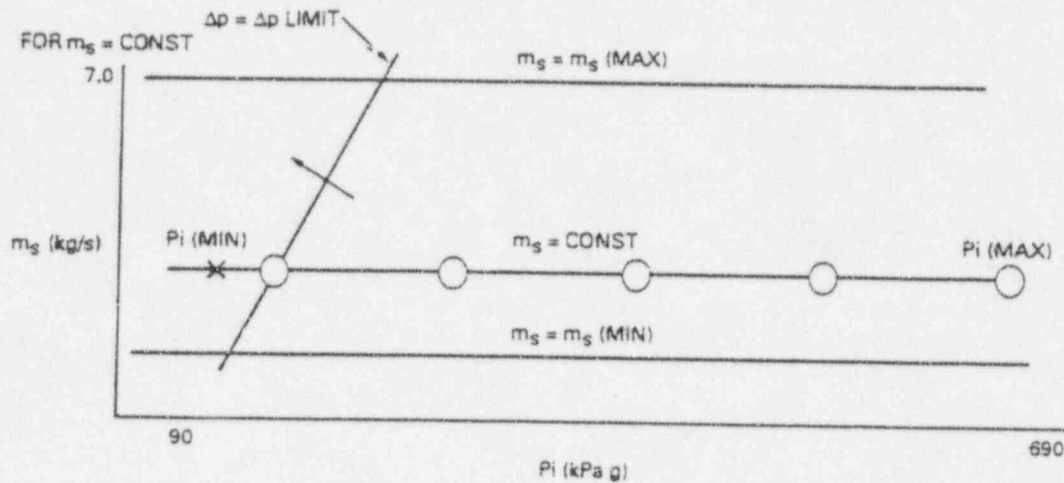

Independent Variables:

1. Pool level - maintain constant at normal level (full).
2. Inlet gas temperature - set at saturation value corresponding to the inlet pressure and gas mixture or the specified degrees of superheat above saturation.
3. Inlet steam flow rate, m_s - see Test Conditions.
4. Inlet air flow rate, m_a - see Test Conditions.
5. Inlet pressure, P_i - see Test Conditions for range of values.

Test Conditions:

See Reference Test Matrix, Appendix A.

5.2.3 Description of Test Type A.1.2

Definition: Two Modules, Steady State - Superheated Steam/Air

General Test Procedure:

Procedure is the same as Tests A.1.1. Repeat three of the saturated test conditions from A.1.1, each at two values of superheat, i.e. six test conditions (each with 5 inlet pressure values). Test conditions to be repeated are 3, 7, and 23. The superheat values are to be determined (TBD) by



analysis prior to testing. The Test Requestor will provide the superheat values to the Test Performer.

Independent Variables:

Same as Tests A.1.1.

Test Conditions:

See Reference Test Matrix, Appendix A.

5.2.4 Description of Test Type A.1.3

Definition: Two Modules, Steady State - Steam Only

When the PCC is tested with steam flow only, the performance can be affected by the presence of noncondensable gas trapped in the PCC tubes. Two conditions will be considered for Tests A.1.3: 1. No air in PCC tubes and, 2. Air in PCC tubes.

General Test Procedure - No air in PCC tubes:

The spectacle flange in the vent line may or may not be closed for these tests. This will be decided on the basis of the shakedown tests.

Purge all air from the system prior to start of testing. The condenser is now similar to the IC, i.e. with steam flow rate as the independent variable, the inlet pressure will adjust to match the capacity of the PCC.

Operate the PCC at the same steam flow rates used in Test Conditions 1 - 30 (7 values) and record data. Inlet pressure should not be allowed to increase above 690 kPa (100 psig).

Independent Variables:

1. Pool level - maintain constant at normal level.
2. Inlet gas temperature - adjust as specified in the Test Conditions according to the measured PCC inlet pressure. Values of superheat to be determined (TBD) by analysis prior to testing.
3. Inlet steam flow rate - see Test Conditions.
4. Inlet air flow rate - no air flow for these tests.

Test Conditions:

See Reference Test Matrix, Appendix A.



General Test Procedure - Air in PCC tubes:

Close spectacle flange on vent line. Purge all air from system with steam prior to start of test. Set up the specified saturated steam flow rate and stabilize operation (inlet pressure). Bleed air slowly into inlet line to PCC at a metered rate and record data as inlet pressure increases. Cease testing when pressure stops increasing or approaches 690 kPa (100 psig).

Independent Variables:

1. Pool level - maintain constant at normal level (full).
2. Inlet gas temperature - adjust to the saturated temperature (or the specified superheat) of the steam at the initial (purged) pressure and maintain constant throughout the test.
3. Inlet steam flow rate - see Test Conditions.
4. Inlet air flow rate - adjust to a rate which will fill the condenser in approximately 15 to 30 minutes at the stabilized inlet pressure.

Test Conditions:

See Reference Test Matrix, Appendix A.

5.2.5 Description of Test Type A.2

Definition: Two Modules, Effect of Pool Water Level

General Test Procedure:

These tests will demonstrate, for a limited set of conditions, the effect of pool water level decrease on the performance of the PCC. It is proposed to do this by recording data while slowly lowering pool water level either by allowing the water to boil away without refilling or by slowly draining. When the low level is reached in the pool, ambient water will be slowly added to refill the pool, while continuing to record the data.

A.2.1 Saturated steam: Purge all air from the system and repeat Test Condition No. 41, allowing the pool water level to decrease to about 50% of normal level or until the inlet pressure reaches approximately 100 psig.

A.2.2 Saturated steam/air mixtures: Repeat Test Conditions 15 and 30, allowing the pool water level to decrease to about 50% of normal level or until the inlet pressure reaches approximately 100 psig. Start with the minimum values of inlet pressure and maintain vent tank discharge valve position throughout the test.



Independent Variables:

1. Pool level - begin test with normal level (full) and allow to decrease to 50% of normal. Slowly refill and end test with pool again at the normal level.
2. Inlet gas temperature - adjust to saturation value corresponding to the inlet pressure and gas mixture.
3. Inlet steam flow rate, ms - see Test Conditions.
4. Inlet air flow rate, ma - see Test Conditions.
5. Inlet pressure, Pi - see Test Conditions. For Conditions 55 and 56 start at the minimum inlet pressure determined for Test Conditions 15 and 30 respectively.

Test Conditions:

See Reference Test Matrix, Appendix A.

5.2.6 Description of Test Type A.3

Definition: Two Modules, Additional Structural Tests

To confirm the PCC structural design adequacy for the SBWR design lifetime, the test program must include testing the PCC for at least five times the number of design basis pressure/temperature cycles. The performance test includes most of these conditions, except for the LOCA and the pneumatic leak testing.

Definition: A.3.1. Simulated LOCA Pressurizations

The design basis is two LOCAs during the sixty year design life of the PCC. For the test, 10 simulated LOCA cycles must be performed.

General Test Procedure:

The PCC is to be rapidly pressurized with saturated steam to 379 kPa(g) (55 psig) and 151°C (303°F). The vent tank discharge valve must be partly open during pressurization to purge air from the PCC tubes and permit heating. The total time period for the pressurization and data recording is approximately 30 minutes. The flow rate of steam required to achieve these conditions can be determined either by shakedown testing or from previously run two-module tests. If the steam supply is not large enough to maintain the required pressure with a steam-only inlet flow to the PCC, air flow can be added. Pre-adjustment of the vent tank discharge valve position by "trial and error" may be necessary.



Independent Variables:

1. Pool level - maintain constant at normal level (full).
2. Pool temperature - start with pool at ambient temperature and allow to heat up in response to PCC performance.
3. Inlet gas temperature - adjust to saturated temperature at 379 kPa (g) (55 psig).
4. Inlet steam flow rate - to be determined.
5. Inlet air flow rate - no air flow for these tests unless it is required to achieve the final required pressure.

Test Conditions:

This procedure is to be performed a total of 10 times. The pressurization transient for the PCC must meet the following requirements:

PCC Inlet Pressure (kPa (g) (psig))	Required Time to Reach Pressure
175 (25.4)	start ⁽¹⁾
249 (36.1)	< 30 sec
261 (37.8)	< 65 sec
379 (55)	< 30 min

(1) The unit is initially pressurized with air at ambient conditions.

Definition: A.3.2. Simulated Pneumatic Leak Test Pressurizations.

The PCC design basis assumes that the unit will be pneumatically pressurized for leak testing 60 times during its design life. Each leak test will consist of closing the inlet, vent and condensate lines and pressurizing the PCC with air to 758 kPa(g) (110 psig). The pressure will be maintained long enough to demonstrate that the PCC does not leak. For the structural test, it is required to simulate five times the number of load cycles produced by these leak tests.



General Test Procedure:

Close off the inlet, vent and condensate lines as necessary to permit pressurization with air to 758 kPa(g) (110 psig). Pressurize with air to the required pressure, hold pressure for approximately 1-2 minutes and release pressure. The unit may be partially filled with water to reduce the time required for pressurizing. The PCC should be checked for leaks by verifying the absence of air bubbles in the pool approximately once for each fifty cycles.

Independent Variables:

1. Pool level - maintain constant at normal level (full).
2. Pool temperature - ambient.
3. Inlet gas temperature - less than 60°C (140°F).
4. Inlet steam flow rate - none required.
5. Inlet air flow rate - sufficient to perform approximately 8 cycles per hour.

Test Conditions:

Perform 300 of these test cycles.

5.2.7 Deleted

5.2.8 Deleted

5.2.9 Description of Test Type B.2

Definition: Effect of Low Density Noncondensibles

General Test Procedure:

Perform tests similar to the two module tests, A.1.3, part 2., except using helium and helium/air mixtures in place of air.

Close spectacle flange on PCC vent line. Purge all air from system with steam prior to start of test. Set up saturated steam flow rate and stabilize operation (inlet pressure). Bleed the noncondensable gas slowly into inlet line to PCC at a metered rate and record data as inlet pressure increases. Cease testing when pressure levels out or approaches 100 psig.



Independent Variables:

1. Pool level - maintain constant at normal level (full).
2. Inlet gas temperature - adjust to the saturated temperature of the steam at the initial (purged) pressure and maintain constant throughout the test.
3. Inlet steam flow rate - see Test Conditions.
4. Inlet air flow rate - see Test Conditions.
5. Inlet helium flow rate - adjust to a rate which will fill the condenser in approximately 15 to 30 minutes.

Test Conditions:

See Reference Test Matrix, Appendix A.

5.3 Data Processing/Analysis General Requirements. The processing and analysis of the recorded test data shall be done by the Test Performer in three steps which are described as "quick look", "preview" and "full processing and analysis". Equipment and software necessary for the specified data processing shall be provided by the Test Performer.

The Test Performer shall prepare a plan for verification of the accuracy of all data acquisition and data reduction software. This plan shall be approved by the Test Requestor and verification shall be completed by the Test Performer prior to the start of testing.

The objective of the "quick look" is to provide all of the information needed to proceed with the preparation for the next test. This shall consist primarily of verification that the objectives of the test run were achieved, identification of any instruments which may have failed or performed incorrectly during the test, and reviewing structural data to insure the integrity of the condenser for the next test. The goal is to complete this phase of the data reduction within 4 hours after the completion of a test.

The "preview" phase has the purposes of providing representative results from the most significant measurements to be used in the "Apparent Test Results" report, specified in Section 3.7.2, and to aid in defining the details of the remainder of the analysis. It may be that the most convenient way to do this analysis is interactively with the data reduction computer. Time history plots of key parameters shall be prepared and examined to determine time periods of significant interest for more detailed analysis. Summary plots and digital data tables of typical performance shall be prepared. Time periods and parameters of most significance shall be selected for processing during the "full processing and analysis" phase. The "preview" is expected to be completed within 2 to 4 days following the test.



The plots and tables for the Final Test Report, specified in Section 3.7.2, will be generated during the "full processing and analysis" phase to be completed within approximately two months after the test. The purpose of this phase is to organize the data in a form that provides an integrated interpretation of the test results to show the performance of the condenser and demonstrate that the test objectives have been achieved.

The following general data reduction software capabilities shall be available:

Conversion of all recorded signals to digital values in engineering units. Units shall be as defined in the SBWR Composite Specification referenced in Paragraph 2.1.g.

Print tables of digital values of recorded signals in engineering units for selected time periods.

Calculate and prepare tables of mean, standard deviation, minimum and maximum value of all measurements (in engineering units) during a specified time period.

Plot graphs of any selected test variable as a function of time (time history) for any selected test time window. Be able to plot groups of 1 to 6 test variables on a single graph.

Spectral analysis for determination of the primary frequencies present in the accelerometer, strain gage, and possibly some pressure signals.

6. ISOLATION CONDENSER TESTS

6.1 General Test Procedures

6.1.1 Specific Test Objectives. The general objectives of the IC test (Paragraph 3.3) can be accomplished by means of the following specific objectives.

6.1.1.1 Thermal Hydraulic

- a. Measure the steady-state heat removal capability over the expected range of the following SBWR conditions:
 - steam pressure
 - concentration of noncondensable gases
 - pool-side bulk average water temperature
 - pool-side water level
- b. Confirm that tube-side heat transfer and flow rates are stable and without large fluctuations.



- c. Confirm that the vent line(s) and the venting strategy for purging noncondensable gases perform as required during IC operation.
- d. Confirm that the condensate return line performs its function as required during steady state and transient operation and that water level oscillations and condensation induced flow oscillations do not impair heat removal capacity.
- e. Measure the heat loss from the IC when it is in the standby mode, with the condensate drain valves closed.
- f. Measure the "drain time" for the IC upper plenum during the IC startup transient.

6.1.1.2 Structural

- a. Demonstrate, using, when possible, prototypical NDE testing methods, that a specified fraction of the required IC thermal cycles, together with unexpected load cycling, results in no excessive deformation, crack initiation or excessive crack growth rate. (The Test Requestor will provide the NDE testing of IC.)
- b. Confirm that the stress levels at critical locations on the IC do not exceed design values for the following conditions:
 - i. Reactor heatup from a cold condition to saturation temperature at reactor operating pressure (IC hot standby) and subsequent cooldown, with the IC condensate return valves closed (i.e., IC does not operate).
 - ii. Isolation condenser startup and operation following a rapid increase from reactor normal operating pressure, and subsequent shutdown of the IC and return to standby at a reduced pressure.
 - iii. Periods of IC operation with constant steam conditions inside the tubes and low temperature (ambient rising to 100°C (212°F)) water on the outside.
- c. Confirm that cyclic stress levels at critical locations on the IC, resulting from flow and/or condensation induced vibration, do not exceed design values during expected periods of IC operation.

6.1.1.3 In Service Inspection. Confirm the adequacy of proposed In Service Inspection (ISI) procedures and methods by performing NDE tests prior to thermal-hydraulic testing and after testing has been completed.



6.1.1.4 Leak Detection Methods. Record reference data for use in evaluation of proposed methods for IC system leak/break detection.

- a. Measure and record the dynamic differential pressure signal from elbow flow meters in the steam supply and condensate return lines during the IC startup transient and at standby and normal operating conditions.
- b. Measure the temperature distribution in the IC inlet pipe with a simulated leak in the IC or IC condensate drain line.

6.2 Required Test Conditions. A reference matrix of test conditions for the IC is presented in Appendix B. This matrix is intended for use in designing the test facility and planning the test program but the final test conditions will be specified in the Test Plan and Procedures document and may differ from those shown in Appendix B.

6.2.1 Description of Tests

6.2.1.1 Thermal-Hydraulic Performance Tests. The thermal-hydraulic performance tests will collect data under various operating conditions of the isolation condenser. The tests are classified under the following types. The test conditions are given in Appendix B.

Type 1 - Performance Data

Steady-state IC operation shall be measured for at least 15 minutes at various pressures.

Type 3 - Non-condensable Gas Effect

After achieving the specified steady-state operation, non-condensable gas will be injected into the IC and allowed to build up. The degradation in thermal-hydraulic performance will be measured. At a specified pressure, the gas will be vented using the top and/or bottom vent lines.

Type 4m - Pool Water Level Effect

After achieving the specified steady-state operation, the water level of the IC pool will be lowered, and the degradation in thermal-hydraulic performance measured.

6.2.1.2 Structural Cycle Tests. The structural tests will essentially be representative of the cyclic duty expected of the isolation condenser as used in the SBWR. Each test will consist of a cycle corresponding to one of the basic types. The cycle types are described below and illustrated in Figure 6-1.

Initial Conditions for All Cycle Types:

The condensate drain valve is closed and the IC is filled with water. The IC pool shall be full and the initial water temperature at the specified value.



Types 2 and 5 - "Normal" IC Operation:

1. Heat up and pressurize with steam from ambient to pressure P1 at a rate of approximately 100°C (180°F) per hour.
2. Allow the system to stabilize at P1 and then open condensate drain valve.
3. As condensation reduces the inlet pressure, increase the inlet steam flow rate as necessary to stabilize the condenser inlet pressure at P2. If the specified value of P2 cannot be sustained at the maximum steam flow rate (20 MW), then perform the test at the maximum sustainable pressure below P2.
4. Continue steady condenser operation at these conditions for a period of time, T2.
5. At the end of the time period, T2, depressurize and cool down the system at approximately 100°C (180°F) per hour.

Type 6 - Reactor Heatup/Cooldown without IC Operation:

1. Heat up and pressurize with steam from ambient to pressure P1 at a rate of approximately 100°C (180°F) per hour.
2. Depressurize and cool down the system at approximately 100°C (180°F) per hour. The condensate drain valve is not opened during this cycle.

Type 7 - Simulate ATWS Event:

1. Heat up and pressurize with steam from ambient to pressure P1 at a rate of approximately 100°C (180°F) per hour.
2. Allow the system to stabilize at P1 and then increase pressure rapidly (approximately 0.5 minutes) to P2 and open condensate drain valve.
3. As condensation reduces the inlet pressure, increase the inlet steam flow rate as necessary to stabilize the condenser inlet pressure at P3. If the specified value of P3 cannot be sustained at the maximum steam flow rate (20 MW), then perform the test at the maximum sustainable pressure below P3.
4. Continue steady condenser operation at these conditions for a period of time, T3.
5. At the end of the time period, T3, depressurize and cool down the system at approximately 100°C (180°F) per hour.

6.2.2 Data Recording. The duration of each cycle will be in the range of 7 to 12 hours and therefore it will not be necessary to record all data at high sample rates throughout each test. It



may be desirable to record some data at very low sample rates and some at high rates for only certain time periods of the test.

6.3 Data Processing/Analysis General Requirements. The general requirements for data processing and analysis for the IC are the same as those specified for the PCC in Paragraph 5.3.

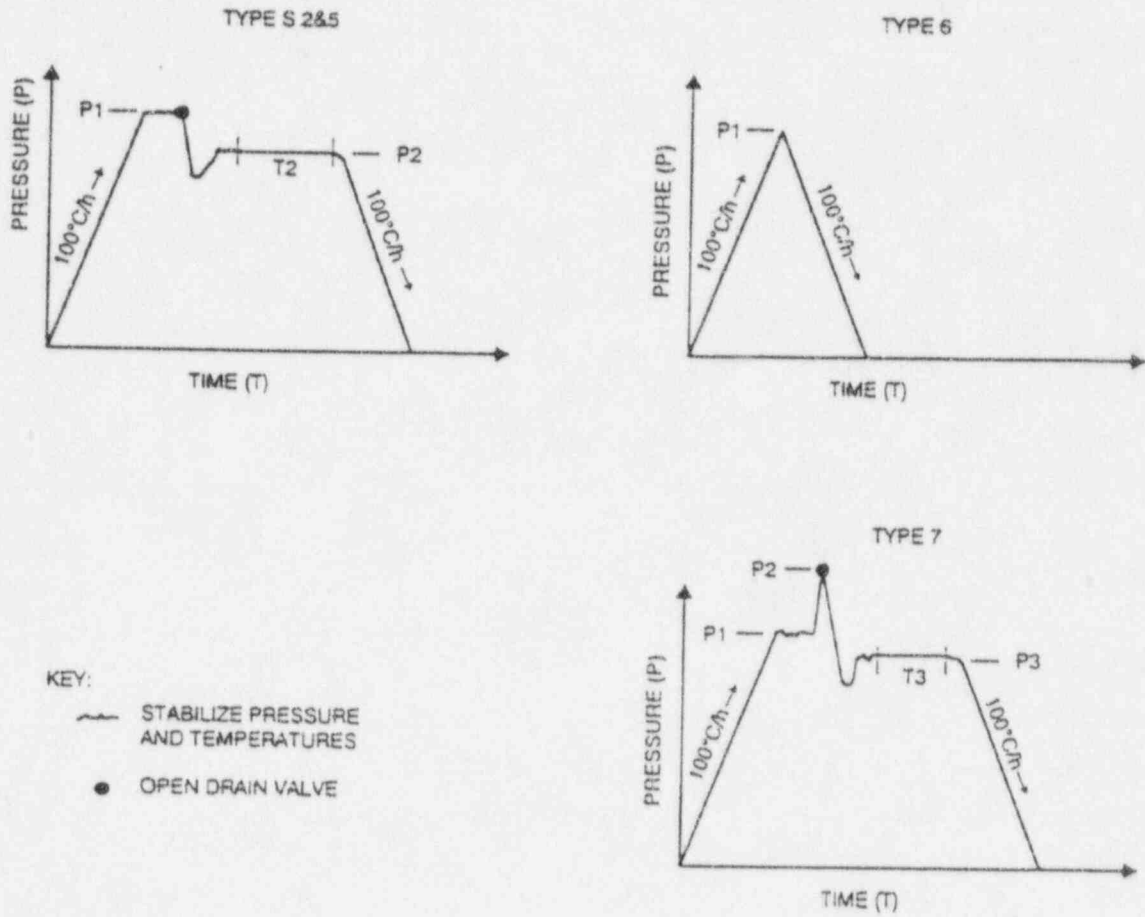

FIGURE 6-1. BASIC IC STRUCTURAL TEST CYCLES



GE Nuclear Energy

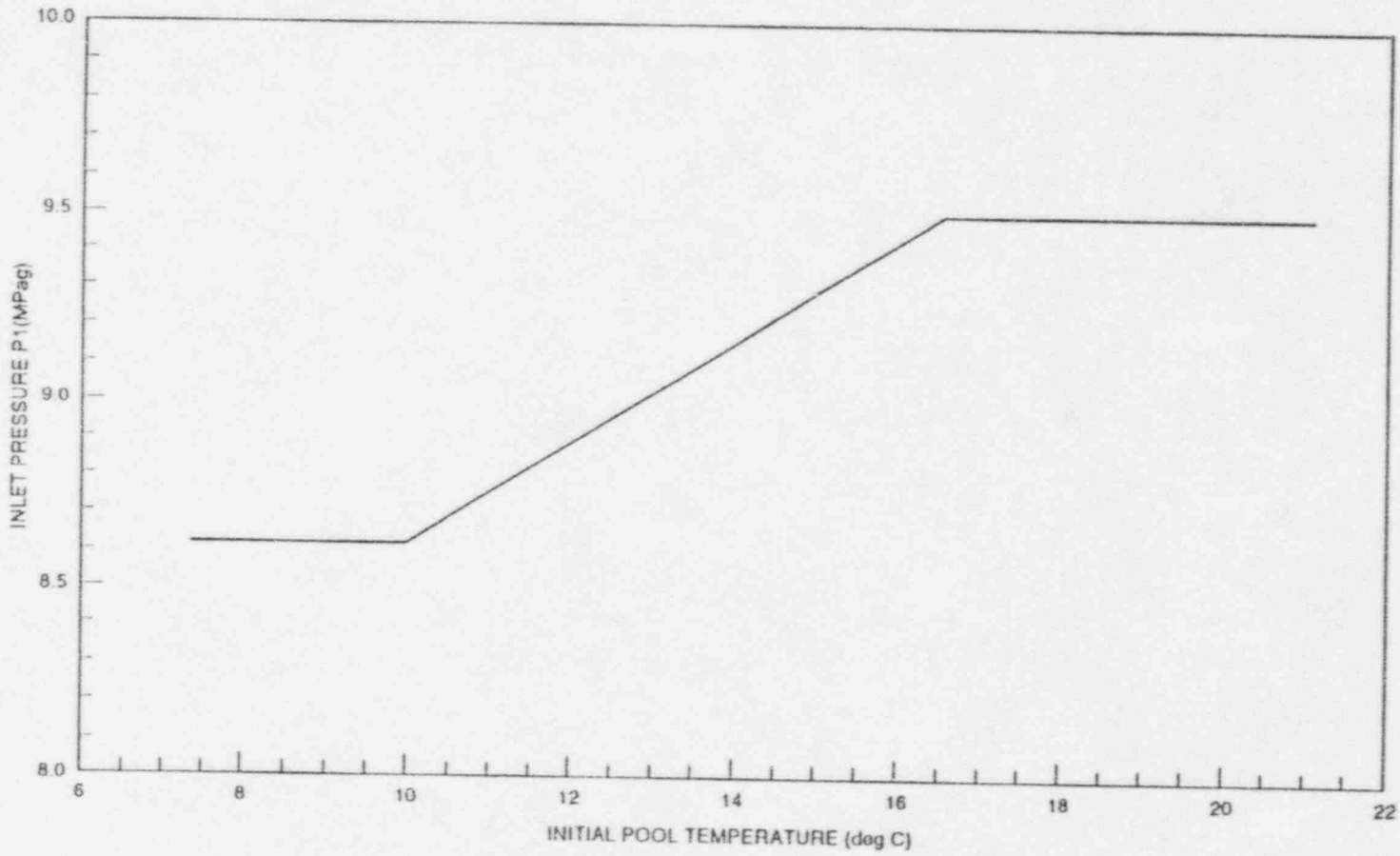

FIGURE 6-2. REQUIRED IC INLET PRESSURE FOR TEST CONDITION NO. 1

23A6999 SH NO. 47
REV. 5



Appendix A - REFERENCE MATRIX OF PCC TEST CONDITIONS

Test Type A.1.1. Steady State Performance - Saturated Steam/Air Mixtures

Test Conditions (See Par. 5.2.2.):

Test Condition Number	Steam Flow kg/s (lb/s)	Air Flow kg/s (lb/s)	Range of Inlet Pressure kPa g (psig)	Superheat deg. C (deg. F)
1*	0.45 (1.0)	0.014 (0.030)	193 - 790 (28 - 115)	0 (0)
2	1.4 (3.0)	0.014 (0.030)	207 - 790 (30 - 115)	0 (0)
3*	2.5 (5.5)	0.027 (0.060)	207 - 790 (30 - 115)	0 (0)
4*	3.6 (8.0)	0.027 (0.060)	207 - 790 (30 - 115)	0 (0)
5*	5.0 (11.0)	0.027 (0.060)	207 - 790 (30 - 115)	0 (0)
6*	5.7 (12.5)	0.027 (0.060)	207 - 790 (30 - 115)	0 (0)
7*	6.6 (14.5)	0.027 (0.060)	207 - 790 (30 - 115)	0 (0)
8*	1.4 (3.0)	0.076 (0.17)	193 - 790 (28 - 115)	0 (0)
9	5.0 (11.0)	0.076 (0.17)	207 - 790 (30 - 115)	0 (0)
10*	5.7 (12.5)	0.076 (0.17)	207 - 790 (30 - 115)	0 (0)
11*	6.6 (14.5)	0.076 (0.17)	207 - 790 (30 - 115)	0 (0)
12*	0.45 (1.0)	0.16 (0.35)	138 - 535 (20 - 78)	0 (0)
13	2.5 (5.5)	0.16 (0.35)	193 - 653 (28 - 95)	0 (0)
14*	3.6 (8.0)	0.16 (0.35)	193 - 790 (28 - 115)	0 (0)
15	5.0 (11.0)	0.16 (0.35)	193 - 790 (28 - 115)	0 (0)
16	6.6 (14.5)	0.16 (0.35)	200 - 790 (29 - 115)	0 (0)
17	2.5 (5.5)	0.41 (0.90)	172 - 604 (25 - 88)	0 (0)
18	5.0 (11.0)	0.41 (0.90)	186 - 639 (27 - 93)	0 (0)
19	5.7 (12.5)	0.41 (0.90)	193 - 653 (28 - 95)	0 (0)
20*	5.0 (11.0)	0.59 (1.29)	179 - 611 (26 - 89)	0 (0)
21*	6.6 (14.5)	0.59 (1.29)	186 - 639 (27 - 93)	0 (0)
22	1.4 (3.0)	0.86 (1.9)	97 - 453 (14 - 66)	0 (0)
23	5.0 (11.0)	0.86 (1.9)	159 - 584 (23 - 85)	0 (0)
24*	5.7 (12.5)	0.86 (1.9)	165 - 597 (24 - 87)	0 (0)
25	6.6 (14.5)	0.86 (1.9)	179 - 611 (26 - 89)	0 (0)

*These tests are of low priority. If necessary, these tests need only to be performed at one inlet pressure. It is preferred that the pressure be near 300 KPag.



Test Type A.1.1 (Continued)

Test Condition Number
26
27
28
29
30

Deleted

Test Duration: It should be possible to do one air flow/steam flow combination at approximately 5 values of inlet pressure in one test day. Total estimated time for Tests A.1.1 is 30 test days.

Test Type A.1.2. Steady State Performance - Superheated Steam/Air Mixtures

Test Conditions (See Para. 5.2.3):

Test Condition Number	Steam Flow kg/s (lb/s)	Air Flow kg/s (lb/s)	Range of Inlet Pressure kPa g (psig)	Superheat deg. C (deg. F)
31	← Deleted →			
32				
33	← Deleted →			
34				
35	5.0 (11.0)	0.86 (1.9)	159 - 584 (23 - 85)	20 (36)
36	5.0 (11.0)	0.86 (1.9)	159 - 584 (23 - 85)	30 (54)

Test Duration: Estimated time to complete Tests A.1.2 is six test days.



Test Type A.1.3. Steady State Performance - Steam Only

Test Conditions - No air in PCC tubes (See Para. 5.2.4):

Test Condition Number	Steam Flow kg/s (lb/s)	Air Flow kg/s (lb/s)	Superheat deg. C (deg. F)
37	0.45 (1.0)	0 (0)	0 (0)
38	1.4 (3.0)	0 (0)	0 (0)
39	2.5 (5.5)	0 (0)	0 (0)
40	3.6 (8.0)	0 (0)	0 (0)
41	5.0 (11.0)	0 (0)	0 (0)
42	5.7 (12.5)	0 (0)	0 (0)
43	6.6 (14.5)	0 (0)	0 (0)
44	1.4 (3.0)	0 (0)	15 (27)
45	1.4 (3.0)	0 (0)	20 (36)
46	1.4 (3.0)	0 (0)	30 (54)
47	5.0 (11.0)	0 (0)	15 (27)
48	5.0 (11.0)	0 (0)	20 (36)
49	5.0 (11.0)	0 (0)	30 (54)

Test Duration: These tests are estimated to require four test days for completion.

Test Conditions - Air in PCC Tubes (See Para. 5.2.4):

Test Condition Number	Steam Flow kg/s (lb/s)	Air Flow kg/s (lb/s)	Superheat deg. C (deg. F)
50	1.4 (3.0)	very low	0 (0)
51	5.0 (11.0)	very low	0 (0)
52	1.4 (3.0)	very low	20 (36)
53	5.0 (11.0)	very low	30 (54)

Test Duration: These tests are estimated to require two test days for completion.



Test Type A.2.1. Effect of Pool Water Level - Saturated Steam

Test Type A.2.2. Effect of Pool Water Level - Saturated Steam/Air Mixtures

Test Conditions:

Test Condition Number	Steam Flow kg/s (lb/s)	Air Flow kg/s (lb/s)	Range of Inlet Pressure kPa g (psig)	Superheat deg. C (deg. F)
54	5.0 (11.0)	0 (0)	(dependent variable)	0 (0)
55	5.0 (11.0)	0.14 (0.31)	(start at minimum)	0 (0)
56	6.6 (14.5)	0.86 (1.9)	(start at minimum)	0 (0)

Test Duration: These tests are estimated to require four test days for completion.

Test Type A.3.1. Additional Structural Tests - Simulated LOCA Pressurization. See Paragraph 5.2.6.

Test Type A.3.2. Additional Structural Tests - Simulated Leak Testing. See Paragraph 5.2.6.

Test Type B.1. Deleted

Test Type B.2. Effect of Low Density Noncondensibles

Test Conditions:

Test Condition Number	Steam Flow kg/s (lb/s)	Helium Flow kg/s (lb/s)	Air Flow kg/s (lb/s)	Superheat deg. C (deg. F)
75	1.4 (3.0)	very low	0 (0)	0 (0)
76	5.0 (11.0)	very low	0 (0)	0 (0)
77	1.4 (3.0)	very low	3.4 X He flow	0 (0)
78	5.0 (11.0)	very low	3.4 X He flow	0 (0)

Test Duration: These tests should be achievable in two test days.



Appendix B - REFERENCE MATRIX OF IC TEST CONDITIONS

Type 1 - Steady-State Performance Test Conditions

Test Condition Number	Inlet Pressure [MPag (psig)]
2	7.920 (1150)
3	7.240 (1050)
4	6.21 (900)
5	5.52 (800)
6	4.83 (700)
7	4.14 (600)
8	2.76 (400)
9	1.38 (200)
10	0.69 (100)
11	0.21 (30)

Notes:

1. Measure steady-state data for 15 minutes.
2. More than one Test Condition can be collected in a single test.
3. To qualify as a structural Type 5 test cycle:
 - 3.1 Initial pool temperature < 32 degrees C (90 degrees F),
 - 3.2 Initial inlet pressure (P1) = 8.618 MPag (1250 psig),
 - 3.3 Maintain inlet pressure for 2 hours (P2) = 8.618 MPag (1250 psig).
4. To qualify as a structural Type 6 test cycle:
 - 4.1 Initial pool temperature < 32 degrees C (90 degrees F),
 - 4.2 Initial inlet pressure (P1) = 8.618 MPag (1250 psig)



Type 3 - Non-Condensable Gas Effects Test Conditions

Test Condition Number	Inlet Pressure, P3 [MPag (psig)]
12	0.48 (70)
13	2.07 (300)

Notes:

1. Hold pressure at P3 for 15 minutes.
2. Inject air/helium mixture until pressure reaches 7.653 MPag (1110 psig).
 - 2.1 Nominal ($\pm 10\%$) ratio of air to helium = 3.6 or nitrogen to helium = 3.5
 - 2.2 Total flow rate sufficient to conduct a test within one test day.
3. Vent from bottom vent until pressure returns to P3 or remains constant.
4. If pressure does not return to P3, vent from top vent until pressure returns to P3 or remains constant.
5. To qualify as a structural Type 5 test cycle:
 - 5.1 Initial pool temperature < 32 degrees C (90 degrees F),
 - 5.2 Initial inlet pressure (P1) = 8.618 MPag (1250 psig),
 - 5.3 Maintain initial inlet pressure for 2 hours (P2) = 8.618 MPag (1250 psig).
6. To qualify as a structural Type 6 test cycle:
 - 6.1 Initial pool temperature < 32 degrees C (90 degrees F),
 - 6.2 Initial inlet pressure (P1) = 8.618 MPag (1250 psig)



Type 4m - Pool Water Level Effects Test Conditions

Test Condition Number	Inlet Pressure, P3 [MPag (psig)]
14	0.48 (70)
15	2.07 (300)

Notes:

1. Hold pressure at P3 for 15 minutes.
2. Lower water level to mid-height of condenser tubes or until pressure reaches 8.618 MPag (1250 psig).
3. Raise water level to normal level and hold for 15 minutes.
4. To qualify as a structural Type 5 test cycle:
 - 5.1 Initial pool temperature < 32 degrees C (90 degrees F),
 - 5.2 Initial inlet pressure (P1) = 8.618 MPag (1250 psig),
 - 5.3 Maintain initial inlet pressure for 2 hours (P2) = 8.618 MPag (1250 psig).
5. To qualify as a structural Type 6 test cycle:
 - 6.1 Initial pool temperature < 32 degrees C (90 degrees F),
 - 6.2 Initial inlet pressure (P1) = 8.618 MPag (1250 psig)

Startup Demonstration Test Conditions

Test Condition Number	Cycle Type	No. of Cycles	Initial Inlet Pressure, P1 MPag (psig)	Inlet Pressure, P2 MPag (psig)	Inlet Pressure, P3 MPag (psig)	Initial Pool Temp. [°C (°F)]
1	2	3	9.480 (1375)	8.618 (1250)		<21 (70)
18	7	1	8.618 (1250)	9.480 (1375)	8.618 (1250)	<32 (90)

Notes:

1. In Test Condition 1, the inlet pressure P1 can be reduced in accordance with Figure 6-2 if the initial pool temperature is less than 17°C (62°F). Hold pressure P2 for at least 15 minutes after the pool has reached a nominal uniform temperature of 100°C.
2. Test Condition 18 should be done at the end of the test series. Hold pressure P3 for at least 15 minutes after the pool has reached a nominal uniform temperature of 100°C.



Structural Cyclic Test Conditions

Test Condition Number	Cycle Type	No. of Cycles	Initial Inlet Pressure, P1 MPag (psig)	Inlet Pressure, P2 MPag (psig)	Notes
16	5	20	8.618 (1250)	8.618 (1250)	1, 2, 3
17	6	5	8.618 (1250)		1, 4

Notes:

1. Initial pool temperature <32 degrees C (90 degrees F).
2. Hold pressure P2 for at least 15 minutes after the pool has reached a nominal uniform temperature of 100°C.
3. Number of cycles of Test Condition 16 can be reduced by number of earlier tests (including shakedown) which meet these criteria. However, at least 2 tests must be done at these conditions with the critical structural instrumentation operational.
4. Number of cycles of Test Condition 17 can be reduced by number of earlier tests which meet these criteria, but not Test Condition 16. However, at least 2 tests must be done at these conditions with the critical structural instrumentation operational.