BWR Full Integral Simulation Test (FIST) Program Facility Description Report

Edited by A. G. Stephens

Nuclear Fuel and Special Projects Division
General Electric Company

Prepared for
U.S. Nuclear Regulatory Commission

and
Electric Power Research Institute

and
General Electric Company

NOTICE

This report was prepared as an account of work sponsored by an agency of the United States Government. Neither the United States Government nor any agency thereof, or any of their employees, makes any warranty, expressed or implied, or assumes any legal liability of responsibility for any third party's use, or the results of such use, of any information, apparatus, product or process disclosed in this report, or represents that its use by such third party would not infringe privately owned rights.

NOTICE

Availability of Reference Materials Cited in NRC Publications

Most documents cited in NRC publications will be available from one of the following sources:

1. The NRC Public Document Room, 1717 H Street, N.W.
Washington, DC 20555
2. The NRC/GPO Sales Program, U.S. Nuclear Regulatory Commission,
Washington, DC 20555
3. The National Technical Information Service, Springfield, VA 22161

Although the listing that follows represents the majority of documents cited in NRC publications, it is not intended to be exhaustive.

Referenced documents available for inspection and copying for a fee from the NRC Public Document Room include NRC correspondence and internal NRC memoranda; NRC Office of Inspection and Enforcement bulletins, circulars, information notices, inspection and investigation notices; Licensee Event Reports; vendor reports and correspondence; Commission papers; and applicant and licensee documents and correspondence.

The following documents in the NUREG series are available for purchase from the NRC/GPO Sales Program: formal NRC staff and contractor reports, NRC-sponsored conference proceedings, and NRC booklets and brochures. Also available are Regulatory Guides, NRC regulations in the *Code of Federal Regulations*, and *Nuclear Regulatory Commission Issuances*.

Documents available from the National Technical Information Service include NUREG series reports and technical reports prepared by other federal agencies and reports prepared by the Atomic Energy Commission, forerunner agency to the Nuclear Regulatory Commission.

Documents available from public and special technical libraries include all open literature items, such as books, journal and periodical articles, and transactions. *Federal Register* notices, federal and state legislation, and congressional reports can usually be obtained from these libraries.

Documents such as theses, dissertations, foreign reports and translations, and non-NRC conference proceedings are available for purchase from the organization sponsoring the publication cited.

Single copies of NRC draft reports are available free, to the extent of supply, upon written request to the Division of Technical Information and Document Control, U.S. Nuclear Regulatory Commission, Washington, DC 20555.

Copies of industry codes and standards used in a substantive manner in the NRC regulatory process are maintained at the NRC Library, 7920 Norfolk Avenue, Bethesda, Maryland, and are available there for reference use by the public. Codes and standards are usually copyrighted and may be purchased from the originating organization or, if they are American National Standards, from the American National Standards Institute, 1430 Broadway, New York, NY 10018.

BWR Full Integral Simulation Test (FIST) Program Facility Description Report

Manuscript Completed: December 1982
Date Published: September 1984

Edited by
A. G. Stephens

Nuclear Fuel and Special Projects Division
General Electric Company
San Jose, CA 95125

Prepared for
Division of Accident Evaluation
Office of Nuclear Regulatory Research
U.S. Nuclear Regulatory Commission
Washington, D.C. 20555
NRC FIN No. B3014

and
Electric Power Research Institute
3412 Hillview Avenue
Palo Alto, CA 94303

and
Nuclear Fuel and Special Projects Division
General Electric Company
San Jose, CA 95125

LEGAL NOTICE

This report was prepared by the General Electric Company as an account of work sponsored by the Nuclear Regulatory Commission, the Electric Power Research Institute, and the General Electric Company. No person acting on behalf of the NRC, the Institute, or members of the Institute, or General Electric Company:

- A. Makes any warranty or representation, express or implied, with respect to the accuracy, completeness, or usefulness of the information contained in this report, or that information, apparatus, method or process disclosed in this report may not infringe privately owned rights, or*
- B. Assumes any liabilities with respect to the use of, or for damages resulting from the use of any information, apparatus, method or process disclosed in this report.*

BWR FULL INTEGRAL SIMULATION TEST PROGRAM
CONTRACT NO. NRC-4-76-215

BWR FULL INTEGRAL SIMULATION TEST (FIST) PROGRAM
FACILITY DESCRIPTION REPORT

A. G. Stephens

APPROVED: *B. Matzner*
B. Matzner, Manager
Thermal Hydraulic
Development

APPROVED: *L. L. Myers*
L. L. Myers, Program Manager
External Programs

APPROVED: *R. L. Crowther*
R. L. Crowther, Manager
Core & Fuel Advanced
Design

APPROVED: *J. E. Wood*
J. E. Wood, Manager
Core & Fuel Technology

NUCLEAR FUEL AND SPECIAL PROJECTS DIVISION • GENERAL ELECTRIC COMPANY
SAN JOSE, CALIFORNIA 95125

GENERAL  ELECTRIC

ABSTRACT

A new boiling water reactor safety test facility (FIST, Full Integral Simulation Test) is described. It will be used to investigate small breaks and operational transients and to tie results from such tests to earlier large-break test results determined in the TLTA. The new facility's full height and prototypical components constitute a major scaling improvement over earlier test facilities. A heated feedwater system, permitting steady-state operation, and a large increase in the number of measurements are other significant improvements. The program background is outlined and program objectives defined. The design basis is presented together with a detailed, complete description of the facility and measurements to be made. An extensive component scaling analysis and prediction of performance are presented. The report is intended to serve as a reference document for those needing detailed information about the facility.

ACKNOWLEDGMENTS

All of the people in the Thermal-Hydraulic Development and LOCA System Technology groups supporting the FIST project have contributed information in one way or another for this report. Their help was appreciated; their pride in their facility seems well justified.

K. F. Cornwell generated the original Scaling Analysis section of the report. She was supported in this by S. A. Allison, W. S. Hwang, and J. E. Thompson. D. W. Danielson and D. A. Wilhelmson provided many answers about the measurement system and test vessel design. Drafts of the report were quickly and expertly typed by G. D. Gatenby, D. A. Cullen, and B. R. Cribbs.

AGS. NRC Technical Representative at FIST, 1982-83.

CONTENTS

ABSTRACT	ii
ACKNOWLEDGMENTS	iii
ACRONYM LIST	vii
LIST OF FIGURES	viii
LIST OF TABLES	x
SUMMARY	xi
1. INTRODUCTION	1-1
1.1 Background	1-1
1.2 Program Objectives, Purposes and Methods	1-1
1.3 Report Organization and Contents	1-2
2. TEST FACILITY DESCRIPTION	2-1
2.1 Fluid Systems	2-1
2.1.1 Test Vessel	2-3
2.1.1.1 Downcomer	2-6
2.1.1.2 Jet Pumps	2-12
2.1.1.3 Lower Plenum and Guide Tube	2-21
2.1.1.4 Bundle and Bypass	2-22
2.1.1.5 Upper Plenum, Standpipe, Separator	2-42
2.1.1.6 Steam Dryer, Manifold and Dome	2-50
2.1.2 Recirculation Loops	2-52
2.1.3 Feedwater and Steam	2-57
2.1.4 Emergency Core Cooling	2-62
2.1.5 Blowdown	2-66
2.2 Process and Experimental Parameter Control Systems	2-68
2.2.1 Process Controls	2-68
2.2.1.1 Test Vessel Pressure, Liquid Level and Temperature	2-70
2.2.1.2 Feedwater	2-70
2.2.1.3 Recirculation Loops and Warmup Operations	2-73
2.2.2 Experimental Parameter Controls	2-74
2.2.2.1 Core Power	2-75
2.2.2.2 Emergency Core Cooling	2-75
2.2.2.3 SRV/ADS	2-75

2.3	Experimental Measurements	2-78
2.3.1	Transducers and Signal Conditioning	2-79
2.3.1.1	Flow	2-83
2.3.1.2	Pressure and Differential Pressure	2-85
2.3.1.3	Temperature, Conductivity and Others	2-87
2.3.2	Data Acquisition System	2-90
2.3.2.1	Equipment	2-90
2.3.2.2	Software	2-92
2.3.3	Data Processing	2-92
2.3.3.1	Measured and Derived Quantity Calculations	2-93
2.3.3.2	Acquisition System	2-95
2.3.3.3	Processing and Storage System	2-96
3.	SCALING ANALYSIS AND PERFORMANCE PREDICTION	3-1
3.1	General	3-1
3.1.1	Background and Scaling Objectives	3-1
3.1.2	Scaling Basis	3-2
3.1.3	Stored Heat/Heat Loss	3-6
3.1.4	Initial and Boundary Conditions	3-7
3.2	Scaling and Performance of Vessel and External Components	3-9
3.2.1	Lower Plenum and Bundle	3-10
3.2.1.1	Lower Plenum Geometrical Considerations	3-10
3.2.1.2	Lower Plenum Stored Heat Considerations	3-10
3.2.1.3	Bundle Power Simulation	3-13
3.2.2	Guide Tube and Bypass	3-15
3.2.2.1	Volume and Leakage Path Considerations	3-15
3.2.2.2	Bypass Stored Heat Considerations	3-21
3.2.2.3	Bypass Cross Sectional and Exit Area Scaling	3-26
3.2.3	Jet Pump Scaling Performance	3-26
3.2.3.1	Performance Characteristics	3-31
3.2.3.2	Jet Pump Flow Interaction and Volume Considerations	3-33
3.2.4	Downcomer	3-38

3.2.4.1	Volume Considerations	3-38
3.2.4.2	Jet Pump Interface with Downcomer	3-38
3.2.4.3	Dryer Skirt Simulation	3-41
3.2.5	Upper Plenum, Separator, Dryer and Dome	3-45
3.2.5.1	Volume Considerations	3-45
3.2.6	Recirculation, Steam and ECC System	3-45
3.2.6.1	Volume Considerations	3-45
3.2.6.2	Steam Line	3-50
3.2.6.3	ECC Systems	3-54
3.3	Summary of Scaling Considerations	3-54
4.	REFERENCES	3-57
	APPENDIX A--FACILITY DRAWING LIST	A-1
	APPENDIX B--MEASUREMENT LIST	B-1
	APPENDIX C--ENGINEERING DATA LIST	C-1
	APPENDIX D--INSTALLED EQUIPMENT LIST	D-1
	APPENDIX E--SOFTWARE LIST	E-1

LIST OF FIGURES

Figure	Title	Page
2-1	Overall View of FIST Test Facility	2-2
2-2	Test Vessel Schematic	2-4
2-3	Downcoming Fluid Region	2-7
2-4	Test Vessel Installation	2-9
2-5	Bottom of Separator Pressure Housing with Standpipe Installed	2-10
2-6	Hinged Expansion Bellows Spool Piece and Upper Plenum	2-11
2-7	Jet Pump Inlet	2-13
2-8	Top of Jet Pump Assembly	2-14
2-9	Drive Line Connection to Inlet Nozzle Assembly	2-15
2-10	Jet Pump Annubar Instrument Washer and Tailpipe/ Downcomer Extension Piece	2-16
2-11	Jet Pump Diffusers	2-17
2-12	Jet Pumps and Downcomer Housing	2-18
2-13	Jet Pump Nomenclature and Dimensions	2-19
2-14	Lower Plenum pipes Looking Up From Below, in Facility Pit	2-23
2-15	Core Inlet	2-25
2-16	Fuel Support and Bypass Flow Areas	2-26
2-17	Front Face of Upper Guide Tube Showing Side Entry Orifice	2-27
2-18	End View of Fuel Support's Circular Main Flow Area; Bypass Flow Area	2-28
2-19	FIST Lower Tie Plate	2-30
2-20	FIST Lower Tie Plate with Buss Bars Installed	2-31
2-21	Bundle Cross Section	2-32
2-22	Bundle Assembly	2-34
2-23	FIST Grid Spacer	2-35
2-24	Channel Comparisons for TLTA and BWR/FIST	2-36
2-25	FIST Axial Power Profile	2-38
2-26	Profiles of Heater Rod Tubing Walls	2-39
2-27	FIST Heater Pattern, First Bundle	2-40
2-28	FIST Heater Rod	2-41
2-29	Bundle/Bypass Outlet	2-43
2-30	Standpipe and Separator	2-45

2-31	Dryer Skirt and Drain	2-46
2-32	Standpipe and Instrument Washer	2-48
2-33	FIST Dryer/Dryer Skirt Design	2-49
2-34	FIST Dryer	2-51
2-35	FIST Piping and Instrumentation Diagram	2-53
2-36	Recirculation Loop No. 2 Pump Installation	2-54
2-37	Recirculation Pump Head Flow Curves	2-55
2-38	Feedwater Heater	2-58
2-39	Hot Feed Pump Head Flow Curve	2-59
2-40	ECC System Schematic	2-63
2-41	ECC System Performance	2-65
2-42	Pressure Control Valve and SRV Exhaust Header	2-69
2-43	Process Control Console	2-71
2-44	Emergency Core Cooling Console	2-76
2-45	Operator Setup Panel	2-77
2-46	Test Vessel Instrumentation	2-80
2-47	Annubar	2-84
2-48	Differential Pressure Transducers Awaiting Calibration	2-86
2-49	Differential Pressure Transducer Installation	2-88
2-50	Conductivity Probe	2-89
2-51	Data Acquisition System Block Diagram	2-91
3-1	FIST and BWR Vessel Schematics	3-3
3-2	Simplified Schematic Flow Diagram	3-5
3-3	Lower Plenum/Bundle Region	3-11
3-4	Lower Plenum/Bundle Regional Volume Distribution	3-12
3-5	Power Decay Curves for Variations in Initial Bundle Power	3-14
3-6	Guide Tube/Bypass Region	3-16
3-7	Guide Tube/Bypass Regional Volume Distribution	3-17
3-8	Bypass Leakage Paths	3-19
3-9	FIST Velocity Limiter Simulation	3-20
3-10	Total Bypass Metal Heat Transfer to Fluid	3-22
3-11	Bypass Exit Vapor Velocities	3-24
3-12	Inside Wall Temperature at the Top of the Bypass	3-25
3-13	FIST Bypass Area Distribution	3-27
3-14	FIST Core Outlet	3-28
3-15	FIST Upper Tie Plate	3-29
3-16	CCFL Curves for the Bypass Exit	3-30
3-17	Lateral Separation of Jet Pumps	3-34

3-18	FIST Jet Pump Baffles	3-35
3-19	Jet Pump Region	3-36
3-20	Jet Pump Regional Volume Distribution	3-37
3-21	Downcomer Region	3-39
3-22	Downcomer Regional Volume Distribution	3-40
3-23	Downcomer Steam Upflow Restriction	3-42
3-24	FIST Expanded Downcomer	3-43
3-25	Dryer Skirt Simulation	3-44
3-26	Upper Plenum/Standpipe/Separator Region	3-46
3-27	Upper Plenum/Standpipe/Separator Regional Volume Distribution	3-47
3-28	Steam Dome Region	3-48
3-29	Steam Dome Regional Volume Distribution	3-49
3-30	FIST Steam Line Configuration	3-51
3-31	BWR/6 Sequence of Events for Steam Line Break	3-52
3-32	FIST Steam Line Break Simulation	3-53
3-33	Vessel Volume Distribution	3-56

LIST OF TABLES

Number	Title	Page
2-1	Jet Pump Characteristics	2-20
2-2	BWR/6-218 Safety Relief Valve Operation	2-61
2-3	Emergency Core Cooling Conditions	2-64
2-4	Break Nozzle Sizes	2-67
2-5	Process Control Functions	2-72
2-6	FIST Experimental Measurement Summary	2-81
2-7	Measurement Distribution by Parameter and Region	2-82
3-1	FIST Initial Conditions	3-8
3-2	Comparisons of Forward Flow Losses	3-31

ACRONYM LIST

ADS.....	Automatic depressurization system
ATWS.....	Anticipated transient without scram
BD/ECC.....	Blowdown emergency core cooling program
BDHT.....	Blowdown heat transfer program
BP.....	Bypass region
BT.....	Boiling transition
BWR.....	Boiling water reactor
CCFL.....	Counter-current flow limiting
DAS.....	Data acquisition system
DBA.....	Design basis accident
DP.....	Differential pressure
ECCS.....	Emergency core cooling system
EPRI.....	Electric Power Research Institute
FIST.....	Fuel Integral Simulation Test (GE facility located in San Jose, CA)
FW.....	Feedwater
GE.....	General Electric Company
GT.....	Guide tube
HPCS.....	High-pressure core spray
JP.....	Jet pump
LOCA.....	Loss-of-coolant accident
LP.....	Lower plenum
LPCI.....	Low-pressure coolant injection
LPCS.....	Low-pressure core spray
psi.....	pounds per square inch
KCIC.....	Reactor core isolation cooling system
RTD.....	Resistance temperature detector
SEO.....	Side entry orifice (located in fuel support casting to orifice bundle inlet flow)
SRV.....	Safety relief valve
SSTF.....	Steam Sector Test Facility (30°) (Facility located at GE in Lynn, Mass., used to study core spray distribution, upper plenum and system response for LOCA)
TLTA.....	Two-loop test apparatus
TRAC.....	Transient Reactor Analysis Code

SUMMARY

The FIST program was initiated to provide BWR safety data from a full height facility and thus eliminate those scaling compromises that caused some performance atypicalities in earlier BWR test facilities. Of principal interest are small-break LOCAs and non-LOCA incidents involving loss of inventory and multiple failures. In particular, such experimental data is sought in order to compare it to predictions of existing code models and thus determine the validity and usefulness of the models and correctness of the assumptions on which the models are based.

FIST is an outdoor, insulated, carbon steel facility. The simulated-reactor (test) vessel is the centerpiece and is mounted in a substantial structural steel framework. The 64-ft-high test vessel has a volume of 180 gal, which represents very closely the BWR to FIST scale factor of 624 to 1. It is designed under ASME Section 8 rules for a pressure of 1325 psia at 600°F. A stress analysis has been performed indicating the vessel can satisfactorily withstand more than the design basis 200 blowdown/quench plus 100 startup/shutdown cycles.

The vessel consists of a side arm in addition to the main vessel. The side arm provides an external downcomer in which two full-height jet pumps are housed, and from which flow is taken to two recirculation loop pumps and returned as drive flow for the jet pumps. The jet pumps are the units from TLTA, modified to be full height and to have scaled tailpipe diameter. The TLTA units were used because of their known characteristics and capability to provide FIST-scaled core flow. The lower plenum houses a simulated guide tube.

The bundle and bypass regions are composed of several prototypical BWR components, including the fuel support and side entry orifice, the lower tieplate base, and a BWR/6 zircaloy channel housing the rod bundle. Leakage paths in the BWR from guide tube, lower plenum, and bundle into the bypass are all simulated in FIST. The bundle consists of 62 heater rods and 2 water rods. The heater rod diameters and pitch are the same as the BWR. The axial power profile is a 150-in.-long chopped cosine, using skin-heated rods. The scaled core power is 4.64 MW. The channel is electrically isolated from the pressure vessel wall.

ECCS nozzles connect into the upper plenum (HPCS, LPCS) and the top of the bypass (LPCI). The side arm connects to the main vessel at the top of the upper plenum, just below the feedwater connection. A standpipe, separator, and dryer are all provided and extend upward from the upper plenum. The BWR dryer skirt and pressure vessel wall form an annulus too thin to be scaled down without impeding liquid level movement. Thus, in FIST, a 76-degree, thicker annular segmental arc is provided instead and all the important BWR liquid levels and associated trips are therefore properly scaled.

The principal external fluid systems in FIST consist of a new steam line and heated feedwater system, the old (TLTA) cold feedwater and ECC systems, and the recirculation loops and blowdown piping. The recirculation pumps were used on TLTA but were refurbished before installation for FIST. The new heated feedwater system includes a 500-gal (net useful) tank with heaters and a pump and controls.

The main process controls on the test vessel are the pressure, controlled by the main steam line valve, the level (hot feed valve) and downcomer liquid temperature (cold feed valve). There are some automatic process controls on the feedwater heater, but most others are manually operated. The initiation of the experiment parameter controls is by a programmable logic controller/sequencer. It initiates the blowdown, start of core power decrease, start of ECC flow, etc.

There are 426 experimental measurements planned for the first test, of which 30% are differential pressure, 26% are heater rod temperatures, 19% are fluid temperatures and 10% are conductivity probes. There are 8 calibrated flow measuring instruments within the test vessel and 14 flow orifices in incoming and outgoing lines. A minicomputer-based data acquisition system is used to store test data directly on magnetic tape. The system's output is used to establish whether, or not, test acceptance criteria are satisfied, and to provide a data tape for further data processing on the INEL computer where record data for each test is finally stored.

Excessive heat release to contained fluid is a generic problem in scaled test facilities due to overscaled metal mass. Interior insulation, sometimes used, is not used in FIST because of large cost, unsatisfactory

previous performance and reduced need for small-break tests. The bypass stored heat may cause CCFL problems at the top of the bypass. The flow area there was increased by a factor of 3, which is the basic limit without major redesign. The FIST jet pumps are expected to have about 4 psi extra pressure drop due mainly to (long) tailpipe and exit losses. Increased drive flow is thus required. The flow area around the top of the jet pumps was also increased to avoid CCFL problems. Various other separate-effects studies were performed and results incorporated into the design. The integral system response study is in progress and will be reported when done. The volume versus height for the BWR and FIST are compared for each of the several regions and are in excellent agreement. Total FIST fluid volume is 24.14 cu ft compared to 24.01 for the scaled BWR.

1. INTRODUCTION

1.1 BACKGROUND

In the design and operation of power reactors, it is imperative that fuel cladding temperatures remain below certain specified values. This inherent limitation must be observed under both normal operating conditions and hypothesized abnormal situations. The ability to predict reactor performance, and hence the operating margin, under postulated conditions largely rests upon the experimental data gathered under simulated reactor conditions.

The BWR Full Integral Simulation Test (FIST) Program⁽¹⁾ is a joint undertaking of the U.S. Nuclear Regulatory Commission (NRC), the Electric Power Research Institute (EPRI) and General Electric Company (GE), planned to advance the safety technology of the BWR. Under the earlier cooperative programs BWR Blowdown Heat Transfer (BDHT) and BWR/Emergency Core Cooling (BD/ECC) by the three parties, the scenarios of loss-of-coolant accidents (LOCAs) were investigated. The hypothetical LOCA events in these studies were mainly focused on the large-break type of accidents, using the Two-Loop Test Apparatus (TLTA) that was originally built under the former BDHT program. The small-break type of LOCA experiments were limited to two in TLTA.

The FIST program was initiated, after previous phases of the BD/ECC program, in response to i) a desire to eliminate the scaling compromises that caused some performance atypicalities in TLTA results, ii) a growing interest in small-break LOCAs in the aftermath of the Three Mile Island Unit 2 accident, and iii) concerns over non-LOCA postulated events involving loss of inventory and multiple systems failures. The FIST facility design aims at these requirements. The program test plan, detailed in Reference 2, includes 21 tests covering small- and large-break LOCAs as well as non-LOCA transients.

1.2 PROGRAM OBJECTIVES, PURPOSES, AND METHODS

The FIST program objectives, abstracted from Reference 1, are stated below:

1. Implement the major (contract) modification to build the FIST facility (which shall be) capable of simulating a spectrum of BWR system loss-of-inventory and selected operational transients.
2. Obtain and evaluate basic data from the test system configuration, which has characteristics similar to a BWR with 8 x 8 fuel bundles, during hypothetical loss-of-inventory and selected system transients.

3. Provide phenomenological understanding and data to assess available best-estimate (reactor safety computer code) models for BWR system and fuel bundles.
4. Perform model development work, as described herein, to assist in the development of best-estimate methods (for) BWR TRAC for operational transients.

Two principal reasons these objectives are sought are:

1. To compare obtained data with the predictions of existing code models to determine the validity and usefulness of the models, and correctness of the assumptions contained in the models, and
2. To learn how (the heavily instrumented) prototypical BWR components respond under, and/or affect, presumably typical reactor safety and operational transient conditions.

The methods used to obtain these objectives are the ones normally employed:

1. Provide additional measurements in the key areas of interest to the computer model developer and the reactor hardware designer, and
2. Invest additional effort in providing improved measurement techniques, in order to provide the data accuracy needed to successfully assess the correctness of the model assumptions.

1.3 REPORT ORGANIZATION AND CONTENTS

The report consists of this introduction, two major sections and five appendices. Section 2 is a detailed and thorough description of the test facility and Section 3 is a similar investigation and reporting of the scaling analysis and prediction of facility performance. The appendices contain the more-easily-tabulated type of information describing the facility, including drawing and photographic lists, measurement lists, engineering data, installed equipment identification and characteristics, and a software list.

The report is intended as a reference document for those who need detailed information about the facility, why it was designed as it was, and what the impact of that design may be on its performance as a scaled BWR test facility. This report, like any other, is only a snapshot taken at a given instant, so at any other time it would be prudent to verify specific details with facility personnel.

2. TEST FACILITY DESCRIPTION

This section of the report includes a description of the FIST test facility, the design bases of its major component parts, and information on the manner in which it is expected to be operated. The section has three parts: descriptions of the fluid systems, the process and experimental parameter control systems, and the experimental measurements.

This is an outdoor test facility, constructed principally of carbon steel piping components that are heavily insulated and otherwise protected from the elements. The test vessel is the centerpiece of the facility and extends approximately 54 ft above ground level and 10 ft below. A substantial system of structural columns and beams, steel floor gratings, and stairways provide access and support to the test vessel as well as the feedwater heater, flash drum, and all of the interconnecting piping (see Figure 2-1). The recirculation loop pumps are mounted in the pit, below the test vessel, but the remainder of the equipment is mounted at grade level. (Appendix C lists equipment elevations.) The facility operating controls and data acquisition system are located in a building adjacent to the test facility tower. Electrical power switchgear is located in a separate adjacent building. However, the power supply for the heater rod bundle is several hundred feet away at the Atlas loop, power being conducted from the one facility to the other via large, underground power cables.

2.1 FLUID SYSTEMS

The FIST fluid systems consist of the simulated reactor (test) vessel and its two recirculation loops, and the other systems that either supply fluid to, or take fluid from, it. These include the hot and cold feedwater, emergency core cooling, and the effluents: steamline, safety relief valve and automatic depressurization system (SKV and ADS), and the simulated-break (blowdown) systems. Normal test facility support systems, e.g., instrument air, etc., are not particularly described here.

As noted in Section 1.1, the FIST program is a part of the continuing BWR safety research program. In terms of physical plant, this means that significant portions of the FIST test facility consist of equipment used previously in the Two-Loop Test Apparatus (TLTA), and in fact the FIST facility is located at the TLTA test site. Thus while the test vessel, hot feedwater and steam systems, and recirculation loop piping are new, the emergency core cooling, cold feedwater and

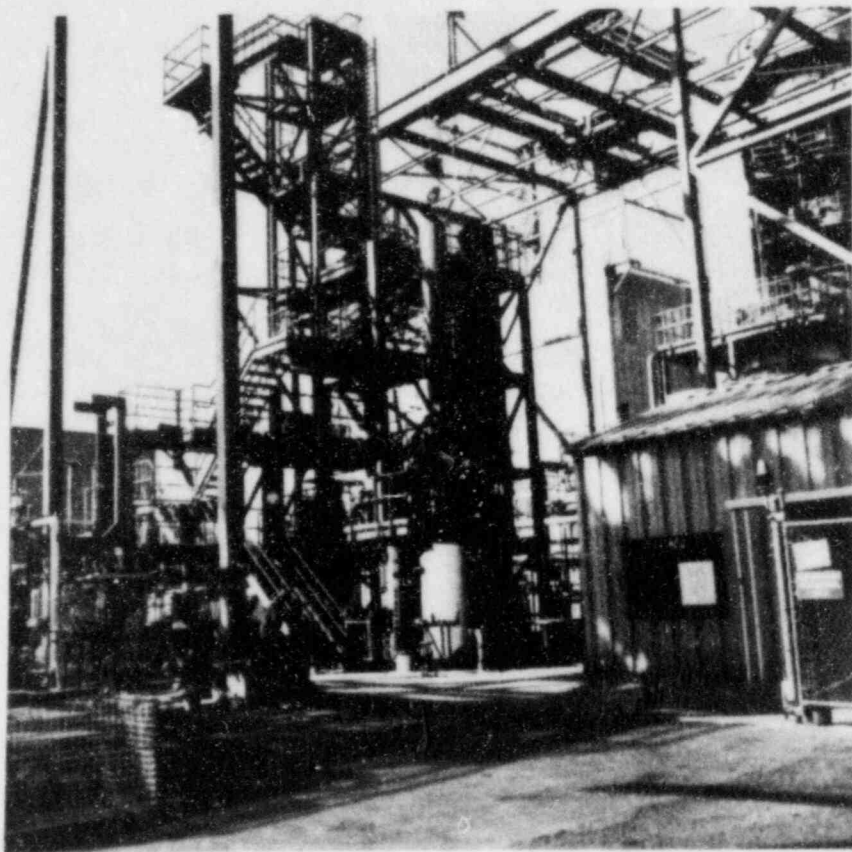

Figure 2-1 Overall View of FIST Test Facility

blowdown systems, and the recirculation pumps were previously used on TLTA. In general, components with 6-series equipment numbers (Appendix D) were purchased specifically for the FIST Facility. Although references to the TLTA Facility Description Report³ and the ECC System Report⁴ are made, the description of the previous TLTA equipment given in the present section is intended to be complete here.

The fluid systems are conservatively designed and where code guidance exists or could be applied, the design satisfies ASME Boiler and Pressure Vessel Code Section 1 or 8 or the Code for Pressure Piping, ANSI B 31.1. Some aspects of the design of the individual fluid systems are indeed related to the BWR/6 design and/or performance, but generally the main simulation and scaling is concerned with the component parts of the test vessel.

2.1.1 Test Vessel

The test vessel is shown schematically in Figure 2-2. As implied in the FIST acronym, the vessel height is (nominally) the same as the BWR/6 vessel;^a and it contains all of the same-function components supplied in the full-scale version. But rather than having an annular downcomer as in the full-size case, the FIST vessel incorporates a side-arm, or external, downcomer that houses two jet pumps and a portion of the lower plenum. It is to this side arm that the recirculation loops are connected.

Taken as a whole, the test vessel is a 64-ft-tall, 180-gal pressure vessel designed for 1311 psig at 600°F. It contains 62 electrical heaters having a total input power of 6.5 MW at 150 volts. Its two safety valves can relieve a total of 38,050 lb/hr at 1311 psig (90% capacity, 3% overpressure). Its main connections include feedwater and steam lines, suction and drive lines for each of the two recirculation loops, and vessel warmup and drain connections at the bottom, and vent and feedwater tank vapor space connections at the top.

A thermal and stress analysis of the vessel was undertaken and resulted⁵ in verification of the conformance of the design to Section 8 of the ASME Boiler and Pressure Vessel Code. The fatigue evaluation verified that the vessel design was more than adequate to meet the design basis. A part of the vessel significant in

a. FIST and BWR/6 vessel heights are discussed in detail in Sections 3.2.1.1 and 3.2.5.1.

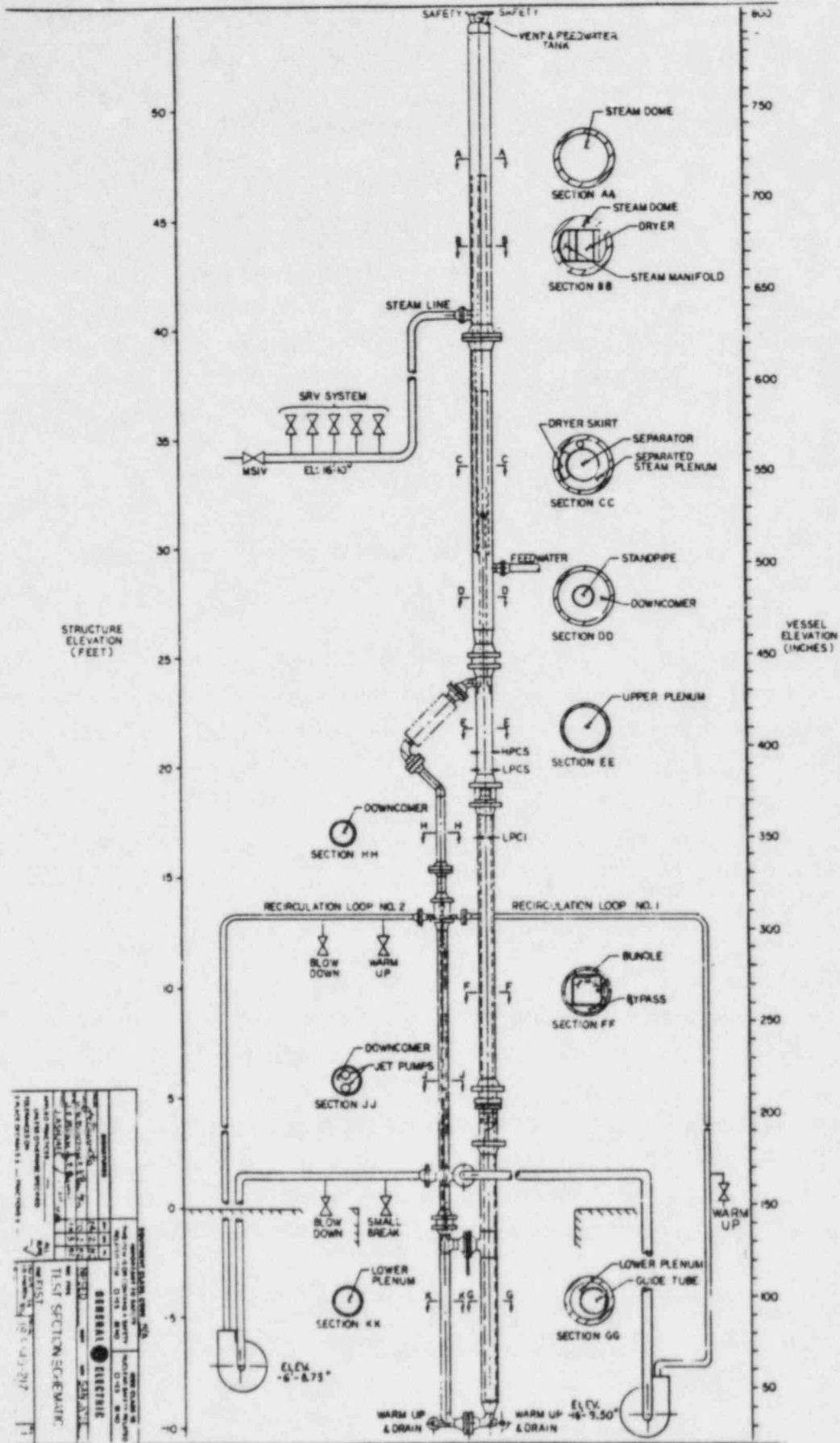

Figure 2-2. Test Vessel Schematic

this respect is the expansion bellows spool piece connecting the top of the side arm to the main vessel. The hinged bellows arrangement accommodates the differential contraction between side arm and main vessel when ECC is injected in one but not the other.

The vessel is supported at the flange at elevation 185, and so grows upward and downward from this point. The recirculating pumps are tied down to baseplates mounted in the pit, at the suction line elevations indicated in Figure 2-2. The feedwater, steam line, and drive line nozzles move upward and warmup/return line nozzles move downward as the facility is brought up to initial-condition temperatures. These displacements are handled by flexibility designed into the corresponding piping runs. A stress analysis of the piping system, and particularly connections to the test vessel was also undertaken, and confirmed⁶ that B31.1 code requirements were satisfied and that the design also meets the design basis.

The major requirements of the FIST vessel design bases are:

1. Vessel height to be same as BWR/6 vessel
2. Vessel total fluid volume to be 1/624th of the BWR/6 vessel volume
3. Distribution of scaled fluid volume over the various vessel components to be correct relative to the BWR (see Appendix C component volumes for the remarkably successful design results of this requirement)
4. The vessel pressure boundary design comply with Section 8 requirements, including paragraph UW-2(c) for steam generators
5. The vessel design be adequate to withstand the fatigue of 200 blowdown/quench cycles plus an additional 1000 normal heatup-cooldown cycles.

An enumeration of the initial (fluid) condition flow path completes the general description of the test vessel. The flow path is as follows, referring again to Figure 2-2.

Feedwater enters at the connection indicated in the figure and flows downward in the annular space outside the standpipe (Section D-D), mixing with the liquid returning from the separator. The combined flow travels down the main portion of the vessel to the point where the top of the side arm connects to it. The flow proceeds through the expansion bellows spool piece and down the external downcomer

to the inlet of the jet pumps. Drive line flow from the recirculation loop pumps induces additional flow down the jet pumps, which discharge into the lower plenum. (Suction flow for the recirculation pumps is taken from the area outside the jet pump tail pipes but inside the downcomer pipe near its bottom as shown in Section J-J.) Two flow paths exist from the side arm back to the main vessel part of the lower plenum: the lower crossover and the middle crossover pipes. Fluid going through either path must still flow upward in the eccentric annular region outside the guide tube (Section G-G) on its way to the bundle inlet. Here the main portion of the flow goes through the side-entry orifice and up through the flow subchannels in the 8 x 8-matrix of (full-length) bundle heater rods. A full-size BWR/6 zircaloy flow channel is used in FIST. Similar to the BWR, it houses the rods and defines the flow boundary. Core bypass flow is controlled by small bleed orifices near the main side-entry orifice. The bypassed liquid flows up outside the square channel but inside the circular pressure boundary (Section F-F). A two-phase mixture flows from the top of the bundle, upward through the upper plenum and inside the standpipe to the liquid/vapor separator. High void fraction fluid from the separator continues up to the steam dryer. (The dryer provides only pressure drop and overflow elevation simulation, no real drying action being intended, although some may occur as the result of flow direction and flow area changes.) The steam flows out into the steam dome and down the manifold (Section B-B), and from there to, and out, the steam line. Large- and small-break LOCA experiments are initiated (from this initial condition flow path) by opening valves in blowdown system lines connected to recirculation loop No. 2.

As shown Figure 2-2, the vessel is segmented, i.e., it consists of a series of pipe spool pieces of varying lengths and diameters. Each spool houses certain internal components already mentioned, each of which has a relatively well-defined function. These spools and components will be described in detail in the sections that follow. Drawing Number 181F145-152 (see Appendix A for facility drawings) details the individual pipe spool pieces, one spool per sheet. Drawing 181F145-150 serves as a vessel assembly and index for these.

2.1.1.1 Downcomer. The downcomer (denoted DC), unlike other scaled parts of the FIST test vessel, extends over several spool pieces. Figure 2-3 shows the downcoming fluid regions in FIST and the reference BWR. The steam manifold and dryer skirt regions included in the figure are discussed in Section 2.1.1.6 and 2.1.1.7 below, so the description in this section starts at the bottom of the

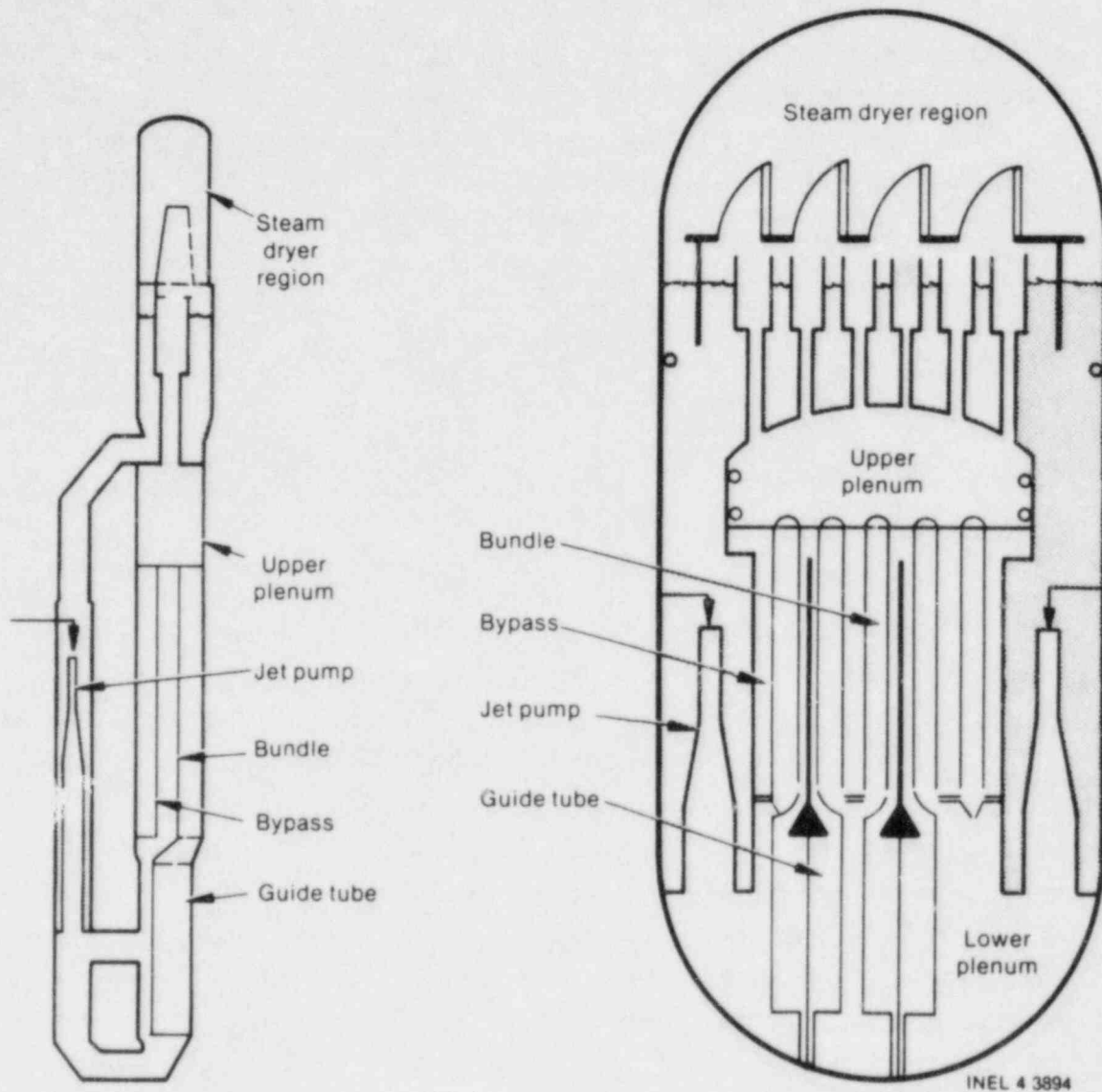

Figure 2-3 Downcoming Fluid Region

dryer skirt, elevation 505^a. The downcomer, then, extends from there to the bottom of the jet pumps. The spool piece part numbers concerned with the downcomer are shown in Figure 2-4 and they and the corresponding pressure boundary and related drawing numbers are listed here for ease of reference and to define more exactly the parts involved. Also, relevant facility photographs listed by subject in Appendix A, are noted, e.g., P-36.

Figure 2-4 Part No.	Name	Pressure Boundary Drawing No.	Flow Boundary or Related Drawing No.
8	Separator Housing	181F145-152 Sheet 8	181F145-165, -181 Sh1
9	Expansion Bellows Spool	181F145-155	No interior components
7	45° Downcomer Spool	181F145-152 Sh7	No interior components
5	Short Spool	181F145-152 Sh5	No interior components
13	Driveline Connection Housing	181F145-152 Sh12	181F145-169, -161; P-36
3	Jet Pump Downcomer Housing	181F145-152 Sh3	181F145-168, -169; P-71

In the separator housing spool, the downcomer liquid fills the annular ring outside the standpipe and inside the spool. The feedwater nozzle connects to the region at elevation 483 and the standpipe Annubar instrument washer (elevation 450) is mounted between the flanged ends of the separator housing and the upper plenum. The enlarged end of the standpipe, (see Figure 2-5) forms a seal within the top of the upper plenum, separating the downcoming liquid from the upflowing two-phase mixture.

The expansion bellows spool piece, Figure 2-6, consists of a central length of pipe with short bellow sections on each end. Weld-neck flanges are connected beyond each bellows and the assembly is mounted within an outer shell that provides maximum movement limits. Like the expansion spool, the 45° ell downcomer

a. Test vessel elevations are given in inches above the reference BWR's zero-elevation point. This is accomplished by use of a match point on the test vessel and the reference BWR. The match point on the test vessel is the centerline of the lower plenum bottom (or lower) crossover pipe. The match point is the height of a cylinder with volume equal to that of the BWR hemispherical bottom head. That point is 31.83 in. above the BWR's zero-elevation point. Thus the FIST lower crossover centerline is established as elevation 31.81 in.

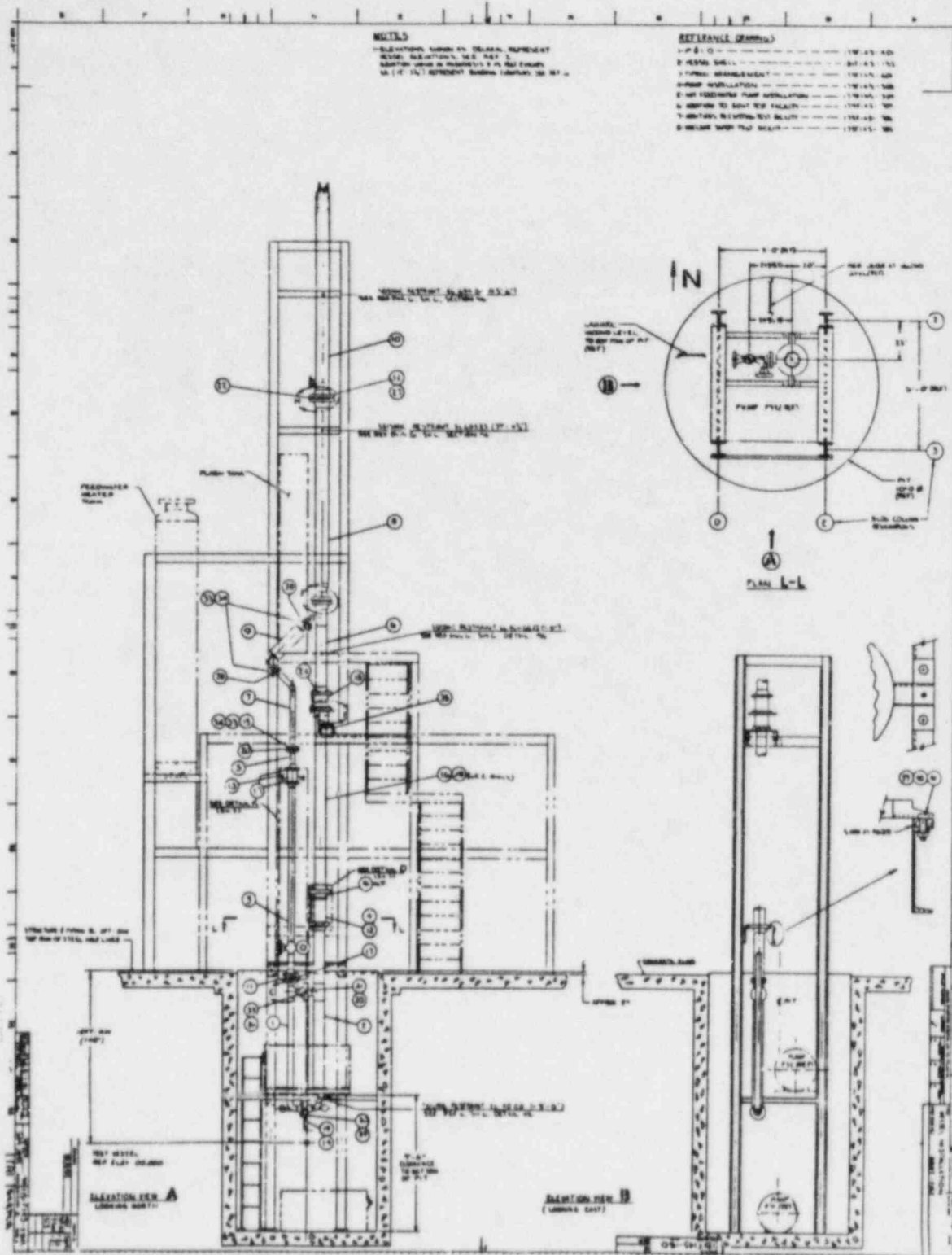

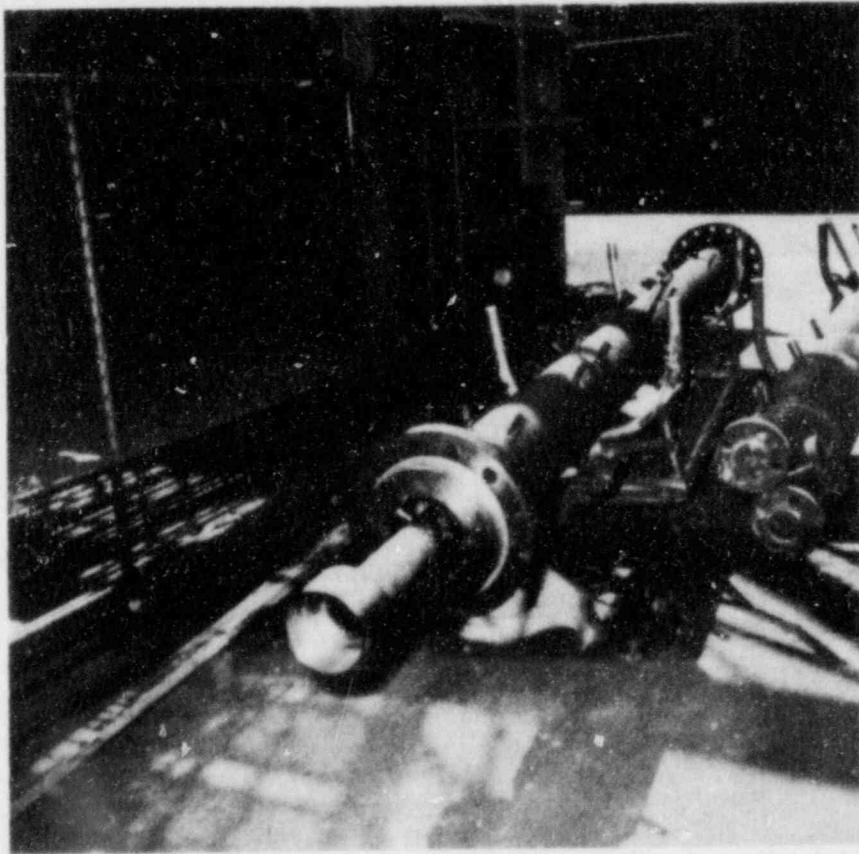

Figure 2-5 Bottom of Separator Pressure Housing with Standpipe Installed

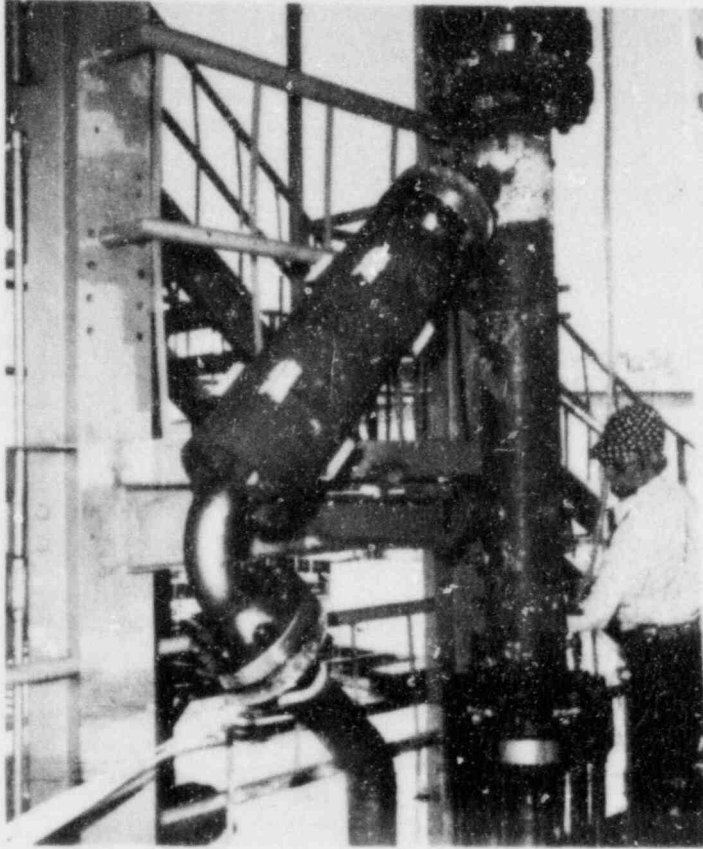

Figure 2-6 Hinged Expansion Bellows Spool Piece and Upper Plenum

spool and the short spool mounted below it have no interior components although there are typical intrusive instruments, e.g., downcomer Annubar, conductivity probe, etc. A reference flow measuring orifice, mounted in the flanged joint between these two spools during shakedown testing, is removed for normal matrix tests.

Figures 2-7, 2-8, and 2-9 show the downcomer housing, the tops of the two jet pumps, and the method of connecting the drive flow lines to the jet pump inlet nozzle assemblies. The last figure also shows that jet pump No. 1 is mounted in the north half and No. 2 in the south half of the downcomer housing. As mentioned earlier, the total flow coming down to the tops of the jet pumps divides, part being induced to flow down the jet pumps by the drive flow, and the remainder flowing down the downcomer, outside the tailpipes, to the recirculation loops to become subsequent drive flow (or, during the course of a LOCA test, to exit the system through the blowdown lines). The recirculation loop nozzles are located at elevation 166 on the jet pump downcomer housing, while the jet pump Annubar instrument washer is mounted between the flanged ends of the housing and the lower plenum. The jet pump tailpipe and downcomer extension piece, Figure 2-10, fits down inside the top of the lower plenum pipe, extending down to the top of the middle crossover flow area. The extension piece forms the bottom of the downcomer, separating it from the lower plenum.

The principal elements of the downcomer design basis are listed below.

1. The FIST downcomer should be of the same height as the reference BWR (bottom of dryer skirt to bottom of jet pumps) and should have 1/624 of its fluid volume.
2. The FIST downcomer total volume in the jet pump region must be sufficient to house two full-length FIST jet pumps.
3. The FIST downcomer must provide for recirculation loop suction and jet pump drive flow connections.
4. Given that an external downcomer is to be used and thus that ECC will be injected in the main vessel but not the downcomer (or vice versa), the downcomer design must accommodate the differential thermal expansion between them.

2.1.1.2 Jet Pumps. The FIST jet pumps (JP) can be described in terms of three performance areas: nozzle and inlet mixer, diffuser, and tailpipe, shown respectively in Figures 2-9, 2-11 and 2-12. Drawings covering the jet pumps include: 181F145-161, 181F145-168, 181F145-169, 181F145-194 and 181F145-196 Sn 1,2. Figure 2-13 and Table 2-1 show dimensions for the FIST, TLT, and scaled

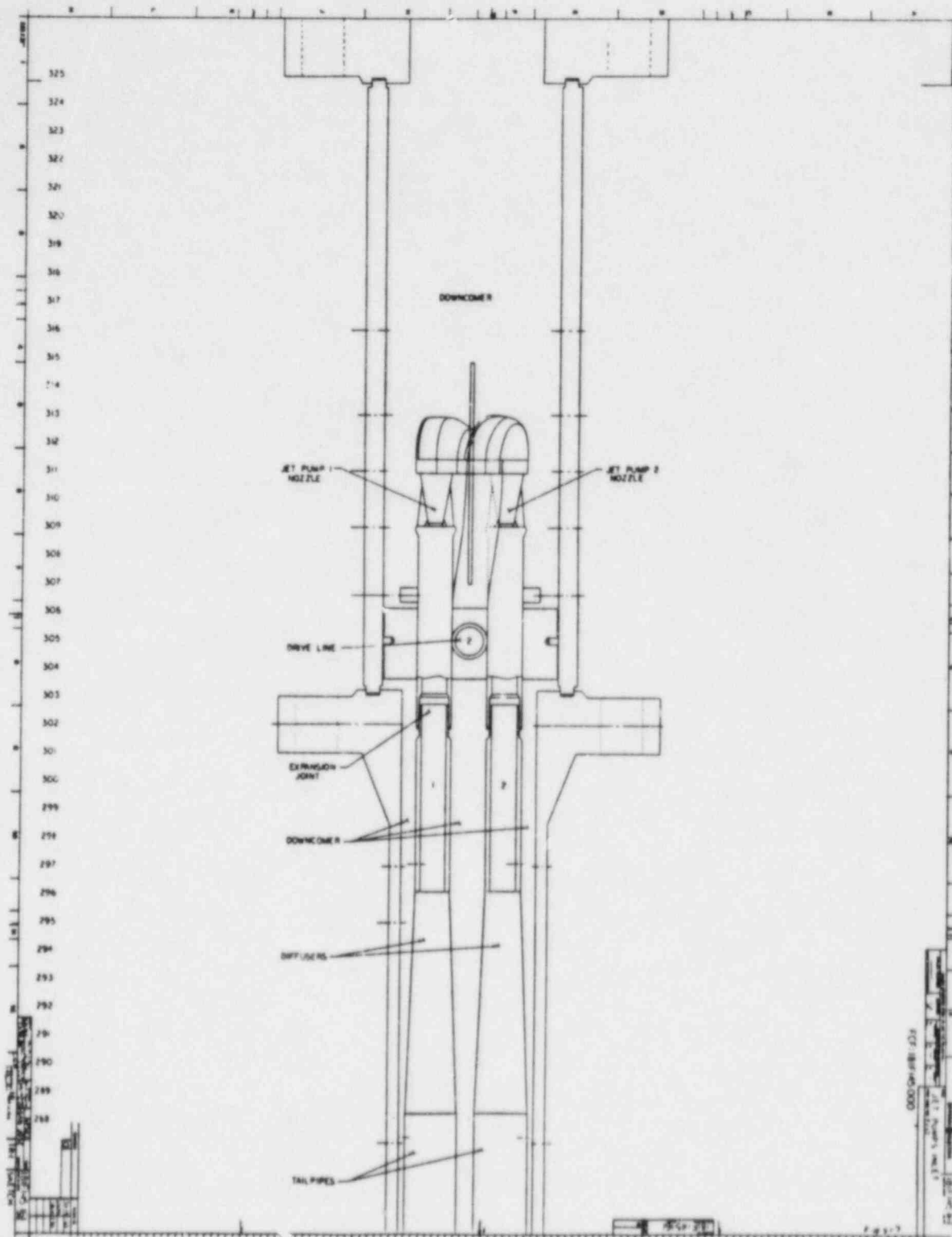

Figure 2-7. Jet Pump Inlet

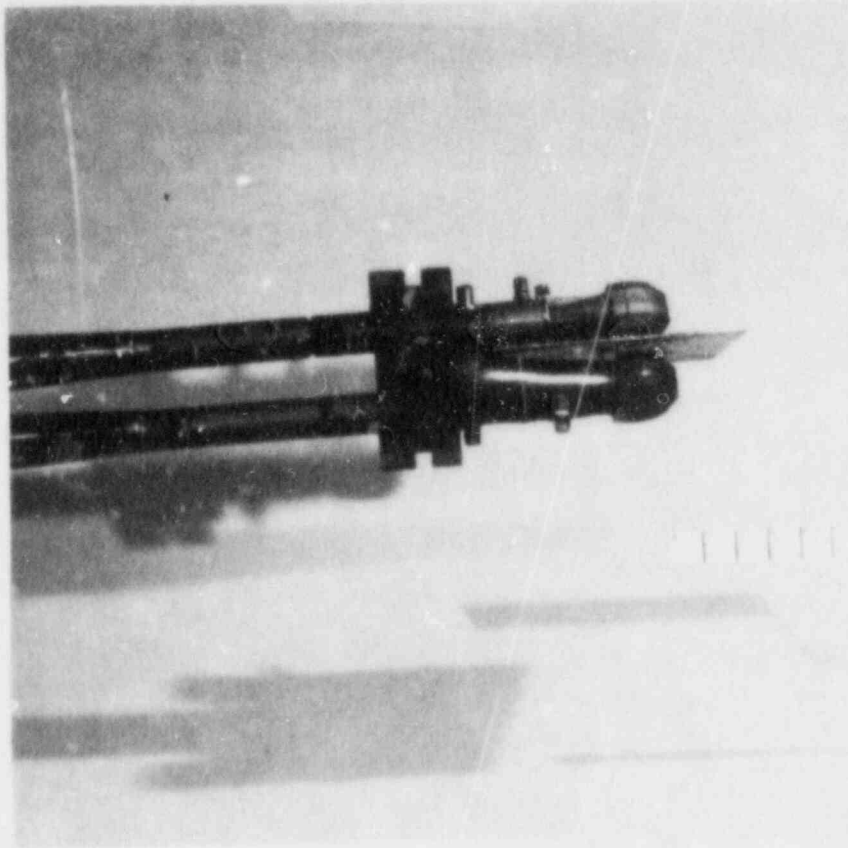

Figure 2-8 Top of Jet Pump Assembly

REV	DATE	BY	CHK	REVISIONS
0				

QTY	PART NAME	DESC	MATL
1	ASM	SUB-ASM THIS DWG	
2	YES SHELL	1B1F145-152P13	
1	JET PUMP	1B1F145-196G1	
2	PIPS/FLANGE	1B1F145-194G3	
2	PIN	MATL-CARBON STL	
1	EXPANSION PIN	MATL-304 STN STL	

FCF: 1B1F145-000

NOTES:
 1. USE .12 NOTCH OF PT 4 AS PILOT HOLE, USE #30 DRILL THRU PT 4 AND .25 DP INTO PT 2.

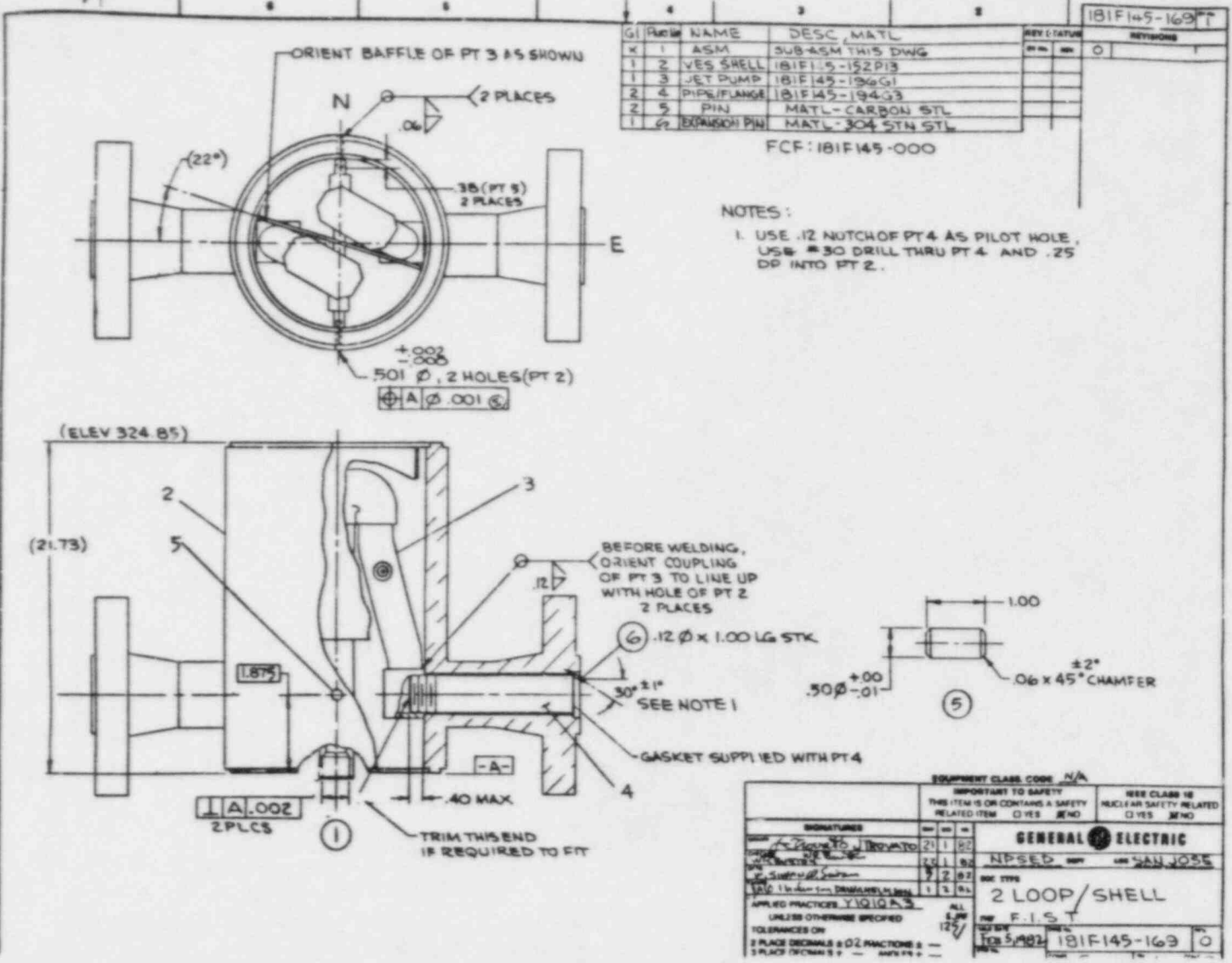

SIGNATURES		DATE	REVISION
[Signature]		21	1
[Signature]		25	1
[Signature]		9	2
[Signature]		1	3

IMPORTANT TO SAFETY		SEE CLASS 1B	
THIS ITEM IS OR CONTAINS A SAFETY RELATED ITEM	YES	NO	NO
	<input type="checkbox"/>	<input type="checkbox"/>	<input type="checkbox"/>

EQUIPMENT CLASS CODE N/A	
GENERAL ELECTRIC	
NPSED	
DATE 5/20/82	
2 LOOP/SHELL	
F.I.S.T.	
TOP 5, 202	1B1F145-169 0

Figure 2-9. Drive Line Connection to Inlet Nozzle Assembly

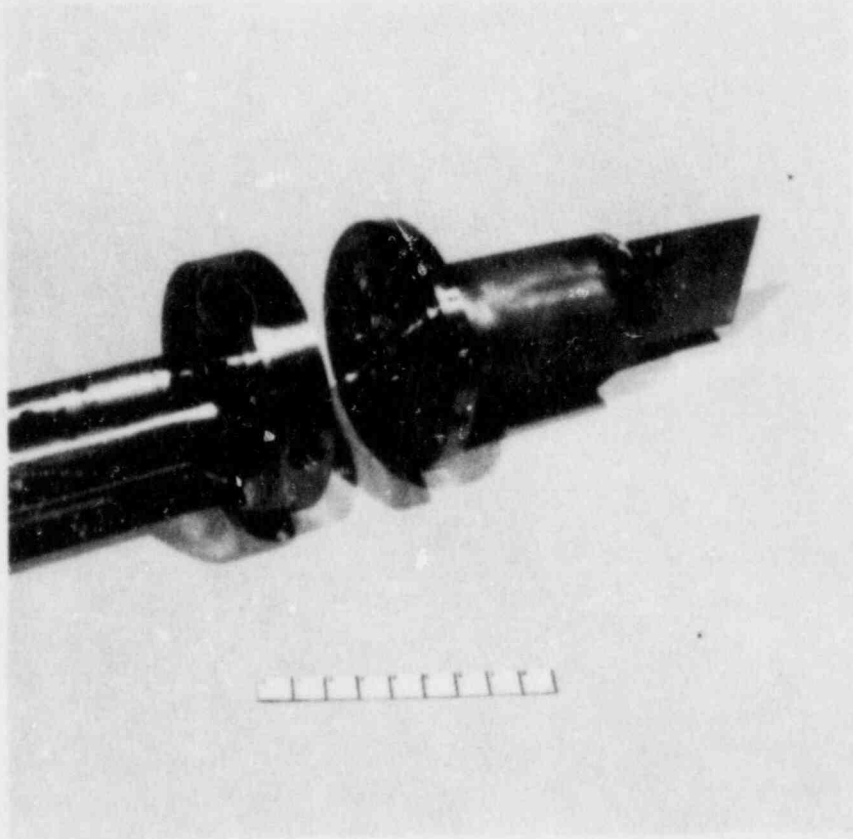

Figure 2-10 Jet Pump Annubar Instrument Washer and Tailpipe/Downcomer
Extension Piece

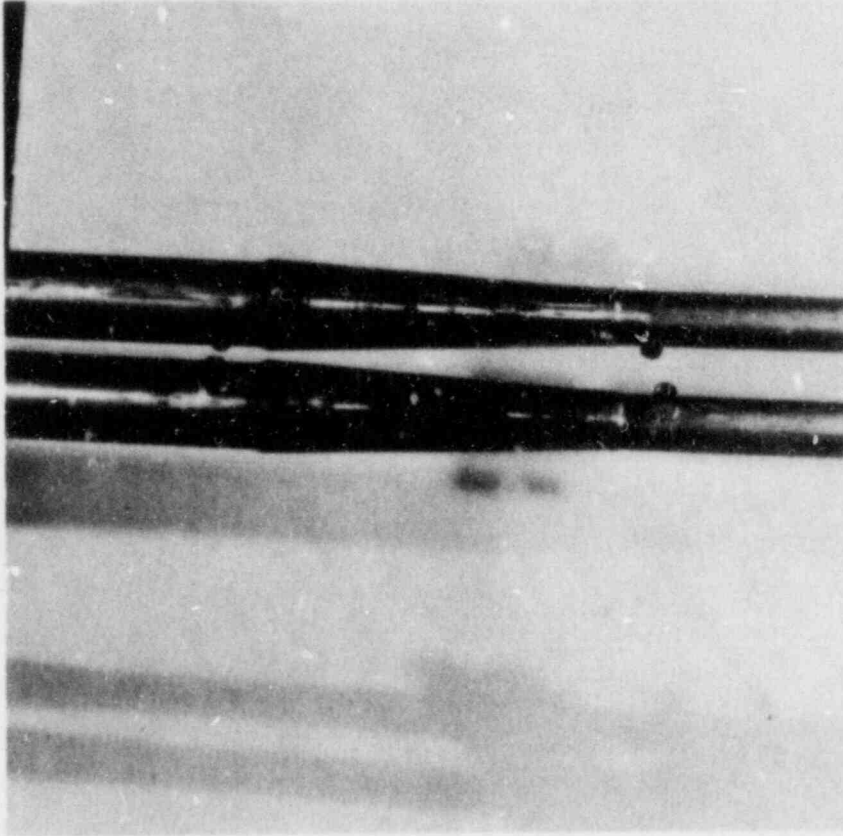

Figure 2-11 Jet Pump Diffusers

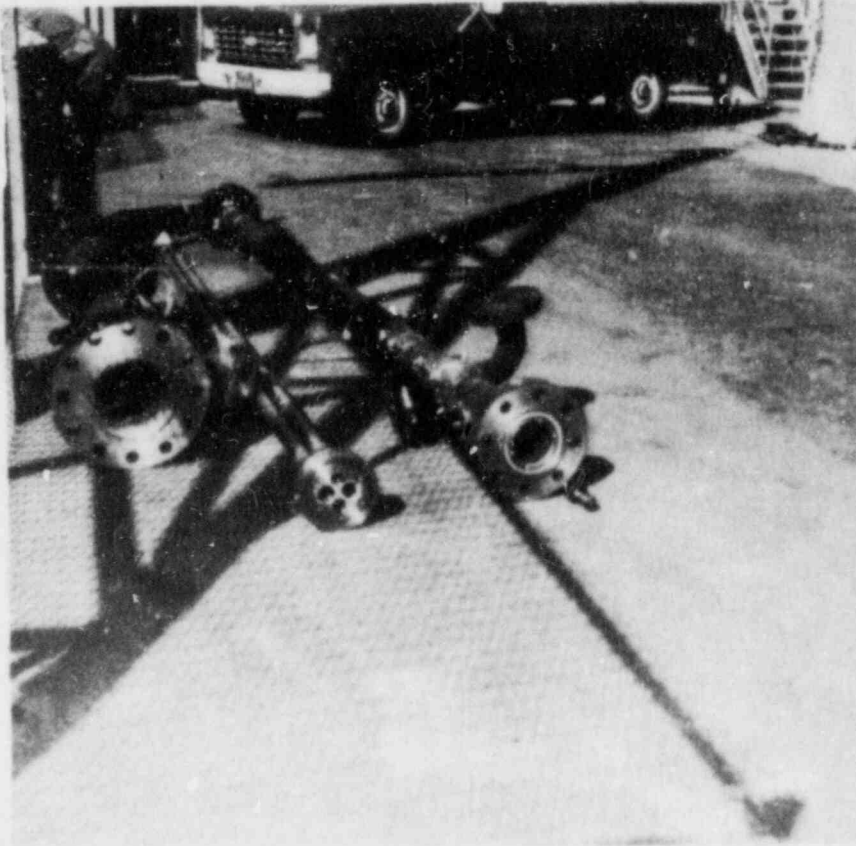
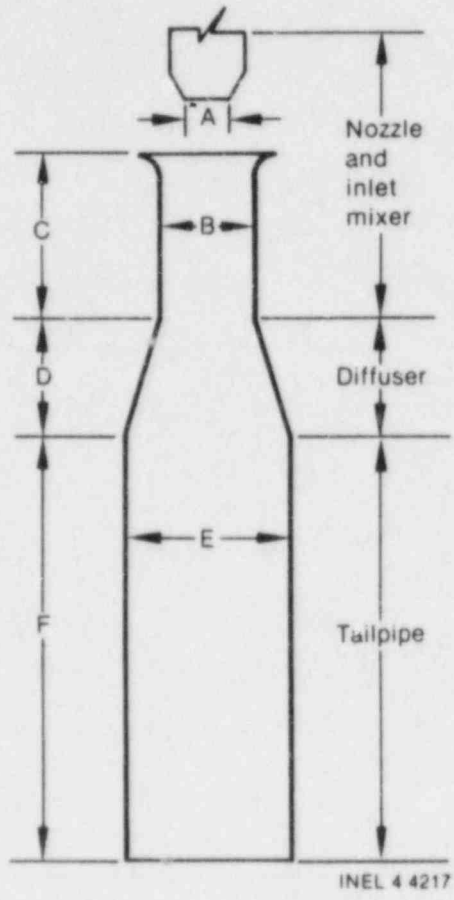

Figure 2-12 Jet Pumps and Downcomer Housing



INEL 4 4217

Figure 2-13 Jet Pump Nomenclature and Dimensions

TABLE 2-1. JET PUMP CHARACTERISTICS

Figure 2-13 Dimension		FIST Design	TLTA Design	BWR/6-218 3-D Scaled
Nozzle Diameter	A	0.45"	0.45"	0.32"
Throat Diameter	B	0.914	0.914"	0.76" (1/7.9)
Length	C	11.41"	11.41"	6.92" (1/7.9)
L/D		12.48	12.48	9.11
Diffuser Length	D	9.13"	13.78	9.39" (1/7.9)
Tailpipe Diameter	E	1.685"	2.125"	1.717" (1/7.9)
Length	F	154.90"	16.68"	5.90" (1/7.0)
L/D		90.22	7.85	3.44
Min Reverse Flow Area (throat area)		0.656 in. ²	0.656 in ²	0.453 in. ²

BWR/6 (hypothetical) jet pumps. The nozzle and throat dimensions of the FIST and TLTA pumps are the same because the TLTA units are being used in FIST to take advantage of their known characteristics and performance. The FIST diffusers were also made from the TLTA diffusers by cutting off approximately 4.65 in. of the downstream end, so that the new outlet ID is close to the scaled BWR/6 ID of 1.717 in. New (smaller ID) tailpipes were then welded to the modified diffusers. The tailpipes were made long enough (155 in.) so that the overall FIST jet pump length is the same as the BWR/6 jet pumps. At both the nozzle-inlet mixers and tailpipe outlets, a separating vane or baffle (Figure 2-9, 2-10) is used to reduce the possibility of atypical interaction between the jet pumps. Satisfactory performance of the jet pumps in FIST is to be verified in scheduled checkout testing, but the capability of the pumps to provide adequate (scaled) core flow is anticipated on the basis of their performance in TLTA. The pumps are highly instrumented with Annubars, conductivity probes, and fluid temperature in addition to many differential pressure measurements. The design bases for the FIST pumps, then, are:

1. The height of the FIST jet pump equals the full BWR/6 jet pump height.
2. The jet pumps are capable of providing scaled core flow.
3. The BWR reverse flow characteristics during a blowdown are simulated.
4. The interaction between the jet pumps is representative of the BWR jet pump interaction.

It is to be noted that the FIST minimum reverse flow area, the throat area, is larger than the scaled BWR/6 value as a result of the use of the TLTA units. To ensure that the third requirement above is met, the drive line blowdown orifice is sized accordingly smaller.

2.1.1.3 Lower Plenum and Guide Tube. The FIST lower plenum is a U-shaped pressure vessel with a crossover connection that ties the two legs together near their tops. Applicable drawings are 181F145-152 Sheets 1,2; also see Figure 2-2. The guide tube is mounted in the main vessel leg (an 8-in. XXH pipe that is thus larger in diameter than its companion. The larger pipe is designated LPB because it confines the upflowing lower plenum fluid before its entry into the bundle. The smaller-diameter leg (a 5-in. Schedule 80 pipe) is designated LPJ and contains most of the downflowing liquid coming from the jet pumps. Flow in the crossover connection at elevation 130 is from the main vessel leg to mix with the jet pump

effluent. The lower plenum is located below grade level in the facility pit and, as shown in Figure 2-14, has piping connections at its bottom crossover for draining the test vessel and also for return of feedwater during system warmup.

The guide tube is a length of 5-in.-OD, thin-wall, stainless-steel tubing noted earlier as being mounted eccentrically in the main vessel leg. It extends from elevation 43 in. near the bottom of the leg to a few inches above the top of the plenum flange at elevation 187. Water in the interior of the guide tube is essentially stagnant although a lower plenum to guide tube leakage path exists at the lowest thermocouple connection in the side of the guide tube. The guide tube is basically open, at its top, to the bundle bypass inlet area, although the flow cross section changes from that of the circular guide tube to the (roughly) semicircular bypass inlet area. The change in cross section occurs at the guide tube adapter plate welded to the top of the tube. A plate bolted to the top side of the adapter restricts the flow further. It simulates the BWR velocity limiter. Drawings detailing the guide tube are: 181F45-178, -189, -191, -192, -193. The upper guide tube or bundle bypass inlet area is described in Section 2.1.1.4.

Measurements of flow (Annubar), pressure, fluid and metal temperature, and liquid level (conductivity probe and differential pressure) are made in both the downflow and upflow legs and in the middle crossover pipe. Liquid level and fluid temperatures are also measured in the interior of the guide tube. Measurements are listed in Appendix B and discussed in Section 2.3.

Design bases for the lower plenum and the guide tube include:

1. Full BWR height and scaled volume are required for lower plenum
2. Guide tube fluid volume should be scaled fraction of lower plenum
3. Provide drain and warmup return connections
4. No interior insulation is to be provided.

2.1.1.4 Bundle and Bypass. The electrically powered bundle of 62 heater rods is, of course, the most important part of the test vessel and facility. The bundle and bypass are described in four parts: inlet, channel assembly and bypass, heater rods, and outlet. As a whole, the bundle and bypass occupy the main vessel leg from approximately elevation 190 to elevation 380. The spool piece pressure boundary is a specially machined 13-ft-length of 8-in. Schedule 80 pipe fitted

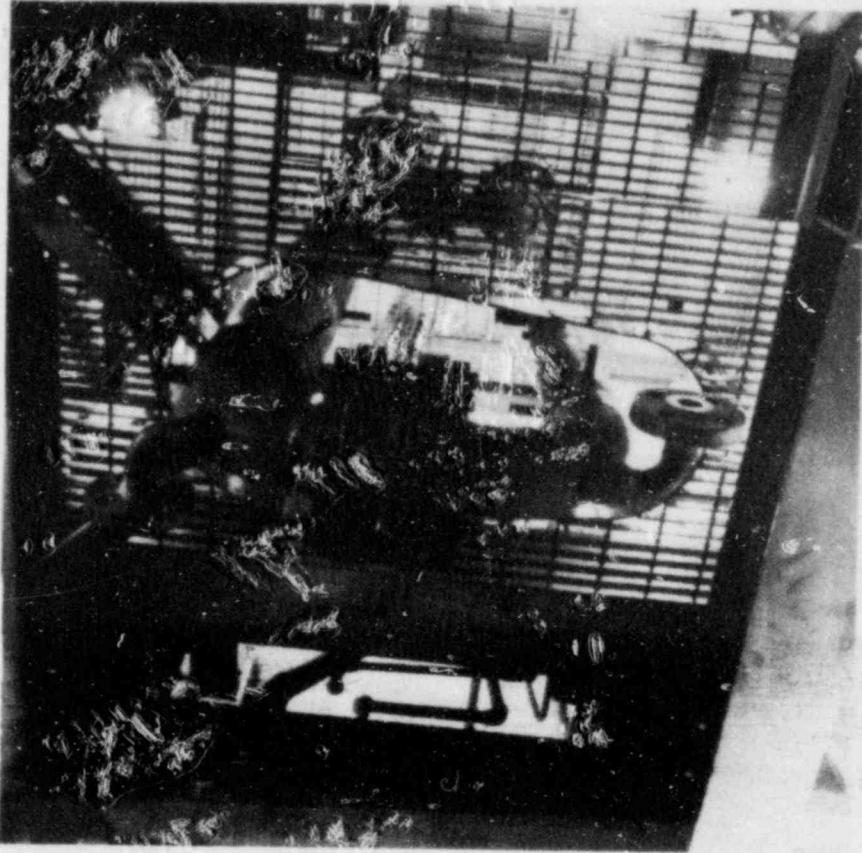

Figure 2-14 Lower Plenum Pipes Looking Up From Below, in Facility Pit

with 900 lb flanges on each end and with four 3/4-in. inlet nozzles (elevation 351) for LPCI flow. Washers and short spools make up the remaining length of pressure boundary above and below the main spool flanges. The list of applicable drawings for the assembly is given below.

<u>Drawing No.</u>	<u>Subject</u>
181F145 - 152 Sheets 4,10,11,13	Pressure Boundary
181F145 - 158	Shell and Filler Plates
181F145 - 162 through 164	Core Inlet, Outlet
181F145 - 170	Bail/Shell Assembly
181F145 - 174 through 177	Thermocouple, Buss Bar, Ceramic Button, Bail
181F145 - 179, -180	Bundle Assembly, Fillers
181F145 - 182 through 190	Heater Rod, Tie Plates, Inlet Piece Parts
181F145 - 198	Channel Expansion
181F145 - 200, -201	Lower Tie Plate Casting
181F145 - 212 through 216	Thermocouple, Voltage Taps, and Seals

INLET

The bundle and bypass inlet is that section of the assembly from the top of the guide tube to and including the lower tieplate and is shown in Figure 2-15. The main flow comes up outside the guide tube but inside the short spool pressure boundary and makes a 90-degree turn, passing through the side entry orifice. The flow immediately makes another 90-degree turn heading again vertically upward past the FIST Annubar, through the fuel support to the three-finger guide at the bottom of the tieplate base casting. This FIST "fuel support" is a quarter section of an actual BWR/6 fuel support. It is welded to the simulated core support plate and the slightly curved front face of the "upper guide tube." Section B-B of Figure 2-16 shows a cross section of the fuel support piece and the upper guide tube front face and semicircular back face at the center of the side entry orifice, elevation 195. The flow going to the core goes through the hole in the front face, then through the smaller side entry orifice hole and then expands out into the trapezoidal shape of the fuel support at that elevation. The bypass flow moves upward in the space inside the semicircular back face but outside the fuel support. As shown in Figure 2-15, that bypass flow comes from two sources: the lower plenum to bypass leakage hole in the front face at elevation 192, and whatever minimal flow may be coming up through the guide tube adapter plate. Figure 2-17 shows the assembly welded to the top of the guide tube. The front face with its hole in front of the side entry orifice hole, the core support plate and fuel support upper end are apparent. The smaller hole below the main flow hole is threaded for installation of the leakage orifice plug. Figure 2-18 shows

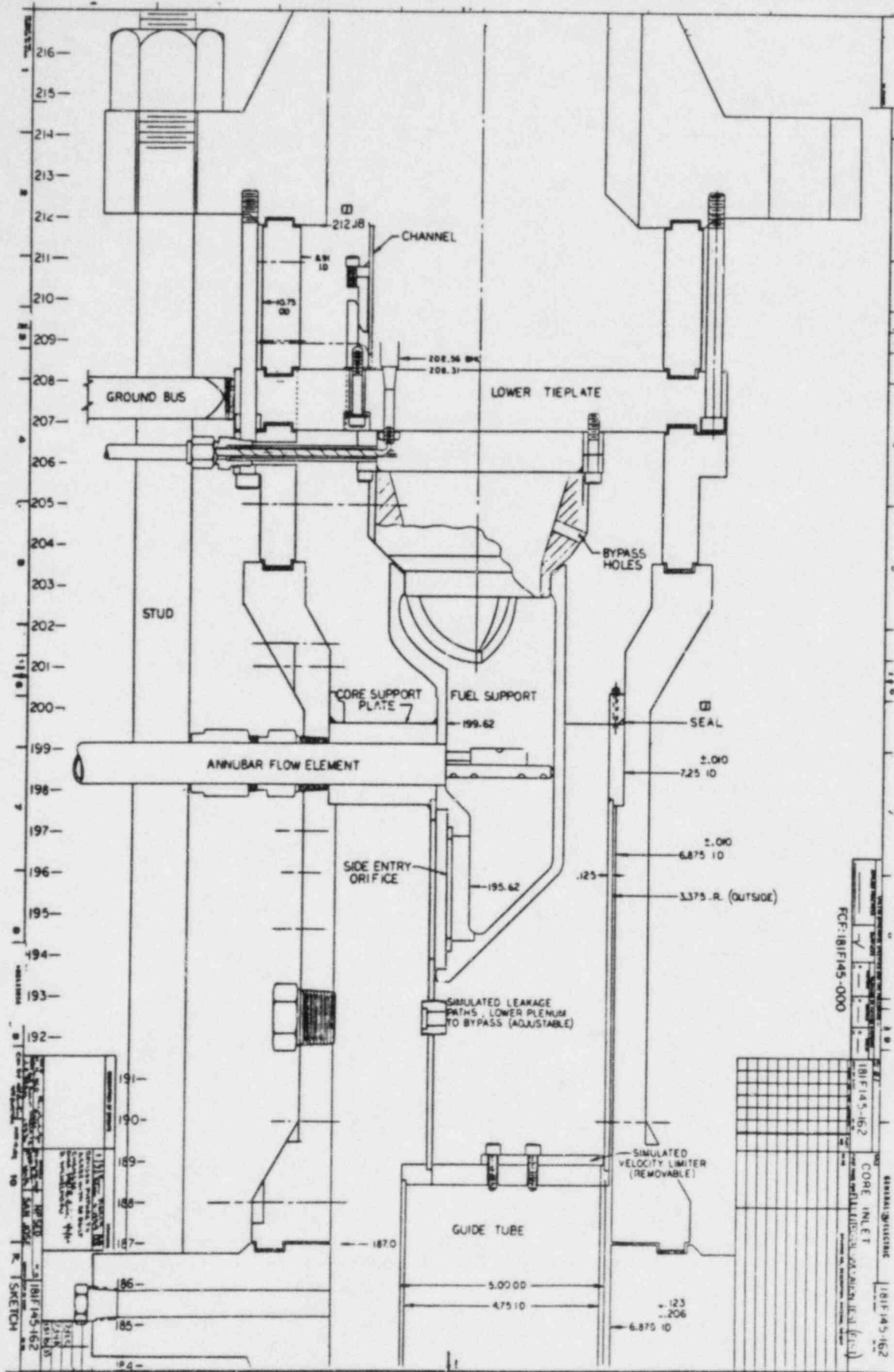

Figure 2-15. Core Inlet

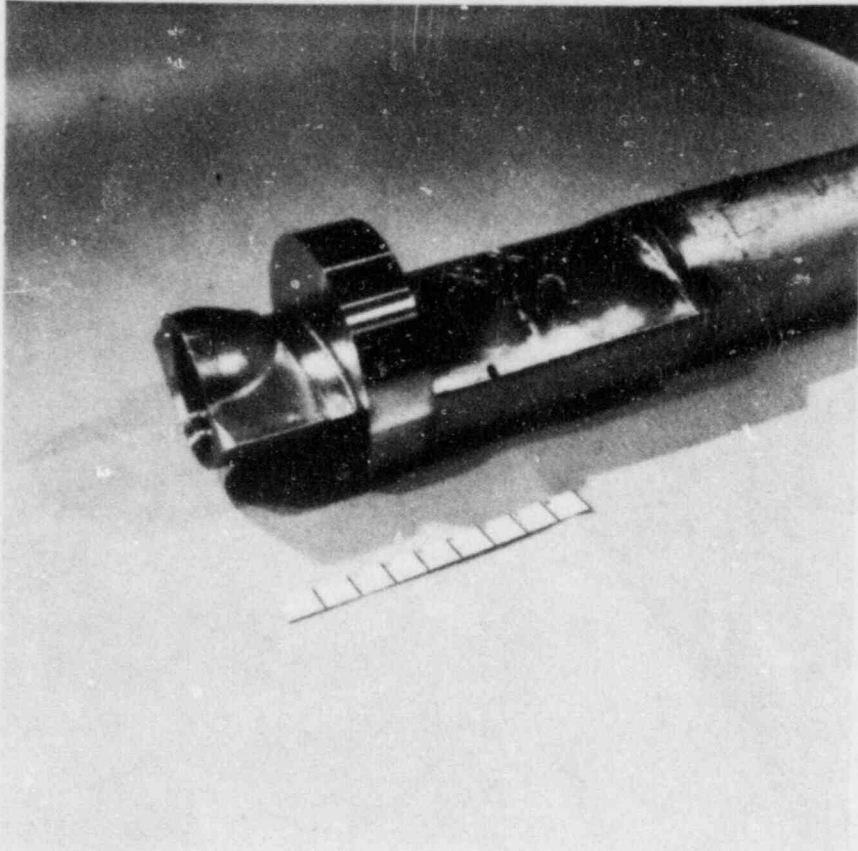

Figure 2-17 Front Face of Upper Guide Tube Showing Side Entry Orifice

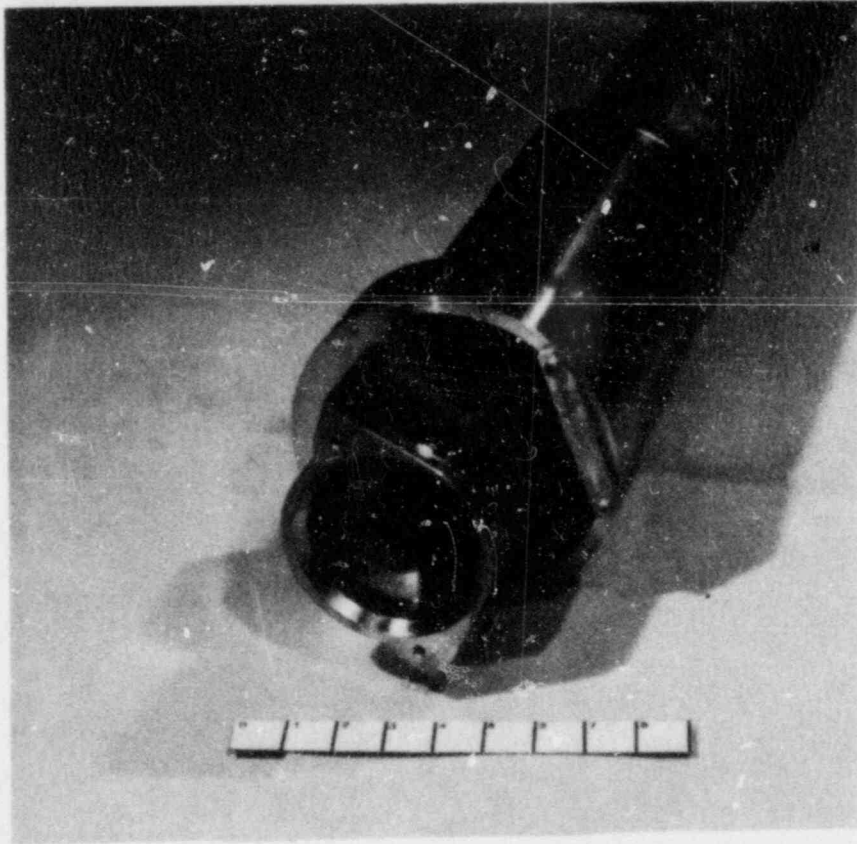

Figure 2-18 End View of Fuel Support's Circular Main Flow Area;
Bypass Flow Area

an end view of the fuel-support piece, which at that elevation is circular. The open area to the right is the bypass flow area.

Returning to Figure 2-15, it can be seen that the lower tieplate base rests down in the fuel support but no seal exists between them, because there are leakage holes machined into the base, permitting additional controlled flow into the bypass area. The tieplate base also accommodates the passage of the heater rod thermocouples from the ends of the heater rods, out through the bypass fluid and the pressure boundary washer. A cooled-thermocouple, low-flow velocimeter probe, not shown in Figure 2-15, is mounted through the washer and base just below the heater-rod-thermocouple penetrations. It is intended to extend the measurable core inlet flow range down into the natural circulation flow rates.

The lower tieplate, Figure 2-19, serves as the heater rod mechanical support, electrical connector between the rods and the buss bars connected to the power cables, and the bottom to the flow channel. Figure 2-20 shows the 1.5-in.-thick, 12-in.-diameter Nickel 200 plate with its 12 silver-plated, 1-in.-square copper buss bars installed. It incorporates the flow passages for both the subchannel flows between the rods, and the four kidney-shaped flow passages for the bypass flow. Thus, the BWR zircaloy square flow channel walls are located between the rod and bypass flow area ports in the plate, and the core flow inside the channel is thus separated from the bypass flow outside the channel, but within the circular pressure boundary.

As shown in Figure 2-15, the tieplate base is bolted to the tieplate which is in turn bolted to the bottom flange of the bundle pressure boundary spool piece. The tieplate and thus also the spool piece are electrically grounded at this point. The channel is isolated electrically from the tieplate and floats at some intermediate voltage between the 150 V (maximum) at the top of the heater rods and the 0 voltage at the lower tieplate. This is accomplished by isolating the lower part of the channel expansion box from the tieplate with a Rulon gasket. The cap screws locating this lower part on the tie plate are isolated from it with sleeves and washers of an asbestos-phenolic material.

CHANNEL ASSEMBLY AND BYPASS

Figure 2-21 shows the bundle pressure-boundary spool piece and a cross sectional view of the assembly. The assembly consists of the carbon steel spool piece wall to which two interior strips are attached, one on the north side, the other on the east. These strips provide two services: they provide surfaces conforming to the

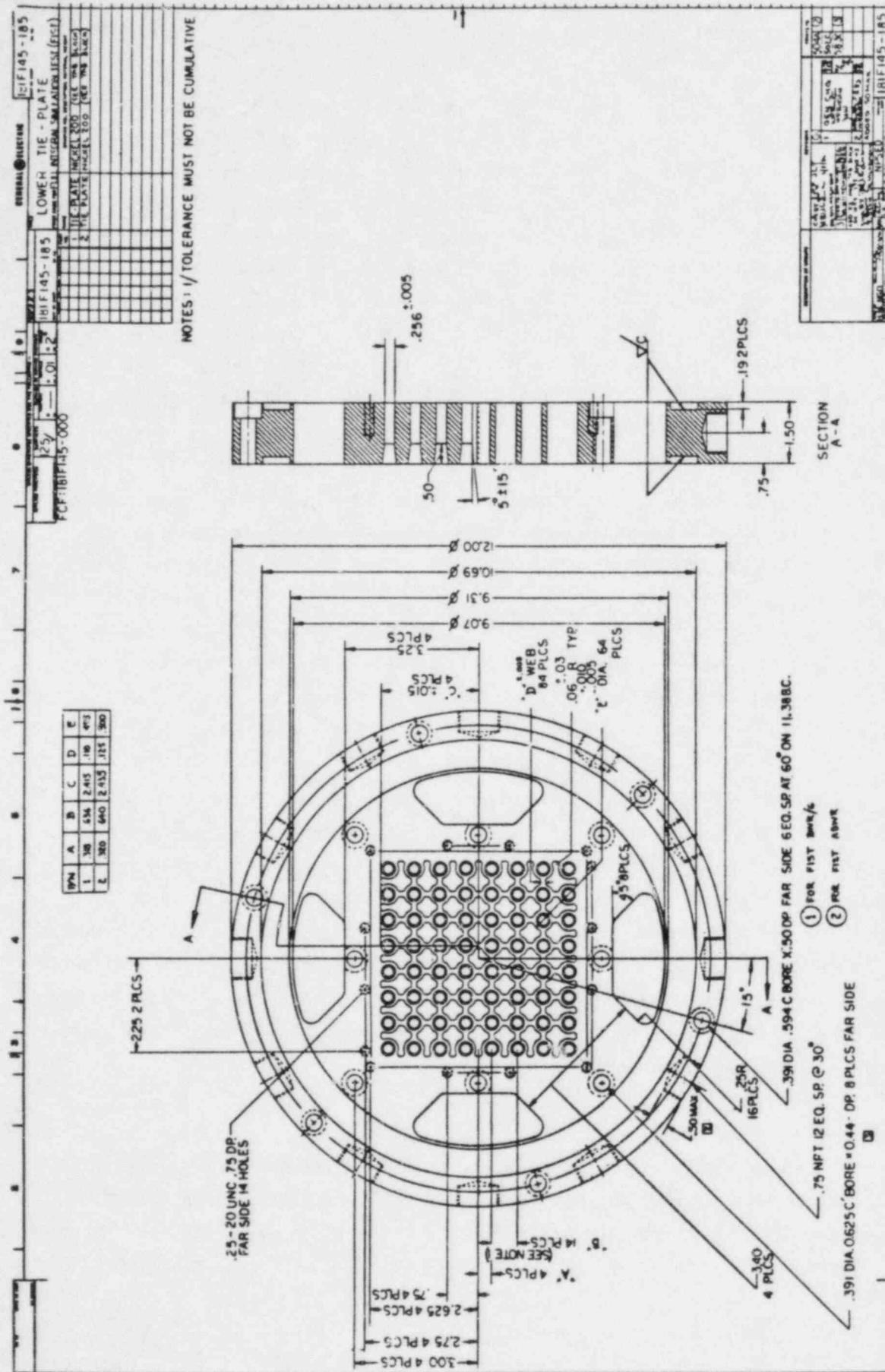

Figure 2-19. FIST Lower Tie Plate

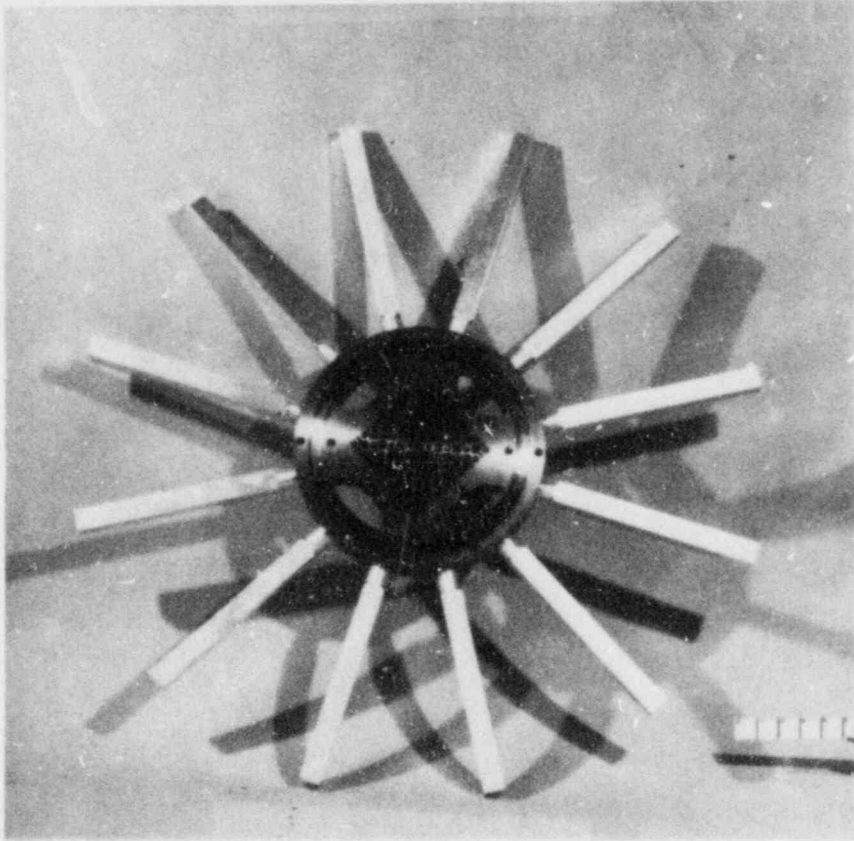

Figure 2-20 FIST Lower Tie Plate with Buss Bars Installed

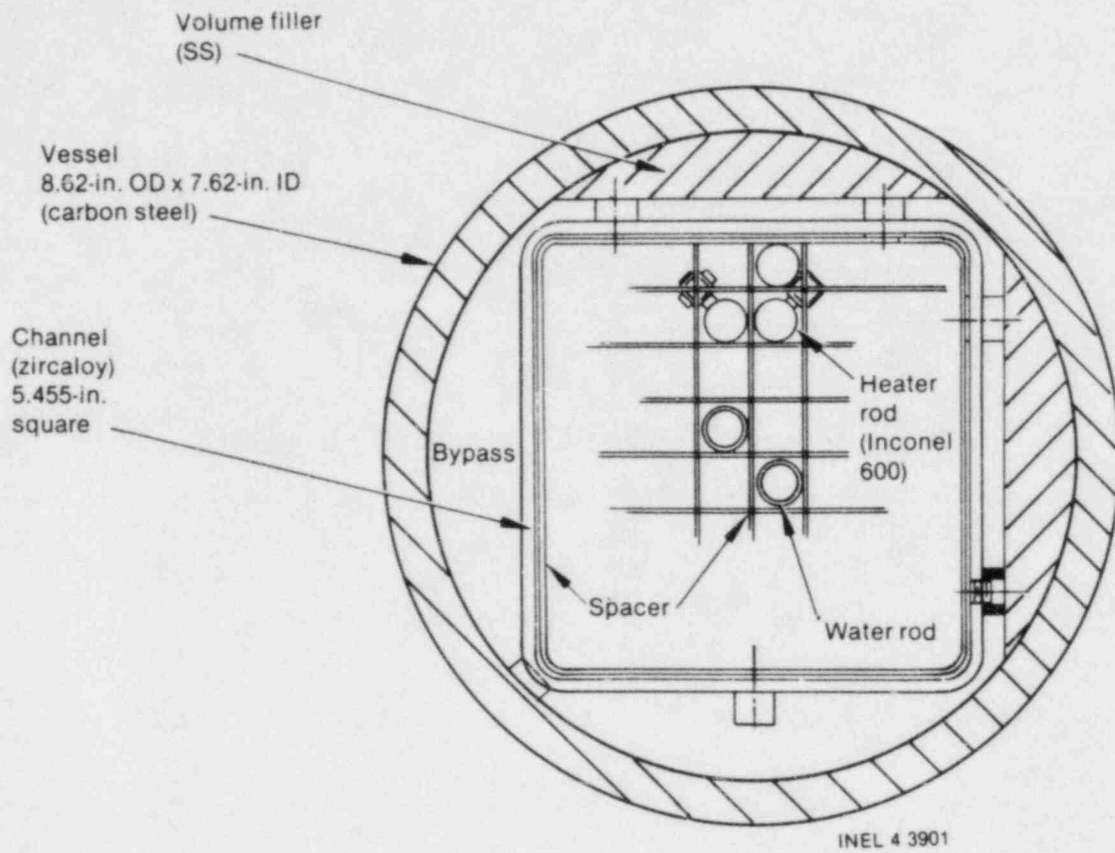

Figure 2-21 Bundle Cross Section

channel geometry to help center the zircaloy channel box within the spool piece, and they reduce the bypass fluid flow area to the scaled area, hence volume, in the full-height bundle. The resulting asymmetry in bypass flow area distribution faithfully reflects the BWR condition that is caused by the control rod blades. The channel is electrically isolated from the pressure boundary and centered by the five ceramic standoffs, two each on the north and east faces and the fifth point at the southwest corner of the channel. Seven sets of these standoffs are located along the height of the channel, one set at each grid spacer. Within the channel, as the figure shows, are the grid spacer and typical heater and water rods.

Figure 2-22 shows the fuel bundle assembly. Apart from the forces that may be transmitted between the rods and the channel via the grid spacers, the weight of the rods is supported by the lower tie plate while the enclosing channel is suspended from above by a flange that rests in a recess in the spool piece top flange. The stainless steel channel flange is bolted to zircaloy support bars welded to the channel, but is electrically isolated from the channel similar to the construction at the lower tieplate. Because of the different support points, the rods and the channel grow in opposite directions during the warmup. The channel expansion is accommodated by the two piece channel expansion box, the upper part of which is attached to the channel, and the lower part to the lower tieplate.

As shown in the figure, seven grid spacers are located at 20.15-in. intervals along the length of the bundle. The spacers are pinned to the channel walls at two points on each of the four sides, with small setscrews. On two sides, these setscrews are used to also support the ceramic standoff sleeves which center the channel as noted earlier. In the interior of the channel, another ceramic button is used with the screw to electrically isolate the grid spacer from the channel wall. It is this clearance that is critical in the new FIST channel/bundle design. Figure 2-23 shows a grid spacer with these ceramic buttons installed. Figure 2-24 contrasts the old TLTA design and the new FIST design which is identical to the BWR/6 arrangement. In the TLTA design, a ceramic liner prevented electrical contact between rods and the stainless-steel channel. Thus, when the rods reached high temperatures that could distort them and perhaps cause them to move enough to contact the channel wall, no consequent low electrical resistance path to ground was formed. In the BWR design, of course, the question of electrical contact is not material, but is of concern in the FIST case. Preliminary testing of the design was successful and various measuring techniques

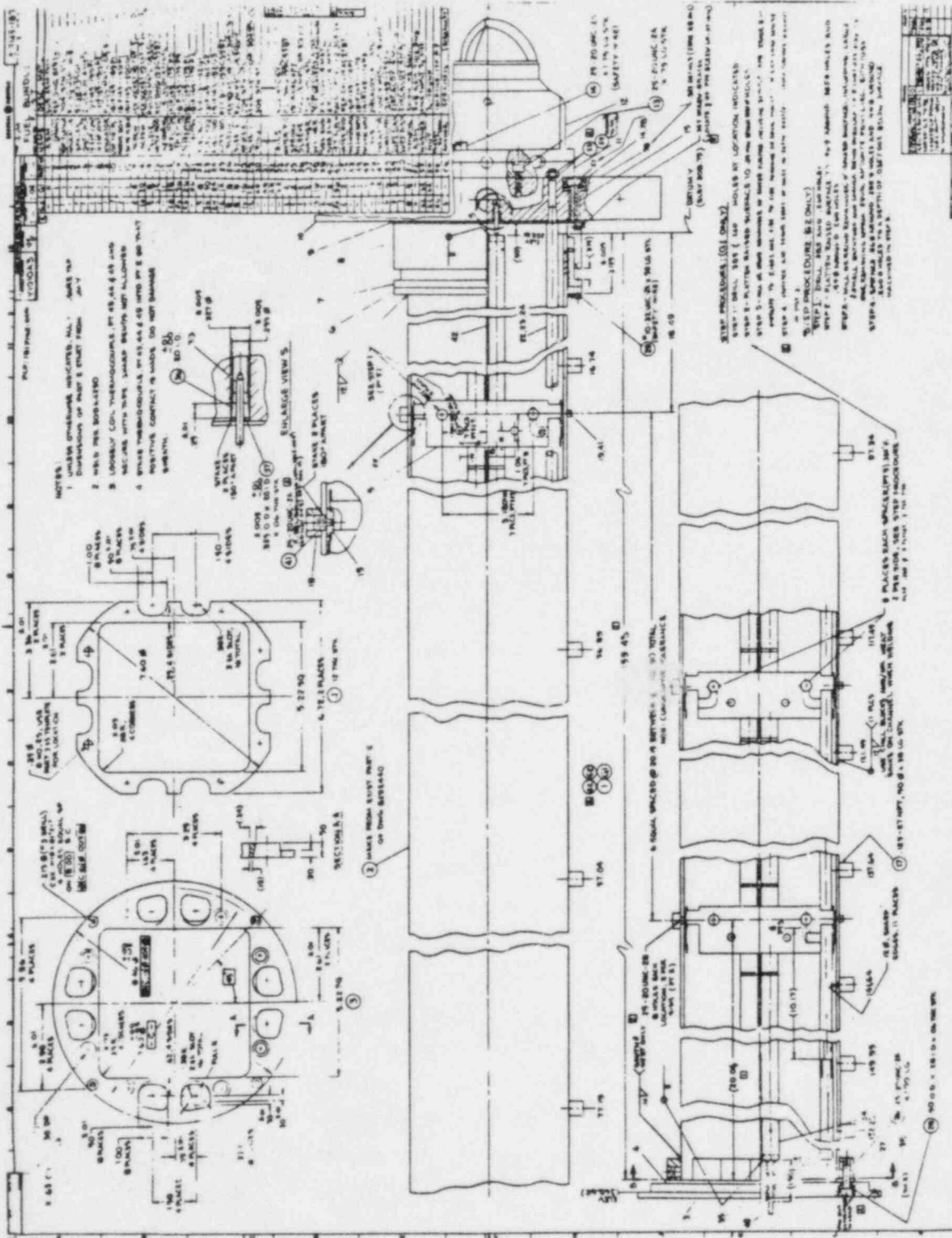

Figure 2-22. Bundle Assembly

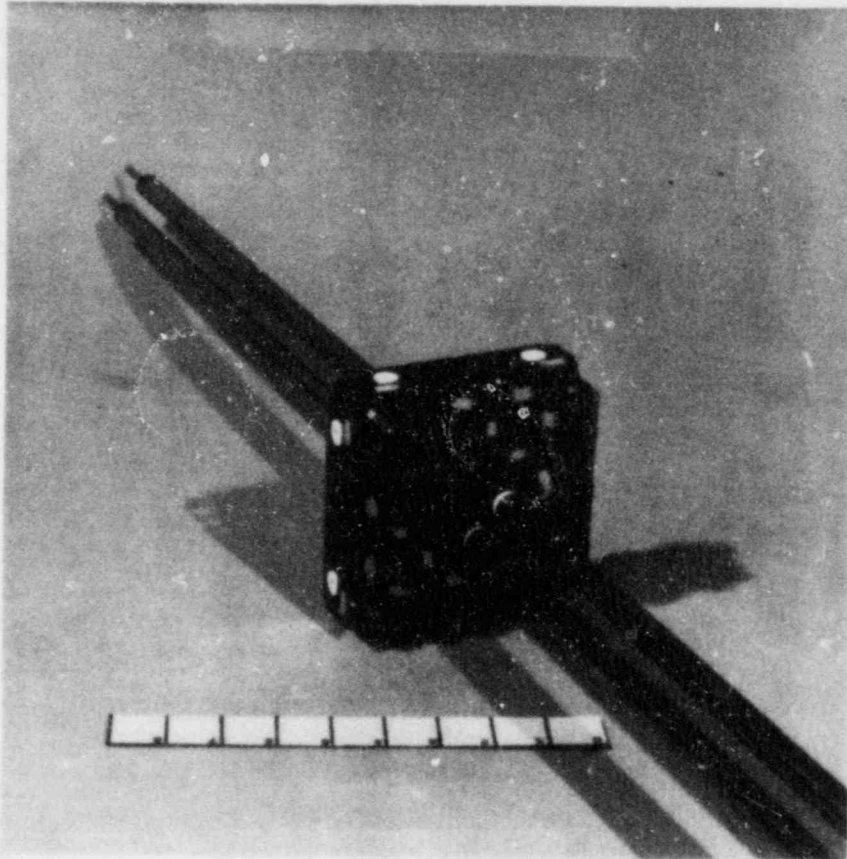

Figure 2-23 FIST Grid Spacer

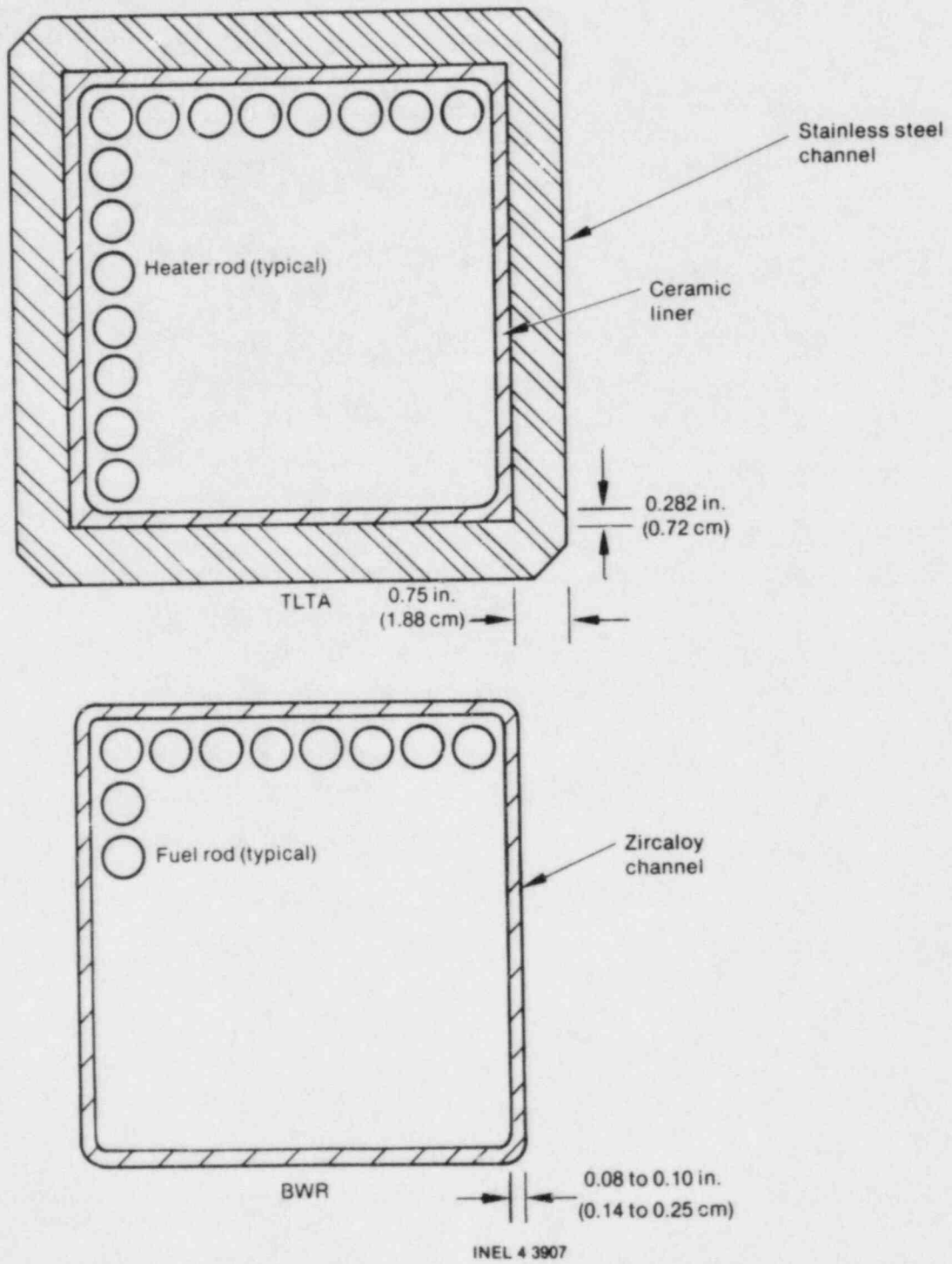

Figure 2-24 Channel Comparisons for TLTA and BWR/FIST

have been incorporated to continuously monitor channel voltages and related parameters. Core power is tripped when conservative channel voltage levels, etc., are exceeded in order to ensure safety of personnel and equipment.

Differential-pressure, liquid-level measurements are made in both the bypass and within the channel. Fluid temperatures in the bypass and wall temperatures on the channel and pressure boundary are also made. Densitometers may be installed to measure average fluid density at a given elevation between a row of rods and a conductivity probe is located in the bypass above the LPCI inlet nozzle.

HEATER RODS

The FIST heater rods are of the skin-heated type, i.e., the heating element is the wall of the heater rod tube. The axially-local volumetric heat generation rate of the conducting tube is dependent on the (local) tube wall cross-sectional area. Thus, by varying the wall thickness along the tube length, a specific axial power shape, such as the cosine shown in Figure 2-25, is obtained. To build a heater having that power shape, two identical 75-in. lengths of tapered-wall-thickness tubing are butt welded at the thinwall ends. Figure 2-26 shows the nominal wall thickness profile of such a length of tubing. The same shape profile but different total power generation in the rod is obtained by adding or subtracting a constant amount to the wall thickness all along the length. Thus the Model 76, 77, and 78 rods shown in the figure generate total powers which are in the ratio 1.04, 1.01 and 0.97 to the average bundle power for the same applied voltage. Figure 2-27 shows the first FIST bundle heater rod pattern. It incorporates 8 Model 76, 30 Model 77 and 24 Model 78 rods and 2 water rods. The pattern simulates the radial and azimuthal power profiles expected in a BWR.

Figure 2-28 shows the FIST heater rod. It is 162.8 in. long, has an OD of 0.483 ± 0.002 in., is constructed of Inconel-600 tubing and has a threaded fitting on each end for securing it between the upper and lower tie plates. The upper end of the rod incorporates a two-piece, sliding-fit pin and solid rod extension piece to accommodate thermal expansion. The extension is made of silver-plated, zirconium-copper No. 150 alloy, i.e., a low-resistance alloy generating little heat. The interior of the 150-in. heated length is filled with a high-temperature ceramic cement in which are embedded up to six Inconel-sheathed, chromel-alumel thermocouples used to measure heater rod temperature. The measuring junctions are in good thermal contact with, but electrically isolated from, the tube interior surface. The first foot of the sheath is swaged to 0.020-in. diameter but the remainder is 0.040 in. The axial distances of the measuring junctions above the

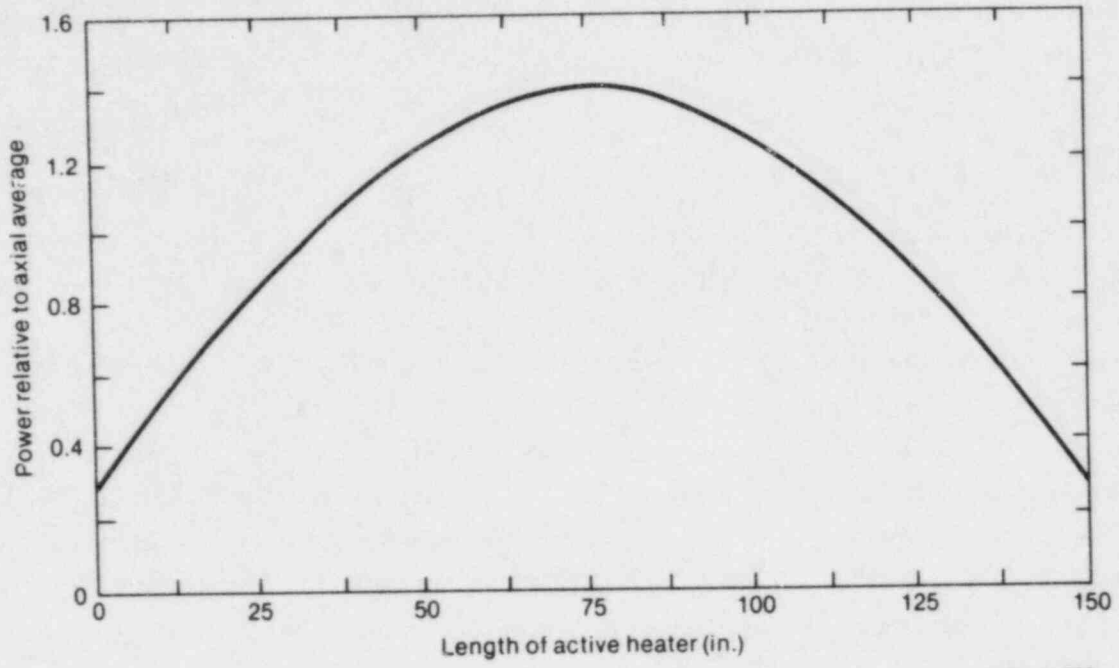

INEL 4 3898

Figure 2-25 FIST Axial Power Profile

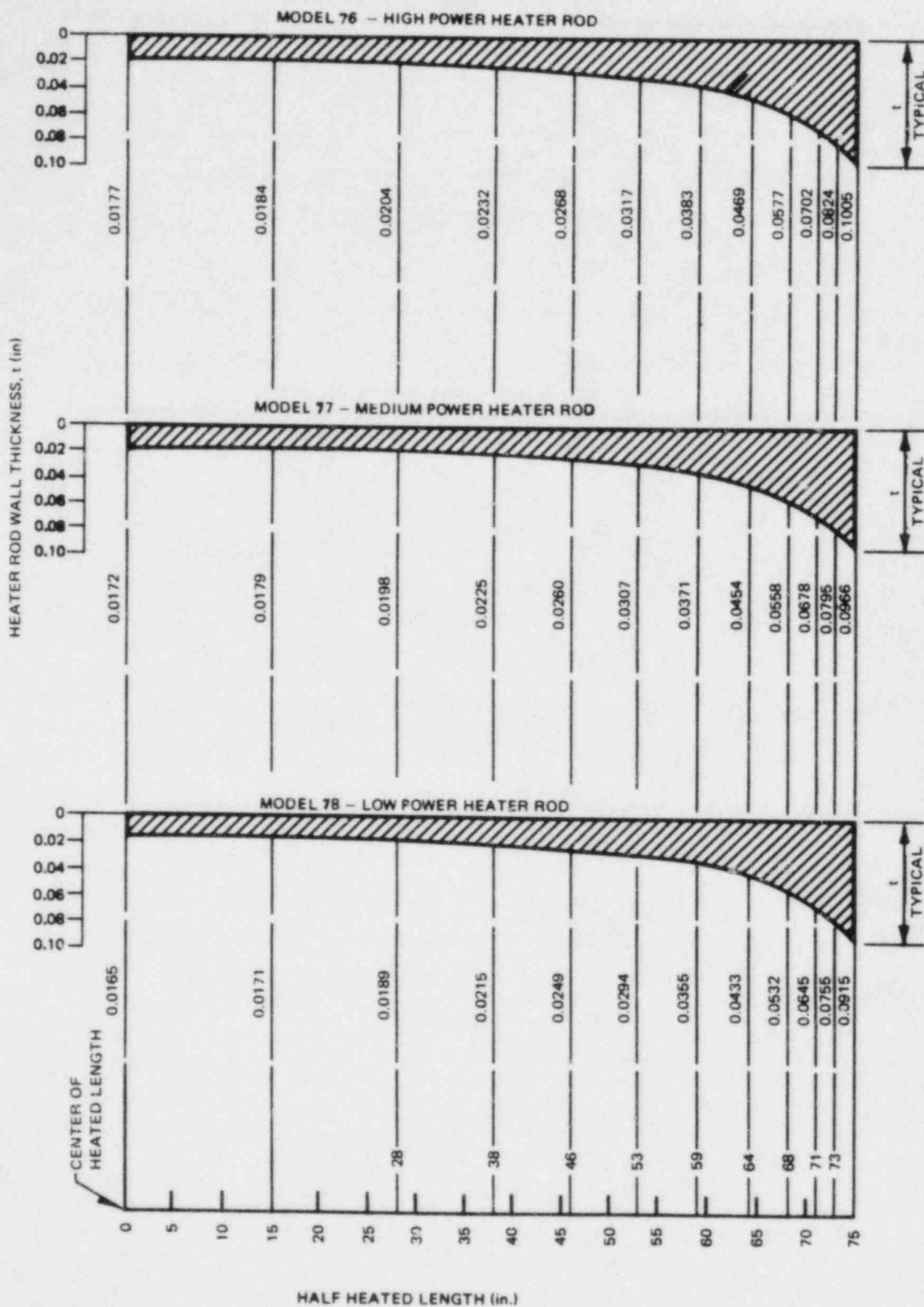
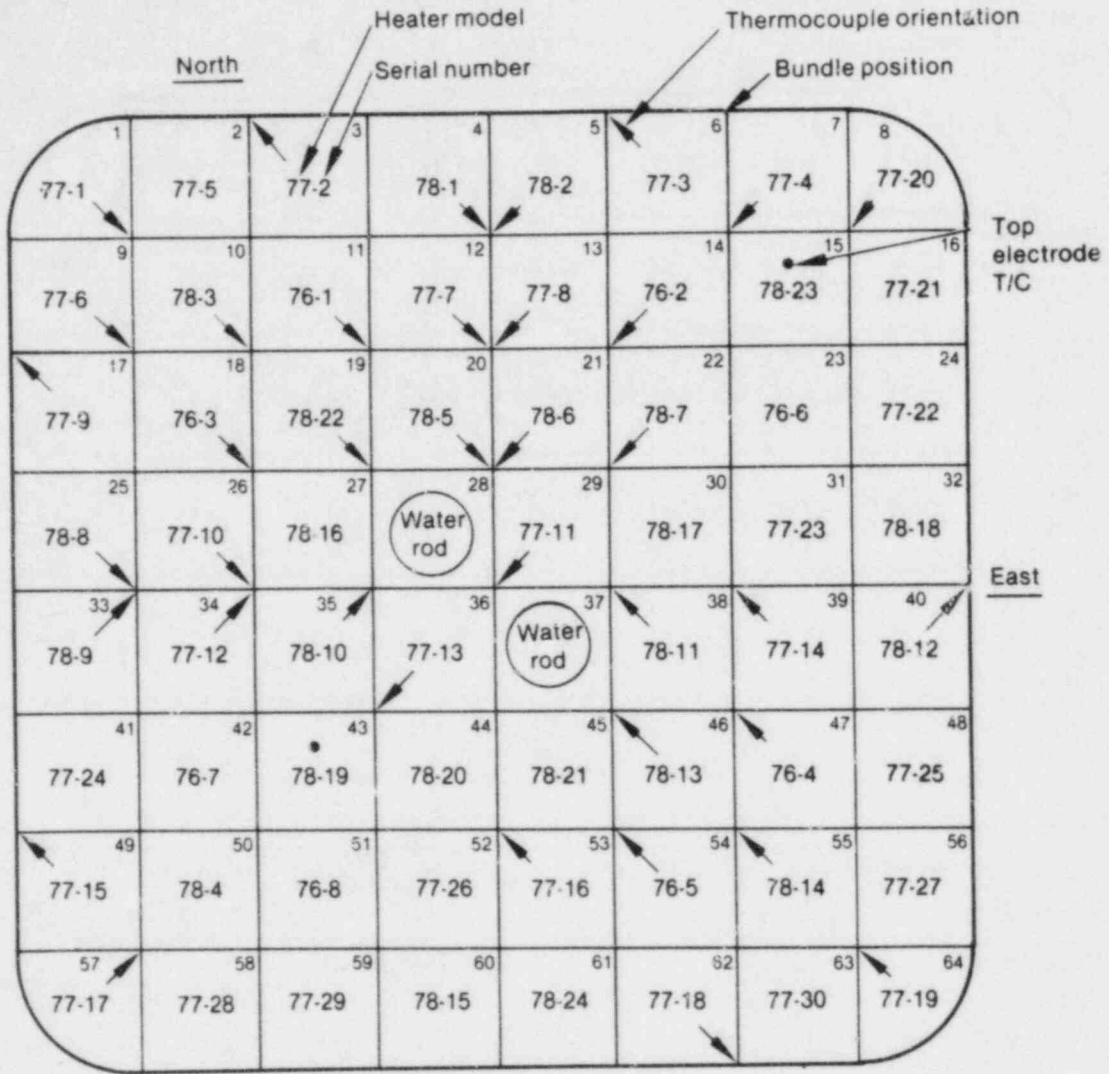

Figure 2-26 Profiles of Heater Rod Tubing Walls



Plan view from above
INEL 4 3903

Figure 2-27 FIST Heater Pattern, First Bundle

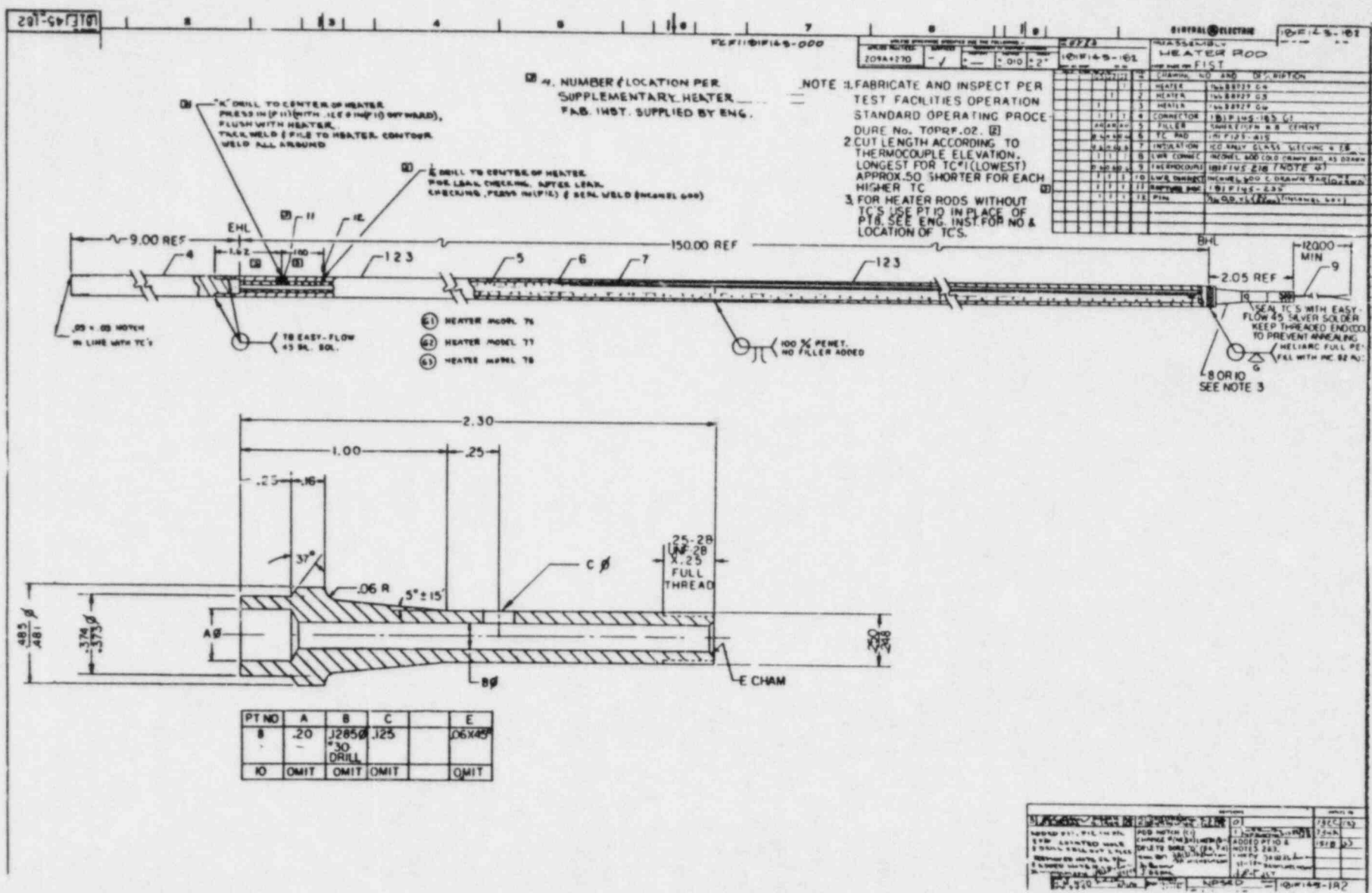

Figure 2-28. FIST Heater Rod

bottom of the heated length are listed for each rod in Appendix D, Table D-5. Heater Rods. The junctions are aligned one above another so that one scribe mark at the end of the rod shows the azimuthal location of all the thermocouples in that rod. The rotational positioning of the rods (thus thermocouples) in the bundle is also shown in Figure 2-27. In general, the rods are positioned so the thermocouples are on the core interior side.

OUTLET

An elevation view of the bundle/bypass outlet section is shown in Figure 2-29. It consists of the channel flange, the upper tie plate, and the bail. As noted earlier, the channel flange, which is shown in Figure 2-22, supports the channel and rests in a recessed groove in the top flange of the bundle pressure boundary. It is electrically isolated from the upper tie plate by a Rulon gasket (as is the pressure boundary washer mounted above the plate). The upper tie plate, like its companion, is an intricately machined, 1.50-in.-thick Nickel 200 plate, which locates the heater rods and the twelve buss bars and power cables. It is 10.5 in. in diameter. The bail consists of three parts: a flange covering the upper tie plate insulating gasket, a short length of channel which continues the flow boundary above the tie plate, and the bundle handle (an inverted U-shaped piece attached to the section of channel). Eight 1-inch-diameter holes are provided for bypass flow in flange, gaskets, tie plate, and bail flange. The bail is bolted to the bottom of the pressure boundary washer.

The major design requirements for the bundle and bypass are given below.

1. The heater rods are to be of the same length, diameter, and rod pitch as in the BWR
2. The rods are to provide a cosine axial heat flux shape with an approximate 1.4 peak to average ratio and are to provide scaled core power to the coolant
3. BWR components are to be used to the maximum practical extent, e.g., the channel wall, grid spacers, fuel support and its side entry orifice, and the lower tie plate base casting
4. Provide scaled bypass flow area and adjustable-resistance leakage paths from bundle to bypass and guide tube to bypass.

2.1.1.5 Upper Plenum, Standpipe, Separator. The upper plenum, standpipe, and separator cover the region from the top of the core to the top of the separator, an approximate 19-ft. length from elevation 371 to 595. The region is important for its steam-water separation function and because the normal and various alarm

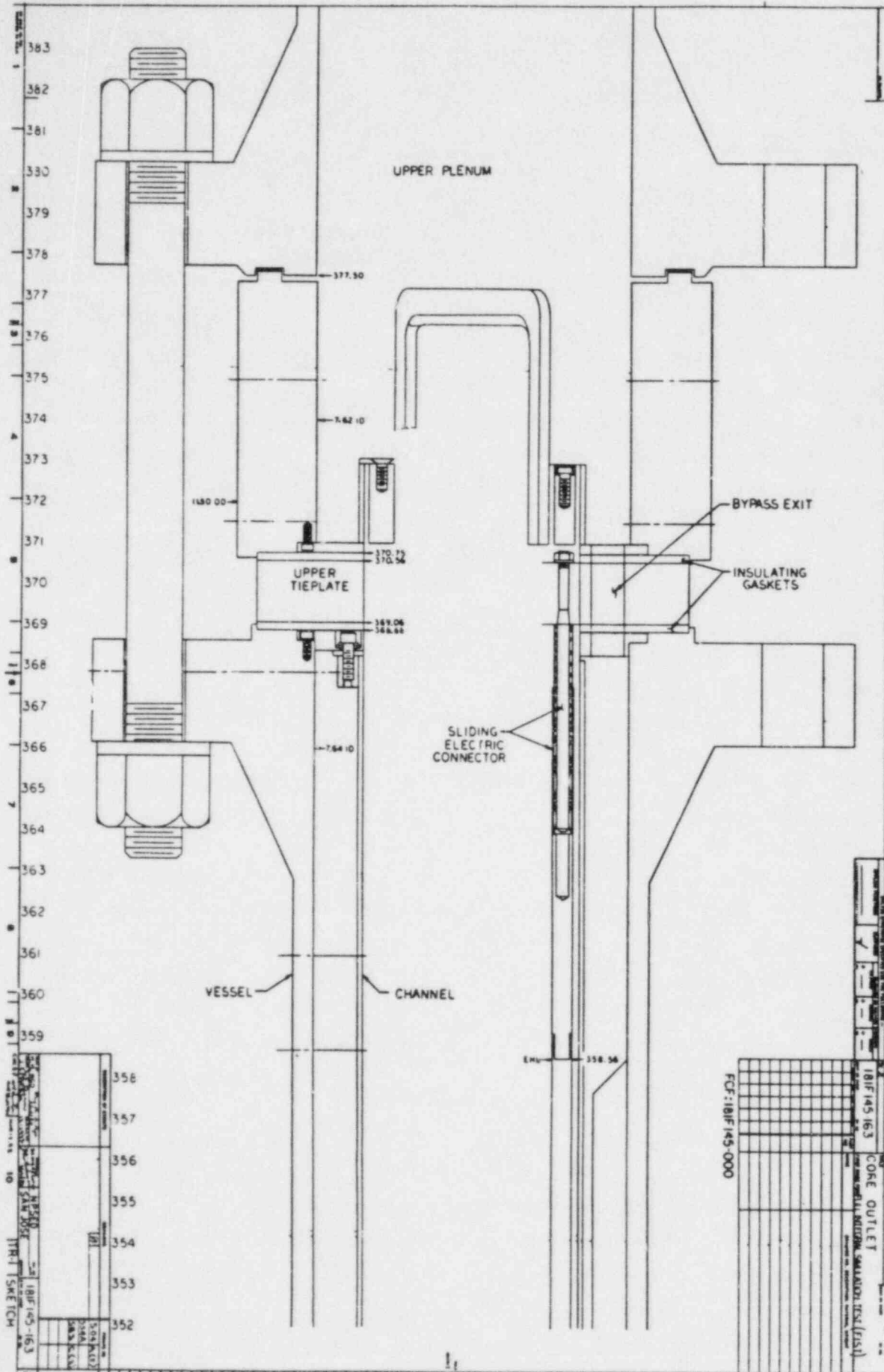

Figure 2-29. Bundle/Bypass Outlet

and trip liquid levels occur in this area. Some applicable design drawings are listed below. Facility photographs of this equipment are listed in Appendix A.

<u>Drawing No.</u>	<u>Subject</u>
181F145-152 Sh 6,8,15	Pressure Boundary
181F145-165	Assembly
181F145-181	Standpipe and Separator
181F145-202	Dryer Skirt, Drain

The upper plenum pressure boundary spool piece is shown in Figure 2-6 (along with the expansion bellows spool). It is a 4-ft. length of 8-in. Schedule 100 pipe fitted with a 900-lb flange at the bottom and an 8-in. x 8-in. x 4-in. Schedule 80 reducing outlet tee and similar flange at the top. A 45-degree elbow and 4-in. flange are welded to the tee branch (elevation 435) for connection to the expansion bellows spool (at the top of the external downcomer). Overall height is approximately 6 ft. Two 3/4-in. nozzles for HPCS inlet flow are located on the east and west sides at elevation 395. Similar arrangements are provided for the LPCS inlet flow at elevation 384. A 2-in.-high seal pad of weld overlay metal is built up at the pipe-to-tee joint, elevation 429, to provide an ID of 7.382 ± 0.002 in. The 3.5-in.-long enlarged bottom end of the standpipe, (OD = 7.370 ± 0.002 in.) extends down into the seal pad and provides the downcomer to upper plenum separation. Figure 2-5 shows this standpipe end protruding from the separator pressure boundary spool piece. This is the distance it extends down into the upper plenum spool.

The separator housing spool is an approximately 14-ft (overall) length of 10-in. Schedule 120 pipe with a 10-in., 900-lb flange at its top and a 10-in. x 8-in. Schedule 80 concentric reducer and an 8-in., 900-lb flange at its bottom. Like the upper plenum spool, the pipe wall thicknesses are chosen to provide the best approximation of the required (scaled) flow cross sectional area. The 3-in. feedwater nozzle is the only major connection and is located on the north side of the spool at elevation 483.

Four components are located within the separator spool: the standpipe, separator, dryer skirt, and dryer drain line. The separator is mounted above the standpipe and the two, with the standpipe Annubar instrument washer, form a single weldment shown in Figure 2-30. The simulated dryer skirt and dryer drain line are attached to a 1/2-in.-thick plate supported about its periphery by a recess in the separator housing top flange, Figure 2-31.

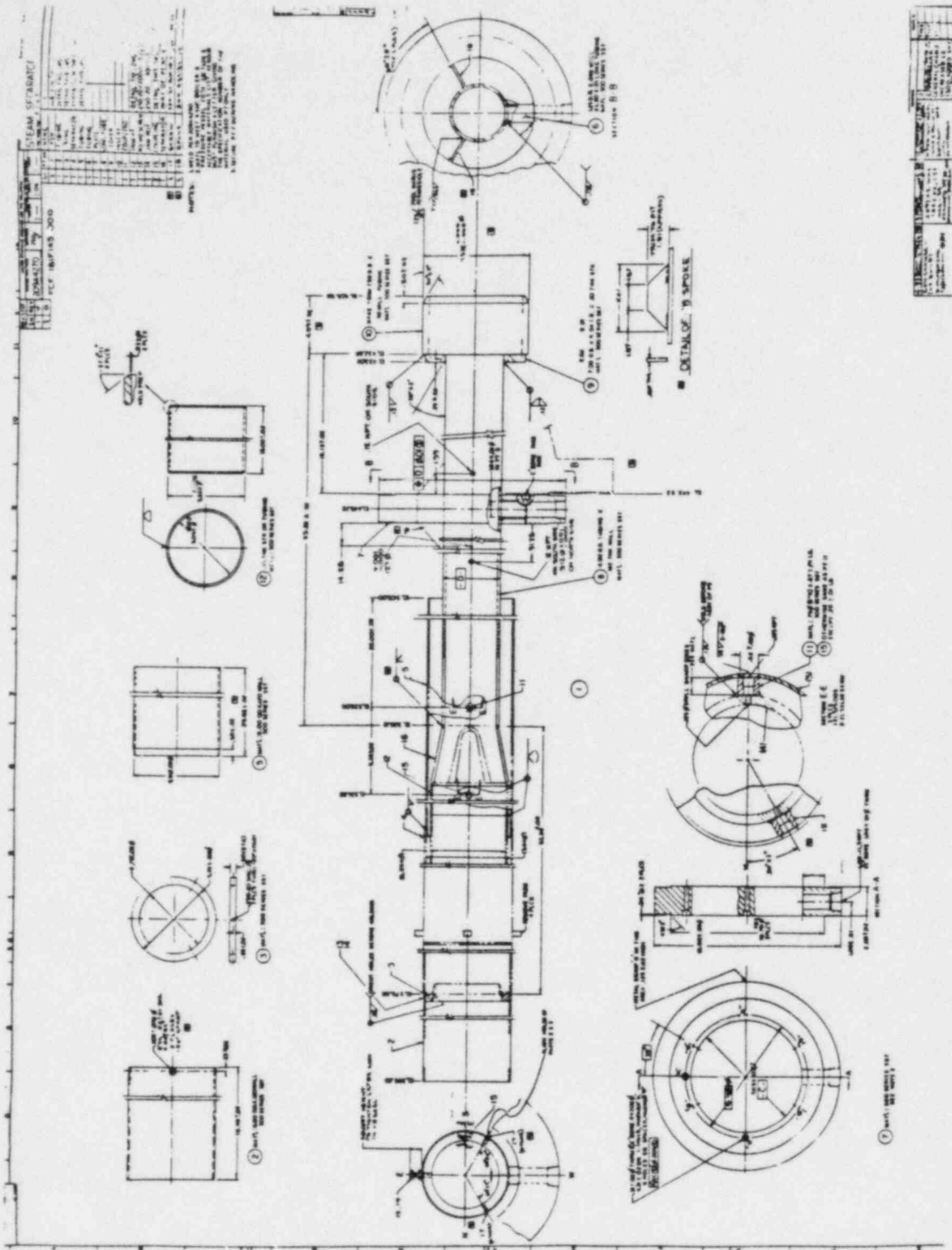

Figure 2-30. Standpipe and Separator

The standpipe/separator assembly is located within the separator housing by the Annubar instrument washer, which mounts between housing and upper plenum spool piece flanges. The instrument washer/standpipe connection is shown in Figure 2-32. The short radial tube connecting washer and pipe houses the Annubar probe. The standpipe is a 7-1/2-ft length of 0.188-in. wall, 4-in.-OD tubing.

The separator came from the TLTA test vessel and was modified for use in FIST. The steam-water mixture entering the separator attains a swirling motion due to passage through the fixed-vane inlet. The liquid, centrifugally forced outward, diverts from the steam and falls back while the vapor continues upward. The elevation of the first separator spillover is important because it determines the maximum static head of liquid obtainable within the shroud. In order to locate the spillover and swirler at the BWR-scaled elevations, the TLTA unit was disassembled and a new section of separator inserted between them. Also, an additional section was added at the top of the old separator in order to have the FIST unit be the full BWR separator height.

A concern regarding scaling of the separator was whether the TLTA unit, which had been scaled from a reference BWR/4 design, could be used in FIST. The matter was resolved when comparisons of BWR/4 and BWR/6 units showed that the exit area of the latter swirlers is only 2% smaller than the former, and that their length is only 5% greater than the BWR/4 unit's length.

Located in the annulus outside the separator but within the pressure boundary spool, are the simulated dryer skirt and dryer drain line, shown in Figure 2-31. In the BWR, the annular region between the dryer skirt wall and the pressure vessel wall is only 6.4 in. wide. Scaled down, that annulus could be expected to exhibit boundary layer effects which would alter water level movement. For this reason, the annular configuration was revised. An annular segment of greater thickness but only 76° wide is used rather than the very thin 360-degree annulus. The total cross sectional flow area in the 76-degree annular segment corresponds to the scaled BWR flow area. It is within this segment that the liquid level measurements that activate various alarms, trips, etc., are made, and as shown in Figure 2-33, the level there is higher than in the remaining 284-degree annulus outside the separator, due to the dryer pressure drop.

The annular segment dryer skirt is 1.28 in. thick, and approximately 5 in. (arc length) wide by 10 ft. long and is located on the west side of the separator housing, under the steam line connection (above it, in the steam dome). The dryer

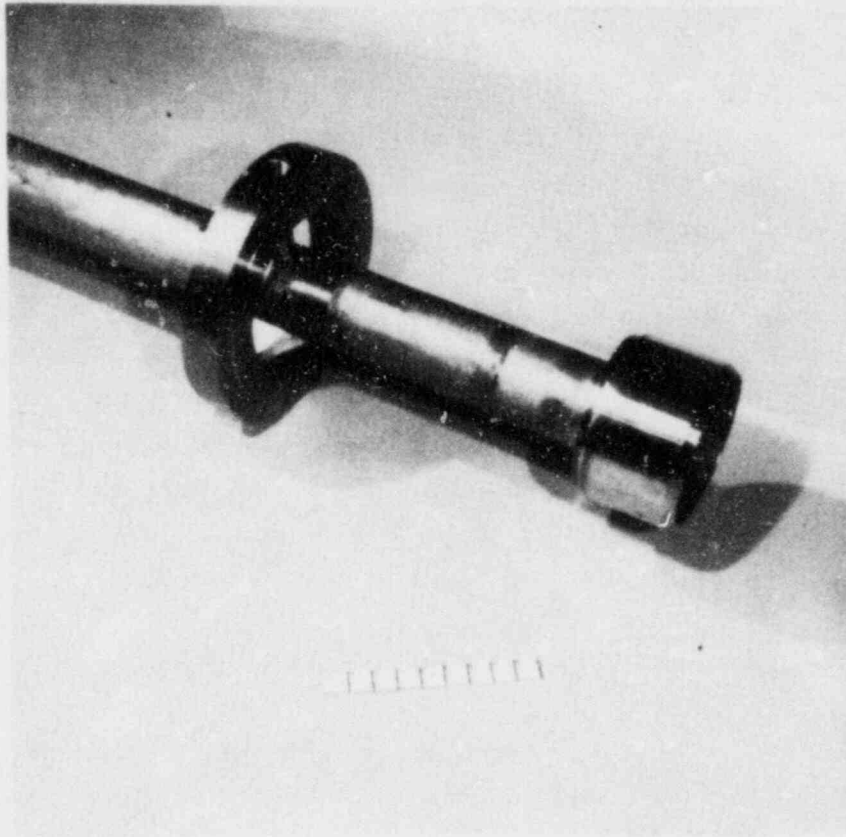

Figure 2-32 Standpipe and Instrument Washer

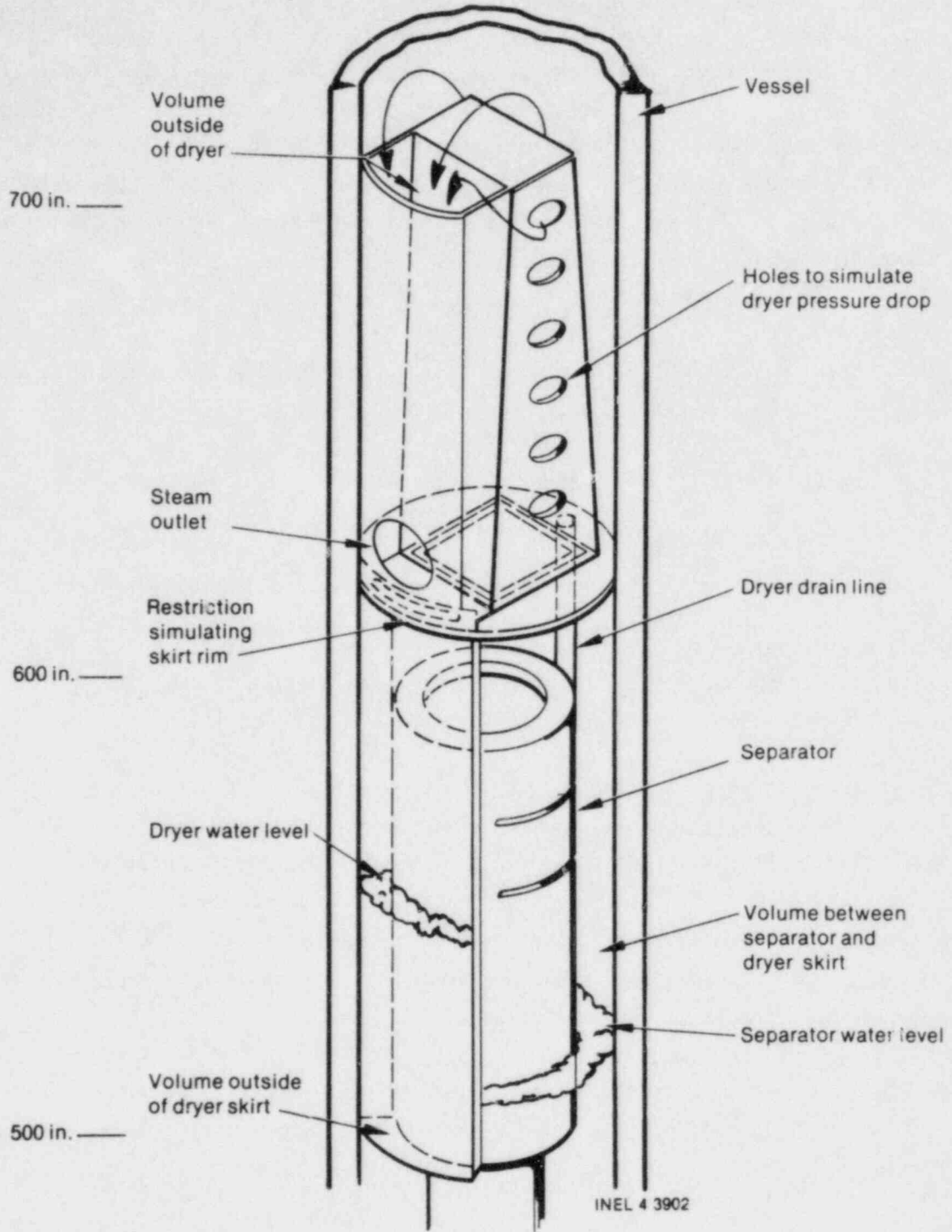

Figure 2-33 FIST Dryer/Dryer Skirt Design

drain line is a 9-ft, 4-in. length of 1.25-in.-OD x 0.125-in.-wall, stainless-steel tubing that is located on the north side of the separator housing. Liquid from the dryer drains down this line to a point under the normal separator water level. The plate to which the skirt and drain line are connected incorporates a central rectangular hole for the dryer inlet. Orifices are incorporated into the plate for both this dryer inlet flow and the connection between the dryer skirt and steam manifold to simulate corresponding resistances in the BWR. A Rulon gasket is used between this plate and the bottom of the dryer to keep the streams separate.

2.1.1.6 Steam Dryer, Manifold and Dome. The main objectives for simulating the steam dryer in the FIST facility are to:

1. Achieve the appropriate pressure drop
2. Simulate the reference BWR flow paths
3. Maintain the correct BWR area variations versus elevation.

The BWR dryers are basically used to ensure that the steam is dry enough to be sent to the turbine. In FIST, no turbines are simulated therefore, the drying function is not a necessary simulation for the facility.

The FIST dryer is shown in Figure 2-34. The steam leaving the separators enters the dryers through a square opening and then passes through two orifices (Region 1). Steam then exits the dryer through three perforated plates (one tapered and two vertical) and enters the region outside the dryers (Region 2). In order to flow out of the vessel, the steam must flow upward (above the top of the dryer) into the steam dome and enter the steam line enclosure (Region 3) flowing downward until it exits the vessel via the steamline.

The description of the scaling criteria used for each region follows:

Region 1

- A. Entrance and Orifices--The flow area of the entrance and the two orifice plates is sized so that the pressure drop of the entire dryer assembly corresponds to the reference BWR pressure drop.
- B. Perforated Plates--The flow area of these plates is scaled from the flow area of the outlet panel in the BWR dryers. Thus, the exit velocity from the FIST dryers should be equivalent to the BWR dryer exit velocity.

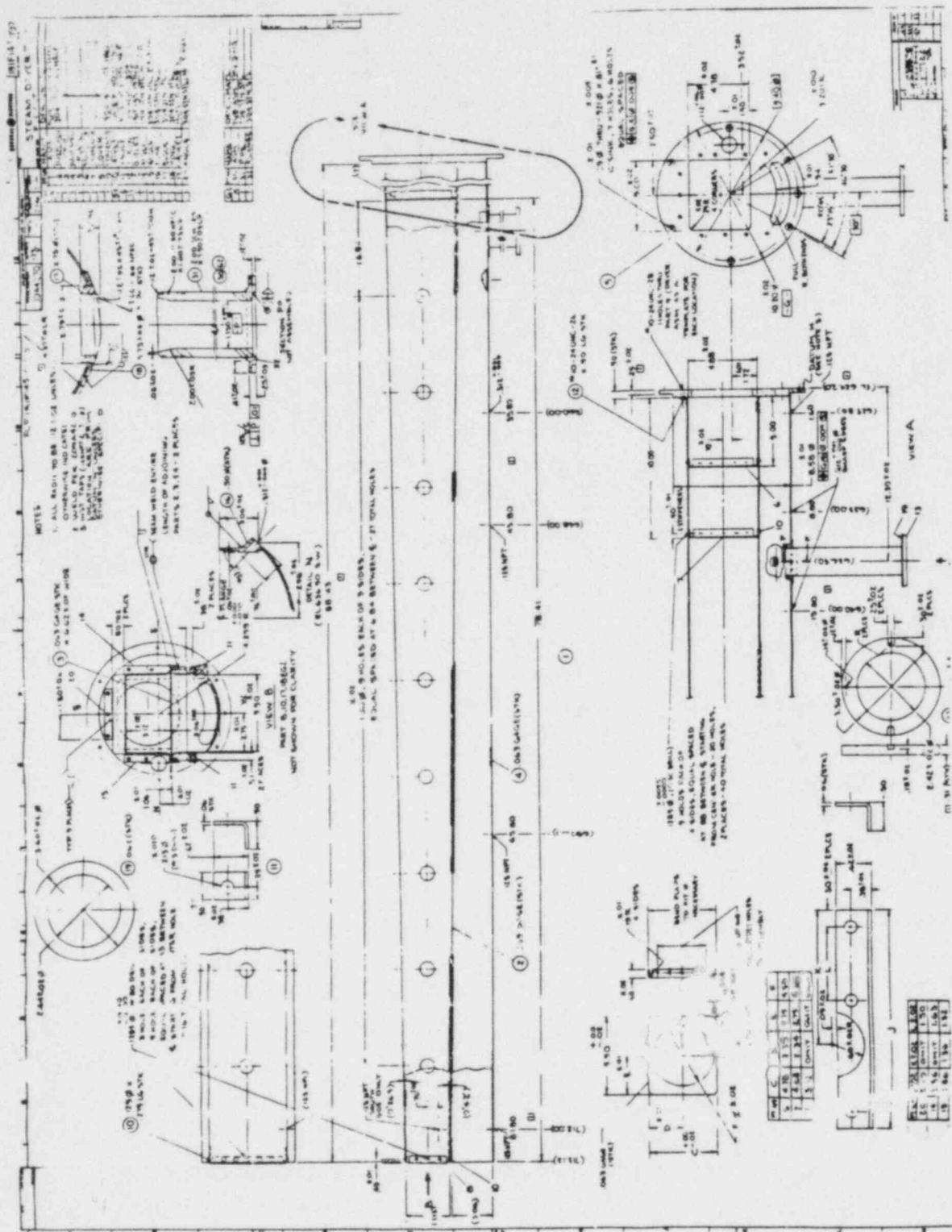

Figure 2-34. FIST Dryer

- C. Top of the dryer--The top plate of the dryer, being consistent with the BWR configuration, contains no steam flow path.
- Region 2 - The volume in this region plus the volume in Region 1 account for the scaled BWR volume contained inside the dryer shroud. The flow area of the dryer drain pipe is scaled from the flow area of the drain channels in the reference BWR dryers.
- Region 3 - The volume in this region corresponds to the scaled BWR volume outside the dryer shroud. It also reflects the vertical tapering that exists in the BWR dryer shroud, thereby maintaining the height versus area variations of the reference BWR.

2.1.2 Recirculation Loops

The two loops and the rest of the fluid systems are shown in Figure 2-35. Each loop independently provides the drive flow for its jet pump, taking suction from near the bottom of the downcomer and returning the flow to the jet pump nozzle. Each loop consists of a standard, fixed-speed centrifugal pump with added flywheel, remotely controlled loop isolation and flow control valves, the suction and drive line piping runs, an orifice flow metering station and other process and experimental instrumentation. The loop piping is Schedule 80 and consists of 1-1/2-in., 2-in., and 3-in. sizes as shown in the figure. Both loops have warmup-return line connections to provide flow paths back to the feedwater heater for startup. Loop No. 2 is the one in which the LOCA break is simulated and to which the blowdown piping is connected. It has additional flow measuring instrumentation to monitor the break flow.

Drawings 179F145-600 through -608 show the piping arrangement and pump installations. The pumps are mounted below ground level in the facility pit at 16 ft 9 in. (No. 1 pump) and 6 ft 9 in. (No. 2) below grade.

Figure 2-36 is a view from grade level looking down at loop No. 2 pump mounted on the pit grating at the -7-ft elevation. (In the foreground are the main vessel (left) and side arm (right) lower plenum pipes.) The pumps, used in TLTA, were refurbished before reinstallation and were fitted with flywheels to provide an approximately correct coastdown time. (The BWR/6 pump coastdown time constants range from 5-8 s.) The head-flow curves for the pumps are given in Figure 2-37 and all additional details on them are given in Appendix D. Instrumentation at the pumps includes pump head, speed, motor power, and outlet temperature. The flow rate is measured downstream of the pumps, (and of the warmup-return line connections) and is both recorded on the experimental measurement system and

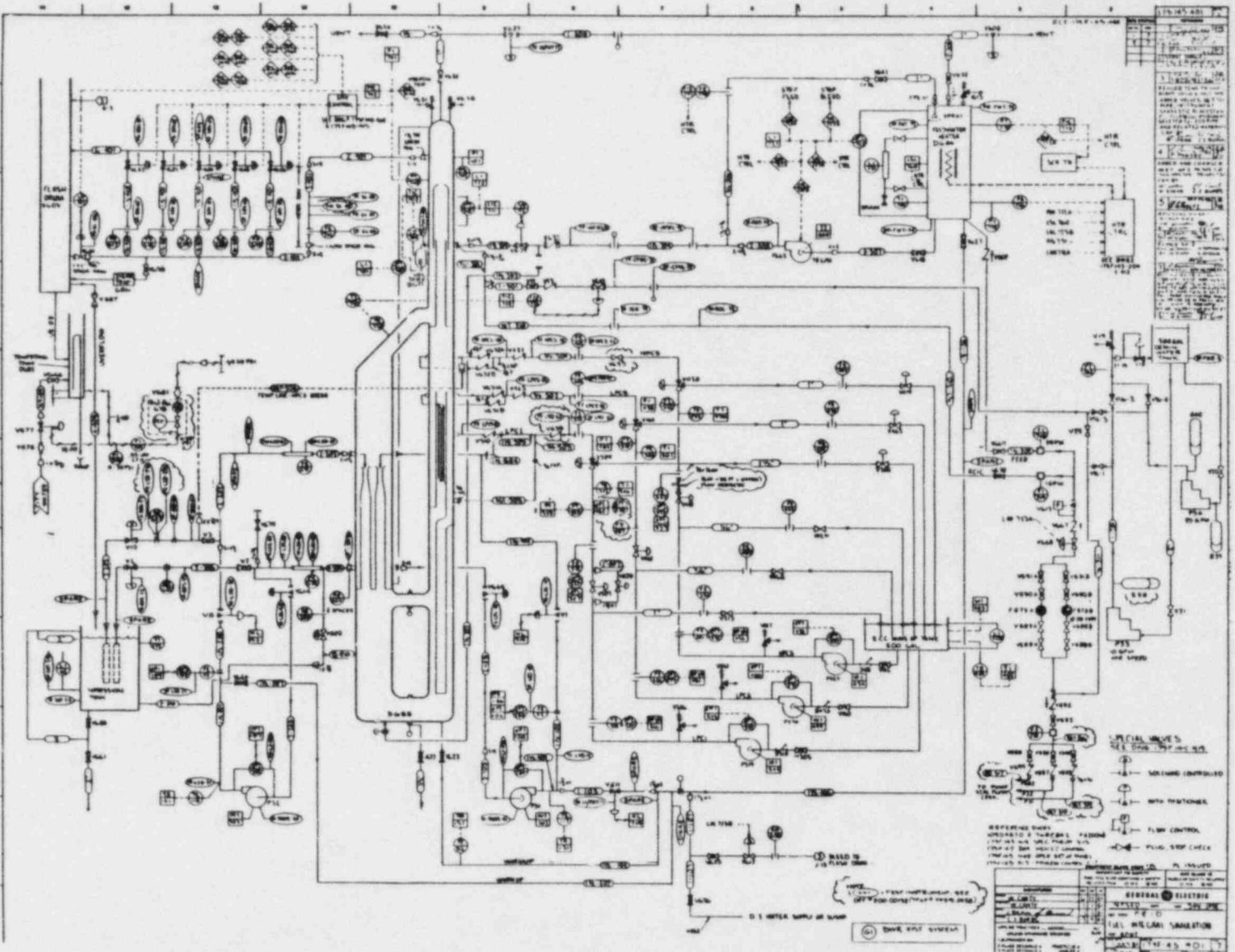

Figure 2-35. FIST Piping and Instrumentation Diagram

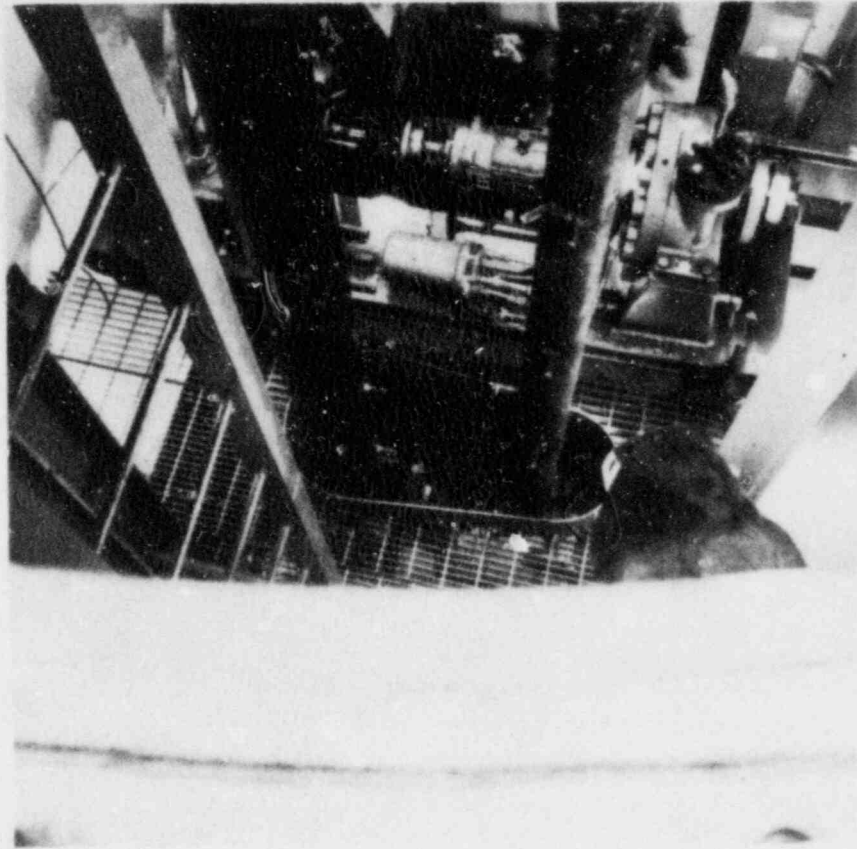

Figure 2-36 Recirculation Loop No. 2 Pump Installation

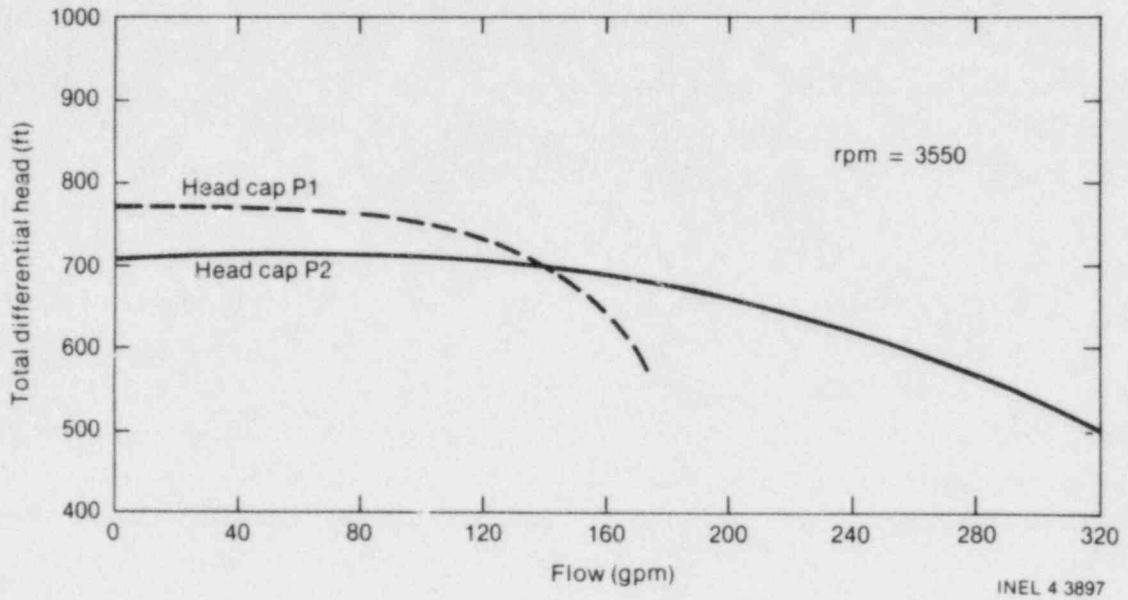

Figure 2-37 Recirculation Pump Head Flow Curves

indicated for the loop operator. The loop flows are controlled by a loop operator who uses pressure regulators supplying proportional signals to the air-operated control valves, V1 and V8. The control valves and the two loop isolation valves, V614 and V664, are provided with solenoid-operated pilot valves in the air-signal lines to permit rapid, remotely controlled isolation of the two loops from the test vessel. The four valves are located at distances along the piping from the test vessel specified such that contained fluid volume between vessel and valves corresponds to the scaled loop volume. This was done so that in large-break tests, when pump coastdown is over, the valves can be closed if desired, and the volume of flashing fluid between vessel and valves will be correctly scaled. Details on all the FIST control valves are given in Appendix D. Manual and relief valves are also covered there.

Large- and small-break LOCA experiment break nozzles and orifices are mounted in, or in blowdown piping connected to, loop No. 2. The large break suction nozzle is located in the downcomer-to-loop outlet connection (R0-663 in Figure 2-35). Thus initial condition flow is through this nozzle, through the drag disk/turbine meter break flow spool piece and then loop isolation valve V614 to the pump. The small-break connection is located in the same area: between the spool piece and the loop/blowdown line-206 tee. Further description of the blowdown system is contained in Section 2.1.5.

During startup, the loop pumps will be used to circulate water back to the feedwater heater through manual valve V624 at loop No. 2 and control valve V611 for loop No. 1.

The major design requirements for the loops are listed below:

1. Provide the necessary initial condition drive flow to the jet pumps so that the scaled BWR core flow is obtained
2. Provide the necessary coastdown drive flow to the jet pumps so that the jet pump flow coastdown characteristics are also simulated
3. Provide connections for blowdown piping and for warmup-return piping for startup
4. Provide the capability of isolating excess loop fluid from the test vessel.

2.1.3 Feedwater and Steam

The feedwater and steam equipment is shown in Figure 2-35. It consists of two tanks, three pumps and a substantial set of control valves, piping and process and experimental measurement and control instrumentation. The equipment can be grouped in terms of hot feedwater, cold feedwater and steam (line), the first and last of these being first purchased for FIST while the cold feedwater equipment was used previously in the TLTA test program. The list of applicable drawings includes ones from electrical, instrumentation, mechanical, piping, etc., all listed in Appendix A. Likewise, details of the equipment can be found in Appendix D and of the instrumentation in Appendix B and Section 2.2.1.1.

Figure 2-38 shows the feedwater heater to be located northwest of the test vessel in the structural support framework. The heater is supported by a cylindrical skirt bolted to the deck plate eight feet above ground level. The skirt encloses (and obscures view of) the bottom dished head of the heater pressure vessel. The vessel is designed for 1450 psig at 650°F under Section I of the Boiler and Pressure Vessel Code. The 900-gal vessel is almost 20 ft tall and incorporates 24 12.0-kW, 480-Vac cartridge heaters extending vertically upward into the vessel through the bottom head. Feedwater leaves the heater via a 3-in. outlet nozzle on the north side of the lower quarter of the straight length. It returns to the vessel through a bypass line from the feed pump discharge via a low flow meter (switch) and enters through the vessel's steam space spray nozzle.

The standard centrifugal hot feedwater pump is mounted at grade level and located directly beneath the feedwater heater. Figure 2-39 is the head-flow curve for that pump.

Several process inputs control heater power or feed pump power as described in Section 2.2.1.1. Hot feedwater flow to the test vessel is controlled by valve V609 operating off test vessel level.

The cold feedwater equipment provides flow through control valve V610 operating from the downcomer liquid temperature at the inlet to the expansion bellows spool piece. The cold feedwater equipment consists of the 500-gal demineralized water tank and two positive displacement pumps, P33 and P34. The pumps both take suction from the tank and their discharge piping is likewise interconnected so that either (or both) pump can supply flow to any of the three locations shown in Figure 2-35: cold feedwater, feed to the hot feedwater return line (10E), and for the reactor core isolation cooling (RCIC) line. The pumps and tank are mounted at

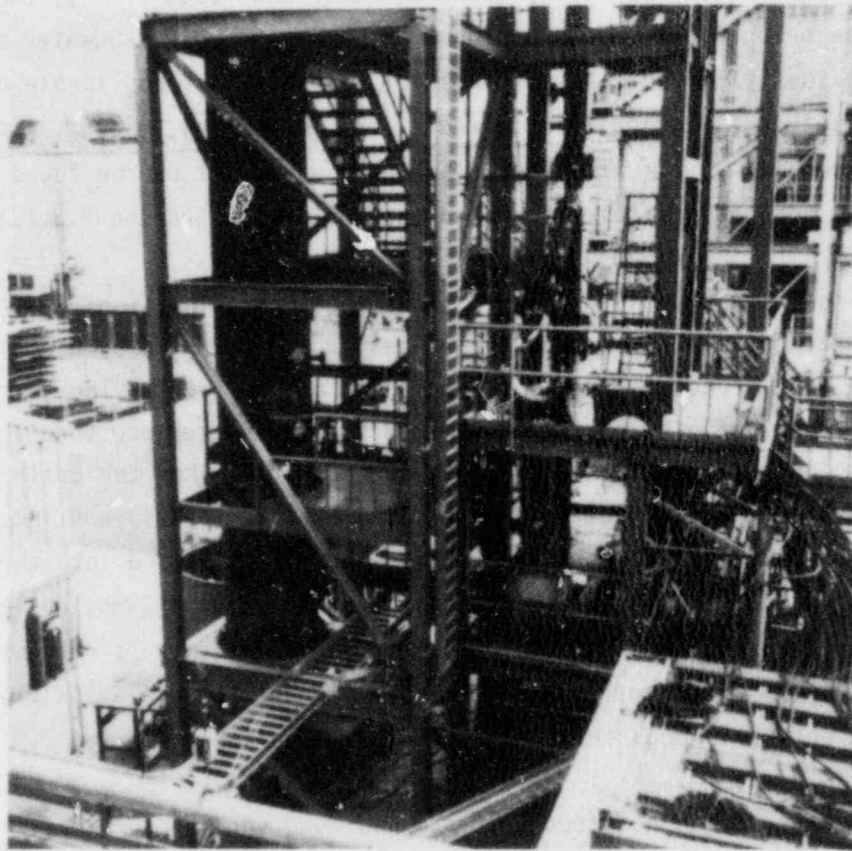

Figure 2-38 Feedwater Heater

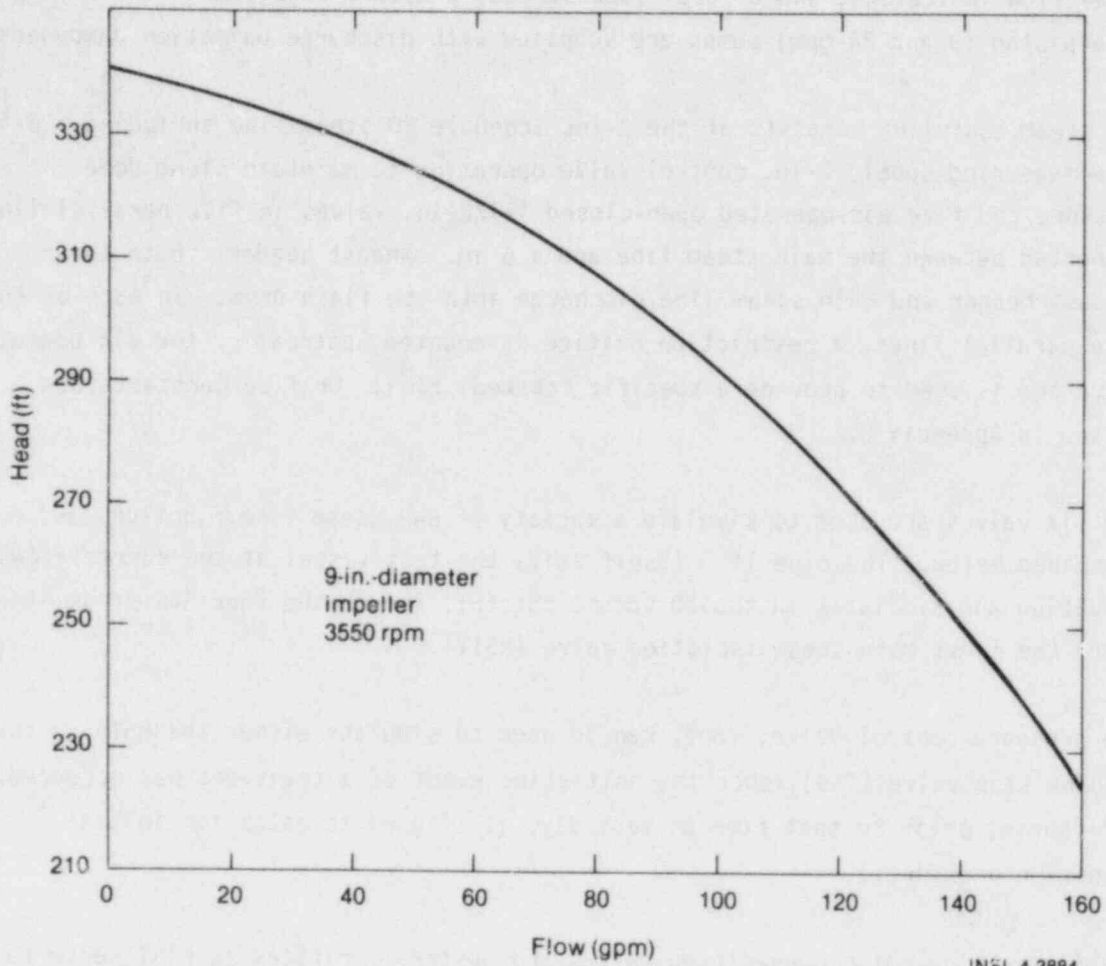

Figure 2-39 Hot Feed Pump Head Flow Curve

grade level, southeast of the test vessel, but west of the emergency core cooling equipment. Dual disposable-cartridge demineralizers and filters are located in the feed/RCIC supply line, along with on-off remotely operated feed valve V668 and local flow indicators, and a local (downstream) pressure regulator. The two- and five-piston (9 and 24 gpm) pumps are supplied with discharge pulsation dampeners.

The steam equipment consists of the 2-in. Schedule 80 steam line including a 3-in. flow measuring spool, 2-in. control valve operating to maintain steam dome pressure and five air-operated open-closed 1-1/2-in. valves in five parallel lines connected between the main steam line and a 6 in. exhaust header. Both the exhaust header and main steam line discharge into the flash drum. In each of the five parallel lines, a restriction orifice is mounted upstream of the air operated valve and is used to provide a specific (choked) flow. Orifice constants are listed in Appendix C.

The six valves are used to simulate a variety of BWR steam line functions as described below. The pipe line itself exits the test vessel at the correct (BWR) elevation and simulates in scaled volume but full length the four BWR steam lines, up to the first main steam isolation valve (MSIV).

The pressure control valve, V601, can be used to simulate either the MSIV or the turbine stop valve (TSV), once the initiating event of a transient has occurred. (Of course, prior to that time on test day, it is used to establish initial condition pressure.)

The five air operated open-closed valves and upstream orifices in FIST serve to simulate the 16 BWR safety relief valves (SRV), since the 16 can be separated by setpoint (process) pressure into five groups. The five orifices are sized to provide the total scaled flow relieved by the BWR valves in that setpoint pressure group. The key elements of the simulation are the discharge flow for each group and the opening/closing pressures. These are listed in Table 2-2.

As indicated in the table, there are two modes of BWR SRV operation, normal relief and low/low set relief. In the former, the valves close 100 psi below the opening pressure; in the latter, lower closing pressures are used, the option being available to the operator.

In addition to the SRV function, the group No. 5 BWR valves are used for the automatic depressurization system (ADS). Similarly in FIST, valve V606 is used to provide this function.

TABLE 2-2. BWR/6-218 SAFETY RELIEF VALVE OPERATION

FIST Valve Number	BWR Group	Normal Relief		Low/Low Set Relief	
		Number of Valves	Open/Close Pressure Setpoint (psig)	Number of Valves	Pressure Setpoint Open/Close (psig)
V602	I	1	1103/1003	1	1033/926
V603	II			1	1073/936
V604	III	8	1113/1013	3	1113/946
V605	IV			4	Non Low/Low Set
V606	V	7	1123/1023	7	Non Low/Low Set

Each BWR valve has a rated capacity of 925,000 lb/hr.
 Response time of SRV valve - Safety operation is 0.3 sec.

Finally, all six FIST valves will be used in a main steam line break simulation.

2.1.4 Emergency Core Cooling

The emergency core cooling (ECC) equipment consists of three systems that appear essentially identical on the P&ID, Figure 2-35. They are the high-pressure core spray (HPCS), the low-pressure core spray (LPCS) and the low-pressure core injection (LPCI). Each of the three systems consists of a pump, various piping runs containing remotely operable valves, and instrumentation to monitor and control the flow of the emergency coolant from a common supply tank to the test vessel. The ensemble was first designed, installed, and used on the TLTA program and has been taken over, in its entirety, for use on FIST. Only the final piping runs connecting the systems to the FIST vessel are new. The new injection locations of each system correspond to the reference BWR injection locations. Details of the pumps, motors, valves, and tank are contained in Appendix D and of the process and experimental measurements in Appendix B.

A description of the set up and calibration of the system is contained in Reference 4. The equipment is located, as it was for TLTA, approximately thirty feet to the southeast of the test vessel at grade level. It is, like the rest of the fluid systems, an outdoor, carbon steel, insulated system. The LPCI is a 1-1/2-in. system while the other two use 3/4-in. piping. The flat bottomed, covered, 500-gal supply tank houses six cartridge heaters used to heat the emergency coolant to the temperature (normally less than 125°F) specified for a given test. The tank is elevated 6 ft above grade to provide adequate suction head to the three horizontal shaft, multistage turbine pumps. Figure 2-40 shows the concept (and nomenclature) common to the three systems for meeting the essential system design requirements of simulating the BWR ECC head-flow characteristics at scaled flow using standard pumps normally available. Valves in the bypass, delivery, and return lines are positioned to provide the closest approximation to the BWR-ECC head-flow curve possible. Not all three of the "runout flow," "shut-off head," and "design point" conditions listed in Table 2-3 can be met, so in practice, the second and third points are attained and the first actual condition is accepted as is. Figure 2-41 shows resulting system performance measured during initial system installation. During a test, the three-way injection valve is closed to the test vessel before ECC initiation, thus providing an open path through the return line to the supply tank. This permits the operator to start the pumps and verify the ECC flow conditions before the time the flow is needed. ECC injection is started by switching a solenoid-operated pilot valve in the air signal line to the three-way valve and thus closing the

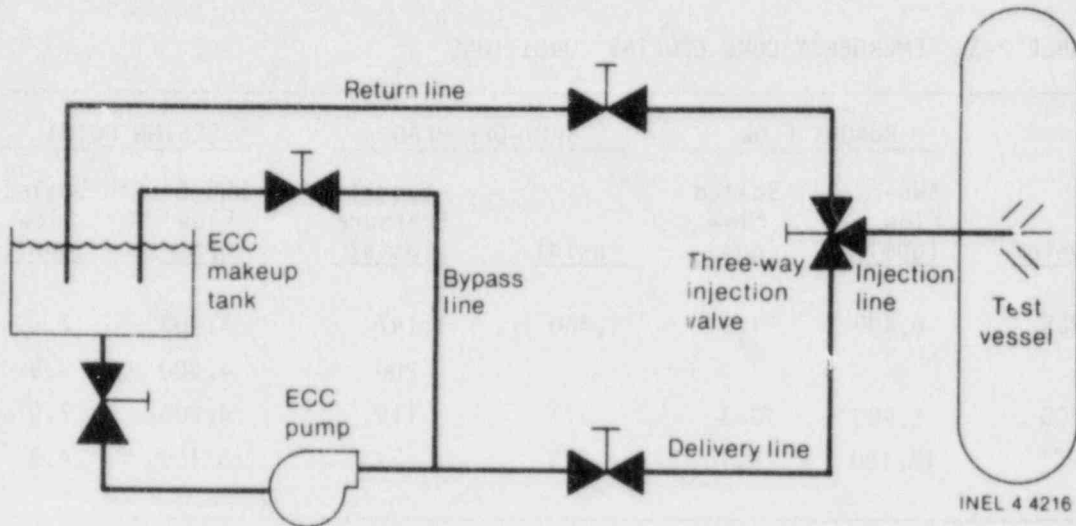

Figure 2-40 ECC System Schematic

TABLE 2-3. EMERGENCY CORE COOLING CONDITIONS

System	RUNOUT FLOW		SHUT-OFF HEAD		DESIGN POINT	
	BWR-6 Flow (gpm)	Scaled Flow (gpm)	(psid)	Vessel Pressure (psia)	BWR-6 Flow (gpm)	Scaled Flow (gpm)
HPCS	6,400	10.3	1,460	1,147	1,400	2.2
				200	4,900	7.9
LPCS	6,400	10.3	271	119	4,900	7.9
LPCI	18,180	29.1	229	24	15,150	24.3

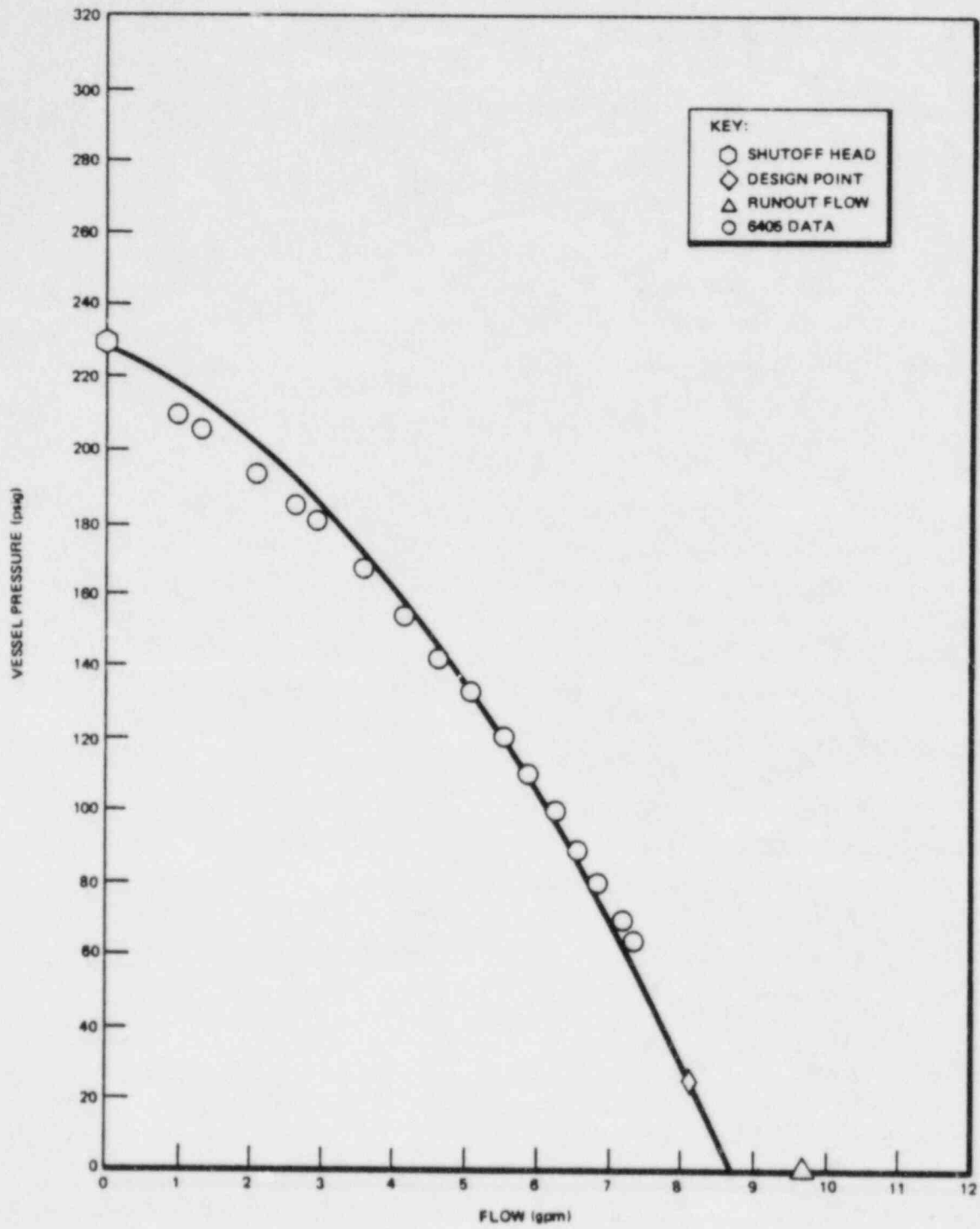

Figure 2-41. ECC System Performance

return line path and opening the path to the test vessel. When system pressure falls below ECC pressure, the check valves open and admit flow to the vessel. The process and control instrumentation occupies a separate single instrument cabinet in the control room.

2.1.5 Blowdown

The blowdown equipment consists of the suppression tank and the piping, control valves and instrumentation involved in initiating a LOCA transient and conducting the effluent from recirculation loop No. 2 to the tank where the generated vapor is condensed. Also discussed here is the flash drum and SRV discharge header, which perform a similar receiving (but not condensing) function for the steam system.

The suppression tank is an open, flat-bottomed, 1300-gal tank (mounted just north of the test vessel at grade level) containing cold water used to condense the blowdown flow. Like the ECC system, the tank was first used on the TLTA test program. The condensing capacity is only that of the contained water, no external cooling system is used. The 3-in., large-break blowdown suction line, the 2-in., large-break blowdown drive line, and the 1-in., small-break blowdown (suction) line all discharge into the tank under the normal initial liquid level. In the case of all three lines, a standard valve (modified to open quickly) is used to initiate the blowdown. Thus, the piping up to and including the valves experiences full system pressure. A nozzle or orifice upstream of the valves constitutes the break plane and it is here that critical flow is established. It is to be noted however, that in a BWR LOCA, the jet pump drive nozzle area limits and controls the drive line blowdown flow if the break area is larger than the nozzle area. Since the FIST jet pump nozzle area is overscaled, it is necessary to use an orifice scaled from the BWR (jet pump nozzle area) to obtain the correct break size and flow rate (see Table 2-4).

None of the blowdown measurements is useful over the entire range of conditions so a variety of techniques are employed. Direct blowdown flow rate measuring instrumentation includes a differential-pressure, liquid-level measurement on the suppression tank, measuring orifices in the blowdown lines (in addition the break flow orifices or nozzle), and turbine-meter, drag-disk spool pieces in the recirculation loop piping. Also, differential-pressure and conductivity-probe measurements are made across the suction line blowdown nozzle.

TABLE 2-4. BREAK NOZZLE SIZES

Test	Break Location	Break Area, ft ²		FIST Orifice Dia., in.	Initial Liquid Flow, lb _m /sec
		BWR	FIST		
DBA BWR/6	Suction	1.878	3.01E-3	0.743 ± 0.005	30
	Drive	0.348	5.6E-4	0.320 ± 0.005	6
DBA, BWR/4	Suction	4.14	7.39E-3	1.164 ± 0.005	74
	Drive	0.348	6.2E-4	0.337 ± 0.005	6
Small Break, w/HPCS	Suction	0.053	8.5E-5	0.125 ± 0.001	1
Small Break, No HPCS	Suction	0.053	8.5E-5	0.125 ± 0.001	1
Small Break w/SRV	Suction	0.053	8.5E-5	0.125 ± 0.001	1
Intermediate Break	Suction	0.2	3.2E-4	0.24 ± 0.02	3

The small-break blowdown line enters near the bottom of the suppression tank, as its elevation above ground level is maintained constant from its connection at the recirculation loop suction line over to the tank. The large-break lines enter the tank from above. The drive line blowdown piping does not exceed the elevation of its nozzle on the downcomer but the suction line blowdown piping does rise above its downcomer nozzle by 6 ft. While this suction blowdown piping does not exceed the top of the jet pumps (this does not affect FIST vessel refill differently from the BWR), the vertical section may act as an unsteady phase separator toward the end of blowdown and cause intermittent submergence of the blowdown nozzle. A similar problem in the small-break blowdown pipe is averted by supplying a small air flow to the piping downstream of the blowdown valve. The flow is adjusted to keep the suppression tank water out of the blowdown line.

The flash drum receives the main steam flow before blowdown initiation, the exhaust steam flow from the SRV header, (see Figure 2-42), the condensate from a small steam trap in parallel with the main steam valve, and the system bleed flow via control valve V612 during warmup operations. The drum is an open-top, closed-bottom, 24-in. pipe, 23 ft tall, located north of the test vessel. Steam flow from the system is vented to the atmosphere via the drum. Condensate collecting in the drum can be drained into the suppression tank directly beneath it. The drum and tank are clearly visible in the center foreground of Figure 2-1.

2.2 PROCESS AND EXPERIMENTAL PARAMETER CONTROL SYSTEMS

The controls are described here in terms of their general use in the experiment: (a) those process controls used to attain initial conditions, recover from the end-of-test condition, and perform routine auxiliary functions, e.g., feed and bleed, fill, drain, perform equipment checkouts, etc.; and (b), the controls used in the sequencing and timing of events specified for a given experiment and to vary the experimental parameters that may change from test to test, e.g., core power, break location and initiation, ECC use, and SRV/ADS involvement. The former controls are described as Process Controls in Section 2.2.1, the latter as Experimental Parameter Controls in Section 2.2.2.

2.2.1 Process Controls

The process controls consist of the instrumentation necessary to:

- (a) provide operator displays--both local indicators at equipment and remote indicators or recorders in the control room

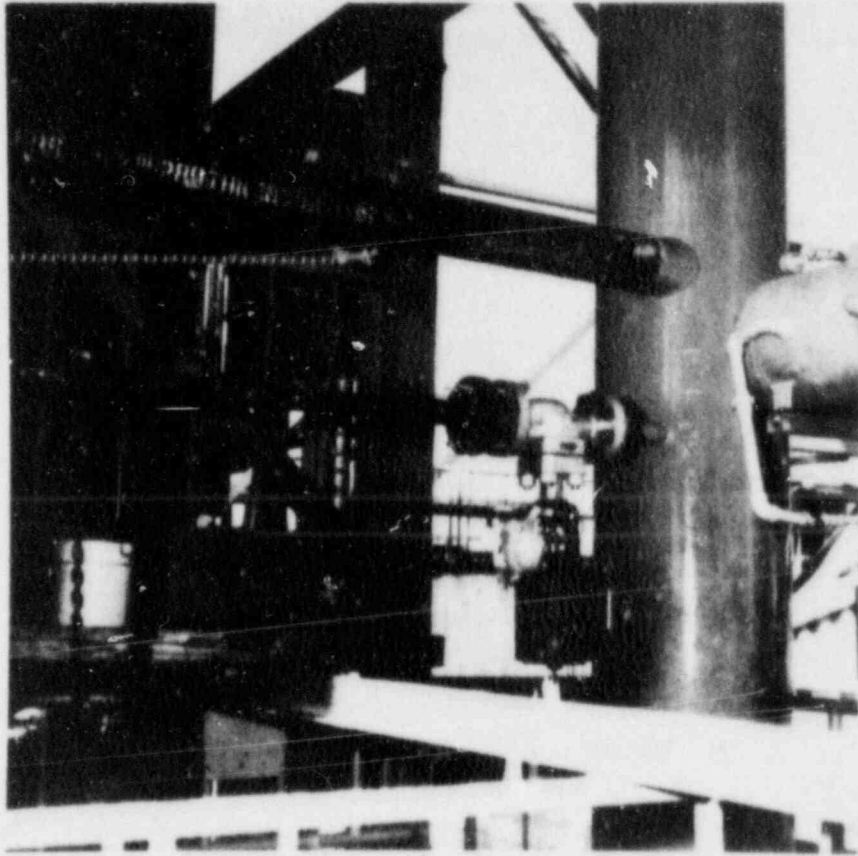

Figure 2-42 Pressure Control Valve and SRV Exhaust Header

- (b) control flows, pressures, levels and feedwater heater power--either manually by operators or automatically
- (c) provide automatic shutdown switching and alarm annunciation to ensure safe operation.

In general, these instruments and controls are separate and distinct from the experimental measurement system. The process controls are shown on the P&ID, Figure 2-35, and details are listed in Appendix B, Table B-4 Process Measurements. One of the process control consoles is shown in Figure 2-43.

2.2.1.1 Test Vessel Pressure, Liquid Level and Temperature. The major automatic control systems used in setting up initial conditions for an experiment are involved with the test vessel fluid conditions. Three separate and independent control loops are used. The test vessel (system) pressure is set by controller PIC-742, which adjusts the steam line control valve, V601, to maintain the pressure within the control band. The test vessel liquid level is set by use of controller LIC-711, which adjusts the hot feedwater line control valve, V609, to maintain the level. The third control loop maintains the downcomer water temperature control point valve by adjusting the cold feedwater control valve, V610. The controller is designated TIC-732. These control functions are described in Table 2-5 and details of all remotely operated valves are given in Appendix D, Table D-4.1 Remotely Operated Valves. The fluid temperature is measured in the downcomer at the expansion joint inlet and reflects the subcooled flows of hot and cold feedwater and the flow of saturated recirculation liquid from the separator. Redundant process indications are provided by the Heise gauge, PI-101, which is located in the control room, and the wide-range vessel level, LI-701, which covers the range from elevation 155 in the downcomer to 790 in the steam dome. The hot feedwater control valve level range extends from elevation 514 to 591 in the separated steam plenum. Corresponding experimental measurements exist for several of the process measurements, permitting on-line comparisons of the independent measurements to verify specific fluid conditions. These corresponding experimental measurements are identified in the Process Measurement Table noted above.

2.2.1.2 Feedwater. There are both hot and cold feedwater fluid systems and controls, the hot system being new for FIST, the cold system being used previously on TLTA.

The principal controls on the hot feedwater heater are the pressure control, PIC-773, which controls power to the 24 12.0-kW vessel cartridge heaters via an

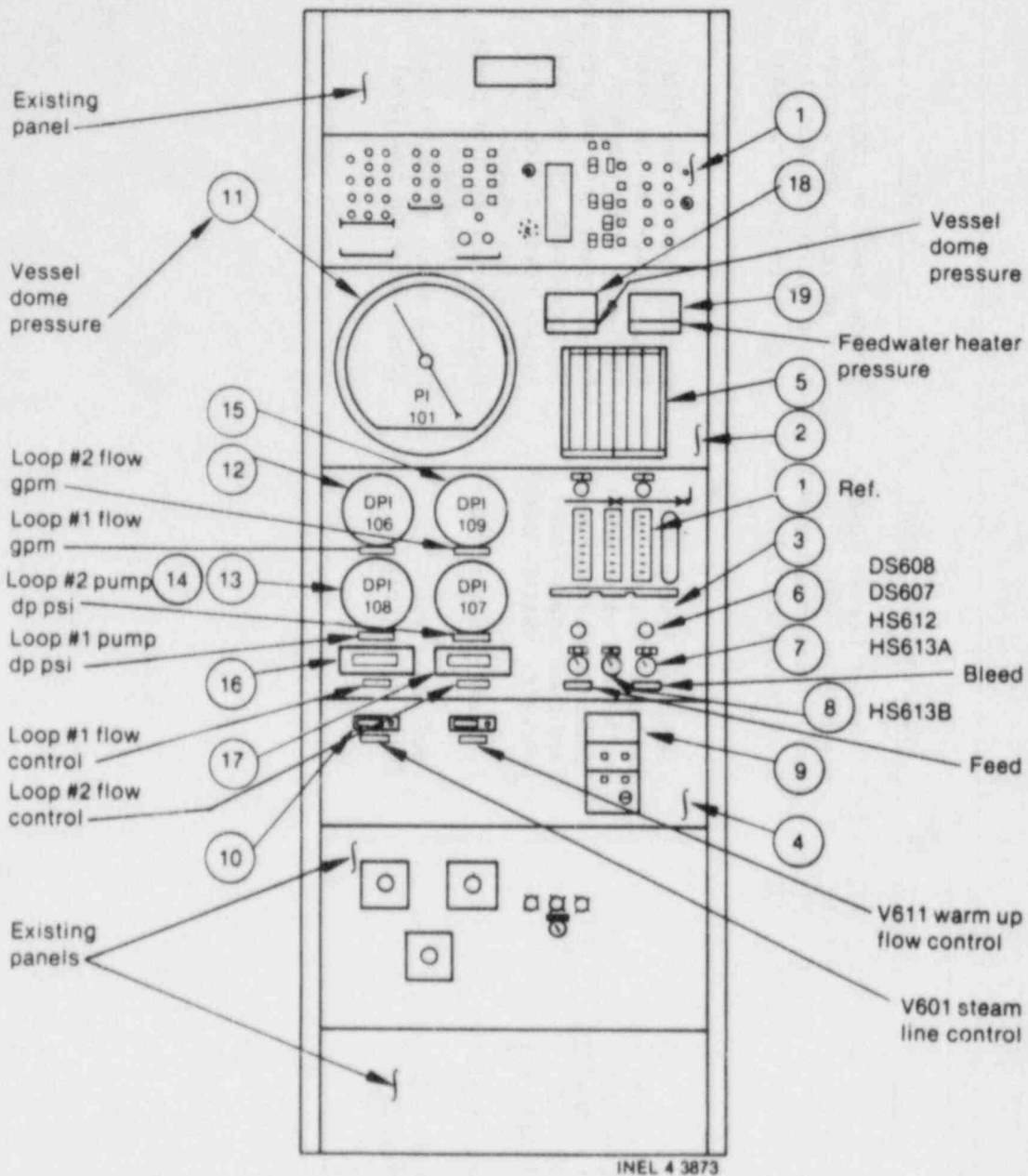

Figure 2-43 Process Control Console

TABLE 2-5. PROCESS CONTROL FUNCTIONS

Controller		Controlled Element	Action
Name	ID		
Feedwater Heater Pressure	PIC-773	Feedwater Heater Power	Reduce power on incr. press.
Test Vessel Pressure	PIC-742	Steam Valve V601	Open valve on incr. press.
Test Vessel Level	LIC-711	Hot Feedwater Valve V609	Close valve on incr. level
Downcomer Temperature	TIC-732	Cold Feedwater Valve V610	Open valve on incr. temp.
Contacts			
Feedwater Return Low Flow FIS-791		Feedwater Heater Power	Reduce power on low flow
Feedwater Heater Low Level LAL-725B		Feedwater Heater Power	Reduce power on low level
Feedwater Heater High Level LAH-722A		Feedwater Heater Power	Increase power on high level
Feedwater Heater High Pressure PAH-772A		Feedwater Heater Power	Reduce power on high pressure
Feedwater Heater Low Level LAH-722B		Feed pump motor Power	Shutdown pump on low level
Feedwater Heater Low Level (Float) LSL-760		Feedwater Heater Power	Reduce Power on low level (redundant)
Feedwater Heater High Pressure PS-776		Feedwater Heater Power	Reduce power on high press. (redundant)
Feedwater Heater High Level LAH-723A		Feed valve V668	Close valve on high level
Feedwater Heater Low Level LAL-723-B		Bleed valve V612	Close valve on low level

2-72

GEAP-22054

SCR power controller, and the heater liquid level, DPT-720, which controls heater and feed pump trips and feed and bleed valves as described below. The heater operates to provide feedwater at the saturation temperature corresponding to the PIC-773 control point pressure. If the pressure, measured by transmitter PT-770, exceeds the setpoint value on switch PAH-772A, the power to the heaters is turned off. The mechanical pressure switch, PS-776, mounted locally at the heater, provides a redundant shutdown function. As shown in Figure 2-35, pressure is one of the three experimental measurements (fluid temperature and liquid level are the others) made on the feedwater heater.

The heater liquid level transmitter provides a signal for control room indication (LI-721) and for comparison against five switch setpoints: on low level, feed pump power is disabled (LAL-722B), cartridge heater power is interrupted (LAL-725B), and bleed valve V612 discharging system fluid to the flash drum, is closed (LAL-723B). On high level, feed (or RCIC) valve V668 admitting cold feedwater to the heater is closed (LAH-723A). Backup indication of heater liquid level is provided by the sight gauge, LI-750; local liquid temperature (TI-780) and pressure (PI-775) measurements at the heater are also provided, all as required by the ASME Boiler and Pressure Vessel Code. A redundant mechanical level (float) switch (LSL-760) is provided to shut off cartridge power on low level. An orifice is mounted in the bypass line from the feed pump discharge back to the feedwater steam space spray nozzle. An associated flow indicating switch (FIS-791) disables cartridge heater power on low flow. Hot feed pump on-off switch, motor current ammeter and cartridge heater switch, and power-meter are located at the control cabinets.

As noted earlier, cold feedwater mixes with the hot at the feedwater nozzle on the test vessel. The cold feed flow rate is adjusted by control valve V610 to provide the downcomer control point temperature set into controller TIC-732. The flow of cold feedwater comes from the demineralized water tank via pump P34. The excess flow provided by the constant speed piston pump, over that permitted by the control valve, is dumped back into the water tank by (upstream) pressure controlled valve, V18.

2.2.1.3 Recirculation Loops and Warmup Operations The recirculation loop centrifugal pumps provide the drive flow for the jet pumps. The centrifugal pumps are driven by constant speed motors and coastdown has been addressed by adding flywheels to the motor/pump installations, so the only control involved with the pumps is the on-off power switches. The head across each centrifugal pump is

indicated in the control room, as is the motor current, fluid discharge temperature, and loop flow. Pump speed and loop flow are recorded on the experimental data system.

The loop flows are controlled by the operator using the control valves V1 and V8 and the flow indicators, DPI-106 and DPI-109. The valves are positioned by adjusting the air pressure using regulators HL-715 and HL-155 mounted at the control console.

During system warmup, the recirculation loops are operated and contribute to the warming of the piping and test vessel. The feedwater heater is used as the main source of heat; the core is not used. Flow from the feedwater heater is routed to the test vessel. The flow is returned to the heater from three locations: recirculation loop No. 2 via manual valve V624; from recirculation loop No. 1 via control valve V611 (hand loader HL-714 at the control console); and from the bottom of the test vessel via manual valve V623. Control valve V607 and manual valves V633 and V635 provide a means of having a common or single vapor space for the test vessel and feedwater heater during joint operation.

A feed and bleed system is used to clean up the system water inventory during initial warmup and between test periods when operating at reduced pressure and temperature. Approximately 2 gpm of demineralized water is injected into the feedwater heater return line, through the use of valves V668, V613, and V669. The first valve shuts off feed flow on high feedwater heater level as noted above. The second listed valve is a regulator used in conjunction with the local rotameter to set the desired flow rate, and the third one is a manual block valve. Adjustment of the control valve V611 balances flow from the test vessel back to the feedwater heater. Manual valve V625 and control valve V612 operate with a restriction orifice, RO-630, in bleeding the equivalent 2 gpm of flow from the test vessel to the flash drum. V612 closes on low feedwater heater level as noted above.

2.2.2 Experimental Parameter Controls

These controls are initiated during a test by the programmable logic controller. The controller consists of (a) input modules that detect operator actions and monitor facility conditions (e.g., test vessel liquid level), (b) output modules that actuate field devices (e.g., open SRVs), turn on panel lights and sound annunciators, and (c) a sequencer that contains the ladder diagram. The diagram is programmed into the sequencer based on the desired operating conditions and

test specification. The program actuates output modules based on the actuation of input devices. The output events can be timed (delayed relative to an input) and sequenced as required, and all events can be initiated from a "Start Test" pushbutton.

2.2.2.1 Core Power The core power controller (an Iveron Model 2100 A Analog Events Programmer) is a control room module that drives the bundle current, hence power, downward along a preprogrammed adjusted decay heat curve, e.g., as shown later in Figure 3-5. Initiation of control is by the sequencer described above. The Iveron converts the discrete input times and percentages into an analog signal sent to the core power supply control circuits at the Atlas loop. This is an open-loop control mode; no feedback of heater-rod temperature, core flow, or void conditions are involved.

2.2.2.2. Emergency Core Cooling. The ECC control cabinet is shown in Figure 2-44. The principal controls are for the pump motors and the three-way valves that enable ECC flow into the test vessel. The HPCS, LPCS, and LPCI system flows are established before injection time with the water being recycled back to the ECC tank. On a signal from the programmable controller, the three-way valves change positions so that the ECC can flow to the test vessel. Note that flow to the vessel does not start at valve actuation but only after the system pressure falls below the ECC pressure, due to the presence of check valves between the three-way valves and the test vessel nozzles. The operator controls the ECC temperature. Heater power and pump motor power are indicated in the control room as are pump heads, control valve positions and supply, delivery and injection flow rates, delivery pressures and temperatures. Injection flows and temperatures are also recorded on the experimental measurement system.

2.2.2.3 SRV/ADS. The operator setup panel includes the SRV/ADS controls and is shown in Figure 2-45. Applicable drawings for the SRV control include 179F145-405 and-413. The reactor system relief valves are simulated by the five on-off control valves V602 through V606 and associated restriction orifices RO-617 through RO-621. The air-operated valves are actuated by solenoid-operated pilot valves in the air lines that in turn receive their signals from the test vessel pressure transmitter PT-740 via the programmable logic controller. The controller sequences and times the openings and closings of the main valves relative to normal and low/low relief modes as in a BWR. Valve V606 is also used for the automatic depressurization system and for steamline breaks through the logic controller. Selection of the "auto" mode (in either the SRV/ADS or valve control

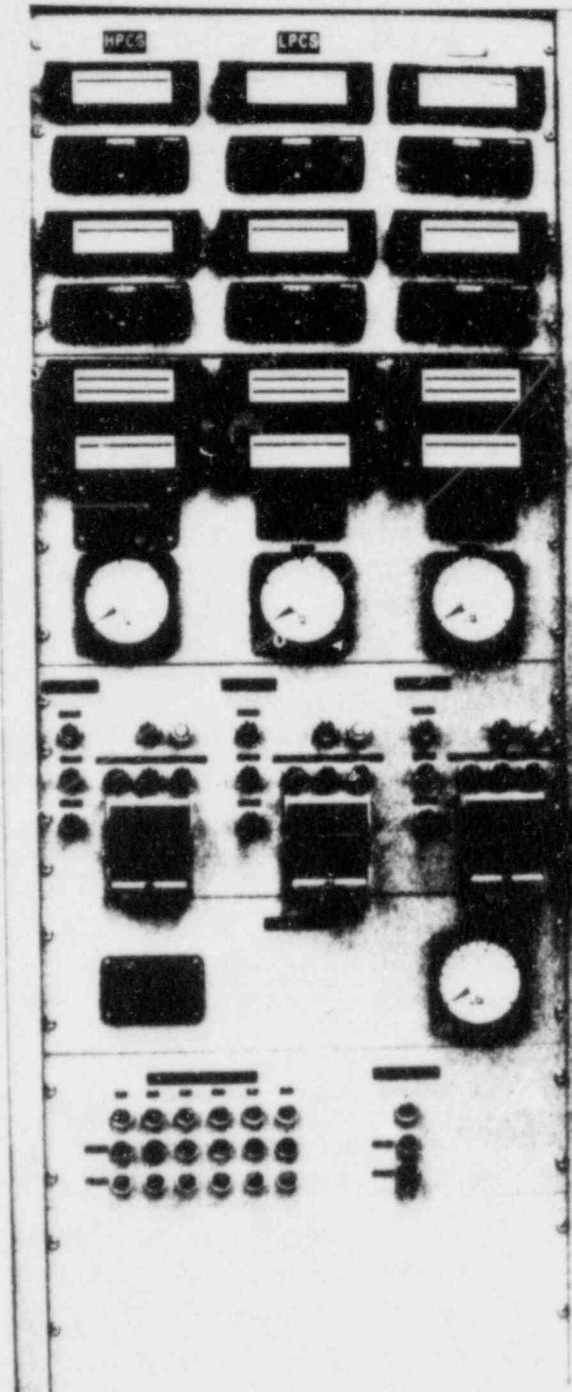
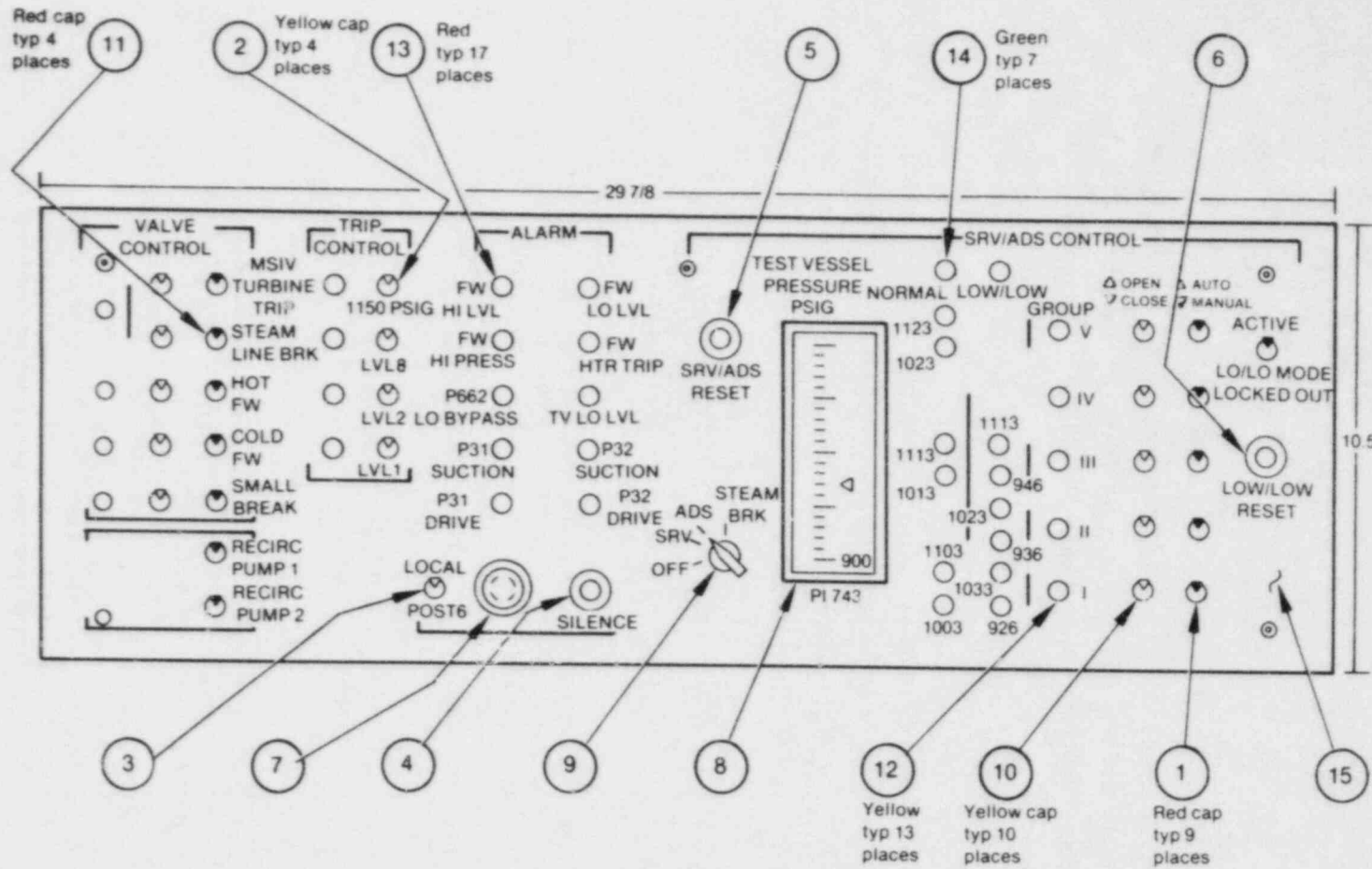

Figure 2-44 Emergency Core Cooling Console

2-77



GEAP-22054

INEL 4 3885

Figure 2-45 Operator Setup Panel

sections of the setup panel) places the selected device under control of the logic controller. "Manual" mode removes the device from the controller and also permits opening/closing of the valves manually. Indicator lights show which valves are open or closed.

2.3 EXPERIMENTAL MEASUREMENTS

The experimental measurements are those obtained to satisfy the program objectives. They will ultimately appear as the body of experimental data describing the phenomena occurring in FIST and against which TRAC calculational results can be compared in an effort to establish the validity and improve the usefulness of that code.

In the design of the measurement system, certain objectives were established on the basis of the program objectives and also on the basis of the measurement experience gained in earlier programs, e.g., TLTA and SSTF. These consist of both general and specific statements that are listed below.

1. Measure the bundle temperature distribution in order to determine the times and location of the onset of boiling transition (BT) as well as the post-BT temperature distribution.
2. Measure the global pressure and distribution system pressure response and obtain sufficient data in order to calculate, as practically as possible, the mass inventory and energy balance of the total system and of key components including the bundle, bypass, lower plenum, guide tube, upper plenum, downcomer, and separation region.
3. Measure the local fluid conditions of two-phase level (or approximate void fraction) and temperature where practical within the system regional volumes, e.g., lower plenum, upper plenum, downcomer, bundle, bypass, and steam dome.
4. Measure local fluid conditions of level and temperature at particular elevations such as the core side entry orifice, lower tie plate, upper tie plate, core plate, jet pump tailpipe discharge, blowdown line suction nozzle inlet, and normal downcomer level.
5. Measure the primary flow rates crossing the system boundaries with sufficient accuracy to enable performing a system mass balance. These flows include blowdown flow, steam line flow, ECCS flows, and feedwater flow.
6. Measure the flow rates within the system internals during normal flow and high flow conditions, and where practical, during low flow conditions. These include loop flows, jet pump forward and reverse flows, bypass flow, bundle flow, and separator flow.

DOCUMENT/ PAGE PULLED

ANO. 8410120002

NO. OF PAGES 1

REASON

PAGE ILLEGIBLE:

HARD COPY FILED AT: PDR CF
OTHER _____

BETTER COPY REQUESTED ON _____

PAGE TOO LARGE TO FILM.

HARD COPY FILED AT: PDR CF
OTHER _____

FILMED ON APERTURE CARD NO. 8410120002-01

7. Make sufficient temperature measurements to enable evaluation of heat loss to atmosphere from the major sections of the vessel system.
8. Provide measurements and calculations needed in the process of assessing whether or not test acceptance criteria have been met. For example, initial conditions such as bundle flow and inlet enthalpy, bundle power, system pressure and vessel liquid level are needed along with experimental parameter measurements and initiation time, etc.

To attain these objectives a measurement plan was developed which placed major reliance on working with simple, dependable instruments and using the measurement expertise developed in prior programs to obtain the maximum amount of information from them. Figure 2-46, the test vessel instrumentation drawing, shows the experimental measurements planned for the test vessel. The measurement indentifications are given in the rectangular boxes and the dots show the elevation and component in which the measurement is made. Process measurements on the vessel are denoted by circles in the figure. Test vessel regions are noted in the figure and cross sectional views are shown to document the asymmetry and configuration of interior components as described earlier in Section 2.1. Explanation of the measurement indentification code is given in Appendix B, Tables B-1 and B-2; the experimental measurements are listed and described in Table B-3, and the process measurements in Table B-4.

Tables 2-6 and 2-7 summarize the 426 experimental measurements. The first table gives a percentage breakdown by parameter and also includes information on spare channels. Table 2-7 gives a breakdown by parameter and region.

2.3.1 Transducers and Signal Conditioning

The term, transducers, is used here in the generic sense that any device is a transducer if it provides an output signal which is reproducibly related to a measurable parameter such as pressure, temperature, etc. The transducers involved here can be grouped according to whether they are considered to have a class-common relation between the parameter and the output signal (e.g., thermocouples) or require individual constants in the engineering units conversion relation, such as differential pressure transducers. The signal conditioning equipment consists of those modules needed to provide power to the transducer and/or condition the transducer output signal in a way necessary for presentation to the data acquisition system.

TABLE 2-6. FIST EXPERIMENTAL MEASUREMENT SUMMARY

<u>Parameter</u>	<u>Number of Measurements</u>	<u>% of Total</u>	<u>Channel Number</u>	<u>Spare Channel</u>
Pressure	8	1.9	0-11	4
Differential Pressure	126	29.9	12-143	6
Miscellaneous	32	7.5	144-175	0
Conductivity	45	10.1	192-239	3
Material Temperature	21	4.9	256-277	1
Fluid Temperature	82	19.3	278-367	8
Heater Rod Temperature	112	26.3	368-479	0
Blank Spare	-	-	176-191;480-495	32
Not Available -32	-	-	240- 55; 496-511	—
	426	100%		54
Summary of ADC Channels		Measurements	- 426	
		Space	- 54	
		Unavailable	- 32	
			<u>512</u>	

TABLE 2-7. MEASUREMENT DISTRIBUTION BY PARAMETER AND REGION

<u>Region</u> <u>Test Vessel</u>	<u>P</u>	<u>TF</u>	<u>AN</u>	<u>NO^a</u>	<u>DP</u>	<u>CP</u>	<u>TW</u>	<u>TC</u>	<u>Other</u>	<u>Total</u>
DC	1	12	1	1	14	12	3	-	-	44
JP	-	6	2	4	8	2	-	-	-	22
LP	2	14	3	1	10	10	5	-	-	45
GT	-	4	-	-	3	1	-	-	-	8
BUIN	-	4	1	1	1	1	-	-	-	8
BU	-	3	-	-	9	1	6	112	8	139
BP	-	10	-	1	5	3	3	-	-	22
UP	1	4	-	-	4	3	2	-	-	14
SP	-	1	1	-	2	1	-	-	-	5
SEP	-	1	-	1	1	-	1	-	-	4
SSP	-	1	-	-	4	1	-	-	-	6
DS	-	2	-	-	4	6	-	-	-	12
DRY	-	-	-	-	1	-	-	-	-	1
SD	1	2	-	-	1	-	1	-	-	5
SM	-	-	-	-	1	4	-	-	-	5
Between Regions	-	-	-	16	5	-	-	-	-	21
	5	64	8	25	73	45	21	112	8	361
<u>External</u>	3	18	-	17	3	-	-	-	24 ^b	65
<u>Total</u>	8	82	8	42	76	45	21	112	32	426

a. Nozzles and orifices

b. Fourteen of these are valve stem position indicators

2.3.1.1 Flow. All of the flow measurements in the FIST facility involve the use of differential pressure transducers except for two turbine flow meters and two cooled-thermocouple, low-flow velocimeters. There are three types of devices in FIST used to determine the flow rate of a single-phase fluid (by measuring the differential pressure developed across it): Annubars, measuring orifice plates at flanged connections in pipelines, and nozzles or interior orifices within the test vessel. There are 8 Annubars, 14 external-orifice plates in incoming and outgoing lines, 24 nozzles and orifices interior to the test vessel and 3 blowdown/break plane nozzles and orifices. The 14 external-orifice plates are expected to experience only single-phase conditions. The Annubars and interior nozzles and orifices will normally be subject to a time during a test after which two-phase-fluid conditions will exist, but single-phase conditions are expected prior to that time. Once the two-phase condition appears, the flow rate calculated from the measured pressure, temperature, and differential pressure is, in general, not correct and so caution must be exercised in the interpretation of such flow measurements. This is also true of the turbine flow meters and the cooled-thermocouple, low-flow velocimeters.

An Annubar drawing is shown in Figure 2-47. It is an intrusive probe that samples the upstream velocity profile at four selected locations, averages the dynamic pressures there, also samples the downstream pressure, and provides the two (pressures) to a differential pressure transducer. As with the other devices, the square root of the product of this differential pressure and the upstream fluid density is basically proportional to the mass flow rate. As noted in the figure, two of the eight stainless steel units are installed in special noncircular flow cross sections. These units require in situ calibration to determine their flow coefficients. The Annubars may be used to also determine flow in the reverse direction although such use also requires an additional calibration and probably still does not produce so accurate nor reproducible a measurement as in the manufacturer's intended flow direction. The two jet pump tailpipe Annubars, AN6 and AN7, were checked in a ballistic calibrator at the INEL.

The orifice plates (usually 1/8-in. thick) are mounted between flanges and centered on the pipe flow area. The flanges are provided with pressure tap connections to which are attached the sense line tubing runs, which end at the differential pressure transducer. The orifice plates are of the sharp-edge type and, where possible, are installed in a manner conforming to ASME fluid metering recommendations concerning upstream and downstream straight pipe runs. Orifice

APPLIED PRACTICES SURVIVAL DESIGN PRACTICES
 TITLE: MODIFIED "ANNUBAR"
 FIRST MADE FOR FINAL INTEGRATION SIMULATION TEST (FIST)
 FCF: 181F145-000

SPECIFICATIONS:

STANDARD MODEL 75 ANNUBAR FOR HORIZONTAL PIPE (INTERNAL TUBES NOT TWISTED)
 EXCEPT: 1. DELETE ALL VALVES AND FITTINGS (SENSE LINES WILL BE CONNECTED TO CLEANOUT HOLES)-REQUIRES SPECIAL SENSOR HEAD WITHOUT TAPS FOR VALVES
 2. DESIGN PRESSURE : 2000 PSIA MINIMUM
 3. DESIGN TEMPERATURE : 900°F MINIMUM
 4. DIMENSIONS - SEE TABLE. VENDOR STANDARD TOLERANCES ON DIMENSIONS ARE ACCEPTABLE

APPLICATION:

1. FLUID : WATER/STEAM
2. OPERATING FLOW : SEE TABLE
3. OPERATING PRESSURES : 14.7 TO 1050 PSIA
4. OPERATING TEMPERATURES : 50°F TO 550°F (EXCEPT 900°F MAX ON MODEL E)
5. MOUNTING HARDWARE : 1 IN. SWAGelok CAT. NO. 55-1610-1-16-BT

NOTES:

1. VENDOR TO SUPPLY CALIBRATION COEFFICIENTS AND EXPECTED DIFFERENTIAL PRESSURE FOR THE FOLLOWING CONDITIONS-ASSUME CIRCULAR FLOW CROSS SECTION FOR ALL CALCULATIONS AND NORMAL FLOW DIRECTION
 A. NOMINAL FLOW CONDITIONS FROM TABLE
 B. MASS FLOW RATE FROM TABLE EXCEPT ALL SUBCOOLED WATER 25 PSIA, 68°F
 2. TYPICAL INSTALLATION SHOWN-ALTERNATE INSTALLATION USES TAP IN SPACER RING BETWEEN FLANGES ON PRESSURE VESSEL
 3. DELETE VENT HOLES (A)

MODEL	"X"	"Y"	"Y" FLOW PATH	DESIGNATION	NOMINAL FLOW CONDITIONS 1050 PSIA 525°F WATER EXCEPT MODEL E
A	10.0	4.813	5" SCH. 80 PIPE	FE-LPJ-AN 1	130,000 LB/HR WATER
B	10.0	1.717	SPECIAL NON-CIRCULAR CROSS SECTION	FE-LPB-AN 2	130,000 LB/HR WATER
C	15.0	2.632	SPECIAL NON-CIRCULAR CROSS SECTION	FE-CORIN-AN 3	130,000 LB/HR WATER
D	10.0	3.826	4" SCH. 80 PIPE	FE-DC-AN 4	130,000 LB/HR WATER
E	15.0	3.624	TUBE I.D.	FE-SP-AN 5	130,000 LB/HR 20% OL. SAT. STEAM/WATER
F	12.0	1.685	SPACER RING I.D.	FE-JP1-AN 6	65,000 LB/HR WATER
F	12.0	1.685	SPACER RING I.D.	FE-JP2-AN 7	65,000 LB/HR WATER
G	12.0	3.826	4" SCH. 80 PIPE	FE-LPJ/J-AN 8	13,000 LB/HR WATER

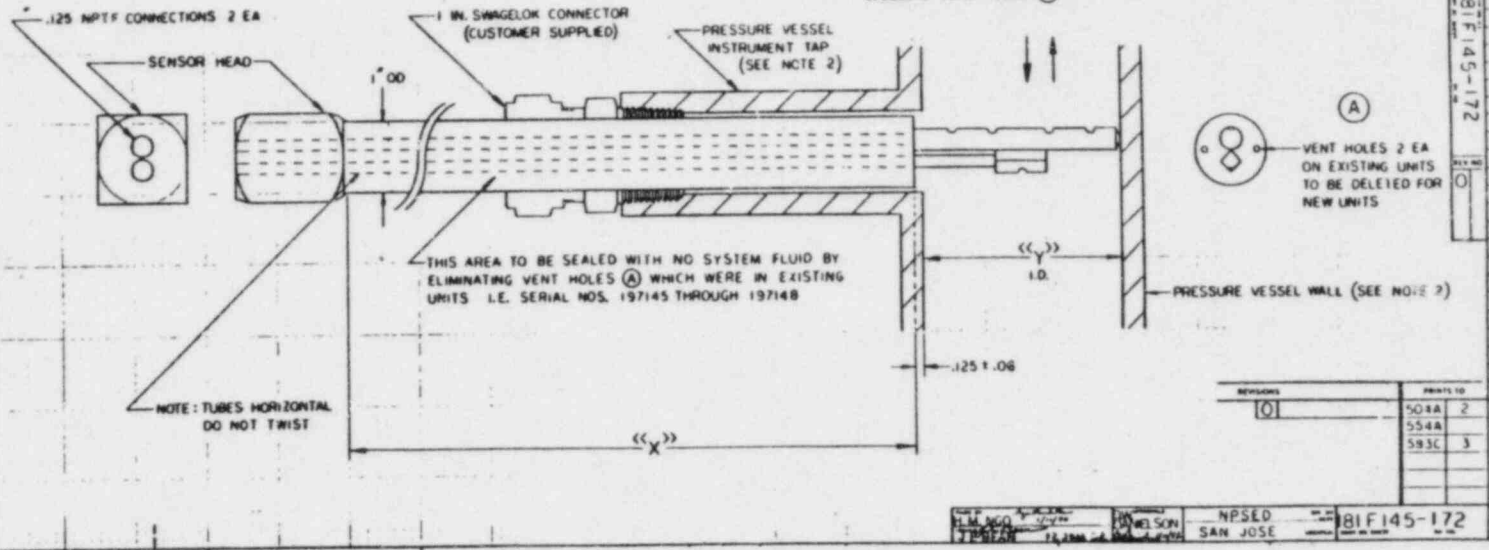

Figure 2-47. Annubar

2-84

GEAP-22054

plate and Annubar dimensions, serial numbers, etc. are listed in Appendix D Table D-8.1, Sensors Having Individual Calibrations.

The nozzles and orifices interior to the test vessel are not basically installed as flow measuring instruments, but rather are installed to control or restrict the flow. However, by incorporating differential pressure measurements across them and performing an in situ calibration, the flow coefficients for most devices can be determined and used subsequently to calculate flow rates during that part of a test when the fluid state is known.

The two full-flow turbine flow meters are part of two break flow instrumented spool pieces (one 2 in., one 3 in. IPS) purchased from Measurements, Incorporated and were used previously on TLTA. They were refurbished and calibrated at room temperature in the INEL ballistic calibrator before being reinstalled for use in FIST. The cooled-thermocouple, low-flow probes are installed in the lower plenum and bundle inlet areas to provide flow rate data during small-break and natural-circulation-flow conditions. They are intrusive probes that use a constant flow of room temperature instrument cooling water and operate on the relation of the heat-transfer coefficient, between the process fluid and the cooling water, to the velocity of the process fluid. The measurement was developed at the INEL and the two units used in FIST were built there.

2.3.1.2 Pressure and Differential Pressure. FIST system pressures are measured by Rosemount Model 1151GP pressure transducers. Differential pressure measurements are made primarily by Rosemount Model 1151DP and (several) Statham Model PDH Series 3000 current output transducers. The few voltage-output transducers used are Statham Model PM 385TC, BLH Model HHD, or Straindyne Model DPT2.0-1000. Figure 2-48 shows a set of transducers awaiting calibration. The units are processed at the site on a Fluke automated-calibration machine. The initial range over which each transducer was calibrated is given in Appendix B, Table B-3. If the ranges are found too large or small during facility checkout testing, the units are recalibrated over a more appropriate range. The main body of transducers are of the 4-20 ma or 10-50 ma output types. The voltage drop across a precision resistor subjected to the 4-20 ma current is presented to the data acquisition system. A typical resistor value is 400 ohms, so that with zero differential pressure across the transducer, the measured voltage drop ("instrument zero") is 1.6 V, while at full-scale pressure difference, the measured voltage drop is 8.0 V. Standard transducer ranges are 30-, 150-, and 750-in. H₂O and 100, 300, and 1000 psid. The Statham current output units have

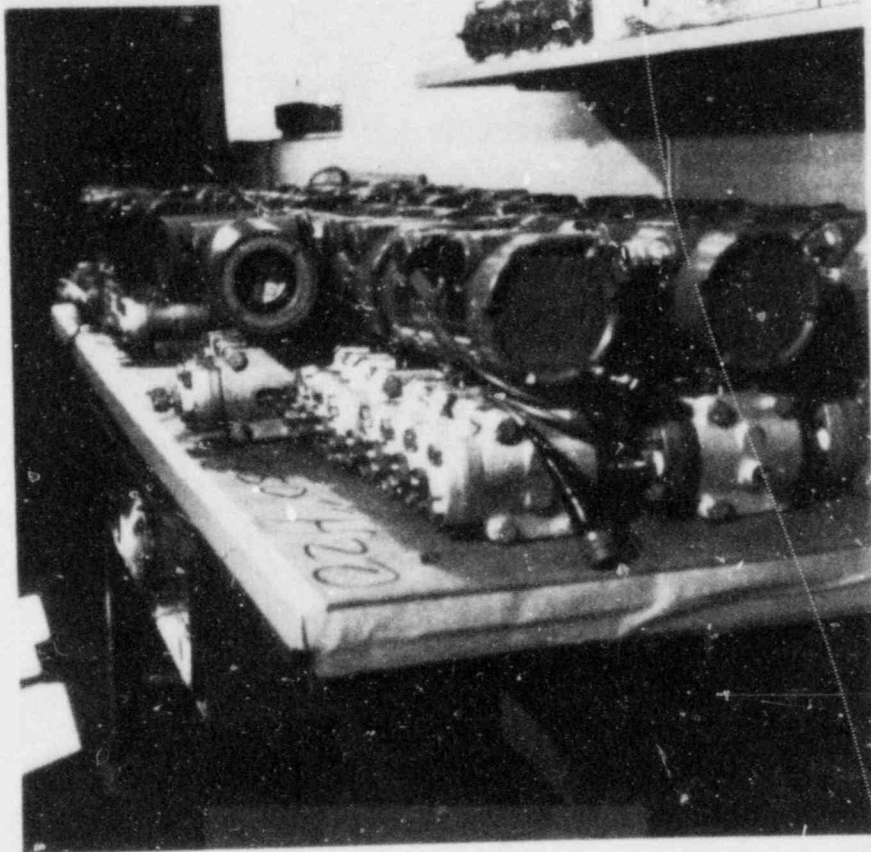

Figure 2-48 Differential Pressure Transducers Awaiting Calibration

ranges of 100-, 200-, 400-, and 750-in. H₂O and 100, 1000 psid. The absolute pressure transducers have a 1500-psi range. Transducers installed or calibrated and ready for use are listed by range and output in Appendix D, Table D-6.1. Figure 2-49 shows the standard installation of a FIST differential pressure transducer. Demineralized water is connected at the transducer to purge air from the sense lines into the facility. Note particularly that the normal manual equalizing valve is replaced by a remotely operable three-way valve that permits an operator to equalize the pressure across the transducer at any time, and thereby measure the aforementioned "instrument zero" value at any time. Thus for a normal test, instrument zero values can be readily determined and subtracted from measured outputs at the beginning and end of the test. This capability is particularly important when the differential pressure to be measured is a small fraction of the transducer range and good accuracy and repeatability are necessary. Signal conditioning equipment (Appendix D, Table D-6.2) for the voltage output transducers consists of Newport Model 80A excitation and balance units and Model 60A or 70A amplifiers with 2K available gain and 10-Vdc filtered outputs.

2.3.1.3 Temperature, Conductivity, and Others. Fluid temperatures are measured with Type J (Iron-Constantan) thermocouples while heater rod thermocouples are Type K (Chromel-Alumel). Wall temperatures also are Type J. The fluid thermocouples are grounded-tip, 1/8-in.-OD, stainless-steel-sheathed, standard commercial units with Type J connectors. Extension wiring carries the signal back to 150°F reference junctions which are located in the control room. The mV outputs from the reference junctions are presented to the data acquisition system. Signal conditioning is the same for Type K thermocouples and reference junctions.

Figure 2-50 shows the type of conductivity probe used in FIST. Signal conditioning circuitry is shown in Dwg. 181F145-171. The probes are used principally to detect falling (or rising) liquid levels, identified by near-step changes in the conditioned output voltage. Intermediate voltage outputs are approximately proportional to two-phase void fraction. Use of the conductivity probes for void-fraction calculation and comparison to that determined from nodal differential pressures is included in Reference 7, Appendix C. The probes provide information at specific point locations, supplementing the differential pressure measurements that give average values over the vessel DP tap height. The system design is similar to that used in TLTA and involves the same type GE-designed probe suitable for BWR operating conditions.

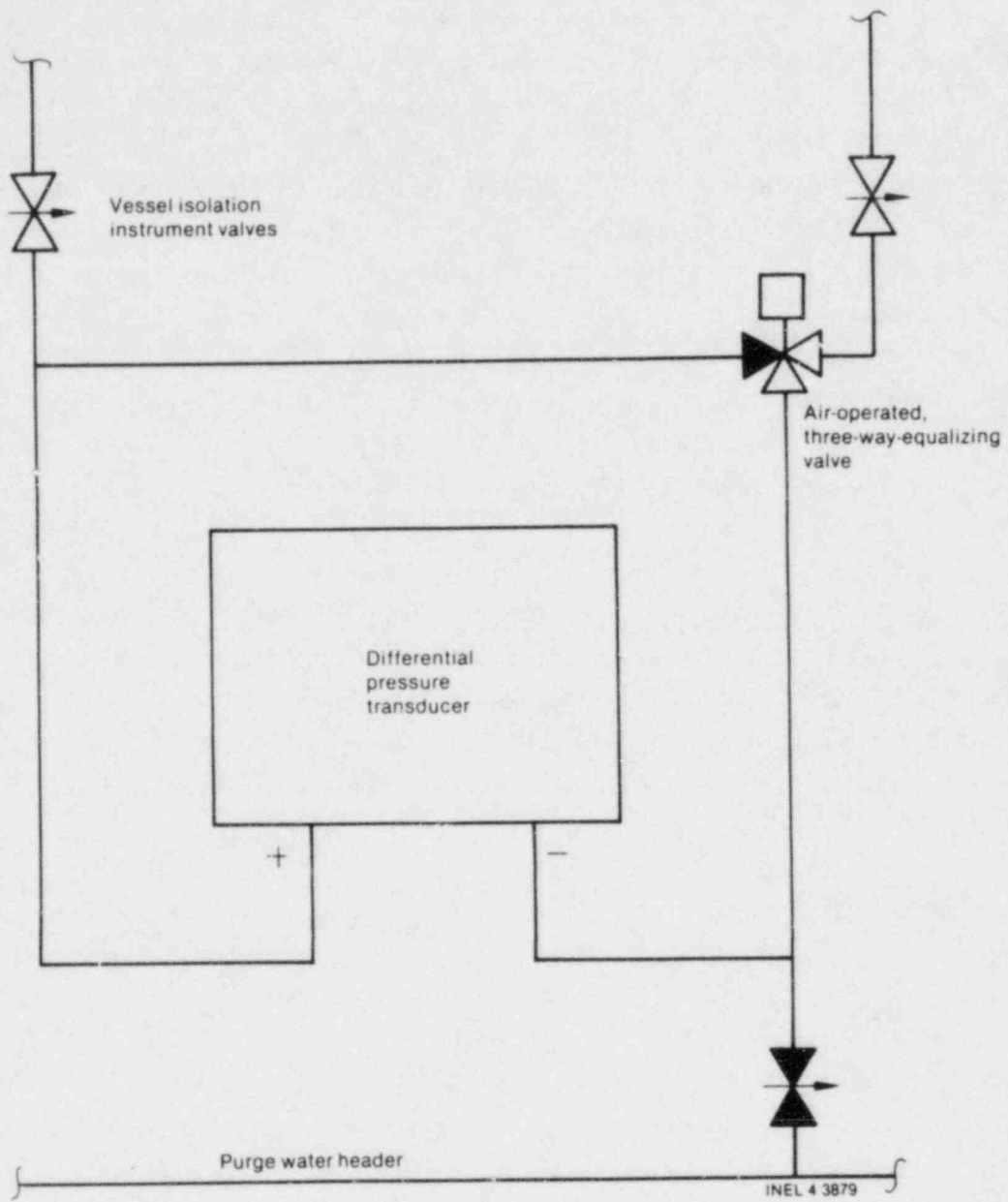

Figure 2-49 Differential Pressure Transducer Installation

Other types of measurements include Schaevitz LVDTs for valve-stem-position indicators, Weston tachometers for pump speed, Ramapo (strain gauge) drag disks used to measure momentum flux in the break flow instrumented spool pieces, bundle voltage and current measurements, and a Yokogawa electrical power transducer. Gamma densitometers will be installed later to measure core fluid densities.

Most of these instruments are further described in Table D-6.3, Sensors Having Class-Common Calibrations.

2.3.2 Data Acquisition System

2.3.2.1 Equipment Figure 2-51 is a block diagram showing the various components of the data acquisition system.

The front end of the system consists of two 256-channel multiplexers and digitizers coordinated through an interface controller that is connected to one of the two direct-memory-access ports on the minicomputer. The high (voltage) level multiplexer, Neff Model 410, handles the pressure transducers, conductivity probes, and miscellaneous 10-Vdc full-scale inputs. The Neff Model 400 unit is a low-level multiplexer that handles all of the thermocouples. The remainder of the system is Hewlett Packard equipment except for the Versatec printer/plotter and its video hard copy controller and a Conrac color television monitor used to display on-line measurements and calculations. As noted in the figure, the minicomputer is an HP F series unit with 256K of memory. It is controlled from either of two Model 2648A graphics terminals supplied with dual cartridge tape units. The acquired data is stored directly on magnetic tape. Two Model 7970E 1600 bpi, phase-encoded, 45-ips tape drives are provided. In addition, the system incorporates a 60-megaword Model 7925M disc subsystem. The time-base generator is used in establishing the scan rate and the 16-bit relay output card provides control (core power trip) and alarm functions.

Acquisition of data occurs in bursts during which the front end equipment operates at, e.g., approximately 12,500 samples (digitizations)/s. With a scan table of 512 channels to be recorded, the 512 numbers would be deposited in a buffer in main frame memory in 40 ms. This would be followed after a time delay of from 0 to some specified amount by another 512-channel scan or burst and another, etc. until the 4K memory buffer is filled. At that time, input data is routed to a second buffer while the first buffer is dumping its data to tape and being reset. While acquisition and storage on tape is the principal function, other functions

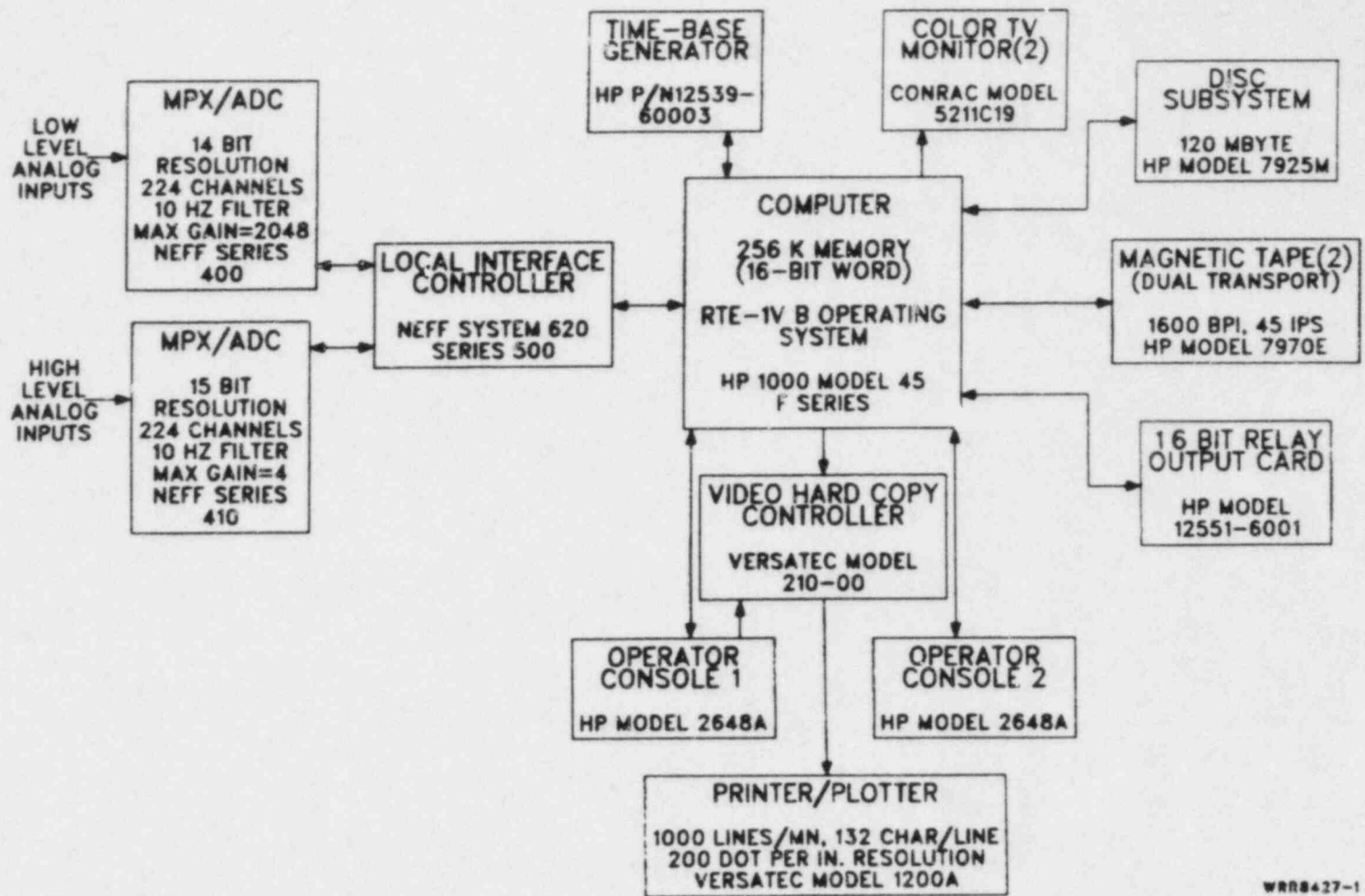

2-91

GEAP-22054

WRR8427-1

Figure 2-51 Data Acquisition System Block Diagram

are also in progress during the course of a test. Limit checking is done to detect various undesirable conditions, e.g., ones harmful to the bundle will cause core power to be tripped if the measured variable exceeds the limit. Also, some amount of on-line calculations and display on the video terminal can be accomplished, depending on acquisition scan rates and extent of the calculations.

The data acquisition equipment is described in detail in Table D-6.4.

2.3.2.2 Software. Appendix E lists and briefly describes 15 software modules available for use on the FIST data acquisition system. Some of these involve housekeeping, e.g., TINIZ, UPZER, and CALIB. Others involve engineering checks intended to be accomplished before a test, e.g., ICHEK and SCHEK or are involved with the data acquisition process, e.g., SETUP, ROP, SCAN, WRMT, and the remainder involve data processing and display. Reference 8 is a data acquisition system hardware and software description and user's guide to be published. It describes in detail the needed inputs, requirements, and outputs for each module as well as all of the other software documentation necessary to understand and operate the computer system.

Considerable attention has been given to providing software tools on the data acquisition system to enable enhanced capability for measurement system verification including pretest, on-line, and posttest checks in both direct measurement engineering units and also derived quantities. Two TV video monitor screens are used to display real-time engineering unit and derived quantity information for data verification and real time test monitoring. A bar chart type format is used to display initial condition data to aid in establishing specified initial conditions for each test. The data acquisition, data verification, and preliminary data review task using the HP computer includes doing essentially all the types of calculations for derived quantities later done in greater scope on the CDC.

Appendix E also lists the three main programs used to process data tapes into plots of measured and calculated parameters on the INEL CYBER system. The use of the acquisition and processing and storage computer systems is discussed in the next section.

2.3.3 Data Processing

Data processing work is done with two computer systems: the Hewlett-Packard-based data acquisition system at the FIST facility, and the large Control

Data Corporation computer at the Idaho National Engineering Laboratory at Idaho Falls, Idaho. Two systems were determined to be necessary because the substantial data-processing task from a previous test and the preparations for the next test were expected to make conflicting demands on the data acquisition system. The HP system does all the data processing tasks needed for data acquisition and initial data review for test acceptance including pretest, on-line, and initial posttest data verification. Thus the role of the data acquisition system is to acquire the data, to be able to do any of the data processing calculations, and to produce plots of all those measurements and derived quantities which are needed to establish test acceptance. Typically about 300 pages of plots are produced on the HP, copied and distributed within 48 hours after test completion.

At the other end, the data for each test ultimately were to be put on the NRC Data Bank, i.e., the INEL computer, so it was considered appropriate to use that machine to also do data processing work. This enables performing a larger quantity of calculations for more detailed output, reducing the output-task burden for the HP. Also this enables the option for reprocessing of data where necessary (e.g., changing calibration coefficients) for final data reduction without using the HP. Thus the role of the INEL computer is to process the raw data tape produced by the data acquisition system and to prepare plots of all 426 measurements as well as the 200 to 300 derived quantities specified for that test. When data review is completed, these files are to be edited and the data transferred to and stored on the Data Bank section of the computer. Of course, when the data files have been generated, direct comparison between the data and TRAC pretest predictions (generated on the same machine) can readily be accomplished.

2.3.3.1 Measured and Derived Quantity Calculations. The information stored on the magnetic tape during the course of the test must be decommutated (demultiplexed) and converted from counts to voltage and from voltage to engineering units. The conversion from counts back to voltage must take into account the total gain (product of fixed and programmable) used by the multiplexer for that channel and the full scale relationship: 10240 mV is equivalent to 32,767 counts. Thus, the i th voltage presented to the multiplexer on channel j is given by Equation (2-1)

$$V_{ij} = \frac{\text{Full Scale Voltage}}{\text{Full Scale Counts}} \cdot \frac{\text{Counts}_{ij}}{\text{Total Gain on Channel } j} \quad (2-1)$$

The conversion from that voltage to a temperature, pressure, etc., requires Equation (2-2) and the coefficients (calibration constants) in it. All of the FIST engineering units conversion equations are quadratic

$$EU = P_1 + P_2V + P_3V^2 \quad (2-2)$$

For all temperatures, P_1 is 150, reflecting the 150°F reference junctions used. For all heater-rod temperatures, P_2 has the same value; similarly P_3 has the same value for all rod temperatures. For all fluid and wall temperatures, P_2 's are alike (but different from P_2 's for the rods), etc. Thus the temperatures have a class-common set of coefficients, and the conductivity probes and valve position indicators are treated similarly. This single set of coefficients (i.e. for, say, fluid and wall temperatures) is listed in the transducer file (CALIB) under transducer No. 204. The single set for rod temperatures is listed there under transducer No. 202, conductivities under No. 200, valve-position indicators under No. 212. For all other measurements, each transducer has its own individual coefficients, listed under its own number in the transducer file.

Equation (2-2) is used in a modified form for pressure and differential pressure type measurements. The equations used are

$$EU = P2(MV-IZ) + P3(MV-IZ)^2 - PZ \quad (2-3)$$

and

$$EU = PZ - P2(MV-IZ) - P3(MV-IZ)^2 \quad (2-4)$$

for flow DP type measurements and for liquid level (density) type measurements, respectively, where

- MV = transducer output in millivolts
- IZ = instrument zero in millivolts
- PZ = process zero in engineering units
- P2 = transducer calibration coefficient (linear term)
- P3 = transducer calibration coefficient (quadratic term).

Instrument zero is defined as the millivolt output of the transducer when on bypass (same pressure applied to both sides of a differential pressure

transducer). The process zero is the engineering unit value of the transducer reading when the process system is zero (flow zero or level zero). Process zero data are measured and stored for level type measurements when the vessel is cold and empty (reading becomes the measured tap elevation spacing). Process zero data for flow measurements are measured with the system hot at zero flow immediately prior to initiating the actual matrix test. The instrument and process zero corrections as used automatically provide compensation corrections for system variations, effectively improving the accuracy of system measurements.

The derived quantities are the parameters calculated from any of the 426 measurements. In particular, a standard group of derived quantities are calculated for all tests. These are all vessel inlet and outlet flow rates, the liquid levels throughout the vessel, various steam table properties, and jet pump performance parameters. General equations used for these are given in the following sections.

2.3.3.2 Acquisition System. The programs XIBIT and FSTDR are used to process data on the data acquisition system. They, in turn, require the housekeeping information found in the work file, the calibration coefficient information found in the transducer file, the steam tables, and the subroutine CALCS, which contains the algorithms used to calculate the various desired quantities.

The work file lists, by channel number, the measurement identification, specific EU conversion equation, transducer number, fixed and programmable gains, status (on or off), the latest instrument zero reading, and process zero value for each of the 426 measurements. It also lists, by derived quantity calculation number, all of the derived quantities to be calculated. For each of these, the input measurement channel(s) are listed as are the constants needed in that calculation. The name of the calculated quantity, its engineering units, and the calculation number (from CALCS) are also given for each derived quantity.

With the transducer number, the values of P2 and P3 (calibration coefficients) can be retrieved from the transducer file and the EU conversion accomplished. The steam tables are a subset of the GE version of the ASME tables, abridged to support identified uses in FIST data processing calculations. The CALCS subroutine lists 24 calculation types, several of which are simple calculator-type routines, e.g., adding, multiplying, averaging, finding maxima/minima, etc. There are also the engineering routines to calculate regional liquid levels, densities,

masses, and various flow calculations. These latter calculations are based on the same equations as those accomplished on the INEL computer and as such are discussed below.

2.3.3.3 Processing and Storage System. The data stored in Data Bank will have been processed by INEL CYBER programs FICON, FIKAL, and FIWIZ to arrive at the 426 measured values in engineering units, and the derived quantities calculated for a given test. The data will also have been processed through an automated data qualification (ADQ) program, the result of which, together with verification results from review of HP data, will be the basis for a data quality tag appended to each measurement for each test. Of the derived quantity calculations accomplished in FIWIZ, the flow rates are the most complex and are described first. The general flow rate equation is

$$w = 0.0997 k d^2 F Y (\rho h)^{\frac{1}{2}} \quad (2-5)$$

w-mass flow rate, lbm/s

ρ -fluid density, lbm/ft³, obtained from steam tables for input

values of P, T -- fluid upstream pressure, psia, and temperature, °F

h-pressure drop, in. H₂O

d-hole diameter for orifice plates, pipe diameter for Annubars, in.

F-dimensionless factor for thermal expansion, Equation (2-6)

Y-dimensionless factor for compressibility (=1 for liquid)

Equation (2-7)

K-dimensionless Reynolds-number-dependent flow coefficient,

Equations (2-9, 2-10)

$$F = a_0 + a_1 (T) \quad (2-6)$$

T - upstream fluid temperature, °F

$$Y = 1.0 - (B h / P \gamma) \quad (2-7)$$

γ - dimensionless specific heat ratio for steam at temperature T,
Equation (2-8)

$$\gamma = 1.333 + T(5.625E-5 + T(-5.387E-7 + 3.2369E-10 T)) \quad (2-8)$$

$$K = K_0 (1.0 + (A / RE)) \quad \text{for orifices} \quad (2-9)$$

$$K = K_b f_0 (1.0 - \exp(-f_1 (RE - 3000)^{0.16667})) \quad \text{Annubars} \quad (2-10)$$

$$RE - \text{Reynolds number} = 15.279 w/d\mu \quad (2-11)$$

w, d are as defined above in lbm/sec, and in.
 μ - fluid viscosity at P, T in lbm/ft·sec

because, as indicated in Equations (2-9, -10, and -11), K is a function of flow rate, an iterative solution might be employed. However, the dependence is considered so weak that the Reynolds number is simply estimated once using Equation (2-12) for orifices. For Annubars, K_b replaces K_0 .

$$RE = 1.523 K_0 d (\rho h)^{\frac{1}{2}} / \mu \quad (2-12)$$

If the critical pressure ratio is exceeded (for steam line and SRV orifices only) the flow rate is calculated using Equation (2-13).

$$w = 0.3712 CW d^2 f(\gamma) (P \rho)^{\frac{1}{2}} \quad (2-13)$$

w, d, P, ρ are as defined above

CW - function of pressure ratio, Equation (2-14)

$f(\gamma)$ - function of γ , the specific heat ratio, Equation (2-15)

$$CW = 0.845 \exp(-0.4835 (P_2/P)^2) \quad (2-14)$$

$$f(\gamma) = (\gamma (2/(\gamma + 1))^n)^{\frac{1}{2}} \quad (2-15)$$

$$n = (\gamma + 1)/(\gamma - 1)$$

P_2 - downstream pressure, also in psia

In the above equations various constants are used: d, a_0 , a_1 , B, K_0 , A, K_b , f_0 , f_1 . Values for these are listed in Appendix C, Table C-3, for each orifice and Annubar. Values of f_0 and f_1 are listed for reverse flow for the Annubars, but a reverse flow condition on an orifice plate causes a computed flow rate of zero. Similar equations are to be used and constants determined for the various restricting nozzles and orifices internal to the test vessel. Data are to be obtained from in situ calibration checks scheduled during facility shakedown testing.

Equations (2-5) through (2-15) apply for single-phase conditions. The pressure and temperature measurements used in the flow calculations are checked (measured temperature versus saturation temperature from measured pressure) to ensure that the fluid condition is subcooled or superheated. If the measured temperature is

within a $\pm 4^\circ\text{F}$ measurement uncertainty band of the saturation value, the fluid condition is assumed to be saturation. This situation is expected for the Annubars in the test vessel and the steam line and SRV orifice plates. If saturation is concluded, nearby conductivity probe information is used, if available, to infer a saturated liquid, as opposed to vapor, condition, and the appropriate density is then requested from the steam tables.

The differential-pressure liquid-level measurements form the basis for an extensive but straightforward set of calculations. There are 68 DP measurements on the test vessel that are set up to produce liquid-level information. The liquid level calculated is, of course, an accurate representation only when there is an actual level per se, i.e., since the measured DP consists of both elevation- and flow-induced pressure drop terms, it can be interpreted as a level during a test only when the latter term is nil compared to the former. Under that condition, the level is given by Equation (2-16).

$$\varepsilon = \text{PZERO} - (\text{P2} + \text{P3}(\text{V} - \text{ZERO})) (\text{V} - \text{ZERO}) \quad (2-16)$$

Thus when the (cold water) level is below the bottom tap, $\varepsilon=0$, and when it is above the top tap, $\text{V} = \text{ZERO}$ and $\varepsilon = \text{PZERO}$, i.e., 100% full. In turn, the nodal density is given by Equation (2-17).

$$\rho = \varepsilon (\text{C1})/\text{PZERO} \quad (2-17)$$

In Equation (2-17), the quantities are as defined above, and $\text{C1}=62.4$. The nodal mass is calculated using Equation (2-17) multiplied by the nodal volume. Nodal masses are added to obtain regional ones and these are added to determine the fluid mass in the vessel. Other calculations performed on the system include range checks, sorting among heater rods and test times for the peak clad temperature, and calculating a blowdown flow rate for the suction blowdown nozzle on the basis of nozzle pressure drop and upstream flow regime determined from conductivity probe measurements.

This completes the description of the facility. The next section addresses scaling and performance prediction of the facility.

3. SCALING ANALYSIS AND PERFORMANCE PREDICTION

3.1 GENERAL

3.1.1 Background and Scaling Objectives

The BD/ECC Program was a BWR safety research program designed to improve and advance the safety technology of the BWR as well as provide a basis for evaluating BWR LOCA phenomena. The primary focus of the BD/ECC Program was on the hypothetical large-break LOCA events, which used the Two Loop Test Apparatus (TLTA) as the fundamental test vehicle. The original mission of this program was completed in 1981.

In the aftermath of the TMI accident in 1979, there has been considerable interest in evaluating the consequences of the more probable small-break events in a BWR system. Hence, the BWR FIST program has evolved with the primary objectives of evaluating BWR phenomena during small-break LOCAs and operational transients which assume degraded systems. Concurrent with the new mission, the upgraded facility has been renamed the BWR Full Integral Simulation Test (FIST) Facility. This facility is designed to model the thermal-hydraulic response of the BWR from the initiation of a given scenario through the entire transient.

The FIST Facility simulates the following key features:

1. Full reactor height
2. Scaled regional volume distribution proportionate to the reference BWR
3. A full-size electrically heated bundle
4. Key functional hydraulic components
5. Heated feedwater system which enables the facility to achieve steady-state operation
6. Prototypical BWR level instrumentation
7. ECC systems and safety relief systems including ADS.

In addition, it provides a better basis for evaluating BWR LOCA phenomena. The facility is also designed and will be used to evaluate the BWR's response to other events such as power and operational transients.

This facility represents a substantial improvement in simulation fidelity over the TLTA. The TLTA was primarily used to investigate the system response during

various BWR LOCAs. The results of these tests have provided an understanding of the BWR LOCA phenomena. However, the TLTA was designed mainly for investigating the blowdown phase of a LOCA and contained some scaling compromises that may have had an effect on the results. Some of the influential compromises were:

1. Atypically short pressure vessel with shortened jet pumps, upper and lower plenum, and steam dome
2. Atypically large downcomer cross-sectional area
3. Atypical bundle "channel" and thermal coupling to bypass
4. Unheated feedwater

These and other scaling compromises are eliminated by the FIST Facility design.

In order to satisfy the program objectives the following scaling objectives were developed:

1. To characterize and quantify differences between FIST and the reference BWR
2. If feasible, minimize these differences either by design modifications or through the operational test procedures
3. Evaluate the effects of the remaining compromises on the system behavior.

3.1.2 Scaling Basis

The FIST Facility is scaled from the BWR/6, 218-in. standard plant. Figure 3-1 gives a side-by-side schematic vessel comparison. The BWR/6 reactor was chosen as the reference because it represents the current product design and the one to be installed in future BWR plants. The 218-in. standard plant has also been used as a reference BWR for the design of other experimental facilities (i.e. Single Heated Bundle and Steam Sector Test Facility, which were used in the BWR Refill/Reflood Program, and the TLTA). Therefore, in order to be consistent and facilitate direct tieback and interpretation of the FIST results with previous experimental results it has again been chosen.

Some of the tests scheduled for the FIST facility are designed to simulate the BWR/4, 218-in. plant's response. These tests will be performed to broaden the data base for this reactor design.

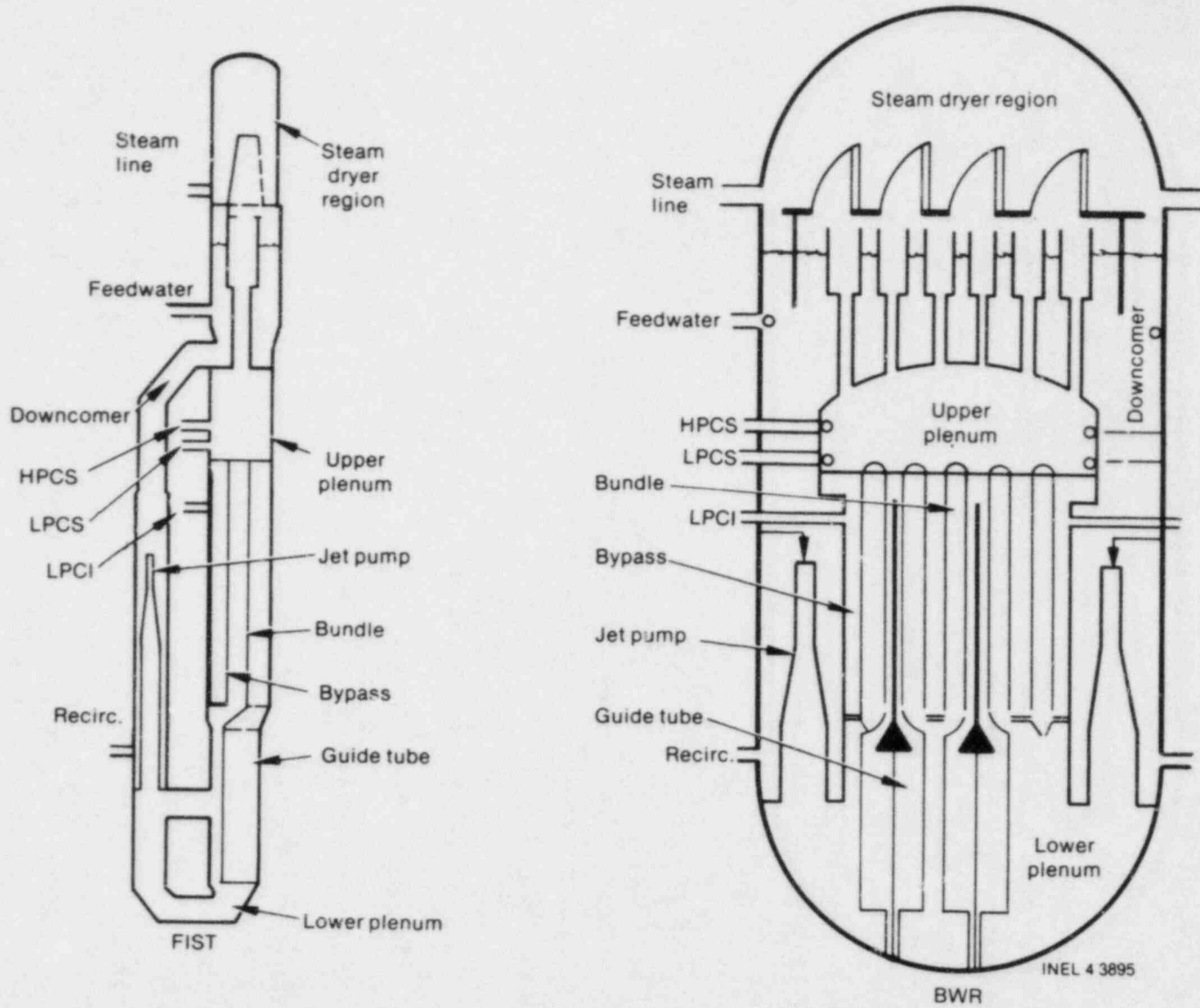

Figure 3-1 FIST and BWR Vessel Schematics

The 218-in. plant was selected for previous BWR safety experiments (e.g. TLTA) because it has the largest ratio of recirculation line size to the contained coolant mass. This large ratio translates into the potential for a faster blowdown with potentially less core cooling in the system.

The scaling criterion used to scale the FIST Facility from the reference BWR is 1 to 624, corresponding to the one fuel bundle in FIST to 624 bundles in the reference BWR. This criterion is used in determining the volume, mass, energy, and flow rates for the system as well as in the geometrical scaling of the regions and components.

The initial thermodynamic conditions in the test apparatus match, as accurately as possible, those of the reference BWR during normal operation. This allows the real-time response of the reactor to be characterized. Figure 3-2 is a simplified schematic flow diagram of the system.

Various studies were performed to assist in the scaling and design of the facility. The purpose of these studies was to determine if the test facility design is capable of performing the tests defined in the test matrix and if the components in the facility are capable of replicating the phenomena expected during the tests.

There were two approaches taken in evaluating the facility design:

1. Separate effect studies, and
2. Integral system response studies.

The separate-effects studies were an integral part of the design of the facility as they were used to provide feedback and recommendations during the design cycle. Most of these studies were performed either on individual regions of the system or on a single component. These studies were either used to determine if the regional geometric scaling was performed such that the FIST Facility would be as representative of the BWR as possible, or if each component simulation would produce the desired performance characteristics. The results of these studies constitute the remainder of this section of the report.

In order to gain an understanding of FIST behavior relative to the BWR/6, a scaling study is being performed using a best-estimate, multidimensional code (TRAC-BD) developed specifically for BWR applications. Models are being developed

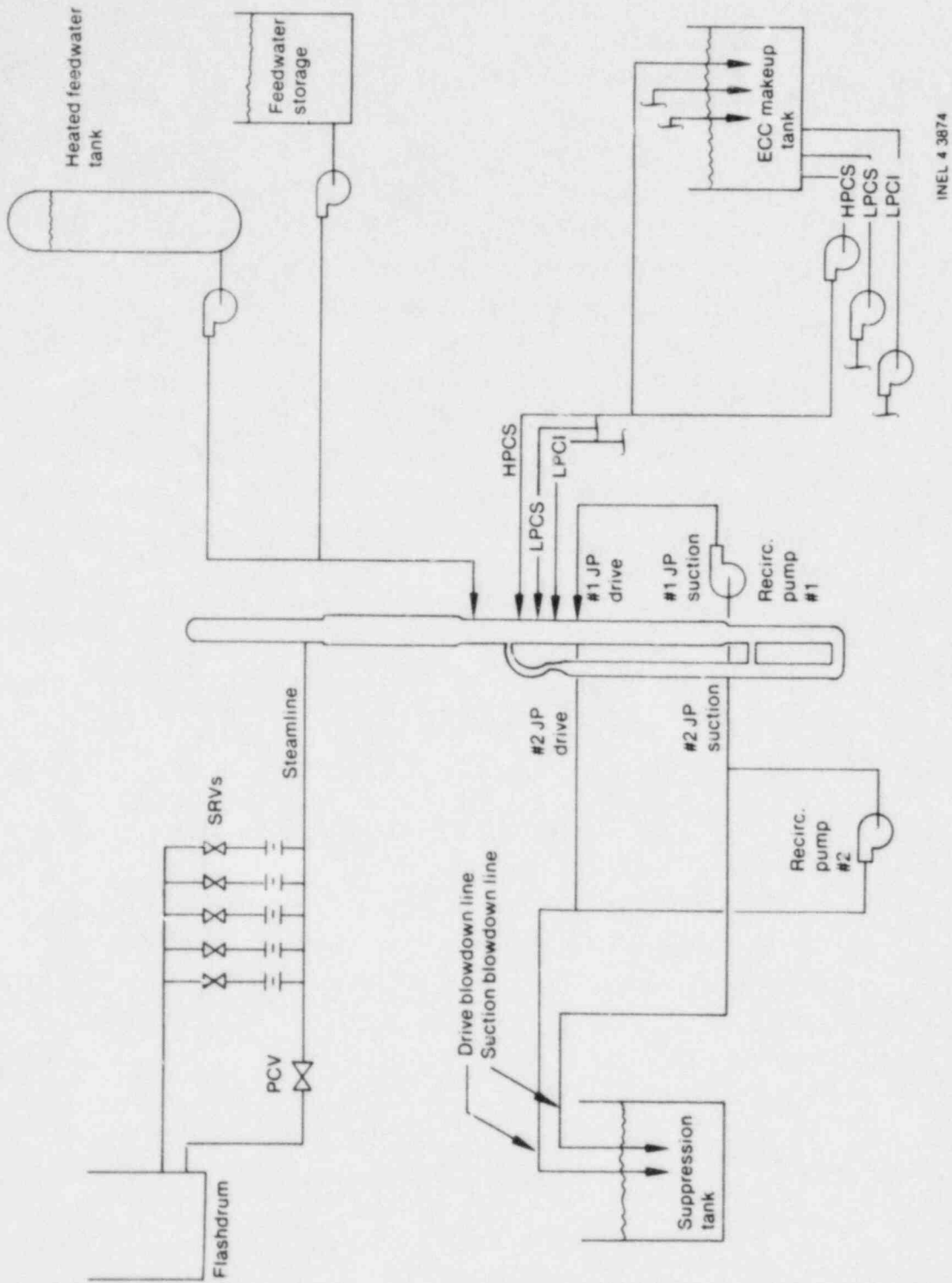

INEL 4 3874

Figure 3-2 Simplified Schematic Flow Diagram

for the BWR/6 and the FIST facilities. A common set of boundary conditions is being applied to both models to determine the relative behavior.

The BWR/6 transient will be calculated using expected boundary conditions for a design-basis, 200% recirculation pump suction break, accident. The BWR/6 boundary conditions will be normalized and applied to the FIST transient calculation. By using the same boundary condition it will be possible to study the vessel responses and conditions without balance of plant influences.

Results of the study will help quantify the known scaling compromises in the FIST Facility and may identify scaling compromises previously unknown. Three-dimensional behavior of the BWR/6 will be compared with the one-dimensional FIST Facility responses. Items of interest at this time are counter-current flow limiting (CCFL) of the bypass, upper tie-plate, and side entry orifice (SEO). FIST, due to subscaling, has more heat slab mass per volume than the BWR/6. The effects of the heat slab masses will be investigated and the system effects quantified. An understanding of the facility performance before testing will be beneficial in test planning and analysis. Thus, the resulting data base from the FIST experiments will be enhanced.

3.1.3 Stored Heat/Heat Loss

As in most scaled facilities, the FIST facility contains an overscaled structural mass. (The overscaling is necessary in order to obtain effective pressure boundaries.) This overscaled metal mass retains excess heat, which will be transferred to the fluid during the system depressurization. The excess stored heat will have the greatest impact on the system response during tests characterized by rapid depressurizations (i.e., large-break LOCAs and tests with ADS actuation).

Some preliminary studies have been performed to identify the potential, local effects of the overscaled mass in both the lower plenum and bypass regions (see Sections 3.2.1.2, 3.2.2.2).

The potential overscaled stored heat effects discussed above logically lead to considering internal insulation in order to reduce the heat transfer rate. However, after an extensive study it was decided that the FIST Facility will contain no internal insulation. This decision was based on the following:

1. The use of internal insulation complicates the understanding and analysis of the phenomena occurring in the vessel, therefore, predictability was chosen over exact replication of BWR phenomena.
2. The state-of-the-art insulation designed for use in high-temperature and -pressure environments has a history of mechanical and construction problems.
3. The insulation required for FIST would be extremely costly to fabricate and install.

The integral system response study will address the differences in system response obtained with the overscaled mass and with an ideally scaled mass.

In slow and long transient tests, i.e., small-break LOCAs and operational transients, the heat loss from the system through the vessel wall and piping may have a significant effect on the system response, particularly in the latter phase of the transient when the bundle decay power is low. The system heat loss rate may be of the same order of magnitude as the decay power.

The experience gained from TLTA testing was used in determining the major contributors of heat loss from the test vessel. This experience has been applied in the design of the FIST external insulation. The vessel heat loss is estimated to be ~30 ~40 kW at 1050 psi, which is much less than that in the TLTA Facility. This heat-loss rate will also decrease proportionally as the system pressure decreases during the transient. In addition, during the shakedown testing, special heat-loss tests are scheduled to be performed.

3.1.4 Initial and Boundary Conditions

A majority of the tests specified in the test matrix can be characterized as relatively slow transients in which the system responds with core averaged parameters, i.e., core averaged power decay, core inlet flow, and others. The major purpose of these tests is to investigate the overall system response under the simulated events. Therefore, the initial conditions shown in Table 3-1 were derived based on the core averaged conditions of the reference BWR/6.

The boundary conditions for each test are highly dependent on the nature of the test being performed. In general, these boundary conditions include the following experiment parameters:

1. Bundle decay power or transient power

TABLE 3-1. FIST INITIAL CONDITIONS

<u>FIST Parameter</u>	<u>Initial Condition</u>
Initial Water Level, ^a ft	46.5
Bundle Power, MW	4.64
Steam Dome Pressure, psia	1040
Lower Plenum Enthalpy, Btu/lb	528
Feedwater Flow, lbm/s	5.54
Feedwater Enthalpy, Btu/lb	398
Steamline Flow, lbm/s	5.54
Steamline Flow Enthalpy, Btu/lb	1191
Jet Pump #1 Flow, lbm/s	18.8
Jet Pump #2 Flow, lbm/s	18.8
Bypass Flow, lbm/s	3.8
Bundle Flow, lbm/s	33.8

a. Referenced to the bottom of the BWR/6.

2. Recirculation pump flow coastdown characteristics
3. System pressure control with the pressure control valve (PCV)
4. Feedwater supply and trip points
5. Main steam isolation valve operation
6. Safety relief valve operation
7. ECCS (HPCS, LPCS and LPCI) operation
8. ADS activation
9. Break size and location
10. Turbine trip simulation.

Scaling concerns involving these parameters are discussed in the sections that follow. The detailed simulation requirements, thus experiment parameter controls, for each test are specified, reviewed, and documented before the test.

3.2 SCALING AND PERFORMANCE OF VESSEL AND EXTERNAL COMPONENTS

The vessel, components, and external systems have been separated into the following categories in order to present the scaling results effectively:

1. Lower plenum/bundle region
2. Guide tube/bypass region
3. Jet pump region
4. Downcomer region
5. Upper plenum, separator, dryer, and dome
6. Recirculation, steam, and ECC system

The results of the scaling studies include discussions involving the geometrical scaling compromises, the method used to determine component simulation, the performance expected from the component design, and volume distribution (volume versus height) for FIST and the scaled BWR.

FIST vessel and internal dimensions were chosen to give regional volumes and areas which are closely scaled (1/624) to the reference BWR/6 while the full heights are maintained. Standard pipes are used in the design of the vessel and internals, except around the channel where a precisely machined pipe is used. Due to the manufacturing tolerances of standard pipes the as-built volumes in all regions,

except the channel and bypass, may be out-of-scale by up to $\pm 5\%$ from the computed design values. The FIST volumes presented in the following sections were evaluated using nominal pipe sizes. The BWR volumes were obtained from standard plant data or found directly from the reference BWR drawings.

3.2.1 Lower Plenum and Bundle

3.2.1.1 Lower Plenum Geometrical Considerations. The FIST and BWR lower plenum (LP)/bundle regions are illustrated in Figure 3-3. As noted earlier, the FIST LP has two flanged connections between the region below the jet pumps and the region below the core, one located directly below the jet pump exit plane, the other at the bottom of the FIST LP. These paths are analogous to the flow path through the shroud support that exists in the reference BWR. Figure 3-4 shows the regional volume distributions for FIST and the scaled BWR. The average height of the hemispherical bottom of the BWR LP was selected as the bottom of the LP for FIST to ensure correct volume scaling, thus making FIST's LP short by approximately 31 in. This, however, is not expected to affect the system response because this region rarely becomes void of liquid, even during large-break LOCA testing. Figure 3-4 shows the connecting pipe volumes as distortions in the relatively smooth volume distribution profile. The lower crossover (pipe) makes up for the shortened LP by concentrating a bit more volume over its relatively short length, such that the fluid volume is nearly equal to the ideally scaled volume. The middle crossover, below the jet pump exit, corrects the remainder of the volume distortion. This short horizontal section also allows the fluid discharging from the jet pumps to freely communicate with the fluid directly beneath the core, as it does in the reference BWR.

3.2.1.2 Lower Plenum Stored Heat Considerations. The metal mass and heat transfer area contained in the LP is ~ 4.5 and ~ 6 times the ideally scaled values, respectively. This results in an overscaled stored heat capacity which, during a rapid system depressurization and the accompanying temperature gradients, will cause an excessive heat release to the fluid. The rate of heat transfer to the fluid is expected to be higher (per bundle) than in the BWR counterpart. For the limiting-design-basis LOCA, this will cause higher vapor generation rates in the LP after bulk LP fluid flashing occurs. However, the effects of overscaled LP metal mass and surface area will not be so severe for smaller breaks or power-transient tests due to their slower depressurization rates. Additional studies have been performed to determine the effects on CCFL at the side-entry

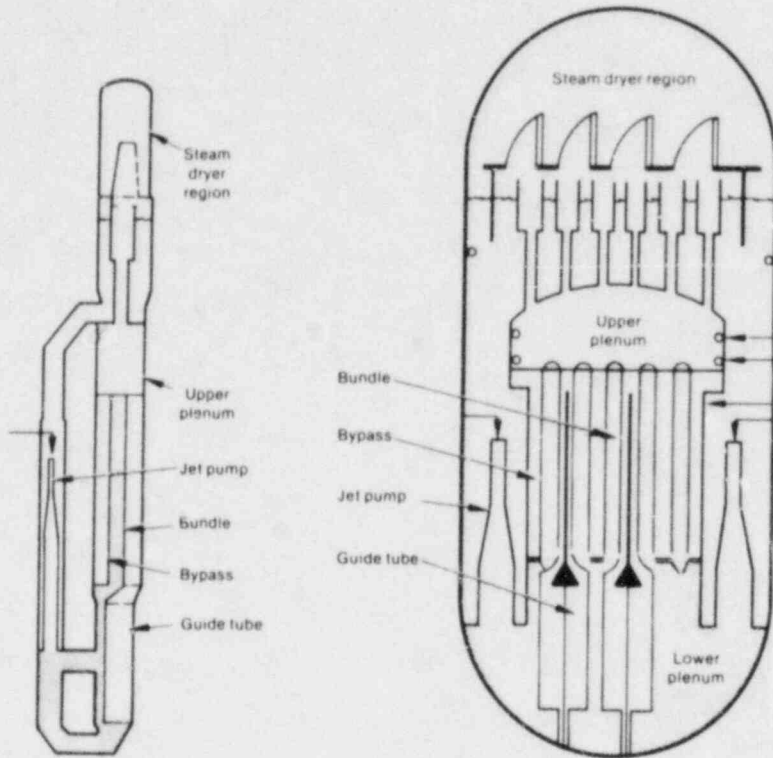

Figure 3-3 Lower Plenum/Bundle Region

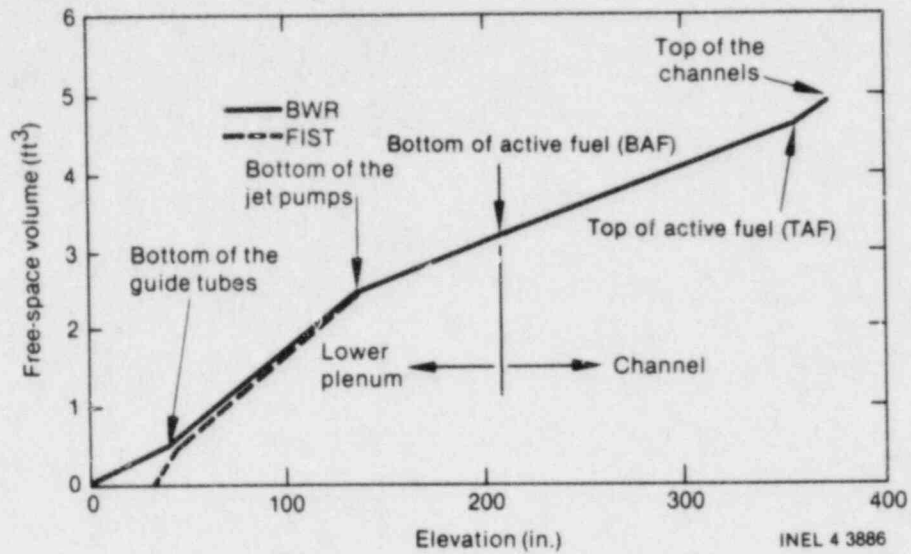

Figure 3-4 Lower Plenum/Bundle Regional Volume Distribution

orifice, the lower-plenum-level transients, and the overall system behavior for the large-break LOCA.

3.2.1.3 Bundle Power Simulation. A major program objective is to investigate the response of the fuel bundle, especially the peak cladding temperature, following a given sequence of events. In a BWR, the stored energy in the individual fuel rods of a bundle is the primary contributor to heatup following a degradation in rod surface heat transfer. The stored energy is determined by the initial fuel temperatures, the local peaking factor distribution, and the fission product decay rate. The simulation of these contributing factors is discussed below.

The initial bundle power for the majority of the tests corresponds to the BWR/6-218 in. core average power of 4.64 MW. In addition, three BWR/4 simulation tests have an initial bundle power of 4.35 MW, which corresponds to the BWR/4 core average power.

The heat flux decay in a BWR fuel bundle is dependent on the initial local power density and varies both from rod to rod and axially. Figure 3-5 shows a comparison of local surface heat flux expected on a fuel rod segment of an 8 x 8 bundle following a scram for a well-cooled situation of three different heat generation rates. The rates considered correspond to the maximum expected value of 12.4 kW/ft (40.7 kW/m) for the linear heat generation rate associated with the peak power bundle, the average central bundle linear heat generation rate of 9.7 kW/ft (31.8 kW/m), and 3.1 kW/ft (10.2 kW/m) for the average peripheral bundle. As is clear in the figure, the higher the linear generation rate, the slower the normalized surface heat flux decays.

In the planned FIST tests, the fuel bundle heat flux decay will be simulated by varying the input voltage to the entire heater bundle in a prescribed manner. It is not possible in the heater bundle to vary the heat flux decay rate axially or from rod to rod separately; therefore, the normalized heat flux decay rate will be the same throughout the bundle.

Two somewhat different methods will be used to determine the power input for the FIST tests. For the TLTA tie-back tests, the method initially used in those tests will be used again. However, for use in the remainder of the FIST program, a second method will be used as follows:

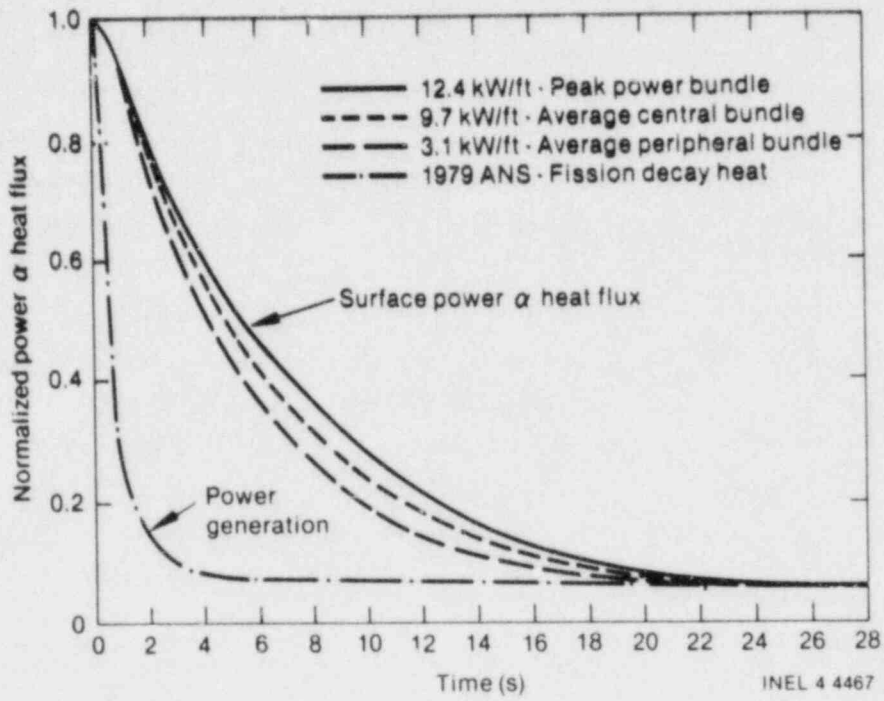

Figure 3-5 Power Decay Curves for Variations in Initial Bundle Power

1. Use the ANS-79 decay curve for an 8 x 8 bundle at 10,000 MWd/t. This is a typical core average exposure.
2. Run a TRAC simulation of the BWR bundle with boundary conditions from a BWR LOCA simulation and using the power decay from (1). Compute the bundle average surface heat flux versus time.
3. Run a TRAC heater rod model using the same boundary conditions as in (2). Adjust the input power so as to match the average surface heat flux decay from (2). The resultant input power decay is the one which should be used to drive the FIST heater rods.

The earlier TLTA method is likely to have resulted in use of a decay rate flatter than the bundle average value. While that approach ensured a conservative simulation of cladding temperature response, the total heat input from the heater rods would have thus been too high and might thereby compromise the accuracy of total system simulation.

The newer method should avoid this problem. The BWR power transients are characterized by a variation in total rod power accompanied by level and distribution changes due to the reactivity feedback, which is a function of a number of space and time dependent parameters (e.g. void fraction, fuel temperature, and water temperature). The FIST Facility is not designed to simulate these reactivity feedback mechanisms, nor does it have the capability to approximate the shifts in power distribution which result from such effects. The electrically heated bundle is, instead, driven so as to approximate the average surface heat flux transient expected for each of the power transients simulated. This approach should provide an adequate simulation of the system response. The fixed axial power profile and local peaking, however, may impact the location and timing of boiling transition for severe transients that lead to a degradation in core cooling.

3.2.2 Guide Tube and Bypass

3.2.2.1 Volume and Leakage Path Considerations. A sketch of the guide tube (GT)/bypass region for FIST and the BWR is shown in Figure 3-6. Figure 3-7 shows the regional volume distributions. The movement of the control rod drive system is not simulated in the FIST Facility; the assumption is made that the control blades are fully inserted. Therefore, the physical volume occupied by these blades (i.e., the volume of fluid displaced by the blades) has been removed from the ideally scaled fluid volume in the GT/bypass region. These volumes represent

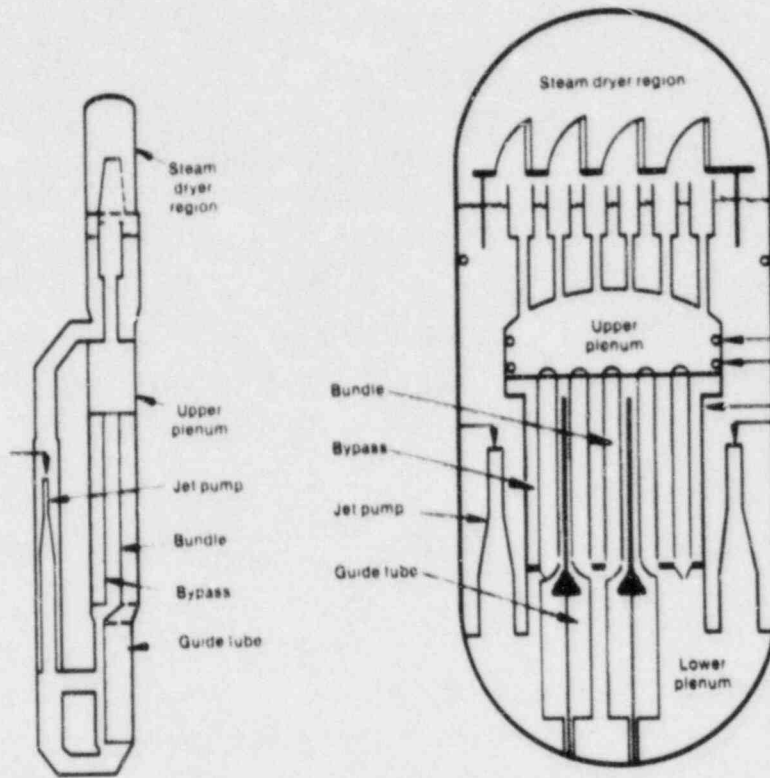

Figure 3-6 Guide Tube/Bypass Region

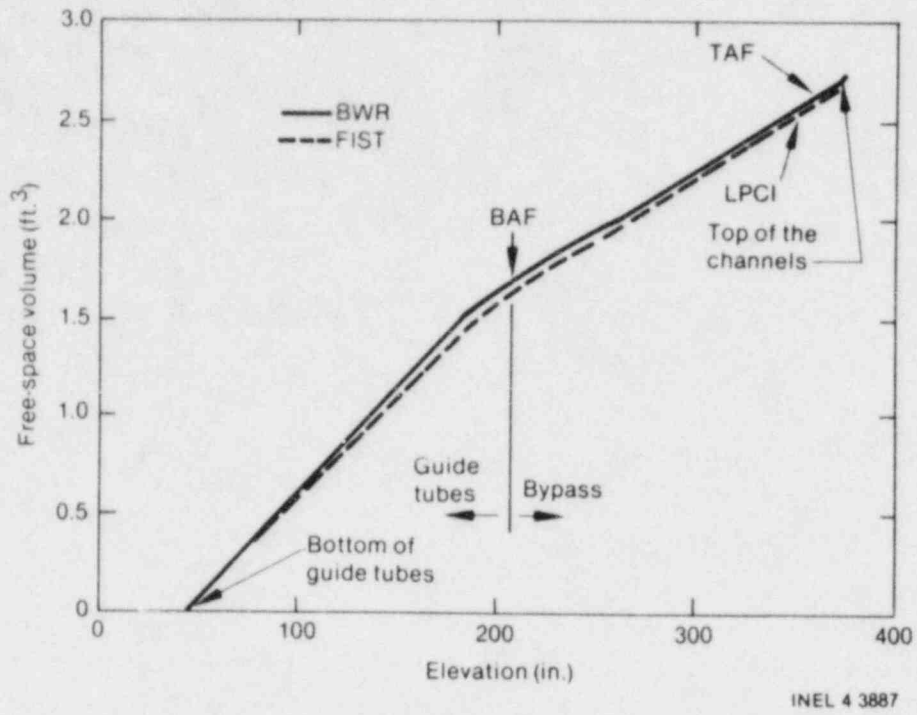

Figure 3-7 Guide Tube/Bypass Regional Volume Distribution

only 2% and 11% of the volumes in the GT and bypass regions, respectively. The total volume in the GT/bypass region is also ~1% less than ideally scaled volume due to size constraints. The assumption of fully inserted control blades will only affect power transient testing and that effect is not expected to be significant.

Leakage paths in the vicinity of the bottom of the bypass are provided in FIST. These leakages are categorized as the LP/bypass and channel/bypass leakages and are shown in Figure 3-8. A very small leakage path is also provided at the bottom of the FIST guide tube to simulate BWR LP-to-guide-tube leakage at the junction between the guide tubes and the control rod drive housings.

For the LP/bypass leakage, one flow path is used to simulate the following BWR flow paths (see numbered flow paths in Figure 3-8b):

1. Between the control rod guide tube and the fuel support (two places)
2. Between the fuel support and the lower tieplate
3. Between the control rod guide tube and the core support plate.

This flow path in FIST is adjustable so that the initial bypass flow will be scaled to the initial BWR bypass flow (between 10 to 12% of the total initial core flow).

The most significant bypass leakage occurs between the channel and the bypass through the lower tieplate leakage holes (flow path 4 in the figure) and through the leakage of the finger springs (path 5 in the figure). The FIST lower tieplate leakage holes have a one-to-one correspondence to the BWR tieplate holes. The leakage through the finger springs is simulated by the expansion box leakage paths.

As noted above, the FIST facility design incorporates the assumption that the control rods have been fully inserted. The flow path between the bypass and guide tube is therefore restricted due to the velocity limiters, which are located at the end of the control rods. This flow restriction may create CCFL at the bypass inlet region which would prevent bypass liquid from freely draining into the guide tube during the transient. The effect of the parachute-shaped velocity limiters in the BWR is simulated in FIST by two restricting orifices as shown in Figure 3-9 and discussed below. Both orifices are removable for non-LOCA tests that do not assume full control rod insertion.

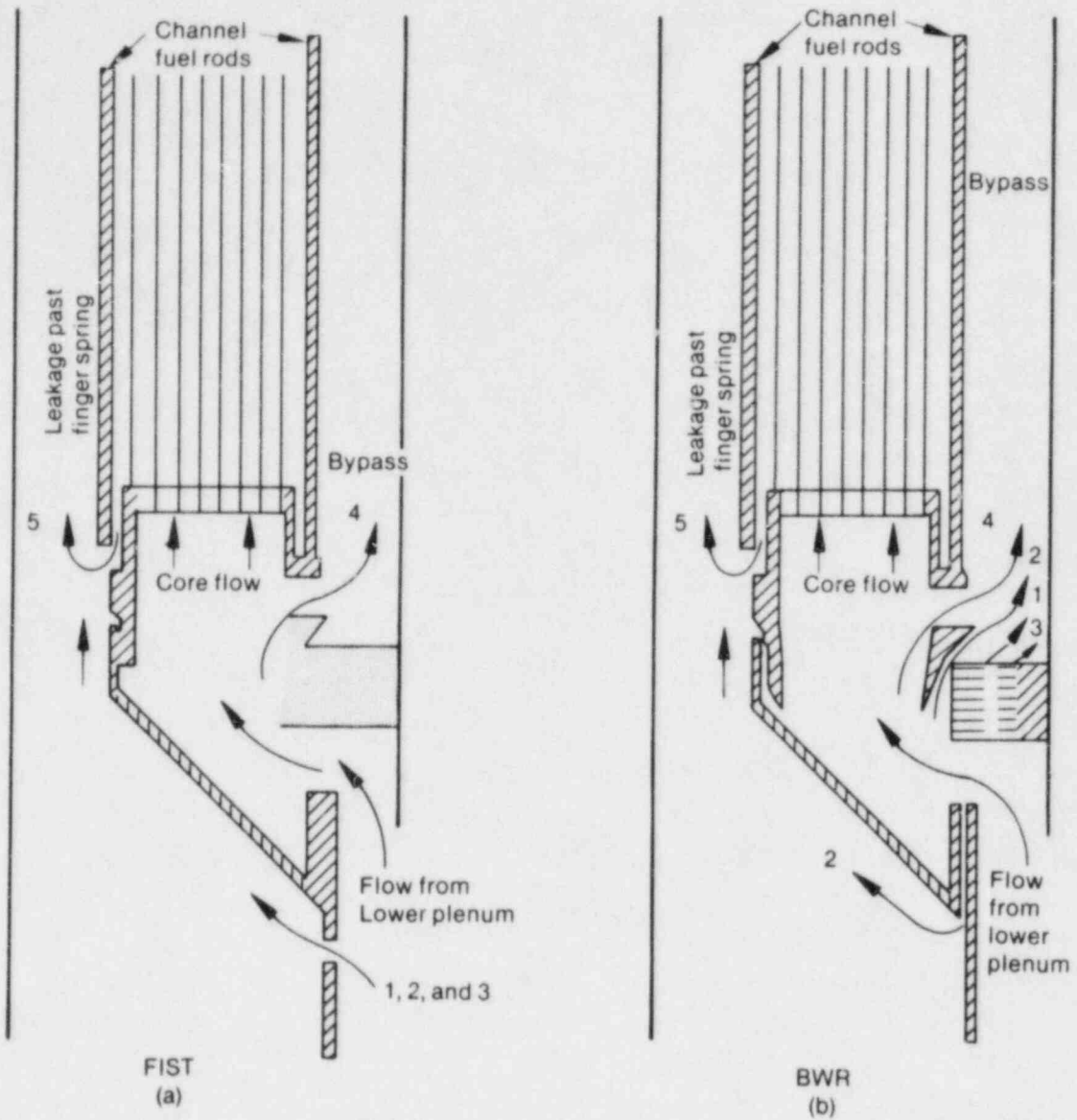

INEL 4 3883

Figure 3-8 Bypass Leakage Paths

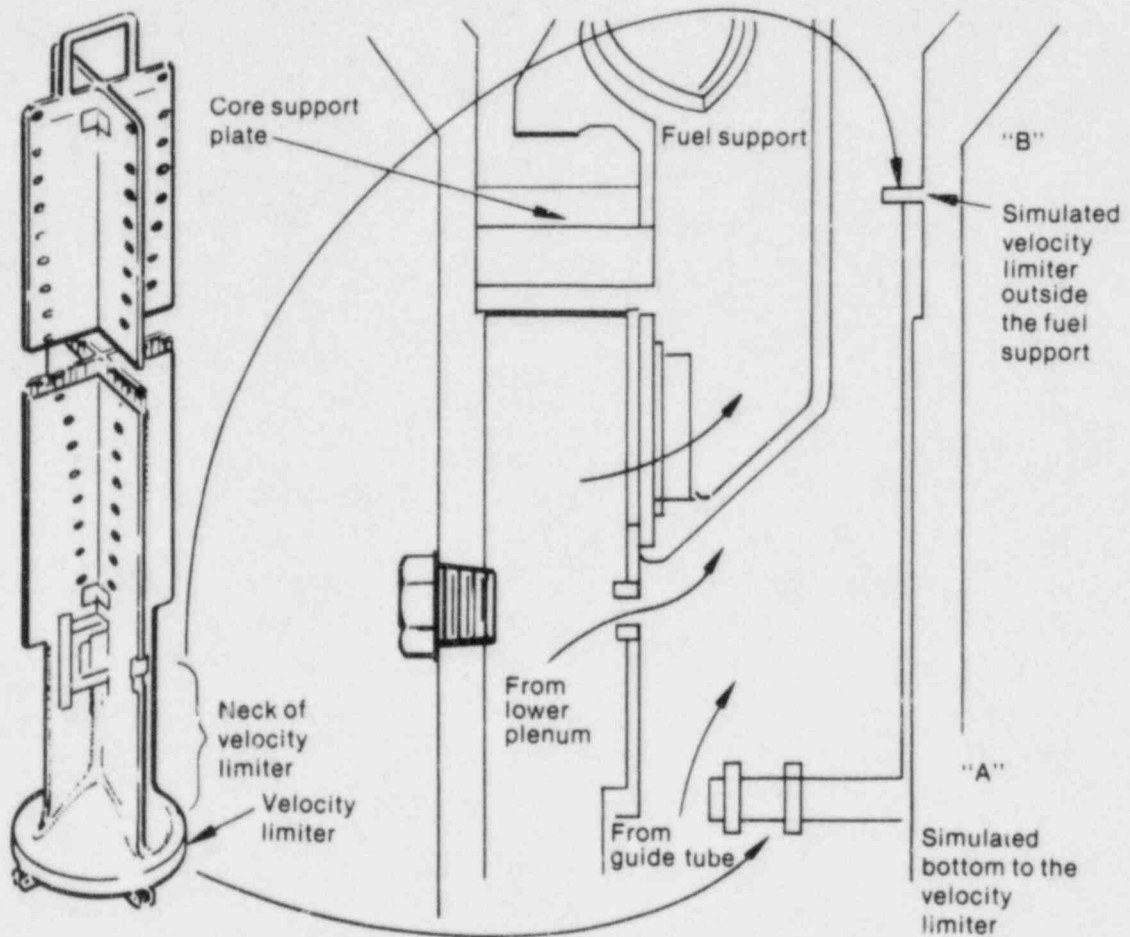

INEL 4 3899

Figure 3-9 FIST Velocity Limiter Simulation

The smallest flowpath, limiting the flow between the guide tubes and bypass, is created by the lower end of the velocity limiter. This restriction, "A" in Figure 3-9, is modeled in FIST by an orifice located at the elevation of the corresponding BWR velocity limiter, when the control blades are fully inserted.

Another restriction "B," is placed in the bypass region of FIST. This restriction represents the flow obstruction due to the insertion of the neck of the velocity limiter (region below the blades but above the parachute-shaped bottom) into the bypass. This restriction is placed at the average height of the neck of the velocity limiter as shown in Figure 3-9.

3.2.2.2 Bypass Stored Heat Considerations. The FIST bypass metal has a volume which is approximately 7.5 times greater than the BWR/6 scaled volume and a surface area which is approximately 1.6 times greater than the BWR/6 scaled area. Since there is no insulation on the inside walls of the FIST vessel, the differences in metal mass and area are expected to affect the heat transfer rate and temperatures in the bypass metal, the two-phase level and vapor generation rate of the bypass fluid, and CCFL at the bypass exit. The effects are expected to be more severe in tests with high depressurization rates (i.e., large-break tests and tests with ADS actuation) since the difference between the metal and fluid temperatures are greatest in these tests, resulting in significant heat transfer rates. To assess the effects on the bypass response, a simple comparative study was done using TRAC to compare the FIST bypass and a scaled BWR/6 bypass. The fluid volume and free flow area for the FIST bypass and the scaled BWR/6 are the same, but the inner radius and metal thickness for the two cases differed because metal surface areas and volumes are different.

No new fluid was allowed to enter or exit the control volume but the contained bypass fluid was allowed to expand and exit through the top.

The pressure transient was a simple linear depressurization derived from data at 10 and 50 s for the TLTA-5A large-break reference Test 6425.

Figure 3-10 shows the wall heat transfer to the fluid for both the FIST and the scaled BWR/6 bypass. For both cases, there is enough stored heat in the metal to produce nucleate boiling after flashing begins (between 14 and 15 s). At the point of maximum difference, right before the two-phase level begins dropping in the FIST bypass, the FIST heat transfer is approximately 6 times larger than the

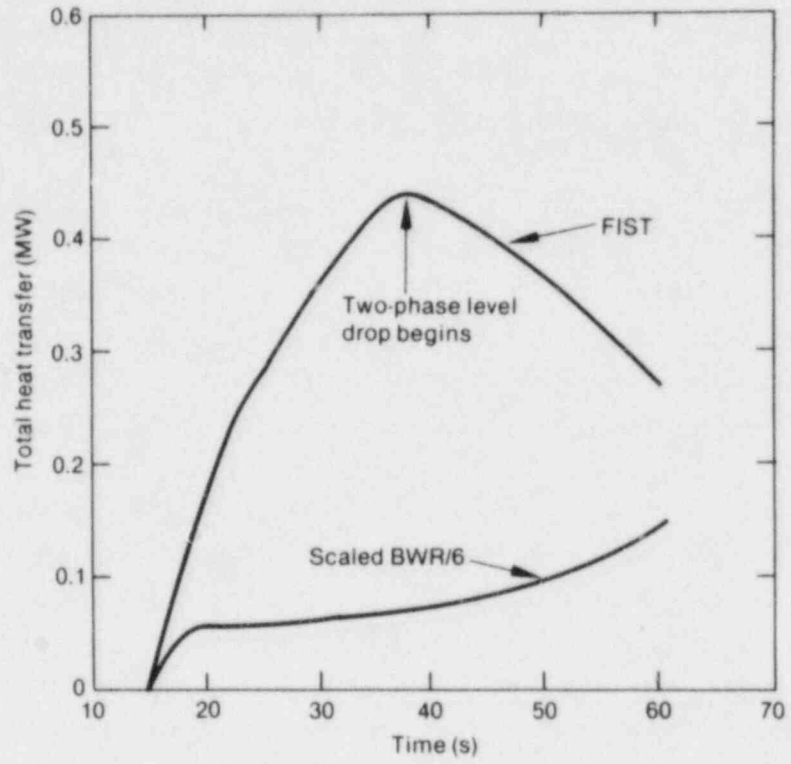

Figure 3-10 Total Bypass Metal Heat Transfer to Fluid

scaled BWR/6. The two-phase level begins dropping in the FIST bypass at approximately 37 s, while the two-phase level never drops in the BWR simulation case for this idealized transient.

Because of this excessively large heat transfer, the calculated exit vapor flow from the FIST bypass is up to two times greater than in the scaled BWR/6 case. This overly large exit flow could be expected to affect CCFL at the bypass exit.

To check the extent of this possible problem, the limiting vapor velocity at the bypass exit was calculated and compared to the exit vapor velocities for the two cases. The Kutataladze CCFL correlation was used to calculate the limiting vapor velocity.

Figure 3-11 shows that after ~40 s, no liquid drainage is expected from either the scaled BWR/6 or FIST bypass since both their vapor velocities are above the limiting case. Between 20 and 40 s, however, the scaled BWR/6 bypass has a vapor velocity which is slightly lower than the limiting case. For this time interval, the calculation indicates the BWR/6 bypass would allow some liquid downflow while the FIST bypass would be completely shutoff by CCFL.

A further complication could arise from the hot metal in the FIST bypass. The calculated wall temperature response at the top of the FIST bypass closely follows the scaled bypass response, as shown in Figure 3-12, until the two phase level begins to drop inside the FIST bypass. But then the FIST temperature remains fairly constant at 534 K while the scaled BWR/6 temperature follows the fluid saturation temperature downward. The major consequence of this will be realized after the LPCI system begins to inject. Some of the subcooled LPCI fluid can be expected to cool the hot bypass metal (particularly the uncovered upper portion) instead of condensing steam in the bypass. This could further affect the CCFL conditions at the bypass exit and interfere with the refilling of the bypass and bundle.

It should be recognized that the analysis used for this study was simplistic so the results are not to be considered accurate predictions of the actual FIST bypass response. However, the results, when used in comparison, do give an indication of how overscaled metal mass and surface area may affect the response.

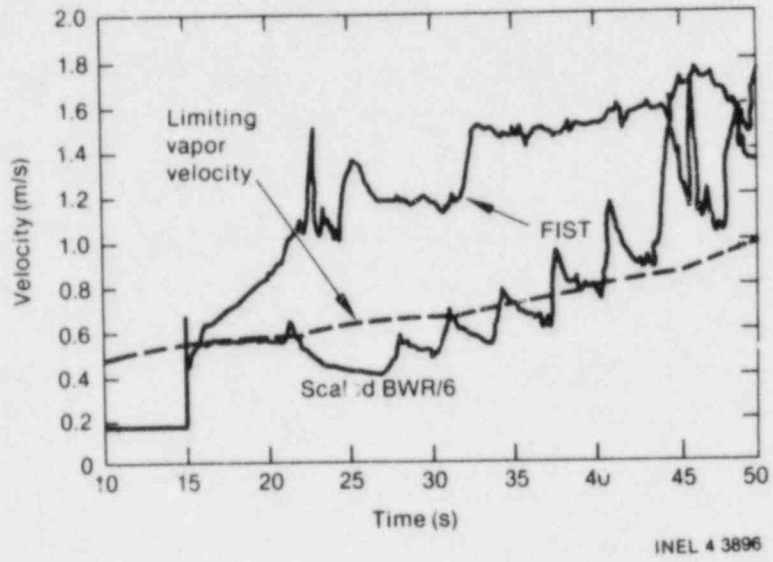
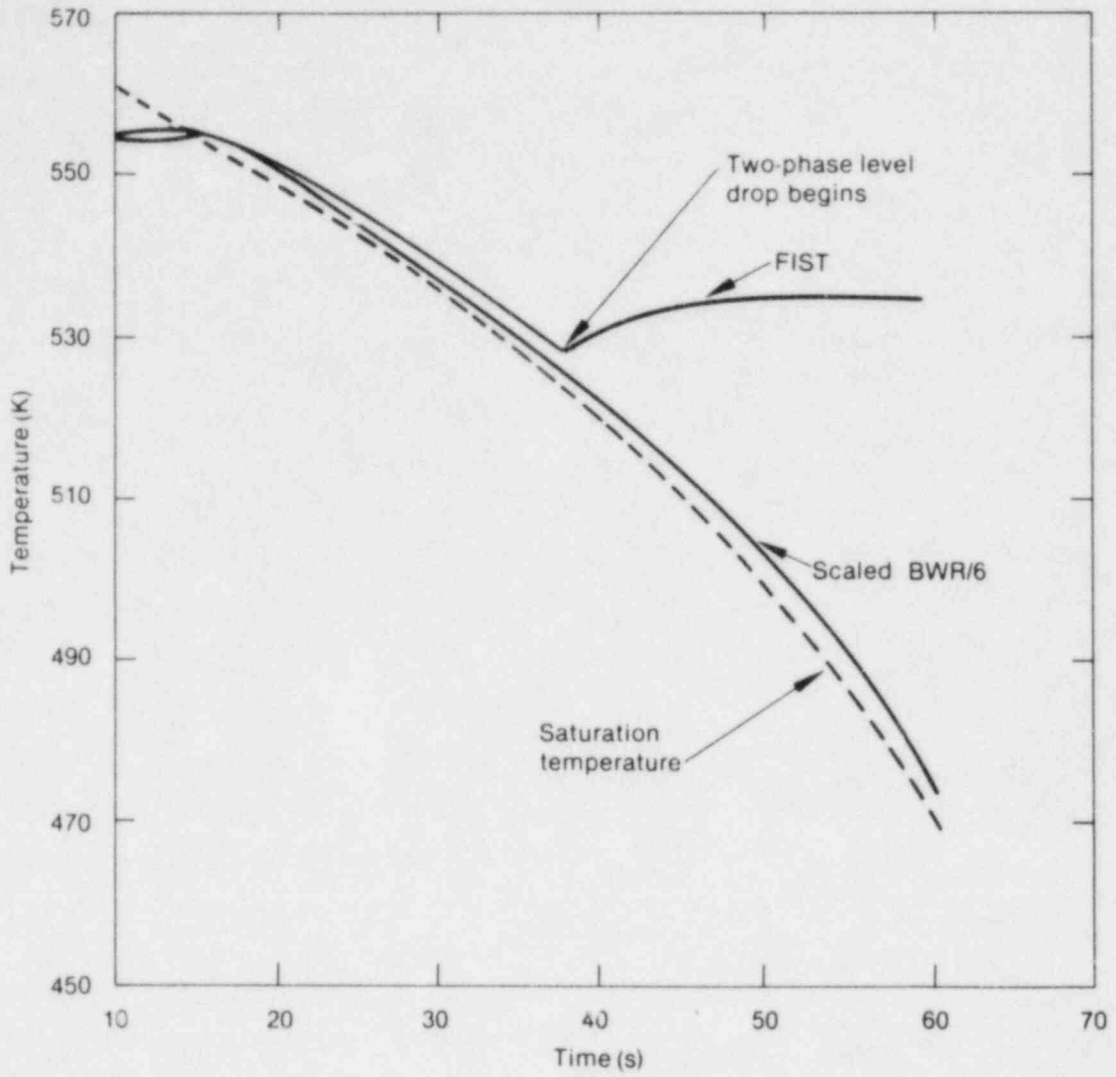

Figure 3-11 Bypass Exit Vapor Velocities



INEL 4 3881

Figure 3-12 Inside Wall Temperature at the Top of the Bypass

3.2.2.3 Bypass Cross-Sectional and Exit Area Scaling.^a The FIST bypass cross-sectional area which has been the subject of the above discussion is distributed as shown in Figure 3-13. This flow area distribution exists up the length of the bundle to the location of the upper tie plate, as shown in Figure 3-14. There the bypass exit area is defined by flow passages in that upper tie plate.

As noted above, the separate-effects calculations indicated that a possible problem existed at the bypass exit area due to an interrelated set of circumstances involved with the initial FIST design. A further data point in these considerations was available from test results from the Steam Sector Test Facility (SSTF), a multi-bundle facility used to investigate CCFL phenomena at the top of the core. In particular, data from that test program indicated the SSTF bypass liquid drainage rate, through the exit flow area, was much higher than that predicted by a one-dimensional CCFL analysis. This is due to the significant three-dimensional effects inherent in both the SSTF and the BWR. Clearly the FIST bypass is one-dimensional and thus the simulation of the BWR would not be desirable in this respect.

As a consequence, the FIST upper tie plate was redesigned and provided with a bypass exit flow area of 6.28 sq in. as opposed to the earlier, ideally-scaled, area of 2.15 sq in. The redesigned tie plate is shown in Figure 3-15. The eight 1-in.-diameter holes constitute the new exit flow area.

Figure 3-16 shows a comparison of the one-dimensional CCFL curves for the original and revised exit flow-areas. The SSTF three-dimensional data point (650 lb/hr steam upflow at 10 gpm liquid downflow) is also plotted in the figure. It shows that the FIST bypass, even with the much larger flow area, is still expected to be more restrictive for liquid drainage than the three-dimensional SSTF bypass. However, the modification made in the tie plate provided the largest practical flow area that could be incorporated without substantially complicating the bundle electrical design.

3.2.3 Jet Pump Scaling Performance

a. Editor's note: A good example of the interaction and feedback of the scaling study and facility design appears in the following text.

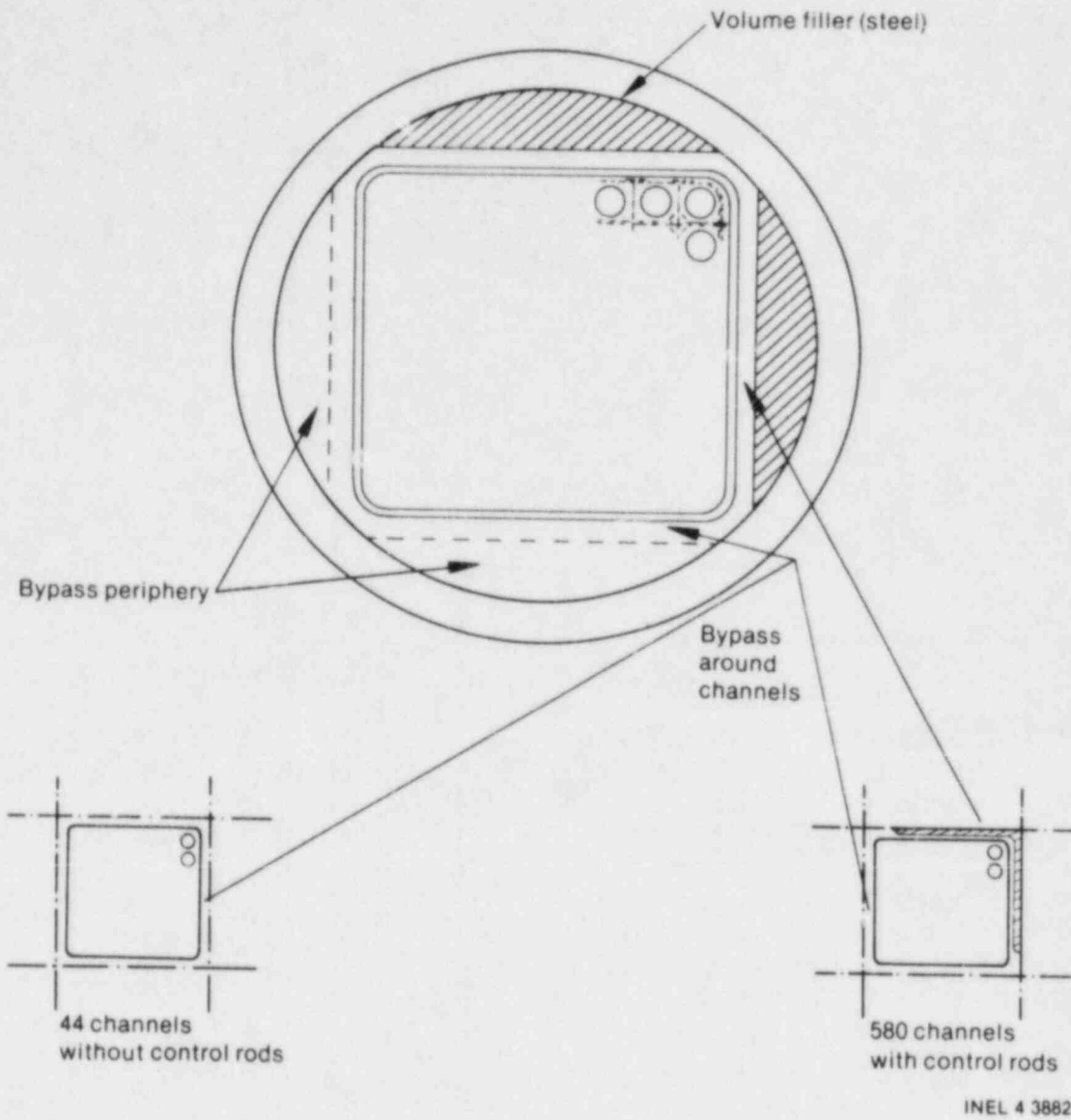

Figure 3-13 FIST Bypass Area Distribution

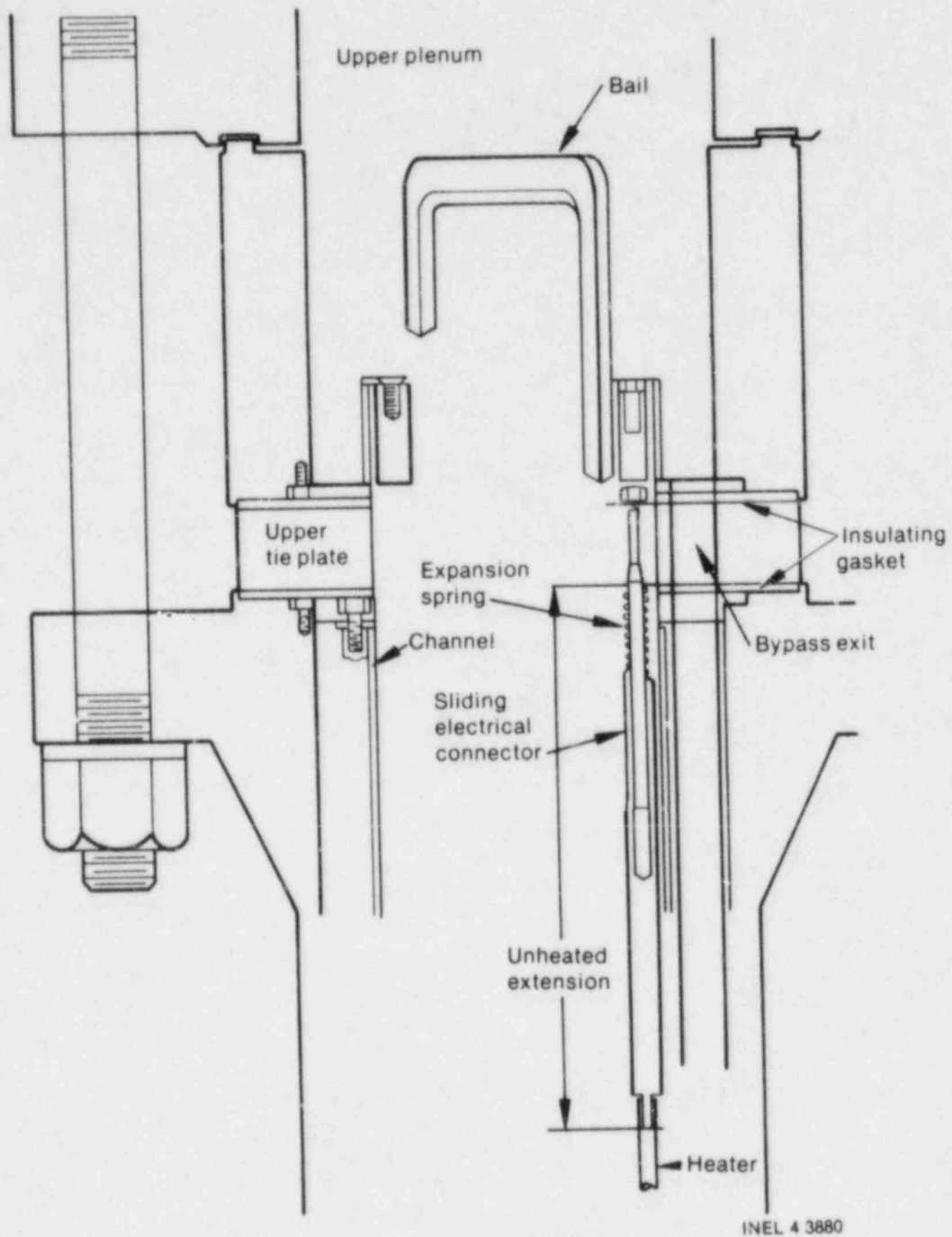

Figure 3-14 FIST Core Outlet

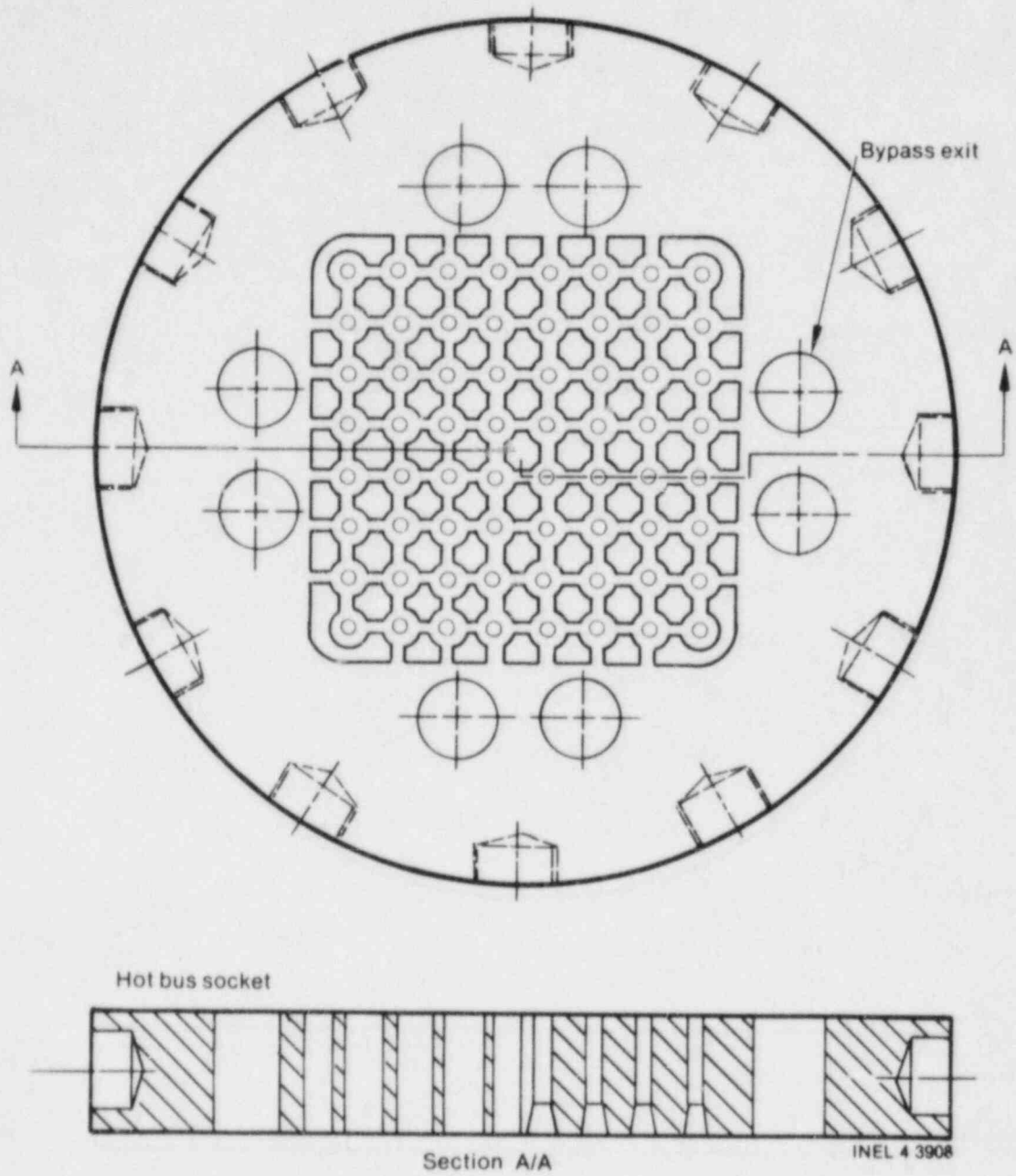

Figure 3-15 FIST Upper Tie Plate

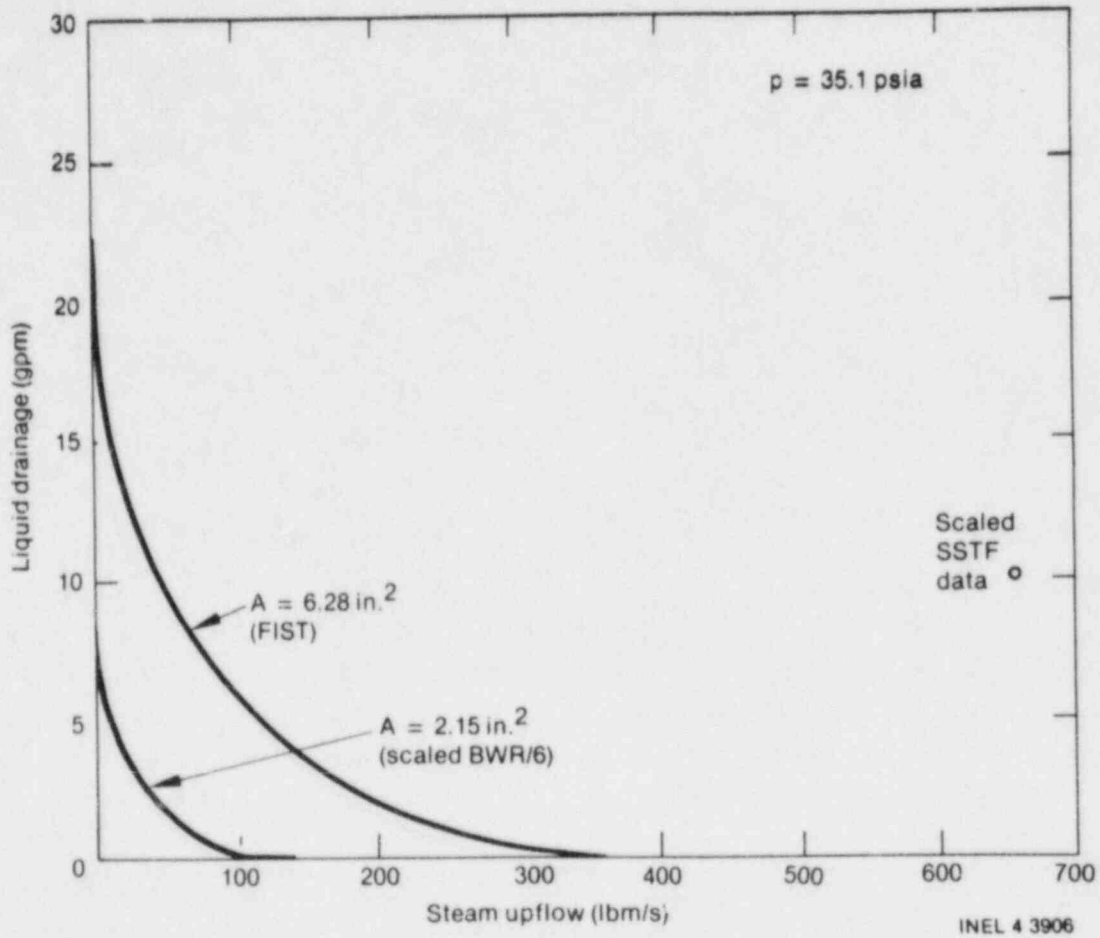

Figure 3-16 CCFL Curves for the Bypass Exit

3.2.3.1 Performance Characteristics. A separate-effects study was performed to evaluate the expected performance of the FIST jet pumps (JP). Table 3-2 presents a comparison of the irreversible losses calculated for the various sections of the FIST and TLTA jet pumps. These calculations were performed assuming a mass flow of 18.8 lbm/s. Entrance, mixing, and throat friction losses are the same for both pumps.

The results indicate roughly a 5-psi increase in irreversible losses in the FIST jet pump compared to the TLTA jet pump. A TRAC analysis of the two jet pump designs supports this conclusion.

TABLE 3-2. COMPARISON OF FORWARD FLOW LOSSES

<u>LOCATION</u>	<u>TLTA Jet Pump</u>	<u>FIST Jet Pump</u>
Diffuser	2.6 psi	2.2 psi
Tailpipe	0.1	3.1
Exit	1.3	3.0
Total	4.0	8.3

The flow losses for reverse flow through the jet pumps at reactor conditions are dominated (80 to 90%) by the exit loss from the jet pump inlet to the downcomer region. This is true for both steam and water flow. The reverse flow coefficient, K_r , can be defined such that

$$\Delta P_r = K_r \rho \frac{v_t^2}{2} \quad (3-1)$$

where

ΔP_r = reverse flow pressure drop

ρ = fluid density

v_t = jet pump throat average velocity

The relationship for the mass flow rate is then

$$\Delta P_r = \frac{K_r \rho}{2} \left(\frac{\dot{m}}{\rho A_t} \right)^2 = k_r \frac{\dot{m}^2}{2 \rho A_t^2}$$

cr

$$\dot{m} = \left(\frac{\Delta P_r 2\rho}{K_r} \right)^{1/2} A_t \tag{3-2}$$

It can be seen from Equation (3-2) that for a given ΔP and state conditions (i.e., $\rho = \text{const}$)

$$\dot{m} \propto A_t / K_r^{1/2}$$

or

$$\dot{M} \propto U_t^2 / K_r^{1/2} \tag{3-3}$$

It is the quotient $(D_t^2 / K_r^{1/2})$, then, that must be correctly scaled in order to ensure an appropriate reverse flow rate.

The value of K_r for liquid flow through a typical BWR jet pump is estimated to be 0.80 - 0.90. The value of K_r for the FIST jet pump is estimated to be 1.40, most of the increase being due to higher L/Ds. Reverse steam flow test data for the TLTA jet pump was used to calculate K_r under these conditions, yielding 1.14 and 1.20 for low- and high-flow conditions, respectively. The long extension for the FIST application brings these values of K_r to 1.25-1.31. A K_r of 1.30 represents an intermediate value of the range between 1.25 and 1.40, and is used in the analysis.

The ratio of expected reverse mass flowrate in FIST to that desired for the optimum scaled BWR/6 facility is then

<u>Scaled BWR/6</u>	<u>FIST</u>
$K_r \sim 0.80 \text{ to } 0.9$	$K_r = 1.30$
$D_t = 0.76''$	$D_t = 0.914''$

$$\frac{\dot{m}_{r \text{ FIST}}}{\dot{m}_{r \text{ Scaled BWR/6}}} = 1.14 - 1.20$$

Summarizing, the increased tailpipe length and decreased diffuser length combine to increase the pressure drop in the FIST jet pump (as compared to the TLTA), but this increase is predicted to be less than 5 psi at rated core flow. An increase in the drive flow to the jet pumps is required in order to compensate for this difference. Section 2.1.2 documents recirculation loop and jet pump flow coastdown requirements.

The reverse-flow-loss coefficients, based on the JP throat area, for the reference BWR JP is between 0.80 and 0.90, the corresponding FIST coefficient is computed to be 1.3. This higher reverse-flow-loss coefficient in FIST is due in part to increased L/D losses in the tailpipe and in part to exit losses which are higher than those for the scaled BWR case. These higher losses result from the fact that the JP nozzle, which is situated directly above the throat and interferes with the exiting flow under reverse conditions, is slightly overscaled from the BWR case. The larger than scaled reverse flow area in FIST (Table 3-1), however, more than compensates for this, resulting in a better blowdown flow simulation. The blowdown rate is estimated to be between 14 to 20% higher than the rate expected in the reference BWR.

3.2.3.2 Jet Pump Flow Interaction and Volume Considerations. In the reference BWR there is a large lateral separation between the jet pumps which are operating from different recirculation loops (see Figure 3-17). The FIST facility cannot simulate this separation, therefore the proximity of the jet pumps is uncharacteristic of the BWR. To minimize the consequences of this design, flow dividers (baffles) are used at the JP inlet and exit. These baffles should minimize the potential for uncharacteristic interaction of the flows of the jet pumps, especially during a blowdown when the flows from the two jet pumps reach their highest relative velocities. The FIST jet pump baffles are shown in Figure 3-18.

A sketch of the jet pump region for FIST and the BWR is shown in Figure 3-19. Figure 3-20 shows the regional volume distributions. The FIST JP volume is overscaled by approximately 62% due to scaling compromises that were made to obtain the desired jet pump performance. This volume difference, however, is small compared to the overall system volume or to the volume in the lower plenum and guide tubes, but can affect the refill/reflood timing. The difference in refill volume between the FIST JP and the scaled BWR JP is less than 5.0% (this considers the volume required to fill the guide tube, channel, and bypass in the region between the bottom of the JPs and the top of the JPs). Consequently the effect on refill/reflood time is expected to be small.

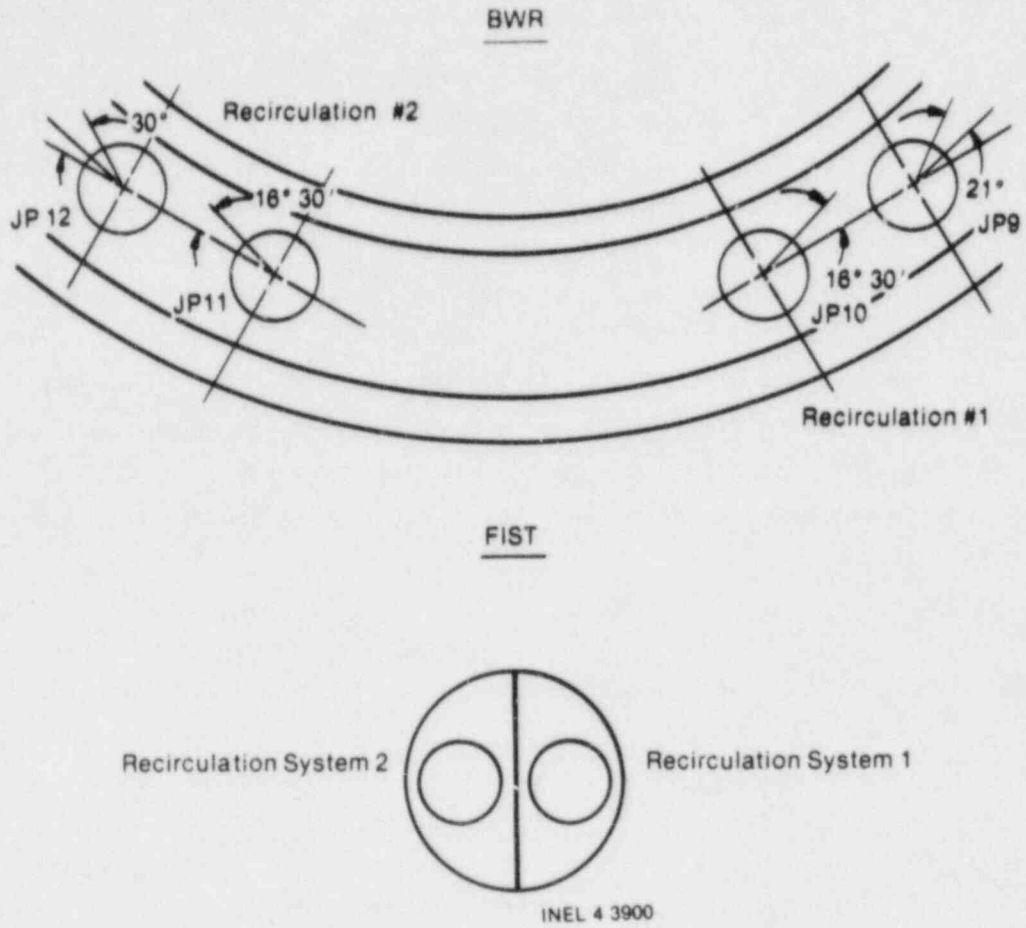

Figure 3-17 Lateral Separation of Jet Pumps

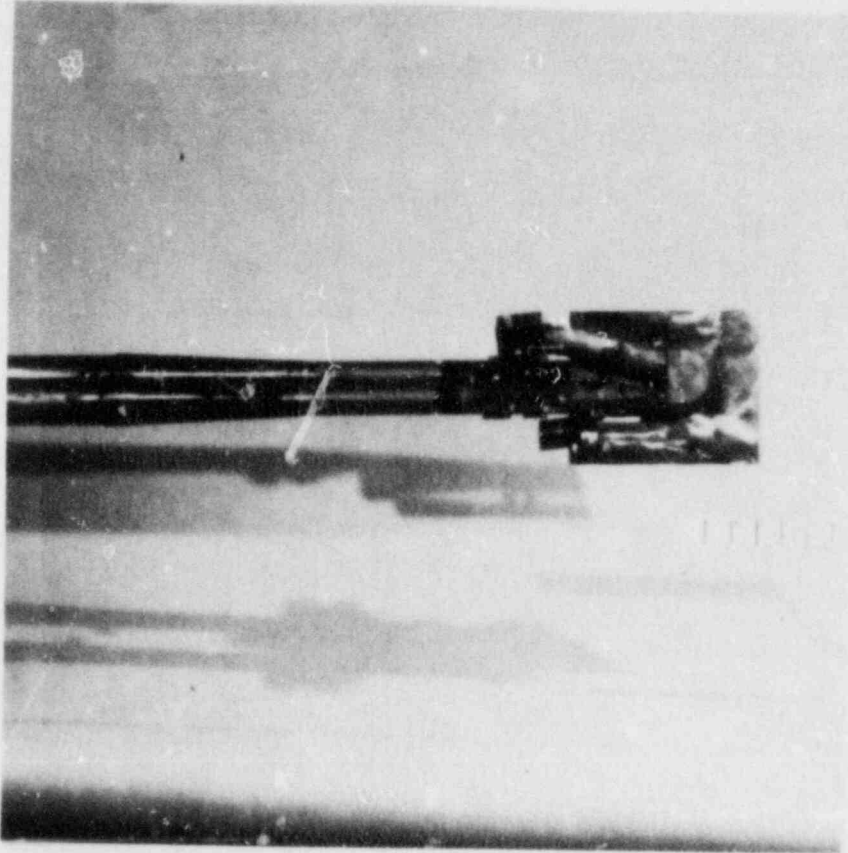

Figure 3-18 FIST Jet Pump Baffles

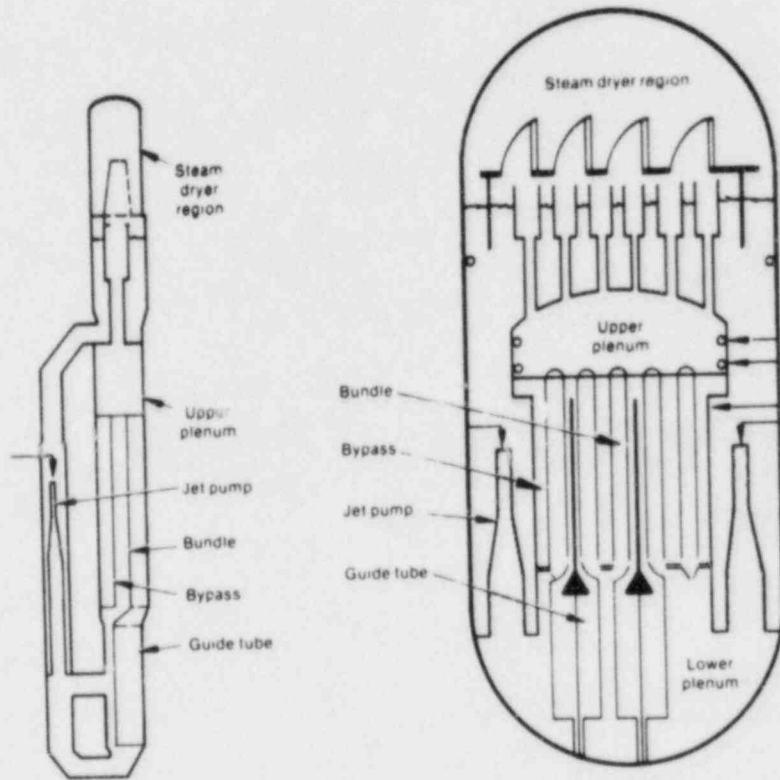
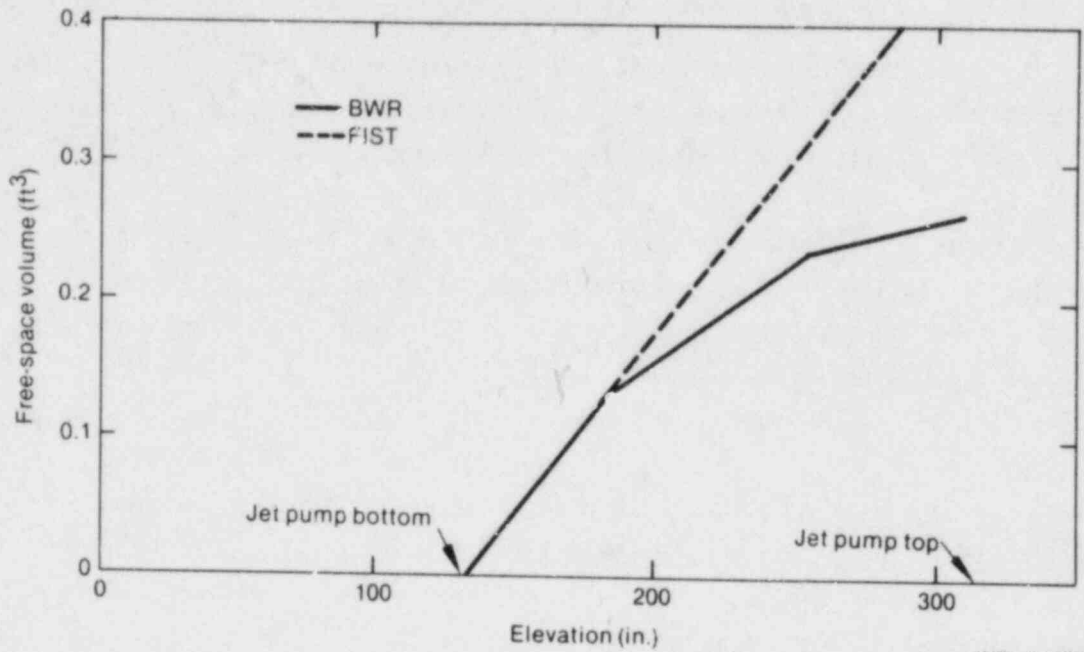

Figure 3-19 Jet Pump Region



INEL 4 4468

Figure 3-20 Jet Pump Regional Volume Distribution

3.2.4 Downcomer

3.2.4.1 Volume Considerations. As described in detail in Section 2.1.1.1, the annular downcomer region in the BWR is modeled in FIST by using an external pipe connected to the main vessel. This region contains part of the lower plenum, the jet pumps, and the downcomer fluid (fluid surrounding the jet pumps).

The use of an external, single-pipe, downcomer has three advantages. First, it permits accurate modeling of both the average scaled cross-sectional area and the representative volume distribution in that region. This, in turn, provides realistic water levels at the appropriate BWR elevations. Second, it produces a more representative ratio of downcomer surface area to fluid volume than could be obtained if an annular downcomer were employed. It also provides the space required to install two jet pumps, each connected to separate recirculation systems. Third, this split configuration i.e., separate downcomer and core region, allows greater access to the core region and facilitates access to the instrumentation.

Accurate modeling of the BWR fluid volume versus height in the downcomer allows realistic simulation of water level transients. The water level movement in the downcomer in the BWR is measured and used for both normal operation and for ECCS activation. FIST includes similar level instrumentation which is used to initiate the ECC system and to control the feedwater system so that the real-time key events occurring in a BWR are simulated. Alternatively, the level instrumentation can also be used as a monitoring device. Also an accurate simulation of the water level provides the appropriate static heads in the vessel that are necessary for the replication of the thermal-hydraulic phenomena (e.g. natural circulation) occurring in a BWR. The FIST and BWR downcomer regions are illustrated in Figure 3-21. Figure 3-22 shows that the downcomer volume distributions for FIST and the scaled BWR are very well matched. Furthermore, for slow loss of inventory events or for long-term transients, the hydrostatic head in the downcomer directly affects the natural flow characteristics. These characteristics should thus be well simulated in FIST.

3.2.4.2 Jet Pump Interface with Downcomer. In the BWR geometry, jet pump nozzle assemblies located directly above the jet pump inlets represent a local flow restriction for reverse flow (Figure 3-23). Although this flow area is fairly well scaled in the current FIST design, the design does not correctly represent the circumferential asymmetry present in the BWR downcomer, namely the

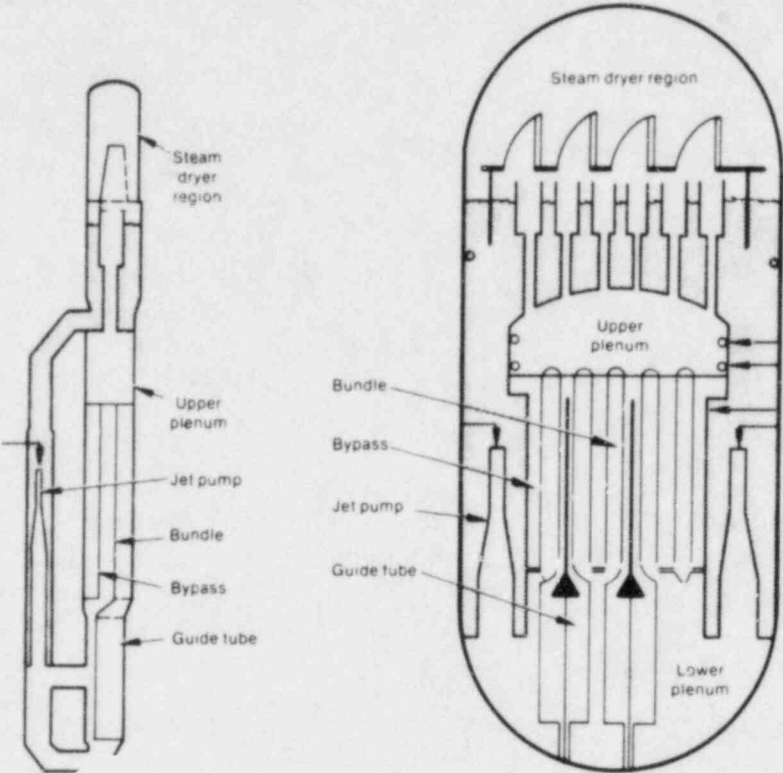
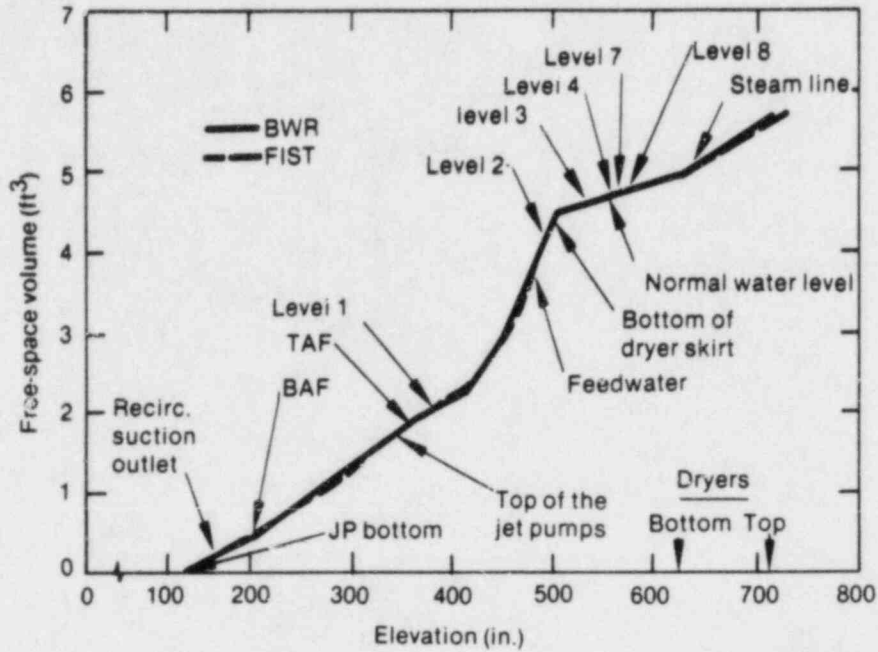

Figure 3-21 Downcomer Region



INEL 4 3889

Figure 3-22 Downcomer Regional Volume Distribution

unrestricted flow paths (between "A" and "B" in Figure 3-23) in the downcomer region located directly above the recirculation suction inlets.

An estimate indicates that during the later phases of a rapid depressurization transient, such as a simulated steam-line break, there may be a high rate of steam flow through the jet pumps resulting from vaporization in the lower plenum. In the reference BWR, there are alternative paths for steam to be diverted in the three-dimensional, annular downcomer region, and thus CCFL in the vicinity of the jet pumps is not expected to occur. However, this steam flow in the FIST design may create a CCFL condition at the restriction, thus creating an unrealistic holdup of liquid above the jet pump, which may produce a nontypical ΔP across the core region during the refill/reflood stages of a transient. In order to minimize the possibility of unrealistic CCFL occurring, the downcomer area around the jet pump nozzle assemblies is slightly enlarged (see Figure 3-24). This design modification does not significantly affect the downcomer volume or the overall design of the downcomer region. It does, however, assist in alleviating the potential for unrealistic CCFL to occur there.

3.2.4.3 Dryer Skirt Simulation. In the reference BWR, the annular region formed between the vessel wall and the dryer skirt (between elevation 505 and elevation 617.25) is 6.4 in. wide. The region between elevation 617.25 and elevation 624.24 is also an annulus with a width of 3.2 in. These two regions if ideally, linearly scaled (1:624 or 1:24.98) would result in annular regions with widths of ~ 0.25 in. and ~ 0.13 in., respectively (Figure 3-25). These narrow gaps and the resulting boundary layer effects may significantly alter system parameters (i.e., water level movement). For this reason the FIST Facility has been designed with an annular segment spanning ~ 76 degrees (for elevation 505 to elevation 617.25). This segment was designed to contain the same volume as that which would have been contained in the ideally scaled annular region. In order to simulate the restriction between elevation 617.25 and 624.24, a slot is cut in the plate that forms the bottom of the dryer (elevation 624.24). The total flow area of the slot corresponds to the ideally scaled area for this region in the BWR. The annular segment is positioned so that it is centered directly under the steam line.

The dryer skirt design is described in Section 2.1.1.6. As noted there, a slot is cut in the plate which forms the bottom of the dryer (see Figure 3-25).

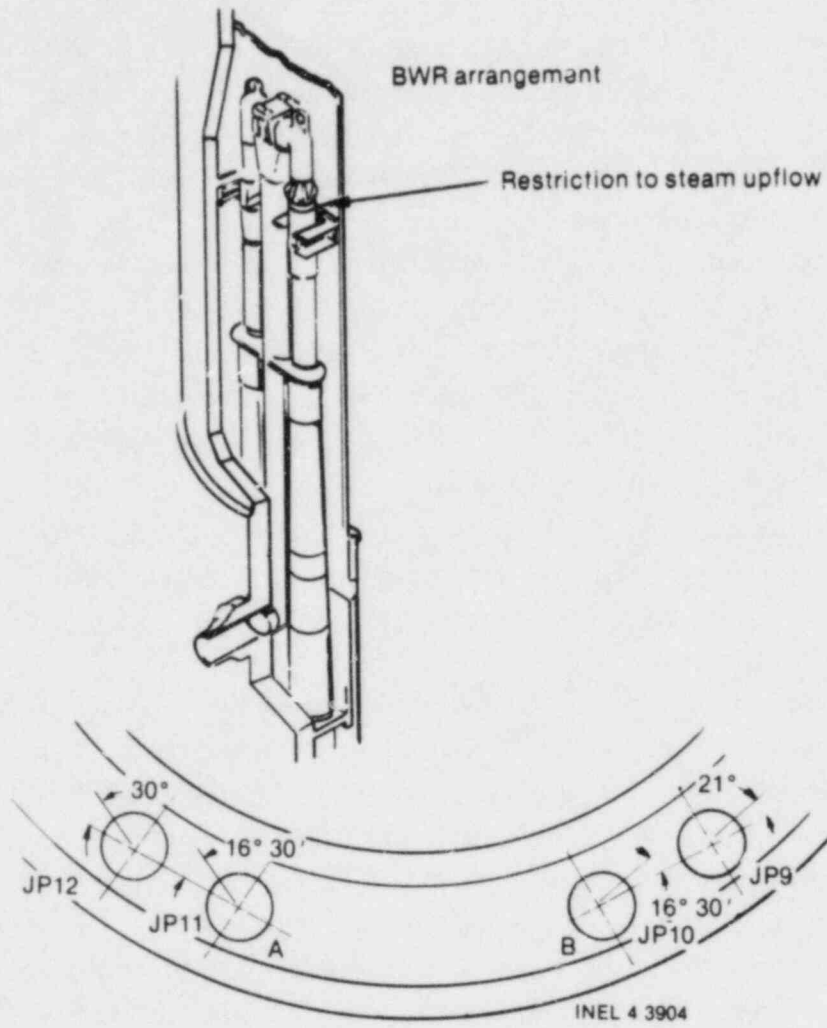
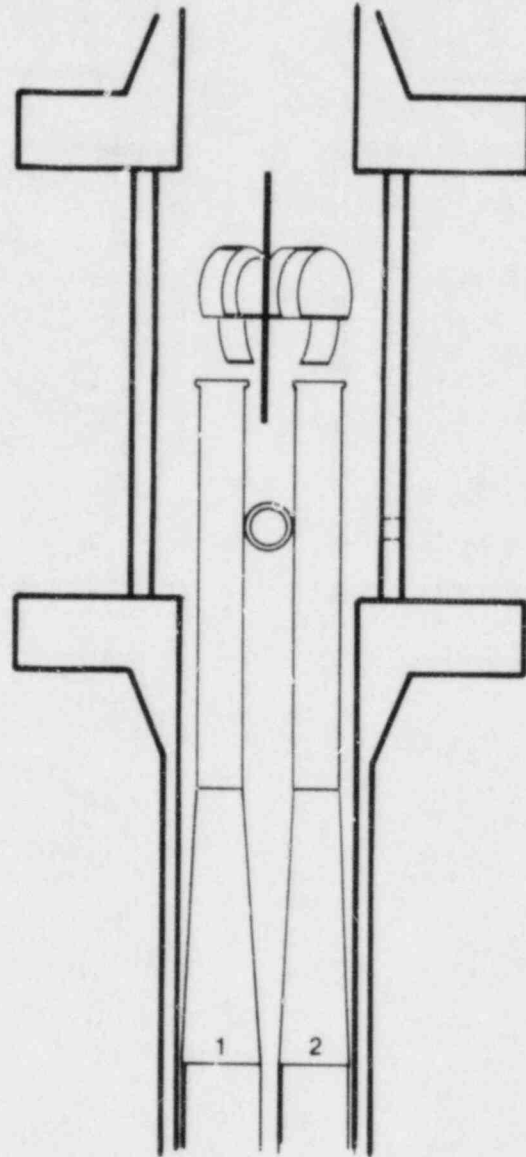
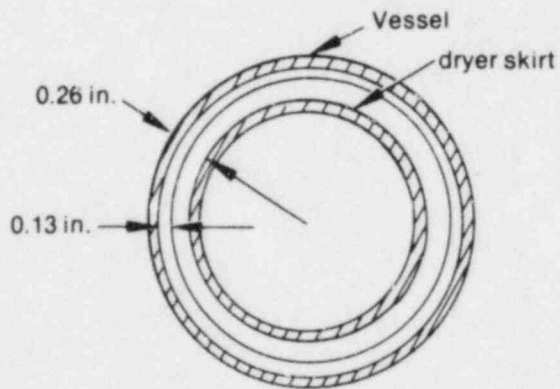
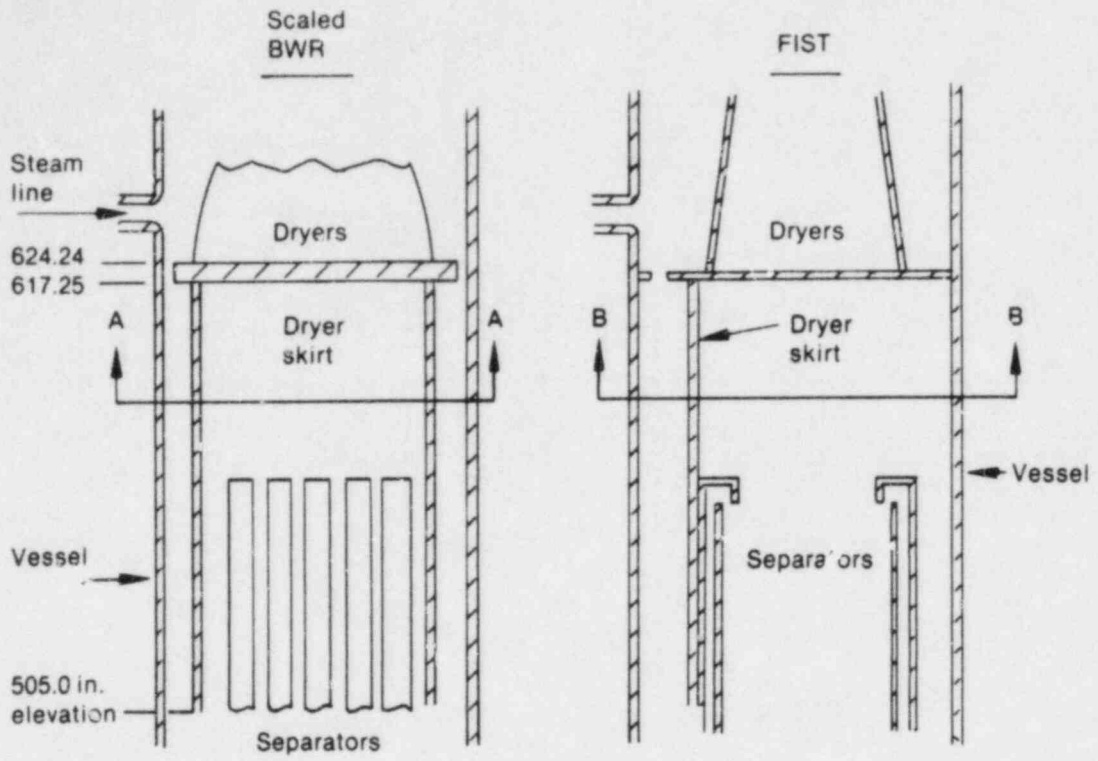

Figure 3-23 Downcomer Steam Upflow Restriction



INEL 4 3905

Figure 3-24 FIST Expanded Downcomer



Section A-A

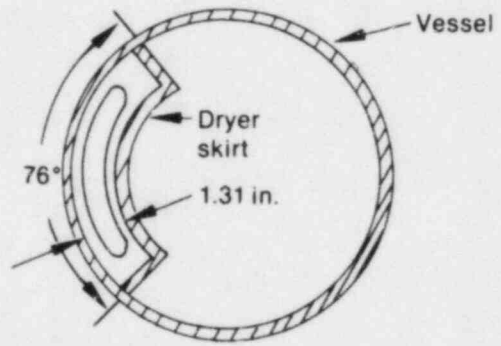

Section B-B

INEL 4 3877

Figure 3-25 Dryer Skirt Simulation

One of the scaling concerns is the potential for CCFL to occur at this slotted restriction. The amount of CCFL occurring in FIST in this region may be larger than that which would occur in the reference BWR under the same conditions. This is due to the necessary overscaling of the FIST metal masses and heat transfer areas. The possibility of this phenomena occurring has been examined preliminarily and determined to be relatively small.

3.2.5 Upper Plenum, Separator, Dryer and Dome

3.2.5.1 Volume Considerations. The upper plenum (UP)/standpipe/separator region is illustrated in Figure 3-26 for FIST and the BWR/6. The volume distributions are presented in Figure 3-27. The two distributions are fairly well matched except at the BWR shroud head dome region. The shroud head dome is simulated in FIST by extending the UP pipe to an appropriate height, giving the correct scaled UP volume. The FIST standpipe was then chosen to give the correct standpipe scaled volume. The FIST UP level in the region corresponding to the BWR shroud head dome will be slightly affected by this geometry difference; however, the overall system response is expected to be uncompromised.

A sketch of the steam-dome region is shown in Figure 3-28, and Figure 3-29 shows the regional volume distributions for FIST and the scaled BWR. The total FIST steam-dome volume is only 1.5% overscaled.

Because of its hemispherical shape, both the volume and the full height of the BWR vessel head cannot be simulated by the FIST vessel. Therefore, the top of the FIST vessel is located at the average height of the hemispherical BWR vessel head, thus providing the correct scaled volume above the dryers.

3.2.6 Recirculation Steam and ECC Systems

3.2.6.1 Volume Considerations. As stated previously, the recirculation loops must be capable of providing scaled jet pump drive flow so that the correct initial conditions are established in the vessel. In order to meet both this objective and other physical constraints (i.e., pump placement and pipe routing), the fluid volume in the loops is overscaled. In tests having rapid system depressurizations, fluid flashing occurs throughout the entire system and redistributes the mass and energy content of various regions. As such, the overscaled mass and energy contained in the loops may flow into the vessel and affect the system performance. Therefore, each loop is equipped with two

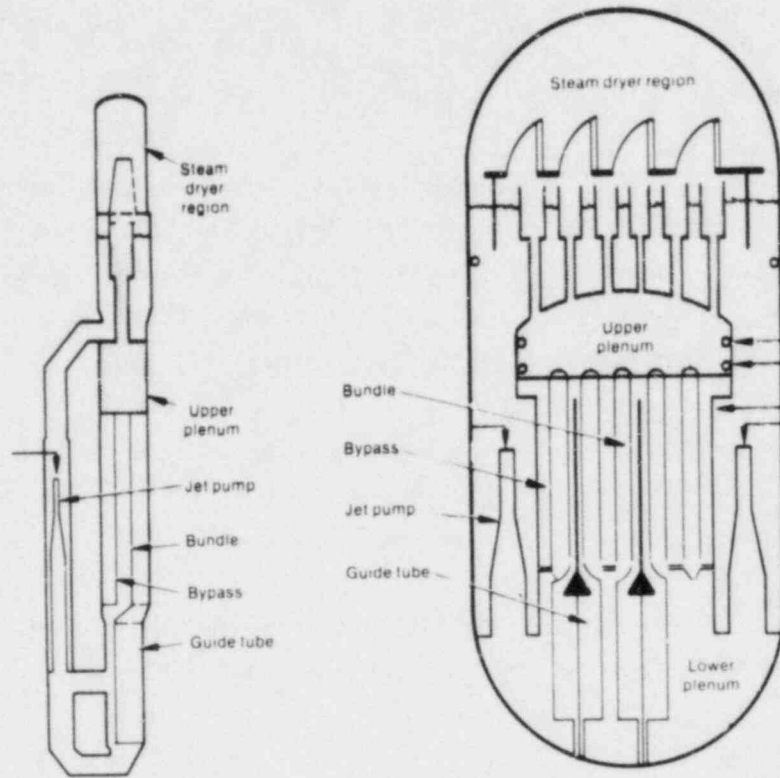

Figure 3-26 Upper Plenum/Standpipe/Separator Region

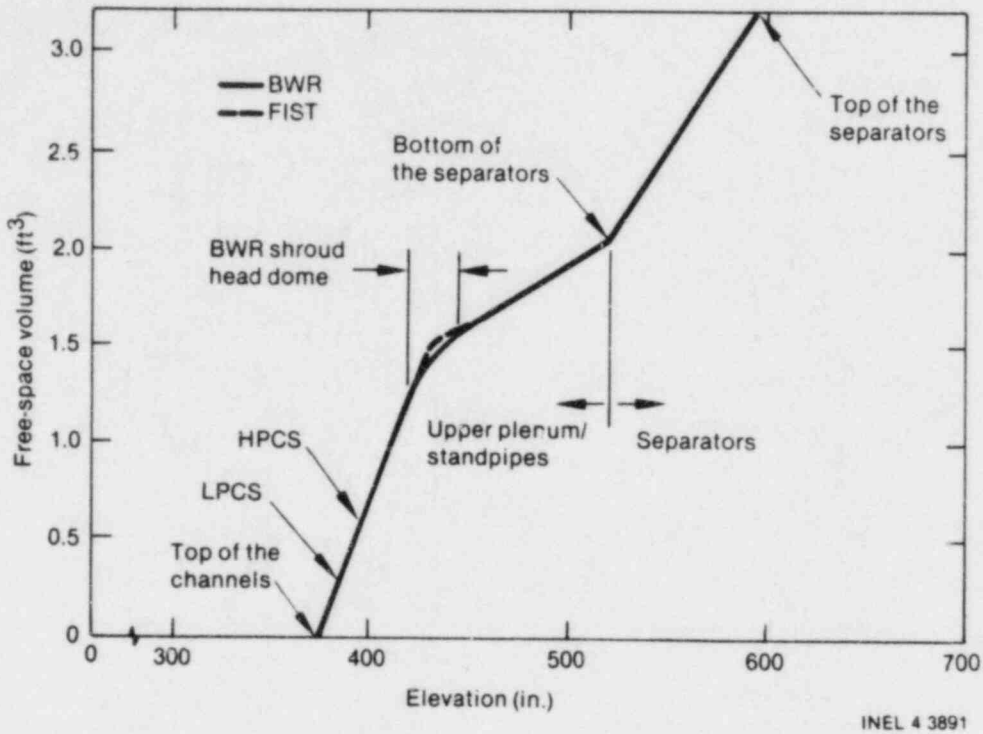

Figure 3-27 Upper Plenum/Standpipe/Separator Regional Volume Distribution

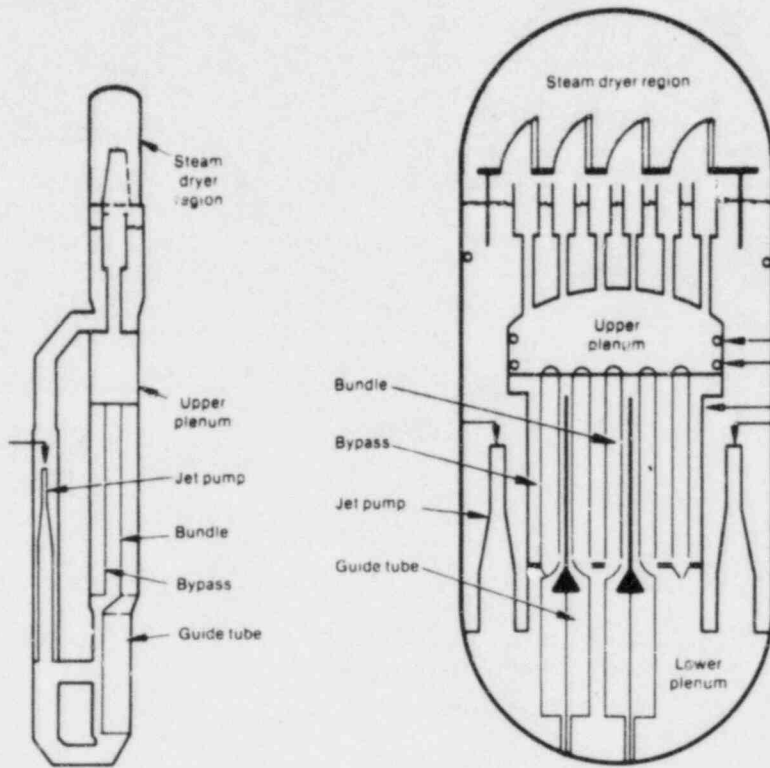

Figure 3-28 Steam Dome Region

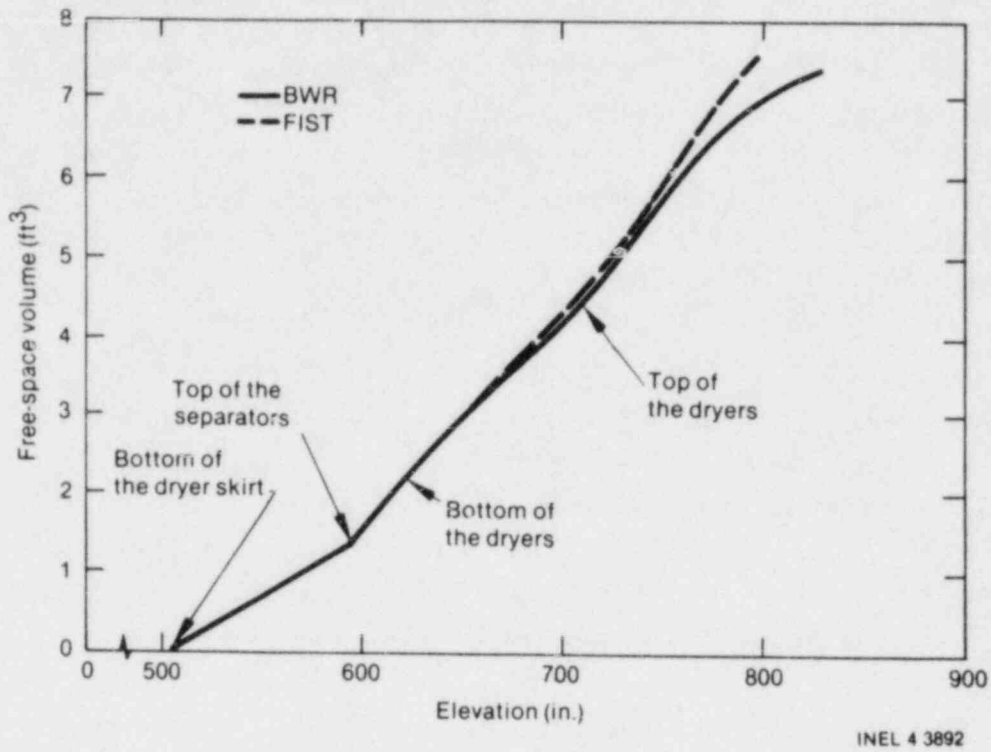

Figure 3-29 Steam Dome Regional Volume Distribution

isolation valves that can be closed after the pumps are tripped and the coastdown is complete, to ensure that the correctly scaled fluid volume is connected to the vessel.

3.2.6.2 Steam Line. A schematic of the steam-line simulation for the FIST facility is shown in Figure 3-30. Standard pipes are used in the steam-line design. With the incorporation of standard piping the fluid volume contained in the lines between the pressure vessel and the first main steam isolation valve (MSIV) is within 7% of the ideally scaled value. The full height of all vertical lengths of piping in the BWR is also preserved; however, the horizontal lengths are shortened to compensate for the slightly overscaled flow area of the standard pipes.

In the reference BWR, there is approximately 100 ft of additional piping downstream of the MSIV before the turbine stop valves (TSV), which are not simulated in FIST. By not simulating this piping, the steam line dynamic response will be affected for turbine trip tests. The FIST steam line should exhibit a higher frequency response, which is expected to affect the timing of the pressure oscillations in the early stages of the transient. However, this is not expected to have a significant impact on the overall system response.

During a steam-line break in the reference BWR, the following sequence of events is expected to occur (refer to Figure 3-31):

1. At ~ 0.1 second after the break the TSVs are closed. Total break flow area = 3.20 sq ft^a = area of one steam line + area of flow limiter, for $0.1 < t < 1.0\text{s}$
2. At ~ 1.0 s the turbine bypass valve is fully open. Total break flow area = 3.363 sq ft^a = steam line area + flow limiter area + turbine bypass area, for $1.0 < t < 4.5$ s
3. At ~ 4.5 s the MSIVs are fully closed. Total break area = 2.536 sq ft^a , for $t > 4.5$ s.

In order to simplify the break simulation, only items 2 and 3 above are incorporated. Therefore, only two break area sizes are represented as shown in Figure 3-32. This method of simulating the break areas is expected to yield conservative results.

a. All areas are BWR scaled values.

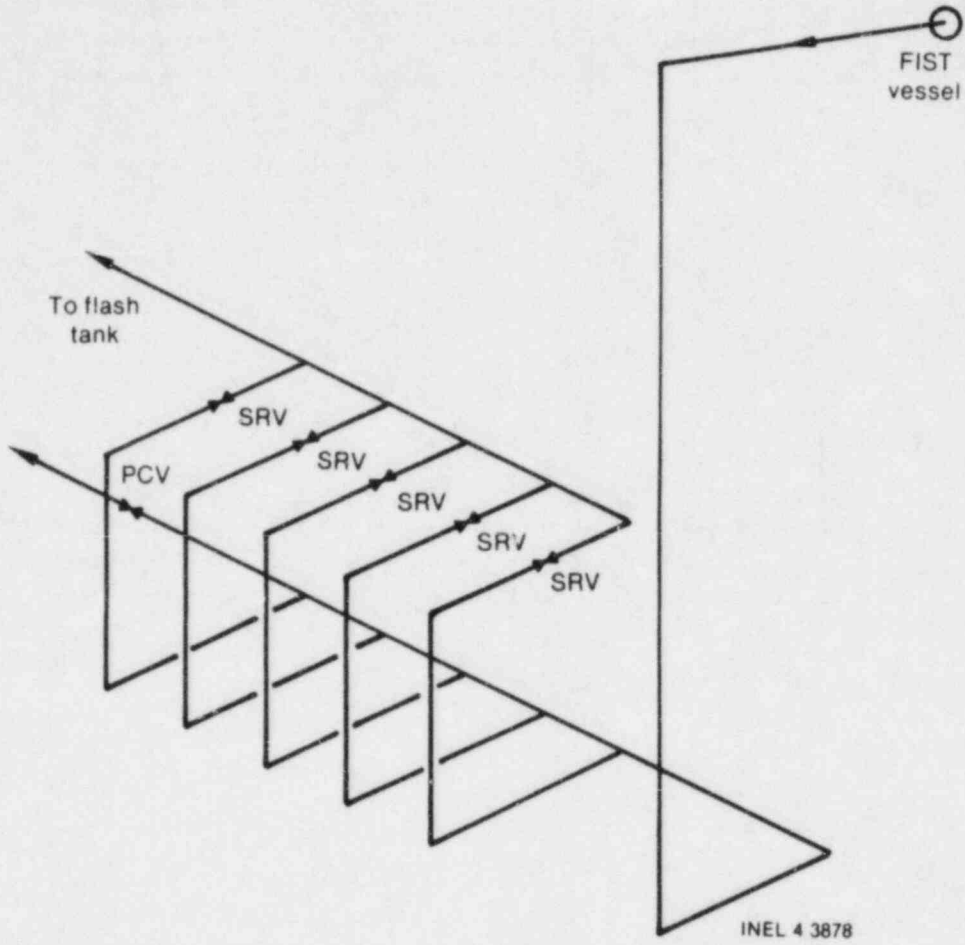
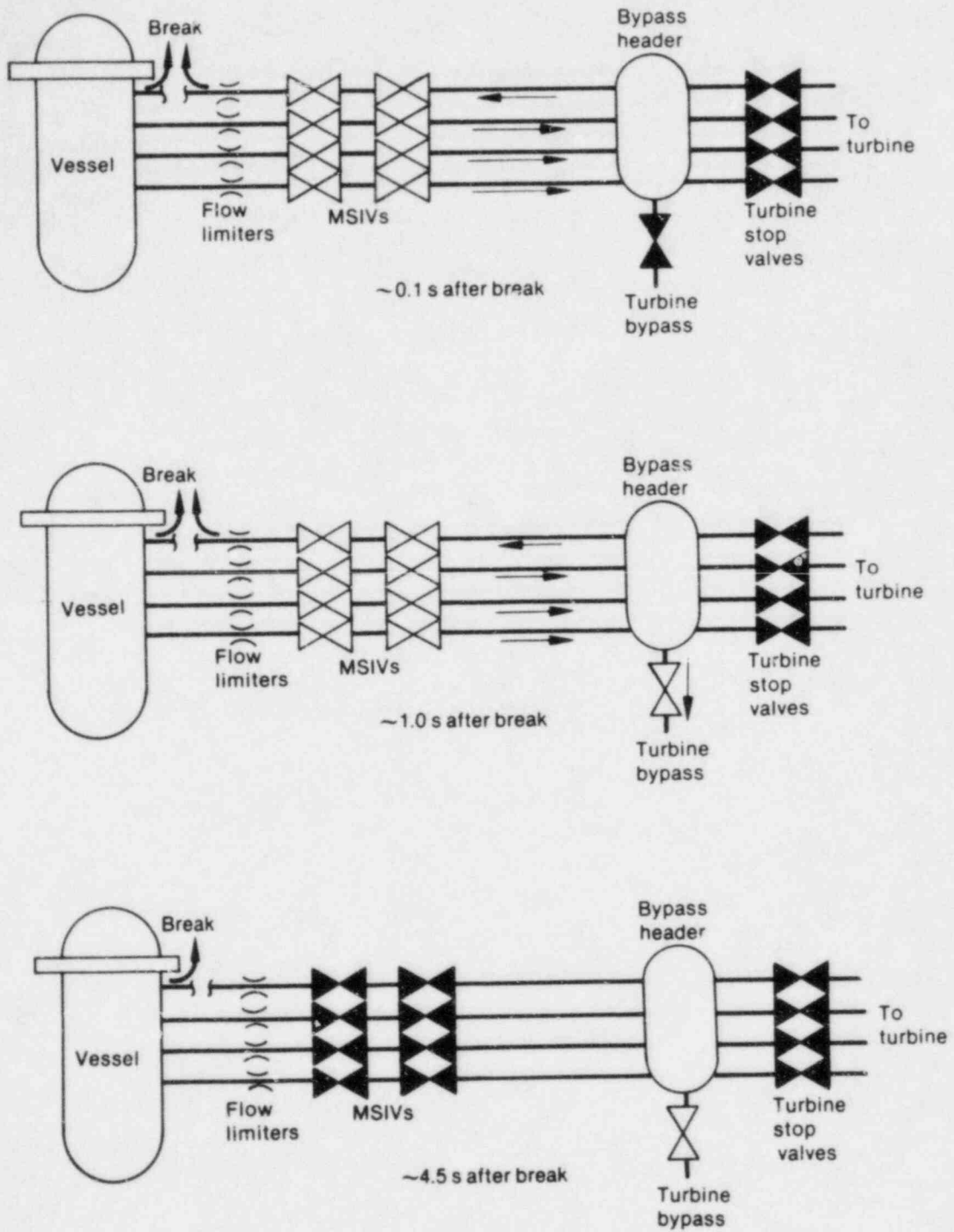
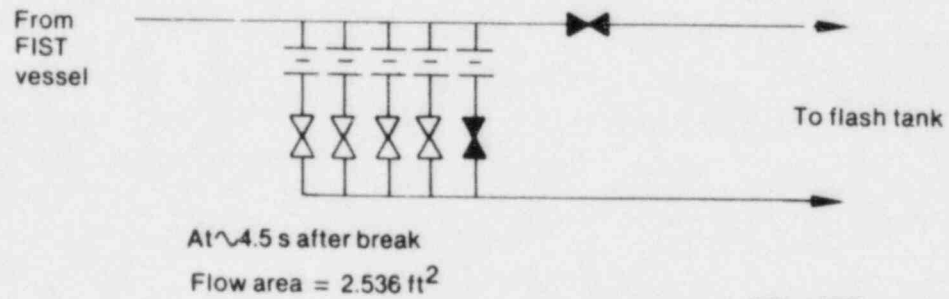
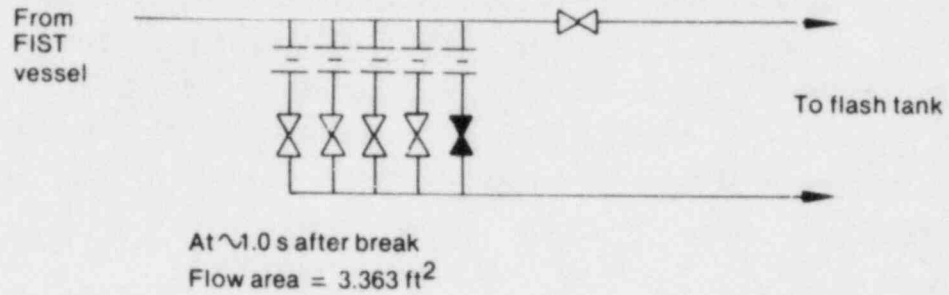
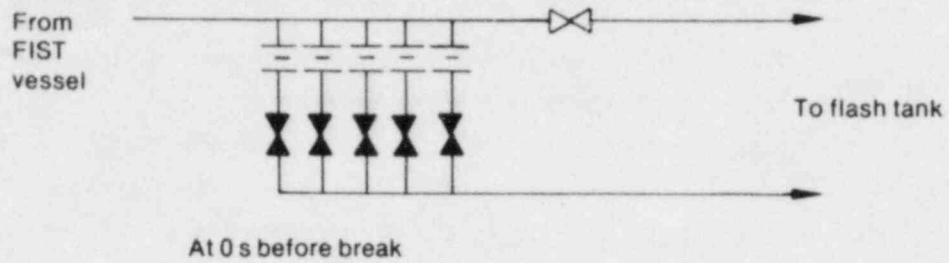

Figure 3-30 FIST Steam Line Configuration



INEL 4 3890

Figure 3-31 BWR/6 Sequence of Events for Steam Line Break



INEL 4 3876

Figure 3-32 FIST Steam Line Break Simulation

The BWR automatic depressurization system is activated only on coincident signals of high drywell pressure and low water level (\leq level 1). Because no containment simulation is included in the FIST facility design, the "occurrence" of high drywell pressure will be based on available BWR evaluations. If high drywell pressure is predicted for a given test, as is the case for LOCA simulations, then the simulated ADS will be activated on low water level. The BWR ADS time delay of 120 s will be implemented in the FIST facility tests. The ADS is simulated in FIST by opening the SRV representing the highest set-point group of the reference BWR. The flow orifice in this SRV line is sized to produce scaled ADS flow.

3.2.6.3 ECC Systems. The BWR HPCS system is activated on either high drywell pressure (≥ 2 psig) or low reactor water level (\leq level 2), and requires a maximum of 27 s for the diesel generator to drive the pump to rated speed and for all valve motion to be completed. This 27 s time delay will be implemented for the FIST LOCA tests so as to be consistent with assumptions used in the current evaluation methods. A nominal time delay of 20 s, however, will be used for the non-LOCA tests as this is more representative of actual BWR performance, when on-site power is available.

The LPCS and LPCI systems are activated on high drywell pressure or low reactor water level (\leq level 1), and require a maximum of 37 s for the pumps to reach rated speed and for all valve motion to be completed. Commencement of the LPCS and LPCI flows is not controlled by this time delay, however, since the vessel pressure does not lower past the shutoff head of the low-pressure pumps until well after 37 s. The timing of the actual injection of flow from the low-pressure ECC systems into the vessel is controlled by the vessel pressure in both the BWR and FIST through the use of a check valve.

3.3 SUMMARY OF SCALING CONSIDERATIONS

The preceding sections have described, region by region, how the FIST facility scaling was performed, such that the facility is capable of satisfying all the criteria specified for it. Each region has been thoroughly examined to determine whether:

1. The volume distribution is proportionate to the reference BWR's volume distribution
2. All local flow restrictions have been modeled appropriately
3. Each component is full reactor height
4. Each component meets the specified simulation criteria.

The scaling study results presented lead to the conclusion that the FIST design meets all the prescribed scaling goals. As a summary, the total vessel volume distributions for FIST and the scaled BWR/6 are compared in Figure 3-33. The regional volume comparison between FIST and the scaled BWR is listed in Appendix C.

In addition, separate-effects studies have been performed to evaluate the local effects of any compromises that were encountered in the scaling process. In order to further evaluate the facility, integral system response studies are being performed to determine the effects any remaining compromises have on the overall system response.

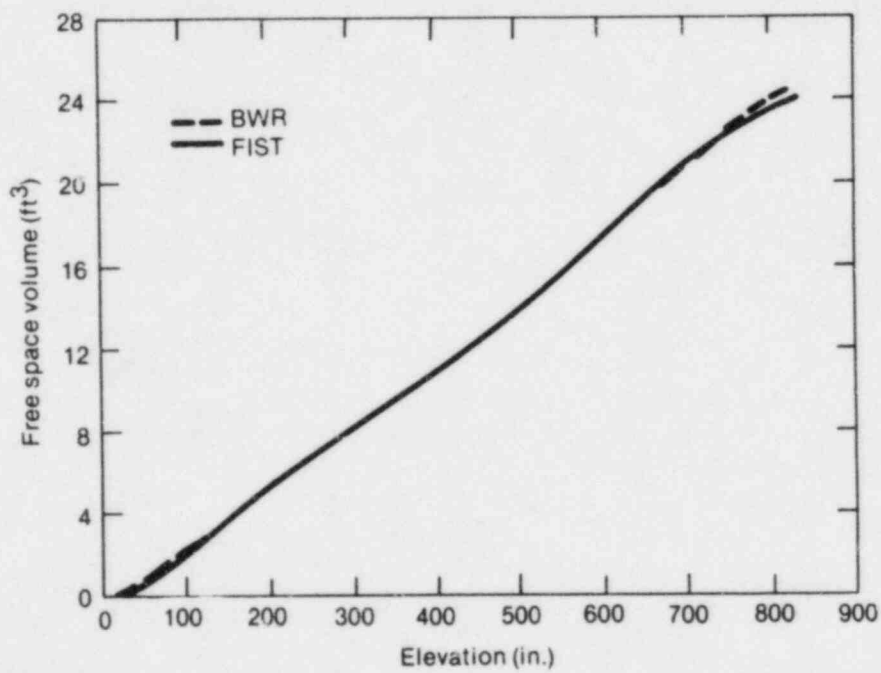
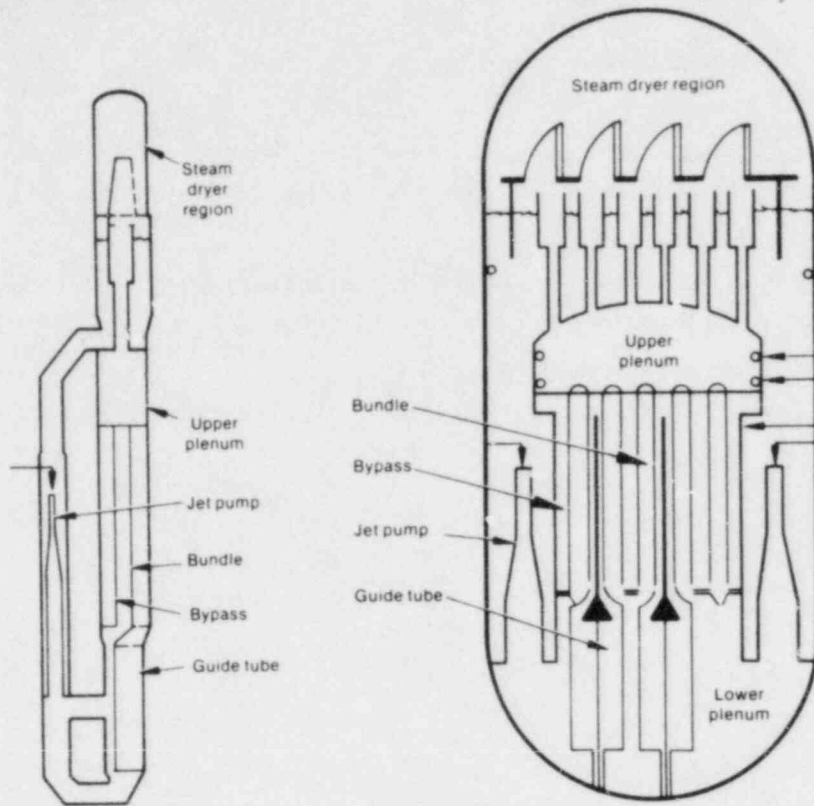

INEL 4 3893

Figure 3-33 Vessel Volume Distribution

4. REFERENCES

1. BWR Full Integral Simulation Test (FIST) Program, Modification No. 11 of the Supplemental Agreement to Contract No. NRC-04-76-215 between General Electric Company, Electric Power Research Institute and the United States Nuclear Regulatory Commission.
2. Thompson, J. E., BWR Full Integral Simulation Test (FIST) Program Test Plan. General Electric Company, May 1982, (GEAP - 22053, EPRI NP-2313, NUREG/CR - 2575).
3. Letzring, W. J., BWR Blowdown/Emergency Core Cooling Program, Preliminary Facility Description Report for the BD/EDDIA Test Phase, General Electric Company, December 1977 (GEAP - 23592).
4. Hayes, C. G., BWR Blowdown/Emergency Core Cooling Program - ECC System Calibration and Performance Verification, General Electric Company, July 1978 (NEDG - 21956, Class I).
5. Jouse, W. C., Seegmiller, D. S., Fors, R. M., and Goodell, R. A., Fatigue Evaluation for the FIST Steam Generator Vessel, Technical Report No. EGG-EA-5785, February 1982, EG&G Idaho, Inc., Idaho Falls, Idaho.
6. Fors, R. M., Stress Analysis for the FIST Piping System, Technical Report No. EGG-EA-5863, May 1982, EG&G Idaho, Inc., Idaho Falls, Idaho.
7. Hwang, W. S., and Schneidman, B. S., BWR Blowdown/Emergency Core Cooling Program--64-Rod Bundle Blowdown Heat Transfer (8 x 8 BDHT) Final Report, General Electric Company, September 1978 (GEAP-NUREG-23977).
8. Nakamura, C. J., Brothers, M. A., Hunter, T. A., Pham, H. V., Tran, V., FIST - 01 Hardware and Software Description and User's Guide, General Electric Company, to be published (NEDE 22256, TIE 82NED116).
9. Lee, L. S., et. al., Comparisons of LOCA Evaluation Model Predictions with Blowdown Heat Transfer Results, General Electric Company, March 1978 (NEUD - 21836).
10. Lee, L. S., Sozzi, G. L., and Allison, S. A., BWR Large Break Simulation Tests-BWR Blowdown/Emergency Core Cooling Program, Volume 1, General Electric Company, March 1981 (GEAP-24962-1, EPRI NP-1783, NUREG/CR-2229).
11. Barton, J. E., Schumacher, D. G., Findlay, J. A., and Caruso, S. C., BWR Refill-Reflood Program, Task 4.4 - 30° SSTF Description Document, General Electric Company, June 1981 (GEAP-24939, EPRI NP-1584, NUREG/CR-2133).
12. Schumacker, D. G., BWR Refill-Reflood Program Task 4.4-CCFL/Refill System Effects Tests (30° Sector) Experimental Task Plan, General Electric Company, April 1981 (GEAP-24893).
13. Schneidman, B., BWR Blowdown/ECC Ninth Quarterly Progress Report, Appendix C, "Evaluation of Reverse Steam Flow Through the Jet Pumps of TLTA."

APPENDIX A
FACILITY DRAWING LIST

APPENDIX A
FACILITY DRAWING LIST

<u>Table Number</u>	<u>Name</u>	<u>Page</u>
A-1	Facility Drawings	A-4
A-2	Facility Photographs	A-10

APPENDIX A
FACILITY DRAWING LIST

<u>Drawing Number</u>	<u>Revision Number</u>	<u>Title</u>
1. <u>Electrical Drawings</u>		
179F145-200		Document list-BDHT Test Facility- Electrical
179F145-201		BDHT Electrical Drawing Index
179F145-202		D.C. Power
179F145-203		Single Line Diagram-Process
179F145-204		Heater Control-Connection
179F145-205		Feedwater Pumps-Connection
179F145-206		Recirculation Pump Connection
179F145-207		Feedwater Vessel Heaters, Interconnection
179F145-208		Hot Feedwater Pump, Interconnection
179F145-209		Cold Feedwater Pump, Interconnection
179F145-210		Recirculation Pump, Interconnection
179F145-211		Light/Duplex, Interconnection
179F145-212		ECC
179F145-213		Single Line Diagram Site
179F145-214		Electric Power and Control Instrumentation
2. <u>Instrumentation</u>		
179F145-400		Document List-BDHT Test Facility Instruments
179F145-401		Process and Instrumentation Diagram
179F145-402		Information Document Feedwater Heater
179F145-403		Two Loop System (C. W. Sys)
179F145-404		Level Measurement Panel Schematic

FACILITY DRAWING LIST (continued)

<u>Drawing Number</u>	<u>Revision Number</u>	<u>Title</u>
2. <u>Instrumentation (continued)</u>		
179F145-405		Operator Setup Panel Schematic
179F145-406		Control Console Assembly
179F145-407		Operator Setup Panel
179F145-408		Level Measurement Panel
179F145-409		Trip Panel
179F145-410		Plate
179F145-411		Plate
179F145-412		Cable Trays Instrument Wiring
179F145-413		Process Control
179F145-414		TI Instrument Layout
179F145-415		Panel Bay 3 Modification
179F145-416		Panel Assembly 1
179F145-417		Panel Assembly 2
179F145-418		Panel Assembly 3
179F145-419		Special Valve Pneumatic System
179F145-420		Block Diagrams
179F145-421		Value LVDT Brackets
3. <u>Mechanical Drawings</u>		
179F145-500		Document List-BDHT Mechanical
179F145-501		Feedwater Heater BDHT
179F145-502		Trolley
179F145-503		F-142X9HTC Pump Outline
179F145-504		Panel Cutout Details
179F145-505		Panel Cutout
179F145-506		Panel Cutout
179F145-507		Panel Chassis

FACILITY DRAWING LIST (continued)

<u>Drawing Number</u>	<u>Revision Number</u>	<u>Title</u>
3. <u>Mechanical Drawings</u> (continued)		
179F145-508		Pump Installation
179F145-509		Hot Feedwater Pump Installation
179F145-510		Junction Box #1
179F145-511		Junction Box #2
179F145-512		Flywheel-P-32 FIST Program
4. <u>Piping Drawings</u>		
179F145-600		Document List--BDHT Piping
179F145-601		Piping Arrangement Water and Steam
179F145-602		Spray Nozzle
179F145-603		Feedwater Mixer
179F145-604		Condensate Pot
179F145-605		Feedwater Mixer
179F145-606		Specification for Mechanical and Piping Services
179F145-607		Feedwater Volume Tank
179F145-608		Vessel and Piping Insulation
5. <u>Structural Drawings</u>		
179F145-705		NSTF--Structural (Rev. 3 of 179F145-702)
179F145-706		Addition to BDHT Support Structure
179F145-707		Vessel Support Frame BDHT
179F145-708		Platform Addition BDHT
179F145-709		Addition to BDHT Test Facility FIST
6. <u>Vessel Drawings</u>		
181F145-150		Vessel Installation
181F145-151		Vessel Insulation
181F145-152	2	Vessel Shell

FACILITY DRAWING LIST (continued)

<u>Drawing Number</u>	<u>Revision Number</u>	<u>Title</u>
6. <u>Vessel Drawings</u> (continued)		
181F145-153	3	Instrument Boss Locations
181F145-154	2	Boss
181F145-155		Expansion Joint
181F145-156	2	Spectacle Flange
181F145-157	2	Dummy Vessel Test Sections
181F145-158		Vessel Shell and Filler Plate Assembly
181F145-159		Shop Vessel
181F145-160		HPCS, LPCS Spray Nozzles
181F145-161		Jet Pump Inlet (Layout)
181F145-162		Core Inlet (Layout)
181F145-163		Core Outlet (Layout)
181F145-164		Fuel Bundle/Shell
181F145-165		Dryer Drain/Steam Separator/Shell
181F145-166		Mobile Heater Fixture (Cart)
181F145-167		Steam Dryer/Shell
181F145-168		Diffuser/Shell
181F145-169		Two-Loop/Shell (Jet Pump Drive Assembly)
181F145-170		Bail/Shell Assembly
181F145-173		Flange Can
181F145-174		Channel Thermocouple
181F145-175	1	Button (Ceramic Insulators)
181F145-176	1	Bail (Channel Exit)
181F145-177	1	Buss Bar
181F145-178		Spring Hook (Bottom of Guide Tube)
181F145-179		Filler Blocks

FACILITY DRAWING LIST (continued)

<u>Drawing Number</u>	<u>Revision Number</u>	<u>Title</u>
6. <u>Vessel Drawings</u> (continued)		
181F145-180	1	Fuel Bundle Assembly
181F145-181	2	Steam Separator
181F145-182	1	Heater
181F145-183	1	Sliding Current Connector
181F145-184	3	Upper Tie-Plate
181F145-185	3	Lower Tie-Plate
181F145-186	1	Upper Guide-Tube
181F145-187		Fuel Support Restrictor
181F145-188	1	Fuel Support
181F145-189		Velocity Limiter Restrictor
181F145-190		Core Support Plate
181F145-191		Guide Tube Bottom
181F145-192		Adapter, Guide Tube
181F145-193	1	Guide Tube Assembly
181F145-194	1	Jet Pump
181F145-195		Flow Restrictor (Orifice Plate)
181F145-196	1	Jet Pump Assembly
181F145-197	1	Dryer
181F145-198		Channel Expansion Box
181F145-200		Lower Tie Plate Base
181F145-201		Lower Tie Plate (Modified BWR/6 Casting)
181F145-202	1	Dryer Drain
181F145-209		Internal Pressure Tap
181F145-210		Dryer Drain Tap (to Condensing Pot)
181F145-211		Guide Tube Tap (SEO)
181F145-212		Channel Voltage Tap

FACILITY DRAWING LIST (continued)

<u>Drawing Number</u>	<u>Revision Number</u>	<u>Title</u>
6.	<u>Vessel Drawings</u>	(continued)
181F145-213		Expansion Box Voltage Tap
181F145-214		Channel TC Seal
181F145-215		Bundle TC Seal
181F145-216		Subchannel Thermocouple Tap
181F145-217		Test Section Schematic
7.	<u>Experiment Instrumentation Drawings</u>	
181F145-171		Liquid Level Signal Conditioner
181F145-172		Annubar
181F145-199		Thermocouple Box
181F145-203		FIST Instrumentation Wiring-Neff 400
181F145-204		FIST Instrumentation Wiring-Neff 410
181F145-205		Vessel Instrumentation Plan
181F145-206		Pressure Transducer Installation
181F145-207		Transducer Junction Box
181F145-208		Bundle Thermocouple Junction Box
181F145-219		Schematic Diagram Test Instrument Tubing
181F145-224		Power Control & Measurement Wiring Connection Diagram
181F145-225		Transducer Mounting Support
181F145-226		Arrangement Dwg Transducer Location Plan
181F145-401		Conductivity Probe

Table A-2. Facility Photographs

1. Subject Index

<u>Subject</u>	<u>Photograph Numbers</u>
Downcomer	P-66, P-67, P-71, P-77
Dryer	P-11, P-12, P-13, P-58, P-59
Expansion Bellows Spool	P-83, P-99
Feedwater Heater	P-33, P-35
Flash Drum	P-37, P-38, P-64, P-76
General Facility View, from East	P-34, P-51, P-70, P-81, P-102, P-103, P-104, P-105, P-84
General Facility View, from Northeast	P-56, P-57, P-65, P-72, P-97, P-98
General Facility View, from West	P-91, P-92, P-93, P-94, P-95
Grid Spacers	P-19, P-20, P-21
Guide Tube	P-5, P-6, P-7, P-14
Jet Pumps	P-22, P-23, P-24, P-25, P-26, P-27, P-28 P-29, P-30, P-31, P-32, P-36
Lower Plenum	P-39, P-46, P-47, P-48, P-49, P-50, P-52 P-53, P-54, P-55, P-68, P-69, P-74
Separator	P-60, P-82, P-88, P-90, P-100, P-101
Standpipe	P-8, P-9, P-10
Steam Dome	P-85, P-86, P-87, P-89
Tie Plates	P-15, P-16, P-17, P-18
Transducers	P-43, P-44, P-45
Transducer Cal Rig	P-40, P-41, P-42
Upper Plenum	P-73

Table A-2. Facility Photographs

2. Numerical Index

<u>Photograph No.</u>	<u>Description</u>
P-4	
P-5	Top of guide tube/core inlet assembly - end view
P-6	Top of guide tube/core inlet assembly - end view closeup
P-7	Bottom of guide tube closeup
P-8	Bottom of standpipe; Annubar instrument washer
P-9	Bottom of standpipe
P-10	Standpipe Annubar instrument washer closeup
P-11	Bottom of steam dryer
P-12	Bottom of steam dryer, manifold
P-13	Top of dryer skirt, drain, dryer inlet
P-14	Overall view of top of guide tube/core inlet assembly
P-15	Upper tie plate with electrodes installed
P-16	Lower tie plate with electrodes installed
P-17	Upper tie plate
P-18	Lower tie plate with electrodes installed
P-19	Grid spacers with two rods - view 1
P-20	Grid spacers with two rods - view 2
P-21	Grid spacer - closeup
P-22	Top of jet pumps - view from eastern or western side
P-23	Top of jet pumps - closeup from eastern side
P-24	Top of jet pumps - view from north side
P-25	Top of jet pumps - closeup from north side
P-26	Jet pump diffusers - closeup
P-27	Jet pump bottom of tail pipe - Annubar instrument washer
P-28	Jet pump Annubar instrument washer end view
P-29	Jet pump Annubar instrument washer and tail pipe extension
P-30	Jet pump tail pipe extension - view 1
P-31	Jet pump tail pipe extension - view 2
P-32	Jet pump tail pipe extension - view 3
P-33	Feedwater heater overall view in support structure - from west side
P-34	Facility and support structure - elevated general view from east - view 1
P-35	Bottom support of feedwater heater, in support structure - from west side
P-36	Jet pump drive line inlet connections on downcomer - end view
P-37	Flash drum laying on ground - lower portion
P-38	Flash drum support plate - looking down into suppression tank
P-39	Lower plenum - under jet pump - overall view
P-40	Transducer calibration equipment - overall
P-41	Transducer calibration equipment - closeup view 1
P-42	Transducer calibration equipment - closeup view 2
P-43	Differential pressure transducers - view 1
P-44	Differential pressure transducers - view 2
P-45	Differential pressure transducers - view 3
P-46	Upper portion of lower plenum pipes - middle crossover - from south side
P-47	Lowest portion of lower plenum - bottom crossover - from below - view 1
P-48	Lowest portion of lower plenum - bottom crossover - from below - view 2

P-49 Bottom crossover - closeup from below
 P-50 Lower plenum and recirculation loop no.2 pump - view from above, north side
 P-51 Facility and support structure - elevated general view from east - view 2
 P-52 Top of lower plenum piping view from above at grade level from north side
 P-53 Top of lower plenum piping - middle crossover - view from above at grade level from north side
 P-54 Top of lower plenum piping - middle crossover - closeup view from above
 P-55 Lower plenum piping from grade level looking down into pit, north side
 P-56 Facility and support structure from grade level, northeast corner looking southwest - view 1
 P-57 Facility and support structure from grade level, northeast corner looking southwest - view 2
 P-58 Bottom of dryer installed in pressure housing - end view 1
 P-59 Bottom of dryer installed in pressure housing - end view 2
 P-60 Bottom of separator pressure housing with standpipe installed
 P-61
 P-62
 P-63
 P-64 Bottom of flash drum
 P-65 General facility view from northeast corner from grade level - view 3
 P-66 Jet pump downcomer housing - lower end
 P-67 Jet pump downcomer housing - lower end closeup
 P-68 Support structure around test vessel at grade level - from west side
 P-69 Support structure around test vessel at grade level from west side - closeup
 P-70 General east side work area - from above, from east
 P-71 Lower end of jet pump assembly, downcomer housing - end view
 P-72 General facility view from northeast corner, from grade level, view 4
 P-73 Upper plenum spool piece - on ground
 P-74 Lower plenum under the jet pump spool piece - on ground
 P-75
 P-76 Main stream line pressure control valve, SRV exhaust header at flashdrum - from southeast
 P-77 Test vessel - main and side arm above top of jet pump
 P-78
 P-79 Upper plenum spool piece being lifted up into position - elevated view from east
 P-80
 P-81 General facility view from east at ground level looking up
 P-82 Separator pressure housing installed in place - view from east on structure
 P-83 Hinged expansion bellows spool piece and upper plenum - installed - view from southwest
 P-84 General facility view of separator pressure housing - elevated view from east
 P-85 Steam dome - start of lift for installation - elevated view from east
 P-86 Steam dome being lifted into position - elevated view from east
 P-87 Steam dome being put in place - elevated view from east
 P-88 View looking up along test vessel from below feed water inlet - east side

P-89 Steam line connection nozzle on steam dome - closeup - in place
P-90 View looking up along test vessel from below - northeast side
P-91 General facility view from southwest corner - elevated view
P-92 View of feedwater heater, flashdrum, suppression tank - elevated view from west side looking down
P-93 General facility view - top of feedwater heater, elevated view from west side - view 1
P-94 General facility view - top of feedwater heater, elevated view from west side - view 2
P-95 View of feedwater heater, facility - elevated, from west side looking down
P-96 BWR FIST PR board on side of control room building
P-97 General facility view from northeast corner, ground level view 5
P-98 General facility view from northeast corner, ground level view 6
P-99 Hinged expansion bellows spool piece and upper plenum installed - view 2
P-100 View looking up along test vessel from below, east side, view 1
P-101 View looking up along test vessel from below, east side, view 2
P-102 Installed test vessel elevated view from east - top portion of vessel
P-103 Installed test vessel elevated view from east - top portion of vessel - view 2
P-104 Installed test vessel elevated view from east - middle portion of vessel
P-105 Installed test vessel elevated view from east - middle portion of vessel - view 2

GEAP-22054

APPENDIX B
MEASUREMENTS LIST

APPENDIX B
MEASUREMENTS LIST

<u>Table Number</u>	<u>Name</u>	<u>Page</u>
B-1	Measurement Type Codes	B-5
B-2	Regional Location Codes	B-6
B-3	Experimental Measurements	B-7
B-4	Process Measurements	B-40

APPENDIX B
MEASUREMENT LIST

The experimental measurement identifier is an alpha-numeric string which describes the measurement type and location in the FIST facility. Twelve (12) characters (maximum) are used on the FIST/HP data acquisition system for this ID. The string is generally composed of three parts which are separated by dashes:

Example

Measurement		Regional		Vessel Elevation
<u>Type</u>	-	<u>Location</u>	-	or
				<u>Other Information</u>
DP	-	LPB	-	EL 032

The measurement type usually consists of two characters as given in Table B-1, Measurement Type Code. The regional location codes are given in Table B-2. These usually consist of three characters, but up to five characters are sometimes used. In the case of differential pressure measurements between vessel regions, both region codes may be used. Vessel elevations are all positive, bottom of vessel being ~30 in.

The heater rod thermocouple identifier gives the core location number for the rod, the heater rod type (power) and the distance in inches the thermocouple is located above the bottom of the heated length:

TC - XX - XX - XXX

_distance above bottom of heated length
_heater rod type (see Table D-5)
_heater rod core location

Example: TC-33-78-105

Process measurement identifiers follow standard I.S.A. symbolization.

TABLE B-1. MEASUREMENT TYPE CODE

<u>Code</u>	<u>Type Measurement</u>
CP	Conductivity Probe
DD	Drag Disc
DP,DF	Differential Pressure
I	Current
KW	Power
N	Pump Speed
PO	Valve Position
PR	Pressure
T	Core Power Cable Temperature
TC	Heater Rod Temperature
TF	Fluid Temperature
TM	Turbine Meter
TW	Wall Temperature
V	Voltage
GD	Gamma Densitometer

TABLE B-2. REGIONAL LOCATION CODES

Code	Location
BDD	Blowdown Section of Drive Line (RECIRC)
BDS	Blowdown Section of Suction Line (RECIRC)
BP	Core Bypass
BU	Bundle
CFWL	Cold Feedwater Line
CH	Channel
DC	Downcomer
DCJ1	Downcomer, JP1 Region
DCJ2	Downcomer, JP2 Region
DRY	Dryer
DS	Dryer Skirt
FWS	Feedwater Storage Tank
FWT	Feedwater Tank
GT	Guide Tube
HFWL	Hot Feedwater Line
HPCS	High Pressure Core Spray (ECC)
JP1	Jet Pump 1
JP2	Jet Pump 2
L1D	Recirc Loop 1 Drive Line
L2D	Recirc Loop 2 Drive Line
LPB	Lower Plenum-Under Bundle
LPCI	Low Pressure Coolant Injection (ECC)
LPCS	Low Pressure Core Spray (ECC)
LPJ	Lower Plenum-Under Jet Pumps
L1S	Recirc Loop 1 Suction Line
L2S	Recirc Loop 2 Suction Line
RCIC	Reactor Core Isolation Cooling
SD	Steam Dome
SEP	Separator
SL	Steam Line
SM	Steam Manifold
SP	Stand Pipe
SSP	Separated Steam Plenum
UP	Upper Plenum

TABLE B-3. EXPERIMENTAL MEASUREMENTS^a

Measurement Identifier	Location Description	Initial Calibration Range	Nominal Cold Leg Length, (in.)	Estimated ^b Uncertainty
<u>Pressure</u>				
PR-LPJ-EL032	Centerline of lower crossover at flange	0,1500 psig		±6 psi
PR-DC-EL133	Bottom of downcomer, outside jet pumps	0,1500 psig		±6 psi
PR-LPB-EL196	At side entry orifice inlet	0,1500 psig		±6 psi
PR-UP-EL421	Upper plenum between sprays and stand pipe inlet	0,1500 psig		±6 psi
PR-SD-EL793	Top of steam dome	0,1500 psig		±6 psi
PR-SL-01	Steam line at orifice	0,1500 psig		±6 psi
PR-L2S-20	Loop number 2 suction line	0,1500 psig		±6 psi
PR-FWT-75	Feedwater tank steam space	0,1500 psig		±6 psi
<u>Differential Pressure</u>				
DP-DC-EL390	In downcomer at exp. joint outlet up to elev 447 outside standpipe	-25,+75 in H ₂ O	57	±0.6% FS
DP-LPB-EL032	Centerline of lower crossover to elev 044 outside guide tube	-7.5,+22.5 in H ₂ O	12	±0.6% FS
DP-LPB-EL044	From elev 044 up to elev 085 outside guide tube in lower plenum upflow	-25,+75 in H ₂ O	41	±0.6% FS
DP-LPB-EL085	From elev 085 up to elev 124 outside guide tube in lower plenum upflow	-25,+75 in H ₂ O	39	±0.6% FS
DP-LPB-EL124	Up to elev 135, below to above upper crossover	-7.5,+22.5 in H ₂ O	11	±0.6% FS
DP-LPB-EL135	Up to elev 157 outside guide tube in lower plenum upflow	-10,+30 in H ₂ O	22	±0.6% FS
DP-LPB-EL157	Up to elev 180 outside guide tube in lower plenum upflow	-10,+30 in H ₂ O	23	±0.6% FS
DP-LPB-EL180	Up to elev 196 at side entry orifice inlet	-7.5,+22.5 in H ₂ O	16	±0.6% FS

B-7

GEAP-22054

TABLE B-3. (continued)

Measurement Identifier	Location Description	Initial Calibration Range	Nominal Cold Leg Length, (in.)	Estimated ^b Uncertainty
<u>Differential Pressure</u> (continued)				
DP-LPJ-EL032	Centerline of lower crossover to elev 044 in lower plenum downflow	-7.5,+22.5 in H ₂ O	12	±0.6% FS
DP-LPJ-EL044	From elev 044 up to elev 085 in lower plenum downflow	-25,+75 in H ₂ O	41	±0.6% FS
DP-LPJ-EL085	From elev 085 up to elev 124 in lower plenum downflow	-25,+75 in H ₂ O	39	±0.6% FS
DP-GT-EL044	From elev 044 inside guide tube to elev 090 inside	-25,+75 in H ₂ O	46	±0.6% FS
DP-GT-EL090	From elev 090 inside guide tube to elev 138 inside	-25,+75 in H ₂ O	48	±0.6% FS
DP-GT-EL138	From elev 138 inside guide tube to elev 186 inside near top	-25,+75 in H ₂ O	48	±0.6% FS
DP-CORIN-196	From the downstream side of the side entry orifice (elev 196) to elev 205 above nosepiece	-30,+30 in H ₂ O	9	±0.6% FS
DP-BU-EL209	Inside the channel, in the bundle, elev 209 (begin heated length) to elev 226 upflow	-75,+75 in H ₂ O	16	±0.6% FS
DP-BU-EL225	Inside the channel, in the bundle, elev 226 to elev 246 upflow	-75,+75 in H ₂ O	21	±0.6% FS
DP-BU-EL246	Inside the channel, in the bundle, elev 246 to elev 266 upflow	-75,+75 in H ₂ O	20	±0.6% FS
DP-BU-EL266	Inside the channel, in the bundle, elev 266 to elev 286 upflow	-75,+75 in H ₂ O	20	±0.6% FS

TABLE B-3. (continued)

Measurement Identifier	Location Description	Initial Calibration Range	Nominal Cold Leg Length, (in.)	Estimated ^b Uncertainty
<u>Differential Pressure</u> (continued)				
DP-BU-EL286	Inside the channel, in the bundle, elev 286 to elev 306 upflow	-75,+75 in H ₂ O	20	±0.6% FS
DP-BU-EL306	Inside the channel, in the bundle, elev 306 to elev 326 upflow	-75,+75 in H ₂ O	20	±0.6% FS
DP-BU-EL326	Inside the channel, in the bundle, elev 326 to elev 346 upflow	-75,+75 in H ₂ O	20	±0.6% FS
DP-BU-EL346	Inside the channel, in the bundle, elev 346 to elev 359 upflow	-75,+75 in H ₂ O	13	±0.6% FS
DP-BU-EL359	In bundle above top of heated length up to elev 368	-75,+75 in H ₂ O	9	±0.6% FS
DP-BP-EL190	In bypass, from above guide tube top to elev 209, begin heated length	-10,+30 in H ₂ O	19	±0.6% FS
DP-BP-EL209	In bypass, outside channel, elev 209 up to elev 246	-25,+75 in H ₂ O	37	±0.6% FS
DP-BP-EL246	In bypass, outside channel, elev 246 up to elev 280	-25,+75 in H ₂ O	34	±0.6% FS
DP-BP-EL280	In bypass, outside channel, elev 280 up to elev 326	-25,+75 in H ₂ O	46	±0.6% FS
DP-BP-EL326	In bypass, outside channel, elev 326 up to elev 368	-25,+75 in H ₂ O	42	±0.6% FS
DP-UP-EL372	In bypass, outside channel, above tie plate to upper plenum elev 379	-7.5,+22.5 in H ₂ O	07	±0.6% FS

TABLE B-3. (continued)

Measurement Identifier	Location Description	Initial Calibration Range	Nominal Cold Leg Length, (in.)	Estimated ^b Uncertainty
<u>Differential Pressure</u> (continued)				
DP-UP-EL379	In upper plenum from elev 379 to elev 390 between LPCS, HPCS	-7.5,+22.5 in H ₂ O	21	±0.6% FS
DP-UP-EL390	In upper plenum between LPCS, HPCS up to elev 400 above HPCS	-7.5,+22.5 in H ₂ O	10	±0.6% FS
DP-UP-EL400	In upper plenum elev 400 up to elev 421	-10,+30 in H ₂ O	21	±0.6% FS
DP-DC-EL133	In downcomer outside jet pumps to elev 163 below recirc. loop conn.	-25,+75 in H ₂ O	30	±0.6% FS
DP-DC-EL163	In downcomer outside jet pumps from below to above (elev 169) recirc. connection	-7.5,+22.5 in H ₂ O	6	±0.6% FS
DP-DC-EL169	In downcomer outside jet pumps elev 169 up to elev 184	-10,+30 in H ₂ O	15	±0.6% FS
DP-DC-EL184	In downcomer outside jet pumps elev 184 up to elev 224	-25,+75 in H ₂ O	40	±0.6% FS
DP-DC-EL224	In downcomer outside jet pumps elev 224 up to elev 260	-25,+75 in H ₂ O	36	±0.6% FS
DP-DC-EL260	In downcomer outside jet pumps elev 260 up to elev 302	-25,+75 in H ₂ O	42	±0.6% FS
DP-DC-EL302	In downcomer, outside jet pumps below drive line conn. to above top of pumps (elev 316)	-10,+30 in H ₂ O	14	±0.6% FS
DP-DC-EL316	In downcomer, elev 316 to elev 358, top of heated length in core	-25,+75 in H ₂ O	42	±0.6% FS

TABLE B-3. (continued)

Measurement Identifier	Location Description	Initial Calibration Range	Nominal Cold Leg Length, (in.)	Estimated ^b Uncertainty
<u>Differential Pressure</u> (continued)				
DP-DC-EL358	In downcomer up to expansion joint outlet flange at elev 390	-25,+75 in H ₂ O	32	±0.6% FS
DP-DC-EL447	In downcomer, outside stand pipe elev 447 up to 470	-25,+75 in H ₂ O	23	±0.6% FS
DP-DC-EL470	In downcomer below feedwater conn. up to elev 502 below dryer skirt	-25,+75 in H ₂ O	32	±0.6% FS
DP-DS-EL502	From elev 502 in downcomer to elev 525 in dryer skirt	-10,+30 in H ₂ O	23	±0.6% FS
DP-DS-EL525	From elev 525 in dryer skirt to elev 550	-25,+75 in H ₂ O	25	±0.6% FS
DP-DS-EL550	From elev 550 in dryer skirt to elev 586	-25,+75 in H ₂ O	36	±0.6% FS
DP-DS-EL586	In dryer skirt from elev 586 to elev 622 near top	-25,+75 in H ₂ O	36	±0.6% FS
DP-SM-EL626	In steam manifold below steam line conn. to top of manifold (elev 712)	-100,+300 in H ₂ O	86	±0.6% FS
DP-SD-EL712	From top of manifold to elev 793 at top steam dome	-100,+300 in H ₂ O	81	±0.6% FS
DP-SP-EL447	In standpipe elev 447 up to elev 502	-25,+75 in H ₂ O	55	±0.6% FS
DP-SP-EL502	In standpipe elev 502 to separator inlet at elev 525	-25,+75 in H ₂ O	23	±0.6% FS
DP-SEP-EL531	From elev 531 in separator to elev 595 below sep. top in plenum	-50,+150 in H ₂ O	64	±0.6% FS
DP-SSP-EL502	In downcomer below skirt to plenum at elev 525	-10,+30 in H ₂ O	23	±0.6% FS

TABLE B-3. (continued)

Measurement Identifier	Location Description	Initial Calibration Range	Nominal Cold Leg Length, (in.)	Estimated ^b Uncertainty
<u>Differential Pressure</u> (continued)				
DP-SSP-EL525	In separated steam plenum from elev 525 to elev 550	-25,+75 in H ₂ O	25	±0.6% FS
DP-SSP-EL550	In separated steam plenum from elev 550 to elev 595	-25,+75 in H ₂ O	45	±0.6% FS
DP-SSP-EL595	In plenum from elev 595 to dryer inlet at elev 622	-25,+75 in H ₂ O	27	±0.6% FS
DP-DRY-EL622	Dryer inlet elev 622 to outlet at elev 712	-450,+150 in H ₂ O	90	±0.6% FS
DP-JP1-EL140	In jet pump No. 1 tailpipe from elev 140 to elev 184	-50,+150 in H ₂ O	44	±0.6% FS
DP-JP2-EL140	In jet pump No. 2 tailpipe from elev 140 to elev 184	-50,+150 in H ₂ O	44	±0.6% FS
DP-JP1-EL184	In jet pump No. 1 tailpipe from elev 184 to elev 224	-50,+150 in H ₂ O	40	±0.6% FS
DP-JP2-EL184	In jet pump No. 2 tailpipe from elev 184 to elev 224	-50,+150 in H ₂ O	40	±0.6% FS
DP-JP1-EL224	In jet pump No. 1 from elev 224 to tailpipe inlet at elev 287	-100,+300 in H ₂ O	63	±0.6% FS
DP-JP2-EL224	In jet pump No. 2 from elev 224 to tailpipe inlet at elev 287	-100,+300 in H ₂ O	63	±0.6% FS
DP-JP1-EL297	In jet pump No. 1 mixer from outlet at elev 297 to inlet at elev 307	-25,+75 in H ₂ O	10	±0.6% FS

B-12

GEAP-22054

TABLE B-3. (continued)

Measurement Identifier	Location Description	Initial Calibration Range	Nominal Cold Leg Length, (in.)	Estimated ^b Uncertainty
<u>Differential Pressure</u> (continued)				
DP-JP2-EL297	In jet pump No. 2 mixer from outlet at elev 297 to inlet at elev 307	-25,+75 in H ₂ O	10	±0.6% FS
DP-DCJ1-EL311	In downcomer on jet pump No. 1 side of baffle to above baffle at elev 316	-7.5,+22.5 in H ₂ O	5	±0.6% FS
DP-DCJ2-EL311	In downcomer on jet pump No. 2 side of baffle to above baffle at elev 316	-7.5,+22.5 in H ₂ O	5	±0.6% FS
DP-FUELZ-C16	From jet pump No. 1 tailpipe at elev 149 to dryer skirt at elev 586	-379.0,-187.1 in H ₂ O	437	±0.6% FS
DP-WR-C38	From bypass at top of heated length, elev 358, to dryer skirt at elev 586	-217.5,-62.9 in H ₂ O	228	±0.6% FS
DP-NR-C50	From elev 509 in dryer skirt to elev 586 in skirt	-66.1,-23.9 in H ₂ O	77	±0.6% FS
DP-UPSET-C51	From elev 509 in dryer skirt to elev 796 in steam dome	-290.7,-164.2 in H ₂ O	287	±0.6% FS
DP-SHTDN-C52	From elev 509 in dryer skirt to elev 796 in steam dome (redun)	-298.8,+97.2 in H ₂ O	287	±0.6% FS
DP-SUP-24	Suppression tank liquid level	-25,+75 in H ₂ O		-- ^c
DP-FWT-74	Feedwater tank liquid level	0,200 in H ₂ O		±0.6% FS
DP-FWS-76	Demineralized water tank liquid level above outlet nozzle	-25,+75 in H ₂ O		±0.6% FS
DF-HFWL-71	Hot feedwater flow, line 304	0,400 in H ₂ O	0	-- ^c

TABLE B-3. (continued)

Measurement Identifier	Location Description	Initial Calibration Range	Nominal Cold Leg Length, (in.)	Estimated ^b Uncertainty
<u>Differential Pressure</u> (continued)				
DF-CFWL-72	Cold feedwater flow, line 301	0,400 in H ₂ O	0	-- ^c
DF-RCIC-73	Reactor core isolation cooling flow, tubing line 310	0,300 in H ₂ O	0	-- ^c
DF-LPJ-AN1	Lower plenum downflow annubar at elev 070	-25,+25 in H ₂ O	0	-- ^c
DF-LPB-AN2	Lower plenum upflow annubar outside guide tube at elev 172	-25,+25 in H ₂ O	0	-- ^c
DF-CORIN-AN3	Core inlet flow annubar above side entry orifice at elev 199	-75,+75 in H ₂ O	0	-- ^c
DF-DC-AN4	Downcomer flow annubar at elev 361	-30,+30 in H ₂ O	0	-- ^c
DF-SN-AN5	Standpipe flow annubar at elev 450	-75,+75 in H ₂ O	0	-- ^c
DF-JP1-AN6	Jet pump No. 1 tailpipe outlet flow annubar at elev 142	-150,+150 in H ₂ O	0	-- ^c
DF-JP2-AN7	Jet pump No. 2 tailpipe outlet flow annubar at elev 142	-150,+150 in H ₂ O	0	-- ^c
DF-LPB/J-AN8	Upper crossover flow annubar at elev 130	-25,+25 in H ₂ O	0	-- ^c
DF-JP1-DIFF	In jet pump No. 1, diffuser inlet (elev 297) to outlet (elev 287)	-1387.4,+388.2 in H ₂ O	10	-- ^c
DF-JP2-DIFF	In jet pump No. 2, diffuser inlet (elev 297) to outlet (elev 287)	-1387.4,+388.2 in H ₂ O	10	-- ^c
DF-DC-OR01	Downcomer reference orifice plate at elev 236 to 338	0,400 in H ₂ O	2	-- ^c

TABLE B-3. (continued)

Measurement Identifier	Location Description	Initial Calibration Range	Nominal Cold Leg Length, (in.)	Estimated ^b Uncertainty
<u>Differential Pressure</u> (continued)				
DF-LP/GT-C01	At elev 044 from inside guide tube to outside guide tube in lower plenum	-150,+150 in H ₂ O	0	--C
DF-LPDC-C11	From lower plenum below jet pumps at elev 124 to downcomer outside JP at elev 133	-500,+250 in H ₂ O	9	±0.6% FS
DF-LPB/J-C12	At elev 124 from lower plenum below jet pumps to same below bundle	-150,+150 in H ₂ O	0	±0.6% FS
DF-LPJP2-C13	From lower plenum below jet pumps at elev 124 to jet pump No. 2 tailpipe at elev 140	-300,+300 in H ₂ O	16	±0.6% FS
DF-LPJP1-C14	From lower plenum below jet pumps at elev 124 to jet pump No. 1 tailpipe at elev 140	-300,+300 in H ₂ O	16	±0.6% FS
DF-BP/LP-C19	At elev 190 from lower plenum to bypass above guide tube	-10,+30 psid	0	--C
DF-GT/BP-C20	From inside guide tube at elev 186 to bypass above guide tube at elev 190	-200,+200 in H ₂ O	4	±0.6% FS
DF-CORIN-C21	At elev 196 from upstream to downstream sides of side entry orifice	-300,+300 in H ₂ O	0	--C
DF-BU/BI-C22	In bundle above nosepiece at elev 205 to begin of heated length at elev 209	-50,+150 in H ₂ O	4	±0.6% FS
DF-BU/BP-C23	At elev 209 from inside to outside channel	-300,+300 in H ₂ O	0	--C

TABLE B-3. (continued)

Measurement Identifier	Location Description	Initial Calibration Range	Nominal Cold Leg Length, (in.)	Estimated ^b Uncertainty
<u>Differential Pressure (continued)</u>				
DF-BDLPD-C24	From lower plenum at side entrance orifice, elev 196, to bypass at top of channel, elev 372	-10,+30 psid	176	±0.6% FS
DF-DCJP2-C30	From downcomer at elev 311 to jet pump No. 2 mixer at elev 307	-150,+150 in H ₂ O	4	±0.6% FS
DF-DCJP1-C31	From downcomer at elev 311 to jet pump No. 1 mixer at elev 307	-75,+75 in H ₂ O	4	±0.6% FS
DF-JP2DL-C33	From jet pump No. 2 drive line at vessel to mixer at elev 307	-1000,+1000 psid	0	±0.6% FS
DF-JP1DL-C34	From jet pump No. 1 drive line at vessel to mixer at elev 307	-1000,+1000 psid	0	±0.6% FS
DF-UP/BU-C35	From inside channel at elev 368 to outside channel at elev 372	-50,+150 in H ₂ O	4	±0.6% FS
DF-UP/BU-C37	In bypass outside channel across tie plate from elev 368 to elev 372	-30,+90 in H ₂ O	4	±0.6% FS
DF-SP/UP-C42	From upper plenum at elev 421 to inside standpipe at elev 447	-600,+200 in H ₂ O	26	±0.6% FS
DF-SP/DC-C49	At elev 502 from inside to outside standpipe	-30,+30 psid	0	±0.6% FS
DF-SWIRL-C54	At separator inlet across swirl vane from elev 525 to elev 531	-300,+300 in H ₂ O	6	±0.6% FS
DF-DS/SM-C62	From steam manifold at elev 626 to dryer skirt at elev 622	-75,+75 in H ₂ O	4	±0.6% FS

TABLE B-3. (continued)

Measurement Identifier	Location Description	Initial Calibration Range	Nominal Cold Leg Length, (in.)	Estimated ^b Uncertainty
<u>Differential Pressure</u> (continued)				
DF-DR/SD-C70	At elev 712 from inside to outside dryer	-75,+75 in H ₂ O	0	±0.6% FS
DF-SRV-01	Across restricting orifice upstream of SRV-01	0,1000 psid		--C
DF-SRV-02	Across restricting orifice upstream of SRV-02	0,1000 psid		--C
DF-SRV-03	Across restricting orifice upstream of SRV-03	0,1000 psid		--C
DF-SRV-04	Across restricting orifice upstream of SRV-04	0,1000 psid		--C
DF-SRV-05	Across restricting orifice upstream of SRV-05	0,1000 psid		--C
DF-SL-06	Steam flow orifice, line 401	-10,+30 psid		--C
DF-L1D-11	Recirc loop No. 1 flow orifice, line 102	0,+150 in H ₂ O		--C
DF-L2D-21	Recirc loop No. 2 flow orifice, line 201	0,+150 in H ₂ O		--C
DF-BDS-20	Recirc loop No. 2 suction line break flow	0,1000 psid	0	--C
DF-BDD-23	Recirc loop No. 2 drive line break flow	-10,+30 psid	0	--C
DF-HPCS-41	High pressure core spray flow orifice, line 501	0,200 in H ₂ O	0	--C
DF-LPCS-51	Low pressure core spray flow orifice, line 502	0,300 in H ₂ O	0	--C
DF-LPCI-61	Low pressure coolant injection flow orifice, line 503	0,300 in H ₂ O	0	--C

TABLE B-3. (continued)

Measurement Identifier	Location Description	Calibration Range	Estimated ^b Uncertainty
<u>Miscellaneous</u>			
I-BUNDLE-0	Bundle electrical current	-.05,+50 kamp	--
V-BUNDLE-0	Bundle voltage	-.05,+160 volt	--
V-CH-EL209	Voltage on channel at elev 209	-.05,+160 volt	--
V-CH-EL362	Voltage on channel at elev 368	-.05,+160 volt	--
KW-BUNDLE-0	Bundle power	.5, 7200 kw	±7 Kw ±0.5% of reading
TF-LPJ-RTD1	In lower plenum down flow at elev. 044	60,800°F	±4°F
TF-DC-RTD2	In downcomer between feedwater nozzle and dryer skirt at elev. 498	60,800°F	±4°F
N-PUMP1-10	Recirc Loop No. 1 pump speed	0,4000 rpm	--
N-PUMP2-20	Recirc Loop No. 2 pump speed	0,4000 rpm	--
DD-L2S-20	Recirc Loop No. 2 suction line 204 drag force	-10,+10 MV	--
DD-L2S-21	Recirc Loop No. 2 suction line 202 drag force	-10,+10 MV	--
TM-L2S-20	Recirc Loop No. 2 suction line 204 turbine meter flow	0,.12 cfs	--
TM-L2S-21	Recirc Loop No. 2 suction line 202 turbine meter flow	0,.12 cfs	--
GD-BU-EL225	At elev 225, average fluid density along east-west path one row north of center-line	0,62.4 lb/ft ³	--
GD-BU-EL286	At elev 286, average fluid density along east-west path one row north of center-line	0,62.4 lb/ft ³	--

TABLE B-3. (continued)

<u>Measurement Identifier</u>	<u>Location Description</u>	<u>Calibration Range</u>	<u>Estimated^b Uncertainty</u>
<u>Miscellaneous</u> (continued)			
GD-BU-EL290	At elev 290, average fluid density along east-west path one row north of centerline	0,62.4 lb/ft ³	--
GD-BU-EL346	At elev 346, average fluid density along east-west path one row north of centerline	0,62.4 lb/ft ³	--
<u>Valve Position</u>			
PO-L1S-10	Stem position of valve 664 in recirc loop No. 1 suction line 105	-.98,+.98 in	--
PO-L1U-11	Stem position of valve 1 in recirc loop No. 1 driveline 102	-.98,+.98 in	--
PO-L2D-21	Stem position of valve 8 in recirc loop No. 2 driveline 208	-.98,+.98 in	--
PO-BDS-22	Stem position of valve 2 in recirc loop No. 2 suction blowdown line 206	-.98,+.98 in	--
PO-BDD-23	Stem position of valve 10 in recirc loop No. 2 drive blowdown line 203	-.98,+.98 in	--
PO-SL-06	Stem position of valve 601 in steam line 401	-.98,+.98 in	--
PO-L1/FWT-17	Stem position of valve 611 in feedwater return line 103	-.98,+.98 in	--
PO-SD/FWT-77	Stem position of valve 607 in vent line 308	-.98,+.98 in	--
PO-L2S-20	Stem position of valve 614 in recirc loop No. 2 suction line 205	-.98,+.98 in	--

TABLE B-3. (continued)

<u>Measurement Identifier</u>	<u>Location Description</u>	<u>Calibration Range</u>	<u>Estimated^b Uncertainty</u>
<u>Valve Position</u> (continued)			
PO-SRV-01	Stem position of valve 602 in steam line 401	-.98,+98 in	--
PO-SRV-02	Stem position of valve 603 in steam line 401	-.98,+98 in	--
PO-SRV-03	Stem position of valve 604 in steam line 401	-.98,+98 in	--
PO-SRV-04	Stem position of valve 605 in steam line 401	-.98,+98 in	--
PO-SRV-05	Stem position of valve 606 in steam line 401	-.98,+98 in	--
<u>Conductivity</u>			
CP-LPB-EL044	In lower plenum upflow, outside guide tube	0,8000 mv	--
CP-LPB-EL085	In lower plenum upflow, outside guide tube	0,8000 mv	--
CP-LPB-EL130	At centerline of upper crossover in upflow outside guide tube	0,8000 mv	--
CP-LPB-EL157	In lower plenum upflow, outside guide tube	0,8000 mv	--
CP-LPB-EL194	In lower plenum just upstream of side entry orifice inlet	0,8000 mv	--
CP-LPB-EL196	In lower plenum at centerline inlet of side entry orifice	0,8000 mv	--
CP-LPJ-EL032	At centerline of lower crossover in flange	0,8000 mv	--
CP-LPJ-EL085	In lower plenum downflow	0,8000 mv	--
CP-LPJ1-EL131	At jet pump No. 1 tailpipe outlet	0,8000 mv	--

TABLE B-3. (continued)

Measurement Identifier	Location Description	Calibration Range	Estimated ^b Uncertainty
<u>Conductivity</u> (continued)			
CP-LPJ2-EL131	At jet pump No. 2 tailpipe outlet	0,8000 mV	--
CP-GT-EL144	In guide tube	0,8000 mV	--
CP-BU-EL372	Inside channel above upper tie plate	0,8000 mV	--
CP-BUIN-E205	Inside bundle inlet above nosepiece, below lower tie plate	0,8000 mV	--
CP-BP-EL190	In bypass above guide tube top	0,8000 mV	--
CP-BP-EL205	In bypass below lower tie plate	0,8000 mV	--
CP-BP-EL361	In bypass above LPCI inlet & above top of heated length	0,8000 mV	--
CP-UP-EL379	In upper plenum below LPCS inlet	0,8000 mV	--
CP-UP-EL400	In upper plenum above HPCS inlet	0,8000 mV	--
CP-UP-EL424	In upper plenum at inlet to standpipe	0,8000 mV	--
CP-SP-EL502	In standpipe below dryer skirt outlet, separator inlet	0,8000 mV	--
CP-SSP-EL622	In separated steam plenum at dryer inlet	0,8000 mV	--
CP-DC-EL160	In downcomer outside jet pumps below recirc loop suction nozzle	0,8000 mV	--
CP-DC-EL167	In recirc loop suction line at downcomer flange	0,8000 mV	--
CP-DC-EL172	In downcomer outside jet pumps above recirc loop suction nozzle	0,8000 mV	--

TABLE B-3. (continued)

Measurement Identifier	Location Description	Calibration Range	Estimated ^b Uncertainty
<u>Conductivity</u> (continued)			
CP-DC-EL180	In downcomer outside jet pumps above recirc loop suction nozzle	0,8000 mV	--
CP-DC-EL302	In downcomer outside jet pump mixers below recirc loop drive nozzle	0,8000 mV	--
CP-DC-EL316	In downcomer just above jet pumps	0,8000 mV	--
CP-DC-EL377	In downcomer at BWR level 1	0,8000 mV	--
CP-DC-EL490	In downcomer, above feedwater connection	0,8000 mV	--
CP-DCJ1-E309	In downcomer at jet pump No. 1 mixer inlet	0,8000 mV	--
CP-DCJ2-E309	In downcomer at jet pump No. 2 mixer inlet	0,8000 mV	--
CP-DS-EL531	In dryer skirt at BWR level 3	0,8000 mV	--
CP-DS-EL553	In dryer skirt at BWR level 4	0,8000 mV	--
CP-DS-EL557	In dryer skirt at BWR normal level	0,8000 mV	--
CP-DS-EL561	In dryer skirt at BWR level 7	0,8000 mV	--
CP-DS-EL576	In dryer skirt at BWR level 8	0,8000 mV	--
CP-DS-EL613	In dryer skirt between separator outlet, dryer inlet	0,8000 mV	--
CP-SM-EL633	In steam manifold below the steam line nozzle	0,8000 mV	--
CP-SM-EL636	In steam manifold at center of steam line outlet nozzle	0,8000 mV	--

TABLE B-3. (continued)

<u>Measurement Identifier</u>	<u>Location Description</u>	<u>Calibration Range</u>	<u>Estimated^b Uncertainty</u>
<u>Conductivity</u>			
<u>(continued)</u>			
CP-SM-EL640	In steam manifold above steam line nozzle	0,8000 mV	--
CP-SM-EL660	In steam manifold	0,8000 mV	--
CP-JP1-EL180	In jet pump No. 1 tailpipe	0,8000 mV	--
CP-JP2-EL180	In jet pump No. 2 tailpipe	0,8000 mV	--
CP-DC-EL166	In recirc loop suction line at vessel flange	0,8000 mV	--
CP-DC-EL167	In recirc loop suction line at vessel flange	0,8000 mV	--
<u>Wall Temperature</u>			
TW-LPB-EL047	At bottom of lower plenum upflow pipe	60,800°F	±4°F
TW-LPB-EL105	Midway up lower plenum upflow pipe	60,800°F	±4°F
TW-LPB-EL157	In lower plenum pipe wall above upper crossover	60,300°F	±4°F
TW-LPJ-EL064	In lower plenum downflow pipe	60,800°F	±4°F
TW-LPJ-EL105	Midway down lower plenum downflow pipe	60,800°F	±4°F
TW-UP-EL390	In upper plenum pipe wall between HPCS, LPCS nozzle	60,800°F	±4°F
TW-UP-EL421	In upper plenum pipe wall at inlet to standpipe	60,800°F	±4°F
TW-SD-EL717	In steam dome pipe wall above top of dryer	60,800°F	±4°F

TABLE B-3. (continued)

Measurement Identifier	Location Description	Calibration Range	Estimated ^b Uncertainty
<u>Wall Temperature</u> (continued)			
TW-DC-EL220	In downcomer pipe wall midway along jet pump tailpipe	60,800°F	±4°F
TW-DC-EL358	In downcomer pipe wall at top of heated core length elev.	60,800°F	±4°F
TW-DC-EL498	In downcomer wall above feedwater nozzle	60,800°F	±4°F
TW-BP-EL240	In pressure vessel wall in core region	60,800°F	±4°F
TW-BP-EL320E	In pressure vessel wall in core region, east side	60,800°F	±4°F
TW-BP-EL320W	In pressure vessel wall in core region, west side	60,800°F	±4°F
TW-CH-235-N	In channel wall, north side	60,800°F	±4°F
TW-CH-235-W	In channel wall, west side	60,800°F	±4°F
TW-CH-295-N	In channel wall, north side	60,800°F	±4°F
TW-CH-295-W	In channel wall, west side	60,800°F	±4°F
TW-CH-355-N	In channel wall, north side between LPCI, top of heated length	60,800°F	±4°F
TW-CH-355-W	In channel wall, west side between LPCI, top of heated length	60,800°F	±4°F
TW-SEP-EL613	In vessel wall between separator outlet, dryer inlet	60,800°F	±4°F

TABLE B-3. (continued)

Measurement Identifier	Location Description	Calibration Range	Estimated ^b Uncertainty
<u>Fluid Temperature</u>			
TF-LPB-EL044	At bottom of lower plenum upflow outside guide tube	60,800°F	±4°F
TF-LPB-EL105	Midway up lower plenum outside guide tube	60,800°F	±4°F
TF-LPB-EL124	In lower plenum upflow below upper crossover, outside guide tube	60,800°F	±4°F
TF-LPB-EL135	In lower plenum upflow above upper crossover, outside guide tube	60,800°F	±4°F
TF-LPB-EL157	In lower plenum upflow above upper crossover	60,800°F	±4°F
TF-LPB-EL194	In lower plenum just upstream of side entry orifice inlet	60,800°F	±4°F
TF-LPJ-EL044	In lower plenum downflow at elev 044	60,800°F	±4°F
TF-LPJ-EL064	In lower plenum downflow	60,800°F	±4°F
TF-LPJ-EL105	Midway down lower plenum downflow	60,800°F	±4°F
TF-LPJ-EL124	In lower plenum downflow at jet pump outlets	60,800°F	±4°F
TF-CT-EL047	In guide tube near bottom	60,800°F	±4°F
TF-GT-EL094	In guide tube part way up	60,800°F	±4°F
TF-GT-EL141	In guide tube above upper crossover	60,800°F	±4°F
TF-GT-EL180	In guide tube near top	60,800°F	±4°F
TF-CORIN-201	In bundle inlet, below nosepiece	60,800°F	±4°F

TABLE B-3. (continued)

Measurement Identifier	Location Description	Calibration Range	Estimated ^b Uncertainty
<u>Fluid Temperature</u> (continued)			
TF-BU-368-1	In bundle below upper tie plate	60,800°F	±4°F
TF-BU-368-2	In bundle below upper tie plate	60,800°F	±4°F
TF-BU-EL372	Inside channel above upper tie plate	60,800°F	±4°F
TF-BP-EL190	In bypass above top of guide tube	60,800°F	±4°F
TF-BP-EL211	In bypass above lower tie plate	60,800°F	±4°F
TF-BP-EL240	In bypass at elev 240	60,800°F	±4°F
TF-BP-EL280	In bypass at elev 280	60,800°F	±4°F
TF-BP-EL320	In bypass at elev 320	60,800°F	±4°F
TF-BP-368-1	In bypass below upper tie plate	60,800°F	±4°F
TF-BP-360-2	In bypass below upper tie plate	60,800°F	±4°F
TF-UP-EL372	In bypass outside channel above upper tie plate	60,800°F	±4°F
TF-UP-EL379	In upper plenum below LPCS inlet	60,800°F	±4°F
TF-UP-EL390	In upper plenum between LPCS, HPCS nozzles	60,800°F	±4°F
TF-UP-EL421	In upper plenum at standpipe inlet	60,800°F	±4°F
TF-SEP-EL531	In separator inlet	60,800°F	±4°F
TF-SSP-EL622	In separated steam plenum at dryer inlet	60,800°F	±4°F
TF-SP-EL465	In standpipe between inlet and feedwater conn. to downcomer	60,800°F	±4°F

TABLE B-3. (continued)

Measurement Identifier	Location Description	Calibration Range	Estimated ^b Uncertainty
<u>Fluid Temperature</u> (continued)			
TF-DC-EL133	At bottom of downcomer outside jet pumps	60,800°F	±4°F
TF-DC-EL184	In downcomer outside jet pumps, above recirc suction line nozzle	60,800°F	±4°F
TF-DC-EL220	In downcomer outside jet pumps	60,800°F	±4°F
TF-DC-EL302	In downcomer outside jet pump mixers below recirc loop drive nozzle.	60,800°F	±4°F
TF-DC-EL316	In downcomer just above jet pumps	60,800°F	±4°F
TF-DC-EL358	In downcomer at top of heated core length elev	60,800°F	±4°F
TF-DC-EL390	In downcomer at expansion joint outlet	50,800°F	±4°F
TF-DC-EL447	In downcomer, main vessel at expansion joint inlet	60,800°F	±4°F
TF-DC-EL465E	In downcomer below feedwater connection, east side	60,800°F	±4°F
TF-DC-EL465W	In downcomer below feedwater connection, west side	60,800°F	±4°F
TF-DC-RTD2	In downcomer between feedwater nozzle and dryer skirt at elev 498	60,800°F	±4°F
TF-DS-EL550	Midway up dryer skirt	60,800°F	±4°F
TF-DS-EL622	At dryer skirt inlet	60,800°F	±4°F
TF-SD-EL717	In steam dome above dryer outlet	60,800°F	±4°F
TF-SD-EL792	At top of steam dome	60,800°F	±4°F
TF-JP1-EL140	In jet pump No. 1 tailpipe near outlet	60,800°F	±4°F

TABLE B-3. (continued)

<u>Measurement Identifier</u>	<u>Location Description</u>	<u>Calibration Range</u>	<u>Estimated^b Uncertainty</u>
<u>Fluid Temperature</u> (continued)			
TF-JP2-EL140	In jet pump No. 2 tailpipe near outlet	60,800°F	±4°F
TF-JP1-EL220	In jet pump No. 1 midway along tailpipe	60,800°F	±4°F
TF-JP2-EL220	In jet pump No. 2 midway along tailpipe	60,800°F	±4°F
TF-JP1-EL285	In jet pump No. 1 at tailpipe inlet	60,800°F	±4°F
TF-JP2-EL285	In jet pump No. 2 at tailpipe inlet	60,800°F	±4°F
T1-LPB-CTC1	Lower plenum low flow probe at elev 147	60,800°F	±4°F
T2-LPB-CTC1	Lower plenum low flow probe cooling water inlet	60,800°F	±4°F
T3-LPB-CTC1	Lower plenum low flow probe cooling water outlet	60,800°F	±4°F
T1-BUIN-CTC2	Core inlet low flow probe at elev 204 between nosepiece, lower tie plate	60,800°F	±4°F
T2-BUIN-CTC2	Core inlet flow probe cooling water inlet	60,800°F	±4°F
T3-BUIN-CTC2	Core inlet flow probe cooling water outlet	60,800°F	±4°F
T1-BP-CTC3	Bypass flow probe at elev 211 above lower tie plate	60,800°F	±4°F
T2-BP-CTC3	Bypass flow probe cooling water inlet	60,800°F	±4°F
T3-BP-CTC3	Bypass flow probe cooling water outlet	60,800°F	±4°F
TF-CFWL-72	Cold feedwater line 301 at measuring orifice	60,800°F	±4°F
TF-FWT-75	Feedwater tank steam space	60,800°F	±4°F

TABLE B-3. (continued)

Measurement Identifier	Location Description	Calibration Range	Estimated ^b Uncertainty
<u>Fluid Temperature</u> (continued)			
TF-FWT-74	Hot feedwater line 305 at feed pump discharge	60,800°F	±4°F
TF-FWL-70	Vessel feedwater line 309 downstream of mixing point	60,800°F	±4°F
TF-HFWL-71	Hot feedwater line 304 at measuring orifice	60,800°F	±4°F
TF-HPCS-40	HPCS injection line between vessel and check valve V421	60,800°F	±4°F
TF-HPCS-41	HPCS injection line 501 at measuring orifice	60,800°F	±4°F
TF-LPCS-51	LPCS delivery line at measuring orifice between valves 462, 464	60,800°F	±4°F
TF-LPCI-60	LPCI injection between vessel and check valve V510	60,800°F	±4°F
TF-LPCI-61	LPCI injection line 503 at measuring orifice	60,800°F	±4°F
TF-L1D-11	Recirc loop No. 1 drive line 102 at measuring orifice	60,800°F	±4°F
TF-L2D-20	Recirc loop No. 2 suction line 204	60,800°F	±4°F
TF-L2D-21	Recirc loop No. 2 drive line 201 at pump discharge	60,800°F	±4°F
TF-B0D-23	Recirc loop No. 2 blowdown drive line	60,800°F	±4°F
TF-BDS-22	Recirc loop No. 2 blowdown suction line 206	60,800°F	±4°F

TABLE B-3. (continued)

Measurement Identifier	Location Description	Calibration Range	Estimated ^b Uncertainty
<u>Fluid Temperature</u> (continued)			
TF-SUP-24	Suppression tank near bottom	60,800°F	±4°F
TF-SL-01	Steam line 401 at measuring orifice	60,800°F	±4°F
T-CABLE-1	Temperature of bundle transmission power cable No. 1	60,800°F	±4°F
T-CABLE-2	Temperature of bundle transmission power cable No. 2	60,800°F	±4°F
T-CABLE-3	Temperature of bundle transmission power cable No. 3	60,800°F	±4°F
<u>Heater Rod Temperature</u>			
TC-01-77-017 ^d	T/C located southeast side of rod	100,1897°F	±0.8% of reading
TC-01-77-097	T/C located southeast side of rod	100,1897°F	±0.8% of reading
TC-01-77-128	T/C located southeast side of rod	100,1897°F	±0.8% of reading
TC-03-77-081	T/C located northwest side of rod	100,1897°F	±0.8% of reading
TC-03-77-101	T/C located northwest side of rod	100,1897°F	±0.8% of reading
TC-03-77-113	T/C located northwest side of rod	100,1897°F	±0.8% of reading
TC-03-77-121	T/C located northwest side of rod	100,1897°F	±0.8% of reading

TABLE B-3. (continued)

<u>Measurement Identifier</u>	<u>Location Description</u>	<u>Calibration Range</u>	<u>Estimated^b Uncertainty</u>
<u>Heater Rod Temperature</u> (continued)			
TC-03-77-133	T/C located northwest side of rod	100,1897°F	±0.8% of reading
TC-04-78-048	T/C located southeast side of rod	100,1897°F	±0.8% of reading
TC-04-78-117	T/C located southeast side of rod	100,1897°F	±0.8% of reading
TC-04-78-137	T/C located southeast side of rod	100,1897°F	±0.8% of reading
TC-05-78-048	T/C located southwest side of rod	100,1897°F	±0.8% of reading
TC-05-78-069	T/C located southwest side of rod	100,1897°F	±0.8% of reading
TC-06-77-128	T/C located northwest side of rod	100,1897°F	±0.8% of reading
TC-06-77-141	T/C located northwest side of rod	100,1897°F	±0.8% of reading
TC-07-77-048	T/C located southwest side of rod	100,1897°F	±0.8% of reading
TC-07-77-069	T/C located southwest side of rod	100,1897°F	±0.8% of reading
TC-07-77-097	T/C located southwest side of rod	100,1897°F	±0.8% of reading
TC-07-77-105	T/C located southwest side of rod	100,1897°F	±0.8% of reading

b-31

GEAP-22054

TABLE B-3. (continued)

<u>Measurement Identifier</u>	<u>Location Description</u>	<u>Calibration Range</u>	<u>Estimated^b Uncertainty</u>
<u>Heater Rod Temperature</u> (continued)			
TC-08-77-097	T/C located southwest side of rod	100,1897°F	±0.8% of reading
TC-08-77-128	T/C located southwest side of rod	100,1897°F	±0.8% of reading
TC-08-77-137	T/C located southwest side of rod	100,1897°F	±0.8% of reading
TC-09-77-033	T/C located southeast side of rod	100,1897°F	±0.8% of reading
TC-09-77-069	T/C located southeast side of rod	100,1897°F	±0.8% of reading
TC-10-78-008	T/C located southeast side of rod	100,1897°F	±0.8% of reading
TC-10-78-088	T/C located southeast side of rod	100,1897°F	±0.8% of reading
TC-10-78-117	T/C located southeast side of rod	100,1897°F	±0.8% of reading
TC-11-76-057	T/C located southeast side of rod	100,1897°F	±0.8% of reading
TC-11-76-077	T/C located southeast side of rod	100,1897°F	±0.8% of reading
TC-11-76-097	T/C located southeast side of rod	100,1897°F	±0.8% of reading
TC-11-76-117	T/C located southeast side of rod	100,1897°F	±0.8% of reading

TABLE B-3. (continued)

<u>Measurement Identifier</u>	<u>Location Description</u>	<u>Calibration Range</u>	<u>Estimated^b Uncertainty</u>
<u>Heater Rod Temperature</u> (continued)			
TC-11-76-137	T/C located southeast side of rod	100,1897°F	±0.8% of reading
TC-12-77-033	T/C located southeast side of rod	100,1897°F	±0.8% of reading
TC-12-77-105	T/C located southeast side of rod	100,1897°F	±0.8% of reading
TC-13-77-117	T/C located southwest side of rod	100,1897°F	±0.8% of reading
TC-13-77-137	T/C located southwest side of rod	100,1897°F	±0.8% of reading
TC-14-76-008	T/C located southwest side of rod	100,1897°F	±0.8% of reading
TC-14-76-033	T/C located southwest side of rod	100,1897°F	±0.8% of reading
TC-17-77-033	T/C located northwest side of rod	100,1897°F	±0.8% of reading
TC-17-77-057	T/C located northwest side of rod	100,1897°F	±0.8% of reading
TC-17-77-077	T/C located northwest side of rod	100,1897°F	±0.8% of reading
TC-18-76-057	T/C located southeast side of rod	100,1897°F	±0.8% of reading
TC-18-76-069	T/C located southeast side of rod	100,1897°F	±0.8% of reading

TABLE B-3. (continued)

<u>Measurement Identifier</u>	<u>Location Description</u>	<u>Calibration Range</u>	<u>Estimated^b Uncertainty</u>
<u>Heater Rod Temperature</u> (continued)			
TC-18-76-105	T/C located southeast side of rod	100, 1897°F	±0.8% of reading
TC-18-76-141	T/C located southeast side of rod	100, 1897°F	±0.8% of reading
TC-19-78-008	T/C located southeast side of rod	100, 1897°F	±0.8% of reading
TC-19-78-048	T/C located southeast side of rod	100, 1897°F	±0.8% of reading
TC-20-78-017	T/C located southeast side of rod	100, 1897°F	±0.8% of reading
TC-20-78-048	T/C located southeast side of rod	100, 1897°F	±0.8% of reading
TC-21-78-069	T/C located southwest side of rod	100, 1897°F	±0.8% of reading
TC-21-78-088	T/C located southwest side of rod	100, 1897°F	±0.8% of reading
TC-22-78-057	T/C located southwest side of rod	100, 1897°F	±0.8% of reading
TC-22-78-077	T/C located southwest side of rod	100, 1897°F	±0.8% of reading
TC-22-78-097	T/C located southwest side of rod	100, 1897°F	±0.8% of reading
TC-25-78-008	T/C located southeast side of rod	100, 1897°F	±0.8% of reading

TABLE B-3. (continued)

<u>Measurement Identifier</u>	<u>Location Description</u>	<u>Calibration Range</u>	<u>Estimated^b Uncertainty</u>
<u>Heater Rod Temperature</u> (continued)			
TC-25-78-137	T/C located southeast side of rod	100,1897°F	±0.8% of reading
TC-26-77-040	T/C located southeast side of rod	100,1897°F	±0.8% of reading
TC-26-77-061	T/C located southeast side of rod	100,1897°F	±0.8% of reading
TC-26-77-081	T/C located southeast side of rod	100,1897°F	±0.8% of reading
TC-26-77-101	T/C located southeast side of rod	100,1897°F	±0.8% of reading
TC-26-77-113	T/C located southeast side of rod	100,1897°F	±0.8% of reading
TC-29-77-033	T/C located southwest side of rod	100,1897°F	±0.8% of reading
TC-29-77-088	T/C located southwest side of rod	100,1897°F	±0.8% of reading
TC-29-77-105	T/C located southwest side of rod	100,1897°F	±0.8% of reading
TC-33-78-077	T/C located northeast side of rod	100,1897°F	±0.8% of reading
TC-33-78-088	T/C located northeast side of rod	100,1897°F	0-0.8% of reading

B-35

GEAP-22054

TABLE B-3. (continued)

<u>Measurement Identifier</u>	<u>Location Description</u>	<u>Calibration Range</u>	<u>Estimated^b Uncertainty</u>
<u>Heater Rod Temperature</u> (continued)			
TC-33-78-097	T/C located northeast side of rod	100, 1897°F	0-0.8% of reading
TC-33-78-105	T/C located northeast side of rod	100, 1897°F	0-0.8% of reading
TC-33-78-117	T/C located northeast side of rod	100, 1897°F	0-0.8% of reading
TC-33-78-128	T/C located northeast side of rod	100, 1897°F	0-0.8% of reading
TC-34-77-008	T/C located northeast side of rod	100, 1897°F	0-0.8% of reading
TC-34-77-017	T/C located northeast side of rod	100, 1897°F	0-0.8% of reading
TC-34-77-048	T/C located northeast side of rod	100, 1897°F	0-0.8% of reading
TC-35-78-069	T/C located northeast side of rod	100, 1897°F	0-0.8% of reading
TC-36-77-017	T/C located southwest side of rod	100, 1897°F	0-0.8% of reading
TC-36-77-017	T/C located southwest side of rod	100, 1897°F	0-0.8% of reading
TC-38-78-128	T/C located northwest side of rod	100, 1897°F	0-0.8% of reading
TC-38-78-137	T/C located northwest side of rod	100, 1897°F	0-0.8% of reading

TABLE B-3. (continued)

Measurement Identifier	Location Description	Calibration Range	Estimated ^b Uncertainty
<u>Heater Rod Temperature</u> (continued)			
TC-36-78-141	T/C located northwest side of rod	100,1897°F	0-0.8% of reading
TC-39-77-033	T/C located northwest side of rod	100,1897°F	0-0.8% of reading
TC-39-77-057	T/C located northwest side of rod	100,1897°F	0-0.8% of reading
TC-39-77-105	T/C located northwest side of rod	100,1897°F	0-0.8% of reading
TC-40-78-088	T/C located northeast side of rod	100,1897°F	0-0.8% of reading
TC-40-78-137	T/C located northeast side of rod	100,1897°F	0-0.8% of reading
TC-46-78-017	T/C located northwest side of rod	100,1897°F	0-0.8% of reading
TC-46-78-048	T/C located northwest side of rod	100,1897°F	0-0.8% of reading
TC-46-78-057	T/C located northwest side of rod	100,1897°F	0-0.8% of reading
TC-47-76-077	T/C located northwest side of rod	100,1897°F	0-0.8% of reading
TC-47-76-097	T/C located northwest side of rod	100,1897°F	0-0.8% of reading
TC-47-76-117	T/C located northwest side of rod	100,1897°F	0-0.8% of reading

TABLE B-3. (continued)

<u>Measurement Identifier</u>	<u>Location Description</u>	<u>Calibration Range</u>	<u>Estimated^b Uncertainty</u>
<u>Heater Rod Temperature</u> (continued)			
TC-49-77-069	T/C located northwest side of rod	100,1897°F	0-0.8% of reading
TC-49-77-088	T/C located northwest side of rod	100,1897°F	±0.8% of reading
TC-53-77-020	T/C located northwest side of rod	100,1897°F	±0.8% of reading
TC-53-77-040	T/C located northwest side of rod	100,1897°F	±0.8% of reading
TC-53-77-061	T/C located northwest side of rod	100,1897°F	±0.8% of reading
TC-53-77-101	T/C located northwest side of rod	100,1897°F	±0.8% of reading
TC-53-77-121	T/C located northwest side of rod	100,1897°F	±0.8% of reading
TC-54-76-069	T/C located northwest side of rod	100,1897°F	±0.8% of reading
TC-54-76-076	T/C located northwest side of rod	100,1897°F	±0.8% of reading
TC-54-76-088	T/C located northwest side of rod	100,1897°F	±0.8% of reading
TC-55-78-008	T/C located northwest side of rod	100,1897°F	±0.8% of reading
TC-55-78-033	T/C located northwest side of rod	100,1897°F	±0.8% of reading

TABLE B-3. (continued)

Measurement Identifier	Location Description	Calibration Range	Estimated ^b Uncertainty
<u>Heater Rod Temperature</u> (continued)			
TC-55-78-076	T/C located northwest side of rod	100,1897°F	±0.8% of reading
TC-57-77-117	T/C located northeast side of rod	100,1897°F	±0.8% of reading
TC-57-77-128	T/C located northeast side of rod	100,1897°F	±0.8% of reading
TC-62-77-077	T/C located southeast side of rod	100,1897°F	±0.8% of reading
TC-62-77-117	T/C located southeast side of rod	100,1897°F	±0.8% of reading
TC-64-77-017	T/C located northwest side of rod	100,1897°F	±0.8% of reading
TC-64-77-097	T/C located northwest side of rod	100,1897°F	±0.8% of reading
TC-64-77-141	T/C located northwest side of rod	100,1897°F	±0.8% of reading
TC-15-78-023	T/C located on electrode	100,1897°F	±0.8% of reading
TC-43-78-152	T/C located on electrode	100,1897°F	±0.8% of reading

a. As of December 1982. See individual test data for any changes for specific tests.

b. GEAP-24962-1, March 1981.

c. Flow measurement differential pressure. Uncertainty is 0.6% of reading ±0.05% of full scale.

d. Distance, in inches, above bottom of heated length (which point is vessel elevation 208.56 in.).

TABLE R-4. PROCESS MEASUREMENTS

<u>Measurement Identifier</u>	<u>Name-Location</u>	<u>Indicated Range</u>	<u>Corresponding Experimental Measurement ID</u>
<u>Differential Pressure</u>			
DP1-106	Loop No. 1 flow	0-10 gpm	DF-L10-11
DP1-107	Loop No. 2 pump DP	(0-100)x4 psid	--
DP1-108	Loop No. 1 pump DP	(0-100)x4 psid	--
DP1-109	Loop No. 2 flow	0-10 gpm	DF-L20-21
DP1-435	HPCS pump DP	0-1000 psid	--
DP1-436	HPCS supply line flow	0-10 psid	--
DP1-437	HPCS delivery line flow	0-10 psid	DF-HPCS-41
DP1-480	LPCS pump DP	0-100 psid	--
DP1-481	LPCS supply line flow	0-10 psid	--
DP1-525	LPCI pump DP	0-500 psid	--
DP1-526	LPCI supply line flow	0-10 psid	--
DP1-527	LPCI delivery line flow	0-10 psid	DF-LPCI-61
FIS-791	Feedwater return flow	Later	--
<u>Electrical Current</u>			
II-800	Hot feedwater pump current	0-20 amp	--
<u>Level</u>			
LI-165	Suppression tank sight glass	Later	DP-SUP-24
LI-400	ECC makeup tank sight glass	Later	--
LI-701	Operating level (DC elev 155 to SD elev 790)	0-100	--
LIC-711	Test vessel level (feed valve control)	0-100	--
LI-713	Test vessel level (SSP elev 514 to SSP elev 591)	0-100	--

TABLE B-4. (Continued)

Measurement Identifier	Name-Location	Indicated Range	Corresponding Experimental Measurement ID
<u>Level (continued)</u>			
LI-721	Feedwater heater level	0-100	DP-FWT-74
LI-750	Feedwater tank sight glass	none	--
LI-821	Fuel zone elev 149-586	-150 to +50 in	DP-FUEL-C16
LI-823	Shutdown elev 509-820	0-400 in	DP-SHUTDOWN-C52
LI-825	Upset elev 509-820	0-180 in	DP-UPSET-C51
LI-827	Wide range elev 358-586	-160-60 in	DP-WR-C38
LI-829	Narrow range elev 509-586	0-60 in.	DP-WR-C50
<u>Pressure</u>			
PI-101	Vessel dome pressure, elev 770	0-1500 psig (Heise)	--
PI-103	Cold feedwater pump discharge pressure	Later	--
PI-438	HPCS delivery line pressure	0-1500 psig	--
PI-483	LPCS delivery line pressure	0-1000 psig	--
PI-528	LPCI delivery line pressure	0-1000 psig	--
PIC-742	Steam dome pressure (valve control)	900-1200 psig	PR-SL-01
PI-743	Test vessel pressure elev 770	900-1200 psig	--
PIC-773	Feedwater tank pressure (steam space)	0-1500 psig	PR-FWT-75
PI-775	Feedwater tank pressure (heater control)	0-1500 psig	--
<u>Temperature</u>			
TR-131-115	Loop No. 2 jump discharge fluid temperature	0-600°F	TF-L2D-21

TABLE B-4. (Continued)

Measurement Identifier	Name-Location	Indicated Range	Corresponding Experimental Measurement ID
<u>Temperature (continued)</u>			
TR-131-116	Warmup return line fluid temperature	0-600°F	--
TR-131-117	Loop No. 1 Pump discharge fluid temperature	0-600°F	TF-L1D-11
TI-132	Suppression tank fluid temperature		TF-SUP-24
TI-402	ECC makeup tank fluid temperature		--
TI-456	HPCS delivery line fluid temperature		TF-HPCS-41
TI-501	LPCS delivery line fluid temperature		TF-LPCS-51
TI-546	LPCI delivery line fluid temperature		TF-LPCI-61
TIC-732	Downcomer fluid temperature, elev 431	300-600°F	TF-DC-EL447
TI-780	Feedwater tank fluid temperature	200-700°F	TF-FWT-75
<u>Electrical Power</u>			
WI-302	Recirc pump loop No. 1 power	0-100 Kw	--
WI-303	Recirc pump loop No. 2 power	0-100 Kw	--
WI-403	ECC makeup tank heater power	0-150 Kw	--
WI-454	HPCS pump power	0-80 Kw	--
WI-499	LPCS pump power	0-40 Kw	--
WI-544	LPCI pump power	0-40 Kw	--

GEAP-22054

APPENDIX C
ENGINEERING DATA LIST

APPENDIX C
ENGINEERING DATA LIST

<u>Table Number</u>	<u>Name</u>	<u>Page</u>
C-1	Test Vessel and Facility Equipment Elevations	C-4
C-2	Vessel Regional Volumes	C-7
C-3	Annubar and Orifice Flow Calculation Constants	C-8 .

TABLE C-1. TEST VESSEL AND FACILITY EQUIPMENT ELEVATIONS

Location Description	Elevation (in.)
<u>TEST VESSEL^d</u>	
Centerline of lower plenum bottom crossover pipe	31.81
Bottom of guide tube (inside)	43.62
Centerline of lower plenum upper crossover pipe	129.56
Bottom of jet pumps	131.47
Top of facility concrete pad (ground level)	148.0
Centerline of recirculation loop suction line nozzles	166.57
Top of guide tube (inside)	188.44
Center of side entry orifice	195.62
Top of lower tie plate	208.31
Bottom of heated length of core	208.56
Centerline of recirculation loop drive line nozzles	305.0
Centerline of LPCI	351.25
Top of heated length of core	358.56
Top of upper tie plate	370.56
BWR Level 1	376.56
Centerline of LPCS	384.44
Centerline of HPCS	395.44
Centerline of feedwater nozzle	483.00
BWR Level 2	490.40
BWR Level 3	530.90
BWR Level 4	553.40
BWR normal level	557.40
BWR Level 7	561.40
BWR Level 8	636.50
Centerline of steam line nozzle	636.50
Top of steam dome (inside)	796.43

TABLE C-1. (continued)

Location Description	Elevation (in.)
<u>RECIRCULATION LOOPS AND SUPPRESSION TANK</u>	
Centerline of loop No. 1 pump suction	-53 1/2
Centerline of loop No. 2 pump suction	67 1/2
Center of small break orifice	168
Center of large break nozzle-suction line	168
Center of large break orifice-drive line	302
Bottom of suppression tank	154 1/2
Top of suppression tank	245
<u>FEEDWATER HEATER AND PUMP</u>	
Bottom of heater vessel bottom flange	308 1/2
Centerline of feedwater outlet nozzle	331 1/2
Top of heater vessel top flange	545
Centerline of feed pump suction	164
<u>STEAM LINE AND FLASH DRUM</u>	
Bottom of flash drum	165
Centerline of bleed line inlet nozzle	299
Centerline of steam line inlet nozzle	331 1/2
Centerline of SRV/ADS inlet nozzle	541
Top of flash drum	541
<u>ECC AND DEMINERALIZED WATER</u>	
Bottom of ECC makeup tank	220
Top of ECC makeup tank	268
Centerline of HPCS pump suction	165 1/2
Centerline of LPCS pump suction	157 1/2
Centerline of LPCI pump suction	157 1/2
Bottom of demineralized water tank	170 1/2

TABLE C-1. (continued)

Location Description	Elevation (in.)
Top of demineralized water tank	242
Centerline of cold feed pump (P-34) suction	165
Centerline of RCIC pump (P-33) suction	164 1/2

a. These test vessel elevations are also relative to the BWR/6 reference elevation, which is near the inside of the bottom of the BWR/6 vessel.

TABLE C-2. VESSEL REGIONAL VOLUMES

<u>Nodal Region</u>	<u>FIST Volume (ft³)</u>	<u>Scaled BWR Volume^a (ft³)</u>
Lower plenum	3.24	3.22
Guide tubes	1.63	1.68
Jet pumps	0.42	0.26
Channel	1.51	1.51
Bypass	1.07	1.05
Downcomer	5.57	5.69
Upper plenum	1.50	1.50
Standpipe	0.54	0.54
Separator	1.15	1.15
Steam dome	<u>7.51</u>	<u>7.41</u>
Total Volume	24.14	24.01

a. Standard BWR/6 Volume Divided by/624.

TABLE C-3. ANNUBAR AND ORIFICE FLOW CALCULATION CONSTANTS^a

Constant	W-LPJ- AN1	W-LPJ- AN2	W-CoRIN -AN3	W-DC- AN4	W-SP- AN5	W-JP1- AN6	W-JP1- AN7	W-LPB/J AN8
D	4.813	1.717	2.632	3.826	3.624	1.685	1.685	3.826
KB	0.7503	0.6259	0.7179	0.7432	0.7403	0.661	0.673	0.7432
B	1.110E-2	9.260E-3	1.031E-2	1.086E-2	1.080E-2	9.199E-3	9.199E-3	1.086E-2
Ao	0.9985	0.9985	0.9985	0.9985	0.9985	0.9985	0.9985	0.9985
A1	1.589E-5	1.589E-5	1.589E-5	1.589E-5	1.589E-5	1.589E-5	1.589E-5	1.589E-5
f0 (reverse)	1.0	1.0	1.0	1.0	1.0	0.9017	0.8767	1.0
f1 (reverse)	8.0	8.0	8.0	8.0	8.0	8.0	8.0	8.0
f0 (forward)	1.012	1.0	1.0	1.014	1.014	1.023	1.023	1.014
f1 (forward)	0.531	8.0	8.0	0.536	0.536	0.527	0.527	0.536

Constant	W- DC-0R01	W- LPCS-51	W- HPCS-41	W- LPCI-61	W- HFWL-71	W- CFWL-72	W- SL-06	W- KCIC-73	W- LID-11	W- L2U-21	W- SRV-01	W- SRV-02	W- SRV-03	W- SRV-04	W- SRV-05
d	2.296	.466	0.408	0.395	0.900	0.574	1.885	0.1362	1.20	1.20	0.229	0.229	0.398	0.459	0.606
Ko	0.6491	0.6259	0.6431	0.6000	0.6533	0.6569	0.6692	0.5974	0.868	0.868	0.6005	0.6004	0.6001	0.6017	0.6105
B	1.642E-2	1.549E-2	1.594E-2	1.485E-2	1.642E-2	1.642E-2	1.704E-2	1.483E-2	2.0E-2	2.0E-2	1.479E-2	1.479E-2	1.485E-2	1.490E-2	1.512E-2
Ao	0.9985	0.9985	0.9985	0.9985	0.9985	0.9985	0.9985	0.9985	0.9985	0.9985	0.9985	0.9985	0.9985	0.9985	0.9985
A1	1.927E-5	1.927E-5	1.927E-5	1.927E-5	1.927E-5	1.927E-5	1.927E-5	1.927E-5	1.927E-5	1.927E-5	1.927E-5	1.927E-5	1.927E-5	1.927E-5	1.927E-5
A	9.956E+2	2.731E+3	2.933E+2	1.949E+2	5.360E+2	4/044E+2	1.018E+3	1.082E+3	1.05E+3	1.05E+3	1.597E+2	1.594E+2	1.955E+2	2.089E+2	2.638E+2

a. Values listed are correct as of 10-8-82. Values derived from subsequent shakedown testing may be different.

GEAP-22054

APPENDIX D
INSTALLED EQUIPMENT LIST

APPENDIX D
INSTALLED EQUIPMENT LIST

<u>Table Number</u>	<u>Name</u>	<u>Page</u>
D-1	Pumps	D-4
D-2	Motors	D-5
D-3	Vessels and Tanks	D-6
D-4	Valves	
D-4.1	Remotely Operated Valves	D-7
D-4.2	Manual Valves	D-9
D-4.3	Relief Valves	D-11
D-5	Heater Rods	D-12
D-6	Experiment Instrumentation	
D-6.1	Sensors Having Individual Calibrations	D-14
D-6.2	Signal Conditioning Equipment	D-19
D-6.3	Sensors Having Class-Common Calibrations	D-20
D-6.4	Data Acquisition Equipment	D-21

TABLE D-1. Pumps

Name and Number	Manufacturer and Model Number	Type/Size	Typical Operating Condition				Suction Discharge Size (inches)	Casing			
			Flow (gpm)	Head (ft)	Speed (rpm)	BHP		Press (psig)	Material	Design	S/N
Feed pump P-662	United pump	Centrifugal F-1-1/2 x 9 HTC	14-89	250	3550		4, 2		Steel	Vertical split	45010-1
Recirc Pump #1 P-31	United pump	Centrifugal F-1-1/2 x 13 HTC					3, 1-1/2		Steel	Vertical split	40286-1
Recirc Pump #2 P-32	United pump	Centrifugal F-1-1/2 x 13 HTC	120	695	3550		3, 1-1/2		Steel	Vertical split	41886-1
RCIC pump P-33	FWI, Inc. Fig. No. 5 P-200A	Piston 1-1/4" x 2-1/4"	23.9	1660 psig	400	26	2, 1	2050	Steel	5 piston	5PP528
Cold feed pump P-34	FWI, Inc. Fig. No. P-100A	Piston 1-1/4 x 2-1/4	9	1440 psig	400	8.7	2, 1	1780	Steel	2 piston	2354A
HPCS pump P-429	Roth 14TALG91052A-SB	Multistage turbine	15	2250	1750	34.8	3, 2	1200	SS	10 stage horizontal shaft	880047
LPCS pump P-474	Siemen & Hirsch CEHY 3105.42	Multistage turbine	10	780	1750	10	2, 1-1/4	600	SS	5 stage horizontal shaft	2332359
LPCI pump P-519	Siemen & Hirsch CEHY 3605.42	Multistage turbine	25	530	1750	10.3	2-1/2, 1-1/2	600	SS	5 stage horizontal shaft	2332360

D-4

GEAP-22054

TABLE D-2. Motors

Name	Manufacturer and Model or Serial Number	HP	RPM	Voltage	Current	Phase, Frequency	Frame	Type	P & ID Pump Number
Feed pump	GE 5K254BL105b	15	3555	460	17.3	3, 60	254T	KS	P-662
Recirc pump #1	GE 5K404XAM904 S/N: EFJ520102	60	1750	460	74	3, 60	404T	K	P-31
Recirc pump #2	Allis Chalmers-123 1-5103-55650-1-1	75	3530	460	85	3, 60	364TS	RG	P-32
RCIC pump	GE 5K256AN205A No. AJ	20	1750	460	25.7	3, 60	256T	K	P-33
Cold feed pump	GE 5K4256Y2WF82 S/N: SX4202062	10	1800	440	13.4	3, 60	256	K	P-34
HPCS pump	GE 5K324BN2650 No. HH	40	1770	460	47	3, 60	324T	K	P-429
LPCS pump	GE 5K254AL205 No. CM	15	1750	460	21	3, 60	254T	K	P-474
LPCI pump	GE 5K254AL205 No. CM	154	1750	460	21	3, 60	254T	K	P-519

D-5

GEAP-22054

TABLE D-3. VESSELS AND TANKS

Name and Number	Size	Design	Design Pressure, Temperature	Material	Number and Capacity of Heaters
Test vessel No. 685	180 gal	Pressurized, heated	1311 psig, 600 °F	Steel	30-1.01P; 24-0.97P; 8-1.04P Total, Max = 7.2 MW
Feedwater heater No. 684	900 gal	Pressurized, heated	1320 psig, 650°F	Steel	14, 300 kW total
Demin water tank	500 gal	Open, unheated	Ambient	Steel	--
ECC make up tank	600 gal	Open, heated	Ambient, 160°F water	Steel	6, 150 kW total
Flash drum No. 683		Open, unheated	Ambient, 600°F steam	Steel	--
Suppression tank		Open, unheated	Ambient, 160°F water	Steel	--

TABLE D-4.1 REMOTELY OPERATED VALVES

Name/ Location	Number	Size (in.)	C _v	Pressure Rating	Use	Type Operator	Type Operation	Control Signal	Position Indicator ID	Manufacturer and Model Number	Material	End Connection
Steam line	V601	2			Throttle	Piston	Air to open	P1-742	PO-SL-06	Valtek	C.S.	Flanged
Hot feed- water	V609	1-1/2	20	900#	Throttle	Diaphragm	Air to open	LIC-711	--	Masoneilan 48-21134	C.S.	Flanged
Cold feedwater	V610	1	1.2	1500#	Throttle	Dia-lever		TIC-732	--	Masoneilan 29111	S.S.	Thread
Recirc loop#1 flow	V1	1-1/2 Y pattern		900#	Throttle	Piston	Air to open	HL- TCAM-24	PO-LID-11	Crane DAU-431	C.S.	Flanged
Recirc loop#2 flow	V8	1-1/2	28	900#	Throttle	Piston	Air to open	HL-155, TCAM-33	PO-L2D-21	Valtek Mark I	C.S.	Flanged
HPCS delivery	V418	1	2.3	1500#	Throttle	Dia- lever	Air to open		--	Masoneilan 29111	S.S.	Thread
HPCS return	V419	1	2.3	1500#	Throttle	Dia- lever	Air to open		--	Masoneilan 29111	S.S.	Thread
LPCS delivery	V462	1	2.3	1500#	Throttle	Dia- lever	Air to open		--	Masoneilan 29111	S.S.	Thread
LPCS return	V463	1	2.3	1500#	Throttle	Dia- lever	Air to open		--	Masoneilan 29111	S.S.	Thread
LPCI delivery	V507	1-1/2	16.0	1500#	Throttle	Piston	Air to close		--	Valtek Mark II	C.S.	Flanged
LPCI return	V508	1-1/2	8	1500#	Throttle	Piston			--	Valtek Mark II	C.S.	Flanged
Warmup- return	V611	1	6.0	900#	Throttle	Diaphragm	HL-		PO-LI/FWT-17	Masoneilan 48-21114	C.S.	Flanged
Suction line blowdown	V2	3	110	900#	Open/ close	Piston	Air to close	TCAM-25	PO-BDS-22	Valtek Mark I	C.S.	Flanged
Drive line blowdown	V10	2	46	900#	Open/ close	Piston	Air to close	TCAM-27	PO-BDD-23	Valtek Mark I	C.S.	Flanged

TABLE D-4.1 (Continued)

Name/ Location	Number	Size (in.)	C _v	Pressure Rating	Use	Type Operator	Type Operation	Control Signal	Position Indicator IU	Manufacturer and Model Number	Material	End Connection
HPCS inj./ return	V420	3/4	8	1500#	3-way	Piston	Air to		--	Valtek Mark II	C.S.	Thread
LPCS inj./ return	V464	3/4	8	1500#	3-way	Piston	Air to		--	Valtek Mark II	C.S.	Thread
LPCI inj./ return	V509	1-1/2	21	900#	3-way	Piston	Air to		--	Valtek Mark II	C.S.	Flanged
Safety relief 01	V602	1-1/2	20	900#	Open/ close	Diaphragm	Air to close	TCAM-50	PO-SRV-01	Masoneilan 48-21134	C.S.	Flanged
Safety relief 02	V603	1-1/2	20	900#	Open/ close	Diaphragm	Air to close	TCAM-52	PO-SRV-02	Masoneilan 48-21134	C.S.	Flanged
Safety relief 03	V604	1-1/2	20	900#	Open/ close	Diaphragm	Air to close	TCAM-54	PO-SRV-03	Masoneilan 48-21134	C.S.	Flanged
Safety relief 04	V605	1-1/2	20	900#	Open/ close	Diaphragm	Air to close	TCAM-56	PO-SRV-04	Masoneilan 48-21134	C.S.	Flanged
Safety relief 05	V606	1-1/2	20	900#	Open/ close	Diaphragm	Air to close	TCAM-58	PO-SRV-05	Masoneilan 48-21134	C.S.	Flanged
SD/FWT vent conn.	V607	1	6.0	900#	Open/ close	Diaphragm			PO-SD/FWT-77	Masoneilan 48-21114	C.S.	Flanged
System vent	V608	1	2.3	1500#	Open/ close	Dia-lever			--	Masoneilan 29111	S.S.	Thread
Bleed	V612	1	2.3	1500#	Open/ close	Dia-lever	Air to open	LAL-723B	--	Masoneilan 29111	S.S.	Thread
Recirc#2 Suction Isolation	V614	3	110	150#	Open/ close	Piston	Air to open	TCAM-32	PO-L2S-20	Valtek Mark I	C.S.	Flanged
Recirc #1 Suction Isolation	V664	2	46	1500#	Open/ close	Piston	Air to open	TCAM-23	PO-L1S-10	Valtek Mark II	C.S.	Flanged
Feed	V668	1	0.6	1500#	Open/ close	Dia-lever	Air to open	LAH-723A	--	Masoneilan 29111	S.S.	Thread

TABLE D-4.2 MANUAL VALVES

Name-Function	Number	Size	Type	Pressure Rating	Material	End Connection	Manufacturer and Figure Number
Test vessel drain	V622	1/2	Globe	2000 ^a	Steel	Thread	Smith 0680
Test vessel warmup	V623	1-1/2	Globe	1500 ^b	Steel	Flange	Hattersley 1876
Loop#2 warmup	V624	1-1/2	Globe	1500 ^b	Steel	Flange	Vogt 10683
Bleed Isol.	V625	1	Globe	2000 ^a	Steel	Weld	Smith 0680
Warmup return	V627	1-1/2	Globe	1500 ^b	Steel	Flange	Rockwell Edwards 5268
Test vessel vent isol.	V633	1	Globe	1500 ^b	Steel	Flange	Hattersley 1876
Manual system vent	V634	1/2	Globe	2000 ^a	Steel	Thread	Smith 0680
Feed tank vent	V635	1	Globe	2000 ^a	Steel	Weld	Smith 0680
DI water supply	V636	1	Globe	2000 ^a	Steel	Weld	Smith 0680
Hot feed vessel check	V637	1-1/2	Check	2000 ^b	Steel	Weld	Vogt SW701
Steam trap isol.	V638	3/4	Globe	1500 ^b	Steel	Flange	Hattersley 1816
Feed pump suction	V640	3	Globe	900 ^b	Steel	Flange	Velan F102-45PS-2TS
Hot feed return	V641	1	Globe	2000 ^a	Steel	Thread	Vogt
Suppression tank recirc	V660	2	Gate	200 ^a	Bronze	Thread	Stockham B106
Suppression tank drain	V661	2	Gate	200 ^a	Bronze	Thread	Stockham B106
RCIC inlet	V666						
RCIC check	V667	1/2	Check	2000 ^a	Steel	Thread	Smith 0680
System feed isol.	V669	1/2	Globe	2000 ^a	Steel	Thread	Smith 0680
RCIC isol.	V670	1/2	Globe	2000 ^a	Steel	Thread	Smith 0680
Small break isol.	V679	1/2	Globe	2000 ^a	Steel	Weld	Smith 0680
Drive blowdown isol.	V3	2	Globe	2500 ^b	Steel	Flange	Valtek Mark II
Suction blowdown isol.	V7	3	Globe	2500 ^b	Steel	Weld	Valtek Mark II

TABLE D-4.2 (continued)

Name-Function	Number	Size	Type	Pressure Rating	Material	End Connection	Manufacturer and Figure Number
Cold feedwater isol.	V12	1	Globe-Y	1500 ^b	Steel	Weld	Velan 376
Cold feed vessel check	V13	1	Check	1500 ^b	Steel	Weld	Velan
HPCS pump suction	V416	2	Gate	300 ^a	Bronze	Thread	Stockham B-120
HPCS vessel check	V421	3/4	Check	1500 ^b	Steel	Thread	Rockwell-Edwards 1838
HPCS bypass	V424	3/4	Globe	2000 ^a	Steel	Thread	Vogt 12141
LPCS pump suction	V460	2	Gate	150 ^a	Bronze	Thread	Powell 150
LPCS vessel check	V465	3/4	Check	1500 ^b	Steel	Thread	Rockwell-Edwards 1838
LPCS bypass	V468	3/4	Globe	2000 ^a	Steel	Thread	Vogt 12141
LPCI pump suction	V505	1-1/2	Gate	2000 ^a	Steel	Thread	Vogt 12111
LPCI vessel check	V510	1-1/2	Check	600 ^b	Steel	Weld	Pacific-1-1/2-30-LC
LPCI bypass	V513	1	Globe	1500 ^b	Steel		Vogt 15141
LPCI throttle		1/2	Globe	800 ^b	Steel	Thread	Vogt 2821
Feed throttle	V16	1	Plug	1440 ^a	Steel	Weld	FWI
Feed isol.	V25	1	Globe-Y	1500 ^a	Steel	Weld	Velan 376

a. At ambient temperature.

b. At elevated temperature, e.g., 800°F.

TABLE D-4.3 RELIEF VALVES

Name	Number	Size	Orifice	Set Pressure (psig)	Capacity	Manufacturer and Model Number	Serial Number
Demin. water return	V18	1/2 x 1/2	--	1050	--	--	--
Cold feed pump relief	V19	1 x 1	--	1260	--	Baird 7601 -1-7B-SH-MP	--
HPCS pump relief	V417	3/4 x 3/4	--	1235	--	Lonergan LC 13	--
LPCS pump relief	V461	3/4 x 3/4	0.13 in.	435	52.08 gpm	Farris 2745	58385-FF
LPCI pump relief	V506	3/4 x 3/4	0.13 in.	385	49.44 gpm	Farris 2745	58384-FF
Feedwater tank safety	V615	2 x 2	0.674 in.	1320	7700 /hr	Consolidated 1914D/P2-1	T608150
Test vessel safety	V650	1-1/2 x 2-1/2	--	1442	25,550 lb/hr	Farris 26FA24-170	58927-A8
Test vessel safety	V651	1-1/2 x 2-1/2	--	1400	23,870 lb/hr	Farris 26FA24-170	58926-A8
Fill system regulator	V613	1/2 x 1/2	--			Kates MFA 9-1B	26689

GEAP-22054

TABLE D-5. HEATER RODS

Core		Manufacturer:	General Electric		
		Total number of rods:	62		
		Heated length:	150.0 in.		
		Rod diameter:	0.483 in.		
Model ^d Number	Serial Number	Number of Installed Thermocouples	Elevations ^b of Installed Thermocouples (in.)	Initial Position of Rod in Core	
76	1	6	33, 57, 77, 97, 117, 137	11	
	2	3	8, 33, 57	14	
	3	6	8, 33, 57, 69, 105, 141	18	
	4	6	33, 57, 77, 97, 117, 137	47	
	5	4	69, 76, 76, 88	54	
	6	0	--	23	
	7	0	--	42	
	8	0	--	51	
77	1	6	17, 40, 77, 97, 128, 141	1	
	2	6	81, 97, 101, 113, 121, 133	3	
	3	4	83, 105, 128, 141	6	
	4	6	17, 48, 69, 97, 105, 128	7	
	5	0	--	2	
	6	4	33, 69, 105, 141	9	
	7	4	33, 57, 69, 105	12	
	8	5	77, 97, 117, 128, 137	13	
	9	6	33, 57, 77, 97, 117, 137	17	
	10	6	20, 40, 61, 81, 101, 113	26	
	11	6	8, 33, 69, 88, 105, 128	29	
	12	6	8, 17, 33, 48, 57, 69	34	
	13	6	17, 48, 57, 77, 97, 117	36	
	14	6	8, 33, 48, 57, 69, 105	39	
	15	4	69, 76, 88, 88	49	
	16	6	20, 40, 61, 81, 101, 121	53	
	17	3	117, 128, 137	57	
	18	4	77, 97, 117, 137	62	
	19	6	17, 48, 77, 97, 128, 141	64	
	20	4	97, 117, 128, 137	8	
	21	0	--	16	
	22	0	--	24	
	23	0	--	31	
	24	0	--	41	
	25	0	--	48	
	26	0	--	52	
	27	0	--	56	
	28	0	--	58	
	29	0	--	59	
	30	0	--	63	
78	1	5	8, 48, 88, 117, 137	4	
	2	2	48, 69	5	
	3	5	8, 3, 88, 117, 137	10	
	4	0	--	50	
	5	3	17, 48, 69	20	
	6	4	69, 69, 88, 88	21	
	7	6	33, 57, 77, 97, 117, 137	22	

TABLE D-5. (continued)

<u>Core</u>	Manufacturer:	General Electric		
	Total number of rods:	62		
	Heated length:	150.0 in.		
	Rod diameter:	0.483 in.		
<u>Model^a Number</u>	<u>Serial Number</u>	<u>Number of Installed Thermocouples</u>	<u>Elevations^b of Installed Thermocouples (in.)</u>	<u>Initial Position of Rod in Core</u>
	8	4	8, 88, 117, 137	25
	9	6	77, 88, 97, 105, 117, 128	33
	10	3	17, 48, 69	35
	11	5	97, 117, 128, 137, 141	38
	12	5	8, 48, 88, 117, 137	40
	13	4	8, 17, 48, 57	46
	14	5	8, 33, 76, 117, 137	55
	15	0	--	60
	16	0	--	27
	17	0	--	30
	18	0	--	32
	19	1	Electrode TC at 152	43
	20	0	--	44
	21	0	--	45
	22	4	8, 17, 48, 57	19
	23	1	Electrode TC at 152	15
	24	0	--	61

<u>a. Heater Kod Type Code Number (model)</u>	<u>Ratio of Actual Rod Power to Core-Average Kod Power</u>	<u>Reference Drawing 181F 145-182</u>
76	1.04	16688929G4
77	1.01	16688929G5
78	0.97	16688929G6

b. Thermocouple elevations are measured upward from the bottom of the heated length which point corresponds to vessel elevation 208.56 in.

<u>ECCS Makeup Tank</u>	Manufacturer:		Watlow	
	Total number of rods:		6	
<u>Model Number</u>	<u>Nominal Power</u>	<u>Voltage</u>	<u>Heated Length, Diameter (in.)</u>	<u>Serial Number</u>
Fire rod T34AX6A	25 kW	480 VAC	20, 0.995	Later

<u>Feedwater Heater</u>	Manufacturer:			
	Total number of rods:		24	
<u>Model Number</u>	<u>Nominal Power</u>	<u>Voltage</u>	<u>Heated Length, Diameter (in.)</u>	<u>Serial Number</u>
	12.5 kW	480 VAC		Later

TABLE D-6.1 SENSORS HAVING INDIVIDUAL CALIBRATIONS

ABSOLUTE AND DIFFERENTIAL PRESSURE TRANSDUCERS										
Manufacturer	Model Number	Full Scale Range	4-20 ma. Output				1u-50 ma Output			
			Transducer Number	Serial Number	Transducer Number	Serial Number	Transducer Number	Serial Number	Transducer Number	Serial Number
Rosemount	1151DP-3-E-12, 1151DP-3-B-12	30 in. H ₂ O	42	387069	47	382269	97	3138		
			44	387073	48	382270	98	9566		
			45	387076			99	15597		
			46	382268			162	18731		
Rosemount	1151DP-4-E-12, 1151DP-4-B-12	150 in. H ₂ O	15	142656	56	373473	100	1242		
			16	142657	57	373474	101	12424		
			17	142658	58	373475	102	12430		
			24	153040	59	373476	103	12431		
			25	153042	60	373477	104	17073		
			26	153043	61	373478	105	17075		
			27	155900	62	373479	106	17076		
			32	161261	63	373480	107	17077		
			33	161262	64	373481	108	17078		
			34	161263	65	373482	109	17081		
			35	161264	66	373483	110	17082		
			36	161265	67	373484	111	17235		
			37	161266	68	373485	112	100965		
			38	161267	69	373486				
			39	161268	70	373487				
			40	161269	71	373488				
			41	161270	72	387238				
			43	387070	73	387239				
			49	356739	146	361815				
			50	356740	151	215889				
51	361889	152	215890							
52	361890	153	215891							
53	373470	154	215892							
54	373471	158	72379							
55	373472	159	72330							
Rosemount	1151DP-5-E-12, 1151DP-5-B-12	750 in. H ₂ O	14	114232	77	402390	113	1554	126	37437
			18	146926	88	78752	114	1689		
			19	152495	89	78756	115	9843		
			20	152496	90	82188	117	13532		
			21	152498	116	13486	118	17138		
			22	152499	147	363195	119	17148		
			28	156194	148	363196	120	35264		
			29	156195	149	363200	121	35267		
			30	156290	150	363209	122	35271		

TABLE D-6.1 (Continued)

ABSOLUTE AND DIFFERENTIAL PRESSURE TRANSDUCERS										
Manufacturer	Model Number	Full Scale Range	4-20 ma. Output				10-50 ma Output			
			Transducer Number	Serial Number	Transducer Number	Serial Number	Transducer Number	Serial Number	Transducer Number	Serial Number
			74	372337	155	146870	123	35272		
			75	351152	156	146969	124	35279		
			76	402388	157	146974	125	37436		
Rosemount	1151DP-6-E-12, 1151DP-6-B-12	100 PSID	23	152638	95	69787	127	5648	133	12887
			31	156472	96	86837	128	5637	134	12888
			91	109106			129	12879	135	12876
			92	114281			130	12880	136	18598
			93	101455			131	12881	137	30193
			94	101456			132	12882	163	16876
Rosemount	1151DP-7-E-12, 1151DP-7-B-12	300 PSID	160	32361			138	7369	140	12568
							139	11178	141	12573
Rosemount	1151DP-8-E-12, 1151DP-8-B-12	1000 PSID	78	389290	81	389293	142	12890		
			79	389291	82	395596				
			80	389292	161	72912				
Rosemount	1151GP-9-E-12, 1151GP-9-B-12	1500 PSIA	83	287279	86	384394	143	53396		
			84	375145	87	384395	144	77515		
			85	375148			145	77522		
Statham	PD3000- 100-18-11	100 in. H ₂ O	5	26845	13	39890				
			8	35473						
Statham	PD3000- 200-18-11	200 in. H ₂ O	9	35935	10	35962				
Statham	PD3000- 400-18-11	400 in. H ₂ O	6	27693	7	29422				
Statham	PDH3000- 030-18-11	750 in. H ₂ O	1	22971	3	21989				
			2	21984	4	22002				
Statham	PDH3000- 100-18-11	100 PSID	11	36552						
Statham	PDH3000- (01m)-18-11	1000 PSID	12	36339						

TABLE D-6.1 (Continued)

ABSOLUTE AND DIFFERENTIAL PRESSURE TRANSDUCERS																																																																					
Manufacturer	Model Number	Full Scale Range	Voltage Output																																																																		
			Transducer Number	Serial Number	Transducer Number	Serial Number																																																															
Statham	PM385TC ± 1-350	1 PSID	195	396	197	552																																																															
			196	400			Statham	PM385TC ± 2.5-350	2.5 PSID	190	745	193	787	191	746	192	786	Statham	PM385TC ± 5-350	5 PSID	189	828			Statham	PM385TC ± 10-350	10 PSID	187	821	188	823	Statham	PM385TC ± 25-350	25 PSID	184	817	186	833	185	818	Statham	PM385TC ± 50-350	50 PSID	181	829	183	831				182	830	BLH	HHD	100 PSID	178	53677	180	53679	179	53678	Straindyne	DPT 2.0-1000	1000 PSID	171	20-121	175	20-128	172
Statham	PM385TC ± 2.5-350	2.5 PSID	190	745	193	787																																																															
			191	746																																																																	
			192	786																																																																	
Statham	PM385TC ± 5-350	5 PSID	189	828																																																																	
Statham	PM385TC ± 10-350	10 PSID	187	821	188	823																																																															
Statham	PM385TC ± 25-350	25 PSID	184	817	186	833																																																															
			185	818			Statham	PM385TC ± 50-350	50 PSID	181	829	183	831				182	830	BLH	HHD	100 PSID	178	53677	180	53679	179	53678	Straindyne	DPT 2.0-1000	1000 PSID	171	20-121	175	20-128	172	20-123	173	20-126	174	20-127																													
Statham	PM385TC ± 50-350	50 PSID	181	829	183	831																																																															
			182	830			BLH	HHD	100 PSID	178	53677	180	53679	179	53678	Straindyne	DPT 2.0-1000	1000 PSID	171	20-121	175	20-128	172	20-123	173	20-126	174				20-127																																						
BLH	HHD	100 PSID	178	53677	180	53679																																																															
			179	53678			Straindyne	DPT 2.0-1000	1000 PSID	171	20-121	175	20-128	172	20-123				173	20-126			174	20-127																																													
Straindyne	DPT 2.0-1000	1000 PSID	171	20-121	175	20-128																																																															
			172	20-123																																																																	
			173	20-126																																																																	
			174	20-127																																																																	

TABLE D-6.1 (Continued)

ANNUBARS			
Manufacturer	Model Number	Serial Number	Probe Length Set For Flow Path Dimension
Dieterich	XANR-73	10690.A.1	4.813
Dieterich	XANR-73	10690.B.1	1.717
Dieterich	XANR-73	10690.C.1	2.632
Dieterich	XANR-73	10690.D.1	3.826
Dieterich	XANR-73	10690.E.1	3.624
Dieterich	XANR-73	10690.F.1	1.685
Dieterich	XANR-73	10690.F.2	1.685
Dieterich	XANR-73	10690.G.1	3.826

ORIFICE PLATES			
Manufacturer	Model Number	Serial Number	Hole Diameter (in.)
		DC-OR01-1	1.722
		DC-OR01-2	2.296
Daniel	520	29489	0.900
Daniel	520	29491	0.574
Daniel	520	29518	0.1362
		HPCS-41	0.408
		LPCS-51	0.466
		LPCI-61	0.395
Daniel	520	29493	1.885
Daniel	520	29523	0.229
Daniel	520	29522	0.229
Daniel	520	29525	0.398
Daniel	520	29527	0.459
Daniel	520	29490	0.606
		L1D-11	1.20
		L2D-21	1.20
Daniel	520	29492	0.317

TABLE D-6.1 (Continued)

TURBINE METERS						
Manufacturer	Model Number	Rotor Serial Number	Number of Blades	Pipe Size	Transducer Number	
Flow Technology		32054		2 in.	206	
Flow Technology		48128		3 in.	207	
DRAG DISKS						
Manufacturer	Model Number	Serial Number	Target Diameter	Pipe Size	Transducer Number	
Ramapo		4612		2 in.	208	
Ramapo		4613		3 in.	209	
ELECTRICAL POWER TRANSDUCER						
Manufacturer	Model Number	Serial Number				
YUKOGAWA Electric Works	2885-11	IC#2318				

TABLE D-6.2 SIGNAL CONDITIONING EQUIPMENT

Item	Manufacturer	Model Number	Serial Number	Description
Power supply				Channel, V supply for
Preamps	Newport	80A		Strain gage excitation and balance, 50 channels
Amplifiers	Newport	60A, 70A		± 10 VD output 2K gain, 3Hz-100KHz filter, 50 channels
Amplifier Rads	Newport	R10A-C	252124-252133	10 channel rack for amplifiers, balance modules
T/C Reference junction	Validyne	TR41-85TT	881	85 channel, 150°F reference, type K T/C's
T/C reference junction	Validyne	TR41S-50TT	8822	50 channel, 150°F reference, type J T/C's
T/C reference junction	Acromag	343	81014	25 channel, 150°F reference, type J T/C's
T/C reference junction	Hy-Cal engineering	202X-J100	47334	100 channel, 150°F reference, type J T/C's
T/C reference junction	Hy-Cal engineering	150-Bx-100-K/100-J	44231	100 channel, 150°F reference, type J or type K T/C's
Conductivity probe circuits	General Electric	Dw3, 181F145-171		64 channels
Turbine meter	Flow Technology	PRI-102A PRI-102FR	161257 161261	Bidirectional, pulse ratemeter

TABLE D-6.3 SENSORS HAVING CLASS-COMMON CALIBRATIONS

Sensor	Manufacturer	Type	Use	Serial Number	Transducer Code Number
Thermocouples	General Electric/ Claud S. Gordon	Chromel-Alumel	Only in heater rods		None 202
Thermocouples	General Electric/ Claud S. Gordon	Iron-Constantan	Fluid, wall temperatures		None 204
Conductivity probes	General Electric	A, B, C; Dwg. 181F145-401	Liquid level		1-46 200
LVDT	SCHAEVITZ	1000 HPD	Valve stem position indicators		212

D-20

GEAP-22054

TABLE B-6.4 DATA ACQUISITION EQUIPMENT

Item	Manufacturer	Model Number	Serial Number	Description
A/C	Heff	System 620 Series 500		
A/C	Heff	System 620 Series 400		256 channel low level multiplexer
A/C	Heff	System 620 Series 410		256 channel high level multiplexer
Minicomputer	Hewlett-Packard	21F		256K Main frame memory with floating point processor, Model 12979B I/O Extender and required interface cards.
Disk	Hewlett-Packard	7925	2153A17055	60 megaword
Tape drive #1	Hewlett-Packard	7970E		1600 bpi, phase encoded, 45 IPS
Tape drive #2	Hewlett-Packard	7970E		1600 bpi, phase encoded, 45 IPS
Terminal #1	Hewlett-Packard	2648A		Graphics terminal w/dual tape cartridge
Terminal #2	Hewlett-Packard	2648A		Graphics terminal w/dual tape cartridge
Printer	Versatec	1200		200 dots/inch
Scanner/ display	Metrascope	M/S 20	70264	
Video monitor	Conrac	5211C19		

GEAP-22054

APPENDIX E
SOFTWARE LIST

APPENDIX E
SOFTWARE LIST

<u>Table Number</u>	<u>Name</u>	<u>Page</u>
E-1	Data Acquisition System	E-4
E-2	Data Processing System	E-7

TABLE E-1. DATA ACQUISITION SYSTEM

Number	Program Name	Description
1.	MPXT	MPXT allows the user to display selected analog signals in millivolts or engineering units. This program can be used as a diagnostic tool to verify the integrity of the signal paths and the operation of the A/D equipment.
2.	TINIZ	Program TINIZ allows the user to create or modify a 'work file'; work files include the PID table and describe a data acquisition run, including the recording plan and requirements for limit checking. Work files are stored permanently on the disk.
3.	CALIB	To modify or look at the contents of the transducer file, the user must run CALIB. The user may add transducers, change data for a transducer or display the contents of the transducer file. When doing an update, the user must provide a password.
4.	HIST	HIST may be run to generate a histogram of signal data in millivolts or engineering units. HIST collects signal data the specified number of time and performs the required conversion calculation. The mean, minimum and maximum values and the distribution around the mean is output.
5.	UPZER	The UPZER program allows the user to update the instrument and process zeros stored in the PID table of the work file. When the process zero is updated, it is compared to an expected value; those channels, whose process zero varies from the expected value in excess of a specific tolerance, will be flagged.
6.	ICHEK	ICHEK performs checks on pressure and temperature readings as well as conductivity probe outputs--ICHEK collects data at a user specified rate for a user-defined period of time. This data is converted to engineering units and an average value for each channel is calculated. The averaged values are displayed and compared to expected values. Those channels that vary from the expected value more than the specified tolerance are printed on the screen.
7.	SCHEK	SCHEK allows the user to perform preliminary pressure balance and mass conservation checks. The user defines columns (strings) of dp readings and groups those which are expected to be equal, together; in the same way, the user defines those flows comprising a control volume and groups those control volumes which are expected to equal, together.

TABLE E-1. (continued)

Number	Program Name	Description
8.	SETUP	SETUP initializes the data acquisition mode including the multiplexer, system common and the on-line calculations and limit checking based on the user input and the selected work file.
9.	ROP	The user runs ROP in the data acquisition mode and enters a command; depending on the command, ROP will schedule another program/programs to run or process the command itself. Programs include SCAN, TCHER, initial conditions bar chart and alpha-numeric displays on video screens.
10.	SCAN	SCAN may be run at 40 millisecond intervals. SCAN schedules the program which reads the multiplexer, MUXRE, update the pointers to the locations into which the multiplexer data is to be read. When a data buffer is filled, if tape recording is on, SCAN initiates the program, WRMT, to write the buffer to tape.
11.	TCHK	The program TCHK performs limit checking of the enabled thermocouples. If a thermocouple exceeds the limits, it is TCHK that trips the power, turns on the alarm light, and initiates the processing to inform the operator.
12.	WRMT	Recording of data to the tape is performed by the program, WRMT. If the user has specified tape recording, WRMT is requested to run by SCAN as each magnetic tap buffer fills.
13.	MEANS	Program MEANS provides a statistical data analysis of a given data acquisition run. Data for a prescribed time interval is processed from magnetic tape and the mean, minimum, maximum, standard deviation, and peak-to-peak values for the user specified engineering unit and derived quantities are calculated.
14.	XIBIT	Program XIBIT provides on-site data reduction of data recorded to a 9-track tape using the FIST data acquisition system. Selected 'A' and/or 'P' values are printed and/or plotted in engineering units or millivolts. (Millivolts apply only to 'A' values).
15.	FSTDR	Program FSTDR allows the user to convert raw test data stored on magnetic tape during data collection to engineering unit format; save that converted data on a "wrapup" magnetic tape; and then display the engineering unit time history in a variety of printed, plotted, or schematic forms. Calculations include all derived quantities.

TABLE E-1. (continued)

Number	Program Name	Description
16.	PMCHK	Program basically the same as SCHEK for pressure balance and mass conservation checks except that data are supplied by magnetic tape. Thus the PMCHK program data quality checks are available for use on actual recorded test data.

TABLE E-2. DATA PROCESSING SYSTEM

<u>Number</u>	<u>Program Name</u>	<u>Description</u>
1.	FICON	Reads data tape and converts counts to MV for each measurement channel and puts data in CWF format for subsequent processing.
2.	FIKAL	Performs engineering unit conversion calculation for each measurement channel using FICON output.
3.	FIWIZ	Performs engineering calculations using FIKAL measurement outputs. Quantities calculated include flows, levels, mass and energy balances.

NRC FORM 335 (7-77)		U.S. NUCLEAR REGULATORY COMMISSION BIBLIOGRAPHIC DATA SHEET		1. REPORT NUMBER (Assigned by DDC) NUREG/CR-2576 GEAP - 22054 EPRI NP - 2214	
4. TITLE AND SUBTITLE (Add Volume No., if appropriate) BWR Full Integral Simulation Test (FIST) -- Facility Description Report				2. (Leave blank)	
7. AUTHOR(S) A. G. Stephens, Editor				3. RECIPIENT'S ACCESSION NO.	
9. PERFORMING ORGANIZATION NAME AND MAILING ADDRESS (Include Zip Code) General Electric Company 175 Curtner Avenue San Jose, California 95125				5. DATE REPORT COMPLETED MONTH YEAR December 1982	
12. SPONSORING ORGANIZATION NAME AND MAILING ADDRESS (Include Zip Code) Division of Accident Evaluation Office of Nuclear Regulatory Research U.S. Nuclear Regulatory Commission Washington, D.C. 20555				6. (Leave blank)	
13. TYPE OF REPORT Technical				7. (Leave blank)	
15. SUPPLEMENTARY NOTES				8. (Leave blank)	
16. ABSTRACT (200 words or less) A new boiling water reactor safety test facility (FIST, Full Integral Simulation Test) is described. It will be used to investigate small breaks and operational transients and to tie results from such tests to earlier large break test results determined in the TLTA. The new facility's full height and prototypical components constitute a major scaling improvement over earlier test facilities. A heated feedwater system, permitting steady state operation, and a large increase in the number of measurements are other significant improvements. Program background is outlined and program objectives defined. Design basis is presented together with a detailed, complete description of the facility and measurements to be made. An extensive component scaling analysis and prediction of performance are presented. The report is intended to serve as a reference document for those needing detailed information about the facility.				9. (Leave blank)	
17. KEY WORDS AND DOCUMENT ANALYSIS				10. PROJECT/TASK/WORK UNIT NO. BWR FIST Program	
17b. IDENTIFIERS/OPEN-ENDED TERMS				11. CONTRACT NO. NRC-04-76-215 PIN No. B3014	
18. AVAILABILITY STATEMENT Unlimited				13. PERIOD COVERED (Inclusive dates)	
19. SECURITY CLASS (This report) Unclassified				14. (Leave blank)	
20. SECURITY CLASS (This page) Unclassified				17a. DESCRIPTORS	
21. NO. OF PAGES				22. PRICE \$	

UNITED STATES
NUCLEAR REGULATORY COMMISSION
WASHINGTON, D.C. 20555

FOURTH-CLASS MAIL
POSTAGE & FEES PAID
USNRC
WASH D C
PERMIT No. 467

OFFICIAL BUSINESS
PENALTY FOR PRIVATE USE, \$300

120555078877 1 1AN1R2
US NRC
ADM-DIV OF TIDC
POLICY & PUB MGT BR-PDR NUREG
W-501
WASHINGTON DC 20555