

ITT GRINNELL VALVE COMPANY INC.
DIA-FLO DIVISION
33 CENTERVILLE ROAD
LANCASTER, PA 17603

SEISMIC CALCULATIONS

FOR

MILL POWER SUPPLY COMPANY
(DUKE POWER)
CATAWBA NUCLEAR STATION

ASME SECTION III, CLASS 2 VALVES

DUKE POWER SPECIFICATION NO. CNS-1205.04-1
ADDENDUM 1-3

ITT GRINNELL DIA-FLO ORDER NO. N79-52207

CALCULATIONS PERFORMED BY

Michael P. Panciera 22 Sept 83
M. J. Panciera, Sen. Prod. Eng. Date

CALCULATIONS APPROVED BY

R. D. Randall 9/22/83
R. D. Randall, Mgr. Prod. Eng. Date

REPORT NO. W-156

8410110218 841011
PDR ADOCK 05000413
P PDR

SEPTEMBER 1983
REV. 1

TABLE OF CONTENTS

	<u>Page No.</u>
1. INTRODUCTION	1
2. METHODS OF ANALYSIS	2
3. LOADING	3
4. RESULTS OF SEISMIC ANALYSIS	4
Appendix A - 2" 150# Stainless Steel Diaphragm Valve w/7NA71 Rotork Actuator	
Appendix B - 4" 150# Stainless Steel Diaphragm Valve w/14NA71 Rotork Actuator	

INTRODUCTION

The purpose of these calculations is to demonstrate that the valves being supplied by ITT Grinnell Dia-Flo Division are designed in accordance with Duke Power Specification No. ^{JER CNS} MCS-1205.04-1 and meet all seismic design requirements of the specification. These calculations apply to the below-listed valves.

<u>Dia-Flo Item No.</u>	<u>Drawing No.</u>	<u>Dia. Valve Description</u>	<u>Duke Power Tag Number</u>
2	SD-C-108417	2"-150 S.S.	5B-263
3	SD-C-108416	4"-150 S.S.	5B-473

One analysis was done for each of the above-listed valves. For the actual seismic calculations, see Appendices A and B.

METHODS OF ANALYSIS

The method of analysis is based on applying a static resultant force resulting from the equivalent earthquake accelerations acting at the center of gravity of the valve assembly. The valves are analyzed assuming worst case mounting.

Principal stresses were calculated for valve component parts (other than the body) which are essential to the pressure integrity or functional adequacy of the valve. These stresses were then compared to the applicable allowable stresses in the 1977 ASME Boiler and Pressure Vessel Code, including the 1978 Winter Addenda. The valve bodies were analyzed by comparing their metal areas and section moduli to the connecting pipe's metal areas and section moduli.

LOADING

For the analysis of these valves, the load combinations considered were those resulting from the Faulted Plant Condition as defined in the design specification since this represents the most severe load case.

The equivalent static forces were calculated by multiplying the applicable valve component part by the appropriate resultant seismic coefficient (i.e., the square root of the sum of the squares of the vertical and both horizontal seismic coefficients).

The vertical seismic coefficient of 3 is determined by taking the 2g coefficient required by design specification and adding 1g to it to account for the valve weight. The horizontal seismic coefficient of 3g's was specified in the design specification.

RESULTS OF THE SEISMIC ANALYSIS

The results of the seismic calculations are as follows:

1. The stresses in the valve components resulting from the applied loads caused by the Faulted Condition were below the allowable stress limits allowed by the 1977 ASME Boiler and Pressure Vessel Code including the 1978 Winter Addenda for normal operating conditions. This demonstrates that the structural and functional integrity of the valve will be maintained for the various plant conditions.
2. The ratios of the valves' section moduli and cross-sectional areas were found to be equal to or in excess of 120% of the attached piping section moduli and cross-sectional areas. This demonstrates that the attached piping, rather than the valve, is the limiting factor in the piping system.

APPENDIX A

2" DIAPHRAGM VALVE
WITH
7NAT1 ROTORK ACTUATOR

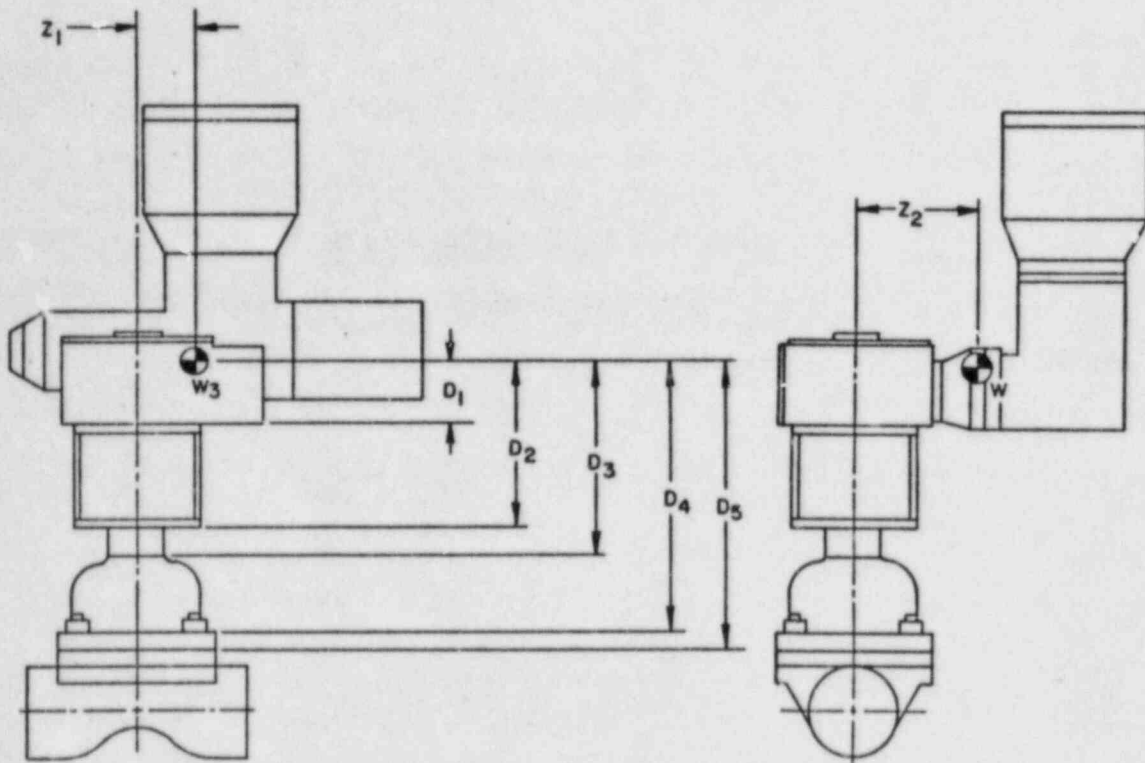

DESIGN DATA FOR A 2 IN. POWER OPERATED DIAPHRAGM VALVE

VALVE ASSEMBLY WEIGHT

$W = 154.9$ LB

DISTANCE FROM THE VALVE CENTER OF GRAVITY TO:

ACTUATOR BRACKET JOINT $D_1 = 3.23$ IN

BOTTOM OF ACTUATOR JOINT $D_2 = 5.73$ IN

BUSHING-BONNET JOINT $D_3 = 6.8$ IN

TOP OF BONNET FLANGE $D_4 = 8.83$ IN

BODY-BONNET JOINT $D_5 = 9.49$ IN

DISTANCE FROM THE VERTICAL CENTERLINE OF THE VALVE TO:

THE VALVE C. G. ALONG THE PIPELINE AXIS $Z_1 = .156$ IN

THE VALVE C. G. PERPENDICULAR TO THE PIPELINE $Z_2 = 1.969$ IN

DESIGN PRESSURE $P = 150$ PSI

DESIGN TEMPERATURE $T = 260$ F

SEISMIC ACCELERATION:

$G_1 = 3$

$G_2 = 3$

HORIZONTAL RESULTANT $G_3 = 4.24$

ACTUATOR-BRACKET BOLTING ANALYSIS

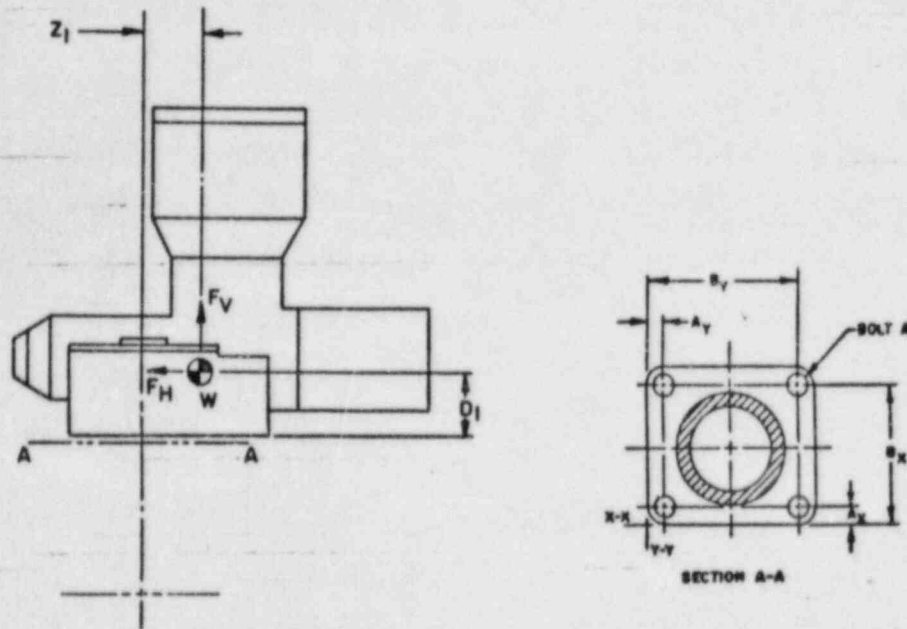

BOLTING DIMENSIONS:

AX = 1.06 IN AY = 1.06 IN
 BX = 3.68 IN BY = 3.68 IN
 BOLT STRESS AREA = .0773 IN²

SEISMIC FORCES ACTING ON THE BOLTING

FH = G * W = 804.884 LB FV = G1 * W = 464.7 LB
 WHERE G IS THE RESULTANT ACCELERATION $(2 * (61^2) + (52^2))^{.5}$

THE GREATEST AXIAL FORCE ON THE BOLTING IS DETERMINED BY SUMMING MOMENTS ABOUT THE X-X AXIS AND THE Y-Y AXIS. THE LOAD ON THE BOLT FURTHEST FROM THE POINT OR LINE ABOUT WHICH THE BONNET FLANGE WOULD PIVOT IF FREE TO MOVE IS DETERMINED.

THE MOMENT IN THE X-X DIRECTION IS:

$$M(XX) = (FH * D1) + (FV * Z1) \\ = (804.88 * 3.23) + (464.70 * 0.16) = 2672.3 \text{ IN-LB}$$

THE MOMENT IN THE Y-Y DIRECTION IS:

$$M(YY) = (FH * D1) + (FV * Z2) \\ = (804.88 * 3.23) + (464.70 * 1.97) = 3514.8 \text{ IN-LB}$$

FORCE ON BOLT A DUE TO MOMENTS ABOUT X-X

$$FX1 = (M(XX) * B(X)) / [2(A(X)^2 + B(X)^2)] \\ = (2672.3 * 3.88) / [2((1.06)^2 + (3.88)^2)] = 320.4 \text{ LB}$$

FORCE ON BOLT A DUE TO MOMENTS ABOUT Y-Y

$$FY1 = (M(YY) * B(Y)) / [2(A(Y)^2 + B(Y)^2)] \\ = (3514.8 * 3.88) / [2((1.06)^2 + (3.88)^2)] = 421.5 \text{ LB}$$

THE FORCE DUE TO A VERTICAL LOAD ON EACH BOLT IS:

$$FV1 = 0.25(FV) = 0.25(464.70) = 116.18 \text{ LB}$$

THE TOTAL LOAD ON BOLT A IS:

$$FVT = FX1 + FY1 + FV1 = 320.44 + 421.47 + 116.18 = 858.09 \text{ LB}$$

THE TOTAL SHEAR FORCE PER BOLT IS:

$$SB = 0.25 * (FH + (FH * Z) / Z4) = 0.25 * (804.88 + (804.88 * 1.98) / 2.00) \\ = 399.97 \text{ LB}$$

WHERE Z4 IS THE DISTANCE FROM THE VALVE VERTICAL CENTER LINE TO THE FURTHEST CAPSCREW AND $Z = [Z1^2 + Z2^2]^{0.5}$.

THE STRESS ON EACH BOLT IS:

$$\text{TENSILE STRESS-SIGMA M} = FVT / AB = 858.09 / .0775 = 11072.1 \text{ PSI}$$

$$\text{SHEAR STRESS-TAU} = SB / AB = 399.97 / .0775 = 5161.0 \text{ PSI}$$

THE PRINCIPLE STRESSES ARE:

THE PRINCIPAL STRESSES AT A-A

$$\text{SIGMA 1} = \left\{ \frac{(\text{SIGMA M} + \text{SIGMA B})}{2} \right\} + \left\{ \left(\frac{(\text{SIGMA M} + \text{SIGMA B})}{2} \right)^2 + (\text{TAU})^2 \right\}^{0.5} \\ = 13104.65 \text{ PSI}$$

$$\text{SIGMA 2} = \left\{ \frac{(\text{SIGMA M} + \text{SIGMA B})}{2} \right\} - \left\{ \left(\frac{(\text{SIGMA M} + \text{SIGMA B})}{2} \right)^2 + (\text{TAU})^2 \right\}^{0.5} \\ = -2032.519 \text{ PSI}$$

BOLT MATERIAL: ASTM A193-B8

YIELD STRENGTH: 30000 PSI

ACTUATOR-BONNET ADAPTER BRACKET ANALYSIS

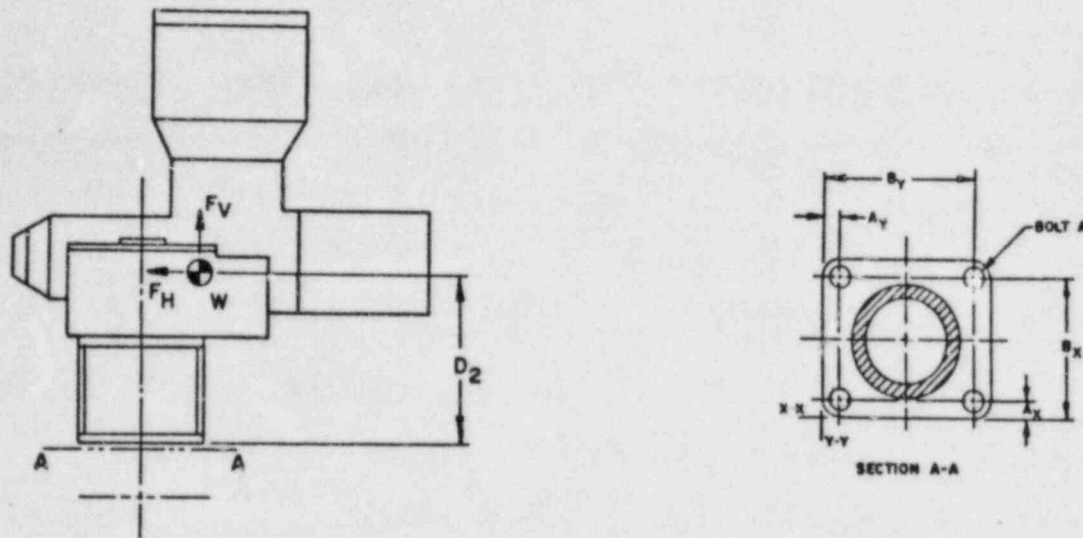

ADAPTER BRACKET POST DIMENSIONS:

AX= 0.30 IN AY= 0.50 IN
 BX= 6.75 IN BY= 3.50 IN
 BOLT STRESS AREA = .1419 IN²

SEISMIC FORCES ACTING ON THE BOLTING

FH=G*W= 804.884 LB FV=G1*W= 464.7 LB
 WHERE G IS THE RESULTANT ACCELERATION $(2*(G1^2)+(G2^2))^{0.5}$

THE GREATEST AXIAL FORCE ON THE BOLTING IS DETERMINED BY SUMMING MOMENTS ABOUT THE X-X AXIS AND THE Y-Y AXIS. THE LOAD ON THE BOLT FURTHEST FROM THE POINT OR LINE ABOUT WHICH THE BONNET FLANGE WOULD PIVOT IF FREE TO MOVE IS DETERMINED.

THE MOMENT IN THE X-X DIRECTION IS:

$$M(XX) = (FH * D2) + (FV * Z1) \\ = (804.88 * 5.73) + (464.70 * 0.16) = 4684.5 \text{ IN-LB}$$

THE MOMENT IN THE Y-Y DIRECTION IS:

$$M(YY) = (FH * D2) + (FV * Z2) \\ = (804.88 * 5.73) + (464.70 * 1.97) = 5527.0 \text{ IN-LB}$$

FORCE ON BOLT A DUE TO MOMENTS ABOUT X-X

$$FX1 = (M(XX) * B(X)) / [2(A(X)^2 + B(X)^2)] \\ = (4684.5 * 6.75) / [2((0.50)^2 + (6.75)^2)] = 345.1 \text{ LB}$$

FORCE ON BOLT A DUE TO MOMENTS ABOUT Y-Y

$$FY1 = (M(YY) * B(Y)) / [2(A(Y)^2 + B(Y)^2)] \\ = (5527.0 * 3.50) / [2((0.50)^2 + (3.50)^2)] = 773.8 \text{ LB}$$

THE FORCE DUE TO A VERTICAL LOAD ON EACH BOLT IS:

$$FV1 = 0.25(FV) = 0.25(464.70) = 116.18 \text{ LB}$$

THE TOTAL LOAD ON BOLT A IS:

$$FVT = FX1 + FY1 + FV1 = 345.10 + 773.78 + 116.18 = 1235.06 \text{ LB}$$

THE TOTAL SHEAR FORCE PER BOLT IS:

$$SB = 0.25 * (FH + (FH * Z) / Z4) = 0.25 * (804.88 + (804.88 * 1.98) / 3.47) \\ = 315.88 \text{ LB}$$

WHERE Z4 IS THE DISTANCE FROM THE VALVE VERTICAL CENTER LINE TO THE FURTHEST CAPSCREW AND $Z = [(Z1)^2 + (Z2)^2]^{0.5}$.

THE STRESS ON EACH BOLT IS:

$$\text{TENSILE STRESS-SIGMA M} = FVT / AB = 1235.06 / .1419 = 8703.7 \text{ PSI}$$

$$\text{SHEAR STRESS-TAU} = SB / AB = 315.88 / .1419 = 2226.1 \text{ PSI}$$

THE PRINCIPAL STRESSES ARE:

THE PRINCIPAL STRESSES AT A-A

$$\text{SIGMA 1} = ((\text{SIGMA M} + \text{SIGMA B}) / 2) + (((\text{SIGMA M} + \text{SIGMA B}) / 2)^2 + (\text{TAU})^2)^{0.5} \\ = 9240.01 \text{ PSI}$$

$$\text{SIGMA 2} = ((\text{SIGMA M} + \text{SIGMA B}) / 2) - (((\text{SIGMA M} + \text{SIGMA B}) / 2)^2 + (\text{TAU})^2)^{0.5} \\ = -536.2954 \text{ PSI}$$

BOLT MATERIAL: ASTM A108

PROOF STRENGTH: 36000 PSI

DONNET-BRACKET ADAPTER BUSHING ANALYSIS

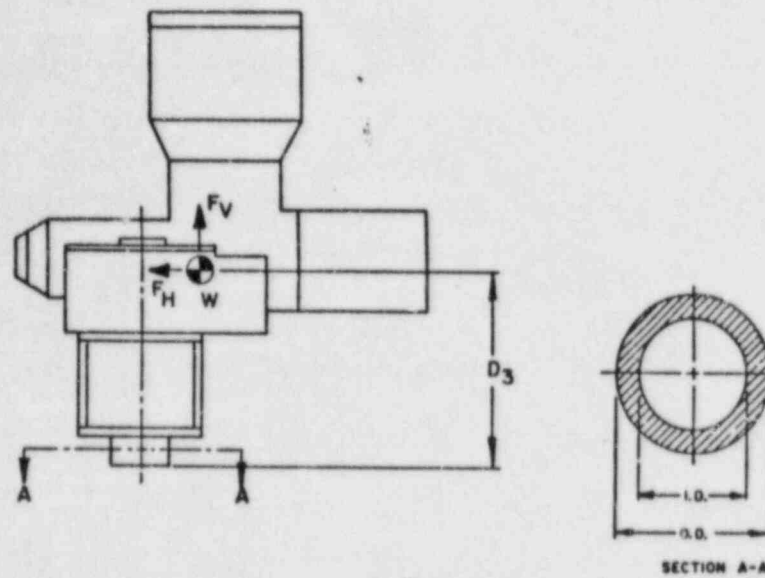

MINIMUM BUSHING SECTION OD = 1.12 IN ID = .757 IN

SEISMIC FORCES AT SECTION A-A

$$\begin{aligned}
 FH &= W * G = 154.90 * 5.20 = 804.9 \text{ LB} \\
 FV &= W * G_1 = 154.90 * 3.00 = 464.7 \text{ LB} \\
 M &= FH * D_3 + FV * Z_{10} = 804.9 * 6.80 + 464.7 * 1.97 = 6388.2 \text{ IN-LB} \\
 &\text{WHERE } Z_{10} \text{ IS THE GREATER OF } Z_1 \text{ OR } Z_2
 \end{aligned}$$

CROSS SECTIONAL PROPERTIES AT SECTION A-A

$$\begin{aligned}
 A &= (\pi/4) * (O.D.^2 - I.D.^2) = (\pi/4) * ((1.12)^2 - (0.76)^2) = 0.54 \text{ IN}^2 \\
 I &= (\pi/64) * (O.D.^4 - I.D.^4) = (\pi/64) * ((1.12)^4 - (0.76)^4) = 0.0611 \text{ IN}^4 \\
 C &= O.D./2 = 1.12/2 = 0.56 \text{ IN}
 \end{aligned}$$

STRESSES DUE TO SEISMIC LOADING AT A-A

$$\begin{aligned}
 \text{TENSILE STRESS} &= \sigma_M = FV/A = 464.70 / 0.54 = 868.38 \text{ PSI} \\
 \text{BENDING STRESS} &= \sigma_B = M * C / I = 6388.21 * 0.56 / 0.06 = 59530.37 \text{ PSI} \\
 \text{SHEAR STRESS} &= \tau = FH/A = 804.89 / 0.54 = 1504.09 \text{ PSI}
 \end{aligned}$$

THE PRINCIPAL STRESSES AT A-A

$$\text{SIGMA 1} = \left(\frac{\text{SIGMA M} + \text{SIGMA B}}{2} \right) + \left(\left(\frac{\text{SIGMA M} + \text{SIGMA B}}{2} \right)^2 + (\text{TAU})^2 \right)^{0.5}$$

$$= 59436.81 \text{ PSI}$$

$$\text{SIGMA 2} = \left(\frac{\text{SIGMA M} + \text{SIGMA B}}{2} \right) - \left(\left(\frac{\text{SIGMA M} + \text{SIGMA B}}{2} \right)^2 + (\text{TAU})^2 \right)^{0.5}$$

$$= -38.06055 \text{ PSI}$$

BUSHING MATERIAL: AISI 4340 ALLOWABLE STRESS 114000 PSI

VALVE BONNET ANALYSIS

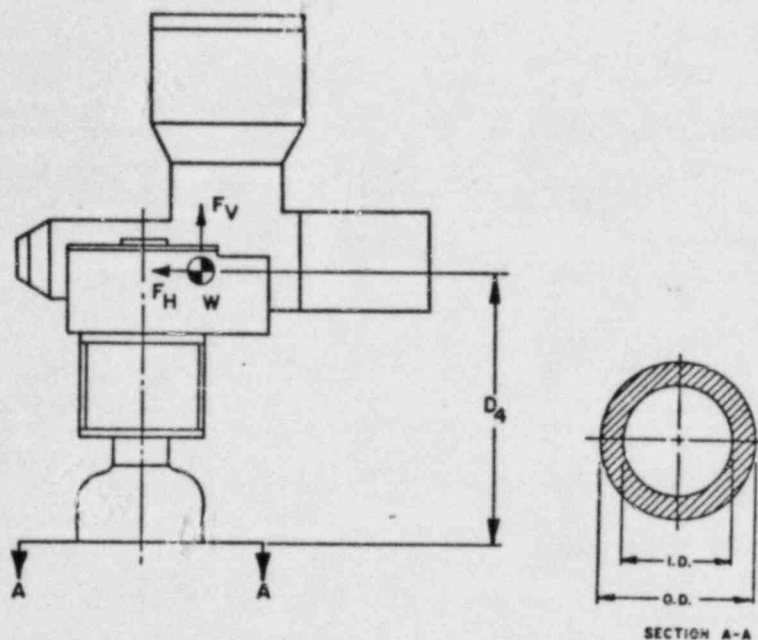

MINIMUM BONNET SECTION O.D. = 3.48 IN I.D. = 3 IN

SEISMIC FORCES AT SECTION A-A

$$\begin{aligned}
 F_H &= W * G = 154.90 * 5.20 = 804.9 \text{ LB} \\
 F_V &= W * G_1 = 154.90 * 3.00 = 464.7 \text{ LB} \\
 M &= F_H * D_4 + F_V * Z_{10} = 804.9 * 8.83 + 464.7 * 1.97 = 8022.1 \text{ IN-LB} \\
 &\text{WHERE } Z_{10} \text{ IS THE GREATER OF } Z_1 \text{ OR } Z_2
 \end{aligned}$$

CROSS SECTIONAL PROPERTIES AT SECTION A-A

$$\begin{aligned}
 A &= (\pi/4) * (O.D.^2 - I.D.^2) = (\pi/4) * ((3.48)^2 - (3.00)^2) = 2.44 \text{ IN}^2 \\
 I &= (\pi/64) * (O.D.^4 - I.D.^4) = (\pi/64) * ((3.48)^4 - (3.00)^4) = 3.2232 \text{ IN}^4 \\
 C &= O.D./2 = 3.48/2 = 1.74 \text{ IN}
 \end{aligned}$$

STRESSES DUE TO SEISMIC LOADING AT A-A

$$\begin{aligned}
 \text{TENSILE STRESS} &= \sigma_M = F_V/A = 464.70/2.44 = 190.22 \text{ PSI} \\
 \text{BENDING STRESS} &= \sigma_B = M * C/I = 8022.1 * 1.74/3.22 = 4330.66 \text{ PSI} \\
 \text{SHEAR STRESS} &= \tau = F_H/A = 804.88/2.44 = 329.46 \text{ PSI}
 \end{aligned}$$

BONNET STRESSES DUE TO INTERNAL PRESSURE

BONNET LONGITUDINAL STRESS = SIGMA L=

$$\begin{aligned} &= \text{PRES.} * \text{ID} / (4 * ((\text{OD} - \text{ID}) / 2)) \\ &= 150.0 * 3.00 / [4 * ((3.48 - 3.00) / 2)] = 468.7 \text{ PSI} \end{aligned}$$

BONNET TANGENTIAL STRESS = SIGMA T=

$$\begin{aligned} &= \text{PRES.} * \text{ID} / (2 * ((\text{OD} - \text{ID}) / 2)) \\ &= 150.0 * 3.00 / [2 * ((3.48 - 3.00) / 2)] = 937.5 \text{ PSI} \end{aligned}$$

THE TOTAL BONNET STRESSES ARE:

$$\begin{aligned} \text{SIGMA Y} &= \text{TENSILE STRESS} + \text{BENDING STRESS} + \text{SIGMA L} \\ &= 190.22 + 4330.7 + 468.7 = 4989.7 \text{ PSI} \end{aligned}$$

$$\text{SIGMA Z} = \text{SIGMA T} = 937.4999 \text{ PSI}$$

$$\text{TAU X-Y} = \text{SHEAR STRESS} = 329.4789 \text{ PSI}$$

THE PRINCIPAL STRESSES CAN BE DETERMINED BY THE FOLLOWING EQUATION

$$(\text{SIGMA P})^3 - \text{I1} * (\text{SIGMA P})^2 + \text{I2} * (\text{SIGMA P}) - \text{I3} = 0$$

$$\begin{aligned} \text{WHERE: } \text{I1} &= \text{SIGMA Y} + \text{SIGMA Z} = 5927.156 \text{ PSI} \\ \text{I2} &= (\text{SIGMA Y}) * (\text{SIGMA Z}) - (\text{TAU XY})^2 = 4569246 \text{ PSI} \\ \text{I3} &= -(\text{TAU XY})^2 * \text{SIGMA Z} = -1.017715\text{E}+08 \text{ PSI} \end{aligned}$$

$$\text{NOTE: SIGMA X} = \text{TAU XZ} = \text{TAU YZ} = 0$$

SOLVING THE ABOVE EQUATION FOR THE PRINCIPAL STRESSES:

$$\begin{aligned} \text{SIGMA 1} &= 5010.261 \text{ PSI} \\ \text{SIGMA 2} &= 935.5935 \text{ PSI} \\ \text{SIGMA 3} &= -18.70325 \text{ PSI} \end{aligned}$$

BONNET MATERIAL: ASME SA-351-CF8
ALLOWABLE STRESS PER THE ASME BOILER AND PRESSURE VESSEL CODE SECTION III

DIVISION 1 TABLE I-7.2 IS: 14800 PSI AT 260 F

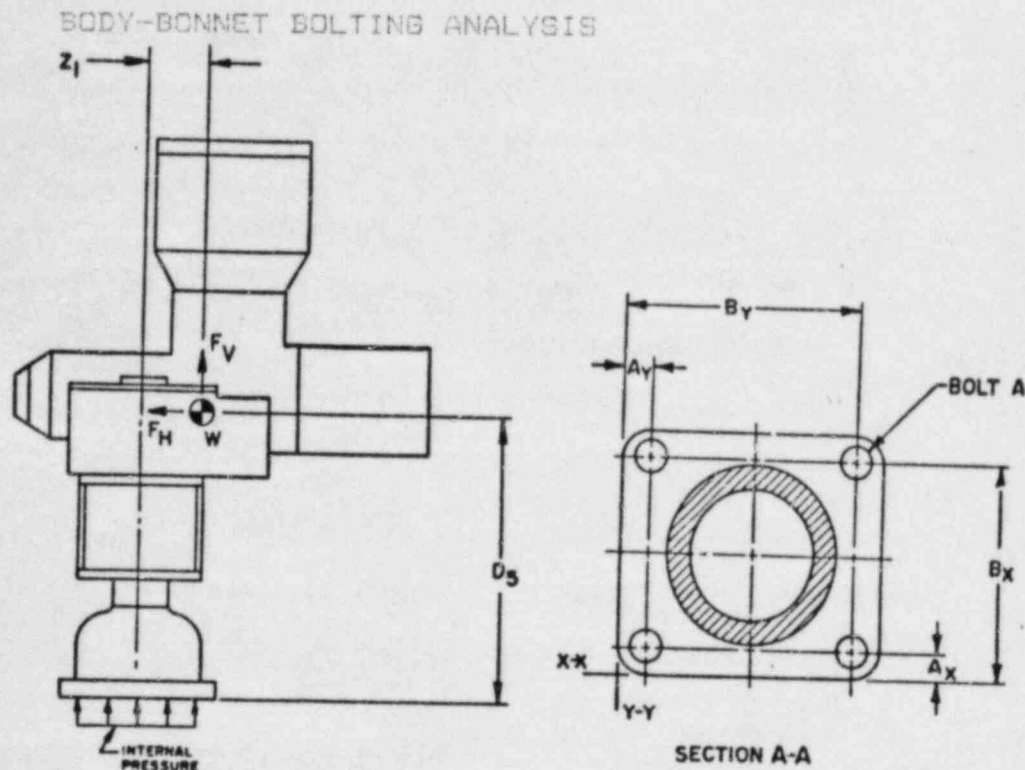

BOLTING DIMENSIONS:

AX= 0.60 IN AY= 0.89 IN
 BX= 3.67 IN BY= 4.15 IN
 BOLT STRESS AREA = .1167 IN²

SEISMIC FORCES ACTING ON THE BOLTING

FH=G*W= 804.884 LB FV=G1*W= 464.7 LB
 WHERE G IS THE RESULTANT ACCELERATION (2*((G1²)+(G2²)))

THE GREATEST AXIAL FORCE ON THE BOLTING IS DETERMINED BY SUMMING MOMENTS ABOUT THE X-X AXIS AND THE Y-Y AXIS. THE LOAD ON THE BOLT FURTHEST FROM THE POINT OR LINE ABOUT WHICH THE BONNET FLANGE WOULD PIVOT IF FREE TO MOVE IS DETERMINED.

THE MOMENT IN THE X-X DIRECTION IS:

$$M(XX) = (FH * D5) + (FV * z1)$$

$$= (804.88 * 9.49) + (464.70 * 0.16) = 7710.8 \text{ IN-LB}$$

THE MOMENT IN THE Y-Y DIRECTION IS:

$$M(YY) = (FH * D5) + (FV * z2)$$

$$= (804.88 * 9.49) + (464.70 * 1.97) = 8553.3 \text{ IN-LB}$$

FORCE ON BOLT A DUE TO MOMENTS ABOUT X-X
 $FX = (M(XX) * B(X)) / [2(A(X)^2 + B(X)^2)]$
 $= (7710.8 * 3.67) / [2((0.60)^2 + (3.67)^2)] = 1023.2 \text{ LB}$

FORCE ON BOLT A DUE TO MOMENTS ABOUT Y-Y
 $FY = (M(YY) * B(Y)) / [2(A(Y)^2 + B(Y)^2)]$
 $= (8553.3 * 4.15) / [2((0.89)^2 + (4.15)^2)] = 985.2 \text{ LB}$

THE FORCE DUE TO A VERTICAL LOAD ON EACH BOLT IS:
 $FV1 = 0.25(FV + (PRES * EFF \text{ AREA}))$
 $= 0.25(464.7 + (150 * PI/4 * (3.00)^2)) = 381.3 \text{ LB}$

THE TOTAL LOAD ON BOLT A IS:
 $FVT = FX1 + FY1 + FV1 = 1023.18 + 985.21 + 381.25 = 2389.63 \text{ LB}$

THE TOTAL SHEAR FORCE PER BOLT IS:
 $SB = 0.25 * (FH + (FH * Z1) / Z4) = 0.25 * (804.88 + (804.88 * 0.16) / 2.24)$
 $= 215.24 \text{ LB}$

WHERE Z4 IS THE DISTANCE FROM THE VALVE VERTICAL CENTER LINE TO THE FURTHEST CAPSCREW.

THE STRESS ON EACH BOLT IS:

TENSILE STRESS-SIGMA M = $FVT/AB = 2389.63/1.187 = 20131.7 \text{ PSI}$

SHEAR STRESS-TAU = $SB/AB = 215.24/1.187 = 1813.3 \text{ PSI}$

THE PRINCIPLE STRESSES ARE:

THE PRINCIPAL STRESSES AT A-A

$SIGMA 1 = ((SIGMA M + SIGMA B) / 2) + (((SIGMA M + SIGMA B) / 2)^2 + (TAU)^2)^{0.5}$
 $= 20293.74 \text{ PSI}$

$SIGMA 2 = ((SIGMA M + SIGMA B) / 2) - (((SIGMA M + SIGMA B) / 2)^2 + (TAU)^2)^{0.5}$
 $= -162.0264 \text{ PSI}$

BOLT MATERIAL: ASME SA-453-660
ALLOWABLE STRESS PER THE ASME BOILER AND PRESSURE VESSEL CODE SECTION III
DIVISION 1 TABLE 1-7.3 IS: 20500 PSI AT 250 F

VALVE BODY ANALYSIS

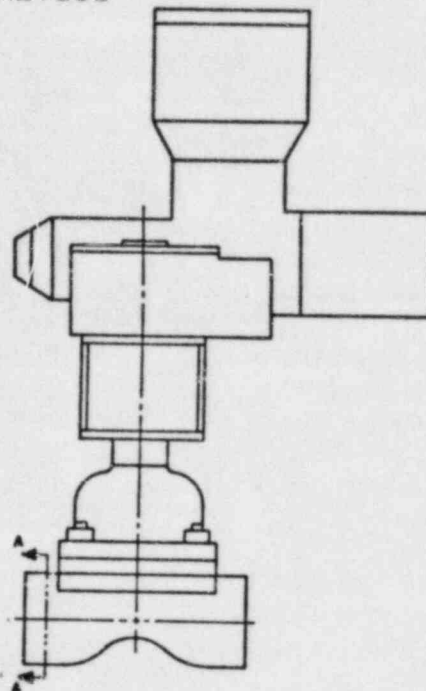

VALVE BODY O.D. AND I.D.

O.D. = 2.5 IN I.D. = 1.94 IN

CROSS SECTIONAL PROPERTIES AT SECTION A-A

$$\begin{aligned} A.V. &= (\pi/4) * [(OD^2) - (ID^2)] \\ &= (\pi/4) * [(2.50)^2 - (1.94^2)] = 1.953 \text{ IN}^2 \\ Z.V. &= (\pi/32) * [(OD^4) - (ID^4)] / OD \\ &= (\pi/32) * [(2.50)^4 - (1.94^4)] / 2.50 = 0.978 \text{ IN}^3 \end{aligned}$$

VALVE BODY MATERIAL: ASME SA-351-CF8
ALLOWABLE STRESS PER THE ASME BOILER AND PRESSURE VESSEL CODE SECTION III
DIVISION 1 TABLE I-7.2 IS: **14860** PSI AT 260 F

ATTACHED PIPING: SCHEDULE 40
PIPE SECTION PROPERTIES: $AP = 1.075 \text{ IN}^2$ $ZP = 0.561 \text{ IN}^3$

PIPE MATERIAL: 312 TP304

ALLOWABLE STRESS PER THE ASME BOILER AND PRESSURE VESSEL CODE SECTION III
DIVISION 1 TABLE I-7.2 IS: **17080** PSI AT 260 F

RATIO OF VALVE BODY METAL AREA TO PIPE METAL AREA IS:

$$(AV/AP) * (ASV/ASP) = (1.953 / 1.075) * (14860 / 17080) = 1.6$$

RATIO OF VALVE BODY SECTION MODULUS TO PIPE SECTION MODULUS IS:

$$(ZV/ZP) * (ASV/ASP) = (0.978 / 0.561) * (14860 / 17080) = 1.5$$

APPENDIX B

4" DIAPHRAGM VALVE
WITH
14NAT1 ROTORK ACTUATOR

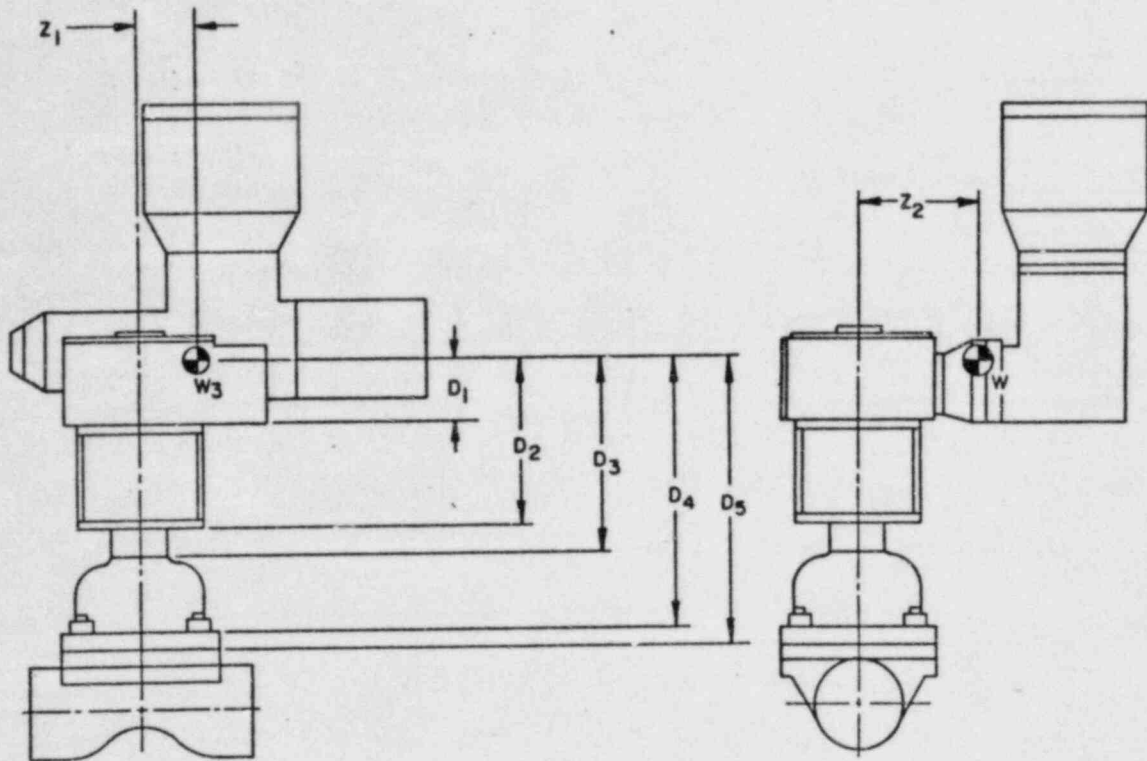

DESIGN DATA FOR A 4 IN. POWER OPERATED DIAPHRAGM VALVE

VALVE ASSEMBLY WEIGHT $W = 312.6$ LB

DISTANCE FROM THE VALVE CENTER OF GRAVITY TO:

ACTUATOR BRACKET JOINT $D_1 = 6.12$ IN

BOTTOM OF ACTUATOR JOINT $D_2 = 9.37$ IN

BUSHING-BONNET JOINT $D_3 = 10.69$ IN

TOP OF BONNET FLANGE $D_4 = 14.23$ IN

BODY-BONNET JOINT $D_5 = 14.92$ IN

DISTANCE FROM THE VERTICAL CENTERLINE OF THE VALVE TO:

THE VALVE C. G. ALONG THE PIPELINE AXIS $Z_1 = 2.91$ IN

THE VALVE C. G. PERPENDICULAR TO THE PIPELINE $Z_2 = 2.75$ IN

DESIGN PRESSURE $P = 150$ PSI DESIGN TEMPERATURE $T = 260$ F

SEISMIC ACCELERATION:

$G_1 = 3$

$G_2 = 3$

HORIZONTAL RESULTANT $G_3 = 4.24$

ACTUATOR-BRACKET BOLTING ANALYSIS

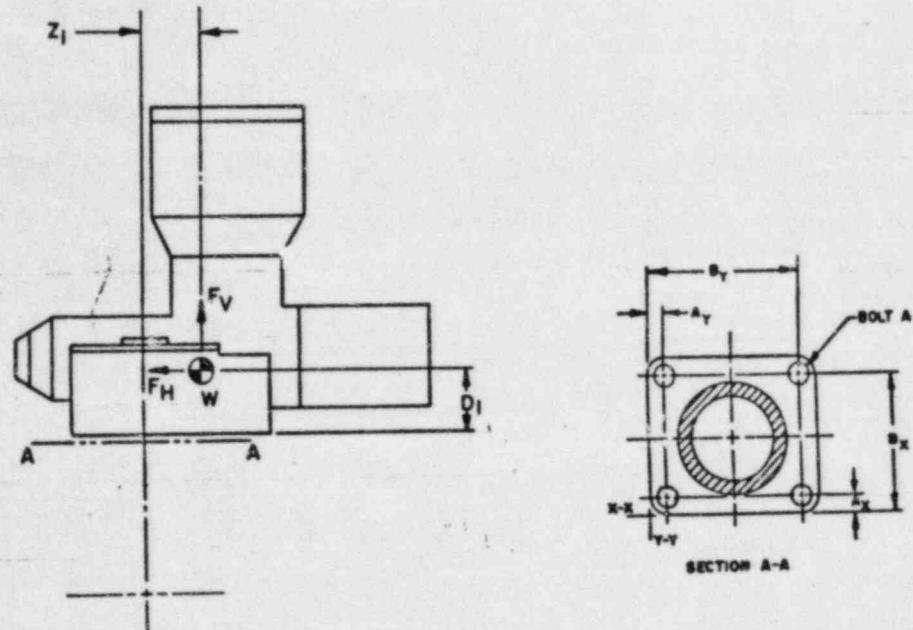

BOLTING DIMENSIONS:

$A_X = 1.62$ IN $A_Y = 1.62$ IN
 $B_X = 3.51$ IN $B_Y = 3.51$ IN
 BOLT STRESS AREA = .226 IN²

SEISMIC FORCES ACTING ON THE BOLTING

$F_H = G * W = 1624.317$ LB $F_V = G_1 * W = 937.8001$ LB
 WHERE G IS THE RESULTANT ACCELERATION $(2 * (G_1^2) + (G_2^2))^{0.5}$

THE GREATEST AXIAL FORCE ON THE BOLTING IS DETERMINED BY SUMMING MOMENTS ABOUT THE X-X AXIS AND THE Y-Y AXIS. THE LOAD ON THE BOLT FURTHEST FROM THE POINT OR LINE ABOUT WHICH THE BONNET FLANGE WOULD PIVOT IF FREE TO MOVE IS DETERMINED.

THE MOMENT IN THE X-X DIRECTION IS:

$$M(XX) = (FH * D1) + (FV * Z1) \\ = (1624.32 * 6.12) + (937.80 * 2.91) = 12669.8 \text{ IN-LB}$$

THE MOMENT IN THE Y-Y DIRECTION IS:

$$M(YY) = (FH * D1) + (FV * Z2) \\ = (1624.32 * 6.12) + (937.80 * 2.75) = 12519.8 \text{ IN-LB}$$

FORCE ON BOLT A DUE TO MOMENTS ABOUT X-X

$$FX1 = (M(XX) * B(X)) / [2(A(X)^2 + B(X)^2)] \\ = (12669.8 * 5.51) / [2((1.62)^2 + (5.51)^2)] = 1058.2 \text{ LB}$$

FORCE ON BOLT A DUE TO MOMENTS ABOUT Y-Y

$$FY1 = (M(YY) * B(Y)) / [2(A(Y)^2 + B(Y)^2)] \\ = (12519.8 * 5.51) / [2((1.62)^2 + (5.51)^2)] = 1045.7 \text{ LB}$$

THE FORCE DUE TO A VERTICAL LOAD ON EACH BOLT IS:

$$FV1 = 0.25(FV) = 0.25(937.80) = 234.45 \text{ LB}$$

THE TOTAL LOAD ON BOLT A IS:

$$FVT = FX1 + FY1 + FV1 = 1058.24 + 1045.70 + 234.45 = 2338.39 \text{ LB}$$

THE TOTAL SHEAR FORCE PER BOLT IS:

$$SB = 0.25 * (FH + (FH * Z) / Z4) = 0.25 * (1624.32 + (1624.32 * 4.00) / 2.75) \\ = 997.17 \text{ LB}$$

WHERE Z4 IS THE DISTANCE FROM THE VALVE VERTICAL CENTER LINE TO THE FURTHEST CAPSCREW AND $Z = [Z1^2 + Z2^2]^{0.5}$.

THE STRESS ON EACH BOLT IS:

$$\text{TENSILE STRESS-SIGMA M} = FVT / AB = 2338.39 / .2260 = 10346.8 \text{ PSI}$$

$$\text{SHEAR STRESS-TAU} = SB / AB = 997.17 / .2260 = 4412.2 \text{ PSI}$$

THE PRINCIPLE STRESSES ARE:

THE PRINCIPAL STRESSES AT A-A

$$\text{SIGMA 1} = ((\text{SIGMA M} + \text{SIGMA B}) / 2) + (((\text{SIGMA M} + \text{SIGMA B}) / 2)^2 + (\text{TAU})^2)^{0.5} \\ = 11972.85 \text{ PSI}$$

$$\text{SIGMA 2} = ((\text{SIGMA M} + \text{SIGMA B}) / 2) - (((\text{SIGMA M} + \text{SIGMA B}) / 2)^2 + (\text{TAU})^2)^{0.5} \\ = -1626.001 \text{ PSI}$$

BOLT MATERIAL: ASTM A193-B8

YEILD STRENGTH: 30000 PSI

ACTUATOR-BONNET ADAPTER BRACKET ANALYSIS

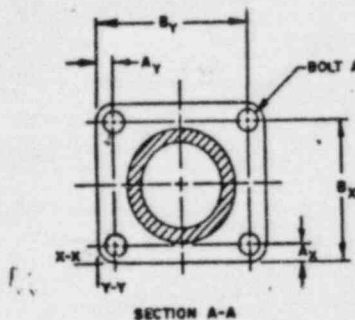
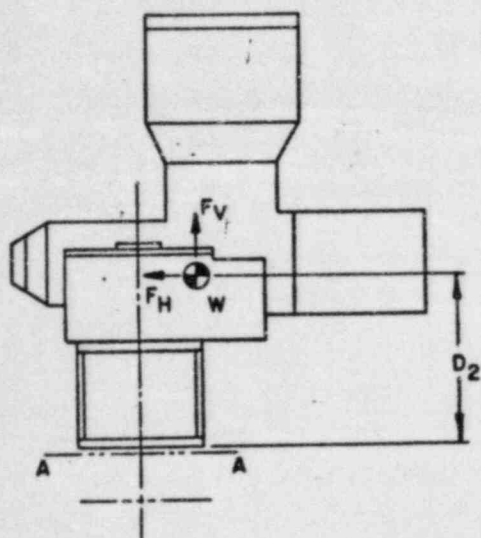

ADAPTER BRACKET POST DIMENSIONS:

$A_x = 0.38$ IN $A_y = 0.38$ IN
 $B_x = 3.57$ IN $B_y = 6.63$ IN
 BOLT STRESS AREA = .226 IN²

SEISMIC FORCES ACTING ON THE BOLTING

$F_H = G * W = 1624.317$ LB $F_V = G_1 * W = 937.8001$ LB
 WHERE G IS THE RESULTANT ACCELERATION $(2 * (G_1^2) + (G_2^2))^{.5}$

THE GREATEST AXIAL FORCE ON THE BOLTING IS DETERMINED BY SUMMING MOMENTS ABOUT THE X-X AXIS AND THE Y-Y AXIS. THE LOAD ON THE BOLT FURTHEST FROM THE POINT OR LINE ABOUT WHICH THE BONNET FLANGE WOULD PIVOT IF FREE TO MOVE IS DETERMINED.

THE MOMENT IN THE X-X DIRECTION IS:

$$M(XX) = (FH * D2) + (FV * Z1) \\ = (1624.32 * 9.37) + (937.80 * 2.91) = 17948.9 \text{ IN-LB}$$

THE MOMENT IN THE Y-Y DIRECTION IS:

$$M(YY) = (FH * D2) + (FV * Z2) \\ = (1624.32 * 9.37) + (937.80 * 2.75) = 17798.8 \text{ IN-LB}$$

FORCE ON BOLT A DUE TO MOMENTS ABOUT X-X

$$FX1 = (M(XX) * B(X)) / [2(A(X)^2 + B(X)^2)] \\ = (17948.9 * 5.57) / [2((0.38)^2 + (5.57)^2)] = 1605.4 \text{ LB}$$

FORCE ON BOLT A DUE TO MOMENTS ABOUT Y-Y

$$FY1 = (M(YY) * B(Y)) / [2(A(Y)^2 + B(Y)^2)] \\ = (17798.8 * 6.63) / [2((0.38)^2 + (6.63)^2)] = 1339.0 \text{ LB}$$

THE FORCE DUE TO A VERTICAL LOAD ON EACH BOLT IS:

$$FV1 = 0.25(FV) = 0.25(937.80) = 234.45 \text{ LB}$$

THE TOTAL LOAD ON BOLT A IS:

$$FVT = FX1 + FY1 + FV1 = 1605.37 + 1339.02 + 234.45 = 3178.83 \text{ LB}$$

THE TOTAL SHEAR FORCE PER BOLT IS:

$$SB = 0.25 * (FH + (FH * Z) / Z4) = 0.25 * (1624.32 + (1624.32 * 4.00) / 4.06) \\ = 806.35 \text{ LB}$$

WHERE Z4 IS THE DISTANCE FROM THE VALVE VERTICAL CENTER LINE
TO THE FURTHEST CAPSCREW AND $Z = [Z1^2 + Z2^2]^{0.5}$.

THE STRESS ON EACH BOLT IS:

$$\text{TENSILE STRESS-SIGMA M} = FVT / AB = 3178.83 / .2260 = 14065.6 \text{ PSI}$$

$$\text{SHEAR STRESS-TAU} = SB / AB = 806.35 / .2260 = 3567.9 \text{ PSI}$$

THE PRINCIPLE STRESSES ARE:

THE PRINCIPAL STRESSES AT A-A

$$\text{SIGMA 1} = ((\text{SIGMA M} + \text{SIGMA B}) / 2) + (((\text{SIGMA M} + \text{SIGMA B}) / 2)^2 + (\text{TAU})^2)^{0.5} \\ = 14918.9 \text{ PSI}$$

$$\text{SIGMA 2} = ((\text{SIGMA M} + \text{SIGMA B}) / 2) - (((\text{SIGMA M} + \text{SIGMA B}) / 2)^2 + (\text{TAU})^2)^{0.5} \\ = -853.2734 \text{ PSI}$$

BOLT MATERIAL: ASTM A108

PROOF STRENGTH: 36000 PSI

BONNET-BRACKET ADAPTER BUSHING ANALYSIS

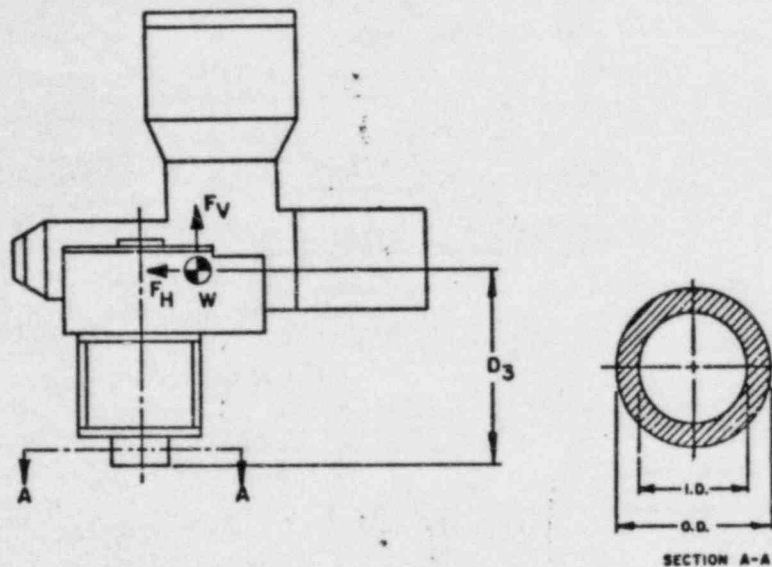

MINIMUM BUSHING SECTION OD = 1.5 IN ID = 1.007 IN

SEISMIC FORCES AT SECTION A-A

$$\begin{aligned}
 F_H &= W * G = 312.60 * 5.20 = 1624.3 \text{ LB} \\
 F_V &= W * G_1 = 312.60 * 3.00 = 937.8 \text{ LB} \\
 M &= F_H * D_3 + F_V * Z_{10} = 1624.3 * 10.69 + 937.8 * 2.91 = 20092.9 \text{ IN-LB} \\
 &\text{WHERE } Z_{10} \text{ IS THE GREATER OF } Z_1 \text{ OR } Z_2
 \end{aligned}$$

CROSS SECTIONAL PROPERTIES AT SECTION A-A

$$\begin{aligned}
 A &= (\pi/4) * (O.D.^2 - I.D.^2) = (\pi/4) * ((1.50)^2 - (1.01)^2) = 0.97 \text{ IN}^2 \\
 I &= (\pi/64) * (O.D.^4 - I.D.^4) = (\pi/64) * ((1.50)^4 - (1.01)^4) = 0.1980 \text{ IN}^4 \\
 C &= O.D./2 = 1.50/2 = 0.75 \text{ IN}
 \end{aligned}$$

STRESSES DUE TO SEISMIC LOADING AT A-A

$$\begin{aligned}
 \text{TENSILE STRESS} &= \sigma_M = F_V/A = 937.80 / 0.97 = 966.09 \text{ PSI} \\
 \text{BENDING STRESS} &= \sigma_B = M/C = 20092.95 * 0.75 / 0.20 = 76096.75 \text{ PSI} \\
 \text{SHEAR STRESS} &= \tau = F_H/A = 1624.32 / 0.97 = 1673.32 \text{ PSI}
 \end{aligned}$$

THE PRINCIPAL STRESSES AT A-A

$$\text{SIGMA 1} = \left(\frac{\text{SIGMA M} + \text{SIGMA B}}{2} \right) + \left(\left(\frac{\text{SIGMA M} + \text{SIGMA B}}{2} \right)^2 + (\text{TAU})^2 \right)^{0.5}$$
$$= 77101.16 \text{ PSI}$$

$$\text{SIGMA 2} = \left(\frac{\text{SIGMA M} + \text{SIGMA B}}{2} \right) - \left(\left(\frac{\text{SIGMA M} + \text{SIGMA B}}{2} \right)^2 + (\text{TAU})^2 \right)^{0.5}$$
$$= -36.31641 \text{ PSI}$$

BUSHING MATERIAL: AISI 4340 ALLOWABLE STRESS 114000 PSI

VALVE BONNET ANALYSIS

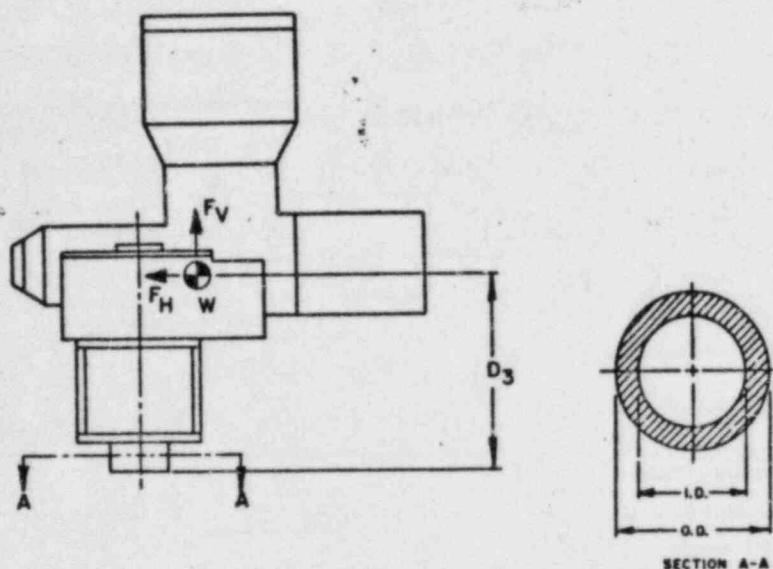

MINIMUM BONNET SECTION O.D. = 5.89 IN I.D. = 5.38 IN

SEISMIC FORCES AT SECTION A-A

$$\begin{aligned}
 F_H &= W * G = 312.60 * 5.20 = 1624.3 \text{ LB} \\
 F_V &= W * G_i = 312.60 * 3.00 = 937.8 \text{ LB} \\
 M &= F_H * D_3 + F_V * Z_{10} = 1624.3 * 14.23 + 937.8 * 2.91 = 25843.0 \text{ IN-LB} \\
 &\text{WHERE } Z_{10} \text{ IS THE GREATER OF } Z_1 \text{ OR } Z_2
 \end{aligned}$$

CROSS SECTIONAL PROPERTIES AT SECTION A-A

$$\begin{aligned}
 A &= (\pi/4) * (O.D.^2 - I.D.^2) = (\pi/4) * ((5.89)^2 - (5.38)^2) = 4.42 \text{ IN}^2 \\
 I &= (\pi/64) * (O.D.^4 - I.D.^4) = (\pi/64) * ((5.89)^4 - (5.38)^4) = 17.5541 \text{ IN}^4 \\
 C &= O.D./2 - 5.89/2 = 2.94 \text{ IN}
 \end{aligned}$$

STRESSES DUE TO SEISMIC LOADING AT A-A

$$\begin{aligned}
 \text{TENSILE STRESS} &= \text{SIGMA}_M = F_V / A = 937.80 / 4.42 = 212.09 \text{ PSI} \\
 \text{BENDING STRESS} &= \text{SIGMA}_B = M * C / I = 25843.03 * 2.94 / 17.55 = 4328.24 \text{ PSI} \\
 \text{SHEAR STRESS} &= \text{TAU} = F_H / A = 1624.32 / 4.42 = 367.34 \text{ PSI}
 \end{aligned}$$

BONNET STRESSES DUE TO INTERNAL PRESSURE

BONNET LONGITUDINAL STRESS = SIGMA L =

$$\begin{aligned} &= \text{PRES.} * \text{ID} / (4 * ((\text{OD} - \text{ID}) / 2)) \\ &= 150.0 * 5.38 / [4 * ((5.88 - 5.38) / 2)] = 807.0 \text{ PSI} \end{aligned}$$

BONNET TANGENTIAL STRESS = SIGMA T =

$$\begin{aligned} &= \text{PRES.} * \text{ID} / (2 * ((\text{OD} - \text{ID}) / 2)) \\ &= 150.0 * 5.38 / [2 * ((5.88 - 5.38) / 2)] = 1614.0 \text{ PSI} \end{aligned}$$

THE TOTAL BONNET STRESSES ARE:

$$\begin{aligned} \text{SIGMA Y} &= \text{TENSILE STRESS} + \text{BENDING STRESS} + \text{SIGMA L} \\ &= 212.09 + 4328.2 + 807.0 = 5347.3 \text{ PSI} \end{aligned}$$

$$\text{SIGMA Z} = \text{SIGMA T} = 1614.002 \text{ PSI}$$

$$\text{TAU X-Y} = \text{SHEAR STRESS} = 367.3445 \text{ PSI}$$

THE PRINCIPAL STRESSES CAN BE DETERMINED BY THE FOLLOWING EQUATION

$$(\text{SIGMA P})^3 - \text{I1} * (\text{SIGMA P})^2 + \text{I2} * (\text{SIGMA P}) - \text{I3} = 0$$

$$\begin{aligned} \text{WHERE: } \text{I1} &= \text{SIGMA Y} + \text{SIGMA Z} = 6961.328 \text{ PSI} \\ \text{I2} &= (\text{SIGMA Y}) * (\text{SIGMA Z}) - (\text{TAU XY})^2 = 8493650 \text{ PSI} \\ \text{I3} &= -(\text{TAU XY})^2 * \text{SIGMA Z} = -2.177965\text{E}+08 \text{ PSI} \end{aligned}$$

$$\text{NOTE: SIGMA X} = \text{TAU XZ} = \text{TAU YZ} = 0$$

SOLVING THE ABOVE EQUATION FOR THE PRINCIPAL STRESSES:

$$\begin{aligned} \text{SIGMA 1} &= 5371.292 \text{ PSI} \\ \text{SIGMA 2} &= 1613.12 \text{ PSI} \\ \text{SIGMA 3} &= -23.06789 \text{ PSI} \end{aligned}$$

BONNET MATERIAL: ASME SA-351-CF8
ALLOWABLE STRESS PER THE ASME BOILER AND PRESSURE VESSEL CODE SECTION III

DIVISION 1 TABLE I-7.2 IS: 14800 PSI AT 260 F

BODY-BONNET BOLTING ANALYSIS

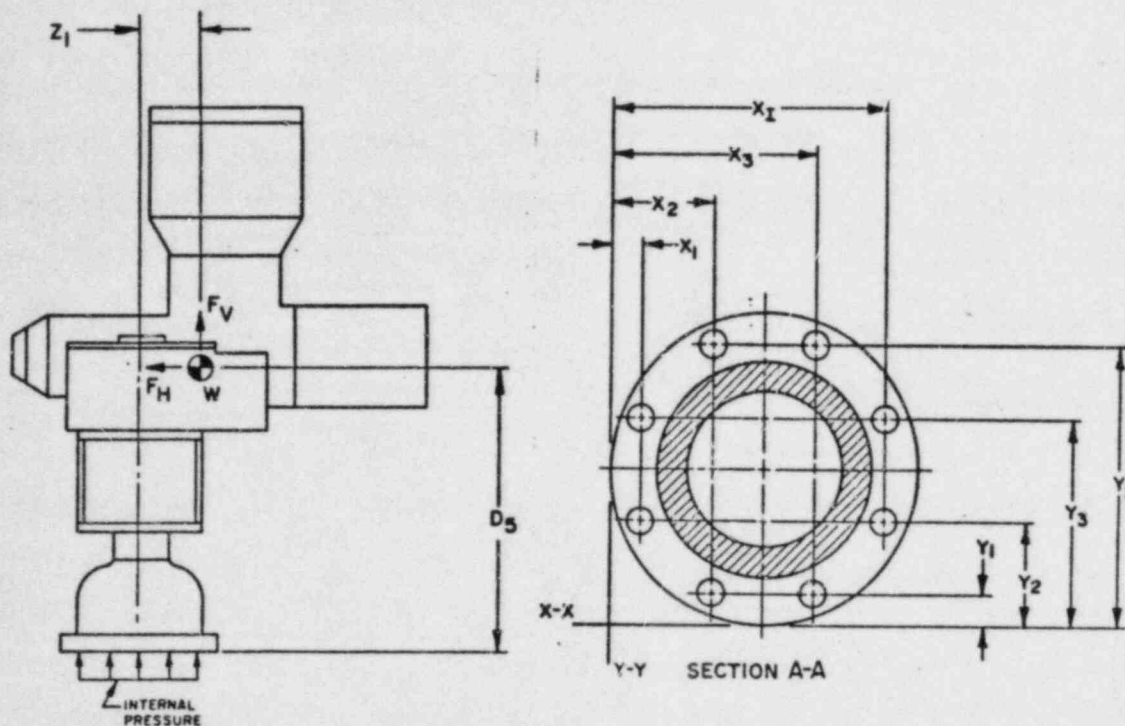

BOLTING DIMENSIONS
 X-X AXIS

I	X(I)	NX(I)
1	1.23	2
2	3.19	2
3	5.81	2
4	7.87	2

Y-Y AXIS

Y(I)	NY(I)
0.91	2
2.74	2
6.33	2
8.19	2

NUMBER OF BODY BONNET BOLTS = NB = 8
 BOLT STRESS AREA = AB = .1519

SEISMIC FORCES ACTING ON THE BOLTING

$FH = G * W = 1624.317 \text{ LB}$

$FV = G1 * W = 937.8001 \text{ LB}$

WHERE G IS THE RESULTANT ACCELERATION $(2 * (G1^2) + (G2^2))$

THE GREATEST AXIAL FORCE ON THE BOLTING IS DETERMINED BY SUMMING MOMENTS ABOUT THE X-X AXIS AND THE Y-Y AXIS. THE LOAD ON THE BOLT FURTHEST FROM THE POINT OR LINE ABOUT WHICH THE BONNET FLANGE WOULD PIVOT IF FREE TO MOVE IS DETERMINED.

THE MOMENT IN THE X-X DIRECTION IS:

$M(X) = (FH * D5) + (FV * z1)$
 $= (1624.32 * 14.92) + (937.30 * 2.91) = 26963.8 \text{ IN-LB}$

THE MOMENT IN THE Y-Y DIRECTION IS:

$$M(YY) = (FH * D5) + (FV * Z2) \\ = (1624.32 * 14.92) + (937.80 * 2.75) = 26813.8 \text{ IN-LB}$$

FORCE ON BOLT A DUE TO MOMENTS ABOUT X-X

$$FX = (M(XX) * X(IMAX)) / [NX(1) * X(1)^2 + NX(2) * X(2)^2 + \dots + NX(I) * X(I)^2] \\ = 988.1 \text{ LB}$$

FORCE ON BOLT A DUE TO MOMENTS ABOUT Y-Y

$$FY = (M(YY) * Y(IMAX)) / [NY(1) * Y(1)^2 + NY(2) * Y(2)^2 + \dots + NY(I) * Y(I)^2] \\ = 950.8 \text{ LB}$$

THE FORCE DUE TO A VERTICAL LOAD ON EACH BOLT IS:

$$FV1 = (FV + (PRES * EFF \text{ AREA})) / NB \\ = (937.80 + (150 * (PI/4) * (5.38)^2)) / 8 = 543.47 \text{ LB}$$

THE TOTAL LOAD ON BOLT A IS:

$$FVT = FX1 + FY1 + FV1 = 988.09 + 950.83 + 543.47 = 2482.38 \text{ LB}$$

THE TOTAL SHEAR FORCE PER BOLT IS:

$$SB = (FH + (FH * 7 * 2 / BCR)) / NB = (1624.3 + (1624.3 * 2.91 * 2 / 3.81)) / 8 = 513.0 \text{ LB}$$

WHERE BCR = BOLT CIRCLE RADIUS = 3.8125 IN

THE STRESS ON EACH BOLT IS:

$$\text{TENSILE STRESS-SIGMA M} = FVT / AB = 2482.38 / .1519 = 16342.2 \text{ PSI}$$

$$\text{SHEAR STRESS-TAU} = SB / AB = 512.99 / .1519 = 3377.2 \text{ PSI}$$

THE PRINCIPLE STRESSES ARE:

THE PRINCIPAL STRESSES AT A-A

$$\text{SIGMA 1} = ((\text{SIGMA M} + \text{SIGMA B}) / 2) + (((\text{SIGMA M} + \text{SIGMA B}) / 2)^2 + (\text{TAU})^2)^{.5} \\ = 17012.6 \text{ PSI}$$

$$\text{SIGMA 2} = ((\text{SIGMA M} + \text{SIGMA B}) / 2) - (((\text{SIGMA M} + \text{SIGMA B}) / 2)^2 + (\text{TAU})^2)^{.5} \\ = -670.3999 \text{ PSI}$$

BOLT MATERIAL: ASME SA-453-660

ALLOWABLE STRESS PER THE ASME BOILER AND PRESSURE VESSEL CODE SECTION III DIVISION 1 TABLE I-7.3 IS: 20500 PSI AT 260 F

VALVE BODY ANALYSIS

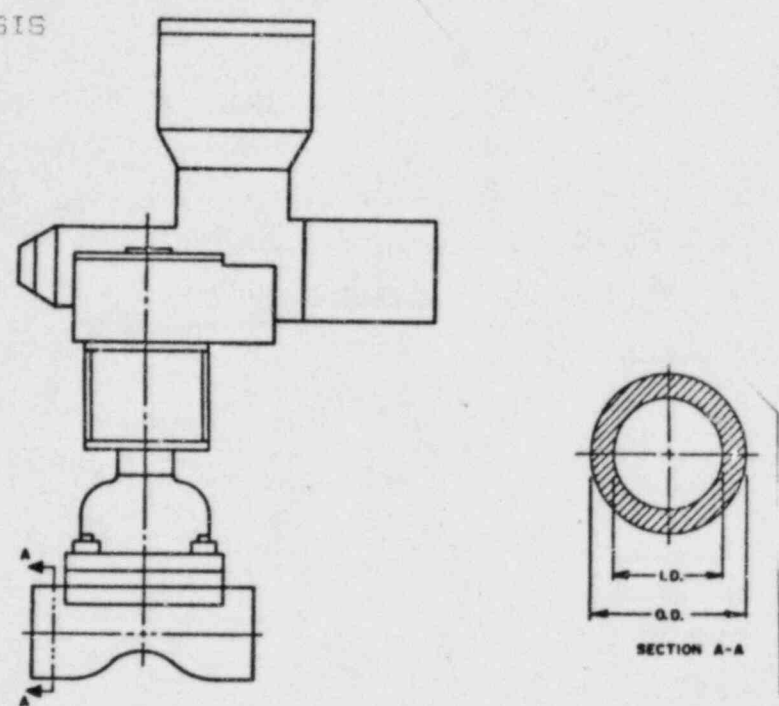

VALVE BODY O.D. AND I.D.

O.D. = 4.5 IN I.D. = 3.81 IN

CROSS SECTIONAL PROPERTIES AT SECTION A-A

$$A.V. = (\pi/4) * [(OD^2) - (ID^2)]$$

$$= (\pi/4) * [(4.50)^2 - (3.81)^2] = 4.503 \text{ IN}^2$$

$$Z.V. = (\pi/32) * [(OD^4) - (ID^4)] / OD$$

$$= (\pi/32) * [(4.50)^4 - (3.81)^4] / 4.50 = 4.349 \text{ IN}^3$$

VALVE BODY MATERIAL: ASME SA-351-CF8
 ALLOWABLE STRESS PER THE ASME BOILER AND PRESSURE VESSEL CODE SECTION III
 DIVISION 1 TABLE I-7.2 IS: **14860** PSI AT 260 F

ATTACHED PIPING: SCHEDULE 40
 PIPE SECTION PROPERTIES: AP= 3.17 IN² ZP= 3.21 IN³

PIPE MATERIAL: 312 TP304

ALLOWABLE STRESS PER THE ASME BOILER AND PRESSURE VESSEL CODE SECTION III
 DIVISION 1 TABLE I-7.2 IS: **17080** PSI AT 260 F

RATIO OF VALVE BODY METAL AREA TO PIPE METAL AREA IS:

$$(AV/AP) * (ASV/ASP) = (4.503 / 3.170) * (14860 / 17080) = 1.2$$

RATIO OF VALVE BODY SECTION MODULUS TO PIPE SECTION MODULUS IS:

$$(ZV/ZP) * (ASV/ASP) = (4.349 / 3.210) * (14860 / 17080) = 1.2$$

ITT GRINNELL 4"-150# VALVE - ITEM 5B-473, ROTORK 14N1 MOUNTED PERPENDICULAR* TO PIPE RUN AXIS - REVISION 1
 0-FREE, 1-FIXED GLOBAL DEGREE OF FREEDOM.

Pillar Steel: SA 193, Grade B7

NODE NUMBER	BOUNDARY CONDITION CODES						NODAL POINT COORDINATES		
	X	Y	Z	XX	YY	ZZ	X	Y	Z
1	0	0	0	0	0	0	0.000	0.000	0.000
2	1	1	1	1	1	1	-5.750	0.000	0.000
3	1	1	1	1	1	1	5.750	0.000	0.000
4	0	0	0	0	0	0	0.000	2.310	0.000
5	0	0	0	0	0	0	0.000	5.750	0.000
6	0	0	0	0	0	0	0.000	7.100	0.000
7	0	0	0	0	0	0	0.000	7.200	0.000
8	0	0	0	0	0	0	-3.120	7.200	2.595
9	0	0	0	0	0	0	3.120	7.200	2.595
10	0	0	0	0	0	0	3.120	7.200	-2.595
11	0	0	0	0	0	0	-3.120	7.200	-2.595
12	0	0	0	0	0	0	-3.120	7.950	2.595
13	0	0	0	0	0	0	3.120	7.950	2.595
14	0	0	0	0	0	0	3.120	7.950	-2.595
15	0	0	0	0	0	0	-3.120	7.950	-2.595
16	0	0	0	0	0	0	-3.120	10.450	2.595
17	0	0	0	0	0	0	3.120	10.450	2.595
18	0	0	0	0	0	0	3.120	10.450	-2.595
19	0	0	0	0	0	0	-3.120	10.450	-2.595
20	0	0	0	0	0	0	-3.120	11.200	2.595
21	0	0	0	0	0	0	3.120	11.200	2.595
22	0	0	0	0	0	0	3.120	11.200	-2.595
23	0	0	0	0	0	0	-3.120	11.200	-2.595
24	0	0	0	0	0	0	0.000	11.200	0.000
25	0	0	0	0	0	0	0.000	17.250	0.000
26	0	0	0	0	0	0	-2.750	17.250	-2.306
27	1	1	1	1	1	1	200.000	200.000	0.000

DESIGN VERIFICATION	
CLIENT	WAKE COUNTY
JOB NO.	043-210
CALC/PROB NO.	136-14
BY: <i>WRC</i>	DATE: 10/10/83
CHKD: <i>WRC</i>	DATE: 10/11/83

APP: WRC 10/11/83
 PROJ. ENG

*Rotated 90° from that shown in assembly dwg. CNM 1205.04-0190



ITT GRINNELL 4"-150# VALVE - ITEM 5B-473, ROTORK 14NMI MOUNTED PERPENDICULAR TO PIPE RUN AXIS - REVISION 1

Pillar Steel: SA 193, Grade B7

MATERIAL NO.	YOUNG S MODULUS (PSI)	POISSON S RATIO	MASS DENSITY (#-S2/IN4)
1	2.930E+07	3.00000E-01	7.3400E-00
2	2.930E+07	3.00000E-01	1.00000E-90

ALL PROPERTIES IN INCH UNITS (AXIAL-AXIS ORIENTED FROM I TO J-NODE OF MEMBER, 1-AXIS LOCATED IN PLANE OF K-NODE ORTHOGONALLY POSITIONED TO AXIAL-AXIS, LOCAL 2-AXIS DEFINED BY RIGHT HAND RULE).

PROPERTY	AXIAL AREA	SHEAR AREA-1	SHEAR AREA-2	TORSION-1	INERTIA-1	INERTIA-2
1	5.353E+00	2.581E+00	2.581E+00	2.404E+01	1.212E+01	1.202E+01
2	4.422E+00	2.211E+00	2.211E+00	3.511E+01	1.733E+01	1.755E+01
3	2.333E+00	1.417E+00	1.417E+00	3.150E+00	1.373E+00	1.575E+00
4	2.337E+00	1.358E+00	1.358E+00	3.820E-01	1.232E+00	9.500E-02
5	1.227E+00	9.200E-01	9.200E-01	2.400E-01	1.213E-01	1.200E-01
6	9.553E-01	4.830E-01	4.830E-01	3.950E-01	1.373E-01	1.970E-01
7	3.341E-01	2.300E-01	2.300E-01	5.300E-03	3.413E-03	3.400E-03
8	1.000E+02	1.000E+02	1.000E+02	1.000E+03	1.000E+03	1.000E+03

DESIGN VERIFICATION	
CLIENT: <i>Grinnell</i>	DATE: <i>10/10/94</i>
JOB NO. <i>1173-210</i>	DATE: <i>10/10/94</i>
CALC/PROB NO. <i>136-1A</i>	DATE: <i>10/10/94</i>
BY: <i>SL</i>	DATE: <i>10/10/94</i>
CHKD BY: <i>1</i>	DATE: <i>10/10/94</i>



Pillar Steel: SA 193, Grade B7

BEAM NO	NODES		MATL		PROP NO
	I	J	K	NO	
1	1	2	27	1	1
2	1	3	27	1	1
3	1	4	27	1	2
4	4	5	27	1	2
5	5	6	27	1	3
6	6	7	27	1	6
7	7	8	1	1	4
8	7	9	1	1	4
9	7	10	1	1	4
10	7	11	1	1	4
11	8	12	1	1	7
12	9	13	1	1	7
13	10	14	1	1	7
14	11	15	1	1	7
15	12	16	1	1	5
16	13	17	1	1	5
17	14	18	1	1	5
18	15	19	1	1	5
19	16	20	1	1	7
20	17	21	1	1	7
21	18	22	1	1	7
22	19	23	1	1	7
23	24	21	27	2	8
24	24	21	27	2	8
25	24	22	27	2	8
26	24	23	27	2	8
27	24	25	27	2	8
28	25	26	27	2	8

ALL UNITS REPRESENTED AS LB, INCHES, SECONDS IN GLOBAL SYSTEM

DESIGN VERIFICATION	
CLIENT	Duke Caterpillar
DWG NO	0043 210
CALC/DWG NO	14-1A
BY	SAC
DATE	10/10/03
CHKD	
DATE	11/11/03

MODE NO	APPLIED LOADS OR MASSES					
	RX	RY	RZ	MX	MY	MZ
25	5.993E-11	5.993E-11	5.993E-11	5.233E+11	5.919E+01	1.156E+01

IMPELLER

ITT GRINNELL 4"-150# VALVE - ITEM 5B-473, ROTORK 14NA1 MOUNTED PERPENDICULAR TO PIPE RUN AXIS - REVISION 1

Pillar Steel: SA 193, Grade B7

ANALYSIS SUMMARY:

MODAL FREQ. (CPS)	MODAL TYPE	Max. Allow. Seismic Load (G) CALCULATED FOR INCLINED OPERATOR STEM (1)		Allow. Restraint Load (lbs)		
		RESULTANT OBE	RESULTANT SSE	RESULTANT OBE	RESULTANT SSE	
20.12	B	9.95	11.98	2436.76	2933.90	
23.95	T		QUALIFIED BY STATIC DEFLECTION TEST			
32.57	B	-	5.2	-	1225.0	

NOTE (1) Resultant applied perpendicular to operator stem axis.

DESIGN VERIFICATION	
CLIENT	WVRE-CAT
JOB NO.	6673-210
CALC/PROB NO.	126-1A
BY: <i>SS</i>	DATE: 11/18
CHKD: <i>MB</i>	DATE: 11/18

Attachment 3

Frequency Report
for
Valves VQ2A and VQ16A