

STEP/SUBSTEP 4.3.5.3, 4.3.5 and 4.3.5.1

Sheet 1 of 2

DATA SHEET 3

VEHICLE DOCUMENT STATUS SHEET

LOG NO.

1X3A061-167
~~AXLABM-10-000~~

REVISION

2000-27-17
~~001~~

DOCUMENT TITLE:

Instructions Solid-state Frequency
Relays ITE-81 IB 7.4.1.7-5 Issue A

FOR INFORMATION ONLY

READ AND DESTROY

VENDOR

BBC BROWN BOWMAN

P.O.

PAV-27 PAV-27253

DATE RECEIVED

10-28-87

DOCUMENT LEGIBLE? YES

NO

IF NO IS CHECKED, THE RESPONSIBLE REVIEWER SHALL DETERMINE IF THE DOCUMENT CAN BE USED IN ITS PRESENT CONDITION. IF IN CAN, THE NORMAL REVIEW CONTINUES. IF IT CAN NOT, THE DOCUMENT MUST BE RETURNED TO DOCUMENT CONTROL FOR REJECTION BACK TO THE VENDOR.

DISCIPLINE REVIEW REQUIRED

STATUS CODE

MAINTENANCE

OPERATIONS

ENGINEERING

HEALTH PHYSICS ORIGINAL

CHEMISTRY

OTHER

1 APPROVED FOR PLANT USE

2 REVISE AND RESUBMIT. VENDOR MAY PROCEED WITH MANUFACTURE SUBJECT TO THE INCORPORATION OF CHANGES INDICATED

3 REVISE AND RESUBMIT. MANUFACTURE MAY NOT PROCEED

S SUPERSEDED BY

V VOID

DCNs INCORPORATED: (IF APPLICABLE)

N/A

NAME OF RESP. DEPT. AND REQUIRED SIGNATURE

DATE: 12/31/87

NAME OF RESP. DEPT. AND REQUIRED SIGNATURE

DATE: 2/16/88

NAME OF RESP. DEPT. AND REQUIRED SIGNATURE

DATE: 7/2/88

SUBSTEP 4.3.5.3.c, 1 and e

Sheet 2 of 2

DATA SHEET 3

VENDOR DOCUMENT STATUS SHEET

(NORMS CROSS REFERENCE SHEET)

LOG NO.

1X3Acoi-167-R-2, ~~AX11A-167-R-2~~
~~AX4AB-9-10, 0007246-4.22~~

REVISION

3L116 25-27
201

EQUIPMENT TAG NUMBER(S)

SERIAL OR MODEL NUMBER(S)

1-1825-53-AAA

222A1175

11825 53-BAB

11825 53-CAC

11825 53-DAD

SYSTEM NUMBER(S)

1825

PROCEDURE(S)
AFFECTED

N/A

INSTALLATION • OPERATION • MAINTENANCE
INSTRUCTIONS**TYPE CO (HI Lo)
OVERCURRENT RELAY**

CAUTION: Before putting relays into service, remove all blocking which may have been inserted for the purpose of securing the parts during shipment, make sure that all moving parts operate freely, inspect the contacts to see that they are clean and close properly, and operate the relay to check the settings and electrical connections.

APPLICATION

The CO relay is a single phase non-directional time overcurrent device. It is used to sense current level above the setting and normally is used to trip a circuit breaker to clear faults. A wide range of characteristics permit applications involving coordination with fuses, reclosers, cold load pickup, motor starting, or essentially fixed time applications.

⊙ The following describes typical applications of the CO Relay:

RELAY TYPE	TIME CURVE	TYPICAL APPLICATIONS
CO-2	Short	1) Differential protection where saturation of current transformers is not expected, or where delayed tripping is permissible. 2) Overcurrent protection, phase or ground, where coordination with downstream devices is not involved and 2 to 60 cycle tripping is allowable.
CO-5	Long	Motor locked rotor protection where allowable locked rotor time is approximately between 10 and 70 seconds.
CO-6	Definite	Overcurrent protection where coordination with downstream devices is not involved and CO-2 is too fast. The operating time of this relay does not vary greatly as current level varies.
CO-7	Moderately Inverse	1) Overcurrent protection where coordination with other devices is required, and generation varies. 2) Backup protection for relays on other circuits.
CO-8	Inverse	
CO-9	Very Inverse	
CO-11	Extremely Inverse	1) Motor protection where allowable locked rotor time is less than 10 sec. 2) Overcurrent protection where coordination with fuses and reclosers is involved, or where cold load pickup or transformer inrush are factors.

All possible contingencies which may arise during installation, operation, or maintenance, and all details and variations of this equipment do not purport to be covered by these instructions. If further information is desired by purchaser regarding his particular installation, operation or maintenance of his equipment, the local Westinghouse Electric Corporation representative should be contacted.

**SUPERSEDES I.L. 41-100D, DATED DECEMBER 1978
and LSpec L914459M, DATED DECEMBER 1978**

⊙ Denotes Changed Since Previous Issue.

EFFECTIVE APRIL 1980

CONSTRUCTION AND OPERATION

The type CO relays consist of an overcurrent unit (CO), either an Indicating Contactor Switch (ICS) or an ac Auxiliary Switch (ACS) and an indicating instantaneous trip unit (IIT) when required.

Electromagnet

The electromagnets for the types CO-5, CO-6, CO-7, CO-8 and CO-9 relays have a main tapped coil located on the center leg of an "E" type laminated structure that produces a flux which divides and returns through the outer legs. A shading coil causes the flux through the left leg to lag the main pole flux. The out-of-phase fluxes thus produced in the air gap cause a contact closing torque.

The electromagnets for the types CO-2 and CO-11 relays have a main coil consisting of a tapped primary winding and a secondary winding. Two identical coils on the outer legs of the lamination structure are connected to the main coil secondary in a manner so that the combination of all the fluxes produced by the electromagnet result in out-of-phase fluxes in the air gap. The out-of-phase air gap fluxes produced cause a contact closing torque.

Indicating Contactor Switch Unit (ICS)

The dc indicating contactor switch is a small clapper type device. A magnetic armature, to which leaf-spring mounted contacts are attached, is attracted to the magnetic core upon energization of the switch. When the switch closes the moving contacts bridge two stationary contacts, completing the trip circuit. Also during this operation two fingers on the armature deflect a spring located on the front of the switch, which allows the operation indicator target to drop.

The front spring, in addition to holding the target, provides restraint for the armature and thus controls the pickup value of the switch.

ac Auxiliary Switch (ACS)

The ac auxiliary switch is a small ac operated clapper device. A magnetic armature, to which

leaf-spring mounted contacts are attached, is attracted to the magnetic core upon energization of the switch. When the switch closes, the moving contacts bridge two stationary contacts completing the trip circuit. Also, during the operation, two fingers on the armature deflect a spring located on the front of the switch which allows the operation indicator target to drop.

A core screw accessible from the top of the switch provides the adjustable pickup range.

Indicating Instantaneous Trip Unit (IIT)

The instantaneous trip unit is a small ac operated clapper type device. A magnetic armature, to which leaf-spring mounted contacts are attached, is attracted to the magnetic core upon energization of the switch. When the switch closes, the moving contacts bridge two stationary contacts completing the trip circuit. Also, during the operation, two fingers on the armature deflect a spring located on the front of the switch which allows the operation indicator target to drop.

A core screw accessible from the top of the switch and taps on the coil provides the adjustable pickup range.

CHARACTERISTICS

The relays are generally available in the following current ranges:

Range	Taps
5-2.5	0.5, 0.6, 0.8, 1.0, 1.5, 2.0, 2.5
1-12	1.0, 1.2, 1.5, 2.0, 2.5, 3.0, 3.5, 4.0, 5.0, 6.0, 7.0, 8.0, 10.0, 12.0

These relays may have either single or double circuit closing contacts for tripping either one or two circuit breakers. The relays are wired per the internal schematics of Fig. 1 to 9.

The time vs. current characteristics are shown in Figs. 10 to 16. These characteristics give the contact closing time for the various time dial settings when the indicated multiples of tap value current are applied to the relay.

○ Trip Circuit

The main contacts will safely close 30 amperes at 250 volts d-c and the seal-in contacts of either the indicating contactor switch or the ac auxiliary switch will safely carry this current long enough to trip a circuit breaker.

The indicating instantaneous trip contacts will safely close 30 amperes at 250 volts dc, and will carry this current long enough to trip a breaker.

○ Indicating Contactor Switch (ICS)

a. The indicating contactor switch has two taps that provide a pickup setting of 0.2 or 2 amperes. To change tapes requires connecting the lead located in front of the tap block to the desired setting by means of a screw connection.

b. Trip Circuit Constants

0.2 ampere tap 6.5 ohms dc resistance
2.0 ampere tap 0.15 ohms dc resistance

○ ac Auxillary Switch (ACS)

a. One of the following ACS units is available in the Hi-Lo Line of relays.

ACS UNIT	CURRENT RANGE	ACS/VOLTAGE DROP RANGE (1)	MINIMUM RECOMMENDED SUPPLY VOLTAGE (2)
0.15	0.2-0.38	40-76	-
0.5	0.75-1.5	14-27	208
1.0	1.5 -3.0	6.8-14	120

- (1) This is the voltage range which will operate the ACS coil only.
(2) When connected a current switch in series with full rated voltage relay or trip coil.

b. Energy Requirements

ACS UNIT	BURDEN IN VOLT-AMPERES AT MINIMUM SETTING	THERMAL CAPACITY AMPERES RATING (COIL)	
		1 second	continuous
0.15	4.5	4.5	0.16
0.5	4.5	18.0	0.63
1.0	4.5	44.0	1.60

SETTINGS

CO Unit

The overcurrent unit setting can be defined by tap setting and time dial position or by tap setting and a specified time of operation at some current multiple of the tap setting (e.g. 4 tap setting, 2 time dial position or 4 tap setting, 0.6 seconds at 6 times tap value current). The tap setting is the minimum current required to make the disc move.

To provide selective circuit breaker operation, a minimum coordinating time of 0.3 seconds plus circuit breaker time is recommended between the relay being set and the relays with which coordination is to be effected.

The connector screw on the terminal plate above the time dial makes connections to various turns on the operating coil. By placing this screw in the various terminal plate holes, the relay will respond to multiples of tap value currents in accordance with the various typical time-current curves.

Caution

Since the tap block connector screw on both the CO unit and IIT unit carries operating current, be sure that the screws are turned tight. In order to avoid opening the current transformer circuits when changing taps under load, connect the spare connector screw in the desired tap position **before** removing the other tap screw from the original tap position.

Instantaneous Reclosing

The factory adjustment of the CO unit contacts provides a contact follow. Where circuit breaker reclosing will be initiated immediately after a trip by the CO contact, the time of the opening of the contacts should be a minimum. This condition is obtained by loosening the stationary contact mounting screw, removing the contact plate and then replacing the plate with the bent end resting against the contact spring.

For double trip relays, the upper stationary contact is adjusted such that the contact spring rests solidly against the back stop. The lower stationary contact is then adjusted such that both stationary contacts make contact simultaneously with their respective moving contact.

Indicating Contactor Switch (ICS)

The only setting required on the ICS unit is the selection of the 0.2 or 2.0 ampere tap setting. This selection is made by connecting the lead located in front of the tap block to the desired setting by means of the connecting screw.

⊙ Indicating Instantaneous Trip (IIT)

The IIT setting is the level of ac current at which it will pickup. It should be set to coordinate with other devices so it will never operate for a fault in a protective zone where tripping should be produced by other devices. The transient reach will not exceed 130% for an 80° circuit angle or 108% for a 60° circuit.

The proper tap must be selected and the core screw must be adjusted to the value of pick-up current desired.

- ⊙ The nameplate data will furnish the actual current range that may be obtained from the IIT unit. It is recommended that the IIT be set on the higher tap where there is a choice of tap settings. For example, for a 20 ampere setting use the 20 to 40 tap rather than the 6 to 20 tap.

⊙ ac Auxillary Switch (ACS)

The core screw must be adjusted to the value of pickup current desired.

INSTALLATION

The relays should be mounted on switchboard panels or their equivalent in a location free from dirt, moisture, excessive vibration and heat. Mount the relay vertically by means of the mounting stud for projection mounting or by means of the four mounting holes on the flange for the semi-flush mounting. Either the stud or the mounting screws may be utilized for grounding the relay. The electrical connections may be made directly to the terminals by means of screws for steel panel mounting or to the terminal stud furnished with the relay for thick panel mounting. The terminal stud may be easily removed or inserted by locking two nuts on the stud and then turning the proper nut with a wrench.

For detail information on the FT case refer to I.L. 41-076.

ADJUSTMENTS & MAINTENANCE

The proper adjustments to insure correct operation of this relay have been made at the factory. Upon receipt of the relay no customer adjustments, other than those covered under "SETTINGS" should be required.

For relays which include an indicating instantaneous trip unit (IIT), the junction of the induction and indicating instantaneous trip coils is brought out to switch jaw #3. With this arrangement the overcurrent units can be tested separately.

Acceptance Check

The following check is recommended to insure that the relay is in proper working order:

1. **Contact**
The index mark on the movement frame will coincide with the "O" mark on the time dial when the stationary contact has moved through approximately one-half of its normal deflection. Therefore, with the stationary contact resting against the backstop, the index mark is offset to the right of the "O" mark by approximately .020". The placement of the various time dial positions in line with the index mark will give operating times as shown on the respective time-current curves. For double trip relays, the follow on the stationary contacts should be approximately 1/32".
2. **Minimum Trip Current**
Set the time dial to position 6 using the lowest tap setting, alternately apply tap value current plus 3% and tap value current minus 3%. The moving contacts should leave the backstop at tap value current plus 3% and should return to the backstop at tap value current minus 3%.
3. **Time Curve**
For type CO-11 relay only, the 1.30 times tap value operating time from the number 6 time dial position is $54.9 \pm 5\%$ seconds and should be checked first. It is important that the 1.30 times tap value current be maintained accurately. The maintaining of this current accurately is

- necessary because of the steepness of the slope of the time-current characteristic (Figure 16). A 1% variation in the 1.30 times tap value current (including measuring instrument deviation) will change the nominal operating time by approximately 4%.

Table I shows the time curve calibration points for the various types of relays. With the time dial set to the indicated position apply the currents specified by Table I, (e.g. for the CO-8, 2 and 20 times tap value current) and measure the operating time of the relay. The .5 to 2.5 amp. relay and all CO-2 relays should be set on the lowest tap. The 1 to 12 amp. relay should be set on the 2 amp. tap with the exception of 1-12 amp. CO-2 relay which should be set on 1 amp. tap. The operating times should equal those of Table I plus or minus 5%.

4. Indicating Instantaneous Trip Unit (IIT)

- The core screw which is adjustable from the top of the trip unit and the tap located on the top of the IIT determines the pickup value. The trip unit has a nominal ratio of adjustment of 1 to 24.

The making of the contacts and target indication should occur at approximately the same instant. Position the stationary contact for a minimum of 1/32" wipe. The bridging moving contact should touch both stationary contacts simultaneously.

Apply sufficient current to operate the IIT. The operation indicator target should drop freely.

5. Indicating Contactor Switch (ICS)

Close the main relay contacts and pass sufficient dc current through the trip circuit to close the contacts of the ICS. This value of current should be not greater than the particular ICS tap setting being used. The operation indicator target should drop freely.

The contact gap should be approximately .047" between the bridging moving contact and the adjustable stationary contacts. The bridging moving contact should touch both stationary contacts simultaneously.

○ 6. ac Auxiliary Switch (ACS)

The core screw which is adjustable from the top of the ACS unit determines the pickup value.

The making of the contacts and target indication should occur at approximately the same instant. Position the stationary contact for a minimum of 1/32" wipe. The bridging moving contact should touch both stationary contacts simultaneously.

- Apply sufficient current to operate the ACS. The operation indicator target should drop freely.

Routine Maintenance

All relays should be inspected and checked periodically to assure proper operation. Generally a visual inspection should call attention to any noticeable changes. A minimum suggested check on the relay system is to close the contacts manually to assure that the breaker trips and the target drops. Then release the contacts and observe that the reset is smooth and positive.

- If an additional time check is desired, pass secondary current through the relay and check the time of operation. It is preferable to make this at several times pick-up current at an expected operating point for the particular application. For the .5 to 2.5 ampere range CO-5 and CO-6 induction unit use the alternative test circuit in Fig. 19 as these relays are affected by a distorted waveform. With this connection the 25/5 ampere current transformers should be worked well below the knee of the saturation (i.e. use 10L50 or better).

All contacts should be periodically cleaned. A contact burnisher #182A836H01 is recommended for this purpose. The use of abrasive material for cleaning contacts is not recommended, because of the danger of embedding small particles in the face of the soft silver and thus impairing the contact.

CALIBRATION

Use the following procedure for calibrating the relay if the relay has been taken apart for repairs or the adjustments disturbed. This procedure should not be used until it is apparent that the relay is not in proper working order. (See "Acceptance Check").

CO Unit

1. Contact

The index mark on the movement frame will coincide with the "O" mark on the time dial when the stationary contact has moved through approximately one-half of its normal deflection. Therefore, with the stationary contact resting against the backstop, the index mark is offset to the right of the "O" mark by approximately .020". The placement of the various time dial positions in line with the index mark will give operating times as shown on the respective time-current curves. For double trip relays, the follow on the stationary contacts should be approximately 1/32".

2. Minimum Trip Current

The adjustment of the spring tension in setting the minimum trip current value of the relay is most conveniently made with the damping magnet removed.

- With the time dial set on "O", wind up the spiral spring by means of the spring adjuster until approximately 6-3/4 convolutions show.

Set the .5-2.5 amp relay and all CO-2 relays on the minimum tap setting. With the exception of CO-2 relay, set the 1-12 amp. relay on the 2 amp. tap setting. Set the 1-12 amp. CO-2 on the 1 amp. tap. Set time dial position 6 on all relays.

Adjust the control spring tension so that the moving contact will leave the backstop at tap value current +1.0% and will return to the backstop at tap value current -1.0%.

3. Time Curve Calibration

Install the permanent magnet. Apply the indicated current per Table I for permanent magnet adjustment (e.g. CO-8, 2 times tap value) and measure the operating time. Adjust the permanent magnet keeper until the operating time corresponds to the value of Table I.

For type CO-11 relay only, the 1.30 times tap value operating time from the number 6 time dial position is $54.9 \pm 5\%$ seconds. It is important that the 1.30 times tap value current be maintained accurately. The maintaining of this current accurately is necessary because of the

steepness of the slope of the time-current characteristic (Fig. 16). A 1% variation in the 1.30 times tap value current (including measuring instrument deviation) will change the nominal operating time by approximately 4%. If the operating time at 1.3 times tap value is not within these limits, a minor adjustment of the control spring will give the correct operating time without any undue effect on the minimum pick-up of the relay. This check is to be made after the 2 times tap value adjustment has been made.

Apply the indicated current per Table I for the electromagnet plug adjustment (e.g. CO-8, 20 times tap value) and measure the operating time. Adjust the proper plug until the operating time corresponds to the value in Table I. (Withdrawing the left hand plug, front view, increases the operating time and withdrawing the right hand plug, front view, decreases the time.) In adjusting the plugs, one plug should be screwed in completely and the other plug run in or out until the proper operating time has been obtained.

Recheck the permanent magnet adjustment. If the operating time for this calibration point has changed, readjust the permanent magnet and then recheck the electromagnet plug adjustment.

4. Indicating Contactor Switch (ICS)

Close the main relay contacts and pass sufficient dc current through the trip circuit to close the contacts of the ICS. This value of current should be not greater than the particular ICS tap setting being used. The operation indicator target should drop freely.

5. ac Auxiliary Switch (ACS)

The core screw must be adjusted to the value of pickup current desired. The nameplate data of the ACS will furnish the actual current range that may be obtained from the ACS unit.

6. Indicating Instantaneous Trip Unit (IIT)

The proper tap must be selected and the core screw adjusted to the value of pickup current desired.

The nameplate data and tap plate of the IIT will furnish the actual current range that may be obtained from the IIT unit.

RENEWAL PARTS

Repair work can be done most satisfactorily at the factory. However, interchangeable parts can be furnished to the customers who are equipped for doing repair work. When ordering parts always give the complete nameplate data.

TABLE I

TIME CURVE CALIBRATION DATA - 50 and 60 Hertz

PERMANENT MAGNET ADJUSTMENT			
RELAY TYPE	TIME DIAL POSITION	CURRENT (MULTIPLES OF TAP VALUE)	OPERATING TIME SECONDS
CO-2	6	3	0.57
CO-5	6	2	37.80
CO-6	6	2	2.46
CO-7	6	2	4.27
CO-8	6	2	13.35
CO-9	6	2	8.87
CO-11	6	2	11.27
ELECTROMAGNET PLUGS			
CO-2	6	20	0.22
CO-5	6	10	14.30
CO-6	6	20	1.19
CO-7	6	20	1.11
CO-8	6	20	1.11
CO-9	6	20	0.65
CO-11	6	20	0.24 Δ

Δ For 50 Hz. CO-11 relay 20 times operating time limits are 0.24 + 10% - 5%.

ENERGY REQUIREMENTS

INSTANTANEOUS TRIP UNIT (IT)											
TYPE OF IT UNIT	RANGES AVAILABLE WITH CORE ADJUSTMENT	TAP SETTING	MINIMUM PICKUP	BURDEN						CONT. RATING AMPS	1 SECOND RATING AMPS
				AT PICKUP			OHMS				
				R	XC	Z	3 TIMES PICKUP	10 TIMES PICKUP	20 TIMES PICKUP		
2-48	2-7	2-7	2	.68	.42	.8	.72	.67	.67	2.5	70
	7-14	7-14	7	.076	.048	.09	.086	.075	.075	7	140
	14-48	14-48	14	.032	.012	.035	.035	.035	.035	10	185
6-144	6-20	6-20	6	.108	.067	.127	.125	.125	.100	7	88
	20-40	20-40	20	.016	.008	.018	.018	.018	.018	16	280
	40-144	40-144	40	.007	.002	.007	.007	.007	.007	25	460

ENERGY REQUIREMENTS CO-2 SHORT TIME RELAY

AMPERE RANGE	TAP	CONTINUOUS RATING (AMPERES)	ONE SECOND RATING (AMPERES)	POWER FACTOR ANGLE ϕ	VOLT AMPERES **			
					AT TAP VALUE CURRENT	AT 3 TIMES TAP VALUE CURRENT	AT 10 TIMES TAP VALUE CURRENT	AT 20 TIMES TAP VALUE CURRENT
0.5/2.5	0.5	0.91	28	58	4.8	39.6	256	790
	0.6	0.96	28	57	4.9	39.8	270	851
	0.8	1.18	28	53	5.0	42.7	308	1024
	1.0	1.37	28	50	5.3	45.4	348	1220
	1.5	1.95	28	40	6.2	54.4	435	1740
	2.0	2.24	28	36	7.2	65.4	580	2280
	2.5	2.50	28	28	7.9	73.6	700	2850
1/12	1.0	1.65	28	55	4.6	37.3	266	895
	1.2	1.90	28	54	4.6	38.0	280	1000
	1.5	2.20	28	53	4.8	40.0	310	1150
	2.0	3.30	28	54	4.8	40.5	315	1180
	2.5	4.00	56	56	4.7	39.2	282	970
	3.0	5.00	56	55	4.9	40.2	295	1050
	3.5	5.50	56	54	4.9	41.0	312	1125
	4.0	6.50	56	53	4.8	41.0	325	1150
	5.0	7.10	230	53	5.1	42.7	330	1200
	6.0	8.80	230	50	5.2	44.0	360	1350
	7.0	9.50	230	48	5.7	48.5	390	1600
	8.0	10.50	230	46	6.2	53.0	475	1800
10.0	12.00	230	40	6.8	61.0	565	2500	
12.0	13.00	230	35	7.8	70.0	680	3300	

Thermal capacities for short times other than one second may be calculated on the basis of time being inversely proportional to the square of the current

ϕ Degrees current lags voltage at tap value current

** Voltages taken with Rectox type voltmeter

ENERGY REQUIREMENTS
CO-5 LONG TIME AND CO-6 DEFINITE MINIMUM TIME RELAYS

AMPERE RANGE	TAP	CONTINUOUS RATING (AMPERES)	ONE SECOND RATING (AMPERES)	POWER FACTOR ANGLE ϕ	VOLT AMPERES**			
					AT TAP VALUE CURRENT	AT 3 TIMES TAP VALUE CURRENT	AT 10 TIMES TAP VALUE CURRENT	AT 20 TIMES TAP VALUE CURRENT
0.5/2.5	0.5	2.7	88	69	3.92	20.6	103	270
	0.6	3.1	88	68	3.96	20.7	106	288
	0.8	3.7	88	67	3.96	21	114	325
	1.0	4.1	88	66	4.07	21.4	122	360
	1.5	5.7	88	62	4.19	23.2	147	462
	2.0	6.8	88	60	4.30	24.9	138	548
	2.5	7.7	88	58	4.37	26.2	180	630
1/12	1.0	4.5	88	69	3.98	21.0	100	265
	1.2	5.5	88	68	3.93	21.3	103	282
	1.5	6.0	88	67	4.00	21.8	109	308
	2.0	7.7	88	66	3.98	21.9	115	340
	2.5	9.5	88	65	3.98	22.2	122	363
	3.0	10.0	230	65	4.02	22.5	125	366
	3.5	12.0	230	65	4.06	23.2	132	403
	4.0	13.5	230	64	4.12	23.5	137	420
	5.0	15.0	230	61	4.18	24.6	150	500
	6.0	17.5	460	60	4.35	25.8	165	570
	7.0	20.5	460	57	4.44	27.0	185	630
	8.0	22.5	460	53	4.54	28.6	211	736
	10.0	23.5	460	48	4.80	32.5	266	940
12.0	26.5	460	42	5.34	37.9	325	1152	

Thermal capacities for short times other than one second may be calculated on the basis of time being inversely proportional to the square of the current

ϕ Degrees current lags voltage at tap value current

** Voltages taken with Rectox type voltmeter

ENERGY REQUIREMENTS

CO-7 MODERATELY INVERSE TIME RELAY								
AMPERE RANGE	TAP	CONTINUOUS RATING (AMPERES)	ONE SECOND RATING (AMPERES)	POWER FACTOR ANGLE ϕ	VOLT AMPERES**			
					AT TAP VALUE CURRENT	AT 3 TIMES TAP VALUE CURRENT	AT 10 TIMES TAP VALUE CURRENT	AT 20 TIMES TAP VALUE CURRENT
0.5/2.5	0.5	2.7	88	68	3.88	20.7	103	278
	0.6	3.1	88	67	3.93	20.9	107	288
	0.8	3.7	88	66	3.93	21.1	114	320
	1.0	4.1	88	64	4.00	21.6	122	356
	1.5	5.7	88	61	4.08	22.9	148	459
	2.0	6.8	88	58	4.24	24.8	174	552
	2.5	7.7	88	56	4.38	25.9	185	640
1/12	1.0	4.5	88	68	3.86	20.6	100	265
	1.2	5.5	88	67	3.82	20.4	104	270
	1.5	6.0	88	66	3.92	21.2	110	300
	2.0	7.7	88	65	3.90	21.8	117	312
	2.5	9.5	88	64	3.90	21.8	123	360
	3.0	10.0	230	63	3.92	22.5	127	390
	3.5	12.0	230	63	3.97	22.7	131	413
	4.0	13.5	230	63	4.02	22.9	136	420
	5.0	15.0	230	60	4.11	24.1	153	490
	6.0	17.5	460	58	4.29	25.5	165	528
	7.0	20.5	460	54	4.43	27.3	189	630
	8.0	22.5	460	50	4.50	30.8	206	732
10.0	23.5	460	46	4.81	32.6	250	970	
12.0	26.5	460	42	5.04	36.9	342	1224	
CO-8 INVERSE TIME AND CO-9 VERY INVERSE TIME RELAYS								
0.5/2.5	0.5	2.7	88	72	2.38	21	132	350
	0.6	3.1	88	71	2.38	21	134	365
	0.8	3.7	88	69	2.40	21.1	142	400
	1.0	4.1	88	67	2.42	21.2	150	440
	1.5	5.7	88	62	2.51	22	170	530
	2.0	6.8	88	57	2.65	23.5	200	675
	2.5	7.7	88	53	2.74	24.8	228	800
1/12	1.0	4.5	88	73	2.33	20	135	347
	1.2	5.5	88	73	2.33	20	135	361
	1.5	6.0	88	72	2.35	20.1	142	383
	2.0	7.7	88	69	2.35	20.2	145	412
	2.5	9.5	88	68	2.36	20.3	146	415
	3.0	10.0	230	67	2.37	20.4	149	420
	3.5	12.0	230	66	2.38	20.9	153	450
	4.0	13.5	230	65	2.40	21.0	157	460
	5.0	15.0	230	63	2.40	21.0	164	500
	6.0	17.5	460	60	2.47	21.6	170	525
	7.0	20.5	460	57	2.51	21.8	180	600
	8.0	22.5	460	55	2.52	22.2	192	672
10.0	23.5	460	48	2.77	24.5	230	830	
12.0	26.5	460	45	2.94	25.4	258	960	

Thermal capacities for short times other than one second may be calculated on the basis of time being inversely proportional to the square of the other current.

ϕ Degrees current lags voltage at tap value current.

** Voltages taken with Rectox type voltmeter.

ENERGY REQUIREMENTS
CO-11 EXTREMELY INVERSE TIME RFLAY

AMPERE RANGE	TAP	CONTINUOUS RATING (AMPERES)	ONE SECOND RATING (AMPERES)	POWER FACTOR ANGLE ϕ	VOLT AMPERES**			
					AT TAP VALUE CURRENT	AT 3 TIMES TAP VALUE CURRENT	AT 10 TIMES TAP VALUE CURRENT	AT 20 TIMES TAP VALUE CURRENT
0.5/2.5	0.5	1.7	56	36	0.72	6.54	71.8	250
	0.6	1.9	56	34	0.75	6.80	75.0	267
	0.8	2.2	56	30	0.81	7.46	84.0	298
	1.0	2.5	56	27	0.89	8.30	93.1	330
	1.5	3.0	56	22	1.13	10.04	115.5	411
	2.0	3.5	56	17	1.30	11.95	136.3	502
	2.5	3.8	56	16	1.48	13.95	160.0	610
1/12	1.0	3.5	56	30	0.82	7.4	82	300
	1.2	4.0	56	29	0.90	8.0	87	324
	1.5	5.5	56	26	0.97	8.6	93	350
	2.0	8.5	56	25	1.00	8.9	96	380
	2.5	10.0	56	24	1.10	9.0	96	377
	3.0	12.5	230	33	0.87	8.0	88	340
	3.5	14.0	230	31	0.88	8.2	88	340
	4.0	15.0	230	29	0.94	8.7	96	366
	5.0	17.0	230	25	1.10	10.0	110	435
	6.0	18.5	460	22	1.25	11.5	120	478
	7.0	20.0	460	20	1.40	12.3	135	560
	8.0	21.5	460	19	1.50	14.0	160	648
10.0	25.0	460	14	1.9	18.3	210	900	
12.0	28.0	460	10	2.4	23.8	276	1200	

Thermal capacities for short times other than one second may be calculated on the basis of time being inversely proportional to the square of the current.

ϕ Degrees current lags voltage at tap value current.

** Voltages taken with Rectox type voltmeter.

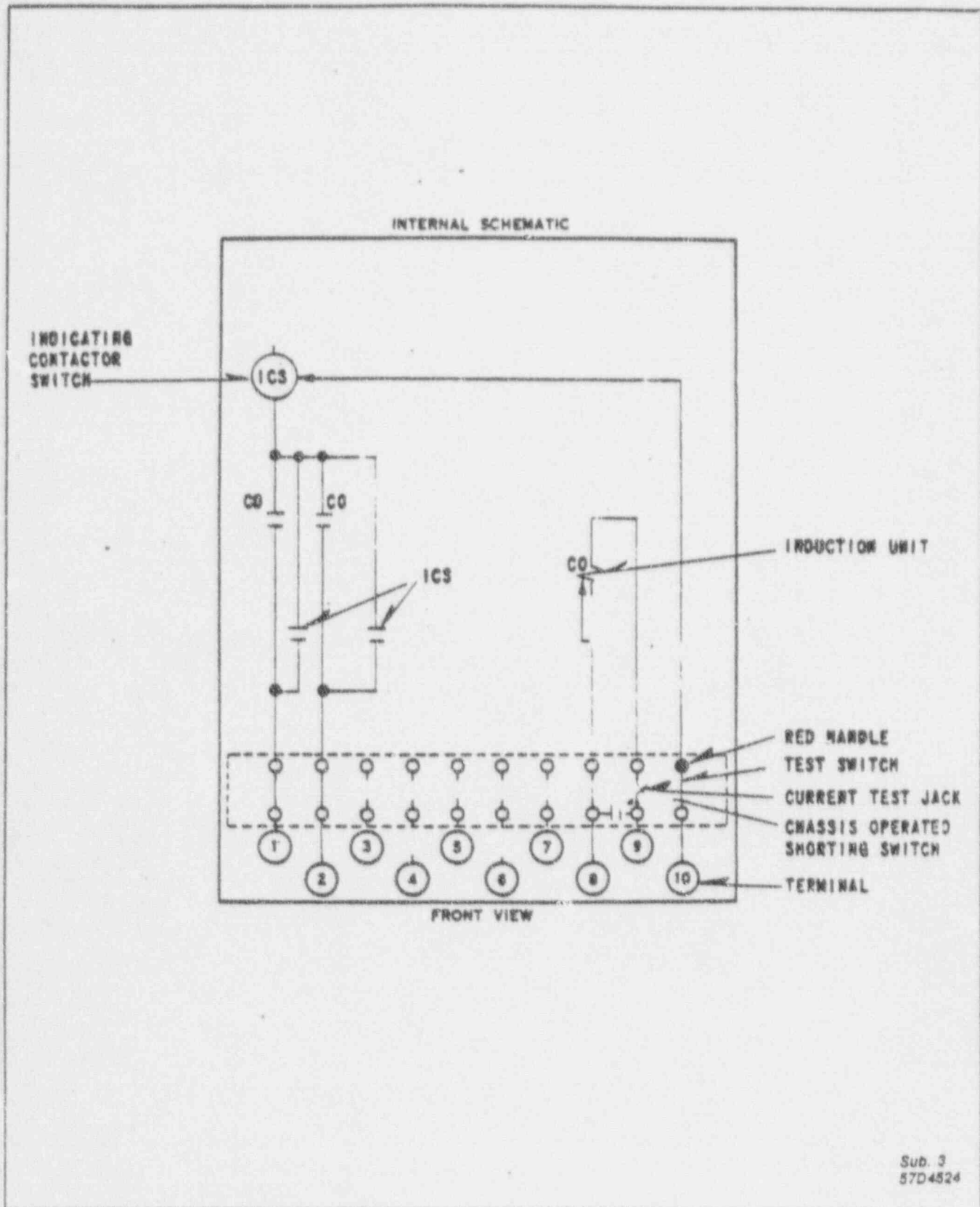
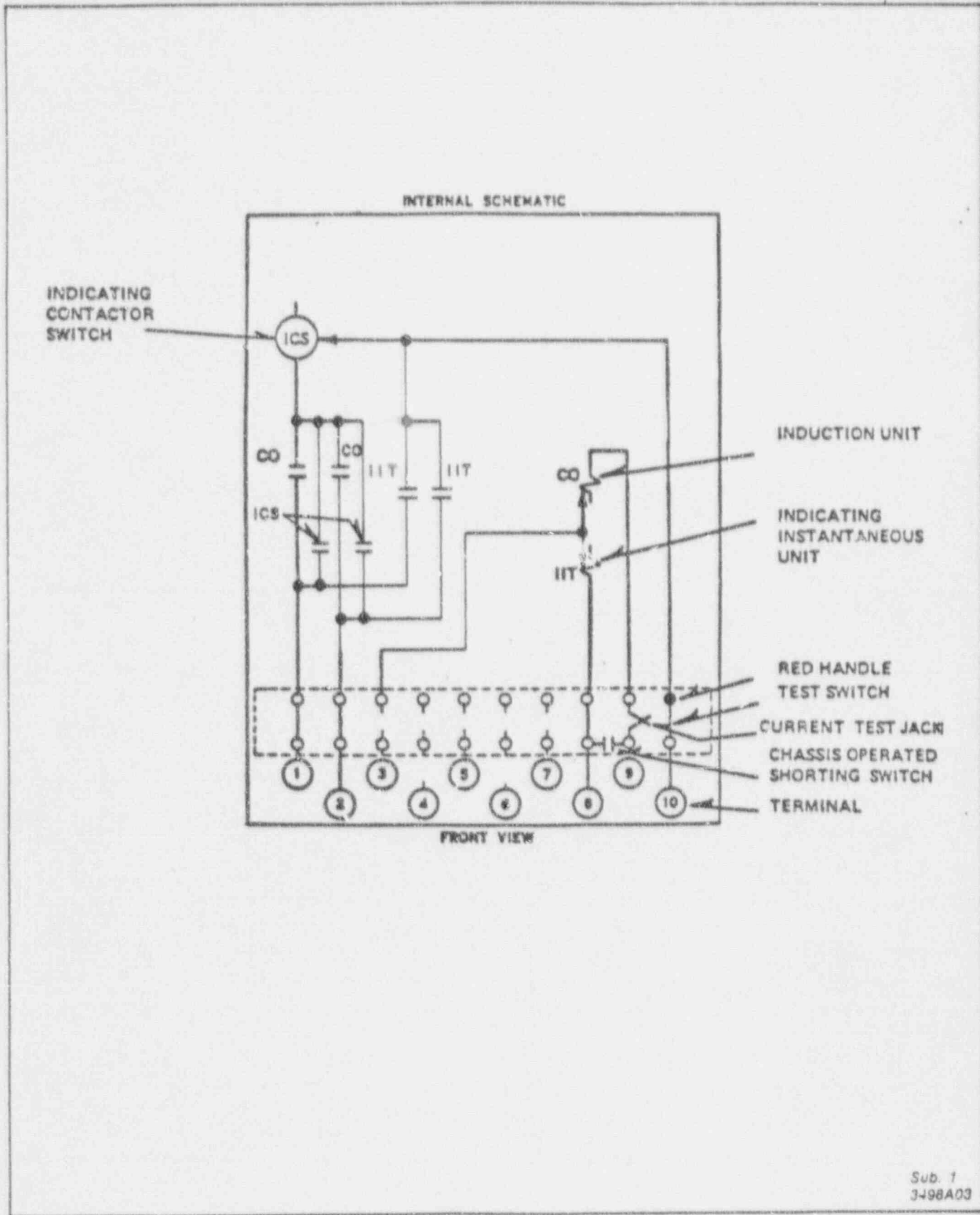

Fig. 1. Internal Schematic of the Double Trip Relay Without IIT



Sub. 1
3498A03

Fig. 2. Internal Schematic of the Double Trip Relay With IIT

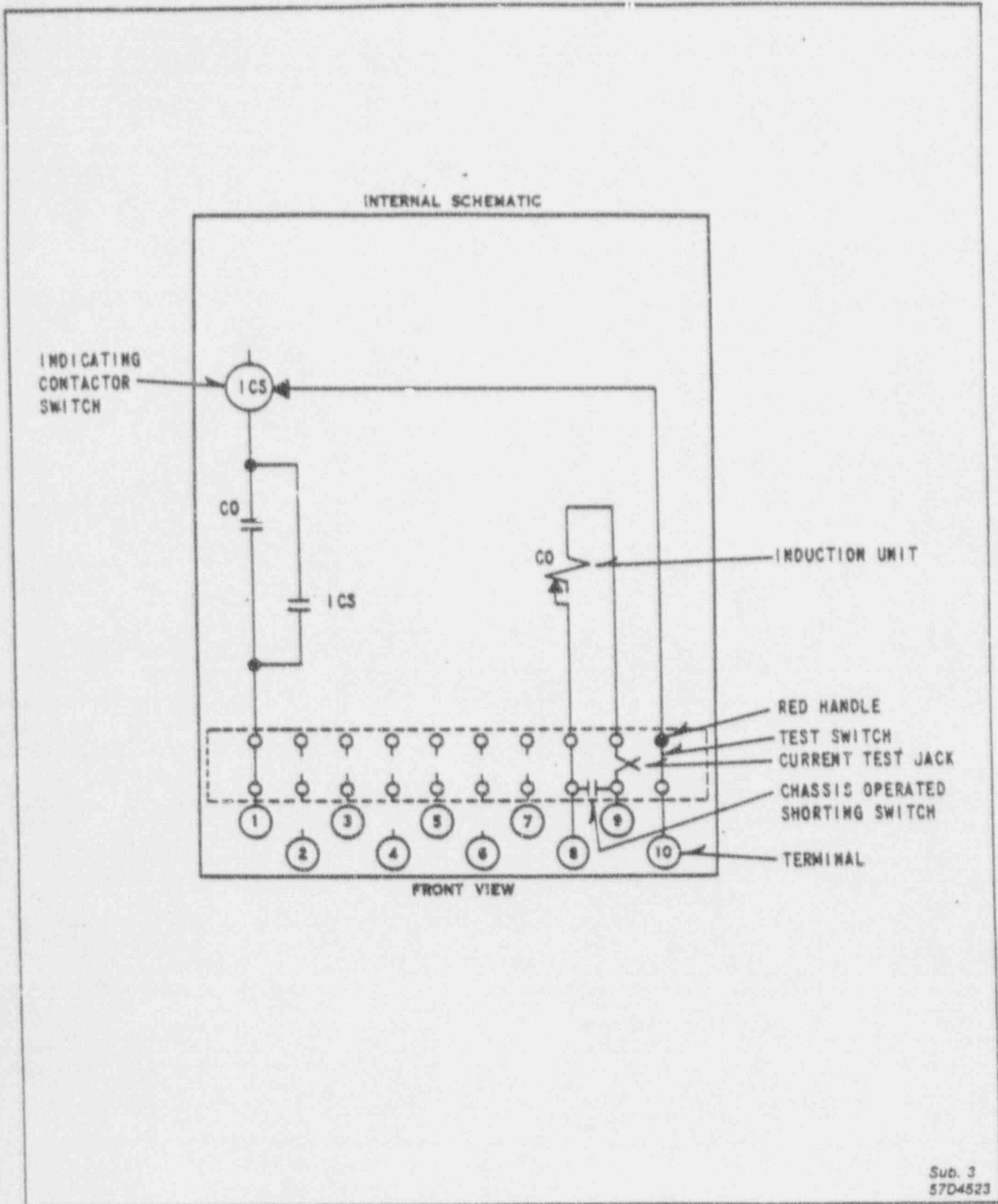
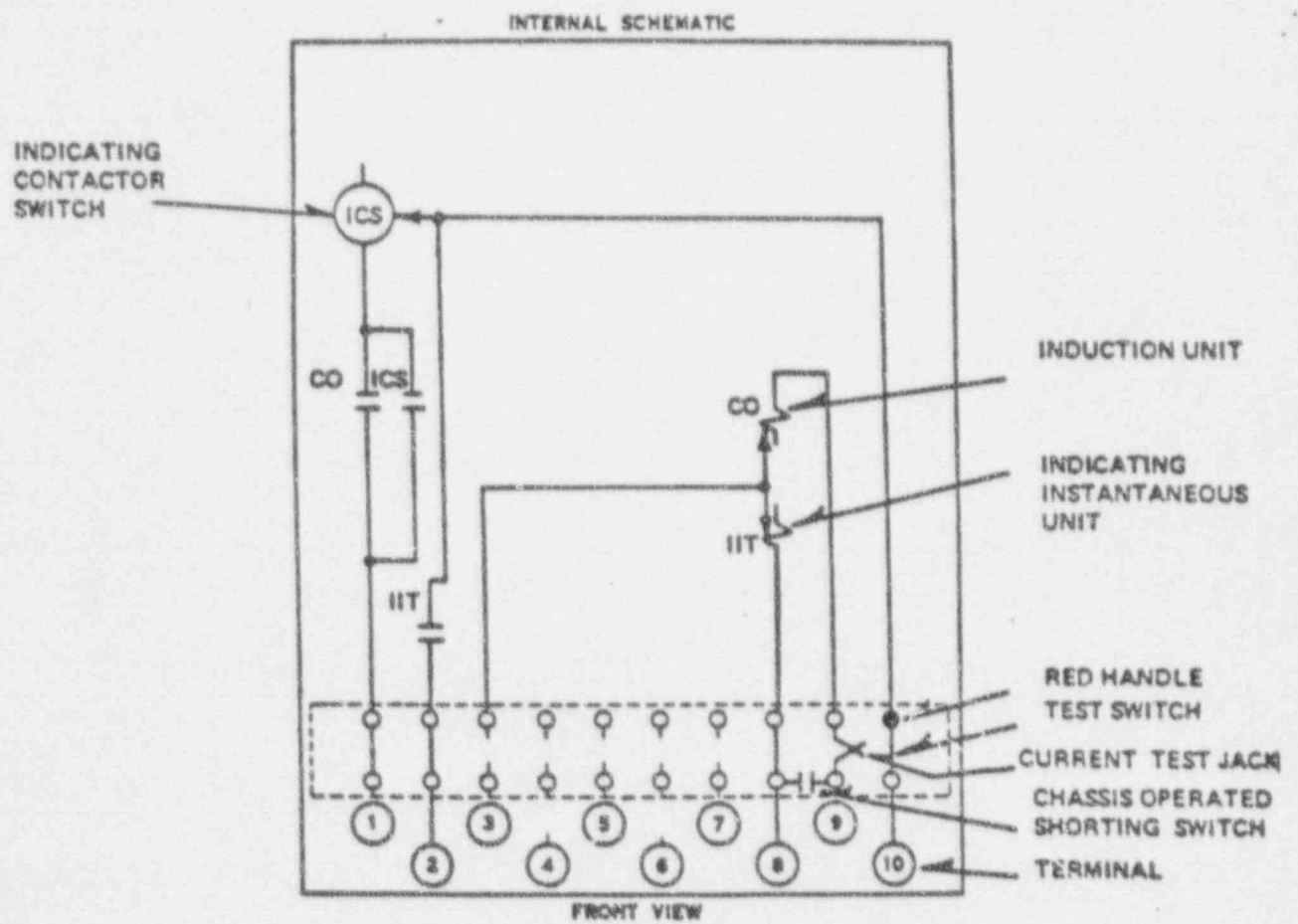
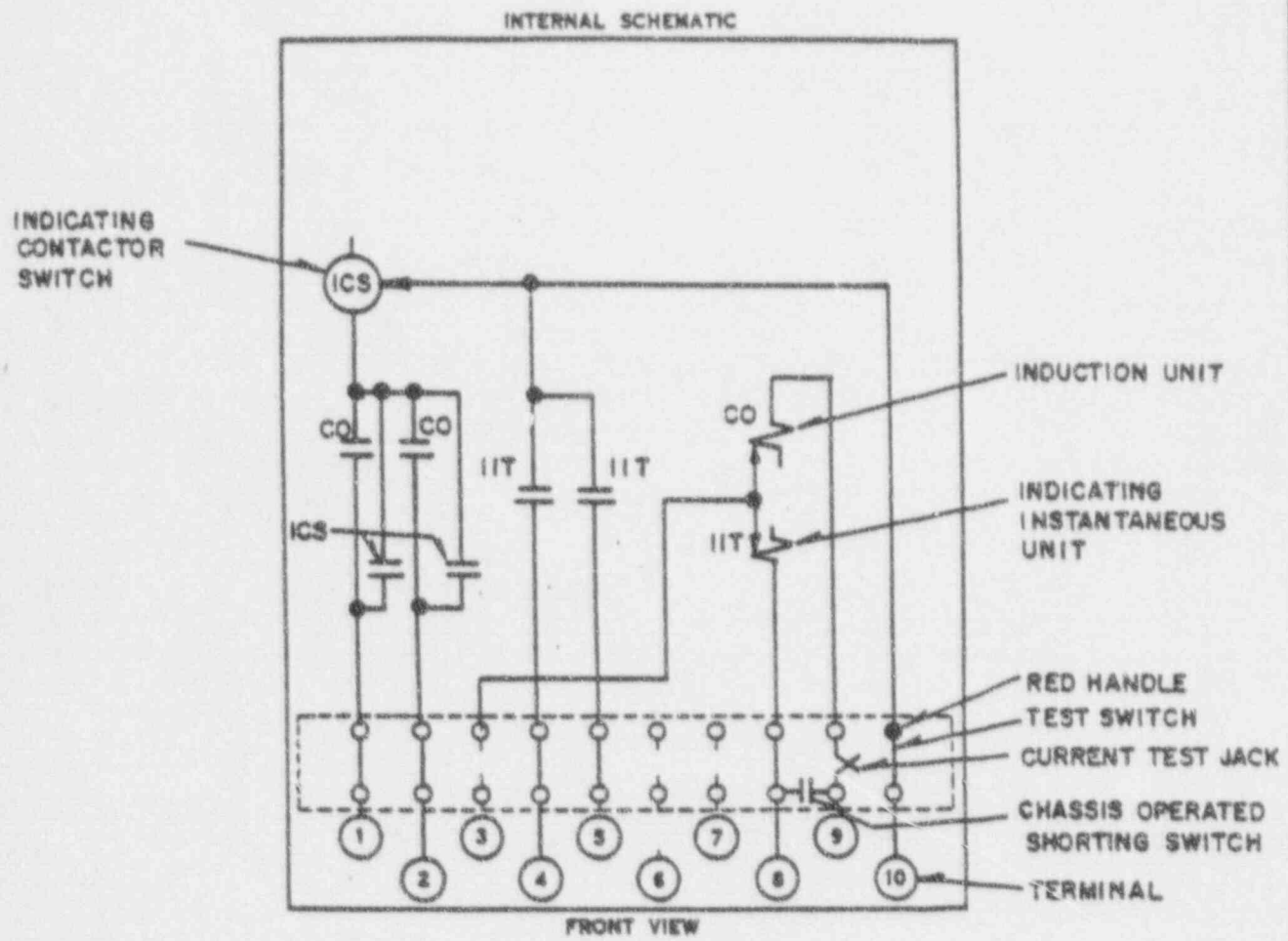

Fig. 3. Internal Schematic of the Single Trip Relay Without IIT



Sub. 1
3498A02

Fig. 4. Internal Schematic of the Single Trip Relay With IIT



Sub. 1
3506A73

Fig. 5. Internal Schematic of Double Trip Relay With IIT to Separate Terminals.

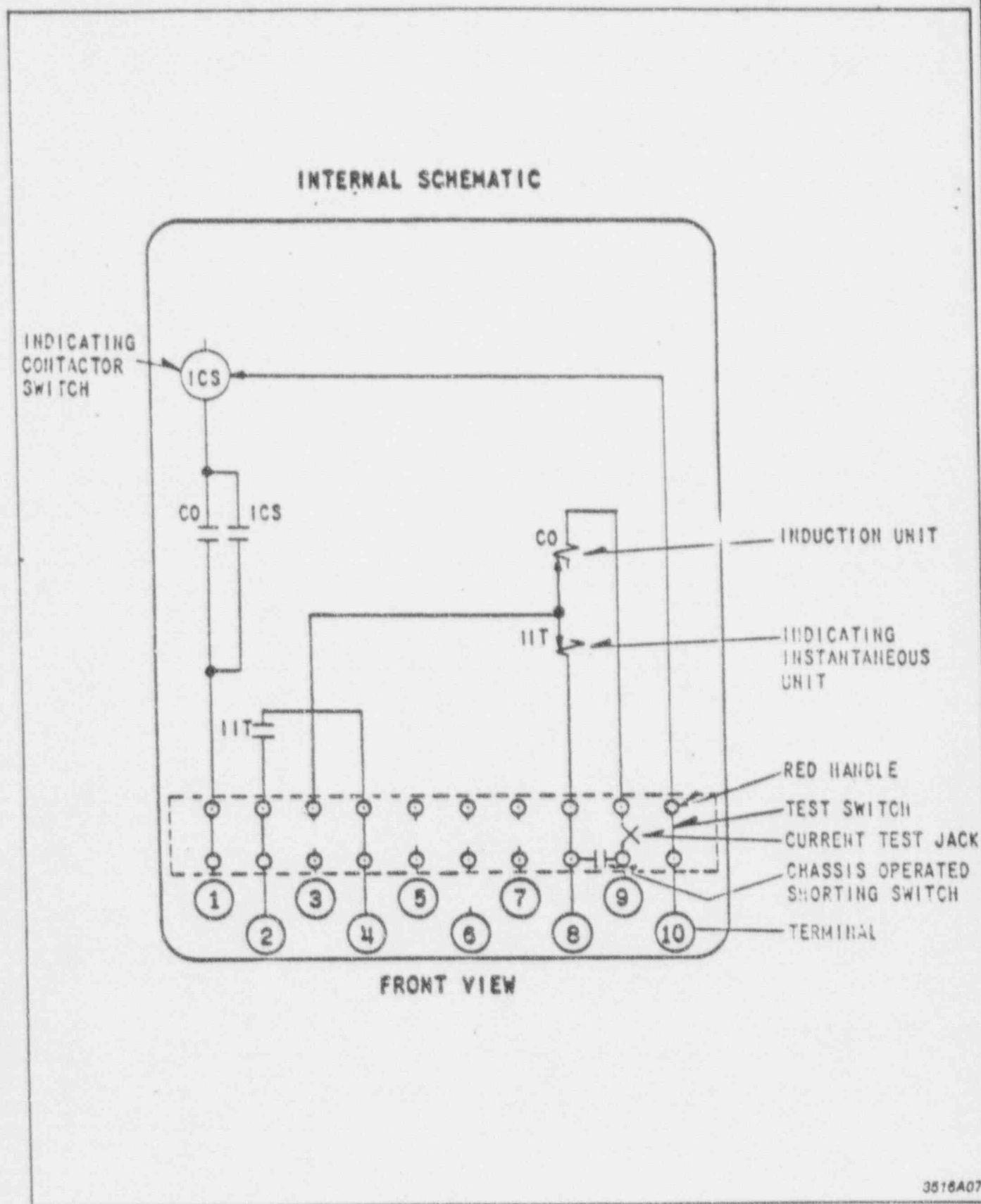
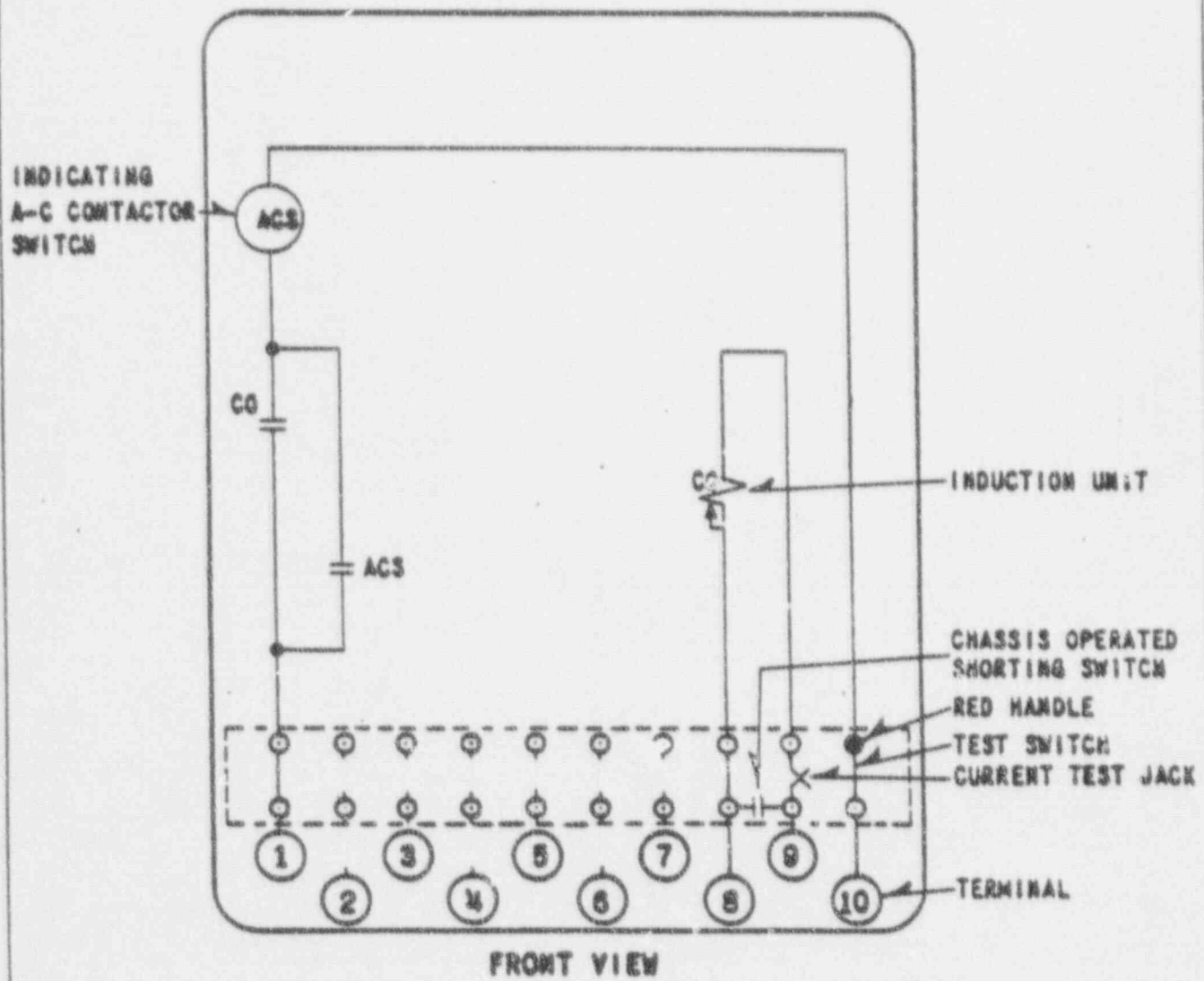

Fig. 6. Internal Schematic of the Single Trip Relay with IIT Contacts wired to Two Separate Terminals

INTERNAL SCHEMATIC



183A680

© Fig. 7. Internal Schematic of the Single Trip Relay with an ACS Unit

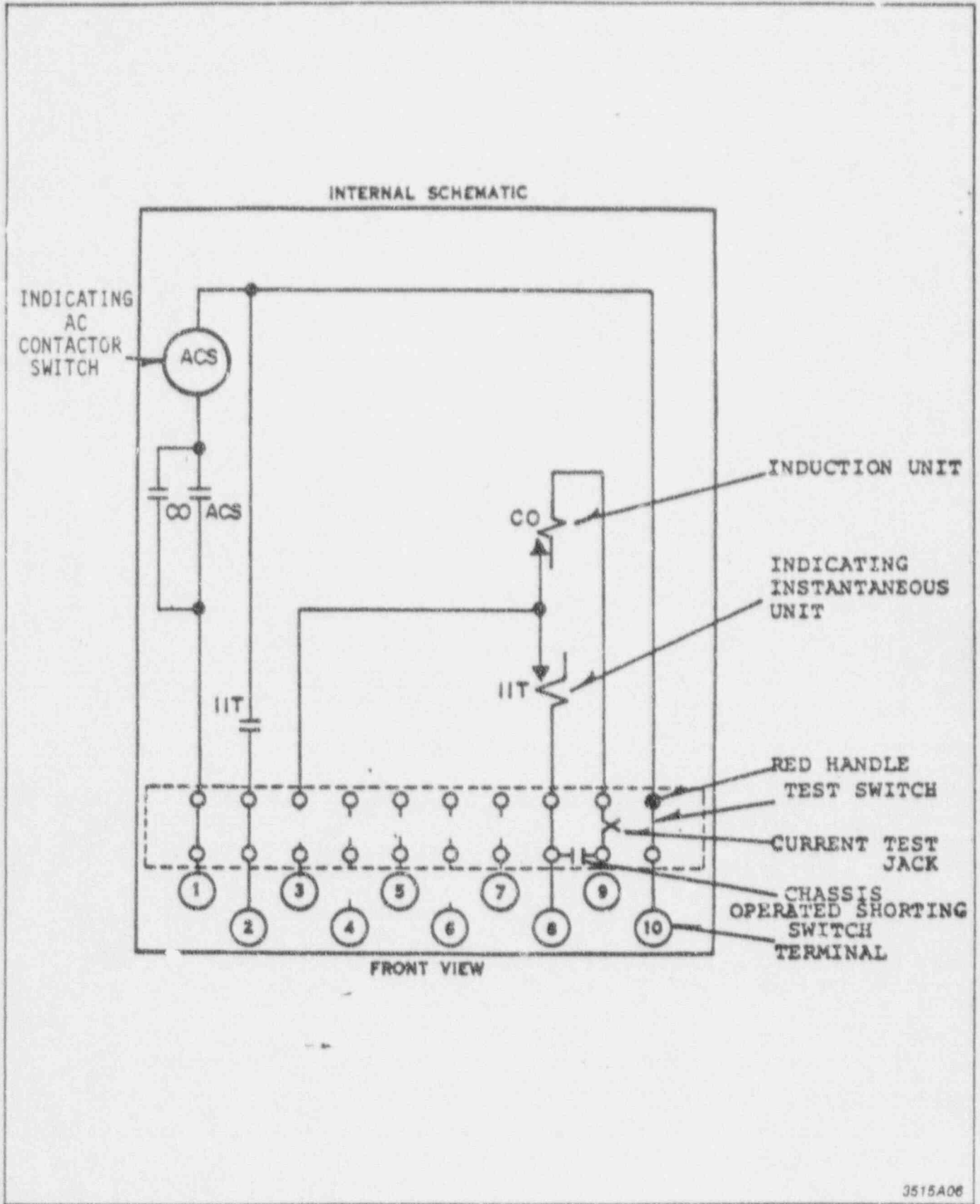
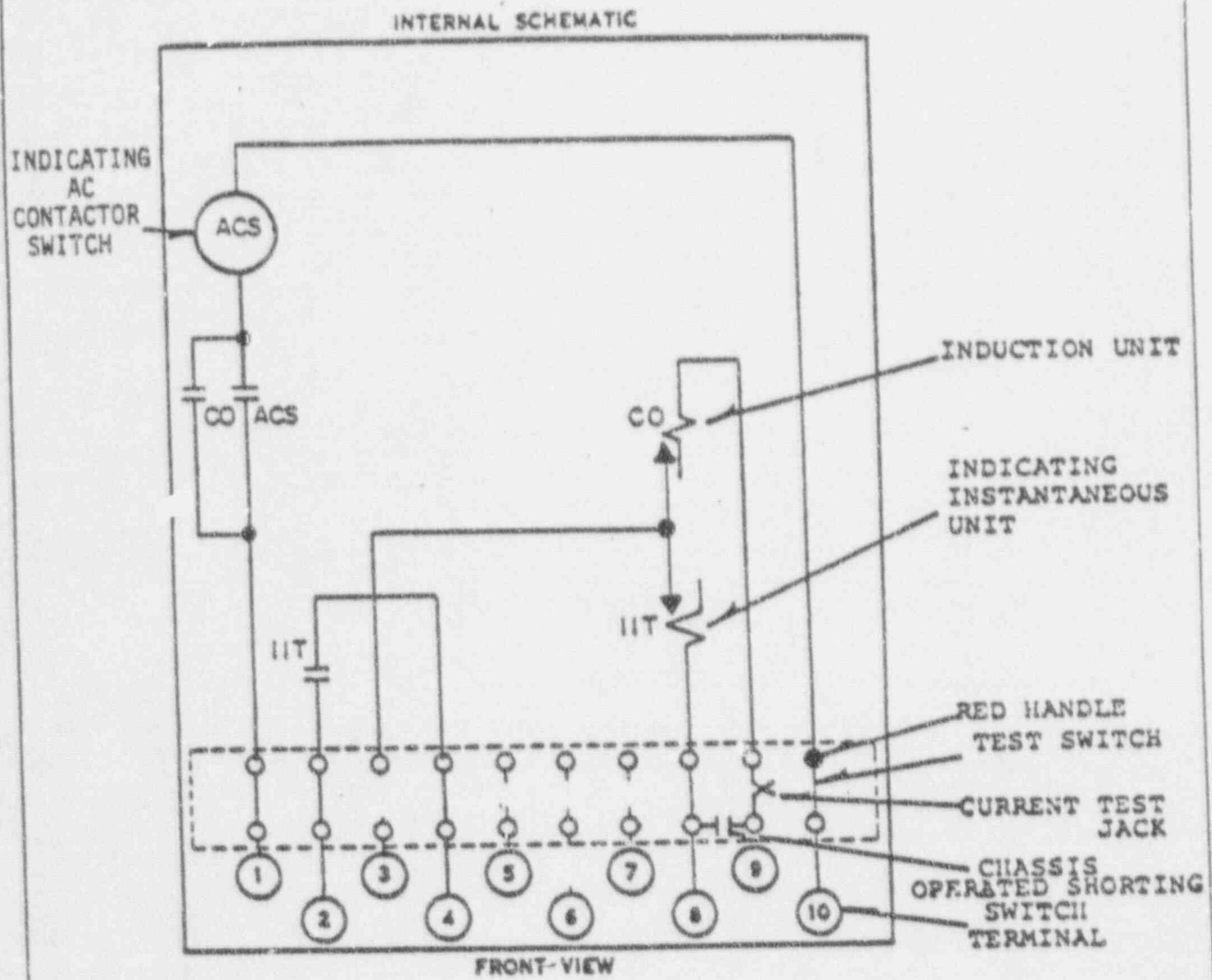
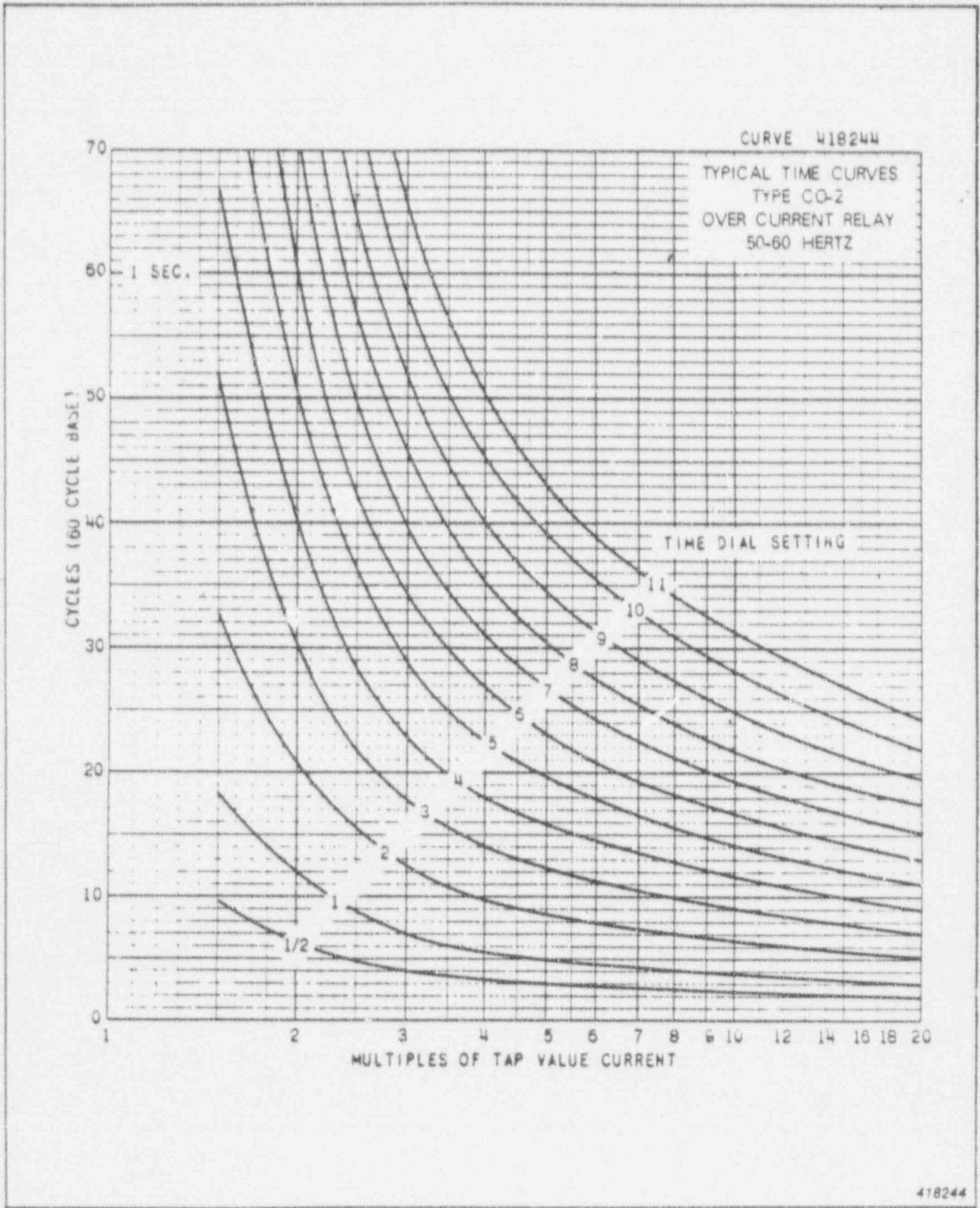

Fig. 8. Internal Schematic of the Single Trip Relay with an ACS unit and IIT



3524A37

© Fig. 9. Internal Schematic of the Single Trip Relay with an ACS Unit and with IIT Contacts Wired to Two Separate Terminals



418244

⊗ Fig. 10. Typical Time Curve of the Type CO-2 Relay

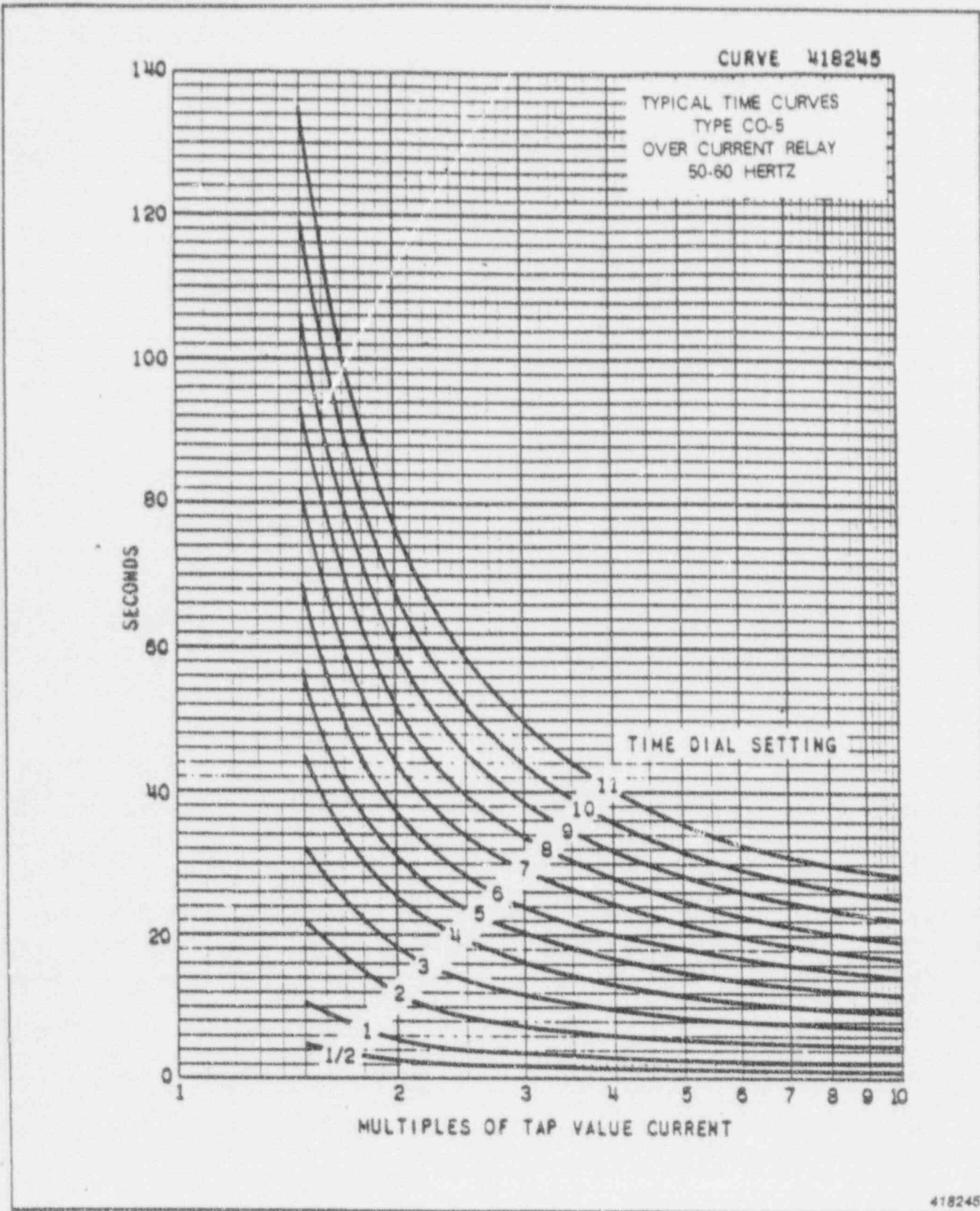

© Fig. 11. Typical Time Curve of the Type CO-5 Relay

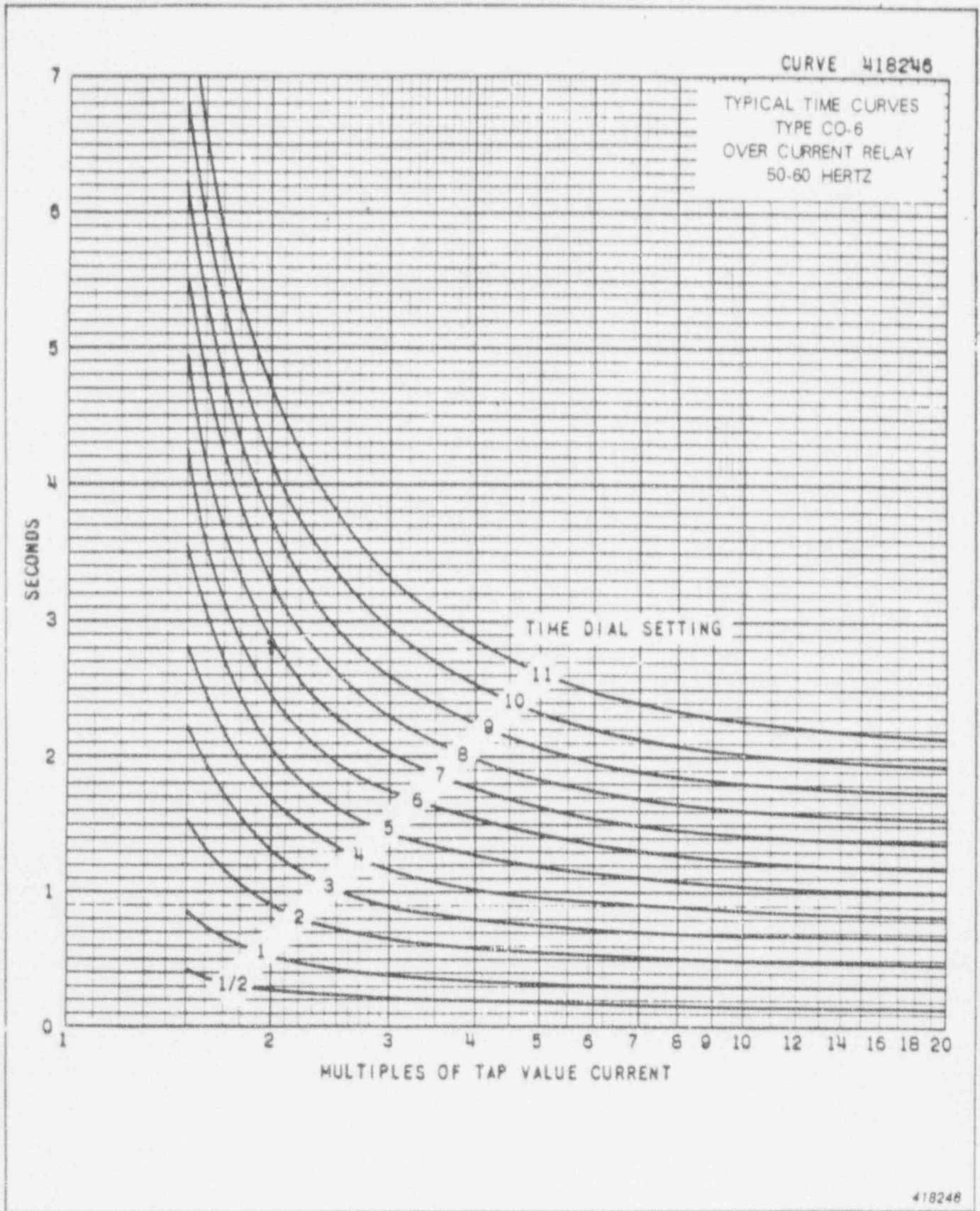

⊙ Fig. 12. Typical Time Curve of the Type CO-6 Relay

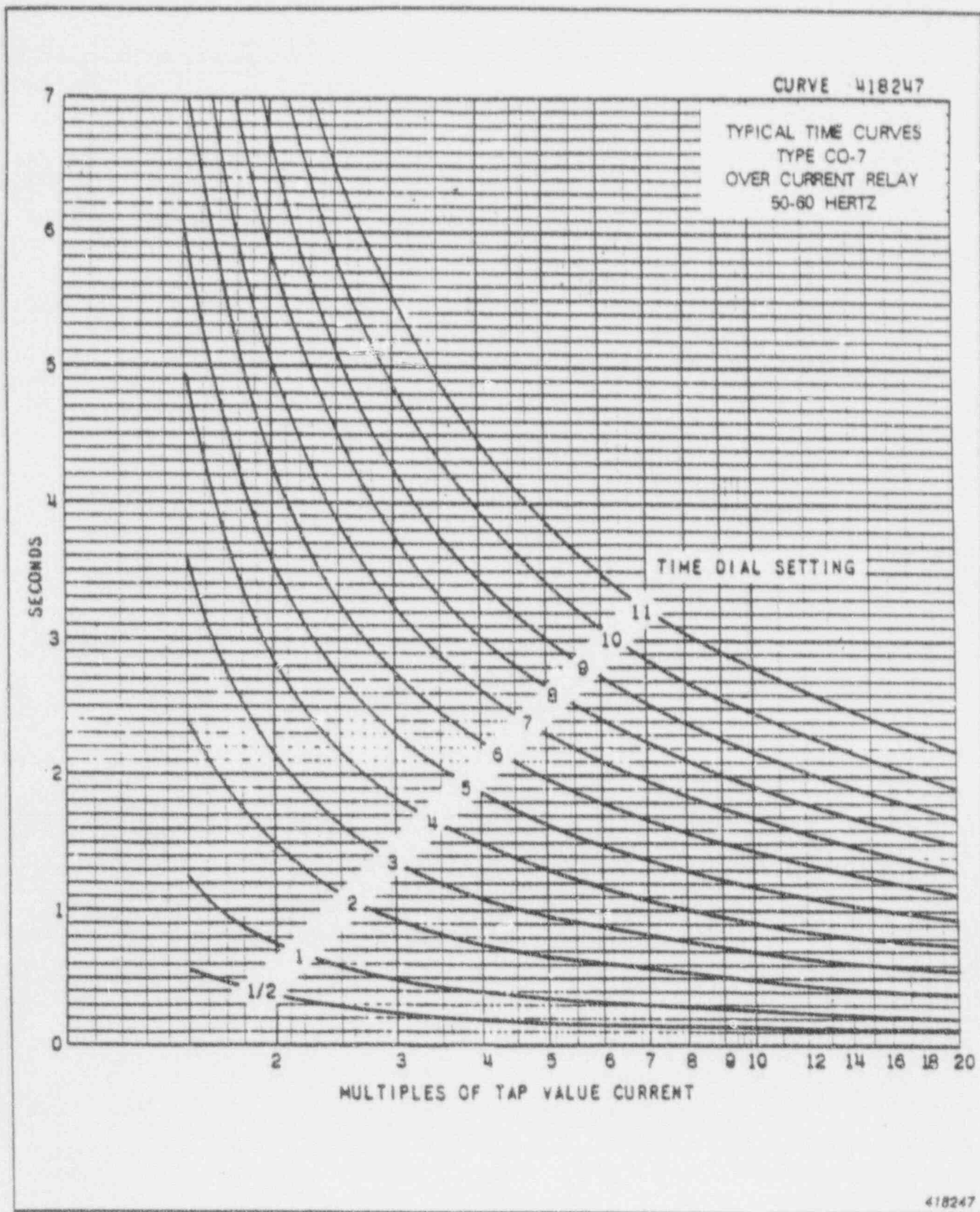

⊙ Fig. 13. Typical Time Curve of the Type CO-7 Relay

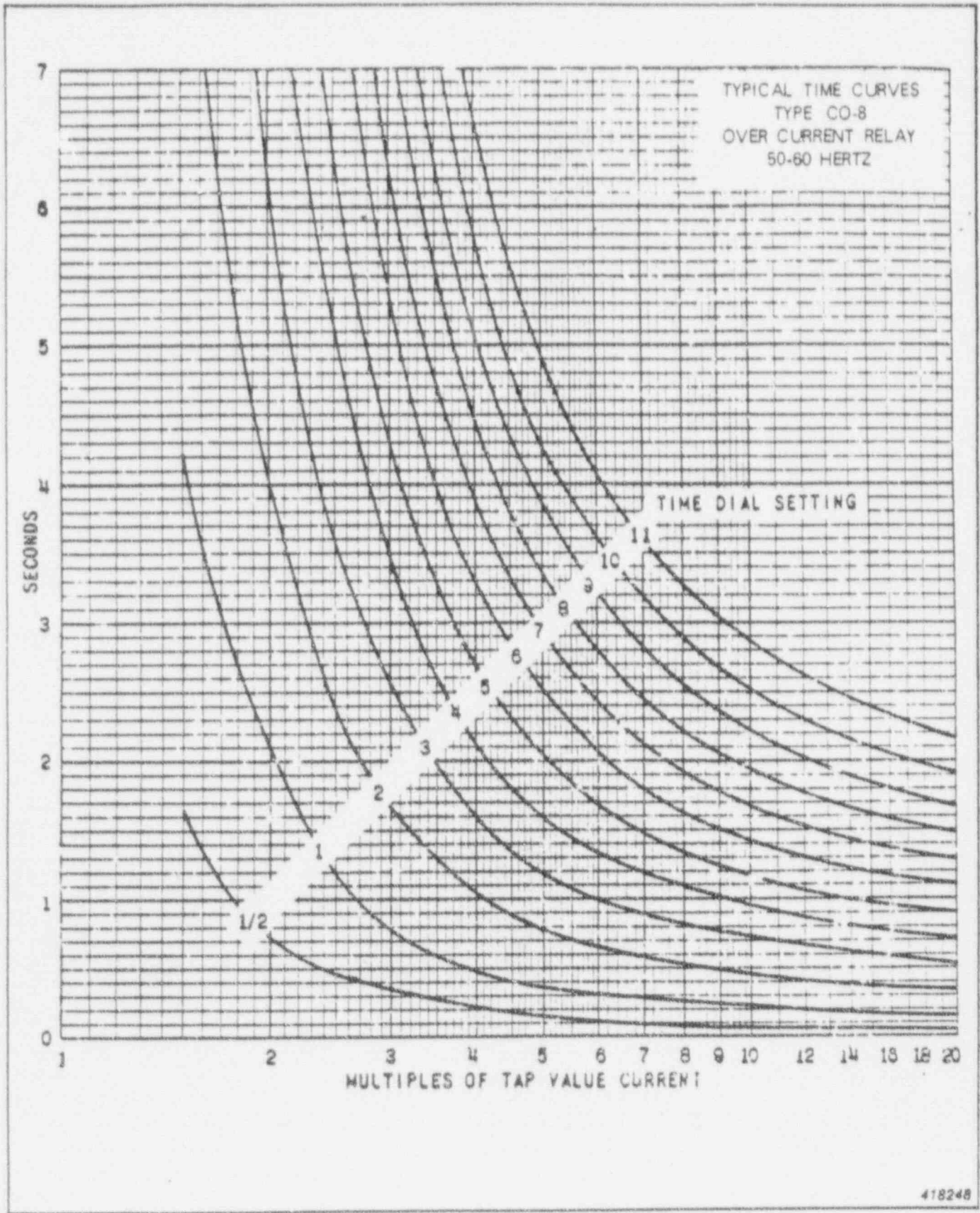

Fig. 14. Typical Time Curve of the Type CO-8 Relay

418248

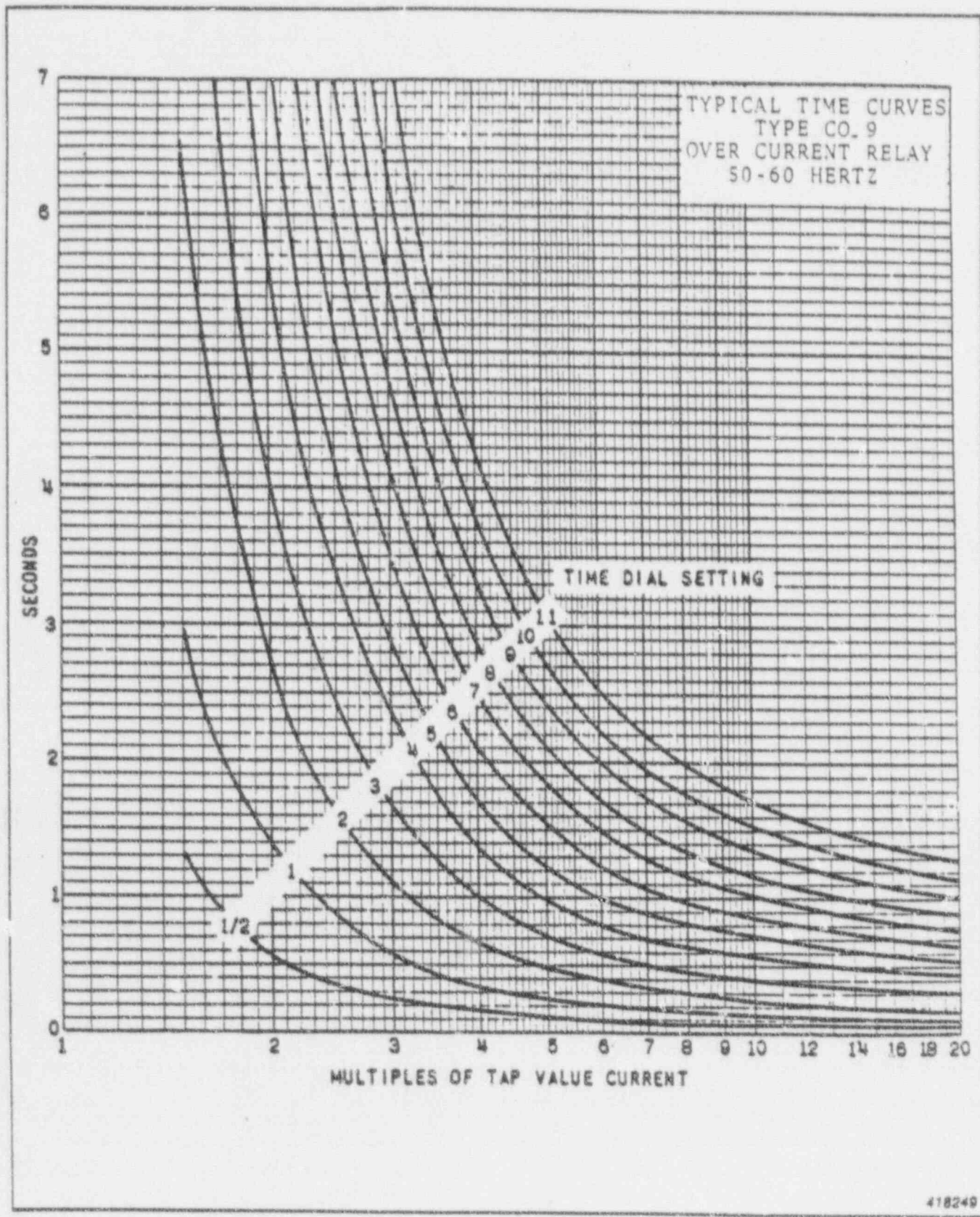

Fig. 15. Typical Time Curve of the Type CO-9 Relay

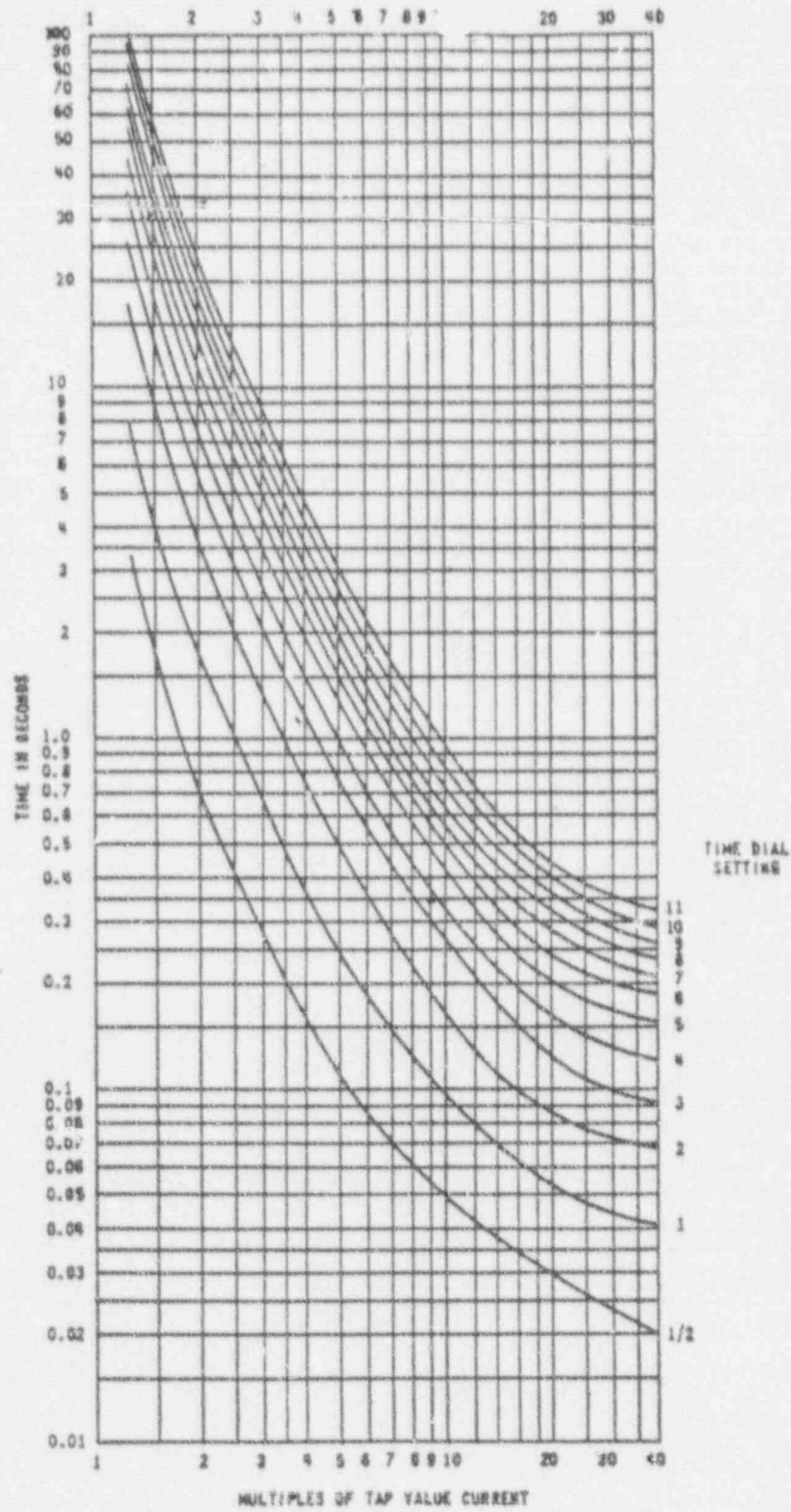

Fig. 16. Typical Time Curve of the Type CO-11 Relay

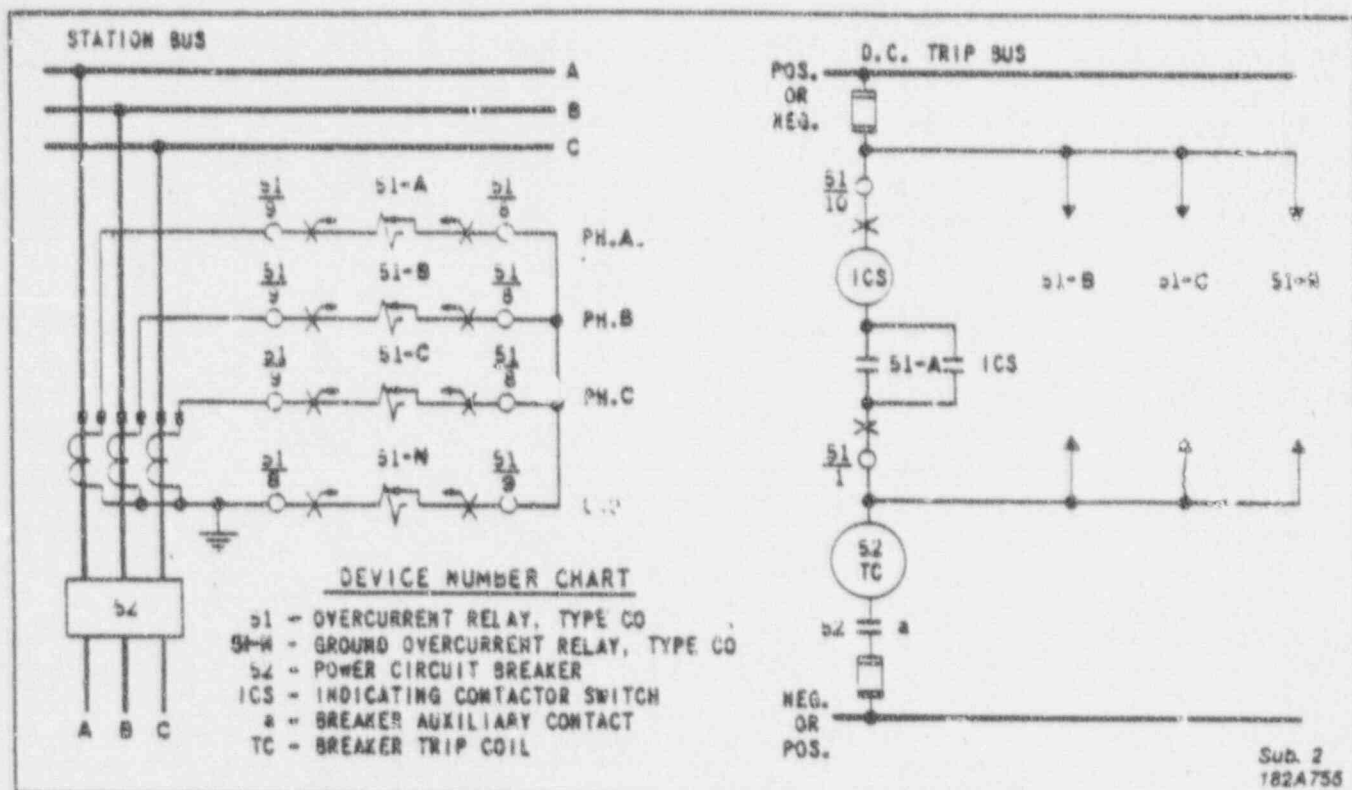

Fig. 17. External Schematic of HiLo CO relay for Phase and Ground Overcurrent Protection on a Three Phase System.

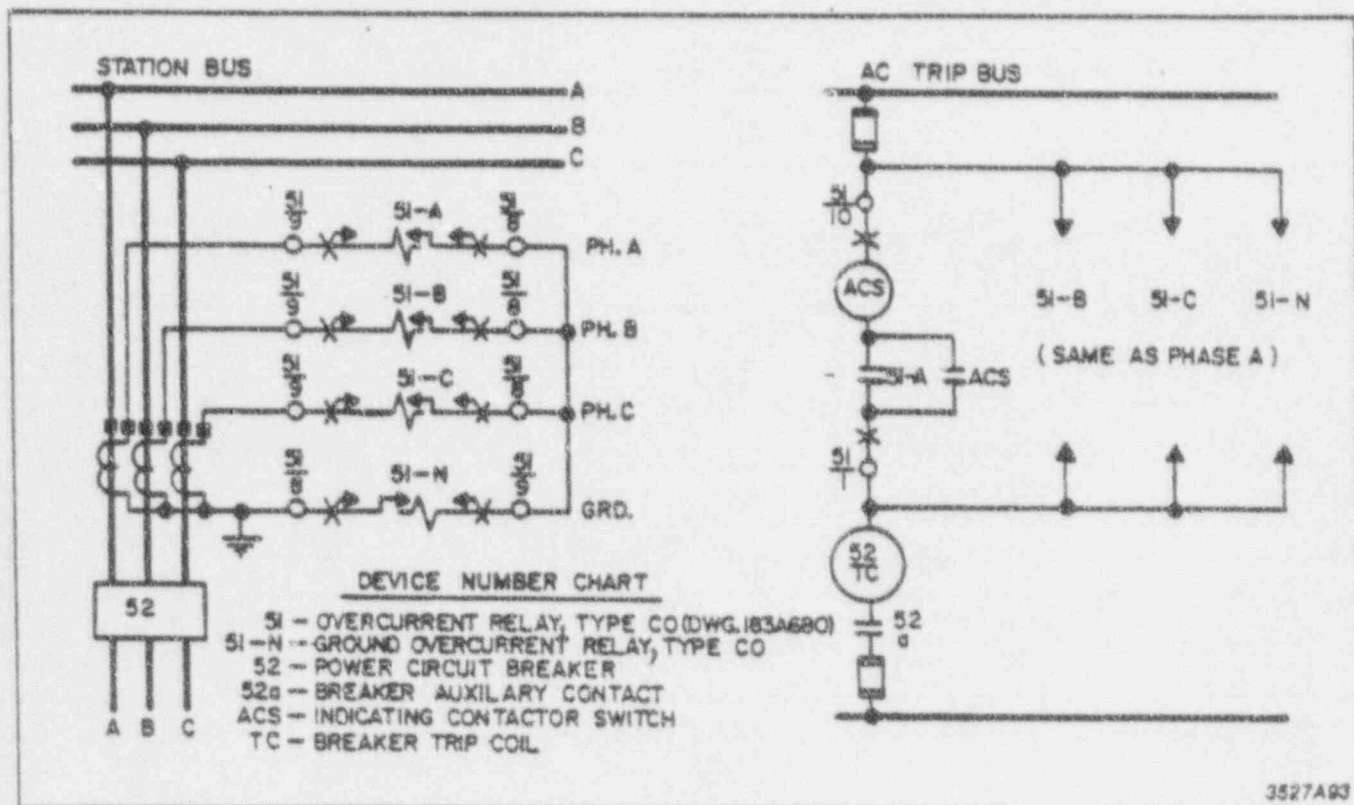
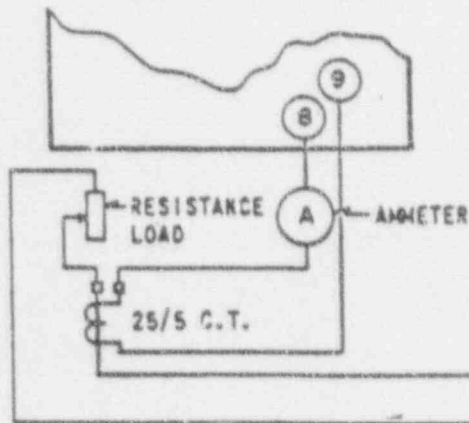
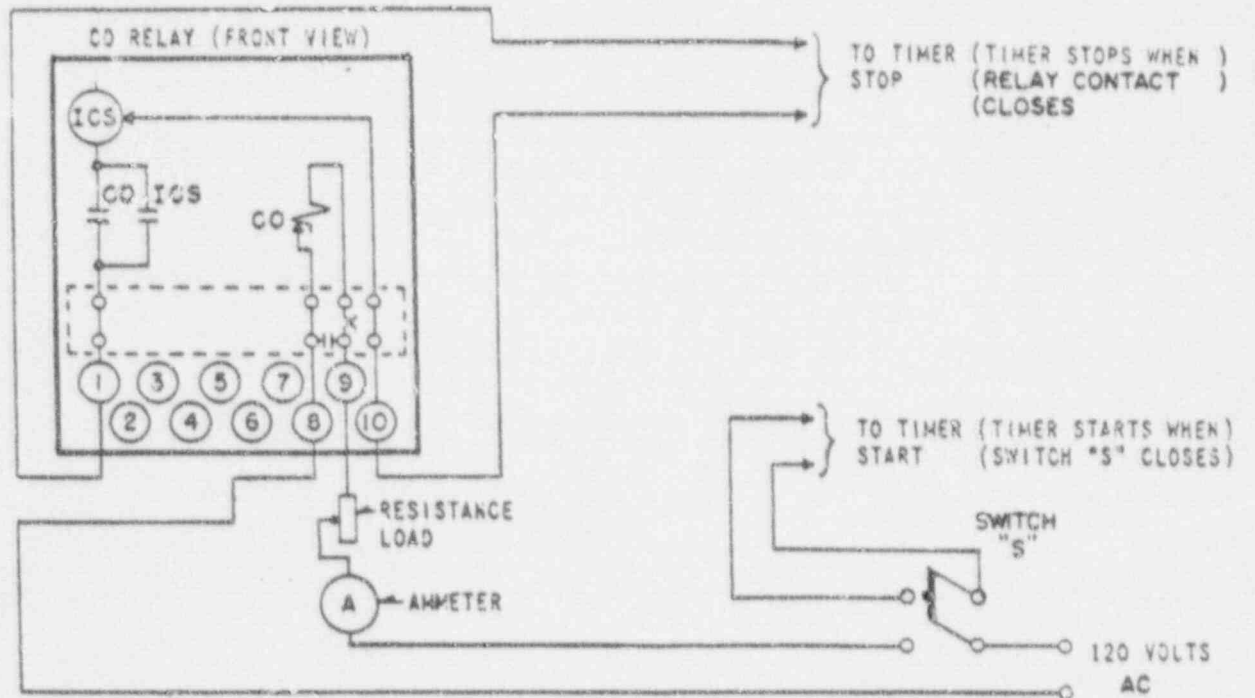

Fig. 18. External Schematic of HiLo CO Relay with ACS Unit for Phase and Ground Protection on a Three Phase System



RELAY SHOULD BE TESTED IN CASE

ALTERNATIVE CONNECTIONS FOR .5 TO 2.5 AMPERE RANGE CO-5 AND CO-6 RELAYS

Sub. 3
3503A43

Fig. 19. Diagram of Test Connections for the Type CO Relay.

RELAY TYPE

FIRST 7 DIGITS OF STYLE NO.

CO-2	265C195
CO-5	264C897
CO-6	264C898
CO-7	264C899
CO-8	264C900
CO-9	264C901
CO-11	265C047

LAST THREE DIGITS OF STYLE NUMBER		RANGE CO #	RANGE IIT	DESCRIPTION	SCHEMATIC
80 HZ	50 HZ				
A01	A21	5-2.5	-	SINGLE TRIP	57D4523 (FIG. 3)
A02	A22	5-2.5	-	DOUBLE TRIP	57D4524 (FIG. 1)
A03	A23	5-2.5	2-48	SINGLE TRIP	3498A02 (FIG. 4)
A04	A24	5-2.5	2-48	DOUBLE TRIP	3498A03 (FIG. 2)
A05	A25	1-12	-	SINGLE TRIP	57D4523 (FIG. 3)
A06	A26	1-12	-	DOUBLE TRIP	57D4524 (FIG. 1)
A07	A27	1-12	6-144	SINGLE TRIP	3498A02 (FIG. 4)
A08	A28	1-12	6-144	DOUBLE TRIP	3498A03 (FIG. 2)
A09	A29	5-2.5	6-144	SINGLE TRIP	3498A02 (FIG. 4)
A10	A30	5-2.5	6-144	DOUBLE TRIP	3498A03 (FIG. 2)
A11	A31	1-12	2-48	SINGLE TRIP	3498A02 (FIG. 4)
A12	A32	1-12	2-48	DOUBLE TRIP	3498A03 (FIG. 2)
A13	A33	5-2.5	2-48	DOUBLE TRIP WITH IIT CONTACTS WIRED TO SEPARATE TERMINALS	3508A73 (FIG. 5)
A14	A34	1-12	6-144	DOUBLE TRIP WITH IIT CONTACTS WIRED TO SEPARATE TERMINALS	3508A73 (FIG. 5)
A15	A35	5-2.5	6-144	DOUBLE TRIP WITH IIT CONTACTS WIRED TO SEPARATE TERMINALS	3508A73 (FIG. 5)
A16	A36	1-12	2-48	DOUBLE TRIP WITH IIT CONTACTS WIRED TO SEPARATE TERMINALS	3508A73 (FIG. 5)
A17		5-2.5	2-48	SINGLE TRIP WITH IIT CONTACTS WIRED TO TWO SEPARATE TERMINALS	3516A07
A18	A38	1-12	6-144	SINGLE TRIP WITH IIT CONTACTS WIRED TO TWO SEPARATE TERMINALS	3516A07
A19		5-2.5	6-144	SINGLE TRIP WITH IIT CONTACTS WIRED TO TWO SEPARATE TERMINALS	3516A07
A20	A40	1-12	2-48	SINGLE TRIP WITH IIT CONTACTS WIRED TO TWO SEPARATE TERMINALS	3516A07

Fig. 20. Style Descriptions of CO Relay with ICS Unit.

Sub. 34
7758349

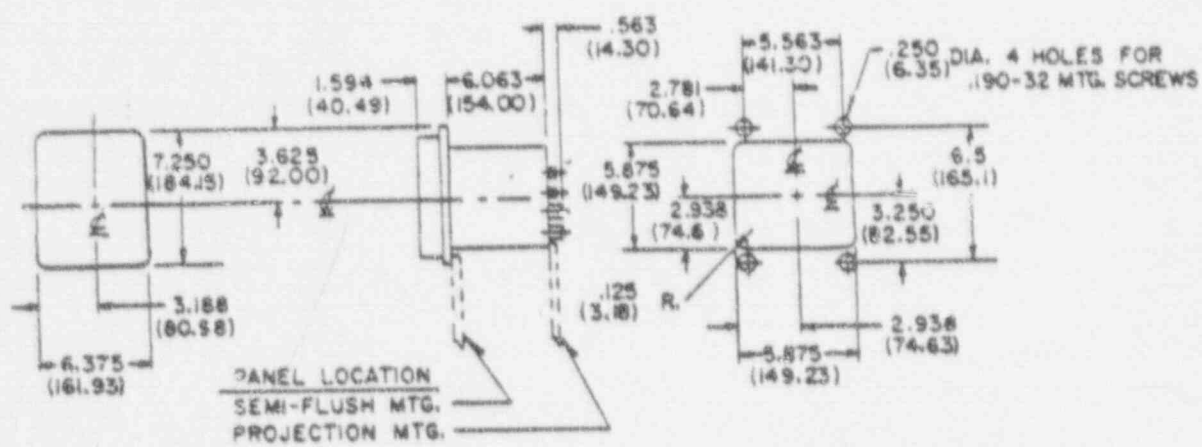

PANEL CUTOUT & DRILLING FOR SEMI-FLUSH MTG.

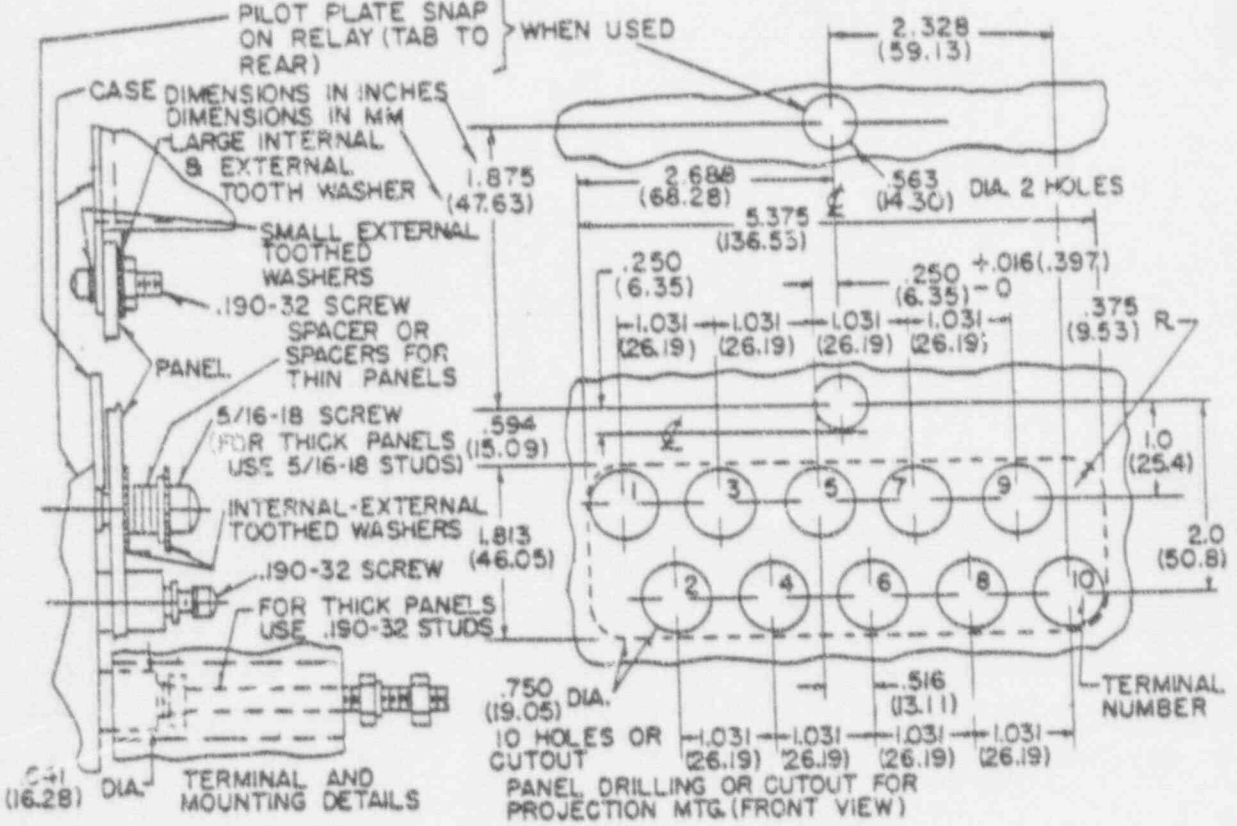

57D7900

Fig. 22. Outline and Drilling Plan for the Type CO Relay.

WESTINGHOUSE ELECTRIC CORPORATION
RELAY-INSTRUMENT DIVISION

CORAL SPRINGS, FL.

Printed in U.S.A.

HI-LO CO RELAYS WITH ACS UNITS

FIRST SEVEN DIGITS OF STYLE NUMBERS ARE 1445C81

LAST THREE DIGITS OF STYLE NO.	RELAY TYPE	RANGE CO	ACS UNITS IN AMPS	RANGE IIT	DESCRIPTION	SCHEMATIC
A01	CO-11	1-12	.5	--	SINGLE TRIP	183A680
A02	CO-11	1-12	1.0	--	SINGLE TRIP	183A680
A03	CO-8	1-12	1.0	--	SINGLE TRIP	183A680
A04	CO-5	1-12	1.0	--	SINGLE TRIP	183A680
A05	CO-5	1-12	1.0	6-144	SINGLE TRIP	3515A06
A06	CO-9	1-12	1.0	6-144	SINGLE TRIP	3515A06
A07	CO-11	1-12	0.5	6-144	SINGLE TRIP	3515A06
A08	CO-9	1-12	1.0	--	SINGLE TRIP	183A680
A09	CO-9	1-12	0.5	--	SINGLE TRIP	183A680
A10	CO-9	1-12	0.5	6-144	SINGLE TRIP	3515A06
A11	CO-2	1-12	0.5	6-144	SINGLE TRIP	3515A06
A12	CO-5	.5-2.5	0.5	--	SINGLE TRIP	183A680
A13	CO-2	1-12	1.0	6-144	SINGLE TRIP	3515A06
A14	CO-9	.5-2.5	1.0	2-48	SINGLE TRIP	3515A06
A17	CO-8	1-12	1.0	6-144	SINGLE TRIP	3515A06
A16	CO-11	1-12	1.0	6-144	SINGLE TRIP	3515A06
A18	CO-8	1-12	.5	6-144	SINGLE TRIP	3515A06
A19	CO-11	.5-2.5	.5	--	SINGLE TRIP	183A680
A20	CO-7	1-12	1	--	SINGLE TRIP	183A680
A23	CO-8	.5-2.5	1	--	SINGLE TRIP	183A680
A24	CO-5	.5-2.5	1	--	SINGLE TRIP	183A680
A25	CO-11	1-12	.15	6-144	SINGLE TRIP	3515A06
A26	CO-8	.5-2.5	.15	2-48	SINGLE TRIP	3515A06
A27	CO-5	1-12	.15	--	SINGLE TRIP	183A680
A28	CO-8	1-12	0.5	2-48	SINGLE TRIP	3515A06
A29	CO-6	1-12	1	--	SINGLE TRIP	183A680
A30	CO-8	1-12	1.0	6-144	SINGLE TRIP	3524A37
A31	CO-9	.5-2.5	0.5	--	SINGLE TRIP	183A680
A32	CO-11	.5-2.5	1.0	--	SINGLE TRIP	183A680
A33	CO-11	.5-2.5	1.0	2-48	SINGLE TRIP	3155A06

Sub. 34
775B349

⊙ Fig. 21. Style Description of CO Relays with ACS Units.