



Pennsylvania Power & Light Company

Two North Ninth Street • Allentown, PA 18101 • 215 / 770-5151

Norman W. Curtis
Vice President-Engineering & Construction-Nuclear
215/770-7501

JUN 01 1984

Dr. Thomas E. Murley
Regional Administrator, Region I
U.S. Nuclear Regulatory Commission
631 Park Avenue
King of Prussia, PA 19406

SUSQUEHANNA STEAM ELECTRIC STATION
FINAL REPORT ON A DEFICIENCY INVOLVING
BASE METAL CRACKING AND BENDING OF
ANGLE FITTINGS
ER 100508 FILE 821-10
PLA-2215

Docket No. 50-388

Reference: (1) PLA-2120 dated March 7, 1984 (first interim report)
(2) PLA-2140 dated March 22, 1984 (second interim report)

Dear Dr. Murley:

This letter serves to provide the Commission with a final report on a deficiency involving cracking and bending in the base metal of angle fittings used on Class 1E electrical raceways and Category 1 HVAC supports. This deficiency was reported under 10CFR50.55(e) as potentially reportable by telephone to Mr. G. Kelly of NRC Region I by Mr. R. M. Harris of PP&L on February 6, 1984.

The attachment to this letter contains a description of the problem, its cause, the safety implications, and the corrective action. Based on our evaluation, we have determined that this deficiency is not reportable.

We trust the Commission will find this report to be satisfactory.

Very truly yours,

N. W. Curtis
Vice President-Engineering & Construction-Nuclear

Attachments

8406120493 840601
PDR ADOCK 05000388
S PDR

JUN 01 1984

Page 2

SSES PLA-2215
ER 100508 File 821-10
Dr. Thomas E. Murley

Copy to:

Mr. Richard C. DeYoung (15)
Director-Office of Inspection & Enforcement
U.S. Nuclear Regulatory Commission
Washington, D.C. 20555

Mr. G. McDonald, Director
Office of Management Information & Program Control
U.S. Nuclear Regulatory Commission
Washington, D.C. 20555

Mr. R. H. Jacobs
U.S. Nuclear Regulatory Commission
P.O. Box 52
Shickshinny, PA 18655

Records Center
Institute of Nuclear Power Operations
1100 Circle 75 Parkway, Suite 1500
Atlanta, GA 30339

JUN 01 1984
RECEIVED

1.0 SUBJECT

Base metal cracking/bending of angle fittings used for seismic Class 1E raceway supports and seismic Category I HVAC duct supports located throughout Susquehanna Steam Electric Station, Units 1 and 2. The fittings were supplied by Unistrut, Powerstrut, B-Line and others.

2.0 INTRODUCTION

The field installation of seismic class 1E raceway supports and seismic category I HVAC duct supports was performed based on the requirements outlined in generic/standard criteria (supports and specifications) developed by engineering and supplied to the field. Included in the generic criteria are limitations on maximum spans between supports and maximum support loadings.

In general, the maximum loading specified for each standard support was based on the following assumptions:

- a) The dead load (used for design) of the support was chosen to cover all uses of that support.
- b) The seismic, SRV and LOCA acceleration values used for the design of each support were the worst case peaks from the floor response spectra for all locations where the support could be used.
- c) The support lengths were the longest allowed for the support and the dead load, amplified by the peak acceleration factors, was applied at the most severe locations on the support from a structural standpoint.

The angle fittings which are the subject of this report are one of many types of connections allowed to be used on the standard supports. The vast majority of angle connections in the plant contain an acute angle fitting in combination with an obtuse angle fitting. Although specific numbers are not available for the actual usage, PP&L estimates that approximately 10% of all supports used single angle fittings and out of this 10% approximately half (5%) may have used single acute angle fittings. See Figure 1 for sketches of connection details.

From the discussion above one can readily see that the phenomenon outlined in this report has the potential for occurrence on only a small number of the actually installed supports. Additionally, it should be noted that the structural evaluation of the supports, and associated angle fittings, due to the generic nature of the installation program, had to be performed, by and large, using the conservative support loading assumptions outlined above. In reality the design basis combination of assumed loading, location, length and load application may not even occur in the plant.

3.0 DESCRIPTION

The fittings of concern are cold bent from ASTM A575 flat plate to an acute (less than 90 degrees) angle. A typical angle fitting is shown in Figure 2. The fittings are used to attach braces to concrete, structural

steel or a strut (supporting the raceway or duct). The braces may support horizontal or vertical loads. See Figures 3, 4 and 5 for typical examples of angle fitting connections.

The braces (and hence the fittings) are axially loaded members. Therefore, the fittings are loaded parallel to one of the two legs.

Horizontal load supporting braces (and the attached fittings) are required only for resisting forces induced during a dynamic event (earthquake or hydrodynamic loadings). These braces and attached fittings are unstressed during normal conditions.

Vertical load supporting braces resist the dead load of the support during normal conditions. These braces are required to resist dynamic forces in addition to dead loads during a seismic or hydrodynamic event. Vertical load supporting braces may act as either tension or compression members in resisting dead load.

4.0 BACKGROUND

Bechtel Power Corporation informed FP&L of a base metal cracking problem with the above mentioned fittings used on other projects. The cracking occurs at the inside of the bend. Seven (7) samples were tested from the warehouse at the jobsite. Non-destructive examination indicated the existence of linear indications in two samples. Bechtel then narrowed the cracking problem to fittings with angles less than 90 degrees.

PP&L initiated extensive inspection and testing programs to gauge the extent of the cracking deficiency. During testing, another area requiring investigation arose. The acute angle fittings reached their ultimate capacity by bending (or a combination of bending plus cracking) near the bolt at loads lower than assumed during the initial design of the connections.

Therefore, the testing program was revised to address both the cracking and bending deficiencies.

In addition, a complete drawing review (supplemented by field walkdowns) was initiated to determine the loading on the angle fittings of raceway and duct supports. The actual fitting loads were then compared to the test results to determine the severity of the cracking/bending deficiency.

5.0 CAUSE

The cracking and bending deficiencies each have their own cause described herein.

5.1 Cracking Deficiency

During fabrication, ASTM A575 flat plate is cold bent to an acute (less than 90 degrees) angle. Although ASTM A575 allows for cold bending, a moderate bend radius is required. The fittings are bent to a sharp radius and in fact the bend may have no radius at all. Therefore, the fittings are subjected to severe cold working causing the material to

become strain age embrittled. If, during installation the angle fittings are subjected to reverse bending by forcing the angle legs apart, the angle bend may crack on the inside radius.

5.2 Bending Deficiency

Connections were designed based on the fact that the angle fittings were not the critical part of the connection. Both the bolts and welds of the fittings are capable of sustaining a minimum normal load of 1500 lbs. and a faulted load of 2250 lbs. Testing results indicate the ultimate load carrying capacity of the angle fitting to be somewhat less than that of the bolts and welds. Therefore, an inconsistency exists between the connection design strength arrived at analytically and the fitting strength determined through testing.

6.0 TECHNICAL EVALUATION

6.1 Field Inspections

6.1.1 Description

To determine if an acute angle fitting cracking problems exists at SSES, a field inspection program was performed. 150 (75 from each unit) random fittings were inspected. Any indication of cracking at the bend was considered a failure. The inside and outside radius of the bend were visually inspected by an inspector qualified in accordance with the "PP&L Nondestructive Training, Qualification and Certification Program".

6.1.2 Results

58 out of the 150 (39%) samples were judged to contain cracks or linear indications. Many of the samples contained lines caused by the press break during the forming operation. These were classified as linear indications. The number of fittings with visible cracks was 16 out of 150 (10.7%).

6.2 Testing

6.2.1 Description

Since the design basis loading on these fittings was known to be small, it was felt that, the cracks and/or linear indications would not limit the ability of the fittings to carry the required loading. As a result, a testing program was performed to prove that their load carrying capability was acceptable. The following were tested.

- a. The acute angle fitting acting alone
- b. The obtuse angle fitting acting alone
- c. The acute angle fitting acting in combination with an obtuse angle fitting.

Because the fittings have different length legs, and since the load carrying capability of the fitting is somewhat a function of the fitting geometric orientation, the fittings had to be tested in both orientations: (1) long leg oriented vertically and (2) short leg oriented vertically.

Static and fatigue tests were performed on the three types of connections mentioned above.

6.2.2 Test Results

The test results are summarized in Table 1.

a. Acute Angle Fittings

29 acute angle fittings, 14 oriented long leg vertical and 15 oriented short leg vertical, were successfully fatigue tested to a minimum of ± 800 lbs. (short leg oriented vertical is the limiting case, see Table 1) for 60 cycles at 5 seconds per cycle. In addition, 121 fittings, 60 oriented long leg vertical and 61 oriented short leg vertical, were static tested to a minimum load (ultimate strength) of 760 lbs. If one test anomaly is ignored, the minimum load is 860 lbs. See Figure 6 for the test fixture and the angle fitting orientation.

b. Obtuse Angle Fittings

Due to the fact that a connection usually consists of one obtuse angle fitting and one acute angle fitting, the obtuse angle fittings were checked for their capacity.

35 fittings (25 oriented long leg vertical and 10 oriented short leg vertical) were static tested to a minimum load of 1380 lbs. (short leg oriented vertical is again limiting). This load is lower than the load stated in Reference (2) as a result of testing completed subsequent to that letter's submittal. See Figure 7 for the test fixture and angle fitting orientation.

c. Combination Angle Fitting Connections

Due to the wide disparity in results between the acute and obtuse angle fitting tests, it was felt that the results could not be adequately combined to determine the capacity of the combined connection using an acute and obtuse fitting attached to the same member. Since the vast majority of the connections used in the construction of the plant used combined angle fittings it was felt necessary to perform a combined test to simulate the actual condition. The test was performed for both orientations using new fittings. See Figure 8 for the test fixture and the angle fitting orientation.

10 connections (5 oriented long leg vertical and 5 oriented short leg vertical) were static tested to a minimum load of 3700 lbs. Being that the obtuse and acute angle fittings are assumed to handle 1380 lbs and 760 lbs respectively, the maximum connection strength is conservatively assumed to be $1380 \text{ lbs} + 760 \text{ lbs} = 2140 \text{ lbs}$ (a 2000 lbs load is conservatively used in all analyses).

6.3 Drawing Review and Field Walkdowns

Drawing reviews and field walkdowns were performed in order to determine the loads on the supports and to compare these loads to the test results given above.

6.3.1 Raceway Supports

Seismic Class 1E raceway supports were fabricated and installed in accordance with drawing ZE53, (or a PP&L drawing using ZE53 as input). ZE53 gives a complete description of various acceptable support types and lists allowable dead loads associated with each support type.

A complete review of ZE53 was performed to determine which of the acceptable raceway support types contained acute angle fittings. For all supports containing these fittings, additional information (including allowable dead load per support, type of brace and number of fittings) was obtained to determine the maximum dead load per connection. This maximum load was compared to the allowable dead load per connection obtained by reducing the allowable fitting loads (760 lbs - acute angle fitting; 2000 lbs - combination angle fitting) by the applicable faulted accelerations. Maximum dead loads less than the allowable loads were considered acceptable. If the maximum load was greater than the allowable further information was required to perform a more refined analysis. Field walkdowns and as-built drawing reviews were performed as required to obtain information for this analysis.

All connection loads were determined to be less than the allowables.

6.3.2 Duct Supports

Seismic Category I duct supports were fabricated and installed in accordance with drawings ZC1129 to ZC1135. These drawings provide similar information to that provided in ZE53.

A generic drawing review was performed to determine which duct support types contained acute angle fittings. For all supports containing these fittings, additional information (including number of fittings and type of brace) was obtained. Then an as-built drawing review was performed to determine the dead loads on the supports.

The fitting dead loads were determined from the support loads. These dead loads were then compared to the allowable dead loads per connection obtained by reducing the allowable fitting loads (760 lbs - acute angle fitting; 2000 lbs - combination angle fitting) by the applicable faulted acceleration. Fitting loads less than the allowable loads were considered acceptable. If the loads were greater than the allowables, a more refined analysis was performed (supplemented by field walkdowns as required).

All connection loads were found to be less than the allowables.

6.4 Results of the Technical Evaluation

The following was concluded from the test results:

- a. No sample failed (separated in two) due to cracking at the bend of the angle fitting.
- b. A new area requiring investigation was discovered as a result of the testing program. The ultimate capacity of the angle fittings is limited by bending near the bolt.
- c. The acute angle fitting can be considered to have a faulted load capacity of 760 lbs.
- d. The combined angle fitting connection can be considered to have a faulted load capacity of 2000 lbs.
- e. The faulted load on each fitting was compared to the test results. No fitting is loaded beyond its capacity.
- f. The cracking deficiency is only a concern if the angle between the two legs of the fitting changes. This angle can change only if bending occurs. The fittings have sufficient strength in bending to limit deformations in the fitting angle to less than that required to cause separation at the bend due to cracking.

7.0 SAFETY IMPLICATIONS

For the following reasons, both deficiencies are not reportable under the provisions of 10CFR50.55(e) and the seismic Category I duct and the seismic Class 1E raceway supports using these fittings are capable of supporting the loads presently imposed upon them during normal as well as faulted conditions:

- 7.1 Cracking of the angle fittings has been shown by testing not to be the primary mode of failure. The phenomenon responsible for the reduced fitting capacity as determined by the test results is that of bending (or bending in combination with cracking).
- 7.2 The actual fitting loads (as determined from the drawing reviews and walkdowns) are lower than the allowable loads arrived at from the test program.

8.0 CORRECTIVE ACTION

The angle fittings have been added to PP&L's "Defective Device List" (DDL), a note is being added on the Spare Parts Inventory Program (SPIP), and a tag has been placed on the spare parts bin containing spare angle fittings. These actions require that engineering approval be obtained prior to quality related installation/use of acute angle fittings.

The PP&L conduit installation specification (C1035) has been revised to restrict the placement of additional loads on specific existing supports that have allowable load limits (on the generic support drawings) exceeding the allowable angle fitting loads.

These corrective actions preclude the possibility of overloading angle fittings.

The conduit and junction box support drawings were not revised since the allowable loads established during testing were above the loads currently specified in these drawings.

mr/el44i:rld

Acute Angle Fitting

Obtuse Angle Fitting

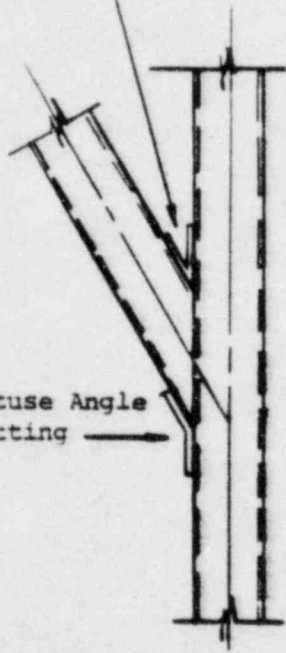

Combination Angle Fitting Connection

Obtuse Angle Fitting

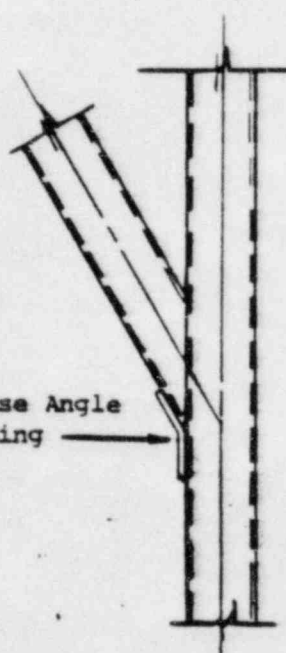

Obtuse Angle Fitting Connection

Acute Angle Fitting

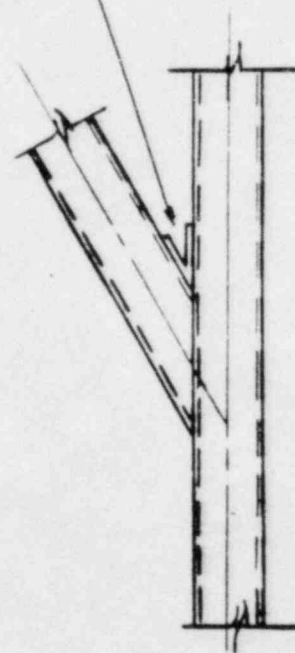

Acute Angle Fitting Connection

Connection Details

FIGURE 1

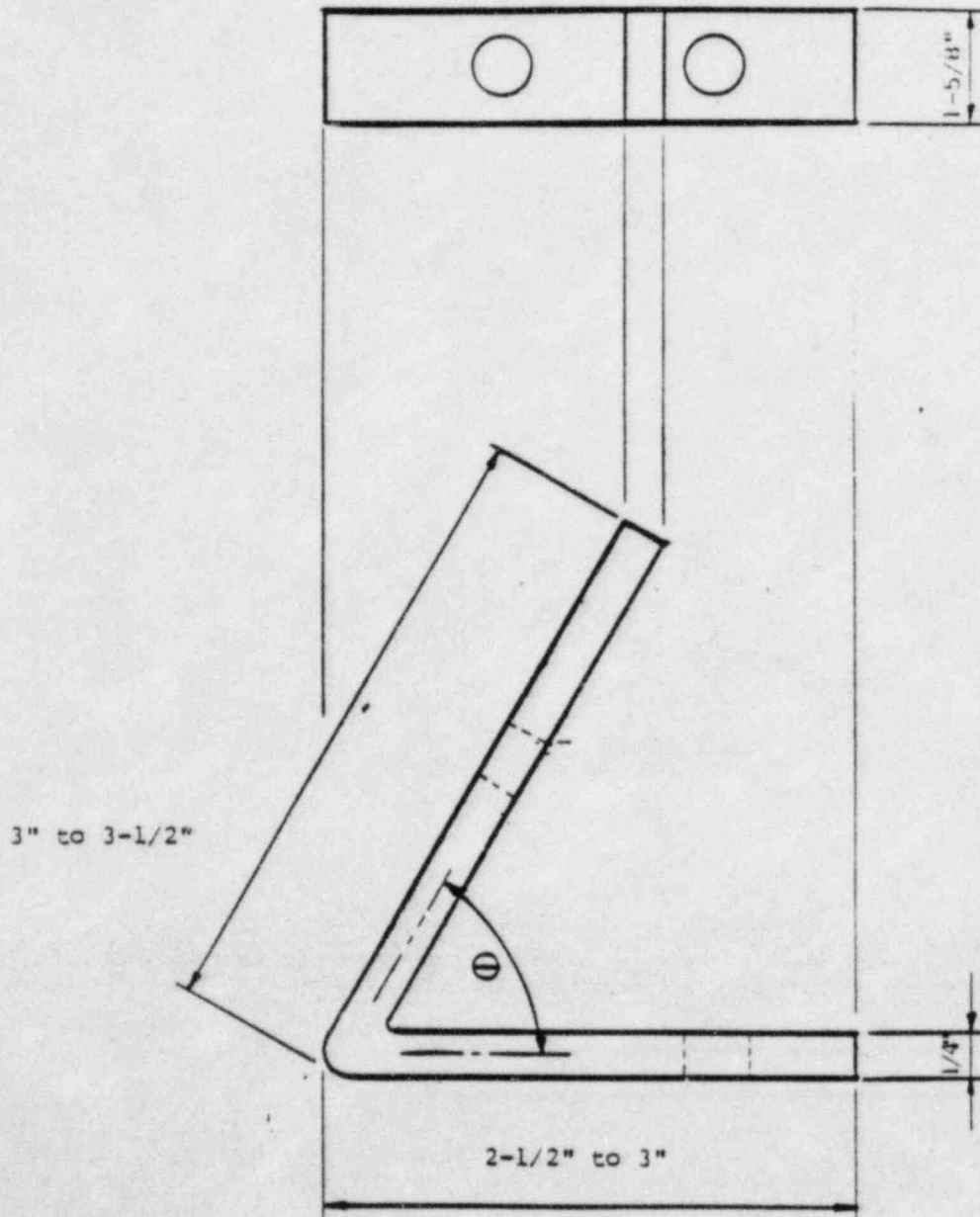

θ Varies from
 37-1/2° to
 67-1/2°

Acute Angle Fitting

FIGURE 2

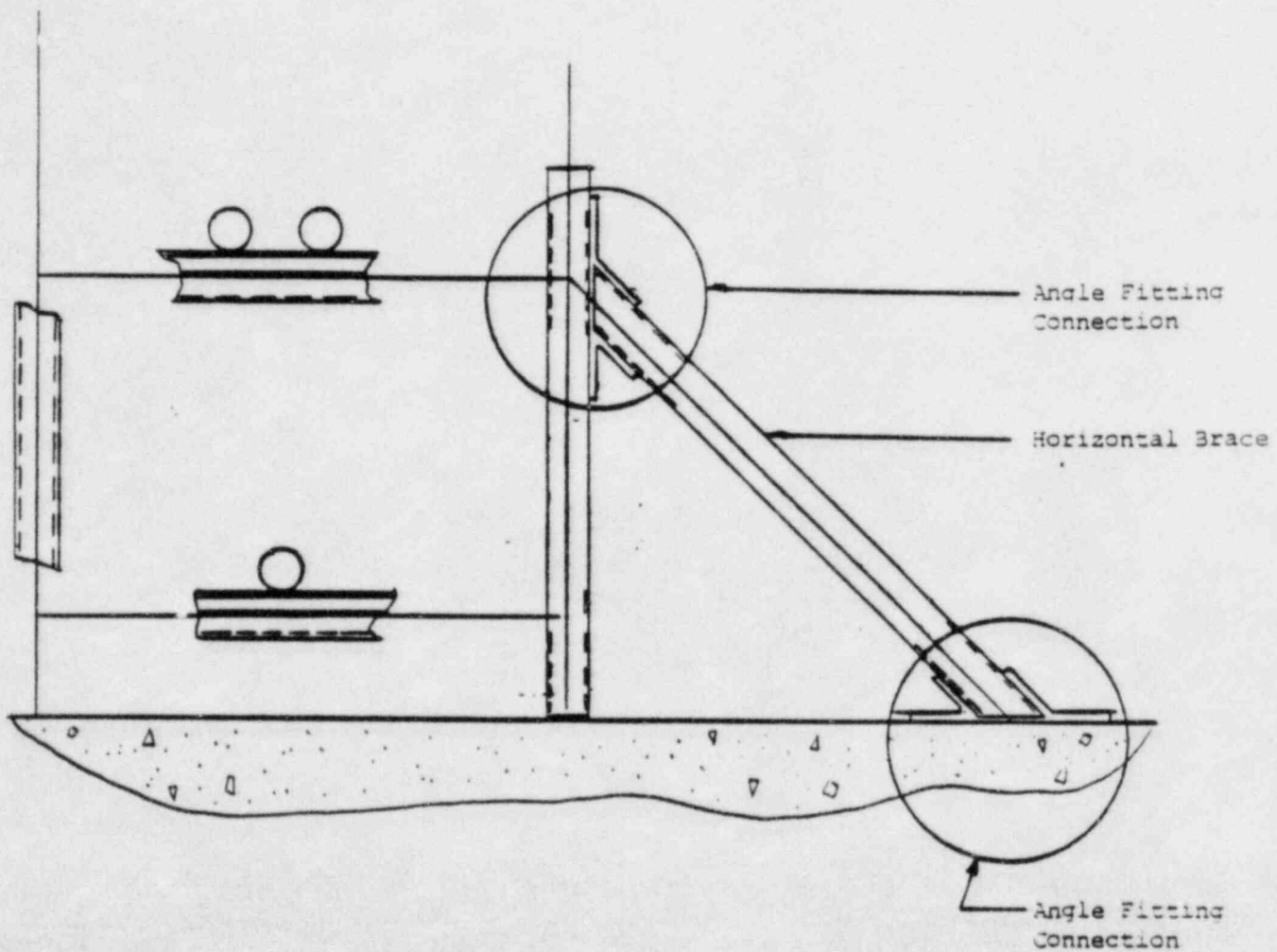

Conduit Support - Elevation

FIGURE 3

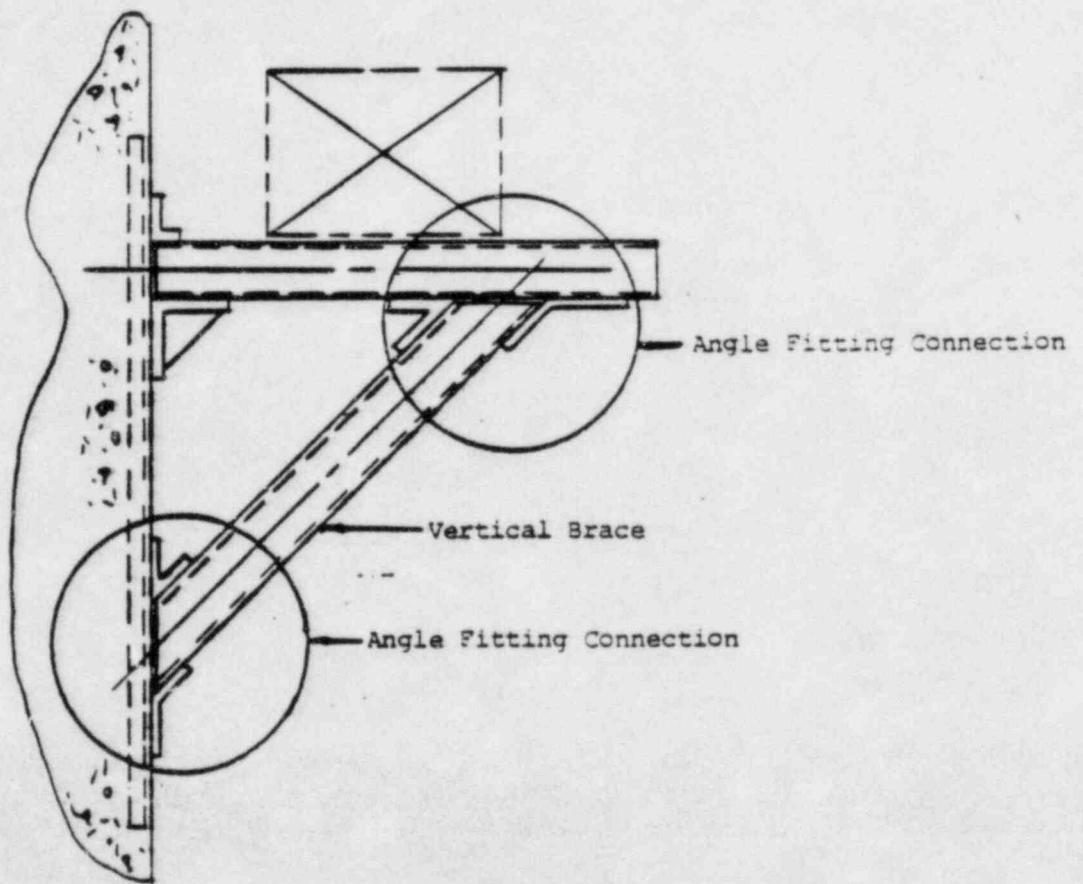

Duct Support - Elevation

FIGURE 4

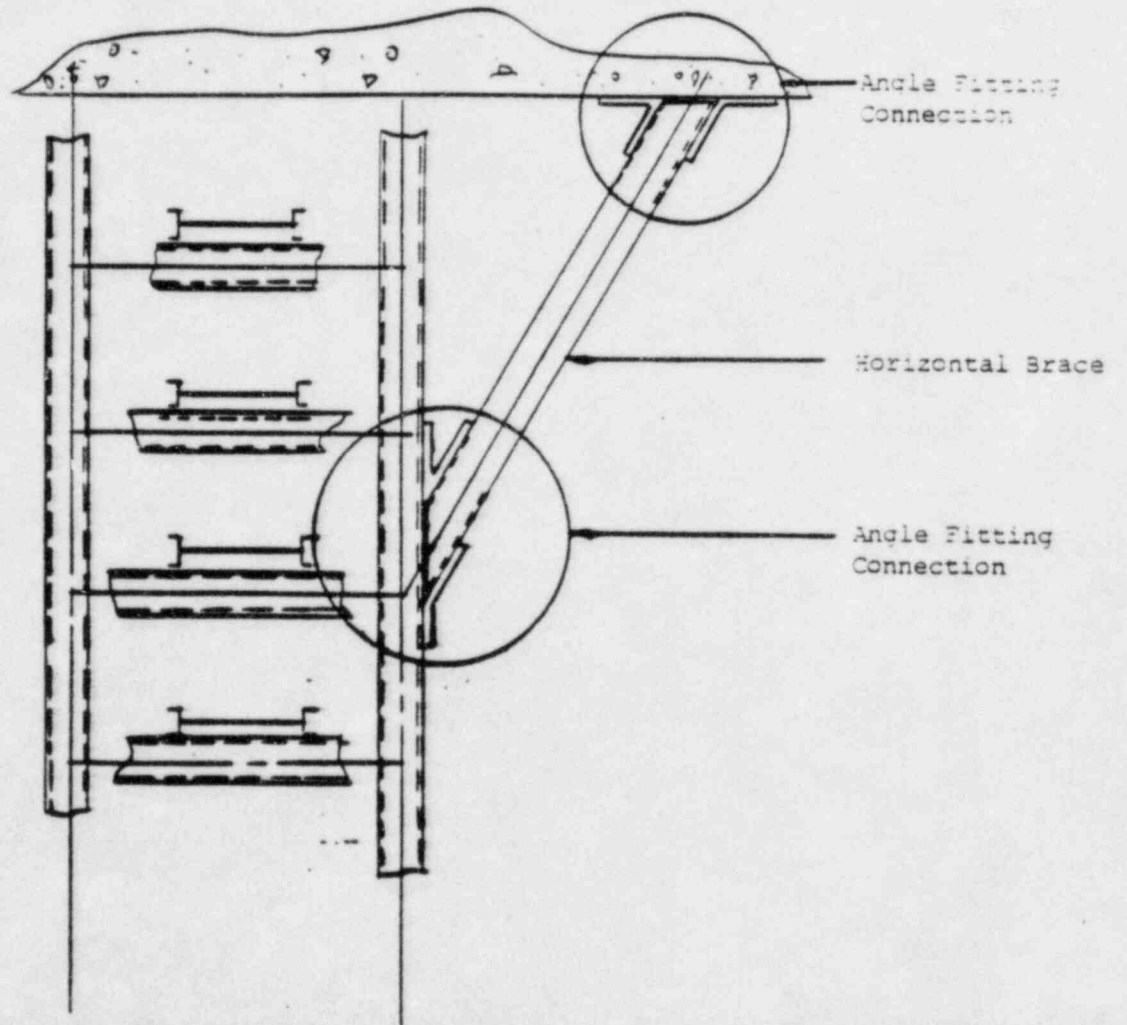

Cable Tray Support - Elevation

FIGURE 5

FIGURE 6
ACUTE ANGLE FITTING TEST ORIENTATION

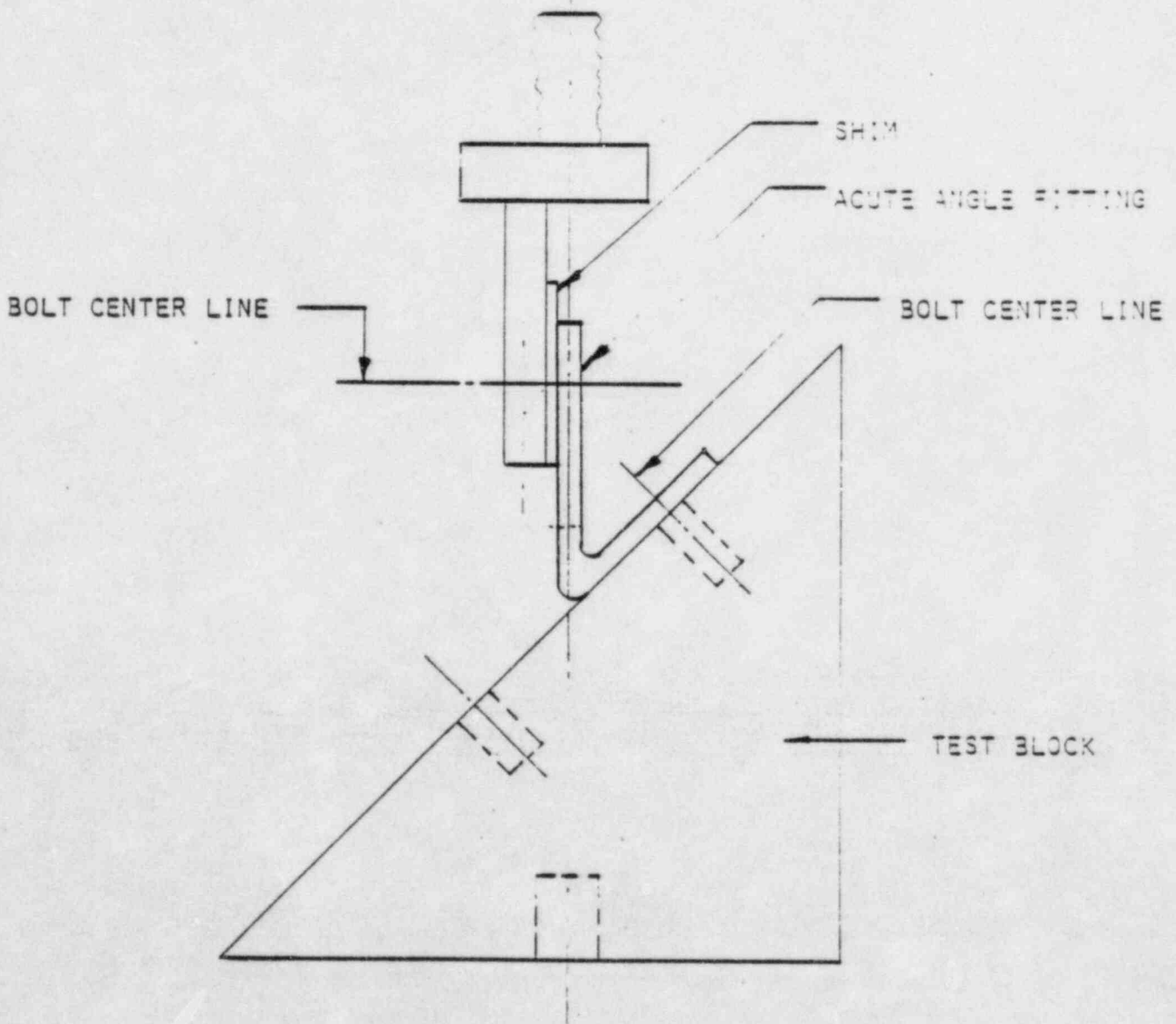

FIGURE 7
OBTUSE ANGLE FITTING ORIENTATION

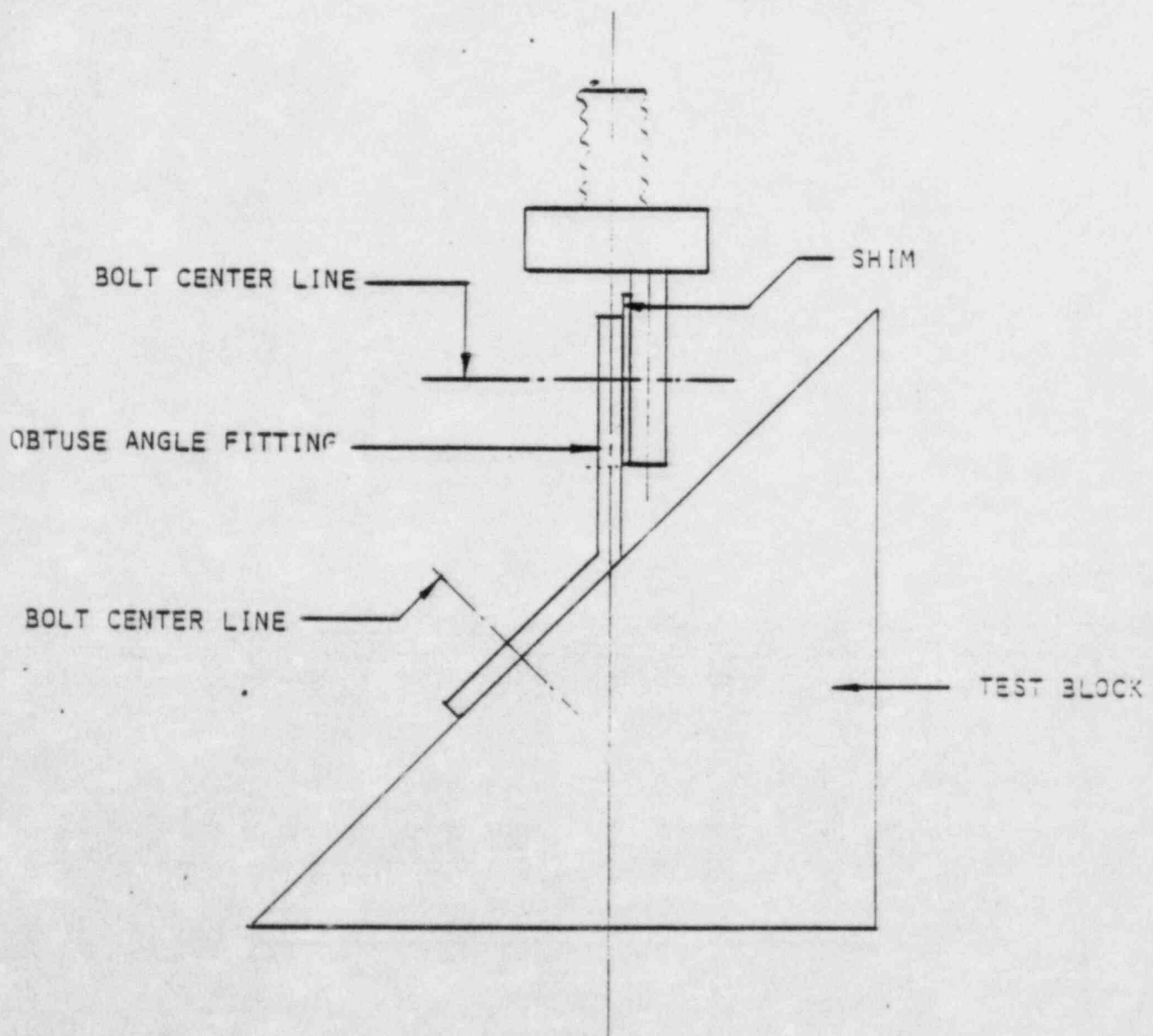

FIGURE 8
COMBINED FITTING TEST

UNISTRUT BOLT TORQUE = 55 A-LBS.

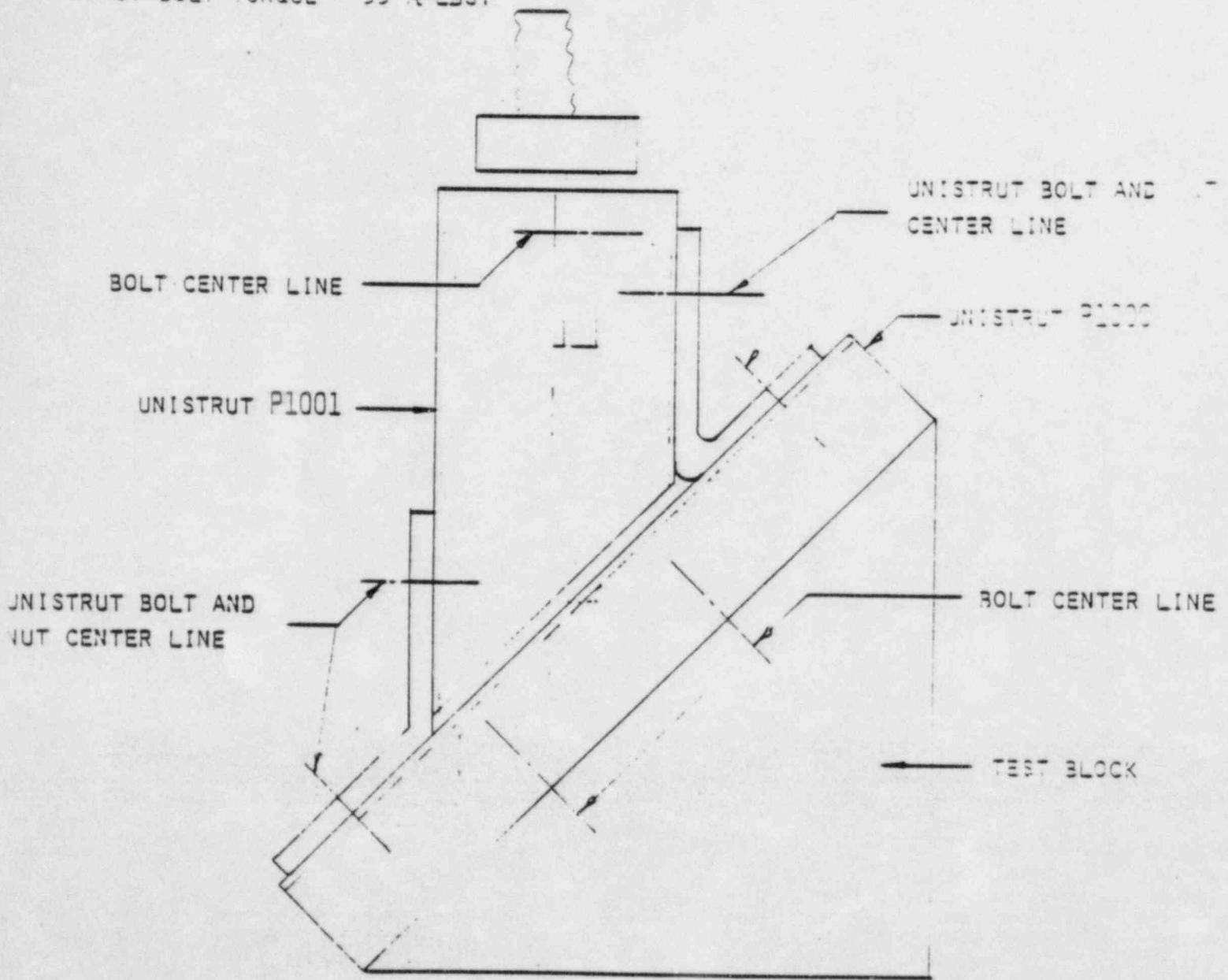

TABLE 1

TEST RESULT SUMMARY

TEST NUMBER	TEST TYPE	CONNECTION TYPE: Single Acute Angle Fitting/ Single Obtuse Angle Fitting/ Combination of Both Fittings	FITTING SOURCE	FITTING ORIENTATION	NUMBER TESTED	MINIMUM LOAD (lbs.)	AVERAGE LOAD (lbs.)	REMARKS
1	Static	Obtuse Angle Fitting	New	Long Leg Vertical	25	5880	7790	
2	Static	Obtuse Angle Fitting	New	Short Leg Vertical	10	1380	2340	
3	Static	Combination of Both Fittings	New	Long Leg Vertical	5	4840	5660	
4	Static	Combination of Both Fittings	New	Short Leg Vertical	5	3700	3900	
5	Static	Acute Angle Fitting	Unit 1	Short Leg Vertical	60	760	1280	Min. Load = 860 lbs. If One Test Anomaly Ignored
6	Static	Acute Angle Fitting	Unit 2	Long Leg Vertical	61	1060	2000	
7	Fatigue	Obtuse Angle Fitting	New	Long Leg Vertical	25	±1000	-	All Fittings Passed Test
8	Fatigue	Acute Angle Fitting	Unit 2	Long Leg Vertical	14	±1000	-	All Fittings Passed Test
9	Fatigue	Acute Angle Fitting	Unit 1	Short Leg Vertical	15	± 800	-	All Fittings Passed Test

Allowable Load = 2000 lbs. Combination Angle Fitting Connection
 = 760 lbs. Acute Angle Fitting Connection
 = 1380 lbs. Obtuse Angle Fitting Connection