



LOUISIANA
POWER & LIGHT

142 DELARONDE STREET
P. O. BOX 600B • NEW ORLEANS, LOUISIANA 70174 • (504) 366-2345

May 30, 1984

W3P84-1526
3-A1.01.04
3-A20.02.02
Q-3-B31

Director of Nuclear Reactor Regulation
Attention: Mr. G.W. Knighton, Chief
Licensing Branch No. 3
Division of Licensing
U.S. Nuclear Regulatory Commission
Washington, D.C. 20555

SUBJECT: Waterford SES Unit 3
Docket No. 50-382
Auxiliary Pressurizer Spray (APS)

REFERENCE: (1) Letter dated March 30, 1984 from G.W. Knighton (NRC)
to R.S. Leddick (LP&L)
(2) W3P84-1009 dated April 12, 1984

Dear Sir:

In your Reference (1) letter you requested that LP&L provide you with a schedule for resolving Staff concerns related to a potential single failure problem in the APS system. By Reference (2) LP&L responded, committing to resolution of the Staff concerns within six months of receipt of an operating license and also committing to provide a justification for interim operation (JIO) prior to exceeding 5% power. The purpose of this letter is to provide you with a brief description of our plan for resolution of this issue as well as a JIO for the period of initial criticality through first refueling.

As you know, LP&L will be conducting tests during the Post Core Hot Functional Testing to measure depressurization rate due to the APS with a charging isolation valve open. The resulting depressurization will be compared to analysis results defining the minimum depressurization rate necessary to meet SGTR criteria. Concurrently, further information will be developed to support the use of the RCS Vents (as described in Reference (2)) in meeting the requirements of BTP RSB 5-1. LP&L is investigating a hardware change that could be implemented prior to the second cycle of operation if testing and analysis demonstrate that the APS is insufficient to meet the position of Reference (1).

8406040219 840530
PDR ADOCK 05000382
A PDR

Boo1
1/1

Page 2
W3P84-1526
3-A1.01.04
3-A20.02.02
Q-3-B31

Enclosed with this letter is a justification for interim operation. LP&L feels that this provides adequate basis to ensure safe plant operation through first cycle.

Should you require further information in this matter, please contact Mike Meisner at (504) 363-8938.

Yours very truly,

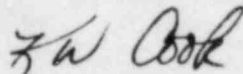

K. W. Cook
Nuclear Support & Licensing Manager

KWC/MJM/ch
Enclosure

cc: E.L. Blake, W.M. Stevenson, J.T. Collins, D.M. Crutchfield,
J. Wilson, G.L. Constable, L.B. Marsh

bcc: R.S. Leddick, R.P. Barkhurst, F.J. Drummond, T.F. Gerrets,
G.G. Hofer (Ebasco), W.A. Cross (LP&L Bethesda), Project Files,
K.R. Iyengar, R.F. Burski, J.B. Holman, S.K. Shete', Nuclear Records,
Licensing Library

WATERFORD 3
Justification for Interim Operation
Auxiliary Pressurizer Spray

The Auxiliary Pressurizer Spray (APS) System is a safety grade system which provides a backup RCS depressurization capability if the main pressurizer spray is not available. The APS is used to meet the natural circulation cooldown requirements of Branch Technical Position RSB 5-1. The APS can also be used to depressurize the RCS during a Steam Generator Tube Rupture (SGTR) with the main pressurizer spray not available (such as with a loss of offsite power).

The NRC has expressed a concern that the APS depressurization may potentially be defeated if one of the two charging line isolation valves (CH-518 or CH-519, see Figure 1) fail to close. This will cause a diversion of flow from the pressurizer spray nozzle and a reduced depressurization rate. Justification for safe full power operation of Waterford 3 prior to final resolution of this concern is based on the following considerations:

1. The probability of failure of the charging isolation valves is very low.
2. To meet the requirements of BTP RSB 5-1, the safety grade pressurizer steam space vent system can be used to depressurize the RCS.
3. The Waterford 3 steam generator design and water chemistry control minimize steam generator tube corrosion such that a tube rupture during the first cycle of operation is extremely unlikely.
4. Depressurization during a SGTR is limited by the need to maintain subcooling margin rather than the depressurization rate achievable by the APS.
5. Preliminary calculations indicate that with a charging line isolation valve open, one-quarter of the APS flow with both charging isolation valves closed goes to the pressurizer spray nozzles. Thus, some depressurization capability is retained.

The charging line isolation valves (CH-518 and CH-519 in the attached figure) are solenoid valves controlled by the operator from the control room. The failure probability of these valves has been evaluated in CEN-239, Supplement 2, "Probabalistic Risk Assessment of the Effect of PORVs on depressurization and Decay Heat Removal", submitted to the NRC by Reference 1. The probability for either charging line isolation valve to fail to close due to a mechanical malfunction is approximately $2.3E-3$. Thus the probability that the effectiveness of the APS will be reduced because these valves fail to close is very low.

Branch Technical Position RSB 5-1 requires the capability to decrease RCS temperature and pressure to shutdown cooling conditions using natural circulation and only safety grade equipment. The APS is used for the final depressurization to the shutdown cooling entry pressure. Compliance with BTP RSB 5-1 is demonstrated in CEN-259, "An Evaluation of the Natural Circulation Cooldown Test Performed at SONGS", submitted to NRC by Reference 2. As stated in that report, the safety grade pressurizer steam space vent system could be used to depressurize the RCS in the unlikely event that the APS was ineffective. Although the maximum depressurization rate for the vent system is less than that for the APS, it is comparable to the depressurization rate achieved in the natural circulation cooldown test performed at SONGS. There is however, more than enough condensate inventory to accommodate a slower depressurization rate.

The design of the Waterford 3 steam generators incorporate many features that assure operational reliability and integrity. Tube supports of an "eggcrate" design and carefully controlled tube fabrication techniques reduce the chance of stress corrosion cracking. The integrity of the steam generator tubing is also protected through the use of strict controls on water chemistry. The use of an all volatile water chemistry treatment and the secondary side blowdown system serve to remove and minimize impurities that may affect steam generator integrity. With these controls, the probability of a steam generator tube rupture occurring during the first cycle of power operation is extremely low.

If a SGTR were to occur, the RCS depressurization rate would not be limited by the maximum rate achievable with the APS. That is, the operator would need to stop the APS flow and depressurization in order to maintain an adequate subcooling margin. Analysis showing this result is included in CEN-239 (Ref. 1). Thus, a reduced APS flow and depressurization rate due to the failure of a charging line isolation valve could still be enough to meet the required depressurization rate to maintain subcooling margin and mitigate the consequences of a SGTR. Also, the pressurizer vent system is available to provide additional depressurization capability. Furthermore, as long as the safety injection termination criteria are met (water level in the pressurizer), the operator could throttle the high pressure safety injection pump flow to supplement the depressurization rate of the APS if needed.

Finally, preliminary calculations have been performed to calculate the flow delivered to the pressurizer spray nozzles with an open charging line isolation valve. These calculations account for the hydraulic resistance and elevation differences in each flow path (charging and spray) to determine the percent flow split between the two paths. Based on these preliminary calculations, one-quarter of the APS flow achieved with both charging valves closed goes to the pressurizer spray nozzles. Although this would result in a reduced depressurization rate relative to the full APS flow capability, it should be sufficient to mitigate the consequences of a SGTR.

In conclusion, Waterford 3 can be operated safely through the end of the first cycle based on the above considerations. This includes the extremely low probability of a SGTR occurring with a concurrent failure of one of the charging line isolation valves to close, the use of alternate methods (pressurizer vent

and throttling HPSI pumps) to depressurize the RCS during a SGTR while maintaining subcooling margin requirements, and preliminary calculations which show that a portion of the flow (one-quarter of the APS flow with no failure) reaches the pressurizer spray nozzles even if a charging line isolation valve fails to close.

Reference 1: W3P83-2197, June 29, 1983

Reference 2: W3P84-0505, February 29, 1984

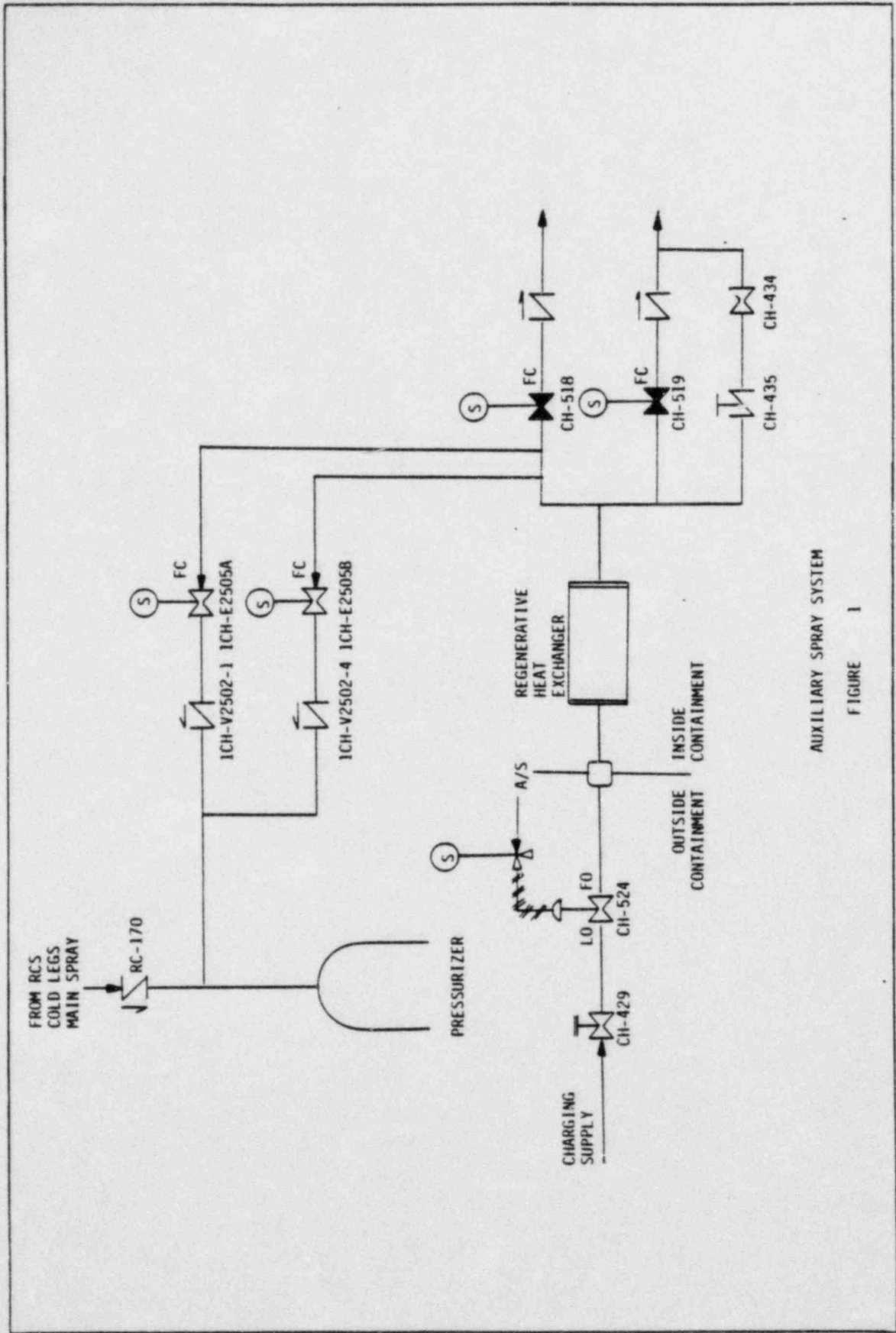

AUXILIARY SPRAY SYSTEM

FIGURE 1