

NSP

NORTHERN STATES POWER COMPANY

MINNEAPOLIS, MINNESOTA 55401

May 5, 1976

Mr Victor Stello, Director
Division of Operating Reactors
U S Nuclear Regulatory Commission
Washington, DC 20555

Dear Mr Stello:

MONTICELLO NUCLEAR GENERATING PLANT
Docket No. 50-263 License No. DPR-22

Planned Modifications to Permit Testing
To Be Conducted in Accordance with 10 CFR 50, Appendix J

- Ref: (a) Letter from K R Goller, USNRC, to L O Mayer, dated August 5, 1975
- (b) Letter from L O Mayer to K R Goller, USNRC, dated September 19, 1975 as revised by letter from L O Mayer, NSP, to V Stello, USNRC, dated May 4, 1976
- (c) NSP License Amendment Request for DPR-22 dated January 30, 1976 as revised by lette. from L O Mayer, NSP to V Stello, USNRC, dated May 4, 1976
- (d) Request for Exemption from Certain Requirements of 10 CFR 50, Appendix J at Monticello, dated May 5, 1976

Reference (a) directed Northern States Power Company to identify planned actions and formulate a schedule to conform to 10 CFR 50, Appendix J. On September 19, 1975, NSP submitted a report which outlined a number of areas where Monticello plant design prohibits full compliance with the Regulation (Reference b). The Monticello plant was designed and constructed several years before the final adoption of Appendix J.

We have carefully reviewed each area where Monticello cannot comply with Appendix J. In those cases where modifications to permit such testing do not provide any significant improvement in the effectiveness of the containment system or increase the protection now provided to the health and safety of the public, we have requested exemption from the requirements of Appendix J (Reference d).

In several cases plant modifications may be necessary to comply with Appendix J testing requirements. The majority of these modifications are required to permit local leakage testing of containment penetrations which were originally believed to be exempt from these tests.

9106100534 760505
PDR ADOCK 05000263
P PDR

5002



Regulatory Docket File

NORTHERN STATES POWER COMPANY

Mr Victor Stello

-2-

May 5, 1976

The following modifications fall in this category and are being considered to resolve conflicts with Appendix J requirements noted in Reference (b):

Instrument Air Isolation Control Valve

Further review of this penetration indicates that the control valve may be tested in the reverse direction utilizing sections of piping installed as part of a plant modification to supply nitrogen to the drywell instrument air header. Testing this valve in the reverse direction will yield a conservative leakage rate measurement.

If testing of this valve is found to be impractical using this method, a test connection and stop valve can be added to the instrument air line to permit Type C testing (Figure 1).

Cooling Water Supply and Return to Drywell Fan Coolers

Test connections and stop valves can be added to the cooling water supply and return lines (Figure 2) to allow Type C tests.

TIP Ball Valves and Purge Supply Valve

An additional ball valve and test connection can be installed in each TIP line to permit leakage testing of the ball valve. An additional stop valve and test connection can be installed in the nitrogen purge supply line to permit leakage testing of the check valve (Figure 3).

CRD Hydraulic Return Inboard Check Valve

Additional test connections can be added on each side of the inboard check valve to allow Type C testing of this valve. Only the outboard check valve is now testable (Figure 4).

Standby Liquid Control System Inboard Check Valve

Additional test connections can be added on each side of the inboard check valve to allow Type C testing of this valve. Only the outboard check valve is now testable (Figure 5).

Following the preparation and submittal of reference (b), a number of additional conflicts with the requirements of Appendix J and isolation valve discrepancies were identified. In each case a modification is being considered:

HPCI Turbine Exhaust Line

The check valves serving as containment isolation for the HPCI turbine steam exhaust line have a history of excessive leakage. Two check valves are installed, one of which is subjected to periodic Type C tests.

Two different modifications are being considered to resolve this problem (Figure 6). The first modification involves installing an additional motor operated valve in the turbine exhaust line. This valve would be subjected to periodic Type C tests and would be considered the containment

NORTHERN STATES POWER COMPANY

Mr Victor Stello

-3-

May 5, 1976

isolation valve in this line. The second modification involves installing redundant isolation valves in the vacuum breaker line. These valves would receive Group 4 isolation signals and would preclude the entry of the post LOCA torus atmosphere into this line. A water seal would then be provided by the water in the suppression pool.

RCIC Turbine Exhaust Line

The check valves serving as containment isolation for the RCIC turbine steam exhaust line have a history of excessive leakage. As in the case of the HPCI system, two check valves are installed. One of these valves satisfies the minimum requirements for containment isolation and is subjected to periodic Type C tests. The other valve (the inboard check valve) cannot be tested in accordance with Appendix J.

Two different modifications are being considered to resolve the check valve leakage problems (Figure 7). These modifications are identical to those being considered for the HPCI system. The first modification involves installing an additional motor operated valve in the turbine exhaust line. The alternate modification involves installing redundant isolation valves in the vacuum breaker line. These valves would receive Group 5 isolation signals.

Demineralized Water Supply to the Drywell

A test connection can be installed to permit Type C testing of the two manual valves in this line (Figure 8).

Service Air Supply to the Drywell

A test connection and additional stop valve can be installed to permit Type C testing of this penetration (Figure 9).

Torus Instrument Air Supply Control Valve

A plant modification was recently completed which added an instrument air supply line to the torus for vacuum breaker exercising (Figure 10). Test connections can be added to this line to permit Type C testing of the control valve.

We believe that all of these modifications can be accomplished under the provisions of 10CFR50.59. None of these changes is deemed to involve an unreviewed safety question.

Prior to beginning detailed engineering work and committing funds for these modifications, it will be necessary to receive confirmation from the Commission of the overall acceptability of our interpretation of the Regulation and our proposed resolution of the areas of non-conformance. In addition to the modifications outlined in this letter, our proposed plan of attaining conformance to Appendix J requires approval of the Technical Specification changes requested in reference (c) and the exemptions requested in reference (d).

NORTHERN STATES POWER COMPANY

Mr Victor Stello

-4-

May 5, 1976

Representatives of NSP are available to discuss these modifications with you in detail and resolve any specific questions which may arise from a review of this letter or any of the other related submittals we have made in response to Reference (a).

Yours very truly,

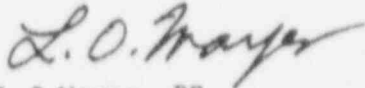

L O Mayer, PE
Manager, Nuclear Support Services

LOM/DM/deb

cc: J G Keppler
G Charnoff
MPCA Attn: J W Ferman

CV-1478 CONTAINMENT ISOLATION VALVE
 REMOTE-MANUAL CONTROL

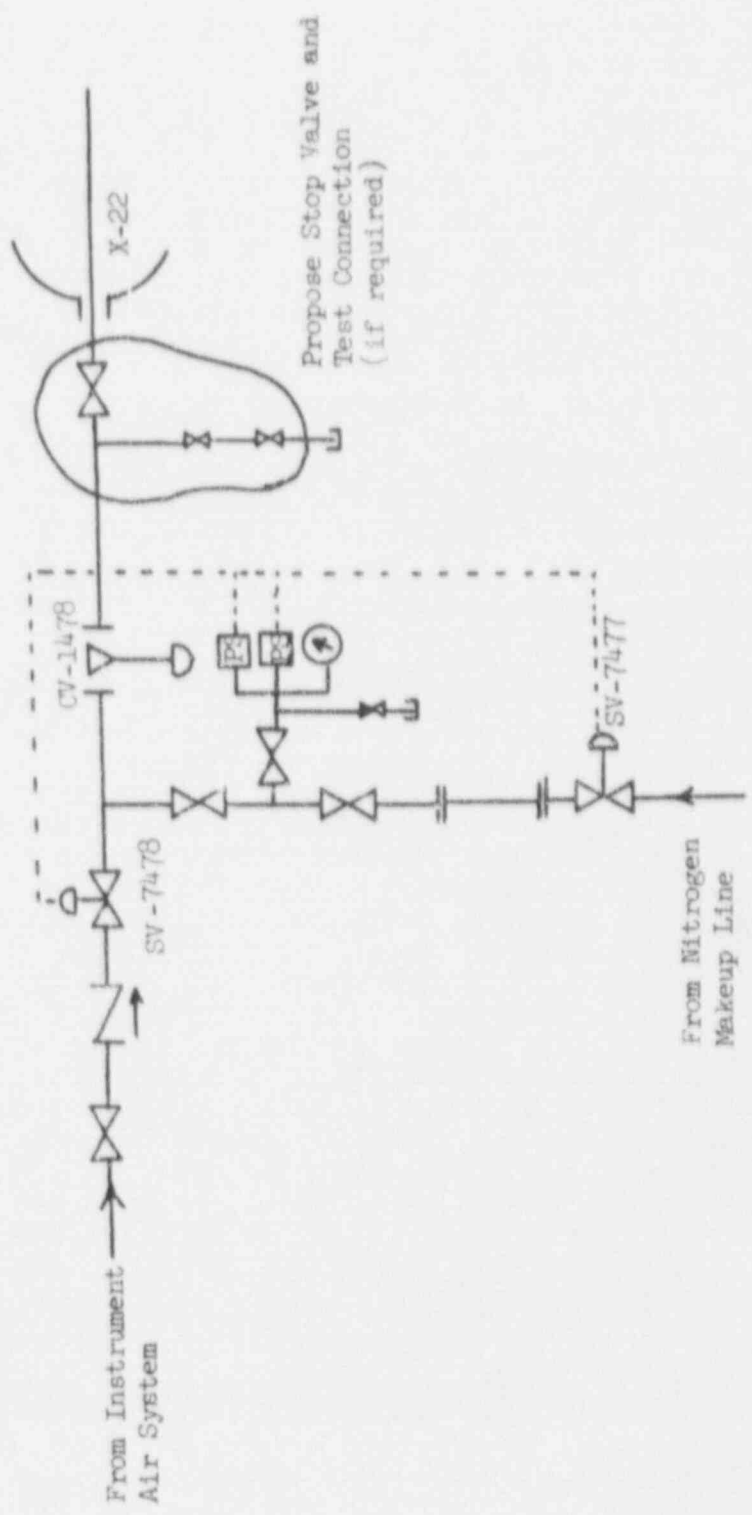

Figure 1. Drywell Instrument Air Containment Penetration

Reference: FSAR Figure 10-3-4

MO-1426 CONTAINMENT ISOLATION VALVE
REMOTE MANUAL CONTROL

RBCC-15 CONTAINMENT ISOLATION VALVE
CHECK VALVE

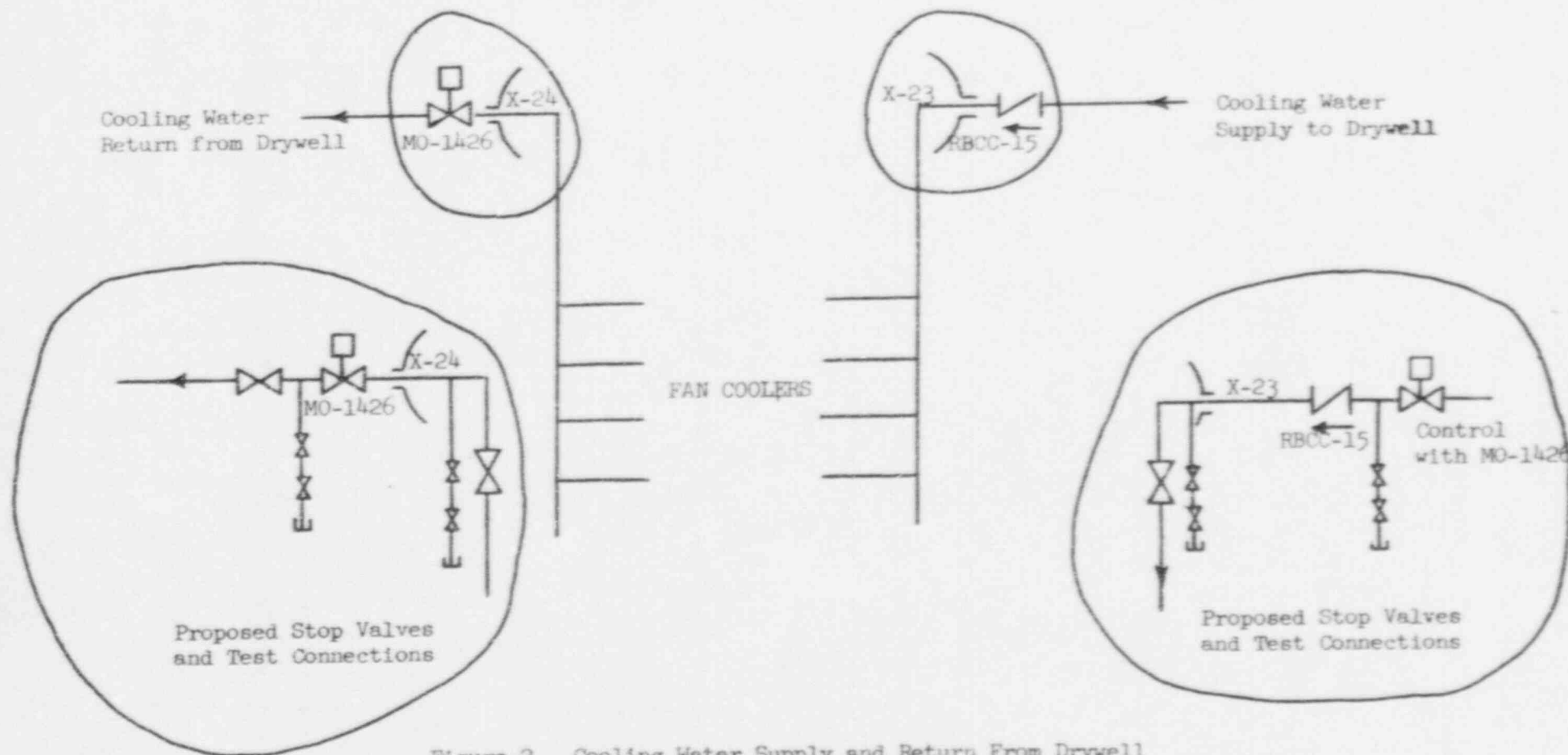

Figure 2. Cooling Water Supply and Return From Drywell
Containment Penetrations

Reference: FSAR Figure 10-4-3

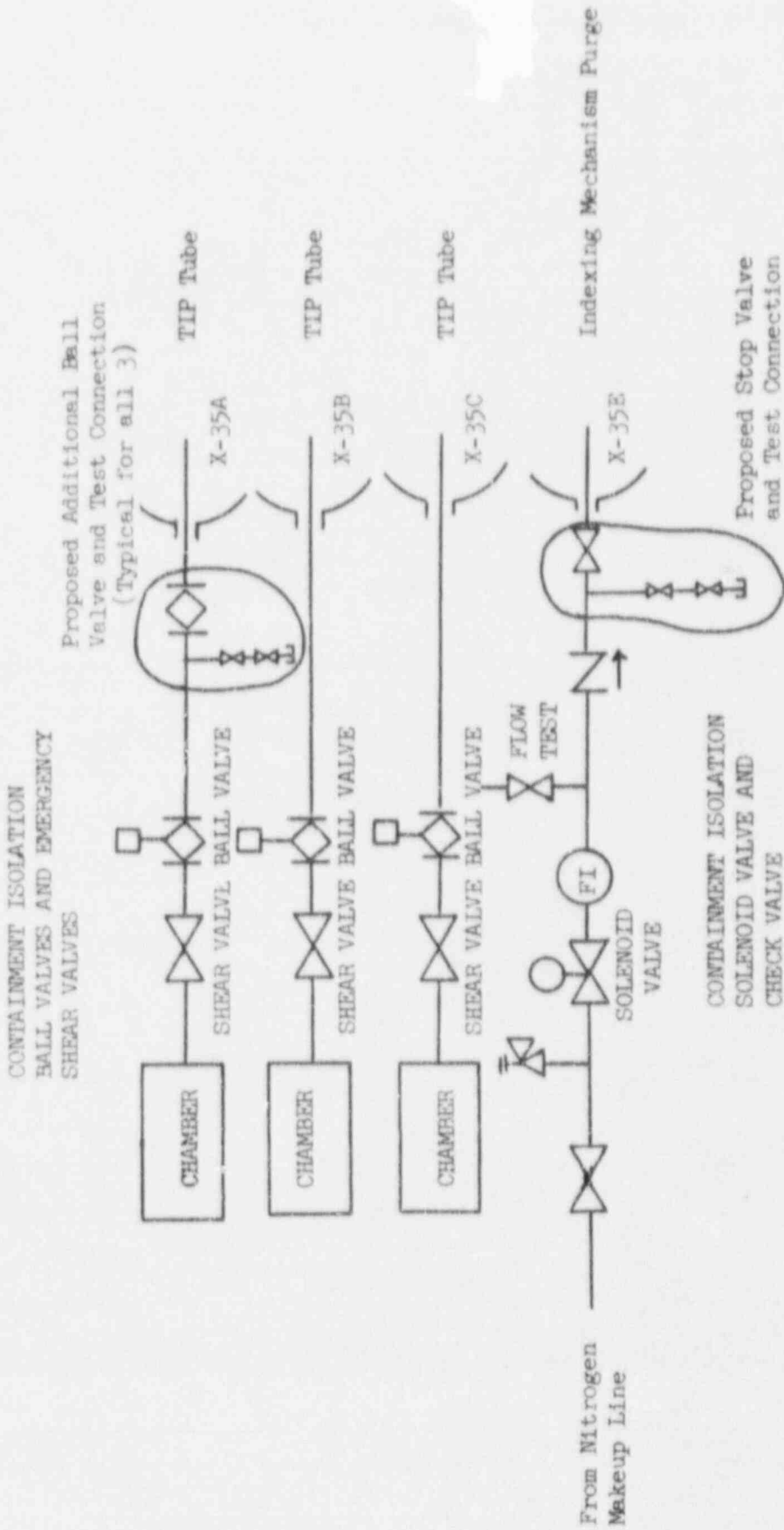

Figure 3. TIP and TIP Purge Containment Penetrations

CRD-31 AND CRD-34
CONTAINMENT ISOLATION VALVES

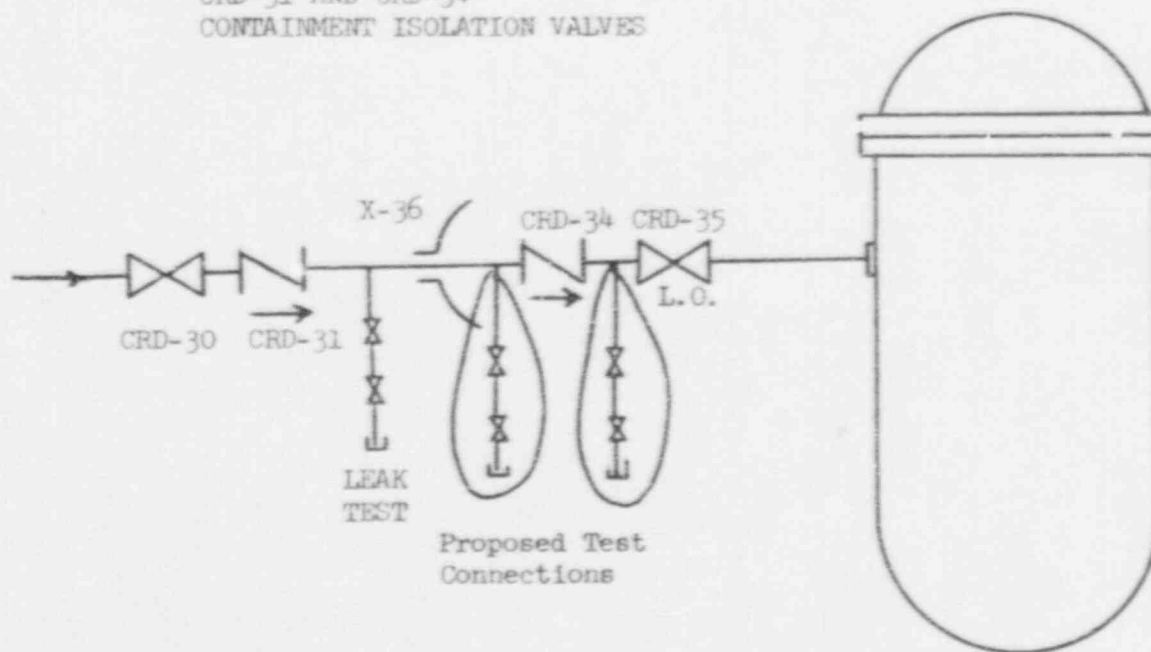

Figure 4. CRD Hydraulic Return Containment Penetration

Reference: PSAR Figure 3-5-5

XP-6 AND XP-7
CONTAINMENT ISOLATION VALVES

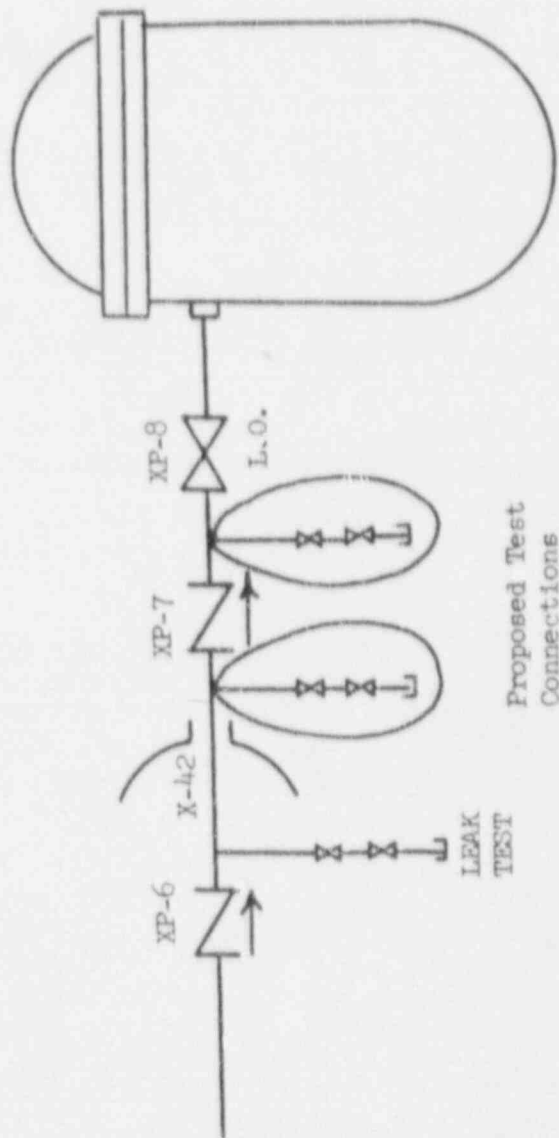

Figure 5. SBLC Containment Penetration

Reference: FSAR Figure 6-6-1

HPCI-9 AND HPCI 10
CONTAINMENT ISOLATION VALVES

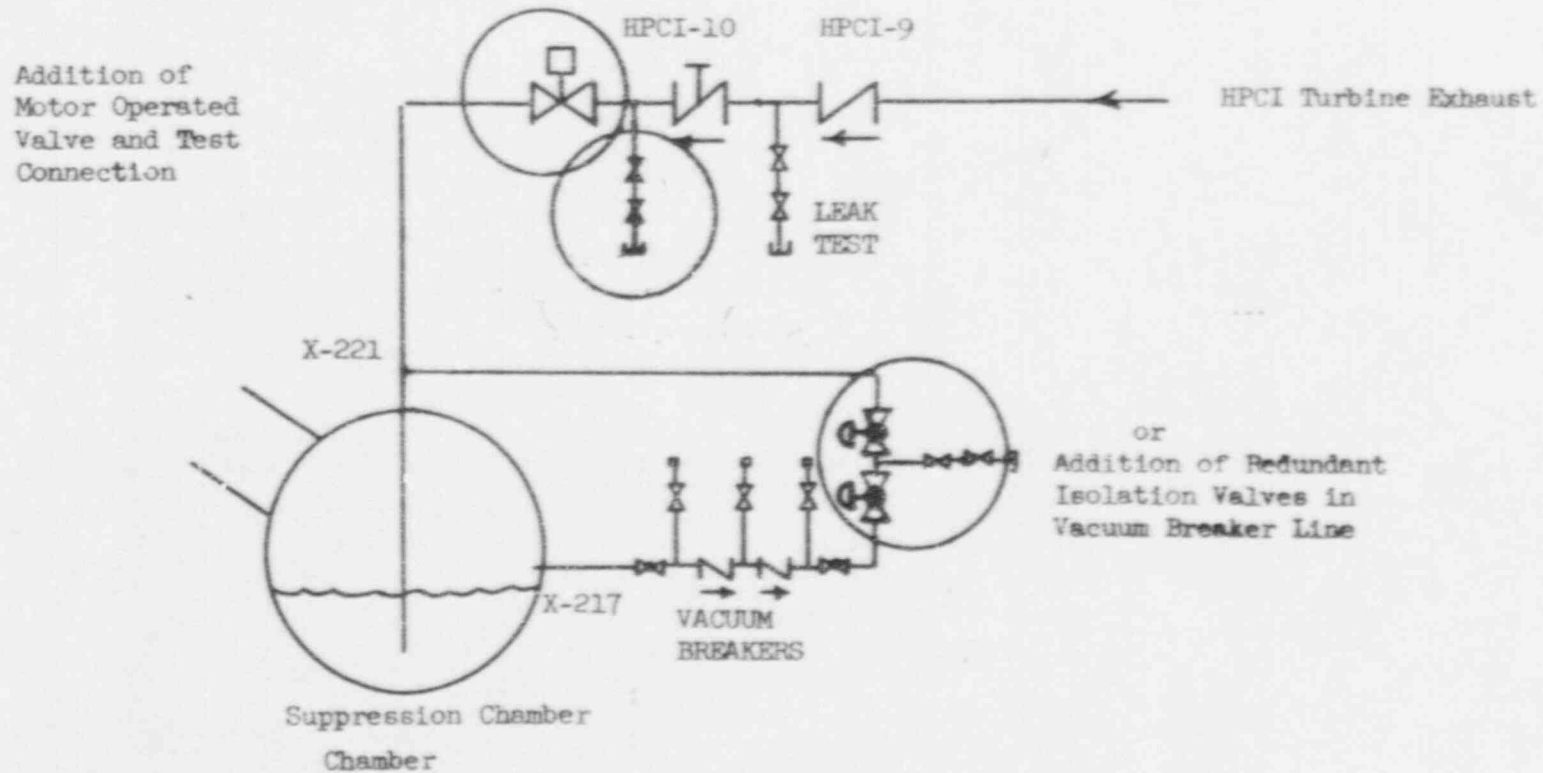

Figure 6. HPCI Turbine Exhaust Containment Penetration

Reference: PSAR Figures 6-2-13a & b

RCIC-9 AND RCIC-10
CONTAINMENT ISOLATION VALVES

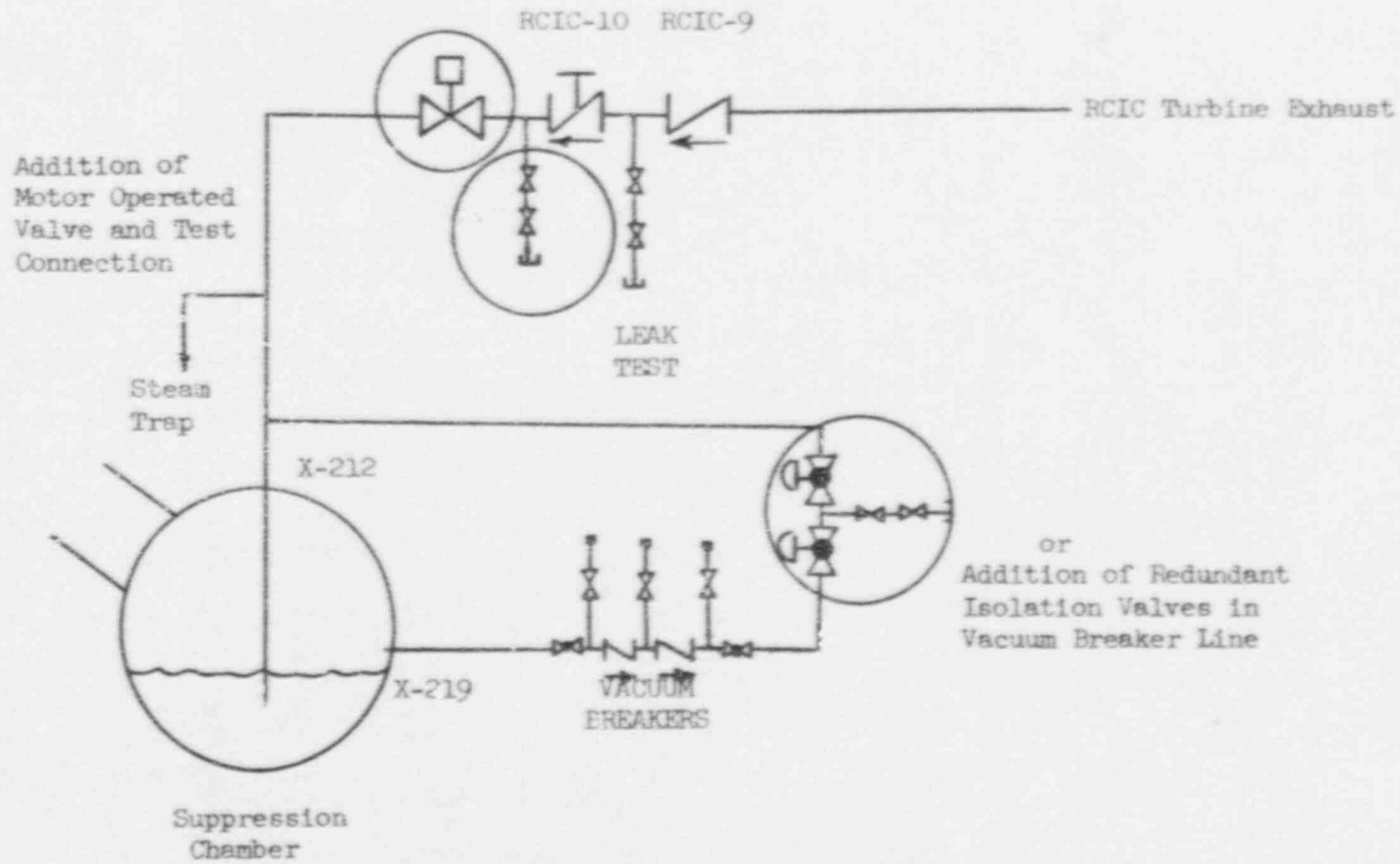
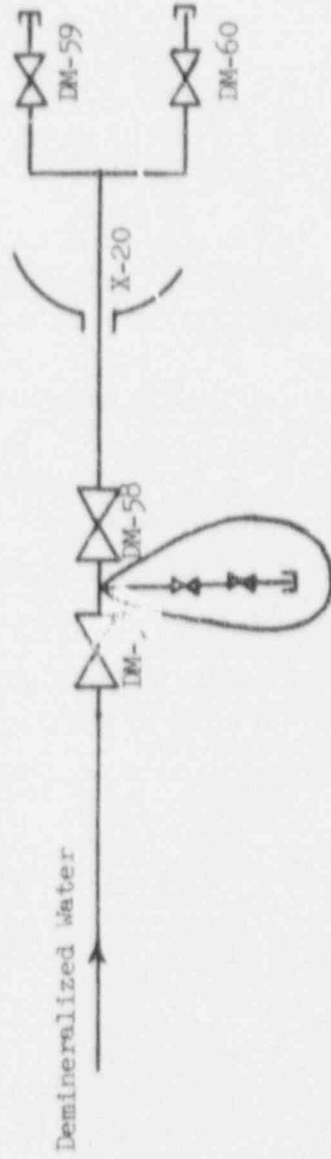

Figure 7. RCIC Turbine Exhaust Containment Penetration

Reference: FSAR Figures 10-2-7a & b

DM-57 AND DM-58
CONTAINMENT ISOLATION VALVES
MANUAL GATE VALVES



Proposed Test
Connection

Figure 8. Demineralized Water Supply Containment Penetration

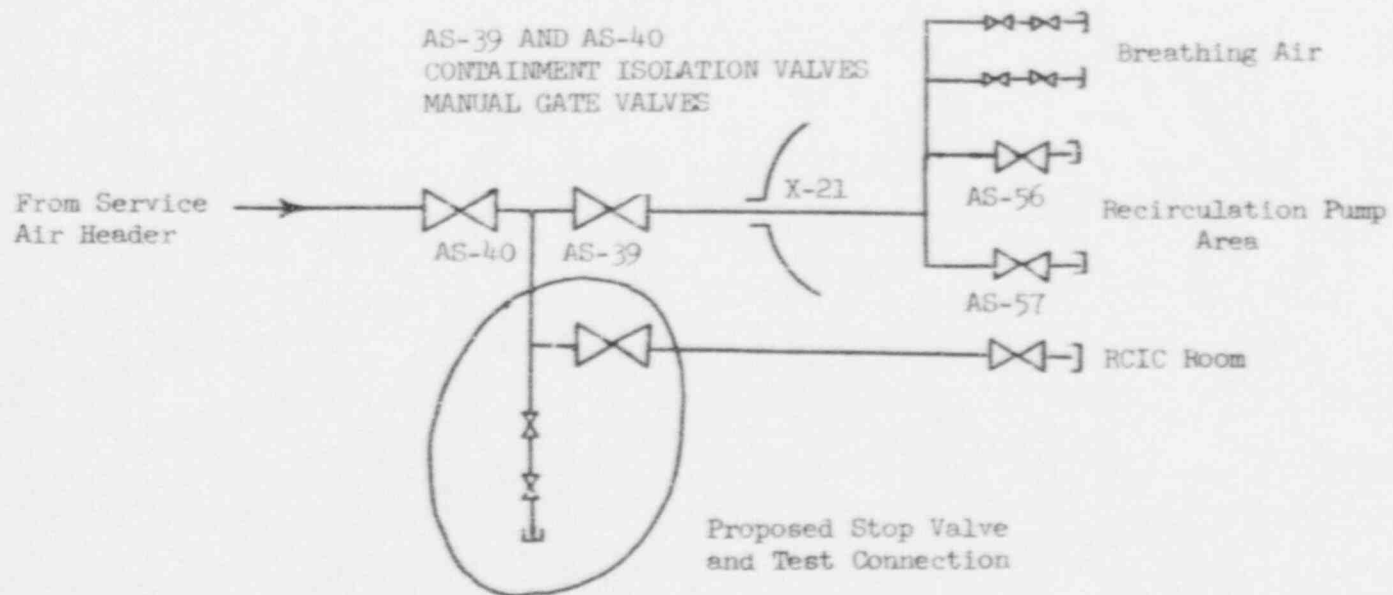

Figure 9. Service Air Supply Containment Penetration

Reference: FSAR Figure 10-3-4

CV-7956 CONTAINMENT ISOLATION VALVE
REMOTE MANUAL CONTROL

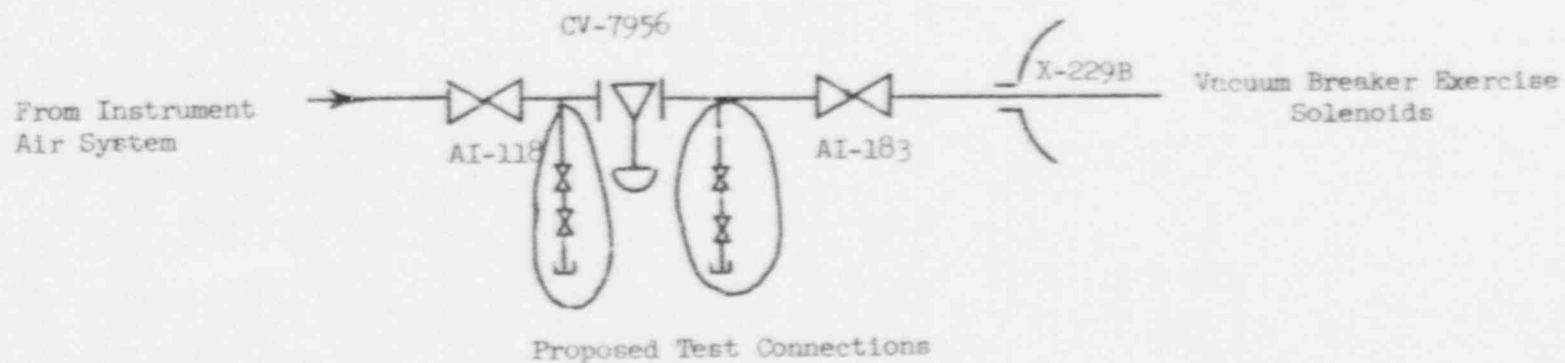

Figure 10. Torus Instrument Air Supply Containment Penetration

NRC DISTRIBUTION FOR P, AT 50 DOCKET MATERIAL

FILE NUMBER

TO:
MR. VICTOR STELLO

FROM:
NORTHERN STATES POWER CO.,
MINNEAPOLIS, MINN.,
L. O. MATER

DATE OF DOCUMENT
5/5/76

DATE RECEIVED
5/17/76

LETTER
 ORIGINAL
 COPY

NOTORIZED
 UNCLASSIFIED

PROP INPUT FORM

NUMBER OF COPIES RECEIVED
ONE SIGNED

DESCRIPTION

LTR. RE OUR LTR. 8/5/75 & THEIR LTR'S
9/19/76, 5/4/76, 1/30/76 & 5/4/76 TRANS
THE FOLLOWING:

ENCLOSURE

PLANNED MODIFICATIONS TO PERMIT TESTING TO BE
CONTINUED IN ACCORDANCE WITH 10 CFR 50
APPENDIX J.

ACKNOWLEDGED

DO NOT REMOVE

PLANT NAME:

MONTICELLO

SAFETY

FOR ACTION/INFORMATION

ENVIRO

5/19/76

RJL

ASSIGNED AD :		ASSIGNED AD :	
BRANCH CHIEF :	ZIEMANN (6)	BRANCH CHIEF :	
PROJECT MANAGER:		PROJECT MANAGER :	
LIC. ASST. :	DIGGS	LIC. ASST. :	

INTERNAL DISTRIBUTION

<input checked="" type="checkbox"/> REG FILE	SYSTEMS SAFETY	PLANT SYSTEMS	ENVIRO TECH
<input checked="" type="checkbox"/> NRC PDR	HELIEMAN	TEDESCO	ERNST
<input checked="" type="checkbox"/> I & E (2)	SCHROEDER	BLHAROYA	BAIJARD
<input checked="" type="checkbox"/> OELD		JAINAS	SPANGLER
<input checked="" type="checkbox"/> GOSSICK & STAFF	ENGINEERING	IPPOLITO	
MIPC	MACCARY		SITE TECH
CASE	KNIGHT	OPERATING REACTORS	GANNILL
HANAUER	SIMMEL	STELLO	STEPP
HARLESS	PAWLICKI		HULMAN
		OPERATING TECH	
PROJECT MANAGEMENT	REACTOR SAFETY	EISENUT (LTR)	SITE ANALYSIS
BOYD	ROSS	SHAO	VOLMER
P. COLLINS	NOVAK	RAER	BUNCH
HOUSTON	ROZTOCZY	SCHWENCER	J. COLLINS
PETERSON	CHECK	GRIEBS	KREGER
MELTZ			
HELTINES	AT & I		
SKOVHOLT	SALTZMAN	SITE SAFETY & ENVIRO	
	RITBERG	ANALYSIS	
		DERTON & MILLER	

EXTERNAL DISTRIBUTION

CONTROL NUMBER

<input checked="" type="checkbox"/> IADR; MINNEAPOLIS, MN.	NATL. LAB	BROOKHAVEN NATL. LAB	5002.
<input checked="" type="checkbox"/> TIC	REG. V-IE	ULRIKSON (ORNL)	
<input checked="" type="checkbox"/> NSJC	I.A. PDR		
<input checked="" type="checkbox"/> ASLB	CONSULTANTS		
<input checked="" type="checkbox"/> ACRS 16 HOLDING/SENT	DIGGS		