

MAR 10 1983

*Docket File*  
*DCS MS-016*

Docket Nos. 50-317  
and 50-318

LICENSEE: BALTIMORE GAS & ELECTRIC COMPANY (BG&E)

FACILITY: Calvert Cliffs Units 1 and 2

SUBJECT: SUMMARY OF A FEBRUARY 24, 1983 MEETING HELD WITH BG&E TO DISCUSS RECENT PROBLEMS WITH THE CALVERT CLIFFS ENGINEERED SAFETY FEATURES ACTUATION SYSTEM (ESFAS).

On February 24, 1983 representatives of the NRC and BG&E met to discuss recent problems at Calvert Cliffs related to spurious operation of the ESFAS. A list of attendees is shown in Attachment 1. BG&E had prepared a presentation to address the various aspects of the subject problem including diagnosis, modifications, testing, and future actions. The BG&E agenda is shown in Attachment 2.

BG&E started their presentation by addressing the contribution of personnel error to the unusually large number of spurious ESFAS operations that have recently occurred at Calvert Cliffs. They expressed their concern in this area and also for other personnel errors in safety-related activities.

BG&E described an evolving "Quality of Work" program at Calvert Cliffs which their management expects will decrease the incidence of personnel error in safety-related activities. This program would include improved training for licensed and non-licensed personnel. Additional contact between BG&E management and plant personnel will be undertaken to increase the awareness of the impact of errors on plant operations. The NRC indicated their desire to visit Calvert Cliffs to discuss matters related to training.

BG&E next made a presentation during which the recent events involving operation of the ESFAS at Units 1 and 2 were characterized as to cause and type of operation. A summary of this material is contained in Attachment 3. Particular attention was given to distinguishing events involving ESFAS actuation (logic modules trip but ESF equipment does not start) from events involving ESFAS initiation (logic modules trip and ESF equipment does operate). This distinction had previously been an area of considerable confusion during NRC/BG&E communications.

BG&E made a presentation during which the 120VAC/125VDC systems were described including the vital inverters and the ESFAS. Attachment 4 contains summary information on these subjects. BG&E described the diagnosis of the ESFAS problems as due to fusing that was inconsistent with power supply vendor recommendations and the existence of a current limiter feature on the vital inverters. This latter feature results in inappropriate inverter response to voltage/current transients. BG&E described their corrective measures which included following manufacturer's recommendations on the use of proper fuse type and size and the removal of the current limiter feature from the inverters. The test program,

OFFICE	.....	.....	.....	.....
SURNAME	.....	.....	.....	.....
	8303230068	830310		
	PDR ADDCK	05000317		
	P	PDR		

MAR 10 1983

- 2 -

used to verify the appropriateness of the corrective measures, was also described.

BG&E indicated that they had conducted a survey of other utilities with similar equipment and had determined that (1) 80% of those contacted did not utilize current limiters on inverters, (2) 10% have had no problems with these current limiters used on inverters, and (3) 10% provided no information.

In conclusion, BG&E expressed the view that the ESFAS problem had been properly diagnosed as an inverter problem and the appropriate modifications have been made. BG&E identified additional action items including a design review of ESFAS actuation cabinets (to be completed in 90 to 180 days) and a reliability study of vital instrumentation (to be completed by the end of 1983). These items are summarized in Attachment 5.

Original signed by:

David H. Jaffe, Project Manager  
Operating Reactors Branch #3  
Division of Licensing

Attachments:  
As stated

OFFICE ▶	ORB#3:DL	ORB#3:DL	ORB#3:DL	ORB#3:DL			
SURNAME ▶	PKentzer	DJaffe:dd	Wieder	RAClark			
DATE ▶	3/7/83	3/10/83	3/ /83	3/ /83			

MEETING SUMMARY DISTRIBUTION

Licensee: Baltimore Gas and Electric Company

\*Copies also sent to those people on service (cc) list for subject plant(s).

Docket File  
NRC PDR  
L PDR  
NSIC  
ORB#3 Rdg  
ORB#3 Summary File  
JHeltemes  
BGrimes  
RAClark  
Project Manager  
PMKreutzer  
OELD  
ELJordan  
JMTaylor  
ACRS-10  
NRC Participants

ATTENDANCE LIST

<u>NAME</u>	<u>ORGANIZATION</u>
D. Jaffe	DL/NRC
J. T. Beard	NRC/DL/ORAB
M. Chiramal	NRC/AEOD
R. A. Clark	NRC/DL/ORB#3
Gary Holahan	NRC/DL/ORAB
J. Tiernan	BG&E - NPD
LBRussell	BG&E - NPD
LFBasso	BG&E - NPD
JT. Carroll	BG&E - NPD
R. F. Ash	BG&E - NPD
J. Persensky	NRC/DHFS/LQB
Dolores Morisseau	NRC/DHFS/LQB
Jim Dahcruist, Jr.	BG&E - EED
L. R. Lepkowski	Vitro GeSupur. Eng.
R. Architzel	NRC SRI, Region I
D. Trimble	NRC, Res. Insp. Region I
K. H. Sebra	BG&E - EED
B. S. Montgomery	BG&E - EED
L. E. Salyards	BG&E - NPD
J.M. Moreira	BG&E - NPD
P. J. Hebrank	BG&E - EED
T. A. Ippolito	NRC - DL

PRESENTATION  
TO NRC  
FEBRUARY 24, 1983

AGENDA

- I. INTRODUCTORY REMARKS ..... (J. A. TIERNAN)
  
- II. SUMMARY OF EVENTS ..... (J. T. CARROLL)
  
- III. EVALUATION OF IMPACT OF INVERTER/ESFAS ANOMALIES ON DESIGN  
ASSUMPTIONS ..... (R. F. ASH)
  - A. INCLUDE FAILURE MODES, LOSS OF POWER/UP POWER
  - B. INDEPENDENCE OF CHANNELS
  
- IV. SUMMARY OF TESTING/MODIFICATIONS ..... (F. BASSO)
  
- V. POSSIBLE EQUIPMENT UPGRADING ..... (R. F. ASH)
  
- VI. SUMMARY REMARKS ..... (J. A. TIERNAN)

ACTUATION - MOST OR ALL LOGIC MODULES TRIP  
BUT ESF EQUIPMENT DOES NOT OPERATE

INITIATION - MOST OR ALL LOGIC MODULES TRIP  
AND ESF EQUIPMENT DOES OPERATE

UNIT 1 ESFAS EVENTS

<u>DATE</u>	<u>MODE</u>	<u>EVENT</u>	<u>CAUSE</u>
11/9	1	AL ACTUATION	OPENED INVERTER DC BREAKER
1/5	1	AL INITIATION	SHORT ON 11 VITAL BUS
2/8	1	ZG TRIPPED	VOLTAGE TRANSIENT ON 14 VITAL BUS

UNIT 2 ESFAS EVENTS

NORMAL VOLTAGE ON VITAL BUS

VOLTAGE TRANSIENT ON VITAL BUS

LOSS OF VOLTAGE ON VITAL BUS

UNIT 2 ESFAS EVENTS

NORMAL VOLTAGE ON VITAL BUS

<u>DATE</u>	<u>MODE</u>	<u>EVENT</u>	<u>CAUSE</u>
11/10	6	SIAS A INITIATION	TWO SENSOR CHANNELS TRIPPED DURING TESTING
11/11	6	SIAS A INITIATION	TWO SENSOR CHANNELS TRIPPED DURING TESTING
11/24	6	UV-B	FAILED POWER SUPPLY
12/1	6	UV-A	FAILED POWER SUPPLY
12/30	5	SIAS A & B INITIATION	ZG DEENERGIZED WHILE ZF TRIPPED FOR STP
1/11	3	SIAS A & B INITIATION	RCS PRESSURE 1525 PSIA

UNIT 2 ESFAS EVENTS  
VOLTAGE TRANSIENT ON VITAL BUS

<u>DATE</u>	<u>MODE</u>	<u>EVENT</u>	<u>CAUSE</u>
12/11	5	AL INITIATION	POST MODIFICATION TESTING OF CST LEVEL INDICATION
12/11	5	AL INITIATION	POST MODIFICATION TESTING OF CST LEVEL INDICATION
1/1	5	AL INITIATION	PLACEMENT OF JUMPER IN RCS PRESSURE TRANSMITTER
2/2	3	AL INITIATION	INVERTER WIRED IMPROPERLY

UNIT 2 ESFAS EVENTS

LOSS OF VOLTAGE ON VITAL BUS

<u>DATE</u>	<u>MODE</u>	<u>EVENT</u>	<u>CAUSE</u>
12/28	5	BL ACTUATION	BLOWN INVERTER INPUT FUSE
1/4	5	AL ACTUATION	SHORT IN RPS A DRAWER
1/31	1	BL ACTUATION	GROUND ON 22 BUS
1/31	3	BL ACTUATION	SHORT ON 22 BUS
2/2	1	BL ACTUATION	BLOWN INVERTER INPUT FUSE

①

VITAL 120V.AC & 125V.DC SINGLE LINE DIAGRAM (TYP. OF 4)

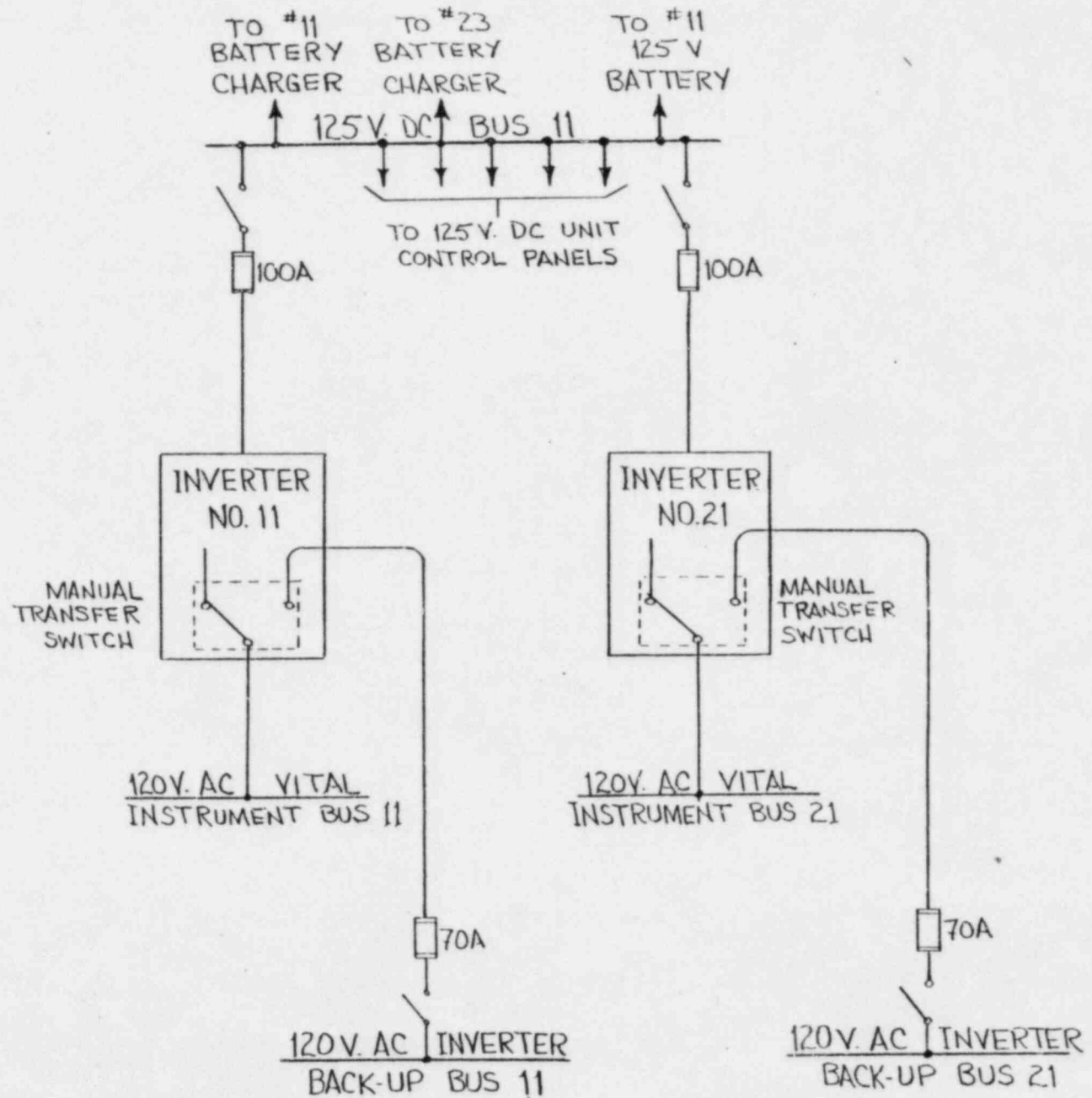

2.

120 V. AC VITAL SYSTEM BEFORE  
FUSE CHANGE-OUT (TYP. FOR INVERTERS 12,  
21 & 22)

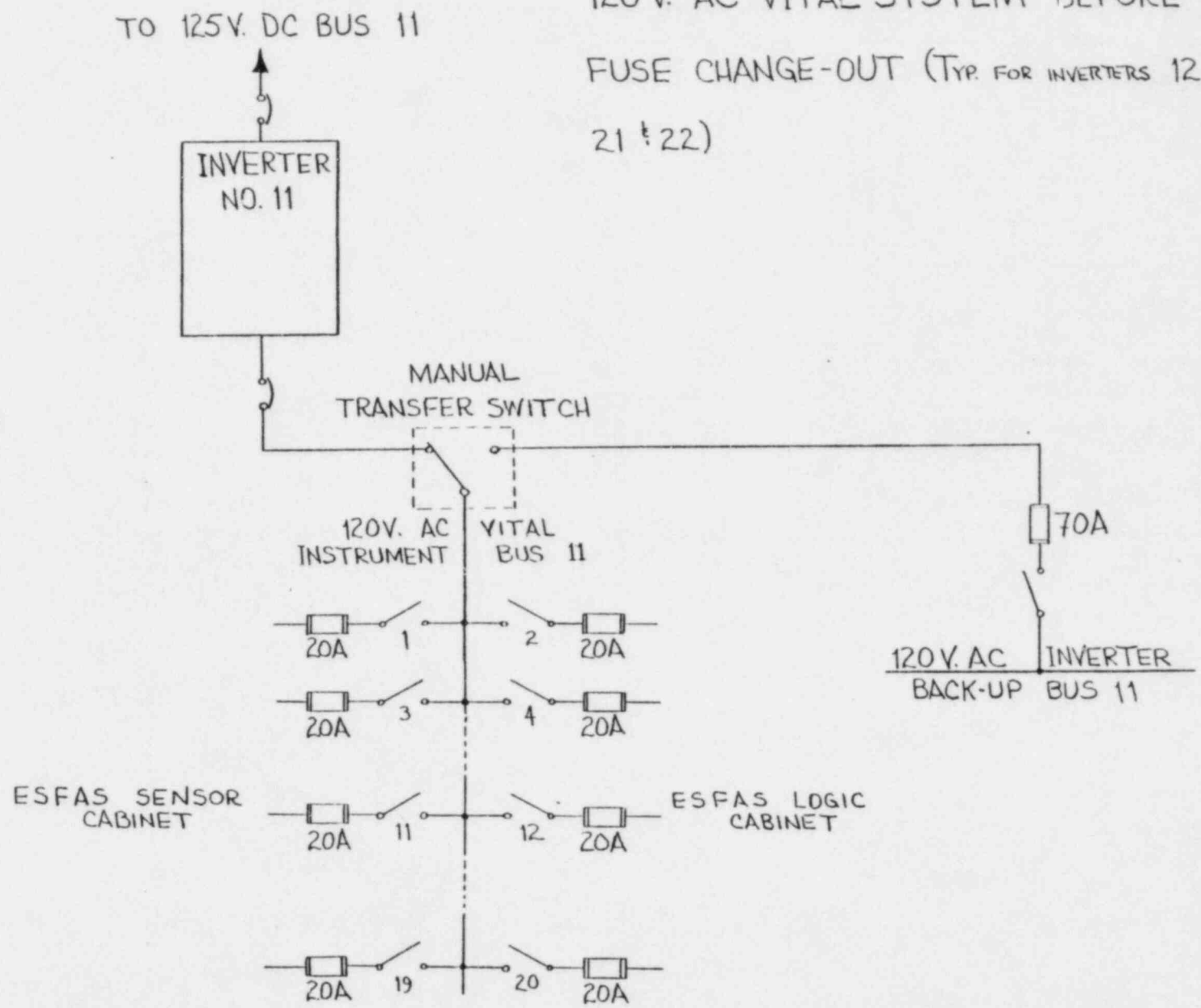

PROBLEMS / SYMPTOMS

1. BLOWING DC INPUT FUSE TO INVERTER BUT NOT OUTPUT FUSES ON LOAD WHERE FAULT OCCURS.
2. INVERTER PROTECTED FROM FAULT CURRENTS BY CURRENT LIMIT FEATURE.
3. UNNECESSARY ESFAS ACTUATION.

PROPOSED SOLUTION

1. FOLLOW MANUFACTURER'S RECOMMENDATIONS TO USE PROPER FUSE TYPE AND SIZE.
2. REMOVE CURRENT LIMIT FEATURE FROM INVERTER.

TEST PROGRAM OBJECTIVES

1. VERIFY ESFAS LOGIC CABINET RESPONSE TO CLEAN DOWNPOWER.  
IF NO ACTUATION, VERIFY RESPONSE TO LOSS OF DC TO INVERTER.
2. VERIFY INVERTER RESPONSE TO STEP LOAD CHANGES AND QUANTIFY  
WHEN INVERTER GOES INTO CURRENT LIMITING (OBTAIN BOTH CURRENT  
AND VOLTAGE).
3. VERIFY INVERTER RESPONSE TO A SHORT CIRCUIT WITH CURRENT  
LIMITER USING 12A AND 15A FUSES.
4. VERIFY INVERTER RESPONSE TO A SHORT CIRCUIT WITHOUT CURRENT  
LIMITER USING 15A FUSES.

6.

HOOK-UP OF DUMMY LOAD BANK TO INVERTER FOR OPERATIONAL CHECK OF CURRENT LIMITER.

TO 125V. DC BUS

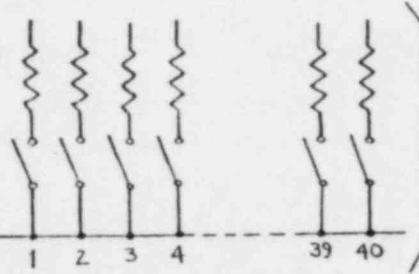

RESISTIVE LOAD BANK OF 40-3AMP LOADS

MANUAL TRANSFER SWITCH

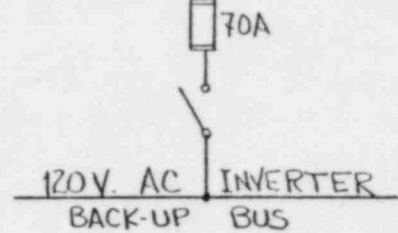
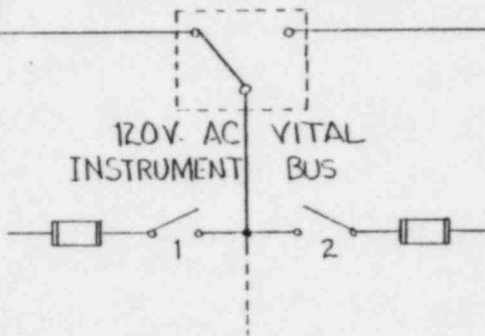

7

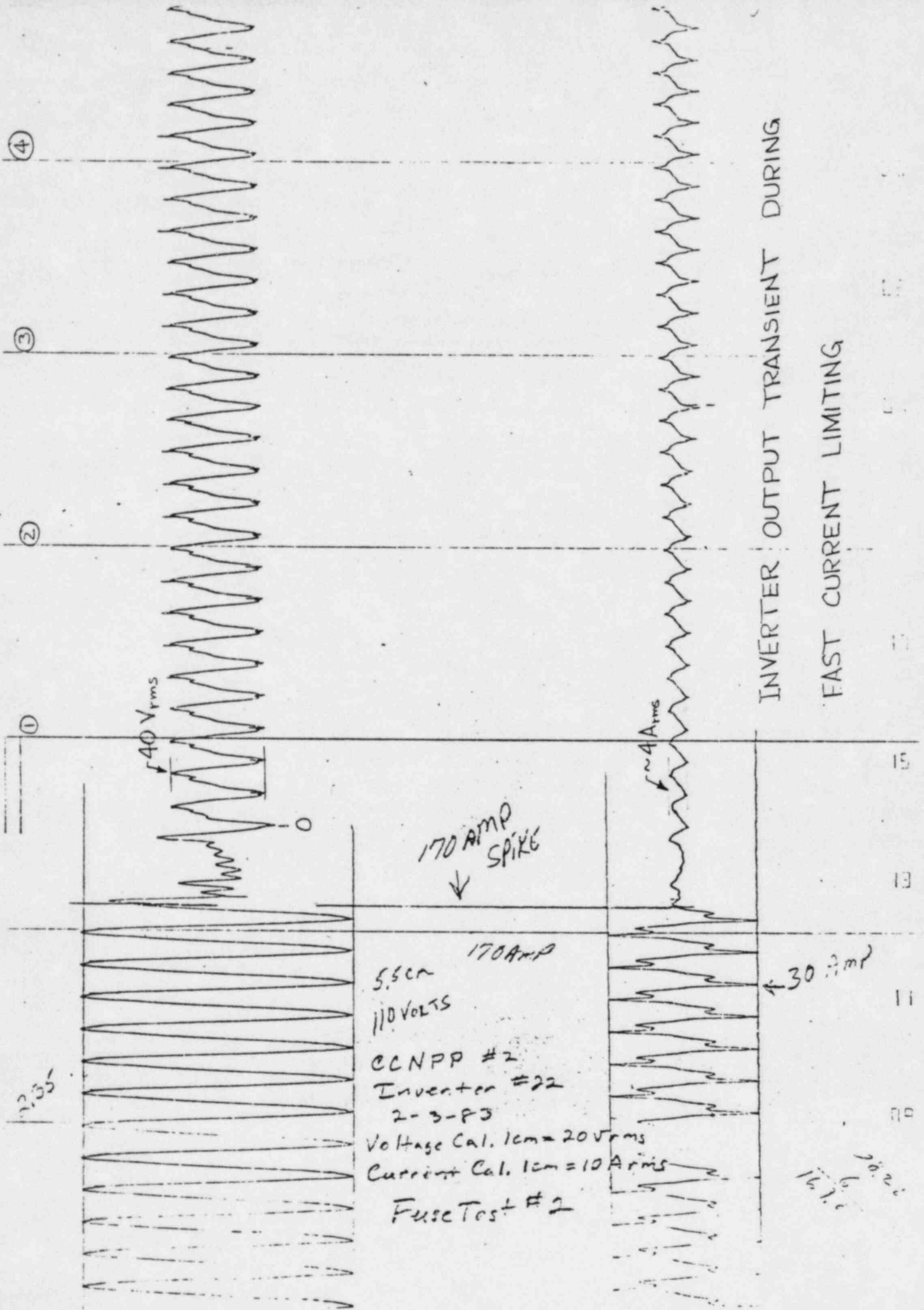

40 Vrms

170 AMP SPIKE

~4 Arms

30 A rms

INVERTER OUTPUT TRANSIENT DURING

FAST CURRENT LIMITING

5.5cm 170 AMP  
 110 VOLTS  
 CCNPP #2  
 Inverter #22  
 2-3-P3  
 Voltage Cal. 1cm = 20 Vrms  
 Current Cal. 1cm = 10 Arms  
 Fuse Test #2

12/11/71

8.

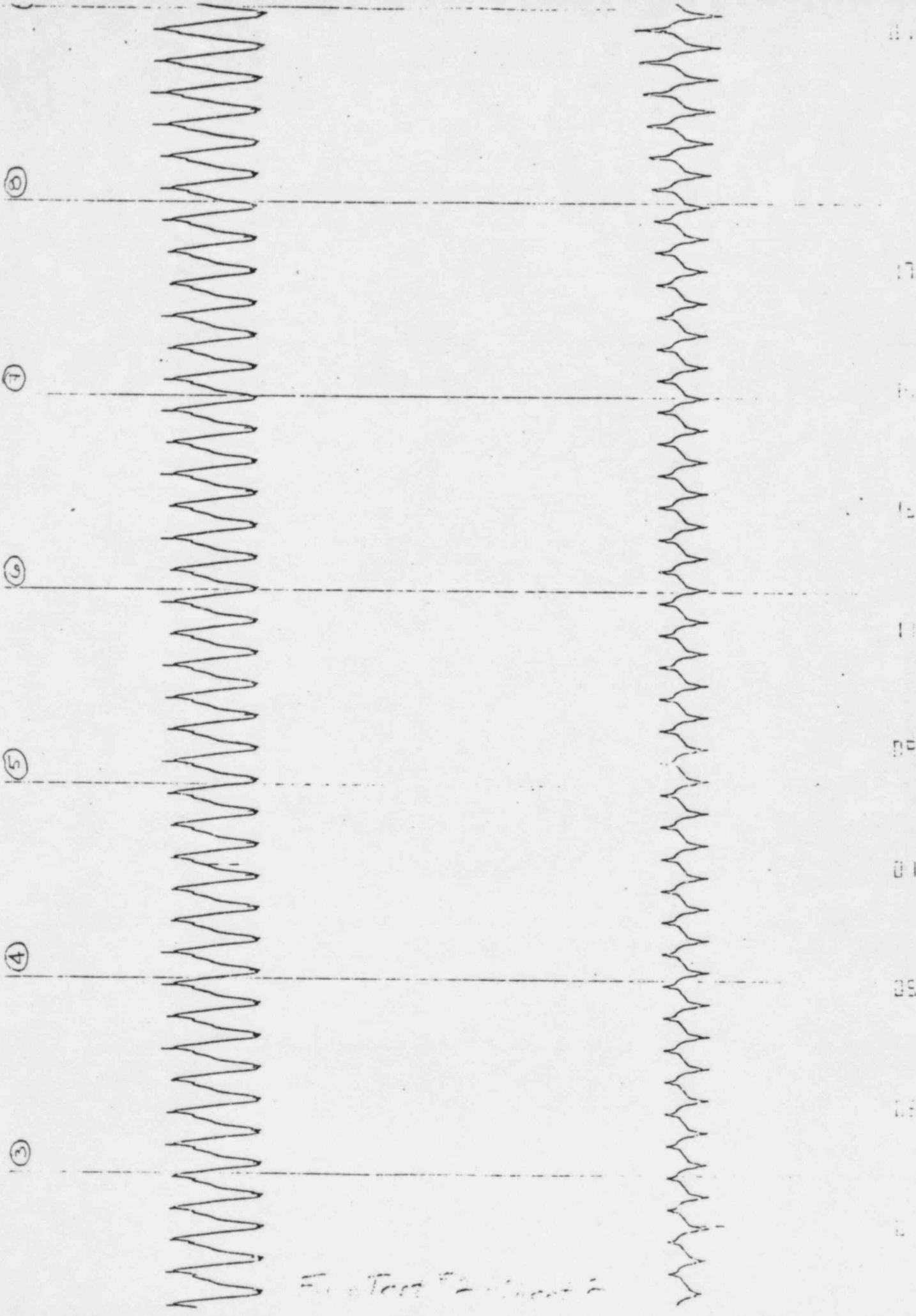

Fig. Test # 2 - 1/2 - 1/2

9

8

9

10

11

12

13

14

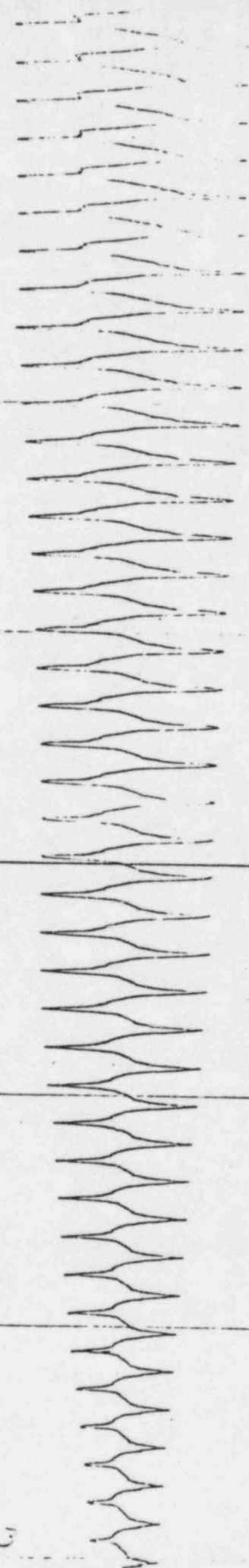
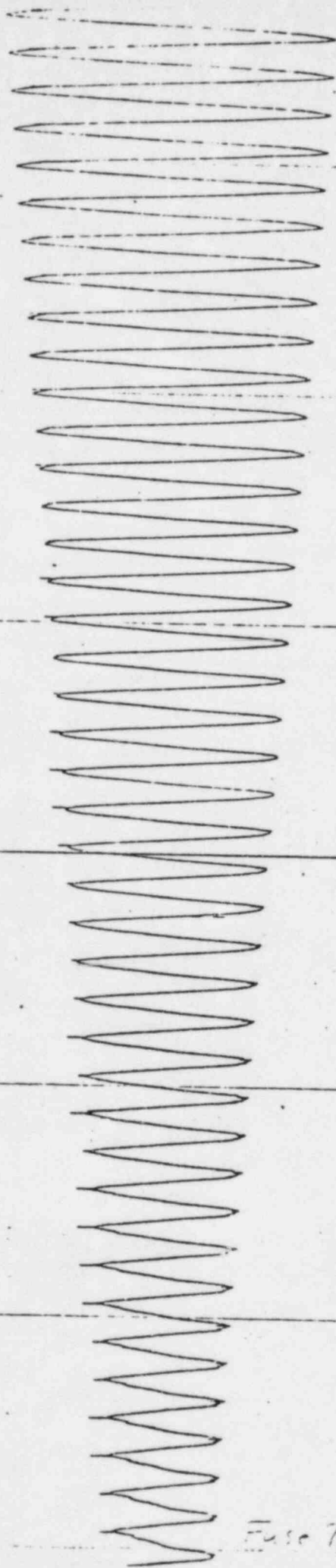

01  
03  
05  
07  
09

Fuse Test #2 - Sheet 3

10

12

13

14

15



1.5 SEC

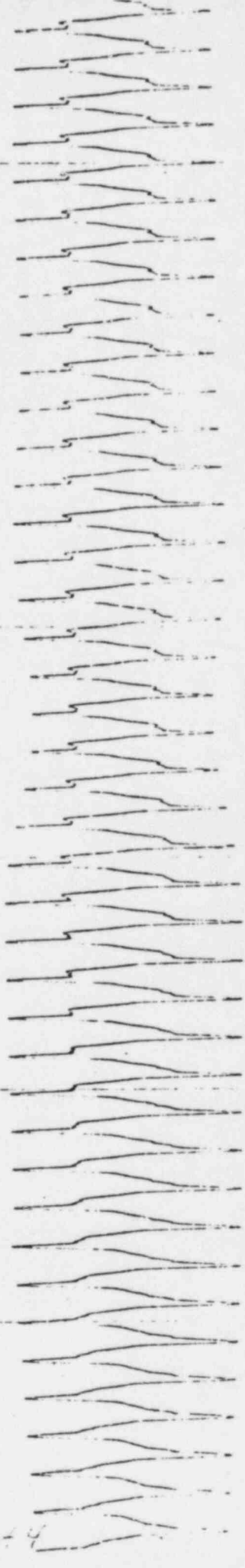

Phase Test For sheet 4

INVERTER RESPONSE TO SHORT CIRCUIT WITHOUT CURRENT LIMITING.

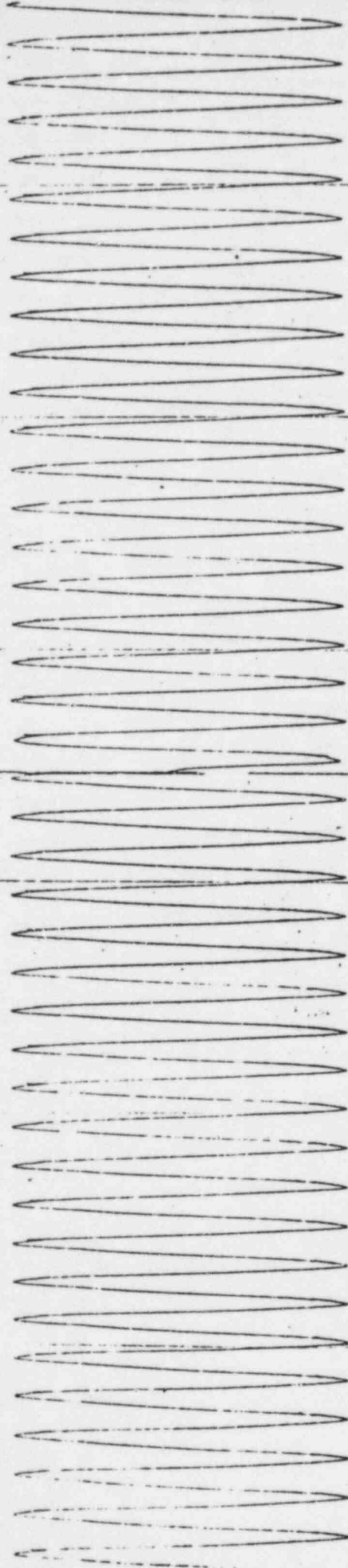

15 Amp  
#5 FUSE

8.4cm

↑  
235 Amp  
SPIKE

CCNPP #2  
Inverter #22  
2-3-83 11:35AM  
Volt. Cal. 1cm = 20Vrms  
Cur. Cal. 1cm = 10Arms  
Fuse Test #5

05  
03  
01  
17  
15  
13  
11  
09  
07  
05

(12.)

## RESULTS OF INVERTER SHORT CIRCUIT TESTS

RUN NO.	FUSE SIZE (AMP)	CURRENT SURGE (AMP)	CURRENT LIMITING	VOLTAGE IMPULSE (VOLTS.)	STEADY STATE VOLTAGE (VOLTS)	VOLTAGE AFTER SURGE (VOLTS.)	DURATION OF SURGE	REMARKS
INVERTER #22 - WITH CURRENT LIMITER INSTALLED								
1	15	122	NO	140	112	114	1 CYCLE	SHORT OCCURRED NEAR VOLTAGE ZERO
2	15	170	YES	156	112	40	1.5 SEC.	BLACKOUT - CURRENT TRACE OFF PAPER
3	12	-	NO	100	114	118	1 CYCLE	NEAR CURRENT ZERO - RESULTS OBSCURED
4	12	96	YES	208	112	38	1.5 SEC.	BLACKOUT - CURRENT TRACE OFF PAPER
INVERTER #22 - WITH CURRENT LIMITER REMOVED								
5	15	235	N/A	192	116	112	1 CYCLE	OCCURRED NEAR VOLTAGE ZERO
6	15	277	N/A	236	116	120	2 CYCLES	OCCURRED NEAR VOLTAGE PEAK
7	15	161	N/A	140	116	112	2 CYCLES	CURRENT TRACE OFF PAPER
INVERTER #21 - WITH CURRENT LIMITER REMOVED								
8	15	172	N/A	NOT CONNECTED	114	114	2 CYCLES	OCCURRED NEAR VOLTAGE ZERO
9	15	178	"	"	114	120	2 CYCLES	OCCURRED HALFWAY TO PEAK
10	15	150	"	"	114	118	2 CYCLES	OCCURRED NEAR VOLTAGE ZERO
11	15	214	"	"	114	120	1 CYCLE	OCCURRED NEAR PEAK
			"	"				

C O N C L U S I O N S

1. REMOVE CL FEATURE - ALLOWS FAULT TO CLEAR (VIA LOAD FUSES) AND PREVENTS VOLTAGE DROP.
2. MEET MANUFACTURER'S RECOMMENDATION FOR PROPER FUSING.
3. ESFAS POWER SUPPLIES WILL NOT SEE VOLTAGE DROP IF FAULT OCCURS.

ACTION ITEMS

- (1) Design review of ESFAS actuation cabinets
  - . power failure ride through features
  - . reliability of power supplies
  - . completion of study 90-180 days
- (2) Reliability studies of vital instrumentation systems
  - . completion by the end of 1983