

SAIC 89/1031



NUCLEAR POWER PLANT SYSTEM SOURCEBOOK

BROWNS FERRY 3

50-296

Editor: Peter Lobner
Author: Peter Lobner

Prepared for:

U.S. Nuclear Regulatory Commission
Washington, D.C. 20555

Contract NRC-03-87-029
FIN D-1763

The logo for SAIC (Science Applications, Inc.) is located in the bottom right corner. It consists of the letters "SAIC" in a bold, italicized, sans-serif font, with horizontal lines extending from the right side of the letters.

8908070300 XA 125pp

TABLE OF CONTENTS

<u>Section</u>		<u>Page</u>
1	SUMMARY DATA ON PLANT.....	1
2	IDENTIFICATION OF SIMILAR NUCLEAR POWER PLANTS.....	1
3	SYSTEM INFORMATION.....	2
	3.1 Reactor Coolant System (RCS).....	9
	3.2 Reactor Core Isolation Cooling (RCIC) System.....	14
	3.3 Emergency Core Cooling System (ECCS).....	19
	3.4 Instrumentation and Control (I&C) Systems.....	33
	3.5 Electric Power System.....	37
	3.6 Control Rod Drive Hydraulic System (CRDHS).....	56
	3.7 Emergency Equipment Cooling Water (EECW) System....	59
	3.8 RHR Service Water (RHRSW) System.....	73
4	PLANT INFORMATION.....	77
	4.1 Site and Building Summary.....	77
	4.2 Facility Layout Drawings.....	77
5	BIBLIOGRAPHY FOR BROWNS FERRY 3.....	106
	APPENDIX A, Definition of Symbols Used in the System and Layout Drawings.....	107
	APPENDIX B, Definition of Terms Used in the Data Tables.....	114

LIST OF FIGURES

<u>Figure</u>		<u>Page</u>
3-1	Cooling Water Systems Functional Diagram for Browns Ferry 1, 2 and 3.....	8
3.1-1	Browns Ferry 3 Nuclear Boiler System.....	11
3.1-2	Browns Ferry 3 Nuclear Boiler System Showing Component Locations.....	12
3.2-1	Browns Ferry 3 Reactor Core Isolation Cooling (RCIC) System.....	16
3.2-2	Browns Ferry 3 Reactor Core Isolation Cooling (RCIC) System Showing Component Locations.....	17
3.3-1	Browns Ferry 3 Condensate Water Sources for ECCS, RCIC and CRDHS Systems.....	23
3.3-2	Browns Ferry 3 High Pressure Coolant Injection (HPCI) System.....	24
3.3-3	Browns Ferry 3 High Pressure Coolant Injection (HPCI) System Showing Component Locations.....	25
3.3-4	Browns Ferry 3 Low Pressure Coolant Injection System.....	26
3.3-5	Browns Ferry 3 Low Pressure Coolant Injection System Showing Component Locations.....	27
3.3-6	Browns Ferry 3 Core Spray System (CSS).....	28
3.3-7	Browns Ferry 3 Core Spray System (CSS) Showing Component Locations.....	29
3.5-1	Browns Ferry 1, 2 and 3 4kV Electric Power Distribution System	40
3.5-2	Browns Ferry 1 and 2 Class 1E AC Electric Power System.....	41
3.5-3	Browns Ferry 3 Class 1E AC Electric Power System.....	42
3.5-4	Browns Ferry 1, 2 and 3 250VDC Plant DC Electric Power System...	43
3.6-1	Simplified Diagram of Portions of the Control Rod Drive Hydraulic System that are Related to the Scram Function.....	58
3.7-1	Simplified Diagram of Emergency Equipment Cooling Water (EECW) System for Browns Ferry 1, 2 and 3.....	61

LIST OF FIGURES

<u>Figure</u>		<u>Page</u>
3.7-2	Browns Ferry 1, 2 and 3 Emergency Equipment Cooling Water (EECW) System.....	62
3.7-3	Browns Ferry 1, 2 and 3 Emergency Equipment Cooling Water (EECW) System Showing Component Locations.....	67
3.8-1	Browns Ferry 1, 2 and 3 RHR Service Water (RHRSW) System.....	74
3.8-2	Browns Ferry 1, 2 and 3 RHR Service Water (RHRSW) System Showing Component Locations.....	75
4-1	Browns Ferry Site Plan.....	78
4-2	General Arrangement of Major Building at the Browns Ferry Site.....	79
4-3	Typical Elevation View of Browns Ferry Reactor and Turbine Buildings.....	80
4-4	Browns Ferry Units 1 Reactor Building Elevation Drawings (section through reactor centerline), Including Units 1 & 2 Diesel Generator Building.....	81
4-5	Browns Ferry Units 2 & 3 Reactor Building Elevation Drawing (section through RHR pump rooms), Including Unit 3 Diesel Generator Building.....	82
4-6	Overall Layout of the Browns Ferry Nuclear Plant, Elevations 519 ft. and 541.5 ft.	83
4-7	Overall Layout of the Browns Ferry Nuclear Plant, Elevations 557 ft. (Turbine Building) and 565 ft. (Reactor Building).....	84
4-8	Overall Layout of the Browns Ferry Nuclear Plant, Elevations 586 ft. (Turbine Building) and 593 ft. (Reactor Building).....	85
4-9	Overall Layout of the Browns Ferry Nuclear Plant, Elevations 617 ft. (Turbine Building) and 621.25 ft. (Reactor Building).....	86
4-10	Browns Ferry Unit 3 Reactor Building - 519 ft. Elevation.....	87
4-11	Browns Ferry Unit 3 Reactor Building - 541.5 ft. Elevation.....	88
4-12	Browns Ferry Unit 3 Reactor Building, Including Unit 3 Diesel Generator Building - 565 ft. Elevation.....	89
4-13	Browns Ferry Unit 3 Reactor Building - 593 ft. Elevation, Including Unit 3 Diesel Generator Building - 583 ft. Elevation.....	90
4-14	Browns Ferry Unit 3 Reactor Building - 606 ft. Elevation.....	91

LIST OF FIGURES

<u>Figure</u>		<u>Page</u>
4-15	Browns Ferry Unit 3 Reactor Building - 617 and 621.5 ft. Elevations.	92
4-16	Browns Ferry Unit 3 Reactor Building - 639 ft. Elevation.....	93
4-17	Browns Ferry Unit 3 Reactor Building - 664 Elevation.....	94
A-1	Key to Symbols in Fluid System Drawings.....	110
A-2	Key to Symbols in Electrical System Drawings.....	112
A-3	Key to Symbols in Facility Layout Drawings.....	113

LIST OF TABLES

<u>Table</u>		<u>Page</u>
3-1	Summary of Browns Ferry 3 Systems Covered in this Report.....	3
3.1-1	Browns Ferry 3 Reactor Coolant System Data Summary for Selected Components.....	13
3.2-1	Browns Ferry 3 Reactor Core Isolation Cooling System Data Summary for Selected Components.....	18
3.3-1	Browns Ferry 3 Emergency Core Cooling System Data Summary for Selected Components.....	30
3.4-1	Matrix of Browns Ferry Control Power Sources.....	36
3.5-1	Browns Ferry 3 Electric Power System Data Summary for Selected Components.....	44
3.5-2	Partial Listing of Electrical Sources and Loads at Browns Ferry 3.....	49
3.7-1	Browns Ferry 3 Emergency Equipment Cooling Water System Data Summary for Selected Components.....	72
3.8-1	Browns Ferry 3 Residual Heat Removal System Data Summary for Selected Components.....	76
4-1	Definition of Browns Ferry 3 Building and Location Codes.....	95
4-2	Partial Listing of Components by Location at Browns Ferry 3.....	98
B-1	Component Type Codes.....	115

CAUTION

The information in this report has been developed over an extended period of time based on a site visit, the Final Safety Analysis Report, system and layout drawings, and other published information. To the best of our knowledge, it accurately reflects the plant configuration at the time the information was obtained, however, the information in this document has not been independently verified by the licensee or the NRC.

NOTICE

This sourcebook will be periodically updated with new and/or replacement pages as appropriate to incorporate additional information on this reactor plant. Technical errors in this report should be brought to the attention of the following:

Mr. Mark Rubin
U.S. Nuclear Regulatory Commission
Office of Nuclear Reactor Regulation
Division of Engineering and Systems Technology
Mail stop 7E4
Washington, D.C. 20555

*With copy to:

Mr. Peter Lobner
Manager, Systems Engineering Division
Science Applications International Corporation
10210 Campus Point Drive
San Diego, CA 92131
(619) 458-2673

Correction and other recommended changes should be submitted in the form of marked up copies of the affected text, tables or figures. Supporting documentation should be included if possible.

**BROWNS FERRY 3
RECORD OF REVISIONS**

REVISION	ISSUE	COMMENTS
0	7/89	Original report

BROWNS FERRY 3 SYSTEM SOURCEBOOK

This sourcebook contains summary information on the Browns Ferry 3 nuclear power plant. There are separate sourcebooks for Browns Ferry 1 and 2. Summary data on this plant are presented in Section 1, and similar nuclear power plants are identified in Section 2. Information on selected reactor plant systems is presented in Section 3, and the site and building layout is illustrated in Section 4. A bibliography of reports that describe features of this plant or site is presented in Section 5. Symbols used in the system and layout drawings are defined in Appendix A. Terms used in data tables are defined in Appendix B.

1. SUMMARY DATA ON PLANT

Basic information on the Browns Ferry 3 nuclear plant is listed below:

- Docket number	50-296
- Operator	Tennessee Valley Authority
- Location	Alabama, 30 miles west of Huntsville
- Commercial operation date	3/77
- Reactor type	BWR/4
- NSSS vendor	General Electric
- Power (MWt/MWe)	3293/1067
- Architect-engineer	Tennessee Valley Authority
- Containment type	Steel drywell and wetwell (Mark I)

2. IDENTIFICATION OF SIMILAR NUCLEAR POWER PLANTS

The Browns Ferry nuclear plant has three General Electric BWR/4 nuclear steam supply systems on the site. These are designated Units 1, 2 and 3. Each unit has a Mark I BWR containment incorporating the drywell/pressure suppression concept. Each has a secondary containment structure of reinforced concrete. Other BWR/4 plants in the United States are as follows:

- Vermont Yankee
- Peach Bottom Units 2 and 3
- Hatch Units 1 and 2
- Cooper Nuclear Station
- Duane Arnold
- Fitzpatrick
- Brunswick Units 1 and 2
- Fermi Unit 2
- Hope Creek Unit 1
- Limerick Units 1 and 2 (Mark II Containment)
- Shoreham (Mark II Containment)
- Susquehanna Units 1 & 2 (Mark II Containment)

Browns Ferry plants use a high pressure coolant injection system, a single mode reactor core isolation cooling system, a low pressure core spray system, and a multi-mode RHR system with no steam condensing capabilities.

3. SYSTEM INFORMATION

This section contains descriptions of selected systems at Browns Ferry 3 in terms of general function, operation, system success criteria, major components, and support system requirements. A summary of major systems at Browns Ferry 3 is presented in Table 3-1. In the "Report Section" column of this table, a section reference (i.e. 3.1, 3.2, etc.) is provided for all systems that are described in this report. An entry of "X" in this column means that the system is not described in this report. In the "FSAR Section Reference" column, a cross-reference is provided to the section of the Final Safety Analysis Report where additional information on each system can be found. Other sources of information on this plant are identified in the bibliography in Section 5.

Several cooling water systems are identified in Table 3-1. The functional relationships that exist among cooling water systems required for safe shutdown are shown in Figure 3-1. Details on the individual cooling water systems are provided in the report sections identified in Table 3-1.

Table 3-1. Summary of Browns Ferry 3 Systems Covered in this Report

<u>Generic System Name</u>	<u>Plant-Specific System Name</u>	<u>Report Section</u>	<u>FSAR Section Reference</u>
Reactor Heat Removal Systems			
- Reactor Coolant System (RCS)	Same	3.1	4
- Reactor Core Isolation Cooling (RCIC) Systems	Same	3.2	4.7
- Emergency Core Cooling Systems (ECCS)	Core Standby Cooling Systems	-	-
- High-Pressure Injection & Recirculation	High-Pressure Coolant Injection (HPCI) System	3.3	6.4.1
- Low-Pressure Injection & Recirculation	Core Spray (CS) System, Low-Pressure Coolant Injection (LPCI) Subsystem (an operating mode of the RHR system)	3.3 3.3	6.4.3 4.8.6.3, 6.4.4
- Automatic Depressurization System (ADS)	Same	3.3	6.4.2
- Decay Heat Removal System (Residual Heat Removal (RHR) System)	Residual Heat Removal (RHR) System (a multi-mode system)	3.3	4.8
- Main Steam and Power Conversion Systems	Main Steam System, Condensate and Reactor Feedwater System, Condenser Circulating Water System	X X X	4.5, 4.6, 4.11 11.8 11.6
- Other Heat Removal Systems	None noted	-	-

3

7/89

Table 3-1. Summary of Browns Ferry 3 Systems Covered in this Report (Continued)

<u>Generic System Name</u>	<u>Plant-Specific System Name</u>	<u>Report Section</u>	<u>FSAR Section Reference</u>
Reactor Coolant Inventory Control Systems			
- Reactor Water Cleanup (RWCU) System	Same	X	4.9
- ECCS	See Core Standby Cooling Systems above	-	-
- Control Rod Drive Hydraulic System (CRDHS)	Control Rod Drive Hydraulic Supply and Discharge Subsystem	3.6	3.4.5.3.1
Containment Systems			
- Primary Containment	Same (drywell and pressure suppression chamber)	X	5.2
- Secondary Containment	Same	X	5.3
- Standby Gas Treatment System (SGTS)	Same	X	5.3.3.7
- Containment Heat Removal Systems			
- Suppression Pool Cooling System	Containment Cooling Subsystem (an operating mode of the RHR system)	X	4.8.6.2
- Containment Spray System	Containment Cooling Subsystem (an operating mode of the RHR system)	X	4.8.6.2
- Containment Fan Cooler System	Primary Containment Cooling System, Reactor Building Heating and Ventilation System	X	5.2.3.7
		X	5.3.3.2

Table 3-... Summary of Browns Ferry 3 Systems Covered in this Report (Continued)

<u>Generic System Name</u>	<u>Plant-Specific System Name</u>	<u>Report Section</u>	<u>FSAR Section Reference</u>
Containment Systems (continued)			
- Containment Normal Ventilation Systems	Primary Containment Normal Heating, Ventilation and Air Conditioning Systems,	X	5.2.3.7
	Reactor Building Heating and Ventilation System	X	5.3.3.2
- Combustible Gas Control Systems	Containment Inerting System,	X	5.2.3.8
	Containment Atmosphere Dilution (CAD) System,	X	5.2.6
	Primary Containment Purge	X	5.3.3.6.3
Reactor and Reactivity Control Systems			
- Reactor Core	Same	X	3
- Control Rod System	Control Rod Drive System	X	3.4
- Chemical Poison System	Standby Liquid Control System (SLCS)	X	3.8
Instrumentation & Control (I&C) Systems			
- Reactor Protection System (RPS)	Same	3.4	7.2
- Engineered Safety Feature Actuation System (ESFAS)	Primary Containment and Reactor Vessel Isolation Control System,	X	7.3
	Core Standby Cooling System Control and Instrumentation	3.3	7.4
- Remote Shutdown System	Packup Control System	3.4	7.18
- Other I&C Systems	Various other systems	X	7.5 to 7.17

5

7/89

Table 3-1. Summary of Browns Ferry 3 Systems Covered in this Report (Continued)

<u>Generic System Name</u>	<u>Plant-Specific System Name</u>	<u>Report Section</u>	<u>FSAR Section Reference</u>
Support Systems			
- Class 1E Electric Power System	Same	3.5	8.5 to 8.9
- Non-Class 1E Electric Power System	Same	X	8
- Diesel Generator Auxiliary Systems	Same	3.5	8.5.3
- Component Cooling Water (CCW) System	Reactor Building Closed Cooling Water (RBCCW) System, Emergency Equipment Cooling Water (EECS) System	X 3.7	10.6 10.10
- Service Water System (SWS)	Raw Cooling Water (RCW) System, Raw Service Water System	X X	10.7 10.8
- Residual Heat Removal Service Water (RHRSW) System	Same	3.8	10.9
- Other Cooling Water Systems	None noted	-	-
- Fire Protection Systems	Same	X	10.11
- Room Heating, Ventilating, and Air-Conditioning (HVAC) Systems	Same	X	10.12
- Instrument and Service Air Systems	Control and Service Air Systems	X	10.14
- Refueling and Spent Fuel Systems	New and Spent Fuel Storage, Fuel Pool Cooling and Cleanup System	X X	10.2, 10.3 10.5

6

7/89

Table 3-1. Summary of Browns Ferry 3 Systems Covered in this Report (Continued)

<u>Generic System Name</u>	<u>Plant-Specific System Name</u>	<u>Report Section</u>	<u>FSAR Section Reference</u>
Support Systems (continued)			
- Radioactive Waste Systems	Radioactive Waste Control Systems	X	9
- Radiation Protection Systems	Shielding and Radiation Protection	X	12.3

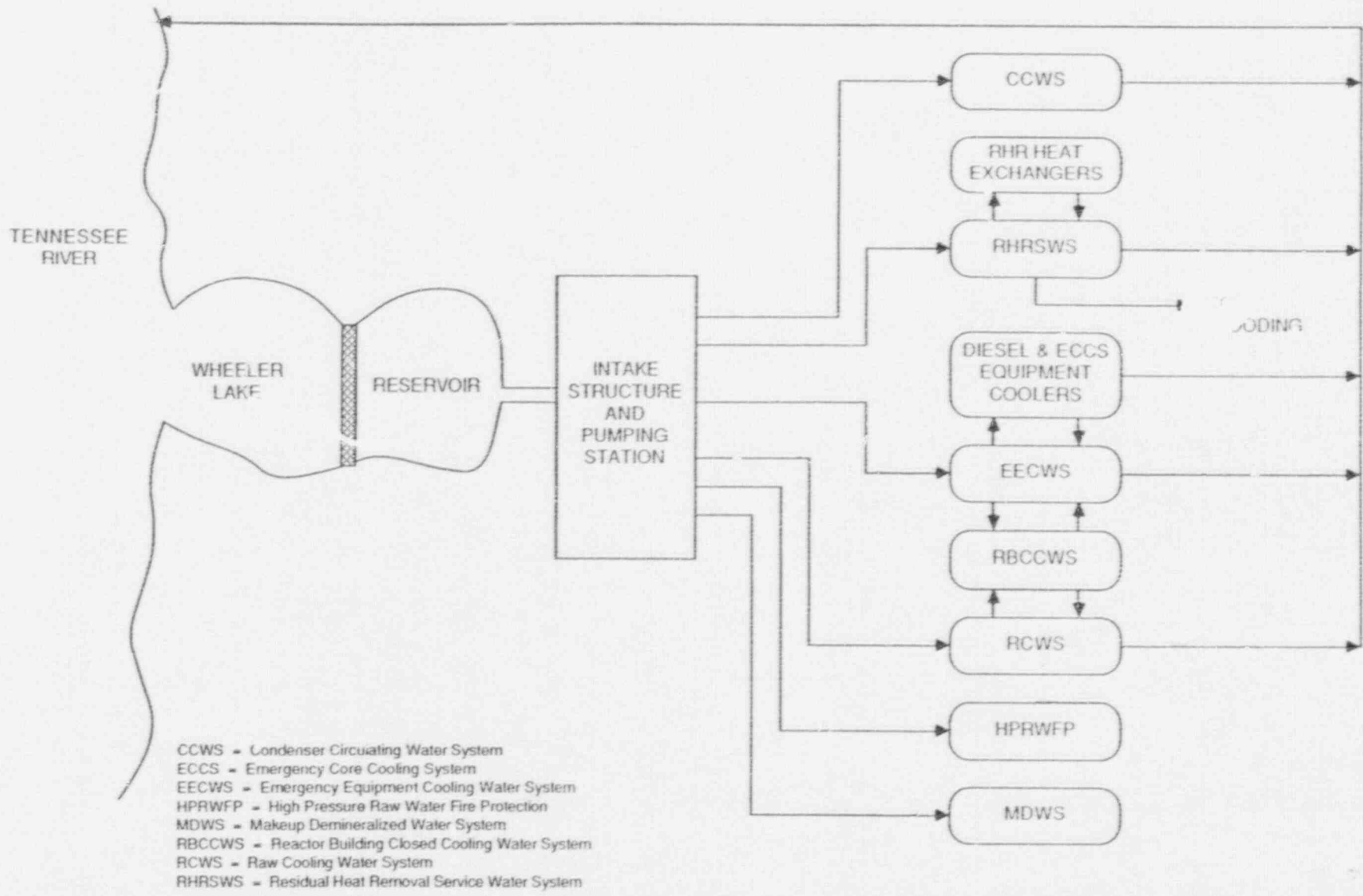

NOTE: At Browns Ferry 2 The RHR Heat Exchangers Also Can Be Supplied From The RCWS.

Figure 3-1. Cooling Water Systems Functional Diagram for Browns Ferry 1, 2 and 3

3.1 REACTOR COOLANT SYSTEM (RCS)

3.1.1 System Function

The RCS, also called the Nuclear Steam Supply System (NSSS), is responsible for directing the steam produced in the reactor to the turbine where it is used to rotate a generator and produce electricity. The RCS pressure boundary also establishes a boundary against the uncontrolled release of radioactive material from the reactor core and primary coolant.

3.1.2 System Definition

The RCS includes: (a) the reactor vessel, (b) two recirculation loops, (c) recirculation pumps, (d) safety valves, and (e) connected piping out to a suitable isolation valve boundary. A simplified diagram of the RCS and important system interfaces is shown in Figure 3.1-1 and 3.1-2. A summary of data on selected RCS components is presented in Table 3.1-1.

3.1.3 System Operation

During power operation, circulation in the RCS is maintained by one recirculation pump in each of the two recirculation loops and the associated jet pumps internal to the reactor vessel. The steam water mixture flows upward in the core to the steam dryers and separators where the entrained liquid is removed. The steam is piped through the main steam lines to the turbine. The separated liquid returns to the core, mixed with the feedwater and is recycled again.

About 1/3 of the liquid in the downcomer region of the reactor vessel is drawn off by the recirculation pumps. The discharge of these pumps is returned to the inlet nozzles of the jet pumps at high velocity. As the liquid enters the jet pumps, the slow moving liquid in the upper region of the downcomer is induced to flow through the jet pumps, producing reactor coolant circulation.

The steam that is produced by the reactor is piped to the turbine via the main steam line. There are two main steam isolation valves (MSIVs) in each main steam line. Condensate from the turbine is returned to the RCS as feedwater.

Following a transient that involves the loss of the main condenser or loss of feedwater, heat from the RCS is dumped to the suppression chamber via safety/relief valves on the main steam lines. A LOCA inside containment or operation of the Automatic Depressurization System (ADS) also dumps heat to the suppression chamber. Makeup to the RCS is provided by the Reactor Core Isolation Cooling (RCIC) system (see Section 3.2) or by the Emergency Core Cooling System (ECCS, see Section 3.3). Heat is transferred from the containment to the ultimate heat sink by the Residual Heat Removal (RHR) system operating in the containment cooling mode. Actuation systems provide for automatic closure of the MSIVs and isolation of other lines connected to the RCS.

3.1.4 System Success Criteria

The RCS success criteria can be described in terms of LOCA and transient mitigation, as follows:

- An unmitigatable LOCA is not initiated.
- If a mitigatable LOCA is initiated, then LOCA mitigating systems are successful.
- If a transient is initiated, then either:
 - RCS integrity is maintained and transient mitigating systems are successful,
 - or

- RCS integrity is not maintained, leading to a LOCA-like condition (i.e. stuck-open safety or relief valve, reactor coolant pump seal failure), and LOCA mitigating systems are successful.

3.1.5 Component Information

- A. RCS
 1. Total volume: Unknown
 2. Water volume: Unknown
 3. Steam volume: Unknown
 4. Steam flow: 13.37×10^6 lb/hr.
 5. Normal operating pressure: 1020 psia
- B. Safety/Relief Valves (13)
 1. Set pressure: 1080 to 1100 psig
 2. Relief capacity: approximately 850,000 to 367,000 lb/hr each
- C. Recirculation Pumps (2)
 1. Rated flow: 46,200 gpm @ 710 ft. head (308 psid)
 2. Type: Vertical centrifugal
- D. Jet Pumps (20)
 1. Total flow: 102.5×10^6 lb/hr @ 76 ft. head (33 psid)

3.1.6 Support Systems and Interfaces

- A. Motive Power
 1. The recirculation pumps are supplied with Nonclass 1E power.
- B. MSIV Operating Power

The instrument air system supports normal operation of the MSIVs. Valve operation is controlled by an AC and a DC solenoid pilot valve. Both solenoid valves must be deenergized to cause MSIV closure. This design prevents spurious closure of an MSIV if a single solenoid valve should fail. MSIVs are designed to fail closed if instrument air is lost or if both AC and DC control power is lost to the solenoid pilot valves. This is achieved by a local dedicated air accumulator for each MSIV and an independent valve closing spring.

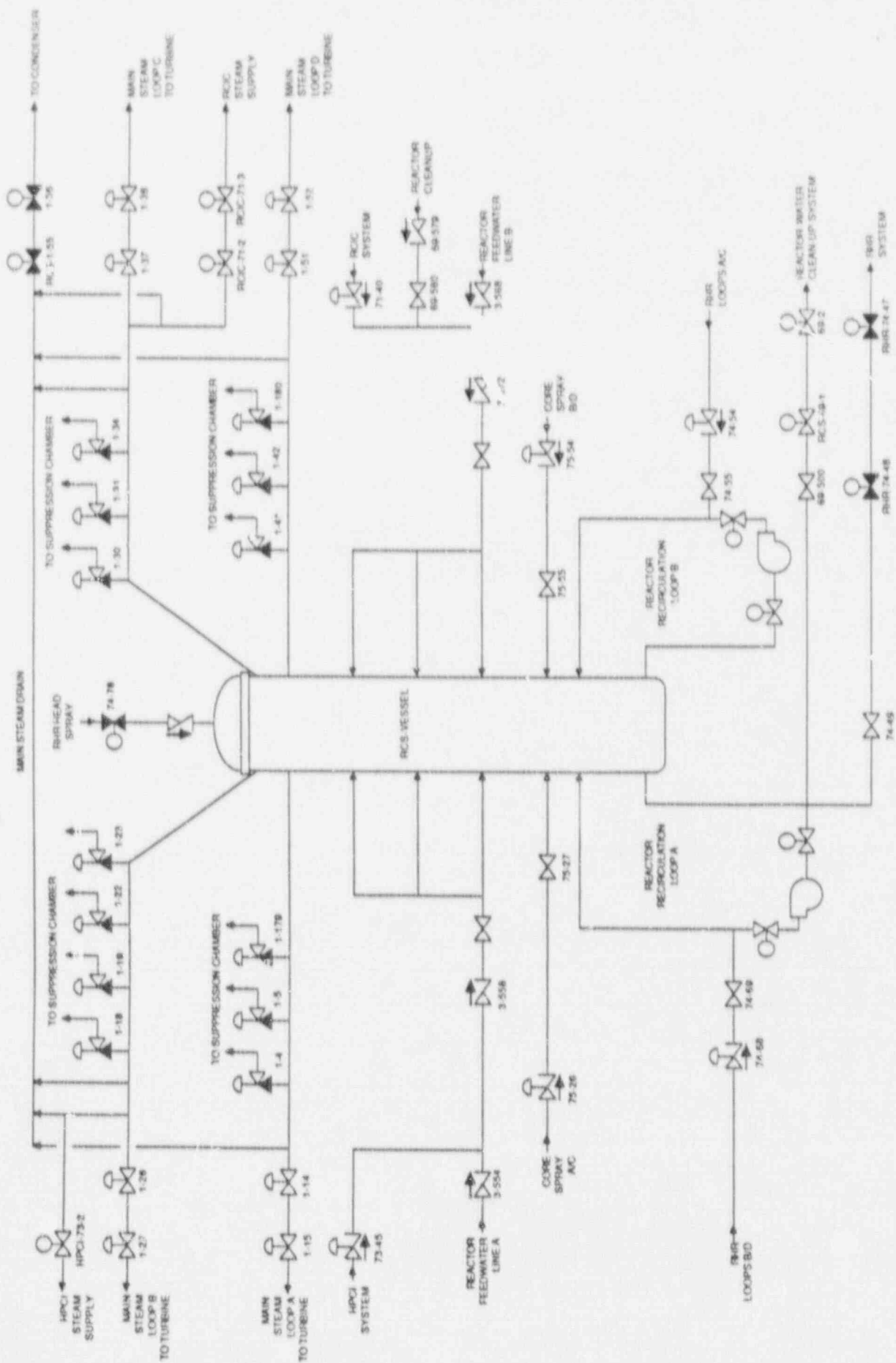

NOTE: SAFETY-RELIEF VALVES (SRVs) 1-15, 1-18, 1-22, 1-25, 1-30, 1-31 AND 1-34 ARE CONTROLLED BY THE AUTOMATIC DEPRESSURIZATION SYSTEM (ADS); SRVs 1-4, 1-18, 1-20, 1-41, 1-42, 1-178 AND 1-180 ARE NON-ADS VALVES THAT CAN BE REMOTELY CONTROLLED BY THE OPERATOR.

Figure 3.1-1. Browns Ferry 3 - Nuclear Boiler System

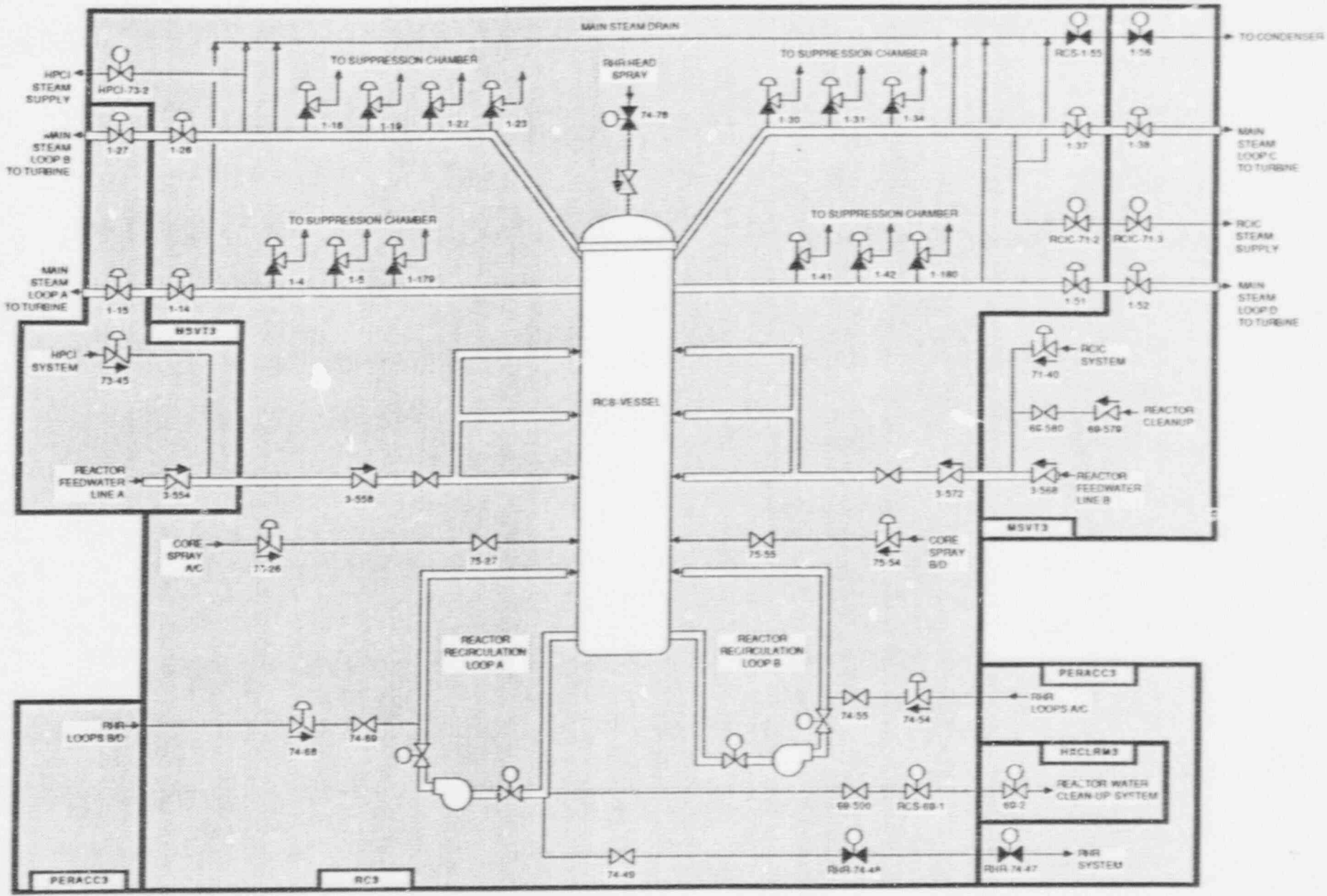

NOTE: SAFETY RELIEF VALVES (SRVS) 1-5, 1-18, 1-22, 1-30, 1-31 AND 1-34 ARE CONTROLLED BY THE AUTOMATIC DEPRESSURIZATION SYSTEM (ADS). SRVS 1-4, 1-18, 1-23, 1-41, 1-42, 1-179 AND 1-183 ARE NON-ADS VALVES THAT CAN BE REMOTELY CONTROLLED BY THE OPERATOR.

Figure 3.1-2. Browns Ferry 3 - Nuclear Boiler System Showing Component Locations

12

7/89

**Table 3.1-1. Browns Ferry 3 Reactor Coolant System Data Summary
for Selected Components**

COMPONENT ID	COMP. TYPE	LOCATION	POWER SOURCE	VOLTAGE	POWER SOURCE LOCATION	EMERG. LOAD GRP
1-179	SRV	RC3	DC-MOV3B	250	SDRMF	I-1
1-18	SRV	RC3	DC-MOV3B	250	SDRMF	I-1
1-180	SRV	RC3	DC-MOV3C	250	565RB3	I-1
1-19	SRV	RC3	DC-MOV3B	250	SDRMF	I-1
1-22	SRV	RC3	DC-MOV3A	250	SDRME	II-1
1-23	SRV	RC3	DC-MOV3C	250	565RB3	I-1
1-30	SRV	RC3	DC-MOV ² A	250	SDRME	II-1
1-31	SRV	RC3	DC-MOV3B	250	SDRMF	I-1
1-34	SRV	RC3	DC-MOV3C	250	565RB3	I-1
1-4	SRV	RC3	DC-MOV3A	250	SDRME	II-1
1-41	SRV	RC3	DC-MOV3A	250	SDRME	II-1
1-42	SRV	RC3	DC-MOV3B	250	SDRMF	I-1
1-5	SRV	RC3	DC-MOV3C	250	565RB3	I-1
HPCI-73-2	MOV	RC3	AC-MOV3A	480	SDRME	I
HPCI-73-3	MOV	TORUS3	DC-MOV3A	250	SDRME	II-1
RCIC-71-2	MOV	RC3	AC-MOV3B	480	SDRMF	II
RCIC-71-3	MOV	MSVT3	DC-MOV3C	250	565RB3	I-1
RCS-1-55	MOV	RC3	AC-MOV3A	480	SDRME	I
RCS-69-1	MOV	RC3	AC-MOV3A	480	SDRME	I
RCS-69-2	MOV	HXCLRM3	DC-MOV3B	250	SDRMF	I-1
RCS-VESSEL	RV	RC3				
RHR-74-47	MOV	PERACC3	DC-MOV3B	250	SDRMF	I-1
RHR-74-48	MOV	RC3	AC-MOV3A	480	SDRME	I

3.2 REACTOR CORE ISOLATION COOLING (RCIC) SYSTEM

3.2.1 System Function

The reactor core isolation cooling system provides adequate core cooling in the event that reactor isolation is accompanied by loss of feedwater flow. This system provides makeup at reactor operating pressure and does not require RCS depressurization.

The RCIC system is not considered to be part of the Emergency Core Cooling System (ECCS, see Section 3.3) and does not have a LOCA mitigating function.

3.2.2 System Definition

The reactor core isolation cooling system consists of a steam-driven turbine pump and associated valves and piping for delivering makeup water from the condensate storage tank (CST) or the suppression pool to the reactor pressure vessel.

Simplified drawings of the reactor core isolation cooling system are shown in Figures 3.2-1 and 3.2-2. The water supply path from the CSTs to the RCIC system are described in Section 3.3. A summary of data on selected RCIC components is presented in Table 3.2-1.

3.2.3 System Operation

During normal operation the RCIC is in standby with the steam supply valve to the RCIC turbine driven pump closed and the pump suction aligned to the condensate storage tank.

Upon receipt of an RPV low water level signal, the turbine-pump steam supply valve is opened and makeup water is supplied to the RPV. The primary water supply for the RCIC is the condensate storage water tank. The suppression pool is used as a backup water supply. Reactor core heat is dumped to the suppression pool via the safety/relief valves which cycle as needed to limit RCS pressure. The RCIC turbine also exhausts to the suppression pool.

3.2.4 System Success Criteria

For the RCIC system to be successful there must be at least one water source and supply path to the turbine-driven pump, an open steam supply path to the turbine, an open discharge path to the RCS, and an open turbine exhaust path to the suppression pool.

3.2.5 Component Information

- A. Steam turbine-driven RCIC pump:
 1. Rated Flow: 600 gpm @ 2800 ft. head (1214 psid)
 2. Rated Capacity: 100%
 3. Type: centrifugal
- B. Condensate Storage Tanks (3)
 1. Capacity: 375,000 gal each

3.2.6 Support System and Interfaces

- A. Control Signals
 1. Automatic
 - a. The RCIC pump is automatically actuated on a reactor vessel low water level signal.
 - b. The RCIC pump is automatically tripped on a reactor vessel high water level signal. It may be necessary to restart the pump manually.

- c. The RCIC system will be automatically isolated if any of the following conditions exist:
- High temperature (200°F) in RCIC steam line space
 - High flow (delta P) in RCIC steam line
 - Low RCIC steam line pressure (50 psig)
 - High exhaust pressure from RCIC turbine
 - Manual isolation

B. Motive Power

1. The RCIC turbine driven pump is supplied with steam from main steam loop C, upstream of the main steam isolation valves.
2. All RCIC valves and supporting equipment are Class 1E loads that are supplied from the DC and AC power systems as described in Section 3.5. The RCIC system is design. 1 to be operable on DC power only.

C. Other

1. Lubrication and cooling for the turbine-driven pump are supplied locally. It should be noted that the pump lube oil cooler is cooled by water diverted from the RCIC pump discharge and returned to the barometric condenser. Design maximum lube oil cooling water temperature is 140°F.
2. The source of RCIC pump room cooling has not been identified. The RCIC pump is located in the northwest pump room in the reactor building where core spray pumps 1A and 1C also are located. Room cooling for the CSS pumps is described in Section 3.3.
3. RCIC pump gland seal leakoff is collected, condensed and returned to the pump suction. A vacuum pump maintains condenser vacuum.

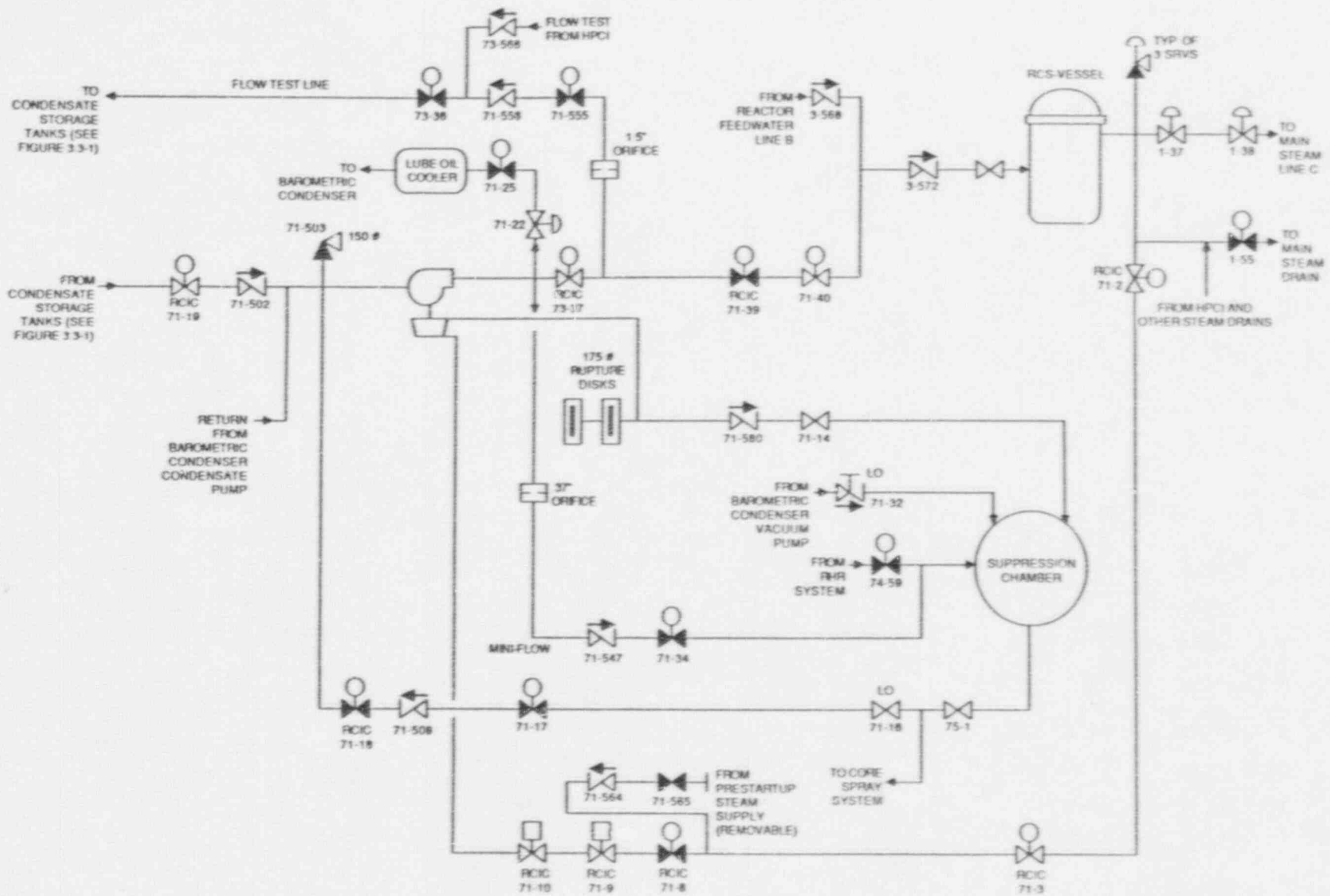

Figure 3.2-1. Browns Ferry 3 Reactor Core Isolation Cooling (RCIC) System

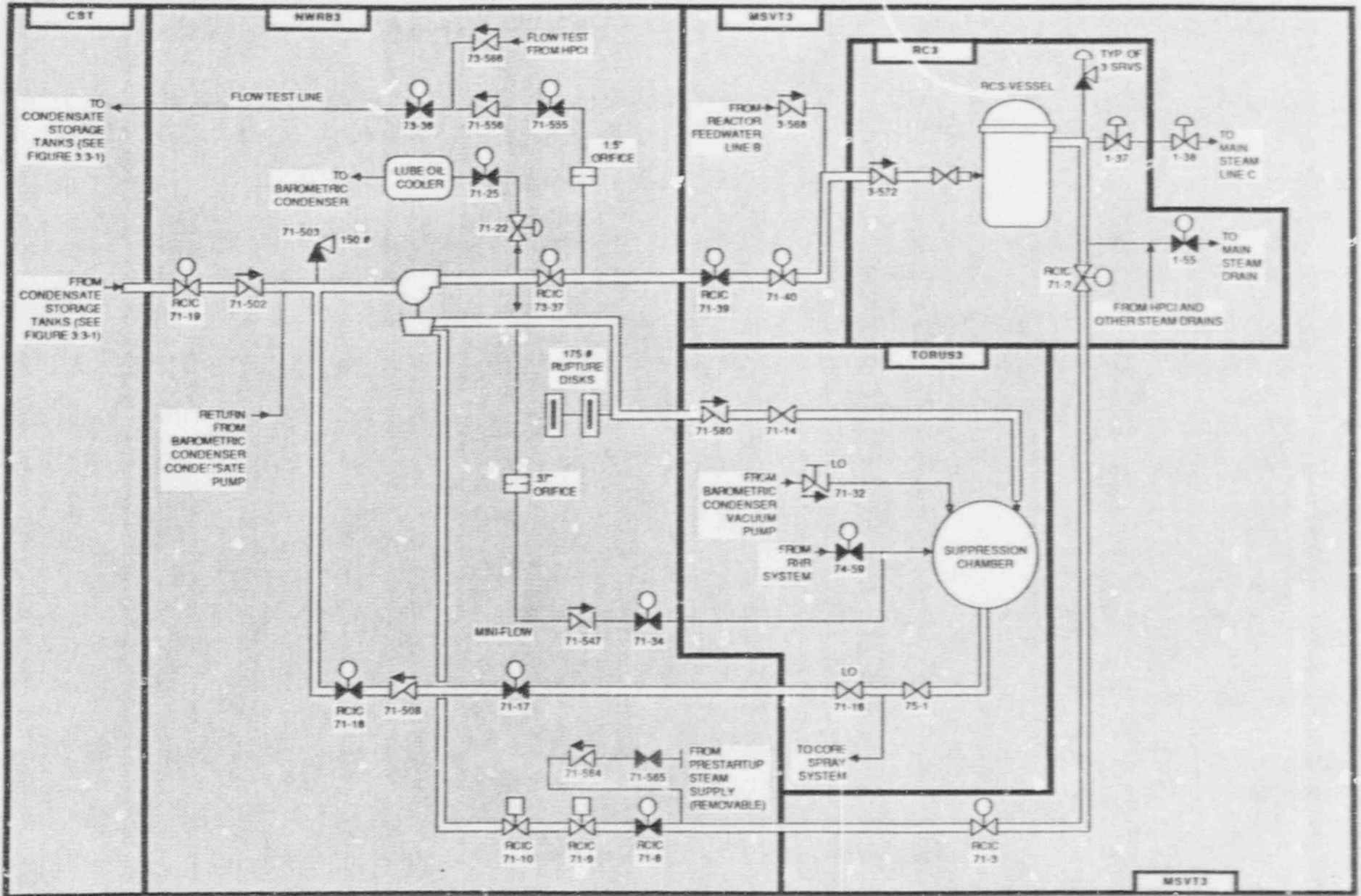

Figure 3.2-2. Browns Ferry 3 Reactor Core Isolation Cooling (RCIC) System Showing Component Locations

Table 3.2-1. Browns Ferry 3 Reactor Core Isolation Cooling System Data Summary for Selected Components

COMPONENT ID	COMP. TYPE	LOCATION	POWER SOURCE	VOLTAGE	POWER SOURCE LOCATION	EMERG. LOAD GRP
2-162	MOV	CST	UNKNOWN	480	480-WO-STG-BLD	
2-166	MOV	CST	UNKNOWN	480	480-WO-STG-BLD	
2-170	MOV	CST	UNKNOWN	480	480-WO-STG-BLD	
CST1	TK	CST				
CST2	TK	CST				
CST3	TK	CST				
RCIC-71-10	HV	NWRB3	DC-MOV3C	250	565RB3	I-1
RCIC-71-17	MOV	NWRB3	DC-MOV3C	250	565RB3	I-1
RCIC-71-18	MOV	NWRB3	DC-MOV3C	250	565RB3	I-1
RCIC-71-19	MOV	NWRB3	DC-MOV3C	250	565RB3	I-1
RCIC-71-2	MOV	RC3	AC-MOV3B	480	SDRMF	I-1
RCIC-71-3	MOV	NWRB3	DC-MOV3C	250	565RB3	I-1
RCIC-71-37	MOV	NWRB3	DC-MOV3C	250	565RB3	I-1
RCIC-71-39	MOV	MSVT3	DC-MOV3C	250	565RB3	I-1
RCIC-71-8	MOV	NWRB3	DC-MOV3C	250	565RB3	I-1
RCIC-71-9	HV	NWRB3	DC-MOV3C	250	565RB3	I-1
RCIC-TDP	TDP	NWRB3				

3.3 EMERGENCY CORE COOLING SYSTEM (ECCS)

3.3.1 System Function

The ECCS is an integrated set of subsystems that perform emergency coolant injection and recirculation functions to maintain reactor core coolant inventory and adequate decay heat removal following a LOCA. The ECCS also performs suppression pool cooling and containment spray functions and has a capability for mitigating transients.

3.3.2 System Definition

The emergency core cooling system consists of the following subsystems:

- High-pressure Coolant Injection (HPCI) System
- Automatic Depressurization System (ADS)
- Core Spray System (CSS)
- Low-pressure Coolant Injection (LPCI) System

The HPCI system provides make-up water to the reactor pressure vessel (RPV) in the event of a small break LOCA which does not result in a rapid depressurization of the reactor vessel. The HPCI system consists of a steam-turbine driven pump, system piping, valves and controls.

The automatic depressurization system (ADS) provides automatic RPV depressurization following a small break LOCA or transient so that the low pressure systems (LPCI and CSS) can provide makeup to the RCS. The ADS utilize 6 of the 13 safety/relief valves that perform the RCS overpressure protection function and discharge the high pressure steam to the suppression pool.

The core spray system supplies make-up water to the reactor vessel at low pressure. The system consists of two independent trains, each of which has two motor-driven pumps to supply water from the suppression pool to a spray sparger in the reactor vessel above the core.

The low-pressure coolant injection system is an operating mode of the Residual Heat Removal (RHR) system, and provides make-up water to the reactor vessel at low pressure. The LPCI system consists of two independent trains each with two motor-driven pumps which deliver water from the suppression pool to one of the RCS recirculation loops.

The condensate storage system, consisting of three Condensate Storage Tanks (CSTs), provides a water source for the ECCS and for the RCIC system. This system is shown in Figure 3.3-1. The HPCI system is shown in Figures 3.3-2 and 3.3-3. Simplified diagrams of the LPCI system are presented in Figures 3.3-4 and 3.3-5 and the core spray system is shown in Figures 3.3-6 and 3.3-7. Interfaces between these systems and the RCS are shown in Section 3.1. A summary of data on selected ECCS components is presented in Table 3.3-1.

3.3.3 System Operation

All ECCS systems normally are in standby. The manner in which the ECCS operates to protect the reactor core is a function of the rate at which coolant is being lost from the RCS. The HPCI system is normally aligned to take a suction on the Condensate Storage Tank (CST). The HPCI system is automatically started in response to decreasing RPV water level, and will serve as the primary source of makeup if RCS pressure remains high. Reactor core heat is dumped to the suppression pool via the safety/relief valves which cycle as needed to limit RCS pressure. The HPCI turbine also exhausts to the suppression pool. Operation of the HPCI system is not directly dependent on AC electric power. If the LOCA is of such a size that the coolant loss exceeds the HPCI system

capacity or if reactor pressure is too low to operate the steam turbine-driven HPCI pump, then the CSS and LPCI systems can provide higher capacity makeup to the reactor vessel.

Automatic depressurization is provided to automatically reduce RCS pressure if a small break has occurred and RPV water level is not maintained by the HPCI system. Rapid depressurization permits flow from the CSS or LPCI systems to enter the vessel. Water is taken from the suppression pool by each of these systems for injection into the core. Both systems can be aligned to take a suction on the CST.

A large LOCA results in rapid depressurization of the RCS. This class of LOCA is mitigated by the CSS or LPCI systems without the need for the ADS.

3.3.4 System Success Criteria

LOCA mitigation requires that both the emergency coolant injection (ECI) and emergency coolant recirculation (ECR) functions be accomplished. The ECCS success criteria are not clearly defined in the Browns Ferry 3 FSAR but can be inferred from pump capacities that are defined based on certain design basis accidents that are considered in the licensing process based on licensing considerations. The ECI system success criteria for a large LOCA are the following:

- 2 of 4 core spray pumps with a suction on the suppression pool, or
- 3 of the 4 low pressure coolant injection pumps with a suction on the suppression pool.

The ECI system success criteria for a small LOCA are the following:

- The high-pressure coolant injection (HPCI) pump with a suction on the suppression pool or the condensate storage tank, or
- The automatic depressurization system (ADS) and 3 of 4 LPCI pumps with a suction on the suppression pool, or
- The automatic depressurization system and 2 of 4 core spray pumps with a suction on the suppression pool.

The success criterion for the ADS is the use of any 3 of 6 ADS valves (Ref. 1). Note that there may be integrated success criteria involving combinations of core spray and LPCI pumps. It is possible that the coolant inventory control function for some small LOCAs can be satisfied by low-capacity high-pressure injection systems such as the control rod drive hydraulic system (see Section 3.6).

The ECR success criteria for LOCAs are related to the ECI success criteria above. All injection systems essentially are operating in a recirculation mode when drawing water from the suppression pool.

For transients, the success criteria for reactor coolant inventory control involve the following:

- Either the reactor core isolation cooling (RCIC) system (not part of the ECCS, see Section 3.2), or
- Small LOCA mitigating systems

For the suppression pool cooling function to be successful, two of four RHR trains must be aligned for containment heat removal and the associated RHR service water train must be operating to complete the heat transfer path from the RHR heat exchangers to the ultimate heat sink.

3.3.5 Component Information

- A. Steam turbine-driven HPCI pump
 - 1. Rated flow: 5000 gpm @ 2800 ft head (1214 psid)
 - 2. Rated capacity: 100%
 - 3. Type: centrifugal
- B. Low-pressure Core Injection (RHR) Pumps (A, B, C and D)
 - 1. Rated flow: 10,000 gpm @ 46 ft. head (20 psid)
 - 2. Rated capacity: 33 1/3%
 - 3. Type: centrifugal
- C. Core spray pumps (A, B, C and D)
 - 1. Rated flow: 3125 gpm @ 582 ft. head (252 psid)
 - 2. Rated capacity: 50%
 - 3. Type: centrifugal
- D. Automatic-depressurization valves (6)
 - 1. Rated capacity: 3 of 6 required
 - 2. Rated flow: approximately 850,000 lb/hr each
- E. Pressure Suppression Chamber
 - 1. Design pressure: 56 psig
 - 2. Design temperature: 281°F
 - 3. Minimum operating temperature: 95°F (assumed)
 - 4. Minimum water volume: 135,000 ft³
- F. RHR Heat Exchangers (A, B, C and D)
 - 1. Rated Capacity: 70 x 10⁶ Btu/hr each
 - 2. Type: Shell-and-tube

3.3.6 Support Systems and Interfaces

- A. Control signals
 - 1. Automatic
 - a. The HPCI pump, core spray pumps and the LPCI pumps and all their associated valves function upon receipt of low water level in the reactor vessel or high pressure in the drywell.
 - b. The HPCI pump is automatically tripped on a reactor vessel high water level signal. It may then be necessary to restart the pump manually.
 - c. The HPCI pump suction is automatically switched to the suppression pool on high suppression pool water level.
 - d. The ADS system is actuated upon coincident signals of the reactor vessel low water level, drywell high pressure and discharge pressure indication on any LPCI or CSS pump but with a 2-min delay.
 - e. LPCI initiation automatically causes all RHR components to perform their function under the LPCI mode.
 - 2. Remote manual

ECCS pumps and valves and the ADS can be actuated by remote manual means from the main control room.

B. Motive Power

1. The ECCS motor-driven pumps and motor-operated valves are Class 1E AC and DC loads that can be supplied from the emergency diesel generator or station battery, as described in Section 3.5.
2. The steam supply valves to the HPCI turbine are Class 1E loads. Valves that must open to start the pump are DC-powered. Normally open isolation valve 73-2 is AC powered.
3. The HPCI turbine-driven pump is supplied with steam from main steam loop B, upstream of the main steam isolation valves.

C. Pump Cooling Water

1. Lubrication and cooling for the HPCI turbine-driven pump are supplied locally. It should be noted that the pump lube oil cooler is cooled by water diverted from the HPCI pump discharge and returned to the pump suction. Design maximum cooling water temperature for the HPCI pump is not known. For the turbine-driven RCIC pump, the limit is 140°F (see Section 3.2).
2. The LPCI (RHR) pump seals are cooled by the emergency equipment cooling water (EECW) system (see Section 3.7).

D. Pump Room Cooling

1. Pump room coolers served by the EECW system are provided for the following pump rooms in the reactor building:

- South-west room	:	LPCI pumps A and C
- South-east room	:	LPCI pumps B and D
- North-west room	:	CSS pumps A and C, RCIC pump
- North-east room	:	CSS pumps B and D

One fan cooler unit is provided in each of the CSS pump rooms and two fan cooler units are in each of the LPCI pump rooms. These fan cooler units are powered from 480 VAC Class 1E MOV boards. The EECW supply to these room coolers is described in Section 3.7.

2. The source of HPCI pump room cooling has not been identified. The HPCI pump room is adjacent to the south-west room containing LPCI pumps A and C, and may share the LPCI room cooler.

E. Other

1. The hydraulic steam turbine stop and governor valves (73-18 and 73-19 respectively) are normally closed. These valves must be opened by a DC-powered auxiliary oil pump in order to start the HPCI pump. A shaft-driven oil pump provides hydraulic pressure to maintain these valves open once the HPCI pump is operating.
2. HPCI pump and valve leakoff is collected and condensed in a gland seal condenser. A condensate pump returns the condensate to the HPCI pump suction. A vacuum pump maintains condenser vacuum. This vacuum pump exhaust to the standby gas treatment system.

3.3.7 Section 3.3. References

1. NUREG/CR-2802, "Interim Reliability Evaluation Program Analysis of the Browns Ferry Unit 1 Nuclear Plant", EG&G Idaho, July 1982.

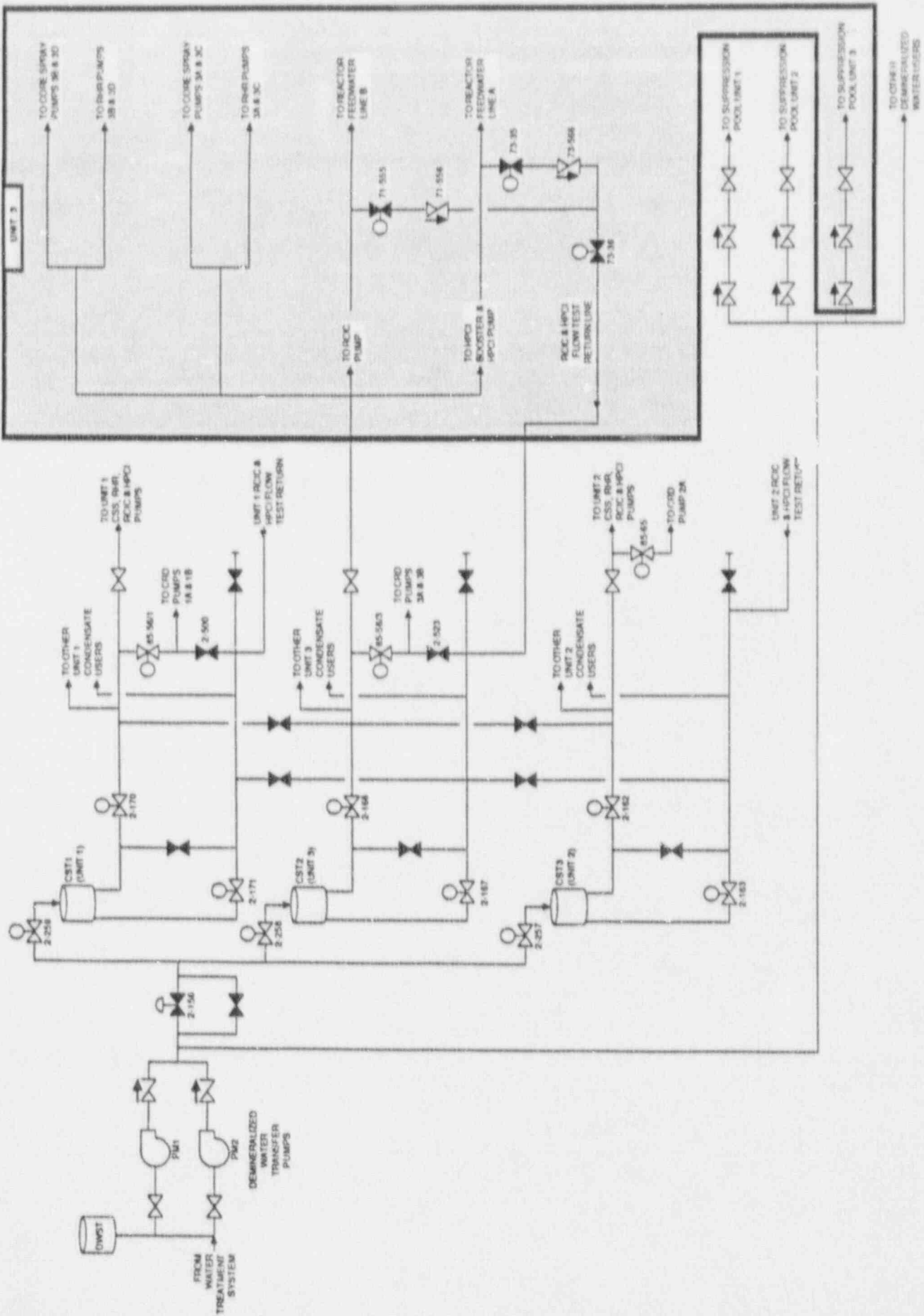
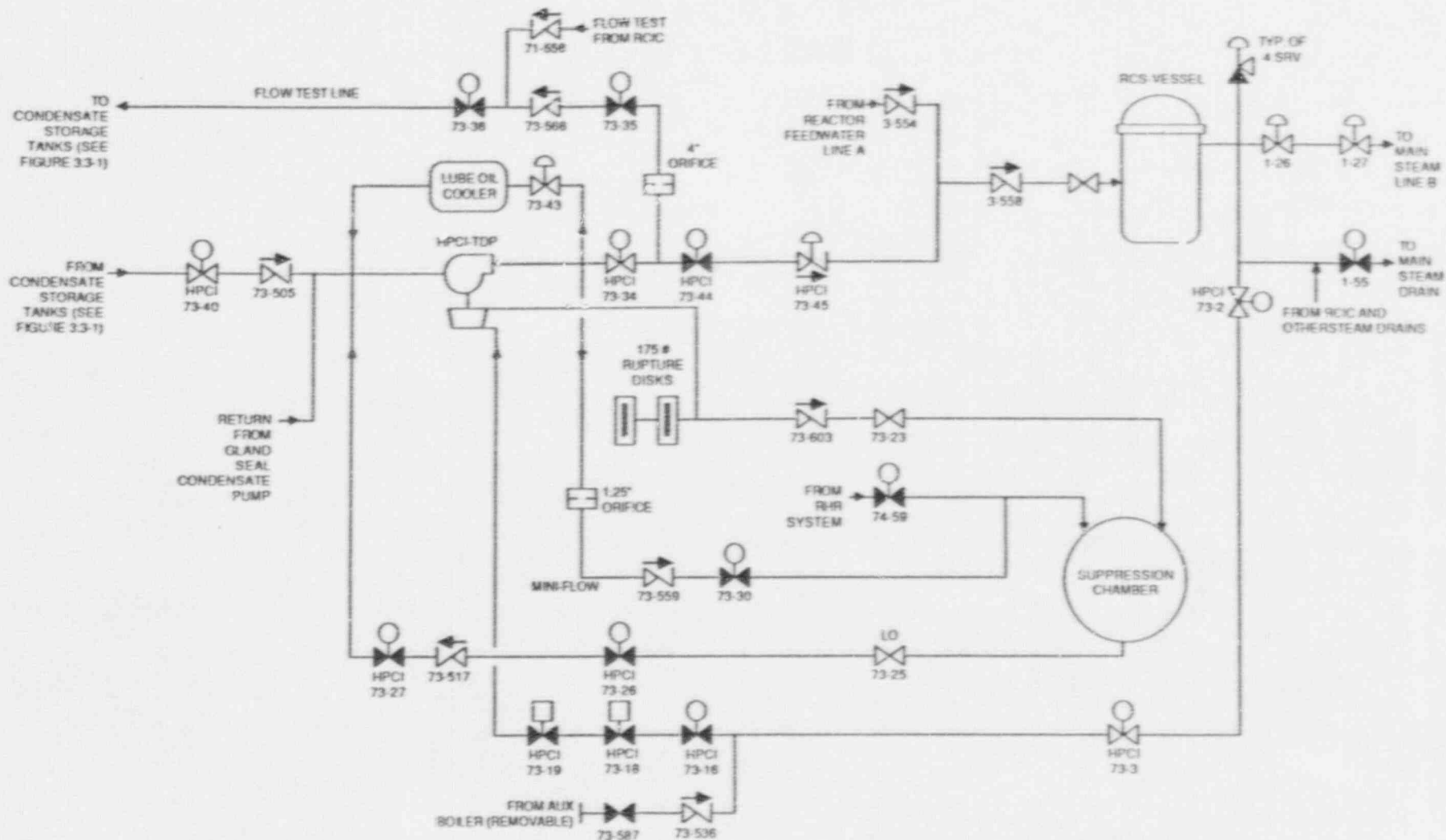
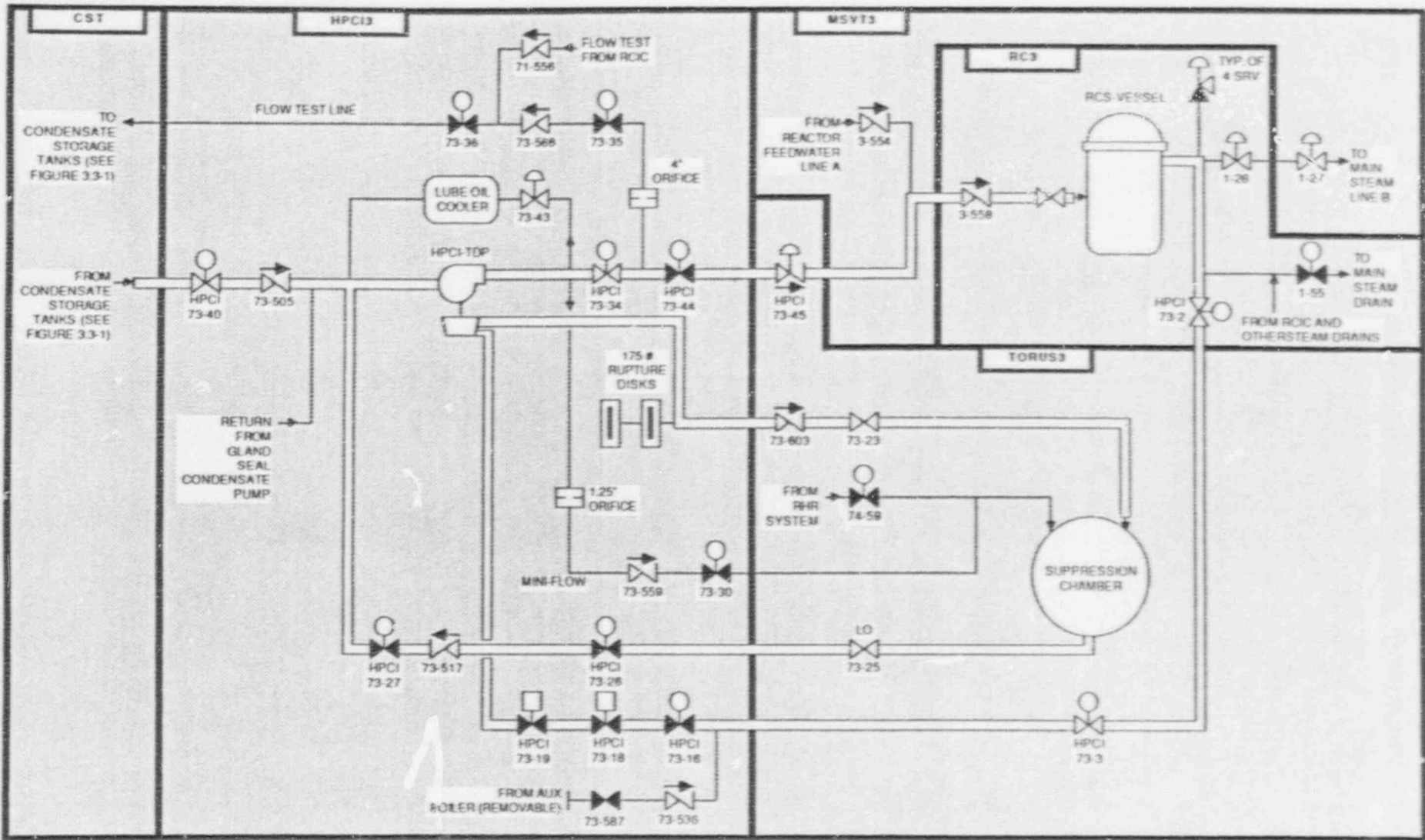

Figure 3.3-1. Browns Ferry 3 Condensate Water Sources for ECCS, RCIC and CRDHS Systems



NOTE: HPCI PUMP AND HPCI BOOSTER ARE SHOWN AS A SINGLE UNIT.

Figure 3.3-2. Browns Ferry 3 High Pressure Coolant Injection (HPCI) System



NOTE: HPCI PUMP AND HPCI BOOSTER ARE SHOWN AS A SINGLE UNIT.

Figure 3.3-3. Browns Ferry 3 High Pressure Coolant Injection (HPCI) System Showing Component Locations

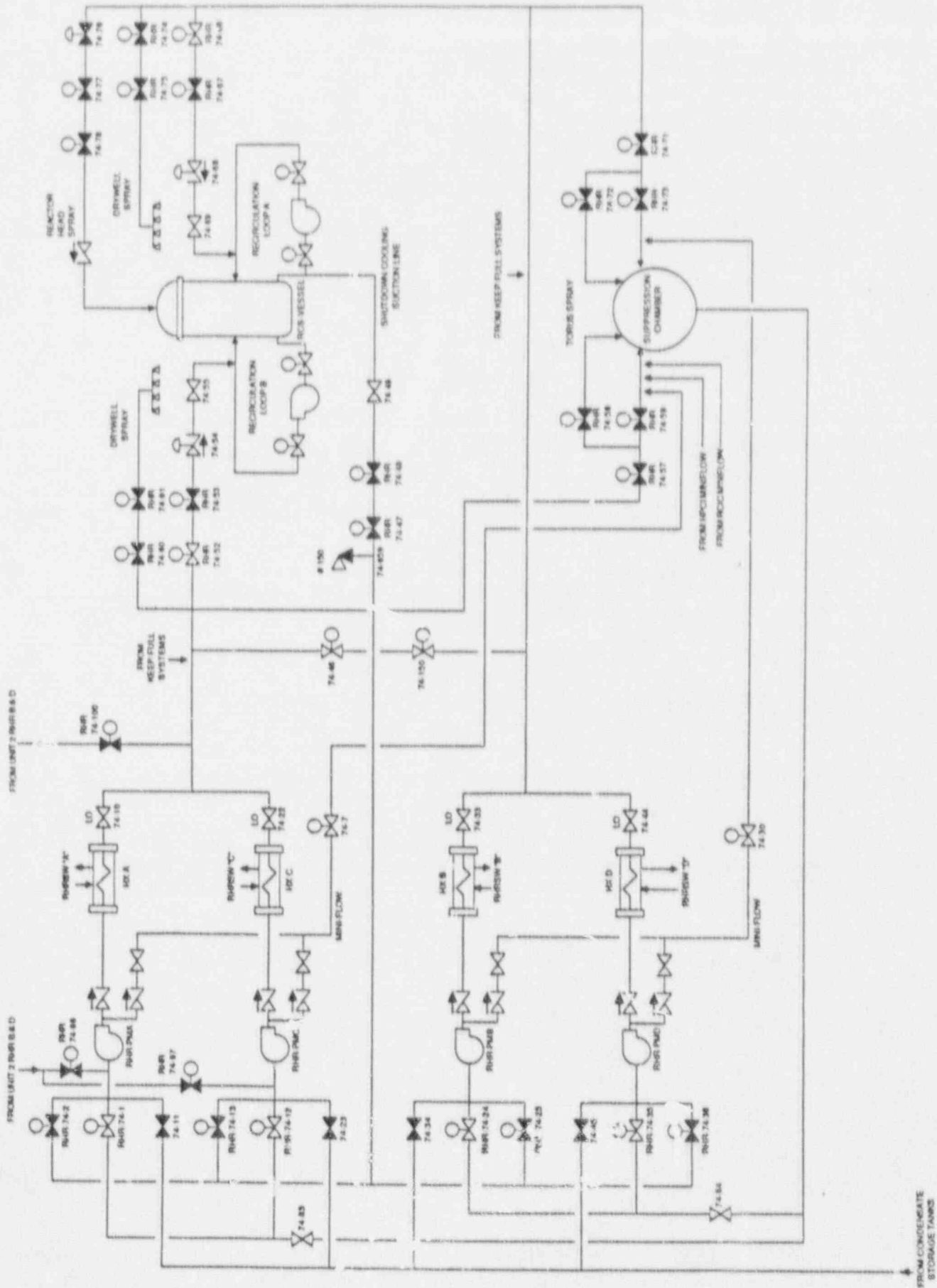

Figure 3.3-4. Browns Ferry 3 Low Pressure Coolant Injection System

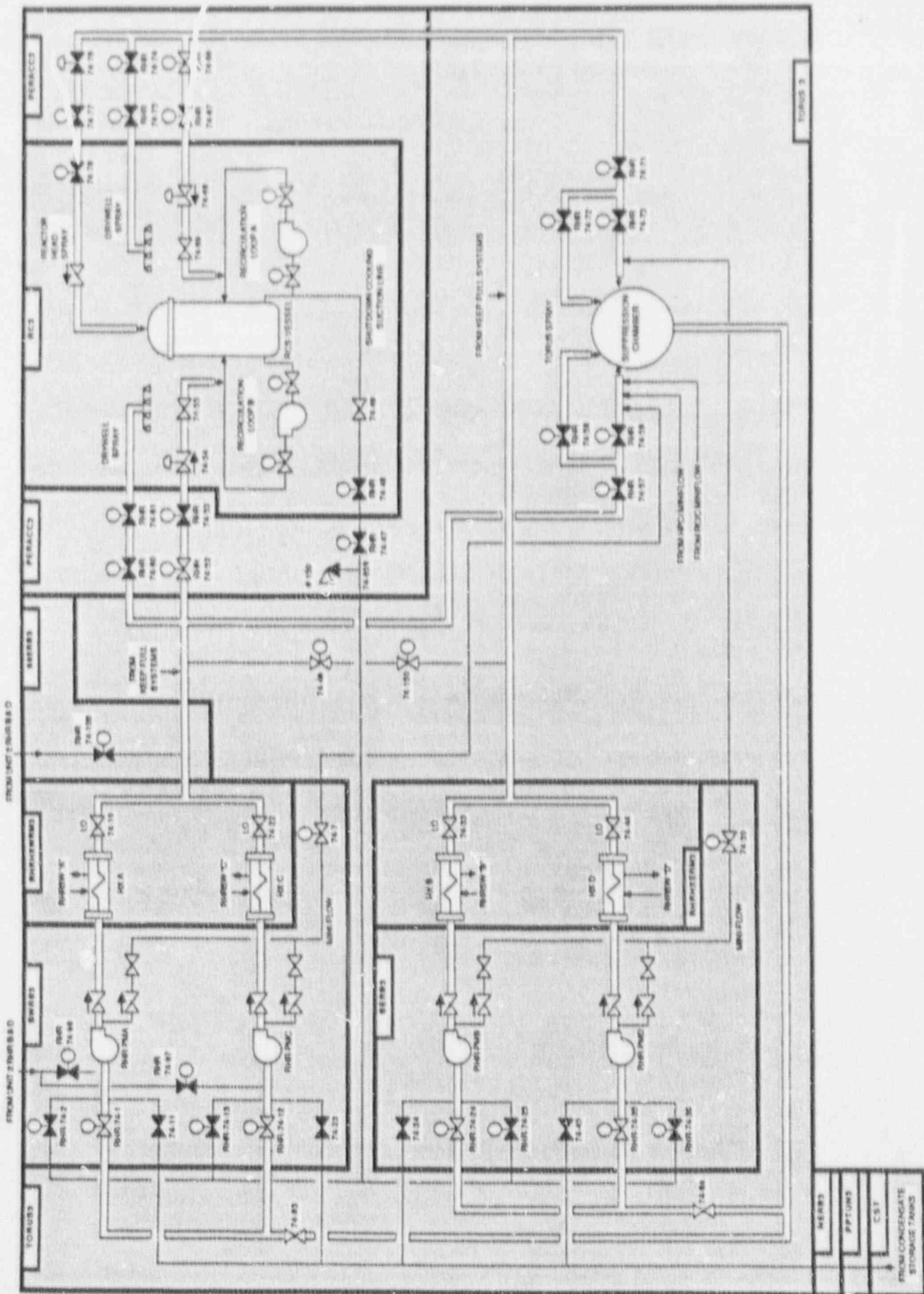

Figure 3.3-5. Browns Ferry 3 Low Pressure Coolant Injection System Showing Component Locations

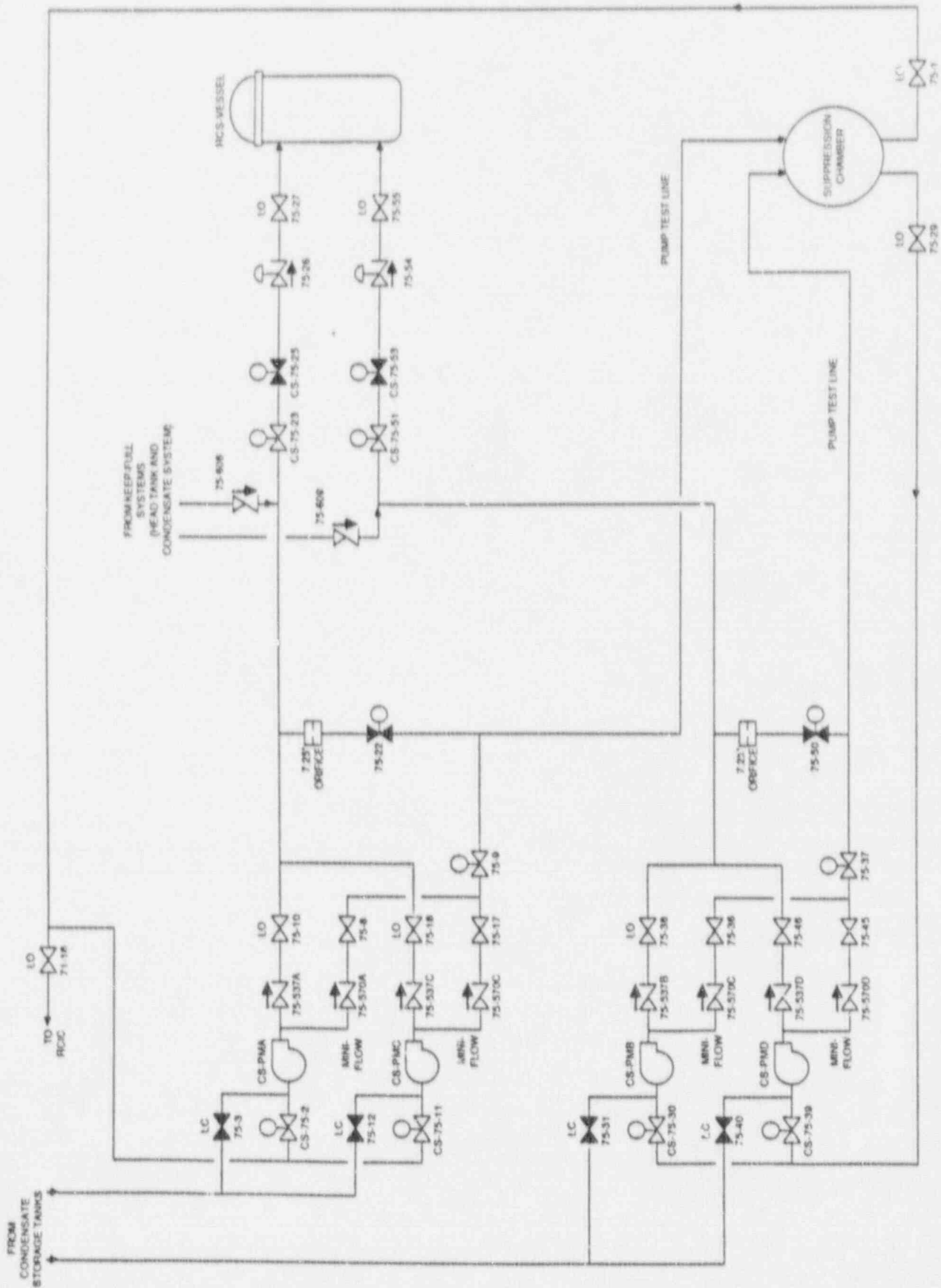

Figure 3.3-6. Browns Ferry 3 Core Spray System (CSS)

29

7/89

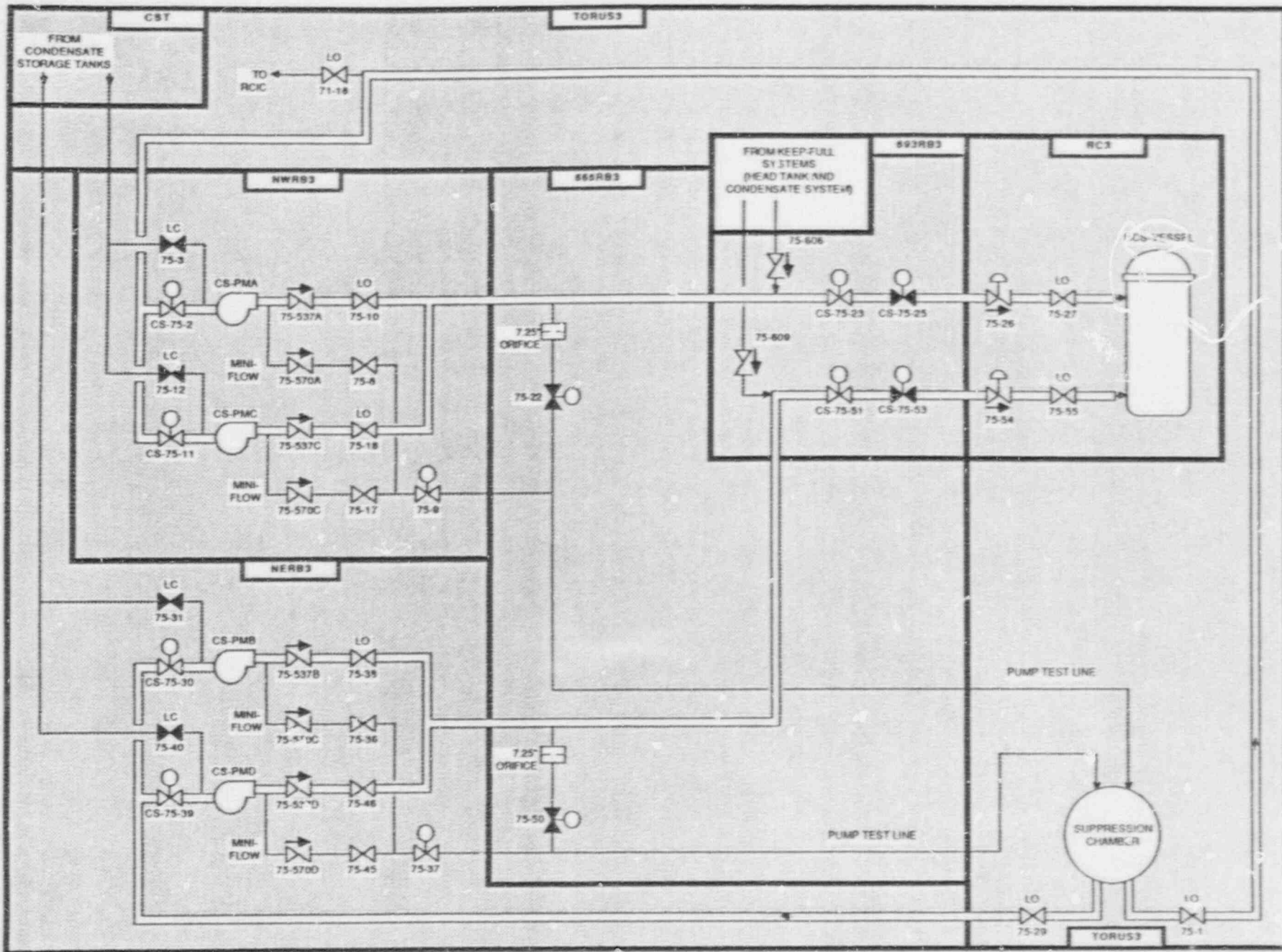

Figure 3.3-7. Browns Ferry 3 Core Spray System (CSS) Showing Component Locations

Table 3.3-1. Browns Ferry 3 Emergency Core Cooling System Data Summary for Selected Components

COMPONENT ID	COMP. TYPE	LOCATION	POWER SOURCE	VOLTAGE	POWER SOURCE LOCATION	EMERG. LOAD GRP
2-162	MOV	CST	UNKNOWN	480	480-WO-STG-BLD	
2-166	MOV	CST	UNKNOWN	480	480-WO-STG-BLD	
2-170	MOV	CST	UNKNOWN	480	480-WO-STG-BLD	
CS-75-11	MOV	NWRB3	AC-MOV3A	480	SDRME	I
CS-75-2	MOV	NWRB3	AC-MOV3A	480	SDRME	I
CS-75-23	MOV	593RB3	AC-MOV3A	480	SDRME	I
CS-75-25	MOV	593RB3	AC-MOV3A	480	SDRME	I
CS-75-30	MOV	NERB3	AC-MOV3B	480	SDRMF	II
CS-75-39	MOV	NERB3	AC-MOV3B	480	SDRMF	II
CS-75-51	MOV	593RB3	AC-MOV3B	480	SDRMF	II
CS-75-53	MOV	593RB3	AC-MOV3B	480	SDRMF	II
CS-PMA	MDP	NWRB3	EP-SB3EA	4160	SDRM3EA	I
CS-PMB	MDP	NERB3	EP-SB3EC	4160	SDRM3EC	II
CS-PMC	MDP	NWRB3	EP-SB3EB	4160	SDRM3EB	I
CS-PMD	MDP	NERB3	EP-SB3ED	4160	SDRM3ED	II
CST1	TK	CST				
CST2	TK	CST				
CST3	TK	CST				
HPCI-73-16	MOV	HPCI3	DC-MOV3A	250	SDRME	II-1
HPCI-73-18	HV	HPCI3				
HPCI-73-19	HV	HPCI3				
HPCI-73-2	MOV	RC3	AC-MOV3A	480	SDRME	I
HPCI-73-26	MOV	HPCI3	DC-MOV3A	250	SDRME	II-1
HPCI-73-27	MOV	HPCI3	DC-MOV3A	250	SDRME	II-1
HPCI-73-3	MOV	TORUS3	DC-MOV3A	250	SDRME	II-1
HPCI-73-34	MOV	HPCI3	DC-MOV3A	250	SDRME	II-1
HPCI-73-40	MOV	HPCI3	DC-MOV3A	250	SDRME	II-1
HPCI-73-44	MOV	HPCI3	DC-MOV3A	250	SDRME	II-1

Table 3.3-1. Browns Ferry 3 Emergency Core Cooling System Data Summary for Selected Components (Continued)

COMPONENT ID	COMP. TYPE	LOCATION	POWER SOURCE	VOLTAGE	POWER SOURCE LOCATION	EMERG. LOAD GRP
HPCI-AUX-OIL	MDP	HPCI3	DC-MOV3A	250	SDRME	II-1
HPCI-TDP	TDP	HPCI3				
RHR-74-1	MOV	SWRB3	AC-MOV3A	480	SDRME	I
RHR-74-100	MOV	565RB3	AC-MOV3B	480	SDRMF	II
RHR-74-12	MOV	SWRB3	AC-MOV3A	480	SDRME	I
RHR-74-13	MOV	SWRB3	AC-MOV3A	480	SDRME	I
RHR-74-2	MOV	SWRB3	AC-MOV3A	480	SDRME	I
RHR-74-24	MOV	SERB3	AC-MOV3B	480	SDRMF	II
RHR-74-25	MOV	SERB3	AC-MOV3B	480	SDRMF	II
RHR-74-35	MOV	SERB3	AC-MOV3B	480	SDRMF	II
RHR-74-36	MOV	SERB3	AC-MOV3B	480	SDRMF	II
RHR-74-52	MOV	PERACC3	AC-MOV3A	480	SDRME	I
RHR-74-53	MOV	PERACC3	AC-MOV3D	480	593RB3	I
RHR-74-57	MOV	TORUS3	AC-MOV3A	480	SDRME	I
RHR-74-58	MOV	TORUS3	AC-MOV3A	480	SDRME	I
RHR-74-59	MOV	TORUS3	AC-MOV3A	480	SDRME	I
RHR-74-60	MOV	PERACC3	AC-MOV3A	480	SDRME	I
RHR-74-61	MOV	PERACC3	AC-MOV3A	480	SDRME	I
RHR-74-66	MOV	PERACC3	AC-MOV3B	480	SDRMF	II
RHR-74-67	MOV	PERACC3	AC-MOV3C	480	565RB3	II
RHR-74-71	MOV	TORUS3	AC-MOV3B	480	SDRMF	II
RHR-74-72	MOV	TORUS3	AC-MOV3B	480	SDRMF	II
RHR-74-73	MOV	TORUS3	AC-MOV3B	480	SDRMF	II
RHR-74-74	MOV	PERACC3	AC-MOV3B	480	SDRMF	II
RHR-74-75	MOV	PERACC3	AC-MOV3B	480	SDRMF	II
RHR-74-96	MOV	SWRB3	AC-MOV3B	480	SDRMF	II
RHR-74-96	MOV	SWRB3	AC-MOV3B	480	SDRMF	II
RHR-74-97	MOV	SWRB3	AC-MOV3B	480	SDRMF	II

Table 3.3-1. Browns Ferry 3 Emergency Core Cooling System Data Summary for Selected Components (Continued)

COMPONENT ID	COMP. TYPE	LOCATION	POWER SOURCE	VOLTAGE	POWER SOURCE LOCATION	EMERG. LOAD GRP
RHR-74-97	MOV	SWRB3	AC-MOV3B	480	SDRMF	II
RHR-PMA	MDP	SWRB3	EP-SB3EA	4160	SDRM3EA	I
RHR-PMC	MDP	SWRB3	EP-SB3EB	4160	SDRM3EB	I
RHR-PMD	MDP	SERB3	EP-SB3ED	4160	SDRM3ED	II

3.4 INSTRUMENTATION AND CONTROL (I&C) SYSTEMS

3.4.1 System Function

The instrumentation and control systems consist of the Reactor Protection System (RPS), other actuation and control systems, and systems for the display of plant information to the operators. The RPS monitors the reactor plant, and alerts the operator to take corrective action before specified limits are exceeded. The RPS will initiate an automatic reactor trip (scram) to rapidly shutdown the reactor when plant conditions exceed one or more specified limits. The other actuation systems will automatically actuate various safety systems based on the specific limits or combinations of limits that are exceeded. A remote shutdown capability is provided to ensure that the reactor can be placed in a safe condition in the event that the main control room must be evacuated.

3.4.2 System Definition

The RPS includes sensor and transmitter units, logic units, and output trip relays that interface with the control circuits for components in the scram portion of the Control Rod Drive Hydraulic System (see Section 3.6). Other actuation and control systems include independent sensor and transmitter units and relay units that interface with the control circuits of many different components in safety systems. Operator instrumentation display systems consist of display panels that are powered from various DC buses (see Section 3.5). Remote shutdown capability is provided at the Backup Control Center.

3.4.3 System Operation

A. RPS

The RPS has four input instrument channels and two output actuation trains. RPS inputs are listed below:

- Neutron monitoring system
- Reactor pressure
- Low water level in reactor vessel
- Turbine stop valve closure
- Turbine control valve fast closure
- Main steam line isolation signal
- Scram discharge header high water level
- Primary containment high pressure
- Main steam line radiation
- Main condenser low vacuum
- Scram valve pilot air header low pressure
- Manual

Both output channels must be de-energized to initiate a scram. The failure of a single component or power supply does not prevent a desired scram or cause an unwanted scram.

B. Other Actuation and Control Systems

Actuation and control systems cause the various safety systems to be started, stopped or realigned as needed to respond to abnormal plant conditions. Details regarding actuation logic are included in the system description of the actuated system.

C. Remote Shutdown

The Backup Control System is a variation of the normal system used in the Main Control Room to shut down the reactor when normal feedwater and electrical control power supplies are not available and the normal heat sinks (i.e. the main steam and power conversion system) may not be available. The Backup Control System is physically and electrically separated from the normal system. The backup system provides a redundant or diverse means to achieve a cold shutdown condition considering the single failure criteria. Reactor pressure is controlled and reduced, while decay heat and sensible heat are removed by dumping steam through the power-operated relief valves to the suppression pool. The reactor pressure boundary is protected by the backup controls so that spurious openings of valves which could cause a loss of coolant or admit high pressure to low pressure piping systems are prevented.

The control switches in the Backup Control System are of the "maintained contact" type, and transfer of any switch to the emergency position is annunciated in the Main Control Room.

3.4.4 System Success Criteria

A. RPS

The RPS uses hindrance logic (normal = 1, trip = 0) in both the input and output logic. Therefore, a channel will be in a trip state when input signals are lost, when control power is lost, or when the channel is temporarily removed from service for testing or maintenance (i.e. the channel has a fail-safe failure mode). A reactor scram will occur upon loss of control power to the RPS. A reactor scram is implemented by the scram pilot valves in the control rod drive hydraulic system (see Section 3.6). Details of the RPS for Browns Ferry 3 have not been determined.

B. Other Actuation Systems

A single component usually receives a signal from only one actuation system output train. Trains A and B must be available in order to automatically actuate their respective components. Actuation systems other than the RPS typically use hindrance input logic (normal = 1, trip = 0) and transmission output logic (normal = 0, trip = 1). In this case, an input channel will be in a trip state when input signals are lost, when control power is lost, or when the channel is temporarily removed from service for testing or maintenance (i.e. the channel has a fail-safe failure mode). Control power is needed for the actuation system output channels to send an actuation signal. Note that there may be some actuation subsystems that utilize hindrance output logic. For these subsystems, loss of control power will cause system or component actuation, as is the case with the RPS. Details of the other actuation systems for Browns Ferry 3 have not been determined.

C. Manually-Initiated Protective Actions

When reasonable time is available, certain protective actions may be performed manually by plant personnel. The control room operators are capable of operating individual components using normal control circuitry, or operating groups of components by manually tripping the RPS or other actuation subsystem. The control room operators also may send qualified persons into

the plant to operate components locally or from some other remote control location (i.e., the remote shutdown panel or a motor control center). To make these judgments, data on key plant parameters must be available to the operators.

3.4.5 Support Systems and Interfaces

A. Control Power

1. RPS
The RPS is powered via motor-generator sets from the 250 VDC Class 1E electric power system.
2. Other actuation and control systems
The distribution of control power to the various front-line safety systems at Browns Ferry is summarized in Table 3.4-1.
3. Operator instrumentation
Specific power supplies for operator instrumentation systems were not identified.

3.4.6 Section 3.4 References

1. Browns Ferry FSAR, Section 7.10.

Table 3.4-1. Matrix of Browns Ferry Control Power Sources

SYSTEM		250 VDC MOV BOARD								
		DC-MOV1A	DC-MOV1B	DC-MOV1C	DC-MOV2A	DC-MOV2B	DC-MOV2C	DC-MOV3A	DC-MOV3B	DC-MOV3C
UNIT 1	MSIV1									
	RCIC1									
	HPCI1									
	ADS1									
	RHR (LPCI) 1A									
	RHR (LPCI) 1B									
	RHR (LPCI) 1C									
	RHR (LPCI) 1D									
	CS 1A									
	CS 1B									
	CS 1C									
	CS 1D									
	LOCAL CONTROL STATION 1									
	UNIT 2	MSIV2								
RCIC2										
HPCI2										
ADS2										
RHR (LPCI) 2A										
RHR (LPCI) 2B										
RHR (LPCI) 2C										
RHR (LPCI) 2D										
CS 2A										
CS 2B										
CS 2C										
CS 2D										
LOCAL CONTROL STATION 2										
UNIT 3		MSIV3								
	RCIC3									
	HPCI3									
	ADS3									
	RHR (LPCI) 3A									
	RHR (LPCI) 3B									
	RHR (LPCI) 3C									
	RHR (LPCI) 3D									
	CS 3A									
	CS 3B									
	CS 3C									
	CS 3D									
	LOCAL CONTROL STATION 3									

- NOTES: (1) Loops A and C of the RHR and CS systems constitute subsystems A of the respective system.
(2) Loops B and D of the RHR and CS systems constitute subsystem B of the respective system.

3.5 ELECTRIC POWER SYSTEM

3.5.1 System Function

The electric power system supplies power to various equipment and systems needed for normal operation and/or response to accidents. The onsite Class 1E electric power system supports the operation of safety class systems and instrumentation needed to establish and maintain a safe shutdown plant condition following an accident, when the normal electric power sources are not available.

3.5.2 System Definition

The onsite Class 1E AC electric power system consists of eight diesel generators, eight 4160 VAC shutdown boards, two 480 VAC shutdown boards at each unit and a variety of 480 VAC AC MOV boards and auxiliary boards at each unit. The Class 1E plant DC power system consists of three 250 VDC batteries and battery boards, one at each unit. The three battery boards supply three DC MOV boards at each unit through a DC power distribution matrix.

The Browns Ferry 4kV electric power distribution system is shown in Figure 3.5-1. The Class 1E AC power distribution system serving Units 1 and 2 is shown in Figure 3.5-2, and the system for Unit 3 is shown in Figure 3.5-3. The Class 1E DC power system for all units is shown in Figure 3.5-4. A summary of data on selected electric power system components is presented in Table 3.5-1. A partial listing of electrical sources and loads is presented in Table 3.5-2.

3.5.3 System Operation

During normal operation, station auxiliary power is taken from the main generators through the unit station service transformers. During startup and shutdown, auxiliary power is supplied from the 500 kV system through the main transformers. Auxiliary power also is available from the 161 kV system. Upon loss of auxiliary power, or in response to an accident signal at any unit, the diesel generators are automatically started. If the 4160 VAC buses are deenergized, the diesel generators are automatically aligned to reenergize the Class 1E electric power system. Large AC loads at Units 1 and 2 are distributed among diesels A, B, C and D. The large AC loads at Unit 3 are distributed among diesels 3A, 3B, 3C and 3D. The AC power system includes many features which permit establishing cross-ties between the 4160 VAC shutdown boards and for providing a backup source of power to each 480 VAC shutdown board. Note in Figures 3.5-2 and 3.5-3 that each AC MOV board can be powered from either of its assigned 480 VAC shutdown boards. Each AC MOV board has a normal source, and will automatically shift to the other 480VAC shutdown board if the normal source is lost.

The 250 VDC plant DC power system provides power to various DC loads including HPCI, RCIC ADS and backup scram valves, engineered safety feature actuation logic, and main steam isolation valve control. This system is shown in Figure 3.5-4. The system is designed to supply all required loads for 30 minutes without recharging. The battery board at each unit normally is supplied from the 480 VAC system via a battery charger. The connected battery is maintained fully charged and is available to support DC loads if power from the battery charger is lost. Although each battery board can be supplied from any one of four battery chargers, the normal alignment is to have a battery board supplied via a battery charger located at the same unit (i.e. battery charger 1 supplying battery board 1). Battery charger 2B actually is a "spare" battery charger and would be used to replace battery charger 1, 2A or 3 if one of the latter must be removed from service.

Note in Figure 3.5-4 that all DC MOV boards have a normal and alternate source of power. At each unit, the three DC MOV boards are normally aligned to different battery boards. This means that two of the three DC MOV boards at a particular unit

normally are being powered from battery boards that are physically located at the other two units.

A 250 VDC control power supply system provides control power for shutdown boards A, B, C, D and 3EB. There are five batteries in this system (one per shutdown board). Each battery can provide control power for three hours without recharging. No figure is provided for this system. Control power for shutdown boards 3EA, 3EC, 3ED, the bus tie board, and the cooling tower switchgear is provided by the 250VDC plant DC power system. There also are 48 VDC and 24 VDC electric power systems to support various communications, instrumentation and annunciator loads.

3.5.4 System Success Criteria

Basic system success criteria for mitigating transients and loss-of-coolant accidents are defined by front-line systems, which then create demands on support systems. Electric power system success criteria are defined as follows, without taking credit for cross-ties that may exist between independent load groups:

- Each Class 1E DC load group is supplied initially from its respective battery (also needed for diesel starting)
- Each Class 1E AC load group is isolated from the non-Class 1E system and is supplied from its respective emergency power source (i.e. diesel generator)
- Power distribution paths to essential loads are intact
- Power to the battery chargers is restored before the batteries are exhausted

3.5.5 Component Information

- A. Standby diesel generators (A, B, C, D, 3A, 3B, 3C and 3D)
 1. Power rating: 950 kW continuous
 2. Rated voltage: 4160 VAC
 3. Manufacturer: General Motors
- B. Station batteries (1, 2 and 3)
 1. Type: Lead-calcium
 2. Cells: 120
 3. Rated capacity: 30 minutes (plant DC power system batteries)
3 hours (control power supply system batteries)

3.5.6 Support Systems and Interfaces

- A. Control Signals
 1. Automatic

The standby diesel generators are automatically started on the following signals:

 - Degraded voltage
 - Accident signal at any unit (drywell high pressure or RPV low water level)
 - Pre-accident signal at any unit
 2. Remote manual

The diesel generators can be started, and many distribution circuit breakers can be operated from the main control room.
- B. Diesel Generator Auxiliary Systems

The following auxiliaries are provided for the emergency diesel generator:

1. Cooling
The emergency equipment cooling water system (see Section 3.7) provides for diesel cooling.
 2. Fueling
A long-term diesel fuel supply is provided beneath each diesel building. This fuel supply is designed to support the operation of six diesel generators for seven days.
 3. Lubrication
Each diesel generator has a self-contained lubrication system.
 4. Starting
Two independent starting air systems are provided for each diesel generator.
 5. Control power
A dedicated 125 VDC battery is provided for each diesel generator. A battery and its associated DC power distribution panel are located in each diesel generator room.
 6. Diesel room ventilation
Diesel room fans are Class 1E loads that are powered from the 480 VAC diesel auxiliary boards.
- C. Shutdown board room and battery room ventilation.
1. Each shutdown board room is ventilated by Class 1E exhaust fans powered from 480 VAC MOV boards. At Unit 3, there also appears to be a shutdown board room air conditioning system that also is powered from Class 1E 480VAC MOV boards.
 2. The battery rooms at Units 1 and 2 are ventilated by Class 1E supply and exhaust fans powered from 480 VAC MOV boards. Ventilation provisions to Unit 3 battery room were not identified.

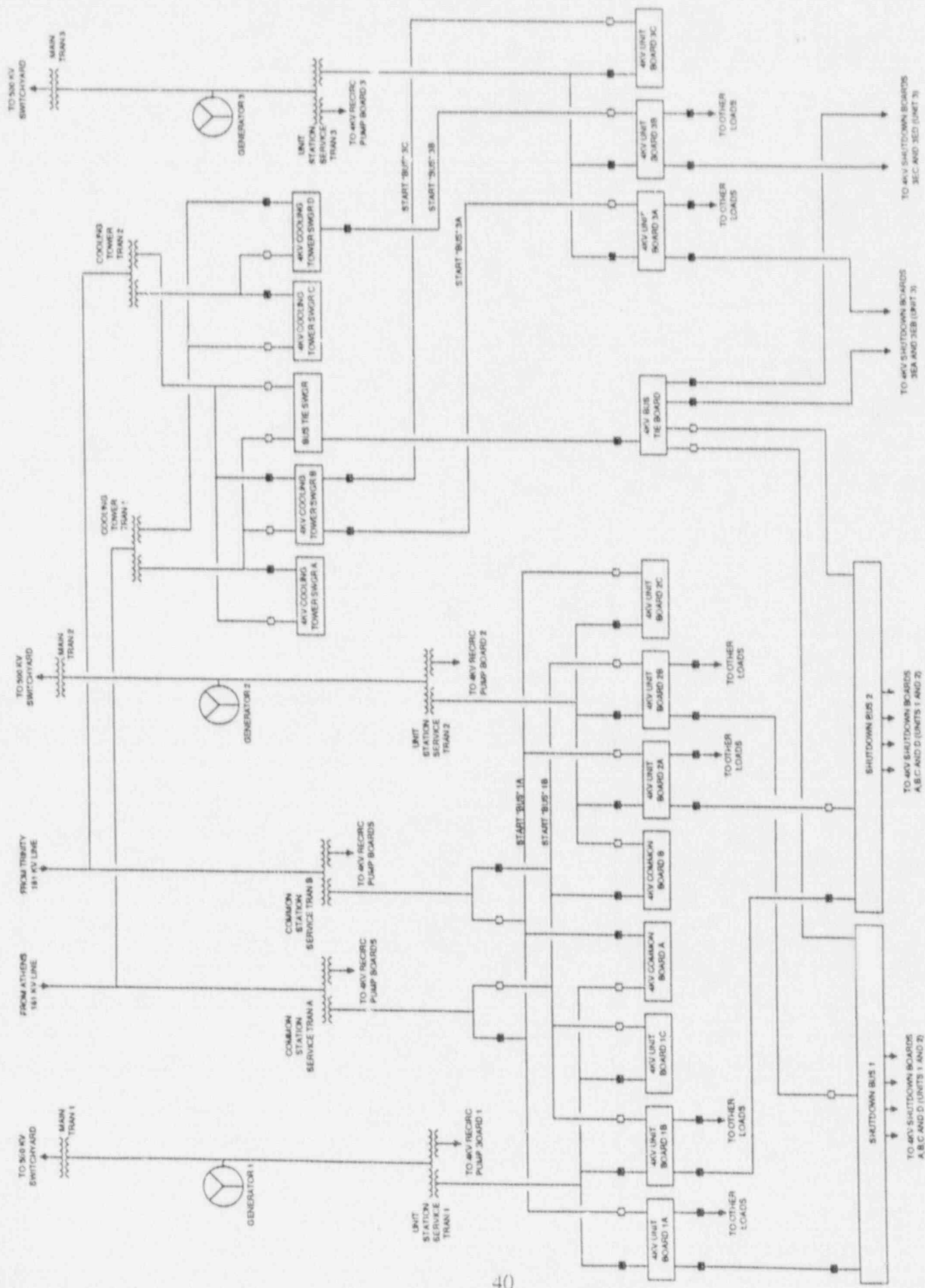

Figure 3.5-1. Browns Ferry 1, 2 and 3 4kV Electric Power Distribution System

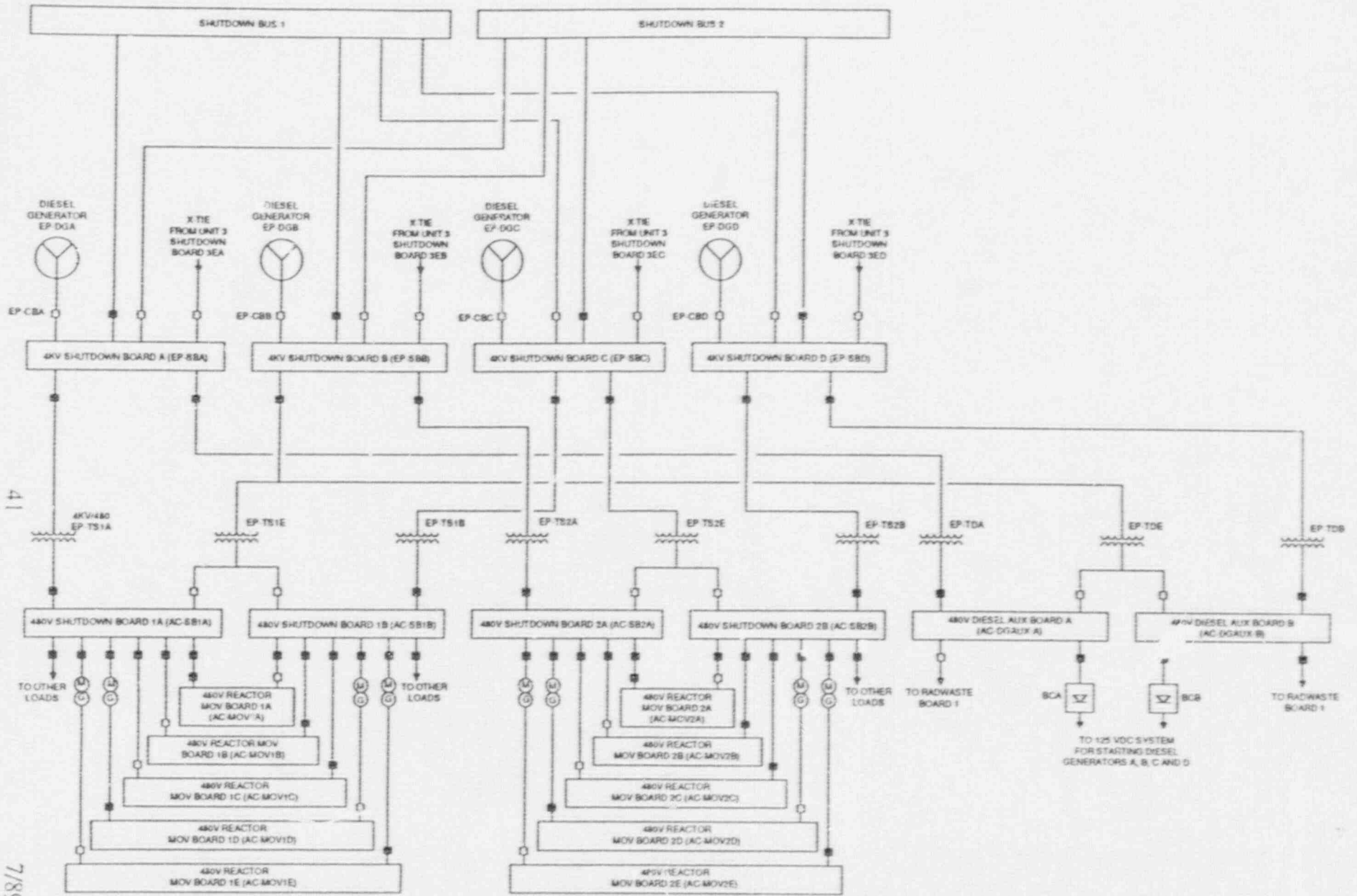

Figure 3.5-2. Browns Ferry 1 and 2 Class 1E AC Electric Power System

41

7/89

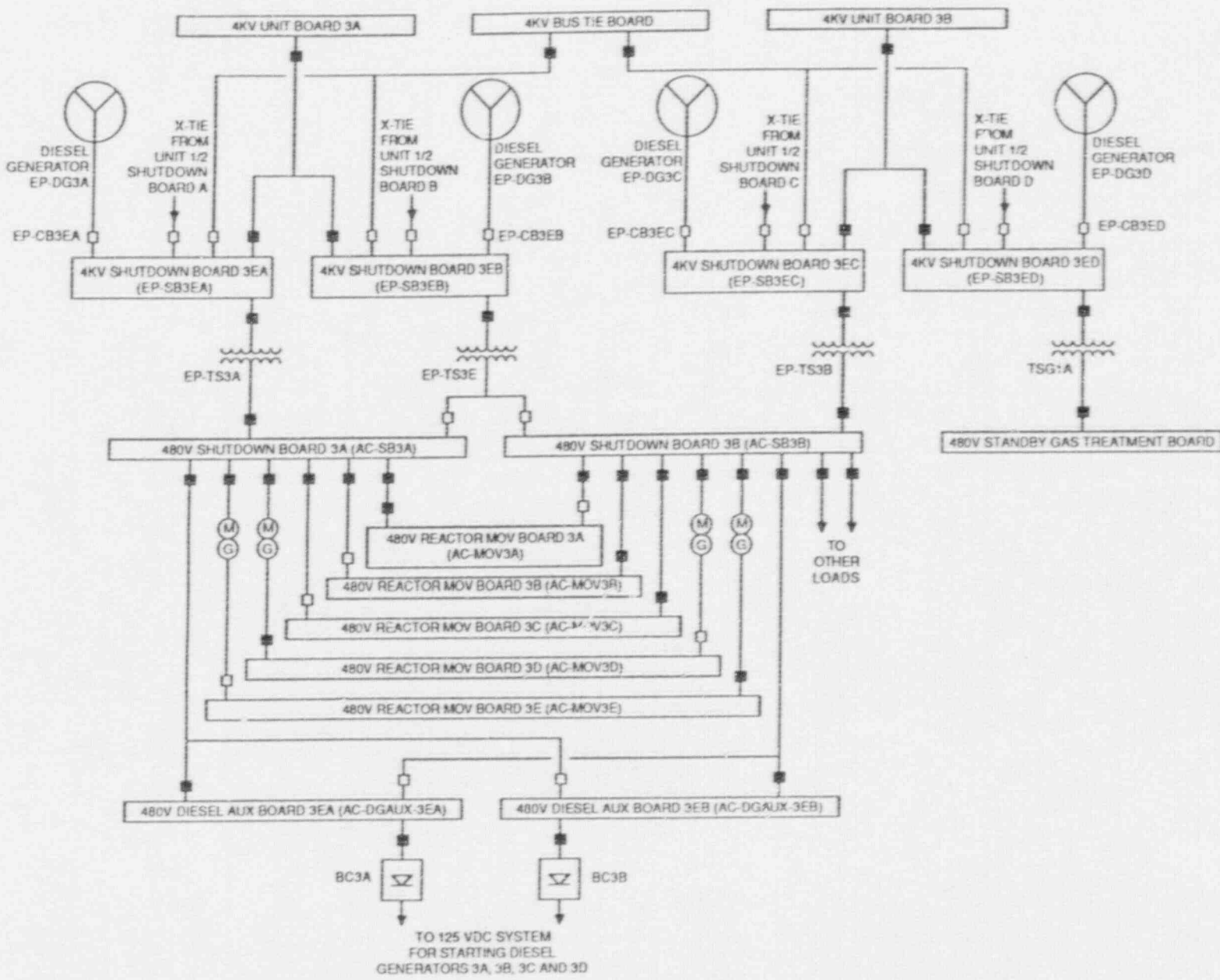

Figure 3.5-3. Browns Ferry 3 Class 1E AC Electric Power System

42

7/89

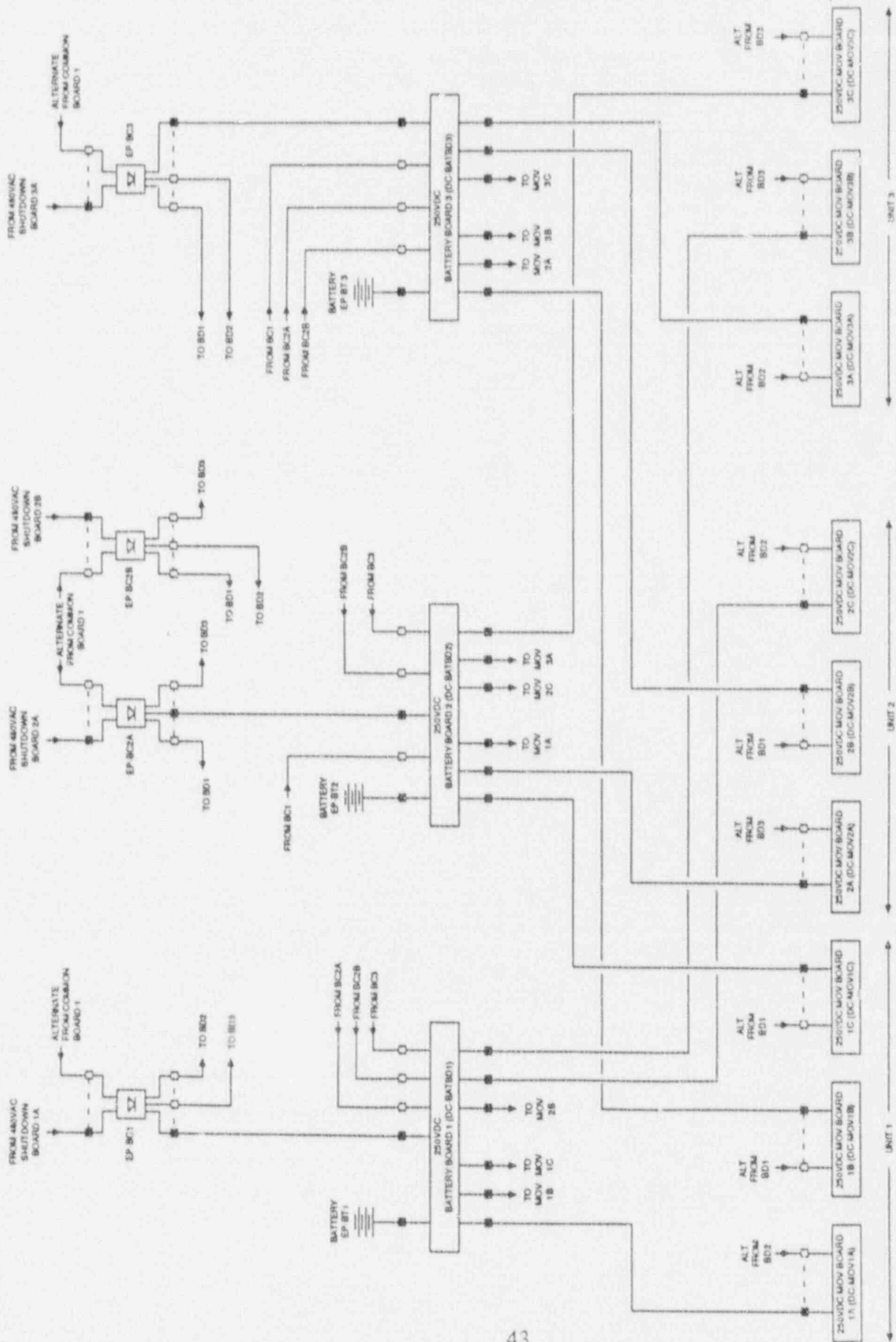

Figure 3.5-4. Browns Ferry 1, 2 and 3 250VDC Plant DC Electric Power System

Table 3.5-1. Browns Ferry 3 Electric Power System Data Summary for Selected Components

COMPONENT ID	COMP. TYPE	LOCATION	POWER SOURCE	VOLTAGE	POWER SOURCE LOCATION	EMERG. LOAD GRP
AC-DGAUX-3EA	MCC	DGHL3	AC-SB3A	480	SDRME	I
AC-DGAUX-3EA	MCC	DGHL3	AC-SB3B	480	SDRME	II
AC-DGAUX-3EB	MCC	DGHL3	AC-SB3B	480	SDRME	II
AC-DGAUX-3EB	MCC	DGHL3	AC-SB3A	480	SDRME	I
AC-DGAUX-A	MCC	DGHL1	EP-TDA	480	DGHL1	I
AC-DGAUX-A	MCC	DGHL1	EP-TDE	480	DGHL1	I
AC-DGAUX-B	MCC	DGHL1	EP-TDB	480	DGHL1	II
AC-DGAUX-B	MCC	DGHL1	EP-TDE	480	DGHL1	I
AC-MOV1A	MCC	SDRMA	AC-SB1A	480	SDRMA	I
AC-MOV1A	MCC	SDRMA	AC-SB1B	480	SDRMA	II
AC-MOV1B	MCC	SDRMA	AC-SB1A	480	SDRMA	I
AC-MOV1B	MCC	SDRMA	AC-SB1B	480	SDRMA	II
AC-MOV1C	MCC	565RB1	AC-SB1A	480	SDRMA	I
AC-MOV1C	MCC	565RB1	AC-SB1B	480	SDRMA	II
AC-MOV1D	MCC	593RB1	AC-SB1A	480	SDRMA	I
AC-MOV1D	MCC	593RB1	AC-SB1B	480	SDRMA	II
AC-MOV1E	MCC	UNKNOWN	AC-SB1A	480	SDRMA	I
AC-MOV1E	MCC	UNKNOWN	AC-SB1B	480	SDRMA	II
AC-MOV2A	MCC	SDRMC	AC-SB2A	480	SDRMC	I
AC-MOV2A	MCC	SDRMC	AC-SB2B	480	SDRMC	II
AC-MOV2B	MCC	SDRMD	AC-SB2B	480	SDRMC	II
AC-MOV2B	MCC	SDRMD	AC-SB2A	480	SDRMC	I
AC-MOV2C	MCC	565RB2	AC-SB2B	480	SDRMC	II
AC-MOV2C	MCC	565RB2	AC-SB2A	480	SDRMC	I
AC-MOV2D	MCC	593RB2	AC-SB2A	480	SDRMC	I
AC-MOV2D	MCC	593RB2	AC-SB2B	480	SDRMC	II
AC-MOV2E	MCC	UNKNOWN	AC-SB2B	480	SDRMC	II
AC-MOV2E	MCC	UNKNOWN	AC-SB2A	480	SDRMC	I

**Table 3.5-1. Browns Ferry 3 Electric Power System Data Summary
for Selected Components (Continued)**

COMPONENT ID	COMP. TYPE	LOCATION	POWER SOURCE	VOLTAGE	POWER SOURCE LOCATION	EMERG. LOAD GRP
AC-MOV3A	MCC	SDRME	AC-SB3A	480	SDRME	I
AC-MOV3A	MCC	SDRME	AC-SB3B	480	SDRME	II
AC-MOV3B	MCC	SDRMF	AC-SB3B	480	SDRME	II
AC-MOV3B	MCC	SDRMF	AC-SB3A	480	SDRME	I
AC-MOV3C	MCC	565RB3	AC-SB3B	480	SDRME	II
AC-MOV3C	MCC	565RB3	AC-SB3A	480	SDRME	I
AC-MOV3D	MCC	593RB3	AC-SB3A	480	SDRME	I
AC-MOV3D	MCC	593RB3	AC-SB3B	480	SDRME	II
AC-MOV3E	MCC	UNKNOWN	AC-SB3B	480	SDRME	II
AC-MOV3E	MCC	UNKNOWN	AC-SB3A	480	SDRMF	I
AC-SB1A	BUS	SDRMA	EP-TS1A	480	621RB1	I
AC-SB1A	BUS	SDRMA	EP-TS1E	480	621RB1	I
AC-SB1B	BUS	SDRMA	EP-TS1B	480	621RB1	II
AC-SB1B	BUS	SDRMA	EP-TS1E	480	621RB1	I
AC-SB2A	BUS	SDRMC	EP-TS2A	480	621RB2	I
AC-SB2A	BUS	SDRMC	EP-TS2E	480	621RB2	II
AC-SB2B	BUS	SDRMC	EP-TS2B	480	621RB2	II
AC-SB2B	BUS	SDRMC	EP-TS2E	480	621RB2	II
AC-SB3A	BUS	SDRME	EP-TS3A	480	621RB3	I
AC-SB3A	BUS	SDRME	EP-TS3E	480	621RB3	I
AC-SB3B	BUS	SDRME	EP-TS3B	480	621RB3	II
AC-SB3B	BUS	SDRME	EP-TS3E	480	621RB3	I
DC-BATBD1	BUS	BATBD1	EP-BT1	250	BATRM1	I-1
DC-BATBD1	BUS	BATBD1	EP-BC1	250	DCEQRM1	I-1
DC-BATBD1	BUS	BATBD1	EP-BC2B	250	DCEQRM2	I-2
DC-BATBD2	BUS	BATBD2	EP-BT2	250	BATRM2	I-2
DC-BATBD2	BUS	BATBD2	EP-BC2A	250	DCEQRM2	I-2
DC-BATBD2	BUS	BATBD2	EP-BC2B	250	DCEQRM2	I-2

Table 3.5-1. Browns Ferry 3 Electric Power System Data Summary
for Selected Components (Continued)

COMPONENT ID	COMP. TYPE	LOCATION	POWER SOURCE	VOLTAGE	POWER SOURCE LOCATION	EMERG. LOAD GRP
DC-BATBD3	BUS	BATBD3	EP-BT3	250	BATRM3	I-3
DC-BATBD3	BUS	BATBD3	EP-BC3	250	DCEQRM3	I-3
DC-BATBD3	BUS	BATBD3	EP-BC2B	250	DCEQRM2	I-3
DC-MOV1A	MCC	SDRMA	DC-BATBD1	250	BATBD1	I-1
DC-MOV1A	MCC	SDRMA	DC-BATBD2	250	BATBD2	I-2
DC-MOV1B	MCC	SDRMB	DC-BATBD1	250	BATBD1	I-1
DC-MOV1B	MCC	SDRMB	DC-BATBD3	250	BATBD3	I-3
DC-MOV1C	MCC	565RB1	DC-BATBD2	250	BATBD2	I-2
DC-MOV1C	MCC	565RB1	DC-BATBD1	250	BATBD1	I-1
DC-MOV2A	MCC	SDRMC	DC-BATBD2	250	BATBD2	I-2
DC-MOV2A	MCC	SDRMC	DC-BATBD3	250	BATBD3	I-3
DC-MOV2B	MCC	SDRMD	DC-BATBD3	250	BATBD3	I-3
DC-MOV2B	MCC	SDRMD	DC-BATBD1	250	BATBD1	I-1
DC-MOV2C	MCC	565RB2	DC-BATBD1	250	BATBD1	I-1
DC-MOV2C	MCC	565RB2	DC-BATBD2	250	BATBD2	I-2
DC-MOV3A	MCC	SDRME	DC-BATBD3	250	BATBD3	I-3
DC-MOV3A	MCC	SDRME	DC-BATBD2	250	BATBD2	I-2
DC-MOV3B	MCC	SDRMF	DC-BATBD1	250	BATBD1	I-1
DC-MOV3B	MCC	SDRMF	DC-BATBD3	250	BATBD3	I-3
DC-MOV3C	MCC	565RB3	DC-BATBD2	250	BATBD2	I-2
DC-MOV3C	MCC	565RB3	DC-BATBD3	250	BATBD3	I-3
EP-BC1	BC	DCEQRM1	AC-SB1A	480	SDRMA	I
EP-BC2A	BC	DCEQRM2	AC-SB2A	480	SDRMC	I
EP-BC2B	BC	DCEQRM2	AC-SB2B	480	SDRMC	II
EP-BC3	BC	DCEQRM3	AC-SB3A	480	SDRME	I
EP-BT1	BATT	BATRM1		250		I-1
EP-BT2	BATT	BATRM2		250		I-2
EP-BT3	BATT	BATRM3		250		I-3

**Table 3.5-1. Browns Ferry 3 Electric Power System Data Summary
for Selected Components (Continued)**

COMPONENT ID	COMP. TYPE	LOCATION	POWER SOURCE	VOLTAGE	POWER SOURCE LOCATION	EMERG. LOAD GRP
EP-CB3EA	CB	SDRM3EA				
EP-CB3EB	CB	SDRM3EB				
EP-CB3EC	CB	SDRM3EC				
EP-CBA	CB	SDRMA				
EP-CBB	CB	SDRMB				
EP-CBC	CB	SDRMC				
EP-CBD	CB	SDRMD				
EP-DG3A	DG	DGRM3A		4160		I
EP-DG3B	DG	DGRM3B		4160		I
EP-DG3C	DG	DGRM3C		4160		II
EP-DG3D	DG	DGRM3D		4160		II
EP-DGA	DG	DGRMA		4160		I
EP-DGB	DG	DGRMB		4160		I
EP-DGC	DG	DGRMC		4160		II
EP-DGD	DG	DGRMD		4160		II
EP-SB3EA	BUS	SDRM3EA	EP-DG3A	4160	DGRM3A	I
EP-SB3EB	BUS	SDRM3EB	EP-DG3B	4160	DGRM3B	I
EP-SB3EC	BUS	SDRM3EC	EP-DG3C	4160	DGRM3C	II
EP-SB3ED	BUS	SDRM3ED	EP-DG3D	4160	DGRM3D	II
EP-SB3ED	CB	SDRM3ED				
EP-SBA	BUS	SDRMA	EP-DGA	4160	DGRMA	I
EP-SBB	BUS	SDRMB	EP-DGB	4160	DGRMB	I
EP-SBC	BUS	SDRMC	EP-DGC	4160	DGRMC	II
EP-SBD	BUS	SDRMD	EP-DGD	4160	DGRMD	II
EP-TDA	TRAN	DGHL1	EP-SBA	4160	SDRMA	I
EP-TDB	TRAN	DGHL1	EP-SBD	4160	SDRMD	II
EP-TDE	TRAN	DGHL1	EP-SBB	4160	SDRMB	I
EP-TS1A	TRAN	621RB1	EP-SBA	4160	SDRMA	I

**Table 3.5-1. Browns Ferry 3 Electric Power System Data Summary
for Selected Components (Continued)**

COMPONENT ID	COMP. TYPE	LOCATION	POWER SOURCE	VOLTAGE	POWER SOURCE LOCATION	EMERG. LOAD GRP
EP-TS1B	TRAN	621RB1	EP-SBC	4160	SDRMC	II
EP-TS1E	TRAN	621RB1	EP-SBB	4160	SDRMB	I
EP-TS2A	TRAN	621RB2	EP-SBB	4160	SDRMB	I
EP-TS2B	TRAN	621RB2	EP-SBD	4160	SDRMD	II
EP-TS2E	TRAN	621RB2	EP-SBC	4160	SDRMC	II
EP-TS3A	TRAN	621RB3	EP-SB3EA	4160	SDRM3EA	I
EP-TS3B	TRAN	621RB3	EP-SB3EC	4160	SDRM3EC	II
EP-TS3E	TRAN	621RB3	EP-SB3EB	4160	SDRM3EB	I

Table 3.5-2. Partial Listing of Electrical Sources and Loads at Browns Ferry 3

POWER SOURCE	VOLTAGE	EMERG LOAD GRP	POWER SOURCE LOCATION	LOAD SYSTEM	LOAD COMPONENT ID	COMP TYPE	COMPONENT LOCATION
AC-DGAUX-A	480	I	DGHL1	EECW	EECW-67-13	MOV	DGHL1
AC-DGAUX-A	480	I	DGHL1	EECW	EECW-67-49	MOV	PUMPRMC
AC-DGAUX-B	480	II	DGHL1	EECW	EECW-67-14	MOV	DGHL1
AC-DGAUX-B	480	II	DGHL1	EECW	EECW-67-46	MOV	PUMPRMD
AC-MOV1B	480	II	SDRMB	EECW	EECW-67-18	MOV	565RB1
AC-MOV1C	480	II	565RB1	EECW	EECW-67-17	MOV	593RB1
AC-MOV2B	480	II	SDRMD	EECW	EECW-67-22	MOV	565RB2
AC-MOV2C	480	II	565RB2	EECW	EECW-67-21	MOV	593RB2
AC-MOV3A	480	I	SDRME	ECCS	CS-75-11	MOV	NWRB3
AC-MOV3A	480	I	SDRME	ECCS	CS-75-2	MOV	NWRB3
AC-MOV3A	480	I	SDRME	ECCS	CS-75-23	MOV	593RB3
AC-MOV3A	480	I	SDRME	ECCS	CS-75-25	MOV	593RB3
AC-MOV3A	480	I	SDRME	ECCS	HPCI-73-2	MOV	RC3
AC-MOV3A	480	I	SDRME	ECCS	RHR-74-1	MOV	SWRB3
AC-MOV3A	480	I	SDRME	ECCS	RHR-74-12	MOV	SWRB3
AC-MOV3A	480	I	SDRME	ECCS	RHR-74-13	MOV	SWRB3
AC-MOV3A	480	I	SDRME	ECCS	RHR-74-2	MOV	SWRB3
AC-MOV3A	480	I	SDRME	ECCS	RHR-74-52	MOV	PERACC3
AC-MOV3A	480	I	SDRME	ECCS	RHR-74-57	MOV	TORUS3
AC-MOV3A	480	I	SDRME	ECCS	RHR-74-58	MOV	TORUS3
AC-MOV3A	480	I	SDRME	ECCS	RHR-74-59	MOV	TORUS3
AC-MOV3A	480	I	SDRME	ECCS	RHR-74-60	MOV	PERACC3
AC-MOV3A	480	I	SDRME	ECCS	RHR-74-61	MOV	PERACC3
AC-MOV3A	480	I	SDRME	RCS	HPCI-73-2	MOV	RC3
AC-MOV3A	480	I	SDRME	RCS	RCS-1-55	MOV	RC3
AC-MOV3A	480	I	SDRME	RCS	RCS-69-1	MOV	RC3
AC-MOV3A	480	I	SDRME	RCS	RHR-74-48	MOV	RC3
AC-MOV3A	480	I	SDRME	RHRSW	23-34	MOV	565RB3
AC-MOV3A	480	I	SDRME	RHRSW	23-40	MOV	565RB3
AC-MOV3B	480	II	SDRMF	ECCS	CS-75-30	MOV	NERB3
AC-MOV3B	480	II	SDRMF	ECCS	CS-75-39	MOV	NERB3
AC-MOV3B	480	II	SDRMF	ECCS	CS-75-51	MOV	593RB3

Table 3.5-2. Partial Listing of Electrical Sources and Loads at Browns Ferry 3 (Continued)

POWER SOURCE	VOLTAGE	EMERG LOAD GRP	POWER SOURCE LOCATION	LOAD SYSTEM	LOAD COMPONENT ID	COMP TYPE	COMPONENT LOCATION
AC-MOV3B	480	II	SDRMF	ECCS	CS-75-53	MOV	593RB3
AC-MOV3B	480	II	SDRMF	ECCS	RHR-74-100	MOV	565RB3
AC-MOV3B	480	II	SDRMF	ECCS	RHR-74-24	MOV	SERB3
AC-MOV3B	480	II	SDRMF	ECCS	RHR-74-25	MOV	SERB3
AC-MOV3B	480	II	SDRMF	ECCS	RHR-74-35	MOV	SERB3
AC-MOV3B	480	II	SDRMF	ECCS	RHR-74-36	MOV	SERB3
AC-MOV3B	480	II	SDRMF	ECCS	RHR-74-66	MOV	PERACC3
AC-MOV3B	480	II	SDRMF	ECCS	RHR-74-71	MOV	TORUS3
AC-MOV3B	480	II	SDRMF	ECCS	RHR-74-72	MOV	TORUS3
AC-MOV3B	480	II	SDRMF	ECCS	RHR-74-73	MOV	TORUS3
AC-MOV3B	480	II	SDRMF	ECCS	RHR-74-74	MOV	PERACC3
AC-MOV3B	480	II	SDRMF	ECCS	RHR-74-75	MOV	PERACC3
AC-MOV3B	480	II	SDRMF	ECCS	RHR-74-96	MOV	SWRB3
AC-MOV3B	480	II	SDRMF	ECCS	RHR-74-96	MOV	SWRB3
AC-MOV3B	480	II	SDRMF	ECCS	RHR-74-97	MOV	SWRB3
AC-MOV3B	480	II	SDRMF	ECCS	RHR-74-97	MOV	SWRB3
AC-MOV3B	480	II	SDRMF	EECW	EECW-67-26	MOV	565RB3
AC-MOV3B	480	II	SDRMF	RCIC	RCIC-71-2	MOV	RC3
AC-MOV3B	480	II	SDRMF	RCS	RCIC-71-2	MOV	RC3
AC-MOV3B	480	II	SDRMF	RHRSW	23-46	MOV	565RB3
AC-MOV3B	480	II	SDRMF	RHRSW	23-52	MOV	565RB3
AC-MOV3C	480	II	565RB3	ECCS	RHR-74-67	MOV	PERACC3
AC-MOV3C	480	II	565RB3	EECW	EECW-67-25	MOV	593RB3
AC-MOV3D	480	I	593RB3	ECCS	RHR-74-53	MOV	PERACC3
AC-SB1A	480	I	SDRMA	EP	AC-MOV1A	MCC	SDRMA
AC-SB1A	480	I	SDRMA	EP	AC-MOV1B	MCC	SDRMA
AC-SB1A	480	I	SDRMA	EP	AC-MOV1C	MCC	565RB1
AC-SB1A	480	I	SDRMA	EP	AC-MOV1D	MCC	593RB1
AC-SB1A	480	I	SDRMA	EP	AC-MOV1E	MCC	UNKNOWN
AC-SB1A	480	I	SDRMA	EP	EP-BC1	BC	DCEORM1
AC-SB1B	480	II	SDRMA	EP	AC-MOV1A	MCC	SDRMA
AC-SB1B	480	II	SDRMA	EP	AC-MOV1B	MCC	SDRMA

Table 3.5-2. Partial Listing of Electrical Sources and Loads at Browns Ferry 3 (Continued)

POWER SOURCE	VOLTAGE	EMERG LOAD GRP	POWER SOURCE LOCATION	LOAD SYSTEM	LOAD COMPONENT ID	COMP TYPE	COMPONENT LOCATION
AC-SB1B	480	II	SDRMA	EP	AC-MOV1C	MCC	565RB1
AC-SB1B	480	II	SDRMA	EP	AC-MOV1D	MCC	593RB1
AC-SB1B	480	II	SDRMA	EP	AC-MOV1E	MCC	UNKNOWN
AC-SB2A	480	I	SDRMC	EP	AC-MOV2A	MCC	SDRMC
AC-SB2A	480	I	SDRMC	EP	AC-MOV2B	MCC	SDRMD
AC-SB2A	480	I	SDRMC	EP	AC-MOV2C	MCC	565RB2
AC-SB2A	480	I	SDRMC	EP	AC-MOV2D	MCC	593RB2
AC-SB2A	480	I	SDRMC	EP	AC-MOV2E	MCC	UNKNOWN
AC-SB2A	480	I	SDRMC	EP	EP-BC2A	BC	DCEQRM2
AC-SB2B	480	II	SDRMC	EP	AC-MOV2A	MCC	SDRMC
AC-SB2B	480	II	SDRMC	EP	AC-MOV2B	MCC	SDRMD
AC-SB2B	480	II	SDRMC	EP	AC-MOV2C	MCC	565RB2
AC-SB2B	480	II	SDRMC	EP	AC-MOV2D	MCC	593RB2
AC-SB2B	480	II	SDRMC	EP	AC-MOV2E	MCC	UNKNOWN
AC-SB2B	480	II	SDRMC	EP	EP-BC2B	BC	DCEQRM2
AC-SB3A	480	I	SDRME	EP	AC-DGAUX-3E A	MCC	DGHL3
AC-SB3A	480	I	SDRME	EP	AC-DGAUX-3E B	MCC	DGHL3
AC-SB3A	480	I	SDRME	EP	AC-MOV3A	MCC	SDRME
AC-SB3A	480	I	SDRME	EP	AC-MOV3B	MCC	SDRMF
AC-SB3A	480	I	SDRME	EP	AC-MOV3C	MCC	565RB3
AC-SB3A	480	I	SDRME	EP	AC-MOV3D	MCC	593RB3
AC-SB3A	480	I	SDRME	EP	AC-MOV3E	MCC	UNKNOWN
AC-SB3A	480	I	SDRME	EP	EP-BC3	BC	DCEQRM3
AC-SB3B	480	II	SDRME	EP	AC-DGAUX-3E A	MCC	DGHL3
AC-SB3B	480	II	SDRME	EP	AC-DGAUX-3E B	MCC	DGHL3
AC-SB3B	480	II	SDRME	EP	AC-MOV3A	MCC	SDRME
AC-SB3B	480	II	SDRME	EP	AC-MOV3B	MCC	SDRMF
AC-SB3B	480	II	SDRME	EP	AC-MOV3C	MCC	565RB3
AC-SB3B	480	II	SDRME	EP	AC-MOV3D	MCC	593RB3
AC-SB3B	480	II	SDRME	EP	AC-MOV3E	MCC	UNKNOWN
DC-BATBD1	250	I-1	BATBD1	EP	DC-MOV1A	MCC	SDRMA
DC-BATBD1	250	I-1	BATBD1	EP	DC-MOV1B	MCC	SDRMB

Table 3.5-2. Partial Listing of Electrical Sources and Loads at Browns Ferry 3 (Continued)

POWER SOURCE	VOLTAGE	EMERG LOAD GRP	POWER SOURCE LOCATION	LOAD SYSTEM	LOAD COMPONENT ID	COMP TYPE	COMPONENT LOCATION
DC-BATBD1	250	I-1	BATBD1	EP	DC-MOV1C	MCC	565RB1
DC-BATBD1	250	I-1	BATBD1	EP	DC-MOV2B	MCC	SDRMD
DC-BATBD1	250	I-1	BATBD1	EP	DC-MOV2C	MCC	565RB2
DC-BATBD1	250	I-1	BATBD1	EP	DC-MOV3B	MCC	SDRMF
DC-BATBD2	250	I-2	BATBD2	EP	DC-MOV1A	MCC	SDRMA
DC-BATBD2	250	I-2	BATBD2	EP	DC-MOV1C	MCC	565RB1
DC-BATBD2	250	I-2	BATBD2	EP	DC-MOV2A	MCC	SDRMC
DC-BATBD2	250	I-2	BATBD2	EP	DC-MOV2C	MCC	565RB2
DC-BATBD2	250	I-2	BATBD2	EP	DC-MOV3A	MCC	SDRME
DC-BATBD2	250	I-2	BATBD2	EP	DC-MOV3C	MCC	565RB3
DC-BATBD3	250	I-3	BATBD3	EP	DC-MOV1B	MCC	SDRMB
DC-BATBD3	250	I-3	BATBD3	EP	DC-MOV2A	MCC	SDRMC
DC-BATBD3	250	I-3	BATBD3	EP	DC-MOV2B	MCC	SDRMD
DC-BATBD3	250	I-3	BATBD3	EP	DC-MOV3A	MCC	SDRME
DC-BATBD3	250	I-3	BATBD3	EP	DC-MOV3B	MCC	SDRMF
DC-BATBD3	250	I-3	BATBD3	EP	DC-MOV3C	MCC	565RB3
DC-MOV3A	250	II-1	SDRME	ECCS	1-22	SRV	RC3
DC-MOV3A	250	II-1	SDRME	ECCS	1-30	SRV	RC3
DC-MOV3A	250	II-1	SDRME	ECCS	HPCI-73-16	MOV	HPCI3
DC-MOV3A	250	II-1	SDRME	ECCS	HPCI-73-26	MOV	HPCI3
DC-MOV3A	250	II-1	SDRME	ECCS	HPCI-73-27	MOV	HPCI3
DC-MOV3A	250	II-1	SDRME	ECCS	HPCI-73-3	MOV	TORUS3
DC-MOV3A	250	II-1	SDRME	ECCS	HPCI-73-34	MOV	HPCI3
DC-MOV3A	250	II-1	SDRME	ECCS	HPCI-73-40	MOV	HPCI3
DC-MOV3A	250	II-1	SDRME	ECCS	HPCI-73-44	MOV	HPCI3
DC-MOV3A	250	II-1	SDRME	ECCS	HPCI-AUX-OIL	MDP	HPCI3
DC-MOV3A	250	II-1	SDRME	RCS	1-22	SRV	RC3
DC-MOV3A	250	II-1	SDRME	RCS	1-30	SRV	RC3
DC-MOV3A	250	II-1	SDRME	RCS	1-4	SRV	RC3
DC-MOV3A	250	II-1	SDRME	RCS	1-41	SRV	RC3
DC-MOV3A	250	II-1	SDRME	RCS	HPCI-73-3	MOV	TORUS3
DC-MOV3B	250	I-1	SDRMF	ECCS	1-19	SRV	RC3

Table 3.5-2. Partial Listing of Electrical Sources and Loads at Browns Ferry 3 (Continued)

POWER SOURCE	VOLTAGE	EMERG LOAD GRP	POWER SOURCE LOCATION	LOAD SYSTEM	LOAD COMPONENT ID	COMP TYPE	COMPONENT LOCATION
DC-MOV3B	250	I-1	SDRMF	ECCS	1-31	SRV	RC3
DC-MOV3B	250	I-1	SDRMF	RCS	1-179	SRV	RC3
DC-MOV3B	250	I-1	SDRMF	RCS	1-18	SRV	RC3
DC-MOV3B	250	I-1	SDRMF	RCS	1-19	SRV	RC3
DC-MOV3B	250	I-1	SDRMF	RCS	1-31	SRV	RC3
DC-MOV3B	250	I-1	SDRMF	RCS	1-42	SRV	RC3
DC-MOV3B	250	I-1	SDRMF	RCS	RCS-69-2	MOV	HXCLRM3
DC-MOV3B	250	I-1	SDRMF	RCS	RHR-74-47	MOV	PERACC3
DC-MOV3C	250	I-1	565RB3	ECCS	1-34	SRV	RC3
DC-MOV3C	250	I-1	565RB3	ECCS	1-5	SRV	RC3
DC-MOV3C	250	I-1	565RB3	RCIC	RCIC-71-10	HV	NWRB3
DC-MOV3C	250	I-1	565RB3	RCIC	RCIC-71-17	MOV	NWRB3
DC-MOV3C	250	I-1	565RB3	RCIC	RCIC-71-18	MOV	NWRB3
DC-MOV3C	250	I-1	565RB3	RCIC	RCIC-71-19	MOV	NWRB3
DC-MOV3C	250	I-1	565RB3	RCIC	RCIC-71-3	MOV	NWRB3
DC-MOV3C	250	I-1	565RB3	RCIC	RCIC-71-37	MOV	NWRB3
DC-MOV3C	250	I-1	565RB3	RCIC	RCIC-71-39	MOV	MSVT3
DC-MOV3C	250	I-1	565RB3	RCIC	RCIC-71-8	MOV	NWRB3
DC-MOV3C	250	I-1	565RB3	RCIC	RCIC-71-9	HV	NWRB3
DC-MOV3C	250	I-1	565RB3	RCS	1-180	SRV	RC3
DC-MOV3C	250	I-1	565RB3	RCS	1-23	SRV	RC3
DC-MOV3C	250	I-1	565RB3	RCS	1-34	SRV	RC3
DC-MOV3C	250	I-1	565RB3	RCS	1-5	SRV	RC3
DC-MOV3C	250	I-1	565RB3	RCS	RCIC-71-3	MOV	MSVT3
EP-BC1	250	I-1	DCEQRM1	EP	DC-BATBD1	BUS	BATBD1
EP-BC2A	250	I-2	DCEQRM2	EP	DC-BATBD2	BUS	BATBD2
EP-BC2B	250	I-2	DCEQRM2	EP	DC-BATBD1	BUS	BATBD1
EP-BC2B	250	I-2	DCEQRM2	EP	DC-BATBD2	BUS	BATBD2
EP-BC2B	250	I-3	DCEQRM2	EP	DC-BATBD3	BUS	BATBD3
EP-BC3	250	I-3	DCEQRM3	EP	DC-BATBD3	BUS	BATBD3
EP-BT1	250	I-1	BATRM1	EP	DC-BATBD1	BUS	BATBD1
EP-BT2	250	I-2	BATRM2	EP	DC-BATBD2	BUS	BATBD2

Table 3.5-2. Partial Listing of Electrical Sources and Loads at Browns Ferry 3 (Continued)

POWER SOURCE	VOLTAGE	EMERG LOAD GRP	POWER SOURCE LOCATION	LOAD SYSTEM	LOAD COMPONENT ID	COMP TYPE	COMPONENT LOCATION
EP-BT3	250	I-3	BATRM3	EP	DC-BATBD3	BUS	BATBD3
EP-DG3A	4160	I	DGRM3A	EP	EP-SB3EA	BUS	SDRM3EA
EP-DG3B	4160	I	DGRM3B	EP	EP-SB3EB	BUS	SDRM3EB
EP-DG3C	4160	II	DGRM3C	EP	EP-SB3EC	BUS	SDRM3EC
EP-DG3D	4160	II	DGRM3D	EP	EP-SB3ED	BUS	SDRM3ED
EP-DGA	4160	I	DGRMA	EP	EP-SBA	BUS	SDRMA
EP-DGB	4160	I	DGRMB	EP	EP-SBB	BUS	SDRMB
EP-DGC	4160	II	DGRMC	EP	EP-SBC	BUS	SDRMC
EP-DGD	4160	II	DGRMD	EP	EP-SBD	BUS	SDRMD
EP-SB3EA	4160	I	SDRM3EA	ECCS	CS-PMA	MDP	NWRB3
EP-SB3EA	4160	I	SDRM3EA	ECCS	RHR-PMA	MDP	SWRB3
EP-SB3EA	4160	I	SDRM3EA	EECW	EECW-PMA3	MDP	PUMPRMA
EP-SB3EA	4160	I	SDRM3EA	EP	EP-TS3A	TRAN	621RB3
EP-SB3EB	4160	I	SDRM3EB	ECCS	CS-PMC	MDP	NWRB3
EP-SB3EB	4160	I	SDRM3EB	ECCS	RHR-PMC	MDP	SWRB3
EP-SB3EB	4160	I	SDRM3EB	EECW	EECW-PMC3	MDP	PUMPRMC
EP-SB3EB	4160	I	SDRM3EB	EP	EP-TS3E	TRAN	621RB3
EP-SB3EC	4160	II	SDRM3EC	ECCS	CS-PMB	MDP	NERB3
EP-SB3EC	4160	II	SDRM3EC	ECCS	RHR-PMB	MDP	SERB3
EP-SB3EC	4160	II	SDRM3EC	EECW	EECW-PMB1	MDP	PUMPRMB
EP-SB3EC	4160	II	SDRM3EC	EP	EP-TS3B	TRAN	621RB3
EP-SB3ED	4160	II	SDRM3ED	ECCS	CS-PMD	MDP	NERB3
EP-SB3ED	4160	II	SDRM3ED	ECCS	RHR-PMD	MDP	SERB3
EP-SB3ED	4160	II	SDRM3ED	EECW	EECW-PMD1	MDP	PUMPRMD
EP-SBA	4160	I	SDRMA	EECW	EECW-PMA1	MDP	PUMPRMA
EP-SBA	4160	I	SDRMA	EP	EP-TDA	TRAN	DGHL1
EP-SBA	4160	I	SDRMA	EP	EP-TS1A	TRAN	621RB1
EP-SBA	4160	I	SDRMA	RHR-SW	SW-A2	MDP	PUMPRMA
EP-SBB	4160	I	SDRMB	EECW	EECW-PMC1	MDP	PUMPRMC
EP-SBB	4160	I	SDRMB	EP	EP-TDE	TRAN	DGHL1
EP-SBB	4160	I	SDRMB	EP	EP-TS1E	TRAN	621RB1
EP-SBB	4160	I	SDRMB	EP	EP-TS2A	TRAN	621RB2

Table 3.5-2. Partial Listing of Electrical Sources and Loads at Browns Ferry 3 (Continued)

POWER SOURCE	VOLTAGE	EMERG LOAD GRP	POWER SOURCE LOCATION	LOAD SYSTEM	LOAD COMPONENT ID	COMP TYPE	COMPONENT LOCATION
EP-SBB	4160	I	SDRMB	RHRSW	SW-C2	MDP	PUMPRMC
EP-SBC	4160	II	SDRMC	EECW	EECW-PMB3	MDP	PUMPRMB
EP-SBC	4160	II	SDRMC	EP	EP-TS1B	TRAN	621RB1
EP-SBC	4160	II	SDRMC	EP	EP-TS2E	TRAN	621RB2
EP-SBC	4160	II	SDRMC	RHRSW	SW-B2	MDP	PUMPRMB
EP-SBD	4160	II	SDRMD	EECW	EECW-PMD3	MDP	PUMPRMD
EP-SBD	4160	II	SDRMD	EP	EP-TDB	TRAN	DGHL1
EP-SBD	4160	II	SDRMD	EP	EP-TS2B	TRAN	621RB2
EP-SBD	4160	II	SDRMD	RHRSW	SW-D2	MDP	PUMPRMD
EP-TDA	480	I	DGHL1	EP	AC-DGAUX-A	MCC	DGHL1
EP-TDB	480	II	DGHL1	EP	AC-DGAUX-B	MCC	DGHL1
EP-TDE	480	I	DGHL1	EP	AC-DGAUX-A	MCC	DGHL1
EP-TDE	480	I	DGHL1	EP	AC-DGAUX-B	MCC	DGHL1
EP-TS1A	480	I	621RB1	EP	AC-SB1A	BUS	SDRMA
EP-TS1B	480	II	621RB1	EP	AC-SB1B	BUS	SDRMA
EP-TS1E	480	I	621RB1	EP	AC-SB1A	BUS	SDRMA
EP-TS1E	480	I	621RB1	EP	AC-SB1B	BUS	SDRMA
EP-TS2A	480	I	621RB2	EP	AC-SB2A	BUS	SDRMC
EP-TS2B	480	II	621RB2	EP	AC-SB2B	BUS	SDRMC
EP-TS2E	480	II	621RB2	EP	AC-SB2A	BUS	SDRMC
EP-TS2E	480	II	621RB2	EP	AC-SB2B	BUS	SDRMC
EP-TS3A	480	I	621RB3	EP	AC-SB3A	BUS	SDRME
EP-TS3B	480	II	621RB3	EP	AC-SB3B	BUS	SDRME
EP-TS3E	480	I	621RB3	EP	AC-SB3A	BUS	SDRME
EP-TS3E	480	I	621RB3	EP	AC-SB3B	BUS	SDRME
UNKNOWN	480		480-WO-STG-BL D	ECCS	2-162	MOV	CST
UNKNOWN	480		480-WO-STG-BL D	ECCS	2-166	MOV	CST
UNKNOWN	480		480-WO-STG-BL D	ECCS	2-170	MOV	CST
UNKNOWN	480		480-WO-STG-BL D	RCIC	2-162	MOV	CST
UNKNOWN	480		480-WO-STG-BL D	RCIC	2-166	MOV	CST
UNKNOWN	480		480-WO-STG-BL D	RCIC	2-170	MOV	CST

3.6 CONTROL ROD DRIVE HYDRAULIC SYSTEM (CRDHS)

3.6.1 System Function

The CRDHS supplies pressurized water to operate and cool the control rod drive mechanisms during normal operation. This system implements a scram command from the reactor protection system (RPS) and drives control rods rapidly into the reactor. The CRDHS also can provide makeup water to the RCS.

3.6.2 System Definition

The CRDHS consists of high-head, low-flow, pumps, piping, filters, control valves, one hydraulic control unit for each control rod drive mechanism, and instrumentation. Water is supplied from condensate and from the condensate storage tank. The CRDHS also includes scram valves, scram accumulators, and a scram discharge volume (dump tank).

Details of the scram portion of typical BWR CRDHS is shown in Figure 3.6-1 (adapted from Ref. 1).

3.6.3 System Operation

During normal operation the CRDHS pumps provide a constant flow for drive mechanism cooling and system pressure stabilization. Excess water not used for cooling is discharged to the RCS. Control rods are driven in or out by the coordinated operation of the direction control valves. Insertion speed is controlled by flow through the insert speed control valve. Rod motion may be either stepped or continuous.

A reactor scram is implemented by pneumatic scram valves in the CRDHS. An inlet scram valve opens to align the insert side of each control rod drive mechanism (CRDM) to its scram accumulator. An outlet scram valve opens to vent the opposite side of each CRDM to the dump tank (or discharge volume) shown in Figure 3.6-2 (from Ref. 2). This coordinated action results in rapid insertion of control rods into the reactor.

Although not intended as a makeup system, the CRDHS can provide a source of cooling water to the RCS during vessel isolation. It is noted in NUREG-0626 (Ref. 3), that this function is particularly important for some BWR/1 and BWR/2 plants for which the CRDHS is the primary source of makeup on vessel isolation. In later model BWR plants, RCS makeup at high pressure is performed by the RCIC (see Section 3.2) and HPCI (see Section 3.3) systems. The maximum RCS makeup rate of the CRDHS is about 200 gpm with both pumps operating (Ref. 4).

3.6.4 System Success Criteria

For the scram function to be accomplished, the following actions must occur in the CRDHS:

- A scram signal must be transmitted by the RPS to the actuated devices (i.e., pilot valves) in the CRDHS.
- The pneumatic inlet scram valve and outlet scram valve must open in the hydraulic control units (HCUs) for the individual control rod drives. This is accomplished by venting the instrument air supply to each valve as follows:
 - Both scram pilot valves in each HCU must be deenergized, or
 - Either backup scram pilot valve must be energized.
- A high-pressure water source must be available from the scram accumulator in each HCU.
- A hydraulic vent path to the scram discharge volume must be available and sufficient collection volume must exist in the scram discharge volume.
- A specified number of control rods must respond and insert into the reactor core (specific number needed is not known).

3.6.5 Component Information

- A. Control rod drive pumps (5 pumps total; 1A, 1B, 2A, 3A and 3B).
 - 1. Rated capacity: 100% (for control rod drive function)
 - 2. Flow rate: 100 gpm @ 3675 ft. head (1593 psid)
 - 3. Type: centrifugal
- B. Condensate Storage Tanks (3)
 - 1. Capacity: 375,000 gal. each

3.6.6 Support Systems and Interfaces

- A. Control Signals
 - 1. Automatic
 - The RPS transmits scram commands to solenoid pilot valves which control the pneumatic scram valves
 - 2. Remote Manual
 - a. A reactor scram can be initiated manually from the control room
 - b. The CRDHS can be operated manually from the control room to insert and withdraw rods, or to inject water into the RCS
- B. Motive Power
 - 1. The power sources for the control rod drive pumps were not identified.

3.6.7 Section 3.6 References

1. NEDO-24708A, "Additional Information Required for NRC Staff Generic Report on Boiling Water Reactors," General Electric Company, December 1980.
2. NUREG/CR-2802, "Interim Reliability Evaluation Program: Analysis of the Browns Ferry Unit 1 Nuclear Plant", EG & G Idaho, July 1982.
3. NUREG-0626, "Generic Evaluation of Feedwater Transients and Small Break Loss-of-Coolant-Accidents in GE-designed Operating Plants and Near-term Operating License Applications," USNRC, January 1980.
4. Harrington, R.M., and Ott, L.J., "The Effect of Small-Capacity, High-Pressure Injection Systems on TQUV Sequences at Browns Ferry Unit One," NUREG/CR-3179, Oak Ridge National Laboratory, September 1983.

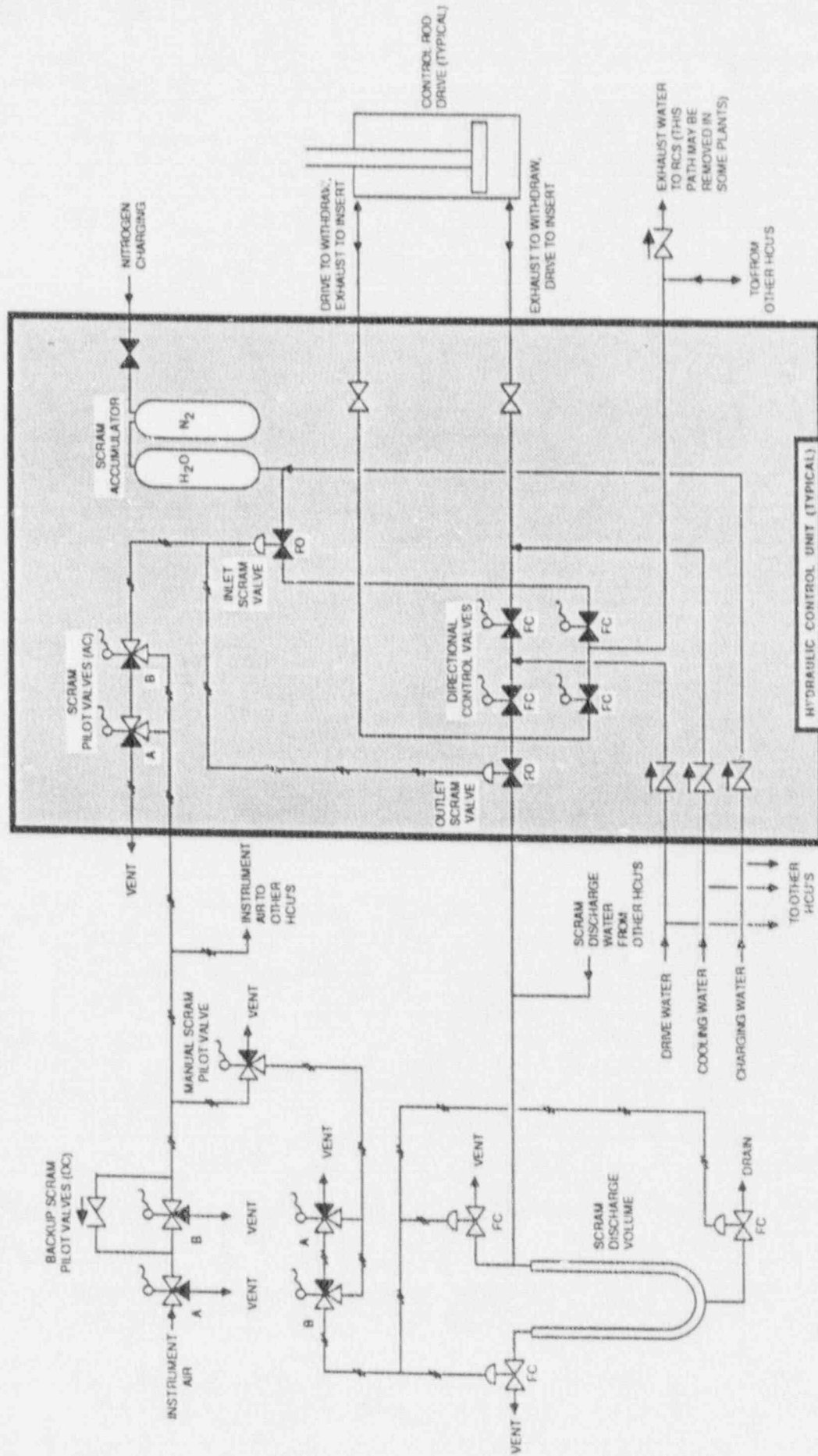

Figure 3.6-1. Simplified Diagram Of Portions Of The Control Rod Drive Hydraulic System That Are Related To The Scram Function

3.7 EMERGENCY EQUIPMENT COOLING WATER (EECW) SYSTEM

3.7.1 System Function

The EECW system provides cooling water from the ultimate heat sink (Wheeler Reservoir) to various component heat loads in the plant, including the diesel generator heat exchangers, RHR and CSS pump room coolers, RHR pump seal coolers, and various other heat loads. The EECW system also serves as a backup for the raw cooling water (RCW) system which is the normal water source for some operating systems, including the reactor building closed cooling water (RBCCW) system.

3.7.2 System Definition

The EECW system consists of four motor-driven service water pumps that take a suction through strainers in the intake structure and supply two headers (North header and South header) that serve all three Browns Ferry units. Cooling water is returned to the ultimate heat sink via a yard drainage system.

A simplified drawing of the EECW system is shown in Figures 3.7-1. More detailed system drawings are shown in Figures 3.7-2 and 3.7-3. A summary of the data on selected EECW system components is presented in Table 3.7-1.

3.7.3 System Operation

The EECW system normally is in standby, with pumps A3, B3, C3 and D3 aligned to supply the EECW headers when required. Two pumps are aligned to each header. The maximum EECW flow rate required by the three unit plant is 9800 gpm, including 4400 gpm for the RBCCW system, air compressor coolers, control room air conditioning chillers and the hydrogen/oxygen analyzer. Three of the four EECW pumps are necessary to supply this maximum flow rate (Ref. 1).

If required, other service water pumps can be realigned from the RHR service water system to the EECW system. This is accomplished by opening manual cross-connect valves between the A and B sets of pumps or motor-operated valves and between the C and D sets of pumps. (see Figure 3.7-1).

3.7.4 System Success Criteria

On a per-unit basis, one service water pump can provide an adequate source of water for the diesel generators. A total of three pumps is required to provide the maximum flow rate required by all three units.

3.7.5 Component Information

- A. Service Water Pumps (A3, B3, C3 and D3)
1. Rated flow: 4500 gpm @ 275 ft. head (119 psid)
 2. Type: vertical turbine

3.7.6 Support Systems and Interfaces

- A. Control Signals
1. Automatic

The EECW pumps automatically start on:

 - Low raw cooling water (RCW) system pressure
 - Diesel generator start
 - Pumps B3 and D3 start for Unit 1/2 diesels
 - Pumps A3 and C3 start for Unit 3 diesels
 - Core spray pump start

- ECCS initiation
 - drywell high pressure or RPV low water level at any unit

2. Remote manual

The EECW pumps can be actuated by remote manual means from the control room.

B. Motive Power

The EECW pumps and valves are Class 1E AC loads that can be powered from the diesel generators as described in Section 3.5. Note that two EECW pumps are supplied from the Unit 1/2 diesels and two are supplied from the Unit 3 diesels.

3.7.7 Section 3.7 References

1. Browns Ferry, FSAR, Section 10.10.

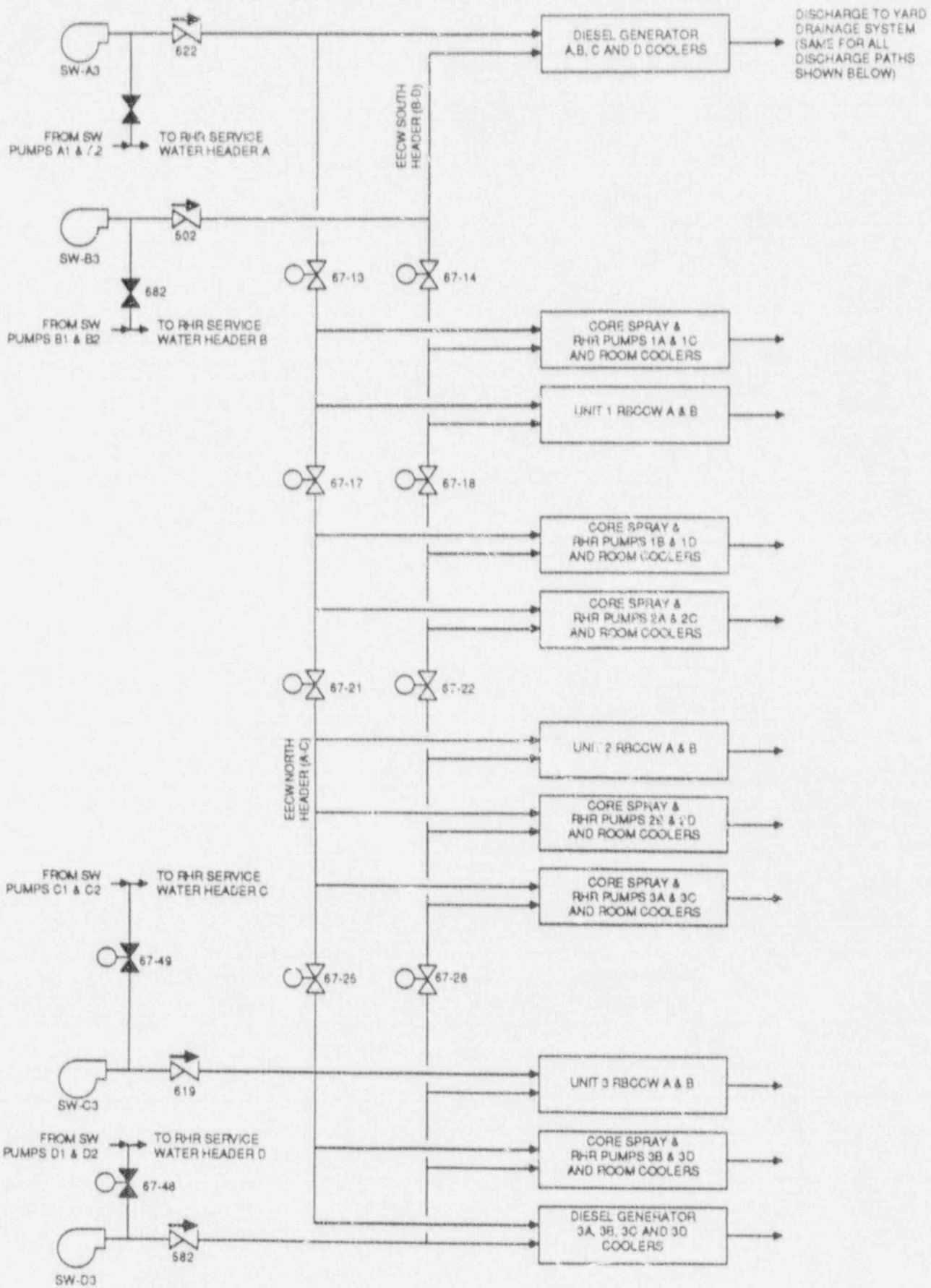
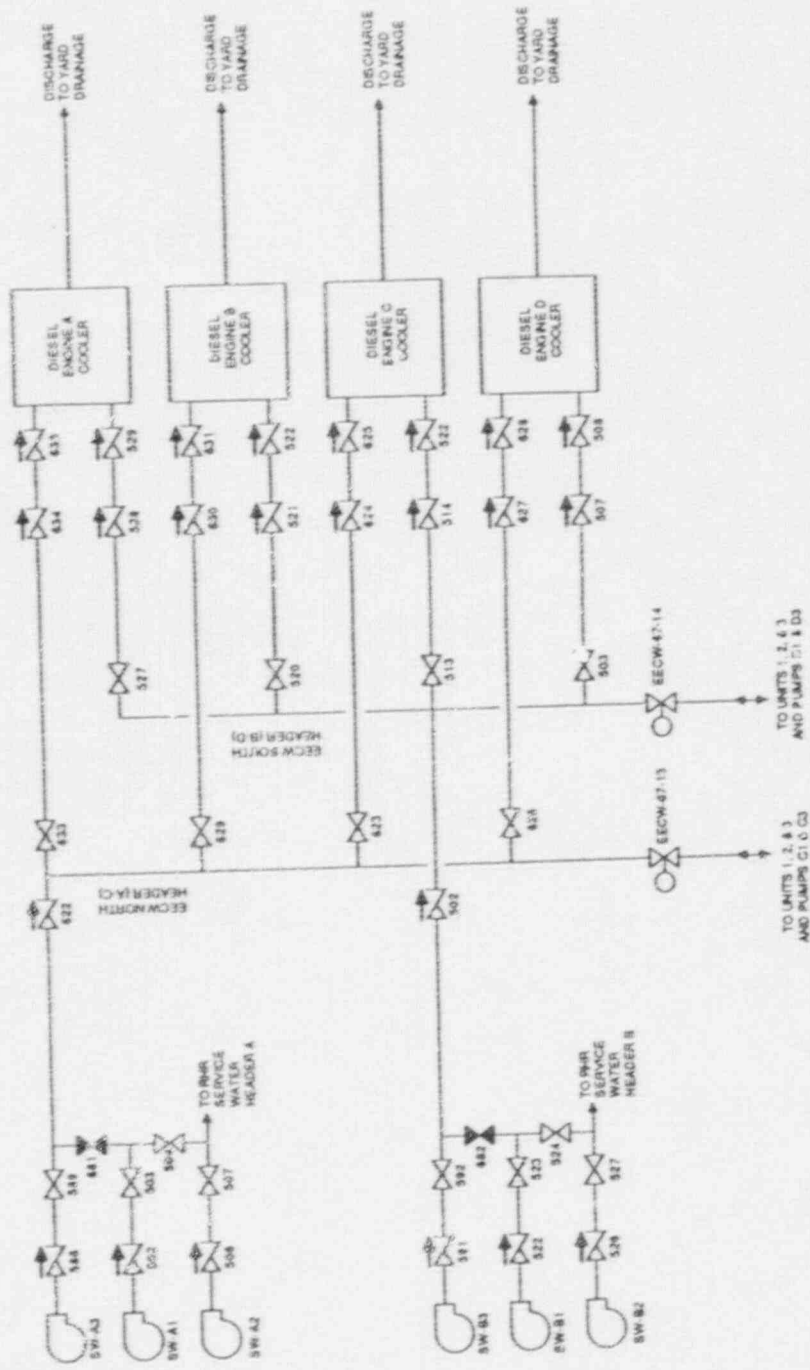

Figure 3.7-1. Simplified Diagram of Emergency Equipment Cooling Water (EECW) System, for Browns Ferry 1, 2 and 3



CONTINUED SHEET 2 OF 3

NOTE: SERVICE WATER PUMPS A3 AND B3 SERVE THE EECW SYSTEM. PUMPS A1, A2, B1, AND B2 ARE NORMALLY ALIGNED TO SUPPLY THE RHR SERVICE WATER SYSTEM. PUMPS A1 AND B1 MAY BE MANUALLY REALIGNED TO SUPPLY THE EECW SYSTEM IF NEEDED.

Figure 3.7-2. Browns Ferry 1, 2, and 3 Emergency Equipment Cooling Water (EECW) System (Sheet 1 of 5)

CONTINUED SHEET 1 OF 5

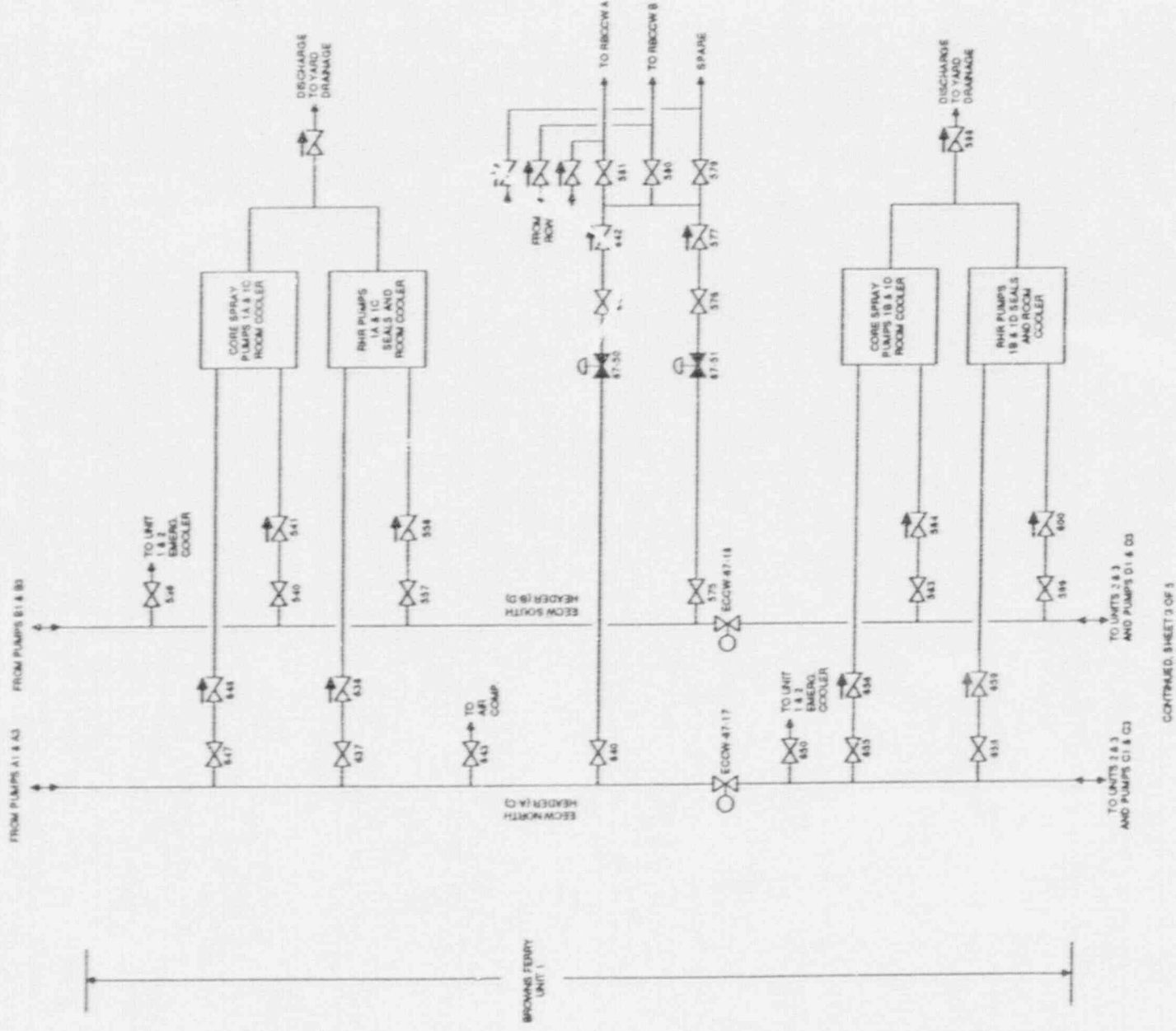
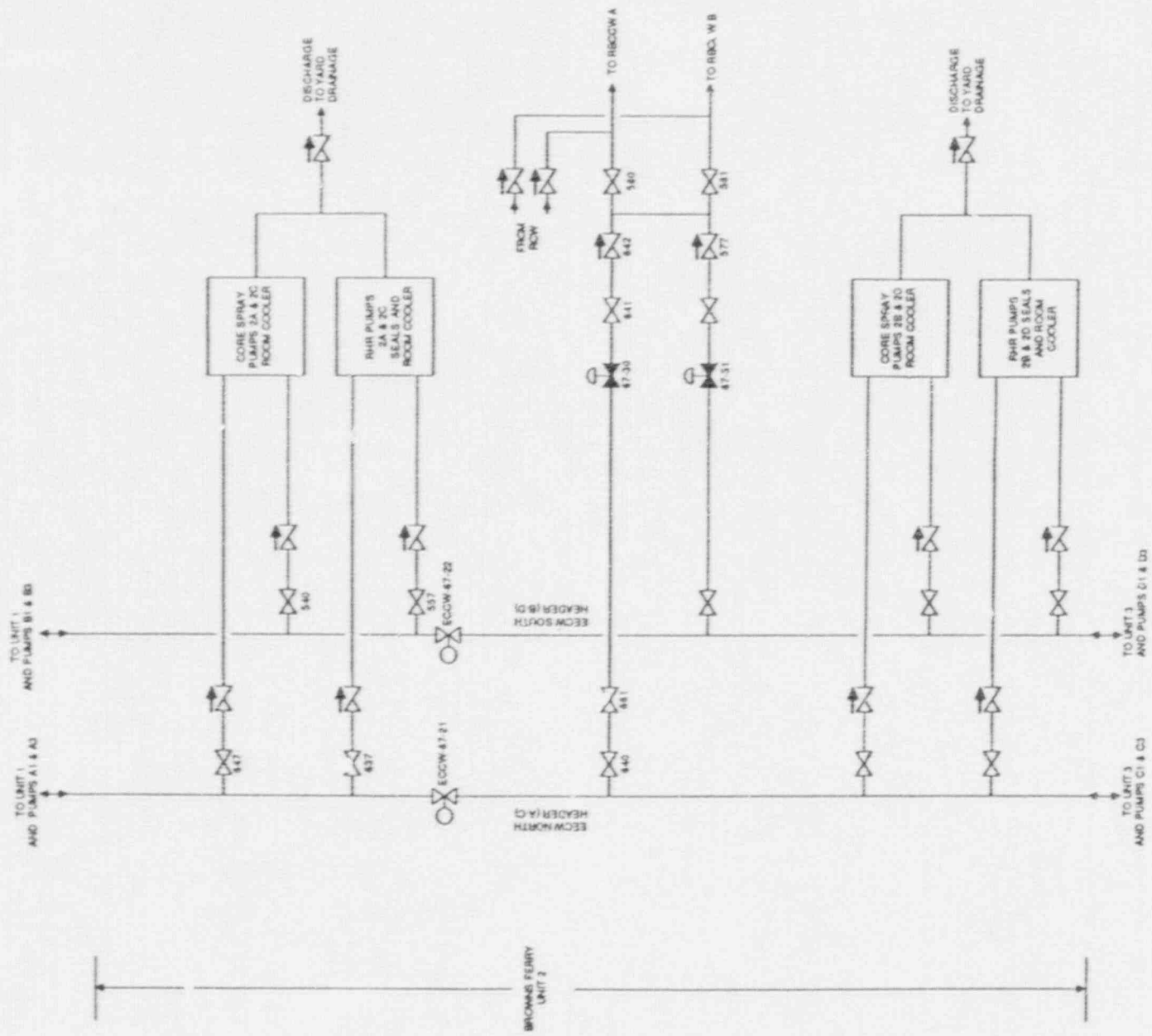

Figure 3.7-2. Browns Ferry 1, 2, and 3 Emergency Equipment Cooling Water (EECW) System (Sheet 2 of 5)

CONTINUED SHEET 2 OF 5



CONTINUED SHEET 4 OF 5

Figure 3.7-2. Browns Ferry 1, 2, and 3 Emergency Equipment Cooling Water (EECW) System (Sheet 3 of 5)

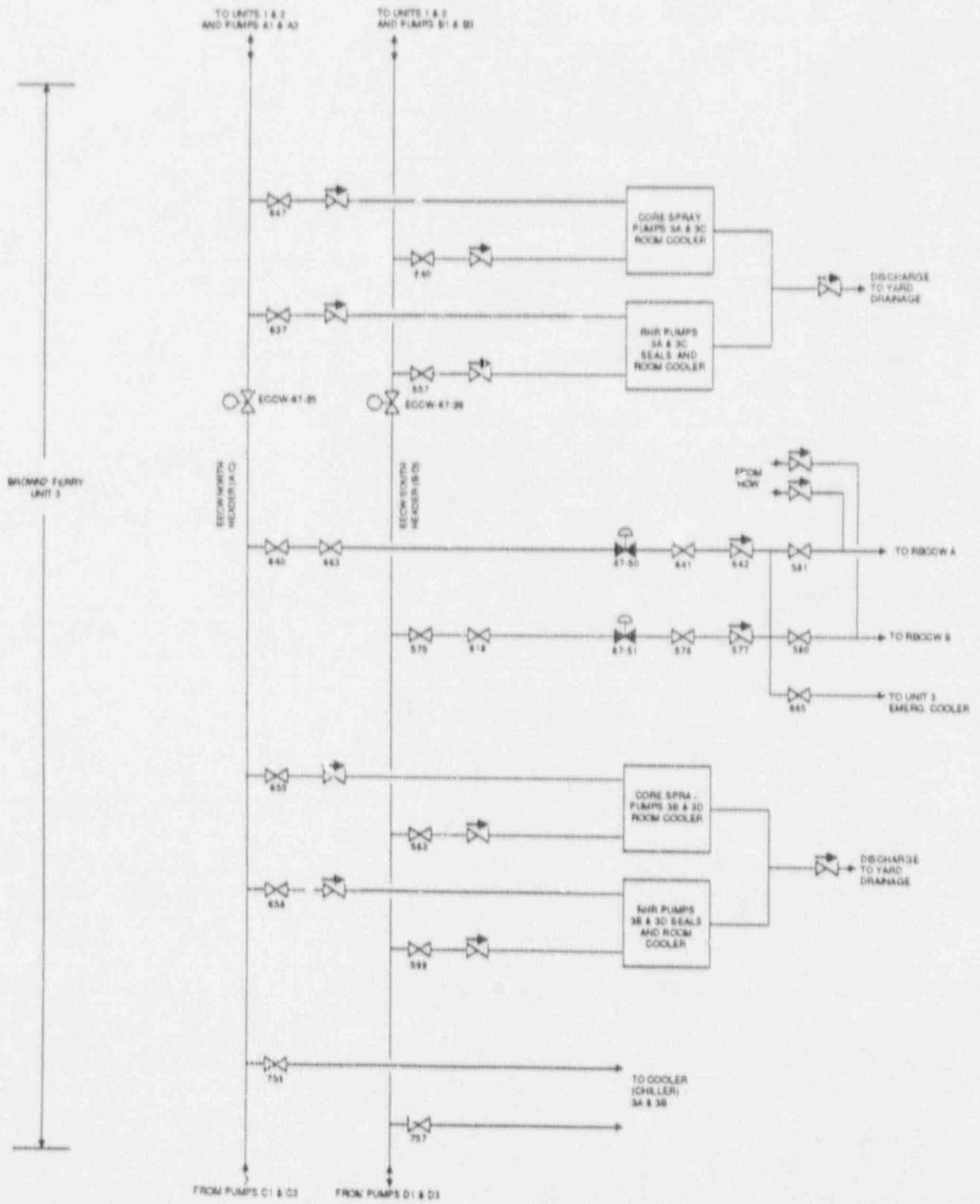
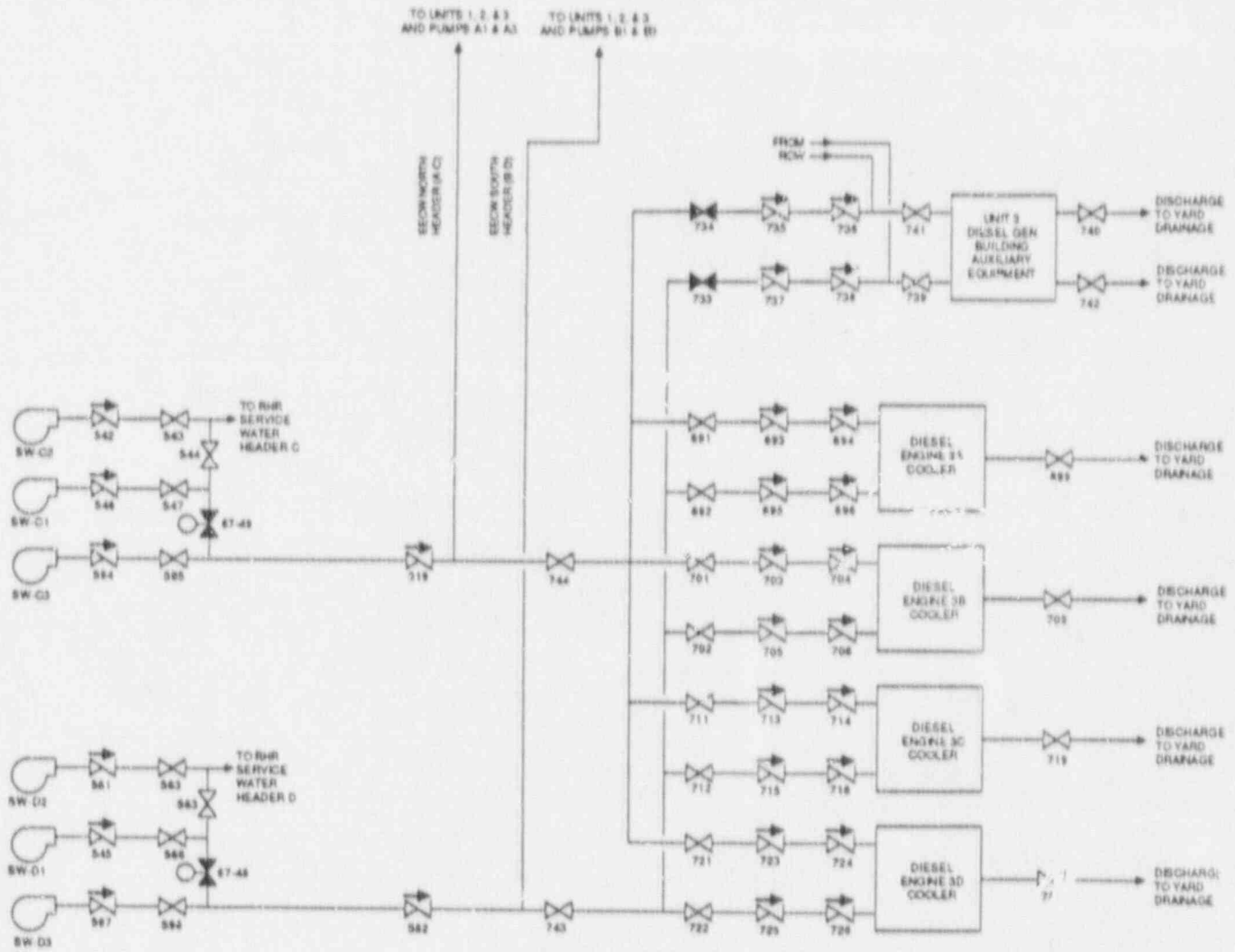
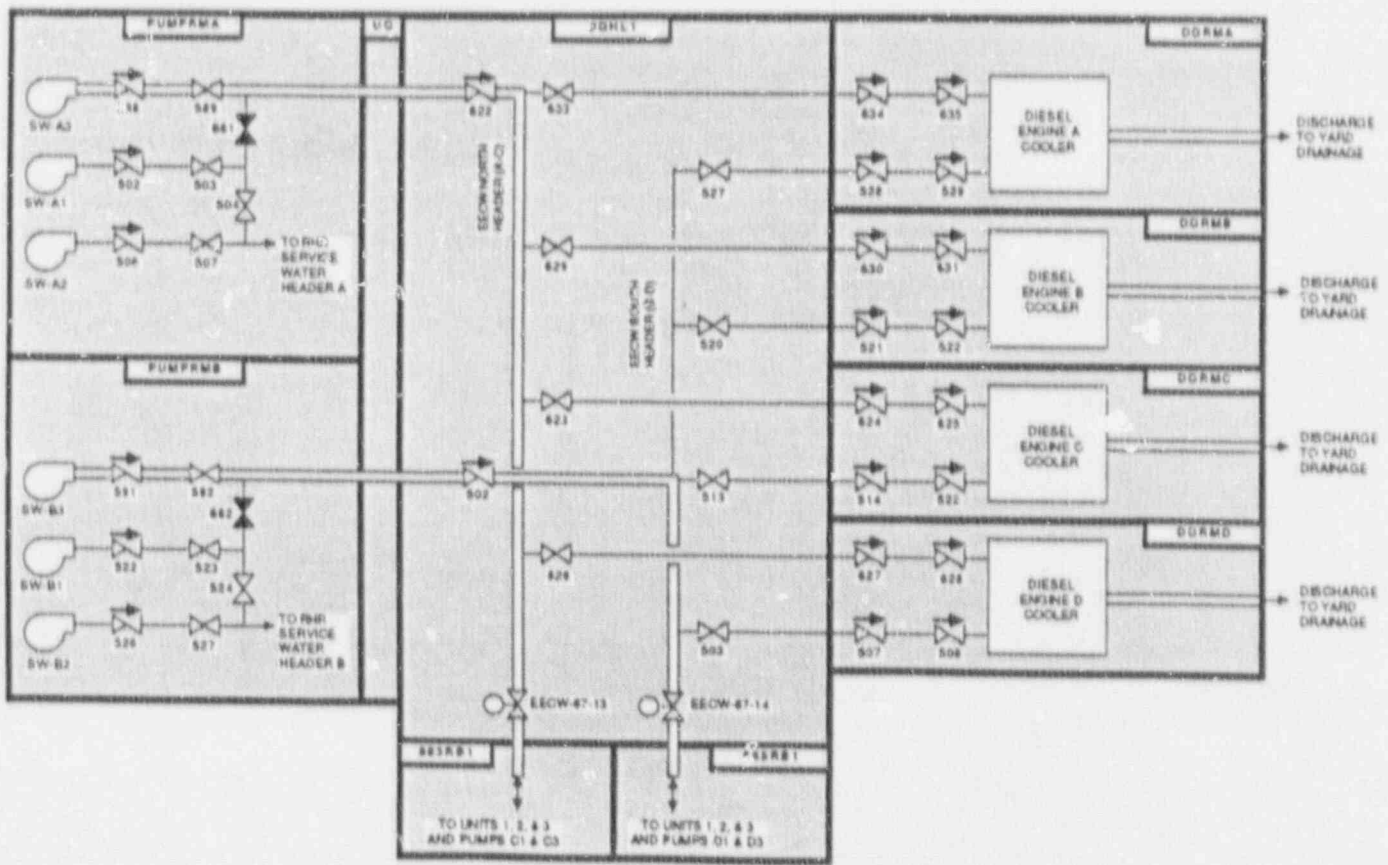

Figure 3.7-2. Browns Ferry 1, 2, and 3 Emergency Equipment Cooling Water (EECW) System (Sheet 4 of 5)



NOTE: SERVICE WATER PUMPS C3 AND D3 SERVE THE ECCW SYSTEM. PUMPS C1, C2, D1, AND D2 ARE NORMALLY ALIGNED TO SUPPLY THE RHR SERVICE WATER SYSTEM. PUMPS C1 AND D1 MAY BE MANUALLY REALIGNED TO SUPPLY THE ECCW SYSTEM IF NEEDED.

Figure 3.7-2. Browns Ferry 1, 2, and 3 Emergency Equipment Cooling Water (ECCW) System (Sheet 5 of 5)



CONTINUED, SHEET 2 OF 5

NOTE: SERVICE WATER PUMPS A3 AND B3 SERVE THE EECW SYSTEM. PUMPS A1, A2, B1, AND B2 ARE NORMALLY ALIGNED TO SUPPLY THE RH-R SERVICE WATER SYSTEM. PUMPS A1 AND B1 MAY BE MANUALLY REALIGNED TO SUPPLY THE EECW SYSTEM IF NEEDED.

Figure 3.7-3. Browns Ferry 1, 2, and 3 Emergency Equipment Cooling Water (EECW) System Showing Component Locations (Sheet 1 of 5)

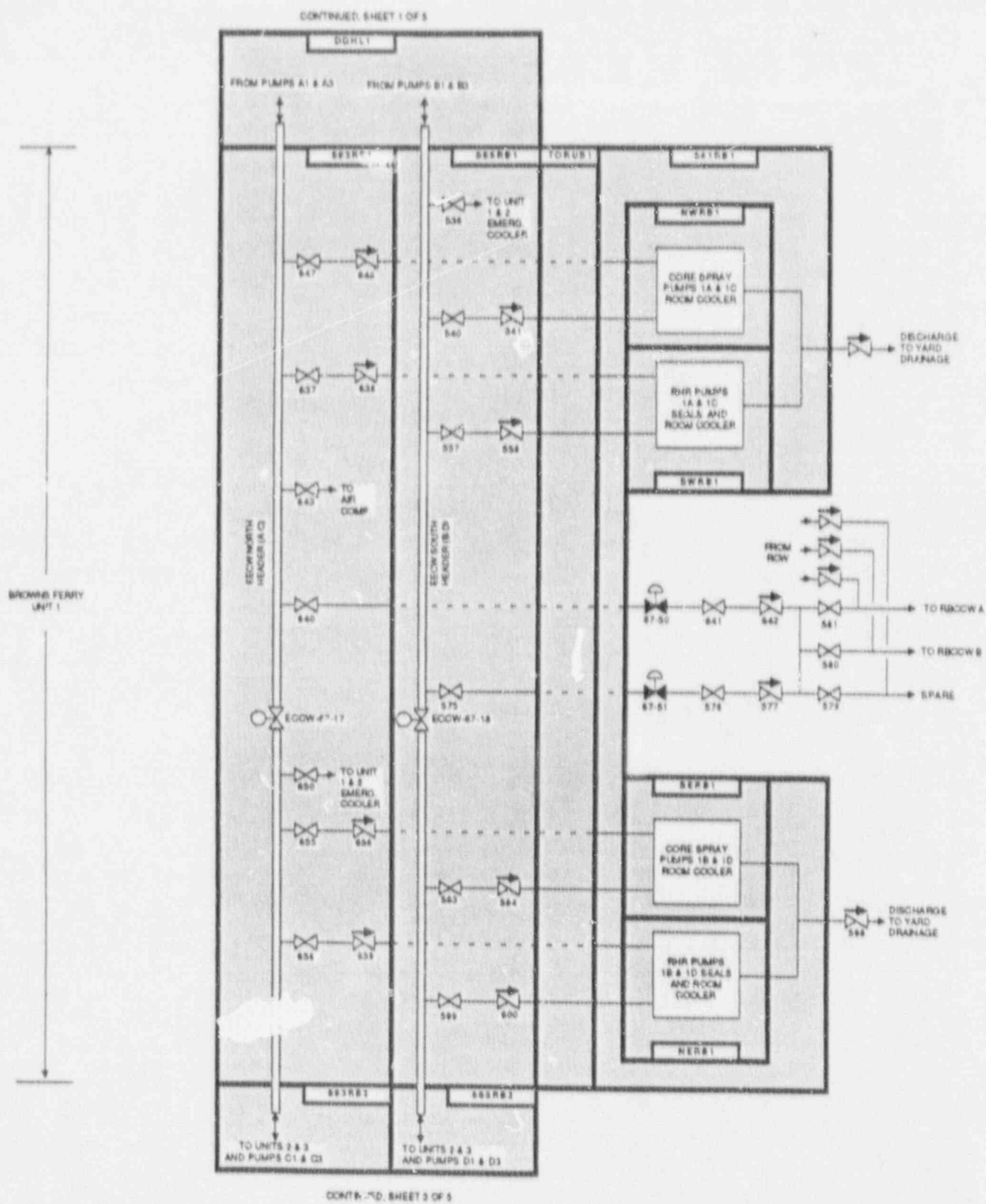

Figure 3.7-3. Browns Ferry 1, 2, and 3 Emergency Equipment Cooling Water (EECW) System Showing Component Locations (Sheet 2 of 5)

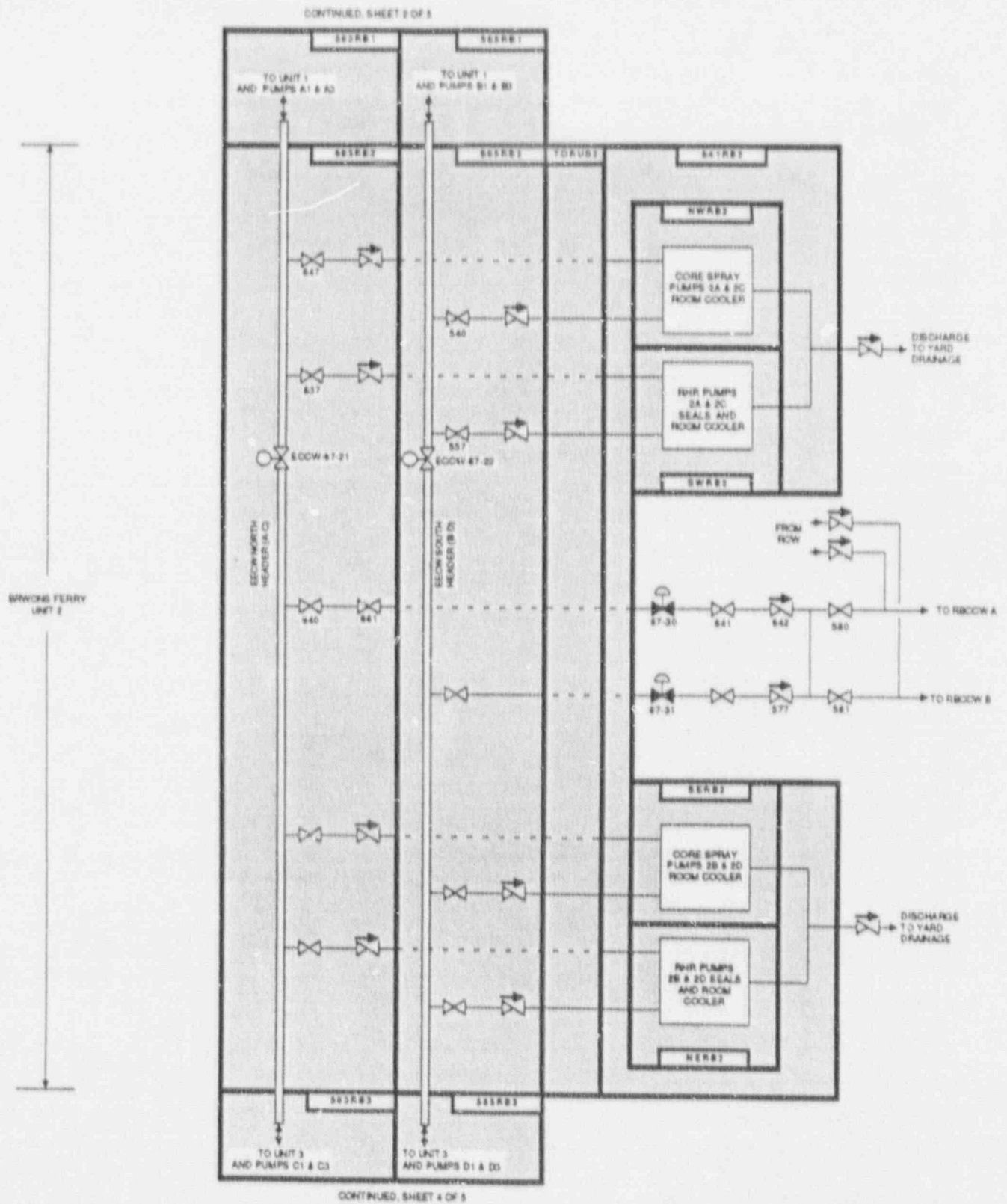

Figure 3.7-3. Browns Ferry 1, 2, and 3 Emergency Equipment Cooling Water (EECW) System Showing Component Locations (Sheet 3 of 5)

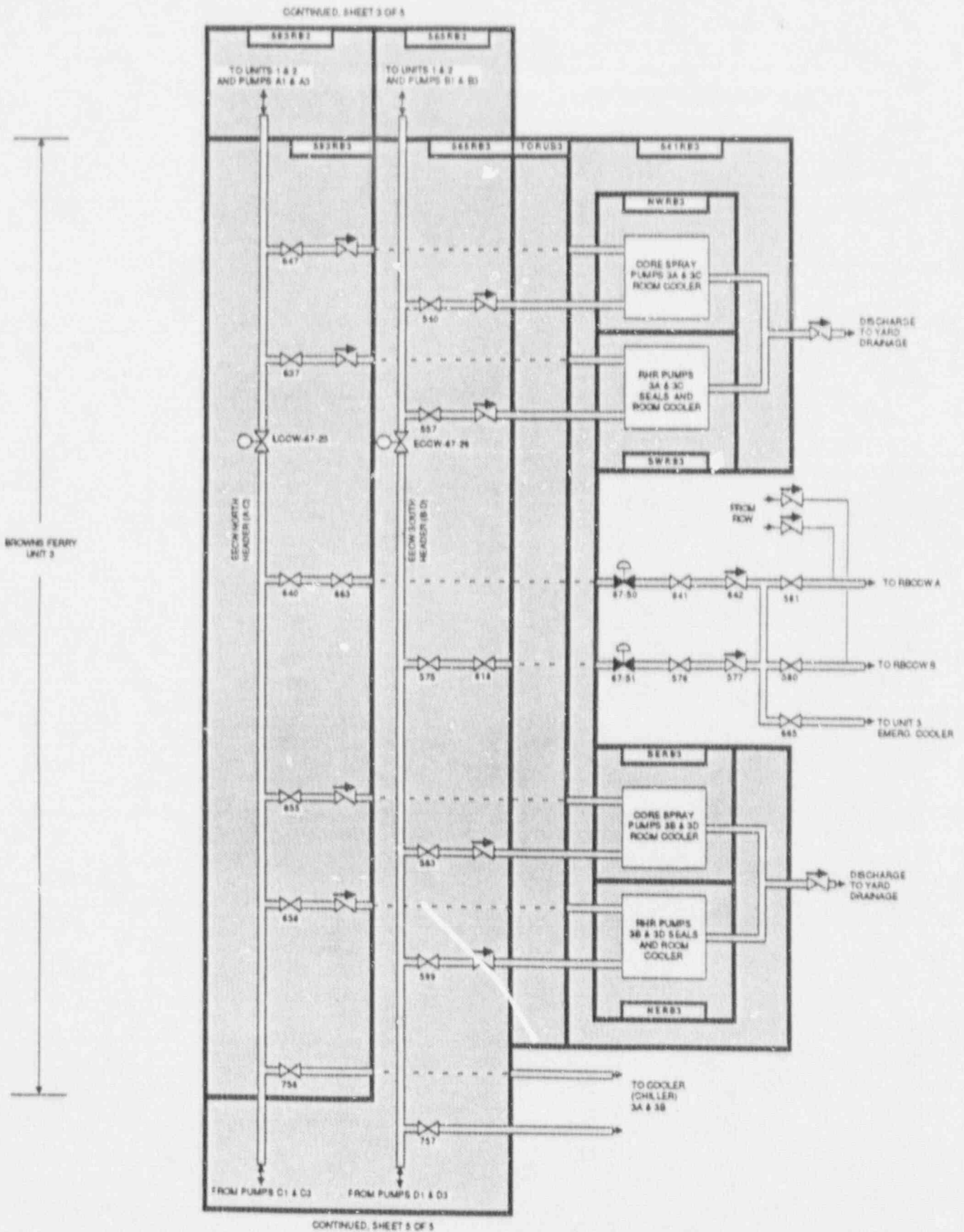
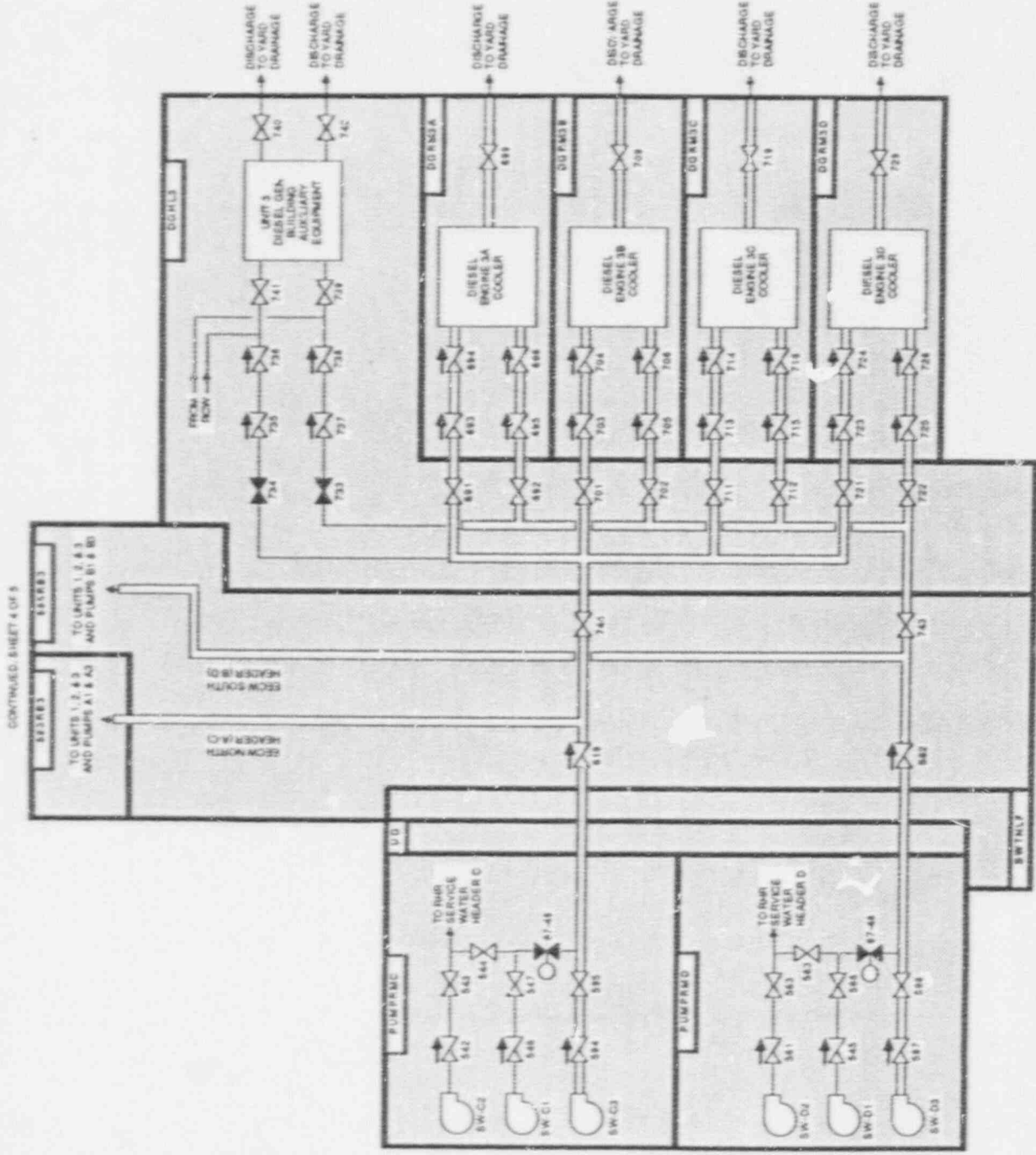

Figure 3.7-3. Browns Ferry 1, 2, and 3 Emergency Equipment Cooling Water (EECW) System Showing Component Locations (Sheet 4 of 5)



NOTE: SERVICE WATER PUMPS C3 AND D3 SERVE THE EECW SYSTEM. PUMPS C1, C2, D1, AND D2 ARE NORMALLY ALIGNED TO SUPPLY THE RHR SERVICE WATER SYSTEM. PUMPS C1 AND D1 MAY BE MANUALLY REALIGNED TO SUPPLY THE EECW SYSTEM IF NEEDED.

Figure 3.7-3. Browns Ferry 1, 2, and 3 Emergency Equipment Cooling Water (EECW) System Showing Component Locations (Sheet 5 of 5)

Table 3.7-1. Browns Ferry 3 Emergency Equipment Cooling Water System Data Summary for Selected Components

COMPONENT ID	COMP. TYPE	LOCATION	POWER SOURCE	VOLTAGE	POWER SOURCE LOCATION	EMERG. LOAD GRP
681	XV	PUMPRMA				
682	XV	PUMPRMB				
EECW-67-13	MOV	DGHL1	AC-DGAUX-A	480	DGHL1	I
EECW-67-14	MOV	DGHL1	AC-DGAUX-B	480	DGHL1	II
EECW-67-17	MOV	593RB1	AC-MOV1C	480	565RB1	II
EECW-67-18	MOV	565RB1	AC-MOV1B	480	SDRMB	II
EECW-67-21	MOV	593RB2	AC-MOV2C	480	565RB2	II
EECW-67-22	MOV	565RB2	AC-MOV2B	480	SDRMD	II
EECW-67-25	MOV	593RB3	AC-MOV3C	480	565RB3	II
EECW-67-26	MCV	565RB3	AC-MOV3B	480	SDRMF	II
EECW-67-48	MOV	PUMPRMD	AC-DGAUX-B	480	DGHL1	II
EECW-67-49	MOV	PUMPRMC	AC-DGAUX-A	480	DGHL1	I
EECW-PMA1	MDP	PUMPRMA	EP-SBA	4160	SDRMA	I
EECW-PMA3	MDP	PUMPRMA	EP-SB3EA	4160	SDRM3EA	I
EECW-PMB1	MDP	PUMPRMB	EP-SB3EC	4160	SDRM3EC	II
EECW-PMB3	MDP	PUMPRMB	EP-SBC	4160	SDRMC	II
EECW-PMC1	MDP	PUMPRMC	EP-SBB	4160	SDRMB	I
EECW-PMC3	MDP	PUMPRMC	EP-SB3EB	4160	SDRM3EB	I
EECW-PMD1	MDP	PUMPRMD	EP-SB3ED	4160	SDRM3ED	II
EECW-PMD3	MDP	PUMPRMD	EP-SBD	4160	SDRMD	II

3.8 RHR SERVICE WATER (RHRSW) SYSTEM

3.8.1 System Function

The RHRSW system provides cooling water from the ultimate heat sink (Wheeler Reservoir) to remove reactor core heat via the RHR heat exchangers. The RHRSW system also serves as the standby coolant supply (SBCS) and can supply makeup to the reactor coolant system when all emergency core cooling systems have failed.

3.8.2 System Definition

The RHRSW system consists of eight motor-driven service pumps (four pairs) that take a suction through strainers in the intake structure and supply four headers that serve the RHR heat exchangers at all three Browns Ferry units.

Simplified diagrams of the RHRSW system are shown in Figures 3.8-1 and 3.8-2. A summary of the data on selected RHRSW system components is presented in Table 3.8-1.

3.8.3 System Operation

The RHRSW system normally is in standby, with two pumps aligned to each of the four RHRSW headers. Within one hour following a design basis accident, six of eight RHRSW pumps will be required to supply cooling water to the RHR heat exchangers.

No cross-connections exist between the four RHRSW headers, but there are cross-connections between the pumps that are aligned to the RHRSW system and the four service water pumps aligned to the EECW system (see Figure 3.8-1).

The RHRSW system can be aligned to supply RCS makeup by opening a cross-tie valve to the RHR system (valve 23-57, two locations). Additional valves in the RHR system also must be aligned to complete the makeup flow path.

3.8.4 System Success Criteria

The cooling water requirements of each RHR heat exchanger can be supplied by one service water pump. There normally are two service water pumps aligned to each RHR heat exchanger.

3.8.5 Component Information

- A. Service Water Pumps (A1, A2, B1, B2, C1, C2, D1 and D2)
 1. Rated flow: 4500 gpm @ 275 ft. head (119 psid)
 2. Rated capacity: 100% of the cooling water required by one RHR heat exchanger
 3. Type: vertical turbine

3.8.6 Support Systems and Interfaces

- A. Control Signals
 1. Automatic
None
 2. Remote manual
The RHRSW pumps are placed in service by remote manual means from any of the three control rooms.
- B. Motive Power
The RHRSW pump and valves are Class 1E AC loads that can be powered from the diesel generators as described in Section 3.5.

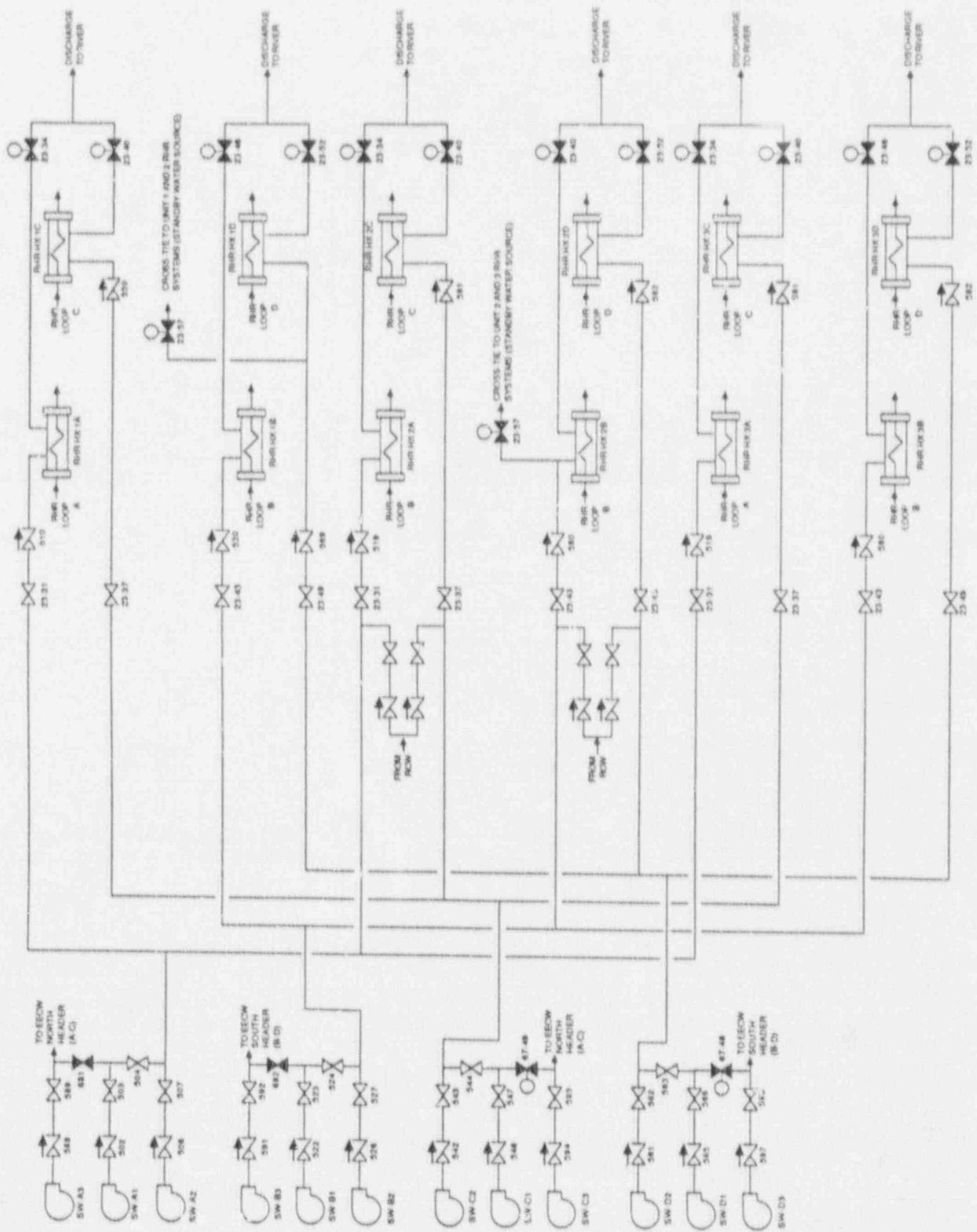

Figure 3.8-1. Browns Ferry 1, 2, and 3 RHR Service Water (RHR SW) System

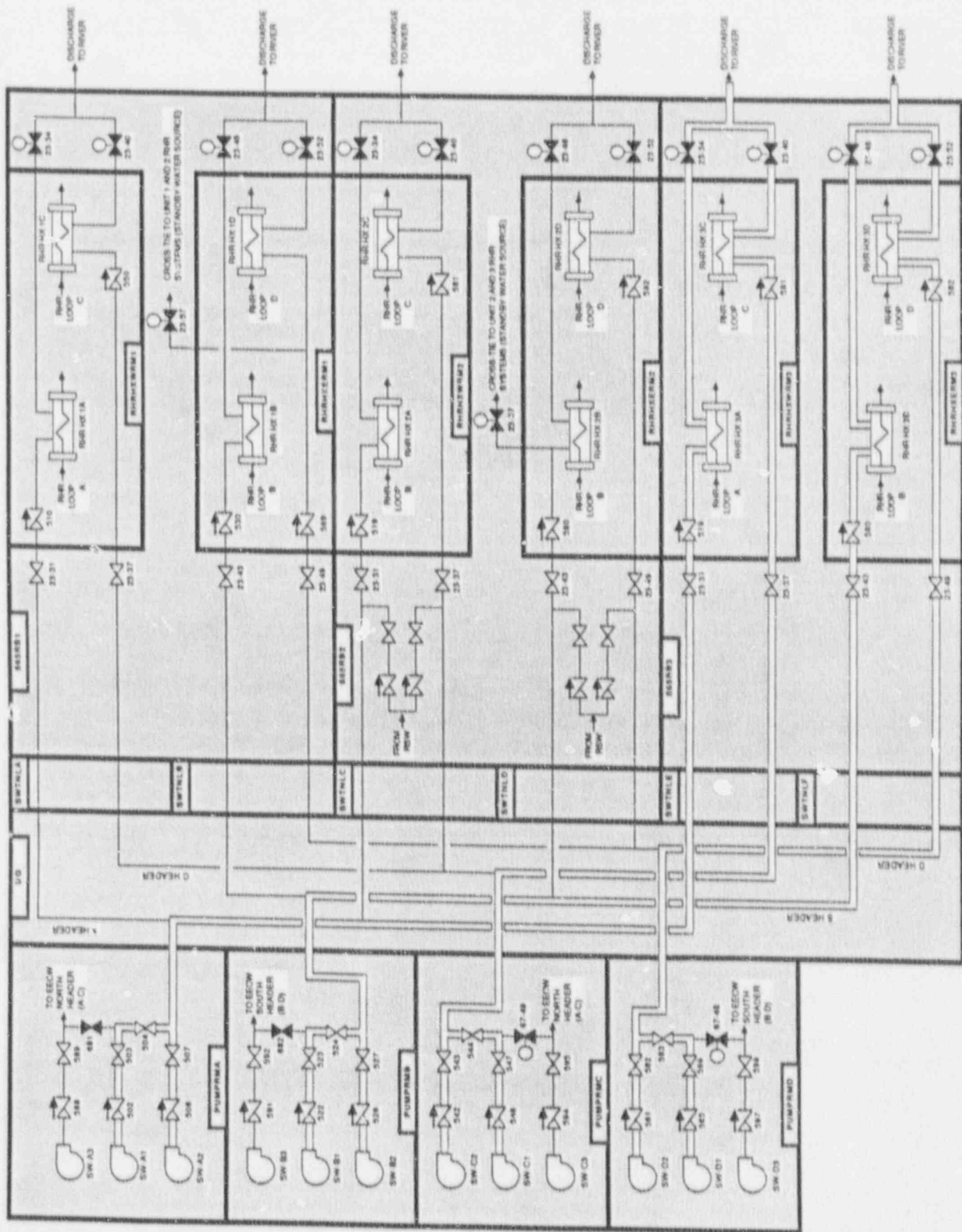

Figure 3.8-2. Browns Ferry 1, 2, and 3 RHR Service Water (RHR/SW) System Showing Component Locations

Table 3.8-1. Browns Ferry 3 RHR Service Water System Data
Summary for Selected Components

COMPONENT ID	COMP. TYPE	LOCATION	POWER SOURCE	VOLTAGE	POWER SOURCE LOCATION	EMERG. LOAD GRP
23-34	MOV	565RB3	AC-MOV3A	480	SDRME	I
23-40	MOV	565RB3	AC-MOV3A	480	SDRME	I
23-46	MOV	565RB3	AC-MOV3B	480	SDRMF	II
23-52	MOV	565RB3	AC-MOV3B	480	SDRMF	II
SW-A2	MDP	PUMPRMA	EP-SE4	4160	SDRMA	I
SW-B2	MDP	PUMPRMB	EP-SBC	4160	SDRMC	II
SW-C2	MDP	PUMPRMC	EP-SBB	4160	SDRMB	I
SW-D2	MDP	PUMPRMD	EP-SBD	4160	SDRMD	II

4. PLANT INFORMATION

4.1 SITE AND BUILDING SUMMARY

The Browns Ferry site is located in Alabama, about 30 miles west of Huntsville. A general view of the site is shown in Figure 4-1 (from Ref. 1) and more details of the major site buildings can be seen in Figure 4-2.

All three reactor buildings and turbine buildings are located side-by-side. Unit 1 is at the west end, and Unit 3 is at the east end. The turbine building is to the north of the reactor building.

There are two diesel generator buildings, each containing four diesel generators. The Unit 1/2 diesel generator building is located at the west end of the reactor building, and the Unit 3 diesel generator building is on the east end. Below each diesel generator building is a long-term diesel fuel oil supply. Additional fuel oil is available in the oil storage tanks to the east of the reactor building complex.

A pumping station to the south-east of the reactor building complex contains the main circulating water pumps and the EECW/RHRSW pumps. These pumps draw water from the Wheeler Reservoir which is the ultimate heat sink for the Browns Ferry site.

The three condensate storage tanks which serve the ECCS, RCIC system and control rod drive hydraulic system are located on the east side of the turbine building.

Other structures on the site include a radwaste building, service building and standby gas treatment facilities on the west side of the reactor/turbine building complex. A sewage treatment plant is located southwest of this complex.

4.2 FACILITY LAYOUT DRAWINGS

An overview of the layout of all three units at the Browns Ferry site is provided in Figures 4-3 to 4-9. Simplified layout drawings for Unit 3 are shown in Figures 4-10 to 4-17. Note that some equipment in systems shared between units (i.e. electric power system, EECW and RHRSW system) are physically located in Unit 1 or Unit 2. Refer to the Sourcebooks for Browns Ferry 1 and 2 for details on the layouts of these units. The service water pump station and some other outlying buildings are not shown in these drawings.

Major rooms, stairways, elevators, and doorways are shown in the simplified layout drawings, however, many interior walls have been omitted for clarity. Labels printed in uppercase correspond to the location codes listed in Table 4-1 and used in the component data listings and system drawings in Section 3. Some additional labels are included for information and are printed in lowercase type.

A listing of components by location is presented in Table 4-2. Components included in Table 4-2 are those found in the system data tables in Section 3, therefore this table is only a partial listing of the components and equipment that are located in a particular room or area of the plant.

4.3 SECTION 4 REFERENCES

1. Heddleson, F.A., "Design Data and Safety Features of Commercial Nuclear Power Plants.", ORNL-NSIC-55, Volume II, Oak Ridge National Laboratory, Nuclear Safety Information Center, January 1972.

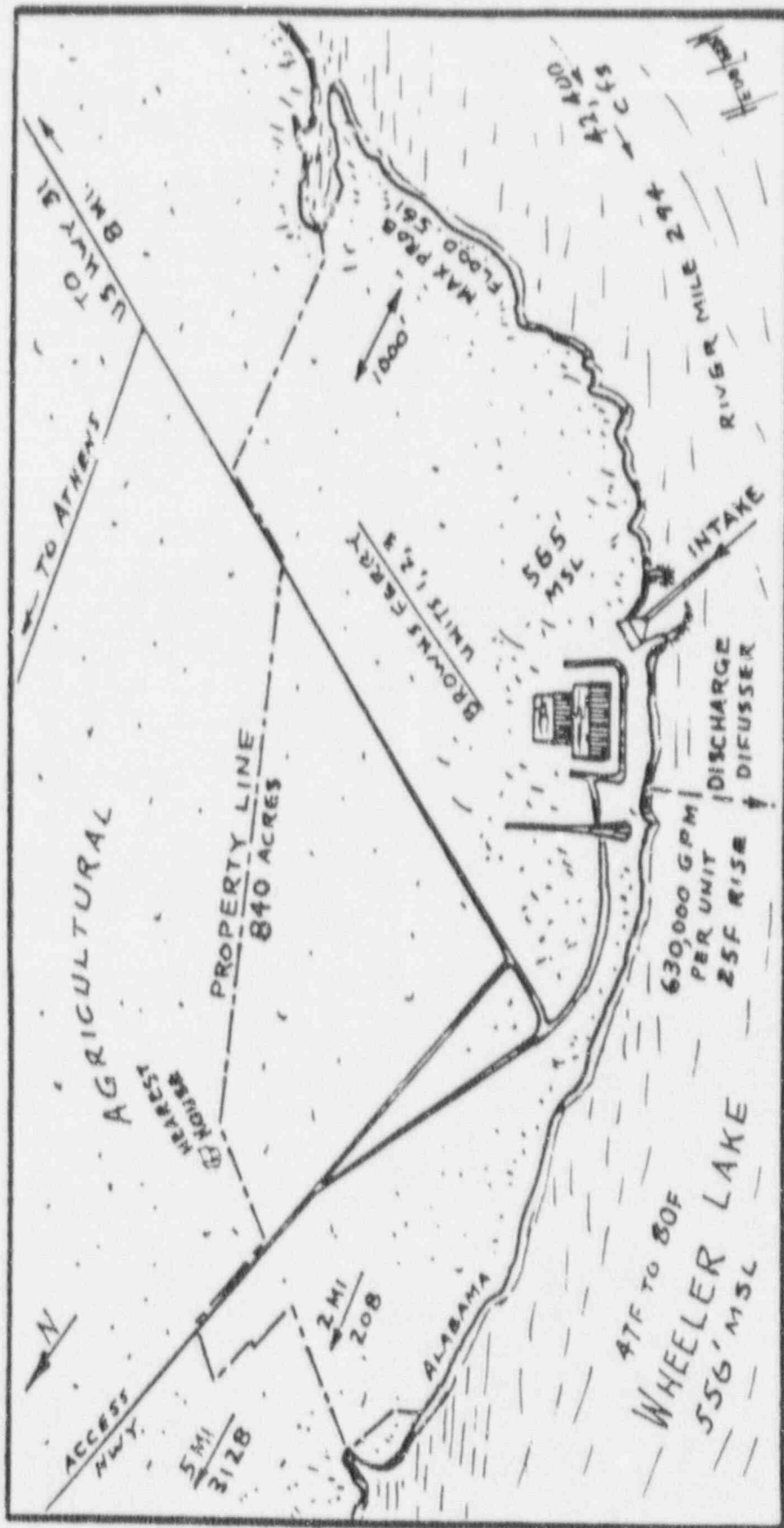

Figure 4-1. General View of Browns Ferry Site and Vicinity

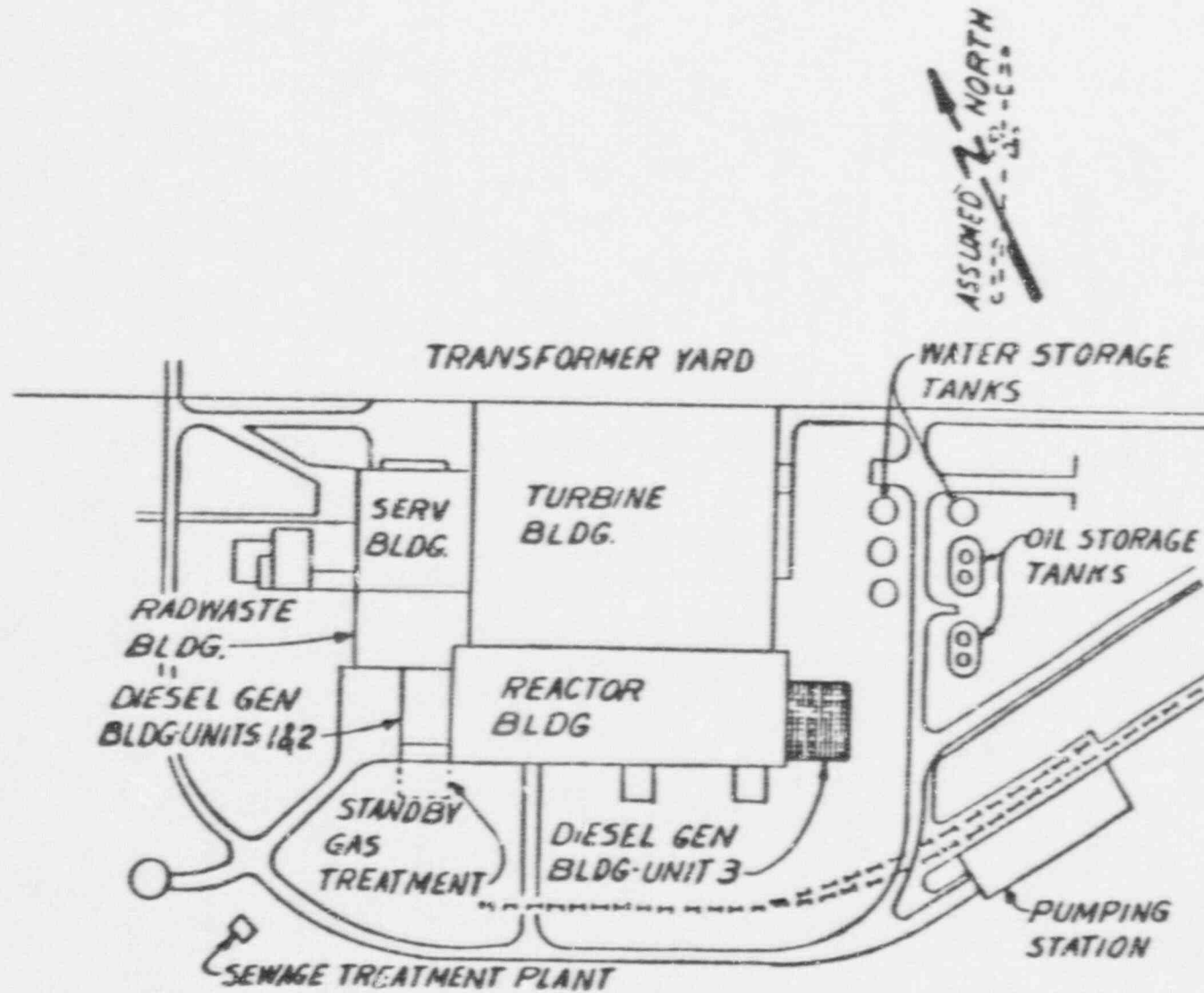

Figure 4-2. General Arrangement of Major Buildings at the Browns Ferry Site

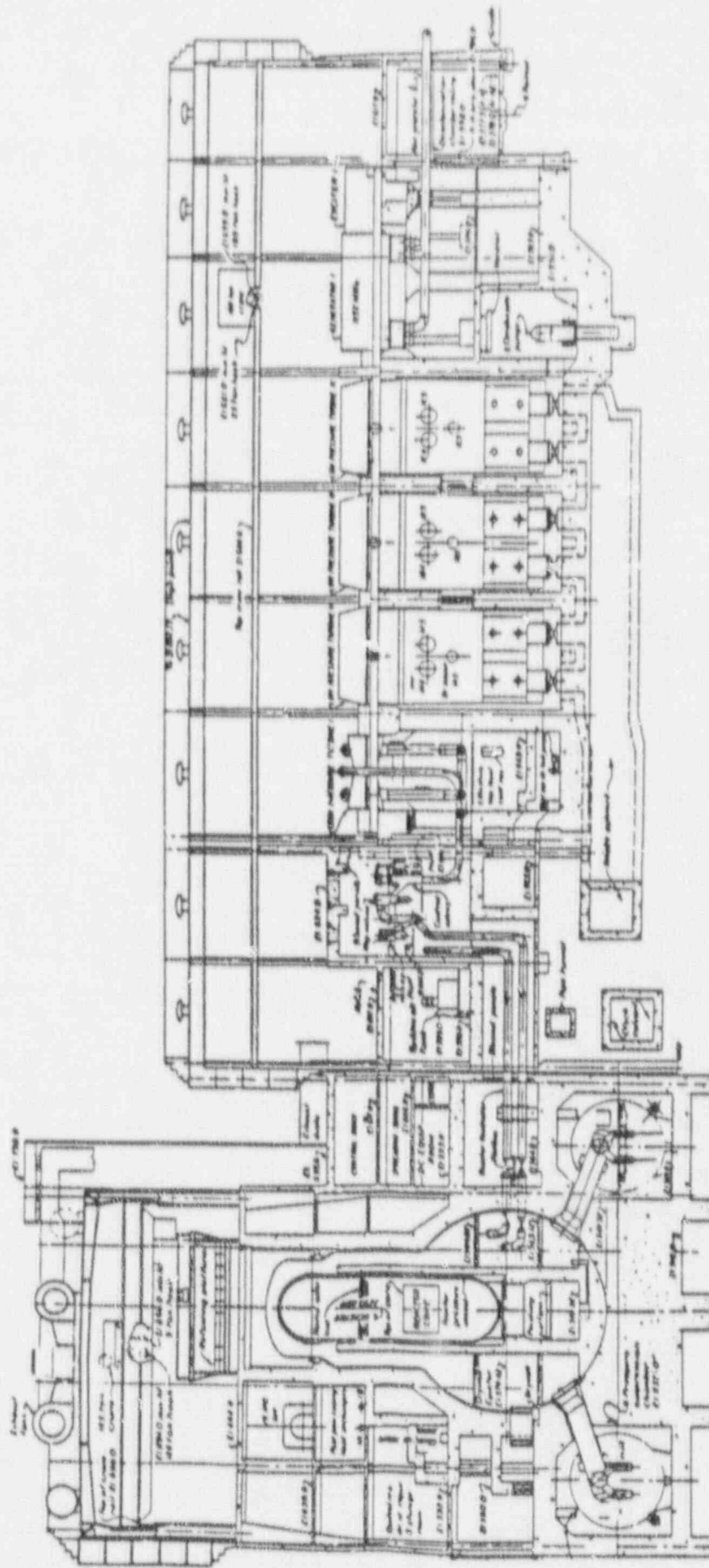

Figure 4-3. Typical Elevation View of Browns Ferry Reactor and Turbine Buildings

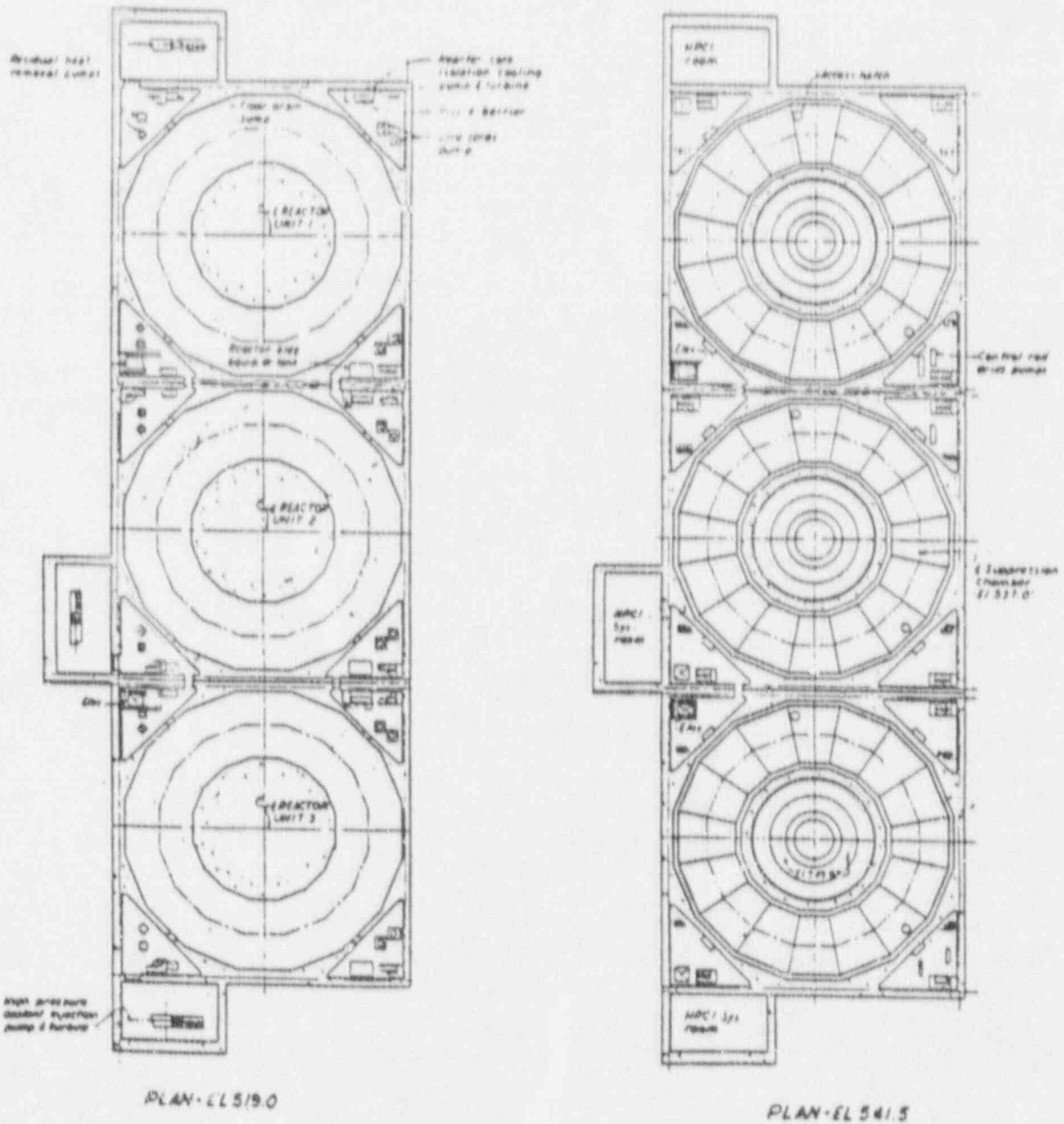
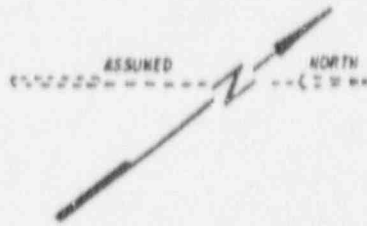

Figure 4-6. Overall Layout of the Browns Ferry Nuclear Plant, Elevations 519 ft. and 541.5 ft.

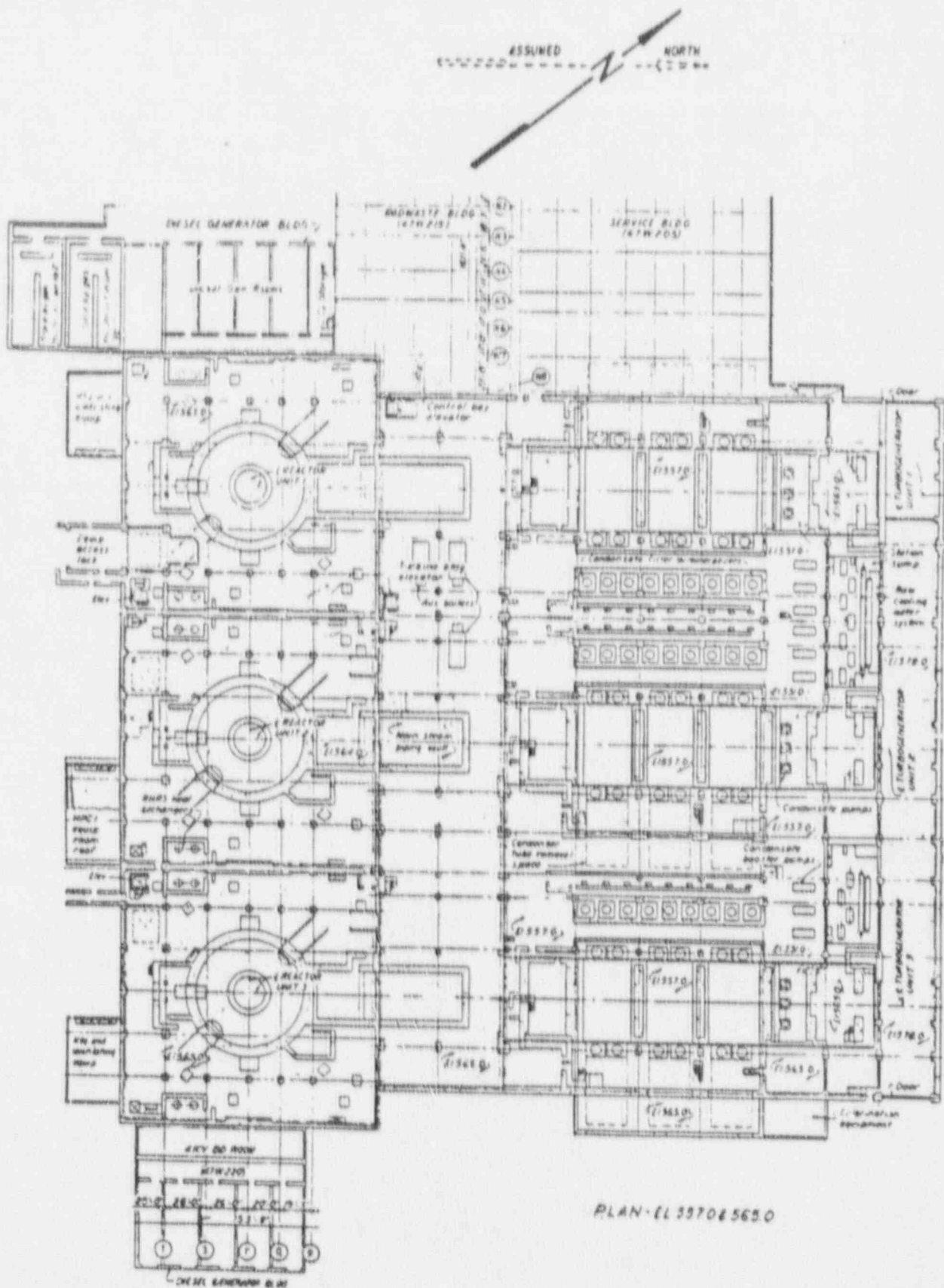

Figure 4-7. Overall Layout of the Browns Ferry Nuclear Plant, Elevations 557 ft. (Turbine Building) and 565 ft. (Reactor Building)

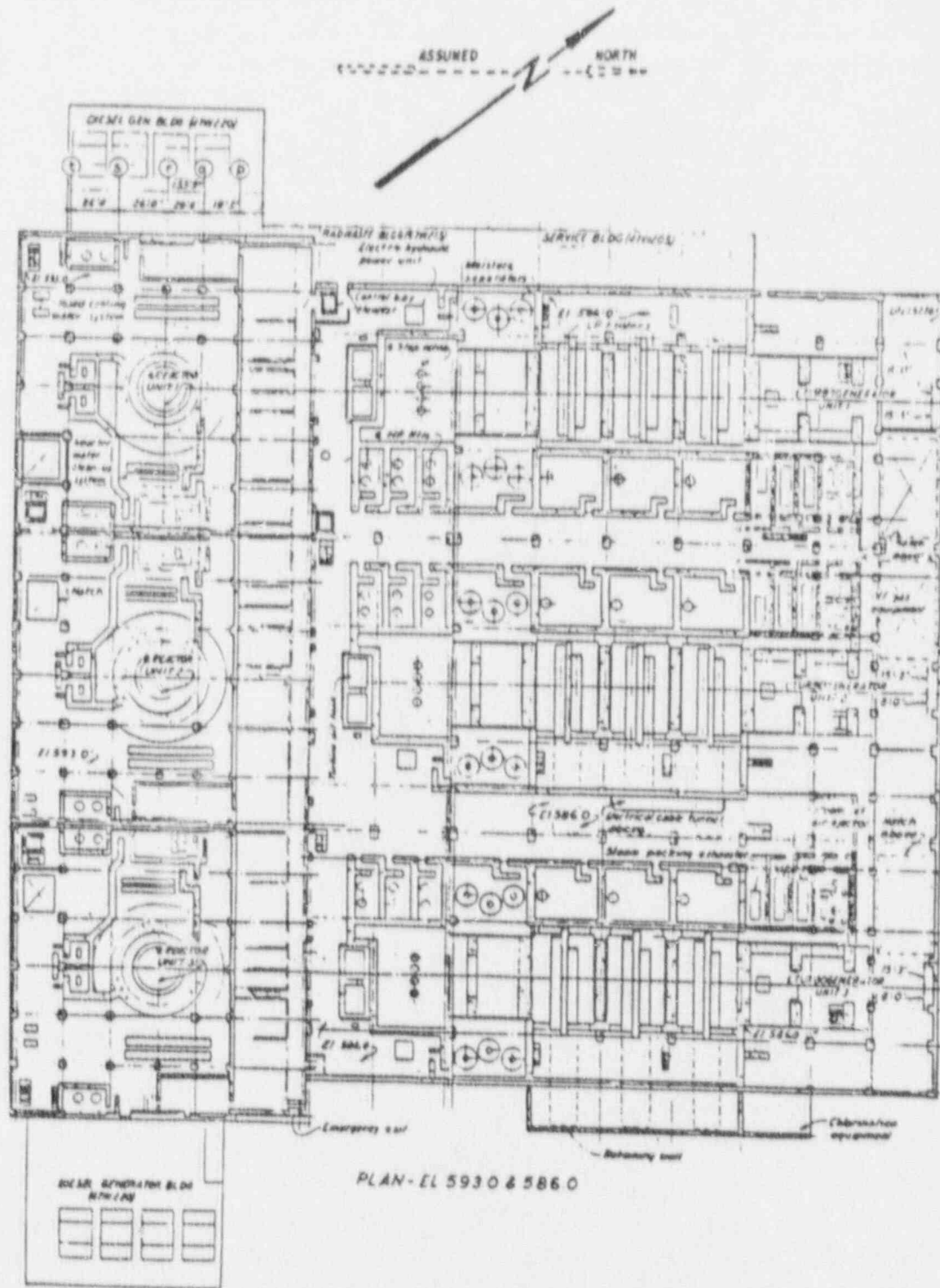

Figure 4-8. Overall Layout of the Browns Ferry Nuclear Plant, Elevations 586 ft. (Turbine Building) and 593 ft. (Reactor Building)

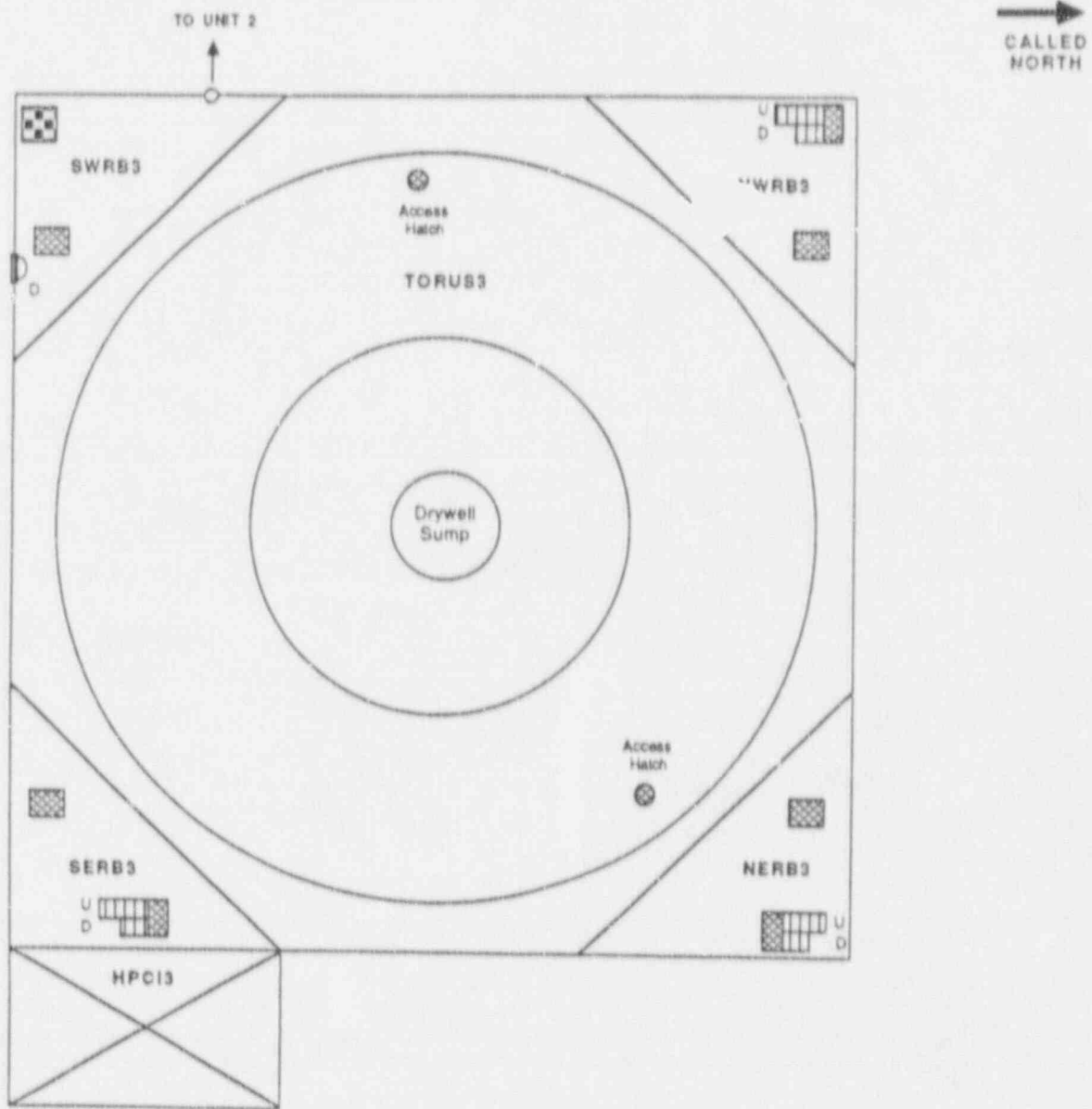

Figure 4-11. Browns Ferry Unit 3 Reactor Building - 541.5 ft. Elevation.

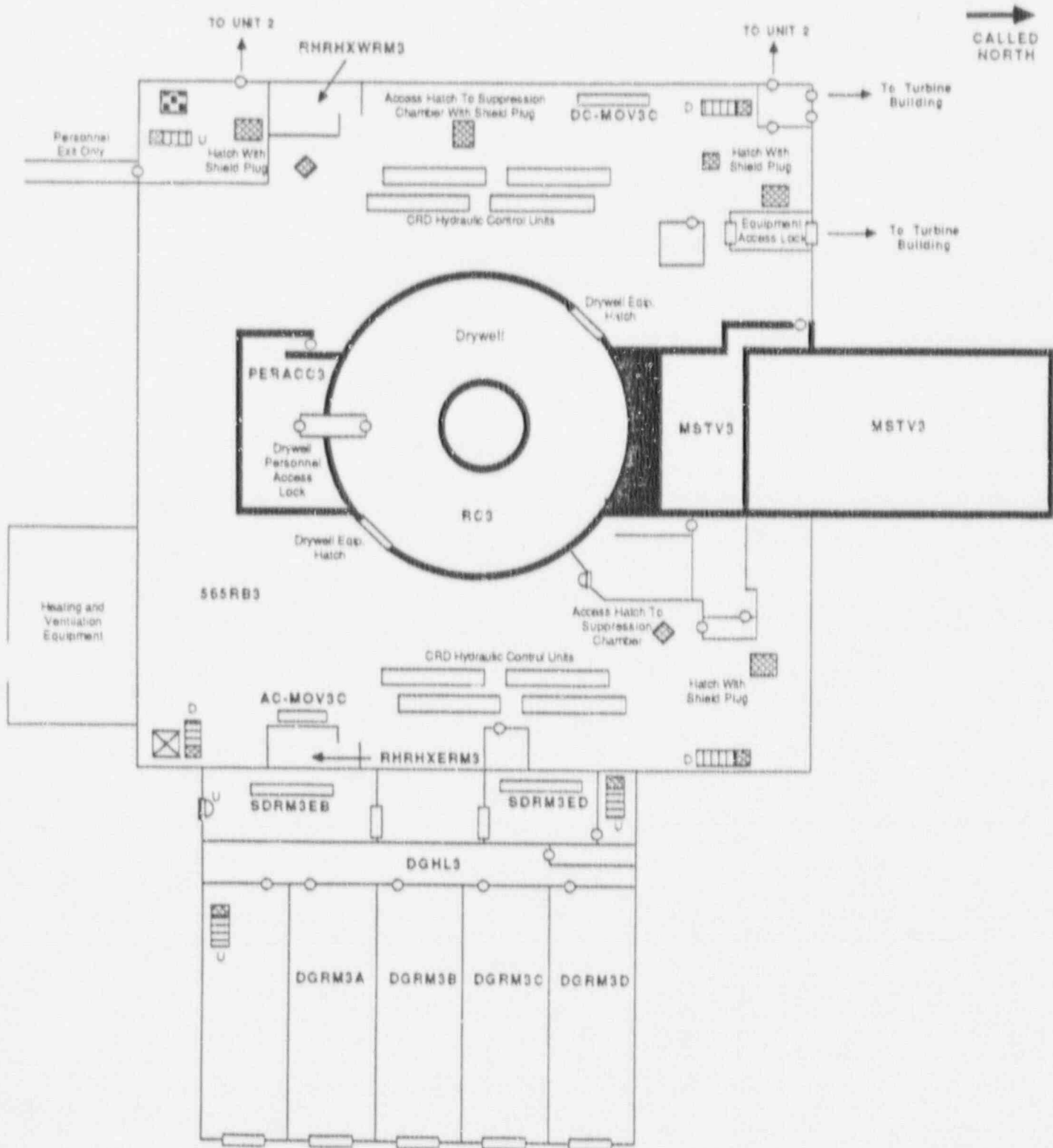

Figure 4-12. Browns Ferry Unit 3 Reactor Building, Including Unit 3 Diesel Generator Building - 565 ft. Elevation.

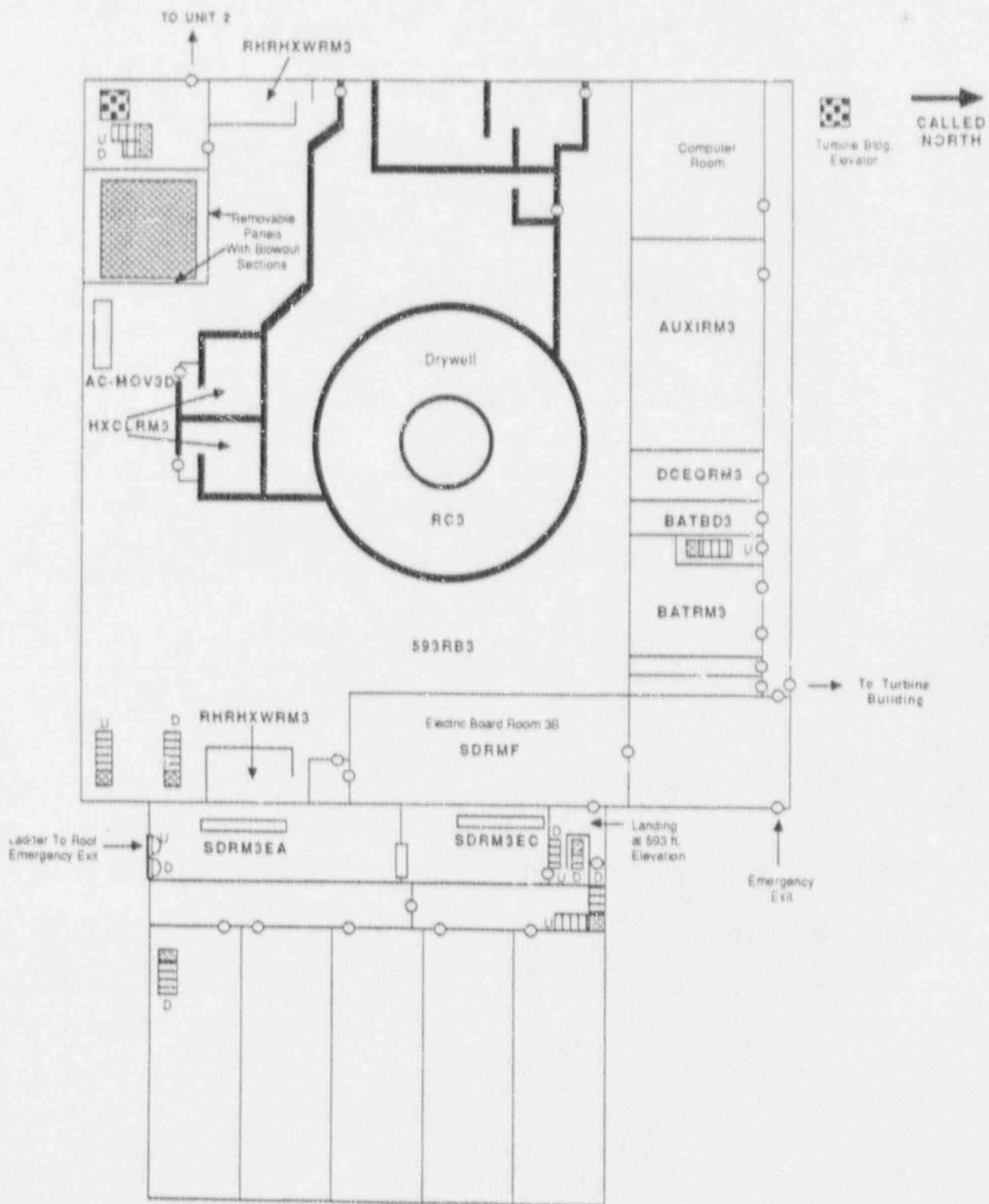

Figure 4-13. Browns Ferry Unit 3 Reactor Building - 593 ft. Elevation, Including Unit 3 Diesel Generator Building - 583 ft. Elevation

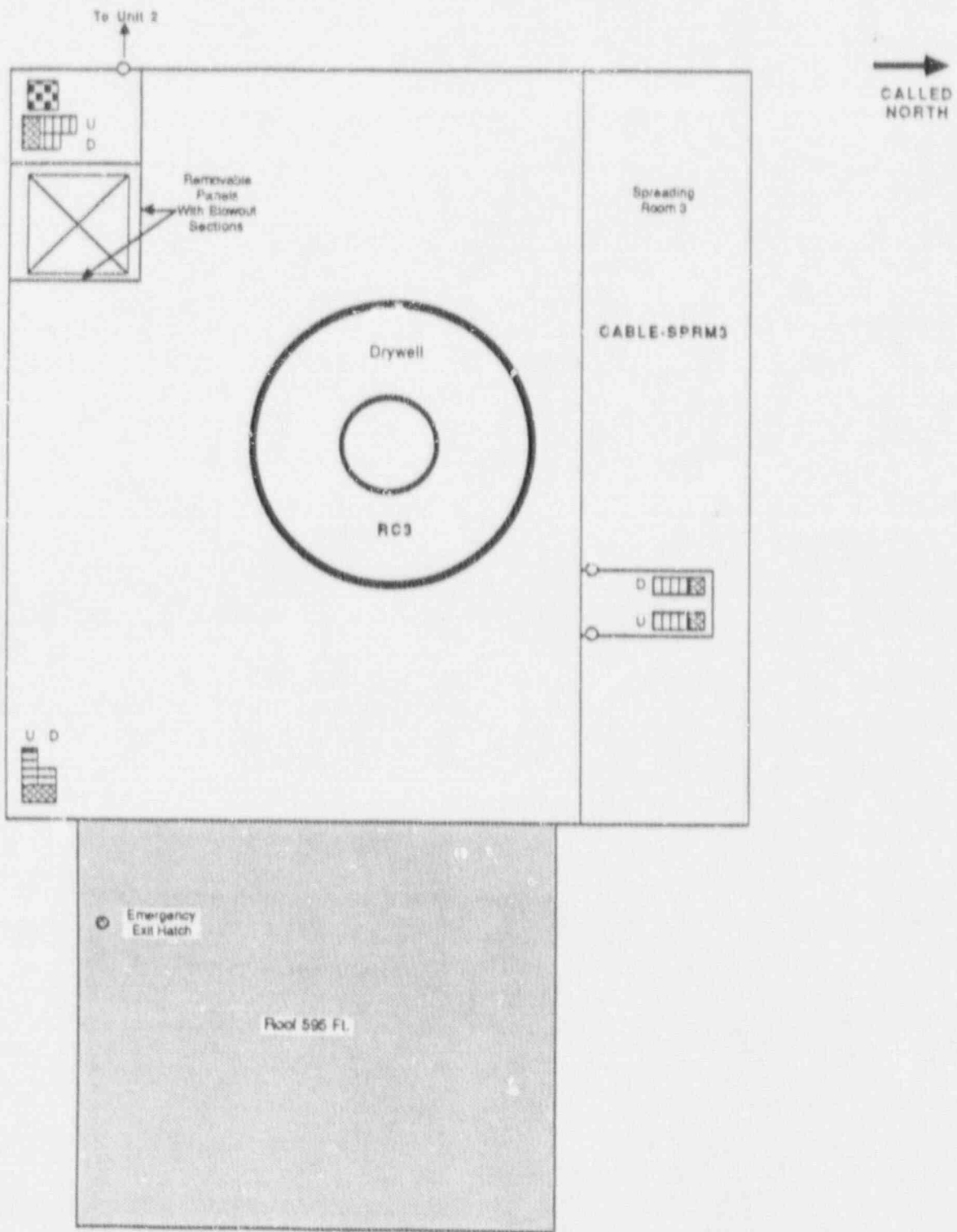

Figure 4-14. Browns Ferry Unit 3 Reactor Building - 606 ft. Elevation.

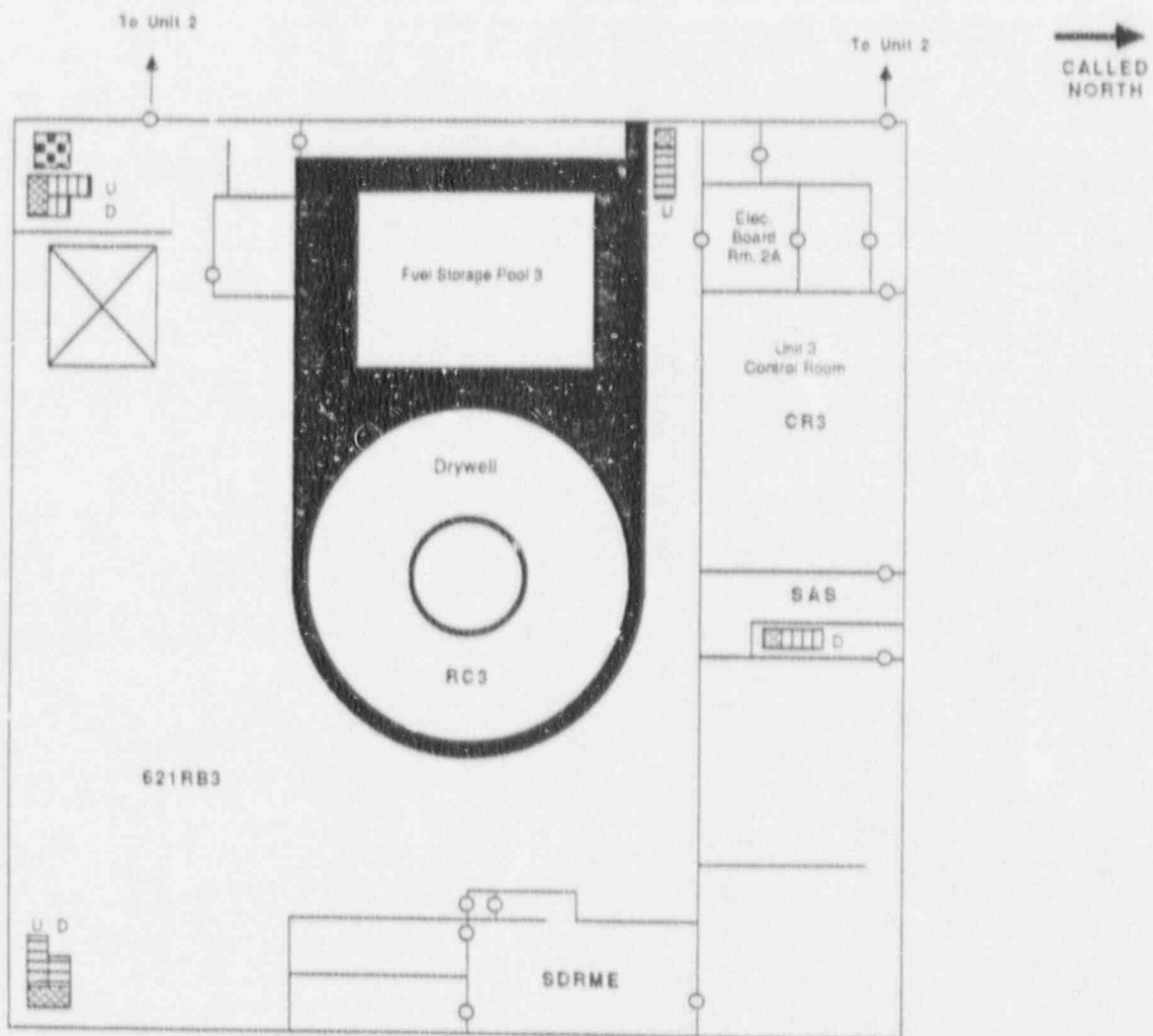

Figure 4-15. Browns Ferry Unit 3 Reactor Building - 617 and 621.5 ft. Elevations.

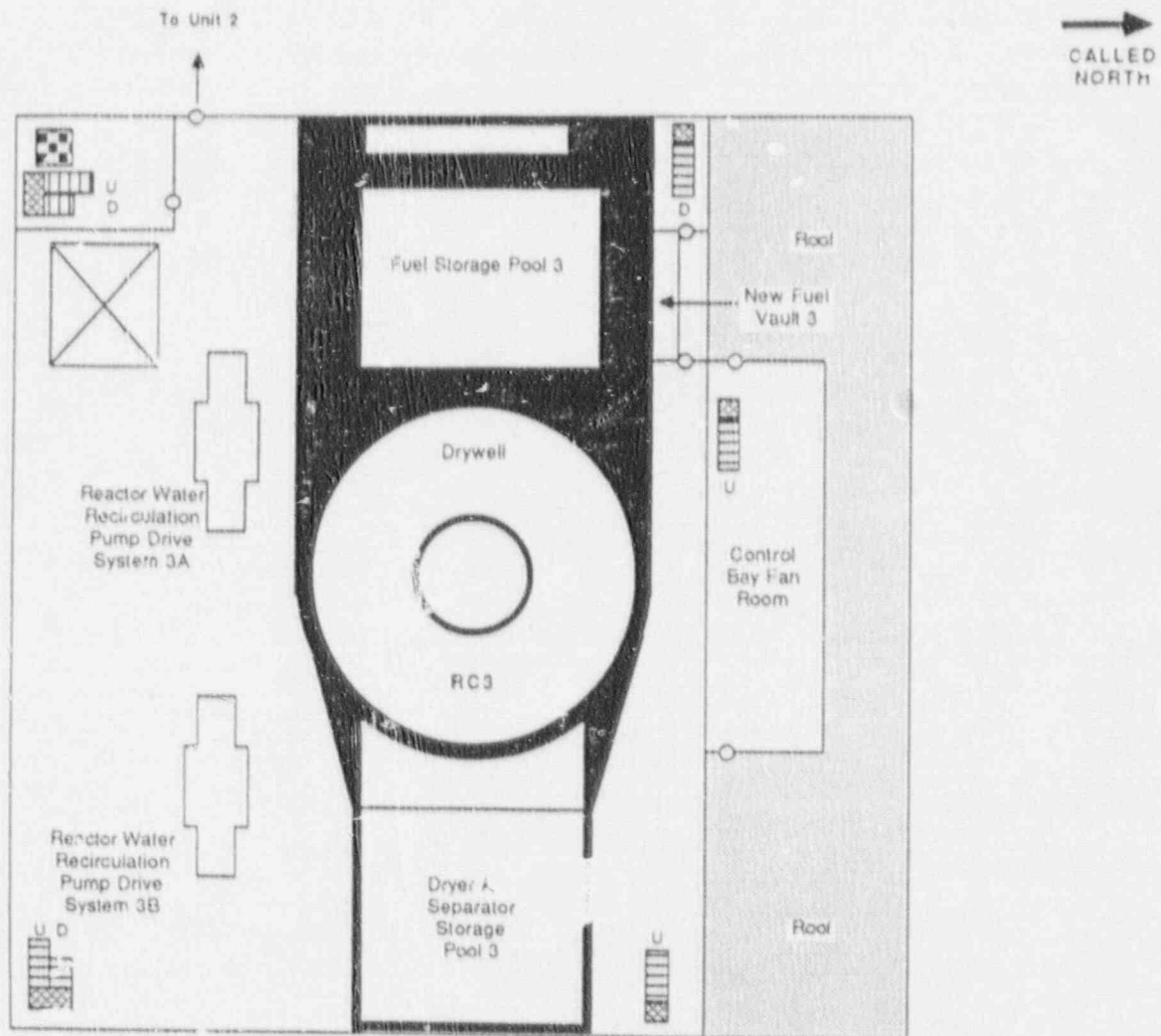

Figure 4-16. Browns Ferry Unit 3 Reactor Building - 639 ft. Elevation.

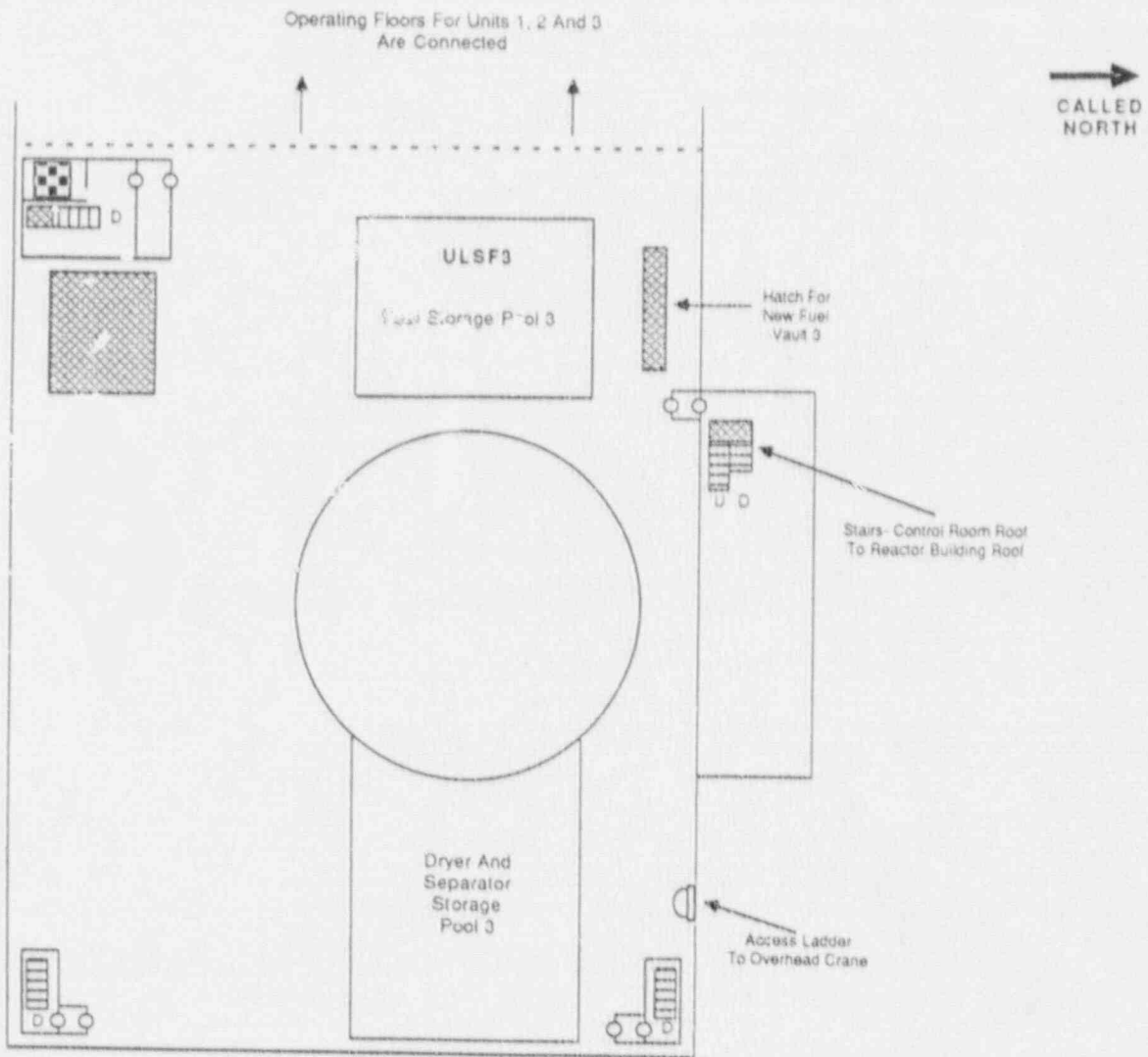

Figure 4-17. Browns Ferry Unit 3 Reactor Building - 664 ft. Elevation.

Table 4-1. Definition of Browns Ferry 3 Building and Location Codes

<u>Codes</u>	<u>Descriptions</u>
1. 480WOSTGBLD	480V Motor Control Center Room, located on the Storage Building
2. 565RB3	565' elevation of the Reactor Building
3. 593RB3	593' elevation of the Reactor Building
4. 621RB3	621' elevation of the Reactor Building
5. AUXIRM3	Auxiliary Instrument Room No. 3, located on 593' elevation of the Control Bay
6. BATBD3	Battery Board No. 3, located in DC Equipment Room No. 3 on the 593' elevation of the Control Bay
7. BATRM3	Battery Room No. 3, located on the 593' elevation of the Control Bay
8. CABLE-SPRM3	Cable Spreading Room for Unit 3, located on the 606' elevation of the Control Bay
9. CR3	Control Room No. 3, located on the 617' elevation of the Control Bay
10. CST	Condensate Storage Tanks, located in Yard Area
11. DCEQRM3	DC Equipment Room for Unit No. 3, located on the 593' elevation of the Control Bay
12. DGHL3	Diesel Generator Hall - hallway just outside of the Diesel Generator Rooms of Unit 3
13. DGRM3A	Diesel Generator Room 3A, located in the Unit 3 DG Building on the 565' elevation
14. DGRM3B	Diesel Generator Room 3B, located in the Unit 3 DG Building on the 565' elevation
15. DGRM3C	Diesel Generator Room 3C, located in the Unit 3 DG Building on the 565' elevation
16. DGRM3D	Diesel Generator Room 3D, located in the Unit 3 DG Building on the 565' elevation
17. HPCI3	High Pressure Coolant Injection Pump Room, located on the 519' elevation of the Reactor Building - southeast corner
18. HXCLRM3	Heat Exchanger Clean Up Room, located on the 593' elevation of the Reactor Building

Table 4-1. Definition of Browns Ferry 3 Building and Location Codes (Continued)

<u>Codes</u>	<u>Descriptions</u>
19. MSVT3	Main Steam Vault, located on the 565' elevation of the Reactor Building
20. NERB3	Pump Room, located on the 519' elevation of the Reactor Building - northeast corner
21. NWRB3	Pump Room, located on the 519' elevation of the Reactor Building - northwest corner
22. PERACC3	Personnel Access Area, located on the 565' elevation of the Reactor Building - south side of Containment
23. PPTUN3	Pipe Tunnel from CST to the Reactor Building 3
24. PUMPRMA	EECW Pump Room A, located at the Pumping Station (Shared, Units 1, 2, & 3)
25. PUMPRMB	EECW Pump Room B, located at the Pumping Station (Shared, Units 1, 2, & 3)
26. PUMPRMC	EECW Pump Room C, located at the Pumping Station (Shared, Units 1, 2, & 3)
27. PUMPRMD	EECW Pump Room D, located at the Pumping Station (Shared, Units 1, 2, & 3)
28. RC3	Reactor Containment
29. RHRHXERM3	Residual Heat Removal System Heat Exchanger, located on the 593' elevation of the Reactor Building - east room
30. RHRHXWRM3	Residual Heat Removal System Heat Exchanger, located on the 593' elevation of the Reactor Building - west room
31. SDRM3EA	4160V Shutdown Board Room 3EA, located on the 593' elevation of Unit 3 - east side
32. SDRM3EB	4160V Shutdown Board Room 3EB - located on the 565' elevation of Unit 3 - east side
33. SDRM3EC	4160V Shutdown Board Room 3EC - located on the 583' elevation of Unit 3 - east side
34. SDRM3ED	4160V Shutdown Board Room 3ED - located on the 565' elevation of Unit 3 - east side
35. SDRME	Shutdown Room E - located on the 621' elevation of the Reactor Building - northeast corner

Table 4-1. Definition of Browns Ferry 3 Building and Location Codes (Continued)

<u>Codes</u>	<u>Descriptions</u>
36. SDRMF	Shutdown Room F, located on the 593' elevation of the Reactor Building - northeast corner
37. SERB3	Pump Room, located on the 519' elevation of the Reactor Building - southeast corner
38. SWRB3	Pump Room located on the 519' elevation of the Reactor Building - southwest corner
39. SWTNLF	Service Water Tunnel F, located on the southeast end of the Reactor Complex (east tunnel entering the Reactor Building from the Pumping Station) Shared, Units 1, 2, & 3 for EECW Piping
40. TORUS3	Suppression Chamber, located on the 519' elevation of the Reactor Building
41. ULSF3	Upper Level of Spent Fuel Area, located on the 664' elevation of the Reactor Building

Table 4-2. Partial Listing of Components by Location at Browns Ferry 3

LOCATION	SYSTEM	COMPONENT ID	COMP TYPE
565RB1	EECW	EECW-67-18	MOV
565RB1	EP	DC-MOV1C	MCC
565RB1	EP	DC-MOV1C	MCC
565RB1	EP	AC-MOV1C	MCC
565RB1	EP	AC-MOV1C	MCC
565RB2	EECW	EECW-67-22	MOV
565RB2	EP	DC-MOV2C	MCC
565RB2	EP	DC-MOV2C	MCC
565RB2	EP	AC-MOV2C	MCC
565RB2	EP	AC-MOV2C	MCC
565RB3	ECCS	RHR-74-100	MOV
565RB3	EECW	EECW-67-28	MOV
565RB3	EP	DC-MOV3C	MCC
565RB3	EP	DC-MOV3C	MCC
565RB3	EP	AC-MOV3C	MCC
565RB3	EP	AC-MOV3C	MCC
565RB3	RHR SW	23-34	MOV
565RB3	RHR SW	23-40	MOV
565RB3	RHR SW	23-46	MOV
565RB3	RHR SW	23-52	MOV
593RB1	EECW	EECW-67-17	MOV
593RB1	EP	AC-MOV1D	MCC
593RB1	EP	AC-MOV1D	MCC
593RB2	EECW	EECW-67-21	MOV
593RB2	EP	AC-MOV2D	MCC
593RB2	EP	AC-MOV2D	MCC
593RB3	ECCS	CS-75-23	MOV
593RB3	ECCS	CS-75-25	MOV
593RB3	ECCS	CS-75-51	MOV
593RB3	ECCS	CS-75-53	MOV
593RB3	EECW	EECW-67-25	MOV
593RB3	EP	AC-MOV3D	MCC

Table 4-2. Partial Listing of Components by Location at Browns Ferry 3 (Continued)

LOCATION	SYSTEM	COMPONENT ID	COMP TYPE
593RB3	EP	AC-MOV3D	MCC
621RB1	EP	EP-TS1A	TRAN
621RB1	EP	EP-TS1B	TRAN
621RB1	EP	EP-TS1E	TRAN
621RB2	EP	EP-TS2A	TRAN
621RB2	EP	EP-TS2B	TRAN
621RB2	EP	EP-TS2E	TRAN
621RB3	EP	EP-TS3A	TRAN
621RB3	EP	EP-TS3B	TRAN
621RB3	EP	EP-TS3E	TRAN
BATBD1	EP	DC-BATBD1	BUS
BATBD1	EP	DC-BATBD1	BUS
BATBD1	EP	DC-BATBD1	BUS
BATBD2	EP	DC-BATBD2	BUS
BATBD2	EP	DC-BATBD2	BUS
BATBD2	EP	DC-BATBD2	BUS
BATBD3	EP	DC-BATBD3	BUS
BATBD3	EP	DC-BATBD3	BUS
BATBD3	EP	DC-BATBD3	BUS
BATRM1	EP	EP-BT1	BATT
BATRM2	EP	EP-BT2	BATT
BATRM3	EP	EP-BT3	BATT
CST	ECCS	CST1	TK
CST	ECCS	2-170	MOV
CST	ECCS	2-166	MOV
CST	ECCS	2-162	MOV
CST	ECCS	CST2	TK
CST	ECCS	CST3	TK
CST	RCIC	2-170	MOV
CST	RCIC	2-166	MOV
CST	RCIC	2-162	MOV
CST	RCIC	CST1	TK

Table 4-2. Partial Listing of Components by Location at Browns Ferry 3 (Continued)

LOCATION	SYSTEM	COMPONENT ID	COMP TYPE
CST	RCIC	CST2	TK
CST	RCIC	CST3	TK
DCEQRM1	EP	EP-BC1	BC
DCEQRM2	EP	EP-BC2A	BC
DCEQRM2	EP	EP-BC2B	BC
DCEQRM3	EP	EP-BC3	BC
DGHL1	EECW	EECW-67-13	MOV
DGHL1	EECW	EECW-67-14	MOV
DGHL1	EP	AC-DGAUX-A	MCC
DGHL1	EP	AC-DGAUX-A	MCC
DGHL1	EP	AC-DGAUX-B	MCC
DGHL1	EP	AC-DGAUX-B	MCC
DGHL1	EP	EP-TDA	TRAN
DGHL1	EP	EP-TDB	TRAN
DGHL1	EP	EP-TDE	TRAN
DGHL3	EP	AC-DGAUX-3EA	MCC
DGHL3	EP	AC-DGAUX-3EA	MCC
DGHL3	EP	AC-DGAUX-3EB	MCC
DGHL3	EP	AC-DGAUX-3EB	MCC
DGRM3A	EP	EP-DG3A	DG
DGRM3B	EP	EP-DG3B	DG
DGRM3C	EP	EP-DG3C	DG
DGRM3D	EP	EP-DG3D	DG
DGRMA	EP	EP-DGA	DG
DGRMB	EP	EP-DGB	DG
DGRMC	EP	EP-DGC	DG
DGRMD	EP	EP-DGD	DG
HPCI3	ECCS	HPCI-73-34	MOV
HPCI3	ECCS	HPCI-73-40	MOV
HPCI3	ECCS	HPCI-TDP	TDP
HPCI3	ECCS	HPCI-73-44	MOV
HPCI3	ECCS	HPCI-73-16	MOV

Table 4-2. Partial Listing of Components by Location at Browns Ferry 3 (Continued)

LOCATION	SYSTEM	COMPONENT ID	COMP TYPE
HPCI3	ECCS	HPCI-73-26	MOV
HPCI3	ECCS	HPCI-73-27	MOV
HPCI3	ECCS	HPCI-73-19	HV
HPCI3	ECCS	HPCI-73-18	HV
HPCI3	ECCS	HPCI-AUX-OIL	MDP
HXCLRM3	RCS	RCS-69-2	MOV
MSVT3	RCIC	RCIC-71-39	MOV
MSVT3	RCS	RCIC-71-3	MOV
NERB3	ECCS	CS-75-30	MOV
NERB3	ECCS	CS-PMB	MDP
NERB3	ECCS	CS-75-39	MOV
NERB3	ECCS	CS-PMD	MDP
NWRB3	ECCS	CS-75-2	MOV
NWRB3	ECCS	CS-PMA	MDP
NWRB3	ECCS	CS-75-11	MOV
NWRB3	ECCS	CS-PMC	MDP
NWRB3	RCIC	RCIC-71-37	MOV
NWRB3	RCIC	RCIC-71-17	MOV
NWRB3	RCIC	RCIC-71-18	MOV
NWRB3	RCIC	RCIC-71-19	MOV
NWRB3	RCIC	RCIC-TDP	TDP
NWRB3	RCIC	RCIC-71-3	MOV
NWRB3	RCIC	RCIC-71-8	MOV
NWRB3	RCIC	RCIC-71-9	HV
NWRB3	RCIC	RCIC-7 10	HV
PERACC3	ECCS	RHR-74-66	MOV
PERACC3	ECCS	RHR-74-74	MOV
PERACC3	ECCS	RHR-74-67	MOV
PERACC3	ECCS	RHR-74-52	MOV
PERACC3	ECCS	RHR-74-60	MOV
PERACC3	ECCS	RHR-74-53	MOV
PERACC3	ECCS	RHR-74-75	MOV

Table 4-2. Partial Listing of Components by Location at Browns Ferry 3 (Continued)

LOCATION	SYSTEM	COMPONENT ID	COMP TYPE
PERACC3	ECCS	RHR-74-61	MOV
PERACC3	RCS	RHR-74-47	MOV
PUMPRMA	EECW	EECW-PMA1	MDP
PUMPRMA	EECW	EECW-PMA3	MDP
PUMPRMA	EECW	681	XV
PUMPRMA	RHRSW	SW-A2	MDP
PUMPRMB	EECW	EECW-PMB1	MDP
PUMPRMB	EECW	EECW-PMB3	MDP
PUMPRMB	EECW	682	XV
PUMPRMB	RHRSW	SW-B2	MDP
PUMPRMC	EECW	EECW-PMC3	MDP
PUMPRMC	EECW	EECW-PMC1	MDP
PUMPRMC	EECW	EECW-67-49	MOV
PUMPRMC	RHRSW	SW-C2	MDP
PUMPRMD	EECW	EECW-PMD3	MDP
PUMPRMD	EECW	EECW-PMD1	MDP
PUMPRMD	EECW	EECW-67-48	MOV
PUMPRMD	RHRSW	SW-D2	MDP
RC3	ECCS	1-5	SRV
RC3	ECCS	HPCI-73-2	MOV
RC3	ECCS	1-19	SRV
RC3	ECCS	1-22	SRV
RC3	ECCS	1-30	SRV
RC3	ECCS	1-31	SRV
RC3	ECCS	1-34	SRV
RC3	RCIC	RCIC-71-2	MOV
RC3	RCS	RCS-VESSEL	RV
RC3	RCS	1-4	SRV
RC3	RCS	RCS-1-55	MOV
RC3	RCS	HPCI-73-2	MOV
RC3	RCS	RCIC-71-2	MOV
RC3	RCS	RCS-69-1	MOV

Table 4-2. Partial Listing of Components by Location at Browns Ferry 3 (Continued)

LOCATION	SYSTEM	COMPONENT ID	CC TYPE
RC3	RCS	1-5	SRV
RC3	RCS	1-18	SRV
RC3	RCS	1-19	SRV
RC3	RCS	1-22	SRV
RC3	RCS	1-23	SRV
RC3	RCS	1-30	SRV
RC3	RCS	1-31	SRV
RC3	RCS	1-34	SRV
RC3	RCS	1-41	SRV
RC3	RCS	1-12	SRV
RC3	RCS	1-179	SRV
RC3	RCS	1-180	SRV
RC3	RCS	RHR-74-48	MOV
SDRM3EA	EP	EP-SB3EA	BUS
SDRM3EA	EP	EP-CB3EA	CB
SDRM3EB	EP	EP-SB3EB	BUS
SDRM3EB	EP	EP-CB3EB	CB
SDRM3EC	EP	EP-SB3EC	BUS
SDRM3EC	EP	EP-CB3EC	CB
SDRM3ED	EP	EP-SB3ED	BUS
SDRM3ED	EP	EP-SB3ED	CB
SDRMA	EP	EP-SBA	BUS
SDRMA	EP	EP-CBA	CB
SDRMA	EP	AC-SB1B	BUS
SDRMA	EP	AC-SB1A	BUS
SDRMA	EP	DC-MOV1A	MCC
SDRMA	EP	AC-SB1B	BUS
SDRMA	EP	AC-SB1A	BUS
SDRMA	EP	AC-MOV1A	MCC
SDRMA	EP	AC-MOV1A	MCC
SDRMA	EP	AC-MOV1B	MCC
SDRMA	EP	AC-MOV1B	MCC

Table 4-2. Partial Listing of Components by Location at Crowns Ferry 3 (Continued)

LOCATION	SYSTEM	COMPONENT ID	COMP TYPE
SDRMA	EP	DC-MOV1A	MCC
SDRMB	EP	EP-SBB	BUS
SDRMB	EP	EP-CBB	CB
SDRMB	EP	DC-MOV1B	MCC
SDRMB	EP	DC-MOV1B	MCC
SDRMC	EP	EP-SBC	BUS
SDRMC	EP	EP-CBC	CB
SDRMC	EP	AC-SB2A	BUS
SDRMC	EP	AC-SB2A	BUS
SDRMC	EP	AC-SB2B	BUS
SDRMC	EP	AC-SB2B	BUS
SDRMC	EP	DC-MOV2A	MCC
SDRMC	EP	DC-MOV2A	MCC
SDRMC	EP	AC-MOV2A	MCC
SDRMC	EP	AC-MOV2A	MCC
SDRMD	EP	EP-SBD	BUS
SDRMD	EP	EP-CBD	CB
SDRMD	EP	DC-MOV2B	MCC
SDRMD	EP	DC-MOV2B	MCC
SDRMD	EP	AC-MOV2B	MCC
SDRMD	EP	AC-MOV2B	MCC
SDRME	EP	AC-SB3A	BUS
SDRME	EP	AC-SB3A	BUS
SDRME	EP	AC-SB3B	BUS
SDRME	EP	AC-SB3B	BUS
SDRME	EP	DC-MOV3A	MCC
SDRME	EP	DC-MOV3A	MCC
SDRME	EP	AC-MOV3A	MCC
SDRME	EP	AC-MOV3A	MCC
SDRMF	EP	DC-MOV3B	MCC
SDRMF	EP	DC-MOV3B	MCC
SDRMF	EP	AC-MOV3B	MCC

Table 4-2. Partial Listing of Components by Location at Browns Ferry 3 (Continued)

LOCATION	SYSTEM	COMPONENT ID	COMP TYPE
SDRMF	EP	AC-MOV3B	MCC
SERB3	ECCS	RHR-PMD	MDP
SERB3	ECCS	RHR-74-24	MOV
SERB3	ECCS	RHR-74-25	MOV
SERB3	ECCS	RHR-74-35	MOV
SERB3	ECCS	RHR-74-36	MOV
SERB3	ECCS	RHR-PMB	MDP
SWRB3	ECCS	RHR-74-2	MOV
SWRB3	ECCS	RHR-74-97	MOV
SWRB3	ECCS	RHR-74-96	MOV
SWRB3	ECCS	RHR-74-96	MOV
SWRB3	ECCS	RHR-74-1	MOV
SWRB3	ECCS	RHR-74-13	MOV
SWRB3	ECCS	RHR-74-12	MOV
SWRB3	ECCS	RHR-74-97	MOV
SWRB3	ECCS	RHR-PMA	MDP
SWRB3	ECCS	RHR-PMC	MDP
TORUS3	ECCS	HPCI-73-3	MOV
TORUS3	ECCS	RHR-74-71	MOV
TORUS3	ECCS	RHR-74-57	MOV
TORUS3	ECCS	RHR-74-72	MOV
TORUS3	ECCS	RHR-74-73	MOV
TORUS3	ECCS	RHR-74-58	MOV
TORUS3	ECCS	RHR-74-59	MOV
TORUS3	RCS	HPCI-73-3	MOV
UNKNOWN	EP	AC-MOV1E	MCC
UNKNOWN	EP	AC-MOV1E	MCC
UNKNOWN	EP	AC-MOV2F	MCC
UNKNOWN	EP	AC-MOV2E	MCC
UNKNOWN	EP	AC-MOV3E	MCC
UNKNOWN	EP	AC-MOV3E	MCC

5. BIBLIOGRAPHY FOR BROWNS FERRY 3

1. INPO/3, NSAC/20, "Analysis of Incomplete Control Rod Insertion at Browns Ferry 3," Institute of Nuclear Power Operations (INPO) and Nuclear Safety Analysis Center (NSAC), December 1980.
2. NUREG/CR-1191, "Conformation of the Original Qualification Test for Electrical Connectors Used at Browns Ferry Nuclear Power Plant Unit 3," Sandia National Laboratories, March 1980.
3. IE Bulletin No. 80-17, "Failure of 76 of 185 Control Rods to Fully Insert During a Scram at a BWR," Nuclear Regulatory Commission, Office of Inspection and Enforcement, July 3, 1980 with Supplement 1, July 18, 1980, Supplement 2, July 22, 1980 and Supplement 3, August 22, 1980.
4. Casto, W.R. (editor), "Partial Failure to Scram at Browns Ferry 3," Nuclear Safety, Vol. 22, No. 2, March - April 1981, pp. 226-229.

APPENDIX A DEFINITION OF SYMBOLS USED IN THE SYSTEM AND LAYOUT DRAWINGS

A1. SYSTEM DRAWINGS

A1.1 Fluid System Drawings

The simplified system drawings are accurate representations of the major flow paths in a system and the important interfaces with other fluid systems. As a general rule, small fluid lines that are not essential to the basic operation of the system are not shown in these drawings. Lines of this type include instrumentation lines, vent lines, drain lines, and other lines that are less than 1/3 the diameter of the connecting major flow path. There usually are two versions of each fluid system drawing; a simplified system drawing, and a comparable drawing showing component locations. The drawing conventions used in the fluid system drawings are the following:

- Flow generally is left to right.
 - Water sources are located on the left and water "users" (i.e., heat loads) or discharge paths are located on the right.
 - One exception is the return flow path in closed loop systems which is right to left.
 - Another exception is the Reactor Coolant System (RCS) drawing which is "vessel-centered", with the primary loops on both sides of the vessel.
 - Horizontal lines always dominate and break vertical lines.
- Component symbols used in the fluid system drawings are defined in Figure A-1.
 - Most valve and pump symbols are designed to allow the reader to distinguish among similar components based on their support system requirements (i.e., electric power for a motor or solenoid, steam to drive a turbine, pneumatic or hydraulic source for valve operation, etc.)
 - Valve symbols allow the reader to distinguish among valves that allow flow in either direction, check (non-return) valves, and valves that perform an overpressure protection function. No attempt has been made to define the specific type of valve (i.e., as a globe, gate, butterfly, or other specific type of valve).
 - Pump symbols distinguish between centrifugal and positive displacement pumps and between types of pump drives (i.e., motor, turbine, or engine).
- Locations are identified in terms of plant location codes defined in Section 4 of this Sourcebook.
 - Location is indicated by shaded "zones" that are not intended to represent the actual room geometry.
 - Locations of discrete components represent the actual physical location of the component.
 - Piping locations between discrete components represent the plant areas through which the piping passes (i.e. including pipe tunnels and underground pipe runs).
 - Component locations that are not known are indicated by placing the components in an unshaded (white) zone.
 - The primary flow path in the system is highlighted (i.e., bold white line) in the location version of the fluid system drawings.

A1.2 Electrical System Drawings

The electric power system drawings focus on the Class 1E portions of the plant's electric power system. Separate drawings are provided for the AC and DC portions of the Class 1E system. There often are two versions of each electrical system drawing; a simplified system drawing, and a comparable drawing showing component locations. The drawing conventions used in the electrical system drawings are the following:

- Flow generally is top to bottom
 - In the AC power drawings, the interface with the switchyard and/or offsite grid is shown at the top of the drawing.
 - In the DC power drawings, the batteries and the interface with the AC power system are shown at the top of the drawing.
 - Vertical lines dominate and break horizontal lines.
- Component symbols used in the electrical system drawings are defined in Figure A-2.
- Locations are identified in terms of plant location codes defined in Section 4 of this Sourcebook.
 - Locations are indicated by shaded "zones" that are not intended to represent the actual room geometry.
 - Locations of discrete components represent the actual physical location of the component.
 - The electrical connections (i.e., cable runs) between discrete components, as shown on the electrical system drawings, DO NOT represent the actual cable routing in the plant.
 - Component locations that are not known are indicated by placing the discrete components in an unshaded (white) zone.

A2. SITE AND LAYOUT DRAWINGS

A2.1 Site Drawings

A general view of each reactor site and vicinity is presented along with a simplified site plan showing the arrangement of the major buildings, tanks, and other features of the site. The general view of the reactor site is obtained from ORNL-NSIC-55 (Ref. 1). The site drawings are approximately to scale, but should not be used to estimate distances on the site. As-built scale drawings should be consulted for this purpose.

Labels printed in bold uppercase correspond to the location codes defined in Section 4 and used in the component data listings and system drawings in Section 3. Some additional labels are included for information and are printed in lowercase type.

A2.2 Layout Drawings

Simplified building layout drawings are developed for the portions of the plant that contain components and systems that are described in Section 3 of this Sourcebook. Generally, the following buildings are included: reactor building, auxiliary building, fuel building, diesel building, and the intake structure or pumphouse. Layout drawings generally are not developed for other buildings.

Symbols used in the simplified layout drawings are defined in Figure A-3. Major rooms, stairways, elevators, and doorways are shown in the simplified layout drawings however, many interior walls have been omitted for clarity. The building layout

drawings, are approximately to scale, should not be used to estimate room size or distances. As-built scale drawings for should be consulted his purpose.

Labels printed in uppercase bolded also correspond to the location codes defined in Section 4 and used in the component data listings and system drawings in Section 3. Some additional labels are included for information and are printed in lowercase type.

A3. APPENDIX A REFERENCES

1. Heddleson, F.A., "Design Data and Safety Features of Commercial Nuclear Power Plants.", ORNL-NSIC-55, Volumes 1 to 4, Oak Ridge National Laboratory, Nuclear Safety Information Center, December 1973 (Vol.1), January 1972 (Vol. 2), April 1974 (Vol. 3), and March 1975 (Vol. 4)

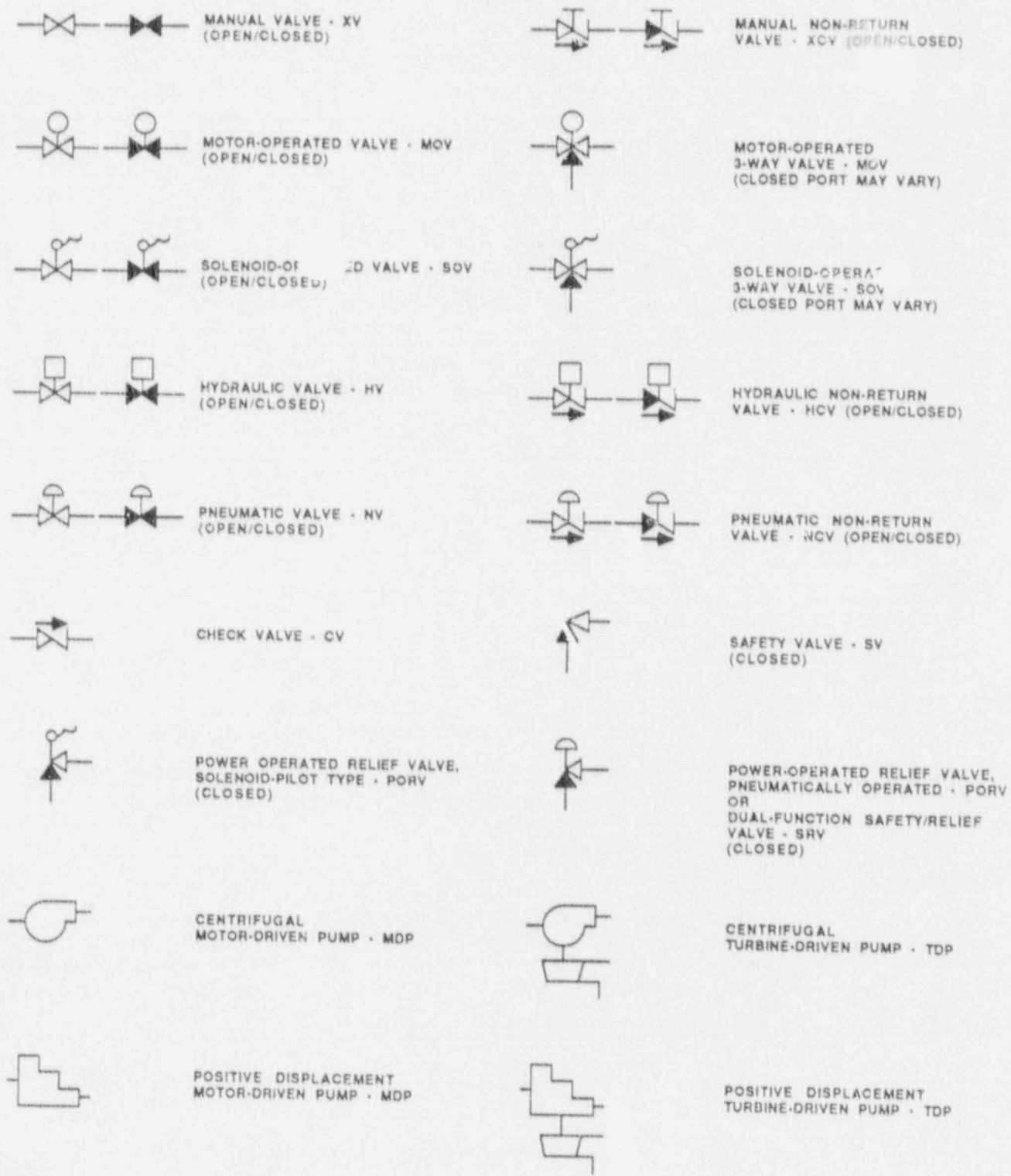

Figure A-1. Key To Symbols In Fluid System Drawings

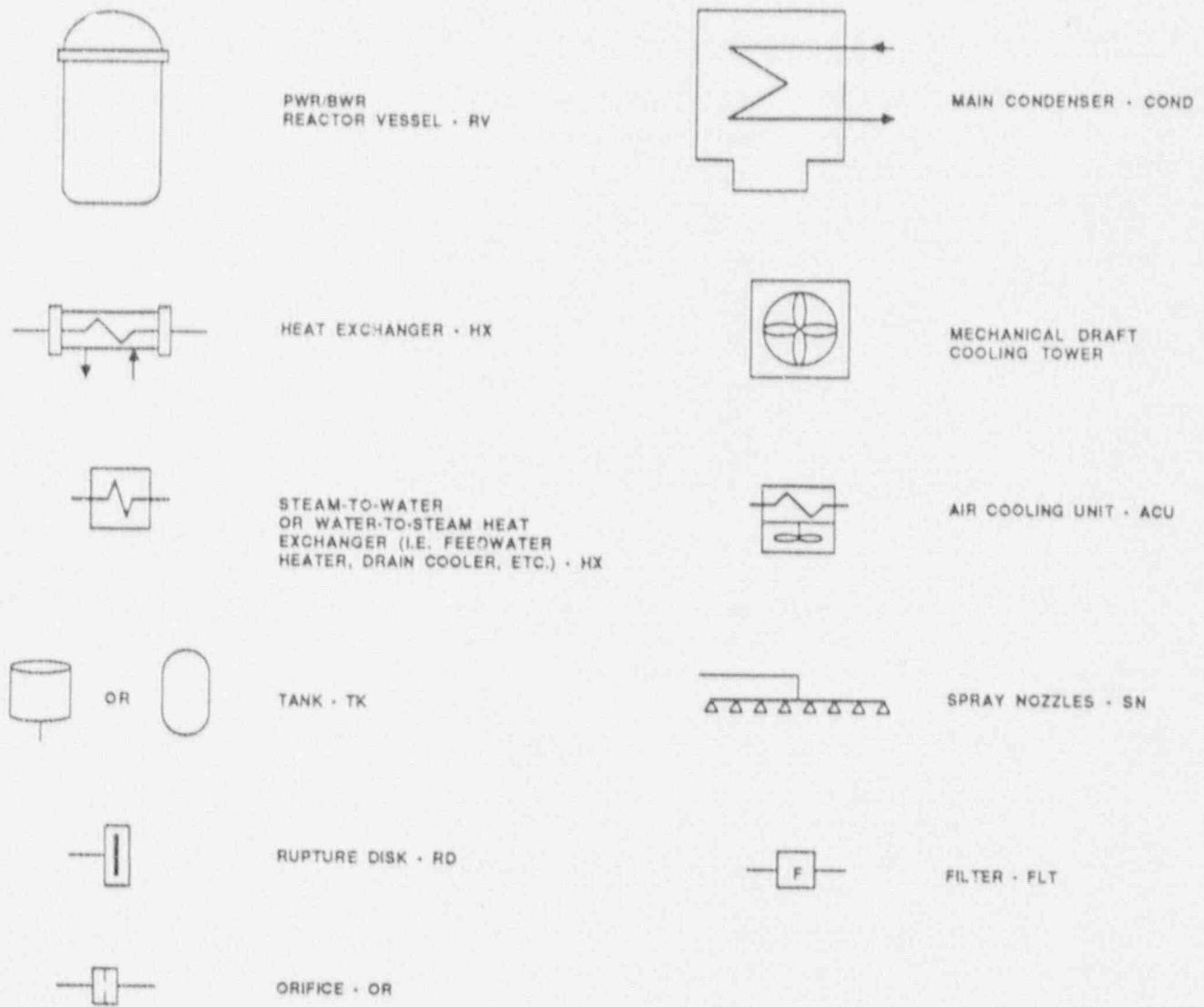

Figure A-1. Key To Symbols In Fluid System Drawings
(Continued)

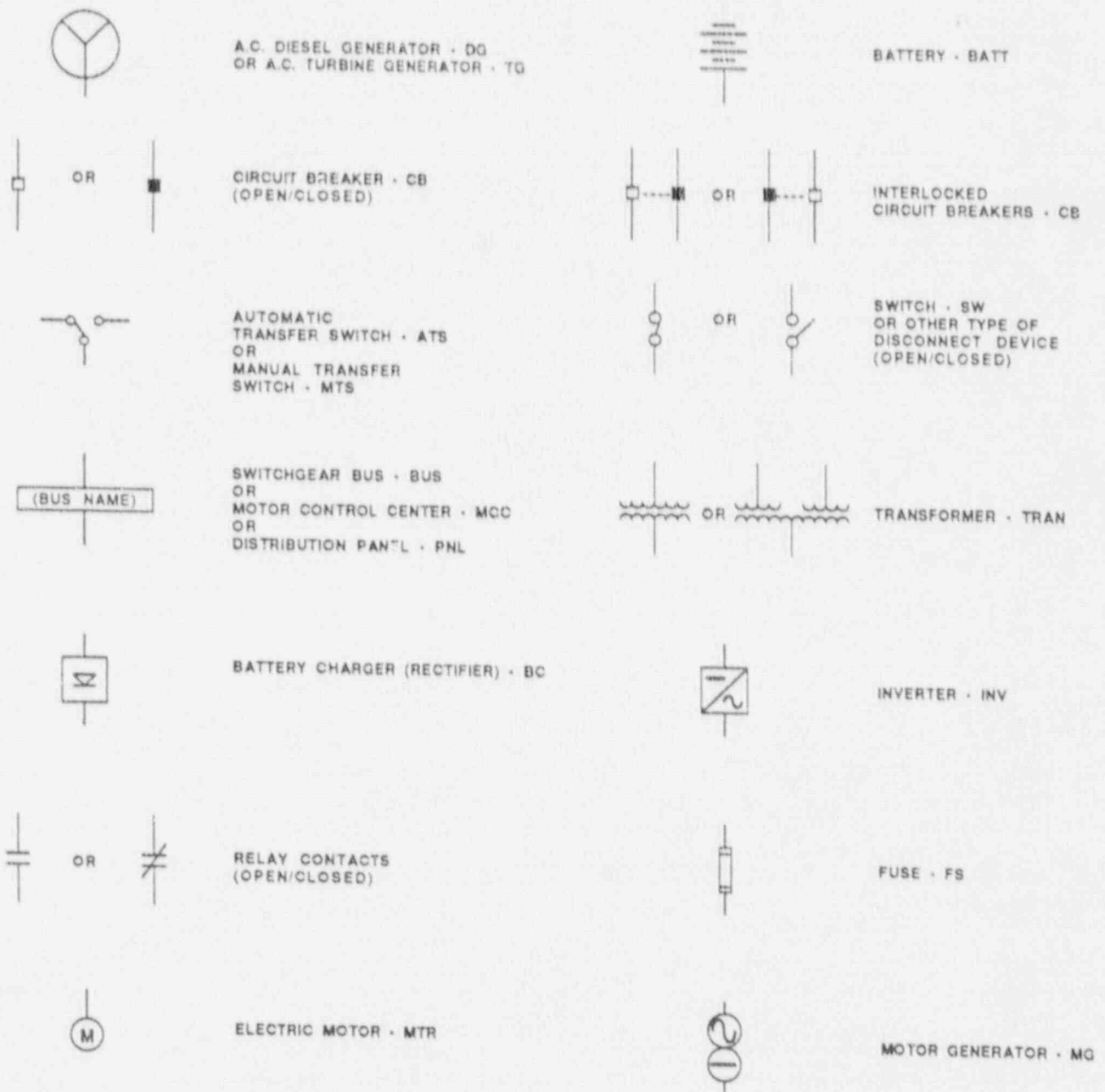

Figure A-2. Key To Symbols In Electrical System Drawings



STAIRS
U = Up
D = Down



SPIRAL
STAIRCASE



LADDER
U = Up
D = Down



ELEVATOR



HATCH OR
GRATING DECK



OPEN AREA
(NO FLOOR)



PERSONNEL DOOR

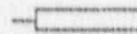

EQUIPMENT DOOR



RAILROAD TRACKS



FENCE LINE



TANK/WATER
AREA

Figure A-3. Key To Symbols In Facility Layout Drawings

APPENDIX B DEFINITION OF TERMS USED IN THE DATA TABLES

Terms appearing in the data tables in Sections 3 and 4 of this Sourcebook are defined as follows:

SYSTEM (also **LOAD SYSTEM**) - All components associated with a particular system description in the Sourcebook have the same system code in the data base. System codes used in this Sourcebook are the following:

<u>Code</u>	<u>Definition</u>
RCS	Reactor Coolant System
RCIC	Reactor Core Isolation Cooling System
ECCS	Emergency Core Cooling Systems (including HPCI, LPCI, LPCS and ADS)
EP	Electric Power System
EECW	Emergency Equipment Cooling Water System
RHR SW	RHR Service Water System

COMPONENT ID (also **LOAD COMPONENT ID**) - The component identification (ID) code in a data table matches the component ID that appears in the corresponding system drawing. The component ID generally begins with a system preface followed by a component number. The system preface is not necessarily the same as the system code described above. For component IDs, the system preface corresponds to what the plant calls the component (e.g. HPI, RHR). An example is HPI-730, denoting valve number 730 in the high pressure injection system, which is part of the ECCS. The component number is a contraction of the component number appearing in the plant piping and instrumentation drawings (P&IDs) and electrical one-line system drawings.

LOCATION (also **COMPONENT LOCATION** and **POWER SOURCE LOCATION**) - Refer to the location codes defined in Section 4.

COMPONENT TYPE (**COMP TYPE**) - Refer to Table B-1 for a list of component type codes.

POWER SOURCE - The component ID of the power source is listed in this field (see **COMPONENT ID**, above). In this data base, a "power source" for a particular component (i.e. a load or a distribution component) is the next higher electrical distribution or generating component in a distribution system. A single component may have more than one power source (i.e. a DC bus powered from a battery and a battery charger).

POWER SOURCE VOLTAGE (also **VOLTAGE**) - The voltage "seen" by a load of a power source is entered in this field. The downstream (output) voltage of a transformer, inverter, or battery charger is used.

EMERGENCY LOAD GROUP (**EMERG LOAD GROUP**) - AC and DC load groups (or electrical divisions) are defined as appropriate to the plant. Generally, AC load groups are identified as AC/A, AC/B, etc. The emergency load group for a third-of-a-kind load (i.e. a "swing" load) that can be powered from either of two AC load groups would be identified as AC/AB. DC load group follows similar naming conventions.

TABLE B-1. COMPONENT TYPE CODES

<u>COMPONENT</u>	<u>COMP TYPE</u>
VALVES:	
Motor-operated valve	MOV
Pneumatic (air-operated) valve	NV or AOV
Hydraulic valve	HV
Solenoid-operated valve	SOV
Manual valve	XV
Check valve	CV
Pneumatic non-return valve	NCV
Hydraulic non-return valve	HCV
Safety valve	SV
Dual function safety/relief valve	SRV
Power-operated relief valve (pneumatic or solenoid-operated)	PORV
PUMPS:	
Motor-driven pump (centrifugal or PD)	MDP
Turbine-driven pump (centrifugal or PD)	TDP
Diesel-driven pump (centrifugal or PD)	DDP
OTHER FLUID SYSTEM COMPONENTS:	
Reactor vessel	RV
Steam generator (U-tube or once-through)	SG
Heat exchanger (water-to-water HX, or water-to-air HX)	HX
Cooling tower	CT
Tank	TANK or TK
Sump	SUMP
Rupture disk	RD
Orifice	ORIF
Filter or strainer	FLT
Spray nozzle	SN
Heaters (i.e. pressurizer heaters)	HTR
VENTILATION SYSTEM COMPONENTS:	
Fan (motor-driven, any type)	FAN
Air cooling unit (air-to-water HX, usually including a fan)	ACU or FCU
Condensing (air-conditioning) unit	COND
EMERGENCY POWER SOURCES:	
Diesel generator	DG
Gas turbine generator	GT
Battery	BATT

TABLE B-1. COMPONENT TYPE CODES (Continued)

<u>COMPONENT</u>	<u>COMP TYPE</u>
ELECTRIC POWER DISTRIBUTION EQUIPMENT:	
Bus or switchgear	BUS
Motor control center	MCC
Distribution panel or cabinet	PNL or CAB
Transformer	TRAN or XFMR
Battery charger (rectifier)	BC or RECT
Inverter	INV
Uninterruptible power supply (a unit that may include battery, battery charger, and inverter)	UPS
Motor generator	MG
Circuit breaker	CB
Switch	SW
Automatic transfer switch	ATS
Manual transfer switch	MTS