

ANALYSIS OF SCRAM DISCHARGE VOLUME SYSTEM PIPING INTEGRITY

G. Alesii
F.R. Hayes
P.P. Stancavage

Approved by:

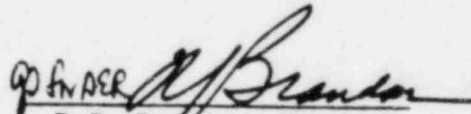

R.J. Brandon, Manager
Nuclear Services Engineering Operation

Approved by:

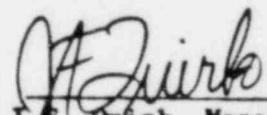

J.F. Quirk, Manager
BWR Systems Licensing

Approved by:

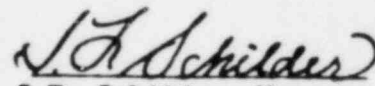

J.F. Schilder, Manager
BWR Generic Programs

This document contains 35 pages.

DISCLAIMER OF RESPONSIBILITY

This document was prepared by or for the General Electric Company. Neither the General Electric Company nor any of the contributors to this document:

- A. Makes any warranty or representation, express or implied, with respect to the accuracy, completeness, or usefulness of the information contained in this document, or that the use of any information disclosed in this document may not infringe privately owned rights; or*
- B. Assumes any responsibility for liability or damage of any kind which may result from the use of any information disclosed in this document.*

TABLE OF CONTENTS

	<u>Page</u>
Abstract	
1.0 Introduction	1
1.1 Background	1
1.2 Purpose	2
2.0 Analysis	3
2.1 Description of SDV System	3
2.2 Fault Tree Diagram	4
2.2.1 General Description	4
2.2.2 SDV Pipe Break Probability	5
2.2.3 Probability of Stuck Open Valves	13
2.2.4 Probability of Breach of SDV Integrity	16
3.0 Summary and Conclusions	26
4.0 References	28
Appendix A - Participating Utilities	

TABLES

	<u>Page</u>
2.1 Characteristics of the SDV System For Various Plants	18
2.2 Break Probabilities Using Experience Approach	20

FIGURES

	<u>Page</u>
2.1 Simplified Schematic of Control Rod Drive System	22
2.2 Typical Scram Discharge Volume Configuration	23
2.3 Fault Tree for Loss of SDV Integrity	24
2.4 Simplified Diagram of a Typical SDV Instrument Air Control	25

ABSTRACT

Analyses of the Boiling Water Reactor (BWR) scram system piping integrity have been performed. The purpose of these analyses is to determine the probability of a loss of SDV piping integrity and to evaluate the contribution of such a loss to a core melt.

The likelihood of a loss of piping integrity was calculated based on a consideration of pipe length, scram frequency and vent and drain valve reliability. Conservative values for the key input values were selected based on BWR plant data and on generic reliability data. Pipe break probabilities were estimated based on the experience data used in the Reactor Safety Study and on a fracture mechanics analysis of the piping system.

The results of these analyses show that the probability of an unisolatable loss of scram system piping integrity for an average plant is 3×10^{-7} per plant year. The probability of core damage resulting from a loss of SDV pipe integrity is approximately 4×10^{-11} events per reactor year. This is significantly below the proposed NRC safety goal for core melt events of 10^{-4} per plant year. Consequently, the probability of a loss of scram system piping integrity leading to core damage is sufficiently low to preclude the necessity of qualification or design modifications of equipment required to detect and/or mitigate the consequences of such an integrity loss.

1.0 Introduction

1.1 Background

In August 1981, the NRC issued the results of a generic review of pipe breaks in the BWR scram system piping in NUREG-0803 "Generic Safety Evaluation Report Regarding Integrity of BWR Scram System Piping". (Reference 1). The NRC concluded that for Mark I and Mark II containment plants the scram system piping is acceptable provided that steps be taken to: (1) ensure the piping integrity, (2) mitigate the consequences of a scram discharge volume (SDV) break, and (3) environmentally qualify the equipment required to detect and/or mitigate the consequences of the break.

The need for mitigation measures and equipment qualification was predicated on an estimated probability of SDV pipe break being sufficiently high that it could not be dismissed. Implicit in this approach is the argument that if the probability of a break in the SDV piping is sufficiently low, then consideration need not be given to mitigation features and equipment qualification for that particular break.

Using a defect rate of 3×10^{-7} per foot of pipe per year and an estimated SDV piping length of 2500 ft, the NRC calculated an SDV failure rate of 10^{-4} per plant year. It noted that this value is extremely conservative since the SDV would be under load less than 1% of the time.

An earlier report, NEDO-24342, "GE Evaluation In Response to NRC Request Regarding BWR Scram System Pipe Breaks" (Reference 2) used WASH-1400 (Reference 3) values to evaluate the SDV break probability. It calculated the ratio of the SDV pipe length to the LOCA sensitive piping length and took into consideration the diameter of the pipes. (LOCA sensitive piping is that piping inside the containment that would result in a loss of reactor coolant in case of a break.) This approach yielded a break probability of 3×10^{-6} /plant year taking into account the fraction of time the SDV piping is pressurized. Both NEDO-24342 and NUREG 0803 used estimated conservative generic plant data.

1.2 Purpose

It is the purpose of this report to perform a more detailed analysis of the failure probability of the SDV taking into account plant specific data, in order to demonstrate that an SDV failure resulting in a substantial leak which could threaten equipment required to detect and/or mitigate the leak is not a credible event.

Three different approaches will be used:

- 1) the NEDO-24342 approach
- 2) the NUREG-0803 approach
- 3) the fracture mechanics approach

The last approach evaluates break probabilities by analyzing the mechanism of crack growth while under repeated stress.

2.0 Analysis

2.1 Description of SDV System

The scram discharge system receives the water exhausted from the control rod drives (CRD) during a reactor scram. For a short time during and following each reactor scram, it contains reactor coolant at full reactor pressure. This section briefly describes the fundamentals of operation of the system.

The scram discharge system, which is depicted in Figure 2.1, consists of the CRD, the CRD withdraw lines, the scram discharge volume and the valves associated with the discharge volume.

During a scram, water from the volumes above the CRD pistons is discharged to the CRD withdraw lines. It flows through the scram valves to the scram discharge volume. The scram discharge volume vent and drain valves are open during normal operation, and close automatically on receipt of a scram signal.

The discharge volume partially fills with the water discharged from the CRDs. Upon completion of a reactor scram, with all control rods fully inserted, water leaking past the CRD seals from the reactor and water from the CRD pump continues to flow into the scram discharge volume. This flow continues until the pressure in the scram discharge volume is equal to the reactor pressure.

When the scram signal is reset by the operator, the scram valves close and the scram discharge volume vent and drain valves open. The scram discharge volume empties and returns to atmospheric pressure, configuring it for normal operation.

The scram valves and the scram discharge volume vent and drain valves are diaphragm actuated. These valves are designed to move into their scram positions when air pressure is removed. Motive air from the reactor building instrument air system is supplied to these valves via solenoid-

operated pilot valves actuated by the reactor protection system. Two normally open manual isolation valves are provided at each hydraulic control unit to isolate the scram discharge volume from the CRD.

The system, because of its simple design, provides a high reliability to scram. Because the valves assume their scram positions when air pressure is removed, the reactor will be shut down automatically if the air supply becomes unavailable.

Figure 2.2 shows additional details of the scram discharge volume itself. To comply with the SDV Safety Evaluation Report (Reference 4) all SDV have or will have two vent valves in series and two drain valves in series. Also, some systems currently have a relief valve. Table 2.1 summarizes the details of each plant including pipe lengths as a function of diameter, design code used, number and types of joints and scram history. The piping system which is of interest for this study is that portion which extends from the check valves upstream of the SDV header up to and including the vent and drain valve piping.

2.2 Fault Tree Diagram

2.2.1 General Description

Figure 2.3 shows a fault tree diagram for the SDV system shown in Figure 2.2. The top event consists of any violation of the integrity of the SDV including pipe breaks and valve malfunctions that would result in water spilling into the reactor building. Two events need to occur; the SDV integrity must be breached and the reactor must be scrammed (i.e., the SDV and associated piping must be pressurized).

There are several ways that the SDV integrity can be breached: (1) a break in the pipe, (2) the relief valve fails open, and (3) two drain and/or two vent valves are stuck open. The relief, drain and vent valves are typically all piped to sumps in the basement. Depending on the size of the sump(s) and capacity of the sump pump(s), stuck open valves during a scram that are not or cannot be reset could lead to eventual overflow

of the sump. For this reason, the stuck open valves are considered as a failure of SDV integrity. However, the consequences are expected to be considerably less significant than those for a break.

2.2.2 SDV Pipe Break Probability

2.2.2.1 Review of NEDO-24342 Approach

The SDV pipe break probability has been previously addressed in NEDO-24342 (Reference 2). NEDO-24342 followed the approach used in Appendix 3 of WASH-1400. It used the assessed break probability for a LOCA. However since the piping length for the SDV is different than the length of LOCA sensitive piping, the probabilities were modified by the ratio of SDV piping length to LOCA sensitive piping length. This approach resulted in a break probability of 3×10^{-4} per year assuming the SDV is constantly pressurized. It estimated that a reactor is scrammed (SDV pressurized) 1% of the time. Thus an overall break probability of 3×10^{-6} /plant year resulted.

2.2.2.2 Review of NUREG-0803 Approach

NUREG-0803 used a different approach than that used in NEDO-24342. It estimated an SDV piping length of 2500 ft and multiplied it by a failure rate of 3×10^{-7} per foot per year to obtain a break probability of 10^{-4} per plant per year. It also noted that the SDV is only pressurized 1% of the time but it did not factor it directly into the break probability. If it were included, the result would have been very similar to that of NEDO-24342.

2.2.2.3 Reevaluation of Break Probability Using Plant Specific Data

2.2.2.3.1 Evaluation Procedure

Using plant specific data, the SDV break probability was reevaluated following both the NUREG-0803 and the NEDO-24342 approaches.

The plant specific data that are being considered are the actual piping diameters, lengths, and scram histories. Following NEDO-24342 the SDV piping was first grouped into three diameter sizes - <2", ≥2" to 6" and >6". (See Table 2.1).

The ratio of these lengths to the length of LOCA sensitive piping of the same diameter grouping were evaluated. The total length of LOCA sensitive piping was taken to be 6000 ft (Reference 5). Following WASH 1400, the total length was equally apportioned among the three pipe groups. Thus each group consists of 2000 ft of pipe.

The median probabilities for a break in 2000 ft of LOCA sensitive piping from WASH 1400 are:

1/2" to 2" diameter	1×10^{-3} /plant year
2" to 6" diameter	3×10^{-4} /plant year
>6" diameter	1×10^{-4} /plant year

Using these values and plant specific data from Table 2.1 the probability of a break was evaluated. The break probability was also evaluated using an approach similar to that in NUREG-0803. This involves multiplying the SDV pipe length by a defect rate of 3×10^{-7} per foot per year. (Reference 3). The final break probability is evaluated by multiplying this preceding product by the fraction of time the plant is scrammed, (i.e., that SDV is pressurized) based on the scram history for that plant.

2.2.2.3.2 Discussion of Results

The SDV pipe break probability was evaluated for the "average" plant and for the "limiting" plant. The average plant refers to a plant having the average pipe lengths, number of scrams and scram duration from the data in Table 2.1. The limiting plant is defined as the plant with the longest pipe lengths, the largest number of scrams and longest average scram duration based on the data compiled in Table 2.1. The results appear in Table 2.2; the following observations can be made:

- a) Both the NEDO-24342 and the NUREG-0803 approaches yield very similar results.

Since the WASH 1400 break probability numbers used in NEDO-24342 are in part derived from the number of defects per foot per year (Reference 3), the similarity of the two results might have been anticipated.

- b) The break probabilities are about two orders of magnitude lower than those obtained in NEDO-24342 and NUREG-0803.

This results from the fact that plant specific data show that the SDV system is pressurized much less than the 1% assumed in the previous analyses. Table 2.2 indicates the fraction of time scrammed (i.e., pressurized) for the average and limiting plant. This is the biggest contributor to the reduction in the break probability.

- c) The dominant contributors to the break probability are pipes of less than 2" in diameter.

This is because most of the SDV piping length is small diameter piping; typically 70% or more is less than 1" in diameter, with resulting low leakage flow rate. If the consequences of a small pipe break could be dismissed this would reduce the consequential pipe break probability by at least another factor of 10.

However, even including small pipes, the resulting break probability based on either the GE or NRC approaches is, on the average, less than 2×10^{-7} per plant year.

Note that no credit has been taken for installation examinations, the design code and piping class, the seismic class and inservice inspection. As indicated in Table 2.1, these factors are present in all plants and would further reduce the break probability.

2.2.2.4 Fracture Mechanics Approach

The two previous methods used to determine the break probabilities are based on accumulated experience. An alternate method is the fracture mechanics approach which examines the failure of pipes due to growth of crack-like defects that may be introduced into welds during fabrication of the pipe. (Reference 6,7). This method will be used to support the results from the experience approaches.

The fracture mechanics approach is described in Reference 6 and has been applied in Reference 7 to analyze the probability of a pipe break in an SDV. It was found that the small pipes bound the large pipes in probability of failure. The small pipes are analyzed in this report following the method used in Reference 7, but using the SDV stress values from NEDO-24342 (Reference 2).

The fracture mechanics approach investigates the probability of low-cycle fatigue causing through-wall crack propagation in the SDV piping system over the plant lifetime. This method assumes that piping failures occur due to the growth of defects introduced into welds during fabrication of the pipe. These initial defects are considered to be randomly distributed in both the number of defects and their size. The failure probability during a stress cycle equals the probability of a crack being larger than the critical crack size, given that a crack exists.

The stress levels assumed for this evaluation are the peak cyclic stresses in the SDV piping. The maximum stresses are (Reference 2):

Pressure	1.5 Ksi
Temperature	1.2 Ksi
Total	2.7 Ksi

Deadweight stresses are not included because they do not contribute to fatigue. Seismic stresses are not accounted for because they contribute a small number of cycles. Typically only one operating basis earthquake

can be expected during plant life ($p < 10^{-2}/\text{ry}$) and the probability of a safe-shutdown earthquake is less than 10^{-4} per reactor year. Water hammer effects on the SDV are not expected to be significant. Fast opening of the scram valve will result in a simple compression (Reference 4) of the SDV since it is empty or near empty of water at the start of a scram. Opening of the drain or vent valves is also not expected to produce significant stresses since they drain into air filled pipes at atmospheric pressure. This will result in simple decompression of the SDV.

Intergranular stress corrosion cracking, as pointed out in NUREG-0803 is not expected to be a potential failure mechanism, because the SDV is pressurized for only a short period of time.

Scram frequencies of 9 (average) and 17 (maximum) per year are used (from Table 2.2). This amounts to 360 and 680 cycles over the plant life, respectively.

The initial crack distribution accounts for the probability that a crack exists and the size distribution of cracks given that a crack exists. The crack probability in a weld of volume, V , is Poisson distributed according to

$$P_c = 1 - e^{-VA} \quad (1)$$

where:

A = crack existence frequency, $10^{-4}/\text{in}^3$

$V = 2\pi(\text{ID})h^2$, inch^3

ID = Pipe ID, inch

h = Pipe thickness, inch

The size distribution of cracks, given that a crack exists, is distributed exponentially with a complementary cumulative distribution

$$\begin{aligned}
 P_{s/c} &= 0 & x > h \\
 P_{s/c} &= \frac{e^{-x/\lambda} - e^{-h/\lambda}}{1 - e^{-h/\lambda}} & 0 \leq x \leq h
 \end{aligned} \tag{2}$$

where λ = crack size distribution parameter = 0.052 and h represents the maximum crack size.

The SDV's undergo preservice proof testing. Positive results from this test insure that no cracks above a certain size, a_p , exist. (If they existed the pipe would fail during the proof test.) Equation (2), thus, becomes:

$$\begin{aligned}
 P_{s/c} &= 0 & x > h \\
 P_{s/c}(a > x) &= \frac{e^{-x/\lambda} - e^{-a_p/\lambda}}{1 - e^{-h/\lambda}} & 0 \leq x \leq a_p
 \end{aligned} \tag{3}$$

where:

a_p is the largest crack size that would survive proof testing = 0.144 inch.

Each stress cycle increases the size of the cracks. The crack growth rate per cycle for stainless steel is given by (Reference 7):

$$\frac{da}{dn} = 10^{-9} (\Delta K)^4$$

where:

$$\frac{da}{dn} = \text{crack growth rate, inches/cycle}$$

$$\begin{aligned}
 \Delta K &= \text{cycle stress intensity factor, ksi-in}^{1/2} \\
 &= \Delta\sigma a^{1/2} \left(\frac{2 + C_1 A + C_2 A^2 + C_3 A^3 + C_4 A^4}{(1-A)^{1/2}} \right)
 \end{aligned}$$

$$A = \frac{a}{h} \quad \Delta\sigma = \text{cyclic stress}$$

$$C_1 = -1.00250 \quad C_3 = -6.21135$$

$$C_2 = 4.79463 \quad C_4 = 1.79864$$

The SDV consists of both stainless and carbon steel. The above relationship applies to stainless steel but it will be applied to carbon steel as well for conservatism.

The crack continues to grow until it reaches a critical size, a_c , at which point the pipe is assumed to fail. The critical crack size is given by (Reference 7):

$$a_c = h (1 - \sigma_{LC} / \sigma_{CS})$$

where

$$\sigma_{LC} = \text{load controlled stress} = \sigma_p + \sigma_{dw}$$

$$\sigma_p = \text{stress due to pressure}$$

$$\sigma_{dw} = \text{stress due to deadweight}$$

$$\begin{aligned} \sigma_{CS} &= \text{critical stress (flow stress)} \\ &= (\text{yield strength} + \text{tensile strength})/2 \\ &= 45 \text{ ksi for stainless and carbon steel (Reference 7)} \end{aligned}$$

To evaluate the pipe failure probability consider the tolerable initial crack size, $a_t(n)$. This represents an initial crack size that would just grow to the critical size after n stress cycles. The probability of failure within n cycles is then equal to the probability of having a crack larger than $a_t(n)$ at time zero. This is given by

$$\begin{aligned} P_{f(\text{cond})}(n) &= P[a > a_t(n)] \\ &= \frac{e^{-a_t(n)/\lambda} - e^{-a_p/\lambda}}{1 - e^{-h/\lambda}} && 0 \leq a_t(n) \leq a_p \\ &= 0 && \text{Otherwise} \end{aligned}$$

The tolerable initial crack sizes, $a_t(n)$, can be evaluated using:

$$a_t(n) = a_t(n-1) - \frac{da}{dn} a = a_t(n-1)$$

Finally, the unconditional average failure rate for the SDV system can be found using

$$\bar{P}_f = P_c \times P_f(\text{cond}) \times L/t$$

where L is the number of welds in the SDV,
 t is the life of the plant and
 $P_f(\text{cond})$ is evaluated over the life of the plant.

This approach resulted in no failures for the aforementioned cyclic stresses (2.7 ksi) for both the average and maximum number of scrams cases. The reason for this is that the cyclic stresses are not sufficient to increase a crack from a_p (the proof test crack size) to the critical crack size, a_c . The minimum stresses that would accomplish this are ~6.5 ksi for 9 scrams/year and ~5.5 ksi for 17 scram/year. This is over twice the peak cyclic stress expected for a typical SDV. This result was obtained even with the use of the following conservative assumptions.

- 1) The influence of in-service inspection was ignored.
- 2) Only pre-service proof test was considered. In-service proof tests were ignored.
- 3) Stress intensity factors were conservatively estimated assuming all cracks to be fully circumferential.
- 4) The initial crack depth distribution for thick piping was used. This has a significant effect on the probability of having cracks greater than tolerable depth.
- 5) Upper bound estimate on fatigue crack growth characteristics was employed.
- 6) Conservative estimate of the flow stress was used.

- 7) All welds in the SDV system were assumed to be subjected to the maximum stress.

These fracture mechanics results support the outcome of the experience approaches which show that the probability of an SDV pipe failure is insignificant.

2.2.3 Probability of Stuck Open Valves

As pointed out in Section 2.2, water from the SDV could spill onto the reactor building basement floor if the two drain valves or the two vent valves or the relief valve (if the plant has one) were to remain open after a scram that could not be reset. This event would not be as serious as a break since no water would be sprayed at the equipment. Typically instead, the water would simply flow to the sump. At this time the reactor building is assumed to be accessible, allowing personnel to close the manual SDV isolation valves. Depending on the actual sump design, flooding may eventually occur.

In summary, the consequences of stuck open SDV vent and drain valves are not as severe as those for a break. Timely operator action before the flooding reaches vital equipment levels will ensure the operability of equipment for detection and mitigation of the valves' failure.

However, since flooding from such an event is conceivable the probability of stuck open valves will be addressed. A typical configuration where the vent, drain and relief valves (if any) are piped to sumps, will be analyzed.

2.2.3.1 Failure Rate of Drain and Vent Valves

Both the drain and vent valves are air actuated globe valves which close upon loss of air. The air is controlled by solenoid operated valves. The vent and drain valves could remain open while the reactor is scrammed if (1) they stick open, (2) the air in them cannot vent, or (3) air from the instrument line is not cut off.

The probability of an air operated valve sticking open is 6.6×10^{-4} /demand (Reference 8). The probability, then, of two drain or vent valves in series sticking open is 4.4×10^{-7} per demand. For the average of 9 scrams per year the probability is 3.9×10^{-6} per reactor year; for the maximum of 17 it is 7.4×10^{-6} /ry.

The air to the vent and drain valves is normally controlled by two solenoid operated valves configured as shown in Figure 2.4. Solenoid valves V3 and V4 each controls one vent and one drain valve. Under normal operating conditions the exhaust port is closed and the other two ports are open. This maintains air pressure on the vent and drain valves to keep them open. When a scram occurs, the air supply port should close and the exhaust port open. This would allow the air from the drain and vent valves to escape and thus close. A failure, however, can be postulated where both the air supply and exhaust ports are plugged. This would prevent the air from the drain and vent valves from escaping and keep them in the open position.

The median probability of a solenoid valve being plugged is 8×10^{-5} /demand (Reference 3). In order for two drain or two vent valves to fail open (1) both solenoid valves need to be plugged or (2) one solenoid valve must plug and one drain or vent valve, not controlled by the plugged solenoid valve, must stick open. The sum of the probabilities for the various combinations is 2.2×10^{-7} /demand. For 9 scrams/year it becomes 2×10^{-6} /ry, for 17 scrams/year it is 3.7×10^{-6} /ry.

Given a scram signal, the air to two drain or two vent valves is maintained only if all four valves fail in the no-scram position. The median probability for a solenoid valve to fail to operate is 1×10^{-3} /demand (Reference 3). The probability for four valves to not operate is thus 1×10^{-12} /demand. Given 9 (17) scrams per year, the probability of the air not being cut off is 1×10^{-11} (2×10^{-11}).

In summary, the probability of either two drain or two vent valves failing open is 6×10^{-6} /ry for 9 scrams a year and 1×10^{-5} /ry for 17 scrams a year.

2.2.3.2 Failure Rate of SDV Relief Valve

Some plants are equipped with an SDV relief valve as shown in Figure 2.2. It was originally installed to comply with ANSI B31.1 for occasional over pressurizations. It was not, and is not specifically required for this system because the SDV pressure is limited to that of the reactor, which has its own pressure relief valves. The typical nominal opening setpoint is 1250 psig with a discharge capacity of 75 ± 25 gpm at 1375 psig. This flow rate is within the capability of most (if not all) sump pumps. For the valve to fail open, the pressure would have to exceed its setpoint and then it would have to fail to reseat. Events that will cause the pressure to exceed 1250 psig are transients such as closure of all main steam isolation valves (MSIV) with flux scram (i.e., failure of four scram position switches), or failure of several relief valves during a pressurization transient such as turbine trip without bypass.

To estimate the probability of a stuck open SDV relief valve, consider the closure of all MSIV transient. The frequency of all MSIV closure with position switch scram is $\sim 0.5/\text{year}$ (Reference 9). The probability of a position switch failing is estimated to be $10^{-2}/\text{demand}$ (Reference 3). Scram will not occur if two switches fail simultaneously; the probability is $10^{-4}/\text{demand}$ or $5 \times 10^{-5}/\text{year}$. The probability that a relief valve will not reseat is $\sim 5 \times 10^{-3}/\text{demand}$ (Reference 8) (it is assumed to be similar to that for a primary relief valve) or $\sim 2 \times 10^{-3}/\text{year}$. Thus the probability that the relief valve will stick open is $\sim 1 \times 10^{-7}/\text{year}$ for closure of all MSIV with flux scram.

The probability of a stuck open SDV relief valve for other events such as turbine trip without bypass with failure of several primary relief valves to open is even lower. The probability of the SDV sticking open is thus conservatively estimated to be $1 \times 10^{-7}/\text{year}$.

2.2.3.3 Other Considerations

Figure 2.2 shows that the SDV system has several calibration valves that are normally locked closed. In addition, the end of each calibration

line is capped. The only credible way that a severe leak could occur from this line is either from a full break or from failure to fully close the valve and recap the line. The former event has already been included under pipe break. The latter depends on the quality of inservice inspection. The NRC through NUREG-0803 has mandated that "surveillance, maintenance, inspection or modification procedures which conceivably have the potential for defeating SDV integrity be reviewed (or modified, if necessary) by licensee on a plant-by-plant basis. These plant-specific reviews should verify that all such procedures contain sufficient guidance to ensure that the loss of SDV system integrity will not occur at times when such integrity should be available." These actions should preclude the valve being left open and the end of the pipe being uncapped.

2.2.4 Probability of Breach of SDV Integrity

The probability of loss of SDV integrity is the sum of the probabilities of pipe failure and valve failure. Based on the calculations previously discussed these probabilities are:

Failure mode	Probability/Reactor year	
	<u>Average Plant</u>	<u>Limiting Plant</u>
Pipe Break	1×10^{-7}	6×10^{-7} (Table 2.2)
Vent valve open	6×10^{-6}	1×10^{-5} (Section 2.2.3.1)
Drain valve open	6×10^{-6}	1×10^{-5} (Section 2.2.3.1)
Relief valve open	1×10^{-7}	1×10^{-7} (Section 2.2.3.2)
All other	<u>Negligible</u>	<u>Negligible</u> (Section 2.2.3.3)
Total	$\sim 1.2 \times 10^{-5}$	$\sim 2 \times 10^{-5}$

These values are based on the scrams not being reset.

NUREG-0803 conservatively estimated the probability of failure to reset scram in 30 minutes at $\sim .5$. This high value was used because of the uncertainty in the post-leak environment that might contribute to the inability to reset.

This argument, however, is not as applicable in the case of stuck open vent or drain valves as it is to pipe break, since valves are not spraying

uncontrollably in the air. Rather, they are discharging into sumps. In this case the operator failure to reset will most likely be the dominant failure-to-reset.

NUREG-0803 used an upper bound value of 0.02 for operator failure to reset.

Thus, using a failure to reset probability of 0.5 in the case of pipe breaks and 0.02 in the case of valve failures, the probabilities of non-isolatable leaks are:

Failure mode	Probability/Reactor year	
	<u>Average Plant</u>	<u>Limiting Plant</u>
Pipe Break	5×10^{-8}	3×10^{-7}
Vent Valve Open	1.2×10^{-7}	2×10^{-7}
Drain Valve Open	1.2×10^{-7}	2×10^{-7}
Relief Valve Open	<u>2×10^{-9}</u>	<u>2×10^{-9}</u>
Total	$\sim 3.0 \times 10^{-7}$	$\sim 7 \times 10^{-7}$

Table 2.1 - Characteristics of the SDV System for the Various Plants

Parameter	Fermi 2	PB 2	PB 3	Duane Arnold	Lime- rick	Fitz	Pil- grim	WNP 2	Hatch 2	Oyster Creek	Sus- que- hanna	Monk- ce)	NMP 1	Brun- swick 1 + 2
Length of Pipe (ft)														
1/2 - < 2"	1700	2023	2053	997	1439	1037	1015	1670	1684	1548	1992	1108	949	1761
2" - 6"	120	582	9	158	140	18	370	293	123	278	181	244	327	303
> 6"	290	11	414	188	170	257	18	147	274	100	289	71	94	241
Instal. Exam. Class	2	1	1	2	2	B31.1	B31.1	1	-	B31.1	(5)	2	-	2
Desg Code + Class	2	B31.1 + GE	B31.1 + GE	1	2	B31.1 + GE	2	Sfty 2 Qual 1	2	(3)	2	B31.1 + GE	B31.1+ Class 1 + GF	B31.1
Seismic Design Class	1	1	1	1	1	1	2	1	1	(4)	1	1	1	1
In Serv. Insp. Class	2 ⁽¹⁾	1	1	1	2	2	ASME XI	ASME XI	2	Surve. for wtr	2	1	1	None
Welded Joints	1044	-	-	941	~905	1044	974	1205	683	957	1097	833	-	1024
Threaded Joints	0	0	0	0	0	0	0	0	0	0	0	0	0	0
Average /yr	(2)	4.3	7.5	8.2	(2)	7.3	9.5	(2)	17	-	(2)	6.8	12.6	17*
Average Scram Dur. min.	(2)	17.5	17.5	5.83	(2)	-	30	(2)	-	-	(2)	16	1	4

() - Number in parenthesis refers to Note.

- - Not Available

* - Average scram/yr for both Brunswick 1 and 2

Notes For Table 2.1

- 1) Visual test all piping while at hydrostatic pressure. Ultrasonic test scram discharge volume and instrument volume (25% of stress welds over 10 years). Frequency is refueling cycle and Class 2 program.
- 2) Plant has not started up yet, so there is no scram data.
- 3) ASA B31.1, ASME I and VIII and ASME Sections III and XI.
- 4) Uniform Building Code with following acceleration values:

.43g Horiz. .29g Vert.
- 5) VT/PT for withdrawal lines, VT/RT for headers and instrument volume.

TABLE 2.2 - BREAK PROBABILITIES USING EXPERIENCE APPROACH

<u>Parameter</u>	<u>Average Plant</u>	<u>Limiting Plant</u>
Length of SDV pipe (ft)		
1/2" to 2" diam.	1496	2023
2" to 6" diam.	225	582
> 6" diam.	183	11
Scrams/year	9	17
Total time to reset per year (min)	91	285
Fraction of time scrammed ⁽¹⁾	1.7×10^{-4}	5.4×10^{-4}
Probability (NEDO-24342) ⁽²⁾	1.3×10^{-7} /reactor year	6×10^{-7} /reactor year
Probability (NUREG-0803) ⁽³⁾	1.0×10^{-7} /reactor year	4.2×10^{-7} /reactor year

() - refers to Notes.

Notes for Table 2.2

1) Fraction of time scrambled is the total time to reset per year divided by the number of minutes in a year.

2) Probability (NEDO-24342)

$$= [(L_1 \times 10^{-3}) + (L_2 \times 3 \times 10^{-4}) + (L_3 \times 10^{-4})] \times F_1 / 2000$$

where: L_1 = Length of SDV piping of 1/2" to 2" diameter

L_2 = Length of SDV piping of 2" to 6" diameter

L_3 = Length of SDV piping of >6" diameter

F_1 = Fraction of time scrambled

3) Probability (NUREG-0803)

$$= (L_1 + L_2 + L_3) \times 3 \times 10^{-7} \times F_1$$

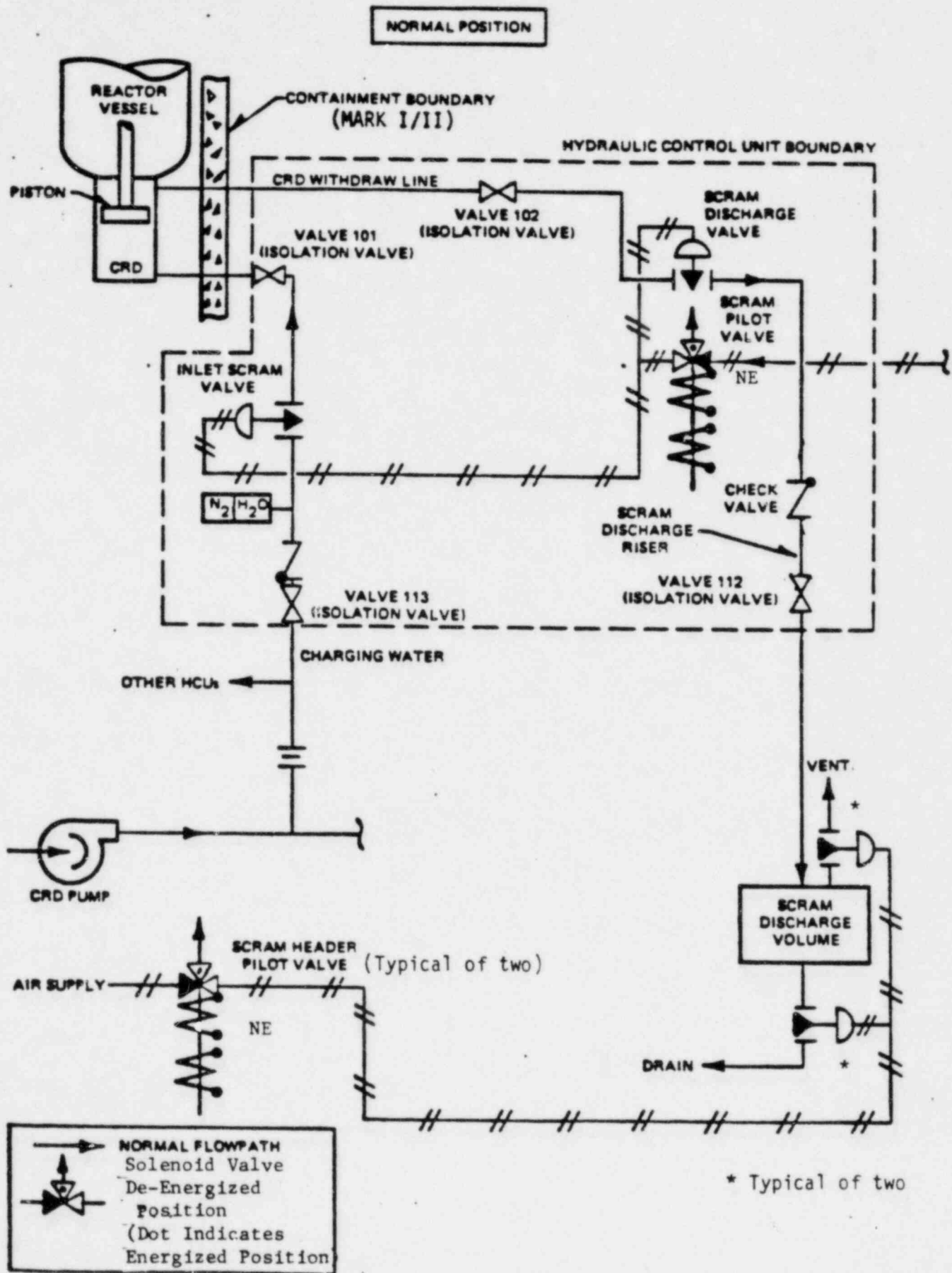

Figure 2.1 Simplified Schematic of Control Rod Drive System

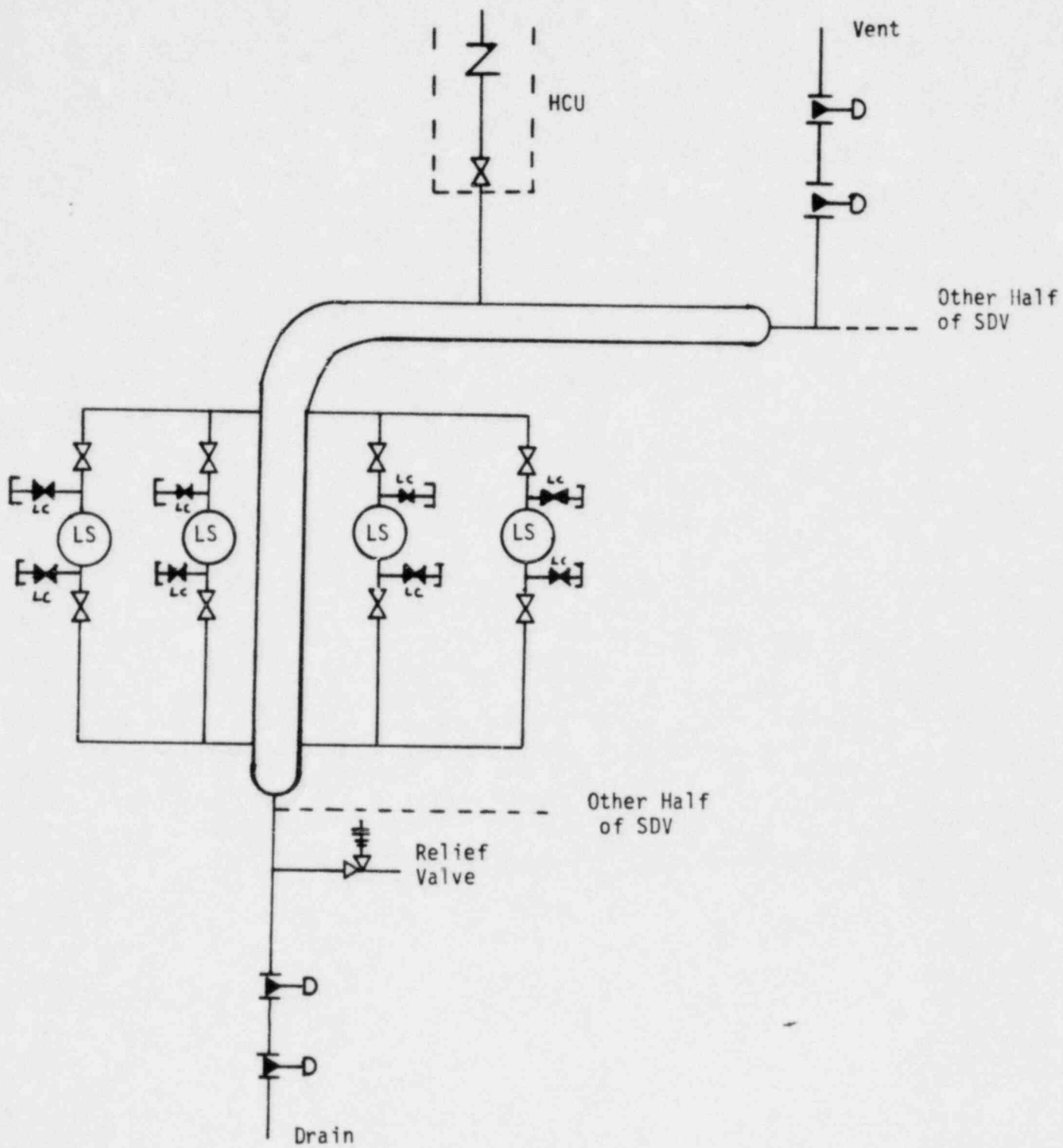

Figure 2.2 - Typical Scram Discharge Volume Configuration (Simplified)

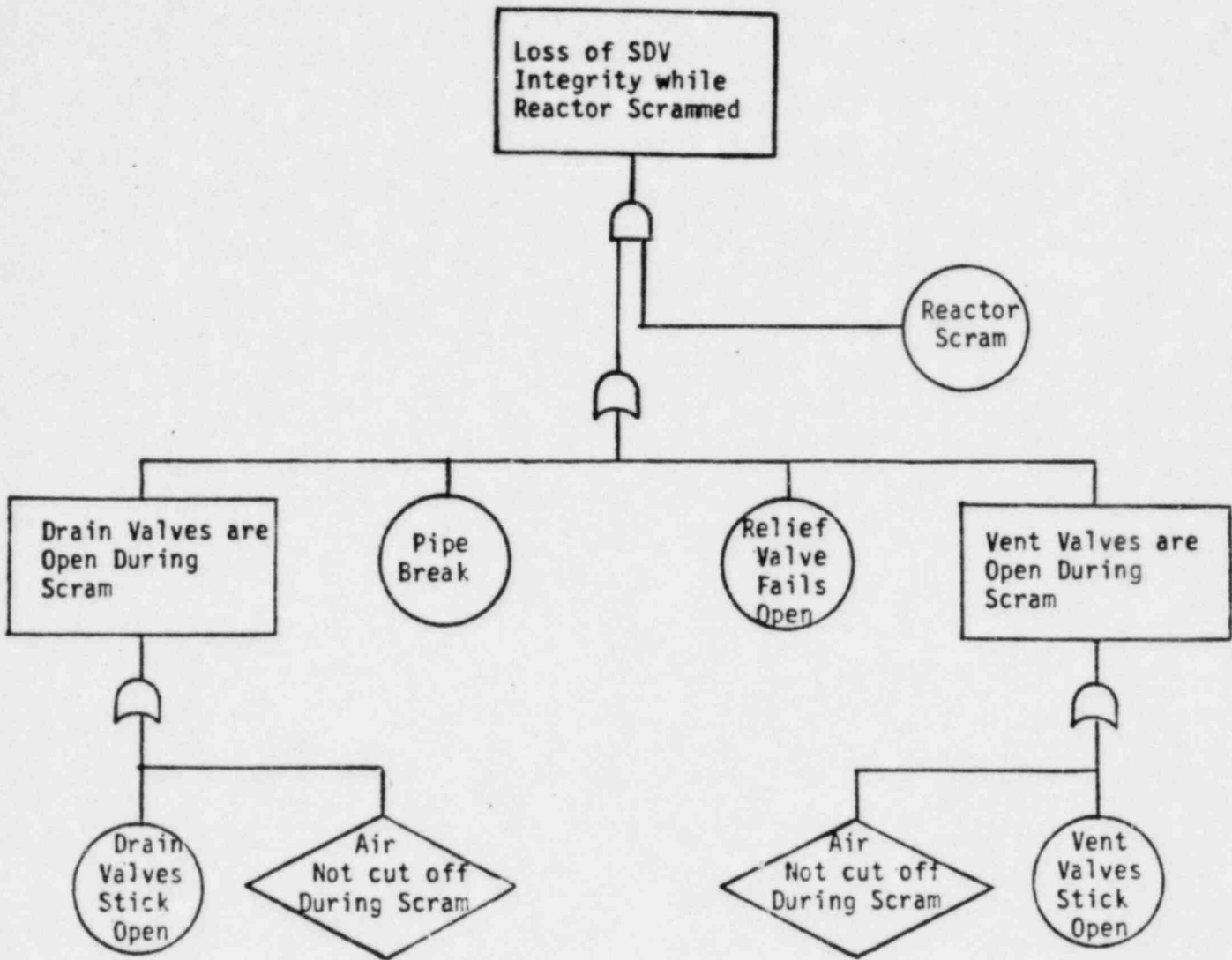

Figure 2.3 - Fault Tree For Loss of SDV Integrity

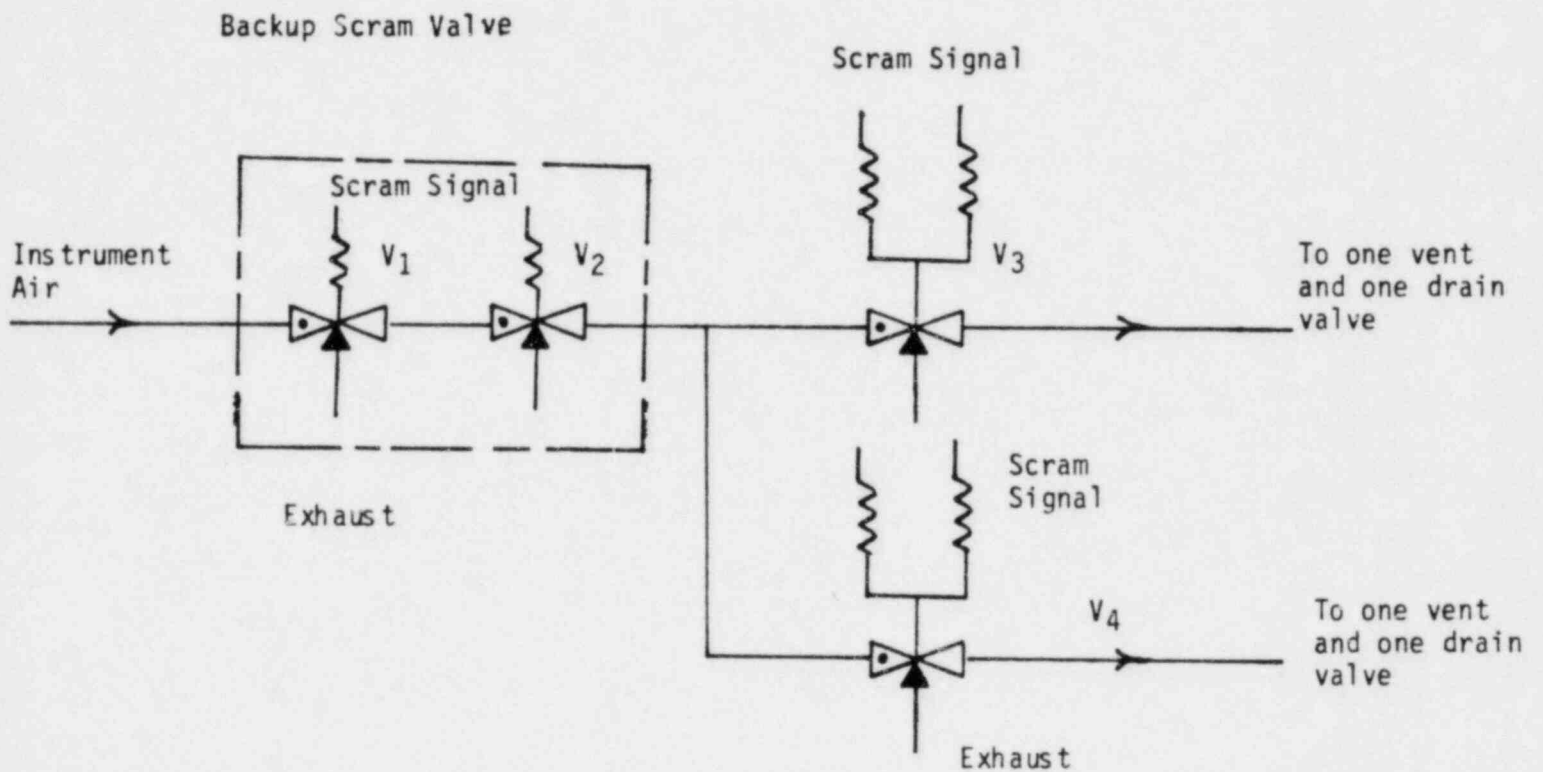

Figure 2.4 Simplified Diagram Of A Typical SDV Instrument Air Control. The position shown is the no-scram position. The dot represents the port that will close upon receipt of the scram signal.

3.0 Summary and Conclusions

NUREG-0803 requires that the equipment used to detect and/or mitigate the consequences of a loss of SDV integrity event be qualified for the environmental conditions of that event. This study concludes that environmental qualification is not necessary due to the low probability of a breach in SDV integrity. It also follows that there is a low probability of core damage resulting from such a breach.

The loss of SDV integrity can occur from any of four failure modes: (1) rupture of the SDV piping upstream of the vent and drain valves, (2) failure of the redundant vent valves to close following a scram, (3) failure of the redundant drain valves to close following a scram or (4) failure of the SDV relief valve. The first failure mode was investigated using methods similar to those used in NUREG-0803 and NEDO-24342. Actual plant data on SDV pipe size and scram frequency was considered for these two approaches. The calculated break probabilities from those two approaches was compared to the calculated probability using a fracture mechanics approach and the results were shown to be consistent.

The probabilities associated with failure of the vent or drain valves to close were calculated based on previous operating history with this type of valve. The probability of an SDV relief valve failure to close was small relative to the other failure modes due to the relatively low frequency of challenge to this valve.

Consideration was given in the probability analysis to the ability of the operator to reset the scram. Due to the more severe environmental conditions, that probability is lower for the SDV pipe break than for the vent or drain valve failure.

The total probability of a breach in SDV integrity is the sum of the individual probabilities for each failure mode. That total probability was determined to be approximately 3×10^{-7} per reactor year.

The probability of a core melt event given the breach in SDV integrity was previously calculated and reported in Section 7.8 of NEDO 24342 and was determined to be 1.2×10^{-4} per plant year. Therefore, the probability of a breach in SDV integrity leading to a core melt is approximately 4×10^{-11} per plant year. This is significantly below the NRC proposed safety goal for core melt events which is 10^{-4} per reactor year.

The NRC, in NUREG-0803, stated that "it was agreed that if the probability of core damage from the postulated scenario (i.e., loss of SDV pipe integrity) was shown to be sufficiently small, no further review, beyond verification of plant specific response applicability, would be necessary". They further noted that "as the review progressed, it became evident that a sufficient data base did not exist to conservatively terminate the generic review on the basis of a quantitative risk assessment". However, considering that the estimated core melt frequency following a loss of SDV integrity is considerably below the proposed NRC safety goal (by ~6 orders of magnitude), this significant margin should be sufficient to account for any perceived sparsity in the data base.

Therefore, it is concluded that the breach of SDV integrity need not be considered for environmental qualification of equipment in the reactor building.

4.0 References

- 1) 'Generic Safety Evaluation Report Regarding Integrity of BWR Scram System Piping', NUREG-0803, August 1981.
- 2) L. F. Fidrych, R. L. Gridley, 'GE Evaluation In Response to NRC Request Regarding BWR Scram System Pipe Break', NEDO-24342, April, 1981.
- 3) 'Reactor Safety Study', WASH-1400, (NUREG-75/014) October 1975.
- 4) NRC Memorandum, 'Generic Safety Evaluation Report - BWR Scram Discharge System', December 1980.
- 5) Farmer, F.G. et.al., 'Screening Values For National Reliability Evaluation Program Reliability Applications', Preliminary Draft, April 1982.
- 6) 'Review and Assessment of Research Relevant to Design Aspects of Nuclear Power Plants Piping Systems', NUREG-0307, July, 1977.
- 7) J. S. Abel, 'Quad Cities Station Units 1 and 2, Dresden Station Units 2 and 3 Plant Specific Response to NUREG-0803', letter to T. J. Rausch, January 25, 1982.
- 8) 'Data Summaries of Licensee Event Reports of Valves at U.S. Commercial Nuclear Power Plants', NUREG/CR-1363, Vol. 3.
- 9) 'ATWS: A Reappraisal, Part 3: Frequency of Anticipated Transients,' EPRI NP-2230, January 1982.
- 10) 'Safety Goals For Nuclear Power Plants: A Discussion Paper', NUREG-0880, February 1982 (Draft).

APPENDIX A

This report applies to the following plants whose owners participated in the report's development:

<u>Participating Utilities</u>	<u>Plant</u>
Boston Edison Co.	Pilgrim
Carolina Power + Light Co.	Brunswick 1 and 2
Detroit Edison Co.	Fermi 2
Georgia Power Co.	Hatch 2
GPU Nuclear	Oyster Creek
Iowa Electric Light and Power Co.	Duane Arnold
Niagara Mohawk Power Co.	Nine Mile Point 1
Northeast Utilities	Millstone
Northern States Power Co.	Monticello
PASNY	Fitzpatrick
Pennsylvania Power + Light Co.	Susquehanna 1 and 2
Philadelphia Electric Co.	Peach Bottom 2 Peach Bottom 3 Limerick 1 and 2
Public Service Electric + Gas Co.	Hope Creek 1
Washington Public Power Supply System	WNP-2