

**EFFECTS OF
VESSEL HEAD VOIDING
DURING
TRANSIENTS AND ACCIDENTS
IN C-E NSSS's**

Prepared for the C-E OWNERS GROUP

NUCLEAR POWER SYSTEMS DIVISION

MARCH, 1982

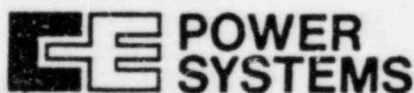

COMBUSTION ENGINEERING, INC.

LEGAL NOTICE

THIS REPORT WAS PREPARED AS AN ACCOUNT OF WORK SPONSORED BY COMBUSTION ENGINEERING, INC. NEITHER COMBUSTION ENGINEERING NOR ANY PERSON ACTING ON ITS BEHALF:

A. MAKES ANY WARRANTY OR REPRESENTATION, EXPRESS OR IMPLIED INCLUDING THE WARRANTIES OF FITNESS FOR A PARTICULAR PURPOSE OR MERCHANTABILITY, WITH RESPECT TO THE ACCURACY, COMPLETENESS, OR USEFULNESS OF THE INFORMATION CONTAINED IN THIS REPORT, OR THAT THE USE OF ANY INFORMATION, APPARATUS, METHOD, OR PROCESS DISCLOSED IN THIS REPORT MAY NOT INFRINGE PRIVATELY OWNED RIGHTS: OR

B. ASSUMES ANY LIABILITIES WITH RESPECT TO THE USE OF, OR FOR DAMAGES RESULTING FROM THE USE OF, ANY INFORMATION, APPARATUS, METHOD OR PROCESS DISCLOSED IN THIS REPORT.

ABSTRACT

This report has been prepared in response to Item II.K.2.17 of NUREG-0737, potential for voiding in the reactor coolant system during transients. Three types of plant transients which have the potential to cause voiding in the reactor vessel upper head region are addressed. These transients are normal operational transients, natural circulation cooldown transients, and the depressurization and overcooling transients addressed in Chapter 15 of the plant Safety Analysis Report. The evaluation concludes that any potential void formation during these transients is not great enough to impair reactor coolant circulation or core coolability.

TABLE of CONTENTS

<u>Section</u>	<u>Title</u>	<u>Page</u>
1.0	INTRODUCTION	1-1
1.1	Purpose	1-1
1.2	Scope	1-1
1.3	Background	1-2
1.4	RCS Voiding	1-2
1.5	Operator's Role in RCS Voiding	1-3
1.6	Format of Report	1-3
1.7	Results of Evaluation	1-4
2.0	TRANSIENTS	2-1
2.1	General	2-1
2.2	Normal Operational Transients	2-2
2.3	Natural Circulation Cooldowns	2-4
2.4	THIS SECTION DELETED	2-7
2.5	THIS SECTION DELETED	2-13
3.0	SIMULATION CAPABILITIES	3-1
3.1	LTC	3-1
3.2	CESEC	3-1
4.0	SUMMARY	4-1
5.0	REFERENCES	5-1

LIST OF APPENDICES

<u>Appendix</u>	<u>Title</u>	<u>Page</u>
A	Typical C-E Emergency Procedure Guidelines Related to RCS Voiding	A-1

LIST OF TABLES

<u>Table</u>	<u>Title</u>	<u>Page</u>
2-1	Typical Parameters for Plant Classes	2-16
2-2	Asymptotic Fluid Temperature Difference (ΔT) Between the Reactor Vessel Upper Head and Upper Plenum Regions	2-17
2-3	Temperature Difference Which Will Cause Stagnation in Isolated Steam Generator for an Asymmetric Cooldown	2-18
2-4	TABLE DELETED	2-19

LIST OF FIGURES

<u>Figure</u>	<u>Title</u>	<u>Page</u>
3-1A	LTC Model	3-4
3-1B	LTC Volume Description	3-5
3-2A	CESEC Nodal Scheme	3-6
3-2B	Physical Description of Nodes	3-7

1.0 INTRODUCTION

1.1 Purpose

This report provides the results of an evaluation on the potential for voiding in the reactor coolant system (RCS) during transients as required by NUREG-0737, Item II.K.2.17 (Reference 1). More specifically the report addresses the following concerns:

1. Situations which will cause voiding,
2. Effects of void formation on system response,
3. Feasibility of preventing voids from forming, and
4. Adequacy of operator guidance for mitigating the consequences of voids or dealing with void formation.

The assessment of void formation on system response for nuclear steam supply systems (NSSSs) designed by C-E shows that any potential void formation during the transients addressed in this report is not great enough to impair reactor coolant circulation or core coolability. The voids calculated to occur in the reactor vessel upper head region during these transients were not predicted to expand beyond the top elevation of the hot legs. This is consistent with test data gathered at the LOFT facility, under more extreme conditions, which demonstrates that natural circulation flow is not significantly affected even when there are small (less than 15% void fraction) amounts of voids in the hot leg.

1.2 Scope

Three types of plant transients which have the potential to cause voiding in the reactor vessel upper head region are 1) normal operational transients (such as plant trips, load changes, cooldown with the reactor coolant pumps (RCPs) running), 2) natural circulation cooldown transients, and 3) the depressurization and overcooling transients addressed in Chapter 15 of the plant Safety Analysis Report (SAR). These three types of plant transients are addressed in this report.

The report additionally addresses the following three issues in providing for the assessment of void formation on system response for NSSSs designed by C-E.

These are 1) the effect of void formation in the reactor vessel upper head region on Emergency Core Cooling System (ECCS) performance, 2) the consequences of non-uniform void mixing in the reactor vessel upper head region on system response, and 3) the effects of hot spots on system response.

The C-E plants addressed in this report are those listed in Table 2-1. These include Ft. Calhoun, Maine Yankee, Palisades, Calver Cliffs Units 1 and 2, Millstone Unit 2, St. Lucie Units 1 and 2, Arkansas Nuclear One Unit 2, San Onofre Units 2 and 3, Waterford Unit 3, Palo Verde Units 1, 2, and 3, Yellow Creek Units 1 and 2, and WNP Units 3 and 5.

1.3 Background

The NRC request to address the RCS voiding concern was originally sent to Babcock and Wilcox (B&W) licensees only. The letter sent by R. W. Reid of the NRC (Reference 3) cited as a general safety concern the coarse representation of analysis models for simulating the reactor vessel upper head region transient response and, therefore, their inability for predicting the effects of voids properly. Item II.K.2.17 of NUREG-0737 made the above request generic to all PWR operating reactors and applicants.

1.4 RCS Voiding

RCS voiding is a phenomenon dependent on the temperature and pressure of the coolant and the amount of coolant inventory in the system. When the system pressure is rapidly reduced as in a depressurization and cooldown event, RCS regions where the flow is small or negligible can become hot spots that reach saturation. This is because the fluid in those regions may thermally lag the rest of the RCS during the depressurization.

The most likely region in the RCS to become saturated is the reactor vessel upper head region. Only a small fraction of the total core/upper plenum flow goes through this region when the reactor coolant pumps are running. The region becomes relatively stagnant when the pumps are shut off. Once the RCS pressure reaches the saturation temperature of the reactor vessel upper head region during a depressurization, voids are likely to form due to flashing of the hot fluid. Additionally, the effect of the heat transfer from the reactor vessel walls and internals enhances the void formation in the upper head region

through boiloff. However, voids in the upper head region, although not desirable, are not an operational concern. The pressurizer normally operates with a void, that is, a steam space. Additionally, the ability of an operator to cope with such a situation was demonstrated during the natural circulation cooldown event at St. Lucie Unit 1 (Reference 6).

Voids may also be formed in an isolated steam generator loop during a cooldown, if the flow in that loop is stagnant and the RCS is depressurized below the isolated steam generator saturation temperature/pressure. However, by conducting non-symmetric cooldowns in a controlled manner, voiding under this circumstance can be prevented.

1.5 Operator's Role in RCS Voiding

The operator's role during RCS voiding situations is to mitigate the consequences of voids while maintaining the critical safety functions (Reference 7). The safety functions being the success paths the operator has to ensure core reactivity control and heat removal and primary system inventory control, pressure control, and heat removal.

The C-E emergency procedure guidelines documented in CEN-152 (Reference 2) provide technical input for utilities owning C-E NSSSs to develop detailed emergency procedures. The C-E guidelines adequately address the steps that the operator can take to prevent voids and mitigate or deal with voids if they do occur. A summary of the C-E emergency procedure guidelines addressing voids is provided in Appendix A.

1.6 Format of Report

Section 2.1 provides the preface for Section 2.0: Transients. Sections 2.2, 2.3, and 2.4 discuss, respectively, the types of plant transients addressed in the report, namely, the normal operational transients, the natural circulation cooldowns, and the SAR Chapter 15 transients. Section 2.5 addresses related issues such as the consequences of non-uniform mixing in the reactor vessel upper head region and the effects of hot spots on system response. The effects of void formation in the reactor vessel upper head region on ECCS performance is addressed in Section 2.4.

Section 3.0 provides a synopsis of the analytical capabilities used by C-E in support of the information presented in the report. Section 3.1 summarizes the capabilities of the LTC code, while Section 3.2 summarizes the capabilities of CESEC.

Section 4.0 provides a summary, in the form of conclusions, of the information presented in Section 2.0.

The references are detailed in Section 5.0.

Appendix A, as previously mentioned in Section 1.5, summarizes the C-E emergency procedure guidelines which address RCS voiding.

1.7 Results of Evaluation

The results of the evaluation show that voiding in the reactor vessel upper head region is not expected to occur for normal operational transients. For natural circulation cooldown transients voiding may occur in the reactor vessel upper head region. However, in the event that voids are formed, the operator guidance provided in C-E's emergency procedures guidelines (Reference 2) adequately address how to control and reduce the voids. Stress calculations performed using conservative assumptions have shown that cooldown of a voided upper head with cooler reactor coolant system water is well within the reactor vessel stress limits. For SAR Chapter 15 transients the impact of voiding will not result in violation of the Nuclear Regulatory Commission (NRC) Standard Review Plan (SRP) requirements for all C-E plants.

Additionally, the report concludes that the consequences of non-uniform mixing in the reactor vessel upper head are of secondary nature when compared to the consequences from not explicitly modelling the reactor vessel upper head region and that hot spots have negligible effects on plant parameters and, more importantly, on transient consequences.

Finally, the report concludes that any potential void formation during the plant transients addressed is not great enough to impair reactor coolant circulation or core coolability.

2.0 TRANSIENTS

2.1 General

Voids in the RCS are formed as a result of not maintaining a subcooled margin in the reactor coolant system. The extent of void formation is mainly affected by the rate of RCS depressurization, the metal structure heat transfer area, the fluid volume in the reactor vessel upper head region, the fraction of vessel flow which passes through the upper head, the cooldown rate of the secondary side, the performance of the ECCS, the ratio of NSSS power level to RCS fluid volume, and the initial steady state fluid conditions. The RCS region of most concern regarding voiding is the reactor vessel upper head region.

Under normal operating conditions the subcooled margin is maintained via the pressurizer pressure control system using the pressurizer sprays and heaters. Since this system is designed to accommodate normal operational transients with adequate subcooled margin, voids in the RCS are highly improbable during normal operating conditions.

During a natural circulation cooldown, circulation of fluid through and cooldown of the reactor vessel upper head are reduced. As a consequence the fluid in this region may reach saturation conditions during depressurization resulting in voids in the upper head.

Subcooled margin cannot be maintained during certain design basis events analyzed in the SARs. These SAR events are the depressurization and rapid cooldown transients. For these events, the pressurizer fluid drains or the system pressure drops to saturation conditions and voids form in the reactor vessel upper head region, where the hottest fluid in the system is located.

The results provided herein are by class of C-E plants. The conclusions apply to all plants considered. Key plant parameters were identified for the C-E plants in order to facilitate categorization of the plants into classes. The C-E plants were categorized under three basic classes: the operating plants, the 3410 Mwt plants, and the 3800 Mwt plants. The C-E plants and the typical parameters for these plant classes are identified in Table 2-1. The significance of including the ratio of upper head volume to RCS volume

is that the larger the upper head volume is, the greater the impact of void formation upon transient RCS pressure. The safety injection actuation setpoint and the high pressure safety injection pump shutoff head are parameters which significantly affect steam line break events. The auxiliary feedwater flow and capacity of the main steam safety valves are parameters which influence the releases during a steam generator tube rupture event. The saturation pressure at the hottest temperature of the system provides an indication as to how low the pressure in the RCS system would have to drop before voids would form.

2.2 Normal Operational Transients

Normal operational transients are defined as those plant events wherein most or all of the RCPs continue running throughout the event. Examples of normal operational transients are plant trips, load changes, and loss of one RCP. These transients have been analyzed in CEN-128 (Reference 4). The calculations have shown that the subcooled margin in the RCS loop, which excludes the reactor vessel upper head region, for these events is at least 50°F.

The reactor vessel upper head region is potentially susceptible to voiding since only a small fraction of the total core/upper plenum flow goes through this region. Typically, this fraction is about one percent when any of the RCPs are running. This flow is sufficient to completely replace the entire reactor vessel upper head region fluid in about two minutes for the operating plants and the 3410 Mwt plants and in about 5 minutes for the 3800 Mwt plants. The forcing functions which determine the reactor vessel upper head region fluid temperature during RCP operation are the mass flow rate into it and the corresponding temperature of that fluid. A detailed energy balance considering conduction, radiation, and convection has shown that the region is typically about 1°F cooler than the core exit/upper plenum region temperature under steady state operating conditions. Hence, the subcooled margin in the reactor vessel upper head region is essentially equal to that of the RCS hot legs under steady state operation.

Under transient conditions, with the RCPs running, there will be a time lag between a change in the core exit/upper plenum temperature and the time when the reactor vessel upper head fluid temperature reaches approximately the same temperature. This time lag is approximately proportional to the ratio of the total thermal masses of the region, including the metal contributions, divided

by the net energy flow rate through the region. Numerically, the time lag for the operating plants and the 3410 Mwt plants has been calculated to be about 8 minutes. For the 3800 Mwt plants, the time lag has been calculated to be about 25 minutes. The time lag and the RCS cooldown rate will then determine the fluid temperature difference between the reactor vessel upper head region and the upper plenum region.

This fluid temperature difference has been calculated for three constant cooldown rates assuming an operator controlled cooldown conducted in such a manner as to maintain a 50°F subcooling in the RCS loop. The asymptotic values reached by the temperature difference for the various cooldown rates are presented in Table 2-2. The reduction in the reactor vessel upper head region subcooling relative to the RCS loop subcooling is at most 4°F for the operating plants and the 3410 Mwt plants. For the 3800 Mwt plants this maximum value is 14°F. Therefore, the reactor vessel upper head region subcooling during cooldowns with RCPs running remains sufficient to preclude any voids from forming in this region even at the maximum controlled cooldown rate allowed by plant Technical Specifications of 100°F/hr.

For a reactor trip from normal operation, a rapid cooldown follows the trip. The loop cooldown as a result of RCS shrinkage will lower the pressurizer pressure and level. For this case, a conservative estimate of the reactor vessel upper head region minimum subcooling during the cooldown can be made from the initial fluid temperature in the region and the minimum RCS pressure. From the results presented in Reference 4 for one pump loss of forced reactor coolant flow, a conservative estimate of the reactor vessel upper head region subcooling was made. The minimum calculated value of about 30°F over the short time interval following a reactor trip when there is no operator action will preclude any voids from forming in this region. The results presented in Reference 4 are typical of the operating plants. However, essentially the same conclusions can be made if similar calculations were to be performed for the 3410 Mwt plants and the 3800 Mwt plants.

In summary, RCS voiding is not expected for C-E plants for normal operational transients. The subcooled margin in the RCS loop expected for these events is typically 50°F or higher; the reactor vessel upper head region subcooling margin can be lower than that for the RCS loop but still high enough to prevent voids from forming.

2.3 Natural Circulation Cooldowns

The preferred mode for performing a plant cooldown is by forced circulation. However, whenever the RCPs are not available, an alternate method for cooling down the plant is by natural circulation. The cooldown of the plant by natural circulation is possible as a result of temperature gradients in the reactor coolant system. Natural circulation cooldowns as specified by C-E guidelines (Reference 2) require at least 20°F subcooling in the reactor coolant system hot legs. The hot leg temperature must be larger than the cold leg temperature for primary to secondary heat transfer to occur. Therefore, maintaining subcooling with respect to the hot leg temperature will generally suffice to prevent the RCS loops from voiding.

RCS voids may be formed under the following circumstances even though steam generator heat removal is being maintained:

1. A rapid enough depressurization so that the reactor vessel upper head region reaches saturation.

As previously stated in Section 2.2 this region receives about one percent of the total core/upper plenum flow when the RCPs are running. However, during natural circulation conditions this is not the case. Instead, the fluid flow into the reactor vessel upper head region is largely due to shrinkage of the fluid in the vessel head caused by conductive cooling heat transfer. As a result, the reactor vessel upper head region fluid is relatively stagnant and will thermally lag the rest of the RCS during a natural circulation cooldown. Failure to account for this lag will result in a steam void being created in the reactor vessel upper head region if the RCS pressure is allowed to drop to the saturation point of the fluid in this region during the cooldown. C-E's emergency procedure guidelines (Reference 2) recommend a rapid cooldown within technical specification limits to enhance the conductive cooling capability of the reactor vessel upper head region (A large temperature difference between the reactor vessel upper head and the RCS fluid will yield a large thermal gradient and a greater heat transfer rate). Additionally, the guidelines recommend that the RCS pressure be maintained as high as possible, within operating restrictions, until the RCS has been cooled down to shutdown cooling initiation temperature and at least 20 hours has elapsed since the start

of cooldown. This cooldown strategy will minimize the possibility of voiding in the reactor vessel upper head region. The time required to cool the reactor vessel upper head region under natural circulation conditions to shutdown cooling entry temperature has been calculated to be about 20 hours for the operating plants and the 3410 Mwt plants and about 55 hours for the 3800 Mwt plants. The larger time requirement of the 3800 Mwt plants is due to the larger volume of water in the reactor vessel upper head region (see Table 2-1) and a smaller flow area to fluid volume ratio than for the other plants.

2. An asymmetric cooldown which results in stagnated flow in one steam generator loop.

An event such as a steam generator tube rupture may require that one steam generator be isolated continuously from the RCS as a heat sink. With one steam generator isolated, the non-isolated unit will carry the total share of the decay heat/sensible heat load. In order to carry the higher heat load, the non-isolated steam generator has to be at a lower secondary temperature than the isolated one. During normal forced flow conditions in the RCS sufficient reverse heat transfer in the isolated unit occurs to maintain the isolated steam generator at the same relative temperature as the non-isolated RCS loop during a plant cooldown. However, with no RCPs operating, that is, under natural circulation flow, the cooler (non-isolated) steam generator will have larger flows than the hotter (isolated) steam generator. This will result from the secondary temperature difference between the two generators. As the secondary temperature difference between the two generators increases the flow in the isolated generator may eventually stagnate leaving the isolated generator in a hot condition. The temperature difference at which stagnation would occur is a function of the decay heat level and, thus, of the time following the reactor trip. Representative values of the temperature difference which will cause stagnation are provided as a function of time after trip in Table 2-3. This condition by itself will not necessarily affect core cooling via natural circulation in the non-isolated steam generator and RCS loop. As long as reactivity control, RCS pressure control, RCS inventory control, and RCS heat removal are properly maintained in the non-isolated loop, sufficient natural circulation flow will be maintained through the

core and operating loop. However, for a hot isolated steam generator, the temperature in that loop will lag the temperature of the non-isolated loop during the cooldown. This situation could present a problem when trying to depressurize the RCS to initiate shutdown cooling. Depressurization of the RCS below the isolated steam generator's saturation temperature/pressure could then cause voids to form in the isolated RCS loop. This could lead to interruption of the natural circulation cooling established in the non-isolated RCS loop or could cause the isolated steam generator to act like the pressurizer and prevent further depressurization to the shutdown cooling entry pressure. Therefore, asymmetric cooldowns will have to proceed more slowly than symmetric cooldowns in order to cool down the isolated steam generator before shutdown cooling is aligned.

CEN-152 (Reference 2) provides for a preferred method and for an alternate method of cooling an isolated steam generator. The preferred method being to start any RCP, if available, and the alternate method is, if possible, to drain (not completely dry) and refill the isolated steam generator secondary water volume. Control of the cooldown in the isolated loop would then be regulated by the refill rate of the cool feedwater.

Although voiding in the reactor vessel upper head region is possible under the natural circulation cooldown condition discussed above, voids can be prevented by allowing sufficient time for the fluid in the reactor vessel upper head region to cool prior to depressurizing the RCS. For asymmetric cooldowns, voids in the RCS loop can be prevented by a controlled cooldown of the isolated steam generator before shutdown cooling is aligned. C-E's emergency procedure guidelines adequately address the potential voiding situations by stating that additional time is required to conduct control natural circulation cooldowns. In addition, the guidelines identify those plant parameters whose changes indicate that a void may exist and provide guidance for eliminating the void. This guidance consists of a drain and fill procedure to control and reduce the voids. Stress calculations using conservative modeling assumptions have shown that filling the reactor vessel upper head regions with cooler reactor coolant system water is well within the reactor vessel stress limits.

THIS PAGE INTENTIONALLY BLANK

THIS PAGE INTENTIONALLY BLANK

THIS PAGE INTENTIONALLY BLANK

THIS PAGE INTENTIONALLY BLANK

THIS PAGE INTENTIONALLY BLANK

THIS PAGE INTENTIONALLY BLANK

THIS PAGE INTENTIONALLY BLANK

THIS PAGE INTENTIONALLY BLANK

THIS PAGE INTENTIONALLY BLANK

TABLE 2-1

Typical Parameters for Plant Classes

Item	Plant Class		
	Operating Plants	3410 Mwt Plants	3800 Mwt Plants
Plants within class	Ft. Calhoun, Maine Yankee, Palisades Calvert Cliffs 1 & 2, Millstone 2, St. Lucie 1&2	Arkansas Nuclear One-2, San Onofre 2&3, Waterford 3	Palo Verde 1,2,&3, Yellow Creek 1&2, WNP 3&5
$\frac{\text{NSSS Power (Mwt)}}{\text{RCS Volume (ft}^3\text{)}}$	≤ 0.24	≤ 0.29	0.28
RCS Volume (ft ³)	11,000	12,000	13,400
$\frac{\text{Upper Head Volume}}{\text{RCS Volume}}$	0.06	0.08	0.14
Safety Injection Actuation Setpoint (psia)	1578	1560	1578
High Pressure Safety Injection Pump Shutoff Head (psia)	1165	1400	1750
Auxiliary Feedwater Flow (% of Initial Flow)	2.2	4.6	5.0
Main Steam Safety Valve Relief Capacity/ Number of Valves (lbm/hr/valve)	868,300 at 900 psia/8	785,000 at 1000 psia/10	1,071,250 at 1345 psia/10
$P_{\text{saturation at } T_{\text{hot}}}$ (psia)	1500	1675	1800

TABLE 2-2

Asymptotic Fluid Temperature Difference (ΔT) Between the Reactor Vessel
Upper Head and the Upper Plenum Regions

<u>RCS Cooldown Rate,</u> <u>$^{\circ}\text{F/hr}$</u>	<u>$\Delta T, ^{\circ}\text{F}$</u>	
	<u>Operating and</u> <u>3410 Mwt Plants</u>	<u>3800 Mwt</u> <u>Plants</u>
50	2	7
75	3	10
100	4	14

TABLE 2-3

Temperature Difference Which Will Cause Stagnation
in Isolated Steam Generator for an Asymmetric Cooldown*

<u>Time After Trip</u> <u>From Full Power, sec</u>	<u>Temperature Difference Between</u> <u>Secondary Sides of Steam Generators, °F</u>
100	~ 150
1000	~ 110
10,000	~ 75
100,000	~ 50

* Flows between isolated and non-isolated loops will be an order of magnitude different.

3.0 SIMULATION CAPABILITIES

The C-E computer codes LTC (Reference 4) and CESEC (Reference 5) were used to generate all of the information related to normal operational transients, natural circulation cooldown transients, and SAR transients discussed in this report. The former code was used for the first two types of transients, while the latter one was used for the SAR transients. A brief summary on each code is presented below.

3.1 LTC

LTC (Reference 4) is a one-dimensional, single-phase system simulation code which models the primary coolant system with 17 nodes and 20 flow paths (see Figures 3-1A and 3-1B). The code conserves subcooled liquid mass and energy in each node and momentum in each flow path. Cold leg asymmetries are not transported to the core or hot legs due to the existence of only series-connected flow paths in the reactor vessel regions. The reactor coolant pumps are explicitly modeled. The pressurizer is modeled as an inhomogeneous nonequilibrium node with phase variation. The reactor vessel closure head region is modeled as a two-phase node. The coupled equation set consists of 51 equations. Except for the pressurizer and vessel closure head nodes, the nodal mass, energy, and state equations are solved simultaneously with the internodal flow path momentum equations. The code does not model two-phase conditions outside the pressurizer and closure head, since one of its independent state variables is temperature.

LTC has been used in support of information presented in References 2 and 4. The code has also been verified against experimental data including the Arkansas Nuclear One Unit 2 turbine trip test and the St. Lucie Unit 1 natural circulation cooldown event.

3.2 CESEC

The CESEC digital computer program (Reference 5) provides for the simulation of a Combustion Engineering NSSS. The program, which calculates the plant response for non-LOCA initiating events for a wide range of operating

conditions, is used by C-E in NSSS and reload licensing analyses, to provide analytical support to the plant start-up tests, and in support of the development of plant emergency procedure guidelines and training packages.

CESEC assumes a node/flow-path network to model the NSSS. The RCS, consisting of the reactor coolant loops, the reactor vessel, and the pressurizer is divided into 26 nodes of constant volume. The nodal scheme given in Figures 3-2A and 3-2B was chosen to appropriately simulate the RCS component volumes and, thus, provide an adequate description of the spatial variation of the coolant properties. Node 26, which is the pressurizer node, is subdivided into a steam and a liquid region having variable volumes. The CESEC pressurizer model assumes the steam and liquid regions to exist in any one of the eight thermodynamic states specified in Reference 5. The fluid in nodes 1 through 25 is assumed to be homogeneous and in thermal equilibrium. The nodal scheme for the reactor vessel allows for the effect of a temperature tilt in the reactor core to be explicitly accounted for during a steam line break event and other non-symmetric events.

During the rapid contraction of the primary coolant which takes place as a result of the limiting depressurization events, the pressurizer empties and/or voids begin to form in the RCS. Since flow through the upper head is only a small fraction of the RCS flow, the temperatures in the upper head remain high and voiding first occurs there. To some extent, the upper head itself then begins to perform the function of a pressurizer. Therefore, the reactor vessel upper head region is explicitly modeled in CESEC to more accurately predict the RCS pressure. The coolant flow from the upper plenum nodes (upstream half) to the vessel head node is specified by user input fractions. The vessel head fluid returning into the outlet plenum nodes (downstream half) is assumed to be evenly distributed.

The thermalhydraulic model solves the conservation of mass and energy equations coupled with the equation of state for each control volume or node. There are 29 equations with 29 unknowns for the case that the pressurizer contains steam and liquid regions. For the case that only one phase exists in the pressurizer, the number of equations and unknowns is reduced to 28. A flow model is used to determine the mass flow rate through each reactor coolant pump. The flow model calculates the mass flow rate through each reactor coolant pump. The model includes explicit simulations of the reactor coolant

pumps and of the effects of natural circulation flow. The calculation is based on a solution of the one-dimensional momentum equation for each pump loop. Each pump loop (4 in all) also considers the reactor vessel, a hot leg, and a steam generator. The loops are divided into a number of nodes whose densities, temperatures, and flows are obtained from the thermalhydraulic model. The flow model calculates the sum of the various forces around each loop. The forces acting on the fluid volume consist of (1) gravitational forces due to density and elevation changes around the loop, (2) viscous forces due to wall friction and geometric expansions and contractions of the piping, and (3) forces due to the RCS pumps. A major assumption of the thermalhydraulic model in CESEC is that the pressure around the reactor coolant loops and vessel is assumed to be uniform.

Assessment of CESEC by C-E includes comparisons of code predictions to existing experimental data for C-E operating plants (including the Arkansas Nuclear One Unit 2 turbine trip test and the St. Lucie Unit 1 natural circulation cooldown event) and to other C-E design codes. This information is presented in Reference 5.

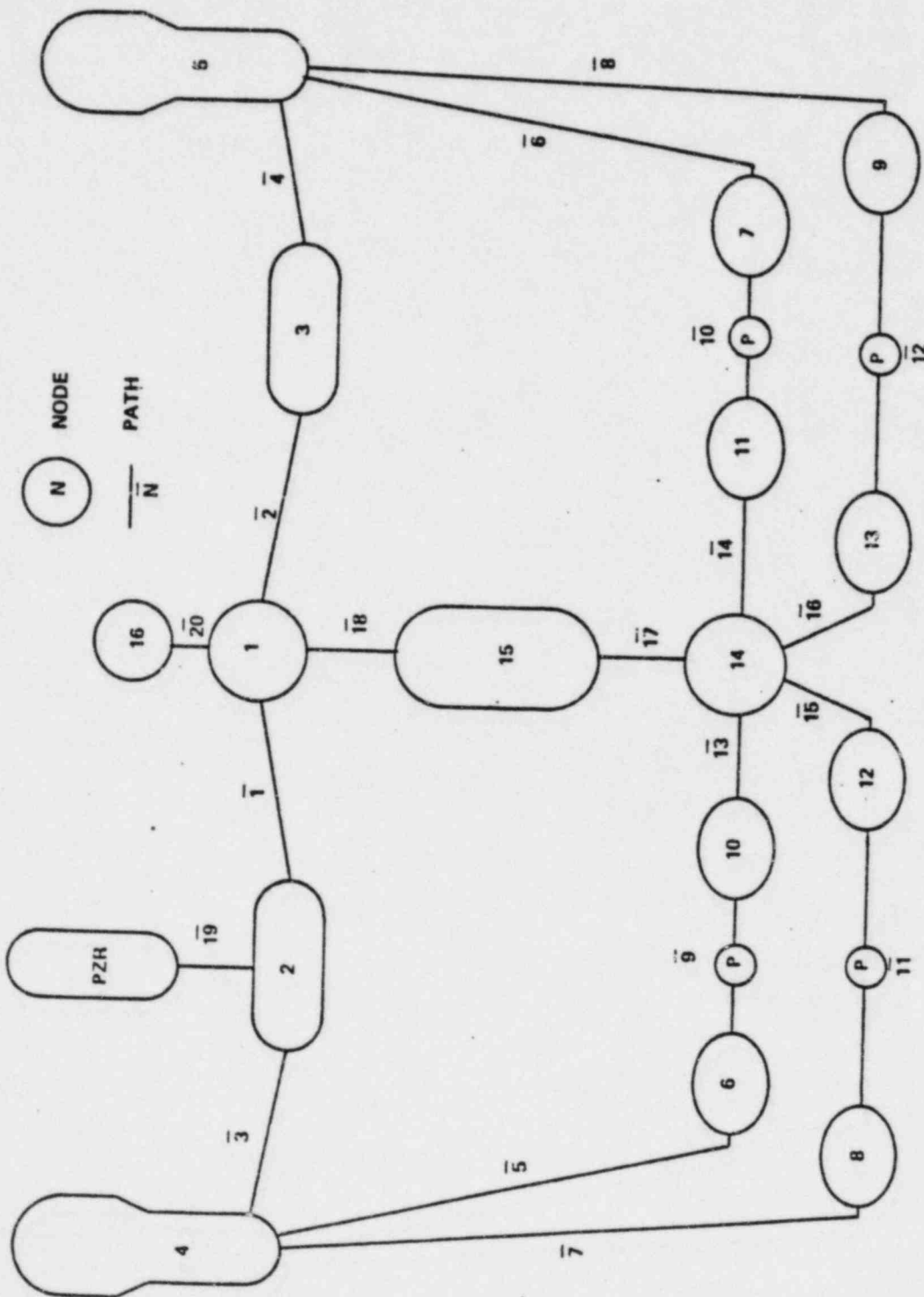
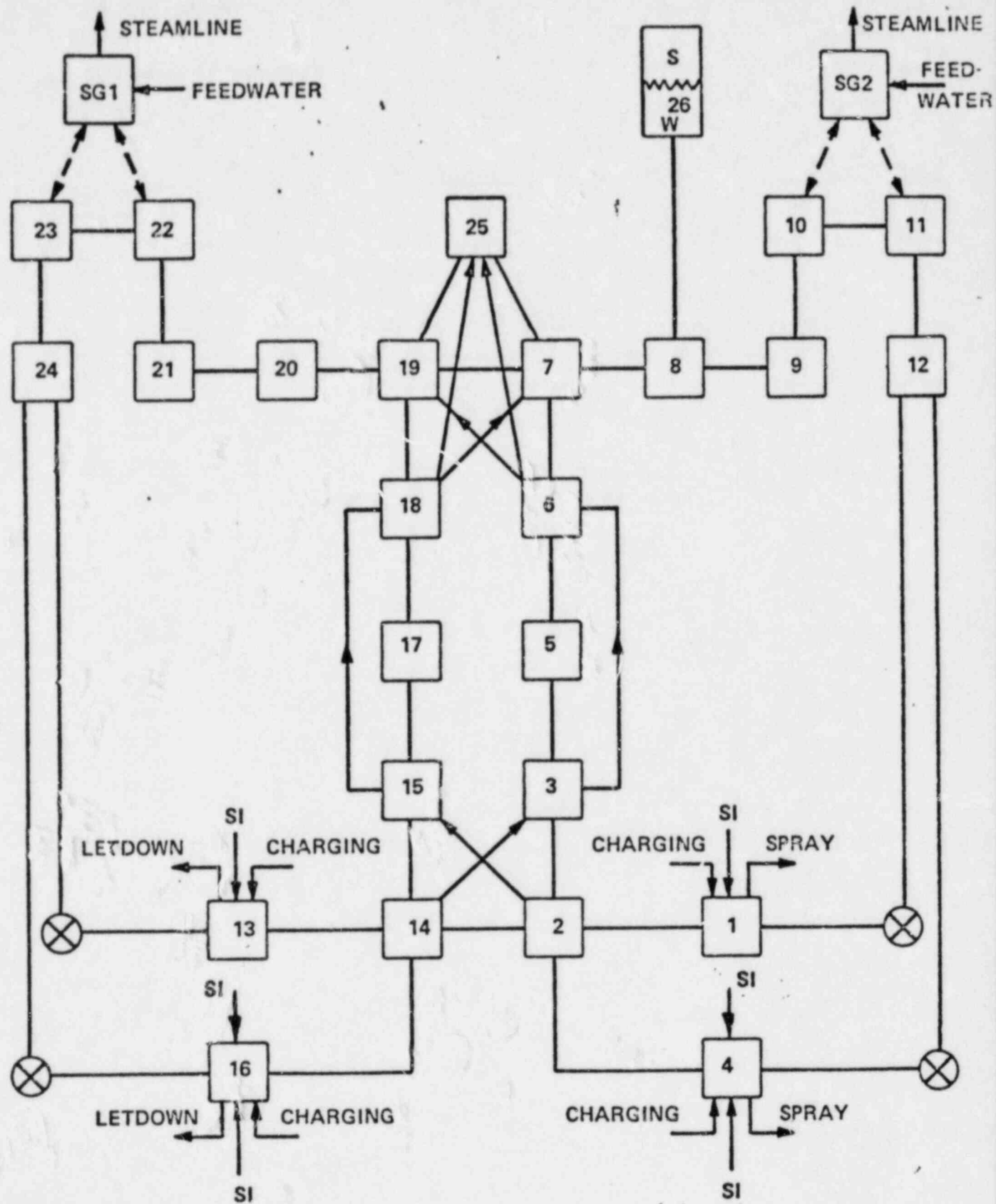

FIGURE 3-1A
LTC MODEL

FIGURE 3-1B

LTC VOLUME DESCRIPTION

<u>VOLUME</u>	
1	Upper Plenum
2	Hot Leg and SG Inlet Plenum
3	Hot Leg and SG Inlet Plenum
4	SG Tubes
5	SG Tubes
6	Pump Suction Leg (plus 1/2 pump volume)
7	Pump Suction Leg (plus 1/2 pump volume)
8	Pump Suction Leg (plus 1/2 pump volume)
9	Pump Suction Leg (plus 1/2 pump volume)
10	Pump Discharge Leg (plus 1/2 pump volume)
11	Pump Discharge Leg (plus 1/2 pump volume)
12	Pump Discharge Leg (plus 1/2 pump volume)
13	Pump Discharge Leg (plus 1/2 pump volume)
14	Downcomer and Lower Plenum
15	Core
16	Upper Head
17	Pressurizer and Surge Line



CESEC NODAL SCHEME
 FIGURE 3-2A

NODEPHYSICAL DESCRIPTION

1	COLD LEG A
2	UPSTREAM HALF OF INLET PLENUM (BEFORE FLOW MIXING)
3	DOWNSTREAM OF INLET PLENUM (AFTER FLOW MIXING)
4	COLD LEG B
5	CORE
6	UPSTREAM HALF OF OUTLET PLENUM
7	DOWNSTREAM HALF OF OUTLET PLENUM
8	HOT LEG
9	STEAM GENERATOR INLET PLENUM
10	UPSTREAM HALF OF STEAM GENERATOR TUBES
11	DOWNSTREAM HALF OF STEAM GENERATOR TUBES
12	STEAM GENERATOR OUTLET PLENUM
13	SAME AS 1 IN OTHER STEAM GENERATOR LOOP
14	SAME AS 2 IN OTHER STEAM GENERATOR LOOP
15	SAME AS 3 IN OTHER STEAM GENERATOR LOOP
16	SAME AS 4 IN OTHER STEAM GENERATOR LOOP
17	SAME AS 5 IN OTHER STEAM GENERATOR LOOP
18	SAME AS 6 IN OTHER STEAM GENERATOR LOOP
19	SAME AS 7 IN OTHER STEAM GENERATOR LOOP
20	SAME AS 8 IN OTHER STEAM GENERATOR LOOP
21	SAME AS 9 IN OTHER STEAM GENERATOR LOOP
22	SAME AS 10 IN OTHER STEAM GENERATOR LOOP
23	SAME AS 11 IN OTHER STEAM GENERATOR LOOP
24	SAME AS 12 IN OTHER STEAM GENERATOR LOOP
25	REACTOR VESSEL UPPER HEAD
26	PRESSURIZER

FIGURE 3-2B

PHYSICAL DESCRIPTION OF NODES

4.0 SUMMARY

The information presented in this report has addressed the issues identified in Section 1.2. The conclusions from this effort are:

1. Voiding in the reactor vessel upper head region is not expected for normal operational transients.
2. Voiding in the reactor vessel upper head region may occur during natural circulation cooldowns. A rapid enough depressurization can result in the reactor vessel upper head region fluid temperature reaching saturation. Additionally, during an asymmetric natural circulation cooldown voids may be formed in the isolated steam generator loop if the flow in that loop is stagnant and the RCS is depressurized below the isolated generator saturation temperature/pressure.

Voiding under any of these circumstances can be prevented by:

- a. Allowing sufficient time for the fluid in the reactor vessel upper head to cool prior to depressurizing the RCS,
 - b. Conducting non-symmetric cooldowns in a controlled manner so as to cool down the isolated steam generator before aligning shutdown cooling.
3. Voiding in the reactor vessel upper head region will likely occur for depressurization events such as a double-ended break of a steam line and a double-ended break of a steam generator tube. However, the SAR analyses performed indicate that voiding is not extensive enough to uncover the reactor vessel hot legs. Additionally, voiding will not result in violation of the SRP requirements for these transients for all C-E plants.
 4. The consequences of non-uniform mixing in the reactor vessel upper head are of secondary nature when compared to the consequences from not explicitly modelling the reactor vessel upper head region.
 5. Hot spots have negligible effect on plant parameters and, more importantly, transient consequences.

Additionally, the evaluation concludes that any potential void formation during the transients addressed is not great enough to impair reactor coolant circulation or core coolability.

As a final remark, it can be stated that C-E's emergency procedure guidelines adequately address the potential voiding situations by stating that additional time is required to conduct controlled natural circulation cooldowns to prevent reactor vessel upper head voiding or stagnated loop voiding for non-symmetric cooldowns. If voids are present, the guidelines provide very specific operator guidance for dealing with voids and mitigating their consequences.

5.0 REFERENCES

1. NUREG-0737, "Clarification of TMI Action Plan Requirements", October, 1980.
2. CEN-152, "Combustion Engineering Emergency Procedure Guidelines", June, 1980.
3. Letter from R. W. Reid, NRC, to Licensees of B&W Plants, "Concern for Voiding During Transients of B&W Plants", January, 1980.
4. CEN-128, "Response of Combustion Engineering Nuclear Steam Supply System to Transients and Accidents", May, 1980.
5. LD-82-001 (dated 1/6/82), "CESEC Digital Simulation of a Combustion Engineering Nuclear Steam Supply System", December, 1981.
6. INPO 2/NSAC 16, "Analysis and Evaluation of St. Lucie Unit 1 Natural Circulation Cooldown", December, 1980.
7. "The Operator's Role and Safety Functions", W. R. Corcoran et al, Atomic Industrial Forum, March 9-12, 1980.

APPENDIX A

Typical

C-E Emergency Procedure Guidelines

Related to RCS Voiding

A.1 General Guidelines During Depressurization

Actions

1. During the RCS depressurization, monitor for void formation. Indications of possibilities of voids are:
 - a) A pressurizer level increase significantly greater than expected while operating auxiliary spray.
 - b) A pressurizer level decrease while operating charging.
 - c) If the PLCS is in automatic, an unanticipated letdown flow greater than charging flow.
2. If voiding of the RCS is indicated, perform the following:
 - a) Isolate letdown.
 - b) Stop the depressurization.
 - c) Stop the RCS cooldown.
 - d) Repressurize the RCS by operating pressurizer heaters or HPSI and charging pumps.
3. [If the void formation is suspected to be non-condensable gases, operate the reactor vessel head vent as necessary to eliminate the gases.]
4. When conditions permit, resume the depressurization to the shutdown cooling system (SCS) initiation pressure.

5. Depressurize the RCS to SCS initiation pressure by manually operating auxiliary spray if the following criteria are satisfied:
 - a) The RCS has been cooled to SCS initiation temperature [300°F], and
 - b) At least [20 hours] has elapsed since the start of the cooldown.

Precautions

1. During all phases of the cooldown, monitor RCS temperature and pressure to avoid exceeding a maximum cooldown rate greater than Technical Specification Limitations.
2. Evaluate condensate storage inventory. Conduct a plant cooldown and enter shutdown cooling prior to depleting condensate storage inventory. Actions for elimination of voids should only be taken if condensate inventory can sustain the extended cooldown to shutdown cooling entry conditions.

A.2 Asymmetric Cooldown

Action

1. If a steam generator is isolated, perform the following activities (listed in order of preference) to prevent voids from forming in the isolated steam generator loop:
 - a) If possible, restart one RCP in each loop to establish cooling of the isolated steam generator.
 - b) Periodically drain and refill the isolated steam generator with feedwater.

Precaution

1. If cooling down by natural circulation with an isolated steam generator, an inverted ΔT (i.e., T_c higher than T_h) may be observed in the idle loop. This is due to a small amount of reverse heat transfer in the isolated steam generator and will have no effect on natural circulation flow in the non-isolated steam generator.

COMBUSTION ENGINEERING, INC.