

PDR Bucket 99900880

return to Mr. Naidu



Weed Instrument

Temperature and Pressure Technology

January 2, 1991

K.R. Naidu
U.S. Nuclear Regulatory Commission
Mail Stop 9D4
Washington, DC 20555

Dear Mr. Naidu,

Attached, you will find a copy of correspondence that was sent per 10CFR21 instructions to "Director, USNRC". This is the same reportable condition we discussed via telephone on 12/14/90.

I felt it would be appropriate to provide you with a copy of this information. I would like to thank you for your assistance in this matter.

Sincerely,

R.M. Seibert
Quality Systems Manager

Handwritten notes:
Add: K.R. Naidu
NRR/DOEA/OGCS
-TEO9 INPO Record Ctr
RES/OSIR/EIB
1/0

9101140040 910102
PDR QA999 EMVWEED
99900880 PDR

WEED INSTRUMENT COMPANY, INC.
P.O. BOX 300 707 Jeffrey Way
Round Rock, Texas 78680-0300 512-255-7043 Telex 776492

110000



Weed Instrument

Temperature and Pressure Technology

January 2, 1991

Director
Office of Nuclear Reactor Regulation
U.S. Nuclear Regulatory Commission
Washington, DC 20555

SUBJECT: LETTER OF NOTIFICATION FOR A 10CFR21 REPORTABLE
CONDITION

To Whom It May Concern:

Following our initial contact, Weed Instrument Company, Inc. has completed its evaluation of a possible defect in pressure transmitters assembled and sold by Weed Instrument Company.

Weed Instrument Company has determined that the nuclear facilities listed on Attachment 1 were affected by this potential defect. Weed has also determined that all Weed produced NE-10 series transmitters are subject to this potential defect. (Weed's earlier letter to you was in error when it identified the transmitters as "NE-11".)

Attachment 2 is Weed Instrument's notification of the problem from Foxboro. It is our understanding that Foxboro has also notified the U.S.N.R.C. about this condition. It should be explained that Weed Instrument Company buys transmitter kits from Foxboro for assembly and resale to nuclear facilities.

The nature of the defect is best described by Attachment 2. It should be noted, however, that the model number listed on the cover page of Attachment 2 is not accurate. All models of the nuclear qualified pressure transmitter were involved, not just NE13DMIHM2. Foxboro has been made aware of this model number error and has promised to revise their letter.

Weed Instrument Company was initially contacted about this condition by telephone on 12/10/90. The letter which fully defined the possible defect was received by FAX on 12/14/90 (See Attachment 2). As of the date of this writing, the corrected copy from Foxboro has not been received. Weed Instrument Company is completing the part 21 notification procedure even though a model number inaccuracy exists in Foxboro's letter to Weed Instrument (See Attachment 2).

WEED INSTRUMENT COMPANY, INC.
P.O. Box 300 707 Jeffrey Way
Round Rock, Texas 78680-0300 512-255-7043
Telefax 512-388-4362 Telex 776492

4101100303-12 pp.

The number and locations of NE-10 series transmitters shipped from Weed Instrument Company that are affected by this potential defect are listed on Attachment 3. This list includes quantity, serial number, description and ship date on all NE-10 series transmitters which contain the possible defect.

Corrective action taken by Weed Instrument to isolate the defective units and notify customers has been completed. This corrective action consisted of a letter of notification (Attachment 4) which was mailed to effected customers on December 20, 1990. Internal procedures have been used at Weed Instrument Company to inspect and segregate defective items which are in stock. The suspected defective brackets in Weed's possession will be scrapped. Foxboro is to provide new brackets to Weed Instrument Company to replace defective units in stock and at customers'. Foxboro has promised replacements by mid January.

Advice given to purchasers is exactly what is stated in the letter of notification (Attachment 4).

It is Weed Instrument Company's desire that all actions that have taken place be clear to you. It is believed that this correspondence will satisfy the requirements of 10CFR21.21. If further documentation is needed, please contact us and we will do whatever is necessary to resolve it.

Because Weed Instrument has not been involved with previous part 21 reporting, Mr. Naidu's advice via telephone was greatly appreciated.

Sincerely,



Robert M. Seibert
Quality Systems Manager

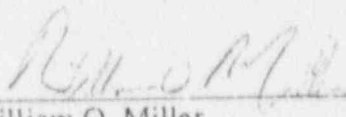

William O. Miller
President

Vice President, Nuclear Power
Consolidated Edison Company
4 Irving Place
New York, NY 10003

Charles Caputo, Technical Services Superintendent
New York Power Authority
Indian Point No. 3 Nuclear Power Plant
Entrance Gate, Broadway
Buchanan, NY 10511

Purchasing and Contracting
Florida Power Corporation
P.O. Box 219
Crystal River, FL 32629

Martin E. Albright, I&C Superintendent
New York Power Authority
Indian Point No. 3 Nuclear Power Plant
Entrance Gate, Broadway
Buchanan, NY 10511

Director of Nuclear Plant Operations
GPU Nuclear
P.O. Box 480
Route 441 South
Middletown, PA 17057

Manager, Nuclear Plant Engineering
Portland General Electric Company
121 SW Salmon Street
Portland, OR 97204
(503) 220-3299

Director of Nuclear Plant Operations
Korea Electric Power Corp.
Yongdong P.O. Box 40
167, Samsung-Dong Kangnam - GU
Seoul, Korea

Manager, Quality Assurance
Southern California Edison Company
23 Parker Street
Irvine, CA 92718
(714) 458-4782

G. S. Thomas
Vice President, Nuclear Production
New Hampshire Yankee
Seabrook Station
Box 300
Seabrook, NH 03874

Tennessee Valley Authority
Nuclear Power
Nuclear Licensing and Regulatory Affairs
ATTN: Manager, Nuclear Experience Review
LP5N156B
1101 Market Street
Chattanooga, TN 37402-2801

T. C. Feigenbaum
Vice President, Engineering and Quality Programs
New Hampshire Yankee
Seabrook Station
Box 300
Seabrook, NH 03874

M. D. Harrington
Lead Engineer - Materials
New Hampshire Yankee
Seabrook Station
Box 300
Seabrook, NH 03874

Director, Nuclear Licensing
New York Power Authority
123 Main Street
White Plains, NY 10601

Mike Peckham, Asst. to the Resident Manager
New York Power Authority
Indian Point No. 3 Nuclear Power Plant
Entrance Gate, Broadway
Buchanan, NY 10511

12/14/1990 15:37

Post-It [®] brand fax transmittal memo 7571		# of pages	11
To	Robert Seibert	From	Instrument
Co.	Weed INSTR	Co.	Instrument
Dept.		Phone #	508 549 2054
Fax #	512-328-4362	Fax #	508 549 4378

Foxboro, MA U.S.A. 02035-2090
Telephone 508-543-8750
Telex 927-602 of TRT 174090

14 December 1990

Mr. Robert Seibert
Weed Instrument
707 Jeffrey Way
Round Rock
TX 78664

Reference: Foxboro Model No. N-E13DM-IHM2
or Spare Part No. N0141FN

In compliance with 10CFR Part 21.21(a)(1) (ii), this letter is to notify you that we may have shipped you either a transmitter with an improperly processed part and/or the part itself. The subject part is Part No. N0141FN, a bracket, and is identified as number 24 in the attached Figure No. 1. The bracket is located in the transmitter topworks at the top of the force bar assembly and provides topworks static alignment and overrange protection. In August of 1989 the bracket material was changed to a 410SS, which requires a two step heat treating process, instead of a single step process, for proper material characteristics. The correct process change was not implemented until Jan.-Feb. 1990. Single step heat treatment of 410SS allows cracks to form near the bracket mounting hole and from which the cracks will continue to propagate, thus weakening the bracket. This discrepancy was discovered only very recently. Weakening brackets may cause one of the following to occur:

- a. Zero Drift and/or Span Drift in the downscale direction
- b. Static Alignment Errors Unable to Realign (DP's only)
- c. Excessive Calibration Non-linearity (>1%) Zero or Elev/Supp Ranges
- d. Inability to adjust from a Zero Based Range to a Suppressed Range Calibration (Using an Elev/Supp Bias Kit)
- e. Greater than normal Overrange Errors

Catastrophic failure of a transmitter with the faulty bracket is not expected based on output performance failure analysis.

Visual inspection will not reveal the existence of cracks because of bracket painting but different bracket finishes do identify suspected or faulty processed brackets. Unfinished/unpainted brackets and brackets with a "Gray" painted finish must be replaced. Brackets with a "Silvery" finish similar to the finish on the "Forcemotor" are correctly processed and replacement is not necessary.



Nuclear Notification
page 2

Thus, transmitter and spare part purchases of the bracket after August 1989 may contain the faulty bracket that requires replacement.

Brackets, Part No. N0141FN, with replacement instructions will be provided free of charge to all users who have the identified faulty transmitters or spare parts. If you have purchased either transmitters or spare parts from The Foxboro Company, you will find attached a listing by serial number and tag number identifying the quantity of each item purchased. This information will help you in ordering replacement parts. Please order these parts through the normal ordering procedure. If there is no attachment then our records do not indicate that you have purchased any of these items and this letter is for your information only.

Use of applicable Foxboro Master Instructions (MI's) will be required to properly align the specific transmitter after bracket installation. It is recommended that only personnel trained in Foxboro Transmitter servicing should perform bracket replacement and transmitter re-alignment. Replacement brackets 24 include screw 25 and locking nut 26 as in Figure No. 1, attached. The mounting screw 23 can be re-used for bracket replacement.

Any questions regarding this notification or these procedures, please contact:

Robert Ringland
The Foxboro Company
(508) 549-6333

Very truly yours,

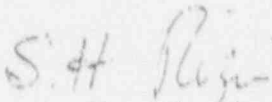

S. H. Rizvi
Manager, Corporate Quality Assurance

baa(PW013890)

Figure No. 1

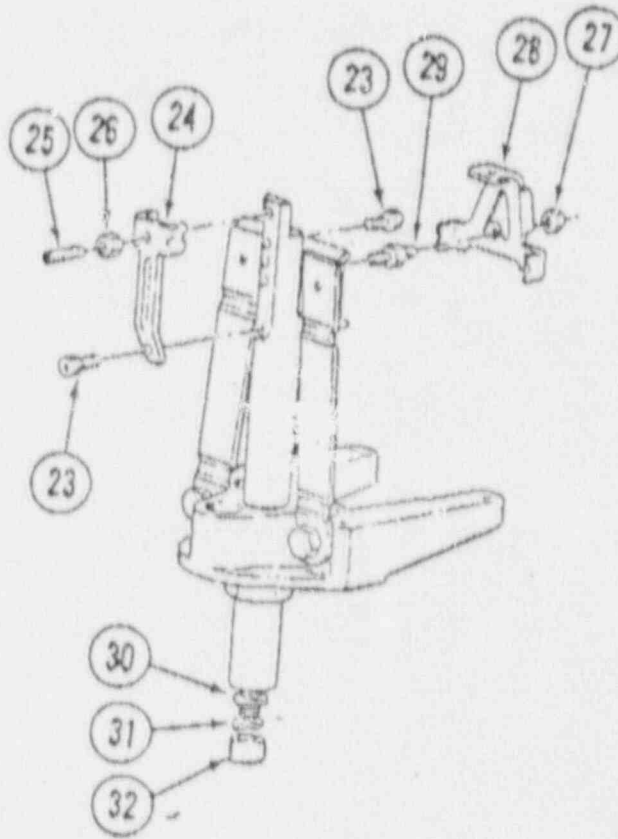

- 23 - Screw, Mounting
- 24 - Bracket, Pt. No. NO141FN
- 25 - Screw
- 26 - Nut, Locking

12/14/1990 15:44

508 5494378 P.01

Post-It™ brand fax transmittal memo 7671		# of pages •	4
To	12042 Subject	From	Herman Kline
Co	Weed Instrument	Co.	Foxboro Co.
Dept		Phone #	508-549-2325
Fax #	512-358-4302	Fax #	508-549-4330

~~AFFECTED~~ POPULATION OF FAULTY N0141FN BRK.
FOR 8/1/89 TILL PRESENT

CUSTOMER NAME SALES/ORDERS REPAIR/ORDERS TOTALS

WEED INSTRUMENT (KITS) 85

This is page 4 of the Foxboro Co Fax.

<u>CUSTOMER ADDRESS</u>	<u>S.O. #</u>	<u>P.O. #</u>	<u>QTY</u>	<u>DESCRIPTION</u>	<u>S/N</u>	<u>DATE SHIPPED</u>
Consolidated Edison Co. Indian Point No. 2 Broadway & Bleakley Ave. Buchanan, NY 10511 Attn: Bill Breckel (914) 526-5177	309473	9695982	(1)	N-E13DM-HIM2-BE	NP0000010	3/29/90
Consolidated Edison Co. Indian Point No. 2 Broadway & Bleakley Ave. Buchanan, NY 10511 Attn: Bill Breckel (914) 526-5177	309837	9696592	(2)	N-E13DM-HIM2-BE	NP0000027	4/16/90
			(2)	N-E11DM-HIB1-C-E	NP0000028 NP0000025 NP0000026	4/16/90
Florida Power Corporation P.O. Box 219 Crystal River, FL 32629 Attn: Bill Davis (904) 563-4344	310645	F740329D	(2)	N-E11GM-IIIE2-B-J-L	NPG000041 NP0000042	6/29/90
GPU Nuclear P.O. Box 480 Route 441 South Midletown, PA 17057 Attn: John C. Portz, C.P.M. (717) 948-8500	310205	TP-086001	(1)	N-E13DM-IAH2-CL	NP0000038	5/30/90
GPU Nuclear P.O. Box 430 Route 441 South Midletown PA 17057 Attn: John C. Portz, C.P.M. (717) 948-8500	310527	TP-087397	(1)	N-E13DM-IIH2-CFL	NP0000044	8/16/90
Korea Electric Power Corp. Yongdong P.O. Box 40 167, Samsong-Dong Kangnam-GU Seoul, Korea Attn: Oh Jong Kwon 011-82-2-550-3114	309914	OH892Y2103A	(1)	N-E13DM-IIH1-CFL	NP0000012	4/12/90

CUSTOMER ADDRESS	S.O. #	P.O. #	QTY	DESCRIPTION	S/N	DATE SHIPPED
New Hampshire Yankee P.O. Box 700 Seabrook, NH 03874 Attn: Peggy C. Loughton (603) 474-9521 X-3496	20947	70514	(1)	N-E13DH-IIH2-BJL	NP0000011	4/27/90
New York Power Authority 125 Main Street White Plains, NY 10601 Attn: Phil Devan (914) 681-6272	311349	S-90-00473	(4)	N-E13DL-IAL2-B	NP0000063 NP0000064 NP0000065 NP0000066	(2) 10/24/90 (2) 10/29/90
New York Power Authority P.O. Box 215 Buchanan, NY 10511 Attn: Cliff Eben (914) 736-8169	310362	90-IP-0697	(1)	N-E11DM-HIC1-BE	NP0000043	7/6/90
New York Power Authority J. A. Fitzpatrick Power Plant P.O. Box 41 Lycoming, NY 13093 Attn: Richard Lefebvre (315) 349-6065	901383	90-1482	(1)	N-E13DM-HAM2-CL (Rework) (Did we originally supply this or is it a Foxboro repair?)		8/10/90 <i>THIS UNIT WAS NOT ORIGINALLY SUPPLIED BY WEED. THIS IS A FOXBORO BUILT TRANSMITTER.</i>
Portland General Electric 121 S.W. Salmon Street Portland, OR 97204 Attn: Frieda Gulker (503) 464-8755	309946	NQ-55010	(1)	N-E13DM-IIH2-B	NP0000024	4/5/90
Southern California Edison P.O. Box 128 San Clemente, CA 92672 Attn: Margaret Cave (714) 368-8184	310081	6J020007	(2)	N-13DM-IIH2-F	NP0000039 NP0000040	5/4/90

CUSTOMER ADDRESS	S.O. #	P.O. #	QTY	DESCRIPTION	S/N	DATE SHIPPED
Tennessee Valley Authority Purchasing Dept. P.O. Box 11127 Chattanooga, TN 37401-2127 Attn: Rick Cutcher (615) 751-5823	309680	90NLC-74563B	(2)	N-E11GH-HAM2-B-G	NP0000008	3/26/90
					NP0000009	
			(4)	N-E13DL-HIL1	NP0000001	(2) 3/20/90
					NP0000002	
					NP0000031	(2) 6/7/90
					NP0000032	
			(10)	N-E13DH-HAH1	NP0000003	(5) 3/20/90
					NP0000004	
					NP0000005	
					NP0000006	
					NP0000007	
					NP0000033	(5) 5/18/90
					NP0000034	
					NP0000035	
					NP0000036	
					NP0000037	
					NP0000030	(1) 6/25/90
		NP0000029	(1) 5/22/90			
		NP0000046	7/30/90			
		NP0000047	8/7/90			
		NP0000048	7/30/90			
		NP0000049				
		NP0000050	7/30/90			
		NP0000051				
		NP0000052	8/3/90			
		NP0000053	7/30/90			
Tennessee Valley Authority Purchasing Dept. P.O. Box 11127 Chattanooga, TN 37401-2127 Attn: Frances Hannah (615) 751-5820	310246	90NLB-842578	(11)	N-E13DM-HIM1-CEK	NP0000013	6/11/90
					NP0000014	
					NP0000015	
					NP0000016	
					NP0000017	
					NP0000018	
					NP0000019	
					NP0000020	
					NP0000021	
					NP0000022	
					NP0000023	

*This is the letter
we are sending.
Will send 12-20-90.
Let me know if
you have any
comments.*

ML

December 19, 1990

RE: Weed Model N-E11 & N-E13 Pressure/DP Transmitters
10CFR21 Notification

Dear :

In compliance with the requirements of NRC 10CFR21, this letter provides notification that Weed Instrument may have supplied you with an improperly processed part. The component is a bracket (P/N N0141FN), located in the transmitter's topworks and attached to the force bar assembly (see Figure No. 1, attached).

Weed Instrument was notified by Foxboro Company (see the attached letter, dated 12-14-90) and has determined that the brackets which we received from Foxboro were provided to our customers since October of 1989. Weed Instrument has not experienced any problems during manufacturing/tests of the transmitters due to bracket N0141FN. Also, we have not experienced any field problems or customer complaints, of any kind, regarding our transmitter's performance.

No instrument failure due to the bracket is expected, but we do agree with Foxboro Company that a weak bracket could lead to calibration drift in the downscale direction, calibration non-linearity, overrange errors, and/or suppressed range calibration problems. The bracket interacts with the static alignment, overrange protection, and transfers the movement of the force bar to the force balance motor.

Weed Instrument will supply replacement parts with instructions at no charge to affected customers and will repair any transmitters manufactured by Weed Instrument, to date, at no cost. We will be contacting each of you to ensure that our customer's requirements are met. You will be kept up to date as we receive further information.

There will be a very small impact on scheduled shipments, since we will not have the correctly processed part available until late January 1991. A list of any equipment supplied to you by Weed Instrument is attached for your reference.

Page 2

If there are any further questions or clarifications required, please contact:

Ricky Gotcher
Nuclear Program Director
Weed Instrument Company, Inc.
707 Jeffrey Way
Round Rock, TX 78664
Ph. (512) 244-3939
Fax (512) 244-0566

Sorry for any inconveniences this matter may have created, and as always, Weed Instrument will strive to supply you with the most reliable nuclear qualified instruments available. Thanks for your consideration in advance.

Sincerely,

Ricky Gotcher
Nuclear Program Director
WEED INSTRUMENT CO., INC.

RG/mdl/189N