

NUREG/CR-5659
SAIC-90/1054

Control Room Habitability System Review Models

Prepared by
H. Gilpin

Science Applications International Corporation

Prepared for
U.S. Nuclear Regulatory Commission

9101040268 901231
PDR NUREG
CR-5659 R PDR

AVAILABILITY NOTICE

Availability of Reference Materials Cited in NRC Publications

Most documents cited in NRC publications will be available from one of the following sources:

1. The NRC Public Document Room, 2120 L Street, NW, Lower Level, Washington, DC 20555
2. The Superintendent of Documents, U.S. Government Printing Office, P.O. Box 37082, Washington, DC 20013-7082
3. The National Technical Information Service, Springfield, VA 22161

Although the listing that follows represents the majority of documents cited in NRC publications, it is not intended to be exhaustive.

Referenced documents available for inspection and copying for a fee from the NRC Public Document Room include NRC correspondence and internal NRC memoranda; NRC Office of Inspection and Enforcement bulletins, circulars, information notices, inspection and investigation notices; Licensee Event Reports; vendor reports and correspondence; Commission papers; and applicant and licensee documents and correspondence.

The following documents in the NUREG series are available for purchase from the GPO Sales Program: formal NRC staff and contractor reports, NRC-sponsored conference proceedings, and NRC booklets and brochures. Also available are Regulatory Guides, NRC regulations in the *Code of Federal Regulations*, and *Nuclear Regulatory Commission Issuances*.

Documents available from the National Technical Information Service include NUREG series reports and technical reports prepared by other federal agencies and reports prepared by the Atomic Energy Commission, forerunner agency to the Nuclear Regulatory Commission.

Documents available from public and special technical libraries include all open literature items, such as books, journal and periodical articles, and transactions. *Federal Register* notices, federal and state legislation, and congressional reports can usually be obtained from these libraries.

Documents such as theses, dissertations, foreign reports and translations, and non-NRC conference proceedings are available for purchase from the organization sponsoring the publication cited.

Single copies of NRC draft reports are available free, to the extent of supply, upon written request to the Office of Information Resources Management, Distribution Section, U.S. Nuclear Regulatory Commission, Washington, DC 20555.

Copies of industry code and standards used in a substantive manner in the NRC regulatory process are maintained at the NRC Library, 7920 Norfolk Avenue, Bethesda, Maryland, and are available there for reference use by the public. Codes and standards are usually copyrighted and may be purchased from the originating organization or, if they are American National Standards, from the American National Standards Institute, 1430 Broadway, New York, NY 10018.

DISCLAIMER NOTICE

This report was prepared as an account of work sponsored by an agency of the United States Government. Neither the United States Government nor any agency thereof, or any of their employees, makes any warranty, expressed or implied, or assumes any legal liability of responsibility for any third party's use, or the results of such use, of any information, apparatus, product or process disclosed in this report, or represents that its use by such third party would not infringe privately owned rights.

NUREG/CR-5659
SAIC-90/1054
1A, 1B

Control Room Habitability System Review Models

Manuscript Completed: November 1990
Date Published: December 1990

Prepared by
H. Gilpin

Science Applications International Corporation
1710 Goodridge Drive
McLean, VA 22102

Prepared for
Division of Safety Issue Resolution
Office of Nuclear Regulatory Research
U.S. Nuclear Regulatory Commission
Washington, DC 20555
NRC FIN D2096

ABSTRACT

This report provides a method of calculating control room operator doses from postulated reactor accidents and chemical spills as part of the resolution of TMI Action Plan III.D.3.4. The computer codes contained in this report use source concentrations calculated by either TACT5, FPPF, or EXTRAN, and transport them via user-defined flow rates to the control room envelope. The codes compute doses to six organs from up to 150 radionuclides (or 1 toxic chemical) for time steps as short as one second. Supporting codes written in Clipper assist in data entry and manipulation, and graphically display the results of the FORTRAN calculations.

TABLE OF CONTENTS

<u>Section</u>	<u>Page</u>
ABSTRACT	iii
LIST OF FIGURES.	vii
PREFACE.	ix
1. INTRODUCTION	1
2. METHODOLOGY.	2
2.1 Source Term Quantification.	2
2.2 Transport to Control Envelope Room Boundary	2
2.3 Control Room Habitability System Effectiveness.	3
2.4 Mathematical Treatment.	5
3. DISCUSSION OF CODES.	8
3.1 CRH	11
3.2 CONHAB.	14
3.3 CHEM.	16
3.4 CRHPLOTR and CRHPLOTG	16
3.5 Data Files.	16
4. USERS GUIDE TO THE COMPUTER CODES.	19
4.1 Radiological Evaluation	19
4.1.1 Executing the CRH Code	20
4.1.2 Executing the CONHAB Code.	40
4.1.3 Executing the CRHPLOTR Code.	42
4.2 Toxic Gas Evaluation.	42
5. CODE INSTALLATION.	44
6. EXAMPLE PROBLEM.	45
7. REFERENCES	47

TABLE OF CONTENTS (Continued)

Appendix

A	CRH CODE LISTING	A-1
B	CONHAB CODE LISTING	B-1
C	CHEM CODE LISTING	C-1
D	CRHPLOTR CODE LISTING	D-1
E	CRHPLOTG CODE LISTING	E-1
F	NUCLIDE LIBRARY ICRP.02	F-1
G	NUCLIDE LIBRARY ICRP.30	G-1
H	DATABASE FILE STRUCTURES	H-1
I	SAMPLE OUTPUT FROM CONHAB	I-1
J	SAMPLE OUTPUT FROM CHEM	J-1

LIST OF FIGURES

	<u>Page</u>
Figure 1 - Control Room Habitability System Model	4
Figure 2 - Radiological Analysis Flowchart.	9
Figure 3 - Toxic Chemical Analysis Flowchart.	10
Figure 4 - CRH Block Diagram.	12
Figure 5 - CONHAB Program Flow.	15
Figures 6 through 22 - Screen Printouts from CRH Code	

PREFACE

Under NRC contract number NRC-03-87-029, Science Applications International Corporation (SAIC) has been tasked to 'develop bases for proposed review procedures and acceptance criteria, with supporting documentation, sufficient to permit revision of the Standard Review Plan in such a manner as to correct all known objections to the current CRHS review.' This report provides a method of calculating control room operator doses from postulated reactor accidents and chemical spills as part of the resolution of TMI Action Plan III.D.3.4. The computer codes contained in this report use source concentrations calculated by either TACT5, FPPF, or EXTRAN, and transport them via user defined flow rates to the control room envelope. The codes compute doses to six organs from up to 150 radionuclides (or 1 toxic chemical) for time steps as short as one second. Supporting codes written in Clipper assist in data entry and manipulation, and graphically display the results of the FORTRAN calculations.

1. INTRODUCTION

General Design Criterion (GDC) 19 requires that every plant have a control room that is protected from "accident conditions, including loss-of-coolant accidents." To determine whether or not an applicant's plant complies with GDC 19, the NRC staff performs an assessment of the plant's control room habitability system (CRHS) using Section 6.4 of the Standard Review Plan (SRP) "Control Room Habitability System." Control room protection is the subject of TMI Action Plan III.D.3.4, "Control Room."

Concerns have been raised by the NRC staff. The concerns may be divided into four components using a systems approach: (a) the challenges to control room habitability, (b) the effectiveness of design features of control room habitability systems and the guidance for their review, (c) the means of assuring adequate testing and maintenance of the CRHS, and (d) the estimation of accident consequences to the control room occupants to be used in implementing GDC 19. This report will address components (b) and (d) by providing a computer based model of the CRHS, and, using source insults calculated by the Fission Product Flow Path code, TACT5, and EXTRAN, by computing doses or exposures to control room occupants from radionuclides or toxic gases.

The new model represents an attempt to provide a more realistic evaluation of control room protection than the steady-state Murphy-Campe model (reference 1) used by the NRC in past control room habitability evaluations. The steady-state model is believed to be more conservative in most cases than a time dependent model. The new model also incorporates an improved, more realistic meteorological dispersion calculation based on recent work by Ramsdell (references 5,6, and 7). The new, time based dispersion calculation correlates well with existing experimental data, and is generally less conservative than the traditional Gaussian plume calculation (reference 7).

2. METHODOLOGY

The proposed model can be broken into three subsections; source term quantification, transport to the control room envelope, and CRHS effectiveness.

2.1 SOURCE TERM QUANTIFICATION

The source term for control room habitability analysis can be broken into two classes, radiological and chemical. Obviously, radiological sources would be used in calculating doses to the control room occupants from postulated reactor accidents, and chemical sources would be used to evaluate toxic gas exposure due to onsite or offsite chemical spills or releases.

The radiological source proposed for use is the standard "TID 14844" source term, which is based upon direct ratios of reactor power levels to determine core radionuclide concentrations. Standard Regulatory Guide 1.3 and 1.4 assumptions are used to determine chemical form, plate out factors, and release fractions. As new source term information from ongoing research becomes available, the model can be easily updated.

2.2 TRANSPORT TO CONTROL ROOM ENVELOPE BOUNDARY

The transport of the source term to the control room boundary can occur either through the plant; for example, ducts, rooms, and penetrations; or through the atmosphere from the point of release to the point of entry into the control room boundary, for example, containment leakage or stack releases. For radiological calculations, the Fission Product Flow Path (FPFP) code (reference 3) is used to calculate through-plant transport of radionuclides, and TACT5 (reference 4) is used to calculate transport of radionuclides up to the point of release to the atmosphere. The CONHAB code discussed later incorporates the dispersion calculation required to calculate the concentrations at the air intakes. For toxic chemical calculations, the

EXTRAN code will transport vapors from the point of release to the control room air intake.

The use of these codes is discussed in the respective references, and will not be discussed here, other than how they interface with the new model.

2.3 CONTROL ROOM HABITABILITY SYSTEM EFFECTIVENESS

It is believed that most existing control room habitability systems can be modeled by a combination of one or more of the following systems:

- 1) Control room pressurization by filtered outside air can be used to reduce the ingress of contaminated air.
- 2) The control room air can be recirculated through filters to remove contamination already in the control room volume.
- 3) Multiple widely separated air intakes can be monitored, and air from the least contaminated used to ventilate the control room.
- 4) Compressed air can be used to either pressurize the control room, or through breathing masks, supply uncontaminated air to the occupants.
- 5) The control room can be sealed to minimize the entrance of contaminants.

Any combination of these at any given time can be modeled by the diagram presented in Figure 1. Note that Figure 1 provides for four separate pathways into the control room volume, two through control room air intakes which presumably take air from the atmosphere, and two 'user defined' pathways which can model other modes of ingress such as adjoining rooms, penetrations, swinging doors, etc. For radiological calculations, the proposed model will use a TACT5 calculated source to one or both air intakes, and an FPPF source to one or both of the 'user defined' sources. For toxic chemical

Figure 1
Control Room Habitability System Model

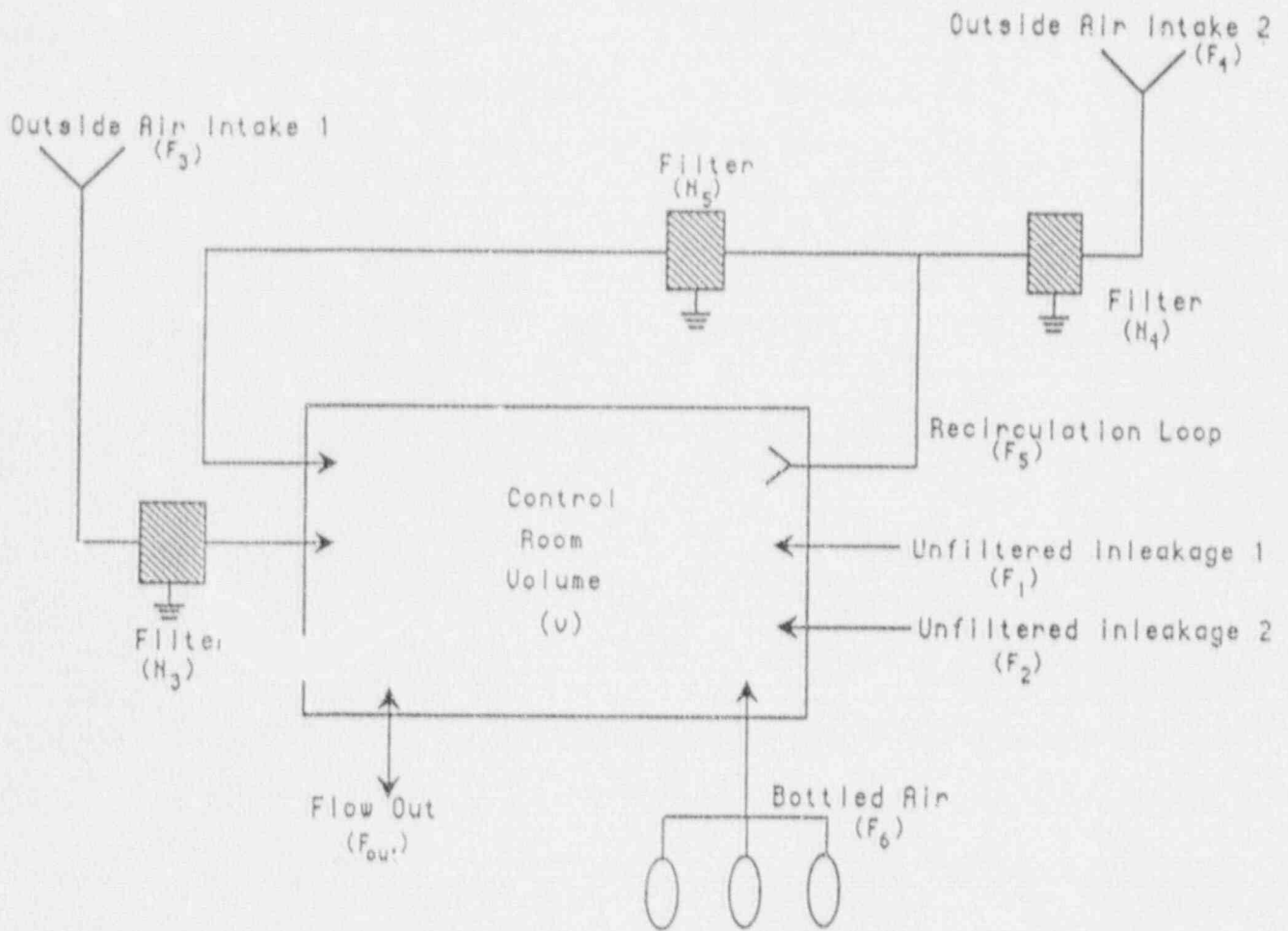

calculations, the model will use a source calculated by EXTRAN to any or all of the four pathways.

Most, if not all, plants realign their system from a 'normal' ventilation mode to an 'accident' mode either automatically or manually through procedure in the event of an accident. Realignments can also occur throughout the course of the accident. Therefore, the parameters appearing in Figure 1 could change at any time during the thirty day period of interest. Additionally, it is anticipated that the source term at the control room boundary will change over the course of the accident. The dose calculation is therefore broken into time steps, the beginning and ending times being determined by the time at which any of the modeled parameters change.

2.4 MATHEMATICAL TREATMENT

For each time interval, the control room air concentration for each contaminant is determined as follows:

Let $A(t)$ represent the activity of a particular nuclide (in curies) at time t in the control room.

Then the rate at which the activity of this nuclide changes is given as

$$\frac{dA(t)}{dt} = (\text{rate of nuclide entering}) - (\text{rate of nuclide leaving})$$

Referring to Figure 1, let C_n represent the concentration (Ci/m^3) at source n , F_n the flow rate (m^3/s) from source n to the control room, and N_n the filter efficiency of filter n for the nuclide in question, then the rate entering the control room from the plant and environment becomes:

$$R_{in} = C_1 F_1 + C_2 F_2 + C_3 F_3 (1 - N_3) + C_4 F_4 (1 - N_4) (1 - N_5)$$

From Figure 1, it is obvious that the flow out of the control room is given as (by conservation of mass):

$$F_{out} = F_1 + F_2 + F_3 + F_4 + F_6$$

Then the rate of activity leaving the control room is given as:

$$R_{out} = F_{out} \frac{A(t)}{V} + F_5 N_5 \frac{A(t)}{V}$$

where V is the volume of the control room (m^3). The second half of this equation represents removal by a recirculation loop filter.

Thus the original equation becomes:

$$\frac{dA(t)}{dt} = R_{in} - A(t) \frac{(F_{out} + F_5 N_5)}{V}$$

Using the integrating factor $e^{t(F_{out} + F_5 N_5)/V}$ and solving yields

$$A(t) = \frac{V}{(F_{out} + F_5 N_5)} R_{in} + c e^{-t(F_{out} + F_5 N_5)/V}$$

Subjecting to the initial condition $A(0) = 0$ gives

$$A(t) = \frac{V}{(F_{out} + F_5 N_5)} R_{in} - \frac{V}{(F_{out} + F_5 N_5)} R_{in} e^{-t(F_{out} + F_5 N_5)/V}$$

which represents the activity in curies in the control room at time 't' for any nuclide of interest. The dose to a person in the control room from this nuclide is computed by multiplying the concentration in the control room by a dose conversion factor and a delta t in seconds, and a breathing rate if other than whole body or skin dose. Each of these doses is then reduced by an occupancy factor, to account for the fact that one individual will not remain in the control room for the entire 30 days, and a geometry factor, if appropriate. The geometry factor is taken from Murphy-Campe as $1173./(V^{.338})$, and represents an attempt to correct for a finite rather than

semi-infinite cloud of gamma emitters, upon which the dose conversion factors are based. Note that radioactive decay and daughter product build-up were not included up to this point in the calculation.

At the end of each time step, the concentrations at each of the four sources and in the control room are decayed, and daughter products added back in. Only the daughter with the largest production factor is used in the calculation. For example, if a nuclide can decay to two or more daughters, only the most probable daughter is used. The total dose to an individual is obtained by summing the dose contributions from each nuclide and each time step.

For a toxic gas analysis, the same formulation above holds, except that there is no decay or geometry factor correction.

3. DISCUSSION OF CODES

Figure 2 represents the flow of information from start to finish for the evaluation of radiological exposure. Figure 3 represents the information flow for toxic chemical exposure evaluation. The description and use of FPPF, TACT5, and EXTRAN is left to the respective users manuals (references 3-5). All three have been modified to produce an output file which can be read by either CONHAB or CHEM.

A detailed tour through each step is described in section 4, the users guide. Basically, to perform a radiological dose calculation, the following steps are performed:

- 1) Review FSAR, SER, and licensee submittals to identify all pathways of radionuclides from the source to the control room boundary.

- 2) For those pathways which involve transport through the building or buildings (not through the atmosphere), run FPPF. Two pathways at a time can be modeled by CONHAB. If there are more than two, perform multiple runs and sum the results of CONHAB.

- 3) For pathways which involve transport through the atmosphere to a control room air intake, run TACT5. Note that it is not necessary to input meteorological information into TACT5 as CONHAB incorporates its own model.

- 4) Examine licensee submittals and FSAR to determine configurations and flow rates for the control room habitability system being evaluated. Run CRH and build the CRHS model.

- 5) From the CRH main menu, select 'Set up for calculation' option and designate the datafiles created in steps 2 through 4. Exit from CRH.

FIGURE 2
RADIOLOGICAL ANALYSIS FLOWCHART

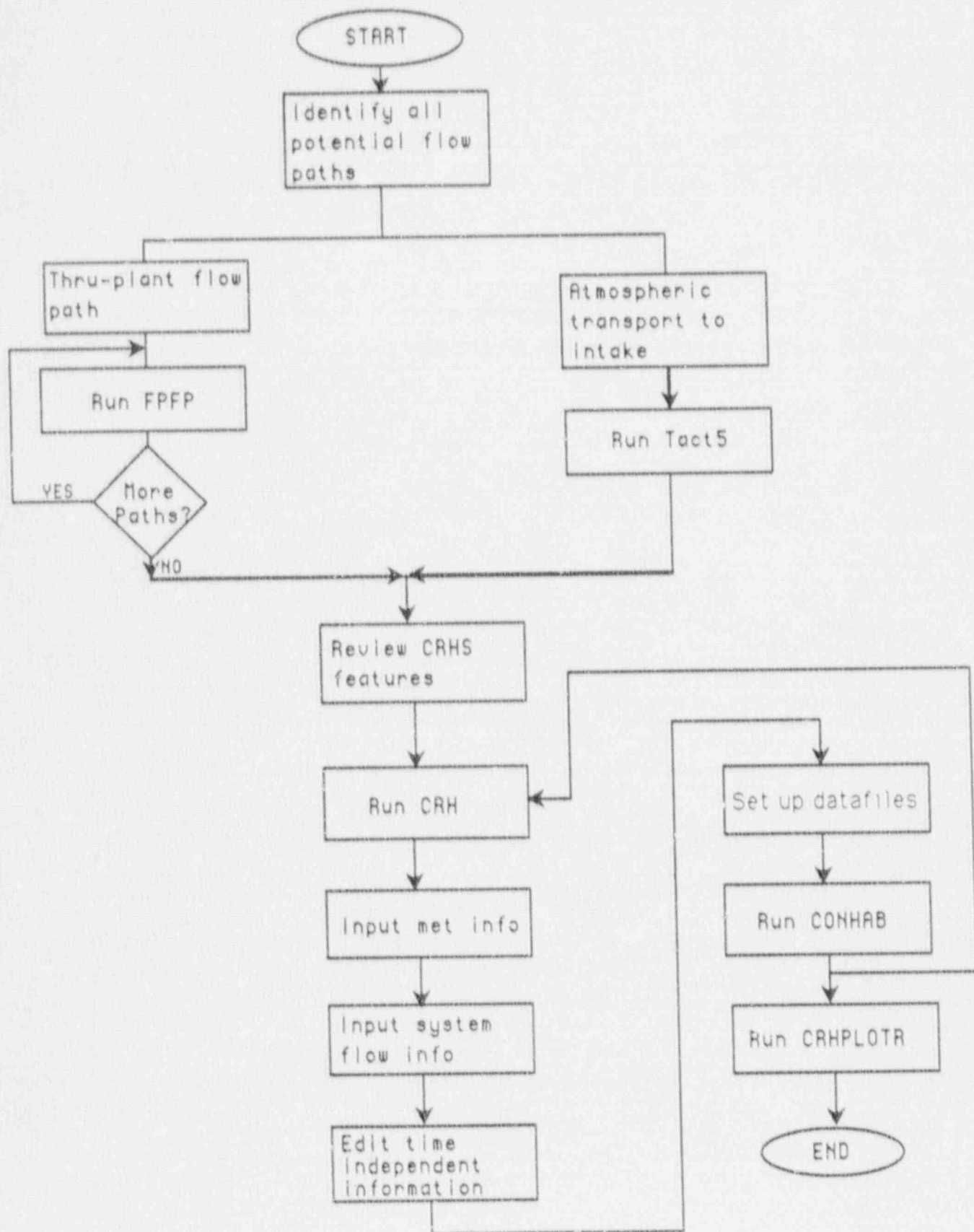
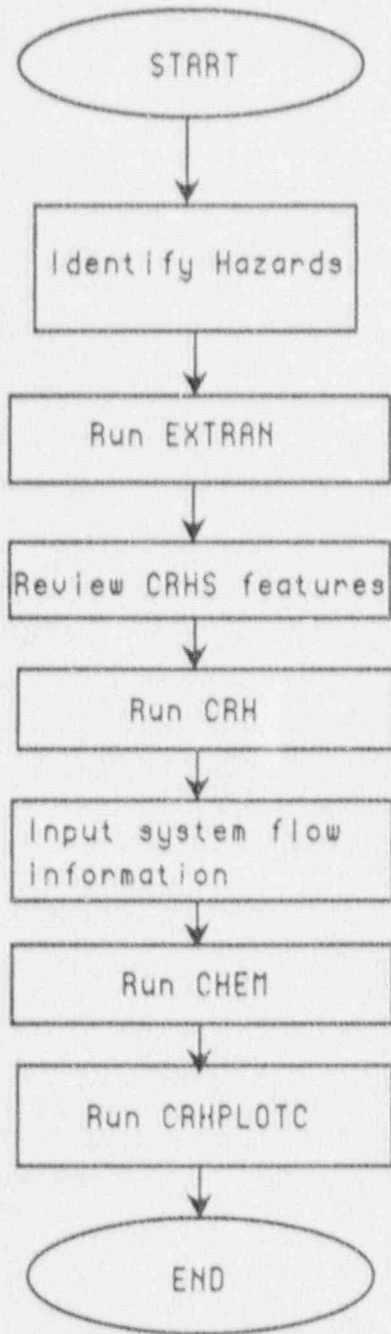

FIGURE 3
TOXIC CHEMICAL ANALYSIS FLOWCHART



6) Run CONHAB to perform dose calculations.

7) If desired, run CRHPLOTR to plot results.

To perform a toxic gas analysis, run EXTRAN instead of FPPF and TACT5, CHEM instead of CONHAB, and CRHPLOTG instead of CRHPLOTR to plot the results. Figure 3 provides a flow chart for performing a toxic gas analysis.

The description of CRH, CONHAB, CHEM, CRHPLOTR and CRHPLOTG follows.

3.1 CRH

The CRH code is a pop-up menu driven program designed to aid in inputting meteorological and system flow data. It also contains a full screen editor for making modifications to data files, assists in managing the datafiles required by CONHAB and CHEM to perform an evaluation, and has context sensitive unit conversion for all parameters (CONHAB and CHEM use predominantly MKS units, the Rem and Curie being the two exceptions). The program itself is written in CLIPPER, a pseudo dBase III compiler, to take advantage of its database functions and editing features. Figure 4 is a block diagram of the CRH code. A program listing is provided in Appendix A.

The primary function of CRH is to allow input of CRHS parameters and meteorological parameters for subsequent use by the CONHAB or CHEM codes. There are five basic 'screens' utilized for data input. All five are discussed in detail in Section 4. Each screen will carry forward information from time step to time step, so that only information that changes will need to be entered. The first screen is the meteorological data input screen. As with all of the input screens, full screen editing is permitted. That is, it is possible to move the cursor around the screen to enter, change, or correct values before they are written to disk. Specifics on cursor movement and data entry are discussed in Section 4.

CRH BLOCK DIAGRAM

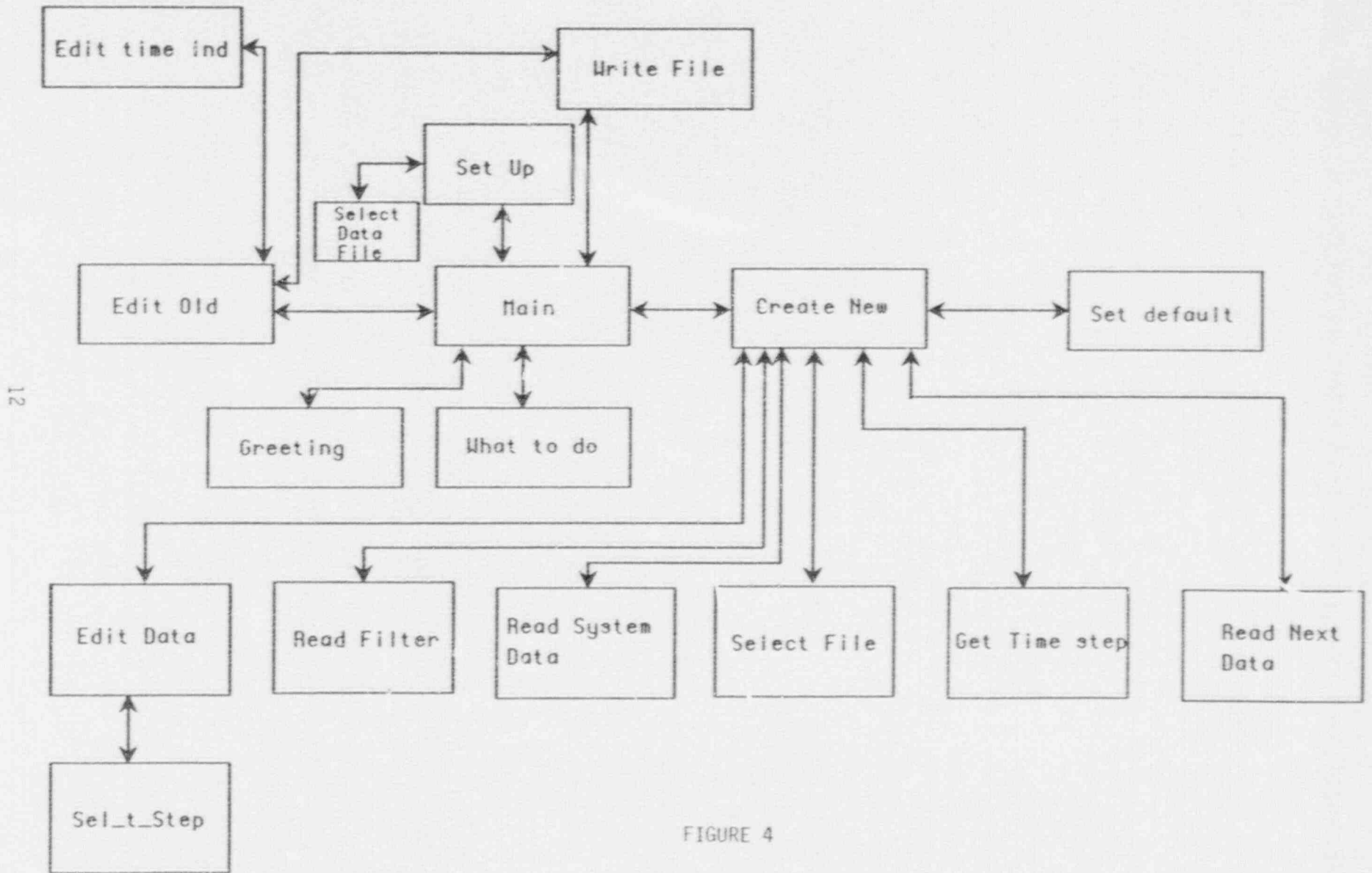

12

FIGURE 4

The next two screens present a graphical representation of the CRHS similar to that shown in Figure 1. The first of these two accepts flow rate and control room volume information. The second accepts filter efficiency data.

The fourth data screen is the edit screen. It lists all data from the previous three screens for each time step and allows full screen editing. This screen may also be used for data input by selecting 'Tabular' rather than 'Graphical' input screens when prompted.

The fifth input screen allows editing of time independent variables such as power level and chemical form fraction. It is accessed from the edit option.

A secondary function of CRH is the assemblage of all data files in preparation for running CONHAB. CONHAB requires six data files as input. CRH will prompt for the selection of filenames for each of these according to a predetermined file naming convention (template). The user is not required to adhere to the naming convention set up in CRH, but for simplicity, it is recommended. Unless specifically changed by the user, the data files will all conform to the following conventions:

System flow data file (created by CRH)	*.DAT
Nuclide data file	ICRP.*
FPPF source term data file (2 req.)	CRHFPPF*.OUT
TACT5 source term data file (2 req.)	CRHTACT*.DAT
Time independent data (power, form frac)	TIMEIND.DAT

CRH creates a separate file named CRHSYS.DAT which contains the names of the selected data files. CONHAB reads this file to determine which data files to use in the calculation.

3.2 CONHAB

The CONHAB code is the calculational program for computing estimated doses due to radiological releases. It reads the file CRHSYS.DAT which is created by CRH, and subsequently opens the files listed for input. It computes control room concentration and associated doses to six organs from up to 122 nuclides, each capable of being modeled as three chemical forms (elemental, organic and particulate), from up to four sources, and 2.6 million time steps (the number of seconds in a month). The code reports dose at each time step and on the hour for the first day, and then at each time step and every 24 hours for 30 days. Each report produces an output file used to plot dose vs. time via the CRHPLOTR program. Figure 5 is a simplified flow chart of the CONHAB program. A FORTRAN listing of the code can be found in Appendix B.

The model incorporated in CONHAB is discussed in the Methodology section above. Radionuclides are introduced as a concentration (Ci/m^3) at up to four intake points, and based on the CRHS alignment as set up by the program CRH, transported to the control room volume. The concentrations at each of the four source locations are updated according to the schedule in the associated datafile. The source concentrations are assumed constant over any time intervals between those set in the source data file. That is, the source concentrations are not reduced as radionuclides are removed to the CRHS. This assumption becomes more conservative as the source volume decreases or the flow rate from the source volume increases. Radioactive decay and daughter product build-up are accounted for at all source locations and the control room. Filtration and dilution are the only other removal mechanisms considered. Deposition and resuspension are not modeled.

For ease of computation, radionuclides are decayed at the end of each time step, rather than integrated over the time step. This assumption is conservative as the maximum concentration of radionuclides present over a particular time step is used in the dose calculation (ie no reduction in quantity by decay before the end of the time step). Note also that radioactive decay is generally small in comparison to other removal processes

CONHAB PROGRAM FLOW

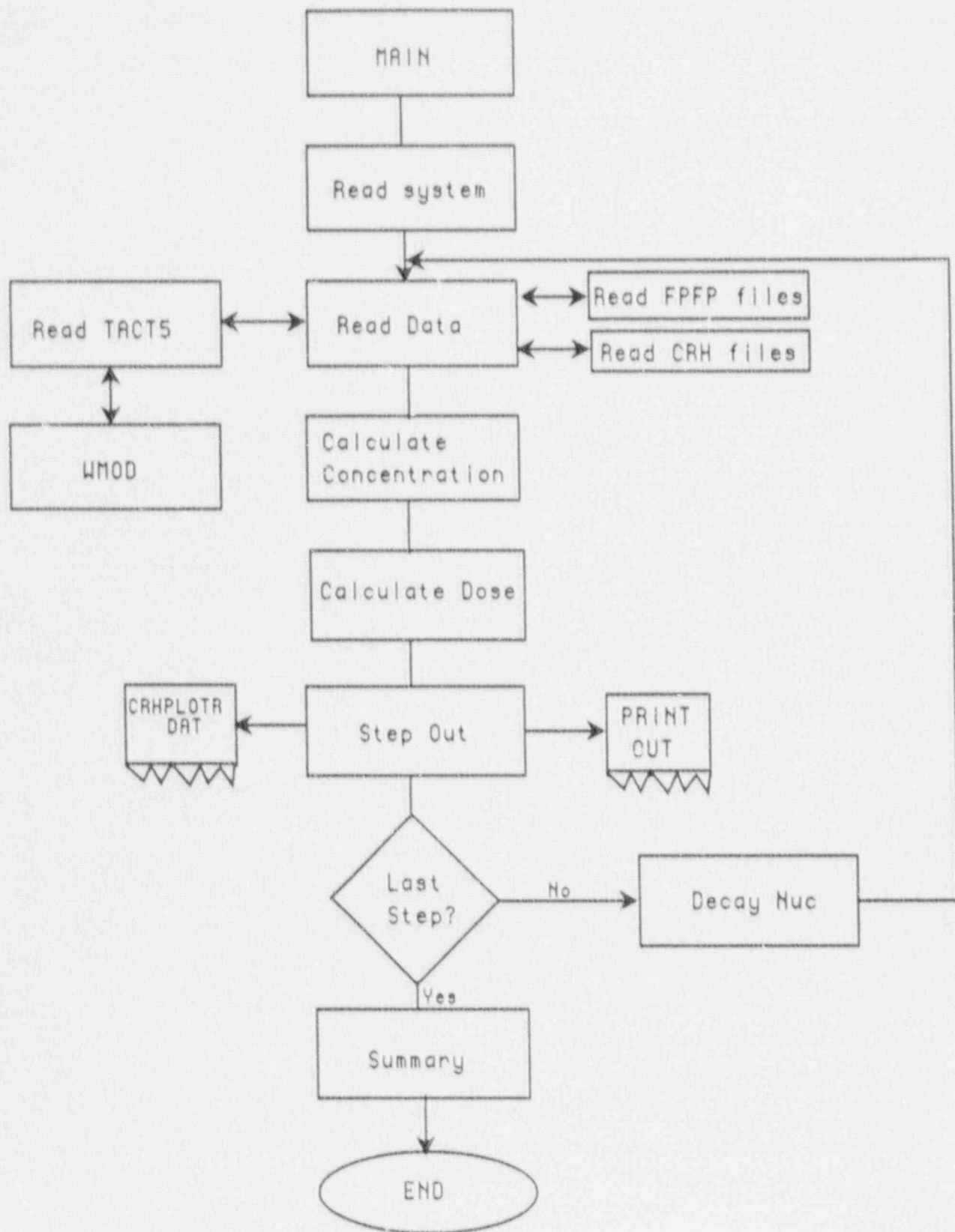

FIGURE 5

in the control room especially if using the TID source term, which contains only relatively long lived radionuclides. Daughter product build-up is a small contributor which somewhat lessens this conservatism.

3.3 CHEM

The CHEM code is the equivalent of CONHAB, only it is used for evaluation of toxic gas concentrations rather than radionuclides. The mathematical model incorporated into the code is identical to that in CONHAB. The only removal process modeled, however, is dilution. The code reads an output file generated by the EXTRAN code (reference 5), and applies this source to each of the four potential entry points to the control room. Since the recirculation loop and all the filters are ineffective in reducing the toxic gas concentration, each of the four entry points are treated identically. Fresh air intake is modeled by using bottled air. The code transports gas into the control room as set up by the CRH code, and reports concentrations, mean concentrations, and exposure at each time step. A data file is generated which can be used by the CRHPLOT program to graphically display the data. Appendix C contains a FORTRAN listing of the CHEM code.

3.4 CRHPLOTR AND CRHPLOT

The CRHPLOTR and CRHPLOT codes plot the results of a radiological or toxic gas analysis, respectively. Both are written in CLIPPER using FLIPPER graphics libraries. They are designed to run correctly on most PC display systems (VGA, EGA, CGA, and Hercules). Both also give the option to print the graphs on a printer. Listings for these codes appear respectively as Appendices D and E.

3.5 DATA FILES

There are two permanent data file libraries, ICRP.02 and ICRP.30. Both of them contain the same types of information, but the ICRP.30 library has been updated to contain dose conversion factors from the International Commission

on Radiation Protection (ICRP) publication 30. It is anticipated that the NRC will approve use of the ICRP 30 data some time in the future. Appendix F contains a listing of ICRP.02, and Appendix G is a listing of ICRP.30.

The files are organized as follows:

line 1: Nuclide name (8 characters)
line 2: Decay rate (1/hr), source (Ci/Mwt) (both 1PE13.6)
line 3: Dose conversion factors for whole body, skin, thyroid, lung, bone, and liver (1P6E13.6)
line 4: Internal identification number (I6), group number (I6), identification number of daughter (I8), daughter production factor (E10.3), secondary daughter ID (I8), and secondary daughter production factor (E10.3)

This is repeated for each of the 122 nuclides in the library. Note that the information for secondary daughter product formation is present, although it not used by the code because it is an insignificant contributor.

There are eight types of data files which contain problem specific information for performing radiological calculations. Seven of these are input to the CONHAB code, and one is an output file from CONHAB.

CRHSYS.DAT - Contains the file names of all data files required for executing a particular problem with the CONHAB code.

TIMEIND.DBF - Contains time independent information: reactor power level, and chemical form fractions for each of the nuclide groups. The .DBF file is a dBase file, and the .DAT is the associated ASCII file. The ASCII file is read by CONHAB.

- user-named.DBF - Contains the information input to the CRH code for
" ".DAT meteorology and system flow. Structure of the files
is presented in Appendix H. The .DBF file is a dBase
file, and the .DAT file is the associated ASCII file
which is read by CONHAB.
- CRHTACT*.DAT - Output from the TACT5 code which is used to provide a
source to either of the two outside air intakes.
- CRHFPPF*.OUT - Output from the FPPF code which is used to provide a
source to the two user defined unfiltered inleakage
pat ways.
- CRHPLOTR.DAT - Output file from CONHAB which is used by CRHPLOTR to
plot dose vs. time on the computer screen for the
current case.

The CHEM program uses only three datafiles, an output file from EXTRAN, a data file created by CRH with system flow information, and an output file produced by CHEM (CRHPLOT.C.DAT) for plotting the results on the computer screen.

4. USERS GUIDE TO THE COMPUTER CODES

This section contains a detailed discussion of the use of the computer codes CRH, CONHAB, CHEM, CRHPLOTR and CRHPLOTG. Before attempting to execute any of these codes, they must be installed on the hard disk of a Personal Computer (PC). Instructions for doing this appear in Section 5, Codes Installation. All five of the codes listed above have been compiled and linked, and are in an executable form (suffix EXE). This section assumes the codes have been installed and are resident in one subdirectory on the hard disk. For convenience, it is recommended that all datafiles also reside in the same directory, with backup files maintained on floppy disk. The codes are discussed in order of execution for performing a standard radiological and toxic chemical evaluation.

4.1 RADIOLOGICAL EVALUATION

The first step in performing a radiological control room evaluation is a review of plant specific information from the FSAR, SER, and any licensee submittals to determine what hazards are present and what potential flow paths exist to transport contaminants to the control room boundary. The flow paths can be divided into those which are through-plant; for example, those which are transported from room to room by ducts, doorways, and passages; or those which are transported by the outside atmosphere to the control room air intakes, for example, containment leakage or stack releases.

For each through-plant pathway, the code FFP (reference 3) must be executed. After each run, a file named CRHFFP.OUT will be created. Rename this file CRHFFP*.OUT, where * is any legal filename character, a letter or number, before performing the next run; CRHFFP.OUT is overwritten every time FFP is executed. Create as many CRHFFP*.OUT files as there are pathways through the plant to the control room, being careful not to give any two the same name. Note, however, that CONHAB can only use two of these at a time. If there are more than two, execute CONHAB multiple times and sum the results. It is much

more convenient and usually sufficient to define only two pathways to begin with.

Choose one of the FPPF output files to be user-defined unfiltered source one, and the other to be user-defined unfiltered source two. It is irrelevant which source is chosen as one or two, but this convention must be carried through the remainder of the problem in order to tell CONHAB which source goes with which flow rate.

For through atmosphere pathways, TACT5 (reference 4) must be run. TACT5 need only be run once regardless of the number of control room air intakes, as the CRH and CONHAB codes contain the required meteorological information to correctly transport the contaminants. The meteorological information does not need to be entered into the TACT5 input deck, because the only information required by CONHAB is the number of curies of each radionuclide released to the environment for each time step in TACT5. This information is automatically written to a file by the new (6/90) version of TACT5. Rename the file CRHTACT.DAT (created by TACT5) CRHTACT*.DAT as before. Make a copy of this file using a different character for '*'.' The DOS commands for these two steps are: c:\RENAME CRHTACT.DAT CRHTACT*.DAT <ret> and c:\COPY CRHTACT*.DAT CRHTACT#.DAT <ret> where '*' and '#' are different characters. CONHAB requires two separate input files, even though they are identical. This allows future flexibility to apply differing sources to each intake.

At this point there will be four source files; two CRHFPPF*.OUT and two CRHTACT*.DAT. The next step is to run the CRH program, which will allow entry of meteorological, system design, and time independent plant specific data.

4.1.1 Executing the CRH Code

Begin execution of the CRH code by typing CRH at the DOS prompt and striking return. Figure 6 will be displayed. Strike any key to continue, and the screen will appear as in Figure 7. This will be referred to as the 'main menu' in CRH. From this menu, the user may either create a new data file,

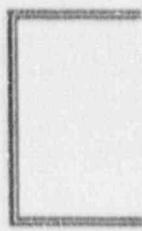

ontrol

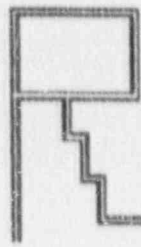

oom



abitability

A program to assist in the preparation of data for the CONHAB and CHEM codes

Developed by:
Howard Gilpin
Science Applications International Corporation
June 1998

<Press any key>

FIGURE 6

Select desired action:

Creates a new data file (or overwrite an old one)

Edit an existing data file

Assign data files in preparation for running calculation

Exit to DOS

FIGURE 7

edit an old data file, edit the time independent information, designate which data files to use in the CONHAB calculation, or exit to DOS.

To create a new input file, highlight 'Create a new data file' as shown in Figure 7 and strike return. The computer will respond with Figure 8. To create a new file, strike return with the highlight on '<create>.' The computer will then prompt for a new file name. Do not include a suffix. The code will automatically add a .DAT suffix to the data file. Enter any eight character designator as a file name. To overwrite an old file which is no longer needed, cursor down with the arrow keys, highlight the file to overwrite, and strike return.

At this point, the program will ask whether to use the graphical input screens or the tabular input screen. The tabular input screen is identical to the edit screen, however the graphical screens are easier to understand. Select the graphical screens by either hitting return or striking 'G.' No carriage return is necessary.

The next prompt asks how many time steps will be entered. It is allowed to enter a number larger than the anticipated number of time steps, and then enter dummy information for time steps after 720 hours (30 days). There should be a time step any time a piece of information such as flow rates, meteorological information, etc. changes. Enter an appropriate number and strike return.

The program will prompt for the first start time as shown in Figure 9. Enter the first start time in either seconds, minutes, or hours; strike return. The 'Select units:' menu will appear. Highlight the units for the time just entered, and strike return. Repeat this step for the end time of the time step, which will also be the start time of the next time step.

The next screen to appear is the 'Meteorological Input' screen as shown in Figure 10. This screen is used to enter parameters which will be used by CONHAB to compute a dispersion factor to be applied to the TACT5 sources. The

Select a file:

<create>

CRHOUT.DBF

CRHOUTC.DBF

CRMET.DBF

EXAMPLE1.DBF

EXAMPLE3.DBF

EXTEST.DBF

TEST1.DBF

TIMEIND.DBF

FIGURE 8

Start time: 0.00
End time: 2.00

Select units:
hours
minutes
seconds

FIGURE 9

Time step start: 0.00 end: 2.00

METEOROLOGICAL INPUT

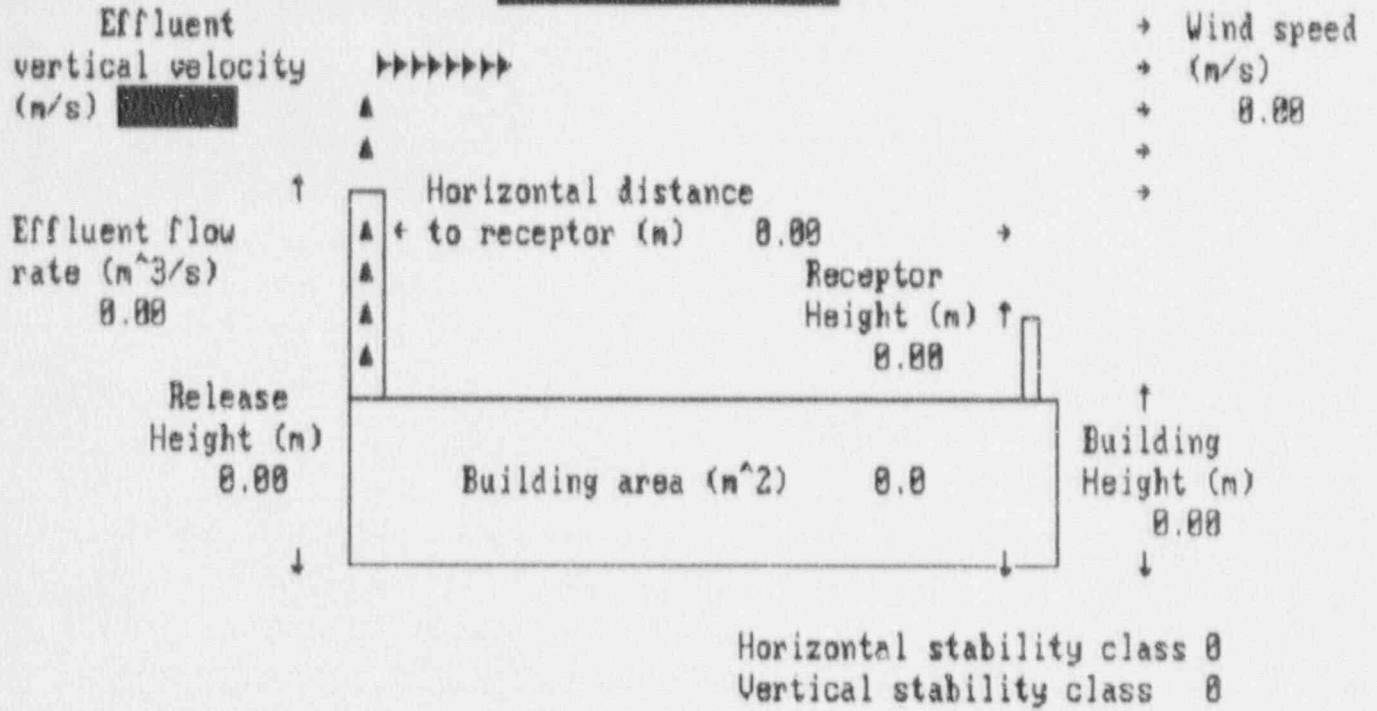

FIGURE 10

current time step start and end times appear in the upper left corner for reference. For each of the parameters, enter the appropriate value and strike return. Do not use scientific notation. The program will respond to the carriage return with the 'Select desired units:' menu as shown in Figure 11. As before, highlight the units for the datum entered and hit return. Note that if the data being entered is already in the default units (mks), the unit menu can be avoided by striking the down arrow key rather than return after entering a number. The last two prompts on the screen, horizontal and vertical stability class, require a number, 1 - 7, which represents the appropriate Pasquill stability class (A=1, B=2, etc.). There are no unit menus for these two parameters.

After entering the vertical stability class value, the program will display the 'Control Room Habitability System Flows' input screen as shown in Figure 12. This screen accepts system flow parameters and an occupancy factor. Enter the parameters as before. There are unit conversion menus for all values except the occupancy factor (see Figure 13). Note that on color monitors, the prompts and the flow paths are color coordinated to assist in identifying which prompt goes with which flow path.

After entering an occupancy factor, the screen will appear as in Figure 14. This screen allows the input of filter efficiencies each of the three filters. A unit conversion menu will prompt for each entry for either fraction or percent units. Upon entering the last filter efficiency, the program will request the next time step start and end time. The entire process is then repeated until all time steps have been entered. Note that for each time step, information has been carried forward from the previous time step. Thus, if a parameter has not changed, the user can simply cursor past it with the arrow keys. Using the return key will have the same effect, however this will cause the unit conversion menus to appear. Note also that any data which was not entered in mks units has been converted to mks at this point. Be careful not to incorrectly change the units to other than the default mks (always the first choice in the unit menus) when using the return key to move through the screen.

Time step start: 0.00 end: 2.00

METEOROLOGICAL INPUT

Effluent vertical velocity (m/s) 3.00

▶▶▶▶▶▶▶▶

Select desired units: m/s

meters/sec

ft/min

ft/sec

miles/hour

Effluent flow rate (m³/s) 0.00

↑

Horizontal distance to receptor (m) 0.00

▲
▲
▲
▲
▲

Recep Height (m) ↑ 0.00

Release Height (m) 0.00

↓

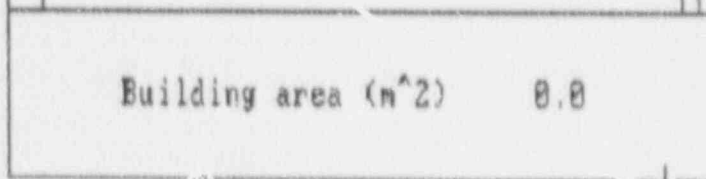

↑ Building Height (m) 0.00
↓

Horizontal stability class 0
Vertical stability class 0

FIGURE 11

Time step start: 0.00 end: 2.00

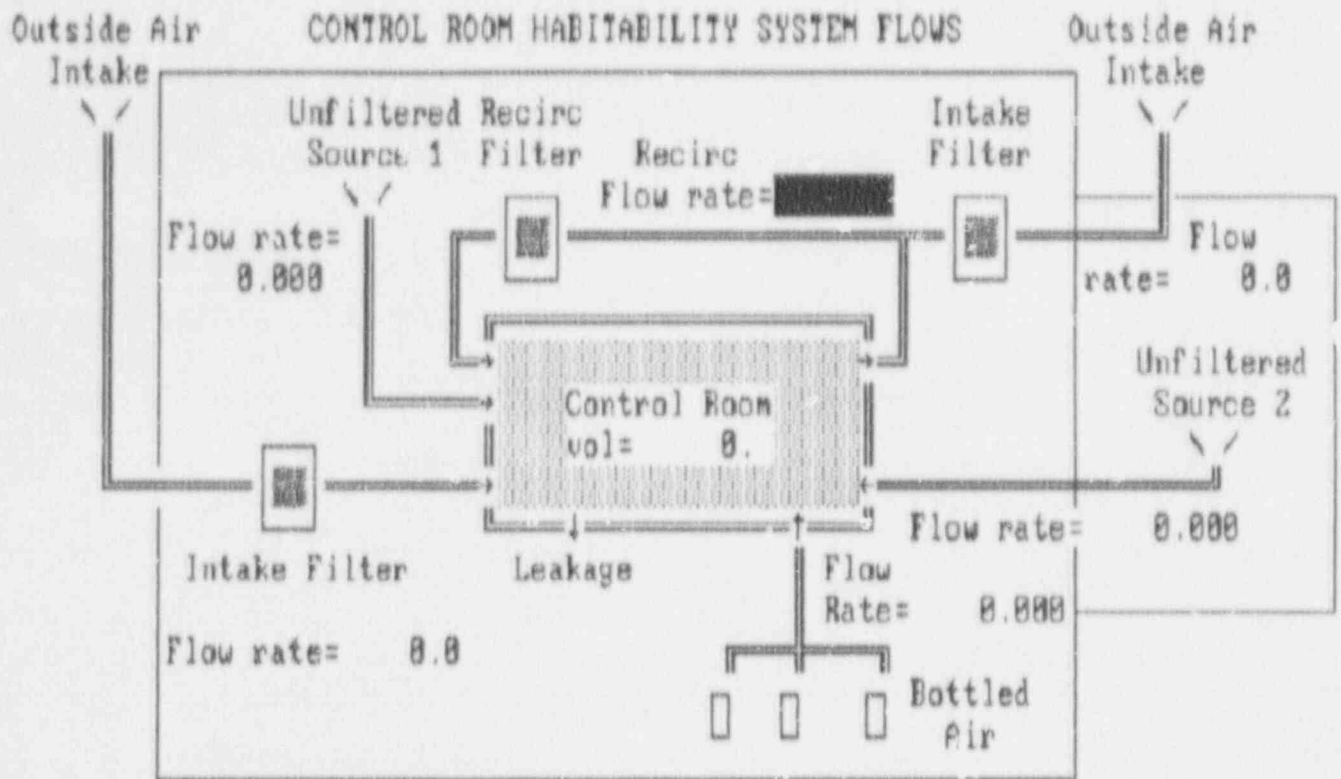

Occupancy Factor 0.0000

FIGURE 12

Time step start: 0.00 end: 2.00

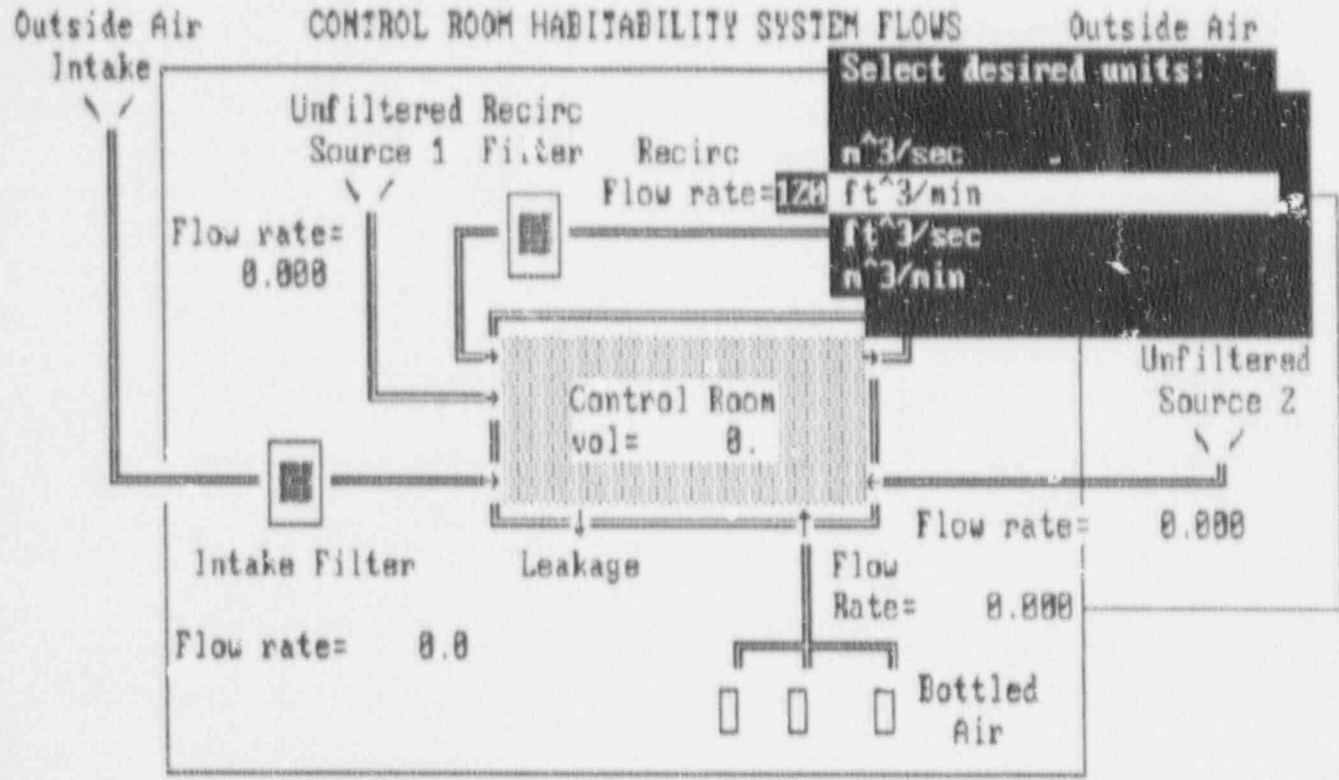

Occupancy Factor 0.0000

FIGURE 13

Time step start: 0.00 end: 2.00

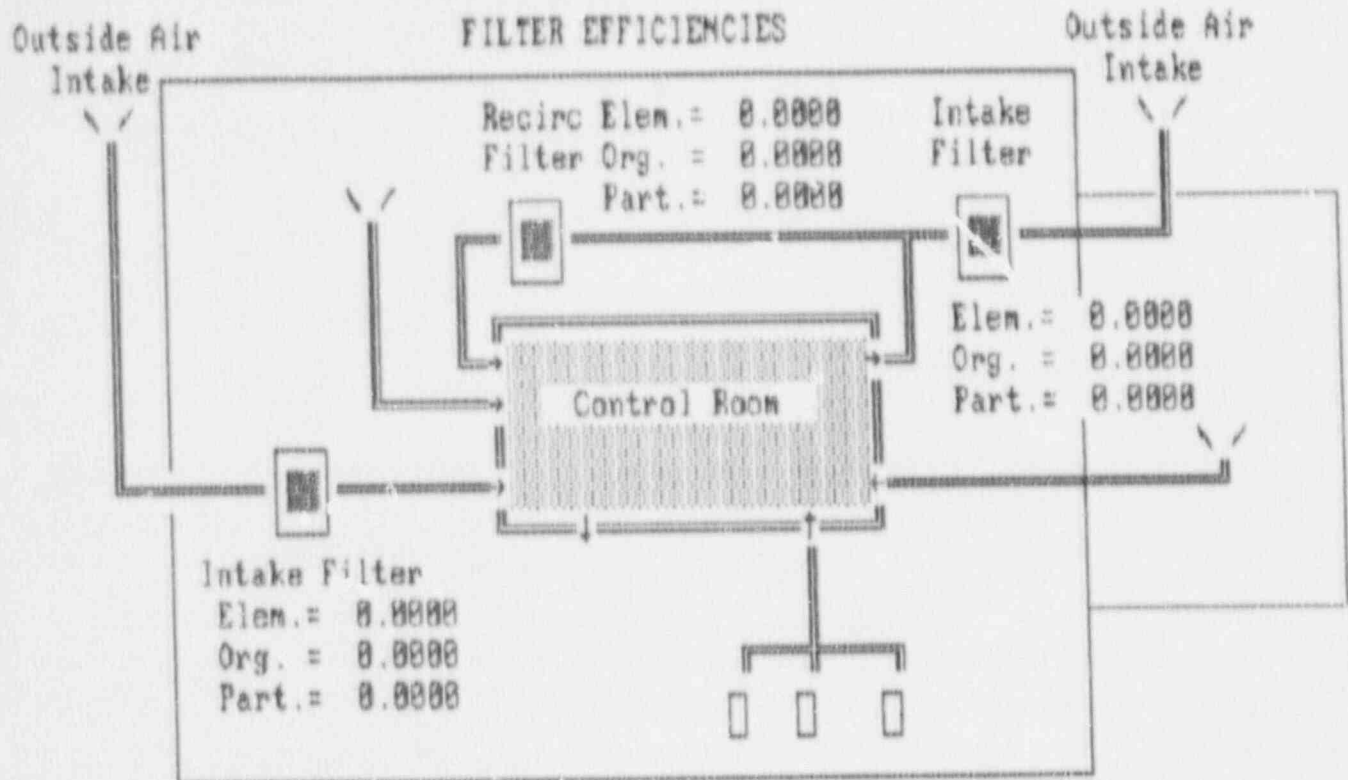

FIGURE 14

After entering the information for the last time step, control is passed back to the main menu. At this point, the data can be edited if necessary by highlighting 'Edit an existing data file' as shown in Figure 15. The program will respond with the edit menu as shown in Figure 16. To edit the time independent data (necessary to change the power level), highlight the first option and strike return. This produces Figure 17, the 'Time Independent Data' edit screen. Using the cursor keys, highlight and change information as necessary. When finished, strike return on the last prompt. This will return control to the edit menu.

To edit the meteorology or system flow information entered above, highlight the 'Edit meteorology and/or system flow data' option as shown in Figure 18 and strike return. The program will then prompt for which file to edit. Highlight the filename entered in the 'Create file' option above; strike return. Note that the menu will scroll to reveal more filenames as the cursor is moved to the bottom of the menu box.

The screen will then appear as in Figure 19, although the time steps listed may be different. Move the highlight to the time step to edit and strike return. When finished editing, strike return over the 'Finished editing' option to return to the edit menu.

Selecting one of the time steps to edit will produce the edit screen as shown in Figure 20. This screen contains all the time dependent information entered with CRH. Use the arrow keys or the return key to highlight and change any of these values. There are no unit conversion menus on this edit screen. Enter all values in the units listed to the right of the screen. Strike return on the control room volume prompt to finish editing this time step. This returns control to Figure 19 to either edit another time step or return to the edit menu.

After selecting 'Finished editing,' the program will return to the main menu. At this point, all data for performing a calculation should be on the hard disk. Highlight the 'Assign data files...' option as shown in Figure 21 and

Select desired action:

Create a new data file (or overwrite an old one)

Edit an existing data file

Assign data files in preparation for running calculation

Exit to DOS

FIGURE 15

```
Select desired action:  
Edit time independent data (form frac, power level)  
Edit meteorology and/or system flow data  
Edit source term data <disabled>  
Return to main menu
```

FIGURE 16

TIME INDEPENDENT DATA

REACTOR POWER LEVEL 2700.00 MWt

ISOTOPIC GROUP	GROUP FRACTIONS		
	ELEMENTAL	ORGANIC	PARTICULATE
HALOGENS	0.9200	0.0500	0.0400
NOBLES	1.0000	0.0000	0.0000
SODIUMS	1.0000	0.0000	0.0000
SOLIDS	1.0000	0.0000	0.0000
PLUTONIUMS	1.0000	0.0000	0.0000

FIGURE 17

Select desired action:

Edit time independent data (burn frag, power level)

Edit meteorology and/or system flow data

Edit source term data <disabled>

Return to main menu

FIGURE 18

Highlight the time step to edit and hit return

Finished editing

8.00 to 8.00

8.00 to 96.00

96.00 to 300.00

300.00 to 720.00

FIGURE 19

Meteorology		Time step	
Building cross sectional area:	6000.00	square meters	start: 0.00
Building height	20.00	meters	end: 8.00
Release height:	30.00	meters	
Effluent vertical velocity:	1.00	meters/sec	
Effluent flow rate:	3.00	cubic meters/sec	
Horizontal distance to receptor:	100.00	meters	
Receptor height:	21.00	meters	
Windspeed:	1.00	meters/sec	
Vertical dispersion class (A-G)	3		
Horizontal dispersion class (A-G)	3	Occupancy Fac.	1.000
System flows			
Flow in from source 1:	0.1000	cubic meters/sec	
Flow in from source 2:	0.0000	cubic meters/sec	
Filtered intake flow rate:	0.000	cubic meters/sec	
Intake filter efficiency:	0.000	0.000	0.000 ele org part fraction
Recirc flow rate:	0.000	cubic meters/sec	
Recirc filter efficiency:	0.990	0.900	0.990 ele org part fraction
Bottled air flow rate:	1.000	cubic meters/sec	
Recirc intake flow rate	0.000	cubic meters/sec	
Recirc intake filter eff.	0.990	0.900	0.990 ele org part fraction
Control room volume:	7075.00	cubic meters	

FIGURE 20

Select desired action:

Create a new data file (or overwrite an old one)

Edit an existing data file

Assign data files in preparation for running calculation

Exit to DOS

FIGURE 21

strike return. This option allows the user to identify which data files to use in the subsequent calculation. The screen will prompt for which meteorology and system flow file to use. Highlight the file created above and strike return. Note that the data file listed here will have a .DAT extension, while the file as listed for editing will have a .DBF extension. The program will then ask which nuclide file to use. Select either ICRP.02 or ICRP.30 and hit return. Next, the program needs to know the user defined unfiltered source 1 file name as created by FPPF. Highlight the filename and strike return. Repeat for unfiltered source 2.

The program will then prompt for each of the two TACT5 source files created by TACT5 as described above. Highlight one of the files and strike return, then repeat for the second file.

The program will then display each of the files selected, as shown in Figure 22. If they are correct, press 'y' or strike return. If not, type 'n' and repeat these steps with the correct file names.

When the file names are correct, type 'y' or strike return to return to the main menu. The files are set up for performing the calculation at this point. Exit to DOS from the main menu.

Changes to the meteorology and system flow data file can be made by executing CRH again and following the instructions for editing above. If no file names have changed, the 'Assign data files...' step may be omitted before rerunning CONHAB.

4.1.2 Executing the CONHAB Code

From the DOS prompt, type 'CONHAB' and strike return. This will begin execution of the calculational code. The program will prompt for an output destination. Type 'CON' to send the output to the screen, 'PRN' to send it to the printer, or a valid filename to produce an ASCII output file which can be printed, viewed, or edited later. The program will then begin echoing input

The following files have been selected:

Meteorology and control room system flow data:	EXAMPLE3.DAT
Nuclear data file:	ICRP.02
User defined unfiltered source 1:	CRHFPP1.OUT
User defined unfiltered source 2:	CRHFPP2.OUT
Source to filtered intake:	CRHTACT4.DAT
Source to recirc loop filtered intake:	CRHTACT5.DAT

Are these selections correct (Y/N)? Y

FIGURE 22

and printing results for each time step to the selected device. A summary table will be printed on the screen regardless of output destination. CONHAB also generates a datafile which is used to plot the data on the computer screen.

4.1.3 Executing the CRHPLOTR Code

Type 'CRHPLOTR' and strike return to begin the plotting routine. Respond appropriately to the questions asked, and the program will plot dose versus time for whole body, thyroid, and skin doses. Hit any key to display individual plots of dose vs. time for the same organs.

4.2 TOXIC GAS EVALUATION

Performing a toxic gas analysis is similar to the procedure previously outlined. Instead of using FPPF and TACT5, the code EXTRAN is executed to compute a toxic gas concentration at the control room air intake. Refer to the EXTRAN manual for performing an EXTRAN calculation. EXTRAN will produce an output file which can be read by the CHEM code. Make note of the file name produced by EXTRAN.

Run the CRH code as described in section 4.1.1 above. When creating a datafile, note that the meteorology input screen can be omitted (enter all zeros and any number between 1 and 7 for the stability classes) because EXTRAN incorporates all atmospheric diffusion calculations. The filter efficiency screen can also be ignored, as the filters have no effect on the toxic gas concentration in the control room. The only screen which contains data required by the CHEM code is the system flow input screen. Enter appropriate information for each time step as described above. The EXTRAN source will be applied to any and all of the four potential pathways into the control room volume for which the user designates a non-zero flow rate.

After entering the system flow parameters, skip the 'Assign data files...' step, as CHEM does not require this. Exit to DOS. Type CHEM at the DOS

prompt and the calculational program will begin execution. It will prompt for both the EXTRAN output file and the system flow file created with CRH. The program will then print instantaneous and mean concentrations, and exposure in the control room for each time step. When the program is finished, type CRHPLOTG at the DCS prompt to plot the results on the computer screen.

5. CODE INSTALLATION

The CRH codes require an IBM-PC or PS-2 compatible microcomputer with a hard disk to operate. A version of the codes which utilize a numeric co-processor is available.

To install the CRH codes on the hard drive of a PC, follow these steps:

- 1) Create a subdirectory.

```
C:\>md crh
```

- 2) Change to the new subdirectory.

```
C:\>cd crh
```

- 3) Insert the CRH disk into drive A of the computer. Copy all of the files into the crh subdirectory.

```
C:\CRH\>copy a:*.*
```

6. EXAMPLE PROBLEM

A sample problem has been included with the distribution disks to allow verification that the codes have been installed and are executing properly. The sample problem uses the following data files:

- o Through atmosphere source as calculated by TACT5 is identical to Example 1 in NUREG/CR-5106 'Users Guide for the TACT5 computer code.' The filenames for these two files are CRHTACT1.DAT and CRHTACT2.DAT.
- o Through plant sources are the sample output from the FPF code, labeled CRHFPP1.DAT and CRHFPP2.DAT on the distribution disk.
- o Meteorology and system flow file EXAMPLE.DAT.
- o ICRP.02 nuclide library.

To execute the sample problem, run CRH and use the 'Assign data files...' option to select each of the files listed above. Then exit to DOS and type CONHAB at the DOS prompt. Select CON to display the output on the screen, PRN to send it to the printer, or a file name to save output to a file for later printing. Note that the code will display a summary table, and that if necessary, the output data can be retrieved from the file CRHPLOTR.DAT, which is always created, regardless of where the output is directed. The CRHPLOTR.DAT file is used as input to the plotting routine CRHPLOTR.EXE. Only the first two and last pages of the output have been included in Appendix I. Sample plots from CRHPLOTR and CRHPLOTG are attached.

Sample input files for the CHEM code are also included. The sample system flow file is named EXAMCHEM.DAT, and the sample EXTRAN output file is EXOUT.OUT. Execute the sample problem by typing CHEM at the DOS prompt and striking return. Enter EXAMCHEM.DAT for the system flow file, and EXOUT.OUT for the EXTRAN output file. The output will be sent to the screen. Again, the output can be retrieved from disk by printing the file CRHPLOTG.DAT, or

the output can be printed by typing <Ctrl> <Print Scrn> after typing the EXTRAN file name but before hitting return. Type <Ctrl><Print Scrn> again to turn the printer off after the code has executed.

7. REFERENCES

- 1 Murphy, K. G., and K. M. Campe, "Nuclear Power Plant Control Room Ventilation System Design for meeting General Design Criterion 19," Proceedings of the 13th AEC Air Cleaning Conference, August 12-15, 1974, San Francisco, California, CONF-740807. U.S. Atomic Energy Commission, Washington, DC.
- 2 Driscoll, J. W., Control Room Habitability Survey of Licensed Commercial Nuclear Power Generating Stations, Argonne National Laboratory, NUREG/CR-4960, October 1988.
- 3 Owczarski, P. C. and D. D. Yasuda, "FPPF: A Code for Following Airborne Fission Products in Generic Nuclear Plant Flow Paths," Pacific Northwest Laboratory, Draft Letter Report, November 1988.
- 4 West, D. B. and H. E. Gilpin, User's Guide for the TACT5 Computer Code, Science Applications International Corporation, NUREG/CR-5106, June 1988.
- 5 Ramsdell, J. V. and G. L. Andrews, EXTRAN: A Computer Code for Estimating Concentrations of Toxic Substances at Control Room Air Intakes, Pacific Northwest Laboratory, NUREG/CR-XXXX, December 1988.
- 6 Ramsdell, J. V., Atmospheric Diffusion for Control Room Habitability Assessments, Pacific Northwest Laboratory, NUREG/CR-5055, May 1988.
- 7 Ramsdell, J. V., "Diffusion in Building Wakes for Ground Level Releases," Atmospheric Research, in press.

APPENDIX A
CRH CODE LISTING

```

*****
* Program to read in data for control room habitability calculations
*
*****
*
*
* Set up system parameters and constants
*
set echo off
set talk off
set escape on
set bell off
std='w+/b'
set color to &std
pup='b/g+,g+/b,,,b/g+'
shadow='n/n,n/n,n/n,n/n,n/n'
finished='N'
whattodo='C'
dat_file='
use crmet
num_fields=fcount()
* define number of fields in database
declare store_prev [num_fields]
*
*
* Go display greeting screen...
*
do greeting
*
*****
* main program loop *
*****
do while finished $ 'nN'

*decide whether to edit or append
do what to do
* returns with either C,E,R, or X to create,edit,run or exit
close database
use crmet
do case
case whattodo='C'  && create a new datafile
do create new
do write_file  && writes out ascii file for fortran program
close database
case whattodo='E'  && edit an existing file
do edit old
case whattodo='R'
DO SET UP
*   RUN: CONHAB.exe  && run code
case whattodo='X'
*exit to dos
clear
@5,1 say 'Returning to the DOS prompt...'
@7,1 say 'To execute the calculational code, type CONHAB at the DOS prompt.'
@9,1 say ' '
wait
finished='Y'
endcase
enddo
return

```

```
*****
* end of program main *
*****
```

```
*****
* PROCEDURES *
*****
```

```
*-----
```

```
procedure create_new
```

```
*
* procedure to create a new datafile
*
```

```
set color to &std
clear
* go get file name to use or create
@1,33 say 'CREATE NEW FILE'
do select_file
copy structure to &dat_file.
use &dat_file
```

```
clear
graphic='G'
@5,1 say 'Use graphic_i input screen (G) or table input (T):' get graphic
read
clear
@5,1 say ''
tsnum='1'
accept 'How many time steps? ' to tsnum
ts=val(tsnum)
* assign default initial start time to 0.0
stime=0.0
append blank
* Begin input of time dependent data
do while ts>0
  clear
  set color to w+/b
  clear
  do get_timestep
  read

  set color to w+/b
  clear
  if graphic$'Gg'

  do read_metdata
  read

  set color to w+/b
  clear
  do read_systemdata
  read

  set color to w+/b
  clear
  do read_filter
  read
```

```

set color to w+/b
else
  do edit_data
  read
endif
*store data into next time step as defaults
if ts>1
  do set_defaults
endif
ts=ts-1
enddo
return
*end of create new input file

```

```

*-----
procedure edit_old
* procedure to edit existing data file
set color to &std
do while .T.
clear
@1,33 say 'MAIN EDIT MENU'
declare bar[6]
bar [1] = ' Select desired action:'
bar [2] = ' '
bar [3] = ' Edit time independent data (form frac,power level)'
bar [4] = ' Edit meteorology and/or system flow data'
bar [5] = ' Edit source term data <disabled>'
bar [6]=' Return to main menu'
declare sel[6]
sel[1]=.F.
sel[2]=.F.
sel[3]=.T. &&reset this flag when time step routine is written
sel[4]=.T.
sel[5]=.F. &&reset this flag when source term data is included
sel[6]=.T.
old_color=setcolor()
set_color to &shadow
@4,10 to 9,76
@4,77 to 9,77
set color to &pup
menuchoice=achoice(3,8,8.75,bar,sel,3)
do case
  case menuchoice=3
    set color to &std+&pup
    clear

    do edit_timeind
    clear
  case menuchoice=4
    do select_file
    use &dat_file.
    clear
    do edit_data
    do write_file && write out ascii file
    close database

  case menuchoice=5

```

```

*do edit source
case menuchoice=6
  set color to &old_color
  return
endcase
clear
enddo
*end of edit_old procedure

```

```

*-----
procedure edit_timeind
use timeind
go top
@ 2, 29 SAY "TIME INDEPENDENT DATA"
@ 4, 5 SAY "REACTOR POWER LEVEL"
@ 4, 25 GET TIMEIND->POWER PICTURE "9999.99"
@ 4, 35 SAY "Mwt"
@ 6, 39 SAY "GROUP FRACTIONS"
@ 7, 5 SAY "ISOTOPIC GROUP" ELEMENTAL ORGANIC PARTICULATE"
@ 9, 5 SAY "HALOGENS"
@ 9, 30 GET TIMEIND->HELE PICTURE "9.9999"
@ 9, 43 GET TIMEIND->HORG PICTURE "9.9999"
@ 9, 56 GET TIMEIND->HPART PICTURE "9.9999"
@ 10, 5 SAY "NOBLES"
@ 10, 30 GET TIMEIND->NELE PICTURE "9.9999"
@ 10, 43 GET TIMEIND->NORG PICTURE "9.9999"
@ 10, 56 GET TIMEIND->NPART PICTURE "9.9999"
@ 11, 5 SAY "SODIUMS"
@ 11, 30 GET TIMEIND->NAELE PICTURE "9.9999"
@ 11, 43 GET TIMEIND->NAORG PICTURE "9.9999"
@ 11, 56 GET TIMEIND->NAPART PICTURE "9.9999"
@ 12, 5 SAY "SOLIDS"
@ 12, 30 GET TIMEIND->SELE PICTURE "9.9999"
@ 12, 43 GET TIMEIND->SORG PICTURE "9.9999"
@ 12, 56 GET TIMEIND->SPART PICTURE "9.9999"
@ 13, 5 SAY "PLUTONIUMS"
@ 13, 30 GET TIMEIND->PELE PICTURE "9.9999"
@ 13, 43 GET TIMEIND->PORG PICTURE "9.9999"
@ 13, 56 GET TIMEIND->PPART PICTURE "9.9999"
@ 0, 0 TO 20, 79 DOUBLE
@ 5, 2 TO 14, 77
@ 8, 3 TO 8, 76
read

```

```

copy to timeind.dat delimited
close databases
return

```

```

*-----
procedure set_up
*this procedure sets up data files for conhab program
set color to &std
close database
do while .T.
clear
@1,1 say 'The FORTRAN program CONHAB needs to know what data files to use...'
@2,1 say 'First, pick which meteorology and system flow file to use'

```

```

wait
ftemp='*.dat'
do sel dat_file
datfile=dat_file
clear
@1,1 say 'Now pick which NUCLIDE DATA FILE to use...'
wait
ftemp='ICRP.*'
DO SEL DAT FILE
nucfile=dat_file
clear
@1,1 say 'Now select SOURCE file for unfiltered source 1 (created by FFPF)...'
wait
ftemp='CRHFPPF*.OUT'
DO SEL DAT FILE
STFILE1=DAT_FILE
CLEAR
@1,1 SAY 'Same thing for unfiltered source 2 ...'
wait
ftemp='CRHFPPF*.OUT'
do sel dat_file
stfile2=dat_file
clear
@1,1 say 'Select SOURCE file for filtered intake 1 (usually from TACT5)...'
wait
ftemp='CRHTACT*.DAT'
do sel dat_file
stfile3=dat_file
clear
@1,1 say 'And the SOURCE file for filtered intake 2 (feeds the recirc loop)...'
wait
ftemp='CRHTACT*.DAT'
do sel dat_file
stfile4=dat_file
clear
answ='Y'
@1,1 say 'The following files have been selected:'
@3,1 say 'Meteorology and control room system flow data: '+ datfile
@4,1 say 'Nuclear data file: '+ nucfile
@5,1 say 'User defined unfiltered source 1: '+ stfile1
@6,1 say 'User defined unfiltered source 2: '+ stfile2
@7,1 say 'Source to filtered intake: '+ stfile3
@8,1 say 'Source to recirc loop filtered intake: '+ stfile4
@15,1 say 'Are these selections correct (Y/N)? ' get answ
read
if answ$'Yy'
  exit
endif
enddo
set alte to crhsys.dat
set alte on
??"0,122,"+datfile+"', '"+nucfile+"', '"+stfile1+"', '"+stfile2+"', '"+stfile3+"', '"+stfile4+"'"
?
set alte off
close alte
clear
@5,1 say 'To execute the calculational code, select Exit to DOS at the next'
@6,1 say 'menu, and then type CONHAB.'
@9,1 say ' '
wait

```

return

```
*-----  
procedure sel_tstep  
* this procedure selects the time step to edit  
* returns nothing, but goto's the correct record for editing  
set color to &std  
clear  
num=lastrec()  
declare bar[num+3]  
declare sel[num+3]  
bar[1]='Highlight the time step to edit and hit return'  
bar[2]=' '  
bar[3]='Finished editing'  
sel[1]=.F.  
sel[2]=.F.  
sel[3]=.T.  
go top  
for n=4 to num+3  
  bar [n]=alltrim(str(tstepbeg,7,2))+ ' to '+alltrim(str(tstepend,7,2))  
  sel[n]=.T.  
  skip  
next  
old_color=setcolor()  
set color to &shadow  
rw=21  
if num<14  
  rw=num+6  
endif  
@4,10 to rw,76  
@4,77 to rw,77  
set color to &pup  
menuchoice=achoice(3,8,20,75,bar,sel,3)  
if menuchoice=3  
  done=.T.  
else  
  goto menuchoice-3  
endif  
set color to &std  
clear  
*end of sel_tstep  
return
```

```
*-----  
procedure edit_data  
done=.F.  
set color to &std+&pup  
do sel_tstep  
do while .not. done  
  
set color to &std+&pup  
clear  
@ 0,0 TO 23,79 DOUBLE  
@ 1,34 SAY "Meteorology"
```

```

@ 1,61 TO 5,78
@ 2,2 SAY "Building cross sectional area:"
@ 2,36 GET bldgarea PICTURE "999999.99"
@ 2,47 SAY "square meters"
@ 2,66 SAY "Time step"
@ 3,2 SAY "Building height "
@ 3,36 GET bldght PICTURE "9999.99"
@ 3,47 SAY "meters"
@ 3,63 SAY "start:"
@ 3,70 get tstepbeg PICTURE "9999.99"
@ 4,2 SAY "Release height:"
@ 4,36 GET relht PICTURE "9999.99"
@ 4,47 SAY "meters"
@ 4,63 SAY "end:"
@ 4,70 get tstepend PICTURE "9999.99"
@ 5,2 SAY "Effluent vertical velocity:"
@ 5,36 GET effvertvel PICTURE "9999.99"
@ 5,47 SAY "meters/sec"
@ 6,2 SAY "Effluent flow rate:"
@ 6,36 GET effflow PICTURE "9999.99"
@ 6,47 SAY "cubic meters/sec"
@ 7,2 SAY "Horizontal distance to receptor:"
@ 7,36 GET horzdist PICTURE "9999.99"
@ 7,47 SAY "meters"
@ 8,2 SAY "Receptor height:"
@ 8,36 GET receptht PICTURE "9999.99"
@ 8,47 SAY "meters"
@ 9,2 SAY "Windspeed:"
@ 9,36 GET windspeed PICTURE "9999.99"
@ 9,47 SAY "meters/sec"
@ 10,2 SAY "Vertical dispersion class (A-G)"
@ 10,36 GET vertclass PICTURE "9"
@ 11,2 SAY "Horizontal dispersion class (A-G)"
@ 11,36 GET horizclass PICTURE "9"
@ 11,40 say "Occupancy Fac." get occfac picture "9.999"
@ 12,33 SAY "System flows"
@ 13,2 SAY "Flow in from source 1:"
@ 13,36 GET flowin1 PICTURE "9999.9999"
@ 13,47 SAY "cubic meters/sec"
@ 14,2 SAY "Flow in from source 2:"
@ 14,36 GET flowin2 PICTURE "9999.9999"
@ 14,47 SAY "cubic meters/sec"
@ 15,2 SAY "Filtered intake flow rate:"
@ 15,36 GET filtflow1 PICTURE "99999.999"
@ 15,47 SAY "cubic meters/sec"
@ 16,2 SAY "Intake filter efficiency:"
@ 16,36 GET filtlele PICTURE "9.999"
@ 16,42 get filtlorg picture "9.999"
@ 16,48 get filtlpart picture "9.999"
@ 16,54 SAY "ele org part fraction"
@ 17,2 SAY "Recirc flow rate:"
@ 17,36 GET filtflow2 PICTURE "99999.999"
@ 17,47 SAY "cubic meters/sec"
@ 18,2 SAY "Recirc filter efficiency:"
@ 18,36 GET filt2ele PICTURE "9.999"
@ 18,42 get filt2org picture "9.999"
@ 18,48 get filt2part picture "9.999"
@ 18,54 SAY "ele org part fraction"
@ 19,2 SAY "Bottled air flow rate:"
@ 19,36 GET flowin3 PICTURE "99999.999"

```

```

@ 19,47 SAY "cubic meters/sec"
@20,2 say "Recirc intake flow rate"
@20,36 get filtflow3 picture "99999.999"
@20,47 say "cubic meters/sec"
@21,2 say "Recirc intake filter eff."
@21,36 get filt3ele picture "9.999"
@21,42 get filt3org picture "9.999"
@21,48 get filt3part picture "9.999"
@21,54 say "ele org part fraction"
@22,2 SAY "Control room volume:"
@22,36 GET crvolume PICTURE "999999.99"
@22,47 SAY "cubic meters"

```

```
read
```

```
clear
```

```
set color to &std+&pup
```

```
do sel_tstep
```

```
enddo
```

```
return
```

```
*-----*
```

```
procedure what_to_do
```

```
*put procedure here to select whether to edit an old data set or create a new
```

```
*one
```

```
*
```

```
* returns whattodo = 'e' to edit or 'c' for new
```

```
whattodo='C'
```

```
set color to &std
```

```
clear
```

```
@1,36 say 'MAIN MENU'
```

```
declare bar[6]
```

```
bar [1] = ' Select desired action:'
```

```
bar [2] = ' '
```

```
bar [3] = ' Create a new data file (or overwrite an old one)'
```

```
bar [4] = ' Edit an existing data file'
```

```
bar [5] = ' Assign data files in preparation for running calculation'
```

```
bar[6]=' Exit to DOS'
```

```
declare sel[6]
```

```
sel[1]=.F.
```

```
sel[2]=.F.
```

```
sel[3]=.T.
```

```
sel[4]=.T.
```

```
sel[5]=.T.
```

```
sel[6]=.T.
```

```
old_color=setcolor()
```

```
set_color to &shadow
```

```
@4,10 to 9,76
```

```
@4,77 to 9,77
```

```
set color to &pup
```

```
menuchoice=achoice(3,8,8,75,bar,sel,3)
```

```
do case
```

```
case menuchoice=3
```

```
whattodo='C'
```

```
case menuchoice=4
```

```
whattodo='E'
```

```
case menuchoice=5
```

```
whattodo='R'
```

```
case menuchoice=6
```

```
whattodo='X'
```

```
endcase
```



```

set color to &old_color
clear
return

```

```

*-----
procedure get_time
@ 4,14 SAY "Start time: "
@ 4,26 GET tstepbeg PICTURE "9999.99" valid time_unit(tstepbeg,"tstepbeg")
@ 5,14 SAY "End time: "
@ 5,26 GET tstepend PICTURE "9999.99" valid time_unit(tstepend,"tstepend")
return

```

```

*-----
procedure greeting
*put hello screen here
clear
set color to &std+&pup
@ 0,0 TO 21,79 DOUBLE

```

```

@ 3,5 SAY "èèèèèèèè"
@ 3,32 SAY "èèèèèèèè"
@ 3,56 SAY "à"
@ 3,62 SAY "à"
@ 4,5 SAY "à"
@ 4,32 SAY "à"
@ 4,39 SAY "à"
@ 4,56 SAY "à"
@ 4,62 SAY "à"
@ 5,5 SAY "à"
@ 5,32 SAY "àèèèèèèè"
@ 5,56 SAY "àèèèèèèè"
@ 6,5 SAY "à"
@ 6,32 SAY "à"
@ 6,35 SAY "àè"
@ 6,56 SAY "à"
@ 6,62 SAY "à"
@ 7,5 SAY "à"
@ 7,32 SAY "à"
@ 7,36 SAY "àè"
@ 7,56 SAY "à"
@ 7,62 SAY "à"
@ 8,5 SAY "àèèèèèèè"
@ 8,14 SAY "ontrol"
@ 8,32 SAY "à"
@ 8,37 SAY "àèè"
@ 8,41 SAY "oom"
@ 8,56 SAY "à"
@ 8,62 SAY "à"
@ 8,64 SAY "abitability"
@ 11,2 SAY "A program to assist in the preparation of data for the CONHAB and CHEM codes"
@ 14,34 SAY "Developed by:"
@ 15,34 SAY "Howard Gilpin"
@ 16,1, SAY "Science Applications International Corporation"
@ 17,36 SAY "June 1990"
@ 19,32 say "<Press any key>"
inkey(0)
return

```

```

*-----
procedure read metdata
*procedure to input graphically met data
set color to b/w
@ 0,0 SAY "Time step start: "
@ 0,17 SAY tstepbeg PICTURE "@TI 9999.99"
@ 0,24 SAY " end: "
@ 0,30 SAY tstepend PICTURE "@TI 9999.99"
@ 2,29 SAY "METEOROLOGICAL INPUT"
set color to g+/b
@ 3,6 SAY "Effluent"
set color to r+/b
@ 3,66 SAY CHR(26)
@ 3,69 SAY "Wind speed"
set color to g+/b
@ 4,1 SAY "vertical velocity"
@ 4,22 SAY REPLICATE(CHR(16), 2)
set color to r+/b
@ 4,66 SAY CHR(26)
@ 4,69 SAY "(m/s)"
set color to g+/b,g+/b
@ 5,1 SAY "(m/s)"
@ 5,7 GET effvertvel PICTURE "9999.99" valid velocity(effvertvel,"effvertvel")
@ 5,21 SAY CHR(30)
set color to r+/b,r+/b
@ 5,66 SAY CHR(26)
@ 5,69 GET windspeed PICTURE "9999.99" valid velocity(windspeed,"windspeed")
set color to g+/b
@ 6,21 SAY CHR(30)
set color to r+/b
@ 6,66 SAY CHR(26)
@ 7,17 SAY CHR(24)
@ 7,20 TO 12,22
set color to gr+/b
@ 7,25 SAY "Horizontal distance"
set color to r+/b
@ 7,66 SAY CHR(26)
set color to bg+/b
@ 8,1 SAY "Effluent flow"
@ 8,21 SAY CHR(30)
set color to gr+/b,gr+/b
@ 8,23 SAY CHR(27)
@ 8,25 SAY "to receptor (m)"
@ 8,41 GET horizdist PICTURE "9999.99" valid dist(horizdist,"horizdist")
@ 8,58 SAY CHR(26)
set color to bg+/b
@ 9,1 SAY "rate (m^3/s)"
@ 9,21 SAY CHR(30)
set color to rb+/b
@ 9,47 SAY "Receptor"
set color to bg+/b,bg+/b
@ 10,3 GET effflow PICTURE "9999.99" valid flow(effflow,"effflow")
@ 10,21 SAY CHR(30)
set color to rb+/b
@ 10,47 SAY "Height (m)"
@ 10,58 SAY CHR(24)
set color to r+/b
@ 10,59 TO 12,60
@ 11,20 SAY ""
set color to bg+/b

```



```

@ 4,7 SAY "\ /"
set color to rb+/b
@ 4,19 SAY "Unfiltered"
set color to gr+/b
@ 4,30 SAY "Recirc"
@ 4,56 SAY "Intake"
set color to w/b
@ 4,68 SAY "\"
@ 4,70 SAY "/"
@ 5,8 SAY "□"
set color to rb+/b
@ 5,20 SAY "Source 1"
set color to gr+/b
@5,30 say "Filter"
set color to r+/b
@5,39 say "Recirc"
set color to gr+/b,gr+/b
@ 5,56 SAY "Filter"
set color to w+/b
@ 5,64 SAY "*"
set color to w/b
@ 5,69 SAY "□"
@ 6,8 SAY "□"
set color to rb+/b
@ 6,22 SAY ">"
@ 6,24 SAY ">"
set color to gr+/b
@ 6,31 TO 8,34
set color to r+/b,r+/b
@ 6,37 SAY "Flow rate="
@ 6,47 GET filtflow2 PICTURE "@I. 99999.9" valid flow(filtflow2,"filtflow2")
set color to gr+/b
@ 6,57 TO 8,60
set color to w+/b
@ 6,63 SAY " "
@ 6,64 TO 16,79
@ 6,64 SAY "üá"
set color to w/b
@ 6,69 SAY "□"
@ 7,8 SAY "□"
set color to rb+/b
@ 7,12 SAY "Flow rate="
@ 7,23 SAY "□"
set color to r+/b
@ 7,28 SAY "ëëë"
@ 7,32 SAY " "
@ 7,35 SAY "ëëëëëëëëëëëëëëëëëë"
set color to w/b
@ 7,55 SAY "ëë"
@ 7,58 SAY " "
@ 7,61 SAY "ëëëÄëëëç¥"
@ 7,71 SAY "Flow"
@ 8,8 SAY "□"
set color to rb+/b,rb+/b
@ 8,12 GET flowin1 PICTURE "@L 99999.999" valid flow (flowin1,"flowin1")
@ 8,23 SAY "□"
set color to r+/b
@ 8,28 SAY "□"
@ 8,54 SAY "□"
set color to w+/b

```

```

@ 8,64 SAY ""
set color to w/b,w/b
@ 8,65 SAY "rate="
@ 8,70 GET filtflow3 PICTURE "99999.9" valid flow(filtflow3,"filtflow3")
@ 9,8 SAY "a"
set color to rb+/b
@ 9,23 SAY "a"
set color to r+/b
@ 9,28 SAY "a"
set color to w+/b
@ 9,30 TO 14,52 DOUBLE
set color to r+/b
@ 9,54 SAY "a"
set color to w+/b
@ 9,64 SAY ""
set color to w/b
@ 10,8 SAY "a"
set color to rb+/b
@ 10,23 SAY "a"
set color to r+/b
@ 10,28 SAY "æ"
@ 10,30 SAY CHR(26)
set color to g+/rb
@ 10,31 SAY "_____ "
set color to r+/b
@ 10,52 SAY CHR(26)
@ 10,53 SAY "æ"
set color to gr+/b,gr+/b
set color to w+/b
@ 10,64 SAY ""
set color to g+/b
@ 10,68 SAY "Unfiltered"
set color to w/b
@ 11,8 SAY "a"
set color to rb+/b
@ 11,23 SAY "ææææææææ"
@ 11,30 SAY CHR(26)
set color to g+/rb
@ 11,31 SAY "_____Control Room_____ "
set color to w+/b
@ 11,64 SAY ""
set color to g+/b
@ 11,69 SAY "Source 2"
set color to w/b
@ 12,8 SAY "a"
set color to gr+/b
@ 12,17 TO 14,20
set color to g+/rb,g+/rb
@ 12,31 SAY "_____vol="
@ 12,39 GET crvolume PICTURE "999999.9" valid volume(crvolume,"crvolume")
@ 12,46 SAY "_____ "
set color to w+/b
@ 12,64 SAY ""
set color to g+/b
@ 12,71 SAY ">"
@ 12,73 SAY "/"
set color to w/b
@ 13,8 SAY "ææææææææææ"
@ 13,18 SAY " "
@ 13,21 SAY "ææææææææææ"

```

```

@ 13,30 SAY CHR(26)
set color to g+/rb
@ 13,31 SAY "-----"
set color to g+/b
@ 13,52 SAY CHR(27)
@ 13,53 SAY "eeeeeeeeeeeeAeeeeeeeeY"
@ 14,35 SAY CHR(25)
set color to bg+/b
@ 14,48 SAY CHR(24)
set color to g+/b,g+/b
@ 14,55 SAY "Flow"
@ 14,60 SAY "rate="
@ 14,65 GET flowin2 PICTURE "@L 99999.999" valid flow(flowin2,"flowin2")
set color to gr+/b
@ 15,13 SAY "Intake Filter"
set color to g+/b
@ 15,32 SAY "Leakage"
set color to bg+/b
@ 15,48 SAY "a Flow"
set color to w+/b
@ 15,64 SAY "*"
set color to gr+/b,gr+/b
set color to bg+/b,bg+/b
@ 16,48 SAY "a Rate="
@ 16,55 GET flowin3 PICTURE "@L 99999.999" valid flow(flowin3,"flowin3")
set color to w+/b
@ 16,64 SAY "Q"
set color to w/b,w/b
@ 17,12 SAY "Flow rate="
@ 17,22 GET filtflow1 PICTURE "@L 99999.9" valid flow(filtflow1,"filtflow1")
set color to bg+/b
@ 17,44 SAY "eeeeeeeeeF"
set color to w+/b
@ 17,64 SAY "*"
set color to bg+/b
@ 18,43 TO 19,44
@ 18,47 TO 19,48
@ 18,52 TO 19,53
@ 18,55 SAY "Bottled"
@ 19,57 SAY "Air"
set color to b/w,b/w
@22,12 say "Occupancy Factor "get occfac valid (occfac>=0 .and. occfac<=1.0)

set color to &std+&pup
return

```

```

*-----
procedure read filter
SET COLOR TO B/W
@ 0,0 SAY " Time step start: "
@ 0,18 SAY tstepbeg PICTURE "@TI 9999.99"
@ 0,25 SAY " end: "
@ 0,31 SAY tstepend PICTURE "@TI 9999.99"
@ 0,38 SAY " "
set color to w/b
@ 2,3 SAY "Outside Air"
@ 2,29 SAY "FILTER EFFICIENCIES"
@ 2,64 SAY "Outside Air"
@ 3,5 SAY "Intake"
@ 3,11 TO 20,64

```



```

@ 18,21 GET filtpart PICTURE "99.9999" valid eff(filtpart,"filtpart")
set color to w/b
@ 18,43 TO 19,44
@ 18,47 TO 19,48
@ 18,52 TO 19,53
set color to g+/b,g+/b
return

```

```

*-----
procedure set_defaults
* carries information for current record forward to next record...
numleft=num_fields
append blank
do while numleft>0
  skip -1
  fld=field(numleft)
  store_prev[numleft]=&fld
  skip
  replace &fld with store_prev[numleft]
  numleft=numleft-1
enddo
replace tstepbeg with tstepend
return

```

```

*-----
procedure select_file
* this procedure selects a database file to create or edit
* places file in use in select area 1
set color to &std
rw=16
num=adir("*.dbf")
declare dbf file[num]
adir("*.dbf",dbf_file)
asort(dbf_file)
old_color=setcolor()
save screen
declare bar[num+3],sel[num+3]
bar [1] = ' Select a file:'
bar [2] = ' '
bar [3] = ' <create>'
cnt=0
sel[1]=.F.
sel[2]=.F.
if whattodo = 'C'
  sel[3]=.T.
else
  sel[3]=.F.
endif
do while cnt<num
bar [cnt+4] = ' '+dbf_file[cnt+1]
sel[cnt+4]=.T.
cnt=cnt+1
enddo
set color to &shadow
if num<10
  rw=num+6
endif
@4,31 to rw,31

```

```

@4,12 to rw,32
set color to &pup
menuchoice=achoice(3,10,15,30,bar,sel,3)
if menuchoice=3
  set color to &shadow
  @7,41 to 11,41
  @7,22 to 11,42
  set color to 'bg+/rb+,rb+/bg+,,,bg+/rb+'
  @6,20 clear to 10,40
  dat_file='
  @7,21 say 'Enter filename:'
  @8,21 get dat_file valid (.not. empty(dat_file))
  read
else
  dat_file=dbf_file[menuchoice 3]
endif
restore screen
set color to &old_color

return
*end of procedure select_file

```

```

*-----
procedure sel_dat_file
* this procedure selects files to use for conhab
set color to &std
rw=16
num=adir(ftemp)
declare dbf_file[num]
adir(ftemp,dbf_file)
asort(dbf_file)
old_color=setcolor()
save screen
declare bar[num+3],sel[num+3]
bar [1] = ' Select a file:'
bar [2] = ' '
bar [3] = '<Not listed>'
cnt=0
sel[1]=.F.
sel[2]=.F.
sel[3]=.T.
do while cnt<num
bar [cnt+4] = ' '+dbf_file[cnt+1]
sel[cnt+4]=.T.
cnt=cnt+1
enddo
set color to &shadow
if num<10
  rw=num+6
endif
@4,31 to rw,31
@4,12 to rw,32
set color to &pup
menuchoice=achoice(3,10,15,30,bar,sel,3)
if menuchoice=3
  set color to &shadow
  @7,41 to 11,41
  @7,22 to 11,42
  set color to 'bg+/rb+,rb+/bg+,,,bg+/rb+'
  @6,20 clear to 10,40

```

```

dat_file='
@7,21 say 'Enter filename:'
@8,21 get dat_file valid (.not. empty(dat_file))
read
else
  dat_file=dbf_file[menuchoice-3]
endif
restore screen
set color to &old_color

return
*end of procedure select_file

```

```

*-----
procedure write_file
commit
pos=at('.',dat_file)
if pos=0
  flnm= left(dat_file,8)+'.dat'
else
  flnm=substr(dat_file,1,pos-1)+'.dat'
endif
copy to &flnm DELIMITED
close
return
*end of procedure write_file

```

```

*****
*** FUNCTIONS ***
*****

```

```

function flow
* this function validates flow inputs and converts as necessary
parameter x,fld
num=fieldnum(&fld)
if (lastkey()=5 .or. lastkey()=24)
  return .T.
endif
save screen
declare par[6]
par [1] = ' Select desired units:'
par [2] = ' '
par [4] = ' ft^3/min'
par [5] = ' ft^3/sec'
par [6] = ' m^3/min'
par [3] = ' m^3/s^~'
declare sel[6]
sel[1]=.F.
sel[2]=.F.
sel[3]=.T.
sel[4]=.T.
sel[5]=.T.
sel[6]=.T.

```

```

old_color=setcolor()
set_color to &shadow
@4,52 to 9,77
@4,76 to 9,76
set_color to &pup
menuchoice=achoice(3,50,8,75,bar,sel,"puphandler",3)
x=&fld
do case
case menuchoice=4
x=x*.0004717
case menuchoice=5
x=x*.0283
case menuchoice=6
x=x/60
endcase
replace &fld with x
restore screen
set_color to &old_color
return .T.

```

```

function area
parameter x, fld
num=fieldnum(&fld)
if (recno(>1) .and. (lastkey()=5 .or. lastkey()=24)
return .T.
endif
save screen
declare bar[4]
bar [1] = ' Select desired units:'
bar [2] = ' '
bar [4] = ' square feet'
bar [3] = ' square meters'
declare sel[4]
sel[1]=.F.
sel[2]=.F.
sel[3]=.T.
sel[4]=.T.
old_color=setcolor()
set_color to &shadow
@4,52 to 7,77
@4,76 to 7,76
set_color to &pup
menuchoice=achoice(3,50,6,75,bar,sel,"puphandler",3)
x=&fld
do case
case menuchoice=4
x=x*.0929
endcase
replace &fld with x
restore screen
set_color to &old_color
return .T.

```

```

function volume
parameter x, fld
num=fieldnum(&fld)
if (recno(>1) .and. (lastkey()=5 .or. lastkey()=24)
return .T.

```

```

endif
save screen
declare bar[4]
bar [1] = ' Select desired units:'
bar [2] = ' '
bar [4] = ' cubic feet'
bar [3] = ' cubic meters'
declare sel[4]
sel[1]=.F.
sel[2]=.F.
sel[3]=.T.
sel[4]=.T.
old_color=setcolor()
set_color to &shadow
@4,52 to 7,77
@4,76 to 7,76
set_color to &pup
menuchoice=achoice(3,50,6.75,bar,sel,"puphandler",3)
x=&fld
do case
case menuchoice=4
  x=x*.0283
endcase
replace &fld with x
restore screen
set_color to &old_color
return .T.

```

```

function velocity
parameter x, fld
num=fieldnum(&fld)
((recno(>1) .and. (lastkey()=5 .or. lastkey()=24)
return .T.
endif
save screen
declare bar[6]
bar [1] = ' Select desired units:'
bar [2] = ' '
bar [4] = ' ft/min'
bar [5] = ' ft/sec'
bar [6] = ' miles/hour'
bar [3] = ' meters/sec'
declare sel[6]
sel[1]=.F.
sel[2]=.F.
sel[3]=.T.
sel[4]=.T.
sel[5]=.T.
sel[6]=.T.
old_color=setcolor()
set_color to &shadow
@4,52 to 9,77
@4,76 to 9,76
set_color to &pup
menuchoice=achoice(3,50,8.75,bar,sel,"puphandler",3)
x=&fld
do case
case menuchoice=4
  x=x*.00508
case menuchoice=5

```

```

x=x*.3048
case menuchoice=6
  x=x*.4476
endcase
replace &fld with x
restore screen
set color to &old_color
return .T.

```

```

function eff
parameter x, fld
num=fieldnum(&fld)
if (recno(>1) .and. (lastkey()=5 .or. lastkey()=24)
  return .T.
endif
save screen
declare bar[4]
bar [1] = ' Select desired units:'
bar [2] = ' '
bar [4] = ' Percent'
bar [3] = ' Fraction'
declare sel[4]
sel[1]=.F.
sel[2]=.F.
sel[3]=.T.
sel[4]=.T.
old_color=setcolor()
set_color to &shadow
@4,52 to 7,77
@4,76 to 7,76
set color to &pup
menuchoice=achoice(3,50,6,75,bar,sel,"puphandler",3)
x=&fld
d) case
case menuchoice=4
  x=x/100.0
endcase
replace &fld with x
restore screen
set color to &old_color
return .T.

```

```

function dist
parameter x, fld
num=fieldnum(&fld)
if (recno(>1) .and. (lastkey()=5 .or. lastkey()=24)
  return .T.
endif
save screen
declare bar[4]
bar [1] = ' Select desired units:'
bar [2] = ' '
bar [4] = ' feet'
bar [3] = ' meters'
declare sel[4]
sel[1]=.F.
sel[2]=.F.
sel[3]=.T.

```

```

sel[4]=.f.
old_color=setcolor()
set_color to &shadow
@4,52 to 7,77
@4,76 to 7,76
set_color to &pup
menuchoice=achoice(3,50,6,75,bar,sel,"puphandler",3)
x=&fld
do case
case menuchoice=4
  x=x*.3048
endcase
replace &fld with x
restore screen
set_color to &old_color
return .T.

```

```

function time unit
parameter x,fld
num=fieldnum(&fld)
if (recno(>1) and. (lastkey()=5 .or. lastkey()=24)
  return .T.
endif
save screen
declare bar[5]
bar [1] = ' Select units:'
bar [2] = ' '
bar [3] = ' hours'
bar [4] = ' minutes'
bar [5] = ' seconds'
declare sel[5]
sel[1]=.F.
sel[2]=.F.
sel[3]=.T.
sel[4]=.T.
sel[5]=.T.
old_color=setcolor()
set_color to &shadow
@4,52 to 8,76
@4,77 to 8,77
set_color to &pup
menuchoice=achoice(3,50,7,75,bar,sel,"puphandler",3)
x=&fld
do case
case menuchoice=4
  x=x/60
case menuchoice=5
  x=x/3600
endcase
replace &fld with x
restore screen
set_color to &old_color
return .T.

```

*end of popup definitions

```

*****
function puphandler

```

```
* handles screen editing for pop up valids and gets
*
parameters mode,curelem,relpos
if mode=3
  do case
  case lastkey()=13
    ret=1
  case lastkey()=27
    ret=0
  otherwise
    ret=2
  endcase
else
  ret=2
endif
return ret
*****
```

APPENDIX B
CONHAB CODE LISTING

```

TSTEPEND=0.
DO 5 I=1,5
  TSEND(I)=0.
5 CONTINUE
DO 6 I=1,6
  CUMDOSE(I)=0.
6 CONTINUE
  ISTEP=1
  TSEND(5)=8.64E4
DO 7 J=1,150
  DO 7 K=1,5
    DO 7 L=1,3
      CONC(K,J,L)=0.0
7 CONTINUE

```

C
C
C
C

DEFINE CONSTANTS:

```

WHOLEBODY=1
SKIN=2
THYROID=3
lung=4
bone=5
liver=6
BR=3.47E-04
OUTFILE=11

```

C

C
C
C
C
C
C
C

```

Go read system information (numnuc,numsteps,...)
sets up datafiles:   SYSTEM FLOWS= #2
                     SOURCE TERMS= #3,#4,#8,#9
                     OUTPUT=      #7

```

Also reads in nuclide data

C

CALL READSYS

CALL ECHOIN

C
C

Begin looping until 30 days is up

C

10 CONTINUE

C
C

```

Check to see what the next time step interval is:
OLDTIME=ELAPTIME
CALL READDATA
ELAPTIME=TSTEPEND*3600
DO 50 M=1,5
  IF (ELAPTIME.GT.TSEND(M)) ELAPTIME=TSEND(M)
50 CONTINUE

```

C
C

```

IF (TSEND(5).EQ.ELAPTIME) TSEND(5)=TSEND(5)+8.64E4
DELTAT=ELAPTIME-OLDTIME
gas=deltat

```

C

ISTEP=ISTEP+1

```

C
C
C      Begin looping thru all nuclides...
C
C      DO 100 NUCLIDE=1,NUMNUC
C
C          Calculate flows in and out
C
C          FLOWOUT=FLOWRATE(1)+FLOWRATE(2)+FLOWRATE(3)+FLOWRATE(4)+
*           FLOWRATE(6)
C
C          Loop over chemical forms
C
C          NF=1
C          IF (GROUP(NUCLIDE).EQ.1) NF=3
C          DO 20 I=1,NF
C             a=(FLOWOUT+FLOWRATE(5)*FILTEFF(1,NUCLIDE,I))/CRVOL
C
C             If a=0, no removal (except decay)
C
C             IF ((a.NE.0.0).AND.(A*DELTAT<80)) THEN
C                CONC(5,NUCLIDE,I)=CONC(5,NUCLIDE,I)*EXP(-A*DELTAT)
C                ACTIN=(CONC(1,NUCLIDE,I)*FLOWRATE(1)+CONC(2,NUCLIDE,I)*
*                   FLOWRATE(2)+CONC(3,NUCLIDE,I)*FLOWRATE(3)*(1-
*                   FILTEFF(3,NUCLIDE,I))+CONC(4,NUCLIDE,I)*FLOWRATE(4)*
*                   (1-FILTEFF(1,NUCLIDE,I))*(1-FILTEFF(2,NUCLIDE,I)))
C                CONC(5,NUCLIDE,I)*CRVOL)
C                CONC(5,NUCLIDE,I)=CONC(5,NUCLIDE,I)+(ACTIN/a-(ACTIN/a)*
*                   (EXP(-a*DELTAT)))/CRVOL
C            ENDIF
C
C          Watch for NaN's as conc gets small...
C
C          IF (CONC(5,NUCLIDE,I).LT.1.0E-30) THEN
C             CONC(5,NUCLIDE,I)=0.0
C          ENDIF
C
C          Calculate doses based on activities...
C
C          DOSE(WHOLEBODY)=CONC(5,NUCLIDE,I)*DCF(NUCLIDE,WHOLE
*          BODY)*DELTAT/(1173/(CRVOL**.338))
C          DOSE(SKIN)=CONC(5,NUCLIDE,I)*DCF(NUCLIDE,SKIN)*
*          DELTAT
C          DOSE(THYROID)=CONC(5,NUCLIDE,I)*DCF(NUCLIDE,THYROID)
*          *BR*DELTAT
C
C          DOSE(LUNG)=CONC(5,NUCLIDE,I)*DCF(NUCLIDE,LUNG)*BR*DELTAT
C          DOSE(BONE)=CONC(5,NUCLIDE,I)*DCF(NUCLIDE,BONE)*BR*DELTAT
C          DOSE(LIVER)=CONC(5,NUCLIDE,I)*DCF(NUCLIDE,LIVER)*BR*DELTAT
C          Sum doses into cumulative dose variables...
C
C          DO 15 NORG=1,6
C             CUMDOSE(NORG)=CUMDOSE(NORG)+DOSE(NORG)*FACOCC
15          CONTINUE
20          CONTINUE
100         CONTINUE
C
C          Go write out time step information to disk and screen...
C

```

```

      CALL STEPOUT
C
C      Go decay away nuclides over current time step and add
C      back in daughters...
C
      CALL DECAYNUC
C
C
C
      IF (ELAPTIME/3600..LT.720.) THEN
        GOTO 10
      ENDIF
C      <----End loop over time (post 30 days at this line)
C
C      Go write out summary information to screen...
C
      CALL SUMMARY
C
      CLOSE(OUTFILE)
      STOP
C
      END
C
      end of MAIN
C
C
C
C-----
      SUBROUTINE READSYS
      CHARACTER*20 DATFILE,NUCFILE,STFILE(4),DEVICE
      CHARACTER*8 NUCNAME(150)
C
C      SUBROUTINE TO READ IN SYSTEM DATA
C      Reads in number of nuclides and time steps, and data file names
C      Also reads in nuclide data
C
      INTEGER DAUGHTER(150),GROUP(150),OUTFILE
      DIMENSION DCF(150,6),DECAY(150),FORMFRAC(5,3),
*             CIMWT(150),DAUFRAC(150)
      COMMON /SYS/ NUMNUC,NUMSTEPS,DATFILE,NUCFILE,STFILE,ISTEP,DELTAT,
*             ELAPTIME
      common /nuc/ dcf,daughter,decay,cimwt,GROUP,NUCNAME,FORMFRAC,
*             POWER,DAUFRAC
      COMMON /OUT/ OUTFILE
C
      WRITE (6,*) 'CHOOSE AN OUTPUT DEVICE:'
      WRITE (6,*)
      WRITE (6,*) 'LPT1      --> Output to printer'
      WRITE (6,*) 'CON       --> Output to screen'
      WRITE (6,*) 'filename --> Output to file'
      WRITE (6,*)
      WRITE (6,*) 'Output device: '
      READ(5,'(1A20)')DEVICE
      OPEN(OUTFILE,FILE=DEVICE)
      OPEN (2,FILE='CRHSYS.DAT',STATUS='OLD',ACCESS='SEQUENTIAL',

```

```
*FORM='FORMATTED')
READ(2,*) NUMSTEPS,NUMNUC,DATFILE,NUCFILE,(STFILE(I),I=1,4)
close(2)
OPEN(2,FILE=NUCFILE,STATUS='OLD',ACCESS='SEQUENTIAL',FORM=
*'FORMATTED')
```

C
C
C

```
READ IN NUCLIDE INFORMATION
```

```
DO 100 N=1,NUMNUC
  READ(2,102) NUCNAME(N)
  READ(2,101) DECAY(N),CIMWT(N)
  READ(2,101) (DCF(N,I),I=1,6)
  READ(2,103) I,GROUP(N),DAUGHTER(N),DAUFRAC(N)
102  FORMAT (1X,A8)
101  FORMAT (1P6E13.6)
103  FORMAT (2I6,1B,E10.3)
100 CONTINUE
CLOSE(2)
OPEN(2,FILE='TIMEIND.DAT',STATUS='OLD',ACCESS='SEQUENTIAL',FORM=
*'FORMATTED')
READ(2,*) POWER,((FORMFRAC(I,J),J=1,3),I=1,5)
CLOSE(2)
```

C

```
OPEN(2,FILE=DATFILE,STATUS='OLD',ACCESS='SEQUENTIAL',FORM=
*'FORMATTED')
OPEN(3,FILE=STFILE(1),STATUS='OLD',ACCESS='SEQUENTIAL',FORM=
*'FORMATTED')
OPEN(4,FILE=STFILE(2),STATUS='OLD',ACCESS='SEQUENTIAL',FORM=
*'FORMATTED')
OPEN(8,FILE=STFILE(3),STATUS='OLD',ACCESS='SEQUENTIAL',FORM=
*'FORMATTED')
OPEN(9,FILE=STFILE(4),STATUS='OLD',ACCESS='SEQUENTIAL',FORM=
*'FORMATTED')
OPEN(7,FILE='CRHOUT.PRN')
OPEN(17,FILE='CRHPLOTR.DAT',STATUS='UNKNOWN')
```

```
RETURN
END
```

C
C
C

```
...end of readsys
```

C-----

```
SUBROUTINE ECHOIN
```

C
C
C

```
Subroutine to echo case input information to printer/screen
```

```
CHARACTER*20 DATFILE,NUCFILE,STFILE(4)
CHARACTER*8 NUCNAME(150)
CHARACTER PGEJECT
INTEGER DAUGHTER(150),GROUP(150),OUTFILE
DIMENSION DCF(150,6),DECAY(150),FORMFRAC(5,3),
*          CIMWT(150),DAUFRAC(150)
COMMON /SYS/ NUMNUC,NUMSTEPS,DATFILE,NUCFILE,STFILE,ISTEP,DELTAT,
*          ELAPTIME
common /nuc/ dcf,daughter,decay,cimwt,GROUP,NUCFILE,FORMFRAC,
*          POWER,DAUFRAC
COMMON /OUT/ OUTFILE
```

C

PGEJECT=CHAR(12)

C

```
WRITE (OUTFILE,*)
WRITE (OUTFILE,1000)
WRITE (OUTFILE,1010)
WRITE (OUTFILE,*)
WRITE (OUTFILE,*)
WRITE (OUTFILE,*)
WRITE (OUTFILE,*)
WRITE (OUTFILE,*)'INPUT DATA FILES FOR THIS CASE:'
WRITE (OUTFILE,*)
WRITE (OUTFILE,*)'Meteorology and system flow data file: ',datfile
WRITE (OUTFILE,*)'Nuclear data file: ',nucfile
WRITE (OUTFILE,*)'Unfiltered source file #1: ',
* stfile(1)
WRITE (OUTFILE,*)'Unfiltered source file #2. ',
* stfile(2)
WRITE (OUTFILE,*)'Source to filtered intake #1: ',
* stfile(3)
WRITE (OUTFILE,*)'Source to filtered intake #2 (recirc): ',
* stfile(4)
WRITE (OUTFILE,*)
WRITE (OUTFILE,*)
WRITE (OUTFILE,*)
WRITE (OUTFILE,*)
WRITE (OUTFILE,*)'TIME INDEPENDENT DATA:'
WRITE (OUTFILE,*)
WRITE (OUTFILE,*)'Reactor Power Level (Mwt): ',power
WRITE (OUTFILE,1020)
WRITE (OUTFILE,1030)
WRITE (OUTFILE,1040)'HALOGENS ',(FORMFRAC(1,I),I=1,3)
WRITE (OUTFILE,1040)'NOBLES ',(FORMFRAC(2,I),I=1,3)
WRITE (OUTFILE,1040)'SODIUMS ',(FORMFRAC(3,I),I=1,3)
WRITE (OUTFILE,1040)'SOLIDS ',(FORMFRAC(4,I),I=1,3)
WRITE (OUTFILE,1040)'PLUTONIUMS',(FORMFRAC(5,I),I=1,3)
```

C

```
1000 FORMAT(34X,'C O N H A B')
1010 FORMAT (23X,'Control Room Habitability Program')
1020 FORMAT (33X,'FORM FRACTIONS')
1030 FORMAT (1X,'ISOTOPIC GROUP',6X,'ELEMENTAL',6X,'ORGANIC',8X,
* 'PARTICULATES')
1040 FORMAT (1X,A10,10X,3(F6.4,9X))
```

```
RETURN
END
```

SUBROUTINE DECAYNUC

C

```
C Decays nuclides in CR and at each of the 4 source locations.
C Decay is calculated over delta-t. Daughters are added back
C in at all locations. Decay and daughter re-evolution off of
C filters has not been added yet. Note that FPPF does not account
C for decay, so READATA automatically decays nuclides from start
C of the accident as they are introduced into the system. After
```

c that, decay takes place as above.

c

```
CHARACTER*8 NUCNAME(150)
INTEGER DAUGHTER(150),GROUP(150)
```

```
DIMENSION FLOWRATE(7),CONC(5,150,3),FILTEFF(3,150,3),
*         DOSE(6),DCF(150,6),DECAY(150),TSEND(5),
*         CIMWT(150),CUMDOSE(6),FORMFRAC(5,3),DAUFRAC(150),a(5,
*         150)
COMMON /MET/ AREA,BHT,RHT,W0,FO,DIST,OHT,U10,IST1,IST2,'Q
COMMON /FLOW/ TSTEPBEG,TSTEPEND,FLOWRATE,CONC,
*         FILTEFF,CRVOL,dose,BR,cumdose,TSEND,FACOC
common /nuc/ dcf,daughter,decay,cimwt,GROUP,NUCNAME,FORMFRAC,
*         POWER,DAUFRAC
COMMON /SYS/ NUMNUC,NUMSTEPS,DATFILE,NUCFILE,STFILE,ISTEP,DELTAT,
*         ELAPTIME
COMMON /GAS/ gas
```

c

c

c

c

c

c

Calculate decay
variable A will contain curies of nuclide decayed
Setting daughter(nucnum)=0 for each nuclide will suppress
daughter ingrowth...

```
deltat=gas
DO 100 N=1,NUMNUC
DO 75 J=1,5
A(J,N)=0.
DO 50 I=1,3
DEKAY=CONC(J,N,I)*(EXP(-DECAY(N)*2.778E-4*DELTAT))
A(J,N)=CONC(J,N,I)-DEKAY
*         +A(J,N)
CONC(J,N,I)=DEKAY
```

```
50 CONTINUE
```

```
75 CONTINUE
```

```
100 CONTINUE
```

c

c

c

Now add in daughters...

```
DO 200 N=1,NUMNUC
IF (DAUGHTER(N).NE.0) THEN
DO 175 J=1,5
DO 150 I=1,3
CONC(J,(DAUGHTER(N)),I)=CONC(J,(DAUGHTER(N)),I)+
*         A(J,N)*FORMFRAC(GROUP(DAUGHTER(N)),I)*DAUFRAC(N)
```

```
150 CONTINUE
```

```
175 CONTINUE
```

```
ENDIF
```

```
200 CONTINUE
```

```
RETURN
```

```
END
```

c ...end of decay

c

c

```
-----*****
SUBROUTINE STEPOUT
```



```

CHARACTER PGEJECT
CHARACTER*20 DATFILE,NUCFILE,STFILE(4)
CHARACTER*8 NUCNAME(150)
INTEGER DAUGHTER(150),GROUP(150),OUTFILE
REAL OHT
DIMENSION FLOWRATE(7),CONC(5,150,3),FILTEFF(3,150,3),
*      DOSE(6),DCF(150,6),DECAY(150),TSEND(5),
*      CIMWT(150),CUMDOSE(6),FORMFRAC(5,3),DAUFRAC(150)
COMMON /MET/ AREA,BHT,RHT,WO,FO,DIST,OHT,U10,IST1,IST2,XQ
COMMON /FLOW/ TSTEPBEG,TSTEPEND,FLOWRATE,CONC,
*      FILTEFF,CRVOL,dose,BR,rumdose,TSEND,FACOCC
common /nuc/ dcf,daughter,decay,cimwt,GROUP,NUCNAME,FORMFRAC,
*      POWER,DAUFRAC
COMMON /SYS/ NUMNUC,NUMSTEPS,DATFILE,NUCFILE,STFILE,ISTEP,DELTAT,
*      ELAPTIME
COMMON /GAS/ gas
COMMON /OUT/ OUTFILE
PGEJECT=CHAR(12)

```

```

C
C
C
WRITE HEADER TO SCREEN

```

```

WRITE (OUTFILE,*)PGEJECT
WRITE (OUTFILE,*)
WRITE (OUTFILE,*)'TIME STEP START: ',(Elaptime-DELTAT)/3600.
WRITE (OUTFILE,*)'TIME STEP END: ',(elaptime)/3600.
WRITE (OUTFILE,*)
WRITE (OUTFILE,*)'Building cross sectional area (m^2): ',area
WRITE (OUTFILE,*)'Building height (m): ',bht
WRITE (OUTFILE,*)'Release height (m): ',rht
WRITE (OUTFILE,*)'Effluent vertical velocity (m/s): ',WO
WRITE (OUTFILE,*)'Effluent flow rate (m^3/s): ',FO
WRITE (OUTFILE,*)'Horizontal distance to receptor (m): ',dist
WRITE (OUTFILE,*)'Air intake height (m): ',oht
WRITE (OUTFILE,*)'Windspeed (m/s): ',u10
WRITE (OUTFILE,*)'Vertical dispersion class: ',ist1
WRITE (OUTFILE,*)'Horizontal dispersion class: ',ist2
WRITE (OUTFILE,*)
WRITE (OUTFILE,*)'Flow in from unfiltered source 1 (m^3/s): ',
*      flowrate(1)
WRITE (OUTFILE,*)'Flow in from unfiltered source 2 (m^3/s): ',
*      flowrate(2)
WRITE (OUTFILE,*)'Filtered intake flow source 1 (m^3/s): ',
*      flowrate(3)
WRITE (OUTFILE,1020)'Filter efficiency #1 (ele,org,part frac): ',
*      (filteff(3,59,1),I=1,3)
WRITE (OUTFILE,*)'Recirculation flow rate (m^3/s): ',
*      flowrate(5)
WRITE (OUTFILE,1020)'Recirc filter efficiency (e,o,p frac): ',
*      (filteff(1,59,1),I=1,3)
WRITE (OUTFILE,*)'Filtered intake flow 2 (feeds recirc): ',
*      flowrate(4)
WRITE (OUTFILE,1020)'Intake 2 filter efficiency (e,o,p frac): ',
*      (filteff(2,59,1),I=1,3)
WRITE (OUTFILE,*)'Bottled air flow rate (m^3/s): ',
*      flowrate(6)

```

```

WRITE (OUTFILE,*) 'Control room volume (m^3):
*          crvol
WRITE (OUTFILE,*)
WRITE (OUTFILE,*)

WRITE (OUTFILE,1000) 'CUMULATIVE DOSE'
WRITE (OUTFILE,1005)
WRITE (OUTFILE,1010)
WRITE (OUTFILE,*)
WRITE (OUTFILE,1045) ELAPTIME/3600., (CUMDOSE(I), I=1,6)
WRITE (17,1050) ELAPTIME/3600., (CUMDOSE(i), I=1,6)

```

```

1000 FORMAT (32X,A15)
1005 FORMAT(1X,'END TIME',1X,' WH BODY ',1X,' SKIN ',1X,
* ' THYROID ',1X,
* ' LUNG ',1X,' BONE ',1X,' LIVER ')
1010 FORMAT(1X,' HOURS ',6(' REM '))
1020 FORMAT (1X,A42,3(F6.4,5X))
1045 FORMAT (1X,1PE9.3,6(1X,1PE9.3))
1050 FORMAT (7(1X,0PF1E.8))
RETURN
END

```

```

c
c end of stepout
c
c
c

```

-----*****
SUBROUTINE SUMMARY

```

CHARACTER*20 DATFILE,NUCFILE,STFILE(4)
CHARACTER*8 NUCNAME(150)
INTEGER DAUGHTER(150),GROUP(150),NUMSTEPS,OUTFILE
REAL OHT
DIMENSION FLOWRATE(7),CONC(5,150,3),FILTEFF(3,150,3),
* DOSE(6),DCF(150,6),DECAY(150),TSEND(5),
* CIMWT(150),CUMDOSE(6),FORMFRAC(5,3),DAUFRAC(150)
COMMON /MET/ AREA,BHT,RHT,W0,FO,DIST,OHT,U10,IST1,IST2,XQ
COMMON /FLOW/ TSTEPBEG,TSTEPEND,FLOWRATE,CONC,
* FILTEFF,CRVOL,dose,BR,cumdose,TSEND,FACOCC
common /nuc/ dcf,daughter,decay,cimwt,GROUP,NUCNAME,FORMFRAC,
* POWER,DAUFRAC
COMMON /SYS/ NUMNUC,NUMSTEPS,DATFILE,NUCFILE,STFILE,ISTEP,DELTAT,
* ELAPTIME
COMMON /GAS/ gas
COMMON /OUT/ OUTFILE

```

```

ITEMP=OUTFILE
C WRITE SUMMARY TO OUTPUT DEVICE AND TO SCREEN
DO 10 I=1,2
WRITE (OUTFILE,*)
WRITE (OUTFILE,*) ' SUMMARY'
WRITE (OUTFILE,*)
WRITE (OUTFILE,*) ' ORGAN ', ' DOSE (REM)'
WRITE (OUTFILE,*) 'WHOLE BODY DOSE: ', CUMDOSE(1)
WRITE (OUTFILE,*) 'SKIN DOSE: ', CUMDOSE(2)
WRITE (OUTFILE,*) 'THYROID DOSE: ', CUMDOSE(3)
WRITE (OUTFILE,*) 'LUNG DOSE: ', CUMDOSE(4)
WRITE (OUTFILE,*) 'BONE DOSE: ', CUMDOSE(5)
WRITE (OUTFILE,*) 'LIVER DOSE: ', CUMDOSE(6)
WRITE (OUTFILE,*)

```



```

      DO 1 J=1,3
      DO 1 I=1,3
      FILTEFF(J,N,I)=FILT(J,I)
1     CONTINUE
      ELSE IF (GROUP(N).EQ.2) THEN
      DO 2 J=1,3
      DO 2 I=1,3
      FILTEFF(J,N,I)=0.0
2     CONTINUE
      ELSE
      DO 3 J=1,3
      DO 3 I=1,3
      FILTEFF(J,N,I)=FILT(J,3)
3     CONTINUE
      ENDIF
10    CONTINUE

```

C
C
C
C

Need to calculate the new X/Q...

```

OLDXQ=XQ
IF (OLDXQ.EQ.0.) OLDXQ=1.
XQ=WMOD(AREA,BHT,RHT,WO,FO,DIST,OHT,U10,IST1,IST2)

```

C
C
C

Need to adjust concentrations at points three and four
to account for the new X/Q...

```

DO 20 NUC=1,NUMNUC
DO 20 M=3,4
DO 20 I=1,3
CONC(M,NUC,I)=CONC(M,NUC,I)*XQ/OLDXQ
20 CONTINUE

```

C

```

RETURN
END

```

C

```

SUBROUTINE READFPF
CHARACTER*20 DATFILE,NUCFILE,STFILE(4)
CHARACTER*8 NUCNAME(150)
INTEGER GROUP(150),DAUGHTER(150)
REAL OHT,mpf,IFRAC,NOBLEFRAC
DIMENSION FLOWRATE(7),CONC(5,150,3),FILTEFF(3,150,3),
*          DOSE(6),DCF(150,6),DECAY(150),TSEND(5),FILT(3,3),
*          CIMWT(150),CUMDOSE(6),FORMFRAC(5,3),daufrac(150)
COMMON /MET/ AREA,BHT,RHT,WO,FO,DIST,OHT,U10,IST1,IST2,XQ
COMMON /FLOW/ TSTEPBEG,TSTEPEND,FLOWRATE,CONC,
*          FILTEFF,CRVOL,dose,BR,cumdose,TSEND,FACOCC
common /nuc/ dcf,daughter,decay,cimwt,GROUP,NUCFILE,FORMFRAC,
*          POWER,daufrac
COMMON /SYS/ NUMNUC,NUMSTEPS,DATFILE,NUCFILE,STFILE,ISTEP,DELTAT,
*          ELAPTIME
COMMON /FIL/ NUMFILE

```

C

fpm=35.315

C

TSOLD=TSEND(NUMFILE)

C

C

if encounter end of file before 720 hours, keep same source.

C

```

* READ(NUMFILE+2,*,end=1000) NOBLEFRAC,IFRAC,PARTFRAC,
  TSEND(NUMFILE)
C
TSEND(NUMFILE)=TSEND(NUMFILE)*60.

C
Now convert these core fractions/ft^3 to ci/m^3 for each
c
nuclide based on group number
C
DO 100 NUC=1,NUMNUC
  IF (GROUP(NUC).EQ.1) FRAC=IFRAC
  IF (GROUP(NUC).EQ.2) FRAC=NOBLEFRAC
  IF (GROUP(NUC).EQ.3) FRAC=PARTFRAC
  IF (GROUP(NUC).EQ.4) FRAC=PARTFRAC
  IF (GROUP(NUC).EQ.5) FRAC=PARTFRAC
  DO 50 I=1,3
    IF ((GROUP(NUC).EQ.1).AND.(I.EQ.3)) FRAC=PARTFRAC
    CI=POWER*CIMWT(NUC)*FORMFRAC(GROUP(NUC),I)*FRAC*fpm
C
    Now decay since time zero because FPP doesn't...
C
    (if decay*tsold is greater than 30, don't decay so as to
C
    avoid NAN's. Decay will be well below anything significant)
C
    IF (DECAY(NUC)*TSOLD/3600.LT.30) THEN
      CONC(NUMFILE,NUC,I)=CI*(EXP(-DECAY(NUC)*(TSOLD)/3600.))
    ENDIF
  50 CONTINUE
  100 CONTINUE
  RETURN
1000 TSEND(NUMFILE)=2.6E6
  RETURN
  END

C
c
Read in TACT5 data as necessary...
SUBROUTINE READTACT
CHARACTER*20 DATFILE,NUCFILE,STFILE(4)
CHARACTER*8 NUCNAME(150),NAME
INTEGER GROUP(150),DAUGHTER(150)
REAL OHT,mpf,IFRAC,NOBLEFRAC
DIMENSION FLOWRATE(7),CONC(5,150,3),FILTEFF(3,150,3),
* DOSE(6),DCF(150,6),DECAY(150),TSEND(5),FILT(3,3),
* CIMWT(150),CUMDOSE(6),FORMFRAC(5,3),daufrac(150)
COMMON /MET/ AREA,BHT,RHT,W0,FO,DIST,OHT,U10,IST1,IST2,XQ
COMMON /FLOW/ TSTEPBEG,TSTEPEND,FLOWRATE,COMC,
* FILTEFF,CRVOL,dose,BR,cumdose,TSEND,FACOCC
common /nuc/ dcf,daughter,decay,cimwt,GROUP,NUCFILE,FORMFRAC,
* POWER,daufrac
COMMON /SYS/ NUMNUC,NUMSTEPS,DATFILE,NUCFILE,STFILE,ISTEP,DELTAT,
* ELAPTIME
COMMON /FIL/ NUMFILE
C
c
Need to convert curies released to a concentration...
C
WRITE (6,*)
WRITE (6,*) 'NUCLIDE ', 'CONCENTRATION AT INTAKE'

DO 300 NUC=1,NUMNUC

```

```

READ(NUMFILE+5,1000) NAME,IGRP,CI
IF (NAME.EQ.' END') THEN
  TSEND(NUMFILE)=CI*3600.
  RETURN
ENDIF
IF (IGRP.EQ.1) THEN
  READ(NUMFILE+5,1000) NAME,IGRP,CI2
  READ(NUMFILE+5,1000) NAME,IGRP,CI3
  CI=CI+CI2+CI3
ENDIF
C
C   Now find name in nuclide list and retrieve index number
C
DO 10 J=1,122
  IF (NAME.EQ.NUCNAME(J)) GOTO 11
10 CONTINUE
11 NC=J
C
C   Now convert to concentration as follows...
C   (Q(Ci)*X/Q(s/m^3)/[windspeed(m/s)*distance(m)])
C   At the same time, multiply by form fractions
C
DO 250 I=1,3
  * CONC(NUMFILE,NC,I)=(CI*XQ*U10/DIST*
    FORMFRAC(IGRP,I))-CONC(NUMFILE,NC,I)
  WRITE (6,*) NAME,CONC(NUMFILE,NC,I)
C
250 CONTINUE
300 CONTINUE
C
C
1000 FORMAT (1X,A8,2X,I10,F16.8)
  return
  end
C   ...end of readdata
C
FUNCTION WMOD(AREA,BHT,RHT,WO,FO,DIST,OHT,U10,IST1,IST2)
C
C   FUNCTION WMOD
C
C   COMPUTES DIFFUSION ESTIMATES FOR RELEASES IN
C   BUILDING WAKES
C
C   REF. RAMSDELL, NUREG/CR-5055
C
C   INPUT:
C       BLDG AREA - AREA
C       BLDG HEIGHT - BHT
C       RELEASE HT - RHT
C       EFFLUENT VERTICAL VELOCITY - WO
C       FLOW (M^3/SEC) - FO
C       HORIZ. DIST TO RECEPTOR (M) - DIST
C       RECEPTOR HEIGHT - OHT
C       WIND SPEED AT 10M - U10
C       VERT DIFF CLASS - IST1
C       HORIZ DIFF CLASS - IST2

```

```

C   OUTPUT:
C   WMOD - X/Q IN S/M^3
C
C   PI=3.1415927
C
C   CO=150.
C   CX=-1.2
C   CU=0.68
C   CA=CX
C
C   CALL SSIGMA (DIST,IST1,IST2,SIGMAZ,SIGMAY)
C
C   PLUMED=PI*SIGMAY*SIGMAZ*U10
C   COMPUTE LIMITING DISTANCE FOR WAKE ENHANCEMENT TO DIFF RATE
C   CL=SQRT(AREA)
C   XS=DIST+ABS(RHT-OHT)
C   XSL=AMINI(XS,20.0*CL)
C   BMOD=CO*U10**CU*SQRT(FLOAT(IST1))*AREA**CA*XSL**CX
C   WXOQ=1.0/(FO+PLUMED+1.0/BMOD)
C   IF (WO .GT. 0. .AND. RHT .GE. BHT) THEN
C   SPLIT H MODEL
C   CALL PROFILE(U10,IST1,RHT,RHU)
C   PLUMED=PI*SIGMAY*SIGMAZ*RHU
C   VEXP=EXP(-0.5*(RHT/SIGMAZ)**2)
C   EMOD=VEXP/PLUMED
C   WR=WO/RHU
C   IF (WR .GT. 1.0) THEN
C   COMPUTE FRACTION OF TIME PLUME IS IN WAKE
C   IF (WR .LE. 1.5) THEN
C     WF=2.58-1.58*WR
C   ELSE IF (WR .LT. 5.0) THEN
C     WF=0.3-0.06*WR
C   ELSE
C     WF=0.0
C   ENDIF
C
C   WMOD=(1.0-WF)*EMOD+WF*WXOQ
C   ELSE
C   PLUME IS IN WAKE ALL OF THE TIME
C   WMOD=WXOQ
C   ENDIF
C
C   ELSE
C   PLUME IS ENTRAINED IN WAKE
C   WMOD=WXOQ
C   ENDIF
C   WRITE (6,*) 'WMOD: ',WMOD
C   RETURN
C   END
C
C   SUBROUTINE SSIGMA(X,STABZ,STABY,SIGMAZ,SIGMAY)
C
C   REAL AY(7),AZ(7,3),BZ(7,3),CZ(7,3)
C   INTEGER STABZ,STABY
C   DATA AY/ 0.3658, .2751, .2089, .1471, .1046, .0722, .0481/

```



```

DATA AZ/.192,.156,.116,.079,.063,.053,.032,
+ .00066,.0382,.113,.222,.211,.086,.052,
+ .00024,.055,.113,1.26,6.73,18.05,10.83/
DATA BZ/.936,.922,.905,.881,.871,.814,.814,
+ 1.941,1.149,.911,.725,.678,.74,.74,
+ 2.094,1.098,.911,.516,.305,.18,.18/
DATA CZ/0.,0.,0.,0.,0.,0.,0.,
+ 9.27,3.3,0.,-1.7,-1.3,-.35,-.21,
+ -9.6,2.,0.,-13.,-34.,-48.6,-29.2/

```

```

ISY=STABY
IF(STABY .LT. 1 .OR. STABY .GT. 7) ISY=STABZ
SIGMAY=AY(ISY)*X**.9031
IF (X.LE. 100.) THEN
  SIGMAZ=AZ(STABZ,1)*X**BZ(STABZ,1)
ELSE IF(X.LE. 1000.) THEN
  SIGMAZ=AZ(STABZ,2)*X**BZ(STABZ,2)+CZ(STABZ,2)
ELSE IF(X.GT.1000.) THEN
  SIGMAZ=AZ(STABZ,3)*X**BZ(STABZ,3)+CZ(STABZ,3)
ENDIF
RETURN
END

```

C

```

SUBROUTINE PROFILE(SPD,IST,SHGHT,RSPD)

```

```

DIMENSION MOL(7)
DATA MOL/-8,-14,-25,-1000,100,40,20/
PI=3.1415927

IF (IST.LE.3)THEN
  Y=(1-16*SHGHT/MOL(IST))**.25
  PSI=ALOG((.5+Y*Y/2)*(.5+Y/2)**2)-2*ATAN(Y)+PI/2
  Y1=(1-16*10./MOL(IST))**.25
  PSI1=ALOG((.5+Y1*Y1/2)*(.5+Y1/2)**2)-2*ATAN(Y1)+PI/2
  RSPD=SPD*(ALOG(SHGHT/.1)-PSI)/(ALOG(10./1)-PSI1)
ELSE IF(IST.GE.5) THEN
  RSPD=SPD*(ALOG(SHGHT/.1)+5.*SHGHT/MOL(IST))
+ /((ALOG(10./1)+5.*10./MOL(IST))
ELSE
  RSPD=SPD*ALOG(SHGHT/.1)/ALOG(10./1)
ENDIF
RETURN
END

```

APPENDIX C
CHEM CODE LISTING

```

C      If a=0, no removal (except decay)
C
IF (A.LT.-88.) A=-87
IF (A.GT.88) A=87
IF (a.NE.0.) THEN
  ACTIN=(CONC(ISTEP)*FLOWRATE(1)+CONC(ISTEP)*
*     FLOWRATE(2)+CONC(ISTEP)*FLOWRATE(3))
  IF (ISTEP.EQ.0) THEN
    CROLD=0.
  ELSE
    CROLD=CRCONC(ISTEP-1)
  ENDIF
  CRCONC(ISTEP)=CROLD*EXP(-a*DELTAT)+
*     (ACTIN/a-(ACTIN/a)*(EXP(-a*DELTAT)))/CRVOL
C
C
  ENDIF
C
  Calculate EXPOSURE AND MEAN...
  IF (ISTEP.EQ.0) EXPOS(ISTEP)=CRCONC(ISTEP)*DELTAT
  IF (ISTEP.GT.0) EXPOS(ISTEP)=EXPOS(ISTEP-1)+CRCONC(ISTEP)*
*     DELTAT
  MEAN(ISTEP)=EXPOS(ISTEP)/((ISTEP+1)*DELTAT)
C
200 CONTINUE
C
C      Go write out summary information to screen...
C
OPEN(7,FILE='CRHPLOT.C.DAT')
WRITE (6,3010)'TIME','CONCENTRATION','EXPOSURE','MEAN CONC'
WRITE (6,3020)'min','g/m^3','g*s/m^3','g/m^3'
DO 300 ISTEP=0,I-1
  WRITE (6,*) TIME(ISTEP),CRCONC(ISTEP),EXPOS(ISTEP),MEAN(ISTEP)
  WRITE (7,3000)TIME(ISTEP),CRCONC(ISTEP),EXPOS(ISTEP),MEAN(ISTEP)
300 CONTINUE
3000 FORMAT (1X,4(OPF16.8))
3010 FORMAT (8X,A4,9X,A13,5X,A8,9X,A9)
3020 FORMAT (8X,A3,14X,A5,10X,A7,10X,A5)
STOP
END

```

APPENDIX D
CRHPLOTR CODE LISTING

```

* PROGRAM CRHPLOTR.PRG
*
* A PLOTTING PROGRAM FOR OUTPUT FROM CONHAB.
*
* REQUIRES SOME FORM OF GRAPHICS ADAPTER
*
* UTILIZES FLIPPER GRAPHICS ROUTINES

clear
prt='N'
@5,1 say 'Send graph to printer? ' get prt
read
clear
if prt$'Yy'
  @1,1 say 'Highlight your printer and hit return...'
  declare prnt[75]
  afill(prnt,"")
  for i=1 to 75
    prnt[i]=prt_load(i,'prx.tbl')
  next i
  prtr=achoice(3,30,20,50,prnt)
  clear
endif
FLIP_INIT(6000)

clear
mdl30='N'
@7,1 say 'Do you have an IBM PS-2 Model 30 (Y/N)? ' get mdl30
read
if mdl30$'Yy'
  set_disply(3)
  graphmode(9)
endif
*

*
min_fh=font_open("rmn8_17.@" )
max_fh=FONT_OPEN("RMN8_21.@" )
sm=font_open("rmn8_12.@" )
*
INITDATA(4)
SET_TYPE(1,2)
set_type(2,2)
set_type(3,2)
*set_type(4,2)
*set_type(5,2)
*
USE CRHOUT.DBF
ZAP
APPEND FROM CRHPLOTR.DAT DELI WITH BLANK
GO TOP
W=0
T=0
TM=0
DO WHILE .NOT. EOF()

if (wb<>0).and.(sk<>0).and.(th<>0)
  STORE_DATA(X,WB,SK,TH)
endif
SKIP

```

```

ENDDO
set_miss(2)
set_mvalue(.0001)
set_mstyle(1)

SET_YLOG(1)
*
G_LABEL("Dose versus Time")
x_label("Time (hours)")
y_label("Dose (rem)")

set_legend(1,"Whole Body")
set_legend(3,"Thyroid")
set_legend(2,"Skin")

set_style(2,2)
set_style(3,3)

set_ln_pat(0,6)
set_ln_pat(2,0)
set_ln_pat(3,0)

SET_G_FONT(max_fh)
SET_S_FONT(min_fh)
set_l_font(min_fh)
*
set_area(0,0,80,100)
set_grid(0)
PLOT()
say_legend(atx(81,2),aty(25,2),1,0)
*

if prt$'Yy'
prt_stat(1)
prt_size(7,6,1)
prt_screen('prn',prtr,'prx.tbl',atx(0,2),aty(0,2),atx(100,2),aty(100,2))
eject
endif
inkey(0)
*

TEXTMODE()

*
*
INITDATA(4)
SET_TYPE(1,2)
*
go top
DO WHILE .NOT. EOF()
STORE_DATA(X,WB,SK,TH)
SKIP
ENDDO
*

```

```

set_yside(0,1)
y_label2(" ")
set_yside(0,0)
G_LABEL("Thyroid Dose")
x_label("Time (hours)")
y_label("Dose (rem)")

set_ln_pat(0,6)
set_yskip(2)
SET_G_FONT(sm)
SET_S_FONT(sm)
set_l_font(sm)
*
set_type(2,0)
set_type(1,0)
set_area(0,0,48,48)
set_grid(0)
PLOT()

set_area(52,0,100,48)
set_type(1,2)
set_type(2,0)
set_type(3,0)
g_label("Whole Body Dose")
pTot()

set_area(0,52,48,100)
set_type(3,0)
set_type(1,0)
set_type(2,2)
g_label("Skin Dose")
pTot()
*
if prt$'Yy'
prt_size(6,8,1)
prt_screen('prn',prtr,"prx.tbl",atx(0,2),aty(0,2),atx(100,2),aty(100,2))
eject
endif

inkey(0)
*
TEXTMODE()
RETURN

```

APPENDIX E
CRHPLOTG CODE LISTING

```

* PROGRAM CRHPLOT.C.PRG
*
* A PROGRAM TO PLOT THE OUTPUT FROM CHEM
*
* USES FLIPPER GRAPHICS ROUTINES
*
FLIP_INIT(6000)
*
clear
prt='N'
@5,1 say 'Send graph to printer? ' get prt
read

if prt$'Yy'
  @1,1 say 'Highlight your printer and hit return...'
  declare prnt[75]
  afill(prnt,"")
  for i=1 to 75
    prnt[i]=prt_load(i,'prx.tbl')
  next i
  prtr=achoice(3,30,20,50,prnt)
  clear
endif

clear
mdl30='N'
@7,1 say 'Do you have an IBM PS-2 Model 30 (Y/N)? ' get mdl30
read
if mdl30$'Yy'
  set_disply(3)
  gm=graphmode(9)
endif
min_fh=font_open("rmn8_17.@")
max_fh=FONT_OPEN("RMN8_21.@")
*
INITDATA(4)
SET_TYPE(1,2)
set_type(2,2)
set_type(3,2)
*
USE CRHOUT.C.DBF
ZAP
APPEND FROM CRHPLOT.C.DAT DELI WITH BLANK
go top
DO WHILE .NOT. EOF()
  if conc=0.0
    conc=.0000001
  endif
  if exp=0.0
    exp=.0000001
  endif
  if mean=0.0
    mean=.0000001
  endif
  STORE_DATA(X,conc,exp,mean)

SKIP
ENDDO

set_ylog(1)

```

```

*
G_LABEL("Toxic Gas Analysis")
x_label("Time (hours)")
y_label("Concentration (g/m^3)")

set_legend(1,"Concentration")
set_legend(3,"Mean Conc.")
set_style(3,3)
set_yskip(10)
set_xskip(3)

set_ln_pat(0,6)
set_ln_pat(3,0)

set_yside(0,1)
set_yside(2,1)
set_yskip(10)
set_ylog(1)
y_label2("Exposure (g*sec/m^3)")
set_style(2,2)
set_legend(2,"Exposure")
set_ln_pat(2,0)

SET_G_FONT(max_fh)
SET_S_FONT(min_fh)
set_l_font(min_fh)
*
set_area(0,0,100,100)
PLOT()
say_legend(atx(51,2),aty(60,2),1,0)
set_yside(0,0)
*

if prt$'Yy'
  prt_stat(1)
  prt_size(7,6,1)
  prt_screen('prn',prtr,'prx.tbl',atx(0,2),aty(0,2),atx(100,2),aty(100,2))
endif

wait
textmode()
return

```

APPENDIX F
NUCLIDE FILE ICRP.02

NA 22									
8.448000E-09	2.384000E-06			1.300000E 04	1.300000E 04	1.300000E 04	1.300000E 04		
0.0	0.0			0	0	0			
1	4	0	0						
NA 24									
1.273000E-05	1.429000E+00			1.278000E 02	1.278000E 03	1.278000E 03	1.280000E 03		
0.0	0.0			0	0	0			
2	4	0	0						
GE 77									
1.703000E-05	3.761000E+01								
0.0	0.0	0.0		0.0		0.0		0.0000000000	
3	3	0	0	0	0	0			
SE 79									
3.381000E-13	6.921000E-03								
0.0	0.0	0.0		0.0	4.470000E 04	0.0		3.830000E 02	
4	3	0	0	0	0				
BR 82									
5.456000E-06	6.905000E+01								
0.0	0.0	0.0		0.0		0.0		0.0	
5	1	0	0	0	0	0			
KR 83M									
1.035000E-04	4.152000E+03								
5.020000E-06	1.148000E-02	0.0			5.201000E-01	0.0		0.0	
6	2	0	0	0	0				
BR 83									
8.021000E-05	2.930000E+03								
0.0	0.0	0.0		0.0		0.0		0.0	
7	1	0	0	0	0	0			
BR 84									
3.646000E-04	4.339000E+03								
0.0	0.0	0.0		0.0		0.0		0.0	
8	1	0	0	0	0	0			
KR 8EM									
4.385000E-05	1.297000E+04								
3.720000E-02	1.189000E-01	0.0			2.919000E 00	0.0		0.0	
9	2	10	0.211	0	0				
KR 85									
2.042000E-09	4.102000E+02								
5.250000E-04	6.880999E-02	0.0			2.416000E 00	0.0		0.0	
10	2	0	0	0	0				
BR 85									
3.850000E-03	4.923000E+03								
0.0	0.0	0.0		0.0		0.0		0.0	
11	1	0	0	0	0	0			
RB 86									
4.289000E-07	1.324000E+02								
0.0	0.0	0.0		0.0		0.0		1.690000E 04	
12	3	0	0	0	0	0			
KR 87									
1.519000E-04	2.335000E+04								
1.870000E-01	5.961000E-01	0.0			1.537000E 01	0.0		0.0	
13	2	0	0	0	0				
KR 88									
6.875000E-05	3.200000E+04								
4.640000E-01	6.627000E-01	0.0			3.136000E 01	0.0		0.0	
14	2	15	1.0	0	0				
RB 88									
6.468000E-04	1.200000E+04								
0.0	0.0	0.0		0.0		0.0		4.840000E 01	
15	3	0	0	0	0	0			
KR 89									
3.630000E-03	3.979000E+04								

5.250000E+01	9.222200E-01	0.0	0.0	0.0	0.0	0.0	0.0
16	2	17	1.0	0	0	0	0
RB 89							
3.629000E-03	1.538000E+04	0.0	0.0	0.0	0.0	0.0	3.200000E 01
0.0	0.0	0.0	0.0	0	0	0	0
17	3	18	1.0	0	0	0	0
SR 89							
1.588000E-07	1.552000E+04	0.0	0.0	0.0	1.749000E 05	3.801000E 04	0.0
0.0	0.0	0.0	0.0	0	0	0	0
18	3	0	0	0	0	0	0
RB 90							
3.982000E-03	1.335000E+04	0.0	0.0	0.0	0.0	0.0	0.0000000000
0.0	0.0	0.0	0.0	0	0	0	0
19	3	0	0	0	0	0	0
SR 90							
8.020999E-10	7.401000E+02	0.0	0.0	0.0	1.196000E 06	1.244000E 07	0.0
0.0	0.0	0.0	0.0	0	0	0	0
20	3	21	1.0	0	0	0	0
Y 90							
2.993000E-06	7.887000E+02	0.0	0.0	0.0	2.120000E+04	2.612000E 02	0.0
0.0	0.0	0.0	0.0	0	0	0	0
21	3	0	0	0	0	0	0
SR 91							
2.005001E-05	2.118000E+04	0.0	0.0	0.0	4.557000E 03	7.741000E 00	0.0
0.0	0.0	0.0	0.0	0.426	0	0	0
22	3	23	0.574	24	0	0	0
Y 91M							
2.293000E-04	1.230000E+04	0.0	0.0	0.0	2.402000E 02	3.264000E-02	0.0
0.0	0.0	0.0	0.0	0	0	0	0
23	3	24	1.0	0	0	0	0
Y 91							
1.383000E-07	2.121000E+04	0.0	0.0	0.0	2.130000E 05	5.781000E 04	0.0
0.0	0.0	0.0	0.0	0	0	0	0
24	3	0	0	0	0	0	0
SR 92							
7.292000E-05	2.508000E+04	0.0	0.0	0.0	2.061000E 03	8.431000E-01	0.0
0.0	0.0	0.0	0.0	0	0	0	0
25	3	26	1.0	0	0	0	0
Y 92							
5.346999E-05	2.535000E+04	0.0	0.0	0.0	1.961000E 03	1.292000E 00	0.0
0.0	0.0	0.0	0.0	0	0	0	0
26	3	0	0	0	0	0	0
SR 93							
1.444000E-03	3.017000E+04	0.0	0.0	0.0	0.0	0.0	0.0
0.0	0.0	0.0	0.0	0	0	0	0
27	3	0	0	0	0	0	0
Y 93							
1.909000E-05	3.163000E+04	0.0	0.0	0.0	6.062000E 03	1.182000E 01	0.0
0.0	0.0	0.0	0.0	0	0	0	0
28	3	29	1.0	0	0	0	0
ZR 93							
2.006000E-14	2.459000E-02	0.0	0.0	0.0	2.129000E 04	5.223000E 04	2.920000E 03
0.0	0.0	0.0	0.0	0	0	0	0
29	3	0	0	0	0	0	0
ZR 95							
1.267000E-07	3.858000E+04	0.0	0.0	0.0	2.214000E 05	1.339000E 04	4.300000E 03
0.0	0.0	0.0	0.0	0	0	0	0
30	3	0	0	0	0	0	0
NB 95							
2.292000E-07	3.842000E+04	0.0	0.0	0.0	6.311000E 04	1.758000E 03	9.770000E 02
0.0	0.0	0.0	0.0	0	0	0	0
31	3	0	0	0	0	0	0

ZR 97									
1.129000E-05	4.197000E+04								
0.0	0.0	0.0					9.839000E 03	1.214000E 01	2.450000E 00
32	3	33	0.947	34			0.053	0	
NB 97M									
1.155000E-02	3.987000E+04								
0.0	0.0	0.0					0.0	0.0	0.0000000000
33	3	34	1.0	0	0	0	0		
NB 97									
1.573000E-04	4.235000E+04								
0.0	0.0	0.0					2.995000E 02	2.777000E-02	7.030000E-03
34	3	0	0	0	0	0	0		
MC 99									
2.874000E-06	4.880000E+04								
0.0	0.0	0.0					1.140000E 04	0.0	1.510000E 03
35	3	36	0.886	0	0	0	0		
TC 99M									
3.183000E-05	4.278000E+04								
0.0	0.0	0.0					9.546001E 01	1.287000E-04	3.640000E-04
36	3	0	0	0	0	0	0		
TC 99									
1.042000E-13	2.534000E-01								
0.0	0.0	0.0					1.011000E 05	3.132001E 01	4.640000E 01
37	3	0	0	0	0	0	0		
TC 101									
8.250000E-04	5.188000E+04								
0.0	0.0	0.0					4.985001E 01	5.215000E-06	7.520000E-06
38	3	0	0	0	0	0	0		
RU 103									
2.025000E-07	5.381000E+04								
0.0	0.0	0.0					6.312000E 04	1.906000E 02	0.0
39	3	0	0	0	0	0	0		
RU 105									
4.221000E-05	4.051000E+04								
0.0	0.0	0.0					1.375000E 03	9.877002E-02	0.0
40	3	0	0	0	0	0	0		
RU 106									
2.197000E-08	2.270000E+04								
0.0	0.0	0.0					1.174000E 06	8.643000E 03	0.0
41	3	42	1.0	0	0	0	0		
RH 106									
2.310000E-02	2.272000E+04								
0.0	0.0	0.0					0.0	0.0	0.0000000000
42	3	0	0	0	0	0	0		
PD 107									
3.139000E-15	3.975000E-03								
0.0	0.0	0.0					9.472000E 03	0.0	8.270000E 01
43	3	0	0	0	0	0	0		
RH 109									
1.925000E-04	1.223000E+04								
0.0	0.0	0.0					0.0	0.0	0.0000000000
44	3	0	0	0	0	0	0		
PD 109									
1.407000E-05	1.277000E+04								
0.0	0.0	0.0					1.852000E 03	0.0	4.630000E-01
45	3	0	0	0	0	0	0		
AG 111									
1.069000E-06	3.159000E+03								
0.0	0.0	0.0					2.333000E 04	4.253000E 01	1.780000E 01
46	3	0	0	0	0	0	0		
IN 115M									
4.220000E-05	9.015000E+02								

0.0 0.0 1.114000E 01 0.0 5.888000E 01 0.0000000000
 47 3 0 0 0 0 0
 SN 123
 2.750000E-04 1.832000E+02
 0.0 0.0 5.665000E 02 2.878000E 05 3.015000E 04 6.670000E 02
 48 3 0 0 0 0 0
 SN 125
 8.443000E-07 5.698000E+02
 0.0 0.0 2.588000E 01 7.367000E 04 1.162000E 03 3.120000E 01
 49 3 50 1.0 0 0 0
 SB 125
 9.158001E-09 6.103000E+02
 0.0 0.0 6.747000E 00 2.175000E 05 6.665000E 03 7.440000E 01
 50 3 51 0.231 0 0 0
 TE 125M
 1.383000E-07 1.253000E+02
 0.0 0.0 1.313000E 02 3.919000E 04 4.268000E 02 1.980000E 02
 51 3 0 0 0 0 0
 SB 126
 6.416000E-07 9.707000E+01
 0.0 0.0 2.746000E 00 9.569000E 04 4.497000E 02 9.130000E 00
 52 3 0 0 0 0 0
 SB 127
 2.069000E-06 4.527000E+03
 0.0 0.0 3.968000E-01 2.048000E 04 3.299001E 01 7.220000E-01
 53 3 54 0.169 55 0.831 0
 TE 127M
 7.637999E-08 6.114000E+02
 0.0 0.0 4.110000E 02 1.200000E 05 1.575000E 03 7.210000E 02
 54 3 55 0.982 0 0 0
 TE 127
 2.055999E-05 4.501000E+03
 0.0 0.0 1.325000E-01 8.137000E 02 1.754000E-01 8.030000E-02
 55 3 0 0 0 0 0
 I 129
 1.294000E-15 0.0000000000
 3.020000E-03 2.435000E-02 5.542000E 06 0.0 2.476000E 03 2.110000E 03
 56 1 0 0 0 0 0
 TE 129M
 2.359000E-07 1.668000E+03
 0.0 0.0 4.297000E 02 1.448000E 05 1.219000E 03 5.840000E 02
 57 3 58 0.629 0 0 0
 TE 129
 1.573000E-04 1.111000E+04
 0.0 0.0 4.872002E-03 2.418000E 02 6.219000E-03 2.990000E-03
 58 3 0 0 0 0 0
 I 131
 9.963996E-07 2.508000E+04
 8.719999E-02 1.655000E-01 1.485000E 06 0.0 3.149000E 03 4.470000E 03
 59 1 60 0.011 0 0 0
 XE 131M
 6.680000E-07 2.595000E+02
 2.920000E-03 3.995000E-02 0.0 1.400000E+00 0.0 0.0
 60 2 0 0 0 0 0
 TE 131
 4.620000E-04 2.741000E+04
 0.0 0.0 1.170000E-03 1.740000E+02 1.390000E-03 7.440000E-04
 61 3 59 1.0 0 0 0
 TE 131M
 6.416000E-06 4.800000E+03
 0.0 0.0 6.879000E 00 1.823000E 04 8.743000E 00 5.450000E 00
 62 3 61 0.222 59 0.778 0

I 132
 8.269001E-05 3.806000E+04
 5.137000E-01 7.927000E-01 5.353000E 04 0.0 1.447000E 02 4.070000E 02
 63 1 0 0 0 0 0
 TE 132
 2.506000E-06 4.115000E+04
 0.0 0.0 2.366000E 01 3.598000E 04 3.253000E 01 2.690000E 01
 64 3 63 1.0 0 0 0
 I 133
 9.219000E-06 5.622000E+04
 1.551000E-01 3.120000E-01 3.970000E 05 0.0 1.077000E 03 1.850000E 03
 65 1 66 0.029 67 0.971 0
 XE 133M
 3.490000E-06 1.384000E+03
 8.000000E-03 5.391000E-02 0.0 1.890000E+00 0.0 0.0
 66 2 67 1.0 0 0 0
 XE 133
 1.522000E-06 5.622000E+04
 9.330000E-03 5.454000E-02 0.0 1.573000E 00 0.0 0.0
 67 2 0 0 0 0 0
 TE 133M
 2.310000E-04 1.789000E+04
 0.0 0.0 6.269000E-03 5.506001E 02 7.243998E-03 5.400000E-03
 68 3 0 0 0 0 0
 I 134
 2.228000E-04 6.575000E+04
 5.327000E-01 8.593000E-01 2.537000E 04 0.0 8.047000E 01 2.160000E 02
 69 1 0 0 0 0 0
 TE 134
 2.750000E-04 3.999000E+04
 0.0 0.0 3.437000E-03 4.377000E 02 3.843000E-03 3.220000E-03
 70 3 69 1.0 0 0 0
 CS 134
 9.551002E-09 1.019000E+03
 0.0 0.0 0.0 1.216000E 04 4.662000E 04 1.060000E 05
 71 3 0 0 0 0 0
 I 135
 2.864000E+05 5.103000E+04
 4.217000E-01 5.803000E-01 1.235000E 05 0.0 3.353999E 02 8.730000E 02
 72 1 73 0.165 74 0.835 0
 XE 135M
 7.400000E-04 1.557000E+04
 9.920000E-02 1.484000E-01 0.0 2.231000E 00 0.0 0.0
 73 2 74 1.0 0 0 0
 XE 135
 2.091999E-05 5.363000E+04
 5.720000E-02 1.620000E-01 0.0 4.061000E 00 0.0 0.0
 74 2 0 0 0 0 0
 CS 135
 7.293001E-15 2.909000E-02
 0.0 0.0 0.0 1.566000E 03 1.459000E 04 1.290000E 04
 75 3 0 0 0 0 0
 I 136
 8.349001E-03 0.0000000000
 6.786000E-01 1.300000E+00 0.0 0.0 0.0 0.0000000000
 76 1 0 0 0 0 0
 CS 136
 6.160000E-07 1.667000E+03
 0.0 0.0 0.0 1.500000E 03 4.879000E 03 1.830000E 04
 77 3 0 0 0 0 0
 XE 137
 2.961000E-03 5.103000E+04

4.530000E-02	5.676000E-01	0.0				1.748000E 01	0.0	0.0
78	2	79	1.0	0	0	0		
CS 137								
7.292000E-10	1.907000E+03					9.400000E 03	5.977000E 04	7.760000E 04
0.0	0.0	0.0				0		
79	3	80	0.946	0	0			
BA 137M								
4.528999E-03	1.811000E+03					0.0	0.0	0.0000000000
0.0	0.0	0.0				0		
80	3	0	0	0	0			
XE 138								
6.796001E-04	4.775000E+04					2.445000E 01	0.0	0.0
2.810000E-01	4.249000E-01	0.0				0		
81	2	82	1.0	0	0			
CS 138								
3.587001E-04	4.878000E+04					6.066000E 00	4.137000E 01	7.760000E 01
0.0	0.0	0.0				0		
82	3	0	0	0	0			
CS 139								
1.216000E-03	4.478000E+04					2.837000E 00	2.557001E 01	3.630000E 01
0.0	0.0	0.0				0		
83	3	0	0	0	0			
BA 139								
1.393000E-04	4.604000E+04					4.697000E 02	1.167000E-01	8.320000E-05
0.0	0.0	0.0				0		
84	3	0	0	0	0			
BA 140								
6.266000E-07	4.274000E+04					1.587000E 05	4.884000E 03	6.130000E 00
0.0	0.0	0.0				0		
85	3	86	1.0	0	0			
LA 140								
4.774000E-06	4.342000E+04					1.701000E 04	4.300999E 01	2.170000E 01
0.0	0.0	0.0				0		
86	3	0	0	0	0			
BA 141								
6.416000E-04	4.345000E+04					2.419000E 02	1.247000E-02	9.410000E-06
0.0	0.0	0.0				0		
87	3	88	1.0	0	0			
LA 141								
4.935999E-05	4.371000E+04					1.345000E 03	5.342000E-01	1.660000E-01
0.0	0.0	0.0				0		
88	3	89	1.0	0	0			
CE 141								
2.506000E-07	4.387000E+04					4.517000E 04	2.494000E 03	1.690000E 03
0.0	0.0	0.0				0		
89	3	0	0	0	0			
BA 142								
1.050000E-03	3.762000E+04					1.487000E 02	3.294000E-03	3.380000E-06
0.0	0.0	0.0				0		
90	3	91	1.0	0	0			
LA 142								
1.255000E-04	3.883000E+04					7.907000E 02	8.535999E-02	3.880000E-02
0.0	0.0	0.0				0		
91	3	0	0	0	0			
CE 143								
6.030000E-06	3.552000E+04					9.972000E 03	2.334000E 01	1.720000E 01
0.0	0.0	0.0				0		
92	3	93	1.0	0	0			
PR 143								
5.854000E-07	3.467000E+04					3.506000E 04	1.168000E 03	4.690000E 02
0.0	0.0	0.0				0		
93	3	0	0	0	0			

CE 144									
2.766000E-08	2.294000E+04								
0.0	0.0		0.0						
94	3	95	0.986	0				9.716000E 05	4.286000E 05
									1.790000E 05
									0
PR 144									
6.676000E-04	2.302000E+04								
0.0	0.0		0.0						
95	3	0	0	0				1.272000E 02	3.763000E-03
									1.560000E-03
									0
ND 147									
7.090000E-07	1.733000E+04								
0.0	0.0		0.0						
96	3	97	1.0	0				2.759000E 04	6.592000E 02
									7.620000E 02
									0
PM 147									
8.718001E-09	4.881000E+03								
0.0	0.0		0.0						
97	3	0	0	0				3.020000E 04	8.368000E 04
									7.870000E 03
									0
ND 149									
9.664999E-05	1.121000E+04								
0.0	0.0		0.0						
98	3	0	0	0				0.0	3.676001E 02
									0.0000000000
									0
PM 149									
3.625000E-06	1.122000E+04								
0.0	0.0		0.0						
99	3	0	0	0				7.206000E 03	3.439000E 01
									4.870000E 00
									0
PM 151									
6.875000E-06	6.828000E+03								
0.0	0.0		0.0						
100	3	0	0	0				3.939000E 03	8.496000E 00
									1.420000E 00
									0
SM 151									
2.168000E-10	7.226000E+01								
0.0	0.0		0.0						
101	3	0	0	0				4.454000E 04	8.589000E 04
									1.480000E 04
									0
EU 155									
1.292000E-08	2.973000E+02								
0.0	0.0		0.0						
102	3	0	0	0				9.463000E 04	1.005000E 05
									1.430000E 04
									0
EU 156									
5.347000E-07	1.575000E+03								
0.0	0.0		0.0						
103	3	0	0	0				8.556000E 04	1.927000E 03
									1.480000E 03
									0
GD 159									
1.069000E-05	3.083000E+02								
0.0	0.0		0.0						
104	3	0	0	0				0.0	6.478000E 02
									0.0000000000
									0
U 235									
3.095999E-17	9.169000E-05								
0.0	0.0		0.0						
105	3	0	0	0				4.896000E 07	1.001000E 07
									0.0
									0
U 237									
1.188000E-06	3.456000E+03								
0.0	0.0		0.0						
106	3	107	1.0	0				1.020000E 04	3.673000E 01
									0.0
									0
NP 237									
1.027000E-14	2.150000E-03								
0.0	0.0		0.0						
107	3	0	0	0				5.215000E 07	1.693000E 09
									1.470000E 08
									0
PU 238									
2.431000E-10	2.775000E+01								
0.0	0.0		0.0						
108	5	0	0	0				1.825000E 08	2.737000E 09
									3.870000E 08
									0
NP 238									
3.819000E-06	7.741000E+02								

0.0		0.0		0.0		1.016000E 04	2.962000E 02	8.000000E 00
109	3	108	1.0	0	0	0		
PU 239								
9.012000E-13		1.227000E+02				1.716000E 08	3.188000E 09	4.310000E 08
0.0		0.0		0.0		0		
110	5	105	1.0	0	0			
U 239								
4.916000E-04		8.928000E+05				0.0	0.0	0.0
0.0		0.0		0.0		0		
111	3	112	1.0	0	0			
NP 239								
3.442000E-06		8.293000E+05				4.702000E 03	2.866000E 01	2.820000E 00
0.0		0.0		0.0		0		
112	3	110	1.0	0	0			
PU 240								
3.342000E-12		7.235000E+01				1.716000E 08	3.183000E 09	4.300000E 08
0.0		0.0		0.0		0		
113	5	0	0	0	0			
PU 241								
1.671000E-09		3.779000E+03				1.517000E 05	6.407000E 07	3.280000E 06
0.0		0.0		0.0		0		
114	5	115	1.0	0	0			
AM 241								
4.803000E-11		1.571000E+01				6.062000E 07	1.013000E 06	3.590000E 08
0.0		0.0		0.0		0		
115	3	107	1.0	0	0			
PU 242								
5.812001E-14		2.110000E-02				1.651000E 08	2.954000E 09	4.150000E 08
0.0		0.0		0.0		0		
116	5	0	0	0	0			
CM 242								
4.936000E-08		9.018000E+02				3.923000E 07	1.483000E 07	1.510000E 07
0.0		0.0		0.0		0		
117	3	108	1.0	0	0			
AM 242M								
1.432000E-10		1.457000E+00				2.443000E 07	1.019000E 09	3.460000E 08
0.0		0.0		0.0		0		
118	3	0	0	0	0			
CM 243								
6.855001E-10		3.528000E-01				6.312000E 07	7.856000E 08	2.970000E 06
0.0		0.0		0.0		0		
119	3	110	0.998	0	0			
AM 243								
2.766000E-12		5.306000E-02				5.747000E 07	1.013000E 09	3.470000E 08
0.0		0.0		0.0		0		
120	3	112	1.0	0	0			
CM 244								
1.248000E-09		1.497000E+00				6.062000E 07	5.904000E 08	2.540000E 08
0.0		0.0		0.0		0		
121	3	113	1.0	0	0			
AM 244								
4.431000E-04		3.186000E+00				0.0	2.985000E 03	0.0000000000
0.0		0.0		0.0		0		
122	3	121	1.0	0	0			

APPENDIX G
NUCLIDE FILE ICRP.30

NA 22
 8.448000E-05 2.384000E-06
 0.0 0.0 1.300000E 04 1.300000E 04 1.300000E 04 1.300000E 04
 1 4 0 0 0 0 0

NA 24
 1.273000E-05 1.429000E+00
 0.0 0.0 1.278000E 03 1.278000E 03 1.278000E 03 1.280000E 03
 2 4 0 0 0 0 0

GE 77
 1.703000E-05 3.761000E+01
 0.0 0.0 0.0 0.0 0.0 0.0000000000
 3 3 0 0 0 0 0

SE 79
 3.381000E-13 6.921000E-03
 0.0 0.0 0.0 4.470000E 04 0.0 3.830000E 02
 4 3 0 0 0 0 0

BR 82
 5.456000E-06 6.905000E+01
 0.0 0.0 0.0 0.0 0.0 0.0
 5 1 0 0 0 0 0

KR 83M
 1.035000E-04 4.152000E+03
 1.270000E-05 0.000000E+00 0.000000E+00 5.201000E-01 0.000000E+00 0.0
 6 2 0 0 0 0 0

BR 83
 8.021000E-05 2.930000E+03
 0.0 0.0 0.0 0.0 0.0 0.0
 7 1 0 0 0 0 0

BR 84
 3.646000E-04 4.339000E+03
 0.0 0.0 0.0 0.0 0.0 0.0
 8 1 0 0 0 0 0

KR 85M
 4.325000E-05 1.297000E+04
 2.310000E-02 4.970000E-02 0.000000E+00 2.919000E 00 0.000000E+00 0.0
 9 2 10 0.211 0 0 0

KR 85
 2.042000E-09 4.102000E+02
 3.310000E-04 4.840000E-02 0.000000E+00 2.416000E 00 0.000000E+00 0.0
 10 2 0 0 0 0 0

BR 85
 3.850000E-03 4.923000E+03
 0.0 0.0 0.0 0.0 0.0 0.0
 11 1 0 0 0 0 0

RB 86
 4.289000E-07 1.324000E+02
 0.0 0.0 0.0 0.0 0.0 1.690000E 04
 12 3 0 0 0 0 0

KR 87
 1.519000E-04 2.335000E+04
 1.330000E-01 3.360000E-01 0.000000E+00 1.537000E 01 0.000000E+00 0.0
 13 2 0 0 0 0 0

KR 88
 6.875000E-05 3.200000E+04
 3.380000E-01 7.760000E-02 0.000000E+00 3.136000E 01 0.000000E+00 0.0
 14 2 15 1.0 0 0 0

RB 88
 6.468000E-04 1.200000E+04
 0.0 0.0 0.0 0.0 0.0 4.840000E 01
 15 3 0 0 0 0 0

KR 89
 3.630000E-03 3.979000E+04
 3.030000E-01 3.470000E-01 0.000000E+00 0.000000E+00 0.000000E+00 0.0
 16 2 17 1.0 0 0 0
 RB 89
 3.629000E-03 1.538000E+04
 0.0 0.0 0.0 0.0 0.0 0.0 0.0 3.200000E 01
 17 3 18 1.0 0 0 0
 SR 89
 1.588000E-07 1.552000E+04
 0.0 0.0 0.0 0.0 1.749000E 05 3.801000E 04 0.0
 18 3 0 0 0 0 0
 RB 90
 3.982000E-03 1.335000E+04
 0.0 0.0 0.0 0.0 0.0 0.0 0.0000000000
 19 3 0 0 0 0 0
 SR 90
 8.020999E-10 7.401000E+02
 0.0 0.0 0.0 1.196000E 06 1.244000E 07 0.0
 20 3 21 1.0 0 0 0
 Y 90
 2.993000E-06 7.887000E+02
 0.0 0.0 0.0 2.120000E+04 2.612000E 02 0.0
 21 3 0 0 0 0 0
 SR 91
 2.005001E-05 2.118000E+04
 0.0 0.0 0.0 4.557000E 03 7.741000E 00 0.0
 22 3 23 0.574 24 0.426 0
 Y 91M
 2.292000E-04 1.230000E+04
 0.0 0.0 0.0 2.402000E 02 3.264000E-02 0.0
 23 3 24 1.0 0 0 0
 Y 91
 1.383000E-07 2.121000E+04
 0.0 0.0 0.0 2.130000E 05 5.781000E 04 0.0
 24 3 0 0 0 0 0
 SR 92
 7.292000E-05 2.508000E+04
 0.0 0.0 0.0 2.061000E 03 8.431000E-01 0.0
 25 3 26 1.0 0 0 0
 Y 92
 5.346999E-05 2.535000E+04
 0.0 0.0 0.0 1.961000E 03 1.292000E 00 0.0
 26 3 0 0 0 0 0
 SR 93
 1.444000E-03 3.017000E+04
 0.0 0.0 0.0 0.0 0.0 0.0
 27 3 0 0 0 0 0
 Y 93
 1.909000E-05 3.163000E+04
 0.0 0.0 0.0 6.062000E 03 1.182000E 01 0.0
 28 3 29 1.0 0 0 0
 ZR 93
 2.006000E-14 2.459000E-02
 0.0 0.0 0.0 2.129000E 04 5.223000E 04 2.920000E 03
 29 3 0 0 0 0 0
 ZR 95
 1.267000E-07 3.858000E+04
 0.0 0.0 0.0 2.214000E 05 1.339000E 04 4.300000E 03
 30 3 0 0 0 0 0

AG 111
 1.069000E-06 3.159000E+03
 0.0 0.0 0.0 2.333000E 04 4.253000E 01 1.780000E 01
 46 3 0 0 0 0 0

IN 115M
 4.220000E-05 9.015000E+02
 0.0 0.0 1.114000E 01 0.0 5.888000E 01 0.0000000000
 47 3 0 0 0 0 0

SN 123
 2.750000E-04 1.832000E+02
 0.0 0.0 5.665000E 02 2.878000E 05 3.015000E 04 6.670000E 02
 48 3 0 0 0 0 0

SN 125
 8.443000E-07 5.698000E+02
 0.0 0.0 2.588000E 01 7.367000E 04 1.162000E 03 3.120000E 01
 49 3 50 1.0 0 0 0

SB 125
 9.158001E-09 6.103000E+02
 0.0 0.0 6.747000E 00 2.175000E 05 6.665000E 03 7.440000E 01
 50 3 51 0.231 0 0 0

TE 125M
 1.383700E-07 1.253000E+02
 0.0 0.0 1.313000E 02 3.919000E 04 4.268000E 02 1.980000E 02
 51 3 0 0 0 0 0

SB 126
 6.416000E-07 9.707000E+01
 0.0 0.0 2.746000E 00 9.569000E 04 4.497000E 02 9.130000E 00
 52 3 0 0 0 0 0

SB 127
 2.069000E-06 4.527000E+03
 0.0 0.0 3.968000E-01 2.048000E 04 3.299001E 01 7.220000E-01
 53 3 55 0.831 54 0.169 0

TE 127M
 7.637999E-08 6.114000E+02
 0.0 0.0 4.110000E 02 1.200000E 05 1.575000E 03 7.210000E 02
 54 3 55 0.982 0 0 0

TE 127
 2.055999E-05 4.501000E+03
 0.0 0.0 1.325000E-01 8.137000E 02 1.754000E-01 8.030000E-02
 55 3 0 0 0 0 0

I 129
 1.294000E-15 0.0000000000
 3.020000E-03 2.435000E-02 5.542000E 06 0.0 2.476000E 03 2.110000E 03
 56 1 0 0 0 0 0

TE 129M
 2.359000E-07 1.568000E+03
 0.0 0.0 4.297000E 02 1.448000E 05 1.219000E 03 5.840000E 02
 57 3 58 0.629 0 0 0

TE 129
 1.573000E-04 1.111000E+04
 0.0 0.0 4.872002E-03 2.418000E 02 6.219000E-03 2.990000E-03
 58 3 0 0 0 0 0

I 131
 9.963996E-07 2.508000E+04
 5.590000E-02 3.070000E-02 1.100000E 06 0.000000E+00 3.149000E 03 4.470000E 03
 59 1 60 0.011 0 0 0

XE 131M
 6.680000E-07 2.595000E+02
 1.250000E-03 1.330000E-02 0.000000E+00 1.400000E+00 0.000000E+00 0.0
 60 2 0 0 0 0 0

TE 131
 4.620000E-04 2.741000E+04
 0.0 0.0 1.170000E-03 1.740000E+02 1.390000E-03 7.440000E-04
 61 3 59 1.0 0 0 0
 TE 131M
 6.416000E-06 4.800000E+03
 0.0 0.0 6.879000E 00 1.823000E 04 8.743000E 00 5.450000E 00
 62 3 59 0.778 61 0.222 0
 I 132
 8.269001E-05 3.806000E+04
 3.550000E-01 1.100000E-01 6.300000E+03 0.000000E+00 1.447000E+02 4.070000E 02
 63 1 0 0 0 0 0
 TE 132
 2.506000E-06 4.115000E+04
 0.0 0.0 2.366000E 01 3.598000E 04 3.253000E 01 2.690000E 01
 64 3 63 1.0 0 0 0
 I 133
 9.219000E-06 5.622000E+04
 9.110000E-02 8.900000E-02 1.800000E+05 0.000000E+00 1.077000E+03 1.850000E 03
 65 1 67 0.971 66 0.029 0
 XE 133M
 3.490000E-06 1.384000E+03
 4.290000E-03 2.960000E-02 0.000000E+00 1.8900E+02+00 0.000000E+00 0.0
 66 2 67 1.0 0 0 0
 XE 133
 1.522000E-06 5.622000E+04
 4.960000E-03 9.670000E-03 0.000000E+00 1.573000E+00 0.000000E+00 0.0
 67 2 0 0 0 0 0
 TE 133M
 2.310000E-04 1.789000E+04
 0.0 0.0 6.269000E-03 5.506001E 02 7.243998E-03 5.400000E-03
 68 3 0 0 0 0 0
 I 134
 2.228000E-04 6.575000E+04
 4.110000E-01 1.420000E-01 1.100000E 03 0.000000E+00 8.047000E+01 2.160000E 02
 69 1 0 0 0 0 0
 TE 134
 2.750000E-04 3.999000E+04
 0.0 0.0 3.437000E-03 4.377000E 02 3.843000E-03 3.220000E-03
 70 3 69 1.0 0 0 0
 CS 134
 9.551002E-09 1.019000E+03
 0.0 0.0 0.0 1.216000E 04 4.662000E 04 1.060000E 05
 71 3 0 0 0 0 0
 I 135
 2.864000E-05 5.103000E+04
 2.490000E-01 7.850000E-02 3.100000E+04 0.000000E+00 3.353999E+02 8.730000E 02
 72 1 74 0.835 73 0.165 0
 XE 135M
 7.400000E-04 1.557000E+04
 6.370000E-02 2.140000E-02 0.000000E+00 2.231000E 00 0.000000E+00 0.0
 73 2 74 1.0 0 0 0
 XE 135
 2.091999E-05 5.363000E+04
 3.590000E-02 6.320000E-02 0.000000E+00 4.061000E 00 0.000000E+00 0.0
 74 2 0 0 0 0 0
 CS 135
 7.293001E-15 2.909000E-02
 0.0 0.0 0.0 1.566000E 03 1.459000E 04 1.290000E 04
 75 3 0 0 0 0 0

7 156
 8 342000E-03 0.00000E+00
 0.0 0.0 0.0 0.0 0.0 0.0000000000
 0 0 0 0 0
 1.637000E+03
 0.0 0.0 1.500000E 03 4.879000E 03 1.830000E 04
 77 3 0 0 0 0 0
 XE 137
 2.961000E-03 5.103000E+04
 2.830000E-02 4.590000E-01 0.000000E+00 1.748000E 01 0.000000E+00 0.0
 78 2 79 1.0 0 0 0
 CS 137
 7.292000E-10 1.907000E+03
 0.0 0.0 0.0 9.400000E 03 5.977000E 04 7.760000E 04
 79 3 80 0.946 0 0 0
 BA 137M
 4.528999E-03 1.811000E+03
 0.0 0.0 0.0 0.0 0.0 0.0000000000
 80 3 0 0 0 0 0
 XE 138
 6.795001E-04 4.775000E+04
 1.870000E-01 1.470000E-01 0.000000E+00 2.445000E 01 0.000000E+00 0.0
 81 2 82 1.0 0 0 0
 CS 138
 3.587001E-04 4.878000E+04
 0.0 0.0 0.0 6.066000E 00 4.137000E 01 7.760000E 01
 82 3 0 0 0 0 0
 CS 139
 1.216000E-03 4.478000E+04
 0.0 0.0 0.0 2.837000E 00 2.557001E 01 3.630000E 01
 83 3 0 0 0 0 0
 BA 139
 1.393000E-04 4.604000E+04
 0.0 0.0 0.0 4.697000E 02 1.167000E-01 8.320000E-05
 84 3 0 0 0 0 0
 BA 140
 6.266000E-07 4.274000E+04
 0.0 0.0 0.0 1.587000E 05 4.884000E 03 6.130000E 00
 85 3 86 1.0 0 0 0
 LA 140
 4.774000E-06 4.342000E+04
 0.0 0.0 0.0 1.701000E 04 4.300999E 01 2.170000E 01
 86 3 0 0 0 0 0
 BA 141
 6.416000E-04 4.345000E+04
 0.0 0.0 0.0 2.419000E 02 1.247000E-02 9.410000E-06
 87 3 88 1.0 0 0 0
 LA 141
 4.935999E-05 4.371000E+04
 0.0 0.0 0.0 1.345000E 03 5.342000E-01 1.660000E-01
 88 3 89 1.0 0 0 0
 CE 141
 2.506000E-07 4.387000E+04
 0.0 0.0 0.0 4.517000E 04 2.494000E 03 1.690000E 03
 89 3 0 0 0 0 0
 BA 142
 1.050000E-03 3.762000E+04
 0.0 0.0 0.0 1.487000E 02 3.294000E-03 3.380000E-06
 90 3 91 1.0 0 0 0

LA 142									
1.255000E-04	3.883000E+04								
0.0	0.0	0.0					7.907000E 02	8.535999E-02	3.880000E-02
91	3	0	0	0	0	0	0		
CE 143									
6.030000E-06	3.552000E+04								
0.0	0.0	0.0							
92	3	93	1.0	0	0	0		9.972000E 03	2.334000E 01
								0	1.720000E 01
PR 143									
5.854000E-07	3.467000E+04								
0.0	0.0	0.0							
93	3	0	0	0	0	0		3.506000E 04	1.168000E 03
								0	4.690000E 02
CE 144									
2.766000E-08	2.294000E+04								
0.0	0.0	0.0							
94	3	95	0.985	0	0	0		9.716000E 05	4.286000E 05
								0	1.790000E 05
PR 144									
6.676000E-04	2.302000E+04								
0.0	0.0	0.0							
95	3	0	0	0	0	0		1.272000E 02	3.763000E-03
								0	1.560000E-03
ND 147									
7.098000E-07	1.733000E+04								
0.0	0.0	0.0							
96	3	97	1.0	0	0	0		2.759000E 04	6.592000E 02
								0	7.620000E 02
PM 147									
8.718001E-09	4.881000E+C3								
0.0	0.0	0.0							
97	3	0	0	0	0	0		6.602000E 04	8.368000E 04
								0	7.870000E 03
ND 149									
9.664999E-05	1.121000E+04								
0.0	0.0	0.0						0.0	3.676001E 02
98	3	0	0	0	0	0		0	0.0000000000
PM 149									
3.625000E-06	1.122000E+04								
0.0	0.0	0.0							
99	3	0	0	0	0	0		7.206000E 03	3.439000E 01
								0	4.870000E 00
PM 151									
6.875000E-06	6.828000E+03								
0.0	0.0	0.0							
100	3	0	0	0	0	0		3.939000E 03	8.496000E 00
								0	1.420000E 00
SM 151									
2.168000E-10	7.226000E+01								
0.0	0.0	0.0							
101	3	0	0	0	0	0		4.454000E 04	8.589000E 04
								0	1.480000E 04
EU 155									
1.292000E-08	2.973000E+02								
0.0	0.0	0.0							
102	3	0	0	0	0	0		9.463000E 04	1.005000E 05
								0	1.430000E 04
EU 156									
5.347000E-07	1.575000E+03								
0.0	0.0	0.0							
103	3	0	0	0	0	0		8.556000E 04	1.927000E 03
								0	1.480000E 03
GD 159									
1.069000E-05	3.083000E+02								
0.0	0.0	0.0						0.0	6.478000E 02
104	3	0	0	0	0	0		0	0.0000000000
U 235									
3.095999E-17	9.169000E-05								
0.0	0.0	0.0							
105	3	0	0	0	0	0		4.896000E 07	1.001000E 07
								0	0.0

U 237									
1.188000E-06	3.456000E+03								
0.0	0.0	0.0	0.0			1.020000E 04	3.673000E 01	0.0	
106	3	107	1.0	0	0	0			
NP 237									
1.027000E-14	2.150000E-03								
0.0	0.0	0.0	0.0			5.215000E 07	1.693000E 09	1.470000E 08	
107	3	0	0	0	0	0			
PU 238									
2.431000E-10	2.775000E+01								
0.0	0.0	0.0	0.0			1.825000E 08	2.737000E 09	3.870000E 08	
108	5	0	0	0	0	0			
NP 238									
3.819000E-06	7.741000E+02								
0.0	0.0	0.0	0.0			1.016000E 04	2.962000E 02	8.000000E 00	
109	3	108	1.0	0	0	0			
PU 239									
9.012000E-13	1.227000E+02								
0.0	0.0	0.0	0.0			1.716000E 08	3.188000E 09	4.310000E 08	
110	5	105	1.0	0	0	0			
U 239									
4.916000E-04	8.928000E+05								
0.0	0.0	0.0	0.0			0.0	0.0	0.0	
111	3	112	1.0	0	0	0			
NP 239									
3.442000E-06	8.293000E+05								
0.0	0.0	0.0	0.0			4.702000E 03	2.866000E 01	2.820000E 00	
112	3	110	1.0	0	0	0			
PU 240									
3.342000E-12	7.235000E+01								
0.0	0.0	0.0	0.0			1.716000E 08	3.183000E 09	4.300000E 08	
113	5	0	0	0	0	0			
PU 241									
1.671000E-09	3.779000E+03								
0.0	0.0	0.0	0.0			1.517000E 05	6.407000E 07	3.280000E 06	
114	5	115	1.0	0	0	0			
AM 241									
4.803000E-11	1.571000E+01								
0.0	0.0	0.0	0.0			6.062000E 07	1.013000E 09	3.590000E 08	
115	3	107	1.0	0	0	0			
PU 242									
5.812001E-14	2.110000E-02								
0.0	0.0	0.0	0.0			1.651000E 08	2.954000E 09	4.150000E 08	
116	5	0	0	0	0	0			
CM 242									
4.936000E-08	9.018000E+02								
0.0	0.0	0.0	0.0			3.923000E 07	1.483000E 07	1.510000E 07	
117	3	108	1.0	0	0	0			
AM 242M									
1.432000E-10	1.457000E+00								
0.0	0.0	0.0	0.0			2.443000E 07	1.019000E 09	3.460000E 08	
118	3	0	0	0	0	0			
CM 243									
6.855001E-10	3.528000E-01								
0.0	0.0	0.0	0.0			6.312000E 07	7.856000E 08	2.970000E 08	
119	3	110	1.0	0	0	0			
AM 243									
2.766000E-12	5.306000E-02								
0.0	0.0	0.0	0.0			5.747000E 07	1.013000E 09	3.470000E 08	
120	3	112	1.0	0	0	0			

CM 244

1.248000E-09 1.497000E+00

0.0 0.0 0.0

121 3 113 1.0 0 0

6.062000E 07 5.904000E 08 2.540000E 08

0

AM 244

4.431000E-04 3.186000E+00

0.0 0.0 0.0

122 3 121 1.0 0 0

0.0

2.985000E 03 0.0000000000

0

APPENDIX H
DATABASE FILE STRUCTURES

Structure for database: A:timeind.dbf

Number of data records: 1

Date of last update : 03/07/90

Field	Field Name	Type	Width	Dec
1	POWER	Numeric	9	2
2	HELE	Numeric	7	4
3	HORG	Numeric	7	4
4	HPART	Numeric	7	4
5	NELE	Numeric	7	4
6	NORG	Numeric	6	4
7	NPART	Numeric	7	4
8	NAELE	Numeric	7	4
9	NAORG	Numeric	7	4
10	NAPART	Numeric	7	4
11	SELE	Numeric	7	4
12	SORG	Numeric	7	4
13	SPART	Numeric	7	4
14	PELE	Numeric	7	4
15	PORG	Numeric	7	4
16	PPART	Numeric	7	4
** Total **			114	

Structure for database: A:crmet.dbf

Number of data records: 0

Date of last update : 03/06/90

Field	Field Name	Type	Width	Dec
1	BLDGAREA	Numeric	9	2
2	BLDGHT	Numeric	7	2
3	RELHT	Numeric	7	2
4	EFFVERTVEL	Numeric	7	2
5	EFFFLOW	Numeric	7	2
6	HORIZDIST	Numeric	7	2
7	RECEPTHT	Numeric	7	2
8	WINDSPEED	Numeric	7	2
9	VERTCLASS	Numeric	1	
10	HORIZCLASS	Numeric	1	
11	TSTEPBEG	Numeric	7	2
12	TSTEPEND	Numeric	7	2
13	FLOWIN1	Numeric	11	4
14	FLOWIN2	Numeric	11	4
15	FLOWIN3	Numeric	11	4
16	FILT1ELE	Numeric	7	4
17	FILT2ELE	Numeric	7	4
18	FILT3ELE	Numeric	7	4
19	FILTFLOW1	Numeric	11	4
20	FILTFLOW2	Numeric	11	4
21	FILTFLOW3	Numeric	11	4
22	ST1	Numeric	7	4
23	ST2	Numeric	7	4
24	ST3	Numeric	7	4
25	STFILT1	Numeric	7	4
26	STFILT2	Numeric	7	4
27	STFILT3	Numeric	7	4
28	CRVOLUME	Numeric	9	2
29	FILT1ORG	Numeric	7	4
30	FILT1PART	Numeric	7	4
31	FILT2ORG	Numeric	7	4
32	FILT2PART	Numeric	7	4
33	FILT3ORG	Numeric	7	4
34	FILT3PART	Numeric	7	4
35	OCCFAC	Numeric	7	4

** Total **

262

APPENDIX I

SAMPLE OUTPUT FROM CONHAB

C O N H A B
Control Room Habitability Program

INPUT DATA FILES FOR THIS CASE:

Meteorology and system flow data file: SXAMPLE.DAT
Nuclear data file: ICRP.02
Unfiltered source file #1: CRHFPP1.OUT
Unfiltered source file #2: CRHFPP2.OUT
Source to filtered intake #1: CRHTACT1.DAT
Source to filtered intake #2 (recirc): CRHTACT2.DAT

TIME INDEPENDENT DATA:

Reactor Power Level (MWt): 2700.00000000

ISOTOPIC GROUP	ELEMENTAL	FORM FRACTIONS	
		ORGANIC	PARTICULATES
HALOGENS	0.9200	0.0500	0.0400
NOBLES	1.0000	0.0000	0.0000
SODIUMS	1.0000	0.0000	0.0000
SOLIDS	1.0000	0.0000	0.0000
PLUTONIUMS	1.0000	0.0000	0.0000

TIME STEP START: 0.0000000E-01
 TIME STEP END: 0.13333334

Building cross sectional area (m²): 6000.00000000
 Building height (m): 20.00000000
 Release height (m): 25.00000000
 Effluent vertical velocity (m/s): 3.00000000
 Effluent flow rate (m³/s): 1.00000000
 Horizontal distance to receptor (m): 100.00000000
 Air intake height (m): 21.00000000
 Windspeed (m/s): 1.00000000
 Vertical dispersion class: 3
 Horizontal dispersion class: 3

Flow in from unfiltered source 1 (m³/s): 0.00000000E-01
 Flow in from unfiltered source 2 (m³/s): 0.00000000E-01
 Filtered intake flow source 1 (m³/s): 0.00000000E-01
 Filter efficiency #1 (ele,org,part frac): 0.9900 0.9000 0.9900
 Recirculation flow rate (m³/s): 5.66039991
 Recirc filter efficiency (e,o,p frac): 0.9900 0.9000 0.9900
 Filtered intake flow 2 (feeds recirc): 0.56599998
 Intake 2 filter efficiency (e,o,p frac): 0.9900 0.9000 0.9900
 Bottled air flow rate (m³/s): 0.00000000E-01
 Control room volume (m³): 8490.00000000

END TIME HOURS	WH BODY REM	SKIN REM	CUMULATIVE DOSE			
			THYROID REM	LUNG REM	BONE REM	LIVER REM
1.333E-01	2.525E-04	2.842E-02	1.887E-03	3.549E-04	4.510E-06	7.670E-06

TIME STEP START: 0.13333334
 TIME STEP END: 2.00000000

Building cross sectional area (m²): 6000.00000000
 Building height (m): 20.00000000
 Release height (m): 25.00000000
 Effluent vertical velocity (m/s): 3.00000000
 Effluent flow rate (m³/s): 1.00000000
 Horizontal distance to receptor (m): 100.00000000
 Air intake height (m): 21.00000000
 Windspeed (m/s): 1.00000000
 Vertical dispersion class: 3
 Horizontal dispersion class: 3

Flow in from unfiltered source 1 (m³/s): 0.00000000E-01
 Flow in from unfiltered source 2 (m³/s): 0.00000000E-01
 Filtered intake flow source 1 (m³/s): 0.00000000E-01
 Filter efficiency #1 (ele,org,part frac): 0.9900 0.9000 0.9900
 Recirculation flow rate (m³/s): 5.66039991
 Recirc filter efficiency (e,o,p frac): 0.9900 0.9000 0.9900
 Filtered intake flow 2 (feeds recirc): 0.56599998
 Intake 2 filter efficiency (e,o,p frac): 0.9900 0.9000 0.9900
 Bottled air flow rate (m³/s): 0.00000000E-01
 Control room volume (m³): 8490.00000000

END TIME HOURS	WH BODY REM	SKIN REM	CUMULATIVE DOSE			
			THYROID REM	LUNG REM	BONE REM	LIVER REM
2.000E+00	4.303E-02	4.843E+00	9.655E-02	6.049E-02	2.321E-04	3.941E-04

TIME STEP START: 2.000E+00
 TIME STEP END: 8.000E+00

Building cross sectional area (m²): 6000.00000000
 Building height (m): 20.00000000
 Release height (m): 25.00000000
 Effluent vertical velocity (m/s): 3.00000000
 Effluent flow rate (m³/s): 1.00000000
 Horizontal distance to receptor (m): 100.00000000
 Air intake height (m): 21.00000000
 Windspeed (m/s): 1.00000000
 Vertical dispersion class: 3
 Horizontal dispersion class: 3

Flow in from unfiltered source 1 (m³/s): 0.00000000E-01
 Flow in from unfiltered source 2 (m³/s): 0.00000000E-01
 Filtered intake flow source 1 (m³/s): 0.00000000E-01
 Filter efficiency #1 (ele,org,part frac): 0.9900 0.9000 0.9900
 Recirculation flow rate (m³/s): 5.66039991
 Recirc filter efficiency (e,o,p frac): 0.9900 0.9000 0.9900
 Filtered intake flow 2 (feeds recirc): 0.28299999
 Intake 2 filter efficiency (e,o,p frac): 0.9900 0.9000 0.9900
 Bottled air flow rate (m³/s): 0.00000000E-01
 Control room volume (m³): 8490.00000000

END TIME HOURS	WH BODY REM	SKIN REM	CUMULATIVE DOSE			
			THYROID REM	LUNG REM	BONE REM	LIVER REM
8.000E+00	3.118E-01	3.727E+01	5.309E-01	4.497E-01	1.255E-03	2.062E-03

TIME STEP START: 8.00000000
 TIME STEP END: 24.00000000

Building cross sectional area (m²): 6000.00000000
 Building height (m): 20.00000000
 Release height (m): 25.00000000
 Effluent vertical velocity (m/s): 3.00000000
 Effluent flow rate (m³/s): 1.00000000
 Horizontal distance to receptor (m): 100.00000000
 Air intake height (m): 21.00000000
 Windspeed (m/s): 1.00000000
 Vertical dispersion class: 3
 Horizontal dispersion class: 3

Flow in from unfiltered source 1 (m³/s): 0.00000000E-01
 Flow in from unfiltered source 2 (m³/s): 0.00000000E-01
 Filtered intake flow source 1 (m³/s): 0.00000000E-01
 Filter efficiency #1 (ele,org,part frac): 0.9900 0.9000 0.9900
 Recirculation flow rate (m³/s): 5.66039991
 Recirc filter efficiency (e,o,p frac): 0.9900 0.9000 0.9900
 Filtered intake flow 2 (feeds recirc): 0.28299999
 Intake 2 filter efficiency (e,o,p frac): 0.9900 0.9000 0.9900
 Bottled air flow rate (m³/s): 0.00000000E-01
 Control room volume (m³): 8490.00000000

END TIME HOURS	WH BODY REM	SKIN REM	CUMULATIVE DOSE			
			THYROID REM	LUNG REM	BONE REM	LIVER REM
2.400E+01	1.841E+00	2.500E+02	3.528E+00	2.850E+00	8.176E-03	1.296E-02

TIME STEP START: 24.00000000
 TIME STEP END: 48.00000000

Building cross sectional area (m²): 6000.00000000
 Building height (m): 20.00000000
 Release height (m): 25.00000000
 Effluent vertical velocity (m/s): 3.00000000
 Effluent flow rate (m³/s): 1.00000000
 Horizontal distance to receptor (m): 100.00000000
 Air intake height (m): 21.00000000
 Windspeed (m/s): 1.00000000
 Vertical dispersion class: 3
 Horizontal dispersion class: 3

Flow in from unfiltered source 1 (m³/s): 0.00000000E-01
 Flow in from unfiltered source 2 (m³/s): 0.00000000E-01
 Filtered intake flow source 1 (m³/s): 0.00000000E-01
 Filter efficiency #1 (ele,org,part frac): 0.9900 0.9000 0.9900
 Recirculation flow rate (m³/s): 5.66039991
 Recirc filter efficiency (e,o,p frac): 0.9900 0.9000 0.9900
 Filtered intake flow 2 (feeds recirc): 0.28299999
 Intake 2 filter efficiency (e,o,p frac): 0.9900 0.9000 0.9900
 Bottled air flow rate (m³/s): 0.23590000
 Control room volume (m³): 8490.00000000

END TIME HOURS	WH BODY REM	SKIN REM	CUMULATIVE DOSE			
			THYROID REM	LUNG REM	BONE REM	LIVER REM
4.800E+01	3.016E+00	4.473E+02	1.085E+01	5.015E+00	2.452E-02	3.754E-02

TIME STEP START: 696.00000000
 TIME STEP END: 720.00000000

Building cross sectional area (m²): 6000.00000000
 Building height (m): 20.00000000
 Release height (m): 25.00000000
 Effluent vertical velocity (m/s): 3.00000000
 Effluent flow rate (m³/s): 1.00000000
 Horizontal distance to receptor (m): 100.00000000
 Air intake height (m): 21.00000000
 Windspeed (m/s): 1.00000000
 Vertical dispersion class: 3
 Horizontal dispersion class: 3

Flow in from unfiltered source 1 (m³/s): 0.00000000E-01
 Flow in from unfiltered source 2 (m³/s): 0.00000000E-01
 Filtered intake flow source 1 (m³/s): 0.00000000E-01
 Filter efficiency #1 (ele,org,part frac): 0.9900 0.9000 0.9900
 Recirculation flow rate (m³/s): 5.65039991
 Recirc filter efficiency (e,o,p frac): 0.9900 0.9000 0.9900
 Filtered intake flow 2 (feeds recirc): 0.28299999
 Intake 2 filter efficiency (e,o,p frac): 0.9900 0.9000 0.9900
 Bottled air flow rate (m³/s): 0.23590000
 Control room volume (m³): 8490.00000000

END TIME HOURS	WH BODY REM	SKIN REM	CUMULATIVE DOSE			
			THYROID REM	LUNG REM	BONE REM	LIVER REM
7.200E+02	5.215E+01	9.988E+03	5.310E+02	1.075E+02	1.166E+00	1.697E+00

SUMMARY

ORGAN	DOSE (REM)
WHOLE BODY DOSE:	52.14751430
SKIN DOSE:	9987.56836000
THYROID DOSE:	530.98608400
LUNG DOSE:	107.54503600
BONE DOSE:	1.16612422
LIVER DOSE:	1.69656670

--> End of calculation <--

Dose versus Time

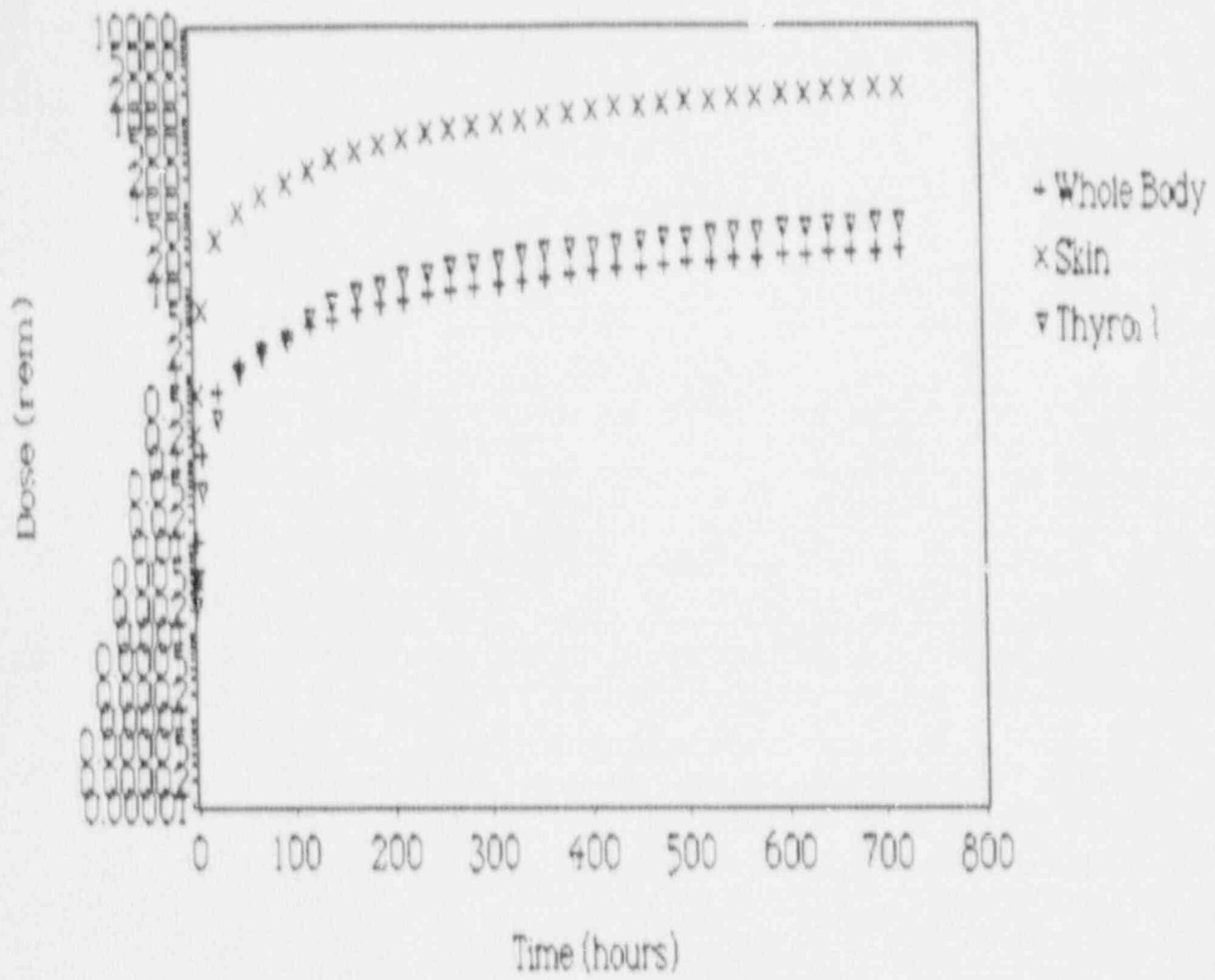

APPENDIX J

SAMPLE OUTPUT FROM CHEM

CHEM CODE

TIME min	CONCENTRATION g/m ³	EXPOSURE g*s/m ³	MEAN CONC g/m ³
0.0000000E-01	1.37873400E-07	6.89366971E-07	1.37873400E-07
5.00000000	1.63820312E-06	8.88038267E-06	8.88038244E-07
10.00000000	8.91709806E-06	5.34658720E-05	3.56439136E-06
15.00000000	2.96821672E-05	2.01876712E-04	1.00938360E-05
20.00000000	7.16643917E-05	5.60198678E-04	2.24079467E-05
25.00000000	1.38497475E-04	1.25268602E-03	4.17562005E-05
30.00000000	2.27981101E-04	2.39259144E-03	6.83597536E-05
35.00000000	3.33763135E-04	4.06140694E-03	1.01535174E-04
40.00000000	4.48164239E-04	6.30222820E-03	1.40049509E-04
45.00000000	5.63941547E-04	9.12193581E-03	1.82438715E-04
50.00000000	6.74826617E-04	1.24960691E-02	2.27201250E-04
55.00000000	7.76032743E-04	1.63762327E-02	2.72937206E-04
60.00000000	8.65296286E-04	2.07027141E-02	3.18503298E-04
65.00000000	9.41607810E-04	2.54107527E-02	3.63010768E-04
70.00000000	1.00457808E-03	3.04336436E-02	4.05781902E-04
75.00000000	9.48029396E-04	3.51737924E-02	4.39672411E-04
80.00000000	8.94663914E-04	3.96471135E-02	4.66436642E-04
85.00000000	8.44302413E-04	4.38686274E-02	4.87429206E-04
90.00000000	7.96775799E-04	4.78525050E-02	5.03710588E-04
95.00000000	7.51924526E-04	5.16121276E-02	5.16121276E-04
100.00000000	7.09597953E-04	5.51601164E-02	5.25334443E-04
105.00000000	6.69653993E-04	5.85083850E-02	5.31894366E-04
110.00000000	6.31958537E-04	6.16681762E-02	5.36245003E-04
115.00000000	5.96384984E-04	6.46501034E-02	5.38750843E-04
120.00000000	5.62813890E-04	6.74641728E-02	5.39713365E-04
125.00000000	5.31132566E-04	7.01198354E-02	5.39383327E-04
130.00000000	5.01234608E-04	7.26260096E-02	5.37970453E-04
135.00000000	4.73019609E-04	7.49911070E-02	5.35650761E-04
140.00000000	4.46392864E-04	7.72230700E-02	5.32572914E-04
145.00000000	4.21264966E-04	7.93293938E-02	5.28862642E-04
150.00000000	3.97551543E-04	8.13171491E-02	5.24626754E-04
155.00000000	3.75172967E-04	8.31930116E-02	5.19956346E-04
160.00000000	3.54054122E-04	8.49632844E-02	5.14929008E-04
165.00000000	3.34124081E-04	8.66339058E-02	5.09611215E-04
170.00000000	3.15315905E-04	8.82104859E-02	5.04059892E-04
175.00000000	2.97566468E-04	8.96983147E-02	4.98323992E-04
180.00000000	2.80816166E-04	9.11023989E-02	4.92445426E-04
185.00000000	2.65008741E-04	9.24274400E-02	4.86460223E-04
190.00000000	2.50091136E-04	9.36778933E-02	4.80399467E-04
195.00000000	2.36013264E-04	9.48579609E-02	4.74209816E-04
200.00000000	2.22727846E-04	9.59715992E-02	4.68154147E-04
205.00000000	2.10190279E-04	9.70225483E-02	4.62012133E-04
210.00000000	1.98358466E-04	9.80143398E-02	4.55880654E-04
215.00000000	1.87192680E-04	9.89503041E-02	4.49774117E-04
220.00000000	1.76655420E-04	9.98335779E-02	4.43704805E-04
225.00000000	1.66711310E-04	0.10066713	4.37683193E-04
230.00000000	1.57326969E-04	0.10145377	4.31718159E-04
235.00000000	1.48470877E-04	0.10219612	4.25817154E-04
240.00000000	1.40113305E-04	0.10289668	4.19986463E-04
245.00000000	1.32226196E-04	0.10355781	4.14231239E-04
250.00000000	1.24783051E-04	0.10418172	4.08555759E-04
255.00000000	1.17758893E-04	0.10477052	4.02963546E-04

260.00000000	1.11130132E-04	0.10532617	3.97457245E-04
265.00000000	1.04874511E-04	0.10585054	3.92039045E-04
270.00000000	9.89710243E-05	0.10634539	3.86710512E-04

A:\>

Toxic Gas Analysis

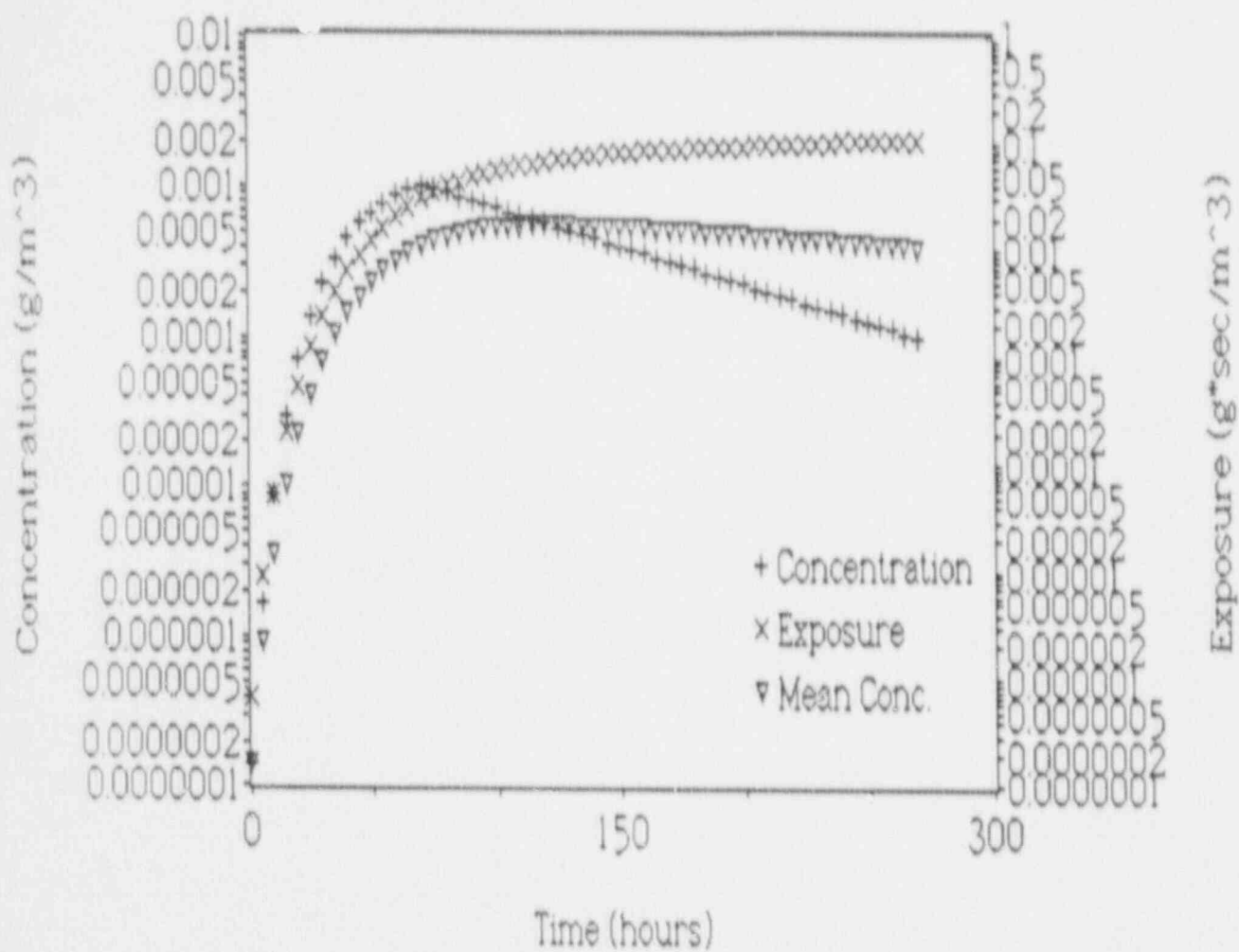

BIBLIOGRAPHIC DATA SHEET

(See instructions on the reverse.)

1. REPORT NUMBER
(Assigned by NRC. Also Vol., Supp., Rev.,
and Addendum Numbers, if any.)

NUREG/CR-5659
SAIC-90/1054

2. TITLE AND SUBTITLE

Control Room Habitability System Review Models

3. DATE REPORT PUBLISHED

MONTH: | YEAR: 1990
December

4. FUNDING OR GRANT NUMBER

D2096

5. AUTHOR(S)

H. Gilpin

6. TYPE OF REPORT

Technical

7. PERIOD COVERED (Inclusive Dates)

11/89-6/90

8. PERFORMING ORGANIZATION - NAME AND ADDRESS (If NRC, provide Division, Office or Region, U.S. Nuclear Regulatory Commission, and mailing address; if contractor, provide name and mailing address.)

Science Applications International Corporation
1710 Goodridge Drive
McLean, VA 22102

9. SPONSORING ORGANIZATION - NAME AND ADDRESS (If NRC, type "Same as above"; if contractor, provide NRC Division, Office or Region, U.S. Nuclear Regulatory Commission, and mailing address.)

Division of Safety Issue Resolution
Office of Nuclear Regulatory Research
U.S. Nuclear Regulatory Commission
Washington, DC 20555

10. SUPPLEMENTARY NOTES

11. ABSTRACT (200 words or less)

This report provides a method of calculating control room operator doses from postulated reactor accidents and toxic chemical spills as part of the resolution of TMI Action Plan III.D.3.4. The computer codes contained in this report use source concentrations calculated by either TACT5, FPFP, or EXTRAN, and transport them via user-defined flow rates to the control room envelope. The codes compute doses to six organs from up to 150 radionuclides (or 1 toxic chemical) for time steps as short as one second. Supporting codes written in Clipper assist in data entry and manipulation, and graphically display the results of the FORTRAN calculations.

12. KEY WORDS/DESCRIPTORS (Use words or phrases that will assist researchers in locating the report.)

Control Room Operator Doses, Toxic Gas Releases, Radiological Releases, Generic Issue 83, GDC-19, Task Action Plan III.D.3.4, Control Room Doses Computer Code

13. AVAILABILITY STATEMENT

Unlimited

14. SECURITY CLASSIFICATION

(This Page)

Unclassified

(This Report)

Unclassified

15. NUMBER OF PAGES

16. PRICE

THIS DOCUMENT WAS PRINTED USING RECYCLED PAPER.

UNITED STATES
NUCLEAR REGULATORY COMMISSION
WASHINGTON, D.C. 20555

OFFICIAL BUSINESS
PENALTY FOR PRIVATE USE, \$300

SPECIAL FOURTH-CLASS RATE
POSTAGE & FEES PAID
USNRC
PERMIT No. 0-87