

---

---

# Procedures for Analyzing the Effectiveness of Siren Systems for Alerting the Public

---

---

Prepared by D. N. Keast, D. A. Towers, G. S. Anderson/BB&N  
J. L. Kenoyer, A. E. Desrosiers/PNL

Bolt Beranek and Newman, Inc.

Pacific Northwest Laboratory

Prepared for  
U.S. Nuclear Regulatory  
Commission

## NOTICE

This report was prepared as an account of work sponsored by an agency of the United States Government. Neither the United States Government nor any agency thereof, or any of their employees, makes any warranty, expressed or implied, or assumes any legal liability of responsibility for any third party's use, or the results of such use, of any information, apparatus, product or process disclosed in this report, or represents that its use by such third party would not infringe privately owned rights.

### Availability of Reference Materials Cited in NRC Publications

Most documents cited in NRC publications will be available from one of the following sources:

1. The NRC Public Document Room, 1717 H Street, N.W.  
Washington, DC 20555
2. The NRC/GPO Sales Program, U.S. Nuclear Regulatory Commission,  
Washington, DC 20555
3. The National Technical Information Service, Springfield, VA 22161

Although the listing that follows represents the majority of documents cited in NRC publications, it is not intended to be exhaustive.

Referenced documents available for inspection and copying for a fee from the NRC Public Document Room include NRC correspondence and internal NRC memoranda; NRC Office of Inspection and Enforcement bulletins, circulars, information notices, inspection and investigation notices; Licensee Event Reports; vendor reports and correspondence; Commission papers; and applicant and licensee documents and correspondence.

The following documents in the NUREG series are available for purchase from the NRC/GPO Sales Program: formal NRC staff and contractor reports, NRC-sponsored conference proceedings, and NRC booklets and brochures. Also available are Regulatory Guides, NRC regulations in the *Code of Federal Regulations*, and *Nuclear Regulatory Commission Issuances*.

Documents available from the National Technical Information Service include NUREG series reports and technical reports prepared by other federal agencies and reports prepared by the Atomic Energy Commission, forerunner agency to the Nuclear Regulatory Commission.

Documents available from public and special technical libraries include all open literature items, such as books, journal and periodical articles, and transactions. *Federal Register* notices, federal and state legislation, and congressional reports can usually be obtained from these libraries.

Documents such as theses, dissertations, foreign reports and translations, and non-NRC conference proceedings are available for purchase from the organization sponsoring the publication cited.

Single copies of NRC draft reports are available free upon written request to the Division of Technical Information and Document Control, U.S. Nuclear Regulatory Commission, Washington, DC 20555.

Copies of industry codes and standards used in a substantive manner in the NRC regulatory process are maintained at the NRC Library, 7920 Norfolk Avenue, Bethesda, Maryland, and are available there for reference use by the public. Codes and standards are usually copyrighted and may be purchased from the originating organization or, if they are American National Standards, from the American National Standards Institute, 1430 Broadway, New York, NY 10018.

# Procedures for Analyzing the Effectiveness of Siren Systems for Alerting the Public

---

Manuscript Completed: February 1982

Date Published: September 1982

Prepared by

D. N. Keast, D. A. Towers, G. S. Anderson/BB&N

J. L. Kenoyer, A. E. Desrosiers/PNL

Bolt Beranek and Newman, Inc.

10 Moulton Street

Cambridge, MA 02238

Pacific Northwest Laboratory

Richland, WA 99352

**Prepared for**

**Division of Emergency Preparedness**

**Office of Inspection and Enforcement**

**U.S. Nuclear Regulatory Commission**

**Washington, D.C. 20555**

**NRC FIN B2311**

## ABSTRACT

NUREG-0654, Revision 1, (Criteria for Preparation and Evaluation of Radiological Emergency Response Plans and Preparedness in Support of Nuclear Power Plants), Appendix 3, discusses requirements of the licensees to implement a prompt notification system within the 10-mile emergency planning zone (EPZ) surrounding a nuclear facility. Sirens are being installed for use as part of or as the entire notification system by many licensees. This report describes a procedure for predicting siren system effectiveness under defined conditions within the EPZ's. The procedure requires a good topographical map and knowledge of the meteorology, demographics, and human activity patterns within the EPZ. The procedure is intended to be applied to systems of sirens and to obtain average results for a large number (30 or more) listener locations.



## SUMMARY

The purpose of this study was to develop a procedure for predicting siren-system effectiveness under defined conditions within emergency planning zones (EPZ's) surrounding nuclear power plants.

Collection and application of the necessary data include the selection of listener sites, the selection of evacuation conditions (sample scenarios) including weather, time of day, and peoples' locations and activities, estimation of background noise levels, definition of siren properties, and acoustic attenuation through building and vehicle structures. Analyses include the computation of the sound level from the siren most likely to be the loudest at each listener site, estimation of alerting probabilities at various locations, and the weighted combination of the results into overall estimates of alerting effectiveness.

The procedure determined from this study permits the estimation of the alerting effectiveness of a siren system under defined conditions in the EPZ's of nuclear power plants. This procedure can be applied to systems of sirens of a large number (30 or more); it is likely to be unreliable for a single siren or single listener.

## TABLE OF CONTENTS

	Page
1.0 INTRODUCTION.....	1
1.1 Background.....	1
1.2 NRC and FEMA Responsibilities.....	2
1.3 Purpose and Scope.....	3
1.4 Caveats.....	4
1.5 Summary.....	5
2.0 OVERVIEW OF THE ANALYSIS PROCEDURE	
2.1 General.....	7
2.2 Input.....	9
2.2.1 Selection of Listener Sites.....	9
2.2.2 Definition of Sample Scenarios.....	9
2.2.3 Estimation of Background Noise Levels	11
2.2.4 Definition of Siren Properties.....	13
2.2.5 Building and Vehicle Attenuations....	14
2.3 Analysis.....	14
2.3.1 Calculation of the Level of the Dominant Siren.....	16
2.3.2 Alerting People.....	16
2.3.3 Results of Analysis.....	17
3.0 RANDOM SELECTION OF LISTENER SITES.....	18
4.0 SELECTION OF SAMPLE SCENARIOS.....	22
4.1 Temperature and Relative Humidity.....	24
4.2 Vertical Temperature Gradient.....	25
4.3 Wind Direction and Vertical Wind-Speed Gradient.....	27
5.0 ESTIMATION OF BACKGROUND NOISE LEVELS.....	29
5.1 Outdoor Background Noise.....	29
5.2 Background Noise Indoors.....	30
5.3 Background Noise in Motor Vehicles.....	33
6.0 SIREN-PERFORMANCE DATA.....	37
7.0 ATTENUATION OF SOUND BY BUILDING AND VEHICLE STRUCTURES.....	38
7.1 Buildings.....	38
7.2 Motor Vehicles.....	40

8.0	COMPUTATION OF THE SOUND LEVEL FOR THE DOMINANT SIREN.....	41
9.0	ALERTING PEOPLE.....	51
9.1	Outdoor Alert.....	51
9.2	Indoor Alert.....	54
	9.2.1 At Home.....	55
	9.2.2 At Work.....	58
9.3	Alert in Motor Vehicles.....	62
10.0	COMPUTATION OF OVERALL ANALYSIS RESULTS.....	68
	REFERENCES .....	71
	APPENDIX A: Estimation of $A_{atm}$	A-i
	APPENDIX B: Dependence of Alert Upon Siren Duration	B-i
	APPENDIX C: Three BASIC Computer Programs to Facilitate the Analysis	C-i

## LIST OF FIGURES

		Following Page #
Figure 2.1	Flow of Computations.....	15
Figure 3.1	Population-Distribution Map for an EPZ at a Nuclear Power Plant.....	19
Figure 8.1	Shielding Attenuation of the Sound from a Point Source by a Rigid Barrier as a Function of Fresnel Number N .....	44
Figure 9.1	Chance of Alert for People Outdoors (4-Minute Stationary Siren).....	52
Figure 9.2	Chance of Alert for People Outdoors (4-Minute Rotating Sirens).....	53
Figure 9.3	Chance of Alert for Awakening People Asleep	56
Figure 9.4	Chance of Alert for People Indoors at Home (4-Minute Stationary Siren).....	59
Figure 9.5	Chance of Alert for People Indoors (4-Minute Rotating Siren).....	60
Figure 9.6	Chance of Alert for People Indoors at Work in Commercial/Institutional Establishments.....	61
Figure 9.7	Maximum Siren Alert Distance for Motorists	66

## LIST OF TABLES

		Page
Table 4.1	Sample Scenarios for the Evaluation of Siren Alerting Capability.....	23
Table 4.2	Pasquill Stability Classes.....	26
Table 5.1	Summary of Outdoor Background Noise Data Used to Develop this Procedure.....	31
Table 5.2	Minimum Background Noise Levels for Generalized Categories of Outdoor Environments	32
Table 5.3	Summary of Indoor Background Noise Data Used to Develop this Procedure.....	34
Table 5.4	Minimum Background Noise Levels for Generalized Categories of Indoor Activities/Environments	35
Table 5.5	Background Noise Inside Motor Vehicles.....	36
Table 7.1	Sound Reduction Through Residential Structures.....	39
Table 7.2	Sound Reduction of Motor Vehicle Structures	40
Table 8.1	Air Absorption Coefficients at 500 Hz .....	45
Table 8.2	Sample Calculation of Atmospheric Attenuation, $A_{atm}$ , Caused by Wind and Temperature Gradients .....	47
Table 8.3	F(R/S) vs. R/S for Computing $X_0$ in Eq. 8.6 .....	49
Table 8.4	Attenuation within the Shadow Zone, $A_{atm}$ , vs. $X_0$ , ft .....	50
Table 9.1	Assumed Activities and Background Noise Environments for People Indoors .....	57
Table 9.2	Data for Analysis of Siren Alert for Motorists .....	64
Table 10.1	Sample Calculation of the Chance of Alert at a Single Listener Site for a Particular Gradient .....	69



## FOREWORD

The work presented in this report was prepared by Bolt, Beranek and Newman Incorporated under subcontract No. B-A2740-A-V which, in turn, was funded under a Related Services Agreement with the U.S. Department of Energy Contract DE-AC06-76RLO 1830.

Procedure for Analyzing the Effectiveness  
of Siren Systems for Alerting the Public

1.0 INTRODUCTION

1.1 Background

As a result of the accident at the Three Mile Island Nuclear Power plant, the Nuclear Regulatory Commission (NRC) has issued a rule requiring their licensees to plan and prepare, much more extensively than in the past, for emergencies at nuclear facilities. Under this rule, a "Plume Exposure Pathway Emergency Planning Zone" (EPZ) having a radius of about 10 miles is established around each nuclear power reactor. Within an EPZ there must be physical means for alerting and providing prompt instructions to the public in the event of a sufficiently severe emergency. The rule states:

"The design objective shall be to have the capability to essentially complete the initial notification of the public within the plume exposure pathway EPZ within about 15 minutes."

The alerting systems are under the control of local public authorities having jurisdiction within the EPZ, and decisions regarding their use must be made promptly by State and local authorities following notification of an emergency by the licensee.

NRC and the Federal Emergency Management Agency (FEMA) have provided a guideline document elaborating upon the requirements of the emergency-planning rule. This document, "Criteria for

Preparation and Evaluation of Radiological Emergency Response Plans and Preparedness in Support of Nuclear Power Plants" (NUREG-0654 and FEMA-REP-1, dated November 1980) contains an "Appendix 3" that attempts to clarify the public alerting requirements. On the basis of Appendix 3, some licensees have installed networks of "air-raid" (i.e., Civil Defense) sirens within the EPZ's for which they are responsible. The licensees have then provided local authorities with some means for remotely controlling these sirens so that they can be operated when necessary. The people within such EPZ's are to be kept informed of the fact that if they hear the sirens, they are immediately to turn on a radio and listen to the Emergency Broadcast Service (EBS) for information on the nature of the emergency, and on protective actions to be taken.

#### 1.2 NRC and FEMA Responsibilities

The NRC and FEMA are charged in various ways with determining each licensee's compliance with the emergency planning rule. This includes, of course, assessing the effectiveness of public alerting systems using sirens. To a considerable extent, such assessments will be based upon "Full-Cycle Tests" during emergency response exercises at nuclear power reactors. Following such exercises, during which the sirens will have actually been operated, the people within each EPZ may be polled to learn whether or not they heard the sirens, and if so whether they knew what was meant by the sound. Such tests not only provide a real-life measure of alerting-system performance (including the level of pertinent public education), they also identify areas where system performance could be improved.

Unfortunately, the performance of a network of outdoor sirens is strongly dependent upon a number of uncontrolled and

unpredictable factors, such as the weather, peoples' activities at the time, whether most people are indoors or outdoors, background noise levels, etc. Hence, it is not readily possible to determine the effectiveness of a siren system under all conditions from a few full-cycle tests under particular conditions. A siren system that is quite effective on a warm summer afternoon might be less effective at 3:00 a.m. on a stormy winter night.

NRC has concluded that an analytical procedure to predict siren-system performance under a prescribed (and assumed) set of conditions would be a useful tool to have, in addition to full-cycle test results, when assessing the performance of alerting systems utilizing sirens. Such a procedure could "model" alerting-system performance under a variety of conditions that would not be easy to test (e.g., conditions during a stormy winter night). Perhaps the model could be "calibrated" based upon full-cycle test results under a known set of conditions, and then used to extrapolate to other conditions. At the very least, the analytical procedure provides insight into the variables that influence siren-system performance, and on the effects of these variables. Hence Bolt Beranek and Newman Inc. (BBN), under subcontract to Battelle Northwest Laboratories, has developed an analytical procedure for estimating the effectiveness of siren systems in EPZ's around nuclear power plants.

### 1.3 Purpose and Scope

The purpose of this report is to describe a procedure for predicting siren-system effectiveness under defined conditions within EPZ's around nuclear power plants. The procedure is described in sufficient detail that the reader can do it himself, provided he has a general technical background and a few tools

(a good topographic map, a hand calculator) and some knowledge of the meteorology, demographics and human activity patterns within the EPZ. He need not be skilled in the fields of acoustics or statistics.

The procedure is intended to be applied to arrays (systems) of sirens in EPZ's, and to obtain average results for a large number (30 or more) listener locations. It is likely to be unreliable for a single siren and/or a single listener. Furthermore it assumes background-noise conditions normally encountered, on the average, inside and outside residences and commercial locations in the United States.

#### 1.4 Caveats

The procedure described here must be viewed as highly preliminary. Its results have never been compared with actual field experience. It is based upon a number of "educated-guess" assumptions about people's locations and activities at various times of the day. It utilizes many simplifications in estimating background noise levels. In particular, it is based upon the fact that, in most settled areas of the U.S., background noise outdoors predominantly results from motor vehicle activity. Indoors, background noise generally comes from machines (typewriters, ventilation systems, home appliances, radio/TV) and conversation. In remote locations or places with atypical lifestyles, the procedure will probably be inadequate.

Finally, the procedure provides an estimate of the percentage of the population that will hear the alerting sounds. It ignores the question of whether or not those hearing such sounds will recognize them, will know the proper response to take, and will indeed take that response. Except in the case of awakening sleepers, the procedure does not consider the natural



tendency of people who hear and recognize alerting sounds to warn other people who may not have heard them. This "avalanche" effect would surely increase the effectiveness of public alerting systems above that estimated from purely technical considerations.

### 1.5 Summary

Section 2 of this report provides an overview of the analysis procedure under two subsections: The first covers the collection and application of the necessary data; and the second covers the mechanics of analysis. The overview is useful to those planning to follow the procedure so that they will know how the various pieces fit together. To other readers who simply want to find out about the procedure but do not plan to actually apply it, Section 2 can be treated as a detailed summary of the procedure.

The various discrete tasks of implementing the procedure are described in subsequent sections in the same order as in the overview of Section 2. The input functions include selection of listener sites (Section 3), selection of evaluation conditions (called "sample scenarios") in Section 4, estimation of background noise levels (Section 5), definition of siren properties in Section 6, and acoustic attenuation through building and vehicle structures (Section 7). The analysis steps consist of Section 8, which describes the computation of the sound level from the siren most likely to be loudest at each listener site, estimation of alerting probabilities at various locations (Section 9), and the weighted combination of the results into overall estimates of alerting effectiveness in Section 10.

Three Appendices are included: a description of the method used to estimate attenuation resulting from wind and temperature gradients, an analysis of siren effectiveness vs. siren sound duration, and a BASIC computer program that eliminates some of the tedium of the computations.

## 2.0 OVERVIEW OF THE ANALYSIS PROCEDURE

### 2.1 General

The analysis procedure can be thought of as having two parts: an "input" part and an "analysis" part. The input part of the procedure involves five steps:

- randomly selecting within an EPZ a number of populated locations ("listener sites") for which detailed analysis will be carried out.
- defining sets of conditions ("sample scenarios") for which the analyses will be performed. Such conditions include the weather, the time of day, and peoples' locations and activities. (For simplicity, the scenarios have been predefined, except for the influence of local weather conditions.)
- estimating background noise levels for each location, and for each scenario. (Background noise levels have been predefined to fit the scenarios, based upon listener site locations.)
- determining siren properties.
- estimating the sound attenuating effects of building and vehicle structures.

Each of these five steps supplies data that are necessary

for the subsequent analysis stage of the procedure.

The analysis part of the procedure is illustrated schematically in Fig. 2.1, and details are given below. It yields the "chance of alert" for a siren-operating period of 4 minutes. (See Appendix B for information on other siren durations.)

The first analysis step is the computation of the sound levels that would be produced outdoors at each listener site from each of the surrounding sirens under each of the scenarios. The loudest of these levels (after allowance for the difference between rotating and stationary sirens) is then used for subsequent computations. This sound level is compared with outdoor background noise-level distributions to estimate the probability of alerting people out of doors. The same dominant-siren level is reduced by the attenuating effect of building structures, and then compared with typical indoor background noise-level distributions (or sleep-disturbance criteria) to estimate the probability of alerting people indoors, both at home and at work.

The probability of alerting people travelling in motor vehicles is handled somewhat differently. It is estimated based upon average siren levels and average siren spacing, compared to the distance travelled by motor vehicles at particular assumed speeds. Available data on the sound-attenuating properties of vehicle structures, and on in-vehicle background noise levels are then used to estimate alerting potential.

The final step in the analysis procedure is to combine the results of the above computations into a "single-number" measure of alerting probability for each scenario, based upon the presumed activities and indoor/outdoor locations of people for that scenario.

## 2.2 Input

### 2.2.1 Selection of Listener Sites

The listener-site selection process is intended to select a number of locations within the EPZ, for each of which detailed analyses will subsequently be carried out. The selection process is population-weighted: that is, it is biased towards the selection of sites in more densely populated areas, and will not select sites in unpopulated areas.

The final results of the analysis are obtained as an average over all sites, so a large number of sites is desirable. Normally, 50 are selected, so that any single site has only a small effect on the final results.

The population-weighted random listener-site selection process is described in detail in Section 3 below. In general, it utilizes population-distribution data by sector and radius of the EPZ, such as are called for in Appendix 4 of NUREG-0654. It requires the use of USGS maps, or equivalent, that show topography and individual building locations. A random-number generator, such as that contained in some pocket calculators, is also required. The sites, once selected, are marked on a good-quality topographic map that also shows all fixed siren locations.

### 2.2.2 Definition of Sample Scenarios

The effectiveness of an array of sirens is strongly dependent upon weather conditions, whether people are indoors, outdoors, and upon what people are doing at the time. In



selecting sets of these conditions as sample scenarios, our objective has been to cover the full range of conditions that might exist within an EPZ - from those conditions most conducive to people hearing the sirens to those conditions where they are least likely to hear them. Four scenarios have been defined: two (presumed) extremes and two others in between:

- A Warm Summer Weekday Afternoon
- A Summer Weekday Night
- A Winter Weekday During Evening Commuting Hours
- A Stormy Winter Night

These are intended to cover a range of the critical parameters:

- people at work vs. at home
- people indoors, outdoors, or in motor vehicles
- people awake vs. asleep
- building (and motor vehicle) windows open or closed
- people at home engaged in "quiet" vs. "noisy" activities
- various meteorological conditions characteristic of the site.

As described in Section 4 below, the user of this procedure need only select the meteorological conditions appropriate for the site during each of these scenarios. The other assumptions regarding the locations of people and their activities have been preselected to simplify the procedure, and cannot be easily changed. The meteorological conditions should

be chosen from data gathered at the site (such as from an EIR or Safety Report for the plant) and should be appropriate for the season and time of day specified in the scenario. It is desirable, if appropriate for the site, to choose different wind directions for each of the four scenarios.

### 2.2.3 Estimation of Background Noise Levels

One's ability to hear a tonal sound, such as a siren sound, is based upon the extent to which the level of that sound exceeds the background noise level measured in a relatively narrow bandwidth centered on the frequency of the tone. For the purpose of this procedure, we have assumed throughout that all sirens operate at a frequency in the vicinity of 630 Hz, and that the background noise level of interest is that in the 630 Hz one-third octave band.

Both indoors and outdoors, background noise in our environment is constantly fluctuating in level. If at some moment it is too loud for a siren to be heard, a moment later it may have decreased so that the siren can be heard. Because we do not know what the level of the background noise will be at any particular time sirens are sounded, we must look at probability distributions of background noise levels, and concentrate on the minima of these distributions. We are not concerned with how loud the background noise may be, or what its average level is; we are only concerned with how quiet it may get because people will hear the siren sounds "between the cracks" of louder interferences.

Outdoor background noise in urban areas and along rural roadways is caused predominantly by motor vehicle traffic. It is

generally insensitive to seasons of the year, but varies markedly with time of day. Minor traffic variations (i.e., less than a factor of 2 in traffic volume) have little effect on the minimum background noise.

In rural areas remote from roadways, outdoor background noise can be seasonal (birds, insects, foliage, etc.) and can vary with the weather (wind, rain, waterflow, surf). Few people live or work in such "natural" acoustic environments. These background noise levels are more difficult to estimate, but being lower in level they are less important than traffic-noise-dominant environments.

Estimated minimum outdoor background noise levels are given in Section 5. These are based upon noise measurements conducted by BBN at a number of locations in the United States. The data typically consist of statistical summaries of background noise at various types of locations. The summaries provide the  $L_{90}$  (sound level exceeded 90% of the time) for 1-minute samples of data in the one-third octave frequency band centered at 630 Hz.\* Such data were used to calculate probable ranges of background noise levels.

Two generalized background noise environments, urban and rural, have been established so that all sample listener sites can be included in one of these categories. In each category, the siren sound level necessary to alert is 9 dB greater than the minimum background noise level that could exist during siren operation.

Indoor background noise is rarely related to outdoor

---

\*The  $L_{90}$  was used as a conservative estimate of the minimum sound level.

background noise. Instead it results from building machinery and appliances, entertainment, or conversation. These are, of course, a function of the activities and locations of the building occupants. Based upon a series of indoor measurements similar to the outdoor ones described above, a set of distributions of indoor background  $L_{90}$ 's for use in this procedure has been developed. To simplify the analysis, these distributions have been weighted by the percentage of people presumed to be engaged in various indoor activities.

Published data are available for background noise levels in motor vehicles. These data have been summarized for use in this procedure. Because background noise in motor vehicles is much less variable (at constant vehicle speed) than background noise in communities and indoors, it has been treated here as steady. The temporal statistics of this background noise have not been used.

#### 2.2.4 Definition of Siren Properties

The procedure requires that the following be known about the sirens to be used:

- The location of each siren, on a topographic map
- The rated sound output of each siren, in dB at 100 ft
- The height of each siren above the local terrain
- Whether each siren is rotating or stationary.

A correlary of the observations about background noise in Section 2.2.3. is the fact that, within limits, siren sounds are more effective if they last for a longer period of time. This is because the probability of occurrence of a lower level of

background noise increases with time. This is discussed in greater detail in Appendix B.

A second correlary is the fact that, in this procedure, rotating sirens are deemed to be less effective than stationary sirens that produce the same maximum sound level at the listener. This is because rotating sirens produce their maximum level at any given listener for only a portion of their operating time. The rest of the time they are pointed elsewhere. In this procedure, rotating sirens are treated as having a sound duration equal to 1/4 of the time they operate.

#### 2.2.5 Building and Vehicle Attenuations

In order to estimate siren sound levels indoors or in vehicles, it is necessary to know how much the sound is attenuated when propagating through such structures. These figures are given in Section 7, as a function of climate and season of the year.

### 2.3 Analysis

All the necessary data have now been accumulated to perform the analysis. As summarized on Fig. 2.1, the analysis consists of computing, separately for each of the four scenarios, the maximum siren sound level at each randomly selected listener site. At each site, some fraction of the people are assumed to be outdoors, some indoors at work, and some indoors at home engaged in various activities. Peoples' locations (indoors or out) and activities vary with the scenario, as do the properties of the buildings they occupy. The background noise also varies with location.



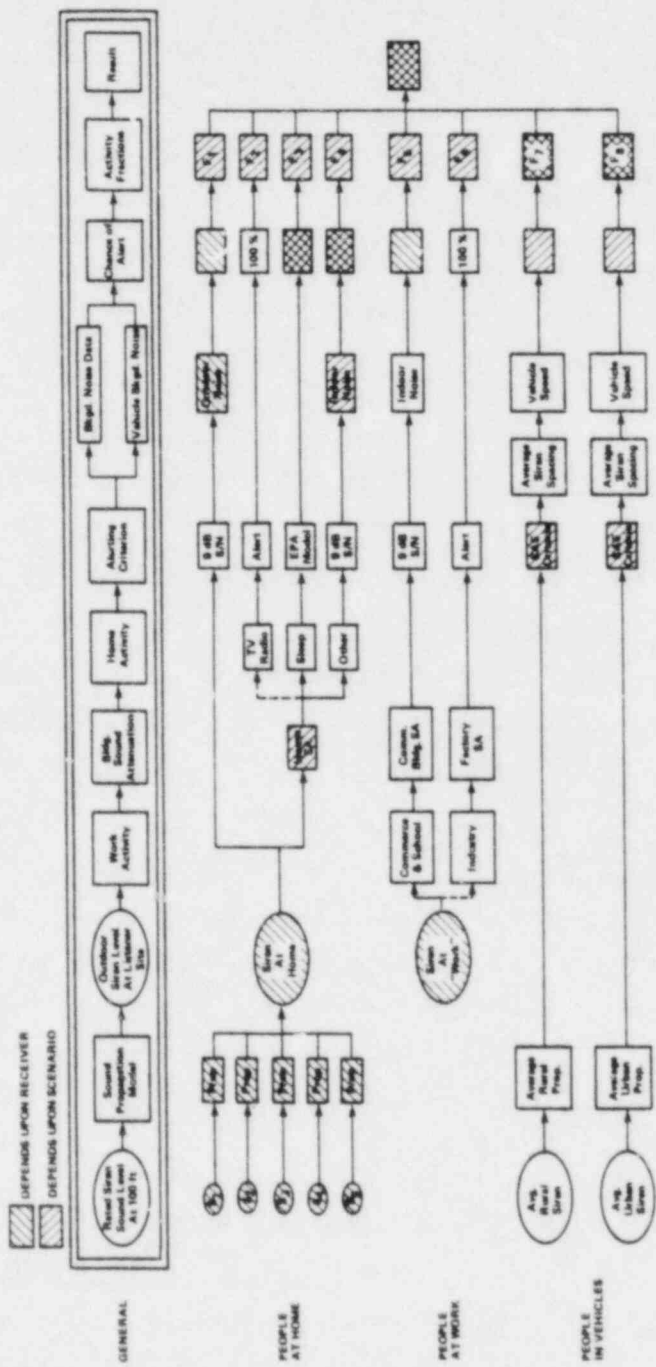

FIG. 2.1. FLOW OF COMPUTATIONS.

Each of the fractional people at each site is assigned a probability of alert based upon the siren signal level and upon the statistics of the background noise, or upon sleep disturbance criteria. The probabilities are summed over the fractions at each site, and then over all sites to estimate the system effectiveness for a given scenario.

### 2.3.1 Calculation of the Level of the Dominant Siren

For each scenario, the outdoor levels produced at each listener site by the various sirens around that site are estimated, based upon meteorological and terrain conditions. The highest of these levels (adjusted for the difference between rotating and stationary sirens described in 2.2.4) is then used for subsequent analysis. Note that this level, and the "dominant" siren that produces it, may vary from scenario to scenario. The procedure is detailed in Section 8.

### 2.3.2 Alerting People

For that fraction of people out of doors at each site, the difference between the siren signal level and the statistics of the outdoor background noise (increased by 9 dB) is used to determine a probability of alert for that site. This is described in Section 9.

The siren signal level is reduced by the pertinent building attenuation and a probability of alert is determined for that fraction of people indoors. This is done separately for fractions at work in commercial establishments, for fractions awake at home, and for fractions of people sleeping at home. That portion of people at work in industrial environments is

assumed to be 100% alerted by other means, as is the fraction listening to radio/TV.

A separate analysis is performed for that portion of the people travelling in automobiles. This is based upon a comparison of average siren spacing with the distance travelled by vehicles at 30 mph in urban areas, and at 55 mph in rural areas. Whether or not the windows of the automobiles are open is based upon the weather conditions of the scenario.

### 2.3.3 Results of Analysis

The final results of the analysis are four single-number estimates of the percentages of the population alerted, one for each scenario. The alert probabilities for all listener sites are averaged separately for those fractions of people assumed to be outdoors, indoors, asleep, etc. These results are then averaged along with the probabilities for occupants of motor vehicles, weighted by activity fractions, to obtain a single-number probability of alert for a scenario.

Normally this process is done separately for listener sites in rural areas (i.e., < 2000 people/sq mi) and in urban areas. The urban and rural percentages are then combined on a population-weighted basis.

### 3.0 RANDOM SELECTION OF LISTENER SITES

The objective of the listener-site-selection process is to identify fifty (50) randomly selected building locations within the EPZ surrounding the nuclear plant. These locations are assumed to be residential or commercial locations and are called herein "listener sites." The steps in the listener site-selection procedure are described below.

Step 1. Obtain a map (see Fig.3.1 for example) showing the populatio. of the EPZ in annular sectors defined by interior circles and radii. This information must then be superimposed on topographical maps of the EPZ.

Population-distribution information is generally available in Environmental and Safety Reports, and may be provided in compliance with Appendix 4 of NUREG-0654.

Step 2. Each annular sector is assigned a designator, such as a letter. A range of numbers is then assigned to each sector according to the population in that sector. For the example shown in Fig. 3.1, Sector A has a population of 11,223 and thus would be assigned numbers 1 through 11,223. Sector B (moving clockwise) has a population of 2,246 and would be assigned numbers from 11,224 to 13,469. Sector C has a population of 1,567 and would be assigned numbers 13,470 through 15,036. This process is continued until each number between 1 and 166,295 (the total estimated population in this case) is assigned to a particular sector. A random number generator (available on a Texas Instruments hand calculator, for example) is then used to select 50

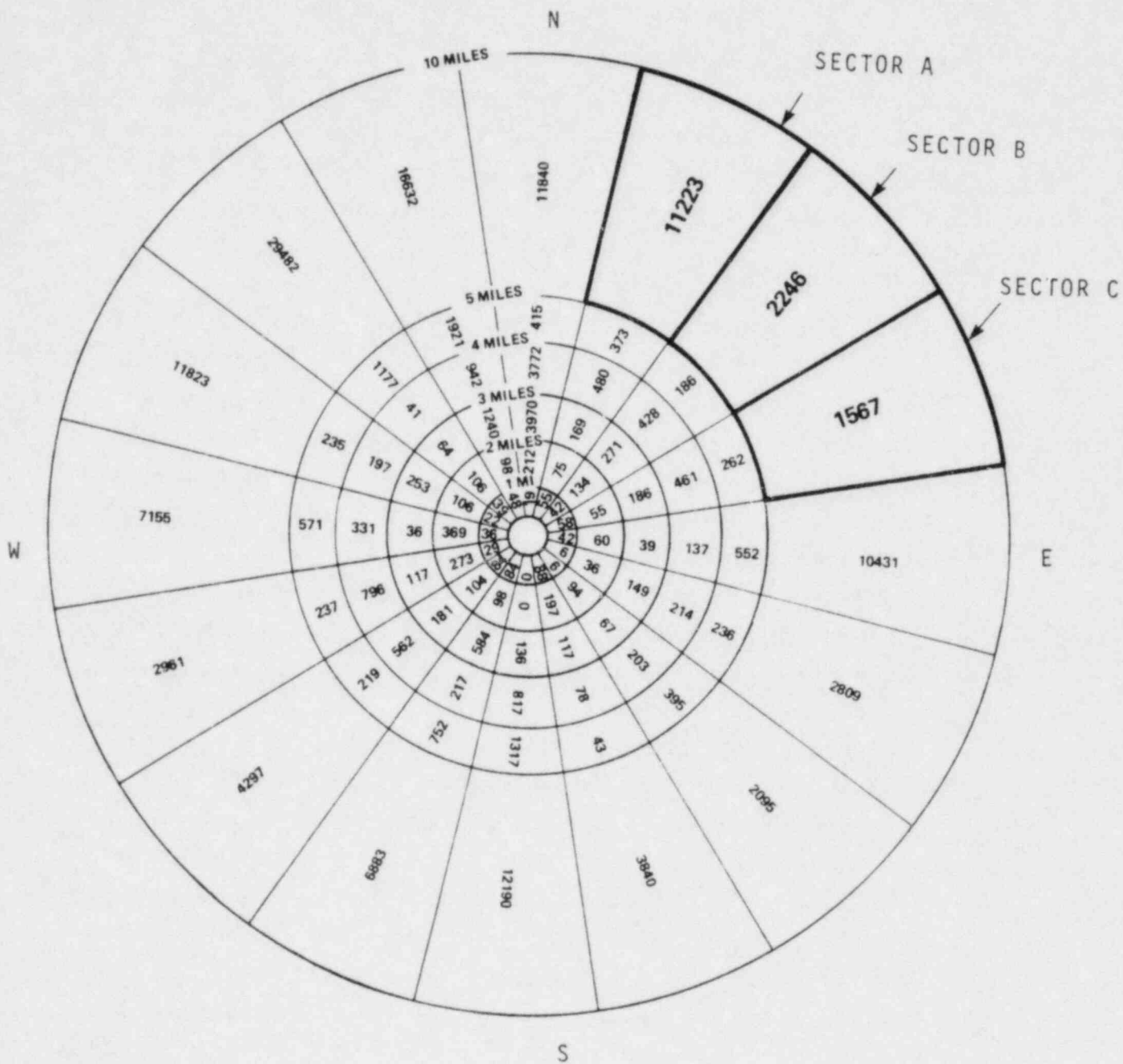

FIG. 3.1. POPULATION-DISTRIBUTION MAP FOR AN EPZ AT A NUCLEAR POWER PLANT.

numbers at random between 1 and 166,295. Each number selected represents one site (to be chosen later) within the sector containing that number. Thus, sectors with larger populations have a greater possibility of including chosen listener sites.

Step 3. Having determined the sector locations of each potential listener site, the next step in the procedure is the selection of the actual sites within the chosen sectors. This is accomplished by first overlaying a rectangular-coordinate grid on each sector of interest on the topographic map. The grid should be composed of boxes with dimensions of approximately 1000 ft per side and each box should be assigned an X and a Y coordinate according to its location on the grid. The grid is positioned such that the X-axis is oriented in the east-west direction and the Y-axis is oriented in the north-south direction, and such that all parts of the sector of interest are covered by a positive (X,Y) coordinate pair box. A random number generator is then used to select random pairs of numbers within the X and Y ranges covering the sector of interest. Each X,Y pair is used to select a particular box on the map. If there are buildings within the box, one of them is arbitrarily chosen as a listener site. If there are no buildings inside the box or if the box falls outside of the sector of interest, that coordinate pair is discarded and another pair is chosen at random.



For urban sites in the pink "building-exclusion" area of the topographic map, a building is always assumed to exist, and is selected at the center of the pink area in the coordinate pair box.

Step 4. The above process is repeated until at least 50 listener sites have been randomly chosen. If, by chance, the chosen sites do not properly reflect the population distribution, then the process may be continued. For example, if it is found that some major urban communities do not include any sample sites, then the selection process can be continued until sufficient urban sites are selected.

These new urban sites can replace the most recently chosen rural sites if desired. This replacement only affects the balance between urban and rural listener sites. Since the subsequent analysis treats urban and rural areas separately, replacement does not bias the results. It merely ensures that no major population concentrations are ignored.

The above procedure results in a pseudo-random sample of 50 specific listener locations, scattered throughout the EPZ in accordance with population distribution. In subsequent steps of this procedure, siren audibility is estimated for people indoors and outdoors at each site. Based on these estimates, statistical conclusions are drawn regarding overall siren coverage.

#### 4.0 SELECTION OF SAMPLE SCENARIOS

Sample scenarios - the specific conditions under which siren performance is evaluated - are an important feature of the analysis procedure. They are also the weakest feature, because they involve assumptions about parameters that have a major effect on the results of the analysis. These parameters include the specific weather conditions, peoples' locations, and the acoustic properties of buildings as they are presumed to exist at the time of siren operation.

For the purposes of this procedure, sample scenarios have been partially defined and are listed in Table 4.1. The user of the procedure need only select specific weather-related conditions representative of the site for each scenario. The other, defined features of the sample scenarios are intended to cover a range of conditions, from those most favorable for siren effectiveness to those least favorable.

In principle, there is no reason why other scenarios, totally different from those in Table 4.1, could not be evaluated. However, this would require the development of new estimates of alerting probability as a function of background noise (see Section 9).

The weather parameters that must be chosen to complete the scenario descriptions are:

- Temperature
- Relative Humidity
- Vertical Temperature Gradient
- Wind Direction
- Vertical Wind-Speed Gradient

TABLE 4.1 SAMPLE SCENARIOS FOR THE EVALUATION OF SIREN ALERTING CAPABILITY.

Scenario	1	2	3	4
Season	Summer	Summer	Winter	Winter
Time of Day	Weekday Afternoon	Late Night	Weekday Evening (rush hour)	Late Night
General Weather	Warm, Clear to Partly Cloudy	Warm, Clear to Partly Cloudy	Cold, Overcast	Stormy
Home/Vehicle Windows**	Open, Closed or Closed (including Storm Windows): Defined on the basis of Site Climatology.			
Percent of People Engaged in Specific Activities				
Outdoors	20%	-	5%	-
In Motor Vehicles*	6	18	25	-
Indoors at Work:				
Commercial	23	3	-	48
Industrial	7	1	-	1
Indoors at Home:				
Sleeping	4	95	-	95
Radio/TV	20	-	14	-
Noisy***	-	-	3	-
Active***	6	-	35	-
Isolated***	4	-	14	-
Quiet***	10	-	4	-

\*Urban/rural (speed) breakdown varies with site, proportional to urban/rural population distribution.

\*\*Window condition varies with climate at plant location.

\*\*\*See Table 5.2 for examples of these activities.

These should be chosen from meteorological data gathered at or near the site, with some understanding of site climatology.

If sufficiently detailed, hour-by-hour weather data are available for the site, representative sets can be chosen for each scenario. In the more general case, scenario weather has to be deduced from summaries of meteorological data. It is important that the values chosen for the parameters be typical sets. Do not use averages, because averages frequently obscure actual conditions that could occur. For example, it is not uncommon at temperate sites to find that relative humidity varies inversely with temperature. Simultaneous occurrence of the average temperature and the average relative humidity is unlikely.

In the cases where scenario weather conditions must be defined from data summaries, the following subsections will provide some guidance.

#### 4.1 Temperature and Relative Humidity

U.S. Weather Bureau reporting stations frequently provide temperature and humidity on an hourly basis, or every 6 hours during the day. Use a pair of these data for the season, general weather, and time of day (Table 4.1) for each scenario.

If only average data are available, use the average maximum temperature for July and the average minimum relative humidity for July for Scenario 1. For Scenario 2, use the average minimum temperature and the average maximum relative humidity for July. For Scenarios 3 and 4, use the average minimum January temperature; with 70% relative humidity for Scenario 3 and 90% relative humidity for Scenario 4. (Other values may be appropriate for desert or subtropical areas.)

#### 4.2 Vertical Temperature Gradient

Every nuclear power plant has a meteorological tower at which the vertical temperature gradient is measured. The problem is, when these data are summarized, information about diurnal variations is destroyed, and it is necessary to fall back on generalizations.

- Scenario 1 is typically characterized by daytime, fair weather instability: a marked temperature decrease with height.
- Scenario 2 is typically characterized by a nocturnal inversion: a marked temperature increase with height.
- Scenarios 3 and 4 are typically characterized by near-neutral conditions: a small decrease in temperature with height.

Environmental Reports usually contain summaries of weather conditions by "(Pasquill) Stability Class," generally in one of the forms listed in Table 4.2. Based upon the frequencies of occurrence of these stability classes at the site, choose:

- Class A ( $-1.0^{\circ}\text{F}/100\text{ ft}$ ) for Scenario 1.
- Class E ( $+0.5^{\circ}\text{F}/100\text{ ft}$ ) for Scenario 2.
- Class D or E ( $-0.5^{\circ}\text{F}/100\text{ ft}$  or  $+0.5^{\circ}\text{F}/100\text{ ft}$ ) for both Scenarios 3 and 4, whichever occurs more frequently during January at the site.

TABLE 4.2  
PASQUILL STABILITY CLASSES

CATEGORY	Temperature Gradient*			Standard Deviation of Wind-Direction Fluctuations
	$^{\circ}\text{F}/100 \text{ ft}$	$^{\circ}\text{F}/1000 \text{ ft}$	$^{\circ}\text{C}/100 \text{ m}$	
A	$\Delta T < -1$	$\Delta T < -10.4$	$\Delta T < -1.9$	$25^{\circ}$
B	$-1 \leq \Delta T < -0.9$	$-10.4 \leq \Delta T < -9.3$	$-1.9 \leq \Delta T < -1.7$	$20^{\circ}$
C	$-0.9 \leq \Delta T < -0.8$	$-9.3 \leq \Delta T < -8.2$	$-1.7 \leq \Delta T < -1.5$	$15^{\circ}$
D	$-0.8 \leq \Delta T < -0.3$	$-8.2 \leq \Delta T < -2.7$	$-1.5 \leq \Delta T < -0.5$	$10^{\circ}$
E	$-0.3 \leq \Delta T < 0.8$	$-2.7 \leq \Delta T < 8.2$	$-0.5 \leq \Delta T < 1.5$	$5^{\circ}$
F	$0.8 \leq \Delta T < 2.2$	$8.2 \leq \Delta T < 22$	$1.5 \leq \Delta T < 4$	$2.5^{\circ}$
G	$2.2 \leq \Delta T$	$22 \leq \Delta T$	$4 \leq \Delta T$	-

\*Upper-level temperature minus lower-level temperature,  
divided by the difference in levels.



Note that the analysis (see Section 8 and Appendix A) also requires a knowledge of the two heights between which the temperature difference is measured. Use the known values for these heights, if available, and convert from temperature gradient to the actual temperature difference between these heights. If the measurement heights are not known, use 330 ft and 100 ft.\* Keep all quantities in English units.

#### 4.3 Wind Direction and Vertical Wind-Speed Gradient

Scenarios 1 and 2 should utilize the prevailing, fair-weather, summer (July) wind conditions at the site; for daytime and nighttime respectively. In hilly terrain, this frequently means up-stream, up-slope winds in the daytime and gentle down-stream, down-slope winds at night. Coastal locations would probably have daytime sea breezes and nighttime land breezes. Scenario 3 should utilize prevailing, light winter (January) winds, whereas Scenario 4 should use winter storm winds.

Environmental Reports frequently contain wind-roses which are useful for defining wind conditions, although they obscure diurnal wind variations. More useful are joint-frequency distributions of wind speed and direction for various stability classes. Using the stability classes selected as described in 4.2 above, these tables can be searched for commonly occurring wind speed and direction conditions to fit each of the scenarios. It is desirable for the four scenarios to have widely different wind directions, if site climatology permits.

Although wind speed is frequently measured at two different heights at nuclear plants, the data are rarely reported in summary documents in the form of gradients. In general, use the

---

\*These heights (equivalent to 100m and 30m) are commonly used for determining temperature gradient.

wind speed that is reported for the greater height, and assume that the speed is 0 at a height of 2 ft in order to compute a vertical wind speed difference. Note that the computations of Section 8 and Appendix A use speeds in ft/sec, and heights in ft.

At many EPZ's the wind speed and direction may vary from location to location within the EPZ. The procedure allows for this possibility, and it may be appropriate to choose different wind speeds and directions for different siren-listener pairs within a given scenario.

## 5.0 ESTIMATION OF BACKGROUND NOISE LEVELS

### 5.1 Outdoor Background Noise

The ability of sirens to alert people outdoors is a function of the magnitude as well as the variability of outdoor background noise levels. The outdoor background noise environment at any given listener site is often caused by motor-vehicle activity, and hence is related to population density (i.e., urban or rural area). Specific nearby noise sources (e.g., airports, industrial plants) can also be controlling. In rural areas, natural sounds such as surf, wind in trees, insects, etc. can predominate. The sound from many of these sources varies with time of day.

Although background noise information for each of the 50 sample listener sites could be obtained by direct measurement over a long period of time, such an approach is usually not practical. The remainder of this section describes a simplified method for estimating background noise levels at the sample listener sites, based on generalized categories of outdoor environments.

As explained in Appendix B, the alerting ability of a siren sound is keyed to the minimum background noise level that occurs at a listener site during the time period when the siren is operating. For the purpose of the present analysis, the sound level exceeded 90 percent of the time ( $L_{90}$ ) during a sounding period is used as a conservative estimate of the minimum sound level. Furthermore, only the background sound energy contained in the one-third octave frequency band centered at 630 Hz (i.e., the frequency band which includes the typical siren tone) is considered. Therefore, the background noise level is defined here as the  $L_{90}$  for the one-third octave band centered at 630 Hz, evaluated over 4-minute periods in the case of stationary

sirens. Since rotating sirens actually produce their rated sound level during only about one-quarter of their operating time at any particular listener location, the background-noise analysis for rotating sirens is based on 1-minute periods.

The estimation procedure for obtaining background noise levels is based on noise measurements conducted by BBN in the vicinity of the Trojan Nuclear Plant in Oregon, near the Indian Point Nuclear Power Station in New York, and upon the body of data in BBN files. The data, summarized on Table 5.1, typically consisted of statistical analyses of background noise, observed at various types of locations. The analyses provide the  $L_{90}$  for 1-minute samples of data in the one-third octave frequency band centered at 630 Hz. These data were used to estimate the range of background noise levels that are likely to exist during any 4-minute period (1 minute for rotating sirens) for a variety of outdoor environments. The results are summarized in Table 5.2, which provides ranges of background noise levels which are expected to exist during 1-minute and 4-minute periods for generalized categories of outdoor environments. The background noise environments are specified for urban and rural areas. Only daytime noise levels are presented since the nighttime scenarios (see Section 4) assume that essentially no people are outdoors at night. Data for the outdoor background noise categories have been combined to obtain the probability distributions shown in Figs. 9.1 and 9.2 (after adding 9 dB).

## 5.2 Background Noise Indoors

Indoor background noise comes predominantly from indoor sources, and varies markedly with the listener's location within the building. Based upon a series of measurements\* made in homes

---

\*The measurement methodology is summarized in Section 2.2.3.

TABLE 5.1 SUMMARY OF OUTDOOR BACKGROUND NOISE  
DATA USED TO DEVELOP THIS PROCEDURE.

CATEGORY	NUMBER OF MEASUREMENT LOCATIONS	NUMBER OF MINUTES MEASURED	TYPICAL NOISE SOURCES
URBAN DAY	17	1060	Stop-and-go road traffic, occasional aircraft, children's voices, dogs barking, lawn mower, loud hi-fi, trains and train whistles, industrial plants, supermarket Muzak, automobile horns
URBAN EVE/NIGHT*	5	299	Stop-and-go road traffic, occasional aircraft, dogs barking, trains and train whistles, crickets, industrial plants, utility mech. equipment
RURAL DAY	22	1314	Rushing stream, chain saw, road traffic, aircraft, trains, bell, industry, motor boats, utility mech. equipment, birds and farm animals, wind in trees, dogs barking, children's voices
RURAL EVE/NIGHT*	3	179	Dogs barking, crickets, road traffic, train whistles, windmill, sirens, industry, wind in trees, dogs barking, aircraft

\*Not used in this procedure.

TABLE 5.2 MINIMUM BACKGROUND NOISE LEVELS FOR GENERALIZED CATEGORIES OF OUTDOOR ENVIRONMENTS.  
(See Figures 9.1 and 9.2 for Distributions)

Generalized Background Noise Environment	Range of Minimum Background Noise Levels <sup>1</sup> (dB)	
	1-Minute Period <sup>2</sup>	4-Minute Period <sup>3</sup>
I. URBAN-DAY <sup>4</sup> (Includes Rural locations within 1000 ft of major roadways)	21-57	21-57
II. RURAL-DAY <sup>5</sup> (Except Rural locations within 1000 ft of major roadways)	17-48	17-47

NOTES:

1. Refers to the range of the minimum (L<sub>90</sub>) sound pressure levels in the 630 Hz one-third octave band during the specified time period.
2. Applicable for analysis of rotating sirens operated for 4 minutes.
3. Applicable for analysis of stationary sirens operated for 4 minutes.
4. Urban locations are defined as the pink "building exclusion" areas of topographic maps, or as those communities with a population density exceeding 2000 people per square mile. Major roadways are defined as roadways with more than one lane in each direction.
5. Rural locations are taken to be all sites not classified as urban (above).



and offices summarized in Table 5.3), generalized categories of indoors background-noise minima have been established. These are listed in Table 5.4.

For simplicity, data for various indoor, at-home categories (i.e., "obviously noisy," "busy and active," "isolated," and "obviously quiet") have been combined in proportion to the activity fractions in Table 4.1 to obtain the probability distributions shown in Figs. 9.4 and 9.5 (after adding 9 dB). The distributions for the commercial working environment, with 9 dB added, are shown on Fig. 9.6.

The analysis pertaining to the awakening of people at sleep does not depend upon background noise. It is assumed that the indoor background noise during sleeping hours is always less than the siren level.

### 5.3 Background Noise in Motor Vehicles

Background noise in motor vehicles depends on the vehicle speed and on window condition (i.e., open or closed). Operation of heater/air-conditioner fans and car radios can also influence the background, but are ignored here. For the purpose of this analysis, it is assumed that motorists in urban areas travel at a speed of 30 mph while motorists in rural areas travel at a speed of 55 mph. Vehicle windows are assumed to be open during the summer (except in climates where air-conditioned cars are common) and closed during the winter. Background noise levels for these conditions are obtained from a recent study performed by the U.S. Department of Transportation (DOT)[1] and are summarized in Table 5.5.

TABLE 5.3 SUMMARY OF INDOOR BACKGROUND NOISE DATA  
USED TO DEVELOP THIS PROCEDURE.

CATEGORY	NUMBER OF MEASUREMENT LOCATIONS	NUMBER OF MINUTES MEASURED	TYPICAL NOISE SOURCES
OBVIOUSLY NOISY	6	108	Music and talking during party, bathroom vent fan, shower, vacuum cleaner, hair dryer
BUSY AND ACTIVE	11	400	Several people talking, children playing, dinner while talking, live music practice, bathroom activities with vent fan off, concentrated music-listening, vacuum cleaner in next room
ISOLATED	5	126	Dishwasher/dryer/washer in next room, background music
OBVIOUSLY QUIET	3	92	Dinner/paperwork alone, reading alone
OFFICE/COMMERCIAL	2	501	Talking, typewriter in next room, paperwork, ventilation noise, general retail-store activities

TABLE 5.4  
 MINIMUM BACKGROUND NOISE LEVELS FOR  
 GENERALIZED CATEGORIES OF INDOOR  
 ACTIVITIES/ENVIRONMENTS

Generalized Activity/Environment	Range of Minimum Background Noise Levels in dB <sup>1</sup>	
	1-Min Period <sup>2</sup>	4-Min Period <sup>2</sup>
At home, obviously noisy <sup>4</sup> (i.e., vacuum cleaning, dishwasher, shower, vent fan on)	41-76	41-73
At home, busy and active <sup>4</sup> (i.e., dinner conversation, kitchen work, playing music, children at play)	21-64	21-54
At home, isolated <sup>4</sup> (i.e., noise-producing activity in adjacent room, soft background music)	23-49	23-38
At home, obviously quiet <sup>4</sup> (i.e., reading, study, eating alone)	11-39	11-28
At work, office and commercial	28-49	28-45

NOTES:

1. Refers to the range of the minimum ( $L_{90}$ ) sound pressure levels in the 630 Hz one-third octave-band.
2. Applicable for analysis of rotating sirens operated for 4 minutes.
3. Applicable for analysis of stationary sirens operated for 4 minutes.
4. To simplify the procedure, these are combined into a single indoor range on the basis of the activity fractions in Table 4.1.

TABLE 5.5  
 BACKGROUND NOISE INSIDE MOTOR VEHICLES [1]

Vehicle Speed (mph)	Vehicle Window Condition	Background Noise: 1/3-Octave Band Sound Pressure Level at 630 Hz (dB)
55	Closed	66
55	Open	68
30	Closed	59
30	Open	64

## 6.0 SIREN-PERFORMANCE DATA

In addition to their locations, three things must be known about each siren installed for the warning system:

- nominal (rated) sound level output at 100 ft, in dB(C)
- approximate mounting height above the terrain
- whether or not it is a rotating or stationary siren.

This information is normally available from the licensee or from manufacturer's literature.

This entire analysis assumes a siren operating frequency in the vicinity of 630 Hz. Some sirens operate at frequencies as low as 450 Hz, and some at frequencies as high as 850 Hz. In general, low-frequency sirens will be slightly more effective, and high frequency sirens slightly less effective than a siren operating at 630 Hz. However, the differences are not believed to be significant when compared to the approximation embodied in this procedure.

## 7.0 ATTENUATION OF SOUND BY BUILDING AND VEHICLE STRUCTURES

Outdoor siren sound levels computed for each listener site must be reduced by the sound attenuation through building walls before estimating alerting potential for that fraction of the population indoors. A similar reduction is necessary for estimating alerting of people in motor vehicles.

### 7.1 Buildings

A number of studies [2,3] have been done of the reduction of sound as it propagates from outside to inside buildings. Results vary widely depending upon structural details of the buildings, upon where within the buildings the measurements are made, and upon the characteristics of the exterior sound sources.

The Society of Automotive Engineers has published a summary of such measurements [3] that is widely used for general-purpose applications such as the analysis procedure addressed herein. Table 7.1, from the SAE summary, is recommended for use. The sound reduction values in this table are for the 500 Hz octave band, which includes the 630 Hz one-third octave band used in the analysis.

In Table 7.1, the term "Cold Climates" refers to data gathered in New York and Boston. The "Warm Climate" data are from Los Angeles and Miami. The differences are significant, and are attributable to the fact that homes in warmer climates typically have larger, less tightly sealed windows than homes in cold climates.



In northeastern and north-central parts of the country, the cold climate figures should be used for residences. Windows should be open for Scenarios 1 and 2, and closed with storm windows for Scenarios 3 and 4. On the west coast and in the south, the warm-climate data should be used, and the decision as to whether the windows are open or closed should be based upon knowledge of local practice, and on the prevalence of residential air conditioning.

For commercial buildings, use the "31 dB" figure for all locales, both cold and warm, since such buildings generally have well-sealed windows.

Table 7.1  
 Sound Reduction Through  
 Residential Structures  
 (500 Hz Octave Band) [3]

	Cold Climates	Warm Climates
Windows Open	16 dB	12 dB
Windows Closed	27 dB	22 dB
Windows & Storm Windows Closed	31 dB	-

## 7.2 Motor Vehicles

The results of measurements of the sound-reduction properties of a number of various types of motor vehicles have been summarized in a DOT report [1]. This material has been abstracted in Table 7.2.

In northeastern locations, we recommend the use of the figure for open windows during the summer (Scenarios 1 and 2) and the closed window figure during the winter. In southern locations where air-conditioned cars are common, the closed-window figure would be applicable all year round.

Table 7.2  
Sound Reduction of  
Motor Vehicle Structures  
(630 Hz 1/3 Octave Band) [1]

Windows Open	13 dB
Windows Closed	21 dB

## 8.0 COMPUTATION OF THE SOUND LEVEL FOR THE DOMINANT SIREN

This section outlines the procedure for determining that siren in the vicinity of each listener site that is expected to produce the highest sound level at that site for each sample scenario. This choice is not always obvious, because the sound level caused by a particular siren at a given listener site depends not only on the sound output of the siren and its distance from the listener, but also on shielding and atmospheric effects (particularly wind direction). Therefore, for each scenario it is generally necessary to evaluate several sirens in the vicinity of each listener site in order to determine the dominant one. As a general rule, the closest, highest-rated, nonshielded sirens should be selected for evaluation at each site. Furthermore, sirens should be chosen such that they are distributed north, south, east, and west of the site (or in any other four mutually perpendicular directions) where possible to account for different wind directions.

The first step in the procedure is to establish the outdoor sound level produced by the selected sirens at each listener location, on a per-scenario basis. This is accomplished by applying adjustments to the rated sound level of each siren for each scenario as follows:

$$L(\text{listener}) = L(\text{siren}) - A_d - A_s - A_{\text{air}} - A_{\text{atm}}, \quad (8.1)$$

where  $L(\text{listener})$  is the outdoor siren sound pressure level at the listener site (dB),  $L(\text{siren})$  is the rated sound pressure level of the siren at 100 ft (dB),  $A_d$  is the distance attenuation (dB),  $A_s$  is the shielding attenuation (dB),  $A_{\text{air}}$  is the air absorption (dB), and  $A_{\text{atm}}$  is the atmospheric attenuation caused by wind and temperature gradients (dB).

The first two adjustments (for distance and shielding) are the same for all scenarios and can be obtained using the topographical maps. Distance attenuation beyond 100 ft is calculated by assuming sound propagation from an acoustic point source with a reduction of 6 dB per distance doubled. It is calculated as follows:

$$A_d = 20 \log_{10} \left( \frac{d}{100} \right), \quad (8.2)$$

where  $d$  is the siren-to-listener distance (ft).

Shielding attenuation ( $A_s$ ) is estimated using the following formula for the attenuation of a rigid straight barrier for sound incident from a point source [4]:

$$\begin{aligned} A_s &= 24 && \text{for } N \geq 12.6 \\ A_s &= 20 \log \left( \frac{\sqrt{2\pi N}}{\tanh \sqrt{2\pi N}} \right) + 5 \text{ dB} && \text{for } -0.2 < N < 12.6 \\ &= 0 && \text{for } N \leq -0.2 \end{aligned} \quad (8.3)$$

where  $N$  is the Fresnel number (dimensionless):

$$N = \mp \frac{2}{\lambda} (A + B - d) \quad (8.4)$$

- $\lambda$  = wavelength of sound in ft (1.79 ft for a 630 Hz siren tone)
- $d$  = straight-line distance between source and receiver, ft
- $A + B$  = shortest path length of wave travel over the barrier between source and receiver, ft
- + sign = receiver in the shadow zone (i.e., barrier obstructs line of sight)
- sign = receiver in the bright zone (i.e., barrier doesn't obstruct line-of-sight)

When  $N$  is negative, the above equation for  $A_s$  is evaluated by replacing  $N$  with  $|N|$ , and by replacing  $\tanh$  with  $\tan$ . Shielding attenuation is limited to a maximum of 24 dB based upon a large body of experimental data. Figure 8.1 provides a graphical means for calculating  $A_s$  as a function of the Fresnel number  $N$ .

Sirens should be assumed to be at a height of 50 ft above terrain level and listener sites may be assumed to be at a height of 5 ft above terrain level, unless more specific information is available. Barrier heights may be obtained from ground contour information on topographical maps.

The adjustments for air absorption and atmospheric effects depend on the meteorological conditions for each particular scenario. Air absorption ( $A_{air}$ ) is a function of distance, frequency, air temperature and relative humidity. Table 8.1 provides estimates of the air absorption coefficient,  $a$ , for siren tones in the frequency region near 500 Hz (containing the 630 Hz one-third octave band), based on air temperatures and relative humidity [5] (use interpolation if necessary). The air absorption is then calculated as follows:

$$A_{air} = (a)(d)/1000 \quad (8.5)$$

where  $A_{air}$  = air molecular absorption, in dB  
 $a$  = air absorption coefficient, in dB/1000 ft  
 $d$  = siren-to-listener site distance, in ft.

The adjustment for atmospheric gradient effects ( $A_{atm}$ ) is based on siren-to-listener azimuth with respect to wind direction and on wind and temperature gradient characteristics. A description of the estimation procedure for  $A_{atm}$  can be found in Appendix A.

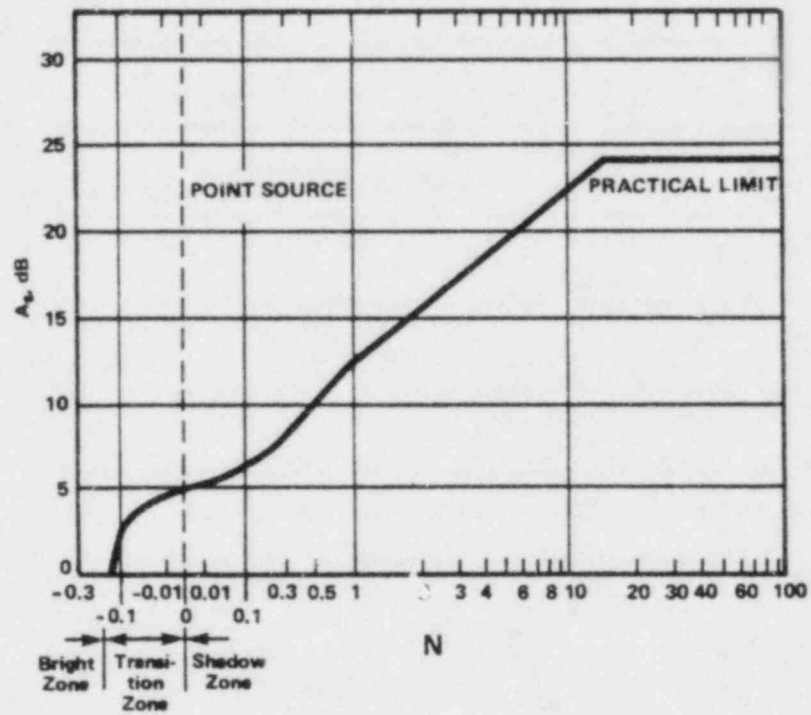

FIG. 8.1. SHIELDING ATTENUATION OF THE SOUND FROM A POINT SOURCE BY A RIGID BARRIER AS A FUNCTION OF FRESNEL NUMBER  $N$  [4] (See Text).



TABLE 8.1 AIR ABSORPTION COEFFICIENTS AT 500 HZ. [5].

Temperature	Relative Humidity (Percent)	Air Absorption Coefficient (dB/1000 ft)
86°F (30°C)	10	1.07
	20	1.13
	30	1.16
	50	1.01
	70	0.82
	90	0.73
68°F (20°C)	10	1.16
	20	0.82
	30	0.82
	50	0.85
	70	0.82
	90	0.79
50°F (10°C)	10	1.86
	20	0.88
	30	0.67
	50	0.61
	70	0.61
	90	0.64
32°F (0°C)	10	2.71
	20	1.52
	30	0.94
	50	0.58
	70	0.49
	90	0.46

An example of the calculation of  $A_{atm}$  is provided in Table 8.2 for a listener located 1500 ft north of a siren. The meteorological input data assumed for this example includes wind direction and vertical differences in temperature and wind speed measured at two heights (125 ft and 35 ft) for each of four sample scenarios. As shown, the vertical profile of air temperature ( $\alpha Z$ ) is calculated based on the temperature difference at the two measurement heights and the vertical profile of wind speed ( $\beta Z$ ) is calculated based on the difference in wind velocity at the two measurement heights. The distance from the siren to the acoustic shadow zone ( $X_o$ ) is then calculated using the following equation:

$$X_o = \frac{47S \cdot f(R/S)}{\sqrt{\beta Z \cos\phi - \alpha Z}} \quad (8.6)$$

where:  $X_o$  = distance to the acoustic shadow, in ft  
 $S$  = source (i.e., siren) height, in ft  
 $R$  = receiver (i.e., listener) height, in ft  
 $\beta Z$  = vertical profile of wind speed, in ft/sec/ln ft  
 $\alpha Z$  = vertical profile of air temperature, in °F/ln ft  
 $\phi$  = angle between the direction from which the wind is coming and the sound path, in degrees (see Fig. A-2 of Appendix A).

Note that Eq. 8.6 is valid only for receiver locations in the upwind sector. If the value under the square root is negative or zero, then the receiver is located in the downwind sector and  $A_{atm} = 0$ .

TABLE 8.2. SAMPLE CALCULATION OF ATMOSPHERIC ATTENUATION,  $A_{atm}$ , CAUSED BY WIND AND TEMPERATURE GRADIENTS. (See Text and Appendix A for details).

Scenario	1	2	3	4
Wind direction, $\theta_w$	0° (N)	45° (NE)	67.5° (ENE)	90° (E)
Temperature Differential $\Delta T^\circ F$ (125'-35')	-1.3	+1.1	-0.7	-0.8
$\alpha Z = \Delta T / (\ln 125' - \ln 35')$	-1.02	+0.86	-0.55	-0.63
Wind Speed, $V_2$ ft/sec @ 125 ft	16.3	17.2	15.8	48.4
$V_1$ ft/sec @ 35 ft	10.1	8.9	11.6	32.3
$\beta Z = (V_2 - V_1) / (\ln 125' - \ln 35')$	4.87	6.52	1.27	12.65
Siren-to-Listener Direction, $\theta_p$	0°	0°	0°	0°
$\phi = \theta_w - \theta_p$	0°	45°	67.5°	90°
$\cos \theta$	+1	+0.707	+0.383	0
$X_o$ (ft)	436	546	1,039	1,333
$D/X_o = 1500/X_o$	3.44	2.75	1.44	1.13
$A_{atm}$ (dB)	20	15	5	0

For the purpose of this example, assume that the siren is mounted at a height of  $S = 50$  ft and the listener is located at a height of  $R = 5$  ft. Therefore,  $R/S = 5/50 = 0.1$  and the parameter  $f(R/S)$  is found to be 0.45 using Table 8.3. By substitution, Eq. (8.6) then reduces to the following:

$$X_o = \frac{1058}{\sqrt{\beta Z} \cos\phi - \alpha Z} \quad (8.7)$$

The angle  $\phi$  is obtained based on the siren-to-listener azimuth with respect to wind direction and  $X_o$  is calculated for each sample scenario using Eq. (8.7) as shown in Table 8.2. Finally,  $A_{atm}$  is determined for each scenario based on the ratio of the siren-to-listener distance ( $D$ ) to  $X_o$  according to Table 8.4. The results in Table 8.2 indicate atmospheric attenuations ranging between 0 and 20 dB, depending on scenario, for the given siren-listener pair.

Application of the above calculations yields the estimated outdoor sound pressure levels for various sirens at each sample listener site, for each of the four scenarios. For the balance of the analysis, only the highest siren level for each scenario at each listener site is used. An exception to this rule is made at listener sites where the sound level of a stationary siren is estimated to be between 0 and 6 dB lower than the sound level of a rotating-type siren, which had been determined to be the loudest siren. In such cases, the stationary siren is selected for further analysis. The reason for this exception is that the maximum sound level produced by a rotating siren is not continuous, and thus the total acoustic energy at the listener (as measured by the single event noise exposure level, or SEL) is approximately 6 dB less than for a stationary (i.e., continuous) siren with the same maximum sound level.

TABLE 8.3

$f\left(\frac{R}{S}\right)$  vs.  $\frac{R}{S}$  for Computing  $X_0$  in Eq. 8.6.

(See Appendix A.)

R/S	f(R/S)
$\leq 0.05$	0.4
0.1	0.45
0.2	0.55
0.3	0.6
0.4	0.7
0.5	0.75
0.7	0.85
0.9	1.0
1	1.05
1.5	1.25
2	1.5
3	1.9
4	2.3
5	2.65
6	3.0
7	3.3
8	3.65
9	3.95
10	4.2
$> 10$	Set $X_0 > D$

Interpolation is permitted, and for manual computations a graph of  $f(R/S)$  vs.  $R/S$  is most useful.

TABLE 8-4. ATTENUATION WITHIN THE SHADOW ZONE,  $A_{\text{atm}}$ ,  
 VS. SIREN-TO-LISTENER DISTANCE, D (FT)  
 $x_0$  (FT)

$\frac{D}{x_0} \leq 1.2$	0 dB
$1.2 < \frac{D}{x_0} \leq 1.7$	5
$1.7 < \frac{D}{x_0} \leq 2.4$	10
$2.4 < \frac{D}{x_0} \leq 3.4$	15
$\frac{D}{x_0} > 3.4$	20



## 9.0 ALERTING PEOPLE

Siren detectability is a function of the siren signal level and of the background noise level in a "critical frequency band" centered at the signal frequency. For this analysis, detectability is estimated based on the signal-to-noise (S/N) difference in the 630 Hz one-third octave frequency band. The chosen criterion for alerting is that the given signal level must be 9 dB or more above the minimum background noise level at any time during the selected siren operating time period of 4 minutes. For siren operating periods other than 4 minutes, an adjustment can be applied as described in Appendix B. The chance of alert while sleeping is based on a sleep-awakening model. The procedure for estimating probability of alert is outlined below.

### 9.1 Outdoor Alert

The chance of alert for people outdoors is determined for each scenario at each listener site using Figs. 9.1 and 9.2, developed based on outdoor background noise data (see Section 5.1). In order to use these figures, two items of information are required: (1) the outdoor siren level, and (2) the generalized category of outdoor background noise environment of the site. The first item is obtained as described in Section 8, while the second item is obtained as described in Section 5.1.

As an example, consider a rural listener site (during the day) located within 1000 ft of a major highway. Assume also that the dominant siren was found to be a rotating-type unit producing an estimated sound level of 57 dB at this listener site for a particular daytime scenario. Entering Fig. 9.2 (for rotating sirens) at 57 dB on the horizontal scale, and moving vertically to intersect the curve corresponding to Urban-Day (which includes rural sites within 1000 ft of a major highway),

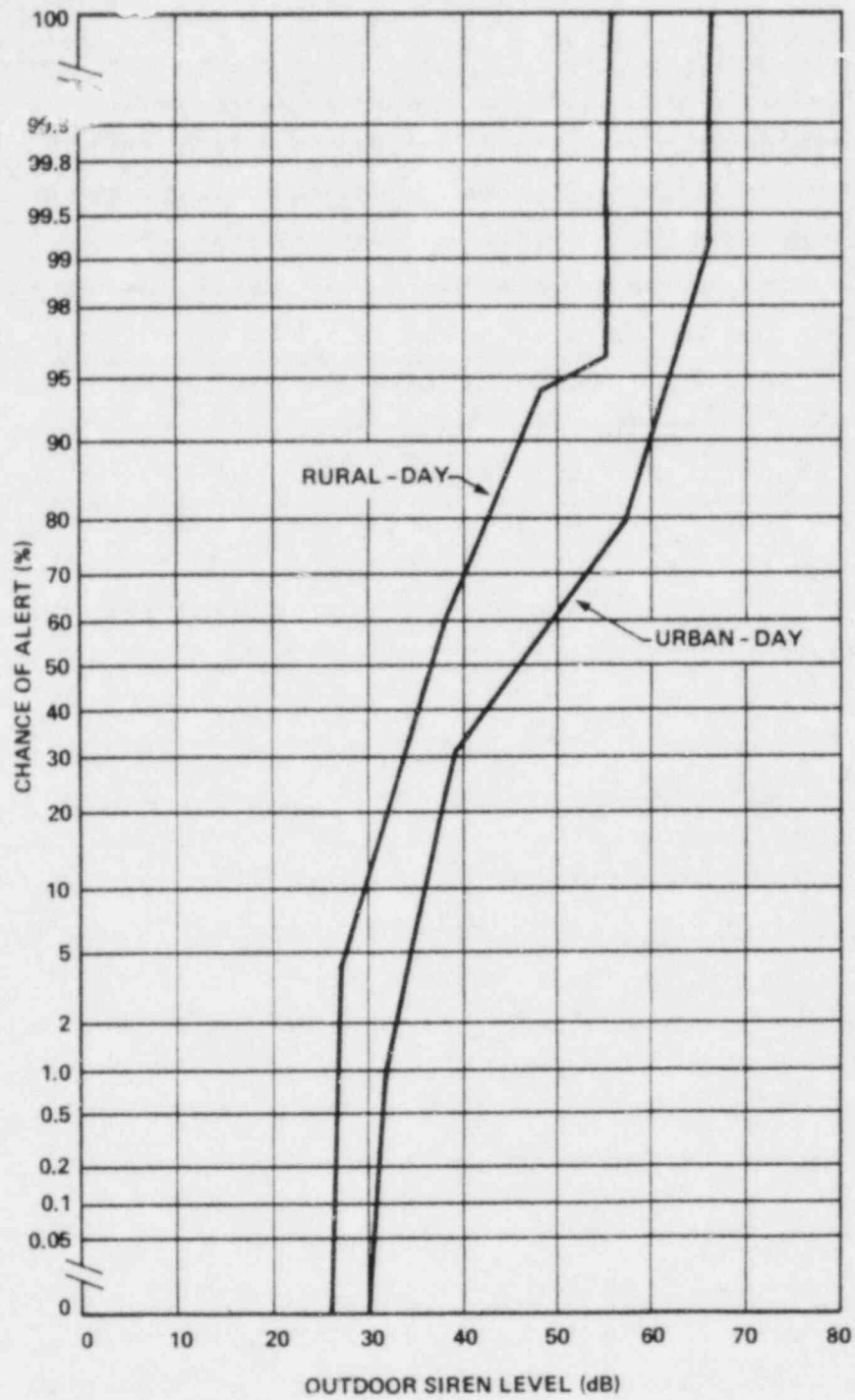

FIG. 9.1. CHANCE OF ALERT FOR PEOPLE OUTDOORS (4-MINUTE STATIONARY SIREN).

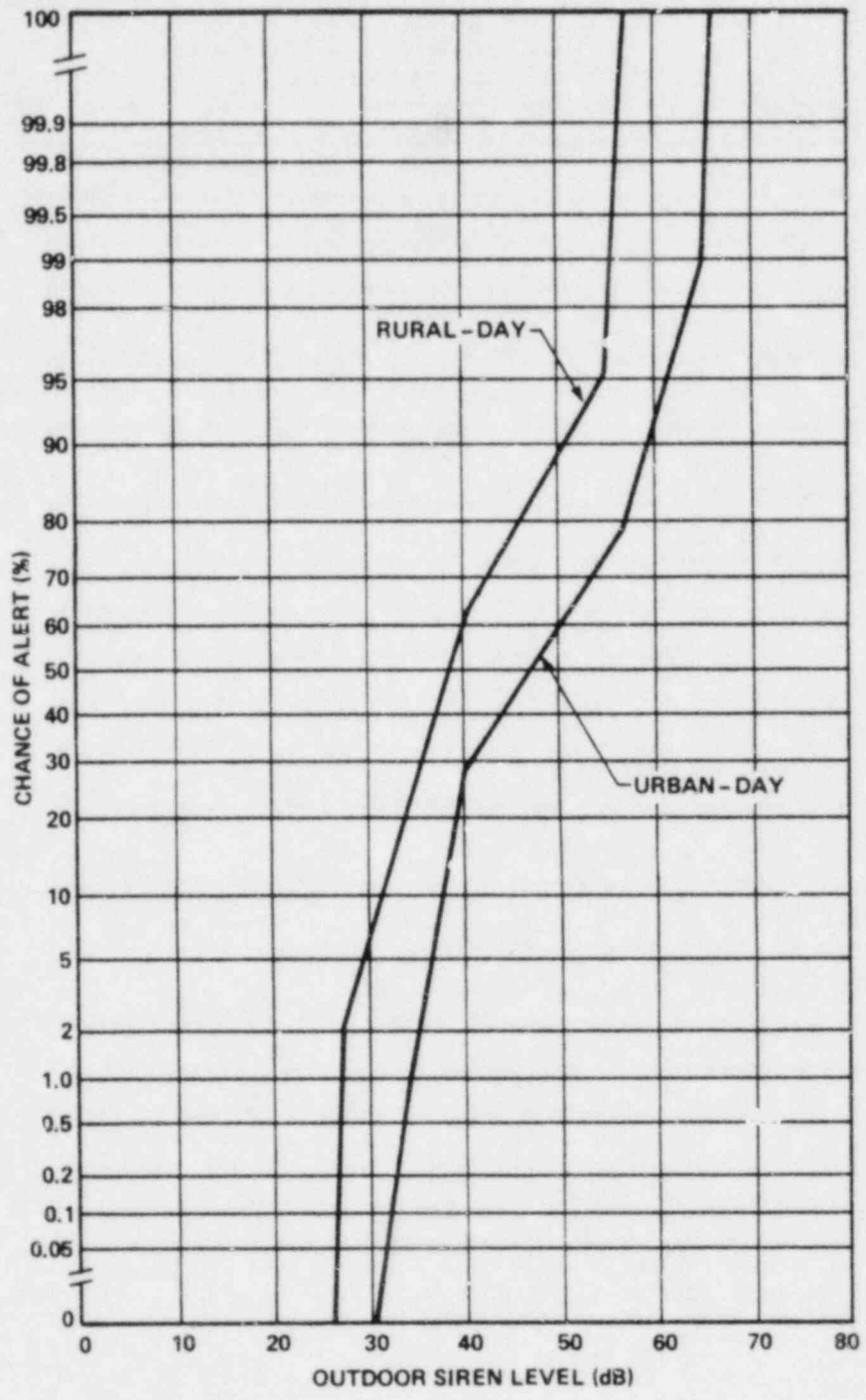

FIG. 9.2. CHANCE OF ALERT FOR PEOPLE OUTDOORS (4-MINUTE ROTATING SIREN).

the chance of alert (reading from the vertical scale) is estimated to be 80 percent. Note that intersect points lying below 0 on the vertical scale are assigned 0-percent chance while those lying above 100 on the vertical scale are assigned 100-percent chance.

In summary, information regarding siren type, estimated siren sound level, background noise environment category and scenario are used in conjunction with Figs. 9.1 or 9.2 to estimate the chance of siren alert outdoors at each listener site. Note that the 9-dB margin above the background noise required to accomplish alert is already built into Figs. 9.1 and 9.2, and thus need not be separately added by the user.

### 9.2 Indoor Alert

In order to estimate the chance of alert indoors, the sound level of the dominant siren outdoors must first be reduced to a corresponding indoor sound level. This must be done separately for each scenario, as follows:

$$\begin{array}{ccc}
 \left( \begin{array}{l} \text{Outdoor Sound Level} \\ \text{of Dominant Siren} \\ \text{Equation 8.1} \end{array} \right) & \text{minus} & \left( \begin{array}{l} \text{Building Sound} \\ \text{Reduction} \\ \text{Table 7.1} \end{array} \right) \\
 \text{Scenario} & & \text{Scenario} \\
 \\ 
 \text{Equals} & & \left( \begin{array}{l} \text{Indoor Sound} \\ \text{Levels for Homes} \\ \text{or Commercial} \\ \text{Structures} \end{array} \right) \\
 & & \text{Scenario}
 \end{array}$$

### 9.2.1 At Home

For the analysis of alerting people indoors at home, three types of activities are considered: (1) listenening to radio or TV, (2) sleeping, or (3) other activities that range from quiet to noisy situations.

For people listening to radio or TV, the chance of alert is assumed to be 100 percent. For people sleeping, the chance of alert is based on the Single Event Level (SEL) of the siren sound indoors - a measure of total acoustic energy - and upon the sleep-awakening model developed by the U.S. Environmental Protection Agency [6]. The graph used for estimating the chance of alert during sleep is shown in Fig. 9.3. For this analysis, the curve for the chance of awakening one out of two sleepers should be used. For example, consider a listener site at which the dominant siren has been determined to be a stationary-type unit producing an estimated indoor sound level of 36 dB for a particular scenario. Figure 9.3 indicates that the indoor SEL for this case would be  $36+24=60$  dB. Entering the figure at 60 dB on the horizontal scale, and moving vertically to intersect the curve for 1 out of 2 sleepers, the chance of alert (i.e., awakening) is estimated to be 30 percent (reading from the vertical scale).

For all other indoor activities at home, the chance of alert is based on classifications of actual indoor background noise measurements under a wide variety of condicions (see Section 5.2). Table 9.1 provides the percentages of people assumed to be engaged in indoor activities for the two daytime scenarios. (For the nighttime scenarios, all people at home are assumed to be sleeping.) Based on these percentages and on the measured indoor background noise data, graphs have been developed for

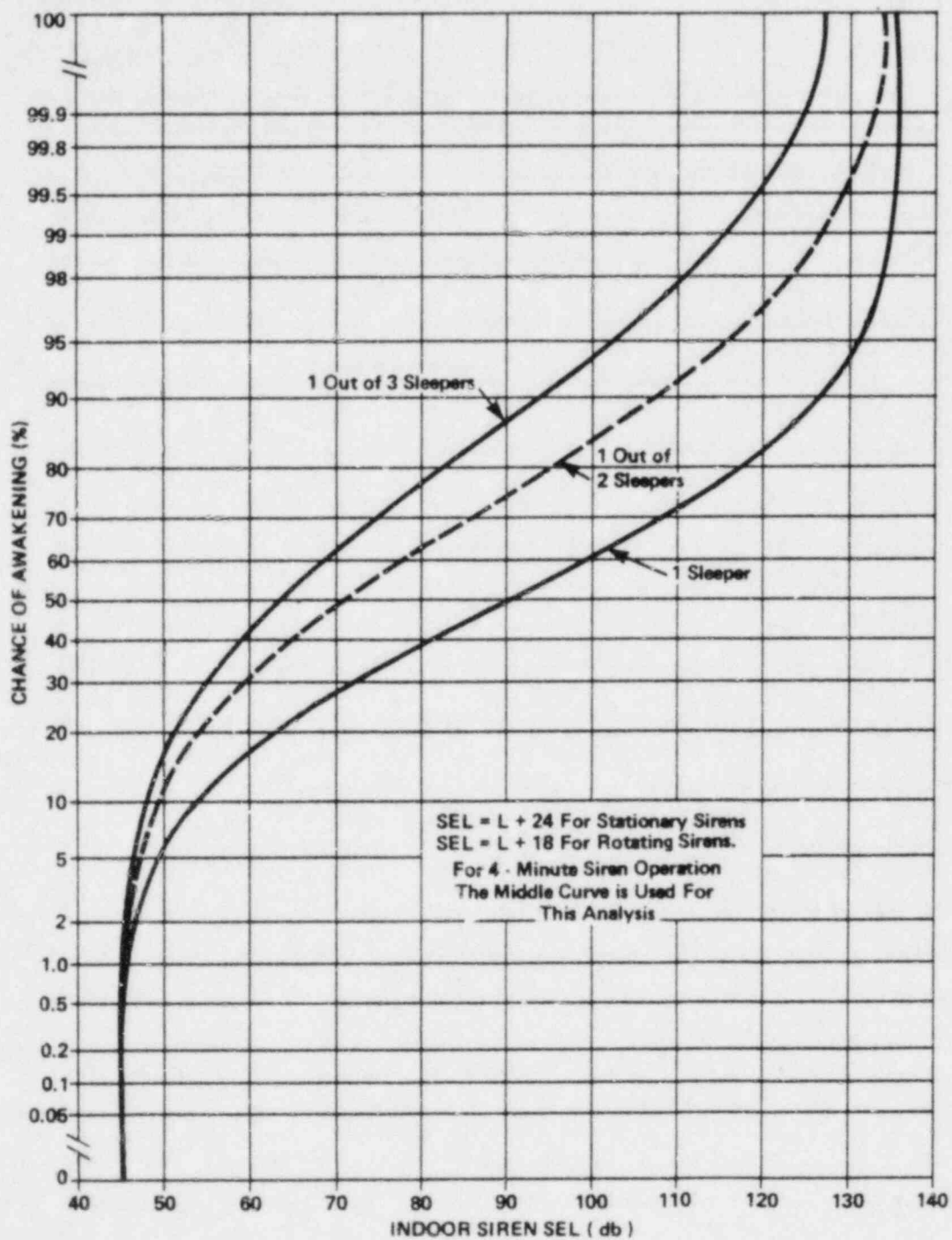

FIG. 9.3. CHANCE OF ALERT FOR AWAKENING PEOPLE ASLEEP [6].



TABLE 9.1 ASSUMED ACTIVITIES AND BACKGROUND NOISE ENVIRONMENTS FOR PEOPLE INDOORS.

Scenario	Percentages of People Engaged in Various Activities Indoors (%)				
	Listening to TV/Radio	Indoor Noise Environment			
		Obviously Noisy <sup>1</sup>	Busy & Active <sup>2</sup>	Isolated <sup>3</sup>	Obviously Quiet <sup>4</sup>
1. Warm Summer Weekday Afternoon	50	--	15	10	25
2. Winter Weekday During Evening Commuting Hours	20	5	50	20	5

NOTES:

1. Vacuum cleaning, dishwasher, shower, vent fan on, etc.
2. Dinner conversation, kitchen work, playing music, children at play, etc.
3. Noise-producing activity in adjacent room, soft background music, etc.
4. Reading, study, eating alone.

estimating the chance of alert as a function of indoor siren level and scenario. These graphs are provided in Fig. 9.4 for 4-minute stationary sirens and in Fig. 9.5 for 4-minute rotating sirens. As an example, consider a listener site at which the dominant siren has been determined to be a stationary unit producing an indoor sound level of 50 dB for Scenario 3. Entering Fig. 9.4 at 50 dB on the horizontal scale, and moving vertically to intersect the curve for Scenario 3, the chance of alert (reading from the vertical scale) is estimated to be 70 percent.

#### 9.2.2 At Work

For the analysis of alerting people at work, two activity categories are considered: (1) commercial/institutional and (2) industrial environments. For industrial locations, it has been assumed that 100 percent of the people will be alerted by some means of communication other than sirens. For commercial/institutional locations, the chance of alert is based on the statistics of background noise measured in a typical office environment (see Section 5.2 ), using Fig. 9.6. This figure provides the chance of alert as a function of indoor siren level.

The assumption is made that on the average, the distribution of siren sound levels at commercial locations is the same as for residential locations. For example, consider a listener site at which the dominant siren has been determined to be a rotating-type unit producing an indoor sound level of 45 dB for a particular scenario, using the outdoor-to-indoor sound reduction for commercial buildings (Section 7.1). Entering Fig. 9.6 at 45 dB on the horizontal scale, and moving vertically to intersect the curve for a 4-minute rotating siren, the chance of alert (reading from the vertical scale) is estimated to be 70 percent.

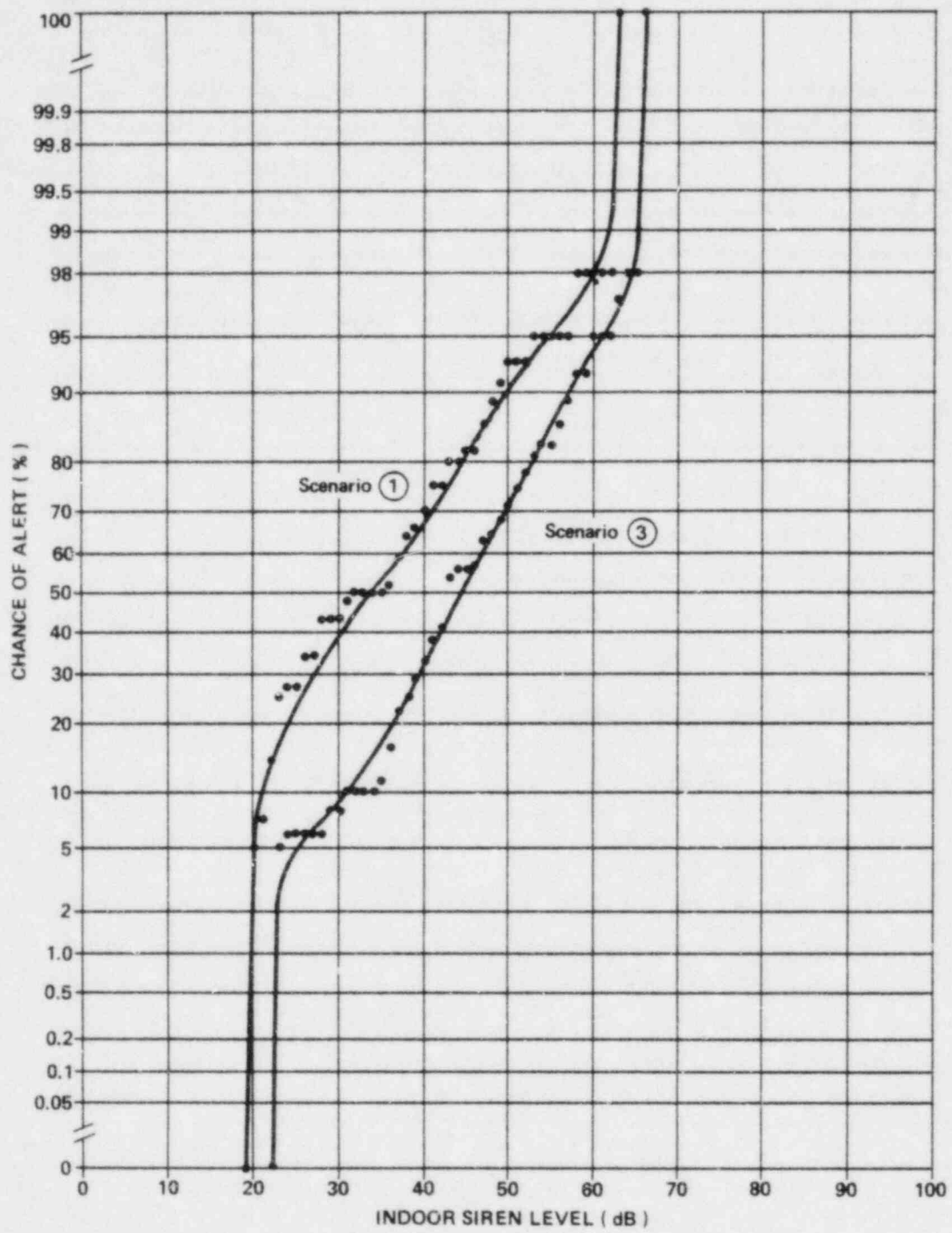

FIG. 9.4. CHANCE OF ALERT FOR PEOPLE INDOORS AT HOME (4-MINUTE STATIONARY SIREN).

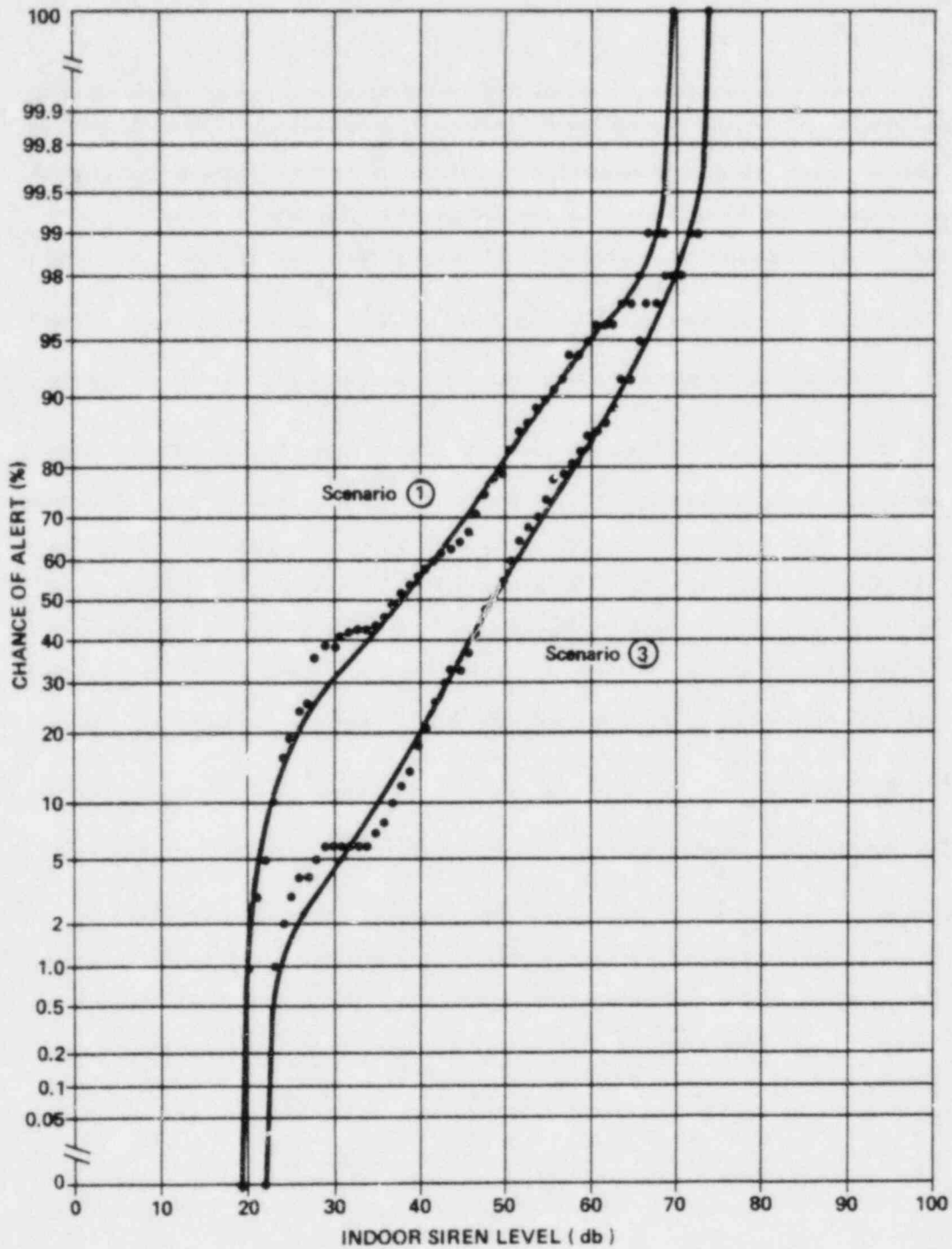

FIG. 9.5. CHANCE OF ALERT FOR PEOPLE INDOORS AT HOME (4-MINUTE ROTATING SIREN).

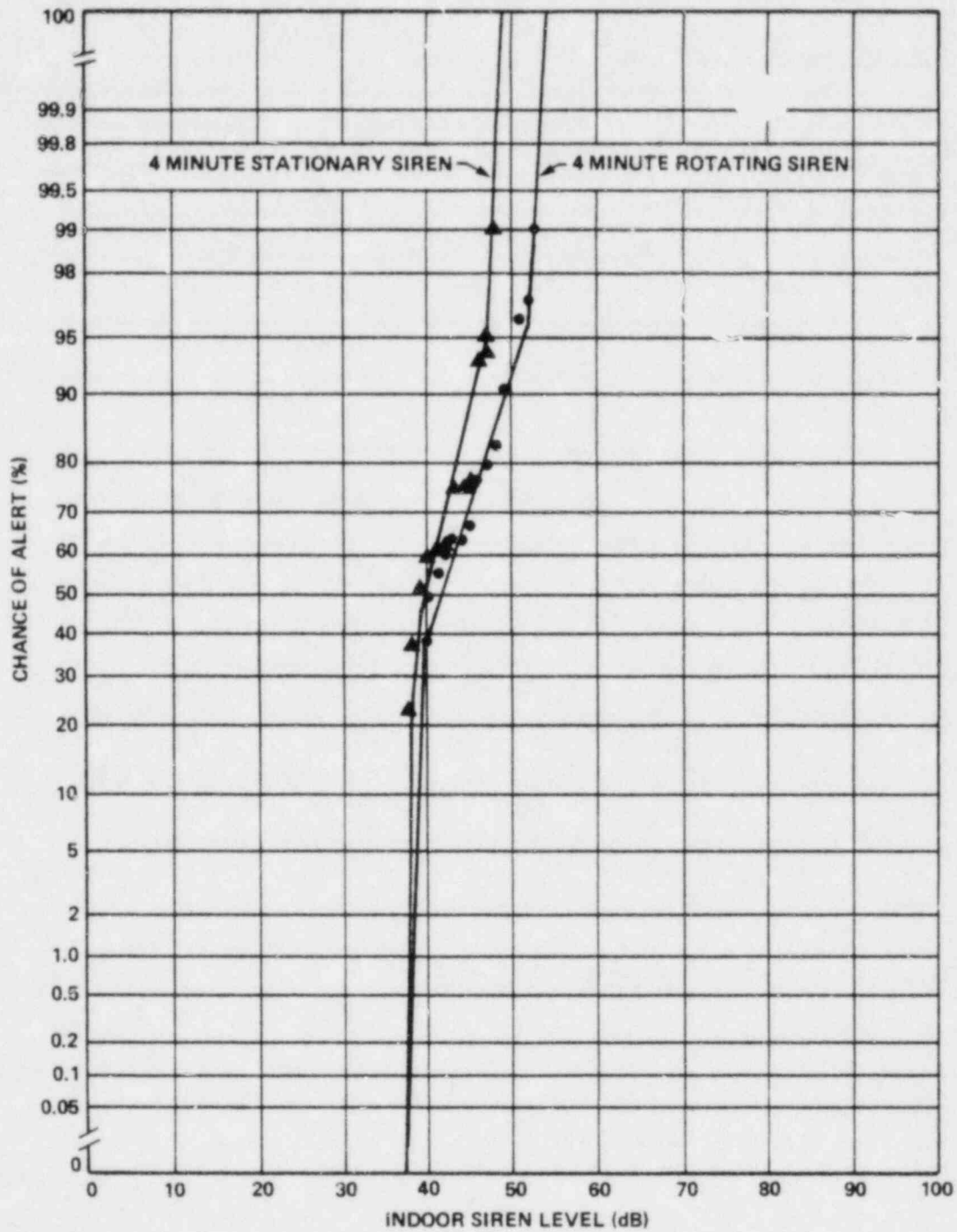

FIG. 9.6. CHANCE OF ALERT FOR PEOPLE INDOORS AT WORK IN COMMERCIAL/ INSTITUTIONAL ESTABLISHMENTS.

### 9.3 Alert in Motor Vehicles

The analysis for the alerting of motorists is based on the assumption of an "average" siren signal strength and spacing throughout the EPZ. Separate analyses are carried out for urban and rural areas. The results for urban areas are then applied to all urban listener sites and the results for rural areas are applied to all rural listener sites.

The "average" siren signal strength is calculated as follows:

$$L(\text{avg.}) = 10 \log_{10} \left[ \frac{1}{n} \sum_{i=1}^n 10 \left( \frac{L(\text{siren})_i}{10} \right) \right] \quad (9.1)$$

where  $L(\text{avg.})$  = energy-average siren signal strength  
at 100 ft, in dB

$L(\text{siren})_i$  = individual siren rated sound pressure  
level at 100 ft, in dB

$n$  = total number of sirens (urban or rural)

The above computation should be performed separately for sirens in urban and rural locations.

The average siren spacing is computed as follows:

$$D = \sqrt{\frac{4A}{n\pi}} \quad (9.2)$$

where  $D$  = average siren spacing, in ft

$A$  = total urban or rural area within the EPZ, in sq ft

$n$  = number of sirens (urban or rural) within the EPZ.



Again, the above computation should be performed separately for urban and rural areas.

The chance that a motorist will pass within the alert range of a siren during its 4-minute operation is estimated as follows:

$$C = \left( \frac{2R + d}{D} \right) 100 \text{ (not to exceed 100\%)} \quad (9.3)$$

where C = chance of alert, in percent

R = maximum alert distance, in feet

d = distance travelled in 4 minutes, in feet

D = average siren spacing, in feet

The maximum alert distance (R) is a function of the average siren signal strength (urban or rural), computed from Eq. 9.1, and the sound level required for alert. Sound levels required for alert are obtained for the various speed and window conditions by combining the background noise data from Section 5.4 with the vehicle sound attenuation from Section 6.2, and then adding 9 dB. The maximum alert distance can then be derived for each driving condition by reducing the average siren source levels for urban and rural areas to the required alerting levels in accordance with the sound propagation models from current NRC guidelines (i.e., 10 dB/distance doubling) [7]. The distance travelled in 4 minutes (d) can be calculated based on vehicle speed, and the average siren spacing can be obtained using Eq. 9.2. The results calculated for the required signal for alert and the 4-minute travel distance are summarized in Table 9.2 for various vehicle speed and window conditions.

TABLE 9.2 DATA FOR ANALYSIS OF SIREN ALERT FOR MOTORISTS.

Area	Vehicle Speed (mph)	Scenario Season	Vehicle Window Condition	Required Signal for Alert (dB)	4-Minute Travel Distance d (ft)
URBAN	30	Winter	Closed	89	10,560
	30	Summer	Open	86	10,560
RURAL	55	Winter	Closed	96	19,360
	55	Summer	Open	90	19,360

The information required to perform the analysis for alert in motor vehicles is provided in Table 9.2 and Fig. 9.7. For example, consider an alerting system with sirens in rural areas having an average signal strength of 115 dB at 100 ft and an average spacing of 4 miles (21,120 ft). Suppose it is required to calculate the chance of alert for motorists in rural areas (55 mph assumed speed) for a wintertime scenario (vehicle windows closed). Table 9.2 indicates that for these conditions, the required signal for alert is 96 dB. Subtracting this value from 115 dB (the average siren signal strength) one obtains a difference of 19 dB. Entering Fig. 9.7 at 19 dB on the horizontal scale, and moving vertically to intersect the curve, the maximum alert distance (R) is determined to be about 375 ft. The distance traveled in 4 minutes (d) is found to be 19,360 ft. (from Table 9.2) and the average siren spacing (D) is 21,120 ft. The chance of alert is then calculated as follows:

$$C = \left( \frac{2R + d}{D} \right) 100 = \left[ \frac{(2)(375) + 19,360}{21,120} \right] 100 = 95\%$$

Now consider an alerting system with urban area sirens having an average signal strength of 125 dB at 100 ft and an average spacing of 1 mile (5,280 ft). Suppose it is required to calculate the chance of alert for motorists in urban areas (30 mph assumed speed) for a summertime scenario (vehicle windows open). Table 9.2 indicates that for these conditions, the required signal for alert is 85 dB. Subtracting this value from 125 dB (the average siren signal strength) one obtains a

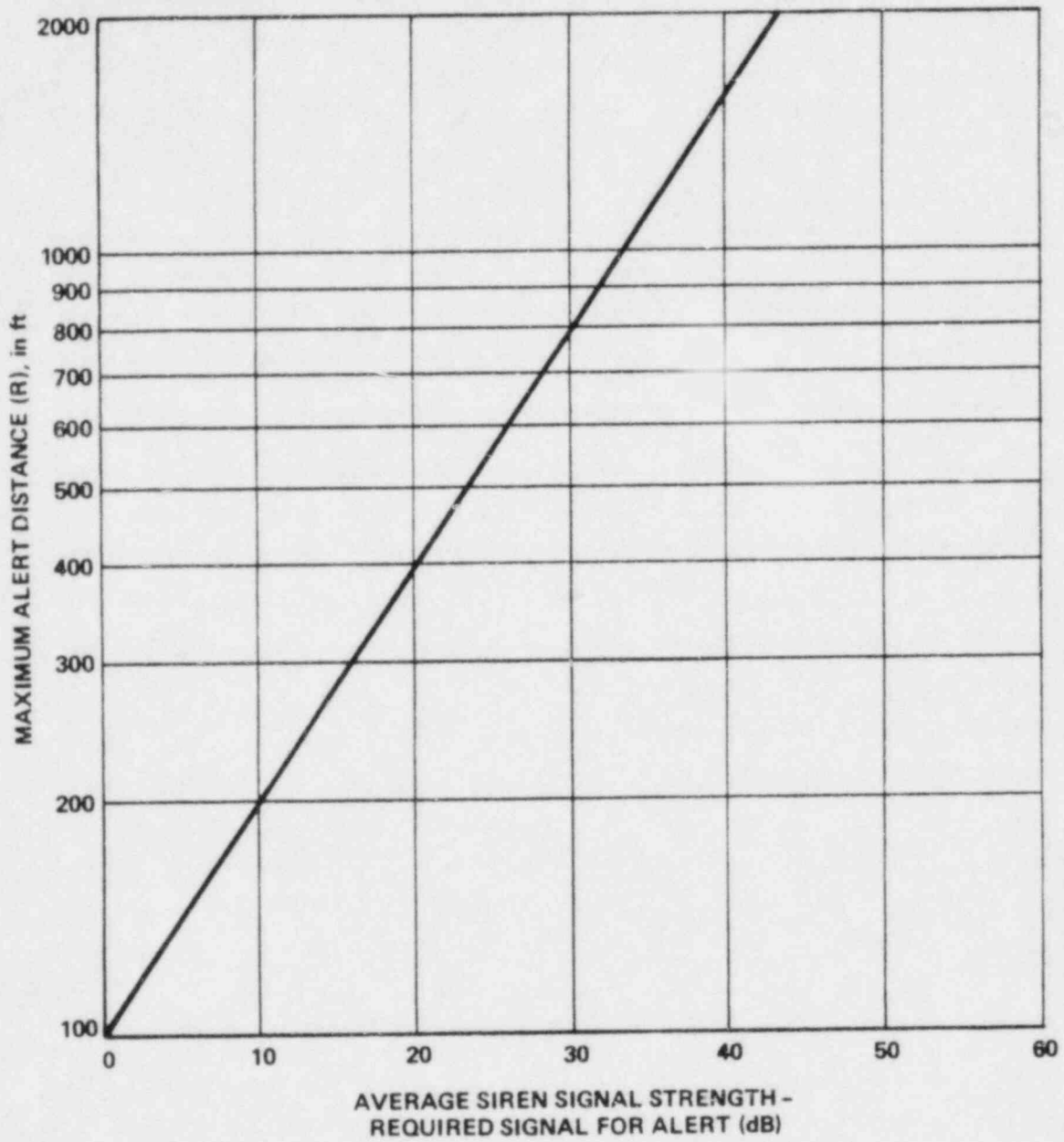

FIG. 9.7. MAXIMUM SIREN ALERT DISTANCE FOR MOTORISTS.

difference of 39 dB. Entering Fig. 9.7 at 39 dB on the horizontal scale, and moving vertically to intersect the curve, the maximum alert distance (R) is determined to be about 1,500 ft. The distance traveled in 4 minutes (d) is found to be 10,560 ft (from Table 9.2) and the average siren spacing (D) is 5,280 ft. The chance of alert is then calculated as follows:

$$C = \left( \frac{2R + d}{D} \right) 100 = \left[ \frac{(2)(1500) + 10,560}{5,280} \right] 100 \approx 257$$

Since the result exceeds 100 percent, the chance of alert is taken to be 100 percent for this example.

The above examples imply that unless a siren system is grossly underdesigned, the chance of alert for motorists should be close to 100 percent in all cases.

## 10.0 COMPUTATION OF OVERALL ANALYSIS RESULTS

At this point in the analysis, the following information should be available for each scenario at each sample listener site: the chance of alert and the activity fraction (i.e., the fraction of people engaged in a particular activity) for each activity category. The overall chance of alert at each site for a particular scenario is calculated as follows:

$$C_s = \sum_{i=1}^n c_i \times f_i \quad (10.1)$$

where  $C_s$  = chance of alert at a given listener site for a particular scenario, in percent

$c_i$  = chance of alert for a given activity category, in percent

$f_i$  = activity fraction

$n$  = total number of activity categories.

An example of this calculation is provided in Table 10.1.

When  $C_s$  has been determined at each listener site for a given scenario, the total urban and rural chances of alert for that scenario are calculated by arithmetically averaging these ( $C_s$ ) results separately for all urban and all rural listener sites. The overall chances of alert for each scenario is then obtained on a population-weighted basis as follows:

$$C_T = \frac{(C_u \times n_u) + (C_r \times n_r)}{(n_u + n_r)} \quad (10.2)$$



TABLE 10.1 SAMPLE CALCULATION OF THE CHANCE OF ALERT AT A SINGLE LISTENER SITE FOR A PARTICULAR SCENARIO.

Activity Description	Chance of Alert (%)	X Activity Fraction	= Result
1. People Outdoors	90	0.20	18
2. People Indoors, at Home, Listening to Radio or TV	100	0.10	10
3. People Indoors, at Home, Sleeping	40	0.05	2
4. People Indoors, at Home, neither Sleeping nor Listening to Radio or TV	80	0.15	12
5. People Indoors, at Work, in Commercial/Institutional Establishments	60	0.30	18
6. People Indoors, at Work, in Industrial Environments	100	0.10	10
7. People in Motor Vehicles	100	0.10	10
TOTAL (Sum)	--	1.00	80

Total Chance of Alert = 80%

where  $C_T$  = overall chance of alert for a given scenario,  
percent

$C_U$  = total chance of alert at urban sites for a  
given scenario, percent

$C_R$  = total chance of alert at rural sites for a  
given scenario, percent

$n_U$  = total urban population

$n_R$  = rural rural population

The end result of the analysis consists of estimate of the overall chance of alert for each sample scenario, for a 4-minute siren operating period. For other operating periods, see Appendix B.

## REFERENCES

1. R.C. Potter et al., "Effectiveness of Audible Warning Devices on Emergency Vehicles," U.S. Department of Transportation, Report DOT-TSC-OST-77-38, Washington, DC (August 1977).
2. D.A. Driscoll, J.P. Dulin, Jr., and D.N. Keast, "Attenuation of Northern Dwellings to a Linear Source of Noise." Presented at the 95th Meeting of the Acoustical Society of America, Providence, R.I. (May 1978).
3. Society of Automotive Engineers, Inc., "House Noise-Reduction Measurements for Use in Studies of Aircraft Flyover Noise," Aerospace Information Report 1081 (October 1971).
4. L.L. Beranek, ed., Noise and Vibration Control, Chapter 7, Section 7.6, McGraw-Hill Book Company (1971).
5. C.M. Harris, ed., Handbook of Noise Control, Chapter 3, McGraw-Hill Book Company (1979).
6. U.S. Environmental Protection Agency, "National Roadway Noise Exposure Model," Draft Report (1980).
7. "Criteria for Preparation and Evaluation of Radiological Emergency Response Plans and Preparedness in Support of Nuclear Power Plants," Nuclear Regulatory Commission, NUREG-0654, Revision 1, Appendix 3, Part C.3.3, Washington, DC (November 1980). (The Federal Emergency Management Agency also publishes this document as FEMA-REP-1.)

APPENDIX A

ESTIMATION OF  $A_{atm}$

### Estimation of $A_{atm}$

The speed of sound in air increases with the square root of the absolute temperature. When the atmosphere is in motion, the speed of sound is the vector sum of its speed in still air and the wind speed. The temperature and wind in the atmosphere near the ground are almost never uniform. Hence, atmospheric nonuniformity produces gradients of the speed of sound, and thus refraction (bending) of sound wave paths. Near the ground, this refraction can have a major effect on the apparent attenuation of sound propagated through the atmosphere.

For the purpose of this procedure we have assumed a horizontally stratified atmosphere in which temperature and wind speed vary only with the logarithm of height above the ground. During the daytime, temperature normally decreases with height (lapse), so that sound waves from a source near the ground are refracted upwards. In the absence of wind, an "acoustic shadow" forms around the source (Fig. A-1a) into which no direct sound waves can penetrate. Marked attenuations are observed at receiving points well into the shadow zone - it is just as if a solid wall had been built around the source. At night a temperature increase with height is common near the ground (inversion) and our "barrier" disappears as in Fig. A-1b.

Near the ground, wind speed almost always increases with height. Because the speed of sound is the vector sum of its speed in still air and the wind vector, a shadow zone can form upwind of the source, but is suppressed downwind (Fig. A-1c).

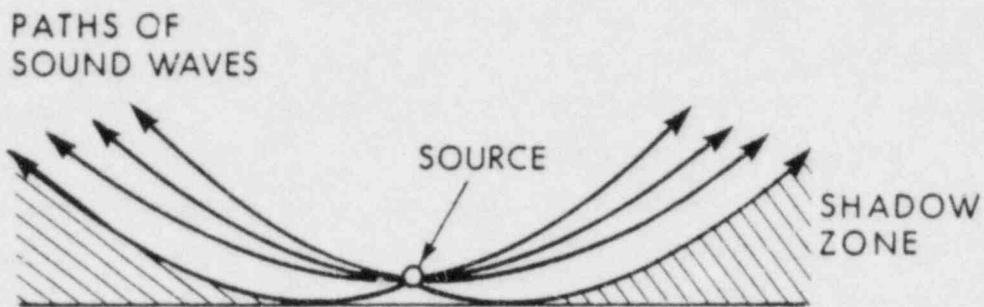

a. TEMPERATURE DECREASING WITH HEIGHT  
Typical Daytime

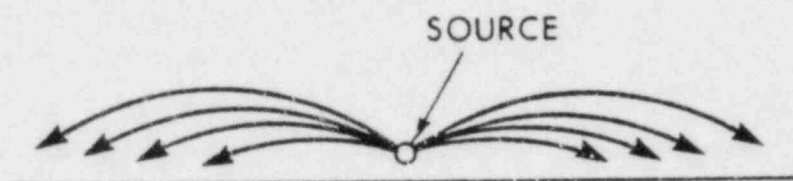

b. TEMPERATURE INCREASING WITH HEIGHT  
Typical Nighttime

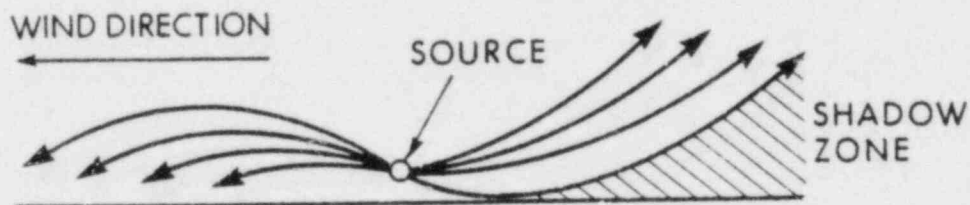

c. WIND SPEED INCREASING WITH HEIGHT  
ABOVE THE GROUND

FIG. A-1. SKETCHES ILLUSTRATING THE EFFECTS OF VERTICAL TEMPERATURE AND WIND GRADIENTS IN FORMING ACOUSTIC SHADOW ZONES.



The combined effects of wind and temperature are usually such as to create acoustic shadows upwind of a source, but not downwind. Only under rare circumstances will a temperature lapse be sufficient to overpower wind effects and create a shadow surrounding a source. It is less rare, but still uncommon for a surface inversion to be sufficiently strong to entirely overcome an upwind shadow.

The general situation is illustrated in plan view on Fig. A-2. A shadow boundary, symmetrical about the wind vector, can exist in the upwind direction from a sound source when the vertical wind gradient effect predominates over any effect caused by a temperature inversion. It is likely that no shadow will exist downwind from the source, for the wind gradient will usually overcome the effect of any temperature lapse. Along a radius at an angle  $\phi_c$  from the wind vector, the shadow boundary (theoretically) approaches an infinite distance from the source.

In the "upwind" sector of Fig. A-2, the sound wave paths are generally concave upwards, as on the right side of Fig. A-1c. In the "downwind" sector, they are generally concave downwards, as on the left side of Fig. A-1c. In the "crosswind" direction, the sound wave paths are approximately straight lines from the source to the receiver.

For the purposes of this propagation model, we have assumed that temperature in the atmosphere,  $T$ , is horizontally uniform and varies with the logarithm of height above the ground,  $z$ .\*

$$T = a \ln z$$

$$a = \frac{T_1 - T_2}{\ln h_2 - \ln h_1} = \frac{\Delta T}{\ln h_2 - \ln h_1} \quad (A-1)$$

$$a: \frac{\partial T}{\partial z} = az^{-1}$$

---

\*This approximation is generally valid close to the ground except during strong surface-based temperature inversions. 1,2

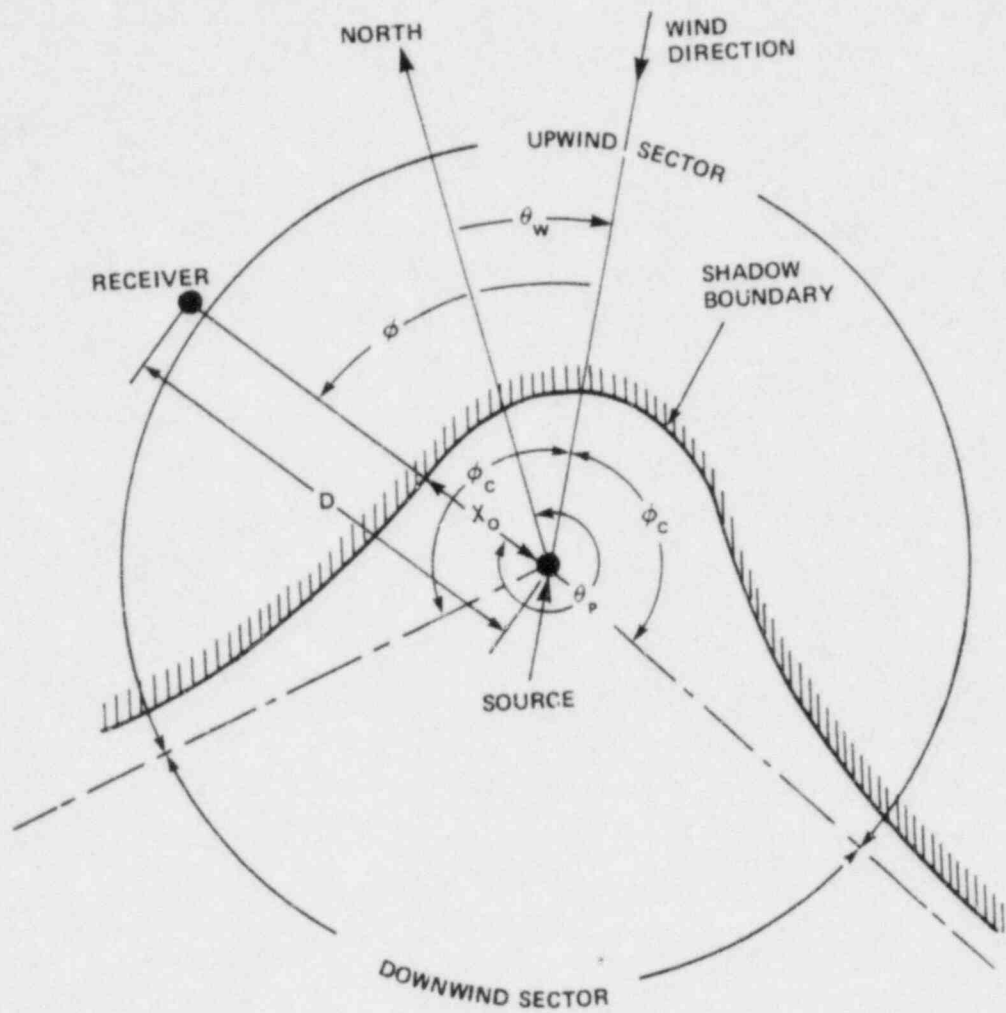

FIG. A-2. PLAN VIEW OF SOUND PROPAGATION SECTORS, WITH PARAMETERS USED TO DESCRIBE THEM (See Text).

The speed of sound,  $c$ , varies directly with the square root of the absolute temperature

$$c = c_0 \left[ \frac{T_0 + a (\ln z - \ln z_0)}{T_0} \right]^{1/2} \approx c_0 \left[ 1 + \frac{a (\ln z - \ln z_0)}{2T_0} \right]$$

where  $c_0$  is the speed of sound at some reference temperature,  $T_0$ , observed at a reference height of  $z_0$ . Thus, the vertical gradient of the speed of sound due to temperature,  $\alpha$ , is:

$$\frac{\partial c}{\partial z} \equiv \alpha = \frac{c_0}{2T_0} a z^{-1} \approx 1.086 a z^{-1} \text{ sec}^{-1} \text{ in English units} \quad (\text{A-2})$$

Note that  $\alpha$  can be positive (inversion) or negative (lapse).

Likewise, we assume that the vertical profile of wind speed,  $\beta$ , varies only with the logarithm of height,  $z$ , so that:\*

$$\beta \equiv \left[ \frac{V_2 - V_1}{\ln h_2 - \ln h_1} \right] z^{-1} \quad (\text{A-3})$$

where  $V_2$  is the speed of height  $h_2$  and  $V_1$  is the speed of height at  $h_1$ . Note that  $\beta$  is always assumed to be positive.

The combined gradient of the speed of sound,  $C$ , resulting from both the temperature and wind gradients is thus

$$C = z(\beta \cos \phi - \alpha) \quad (\text{A-4})$$

---

\*This is a shakier simplification than that for the temperature profile, [1] and normally holds only for near-neutral conditions [3]. The actual shape of the wind profile is a function of surface roughness, and of vertical momentum transfer due to thermal instability.

where  $\phi$  is the angle between the direction from which the wind is coming and the sound path (Fig. A-2.).

Each sound path can be classified as "upwind", or "downwind" for a given sample of meteorological data, on the basis of the following steps.

a. If  $\alpha$  is positive and greater than  $\beta$  ( $\alpha > \beta$ ; so that  $C$  would be negative for all values of  $\phi$ ), then no shadow zone can exist and all paths are classified as "downwind". This is the strong-inversion, low-wind condition.

b. If  $\alpha$  is negative and numerically larger than  $\beta$  (i.e.,  $|\alpha| > \beta$ , so that  $C$  would be positive for all values of  $\phi$ ), then the shadow zone completely surrounds the source and all paths are classified as "upwind". This is the strong-lapse, low-wind condition.

c. If  $|\alpha| \leq \beta$ , then the "critical angle",  $\phi_c$ , (where temperature, and wind effects cancel) is calculated by setting  $C = 0$  in Eq. A-4

$$C = z(\beta \cos \phi_c - \alpha) = 0$$

$$\phi_c = \cos^{-1} \frac{\alpha}{\beta} \quad (A-5)$$

where  $0 \leq \phi_c \leq 180^\circ$

It is now necessary to do some coordinate transformations of the azimuthal data, entered relative to true North, to bearings relative to the direction from which the wind blows. Refer to Fig. A-2. The wind-sound angle,  $\phi$ , is:

$$\phi = \left| \theta_p - \theta_w \right|, \text{ or if } \left| \theta_p - \theta_w \right| > 180^\circ:$$

$$\phi = 360 - \left| \theta_p - \theta_w \right| \quad (A-6)$$

Examine the difference  $\phi_c - \phi$  :

If  $\phi < \phi_c$  then the path is an "upwind" path.

If  $\phi > \phi_c$  then the path is a "downwind" path.

It is clear that this simplified model does not take into consideration some common effects, such as changes of wind direction with height and location and upper level inversions, which can lead to significant sound propagation to distances quite remote from a source.

#### Computing the Distance to the Shadow-Zone Boundary, X

Nyborg and Mintzer[4] have derived an expression for the distance,  $X_0$  (See Fig. A-2), from a sound source to the boundary of its shadow zone at the height of the receiver, R, ft above local ground, and in the presence of a vertical sound velocity gradient which varies with the logarithm of height. Their work has been adapted for this procedure in the following form:

$$X_0 = S \sqrt{\frac{2c_0}{C}} \cdot f\left(\frac{R}{S}\right) \text{ feet}$$
$$\frac{47S}{\sqrt{C}} \cdot f\left(\frac{R}{S}\right) \text{ in English units} \quad (\text{A-7})$$

where S is the effective source height in feet above local ground, and the function  $f\left(\frac{R}{S}\right)$  is obtained from Table A-1. The distance  $X_0$  is in feet and is assumed to be frequency-independent.

### Attenuation within the Shadow Zone, $A_s$

Theoretically, the attenuation within a shadow zone can be arbitrarily large for large distances beyond the shadow boundary. In practice, more than 25-30 dB is rarely observed because the loss of sound energy from the direct waves is partially replaced by the energy of indirect waves scattered from turbulence, ground surface roughness, etc.

In this procedure, we have used representative values derived from the experimental work of Parkin and Scholes [6,7] and Weiner and Keast [8]. The recommended values (Table A-2) have an upper limit of 20 dB. Attenuation because of a shadow zone has occasionally been observed to decrease somewhat at extreme distances relative to closer-in distances. The conservative values in Table A-2 allow for this possibility.



TABLE A-1

$f\left(\frac{R}{S}\right)$  vs.  $\frac{R}{S}$  for computing  $X_0$  in Eq. (A-7)

(after Nyberg and Mintzer<sup>4/</sup>)

R/S	f(R/S)
$\leq 0.05$	0.4
0.1	0.45
0.2	0.55
0.3	0.6
0.4	0.7
0.5	0.75
0.7	0.85
0.9	1.0
1	1.05
1.5	1.25
2	1.5
3	1.9
4	2.3
5	2.65
6	3.0
7	3.3
8	3.65
9	3.95
10	4.2
$> 10$	Set $X_0 > D$

Interpolation is permitted, and for manual computations a graph of  $f(R/S)$  vs.  $R/S$  is most useful.<sup>5/</sup>

TABLE A-2. ATTENUATION WITHIN THE SHADOW ZONE,  $A_{\text{atm}}$ ,  
 VS.  $X_0$ , ft.

$\frac{D}{X_0} \leq 1.2$	0 dB
$1.2 < \frac{D}{X_0} \leq 1.7$	5
$1.7 < \frac{D}{X_0} \leq 2.4$	10
$2.4 < \frac{D}{X_0} \leq 3.4$	15
$\frac{D}{X_0} > 3.4$	20

REFERENCES TO APPENDIX A

1. Keast, D.N. and F.M. Wiener, "An Empirical Method for Estimating Wind Profiles over Open, Level Ground," Trans. Am. Geophys. Union 39, (5), pp. 858-864, October 1958.
2. Sutton, O.G., Micrometeorology, McGraw-Hill Book Co., London, Sect. 6.4, p. 206, 1953.
3. Ibid, Sect. 7.2, p. 232 et seq.
4. Nyborg, W.L. and D. Mintzer, "Review of Sound Propagation in the Lower Atmosphere," WADC Technical Report 54-602, Sect. 1.5.5, p.50 et seq., May 1955.
5. Ibid, Fig. 16, p. 54.
6. Parkin, P.H. and W.E. Scholes, "The Horizontal Propagation of Sound from a Jet Engine Close to the Ground, at Radlett," J. Sound and Vibration, 1, pp. 1-15, 1964.
7. Parkin, P.H. and W.E. Scholes, "The Horizontal Propagation of Sound from a Jet Engine Close to the Ground, at Hatfield," J. Sound and Vibration, 2 (4), pp. 353-374, 1965.
8. Wiener, F.M. and D.N. Keast, "Experimental Study of the Propagation of Sound Over Ground," J. Acoust. Soc. Am., 31 724-733, 1959.

APPENDIX B

DEPENDENCE OF ALERT  
UPON SIREN DURATION

## APPENDIX B. DEPENDENCE OF ALERT UPON SIREN DURATION

In the main body of this report, the chances of alert are predicted for a four-minute period of siren operation (here called siren duration). In this appendix, predictions are generalized for longer and shorter siren durations. This appendix will allow readers to convert four-minute results to results for other siren durations.

This appendix begins with an overview of the relationship between siren level and siren duration, and how this relationship affects the chances of alert. It continues with development of the mathematics of this relationship, and then summarizes results for the reader's use.

### Overview

Table B-1 is a typical "chance-of-alert" table for a particular background-noise environment. Siren durations are listed across the top, and siren levels down the left side. Within the table are the chances of alert, from 100 down to zero percent. In the main body of this report, results are based upon the four-minute columns of tables such as this one.\* Variations within the table are related to fluctuating background

---

\*And upon the one-minute columns for rotating sirens.

TABLE B-1. TYPICAL CHANCE-OF-ALERT TABLE FOR A PARTICULAR BACKGROUND-NOISE ENVIRONMENT.

SIREN LEVEL	SIREN DURATION (MINUTES)															
	1	2	3	4	5	6	7	8	9	10	11	12	13	14	15	16
74	100	100	100	100	100	100	100	100	100	100	100	100	100	100	100	100
73	99	100	100	100	100	100	100	100	100	100	100	100	100	100	100	100
72	99	99	100	100	100	100	100	100	100	100	100	100	100	100	100	100
71	99	99	100	100	100	100	100	100	100	100	100	100	100	100	100	100
70	99	99	100	100	100	100	100	100	100	100	100	100	100	100	100	100
69	99	99	100	100	100	100	100	100	100	100	100	100	100	100	100	100
68	97	99	100	100	100	100	100	100	100	100	100	100	100	100	100	100
67	97	99	100	100	100	100	100	100	100	100	100	100	100	100	100	100
66	95	99	100	100	100	100	100	100	100	100	100	100	100	100	100	100
65	92	95	99	99	99	100	100	100	100	100	100	100	100	100	100	100
64	92	95	99	99	99	100	100	100	100	100	100	100	100	100	100	100
63	99	92	95	97	95	100	100	100	100	100	100	100	100	100	100	100
62	87	91	94	95	95	99	100	100	100	100	100	100	100	100	100	100
61	86	90	94	95	95	99	100	100	100	100	100	100	100	100	100	100
60	85	90	93	95	95	99	100	100	100	100	100	100	100	100	100	100
59	83	87	90	92	94	95	100	97	100	100	100	100	100	100	100	100
58	81	85	90	92	94	95	100	97	100	100	100	100	100	100	100	100
57	79	83	88	89	90	93	94	94	95	95	95	95	100	94	100	93
56	78	82	87	86	88	90	94	94	95	95	95	95	100	94	100	93
55	74	79	82	83	84	85	89	87	89	92	91	90	95	89	94	87
54	70	78	81	83	84	85	89	87	89	92	91	90	95	89	94	87
53	68	75	80	81	84	85	89	87	89	92	91	90	95	89	94	87
52	65	73	77	78	82	83	86	84	89	89	87	90	95	89	94	87
51	60	70	74	75	79	81	83	81	85	84	83	85	89	83	89	80
50	55	65	70	71	74	78	81	81	82	80	83	85	84	83	81	80
49	51	61	67	68	70	76	78	81	79	80	83	85	84	83	81	80
48	49	57	63	63	65	71	75	74	75	76	79	81	79	83	75	80
47	42	54	60	63	64	71	75	71	75	75	74	81	79	83	75	80
46	37	47	54	57	59	67	69	68	71	72	70	75	74	78	69	73
45	33	44	50	55	55	64	67	65	71	68	70	75	68	78	69	73
44	33	43	50	55	55	64	67	65	69	70	75	68	78	69	73	73
43	30	40	45	54	52	57	64	65	68	70	71	69	78	69	73	73
42	25	33	37	41	42	49	50	55	55	57	57	62	58	61	56	60
41	21	28	35	38	40	45	50	55	57	56	57	62	58	61	56	60
40	18	24	30	33	34	38	42	48	46	44	52	57	53	50	56	60
39	14	20	24	29	30	36	36	42	43	40	48	52	47	44	50	60
38	12	17	20	25	28	33	33	39	43	40	48	48	47	44	50	53
37	10	15	19	22	24	31	31	38	39	36	43	43	47	44	50	53
36	8	12	14	16	18	21	22	26	29	24	30	29	32	33	31	33
35	7	9	10	11	12	14	14	16	18	16	17	19	21	22	19	20
34	6	8	8	10	10	12	11	13	14	16	17	19	16	17	13	13
33	6	8	8	10	10	12	11	13	14	16	17	19	16	17	13	13
32	6	8	8	10	10	12	11	13	14	16	17	19	16	17	13	13
31	6	8	8	10	10	12	11	13	14	16	17	19	16	17	13	13
30	6	7	7	8	8	10	8	10	11	12	13	14	11	11	13	13
29	6	7	7	8	8	10	8	10	11	12	13	14	11	11	13	13
28	5	6	6	6	6	7	6	6	7	8	9	10	5	6	6	7
27	4	6	5	6	6	7	6	6	7	8	9	10	5	6	6	7
26	4	6	5	6	6	7	6	6	7	8	9	10	5	6	6	7
25	3	5	5	6	6	7	6	6	7	8	9	10	5	6	6	7
24	2	4	5	6	6	7	6	6	7	8	9	10	5	6	6	7
23	1	2	4	5	0	7	6	0	7	0	9	10	0	6	0	0



noise in the listener's environment.\*\*

In this table, the chance of alert is 100 percent when the siren level is much higher than the background noise could ever be at the listener. When the siren level is 74 dB, for example, the siren will definitely alert the listener even for siren durations as short as one minute.

The chance of alert is zero percent when the siren level is low, say 20 dB or less, no matter how long the siren sounds. The background noise is always sufficient to mask (acoustically cover up) such low siren levels.

For siren signals of intermediate levels, the chance of alert falls between 100 and 0 percent, in the detailed manner shown. These intermediate details follow from the fluctuations of the background noise, from minute to minute.

For these intermediate siren levels, the chance of alert increases with siren duration as indicated in the table. For a

---

\*\*Precision within Table B-1 degrades for longer siren durations (to the right) and for lower siren levels (to the bottom). For longer siren durations, precision suffers from the limited amount of total data that underlie the table. These data include 250 minutes of background noise, which is only about eight times the longest siren duration. For lower siren levels, precision suffers from the very small percentage of time that these low siren levels will alert the listener. Although the amount of data is large compared to the siren durations, the background noise is rarely low enough to contribute to the statistics at these low siren levels. For longer siren durations and lower siren levels combined, the precision is particularly bad.

siren level of 50 dB, for example, the chance of alert is 71 percent if the siren is sounded for four minutes. If this duration is doubled to eight minutes, the chance of alert increases to 81 percent.

How can this increase with duration be understood mathematically? If such understanding results in a particular mathematical pattern, then this pattern can be used to convert four-minute results to results for other siren durations. The search for this mathematical pattern is the subject of the next section.

#### **Development of the Mathematics**

The search for patterns within tables of numbers is necessarily an exploratory matter. First, some underlying mathematics must be postulated, and then a numerical pattern must be sought with this mathematics as guidance. Once a preliminary pattern is discovered, it must be simplified to be of use, and then must be generalized for other similar tables. Ideally, the pattern will emerge as a simple equation, with a small number of adjustable constants.

The steps involved in developing such a pattern are:

- preparation
- underlying mathematics and its simplification
- exploratory graphs, guided by the mathematics
- simplification and generalization to all other tables

These steps are discussed next.

### Preparation

Figure B-1 shows typical background noise as it fluctuates over a one-minute period. The fluctuations are generally large, as shown here. In this background noise, a listener will be alerted by a siren whenever it is 9 decibels or more above the background noise level.\* The figure shows a siren that produces a steady 49 dB at the listener. A dashed line 9 dB below the siren level denotes the alerting threshold. During the shaded time intervals below this threshold, the siren will alert the listener.

This siren level has succeeded in alerting the listener during its one-minute duration. However, a siren level some 7 dB lower would not alert because the background noise would always be above its lowered threshold line of 33 dB.

---

\*Throughout this appendix, background noise includes the noise in a 1/3-octave frequency band centered at 630 Hz, a typical siren operating frequency. Dictated by the physiology of the ear, only this 1/3-octave band is available to mask, or cover up, the pure-tone signal of typical sirens. Siren levels are usually measured as overall sound levels, though the same values would be measured using only a 1/3-octave frequency band filter.

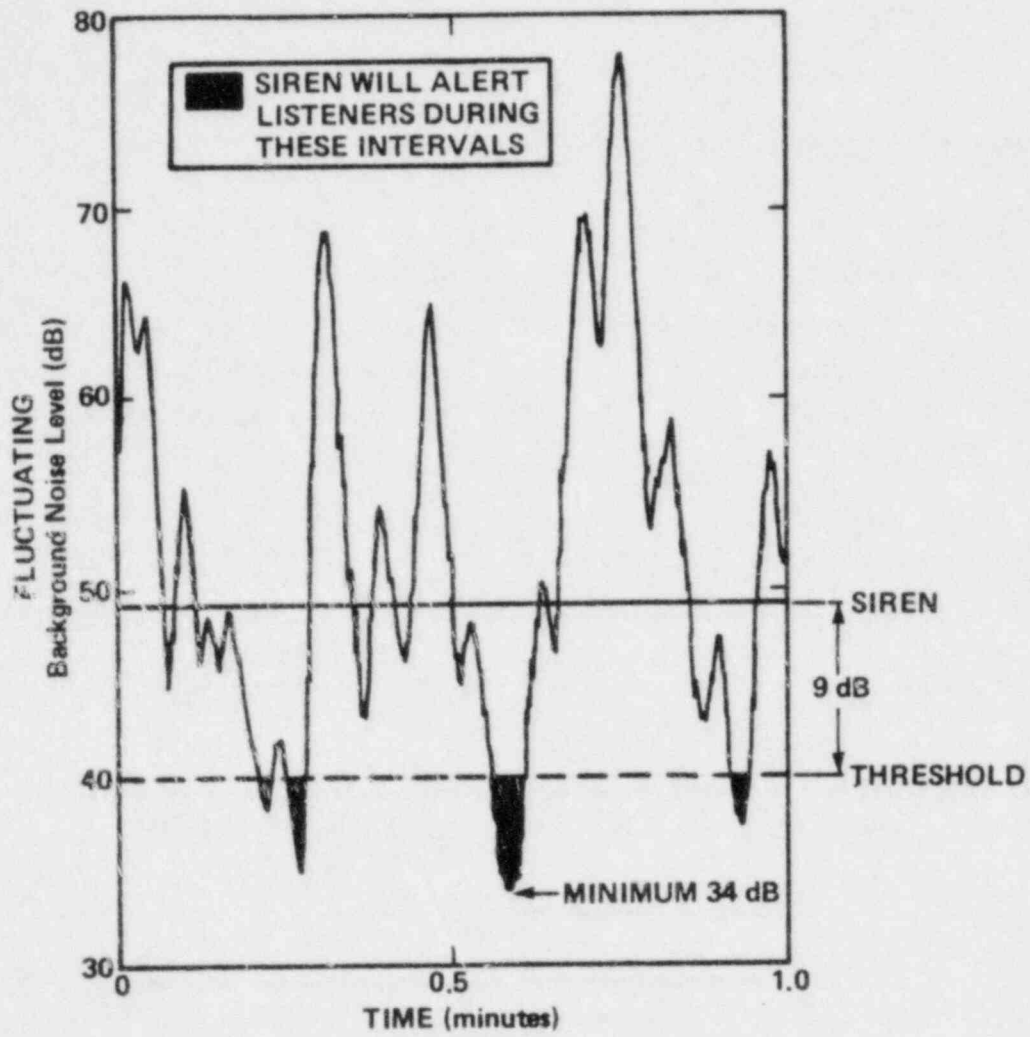

FIG. B-1. BACKGROUND NOISE LEVEL AS A FUNCTION OF TIME.

This figure suggests another way to phrase the alerting question. Instead of asking if the siren is loud enough to cause alert, one could ask: For a given siren level, is the background noise ever low enough to allow alert? Since the background noise is continually fluctuating, this question is inherently a statistical question. Its answer depends upon the statistics of the background noise fluctuations.

The answer to the above question is: Yes, alert will occur during this one-minute period if

$$(L_{\text{background}})_{\text{minimum}} \leq L_{\text{siren}} - 9\text{dB}$$

Otherwise, the siren will fail to alert the listener. The only statistic of interest, therefore, is the minimum background noise level during this one-minute period.\*

Figure B-2 shows a series of one-minute minima for forty successive one-minute time periods. Every minute's minimum is different, as the figure shows. These 40 minima were measured over a 40-minute time period, and are part of a much larger set (approximately 250) of total data. For the siren level shown, 35 percent of the minima (14 out of 40) fall below the threshold line. Therefore, this siren level in this background noise has a 35 percent chance of alert -- when sounded for a duration of one minute.

---

\*Our analysis for this study actually utilized the 90-percentile background noise level, rather than the minimum level. The 90-percentile noise level is the level exceeded 90 percent of the time; the remaining 10 percent of the noise falls below this level. Use of the 90-percentile noise level adds a measure of conservatism to the results, since it requires slightly higher siren levels before alert is predicted.

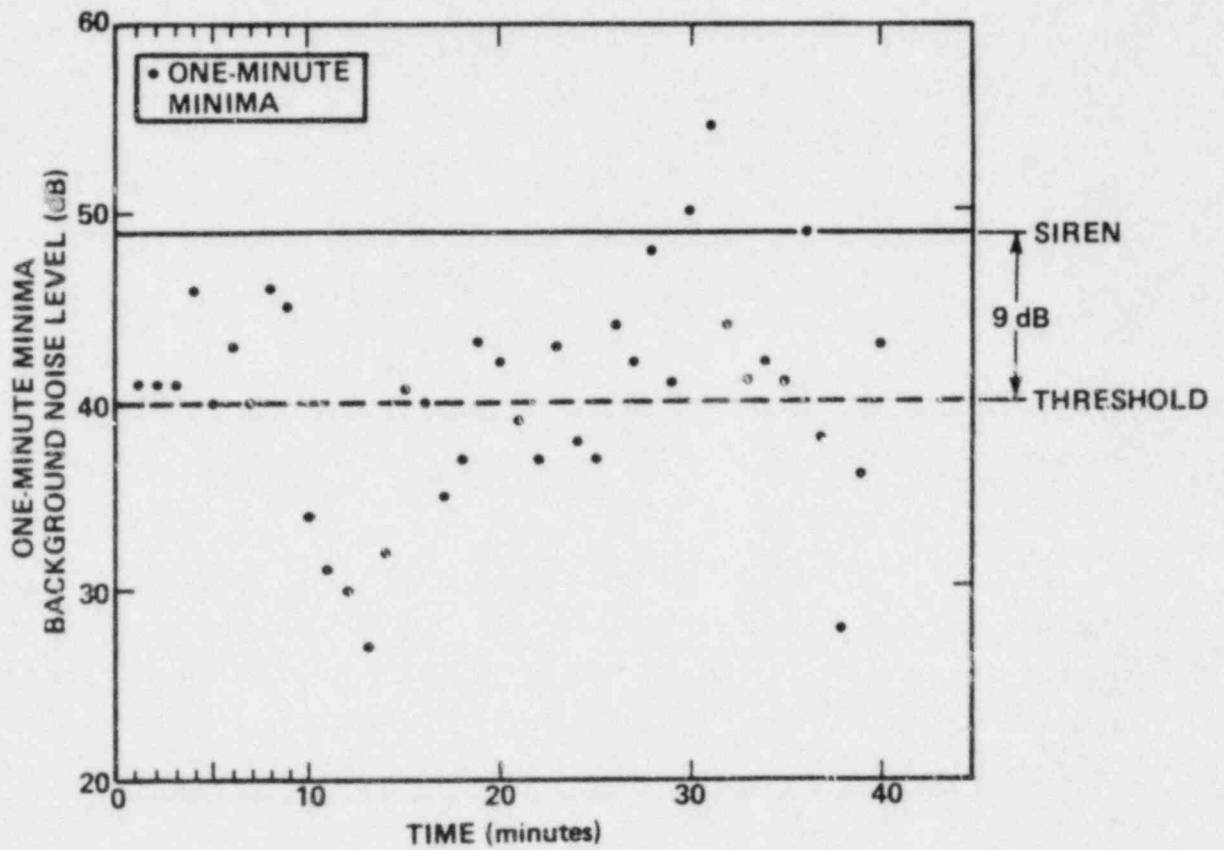

FIG. B-2. MINIMUM BACKGROUND NOISE LEVELS OBSERVED IN ONE-MINUTE INTERVALS FOR A 40-MINUTE TIME PERIOD.



This plot applies only to sirens sounded for one minute, since the background-noise minima are one-minute minima. Stated another way, when a siren is sounded for one minute, it has an equal chance of encountering any of these forty one-minute time periods, which represent all one-minute periods. During 35 percent of these minutes it will alert the listener, since the noise falls below the alerting threshold at least once during those minutes.

Next, say that the siren is sounded for four minutes. Figure B-3 shows the four-minute minima of interest - as circled dots. Each of these is just the lowest of four one-minute minima in each four-minute grouping. Of these four-minute minima, 60 percent (6 out of 10) fall below the threshold line. Therefore, this siren level in this background noise has a 60 percent chance of alert when sounded for a duration of four minutes. Note that the chance of alert has increased with the siren duration.

Needed is mathematics that relates the one-minute chance of alert to the four-minute chance, and to the chances for all other siren durations as well. This mathematics is based upon probabilities  $P$ , rather than upon "chances." A 35 percent chance of alert is equivalent to a probability  $P$  of 0.35. Moreover, this mathematics is based upon the probability of failure to alert, rather than success in alerting.

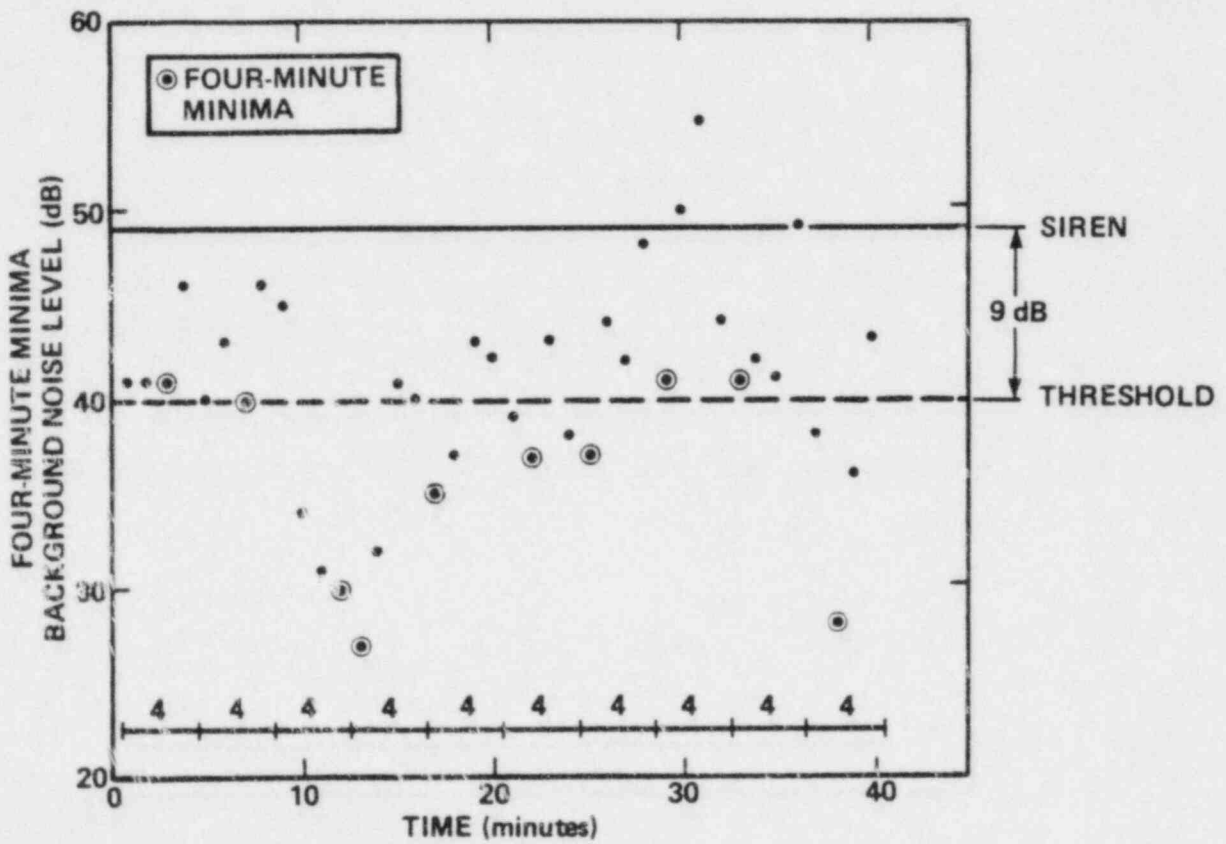

FIG. B-3. MINIMUM BACKGROUND NOISE LEVELS OBSERVED IN FOUR-MINUTE INTERVALS FOR A 40-MINUTE TIME PERIOD (FROM FIG. B-2).

Chance of Success	Probability	
	of Success	of Failure
100%	1.0	0
80%	0.8	0.2
60%	0.6	0.4
40%	0.4	0.6
20%	0.2	0.8
0%	0	1.0

Note that

$$P_{\text{failure}} = 1 - P_{\text{success}}$$

and that failure occurs when minima points are above the threshold line.

#### Underlying Mathematics and its Simplification

Figure B-2 above contains one-minute minima for a total time period of forty minutes. All the points in this figure are collapsed onto the vertical axis in Fig. B-4, at the left. They form a "cloud" of points denser at intermediate noise levels and sparser for higher and lower levels. This is a probability "cloud," in which area is proportional to the probability (density) of one-minute minima.

For any one-minute period, the probability of failure is proportional to the "cloud" area above the threshold line. This upper area, divided by the total cloud area, is the probability

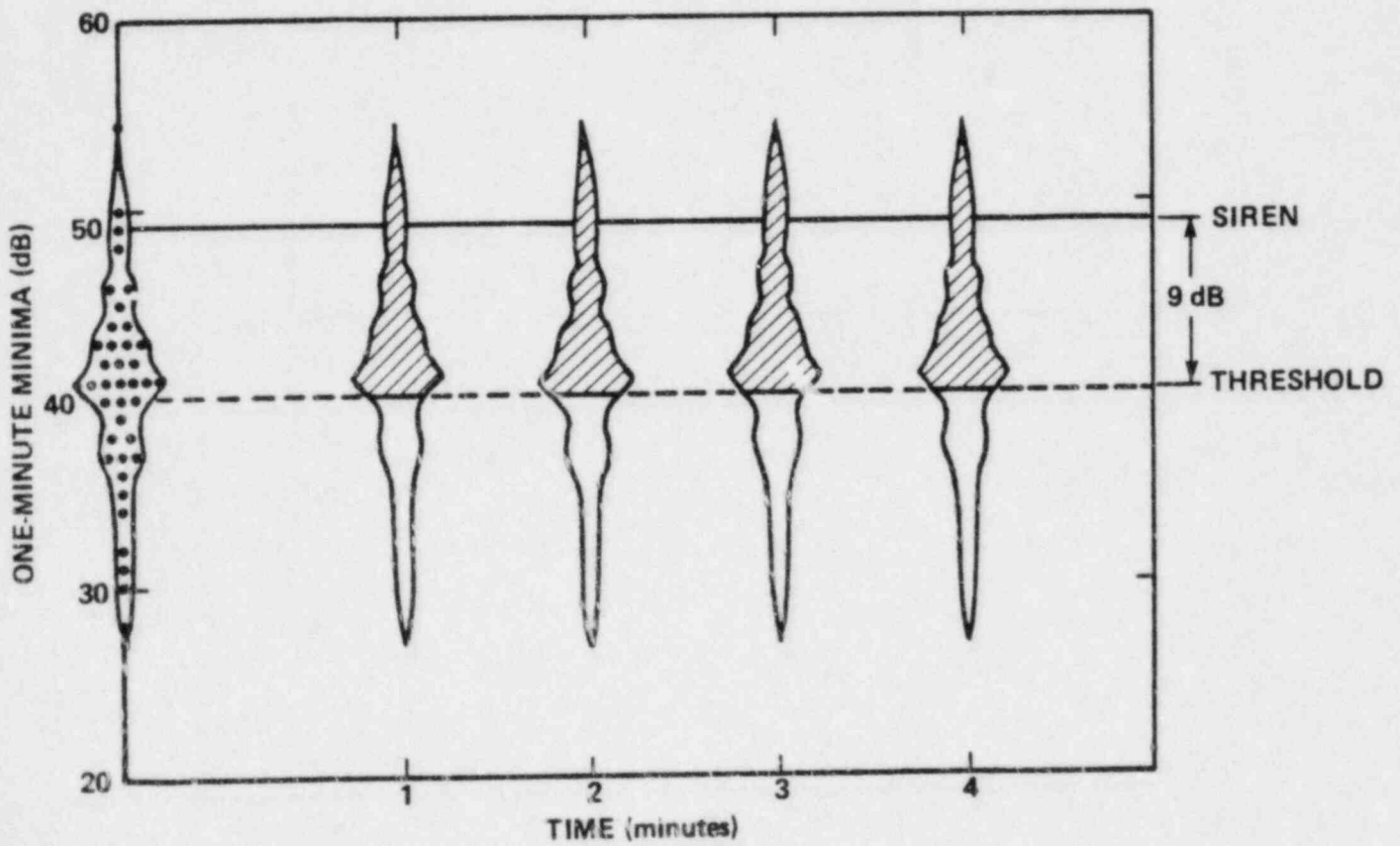

FIG. B-4. PROBABILITY "CLOUDS" FOR ONE-MINUTE BACKGROUND-NOISE MINIMA IN SUCCESSIVE MINUTES, ASSUMING EACH MINUTE IS STATISTICALLY INDEPENDENT OF ALL OTHER MINUTES.

that the background noise will exceed the threshold level throughout any one-minute period -- that is, the probability that the siren will fail to alert the listener. This one-minute probability of failure is  $(1-0.35) = 0.65$  for the example shown.

To the right in the figure, this cloud is duplicated at each of four successive minutes. If we assume these four minutes to be independent of one another, this probability cloud would apply equally to all of them, as shown. Let us assume this to be the case for a moment. Then, for the siren to fail after four minutes, it must fail for each of the one-minute periods. Therefore, the probability of failure after four minutes is

$$\begin{aligned} P(4) &= (P_1)(P_2)(P_3)(P_4) \\ &= (P_1)^4 \end{aligned}$$

In this equation,  $P(4)$  means the probability of failure after a total of four minutes have gone by, while  $P_4$  means the probability of failure during the fourth minute only.\*

This equation, however, is valid only if the one-minute periods are independent of one another. A glance at Fig. B-2 above indicates that they are not independent. For example, for a one-minute period with a very low minimum, the following minute probably also has a low minimum. There is a regularity in the successive minima; they are not independent. For this reason, the cloud picture must be modified to that of Fig. B-5.

---

\*If we had worked with probabilities of success, combining four minutes into one equation would be far more complicated. That is why we choose to work with failure instead. As the very last step, we shall convert from failure back to success.

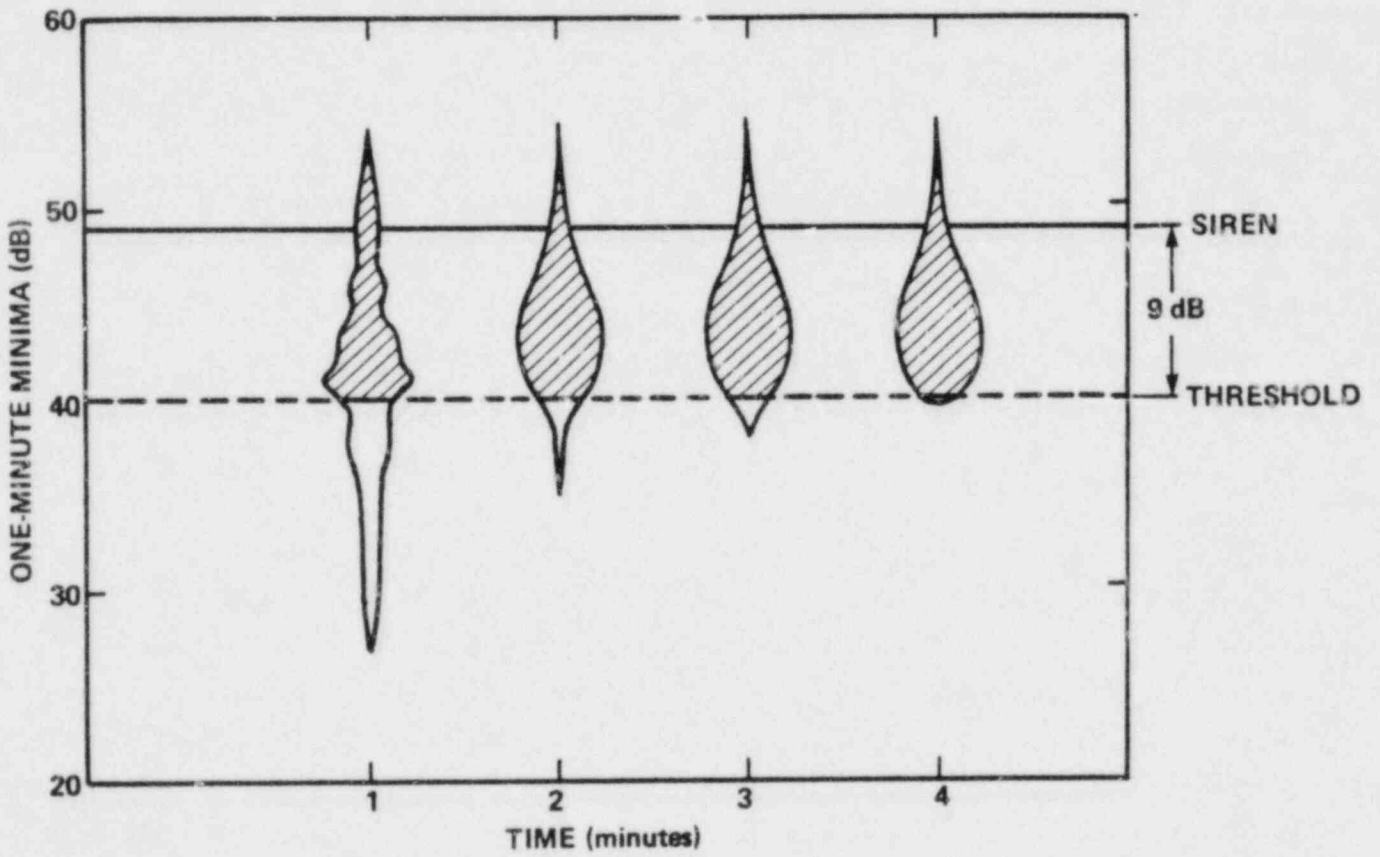



FIG. B-5. PROBABILITY "CLOUDS" FOR ONE-MINUTE BACKGROUND-NOISE MINIMA IN SUCCESSIVE MINUTES, ASSUMING MINIMA IN SUCCESSIVE MINUTES ARE NOT INDEPENDENT.



In Fig. B-5, the first minute's cloud is unchanged from Fig. B-4. However, the second minute's cloud represents the conditional probability of: "failure during minute two, given that failure occurred during minute one." In other words, the cloud at minute two represents the probability that the second minute's minimum will be above the threshold, given that the first minute's was also above the threshold. Mathematically, we write  $P_{2:1}$  for this conditional probability. Then

$$P(4) = (P_1)(P_{2:1})(P_{3:1,2})(P_{4:1,2,3})$$

conditional probabilities

Note that  $P_{2:1}$  is greater than the independent  $P_2$ .

$$P_{2:1} > P_1$$

This increase is due to the regularity between successive minutes -- technically to the correlation between successive minute's minima. The higher the correlation between successive minima, the more this probability cloud will condense above the threshold line. The remaining clouds condense even more above the line, since they are failure probabilities, given that several failures have preceded.

A short numerical example will be useful here. For no correlation, we have

$$P(4) = (0.65)(0.65)(0.65)(0.65)$$

$$P(4) = (0.65)^4 = 0.18$$

and therefore the probability of success is 0.82. For some

correlation, we have

$$P(4) = (0.65)(0.8)(0.85)(0.9)$$
$$P(4) \approx 0.40$$

for a probability of success of 0.60. And for full correlation we have

$$P(4) = (0.65)(1.0)(1.0)(1.0)$$
$$P(4) = 0.65$$

for a probability of success of 0.35.

In general,

$$P(n) = (P_1)(P_{2:1})(P_{3:1,2}) \dots (P_{n:1,2,3,\dots,n-1})$$
$$= (P_1)^n \text{ for no correlation} \quad (B-1)$$
$$= P_1 \text{ for full correlation}$$

The upper half of Fig. B-6 illustrates graphically how the probability of failure thus decreases with increasing time -- that is, with increasing siren duration. The probability of success therefore increases with siren duration, as shown in the bottom half of the figure. (This figure is an example only, not a general result.)

Note for large correlation between successive minima, there is not as much benefit in sounding the siren longer. If the siren fails to alert during the first minute, it will most likely fail to alert thereafter, because the first minute is nearly identical to all subsequent minutes.

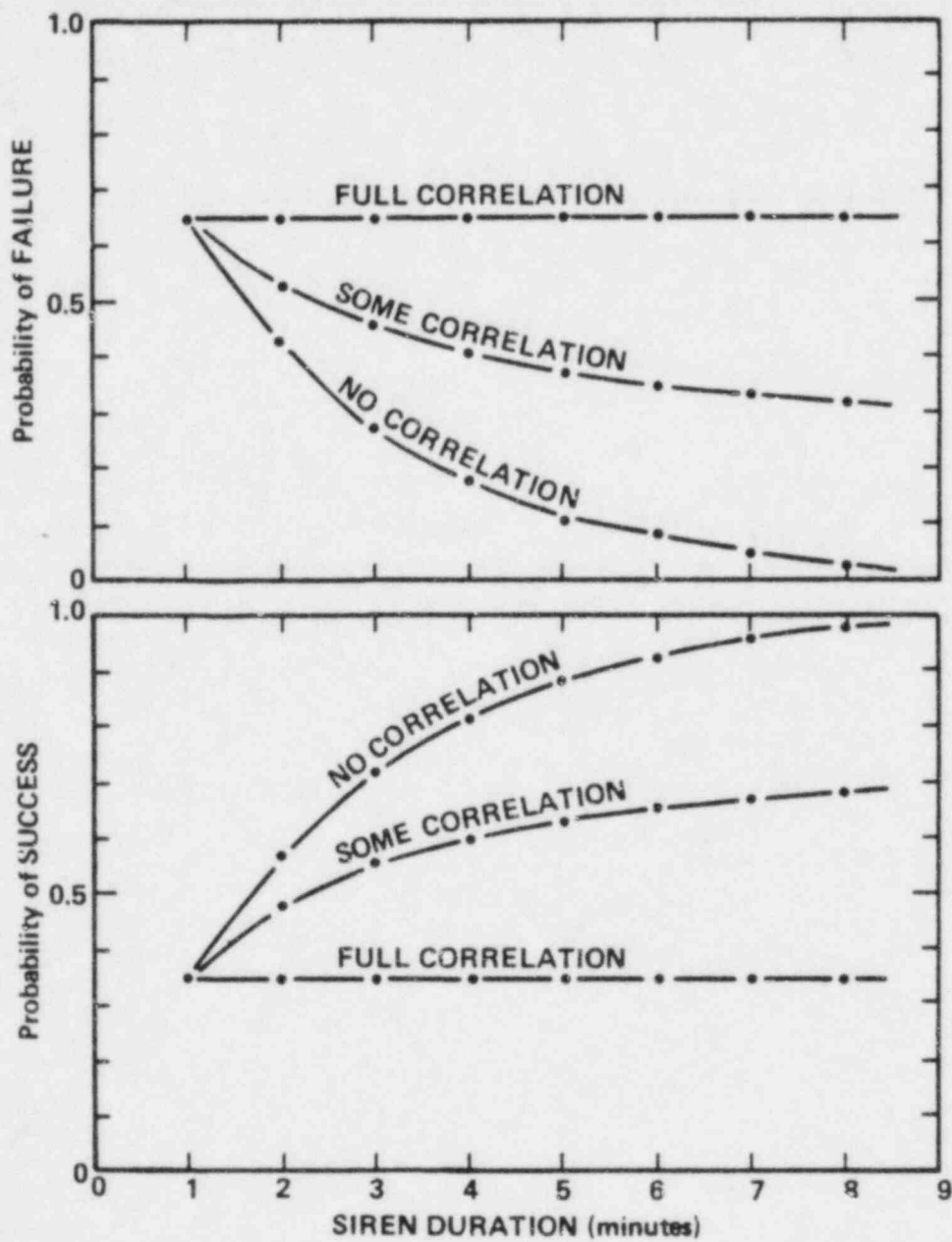

FIG. B-6. GRAPHIC ILLUSTRATION OF SIREN-ALERTING PROBABILITIES VS. SIREN DURATION, FOR VARIOUS AMOUNTS OF CORRELATION BETWEEN BACKGROUND-NOISE MINIMA IN SUCCESSIVE MINUTES (Example Only).

This underlying mathematics resides in Eq. B-1 above. In Eq. B-1, the notation  $P_{n:1,2,3,\dots,n-1}$  reminds us that  $P_n$  is a conditional probability, which assumes the siren failed during all previous minutes. We next simplify, so that this  $P_n$  assumes failure only during the immediately preceding minute. Mathematically,

$$P_{n:1,2,3,\dots,n-1} = P_{n:n-1}$$

Let

$$P_{n:n-1} = CP_1$$

where C contains all the conditional aspects of the probability. The term  $P_1$  is the unconditional probability for the first minute. Then

$$P(n) = (P_1)(CP_1)(CP_1) \dots (CP_1)$$

$$P(n) = P_1^n C^{n-1} \tag{B-2}$$

Note that for no correlation,

$$C = 1 \tag{B-3}$$

and therefore

$P(n) = P_1^n$   
as before. For full correlation,

$$C = \frac{1}{P_1} \tag{B-4}$$

to make

$$\begin{aligned} P(n) &= P_1^n \left(\frac{1}{P_1}\right)^{n-1} \\ &= P_1 \end{aligned}$$

as before.

Eq. B-2 is the desired simplification. In the following section, we graph measured background data, to explore the nature of C, for correlations typically present in measured background noise data.

#### Exploratory Graphs, Guided by the Mathematics

To explore for C graphically, we first take the logarithm of Eq. B-2.

$$\begin{aligned} P(n) &= P_1^n C^{n-1} \\ \log P(n) &= n \log P_1 + (n-1) \log C \\ \log P(n) &= -\log C + n [\log CP_1] \end{aligned} \tag{B-5}$$

If  $\log P(n)$  is then plotted against  $n$ , the resulting straight line should have a vertical intercept of  $-\log C$  and a slope of  $\log CP_1$ . After some curve-smoothing on linear paper, on Fig. B-7 we logarithmically plot part of the data in Table B-1. above. Each line is for a different representative siren level, labelled (1) through (5).

Of course, the linear curve-smoothing helped line up the points shown here. Even so, the regression fit to straight lines for each siren level is very good. Note however, that the vertical intercepts and the slopes vary from curve to curve. Therefore, C must vary with siren level.

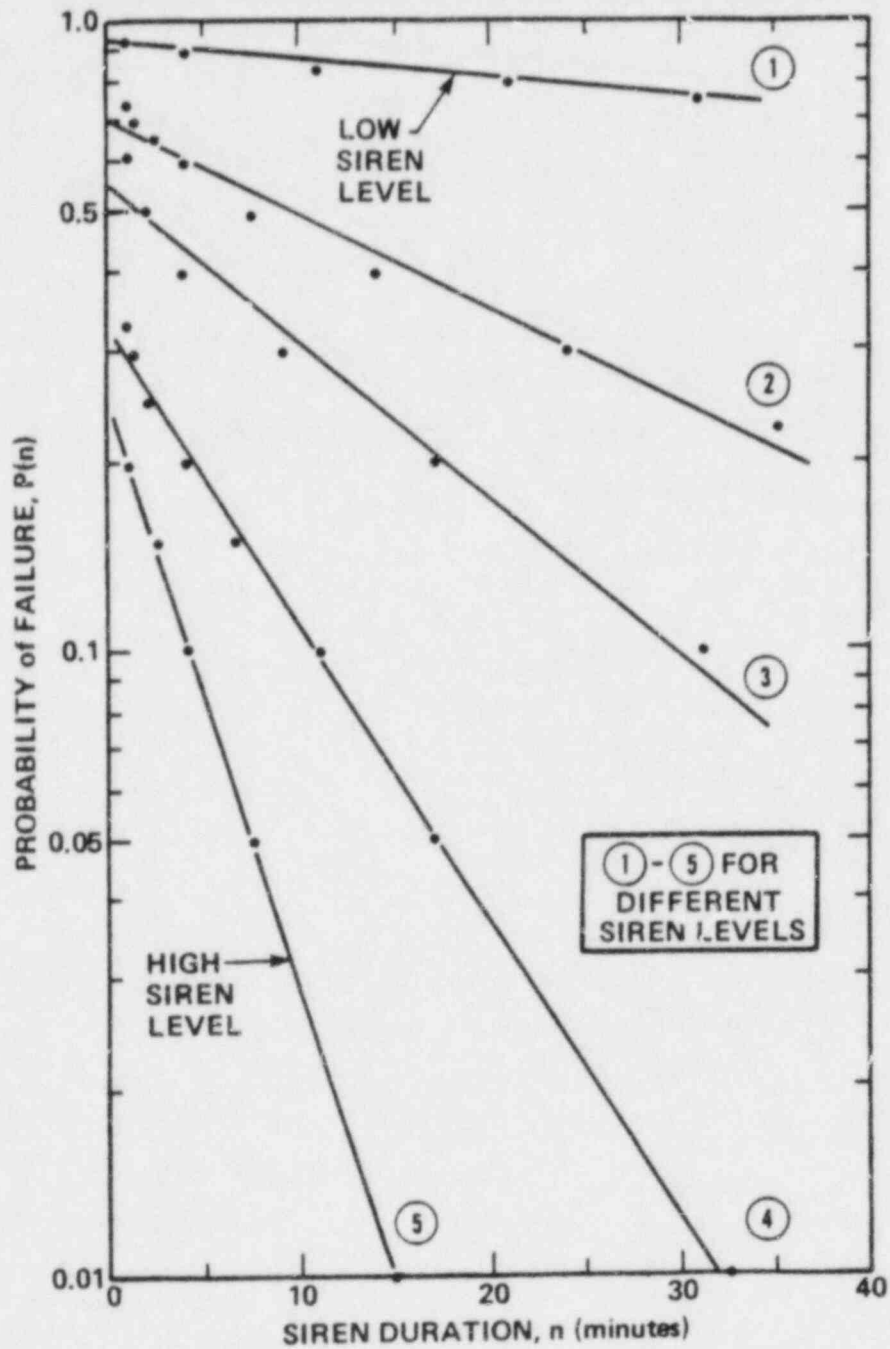

FIG. B-7. LOGARITHM OF THE PROBABILITY OF SIREN FAILURE-TO-ALERT VS. SIREN DURATION FOR FIVE DIFFERENT SIREN LEVELS, DERIVED FROM THE DATA IN TABLE B-1.



We then set each intercept equal to  $-\log C$  and each slope equal to  $\log CP_1$ , and solve for  $C$  and  $P_1$  -- separately for each straight line.

Line Number	C	$P_1$
1	1.073	0.925
2	1.426	0.678
3	1.816	0.520
4	3.062	0.293
5	4.064	0.199

From Eq. B-4 above, we suspect that  $C$  may be a power function of  $P_1$ , and so we plot  $\log C$  against  $\log P_1$  in Fig. B-8. On this plot, the straight-line fit is also very good. It yields:

$$C = (P_1)^{-0.87}$$

It seems to make sense, based upon this limited analysis, to generalize to

$$C = (P_1)^{-\rho}$$

where  $\rho$  (rho) denotes a correlation coefficient. Zero correlation would then make

$$C = (P_1)^0 = 1$$

and full correlation would make

$$C = (P_1)^{-1} = \frac{1}{P_1}$$

These agree with Eqs. B-3 and B-4 above.

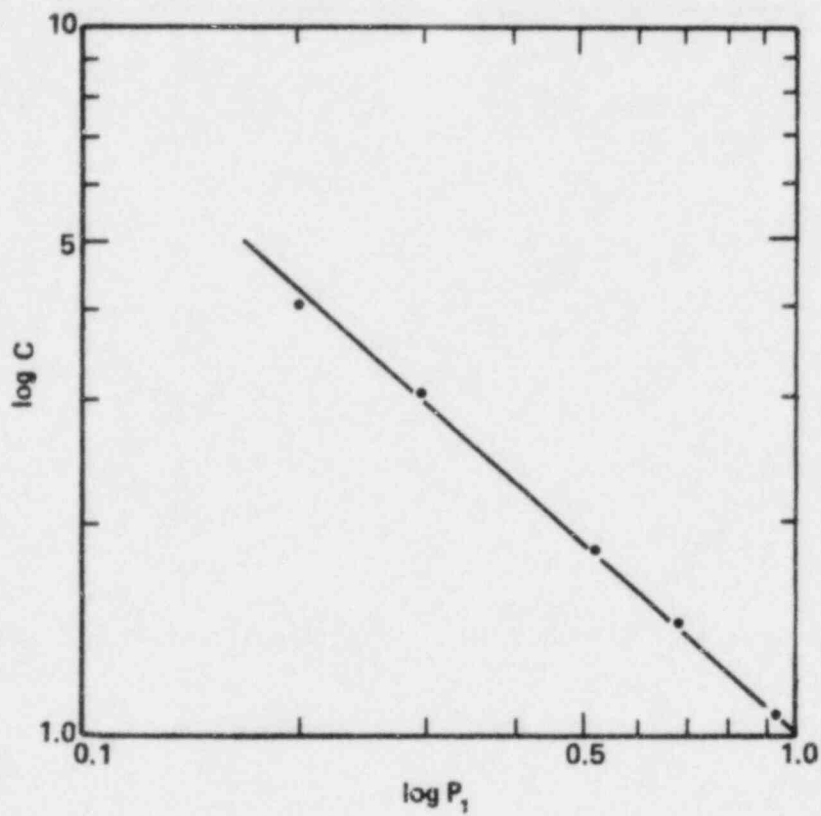

FIG. B-8. PLOT OF VALUES OF CUMULATIVE CONDITIONAL PROBABILITIES (LOG C) VS. PROBABILITY OF FAILURE IN THE FIRST MINUTE (LOG  $P_1$ ), DERIVED FROM FIG. B-7.

In summary then, the time-pattern within Table B-1 can be written as

$$P(n) = (P_1)^{n-0.87(n-1)} = (P_1)^{0.87 + 0.13n} \quad (B-6)$$

The two constants in the exponent sum to 1.00, and depend upon correlation within the background noise, from minute to minute. Moreover, Eq. B-6 depends upon the siren level through  $P_1$ , which varies with siren level.

Next, we simplify Eq. B-6 so it may be generalized to a wide variety of noise-level tables, not just Table B-1 above.

Eq. B-6 is valid for all siren levels, in the presence of the particular background noise used to develop Table B-1. Its general form is

$$\begin{aligned} P(n) &= (P_1)^n C^{n-1} \\ &= (P_1)^n (P_1)^{-\rho(n-1)} \\ &= (P_1)^{\rho + n(1-\rho)} \end{aligned} \quad (B-7)$$

In logarithmic form,

$$\begin{aligned} \log P(n) &= \rho + n(1-\rho) \log P_1 \\ &= \rho \log P_1 + n(1-\rho) \log P_1 \end{aligned} \quad (B-8)$$

With  $\log P(n)$  plotted against  $n$ , this is the equation of a straight line with vertical intercept  $\rho \log P_1$  and slope  $(1-\rho) \log P_1$ .

A normal regression fit would solve for the two variables  $\rho$  and  $P_1$ , separately for each of the siren levels (as shown in Fig. B-7, for instance). However, there is a relationship above

that implies  $\rho$  to be a constant, independent of the siren level. Therefore, we wish to collapse all curves, for all siren levels, to a single curve. For this purpose, we manipulate Eq. B-8 as follows:

$$\begin{aligned} \log P(n) &= \rho + n(1-\rho) \log P_1 \\ \frac{\log P(n)}{\log P_1} &= \rho + n(1-\rho) \\ &= 1 + (n-1)(1-\rho) \end{aligned} \tag{B-9}$$

Hence, plotting  $(\log P(n)/\log P_1)$  against  $(n-1)$  yields a straight line of intercept 1 and slope  $(1-\rho)$ , independent of siren level. In other words, each curve in Fig. B-7 has been normalized to its value of  $P_1$ , and all curves have been collapsed into one.

We will have need below for a similar equation, but normalized to the probability at four minutes, rather than at one minute. We develop this next.

In the graphs above, letter  $n$  was interpreted as progressing in one-minute steps ( $n=1,2,3$  equals  $t=1,2,3$ ). However, nothing in the mathematics requires this interpretation. Any time interval could be taken as the basic interval  $n$  above. In particular, the basic time interval could be taken as four minutes. Then four-minute minima ( $n=1$ ) would combine into eight-minute minima ( $n=2$ ), and so forth. The result would be Eq. B-9 above, but with

$$\begin{aligned} n &= 4t \text{ (in minutes)} \\ \text{and } P_1 &= P_{(n=1)} = P_{(t = 4 \text{ minutes})} \end{aligned}$$

Figure B-9 schematically compares these one-minute and four-minute normalizations.\* For the one-minute normalization on top:  $n=t$ , and therefore  $n-1 = t-1$ , as shown on the first horizontal axis. Plotted horizontally is the range

$$0 \leq t - 1 \leq 3$$

$$1 \leq t \leq 4$$

The small plotted points represent the tabulated values for these four minutes, collapsed into one line by the  $P_1$  normalization. The line is fit by linear regression and has slope  $(1-\rho)$ .

This upper portion of Fig. B-9 is for rotating sirens. As explained in the main text, rotating sirens are less effective in alerting the public, since they produce their maximum siren level for only a portion of their duration. For this reason, four-minute results for rotating sirens are derived from the one-minute background-noise statistics. In the figure, the third horizontal scale shows the corresponding siren durations for rotating sirens. The normalization is therefore to a four-minute siren duration, and the graph extends up to a maximum of 16 minutes.

---

\*Note that the lines in Fig. B-9 rise rather than fall to the right, as does Fig. B-7, for this reason: In Fig. B-7, the actual logarithms on the vertical axis are negative, since the  $P(n)$ 's are less than unity. Therefore, this vertical axis actually decreases, from zero at the top to minus-two at the bottom. For increasing  $n$ , then, the curves take on increasingly large negative values (for example: -1, -1.5, -2). Fig. B-9 is normalized by  $\log P_1$ , however, which is also negative, and which turns these increasingly negative values into increasingly positive values. Therefore, the lines rise in Fig. B-9.

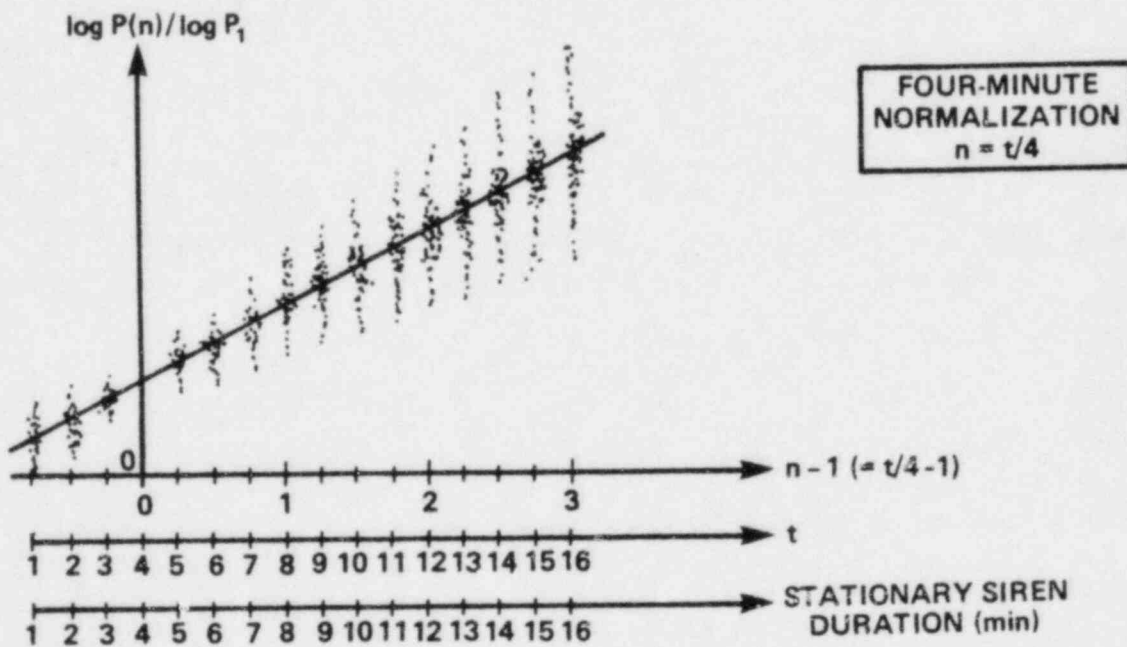
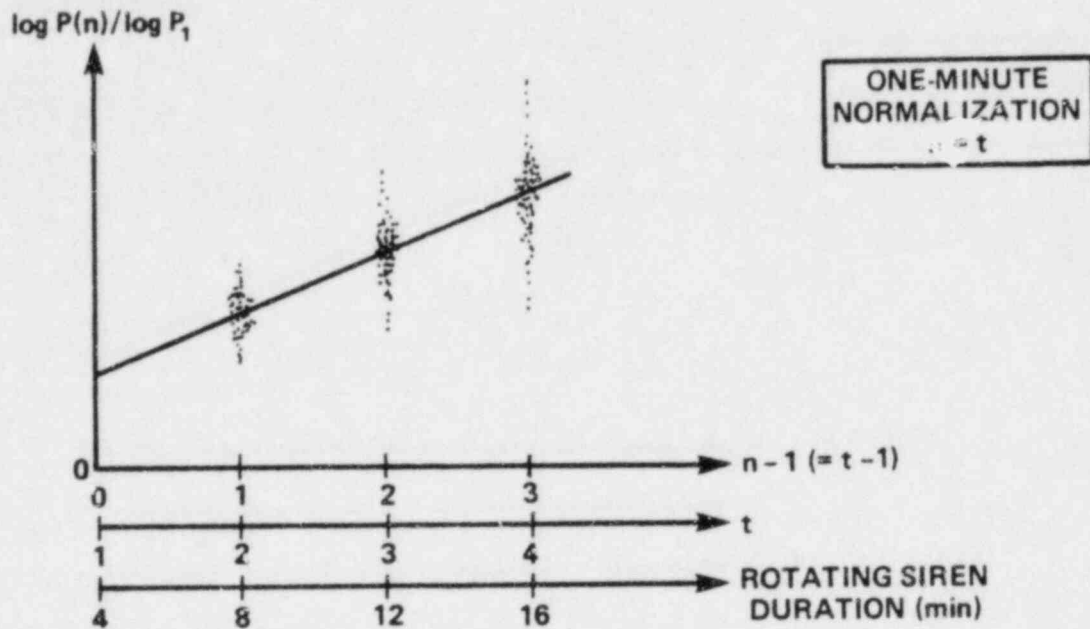

FIG. B-9. SKETCH OF ONE-MINUTE AND FOUR-MINUTE NORMALIZATIONS TO SHOW RELATIONSHIP BETWEEN VARIABLE N AND SIREN DURATIONS.



For the four-minute normalization at the bottom of the figure:  $n = t/4$ , and therefore  $n-1 = t/4 - 1$ , as shown. Plotted horizontally is the range

$$-\frac{3}{4} \leq \frac{t}{4} - 1 \leq 3$$

$$\frac{1}{4} \leq \frac{t}{4} \leq 4$$

$$1 \leq t \leq 16$$

The second horizontal scale shows time  $t$  and is identical to the third scale, which shows duration of stationary sirens. The normalization is therefore to a four-minute siren duration, and the graph extends up to a maximum duration of 16 minutes.

Using these equations and normalizations, the curve-fitting procedure was applied to six background-noise tables -- tables similar to Table B-1 -- developed from data measured at 74 different indoor and outdoor locations. In this curve-fitting, no linear smoothing was used, and data from all siren levels were used without omission. Table B-2 contains the resulting slopes.

These slopes were next converted to  $\rho$ , assuming that they equal  $(1-\rho)$ , as labelled in the table. The resulting twelve values of  $\rho$  were plotted against the corresponding values  $R_{xx}$  of the auto correlation function, to obtain

$$R_{xx} = -0.034 + 1.051\rho$$

This regression equation has a correlation coefficient (between values of  $\rho$  and  $R_{xx}$ ) of 0.85, which is satisfactorily high.

TABLE B-2. SLOPES RESULTING FROM ALL SIREN LEVEL DATA.

Listener Location	Subclass	Resulting Slopes (1-p)	
		Stationary Sirens	Rotating Sirens
Indoors	Scenario 1	0.217	0.142
	Scenario 3	0.274	0.254
Outdoors	Rural, day	0.164	0.177
	Urban, day	0.065	0.103
	Rural, eve/night	0.150	0.075
	Urban, eve/night	0.046	0.039

In the next section, we collect these results into a form of use to the reader.

### Summary of Results

Figure B-10 contains the results of the analysis above. This figure is used as follows:

- Convert the four-minute "chance of alert" to a "probability of failure-to-alert":

$$P = 1 - (\text{Chance of alert})/100$$

- Raise this value to the exponent determined from Fig. B-10, for the particular siren duration of interest.

$$P = (P_{4\text{-min}})^{\text{Exponent}} \quad (\text{B-10})$$

- Convert this "probability of failure-to-alert" back to a "chance of alert":

$$\text{Chance of alert} = 100 (1-P)$$

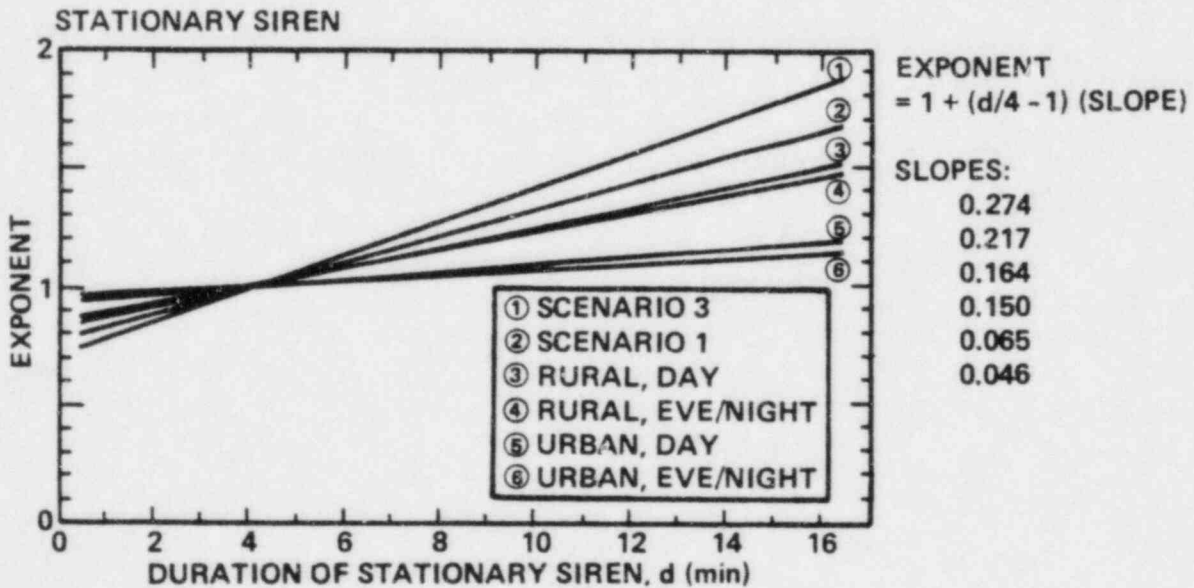
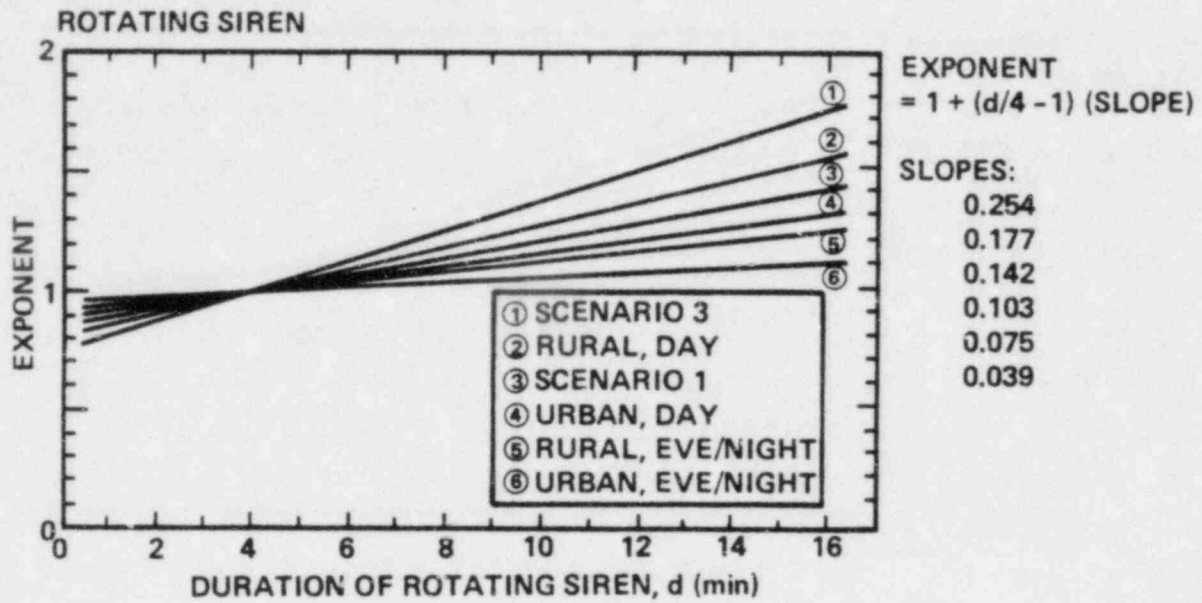

FIG. B-10. GRAPH OF EXPONENT FOR USE IN EQ. B-10. (Developed from data measured at 74 different locations for the six scenarios - see text.)

APPENDIX C

SET OF BASIC COMPUTER PROGRAMS  
TO FACILITATE THE ANALYSIS

SIRENINPUT.B20

Thursday, April 8, 1982 23:22:02

```
00100 ONERROR GOTO 310
00110 PRINT "IF AT ANY TIME YOU WANT TO EXIT THE PROGRAM HIT CONTROL-C"
00120 INPUT "NAME OF FILE CONTAINING SIREN DATA";SFILE$
00130 INPUT "TOTAL NUMBER OF SIRENS PLEASE";NSIRENS
00140 DIM #1,SIREN$(200),XS(200),YS(200),ZS(200),SPL(200)
00150 GOSUB 330
00160 INPUT "WHICH SIREN DO YOU WANT TO START WITH";I
00170 PRINT
00180 PRINT "FOR EACH SIREN PLEASE TYPE IN A DESCRIPTOR,X,Y,AND Z COORDI
NATES,AND"
00190 PRINT " A SOUND PRESSURE LEVEL AT 100 FEET"
00200 PRINT\PRINT
00210PRINT SFILE$\PRINT
00220 OPEN SFILE$ AS FILE #1,VIRTUAL
00230 ONERROR GOTO 450
00240 FOR N=I TO NSIRENS
00250 PRINT "SIREN";N;
00260 INPUT SIREN$(N),XS(N),YS(N),ZS(N),SPL(N)
00270 IF LEFT$(SIREN$(N),1)#"S"AND LEFT$(SIREN$(N),1)#"R" THEN GOSUB 470
\GO TO 250
00280 NEXT N
00290 CLOSE #1
00300 GOTO 530
00310 RESUME
00330 INPUT "DO YOU WANT A HARDCOPY OF THE FILE Y\N";Y$
00340 IF Y$="N" THEN RETURN
00350 PRINT\PRINT\PRINT
00360 PRINT SFILE$
00370 PRINT "SIREN# SIREN NAME X Y Z SPL@100
FT"
00380 :### 'LLLLLLLLL #####.### #####.### ###.### ###
00390 OPEN SFILE$ AS FILE #1, VIRTUAL
00400 FOR N=1 TO NSIRENS
00410 PRINT USING 380,N,SIREN$(N),XS(N),YS(N),ZS(N),SPL(N)
00420 NEXT N
00430 CLOSE #1
00440 RETURN
00450 GOSUB 470
00460 RESUME 250
00470 PRINT\PRINT " THE DESCRIPTOR SHOULD START WITH S OR R (FOR STATION
ARY OR ROTATING) "
00480 PRINT " AND SHOULD BE ENCLOSED IN QUOTES"
00490 PRINT " THERE SHOULD BE COMMAS BETWEEN EACH ENTRY"
00500 PRINT " DECIMAL POINTS ARE OPTIONAL"
00510 PRINT ' FOR EXAMPLE : "R 11",1024,1100.4,25,114'
00520 PRINT\RETURN
00530 END
```

COORDIN.B20

Thursday, April 8, 1982 23:07:28

```
00100 ONERROR GOTO 330
00110 dim #1,mulx(3),muly(3),mulz(3),subx(3),suby(3),subz(3)
00120 input "name of coordinate transform file";sfile$
00130 open sfile$ as file#1,virtual
00140 INPUT "DO YOU WANT A HARDCOPY OF THE FILE";Y$
00150 IF Y$="Y"GOTO 240
00160 PRINT
00170 for i = 1 to 3
00180 IF I=1 THEN PRINT "FOR SIRENS"
00190 IF I=2 THEN PRINT "FOR LISTENERS"
00200 IF I=3 THEN PRINT "FOR BARRIERS"
00210 INPUT "MULX,MULY,MULZ,SUBX,SUBY,SUBZ";MULX(I),MULY(I),MULZ(I),SUBX
(I),SUBY(I),SUBZ(I)
00220 next i
00230 PRINT
00240 PRINT "      MULX      MULY      MULZ      ADDX      ADDY      AD
DZ"
00250 FOR I=1 TO 3
00260 IF I=1 THEN PRINT "FOR SIRENS"
00270 IF I=2 THEN PRINT "FOR LISTENERS"
00280 IF I=3 THEN PRINT "FOR BARRIERS"
00290 PRINT USING 300,MULX(I),MULY(I),MULZ(I),SUBX(I),SUBY(I),SUBZ(I)
00300 :####.###  ####.###  ####.###  ####.###  ####.###  ####.###
00310 NEXT I
00320 PRINT\PRINT\STOP
00330 RESUME
00340 end
```



LISTENERINPUT.B20

Thursday, April 8, 1982 23:10:48

```
00100 ONERROR GOTO 740
00110 PRINT "TO EXIT THE PROGRAM AT ANY TIME HIT CONTROL-C"
00120 INPUT "NAME OF FILE CONTAINING LISTENER DATA";SFILE$
00130 input "TOTAL NUMBER OF LISTENER SITES";NLISNS
00140 dim #1,lisn$(300),xl(300),yl(300),zl(300),rodis(300),siren(300,10)
,lout(300,10)
00150 GOSUB 440
00160 OPEN SFILE$ AS FILE#1,VIRTUAL
00170 PRINT
00180 INPUT "WHICH LISTENER SITE DO YOU WANT TO START WITH";I
00190 PRINT
00200 PRINT "FOR EACH LISTENER SITE ENTER DESCRIPTOR AND X,Y,Z COORDINAT
ES"
00210 PRINT " DESCRIPTOR SHOULD BE IN QUOTES AND START WITH U OR R (FOR
URBAN/RURAL)"
00220 PRINT\PRINT
00230PRINT SFILE$\PRINT
00240 FOR N=I TO NLISNS
00250 PRINT
00260 PRINT "LISTENER SITE";N;
00270 ONERROR GOTO 700
00280 INPUT LISN$(N),XL(N),YL(N),ZL(N)
00290 IF LEFT$(LISN$(N),1)="U" OR LEFT$(LISN$(N),1)="R" THEN GOTO 320
00300 GOSUB 620
00310 GO TO 260
00320 RODIS(N) = 0
00330 if left$(lisn$(n),1)="U" then goto 380
00340 ONERROR GOTO 720
00350 PRINT\ INPUT "IS THIS RURAL SITE WITHIN 1000 FEET OF A ROADWAY";YE
SNO$
00360 PRINT\IF YESNO$#"Y" AND YESNO$#"N" THEN PRINT "Y OR N ONLY PLEASE"
\GOTO 350
00370 IF YESNO$ = "Y" THEN RODIS(N) = 1
00380 NEXT N
00390 CLOSE #1
00400 STOP
00440 INPUT "DO YOU WANT A HARDCOPY OF THE FILE Y\N";Y$
00450 IF Y$="N" THEN RETURN
00460 PRINT\PRINT\PRINT
00470 PRINT SFILE$
00480 PRINT
00490 PRINT "SITE # SITE NAME X Y Z RURAL
ROAD"
00500 :### 'LLLLLLLLLL #####.### #####.### #####.###
00510 OPEN SFILE$ AS FILE #1, VIRTUAL
00520 FOR N=1 TO NLISNS
00530 PRINT USING 500,N,LISN$(N),XL(N),YL(N),ZL(N);
00540 IF LEFT$(LISN$(N),1)="U" THEN PRINT " -"\GO TO 580
00550 IF RODIS(N)=1 THEN PRINT " NEAR"\GO TO 580
00560 IF RODIS(N)=0 THEN PRINT " FAR"\GO TO 580
```

```
00570 PRINT "URBAN ROAD NEITHER NEAR OR FAR - LINO 535 "\STOP
00580 REM
00590 NEXT N
00600 CLOSE #1
00610 RETURN
00620 PRINT
00630 PRINT "DESCRIPTOR SHOULD START WITH EITHER U OR R (FOR URBAN OR RU
RAL)"
00640 PRINT "THE ENTIRE DFSCRIPTOR SHOULD BE ENCLOSED IN DOUBLE QUOTES"
00650 PRINT "AND FOLLOWED BY THE X,Y,AND Z COORDINATES"
00660 PRINT "THERE SHOULD BE COMMAS AFTER THE DESCRIPTOR AND BETWEEN THE
COORDINATES"
00670 PRINT 'FOR EXAMPLE : "U X11",1513.4,2134.6,56.4'
00680 PRINT\PRINT
00690 RETURN
00700 GOSUB 620
00710 RESUME 260
00720 PRINT "Y OR N ONLY PLEASE "
00730 RESUME 350
00740 RESUME
00750 END
```

SCEENARIOINPUT.B20

Thursday, April 8, 1982 23:20:29

```
00100 ONERROR GOTO 561
00110 PRINT "TO EXIT THE PROGRAM AT ANY TIME HIT CONTROL-C"
00120 INPUT "NAME OF FILE CONTAINING SCENARIO DATA";SFILES$
00130 INPUT "NUMBER OF SCENARIOS PLEASE";NSCEN
00140 DIM #1,AMOL(10),WIND(10),NRES(10),NRCM(10),F1(10),F2(10),F3(10),F4
(10),F5(10),F6(10),F7(10),F8(10),INP(10),PU30(10),PR55(10),MUL(10),ADD(1
0)
00150 GOSUB 400
00160 INPUT "WHICH SCENARIO DO YOU WANT TO START WITH";I
00170 PRINT\PRINT
00180PRINT SFILES$\PRINT
00190 FOR N=I TO NSCEN
00200 OPEN SFILES$ AS FILE #1,VIRTUAL
00210 PRINT\PRINT
00220 PRINT "THIS IS DATA FOR SCENARIO NUMBER";N
00230 input "AIR ABSORPTION ";AMOL(N)
00240 INPUT "WIND DIRECTION";WIND(N)
00250 INPUT "RESIDENTIAL NOISE REDUCTION";NRES(N)
00260 INPUT "COMMERCIAL NOISE REDUCTION";NRCM(N)
00270 INPUT "EIGHT ACTIVITY FRACTION";F1(N),F2(N),F3(N),F4(N),F5(N),F6(N
),F7(N),F8(N)
00280 XX=F1(N)+F2(N)+F3(N)+F4(N)+F5(N)+F6(N)+F7(N)+F8(N)
00290 IF XX<.99 OR XX>1.01 THEN PRINT "ACTIVITY FRACTIONS SHOULD ADD TO
1"\GO TO 270
00300 INPUT "INDOOR PROBABILITY DISTRIBUTION";INP(N)
00310 IF INP(N)=1 OR INP(N)=3 THEN GO TO 320 ELSE PRINT "INDOOR PROBABIL
ITY DISTRIBUTION SHOULD BE EITHER 1 OR 3"\GO TO 300
00320 INPUT "PROBABILITY OF ALERT OF URBAN DRIVERS";PU30(N)
00330 INPUT "PROBABILITY OF ALERT OF RURAL DRIVERS";PR55(N)
00333 INPUT "ATMOSPHERIC MUL,ADD";MUL(N),ADD(N)
00340 CLOSE #1
00350 NEXT N
00360 GOTO 570
00400 INPUT "DO YOU WANT A HARDCOPY OF THE FILE Y\N";Y$
00410 IF Y$="N" THEN RETURN
00420 PRINT\PRINT
00430 PRINT SFILES$
00435 PRINT
00440 PRINT "SCEN# AMOL WIND NRES NCRM F1 F2 F3 F4 F5 F
6 F7 F8"
00450 : ## ##.## ### ##. ##. .### .### .### .### .### .### .#
## .###
00460 OPEN SFILES$ AS FILE #1, VIRTUAL
00470 FOR N=1 TO NSCEN
00480 PRINT USING 450,N,AMOL(N),WIND(N),NRES(N),NRCM(N),F1(N),F2(N),F3(N
),F4(N),F5(N),F6(N),F7(N),F8(N)
00490 NEXT N
00495 PRINT\PRINT\PRINT
00500 PRINT "INP PU30 PR55 MUL ADD"
00510 FOR N=1 TO NSCEN
```

```
00520 PRINT USING 540,INP(N),PU30(N),PR55(N),MUL(N),ADD(N)
00530 NEXT N
00540 :###      #.###  #.###  ##.###  ##.###
00545 PRINT\PRINT\PRINT
00550 CLOSE #1
00560 RETURN
00561 RESUME
00570 END
```

PICK1.B20

Thursday, April 8, 1982 23:13:14

```
00100 DIM #1,SIREN$(200),XS(200),YS(200),ZS(200),SPL(200)
00110 dim #2,lisn$(300),xl(300),yl(300),zl(300),rodis(300),siren(300,10)
,lout(300,10)
00120 DIM #3,AMOL(10),WIND(10),NRES(10),NRCM(10),F1(10),F2(10),F3(10),F4
(10),F5(10),F6(10),F7(10),F8(10),INP(10),PU30(10),PR55(10),MUL(10),ADD(1
0)
00130 dim#4,mulx(3),muly(3),mulz(3),subx(3),suby(3),subz(3)
00140 ONERROR GOTO 1490
00150 INPUT "NUMBER OF SCENARIOS PLEASE";NSCEN
00160 INPUT "PLEASE TYPE IN THE FILE NAME FOR THE SIREN DATA";SFILE$
00170 OPEN SFILE$ AS FILE #1,VIRTUAL
00180 INPUT "PLEASE TYPE IN THE FILE NAME FOR THE LISTENER DATA";LFILE$
00190 OPEN LFILE$ AS FILE #2,VIRTUAL
00200 INPUT "PLEASE TYPE IN THE FILE NAME FOR THE SCENARIO DATA";SCFILE$
00210 OPEN SCFILE$ AS FILE#3, VIRTUAL
00220 INPUT "PLEASE TYPE IN THE FILE NAME FOR THE COORDINATE TRANSFORM";
CFILE$
00230 OPEN CFILE$ AS FILE #4,VIRTUAL
00240 REM ***** START LISTENER LOOP *****
00250 INPUT "PLEASE TYPE IN THE NUMBER OF A LISTENER SITE";LISN
00260 FOR N=1 TO NSCEN
00270 IF SIREN(LISN,N)=0 THEN GOTO 300
00280 PRINT "SCENARIO";N;"THIS LISTENER EVALUATED ALREADY - LOUT=";LOUT(
LISN,N);"SIREN=";SIREN(LISN,N)
00290 INPUT "DO YOU WANT TO CONTINUE";YESNO$\IF YESNO$#"Y"GOTO 250
00300 SIREN(LISN,N)=0
00310 LOUT(LISN,N)=0
00320 NEXT N
00330 lx=(xl(lisn)-subx(2))*mulx(2)
00340 ly=(yl(lisn)-suby(2))*muly(2)
00350 lz=(zl(lisn)-subz(2))*mulz(2)
00360 REM ***** START SIREN LOOP *****
00370 INPUT "PLEASE TYPE IN THE THE NUMBER OF A SIREN";SIREN
00380 sx=(xs(siren)-subx(1))*mulx(1)
00390 sy=(ys(siren)-suby(1))*muly(1)
00400 sz=(zs(siren)-subz(1))*mulz(1)
00410 BIG=0
00420 L3=FND(SX,SY,SZ,LX,LY,LZ)
00430 REM ***** START BARRIER LOOP*****
00440 ONERROR GOTO 1360
00450 PRINT\INPUT "BARRIER HEIGHT AND DISTANCE FROM SIREN";ZB,DS
00460 bz=(zb -subz(3))*mulz(3)
00470 bdis=ds *mulx(3)
00480 ANSWER = FNASH(SIREN,LISN)
00490 PRINT USING 500,ANSWER
00500 :THE SHIELDING VALUE FOR THAT BARRIER IS ###.# dB
00510 IF ANSWER>BIG THEN BIG=ANSWER
00520 GO TO 450
00530 REM START SCENARIO DEPENDANT STUFF
00540 ROT=0\IF LEFT$(SIREN$(SIREN),1)="R" THEN ROT=6\PRINT "6 dB PENALTY
```

```

FOR ROTATING"
00550 ONERROR GOTO 570
00560 PRINT
00570 INPUT "ANY SPECIAL WIND CONDITIONS";YESNO$
00580 PRINT
00590 IF YESNO$ # "Y" AND YESNO$ # "N" THEN PRINT "Y OR N ONLY PLEASE"\G
O TO 570
00600 IF YESNO$ = "N" THEN FOR N=1 TO NSCEN\ WIN(N)=WIND(N)\NEXT N\GO TO
710
00610 ONERROR GOTO 670
00620 FOR N=1 TO NSCEN
00630 PRINT "WIND DIRECTION FOR SCENARIO";N;
00640 INPUT WIN(N)
00650 NEXT N
00660 GO TO 710
00670 REM HERE IF HIT RETURN FOR SPECIAL WIND CONDITONS
00680 WIN(N)=WIND(N)\PRINT "USING STANDARD WIND DIRECTION FOR SCENARIO";
N;"OF";WIN(N);" DEGREES"
00690 PRINT
00700 RESUME 650
00710 PRINT\PRINT "SCEN #   LEVEL       ATOT       AD       ATM   ASH   AMOL"
00720 FOR N=1 TO NSCEN
00730 WINS=WIN(N)
00740 AD=FNAD(SIREN,LISN)
00750 ATM=FNATM(SIREN,LISN)
00760 AMOL=FNAMOL(SIREN,LISN)
00770 ATOT=AD+ATM+ASH+AMOL
00780 LEVEL=SPL(SIREN)-ATOT-ROT
00790 print using 800,n,level,atot,ad,atm,ash,amol
00800 :#####   .#   .#   .#   .#   .#   .#   .#
00810 ROTP=0\IF LEFT$(SIREN$(SIREN(LISN,N)),1)="R"THEN ROTP=6
00820 if level>lout(lisn,n)-ROTP then lout(lisn,n)=spl(siren)-atot\siren
(lisn,n)=siren
00830 next n
00840 ONERROR GOTO 1490
00850 PRINT\INPUT "MORE SIRENS FOR THIS LISTENER";Y$\PRINT
00860 IF Y$="Y" THEN GOTO 370
00870 PRINT
00880 PRINT "FOR LISTENER SITE";I:ISN;"(";LISN$(LISN);)" "
00890 PRINT "   SCEN #       LOUT       SIREN #   "
00900 FOR N=1 TO NSCEN
00910 PRINT USING 920,N,LOUT(LISN,N),SIREN(LISN,N)
00920 :#####   .#       .#
00930 NEXT N
00940 PRINT\INPUT "AN/OTHER LISTENER SITE";Y$\PRINT
00950 IF Y$="Y"THEN GOTO 250
00960 PRINT\PRINT "GOOD-BYE"\PRINT\STOP
00970 REM ***** FUNCTION FOR SHIELDING ***
00980 DEF FNASH(SIREN,LISN)
00990 L3=FND(SX,SY,SZ,LX,LY,LZ)
01000 FOO=FND(SX,SY,0,LX,LY,0)
01010 IF BDIS>FOO THEN PRINT \PRINT "DISTANCE TO BARRIER TOO BIG"\A=0\GO
TO 1110
01020 L2=SQRT((FOO-BDIS)**2 + (LZ-BZ)**2)
01030 L1=SQRT((BDIS)**2 + (SZ-BZ)**2)

```



```

01040 NN=(L1+L2-L3)*1.12
01050 IF BZ < (SZ + BDIS*(LZ-SZ)/FOO) THEN NN=-1.0*NN
01060 IF NN<-.2 THEN A=0\GO TO 1110
01070 IF NN>12.64 THEN A=24\GO TO 1110
01080 IF NN==0 THEN A=5 \ GOTO 1110
01090 IF NN>=0 THEN A=20*LOG10(SQRT(2*PI*NN)/FNTH(SQRT(2*PI*NN)))+5
01100 IF NN<0 THEN A=20*LOG10(SQRT(-2*PI*NN)/TAN(SQRT(-2*PI*NN)))+5
01110 FNASH=A
01120 FNEEND
01130 DEF FND(X1,X2,X3,Y1,Y2,Y3)=SQR((X1-Y1)**2+(X2-Y2)**2+(X3-Y3)**2)
01140 DEF FNTH(X)=(EXP(X)-EXP(-X))/(EXP(X)+EXP(-X))
01150 DEF FNAD(SIREN,LISN)
01160 FNAD=20*LOG10(L3/100)
01170 FNEEND
01180 DEF FNAMOL(SIREN,LISN)
01190 FNAMOL=AMOL(N)*L3/1000
01200 FNEEND
01210 REM ***** FUNCTION FOR ATMOSPHERIC ABSORPTION *****
01220 DEF FNATM(SIREN,LISN)
01230 THETA = MOD(WINS,360)/360*2*PI
01240 S2R=ATN2((LX-SX),(LY-SY))
01250 ANG=MOD(S2R-THETA+2*PI,2*PI)
01260 FOO=MUL(N)*COS(ANG)-ADD(N)
01270 IF FOO<=0 THEN FNATM=0\GO TO 1340
01280 XNOT=1057/(SQRT(FOO))
01290 IF L3 <= 1.2 * XNOT THEN FNATM=0\GOTO 1340
01300 IF L3 <= 1.7 * XNOT THEN FNATM=5\GOTO 1340
01310 IF L3 <= 2.4 * XNOT THEN FNATM=10\GOTO 1340
01320 IF L3 <= 3.4 * XNOT THEN FNATM=15\GO TO 1340
01330 FNATM=7.0
01340 FNEEND
01350 REM ***** THIS AREA IS FOR CHOOSING THE SHIELDING VALUE *****
01360 RESUME 1370
01370 ONERROR GOTO 1490
01380 PRINT USING 1390,BIG;
01390 :SHALL WE USE ##.# AS THE SHIELDING VALUE
01400 INPUT YESNO$
01410 IF YESNO$ # "Y" AND YESNO$ # "N" THEN PRINT "Y OR N ONLY PLEASE"\G
O TO 1380
01420 IF YESNO$="Y" THEN ASH=BIG\BIG=0\GOTO 530
01430 ONERROR GOTO 1490
01440 INPUT "DO YOU WANT TO CONTINUE LOOKING AT BARRIERS HERE";YESNO$
01450 IF YESNO$ # "Y" AND YESNO$ # "N" THEN PRINT "Y OR N ONLY PLEASE"\G
O TO 1440
01460 IF YESNO$="Y" THEN GOTO 440
01470 INPUT "WHAT SHALL WE USE AS THE SHIELDING VALUE";ASH
01480 BIG=0 \ GOTO 530
01490 RESUME
01500 END

```



PROBS.B20

Thursday, April 8, 1982 23:25:02

```
00100 DIM #1,SIREN$(200),XS(200),YS(200),ZS(200),SPL(200)
00110 dim #2,lisn$(300),xl(300),yl(300),zl(300),rodis(300),siren(300,10)
,lout(300,10),PT(300,10)
00120 DIM #3,AMOL(10),WIND(10),NRES(10),NRCM(10),F1(10),F2(10),F3(10),F4
(10),F5(10),F6(10),F7(10),F8(10),INP(10),PU30(10),PR55(10),MUL(10),ADD(1
0)
00130 INPUT "PLEASE TYPE IN THE FILE NAME FOR THE SIREN DATA";SFILE$
00140 OPEN SFILE$ AS FILE #1,VIRTUAL
00150 INPUT "PLEASE TYPE IN THE FILE NAME FOR THE LISTENER DATA";LFILE$
00160 OPEN LFILE$ AS FILE #2,VIRTUAL
00170 INPUT "PLEASE TYPE IN THE FILE NAME FOR THE SCENARIO DATA";SCFILE$
00180 OPEN SCFILE$ AS FILE#3, VIRTUAL
00190 REM
00200 INPUT"NUMBER OF LISTENERS";NLISN
00210 INPUT "NUMBER OF SCENARIOS";NSCEN
00215 PRINT
00220 PRINT " P1 P2 P3 P4 P5 P6 P7 P8 P
T"
00230 FOR L=1 TO NLISN
00240 print "listener";l
00250 FOR C=1 TO NSCEN
00260 REM
00270 X=LOUT(L,C)
00280 IF LEFT$(SIREN$(SIREN(L,C)),1)="S" THEN GO TO 320
00290 IF LEFT$(SIREN$(SIREN(L,C)),1)="R" THEN GO TO 440
00300 PRINT "SIREN NUMBER";SIREN(L,C);"NOT ROT OR STATIONARY"\STOP
00310 REM ***** STATIONARY SIREN *****
00320 IF LEFT$(LISN$(L),1)="R" AND RODIS(L)=0 THEN GOTO 380
00330 IF X <= 32.0 THEN M=35.15 \ SIG=1.355 \ GO TO 570
00340 IF X <= 39.0 THEN M=41.00 \ SIG= 3.871 \ GO TO 570
00350 IF X <= 56.6 THEN M=45.95 \ SIG= 13.66 \ GO TO 570
00360 IF X <= 64.7 THEN M=52.25 \ SIG= 5.613 \ GO TO 570
00370 M=62.45 \ SIG= 1.011 \ GO TO 570
00380 REM ***** STATIONARY SIREN AND RURAL/FAR FROM ROAD
00390 IF X <= 27.1 THEN M=27.90 \ SIG=0.4731 \ GO TO 570
00400 IF X <= 36.9 THEN M=36.50 \ SIG=5.634 \ GO TO 570
00410 IF X <= 48.2 THEN M=36.35 \ SIG=7.591 \ GO TO 570
00420 IF X <= 54.8 THEN M=-15.7 \ SIG=40.86 \ GO TO 570
00430 M=53.95 \ SIG=0.4946 \ GO TO 570
00440 REM ***** ROTATING SIRENS ***
00450 IF LEFT$(LISN$(L),1)="R" AND RODIS(L)=0 THEN GO TO 520
00460 REM ***** ROTATING SIREN AND URBAN OR RURAL/CLOSE ROAD
00470 IF X <= 34.0 THEN M=40.10 \ SIG=2.6237 \ GO TO 570
00480 IF X <= 41.1 THEN M=42.95 \ SIG= 3.849 \ GO TO 570
00490 IF X <= 56.4 THEN M=47.00 \ SIG=12.30 \ GO TO 570
00500 IF X <= 65.0 THEN M=52.20 \ SIG=5.505 \ GO TO 570
00510 M=63.05 \ SIG=0.8387 \ GO TO 570
00520 REM ***** ROTATING SIREN AND RURAL/FAR FROM ROAD
00530 IF X <= 27.0 THEN M=28.55 \ SIG=0.7527 \ GO TO 570
00540 IF X <= 40.2 THEN M=34.35 \ SIG=5.527 \ GO TO 570
```

```

00550 IF X <= 54.8 THEN M=36.50 \ SIG=10.97 \ GO TO 570
00560 M=52.95 \ SIG=1.140 \ GO TO 570
00570 P=FNPPP(X,M,SIG)
00580 SAVE(1)=P \ P(1)=P*F1(C) \ GO TO 720
00590 REM
00600 DEF FNPPP(XXX,MMM,SSIG)
00610 Z=(XXX-MMM)/SSIG
00620 IF ABS(Z)>9.2 THEN YYY=0\GO TO 680
00630 gam=(1+0.2316419*abs(z))**-1
00640 A=0.31938153 \ B=0.356563782 \ CCC=1.791477937
00650 D=1.821255978 \ E=1.330274429
00660 FOO=(1/SQRT(2*PI*EXP(Z**2)))
00670 YYY=FOO*(A*GAM - B*GAM**2 + CCC*GAM**3 - D*GAM**4 +E*GAM**5)
00680 IF Z>=0 THEN YYY=1-YYY
00690 FNPPP=YYY
00700 FNEND
00710 REM
00720 SAVE(2)=1.0 \ P(2)=F2(C)
00730 REM
00740 SELIN=LOUT(L,C)-NRES(C)+24
00750 IF LEFT$(SIREN$(SIREN(L,C)),1)="R" THEN SELIN=SELIN-6
00760 P=FNSLEEP(SELIN)
00770 SAVE(3)=P \ P(3)=P*F3(C)
00780 GOTO 830
00790 DEF FNSLEEP(SEL)
00800 XXXX=-1.235 + (3.289*10**-2)*SEL - (1.21*10**-4)*(SEL**2)
00805 IF XXXX < 0 THEN XXXX=0
00806 FNSLEEP=XXXX
00810 FNEND
00820 REM
00830 LIN=LOUT(L,C)-NRES(C)
00840 IF LEFT$(SIREN$(SIREN(L,C)),1)="R" THEN GO TO 940
00850 ON INP(C) GOTO 860,860,900
00860 IF LIN<=19.5 THEN M=21.0 \ SIG=0.56 \ GO TO 1030
00870 IF LIN<=22.5 THEN M=26.4 \ SIG=3.76 \ GO TO 1030
00880 IF LIN<=61.5 THEN M=33.2 \ SIG=13.0 \ GO TO 1030
00890 M=60.8 \ SIG=0.67 \ GO TO 1030
00900 IF LIN<=22.5 THEN M=24.0 \ SIG=0.54 \ GO TO 1030
00910 IF LIN<=31.5 THEN M=59.4 \ SIG=21.3 \ GO TO 1030
00920 IF LIN<=64.5 THEN M=44.6 \ SIG=9.72 \ GO TO 1030
00930 M=62.6 \ SIG=0.86 \ GO TO 1030
00940 ON INP(C) GOTO 950,950,1000
00950 IF LIN<=20.5 THEN M=22.8 \ SIG=0.92 \ GO TO 1030
00960 IF LIN<=27.5 THEN M=30.0 \ SIG=4.74 \ GO TO 1030
00970 IF LIN<=42.5 THEN M=36.2 \ SIG=22.0 \ GO TO 1030
00980 IF LIN<=67.5 THEN M=39.2 \ SIG=12.2 \ GO TO 1030
00990 M=64.1 \ SIG=1.46 \ GO TO 1030
01000 IF LIN<=22.5 THEN M=24.6 \ SIG=0.65 \ GO TO 1030
01010 IF LIN<=70.5 THEN M=48.0 \ SIG=11.1 \ GO TO 1030
01020 M=67.1 \ SIG=1.68 \ GO TO 1030
01030 P=FNPPP(LIN,M,SIG)
01040 SAVE(4)=P \ P(4)=P*F4(C)
01050 REM
01060 LIN=LOUT(L,C)-NRCM(C)
01070 IF LEFT$(SIREN$(SIREN(L,C)),1)="R" THEN GOTO 1110

```

```

01080 IF LIN < 38.1 THEN M=38.15\SIG=0.237\GO TO 1140
01090 IF LIN < 47.4 THEN M=39.75\SIG=4.409\GO TO 1140
01100 M=45.7\SIG=0.989\GO TO 1140
01110 IF LIN < 39.3 THEN M=39.55\SIG=0.667\GO TO 1140
01120 IF LIN < 51.7 THEN M=41.5 \SIG=6.02\GO TO 1140
01130 M=49.7 \SIG=1.204
01140 P=FNPPP(LIN,M,SIG)\SAVE(5)=P \P(5)=P*F5(C)
01150 REM
01160 REM INDUSTRIAL PROB OF ALERT IS 1.0 (WORKERS UNITE)
01170 SAVE(6)=1.0 \P(6)=1.0*F6(C)
01180 REM
01200 SAVE(7)=PU30(C) \ P(7)=F7(C)*PU30(C)
01210 SAVE(8)=PR55(C) \ P(8)=F8(C)*PR55(C)
01230 pt(1,c)=0.0
01240 FOR I=1 TO 8
01250 : ##.###
01260 print using 1250,save(i);
01270 pt(1,c)=pt(1,c)+p(i)
01280 next i\print using 1300,pt(1,c)
01290 NEXT C
01300 : ##.####
01310 NEXT L
01320 print\input " rural, urban populations";rurpop,urbpop
01330 numurb=0
01340 numrur=0
01350 for c=1 to nscen\pturb(c)=0.0\ptrur(c)=0.0\next c
01360 rem start rural,urban and overall prob calcs
01370 for l=1 to nlist
01380 if left$(list$(l),1)="R" then go to 1460
01390 if left$(list$(l),1)#"U" then print "lis not rur or urban -lis #";
l\go to 1510
01400 rem here for urban
01410 numurb=numurb+1
01420 for c=1 to nscen
01430 pturb(c)=pturb(c)+pt(1,c)
01440 next c
01450 go to 1510
01460 rem here for rural
01470 numrur=numrur+1
01480 for c=1 to nscen
01490 ptrur(c)=ptrur(c)+pt(1,c)
01500 next c
01510 next l
01515 PRINT
01520 print " ptrur pturb ptall"
01530 for c=1 to nscen
01540 pturb(c)=pturb(c)/numurb
01550 ptrur(c)=ptrur(c)/numrur
01560 ptall(c)=(ptrur(c)*rurpop + pturb(c)*urbpop)/(rurpop+urbpop)
01570 print using 1580,ptrur(c),pturb(c),ptall(c)
01580 : ##.### ##.### ##.###
01590 next c
01600 close #1
01610 close #2
01620 close #3
01630 end

```

LISTENEROUTPUT.B20

Thursday, April 8, 1982 23:12:24

```
00050 DIM #1,LISN$(300),XL(300),YL(300),ZL(300),RODIS(300),SIREN(300,10)
,LOUT(300,10),PT(300,10)
00060 DIM #2,SIREN$(200),XS(200),YS(200),ZS(200),SPL(200)
00110 input "name of Listner file";sfile$
00115 open sfile$ as file #1,virtual
00116 input "name of siren file";sifile$
00117 open sifile$ as file #2 , virtual
00120 INPUT "NUMBER OF LISTENER SITES";NLIS
00130 input "number of scenarios";nscen
00133 print\ print
00135 print "lis #      listener name      siren #      siren name          lout"
00137 print
00140 for nL=1 to nLis
00145 print using 150,nL,Lisn$(nL),siren(nL,1),siren$(siren(nL,1)),Lout(
nL,1)
00150 :####      'LLLLLLLLLL      ####      'LLLLLLLLLLLL      ###.#
00155 for ns=2 to nscen
00160 print using 165,siren(nL,ns),siren$(siren(nL,ns)),Lout(nL,ns)
00165      :                      ####      'LLLLLLLLLLLL      ###.#
00170 next ns
00173 print
00175 next nL
00177 cLose #1
00178 close #2
00180 end
```

DISTRIBUTION LIST

No. of  
Copies

OFFSITE

	A. A. Churm DOE Patent Division 9800 S. Cass Avenue Argonne, IL 60439	AV Robinson PD Robinson JM Selby GA Stoetzel KL Swinth VW Thomas
100	U.S. Nuclear Regulatory Commission Division of Technical Information and Document Control 7920 Norfolk Avenue Bethesda, MD 20014	Technical Information (5) Publishing Coordination (2)
2	DOE Technical Information Center  Office of Inspection and Enforcement Division of Emergency Preparedness Emergency Preparedness Development Branch Air Rights Building 4450 Montgomery Bethesda, MD 20014	

Pacific Northwest Laboratory (34)

EH Carbaugh  
CJ Card  
CD Corbit  
PL Cummings  
AE Desrosiers  
TH Essig  
RL Gilchrist  
SC Hawley  
WN Herrington III  
EE Hickey  
CD Hooker  
JL Kenoyer  
GJ Laughlin  
JC Mann  
GA Martin  
MA McLean  
MP Moeller  
LH Munson  
BL Murphy  
BD Pickett  
RW Poeton



<b>NRC FORM 335</b> <small>(11-81)</small>		<b>U.S. NUCLEAR REGULATORY COMMISSION</b> <b>BIBLIOGRAPHIC DATA SHEET</b>		<b>1. REPORT NUMBER (Assigned by DDC)</b> NUREG/CR-2654 PNL-4227	
<b>4. TITLE AND SUBTITLE (Add Volume No., if appropriate)</b> Procedures for Analyzing the Effectiveness of Siren Systems for Alerting the Public				<b>2. (Leave blank)</b>	
<b>7. AUTHOR(S)</b> D.N. Keast, D.A. Towers, G.S. Anderson/BB&N J.L. Kenoyer, A.E. Desrosiers/PNL				<b>5. DATE REPORT COMPLETED</b> MONTH: February      YEAR: 1982	
<b>9. PERFORMING ORGANIZATION NAME AND MAILING ADDRESS (Include Zip Code)</b> Bolt Beranek & Newman Inc. Pacific Northwest Laboratory 10 Moulton Street P. O. Box 999 Cambridge, MA 02238 Richland, WA 99352				<b>DATE REPORT ISSUED</b> MONTH: September      YEAR: 1982	
<b>12. SPONSORING ORGANIZATION NAME AND MAILING ADDRESS (Include Zip Code)</b> Division of Emergency Preparedness Office of Inspection and Enforcement U.S. Nuclear Regulatory Commission Washington, D. C. 20555				<b>10. PROJECT/TASK/WORK UNIT NO.</b>  <b>11. FIN NO.</b> B2311	
<b>13. TYPE OF REPORT</b>			<b>PERIOD COVERED (Inclusive dates)</b>		
<b>15. SUPPLEMENTARY NOTES</b>				<b>14. (Leave blank)</b>	
<b>16. ABSTRACT (200 words or less)</b> <p>NUREG-0654, Revision 1 (Criteria for Preparation and Evaluation of Radiological Emergency Response Plans and Preparedness in Support of Nuclear Power Plants), Appendix 3, discusses requirements of the licensees to implement a prompt notification system within the 10-mile emergency planning zone (EPZ) surrounding a nuclear facility. Sirens are being installed for use as part of or as the entire notification system by many licensees. This report describes a procedure for predicting siren system effectiveness under defined conditions within the EPZ's. The procedure requires a good topographical map and knowledge of the meteorology, demographics, and human activity patterns within the EPZ. The procedure is intended to be applied to systems of sirens and to obtain average results for a large number (30 or more) listener locations.</p>					
<b>17. KEY WORDS AND DOCUMENT ANALYSIS</b>			<b>17a. DESCRIPTORS</b>		
<b>17b. IDENTIFIERS/OPEN-ENDED TERMS</b>					
<b>18. AVAILABILITY STATEMENT</b>  Unlimited			<b>19. SECURITY CLASS (This report)</b> Unclassified		<b>21. NO. OF PAGES</b>
			<b>20. SECURITY CLASS (This page)</b> Unclassified		<b>22. PRICE</b> \$

UNITED STATES  
NUCLEAR REGULATORY COMMISSION  
WASHINGTON, D.C. 20555

OFFICIAL BUSINESS  
PENALTY FOR PRIVATE USE, \$300

FOURTH CLASS MAIL  
POSTAGE & FEES PAID  
USNRC  
WASH. D.C.  
PERMIT No. 567