

NUREG-0837
Vol. 13, No. 4

NRC TLD Direct Radiation Monitoring Network

Progress Report
October-December 1993

U.S. Nuclear Regulatory Commission

NRC Region I

R. Struckmeyer



9404060261 940331
PDR NUREG
0837 R PDR

Available from

Superintendent of Documents
U.S. Government Printing Office
Mail Stop SSOP
Washington, DC 20402-9328

A year's subscription consists of 4 issues for
this publication.

Single copies of this publication
are available from
National Technical Information Service
Springfield, VA 22161

NUREG-0837
Vol. 13, No. 4

NRC TLD Direct Radiation Monitoring Network

Progress Report
October-December 1993

Manuscript Completed: March 1994
Date Published: March 1994

R. Struckmeyer

Region I
U.S. Nuclear Regulatory Commission
King of Prussia, PA 19406



ABSTRACT

This report presents the results of the NRC Direct Radiation Monitoring Network for the fourth quarter of 1993. It provides the ambient radiation levels measured in the vicinity of 75 sites throughout the United States. In addition, it describes the equipment used, monitoring station selection criteria, characterization of the dosimeter response, calibration procedures, statistical methods, intercomparison, and quality assurance program.

CONTENTS

	<u>Page</u>
ABSTRACT	iii
SUMMARY	1
1. INTRODUCTION	4
2. DOSIMETER SITE SELECTION CRITERIA	5
2.1 TLD Network Stations Within Five Miles of the Plant Site	5
2.2 TLD Network Stations Beyond Five Miles of the Plant Site	5
2.3 Collocated TLD Stations	5
2.4 Emergency TLD Placement	5
3. EQUIPMENT AND GENERAL PROCEDURES	7
3.1 Dosimetry System	7
3.2 Field Container	8
3.3 Exchange Procedures	8
4. CALIBRATION	12
4.1 Facilities	12
4.2 Procedures for Calibrating Dosimeters	12
5. ESTIMATION OF TRANSIT EXPOSURE	13
6. STATISTICAL METHODS	15
7. QUALITY ASSURANCE PROGRAM	18
7.1 Dosimeter Quality Control	18
7.2 Reader Quality Control	18
7.3 Quality Assurance Audits	19
8. INTERCOMPARISON	20
8.1 Description	20
8.2 Results	20
8.3 Discussion	20
9. SUMMARY OF OPERATING EXPERIENCES	21
10. ENVIRONMENTAL DIRECT RADIATION MONITORING DATA FOR NRC LICENSED NUCLEAR POWER REACTORS	23

CONTENTS (Continued)

Page

LIST OF FIGURES

1.	Illustrations of Dosimeter Placement	6
2.	TLD Badge Construction	10
3.	TLD Reader - Reading Method and Construction	11

LIST OF TABLES

1.	Standard Windrose Sectors Used in Selecting TLD Station Locations	3
2.	Calcium Sulfate Energy Response	9
3.	Control Dosimeter Summary	14
4.	Sites Monitored During Fourth Quarter, 1993	22

SUMMARY

The U.S. Nuclear Regulatory Commission (NRC) Direct Radiation Monitoring Network is operated by the NRC in cooperation with participating states to provide continuous measurement of the ambient radiation levels around licensed NRC facilities, primarily power reactors. Ambient radiation levels result from naturally occurring radionuclides present in the soil, cosmic radiation constantly bombarding the earth from outer space, and the contribution, if any, from the monitored facilities and other man-made sources. The Network is intended to measure radiation levels during routine facility operations and to establish background radiation levels used to assess the radiological impact of an unusual condition, such as an accident.

This report describes the program objectives, scope, and methodology of the monitoring program and presents the radiation levels measured during the fourth quarter of 1993. (Radiation level measurements are made at NRC licensed nuclear facilities under construction, as well as those in operation.) In addition, it describes the equipment used, monitoring station selection criteria, and the quality assurance program.

All radiation measurements are made using small, passive detectors called thermoluminescent dosimeters (TLDs), which provide a quantitative measurement of the radiation levels in the area in which they are placed. The National Bureau of Standards (NBS)* has performed an independent study of the following characteristics of the NRC dosimetry system: energy response, angular dependence, temperature and humidity sensitivity, fading, light dependence, self-irradiation, and reproducibility. NBS has also tested the response of the NRC's dosimetry system against the requirements of ANSI N545-1975 and NRC Regulatory Guide 4.13. Details of this testing can be found in NUREG/CR-3775. Each site is monitored by arranging approximately 30 to 50 TLD stations in two concentric rings extending to about five miles from the facility. (Some sites have fewer than 30 TLDs due to their location next to large bodies of water.) All TLD stations are outside the site boundary of the facility.

Section 10 presents the radiation levels measured around the 75 facilities monitored by the Network during the fourth quarter of 1993. There are 72 different sets of dosimeters because, in some instances, two power reactor facilities are monitored by the same set of dosimeters (e.g., Kewaunee and Point Beach). The radiation levels are presented as gross and net exposures. The gross exposure includes naturally occurring background radiation and the exposure received during transport and storage of the TLD. The gross exposure may also include radiation resulting from a facility's operation. Net exposures are obtained by subtracting an estimate of the exposure during transit from the gross exposure recorded by the dosimeter. All exposures are normalized to a 90-day quarter ("standard quarter") and reported in units of milliroentgens (mR). Station numbers for which no data are reported include stations which have been deleted, stations for which the TLD was lost during the quarter, or stations for which the TLD was damaged.

* Now the National Institute of Standards and Technology (NIST)

Four sets of information are presented for each site. The first set includes the TLD station number, its direction and distance from the site, the integrated gross exposure for the period, the net exposure normalized to a 90-day standard quarter, and the historical average net exposure and standard deviation (the latter are combined under the heading "Hist. Range"). The current field measurements are listed with their respective random and total uncertainties.

The uncertainties are listed in the following format:

$$X \pm S_x; U_x$$

where: X = value of the result
 S_x = random uncertainty expressed as one standard deviation
 U_x = combined total uncertainty

The second set of data summarizes the average net exposure measured in each of the 16 standard windrose sectors (see Table 1) around the facility, normalized to a standard quarter. Also this set of data summarizes the average net exposure measured at three ranges of distances from the facility, normalized to a standard quarter. When average net exposures cannot be reported because of the unavailability of the site's control dosimeters, the average gross exposures, normalized to a standard quarter, are reported in the sector and distance data tables.

The third set of information describes geographic locations of the TLDs around the nuclear power plants. A detailed list of the TLD station locations for each site in the NRC program, as of December 31, 1993 is included. Each location is designated by a station number and is completely identified by azimuth and radial distance from the site, and physical description. Specific details of the physical location have been omitted to maintain the security of the stations.

The fourth set of data illustrates the fourth quarter measured dose around a site. Due to the constraints of digitizing the entire monitoring area onto the limited space on the map, some TLD data are not included.

Beginning with Volume 10, Number 4 of this report, an additional column of data was added alongside the individual TLD gross and net exposure data for each monitored site. The new information consists of the historical average and standard deviation for each TLD station. Sufficient data have been collected during the more than ten years that this program has been in existence to allow meaningful statistics to be calculated.

This report is one of a continuing series of technical reports covering the results and experiences of the operation of the NRC TLD Direct Radiation Monitoring Network. Suggestions on methods to improve the presentation or analysis of the data contained in this NUREG are appreciated and should be submitted to NRC Region I, 475 Allendale Road, King of Prussia, Pennsylvania 19406, ATTN: Radiation Dosimetry Specialist.

Table 1
Standard Windrose Sectors
Used in Selecting TLD Station Locations

Sector Name	Azimuth**
N*	348.75° - 11.25°
NNE	11.25° - 33.75°
NE	33.75° - 56.25°
ENE	56.25° - 78.75°
E	78.75° - 101.25°
ESE	101.25° - 123.75°
SE	123.75° - 146.25°
SSE	146.25° - 168.75°
S	168.75° - 191.25°
SSW	191.25° - 213.75°
SW	213.75° - 236.25°
WSW	236.25° - 258.75°
W	258.75° - 281.25°
WNW	281.25° - 303.75°
NW	303.75° - 326.25°
NNW	326.25° - 348.75°

* North (0° and 360°) is defined as True North.

** The principal airborne radioactivity release point (vent or stack) at each site is considered to be the center of a circle. The area of each circle is divided into 16 standard windrose sectors, each of 22.5° arc. These sectors are standardly used in the nuclear power industry to describe direction from a site.

1. INTRODUCTION

The NRC TLD Direct Radiation Monitoring Network was established in August 1979 by the NRC Office of Inspection and Enforcement (IE) to measure ambient radiation levels around NRC licensed facilities and to provide the NRC staff with prompt, independent data in emergency response and assessments. The need for such a Network was identified during the experiences at Three Mile Island (TMI) and subsequent reviews. The Network is a cooperative effort between the Office of Nuclear Reactor Regulation (NRR) headquarters, NRC Regional Offices, and participating states. The operation of the program (consisting, in part, of processing badges, shipping and packaging, data processing, and reporting) is the responsibility of the Facilities Radiological Safety and Safeguards Branch, NRC Region I, in King of Prussia, Pennsylvania.

At most sites the TLD badges are exchanged and placed in the field locations by state agencies participating under a cooperative agreement with the NRC. For sites located in nonparticipating states, the field work is performed by individuals under contract to the NRC. The dosimeters are exchanged, shipped, and processed in Region I on a quarterly schedule. The program is further described in the TMI Action Plan, Item III.D.2.4(2), NUREG-0660, "Nuclear Action Plan Developed as a Result of the TMI-2 Accident."

After the Three Mile Island accident, the NRC determined that relying solely on licensee estimates of population exposure during an accident situation was unacceptable. The NRC decided to develop its own program to provide the data needed to independently assess the radiological impact of an accident. The principal objectives of this program are to:

- (1) Assure uniform treatment of dosimeters with respect to handling, shipping, calibrating, reading, and data processing for all monitored facilities in the United States;
- (2) Establish preoperational, baseline radiation dose levels, whenever possible, for each nuclear power reactor facility;
- (3) Provide ongoing environmental radiation dosimetry data during routine operations;
- (4) Provide post-accident estimates of population exposures;
- (5) Allow for independent verification of the adequacy of NRC licensees' environments' radiation monitoring program; and
- (6) Provide uniform, consistent environmental radiation monitoring data for use by the Congress, Federal and state agencies, the monitored facilities, and the public.

2. DOSIMETER SITE SELECTION CRITERIA

Since the variation in site characteristics is great, the staff endeavored to establish criteria that were as general as possible. The criteria have been used with great flexibility in the actual establishment of dosimetry stations in the field. In each case site data were obtained from information supplied by licensees in their Preliminary and Final Safety Analysis Reports (PSARs and FSARs), U.S. Geological Survey (USGS) topographical maps, Aerial Monitoring System (AMS) data, and state and local maps. Figure 1 illustrates the placement of dosimeters around a typical site.

2.1 TLD Network Stations Within Five Miles of the Plant Site

Around each site, TLD network stations are distributed in two concentric rings outside the licensee owner-controlled property. In each ring, one TLD station is located in each appropriate standard windrose sector. These sectors are defined in Table 1 and are those customarily used in the nuclear power industry. Dosimeter stations are not placed in sectors that consist entirely of open water or in sectors that are unoccupied or inaccessible. The inner ring is located between the licensee owner-controlled boundary and an imaginary circle of two miles radius centered on the site airborne radioactivity release point. The remaining stations are five miles or more from the plant site, as discussed below. One station is located at or close to the nearest residence to the site.

2.2 TLD Network Stations Beyond Five Miles of the Plant Site

Beyond five miles from the boundary of the owner-controlled area, TLD stations are also established at major population centers and at places of high public interest not already covered by the stations described above. Up to three stations are also established in a predominantly upwind direction to serve as indication of the ambient radiation levels that are not expected to be influenced by plant operations.

2.3 Collocated TLD Stations

At each monitored facility, several (normally five) stations are placed side by side with those of the licensee to allow for independent verification of the licensee's environmental radiation monitoring program. These stations are generally within the five mile radius.

2.4 Emergency TLD Placement

In addition to the locations monitored during normal reactor operations, additional dosimeters would be placed around the site in the event of an incident during which continued releases of radioactive material were expected. The number and locations of such dosimeters would be determined by the anticipated duration and severity of the releases as well as the meteorological conditions prevailing during the incident.

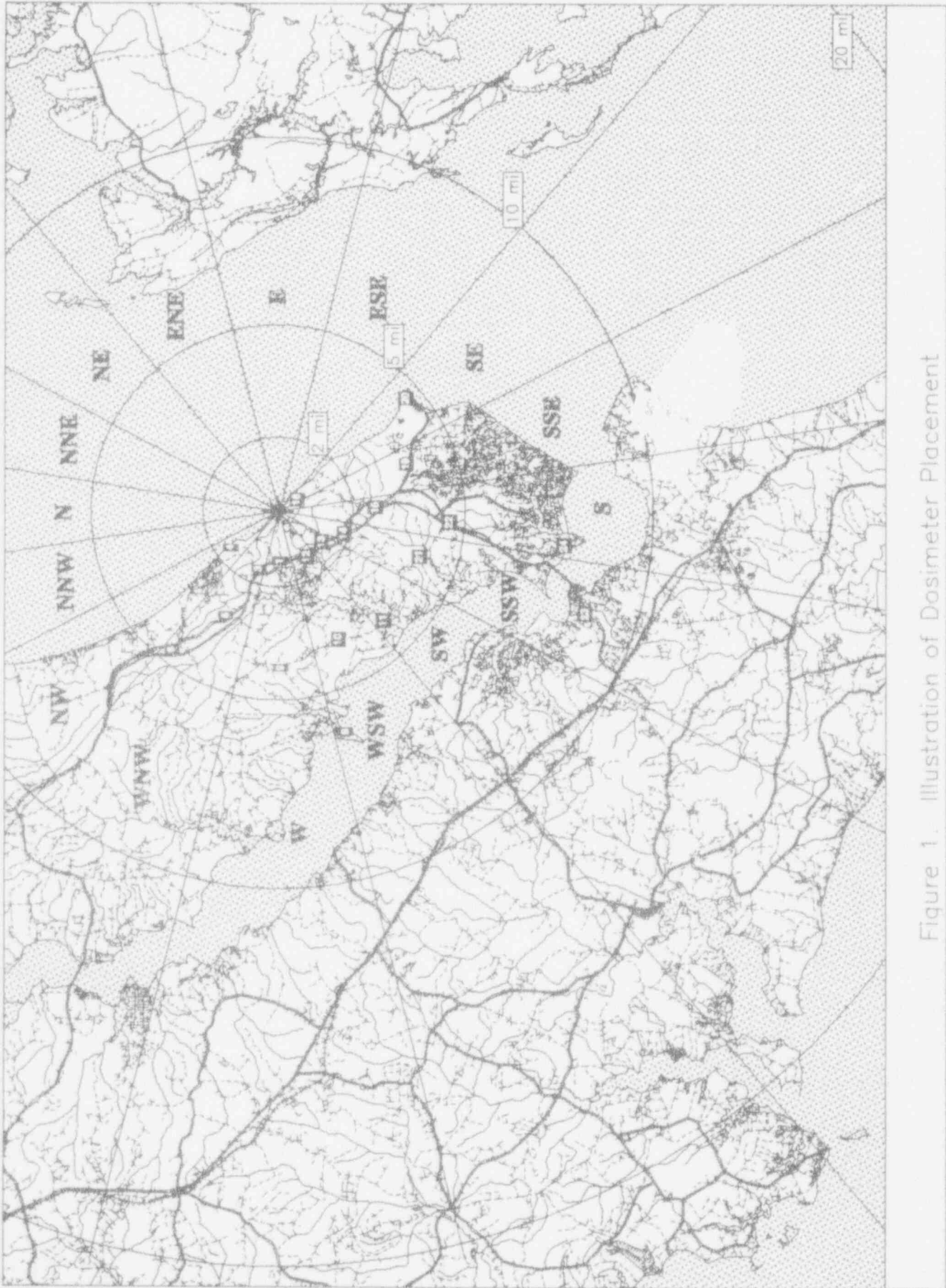

Figure 1. Illustration of Dosimeter Placement

3. EQUIPMENT AND GENERAL PROCEDURES

3.1 Dosimetry System

The NRC TLD program routinely employs the Panasonic* Model UD-801 thermoluminescent dosimeter and Model UD-710A automatic dosimeter reader. A Panasonic Model UD-702E manual dosimeter reader is also available and may be taken to a site in the event of an incident which required the processing of dosimeters near the site. The dosimeter has four thermoluminescent elements to measure radiation exposure. It consists of two elements of natural lithium borate activated with copper ($\text{Li}_2\text{B}_4\text{O}_7:\text{Cu}$), and two elements of calcium sulfate activated with thulium ($\text{CaSO}_4:\text{Tm}$). One lithium borate element uses an "open" window of 3 mg/cm^2 to minimize attenuation of beta radiation; the other incorporates a 160 mg/cm^2 plastic filter. These values are in addition to the filtration imposed by the polyamide backing (11 mg/cm^2) on one face and the teflon window (28 mg/cm^2) on the opposite face of each element.

Each of the two calcium sulfate elements is covered by an 850 mg/cm^2 lead filter (plus 160 mg/cm^2 of plastic) to attenuate low-energy photon radiation in a manner that is intended to compensate for the over-response of calcium sulfate in this portion of energy spectrum. The average response of the two calcium sulfate elements is used to determine exposure during routine operations. (See Figure 2.) The energy dependence of the calcium sulfate elements as determined by the National Bureau of Standards (NBS)** is shown in Table 3. For further details of the NBS testing, see NUREG/CR-2560, NUREG/CR-3120, and NUREG/CR-3775.

The automatic dosimeter reader consists of a badge transport and insertion mechanism, a heat source, a carbon-14 (C-14) activated reference light source, a light measurement system, and a microprocessor controller. Up to 500 TLD badges may be loaded into 10 magazines of the automatic sample changer that is attached to the reader, or single 50-badge magazines may be loaded manually. The magazine is automatically advanced to admit badges into the reading mechanism. In the mechanism, the dosimeter portion (card) of the badge is withdrawn from the holder. Each phosphor is then heated and its light output measured. When all four phosphors have been read, the card is inserted into the holder, the holder is lowered into the magazine, and the process is repeated for the next badge. (See Figure 3.) The manual dosimeter reader is similar in the reading process but dosimeters are manually inserted into the reader one at a time.

* Mention of a specific product in this report does not constitute an endorsement by the U.S. Nuclear Regulatory Commission.

** Now the National Institute of Standards and Technology (NIST)

3.2 Field Container

The dosimeter for each station is placed in a moisture-resistant polyester pouch inside a polypropylene mesh cylindrical cartridge approximately 15 cm long and 5 cm in diameter. The thickness of the pouch is approximately 5.5 mg/cm². The cartridge is attached by wire or polyester straps to a relatively permanent structure, usually a utility pole. This container provides physical security with minimum attenuation of photon radiation. It is placed approximately three meters above the ground to minimize vandalism.

3.3 Exchange Procedures

Prior to shipment, all dosimeters are calibrated by the NRC (Section 4). All dosimeters are then annealed at the Region I office and packaged for shipment. The packages are then mailed to the contractors, usually representatives of the radiological health department of the state in which the reactor is situated. In some instances, the NRC has contracted with private individuals to exchange the dosimeters.

The contractors receive the packages, travel to the sites, and exchange the dosimeters with those of the previous quarter. The contractors have been provided with lead casks in which they store the control dosimeters during the field period. At the end of the quarter, these control dosimeters are removed from the storage cask and returned by mail with the field dosimeters. The use of control dosimeters to estimate transit exposure is discussed in Section 5.

When returned to the NRC Region I office, the dosimeters are processed, using the automatic TLD reader. They are then recalibrated to establish the current response of the dosimeter and to check for dosimeter response variability.

Table 2
Calcium Sulfate Energy Response

Panasonic Model UD 801
Dosimeter Response Per Unit Exposure Relative to That
For Cesium-137 and Cobalt-60 Gamma Radiation

<u>Effective Energy (KeV)</u>	<u>Average (Element 3 + Element 4) Response</u>	
	<u>Cs-137</u>	<u>Co-60</u>
38	0.39	0.45
70	0.80	0.92
117	0.54	0.63
167	0.70	0.81
210	0.79	0.90
662	1.00	1.14
1250	0.88	1.00

Conditions: Unidirectional beam of radiation.
Dosimeters mounted in Panasonic dosimeter hangers.

ANSI N545-1975 Specification: Energy (keV) Required Response

80-300	.80 - 1.20
< 80	< 2

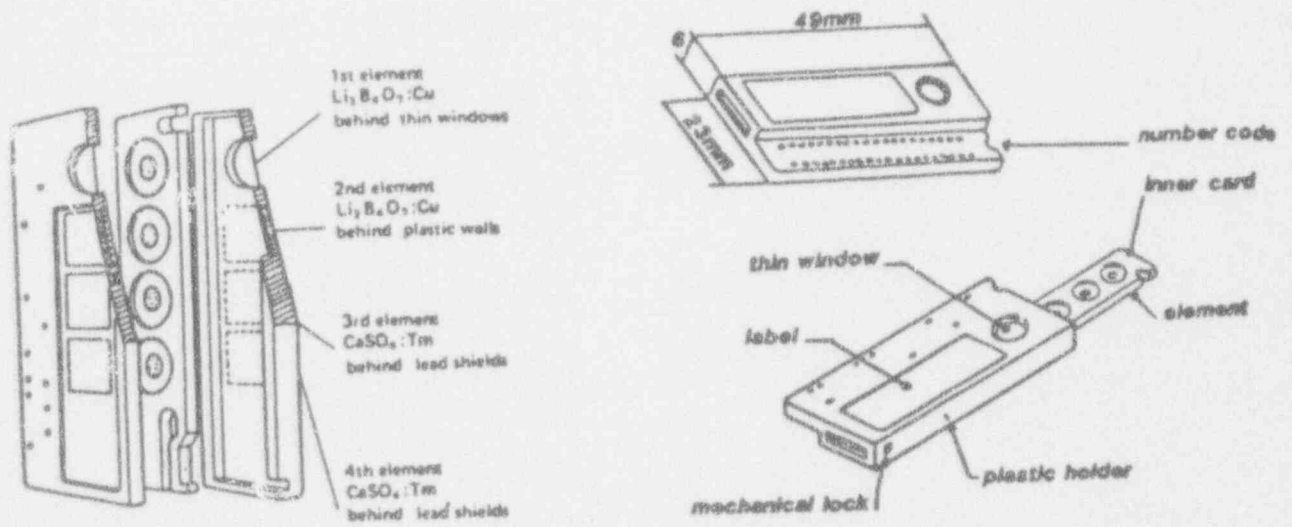

Figure 2. TLD Badge Construction

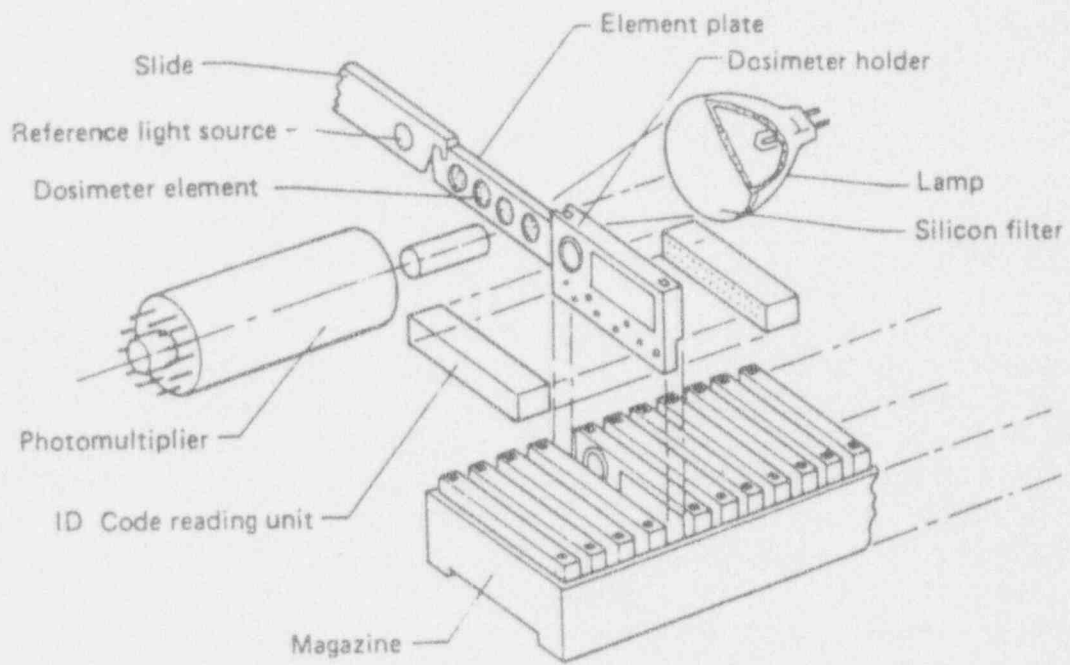

Figure 3. TLD Reader - Reading Method and Construction

4. CALIBRATION

4.1 Facilities

Two calibration facilities are available for use in the program. One facility contains a panoramic irradiator with a 120-cm diameter rotating table. The irradiator has a nominal 120-millicurie cesium-137 gamma radiation source that currently delivers an exposure rate of approximately 1.8 mR/minute at 50 cm from the source. The exposures received by the badges are monitored, using a 33cm³ air ionization chamber and a Victoreen model #550 high-precision electrometer with calibration traceable to the National Institute of Standards and Technology. The ionization chamber is placed directly over the TLD badges; the radiation field around the table is uniform within $\pm 3\%$. The exposure period is controlled by the use of a timer accurate to within ± 0.1 seconds. The exposure rate on the table has been confirmed by exposing dosimeters provided and read by the National Institute of Standards and Technology. The dosimeters exposed at this facility are selected from a set with precisely determined element calibration factors (ECFs). They are used for calibration of the TLD reader.

The NRC TLD program also uses a Williston Elin TLD Irradiator (Model WE-2001).^{*} The major components of the WE-2001 are the electronic console including the irradiation timer and the display module, a lead castle which contains the irradiation source (Cs-137), and the magazine rack. Up to 500 TLD badges may be loaded into 10 magazines of the automatic sample changer that is integral to the irradiator. The magazine is automatically advanced to admit TLDs into the irradiation chamber. Immediately following the calibration of the TLD reader, dosimeters with precisely-known ECFs are exposed in the WE-2001, then read in order to determine its exposure rate. This permits the WE-2001 irradiator to be used in the determination of the ECFs of the field TLDs.

4.2 Procedures for Calibrating Field Dosimeters

Element calibration factors (ECFs) are determined quarterly for field dosimeters. During each calibration, each TLD badge is exposed to approximately 40 mR. The irradiated badges are stored for about 24 hours before reading to allow for the rapid fading of the low-temperature glow peak of the lithium borate elements. After the badges have been read, the ratio of recorded exposure to delivered exposure is calculated and recorded for each of the four elements of each dosimeter. These ECFs are subsequently used to modify the raw element readings to determine exposure.

* Mention of a specific product in this report does not constitute an endorsement by the U.S. Nuclear Regulatory Commission.

5. ESTIMATION OF TRANSIT EXPOSURE

Field dosimeters receive exposure both while in transit to and from the placement contractor and while in storage at the contractor's facility, as well as while they are at their monitoring locations. To determine the field exposure, it is necessary to estimate this additional exposure, which is designated transit exposure.

Two control dosimeters are sent to each contractor to estimate the transit exposure. Control #1 remains unshielded, except when stored in the NRC-provided lead cask at the contractor's facility. This cask provides 2.75 inches of lead shielding. Control #2 is no longer used. Control #3 is used to indicate whether a significant exposure was received by the dosimeters while in transit from the NRC office in King of Prussia, Pennsylvania, to the contractors. It is shipped unshielded with the new batch of dosimeters to the contractor and returned unshielded with the previous quarter's dosimeters. If an unacceptably high transit exposure is detected by this dosimeter as a result of its shipment to the site, a new set of field dosimeters will be sent to the contractor for an early exchange.

The exposure to Control #1 is the sum of the transit exposure and the exposure received while in storage during the quarter. The exposure rate during storage is estimated to be 0.09 ± 0.03 mR per day and is based on previous measurements. For information on how the exposure rate in the cask was previously estimated, refer to Appendix A of NUREG-0837, Volume 2, Number 4. The transit exposure to the field dosimeters is estimated by taking the difference between the exposure measured by Control #1 and the exposure calculated to have been received by Control #1 while in storage in the contractor's lead cask. The storage exposure rate is essentially due only to the cosmic ray component of the local natural background radiation.

Likely sources of transit exposure include shipments of medical and other radioisotopes in the mail, as well as natural terrestrial and cosmic radiation.

A summary of the control dosimeter placement and usage is included in Table 3 of this report.

Table 3

Control Dosimeter Summary

	Control #1	Control #3
Purpose of Control:	Determination of round trip transit exposure	Determination of one-way transit exposure from NRC to field
During Shipment to Contractor:	Unshielded, with field dosimeters	Unshielded, with field dosimeters
Storage Prior to Field Placement:	Unshielded, with field dosimeters	Unshielded, with field dosimeters
Storage During Quarter:	In lead shield	Not stored; returned with field dosimeters from previous quarter
Storage After Field Exchange (prior to return):	Unshielded, with field dosimeters	Unshielded, with field dosimeters*
During Shipment to NRC:	Unshielded, with field dosimeters	Unshielded, with field dosimeters*

* Applies to the control #3 dosimeter for the next quarter

6. STATISTICAL METHODS

The total uncertainty of the reported exposures is a combination of the random and systematic components of uncertainty. The random component is primarily the statistical uncertainty in the reading of the TLD elements themselves. Based on repeated known exposures, this uncertainty for the calcium sulfate elements used to determine exposure is estimated to be approximately three percent ($\pm 3\%$) for one standard deviation. There are several systematic components of uncertainty, including:

Source of Uncertainty	Value of Parameter	Uncertainty of Parameter
Energy-Directional Response	1.0	0.14 *
Fading	1.0	0.05 **
Calibration	Element Calibration Factor	0.03 x Element Calibration Factor
Estimate of Storage Shield Exposure Rate	0.0825 mR/day	0.0265 mR/day ***

* Estimate based on NBS testing of dosimeters.

** Estimate based on NRC measurements of calcium sulfate element fading.

*** Estimate reflects observed variation of past measurement of storage exposure rate.

These uncertainties are propagated according to established statistical methods for propagation of uncertainty. Since one component of the systematic uncertainty is greater than one-third the sum of all the components, the overall uncertainty was calculated by taking the square root of the sum of the variances of all the components. This is in accordance with U.S. Environmental Protection Agency (EPA) recommendations contained in "Upgrading Environmental Radiation Data" - Health Physics Society Committee Report HPSR-1, 1980. The uncertainty of the adjusted exposure is determined by combining the uncertainties of the gross and transit exposures.

The uncertainties are listed in the following format:

$$X \pm S_x; U_x$$

where: X = value of the result
 S_x = random uncertainty expressed as one standard deviation
 U_x = combined total uncertainty

Example of Uncertainty Estimation

Assumptions:	Gross Field Exposure	=	25 mR
	Control 1 Exposure	=	10 mR
	Time in Field	=	90 days

A. Gross Field Exposure Uncertainty

$$\text{Random Uncertainty} = (25 \text{ mR})(0.03) = 0.75 \text{ mR}$$

Systematic Uncertainty:

$$\text{Calibration} = (25 \text{ mR})(0.03) = 0.75 \text{ mR}$$

$$\text{Fading} = (25 \text{ mR})(0.05) = 1.25 \text{ mR}$$

$$\text{Energy-Directional Dependence} = (25 \text{ mR})(0.14) = 3.50 \text{ mR}$$

$$\text{Total Uncertainty} = [(0.75)^2 + (1.25)^2 + (3.50)^2]^{1/2} = 3.86 \text{ mR}$$

$$\text{Gross Field Exposure} = 25 \pm 0.8 ; 3.9 \text{ mR}$$

B. Control 1 Exposure Uncertainty

$$\text{Random Uncertainty} = (10 \text{ mR})(0.03) = 0.30 \text{ mR}$$

Systematic Uncertainty:

$$\text{Calibration} = (10 \text{ mR})(0.03) = 0.30 \text{ mR}$$

$$\text{Fading} = (10 \text{ mR})(0.05) = 0.50 \text{ mR}$$

$$\text{Energy-Directional Dependence} = (10 \text{ mR})(0.14) = 1.40 \text{ mR}$$

$$\text{Total Uncertainty} = 1.55 \text{ mR}$$

$$\text{Control 1 Exposure} = 10 \pm 0.3 ; 1.6 \text{ mR}$$

C. Transit Exposure Uncertainty

The uncertainty of the transit exposure is determined by combining the uncertainty of the Control 1 measurement with the uncertainty of the storage exposure.

$$\text{Storage Exposure} = (90 \text{ days})(0.0825 \text{ mR/day}) = 7.43 \text{ mR}$$

$$\text{Storage Exposure Uncertainty} = (90 \text{ days})(0.0265 \text{ mR/day}) = 2.38 \text{ mR}$$

This uncertainty is treated as a systematic uncertainty. The transit exposure is estimated as the difference between the Control 1 measured exposure and the estimated storage exposure. The uncertainty is determined by combining their associated uncertainties.

$$\begin{aligned} \text{Transit Exposure} &= (10 \text{ mR}) - (7.4 \text{ mR}) = 2.6 \text{ mR} \\ \text{Systematic Uncertainty} & \\ \text{of Transit Exposure} &= [(1.55)^2 + (2.38)^2]^{1/2} = 2.84 \text{ mR} \\ \text{Transit Exposure} &= 2.6 \pm 0.3 ; 2.8 \text{ mR} \end{aligned}$$

D. Net Field Exposure Uncertainty

The net field exposure is the difference between the gross field exposure and the transit exposure. The uncertainty is determined by combining the associated uncertainties.

$$\begin{aligned} \text{Net Field Exposure} &= (25 \text{ mR}) - (2.6 \text{ mR}) = 22.4 \text{ mR} \\ \text{Random Uncertainty} &= [(0.8)^2 + (0.3)^2]^{1/2} = 0.9 \text{ mR} \\ \text{Systematic Uncertainty} &= [(3.86)^2 + (2.84)^2]^{1/2} = 4.8 \text{ mR} \\ \text{Net Field Exposure} &= 22.4 \pm 0.9 ; 4.8 \text{ mR} \end{aligned}$$

If the time had not been 90 days, the net field exposure and its associated uncertainties would be adjusted and reported as exposure per 90 days.

E. Historical Average Exposure Uncertainty

The uncertainty of the historical average exposure is expressed as the unbiased standard deviation of the population normalized net field exposures reported from 1982 (or earliest available period after 1982) to the present quarter. Quarters for which net exposures could not be calculated are not included in the historical average. Data deemed to be anomalous (due to exposure in transit, etc.) also are not included in the historical average.

7. QUALITY ASSURANCE PROGRAM

The NRC TLD Quality Assurance (QA) program consists of the planned and systematic actions necessary to provide adequate confidence in the accuracy and precision of the measurements obtained through the NRC TLD Direct Radiation Monitoring Network. These measurements utilize instrumentation located in the Region I Dosimetry Laboratory. The QA program for these measurements has been established in order to:

- (1) Provide a means of relating the results of the measurements to the U.S. National Institute of Standards and Technology (NIST), whenever possible;
- (2) Obtain a measure of confidence in the accuracy and precision of the data; and
- (3) Identify any deficiencies in monitoring and analyses so that corrective actions can be taken.

The following sections describe the procedures for ensuring the quality of proper measurements.

7.1 Dosimeter Quality Control

Before dosimeters are placed into service, they must pass the following tests:

7.1.1 Visual Inspection

Badges are visually inspected to ensure that the elements are of the correct type and have the right filtration.

7.1.2 Identification Number and Dosimeter Type

Dosimeters are read by the TLD reader and the badge identification numbers reported on the TLD reader output are compared with the corresponding numbers on the badge labels. Any deviations are corrected prior to dosimeter calibration or use.

7.1.3 Element Calibration Factors

Element calibration factors (see section 4 of this report) are determined for all dosimeters upon being placed into service. Dosimeters for which any element calibration factor falls below 0.5 are withdrawn from service.

7.2 Reader Quality Control

The calibration of the TLD reader is verified after any significant servicing or maintenance. In addition, a Quality Control (QC) check is routinely performed on the reader to determine

system trends, to apply corrections as necessary, and to ensure that the system is operational. The WE-2001 irradiator described in Section 4.1 is used to irradiate each dosimeter element. These dosimeters previously have been calibrated with a cesium-137 source to establish their element correction factors. A depleted uranium slab is also available for irradiation of dosimeters. This source serves primarily as a check on the reproducibility of readings between reader calibrations. In addition, the following system parameters are measured and printed by the reader.

7.2.1 Sensitivity Correction Factor

Prior to reading a rack of up to 50 dosimeters, the TLD reader determines the sensitivity correction factor. This factor is the ratio of the mean of 10 reference carbon-14 light source measurements to a constant reference reading. This factor is automatically applied by the reader to all badge readings to correct for changes in light transmission through the reader's optics. The reader will not operate if this factor is greater than 1.1 or less than 0.9.

7.2.2 Dark Counts

The dark count (from electronic noise, light leaks, thermionic emissions) is measured by the reader before it reads each badge. The dark count is usually less than five counts. The reader will not operate if the measured dark count is greater than 20 counts.

7.2.3 Reference Element Counts

A pin hole on the slide mechanism (that moves the dosimeters horizontally into the heating path) is briefly aligned between the heating lamp and the photomultiplier tube, allowing a small amount of light to pass from the lamp to the PMT. This reference element (RE) reading serves as a check of the integrity of the filters in the light path. The RE is usually less than 20 counts. The reader will not operate if the measured RE is greater than 600 counts.

7.3 Quality Assurance Audits

The NRC TLD Direct Radiation Monitoring Network is monitored on a regular basis by the NRC Region I Radiation Dosimetry Specialist. In addition to this continuing evaluation, the program will be audited by a member of management designated by the Region I Administrator. This audit ensures that all operations, maintenance, calibration, and quality control activities are being performed in accordance with approved procedures. The results of these audits will be documented and reported to the Region I Regional Administrator. Deficiencies identified will be resolved as soon as practicable and the Region I Regional Administrator is informed of their resolution.

8. INTERCOMPARISON

8.1 Description

The Tenth International Intercomparison of Environmental Dosimeters was performed jointly by the U.S. Department of Energy and Idaho State University in 1993. One hundred and two (102) foreign and domestic dosimetry laboratories participated in this study, including the NRC TLD Laboratory.

The project's sponsor exposed dosimeters at a field site, and to two levels from a Cs-137 source in the laboratory. Those exposed dosimeters were then distributed to all participants to determine the net exposure.

The NRC TLD Laboratory read its exposed dosimeters (TLDs). The element calibration factors (ECFs) of those TLDs were then determined, as discussed in Section 4.2. The net exposure was calculated by applying the ECF correction and subtracting the transit exposure.

8.2 Results

The results shown below are from the Tenth Intercomparison Preliminary Report, August 23, 1993. A final report has not been issued. The data in that report were presented in units of microGray (μGy). To be consistent with the way data are presented in this report of the NRC TLD Direct Radiation Monitoring Network, the data have been converted to units of milliroentgen (mR) using a factor of $8.76 \mu\text{Gy}$ per mR.

Exposure type	Est. Delivered Exposure \pm uncertainty (mR)	NRC Measured Exposure (mean \pm s.d.) (mR)	Ratio*	All Participants (mean \pm s.d.) (mR)
Field Site	27.1 ± 1.6	24.7 ± 9.8	0.91	26.4 ± 5.1
Cs-137 (low)	25.9 ± 1.3	26.1 ± 10.0	1.01	25.0 ± 4.7
Cs-137 (high)	72.7 ± 1.9	72.5 ± 17.4	1.00	69.8 ± 10.2

*Ratio is defined as: NRC Measured Exposure / Est. Delivered Exposure

8.3 Discussion

The NRC's results are in excellent agreement with the laboratory exposures reported by the sponsor of the Tenth International Intercomparison of Environmental Dosimeters. The result for the Field Site was acceptable, considering that the Intercomparison sponsor found it necessary to derive an estimated delivered field exposure for a period of about four weeks, during which heavy snow precluded servicing the high pressure argon ion chambers that were used for measuring this exposure.

The NRC TLD Laboratory will report the results of future intercomparison studies as they become available.

9. SUMMARY OF OPERATING EXPERIENCES

Since the inception of this program, many problems common to environmental monitoring programs have been experienced. Many of the problems were associated with the field sampling. Environmental monitoring devices are vulnerable to vandalism and mischief. The manner in which NRC TLDs are packaged and installed was designed to protect the dosimeter from the elements and curious individuals. NRC TLD dosimeters have been vandalized, shot, melted in a forest fire, and stolen. The recovery rate (that is, the percentage of return) has averaged approximately 95% which has been acceptable, considering the nature and scope of the program.

The equipment and procedures used by the NRC TLD Direct Radiation Monitoring Network generally satisfied the requirements of the program for 1993.

Table 4 lists all licensed facilities included in the Network as of December 31, 1993.

Table 4

Sites Monitored During
Fourth Quarter, 1993

1.	Arkansas Nuclear One	37.	Millstone
2.	Beaver Valley	38.	Monticello
3.	Big Rock Point	39.	North Anna
4.	Braidwood	40.	Oconee
5.	Browns Ferry	41.	Oyster Creek
6.	Brunswick	42.	Palisades
7.	Byron	43.	Palo Verde
8.	Callaway	44.	Peach Bottom
9.	Calvert Cliffs	45.	Perry
10.	Catawba	46.	Pilgrim
11.	Clinton	47.	Prairie Island
12.	Comanche Peak	48.	Quad Cities
13.	D. C. Cook	49.	Rancho Seco
14.	Cooper	50.	River Bend
15.	Crystal River	51.	Robinson
16.	Davis-Besse	52.	St. Lucie
17.	Diablo Canyon	53.	Salem/Hope Creek
18.	Dresden	54.	San Onofre
19.	Duane Arnold	55.	Seabrook
20.	Farley	56.	Sequoyah
21.	Fermi	57.	Shoreham
22.	FitzPatrick/Nine Mile Point	58.	South Texas
23.	Fort Calhoun	59.	Summer
24.	Fort St. Vrain	60.	Surry
25.	Ginna	61.	Susquehanna
26.	Grand Gulf	62.	Three Mile Island
27.	Haddam Neck	63.	Trojan
28.	Harris	64.	Turkey Point
29.	Hatch	65.	Vermont Yankee
30.	Indian Point	66.	Vogtle
31.	Kewaunee/Point Beach	67.	Washington Nuclear 2
32.	Lacrosse	68.	Waterford
33.	LaSalle	69.	Watts Barr
34.	Limerick	70.	Wolf Creek
35.	Maine Yankee	71.	Yankee Rowe
36.	McGuire	72.	Zion

10. ENVIRONMENTAL DIRECT RADIATION MONITORING DATA FOR NRC
LICENSED NUCLEAR POWER REACTORS

Individual site data reports begin on the following page.

ARKANSAS

TLD Direct Radiation Environmental Monitoring

For the period 930913-940209 150 Days

Field Time: 99 Days

NRC Sta	Location Azimuth/Dist (Deg)/(Mi)		Gross Exposure (mR) +-Rdm; Tot.	Net Exposure Rate (mR/Std. Qtr.) +-Rdm; Tot.	Hist. Range Net Exp Rate +-1 Std Dev
1	4	0.4	26.5 +- 0.8; 4.0	16.9 +- 0.8; 4.9	17.8 +- 1.8
2	353	4.1	26.1 +- 0.8; 3.9	16.5 +- 0.8; 4.8	17.7 +- 1.9
3	32	1.3	26.3 +- 0.8; 3.9	16.8 +- 0.8; 4.8	18.5 +- 2.1
4	13	3.3	25.1 +- 0.8; 3.8	15.7 +- 0.8; 4.7	17.0 +- 1.9
5	53	1.5	26.0 +- 0.8; 3.9	16.5 +- 0.8; 4.8	17.7 +- 2.0
6	37	3.6	25.9 +- 0.8; 3.9	16.4 +- 0.8; 4.8	16.8 +- 1.6
7	78	2.5	27.9 +- 0.8; 4.2	18.2 +- 0.9; 5.0	19.2 +- 2.2
8	60	3.2	28.3 +- 0.8; 4.2	18.6 +- 0.9; 5.0	20.2 +- 2.7
9	92	0.5	28.8 +- 0.9; 4.3	19.0 +- 0.9; 5.1	19.3 +- 2.3
10	83	5.5	26.3 +- 0.8; 4.0	16.8 +- 0.8; 4.8	17.8 +- 1.9
11	122	2.1	25.3 +- 0.8; 3.8	15.8 +- 0.8; 4.7	16.6 +- 1.9
12	109	6.8	27.0 +- 0.8; 4.1	17.4 +- 0.9; 4.9	18.4 +- 1.9
13	138	2.6	24.0 +- 0.7; 3.6	14.7 +- 0.8; 4.6	15.2 +- 1.7
14	130	4.9	25.4 +- 0.8; 3.8	16.0 +- 0.8; 4.7	16.2 +- 2.0
16	167	4.4	25.4 +- 0.8; 3.8	16.0 +- 0.8; 4.7	17.9 +- 1.7
17	171	0.4	26.3 +- 0.8; 3.9	16.7 +- 0.8; 4.8	17.3 +- 2.0
18	189	3.2	26.6 +- 0.8; 4.0	17.0 +- 0.8; 4.9	17.7 +- 1.9
19	205	2.9	26.2 +- 0.8; 3.9	16.7 +- 0.8; 4.8	16.9 +- 2.0
20	195	5.8	25.3 +- 0.8; 3.8	15.9 +- 0.8; 4.7	16.3 +- 2.2
21	235	0.5	28.3 +- 0.8; 4.2	18.5 +- 0.9; 5.0	19.7 +- 2.0
22	230	3.6	23.5 +- 0.7; 3.5	14.2 +- 0.8; 4.6	14.4 +- 1.6
23	257	2.8	24.5 +- 0.7; 3.7	15.1 +- 0.8; 4.7	16.2 +- 1.8
24	243	4.5	25.5 +- 0.8; 3.8	16.0 +- 0.8; 4.7	17.1 +- 1.7
25	279	1.2	29.2 +- 0.9; 4.4	19.4 +- 0.9; 5.1	20.4 +- 2.1
26	263	4.3	25.6 +- 0.8; 3.8	16.1 +- 0.8; 4.8	17.6 +- 2.0
27	298	0.4	27.1 +- 0.8; 4.1	17.5 +- 0.9; 4.9	18.9 +- 2.0
28	293	5.8	26.2 +- 0.8; 3.9	16.7 +- 0.8; 4.8	17.2 +- 2.1
29	326	1.9	27.0 +- 0.8; 4.1	17.4 +- 0.9; 4.9	18.1 +- 2.0
30	308	4.8	27.2 +- 0.8; 4.1	17.6 +- 0.9; 4.9	18.0 +- 2.0
31	345	1.3	28.0 +- 0.8; 4.2	18.3 +- 0.9; 5.0	18.7 +- 2.1
32	335	4.2	24.5 +- 0.7; 3.7	15.1 +- 0.8; 4.6	16.0 +- 2.0
33	110	0.8	26.9 +- 0.8; 4.0	17.3 +- 0.9; 4.9	18.8 +- 2.1
39	112	6.0	26.5 +- 0.8; 4.0	17.0 +- 0.8; 4.9	18.6 +- 2.0
40	147	8.0	26.5 +- 0.8; 4.0	16.9 +- 0.8; 4.8	18.8 +- 1.9
41	106	17.0	27.5 +- 0.8; 4.1	17.8 +- 0.9; 5.0	18.1 +- 1.5
42	310	17.0	24.6 +- 0.7; 3.7	15.2 +- 0.8; 4.7	16.2 +- 2.0
43	105	5.2	25.7 +- 0.8; 3.8	16.2 +- 0.8; 4.8	18.6 +- 2.0
44	315	13.0	26.7 +- 0.8; 4.0	17.1 +- 0.8; 4.9	17.8 +- 2.1
45	47	8.9	24.1 +- 0.7; 3.6	14.8 +- 0.8; 4.6	15.9 +- 2.2
46	115	8.3	28.8 +- 0.9; 4.3	19.0 +- 0.9; 5.1	18.4 +- 2.1
47	208	20.0	25.6 +- 0.8; 3.8	16.1 +- 0.8; 4.8	18.7 +- 2.6
48	179	19.0	26.9 +- 0.8; 4.0	17.3 +- 0.9; 4.9	18.4 +- 2.2
49	150	22.0	27.1 +- 0.8; 4.1	17.5 +- 0.9; 4.9	19.9 +- 1.9

Transit Dose = 7.9 +- 0.5; 3.6

ARKANSAS

For the period 930913-940209

TLD Direct Radiation Environmental Monitoring

Azimuth (degrees)	Ave. Exposure Rate (mR/Std.Qtr.) +- Std.Dev.	Number In Group
348.76 - 11.25 N	16.7 +- 0.3	2
11.26 - 33.75 NNE	16.2 +- 0.8	2
33.76 - 56.25 NE	15.9 +- 0.9	3
56.26 - 78.75 ENE	18.4 +- 0.2	2
78.76 - 101.25 E	17.9 +- 1.5	2
101.26 - 123.75 ESE	17.2 +- 1.1	7
123.76 - 146.25 SE	15.3 +- 0.9	2
146.26 - 168.75 SSE	16.4 +- 0.7	2
168.76 - 191.25 S	16.9 +- 0.2	2
191.26 - 213.75 SSW	16.3 +- 0.6	2
213.76 - 236.25 SW	16.4 +- 3.1	2
236.26 - 258.75 WSW	15.6 +- 0.6	2
258.76 - 281.25 W	17.8 +- 2.3	2
281.26 - 303.75 WNW	17.1 +- 0.6	2
303.76 - 326.25 NW	16.8 +- 1.1	4
326.26 - 348.75 NNW	16.7 +- 2.3	2

Distance From Reactor (miles)	Ave. Exposure Rate (mR/Std.Qtr.) +- Std.Dev.	Number In Group
0 - 2	17.7 +- 1.0	11
2 - 5	16.2 +- 1.2	17
> 5	16.7 +- 1.1	12
Upwind Control	17.0 +- 0.7	3

ARKANSAS
TLD Direct Radiation Environmental Monitoring

NRC Station	Location		Description
	Azimuth / Degree	Distance / Mile	
1	4	0.4	S. OF HERSHEL BENNETT HOME
2	353	4.1	E. PT. CHURCH
3	32	1.3	N. OF U.S. 64
4	13	3.3	N. OF FARM RD.
5	53	1.5	U.S. 64 & FARM RD.
6	37	3.6	MAP COORDINATE 522
7	78	2.5	MISSION CEMETERY
8	60	3.2	COORDINATE 477
9	92	0.5	METEOR. TOWER
10	83	5.5	COORDINATE 356
11	122	2.1	COORDINATE 354
12	109	6.8	AP&L (RUSSELLVILLE)
13	138	2.6	COORDINATE 372
14	130	4.9	SKYLINE DR.
16	167	4.4	HWY. 22 & LITTLE HAYES CR.
17	171	0.4	MAY CEMETERY
18	189	3.2	HWY. 22
19	205	2.9	HWY. 22
20	195	5.8	SUNSET PT.
21	235	0.5	AP&L LODGE
22	230	3.6	HWY. 22
23	257	2.8	PLEDGER CEMETERY
24	243	4.5	DELAWARE
25	279	1.2	SHALE PT.
26	263	4.3	RD. TO RIVER MTN.
27	298	0.4	SWAN CEMETERY
28	293	5.8	FINEY
29	326	1.9	LONDON
30	308	4.8	COORDINATE 621
31	345	1.3	HWY. 64
32	335	4.2	MARTIN CHAPEL
33	110	0.8	HOME OF D. H. DOUGLAS
39	112	6.0	RUSSELLVILLE HIGH SCHOOL
40	147	8.0	DARDANELL HIGH SCHOOL
41	106	17.0	ATKINS
42	310	17.0	CLARKSVILLE
43	105	5.2	POLYTECHNIC COLLEGE
44	315	13.0	LAMAR ELEMENTARY SCHOOL
45	47	8.9	DOVER HIGH SCHOOL
46	115	8.3	RUSSELLVILLE AIRPORT
47	208	20.0	DANVILLE UTILITY SUBSTATION
48	179	19.0	POST OFFICE
49	150	22.0	PERRY CASA HIGH SCHOOL

NRC TLD DOSES FOR ARKANSAS AREA

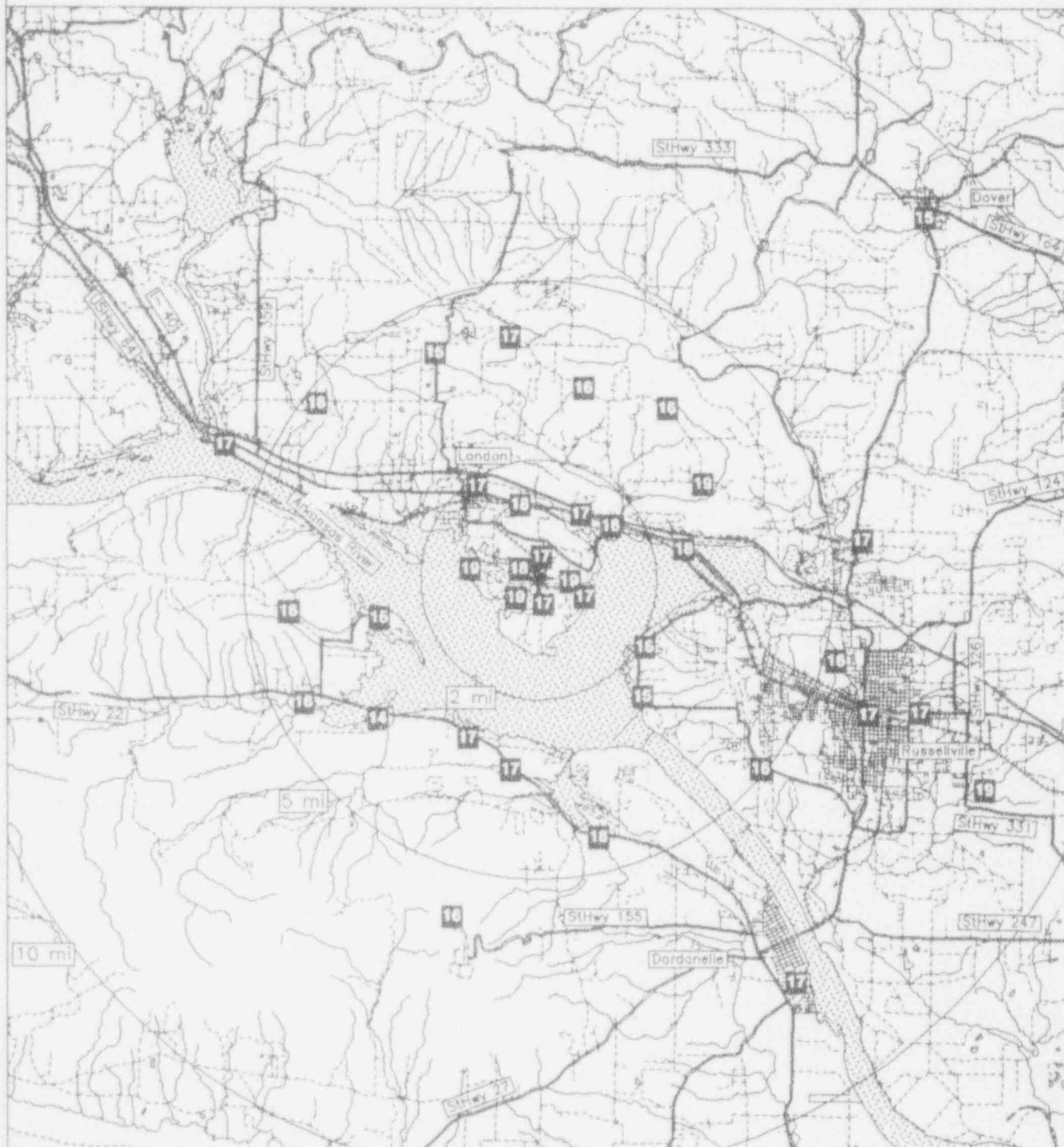

Miles

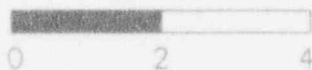

Legend



Water

Highways

Railroads

Roads



Plant..site

BEAVER VALLEY

TLD Direct Radiation Environmental Monitoring

For the period 930915-940215 154 Days

Field Time: 99 Days

NRC Sta	Location		Gross Exposure (mR)		Net Exposure Rate (mR/Std. Qtr.)		Hist. Range Net Exp Rate	
	Azimuth/ (Deg)	Dist (Mi)	+-Rdm; Tot.		+-Rdm; Tot.		+-1 Std Dev	
1	340	15.8	26.8	+- 0.8; 4.0	16.7	+- 0.9; 4.9	17.2	+- 1.8
2	3	13.1	26.7	+- 0.8; 4.0	16.6	+- 0.9; 4.9	17.4	+- 1.6
4	30	11.9	27.1	+- 0.8; 4.1	17.0	+- 0.9; 4.9	19.8	+- 2.0
5	53	8.2	27.3	+- 0.8; 4.1	17.2	+- 0.9; 5.0	18.7	+- 1.5
6	58	9.1	28.4	+- 0.9; 4.3	18.1	+- 0.9; 5.1	19.5	+- 1.6
7	97	8.0	29.6	+- 0.9; 4.4	19.3	+- 0.9; 5.2	19.8	+- 1.8
8	110	4.2	28.1	+- 0.8; 4.2	17.9	+- 0.9; 5.0	19.1	+- 1.6
9	111	1.9	29.5	+- 0.9; 4.4	19.2	+- 0.9; 5.2	20.0	+- 1.9
10	92	2.2	28.0	+- 0.8; 4.2	17.8	+- 0.9; 5.0	19.5	+- 1.3
11	64	3.6	28.3	+- 0.8; 4.2	18.1	+- 0.9; 5.1	19.7	+- 2.0
12	148	4.0	30.8	+- 0.9; 4.6	20.4	+- 1.0; 5.3	21.0	+- 1.2
13	171	4.4	27.9	+- 0.8; 4.2	17.7	+- 0.9; 5.0	18.7	+- 1.7
14	183	4.4	27.2	+- 0.8; 4.1	17.1	+- 0.9; 5.0	18.5	+- 1.4
15	198	3.6	28.5	+- 0.9; 4.3	18.2	+- 0.9; 5.1	18.9	+- 1.7
16	254	5.7	27.2	+- 0.8; 4.1	17.1	+- 0.9; 5.0	18.4	+- 1.5
17	267	6.5	26.7	+- 0.8; 4.0	16.6	+- 0.9; 4.9	17.8	+- 1.7
18	231	2.5	27.2	+- 0.8; 4.1	17.1	+- 0.9; 5.0	18.8	+- 1.6
19	266	2.5	29.3	+- 0.9; 4.4	19.0	+- 0.9; 5.2	20.3	+- 1.6
20	291	3.8	26.2	+- 0.8; 3.9	16.2	+- 0.8; 4.9	17.2	+- 2.0
21	298	2.4	30.3	+- 0.9; 4.5	19.9	+- 0.9; 5.3	20.9	+- 1.7
22	219	1.5	27.0	+- 0.8; 4.0	16.9	+- 0.9; 4.9	17.8	+- 1.2
23	252	2.4	30.3	+- 0.9; 4.5	19.9	+- 0.9; 5.3	21.2	+- 2.4
24	207	2.2	29.4	+- 0.9; 4.4	19.1	+- 0.9; 5.2	19.7	+- 1.7
25	187	2.2	29.9	+- 0.9; 4.5	19.6	+- 0.9; 5.2	20.1	+- 1.7
26	158	2.2	27.2	+- 0.8; 4.1	17.1	+- 0.9; 5.0	19.2	+- 1.7
27	135	1.9	28.5	+- 0.9; 4.3	18.3	+- 0.9; 5.1	19.9	+- 1.4
28	99	1.4	29.2	+- 0.9; 4.4	18.9	+- 0.9; 5.2	20.4	+- 1.9
29	64	1.4	27.2	+- 0.8; 4.1	17.1	+- 0.9; 5.0	18.6	+- 1.8
30	53	1.0	28.5	+- 0.9; 4.3	18.2	+- 0.9; 5.1	19.1	+- 1.6
31	320	1.4	Missing Dosimeter		No Net Data		21.3	+- 2.0
32	320	3.5	27.6	+- 0.8; 4.1	17.5	+- 0.9; 5.0	19.0	+- 1.8
33	335	2.5	27.9	+- 0.8; 4.2	17.7	+- 0.9; 5.0	19.2	+- 1.7
34	340	5.2	23.8	+- 0.7; 3.6	14.0	+- 0.8; 4.6	17.2	+- 2.1
35	4	3.5	28.7	+- 0.9; 4.3	18.5	+- 0.9; 5.1	19.8	+- 1.9
36	23	3.2	30.3	+- 0.9; 4.5	19.9	+- 0.9; 5.3	22.0	+- 1.8
37	42	2.8	25.9	+- 0.8; 3.9	15.9	+- 0.8; 4.8	16.6	+- 1.2
38	27	1.6	25.9	+- 0.8; 3.9	15.9	+- 0.8; 4.8	17.8	+- 2.0
39	348	1.6	28.2	+- 0.8; 4.2	18.0	+- 0.9; 5.1	19.1	+- 1.7
40	340	15.8	24.6	+- 0.7; 3.7	14.8	+- 0.8; 4.7	16.5	+- 1.7
41	340	15.8	25.3	+- 0.8; 3.8	15.4	+- 0.8; 4.8	17.0	+- 1.5

Transit Dose = 8.4 +- 0.5; 3.6

BEAVER VALLEY
For the period 930915-940215

TLD Direct Radiation Environmental Monitoring

Azimuth (degrees)	Ave. Exposure Rate (mR/Std.Qtr.) +- Std.Dev.	Number In Group
348.76 - 11.25 N	17.6 +- 1.3	2
11.26 - 33.75 NNE	17.6 +- 2.1	3
33.76 - 56.25 NE	17.1 +- 1.2	3
56.26 - 78.75 ENE	17.8 +- 0.6	3
78.76 - 101.25 E	18.7 +- 0.8	3
101.26 - 123.75 ESE	18.5 +- 0.9	2
123.76 - 146.25 SE	18.3 +- 0.0	1
146.26 - 168.75 SSE	18.8 +- 2.3	2
168.76 - 191.25 S	18.1 +- 1.3	3
191.26 - 213.75 SSW	18.7 +- 0.6	2
213.76 - 236.25 SW	17.0 +- 0.1	2
236.26 - 258.75 WSW	18.5 +- 2.0	2
258.76 - 281.25 W	17.8 +- 1.7	2
281.26 - 303.75 WNW	18.0 +- 2.6	2
303.76 - 326.25 NW	17.5 +- 0.0	1
326.26 - 348.75 NNW	16.6 +- 2.2	3

Distance From Reactor (miles)	Ave. Exposure Rate (mR/Std.Qtr.) +- Std.Dev.	Number In Group
0 - 2	17.8 +- 1.1	8
2 - 5	18.2 +- 1.3	20
> 5	17.0 +- 1.5	8
Upwind Control	15.6 +- 1.0	3

BEAVER VALLEY
TLD Direct Radiation Environmental Monitoring

NRC Station	Location		Description
	Azimuth / Degree	Distance / Mile	
1	340	15.8	EAST PALESTINE ,OHIO
2	3	13.1	DARLINGTON
4	30	11.9	BEAVER FALLS
5	53	8.2	BEAVER
6	58	9.1	MONACA
7	97	8.0	ALIQUIPPA
8	110	4.2	SHANNON ROAD
9	111	1.9	PA 18 & GREEN GARDEN ROAD
10	92	2.2	PA 18
11	64	3.6	PA 18 & BAUER ROAD
12	148	4.0	PA 18 & SERVICE CHURCH ROAD
13	171	4.4	PA 151
14	183	4.4	US 30 & PLEASANT HILL ROAD
15	198	3.6	REED SCHOOL ROAD
16	254	5.7	US 30 & WV 8
17	267	6.5	CHESTER, WEST VIRGINIA
18	231	2.5	HOOKSTOWN
19	266	2.5	HILL ROAD
20	291	3.8	GEORGETOWN
21	298	2.4	RIVER OPPOSITE MIDLAND
22	219	1.5	PA 168 FARM
23	252	2.4	HILL ROAD
24	207	2.2	MCCLEARY ROAD
25	187	2.2	MCCLEARY & SHAFFER ROADS
26	158	2.2	SHIVLER & MC CLEARY ROADS
27	135	1.9	MCCLEARY ROAD
28	99	1.4	SHIPPINGPORT HILL RD
29	64	1.4	SHIPPINGPORT HILL & COTTER ROADS
30	53	1.0	SHIPPINGPORT
31	320	1.4	MIDLAND
32	320	3.5	PA 168 & EASTWOOD DRIVE
33	335	2.5	FOREST HILL ROAD
34	340	5.2	FAIRVIEW
35	4	3.5	ENGLE ROAD
36	23	3.2	ENGLE ROAD
37	42	2.8	OHIOVIEW
38	27	1.6	INDUSTRY
39	348	1.6	BELL TELEPHONE BUILDING
40	340	15.8	EAST PALESTINE, OHIO
41	340	15.8	EAST PALESTINE, OHIO

NRC TLD DOSES FOR BEAVER VALLEY AREA

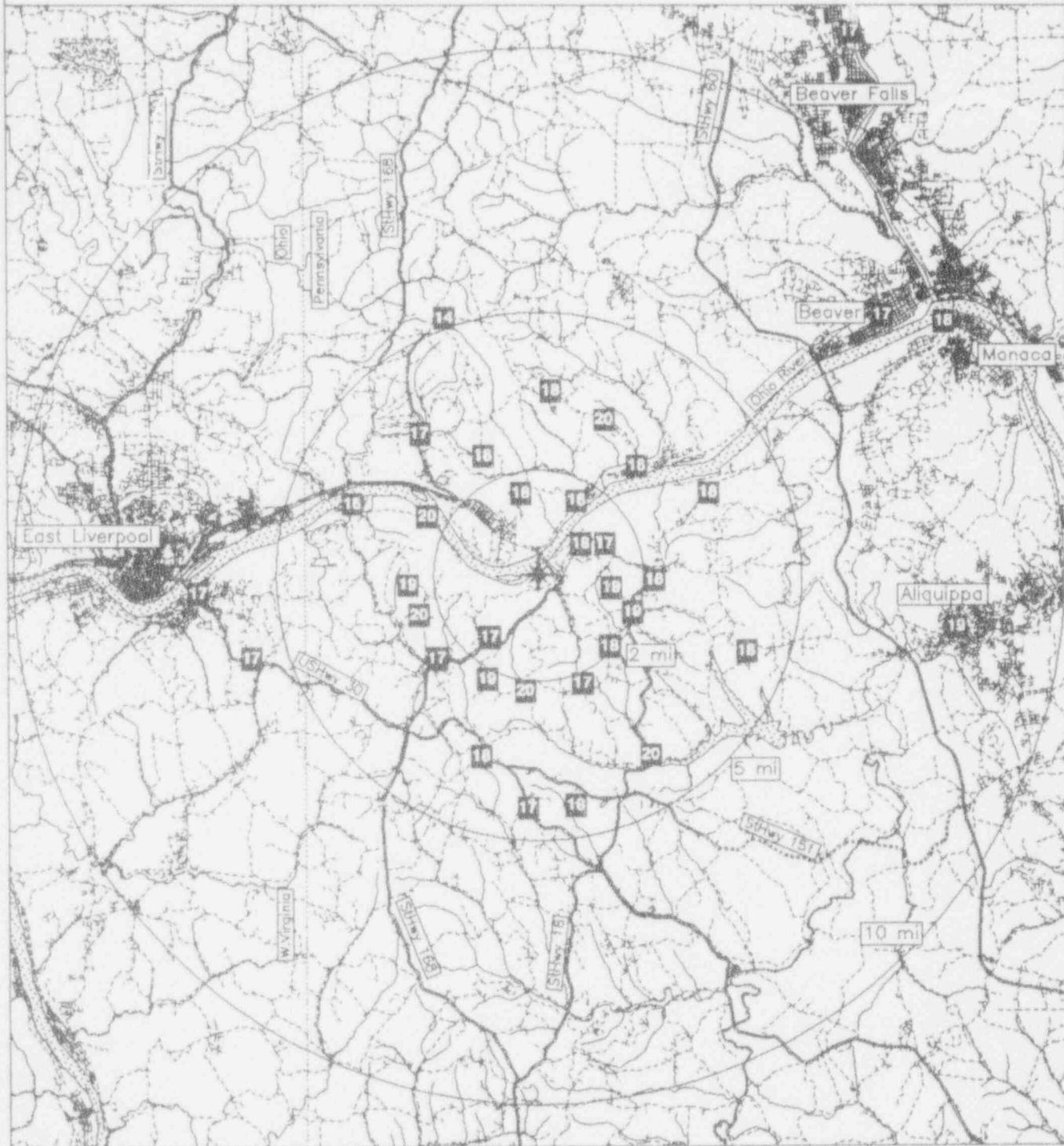

Miles

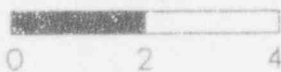

Legend

- Water
- Highways
- Roads
- Plant..site

BIG ROCK
 TLD Direct Radiation Environmental Monitoring
 For the period 930914-940127 136 Days
 Field Time: 96 Days

NRC Sta	Location		Gross Exposure (mR)		Net Exposure Rate (mR/Std. Qtr.)		Hist. Range Net Exp Rate	
	Azimuth/ (Deg)	Dist (Mi)	+-Rdm; Tot.		+-Rdm; Tot.		+-1 Std Dev	
1	208	4.9	19.2	+- 0.6; 2.9	14.0	+- 0.6; 4.0	13.8	+- 1.6
2	220	3.6	17.6	+- 0.5; 2.6	12.5	+- 0.6; 3.8	12.7	+- 1.9
3	204	2.4	19.4	+- 0.6; 2.9	14.2	+- 0.6; 4.0	13.0	+- 2.2
4	176	3.3	18.6	+- 0.6; 2.8	13.5	+- 0.6; 3.9	12.7	+- 1.9
5	161	4.6	18.2	+- 0.5; 2.7	13.1	+- 0.6; 3.9	13.3	+- 1.9
6	133	4.7	21.3	+- 0.6; 3.2	16.0	+- 0.7; 4.2	14.4	+- 1.9
7	116	3.7	21.1	+- 0.6; 3.2	15.8	+- 0.7; 4.2	15.1	+- 2.0
8	111	4.7	21.6	+- 0.6; 3.2	16.3	+- 0.7; 4.2	14.7	+- 2.3
9	98	4.5	18.7	+- 0.6; 2.8	13.5	+- 0.6; 3.9	13.3	+- 1.8
10	88	12.0	18.8	+- 0.6; 2.8	13.6	+- 0.6; 3.9	12.7	+- 1.7
11	83	16.0	16.3	+- 0.5; 2.4	11.3	+- 0.6; 3.7	13.3	+- 2.3
12	83	16.0	16.5	+- 0.5; 2.5	11.5	+- 0.6; 3.7	12.9	+- 2.0
13	83	16.0	17.8	+- 0.5; 2.7	12.7	+- 0.6; 3.9	12.7	+- 1.7
14	77	3.4	18.2	+- 0.5; 2.7	13.1	+- 0.6; 3.9	12.1	+- 1.7
15	96	1.8	19.6	+- 0.6; 2.9	14.4	+- 0.6; 4.0	14.1	+- 1.9
16	118	2.0	20.2	+- 0.6; 3.0	14.9	+- 0.7; 4.1	13.9	+- 2.1
17	134	2.0	19.8	+- 0.6; 3.0	14.6	+- 0.7; 4.0	13.6	+- 1.7
18	222	1.9	16.4	+- 0.5; 2.5	11.4	+- 0.6; 3.7	12.4	+- 2.1
19	194	1.4	21.8	+- 0.7; 3.3	16.5	+- 0.7; 4.2	15.2	+- 2.0
20	179	1.5	18.8	+- 0.6; 2.8	13.7	+- 0.6; 4.0	13.4	+- 1.8
21	153	1.1	19.1	+- 0.6; 2.9	13.9	+- 0.6; 4.0	13.1	+- 1.6

Transit Dose = 4.3 +- 0.4; 3.1

BIG ROCK

For the period 930914-940127

TLD Direct Radiation Environmental Monitoring

Azimuth (degrees)	Ave. Exposure Rate (mR/Std.Qtr.) +- Std.Dev.	Number In Group
348.76 - 11.25 N	No Data +- No Data	0
11.26 - 33.75 NNE	No Data +- No Data	0
33.76 - 56.25 NE	No Data +- No Data	0
56.26 - 78.75 ENE	13.1 +- 0.0	1
78.76 - 101.25 E	13.8 +- 0.5	3
101.26 - 123.75 ESE	15.7 +- 0.7	3
123.76 - 146.25 SE	15.3 +- 1.0	2
146.26 - 168.75 SSE	13.5 +- 0.6	2
168.76 - 191.25 S	13.6 +- 0.1	2
191.26 - 213.75 SSW	14.9 +- 1.4	3
213.76 - 236.25 SW	12.0 +- 0.8	2
236.26 - 258.75 WSW	No Data +- No Data	0
258.76 - 281.25 W	No Data +- No Data	0
281.26 - 303.75 WNW	No Data +- No Data	0
303.76 - 326.25 NW	No Data +- No Data	0
326.26 - 348.75 NNW	No Data +- No Data	0

Distance From Reactor (miles)	Ave. Exposure Rate (mR/Std.Qtr.) +- Std.Dev.	Number In Group
0 - 2	14.2 +- 1.5	7
2 - 5	14.2 +- 1.3	10
> 5	13.6 +- 0.0	1
Upwind Control	11.8 +- 0.8	3

BIG ROCK
TLD Direct Radiation Environmental Monitoring

NRC Station	Location		Description
	Azimuth / Degree	Distance / Mile	
1	208	4.9	MICHIGAN 66
2	220	3.6	PETOSKY (US 31) & PROSPECT
3	204	2.4	COUNTY RD. 56
4	176	3.3	QUARTER LINE RD.
5	161	4.6	COUNTY RD. 56
6	133	4.7	QUARTER LINE RD. & MAPLE GROVE RD.
7	116	3.7	STOLT RD. & MAPLE GROVE RD.
8	111	4.7	STOLT RD. & MURRAY RD.
9	98	4.5	MURRAY RD & BAY SHORE RD.
10	88	12.0	PETOSKY (MI)
11	83	16.0	BAYVIEW (MI)
12	83	16.0	BAYVIEW (MI)
13	83	16.0	BAYVIEW (MI)
14	77	3.4	US 31
15	96	1.8	BURGESS RD.
16	118	2.0	OLD 31 RD.
17	134	2.0	OLD 31 RD.
18	222	1.9	PA-BA-SHAN LANE
19	194	1.4	NEAR US 31
20	179	1.5	US 31 (NEAR CHARLOVOIX ROD & GUN CLUB)
21	153	1.1	US 31

NRC TLD DOSES FOR BIG ROCK POINT AREA

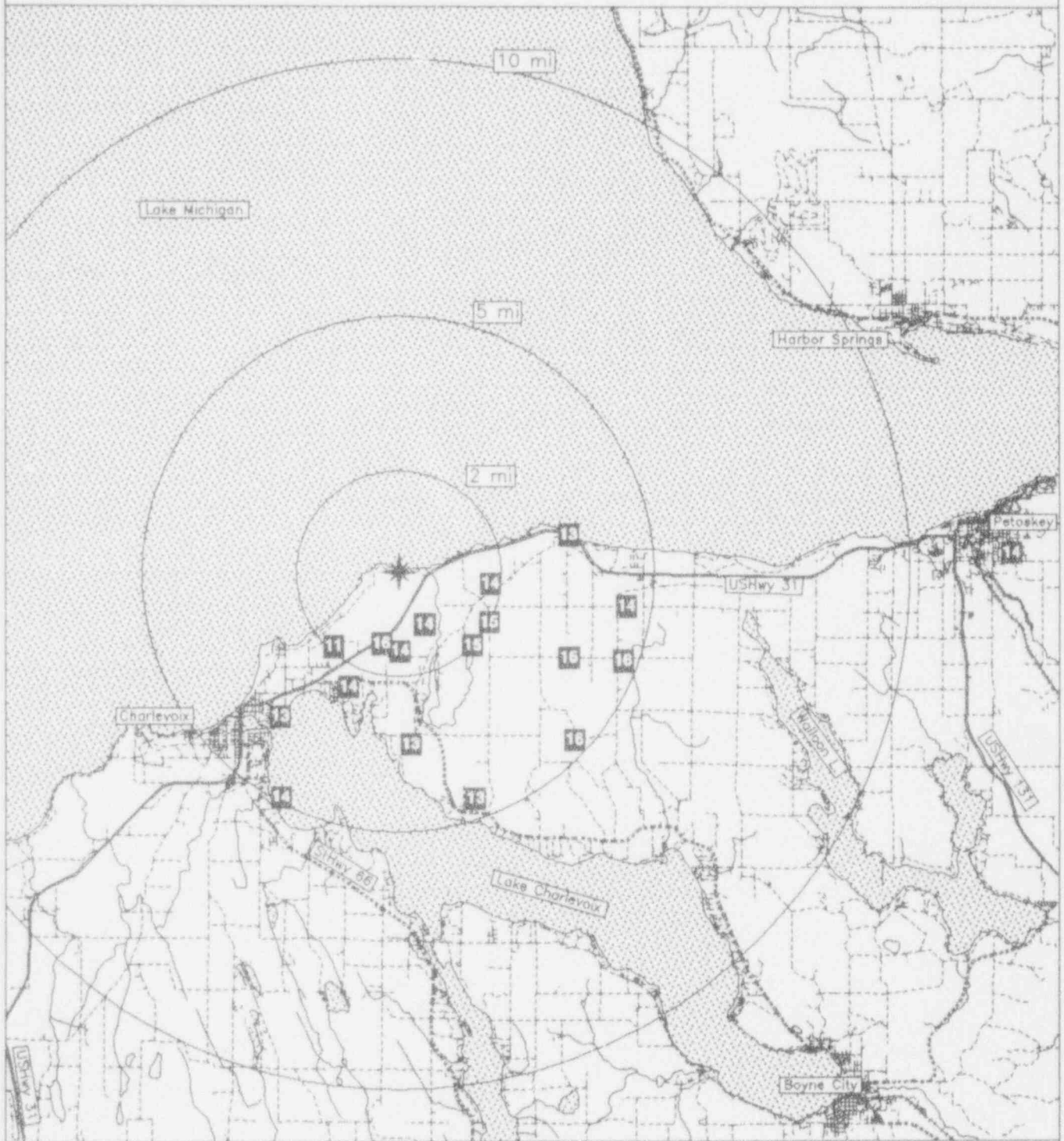

Miles

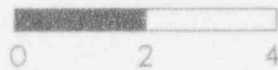

Legend

- Water
- Highways
- Railroads
- Roads
- Plant site

BRAIDWOOD

TLD Direct Radiation Environmental Monitoring

For the period 930914-940202 142 Days

Field Time: 100 Days

NRC Sta	Location Azimuth/Dist (Deg)/(Mi)	Gross Exposure (mR) +-Rdm; Tot.	Net Exposure Rate (mR/Std. Qtr.) +-Rdm; Tot.	Hist. Range Net Exp Rate +-1 Std Dev
1	28 0.8	18.7 +- 0.6; 2.8	10.0 +- 0.7; 4.1	14.0 +- 3.3
2	29 1.3	22.1 +- 0.7; 3.3	13.0 +- 0.7; 4.4	14.8 +- 2.2
3	53 2.0	17.7 +- 0.5; 2.6	9.0 +- 0.6; 4.0	12.4 +- 3.3
4	72 2.1	23.6 +- 0.7; 3.5	14.4 +- 0.8; 4.5	14.9 +- 2.1
5	87 2.0	21.8 +- 0.7; 3.3	12.8 +- 0.7; 4.4	14.5 +- 2.5
6	119 2.5	18.1 +- 0.5; 2.7	9.4 +- 0.6; 4.0	14.0 +- 3.2
7	133 3.3	24.0 +- 0.7; 3.6	14.7 +- 0.8; 4.6	15.0 +- 2.1
8	151 3.3	22.0 +- 0.7; 3.3	12.9 +- 0.7; 4.4	14.2 +- 2.1
9	172 3.9	23.2 +- 0.7; 3.5	14.1 +- 0.8; 4.5	18.9 +- 4.5
10	197 2.8	21.5 +- 0.6; 3.2	12.5 +- 0.7; 4.3	15.1 +- 2.5
11	212 1.4	21.8 +- 0.7; 3.3	12.7 +- 0.7; 4.3	14.0 +- 2.1
12	232 1.0	20.7 +- 0.6; 3.1	11.8 +- 0.7; 4.3	13.8 +- 2.8
13	255 1.0	22.7 +- 0.7; 3.4	13.6 +- 0.7; 4.4	13.9 +- 1.9
14	278 1.2	23.9 +- 0.7; 3.6	14.6 +- 0.8; 4.5	14.7 +- 2.4
15	310 1.3	22.5 +- 0.7; 3.4	13.4 +- 0.7; 4.4	14.5 +- 2.3
16	342 1.3	18.0 +- 0.5; 2.7	9.3 +- 0.6; 4.0	12.3 +- 3.1
17	8 1.5	22.5 +- 0.7; 3.4	13.4 +- 0.7; 4.4	14.6 +- 2.4
18	18 3.5	23.6 +- 0.7; 3.5	14.4 +- 0.8; 4.5	18.2 +- 3.7
19	42 6.3	19.7 +- 0.6; 3.0	10.9 +- 0.7; 4.2	13.7 +- 2.8
20	69 5.7	22.8 +- 0.7; 3.4	13.7 +- 0.8; 4.4	15.8 +- 2.7
21	86 7.0	23.7 +- 0.7; 3.5	14.4 +- 0.8; 4.5	16.9 +- 2.4
22	103 11.4	20.5 +- 0.6; 3.1	11.6 +- 0.7; 4.2	16.0 +- 3.7
23	45 4.9	24.1 +- 0.7; 3.6	14.8 +- 0.8; 4.6	15.5 +- 2.2
24	70 4.2	23.0 +- 0.7; 3.5	13.9 +- 0.8; 4.5	14.5 +- 2.4
25	86 4.1	18.0 +- 0.5; 2.7	9.4 +- 0.6; 4.0	12.7 +- 3.2
26	125 5.0	18.4 +- 0.6; 2.8	9.7 +- 0.7; 4.1	13.5 +- 3.6
27	142 7.2	Missing Dosimeter	No Net Data	17.0 +- 2.9
28	161 6.1	23.5 +- 0.7; 3.5	14.3 +- 0.8; 4.5	14.7 +- 2.3
29	180 5.9	24.7 +- 0.7; 3.7	15.4 +- 0.8; 4.6	19.1 +- 3.6
30	187 5.8	27.7 +- 0.8; 4.2	18.1 +- 0.9; 4.9	20.0 +- 2.9
31	225 5.4	25.5 +- 0.8; 3.8	16.1 +- 0.8; 4.7	17.5 +- 2.4
32	253 4.0	23.3 +- 0.7; 3.5	14.2 +- 0.8; 4.5	15.2 +- 2.3
33	289 4.1	24.0 +- 0.7; 3.6	14.8 +- 0.8; 4.6	16.6 +- 2.6
34	315 4.0	24.0 +- 0.7; 3.6	14.7 +- 0.8; 4.6	16.0 +- 2.4
35	333 4.0	18.5 +- 0.6; 2.8	9.8 +- 0.7; 4.1	15.1 +- 2.7
36	0 5.5	22.6 +- 0.7; 3.4	13.5 +- 0.7; 4.4	14.9 +- 2.7
37	21 5.0	16.7 +- 0.5; 2.5	8.1 +- 0.6; 3.9	12.6 +- 3.5
38	224 14.7	21.2 +- 0.6; 3.2	12.3 +- 0.7; 4.3	14.2 +- 2.8
39	224 14.7	21.0 +- 0.6; 3.1	12.0 +- 0.7; 4.3	14.0 +- 2.4
40	187 10.3	26.2 +- 0.8; 3.9	16.8 +- 0.8; 4.8	18.1 +- 3.2

Transit Dose = 7.5 +- 0.5; 3.6

BRAIDWOOD

For the period 930914-940202

TLD Direct Radiation Environmental Monitoring

Azimuth (degrees)	Ave. Exposure Rate (mR/Std.Qtr.) +- Std.Dev.	Number In Group
348.76 - 11.25 N	13.4 +- 0.0	2
11.26 - 33.75 NNE	11.4 +- 2.8	4
33.76 - 56.25 NE	11.6 +- 3.0	3
56.26 - 78.75 ENE	14.0 +- 0.4	3
78.76 - 101.25 E	12.2 +- 2.6	3
101.26 - 123.75 ESE	10.5 +- 1.6	2
123.76 - 146.25 SE	12.2 +- 3.5	2
146.26 - 168.75 SSE	13.6 +- 0.9	2
168.76 - 191.25 S	15.8 +- 2.1	3
191.26 - 213.75 SSW	12.6 +- 0.2	2
213.76 - 236.25 SW	13.4 +- 2.4	3
236.26 - 258.75 WSW	13.9 +- 0.4	2
258.76 - 281.25 W	14.6 +- 0.0	1
281.26 - 303.75 WNW	14.8 +- 0.0	1
303.76 - 326.25 NW	14.0 +- 0.9	2
326.26 - 348.75 NNW	9.6 +- 0.4	2

Distance From Reactor (miles)	Ave. Exposure Rate (mR/Std.Qtr.) +- Std.Dev.	Number In Group
0 - 2	12.2 +- 1.9	11
2 - 5	12.6 +- 2.4	16
> 5	14.0 +- 2.2	10
Upwind Control	14.4 +- 3.4	2

BRAIDWOOD
TLD Direct Radiation Environmental Monitoring

NRC Station	Location		Description
	Azimuth / Degree	Distance / Mile	
1	28	0.8	IL-53 9TH POLE S OF DIV. ST.
2	29	1.3	DIV. ST. & IL-129
3	53	2.0	ON IL-113 - 0.8 MI E. OF IL-53
4	72	2.1	ESSEX RD. - 0.5 MI S. OF IL-113
5	87	2.0	2ND POLE S. OF SMILEY RD & ESSEX RD
6	119	2.5	ESSEX RD. NR BRAIDWOOD TRAIN. CTR.
7	133	3.3	ESSEX RD (1.3 MI.S) / TAMMEN TREEBERRY FARM
8	151	3.3	COUNTY LINE / .5 MI W. OF ESSEX
9	172	3.9	W500N (PONDEROSA CLUB SIGN)
10	197	2.8	KANKAKEE RD & DONDANVILLE RD (W1900N & N600W)
11	212	1.4	KANKAKEE RD. NR HOUSE ON HILL
12	232	1.0	KANKAKEE RD. & RT. 53
13	255	1.0	KANKAKEE RD. JUST N. OF IL-129
14	278	1.2	KANKAKEE RD. UNDER TRANS. LINES
15	310	1.3	KANKAKEE RD. & IS-55 FRONTAGE
16	342	1.3	KENNEDY & ENGLISH STS.
17	8	1.5	BRAIDWOOD ELEM. SCH.
18	18	3.5	COAL CITY & NOVY RDS
19	42	6.3	WILMINGTON (MAIN STREET)
20	69	5.7	IL-102 & RIVALS TURNOFF
21	86	7.0	IL-102 & MANTENO RD.
22	103	11.4	IL-102 KANKAKEE ST PARK ENTRANCE
23	45	4.9	RIVER RD & JOHNSON RD
24	70	4.2	RIVER & IL-113
25	86	4.1	ZIILM RD (351S & 224W)
26	125	5.0	ZIILM RD/375 S & 224 W
27	142	7.2	W1400N & N300W
28	161	6.1	W1600N & N300W
29	180	5.9	ON N300W (2.2 MI PAST #28)
30	187	5.8	W1900N & N300W
31	225	5.4	RT 53, NORTH EDGE OF GARDNER
32	253	4.0	CARBON HILL RD & BRACERVILLE RD
33	289	4.1	CARBON HILL RD & GORMAN RD
34	315	4.0	NEAR COAL CITY WATER TOWER ON BROADWAY
35	333	4.0	5TH IN EILEEN BETW RR TRACKS
36	0	5.5	MURPHY & COOPER RDS
37	21	5.0	IL-129 S. OF I-55 (FIRST GRAVEL RD)
38	224	14.7	GROCERY STORE LOT IN DWIGHT
39	224	14.7	GROCERY STORE LOT IN DWIGHT
40	187	10.3	POLE AFTER "Y" OFF IL-17 AT REDDICK

NRC TLD DOSES FOR BRAIDWOOD AREA

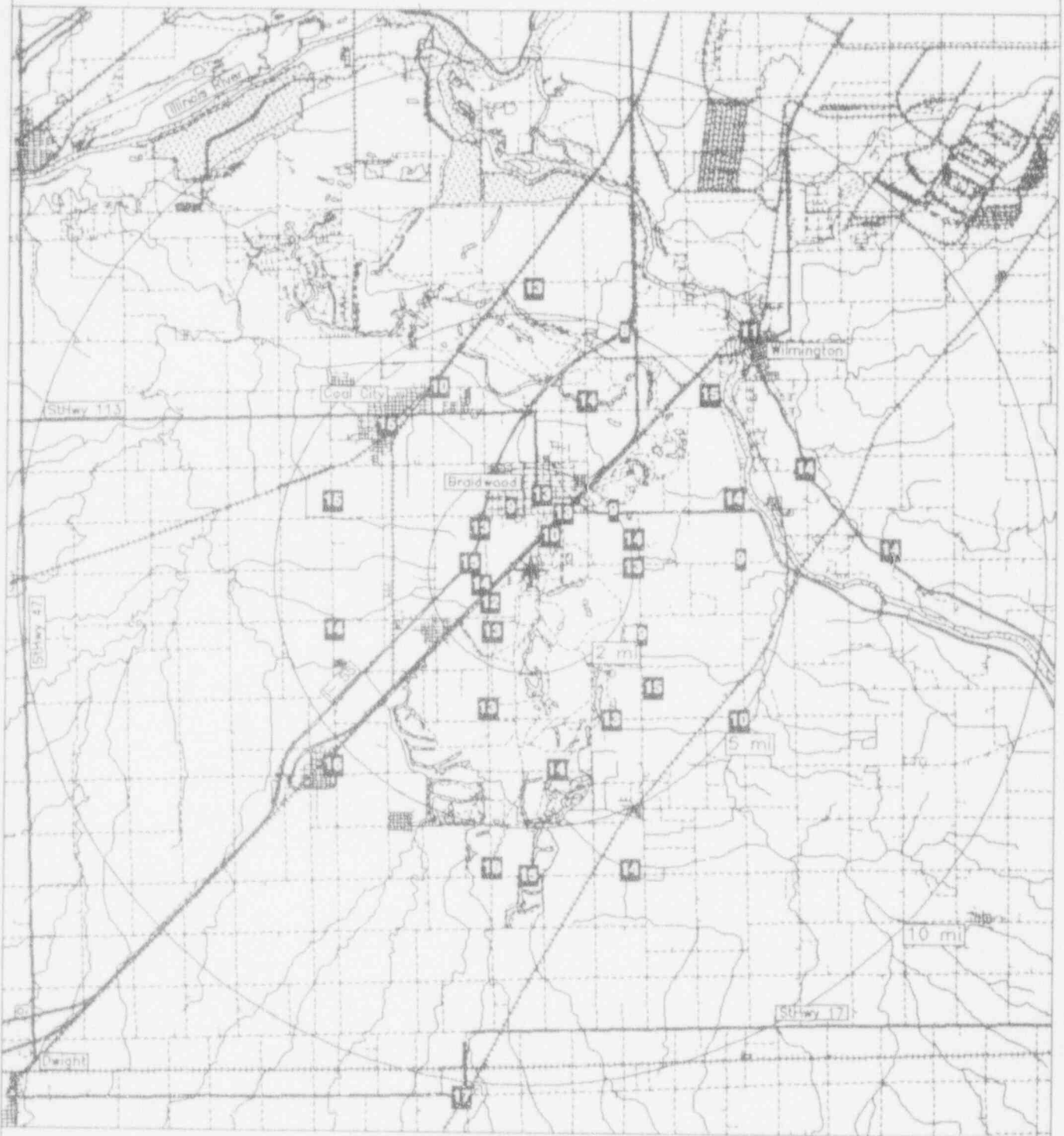

Miles

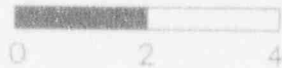

Legend

- Water
- Highways
- Railroads
- Roads
- Plant site

BROWNS FERRY

TLD Direct Radiation Environmental Monitoring

For the period 930915-940208 147 Days

Field Time: 100 Days

NRC Sta	Location		Gross	Net Exposure Rate	Hist. Range
	Azimuth/Dist (Deg)/(Mi)		Exposure (mR) +-Rdm; Tot.	(mR/Std. Qtr.) +-Rdm; Tot.	Net Exp Rate +-1 Std Dev
1	130	9.0	19.4 +- 0.6; 2.9	11.8 +- 0.7; 4.0	14.2 +- 1.8
2	133	5.5	22.8 +- 0.7; 3.4	14.9 +- 0.7; 4.4	15.0 +- 2.0
3	153	4.3	19.5 +- 0.6; 2.9	12.0 +- 0.7; 4.1	14.6 +- 2.0
4	210	5.8	22.6 +- 0.7; 3.4	14.7 +- 0.7; 4.3	17.6 +- 2.2
5	220	6.0	21.0 +- 0.6; 3.2	13.3 +- 0.7; 4.2	15.0 +- 2.0
6	245	4.5	24.7 +- 0.7; 3.7	16.6 +- 0.8; 4.5	18.4 +- 2.3
7	269	1.9	22.2 +- 0.7; 3.3	14.4 +- 0.7; 4.3	16.4 +- 2.0
8	257	11.0	21.3 +- 0.6; 3.2	13.5 +- 0.7; 4.2	15.6 +- 2.0
9	295	7.0	20.8 +- 0.6; 3.1	13.1 +- 0.7; 4.2	16.4 +- 2.4
10	292	4.5	22.2 +- 0.7; 3.3	14.4 +- 0.7; 4.3	16.4 +- 2.0
11	269	1.9	22.4 +- 0.7; 3.4	14.6 +- 0.7; 4.3	16.6 +- 2.0
12	240	2.6	20.7 +- 0.6; 3.1	13.0 +- 0.7; 4.2	15.6 +- 2.1
13	220	1.7	Missing Dosimeter	No Net Data	18.7 +- 2.8
14	268	17.0	22.3 +- 0.7; 3.3	14.5 +- 0.7; 4.3	17.2 +- 2.1
15	201	3.0	22.9 +- 0.7; 3.4	15.0 +- 0.7; 4.4	17.1 +- 2.0
16	181	3.0	20.1 +- 0.6; 3.0	12.5 +- 0.7; 4.1	15.8 +- 2.3
17	50	9.5	22.7 +- 0.7; 3.4	14.8 +- 0.7; 4.3	17.3 +- 2.0
18	51	3.5	21.7 +- 0.6; 3.2	13.9 +- 0.7; 4.3	15.6 +- 1.8
19	62	3.2	20.8 +- 0.6; 3.1	13.1 +- 0.7; 4.2	16.2 +- 2.1
20	86	2.8	24.8 +- 0.7; 3.7	16.7 +- 0.8; 4.6	18.5 +- 2.1
21	111	3.1	25.2 +- 0.8; 3.8	17.0 +- 0.8; 4.6	19.2 +- 2.3
22	64	1.1	25.8 +- 0.8; 3.9	17.6 +- 0.8; 4.7	19.8 +- 2.1
23	90	26.0	20.8 +- 0.6; 3.1	13.1 +- 0.7; 4.2	16.7 +- 2.3
24	111	0.8	24.4 +- 0.7; 3.7	16.4 +- 0.8; 4.5	17.8 +- 1.9
25	46	2.2	23.0 +- 0.7; 3.5	15.1 +- 0.7; 4.4	17.9 +- 2.2
26	26	1.7	26.2 +- 0.8; 3.9	18.0 +- 0.8; 4.7	19.6 +- 2.4
27	333	1.7	22.5 +- 0.7; 3.4	14.6 +- 0.7; 4.3	16.5 +- 2.0
28	335	1.0	21.9 +- 0.7; 3.3	14.1 +- 0.7; 4.3	18.2 +- 2.5
29	27	3.8	23.0 +- 0.7; 3.4	15.0 +- 0.7; 4.4	17.8 +- 2.1
30	0	4.0	20.5 +- 0.6; 3.1	12.8 +- 0.7; 4.1	15.1 +- 1.9
31	340	5.3	23.3 +- 0.7; 3.5	15.4 +- 0.7; 4.4	18.3 +- 2.1
32	312	12.0	22.6 +- 0.7; 3.4	14.7 +- 0.7; 4.3	17.8 +- 2.4
33	0	1.5	25.0 +- 0.7; 3.7	16.8 +- 0.8; 4.6	19.2 +- 2.1
34	52	7.0	21.8 +- 0.7; 3.3	14.0 +- 0.7; 4.3	16.4 +- 2.4
35	95	5.4	21.8 +- 0.7; 3.3	14.0 +- 0.7; 4.3	17.0 +- 2.1
36	68	5.6	23.0 +- 0.7; 3.4	15.1 +- 0.7; 4.4	17.9 +- 2.3
37	149	7.8	23.6 +- 0.7; 3.5	15.6 +- 0.7; 4.4	16.3 +- 2.0
38	164	7.0	19.3 +- 0.6; 2.9	11.8 +- 0.7; 4.0	13.8 +- 2.1

Transit Dose = 6.2 +- 0.4; 3.4

BROWNS FERRY
For the period 930915-940208

TLD Direct Radiation Environmental Monitoring

Azimuth (degrees)	Ave. Exposure Rate (mR/Std.Qtr.) +- Std.Dev.	Number In Group
348.76 - 11.25 N	14.8 +- 2.8	2
11.26 - 33.75 NNE	16.5 +- 2.1	2
33.76 - 56.25 NE	14.4 +- 0.6	4
56.26 - 78.75 ENE	15.3 +- 2.2	3
78.76 - 101.25 E	14.6 +- 1.9	3
101.26 - 123.75 ESE	16.7 +- 0.5	2
123.76 - 146.25 SE	13.4 +- 2.2	2
146.26 - 168.75 SSE	13.1 +- 2.2	3
168.76 - 191.25 S	12.5 +- 0.0	1
191.26 - 213.75 SSW	14.9 +- 0.2	2
213.76 - 236.25 SW	13.3 +- 0.0	1
236.26 - 258.75 WSW	14.8 +- 2.6	2
258.76 - 281.25 W	14.5 +- 0.1	2
281.26 - 303.75 WNW	13.7 +- 0.9	2
303.76 - 326.25 NW	14.7 +- 0.0	1
326.26 - 348.75 NNW	14.7 +- 0.6	3

Distance From Reactor (miles)	Ave. Exposure Rate (mR/Std.Qtr.) +- Std.Dev.	Number In Group
0 - 2	15.8 +- 1.6	8
2 - 5	14.4 +- 1.7	13
> 5	14.0 +- 1.2	14
Upwind Control	14.0 +- 0.7	2

BROWNS FERRY
 TLD Direct Radiation Environmental Monitoring

NRC Station	Location		Description
	Azimuth Degree	Distance / Mile	
1	130	9.0	DECATUR
2	133	5.5	FINLEY IS. RD.
3	153	4.3	LEWIS LANE
4	210	5.8	TENN. VALLEY JR. HIGH SCHOOL
5	220	6.0	HILLSBORO
6	245	4.5	DAVID TEMPLE CH.
7	269	1.9	PORTER CEMETERY
8	257	11.0	COURTLAND HOSPITAL
9	295	7.0	SPRING CR. & LOCK RD.
10	292	4.5	MALLARD CR. RD.
11	269	1.9	LAKEVIEW CABINS
12	240	2.6	DAVIS FARM
13	220	1.7	BROWNS FERRY RD.
14	268	17.0	TOWN CREEK
15	201	3.0	BAKER BOTTOM RD.
16	181	3.0	STATE PIC STATION
17	50	9.5	ATHENS RD. & RT. 72
18	51	3.5	ATHENS RD. & COWFORD RD.
19	62	3.2	OAK GROVE CHURCH
20	36	2.8	COWFORD RD.
21	111	3.1	END OF COWFORD RD.
22	64	1.1	COX CEMETERY
23	90	26.0	HUNTSVILLE
24	111	0.8	BFNP METEOROLOGICAL TOWER
25	46	2.2	LAWNGATE
26	26	1.7	INTERSECTION ON LAWNGATE RD.
27	333	1.7	POPLAR PT.
28	335	1.0	PARADISE SHORES
29	27	3.8	SEVEN MILE POST RD. & RT. 24
30	0	4.0	RIPLEY CITY HALL
31	340	5.3	SNAKE RD.
32	312	12.0	ROLAND EZELL RESIDENCE
33	0	1.5	SHAW RD. & LAWNGATE RD.
34	52	7.0	TURNER CHAPEL SCHOOL
35	95	5.4	BEULAH BAY RD.
36	68	5.6	MOORESVILLE RD.
37	149	7.8	TVA SUBSTATION
38	164	7.0	TREE BETWEEN TRINITY TOWN HALL & FIRE CO.

NRC TLD DOSES FOR BROWNS FERRY AREA

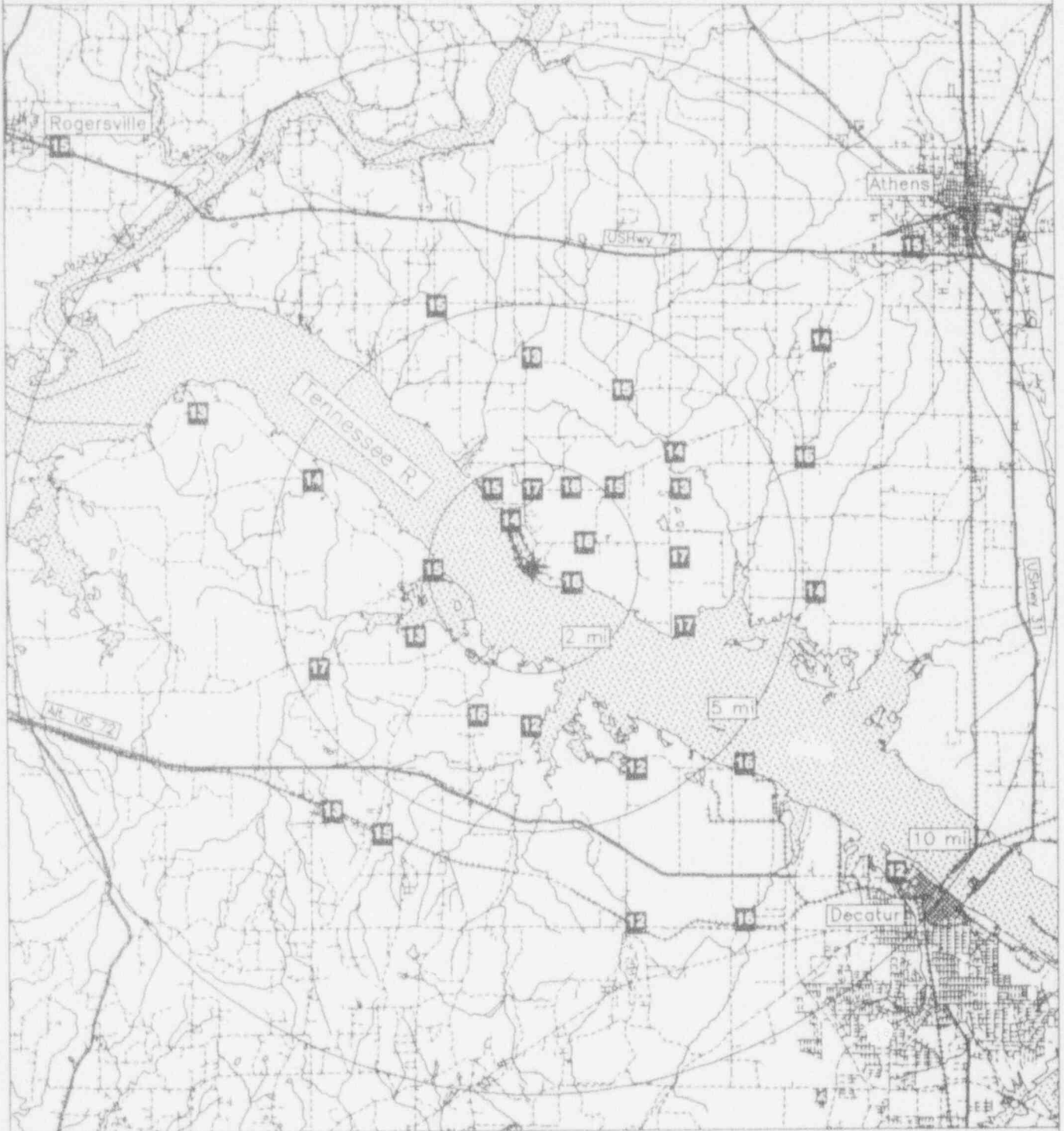

Miles

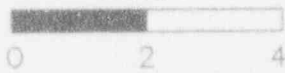

Legend

Water

Railroads

Plant site

Highways

Roads

BRUNSWICK

TLD Direct Radiation Environmental Monitoring

For the period 930915-940201 140 Days

Field Time: 92 Days

NRC Sta	Location Azimuth/Dist (Deg)/(Mi)	Gross Exposure (mR) +-Rdm; Tot.	Net Exposure Rate (mR/Std. Qtr.) +-Rdm; Tot.	Hist. Range Net Exp Rate +-1 Std Dev
1	260 2.2	14.2 +- 0.4; 2.1	8.3 +- 0.6; 3.7	10.5 +- 1.5
2	245 3.4	14.3 +- 0.4; 2.1	8.3 +- 0.6; 3.7	10.4 +- 1.5
3	231 3.8	Missing Dosimeter	No Net Data	10.2 +- 1.4
4	210 4.9	15.8 +- 0.5; 2.4	9.8 +- 0.6; 3.9	12.8 +- 1.5
5	186 4.3	15.8 +- 0.5; 2.4	9.8 +- 0.6; 3.9	12.6 +- 1.7
6	270 4.5	14.0 +- 0.4; 2.1	8.0 +- 0.6; 3.7	10.5 +- 1.3
7	272 4.4	14.6 +- 0.4; 2.2	8.7 +- 0.6; 3.8	11.3 +- 1.4
8	73 1.3	15.5 +- 0.5; 2.3	9.5 +- 0.6; 3.8	12.6 +- 1.5
9	97 1.0	15.6 +- 0.5; 2.3	9.6 +- 0.6; 3.8	12.4 +- 1.4
10	120 1.5	16.3 +- 0.5; 2.5	10.3 +- 0.6; 3.9	12.5 +- 1.4
11	131 0.9	15.8 +- 0.5; 2.4	9.8 +- 0.6; 3.9	12.2 +- 1.4
12	156 1.1	16.9 +- 0.5; 2.5	10.9 +- 0.6; 4.0	12.7 +- 1.5
13	180 1.1	15.2 +- 0.5; 2.3	9.2 +- 0.6; 3.8	11.8 +- 1.3
14	194 2.4	13.8 +- 0.4; 2.1	7.8 +- 0.6; 3.7	11.7 +- 1.5
15	201 2.0	15.3 +- 0.5; 2.3	9.3 +- 0.6; 3.8	11.2 +- 1.4
16	218 1.2	Missing Dosimeter	No Net Data	12.6 +- 1.5
17	252 1.1	16.2 +- 0.5; 2.4	10.2 +- 0.6; 3.9	12.3 +- 1.4
18	272 1.2	14.2 +- 0.4; 2.1	8.2 +- 0.6; 3.7	12.0 +- 1.6
19	19 1.1	14.8 +- 0.4; 2.2	8.8 +- 0.6; 3.8	11.4 +- 1.5
20	2 1.1	14.1 +- 0.4; 2.1	8.1 +- 0.6; 3.7	11.2 +- 1.7
21	288 1.3	14.4 +- 0.4; 2.2	8.4 +- 0.6; 3.7	10.6 +- 1.9
22	307 1.5	15.5 +- 0.5; 2.3	9.5 +- 0.6; 3.8	10.9 +- 1.4
23	338 2.1	15.5 +- 0.5; 2.3	9.5 +- 0.6; 3.8	11.9 +- 1.5
24	325 4.9	14.6 +- 0.4; 2.2	8.6 +- 0.6; 3.8	10.8 +- 1.3
25	338 3.8	16.2 +- 0.5; 2.4	10.2 +- 0.6; 3.9	11.9 +- 1.5
26	356 5.2	14.2 +- 0.4; 2.1	8.2 +- 0.6; 3.7	11.0 +- 1.3
27	30 6.4	14.9 +- 0.4; 2.2	8.9 +- 0.6; 3.8	10.7 +- 1.5
28	43 9.0	13.6 +- 0.4; 2.0	7.7 +- 0.6; 3.7	12.3 +- 1.9
29	50 8.5	14.2 +- 0.4; 2.1	8.2 +- 0.6; 3.7	11.7 +- 1.7
30	59 7.2	15.5 +- 0.5; 2.3	9.5 +- 0.6; 3.8	11.9 +- 1.6
31	65 6.5	15.3 +- 0.5; 2.3	9.3 +- 0.6; 3.8	11.9 +- 1.5
32	74 5.8	14.9 +- 0.4; 2.2	8.9 +- 0.6; 3.8	12.6 +- 1.8
33	88 4.1	Damaged Dosimeter	No Net Data	11.1 +- 1.7
34	12 17.0	15.9 +- 0.5; 2.4	9.9 +- 0.6; 3.9	12.4 +- 1.4
35	16 18.0	15.3 +- 0.5; 2.3	9.3 +- 0.6; 3.8	11.0 +- 1.5
36	284 15.0	16.4 +- 0.5; 2.5	10.4 +- 0.6; 3.9	12.3 +- 2.1
37	284 16.0	13.8 +- 0.4; 2.1	7.8 +- 0.6; 3.7	13.1 +- 1.7
38	284 15.0	14.6 +- 0.4; 2.2	8.6 +- 0.6; 3.8	12.1 +- 1.5
39	287 4.6	13.9 +- 0.4; 2.1	7.9 +- 0.6; 3.7	11.1 +- 1.4
40	271 0.7	16.5 +- 0.5; 2.5	10.5 +- 0.6; 3.9	13.2 +- 1.6

Transit Dose = 5.8 +- 0.4; 3.2

BRUNSWICK

For the period 930915-940201

TLD Direct Radiation Environmental Monitoring

Azimuth (degrees)	Ave. Exposure Rate (mR/Std.Qtr.) +- Std.Dev.	Number In Group
348.76 - 11.25 N	8.2 +- 0.1	2
11.26 - 33.75 NNE	9.2 +- 0.5	4
33.76 - 56.25 NE	8.0 +- 0.4	2
56.26 - 78.75 ENE	9.3 +- 0.3	4
78.76 - 101.25 E	9.6 +- 0.0	1
101.26 - 123.75 ESE	10.3 +- 0.0	1
123.76 - 146.25 SE	9.8 +- 0.0	1
146.26 - 168.75 SSE	10.9 +- 0.0	1
168.76 - 191.25 S	9.5 +- 0.4	2
191.26 - 213.75 SSW	9.0 +- 1.0	3
213.76 - 236.25 SW	No Data +- No Data	0
236.26 - 258.75 WSW	9.3 +- 1.3	2
258.76 - 281.25 W	8.7 +- 1.0	5
281.26 - 303.75 WNW	8.2 +- 0.3	2
303.76 - 326.25 NW	9.1 +- 0.6	2
326.26 - 348.75 NNW	9.9 +- 0.5	2

Distance From Reactor (miles)	Ave. Exposure Rate (mR/Std.Qtr.) +- Std.Dev.	Number In Group
0 - 2	9.5 +- 0.9	14
2 - 5	8.8 +- 0.9	11
> 5	8.9 +- 0.7	9
Upwind Control	9.0 +- 1.3	3

BRUNSWICK
 TLD Direct Radiation Environmental Monitoring

NRC Station	Location		Description
	Azimuth Degree	Distance / Mile	
1	260	2.2	BEMC SUBSTATION RT. 133
2	245	3.4	HWY. 133 & RD. 1101
3	231	3.8	STANDARD PRODUCTS
4	210	4.9	CASWELL BEACH
5	186	4.3	FORT CASWELL DOCK
6	270	4.5	S. BRUNSWICK CO. LANDFILL
7	272	4.4	BRUNSWICK CO. LAND ON RT. 211
8	73	1.3	HWY. 1528 (INTAKE CANAL)
9	97	1.0	HWY. 1528 (S. OF CANAL)
10	120	1.5	RD. 1534
11	131	0.9	HWY. 1528 & RD. 1534
12	156	1.1	SUBSTATION (RT. 1528)
13	180	1.1	HWY. 1527
14	194	2.4	E. LEONARD & N. ATLANTIC ST.
15	201	2.0	E. 11TH ST.
16	218	1.2	HWY. 87 (N. OF HWY. 211)
17	252	1.1	HWY. 87 & BSEP ACCESS RD.
18	272	1.2	HWY. 87 (0.5 N. ACCESS RD.)
19	19	1.1	RD. 1525 (2.0 E. OF HWY. 87)
20	2	1.1	RD. 1525 (1.6 E. OF HWY. 87)
21	288	1.3	HWY. 87 (0.3 N. OF RD. 1525)
22	307	1.5	HWY. 87 (0.7 N. OF RD. 1525)
23	338	2.1	SUNNY PT. ACCESS RD.
24	325	4.9	BOLLING SPRINGS LAKES
25	338	3.8	HWY. 133 & ORTON CR.
26	356	5.2	HWY. 133 (2 MILES N. OF ORTON CR.)
27	30	6.4	SUNNY PT. (N. GATE)
28	43	9.0	HWY. 421 (SNOW CUT)
29	50	8.5	RT. 421 & LUMBERTON ST.
30	59	7.2	RT. 421 & OCEAN VIEW DR.
31	65	6.5	KURE BEACH WATER TOWER
32	74	5.8	FORT FISHER AFB
33	88	4.1	FEDERAL PT. FERRY LANDING
34	12	17.0	SHIPYARD BLVD. & WORTH DR.
35	16	18.0	SHIPYARD BLVD. & NEWKIRK AVE.
36	284	15.0	SUPPLY (NC RT. 211 & RD. 1115)
37	284	16.0	SUPPLY (NC RT. 211 & RT. 17)
38	284	15.0	SUPPLY (NC RT. 17 & RD. 1115)
39	287	4.6	ANTIOCH BAPTIST CHURCH
40	271	0.7	0.5 MILES E. OF HWY. 87

NRC TLD DOSES FOR BRUNSWICK AREA



Miles

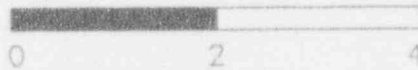

Legend

- Water
- Highways
- Railroads
- Roads
- Plant..site

BYRON

TLD Direct Radiation Environmental Monitoring

For the period 930914-940202 142 Days

Field Time: 99 Days

NRC Sta	Location Azimuth/Dist (Deg)/(Mi)		Gross Exposure (mR) +-Rdm; Tot.	Net Exposure Rate (mR/Std. Qtr.) +-Rdm; Tot.	Hist. Range Net Exp Rate +-1 Std Dev
1	10	1.1	24.7 +- 0.7; 3.7	19.3 +- 0.7; 4.4	19.0 +- 2.0
2	27	1.0	23.6 +- 0.7; 3.5	18.3 +- 0.7; 4.3	18.5 +- 2.0
3	53	1.6	22.2 +- 0.7; 3.3	17.0 +- 0.7; 4.2	17.3 +- 1.8
4	68	1.6	27.6 +- 0.8; 4.1	21.9 +- 0.8; 4.7	20.2 +- 2.3
5	97	1.4	28.0 +- 0.8; 4.2	22.2 +- 0.8; 4.8	20.7 +- 2.0
6	120	1.3	26.0 +- 0.8; 3.9	20.4 +- 0.8; 4.6	18.7 +- 1.8
7	146	1.4	28.3 +- 0.8; 4.2	22.5 +- 0.8; 4.8	19.9 +- 2.6
8	175	2.2	25.1 +- 0.8; 3.8	19.6 +- 0.8; 4.5	18.7 +- 1.7
9	177	0.6	21.6 +- 0.6; 3.2	16.5 +- 0.7; 4.1	16.0 +- 1.7
10	183	0.5	27.0 +- 0.8; 4.0	21.3 +- 0.8; 4.7	18.5 +- 2.2
11	193	0.6	26.1 +- 0.8; 3.9	20.5 +- 0.8; 4.6	17.7 +- 2.1
12	220	0.9	23.1 +- 0.7; 3.5	17.9 +- 0.7; 4.3	18.2 +- 1.8
13	239	0.8	22.6 +- 0.7; 3.4	17.3 +- 0.7; 4.2	17.5 +- 1.6
14	262	0.7	26.4 +- 0.8; 4.0	20.8 +- 0.8; 4.6	18.9 +- 2.2
15	283	0.8	25.2 +- 0.8; 3.8	19.7 +- 0.8; 4.5	18.0 +- 2.0
16	303	1.0	23.0 +- 0.7; 3.5	17.8 +- 0.7; 4.3	16.6 +- 1.8
17	326	1.6	24.0 +- 0.7; 3.6	18.6 +- 0.7; 4.3	16.2 +- 2.1
18	23	4.0	20.9 +- 0.6; 3.1	15.8 +- 0.7; 4.0	15.7 +- 1.5
19	17	4.1	19.2 +- 0.6; 2.9	14.3 +- 0.6; 3.9	14.3 +- 1.3
20	5	4.3	Missing Dosimeter	No Net Data	17.1 +- 1.9
21	340	4.2	21.2 +- 0.6; 3.2	16.1 +- 0.7; 4.1	18.6 +- 2.2
22	322	4.9	25.9 +- 0.8; 3.9	20.4 +- 0.8; 4.5	18.6 +- 2.5
23	298	6.9	21.2 +- 0.6; 3.2	16.1 +- 0.7; 4.1	15.7 +- 1.5
24	262	4.8	20.6 +- 0.6; 3.1	15.5 +- 0.6; 4.0	15.8 +- 1.6
25	244	4.6	21.7 +- 0.6; 3.2	16.5 +- 0.7; 4.1	15.7 +- 1.5
26	224	4.8	21.3 +- 0.6; 3.2	16.1 +- 0.7; 4.1	16.3 +- 2.0
27	208	5.2	18.8 +- 0.6; 2.8	13.9 +- 0.6; 3.8	14.7 +- 1.4
28	209	14.0	19.9 +- 0.6; 3.0	14.9 +- 0.6; 3.9	14.3 +- 1.3
29	215	13.0	22.5 +- 0.7; 3.4	17.2 +- 0.7; 4.2	17.3 +- 1.8
30	215	13.0	23.2 +- 0.7; 3.5	17.9 +- 0.7; 4.3	18.3 +- 2.0
31	204	4.6	18.6 +- 0.6; 2.8	13.7 +- 0.6; 3.8	13.4 +- 1.5
32	178	4.4	18.9 +- 0.6; 2.8	14.0 +- 0.6; 3.9	16.0 +- 1.4
33	155	3.9	23.2 +- 0.7; 3.5	17.9 +- 0.7; 4.3	17.6 +- 1.7
34	138	4.6	24.0 +- 0.7; 3.6	18.6 +- 0.7; 4.3	17.7 +- 1.8
35	118	4.4	23.6 +- 0.7; 3.5	18.3 +- 0.7; 4.3	18.8 +- 2.2
36	81	3.8	22.1 +- 0.7; 3.3	16.9 +- 0.7; 4.2	16.8 +- 1.9
37	70	5.5	22.3 +- 0.7; 3.3	17.1 +- 0.7; 4.2	16.3 +- 2.0
38	45	4.0	20.3 +- 0.6; 3.0	15.2 +- 0.6; 4.0	15.0 +- 1.8
39	40	6.8	23.7 +- 0.7; 3.6	18.4 +- 0.7; 4.3	18.0 +- 1.5
40	45	15.0	19.0 +- 0.6; 2.9	14.1 +- 0.6; 3.9	14.3 +- 1.3
41	220	3.0	26.4 +- 0.8; 4.0	20.8 +- 0.8; 4.6	19.4 +- 2.3

Transit Dose = 3.5 +- 0.4; 3.2

BYRON

For the period 930914-940202

TLD Direct Radiation Environmental Monitoring

Azimuth (degrees)	Ave. Exposure Rate (mR/Std.Qtr.) +- Std.Dev.	Number In Group
348.76 - 11.25 N	19.3 +- 0.0	1
11.26 - 33.75 NNE	16.1 +- 2.0	3
33.76 - 56.25 NE	16.2 +- 1.9	4
56.26 - 78.75 ENE	19.5 +- 3.5	2
78.76 - 101.25 E	19.6 +- 3.8	2
101.26 - 123.75 ESE	19.4 +- 1.5	2
123.76 - 146.25 SE	20.6 +- 2.7	2
146.26 - 168.75 SSE	17.9 +- 0.0	1
168.76 - 191.25 S	17.9 +- 3.3	4
191.26 - 213.75 SSW	16.1 +- 3.9	3
213.76 - 236.25 SW	18.3 +- 2.4	3
236.26 - 258.75 WSW	16.9 +- 0.6	2
258.76 - 281.25 W	18.2 +- 3.7	2
281.26 - 303.75 WNW	17.9 +- 1.8	3
303.76 - 326.25 NW	19.5 +- 1.2	2
326.26 - 348.75 NNW	16.1 +- 0.0	1

Distance From Reactor (miles)	Ave. Exposure Rate (mR/Std.Qtr.) +- Std.Dev.	Number In Group
0 - 2	19.5 +- 2.0	16
2 - 5	16.9 +- 2.2	16
> 5	15.9 +- 1.9	5
Upwind Control	16.7 +- 1.6	3

BYRON

TLD Direct Radiation Environmental Monitoring

NRC Station	Location		Description
	Azimuth / Degree	Distance / Mile	
1	10	1.1	CLOSEST DOWNWIND RES. OFF GERMAN CHURCH RD
2	27	1.0	GERMAN CHURCH RD. NORTH OF PLANT
3	53	1.6	WOODBINE&BLACK WALNUT RDS.
4	68	1.6	BLACK WALNUT RD.
5	97	1.4	BLACK WALNUT RD.
6	120	1.3	BLACK WALNUT RD.
7	146	1.4	HOLCOMB RD.
8	175	2.2	GERMAN CHURCH RD. (CLOSEST DAIRY)
9	177	0.6	DEERPATH RD.
10	183	0.5	DEERPATH RD.
11	193	0.6	DEERPATH RD.
12	220	0.9	RAZORVILLE RD.
13	239	0.8	RAZORVILLE RD.
14	262	0.7	RAZORVILLE RD.
15	283	0.8	RAZORVILLE RD.
16	303	1.0	RAZORVILLE RD.
17	326	1.6	RAZORVILLE RD.
18	23	4.0	BYRON WATER TOWER ON MARKET ST.
19	17	4.1	ACROSS FROM HIGH SCHOOL ON COLFAX ST.
20	5	4.3	E. MILL RD
21	340	4.2	CONGER RD/IL 72
22	322	4.9	IL 72/STONE SCH RD
23	298	6.9	IL 72 IN LEAF RIVER
24	262	4.8	SILVER CR RD (S. OF MIDTOWN RD)
25	244	4.6	LIMEKILN RD
26	224	4.8	IL 64
27	208	5.2	4TH/ADAMS (OREGON)
28	209	14.0	IL 2/BROAD ST.
29	215	13.0	RIDGE RD/HOUSE RD
30	215	13.0	RIDGE RD/HOUSE RD
31	204	4.6	IL 64
32	178	4.4	IL 64/GERMAN CHURCH RD
33	155	3.9	BRICK RD & ROCK HOLLOW RD
34	138	4.6	BRICK RD/CHANA RD
35	118	4.4	STILLMAN RD
36	81	3.8	WELD PARK RD/COX RD
37	70	5.5	IL 72/STILLMAN RD
38	45	4.0	IL 72/KISHWAUKEE RD
39	40	6.8	CRESTVIEW RD. 0.9 MI N. OF KISHWAUKEE
40	45	15.0	US 251 S. OF US 20 (ROCKFORD)
41	220	3.0	RIVER RD NEAR STATE PARK

NRC TLD DOSES FOR BYRON AREA

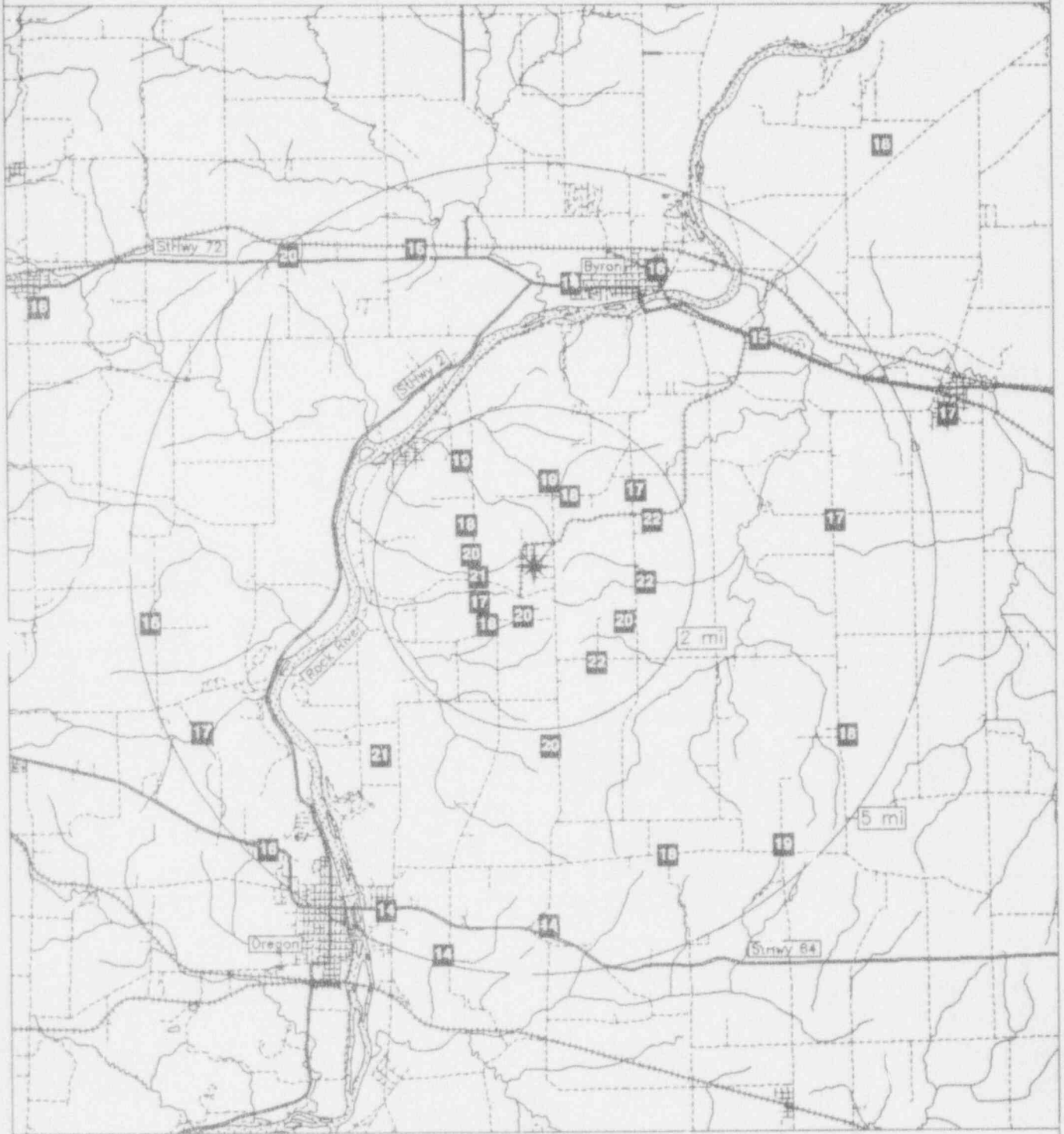

Miles

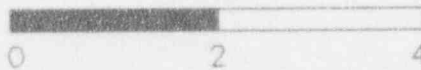

Legend

- Water
- Highways
- Railroads
- Roads
- Plant site

CALLAWAY

TLD Direct Radiation Environmental Monitoring

For the period 930914-940208 148 Days

Field Time: 97 Days

NRC Sta	Location		Gross Exposure (mR)		Net Exposure Rate (mR/Std. Qtr.)		Hist. Range Net Exp Rate	
	Azimuth/Dist (Deg)/(Mi)		+-Rdm; Tot.		+-Rdm; Tot.		+-1 Std Dev	
1	247	2.1	31.1	+- 0.9; 4.7	22.8	+- 1.0; 5.3	20.8	+- 2.8
2	259	1.4	28.8	+- 0.9; 4.3	20.6	+- 0.9; 5.1	19.5	+- 2.2
3	282	1.3	29.7	+- 0.9; 4.5	21.5	+- 0.9; 5.2	19.5	+- 1.7
4	304	1.3	29.4	+- 0.9; 4.4	21.2	+- 0.9; 5.2	20.3	+- 2.7
5	330	1.7	23.6	+- 0.7; 3.5	15.9	+- 0.8; 4.5	18.2	+- 2.0
6	1	1.7	24.0	+- 0.7; 3.6	16.2	+- 0.8; 4.6	17.0	+- 0.8
7	23	2.0	24.9	+- 0.7; 3.7	17.0	+- 0.8; 4.7	17.1	+- 1.0
8	77	0.7	25.6	+- 0.8; 3.8	17.7	+- 0.8; 4.7	17.8	+- 0.8
9	85	1.4	25.2	+- 0.8; 3.8	17.3	+- 0.8; 4.7	18.7	+- 1.1
10	98	1.5	24.0	+- 0.7; 3.6	16.2	+- 0.8; 4.6	17.3	+- 0.9
11	121	2.0	29.3	+- 0.9; 4.4	21.1	+- 0.9; 5.1	18.5	+- 2.8
12	140	2.0	27.9	+- 0.8; 4.2	19.8	+- 0.9; 5.0	18.3	+- 2.0
13	158	2.5	24.3	+- 0.7; 3.6	16.5	+- 0.8; 4.6	17.7	+- 1.0
14	183	3.7	Damaged Dosimeter		No Net Data		19.0	+- 1.1
15	188	1.7	25.1	+- 0.8; 3.8	17.2	+- 0.8; 4.7	18.5	+- 1.1
16	202	0.7	24.5	+- 0.7; 3.7	16.7	+- 0.8; 4.6	17.4	+- 1.0
17	237	0.7	28.7	+- 0.9; 4.3	20.6	+- 0.9; 5.1	19.1	+- 1.9
18	312	11.0	24.3	+- 0.7; 3.6	16.5	+- 0.8; 4.6	17.8	+- 1.8
19	292	10.0	24.1	+- 0.7; 3.6	16.3	+- 0.8; 4.6	17.5	+- 1.0
20	268	9.0	25.8	+- 0.8; 3.9	17.9	+- 0.8; 4.6	18.0	+- 0.8
21	247	8.0	30.7	+- 0.9; 4.6	22.5	+- 0.9; 5.1	20.0	+- 2.2
22	225	8.0	24.8	+- 0.7; 3.7	16.9	+- 0.8; 4.7	17.6	+- 1.0
23	220	8.0	25.2	+- 0.8; 3.8	17.3	+- 0.8; 4.7	19.3	+- 2.0
24	205	5.5	23.2	+- 0.7; 3.5	15.5	+- 0.8; 4.5	16.4	+- 2.3
25	157	4.0	30.8	+- 0.9; 4.6	22.5	+- 0.9; 5.3	20.3	+- 2.4
26	134	5.0	24.2	+- 0.7; 3.6	16.4	+- 0.8; 4.6	16.1	+- 0.9
27	115	4.2	30.3	+- 0.9; 4.5	22.0	+- 0.9; 5.2	20.7	+- 2.4
28	95	3.5	30.5	+- 0.9; 4.6	22.2	+- 0.9; 5.3	20.6	+- 2.1
29	67	3.4	26.7	+- 0.8; 4.0	18.7	+- 0.8; 4.9	19.5	+- 1.1
30	48	4.5	23.7	+- 0.7; 3.6	15.9	+- 0.8; 4.5	16.7	+- 0.8
31	14	6.5	26.9	+- 0.8; 4.0	18.9	+- 0.9; 4.9	18.8	+- 1.0
32	2	5.1	25.6	+- 0.8; 3.8	17.7	+- 0.8; 4.7	18.8	+- 0.9
33	335	3.6	23.3	+- 0.7; 3.5	15.6	+- 0.8; 4.5	16.2	+- 1.0
34	288	4.3	27.1	+- 0.8; 4.1	19.1	+- 0.9; 4.9	18.8	+- 1.1
35	310	5.2	26.0	+- 0.8; 3.9	18.1	+- 0.8; 4.8	18.7	+- 1.1
36	264	3.2	24.6	+- 0.7; 3.7	16.8	+- 0.8; 4.6	14.4	+- 1.1
37	237	3.0	29.2	+- 0.9; 4.4	21.1	+- 0.9; 5.1	19.6	+- 1.8
38	270	15.0	27.8	+- 0.8; 4.2	19.8	+- 0.9; 5.0	16.3	+- 1.8
39	270	15.0	29.1	+- 0.9; 4.4	21.0	+- 0.9; 5.1	16.4	+- 2.7
40	203	20.0	26.0	+- 0.8; 3.9	18.1	+- 0.8; 4.8	18.5	+- 0.8

Transit Dose = 6.5 +- 0.4; 3.4

CALLAWAY

For the period 930914-940208

TLD Direct Radiation Environmental Monitoring

Azimuth (degrees)	Ave. Exposure Rate (mR/Std.Qtr.) +- Std.Dev.	Number In Group
348.76 - 11.25 N	17.0 +- 1.1	2
11.26 - 33.75 NNE	18.0 +- 1.3	2
33.76 - 56.25 NE	15.9 +- 0.0	1
56.26 - 78.75 ENE	18.2 +- 0.8	2
78.76 - 101.25 E	18.6 +- 3.2	3
101.26 - 123.75 ESE	21.6 +- 0.7	2
123.76 - 146.25 SE	18.1 +- 2.4	2
146.26 - 168.75 SSE	19.5 +- 4.3	2
168.76 - 191.25 S	17.2 +- 0.0	1
191.26 - 213.75 SSW	16.1 +- 0.8	2
213.76 - 236.25 SW	17.1 +- 0.3	2
236.26 - 258.75 WSW	21.7 +- 1.1	4
258.76 - 281.25 W	18.4 +- 2.0	3
281.26 - 303.75 WNW	18.9 +- 2.6	3
303.76 - 326.25 NW	18.6 +- 2.4	3
326.26 - 348.75 NNW	15.7 +- 0.2	2

Distance From Reactor (miles)	Ave. Exposure Rate (mR/Std.Qtr.) +- Std.Dev.	Number In Group
0 - 2	18.5 +- 2.2	14
2 - 5	19.1 +- 2.9	12
> 5	17.7 +- 1.9	10
Upwind Control	19.6 +- 1.4	3

CALLAWAY
TLD Direct Radiation Environmental Monitoring

NRC Station	Location		Description
	Azimuth / Degree	Distance / Mile	
1	247	2.1	HWY CC ON PN 18769
2	359	1.4	HWY CC ON PN 18747
3	282	1.3	HWY AD ON PN 185580
4	304	1.3	HWY CC ON PN 18450
5	330	1.7	HWY CC AND O - PN 28613
6	1	1.7	RT O AND DD - PN 28139
7	23	2.0	RT O - UNION CITY ST. - PN 31094
8	77	0.7	RT DD - PN 28151
9	85	1.4	RT DD - GRAVEL RD - PN 30956
10	98	1.5	RT DD - CONSERVATION PARKING LOT
11	121	2.0	RT DD - PN 2 N 310
12	140	2.0	RT DD - PN 06871
13	158	2.5	RT DD - PN 06851
14	183	3.7	RT DD & HWY 94 - PN 06754
15	188	1.7	RT 336(MICRO TWR)PN-18716
16	202	0.7	RT 336(HEAVY HAUL RD) NO #
17	237	0.7	RT 336-NO PN-NEAR PARK LOT
18	312	11.0	NE OF FULTON ON Z-PN21544
19	292	10.0	RT C-S. OF FULTON- NO PN
20	268	9.0	RT C - PN 53655
21	247	8.0	RT C - RANCH HOUSE PN 5/40
22	225	8.0	RT C-S CALLOWAY RII SCH PN5/25K
23	220	8.0	RT C-RIVERVIEW NURS HM PN 5V/1
24	205	5.5	RT C - HWY 66 & KATY TRAIL TELEPHONE POST
25	157	4.0	HWY 94-NEAR GRAY BARN PN 12182
26	134	5.0	PORTLAND-NEAR CH BELL PN 125/11
27	115	4.2	HWY 94 & RT D - PN 11935
28	95	3.5	RT D - PN 13000
29	67	3.4	RT D - PN 12955
30	48	4.5	RT D (PAST RT K) PN 12818
31	14	6.5	YUCATAN BAPTIST CH. PN 12670
32	2	5.1	BEFORE MOHEGAN RD. PN 19139
33	335	3.6	RT CC - POLE(L. SIDE OF RD)
34	288	4.3	RT O - PN 18145
35	310	5.2	GRAVEL RD. - PN 17516
36	264	3.2	RT AD - BRIDGE POST(RT. SIDE)
37	237	3.0	RT CC - POLE AT X SEC WITH SIDE RD.
38	270	15.0	CHURCH AT HWY OLD 63 & GLENWOOD DR. (NB0049)
39	270	15.0	NEW BLOOMFIELD - BEHIND STORE
40	203	20.0	HOLTS SUMMIT-BY CHIROPRACTIC CLINIC

NRC TLD DOSES FOR CALLAWAY AREA

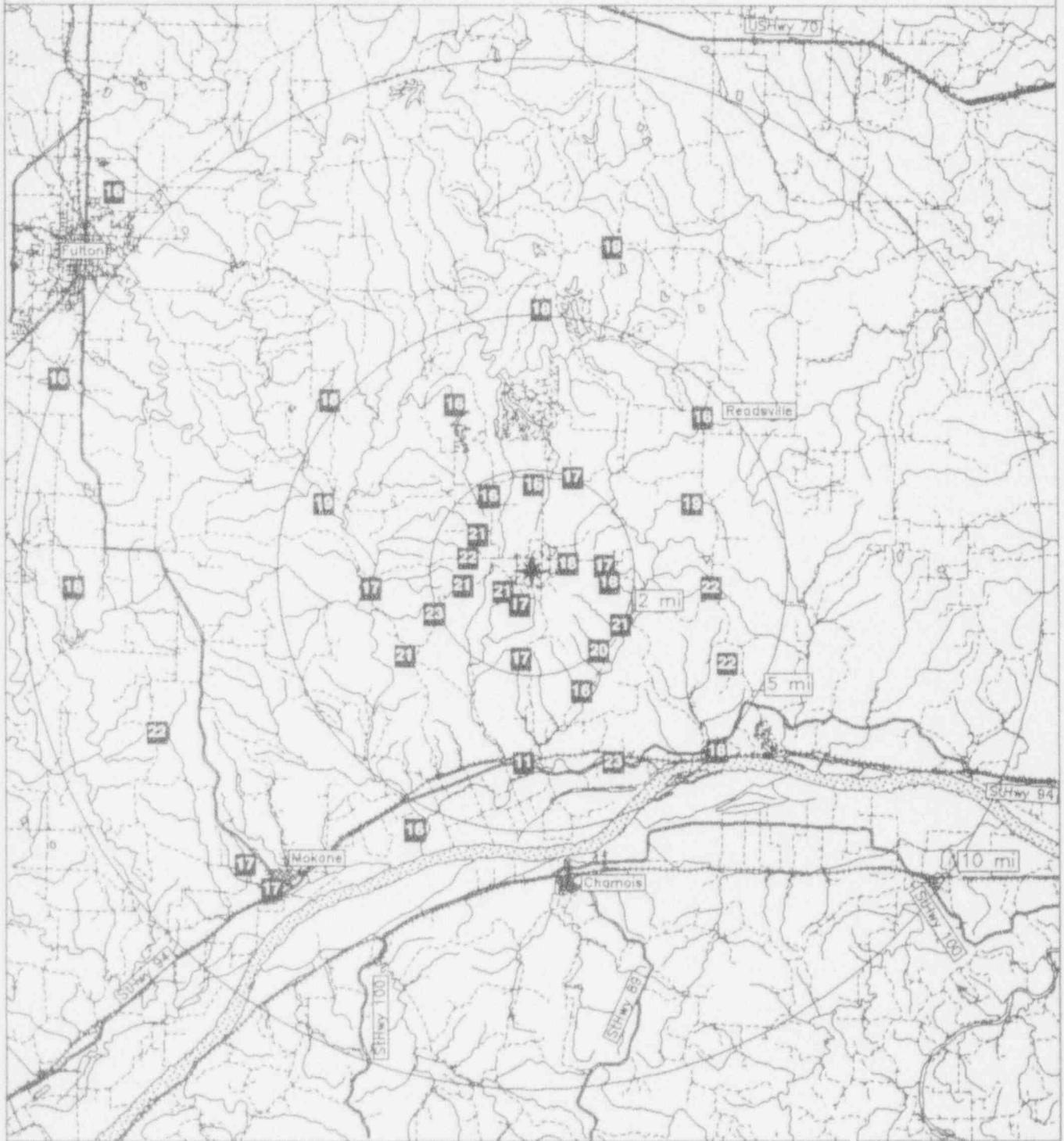

Miles

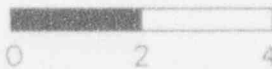

Legend

Water

Highways

Railroads

Roads

Plant..site

CALVERT CLIFFS
 TLD Direct Radiation Environmental Monitoring
 For the period 930915-940203 142 Days
 Field Time: 99 Days

NRC Sta	Location Azimuth/Dist (Deg)/(Mi)		Gross Exposure (mR) +-Rdm; Tot.	Net Exposure Rate (mR/Std. Qtr.) +-Rdm; Tot.	Hist. Range Net Exp Rate +-1 Std Dev
1	275	1.5	20.4 +- 0.6; 3.1	16.2 +- 0.6; 3.9	13.6 +- 2.0
3	284	1.7	20.6 +- 0.6; 3.1	16.4 +- 0.6; 4.0	13.2 +- 1.8
4	323	2.4	18.6 +- 0.6; 2.8	14.6 +- 0.6; 3.8	13.3 +- 1.3
5	297	3.1	21.1 +- 0.6; 3.2	16.9 +- 0.6; 4.0	14.0 +- 1.9
6	324	4.7	21.7 +- 0.7; 3.3	17.4 +- 0.7; 4.1	14.0 +- 1.9
7	324	5.5	18.1 +- 0.5; 2.7	14.2 +- 0.6; 3.7	12.4 +- 1.7
8	256	6.1	19.4 +- 0.6; 2.9	15.4 +- 0.6; 3.9	12.1 +- 2.1
9	273	4.1	17.9 +- 0.5; 2.7	14.0 +- 0.6; 3.7	13.2 +- 1.5
10	253	3.7	21.9 +- 0.7; 3.3	17.6 +- 0.7; 4.1	14.6 +- 1.7
11	230	4.0	19.7 +- 0.6; 3.0	15.6 +- 0.6; 3.9	14.6 +- 1.3
12	243	1.3	19.6 +- 0.6; 2.9	15.6 +- 0.6; 3.9	14.1 +- 1.3
13	222	1.5	22.6 +- 0.7; 3.4	18.3 +- 0.7; 4.2	15.2 +- 1.9
14	208	1.8	17.5 +- 0.5; 2.6	13.7 +- 0.6; 3.7	11.8 +- 1.4
15	176	2.4	25.0 +- 0.7; 3.7	20.4 +- 0.7; 4.4	16.4 +- 2.0
16	160	1.5	21.1 +- 0.6; 3.2	16.9 +- 0.6; 4.0	15.6 +- 1.4
19	159	3.8	19.6 +- 0.6; 2.9	15.5 +- 0.6; 3.9	13.9 +- 1.5
20	139	4.7	20.0 +- 0.6; 3.0	15.9 +- 0.6; 3.9	12.5 +- 1.9
21	201	4.0	19.9 +- 0.6; 3.0	15.8 +- 0.6; 3.9	13.3 +- 1.4
22	187	4.7	17.7 +- 0.5; 2.7	13.8 +- 0.6; 3.7	12.9 +- 1.1
23	201	8.7	20.1 +- 0.6; 3.0	16.0 +- 0.6; 3.9	13.8 +- 1.4
24	190	7.8	16.4 +- 0.5; 2.5	12.6 +- 0.5; 3.6	12.2 +- 1.2
25	325	6.7	18.6 +- 0.6; 2.8	14.6 +- 0.6; 3.8	13.1 +- 1.3
26	314	11.0	17.6 +- 0.5; 2.6	13.7 +- 0.6; 3.7	12.3 +- 1.4
27	314	11.0	18.1 +- 0.5; 2.7	14.2 +- 0.6; 3.7	12.6 +- 1.2
28	315	10.0	21.4 +- 0.6; 3.2	17.1 +- 0.7; 4.0	15.1 +- 1.7
29	186	12.0	20.6 +- 0.6; 3.1	16.5 +- 0.6; 4.0	15.1 +- 1.3

Transit Dose = 2.5 +- 0.3; 3.1

CALVERT CLIFFS
For the period 930915-940203

TLD Direct Radiation Environmental Monitoring

Azimuth (degrees)	Ave. Exposure Rate (mR/Std.Qtr.) +- Std.Dev.	Number In Group
348.75 - 11.25 N	No Data +- No Data	0
11.26 - 33.75 NNE	No Data +- No Data	0
33.76 - 56.25 NE	No Data +- No Data	0
56.26 - 78.75 ENE	No Data +- No Data	0
78.76 - 101.25 E	No Data +- No Data	0
101.26 - 123.75 ESE	No Data +- No Data	0
123.76 - 146.25 SE	15.9 +- 0.0	1
146.26 - 168.75 SSE	16.2 +- 1.0	2
168.76 - 191.25 S	15.8 +- 3.5	4
191.26 - 213.75 SSW	15.1 +- 1.3	3
213.76 - 236.25 SW	17.0 +- 1.9	2
236.26 - 258.75 WSW	16.2 +- 1.2	3
258.76 - 281.25 W	15.1 +- 1.6	2
281.26 - 303.75 WNW	16.6 +- 0.3	2
303.76 - 326.25 NW	15.2 +- 1.5	4
326.26 - 348.75 NNW	No Data +- No Data	0

Distance From Reactor (miles)	Ave. Exposure Rate (mR/Std.Qtr.) +- Std.Dev.	Number In Group
0 - 2	16.2 +- 1.5	6
2 - 5	16.1 +- 1.9	11
> 5	14.9 +- 1.4	6
Upwind Control	15.0 +- 1.8	3

CALVERT CLIFFS
TLD Direct Radiation Environmental Monitoring

NRC Station	Location		Description
	Azimuth / Degree	Distance / Mile	
1	275	1.5	ROUTE 2, KNOTTY PINE
3	284	1.7	ROUTE 2
4	323	2.4	LONG BEACH
5	297	3.1	ROUTE 2 AND PARRAN ROAD
6	324	4.7	ROUTE 2, CLIFFS MOTEL
7	324	5.5	GOVERNOR RUN
8	256	6.1	BROOMES ISLAND
9	273	4.1	ROUTE 265 (BOWEN ROAD)
10	253	3.7	WALLVILLE
11	230	4.0	ST. LEONARD CREEK
12	243	1.3	ROUTE 2
13	222	1.5	ROUTE 2 (JOHNS CREEK)
14	208	1.8	LUSBY
15	176	2.4	ROUTE 2, MIDDLEHAM CHAPEL
16	160	1.5	CAMP CANOY (BEFORE GEORGE'S GARAGE)
19	159	3.8	ROUTE 497 & LITTLE COVE POINT ROAD
20	139	4.7	COVE POINT
21	201	4.0	MILL BRIDGE ROAD & TURNER ROAD
22	187	4.7	APPEAL
23	201	8.7	S. PAXTUENT BEACH RD.
24	190	7.8	SOLOMONS ISLAND
25	325	6.7	SCIENTIST CLIFFS
26	314	11.0	PRINCE FREDERICK
27	314	11.0	PRINCE FREDERICK
28	315	10.0	PRINCE FREDERICK
29	186	12.0	LEXINGTON PARK

NRC TLD DOSES FOR CALVERT CLIFFS AREA

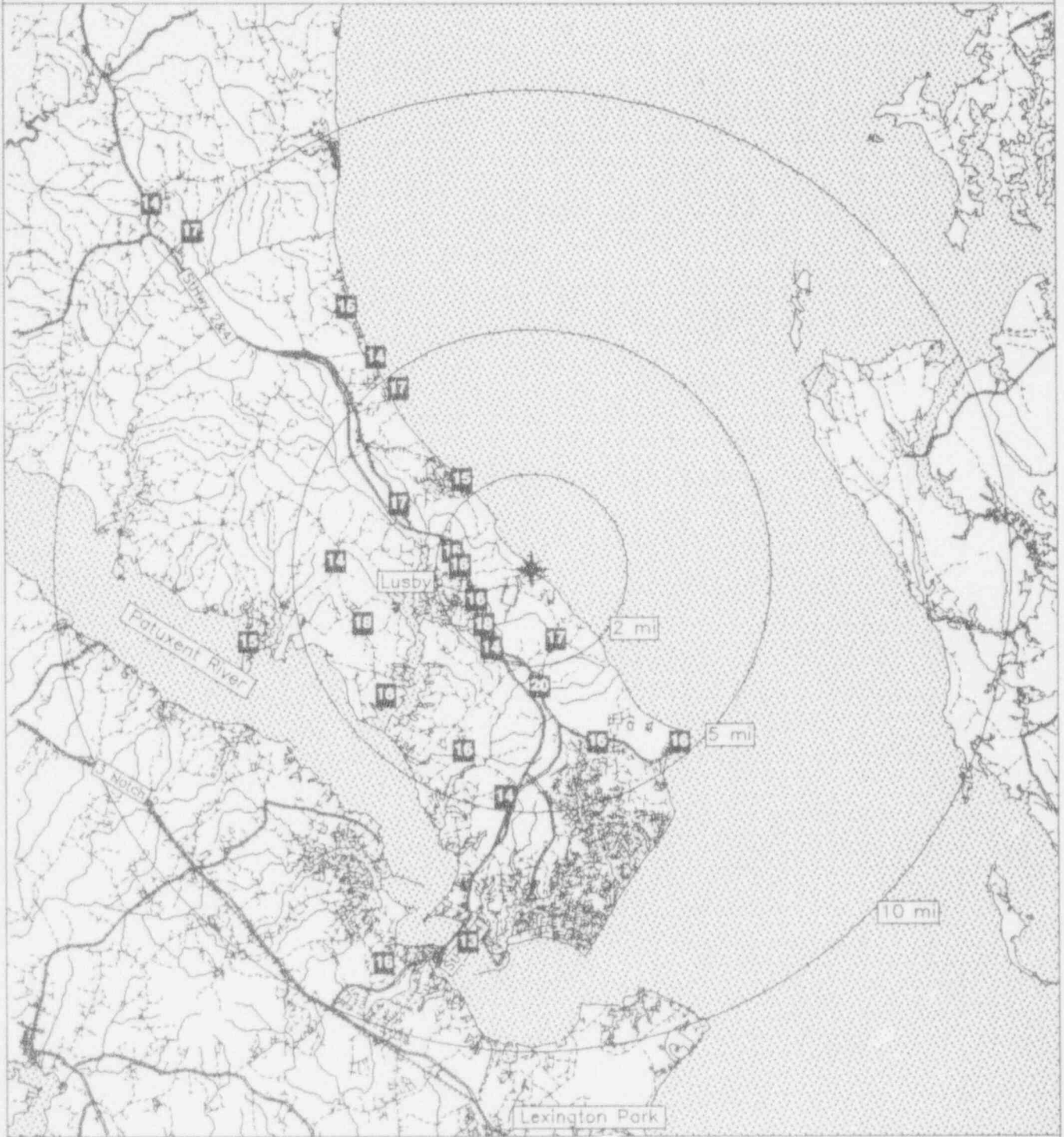

Miles

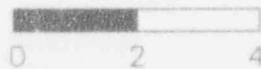

Legend



Water

Highways

Railroads

Roads



Plant..site

CATAWBA

TLD Direct Radiation Environmental Monitoring

For the period 930915-940209 148 Days

Field Time: 111 Days

NRC Sta	Location		Gross	Net Exposure Rate	Hist. Range
	Azimuth/Dist (Deg)/(Mi)		Exposure (mR) +-Rdm; Tot.	(mR/Std. Qtr.) +-Rdm; Tot.	Net Exp Rate +-1 Std Dev
1	134	0.1	30.3 +- 0.9; 4.5	17.8 +- 0.9; 4.9	18.9 +- 3.1
2	162	0.4	25.4 +- 0.8; 3.8	13.9 +- 0.8; 4.4	15.8 +- 2.6
3	132	0.8	29.5 +- 0.9; 4.4	17.1 +- 0.8; 4.8	18.7 +- 2.8
4	111	1.3	27.2 +- 0.8; 4.1	15.3 +- 0.8; 4.6	16.0 +- 2.4
5	45	0.7	Missing Dosimeter	No Net Data	16.0 +- 2.2
6	298	1.3	29.6 +- 0.9; 4.4	17.2 +- 0.8; 4.8	17.6 +- 2.6
7	4	0.6	25.7 +- 0.8; 3.8	14.1 +- 0.8; 4.5	15.3 +- 2.6
8	332	1.5	29.5 +- 0.9; 4.4	17.2 +- 0.8; 4.8	19.7 +- 2.6
9	318	1.6	21.1 +- 0.6; 3.2	10.3 +- 0.7; 4.1	12.8 +- 2.8
10	176	1.8	27.2 +- 0.8; 4.1	15.3 +- 0.8; 4.6	16.9 +- 3.0
11	203	1.5	27.7 +- 0.8; 4.2	15.7 +- 0.8; 4.6	16.9 +- 2.7
12	225	1.5	27.7 +- 0.8; 4.2	15.7 +- 0.8; 4.6	17.3 +- 2.9
13	250	1.9	24.3 +- 0.7; 3.7	13.0 +- 0.7; 4.4	14.5 +- 3.0
14	270	1.4	21.0 +- 0.6; 3.2	10.3 +- 0.7; 4.1	12.8 +- 2.7
15	331	3.0	24.5 +- 0.7; 3.7	13.1 +- 0.7; 4.4	14.2 +- 3.0
16	311	3.9	22.0 +- 0.7; 3.3	11.1 +- 0.7; 4.2	13.4 +- 2.9
17	296	9.5	29.0 +- 0.9; 4.3	16.7 +- 0.8; 4.8	18.2 +- 2.7
18	324	4.8	24.2 +- 0.7; 3.6	12.9 +- 0.7; 4.3	15.5 +- 3.1
19	352	4.8	22.9 +- 0.7; 3.4	11.8 +- 0.7; 4.2	13.3 +- 2.8
20	22	4.0	27.5 +- 0.8; 4.1	15.5 +- 0.8; 4.6	16.8 +- 2.8
21	290	3.9	25.4 +- 0.8; 3.8	13.9 +- 0.8; 4.4	15.2 +- 2.6
22	266	4.0	26.5 +- 0.8; 4.0	14.7 +- 0.8; 4.5	16.2 +- 2.9
23	251	4.0	20.7 +- 0.6; 3.1	10.0 +- 0.7; 4.1	11.4 +- 2.8
24	229	3.9	22.7 +- 0.7; 3.4	11.6 +- 0.7; 4.2	12.3 +- 2.8
25	202	4.4	27.6 +- 0.8; 4.1	15.7 +- 0.8; 4.6	17.4 +- 2.2
26	51	4.3	30.0 +- 0.9; 4.5	17.6 +- 0.8; 4.9	18.2 +- 2.3
27	64	7.9	20.6 +- 0.6; 3.1	10.0 +- 0.7; 4.1	11.8 +- 2.4
28	61	4.9	26.3 +- 0.8; 3.9	14.6 +- 0.8; 4.5	15.3 +- 2.6
29	49	1.9	24.4 +- 0.7; 3.7	13.1 +- 0.7; 4.4	15.3 +- 3.6
30	64	1.8	25.2 +- 0.8; 3.8	13.7 +- 0.7; 4.4	15.0 +- 2.5
31	87	1.6	25.3 +- 0.8; 3.8	13.8 +- 0.7; 4.4	14.4 +- 2.6
32	121	2.6	27.7 +- 0.8; 4.2	15.7 +- 0.8; 4.6	15.5 +- 2.6
33	114	7.6	Missing Dosimeter	No Net Data	14.6 +- 3.2
34	93	4.5	27.1 +- 0.8; 4.1	15.2 +- 0.8; 4.6	17.2 +- 3.1
35	132	4.3	33.6 +- 1.0; 5.0	20.5 +- 0.9; 5.2	20.6 +- 2.6
36	163	8.9	22.2 +- 0.7; 3.3	11.2 +- 0.7; 4.2	12.5 +- 2.4
37	173	4.9	24.3 +- 0.7; 3.6	13.0 +- 0.7; 4.4	13.7 +- 2.2
38	157	4.6	32.0 +- 1.0; 4.8	19.2 +- 0.9; 5.0	18.3 +- 2.2
39	248	10.0	25.5 +- 0.8; 3.8	14.0 +- 0.8; 4.5	16.2 +- 3.6
40	229	12.0	27.7 +- 0.8; 4.1	15.7 +- 0.8; 4.6	15.1 +- 2.5
41	218	13.0	Missing Dosimeter	No Net Data	12.9 +- 3.4
42	213	16.0	27.3 +- 0.8; 4.1	15.4 +- 0.8; 4.6	15.6 +- 2.2

Transit Dose = 8.3 +- 0.5; 3.9

CATAWBA

For the period 930915-940209

TLD Direct Radiation Environmental Monitoring

Azimuth (degrees)	Ave. Exposure Rate (mR/Std.Qtr.) +- Std.Dev.	Number In Group
348.76 - 11.25 N	12.9 +- 1.6	2
11.26 - 33.75 NNE	15.5 +- 0.0	1
33.76 - 56.25 NE	15.3 +- 3.2	2
56.26 - 78.75 ENE	12.7 +- 2.4	3
78.76 - 101.25 E	14.5 +- 1.0	2
101.26 - 123.75 ESE	15.5 +- 0.3	2
123.76 - 146.25 SE	18.5 +- 1.8	3
146.26 - 168.75 SSE	14.8 +- 4.1	3
168.76 - 191.25 S	14.1 +- 1.6	2
191.26 - 213.75 SSW	15.7 +- 0.1	2
213.76 - 236.25 SW	13.7 +- 2.9	2
236.26 - 258.75 WSW	12.3 +- 2.1	3
258.76 - 281.25 W	12.5 +- 3.1	2
281.26 - 303.75 WNW	15.9 +- 1.8	3
303.76 - 326.25 NW	11.4 +- 1.3	3
326.26 - 348.75 NNW	15.1 +- 2.9	2

Distance From Reactor (miles)	Ave. Exposure Rate (mR/Std.Qtr.) +- Std.Dev.	Number In Group
0 - 2	14.6 +- 2.3	16
2 - 5	14.5 +- 2.8	17
> 5	13.0 +- 3.0	4
Upwind Control	15.5 +- 0.2	2

CATAWBA
TLD Direct Radiation Environmental Monitoring

NRC Station	Location		Description
	Azimuth / Degree	Distance / Mile	
1	134	0.1	CATAWBA OVERLOOK CENTER
2	162	0.4	DISCHARGE CANAL
3	132	0.8	CONCORD RD.
4	111	1.3	ENT. COMMODORE YACHT CLUB
5	45	0.7	BLUEBIRD LN.
6	298	1.3	DUKE POWER SUBSTATION
7	4	0.6	DPC ENVIRON. MONITOR. STATION
8	332	1.5	HV POWER LINES
9	318	1.6	JCT HWY 274 & LIBERTY HILL RD.
10	176	1.8	S. OF MARTHA'S VINEYARD RD.
11	203	1.5	ALLISON CR. RD.(W. OF BARDALE RD.)
12	225	1.5	ALLISON CR. RD.(W. OF GRANVILLA RD)
13	250	1.9	ALLISON CR. PRESBYTERIAN CHURCH
14	270	1.4	ALLISON CREEK LANDING
15	331	3.0	BETHEL BAPTIST CHURCH
16	311	3.9	BETHEL SCHOOL
17	296	9.5	CLOVER POST OFFICE
18	324	4.8	CHANDLER RD OFF BETHEL SCH. RD
19	352	4.8	BETHEL LUMBER CO.
20	22	4.0	HUNGRY FISHERMAN RESTAURANT
21	290	3.9	INTERSEC. C.R. 114 & 152
22	266	4.0	INTERSEC. HWY 49 & C.R. 54
23	251	4.0	INTERSEC. HWYS 54 & 80
24	229	3.9	HV POWER LINE (HWY 54)
25	202	4.4	CARTER LUMBER CO.
26	51	4.3	HV POWER LINE(HWY 49 & PLEASANT HILL RD)
27	64	7.9	CAROWINDS AMUSEMENT PARK
28	61	4.9	INTERSEC. HAMILTON & STEELE CR. RDS
29	49	1.9	INTERSEC. SNUG HARBOR & KALABASH RDS
30	64	1.8	S. ON SNUG HARBOR RD
31	87	1.6	JUNC. BANKHEAD RD & WILBANKS RD
32	121	2.6	TEGA CAY(DPC SUBSTATION)
33	114	7.6	TEXACO C&S SUPERETTE (FT. MILL)
34	93	4.5	FT. MILL TELEPHONE CO.
35	132	4.3	SC WILDLIFE RESOURCES STATION
36	163	8.9	VILLAGE GAS PUMPS (C.R. 274)
37	173	4.9	BRYANT AIRPORT
38	157	4.6	JCT TWIN LAKES RD & HOMESTEAD RD
39	248	10.0	YORK COUNTY HEALTH CENTER
40	229	12.0	PHILADELPHIA UNITED CHURCH
41	218	13.0	JCT. HWY 321 & DAVES RD
42	213	16.0	FIRE DEPT & POST OFF.(MCCONNELLS, SC)

NRC TLD DOSES FOR CATAWBA AREA

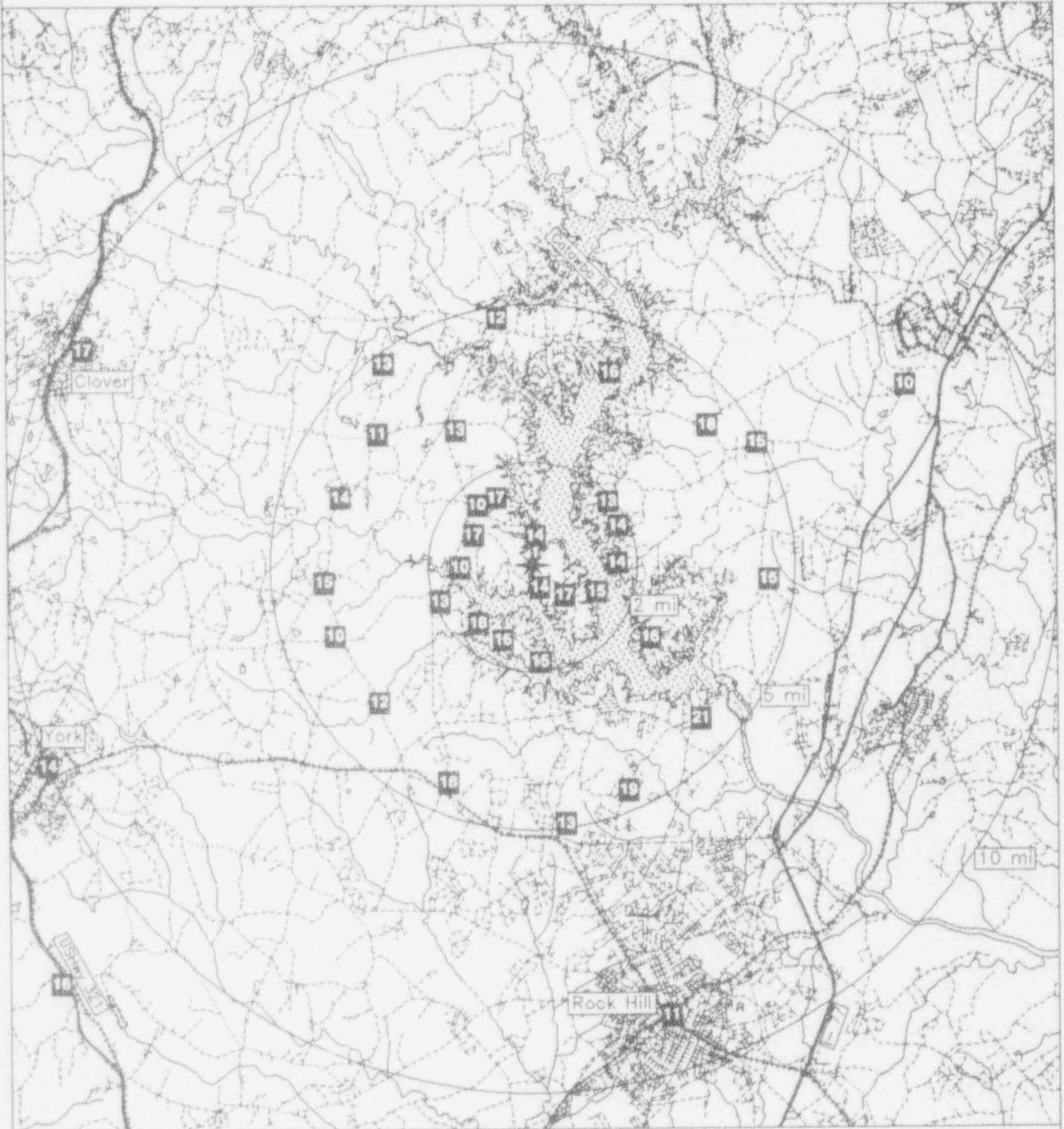

Miles

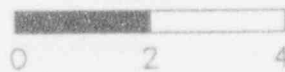

Legend

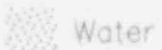

Water



Railroads



Plant..site



Highways



Roads

CLINTON

TLD Direct Radiation Environmental Monitoring

For the period 930914-940203 143 Days

Field Time: 108 Days

NRC Sta	Location		Gross Exposure (mR)		Net Exposure Rate (mR/Std. Qtr.)		Hist. Range Net Exp Rate	
	Azimuth/Dist (Deg)/(Mi)		+Rdm;	Tot.	+Rdm;	Tot.	+1 Std Dev	
1	5	0.6	23.8	+ 0.7; 3.6	17.0	+ 0.7; 4.1	18.9	+ 2.5
2	40	0.7	25.7	+ 0.8; 3.9	18.7	+ 0.7; 4.3	18.6	+ 1.6
3	35	0.8	30.1	+ 0.9; 4.5	22.3	+ 0.8; 4.7	21.2	+ 1.9
4	163	0.5	25.7	+ 0.8; 3.9	18.7	+ 0.7; 4.3	19.3	+ 1.9
5	210	0.5	24.8	+ 0.7; 3.7	17.9	+ 0.7; 4.2	19.4	+ 1.9
6	223	0.6	26.0	+ 0.8; 3.9	18.9	+ 0.7; 4.3	19.5	+ 1.8
7	235	0.8	25.0	+ 0.7; 3.7	18.0	+ 0.7; 4.2	18.8	+ 1.6
8	62	1.9	24.0	+ 0.7; 3.6	17.2	+ 0.7; 4.1	18.4	+ 1.6
9	78	1.8	24.8	+ 0.7; 3.7	17.9	+ 0.7; 4.2	18.4	+ 1.5
10	79	2.6	25.4	+ 0.8; 3.8	18.4	+ 0.7; 4.3	18.7	+ 2.1
11	100	2.3	25.5	+ 0.8; 3.8	18.5	+ 0.7; 4.3	18.4	+ 1.5
12	115	3.0	25.8	+ 0.8; 3.9	18.8	+ 0.7; 4.3	16.4	+ 2.0
13	127	3.2	25.2	+ 0.8; 3.8	18.2	+ 0.7; 4.2	18.5	+ 1.6
14	155	2.1	24.8	+ 0.7; 3.7	17.8	+ 0.7; 4.2	18.9	+ 1.6
15	185	3.0	23.8	+ 0.7; 3.6	17.0	+ 0.7; 4.1	19.2	+ 2.1
16	203	3.2	22.8	+ 0.7; 3.4	16.2	+ 0.6; 4.0	18.0	+ 1.6
17	230	3.7	24.5	+ 0.7; 3.7	17.6	+ 0.7; 4.2	17.9	+ 1.8
18	255	2.8	25.1	+ 0.8; 3.8	18.2	+ 0.7; 4.2	19.1	+ 1.6
19	275	2.3	24.5	+ 0.7; 3.7	17.6	+ 0.7; 4.2	18.5	+ 1.6
20	302	0.9	24.9	+ 0.7; 3.7	18.0	+ 0.7; 4.2	18.0	+ 1.6
21	336	0.8	25.1	+ 0.8; 3.8	18.1	+ 0.7; 4.2	17.9	+ 1.8
22	0	0.6	24.4	+ 0.7; 3.7	17.6	+ 0.7; 4.2	18.6	+ 2.0
23	358	4.6	26.8	+ 0.8; 4.0	19.5	+ 0.7; 4.4	19.1	+ 1.8
24	20	3.9	23.9	+ 0.7; 3.6	17.1	+ 0.7; 4.1	18.3	+ 1.7
25	46	5.0	24.5	+ 0.7; 3.7	17.7	+ 0.7; 4.2	18.9	+ 1.5
26	62	5.5	22.8	+ 0.7; 3.4	16.2	+ 0.6; 4.0	17.0	+ 1.6
27	90	4.8	24.5	+ 0.7; 3.7	17.7	+ 0.7; 4.2	17.7	+ 1.8
28	115	5.2	22.4	+ 0.7; 3.4	15.9	+ 0.6; 4.0	17.3	+ 1.5
29	128	5.1	23.9	+ 0.7; 3.6	17.2	+ 0.7; 4.1	18.2	+ 1.6
30	153	5.8	25.8	+ 0.8; 3.9	18.7	+ 0.7; 4.3	18.5	+ 1.7
31	173	5.2	24.5	+ 0.7; 3.7	17.6	+ 0.7; 4.2	18.0	+ 1.5
32	205	4.7	22.9	+ 0.7; 3.4	16.3	+ 0.6; 4.0	18.1	+ 1.6
33	238	6.1	25.1	+ 0.8; 3.8	18.1	+ 0.7; 4.2	18.2	+ 1.7
34	252	5.8	22.6	+ 0.7; 3.4	16.1	+ 0.6; 4.0	17.8	+ 2.3
35	260	6.6	19.2	+ 0.6; 2.9	13.2	+ 0.6; 3.7	15.0	+ 1.8
36	272	4.8	23.3	+ 0.7; 3.5	16.7	+ 0.7; 4.1	18.5	+ 1.7
37	288	4.8	22.3	+ 0.7; 3.3	15.8	+ 0.6; 4.0	17.5	+ 1.7
38	297	7.6	22.9	+ 0.7; 3.4	16.3	+ 0.6; 4.0	16.2	+ 1.5
39	315	5.1	23.2	+ 0.7; 3.5	16.5	+ 0.7; 4.1	18.5	+ 2.0
40	342	4.8	25.3	+ 0.8; 3.8	18.3	+ 0.7; 4.2	18.2	+ 1.5
41	65	12.0	21.9	+ 0.7; 3.3	15.4	+ 0.6; 3.9	17.7	+ 2.1
42	148	12.0	23.2	+ 0.7; 3.5	16.5	+ 0.7; 4.1	18.5	+ 2.0
43	148	12.0	24.5	+ 0.7; 3.7	17.6	+ 0.7; 4.2	18.8	+ 1.6
44	206	14.0	20.9	+ 0.6; 3.1	14.6	+ 0.6; 3.9	15.8	+ 1.6

Transit Dose = 3.3 +- 0.4; 3.4

CLINTON

For the period 930914-940203

TLD Direct Radiation Environmental Monitoring

Azimuth (degrees)	Ave. Exposure Rate (mR/Std.Qtr.) +- Std.Dev.	Number In Group
348.76 - 11.25 N	18.0 +- 1.3	3
11.26 - 33.75 NNE	17.1 +- 0.0	1
33.76 - 56.25 NE	19.5 +- 2.4	3
56.26 - 78.75 ENE	16.7 +- 1.1	4
78.76 - 101.25 E	18.2 +- 0.4	3
101.26 - 123.75 ESE	17.3 +- 2.0	2
123.76 - 146.25 SE	17.7 +- 0.7	2
146.26 - 168.75 SSE	18.4 +- 0.5	3
168.76 - 191.25 S	17.3 +- 0.4	2
191.26 - 213.75 SSW	16.8 +- 0.9	3
213.76 - 236.25 SW	18.2 +- 0.6	3
236.26 - 258.75 WSW	17.4 +- 1.2	3
258.76 - 281.25 W	15.8 +- 2.3	3
281.26 - 303.75 WNW	16.7 +- 1.1	3
303.76 - 326.25 NW	16.5 +- 0.0	1
326.26 - 348.75 NNW	18.2 +- 0.1	2

Distance From Reactor (miles)	Ave. Exposure Rate (mR/Std.Qtr.) +- Std.Dev.	Number In Group
0 - 2	18.4 +- 1.4	12
2 - 5	17.6 +- 1.0	18
> 5	16.5 +- 1.5	11
Upwind Control	16.2 +- 1.5	3

CLINTON
 TLD Direct Radiation Environmental Monitoring

NRC Station	Location		Description
	Azimuth / Degree	Distance / Mile	
1	5	0.6	IL. 54
2	40	0.7	IL. POWER CO. RD.
3	35	0.8	I.P.C. RD. (NE) & IL. 54
4	163	0.5	I.P.C. FENCE
5	210	0.5	I.P.C. FENCE
6	223	0.6	I.P.C. FENCE
7	235	0.8	I.P.C. FENCE
8	62	1.9	IL. 54 & COUNTY 10
9	78	1.8	CTY. 10
10	79	2.6	DEWITT (T-INTER.) 1880E & 845N
11	100	2.3	MASCOUTIN ST. PK. OFF CTY 14
12	115	3.0	COUNTY 14
13	127	3.2	CTY. 14 & CTY. 5
14	155	2.1	CTY. 5 (CLINTON LK. MARINA SIGN)
15	185	3.0	IL. 10 (RESTRICTED AREA)
16	203	3.2	IL. 10
17	230	3.7	W. ACCESS RD. OFF IL-10 (POLE BY LINE)
18	255	2.8	W. ACCESS RD. OFF IL-10 ("T" INTER)
19	275	2.3	W. ACCESS RD. (NEAR IL. 54)
20	302	0.9	IL. 54 (R.R. XING)
21	336	0.8	IL. 54 (VISITOR CNTR.)
22	0	0.6	IL. 54 ON TRANSMISSION POLE
23	358	4.6	INTER. ~ 1.5 MI. E. OF CTY. 16 1300N/1650E
24	20	3.9	CTY. 10 & 1790E
25	46	5.0	CTY. 10 & 2000E
26	62	5.5	IL. 54 & IL. 48
27	90	4.8	IL. 48 ~ 2.7 MI. FROM IL 54
28	115	5.2	IL. 48 3RD INTER. AFTER #27
29	128	5.1	IL. 10 (NEAR WELDON)
30	153	5.8	CTY. 14 & CTY. 15 300N/1900E
31	173	5.2	CTY. 15 & CTY. 5 300N/1700E
32	205	4.7	1400 E & 300N RDS.
33	238	6.1	CTY. 18 (1200E)
34	252	5.8	1100E/640N
35	260	6.6	CLINTON CENTER STREET (SUBST)
36	272	4.8	1150 E 0.8 MI PAST IL-54
37	288	4.8	950N/1200E
38	297	7.6	WAPELLA WATER TOWER OFF US-51
39	315	5.1	CTY 10 / 1300E
40	342	4.8	ON CTY. 16
41	65	12.0	FARMER CITY STATE BANK ON IL-54
42	148	12.0	ARGENTA MUNIC. BLDG. (NR. WTR. TWR) OFF CTY. 5
43	148	12.0	ARGENTA MUNIC. BLDG. (NR. WTR. TWR) OFF CTY. 5
44	206	14.0	EMERY (RR CROSSING) OFF IL-51

NRC TLD DOSES FOR CLINTON AREA

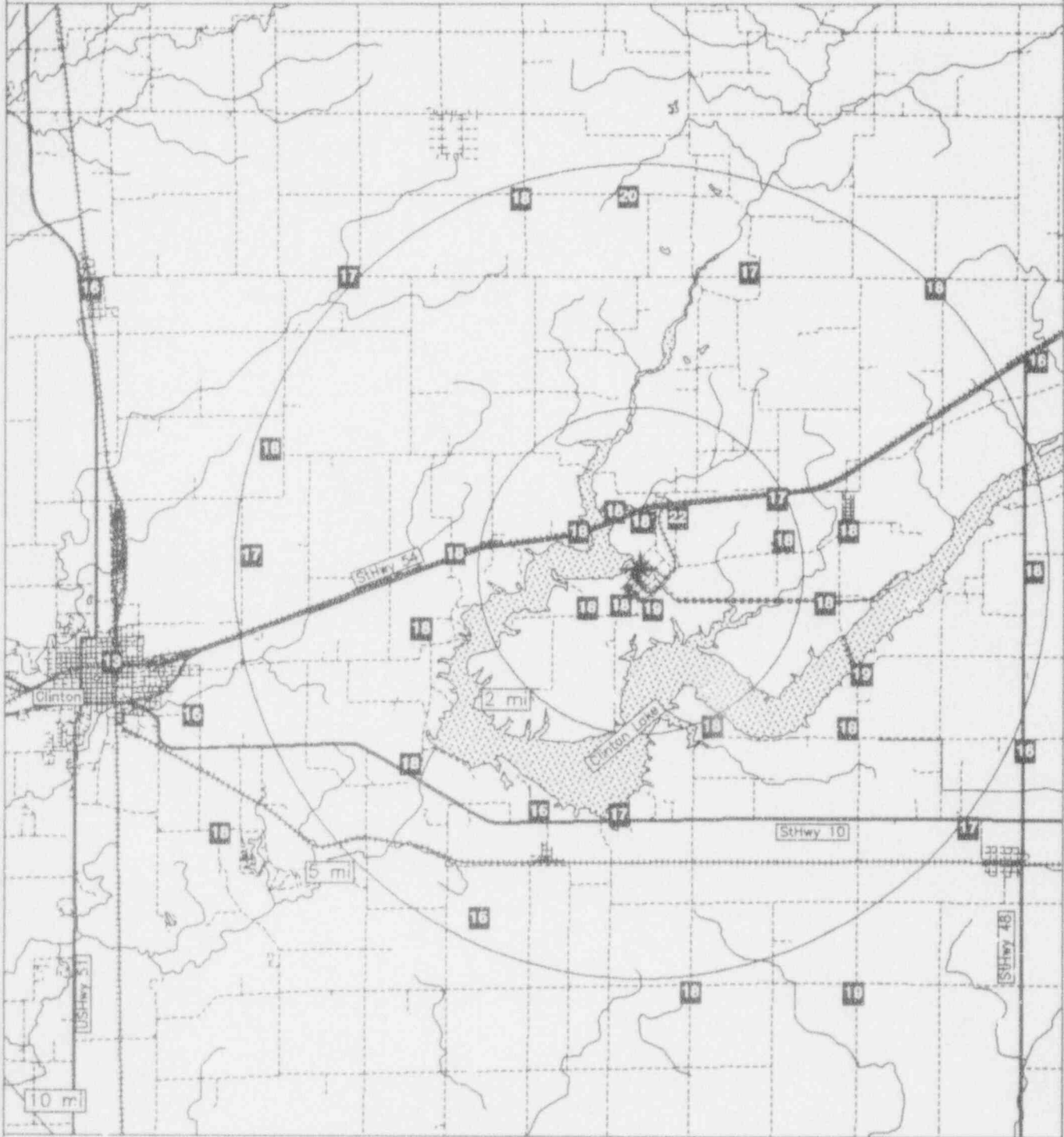

Miles

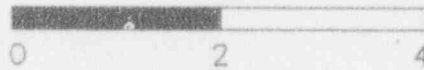

Legend

- Water
- Highways
- Railroads
- Roads
- Plant..site

COMANCHE PEAK

TLD Direct Radiation Environmental Monitoring

For the period 930913-940201 142 Days

Field Time: 85 Days

NRC Sta	Location Azimuth/Dist (Deg)/(Mi)		Gross Exposure (mR) +-Rdm; Tot.	Net Exposure Rate (mR/Std. Qtr.) +-Rdm; Tot.	Hist. Range Net Exp Rate +-1 Std Dev
1	306	1.4	20.4 +- 0.6; 3.1	15.1 +- 0.8; 4.5	15.2 +- 1.0
2	285	1.5	20.9 +- 0.6; 3.1	15.7 +- 0.8; 4.6	15.5 +- 1.3
3	268	1.1	18.5 +- 0.6; 2.8	13.1 +- 0.7; 4.3	14.3 +- 0.9
4	253	0.9	20.2 +- 0.6; 3.0	14.9 +- 0.8; 4.5	15.4 +- 1.2
5	218	1.0	20.1 +- 0.6; 3.0	14.8 +- 0.8; 4.5	15.7 +- 1.3
6	200	1.0	20.8 +- 0.6; 3.1	15.5 +- 0.8; 4.6	13.5 +- 1.1
7	180	1.4	19.6 +- 0.6; 2.9	14.3 +- 0.7; 4.4	13.8 +- 1.2
8	163	1.6	Damaged Dosimeter	No Net Data	15.7 +- 1.3
9	140	1.3	21.0 +- 0.6; 3.1	15.7 +- 0.8; 4.6	15.6 +- 0.9
10	118	1.5	20.8 +- 0.6; 3.1	15.5 +- 0.8; 4.6	13.6 +- 1.1
11	93	1.9	23.7 +- 0.7; 3.6	18.6 +- 0.9; 4.9	14.7 +- 2.8
12	73	2.4	22.3 +- 0.7; 3.3	17.1 +- 0.8; 4.8	17.2 +- 1.1
13	245	1.7	19.8 +- 0.6; 3.0	14.5 +- 0.8; 4.5	14.0 +- 1.0
14	156	4.3	20.5 +- 0.6; 3.1	15.2 +- 0.8; 4.5	13.9 +- 1.2
15	186	7.0	20.2 +- 0.6; 3.0	14.9 +- 0.8; 4.5	14.9 +- 1.5
16	183	4.1	20.0 +- 0.6; 3.0	14.7 +- 0.8; 4.5	16.0 +- 1.5
17	205	4.3	20.6 +- 0.6; 3.1	15.3 +- 0.8; 4.6	15.3 +- 0.9
18	225	3.4	18.4 +- 0.6; 2.8	13.0 +- 0.7; 4.3	12.9 +- 1.2
19	245	5.2	20.7 +- 0.6; 3.1	15.4 +- 0.8; 4.6	15.4 +- 0.8
20	264	5.8	19.8 +- 0.6; 3.0	14.5 +- 0.8; 4.5	13.7 +- 0.9
21	258	3.2	20.4 +- 0.6; 3.1	15.1 +- 0.8; 4.5	13.7 +- 1.1
22	284	5.1	19.0 +- 0.6; 2.8	13.6 +- 0.7; 4.4	13.4 +- 1.1
23	313	5.8	21.8 +- 0.7; 3.3	16.6 +- 0.8; 4.7	15.0 +- 1.0
24	332	4.9	19.2 +- 0.6; 2.9	13.8 +- 0.7; 4.4	14.2 +- 1.0
25	9	4.6	21.2 +- 0.6; 3.2	16.0 +- 0.8; 4.6	14.9 +- 1.3
26	26	4.5	21.0 +- 0.6; 3.2	15.8 +- 0.8; 4.6	14.5 +- 1.2
27	47	4.1	20.3 +- 0.6; 3.0	15.0 +- 0.8; 4.5	14.2 +- 1.1
28	6	1.8	21.0 +- 0.6; 3.2	15.8 +- 0.8; 4.6	14.6 +- 1.1
29	16	1.9	21.0 +- 0.6; 3.1	15.7 +- 0.8; 4.6	14.5 +- 1.2
30	102	3.0	21.6 +- 0.6; 3.2	16.4 +- 0.8; 4.7	15.5 +- 1.4
31	108	3.9	20.8 +- 0.6; 3.1	15.6 +- 0.8; 4.6	14.9 +- 1.4
32	135	4.6	21.4 +- 0.6; 3.2	16.2 +- 0.8; 4.7	15.6 +- 1.4
33	152	6.3	20.2 +- 0.6; 3.0	14.9 +- 0.8; 4.5	13.7 +- 1.1
34	47	2.9	19.0 +- 0.6; 2.9	13.6 +- 0.7; 4.4	13.4 +- 1.5
35	85	4.8	20.4 +- 0.6; 3.1	15.1 +- 0.8; 4.5	15.1 +- 1.5
36	115	7.5	20.4 +- 0.6; 3.1	15.1 +- 0.8; 4.5	15.0 +- 1.4
37	355	9.4	20.2 +- 0.6; 3.0	14.9 +- 0.8; 4.5	14.6 +- 2.7
38	337	9.2	21.0 +- 0.6; 3.1	15.7 +- 0.8; 4.6	14.3 +- 1.4
39	310	9.9	19.4 +- 0.6; 2.9	14.0 +- 0.7; 4.4	14.5 +- 1.5
40	302	8.1	19.7 +- 0.6; 3.0	14.4 +- 0.8; 4.5	13.8 +- 1.6
41	248	7.9	22.0 +- 0.7; 3.3	16.8 +- 0.8; 4.7	15.9 +- 1.3
42	90	0.5	20.3 +- 0.6; 3.1	15.0 +- 0.8; 4.5	13.9 +- 1.6
43	18	9.8	20.3 +- 0.6; 3.0	15.0 +- 0.8; 4.5	15.0 +- 1.5
44	263	1.7	19.3 +- 0.6; 2.9	13.9 +- 0.7; 4.4	13.2 +- 1.6
45	218	12.0	21.2 +- 0.6; 3.2	16.0 +- 0.8; 4.6	15.0 +- 1.4
46	140	12.0	20.5 +- 0.6; 3.1	15.2 +- 0.8; 4.5	14.7 +- 1.4
47	301	21.0	19.9 +- 0.6; 3.0	14.6 +- 0.8; 4.5	14.7 +- 1.4

Transit Dose = 6.1 +- 0.4; 3.0

COMANCHE PEAK
For the period 930913-940201

TLD Direct Radiation Environmental Monitoring

Azimuth (degrees)	Ave. Exposure Rate (mR/Std.Qtr.) +- Std.Dev.	Number In Group
348.76 - 11.25 N	15.6 +- 0.6	3
11.26 - 33.75 NNE	15.5 +- 0.5	3
33.76 - 56.25 NE	14.3 +- 1.0	2
56.26 - 78.75 ENE	17.1 +- 0.0	1
78.76 - 101.25 E	16.3 +- 2.1	3
101.26 - 123.75 ESE	15.7 +- 0.6	4
123.76 - 146.25 SE	15.7 +- 0.5	3
146.26 - 168.75 SSE	15.1 +- 0.2	2
168.76 - 191.25 S	14.6 +- 0.3	3
191.26 - 213.75 SSW	15.4 +- 0.1	2
213.76 - 236.25 SW	14.6 +- 1.5	3
236.26 - 258.75 WSW	15.3 +- 0.9	5
258.76 - 281.25 W	13.8 +- 0.7	3
281.26 - 303.75 WNW	14.6 +- 0.9	4
303.76 - 326.25 NW	15.3 +- 1.3	3
326.26 - 348.75 NNW	14.8 +- 1.4	2

Distance From Reactor (miles)	Ave. Exposure Rate (mR/Std.Qtr.) +- Std.Dev.	Number In Group
0 - 2	15.2 +- 1.2	15
2 - 5	15.2 +- 1.1	15
> 5	15.1 +- 0.9	16
Upwind Control	No Data +- No Data	0

COMANCHE PEAK
TLD Direct Radiation Environmental Monitoring

NRC Station	Location		Description
	Azimuth / Degree	Distance / Mile	
1	306	1.4	SITE OF TEXAS TLD#1
2	285	1.5	SITE OF TEXAS TLD#2
3	268	1.1	SITE OF TEXAS TLD#3
4	253	0.9	SITE OF TEXAS TLD#4
5	218	1.0	SITE OF TEXAS TLD#5
6	200	1.0	SITE OF TEXAS TLD#6
7	180	1.4	ST OF TEX#7
8	163	1.6	SITE OF TEXAS TLD#8
9	140	1.3	SITE OF TEXAS TLD#9
10	118	1.5	SITE OF TEXAS TLD#10
11	93	1.9	SITE OF TEXAS TLD#11
12	73	2.4	SITE OF TEXAS TLD#12
13	245	1.7	FM201-0.6 MI S. OF GATE
14	156	4.3	HWY 67 AT FOSSIL VILLAGE SHOPPING CTR.
15	186	7.0	HWY 67 AT CR 2008
16	183	4.1	HWY 67 AT 205
17	205	4.3	DINOSAUR ST. PARK
18	225	3.4	UTILITY POLE (ON CR1011 AT TOP OF HILL)
19	245	5.2	RUNNING M RANCH
20	264	5.8	SIREN POLE #19
21	258	3.2	SIREN POLE #7
22	284	5.1	SIREN POLE #18
23	313	5.8	HWY 206 & 51
24	332	4.9	HWY 212 (S&J OPERATING CO. GATE)
25	9	4.6	HWY 144 & 2425
26	26	4.5	RD 310A
27	47	4.1	HWY 310 & 2425
28	6	1.8	SITE OF TEXAS TLD#14
29	16	1.9	SITE OF TEXAS TLD#46
30	102	3.0	HAPPY HILLS CHILD. HOME
31	108	3.9	FM RD 200
32	135	4.6	HWY 67 AT 144
33	152	6.3	HWY 56-CABLE SIGN
34	47	2.9	HWY 144 & 213B
35	85	4.8	SITE OF TEXAS TLD#39
36	115	7.5	HWY 200 & 402
37	355	9.4	HOOD CTY.HOSP. (TEXAS TLD#79)
38	337	9.2	HWY 377 & 203
39	310	9.9	CITY OF TOLAR
40	302	8.1	HWY 56
41	248	7.9	CR 205 & HWY 51
42	90	0.5	ON SITE(COMMANCHE PK PLANT)
43	18	9.8	SITE OF TEXAS TLD#30
44	263	1.7	NEXT TO MAIN GATE
45	218	12.0	CHALK MT(JACKSONS TEXACO)
46	140	12.0	CITY OF BRAZOS PT.
47	301	21.0	CITY OF LIPAN

NRC TLD DOSES FOR COMANCHE PEAK AREA

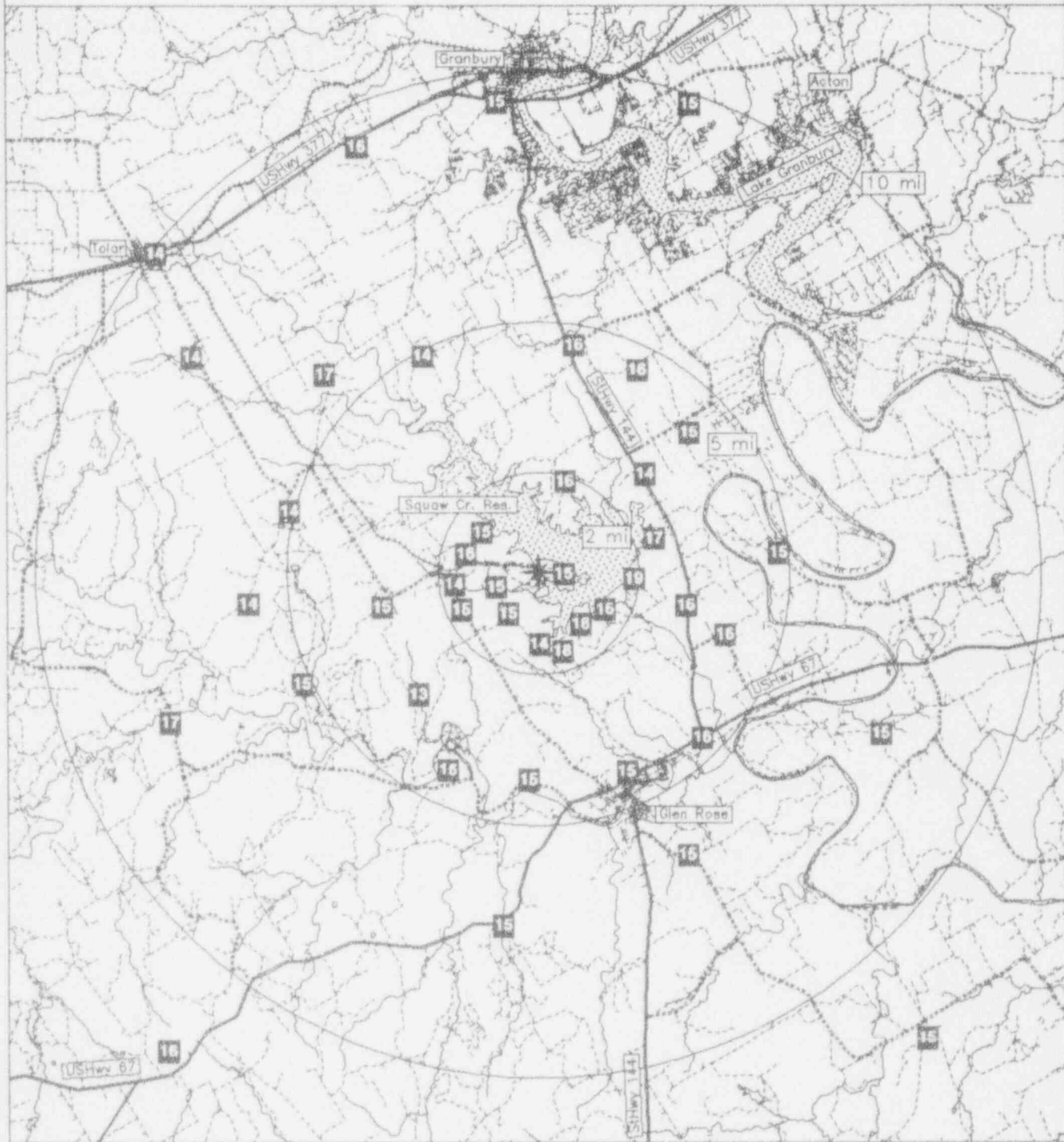

Miles

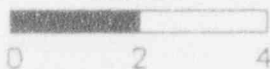

Legend

- Water
- Highways
- Railroads
- Roads
- Plant site

COOPER
 TLD Direct Radiation Environmental Monitoring
 For the period 930913-940209 150 Days
 Field Time: 104 Days

NRC Sta	Location Azimuth/Dist (Deg)/(Mi)		Gross Exposure (mR) +-Rdm; Tot.	Net Exposure Rate (mR/Std. Qtr.) +-Rdm; Tot.	Hist. Range Net Exp Rate +-1 Std Dev
1	350	2.4	27.4 +- 0.8; 4.1	18.7 +- 0.8; 4.7	19.2 +- 3.3
2	6	3.5	27.9 +- 0.8; 4.2	19.1 +- 0.8; 4.7	20.2 +- 3.4
3	18	2.7	27.6 +- 0.8; 4.1	18.9 +- 0.8; 4.7	20.8 +- 3.5
4	16	3.2	28.0 +- 0.8; 4.2	19.2 +- 0.8; 4.7	20.9 +- 3.4
5	47	1.9	28.5 +- 0.9; 4.3	19.6 +- 0.8; 4.8	20.7 +- 3.4
6	40	3.6	28.2 +- 0.8; 4.2	19.4 +- 0.8; 4.8	20.0 +- 3.5
7	75	2.7	27.4 +- 0.8; 4.1	18.7 +- 0.8; 4.7	19.9 +- 3.7
8	55	2.8	26.7 +- 0.8; 4.0	18.0 +- 0.8; 4.6	20.0 +- 3.6
9	80	2.1	28.8 +- 0.9; 4.3	19.9 +- 0.8; 4.8	21.4 +- 3.4
10	98	3.7	27.1 +- 0.8; 4.1	18.4 +- 0.8; 4.6	19.8 +- 3.4
11	118	2.3	29.1 +- 0.9; 4.4	20.1 +- 0.8; 4.8	21.3 +- 3.5
12	109	4.6	27.5 +- 0.8; 4.1	18.8 +- 0.8; 4.7	21.3 +- 3.3
13	141	3.2	28.4 +- 0.9; 4.3	19.6 +- 0.8; 4.8	20.8 +- 3.3
14	126	5.6	26.0 +- 0.8; 3.9	17.4 +- 0.8; 4.5	18.7 +- 2.7
15	159	2.7	27.4 +- 0.8; 4.1	18.6 +- 0.8; 4.7	19.9 +- 3.4
16	167	4.9	29.9 +- 0.9; 4.5	20.8 +- 0.9; 4.9	21.0 +- 3.6
17	205	0.3	28.5 +- 0.9; 4.3	19.6 +- 0.8; 4.8	20.3 +- 3.0
18	186	4.7	29.7 +- 0.9; 4.5	20.7 +- 0.9; 4.9	21.4 +- 3.5
19	213	3.0	27.9 +- 0.8; 4.2	19.1 +- 0.8; 4.7	20.3 +- 3.3
20	195	4.9	29.0 +- 0.9; 4.4	20.0 +- 0.8; 4.8	21.4 +- 3.3
21	222	2.0	26.9 +- 0.8; 4.0	18.2 +- 0.8; 4.6	19.1 +- 3.0
22	215	5.7	29.7 +- 0.9; 4.4	20.6 +- 0.9; 4.9	21.5 +- 3.6
23	256	1.5	28.9 +- 0.9; 4.3	19.9 +- 0.8; 4.8	21.0 +- 3.4
24	238	5.2	28.0 +- 0.8; 4.2	19.2 +- 0.8; 4.7	21.3 +- 3.8
25	276	2.2	29.4 +- 0.9; 4.4	20.4 +- 0.9; 4.9	21.7 +- 3.2
26	260	3.8	30.2 +- 0.9; 4.5	21.1 +- 0.9; 5.0	21.5 +- 3.0
27	301	1.8	28.8 +- 0.9; 4.3	19.9 +- 0.8; 4.8	21.2 +- 3.2
28	286	4.3	28.5 +- 0.9; 4.3	19.6 +- 0.8; 4.8	20.8 +- 3.5
29	324	2.8	27.8 +- 0.8; 4.2	19.0 +- 0.8; 4.7	20.4 +- 3.8
30	333	3.7	28.5 +- 0.9; 4.3	19.6 +- 0.8; 4.8	21.0 +- 3.5
31	343	2.6	28.7 +- 0.9; 4.3	19.8 +- 0.8; 4.8	21.0 +- 3.0
32	333	3.7	29.1 +- 0.9; 4.4	20.1 +- 0.8; 4.8	20.7 +- 3.4
33	215	1.0	29.8 +- 0.9; 4.5	20.7 +- 0.9; 4.9	21.2 +- 3.7
34	175	18.0	30.0 +- 0.9; 4.5	20.9 +- 0.9; 4.9	21.7 +- 3.7
35	333	23.0	27.9 +- 0.8; 4.2	19.1 +- 0.8; 4.7	19.8 +- 3.4
36	210	19.0	29.2 +- 0.9; 4.4	20.2 +- 0.8; 4.9	20.8 +- 3.5
37	64	7.0	33.5 +- 1.0; 5.0	23.9 +- 0.9; 5.3	24.2 +- 4.4
38	329	9.0	32.1 +- 1.0; 4.8	22.7 +- 0.9; 5.2	22.9 +- 3.4
39	273	10.0	28.5 +- 0.9; 4.3	19.6 +- 0.8; 4.8	20.2 +- 3.8
40	300	2.5	32.0 +- 1.0; 4.8	22.6 +- 0.9; 5.1	23.3 +- 3.3
42	93	3.5	27.8 +- 0.8; 4.2	19.0 +- 0.8; 4.7	20.1 +- 3.4
43	270	2.2	29.3 +- 0.9; 4.4	20.3 +- 0.8; 4.9	21.0 +- 3.6

Transit Dose = 5.9 +- 0.4; 3.5

COOPER

For the period 930913-940209

TLD Direct Radiation Environmental Monitoring

Azimuth (degrees)	Ave. Exposure Rate (mR/Std.Qtr.) +- Std.Dev.	Number In Group
348.76 - 11.25 N	19.1 +- 0.0	1
11.26 - 33.75 NNE	19.0 +- 0.3	2
33.76 - 56.25 NE	19.0 +- 0.8	3
56.26 - 78.75 ENE	21.3 +- 3.7	2
78.76 - 101.25 E	19.1 +- 0.8	3
101.26 - 123.75 ESE	19.4 +- 0.9	2
123.76 - 146.25 SE	18.5 +- 1.5	2
146.26 - 168.75 SSE	19.7 +- 1.5	2
168.76 - 191.25 S	20.7 +- 0.0	1
191.26 - 213.75 SSW	19.6 +- 0.5	3
213.76 - 236.25 SW	19.8 +- 1.4	3
236.26 - 258.75 WSW	19.6 +- 0.5	2
258.76 - 281.25 W	20.4 +- 0.6	4
281.26 - 303.75 WNW	20.7 +- 1.7	3
303.76 - 326.25 NW	19.0 +- 0.0	1
326.26 - 348.75 NNW	20.6 +- 1.5	4

Distance From Reactor (miles)	Ave. Exposure Rate (mR/Std.Qtr.) +- Std.Dev.	Number In Group
0 - 2	19.7 +- 0.8	6
2 - 5	19.6 +- 1.0	27
> 5	20.6 +- 2.4	6
Upwind Control	20.1 +- 0.9	3

COOPER
TLD Direct Radiation Environmental Monitoring

NRC Station	Location		Description
	Azimuth / Degree	Distance / Mile	
1	363	2.4	STATE RECREATION AREA
2	6	3.5	0.5 MILES N. OF US 136
3	18	2.7	0.6 MILES S. OF US 136
4	16	3.2	1.5 MILES W. OF HWY. U
5	47	1.9	0.9 MILES W. OF PHELPS CITY
6	40	3.6	PHELPS CITY
7	75	2.7	HWY. U (1.5 MILES S. OF US 136)
8	55	2.8	HWY. U (0.5 MILES S. OF US 136)
9	80	2.1	FARMHOUSE
10	98	3.7	LANGDON
11	118	2.3	LANGDON
12	109	4.6	GRAIN STG. BIN
13	141	3.2	BM 883
14	126	5.6	ROCK CREEK DITCH
15	159	2.7	PAST END OF HWY. U
16	167	4.9	HWY. 67 (2.3 MI. S OF L. NEMAHA R.)
17	205	0.3	SOUTH OF PLANT AT AIR SAMPLER
18	186	4.7	HWY. 67 (2.3 MI. S OF L. NEMAHA R.)
19	213	3.0	N. OF NEMAHA BRIDGE
20	195	4.9	HWY. 67 (2.3 MI. S OF L. NEMAHA R.)
21	222	2.0	NPPD AIR SAMPLER AT NEMAHA
22	215	5.7	HWY. 67 (2.3 MI. S OF L. NEMAHA R.)
23	256	1.5	HWY. 67 (N. OF RD. TO REACTOR)
24	238	5.2	HWY. 67 (0.2 MI. S OF L. NEMAHA R.)
25	276	2.2	HWY. 67 (2 MILES S. OF US 136)
26	260	3.8	HWY. 67 (3 MILES S. OF US 136)
27	301	1.8	HWY. 67 (1.3 MILES S. OF US 136)
28	286	4.3	US 136 (2.6 MI. W OF SOUTHBOUND 67)
29	324	2.8	HWY. 67 & US 136
30	333	3.7	HWY. 67 (1 MILE N. OF US 136)
31	343	2.6	BROWNVILLE
32	333	3.7	US 136 (0.6 MI. W OF SOUTHBOUND 67)
33	215	1.0	MOORE RESIDENCE
34	175	18.0	FALLS CITY
35	333	23.0	NEBRASKA CITY
36	210	19.0	US 73 & US 75
37	64	7.0	ROCK PORT
38	329	9.0	PERU
39	273	10.0	AUBURN
40	300	2.5	HAPPY HOLLOW SCHOOL
42	93	3.5	HWY. U & E (LANGDON)
43	270	2.2	LANGDON HWY U& E

NRC TLD DOSES FOR COOPER AREA

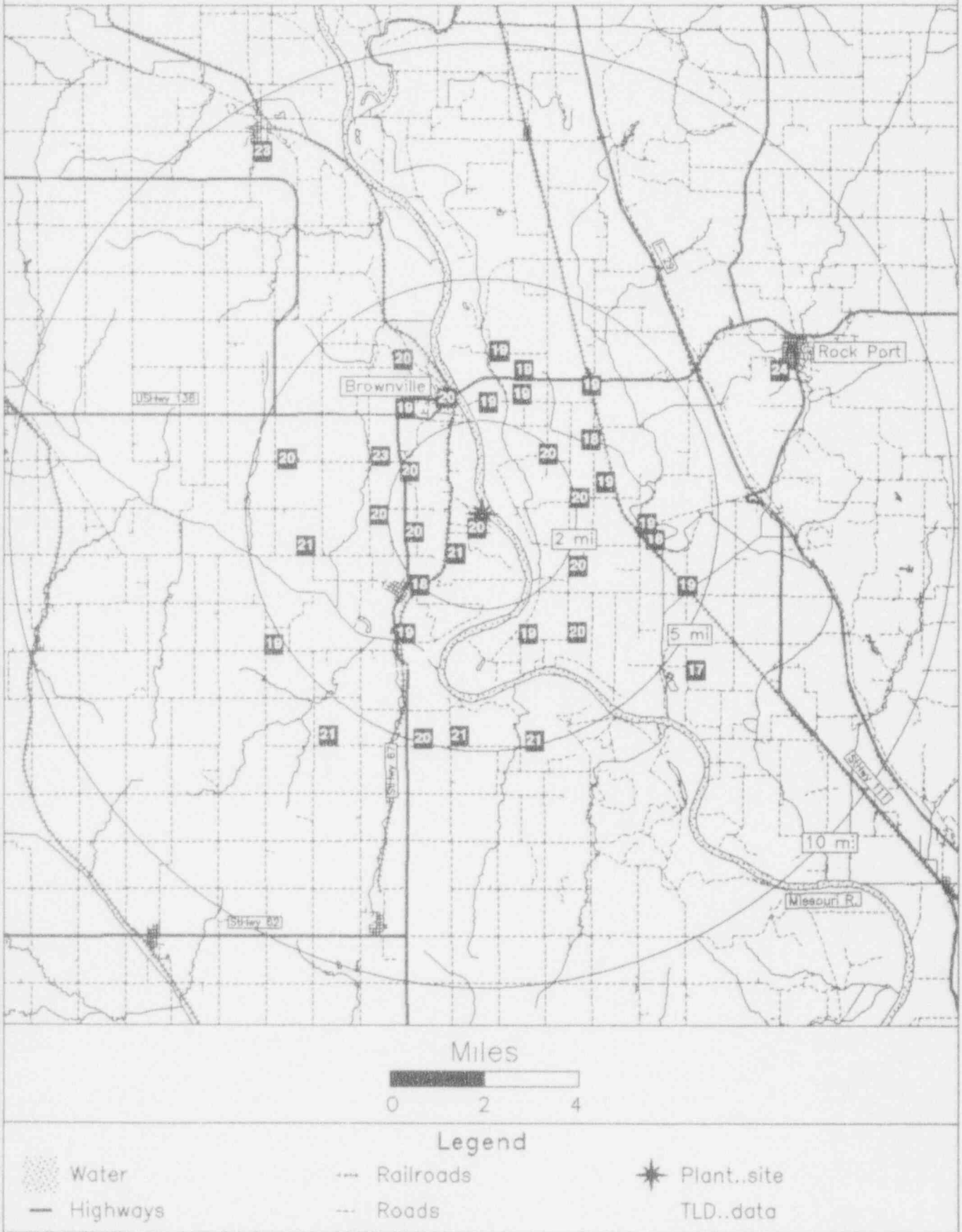

CRYSTAL RIVER

TLD Direct Radiation Environmental Monitoring

For the period 930915-940203 142 Days

Field Time: 100 Days

NRC Sta	Location		Gross Exposure (mR)		Net Exposure Rate (mR/Std. Qtr.)		Hist. Range Net Exp Rate	
	Azimuth/ (Deg)	Dist (Mi)	+-Rdm; Tot.		+-Rdm; Tot.		+-1 Std Dev	
6	61	4.2	16.7	+- 0.5; 2.5	12.0	+- 0.5; 3.6	12.9	+- 4.7
7	50	3.8	16.0	+- 0.5; 2.4	11.4	+- 0.5; 3.6	12.8	+- 4.6
8	20	5.2	17.4	+- 0.5; 2.6	12.7	+- 0.6; 3.7	13.5	+- 4.4
9	6	5.4	18.3	+- 0.5; 2.7	13.4	+- 0.6; 3.8	15.5	+- 5.1
10	348	5.0	18.6	+- 0.6; 2.8	13.8	+- 0.6; 3.8	14.7	+- 4.7
11	334	4.8	18.0	+- 0.5; 2.7	13.2	+- 0.6; 3.7	14.1	+- 4.7
12	318	4.8	18.1	+- 0.5; 2.7	13.2	+- 0.6; 3.8	13.7	+- 5.1
13	79	3.8	16.9	+- 0.5; 2.5	12.2	+- 0.6; 3.7	14.1	+- 4.9
14	95	4.1	17.2	+- 0.5; 2.6	12.4	+- 0.6; 3.7	13.7	+- 4.9
15	89	1.8	19.2	+- 0.6; 2.9	14.3	+- 0.6; 3.9	15.9	+- 4.9
16	113	5.0	16.7	+- 0.5; 2.5	12.0	+- 0.5; 3.6	13.2	+- 5.1
17	133	5.5	16.7	+- 0.5; 2.5	12.0	+- 0.5; 3.6	14.5	+- 5.2
18	74	8.1	15.9	+- 0.5; 2.4	11.3	+- 0.5; 3.6	13.1	+- 4.9
19	127	7.6	16.9	+- 0.5; 2.5	12.2	+- 0.6; 3.7	13.7	+- 4.8
20	150	12.0	16.3	+- 0.5; 2.5	11.7	+- 0.5; 3.6	12.7	+- 4.7
21	159	13.0	16.9	+- 0.5; 2.5	12.2	+- 0.6; 3.7	14.1	+- 5.0
22	150	13.0	18.0	+- 0.5; 2.7	13.2	+- 0.6; 3.7	13.5	+- 5.1
23	150	21.0	Missing Dosimeter		No Net Data		14.3	+- 5.3
24	150	21.0	15.9	+- 0.5; 2.4	11.3	+- 0.5; 3.6	12.7	+- 4.9
25	56	6.1	15.8	+- 0.5; 2.4	11.2	+- 0.5; 3.6	15.5	+- 5.4
26	357	5.2	18.6	+- 0.6; 2.8	13.7	+- 0.6; 3.8	14.5	+- 4.7
27	90	13.0	17.4	+- 0.5; 2.6	12.7	+- 0.6; 3.7	13.8	+- 5.0
28	140	4.8	17.9	+- 0.5; 2.7	13.1	+- 0.6; 3.7	14.3	+- 4.8

Transit Dose = 3.4 +- 0.3; 3.2

CRYSTAL RIVER
For the period 930915-940203

TLD Direct Radiation Environmental Monitoring

Azimuth (degrees)	Ave. Exposure Rate (mR/Std.Qtr.) +- Std.Dev.	Number In Group
348.76 - 11.25 N	13.6 +- 0.2	2
11.26 - 33.75 NNE	12.7 +- 0.0	1
33.76 - 56.25 NE	11.3 +- 0.1	2
56.26 - 78.75 ENE	11.7 +- 0.5	2
78.76 - 101.25 E	12.9 +- 0.9	4
101.26 - 123.75 ESE	12.0 +- 0.0	1
123.76 - 146.25 SE	12.4 +- 0.6	3
146.26 - 168.75 SSE	12.0 +- 0.4	2
168.76 - 191.25 S	No Data +- No Data	0
191.26 - 213.75 SSW	No Data +- No Data	0
213.76 - 236.25 SW	No Data +- No Data	0
236.26 - 258.75 WSW	No Data +- No Data	0
258.76 - 281.25 W	No Data +- No Data	0
281.26 - 303.75 WNW	No Data +- No Data	0
303.76 - 326.25 NW	13.2 +- 0.0	1
326.26 - 348.75 NNW	13.5 +- 0.4	2

Distance From Reactor (miles)	Ave. Exposure Rate (mR/Std.Qtr.) +- Std.Dev.	Number In Group
0 - 2	14.3 +- 0.0	1
2 - 5	12.6 +- 0.8	9
> 5	12.3 +- 0.8	10
Upwind Control	12.2 +- 1.3	2

CRYSTAL RIVER
TLD Direct Radiation Environmental Monitoring

NRC Station	Location		Description
	Azimuth / Degree	Distance / Mile	
6	61	4.2	BASSWOOD RD & CALADIUM ST.
7	50	3.8	RT. 19
8	20	5.2	RT. 40 & RT. 19
9	6	5.4	CRACKERTOWN
10	348	5.0	COAST GUARD STATION
11	334	4.8	RT. 40
12	318	4.8	PUMPKIN ISLAND
13	79	3.8	RED LEVEL BAPTIST CHURCH
14	95	4.1	TALLAHASSEE RD.
15	89	1.8	PLANT ACCESS ROAD
16	113	5.0	OAK LANE RD.
17	133	5.5	STATE ARCHEOLOGICAL SITE
18	74	8.1	DEROSA VILLAGE
19	127	7.6	RT. 19 & RT. 495
20	150	12.0	HOMOSASSA SPRINGS
21	159	13.0	HOMOSASSA
22	150	13.0	RT. 19
23	150	21.0	RIGHT ROAD OFF RT. 19
24	150	21.0	RIGHT ROAD OFF RT. 1
25	56	6.1	CORP. OF ENGINEERS SPILLWAY & DAM
26	357	5.2	RIVERSIDE RD. & 52ND ST.
27	90	13.0	BEVERLY HILLS
28	140	4.8	MARINE SCIENCE STATION

NRC TLD DOSES FOR CRYSTAL RIVER AREA

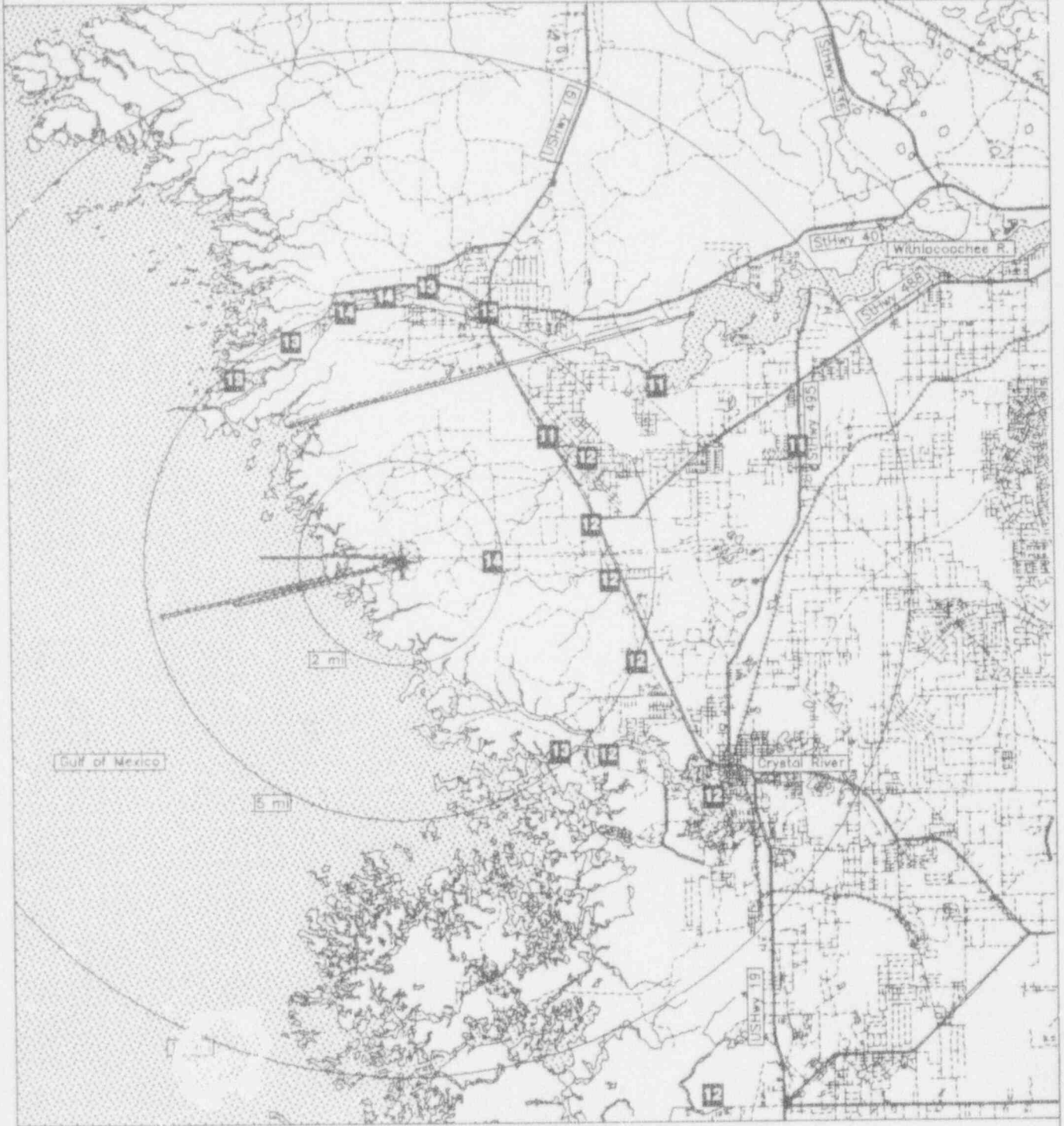

Miles

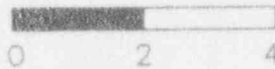

Legend

- Water
- Highways
- Railroads
- Roads
- Plant..site

DAVIS BESSE

TLD Direct Radiation Environmental Monitoring

For the period 930914-940202 142 Days

Field Time: 107 Days

NRC Sta	Location		Gross	Net Exposure Rate	Hist. Range
	Azimuth/Dist (Deg)/(Mi)		Exposure (mR) +-Rdm; Tot.	(mR/Std. Qtr.) +-Rdm; Tot.	Net Exp Rate +-1 Std Dev
1	50	0.6	17.0 +- 0.5; 2.5	13.6 +- 0.5; 3.4	12.2 +- 1.5
2	86	0.9	18.0 +- 0.5; 2.7	14.5 +- 0.5; 3.5	13.5 +- 1.6
3	116	1.4	17.2 +- 0.5; 2.6	13.8 +- 0.5; 3.4	12.8 +- 1.6
4	172	0.8	18.1 +- 0.5; 2.7	14.6 +- 0.5; 3.5	16.0 +- 2.3
5	200	1.5	25.2 +- 0.8; 3.8	20.5 +- 0.7; 4.2	19.1 +- 2.2
6	226	1.0	20.0 +- 0.6; 3.0	16.2 +- 0.6; 3.7	16.2 +- 1.7
7	249	1.5	21.4 +- 0.6; 3.2	17.4 +- 0.6; 3.8	16.9 +- 1.8
8	267	1.8	20.6 +- 0.6; 3.1	16.7 +- 0.6; 3.7	17.3 +- 2.1
9	285	1.8	21.7 +- 0.7; 3.3	17.6 +- 0.6; 3.8	17.4 +- 2.0
10	306	1.5	17.9 +- 0.5; 2.7	14.4 +- 0.5; 3.5	15.0 +- 2.0
11	344	0.9	18.3 +- 0.5; 2.7	14.8 +- 0.5; 3.5	14.5 +- 1.6
12	142	4.5	23.8 +- 0.7; 3.6	19.4 +- 0.6; 4.0	17.9 +- 1.9
13	158	4.0	23.5 +- 0.7; 3.5	19.2 +- 0.6; 4.0	19.2 +- 2.2
14	180	3.8	21.1 +- 0.6; 3.2	17.2 +- 0.6; 3.8	16.0 +- 1.8
15	207	4.8	23.8 +- 0.7; 3.6	19.4 +- 0.6; 4.0	17.1 +- 2.2
16	225	4.5	22.2 +- 0.7; 3.3	18.1 +- 0.6; 3.9	17.2 +- 1.9
17	254	2.7	26.6 +- 0.8; 4.0	21.7 +- 0.7; 4.3	20.6 +- 2.2
18	269	3.0	22.1 +- 0.7; 3.3	17.9 +- 0.6; 3.9	17.7 +- 2.0
19	295	5.3	24.8 +- 0.7; 3.7	20.3 +- 0.7; 4.1	19.2 +- 2.0
20	25	0.5	17.0 +- 0.5; 2.6	13.7 +- 0.5; 3.4	12.4 +- 2.0
21	132	9.7	21.4 +- 0.6; 3.2	17.4 +- 0.6; 3.8	16.7 +- 1.7
22	210	6.5	21.0 +- 0.6; 3.1	17.0 +- 0.6; 3.8	17.7 +- 3.7

Transit Dose = 0.7 +- 0.3; 3.2

DAVIS BESSE
For the period 930914-940202

TLD Direct Radiation Environmental Monitoring

Azimuth (degrees)	Ave. Exposure Rate (mR/Std.Qtr.) +- Std.Dev.	Number In Group
348.76 - 11.25 N	No Data +- No Data	0
11.26 - 33.75 NNE	13.7 +- 0.0	1
33.76 - 56.25 NE	13.6 +- 0.0	1
56.26 - 78.75 ENE	No Data +- No Data	0
78.76 - 101.25 E	14.5 +- 0.0	1
101.26 - 123.75 ESE	13.8 +- 0.0	1
123.76 - 146.25 SE	19.4 +- 0.0	1
146.26 - 168.75 SSE	19.2 +- 0.0	1
168.76 - 191.25 S	15.9 +- 1.8	2
191.26 - 213.75 SSW	20.0 +- 0.8	2
213.76 - 236.25 SW	17.1 +- 1.3	2
236.26 - 258.75 WSW	19.6 +- 3.0	2
258.76 - 281.25 W	17.3 +- 0.9	2
281.26 - 303.75 WNW	19.0 +- 1.8	2
303.76 - 326.25 NW	14.4 +- 0.0	1
326.26 - 348.75 NNW	14.8 +- 0.0	1

Distance From Reactor (miles)	Ave. Exposure Rate (mR/Std.Qtr.) +- Std.Dev.	Number In Group
0 - 2	15.7 +- 2.1	12
2 - 5	19.0 +- 1.5	7
> 5	20.3 +- 0.0	1
Upwind Control	17.2 +- 0.2	2

DAVIS BESSE
TLD Direct Radiation Environmental Monitoring

NRC Station	Location		Description
	Azimuth / Degree	Distance / Mile	
1	50	0.6	SITE BOUNDARY NEAR INTAKE
2	86	0.9	SITE BOUNDARY
3	116	1.4	SITE BOUNDARY - FOUSSAINT R. STORM DRAIN
4	172	0.8	SITE BOUNDARY - LOCUST PT. & RIVER
5	200	1.5	ALONG LEVTZ
6	226	1.0	RT. 2 AT FENCE BOUNDARY
7	249	1.5	ZETZER RD.
8	267	1.8	HUMPHREY & DUFF WASHA
9	285	1.8	RT. 2 & HUMPHREY
10	306	1.5	LONG BEACH - HUMPHREY & HOLLYWOOD
11	344	0.9	SAND BEACH - RUSSELL RD.
12	142	4.5	ERIE INDUSTRIAL PARK
13	158	4.0	RYMERS RD. & RT. 15
14	180	3.8	RT. 15 & TOUSSAINT RD.
15	207	4.8	BEHLMAN RD. & BIER
16	225	4.5	GENZMAN RD. & RT. 190
17	254	2.7	EARL MOORE FARM - BOYLEN RD.
18	269	3.0	HWY. 19 UNDER TRANSMISSION LINES
19	295	5.3	MM-CC STATE PARK (ADMINISTRATION BUILDING)
20	25	0.5	RESIDENCE
21	132	9.7	4TH & MADISON
22	210	6.5	CHURCH & WALNUT

NRC TLD DOSES FOR DAVIS-BESSE AREA

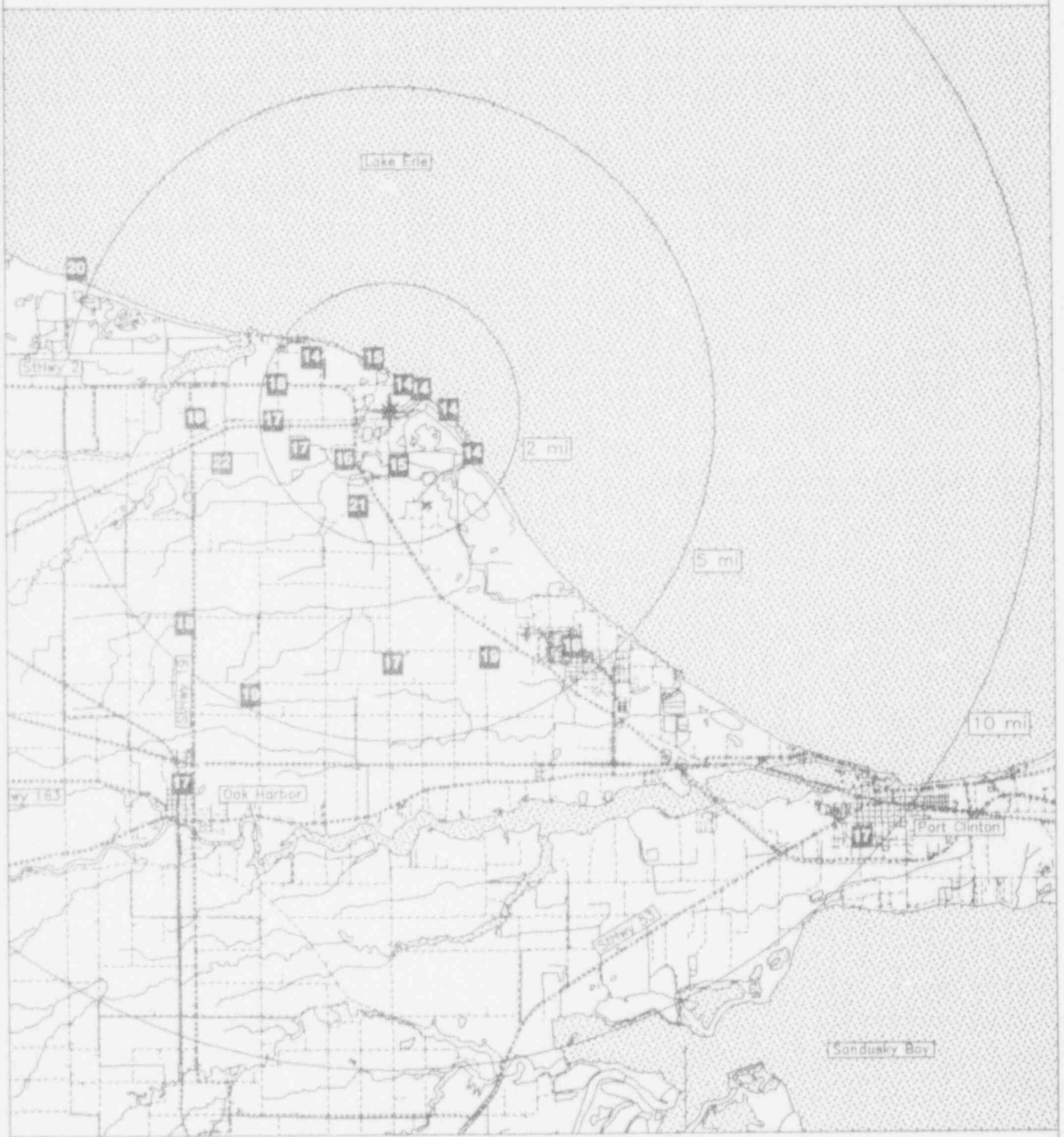

Miles



Legend

- Water
- Railroads
- Plant site
- Highways
- Roads

DC COOK
 TLD Direct Radiation Environmental Monitoring
 For the period 930914-940201 141 Days
 Field Time: 92 Days

NRC Sta	Location Azimuth/Dist (Deg)/(Mi)	Gross Exposure (mR) +-Rdm; Tot.	Net Exposure Rate (mR/Std. Qtr.) +-Rdm; Tot.	Hist. Range Net Exp Rate +-1 Std Dev
1	54 1.7	19.0 +- 0.6; 2.9	13.5 +- 0.7; 4.1	14.5 +- 2.1
2	67 1.3	22.9 +- 0.7; 3.4	17.3 +- 0.8; 4.5	16.7 +- 2.5
3	89 1.1	17.6 +- 0.5; 2.6	12.2 +- 0.6; 4.0	13.5 +- 2.3
4	58 0.7	17.0 +- 0.5; 2.6	11.6 +- 0.6; 3.9	13.6 +- 2.4
5	19 2.3	18.0 +- 0.5; 2.7	12.6 +- 0.6; 4.0	14.3 +- 2.0
6	111 1.6	18.3 +- 0.6; 2.8	12.9 +- 0.7; 4.1	14.2 +- 2.2
7	135 1.5	17.9 +- 0.5; 2.7	12.4 +- 0.6; 4.0	13.8 +- 2.4
8	158 1.4	22.6 +- 0.7; 3.4	17.0 +- 0.8; 4.5	16.0 +- 2.7
9	171 1.9	19.0 +- 0.6; 2.8	13.5 +- 0.7; 4.1	13.5 +- 2.0
10	199 1.5	18.3 +- 0.5; 2.7	12.8 +- 0.7; 4.1	13.9 +- 2.1
11	195 3.9	18.0 +- 0.5; 2.7	12.6 +- 0.6; 4.0	13.8 +- 2.3
12	200 6.6	Missing Dosimeter	No Net Data	14.6 +- 2.3
13	179 3.9	22.3 +- 0.7; 3.3	16.7 +- 0.8; 4.5	17.0 +- 2.3
14	151 4.4	22.2 +- 0.7; 3.3	16.6 +- 0.8; 4.4	17.9 +- 2.4
15	130 4.6	24.1 +- 0.7; 3.6	18.5 +- 0.8; 4.7	18.0 +- 2.0
16	110 3.7	19.3 +- 0.6; 2.9	13.8 +- 0.7; 4.1	15.4 +- 1.9
17	88 3.6	Missing Dosimeter	No Net Data	14.8 +- 1.9
18	67 3.8	19.7 +- 0.6; 3.0	14.2 +- 0.7; 4.2	15.1 +- 2.6
19	24 3.8	17.0 +- 0.5; 2.6	11.6 +- 0.6; 3.9	14.0 +- 2.6
20	43 3.3	Missing Dosimeter	No Net Data	16.3 +- 3.1
21	26 9.9	22.6 +- 0.7; 3.4	17.1 +- 0.8; 4.5	17.8 +- 4.3
22	121 18.0	20.8 +- 0.6; 3.1	15.3 +- 0.7; 4.3	14.8 +- 2.1
23	121 18.0	19.6 +- 0.6; 2.9	14.1 +- 0.7; 4.2	15.0 +- 2.4
24	121 18.0	Missing Dosimeter	No Net Data	16.9 +- 2.6

Transit Dose = 5.2 +- 0.4; 3.1

DC COOK

For the period 930914-940201

TLD Direct Radiation Environmental Monitoring

Azimuth (degrees)	Ave. Exposure Rate (mR/Std.Qtr.) +- Std.Dev.	Number In Group
348.76 - 11.25 N	No Data +- No Data	0
11.26 - 33.75 NNE	13.7 +- 2.9	3
33.76 - 56.25 NE	13.5 +- 0.0	1
56.26 - 78.75 ENE	14.3 +- 2.9	3
78.76 - 101.25 E	12.2 +- 0.0	1
101.26 - 123.75 ESE	13.3 +- 0.6	2
123.76 - 146.25 SE	15.5 +- 4.3	2
146.26 - 168.75 SSE	16.8 +- 0.3	2
168.76 - 191.25 S	15.1 +- 2.3	2
191.26 - 213.75 SSW	12.7 +- 0.2	2
213.76 - 236.25 SW	No Data +- No Data	0
236.26 - 258.75 WSW	No Data +- No Data	0
258.76 - 281.25 W	No Data +- No Data	0
281.26 - 303.75 WNW	No Data +- No Data	0
303.76 - 326.25 NW	No Data +- No Data	0
326.26 - 348.75 NNW	No Data +- No Data	0

Distance From Reactor (miles)	Ave. Exposure Rate (mR/Std.Qtr.) +- Std.Dev.	Number In Group
0 - 2	13.7 +- 2.1	9
2 - 5	14.6 +- 2.5	8
> 5	17.1 +- 0.0	1
Upwind Control	14.7 +- 0.8	2

DC COOK
TLD Direct Radiation Environmental Monitoring

NRC Station	Location		Description
	Azimuth Degree	Distance / Mile	
1	54	1.7	RED ARROW HWY. (US 31)
2	67	1.3	RED ARROW HWY. & LINCO RD.
3	89	1.1	RED ARROW HWY. & ROAD TO PLANT
4	58	0.7	WILLOW RD.
5	19	2.3	GRAND MERE RD.
6	111	1.6	JERICO RD. & LIVINGSTON RD.
7	135	1.5	GAST RD.
8	158	1.4	LEMON CREEK RD. & RED ARROW HWY.
9	171	1.9	RED ARROW HWY.
10	199	1.5	DUNEWOOD DR.
11	195	3.9	HILDEBRANT RD.
12	200	6.6	SAWYER RD. & RED ARROW HWY.
13	179	3.9	SNOW RD. & BALDWIN RD.
14	151	4.4	SNOW RD. & DATE RD.
15	130	4.6	CLEVELAND AVE. & SKALA RD.
16	110	3.7	CLEVELAND AVE. & LEMON CREEK RD.
17	88	3.6	CLEVELAND AVE. & MARRS RD.
18	67	3.8	CLEVELAND AVE. & ROCKY WEED RD.
19	24	3.8	THORNTON RD & MARQUETTE WJODS RD.
20	43	3.3	JOHN BEEVS RD.
21	26	9.9	DOWNTOWN ST. JOSEPH (MI)
22	121	18.0	NILES (MI)
23	121	18.0	NILES (MI)
24	121	18.0	NILES (MI)

NRC TLD DOSES FOR D.C. COOK AREA

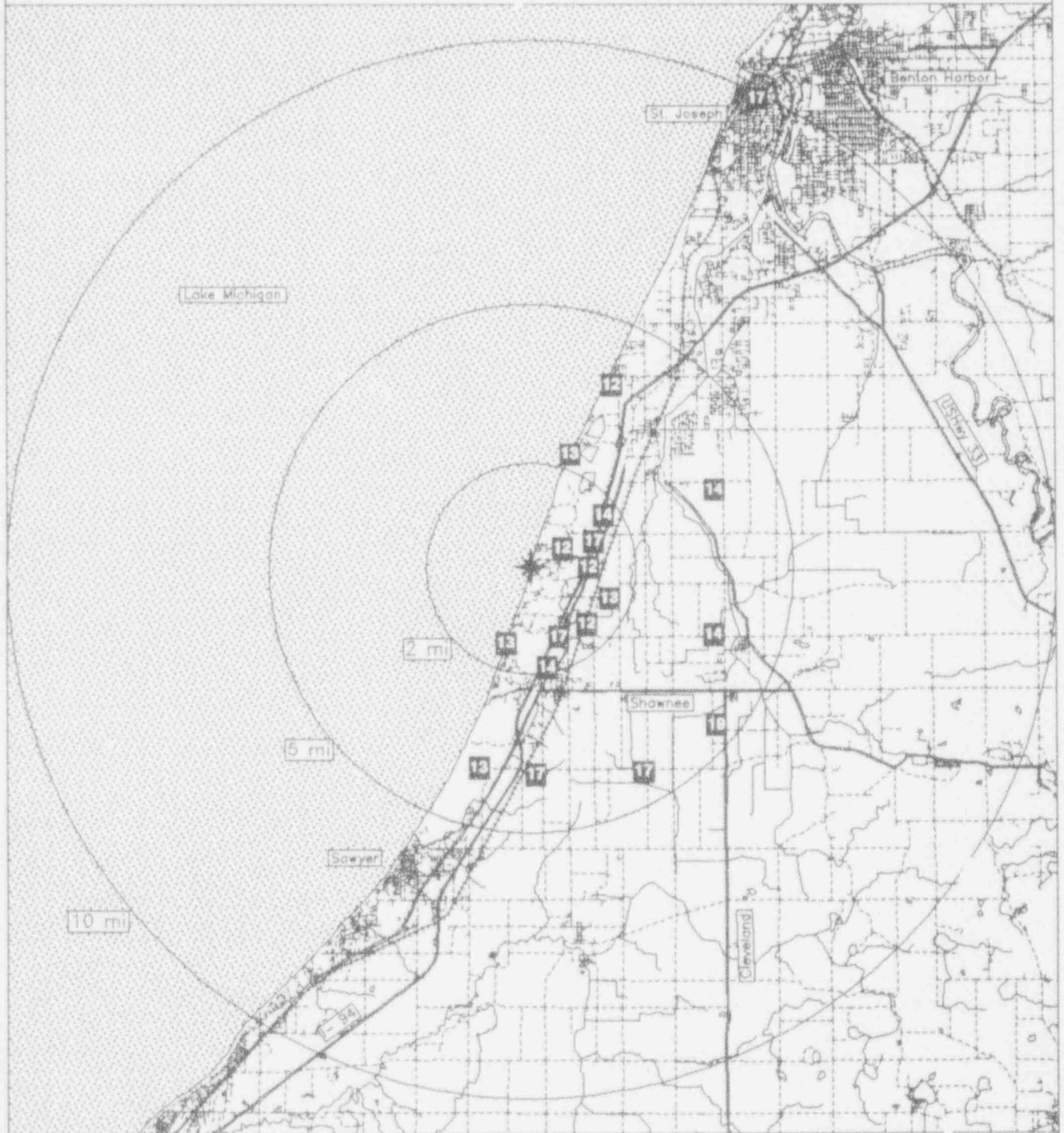

Miles



Legend



Water

Highways

Railroads

Roads



Plant site

DIABLO CANYON

TLD Direct Radiation Environmental Monitoring

For the period 930914-940127 136 Days

Field Time: 100 Days

NRC Sta	Location Azimuth/Dist (Deg)/(Mi)		Gross Exposure (mR) +-Rdm; Tot.	Net Exposure Rate (mR/Std. Qtr.) +-Rdm; Tot.	Hist. Range Net Exp Rate +-1 Std Dev
1	132	0.9	30.6 +- 0.9; 4.6	22.9 +- 0.9; 5.1	23.2 +- 1.7
2	119	3.9	26.8 +- 0.8; 4.0	19.5 +- 0.8; 4.7	21.1 +- 1.6
3	107	7.2	24.1 +- 0.7; 3.6	17.0 +- 0.7; 4.4	19.6 +- 1.6
4	111	10.3	25.0 +- 0.7; 3.7	17.9 +- 0.8; 4.5	18.7 +- 1.7
5	115	13.9	26.3 +- 0.8; 4.0	19.1 +- 0.8; 4.6	19.9 +- 1.8
6	68	9.4	25.7 +- 0.8; 3.9	18.5 +- 0.8; 4.6	18.2 +- 1.8
7	359	11.1	23.7 +- 0.7; 3.6	16.7 +- 0.7; 4.4	16.3 +- 2.4
8	359	6.6	19.7 +- 0.6; 3.0	13.1 +- 0.6; 4.0	14.7 +- 1.7
9	339	4.8	20.0 +- 0.6; 3.0	13.3 +- 0.7; 4.0	13.6 +- 1.4
10	327	3.6	20.9 +- 0.6; 3.1	14.2 +- 0.7; 4.1	14.8 +- 2.6
11	325	1.2	20.5 +- 0.6; 3.1	13.8 +- 0.7; 4.1	14.5 +- 1.8
12	36	20.7	29.3 +- 0.9; 4.4	21.7 +- 0.9; 5.0	21.0 +- 1.4
13	36	20.7	28.8 +- 0.9; 4.3	21.3 +- 0.9; 4.9	20.8 +- 2.0
14	36	20.7	29.3 +- 0.9; 4.4	21.7 +- 0.9; 5.0	21.2 +- 1.6

Transit Dose = 5.2 +- 0.4; 3.3

DIABLO CANYON
For the period 930914-940127

TLD Direct Radiation Environmental Monitoring

Azimuth (degrees)	Ave. Exposure Rate (mR/Std.Qtr.) +- Std.Dev.	Number In Group
348.76 - 11.25 N	14.9 +- 2.5	2
11.26 - 33.75 NNE	No Data +- No Data	0
33.76 - 56.25 NE	No Data +- No Data	0
56.26 - 78.75 ENE	18.5 +- 0.0	1
78.76 - 101.25 E	No Data +- No Data	0
101.26 - 123.75 ESE	18.4 +- 1.1	4
123.76 - 146.25 SE	22.9 +- 0.0	1
146.26 - 168.75 SSE	No Data +- No Data	0
168.76 - 191.25 S	No Data +- No Data	0
191.26 - 213.75 SSW	No Data +- No Data	0
213.76 - 236.25 SW	No Data +- No Data	0
236.26 - 258.75 WSW	No Data +- No Data	0
258.76 - 281.25 W	No Data +- No Data	0
281.26 - 303.75 WNW	No Data +- No Data	0
303.76 - 326.25 NW	13.8 +- 0.0	1
326.26 - 348.75 NNW	13.8 +- 0.6	2

Distance From Reactor (miles)	Ave. Exposure Rate (mR/Std.Qtr.) +- Std.Dev.	Number In Group
0 - 2	18.3 +- 6.5	2
2 - 5	15.7 +- 3.3	3
> 5	17.0 +- 2.1	6
Upwind Control	21.6 +- 0.2	3

DIABLO CANYON
 TLD Direct Radiation Environmental Monitoring

NRC Station	Location		Description
	Azimuth Degree	Distance / Mile	
1	132	0.9	SITE ENTRANCE RD.
2	119	3.9	SITE ENTRANCE RD.
3	107	7.2	SAN MIGUEL ST.
4	111	10.3	CORNER NAOMI AVE.
5	115	13.9	CORNER ATLANTIC CITY AVE.
6	68	9.4	PREFUMO CANYON RD.
7	359	11.1	PG&E MORROW BAY PLANT
8	359	6.6	PECHO VALLEY RD.
9	339	4.8	MONTANO DEORO PARK
10	327	3.6	PRIV. RD. END OF PECHO VALLEY
11	325	1.2	PRIV. RD. N. OF PLANT
12	36	20.7	SAN DIEGO RD.
13	36	20.7	SAN DIEGO RD.
14	36	20.7	SAN DIEGO RD.

NRC TLD DOSES FOR DIABLO CANYON AREA

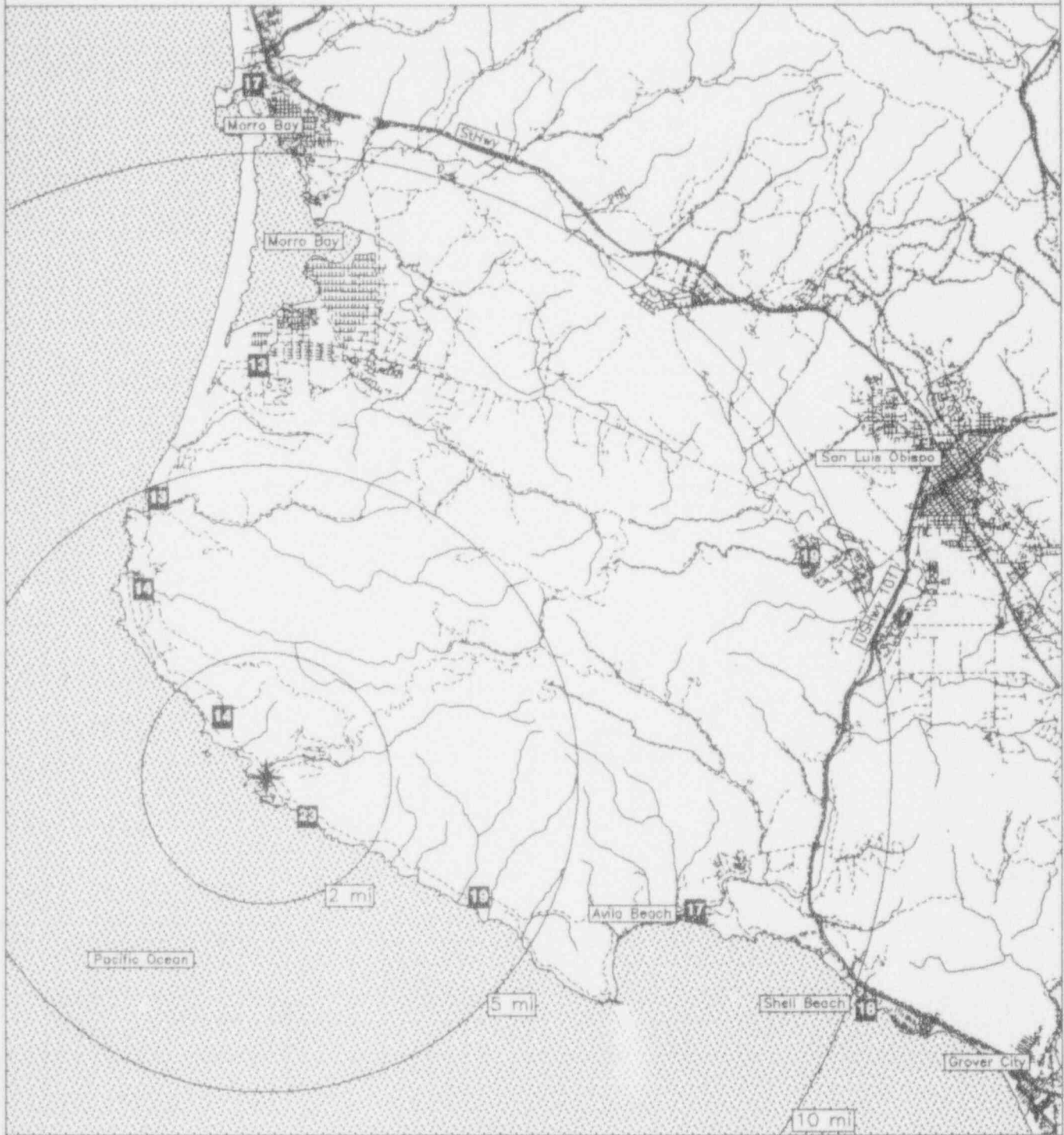

Miles

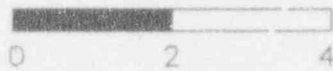

Legend

- Water
- Highways
- Railroads
- Roads
- Plant..site

DRESDEN

TLD Direct Radiation Environmental Monitoring

For the period 930914-940202 142 Days

Field Time: 100 Days

NRC Sta	Location Azimuth/Dist (Deg)/(Mi)	Gross Exposure (mR) +-Rdm; Tot.	Net Exposure Rate (mR/Std. Qtr.) +-Rdm; Tot.	Hist. Range Net Exp Rate +-1 Std Dev
1	70 4.2	22.7 +- 0.7; 3.4	16.8 +- 0.7; 4.2	17.2 +- 2.8
2	76 3.9	19.2 +- 0.6; 2.9	13.7 +- 0.6; 3.9	16.6 +- 3.3
3	108 3.2	22.3 +- 0.7; 3.3	16.4 +- 0.7; 4.2	17.5 +- 2.7
4	142 1.3	20.6 +- 0.6; 3.1	14.9 +- 0.6; 4.0	14.5 +- 2.9
5	115 1.5	Damaged Dosimeter	No Net Data	14.5 +- 2.5
6	180 1.9	21.5 +- 0.6; 3.2	15.7 +- 0.7; 4.1	17.6 +- 3.2
7	179 0.5	21.7 +- 0.7; 3.3	15.9 +- 0.7; 4.1	16.7 +- 2.6
8	180 0.7	20.0 +- 0.6; 3.0	14.4 +- 0.6; 4.0	14.5 +- 2.5
9	253 0.5	23.9 +- 0.7; 3.6	17.9 +- 0.7; 4.3	18.0 +- 2.9
10	254 1.3	28.5 +- 0.9; 4.3	22.0 +- 0.8; 4.8	23.6 +- 4.3
11	250 1.5	19.9 +- 0.6; 3.0	14.2 +- 0.6; 4.0	15.1 +- 3.0
12	263 2.1	22.7 +- 0.7; 3.4	16.8 +- 0.7; 4.2	18.0 +- 2.6
13	180 4.0	18.9 +- 0.6; 2.8	13.4 +- 0.6; 3.9	13.9 +- 2.5
14	158 4.8	20.6 +- 0.6; 3.1	14.9 +- 0.6; 4.0	15.1 +- 2.4
15	137 4.2	18.8 +- 0.6; 2.8	13.2 +- 0.6; 3.9	15.4 +- 2.8
16	134 8.4	20.5 +- 0.6; 3.1	14.8 +- 0.6; 4.0	14.9 +- 2.5
17	189 7.4	20.9 +- 0.6; 3.1	15.1 +- 0.7; 4.0	15.8 +- 2.6
18	203 4.1	18.0 +- 0.5; 2.7	12.5 +- 0.6; 3.8	13.8 +- 3.1
19	231 4.0	20.7 +- 0.6; 3.1	15.0 +- 0.7; 4.0	18.7 +- 3.2
20	244 6.4	21.1 +- 0.6; 3.2	15.3 +- 0.7; 4.1	16.2 +- 3.1
21	258 8.6	22.4 +- 0.7; 3.4	16.5 +- 0.7; 4.2	17.0 +- 2.6
22	269 4.4	19.2 +- 0.6; 2.9	13.6 +- 0.6; 3.9	14.7 +- 2.6
23	295 3.3	20.1 +- 0.6; 3.0	14.5 +- 0.6; 4.0	15.2 +- 1.5
24	311 3.9	22.1 +- 0.7; 3.3	16.3 +- 0.7; 4.2	16.1 +- 3.0
25	340 4.7	24.0 +- 0.7; 3.6	17.9 +- 0.7; 4.4	18.9 +- 3.1
26	7 4.4	21.2 +- 0.6; 3.2	15.5 +- 0.7; 4.1	15.6 +- 2.8
27	355 2.0	26.1 +- 0.8; 3.9	19.9 +- 0.8; 4.6	20.5 +- 3.1
28	327 1.7	27.1 +- 0.8; 4.1	20.7 +- 0.8; 4.7	21.0 +- 2.8
29	318 1.4	22.8 +- 0.7; 3.4	16.9 +- 0.7; 4.2	18.2 +- 3.3
30	295 2.0	19.7 +- 0.6; 2.9	14.0 +- 0.6; 3.9	15.6 +- 3.4
31	30 1.5	24.1 +- 0.7; 3.6	18.0 +- 0.7; 4.4	19.5 +- 3.1
32	48 1.9	27.0 +- 0.8; 4.0	20.6 +- 0.8; 4.7	20.8 +- 3.1
33	76 1.4	23.9 +- 0.7; 3.6	17.8 +- 0.7; 4.3	19.2 +- 3.1
34	90 1.4	21.6 +- 0.6; 3.2	15.8 +- 0.7; 4.1	17.9 +- 3.6
35	26 4.5	22.2 +- 0.7; 3.3	16.3 +- 0.7; 4.2	17.7 +- 2.9
36	42 3.6	20.9 +- 0.6; 3.1	15.2 +- 0.7; 4.1	16.1 +- 3.0
37	52 11.5	21.8 +- 0.7; 3.3	16.0 +- 0.7; 4.1	17.0 +- 3.3
38	274 21.5	23.1 +- 0.7; 3.5	17.2 +- 0.7; 4.3	17.9 +- 3.3
39	274 21.5	22.5 +- 0.7; 3.4	16.6 +- 0.7; 4.2	17.7 +- 3.1
40	275 21.5	24.1 +- 0.7; 3.6	18.0 +- 0.7; 4.4	19.2 +- 3.6

Transit Dose = 4.1 +- 0.4; 3.2

DFESDEN

For the period 930914-940202

TLD Direct Radiation Environmental Monitoring

Azimuth (degrees)	Ave. Exposure Rate (mR/Std.Qtr.) +- Std.Dev.	Number In Group
348.76 - 11.25 N	17.7 +- 3.1	2
11.26 - 33.75 NNE	17.2 +- 1.2	2
33.76 - 56.25 NE	17.3 +- 2.9	3
56.26 - 78.75 ENE	16.1 +- 2.2	3
78.76 - 101.25 E	15.8 +- 0.0	1
101.26 - 123.75 ESE	16.4 +- 0.0	1
123.76 - 146.25 SE	14.3 +- 0.9	3
146.26 - 168.75 SSE	14.9 +- 0.0	1
168.76 - 191.25 S	14.9 +- 1.0	5
191.26 - 213.75 SSW	12.5 +- 0.0	1
213.76 - 236.25 SW	15.0 +- 0.0	1
236.26 - 258.75 WSW	17.2 +- 3.0	5
258.76 - 281.25 W	15.2 +- 2.3	2
281.26 - 303.75 WNW	14.3 +- 0.3	2
303.76 - 326.25 NW	16.6 +- 0.4	2
326.26 - 348.75 NNW	19.3 +- 2.0	2

Distance From Reactor (miles)	Ave. Exposure Rate (mR/Std.Qtr.) +- Std.Dev.	Number In Group
0 - 2	17.2 +- 2.6	15
2 - 5	15.1 +- 1.6	16
> 5	15.5 +- 0.7	5
Upwind Control	17.3 +- 0.7	3

DRESDEN
TLD Direct Radiation Environmental Monitoring

NRC Station	Location		Description
	Azimuth / Degree	Distance / Mile	
1	70	4.2	FRONTAGE RD.
2	76	3.9	FRONTAGE RD.
3	108	3.2	BLODGETT & N. RIVER RD.
4	142	1.3	COUNTY LINE RD. & BLODGETT RD.
5	115	1.5	DESPLAINES RIVER RD.
6	180	1.9	DRESDEN RD.
7	179	0.5	PLANT ENTRANCE - DRESDEN RD.
8	180	0.7	TAMARACK LANE
9	253	0.5	COLLINS RD.
10	254	1.3	COLLINS RD.
11	250	1.5	COLLINS RD.
12	263	2.1	COLLINS RD.
13	180	4.0	DRESDEN RD.
14	158	4.8	MURPHY RD.
15	137	4.2	GREER RD. & PINE BLUFF RD.
16	134	8.4	MAIN ST. (WILMINGTON)
17	189	7.4	COAL CITY WATER TOWER ON BROADWAY
18	203	4.1	COAL CITY RD. & CARPER RD.
19	231	4.0	JUGTOWN RD.
20	244	6.4	PINE BLUFF RD. & OLD PINE BLUFF RD.
21	258	8.6	NETTLE ST. SUBSTATION
22	269	4.4	CEMETERY RD. (ARMSTRONG)
23	301	3.5	TABLER RD. & U.S. 6 INTERSECTION
24	311	3.9	SAND RIDGE RD. & TABLER RD.
25	340	4.7	MINOOKA RD.
26	7	4.4	WABENA AVE.
27	355	2.0	RIDGE RD. & U.S. 6
28	327	1.7	MCLINDON RD.
29	318	1.4	HANSEN RD. & MCLINDON RD.
30	295	2.0	CEMETERY RD.
31	30	1.5	HANSEN RD.
32	48	1.9	MCKINLEY WOODS RD IN SECTS 19&30 (T.34N-R.9E)
33	76	1.4	MCKINLEY WOODS RD IN SECTS 19&30 (T.34N-R.9E)
34	90	1.4	MCKINLEY WOODS RD IN SECTS 19&30 (T.34N-R.9E)
35	26	4.5	OFF MCEVILLY RD AT NORTHCREST DRIVE
36	42	3.6	CENTER ST.
37	52	11.5	OFF U.S. 6 AT BRANDON RD. LOCK & DAM
38	274	21.5	INT. OF N 31 & E 24 ST.
39	274	21.5	INT. OF N 31 & E 24 ST.
40	275	21.5	INT. OF E 24 & N 32 ST.

NRC TLD DOSES FOR DRESDEN AREA

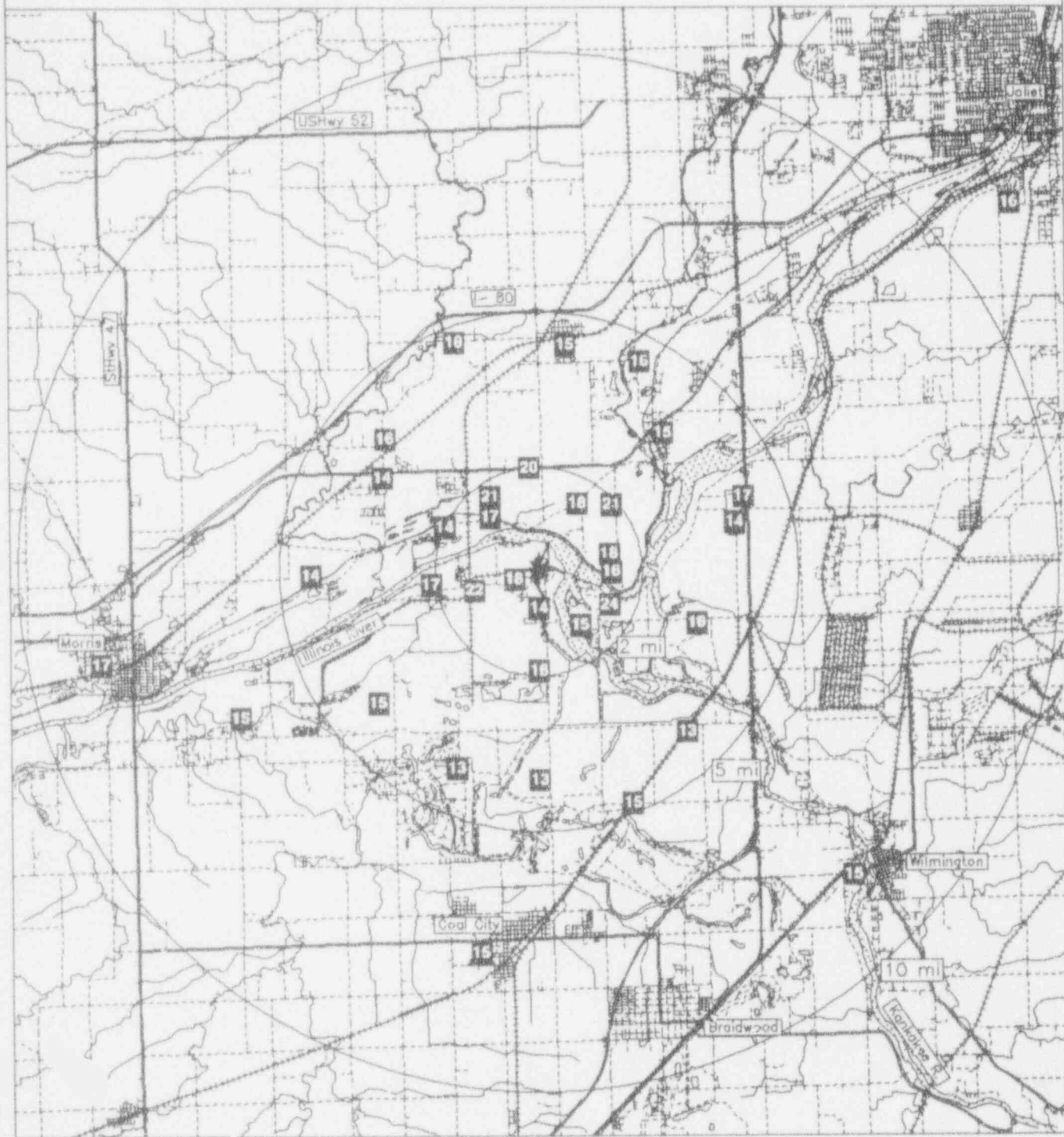

Miles

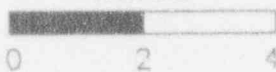

Legend



Water

--- Railroads



Plant site

— Highways

--- Roads

DUANE ARNOLD

TLD Direct Radiation Environmental Monitoring

For the period 930914-940127 136 Days

Field Time: 91 Days

NRC Sta	Location		Gross	Net Exposure Rate	Hist. Range
	Azimuth/Dist (Deg)/(Mi)	Exposure (mR) +-Rdm; Tot.	(mR/Std. Qtr.) +-Rdm; Tot.	Net Exp Rate +-1 Std Dev	
1	163	9.7	20.6 +- 0.6; 3.1	18.0 +- 0.7; 4.1	16.5 +- 2.1
2	170	6.2	21.1 +- 0.6; 3.2	18.5 +- 0.7; 4.2	18.7 +- 1.9
3	180	3.5	19.2 +- 0.6; 2.9	16.6 +- 0.6; 4.0	15.4 +- 1.4
4	216	2.9	22.8 +- 0.7; 3.4	20.2 +- 0.7; 4.4	18.7 +- 2.4
5	201	2.5	18.8 +- 0.6; 2.8	16.2 +- 0.6; 3.9	15.2 +- 1.8
6	213	1.0	21.0 +- 0.6; 3.2	18.4 +- 0.7; 4.2	17.0 +- 1.9
7	248	1.0	22.4 +- 0.7; 3.4	19.8 +- 0.7; 4.3	18.9 +- 2.1
8	279	1.0	22.0 +- 0.7; 3.3	19.3 +- 0.7; 4.3	18.5 +- 2.0
9	298	1.0	23.2 +- 0.7; 3.5	20.6 +- 0.7; 4.4	19.5 +- 2.4
10	320	1.5	22.9 +- 0.7; 3.4	20.3 +- 0.7; 4.4	18.7 +- 2.2
11	343	1.0	23.2 +- 0.7; 3.5	20.5 +- 0.7; 4.4	19.4 +- 2.2
12	359	1.2	21.5 +- 0.6; 3.2	18.9 +- 0.7; 4.2	18.3 +- 2.0
13	237	0.5	20.4 +- 0.6; 3.1	17.8 +- 0.7; 4.1	17.5 +- 2.0
14	259	3.9	22.3 +- 0.7; 3.3	19.6 +- 0.7; 4.3	18.0 +- 2.2
15	272	5.0	18.6 +- 0.6; 2.8	16.0 +- 0.6; 3.9	15.2 +- 1.8
16	285	5.0	19.2 +- 0.6; 2.9	16.6 +- 0.6; 4.0	16.8 +- 1.8
17	308	4.5	23.3 +- 0.7; 3.5	20.7 +- 0.8; 4.5	18.8 +- 2.2
18	340	4.5	18.7 +- 0.6; 2.8	16.2 +- 0.6; 3.9	15.6 +- 1.6
19	291	15.0	20.7 +- 0.6; 3.1	18.1 +- 0.7; 4.2	17.0 +- 1.7
20	291	15.0	22.3 +- 0.7; 3.3	19.6 +- 0.7; 4.3	17.9 +- 2.1
21	291	15.0	20.8 +- 0.6; 3.1	18.2 +- 0.7; 4.2	16.5 +- 1.8
22	358	6.1	20.7 +- 0.6; 3.1	18.1 +- 0.7; 4.2	15.8 +- 1.6
23	7	2.9	18.9 +- 0.6; 2.8	16.4 +- 0.6; 4.0	15.3 +- 1.8
24	28	3.0	23.7 +- 0.7; 3.6	21.1 +- 0.8; 4.5	18.6 +- 2.1
25	39	3.5	21.6 +- 0.6; 3.2	18.9 +- 0.7; 4.3	17.2 +- 1.8
26	64	3.8	21.5 +- 0.6; 3.2	18.9 +- 0.7; 4.2	17.7 +- 1.8
27	50	1.9	19.8 +- 0.6; 3.0	17.2 +- 0.7; 4.1	15.6 +- 1.8
28	72	2.3	19.8 +- 0.6; 3.0	17.2 +- 0.7; 4.1	17.3 +- 1.6
29	91	3.0	19.8 +- 0.6; 3.0	17.2 +- 0.7; 4.1	15.5 +- 1.8
30	93	1.8	22.2 +- 0.7; 3.3	19.5 +- 0.7; 4.3	19.0 +- 1.8
31	113	2.0	23.7 +- 0.7; 3.5	21.0 +- 0.8; 4.5	19.2 +- 1.8
32	141	1.6	19.8 +- 0.6; 3.0	17.2 +- 0.7; 4.1	15.5 +- 1.8
33	153	1.5	22.5 +- 0.7; 3.4	19.9 +- 0.7; 4.4	17.6 +- 1.9
34	177	1.2	Damaged Dosimeter	No Net Data	15.8 +- 2.6
35	153	4.2	18.8 +- 0.6; 2.8	16.3 +- 0.6; 4.0	15.1 +- 1.8
36	135	4.1	19.7 +- 0.6; 3.0	17.1 +- 0.7; 4.0	16.5 +- 1.8
37	111	4.6	25.5 +- 0.8; 3.8	22.8 +- 0.8; 4.7	18.7 +- 1.8
38	123	5.1	23.3 +- 0.7; 3.5	20.6 +- 0.8; 4.4	18.7 +- 1.9
39	132	7.0	19.9 +- 0.6; 3.0	17.3 +- 0.7; 4.1	15.8 +- 1.6
40	139	7.6	19.0 +- 0.6; 2.8	16.4 +- 0.6; 4.0	16.6 +- 1.6

Transit Dose = 2.4 +- 0.3; 2.8

DUANE ARNOLD
For the period 930914-940127

TLD Direct Radiation Environmental Monitoring

Azimuth (degrees)	Ave. Exposure Rate (mR/Std.Qtr.) +- Std.Dev.	Number In Group
348.76 - 11.25 N	17.8 +- 1.3	3
11.26 - 33.75 NNE	21.1 +- 0.0	1
33.76 - 56.25 NE	18.1 +- 1.2	2
56.26 - 78.75 ENE	18.0 +- 1.2	2
78.76 - 101.25 E	18.4 +- 1.6	2
101.26 - 123.75 ESE	21.5 +- 1.2	3
123.76 - 146.25 SE	17.0 +- 0.4	4
146.26 - 168.75 SSE	18.0 +- 1.8	3
168.76 - 191.25 S	17.6 +- 1.3	2
191.26 - 213.75 SSW	17.3 +- 1.6	2
213.76 - 236.25 SW	20.2 +- 0.0	1
236.26 - 258.75 WSW	18.8 +- 1.4	2
258.76 - 281.25 W	18.3 +- 2.0	3
281.26 - 303.75 WNW	18.6 +- 2.8	2
303.76 - 326.25 NW	20.5 +- 0.3	2
326.26 - 348.75 NNW	18.3 +- 3.1	2

Distance From Reactor (r ¹ les)	Ave. Exposure Rate (mR/Std.Qtr.) +- Std.Dev.	Number In Group
0 - 2	19.3 +- 1.3	13
2 - 5	18.1 +- 2.1	17
> 5	18.1 +- 1.4	6
Upwind Control	18.7 +- 0.9	3

DUANE ARNOLD
TLD Direct Radiation Environmental Monitoring

NRC Station	Location		Description
	Azimuth / Degree	Distance / Mile	
1	163	9.7	EDGEWOOD RD.
2	170	6.2	HWY. 94 (COVINGTON)
3	180	3.5	PUBLIC USE AREA #11 (CHAIN BRIDGE RD)
4	216	2.9	E. 36 & HWY 94
5	201	2.5	MAJOR JCT IN PALO (E36 & W36)
6	213	1.0	COMP RD
7	248	1.0	S. OF R.R. ON W36 (PALO MARSH RD)
8	279	1.0	W36 PAST CULVERT
9	298	1.0	W36 E. SIDE FENCEPOST
10	320	1.5	W36 & MCCLINTOCK RD.
11	343	1.0	MCCLINTOCK RD.-E.
12	359	1.2	N. ON PRIVATE DRIVE
13	237	0.5	POWER PLANT RD.
14	259	3.9	BEAR CREEK RD AFTER CURVE
15	272	5.0	SHELLSBURG
16	285	5.0	W26
17	308	4.5	E24
18	340	4.5	E24 IN 'LEWIS PRESERVE' (LEWIS ACC.RD)
19	291	15.0	2ND AVE-VINTON LUTHERAN HOME
20	291	15.0	VINTON LUTHERAN HOME
21	291	15.0	HWY. 150
22	358	6.1	SUMMIT & IOWA STS (IN CENTER PT)
23	7	2.9	DREW LANE
24	28	3.0	QUAIL RIDGE RD
25	39	3.5	HWY 150 (TULL LN & CENTER PT RD)
26	64	3.8	HWY 150 (HAGERMAN RD & CENTER PT RD)
27	50	1.9	PONDS LANE
28	72	2.3	ON FENCE POST (STANDLEA RD)
29	91	3.0	FRONT DRIVE IN TODDVILLE
30	93	1.8	FEATHER RIDGE RD & WICKIUP HILL RD
31	113	2.0	N. OF KUEHL RESIDENCE (FEATHER RIDGE RD)
32	141	1.6	MORRIS HILLS RD & HORSESHOE LANE RD
33	153	1.5	MORRIS HILLS RD
34	177	1.2	FENCEPOST NEAR N. GATE (MORRIS HILLS RD)
35	153	4.2	BLAIRS FERRY RD AT CURVE
36	135	4.1	MILBURN RD. & OAK GROVE RD
37	111	4.6	CENTER POINT RD & SINGER HILL LANE
38	123	5.1	CENTER POINT RD & TOWER TERRACE RD
39	132	7.0	1ST AVE & CENTER PT RD IN HIAWATHA
40	139	7.6	J AVE & MAPLEWOOD DR IN CEDAR RAPIDS

NRC TLD DOSES FOR DUANE ARNOLD AREA

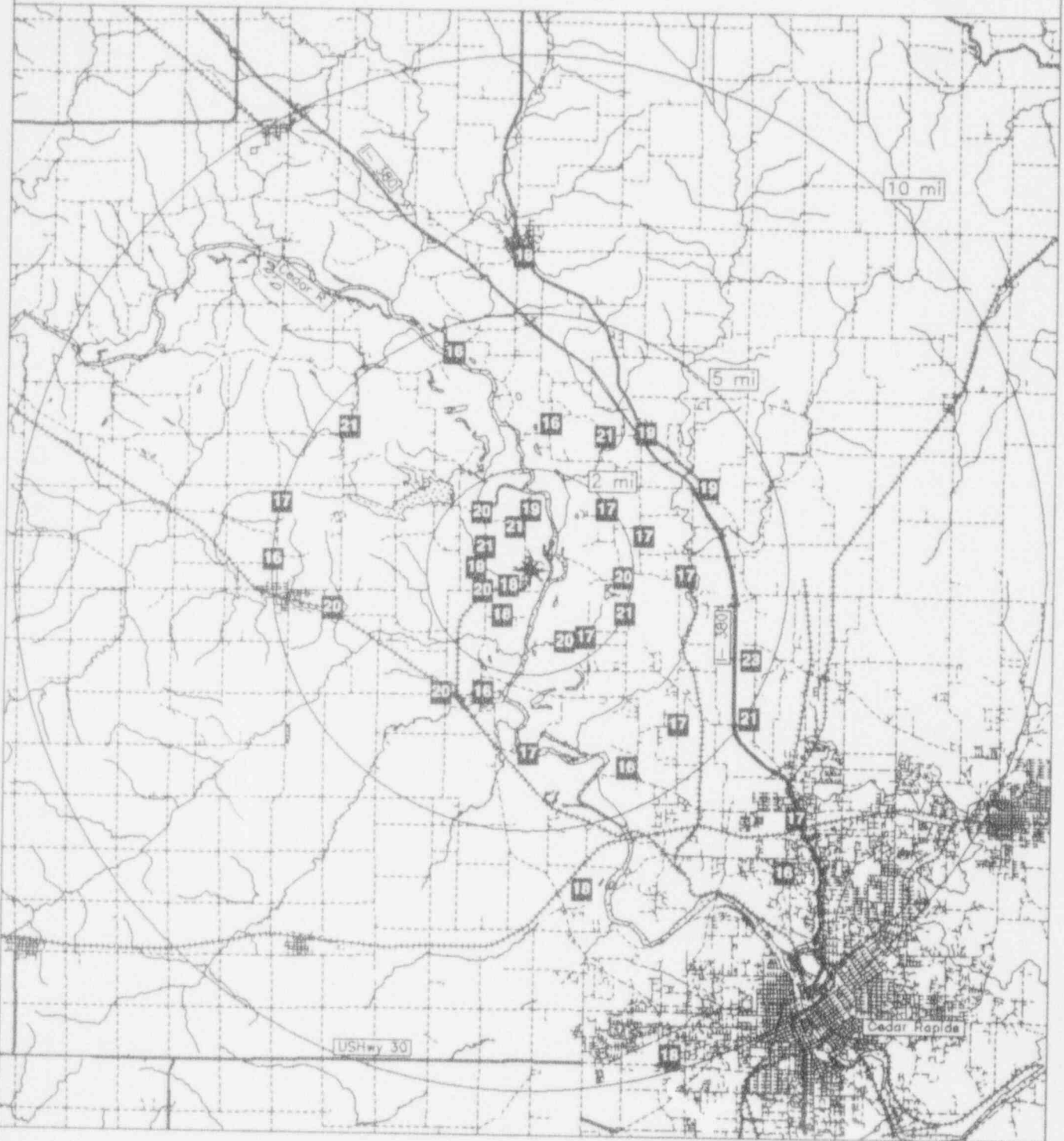

Miles

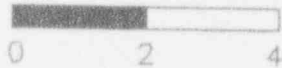

Legend

Water

Highways

Railroads

Roads

Plant site

FARLEY

TLD Direct Radiation Environmental Monitoring

For the period 930915-940209 148 Days

Field Time: 94 Days

NRC Sta	Location		Gross Exposure (mR)		Net Exposure Rate (mR/Std. Qtr.)		Hist. Range Net Exp Rate	
	Azimuth/Dist (Deg)/(Mi)		+-Rdm; Tot.		+-Rdm; Tot.		+-1 Std Dev	
1	268	15.0	17.9	+- 0.5; 2.7	11.1	+- 0.7; 4.0	14.4	+- 2.6
2	252	7.8	18.1	+- 0.5; 2.7	11.3	+- 0.7; 4.1	14.6	+- 2.6
3	217	6.1	19.9	+- 0.6; 3.0	13.0	+- 0.7; 4.2	15.7	+- 2.2
4	155	5.7	23.8	+- 0.7; 3.6	16.8	+- 0.8; 4.6	18.6	+- 2.2
5	170	5.1	20.5	+- 0.6; 3.1	13.6	+- 0.7; 4.3	15.6	+- 2.2
6	197	4.5	19.2	+- 0.6; 2.9	12.4	+- 0.7; 4.2	14.6	+- 2.2
7	191	2.4	21.3	+- 0.6; 3.2	14.3	+- 0.7; 4.4	18.3	+- 2.7
8	200	1.8	21.2	+- 0.6; 3.2	14.3	+- 0.7; 4.4	15.7	+- 2.3
9	220	1.2	18.7	+- 0.6; 2.8	11.9	+- 0.7; 4.1	14.1	+- 2.3
10	254	0.9	21.6	+- 0.6; 3.2	14.7	+- 0.7; 4.4	16.2	+- 2.1
11	300	0.9	21.4	+- 0.6; 3.2	14.4	+- 0.7; 4.4	16.0	+- 2.1
12	319	1.1	20.3	+- 0.6; 3.0	13.4	+- 0.7; 4.3	16.4	+- 2.4
13	338	1.3	19.3	+- 0.6; 2.9	12.5	+- 0.7; 4.2	14.7	+- 2.1
14	256	1.2	18.8	+- 0.6; 2.8	12.0	+- 0.7; 4.1	15.0	+- 2.3
15	16	1.3	24.0	+- 0.7; 3.6	17.0	+- 0.8; 4.7	20.4	+- 2.2
16	264	1.6	19.5	+- 0.6; 2.9	12.6	+- 0.7; 4.2	15.1	+- 2.2
17	253	3.5	23.1	+- 0.7; 3.5	16.1	+- 0.8; 4.6	17.2	+- 2.2
18	233	3.2	19.5	+- 0.6; 2.9	12.6	+- 0.7; 4.2	15.3	+- 2.2
19	267	4.5	20.1	+- 0.6; 3.0	13.2	+- 0.7; 4.3	16.2	+- 2.2
20	295	3.8	20.0	+- 0.6; 3.0	13.1	+- 0.7; 4.2	16.3	+- 2.7
21	315	4.6	19.6	+- 0.6; 2.9	12.7	+- 0.7; 4.2	14.6	+- 2.4
22	332	4.3	18.7	+- 0.6; 2.8	11.9	+- 0.7; 4.1	14.5	+- 2.1
23	251	4.8	19.1	+- 0.6; 2.9	12.2	+- 0.7; 4.2	14.1	+- 2.2
24	32	5.3	21.0	+- 0.6; 3.1	14.1	+- 0.7; 4.3	16.5	+- 2.1
25	54	6.2	18.7	+- 0.6; 2.8	11.8	+- 0.7; 4.1	14.3	+- 2.3
26	64	5.5	20.8	+- 0.6; 3.1	13.9	+- 0.7; 4.3	16.0	+- 2.2
27	88	4.7	20.2	+- 0.6; 3.0	13.3	+- 0.7; 4.3	15.7	+- 2.2
28	124	5.1	21.2	+- 0.6; 3.2	14.2	+- 0.7; 4.4	16.4	+- 2.1
29	153	4.1	20.2	+- 0.6; 3.0	13.3	+- 0.7; 4.3	15.7	+- 2.2
30	142	3.6	19.2	+- 0.6; 2.9	12.4	+- 0.7; 4.2	14.4	+- 2.0
31	130	3.0	17.5	+- 0.5; 2.6	10.7	+- 0.6; 4.0	13.5	+- 2.3
32	110	2.8	18.2	+- 0.5; 2.7	11.4	+- 0.7; 4.1	14.5	+- 2.4
33	78	2.6	18.6	+- 0.6; 2.8	11.7	+- 0.7; 4.1	14.4	+- 2.5
34	58	2.2	17.8	+- 0.5; 2.7	11.0	+- 0.7; 4.0	13.2	+- 2.3
35	34	2.4	24.7	+- 0.7; 3.7	17.6	+- 0.8; 4.7	19.4	+- 2.3
36	19	2.7	21.8	+- 0.7; 3.3	14.8	+- 0.7; 4.4	16.8	+- 2.1
37	284	10.0	19.5	+- 0.6; 2.9	12.6	+- 0.7; 4.2	15.7	+- 2.3
38	289	15.0	22.9	+- 0.7; 3.4	15.9	+- 0.8; 4.5	15.0	+- 3.4
39	293	15.0	22.8	+- 0.7; 3.4	15.8	+- 0.8; 4.5	16.7	+- 1.9

Transit Dose = 6.3 +- 0.4; 3.3

FARLEY

For the period 930915-940209

TLD Direct Radiation Environmental Monitoring

Azimuth (degrees)	Ave. Exposure Rate (mR/Std.Qtr.) +- Std.Dev.	Number In Group
348.76 - 11.25 N	No Data +- No Data	0
11.26 - 33.75 NNE	15.3 +- 1.5	3
33.76 - 56.25 NE	14.7 +- 4.1	2
56.26 - 78.75 ENE	12.2 +- 1.5	3
78.76 - 101.25 E	13.3 +- 0.0	1
101.26 - 123.75 ESE	11.4 +- 0.0	1
123.76 - 146.25 SE	12.4 +- 1.8	3
146.26 - 168.75 SSE	15.0 +- 2.4	2
168.76 - 191.25 S	14.0 +- 0.5	2
191.26 - 213.75 SSW	13.3 +- 1.3	2
213.76 - 236.25 SW	12.5 +- 0.6	3
236.26 - 258.75 WSW	13.3 +- 2.0	5
258.76 - 281.25 W	12.3 +- 1.1	3
281.26 - 303.75 WNW	13.8 +- 1.0	2
303.76 - 326.25 NW	13.1 +- 0.4	2
326.26 - 348.75 NNW	12.2 +- 0.5	2

Distance From Reactor (miles)	Ave. Exposure Rate (mR/Std.Qtr.) +- Std.Dev.	Number In Group
0 - 2	13.6 +- 1.6	9
2 - 5	13.0 +- 1.7	18
> 5	13.3 +- 1.8	5
Upwind Control	14.8 +- 1.9	3

FARLEY

TLD Direct Radiation Environmental Monitoring

NRC Station	Location		Description
	Azimuth / Degree	Distance / Mile	
1	268	15.0	DOTHAN
2	252	7.8	ASHFORD (AL)
3	217	6.1	PANSEY (AL)
4	155	5.7	GORDON LANDING (AL)
5	170	5.1	MARSH RESIDENCE
6	197	4.5	PHIL. CHURCH RD.
7	191	2.4	HWY. 95 AT CEDAR CR.
8	200	1.8	UNION SPRINGS CHURCH RD.
9	220	1.2	WHATLEY FARM
10	254	0.9	FRONT GATE (AT SITE)
11	300	0.9	HWY. 95
12	319	1.1	HWY. 95 (FARLEY SITE)
13	338	1.3	DAMSITE RD.
14	256	1.2	PIC STATION
15	16	1.3	DAMSITE RD.
16	264	1.6	RT. 42
17	253	3.5	LANDFILL
18	233	3.2	UNION SPRINGS CHURCH
19	267	4.5	OAKY GROVE CH.
20	295	3.8	RT. 75 & RT. 33
21	315	4.6	HWY. 52 (AL)
22	332	4.3	HWY. 52 (AL)
23	251	4.8	COLUMBIA (AL)
24	32	5.3	HILTON (GA)
25	54	6.2	SAWHATCHEE (GA)
26	64	5.5	RD. 26 (GA)
27	88	4.7	CEDAR SPRINGS TOWER
28	124	5.1	CEDAR SPRINGS
29	153	4.1	HWY. 273 (GA)
30	142	3.6	HWY. 370 (GA)
31	130	3.0	HWY. 370 (GA)
32	110	2.8	HWY. 370 (GA)
33	78	2.6	HWY. 370 (GA)
34	58	2.2	RD. 81
35	34	2.4	RD. 81
36	19	2.7	ANDREWS LOCK & DAM RD.
37	284	10.0	WEBB (AL)
38	289	15.0	HWY. 431 (AL)
39	293	15.0	AL HWY. 431

NRC TLD DOSES FOR FARLEY AREA

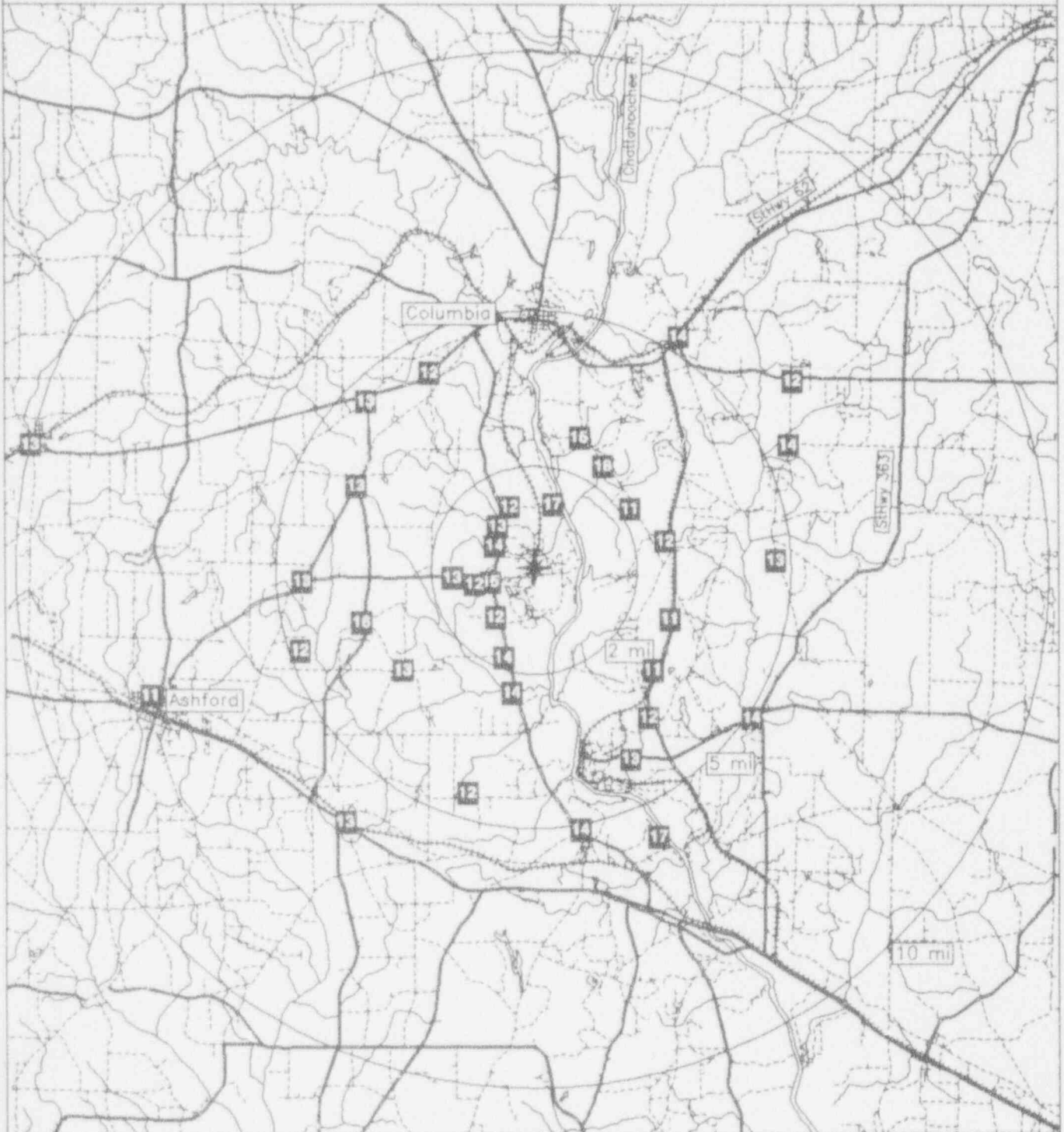

Miles



Legend

— Highways

- - - Railroads

--- Roads

★ Plant..site

FERMI

TLD Direct Radiation Environmental Monitoring

For the period 930914-940127 136 Days

Field Time: 97 Days

NRC Sta	Location		Gross Exposure (mR)		Net Exposure Rate (mR/Std. Qtr.)		Hist. Range Net Exp Rate	
	Azimuth/Dist (Deg)/(Mi)		+-Rdm; Tot.		+-Rdm; Tot.		+-1 Std Dev	
1	38	2.1	16.3	+- 0.5; 2.4	10.5	+- 0.6; 3.7	14.0	+- 3.3
2	22	2.3	20.1	+- 0.6; 3.0	14.1	+- 0.7; 4.1	15.4	+- 3.2
3	350	1.8	28.1	+- 0.8; 4.2	21.5	+- 0.9; 4.9	20.1	+- 2.2
4	345	1.9	21.8	+- 0.7; 3.3	15.6	+- 0.7; 4.3	16.2	+- 2.4
5	346	1.4	21.9	+- 0.7; 3.3	15.9	+- 0.7; 4.3	17.4	+- 2.4
6	310	1.3	22.8	+- 0.7; 3.4	16.6	+- 0.7; 4.4	17.4	+- 2.7
7	298	1.4	22.5	+- 0.7; 3.4	16.3	+- 0.7; 4.3	17.0	+- 2.3
8	277	1.6	22.8	+- 0.7; 3.4	16.6	+- 0.7; 4.4	17.2	+- 2.1
9	238	1.0	20.4	+- 0.6; 3.1	14.4	+- 0.7; 4.1	15.7	+- 3.1
10	225	1.5	19.9	+- 0.6; 3.0	13.9	+- 0.7; 4.1	14.4	+- 2.4
11	193	0.8	22.0	+- 0.7; 3.3	15.8	+- 0.7; 4.3	17.0	+- 2.1
12	183	0.9	21.4	+- 0.6; 3.2	15.3	+- 0.7; 4.2	16.8	+- 2.3
13	175	0.8	21.5	+- 0.6; 3.2	15.4	+- 0.7; 4.2	16.4	+- 2.2
14	260	1.7	26.8	+- 0.8; 4.0	20.3	+- 0.8; 4.8	18.5	+- 2.2
15	245	2.5	20.4	+- 0.6; 3.1	14.4	+- 0.7; 4.1	15.7	+- 2.4
16	236	5.0	23.7	+- 0.7; 3.6	17.4	+- 0.8; 4.4	19.2	+- 2.0
17	225	6.8	17.9	+- 0.5; 2.7	12.1	+- 0.6; 3.9	13.7	+- 2.5
18	250	7.8	17.0	+- 0.5; 2.5	11.2	+- 0.6; 3.8	13.9	+- 2.8
19	277	6.0	19.3	+- 0.6; 2.9	13.3	+- 0.6; 4.0	14.4	+- 2.2
20	297	6.0	19.8	+- 0.6; 3.0	13.8	+- 0.7; 4.1	16.4	+- 2.8
21	320	3.8	22.8	+- 0.7; 3.4	16.6	+- 0.7; 4.4	16.0	+- 1.3
22	340	4.7	22.6	+- 0.7; 3.4	16.4	+- 0.7; 4.3	17.7	+- 2.2
23	358	4.3	24.8	+- 0.7; 3.7	18.4	+- 0.8; 4.6	18.2	+- 2.6
24	23	5.0	24.6	+- 0.7; 3.7	18.3	+- 0.8; 4.5	19.3	+- 2.3
25	25	7.0	18.1	+- 0.5; 2.7	12.2	+- 0.6; 3.9	14.3	+- 2.4
26	0	7.0	19.1	+- 0.6; 2.9	13.2	+- 0.6; 4.0	15.1	+- 2.5
27	342	8.0	21.6	+- 0.6; 3.2	15.5	+- 0.7; 4.2	16.2	+- 2.4
28	320	9.5	18.9	+- 0.6; 2.8	13.0	+- 0.6; 4.0	15.3	+- 2.1
29	290	11.0	24.0	+- 0.7; 3.6	17.7	+- 0.8; 4.5	17.7	+- 2.2
30	270	11.0	24.6	+- 0.7; 3.7	18.3	+- 0.8; 4.5	18.5	+- 2.3
31	245	10.0	20.3	+- 0.6; 3.0	14.3	+- 0.7; 4.1	15.6	+- 2.2
32	220	11.0	19.5	+- 0.6; 2.9	13.5	+- 0.7; 4.0	16.5	+- 2.4
33	270	15.0	19.6	+- 0.6; 2.9	13.6	+- 0.7; 4.0	14.9	+- 2.2
34	270	15.0	20.3	+- 0.6; 3.0	14.3	+- 0.7; 4.1	15.1	+- 2.1
35	290	16.0	21.5	+- 0.6; 3.2	15.4	+- 0.7; 4.2	16.1	+- 2.1
36	350	0.8	17.9	+- 0.5; 2.7	12.0	+- 0.6; 3.9	15.5	+- 3.3
37	330	0.7	20.2	+- 0.6; 3.0	14.2	+- 0.7; 4.1	16.2	+- 2.6
38	310	0.7	21.0	+- 0.6; 3.2	14.9	+- 0.7; 4.2	15.9	+- 3.2
39	23	10.0	24.6	+- 0.7; 3.7	18.3	+- 0.8; 4.5	17.2	+- 2.2
40	0	9.0	24.8	+- 0.7; 3.7	18.5	+- 0.8; 4.6	18.2	+- 2.1
41	348	9.0	19.2	+- 0.6; 2.9	13.2	+- 0.6; 4.0	14.3	+- 2.5

Transit Dose = 4.9 +- 0.4; 3.2

FERMI

For the period 930914-940127

TLD Direct Radiation Environmental Monitoring

Azimuth (degrees)	Ave. Exposure Rate (mR/Std.Qtr.) +- Std.Dev.	Number In Group
348.76 - 11.25 N	16.7 +- 4.0	5
11.26 - 33.75 NNE	15.7 +- 3.0	4
33.76 - 56.25 NE	10.5 +- 0.0	1
56.26 - 78.75 ENE	No Data +- No Data	0
78.76 - 101.25 E	No Data +- No Data	0
101.26 - 123.75 ESE	No Data +- No Data	0
123.76 - 146.25 SE	No Data +- No Data	0
146.26 - 168.75 SSE	No Data +- No Data	0
168.76 - 191.25 S	15.4 +- 0.1	2
191.26 - 213.75 SSW	15.8 +- 0.0	1
213.76 - 236.25 SW	14.2 +- 2.3	4
236.26 - 258.75 WSW	13.6 +- 1.6	4
258.76 - 281.25 W	17.1 +- 2.9	4
281.26 - 303.75 WNW	15.9 +- 1.9	3
303.76 - 326.25 NW	15.3 +- 1.7	4
326.26 - 348.75 NNW	15.1 +- 1.2	6

Distance From Reactor (miles)	Ave. Exposure Rate (mR/Std.Qtr.) +- Std.Dev.	Number In Group
0 - 2	15.9 +- 2.4	15
2 - 5	15.8 +- 2.7	8
> 5	14.5 +- 2.5	15
Upwind Control	14.4 +- 0.9	3

FERMI
TLD Direct Radiation Environmental Monitoring

NRC Station	Location		Description
	Azimuth / Degree	Distance / Mile	
1	38	2.1	ESTRAL BEACH
2	22	2.3	PORT SUNLIGHT
3	350	1.8	STRONG&TROMBLY RDS.
4	345	1.9	SWAN VIEW DR.
5	346	1.4	POST&LEROUX RDS.
6	310	1.3	M.SMITH FARM
7	298	1.4	FERMI DR.&LEROUX RD.
8	277	1.6	TOLL(N. DIXIE&LEROUX RDS.)
9	238	1.0	FERMI ENTRANCE
10	225	1.5	ELM AND MAIN ST.
11	193	0.8	VENT PIPE(P.T. AUX PEAX RD.)
12	183	0.9	DEWEY RD.
13	175	0.8	LONG RD.
14	260	1.7	JEFFERSON HIGH SCH.
15	245	2.5	WOODLAND BEACH
16	236	5.0	STERLING PARK
17	225	6.8	ENTRANCE TO DECO
18	250	7.8	ST. MARY'S PARK
19	277	6.0	DECO SUBSTATION
20	297	6.0	RT. 24&BUHL RD.
21	320	3.8	NEWPORT POST OFFICE
22	340	4.7	BRANDO&LABO RDS.
23	358	4.3	LABO&N.DIXIE HWY.
24	23	5.0	SHOOTING RANGE
25	25	7.0	CAMPAU RD.
26	0	7.0	S.ROCKWOOD
27	342	8.0	ROCKWOOD RD.
28	320	9.5	CARLETON TOWN
29	290	11.0	FINZEL RD.
30	270	11.0	RAISINVILLE RD.
31	245	10.0	HERR RD.
32	220	11.0	MORTAR RD.
33	270	15.0	LEWIS RD.
34	270	15.0	LEWIS RD.
35	290	16.0	MAYBEE RD.
36	350	0.8	TOLL-FISHER RD.(SITE)
37	330	0.7	TOLL RD.(SITE BOUNDRY)
38	310	0.7	TOLL RD.(SITE BOUNDRY)
39	23	10.0	GIBRALTAR & TURNPIKE
40	0	9.0	CAHILL RD.
41	348	9.0	RT. 24 & S. HURON DR. OPP. STATE POLICE STA.

NRC TLD DOSES FOR FERMI AREA

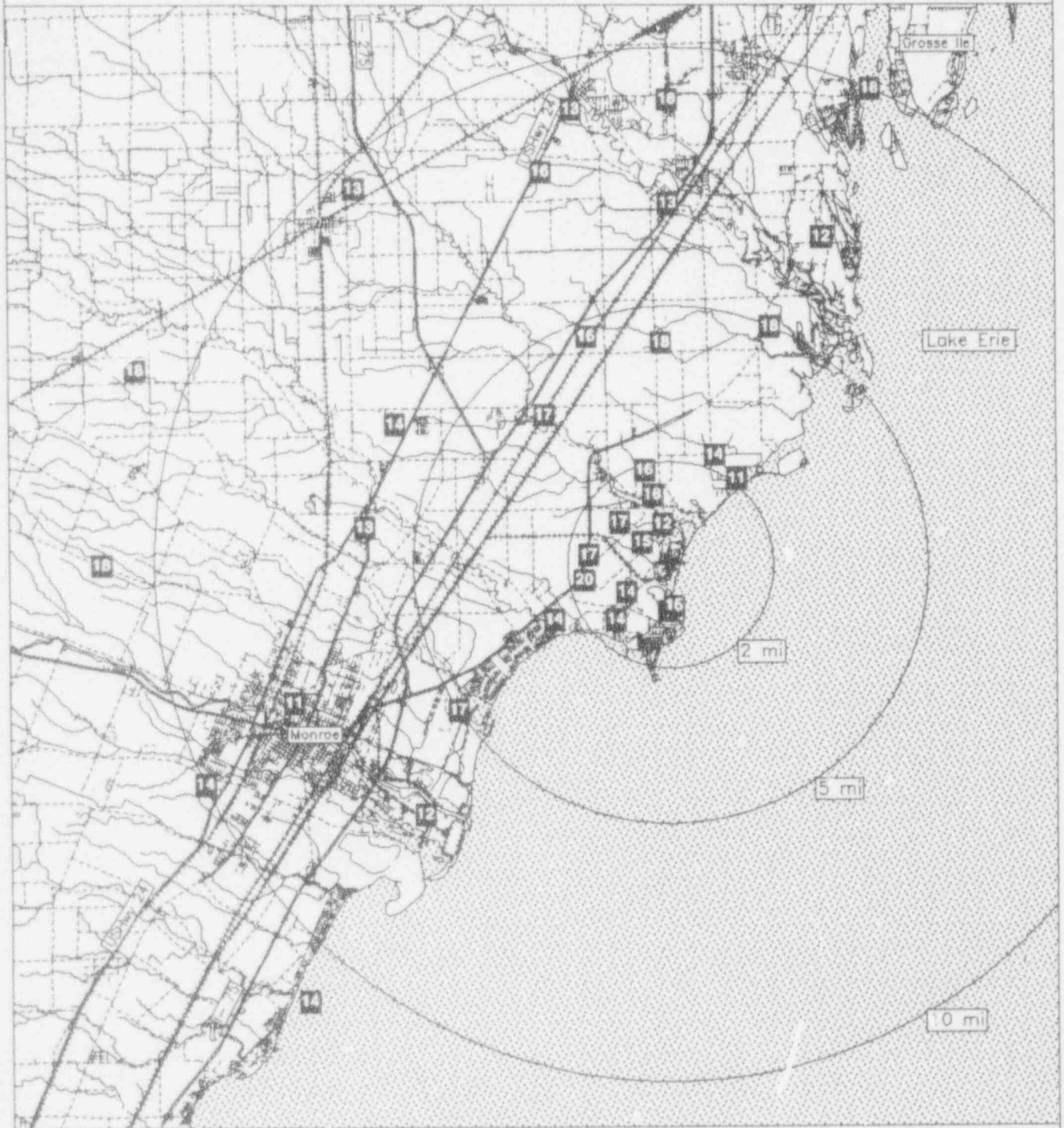

Miles

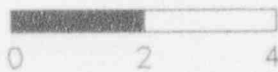

Legend

- Water
- Railroads
- Plant..site
- Highways
- Roads

FITZ/NMP

TLD Direct Radiation Environmental Monitoring

For the period 930915-940201 140 Days

Field Time: 84 Days

NRC Sta	Location Azimuth/Dist (Deg)/(Mi)		Gross Exposure (mR) +-Rdm; Tot.	Net Exposure Rate (mR/Std. Qtr.) +-kdm; Tot.	Hist. Range Net Exp Rate +-1 Std Dev
1	230	6.9	19.7 +- 0.6; 3.0	14.6 +- 0.8; 4.5	14.7 +- 1.4
2	184	14.0	21.3 +- 0.6; 3.2	16.2 +- 0.8; 4.7	15.8 +- 1.4
3	122	8.4	19.2 +- 0.6; 2.9	14.0 +- 0.7; 4.4	14.4 +- 1.6
4	76	11.0	Damaged Dosimeter	No Net Data	14.9 +- 1.0
5	91	6.8	20.5 +- 0.6; 3.1	15.4 +- 0.8; 4.6	15.4 +- 1.7
6	112	4.3	19.9 +- 0.6; 3.0	14.8 +- 0.8; 4.5	15.1 +- 1.1
7	138	4.3	Missing Dosimeter	No Net Data	15.1 +- 1.3
8	152	3.6	18.7 +- 0.6; 2.8	13.5 +- 0.7; 4.4	15.1 +- 1.4
9	183	3.9	19.7 +- 0.6; 3.0	14.6 +- 0.8; 4.5	15.4 +- 1.0
10	205	4.5	18.4 +- 0.6; 2.8	13.1 +- 0.7; 4.3	14.4 +- 1.5
11	220	4.4	19.9 +- 0.6; 3.0	14.8 +- 0.8; 4.5	15.3 +- 1.2
12	230	6.1	20.3 +- 0.6; 3.0	15.2 +- 0.8; 4.6	15.5 +- 1.3
13	245	1.8	20.2 +- 0.6; 3.0	15.1 +- 0.8; 4.5	15.2 +- 1.2
14	223	1.8	19.0 +- 0.6; 2.9	13.9 +- 0.7; 4.4	14.7 +- 1.3
15	204	2.0	18.4 +- 0.6; 2.8	13.1 +- 0.7; 4.3	14.7 +- 1.6
16	181	1.8	19.5 +- 0.6; 2.9	14.4 +- 0.8; 4.5	14.9 +- 1.2
17	157	1.9	18.4 +- 0.6; 2.8	13.1 +- 0.7; 4.3	15.1 +- 1.1
18	137	1.6	19.5 +- 0.6; 2.9	14.4 +- 0.8; 4.5	14.7 +- 1.2
19	115	1.2	18.8 +- 0.6; 2.8	13.6 +- 0.7; 4.4	14.9 +- 1.6
20	92	1.1	19.2 +- 0.6; 2.9	14.0 +- 0.7; 4.4	15.5 +- 1.3
21	229	20.0	19.6 +- 0.6; 2.9	14.5 +- 0.8; 4.5	14.8 +- 1.4
22	229	20.0	19.1 +- 0.6; 2.9	13.9 +- 0.7; 4.4	14.5 +- 1.2
23	229	20.0	19.6 +- 0.6; 2.9	14.5 +- 0.8; 4.5	14.7 +- 1.2
24	196	8.0	19.1 +- 0.6; 2.9	13.9 +- 0.7; 4.4	14.5 +- 1.5
25	168	7.2	19.6 +- 0.6; 2.9	14.4 +- 0.8; 4.5	14.3 +- 1.2
26	152	0.6	20.9 +- 0.6; 3.1	15.8 +- 0.8; 4.6	16.1 +- 1.2

Transit Dose = 6.1 +- 0.4; 3.0

FITZ/NMP

For the period 930915-940201

TLD Direct Radiation Environmental Monitoring

Azimuth (degrees)	Ave. Exposure Rate (mR/Std.Qtr.) +- Std.Dev.	Number In Group
348.76 - 11.25 N	No Data +- No Data	0
11.26 - 33.75 NNE	No Data +- No Data	0
33.76 - 56.25 NE	No Data +- No Data	0
56.26 - 78.75 ENE	No Data +- No Data	0
78.76 - 101.25 E	14.7 +- 1.0	2
101.26 - 123.75 ESE	14.1 +- 0.6	3
123.76 - 146.25 SE	14.4 +- 0.0	1
146.26 - 168.75 SSE	14.2 +- 1.2	4
168.76 - 191.25 S	15.1 +- 1.0	3
191.26 - 213.75 SSW	13.4 +- 0.5	3
213.76 - 236.25 SW	14.6 +- 0.6	4
236.26 - 258.75 WSW	15.1 +- 0.0	1
258.76 - 281.25 W	No Data +- No Data	0
281.26 - 303.75 WNW	No Data +- No Data	0
303.76 - 326.25 NW	No Data +- No Data	0
326.26 - 348.75 NNW	No Data +- No Data	0

Distance From Reactor (miles)	Ave. Exposure Rate (mR/Std.Qtr.) +- Std.Dev.	Number In Group
0 - 2	14.1 +- 0.9	9
2 - 5	14.2 +- 0.8	5
> 5	14.8 +- 0.8	7
Upwind Control	14.3 +- 0.3	3

FITZ/NMP

TLD Direct Radiation Environmental Monitoring

NRC Station	Location		Description
	Azimuth / Degree	Distance / Mile	
1	230	6.9	OAK HILL SCHOOL
2	184	14.0	FULTON
3	122	8.4	MEXICO
4	76	11.0	SELKIRK SHORES PARK
5	91	6.8	MEXICO PT. BOAT LAUNCH
6	112	4.3	DEMSTER BEACH RD.
7	138	4.3	ALBRIGHT RD.
8	152	3.6	MIDDLE RD.
9	183	3.9	DUKE RD.
10	205	4.5	CREMERY RD.
11	220	4.4	Z RIDGE FARM
12	230	6.1	ST. PAUL'S ST.
13	245	1.8	LAKEVIEW WATERFRONT
14	223	1.8	LAKEVIEW RD.
15	204	2.0	MINER RD.
16	181	1.8	HOPKINS RESIDENCE
17	157	1.9	PARKHURST RD.
18	137	1.6	DAWNS BEAUTY SHOP
19	115	1.2	LAKE RD.
20	92	1.1	NOYES RESIDENCE
21	229	20.0	FAIR HAVEN STATE PARK
22	229	20.0	FAIR HAVEN STATE PARK
23	229	20.0	FAIR HAVEN STATE PARK
24	196	8.0	FROST ROAD
25	168	7.2	O'CONNOR RD.
26	152	0.6	NEAREST RESIDENT

NRC TLD DOSES FOR FITZPATRICK & NINE MILE PT AREA

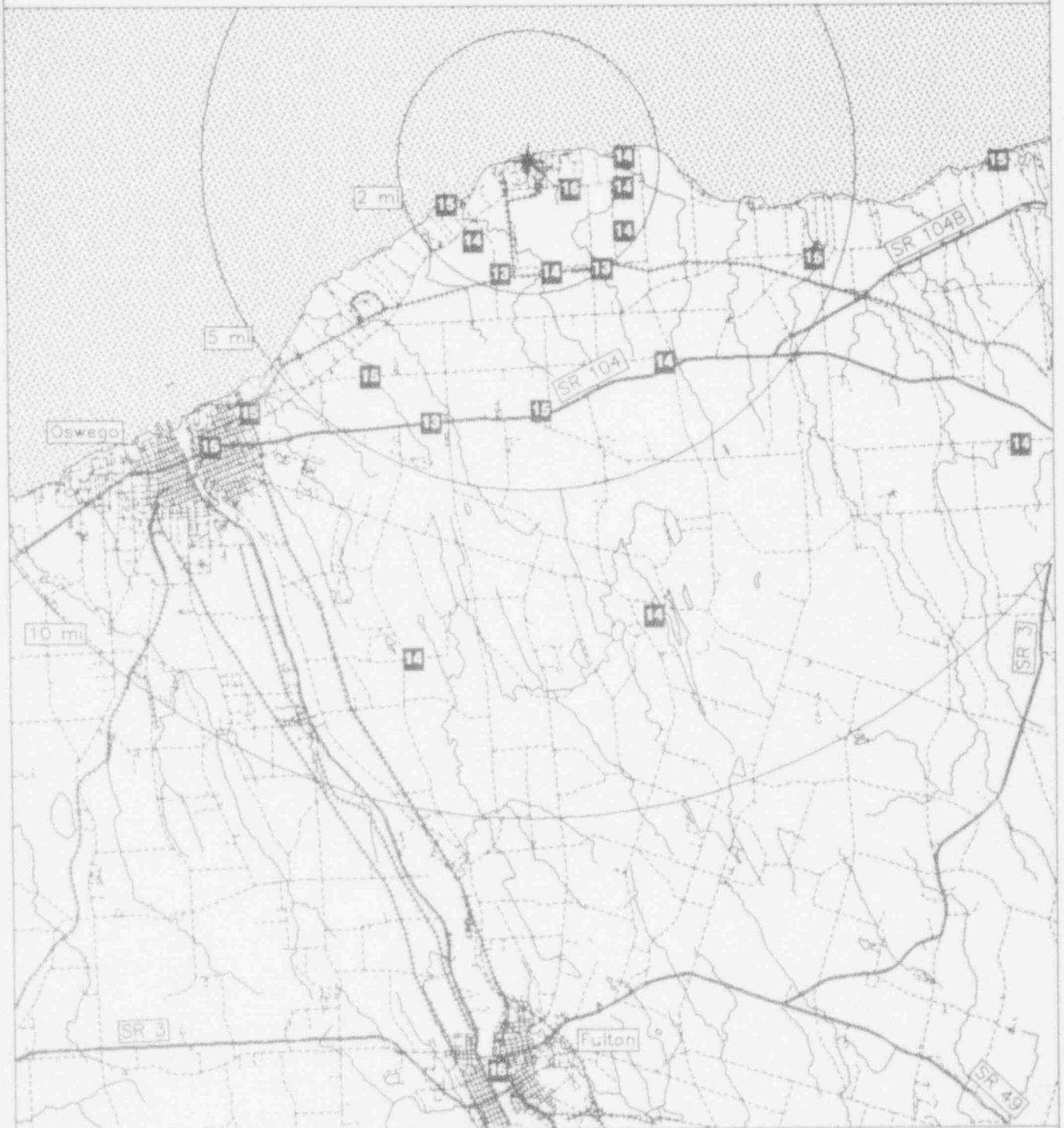

Miles

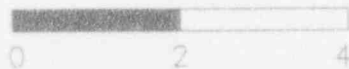

Legend

- Water
- Highways
- Railroads
- Roads
- Plant..site

FORT CALHOUN
 TLD Direct Radiation Environmental Monitoring
 For the period 930914-940209 149 Days
 Field Time: 100 Days

NRC Sta	Location Azimuth/Dist (Deg)/(Mi)		Gross Exposure (mR) +-Rdm; Tot.	Net Exposure Rate (mR/Std. Qtr.) +-Rdm; Tot.	Hist. Range Net Exp Rate +-1 Std Dev
1	358	2.0	27.1 +- 0.8; 4.1	19.2 +- 0.8; 4.8	19.0 +- 2.7
2	351	4.6	27.9 +- 0.8; 4.2	19.8 +- 0.8; 4.8	19.7 +- 2.9
3	30	2.5	27.6 +- 0.8; 4.1	19.6 +- 0.8; 4.8	19.5 +- 2.7
4	27	4.6	26.1 +- 0.8; 3.9	18.2 +- 0.8; 4.7	20.1 +- 1.8
5	53	1.9	26.6 +- 0.8; 4.0	18.7 +- 0.8; 4.7	19.1 +- 2.6
6	37	3.9	28.8 +- 0.9; 4.3	20.7 +- 0.9; 4.9	20.0 +- 2.6
7	76	2.3	27.6 +- 0.8; 4.1	19.6 +- 0.8; 4.8	20.4 +- 2.7
8	59	5.2	27.8 +- 0.8; 4.2	19.8 +- 0.8; 4.8	19.4 +- 2.8
9	100	2.3	26.7 +- 0.8; 4.0	18.8 +- 0.8; 4.7	17.8 +- 2.7
10	88	5.6	27.8 +- 0.8; 4.2	19.8 +- 0.8; 4.8	20.2 +- 2.8
11	122	2.3	28.0 +- 0.8; 4.2	19.9 +- 0.8; 4.9	19.9 +- 2.1
12	105	5.7	27.2 +- 0.8; 4.1	19.3 +- 0.8; 4.8	19.2 +- 2.5
13	145	1.9	27.6 +- 0.8; 4.1	19.6 +- 0.8; 4.8	20.3 +- 2.3
14	128	5.5	27.8 +- 0.8; 4.2	19.8 +- 0.8; 4.8	20.0 +- 3.0
15	157	1.9	28.3 +- 0.8; 4.2	20.2 +- 0.9; 4.9	21.0 +- 2.5
16	150	4.9	27.6 +- 0.8; 4.1	19.6 +- 0.8; 4.8	20.4 +- 2.6
17	173	0.5	27.4 +- 0.8; 4.1	19.4 +- 0.8; 4.8	20.0 +- 3.0
18	173	5.3	28.6 +- 0.9; 4.3	20.5 +- 0.9; 4.9	21.1 +- 2.6
19	212	2.5	29.6 +- 0.9; 4.4	21.4 +- 0.9; 5.0	22.6 +- 2.6
20	204	5.3	28.8 +- 0.9; 4.3	20.6 +- 0.9; 4.9	21.3 +- 2.6
21	233	2.0	28.9 +- 0.9; 4.3	20.7 +- 0.9; 4.9	21.6 +- 2.7
22	224	4.6	28.2 +- 0.8; 4.2	20.2 +- 0.9; 4.9	21.8 +- 2.7
23	239	0.6	28.8 +- 0.9; 4.3	20.7 +- 0.9; 4.9	20.1 +- 2.7
24	243	6.9	25.8 +- 0.8; 3.9	17.9 +- 0.8; 4.6	18.5 +- 2.6
25	269	3.3	29.6 +- 0.9; 4.4	21.4 +- 0.9; 5.0	22.0 +- 3.1
26	262	5.9	31.3 +- 0.9; 4.7	22.9 +- 0.9; 5.2	22.2 +- 2.7
27	350	3.0	25.6 +- 0.8; 3.8	17.8 +- 0.8; 4.6	19.3 +- 4.2
28	292	5.0	29.9 +- 0.9; 4.5	21.7 +- 0.9; 5.1	20.4 +- 2.5
29	311	2.4	28.6 +- 0.9; 4.3	20.5 +- 0.9; 4.9	20.5 +- 2.7
30	310	5.5	29.9 +- 0.9; 4.5	21.7 +- 0.9; 5.1	21.1 +- 2.4
31	340	2.3	27.1 +- 0.8; 4.1	19.2 +- 0.8; 4.8	19.6 +- 2.9
32	338	5.3	Missing Dosimeter	No Net Data	20.2 +- 2.6
33	182	0.5	27.3 +- 0.8; 4.1	19.4 +- 0.8; 4.8	20.2 +- 2.5
35	127	2.2	26.8 +- 0.8; 4.0	18.9 +- 0.8; 4.7	18.8 +- 2.0
39	150	5.0	26.3 +- 0.8; 3.9	18.5 +- 0.8; 4.7	18.5 +- 2.0
40	73	9.5	28.2 +- 0.8; 4.2	20.1 +- 0.9; 4.9	20.5 +- 2.9
43	29	8.0	26.3 +- 0.8; 3.9	18.4 +- 0.8; 4.7	19.0 +- 3.0
44	65	3.5	25.8 +- 0.8; 3.9	18.0 +- 0.8; 4.6	18.0 +- 2.6
45	182	4.2	28.8 +- 0.9; 4.3	20.7 +- 0.9; 4.9	20.7 +- 2.4
47	298	4.5	26.9 +- 0.8; 4.0	19.0 +- 0.8; 4.7	19.9 +- 2.9
48	13	14.0	27.0 +- 0.8; 4.0	19.0 +- 0.8; 4.7	19.7 +- 1.8
49	207	18.0	29.9 +- 0.9; 4.5	21.7 +- 0.9; 5.1	21.0 +- 3.0

Transit Dose = 5.8 +- 0.4; 3.4

FORT CALHOUN
For the period 930914-940209

TLD Direct Radiation Environmental Monitoring

Azimuth (degrees)	Ave. Exposure Rate (mR/Std.Qtr.) +- Std.Dev.	Number In Group
348.76 - 11.25 N	18.9 +- 1.0	3
11.26 - 33.75 NNE	18.7 +- 0.7	3
33.76 - 56.25 NE	19.7 +- 1.4	2
56.26 - 78.75 ENE	19.4 +- 0.9	4
78.76 - 101.25 E	19.3 +- 0.7	2
101.26 - 123.75 ESE	19.6 +- 0.5	2
123.76 - 146.25 SE	19.4 +- 0.5	3
146.26 - 168.75 SSE	19.4 +- 0.9	3
168.76 - 191.25 S	20.0 +- 0.7	4
191.26 - 213.75 SSW	21.0 +- 0.5	2
213.76 - 236.25 SW	20.4 +- 0.4	2
236.26 - 258.75 WSW	19.3 +- 1.9	2
258.76 - 281.25 W	22.1 +- 1.1	2
281.26 - 303.75 WNW	20.3 +- 1.9	2
303.76 - 326.25 NW	21.1 +- 0.8	2
326.26 - 348.75 NNW	19.2 +- 0.0	1

Distance From Reactor (miles)	Ave. Exposure Rate (mR/Std.Qtr.) +- Std.Dev.	Number In Group
0 - 2	19.7 +- 0.7	8
2 - 5	19.7 +- 1.1	20
> 5	20.1 +- 1.4	11
Upwind Control	20.3 +- 1.9	2

FORT CALHOUN
 TLD Direct Radiation Environmental Monitoring

NRC Station	Location		Description
	Azimuth / Degree	Distance / Mile	
1	358	2.0	DIRT RD. (1 MILE E. OF MISSOURI R.)
2	351	4.6	COTTONWOOD MARINA
3	30	2.5	HWY. 30 (2 MILES E. OF MISSOURI R.)
4	27	4.6	OLD SOLDIER R. DITCH
5	53	1.9	DIRT FARM RD. NEAR US 30
5	37	3.9	GRAVEL RD. NEAR US 30
7	76	2.3	DESOTO REFUGE
8	59	5.2	CALIF. JUNCT. (1ST INTERSEC. N OF RR)
9	100	2.3	RIVER GAUGING STATION
10	88	5.6	FARM RD. NEAR US 30
11	122	2.3	DESOTO REGUGE ENTRANCE GATE
12	105	5.7	FARMHOUSE NEAR US 30
13	145	1.9	DESOTO
14	128	5.5	TRAILER PARK
15	157	1.9	INTERSECTION P226 & P39
16	150	4.9	CEMETERY (CLAY RD.)
17	173	0.5	NEAR PLANT ENTRANCE
18	173	5.3	INTERSECTION P39 & P132
19	212	2.5	COUNTY RD. P35 (AT INTERSEC-GRAVEL RD)
20	204	5.3	COUNTY RD. P34 (0.5 MI. E OF HWY 133)
21	233	2.0	COUNTY RD. P35 (1.3 MI N OF RL. P128)
22	224	4.6	HWY. 133 (3.4 MILES S. OF BLAIR)
23	239	0.6	1 MILE N. ON HWY. 73 FROM PLANT ENTRANCE
24	243	6.9	KENNARD
25	269	3.3	HWY. 30 & 133
26	262	5.9	COUNTY RDS. P26 & P27
27	350	3.0	BLAIR
28	292	5.0	BLAIR FARMHOUSE
29	311	2.4	ANIMAL CONTROL BLDG.
30	310	5.5	US 73 NEAR ROAD TO CHURCH
31	340	2.3	FIRST INTERSECTION W. OF BLAIR RD.
32	338	5.3	COTTONWOOD MARINA
33	182	0.5	GREENHOUSE PLANT ENTRANCE
35	127	2.2	SMITH FARM
39	150	5.0	FORT ATKINSON
40	73	9.5	MISSOURI VALLEY
43	29	8.0	MODALE SCHOOL
44	65	3.5	CLOSED PICNIC AREA - DESOTO REFUGE
45	182	4.2	SCHOOL #8
47	298	4.5	DANA COLLEGE
48	13	14.0	1 MILE EAST OF MONDAMIN
49	207	18.0	ELKHORN

NRC TLD DOSES FOR FORT CALHOUN AREA

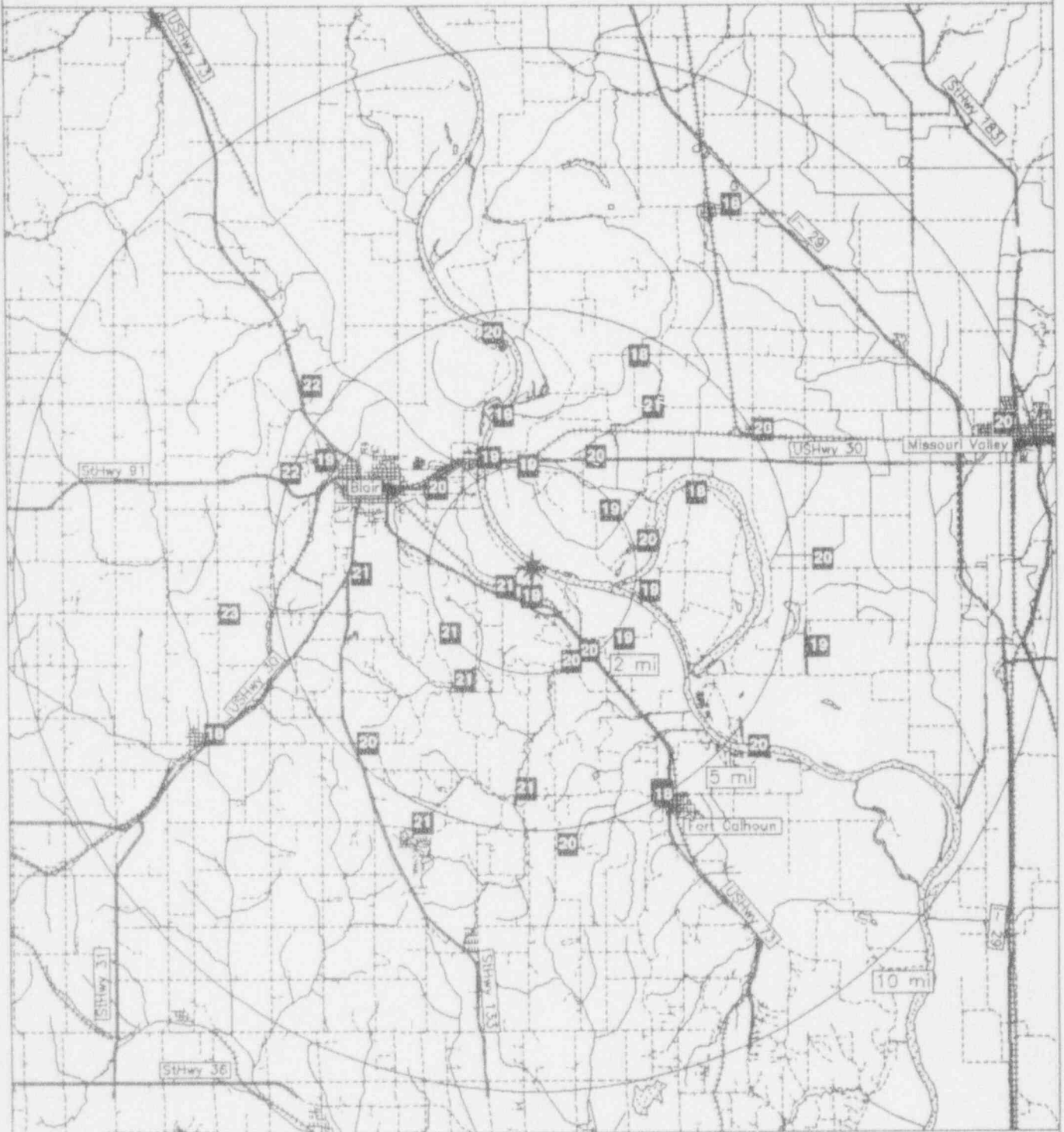

Miles

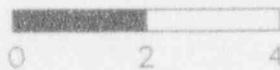

Legend

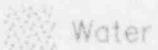

Water

Highways

Railroads

Roads



Plant..site

FORT ST. VRAIN

TLD Direct Radiation Environmental Monitoring

For the period 930913-940202 143 Days

Field Time: 84 Days

NRC Sta	Location Azimuth/Dist (Deg)/(Mi)		Gross Exposure (mR) +-Rdm; Tot.	Net Exposure Rate (mR/Std. Qtr.) +-Rdm; Tot.	Hist. Range Net Exp Rate +-1 Std Dev
1	8	0.8	39.9 +- 1.2; 6.0	28.1 +- 1.4; 7.6	30.0 +- 3.1
2	2	3.3	41.2 +- 1.2; 6.2	29.4 +- 1.5; 7.8	29.4 +- 3.2
3	29	2.6	39.3 +- 1.2; 5.9	27.5 +- 1.4; 7.5	29.8 +- 3.4
4	17	5.4	40.0 +- 1.2; 6.0	28.1 +- 1.4; 7.6	30.1 +- 3.5
5	54	2.1	40.0 +- 1.2; 6.0	28.2 +- 1.4; 7.6	28.7 +- 3.5
6	48	4.8	43.1 +- 1.3; 6.5	31.5 +- 1.5; 8.0	30.8 +- 3.0
7	76	2.6	41.2 +- 1.2; 6.2	29.5 +- 1.5; 7.8	31.7 +- 3.3
8	58	4.2	41.7 +- 1.3; 6.3	30.0 +- 1.5; 7.9	30.4 +- 3.0
9	100	1.5	39.4 +- 1.2; 5.9	27.5 +- 1.4; 7.5	30.8 +- 3.2
10	87	4.5	39.6 +- 1.2; 5.9	27.8 +- 1.4; 7.6	29.3 +- 3.1
11	118	1.6	42.7 +- 1.3; 6.4	31.1 +- 1.5; 8.0	33.0 +- 3.5
12	104	3.0	40.9 +- 1.2; 6.1	29.1 +- 1.5; 7.7	32.3 +- 3.0
13	143	1.6	41.5 +- 1.2; 6.2	29.7 +- 1.5; 7.8	30.9 +- 3.2
14	128	4.5	39.9 +- 1.2; 6.0	28.1 +- 1.4; 7.6	30.8 +- 2.9
15	168	2.3	38.6 +- 1.2; 5.8	26.6 +- 1.4; 7.4	28.5 +- 2.9
16	148	4.6	39.1 +- 1.2; 5.9	27.2 +- 1.4; 7.5	28.6 +- 3.0
17	182	0.8	39.4 +- 1.2; 5.9	27.5 +- 1.4; 7.5	30.3 +- 3.1
18	175	4.8	39.0 +- 1.2; 5.9	27.1 +- 1.4; 7.5	30.8 +- 3.3
19	210	0.9	41.6 +- 1.2; 6.2	29.9 +- 1.5; 7.8	31.0 +- 3.0
20	200	2.9	39.1 +- 1.2; 5.9	27.2 +- 1.4; 7.5	30.7 +- 3.4
21	234	1.3	40.2 +- 1.2; 6.0	28.4 +- 1.5; 7.6	31.5 +- 3.0
22	216	3.3	39.3 +- 1.2; 5.9	27.4 +- 1.4; 7.5	28.7 +- 3.1
23	254	2.5	39.3 +- 1.2; 5.9	27.5 +- 1.4; 7.5	29.2 +- 3.1
24	244	3.8	40.1 +- 1.2; 6.0	28.3 +- 1.5; 7.6	29.3 +- 3.0
25	278	1.5	39.5 +- 1.2; 5.9	27.6 +- 1.4; 7.5	28.4 +- 2.8
26	263	5.4	39.9 +- 1.2; 6.0	28.1 +- 1.4; 7.6	29.7 +- 3.4
27	297	1.7	38.7 +- 1.2; 5.8	26.8 +- 1.4; 7.4	28.3 +- 3.1
28	284	5.6	40.0 +- 1.2; 6.0	28.1 +- 1.4; 7.6	29.3 +- 2.8
29	317	0.9	37.8 +- 1.1; 5.7	25.9 +- 1.4; 7.3	28.7 +- 3.1
30	305	4.2	35.8 +- 1.1; 5.4	23.7 +- 1.3; 7.1	27.1 +- 2.9
31	338	1.4	39.0 +- 1.2; 5.8	27.1 +- 1.4; 7.5	28.8 +- 3.1
32	330	5.0	36.5 +- 1.1; 5.5	24.4 +- 1.3; 7.1	26.3 +- 3.2
33	267	6.5	36.8 +- 1.1; 5.5	24.8 +- 1.4; 7.2	29.5 +- 3.5
34	130	3.7	37.6 +- 1.1; 5.6	25.6 +- 1.4; 7.3	29.1 +- 3.2
35	270	0.1	37.4 +- 1.1; 5.6	25.4 +- 1.4; 7.3	28.6 +- 3.3
38	345	6.7	40.0 +- 1.2; 6.0	28.2 +- 1.4; 7.6	30.6 +- 3.3
39	10	6.0	37.3 +- 1.1; 5.6	25.2 +- 1.4; 7.2	28.9 +- 3.4
40	63	6.0	38.1 +- 1.1; 5.7	26.2 +- 1.4; 7.4	28.7 +- 3.4
41	165	12.0	41.2 +- 1.2; 6.2	29.4 +- 1.5; 7.8	31.9 +- 2.8
42	248	13.0	44.9 +- 1.3; 6.7	33.4 +- 1.6; 8.3	33.4 +- 3.6
45	198	11.0	41.6 +- 1.2; 6.2	29.9 +- 1.5; 7.8	30.1 +- 3.1
46	39	16.0	37.7 +- 1.1; 5.7	25.7 +- 1.4; 7.3	27.9 +- 3.3
47	357	17.0	37.1 +- 1.1; 5.6	25.0 +- 1.4; 7.2	26.9 +- 3.2
48	171	18.0	40.5 +- 1.2; 6.1	28.7 +- 1.5; 7.7	30.5 +- 3.1
49	360	0.5	41.2 +- 1.2; 6.2	29.5 +- 1.5; 7.8	32.2 +- 3.1

Transit Dose = 13.7 +- 0.6; 3.8

FORT ST. VRAIN
For the period 930913-940202

TLD Direct Radiation Environmental Monitoring

Azimuth (degrees)	Ave. Exposure Rate (mR/Std.Qtr.) +- Std.Dev.	Number In Group
348.76 - 11.25 N	27.6 +- 2.2	3
11.26 - 33.75 NNE	27.8 +- 0.5	2
33.76 - 56.25 NE	28.5 +- 2.9	3
56.26 - 78.75 ENE	28.5 +- 2.1	3
78.76 - 101.25 E	27.6 +- 0.2	2
101.26 - 123.75 ESE	30.1 +- 1.4	2
123.76 - 146.25 SE	27.8 +- 2.1	3
146.26 - 168.75 SSE	27.7 +- 1.5	3
168.76 - 191.25 S	27.3 +- 0.3	2
191.26 - 213.75 SSW	29.0 +- 1.5	3
213.76 - 236.25 SW	27.9 +- 0.7	2
236.26 - 258.75 WSW	29.7 +- 3.2	3
258.76 - 281.25 W	26.4 +- 1.6	4
281.26 - 303.75 WNW	27.4 +- 0.9	2
303.76 - 326.25 NW	24.8 +- 1.5	2
326.26 - 348.75 NNW	26.6 +- 1.9	3

Distance From Reactor (miles)	Ave. Exposure Rate (mR/Std.Qtr.) +- Std.Dev.	Number In Group
0 - 2	27.9 +- 1.7	12
2 - 5	27.7 +- 1.9	19
> 5	27.9 +- 2.5	11
Upwind Control	27.7 +- 2.4	3

FORT ST. VRAIN
TLD Direct Radiation Environmental Monitoring

NRC Station	Location		Description
	Azimuth / Degree	Distance / Mile	
1	8	0.8	0.7 MILES N. & 0.1 MILES E. OF REACTOR
2	2	3.3	RD 42
3	29	2.6	RD 23 & RD 40
4	17	5.4	RD 46 & RD 23
5	54	2.1	FARM HOUSE ON RD 38
6	48	4.8	HWY. 60 & RD 42
7	76	2.6	RD. 25
8	58	4.2	HWY. 60 & RD. 40
9	100	1.5	RD. 23
10	87	4.5	RD. 36 & RD. 29
11	118	1.6	RD. 23
12	104	3.0	RD. 34
13	143	1.6	RD. 32 & RD. 21
14	128	4.5	NILES MILLER DAIRY
15	168	2.3	RD. 21 AT BEEMAN'S DITCH
16	148	4.6	RD. 28
17	182	0.8	RD. 34
18	175	4.8	RD. 26
19	210	0.9	RD. 19 & RD. 34
20	200	2.9	RD. 19 & HWY. 66
21	234	1.3	RD. 34
22	216	3.3	RD. 17
23	254	2.5	RD. 34 & RD. 15
24	244	3.8	RD. 13 & RD. 32
25	278	1.5	RD. 17 & RD. 36
26	263	5.4	RD. 34
27	297	1.7	RD. 17 & RD. 36 1/2
28	284	5.6	RD. 38
29	317	0.9	RD. 36 1/2 & RD. 19
30	305	4.2	RD. 13 & RD. 40
31	338	1.4	RD. 19 & RD. 38
32	330	5.0	RD. 44 & RD. 15
33	267	6.5	MEAD ELEMENTARY SCHOOL
34	130	3.7	PLATTEVILLE ELEMENTARY SCHOOL
35	270	0.1	VISTOR'S CENTER AT PLANT
38	345	6.7	LETFORD ELEMENTARY SCHOOL
39	10	6.0	MILLIKEN MIDDLE SCHOOL
40	63	6.0	GILCREST
41	165	12.0	FT. LUPTON
42	248	13.0	LONGMONT SCHOOL
45	198	11.0	FREDERICK JR./SR. HIGH SCHOOL
46	39	16.0	GREELEY ELECTRICAL SUBSTATION
47	357	17.0	WINDSOR
48	171	18.0	BRIGHTON
49	360	0.5	RD. 19

NRC TLD DOSES FOR FORT ST. VRAIN AREA

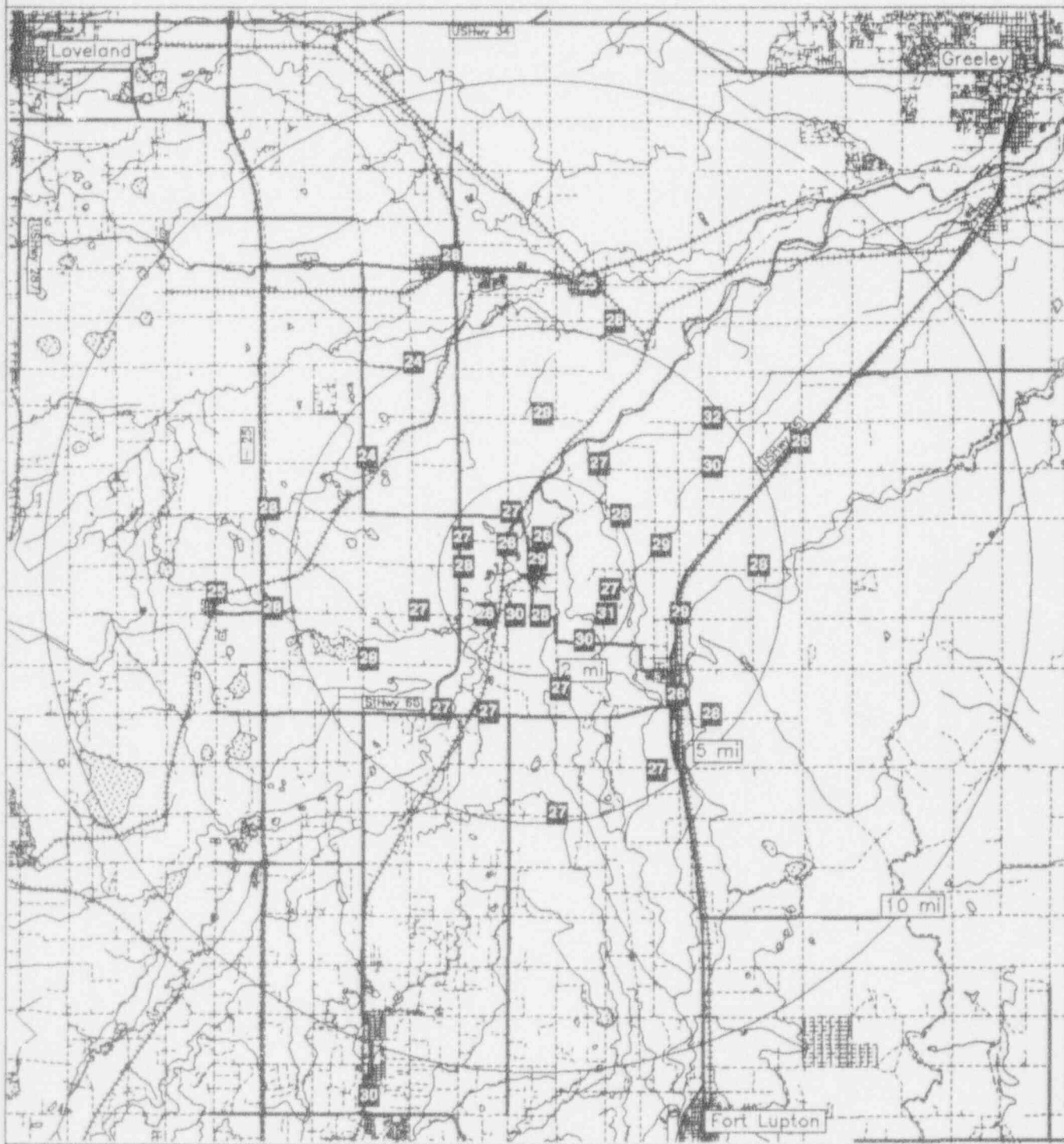

Miles

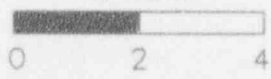

Legend

- Water
- Highways
- Railroads
- Roads
- Plant..site
- TLD..data

GINNA

TLD Direct Radiation Environmental Monitoring

For the period 930915-940202 141 Days

Field Time: 84 Days

NRC Sta	Location Azimuth/Dist (Deg)/(Mi)	Gross Exposure (mR) +-Rdm; Tot.	Net Exposure Rate (mR/Std. Qtr.) +-Rdm; Tot.	Hist. Range Net Exp Rate +-1 Std Dev
1	95 1.7	19.6 +- 0.6; 2.9	14.0 +- 0.8; 4.5	15.0 +- 1.3
2	108 1.1	18.8 +- 0.6; 2.8	13.2 +- 0.7; 4.4	14.8 +- 1.5
3	142 1.7	19.5 +- 0.6; 2.9	14.0 +- 0.8; 4.5	14.6 +- 1.7
4	154 1.5	18.4 +- 0.6; 2.8	12.8 +- 0.7; 4.4	15.4 +- 1.8
5	174 1.4	19.5 +- 0.6; 2.9	14.0 +- 0.8; 4.5	15.5 +- 1.8
6	212 1.6	18.7 +- 0.6; 2.8	13.1 +- 0.7; 4.4	14.4 +- 1.7
7	244 0.9	18.5 +- 0.6; 2.8	13.0 +- 0.7; 4.4	14.3 +- 1.7
8	230 0.6	19.2 +- 0.6; 2.9	13.7 +- 0.8; 4.5	15.3 +- 2.1
10	266 1.5	19.1 +- 0.6; 2.9	13.5 +- 0.7; 4.4	14.8 +- 1.7
11	264 4.6	20.6 +- 0.6; 3.1	15.2 +- 0.8; 4.6	16.1 +- 1.1
12	245 3.8	Missing Dosimeter	No Net Data	14.7 +- 1.8
13	235 4.2	17.1 +- 0.5; 2.6	11.5 +- 0.7; 4.2	14.1 +- 1.5
14	200 3.8	16.4 +- 0.5; 2.5	10.6 +- 0.7; 4.1	14.0 +- 1.8
15	178 3.4	19.8 +- 0.6; 3.0	14.3 +- 0.8; 4.5	15.0 +- 1.4
16	160 3.7	18.5 +- 0.6; 2.8	12.9 +- 0.7; 4.4	13.9 +- 1.8
17	134 3.8	16.6 +- 0.5; 2.5	10.9 +- 0.7; 4.2	14.1 +- 1.7
18	115 4.3	18.2 +- 0.5; 2.7	12.6 +- 0.7; 4.3	14.9 +- 1.6
19	88 4.0	16.8 +- 0.5; 2.5	11.1 +- 0.7; 4.2	14.1 +- 1.7
20	90 6.2	19.6 +- 0.6; 2.9	14.1 +- 0.8; 4.5	13.4 +- 1.5
21	123 7.6	16.9 +- 0.5; 2.5	11.2 +- 0.7; 4.2	13.6 +- 1.8
22	151 11.0	18.0 +- 0.5; 2.7	12.4 +- 0.7; 4.3	13.9 +- 1.6
23	105 12.0	Missing Dosimeter	No Net Data	14.7 +- 2.0
24	212 14.0	22.6 +- 0.7; 3.4	17.4 +- 0.8; 4.9	18.3 +- 1.3
25	223 13.0	18.7 +- 0.6; 2.8	13.1 +- 0.7; 4.4	14.2 +- 2.0
26	242 16.0	20.0 +- 0.6; 3.0	14.6 +- 0.8; 4.5	16.0 +- 1.4
27	254 14.0	21.1 +- 0.6; 3.2	15.7 +- 0.8; 4.7	15.9 +- 1.8
28	234 6.9	19.0 +- 0.6; 2.9	13.5 +- 0.7; 4.4	14.4 +- 1.5
29	185 0.3	19.6 +- 0.6; 2.9	14.1 +- 0.8; 4.5	15.7 +- 1.3
30	264 15.0	17.8 +- 0.5; 2.7	12.2 +- 0.7; 4.3	13.9 +- 1.8

Transit Dose = 6.4 +- 0.4; 3.0

GINNA
For the period 930915-940202

TLD Direct Radiation Environmental Monitoring

Azimuth (degrees)	Ave. Exposure Rate (mR/Std.Qtr.) +- Std.Dev.	Number In Group
348.76 - 11.25 N	No Data +- No Data	0
11.26 - 33.75 NNE	No Data +- No Data	0
33.76 - 56.25 NE	No Data +- No Data	0
56.26 - 78.75 ENE	No Data +- No Data	0
78.76 - 101.25 E	13.1 +- 1.7	3
101.26 - 123.75 ESE	12.3 +- 1.0	3
123.76 - 146.25 SE	12.4 +- 2.2	2
146.26 - 168.75 SSE	12.7 +- 0.2	3
168.76 - 191.25 S	14.1 +- 0.2	3
191.26 - 213.75 SSW	13.7 +- 3.4	3
213.76 - 236.25 SW	12.9 +- 1.0	4
236.26 - 258.75 WSW	13.0 +- 0.0	1
258.76 - 281.25 W	14.4 +- 1.2	2
281.26 - 303.75 WNW	No Data +- No Data	0
303.76 - 326.25 NW	No Data +- No Data	0
326.26 - 348.75 NNW	No Data +- No Data	0

Distance From Reactor (miles)	Ave. Exposure Rate (mR/Std.Qtr.) +- Std.Dev.	Number In Group
0 - 2	13.5 +- 0.5	10
2 - 5	12.4 +- 1.7	8
> 5	13.6 +- 2.1	6
Upwind Control	14.1 +- 1.8	3

GINNA
TLD Direct Radiation Environmental Monitoring

NRC Station	Location		Description
	Azimuth / Degree	Distance / Mile	
1	95	1.7	ONTARIO BOAT LAUNCH
2	108	1.1	LAKE RD. & KNICKERBOCKER RD.
3	142	1.7	KNICKERBOCKER RD. & BRICK CHURCH RD.
4	154	1.5	BRICK CHURCH RD.
5	174	1.4	ONTARIO CENTER RD. & BRICK CHURCH RD.
6	212	1.6	SLOCUM RD. & BRICK CHURCH RD.
7	244	0.9	LAKE RD. & SLOCUM RD.
8	230	0.6	LAKE RD.
10	266	1.5	EAGLE CLIFF FARM
11	264	4.6	LAKE RD. & SALT RD.
12	245	3.8	COUNTY LINE RD. & WOODWARD RD.
13	235	4.2	COUNTY LINE RD. & BERG RD.
14	200	3.8	RT. 104 (SUBSTATION #204)
15	178	3.4	RT. 104 (SUBSTATION #205)
16	160	3.7	RT. 104 & FURNACE RD.
17	134	3.8	FISHER RD & KENYON RD.
18	115	4.3	SEELY RD. & STONY LONESOME RD.
19	88	4.0	STONY LONESOME RD. & LAKE RD.
20	90	6.2	PULTNEYVILLE
21	123	7.6	WILLIAMSON
22	151	11.0	MARION
23	105	12.0	SODUS
24	212	14.0	FAIRPORT
25	223	13.0	PENFIELD
26	242	16.0	ROCHESTER MUSEUM
27	254	14.0	IRONDEQUIT TOWN HALL
28	234	6.9	WEBSTER
29	185	0.3	FARM IN FRONT OF PLANT
30	264	15.0	ROCHESTER

NRC TLD DOSES FOR GINNA AREA



Miles

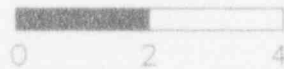

Legend

- Water
- Highways
- Railroads
- Roads
- Plant..site

GRAND GULF

TLD Direct Radiation Environmental Monitoring

For the period 930915-940201 140 Days

Field Time: 99 Days

NRC Sta	Location		Gross	Net Exposure Rate	Hist. Range
	Azimuth/Dist (Deg)/(Mi)		Exposure (mR) +-Rdm; Tot.	(mR/Std. Qtr.) +-Rdm; Tot.	Net Exp Rate +-1 Std Dev
1	337	2.0	20.2 +- 0.6; 3.0	14.6 +- 0.6; 4.0	16.7 +- 2.0
2	351	1.6	20.7 +- 0.6; 3.1	15.1 +- 0.7; 4.1	14.9 +- 1.6
3	20	1.5	22.8 +- 0.7; 3.4	17.0 +- 0.7; 4.3	17.4 +- 1.9
4	51	2.3	22.9 +- 0.7; 3.4	17.1 +- 0.7; 4.3	16.5 +- 1.8
5	68	2.7	23.1 +- 0.7; 3.5	17.3 +- 0.7; 4.3	17.6 +- 1.8
6	47	4.1	20.9 +- 0.6; 3.1	15.3 +- 0.7; 4.1	15.8 +- 1.7
7	68	4.9	24.5 +- 0.7; 3.7	18.6 +- 0.7; 4.4	19.0 +- 1.7
8	91	3.2	25.3 +- 0.8; 3.8	19.3 +- 0.8; 4.5	18.8 +- 1.6
9	81	1.0	23.9 +- 0.7; 3.6	18.0 +- 0.7; 4.4	17.2 +- 1.8
10	109	0.6	24.7 +- 0.7; 3.7	18.7 +- 0.8; 4.5	18.8 +- 1.6
11	139	0.8	25.7 +- 0.8; 3.9	19.7 +- 0.8; 4.6	18.7 +- 1.7
12	185	1.6	23.6 +- 0.7; 3.5	17.7 +- 0.7; 4.3	17.7 +- 1.6
13	207	1.9	25.6 +- 0.8; 3.8	19.6 +- 0.8; 4.6	18.7 +- 1.7
14	247	1.5	22.2 +- 0.7; 3.3	16.5 +- 0.7; 4.2	18.7 +- 5.7
15	130	4.2	23.4 +- 0.7; 3.5	17.5 +- 0.7; 4.3	18.3 +- 1.6
16	122	4.8	24.5 +- 0.7; 3.7	18.5 +- 0.7; 4.4	18.2 +- 1.5
17	135	5.3	23.1 +- 0.7; 3.5	17.2 +- 0.7; 4.3	16.9 +- 1.6
18	147	4.3	21.5 +- 0.6; 3.2	15.9 +- 0.7; 4.1	15.3 +- 1.4
19	224	6.8	Missing Dosimeter	No Net Data	18.5 +- 1.4
20	172	3.6	21.1 +- 0.6; 3.2	15.5 +- 0.7; 4.1	16.4 +- 1.5
21	291	12.0	22.7 +- 0.7; 3.4	17.0 +- 0.7; 4.3	16.7 +- 1.5
22	332	8.0	23.7 +- 0.7; 3.6	17.8 +- 0.7; 4.4	19.2 +- 1.8
23	310	7.9	18.3 +- 0.5; 2.7	12.9 +- 0.6; 3.8	16.0 +- 2.6
24	281	7.0	21.9 +- 0.7; 3.3	16.2 +- 0.7; 4.2	16.3 +- 1.6
25	291	4.8	24.4 +- 0.7; 3.7	18.5 +- 0.7; 4.4	17.9 +- 1.7
26	248	9.5	22.1 +- 0.7; 3.3	16.4 +- 0.7; 4.2	16.7 +- 1.7
27	239	13.0	21.2 +- 0.6; 3.2	15.5 +- 0.7; 4.1	16.0 +- 1.6
29	90	0.9	23.9 +- 0.7; 3.6	18.0 +- 0.7; 4.4	17.5 +- 1.6
30	67	51.0	17.6 +- 0.5; 2.6	12.3 +- 0.6; 3.8	14.1 +- 1.5
31	67	51.0	18.9 +- 0.6; 2.8	13.4 +- 0.6; 3.9	14.3 +- 2.0
32	67	51.0	18.7 +- 0.6; 2.8	13.3 +- 0.6; 3.9	13.9 +- 1.6
33	206	4.8	24.4 +- 0.7; 3.7	18.5 +- 0.7; 4.4	18.2 +- 1.8

Transit Dose = 4.1 +- 0.4; 3.2

GRAND GULF

For the period 930915-940201

TLD Direct Radiation Environmental Monitoring

Azimuth (degrees)	Ave. Exposure Rate (mR/Std.Qtr.) +- Std.Dev.	Number In Group
348.76 - 11.25 N	15.1 +- 0.0	1
11.26 - 33.75 NNE	17.0 +- 0.0	1
33.76 - 56.25 NE	16.2 +- 1.3	2
56.26 - 78.75 ENE	17.9 +- 0.9	2
78.76 - 101.25 E	18.4 +- 0.7	3
101.26 - 123.75 ESE	18.6 +- 0.1	2
123.76 - 146.25 SE	18.1 +- 1.3	3
146.26 - 168.75 SSE	15.9 +- 0.0	1
168.76 - 191.25 S	16.6 +- 1.6	2
191.26 - 213.75 SSW	19.0 +- 0.8	2
213.76 - 236.25 SW	No Data +- No Data	0
236.26 - 258.75 WSW	16.1 +- 0.5	3
258.76 - 281.25 W	16.2 +- 0.0	1
281.26 - 303.75 WNW	17.7 +- 1.1	2
303.76 - 326.25 NW	12.9 +- 0.0	1
326.26 - 348.75 NNW	16.2 +- 2.3	2

Distance From Reactor (miles)	Ave. Exposure Rate (mR/Std.Qtr.) +- Std.Dev.	Number In Group
0 - 2	17.5 +- 1.7	10
2 - 5	17.4 +- 1.4	11
> 5	16.1 +- 1.6	7
Upwind Control	13.0 +- 0.6	3

GRAND GULF
TLD Direct Radiation Environmental Monitoring

NRC Station	Location		Description
	Azimuth / Degree	Distance / Mile	
1	337	2.0	FT. COBUN
2	351	1.6	GRAND GULF ST. PARK
3	20	1.5	EVAC. SIGN E. OF GRAND GULF
4	51	2.3	E. OF STATION 3
5	68	2.7	UNDERGROUND CABLE SIGN
6	47	4.1	N. OF YMCA CAMP
7	68	4.9	BONNER BEAUTY SHOP
8	91	3.2	LAKE CLAIBORNE
9	81	1.0	W. OF SPRING HILL BAPTIST CHURCH
10	109	0.6	NEAR ROAD BED SIGN ESE OF PLANT
11	139	0.8	OPEN FIELD SE OF PLANT
12	185	1.6	S. OF PLANT
13	207	1.9	UNDERGROUND CABLE SIGN
14	247	1.5	WSW OF PLANT BY MISS. RIVER
15	130	4.2	A.W. WATSON JR. HIGH SCHOOL
16	122	4.8	PORT GIBSON SUBSTATION
17	135	5.3	VINE ST.
18	147	4.3	CENTERS CR.
19	224	6.8	WINDSOR RUINS
20	172	3.6	NEAR MISS. AIR SAMPLING STATION
21	291	12.0	NEWELLTON
22	332	8.0	TOP OF LEVY
23	310	7.9	YUCATAN HUNTING CLUB
24	281	7.0	LAKE ST. JOSEPH
25	291	4.8	WINTER QUARTERS
26	248	9.5	LAKE BRUIN STATE PARK
27	239	13.0	ST. JOSEPH
29	90	0.9	MAGIE JACKSON TRAILER
30	67	51.0	JACKSON (MISSISSIPPI)
31	67	51.0	JACKSON (MISSISSIPPI)
32	67	51.0	JACKSON (MISSISSIPPI)
33	206	4.8	EAST OF WINDSOR RUINS

NRC TLD DOSES FOR GRAND GULF AREA

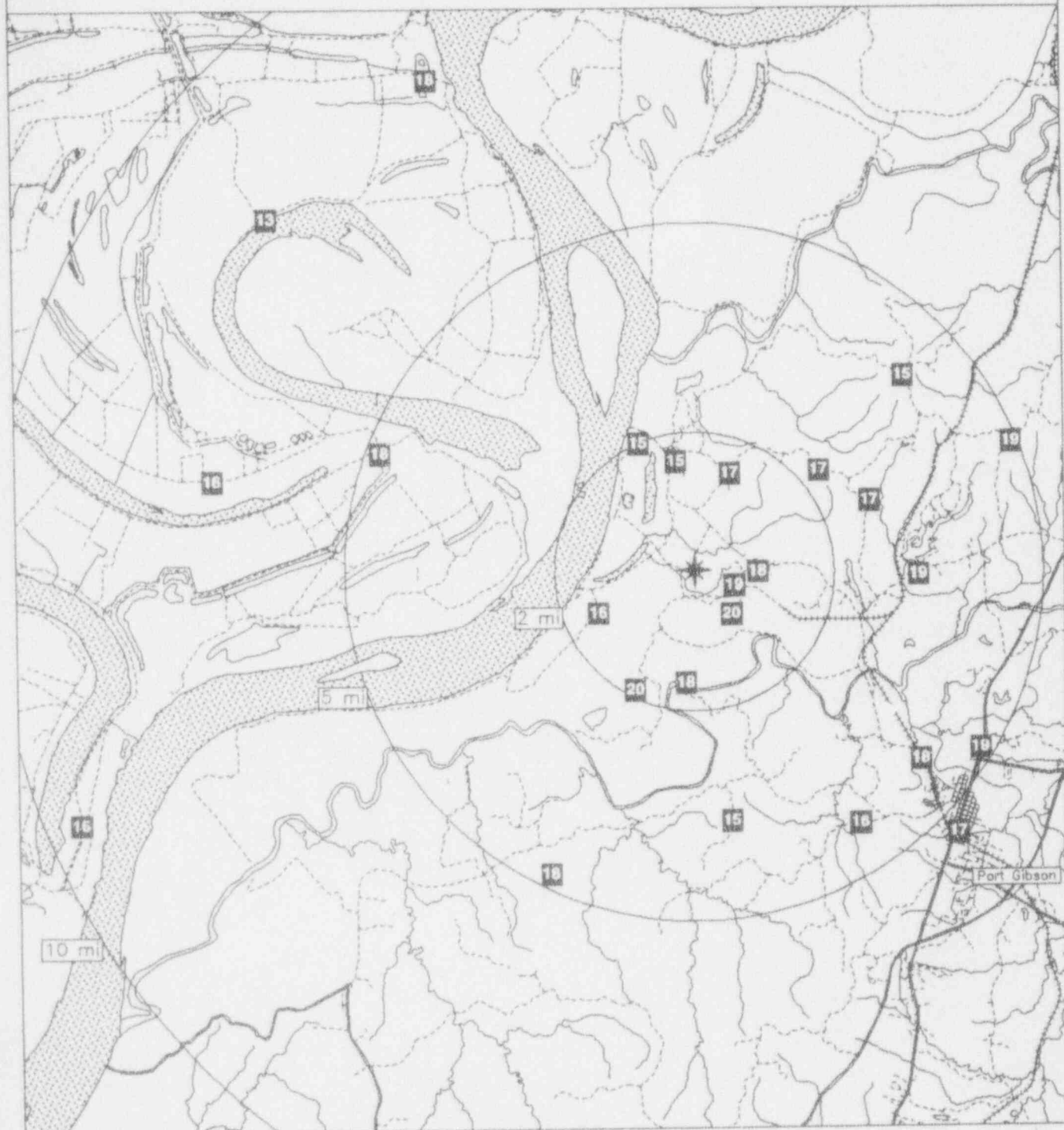

Miles

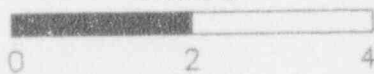

Legend

 Water

 Highways

 Railroads

 Roads

 Plant..site

HADDAM NECK

TLD Direct Radiation Environmental Monitoring

For the period 930915-940201 140 Days

Field Time: 94 Days

NRC Sta	Location Azimuth/Dist (Deg)/(Mi)		Gross Exposure (mR) +-Rdm; Tot.	Net Exposure Rate (mR/Std. Qtr.) +-Rdm; Tot.	Hist. Range Net Exp Rate +-1 Std Dev
2	17	2.6	24.4 +- 0.7; 3.7	19.4 +- 0.8; 4.6	18.8 +- 1.9
3	45	1.9	24.2 +- 0.7; 3.6	19.2 +- 0.8; 4.5	18.4 +- 2.6
4	67	2.3	23.7 +- 0.7; 3.5	18.7 +- 0.8; 4.5	17.7 +- 1.7
5	93	1.6	22.2 +- 0.7; 3.3	17.3 +- 0.7; 4.3	16.1 +- 1.6
6	115	2.3	20.9 +- 0.6; 3.1	16.1 +- 0.7; 4.2	15.6 +- 1.8
7	143	1.9	22.7 +- 0.7; 3.4	17.8 +- 0.7; 4.4	17.6 +- 1.9
8	165	0.9	21.9 +- 0.7; 3.3	17.0 +- 0.7; 4.3	16.8 +- 1.4
9	174	1.3	23.9 +- 0.7; 3.6	19.0 +- 0.8; 4.5	18.2 +- 1.9
10	195	0.7	21.3 +- 0.6; 3.2	16.4 +- 0.7; 4.2	16.1 +- 1.7
12	241	0.8	22.9 +- 0.7; 3.4	17.9 +- 0.7; 4.4	17.2 +- 1.6
13	263	0.8	21.2 +- 0.6; 3.2	16.3 +- 0.7; 4.2	15.9 +- 1.7
14	290	1.9	23.2 +- 0.7; 3.5	18.2 +- 0.7; 4.4	17.7 +- 1.8
15	311	1.5	21.0 +- 0.6; 3.1	16.1 +- 0.7; 4.2	15.4 +- 1.7
16	341	1.3	Missing Dosimeter	No Net Data	16.7 +- 1.6
17	360	2.3	24.5 +- 0.7; 3.7	19.5 +- 0.8; 4.6	19.5 +- 1.8
18	222	2.5	21.7 +- 0.7; 3.3	16.9 +- 0.7; 4.3	16.0 +- 1.7
19	269	3.0	20.5 +- 0.6; 3.1	15.7 +- 0.7; 4.2	16.0 +- 1.8
20	66	3.2	21.4 +- 0.6; 3.2	16.6 +- 0.7; 4.3	16.5 +- 1.7
21	91	2.8	22.5 +- 0.7; 3.4	17.6 +- 0.7; 4.4	18.1 +- 1.9
22	112	3.2	22.8 +- 0.7; 3.4	17.9 +- 0.7; 4.4	16.8 +- 1.9
23	137	2.9	21.4 +- 0.6; 3.2	16.6 +- 0.7; 4.3	16.5 +- 2.1
24	155	7.1	19.6 +- 0.6; 2.9	14.8 +- 0.7; 4.1	15.8 +- 1.5
25	175	5.7	21.6 +- 0.6; 3.2	16.7 +- 0.7; 4.3	16.1 +- 1.7
26	196	2.5	20.1 +- 0.6; 3.0	15.3 +- 0.7; 4.1	15.4 +- 1.6
27	225	1.1	21.8 +- 0.7; 3.3	16.9 +- 0.7; 4.3	17.4 +- 2.0
28	250	3.5	21.1 +- 0.6; 3.2	16.2 +- 0.7; 4.2	17.0 +- 2.6
29	340	20.0	23.9 +- 0.7; 3.6	18.9 +- 0.8; 4.5	20.6 +- 4.1
30	286	3.2	21.5 +- 0.6; 3.2	16.6 +- 0.7; 4.3	16.0 +- 1.7
31	322	2.7	21.5 +- 0.6; 3.2	16.6 +- 0.7; 4.3	17.2 +- 1.7
32	327	2.9	24.9 +- 0.7; 3.7	19.8 +- 0.8; 4.6	19.0 +- 1.7
33	359	6.4	21.1 +- 0.6; 3.2	16.2 +- 0.7; 4.2	16.0 +- 1.4
35	54	10.0	21.9 +- 0.7; 3.3	17.0 +- 0.7; 4.3	16.7 +- 1.7
36	72	8.8	24.4 +- 0.7; 3.7	19.4 +- 0.8; 4.6	19.0 +- 1.7
37	149	6.8	20.3 +- 0.6; 3.1	15.5 +- 0.7; 4.1	15.4 +- 1.6
38	158	5.9	19.3 +- 0.6; 2.9	14.5 +- 0.7; 4.0	15.1 +- 1.7
39	267	8.8	20.8 +- 0.6; 3.1	15.9 +- 0.7; 4.2	16.5 +- 1.8
40	303	9.1	22.3 +- 0.7; 3.3	17.4 +- 0.7; 4.3	18.1 +- 1.4
41	313	9.6	22.2 +- 0.7; 3.3	17.3 +- 0.7; 4.3	16.3 +- 1.6
42	320	13.0	23.2 +- 0.7; 3.5	18.3 +- 0.7; 4.4	18.3 +- 1.8
43	324	18.0	20.8 +- 0.6; 3.1	16.0 +- 0.7; 4.2	15.9 +- 1.4
44	328	15.0	22.8 +- 0.7; 3.4	17.8 +- 0.7; 4.4	17.6 +- 1.8
45	343	18.0	24.0 +- 0.7; 3.6	19.1 +- 0.8; 4.5	18.4 +- 1.9
46	144	5.0	23.5 +- 0.7; 3.5	18.5 +- 0.8; 4.5	17.3 +- 2.1
49	340	20.0	22.8 +- 0.7; 3.4	17.9 +- 0.7; 4.4	17.9 +- 1.9

Transit Dose = 4.2 +- 0.4; 3.1

HADDAM NECK
For the period 930915-940201

TLD Direct Radiation Environmental Monitoring

Azimuth (degrees)	Ave. Exposure Rate (mR/Std.Qtr.) +- Std.Dev.	Number In Group
348.76 - 11.25 N	17.9 +- 2.3	2
11.26 - 33.75 NNE	19.4 +- 0.0	1
33.76 - 56.25 NE	18.1 +- 1.5	2
56.26 - 78.75 ENE	18.2 +- 1.5	3
78.76 - 101.25 E	17.4 +- 0.2	2
101.26 - 123.75 ESE	17.0 +- 1.3	2
123.76 - 146.25 SE	17.6 +- 1.0	3
146.26 - 168.75 SSE	15.5 +- 1.1	4
168.75 - 191.25 S	17.8 +- 1.6	2
191.26 - 213.75 SSW	15.9 +- 0.8	2
213.76 - 236.25 SW	16.9 +- 0.1	2
236.26 - 258.75 WSW	17.1 +- 1.2	2
258.76 - 281.25 W	16.0 +- 0.3	3
281.26 - 303.75 WNW	17.4 +- 0.8	3
303.76 - 326.25 NW	16.9 +- 1.0	5
326.26 - 348.75 NNW	18.9 +- 0.8	4

Distance From Reactor (miles)	Ave. Exposure Rate (mR/Std.Qtr.) +- Std.Dev.	Number In Group
0 - 2	17.5 +- 1.0	11
2 - 5	17.4 +- 1.4	16
> 5	17.0 +- 1.5	15
Upwind Control	17.9 +- 0.0	1

HADDAM NECK
TLD Direct Radiation Environmental Monitoring

NRC Station	Location		Description
	Azimuth / Degree	Distance / Mile	
2	17	2.6	LEESVILLE SUBSTA.
3	45	1.9	FRANK DAVIS RESORT
4	67	2.3	RT. 149 & RT. 151
5	93	1.6	STATE RT. 149
6	115	2.3	ON MORTIMER GELSTON FARM
7	143	1.9	SUBSTA. ON RT. 9A
8	165	0.9	PLAINS ROAD
9	174	1.3	PLAINS ROAD
10	195	0.7	MIDDLESEX EXT. CENTER
12	241	0.8	JAIL HILL ROAD
13	263	0.8	WALKLEY HILL RD. & RT. 9A
14	290	1.9	WALKLEY HILL ROAD
15	311	1.5	ROCK LANDING
16	341	1.3	UPPER ROAD
17	360	2.3	PINE BROOK
18	222	2.5	BEAVER MEADOW ROAD
19	269	3.0	SKINNER ROAD
20	66	3.2	EAST HADDAM PUBLIC LIBRARY
21	91	2.8	ORCHARD ST.
22	112	3.2	SUBSTA. ON RT. 151
23	137	2.9	GOODSPEED OPERA HOUSE
24	155	7.1	MONSANTO PLANT
25	175	5.7	CHESTER(RT.148)
26	196	2.5	TURKEY HILL ROAD
27	225	1.1	JAIL HILL ROAD
28	250	3.5	HADDAM JR. HIGH
29	340	20.0	CONN.STATE(SEcurity)
30	286	3.2	CL&P SUBSTA.(HIGGANUM)
31	322	2.7	CLARKHURST ROAD
32	327	2.9	HURD PARK ROAD
33	359	6.4	EAST HAMPTON FIRE DEPT.
35	54	10.0	COLCHESTER STATE POLICE
36	72	8.8	LAKE HAYWOOD AREA
37	149	6.8	ST.JOHN'S SCHOOL
38	158	5.9	CHESTER FIRE CO.
39	267	8.8	COGINCHAUG HIGH SCH.
40	303	9.1	OLD GAS WORKS
41	313	9.6	U.S. POST OFFICE
42	320	13.0	CROMWELL FIRE CO.
43	324	18.0	NEWINGTON CHILDREN'S HOSP.
44	328	15.0	ROCKY HILL FIRE STA.
45	343	18.0	WETHERSFIELD(CONN)
46	144	5.0	FOUNDER SCHOOL
49	340	20.0	CONN. STATE CAPITOL

NRC TLD DOSES FOR HADDAM NECK AREA

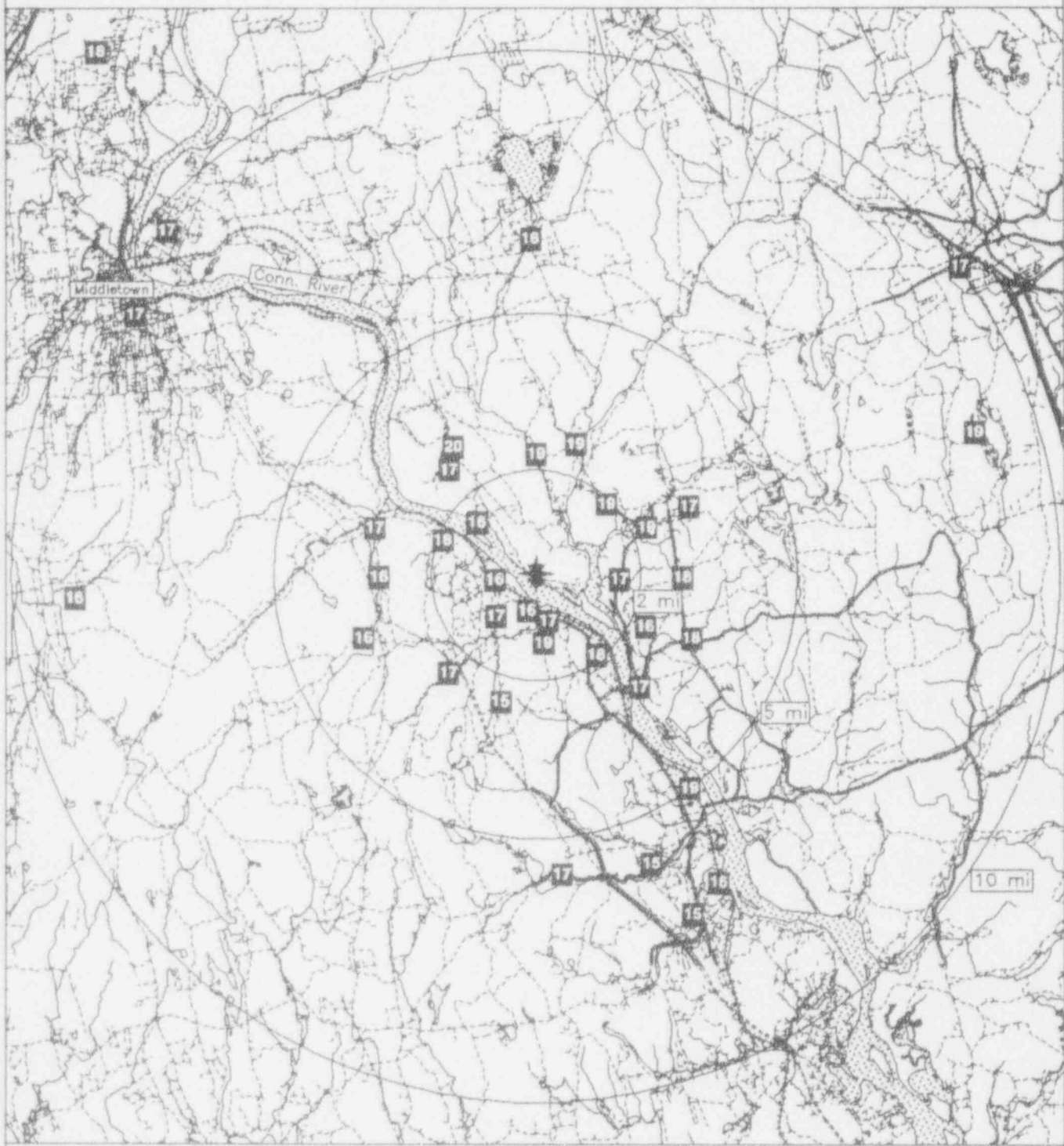

Miles

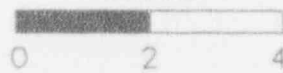

Legend



Water

--- Railroads



Plant site

— Highways

--- Roads

HARRIS

TLD Direct Radiation Environmental Monitoring
 For the period 930915-940203 142 Days
 Field Time: 99 Days

NRC Sta	Location		Gross Exposure (mR)		Net Exposure Rate (mR/Std. Qtr.)		Hist. Range Net Exp Rate	
	Azimuth/Dist (Deg)/(Mi)		+Rdm;	Tot.	+Rdm;	Tot.	+1	Std Dev
1	36	2.6	22.2	+ 0.7; 3.3	16.1	+ 0.7; 4.2	17.1	+ 2.3
2	25	3.2	18.6	+ 0.6; 2.8	12.9	+ 0.6; 3.9	14.9	+ 3.7
3	5	2.5	20.9	+ 0.6; 3.1	14.9	+ 0.7; 4.1	17.3	+ 1.8
4	27	1.5	19.5	+ 0.6; 2.9	13.7	+ 0.6; 4.0	18.0	+ 2.4
5	36	0.9	18.2	+ 0.5; 2.7	12.5	+ 0.6; 3.8	14.7	+ 1.9
6	68	0.8	17.4	+ 0.5; 2.6	11.8	+ 0.6; 3.8	12.9	+ 3.5
7	98	0.7	19.5	+ 0.6; 2.9	13.7	+ 0.6; 4.0	15.8	+ 1.8
8	232	0.7	17.8	+ 0.5; 2.7	12.1	+ 0.6; 3.8	14.0	+ 3.5
9	190	0.8	16.8	+ 0.5; 2.5	11.2	+ 0.6; 3.7	12.5	+ 3.6
10	158	0.7	17.6	+ 0.5; 2.6	11.9	+ 0.6; 3.8	13.9	+ 3.7
11	42	4.7	24.7	+ 0.7; 3.7	18.4	+ 0.8; 4.5	19.8	+ 2.4
12	40	8.6	21.1	+ 0.6; 3.2	15.2	+ 0.7; 4.1	16.5	+ 3.5
13	298	13.0	17.6	+ 0.5; 2.6	11.9	+ 0.6; 3.8	13.6	+ 3.7
14	298	12.0	17.7	+ 0.5; 2.7	12.0	+ 0.6; 3.8	14.3	+ 3.8
15	298	11.0	17.3	+ 0.5; 2.6	11.7	+ 0.6; 3.8	12.9	+ 3.8
16	332	4.8	20.0	+ 0.6; 3.0	14.2	+ 0.6; 4.0	14.4	+ 3.8
17	291	4.5	16.4	+ 0.5; 2.5	10.9	+ 0.6; 3.7	13.1	+ 3.4
18	270	5.1	16.9	+ 0.5; 2.5	11.3	+ 0.6; 3.7	14.4	+ 3.5
19	240	5.1	20.5	+ 0.6; 3.1	14.6	+ 0.7; 4.1	16.9	+ 3.7
20	227	4.8	16.8	+ 0.5; 2.5	11.2	+ 0.6; 3.7	12.5	+ 3.5
21	208	4.8	16.4	+ 0.5; 2.5	10.8	+ 0.6; 3.7	12.4	+ 3.7
22	190	4.6	18.5	+ 0.6; 2.8	12.8	+ 0.6; 3.9	14.3	+ 3.4
23	151	4.8	19.5	+ 0.6; 2.9	13.7	+ 0.6; 4.0	13.9	+ 3.9
24	132	4.7	17.4	+ 0.5; 2.6	11.8	+ 0.6; 3.8	13.7	+ 3.9
25	112	5.0	20.1	+ 0.6; 3.0	14.2	+ 0.6; 4.0	15.8	+ 3.6
26	92	4.6	16.6	+ 0.5; 2.5	11.0	+ 0.6; 3.7	12.9	+ 2.8
27	115	2.8	Damaged Dosimeter		No Net Data		14.5	+ 2.4
28	135	2.3	14.1	+ 0.4; 2.1	8.7	+ 0.5; 3.5	11.6	+ 3.7
29	164	2.2	17.6	+ 0.5; 2.6	12.0	+ 0.6; 3.8	14.9	+ 3.8
30	49	2.2	17.6	+ 0.5; 2.6	11.9	+ 0.6; 3.8	14.2	+ 3.4
31	276	1.8	17.4	+ 0.5; 2.6	11.8	+ 0.6; 3.8	14.0	+ 3.6
32	292	1.7	21.4	+ 0.6; 3.2	15.4	+ 0.7; 4.1	17.8	+ 2.1
33	314	1.4	19.8	+ 0.6; 3.0	13.9	+ 0.6; 4.0	16.2	+ 3.6
34	329	1.3	22.1	+ 0.7; 3.3	16.1	+ 0.7; 4.2	16.2	+ 3.7
35	350	4.5	19.1	+ 0.6; 2.9	13.3	+ 0.6; 3.9	16.5	+ 1.9
36	338	4.4	17.8	+ 0.5; 2.7	12.1	+ 0.6; 3.8	16.9	+ 4.0
37	16	4.9	18.4	+ 0.6; 2.8	12.7	+ 0.6; 3.9	16.2	+ 2.6
38	68	4.8	16.6	+ 0.5; 2.5	11.0	+ 0.6; 3.7	12.9	+ 1.9
39	80	6.9	18.6	+ 0.6; 2.8	12.9	+ 0.6; 3.9	15.1	+ 1.8
40	80	6.9	Damaged Dosimeter		No Net Data		14.3	+ 2.2
41	118	9.7	23.2	+ 0.7; 3.5	17.1	+ 0.7; 4.3	19.0	+ 3.8
42	260	1.1	17.7	+ 0.5; 2.7	12.0	+ 0.6; 3.8	14.0	+ 3.6
43	333	1.7	20.1	+ 0.6; 3.0	14.2	+ 0.6; 4.0	15.9	+ 4.3
44	50	24.0	24.1	+ 0.7; 3.6	17.9	+ 0.7; 4.4	20.4	+ 3.9

Transit Dose = 4.5 +- 0.4; 3.2

HARRIS

For the period 930915-940203

TLD Direct Radiation Environmental Monitoring

Azimuth (degrees)	Ave. Exposure Rate (mR/Std.Qtr.) +- Std.Dev.	Number in Group
348.76 - 11.25 N	14.1 +- 1.2	2
11.26 - 33.75 NNE	13.1 +- 0.5	3
33.76 - 56.25 NE	15.3 +- 2.7	6
56.26 - 78.75 ENE	11.4 +- 0.5	2
78.76 - 101.25 E	12.5 +- 1.3	3
101.26 - 123.75 ESE	15.6 +- 2.0	2
123.76 - 146.25 SE	10.3 +- 2.1	2
146.26 - 168.75 SSE	12.5 +- 1.0	3
168.76 - 191.25 S	12.0 +- 1.1	2
191.26 - 213.75 SSW	10.8 +- 0.0	1
213.76 - 236.25 SW	11.7 +- 0.6	2
236.26 - 258.75 WSW	14.6 +- 0.0	1
258.76 - 281.25 W	11.7 +- 0.4	3
281.26 - 303.75 WNW	13.1 +- 3.2	2
303.76 - 326.25 NW	13.9 +- 0.0	1
326.26 - 348.75 NNW	14.2 +- 1.6	4

Distance From Reactor (miles)	Ave. Exposure Rate (mR/Std.Qtr.) +- Std.Dev.	Number In Group
0 - 2	13.1 +- 1.5	13
2 - 5	12.7 +- 2.1	20
> 5	14.8 +- 2.5	6
Upwind Control	11.9 +- 0.2	3

HARRIS
TLD Direct Radiation Environmental Monitoring

NRC Station	Location		Description
	Azimuth / Degree	Distance / Mile	
1	36	2.6	N.OF SHE&E CENTER ON SR 1127
2	25	3.2	SR 1127 ACROSS 1ST BAPTIST CHURCH
3	5	2.5	SR 1134, SOUTH OF OLD US 1
4	27	1.5	OLD ROAD BED, EAST OF SR 1134
5	36	0.9	JUNCTION SR 1134 & SR 1135
6	68	0.8	DIRT RD EXTENSION OF SR 1134
7	98	0.7	DIRT RD EXTENSION OF SR 1134
8	232	0.7	ROAD ADJACENT TO THE INTAKE CANAL
9	190	0.8	EAST SIDE OF RD,SOUTH OF POWERLINES
10	158	0.7	POWER LINE RIGHT OF WAY
11	42	4.7	US 1 AT SR 1149 OVERPASS
12	40	8.6	JONES PARK, APEX, NC
13	298	13.0	CP&L OFFICE ON 15-501, PITTSBORO
14	298	12.0	PITTSBORO CHRISTIAN HOME
15	298	11.0	JUNCTION US64 & SR 1943
16	332	4.8	EAST SIDE OF SR 1008,POLE #2054
17	291	4.5	INTERSECTION SRS 1910,1909,AND 1908
18	270	5.1	SR 1908 EXIT RAMP OF US 1
19	240	5.1	NESTE RESIN CORP. PARKING LOT
20	227	4.8	NORTHSIDE OF SR 1924 AT POWER LN
21	208	4.8	NC HWY42 ACROSS BUCKHORN U.M. CHURCH LOT
22	190	4.6	NORTH OF SPILLWAY MAINTENANCE
23	151	4.8	JUNCTION SR 1402&1401 ON S. 1402
24	132	4.7	SR 1116,NEAR SPRINGS CHURCH
25	112	5.0	POWER LINE RIGHT-OF WAY,NEAR SR1116
26	92	4.6	WEST OF SR 1115 NEAR HOUSE & BARN
27	115	2.8	SR 1127 WEST,JUNCTION SR 1127,1115&1130
28	135	2.3	SR 1130,1 MI SOUTH, HOLLEMAN'S
29	164	2.2	SR 1130 SOUTH OF STATION 28
30	49	2.2	REAR HARRIS ENERGY & ENV.CENTER
31	276	1.8	SR 1191
32	292	1.7	US 1 NEAR CHATHAM-WAKE CTY LINE
33	314	1.4	US 1 NEAR HARRIS LAKE
34	329	1.3	US1 .2 MI NORTH OF RAILROAD OVERPASS
35	350	4.5	SR1142 ON UNDERGROUND CABLE SIGN
36	338	4.4	SR1142 END OF ROAD NEXT TO ROADBED
37	16	4.9	SR 1142,YARD OF DAIRY BARN
38	68	4.8	SR1152,1.2MI SOUTH OF 1152
39	80	6.9	EARP ST. HOLLY SPRINGS,NC
40	80	6.9	NORTH OF JUNCTION SR 1393 & 1421
41	118	9.7	CENTURY 21 OFC PARKING LOT
42	260	1.1	ACCESS RD(EAST),TO AUX.RESERVOIR
43	333	1.7	SR 1136 AT RESIDENCE (MOBILE HOME)
44	50	24.0	1330 ST.MARY'S ST., RALEIGH NC

NRC TLD DOSES FOR HARRIS AREA

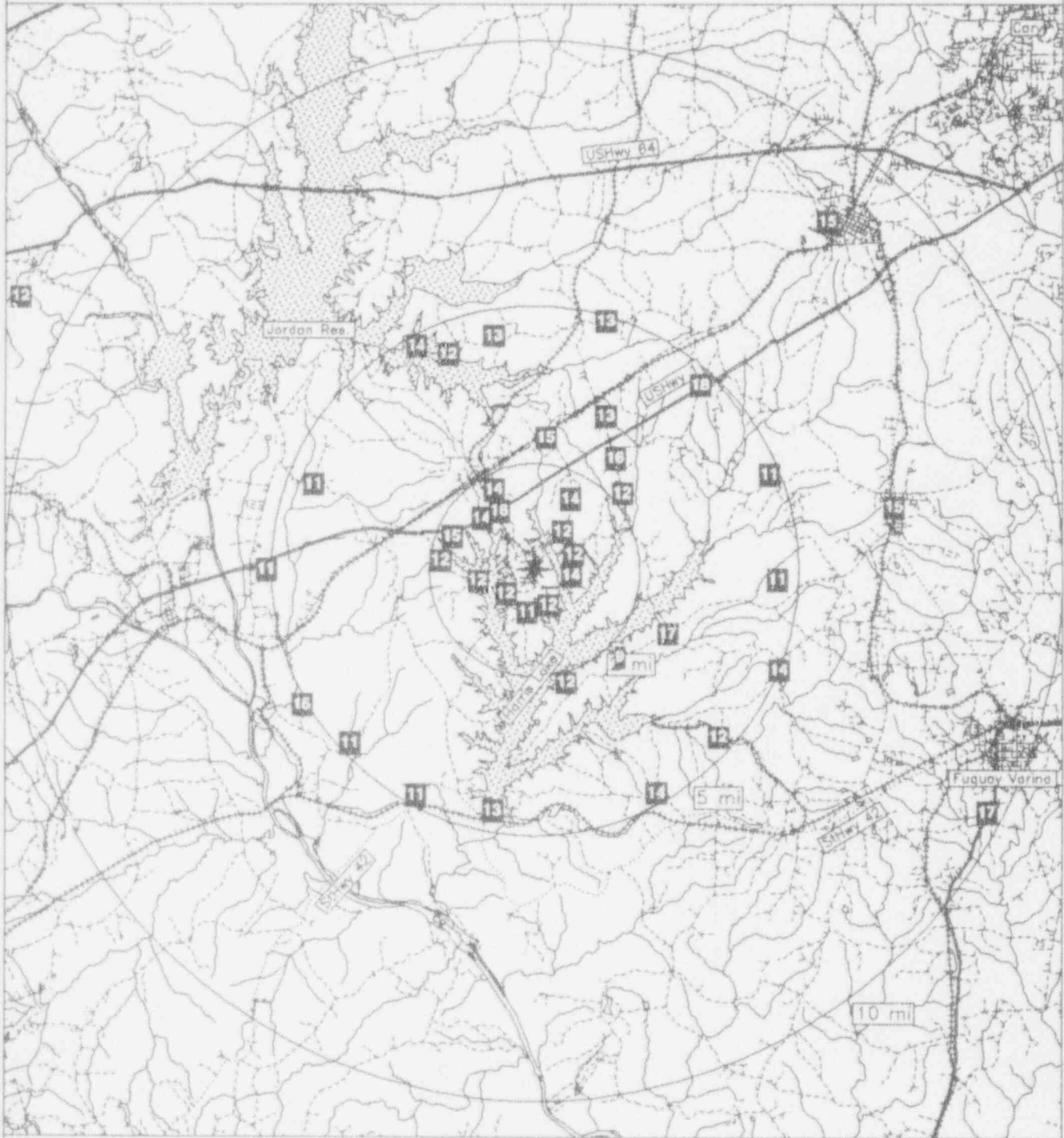

Miles

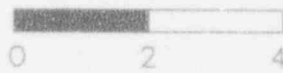

Legend



Water



Highways

--- Railroads

--- Roads



Plant..site

HATCH

TLD Direct Radiation Environmental Monitoring

For the period 930914-940209 149 Days

Field Time: 100 Days

NRC Sta	Location		Gross Exposure (mR)		Net Exposure Rate (mR/Std. Qtr.)		Hist. Range Net Exp Rate	
	Azimuth/ (Deg)	Dist (Mi)	+-Rdm; Tot.		+-Rdm; Tot.		+-1 Std Dev	
1	342	23.0	24.0	+- 0.7; 3.6	15.6	+- 0.8; 4.5	16.3	+- 2.4
2	359	7.7	22.4	+- 0.7; 3.4	14.2	+- 0.7; 4.3	14.4	+- 2.4
3	354	4.5	21.6	+- 0.6; 3.2	13.5	+- 0.7; 4.3	14.3	+- 2.5
4	336	2.9	20.6	+- 0.6; 3.1	12.6	+- 0.7; 4.2	13.3	+- 2.3
5	309	4.6	20.6	+- 0.6; 3.1	12.6	+- 0.7; 4.2	13.7	+- 2.4
6	297	5.6	23.2	+- 0.7; 3.5	14.9	+- 0.7; 4.4	15.8	+- 2.6
7	24	2.8	21.3	+- 0.6; 3.2	13.2	+- 0.7; 4.2	14.1	+- 2.7
8	49	2.0	21.2	+- 0.6; 3.2	13.2	+- 0.7; 4.2	14.0	+- 2.4
9	49	10.0	20.8	+- 0.6; 3.1	12.8	+- 0.7; 4.2	13.8	+- 2.4
10	28	4.8	21.0	+- 0.6; 3.1	12.9	+- 0.7; 4.2	14.4	+- 2.4
11	67	5.0	22.0	+- 0.7; 3.3	13.8	+- 0.7; 4.3		+- 2.3
12	50	5.1	26.0	+- 0.8; 3.9	17.4	+- 0.8; 4.7		+- 2.8
13	353	2.0	20.4	+- 0.6; 3.1	12.4	+- 0.7; 4.2		+- 2.3
14	341	1.6	21.7	+- 0.7; 3.3	13.6	+- 0.7; 4.3	14.8	+- 2.6
15	147	10.0	19.7	+- 0.6; 3.0	11.8	+- 0.7; 4.1	13.1	+- 2.2
16	232	0.9	19.0	+- 0.6; 2.8	11.1	+- 0.7; 4.0	13.3	+- 2.2
17	205	1.6	21.3	+- 0.6; 3.2	13.2	+- 0.7; 4.2	14.4	+- 2.4
18	192	4.2	17.2	+- 0.5; 2.6	9.5	+- 0.6; 3.9	11.7	+- 2.1
19	184	4.2	18.2	+- 0.5; 2.7	10.5	+- 0.6; 4.0	11.5	+- 2.3
20	165	4.6	20.1	+- 0.6; 3.0	12.1	+- 0.7; 4.1	12.3	+- 2.4
21	135	4.4	19.8	+- 0.6; 3.0	11.9	+- 0.7; 4.1	13.0	+- 2.2
22	120	4.1	19.8	+- 0.6; 3.0	11.9	+- 0.7; 4.1	13.6	+- 2.6
23	107	3.7	19.3	+- 0.6; 2.9	11.4	+- 0.7; 4.1	13.6	+- 2.3
24	123	14.0	19.3	+- 0.6; 2.9	11.4	+- 0.7; 4.1	12.4	+- 2.3
25	114	12.0	20.9	+- 0.6; 3.1	12.8	+- 0.7; 4.2	13.6	+- 2.3
26	142	1.8	21.5	+- 0.6; 3.2	13.4	+- 0.7; 4.3	14.4	+- 2.4
27	157	2.2	20.5	+- 0.6; 3.1	12.5	+- 0.7; 4.2	13.5	+- 2.2
28	171	0.9	21.3	+- 0.6; 3.2	13.2	+- 0.7; 4.2	14.6	+- 2.2
29	253	1.0	20.5	+- 0.6; 3.1	12.4	+- 0.7; 4.2	13.8	+- 3.3
30	270	1.0	22.4	+- 0.7; 3.4	14.2	+- 0.7; 4.3	15.3	+- 3.0
31	292	1.1	20.7	+- 0.6; 3.1	12.6	+- 0.7; 4.2	13.9	+- 2.4
32	268	4.2	20.2	+- 0.6; 3.0	12.2	+- 0.7; 4.1	13.7	+- 2.2
33	248	4.3	18.7	+- 0.6; 2.8	10.8	+- 0.6; 4.0	12.3	+- 2.4
34	216	4.1	18.8	+- 0.6; 2.8	10.9	+- 0.6; 4.0	11.6	+- 2.3
35	234	12.0	21.8	+- 0.7; 3.3	13.6	+- 0.7; 4.3	13.7	+- 2.4
36	182	10.0	Missing Dosimeter		No Net Data		13.2	+- 2.9
37	177	10.0	19.8	+- 0.6; 3.0	11.8	+- 0.7; 4.1	12.6	+- 2.3
38	323	12.0	23.1	+- 0.7; 3.5	14.8	+- 0.7; 4.4	15.1	+- 2.4
39	321	13.0	22.7	+- 0.7; 3.4	14.4	+- 0.7; 4.4	15.4	+- 2.4
40	323	12.0	23.2	+- 0.7; 3.5	14.9	+- 0.7; 4.4	15.3	+- 2.4

Transit Dose = 6.6 +- 0.4; 3.5

HATCH

For the period 930914-940209

TLD Direct Radiation Environmental Monitoring

Azimuth (degrees)	Ave. Exposure Rate (mR/Std.Qtr.) +- Std.Dev.	Number In Group
348.76 - 11.25 N	13.3 +- 0.9	3
11.26 - 33.75 NNE	13.1 +- 0.2	2
33.76 - 56.25 NE	14.5 +- 2.6	3
56.26 - 78.75 ENE	13.8 +- 0.0	1
78.76 - 101.25 E	No Data +- No Data	0
101.26 - 123.75 ESE	11.9 +- 0.7	4
123.76 - 146.25 SE	12.6 +- 1.1	2
146.26 - 168.75 SSE	12.1 +- 0.3	3
168.76 - 191.25 S	11.8 +- 1.4	3
191.26 - 213.75 SSW	11.4 +- 2.6	2
213.76 - 236.25 SW	11.9 +- 1.5	3
236.26 - 258.75 WSW	11.6 +- 1.1	2
258.76 - 281.25 W	13.2 +- 1.4	2
281.26 - 303.75 WNW	13.8 +- 1.6	2
303.76 - 326.25 NW	12.6 +- 0.0	1
326.26 - 348.75 NNW	13.9 +- 1.6	3

Distance From Reactor (miles)	Ave. Exposure Rate (mR/Std.Qtr.) +- Std.Dev.	Number In Group
0 - 2	12.9 +- 0.8	10
2 - 5	12.0 +- 1.2	16
> 5	13.6 +- 1.9	10
Upwind Control	14.7 +- 0.3	3

HATCH
TLD Direct Radiation Environmental Monitoring

NRC Station	Location		Description
	Azimuth / Degree	Distance / Mile	
1	342	23.0	VIDALIA FIRE STATION
2	359	7.7	TOOMBS CENTRAL SCHOOL
3	354	4.5	HWY. 1 & RD. 43
4	336	2.9	HWY. 107 (TAYLOR CHAPEL)
5	309	4.6	RD. S 1125
6	297	5.6	GRAYS LANDING
7	24	2.8	DEAD RIVER RD.
8	49	2.0	DEAD RIVER RD.
9	49	10.0	GA STATE PRISON
10	28	4.8	RD. 30
11	67	5.0	PROVIDENCE CHURCH
12	50	5.1	MARVEY CHURCH
13	353	2.0	RD. 49
14	41	1.6	WILLIAMS CR. BRIDGE
15	47	10.0	MCTIER CHURCH
16	232	0.9	HWY. 1 AT POND
17	205	1.6	HWY. 1 NEAR HVT LINES
18	192	4.2	ALTOMADA SCH.
19	184	4.2	RD. 538
20	165	4.6	RD. 538 AT POND
21	135	4.4	RD. 380 & 377
22	120	4.1	RD. 377 & 382
23	107	3.7	RD. 382
24	123	14.0	BETHEL CHURCH
25	114	12.0	OAK GROVE CHURCH
26	142	1.8	RD. 386
27	157	2.2	RD. 383
28	171	0.9	RD. 383 (N.R.)
29	253	1.0	CALVARY CHURCH
30	270	1.0	RD. 467
31	292	1.1	RD. 467
32	268	4.2	RD. 3 & 1
33	248	4.3	RD. 1 & 11
34	216	4.1	MELTON CHAPEL
35	234	12.0	GRAHAM (GA)
36	182	10.0	SHELL STATION
37	177	10.0	BAXLEY SUBSTATION
38	323	12.0	SUBSTATION (ALSTON GA)
39	321	13.0	HWY. 135 & RT. 107
40	323	12.0	RT. 107 AND RT. 113

NRC TLD DOSES FOR HATCH AREA

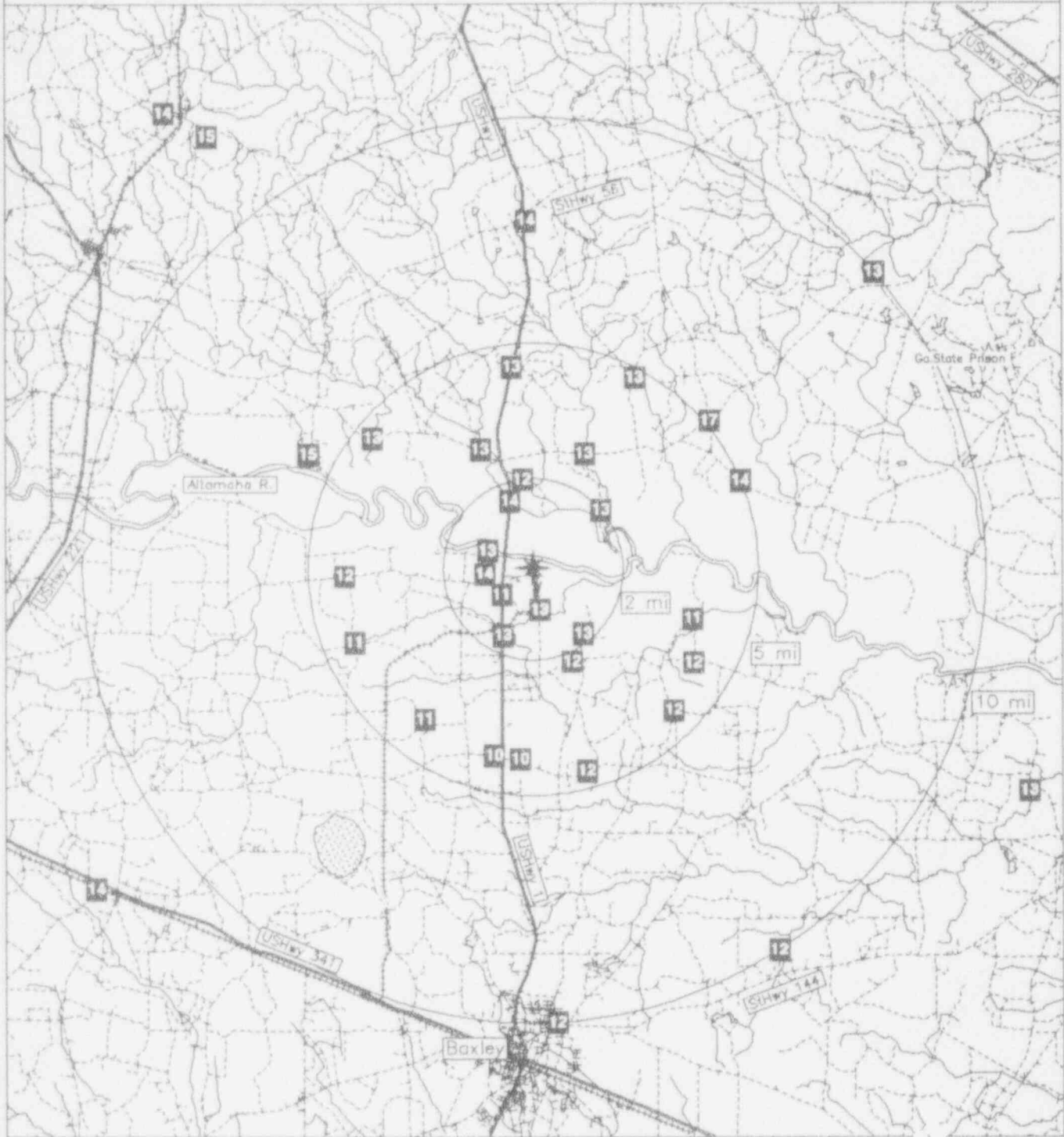

Miles

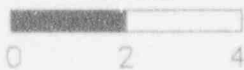

Legend

- Water
- Highways
- Railroads
- Roads
- Plant..site

INDIAN POINT

TLD Direct Radiation Environmental Monitoring

For the period 930915-940127 135 Days

Field Time: 85 Days

NRC Sta	Location Azimuth/Dist (Deg)/(Mi)		Gross Exposure (mR) +-Rdm; Tot.	Net Exposure Rate (mR/Std. Qtr.) +-Rdm; Tot.	Hist. Range Net Exp Rate +-1 Std Dev
1	52	1.4	Damaged Dosimeter	No Net Data	12.9 +- 1.7
2	53	1.0	18.7 +- 0.6; 2.8	13.3 +- 0.7; 4.3	15.0 +- 2.1
3	61	1.5	20.1 +- 0.6; 3.0	14.8 +- 0.8; 4.5	15.0 +- 1.5
4	89	1.2	20.6 +- 0.6; 3.1	15.3 +- 0.8; 4.6	15.3 +- 1.7
5	107	0.9	19.3 +- 0.6; 2.9	14.0 +- 0.7; 4.4	15.6 +- 1.5
6	90	0.5	19.1 +- 0.6; 2.9	13.7 +- 0.7; 4.4	15.9 +- 1.6
7	133	0.8	18.6 +- 0.6; 2.8	13.2 +- 0.7; 4.3	15.1 +- 2.0
8	158	0.8	19.8 +- 0.6; 3.0	14.5 +- 0.8; 4.5	15.8 +- 1.4
9	188	1.2	19.6 +- 0.6; 2.9	14.2 +- 0.7; 4.4	16.9 +- 1.7
10	206	0.9	19.1 +- 0.6; 2.9	13.8 +- 0.7; 4.4	15.4 +- 1.8
11	170	1.1	17.5 +- 0.5; 2.6	12.1 +- 0.7; 4.2	13.6 +- 1.5
12	155	2.3	20.0 +- 0.6; 3.0	14.7 +- 0.8; 4.5	14.9 +- 1.9
13	136	3.2	20.0 +- 0.6; 3.0	14.7 +- 0.8; 4.5	14.9 +- 1.6
14	107	3.1	18.7 +- 0.6; 2.8	13.3 +- 0.7; 4.3	13.9 +- 1.7
15	94	3.8	19.0 +- 0.6; 2.8	13.6 +- 0.7; 4.4	14.8 +- 1.4
16	142	5.7	Missing Dosimeter	No Net Data	16.3 +- 1.6
18	147	9.1	21.2 +- 0.6; 3.2	16.0 +- 0.8; 4.6	16.2 +- 1.6
19	137	12.0	18.4 +- 0.6; 2.8	13.0 +- 0.7; 4.3	15.1 +- 2.3
20	129	12.0	19.0 +- 0.6; 2.8	13.6 +- 0.7; 4.4	15.1 +- 1.7
22	74	7.5	18.8 +- 0.6; 2.8	13.4 +- 0.7; 4.4	15.6 +- 1.6
23	5	100.0	22.5 +- 0.7; 3.4	17.3 +- 0.8; 4.8	16.8 +- 1.5
24	5	100.0	22.4 +- 0.7; 3.4	17.2 +- 0.8; 4.8	16.7 +- 1.7
25	65	4.1	17.4 +- 0.5; 2.6	11.9 +- 0.7; 4.2	15.0 +- 1.8
26	40	4.0	22.6 +- 0.7; 3.4	17.5 +- 0.8; 4.8	18.0 +- 1.4
27	25	5.3	21.6 +- 0.6; 3.2	16.4 +- 0.8; 4.7	16.3 +- 1.8
28	24	2.9	19.9 +- 0.6; 3.0	14.6 +- 0.8; 4.5	15.7 +- 1.5
29	22	2.1	19.4 +- 0.6; 2.9	14.1 +- 0.7; 4.4	15.6 +- 1.6
30	8	1.9	18.3 +- 0.5; 2.7	12.9 +- 0.7; 4.3	16.8 +- 1.7
31	356	5.0	18.8 +- 0.6; 2.8	13.5 +- 0.7; 4.4	16.0 +- 1.8
32	330	3.7	Missing Dosimeter	No Net Data	17.2 +- 1.7
33	338	4.7	21.3 +- 0.6; 3.2	16.1 +- 0.8; 4.6	17.5 +- 1.5
34	354	7.0	22.7 +- 0.7; 3.4	17.5 +- 0.8; 4.8	19.3 +- 3.0
35	297	4.4	20.4 +- 0.6; 3.1	15.1 +- 0.8; 4.5	16.6 +- 1.8
36	309	3.6	29.2 +- 0.9; 4.4	24.5 +- 1.0; 5.6	22.8 +- 6.8
37	350	1.1	20.0 +- 0.6; 3.0	14.7 +- 0.8; 4.5	17.0 +- 1.5
38	337	0.9	20.8 +- 0.6; 3.1	15.6 +- 0.8; 4.6	16.8 +- 1.6
39	315	1.0	19.3 +- 0.6; 2.9	14.0 +- 0.7; 4.4	15.4 +- 1.5
40	294	1.1	Damaged Dosimeter	No Net Data	17.0 +- 2.0
41	274	1.1	21.2 +- 0.6; 3.2	15.9 +- 0.8; 4.6	18.6 +- 1.9
42	248	1.5	20.4 +- 0.6; 3.1	15.1 +- 0.8; 4.5	17.5 +- 2.0
44	5	100.0	21.7 +- 0.6; 3.2	16.4 +- 0.8; 4.7	16.6 +- 1.7
45	227	2.4	19.2 +- 0.6; 2.9	13.8 +- 0.7; 4.4	16.8 +- 2.2
46	209	3.2	18.2 +- 0.5; 2.7	12.8 +- 0.7; 4.3	15.3 +- 2.2
47	218	5.3	19.8 +- 0.6; 3.0	14.5 +- 0.8; 4.5	15.4 +- 1.6
48	201	4.6	20.8 +- 0.6; 3.1	15.5 +- 0.8; 4.6	16.2 +- 1.5
49	187	5.2	17.3 +- 0.5; 2.6	11.8 +- 0.7; 4.2	14.1 +- 1.7
50	171	7.1	20.0 +- 0.6; 3.0	14.7 +- 0.8; 4.5	14.5 +- 1.6

Transit Dose = 6.1 +- 0.4; 3.0

INDIAN POINT

For the period 930915-940127

TLD Direct Radiation Environmental Monitoring

Azimuth (degrees)	Ave. Exposure Rate (mR/Std.Qtr.) +- Std.Dev.	Number In Group
348.76 - 11.25 N	14.7 +- 2.1	4
11.26 - 33.75 NNE	15.0 +- 1.2	3
33.76 - 56.25 NE	15.4 +- 2.9	2
56.26 - 78.75 ENE	13.4 +- 1.4	3
78.76 - 101.25 E	14.2 +- 0.9	3
101.26 - 123.75 ESE	13.7 +- 0.4	2
123.76 - 146.25 SE	13.6 +- 0.8	4
146.26 - 168.75 SSE	15.1 +- 0.8	3
168.76 - 191.25 S	13.2 +- 1.4	4
191.26 - 213.75 SSW	14.0 +- 1.4	3
213.76 - 236.25 SW	14.2 +- 0.5	2
236.26 - 258.75 WSW	15.1 +- 0.0	1
258.76 - 281.25 W	15.9 +- 0.0	1
281.26 - 303.75 WNW	15.1 +- 0.0	1
303.76 - 326.25 NW	19.2 +- 7.4	2
326.26 - 348.75 NNW	15.8 +- 0.3	2

Distance From Reactor (miles)	Ave. Exposure Rate (mR/Std.Qtr.) +- Std.Dev.	Number In Group
0 - 2	14.2 +- 1.0	16
2 - 5	15.0 +- 2.9	15
> 5	14.6 +- 1.8	9
Upwind Control	17.0 +- 0.5	3

INDIAN POINT

TLD Direct Radiation Environmental Monitoring

NRC Station	Location		Description
	Azimuth Degree	Distance / Mile	
1	52	1.4	VALERIE HOME
2	53	1.0	CHARBS PT.
3	61	1.5	FRANKLIN ST.
4	89	1.2	WASHINGTON ST.
5	107	0.9	POST RD. (ALBANY-NY)
6	90	0.5	BROADWAY
7	133	0.8	FIRST ST.
8	158	0.8	WEST CHESTER AVE.
9	188	1.2	WESTCHESTER AVE.
10	206	0.9	NYU RADIO TOWER
11	170	1.1	MONTROSE PT.
12	155	2.3	DUTCH ST.
13	136	3.2	WATCH HILL RD.
14	107	3.1	WATCH HILL RD.
15	94	3.8	FURNACE DOCK RD.
16	142	5.7	CROTON-ON-HUDSON
18	147	9.1	OSSINING
19	137	12.0	PLEASANTVILLE
20	129	12.0	CHAPPAQUA
22	74	7.5	NAT. GUARD ARMORY
23	5	100.0	UWC - ALBANY
24	5	100.0	UWC - ALBANY
25	65	4.1	CROMPOUND RD.
26	40	4.0	LOCUST AVE.
27	25	5.3	GALLOWS HILL RD.
28	24	2.9	ROA HOOK RD.
29	22	2.1	POLICE STATION
30	8	1.9	CORTLANDT TOWNSHIP GARAGE
31	356	5.0	RT. 9D
32	330	3.7	BEAR MTN. BRIDGE
33	338	4.7	GARRISON RD.
34	354	7.0	LADYCLIFF COLLEGE
35	297	4.4	ANTHONY WAYNE RECREATION AREA
36	309	3.6	PERKINS MEM. OBSERVATORY
37	350	1.1	JONES POINT
38	337	0.9	JONES POINT
39	315	1.0	RT. 202
40	294	1.1	RT. 202
41	274	1.1	GAYS HILL RD
42	248	1.5	MOTT FARM RD.
44	5	100.0	UWC - ALBANY
45	227	2.4	WAYNE AVE.
46	209	3.2	STONY PT.
47	218	5.3	THIELLS
48	201	4.6	WEST HAVERSTRAW
49	187	5.2	HAVERSTRAW
50	171	7.1	RT. 9W

NRC TLD DOSES FOR INDIAN POINT AREA



Miles

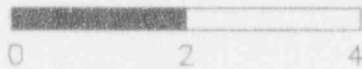

Legend

- Water
- Highways
- Railroads
- Roads
- Plant..site

KEWAUNEE/PT. BEACH

TLD Direct Radiation Environmental Monitoring

For the period 930914-940208 148 Days

Field Time: 104 Days

NRC Sta	Location Azimuth/Dist (Deg)/(Mi)		Gross Exposure (mR) +-Rdm; Tot.	Net Exposure Rate (mR/Std. Qtr.) +-Rdm; Tot.	Hist. Range Net Exp Rate +-1 Std Dev
1	189	8.1	20.3 +- 0.6; 3.0	11.1 +- 0.7; 4.1	12.5 +- 1.8
2	195	7.0	23.9 +- 0.7; 3.6	14.2 +- 0.7; 4.4	17.4 +- 2.0
3	163	4.9	20.9 +- 0.6; 3.1	11.5 +- 0.7; 4.2	13.1 +- 2.0
4	183	3.3	25.3 +- 0.8; 3.8	15.4 +- 0.8; 4.6	16.4 +- 2.2
5	210	3.2	20.1 +- 0.6; 3.0	10.8 +- 0.7; 4.1	12.3 +- 2.2
6	223	3.7	24.5 +- 0.7; 3.7	14.7 +- 0.8; 4.5	16.5 +- 2.3
7	242	5.7	22.3 +- 0.7; 3.4	12.8 +- 0.7; 4.3	14.0 +- 1.7
8	202	1.8	Damaged Dosimeter	No Net Data	17.1 +- 1.8
9	180	1.8	Damaged Dosimeter	No Net Data	15.7 +- 2.0
10	158	1.9	20.6 +- 0.6; 3.1	11.3 +- 0.7; 4.1	12.9 +- 2.0
11	235	1.2	25.9 +- 0.8; 3.9	15.9 +- 0.8; 4.6	16.9 +- 2.2
12	258	1.4	23.8 +- 0.7; 3.6	14.1 +- 0.7; 4.4	15.4 +- 2.2
13	273	1.4	23.7 +- 0.7; 3.6	14.0 +- 0.7; 4.4	15.7 +- 2.1
14	290	0.9	25.0 +- 0.7; 3.7	15.1 +- 0.8; 4.5	16.6 +- 1.9
15	333	0.8	23.1 +- 0.7; 3.5	13.5 +- 0.7; 4.4	15.5 +- 2.1
16	342	1.9	23.8 +- 0.7; 3.6	14.1 +- 0.7; 4.4	15.4 +- 2.0
17	317	2.0	20.9 +- 0.6; 3.1	11.6 +- 0.7; 4.2	13.7 +- 2.7
18	310	3.4	26.5 +- 0.8; 4.0	16.4 +- 0.8; 4.7	17.7 +- 1.8
19	293	4.0	21.9 +- 0.7; 3.3	12.4 +- 0.7; 4.3	14.8 +- 2.4
20	273	4.0	21.8 +- 0.7; 3.3	12.4 +- 0.7; 4.3	14.5 +- 2.4
21	300	5.6	23.1 +- 0.7; 3.5	13.4 +- 0.7; 4.4	14.6 +- 1.8
22	316	5.9	25.0 +- 0.7; 3.7	15.1 +- 0.8; 4.5	15.3 +- 2.0
23	345	2.7	25.8 +- 0.8; 3.9	15.8 +- 0.8; 4.6	16.7 +- 2.2
24	219	1.3	22.5 +- 0.7; 3.4	12.9 +- 0.7; 4.3	14.9 +- 2.0
25	247	1.4	24.9 +- 0.7; 3.7	15.1 +- 0.8; 4.5	16.5 +- 1.8
26	263	1.3	25.5 +- 0.8; 3.8	15.5 +- 0.8; 4.6	16.2 +- 2.0
27	290	1.4	27.3 +- 0.8; 4.1	17.2 +- 0.8; 4.8	16.7 +- 2.0
28	320	1.3	24.1 +- 0.7; 3.6	14.3 +- 0.8; 4.5	16.8 +- 2.3
29	342	1.1	23.5 +- 0.7; 3.5	13.8 +- 0.7; 4.4	15.8 +- 2.8
30	329	0.6	25.4 +- 0.8; 3.8	15.5 +- 0.8; 4.6	16.4 +- 1.9
31	13	1.0	23.2 +- 0.7; 3.5	13.6 +- 0.7; 4.4	14.7 +- 1.9
32	353	2.1	25.1 +- 0.8; 3.8	15.2 +- 0.8; 4.5	16.1 +- 1.9
33	301	3.9	22.9 +- 0.7; 3.4	13.3 +- 0.7; 4.3	15.2 +- 2.0
34	299	8.4	24.7 +- 0.7; 3.7	14.8 +- 0.8; 4.5	15.8 +- 1.8
35	323	3.8	21.4 +- 0.6; 3.2	12.0 +- 0.7; 4.2	14.1 +- 2.2
36	336	3.3	25.3 +- 0.8; 3.8	15.4 +- 0.8; 4.6	16.4 +- 2.2
37	6	3.1	21.8 +- 0.7; 3.3	12.3 +- 0.7; 4.2	14.5 +- 1.9
38	14	3.7	22.6 +- 0.7; 3.4	13.0 +- 0.7; 4.3	15.3 +- 1.9
39	13	7.6	24.3 +- 0.7; 3.6	14.5 +- 0.8; 4.5	13.1 +- 1.7
40	247	4.3	28.7 +- 0.9; 4.3	18.3 +- 0.9; 4.9	17.9 +- 2.0
41	8	23.0	19.9 +- 0.6; 3.0	10.7 +- 0.7; 4.1	13.2 +- 2.5
42	8	23.0	22.1 +- 0.7; 3.3	12.6 +- 0.7; 4.3	13.6 +- 2.0
43	8	23.0	20.0 +- 0.6; 3.0	10.8 +- 0.7; 4.1	12.8 +- 2.1

Transit Dose = 7.5 +- 0.5; 3.7

KEWAUNEE/PT. BEACH
For the period 930914-940208

TLD Direct Radiation Environmental Monitoring

Azimuth (degrees)	Ave. Exposure Rate (mR/Std.Qtr.) +- Std.Dev.	Number In Group
348.76 - 11.25 N	13.8 +- 2.0	2
11.26 - 33.75 NNE	13.7 +- 0.7	3
33.76 - 56.25 NE	No Data +- No Data	0
56.26 - 78.75 ENE	No Data +- No Data	0
78.76 - 101.25 E	No Data +- No Data	0
101.26 - 123.75 ESE	No Data +- No Data	0
123.76 - 146.25 SE	No Data +- No Data	0
146.26 - 168.75 SSE	11.4 +- 0.2	2
168.76 - 191.25 S	13.2 +- 3.0	2
191.26 - 213.75 SSW	12.5 +- 2.4	2
213.76 - 236.25 SW	14.5 +- 1.5	3
236.26 - 258.75 WSW	15.1 +- 2.3	4
258.76 - 281.25 W	14.0 +- 1.6	3
281.26 - 303.75 WNW	14.4 +- 1.7	6
303.76 - 326.25 NW	13.9 +- 2.1	5
326.26 - 348.75 NNW	14.7 +- 1.0	6

Distance From Reactor (miles)	Ave. Exposure Rate (mR/Std.Qtr.) +- Std.Dev.	Number In Group
0 - 2	14.2 +- 1.5	16
2 - 5	13.9 +- 2.1	15
> 5	13.7 +- 1.4	7
Upwind Control	11.4 +- 1.1	3

KEWAUNEE/PT. BEACH
TLD Direct Radiation Environmental Monitoring

NRC Station	Location		Description
	Azimuth / Degree	Distance / Mile	
1	189	8.1	HWY. 42 & 34TH AVE.
2	195	7.0	COUNTY RD. VV & TANNERY RD.
3	163	4.9	PT. BEACH STATE PARK
4	183	3.3	LAKE SHORE RD. & RAVINE DR.
5	210	3.2	ELECTRICAL POWER SUBSTATION ON COUNTY RD. V
6	223	3.7	COUNTY RD. V & TANNERY RD.
7	242	5.7	COUNTY RD. V
8	202	1.8	IRISH RD.
9	180	1.8	IRISH RD.
10	158	1.9	IRISH RD. & LAKE SHORE RD.
11	235	1.2	NUCLEAR RD. & TWIN ELDER RD.
12	258	1.4	HWY. 42
13	273	1.4	HWY. 42
14	290	0.9	TAPAWINGO RD.
15	333	0.8	LAKE SHORE RD.
16	342	1.9	TWO CREEKS RD. & LAKE SHORE RD.
17	317	2.0	TWO CREEKS RD. & HWY. 42
18	310	3.4	ZANDER RD. & TANNERY RD.
19	293	4.0	SAXONBURG RD.
20	273	4.0	SAXONBURG RD. & TAPAWINGO RD.
21	300	5.6	TISCH MILLS
22	316	5.9	NUCLEAR RD. & COUNTY RD. B
23	345	2.7	LAKE SHORE RD.
24	219	1.3	COUNTY RD. BB & RADAJACK LANE
25	247	1.4	WOODSIDE AVE.
26	263	1.3	WOODSIDE AVE.
27	290	1.4	WOODSIDE AVE.
28	320	1.3	SANDY BAY RD.
29	342	1.1	SANDY BAY RD. & HWY. 42
30	329	0.6	HWY. 42
31	13	1.0	SANDY BAY RD. & CEMETERY RD.
32	353	2.1	HWY. 42 & LAKE SHORE RD./COUNTY RD. G
33	301	3.9	COUNTY RD. G
34	299	8.4	HWY. 163
35	323	3.8	TOWN HALL RD.
36	336	3.3	OLD SETTLER RD. & WOODSIDE AVE.
37	6	3.1	OLD SETTLER RD.
38	14	3.7	LAKE SHORE RD. & LAKE RD.
39	13	7.6	HWY. 42
40	247	4.3	ASPEN RD. & SAXONBURG RD.
41	8	23.0	UWC - HWY. 42
42	8	23.0	UWC - HWY. 42
43	8	23.0	UWC - HWY. 42

NRC TLD DOSES FOR KEWAUNEE AREA

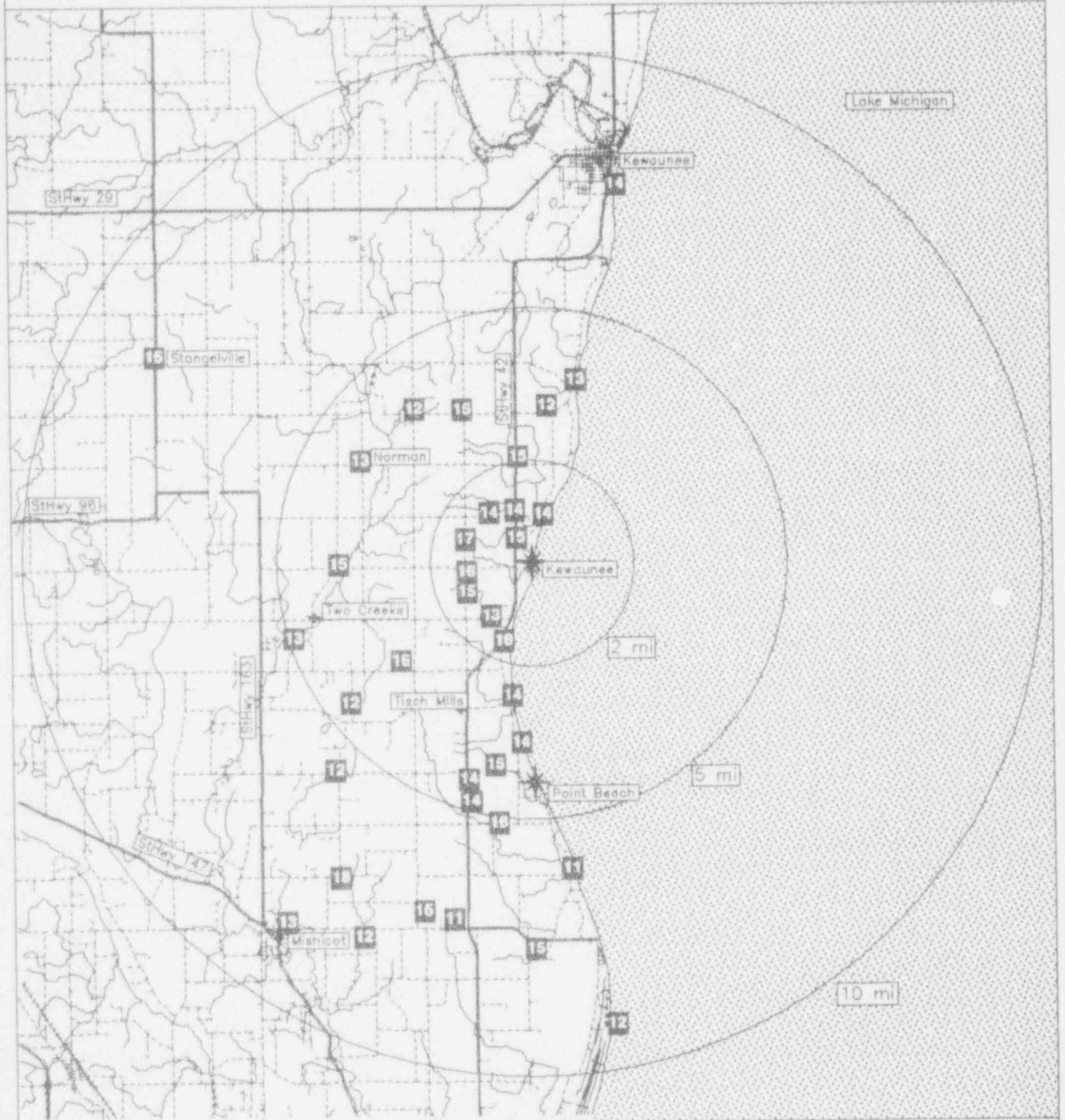

Miles

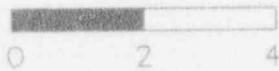

Legend



Water

Highways

Railroads

Roads



Plant site

LACROSSE

TLD Direct Radiation Environmental Monitoring

For the period 930914-940203 143 Days

Field Time: 92 Days

NRC Sta	Location		Gross Exposure (mR)		Net Exposure Rate (mR/Std. Qtr.)		Hist. Range Net Exp Rate	
	Azimuth/Dist (Deg)/(Mi)		+Rdm; Tot.		+Rdm; Tot.	+Rdm; Tot.	+1 Std Dev	-1 Std Dev
1	5	20.0	20.6	+ 0.6; 3.1	13.2	+ 0.7; 4.4	15.0	+ 1.9
2	5	20.0	21.9	+ 0.7; 3.3	14.4	+ 0.8; 4.6	15.2	+ 1.6
3	3	20.0	23.2	+ 0.7; 3.5	15.7	+ 0.8; 4.7	15.7	+ 1.5
4	343	3.8	20.9	+ 0.6; 3.1	13.4	+ 0.8; 4.4	15.1	+ 1.6
5	313	3.8	23.6	+ 0.7; 3.5	16.1	+ 0.8; 4.7	17.4	+ 2.8
6	291	3.0	22.4	+ 0.7; 3.4	14.8	+ 0.8; 4.6	16.2	+ 1.5
7	261	4.8	23.8	+ 0.7; 3.6	16.2	+ 0.8; 4.7	17.7	+ 1.7
8	249	3.2	23.1	+ 0.7; 3.5	15.6	+ 0.8; 4.7	17.5	+ 1.8
9	214	5.0	27.4	+ 0.8; 4.1	19.8	+ 0.9; 5.2	15.7	+ 1.7
10	171	9.8	21.9	+ 0.7; 3.3	14.3	+ 0.8; 4.5	14.3	+ 1.4
11	176	5.1	21.9	+ 0.7; 3.3	14.4	+ 0.8; 4.6	14.8	+ 1.1
12	165	4.9	24.1	+ 0.7; 3.6	16.6	+ 0.8; 4.8	16.3	+ 1.4
13	138	3.5	24.1	+ 0.7; 3.6	16.6	+ 0.8; 4.8	16.6	+ 1.7
14	114	4.2	24.2	+ 0.7; 3.6	16.7	+ 0.8; 4.8	15.5	+ 1.5
15	97	3.9	21.9	+ 0.7; 3.3	14.4	+ 0.8; 4.5	14.8	+ 1.0
16	94	3.0	23.2	+ 0.7; 3.5	15.7	+ 0.8; 4.7	16.8	+ 1.7
17	105	2.0	20.6	+ 0.6; 3.1	13.1	+ 0.7; 4.4	17.0	+ 2.0
18	52	1.5	20.9	+ 0.6; 3.1	13.4	+ 0.8; 4.4	14.4	+ 1.5
19	16	1.5	22.6	+ 0.7; 3.4	15.0	+ 0.8; 4.6	14.7	+ 1.3
20	1	1.0	19.6	+ 0.6; 2.9	12.1	+ 0.7; 4.3	13.9	+ 1.3
21	358	0.5	23.6	+ 0.7; 3.5	16.1	+ 0.8; 4.7	17.3	+ 1.4
22	180	0.6	24.8	+ 0.7; 3.7	17.2	+ 0.8; 4.9	16.3	+ 1.4
23	134	1.7	21.2	+ 0.6; 3.2	13.7	+ 0.8; 4.5	16.8	+ 1.5
24	58	0.6	25.2	+ 0.8; 3.8	17.6	+ 0.9; 4.9	17.4	+ 1.8
25	59	3.1	22.9	+ 0.7; 3.4	15.4	+ 0.8; 4.7	17.5	+ 1.6
26	16	1.5	23.9	+ 0.7; 3.6	16.4	+ 0.8; 4.8	16.6	+ 1.7
27	26	5.1	21.4	+ 0.6; 3.2	13.9	+ 0.8; 4.5	15.5	+ 1.3
28	25	7.0	24.0	+ 0.7; 3.6	16.4	+ 0.8; 4.8	14.2	+ 1.7
29	4	4.8	23.2	+ 0.7; 3.5	15.7	+ 0.8; 4.7	16.1	+ 1.7

Transit Dose = 7.2 +- 0.4; 3.3

LACROSSE

For the period 930914-940203

TLD Direct Radiation Environmental Monitoring

Azimuth (degrees)	Ave. Exposure Rate (mR/Std.Qtr.) +- Std.Dev.	Number In Group
348.76 - 11.25 N	14.6 +- 2.2	3
11.26 - 33.75 NNE	15.4 +- 1.2	4
33.76 - 56.25 NE	13.4 +- 0.0	1
56.26 - 78.75 ENE	16.5 +- 1.6	2
78.76 - 101.25 E	15.0 +- 0.9	2
101.26 - 123.75 ESE	14.9 +- 2.5	2
123.76 - 146.25 SE	15.1 +- 2.0	2
146.26 - 168.75 SSE	16.6 +- 0.0	1
168.76 - 191.25 S	15.3 +- 1.6	3
191.26 - 213.75 SSW	No Data +- No Data	0
213.76 - 236.25 SW	19.8 +- 0.0	1
236.26 - 258.75 WSW	15.6 +- 0.0	1
258.76 - 281.25 W	16.2 +- 0.0	1
281.26 - 303.75 WNW	14.8 +- 0.0	1
303.76 - 326.25 NW	16.1 +- 0.0	1
326.26 - 348.75 NNW	13.4 +- 0.0	1

Distance From Reactor (miles)	Ave. Exposure Rate (mR/Std.Qtr.) +- Std.Dev.	Number In Group
0 - 2	15.0 +- 2.0	9
2 - 5	15.9 +- 1.5	13
> 5	14.8 +- 1.1	4
Upwind Control	14.4 +- 1.3	3

LACROSSE
TLD Direct Radiation Environmental Monitoring

NRC Station	Location		Description
	Azimuth / Degree	Distance / Mile	
1	5	20.0	STATE OFFICE BLDG.
2	5	20.0	STATE OFFICE BLDG.
3	3	20.0	ST. DOMINIC'S MONASTERY
4	343	3.8	BROWNSVILLE
5	313	3.8	RENO - HWY. 26 (POLE #BC1B94)
6	291	3.0	TREE ACROSS FROM STOP SIGN
7	261	4.8	HOUSTON CTY. RD. 14
8	249	3.2	RR NEXT TO HWY. 26
9	214	5.0	NEW ALBIN (LEFT OF HWY. 26)
10	171	9.8	DESOTO (WI)
11	176	5.1	VICTORY
12	165	4.9	COUNTY RD.
13	138	3.5	BAD AXE RD.
14	114	4.2	WARREN RD.
15	97	3.9	CREEK RD.
16	94	3.0	HWY. 56 (S. SIDE)
17	105	2.0	MOUND RIDGE RD.
18	52	1.5	HWY. 56 (TRUCK HILL SIGN)
19	16	1.5	HWY. 56 & COUNTY K RD.
20	1	1.0	GENOA
21	358	0.5	LOCK & DAM #8
22	180	0.6	HWY 35
23	134	1.7	PEDRETTI FARM
24	58	0.6	MALIN FARM
25	59	3.1	COUNTY K (LEFT SIDE)
26	16	1.5	COUNTY O RD.
27	26	5.1	BIRCHLAWN FARM
28	25	7.0	THUNDER COULEE
29	4	4.8	HWY. 35 AT WAYSIDE

NRC TLD DOSES FOR LACROSSE AREA

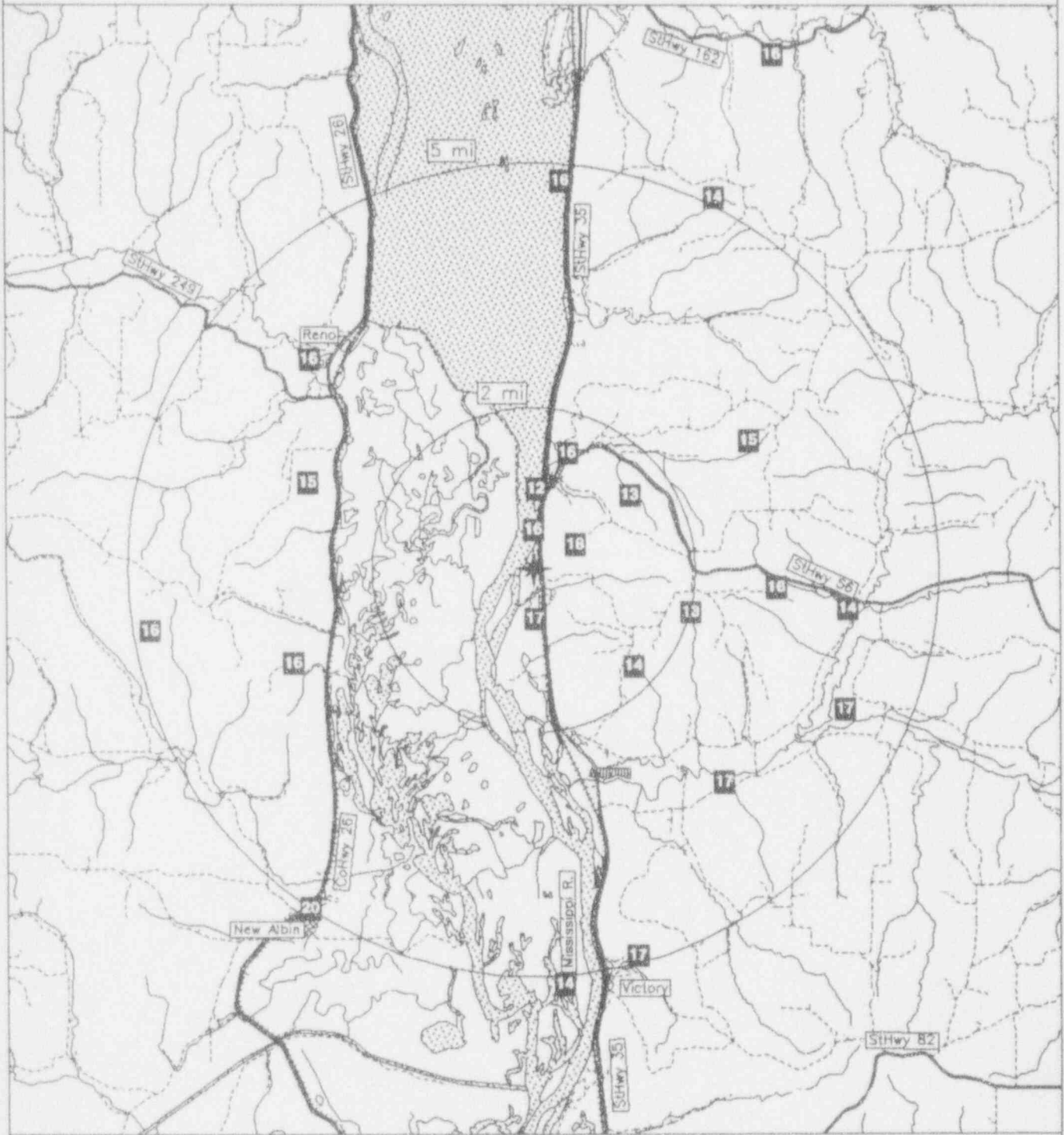

Miles

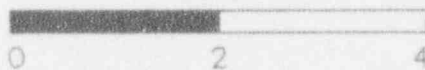

Legend

- Water
- Highways
- Railroads
- Roads
- Plant..site

LASALLE

TLD Direct Radiation Environmental Monitoring

For the period 930914-940201 141 Days

Field Time: 100 Days

NRC Sta	Location		Gross	Net Exposure Rate	Hist. Range
	Azimuth/Dist (Deg)/(Mi)		Exposure (mR) +-Rdm; Tot.	(mR/Std. Qtr.) +-Rdm; Tot.	Net Exp Rate +-1 Std Dev
1	302	10.0	20.8 +- 0.6; 3.1	15.8 +- 0.6; 4.0	17.2 +- 1.2
2	335	5.3	24.8 +- 0.7; 3.7	19.4 +- 0.7; 4.4	19.6 +- 1.6
3	343	5.8	21.1 +- 0.6; 3.2	16.1 +- 0.6; 4.0	15.6 +- 1.3
4	38	5.5	25.9 +- 0.8; 3.9	20.3 +- 0.8; 4.5	18.8 +- 2.5
5	39	4.3	19.4 +- 0.6; 2.9	14.5 +- 0.6; 3.9	14.6 +- 1.2
6	27	3.8	22.3 +- 0.7; 3.3	17.1 +- 0.7; 4.1	17.2 +- 1.3
7	2	4.1	24.8 +- 0.7; 3.7	19.4 +- 0.7; 4.4	19.5 +- 1.4
8	304	4.6	24.5 +- 0.7; 3.7	19.1 +- 0.7; 4.4	19.1 +- 1.5
9	292	3.9	21.7 +- 0.7; 3.3	16.6 +- 0.7; 4.1	19.4 +- 2.7
10	281	3.7	26.0 +- 0.8; 3.9	20.4 +- 0.8; 4.5	18.9 +- 1.8
11	248	4.0	23.7 +- 0.7; 3.6	18.4 +- 0.7; 4.3	18.3 +- 1.3
12	222	12.0	22.9 +- 0.7; 3.4	17.6 +- 0.7; 4.2	17.5 +- 1.2
13	212	18.0	23.3 +- 0.7; 3.5	18.1 +- 0.7; 4.2	18.2 +- 1.2
14	212	18.0	23.7 +- 0.7; 3.6	18.4 +- 0.7; 4.3	18.8 +- 1.3
15	212	18.0	24.3 +- 0.7; 3.6	18.9 +- 0.7; 4.3	18.6 +- 1.5
16	215	4.4	24.8 +- 0.7; 3.7	19.4 +- 0.7; 4.4	19.7 +- 1.2
17	204	4.0	25.0 +- 0.7; 3.7	19.5 +- 0.7; 4.4	19.0 +- 1.3
18	173	4.6	23.8 +- 0.7; 3.6	18.5 +- 0.7; 4.3	19.4 +- 1.3
19	174	6.4	22.0 +- 0.7; 3.3	16.8 +- 0.7; 4.1	17.1 +- 1.1
20	158	3.6	23.0 +- 0.7; 3.5	17.8 +- 0.7; 4.2	18.6 +- 1.4
21	124	4.2	23.8 +- 0.7; 3.6	18.5 +- 0.7; 4.3	19.3 +- 1.7
22	114	3.8	24.0 +- 0.7; 3.6	18.6 +- 0.7; 4.3	18.7 +- 1.2
23	97	4.5	23.8 +- 0.7; 3.6	18.5 +- 0.7; 4.3	18.0 +- 1.4
24	72	4.7	25.4 +- 0.8; 3.8	19.9 +- 0.8; 4.5	19.7 +- 1.5
25	41	2.0	24.7 +- 0.7; 3.7	19.3 +- 0.7; 4.4	18.8 +- 1.4
26	11	1.6	23.8 +- 0.7; 3.6	18.5 +- 0.7; 4.3	18.5 +- 1.3
27	358	1.5	23.4 +- 0.7; 3.5	18.1 +- 0.7; 4.3	19.3 +- 1.2
28	336	1.6	22.9 +- 0.7; 3.4	17.7 +- 0.7; 4.2	18.2 +- 1.3
29	310	2.3	22.9 +- 0.7; 3.4	17.7 +- 0.7; 4.2	17.5 +- 1.6
30	301	2.0	26.8 +- 0.8; 4.0	21.2 +- 0.8; 4.6	20.8 +- 1.4
31	271	1.7	24.4 +- 0.7; 3.7	19.0 +- 0.7; 4.4	18.3 +- 1.3
32	256	1.8	Damaged Dosimeter	No Net Data	19.1 +- 1.4
33	227	2.4	25.9 +- 0.8; 3.9	20.4 +- 0.8; 4.5	20.3 +- 1.5
34	204	1.7	24.6 +- 0.7; 3.7	19.2 +- 0.7; 4.4	18.6 +- 1.3
35	165	1.6	27.4 +- 0.8; 4.1	21.7 +- 0.8; 4.7	19.2 +- 2.0
36	149	1.8	26.3 +- 0.8; 3.9	20.7 +- 0.8; 4.5	19.5 +- 1.4
37	139	2.1	24.0 +- 0.7; 3.6	18.6 +- 0.7; 4.3	18.8 +- 1.2
38	111	1.5	21.6 +- 0.6; 3.2	16.5 +- 0.7; 4.1	16.8 +- 1.2
39	265	0.6	25.9 +- 0.8; 3.9	20.3 +- 0.8; 4.5	19.7 +- 1.6

Transit Dose = 3.3 +- 0.3; 3.2

LASALLE

For the period 930914-940201

TLD Direct Radiation Environmental Monitoring

Azimuth (degrees)	Ave. Exposure Rate (mR/Std.Qtr.) +- Std.Dev.	Number In Group
348.76 - 11.25 N	18.7 +- 0.6	3
11.26 - 33.75 NNE	17.1 +- 0.0	1
33.76 - 56.25 NE	18.0 +- 3.1	3
56.26 - 78.75 ENE	19.9 +- 0.0	1
78.76 - 101.25 E	18.5 +- 0.0	1
101.26 - 123.75 ESE	17.6 +- 1.5	2
123.76 - 146.25 SE	18.5 +- 0.1	2
146.26 - 168.75 SSE	20.1 +- 2.0	3
168.76 - 191.25 S	17.6 +- 1.2	2
191.26 - 213.75 SSW	19.4 +- 0.3	2
213.76 - 236.25 SW	19.1 +- 1.4	3
236.26 - 258.75 WSW	18.4 +- 0.0	1
258.76 - 281.25 W	19.9 +- 0.8	3
281.26 - 303.75 WNW	17.8 +- 2.9	3
303.76 - 326.25 NW	18.4 +- 1.0	2
326.26 - 348.75 NNW	17.7 +- 1.6	3

Distance From Reactor (miles)	Ave. Exposure Rate (mR/Std.Qtr.) +- Std.Dev.	Number In Group
0 - 2	19.3 +- 1.6	11
2 - 5	18.5 +- 1.4	18
> 5	17.7 +- 1.8	6
Upwind Control	18.4 +- 0.4	3

LASALLE
TLD Direct Radiation Environmental Monitoring

NRC Station	Location		Description
	Azimuth / Degree	Distance / Mile	
1	302	10.0	MCKINLEY & CATHERINE STRS. (OTTAWA)
2	335	5.3	E 22 RD. (CTY. 15) N2653/E2350
3	343	5.8	AURORA ST. & WALLACE ST. (MARSEILLES)
4	38	5.5	OAK ST. (SENECA)
5	39	4.3	N. 2553 RD. (CTY 36)
6	27	3.8	N. 2553 RD. (CTY 36)
7	2	4.1	N. 2553 RD. (CTY 36)
8	304	4.6	N. 24 & E. 22 RD.
9	292	3.9	N. 23 & E. 22 RD.
10	281	3.7	N. 22 & E. 22 RD.
11	248	4.0	N. 20 & E. 22 RD.
12	222	12.0	ILLINOIS ST. (STREATOR)
13	212	18.0	HWY. 23
14	212	18.0	HWY. 23
15	212	18.0	2650N/500E
16	215	4.4	N. 18 RD.
17	204	4.0	N. 18 & E. 24 RD.
18	173	4.6	N. 17 RD.
19	174	6.4	PLUMB ST. & MORTON ST. (RANSOM)
20	158	3.6	N. 18 & E. 27 RD.
21	124	4.2	HWY. 170
22	114	3.8	HWY. 170 & N. 20 RD.
23	97	4.5	N. 21 & E. 30 RD.
24	72	4.7	N. 23 ST. & E. 30 RD.
25	41	2.0	N. 23 RD.
26	11	1.6	N23 / E2609
27	358	1.5	N. 23 RD.
28	336	1.6	E. 25 & N. 23 RD.
29	310	2.3	E. 24 & N. 23 RD.
30	301	2.0	E. 24 RD.
31	271	1.7	E. 24 RD.
32	256	1.8	N. 21 & E. 24 RD.
33	227	2.4	N. 20 & E. 24 RD.
34	204	1.7	N. 20 & E. 25 RD.
35	165	1.6	N. 20 & E. 26 RD.
36	149	1.8	N. 20 RD.
37	139	2.1	E. 27 & N. 20 RD.
38	111	1.5	N. 21 & E. 27 RD.
39	265	0.6	E. 25 RD.

NRC TLD DOSES FOR LASALLE AREA

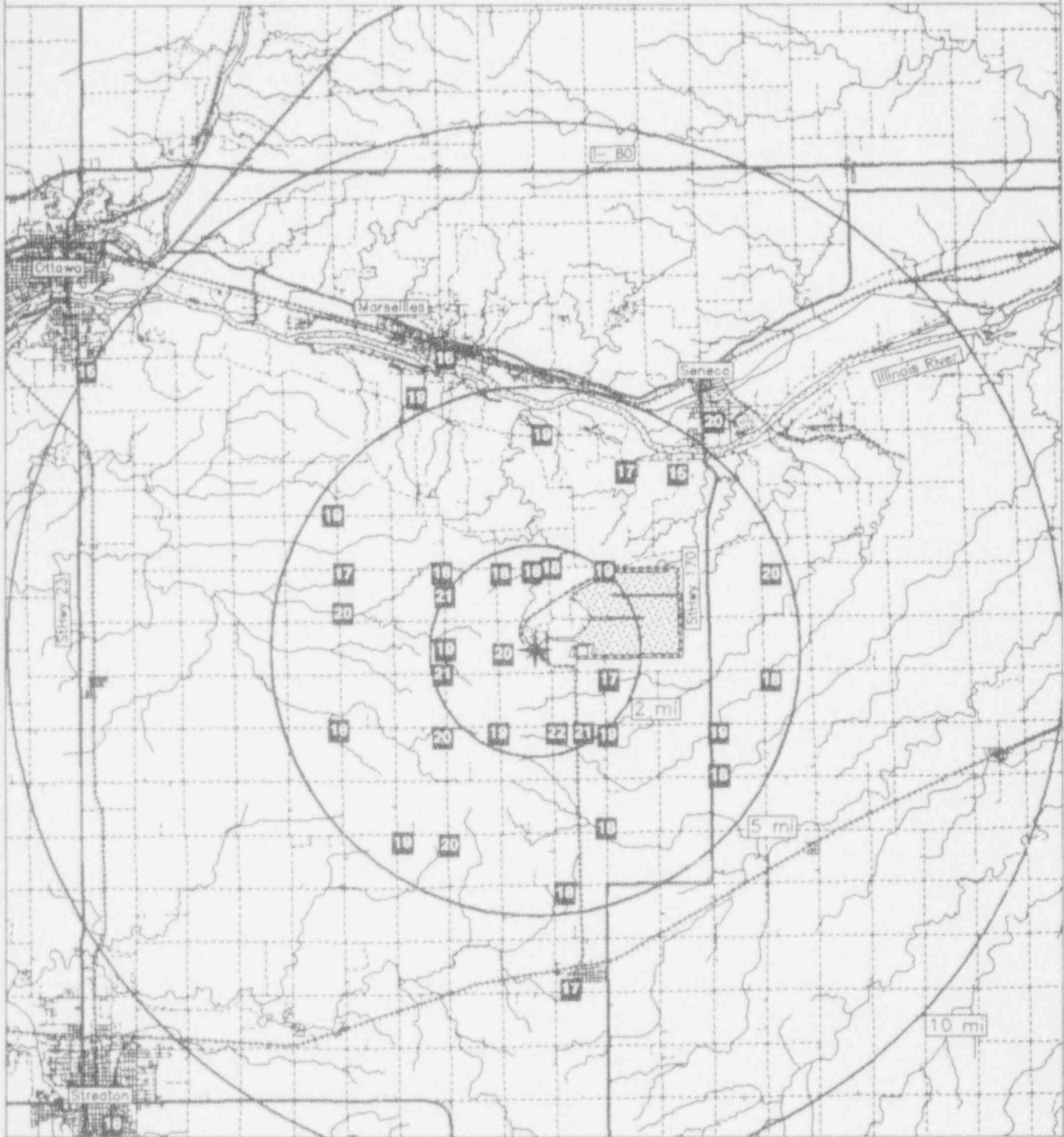

Miles

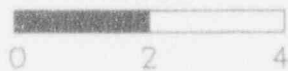

Legend

-  Water
-  Railroads
-  Plant site
-  Highways
-  Roads

LIMERICK

TLD Direct Radiation Environmental Monitoring

For the period 930915-940127 135 Days

Field Time: 92 Days

NRC Sta	Location		Gross	Net Exposure Rate	Hist. Range
	Azimuth/Dist (Deg)/(Mi)		Exposure (mR) +-Rdm; Tot.	(mR/Std. Qtr.) +-Rdm; Tot.	Net Exp Rate +-1 Std Dev
1	115	8.5	26.7 +- 0.8; 4.0	22.9 +- 0.8; 4.9	23.1 +- 1.8
3	85	3.7	22.0 +- 0.7; 3.3	18.3 +- 0.7; 4.3	19.1 +- 1.4
4	46	3.3	23.1 +- 0.7; 3.5	19.4 +- 0.7; 4.4	19.7 +- 1.6
5	20	3.7	23.2 +- 0.7; 3.5	19.5 +- 0.8; 4.5	19.6 +- 1.6
6	7	4.6	23.0 +- 0.7; 3.4	19.3 +- 0.7; 4.4	20.5 +- 1.5
7	340	7.2	21.1 +- 0.6; 3.2	17.4 +- 0.7; 4.2	18.2 +- 1.9
8	332	4.0	22.4 +- 0.7; 3.4	18.7 +- 0.7; 4.4	19.2 +- 1.5
9	313	3.4	22.8 +- 0.7; 3.4	19.1 +- 0.7; 4.4	19.4 +- 1.7
10	291	4.9	23.4 +- 0.7; 3.5	19.7 +- 0.8; 4.5	20.8 +- 1.7
11	304	3.0	28.0 +- 0.8; 4.2	24.2 +- 0.9; 5.0	24.6 +- 1.7
12	316	1.9	21.6 +- 0.6; 3.2	17.9 +- 0.7; 4.3	18.4 +- 1.6
13	347	1.9	23.7 +- 0.7; 3.6	19.9 +- 0.8; 4.5	20.6 +- 1.6
14	339	1.5	20.9 +- 0.6; 3.1	17.3 +- 0.7; 4.2	17.5 +- 1.4
15	41	1.7	21.4 +- 0.6; 3.2	17.7 +- 0.7; 4.3	18.6 +- 1.6
16	66	2.6	21.1 +- 0.6; 3.2	17.4 +- 0.7; 4.2	19.6 +- 1.6
17	5	0.6	20.7 +- 0.6; 3.1	17.0 +- 0.7; 4.2	18.8 +- 1.8
18	300	0.7	23.5 +- 0.7; 3.5	19.7 +- 0.8; 4.5	18.9 +- 1.9
19	291	0.7	21.5 +- 0.6; 3.2	17.8 +- 0.7; 4.3	18.6 +- 1.7
20	260	0.7	21.6 +- 0.6; 3.2	17.9 +- 0.7; 4.3	18.2 +- 1.6
21	234	0.9	21.6 +- 0.6; 3.2	17.9 +- 0.7; 4.3	18.5 +- 1.7
22	210	1.1	22.5 +- 0.7; 3.4	18.8 +- 0.7; 4.4	19.2 +- 1.4
23	174	1.7	21.1 +- 0.6; 3.2	17.4 +- 0.7; 4.2	17.2 +- 1.4
24	149	1.5	22.0 +- 0.7; 3.3	18.3 +- 0.7; 4.3	17.6 +- 1.7
25	124	1.0	23.1 +- 0.7; 3.5	19.4 +- 0.7; 4.4	19.9 +- 1.6
26	114	1.1	22.2 +- 0.7; 3.3	18.5 +- 0.7; 4.3	20.2 +- 1.7
27	160	1.0	22.5 +- 0.7; 3.4	18.8 +- 0.7; 4.4	19.2 +- 1.5
28	81	1.0	21.5 +- 0.6; 3.2	17.8 +- 0.7; 4.3	18.7 +- 1.8
29	51	0.7	22.9 +- 0.7; 3.4	19.2 +- 0.7; 4.4	19.1 +- 1.6
30	144	3.2	25.6 +- 0.8; 3.8	21.8 +- 0.8; 4.7	22.5 +- 1.8
31	158	2.6	21.9 +- 0.7; 3.3	18.2 +- 0.7; 4.3	19.3 +- 2.2
32	153	7.3	21.7 +- 0.7; 3.3	18.1 +- 0.7; 4.3	17.9 +- 1.6
33	186	4.2	21.0 +- 0.6; 3.1	17.3 +- 0.7; 4.2	17.1 +- 1.7
34	194	3.8	19.7 +- 0.6; 3.0	16.1 +- 0.7; 4.1	17.2 +- 1.6
35	229	5.1	23.0 +- 0.7; 3.4	19.3 +- 0.7; 4.4	18.9 +- 1.6
36	251	4.1	24.7 +- 0.7; 3.7	21.0 +- 0.8; 4.6	19.1 +- 1.9
37	270	3.0	19.9 +- 0.6; 3.0	16.2 +- 0.7; 4.1	15.9 +- 1.6
38	293	11.9	23.8 +- 0.7; 3.6	20.1 +- 0.8; 4.5	20.5 +- 2.0
39	293	11.9	23.9 +- 0.7; 3.6	20.1 +- 0.8; 4.5	20.5 +- 1.8
40	293	11.9	24.2 +- 0.7; 3.6	20.5 +- 0.8; 4.6	21.0 +- 1.7
41	126	2.9	20.1 +- 0.6; 3.0	16.4 +- 0.7; 4.1	16.2 +- 1.7
42	111	4.3	22.6 +- 0.7; 3.4	18.9 +- 0.7; 4.4	19.1 +- 1.8

Transit Dose = 3.3 +- 0.3; 2.9

LIMERICK

For the period 930915-940127

TLD Direct Radiation Environmental Monitoring

Azimuth (degrees)	Ave. Exposure Rate (mR/Std.Qtr.) +- Std.Dev.	Number In Group
348.76 - 11.25 N	18.1 +- 1.6	2
11.26 - 33.75 NNE	19.5 +- 0.0	1
33.76 - 56.25 NE	18.8 +- 0.9	3
56.26 - 78.75 ENE	17.4 +- 0.0	1
78.76 - 101.25 E	18.1 +- 0.4	2
101.26 - 123.75 ESE	20.1 +- 2.5	3
123.76 - 146.25 SE	19.2 +- 2.7	3
146.26 - 168.75 SSE	18.3 +- 0.3	4
168.76 - 191.25 S	17.3 +- 0.1	2
191.26 - 213.75 SSW	17.5 +- 2.0	2
213.76 - 236.25 SW	18.6 +- 1.0	2
236.26 - 258.75 WSW	21.0 +- 0.0	1
258.76 - 281.25 W	17.1 +- 1.2	2
281.26 - 303.75 WNW	19.1 +- 1.1	3
303.76 - 326.25 NW	20.4 +- 3.3	3
326.26 - 348.75 NNW	18.3 +- 1.2	4

Distance From Reactor (miles)	Ave. Exposure Rate (mR/Std.Qtr.) +- Std.Dev.	Number In Group
0 - 2	18.3 +- 0.9	17
2 - 5	18.9 +- 2.1	17
> 5	19.4 +- 2.5	4
Upwind Control	20.2 +- 0.2	3

LIMERICK
TLD Direct Radiation Environmental Monitoring

NRC Station	Location		Description
	Azimuth / Degree	Distance / Mile	
1	115	8.5	YERKES ROAD
3	85	3.7	ARROW CAMERA SHOP
4	46	3.3	HOFFMAN NURSERY
5	20	3.7	SWAMP PIKE & FAUST ROAD
6	7	4.6	SWAMP PIKE & ROMIG ROAD
7	340	7.2	SOUTH MADISON STREET
8	332	4.0	SMITH RESIDENCE
9	313	3.4	NORTH END FIRE CO.
10	291	4.9	PRINCE STREET
11	304	3.0	LINCOLN SUBSTATION
12	316	1.9	POTTSTOWN MEDICAL CTR.
13	347	1.9	POTTSGROVE ELEM. SCH.
14	339	1.5	SANATOGA FIRE CO.
15	41	1.7	SAWCHUCK'S GARAGE
16	66	2.6	LIMERICK TWP.MUNICIPAL BLDG.
17	5	0.6	SANATOGA & EVERGREEN RDS.
18	300	0.7	GOWEN RESIDENCE
19	291	0.7	SANATOGA RD. R.R. TRACKS
20	260	0.7	EASTERN WAREHOUSES
21	234	0.9	SANATOGA ROAD
22	210	1.1	WUNDERLICH'S GARAGE
23	174	1.7	PA724 & LINFIELD ROAD
24	149	1.5	MINI MART
25	124	1.0	LIMERICK CENTER ROAD
26	114	1.1	BROWNBACK ROAD
27	160	1.0	LONGVIEW ROAD
28	81	1.0	EVANS CREEK
29	51	0.7	BESSE BELLE FARM
30	144	3.2	PENNHURST SCHOOL ENTRANCE
31	158	2.6	PENNHURST RESERVOIR
32	153	7.3	WHEATLAND SUBSTATION
33	186	4.2	SEVEN STARS INN
34	194	3.8	RIDGE FIRE COMPANY
35	229	5.1	RIDGE RESTAURANT
36	251	4.1	DRIVING RANGE
37	270	3.0	CEDARVILLE ROAD
38	293	11.9	DANIEL BOONE HOMESTEAD
39	293	11.9	DANIEL BOONE HOMESTEAD
40	293	11.9	DANIEL BOONE HOMESTEAD
41	126	2.9	STECKEL RESIDENCE
42	111	4.3	MINGO CHURCH

NRC TLD DOSES FOR LIMERICK AREA

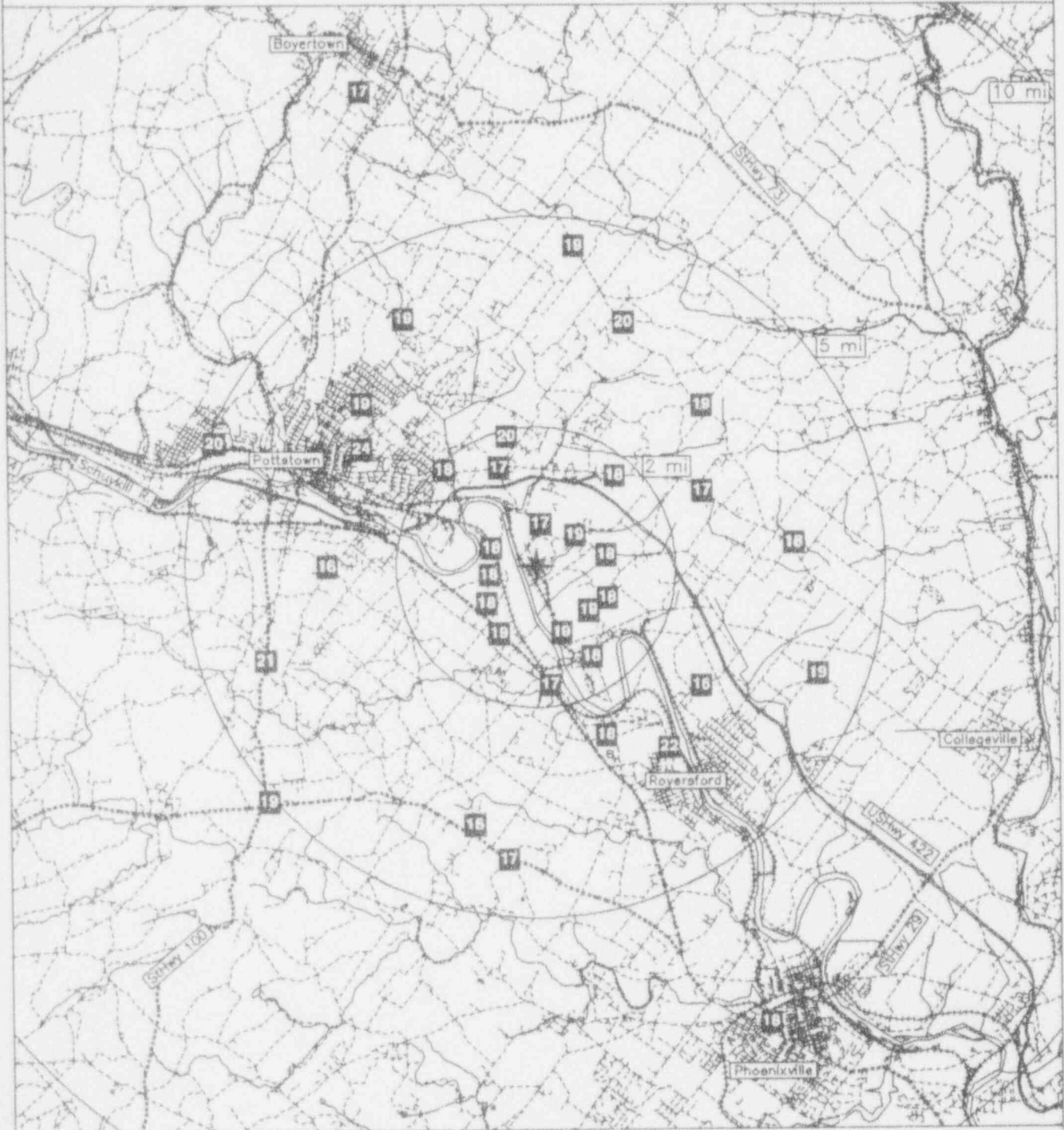

Miles

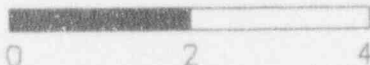

Legend

- Water
- Highways
- Railroads
- Roads
- Plant site

MAINE YANKEE

TLD Direct Radiation Environmental Monitoring

For the period 930915-940215 154 Days

Field Time: 99 Days

NRC Sta	Location		Gross Exposure (mR)		Net Exposure Rate (mR/Std. Qtr.)		Hist. Range Net Exp Rate	
	Azimuth/ (Deg)	Dist (Mi)	+Rdm	Tot.	+Rdm	Tot.	+1 Std Dev	-1 Std Dev
1	340	1.0	27.3	+ 0.8; 4.1	21.3	+ 0.8; 4.7	18.8	+ 2.2
2	6	1.4	25.9	+ 0.8; 3.9	20.0	+ 0.8; 4.6	17.8	+ 2.5
3	23	1.5	25.2	+ 0.8; 3.8	19.4	+ 0.8; 4.5	17.4	+ 2.0
4	44	1.8	24.5	+ 0.7; 3.7	18.8	+ 0.7; 4.4	17.3	+ 2.6
5	116	0.5	24.5	+ 0.7; 3.7	18.8	+ 0.7; 4.4	17.3	+ 2.4
6	168	1.0	27.0	+ 0.8; 4.0	21.0	+ 0.8; 4.7	18.1	+ 2.2
7	185	1.6	25.7	+ 0.8; 3.9	19.9	+ 0.8; 4.5	16.8	+ 1.8
8	195	2.3	26.6	+ 0.8; 4.0	20.7	+ 0.8; 4.6	17.7	+ 2.4
9	209	3.8	26.3	+ 0.8; 3.9	20.4	+ 0.8; 4.6	17.2	+ 2.1
10	310	1.7	25.4	+ 0.8; 3.8	19.5	+ 0.8; 4.5	17.3	+ 2.5
11	290	1.8	29.1	+ 0.9; 4.4	22.9	+ 0.9; 4.9	19.8	+ 2.8
12	275	1.7	28.0	+ 0.8; 4.2	22.0	+ 0.8; 4.8	18.9	+ 2.3
13	256	1.9	27.1	+ 0.8; 4.1	21.1	+ 0.8; 4.7	17.5	+ 2.5
14	232	2.5	27.9	+ 0.8; 4.2	21.8	+ 0.8; 4.8	18.5	+ 1.6
15	227	5.3	28.1	+ 0.8; 4.2	22.0	+ 0.8; 4.8	18.3	+ 2.5
16	246	4.4	29.1	+ 0.9; 4.4	22.9	+ 0.9; 4.9	19.5	+ 2.4
17	250	6.6	33.0	+ 1.0; 5.0	26.5	+ 1.0; 5.4	23.6	+ 2.2
18	268	4.7	27.9	+ 0.8; 4.2	21.9	+ 0.8; 4.8	18.5	+ 2.3
19	283	4.4	26.8	+ 0.8; 4.0	20.8	+ 0.8; 4.7	17.9	+ 1.6
20	305	4.7	25.5	+ 0.8; 3.8	19.7	+ 0.8; 4.5	17.7	+ 2.8
21	300	2.9	25.8	+ 0.8; 3.9	19.9	+ 0.8; 4.6	18.3	+ 2.5
22	332	2.7	26.9	+ 0.8; 4.0	20.9	+ 0.8; 4.7	19.2	+ 2.8
23	20	3.9	28.3	+ 0.8; 4.2	22.2	+ 0.8; 4.8	18.8	+ 2.6
24	23	3.0	27.4	+ 0.8; 4.1	21.4	+ 0.8; 4.7	19.2	+ 2.6
25	42	4.7	28.3	+ 0.8; 4.2	22.2	+ 0.8; 4.8	18.8	+ 2.4
26	60	15.0	26.2	+ 0.8; 3.9	20.3	+ 0.8; 4.6	17.2	+ 2.5
27	62	16.0	19.5	+ 0.6; 2.9	14.2	+ 0.6; 3.9	16.1	+ 2.1
28	63	16.0	25.8	+ 0.8; 3.9	19.9	+ 0.8; 4.6	17.4	+ 2.2
29	64	2.1	28.5	+ 0.9; 4.3	22.4	+ 0.8; 4.8	20.1	+ 2.8
30	84	1.5	23.9	+ 0.7; 3.6	18.2	+ 0.7; 4.4	16.9	+ 2.0
31	115	1.6	23.2	+ 0.7; 3.5	17.6	+ 0.7; 4.3	17.2	+ 2.4
32	135	2.0	23.7	+ 0.7; 3.6	18.0	+ 0.7; 4.3	16.4	+ 2.1
33	66	3.5	26.3	+ 0.8; 3.9	20.3	+ 0.8; 4.6	17.7	+ 2.4
34	97	4.9	27.1	+ 0.8; 4.1	21.1	+ 0.8; 4.7	18.5	+ 2.0
35	123	4.8	27.9	+ 0.8; 4.2	21.8	+ 0.8; 4.8	18.7	+ 1.9
36	140	4.9	25.1	+ 0.8; 3.8	19.3	+ 0.8; 4.5	17.7	+ 3.0
37	151	6.0	28.0	+ 0.8; 4.2	21.9	+ 0.8; 4.8	18.6	+ 2.5
38	152	4.2	28.2	+ 0.8; 4.2	22.1	+ 0.8; 4.8	19.3	+ 2.2
39	172	4.9	26.6	+ 0.8; 4.0	20.6	+ 0.8; 4.6	17.5	+ 1.9
40	156	7.4	25.1	+ 0.8; 3.8	19.3	+ 0.8; 4.5	18.1	+ 2.0

Transit Dose = 3.9 +- 0.4; 3.2

MAINE YANKEE
For the period 930915-940215

TLD Direct Radiation Environmental Monitoring

Azimuth (degrees)	Ave. Exposure Rate (mR/Std.Qtr.) +- Std.Dev.	Number In Group
348.76 - 11.25 N	20.0 +- 0.0	1
11.26 - 33.75 NNE	21.0 +- 1.5	3
33.76 - 56.25 NE	20.5 +- 2.4	2
56.26 - 78.75 ENE	21.4 +- 1.5	2
78.76 - 101.25 E	19.6 +- 2.1	2
101.26 - 123.75 ESE	19.4 +- 2.2	3
123.76 - 146.25 SE	18.7 +- 0.9	2
146.26 - 168.75 SSE	21.1 +- 1.3	4
168.76 - 191.25 S	20.2 +- 0.5	2
191.26 - 213.75 SSW	20.5 +- 0.2	2
213.76 - 236.25 SW	21.9 +- 0.1	2
236.26 - 258.75 WSW	23.5 +- 2.7	3
258.76 - 281.25 W	21.9 +- 0.1	2
281.26 - 303.75 WNW	21.2 +- 1.5	3
303.76 - 326.25 NW	19.6 +- 0.1	2
326.26 - 348.75 NNW	21.1 +- 0.3	2

Distance From Reactor (miles)	Ave. Exposure Rate (mR/Std.Qtr.) +- Std.Dev.	Number In Group
0 - 2	19.9 +- 1.6	14
2 - 5	21.2 +- 1.0	19
> 5	22.4 +- 3.0	4
Upwind Control	18.1 +- 3.4	3

MAINE YANKEE
TLD Direct Radiation Environmental Monitoring

NRC Station	Location		Description
	Azimuth / Degree	Distance / Mile	
1	340	1.0	ACCESS RD. & RT. 144
2	6	1.4	RT. 144
3	23	1.5	RT. 144
4	44	1.8	OLD RT. 144 & RT. 144
5	116	0.5	RT. 144
6	168	1.0	WEST PORT VOLUNTEER
7	185	1.6	RT. 144
8	195	2.3	BAY SHORE RD.
9	209	3.8	HARRISON'S TRAILER
10	310	1.7	MONTSWEAG BROOK
11	290	1.8	RT. 1 & MONTSWEAG RD.
12	275	1.7	MONTSWEAG RD.
13	256	1.9	MONTSWEAG RD.
14	232	2.5	MURPHY'S CORNER
15	227	5.3	HOCKOMOCK RD.
16	246	4.4	MURPHY'S CORNER RD.
17	250	6.6	BATH FIRE STATION
18	268	4.7	RT. 127
19	283	4.4	RT. 127 & OLD STAGE RD.
20	305	4.7	RT. 127 & DANA HILL RD.
21	300	2.9	OLD STAGE RD. & MEADOW RD.
22	332	2.7	OLD STAGE RD.
23	20	3.9	WISCASSET COURT HOUSE
24	23	3.0	MASON STATION
25	42	4.7	RT. 1 & RT. 27
26	60	15.0	UWC (WALDOBORO)
27	62	16.0	UWC (WALDOBORO)
28	63	16.0	UWC (WALDOBORO)
29	64	2.1	CROSS POINT RD.
30	84	1.5	CROSS POINT RD.
31	115	1.6	CROSS POINT RD. & MILL RD.
32	135	2.0	CROSS POINT RD.
33	66	3.5	EDGECOMB FIRE CO.
34	97	4.9	RIVER RD.
35	123	4.8	RIVER RD. & RT. 27
36	140	4.9	ADAMS POND RD. & DOVER RD.
37	151	6.0	INT. OF RT 27 (BACK RIVER RD) & CORREY LN
38	152	4.2	BACK RIVER RD. & GRAY RD.
39	172	4.9	BARTERS ISLAND
40	156	7.4	BOOTHBAY FIRE STATION

NRC TLD DOSES FOR MAINE YANKEE AREA



Miles

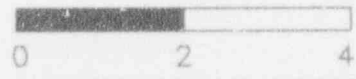

Legend

- Water
- Highways
- Railroads
- Roads
- Plant..site

MCGUIRE

TLD Direct Radiation Environmental Monitoring

For the period 930914-940201 141 Days

Field Time: 92 Days

NRC Sta	Location Azimuth/Dist (Deg)/(Mi)	Gross Exposure (mR) +-Rdm; Tot.	Net Exposure Rate (mR/Std. Qtr.) +-Rdm; Tot.	Hist. Range Net Exp Rate +-1 Std Dev	
1	97	0.5	18.6 +- 0.6; 2.8	12.1 +- 0.7; 4.2	14.5 +- 2.8
2	323	1.6	22.3 +- 0.7; 3.4	15.7 +- 0.8; 4.5	16.9 +- 2.5
3	336	1.7	23.0 +- 0.7; 3.4	16.3 +- 0.8; 4.6	18.1 +- 2.8
4	303	2.9	20.3 +- 0.6; 3.0	13.7 +- 0.7; 4.3	16.5 +- 3.5
5	321	3.9	21.0 +- 0.6; 3.2	14.4 +- 0.7; 4.4	16.5 +- 2.7
6	334	3.7	20.1 +- 0.6; 3.0	13.5 +- 0.7; 4.3	16.4 +- 2.9
7	352	3.5	17.0 +- 0.5; 2.5	10.4 +- 0.6; 4.0	14.9 +- 2.5
8	287	2.0	25.2 +- 0.8; 3.8	18.5 +- 0.8; 4.8	17.5 +- 3.4
9	273	1.9	16.8 +- 0.5; 2.5	10.3 +- 0.6; 4.0	16.1 +- 3.4
10	244	1.7	18.4 +- 0.6; 2.8	11.9 +- 0.7; 4.1	15.1 +- 2.6
11	225	2.1	16.5 +- 0.5; 2.5	10.0 +- 0.6; 4.0	14.7 +- 2.4
12	212	3.6	20.9 +- 0.6; 3.1	14.3 +- 0.7; 4.4	16.4 +- 2.6
13	232	4.4	26.4 +- 0.8; 4.0	19.6 +- 0.9; 5.0	22.0 +- 2.7
14	253	3.7	23.8 +- 0.7; 3.6	17.1 +- 0.8; 4.7	19.2 +- 3.0
15	261	4.2	19.1 +- 0.6; 2.9	12.6 +- 0.7; 4.2	15.0 +- 2.5
16	288	4.3	27.0 +- 0.8; 4.1	20.3 +- 0.9; 5.1	22.1 +- 2.7
17	288	17.0	29.4 +- 0.9; 4.4	22.6 +- 1.0; 5.3	23.8 +- 6.3
18	287	2.0	23.9 +- 0.7; 3.6	17.3 +- 0.8; 4.7	21.1 +- 3.1
19	286	17.0	23.1 +- 0.7; 3.5	16.4 +- 0.8; 4.6	22.3 +- 3.5
20	233	18.0	24.8 +- 0.7; 3.7	18.1 +- 0.8; 4.8	21.7 +- 2.8
21	204	10.0	20.3 +- 0.6; 3.0	13.7 +- 0.7; 4.3	16.1 +- 2.7
22	239	9.5	20.5 +- 0.6; 3.1	13.9 +- 0.7; 4.3	17.4 +- 2.8
23	115	4.9	16.1 +- 0.5; 2.4	9.6 +- 0.6; 3.9	13.7 +- 2.7
24	132	4.9	17.2 +- 0.5; 2.6	10.7 +- 0.6; 4.0	14.0 +- 2.6
25	156	4.0	15.5 +- 0.5; 2.3	9.0 +- 0.6; 3.9	11.9 +- 2.5
26	175	3.7	17.7 +- 0.5; 2.7	11.2 +- 0.7; 4.1	14.0 +- 2.6
27	198	4.3	24.6 +- 0.7; 3.7	18.0 +- 0.8; 4.8	19.3 +- 3.1
28	169	13.0	16.9 +- 0.5; 2.5	10.4 +- 0.6; 4.0	14.7 +- 2.8
29	155	13.0	18.6 +- 0.6; 2.8	12.1 +- 0.7; 4.2	14.3 +- 2.4
30	146	14.0	17.7 +- 0.5; 2.6	11.1 +- 0.7; 4.1	13.4 +- 2.5
31	143	1.9	15.9 +- 0.5; 2.4	9.4 +- 0.6; 3.9	14.2 +- 2.9
32	155	1.3	19.1 +- 0.6; 2.9	12.5 +- 0.7; 4.2	14.7 +- 2.4
33	178	1.6	16.4 +- 0.5; 2.5	9.9 +- 0.6; 4.0	13.2 +- 2.3
34	108	2.0	18.7 +- 0.6; 2.8	12.2 +- 0.7; 4.2	15.0 +- 2.6
35	93	2.2	Damaged Dosimeter	No Net Data	14.6 +- 2.9
36	68	2.5	18.8 +- 0.6; 2.8	12.3 +- 0.7; 4.2	14.8 +- 2.6
37	82	4.7	17.7 +- 0.5; 2.7	11.2 +- 0.7; 4.1	14.5 +- 2.4
38	64	4.9	17.4 +- 0.5; 2.6	10.9 +- 0.7; 4.0	14.8 +- 2.3
39	42	5.0	19.8 +- 0.6; 3.0	13.2 +- 0.7; 4.3	18.4 +- 2.5
40	26	4.3	17.4 +- 0.5; 2.6	10.9 +- 0.7; 4.0	15.2 +- 2.8
41	42	2.0	16.9 +- 0.5; 2.5	10.4 +- 0.6; 4.0	12.8 +- 2.4
42	21	1.6	20.0 +- 0.6; 3.0	13.4 +- 0.7; 4.3	17.0 +- 2.8
43	8	2.6	22.3 +- 0.7; 3.3	15.7 +- 0.8; 4.5	18.1 +- 2.6
44	37	13.0	24.5 +- 0.7; 3.7	17.8 +- 0.8; 4.8	21.6 +- 3.0
45	78	19.0	27.7 +- 0.8; 4.2	20.9 +- 0.9; 5.1	24.0 +- 3.1
46	94	19.0	20.6 +- 0.6; 3.1	14.0 +- 0.7; 4.4	18.1 +- 2.2

Transit Dose = 6.3 +- 0.4; 3.2

MCGUIRE

For the period 930914-940201

TLD Direct Radiation Environmental Monitoring

Azimuth (degrees)	Ave. Exposure Rate (mR/Std.Qtr.) +- Std.Dev.	Number In Group
348.76 - 11.25 N	13.1 +- 3.7	2
11.26 - 33.75 NNE	12.2 +- 1.8	2
33.76 - 56.25 NE	13.8 +- 3.7	3
56.26 - 78.75 ENE	14.7 +- 5.4	3
78.76 - 101.25 E	12.4 +- 1.5	3
101.26 - 123.75 ESE	10.9 +- 1.8	2
123.76 - 146.25 SE	10.4 +- 0.9	3
146.26 - 168.75 SSE	11.2 +- 1.9	3
168.76 - 191.25 S	10.5 +- 0.6	3
191.26 - 213.75 SSW	15.3 +- 2.3	3
213.76 - 236.25 SW	15.9 +- 5.2	3
236.26 - 258.75 WSW	14.3 +- 2.7	3
258.76 - 281.25 W	11.4 +- 1.6	2
281.26 - 303.75 WNW	17.5 +- 3.4	3
303.76 - 326.25 NW	15.1 +- 0.9	2
326.26 - 348.75 NNW	14.9 +- 2.0	2

Distance From Reactor (miles)	Ave. Exposure Rate (mR/Std.Qtr.) +- Std.Dev.	Number In Group
0 - 2	12.7 +- 2.8	12
2 - 5	13.3 +- 3.3	21
> 5	14.7 +- 3.5	9
Upwind Control	18.8 +- 3.4	3

MCGUIRE
 TLD Direct Radiation Environmental Monitoring

NRC Station	Location		Description
	Azimuth / Degree	Distance / Mile	
1	97	0.5	SITE RD. (S. OF ENVIR. LAB.)
2	323	1.6	RT. 1395 (1.6 MILES N. OF RT. 73)
3	336	1.7	RT. 1393 (0.4 MILES E. OF RT. 1395)
4	303	2.9	DELMAR STUDIOS
5	321	3.9	ACROSS FROM E. LINCOLN ANIMAL HOSP
6	334	3.7	OLD EBENEZER CH.
7	352	3.5	HOLIDAY LAND FAMILY CAMPING RESORT
8	287	2.0	RT. 73 (0.1 MILES E. OF RT. 1396)
9	273	1.9	MARTHA'S CHAPEL (REAR OF LOT)
10	244	1.7	RT. 1396 (0.2 MILES S. OF RT. 1397)
11	225	2.1	RT. 1396 AT RAILROAD TRACKS
12	212	3.6	RT. 1396 NEAR JOHNSON CR.
13	232	4.4	CASTANEA CH.
14	253	3.7	LOWESVILLE SQUARE (NCNB)
15	261	4.2	0.7 MILES W. OF RT. 16 & HILLS CH.
16	288	4.3	LINCOLN HIGH SCHOOL
17	288	17.0	RT. 321 & RT. 1231
18	287	2.0	RT. 73 (0.1 MILES E.)
19	286	17.0	MCKENDREE CH.
20	233	18.0	GASTONIA (MCDONALDS)
21	204	10.0	MT. HOLLY SCH.
22	239	9.5	CRONLANDS HARDWARE (STANLEY)
23	115	4.9	RT. 2138 (0.1 MILES)
24	132	4.9	RT. 2138 & RT. 2117
25	156	4.0	RT. 2074 & RT. 2128
26	175	3.7	MCDOWELL CR.
27	198	4.3	END OF RT. 2074
28	169	13.0	BROWNS AVE. (CHARLOTTE)
29	155	13.0	BEATTIES FORD RD. (CHARLOTTE)
30	146	14.0	GRAHAM ST. (CHARLOTTE)
31	143	1.9	UNION GROVE CH.
32	155	1.3	RT. 2133 (0.9 MILES W. OF RT. 2128)
33	178	1.6	RT. 2133 (1.5 MILES W. OF RT. 2128)
34	108	2.0	GILEAD VOLUNTEER FIRE DEPT.
35	93	2.2	RT. 73 & TERRY LANE
36	68	2.5	NORMAN ISLAND DR.
37	82	4.7	RT. 21 & RT. 2145
38	64	4.9	RT. 21 & RT. 2147
39	42	5.0	ANCHORAGE SHIPYARD
40	26	4.3	BETHEL CH. RD. & STAGHORN CT.
41	42	2.0	RT. 2149 (1.1 MILES S. OF RT. 2151)
42	21	1.6	MOLLYPOP LANE
43	8	2.6	JETTON RD. & CASUAL CAY RD.
44	37	13.0	MOORESVILLE RAILROAD CROSSING
45	78	19.0	N. KANNAPOLIS METHODIST CH.
46	94	19.0	CONCORD

NRC TLD DOSES FOR McGUIRE AREA

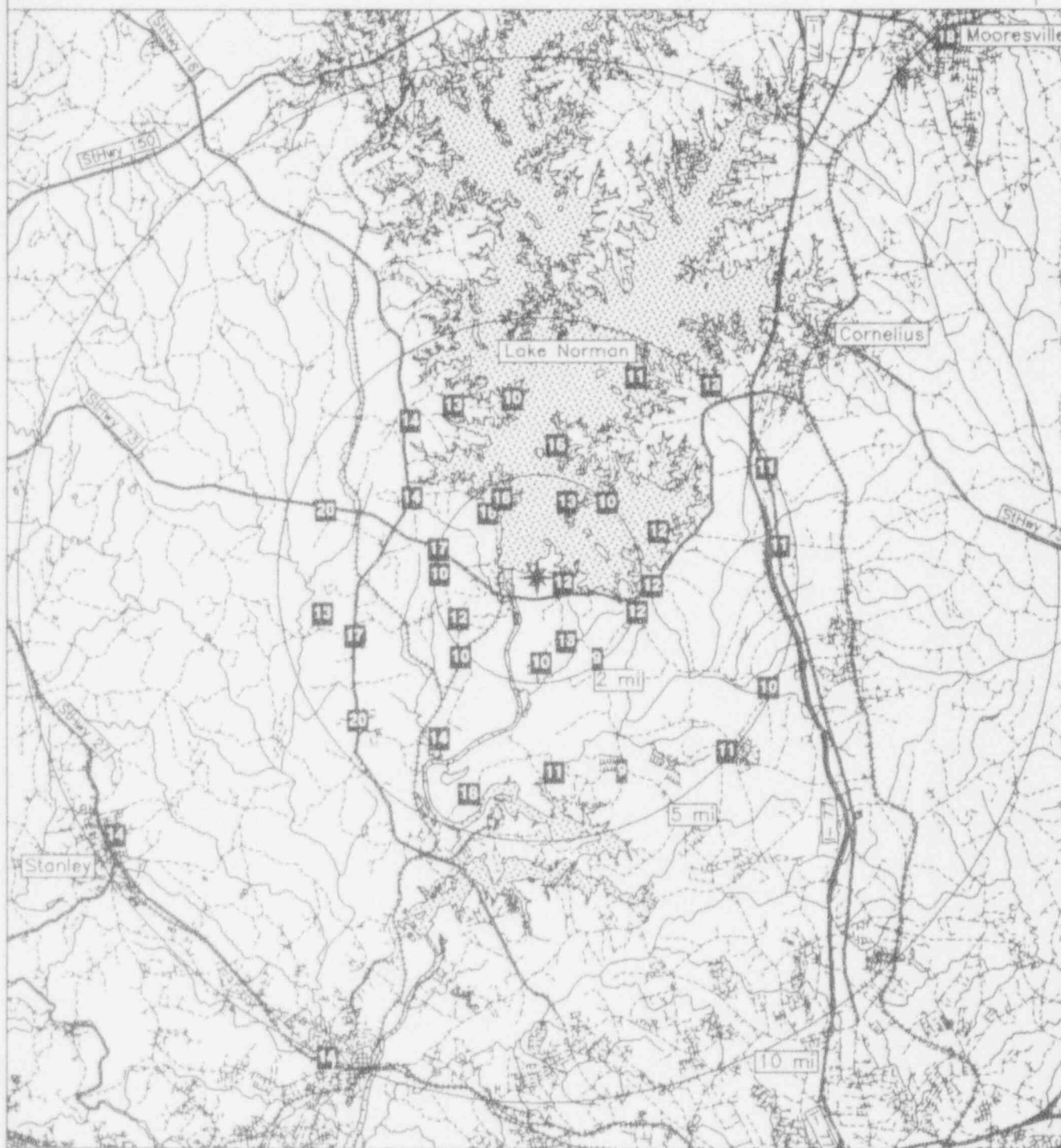

Miles

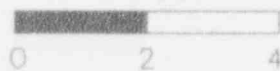

Legend

Water
Highways

Railroads
Roads

Plant site

MILLSTONE

TLD Direct Radiation Environmental Monitoring

For the period 930915-940201 140 Days

Field Time: 99 Days

NRC Sta	Location Azimuth/Dist (Deg)/(Mi)	Gross Exposure (mR) +-Rdm; Tot.	Net Exposure Rate (mR/Std. Qtr.) +-Rdm; Tot.	Hist. Range Net Exp Rate +-1 Std Dev	
1	0	1.0	24.2 +- 0.7; 3.6	19.4 +- 0.7; 4.3	19.6 +- 1.8
2	24	1.3	18.9 +- 0.6; 2.8	14.6 +- 0.6; 3.8	15.1 +- 1.7
3	47	1.5	24.9 +- 0.7; 3.7	20.0 +- 0.7; 4.4	19.4 +- 1.7
4	60	1.7	24.0 +- 0.7; 3.6	19.2 +- 0.7; 4.3	17.6 +- 1.8
5	85	1.3	23.8 +- 0.7; 3.6	19.0 +- 0.7; 4.3	18.8 +- 1.6
6	110	1.8	23.8 +- 0.7; 3.6	19.0 +- 0.7; 4.3	18.4 +- 1.8
7	67	5.3	24.2 +- 0.7; 3.6	19.4 +- 0.7; 4.3	19.5 +- 2.3
8	49	5.3	26.0 +- 0.8; 3.9	21.1 +- 0.8; 4.5	19.4 +- 1.9
9	84	5.2	22.2 +- 0.7; 3.3	17.6 +- 0.7; 4.1	17.9 +- 1.6
11	232	2.5	22.2 +- 0.7; 3.3	17.6 +- 0.7; 4.1	17.3 +- 1.8
12	256	2.4	26.1 +- 0.8; 3.9	21.2 +- 0.8; 4.5	19.6 +- 1.7
13	274	2.2	25.3 +- 0.8; 3.8	20.4 +- 0.8; 4.5	19.4 +- 1.8
14	295	1.9	27.5 +- 0.8; 4.1	22.4 +- 0.8; 4.7	20.4 +- 2.3
15	315	1.5	20.3 +- 0.6; 3.0	15.9 +- 0.6; 4.0	15.7 +- 1.8
16	339	1.2	24.6 +- 0.7; 3.7	19.8 +- 0.7; 4.4	19.6 +- 1.7
17	353	3.5	24.1 +- 0.7; 3.6	19.3 +- 0.7; 4.3	18.5 +- 1.9
18	24	3.5	24.3 +- 0.7; 3.6	19.5 +- 0.7; 4.4	19.1 +- 2.0
19	33	3.0	27.0 +- 0.8; 4.0	21.9 +- 0.8; 4.6	20.5 +- 2.1
20	82	4.0	23.1 +- 0.7; 3.5	18.4 +- 0.7; 4.2	17.9 +- 1.2
22	59	3.7	25.3 +- 0.8; 3.8	20.4 +- 0.8; 4.5	20.1 +- 2.0
28	257	5.8	25.5 +- 0.8; 3.8	20.6 +- 0.8; 4.5	21.6 +- 3.1
29	272	3.7	28.1 +- 0.8; 4.2	22.9 +- 0.8; 4.8	21.1 +- 2.2
30	295	3.5	27.3 +- 0.8; 4.1	22.2 +- 0.8; 4.7	20.9 +- 2.1
31	317	3.6	23.4 +- 0.7; 3.5	18.7 +- 0.7; 4.3	18.1 +- 1.9
32	327	4.3	27.2 +- 0.8; 4.1	22.1 +- 0.8; 4.7	21.2 +- 1.9
33	41	4.7	24.9 +- 0.7; 3.7	20.0 +- 0.7; 4.4	19.6 +- 1.9
34	54	5.5	26.1 +- 0.8; 3.9	21.1 +- 0.8; 4.5	20.7 +- 2.1
37	354	6.8	24.5 +- 0.7; 3.7	19.7 +- 0.7; 4.4	19.0 +- 1.8
39	1	5.7	23.8 +- 0.7; 3.6	19.0 +- 0.7; 4.3	18.6 +- 1.7
40	278	8.7	21.3 +- 0.6; 3.2	16.7 +- 0.7; 4.0	16.6 +- 1.9
41	34	11.0	29.8 +- 0.9; 4.5	24.5 +- 0.9; 4.9	24.3 +- 1.9
42	84	8.0	24.0 +- 0.7; 3.6	19.2 +- 0.7; 4.3	18.8 +- 1.8
46	41	0.6	23.3 +- 0.7; 3.5	18.6 +- 0.7; 4.2	18.3 +- 1.9
48	4	40.0	28.8 +- 0.9; 4.3	23.6 +- 0.8; 4.8	23.8 +- 2.5
49	4	40.0	29.3 +- 0.9; 4.4	24.0 +- 0.9; 4.9	23.9 +- 2.6

Transit Dose = 2.9 +- 0.3; 3.1

MILLSTONE

For the period 930915-940201

TLD Direct Radiation Environmental Monitoring

Azimuth (degrees)	Ave. Exposure Rate (mR/Std.Qtr.) +- Std.Dev.	Number In Group
348.76 - 11.25 N	19.4 +- 0.3	4
11.26 - 33.75 NNE	18.7 +- 3.7	3
33.76 - 56.25 NE	20.9 +- 2.0	6
56.26 - 78.75 ENE	19.7 +- 0.6	3
78.76 - 101.25 E	18.5 +- 0.7	4
101.26 - 123.75 ESE	19.0 +- 0.0	1
123.76 - 146.25 SE	No Data +- No Data	0
146.26 - 168.75 SSE	No Data +- No Data	0
168.76 - 191.25 S	No Data +- No Data	0
191.26 - 213.75 SSW	No Data +- No Data	0
213.76 - 236.25 SW	17.6 +- 0.0	1
236.26 - 258.75 WSW	20.9 +- 0.4	2
258.76 - 281.25 W	20.0 +- 3.1	3
281.26 - 303.75 WNW	22.3 +- 0.2	2
303.76 - 326.25 NW	17.3 +- 2.0	2
326.26 - 348.75 NNW	20.9 +- 1.7	2

Distance From Reactor (miles)	Ave. Exposure Rate (mR/Std.Qtr.) +- Std.Dev.	Number In Group
0 - 2	18.8 +- 2.2	10
2 - 5	20.4 +- 1.7	13
> 5	19.9 +- 2.1	10
Upwind Control	23.8 +- 0.3	2

MILLSTONE
TLD Direct Radiation Environmental Monitoring

NRC Station	Location		Description
	Azimuth / Degree	Distance / Mile	
1	0	1.0	ALBACORE DRIVE
2	24	1.3	GARDNERS WOOD ROAD
3	47	1.5	LAMPHERE ROAD
4	60	1.7	NEW LONDON COUNTRY CLUB
5	85	1.3	PLEASURE BEACH FIRE STATION
6	110	1.8	SEASIDE POINT
7	67	5.3	EASTERN POINT SCHOOL
8	49	5.3	NEW LONDON PIER
9	84	5.2	AVERY POINT
11	232	2.5	OLD BLACK POINT ROAD
12	256	2.4	BILLOW ROAD
13	274	2.2	TERRACE ROAD
14	295	1.9	COLUMBUS AVENUE
15	315	1.5	SMITH AVE.
16	339	1.2	HILLYER'S BAIT SHOP
17	353	3.5	OSWEGATCHIE FIRE STATION
18	24	3.5	FOY PLAIN ROAD
19	33	3.0	WATERFORD POLICE DEPT.
20	82	4.0	NEW LONDON LIGHT HOUSE
22	59	3.7	LAWRENCE HOSPITAL
28	257	5.8	POLICE STA.-SOUND VIEW
29	272	3.7	GIANTS NECK ROAD
30	295	3.5	COREY LN.
31	317	3.6	EAST LYME HIGH SCHOOL
32	327	4.3	FLANDERS SUB.
33	41	4.7	HIGH SCHOOL-NEW LONDON
34	54	5.5	FORT GRISWOLD
37	354	6.8	KONOMOC RESERVOIR
39	1	5.7	WATERFORD MAINTENANCE GARAGE
40	278	8.7	OLD LYME SUB.
41	34	11.0	STODDARDS WHARF ROAD
42	84	8.0	MUMFORD COVE
46	41	0.6	GUNSHOT RD-POLE #3735
48	4	40.0	ASHFORD/CONN
49	4	40.0	ASHFORD/CONN

NRC TLD DOSES FOR MILLSTONE AREA



Miles

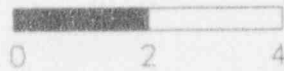

Legend

- Water
- Highways
- Railroads
- Roads
- Plant site

MONTICELLO

TLD Direct Radiation Environmental Monitoring

For the period 930914-940208 148 Days

Field Time: 101 Days

NRC Sta	Location		Gross Exposure (mR)		Net Exposure Rate (mR/Std. Qtr.)		Hist. Range Net Exp Rate	
	Azimuth/Dist (Deg)/(Mi)		+Rdm; Tot.		+Rdm; Tot.		+1 Std Dev	
1	133	3.6	22.8	+ 0.7; 3.4	16.4	+ 0.7; 4.2	16.9	+ 1.3
2	163	4.6	23.5	+ 0.7; 3.5	17.0	+ 0.7; 4.3	17.5	+ 1.3
3	183	4.1	25.1	+ 0.8; 3.8	18.4	+ 0.8; 4.5	17.8	+ 1.3
4	206	4.3	23.9	+ 0.7; 3.6	17.4	+ 0.7; 4.3	17.6	+ 1.4
5	230	4.2	26.3	+ 0.8; 3.9	19.5	+ 0.8; 4.6	19.1	+ 1.7
6	253	4.6	23.5	+ 0.7; 3.5	17.0	+ 0.7; 4.3	17.9	+ 1.5
7	269	4.4	24.1	+ 0.7; 3.6	17.5	+ 0.7; 4.4	17.3	+ 1.4
8	286	4.0	24.8	+ 0.7; 3.7	18.2	+ 0.7; 4.4	18.1	+ 1.5
9	274	1.9	22.5	+ 0.7; 3.4	16.1	+ 0.7; 4.2	17.1	+ 1.2
10	244	1.3	21.7	+ 0.7; 3.3	15.4	+ 0.7; 4.1	15.5	+ 1.4
11	226	0.9	24.4	+ 0.7; 3.7	17.8	+ 0.7; 4.4	16.8	+ 1.4
12	181	1.8	23.2	+ 0.7; 3.5	16.7	+ 0.7; 4.3	17.1	+ 1.4
13	137	1.7	23.8	+ 0.7; 3.6	17.3	+ 0.7; 4.3	17.2	+ 1.3
14	155	1.0	23.8	+ 0.7; 3.6	17.3	+ 0.7; 4.3	17.1	+ 1.2
15	208	0.6	23.2	+ 0.7; 3.5	16.8	+ 0.7; 4.3	16.6	+ 1.3
16	284	2.0	22.7	+ 0.7; 3.4	16.3	+ 0.7; 4.2	16.7	+ 1.1
17	113	1.6	23.3	+ 0.7; 3.5	16.8	+ 0.7; 4.3	16.8	+ 1.7
18	85	1.1	22.8	+ 0.7; 3.4	16.4	+ 0.7; 4.2	16.6	+ 1.3
19	63	1.2	23.7	+ 0.7; 3.6	17.2	+ 0.7; 4.3	16.9	+ 1.4
20	37	1.7	22.8	+ 0.7; 3.4	16.4	+ 0.7; 4.2	16.9	+ 1.1
21	23	0.8	23.1	+ 0.7; 3.5	16.7	+ 0.7; 4.3	17.0	+ 1.2
22	354	0.7	23.4	+ 0.7; 3.5	16.9	+ 0.7; 4.3	17.3	+ 1.4
23	338	0.8	23.8	+ 0.7; 3.6	17.3	+ 0.7; 4.3	17.1	+ 1.3
24	307	1.8	22.8	+ 0.7; 3.4	16.4	+ 0.7; 4.2	17.1	+ 1.4
25	339	4.1	23.4	+ 0.7; 3.5	16.9	+ 0.7; 4.3	16.6	+ 1.3
26	320	6.0	22.9	+ 0.7; 3.4	16.4	+ 0.7; 4.2	16.5	+ 1.6
27	354	4.5	23.4	+ 0.7; 3.5	16.9	+ 0.7; 4.3	16.9	+ 1.5
28	17	3.7	22.0	+ 0.7; 3.3	15.7	+ 0.7; 4.2	15.9	+ 1.3
29	50	4.0	21.3	+ 0.6; 3.2	15.1	+ 0.7; 4.1	15.9	+ 1.5
30	77	3.6	23.6	+ 0.7; 3.5	17.1	+ 0.7; 4.3	16.9	+ 1.3
31	115	3.3	22.6	+ 0.7; 3.4	16.2	+ 0.7; 4.2	16.8	+ 1.4
32	90	4.6	20.4	+ 0.6; 3.1	14.2	+ 0.6; 4.0	16.2	+ 2.1
33	323	16.0	23.2	+ 0.7; 3.5	16.7	+ 0.7; 4.3	16.6	+ 1.5
34	323	16.0	22.5	+ 0.7; 3.4	16.1	+ 0.7; 4.2	16.5	+ 1.4
35	323	16.0	23.5	+ 0.7; 3.5	17.0	+ 0.7; 4.3	17.3	+ 1.5

Transit Dose = 4.4 +- 0.4; 3.3

MONTICELLO

For the period 930914-940208

TLD Direct Radiation Environmental Monitoring

Azimuth (degrees)	Ave. Exposure Rate (mR/Std.Qtr.) +- Std.Dev.	Number In Group
348.76 - 11.25 N	16.9 +- 0.0	2
11.26 - 33.75 NNE	16.2 +- 0.7	2
33.76 - 56.25 NE	15.7 +- 1.0	2
56.26 - 78.75 ENE	17.2 +- 0.0	2
78.76 - 101.25 E	15.3 +- 1.5	2
101.26 - 123.75 ESE	16.5 +- 0.4	2
123.76 - 146.25 SE	16.8 +- 0.6	2
146.26 - 168.75 SSE	17.1 +- 0.2	2
168.76 - 191.25 S	17.6 +- 1.2	2
191.26 - 213.75 SSW	17.1 +- 0.4	2
213.76 - 236.25 SW	18.7 +- 1.2	2
236.26 - 258.75 WSW	16.2 +- 1.1	2
258.76 - 281.25 W	16.8 +- 1.0	2
281.26 - 303.75 WNW	17.2 +- 1.3	2
303.76 - 326.25 NW	16.4 +- 0.0	2
326.26 - 348.75 NNW	17.1 +- 0.3	2

Distance From Reactor (miles)	Ave. Exposure Rate (mR/Std.Qtr.) +- Std.Dev.	Number In Group
0 - 2	16.7 +- 0.6	16
2 - 5	16.9 +- 1.3	15
> 5	16.4 +- 0.0	1
Upwind Control	16.6 +- 0.4	3

MONTICELLO
 TLD Direct Radiation Environmental Monitoring

NRC Station	Location		Description
	Azimuth Degree	Distance / Mile	
1	133	3.6	WASHINGTON AVE.
2	163	4.6	COUNTY RD 25
3	183	4.1	COUNTY RD. 106 AND CAHILL AVE.
4	206	4.3	ACACIA AVE.
5	230	4.2	VANLITH RESIDENCE
6	253	4.6	COUNTY RD. 111
7	269	4.4	COUNTY RD. 111 (NEAR CHURCH)
8	286	4.0	W. BERGGUIST PROPERTY
9	274	1.9	SECTION 31 (T. 122 N. - R. 25 W.)
10	244	1.3	ORCHARD DR.
11	226	0.9	ORCHARD DR.
12	181	1.8	INTERSECTION COUNTY RD. 39
13	137	1.7	OTTERCREEK RD.
14	155	1.0	W. RIVER ST./COUNTY RD. 75
15	208	0.6	120TH STREET,N.E. & RD. 75
16	284	2.0	COUNTY RD. 75
17	113	1.6	COUNTY RD. 11
18	85	1.1	COUNTY RD. 11
19	63	1.2	COUNTY RD. 11
20	37	1.7	COUNTY RD. 11 & 84TH AVE.
21	23	0.8	SHERBURNE AVE(SOUTH)
22	354	0.7	SHERBURNE AVE(SOUTH)
23	338	0.8	SHERBURNE AVE(SOUTH)
24	307	1.8	BENCHMARK 948(SHERBURNE AVE)
25	339	4.1	PLEASANT ST.
26	320	6.0	COUNTY RD. 53
27	354	4.5	COUNTY RD. 67/4
28	17	3.7	COUNTY RD. 11/73
29	50	4.0	COUNTY RD. 73/81
30	77	3.6	COUNTY RD. 73/196TH ST.
31	115	3.3	LAKE ST./MARTIN AVENUE
32	90	4.6	LAKE ST.&MN AVE.(WARNING SIREN)
33	323	16.0	COUNTY RD. 3
34	323	16.0	COUNTY RD. 3
35	323	16.0	COUNTY RD. 3

NRC TLD DOSES FOR MONTICELLO AREA

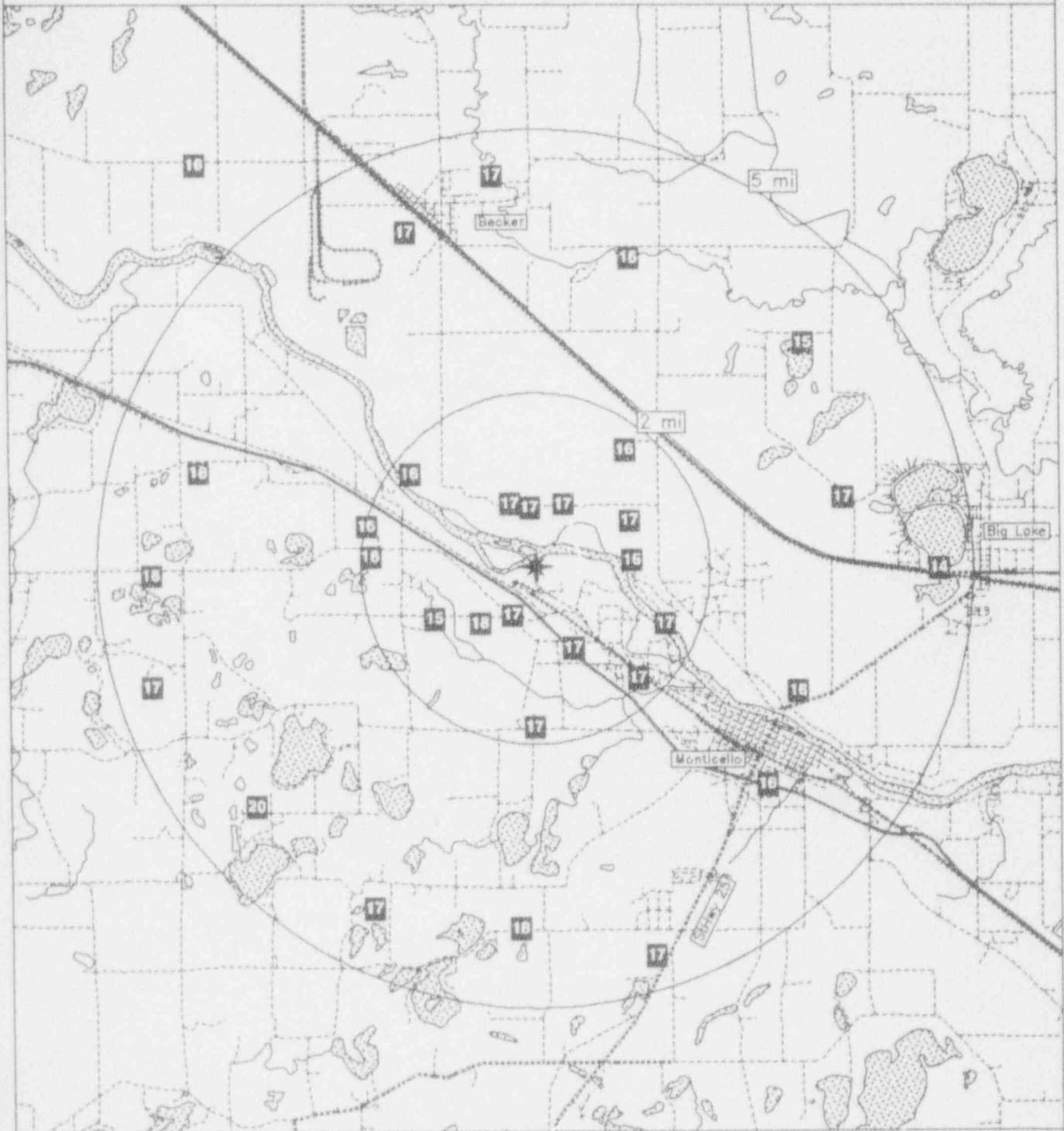

Miles

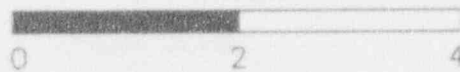

Legend

- Water
- Highways
- Railroads
- Roads
- Plant..site

NORTH ANNA

TLD Direct Radiation Environmental Monitoring

For the period 930914-940202 142 Days

Field Time: 92 Days

NRC Sta	Location Azimuth/Dist (Deg)/(Mi)		Gross Exposure (mR) +-Rdm; Tot.	Net Exposure Rate (mR/Std. Qtr.) +-Rdm; Tot.	Hist. Range Net Exp Rate +-1 Std Dev
1	243	1.8	26.3 +- 0.8; 3.9	19.2 +- 0.9; 5.0	21.1 +- 1.6
2	263	1.6	24.0 +- 0.7; 3.6	16.9 +- 0.8; 4.7	17.9 +- 1.4
3	296	1.0	22.4 +- 0.7; 3.4	15.3 +- 0.8; 4.6	18.1 +- 1.5
4	311	1.3	28.7 +- 0.9; 4.3	21.5 +- 0.9; 5.3	22.3 +- 1.5
5	329	1.3	24.5 +- 0.7; 3.7	17.4 +- 0.8; 4.8	19.0 +- 1.3
6	231	3.9	27.0 +- 0.8; 4.0	19.8 +- 0.9; 5.1	20.5 +- 1.4
7	224	1.7	25.4 +- 0.8; 3.8	18.3 +- 0.9; 4.9	19.9 +- 1.4
8	210	1.6	24.3 +- 0.7; 3.6	17.2 +- 0.8; 4.8	18.3 +- 1.4
9	181	1.4	22.6 +- 0.7; 3.4	15.5 +- 0.8; 4.6	16.1 +- 1.4
10	155	1.0	29.2 +- 0.9; 4.4	22.0 +- 1.0; 5.3	23.9 +- 1.6
11	136	1.6	24.2 +- 0.7; 3.6	17.1 +- 0.8; 4.8	18.2 +- 1.7
12	163	3.5	24.9 +- 0.7; 3.7	17.8 +- 0.8; 4.8	19.3 +- 1.5
13	190	3.3	23.7 +- 0.7; 3.6	16.6 +- 0.8; 4.7	17.7 +- 1.4
14	205	4.9	22.2 +- 0.7; 3.3	15.1 +- 0.8; 4.5	17.0 +- 1.2
15	140	4.2	24.8 +- 0.7; 3.7	17.7 +- 0.8; 4.8	19.1 +- 1.3
16	113	4.9	29.4 +- 0.9; 4.4	22.2 +- 1.0; 5.4	23.0 +- 1.7
17	93	3.3	21.8 +- 0.7; 3.3	14.8 +- 0.8; 4.5	16.2 +- 1.3
18	64	4.1	26.1 +- 0.8; 3.9	18.9 +- 0.9; 5.0	19.2 +- 1.5
19	78	2.7	37.2 +- 1.1; 5.6	29.8 +- 1.2; 6.3	28.3 +- 1.5
20	97	1.9	27.2 +- 0.8; 4.1	20.0 +- 0.9; 5.1	20.3 +- 1.8
21	105	1.7	21.0 +- 0.6; 3.1	14.0 +- 0.7; 4.4	16.8 +- 1.3
22	60	2.4	22.3 +- 0.7; 3.3	15.3 +- 0.8; 4.6	17.2 +- 1.4
23	37	1.4	25.0 +- 0.7; 3.7	17.9 +- 0.8; 4.8	19.0 +- 1.4
24	16	1.6	29.6 +- 0.9; 4.4	22.4 +- 1.0; 5.4	23.9 +- 1.6
25	48	3.5	20.2 +- 0.6; 3.0	13.2 +- 0.7; 4.3	16.1 +- 2.0
26	17	3.7	25.2 +- 0.8; 3.8	18.1 +- 0.9; 4.9	19.4 +- 1.4
27	3	4.8	23.2 +- 0.7; 3.5	16.1 +- 0.8; 4.7	17.4 +- 1.8
28	348	4.0	23.5 +- 0.7; 3.5	16.4 +- 0.8; 4.7	17.4 +- 1.4
29	2	1.9	22.5 +- 0.7; 3.4	15.4 +- 0.8; 4.6	16.8 +- 1.1
30	284	5.0	22.5 +- 0.7; 3.4	15.4 +- 0.8; 4.6	17.3 +- 1.5
31	310	4.7	26.5 +- 0.8; 4.0	19.3 +- 0.9; 5.0	20.3 +- 1.8
32	273	4.9	23.0 +- 0.7; 3.5	16.0 +- 0.8; 4.6	14.1 +- 1.8
33	257	5.1	Missing Dosimeter	No Net Data	18.4 +- 1.7
34	242	7.1	25.0 +- 0.8; 3.8	17.9 +- 0.8; 4.9	19.5 +- 1.6
35	255	11.0	23.8 +- 0.7; 3.6	16.7 +- 0.8; 4.7	18.4 +- 1.9
36	248	15.0	25.1 +- 0.8; 3.8	18.0 +- 0.8; 4.9	18.3 +- 1.4
37	247	17.0	23.3 +- 0.7; 3.5	16.2 +- 0.8; 4.7	17.6 +- 1.3
38	244	19.0	21.8 +- 0.7; 3.3	14.8 +- 0.8; 4.5	16.8 +- 1.7

Transit Dose = 6.7 +- 0.4; 3.2

NORTH ANNA
For the period 930914-940202

TLD Direct Radiation Environmental Monitoring

Azimuth (degrees)	Ave. Exposure Rate (mR/Std.Qtr.) +- Std.Dev.	Number In Group
348.76 - 11.25 N	15.8 +- 0.5	2
11.26 - 33.75 NNE	20.2 +- 3.0	2
33.76 - 56.25 NE	15.5 +- 3.3	2
56.26 - 78.75 ENE	21.3 +- 7.6	3
78.76 - 101.25 E	17.4 +- 3.7	2
101.26 - 123.75 ESE	18.1 +- 5.8	2
123.76 - 146.25 SE	17.4 +- 0.4	2
146.26 - 168.75 SSE	19.9 +- 2.9	2
168.76 - 191.25 S	16.1 +- 0.8	2
191.26 - 213.75 SSW	16.2 +- 1.5	2
213.76 - 236.25 SW	19.1 +- 1.1	2
236.26 - 258.75 WSW	17.9 +- 1.2	3
258.76 - 281.25 W	16.4 +- 0.7	2
281.26 - 303.75 WNW	15.4 +- 0.1	2
303.76 - 326.25 NW	20.4 +- 1.5	2
326.26 - 348.75 NNW	16.9 +- 0.7	2

Distance From Reactor (miles)	Ave. Exposure Rate (mR/Std.Qtr.) +- Std.Dev.	Number In Group
0 - 2	18.0 +- 2.6	15
2 - 5	17.8 +- 3.8	17
> 5	17.3 +- 0.8	2
Upwind Control	16.3 +- 1.6	3

NORTH ANNA
TLD Direct Radiation Environmental Monitoring

NRC Station	Location		Description
	Azimuth / Degree	Distance / Mile	
1	243	1.8	RT. 700 & RT. 652
2	263	1.6	RT. 685 (0.4 MILES N. OF RT. 652)
3	296	1.5	RT. 685 (1.5 MILES N. OF RT. 652)
4	311	1.3	RT. 685 (1.6 MILES N. OF RT. 652)
5	329	1.3	RT. 685 (2.1 MILES N. OF RT. 652)
6	231	3.9	RT. 700 & RT. 712
7	224	1.7	LAUREL HILL CHURCH
8	210	1.6	RT. 652 (0.8 MILES E. OF RT. 700)
9	181	1.4	RT. 652 & RD. 1205
10	155	1.0	S. SHORE OF LAKE ANNA
11	136	1.6	RT. 614 (1.2 MILES N. OF RT. 652)
12	163	3.5	INTERSECTION OF RT. 652 & RD. 728
13	190	3.3	TRICE DAIRY RD.
14	205	4.9	RT. 614 & RT. 618
15	140	4.2	RT. 622 (0.5 MILES N. OF RT. 701)
16	113	4.9	RT. 601 & RT. 622
17	93	3.3	RT. 601 (2.2 MILES N. OF LEVY)
18	64	4.1	RT. 614 (1.6 MILES NE OF RT. 601)
19	78	2.7	RT. 601 & RT. 614 (LEWISTON)
20	97	1.9	RT. 614 (1 MILE S. OF RT. 601)
21	105	1.7	RT. 614 (N. SHORE OF LAKE ANNA)
22	60	2.4	RT. 601 & RT. 689
23	37	1.4	RT. 713 (0.9 MILES S. OF RT. 601)
24	16	1.6	0.5 MILES NW OF RT. 713 ON DIRT RD.
25	48	3.5	RT. 665 (1.1 MILES W. OF RT. 601)
26	17	3.7	GOOD HOPE CHURCH ON RT. 601
27	3	4.8	RT. 601 & RIDGE RD.
28	348	4.0	RT. 643 (0.7 MILES NW OF RT. 655)
29	2	1.9	RT. 208 IN GLENORA
30	284	5.0	WARES CROSSROADS
31	310	4.7	RT. 663 (N. SHORE OF LAKE ANNA)
32	273	4.9	HWY. 522
33	257	5.1	HWY. 522 & RT. 720
34	242	7.1	MINERAL GRADE SCHOOL
35	255	11.0	HWY. 32 & RT. 208 (LA)
36	248	15.0	S. ANNA RD. & RT. 208
37	247	17.0	RT. 208 & RT. 640
38	244	19.0	RT. 208 & HWY. 64

NRC TLD DOSES FOR NORTH ANNA AREA



Miles

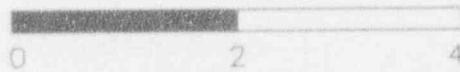

Legend

- Water
- Highways
- Railroads
- Roads
- Plant..site

OCONEE

TLD Direct Radiation Environmental Monitoring

For the period 930914-940203 143 Days

Field Time: 106 Days

NRC Sta	Location		Gross Exposure (mR)		Net Exposure Rate (mR/Std. Qtr.)		Hist. Range Net Exp Rate	
	Azimuth (Deg)	Dist (Mi)	+-Rdm; Tot.		+-Rdm; Tot.		+-1 Std Dev	
1	158	7.5	28.8	+- 0.9; 4.3	21.2	+- 0.8; 4.7	22.8	+- 2.3
2	133	4.9	33.9	+- 1.0; 5.1	25.5	+- 0.9; 5.2	25.7	+- 2.3
3	119	4.3	33.8	+- 1.0; 5.1	25.4	+- 0.9; 5.2	24.5	+- 2.1
4	84	4.7	31.5	+- 0.9; 4.7	23.5	+- 0.9; 4.9	24.8	+- 1.7
5	65	4.0	32.2	+- 1.0; 4.8	24.1	+- 0.9; 5.0	23.8	+- 2.7
6	52	1.8	32.4	+- 1.0; 4.9	24.2	+- 0.9; 5.0	25.0	+- 2.3
7	22	3.5	33.7	+- 1.0; 5.1	25.3	+- 0.9; 5.2	25.3	+- 2.1
8	33	1.4	31.5	+- 0.9; 4.7	23.4	+- 0.9; 4.9	24.9	+- 2.8
9	52	1.8	26.9	+- 0.8; 4.0	19.6	+- 0.8; 4.5	19.9	+- 1.9
10	67	1.1	26.9	+- 0.8; 4.0	19.6	+- 0.8; 4.5	17.2	+- 2.5
11	107	1.9	26.1	+- 0.8; 3.9	18.9	+- 0.7; 4.4	19.4	+- 1.9
12	87	1.0	29.9	+- 0.9; 4.5	22.1	+- 0.8; 4.8	22.2	+- 2.2
13	142	0.7	28.6	+- 0.9; 4.3	21.0	+- 0.8; 4.6	22.8	+- 1.7
14	166	0.7	22.7	+- 0.7; 3.4	16.0	+- 0.7; 4.1	19.5	+- 2.1
15	226	1.7	29.9	+- 0.9; 4.5	22.1	+- 0.8; 4.8	22.0	+- 2.0
16	207	1.4	28.1	+- 0.8; 4.2	20.6	+- 0.8; 4.6	21.5	+- 1.7
17	182	2.2	24.1	+- 0.7; 3.6	17.2	+- 0.7; 4.2	18.4	+- 1.7
18	186	3.8	Missing Dosimeter		No Net Data		19.5	+- 1.9
19	155	4.1	32.1	+- 1.0; 4.8	24.0	+- 0.9; 5.0	23.6	+- 0.9
20	203	8.4	25.3	+- 0.8; 3.8	18.2	+- 0.7; 4.3	18.3	+- 2.4
21	210	4.6	25.6	+- 0.8; 3.8	18.4	+- 0.7; 4.3	19.6	+- 2.1
22	227	4.8	28.3	+- 0.8; 4.2	20.7	+- 0.8; 4.6	21.6	+- 2.9
23	240	3.6	25.2	+- 0.8; 3.8	18.1	+- 0.7; 4.3	20.4	+- 2.5
24	268	3.6	32.4	+- 1.0; 4.9	24.3	+- 0.9; 5.0	24.1	+- 1.9
25	257	1.9	24.4	+- 0.7; 3.7	17.4	+- 0.7; 4.2	19.3	+- 2.2
26	293	3.6	30.2	+- 0.9; 4.5	22.3	+- 0.8; 4.8	21.1	+- 2.3
27	311	3.5	25.3	+- 0.8; 3.8	18.2	+- 0.7; 4.3	18.2	+- 1.6
28	288	2.0	26.4	+- 0.8; 4.0	19.1	+- 0.7; 4.4	20.3	+- 2.1
29	275	1.8	25.2	+- 0.8; 3.8	18.1	+- 0.7; 4.3	19.3	+- 1.7
30	321	1.8	29.6	+- 0.9; 4.4	21.9	+- 0.8; 4.7	21.7	+- 2.0
31	344	2.0	23.6	+- 0.7; 3.5	16.7	+- 0.7; 4.2	17.5	+- 2.0
32	336	3.7	34.1	+- 1.0; 5.1	25.7	+- 0.9; 5.2	26.0	+- 2.3
33	358	4.5	28.1	+- 0.8; 4.2	20.6	+- 0.8; 4.6	21.7	+- 2.5
34	256	9.4	36.1	+- 1.1; 5.4	27.4	+- 1.0; 5.4	27.6	+- 2.2
35	149	21.0	30.0	+- 0.9; 4.5	22.2	+- 0.8; 4.8	22.9	+- 2.5
36	126	8.2	30.6	+- 0.9; 4.6	22.7	+- 0.8; 4.8	24.6	+- 2.2
37	96	9.7	33.3	+- 1.0; 5.0	25.0	+- 0.9; 5.1	24.2	+- 1.7
38	32	16.0	38.7	+- 1.2; 5.8	29.6	+- 1.0; 5.7	30.2	+- 3.2
39	31	16.0	Missing Dosimeter		No Net Data		25.4	+- 3.1
40	29	16.0	35.5	+- 1.1; 5.3	26.9	+- 1.0; 5.4	27.0	+- 1.8

Transit Dose = 3.9 +- 0.4; 3.4

OCONEE

For the period 930914-940203

TLD Dire Radiation Environmental Monitoring

Azimuth (degrees)	Ave. Exposure Rate (mR/Std.Qtr.) +- Std.Dev.	Number In Group
348.76 - 11.25 N	20.6 +- 0.0	1
11.26 - 33.75 NNE	24.4 +- 1.3	2
33.76 - 56.25 NE	21.9 +- 3.3	2
56.26 - 78.75 ENE	21.8 +- 3.2	2
78.76 - 101.25 E	23.5 +- 1.4	3
101.26 - 123.75 ESE	22.1 +- 4.6	2
123.76 - 146.25 SE	23.1 +- 2.3	3
146.26 - 168.75 SSE	20.8 +- 3.4	4
168.76 - 191.25 S	17.2 +- 0.0	1
191.26 - 213.75 SSW	19.1 +- 1.3	3
213.76 - 236.25 SW	21.4 +- 1.0	2
236.26 - 258.75 WSW	21.0 +- 5.5	3
258.76 - 281.25 W	21.2 +- 4.4	2
281.26 - 303.75 WNW	20.7 +- 2.3	2
303.76 - 326.25 NW	20.0 +- 2.6	2
326.26 - 348.75 NNW	21.2 +- 6.3	2

Distance From Reactor (miles)	Ave. Exposure Rate (mR/Std.Qtr.) +- Std.Dev.	Number In Group
0 - 2	20.1 +- 2.4	15
2 - 5	22.2 +- 3.1	15
> 5	22.8 +- 3.1	6
Upwind Control	28.2 +- 1.9	2

OCONEE

TLD Direct Radiation Environmental Monitoring

NRC Station	Location		Description
	Azimuth / Degree	Distance / Mile	
1	158	7.5	CLEMSON
2	133	4.9	LAWRENCE CHAPEL
3	119	4.3	PLEASANT HILL CHURCH
4	84	4.7	SIX MILE MICROWAVE TOWER
5	65	4.0	HWY. 133
6	52	1.8	HWY. 183
7	22	3.5	HWY. 157 (BANKS RESIDENCE)
8	33	1.4	WARPATH LANDING
9	52	1.8	HWY. 183 S. OF WARPATH RD.
10	67	1.1	HWY. 183 (1 MILE S. OF WARPATH RD.)
11	107	1.9	HWY. 160 (BAIT SHOP)
12	87	1.0	HWY. 183 (1.5 MILES S. OF WARPATH RD.)
13	142	0.7	HWY. 6 (BEAVER COLONY)
14	166	0.7	HWY. 6 (0.7 MILES S. OF HWY. 183)
15	226	1.7	HWY. 15 (MORGAN MEMORIAL CHAPEL)
16	207	1.4	HWY. 15 AT HWY. 37
17	182	2.2	HWY. 130 AT DIRT RD.
18	186	3.8	HWY. 130 (1.0 MILES N. OF NEWRY)
19	155	4.1	ISSAQUEENA LAKE RD.
20	203	8.4	SENECA WATER TOWER
21	210	4.6	SUBDIVISION OFF HWY. 588
22	227	4.8	HWY. 188 NEAR BRIDGE
23	240	3.6	NEW HOPE CHURCH
24	268	3.6	KEOWEE HIGH SCHOOL
25	257	1.9	TRAMMEL RD.
26	293	3.6	HIGHWAY 201 AT HWY. 92
27	311	3.5	STAMP CR. ACCESS AREA
28	288	2.0	HIGH FALLS CHURCH
29	275	1.8	DUKE CAMPGROUND
30	321	1.8	KEOWEE KEY GUARD HOUSE
31	344	2.0	MCCALL RESIDENCE
32	336	3.7	STAMP CR. CHURCH
33	358	4.5	KEOWEE TOWN LANDING
34	256	9.4	WALHALLA
35	149	21.0	ANDERSON
36	126	8.2	CENTRAL
37	96	9.7	LIBERTY
38	32	16.0	HOLLY SPRINGS CHURCH
39	31	16.0	HOLLY SPRINGS GROCERY
40	29	16.0	SLIDING ROCK RD. & HWY. 178

NRC TLD DOSES FOR OCONEE AREA



Miles

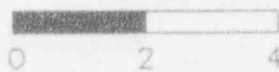

Legend



Water

Highways

Railroads

Roads



Plant site

OYSTER CREEK

TLD Direct Radiation Environmental Monitoring

For the period 930915-940202 141 Days

Field Time: 92 Days

NRC Sta	Location		Gross Exposure (mR)		Net Exposure Rate (mR/Std. Qtr.)		Hist. Range Net Exp Rate	
	Azimuth/ (Deg)	Dist (Mi)	+-Rdm; Tot.		+-Rdm; Tot.		+-1 Std Dev	
1	141	0.5	15.6	+- 0.5; 2.3	11.2	+- 0.6; 3.7	11.4	+- 1.2
2	120	0.9	15.4	+- 0.5; 2.3	11.0	+- 0.6; 3.7	11.4	+- 1.5
3	105	1.5	16.7	+- 0.5; 2.5	12.3	+- 0.6; 3.8	12.5	+- 1.4
4	127	1.5	15.8	+- 0.5; 2.4	11.4	+- 0.6; 3.7	11.3	+- 3.0
5	137	1.3	16.9	+- 0.5; 2.5	12.4	+- 0.6; 3.3	11.6	+- 3.2
6	158	1.2	15.8	+- 0.5; 2.4	11.4	+- 0.6; 3.7	11.3	+- 2.8
7	176	2.2	16.5	+- 0.5; 2.5	12.0	+- 0.6; 3.8	11.9	+- 3.1
8	179	1.6	16.2	+- 0.5; 2.4	11.7	+- 0.6; 3.8	11.7	+- 3.0
9	159	2.8	15.7	+- 0.5; 2.4	11.2	+- 0.6; 3.7	10.5	+- 2.8
10	187	8.4	17.2	+- 0.5; 2.6	12.7	+- 0.6; 3.9	11.5	+- 3.0
11	173	4.4	15.3	+- 0.5; 2.3	10.9	+- 0.6; 3.7	11.8	+- 3.1
12	196	4.2	15.9	+- 0.5; 2.4	11.4	+- 0.6; 3.8	12.3	+- 1.7
13	198	8.6	15.8	+- 0.5; 2.4	11.4	+- 0.6; 3.7	10.7	+- 2.7
14	185	10.0	16.9	+- 0.5; 2.5	12.5	+- 0.6; 3.9	13.9	+- 1.7
15	171	11.0	16.4	+- 0.5; 2.5	12.0	+- 0.6; 3.8	11.0	+- 2.8
16	154	8.2	16.9	+- 0.5; 2.5	12.4	+- 0.6; 3.8	11.7	+- 2.9
17	126	6.3	17.2	+- 0.5; 2.6	12.7	+- 0.6; 3.9	12.7	+- 1.8
18	220	4.6	16.3	+- 0.5; 2.4	11.9	+- 0.6; 3.8	10.9	+- 2.9
19	231	2.3	16.5	+- 0.5; 2.5	12.1	+- 0.6; 3.8	11.1	+- 2.6
20	211	1.6	15.4	+- 0.5; 2.3	11.0	+- 0.6; 3.7	10.7	+- 2.6
22	258	1.5	16.4	+- 0.5; 2.5	11.9	+- 0.6; 3.8	11.3	+- 2.8
23	271	1.2	14.0	+- 0.4; 2.1	9.6	+- 0.5; 3.6	11.2	+- 3.1
24	297	1.3	Missing Dosimeter		No Net Data		11.9	+- 3.3
25	318	1.5	15.2	+- 0.5; 2.3	10.8	+- 0.6; 3.7	10.9	+- 3.0
26	341	3.2	18.9	+- 0.6; 2.8	14.4	+- 0.7; 4.0	13.2	+- 1.8
27	330	4.6	16.3	+- 0.5; 2.4	11.9	+- 0.6; 3.8	11.9	+- 3.1
28	358	3.2	14.6	+- 0.4; 2.2	10.2	+- 0.5; 3.6	11.1	+- 2.9
29	4	1.8	16.6	+- 0.5; 2.5	12.1	+- 0.6; 3.8	11.5	+- 2.9
30	19	0.8	15.8	+- 0.5; 2.4	11.3	+- 0.6; 3.7	11.5	+- 1.3
31	69	1.4	19.3	+- 0.6; 2.9	14.8	+- 0.7; 4.1	11.9	+- 3.2
32	78	2.5	15.6	+- 0.5; 2.3	11.1	+- 0.6; 3.7	10.9	+- 1.6
33	85	2.2	14.2	+- 0.4; 2.1	9.8	+- 0.5; 3.6	10.7	+- 2.7
34	38	1.7	15.5	+- 0.5; 2.3	11.0	+- 0.6; 3.7	11.6	+- 1.5
35	24	1.9	15.6	+- 0.5; 2.3	11.2	+- 0.6; 3.7	12.4	+- 3.5
36	50	3.0	15.3	+- 0.5; 2.3	10.9	+- 0.6; 3.7	12.7	+- 2.0
37	46	4.8	15.1	+- 0.5; 2.3	10.7	+- 0.6; 3.7	11.2	+- 1.4
38	27	4.0	16.7	+- 0.5; 2.5	12.2	+- 0.6; 3.8	12.4	+- 3.2
39	12	8.9	16.4	+- 0.5; 2.5	11.9	+- 0.6; 3.8	11.9	+- 2.9
40	10	8.7	15.4	+- 0.5; 2.3	10.9	+- 0.6; 3.7	11.0	+- 2.8
41	3	9.9	17.6	+- 0.5; 2.6	13.1	+- 0.6; 3.9	11.8	+- 3.3
42	38	10.0	16.4	+- 0.5; 2.5	12.0	+- 0.6; 3.8	12.4	+- 1.6
43	46	9.1	18.7	+- 0.6; 2.8	14.2	+- 0.6; 4.0	14.1	+- 3.5
44	73	6.5	15.4	+- 0.5; 2.3	10.9	+- 0.6; 3.7	10.8	+- 2.8
45	79	6.0	16.8	+- 0.5; 2.5	12.3	+- 0.6; 3.8	12.3	+- 3.1
46	278	20.0	16.8	+- 0.5; 2.5	12.3	+- 0.6; 3.8	12.3	+- 2.9
47	278	20.0	17.0	+- 0.5; 2.5	12.5	+- 0.6; 3.9	12.4	+- 2.9

Transit Dose = 4.2 +- 0.4; 3.0

OYSTER CREEK
For the period 930915-940202

TLD Direct Radiation Environmental Monitoring

Azimuth (degrees)	Ave. Exposure Rate (mR/Std.Qtr.) +- Std.Dev.	Number In Group
348.76 - 11.25 N	11.6 +- 1.3	4
11.26 - 33.75 NNE	11.7 +- 0.5	4
33.76 - 56.25 NE	11.8 +- 1.5	5
56.26 - 78.75 ENE	12.3 +- 2.2	3
78.76 - 101.25 E	11.0 +- 1.8	2
101.26 - 123.75 ESE	11.6 +- 0.9	2
123.76 - 146.25 SE	11.9 +- 0.8	4
146.26 - 168.75 SSE	11.7 +- 0.6	3
168.76 - 191.25 S	12.0 +- 0.6	6
191.26 - 213.75 SSW	11.3 +- 0.3	3
213.76 - 236.25 SW	12.0 +- 0.2	2
236.26 - 258.75 WSW	11.9 +- 0.0	1
258.76 - 281.25 W	9.6 +- 0.0	1
281.26 - 303.75 WNW	No Data +- No Data	0
303.76 - 326.25 NW	10.8 +- 0.0	1
326.26 - 348.75 NNW	13.1 +- 1.8	2

Distance From Reactor (miles)	Ave. Exposure Rate (mR/Std.Qtr.) +- Std.Dev.	Number In Group
0 - 2	11.6 +- 1.1	16
2 - 5	11.5 +- 1.1	14
> 5	12.2 +- 0.9	13
Upwind Control	12.4 +- 0.1	2

OYSTER CREEK
TLD Direct Radiation Environmental Monitoring

NRC Station	Location		Description
	Azimuth Degree	Distance / Mile	
1	141	0.5	BAY PARKWAY AVE.
2	120	0.9	BAY PARKWAY AVE.
3	105	1.5	COMPASS ROAD
4	127	1.5	NORTH OF FRESH CREEK
5	137	1.3	LIGHTHOUSE ROAD
6	158	1.2	WARETOWN SUBSTATION
7	176	2.2	WARETOWN SUBSTATION
8	179	1.6	AHEARNS SEAFOOD MARKET
9	159	2.8	BARNEGAT BEACH
10	187	8.4	BAYSHORE DRIVE
11	173	4.4	BAYSHORE DRIVE
12	196	4.2	BARNEGATE ELEMENTARY SCHOOL
13	198	8.6	MONAHAWKIN
14	185	10.0	MARGUS MARINA
15	171	11.0	LONG BEACH BLVD.&8TH ST.
16	154	8.2	LONG BEACH BLVD.& 70TH ST.
17	126	6.3	6TH AND BAY AVE.
18	220	4.6	BARNEGAT ESTATES
19	231	2.3	GARDEN STATE PARKWAY INTERCHANGE#69
20	211	1.6	ROUTE 532(WARETOWN CREEK)
22	258	1.5	GARDEN STATE PARKWAY
23	271	1.2	GARDEN STATE PARKWAY
24	297	1.3	GARDEN STATE PARKWAY
25	318	1.5	GARDEN STATE PARKWAY
26	341	3.2	PARKSIDE DRIVE
27	330	4.6	LACEY ROAD
28	358	3.2	LACEY TOWNSHIP MUNICIPAL BLDG.
29	4	1.8	LAKE BARNEGAT SOUTH SHORE
30	19	0.8	CLEAR WATER DRIVE
31	69	1.4	BEACH BLVD.
32	78	2.5	BEACH BLVD.
33	85	2.2	BEACH BLVD.
34	38	1.7	BAY AVE.
35	24	1.9	LACEY ROAD
36	50	3.0	SUNRISE BLVD.
37	46	4.8	LAUREL BLVD.
38	27	4.0	LANOKA FIRE AND FIRST AID STATION
39	12	8.9	ADMIRAL FARRAGUT ACADEMY
40	10	8.7	PROSPECT AVE.
41	3	9.9	FRANKLIN AVE.
42	38	10.0	J STREET
43	46	9.1	ISLAND BEACH STATE PARK
44	73	6.5	ISLAND BEACH STATE PARK
45	79	6.0	ISLAND BEACH STATE PARK
46	278	20.0	LEBANON STATE PARK
47	278	20.0	LEBANON STATE PARK

NRC TLD DOSES FOR OYSTER CREEK AREA



Miles

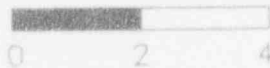

Legend

- Water
- Highways
- Railroads
- Roads
- Plant site

PALISADES

TLD Direct Radiation Environmental Monitoring
 For the period 930914-940201 141 Days
 Field Time: 92 Days

NRC Sta	Location Azimuth/Dist (Deg)/(Mi)	Gross Exposure (mR) +-Rdm; Tot.	Net Exposure Rate (mR/Std. Qtr.) +-Rdm; Tot.	Hist. Range Net Exp Rate +-1 Std Dev
1	195 4.9	19.7 +- 0.6; 3.0	13.7 +- 0.7; 4.2	13.6 +- 2.0
2	173 4.6	18.1 +- 0.5; 2.7	12.1 +- 0.7; 4.1	14.2 +- 2.3
3	156 3.9	21.7 +- 0.6; 3.2	15.6 +- 0.7; 4.4	15.2 +- 1.9
4	132 4.6	20.8 +- 0.6; 3.1	14.7 +- 0.7; 4.3	14.2 +- 2.0
5	118 3.3	22.1 +- 0.7; 3.3	16.0 +- 0.8; 4.5	15.1 +- 2.3
6	152 1.8	17.2 +- 0.5; 2.6	11.2 +- 0.6; 4.0	14.0 +- 2.1
7	196 2.2	19.5 +- 0.6; 2.9	13.5 +- 0.7; 4.2	13.6 +- 2.0
8	178 1.6	19.0 +- 0.6; 2.9	13.0 +- 0.7; 4.2	14.6 +- 2.2
9	200 0.9	20.0 +- 0.6; 3.0	14.0 +- 0.7; 4.3	14.0 +- 2.1
10	124 1.8	18.1 +- 0.5; 2.7	12.1 +- 0.7; 4.1	14.5 +- 2.8
11	107 1.6	21.3 +- 0.6; 3.2	15.2 +- 0.7; 4.4	14.6 +- 2.0
12	90 1.5	17.6 +- 0.5; 2.6	11.6 +- 0.6; 4.0	13.7 +- 2.2
13	65 1.7	21.1 +- 0.6; 3.2	15.1 +- 0.7; 4.4	14.2 +- 2.0
14	51 1.9	Missing Dosimeter	No Net Data	14.0 +- 1.9
15	74 3.7	18.5 +- 0.6; 2.8	12.5 +- 0.7; 4.1	13.2 +- 2.4
16	90 3.6	17.7 +- 0.5; 2.7	11.8 +- 0.7; 4.0	13.2 +- 2.4
17	98 10.0	20.6 +- 0.6; 3.1	14.5 +- 0.7; 4.3	15.2 +- 2.0
18	47 4.5	21.8 +- 0.7; 3.3	15.7 +- 0.7; 4.4	16.0 +- 2.0
19	23 1.5	17.2 +- 0.5; 2.6	11.2 +- 0.6; 4.0	13.2 +- 2.6
20	32 4.8	21.2 +- 0.6; 3.2	15.2 +- 0.7; 4.4	15.8 +- 2.4
21	29 7.0	20.9 +- 0.6; 3.1	14.8 +- 0.7; 4.3	15.0 +- 1.8
22	99 15.0	20.9 +- 0.6; 3.1	14.9 +- 0.7; 4.4	15.4 +- 2.2
23	98 18.0	21.2 +- 0.6; 3.2	15.2 +- 0.7; 4.4	15.3 +- 2.0
24	98 18.0	20.3 +- 0.6; 3.0	14.3 +- 0.7; 4.3	15.2 +- 2.2

Transit Dose = 5.7 +- 0.4; 3.2

PALJSADES

For the period 930914-940201

TLD Direct Radiation Environmental Monitoring

Azimuth (degrees)	Ave. Exposure Rate (mR/Std.Qtr.) +- Std.Dev.	Number In Group
348.76 - 11.25 N	No Data +- No Data	0
11.26 - 33.75 NNE	13.7 +- 2.2	3
33.76 - 56.25 NE	15.7 +- 0.0	1
56.26 - 78.75 ENE	13.8 +- 1.8	2
78.76 - 101.25 E	12.6 +- 1.7	3
101.26 - 123.75 ESE	15.6 +- 0.5	2
123.76 - 146.25 SE	13.4 +- 1.8	2
146.26 - 168.75 SSE	13.4 +- 3.1	2
168.76 - 191.25 S	12.5 +- 0.6	2
191.26 - 213.75 SSW	13.7 +- 0.2	3
213.76 - 236.25 SW	No Data +- No Data	0
236.26 - 258.75 WSW	No Data +- No Data	0
258.76 - 281.25 W	No Data +- No Data	0
281.26 - 303.75 WNW	No Data +- No Data	0
303.76 - 326.25 NW	No Data +- No Data	0
326.26 - 348.75 NNW	No Data +- No Data	0

Distance From Reactor (miles)	Ave. Exposure Rate (mR/Std.Qtr.) +- Std.Dev.	Number In Group
0 - 2	12.9 +- 1.7	8
2 - 5	14.1 +- 1.6	10
> 5	14.7 +- 0.2	2
Upwind Control	14.8 +- 0.5	3

PALISADES
TLD Direct Radiation Environmental Monitoring

NRC Station	Location		Description
	Azimuth Degree	Distance / Mile	
1	195	4.9	BLJE STAR HWY. (US 33)
2	173	4.6	76TH ST.
3	156	3.9	76TH ST. & 38TH AVE.
4	132	4.6	36TH AVE.
5	118	3.3	COUNTY RD. 378 (30TH AVE.)
6	152	1.8	77.5 ST. & 30TH AVE.
7	196	2.2	32ND AVE.
8	178	1.6	BLUE STAR HWY. (US 33)
9	200	0.9	PALISADES PARK COUNTRY CLUB
10	124	1.8	28TH AVE. & 76TH ST.
11	107	1.6	76TH ST.
12	90	1.5	76TH ST. & 24TH ST.
13	65	1.7	76TH ST.
14	51	1.9	76TH ST.
15	74	3.7	72ND ST. & COUNTY RD. 380 (20TH AVE.)
16	90	3.6	72ND ST. & 24TH AVE.
17	98	10.0	COUNTY RD. 378
18	47	4.5	12TH AVE.
19	23	1.5	18TH AVE.
20	32	4.8	MICHIGAN 43 & BLUE STAR HWY. (US 33)
21	29	7.0	PHOENIX RD.
22	99	15.0	MICHIGAN 43
23	98	18.0	MICHIGAN 43
24	98	18.0	MICHIGAN 43

NRC TLD DOSES FOR PALISADES AREA

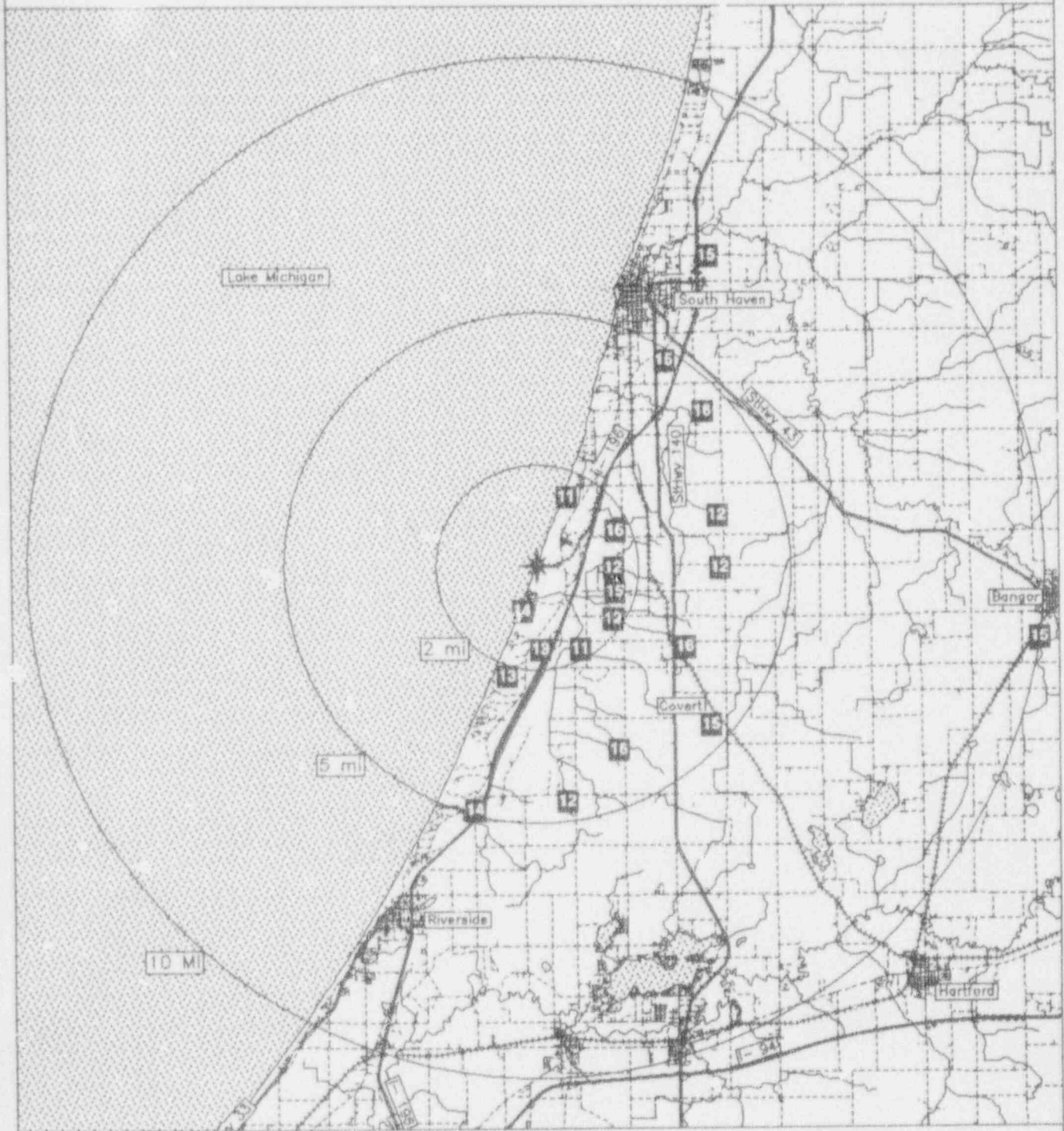

Miles

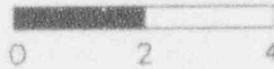

Legend

Water

Highways

Railroads

Roads

Plant..site

PALO VERDE

TLD Direct Radiation Environmental Monitoring

For the period 930913-940127 137 Days

Field Time: 91 Days

NRC Sta	Location Azimuth/Dist (Deg)/(Mi)		Gross Exposure (mR) +-Rdm; Tot.	Net Exposure Rate (mR/Std. Qtr.) +-Rdm; Tot.	Hist. Range Net Exp Rate +-1 Std Dev
1	74	23.0	24.3 +- 0.7; 3.6	19.4 +- 0.8; 4.7	20.1 +- 1.6
2	92	21.0	24.3 +- 0.7; 3.6	19.3 +- 0.8; 4.7	20.8 +- 1.9
3	89	15.0	25.4 +- 0.8; 3.8	20.4 +- 0.8; 4.8	20.2 +- 1.9
4	103	11.0	24.4 +- 0.7; 3.7	19.4 +- 0.8; 4.7	20.5 +- 1.9
5	140	7.4	25.9 +- 0.8; 3.9	20.9 +- 0.8; 4.9	21.5 +- 1.8
6	142	3.1	24.3 +- 0.7; 3.6	19.4 +- 0.8; 4.7	20.7 +- 1.7
7	162	2.6	25.5 +- 0.8; 3.8	20.5 +- 0.8; 4.8	20.7 +- 1.7
8	168	2.6	25.3 +- 0.8; 3.8	20.3 +- 0.8; 4.8	20.9 +- 1.9
9	193	2.6	27.1 +- 0.8; 4.1	22.1 +- 0.9; 5.0	22.3 +- 1.7
10	215	3.1	27.1 +- 0.8; 4.1	22.1 +- 0.9; 5.0	22.2 +- 1.9
11	200	1.7	26.1 +- 0.8; 3.9	21.1 +- 0.9; 4.9	22.3 +- 1.7
12	214	1.0	25.1 +- 0.8; 3.8	20.1 +- 0.8; 4.8	21.5 +- 1.7
13	242	0.7	27.2 +- 0.8; 4.1	22.2 +- 0.9; 5.0	23.7 +- 2.0
14	263	0.6	25.6 +- 0.8; 3.8	20.6 +- 0.8; 4.8	22.1 +- 1.9
15	295	0.6	25.0 +- 0.8; 3.8	20.1 +- 0.8; 4.8	21.6 +- 1.8
16	325	1.0	25.6 +- 0.8; 3.8	20.6 +- 0.8; 4.8	21.6 +- 1.7
17	347	1.8	26.9 +- 0.8; 4.0	21.9 +- 0.9; 5.0	22.3 +- 1.8
18	C	2.4	27.2 +- 0.8; 4.1	22.2 +- 0.9; 5.0	22.9 +- 1.8
19	18	1.5	24.2 +- 0.7; 3.6	19.2 +- 0.8; 4.7	20.4 +- 1.6
20	37	2.0	26.2 +- 0.8; 3.9	21.2 +- 0.9; 4.9	21.4 +- 1.5
21	58	2.3	26.4 +- 0.8; 4.0	21.4 +- 0.9; 4.9	22.5 +- 1.9
22	75	2.8	27.3 +- 0.8; 4.1	22.3 +- 0.9; 5.0	22.9 +- 1.6
23	93	4.4	26.3 +- 0.8; 4.0	21.4 +- 0.9; 4.9	22.0 +- 1.8
24	101	3.3	Missing Dosimeter	No Net Data	21.8 +- 2.3
25	346	2.9	Damaged Dosimeter	No Net Data	21.8 +- 1.8
26	334	4.3	29.5 +- 0.9; 4.4	24.5 +- 0.9; 5.3	24.3 +- 1.8
27	333	7.9	30.6 +- 0.9; 4.6	25.5 +- 1.0; 5.4	24.6 +- 2.5
28	0	7.0	27.9 +- 0.8; 4.2	22.9 +- 0.9; 5.1	22.6 +- 1.8
29	9	4.2	28.2 +- 0.8; 4.2	23.2 +- 0.9; 5.1	23.6 +- 1.8
30	27	3.6	28.0 +- 0.8; 4.2	23.0 +- 0.9; 5.1	23.2 +- 1.9
31	49	3.5	26.8 +- 0.8; 4.0	21.8 +- 0.9; 5.0	23.5 +- 1.7
32	120	3.3	28.2 +- 0.8; 4.2	23.2 +- 0.9; 5.1	24.2 +- 1.9

Transit Dose = 4.7 +- 0.4; 3.0

PALO VERDE

For the period 930913-940127

TLD Direct Radiation Environmental Monitoring

Azimuth (degrees)	Ave. Exposure Rate (mR/Std.Qtr.) +- Std.Dev.	Number In Group
348.76 - 11.25 N	22.8 +- 0.5	3
11.26 - 33.75 NNE	21.1 +- 2.7	2
33.76 - 56.25 NE	21.5 +- 0.4	2
56.26 - 78.75 ENE	21.9 +- 0.6	2
78.76 - 101.25 E	21.4 +- 0.0	1
101.26 - 123.75 ESE	21.3 +- 2.7	2
123.76 - 146.25 SE	20.1 +- 1.1	2
146.26 - 168.75 SSE	20.4 +- 0.1	2
168.76 - 191.25 S	No Data +- No Data	0
191.26 - 213.75 SSW	21.6 +- 0.7	2
213.76 - 236.25 SW	21.1 +- 1.4	2
236.26 - 258.75 WSW	22.2 +- 0.0	1
258.76 - 281.25 W	20.6 +- 0.0	1
281.26 - 303.75 WNW	20.1 +- 0.0	1
303.76 - 326.25 NW	20.6 +- 0.0	1
326.26 - 348.75 NNW	24.0 +- 1.9	3

Distance From Reactor (miles)	Ave. Exposure Rate (mR/Std.Qtr.) +- Std.Dev.	Number In Group
0 - 2	20.8 +- 0.9	9
2 - 5	22.0 +- 1.3	14
> 5	22.2 +- 2.6	4
Upwind Control	19.7 +- 0.6	3

PALO VERDE
TLD Direct Radiation Environmental Monitoring

NRC Station	Location		Description
	Azimuth / Degree	Distance / Mile	
1	74	23.0	SCOTT LIBBY SCHOOL
2	92	21.0	LIBERTY SCHOOL
3	89	15.0	BUCKEYE
4	103	11.0	PALO VERDE SCHOOL
5	140	7.4	ARLINGTON SCHOOL
6	142	3.1	APS SUBSTATION
7	162	2.6	ELLIOT ROAD (2.2MI.W.OF 355TH AVE.)
8	168	2.6	ELLIOT ROAD RR CROSSING
9	193	2.6	ELLIOT & WINTERSBURG ROAD
10	215	3.1	ELLIOT ROAD RESIDENCE
11	200	1.7	1MI.N.ON WINTERSBURG RD(FROM ELLIOT RD.)
12	214	1.0	1.7MI.N. WINTERSBURG RD(FROM ELLIOT RD.)
13	242	0.7	2MI.N. WINTERSBURG RD(FROM ELLIOT RD.)
14	263	0.6	2.5MI.N. WINTERSBURG RD(FROM ELLIOT RD.)
15	295	0.6	WINTERSBURG RD.(PALO VERDE GATE#2)
16	325	1.0	3.6MI.N.WINTERSBURG RD(FROM ELLIOT RD.)
17	347	1.8	4.7MI.N.WINTERSBURG RD(FROM ELLIOT RD.)
18	0	2.4	WINTERSBURG
19	18	1.5	ED THOMAS RESIDENCE
20	37	2.0	BUCKEYE-SALOME RD.(NEAR GATE#14)
21	58	2.3	GUY POLE(BUCKEYE-SALOME ROAD)
22	75	2.8	ROGERS RES. AT 355TH & SALOME
23	93	4.4	INTERSECT. BUCKEYE-SALOME&339TH AVE.
24	101	3.3	BASELINE ROAD&351ST AVE.
25	346	2.9	NEAR BUCKEYE SALOME&WINTERSBURG RD.
26	334	4.3	INTERSECTION BUCKEYE-SALOME RD.&395TH AVE.
27	333	7.9	TONOPAH
28	0	7.0	RUTH FISHER SCHOOL
29	9	4.2	VAN BUREN & 371ST AVE (STOP SIGN, SE CORNER)
30	27	3.6	BUCKEYE ROAD & 363RD AVE.
31	49	3.5	BUCKEYE ROAD & 355TH AVE.
32	120	3.3	355TH AVE. & DOBBINS ROAD

NRC TLD DOSES FOR PALO VERDE AREA

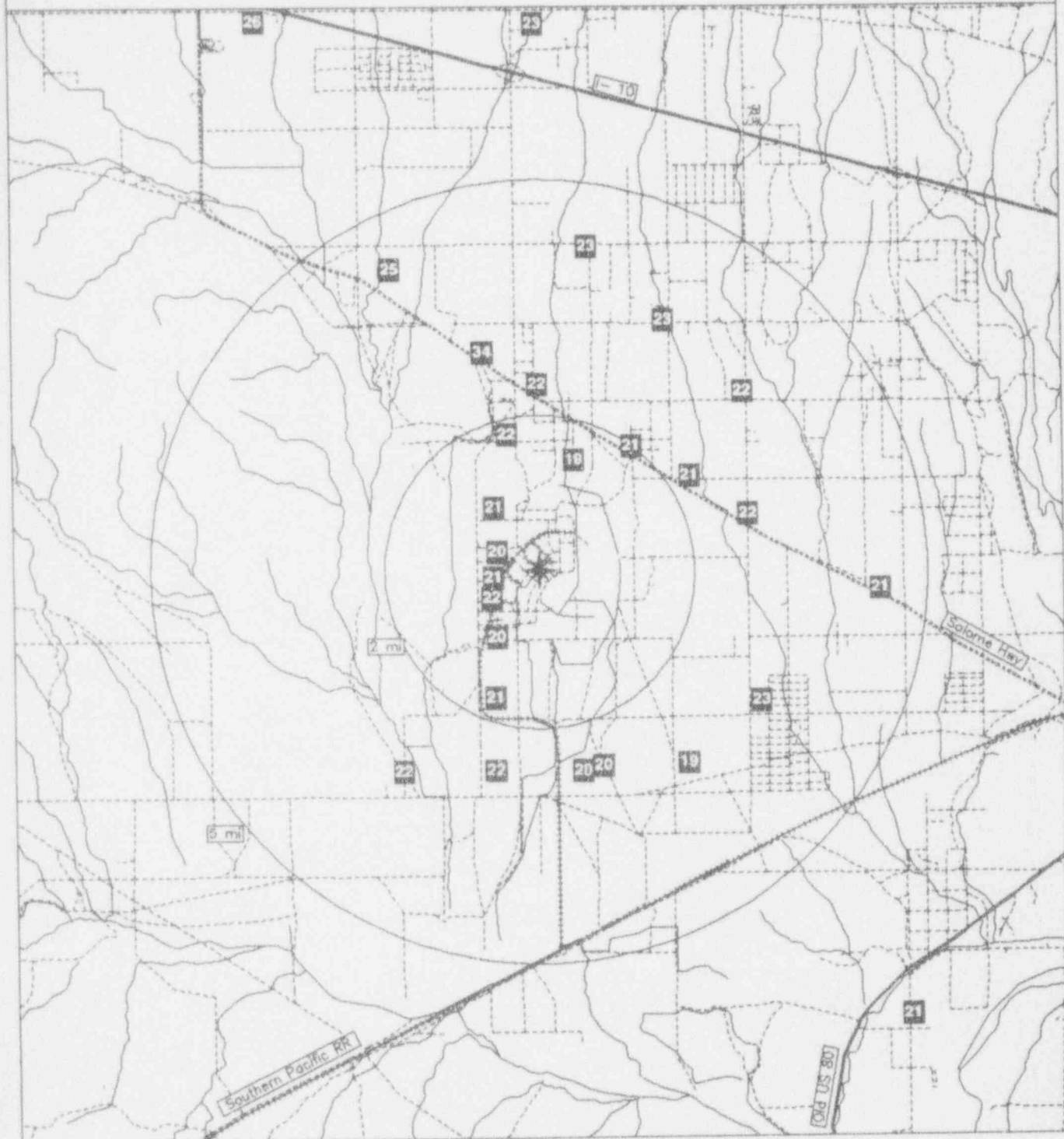

Miles

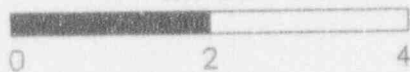

Legend

- Highways
- Railroads
- Roads
- ★ Plant site

PEACH BOTTOM

TLD Direct Radiation Environmental Monitoring

For the period 930915-940127 135 Days

Field Time: 89 Days

NRC Sta	Location		Gross Exposure (mR)		Net Exposure Rate (mR/Std. Qtr.)		Hist. Range Net Exp Rate	
	Azimuth/ (Deg)	Dist (Mi)	+-Rdm; Tot.		+-Rdm; Tot.		+-1 Std Dev	
1	330	10.3	21.8	+- 0.7; 3.3	17.9	+- 0.7; 4.4	15.7	+- 1.4
2	33	10.5	22.0	+- 0.7; 3.3	18.2	+- 0.8; 4.5	17.0	+- 1.2
3	21	4.8	21.5	+- 0.6; 3.2	17.7	+- 0.7; 4.4	17.9	+- 1.4
4	3	5.0	20.9	+- 0.6; 3.1	17.0	+- 0.7; 4.3	17.0	+- 1.5
5	344	4.1	21.5	+- 0.6; 3.2	17.6	+- 0.7; 4.4	17.4	+- 1.4
6	1	2.2	22.7	+- 0.7; 3.4	18.8	+- 0.8; 4.5	19.1	+- 1.4
7	26	2.4	21.3	+- 0.6; 3.2	17.4	+- 0.7; 4.4	18.1	+- 1.3
8	55	2.8	22.6	+- 0.7; 3.4	18.7	+- 0.8; 4.5	18.7	+- 1.5
9	42	2.0	22.2	+- 0.7; 3.3	18.4	+- 0.8; 4.5	17.2	+- 1.2
10	62	1.7	23.6	+- 0.7; 3.5	19.8	+- 0.8; 4.6	18.7	+- 2.6
11	96	1.9	18.3	+- 0.6; 2.8	14.5	+- 0.7; 4.1	19.2	+- 1.4
12	105	2.3	21.3	+- 0.6; 3.2	17.5	+- 0.7; 4.4	14.1	+- 0.9
13	72	5.0	20.6	+- 0.6; 3.1	16.7	+- 0.7; 4.3	16.8	+- 1.6
14	85	4.6	23.1	+- 0.7; 3.5	19.2	+- 0.8; 4.6	18.7	+- 1.6
15	109	4.3	23.0	+- 0.7; 3.4	19.1	+- 0.8; 4.6	19.2	+- 1.6
16	130	4.6	17.3	+- 0.5; 2.6	13.4	+- 0.6; 3.9	13.7	+- 1.5
17	157	8.9	17.8	+- 0.5; 2.7	13.9	+- 0.6; 4.0	15.4	+- 1.4
18	163	4.6	20.9	+- 0.6; 3.1	17.0	+- 0.7; 4.3	16.6	+- 1.3
19	183	3.9	23.2	+- 0.7; 3.5	19.4	+- 0.8; 4.6	18.9	+- 1.3
20	201	4.8	21.9	+- 0.7; 3.3	18.1	+- 0.7; 4.4	18.8	+- 1.7
21	196	2.3	23.3	+- 0.7; 3.5	19.5	+- 0.8; 4.6	19.2	+- 1.6
22	182	1.7	22.6	+- 0.7; 3.4	18.8	+- 0.8; 4.5	18.7	+- 1.3
23	157	1.8	25.0	+- 0.8; 3.8	21.2	+- 0.8; 4.8	21.6	+- 1.8
24	219	1.8	25.5	+- 0.8; 3.8	21.7	+- 0.8; 4.9	20.7	+- 1.5
25	249	1.7	24.4	+- 0.7; 3.7	20.6	+- 0.8; 4.7	19.7	+- 1.5
26	269	1.8	24.8	+- 0.7; 3.7	21.0	+- 0.8; 4.8	20.3	+- 1.6
27	286	1.9	21.7	+- 0.7; 3.3	17.9	+- 0.7; 4.4	17.6	+- 0.9
28	323	1.8	20.1	+- 0.6; 3.0	16.2	+- 0.7; 4.2	16.1	+- 1.5
29	286	3.6	25.0	+- 0.8; 3.8	21.2	+- 0.8; 4.8	21.2	+- 1.3
30	262	4.0	25.4	+- 0.8; 3.8	21.6	+- 0.8; 4.9	20.7	+- 1.6
31	261	9.9	Damaged Dosimeter		No Net Data		21.2	+- 1.5
32	247	3.2	22.3	+- 0.7; 3.3	18.4	+- 0.8; 4.5	18.5	+- 1.3
33	235	3.6	17.6	+- 0.5; 2.6	13.7	+- 0.6; 4.0	13.9	+- 1.4
34	319	4.9	24.3	+- 0.7; 3.6	20.5	+- 0.8; 4.7	19.6	+- 1.5
35	149	0.7	21.7	+- 0.7; 3.3	17.8	+- 0.7; 4.4	17.6	+- 1.4
36	147	17.9	18.1	+- 0.5; 2.7	14.2	+- 0.6; 4.0	14.0	+- 1.0
37	147	17.9	18.7	+- 0.6; 2.8	14.8	+- 0.7; 4.1	14.7	+- 1.3
38	147	17.9	18.1	+- 0.5; 2.7	14.2	+- 0.6; 4.0	14.5	+- 1.1

Transit Dose = 4.0 +- 0.3; 2.9

PEACH BOTTOM

For the period 930915-940127

TLD Direct Radiation Environmental Monitoring

Azimuth (degrees)	Ave. Exposure Rate (mR/Std.Qtr.) +- Std.Dev.	Number In Group
348.76 - 11.25 N	17.9 +- 1.3	2
11.26 - 33.75 NNE	17.7 +- 0.4	3
33.76 - 56.25 NE	18.5 +- 0.3	2
56.26 - 78.75 ENE	18.3 +- 2.2	2
78.76 - 101.25 E	16.8 +- 3.4	2
101.26 - 123.75 ESE	18.3 +- 1.2	2
123.76 - 146.25 SE	13.4 +- 0.0	1
146.26 - 168.75 SSE	17.5 +- 3.0	4
168.76 - 191.25 S	19.1 +- 0.5	2
191.26 - 213.75 SSW	18.8 +- 1.0	2
213.76 - 236.25 SW	17.7 +- 5.7	2
236.26 - 258.75 WSW	19.5 +- 1.5	2
258.76 - 281.25 W	21.3 +- 0.4	2
281.26 - 303.75 WNW	19.5 +- 2.4	2
303.76 - 326.25 NW	18.3 +- 3.0	2
326.26 - 348.75 NNW	17.8 +- 0.2	2

Distance From Reactor (miles)	Ave. Exposure Rate (mR/Std.Qtr.) +- Std.Dev.	Number In Group
0 - 2	18.9 +- 2.3	11
2 - 5	18.1 +- 2.1	20
> 5	16.7 +- 2.4	3
Upwind Control	14.4 +- 0.3	3

PEACH BOTTOM
 TLD Direct Radiation Environmental Monitoring

NRC Station	Location		Description
	Azimuth / Degree	Distance / Mile	
1	330	10.3	PEQUEA
2	33	10.5	QUARRYVILLE
3	21	4.8	RIVER ROAD
4	3	5.0	RIVER ROAD & SUSQUEHANNOCK DRIVE
5	344	4.1	RMC ECOLOGICAL LABORATORY
6	1	2.2	DRUMORE
7	26	2.4	HARMONY RIDGE & BALD EAGLE RDS.
8	55	2.8	CHERRY HILL & SLATE HILL RDS.
9	42	2.0	BALD EAGLE RD. 90 DEG. BEND
10	62	1.7	FULTON WEATHER STATION
11	96	1.9	PETERS CREEK
12	105	2.3	PEACH BOTTOM
13	72	5.0	WAKEFIELD
14	85	4.6	PILOTTOWN ROAD
15	109	4.3	PLEASANT GROVE CHURCH
16	130	4.6	ST. PATRICK'S CHAPEL
17	157	8.9	DARLINGTON, MD
18	163	4.6	BROAD CREEK
19	183	3.9	CORNERSTONE CHURCH
20	201	4.8	MOUNT VERNON CHURCH
21	196	2.3	ORCHARD ROAD
22	182	1.7	ORCHARD ROAD & KRICK ROAD
23	157	1.8	ORCHARD CAMPGROUND
24	219	1.8	FLINTVILLE & ATOM ROADS
25	249	1.7	WILEY ROAD
26	269	1.8	AILES ROAD
27	286	1.9	FLINTVILLE & PAPER MILL ROADS
28	323	1.8	COLD CABIN PARK
29	286	3.6	PA74 AND PAPER MILL ROAD
30	262	4.0	SCOTT CREEK
31	261	9.9	REID RESIDENCE
32	247	3.2	LAY ROAD
33	235	3.6	DELTA
34	319	4.9	NORMAN WOOD BRIDGE
35	149	0.7	BURK RESIDENCE
36	147	17.9	HAVRE DE GRACE, MD
37	147	17.9	HAVRE DE GRACE, MD
38	147	17.9	HAVRE DE GRACE, MD

NRC TLD DOSES FOR PEACH BOTTOM AREA

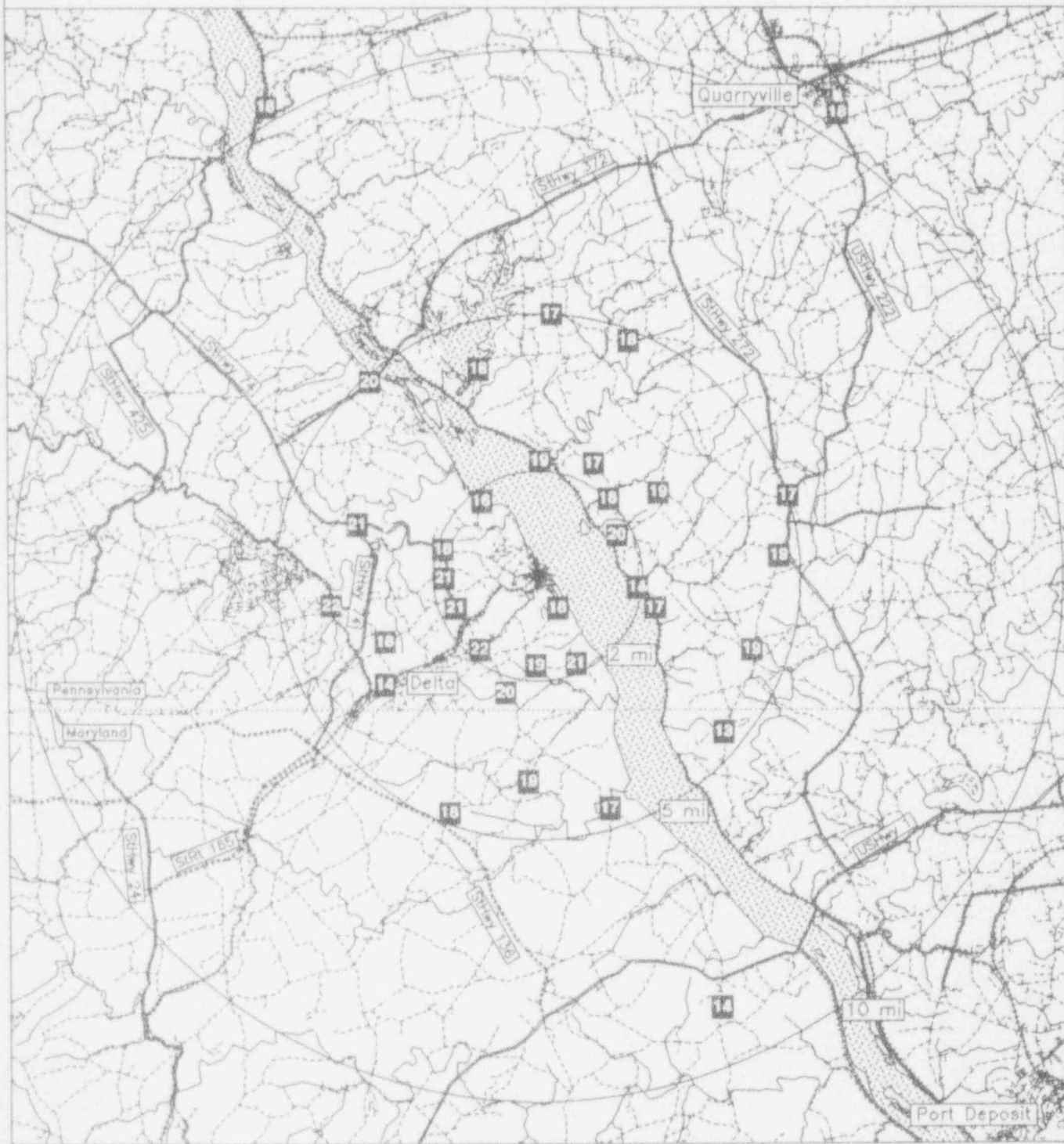

Miles

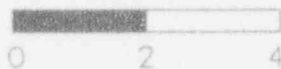

Legend

Water

Railroads

Plant..site

Highways

Roads

PERRY

TLD Direct Radiation Environmental Monitoring

For the period 930914-940202 142 Days

Field Time: 106 Days

NRC Sta	Location		Gross Exposure (mR)		Net Exposure Rate (mR/Std. Qtr.)		Hist. Range Net Exp Rate	
	Azimuth/ (Deg)	Dist (Mi)	+-Rdm; Tot.		+-Rdm; Tot.		+-1 Std Dev	
1	72	5.0	20.1	+- 0.6; 3.0	15.4	+- 0.6; 3.8	16.2	+- 2.1
3	88	5.5	20.7	+- 0.6; 3.1	15.8	+- 0.6; 3.8	16.2	+- 2.1
4	112	6.0	21.6	+- 0.6; 3.2	16.6	+- 0.6; 3.9	17.1	+- 2.2
5	130	4.0	21.4	+- 0.6; 3.2	16.4	+- 0.6; 3.9	16.9	+- 2.4
6	155	5.0	23.1	+- 0.7; 3.5	17.8	+- 0.6; 4.0	19.9	+- 1.6
7	178	5.2	22.2	+- 0.7; 3.3	17.1	+- 0.6; 3.9	17.7	+- 1.9
8	205	4.6	22.7	+- 0.7; 3.4	17.5	+- 0.6; 4.0	17.5	+- 3.5
9	220	5.2	21.2	+- 0.6; 3.2	16.3	+- 0.6; 3.9	16.2	+- 2.0
10	225	7.4	20.6	+- 0.6; 3.1	15.8	+- 0.6; 3.8	17.6	+- 2.1
11	240	5.8	24.0	+- 0.7; 3.6	18.6	+- 0.7; 4.1	18.9	+- 2.2
12	225	19.0	21.8	+- 0.7; 3.3	16.8	+- 0.6; 3.9	16.6	+- 2.4
13	225	19.0	20.6	+- 0.6; 3.1	15.7	+- 0.6; 3.8	16.0	+- 2.3
14	212	12.0	26.5	+- 0.8; 4.0	20.8	+- 0.7; 4.4	22.0	+- 2.3
15	248	1.4	20.6	+- 0.6; 3.1	15.8	+- 0.6; 3.8	16.1	+- 2.2
16	225	0.8	18.3	+- 0.5; 2.7	13.8	+- 0.5; 3.6	16.2	+- 3.2
17	205	0.7	19.7	+- 0.6; 3.0	15.0	+- 0.6; 3.7	14.2	+- 2.0
18	180	0.8	19.6	+- 0.6; 2.9	14.9	+- 0.6; 3.7	15.6	+- 2.3
19	152	1.8	19.2	+- 0.6; 2.9	14.6	+- 0.6; 3.7	16.5	+- 2.3
20	123	1.6	17.5	+- 0.5; 2.6	13.2	+- 0.5; 3.5	14.5	+- 2.1
21	105	1.4	20.4	+- 0.6; 3.1	15.6	+- 0.6; 3.8	14.9	+- 2.1
22	85	1.2	18.8	+- 0.6; 2.8	14.3	+- 0.6; 3.7	16.6	+- 3.3
23	65	1.4	20.5	+- 0.6; 3.1	15.6	+- 0.6; 3.8	16.4	+- 2.3
24	40	0.6	20.7	+- 0.6; 3.1	15.9	+- 0.6; 3.8	15.6	+- 2.3
25	40	0.6	24.5	+- 0.7; 3.7	19.1	+- 0.7; 4.2	18.0	+- 3.7
26	182	2.8	19.6	+- 0.6; 2.9	14.9	+- 0.6; 3.7	16.9	+- 3.2
27	175	2.8	18.1	+- 0.5; 2.7	13.7	+- 0.5; 3.6	16.9	+- 3.4

Transit Dose = 2.0 +- 0.3; 3.2

PERRY

For the period 930914-940202

TLD Direct Radiation Environmental Monitoring

Azimuth (degrees)	Ave. Exposure Rate (mR/Std.Qtr.) +- Std.Dev.	Number In Group
348.76 - 11.25 N	No Data +- No Data	0
11.26 - 33.75 NNE	No Data +- No Data	0
33.76 - 56.25 NE	17.5 +- 2.3	2
56.26 - 78.75 ENE	15.5 +- 0.2	2
78.76 - 101.25 E	15.1 +- 1.1	2
101.26 - 123.75 ESE	15.1 +- 1.8	3
123.76 - 146.25 SE	16.4 +- 0.0	1
146.26 - 168.75 SSE	16.2 +- 2.3	2
168.76 - 191.25 S	15.1 +- 1.4	4
191.26 - 213.75 SSW	16.3 +- 1.8	2
213.76 - 236.25 SW	15.3 +- 1.3	3
236.26 - 258.75 WSW	17.2 +- 2.0	2
258.76 - 281.25 W	No Data +- No Data	0
281.26 - 303.75 WNW	No Data +- No Data	0
303.76 - 326.25 NW	No Data +- No Data	0
326.26 - 348.75 NNW	No Data +- No Data	0

Distance From Reactor (miles)	Ave. Exposure Rate (mR/Std.Qtr.) +- Std.Dev.	Number In Group
0 - 2	15.2 +- 1.5	11
2 - 5	15.9 +- 1.6	6
> 5	16.7 +- 1.1	6
Upwind Control	17.8 +- 2.7	3

PERRY

TLD Direct Radiation Environmental Monitoring

NRC Station	Location		Description
	Azimuth Degree	Distance / Mile	
1	72	5.0	CHAPEL ACROSS FROM REDBIRD RD.
3	88	5.5	HUBBARD RD.-NEAR RT. 20
4	112	6.0	HUBBARD RD (LAKE ST) NEAR RT 84
5	130	4.0	WOOD & S. RIDGE RD (RT 84)
6	155	5.0	TURNEY & RIVER RD
7	178	5.2	WEBB & RIVER RD
8	205	4.6	LANE RD AT RR TRACKS
9	220	5.2	HALE & LEE RDS (NEAR SCH.)
10	225	7.4	FORBES ST-PAINESVILLE NEAR RT 20
11	240	5.8	HARDY RD BY LAKE ERIE
12	225	19.0	ST CLAIR INTL. HYDRA. PARKING LOT
13	225	19.0	ST CLAIR INTL. HYDRA. PARKING LOT
14	212	12.0	AUBURN-CONCORD RDS
15	248	1.4	PARMLY RD PARK BY L. ERIE
16	225	0.8	PARMLY RD ACROSS FM SUBSTATION
17	205	0.7	PARMLY RD ACROSS FR TEST FAC.
18	180	0.8	PARMLY RD ENTRANCE TO PARK LOT
19	152	1.8	RT 20 NEAR PARMLY RD
20	123	1.6	RT 20 - ANTIOCH RD
21	105	1.4	2941 ANTIOCH RD (HOME)
22	85	1.2	2828 ANTIOCH RD (HOME)
23	65	1.4	ANTIOCH RD
24	40	0.6	END LOCKWOOD CIR.
25	40	0.6	LOCKWOOD RD
26	182	2.8	3911 CENTER RD - PERRY
27	175	2.8	4274 MANCHESTER ST - PERRY

NRC TLD DOSES FOR PERRY AREA

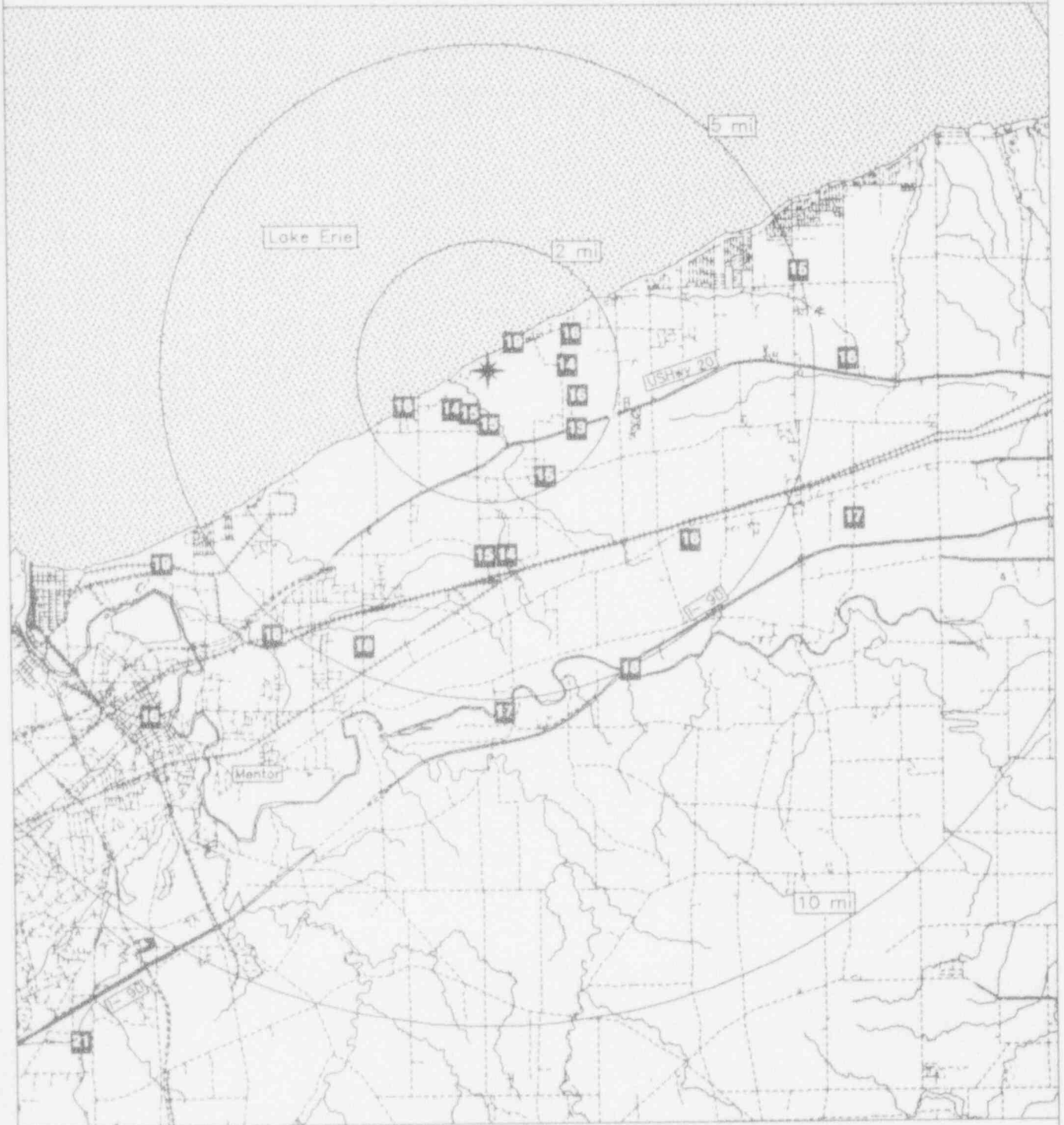

Miles

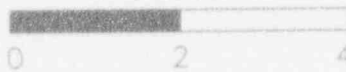

Legend

Water

Highways

Railroads

Roads



Plant site

PILGRIM

TLD Direct Radiation Environmental Monitoring

For the period 930915-940203 142 Days

Field Time: 90 Days

NRC Sta	Location		Gross		Net Exposure Rate		Hist. Range	
	Azimuth/Dist (Deg)/(Mi)		Exposure (mR) +-Rdm; Tot.		(mR/Std. Qtr.) +-Rdm; Tot.		Net Exp Rate +-1 Std Dev	
1	288	0.1	125.6	+- 3.8; 18.8	No Net Data		44.5	+-29.0
2	310	0.2	28.6	+- 0.9; 4.3	No Net Data		16.8	+- 2.7
5	289	0.7	28.1	+- 0.8; 4.2	No Net Data		16.3	+- 2.1
6	261	1.7	26.0	+- 0.8; 3.9	No Net Data		14.5	+- 1.7
7	270	0.5	29.0	+- 0.9; 4.4	No Net Data		18.4	+- 2.5
8	247	0.3	28.3	+- 0.8; 4.2	No Net Data		16.5	+- 1.7
9	224	0.3	28.4	+- 0.9; 4.3	No Net Data		15.0	+- 2.2
10	205	0.3	30.2	+- 0.9; 4.5	No Net Data		16.4	+- 3.4
11	184	0.3	32.0	+- 1.0; 4.8	No Net Data		17.9	+- 3.4
12	159	0.4	27.2	+- 0.8; 4.1	No Net Data		16.0	+- 2.4
13	146	0.7	23.7	+- 0.7; 3.6	No Net Data		13.5	+- 1.7
14	155	1.0	27.0	+- 0.8; 4.0	No Net Data		15.1	+- 2.5
16	136	1.3	24.1	+- 0.7; 3.6	No Net Data		13.7	+- 1.6
18	212	0.8	24.2	+- 0.7; 3.6	No Net Data		14.1	+- 4.4
19	232	1.0	25.0	+- 0.7; 3.7	No Net Data		13.6	+- 1.7
21	256	1.6	23.7	+- 0.7; 3.6	No Net Data		13.4	+- 2.5
22	130	2.5	24.7	+- 0.7; 3.7	No Net Data		13.9	+- 2.0
23	146	3.4	25.9	+- 0.8; 3.9	No Net Data		13.3	+- 2.1
25	168	1.5	26.5	+- 0.8; 4.0	No Net Data		14.1	+- 1.8
26	180	1.3	23.1	+- 0.7; 3.5	No Net Data		12.2	+- 1.8
27	231	1.8	23.5	+- 0.7; 3.5	No Net Data		13.5	+- 1.8
30	153	2.2	28.5	+- 0.9; 4.3	No Net Data		16.1	+- 1.7
31	179	2.5	24.9	+- 0.7; 3.7	No Net Data		13.0	+- 1.8
32	217	2.6	22.7	+- 0.7; 3.4	No Net Data		12.2	+- 2.0
33	234	2.5	24.2	+- 0.7; 3.6	No Net Data		13.7	+- 2.2
37	264	4.2	25.3	+- 0.8; 3.8	No Net Data		14.4	+- 1.8
38	152	3.5	23.2	+- 0.7; 3.5	No Net Data		13.0	+- 2.3
39	155	5.3	23.0	+- 0.7; 3.5	No Net Data		11.8	+- 1.4
40	272	4.6	26.3	+- 0.8; 3.9	No Net Data		15.1	+- 1.8
42	281	4.6	24.7	+- 0.7; 3.7	No Net Data		13.2	+- 2.0
43	291	5.8	26.5	+- 0.8; 4.0	No Net Data		15.8	+- 1.8
45	197	6.0	24.4	+- 0.7; 3.7	No Net Data		12.7	+- 2.5
47	301	26.0	28.0	+- 0.8; 4.2	No Net Data		15.0	+- 1.9
48	301	26.0	29.6	+- 0.9; 4.4	No Net Data		15.8	+- 2.1
49	301	26.0	26.1	+- 0.8; 3.9	No Net Data		14.6	+- 1.8

No Transit Dose Calculated. (Transit Control Is Damaged.)

PILGRIM

For the period 930915-940203

TLD Direct Radiation Environmental Monitoring

Azimuth (degrees)	Ave. Exposure Rate (mR/Std.Qtr.) +- Std.Dev.	Number In Group
348.76 - 11.25 N	No Data +- No Data	0
11.26 - 33.75 NNE	No Data +- No Data	0
33.76 - 56.25 NE	No Data +- No Data	0
56.26 - 78.75 ENE	No Data +- No Data	0
78.76 - 101.25 E	No Data +- No Data	0
101.26 - 123.75 ESE	No Data +- No Data	0
123.76 - 146.25 SE	15.6 +- 0.6	4
146.26 - 168.75 SSE	16.4 +- 1.4	6
168.76 - 191.25 S	16.9 +- 3.0	3
191.26 - 213.75 SSW	16.6 +- 2.2	3
213.76 - 236.25 SW	15.7 +- 1.4	5
236.26 - 258.75 WSW	16.5 +- 2.0	2
258.76 - 281.25 W	16.6 +- 1.1	5
281.26 - 303.75 WNW	38.1 +- 36.0	3
303.76 - 326.25 NW	18.1 +- 0.0	1
326.26 - 348.75 NNW	No Data +- No Data	0

Distance From Reactor (miles)	Ave. Exposure Rate (mR/Std.Qtr.) +- Std.Dev.	Number In Group
0 - 2	20.2 +- 14.5	19
2 - 5	15.9 +- 1.0	10
> 5	15.6 +- 1.1	3
Upwind Control	17.7 +- 1.1	3

PILGRIM
TLD Direct Radiation Environmental Monitoring

NRC Station	Location		Description
	Azimuth / Degree	Distance / Mile	
1	288	0.1	PILGRIM OVERLOOK
2	310	0.2	STATION PARKING AREA
5	289	0.7	ROCKY HILL ROAD
6	261	1.7	ROCKY HILL ROAD
7	270	0.5	ROCKY HILL ROAD
8	247	0.3	ROCKY HILL ROAD
9	224	0.3	ROCKY HILL ROAD
10	205	0.3	ROCKY HILL ROAD
11	184	0.3	ROCKY HILL ROAD
12	159	0.4	ROCKY HILL ROAD
13	146	0.7	ROCKY HILL ROAD
14	155	1.0	ROCKY HILL ROAD
16	136	1.3	WHITE HORSE BEACH
18	212	0.8	CLEFT ROCK & RT 3A
19	232	1.0	RT 3A
21	256	1.6	RT 3A
22	130	2.5	MANOMET POINT
23	146	3.4	MANOMET ELEMENTARY
25	168	1.5	RT 3A / BALLFIELD
26	180	1.3	RT 3A
27	231	1.8	DOTON ROAD
30	153	2.2	NEW BEDFORD SUBSTATION
31	179	2.5	BEAVER DAM ROAD
32	217	2.6	OLD SANDWICH ROAD
33	234	2.5	SANDWICH & CLIFFORD
37	264	4.2	SANDWICH ROAD SUBSTATION
38	152	3.5	CHURCH HILL LANDING
39	155	5.3	SURFSIDE BEACH
40	272	4.6	JORDAN HOSPITAL
42	281	4.6	PLYMOUTH BRANCH LIBRARY / QUINCY COLLEGE
43	291	5.8	NORTH PLYMOUTH
45	197	6.0	SHAW RESIDENCE
47	301	26.0	WEYMOUTH
48	301	26.0	WEYMOUTH
49	301	26.0	WEYMOUTH

NRC TLD DOSES FOR PILGRIM AREA

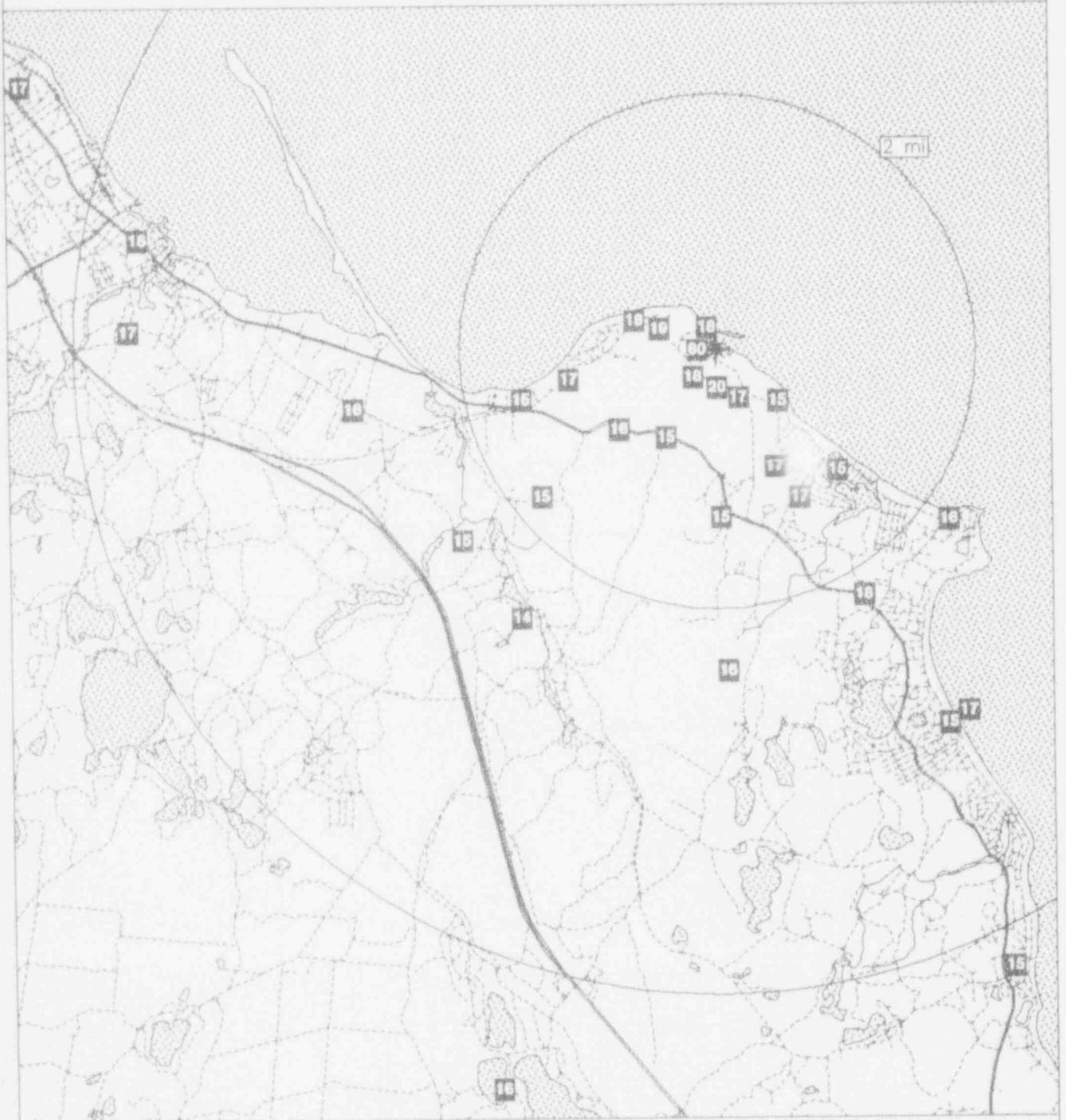

Miles

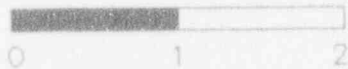

Legend

- Water
- Highways
- Railroads
- Roads
- Plant..site

PRAIRIE ISLAND

TLD Direct Radiation Environmental Monitoring

For the period 930913-940208 149 Days

Field Time: 105 Days

NRC Sta	Location		Gross Exposure (mR)		Net Exposure Rate (mR/Std. Qtr.)		Hist. Range Net Exp Rate	
	Azimuth/Dist (Deg)/(Mi)		+-Rdm; Tot.		+-Rdm; Tot.		+-1 Std Dev	
1	312	16.5	21.3	+- 0.6; 3.2	15.1	+- 0.6; 4.0	17.7	+- 2.2
2	310	15.0	22.0	+- 0.7; 3.3	15.7	+- 0.6; 4.0	16.9	+- 2.1
3	310	15.0	21.5	+- 0.6; 3.2	15.2	+- 0.6; 4.0	17.0	+- 2.3
4	308	5.5	24.1	+- 0.7; 3.6	17.5	+- 0.7; 4.2	17.5	+- 1.9
5	297	4.1	22.4	+- 0.7; 3.4	16.0	+- 0.7; 4.1	16.1	+- 1.9
6	287	1.3	20.6	+- 0.6; 3.1	14.4	+- 0.6; 3.9	16.8	+- 2.2
7	313	0.8	20.8	+- 0.6; 3.1	14.6	+- 0.6; 3.9	15.1	+- 1.8
8	244	0.5	22.8	+- 0.7; 3.4	16.3	+- 0.7; 4.1	16.3	+- 1.9
9	194	0.6	22.8	+- 0.7; 3.4	16.4	+- 0.7; 4.1	16.7	+- 1.6
10	155	0.5	24.3	+- 0.7; 3.7	17.7	+- 0.7; 4.2	17.4	+- 1.8
11	129	1.6	21.6	+- 0.6; 3.2	15.3	+- 0.6; 4.0	15.6	+- 1.7
12	153	1.4	22.7	+- 0.7; 3.4	16.3	+- 0.7; 4.1	16.4	+- 1.6
13	217	0.6	23.6	+- 0.7; 3.5	17.0	+- 0.7; 4.2	16.8	+- 1.8
14	178	0.8	23.8	+- 0.7; 3.6	17.2	+- 0.7; 4.2	16.6	+- 1.8
15	272	1.9	21.1	+- 0.6; 3.2	14.9	+- 0.6; 3.9	15.8	+- 1.9
16	262	4.6	24.6	+- 0.7; 3.7	17.9	+- 0.7; 4.3	17.9	+- 2.4
17	250	4.3	23.7	+- 0.7; 3.6	17.1	+- 0.7; 4.2	17.4	+- 1.9
18	225	4.1	27.0	+- 0.8; 4.0	19.9	+- 0.8; 4.5	17.7	+- 3.1
19	233	6.7	20.6	+- 0.6; 3.1	14.5	+- 0.6; 3.9	15.5	+- 2.0
20	200	4.9	26.3	+- 0.8; 3.9	19.3	+- 0.7; 4.4	18.6	+- 2.1
21	187	4.7	26.4	+- 0.8; 4.0	19.4	+- 0.7; 4.4	19.1	+- 2.2
22	160	4.4	24.0	+- 0.7; 3.6	17.4	+- 0.7; 4.2	17.5	+- 2.1
23	140	4.7	26.0	+- 0.8; 3.9	19.1	+- 0.7; 4.4	18.0	+- 2.0
24	131	6.6	25.2	+- 0.8; 3.8	18.5	+- 0.7; 4.3	17.4	+- 2.0
25	117	4.9	22.8	+- 0.7; 3.4	16.4	+- 0.7; 4.1	16.3	+- 1.9
26	88	1.9	22.7	+- 0.7; 3.4	16.3	+- 0.7; 4.1	16.8	+- 1.8
27	69	1.8	23.6	+- 0.7; 3.5	17.0	+- 0.7; 4.2	16.8	+- 2.2
28	47	1.6	Damaged Dosimeter		No Net Data		17.1	+- 2.2
29	19	1.5	22.7	+- 0.7; 3.4	16.2	+- 0.7; 4.1	15.9	+- 2.0
30	356	1.9	23.3	+- 0.7; 3.5	16.8	+- 0.7; 4.1	16.3	+- 2.2
31	346	2.4	25.9	+- 0.8; 3.9	19.0	+- 0.7; 4.4	18.3	+- 2.1
32	340	3.8	26.3	+- 0.8; 3.9	19.3	+- 0.7; 4.4	19.2	+- 2.1
33	8	4.6	26.5	+- 0.8; 4.0	19.5	+- 0.8; 4.5	19.1	+- 2.0
34	17	4.7	26.5	+- 0.8; 4.0	19.5	+- 0.8; 4.5	18.9	+- 2.2
35	45	11.0	22.9	+- 0.7; 3.4	16.5	+- 0.7; 4.1	16.9	+- 1.8
36	48	4.7	26.3	+- 0.8; 3.9	19.4	+- 0.7; 4.4	18.7	+- 2.1
37	61	4.2	25.6	+- 0.8; 3.8	18.7	+- 0.7; 4.4	19.0	+- 1.9
38	86	4.9	25.4	+- 0.8; 3.8	18.6	+- 0.7; 4.3	18.7	+- 2.1
39	107	9.1	22.1	+- 0.7; 3.3	15.8	+- 0.7; 4.0	16.5	+- 1.9
40	111	3.7	22.0	+- 0.7; 3.3	15.7	+- 0.6; 4.0	16.5	+- 1.8

Transit Dose = 3.7 +- 0.4; 3.3

PRAIRIE ISLAND
For the period 930913-940208

TLD Direct Radiation Environmental Monitoring

Azimuth (degrees)	Ave. Exposure Rate ($\mu\text{R}/\text{Std.Qtr.}$) \pm Std.Dev.	Number In Group
348.76 - 11.25 N	18.2 \pm 1.9	2
11.26 - 33.75 NNE	17.9 \pm 2.3	2
33.76 - 56.25 NE	17.9 \pm 2.0	2
56.26 - 78.75 ENE	17.9 \pm 1.2	2
78.76 - 101.25 E	17.4 \pm 1.6	2
101.26 - 123.75 ESE	15.9 \pm 0.4	3
123.76 - 146.25 SE	17.6 \pm 2.0	3
146.26 - 168.75 SSE	17.1 \pm 0.7	3
168.76 - 191.25 S	18.3 \pm 1.6	2
191.26 - 213.75 SSW	17.9 \pm 2.1	2
213.76 - 236.25 SW	17.2 \pm 2.7	3
236.26 - 258.75 WSW	16.7 \pm 0.6	2
258.76 - 281.25 W	16.4 \pm 2.1	2
281.26 - 303.75 WNW	15.2 \pm 1.1	2
303.76 - 326.25 NW	16.1 \pm 2.0	2
326.26 - 348.75 NNW	19.2 \pm 0.2	2

Distance From Reactor (miles)	Ave. Exposure Rate ($\text{mR}/\text{Std.Qtr.}$) \pm Std.Dev.	Number In Group
0 - 2	16.2 \pm 1.0	14
2 - 5	18.4 \pm 1.4	17
> 5	16.5 \pm 1.5	5
Upwind Control	15.3 \pm 0.3	3

PRAIRIE ISLAND
TLD Direct Radiation Environmental Monitoring

NRC Station	Location		Description
	Azimuth / Degree	Distance / Mile	
1	312	16.5	HASTINGS (MN)
2	310	15.0	HASTINGS (MN)
3	310	15.0	HASTINGS (MN)
4	308	5.5	COUNTY RD. 18
5	297	4.1	COUNTY RD. 18
6	287	1.3	COUNTY RD. 18
7	313	0.8	COUNTY RD. 18/RD. TO RESERVATION
8	244	0.5	COUNTY RD. 18
9	194	0.6	COUNTY RD. 18
10	155	0.5	SUTER RESIDENCE
11	129	1.6	LOCK & DAM 3
12	153	1.4	COUNTY RD. 18
13	217	0.6	COUNTY RD. 18
14	178	0.8	COUNTY RD. 18
15	272	1.9	SOUTH ACCESS RD.
16	262	4.6	NW OF US. 61/COUNTY RD. 18
17	250	4.3	U.S. 61
18	225	4.1	Y - INTERSECT. SECTIONS 13/14/23/24 ADJOIN
19	233	6.7	COUNTY RD. 7 IN WELCH
20	200	4.9	LEESON LANE
21	187	4.7	T - INTERSECTION BETWEEN SECTIONS 29 & 32
22	160	4.4	COUNTY RD. 53
23	140	4.7	TYLER RD.
24	131	6.6	RED WING (CITY HALL)
25	117	4.9	TIMBERLANE RD.
26	88	1.9	LOWER RIVER RD.
27	69	1.8	LOWER RIVER RD.
28	47	1.6	LOWER RIVER RD.
29	19	1.5	LOWER RIVER RD.
30	356	1.9	LOWER RIVER RD.
31	345	2.4	WIND RIVER RD.
32	340	3.8	HOLST RD./AVERY AVE.
33	8	4.6	OAK RIDGE RD./SPRING GREEN RD.
34	17	4.7	COUNTY RD 00
35	45	11.0	ELLSWORTH (WI)
36	48	4.7	COUNTY RD. K
37	61	4.2	NELSON DR.
38	86	4.9	FISHER COULEE RD.
39	107	9.1	HWY. 35 (WI)
40	111	3.7	COUNTY RD. K

NRC TLD DOSES FOR PRAIRIE ISLAND AREA

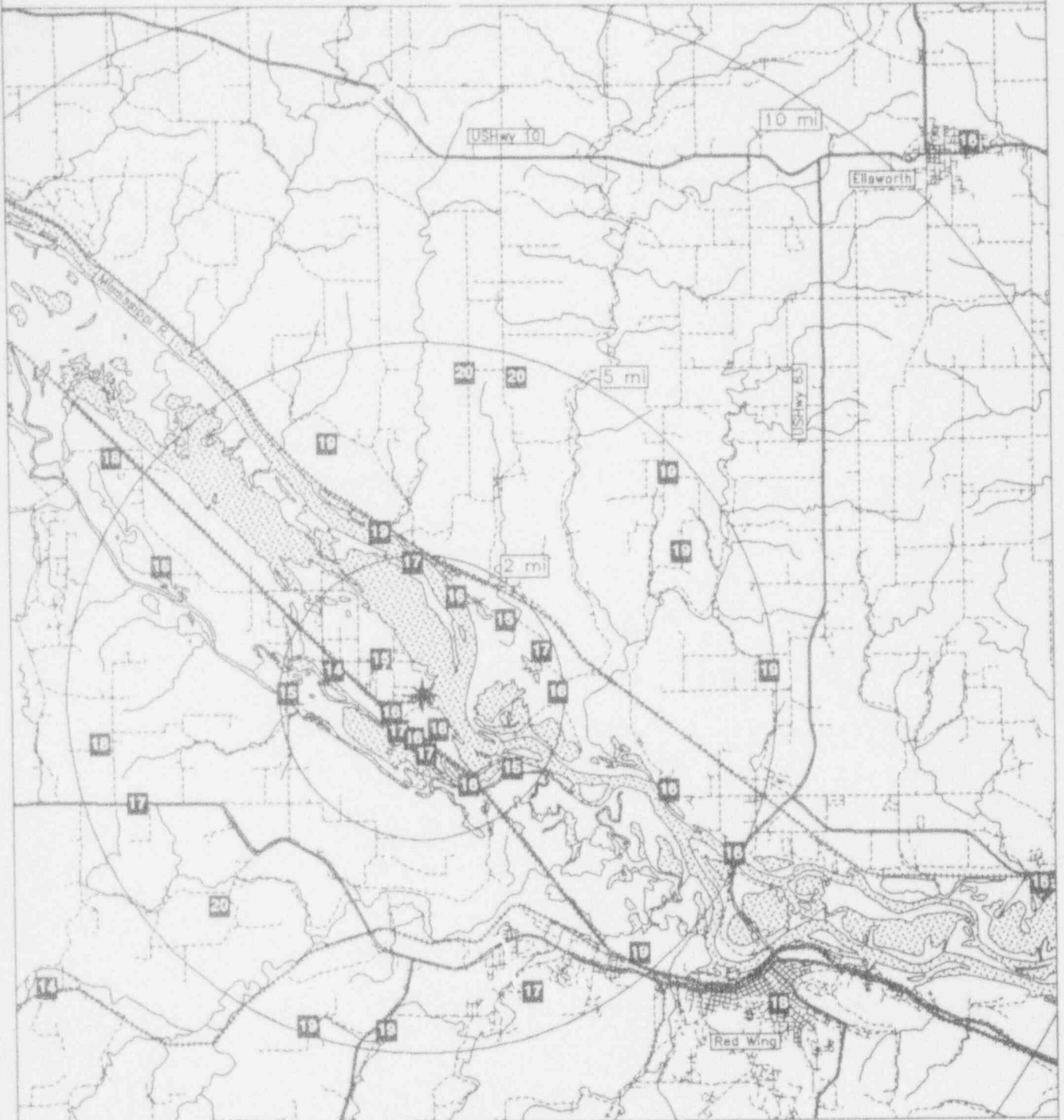

Miles

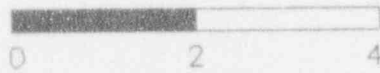

Legend

- Water
- Highways
- Railroads
- Roads
- Plant..site

QUAD CITIES

TLD Direct Radiation Environmental Monitoring

For the period 930913-940201 142 Days

Field Time: 99 Days

NRC Sta	Location		Gross	Net Exposure Rate	Hist. Range
	Azimuth/ (Deg)/(Mi)	Dist (Mi)	Exposure (mR) +-Rdm; Tot.	(mR/Std. Qtr.) +-Rdm; Tot.	Net Exp Rate +-1 Std Dev
1	3	0.7	18.1 +- 0.5; 2.7	13.8 +- 0.6; 3.8	15.0 +- 1.6
2	16	1.2	21.5 +- 0.6; 3.2	16.9 +- 0.7; 4.1	17.4 +- 2.2
3	35	1.7	19.7 +- 0.6; 3.0	15.2 +- 0.6; 3.9	15.1 +- 1.6
4	45	1.1	20.6 +- 0.6; 3.1	16.0 +- 0.6; 4.0	15.9 +- 1.6
5	90	0.8	21.3 +- 0.6; 3.2	16.6 +- 0.7; 4.1	15.6 +- 1.7
6	138	1.1	22.1 +- 0.7; 3.3	17.4 +- 0.7; 4.1	16.2 +- 1.7
7	175	1.8	20.5 +- 0.6; 3.1	15.9 +- 0.6; 4.0	16.3 +- 1.8
8	165	2.0	21.8 +- 0.7; 3.3	17.1 +- 0.7; 4.1	16.4 +- 1.5
9	186	3.1	20.3 +- 0.6; 3.0	15.7 +- 0.6; 4.0	15.9 +- 1.5
10	188	7.7	16.6 +- 0.5; 2.5	12.4 +- 0.5; 3.6	16.2 +- 4.6
11	156	4.2	22.1 +- 0.7; 3.3	17.4 +- 0.7; 4.1	16.8 +- 1.7
12	142	4.8	21.9 +- 0.7; 3.3	17.2 +- 0.7; 4.1	16.5 +- 1.9
13	123	3.3	21.4 +- 0.6; 3.2	16.7 +- 0.7; 4.1	16.2 +- 1.7
14	122	2.0	19.0 +- 0.6; 2.9	14.6 +- 0.6; 3.8	15.0 +- 1.8
15	86	2.8	21.2 +- 0.6; 3.2	16.6 +- 0.7; 4.0	17.2 +- 1.7
16	57	4.4	24.8 +- 0.7; 3.7	19.8 +- 0.7; 4.4	19.0 +- 1.7
17	48	6.1	21.5 +- 0.6; 3.2	16.9 +- 0.7; 4.1	16.5 +- 1.6
18	39	9.4	20.2 +- 0.6; 3.0	15.7 +- 0.6; 3.9	15.7 +- 1.4
19	34	4.7	20.4 +- 0.6; 3.1	15.9 +- 0.6; 4.0	15.5 +- 1.7
20	16	4.3	21.8 +- 0.7; 3.3	17.1 +- 0.7; 4.1	16.6 +- 1.8
21	352	4.2	21.7 +- 0.6; 3.2	17.0 +- 0.7; 4.1	18.7 +- 2.9
22	328	4.1	23.7 +- 0.7; 3.5	18.8 +- 0.7; 4.3	18.6 +- 1.8
23	337	5.7	23.5 +- 0.7; 3.5	18.6 +- 0.7; 4.3	17.0 +- 1.7
24	310	4.4	23.2 +- 0.7; 3.5	18.4 +- 0.7; 4.2	18.3 +- 1.9
25	295	4.1	21.4 +- 0.6; 3.2	16.8 +- 0.7; 4.1	16.3 +- 1.8
26	278	6.9	18.8 +- 0.6; 2.8	14.4 +- 0.6; 3.8	14.4 +- 1.7
27	260	4.3	21.8 +- 0.7; 3.3	17.1 +- 0.7; 4.1	16.2 +- 1.9
28	253	4.0	21.5 +- 0.6; 3.2	16.8 +- 0.7; 4.1	16.7 +- 1.8
29	352	2.8	22.7 +- 0.7; 3.4	17.9 +- 0.7; 4.2	17.5 +- 1.8
30	335	1.9	21.6 +- 0.6; 3.2	16.9 +- 0.7; 4.1	17.1 +- 1.7
31	305	2.6	21.0 +- 0.6; 3.1	16.4 +- 0.6; 4.0	17.3 +- 2.2
32	285	2.5	19.0 +- 0.6; 2.8	14.5 +- 0.6; 3.8	15.1 +- 2.4
33	257	2.0	21.5 +- 0.6; 3.2	16.9 +- 0.7; 4.1	16.7 +- 2.2
34	248	2.2	21.6 +- 0.6; 3.2	16.9 +- 0.7; 4.1	16.7 +- 1.6
35	229	2.6	19.9 +- 0.6; 3.0	15.4 +- 0.6; 3.9	15.8 +- 1.8
36	204	3.4	20.4 +- 0.6; 3.1	15.9 +- 0.6; 4.0	16.4 +- 2.4
37	194	9.3	20.5 +- 0.6; 3.1	15.9 +- 0.6; 4.0	16.7 +- 3.3
38	224	4.9	21.3 +- 0.6; 3.2	16.7 +- 0.7; 4.1	17.4 +- 2.0
39	301	14.0	19.7 +- 0.6; 3.0	15.2 +- 0.6; 3.9	15.6 +- 1.7
40	301	14.0	18.5 +- 0.6; 2.8	14.1 +- 0.6; 3.8	15.5 +- 1.9
41	301	14.0	19.3 +- 0.6; 2.9	14.8 +- 0.6; 3.9	15.0 +- 1.8

Transit Dose = 3.0 +- 0.3; 3.1

QUAD CITIES
For the period 930913-940201

TLD Direct Radiation Environmental Monitoring

Azimuth (degrees)	Ave. Exposure Rate (mR/Std.Qtr.) +- Std.Dev.	Number In Group
348.76 - 11.25 N	16.2 +- 2.2	3
11.26 - 33.75 NNE	17.0 +- 0.2	2
33.76 - 56.25 NE	15.9 +- 0.6	5
56.26 - 78.75 ENE	19.8 +- 0.0	1
78.76 - 101.25 E	16.6 +- 0.0	2
101.26 - 123.75 ESE	15.7 +- 1.5	2
123.76 - 146.25 SE	17.3 +- 0.1	2
146.26 - 168.75 SSE	17.3 +- 0.2	2
168.76 - 191.25 S	14.7 +- 2.0	3
191.26 - 213.75 SSW	15.9 +- 0.0	2
213.76 - 236.25 SW	16.0 +- 0.9	2
236.26 - 258.75 WSW	16.9 +- 0.0	3
258.76 - 281.25 W	15.7 +- 1.9	2
281.26 - 303.75 WNW	15.7 +- 1.6	2
303.76 - 326.25 NW	17.4 +- 1.4	2
326.26 - 348.75 NNW	18.1 +- 1.1	3

Distance From Reactor (miles)	Ave. Exposure Rate (mR/Std.Qtr.) +- Std.Dev.	Number In Group
0 - 2	16.1 +- 1.2	11
2 - 5	16.9 +- 1.2	21
> 5	15.6 +- 2.1	6
Upwind Control	14.7 +- 0.6	3

QUAD CITIES
TLD Direct Radiation Environmental Monitoring

NRC Station	Location		Description
	Azimuth / Degree	Distance / Mile	
1	3	0.7	RIVER RD. ACROSS FROM MAILBOX #21124
2	16	1.2	RIVER RD. & 222ND AVE.
3	35	1.7	222 AVE. N. & HWY. 84
4	45	1.1	HWY. 84
5	90	0.8	HWY. 84
6	138	1.1	192 AVE. N. & 236 ST.
7	175	1.8	178 AVE. N. & HWY 84
8	165	2.0	236 ST. N. & 178 AVE. N.
9	186	3.1	CORDOVA WATER TOWER ON 9TH ST.
10	188	7.7	AGNES ST. & HWY. 84
11	156	4.2	COUNTY RD. BB (150 AVEN)
12	142	4.8	COUNTY RD. BB (150 AVEN)
13	123	3.3	266 ST. & 178 AVE. N.
14	122	2.0	192 AVE. N. & 250 ST. N.
15	86	2.8	206 AVE. N. & 266 ST. N.
16	57	4.4	MEREDOSIA RD.
17	48	6.1	PEARL ST. (4TH ST.) IN ALBANY
18	39	9.4	CLINTON (IA) IN NW. RR YARD ON 18TH PLACE
19	34	4.7	13TH AVE. AT RR CROSSING IN CAMANCHE (IA)
20	16	4.3	9TH ST. ~1.5 MI FROM 9TH AV. (RIGHT OFF US67)
21	352	4.2	CNTY Z40 & F21
22	328	4.1	365TH AVE PAST DRIVEWAY
23	337	5.7	4TH ST. (LOW MOOR)
24	310	4.4	GRAVEL RD. NEAR SMALL BARNS
25	295	4.1	COUNTY Z36 & 365TH AVE
26	278	6.9	COUNTY RD. Z30, AFTER "T" INTER (MCCAUSLAND)
27	260	4.3	2.5 MI. FROM COUNTY RD. F33 ON 260TH ST.
28	253	4.0	COUNTY RD. F33 ON 260TH ST.
29	352	2.8	U.S. 67 & 400TH AVE.
30	335	1.9	HANSON'S BOAT DOCKS OFF U.S. 67
31	305	2.6	U.S. 67
32	285	2.5	U.S. 67 (PAST FOLLETS)
33	257	2.0	PRINCETON WILDLIFE AREA OFF 286TH ST.
34	248	2.2	283RD AVE. & 280TH ST.
35	229	2.6	280TH ST.
36	204	3.4	RIVER DRIVE (288TH AVE.) AT END OF ROAD
37	194	9.3	U.S. 67 & HOLLAND ST. (LECLAIRE)
38	224	4.9	270TH AVE. & 257TH ST.
39	301	14.0	INDUSTRIAL STREET - DEWITT, IA
40	301	14.0	INDUSTRIAL STREET - DEWITT, IA
41	301	14.0	DIESEL GEN. STA. OFF U.S. 61, DEWITT, IA

NRC TLD DOSES FOR QUAD CITIES AREA

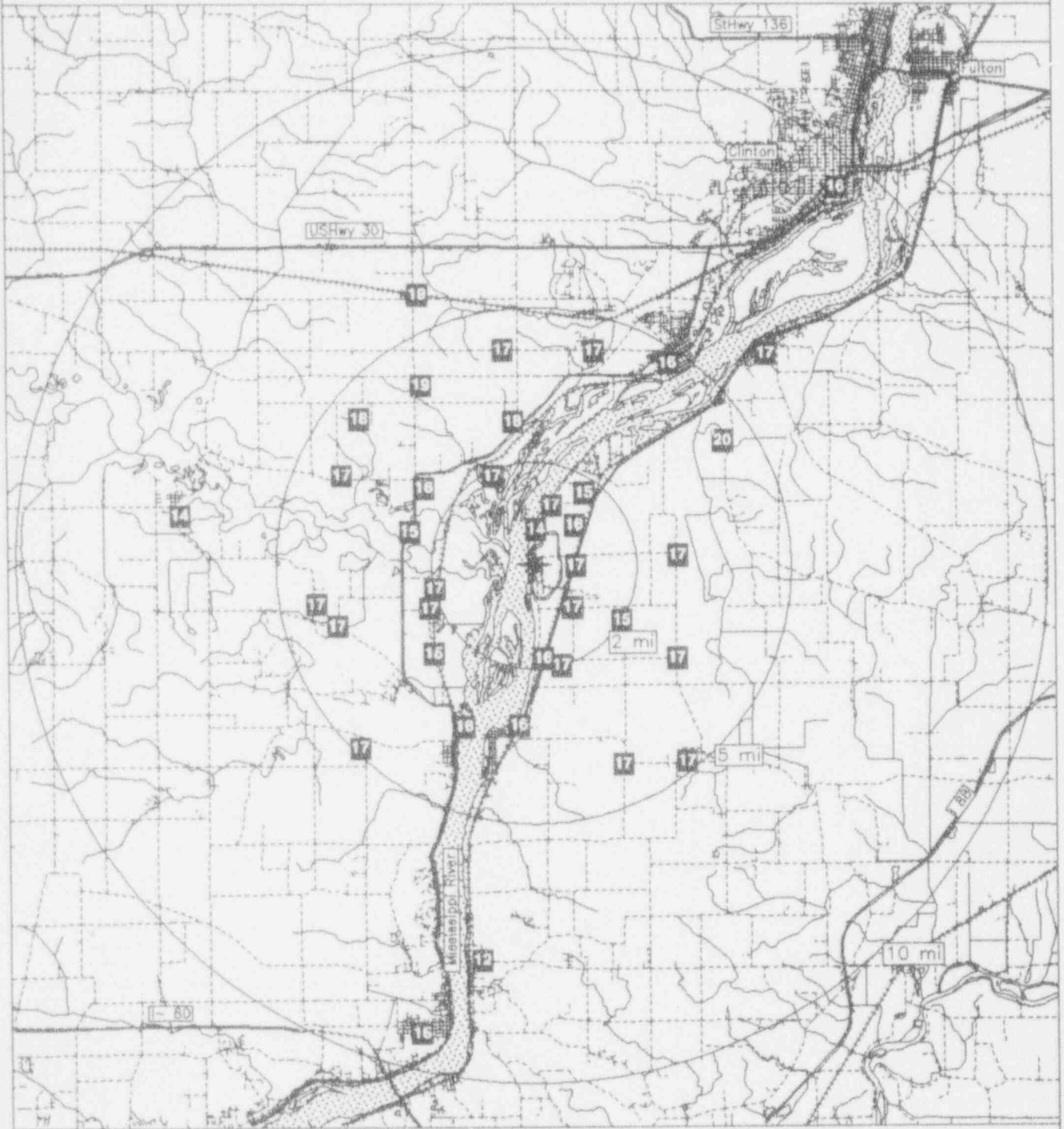

Miles

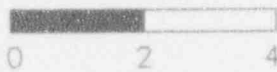

Legend

- Water
- Highways
- Railroads
- Roads
- Plant..site

RANCHO SECO

TLD Direct Radiation Environmental Monitoring

For the period 930913-940127 137 Days

Field Time: 86 Days

NRC Sta	Location		Gross	Net Exposure Rate	Hist. Range
	Azimuth/Dist (Deg)/(Mi)		Exposure (mR) +-Rdm; Tot.	(mR/Std. Qtr.) +-Rdm; Tot.	Net Exp Rate +-1 Std Dev
1	288	16.0	20.9 +- 0.6; 3.1	15.3 +- 0.8; 4.6	16.4 +- 3.0
2	239	12.0	20.9 +- 0.6; 3.1	15.3 +- 0.8; 4.6	17.8 +- 1.9
3	213	16.0	23.4 +- 0.7; 3.5	17.9 +- 0.8; 4.9	18.9 +- 1.8
4	149	9.9	22.2 +- 0.7; 3.3	16.7 +- 0.8; 4.7	16.9 +- 2.6
5	108	8.2	27.2 +- 0.8; 4.1	22.0 +- 1.0; 5.3	22.8 +- 2.1
6	86	10.0	18.7 +- 0.6; 2.8	13.0 +- 0.7; 4.3	14.9 +- 2.1
7	83	9.7	19.8 +- 0.6; 3.0	14.1 +- 0.7; 4.4	14.7 +- 1.6
8	37	7.1	19.8 +- 0.6; 3.0	14.2 +- 0.7; 4.4	15.1 +- 1.9
9	65	0.8	21.3 +- 0.6; 3.2	15.7 +- 0.8; 4.6	16.0 +- 2.0
10	43	0.7	21.5 +- 0.6; 3.2	15.9 +- 0.8; 4.6	17.0 +- 2.4
11	92	0.2	Damaged Dosimeter	No Net Data	15.5 +- 2.0
12	131	1.6	19.7 +- 0.6; 3.0	14.1 +- 0.7; 4.4	14.6 +- 1.6
13	358	0.6	24.0 +- 0.7; 3.6	18.5 +- 0.9; 4.9	17.4 +- 1.9
14	323	0.7	21.5 +- 0.6; 3.2	16.0 +- 0.8; 4.6	16.3 +- 1.8
15	151	0.7	19.6 +- 0.6; 2.9	13.9 +- 0.7; 4.4	15.5 +- 1.8
16	219	0.9	21.8 +- 0.7; 3.3	16.2 +- 0.8; 4.7	16.4 +- 1.8
17	245	1.5	21.8 +- 0.7; 3.3	16.3 +- 0.8; 4.7	15.4 +- 1.7
18	254	2.3	20.9 +- 0.6; 3.1	15.3 +- 0.8; 4.6	15.1 +- 1.5
19	323	7.0	22.4 +- 0.7; 3.4	16.9 +- 0.8; 4.7	16.8 +- 2.0
20	309	6.3	21.6 +- 0.6; 3.2	16.0 +- 0.8; 4.6	17.2 +- 2.1
21	279	5.7	20.8 +- 0.6; 3.1	15.2 +- 0.8; 4.5	16.2 +- 1.9
22	244	6.4	22.3 +- 0.7; 3.3	16.8 +- 0.8; 4.7	17.4 +- 1.7
23	217	4.6	21.5 +- 0.6; 3.2	15.9 +- 0.8; 4.6	16.4 +- 1.7
24	350	11.0	21.4 +- 0.6; 3.2	15.9 +- 0.8; 4.6	16.5 +- 1.8
25	318	17.0	21.6 +- 0.6; 3.2	16.1 +- 0.8; 4.6	17.1 +- 1.8
26	311	22.0	Missing Dosimeter	No Net Data	17.4 +- 1.8
27	306	27.0	20.9 +- 0.6; 3.1	15.3 +- 0.8; 4.6	15.7 +- 1.8
28	306	27.0	21.3 +- 0.6; 3.2	15.8 +- 0.8; 4.6	15.8 +- 1.5
29	306	27.0	21.6 +- 0.6; 3.2	16.0 +- 0.8; 4.6	15.9 +- 2.6
30	306	27.0	22.4 +- 0.7; 3.4	16.9 +- 0.8; 4.7	15.4 +- 2.0

Transit Dose = 6.3 +- 0.4; 3.0

RANCHO SECO
For the period 930913-940127

TLD Direct Radiation Environmental Monitoring

Azimuth (degrees)	Ave. Exposure Rate (mR/Std.Qtr.) +- Std.Dev.	Number In Group
348.76 - 11.25 N	17.2 +- 1.9	2
11.26 - 33.75 NNE	No Data +- No Data	0
33.76 - 56.25 NE	15.1 +- 1.2	2
56.26 - 78.75 ENE	15.7 +- 0.0	1
78.76 - 101.25 E	13.6 +- 0.8	2
101.26 - 123.75 ESE	22.0 +- 0.0	1
123.76 - 146.25 SE	14.1 +- 0.0	1
146.26 - 168.75 SSE	15.3 +- 1.9	2
168.76 - 191.25 S	No Data +- No Data	0
191.26 - 213.75 SSW	17.9 +- 0.0	1
213.76 - 236.25 SW	16.1 +- 0.2	2
236.26 - 258.75 WSW	15.9 +- 0.8	4
258.76 - 281.25 W	15.2 +- 0.0	1
281.26 - 303.75 WNW	15.3 +- 0.0	1
303.76 - 326.25 NW	16.3 +- 0.5	6
326.26 - 348.75 NNW	No Data +- No Data	0

Distance From Reactor (miles)	Ave. Exposure Rate (mR/Std.Qtr.) +- Std.Dev.	Number In Group
0 - 2	15.8 +- 1.4	8
2 - 5	15.6 +- 0.4	2
> 5	16.1 +- 2.0	16
Upwind Control	15.5 +- 0.4	2

RANCHO SECO
TLD Direct Radiation Environmental Monitoring

NRC Station	Location		Description
	Azimuth / Degree	Distance / Mile	
1	288	16.0	ELK GROVE
2	239	12.0	ELM AVE.
3	213	16.0	N. CLUFF AVE.
4	149	9.9	FISH HATCHERY
5	108	8.2	HWY. 88
6	86	10.0	PRESTON SCHOOL
7	83	9.7	FOREST FIRE ACADEMY
8	37	7.1	CARBONDALE RD.
9	65	0.8	MARCIEL PROPERTY
10	43	0.7	PLANT ACCESS RD.
11	92	0.2	PVI SOLAR PLANT
12	131	1.6	RESERVOIR UTILITY SHED
13	358	0.6	HWY. 104 N. OF PLANT
14	323	0.7	HWY. 104 & R.R. SPUR
15	151	0.7	CLAY EAST RD. (END)
16	219	0.9	CLAY EAST RD. SW OF PLANT
17	245	1.5	HERALD SCHOOL
18	254	2.3	'OLD' CLAY STATION RD.
19	323	7.0	TARVENOR RD.
20	309	6.3	ROGER MILLER RESIDENCE
21	279	5.7	WOODS RD.
22	244	6.4	HWY. 104 & ALTA MESA RD.
23	217	4.6	BORDEN RD.
24	350	11.0	CONSUMNES RIVER SCHOOL
25	318	17.0	BRADSHAW RD.
26	311	22.0	HOWE AVE.
27	306	27.0	3RD ST. (SACRAMENTO, CROCKER ART MUSEUM)
28	306	27.0	3RD ST. (SACRAMENTO)
29	306	27.0	601 N. 7TH STREET
30	306	27.0	601 N. 7TH STREET

NRC TLD DOSES FOR RANCHO SECO AREA

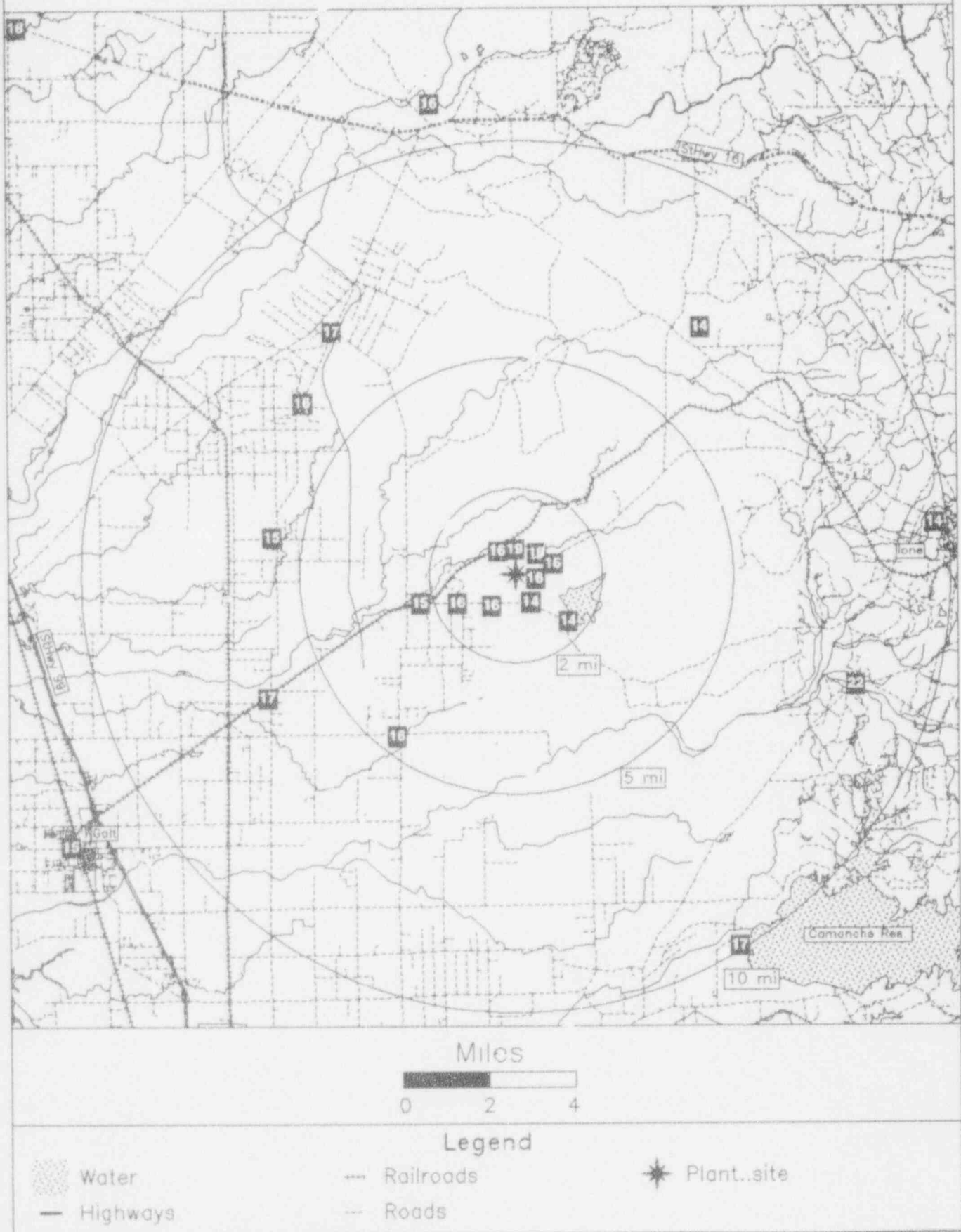

RIVER BEND

TLD Direct Radiation Environmental Monitoring

For the period 931006-940208 126 Days

Field Time: 91 Days

NRC Sta	Location		Gross Exposure (mR)		Net Exposure Rate (mR/Std. Qtr.)		Hist. Range Net Exp Rate	
	Azimuth/ (Deg)	Dist (Mi)	+-Rdm; Tot.		+-Rdm; Tot.		+-1 Std Dev	
1	348	1.3	18.3	+- 0.5; 2.7	16.7	+- 0.6; 3.8	18.1	+- 2.2
2	42	1.1	19.6	+- 0.6; 2.9	18.0	+- 0.6; 4.0	18.3	+- 2.3
3	61	1.1	19.3	+- 0.6; 2.9	17.7	+- 0.6; 4.0	19.2	+- 2.2
4	90	0.8	19.6	+- 0.6; 2.9	18.0	+- 0.6; 4.0	18.2	+- 2.0
5	107	0.6	18.9	+- 0.6; 2.8	17.3	+- 0.6; 3.9	19.0	+- 1.8
6	136	0.8	20.2	+- 0.6; 3.0	18.6	+- 0.7; 4.0	19.3	+- 2.4
7	166	1.0	16.2	+- 0.5; 2.4	14.6	+- 0.5; 3.6	16.2	+- 1.7
8	182	0.9	17.6	+- 0.5; 2.6	16.0	+- 0.6; 3.8	17.3	+- 2.2
9	195	0.6	18.4	+- 0.6; 2.8	16.8	+- 0.6; 3.9	17.1	+- 2.1
10	225	0.7	19.3	+- 0.6; 2.9	17.7	+- 0.6; 4.0	17.7	+- 2.2
11	254	0.4	17.8	+- 0.5; 2.7	16.2	+- 0.6; 3.8	17.5	+- 2.3
12	276	0.6	20.2	+- 0.6; 3.0	18.6	+- 0.7; 4.1	18.6	+- 1.9
13	295	0.6	19.7	+- 0.6; 3.0	18.1	+- 0.6; 4.0	19.3	+- 2.0
14	320	0.9	19.8	+- 0.6; 3.0	18.2	+- 0.6; 4.0	18.2	+- 2.2
15	332	2.1	19.9	+- 0.6; 3.0	18.3	+- 0.6; 4.0	19.0	+- 2.0
16	312	2.7	19.4	+- 0.6; 2.9	17.8	+- 0.6; 4.0	18.0	+- 2.8
17	302	3.1	18.0	+- 0.5; 2.7	16.4	+- 0.6; 3.8	16.2	+- 2.2
18	278	3.8	17.1	+- 0.5; 2.6	15.5	+- 0.6; 3.7	15.4	+- 2.5
19	242	2.8	21.3	+- 0.6; 3.2	19.7	+- 0.7; 4.2	19.8	+- 2.4
20	195	5.4	19.2	+- 0.6; 2.9	17.6	+- 0.6; 3.9	18.0	+- 2.6
21	215	3.0	19.4	+- 0.6; 2.9	17.8	+- 0.6; 4.0	18.5	+- 2.3
22	233	7.1	18.1	+- 0.5; 2.7	16.5	+- 0.6; 3.8	15.3	+- 2.5
23	246	9.7	19.9	+- 0.6; 3.0	18.3	+- 0.6; 4.0	18.0	+- 2.1
24	234	7.3	18.8	+- 0.6; 2.8	17.2	+- 0.6; 3.9	16.0	+- 2.5
25	185	7.6	20.6	+- 0.6; 3.1	19.0	+- 0.7; 4.1	18.4	+- 2.5
26	322	7.7	17.7	+- 0.5; 2.7	16.1	+- 0.6; 3.8	17.5	+- 2.5
27	328	10.0	19.8	+- 0.6; 3.0	18.2	+- 0.6; 4.0	18.9	+- 2.1
28	340	7.2	18.6	+- 0.6; 2.8	17.1	+- 0.6; 3.9	18.5	+- 2.0
29	354	9.5	18.4	+- 0.6; 2.8	16.8	+- 0.6; 3.9	17.5	+- 2.2
30	360	5.1	Missing Dosimeter		No Net Data		19.0	+- 2.2
31	221	6.9	20.6	+- 0.6; 3.1	19.0	+- 0.7; 4.1	18.8	+- 1.9
32	40	4.9	18.8	+- 0.6; 2.8	17.2	+- 0.6; 3.9	18.1	+- 2.2
33	52	8.7	15.3	+- 0.5; 2.3	13.8	+- 0.5; 3.5	15.6	+- 1.8
34	65	8.4	18.9	+- 0.6; 2.8	17.3	+- 0.6; 3.9	17.3	+- 2.2
35	87	6.6	17.4	+- 0.5; 2.6	15.9	+- 0.6; 3.8	16.0	+- 2.0
36	326	5.8	18.9	+- 0.6; 2.8	17.3	+- 0.6; 3.9	18.4	+- 2.5
37	329	22.0	18.5	+- 0.6; 2.8	16.9	+- 0.6; 3.9	17.8	+- 2.0
38	111	3.8	17.5	+- 0.5; 2.6	15.9	+- 0.6; 3.8	17.1	+- 2.3
39	131	5.6	19.8	+- 0.6; 3.0	18.2	+- 0.6; 4.0	17.7	+- 2.3
40	155	6.2	18.9	+- 0.6; 2.8	17.4	+- 0.6; 3.9	18.5	+- 2.4
41	120	9.0	16.2	+- 0.5; 2.4	14.7	+- 0.5; 3.6	17.5	+- 1.7
42	121	11.0	16.0	+- 0.5; 2.4	14.5	+- 0.5; 3.6	15.6	+- 2.0
43	180	1.1	20.3	+- 0.6; 3.1	18.7	+- 0.7; 4.1	19.7	+- 2.4
44	150	28.0	16.3	+- 0.5; 2.4	14.7	+- 0.6; 3.6	15.2	+- 2.3

Transit Dose = 1.4 +- 0.3; 2.8

RIVER BEND

For the period 931006-940208

TLD Direct Radiation Environmental Monitoring

Azimuth (degrees)	Ave. Exposure Rate (mR/Std.Qtr.) +- Std.Dev.	Number In Group
348.76 - 11.25 N	16.8 +- 0.0	1
11.26 - 33.75 NNE	No Data +- No Data	0
33.76 - 56.25 NE	16.3 +- 2.2	3
56.26 - 78.75 ENE	17.5 +- 0.3	2
78.76 - 101.25 E	16.9 +- 1.5	2
101.26 - 123.75 ESE	15.6 +- 1.3	4
123.76 - 146.25 SE	18.4 +- 0.3	2
146.26 - 168.75 SSE	16.0 +- 1.9	2
168.76 - 191.25 S	17.9 +- 1.7	3
191.26 - 213.75 SSW	17.2 +- 0.5	2
213.76 - 236.25 SW	17.7 +- 0.9	5
236.26 - 258.75 WSW	18.1 +- 1.8	3
258.76 - 281.25 W	17.1 +- 2.2	2
281.26 - 303.75 WNW	17.3 +- 1.2	2
303.76 - 326.25 NW	17.4 +- 0.9	4
326.26 - 348.75 NNW	17.4 +- 0.7	5

Distance From Reactor (miles)	Ave. Exposure Rate (mR/Std.Qtr.) +- Std.Dev.	Number In Group
0 - 2	17.4 +- 1.2	15
2 - 5	17.3 +- 1.4	8
> 5	16.9 +- 1.4	19
Upwind Control	14.7 +- 0.0	1

RIVER BEND
TLD Direct Radiation Environmental Monitoring

NRC Station	Location		Description
	Azimuth Degree	Distance / Mile	
1	348	1.3	BEHIND TRN CNTR ON AIR SMPL FENCE
2	42	1.1	500' FROM TOM'S KITCH. ACROSS FROM OLD HWY 61
3	61	1.1	STUB POLE ON POWELL STA. RD. PAST WHITE FENCE
4	90	0.8	0.5 MI PAST TLD#3, POWELL STA. RD.
5	107	0.6	STUB POLE, R.SIDE POWELL STA. RD. PAST CHURCH
6	136	0.8	STUB POLE, 5 POLES BACK FROM RAILROAD TRACK
7	166	1.0	STUB POLE PAST RR TRACKS ON POWELL STATION RD
8	182	0.9	POWELL STA. RD. ADJACENT TO GATE 23
9	195	0.6	UTIL POLE #10177 ON L NR RIVER ACCESS RD.
10	225	0.7	LA 965, 1ST UTIL POLE N OF RIVER ACSS RD.
11	254	0.4	3RD UTILITY POLE ON R. PAST OLD RR TRACKS
12	276	0.6	UTILITY POLE BETWEEN GATES 13 & 14
13	295	0.6	CORNER OF GARDEN #1 NR MET TOWER AIR SAMPLER
14	320	0.9	UTILITY POLE NEAR DRIVEWAY OF LEET'S RES.
15	332	2.1	UTILITY POLE JCT. OF LA 965 & US 61
16	312	2.7	FRONT OF CHURCH ACROSS FROM W.FELICIANA HOSP
17	302	3.1	UTIL POLE, L SIDE OF ST.FRANCISVILLE BANK
18	278	3.8	UTILITY POLE, ST.FRANCISVILLE FERRY LANDING
19	242	2.8	UTIL POLE, 1.2 MI.FROM #21 PAST BIG CAJUN II
20	195	5.4	STUB POLE AT INT. OF LA 414 & 415
21	215	3.0	UTILITY POLE AT TRUCK ENTR. TO BIG CAJUN II
22	233	7.1	POLE, FRONT LEFT SIDE OF POINTE COURT HOUSE
23	246	9.7	UTIL POLE, LA 1/10 & 3131, FRNT OF TRACTOR CO
24	234	7.3	UTILITY POLE, LA413 & LA414 NR GROCERY
25	185	7.6	UTILITY POLE, LA415 & LA416/CAL & MARY'S R.
26	322	7.7	LA66 & SOLITUDE RD ON SOLITUDE SIGN
27	328	10.0	LA66 & LA968 (HIGHLAND RD), LEFT SIDE ON FENCE
28	340	7.2	US 61 & CEDAR LANE ON UTILITY POLE
29	354	9.5	UTILITY POLE AT INT. OF US 61 & LA 421
30	360	5.1	UTIL POLE, LA10 & BAINS RD (WF2) AT CHURCH
31	221	6.9	STUB POLE, LA965/AUDUBON LN PAST OAKLEY
32	40	4.9	STUB POLE AT INTERSECTION OF LA 965 & LA 966
33	52	8.7	UTILITY POLE IN FRONT OF JACKSON TOWN HALL
34	65	8.4	UTILITY POLE, LA 68 & DIXON CORRECT. INST.
35	87	6.6	GSU GRAVEL PWR. CTR. LEFT SIDE PAST DIXON
36	326	5.8	US61/W.FELICIANA 2(BAINS RD)@ WFHS
37	329	22.0	UTILITY POLE, END OF LA 66/ANGOLA ST. PEN.
38	111	3.8	US 61 & LA 954 NEAR CATTLE GUARD
39	131	5.6	US 61 & LA 68 BEHIND SERVICE STA
40	155	6.2	1ST UTIL POLE, PLAINS-PORT HUDSON & LA 3113
41	120	9.0	UTIL POLE, PLAINS-PORT HUD. & LA964 AT STORE
42	121	11.0	LA64 & 40TH ST., FRONT OF ZACHARY HIGH SCHOOL
43	180	1.1	POWELL STA RD ACROSS FROM FOREST PLANTATION
44	150	28.0	AMERICA & ST.CHAS.ST BEHIND GSU ON NORTH BLVD

NRC TLD DOSES FOR RIVER BEND AREA

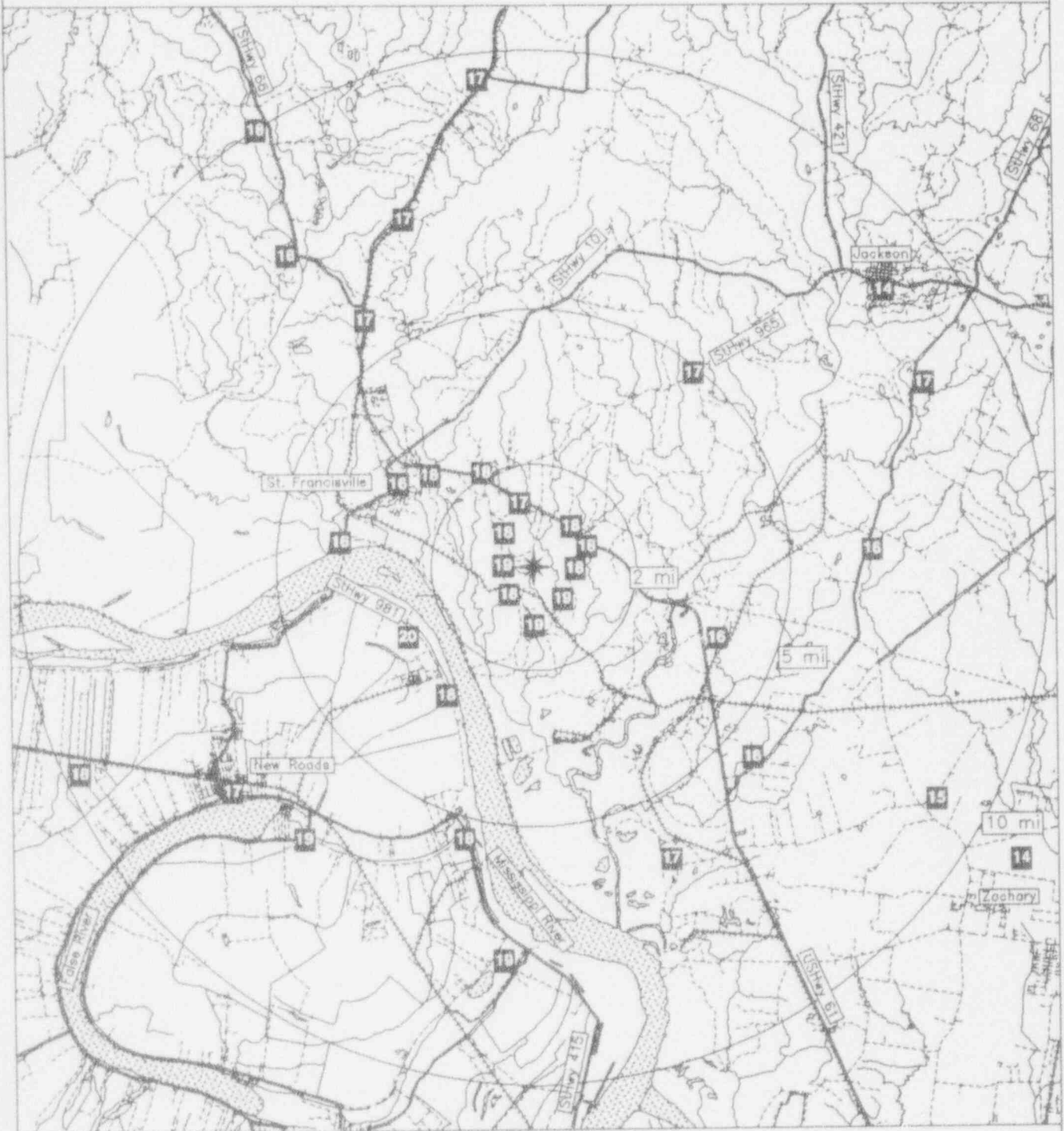

Miles

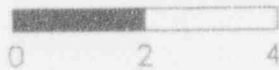

Legend

Water

Railroads

Plant site

Highways

Roads

ROBINSON

TLD Direct Radiation Environmental Monitoring

For the period 930914-940203 143 Days

Field Time: 108 Days

NRC Sta	Location		Gross	Net Exposure Rate	Hist. Range
	Azimuth/Dist (Deg)/(Mi)		Exposure (mR) +-Rdm; Tot.	(mR/Std. Qtr.) +-Rdm; Tot.	Net Exp Rate +-1 Std Dev
1	191	0.2	21.1 +- 0.6; 3.2	14.0 +- 0.6; 3.9	14.6 +- 1.1
2	151	1.9	29.5 +- 0.9; 4.4	21.1 +- 0.8; 4.7	21.7 +- 2.3
3	134	2.0	25.2 +- 0.8; 3.8	17.5 +- 0.7; 4.3	17.8 +- 1.4
4	119	1.9	20.6 +- 0.6; 3.1	13.7 +- 0.6; 3.9	14.3 +- 0.9
5	89	2.1	Missing Dosimeter	No Net Data	18.0 +- 1.1
6	65	1.0	23.8 +- 0.7; 3.6	16.3 +- 0.7; 4.2	16.2 +- 1.2
7	46	1.8	21.4 +- 0.6; 3.2	14.2 +- 0.6; 3.9	17.1 +- 1.7
8	27	1.9	24.1 +- 0.7; 3.6	16.5 +- 0.7; 4.2	17.0 +- 1.3
9	22	3.5	22.4 +- 0.7; 3.4	15.1 +- 0.6; 4.0	16.6 +- 1.9
10	0	5.0	25.1 +- 0.8; 3.8	17.3 +- 0.7; 4.3	17.9 +- 1.4
11	51	4.8	26.6 +- 0.8; 4.0	18.6 +- 0.7; 4.4	19.3 +- 1.0
12	67	4.1	21.7 +- 0.7; 3.3	14.5 +- 0.6; 4.0	14.6 +- 1.6
13	87	4.5	23.8 +- 0.7; 3.6	16.3 +- 0.7; 4.2	15.2 +- 1.0
14	109	5.0	24.5 +- 0.7; 3.7	16.9 +- 0.7; 4.2	25.8 +- 1.2
15	118	4.8	Missing Dosimeter	No Net Data	16.3 +- 2.0
16	138	5.3	24.6 +- 0.7; 3.7	17.0 +- 0.7; 4.2	16.8 +- 1.5
17	115	17.1	21.8 +- 0.7; 3.3	14.6 +- 0.6; 4.0	15.2 +- 1.9
18	199	12.6	24.6 +- 0.7; 3.7	16.9 +- 0.7; 4.2	16.3 +- 1.1
19	208	4.8	29.6 +- 0.9; 4.4	21.1 +- 0.8; 4.7	21.9 +- 2.5
20	225	4.0	26.4 +- 0.8; 4.0	18.4 +- 0.7; 4.4	19.6 +- 1.3
21	178	4.6	18.4 +- 0.6; 2.8	11.8 +- 0.6; 3.7	12.7 +- 1.3
22	167	3.7	23.4 +- 0.7; 3.5	16.0 +- 0.7; 4.1	16.1 +- 1.0
23	181	2.3	22.3 +- 0.7; 3.3	15.1 +- 0.6; 4.0	15.5 +- 1.1
24	194	2.0	27.1 +- 0.8; 4.1	19.0 +- 0.8; 4.5	19.1 +- 1.1
25	228	2.1	27.0 +- 0.8; 4.0	18.9 +- 0.7; 4.4	18.0 +- 1.3
26	245	1.5	21.4 +- 0.6; 3.2	14.3 +- 0.6; 3.9	14.2 +- 1.6
27	273	1.8	20.8 +- 0.6; 3.1	13.7 +- 0.6; 3.9	13.8 +- 1.1
28	287	2.0	20.0 +- 0.6; 3.0	13.1 +- 0.6; 3.8	13.4 +- 1.2
29	311	1.6	24.2 +- 0.7; 3.6	16.6 +- 0.7; 4.2	17.4 +- 0.9
30	334	1.9	21.7 +- 0.7; 3.3	14.6 +- 0.6; 4.0	16.3 +- 1.7
31	351	2.1	20.6 +- 0.6; 3.1	13.6 +- 0.6; 3.9	15.2 +- 2.0
32	333	4.0	23.9 +- 0.7; 3.6	16.4 +- 0.7; 4.2	16.4 +- 1.2
33	318	4.7	25.8 +- 0.8; 3.9	18.0 +- 0.7; 4.3	17.8 +- 1.2
34	310	6.9	23.2 +- 0.7; 3.5	15.8 +- 0.7; 4.1	15.6 +- 2.0
35	295	4.0	30.3 +- 0.9; 4.5	21.7 +- 0.8; 4.8	20.6 +- 1.4
36	269	4.8	26.9 +- 0.8; 4.0	18.8 +- 0.7; 4.4	18.4 +- 1.8
37	252	4.6	24.7 +- 0.7; 3.7	17.0 +- 0.7; 4.2	17.3 +- 1.4
38	274	10.7	22.8 +- 0.7; 3.4	15.4 +- 0.7; 4.1	18.4 +- 3.2
39	286	15.3	Missing Dosimeter	No Net Data	15.1 +- 1.2
40	289	16.5	21.1 +- 0.6; 3.2	14.0 +- 0.6; 3.9	14.2 +- 1.1
41	291	17.5	20.6 +- 0.6; 3.1	13.6 +- 0.6; 3.9	15.4 +- 1.4

Transit Dose = 4.3 +- 0.4; 3.5

ROBINSON

For the period 930914-940203

TLD Direct Radiation Environmental Monitoring

Azimuth (degrees)	Ave. Exposure Rate (mR/Std.Qtr.) +- Std.Dev.	Number In Group
348.76 - 11.25 N	15.5 +- 2.6	2
11.26 - 33.75 NNE	15.8 +- 1.0	2
33.76 - 56.25 NE	16.4 +- 3.1	2
56.26 - 78.75 ENE	15.4 +- 1.3	2
78.76 - 101.25 E	16.3 +- 0.0	1
101.26 - 123.75 ESE	15.0 +- 1.6	3
123.76 - 146.25 SE	17.2 +- 0.3	2
146.26 - 168.75 SSE	18.5 +- 3.6	2
168.76 - 191.25 S	13.6 +- 1.7	3
191.26 - 213.75 SSW	19.0 +- 2.1	3
213.76 - 236.25 SW	18.7 +- 0.4	2
236.26 - 258.75 WSW	15.6 +- 1.9	2
258.76 - 281.25 W	16.0 +- 2.6	3
281.26 - 303.75 WNW	17.4 +- 6.1	2
303.76 - 326.25 NW	16.8 +- 1.1	3
326.26 - 348.75 NNW	15.5 +- 1.3	2

Distance From Reactor (miles)	Ave. Exposure Rate (mR/Std.Qtr.) +- Std.Dev.	Number In Group
0 - 2	15.7 +- 2.4	13
2 - 5	17.0 +- 2.5	18
> 5	16.0 +- 1.0	5
Upwind Control	13.8 +- 0.3	2

ROBINSON
TLD Direct Radiation Environmental Monitoring

NRC Station	Location		Description
	Azimuth Degree	Distance / Mile	
1	191	0.2	0.1 MILES S. OF VISITORS CENTER
2	151	1.9	HWY. 151 (1.7 MILES S. OF RT. 23)
3	134	2.0	RT. 39 (150 YARDS S. OF RAILROAD TRACKS)
4	119	1.9	RT. 824 (0.4 MILES N. OF RT. 39)
5	89	2.1	RT. 824 (1.5 MILES N. OF RT. 39)
6	65	1.0	RT. 39 (0.5 MILES N. OF RT. 23)
7	46	1.8	RT. 39 & RT. 737
8	27	1.9	RT. 737 (EASTERLINGS LANDING RD.)
9	22	3.5	RT. 21 & RT. 752
10	0	5.0	RT. 346 (0.5 MILES W. OF RT. 46)
11	51	4.8	RT. 20 (3.1 MILES S. OF RT. 346)
12	67	4.1	RT. 20 (0.2 MILES S. OF LOOKOUT TOWER)
13	87	4.5	JOHNSONS FENCE & AWNING
14	109	5.0	HWY. 15 AT ST. MARYS CHURCH/SCHOOL
15	118	4.8	W. CAROLINA AVE. & ARMORY ST.
16	138	5.3	MILLER RD.
17	115	17.1	HWY. 151 (DARLINGTON)
18	199	12.6	HWY. 15 (BISHOPVILLE)
19	208	4.8	RT. 13 (100 YARDS N. OF RT. 14)
20	225	4.0	RT. 85 (1.6 MILES N. OF RT. 14)
21	178	4.6	RT. 772 (KELLYBELL CH.)
22	167	3.7	RT. 12 AT KELLYTOWN CH.
23	181	2.3	RT. 53 & RT. 200
24	194	2.0	RT. 53 AT HVT LINES
25	228	2.1	GUM SWAMP CH.
26	245	1.5	RT. 761 (0.5 MILES N. OF RT. 23)
27	273	1.8	RT. 761 (1.3 MILES N. OF RT. 23)
28	287	2.0	RT. 761 & RT. 176
29	311	1.6	HWY. 151 & RT. 176
30	334	1.9	RT. 172 (0.6 MILES E. OF HWY. 151)
31	351	2.1	MARGINAL RD.
32	333	4.0	RT. 346 AT RAILROAD TRACKS
33	318	4.7	HWY. 151 AT RT. 711
34	310	6.9	HWY. 151 (MCBEE)
35	295	4.0	RT. 711 (1.9 MILES S. OF HWY. 151)
36	269	4.8	RT. 31 AT UNION CH.
37	252	4.6	RT. 23 AT RT. 722
38	274	10.7	HWY. 341 (BETHUNE)
39	286	15.3	HWY. 341 (5 MILES NW OF HWY. 1)
40	289	16.5	HWY. 341 AT RT. 42)
41	291	17.5	HWY. 341 (1.3 MILES NW OF RT. 42)

NRC TLD DOSES FOR ROBINSON AREA

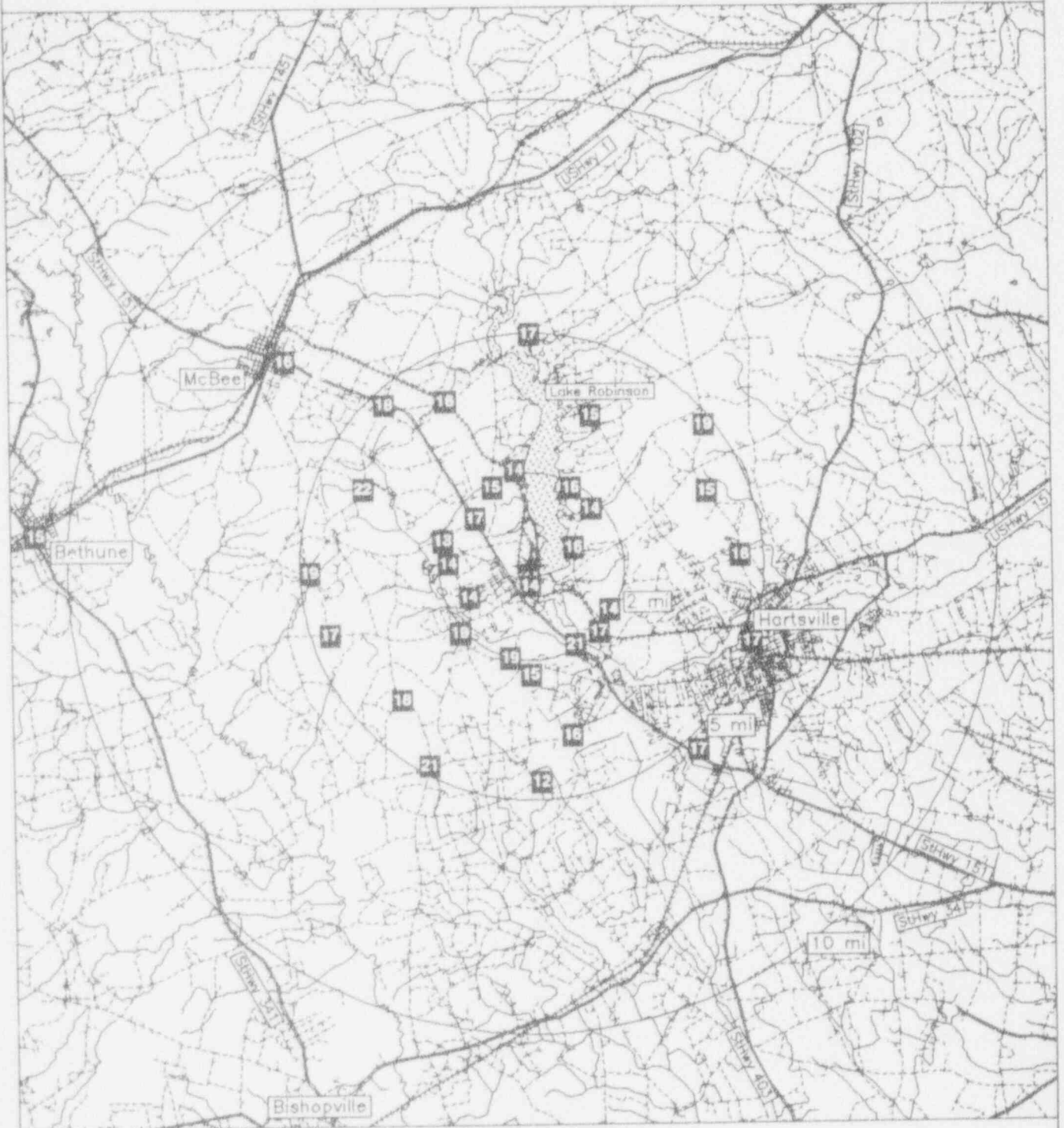

Miles

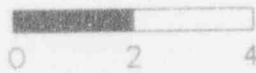

Legend



Water



Railroads



Plant site



Highways



Roads

SALEM (DE)

TLD Direct Radiation Environmental Monitoring

For the period 930916-940202 140 Days

Field Time: 92 Days

NRC Sta	Location		Gross	Net Exposure Rate	Hist. Range
	Azimuth/Dist (Deg)/(Mi)		Exposure (mR) +-Rdm; Tot.	(mR/Std. Qtr.) +-Rdm; Tot.	Net Exp Rate +-1 Std Dev
17	331	4.2	Missing Dosimeter	No Net Data	17.3 +- 2.4
18	320	3.8	17.0 +- 0.5; 2.6	12.8 +- 0.6; 3.8	14.3 +- 1.3
19	299	3.4	21.7 +- 0.6; 3.2	17.3 +- 0.7; 4.3	16.2 +- 1.6
20	330	9.5	24.1 +- 0.7; 3.6	19.7 +- 0.8; 4.6	19.6 +- 1.6
21	276	3.6	21.5 +- 0.6; 3.2	17.2 +- 0.7; 4.3	18.3 +- 1.6
22	266	4.7	21.8 +- 0.7; 3.3	17.5 +- 0.7; 4.3	17.9 +- 1.2
23	257	4.4	21.9 +- 0.7; 3.3	17.6 +- 0.7; 4.3	17.5 +- 1.5
24	240	4.4	Damaged Dosimeter	No Net Data	18.1 +- 1.4
25	217	4.9	21.6 +- 0.6; 3.2	17.3 +- 0.7; 4.3	18.0 +- 1.6
26	204	3.9	21.1 +- 0.6; 3.2	16.8 +- 0.7; 4.3	16.5 +- 1.4
27	188	4.2	21.5 +- 0.6; 3.2	17.2 +- 0.7; 4.3	19.4 +- 2.6
28	319	18.1	23.7 +- 0.7; 3.6	19.3 +- 0.8; 4.5	19.7 +- 2.0
29	265	6.7	18.3 +- 0.5; 2.7	14.0 +- 0.6; 4.0	15.0 +- 1.3
30	340	12.2	18.0 +- 0.5; 2.7	13.8 +- 0.6; 3.9	14.7 +- 1.8
31	0	18.2	21.3 +- 0.6; 3.2	17.0 +- 0.7; 4.3	17.3 +- 1.3
32	338	8.1	19.7 +- 0.6; 2.9	15.4 +- 0.7; 4.1	15.5 +- 1.5
33	265	9.8	21.3 +- 0.6; 3.2	17.0 +- 0.7; 4.3	17.8 +- 1.4
34	207	11.6	20.8 +- 0.6; 3.1	16.4 +- 0.7; 4.2	17.0 +- 1.6

Transit Dose = 4.0 +- 0.3; 3.0

SALEM (DE)

For the period 930916-940202

TLD Direct Radiation Environmental Monitoring

Azimuth (degrees)	Ave. Exposure Rate (mR/Std.Qtr.) +- Std.Dev.	Number In Group
348.76 - 11.25 N	No Data +- No Data	0
11.26 - 33.75 NNE	No Data +- No Data	0
33.76 - 56.25 NE	No Data +- No Data	0
56.26 - 78.75 ENE	No Data +- No Data	0
78.76 - 101.25 E	No Data +- No Data	0
101.26 - 123.75 ESE	No Data +- No Data	0
123.76 - 146.25 SE	No Data +- No Data	0
146.26 - 168.75 SSE	No Data +- No Data	0
168.76 - 191.25 S	17.2 +- 0.0	1
191.26 - 213.75 SSW	16.6 +- 0.2	2
213.76 - 236.25 SW	17.3 +- 0.0	1
236.26 - 258.75 WSW	17.6 +- 0.0	1
258.76 - 281.25 W	16.4 +- 1.6	4
281.26 - 303.75 WNW	17.3 +- 0.0	1
303.76 - 326.25 NW	12.8 +- 0.0	1
326.26 - 348.75 NNW	17.5 +- 3.0	2

Distance From Reactor (miles)	Ave. Exposure Rate (mR/Std.Qtr.) +- Std.Dev.	Number In Group
0 - 2	No Data +- No Data	0
2 - 5	16.7 +- 1.6	8
> 5	16.5 +- 2.1	5
Upwind Control	16.7 +- 2.8	3

SALEM (DE)
TLD Direct Radiation Environmental Monitoring

NRC Station	Location		Description
	Azimuth / Degree	Distance / Mile	
17	331	4.2	PORT PENN (DEL.)
18	320	3.8	AUGUSTINE BEACH (DEL.)
19	299	3.4	BAY VIEW BEACH
20	330	9.5	ROUTE #9
21	276	3.6	GETTY OIL CO.
22	266	4.7	NEAR EMERSON FARM
23	257	4.4	THOMAS LANDING
24	240	4.4	BOLTON FARM
25	217	4.9	TAYLORS BRIDGE
26	204	3.9	EAST OF TAYLORS BRIDGE
27	188	4.2	E. OF TAYLORS BRIDGE (ROADS END)
28	319	18.1	NEWARK (DEL.)
29	265	6.7	ODESSA
30	340	12.2	OMMELANDEN
31	0	18.2	WILMINGTON (DEL.)
32	338	8.1	DELAWARE CITY MARINA
33	265	9.8	NATIONAL GUARD ARMORY (MIDDLETOWN)
34	207	11.6	SMYRNA (DEL)

NRC TLD DOSES FOR SALEM – HOPE CREEK AREA

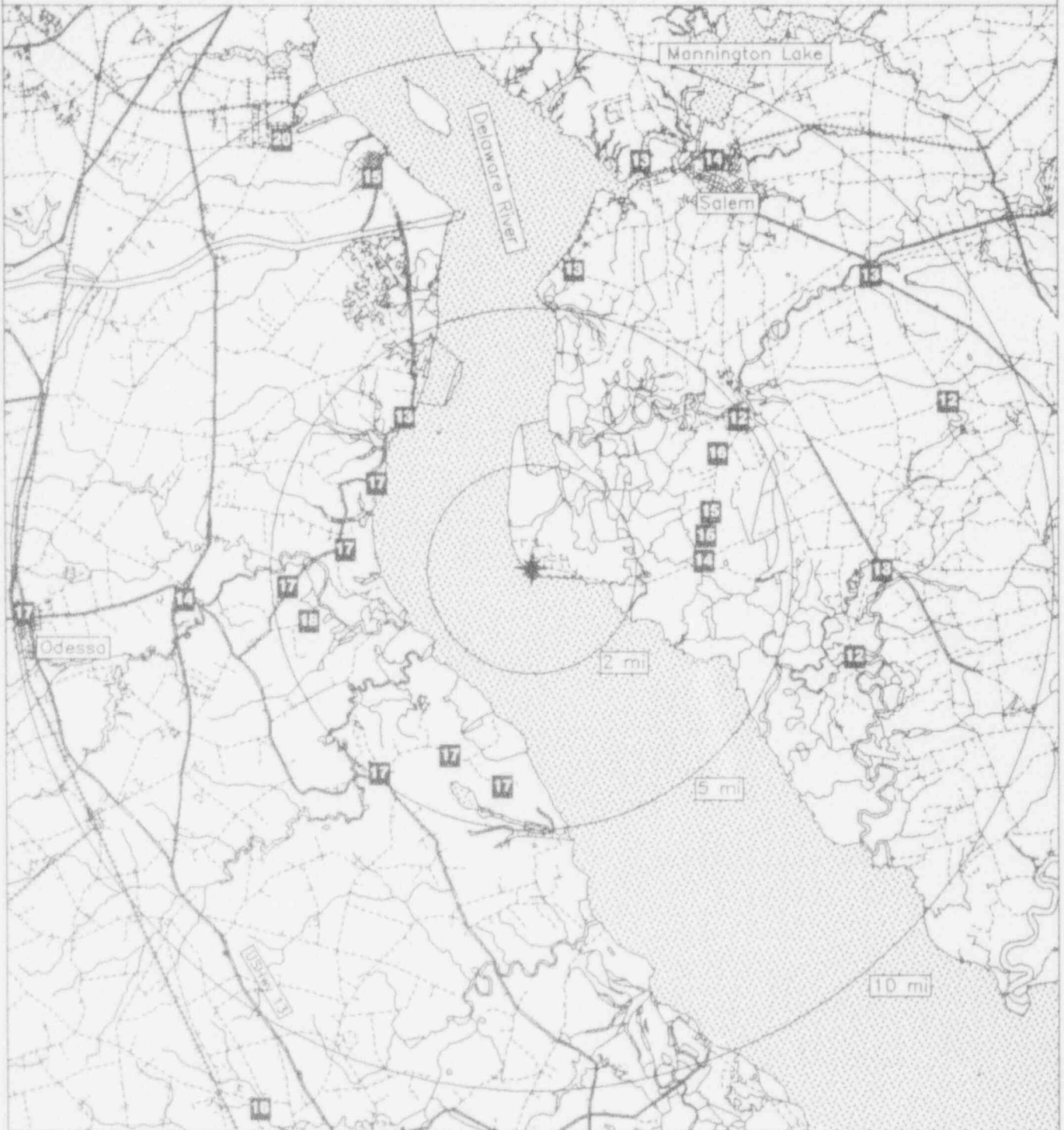

Miles



Legend

Water

Railroads

Plant..site

Highways

Roads

SALEM (NJ)

TLD Direct Radiation Environmental Monitoring

For the period 930916-940202 140 Days

Field Time: 92 Days

NRC Sta	Location		Gross	Net Exposure Rate	Hist. Range
	Azimuth/Dist (Deg)/(Mi)		Exposure (mR) +-Rdm; Tot.	(mR/Std. Qtr.) +-Rdm; Tot.	Net Exp Rate +-1 Std Dev
1	87	3.3	18.7 +- 0.6; 2.8	14.0 +- 0.7; 4.0	14.3 +- 1.0
2	79	3.4	19.4 +- 0.6; 2.9	14.7 +- 0.7; 4.1	14.2 +- 1.1
3	72	3.6	19.2 +- 0.6; 2.9	14.5 +- 0.7; 4.1	17.0 +- 2.4
4	58	4.2	20.3 +- 0.6; 3.0	15.6 +- 0.7; 4.2	15.5 +- 1.7
5	54	4.9	16.6 +- 0.5; 2.5	12.0 +- 0.6; 3.8	13.6 +- 1.6
6	68	8.6	16.5 +- 0.5; 2.5	11.9 +- 0.6; 3.8	12.3 +- 1.4
7	40	5.7	Missing Dosimeter	No Net Data	13.9 +- 1.2
8	116	12.0	18.3 +- 0.5; 2.7	13.6 +- 0.6; 4.0	13.9 +- 1.3
10	8	5.8	17.8 +- 0.5; 2.7	13.2 +- 0.6; 4.0	14.2 +- 1.5
11	15	8.1	18.0 +- 0.5; 2.7	13.3 +- 0.6; 4.0	13.3 +- 1.2
12	24	8.6	18.3 +- 0.5; 2.7	13.6 +- 0.6; 4.0	13.4 +- 1.2
13	49	8.6	17.4 +- 0.5; 2.6	12.8 +- 0.6; 3.9	12.9 +- 1.4
14	90	6.7	18.0 +- 0.5; 2.7	13.4 +- 0.6; 4.0	12.5 +- 1.2
15	105	6.4	17.0 +- 0.5; 2.5	12.3 +- 0.6; 3.9	12.5 +- 1.6

Transit Dose = 4.4 +- 0.4; 3.0

SALEM (NJ)

For the period 930916-940202

TLD Direct Radiation Environmental Monitoring

Azimuth (degrees)	Ave. Exposure Rate (mR/Std.Qtr.) +- Std.Dev.	Number In Group
348.76 - 11.25 N	13.2 +- 0.0	1
11.26 - 33.75 NNE	13.5 +- 0.2	2
33.76 - 56.25 NE	12.4 +- 0.6	2
56.26 - 78.75 ENE	14.0 +- 1.0	3
78.76 - 101.25 E	14.0 +- 0.7	3
101.26 - 123.75 ESE	13.0 +- 0.9	2
123.76 - 146.25 SE	No Data +- No Data	0
146.26 - 168.75 SSE	No Data +- No Data	0
168.76 - 191.25 S	No Data +- No Data	0
191.26 - 213.75 SSW	No Data +- No Data	0
213.76 - 236.25 SW	No Data +- No Data	0
236.26 - 258.75 WSW	No Data +- No Data	0
258.76 - 281.25 W	No Data +- No Data	0
281.26 - 303.75 WNW	No Data +- No Data	0
303.76 - 326.25 NW	No Data +- No Data	0
326.26 - 348.75 NNW	No Data +- No Data	0

Distance From Reactor (miles)	Ave. Exposure Rate (mR/Std.Qtr.) +- Std.Dev.	Number In Group
0 - 2	No Data +- No Data	0
2 - 5	14.2 +- 1.3	5
> 5	13.0 +- 0.6	8
Upwind Control	No Data +- No Data	0

SALEM (NJ)
 TLD Direct Radiation Environmental Monitoring

NRC Station	Location		Description
	Azimuth Degree	Distance / Mile	
1	87	3.3	ALLOWAY CREEK NECK ROAD
2	79	3.4	ALLOWAY CREEK NECK ROAD
3	72	3.6	ALLOWAY CREEK NECK ROAD
4	58	4.2	BUTTONWOOD AVE.
5	54	4.9	LOWER ALLOWAY CREEK TOWNSHIP BLDG.
6	68	8.6	TATTLETOWN JERICHO RD.
7	40	5.7	LOCUST ISLAND ROAD
8	116	12.0	GREENWICH N.J.
10	8	5.8	FT. ELFSBORG ROAD
11	15	8.1	SINNICKSON LANDING RD.
12	24	8.6	NORTH SALEM(N.J.)
13	49	8.6	QUINTON TOWNSHIP BLDG.
14	90	6.7	LOWER ALLOWAY ELEMENTARY SCHOOL
15	105	6.4	STOW NECK ROAD

NRC TLD DOSES FOR SALEM - HOPE CREEK AREA



Miles

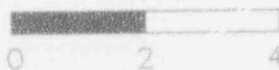

Legend

Water

Railroads

Plant site

Highways

Roads

SAN ONOFRE

TLD Direct Radiation Environmental Monitoring

For the period 930913-940201 142 Days

Field Time: 97 Days

NRC Sta	Location		Gross Exposure (mR)		Net Exposure Rate (mR/Std. Qtr.)		Hist. Range Net Exp Rate	
	Azimuth/ (Deg)	Dist (Mi)	+-Rdm; Tot.		+-Rdm; Tot.		+-1 Std Dev	
1	346	35.0	32.1	+- 1.0; 4.8	24.7	+- 1.0; 5.4	24.3	+- 3.1
2	346	35.0	31.1	+- 0.9; 4.7	23.8	+- 0.9; 5.3	23.9	+- 2.8
3	346	35.0	30.5	+- 0.9; 4.6	23.2	+- 0.9; 5.2	24.1	+- 3.0
4	327	11.0	22.8	+- 0.7; 3.4	16.1	+- 0.7; 4.4	17.6	+- 3.1
5	308	14.0	26.7	+- 0.8; 4.0	19.7	+- 0.8; 4.8	20.3	+- 2.9
6	307	10.0	24.7	+- 0.7; 3.7	17.8	+- 0.8; 4.6	17.8	+- 2.8
7	318	6.3	25.6	+- 0.8; 3.8	18.6	+- 0.8; 4.7	18.5	+- 3.1
8	322	5.1	27.0	+- 0.8; 4.1	20.0	+- 0.8; 4.8	20.2	+- 2.8
9	311	3.3	25.7	+- 0.8; 3.8	18.7	+- 0.8; 4.7	18.0	+- 2.5
10	331	3.3	27.2	+- 0.8; 4.1	20.1	+- 0.8; 4.9	20.6	+- 4.2
11	300	2.6	25.8	+- 0.8; 3.9	18.8	+- 0.8; 4.7	19.6	+- 2.4
12	285	0.5	30.4	+- 0.9; 4.6	23.1	+- 0.9; 5.2	20.8	+- 3.8
13	320	2.4	24.6	+- 0.7; 3.7	17.8	+- 0.8; 4.6	18.7	+- 3.0
14	320	1.7	24.5	+- 0.7; 3.7	17.7	+- 0.8; 4.6	18.7	+- 3.0
15	333	1.2	23.7	+- 0.7; 3.6	16.9	+- 0.8; 4.5	19.1	+- 2.5
16	30	1.9	29.1	+- 0.9; 4.4	21.9	+- 0.9; 5.1	21.4	+- 3.1
17	8	1.3	22.9	+- 0.7; 3.4	16.1	+- 0.7; 4.4	16.4	+- 2.7
18	39	2.0	30.1	+- 0.9; 4.5	22.8	+- 0.9; 5.2	22.7	+- 3.1
19	55	2.9	25.0	+- 0.7; 3.7	18.1	+- 0.8; 4.6	19.1	+- 3.0
20	77	4.1	27.6	+- 0.8; 4.1	20.5	+- 0.9; 4.9	21.1	+- 3.0
21	87	4.7	29.1	+- 0.9; 4.4	21.9	+- 0.9; 5.1	21.0	+- 2.7
22	25	3.4	30.7	+- 0.9; 4.6	23.4	+- 0.9; 5.2	22.8	+- 3.1
23	357	3.5	27.8	+- 0.8; 4.2	20.7	+- 0.9; 4.9	21.5	+- 3.6
24	25	0.4	25.0	+- 0.7; 3.7	18.1	+- 0.8; 4.6	18.9	+- 2.8
25	81	0.4	28.1	+- 0.8; 4.2	21.0	+- 0.9; 5.0	18.2	+- 3.0
26	126	2.1	21.4	+- 0.6; 3.2	14.8	+- 0.7; 4.3	16.2	+- 3.2
27	130	8.6	21.1	+- 0.6; 3.2	14.4	+- 0.7; 4.2	16.4	+- 3.2
28	99	8.9	21.5	+- 0.6; 3.2	14.8	+- 0.7; 4.3	16.8	+- 3.3
29	135	11.0	23.3	+- 0.7; 3.5	16.5	+- 0.7; 4.4	16.9	+- 3.3
30	126	2.0	18.9	+- 0.6; 2.8	12.5	+- 0.6; 4.0	13.3	+- 2.9
31	128	3.7	22.6	+- 0.7; 3.4	15.9	+- 0.7; 4.4	14.9	+- 2.2
32	140	22.0	25.2	+- 0.8; 3.8	18.3	+- 0.8; 4.6	19.4	+- 3.1
33	120	26.0	24.1	+- 0.7; 3.6	17.3	+- 0.8; 4.5	15.9	+- 2.6

Transit Dose = 5.5 +- 0.4; 3.3

SAN ONOFRE
For the period 930913-940201

TLD Direct Radiation Environmental Monitoring

Azimuth (degrees)	Ave. Exposure Rate (mR/Std.Qtr.) +- Std.Dev.	Number In Group
348.76 - 11.25 N	18.4 +- 3.2	2
11.26 - 33.75 NNE	21.1 +- 2.8	3
33.76 - 56.25 NE	20.5 +- 3.4	2
56.26 - 78.75 ENE	20.5 +- 0.0	1
78.76 - 101.25 E	19.2 +- 3.8	3
101.26 - 123.75 ESE	17.3 +- 0.0	1
123.76 - 146.25 SE	15.4 +- 2.0	6
146.26 - 168.75 SSE	No Data +- No Data	0
168.76 - 191.25 S	No Data +- No Data	0
191.26 - 213.75 SSW	No Data +- No Data	0
213.76 - 236.25 SW	No Data +- No Data	0
236.26 - 258.75 WSW	No Data +- No Data	0
258.76 - 281.25 W	No Data +- No Data	0
281.26 - 303.75 WNW	20.9 +- 3.0	2
303.76 - 326.25 NW	18.6 +- 0.9	7
326.26 - 348.75 NNW	17.7 +- 2.1	3

Distance From Reactor (miles)	Ave. Exposure Rate (mR/Std.Qtr.) +- Std.Dev.	Number In Group
0 - 2	18.9 +- 3.6	9
2 - 5	19.2 +- 2.5	11
> 5	17.4 +- 1.9	10
Upwind Control	23.9 +- 0.8	3

SAN ONOFRE
 TLD Direct Radiation Environmental Monitoring

NRC Station	Location		Description
	Azimuth Degree	Distance / Mile	
1	346	35.0	FEATHERLY PARK
2	346	35.0	FEATHERLY PARK
3	346	35.0	FEATHERLY PARK
4	327	11.0	S. COAST HOSPITAL
5	308	14.0	FIRE STATION
6	307	10.0	DANA PT. HARBOR
7	318	6.3	COMMUN DEV DEPT, SAN CLEMENTE
8	322	5.1	CIVIC CTR. (SAN CLEMENTE)
9	311	3.3	CYPRUS SHORES ENTRANCE
10	331	3.3	SAN CLEMENTE RANCH ENTRANCE
11	300	2.6	U.S. COAST GUARD
12	285	0.5	SAN ONOFRE SURFING BEACH
13	320	2.4	SAN CLEMENTE RANCH OFFICE
14	320	1.7	SAN ONOFRE ELEMENTARY SCHOOL
15	333	1.2	SAN ONOFRE MOBILE HOME PARK
16	30	1.9	BASILONE RD.
17	8	1.3	BASILONE RD.
18	39	2.0	CAMP SAN ONOFRE FIRE STATION
19	55	2.9	CAMP SAN ONOFRE
20	77	4.1	CAMP HORNO
21	87	4.7	CAMP HORNO
22	25	3.4	SAN MATEO RD.
23	357	3.5	CAMP SAN MATEO
24	25	0.4	OLD RT. 101
25	81	0.4	OLD RT. 101
26	126	2.1	BORDER PATROL STATION
27	130	8.6	STUART MESA RD. AREA
28	99	8.9	CAMP LOS PULGAS
29	135	11.0	STUART MESA RD.
30	126	2.0	SAN ONOFRE STATE CAMPING AREA
31	128	3.7	SAN ONOFRE STATE PARK
32	140	22.0	OCEANSIDE FIRE STATION
33	120	26.0	VISTA COUNTY OFFICES

NRC TLD DOSES FOR SAN ONOFRE AREA

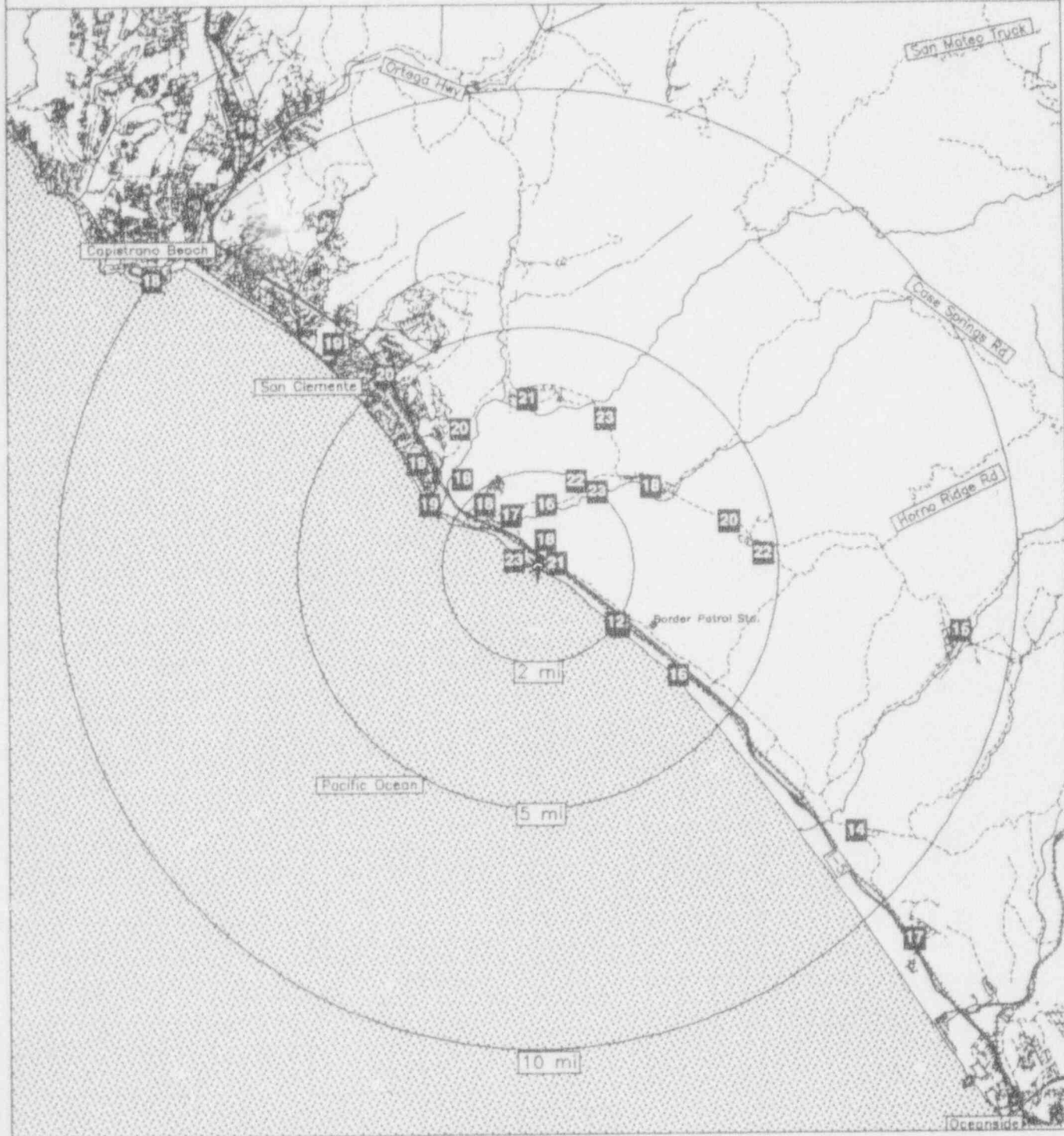

Miles

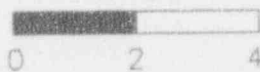

Legend



Highways

Railroads

Roads



Plant site

SEABROOK

TLD Direct Radiation Environmental Monitoring

For the period 930915-940209 148 Days

Field Time: 108 Days

NRC Sta	Location		Gross	Net Exposure Rate	Hist. Range
	Azimuth/Dist (Deg)/(Mi)	Exposure (mR) +-Rdm; Tot.	(mR/Std. Qtr.) +-Rdm; Tot.	Net Exp Rate +-1 Std Dev	
1	154 0.6	24.0 +- 0.7; 3.6	19.6 +- 0.6; 4.0	17.5 +- 2.6	
2	178 0.7	22.9 +- 0.7; 3.4	18.6 +- 0.6; 3.9	16.9 +- 2.4	
3	207 0.7	24.0 +- 0.7; 3.6	19.6 +- 0.6; 4.0	16.2 +- 2.6	
4	224 0.9	24.8 +- 0.7; 3.7	20.3 +- 0.7; 4.1	17.8 +- 2.8	
5	243 1.2	23.6 +- 0.7; 3.5	19.2 +- 0.6; 4.0	16.2 +- 2.8	
6	294 1.0	23.6 +- 0.7; 3.5	19.2 +- 0.6; 4.0	17.1 +- 2.5	
7	267 0.7	23.8 +- 0.7; 3.6	19.4 +- 0.6; 4.0	16.6 +- 2.5	
8	320 1.1	25.7 +- 0.8; 3.9	21.0 +- 0.7; 4.2	17.6 +- 2.8	
9	329 1.6	27.5 +- 0.8; 4.1	22.5 +- 0.7; 4.3	19.1 +- 3.0	
10	357 1.9	23.5 +- 0.7; 3.5	19.2 +- 0.6; 4.0	16.6 +- 2.6	
11	18 2.5	23.4 +- 0.7; 3.5	19.1 +- 0.6; 4.0	17.3 +- 2.7	
12	46 1.9	22.8 +- 0.7; 3.4	18.5 +- 0.6; 3.9	16.3 +- 3.6	
13	83 1.7	24.8 +- 0.7; 3.7	20.2 +- 0.7; 4.1	17.0 +- 2.6	
14	43 4.1	24.9 +- 0.7; 3.7	20.4 +- 0.7; 4.1	17.6 +- 2.5	
15	358 4.2	24.9 +- 0.7; 3.7	20.3 +- 0.7; 4.1	17.7 +- 2.6	
16	18 11.8	25.4 +- 0.8; 3.8	20.7 +- 0.7; 4.1	17.9 +- 2.6	
17	321 7.4	26.5 +- 0.8; 4.0	21.7 +- 0.7; 4.2	18.8 +- 3.0	
18	291 3.9	23.9 +- 0.7; 3.6	19.5 +- 0.6; 4.0	17.6 +- 2.4	
19	267 3.7	23.7 +- 0.7; 3.6	19.3 +- 0.6; 4.0	17.4 +- 3.6	
20	251 4.2	27.3 +- 0.8; 4.1	22.4 +- 0.7; 4.3	18.9 +- 2.9	
21	228 4.7	22.2 +- 0.7; 3.3	18.1 +- 0.6; 3.8	16.9 +- 2.9	
22	209 6.2	25.8 +- 0.8; 3.5	21.1 +- 0.7; 4.2	19.3 +- 2.7	
23	187 6.5	26.6 +- 0.8; 4.0	21.8 +- 0.7; 4.3	19.1 +- 2.8	
24	163 7.1	22.4 +- 0.7; 3.4	18.2 +- 0.6; 3.9	15.6 +- 2.5	
25	174 4.0	23.1 +- 0.7; 3.5	18.9 +- 0.6; 3.9	16.2 +- 2.9	
26	157 4.0	23.3 +- 0.7; 3.5	19.0 +- 0.6; 3.9	16.4 +- 2.5	
27	136 2.4	24.0 +- 0.7; 3.6	19.6 +- 0.6; 4.0	17.1 +- 2.8	
28	118 1.6	22.5 +- 0.7; 3.4	18.3 +- 0.6; 3.9	16.1 +- 2.4	
30	67 2.1	26.0 +- 0.8; 3.9	21.3 +- 0.7; 4.2	18.1 +- 2.6	
31	335 5.5	25.8 +- 0.8; 3.9	21.1 +- 0.7; 4.2	17.8 +- 2.5	
32	318 3.2	26.7 +- 0.8; 4.0	21.8 +- 0.7; 4.3	18.6 +- 2.9	
33	230 19.3	23.3 +- 0.7; 3.5	19.0 +- 0.6; 3.9	17.4 +- 3.4	
34	230 19.3	25.8 +- 0.8; 3.9	21.1 +- 0.7; 4.2	17.8 +- 3.0	
35	230 19.3	24.7 +- 0.7; 3.7	20.2 +- 0.7; 4.1	19.2 +- 3.7	

Transit Dose = 0.5 +- 0.3; 3.2

SEABROOK

For the period 930915-940209

TLD Direct Radiation Environmental Monitoring

Azimuth (degrees)	Ave. Exposure Rate (mR/Std.Qtr.) +- Std.Dev.	Number In Group
348.76 - 11.25 N	19.8 +- 0.8	2
11.26 - 33.75 NNE	19.9 +- 1.2	2
33.76 - 56.25 NE	19.5 +- 1.3	2
56.26 - 78.75 ENE	21.3 +- 0.0	1
78.76 - 101.25 E	20.2 +- 0.0	1
101.26 - 123.75 ESE	18.3 +- 0.0	1
123.76 - 146.25 SE	19.6 +- 0.0	1
146.26 - 168.75 SSE	18.9 +- 0.7	3
168.76 - 191.25 S	19.8 +- 1.7	3
191.26 - 213.75 SSW	20.4 +- 1.1	2
213.76 - 236.25 SW	19.5 +- 1.2	3
236.26 - 258.75 WSW	20.8 +- 2.2	2
258.76 - 281.25 W	19.4 +- 0.0	2
281.26 - 303.75 WNW	19.4 +- 0.2	2
303.76 - 326.25 NW	21.3 +- 0.5	2
326.26 - 348.75 NNW	21.8 +- 1.0	2

Distance From Reactor (miles)	Ave. Exposure Rate (mR/Std.Qtr.) +- Std.Dev.	Number In Group
0 - 2	19.7 +- 1.1	13
2 - 5	19.8 +- 1.2	11
> 5	20.7 +- 1.2	7
Upwind Control	20.6 +- 1.4	3

SEABROOK
TLD Direct Radiation Environmental Monitoring

NRC Station	Location		Description
	Azimuth / Degree	Distance / Mile	
1	154	0.6	END OF RAILROAD AVE.
2	178	0.7	CAUSEWAY ST.
3	207	0.7	DIRT ROAD OFF DEPOT RD.
4	224	0.9	RR OVERPASS ON DEPOT RD.
5	243	1.2	PINE ST. & RT. 1A
6	294	1.0	PAGES LANE
7	267	0.7	ROCKS RD.
8	320	1.1	BRIMERS LANE
9	329	1.6	LINCOLN AKERMAN SCH.
10	357	1.9	MARSHVIEW RESTAURANT
11	18	2.5	WINNACUNNET HIGH SCHOOL
12	46	1.9	GLADE PATH RD.
13	83	1.7	N.H. LOBSTER CO.
14	43	4.1	SCRUB-A-DUB LAUNDRY
15	358	4.2	RT. 101C & RT. 51
16	18	11.8	N. CONGREGATIONAL PARISH
17	321	7.4	EXETER
18	291	3.9	DOW LANE
19	267	3.7	LOCUST ST.
20	251	4.2	RT. 150 AND STREAM
21	228	4.7	MT. PROSPECT CEMETERY
22	209	6.2	ST. MARYS CEMETERY
23	187	6.5	COFFIN COURT
24	163	7.1	PLUM ISLAND
25	174	4.0	LONG HILL CEMETERY
26	157	4.0	E TO Z PARKING
27	136	2.4	SEABROOK BEACH
28	118	1.6	RIVER ST.
30	67	2.1	ASHWORTH AVE.
31	335	5.5	PHINNEY LANE
32	318	3.2	WESTVIEW CEMETERY
33	230	19.3	LAWRENCE (MASS.)
34	230	19.3	LAWRENCE (MASS.)
35	230	19.3	LAWRENCE (MASS.)

NRC TLD DOSES FOR SEABROOK AREA

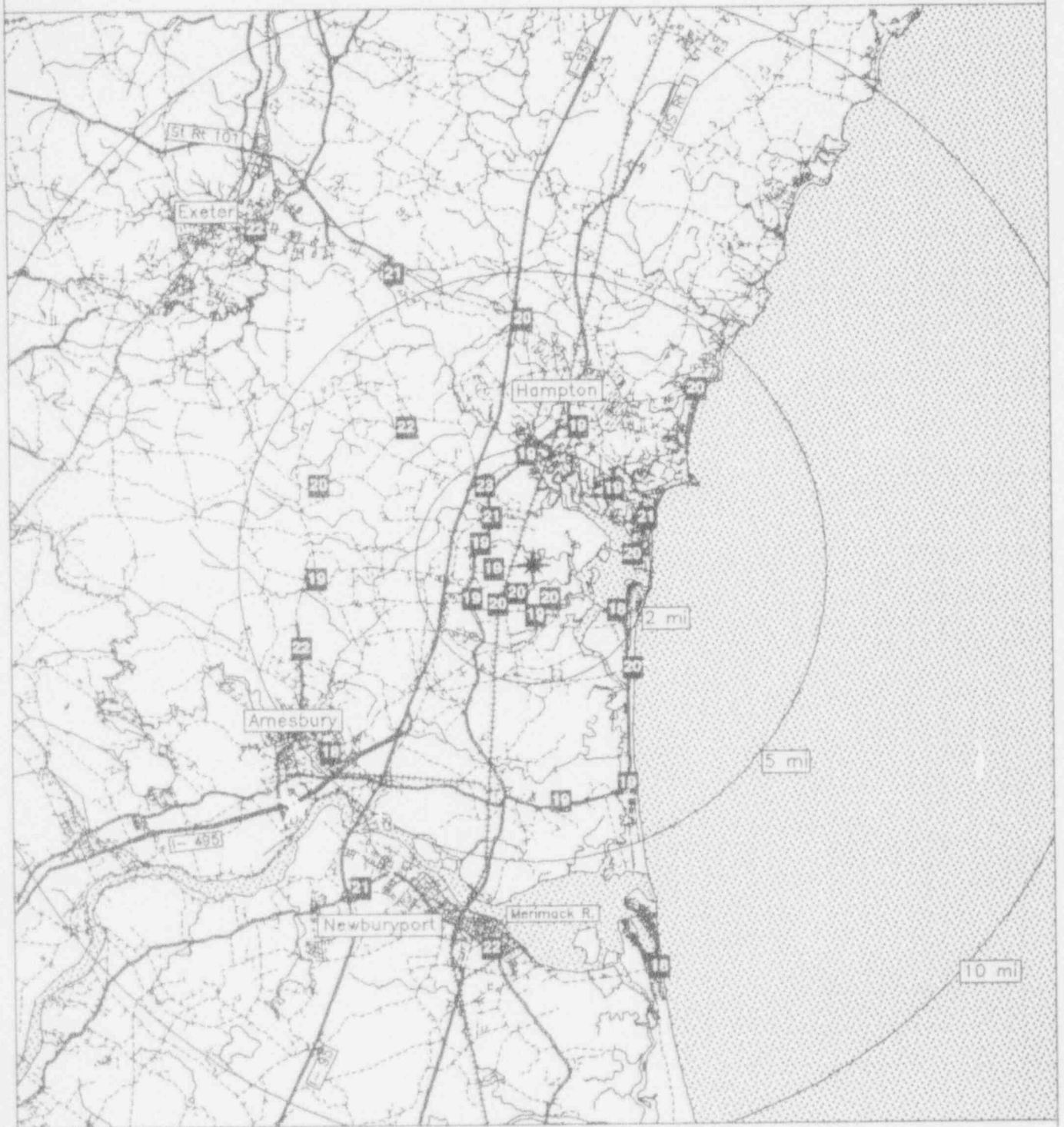

Miles

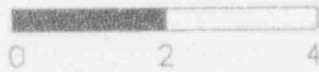

Legend

- Water
- Highways
- Railroads
- Roads
- Plant..site

SEQUOYAH

TLD Direct Radiation Environmental Monitoring

For the period 930914-940203 143 Days

Field Time: 104 Days

NRC Sta	Location		Gross Exposure (mR)		Net Exposure Rate (mR/Std. Qtr.)		Hist. Range Net Exp Rate	
	Azimuth/ (Deg)	Dist (Mi)	+-Rdm; Tot.		+-Rdm; Tot.		+-1 Std Dev	
1	218	12.0	21.7	+ - 0.6; 3.2	16.2	+ - 0.6; 4.0	16.9	+ - 1.3
2	206	13.0	19.4	+ - 0.6; 2.9	14.3	+ - 0.6; 3.8	14.3	+ - 1.2
3	203	3.9	26.4	+ - 0.8; 4.0	20.3	+ - 0.7; 4.4	20.0	+ - 1.4
4	199	2.0	24.6	+ - 0.7; 3.7	18.7	+ - 0.7; 4.3	16.5	+ - 1.3
5	181	1.4	27.2	+ - 0.8; 4.1	21.0	+ - 0.8; 4.5	21.0	+ - 1.4
6	153	1.5	20.9	+ - 0.6; 3.1	15.6	+ - 0.6; 3.9	15.5	+ - 1.1
7	139	1.9	20.2	+ - 0.6; 3.0	14.9	+ - 0.6; 3.8	14.6	+ - 1.0
8	115	1.8	20.3	+ - 0.6; 3.0	15.0	+ - 0.6; 3.9	16.0	+ - 1.9
9	84	1.6	18.0	+ - 0.5; 2.7	13.0	+ - 0.6; 3.7	13.7	+ - 1.4
10	66	1.3	20.9	+ - 0.6; 3.1	15.5	+ - 0.6; 3.9	15.6	+ - 1.2
11	45	1.5	22.9	+ - 0.7; 3.4	17.3	+ - 0.7; 4.1	16.6	+ - 1.3
12	14	2.0	24.2	+ - 0.7; 3.6	18.4	+ - 0.7; 4.2	18.6	+ - 1.1
13	2	2.1	23.9	+ - 0.7; 3.6	18.2	+ - 0.7; 4.2	18.8	+ - 1.4
14	19	3.9	20.9	+ - 0.6; 3.1	15.5	+ - 0.6; 3.9	15.9	+ - 1.1
15	48	4.0	17.5	+ - 0.5; 2.6	12.7	+ - 0.5; 3.6	13.7	+ - 1.1
16	65	4.9	20.9	+ - 0.6; 3.1	15.5	+ - 0.6; 3.9	15.7	+ - 1.1
17	90	3.9	20.6	+ - 0.6; 3.1	15.3	+ - 0.6; 3.9	17.5	+ - 1.5
18	111	3.4	21.0	+ - 0.6; 3.2	15.7	+ - 0.6; 3.9	16.2	+ - 1.5
19	135	3.4	21.4	+ - 0.6; 3.2	16.0	+ - 0.6; 4.0	15.9	+ - 1.1
20	158	3.4	21.1	+ - 0.6; 3.2	15.8	+ - 0.6; 3.9	14.2	+ - 2.0
21	184	4.6	26.3	+ - 0.8; 3.9	20.2	+ - 0.7; 4.4	18.5	+ - 2.3
22	233	11.0	19.6	+ - 0.6; 2.9	14.4	+ - 0.6; 3.8	14.3	+ - 1.5
23	219	4.9	22.9	+ - 0.7; 3.4	17.3	+ - 0.7; 4.1	17.7	+ - 1.5
24	241	4.3	19.8	+ - 0.6; 3.0	14.6	+ - 0.6; 3.8	15.6	+ - 1.2
25	235	2.0	17.1	+ - 0.5; 2.6	12.3	+ - 0.5; 3.6	13.2	+ - 1.1
26	248	1.5	Missing Dosimeter		No Net Data		15.5	+ - 2.0
27	266	1.2	19.6	+ - 0.6; 2.9	14.4	+ - 0.6; 3.8	14.6	+ - 1.0
28	291	1.2	19.5	+ - 0.6; 2.9	14.3	+ - 0.6; 3.8	15.7	+ - 1.4
29	309	1.2	21.7	+ - 0.7; 3.3	16.3	+ - 0.6; 4.0	15.9	+ - 1.4
30	330	0.5	22.1	+ - 0.7; 3.3	16.6	+ - 0.6; 4.0	16.7	+ - 1.3
31	339	1.8	21.9	+ - 0.7; 3.3	16.4	+ - 0.6; 4.0	16.9	+ - 1.2
32	355	4.9	19.2	+ - 0.6; 2.9	14.1	+ - 0.6; 3.8	14.7	+ - 1.2
33	334	3.6	19.4	+ - 0.6; 2.9	14.3	+ - 0.6; 3.8	14.6	+ - 1.4
34	317	4.4	21.1	+ - 0.6; 3.2	15.7	+ - 0.6; 3.9	15.2	+ - 1.7
35	277	5.6	21.6	+ - 0.6; 3.2	16.1	+ - 0.6; 4.0	16.3	+ - 1.2
36	283	3.6	18.0	+ - 0.5; 2.7	13.1	+ - 0.6; 3.7	14.3	+ - 1.1
37	273	4.4	21.2	+ - 0.6; 3.2	15.8	+ - 0.6; 3.9	15.1	+ - 1.3
38	302	19.0	19.6	+ - 0.6; 2.9	14.5	+ - 0.6; 3.8	15.2	+ - 1.2
39	290	18.0	21.6	+ - 0.6; 3.2	16.2	+ - 0.6; 4.0	16.3	+ - 1.1
40	289	18.0	20.1	+ - 0.6; 3.0	14.9	+ - 0.6; 3.8	14.9	+ - 1.1
41	318	6.1	20.7	+ - 0.6; 3.1	15.3	+ - 0.6; 3.9	15.8	+ - 1.1

Transit Dose = 2.9 + - 0.3; 3.3

SEQUOYAH
For the period 930914-940203

TLD Direct Radiation Environmental Monitoring

Azimuth (degrees)	Ave. Exposure Rate (mR/Std.Qtr.) +- Std.Dev.	Number In Group
348.76 - 11.25 N	16.1 +- 2.9	2
11.26 - 33.75 NNE	17.0 +- 2.0	2
33.76 - 56.25 NE	15.0 +- 3.3	2
56.26 - 78.75 ENE	15.5 +- 0.0	2
78.76 - 101.25 E	14.1 +- 1.6	2
101.26 - 123.75 ESE	15.4 +- 0.5	2
123.76 - 146.25 SE	15.4 +- 0.7	2
146.26 - 168.75 SSE	15.7 +- 0.1	2
168.76 - 191.25 S	20.6 +- 0.6	2
191.26 - 213.75 SSW	17.8 +- 3.1	3
213.76 - 236.25 SW	15.0 +- 2.2	4
236.26 - 258.75 WSW	14.6 +- 0.0	1
258.76 - 281.25 W	15.4 +- 0.9	3
281.26 - 303.75 WNW	13.7 +- 0.9	2
303.76 - 326.25 NW	15.8 +- 0.5	3
326.26 - 348.75 NNW	15.7 +- 1.3	3

Distance From Reactor (miles)	Ave. Exposure Rate (mR/Std.Qtr.) +- Std.Dev.	Number In Group
0 - 2	16.0 +- 2.3	15
2 - 5	15.9 +- 2.1	17
> 5	15.3 +- 0.9	5
Upwind Control	15.2 +- 0.9	3

SEQUOYAH

TLD Direct Radiation Environmental Monitoring

NRC Station	Location		Description
	Azimuth / Degree	Distance / Mile	
1	218	12.0	KINGS PT. RD. & HWY. 58
2	206	13.0	SHALLOWFORD RD. & HWY. 153
3	203	3.9	HARRISON BAY STATE PARK
4	199	2.0	MCRNING GLORY FARMS
5	181	1.4	ORR SLOUGH
6	153	1.5	9420 HARRISON BAY RD.
7	139	1.9	HARRISON BAY RD. AT BIRCHWOOD PK
8	115	1.8	BIRCHWOOD PK NEAR IGOU FERRY RD
9	84	1.6	10404 BIRCHWOOD PIKE
10	66	1.3	BIRCHWOOD PIKE AT LYNN RD.
11	45	1.5	TVA PUBLIC USE AREA
12	14	2.0	WARE BRANCH LANE
13	2	2.1	6304 DOGWOOD DR.
14	19	3.9	HENRY RD.
15	48	4.0	GAMBLE RD. (BOX 279)
16	65	4.9	GAMBLE RD.
17	90	3.9	DOLLY POND ROAD
18	111	3.4	NEW SHEPHERD HILL CHURCH
19	135	3.4	TVA SUBSTATION
20	158	3.4	BIRCHWOOD PIKE
21	184	4.6	3RD UTILITY POLE, HWY 58
22	233	11.0	NORTHGATE MALL
23	219	4.9	GOLD PT. CIRCLE RD.
24	241	4.3	DALLAS SCHOOL
25	235	2.0	HARBOR LIGHTS MARINA
26	248	1.5	N. OF BASE BAY MARINA
27	266	1.2	HIXSON PIKE & IGOU FERRY RD.
28	291	1.2	HIXSON PIKE S. OF IGOU FERRY RD.
29	309	1.2	EXXON STATION
30	330	0.5	IGOU FERRY RD. & STONESAGE RD.
31	339	1.8	STONESAGE RD. AT POINT PLACE RD.
32	355	4.9	ARMSTRONG RD.
33	334	3.6	CERA CLUB
34	317	4.4	DALLAS HOLLOW RD.
35	277	5.6	SODDY-DAISY OFF DEPOT RD.
36	283	3.6	JOHN H. ALLEN SCHOOL
37	273	4.4	SEQUOYHA HEALTH CENTER
38	302	19.0	FIRST BAPTIST CHURCH (DUNLAP)
39	290	18.0	HWY. 127 & HWY. 28
40	289	18.0	HWY. 127 S. OF DUNLAP
41	318	6.1	SOLDY ELEMENTARY SCHOOL

NRC TLD DOSES FOR SEQUOYAH AREA



Miles

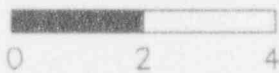

Legend

- Water
- Highways
- Railroads
- Roads
- Plant..site

SHOREHAM

TLD Direct Radiation Environmental Monitoring
 For the period 930915-940127 135 Days
 Field Time: 84 Days

NRC Sta	Location Azimuth/Dist (Deg)/(Mi)	Gross Exposure (mR) +-Rdm; Tot.	Net Exposure Rate (mR/Std. Qtr.) +-Rdm; Tot.	Hist. Range Net Exp Rate +-1 Std Dev
1	262 10.0	17.9 +- 0.5; 2.7	13.0 +- 0.7; 4.3	13.6 +- 1.6
2	268 4.4	18.1 +- 0.5; 2.7	13.3 +- 0.7; 4.3	14.6 +- 1.6
3	256 3.2	Missing Dosimeter	No Net Data	13.9 +- 1.6
4	268 2.1	18.7 +- 0.6; 2.8	14.0 +- 0.7; 4.3	15.0 +- 1.0
5	243 1.7	18.8 +- 0.6; 2.8	14.0 +- 0.7; 4.3	14.7 +- 1.2
7	136 1.5	20.5 +- 0.6; 3.1	15.9 +- 0.8; 4.6	15.4 +- 3.1
8	116 0.9	21.6 +- 0.6; 3.2	17.1 +- 0.8; 4.7	17.2 +- 1.4
9	91 0.8	17.9 +- 0.5; 2.7	13.1 +- 0.7; 4.3	13.9 +- 1.5
10	73 0.7	17.0 +- 0.5; 2.6	12.1 +- 0.7; 4.2	13.3 +- 1.2
11	62 0.7	15.8 +- 0.5; 2.4	10.8 +- 0.7; 4.0	12.7 +- 1.5
12	75 1.6	17.4 +- 0.5; 2.6	12.6 +- 0.7; 4.2	13.8 +- 1.4
13	88 2.1	18.7 +- 0.6; 2.8	14.0 +- 0.7; 4.3	14.5 +- 1.5
14	119 4.6	17.5 +- 0.5; 2.6	12.6 +- 0.7; 4.2	13.4 +- 1.5
15	110 10.0	17.5 +- 0.5; 2.6	12.6 +- 0.7; 4.2	14.5 +- 1.7
16	138 14.0	17.6 +- 0.5; 2.6	12.8 +- 0.7; 4.2	13.6 +- 1.6
17	162 12.0	17.0 +- 0.5; 2.6	12.1 +- 0.7; 4.2	13.8 +- 2.4
18	174 11.0	20.7 +- 0.6; 3.1	16.1 +- 0.8; 4.6	13.9 +- 1.8
19	189 5.1	17.9 +- 0.5; 2.7	13.1 +- 0.7; 4.3	13.7 +- 1.4
21	163 2.5	Missing Dosimeter	No Net Data	13.6 +- 1.7
22	149 1.5	18.8 +- 0.6; 2.8	14.0 +- 0.7; 4.4	15.0 +- 1.6
23	177 1.3	17.2 +- 0.5; 2.6	12.3 +- 0.7; 4.2	14.5 +- 1.4
24	196 1.2	17.9 +- 0.5; 2.7	13.0 +- 0.7; 4.2	13.7 +- 1.3
25	217 1.5	16.1 +- 0.5; 2.4	11.1 +- 0.7; 4.1	13.1 +- 1.6
26	215 4.6	16.3 +- 0.5; 2.5	11.4 +- 0.7; 4.1	12.4 +- 1.5
27	205 4.2	17.4 +- 0.5; 2.6	12.6 +- 0.7; 4.2	13.9 +- 1.5
28	233 11.0	17.5 +- 0.5; 2.6	12.6 +- 0.7; 4.2	13.4 +- 1.3
29	224 13.0	15.6 +- 0.5; 2.3	10.6 +- 0.6; 4.0	13.0 +- 1.3
30	202 14.0	18.5 +- 0.6; 2.8	13.7 +- 0.7; 4.3	13.9 +- 1.3
31	210 15.0	16.8 +- 0.5; 2.5	11.9 +- 0.7; 4.1	13.1 +- 1.2
32	210 15.0	18.4 +- 0.6; 2.8	13.6 +- 0.7; 4.3	13.7 +- 1.7
33	210 15.0	16.9 +- 0.5; 2.5	12.0 +- 0.7; 4.1	12.9 +- 1.5
34	27 0.2	15.5 +- 0.5; 2.3	10.5 +- 0.6; 4.0	12.9 +- 2.4
35	50 0.3	19.4 +- 0.6; 2.9	14.6 +- 0.7; 4.4	15.2 +- 1.6
36	133 3.9	18.0 +- 0.5; 2.7	13.2 +- 0.7; 4.3	14.6 +- 1.6

Transit Dose = 5.7 +- 0.4; 2.9

SHOREHAM

For the period 930915-940127

TLD Direct Radiation Environmental Monitoring

Azimuth (degrees)	Ave. Exposure Rate (mR/Std.Qtr.) +- Std.Dev.	Number In Group
348.76 - 11.25 N	No Data +- No Data	0
11.26 - 33.75 NNE	10.5 +- 0.0	1
33.76 - 56.25 NE	14.6 +- 0.0	1
56.26 - 78.75 ENE	11.8 +- 0.9	3
78.76 - 101.25 E	13.5 +- 0.6	2
101.26 - 123.75 ESE	14.1 +- 2.6	3
123.76 - 146.25 SE	14.0 +- 1.7	3
146.26 - 168.75 SSE	13.1 +- 1.3	2
168.76 - 191.25 S	13.8 +- 2.0	3
191.26 - 213.75 SSW	13.1 +- 0.6	3
213.76 - 236.25 SW	11.4 +- 0.8	4
236.26 - 258.75 WSW	14.0 +- 0.0	1
258.76 - 281.25 W	13.4 +- 0.5	3
281.26 - 303.75 WNW	No Data +- No Data	0
303.76 - 326.25 NW	No Data +- No Data	0
326.26 - 348.75 NNW	No Data +- No Data	0

Distance From Reactor (miles)	Ave. Exposure Rate (mR/Std.Qtr.) +- Std.Dev.	Number In Group
0 - 2	13.2 +- 1.9	13
2 - 5	13.0 +- 0.9	7
> 5	12.9 +- 1.5	9
Upwind Control	12.5 +- 1.0	3

SHOREHAM
 TLD Direct Radiation Environmental Monitoring

NRC Station	Location		Description
	Azimuth / Degree	Distance / Mile	
1	262	10.0	MATHOR MEM. HOSP.
2	268	4.4	LONG VIEW AVE. (ON POLE NYT #5)
3	256	3.2	JUPITER & KING RD.
4	268	2.1	BRIARCLIFF SCH
5	243	1.7	MILLER AVE SCH.
7	136	1.5	DOGWOOD DR.
8	116	0.9	DANBY RESIDENCE
9	91	0.8	PONDVIEW RD.
10	73	0.7	SUNSET BLVD
11	62	0.7	OAK ST.
12	75	1.6	ORPHANAGE
13	88	2.1	WILDWOOD STATE PARK
14	119	4.6	SOUTH PATH RD.
15	110	10.0	PULASKI ST.
16	138	14.0	WESTHAMPTON CH.
17	162	12.0	CENTER MORICHES
18	174	11.0	MASTIC FIRE DEPT.
19	189	5.1	BROOKHAVEN LABS
21	163	2.5	LAKE PANAMOKA
22	149	1.5	GATEWAY DR.
23	177	1.3	E. OF RANDALL RD
24	196	1.2	FENCEHILL RD
25	217	1.5	HUCK FINN LN.
26	215	4.6	WHISKEY RD.
27	205	4.2	RIDGE SCH.
28	233	11.0	SELDON
29	224	13.0	FARMINGVILLE
30	202	14.0	HAGERMAN FIRE CO.
31	210	15.0	PATCHOGUE
32	210	15.0	PATCHOGUE
33	210	15.0	PATCHOGUE
34	27	0.2	END OF SOUND RD.
35	50	0.3	FIELD & TENNIS CLUB
36	133	3.9	GRUMAN AIRPORT

NRC TLD DOSES FOR SHOREHAM AREA



Miles

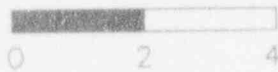

Legend

- Water
- Highways
- Railroads
- Roads
- Plant site

SOUTH TEXAS

TLD Direct Radiation Environmental Monitoring

For the period 930913-940208 149 Days

Field Time: 99 Days

NRC Sta	Location		Gross Exposure (mR)		Net Exposure Rate (mR/Std. Qtr.)		Hist. Range Net Exp Rate	
	Azimuth/Dist (Deg)/(Mi)		+-Rdm; Tot.		+-Rdm; Tot.		+-1 Std Dev	
1	90	1.0	23.8	+- 0.7; 3.6	18.5	+- 0.7; 4.3	16.3	+- 2.5
2	63	1.0	24.6	+- 0.7; 3.7	19.2	+- 0.7; 4.4	17.3	+- 2.1
3	40	1.0	23.9	+- 0.7; 3.6	18.6	+- 0.7; 4.3	17.8	+- 2.0
4	19	1.0	22.5	+- 0.7; 3.4	17.4	+- 0.7; 4.2	16.8	+- 2.1
5	4	0.9	22.4	+- 0.7; 3.4	17.2	+- 0.7; 4.2	16.7	+- 2.0
6	339	0.9	23.6	+- 0.7; 3.5	18.3	+- 0.7; 4.3	17.0	+- 2.2
7	318	1.0	22.6	+- 0.7; 3.4	17.4	+- 0.7; 4.2	16.4	+- 2.0
8	294	1.1	26.1	+- 0.8; 3.9	20.6	+- 0.8; 4.6	19.3	+- 2.2
9	267	1.3	26.9	+- 0.8; 4.0	21.3	+- 0.8; 4.7	19.4	+- 2.0
10	126	0.3	22.1	+- 0.7; 3.3	17.0	+- 0.7; 4.2	15.4	+- 2.0
11	180	0.1	23.6	+- 0.7; 3.5	18.4	+- 0.7; 4.3	16.0	+- 2.8
12	257	0.5	21.9	+- 0.7; 3.3	16.8	+- 0.7; 4.1	14.9	+- 2.2
13	262	0.9	21.1	+- 0.6; 3.2	16.1	+- 0.7; 4.1	15.1	+- 2.2
14	250	1.3	22.0	+- 0.7; 3.3	16.9	+- 0.7; 4.1	15.5	+- 2.0
15	227	2.4	21.8	+- 0.7; 3.3	16.7	+- 0.7; 4.1	14.3	+- 2.1
16	210	3.7	20.5	+- 0.6; 3.1	15.5	+- 0.6; 4.0	13.9	+- 2.2
17	175	3.6	19.6	+- 0.6; 2.9	14.7	+- 0.6; 3.9	14.2	+- 2.0
18	158	3.7	21.0	+- 0.6; 3.1	15.9	+- 0.7; 4.0	14.3	+- 2.0
19	143	3.3	19.2	+- 0.6; 2.9	14.3	+- 0.6; 3.9	14.0	+- 2.3
20	122	2.3	21.4	+- 0.6; 3.2	16.3	+- 0.7; 4.1	15.4	+- 2.5
21	121	1.1	20.9	+- 0.6; 3.1	15.9	+- 0.7; 4.0	14.9	+- 2.2
22	257	2.5	24.1	+- 0.7; 3.6	18.7	+- 0.7; 4.4	16.3	+- 2.0
23	262	4.5	26.8	+- 0.8; 4.0	21.2	+- 0.8; 4.6	18.6	+- 2.0
24	282	4.7	23.0	+- 0.7; 3.4	17.8	+- 0.7; 4.2	16.7	+- 2.4
25	304	5.8	23.3	+- 0.7; 3.5	18.1	+- 0.7; 4.3	15.3	+- 2.3
26	242	5.4	23.3	+- 0.7; 3.5	18.1	+- 0.7; 4.3	16.5	+- 2.3
27	223	5.0	23.5	+- 0.7; 3.5	18.2	+- 0.7; 4.3	16.4	+- 2.3
28	236	9.6	21.5	+- 0.6; 3.2	16.4	+- 0.7; 4.1	14.5	+- 2.4
29	259	10.0	23.8	+- 0.7; 3.6	18.5	+- 0.7; 4.3	15.7	+- 2.1
30	291	6.2	22.4	+- 0.7; 3.4	17.2	+- 0.7; 4.2	16.7	+- 1.8
31	323	7.8	23.7	+- 0.7; 3.6	18.4	+- 0.7; 4.3	18.1	+- 5.4
32	335	7.4	29.2	+- 0.9; 4.4	23.4	+- 0.9; 4.9	21.0	+- 2.1
33	351	5.5	21.9	+- 0.7; 3.3	16.7	+- 0.7; 4.1	14.8	+- 2.2
34	88	4.4	20.6	+- 0.6; 3.1	15.6	+- 0.6; 4.0	15.3	+- 2.2
35	89	6.7	20.7	+- 0.6; 3.1	15.7	+- 0.6; 4.0	14.6	+- 2.3
36	121	3.9	Missing Dosimeter		No Data		16.1	+- 2.6
37	145	8.8	21.8	+- 0.7; 3.3	16.7	+- 0.7; 4.1	14.6	+- 2.0
38	297	12.0	20.9	+- 0.6; 3.1	15.8	+- 0.7; 4.0	14.9	+- 2.3
39	321	9.3	24.1	+- 0.7; 3.6	18.8	+- 0.7; 4.4	17.6	+- 2.1
40	353	12.0	21.1	+- 0.6; 3.2	16.1	+- 0.7; 4.1	14.3	+- 1.8
41	13	18.0	22.4	+- 0.7; 3.4	17.2	+- 0.7; 4.2	15.9	+- 2.1
42	21	5.7	25.0	+- 0.8; 3.8	19.6	+- 0.8; 4.5	16.6	+- 2.4
43	39	5.8	24.9	+- 0.7; 3.7	19.5	+- 0.7; 4.4	17.0	+- 2.0
44	53	5.1	23.1	+- 0.7; 3.5	17.9	+- 0.7; 4.3	18.4	+- 2.5
45	69	7.3	21.1	+- 0.6; 3.2	16.1	+- 0.7; 4.1	14.9	+- 2.3
46	66	17.0	27.2	+- 0.8; 4.1	21.6	+- 0.8; 4.7	19.2	+- 1.8

Transit Dose = 3.5 +- 0.3; 3.2

SOUTH TEXAS

For the period 930913-940208

TLD Direct Radiation Environmental Monitoring

Azimuth (degrees)	Ave. Exposure Rate (mR/Std.Qtr.) +- Std.Dev.	Number In Group
348.76 - 11.25 N	17.0 +- 0.4	2
11.26 - 33.75 NNE	18.5 +- 1.6	2
33.76 - 56.25 NE	18.6 +- 0.8	3
56.26 - 78.75 ENE	19.0 +- 2.8	3
78.76 - 101.25 E	16.6 +- 1.6	3
101.26 - 123.75 ESE	16.1 +- 0.3	2
123.76 - 146.25 SE	16.0 +- 1.5	3
146.26 - 168.75 SSE	15.9 +- 0.0	1
168.76 - 191.25 S	16.5 +- 2.6	2
191.26 - 213.75 SSW	15.5 +- 0.0	1
213.76 - 236.25 SW	17.1 +- 1.0	3
236.26 - 258.75 WSW	17.6 +- 1.0	4
258.76 - 281.25 W	19.3 +- 2.5	4
281.26 - 303.75 WNW	18.5 +- 1.8	3
303.76 - 326.25 NW	18.2 +- 0.6	4
326.26 - 348.75 NNW	20.8 +- 3.6	2

Distance From Reactor (miles)	Ave. Exposure Rate (mR/Std.Qtr.) +- Std.Dev.	Number In Group
0 - 2	18.0 +- 1.5	15
2 - 5	16.8 +- 2.0	11
> 5	18.3 +- 2.0	16
Upwind Control	16.4 +- 0.7	3

SOUTH TEXAS
TLD Direct Radiation Environmental Monitoring

NRC Station	Location		Description
	Azimuth / Degree	Distance / Mile	
1	90	1.0	NW CORNER OF STPEGS VISITORS CENTER
2	63	1.0	W SIDE OF FM 521(0.5 MI NNW OF TLD #1)
3	40	1.0	E SIDE OF FM 521(0.4 MI NNW OF TLD#2)
4	19	1.0	N SIDE OF FM 521(0.4 MI NW OF TLD#3)
5	4	0.9	S SIDE OF FM 521(0.3 MI W OF TLD#4)
6	339	0.9	S FIDE OF FM 521(0.4 MI W OF TLD#5)
7	318	1.0	S SIDE OF FM 521(0.4MI WSW OF TLD#6)
8	294	1.1	S SIDE OF FM 521(0.5 MI SW OF TLD#7)
9	267	1.3	S SIDE OF FM 521(0.6 MI SSW OF TLD#8)
10	126	0.3	ON DIKE OF RESERVOIR
11	180	0.1	ON DIKE OF RESERVOIR
12	257	0.5	ON DIKE OF RESERVOIR
13	262	0.9	ON DIKE OF RESERVOIR
14	250	1.3	ON DIKE OF RESERVOIR
15	227	2.4	ON DIKE OF RESERVOIR
16	210	3.7	ON DIKE OF RESERVOIR
17	175	3.6	ON DIKE OF RESERVOIR
18	158	3.7	ON DIKE OF RESERVOIR
19	143	3.3	ON DIKE OF RESERVOIR
20	122	2.3	ON DIKE OF RESERVOIR
21	121	1.1	ON DIKE OF RESERVOIR
22	257	2.5	INTERSECTION OF FM 521 & CANAL
23	262	4.5	0.1MI N OF FM 521 & FM 1095
24	282	4.7	1.9 MI N OF FM 521 AND FM 1095
25	304	5.8	E OF FM 521 & WILSON CR CEMETERY RD.
26	242	5.4	SW OF FM 1095 AND ELLIS ROAD
27	223	5.0	1.4 MI E OF FM 1095 & CITRUS GROVE RD.
28	236	9.6	0.1 MI S OF FM 1095 & KING RD.(WHITE BLDG.)
29	259	10.0	0.1 MI W OF HWY 35 & HARRISON RD.
30	291	6.2	TRES PALASIOS OAKS,E OF FM 2853
31	323	7.8	1.1MI E OF FM 1045 & ROAD PARALLEL TO RR.
32	335	7.4	1.7 MI E OF TLD# 31
33	351	5.5	2.2MI S OF FM 1468 & ROAD PARALLEL TO RR.
34	88	4.4	1.4 MI E OF COLORADO RIVER BRIDGE
35	89	6.7	AT OXYCHEM PLANT ON HWY 60
36	121	3.9	3.1 MI W OF HWY 60 & RD TO SELKIRK IS.
37	145	8.8	NE OF LEWIS & MARKET STREETS
38	297	12.0	BLESSING WATER TOWER, BLESSING
39	321	9.3	0.1 MI SW OF HWY 35 & FM 1045
40	353	12.0	MARKHAM POST OFFICE, MARKHAM
41	13	18.0	0.4MI W OF HWY 60 & THOMPSON DR.,BAY CITY
42	21	5.7	NE OF CELANESE PLANT
43	39	5.8	0.8MI S OF FM 3057 & FM 2668
44	53	5.1	1.7MI SE OF TLD#43(W OF FM 2668)
45	69	7.3	SW CORNER OF HWY 60 AND FM 2078
46	66	17.0	11.4MI E OF HWY 60 & FM 521,ON 521

NRC TLD DOSES FOR SOUTH TEXAS AREA

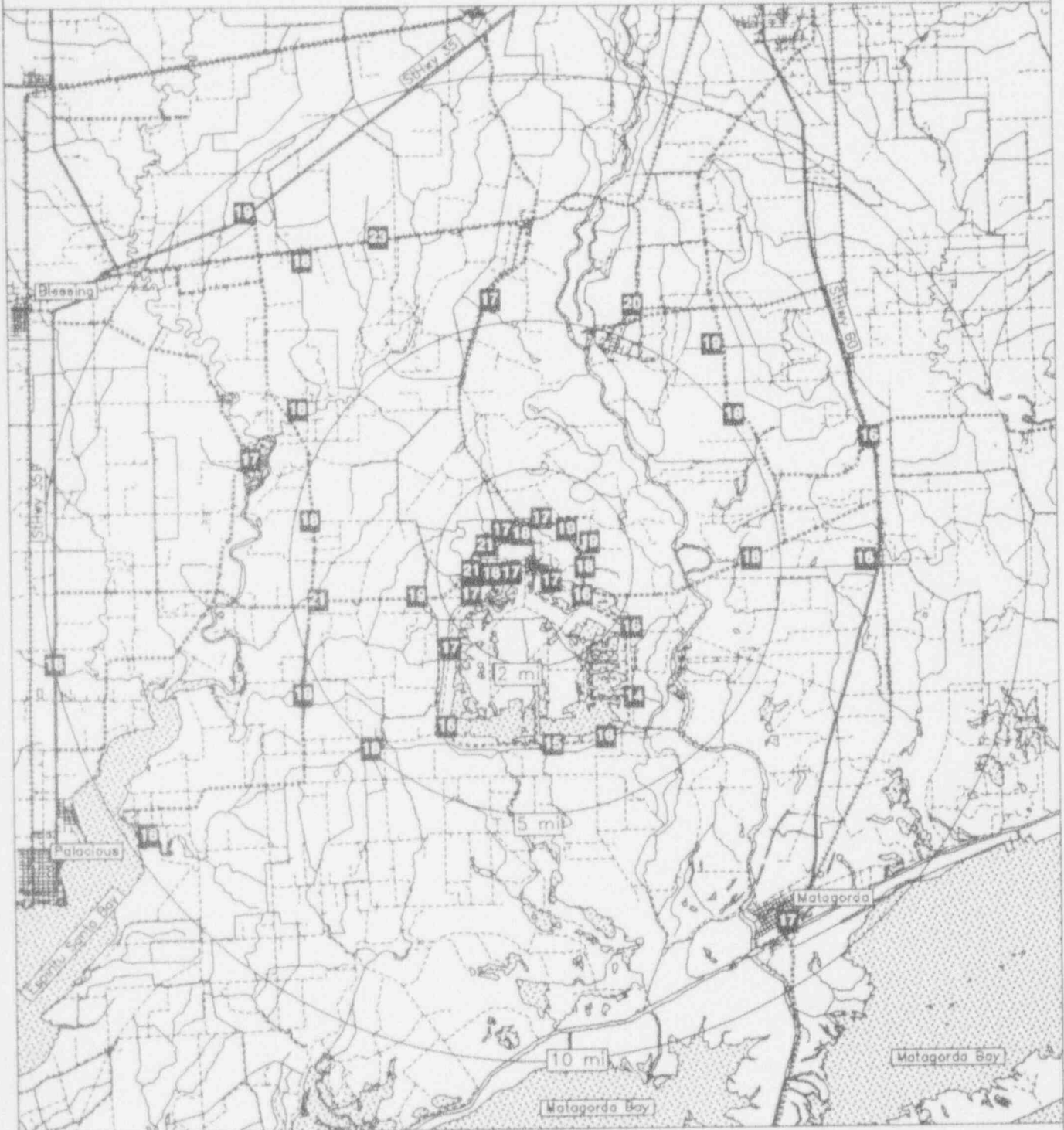

Miles

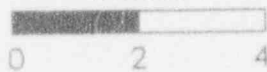

Legend



Water

Highways

Railroads

Roads



Plant..site

ST. LUCIE

TLD Direct Radiation Environmental Monitoring

For the period 930914-940203 143 Days

Field Time: 99 Days

NRC Sta	Location Azimuth/Dist (Deg)/(Mi)		Gross Exposure (mR) +-Rdm; Tot.	Net Exposure Rate (mR/Std. Qtr.) +-Rdm; Tot.	Hist. Range Net Exp Rate +-1 Std Dev
1	20	0.3	18.3 +- 0.6; 2.8	15.1 +- 0.6; 3.7	14.4 +- 3.6
2	45	0.2	17.6 +- 0.5; 2.6	14.5 +- 0.6; 3.6	15.3 +- 3.6
3	67	0.2	16.6 +- 0.5; 2.5	13.6 +- 0.5; 3.6	16.4 +- 4.4
4	92	0.3	17.7 +- 0.5; 2.6	14.5 +- 0.6; 3.6	13.9 +- 3.6
5	115	0.4	Damaged Dosimeter	No Net Data	13.4 +- 3.6
6	143	1.1	15.9 +- 0.5; 2.4	12.9 +- 0.5; 3.5	12.3 +- 3.4
7	150	2.0	14.4 +- 0.4; 2.2	11.6 +- 0.5; 3.4	12.0 +- 3.5
8	154	4.7	16.8 +- 0.5; 2.5	13.7 +- 0.5; 3.6	13.0 +- 3.7
9	152	23.0	16.9 +- 0.5; 2.5	13.8 +- 0.5; 3.6	13.4 +- 3.7
10	152	23.0	16.5 +- 0.5; 2.5	13.5 +- 0.5; 3.5	13.9 +- 4.9
11	152	23.0	17.9 +- 0.5; 2.7	14.7 +- 0.6; 3.7	15.0 +- 4.8
12	168	14.0	16.5 +- 0.5; 2.5	13.4 +- 0.5; 3.5	13.3 +- 3.4
13	185	10.0	17.1 +- 0.5; 2.6	14.0 +- 0.5; 3.6	13.6 +- 3.5
14	183	11.0	16.5 +- 0.5; 2.5	13.4 +- 0.5; 3.5	15.8 +- 3.6
15	170	8.0	16.3 +- 0.5; 2.4	13.2 +- 0.5; 3.5	13.2 +- 3.7
16	196	7.0	16.9 +- 0.5; 2.5	13.8 +- 0.5; 3.6	13.6 +- 3.6
17	229	7.9	18.8 +- 0.6; 2.8	15.5 +- 0.6; 3.7	15.7 +- 4.5
18	250	6.6	Missing Dosimeter	No Net Data	12.7 +- 3.6
19	247	4.8	16.2 +- 0.5; 2.4	13.2 +- 0.5; 3.5	13.2 +- 3.7
20	229	5.0	16.2 +- 0.5; 2.4	13.2 +- 0.5; 3.5	13.5 +- 3.5
21	208	3.8	16.3 +- 0.5; 2.4	13.2 +- 0.5; 3.5	13.0 +- 4.0
22	187	3.8	17.7 +- 0.5; 2.7	14.5 +- 0.6; 3.6	13.3 +- 3.7
23	203	2.6	17.1 +- 0.5; 2.6	14.0 +- 0.5; 3.6	13.4 +- 3.5
24	245	1.9	16.3 +- 0.5; 2.4	13.2 +- 0.5; 3.5	13.1 +- 3.6
25	280	2.2	Missing Dosimeter	No Net Data	13.8 +- 3.7
26	299	3.1	16.5 +- 0.5; 2.5	13.4 +- 0.5; 3.5	13.8 +- 3.6
27	305	3.8	16.2 +- 0.5; 2.4	13.2 +- 0.5; 3.5	13.4 +- 3.6
28	276	4.0	15.8 +- 0.5; 2.4	12.8 +- 0.5; 3.5	12.9 +- 3.5
29	293	5.8	16.9 +- 0.5; 2.5	13.8 +- 0.5; 3.6	13.2 +- 3.6
30	316	7.7	16.9 +- 0.5; 2.5	13.8 +- 0.5; 3.6	13.2 +- 3.7
32	300	11.0	17.1 +- 0.5; 2.6	14.0 +- 0.5; 3.6	14.1 +- 3.5
33	322	8.7	16.9 +- 0.5; 2.5	13.8 +- 0.5; 3.6	14.6 +- 3.6
34	339	8.8	17.0 +- 0.5; 2.5	13.9 +- 0.5; 3.6	14.0 +- 3.7
35	342	2.9	16.0 +- 0.5; 2.4	13.0 +- 0.5; 3.5	12.8 +- 3.6
36	346	1.9	17.9 +- 0.5; 2.7	14.7 +- 0.6; 3.7	14.1 +- 3.6
37	353	1.0	17.4 +- 0.5; 2.6	14.2 +- 0.5; 3.6	13.4 +- 3.9
38	226	2.0	Missing Dosimeter	No Net Data	13.5 +- 3.6

Transit Dose = 1.7 +- 0.3; 3.0

ST. LUCIE

For the period 930914-940203

TLD Direct Radiation Environmental Monitoring

Azinuth (degrees)	Ave. Exposure Rate (mR/Std.Qtr.) +- Std.Dev.	Number In Group
348.76 - 11.25 N	14.2 +- 0.0	1
11.26 - 33.75 NNE	15.1 +- 0.0	1
33.76 - 56.25 NE	14.5 +- 0.0	1
56.26 - 78.75 ENE	13.6 +- 0.0	1
78.76 - 101.25 E	14.5 +- 0.0	1
101.26 - 123.75 ESE	No Data +- No Data	0
123.76 - 146.25 SE	12.9 +- 0.0	1
146.26 - 168.75 SSE	12.9 +- 1.2	3
168.76 - 191.25 S	13.8 +- 0.6	4
191.26 - 213.75 SSW	13.7 +- 0.4	3
213.76 - 236.25 SW	14.3 +- 1.7	2
236.26 - 258.75 WSW	13.2 +- 0.1	2
258.76 - 281.25 W	12.8 +- 0.0	1
281.26 - 303.75 WNW	13.7 +- 0.3	3
303.76 - 326.25 NW	13.6 +- 0.4	3
326.26 - 348.75 NNW	13.9 +- 0.8	3

Distance From Reactor (miles)	Ave. Exposure Rate (mR/Std. Qtr.) +- Std.Dev.	Number In Group
0 - 2	13.8 +- 1.1	9
2 - 5	13.4 +- 0.5	10
> 5	13.9 +- 0.6	11
Upwind Control	14.0 +- 0.6	3

ST. LUCIE
TLD Direct Radiation Environmental Monitoring

NRC Station	Location		Description
	Azimuth / Degree	Distance / Mile	
1	20	0.3	RT. A1A - BIG MUD CREEK
2	45	0.2	RT. A1A
3	67	0.2	RT. A1A
4	92	0.3	RT. A1A
5	115	0.4	RT. A1A
6	143	1.1	RT. A1A
7	150	2.0	RT. A1A
8	154	4.7	RT. A1A - OCEANA CONDOMINIUMS
9	152	23.0	HOBE SOUND
10	152	23.0	HOBE SOUND
11	152	23.0	HOBE SOUND
12	168	14.0	PORT SALERNO
13	185	10.0	STUART
14	183	11.0	STUART SUBSTATION
15	170	8.0	JENSEN BEACH
16	196	7.0	JENSEN BEACH SUBSTATION
17	229	7.9	PORT ST. LUCIE
18	250	6.6	PORT ST. LUCIE BAPTIST CHURCH
19	247	4.8	RT. 1
20	229	5.0	RT. 1 & WALTON RD.
21	208	3.8	WALTON RD.
22	187	3.8	RT. 707
23	203	2.6	RT. 707
24	245	1.9	RT. 707
25	280	2.2	RT. 707
26	299	3.1	RT. 707
27	305	3.8	RT. 707 & RT. 712
28	276	4.0	SILVER OAK DR.
29	293	5.8	WHITE CITY SUBSTATION
30	316	7.7	SUNRISE BLVD. & VIRGINIA AVE.
32	300	11.0	UNIV. OF FLA. AGRICULTURAL RESEARCH CENTER
33	322	8.7	ST. LUCIE COUNTY HEALTH DEPT.
34	339	8.8	RT. A1A & HERNANDO ST.
35	342	2.9	RT. A1A
36	346	1.9	RT. A1A - LITTLE MUD CREEK
37	353	1.0	RT. A1A - BLIND CREEK
38	226	2.0	RT. 707

NRC TLD DOSES FOR ST. LUCIE AREA

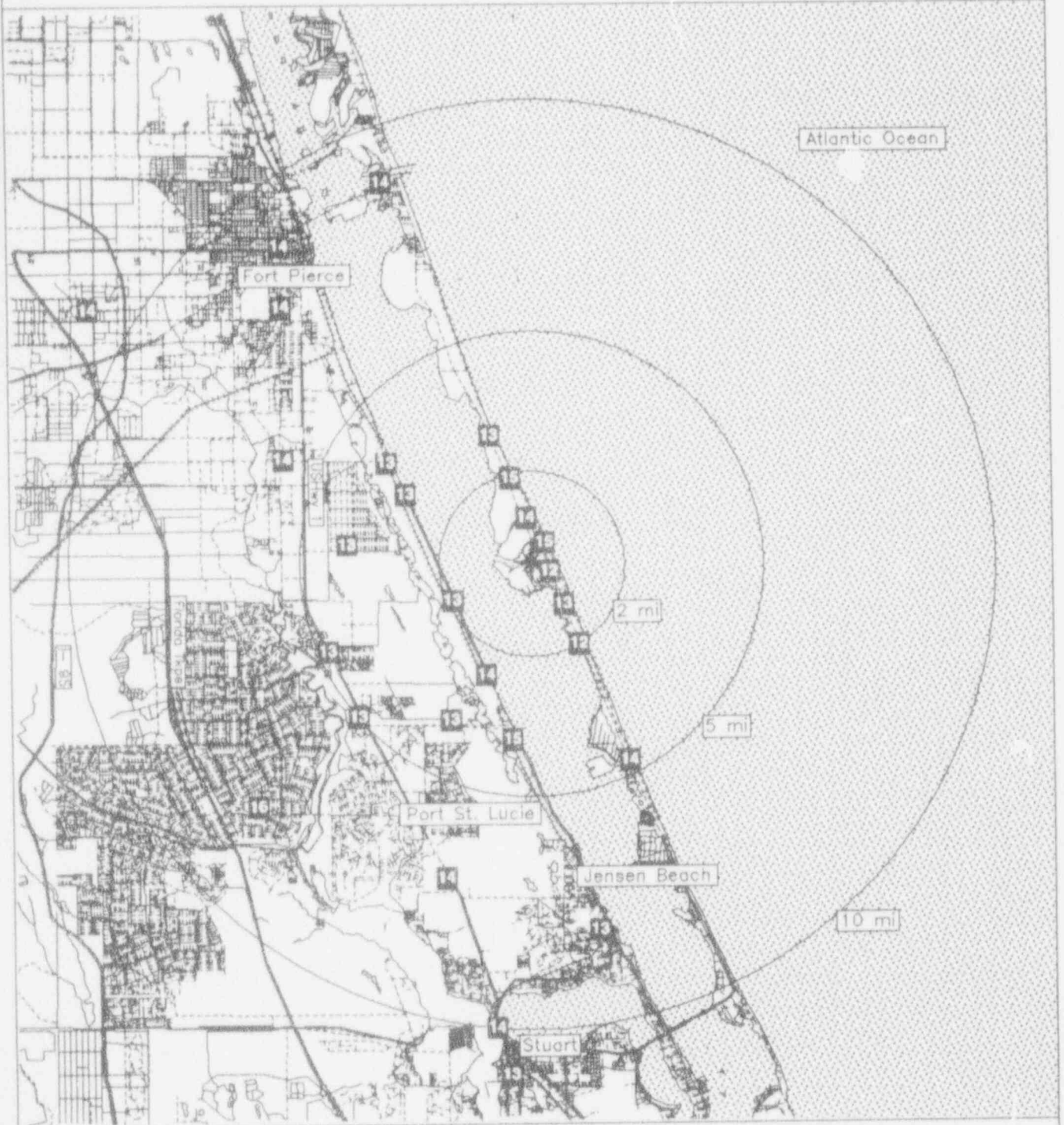

Miles

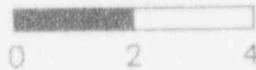

Legend

Water

Highways

Railroads

Roads

Plant..site

SUMMER

TLD Direct Radiation Environmental Monitoring

For the period 930914-940201 141 Days

Field Time: 104 Days

NRC Jta	Location		Gross Exposure (mR)		Net Exposure Rate (mR/Std. Qtr.)		Hist. Range Net Exp Rate	
	Azimuth/Dist (Deg)/(Mi)		+-Rdm; Tot.		+-Rdm; Tot.		+-1 Std Dev	
1	199	3.7	28.0	+- 0.8; 4.2	18.9	+- 0.8; 4.7	21.6	+- 2.9
2	111	1.0	27.2	+- 0.8; 4.1	18.2	+- 0.8; 4.7	19.9	+- 2.6
3	340	4.1	28.9	+- 0.9; 4.3	19.7	+- 0.8; 4.8	23.1	+- 3.1
4	192	9.3	30.0	+- 0.9; 4.5	20.6	+- 0.9; 5.0	21.2	+- 1.7
5	72	1.8	29.2	+- 0.9; 4.4	19.9	+- 0.9; 4.9	22.7	+- 2.7
6	54	1.5	31.5	+- 0.9; 4.7	21.9	+- 0.9; 5.1	22.1	+- 1.9
7	46	3.0	34.8	+- 1.0; 5.2	24.8	+- 1.0; 5.5	27.1	+- 2.8
8	31	3.0	38.3	+- 1.1; 5.7	27.8	+- 1.1; 5.8	28.3	+- 3.0
9	13	3.9	37.9	+- 1.1; 5.7	27.4	+- 1.1; 5.8	27.3	+- 2.2
10	7	4.0	35.6	+- 1.1; 5.3	25.5	+- 1.0; 5.5	26.1	+- 1.7
11	349	4.3	33.0	+- 1.0; 4.9	23.2	+- 0.9; 5.3	22.4	+- 3.2
12	323	5.0	33.7	+- 1.0; 5.1	23.8	+- 1.0; 5.3	24.4	+- 2.3
13	333	3.0	36.2	+- 1.1; 5.4	26.0	+- 1.0; 5.6	24.7	+- 1.9
14	255	2.8	28.2	+- 0.8; 4.2	19.0	+- 0.8; 4.8	19.3	+- 3.5
15	308	5.6	32.1	+- 1.0; 4.8	22.4	+- 0.9; 5.2	25.9	+- 2.1
16	64	3.5	39.0	+- 1.2; 5.9	28.4	+- 1.1; 5.9	26.6	+- 3.1
17	98	3.1	33.7	+- 1.0; 5.1	23.8	+- 1.0; 5.3	23.3	+- 2.0
18	114	3.5	33.7	+- 1.0; 5.1	23.8	+- 1.0; 5.3	23.0	+- 1.9
19	132	2.0	30.0	+- 0.9; 4.5	20.6	+- 0.9; 5.0	20.9	+- 2.1
20	152	4.5	21.1	+- 0.6; 3.2	12.9	+- 0.7; 4.1	14.3	+- 2.8
21	133	4.1	25.4	+- 0.8; 3.8	16.7	+- 0.8; 4.5	15.9	+- 1.8
22	157	2.4	29.4	+- 0.9; 4.4	20.1	+- 0.9; 4.9	17.9	+- 2.2
23	173	2.4	31.2	+- 0.9; 4.7	21.6	+- 0.9; 5.1	20.1	+- 2.1
24	185	3.9	29.2	+- 0.9; 4.4	20.0	+- 0.9; 4.9	19.4	+- 2.2
25	210	3.3	28.3	+- 0.8; 4.2	19.1	+- 0.8; 4.8	19.3	+- 1.8
26	217	3.3	27.5	+- 0.8; 4.1	18.4	+- 0.8; 4.7	17.6	+- 2.1
27	231	3.1	22.8	+- 0.7; 3.4	14.4	+- 0.7; 4.3	15.3	+- 2.3
28	267	2.7	31.0	+- 0.9; 4.7	21.5	+- 0.9; 5.1	22.3	+- 2.1
29	276	3.4	33.0	+- 1.0; 5.0	23.2	+- 0.9; 5.3	23.7	+- 1.8
30	293	3.8	Missing Dosimeter		No Net Data		25.3	+- 4.2
31	244	3.6	27.6	+- 0.8; 4.1	18.5	+- 0.8; 4.7	20.7	+- 3.5
32	247	6.2	32.9	+- 1.0; 4.9	23.1	+- 0.9; 5.2	23.4	+- 2.2
33	218	9.0	30.1	+- 0.9; 4.5	20.7	+- 0.9; 5.0	20.4	+- 1.9
34	192	9.3	30.1	+- 0.9; 4.5	20.7	+- 0.9; 5.0	20.5	+- 1.9
35	184	14.1	25.8	+- 0.8; 3.9	17.0	+- 0.8; 4.5	16.3	+- 1.9
36	183	14.6	20.7	+- 0.6; 3.1	12.5	+- 0.7; 4.1	15.1	+- 2.9
37	182	14.8	20.0	+- 0.6; 3.0	11.9	+- 0.6; 4.0	14.2	+- 3.0
38	148	20.8	29.2	+- 0.9; 4.4	19.9	+- 0.8; 4.9	21.4	+- 2.7
39	140	25.0	30.7	+- 0.9; 4.6	21.2	+- 0.9; 5.0	22.7	+- 2.4
40	135	23.1	28.2	+- 0.8; 4.2	19.0	+- 0.8; 4.8	20.1	+- 3.5

Transit Dose = 6.2 +- 0.4; 3.5

SUMMER

For the period 930914-940201

TLD Direct Radiation Environmental Monitoring

Azimuth (degrees)	Ave. Exposure Rate (mR/Std.Qtr.) +- Std.Dev.	Number In Group
348.76 - 11.25 N	24.3 +- 1.6	2
11.26 - 33.75 NNE	27.6 +- 0.3	2
33.76 - 56.25 NE	23.3 +- 2.1	2
56.26 - 78.75 ENE	24.2 +- 6.0	2
78.76 - 101.25 E	23.8 +- 0.0	1
101.26 - 123.75 ESE	21.0 +- 4.0	2
123.76 - 146.25 SE	19.4 +- 2.0	4
146.26 - 168.75 SSE	17.6 +- 4.1	3
168.76 - 191.25 S	20.8 +- 1.2	2
191.26 - 213.75 SSW	19.8 +- 1.0	4
213.76 - 236.25 SW	17.8 +- 3.2	3
236.26 - 258.75 WSW	20.2 +- 2.5	3
258.76 - 281.25 W	22.4 +- 1.2	2
281.26 - 303.75 WNW	No Data +- No Data	0
303.76 - 326.25 NW	23.1 +- 1.0	2
326.26 - 348.75 NNW	22.8 +- 4.5	2

Distance From Reactor (miles)	Ave. Exposure Rate (mR/Std.Qtr.) +- Std.Dev.	Number In Group
0 - 2	20.1 +- 1.5	4
2 - 5	21.6 +- 4.1	24
> 5	21.0 +- 1.3	8
Upwind Control	13.8 +- 2.7	3

SUMMER
TLD Direct Radiation Environmental Monitoring

NRC Station	Location		Description
	Azimuth / Degree	Distance / Mile	
1	199	3.7	WICKER'S STORE
2	111	1.0	RT. 311 (0.3 MILES W. OF RT. 215)
3	340	4.1	RT. 257 & RT. 383
4	192	9.3	RT. 215 (0.5 MILES N. OF RT. 113)
5	72	1.8	WHITE HALL SCHOOL
6	54	1.5	RT. 224 (0.5 MILES N. OF RT. 213/215)
7	46	3.0	RT. S.20.359
8	31	3.0	RT. 213/215 (0.5 MILES N. OF RT. 359)
9	13	3.9	RT. 215 & RT. 11
10	7	4.0	RT. 11 (0.7 MILES W. OF RT. 215)
11	349	4.3	RT. 11 (0.7 MILES E. OF RT. 257)
12	323	5.0	RT. 651 (2.2 MILES W. OF RT. 257)
13	333	3.0	RT. 257 (2.3 MILES S. OF RT. 283)
14	255	2.8	RT. 28 (CANNONS CREEK)
15	308	5.6	RT. 28 & RT. 97)
16	64	3.5	OLD BRICK CH.
17	98	3.1	RT. 247
18	114	3.5	STELLA HILL RESIDENCE
19	132	2.0	RT. 213/215
20	152	4.5	LOOKOUT TOWER RD.
21	133	4.1	ROCK HILL CH.
22	157	2.4	RT. 213
23	173	2.4	RT. 216
24	185	3.9	MOUNT HERMAN CH
25	210	3.3	RT. 28 (0.8 MILES N. OF RT. 213)
26	217	3.3	RT. 28 (1.2 MILES N. OF RT. 213)
27	231	3.1	RT. 28 (2.1 MILES N. OF RT. 213)
28	267	2.7	RT. 28 (1.6 MILES N OF RT. 33)
29	276	3.4	RT. 98 (0.5 MILES W. OF RT. 28)
30	293	3.8	PARR RESERVOIR
31	244	3.6	RT. 33 (0.8 MILES W. OF RT. 28)
32	247	6.2	POMARIA FIRE DEPT.
33	218	9.0	RT. 202 & RT. 76
34	192	9.3	RT. 76 & CLARK ST.
35	184	14.1	RT. 270 & PUTNAM RD.
36	183	14.6	RT. 270 (0.5 MILES S. OF PUTNAM RD.)
37	182	14.8	RT. 270 & RT. 1254
38	148	20.8	MAJIK MARKET
39	140	25.0	S.C. DEPT. OF HEALTH
40	135	23.1	RT. 321 & BUCKNER ST.

NRC TLD DOSES FOR SUMMER AREA

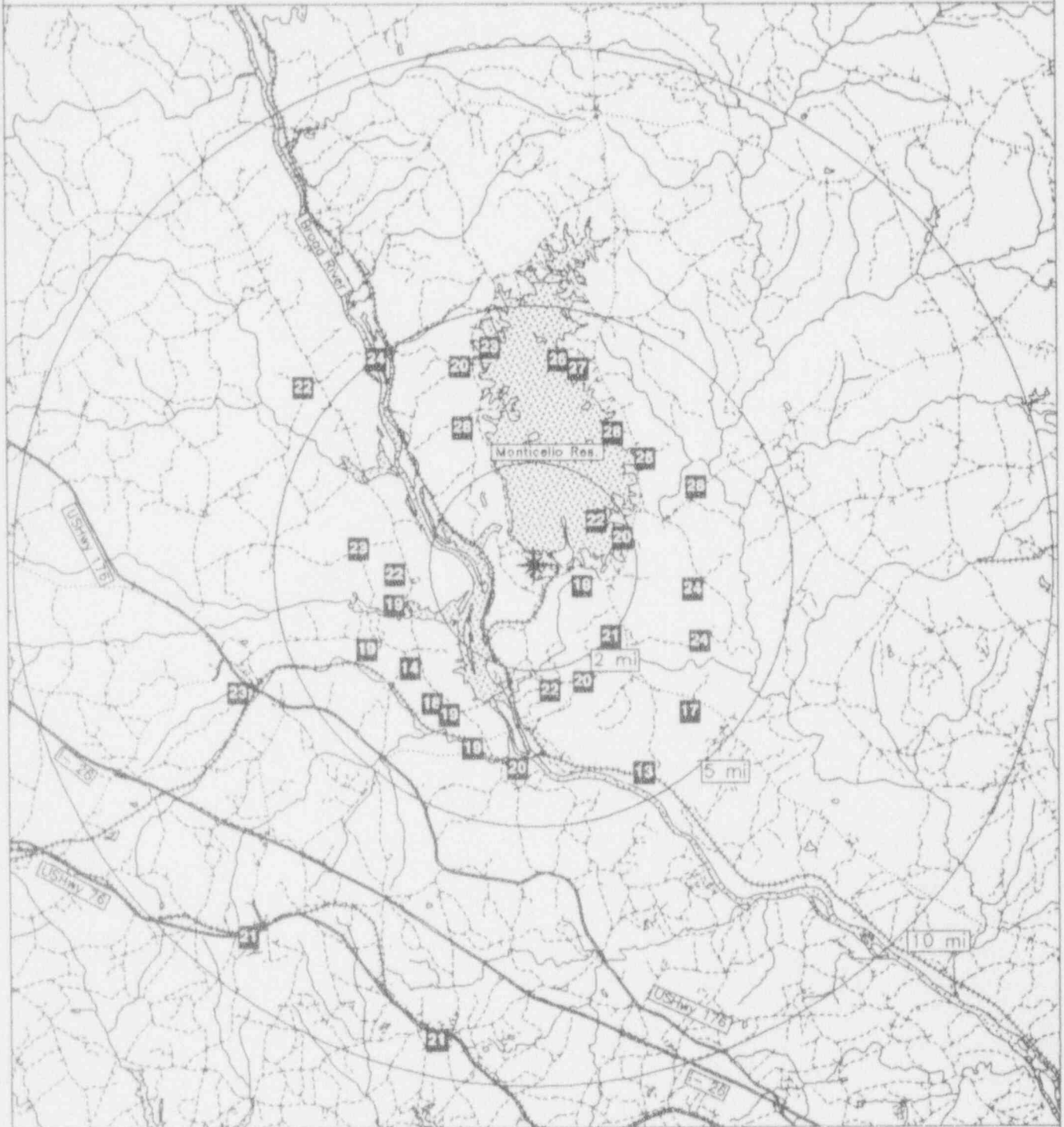

Miles

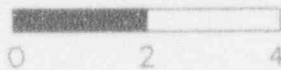

Legend

- | | | |
|----------|-----------|-------------|
| Water | Railroads | Plant..site |
| Highways | Roads | |

SURRY

TLD Direct Radiation Environmental Monitoring

For the period 930914-940203 143 Days

Field Time: 99 Days

NRC Sta	Location Azimuth/Dist (Deg)/(Mi)		Gross Exposure (mR) +-Rdm; Tot.	Net Exposure Rate (mR/Std. Qtr.) +-Rdm; Tot.	Hist. Range Net Exp Rate +-1 Std Dev
1	18	19.0	21.4 +- 0.6; 3.2	15.4 +- 0.7; 4.1	15.7 +- 1.2
2	129	17.0	21.1 +- 0.6; 3.2	15.2 +- 0.7; 4.1	17.2 +- 1.3
3	162	17.0	21.9 +- 0.7; 3.3	15.9 +- 0.7; 4.2	15.9 +- 1.3
4	162	17.0	20.7 +- 0.6; 3.1	14.8 +- 0.7; 4.1	13.2 +- 1.6
5	156	5.1	24.2 +- 0.7; 3.6	18.0 +- 0.7; 4.4	17.7 +- 1.4
6	189	4.1	20.7 +- 0.6; 3.1	14.8 +- 0.7; 4.1	14.7 +- 1.6
7	202	2.2	22.2 +- 0.7; 3.3	16.2 +- 0.7; 4.2	14.7 +- 1.5
8	183	1.6	23.7 +- 0.7; 3.6	17.6 +- 0.7; 4.4	17.2 +- 1.3
9	243	0.2	27.2 +- 0.8; 4.1	20.7 +- 0.8; 4.7	20.2 +- 1.5
10	269	0.1	27.9 +- 0.8; 4.2	21.4 +- 0.8; 4.8	23.1 +- 2.6
11	304	0.1	26.3 +- 0.8; 3.9	19.9 +- 0.8; 4.6	23.6 +- 3.5
12	334	0.2	28.8 +- 0.9; 4.3	22.1 +- 0.9; 4.9	23.4 +- 2.5
13	10	1.2	22.8 +- 0.7; 3.4	16.7 +- 0.7; 4.3	16.3 +- 1.4
14	21	2.0	22.5 +- 0.7; 3.4	16.4 +- 0.7; 4.2	16.7 +- 1.5
15	203	4.5	22.1 +- 0.7; 3.3	16.1 +- 0.7; 4.2	15.2 +- 1.4
16	224	3.7	20.4 +- 0.6; 3.1	14.5 +- 0.7; 4.0	14.0 +- 1.2
17	212	2.0	23.9 +- 0.7; 3.6	17.7 +- 0.7; 4.4	17.2 +- 1.4
18	248	5.1	22.0 +- 0.7; 3.3	16.0 +- 0.7; 4.2	14.6 +- 1.5
19	259	8.1	22.9 +- 0.7; 3.4	16.8 +- 0.7; 4.3	15.3 +- 2.3
20	285	5.0	16.4 +- 0.5; 2.5	10.9 +- 0.6; 3.7	10.8 +- 1.5
21	270	4.1	25.2 +- 0.8; 3.8	18.9 +- 0.8; 4.5	18.7 +- 1.5
22	123	12.0	24.1 +- 0.7; 3.6	17.9 +- 0.7; 4.4	20.7 +- 2.7
23	102	11.0	28.3 +- 0.8; 4.2	21.7 +- 0.8; 4.8	22.8 +- 2.1
24	106	4.9	25.0 +- 0.8; 3.8	18.7 +- 0.8; 4.5	17.8 +- 1.5
25	90	5.2	23.1 +- 0.7; 3.5	17.0 +- 0.7; 4.3	17.0 +- 1.5
26	69	5.1	27.5 +- 0.8; 4.1	21.0 +- 0.8; 4.8	21.3 +- 1.6
27	23	5.3	25.3 +- 0.8; 3.8	19.0 +- 0.8; 4.5	18.4 +- 1.5
28	49	5.0	24.8 +- 0.7; 3.7	18.6 +- 0.8; 4.5	18.7 +- 1.6
29	7	6.8	23.5 +- 0.7; 3.5	17.3 +- 0.7; 4.3	17.9 +- 1.5
30	359	6.5	22.3 +- 0.7; 3.3	16.3 +- 0.7; 4.2	15.7 +- 1.5
31	1	4.6	19.5 +- 0.6; 2.9	13.7 +- 0.6; 4.0	13.3 +- 2.5
32	332	3.8	22.1 +- 0.7; 3.3	16.1 +- 0.7; 4.2	16.4 +- 1.8
33	314	5.4	25.2 +- 0.8; 3.8	18.9 +- 0.8; 4.5	17.5 +- 1.3
34	308	6.4	21.9 +- 0.7; 3.3	15.9 +- 0.7; 4.2	16.4 +- 1.6
35	348	5.3	21.0 +- 0.6; 3.2	15.1 +- 0.7; 4.1	15.5 +- 1.4
36	43	15.0	22.5 +- 0.7; 3.4	16.4 +- 0.7; 4.2	16.1 +- 1.5
37	340	15.0	20.8 +- 0.6; 3.1	14.9 +- 0.7; 4.1	14.4 +- 1.4
38	39	16.0	24.0 +- 0.7; 3.6	17.8 +- 0.7; 4.4	16.0 +- 2.4
39	153	1.9	Missing Dosimeter	No Net Data	18.6 +- 1.6
40	144	2.1	Missing Dosimeter	No Net Data	16.0 +- 1.7

Transit Dose = 4.4 +- 0.4; 3.2

SURRY

For the period 930914-940203

TLD Direct Radiation Environmental Monitoring

Azimuth (degrees)	Ave. Exposure Rate (mR/Std.Qtr.) +- Std.Dev.	Number In Group
348.76 - 11.25 N	16.0 +- 1.6	4
11.26 - 33.75 NNE	17.0 +- 1.8	3
33.76 - 56.25 NE	18.6 +- 0.0	1
56.26 - 78.75 ENE	21.0 +- 0.0	1
78.76 - 101.25 E	17.0 +- 0.0	1
101.26 - 123.75 ESE	19.4 +- 2.0	3
123.76 - 146.25 SE	15.2 +- 0.0	1
146.26 - 168.75 SSE	16.2 +- 1.6	3
168.76 - 191.25 S	16.2 +- 1.9	2
191.26 - 213.75 SSW	16.6 +- 0.9	3
213.76 - 236.25 SW	14.5 +- 0.0	1
236.26 - 258.75 WSW	18.4 +- 3.4	2
258.76 - 281.25 W	19.0 +- 2.3	3
281.26 - 303.75 WNW	10.9 +- 0.0	1
303.76 - 326.25 NW	18.2 +- 2.1	3
326.26 - 348.75 NNW	17.8 +- 3.8	3

Distance From Reactor (miles)	Ave. Exposure Rate (mR/Std.Qtr.) +- Std.Dev.	Number In Group
0 - 2	19.1 +- 2.2	8
2 - 5	15.8 +- 2.5	10
> 5	17.2 +- 2.0	17
Upwind Control	16.3 +- 1.5	3

SURRY
TLD Direct Radiation Environmental Monitoring

NRC Station	Location		Description
	Azimuth / Degree	Distance / Mile	
1	18	19.0	HAMPTON COLISEUM
2	129	17.0	NEWPORT NEWS
3	162	17.0	W. SIDE JAMES R. (RT. 258)
4	162	17.0	SMITHFIELD SQ. SHOPPING CTR.
5	156	5.1	RUSHMERE SHORES
6	189	4.1	RT. 628 & RT. 617
7	202	2.2	CHIPPOAKS PLANTATION
8	183	1.6	RT. 650 & PUBLIC BOAT LANDING
9	243	0.2	0.2 MILES S. SURRY MAIN GATE
10	269	0.1	0.1 MILES S. SURRY MAIN GATE
11	304	0.1	SURRY MAIN GATE
12	334	0.2	0.1 MILES N. SURRY MAIN GATE
13	10	1.2	RT. 650 (1 MILE N. OF SURRY MAIN GATE)
14	21	2.0	HOMWOOD & VA AIR SAMPLER
15	203	4.5	BARONS CASTLE CH.
16	224	3.7	RT. 634 & RT. 633
17	212	2.0	CHIPPOAKS PLANTATION (WEST)
18	248	5.1	ALLIANCE INTERSECTION
19	259	8.1	LEBANON BAPT.CH.PKG.LOT
20	285	5.0	SCOTLAND FERRY DOCK
21	270	4.1	RT. 636 & RT. 637
22	123	12.0	HIDEN BLVD. & MADISON W.
23	102	11.0	PATRICK HENRY AIRPORT
24	106	4.9	WAGNER BLDG.
25	90	5.2	FORT EUSTICE
26	69	5.1	BADISCHE CORP.
27	23	5.3	BUSCHE GARDENS
28	49	5.0	RT. 667 (0.4 MILES OFF RT. 1)
29	7	6.8	RT. 637 (TRAILER PARK)
30	359	6.5	WILLIAMSBURG SEWAGE PLANT
31	1	4.6	COLONIAL NAT. HISTORIC PKWY.
32	332	3.8	NATIONAL MEMORIAL PARK SIGN
33	314	5.4	NATIONAL PARK MAINTENANCE AREA
34	308	6.4	JAMESTOWN FESTIVAL PARK
35	348	5.3	WILLIMSBURG JAMESTOWN AIRPORT
36	43	15.0	RT. 60 & RT. 607
37	340	15.0	RT. 60 & BUSH SPRING RD.
38	39	16.0	RT. 60 & CHICK HOMING ST.
39	153	1.9	PUBLIC BOAT LANDING RD.
40	144	2.1	PUBLIC BOAT LANDING

NRC TLD DOSES FOR SURRY AREA

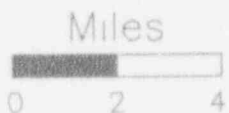

Legend

- Water
- Highways
- Railroads
- Roads
- Plant..site

SUSQUEHANNA

TLD Direct Radiation Environmental Monitoring

For the period 930915-940127 135 Days

Field Time: 92 Days

NRC Sta	Location Azimuth/Dist (Deg)/(Mi)		Gross Exposure (mR) +-Rdm; Tot.	Net Exposure Rate (mR/Std. Qtr.) +-Rdm; Tot.	Hist. Range Net Exp Rate +-1 Std Dev
1	19	1.4	22.9 +- 0.7; 3.4	19.5 +- 0.7; 4.4	18.8 +- 2.4
2	358	1.4	23.9 +- 0.7; 3.6	20.4 +- 0.8; 4.5	19.0 +- 1.9
3	332	1.6	21.4 +- 0.6; 3.2	18.0 +- 0.7; 4.2	17.7 +- 1.7
4	315	1.8	21.3 +- 0.6; 3.2	17.9 +- 0.7; 4.2	17.4 +- 1.9
5	287	1.7	24.1 +- 0.7; 3.6	20.6 +- 0.8; 4.5	19.0 +- 1.8
6	270	1.3	22.5 +- 0.7; 3.4	19.1 +- 0.7; 4.4	18.8 +- 1.7
7	239	1.8	21.4 +- 0.6; 3.2	18.1 +- 0.7; 4.2	17.8 +- 1.8
8	217	2.0	25.8 +- 0.8; 3.9	22.3 +- 0.8; 4.7	21.2 +- 2.0
9	201	1.5	23.1 +- 0.7; 3.5	19.6 +- 0.7; 4.4	19.0 +- 1.8
10	185	1.3	20.6 +- 0.6; 3.1	17.3 +- 0.7; 4.2	17.4 +- 1.4
11	243	5.1	22.8 +- 0.7; 3.4	19.4 +- 0.7; 4.4	19.0 +- 1.9
12	252	4.6	21.8 +- 0.7; 3.3	18.4 +- 0.7; 4.3	18.2 +- 1.6
13	274	3.4	25.0 +- 0.7; 3.7	21.5 +- 0.8; 4.6	21.0 +- 1.7
14	286	3.6	23.5 +- 0.7; 3.5	20.0 +- 0.8; 4.5	19.5 +- 1.8
15	1	3.9	23.8 +- 0.7; 3.6	20.4 +- 0.8; 4.5	20.1 +- 1.8
16	334	4.1	22.3 +- 0.7; 3.3	18.9 +- 0.7; 4.3	19.5 +- 2.0
17	312	4.4	23.5 +- 0.7; 3.5	20.1 +- 0.8; 4.5	18.6 +- 1.9
18	33	5.0	22.7 +- 0.7; 3.4	19.3 +- 0.7; 4.4	19.4 +- 1.5
19	45	9.9	22.9 +- 0.7; 3.4	19.5 +- 0.7; 4.4	19.6 +- 1.6
20	65	4.7	24.8 +- 0.7; 3.7	21.4 +- 0.8; 4.6	20.8 +- 1.8
21	43	3.3	26.7 +- 0.8; 4.0	23.2 +- 0.8; 4.8	21.5 +- 1.8
22	33	0.9	24.2 +- 0.7; 3.6	20.7 +- 0.8; 4.5	18.2 +- 2.4
23	57	1.2	20.4 +- 0.6; 3.1	17.0 +- 0.7; 4.1	17.5 +- 1.5
24	87	1.4	24.1 +- 0.7; 3.6	20.7 +- 0.8; 4.5	19.1 +- 1.7
25	111	1.4	23.1 +- 0.7; 3.5	19.7 +- 0.7; 4.4	18.7 +- 1.9
26	137	1.5	23.4 +- 0.7; 3.5	20.0 +- 0.8; 4.5	18.9 +- 1.7
27	152	1.5	23.1 +- 0.7; 3.5	19.6 +- 0.7; 4.4	19.6 +- 1.7
28	107	3.6	25.0 +- 0.7; 3.7	21.5 +- 0.8; 4.6	21.3 +- 5.2
29	99	4.3	24.4 +- 0.7; 3.7	21.0 +- 0.8; 4.6	20.2 +- 1.8
30	138	3.6	24.1 +- 0.7; 3.6	20.7 +- 0.8; 4.5	20.4 +- 1.9
31	162	3.4	26.5 +- 0.8; 4.0	23.0 +- 0.8; 4.8	21.6 +- 2.3
32	176	3.5	25.5 +- 0.8; 3.8	22.0 +- 0.8; 4.7	20.2 +- 2.1
33	192	3.2	25.7 +- 0.8; 3.8	22.2 +- 0.8; 4.7	21.1 +- 2.0
34	231	4.4	23.3 +- 0.7; 3.5	19.9 +- 0.8; 4.4	19.4 +- 2.1
35	134	12.3	24.0 +- 0.7; 3.6	20.6 +- 0.8; 4.5	19.7 +- 2.1
36	114	13.5	26.8 +- 0.8; 4.0	23.3 +- 0.8; 4.9	21.9 +- 2.2
37	150	15.6	22.9 +- 0.7; 3.4	19.5 +- 0.7; 4.4	19.1 +- 1.9

Transit Dose = 3.0 +- 0.3; 2.9

SUSQUEHANNA
For the period 930915-940127

TLD Direct Radiation Environmental Monitoring

Azimuth (degrees)	Ave. Exposure Rate (mR/Std.Qtr.) +- Std.Dev.	Number In Group
348.76 - 11.25 N	20.4 +- 0.1	2
11.26 - 33.75 NNE	19.8 +- 0.8	3
33.76 - 56.25 NE	21.3 +- 2.6	2
56.26 - 78.75 ENE	19.2 +- 3.1	2
78.76 - 101.25 E	20.8 +- 0.2	2
101.26 - 123.75 ESE	20.6 +- 1.3	2
123.76 - 146.25 SE	20.3 +- 0.5	2
146.26 - 168.75 SSE	21.3 +- 2.4	2
168.76 - 191.25 S	19.7 +- 3.4	2
191.26 - 213.75 SSW	20.9 +- 1.8	2
213.76 - 236.25 SW	21.1 +- 1.7	2
236.26 - 258.75 WSW	18.6 +- 0.7	3
258.76 - 281.25 W	20.3 +- 1.7	2
281.26 - 303.75 WNW	20.3 +- 0.4	2
303.76 - 326.25 NW	19.0 +- 1.6	2
326.26 - 348.75 NNW	18.5 +- 0.6	2

Distance From Reactor (miles)	Ave. Exposure Rate (mR/Std.Qtr.) +- Std.Dev.	Number In Group
0 - 2	19.4 +- 1.4	16
2 - 5	20.8 +- 1.4	16
> 5	19.4 +- 0.1	2
Upwind Control	21.1 +- 2.0	3

SUSQUEHANNA
 TLD Direct Radiation Environmental Monitoring

NRC Station	Location		Description
	Azimuth Degree	Distance / Mile	
1	19	1.4	US11 AND MINGLE INN RD.
2	358	1.4	MINGLE INN ROAD
3	332	1.6	WALTON POWER LINE
4	315	1.8	MINGLE INN ROAD TRAILER PARK
5	287	1.7	STONE CHURCH RD.
6	270	1.3	WALKER RUN CREEK
7	239	1.8	MARKET ST. & DENN'S ROAD
8	217	2.0	SALEM TOWNSHIP FIRE CO.
9	201	1.5	U.S.11 AND RIVER ROAD
10	185	1.3	SOUTH TRANSMISSION LINE
11	243	5.1	BERWICK SUBSTATION
12	252	4.6	BERWICK HOSPITAL
13	274	3.4	MOORE'S HILL & VARNER'S HOL. RDS.
14	286	3.6	MOORE'S HILL & MINGLE INN RDS.
15	1	3.9	WEST END COAL COMPANY
16	334	4.1	SHICKSHINNY VALLEY RD.
17	312	4.4	SHICKSHINNY VALLEY CHURCH
18	33	5.0	THE HIDEOUT
19	45	9.9	SHEATOWN
20	65	4.7	RUCKLES HILL ROAD
21	43	3.3	POND HILL-LILY LAKE FIRE CO.
22	33	0.9	ENERGY INFORMATION CENTER
23	57	1.2	STONE CRUSHER TRAIL
24	87	1.4	PA239 & RUCKLES HILL ROAD
25	111	1.4	PA239 N. OF WAPWALLOPEN
26	137	1.5	HELLER'S ORCHARD STORE
27	152	1.5	WAPWALLOPEN POST OFFICE
28	107	3.6	ST. PETER'S REFORMED CHURCH
29	99	4.3	ST. MARY'S RD. & KINGSBERRY DR.
30	138	3.6	STATE ROAD
31	162	3.4	NESCOPECK TWP. MAINT. BLDG
32	176	3.5	NESCOPECK TWP. FIRE COMPANY
33	192	3.2	MT. ZION CHURCH
34	231	4.4	MAPLE STREET
35	134	12.3	HAZLETON
36	114	13.5	FREELAND
37	150	15.6	MCADOO

NRC TLD DOSES FOR SUSQUEHANNA AREA

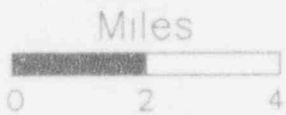

Legend

- Water
- Railroads
- Plant..site
- Highways
- Roads

THREE MILE ISLAND

TLD Direct Radiation Environmental Monitoring

For the period 930915-940127 135 Days

Field Time: 93 Days

NRC Sta	Location		Gross Exposure (mR)		Net Exposure Rate (mR/Std. Qtr.)		Hist. Range Net Exp Rate	
	Azimuth/ (Deg)	Dist (Mi)	+Rdm	Tot.	+Rdm	Tot.	+1	Std Dev
1	95	5.9	21.2 +- 0.6	3.2	17.6 +- 0.7	4.2	15.7 +- 2.4	
2	102	3.9	23.1 +- 0.7	3.5	19.5 +- 0.7	4.4	17.9 +- 2.4	
3	110	2.7	17.0 +- 0.5	2.5	13.5 +- 0.6	3.8	13.7 +- 2.9	
4	162	1.8	19.6 +- 0.6	2.9	16.0 +- 0.6	4.0	15.1 +- 2.4	
5	161	2.3	19.9 +- 0.6	3.0	16.3 +- 0.7	4.1	15.2 +- 2.2	
6	152	1.1	19.9 +- 0.6	3.0	16.3 +- 0.7	4.1	15.8 +- 2.3	
7	123	0.5	18.0 +- 0.5	2.7	14.5 +- 0.6	3.9	14.0 +- 2.2	
8	87	0.4	21.9 +- 0.7	3.3	18.3 +- 0.7	4.3	15.6 +- 2.5	
9	61	0.5	18.4 +- 0.6	2.8	14.9 +- 0.6	3.9	14.6 +- 2.0	
10	1	1.7	20.4 +- 0.6	3.1	16.8 +- 0.7	4.1	14.6 +- 2.6	
11	27	0.8	19.5 +- 0.6	2.9	16.0 +- 0.6	4.0	14.7 +- 2.2	
12	48	1.0	20.0 +- 0.6	3.0	16.4 +- 0.7	4.1	15.0 +- 2.5	
13	19	2.0	19.8 +- 0.6	3.0	16.2 +- 0.7	4.0	15.3 +- 2.3	
14	358	2.4	18.7 +- 0.6	2.8	15.2 +- 0.6	3.9	13.8 +- 2.6	
15	132	9.0	22.2 +- 0.7	3.3	18.5 +- 0.7	4.3	17.6 +- 2.6	
16	0	3.0	17.4 +- 0.5	2.6	13.9 +- 0.6	3.8	13.9 +- 2.5	
18	347	3.5	23.0 +- 0.7	3.5	19.4 +- 0.7	4.4	17.7 +- 2.8	
19	343	3.1	20.9 +- 0.6	3.1	17.3 +- 0.7	4.2	16.1 +- 2.2	
20	318	5.0	20.5 +- 0.6	3.1	16.9 +- 0.7	4.1	14.8 +- 2.2	
21	348	2.7	16.3 +- 0.5	2.4	12.9 +- 0.6	3.7	12.0 +- 2.2	
22	17	3.1	20.8 +- 0.6	3.1	17.2 +- 0.7	4.2	15.4 +- 2.4	
23	64	3.7	16.9 +- 0.5	2.5	13.4 +- 0.6	3.8	12.5 +- 2.2	
24	44	3.6	21.1 +- 0.6	3.2	17.4 +- 0.7	4.2	16.3 +- 2.5	
25	327	0.4	Missing Dosimeter		No Net Data		12.6 +- 3.0	
27	7	7.1	25.0 +- 0.7	3.7	21.2 +- 0.8	4.6	19.8 +- 2.5	
29	293	0.4	Missing Dosimeter		No Net Data		15.5 +- 2.7	
30	314	1.1	Missing Dosimeter		No Net Data		16.6 +- 2.3	
31	303	8.6	18.2 +- 0.5	2.7	14.7 +- 0.6	3.9	13.4 +- 2.1	
32	297	7.6	21.6 +- 0.6	3.2	18.0 +- 0.7	4.2	16.7 +- 2.2	
33	302	5.8	17.2 +- 0.5	2.6	13.7 +- 0.6	3.8	13.2 +- 2.3	
34	296	2.3	20.8 +- 0.6	3.1	17.2 +- 0.7	4.2	15.9 +- 2.3	
35	308	1.8	21.2 +- 0.6	3.2	17.6 +- 0.7	4.2	16.0 +- 2.0	
36	265	1.2	17.5 +- 0.5	2.6	14.0 +- 0.6	3.8	12.4 +- 2.4	
37	256	1.4	18.1 +- 0.5	2.7	14.5 +- 0.6	3.9	13.2 +- 2.2	
38	225	1.9	20.0 +- 0.6	3.0	16.4 +- 0.7	4.1	16.4 +- 2.1	
39	204	2.0	17.4 +- 0.5	2.6	13.9 +- 0.6	3.8	12.7 +- 2.2	
40	202	2.5	18.6 +- 0.6	2.8	15.0 +- 0.6	3.9	14.2 +- 2.2	
41	184	12.6	20.5 +- 0.6	3.1	16.9 +- 0.7	4.1	16.0 +- 2.3	
42	259	7.4	20.6 +- 0.6	3.1	17.0 +- 0.7	4.1	15.5 +- 2.2	
43	268	6.2	19.7 +- 0.6	3.0	16.1 +- 0.7	4.0	16.7 +- 2.7	
44	249	4.3	19.3 +- 0.6	2.9	15.7 +- 0.6	4.0	14.5 +- 2.2	
45	221	0.5	Missing Dosimeter		No Net Data		13.2 +- 2.5	
46	171	3.0	20.5 +- 0.6	3.1	16.9 +- 0.7	4.1	14.7 +- 2.7	
47	177	5.7	18.6 +- 0.6	2.8	15.1 +- 0.6	3.9	14.9 +- 2.4	
48	181	9.1	25.5 +- 0.8	3.8	21.7 +- 0.8	4.7	21.6 +- 2.9	
49	199	1.0	Missing Dosimeter		No Net Data		14.7 +- 2.3	
50	145	4.9	22.7 +- 0.7	3.4	19.1 +- 0.7	4.4	16.7 +- 2.8	

Transit Dose = 3.0 +- 0.3; 2.9

THREE MILE ISLAND
For the period 930915-940127

TLD Direct Radiation Environmental Monitoring

Azimuth (degrees)	Ave. Exposure Rate (mR/Std.Qtr.) +- Std.Dev.	Number In Group
348.76 - 11.25 N	16.8 +- 3.2	4
11.26 - 33.75 NNE	16.5 +- 0.7	3
33.76 - 56.25 NE	16.9 +- 0.7	2
56.26 - 78.75 ENE	14.2 +- 1.0	2
78.76 - 101.25 E	17.9 +- 0.5	2
101.26 - 123.75 ESE	15.8 +- 3.2	3
123.76 - 146.25 SE	18.8 +- 0.4	2
146.26 - 168.75 SSE	16.2 +- 0.2	3
168.76 - 191.25 S	17.7 +- 2.9	4
191.26 - 213.75 SSW	14.5 +- 0.8	2
213.76 - 236.25 SW	16.4 +- 0.0	1
236.26 - 258.75 WSW	15.7 +- 0.0	1
258.76 - 281.25 W	16.6 +- 0.6	2
281.26 - 303.75 WNW	15.9 +- 2.0	4
303.76 - 326.25 NW	16.9 +- 0.0	1
326.26 - 348.75 NNW	16.5 +- 3.3	3

Distance From Reactor (miles)	Ave. Exposure Rate (mR/Std.Qtr.) +- Std.Dev.	Number In Group
0 - 2	16.0 +- 1.2	11
2 - 5	16.3 +- 2.1	17
> 5	17.3 +- 2.5	11
Upwind Control	15.4 +- 1.9	3

THREE MILE ISLAND
TLD Direct Radiation Environmental Monitoring

NRC Station	Location		Description
	Azimuth / Degree	Distance / Mile	
1	95	5.9	TURNPIKE ROAD AND PA 241
2	102	3.9	TURNPIKE ROAD AND BOSSLER ROAD
3	110	2.7	TURNPIKE ROAD AND HILLSDALE ROAD
4	162	1.8	FALMOUTH
5	161	2.3	COLLINS SUBSTATION
6	152	1.1	RED HILL FARM MARKET
7	123	0.5	500 KEV SUBSTATION
8	87	0.4	PA 441 & MEADOW LANE
9	61	0.5	PA 441 AND LAUREL ROAD
10	1	1.7	980 LINE
11	7	0.8	GEYER'S CHURCH ROAD AND PA 441
12	48	1.0	GINGRICH ROAD
13	19	2.0	HILLSDALE DRIVE
14	358	2.4	GRUBB STREET
15	132	9.0	CARGILL TANKS
16	0	3.0	RACE AND CONEWAGO STREETS
18	347	3.5	GRANDVIEW ELEMENTARY
19	343	3.1	PENN STATE HBG ENTRANCE
20	318	5.0	HIGHSPIRE FIRE COMPANY
21	348	2.7	MANSBERGER ELEMENTARY
22	17	3.1	STARLITE MOTEL
23	64	3.7	PA 230 AND DEODATE ROAD
24	44	3.6	LONDONBERRY ELEMENTARY
25	327	0.4	KOHR ISLAND
27	7	7.1	VINE STREET AND US 322
29	293	0.4	SHELLEY ISLAND
30	314	1.1	HILL ISLAND
31	303	8.6	MEADOWBROOK ROAD
32	297	7.6	OLD YORK ROAD & THE PA TURNPIKE
33	302	5.8	MARSH RUN ROAD
34	296	2.3	PA 262 AND PA 392
35	308	1.8	STILLHOUSE ROAD
36	265	1.2	GOLDSBORO BOAT RAMP
37	256	1.4	GOLDSBORO CEMENT BRIDGE
38	225	1.9	PA 262 AND RIVER ROAD
39	204	2.0	PA 262 NEAR THE R.R. TRACKS
40	202	2.5	PA 295 AND PA 382
41	184	12.6	YORK SUBSTATION
42	259	7.4	PA 382 AND PA 177
43	268	6.2	PA 177 AND PA 392
44	249	4.3	ROXBERRY AND LEWISBERRY ROADS
45	221	0.5	NORTH END OF BEECH ISLAND
46	171	3.0	LANDVALE ST. AND PA. AVE.
47	177	5.7	GEORGE ST. & MEETING HOUSE RD.
48	181	9.1	PA 181 AND PA 238
49	199	1.0	SOUTH END OF BEECH ISLAND
50	145	4.9	BAINBRIDGE ELEMENTARY

NRC TLD DOSES FOR THREE MILE ISLAND AREA



Miles

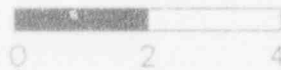

Legend

- Water
- Railroads
- Plant site
- Highways
- Roads

TROJAN

TLD Direct Radiation Environmental Monitoring

For the period 930913-940127 137 Days

Field Time: 88 Days

NRC Sta	Location Azimuth/Dist (Deg)/(Mi)		Gross Exposure (mR) +-Rdm; Tot.	Net Exposure Rate (mR/Std. Qtr.) +-Rdm; Tot.	Hist. Range Net Exp Rate +-1 Std Dev
1	340	0.6	18.7 +- 0.6; 2.8	13.5 +- 0.7; 4.2	12.2 +- 1.1
2	334	1.5	20.0 +- 0.6; 3.0	14.8 +- 0.7; 4.4	14.7 +- 0.9
3	340	1.7	17.6 +- 0.5; 2.6	12.4 +- 0.7; 4.1	11.8 +- 0.8
4	328	3.9	18.2 +- 0.5; 2.7	12.9 +- 0.7; 4.2	12.7 +- 1.1
5	308	4.6	20.5 +- 0.6; 3.1	15.3 +- 0.7; 4.4	14.3 +- 1.2
6	312	4.5	Missing Dosimeter	No Net Data	15.1 +- 1.7
7	267	4.6	20.6 +- 0.6; 3.1	15.4 +- 0.7; 4.4	14.7 +- 0.9
8	274	3.8	20.7 +- 0.6; 3.1	15.5 +- 0.7; 4.4	15.4 +- 1.1
9	279	1.7	20.8 +- 0.6; 3.1	15.6 +- 0.7; 4.4	14.6 +- 1.3
10	263	2.0	20.6 +- 0.6; 3.1	15.5 +- 0.7; 4.4	15.2 +- 0.9
11	245	1.6	21.4 +- 0.6; 3.2	16.2 +- 0.8; 4.5	16.2 +- 1.6
12	223	1.2	21.9 +- 0.7; 3.3	16.7 +- 0.8; 4.6	16.5 +- 1.5
13	196	1.1	21.2 +- 0.6; 3.2	16.0 +- 0.8; 4.5	15.3 +- 1.0
14	180	1.2	19.9 +- 0.6; 3.0	14.7 +- 0.7; 4.3	14.4 +- 1.1
15	165	1.7	17.2 +- 0.5; 2.6	12.0 +- 0.7; 4.1	13.4 +- 1.4
16	212	3.9	20.5 +- 0.6; 3.1	15.3 +- 0.7; 4.4	16.1 +- 2.2
17	230	3.5	19.7 +- 0.6; 2.9	14.4 +- 0.7; 4.3	15.8 +- 1.3
18	162	9.3	21.6 +- 0.6; 3.2	16.4 +- 0.8; 4.5	15.8 +- 1.3
19	172	5.0	19.9 +- 0.6; 3.0	14.7 +- 0.7; 4.3	16.1 +- 1.5
20	334	5.8	18.2 +- 0.5; 2.7	13.0 +- 0.7; 4.2	13.0 +- 1.3
21	345	5.5	19.0 +- 0.6; 2.9	13.8 +- 0.7; 4.2	13.5 +- 1.2
22	356	5.5	18.1 +- 0.5; 2.7	12.9 +- 0.7; 4.2	12.5 +- 1.4
23	8	3.9	17.7 +- 0.5; 2.7	12.5 +- 0.7; 4.1	12.1 +- 1.4
24	15	3.7	18.6 +- 0.6; 2.8	13.4 +- 0.7; 4.2	13.3 +- 1.3
25	27	1.9	17.4 +- 0.5; 2.6	12.1 +- 0.7; 4.1	12.2 +- 1.3
26	37	2.1	20.5 +- 0.6; 3.1	15.3 +- 0.7; 4.4	14.9 +- 1.5
27	60	2.9	20.7 +- 0.6; 3.1	15.5 +- 0.7; 4.4	15.1 +- 1.2
28	55	4.5	18.7 +- 0.6; 2.8	13.5 +- 0.7; 4.2	13.7 +- 1.7
29	69	1.6	17.4 +- 0.5; 2.6	12.1 +- 0.7; 4.1	13.1 +- 2.0
30	83	3.9	17.9 +- 0.5; 2.7	12.6 +- 0.7; 4.1	12.7 +- 1.3
31	93	2.7	20.3 +- 0.6; 3.1	15.1 +- 0.7; 4.4	15.4 +- 1.4
32	119	2.2	20.3 +- 0.6; 3.0	15.1 +- 0.7; 4.4	15.5 +- 1.4
33	106	5.3	18.2 +- 0.5; 2.7	13.0 +- 0.7; 4.2	14.8 +- 2.8
34	134	2.5	18.3 +- 0.5; 2.7	13.1 +- 0.7; 4.2	12.5 +- 1.3
35	145	4.7	18.8 +- 0.6; 2.8	13.5 +- 0.7; 4.2	13.1 +- 1.3
36	270	17.0	19.1 +- 0.6; 2.9	13.8 +- 0.7; 4.3	15.5 +- 2.3
37	270	17.0	19.2 +- 0.6; 2.9	14.0 +- 0.7; 4.3	16.7 +- 2.3
38	270	17.0	21.2 +- 0.6; 3.2	16.0 +- 0.8; 4.5	16.4 +- 1.5

Transit Dose = 5.5 +- 0.4; 3.0

TROJAN

For the period 930913-940127

TLD Direct Radiation Environmental Monitoring

Azimuth (degrees)	Ave. Exposure Rate (mR/Std.Qtr.) +- Std.Dev.	Number In Group
348.76 - 11.25 N	12.7 +- 0.3	2
11.26 - 33.75 NNE	12.8 +- 0.9	2
33.76 - 56.25 NE	14.4 +- 1.3	2
56.26 - 78.75 ENE	13.8 +- 2.4	2
78.76 - 101.25 E	13.9 +- 1.8	2
101.26 - 123.75 ESE	14.0 +- 1.5	2
123.76 - 146.25 SE	13.3 +- 0.3	2
146.26 - 168.75 SSE	14.2 +- 3.1	2
168.76 - 191.25 S	14.7 +- 0.0	2
191.26 - 213.75 SSW	15.6 +- 0.5	2
213.76 - 236.25 SW	15.6 +- 1.6	2
236.26 - 258.75 WSW	16.2 +- 0.0	1
258.76 - 281.25 W	15.5 +- 0.1	4
281.26 - 303.75 WNW	No Data +- No Data	0
303.76 - 326.25 NW	15.3 +- 0.0	1
326.26 - 348.75 NNW	13.4 +- 0.8	6

Distance From Reactor (miles)	Ave. Exposure Rate (mR/Std.Qtr.) +- Std.Dev.	Number In Group
0 - 2	14.3 +- 1.8	12
2 - 5	14.3 +- 1.1	17
> 5	13.8 +- 1.5	5
Upwind Control	14.6 +- 1.2	3

TROJAN
TLD Direct Radiation Environmental Monitoring

NRC Station	Location		Description
	Azimuth / Degree	Distance / Mile	
1	340	0.6	SCHOOL ST. (END)
2	334	1.5	THOMPSON RESIDENCE
3	340	1.7	JACK FALLS RD.
4	328	3.9	HWY. 30 NEAR RAINIER
5	308	4.6	FERNHILL RD.
6	312	4.5	FERNCREST DRIVE
7	267	4.6	ZIMMER RD.
8	274	3.8	HUTCHISON RD.
9	279	1.7	NEER CITY RD.
10	263	2.0	BROWNLEE RD.
11	245	1.6	LIRES RESIDENCE
12	223	1.2	NEER CITY RD. & P-45
13	196	1.1	CEMETERY RD.
14	180	1.2	NEER'S RESIDENCE
15	165	1.7	NICOLAI RD.
16	212	3.9	FAIRVIEW RD.
17	230	3.5	WALKER RD.
18	162	9.3	REICHHOLD CHEMICALS
19	172	5.0	TIDE CR. RD.
20	334	5.8	LONGVIEW (WASHINGTON)
21	345	5.5	TENNANT RD.
22	356	5.5	TALLEY RD.
23	8	3.9	SIGNS FOR THE LORD
24	15	3.7	ROSE VALLEY RD.
25	27	1.9	CARROLLS BLUFF
26	37	2.1	MT. PLEASANT RD.
27	60	2.9	MT. PLEASANT CEMETERY
28	55	4.5	NEAR KOOL RD.
29	69	1.6	OLD 99 SOUTH
30	83	3.9	SALMON FISH HATCHERY
31	93	2.7	SPENCER CR. RD.
32	119	2.2	OLD 99 SOUTH (N. OF ELM)
33	106	5.3	CHINA GARDEN RD.
34	134	2.5	SPENCER CR. RD
35	145	4.7	OLD 99 SOUTH NEAR KILKELLY RD.
36	270	17.0	HWY. 47
37	270	17.0	HWY. 47
38	270	17.0	HWY. 47

NRC TLD DOSES FOR TROJAN AREA

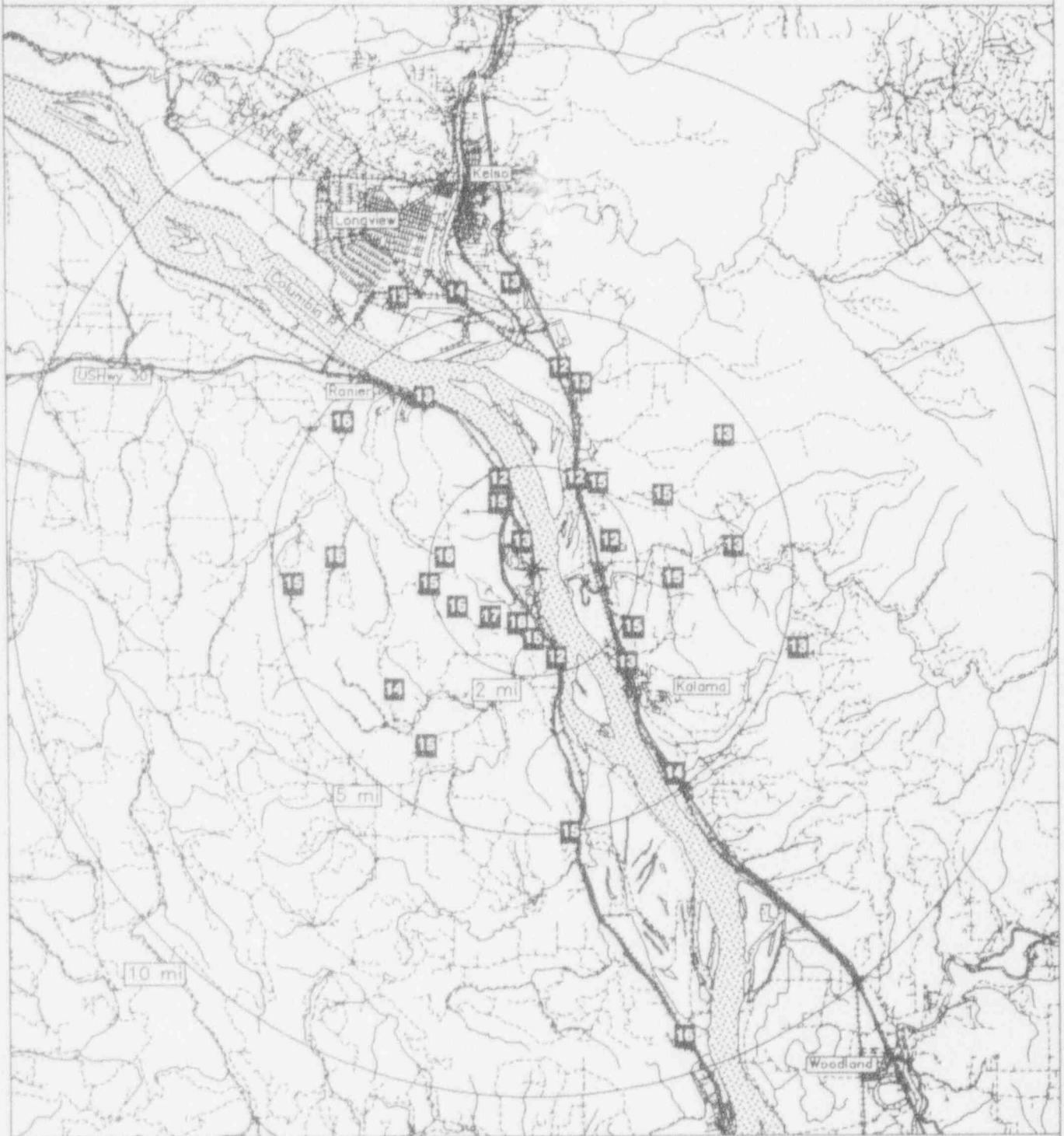

Miles

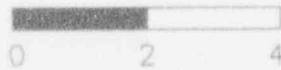

Legend



Water

Highways

Railroads

Roads



Plant site

TURKEY POINT

TLD Direct Radiation Environmental Monitoring

For the period 930914-940203 143 Days

Field Time: 98 Days

NRC Sta	Location Azimuth/Dist (Deg)/(Mi)	Gross Exposure (mR) +-Rdm; Tot.	Net Exposure Rate (mR/Std. Qtr.) +-Rdm; Tot.	Hist. Range Net Exp Rate +-1 Std Dev
1	310 1.3	17.0 +- 0.5; 2.5	12.0 +- 0.6; 3.7	11.8 +- 3.5
2	292 2.4	15.9 +- 0.5; 2.4	11.0 +- 0.5; 3.6	12.0 +- 3.6
3	340 1.9	17.5 +- 0.5; 2.6	12.5 +- 0.6; 3.8	12.3 +- 3.9
4	354 2.0	17.2 +- 0.5; 2.6	12.1 +- 0.6; 3.7	12.4 +- 3.9
5	314 3.8	17.1 +- 0.5; 2.6	12.0 +- 0.6; 3.7	11.9 +- 3.6
6	331 4.2	Missing Dosimeter	No Net Data	11.4 +- 3.6
7	291 5.4	16.7 +- 0.5; 2.5	11.7 +- 0.6; 3.7	12.3 +- 4.0
8	263 5.1	15.5 +- 0.5; 2.3	10.6 +- 0.5; 3.6	10.8 +- 3.2
9	242 5.7	17.4 +- 0.5; 2.6	12.4 +- 0.6; 3.8	11.8 +- 4.1
10	234 6.2	17.0 +- 0.5; 2.6	12.0 +- 0.6; 3.7	12.3 +- 3.8
11	220 6.2	16.4 +- 0.5; 2.5	11.4 +- 0.6; 3.7	11.9 +- 4.1
12	213 6.9	17.0 +- 0.5; 2.6	12.0 +- 0.6; 3.7	11.6 +- 3.5
13	199 10.0	16.5 +- 0.5; 2.5	11.5 +- 0.6; 3.7	12.2 +- 3.7
14	90 10.0	15.6 +- 0.5; 2.3	10.7 +- 0.5; 3.6	11.8 +- 3.7
15	180 10.0	18.4 +- 0.6; 2.8	13.2 +- 0.6; 3.9	13.8 +- 3.8
16	171 10.0	19.0 +- 0.6; 2.9	13.8 +- 0.6; 3.9	13.8 +- 3.9
17	165 9.0	17.9 +- 0.5; 2.7	12.8 +- 0.6; 3.8	13.3 +- 3.8
18	203 16.0	18.6 +- 0.6; 2.8	13.4 +- 0.6; 3.9	12.6 +- 3.7
19	203 16.0	17.8 +- 0.5; 2.7	12.7 +- 0.6; 3.8	12.6 +- 3.8
20	203 16.0	18.7 +- 0.6; 2.8	13.5 +- 0.6; 3.9	13.8 +- 3.5
21	268 8.7	14.4 +- 0.4; 2.2	9.6 +- 0.5; 3.5	11.0 +- 3.8
22	256 8.0	Missing Dosimeter	No Net Data	12.6 +- 3.7
23	275 9.0	15.7 +- 0.5; 2.4	10.8 +- 0.5; 3.6	11.9 +- 3.9
24	285 9.0	19.1 +- 0.6; 2.9	13.9 +- 0.6; 3.9	14.1 +- 4.0
25	293 8.7	19.0 +- 0.6; 2.8	13.8 +- 0.6; 3.9	14.5 +- 3.6
26	301 8.4	18.4 +- 0.6; 2.8	13.2 +- 0.6; 3.9	13.9 +- 3.6
27	311 8.3	17.2 +- 0.5; 2.6	12.2 +- 0.6; 3.8	12.6 +- 3.5
28	327 8.2	18.9 +- 0.6; 2.8	13.7 +- 0.6; 3.9	14.1 +- 3.7
29	339 9.3	18.3 +- 0.5; 2.7	13.1 +- 0.6; 3.8	13.5 +- 3.8
30	350 8.7	16.6 +- 0.5; 2.5	11.6 +- 0.6; 3.7	12.7 +- 3.6
31	359 9.9	18.0 +- 0.5; 2.7	12.9 +- 0.6; 3.8	12.9 +- 3.6
32	2 18.0	18.8 +- 0.6; 2.8	13.7 +- 0.6; 3.9	13.4 +- 3.6
33	2 22.0	18.5 +- 0.6; 2.8	13.3 +- 0.6; 3.9	13.4 +- 3.7
34	18 24.0	16.9 +- 0.5; 2.5	11.8 +- 0.6; 3.7	13.6 +- 4.0
35	28 22.0	16.0 +- 0.5; 2.4	11.1 +- 0.6; 3.6	13.2 +- 4.3
36	15 0.3	14.9 +- 0.4; 2.2	10.1 +- 0.5; 3.6	11.7 +- 3.7
37	228 0.5	18.6 +- 0.6; 2.8	13.5 +- 0.6; 3.9	13.4 +- 3.9

Transit Dose = 4.0 +- 0.4; 3.2

TURKEY POINT
For the period 930914-940203

TLD Direct Radiation Environmental Monitoring

Azimuth (degrees)	Ave. Exposure Rate (mR/Std.Qtr.) +- Std.Dev.	Number In Group
348.76 - 11.25 N	12.7 +- 0.8	5
11.26 - 33.75 NNE	11.0 +- 0.9	3
33.76 - 56.25 NE	No Data +- No Data	0
56.26 - 78.75 ENE	No Data +- No Data	0
78.76 - 101.25 E	10.7 +- 0.0	1
101.26 - 123.75 ESE	No Data +- No Data	0
123.76 - 146.25 SE	No Data +- No Data	0
146.26 - 168.75 SSE	12.8 +- 0.0	1
168.76 - 191.25 S	13.5 +- 0.4	2
191.26 - 213.75 SSW	11.8 +- 0.3	2
213.76 - 236.25 SW	12.3 +- 1.1	3
236.26 - 258.75 WSW	12.4 +- 0.0	1
258.76 - 281.25 W	10.3 +- 0.7	3
281.26 - 303.75 WNW	12.7 +- 1.3	5
303.76 - 326.25 NW	12.1 +- 0.1	3
326.26 - 348.75 NNW	13.1 +- 0.6	3

Distance From Reactor (miles)	Ave. Exposure Rate (mR/Std.Qtr.) +- Std.Dev.	Number In Group
0 - 2	12.0 +- 1.2	5
2 - 5	11.5 +- 0.8	2
> 5	12.3 +- 1.2	25
Upwind Control	13.2 +- 0.5	3

TURKEY POINT
TLD Direct Radiation Environmental Monitoring

NRC Station	Location		Description
	Azimuth / Degree	Distance / Mile	
1	310	1.3	SITE RD. & PALM DR.
2	292	2.4	PALM DR (1.2 MILES W. OF SITE RD.)
3	340	1.9	HOMESTEAD BAYFRONT PARK
4	354	2.0	HOMESTEAD BAYFRONT PARK (BOAT LAUNCH)
5	314	3.8	WAREHAUSER SHRIMP FARM
6	331	4.2	S. ALLAPATTAH DR.
7	291	5.4	N. CANAL DR. & TALLAHASSEE RD.
8	263	5.1	S. OF CANAL DR. ON TALLAHASSEE RD.
9	242	5.7	TALLAHASSEE RD. (4.5 MILES S. OF CANAL RD.)
10	234	6.2	TALLAHASSEE RD. (5.6 MILES S. OF CANAL RD.)
11	220	6.2	OFF TALLAHASSEE RD ON DIRT RD W/ STEEL BARR.
12	213	6.9	OFF TALLAHASSEE RD. ON DIRT RD. AT LEVEE
13	199	10.0	CARD SOUND RD.
14	90	10.0	CARD SOUND RD. AT BARNES PT.
15	180	10.0	CARD SOUND RD. AT STEAMBOAT CR.
16	171	10.0	CARD SOUND RD. (RT. 905)
17	165	9.0	KEY LARGO CLUB GATEHOUSE
18	203	16.0	HWY. 1 (6 MILES N. OF RT. 905)
19	203	16.0	HWY. 1 (6.4 MILES N. OF RT. 905)
20	203	16.0	HWY. 1 (6.4 MILES N. OF RT. 905)
21	268	8.7	NAVY SECURITY COMPLEX
22	256	8.0	CARD SOUND RD. (2.2 MILES SE OF RT. 1)
23	275	9.0	HWY. 1 (1 MILE N. OF CARD SOUND RD.)
24	285	9.0	HWY. 1 & MOWRY ST.
25	293	8.7	HWY. 1 & KINGS HWY.
26	301	8.4	HWY. 1 & BISCAYNE BLVD.
27	311	8.3	HWY. 1 & SW 145TH ST.
28	327	8.2	COCONUT PALM DR.
29	339	9.3	HWY. 1 & SW 220TH ST.
30	350	8.7	OLD CUTLER RD. & SW 223RD ST.
31	359	9.9	FRANJO RD.
32	2	18.0	HWY. 1 & SW 104TH ST.
33	2	22.0	HWY. 1 & GRANADA RD.
34	18	24.0	NATOMA SUBSTATION
35	28	22.0	CRANDON BLVD. & EASTWOOD DR.
36	15	0.3	TURKEY PT. BEACH
37	228	0.5	TURKEY PT. BOY SCOUT CAMP

NRC TLD DOSES FOR TURKEY POINT AREA

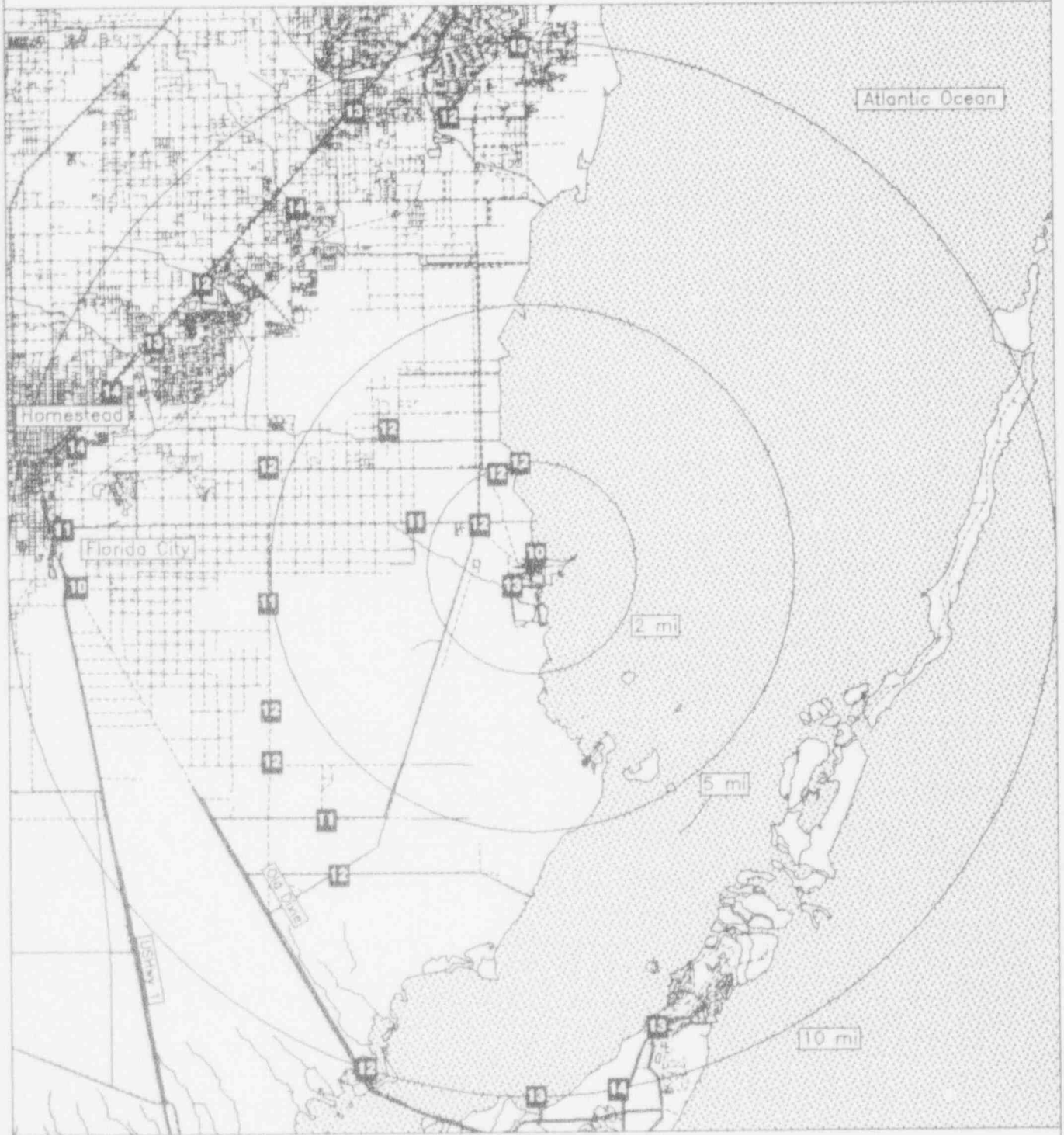

Miles

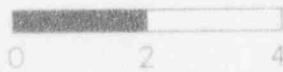

Legend

- Water
- Highways
- Railroads
- Roads
- Plant site

VERMONT YANKEE

TLD Direct Radiation Environmental Monitoring

For the period 930915-940208 147 Days

Field Time: 84 Days

NRC Sta	Location Azimuth/Dist (Deg)/(Mi)		Gross Exposure (mR) +-Rdm; Tot.	Net Exposure Rate (mR/Std. Qtr.) +-Rdm; Tot.	Hist. Range Net Exp Rate +-1 Std Dev
1	142	1.0	23.2 +- 0.7; 3.5	18.0 +- 0.9; 4.9	15.9 +- 2.1
2	158	1.0	22.4 +- 0.7; 3.4	17.1 +- 0.8; 4.8	16.9 +- 1.7
3	184	1.3	21.2 +- 0.6; 3.2	15.8 +- 0.8; 4.7	16.3 +- 1.6
4	201	1.4	22.9 +- 0.7; 3.4	17.6 +- 0.9; 4.9	16.8 +- 1.8
5	220	1.6	23.7 +- 0.7; 3.6	18.5 +- 0.9; 5.0	16.9 +- 2.0
6	157	3.4	26.7 +- 0.8; 4.0	21.7 +- 1.0; 5.4	16.9 +- 2.3
7	189	4.9	22.9 +- 0.7; 3.4	17.6 +- 0.9; 4.9	16.7 +- 1.8
8	201	13.0	22.7 +- 0.7; 3.4	17.4 +- 0.8; 4.9	16.3 +- 1.6
9	208	5.8	22.6 +- 0.7; 3.4	17.3 +- 0.8; 4.8	16.4 +- 1.7
10	232	3.7	24.8 +- 0.7; 3.7	19.7 +- 0.9; 5.1	18.9 +- 2.0
11	277	2.9	24.4 +- 0.7; 3.7	19.2 +- 0.9; 5.1	17.5 +- 2.0
12	292	1.4	23.6 +- 0.7; 3.5	18.3 +- 0.9; 5.0	17.3 +- 2.1
13	314	1.4	22.5 +- 0.7; 3.4	17.2 +- 0.8; 4.8	16.7 +- 1.9
14	310	4.2	22.2 +- 0.7; 3.3	16.9 +- 0.8; 4.8	16.5 +- 1.5
15	299	4.3	22.1 +- 0.7; 3.3	16.8 +- 0.8; 4.8	16.1 +- 3.1
16	270	4.5	19.7 +- 0.6; 3.0	14.2 +- 0.8; 4.5	15.0 +- 1.8
17	331	5.0	22.6 +- 0.7; 3.4	17.3 +- 0.8; 4.9	17.3 +- 1.6
18	290	19.0	23.7 +- 0.7; 3.6	18.5 +- 0.9; 5.0	18.9 +- 1.9
19	290	19.0	22.2 +- 0.7; 3.3	16.9 +- 0.8; 4.8	18.4 +- 2.0
20	290	19.0	23.8 +- 0.7; 3.6	18.5 +- 0.9; 5.0	18.5 +- 1.9
21	359	3.2	22.5 +- 0.7; 3.4	17.1 +- 0.8; 4.8	17.0 +- 1.7
23	334	2.2	21.7 +- 0.7; 3.3	16.4 +- 0.8; 4.7	16.4 +- 1.8
24	4	0.9	22.6 +- 0.7; 3.4	17.3 +- 0.8; 4.9	17.1 +- 1.7
25	30	1.0	22.5 +- 0.7; 3.4	17.1 +- 0.8; 4.8	16.0 +- 1.8
26	72	1.5	23.7 +- 0.7; 3.5	18.4 +- 0.9; 5.0	17.5 +- 1.6
27	44	0.7	22.9 +- 0.7; 3.4	17.6 +- 0.9; 4.9	16.7 +- 1.8
28	39	2.8	24.2 +- 0.7; 3.6	19.0 +- 0.9; 5.0	18.2 +- 2.4
29	25	3.8	25.2 +- 0.8; 3.8	20.0 +- 0.9; 5.2	19.7 +- 2.1
30	72	2.7	24.3 +- 0.7; 3.7	19.2 +- 0.9; 5.1	19.2 +- 2.7
31	85	2.0	23.1 +- 0.7; 3.5	17.9 +- 0.9; 4.9	17.1 +- 1.9
32	111	1.8	22.9 +- 0.7; 3.4	17.6 +- 0.9; 4.9	16.8 +- 1.8
33	134	4.0	21.6 +- 0.6; 3.2	16.2 +- 0.8; 4.7	16.7 +- 1.7
34	151	6.0	21.5 +- 0.6; 3.2	16.2 +- 0.8; 4.7	14.9 +- 1.6
35	111	4.3	24.0 +- 0.7; 3.6	18.8 +- 0.9; 5.0	18.9 +- 1.8
36	92	4.7	25.0 +- 0.7; 3.7	19.9 +- 0.9; 5.1	19.3 +- 1.9
37	50	15.0	27.4 +- 0.8; 4.1	22.4 +- 1.0; 5.5	20.8 +- 1.4
39	222	0.3	24.6 +- 0.7; 3.7	19.4 +- 0.9; 5.1	18.4 +- 1.7
40	250	3.0	22.9 +- 0.7; 3.4	17.6 +- 0.9; 4.9	17.3 +- 1.8

Transit Dose = 6.5 +- 0.4; 3.0

VERMONT YANKEE
For the period 930915-940208

TLD Direct Radiation Environmental Monitoring

Azimuth (degrees)	Ave. Exposure Rate (mR/Std.Qtr.) +- Std.Dev.	Number In Group
348.76 - 11.25 N	17.2 +- 0.1	2
11.26 - 33.75 NNE	18.6 +- 2.0	2
33.76 - 56.25 NE	22.4 +- 0.0	1
56.26 - 78.75 ENE	19.2 +- 0.0	1
78.76 - 101.25 E	18.9 +- 1.4	2
101.26 - 123.75 ESE	18.2 +- 0.8	2
123.76 - 146.25 SE	17.1 +- 1.2	2
146.26 - 168.75 SSE	18.3 +- 3.0	3
168.76 - 191.25 S	16.7 +- 1.3	2
191.26 - 213.75 SSW	17.4 +- 0.2	3
213.76 - 236.25 SW	19.2 +- 0.6	3
236.26 - 258.75 WSW	17.6 +- 0.0	1
258.76 - 281.25 W	16.7 +- 3.5	2
281.26 - 303.75 WNW	17.8 +- 0.9	5
303.76 - 326.25 NW	17.1 +- 0.2	2
326.26 - 348.75 NNW	16.8 +- 0.7	2

Distance From Reactor (miles)	Ave. Exposure Rate (mR/Std.Qtr.) +- Std.Dev.	Number In Group
0 - 2	17.6 +- 0.9	12
2 - 5	18.0 +- 1.9	16
> 5	18.2 +- 2.1	7
Upwind Control	18.3 +- 0.7	3

VERMONT YANKEE
 TLD Direct Radiation Environmental Monitoring

NRC Station	Location		Description
	Azimuth Degree	Distance / Mile	
1	142	1.0	SMEAD LUMBER CO.
2	158	1.0	STEBBINS RD.
3	184	1.3	RT. 142 & POND RD.
4	201	1.4	WEST RD. & EDGEWOOD PARK RD.
5	220	1.6	FAIRMAN RD.
6	157	3.4	POND RD. & HOUGHTON HILL RD.
7	189	4.9	HUCKLE HILL RD.
8	201	13.0	GREENFIELD
9	208	5.8	RT. 5 & COUCH RD.
10	232	3.7	RT. 5
11	277	2.9	RT. 5
12	292	1.4	TYLER HILL RD.
13	314	1.4	RT. 142
14	310	4.2	RT. 5 & GUILFORD CTR RD.
15	299	4.3	GUILFORD CTR RD.
16	270	4.5	WEATHER HEAD HOLLOW RD. & STONY HILL RD.
17	331	5.0	BRATTLEBORO HIGH SCHOOL
18	290	19.0	WILMINGTON
19	290	19.0	WILMINGTON
20	290	19.0	WILMINGTON
21	359	3.2	MEETINGHOUSE RD.
23	334	2.2	HINSDALE RACEWAY
24	4	0.9	RT. 119
25	30	1.0	RT. 119
26	72	1.5	RT. 119
27	44	0.7	RT. 119 & PROSPECT RD.
28	39	2.8	RT. 63 & OLD CHESTERFIELD RD.
29	25	3.8	RT. 63
30	72	2.7	RT. 119
31	85	2.0	DEPOT ST.
32	111	1.8	RT. 63
33	134	4.0	RT. 63
34	151	6.0	NORTHFIELD
35	111	4.3	RIGHT SIDE RD. OFF ASHUELOT RD.
36	92	4.7	ASHUELOT RD.
37	50	15.0	KEENE
39	222	0.3	GOV. HUNT RD.
40	250	3.0	RT. 5

NRC TLD DOSES FOR VERMONT YANKEE AREA

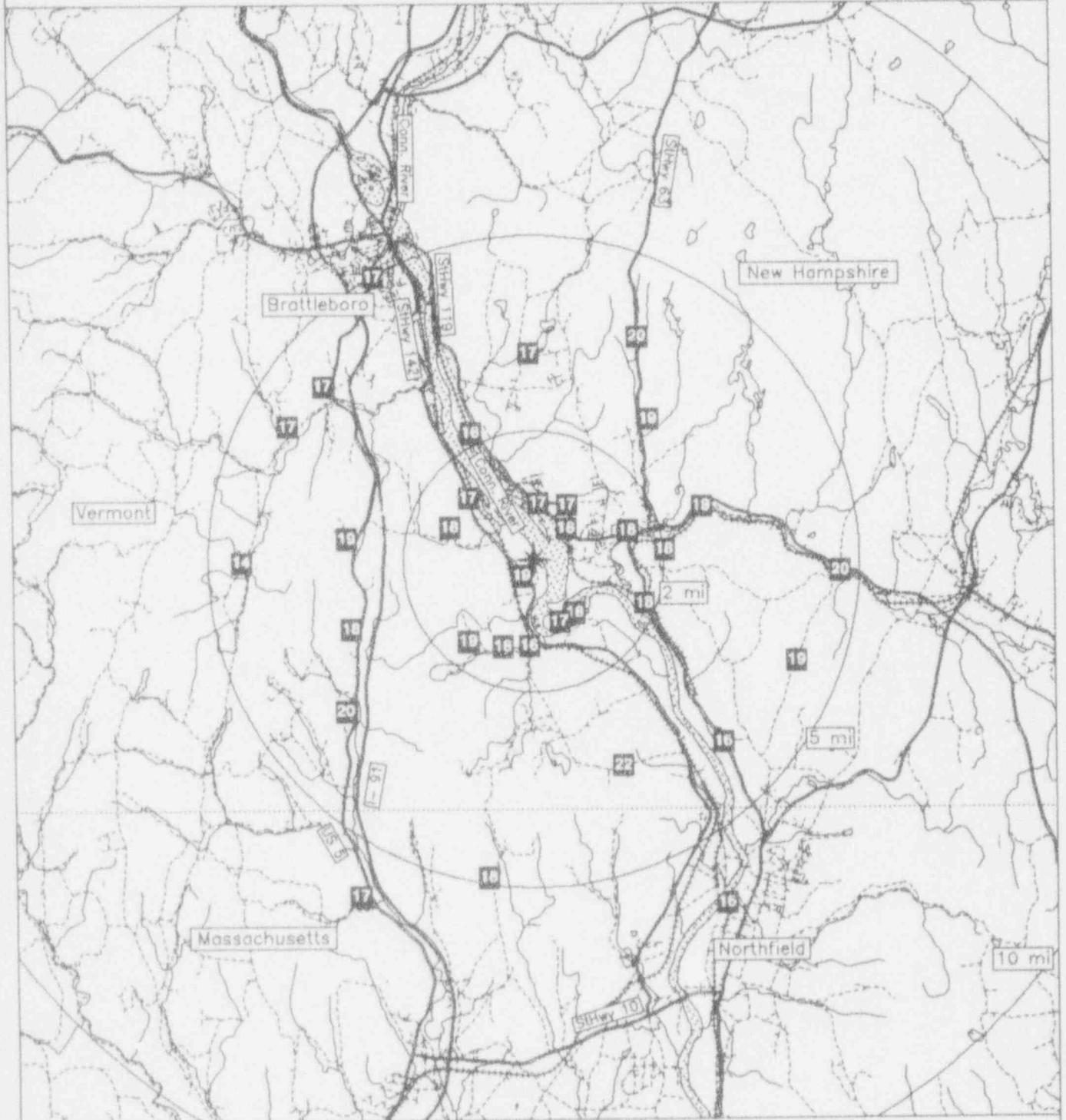

Miles

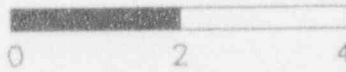

Legend

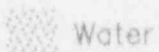

Water



Railroads



Plant site

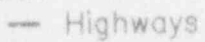

Highways



Roads

VOGTLE (GA)

TLD Direct Radiation Environmental Monitoring

For the period 930914-940208 148 Days

Field Time: 101 Days

NRC Sta	Location Azimuth/Dist (Deg)/(Mi)		Gross Exposure (mR) +-Rdm; Tot.	Net Exposure Rate (mR/Std. Qtr.) +-Rdm; Tot.	Hist. Range Net Exp Rate +-1 Std Dev
1	298	1.6	22.2 +- 0.7; 3.3	11.9 +- 0.7; 4.4	14.3 +- 1.8
2	309	1.6	23.0 +- 0.7; 3.5	12.6 +- 0.8; 4.5	14.2 +- 2.0
3	336	1.4	20.8 +- 0.6; 3.1	10.7 +- 0.7; 4.3	14.3 +- 2.7
4	270	1.3	21.4 +- 0.6; 3.2	11.2 +- 0.7; 4.4	14.1 +- 2.1
5	247	1.2	22.4 +- 0.7; 3.4	12.1 +- 0.8; 4.5	14.7 +- 1.8
6	215	1.2	26.2 +- 0.8; 3.9	15.5 +- 0.8; 4.8	18.1 +- 2.0
7	205	1.2	27.3 +- 0.8; 4.1	16.5 +- 0.9; 4.9	17.3 +- 1.7
8	180	1.1	27.5 +- 0.8; 4.1	16.6 +- 0.9; 4.9	17.2 +- 1.7
9	153	1.2	24.8 +- 0.7; 3.7	14.3 +- 0.8; 4.7	15.7 +- 2.1
10	134	3.2	24.9 +- 0.7; 3.7	14.4 +- 0.8; 4.7	17.2 +- 1.9
11	103	1.1	20.6 +- 0.6; 3.1	10.5 +- 0.7; 4.3	12.9 +- 3.0
12	134	3.3	23.6 +- 0.7; 3.5	13.2 +- 0.8; 4.6	14.9 +- 2.0
13	123	4.2	23.2 +- 0.7; 3.5	12.9 +- 0.8; 4.5	15.3 +- 1.7
14	141	4.6	20.0 +- 0.6; 3.0	10.0 +- 0.7; 4.3	14.4 +- 3.6
15	153	5.3	21.4 +- 0.6; 3.2	11.2 +- 0.7; 4.4	13.3 +- 1.8
16	162	6.3	23.0 +- 0.7; 3.4	12.6 +- 0.8; 4.5	15.3 +- 2.3
17	157	7.3	21.4 +- 0.6; 3.2	11.2 +- 0.7; 4.4	18.1 +- 2.5
18	191	4.8	22.1 +- 0.7; 3.3	11.8 +- 0.7; 4.4	13.7 +- 1.9
19	208	4.7	21.4 +- 0.6; 3.2	11.2 +- 0.7; 4.4	13.0 +- 2.0
20	232	4.9	21.3 +- 0.6; 3.2	11.1 +- 0.7; 4.4	13.6 +- 2.1
21	250	5.6	22.4 +- 0.7; 3.4	12.1 +- 0.8; 4.5	14.6 +- 2.0
22	264	4.3	21.2 +- 0.6; 3.2	11.1 +- 0.7; 4.4	14.2 +- 2.1
23	301	4.2	Missing Dosimeter	No Net Data	14.8 +- 2.0
24	308	4.6	20.1 +- 0.6; 3.0	10.1 +- 0.7; 4.3	14.8 +- 2.7
25	329	6.7	22.7 +- 0.7; 3.4	12.4 +- 0.8; 4.5	16.4 +- 3.1
26	258	15.0	25.9 +- 0.8; 3.9	15.2 +- 0.8; 4.8	17.4 +- 2.3
27	300	13.0	27.3 +- 0.8; 4.1	16.5 +- 0.9; 4.9	17.1 +- 1.5
28	330	30.0	22.6 +- 0.7; 3.4	12.3 +- 0.8; 4.5	14.4 +- 2.2

Transit Dose = 8.8 +- 0.5; 3.7

VOGTLE (GA)
For the period 930914-940208

TLD Direct Radiation Environmental Monitoring

Azimuth (degrees)	Ave. Exposure Rate (mR/Std.Qtr.) +- Std.Dev.	Number In Group
348.76 - 11.25 N	No Data +- No Data	0
11.26 - 33.75 NNE	No Data +- No Data	0
33.76 - 56.25 NE	No Data +- No Data	0
56.26 - 78.75 ENE	No Data +- No Data	0
78.76 - 101.25 E	No Data +- No Data	0
101.26 - 123.75 ESE	11.7 +- 1.6	2
123.76 - 146.25 SE	12.5 +- 2.3	3
146.26 - 168.75 SSE	12.3 +- 1.5	4
168.76 - 191.25 S	14.2 +- 3.4	2
191.26 - 213.75 SSW	13.9 +- 3.8	2
213.76 - 236.25 SW	13.3 +- 3.1	2
236.26 - 258.75 WSW	12.1 +- 0.0	2
258.76 - 281.25 W	11.1 +- 0.1	2
281.26 - 303.75 WNW	11.9 +- 0.0	1
303.76 - 326.25 NW	11.4 +- 1.8	2
326.26 - 348.75 NNW	11.6 +- 1.2	2

Distance From Reactor (miles)	Ave. Exposure Rate (mR/Std.Qtr.) +- Std.Dev.	Number In Group
0 - 2	13.2 +- 2.3	10
2 - 5	11.7 +- 1.5	9
> 5	11.9 +- 0.7	5
Upwind Control	14.7 +- 2.2	3

VOGTLE (GA)
TLD Direct Radiation Environmental Monitoring

NRC Station	Location		Description
	Azimuth Degree	Distance / Mile	
1	298	1.6	HANCOCK LANDING & RIVER RD
2	309	1.6	0.7 MI. EAST OF RIVER RD(FROM ST.1)
3	336	1.4	HANCOCK LANDING RD AT G.P. AIR SAMPLER
4	270	1.3	RIVER RD, I MI S.OF HANCOCK LANDING RD
5	247	1.2	RIVER RD AT DELAGLE MHP
6	215	1.2	INTERSECTION OF RIVER & CC ROADS
7	205	1.2	RIVER RD 0.3 MI NW OF TLD STATION 18
8	180	1.1	RIVER RD 0.4 MI E OF TLD STATION 7
9	153	1.2	RIVER RD 0.5 MI E OF TLD STATION 8
10	134	3.2	RIVER RD AT PLANT GATE 3
11	103	1.1	PLANT WILSON BOUNDARY RD
12	134	3.3	NEAR RESIDENCE OF OLD RIVER RD
13	123	4.2	GRIFFINS LANDING RD
14	141	4.6	GRIFFINS LANDING AND EARLE DIXON RDS
15	153	5.3	GRIFFINS LANDING & CHANCE RDS
16	162	6.3	GRC/ERN AIR CABINETS
17	157	7.3	CITY OF GIRARD
18	191	4.8	GA HWY 23 & THOMPSON BRIDGE RD
19	208	4.7	GA HWY 23, 1.5 MI NW OF TLD STATION 18
20	232	4.9	GA HWY 23 & ESKEW ROAD
21	250	5.6	GA HWY 23 & HANCOCK LANDING RD
22	264	4.3	HANCOCK LANDING & CLAXTON LIVERLY RDS
23	301	4.2	RIVER RD AND HATCHER ROAD
24	308	4.6	PIONEER TRAILER PARK ON RIVER RD
25	329	6.7	SHELL BLUFF LANDING
26	258	15.0	GP DISTRICT OFFI. IN WAYNESBORO
27	300	13.0	MCBEAN FIRE STATION
28	330	30.0	GA WELCOME CENTER I-20 W, AUGUSTA

NRC TLD DOSES FOR VOGTLE AREA

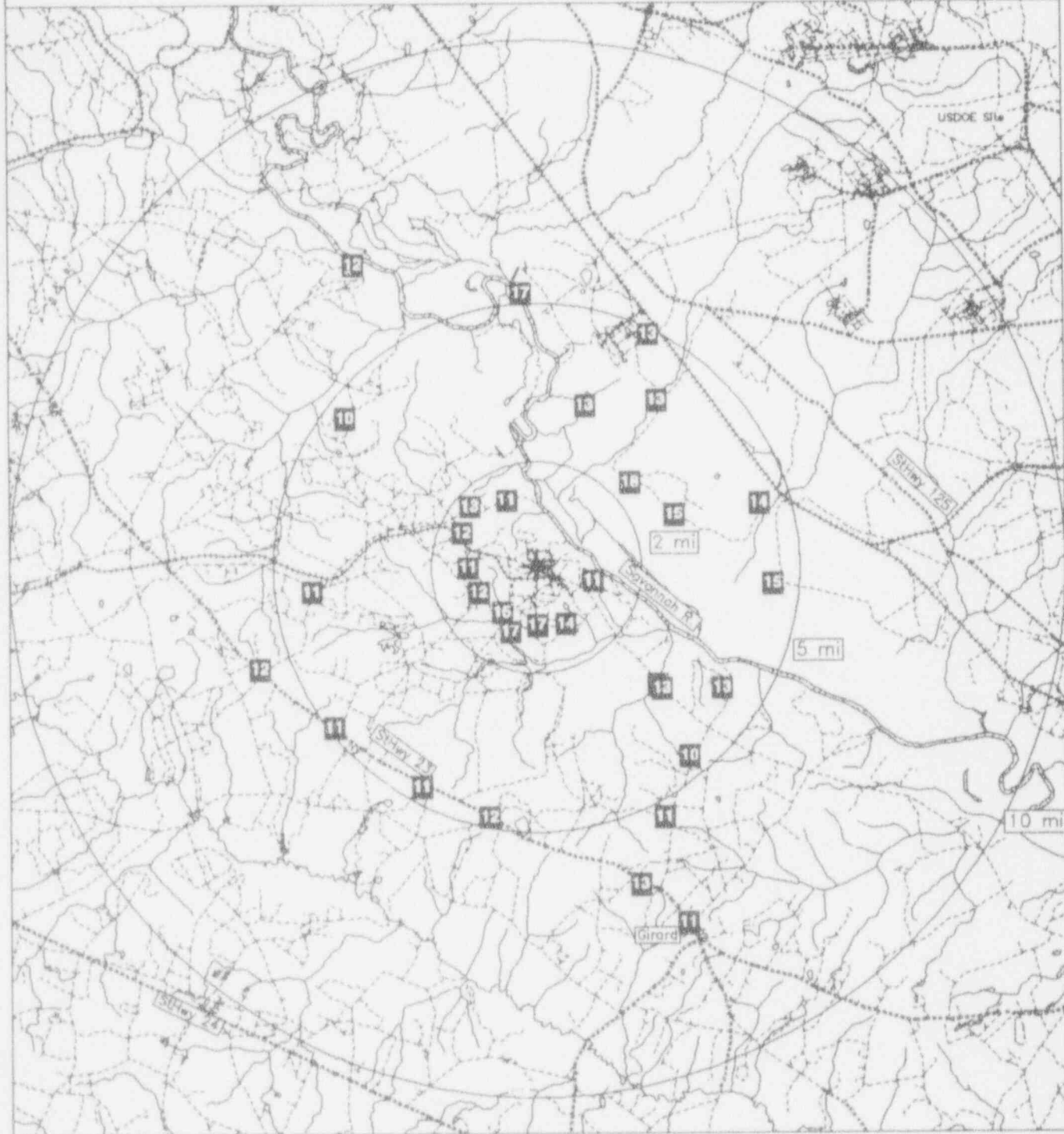

Miles

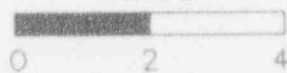

Legend



Water



Railroads



Roads



Plant site

VOGTLE (SC)
 TLD Direct Radiation Environmental Monitoring
 For the period 930914-940208 148 Days
 Field Time: 101 Days

NRC Sta	Location		Gross Exposure (mR)		Net Exposure Rate (mR/Std. Qtr.)		Hist. Range Net Exp Rate	
	Azimuth/ (Deg)	Dist (Mi)	+-Rdm; Tot.		+-Rdm; Tot.		+-1 Std Dev	
31	357	5.2	25.7	+ - 0.8; 3.9	16.7	+ - 0.8; 4.7	17.5	+ - 4.0
32	26	4.9	21.2	+ - 0.6; 3.2	12.6	+ - 0.7; 4.2	12.2	+ - 2.7
33	17	3.2	21.4	+ - 0.6; 3.2	12.8	+ - 0.7; 4.3	12.5	+ - 2.6
34	36	3.9	21.2	+ - 0.6; 3.2	12.6	+ - 0.7; 4.2	13.9	+ - 2.5
35	48	2.4	27.0	+ - 0.8; 4.1	17.8	+ - 0.8; 4.8	18.5	+ - 2.9
36	69	2.8	24.2	+ - 0.7; 3.6	15.3	+ - 0.8; 4.5	14.3	+ - 2.8
37	74	4.4	22.5	+ - 0.7; 3.4	13.8	+ - 0.7; 4.3	14.0	+ - 4.4
38	94	4.5	23.4	+ - 0.7; 3.5	14.6	+ - 0.7; 4.4	13.5	+ - 2.8

Transit Dose = 7.0 + - 0.5; 3.5

VOGTLE (SC)
For the period 930914-940208

TLD Direct Radiation Environmental Monitoring

Azimuth (degrees)	Ave. Exposure Rate (mR/Std.Qtr.) +- Std.Dev.	Number In Group
348.76 - 11.25 N	16.7 +- 0.0	1
11.26 - 33.75 NNE	12.7 +- 0.1	2
33.76 - 56.25 NE	15.2 +- 3.7	2
56.26 - 78.75 ENE	14.5 +- 1.1	2
78.76 - 101.25 E	14.6 +- 0.0	1
101.26 - 123.75 ESE	No Data +- No Data	0
123.76 - 146.25 SE	No Data +- No Data	0
146.26 - 168.75 SSE	No Data +- No Data	0
168.76 - 191.25 S	No Data +- No Data	0
191.26 - 213.75 SSW	No Data +- No Data	0
213.76 - 236.25 SW	No Data +- No Data	0
236.26 - 258.75 WSW	No Data +- No Data	0
258.76 - 281.25 W	No Data +- No Data	0
281.26 - 303.75 WNW	No Data +- No Data	0
303.76 - 326.25 NW	No Data +- No Data	0
326.26 - 348.75 NNW	No Data +- No Data	0

Distance From Reactor (miles)	Ave. Exposure Rate (mR/Std.Qtr.) +- Std.Dev.	Number In Group
0 - 2	No Data +- No Data	0
2 - 5	14.2 +- 1.9	7
> 5	16.7 +- 0.0	1
Upwind Control	No Data +- No Data	0

VOGTLE (SC)
TLD Direct Radiation Environmental Monitoring

NRC Station	Location		Description
	Azimuth / Degree	Distance / Mile	
31	357	5.2	SRP BOAT DOCK(SC)
32	26	4.9	SRP A-12 & SEABOARD COAST RR (SC)
33	17	3.2	1.2 MI FROM INTERSEC.DIRT RD & SRP A12.2
34	36	3.9	INTERSEC.OF SRP A-13 & SRP A-13.2(SC)
35	48	2.4	INTERSEC.OF SRP A-13 & BEAR TRACK RD(SC)
36	69	2.8	2ND INTERSEC. SRP A-13 & BEAR RD(SC)
37	74	4.4	INTERSEC.OF A-13 & SRP A-13.2 (SC)
38	94	4.5	INTERSEC.OF SRP A-17 & WILSON RD(SC)

NRC TLD DOSES FOR VOGTLE AREA

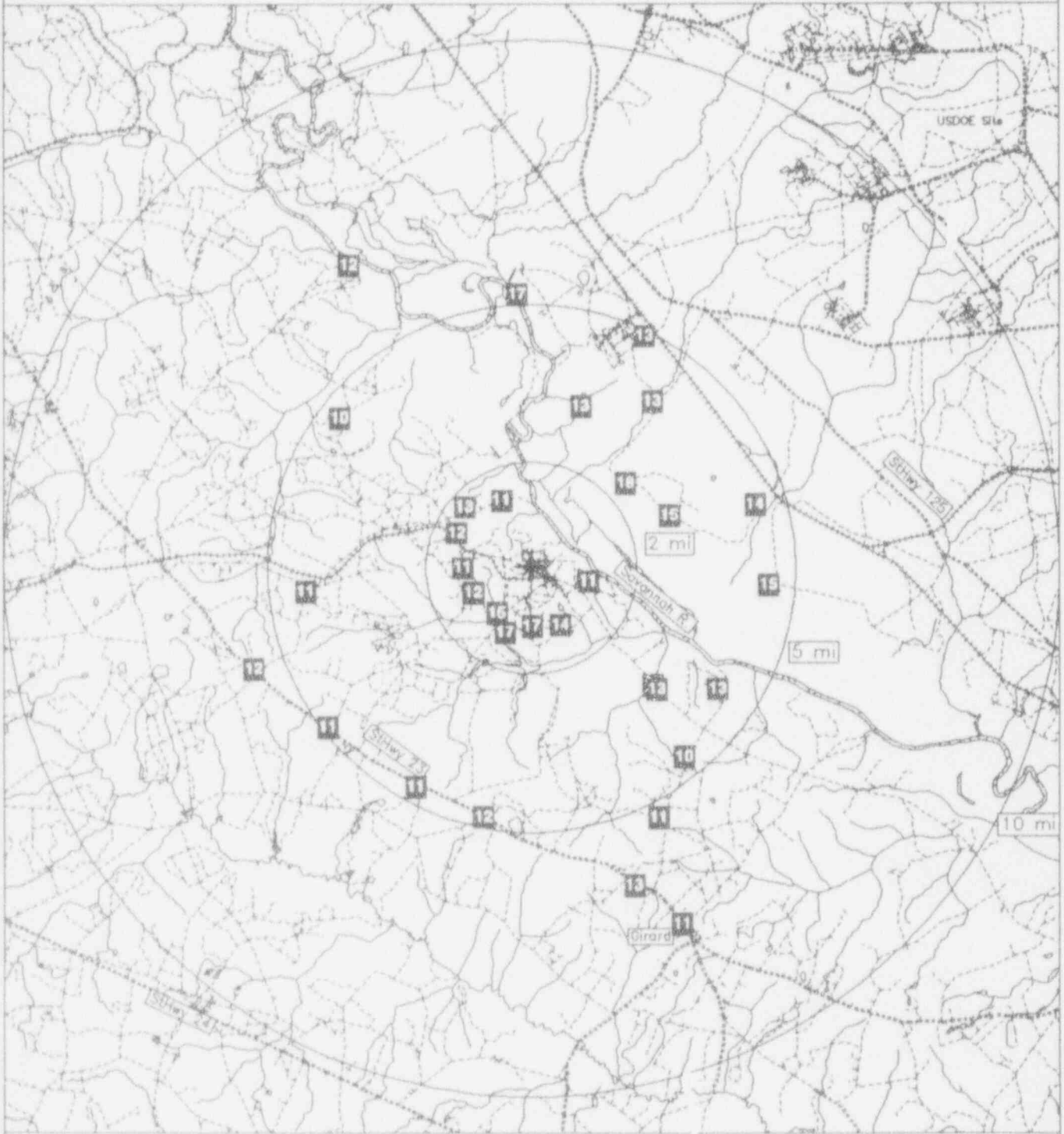

Miles

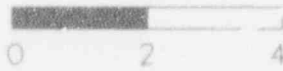

Legend



Water



Railroads



Roads



Plant site

WASHINGTON NUCLEAR 2
 TLD Direct Radiation Environmental Monitoring
 For the period 930913-940127 137 Days
 Field Time: 96 Days

NRC Sta	Location		Gross	Net Exposure Rate	Hist. Range
	Azimuth/Dist (Deg)/(Mi)		Exposure (mR) +-Rdm; Tot.	(mR/Std. Qtr.) +-Rdm; Tot.	Net Exp Rate +-1 Std Dev
1	174	12.0	24.0 +- 0.7; 3.6	17.7 +- 0.8; 4.5	17.9 +- 1.0
2	163	11.0	23.0 +- 0.7; 3.4	16.8 +- 0.7; 4.4	17.6 +- 1.1
3	161	9.0	23.8 +- 0.7; 3.6	17.6 +- 0.8; 4.5	17.3 +- 1.0
4	152	5.0	25.1 +- 0.8; 3.8	18.8 +- 0.8; 4.6	18.7 +- 1.1
5	195	2.0	24.5 +- 0.7; 3.7	18.2 +- 0.8; 4.6	17.9 +- 1.0
6	220	1.5	24.0 +- 0.7; 3.6	17.8 +- 0.8; 4.5	18.0 +- 1.5
7	92	3.0	25.4 +- 0.8; 3.8	19.0 +- 0.8; 4.7	19.2 +- 1.4
8	155	1.0	22.8 +- 0.7; 3.4	16.6 +- 0.7; 4.4	17.2 +- 1.4
9	130	0.5	25.0 +- 0.8; 3.8	18.7 +- 0.8; 4.6	18.2 +- 1.2
10	70	0.5	25.1 +- 0.8; 3.8	18.8 +- 0.8; 4.6	18.4 +- 1.5
11	25	0.8	24.6 +- 0.7; 3.7	18.3 +- 0.8; 4.6	18.4 +- 1.1
12	315	0.5	25.8 +- 0.8; 3.9	19.5 +- 0.8; 4.7	18.6 +- 1.5
13	290	0.5	33.2 +- 1.0; 5.0	26.4 +- 1.0; 5.5	22.2 +- 3.1
14	270	0.5	25.2 +- 0.8; 3.8	18.8 +- 0.8; 4.6	18.4 +- 1.4
15	245	1.8	24.9 +- 0.7; 3.7	18.6 +- 0.8; 4.6	18.6 +- 1.1
16	285	3.0	25.1 +- 0.8; 3.8	18.8 +- 0.8; 4.6	19.1 +- 1.3
17	240	4.0	23.5 +- 0.7; 3.5	17.3 +- 0.8; 4.5	17.3 +- 1.3
18	198	7.0	22.7 +- 0.7; 3.4	16.6 +- 0.7; 4.4	17.1 +- 1.5
19	173	8.5	24.3 +- 0.7; 3.6	18.0 +- 0.8; 4.5	18.3 +- 1.2
20	150	20.0	24.8 +- 0.7; 3.7	18.5 +- 0.8; 4.6	18.4 +- 1.1
21	114	7.0	23.8 +- 0.7; 3.6	17.6 +- 0.8; 4.5	18.8 +- 1.6
22	120	8.0	23.5 +- 0.7; 3.5	17.2 +- 0.8; 4.5	17.8 +- 1.1
23	134	6.0	27.5 +- 0.8; 4.1	21.0 +- 0.9; 4.9	20.1 +- 1.4
24	110	4.0	29.6 +- 0.9; 4.4	23.0 +- 0.9; 5.1	22.0 +- 1.4
25	85	5.0	25.1 +- 0.8; 3.8	18.8 +- 0.8; 4.6	18.7 +- 1.4
26	65	5.0	28.2 +- 0.8; 4.2	21.7 +- 0.9; 5.0	20.4 +- 1.6
27	53	4.0	25.6 +- 0.8; 3.8	19.3 +- 0.8; 4.7	18.0 +- 1.4
28	44	8.0	25.6 +- 0.8; 3.8	19.3 +- 0.8; 4.7	20.0 +- 1.7
29	33	10.0	24.7 +- 0.7; 3.7	18.4 +- 0.8; 4.6	18.4 +- 1.9
30	8	9.5	27.1 +- 0.8; 4.1	20.7 +- 0.8; 4.9	19.7 +- 1.6
31	215	15.0	24.0 +- 0.7; 3.6	17.7 +- 0.8; 4.5	17.6 +- 1.3

Transit Dose = 5.1 +- 0.4; 3.2

WASHINGTON NUCLEAR 2
For the period 930913-940127

TLD Direct Radiation Environmental Monitoring

Azimuth (degrees)	Ave. Exposure Rate (mR/Std.Qtr.) +- Std.Dev.	Number In Group
348.76 - 11.25 N	20.7 +- 0.0	1
11.26 - 33.75 NNE	18.4 +- 0.0	2
33.76 - 56.25 NE	19.3 +- 0.0	2
56.26 - 78.75 ENE	20.2 +- 2.0	2
78.76 - 101.25 E	18.9 +- 0.1	2
101.26 - 123.75 ESE	19.3 +- 3.2	3
123.76 - 146.25 SE	19.9 +- 1.6	2
146.26 - 168.75 SSE	17.7 +- 1.0	5
168.76 - 191.25 S	18.0 +- 0.0	1
191.26 - 213.75 SSW	17.4 +- 1.2	2
213.76 - 236.25 SW	17.8 +- 0.0	1
236.26 - 258.75 WSW	17.9 +- 0.9	2
258.76 - 281.25 W	18.8 +- 0.0	1
281.26 - 303.75 WNW	22.6 +- 5.4	2
303.76 - 326.25 NW	19.5 +- 0.0	1
326.26 - 348.75 NNW	No Data +- No Data	0

Distance From Reactor (miles)	Ave. Exposure Rate (mR/Std.Qtr.) +- Std.Dev.	Number In Group
0 - 2	19.2 +- 2.6	10
2 - 5	19.6 +- 1.8	8
> 5	18.3 +- 1.5	11
Upwind Control	17.7 +- 0.0	2

WASHINGTON NUCLEAR 2
TLD Direct Radiation Environmental Monitoring

NRC Station	Location		Description
	Azimuth / Degree	Distance / Mile	
1	174	12.0	STEVENS DR. & VAN GIESEN ST.
2	163	11.0	HANDFORD SCHOOL
3	161	9.0	BENTON BLVD.
4	152	5.0	RT.4 AT RR CROSSING
5	195	2.0	RT.4& WNP 1-4 ACCESS RD.
6	220	1.5	RT. 4 N. OF FFTF ACCESS RD.
7	92	3.0	WNP-2 INTAKE STRUCTURE
8	155	1.0	WNP 1-4 ACCESS RD. & WNP-2 CUTOFF
9	130	0.5	WNP-2 CUTOFF&WASTE WTR TRTMNT ACC.RD.
10	70	0.5	WNP-4 EXCLUS.BOUNDARY BY WNP-2 CUTOFF
11	25	0.8	N.W.CORNER WNP-4 EXCLUSION BOUNDARY
12	315	0.5	B.P.A.H.J. ASHE SUBSTATION
13	290	0.5	WNP-2 EXCLUSION BOUNDARY
14	270	0.5	WPPSS METEOROLOGY STATION
15	245	1.8	RT.4&WNP-2 ACCESS ROAD
16	285	3.0	WYE BARRICADE
17	240	4.0	RT.10 & FFTF ACCESS ROAD
18	198	7.0	B.P.A. WHITE BLUFF SUBSTATION
19	173	8.5	HORN RAPIDS ROAD ACROSS FROM EXXON
20	150	20.0	RD.#36 & RUBY IN PASCO
21	114	7.0	EDWIN MARKHAM SCHOOL
22	120	8.0	BPA BAXTER SUBSTATION
23	134	6.0	COTTONWOOD ROAD N. OF PASCO
24	110	4.0	END OF FIR ROAD N.W. OF PASCO
25	85	5.0	GLENWOOD & GUM INTERSECTION
26	65	5.0	ELTOPIA RINGOLD ROAD
27	53	4.0	RINGOLD FISH HATCHERY
28	44	8.0	RD.#170 & KLAMATH INTERSECTION
29	33	10.0	WAHLUKE SO. & BASIN HILL RD. INTERSECTION
30	8	9.5	HOLLINGSWORTH & MT. VISTA RD.
31	215	15.0	ACORD & WHAN RD. INTERSECTION

NRC TLD DOSES FOR WNP-2 AREA

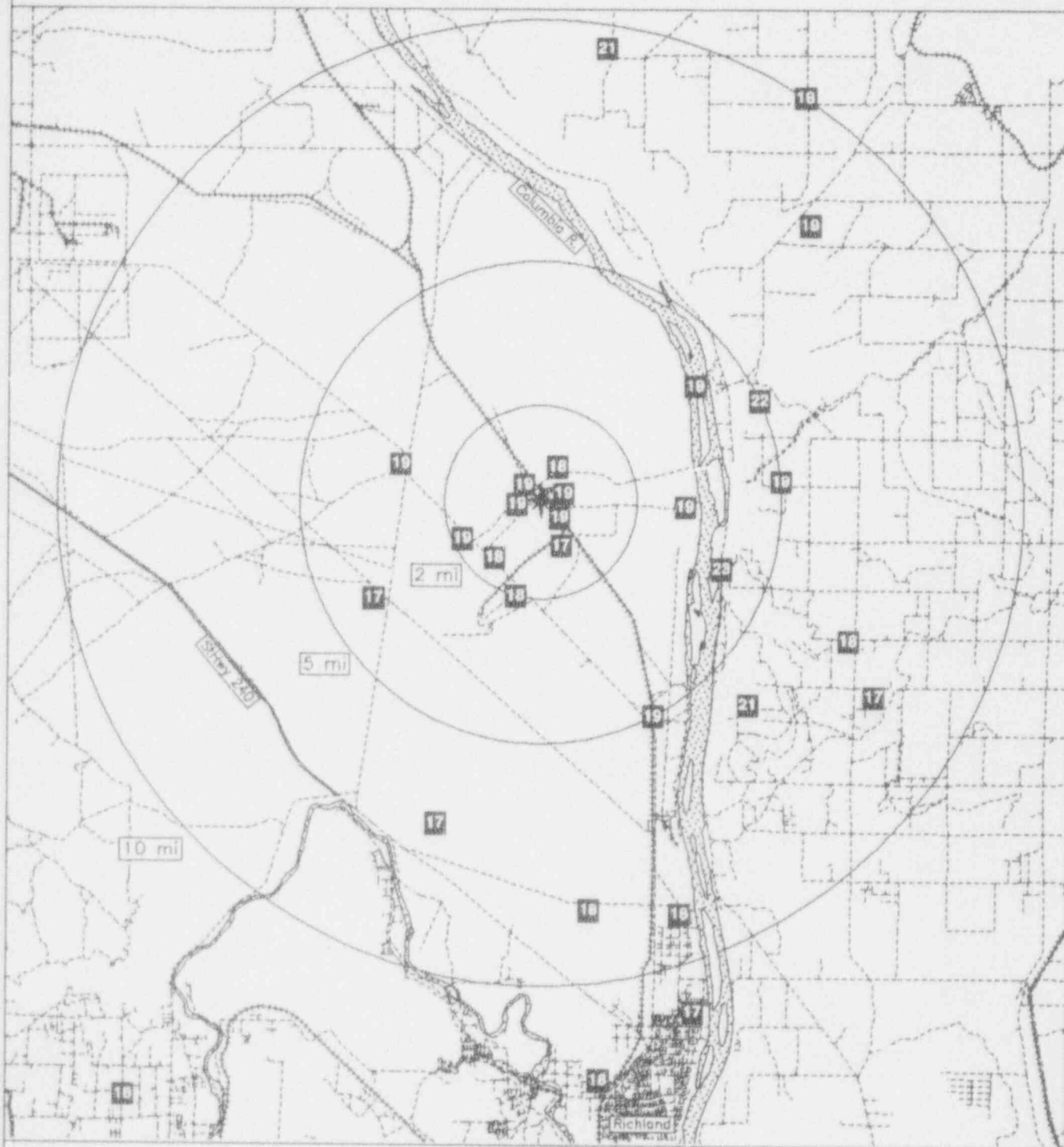

Miles

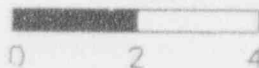

Legend

Water

Highways

Railroads

Roads

Plant..site

WATERFORD

TLD Direct Radiation Environmental Monitoring

For the period 931006-940209 127 Days

Field Time: 91 Days

NRC Sta	Location Azimuth/Dist (Deg)/(Mi)		Gross Exposure (mR) +-Rdm; Tot.	Net Exposure Rate (mR/Std. Qtr.) +-Rdm; Tot.	Hist. Range Net Exp Rate +-1 Std Dev
1	101	0.4	17.0 +- 0.5; 2.5	15.3 +- 0.6; 3.7	16.0 +- 2.5
2	116	1.1	14.6 +- 0.4; 2.2	12.9 +- 0.5; 3.5	15.8 +- 2.7
3	132	1.3	19.8 +- 0.6; 3.0	18.1 +- 0.6; 4.0	17.9 +- 2.7
4	160	1.8	16.8 +- 0.5; 2.5	15.1 +- 0.6; 3.7	15.9 +- 2.5
5	183	1.4	18.3 +- 0.5; 2.7	16.5 +- 0.6; 3.9	15.4 +- 2.4
6	202	1.2	16.4 +- 0.5; 2.5	14.7 +- 0.6; 3.7	16.1 +- 2.8
7	226	1.2	16.2 +- 0.5; 2.4	14.5 +- 0.6; 3.6	15.5 +- 2.4
8	248	1.3	18.6 +- 0.6; 2.8	16.9 +- 0.6; 3.9	17.4 +- 2.4
9	265	1.9	15.9 +- 0.5; 2.4	14.2 +- 0.5; 3.6	14.9 +- 2.8
10	186	4.2	19.8 +- 0.6; 3.0	18.0 +- 0.6; 4.0	17.2 +- 2.5
11	315	4.4	16.4 +- 0.5; 2.5	14.7 +- 0.6; 3.7	16.6 +- 2.5
12	328	4.1	18.3 +- 0.5; 2.7	16.6 +- 0.6; 3.9	17.3 +- 2.6
13	309	0.8	17.1 +- 0.5; 2.6	15.4 +- 0.6; 3.7	15.4 +- 2.4
14	273	0.9	19.8 +- 0.6; 3.0	18.0 +- 0.6; 4.0	17.7 +- 3.2
15	292	0.8	Missing Dosimeter	No Net Data	14.3 +- 2.7
16	335	0.5	15.6 +- 0.5; 2.3	13.9 +- 0.5; 3.6	13.9 +- 2.3
17	120	4.3	16.8 +- 0.5; 2.5	15.1 +- 0.6; 3.7	13.9 +- 2.6
18	145	3.5	17.1 +- 0.5; 2.6	15.4 +- 0.6; 3.7	14.5 +- 1.6
19	153	8.1	18.1 +- 0.5; 2.7	16.4 +- 0.6; 3.8	16.3 +- 2.7
20	133	8.1	17.1 +- 0.5; 2.6	15.4 +- 0.6; 3.7	16.5 +- 2.6
21	116	6.7	17.7 +- 0.5; 2.7	16.0 +- 0.6; 3.8	15.2 +- 2.7
22	95	4.3	16.8 +- 0.5; 2.5	15.1 +- 0.6; 3.7	15.7 +- 2.5
23	86	2.6	17.2 +- 0.5; 2.6	15.5 +- 0.6; 3.7	15.4 +- 2.6
24	66	4.2	20.0 +- 0.6; 3.0	18.3 +- 0.7; 4.0	18.5 +- 2.7
25	37	3.5	18.1 +- 0.5; 2.7	16.4 +- 0.6; 3.8	16.9 +- 2.6
26	23	3.8	15.9 +- 0.5; 2.4	14.2 +- 0.5; 3.6	14.5 +- 2.7
27	350	4.9	17.2 +- 0.5; 2.6	15.5 +- 0.6; 3.7	15.6 +- 2.5
28	335	5.0	17.0 +- 0.5; 2.5	15.3 +- 0.6; 3.7	16.0 +- 2.6
29	6	2.8	15.5 +- 0.5; 2.3	13.8 +- 0.5; 3.6	14.4 +- 2.7
30	356	1.1	19.9 +- 0.6; 3.0	18.1 +- 0.6; 4.0	15.5 +- 2.9
31	15	0.8	16.7 +- 0.5; 2.5	15.0 +- 0.6; 3.7	16.6 +- 2.9
32	40	0.8	13.9 +- 0.4; 2.1	12.2 +- 0.5; 3.4	14.6 +- 2.9
33	69	1.1	Missing Dosimeter	No Net Data	16.2 +- 3.7
34	292	15.0	17.3 +- 0.5; 2.6	15.6 +- 0.6; 3.8	16.0 +- 2.9
35	282	27.0	19.5 +- 0.6; 2.9	17.7 +- 0.6; 4.0	17.9 +- 2.9
36	268	21.0	15.6 +- 0.5; 2.3	13.9 +- 0.5; 3.6	14.8 +- 2.9

Transit Dose = 1.5 +- 0.3; 2.8

WATERFORD

For the period 931006-940209

TLD Direct Radiation Environmental Monitoring

Azimuth (degrees)	Ave. Exposure Rate (mR/Std.Qtr.) +- Std.Dev.	Number In Group
348.76 - 11.25 N	15.8 +- 2.2	3
11.26 - 33.75 NNE	14.6 +- 0.5	2
33.76 - 56.25 NE	14.3 +- 2.9	2
56.26 - 78.75 ENE	18.3 +- 0.0	1
78.76 - 101.25 E	15.3 +- 0.2	3
101.26 - 123.75 ESE	14.6 +- 1.6	3
123.76 - 146.25 SE	16.3 +- 1.5	3
146.26 - 168.75 SSE	15.7 +- 0.9	2
168.76 - 191.25 S	17.3 +- 1.1	2
191.26 - 213.75 SSW	14.7 +- 0.0	1
213.76 - 236.25 SW	14.5 +- 0.0	1
236.26 - 258.75 WSW	16.9 +- 0.0	1
258.76 - 281.25 W	16.1 +- 2.7	2
281.26 - 303.75 WNW	No Data +- No Data	0
303.76 - 326.25 NW	15.0 +- 0.4	2
326.26 - 348.75 NNW	15.3 +- 1.3	3

Distance From Reactor (miles)	Ave. Exposure Rate (mR/Std.Qtr.) +- Std.Dev.	Number In Group
0 - 2	15.4 +- 1.8	15
2 - 5	15.7 +- 1.3	13
> 5	15.9 +- 0.5	3
Upwind Control	15.8 +- 1.9	3

WATERFORD
 TLD Direct Radiation Environmental Monitoring

NRC Station	Location		Description
	Azimuth / Degree	Distance / Mile	
1	101	0.4	UTILITY POLE NEAR RIVER ROAD ENTR TO W-3
2	116	1.1	CORNER OF FENCE OF LP&L SUBSTATION ON 3142
3	132	1.3	UTILITY POLE AT WITCO EMPLOYEES ENTRANCE
4	160	1.8	ROAD SIGN AT INT. OF LA 3142 & LA 3127
5	183	1.4	CORNER OF FENCE TEXACO VALVE STATION, LA 3127
6	202	1.2	GATE POST AT ENT. TO W-3 TRAINING CENTER/EOC
7	226	1.2	STEEL GATE POST # 97 ON LA 3127
8	248	1.3	STEEL FENCE POST 2.3 MI W. OF LA 3127 & 3142
9	265	1.9	ROAD SIGN AT INT. OF LA 3127 & LA 3141
10	186	4.2	PARISH BOUNDARY ROAD SIGN ON LA 3127
11	315	4.4	UTILITY POLE AT ENTR. TO GOLD MINE PLANTATION
12	328	4.1	UT. POLE, 1 MI E OF GOLD MINE PLNTN ON RIVER RD
13	309	0.8	AIR SAMP STA ON RIV RD NR LA 3141
14	273	0.9	RR (1/2) SIGN SIDE OF KILLONA SCH
15	292	0.8	AIR SAMP STATION 0.3 MI N. OF KILLONA SCHOOL
16	335	0.5	FENCE AROUND WATERFORD 1&2 INTAKE
17	120	4.3	UTILITY POLE FRONT OF ST. CHARLES CRT HSE
18	145	3.5	ROAD SIGN S. SIDE OF LA 3127 & LA 3160
19	153	8.1	UTIL POLE, ENTRANCE TO HAHNVILLE SCH. HWY 90
20	133	8.1	FENCE BEHIND LP&L LULING DISTRICT OFFICE
21	116	6.7	UTIL POLE BEFORE ENTRANCE TO DESTREHAN H.S.
22	95	4.3	UTILITY POLE NEAR LA 48 & LA 627/GOOD HOPE
23	86	2.6	UTIL POLE NEAR ENTR TO SHELL CHEM NORCO PLANT
24	66	4.2	UTILITY POLE NR ENTR NORCO LIONS REC. PARK
25	37	3.5	SPILLWAY SIGN NEAR US61/LA628 NXT TO SPILLWAY
26	23	3.8	UTILITY POLE AT DOT WEIGH STATION ON US 61
27	350	4.9	UTIL POLE ACROSS FROM TWIN OAKS NURSING HOME
28	335	5.0	MILESVILLE SCH NR LEVEE IN LAPLACE
29	6	2.8	UTILITY POLE FRONT OF BAYOU STEEL, RIVER RD
30	356	1.1	BACK RIGHT OF LA 628 FENCE FOR WATER TOWER
31	15	0.8	GATE ENTR TO POWER TOWER NEXT TO LITTLE GYPSY
32	40	0.8	R CORNER FENCE, LITTLE GYPSY INTAKE
33	69	1.1	L SIDE SPILLWAY GATE NR MONTZ PARK
34	292	15.0	ROAD SIGN AT US61/LA641 NEAR RESERVE, LA
35	282	27.0	UTILITY POLE SOUTH OF SUNSHINE BRIDGE
36	268	21.0	UTILITY POLE FRONT OF ST. JAMES PO, RIVER RD.

NRC TLD DOSES FOR WATERFORD AREA



Miles

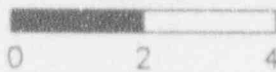

Legend

- Water
- Railroads
- Plant..site
- Highways
- Roads

WATTS BAR

TLD Direct Radiation Environmental Monitoring

For the period 930914-940208 148 Days

Field Time: 106 Days

NRC Sta	Location		Gross Exposure (mR)		Net Exposure Rate (mR/Std. Qtr.)		Hist. Range Net Exp Rate	
	Azimuth/ (Deg)	Dist (Mi)	+-Rdm; Tot.		+-Rdm; Tot.		+-1 Std Dev	
1	337	0.9	23.5	+- 0.7; 3.5	17.9	+- 0.7; 4.1	17.1	+- 2.3
2	314	2.1	23.1	+- 0.7; 3.5	17.6	+- 0.7; 4.0	17.3	+- 2.4
3	297	1.9	22.7	+- 0.7; 3.4	17.2	+- 0.6; 4.0	17.3	+- 2.6
4	272	2.0	23.2	+- 0.7; 3.5	17.7	+- 0.7; 4.1	16.7	+- 2.5
5	251	1.9	27.0	+- 0.8; 4.1	20.9	+- 0.7; 4.4	19.0	+- 2.4
6	235	1.8	25.5	+- 0.8; 3.8	19.6	+- 0.7; 4.3	20.6	+- 2.9
7	230	3.8	27.8	+- 0.8; 4.2	21.6	+- 0.8; 4.5	19.3	+- 2.7
8	208	3.6	25.9	+- 0.8; 3.9	20.0	+- 0.7; 4.3	18.0	+- 2.6
9	249	4.2	24.0	+- 0.7; 3.6	18.4	+- 0.7; 4.1	15.4	+- 2.3
10	266	3.1	24.5	+- 0.7; 3.7	18.8	+- 0.7; 4.2	16.6	+- 2.3
11	289	3.3	20.7	+- 0.6; 3.1	15.6	+- 0.6; 3.8	14.2	+- 2.3
12	310	4.7	21.1	+- 0.6; 3.2	15.9	+- 0.6; 3.9	14.6	+- 2.4
13	337	3.6	24.6	+- 0.7; 3.7	18.8	+- 0.7; 4.2	15.3	+- 2.8
14	330	7.0	22.1	+- 0.7; 3.3	16.7	+- 0.6; 4.0	15.2	+- 2.3
15	350	4.7	25.8	+- 0.8; 3.9	19.9	+- 0.7; 4.3	18.6	+- 2.7
16	7	1.1	28.9	+- 0.9; 4.3	22.5	+- 0.8; 4.6	19.9	+- 2.7
17	23	1.6	19.7	+- 0.6; 3.0	14.7	+- 0.6; 3.7	13.1	+- 2.1
18	41	2.3	23.1	+- 0.7; 3.5	17.5	+- 0.7; 4.0	16.1	+- 2.5
19	69	1.3	26.4	+- 0.8; 4.0	20.4	+- 0.7; 4.4	18.6	+- 2.2
20	89	1.2	24.8	+- 0.7; 3.7	19.0	+- 0.7; 4.2	20.2	+- 2.7
21	114	1.1	22.8	+- 0.7; 3.4	17.3	+- 0.6; 4.0	15.7	+- 2.3
22	141	1.0	25.6	+- 0.8; 3.8	19.7	+- 0.7; 4.3	19.1	+- 2.3
23	163	1.1	30.8	+- 0.9; 4.6	24.1	+- 0.8; 4.8	21.9	+- 2.6
24	187	1.1	26.8	+- 0.8; 4.0	20.7	+- 0.7; 4.4	18.0	+- 2.6
25	203	1.2	20.1	+- 0.6; 3.0	15.0	+- 0.6; 3.8	18.2	+- 2.8
26	184	5.9	25.3	+- 0.8; 3.8	19.5	+- 0.7; 4.3	17.8	+- 3.0
27	176	4.5	24.7	+- 0.7; 3.7	18.9	+- 0.7; 4.2	17.3	+- 2.6
28	161	3.5	24.2	+- 0.7; 3.6	18.5	+- 0.7; 4.1	16.1	+- 2.2
29	144	3.0	24.1	+- 0.7; 3.6	18.5	+- 0.7; 4.1	16.7	+- 2.5
30	117	3.1	22.1	+- 0.7; 3.3	16.7	+- 0.6; 4.0	15.8	+- 2.6
31	97	4.0	24.1	+- 0.7; 3.6	18.4	+- 0.7; 4.1	16.2	+- 2.5
32	76	4.1	20.4	+- 0.6; 3.1	15.3	+- 0.6; 3.8	13.7	+- 2.3
33	32	4.1	24.3	+- 0.7; 3.6	18.6	+- 0.7; 4.2	16.9	+- 2.5
34	36	4.7	20.0	+- 0.6; 3.0	15.0	+- 0.6; 3.8	13.8	+- 2.3
35	38	19.0	23.5	+- 0.7; 3.5	17.9	+- 0.7; 4.1	15.6	+- 2.4
36	38	19.0	22.5	+- 0.7; 3.4	17.1	+- 0.6; 4.0	16.6	+- 4.0
37	38	19.0	25.2	+- 0.8; 3.8	19.4	+- 0.7; 4.2	17.2	+- 2.4

Transit Dose = 2.4 +- 0.3; 3.3

WATTS BAR

For the period 930914-940208

TLD Direct Radiation Environmental Monitoring

Azimuth (degrees)	Ave. Exposure Rate (mR/Std.Qtr.) +- Std.Dev.	Number In Group
348.76 - 11.25 N	21.2 +- 1.8	2
11.26 - 33.75 NNE	16.6 +- 2.8	2
33.76 - 56.25 NE	16.3 +- 1.8	2
56.26 - 78.75 ENE	17.8 +- 3.6	2
78.76 - 101.25 E	18.7 +- 0.4	2
101.26 - 123.75 ESE	17.0 +- 0.4	2
123.76 - 146.25 SE	19.1 +- 0.9	2
146.26 - 168.75 SSE	21.3 +- 4.0	2
168.76 - 191.25 S	19.7 +- 0.9	3
191.26 - 213.75 SSW	17.5 +- 3.5	2
213.76 - 236.25 SW	20.6 +- 1.4	2
236.26 - 258.75 WSW	19.6 +- 1.8	2
258.76 - 281.25 W	18.2 +- 0.8	2
281.26 - 303.75 WNW	16.4 +- 1.2	2
303.76 - 326.25 NW	16.7 +- 1.2	2
326.26 - 348.75 NNW	17.8 +- 1.1	3

Distance From Reactor (miles)	Ave. Exposure Rate (mR/Std.Qtr.) +- Std.Dev.	Number In Group
0 - 2	19.1 +- 2.6	14
2 - 5	18.0 +- 1.8	18
> 5	18.1 +- 1.9	2
Upwind Control	18.1 +- 1.2	3

WATTS BAR
 TLD Direct Radiation Environmental Monitoring

NRC Station	Location		Description
	Azimuth / Degree	Distance / Mile	
1	337	0.9	EAST OF PLANT ACCESS RD.
2	314	2.1	HWY. 68 & OLD DIXIE HWY.
3	297	1.9	OLD DIXIE HWY. (HOUSE #286)
4	272	2.0	OLD DIXIE HWY. (NEAR BRIDGE)
5	251	1.9	NEAR YELLOW CR. BAPTIST CHURCH
6	235	1.8	END OF ROAD PAST YELLOW CR. BAPTIST CHURCH
7	230	3.8	INTERSECTION - BREEDENTON FERRY RD.
8	208	3.6	BOGLES CHAPEL
9	249	4.2	INTERSECTION - OLD DIXIE HWY.
10	266	3.1	INTERSECTION - OLD DIXIE HWY.
11	289	3.3	J&H PALLET CO.
12	310	4.7	HWY. 68 & WOLFE CR. RD.
13	337	3.6	WOLFE CR. RD. INTERSECTION
14	330	7.0	WATER TREATMENT PLANT
15	350	4.7	WELSH RESIDENCE
16	7	1.1	WATTS BAR DAM SUBSTATION
17	23	1.6	BEACH PARKING AREA
18	41	2.3	NEAR MEIGS CO. TRASH COMPACTOR
19	69	1.3	RIVER RD. NEAR CHICKEN SHED
20	89	1.2	HIGH TENSION TOWER
21	114	1.1	RIVER RD. BURNED-OUT HOUSE
22	141	1.0	RIVER RD. RED BRICK HOUSE
23	163	1.1	RIVER RD. NEAR STONEWALL
24	187	1.1	CAPTAIN JOHN'S RESTAURANT
25	203	1.2	NEAR BOAT DOCK OFF RIVER RD.
26	184	5.9	ARRANT RD. & RIVER RD.
27	176	4.5	EAVES FERRY RD. & HWY. 58
28	161	3.5	HOUSE #584
29	144	3.0	FAIRVIEW SCHOOL
30	117	3.1	BMLHT 771/772
31	97	4.0	FEZZELL RD. & HWY. 58
32	76	4.1	HICKORY FLAT CHURCH
33	32	4.1	NEAR BIVENS LAKESIDE MARKET
34	36	4.7	SAM'S BOAT DOCK
35	38	19.0	NEAR EXXON STATION - GEN'L STORE
36	38	19.0	PARKING AREA OFF HWY. 68
37	38	19.0	OFF HWY. 68 AT RED BARN WITH SILO

NRC TLD DOSES FOR WATTS BAR AREA

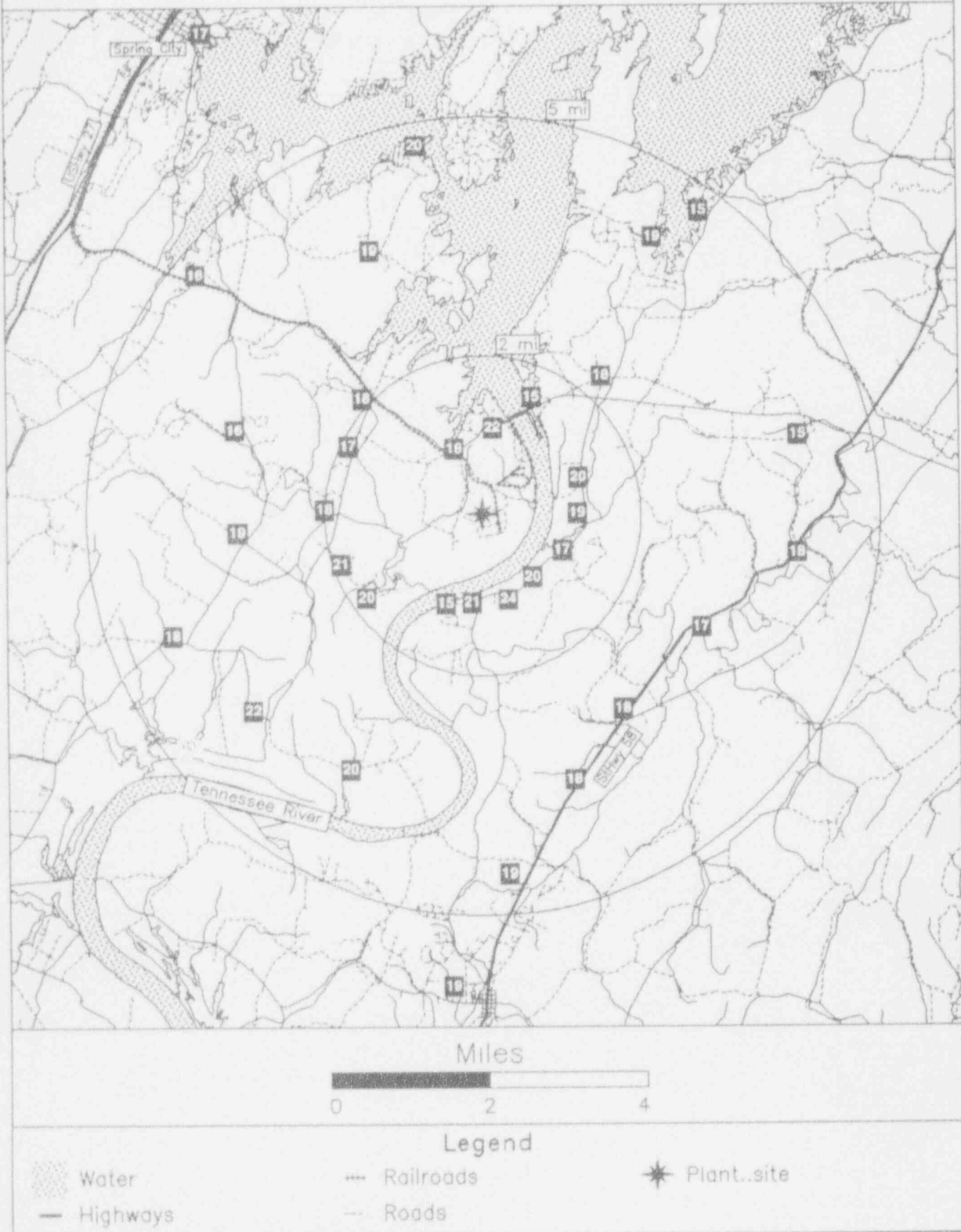

WOLF CREEK

TLD Direct Radiation Environmental Monitoring

For the period 930913-940203 144 Days

Field Time: 93 Days

NRC Sta	Location		Gross Exposure (mR)		Net Exposure Rate (mR/Std. Qtr.)		Hist. Range Net Exp Rate	
	Azimuth/ (Deg)	Dist (Mi)	+-Rdm; Tot.		+-Rdm; Tot.		+-1 Std Dev	
1	316	2.9	29.1	+ - 0.9; 4.4	22.3	+ - 0.9; 5.2	19.6	+ - 1.9
2	330	1.8	27.3	+ - 0.8; 4.1	20.6	+ - 0.9; 5.0	18.5	+ - 1.8
3	360	2.8	26.7	+ - 0.8; 4.0	20.0	+ - 0.9; 5.0	18.9	+ - 1.9
4	355	1.6	25.6	+ - 0.8; 3.8	19.0	+ - 0.8; 4.8	19.6	+ - 2.0
5	31	1.8	26.8	+ - 0.8; 4.0	20.1	+ - 0.9; 5.0	19.6	+ - 2.1
6	47	2.0	22.6	+ - 0.7; 3.4	16.0	+ - 0.8; 4.5	17.4	+ - 2.1
7	70	1.6	25.3	+ - 0.8; 3.8	18.6	+ - 0.8; 4.8	18.2	+ - 2.0
8	90	1.7	29.1	+ - 0.9; 4.4	22.3	+ - 0.9; 5.2	20.2	+ - 1.9
9	111	2.4	27.5	+ - 0.8; 4.1	20.8	+ - 0.9; 5.1	19.6	+ - 1.9
10	137	2.5	26.5	+ - 0.8; 4.0	19.8	+ - 0.9; 4.9	19.2	+ - 1.9
11	157	3.4	28.4	+ - 0.9; 4.3	21.6	+ - 0.9; 5.2	20.6	+ - 1.9
12	184	3.3	28.5	+ - 0.9; 4.3	21.8	+ - 0.9; 5.2	20.1	+ - 1.8
13	213	2.9	25.5	+ - 0.8; 3.8	18.8	+ - 0.8; 4.8	19.7	+ - 2.0
14	233	2.4	27.9	+ - 0.8; 4.2	21.2	+ - 0.9; 5.1	19.9	+ - 2.0
15	248	2.2	26.5	+ - 0.8; 4.0	19.8	+ - 0.9; 4.9	19.4	+ - 1.8
16	278	2.1	26.0	+ - 0.8; 3.9	19.3	+ - 0.9; 4.9	19.7	+ - 1.7
17	270	3.4	24.0	+ - 0.7; 3.6	17.4	+ - 0.8; 4.7	16.0	+ - 1.7
18	263	4.2	30.7	+ - 0.9; 4.6	23.9	+ - 1.0; 5.4	21.4	+ - 2.0
19	257	5.0	25.9	+ - 0.8; 3.9	19.3	+ - 0.9; 4.9	19.5	+ - 2.0
20	280	3.9	25.6	+ - 0.8; 3.8	18.9	+ - 0.8; 4.8	18.3	+ - 1.5
21	298	3.9	26.7	+ - 0.8; 4.0	20.0	+ - 0.9; 5.0	19.8	+ - 1.7
22	319	4.8	24.4	+ - 0.7; 3.7	17.7	+ - 0.8; 4.7	18.1	+ - 2.2
23	332	5.0	26.8	+ - 0.8; 4.0	20.1	+ - 0.9; 5.0	19.2	+ - 1.8
24	19	3.9	27.9	+ - 0.8; 4.2	21.1	+ - 0.9; 5.1	19.6	+ - 1.8
25	35	4.4	24.3	+ - 0.7; 3.6	17.7	+ - 0.8; 4.7	17.1	+ - 1.7
26	67	4.3	24.6	+ - 0.7; 3.7	18.0	+ - 0.8; 4.7	18.3	+ - 1.9
27	88	4.1	28.3	+ - 0.8; 4.2	21.5	+ - 0.9; 5.1	19.4	+ - 2.1
28	110	4.5	27.9	+ - 0.8; 4.2	21.1	+ - 0.9; 5.1	19.8	+ - 1.7
29	128	4.4	27.3	+ - 0.8; 4.1	20.6	+ - 0.9; 5.0	20.3	+ - 2.1
30	112	16.0	22.5	+ - 0.7; 3.4	15.9	+ - 0.8; 4.5	17.4	+ - 2.0
31	127	9.4	25.1	+ - 0.8; 3.8	18.5	+ - 0.8; 4.8	17.1	+ - 1.8
32	62	11.0	23.2	+ - 0.7; 3.5	16.6	+ - 0.8; 4.6	17.5	+ - 2.0
33	153	5.2	25.2	+ - 0.8; 3.8	18.5	+ - 0.8; 4.8	19.1	+ - 2.0
34	174	4.7	28.0	+ - 0.8; 4.2	21.3	+ - 0.9; 5.1	20.3	+ - 1.9
35	197	5.2	29.2	+ - 0.9; 4.4	22.4	+ - 0.9; 5.3	20.5	+ - 2.1
36	224	4.8	25.7	+ - 0.8; 3.9	19.1	+ - 0.8; 4.9	18.3	+ - 1.7
37	220	14.0	22.3	+ - 0.7; 3.3	15.7	+ - 0.8; 4.5	15.6	+ - 1.6
38	253	6.5	28.7	+ - 0.9; 4.3	21.9	+ - 0.9; 5.2	19.9	+ - 2.3
39	278	10.0	25.7	+ - 0.8; 3.9	19.0	+ - 0.8; 4.9	19.0	+ - 2.0
40	285	15.0	24.2	+ - 0.7; 3.6	17.6	+ - 0.8; 4.7	16.9	+ - 1.6
41	292	6.7	23.9	+ - 0.7; 3.6	17.3	+ - 0.8; 4.7	18.3	+ - 2.0
42	345	13.0	28.7	+ - 0.9; 4.3	22.0	+ - 0.9; 5.2	20.3	+ - 1.9
43	5	7.5	26.0	+ - 0.8; 3.9	19.3	+ - 0.9; 4.9	19.7	+ - 1.9
44	20	8.3	28.8	+ - 0.9; 4.3	22.0	+ - 0.9; 5.2	19.9	+ - 1.7
45	315	7.5	Damaged Dosimeter		No Net Data		21.0	+ - 1.9
46	341	7.7	27.2	+ - 0.8; 4.1	20.5	+ - 0.9; 5.0	20.0	+ - 1.3
47	355	1.0	28.0	+ - 0.8; 4.2	21.2	+ - 0.9; 5.1	18.3	+ - 1.4

Transit Dose = 6.0 +- 0.4; 3.2

WOLF CREEK

For the period 930913-940203

TLD Direct Radiation Environmental Monitoring

Azimuth (degrees)	Ave. Exposure Rate (mR/Std.Qtr.) +- Std.Dev.	Number In Group
348.76 - 11.25 N	19.9 +- 1.0	4
11.26 - 33.75 NNE	21.1 +- 0.9	3
33.76 - 56.25 NE	16.9 +- 1.2	2
56.26 - 78.75 ENE	17.7 +- 1.0	3
78.76 - 101.25 E	21.9 +- 0.6	2
101.26 - 123.75 ESE	19.3 +- 2.9	3
123.76 - 146.25 SE	19.6 +- 1.1	3
146.26 - 168.75 SSE	20.1 +- 2.2	2
168.76 - 191.25 S	21.5 +- 0.4	2
191.26 - 213.75 SSW	20.6 +- 2.6	2
213.76 - 236.25 SW	18.6 +- 2.8	3
236.26 - 258.75 WSW	20.3 +- 1.4	3
258.76 - 281.25 W	19.7 +- 2.4	5
281.26 - 303.75 WNW	18.3 +- 1.5	3
303.76 - 326.25 NW	20.0 +- 3.2	2
326.26 - 348.75 NNW	20.8 +- 0.8	4

Distance From Reactor (miles)	Ave. Exposure Rate (mR/Std.Qtr.) +- Std.Dev.	Number In Group
0 - 2	19.7 +- 2.1	7
2 - 5	20.1 +- 1.6	25
> 5	19.1 +- 2.3	14
Upwind Control	No Data +- No Data	0

WOLF CREEK
TLD Direct Radiation Environmental Monitoring

NRC Station	Location		Description
	Azimuth Degree	Distance / Mile	
1	316	2.9	EOC ON TELEPHONE POLE
2	330	1.8	NORTH GATEPOST
3	360	2.8	WITH LICENSEE AIR SAMPLERS
4	355	1.6	NEAREST RESIDENCE
5	31	1.8	1ST POLE EAST(N. SIDE OF ROAD)
6	47	2.0	1ST UTILITY POLE S. OF STOP SIGN
7	70	1.6	CORNER FENCEPOST(W. SIDE OF ROAD)
8	90	1.7	GIFFORD'S RESIDENCE
9	111	2.4	WHITE HOUSE YARD
10	137	2.5	CO-LOCATED WITH KS AND KG&E
11	157	3.4	LOGAN CEMETARY FENCEPOST
12	184	3.3	ON ROAD TO DAM
13	213	2.9	CO-LOCATED WITH KS ON METER POLE
14	233	2.4	CO-LOCATED WITH KG&E NEAR WITHERS
15	248	2.2	FENCEPOST SW CORNER
16	278	2.1	KG&E PROPERTY FENCEPOST
17	270	3.4	RIVERSIDE EAST WORK AREA
18	263	4.2	RIVERSIDE WEST
19	257	5.0	POLE ON SW CORNER
20	280	3.9	DAM SITE PUBLIC USE AREA
21	298	3.9	NW CORNER OF NEW STRAWN
22	319	4.8	NE CRNR OF INTRST
23	332	5.0	NE CORNER OF INTERSECTION BY AIRPORT
24	19	3.9	NW CORNER OF INTERSECTION
25	35	4.4	NE CORNER OF INTERSECTION
26	67	4.3	CORNER POST SW OF T-INTERSECTION
27	88	4.1	NE OF INTERSECTION
28	110	4.5	CO-LOCATED WITH KG&E
29	128	4.4	S. SIDE OF FAS 10
30	112	16.0	WESTPHALIA-NEAR SCHOOL
31	127	9.4	ALICEVILLE
32	62	11.0	LEROY
33	153	5.2	POLE ON N. SIDE OF ROAD
34	174	4.7	SW CORNER OF INTERSECTION
35	197	5.2	POLE WEST OF INTERSECTION
36	224	4.8	BURLINGTON(COUNTY COURT HOUSE)
37	220	14.0	GRIDLEY CORNER(1ST AND MAIN)
38	253	6.5	OTTER CREEK CAMPGROUND
39	278	10.0	S. SIDE OF INTERSECTION
40	285	15.0	HARTFORD (CO-LOCATED W KS AND KG&E)
41	292	6.7	TRANSFORMER POLE(N. SIDE OF ROAD)
42	345	13.0	BETO JUNCTION W OF HIWAY 75
43	5	7.5	HALL'S SUMMIT
44	20	8.3	WAVERLY ON POLE W. OF SUNSET MANOR
45	315	7.5	SE CORNER OF T-INTERSECTION
46	341	7.7	FAS 1133 TO HALL'S SUMMIT
47	355	1.0	1ST POLE N. OF FENCE ON ACCESS ROAD

NRC TLD DOSES FOR WOLF CREEK AREA

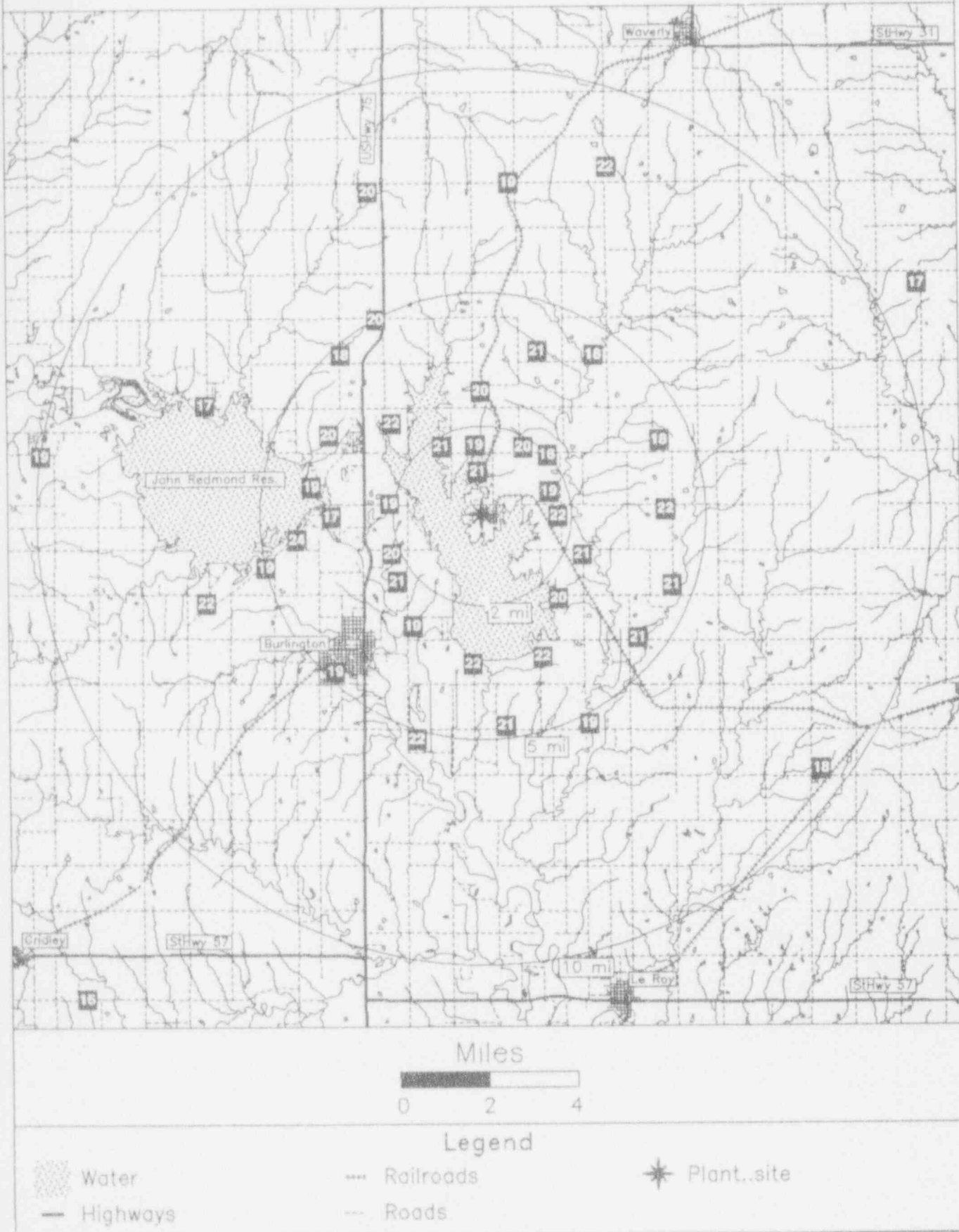

YANKEE ROWE

TLD Direct Radiation Environmental Monitoring

For the period 930916-940201 139 Days

Field Time: 86 Days

NRC Sta	Location		Gross Exposure (mR)		Net Exposure Rate (mR/Std. Qtr.)		Hist. Range Net Exp Rate	
	Azimuth/ (Deg)	Dist (Mi)	+-Rdm; Tot.		+-Rdm; Tot.		+-1 Std Dev	
1	0	0.8	23.2	+- 0.7; 3.5	17.0	+- 0.9; 4.9	18.7	+- 2.0
2	265	14.0	22.5	+- 0.7; 3.4	16.2	+- 0.8; 4.8	16.2	+- 1.9
3	137	12.0	22.7	+- 0.7; 3.4	16.4	+- 0.8; 4.8	16.1	+- 1.7
5	85	2.2	21.9	+- 0.7; 3.3	15.6	+- 0.8; 4.7	15.3	+- 1.8
6	118	2.6	22.1	+- 0.7; 3.3	15.8	+- 0.8; 4.8	15.3	+- 1.6
7	137	2.1	24.7	+- 0.7; 3.7	18.5	+- 0.9; 5.1	17.3	+- 1.8
8	153	1.7	22.6	+- 0.7; 3.4	16.4	+- 0.8; 4.8	16.0	+- 1.2
9	176	1.1	22.4	+- 0.7; 3.4	16.1	+- 0.8; 4.8	15.9	+- 1.5
10	203	0.5	23.2	+- 0.7; 3.5	17.0	+- 0.9; 4.9	16.7	+- 2.1
11	219	0.6	23.4	+- 0.7; 3.5	17.2	+- 0.9; 4.9	16.8	+- 1.5
12	239	1.1	22.5	+- 0.7; 3.4	16.2	+- 0.8; 4.8	19.8	+- 2.2
13	272	1.8	23.6	+- 0.7; 3.5	17.3	+- 0.9; 4.9	17.6	+- 2.2
14	292	1.3	26.0	+- 0.8; 3.9	19.8	+- 0.9; 5.2	17.9	+- 2.0
15	315	1.6	25.2	+- 0.8; 3.8	19.0	+- 0.9; 5.1	18.3	+- 2.0
16	348	1.4	24.2	+- 0.7; 3.6	17.9	+- 0.9; 5.0	17.8	+- 1.7
17	358	2.8	24.4	+- 0.7; 3.7	18.2	+- 0.9; 5.0	16.8	+- 2.1
18	21	2.8	21.5	+- 0.6; 3.2	15.1	+- 0.8; 4.7	15.5	+- 1.9
19	43	5.8	22.5	+- 0.7; 3.4	16.2	+- 0.8; 4.8	16.7	+- 1.4
20	75	6.0	25.5	+- 0.8; 3.8	19.4	+- 0.9; 5.2	17.7	+- 2.0
21	98	6.0	21.5	+- 0.6; 3.2	15.2	+- 0.8; 4.7	14.7	+- 1.6
22	104	5.2	20.3	+- 0.6; 3.0	13.9	+- 0.8; 4.6	13.6	+- 1.4
23	133	5.7	22.1	+- 0.7; 3.3	15.8	+- 0.8; 4.8	13.5	+- 1.5
24	157	7.5	19.9	+- 0.6; 3.0	13.5	+- 0.8; 4.5	14.3	+- 1.9
25	184	6.3	23.4	+- 0.7; 3.5	17.2	+- 0.9; 4.9	16.3	+- 1.8
27	225	5.9	23.2	+- 0.7; 3.5	16.9	+- 0.9; 4.9	17.2	+- 2.1
29	269	3.5	23.1	+- 0.7; 3.5	16.9	+- 0.9; 4.9	17.2	+- 2.0
32	342	3.3	Missing Dosimeter		No Net Data		17.1	+- 1.7
34	48	7.3	22.3	+- 0.7; 3.3	16.0	+- 0.8; 4.8	17.4	+- 1.8
35	39	2.3	19.1	+- 0.6; 2.9	12.7	+- 0.7; 4.4	14.4	+- 1.7
47	260	9.6	23.3	+- 0.7; 3.5	17.0	+- 0.9; 4.9	16.6	+- 1.5
48	261	9.0	25.1	+- 0.8; 3.8	19.0	+- 0.9; 5.1	18.6	+- 1.8

Transit Dose = 7.0 +- 0.4; 3.1

YANKEE ROWE

For the period 930916-940201

TLD Direct Radiation Environmental Monitoring

Azimuth (degrees)	Ave. Exposure Rate (mR/Std.Qtr.) +- S ^t d.Dev.	Number In Group
348.76 - 11.25 N	17.6 +- 0.9	2
11.26 - 33.75 NNE	15.1 +- 0.0	1
33.76 - 56.25 NE	14.9 +- 2.0	3
56.26 - 78.75 ENE	19.4 +- 0.0	1
78.76 - 101.25 E	15.4 +- 0.3	2
101.26 - 123.75 ESE	14.9 +- 1.3	2
123.76 - 146.25 SE	16.9 +- 1.4	3
146.26 - 168.75 SSE	15.0 +- 2.0	2
168.76 - 191.25 S	16.6 +- 0.8	2
191.26 - 213.75 SSW	17.0 +- 0.0	1
213.76 - 236.25 SW	17.1 +- 0.1	2
236.26 - 258.75 WSW	16.2 +- 0.0	1
258.76 - 281.25 W	16.8 +- 0.6	3
281.26 - 303.75 WNW	19.8 +- 0.0	1
303.76 - 326.25 NW	19.0 +- 0.0	1
326.26 - 348.75 NNW	17.9 +- 0.0	1

Distance From Reactor (miles)	Ave. Exposure Rate (mR/Std.Qtr.) +- Std.Dev.	Number In Group
0 - 2	17.4 +- 1.2	10
2 - 5	16.1 +- 2.0	7
> 5	16.1 +- 1.6	11
Upwind Control	18.0 +- 1.4	2

YANKEE ROWE
 TLD Direct Radiation Environmental Monitoring

NRC Station	Location		Description
	Azimuth / Degree	Distance / Mile	
1	0	0.8	VT/MASS LINE-READSBORO ROAD
2	265	14.0	WILLIAMSTOWN SUBSTATION
3	137	12.0	CREAMERY AVE. (BUCKLAND)
5	85	2.2	WEST OF LESHURES ROAD
6	118	2.6	LESHURES & FORD HILL ROAD
7	137	2.1	FORD HILL & MIDDLETOWN ROADS
8	153	1.7	E. MILES RESIDENCE
9	176	1.1	MONROE HILL ROAD
10	203	0.5	MONROE HILL ROAD
11	219	0.6	MONROE HILL ROAD
12	239	1.1	MONROE BRIDGE
13	272	1.8	MAIN ROAD & DAVIS ROAD
14	292	1.3	MAIN ROAD
15	315	1.6	MAIN ROAD
16	348	1.4	BOSLEY HILL ROAD
17	358	2.8	VT. RT. 100
18	21	2.8	VT. RT. 100 & POTTERS ROAD
19	43	5.8	VT. RT. 100
20	75	6.0	VT. RT. 8A
21	98	6.0	MASS. RT. 8A
22	104	5.2	MASS. RT. 8A
23	133	5.7	MASS. RT. 8A & DELL ROAD
24	157	7.5	MASS. RTS. 8A & 2
25	184	6.3	COLD RIVER STATE PARK
27	225	5.9	RT. 2 & CHURCH ROAD
29	269	3.5	NORTH ROAD
32	342	3.3	READSBORO FIREHOUSE
34	48	7.3	JACKSONVILLE
35	39	2.3	POTTERS ROAD
47	260	9.6	NORTH ADAMS
48	261	9.0	NORTH ADAMS HOSPITAL

NRC TLD DOSES FOR YANKEE ROWE AREA

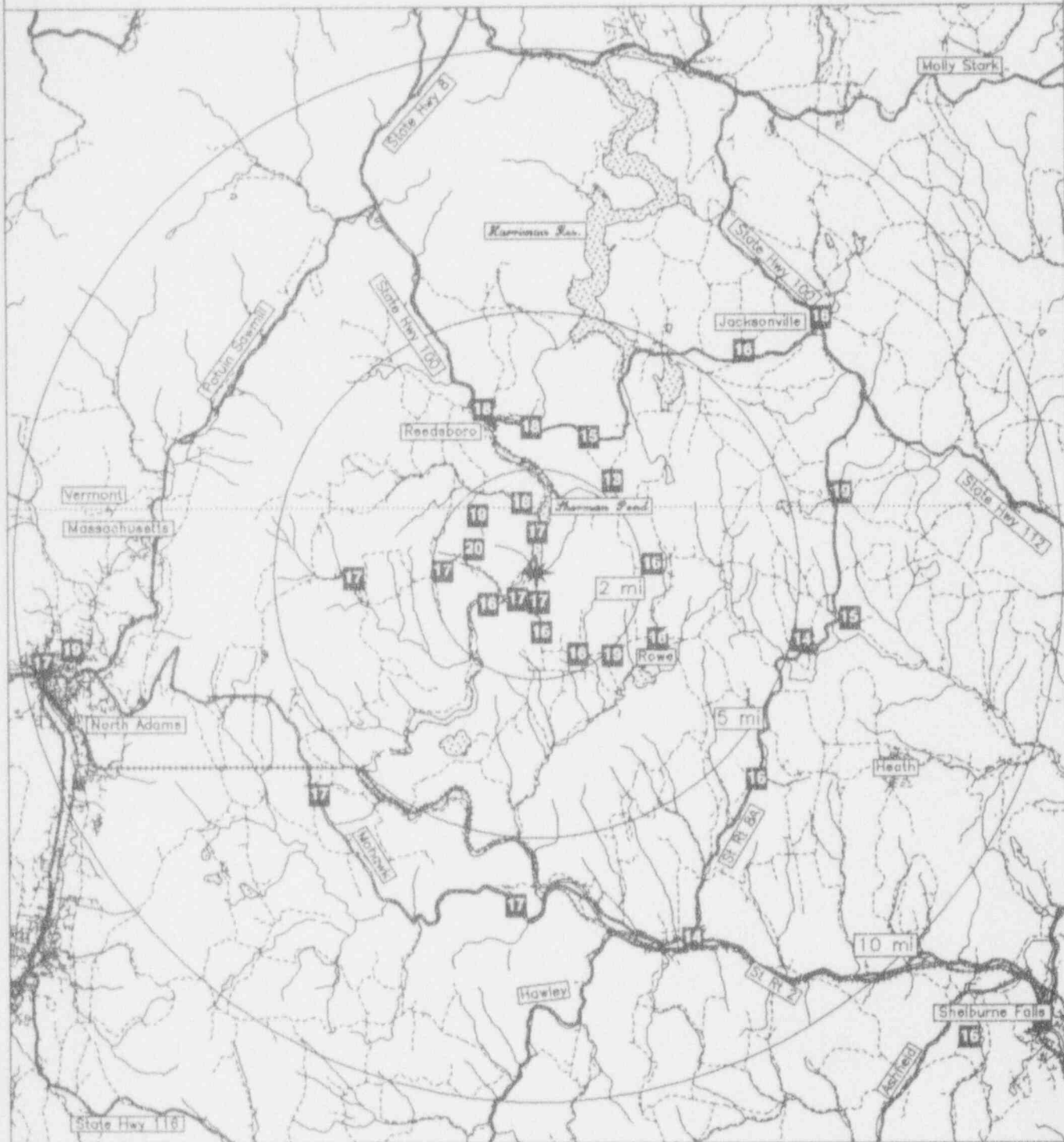

Miles

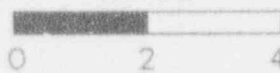

Legend

- Water
- Railroads
- Plant..site
- Highways
- Roads

ZION

TLD Direct Radiation Environmental Monitoring
 For the period 930913-940201 142 Days
 Field Time: 99 Days

NRC Sta	Location Azimuth/Dist (Deg)/(Mi)	Gross Exposure (mR) +-Rdm; Tot.	Net Exposure Rate (mR/Std. Qtr.) +-Rdm; Tot.	Hist. Range Net Exp Rate +-1 Std Dev
1	310 0.8	18.4 +- 0.6; 2.8	13.2 +- 0.6; 3.8	15.5 +- 1.8
2	192 1.0	17.8 +- 0.5; 2.7	12.7 +- 0.6; 3.8	12.9 +- 2.0
3	187 1.9	18.0 +- 0.5; 2.7	12.8 +- 0.6; 3.8	14.1 +- 2.0
4	219 2.4	22.2 +- 0.7; 3.3	16.7 +- 0.7; 4.2	16.9 +- 1.9
5	257 1.8	Missing Dosimeter	No Net Data	17.0 +- 2.2
6	250 1.2	20.4 +- 0.6; 3.1	15.0 +- 0.6; 4.0	15.9 +- 1.9
7	293 1.6	21.6 +- 0.6; 3.2	16.1 +- 0.7; 4.1	16.8 +- 1.8
8	310 1.8	18.9 +- 0.6; 2.8	13.6 +- 0.6; 3.9	14.7 +- 2.0
9	343 2.6	19.5 +- 0.6; 2.9	14.2 +- 0.6; 3.9	15.2 +- 1.9
10	356 4.5	19.5 +- 0.6; 2.9	14.2 +- 0.6; 3.9	14.5 +- 2.0
11	337 4.5	21.4 +- 0.6; 3.2	15.9 +- 0.7; 4.1	16.5 +- 2.4
12	310 4.0	24.0 +- 0.7; 3.6	18.3 +- 0.7; 4.4	18.6 +- 2.1
13	293 3.5	24.9 +- 0.7; 3.7	19.1 +- 0.8; 4.5	19.2 +- 2.1
14	280 4.5	23.5 +- 0.7; 3.5	17.8 +- 0.7; 4.3	18.5 +- 2.0
15	232 3.2	21.7 +- 0.7; 3.3	16.2 +- 0.7; 4.1	17.6 +- 2.2
16	220 3.5	23.3 +- 0.7; 3.5	17.6 +- 0.7; 4.3	17.9 +- 1.9
17	198 4.5	20.9 +- 0.6; 3.1	15.4 +- 0.7; 4.1	15.8 +- 1.9
18	206 2.8	19.6 +- 0.6; 2.9	14.2 +- 0.6; 3.9	15.3 +- 2.0
19	327 1.7	20.1 +- 0.6; 3.0	14.7 +- 0.6; 4.0	15.3 +- 2.2
20	197 15.0	24.3 +- 0.7; 3.7	18.6 +- 0.7; 4.4	18.8 +- 2.2
21	352 7.9	20.3 +- 0.6; 3.0	14.9 +- 0.6; 4.0	14.8 +- 2.2
22	348 9.3	19.2 +- 0.6; 2.9	13.9 +- 0.6; 3.9	15.0 +- 2.2
23	336 8.5	22.4 +- 0.7; 3.4	16.8 +- 0.7; 4.2	17.5 +- 2.7
24	314 5.8	23.3 +- 0.7; 3.5	17.6 +- 0.7; 4.3	17.2 +- 1.4
25	220 6.3	21.6 +- 0.6; 3.2	16.1 +- 0.7; 4.1	16.2 +- 2.1
26	195 8.0	20.5 +- 0.6; 3.1	15.1 +- 0.6; 4.0	15.3 +- 1.9
28	197 15.0	24.0 +- 0.7; 3.6	18.3 +- 0.7; 4.4	18.7 +- 1.8
30	320 9.8	22.6 +- 0.7; 3.4	17.0 +- 0.7; 4.2	17.8 +- 1.8
31	229 8.0	20.5 +- 0.6; 3.1	15.1 +- 0.6; 4.0	16.5 +- 1.8
32	193 15.0	23.6 +- 0.7; 3.5	17.9 +- 0.7; 4.3	19.0 +- 1.7

Transit Dose = 3.9 +- 0.4; 3.2

ZION

For the period 930913-940201

TLD Direct Radiation Environmental Monitoring

Azimuth (degrees)	Ave. Exposure Rate (mR/Std.Qtr.) +- Std.Dev.	Number In Group
348.76 - 11.25 N	14.5 +- 0.5	2
11.26 - 33.75 NNE	No Data +- No Data	0
33.76 - 56.25 NE	No Data +- No Data	0
56.26 - 78.75 ENE	No Data +- No Data	0
78.76 - 101.25 E	No Data +- No Data	0
101.26 - 123.75 ESE	No Data +- No Data	0
123.76 - 146.25 SE	No Data +- No Data	0
146.26 - 168.75 SSE	No Data +- No Data	0
168.76 - 191.25 S	12.8 +- 0.0	1
191.26 - 213.75 SSW	14.4 +- 1.2	4
213.76 - 236.25 SW	16.3 +- 0.9	5
236.26 - 258.75 WSW	15.0 +- 0.0	1
258.76 - 281.25 W	17.8 +- 0.0	1
281.26 - 303.75 WNW	17.6 +- 2.1	2
303.76 - 326.25 NW	15.9 +- 2.4	5
326.26 - 348.75 NNW	15.1 +- 1.2	5

Distance From Reactor (miles)	Ave. Exposure Rate (mR/Std.Qtr.) +- Std.Dev.	Number In Group
0 - 2	14.0 +- 1.3	7
2 - 5	16.3 +- 1.7	11
> 5	15.8 +- 1.3	8
Upwind Control	18.3 +- 0.3	3

ZION
TLD Direct Radiation Environmental Monitoring

NRC Station	Location		Description
	Azimuth Degree	Distance / Mile	
1	310	0.8	SHILOH BLVD. NEAR RECYCLING CENTER
2	192	1.0	ILLINOIS BEACH STATE PARK N. PARKING AREA
3	187	1.9	ILLINOIS BEACH STATE PARK AT NATURE CENTER
4	219	2.4	BEACH RD. & NORTH AVE.
5	257	1.8	ELMWOOD SCHOOL ON 31ST ST.
6	250	1.2	BEHIND CITY HALL (29TH ST.)
7	293	1.6	23RD & ESHCOL
8	310	1.8	JUST BEFORE 17TH & SHERIDAN RD.
9	343	2.6	OLD WINTHROP HARBOR PUBLIC WORKS BLDG
10	356	4.5	(WISCONSIN) END OF 116TH ST.
11	337	4.5	TOBIN - 116TH ST. & 22ND AVE.
12	310	4.0	ZION FREEDOM CHAPEL ON KENOSHA RD.
13	293	3.5	KENOSHA RD. & HWY. 173
14	280	4.5	21ST ST. & FOREST VIEW RD.
15	232	3.2	BEACH ROAD AT LEWIS AVE.
16	220	3.5	1521 YORK HOUSE ROAD
17	198	4.5	SUBSTATION AT GREENWOOD AVE & SHERIDAN RD.
18	206	2.8	YORK HOUSE RD. & SHERIDAN
19	327	1.7	LAKE CNTY WATER TREATMENT PLANT ON 17TH ST. E
20	197	15.0	ILLINOIS STATE RT. 60
21	352	7.9	SUBSTATION - 7TH AVE. & 80TH ST.
22	348	9.3	MARTIN LUTHER KING DRIVE
23	336	8.5	75TH ST. AT RR CROSSING
24	314	5.8	RT 31 & COUNTY M/L
25	220	6.3	RT. 131 & 132
26	195	8.0	SUBSTATION AT 12TH & GREENFIELD ST.
28	197	15.0	ILLINOIS STATE RT. 60
30	320	9.8	PLEASANT PRAIRIE SCHOOL ON COUNTY-C (WISC)
31	229	8.0	WARREN TWP HIGH SCHOOL ON O'PLAINE RD. (#487)
32	193	15.0	SAUNDERS RD AT IL-60 NEAR I-94

NRC TLD DOSES FOR ZION AREA

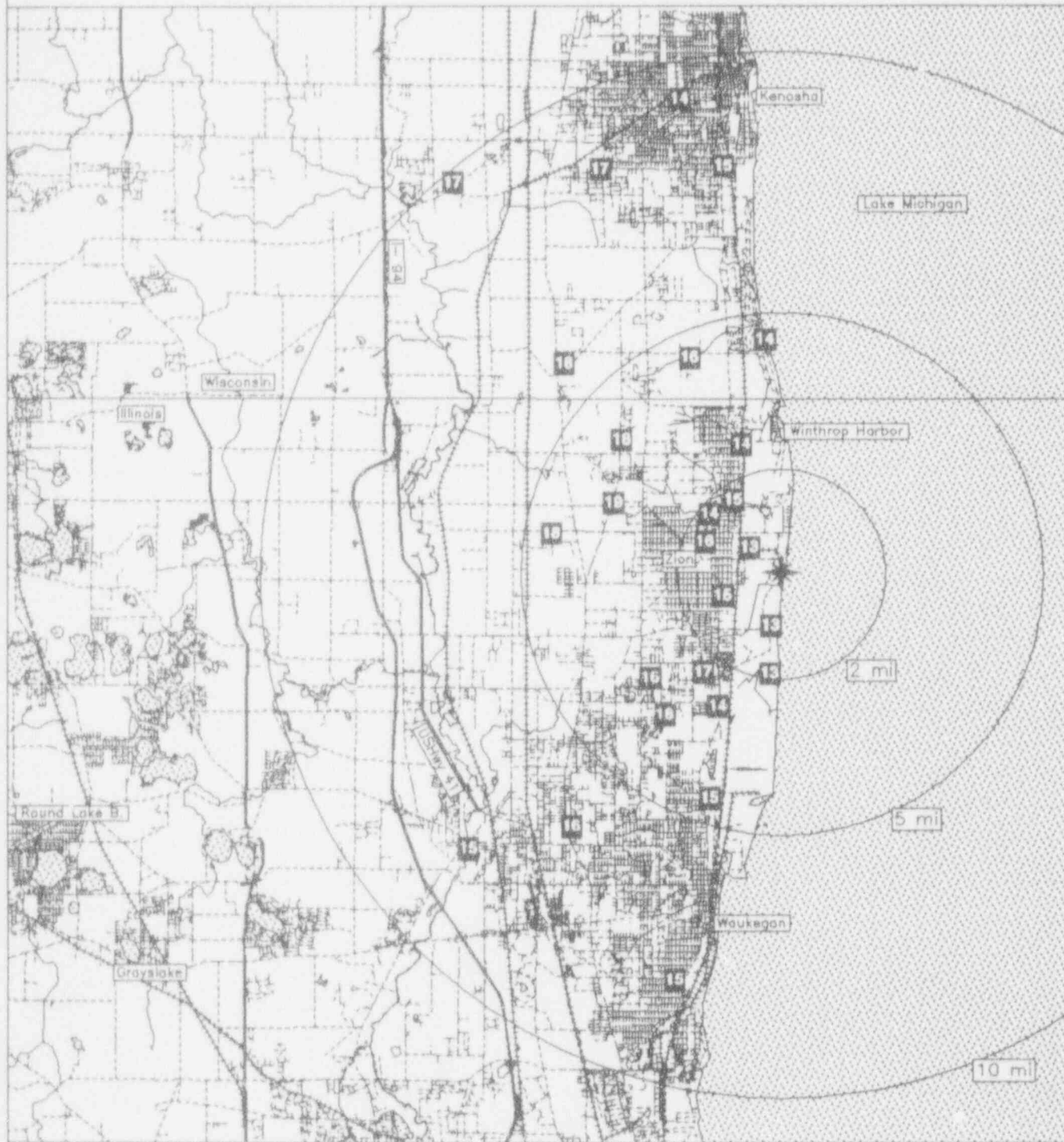

Miles

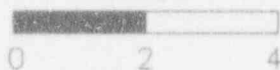

Legend

Water
 Highways

Railroads
 Roads

Plant..site

BIBLIOGRAPHIC DATA SHEET

(See instructions on the reverse)

1. REPORT NUMBER
*(Assigned by NRC. Add Vol., Supp., Rev.,
and Addendum Numbers, if any.)*

NUREG-0837
Vol. 13, No. 4

2. TITLE AND SUBTITLE

NRC TLD Direct Radiation Monitoring Network
Progress Report (October - December, 1993)

3. DATE REPORT PUBLISHED

MONTH YEAR

March 1994

4. FIN OR GRANT NUMBER

5. AUTHOR(S)

R. Struckmeyer

6. TYPE OF REPORT

Quarterly

7. PERIOD COVERED *(Inclusive Dates)*

October-December 1993

8. PERFORMING ORGANIZATION - NAME AND ADDRESS *(If NRC, provide Division, Office or Region, U.S. Nuclear Regulatory Commission, and mailing address. If contractor, provide name and mailing address.)*

Region I
U.S. Nuclear Regulatory Commission
King of Prussia, PA 19406

9. SPONSORING ORGANIZATION - NAME AND ADDRESS *(If NRC, type "Same as above". If contractor, provide NRC Division, Office or Region, U.S. Nuclear Regulatory Commission, and mailing address.)*

Same as 8. above

10. SUPPLEMENTARY NOTES

11. ABSTRACT *(200 words or less)*

This report provides the status and results of the NRC Thermoluminescent Dosimeter (TLD) Direct Radiation Monitoring Network. It presents the radiation levels measured in the vicinity of NRC licensed facilities throughout the country for the fourth quarter of 1993.

12. KEY WORDS/DESCRIPTORS *(List words or phrases that will assist researchers in locating the report.)*

Thermoluminescent Dosimeter (TLD) Direct Radiation Monitoring
Network

ambient radiation levels

13. AVAILABILITY STATEMENT

Unlimited

14. SECURITY CLASSIFICATION

(This Page)

Unclassified

(This Report)

Unclassified

15. NUMBER OF PAGES

16. PRICE

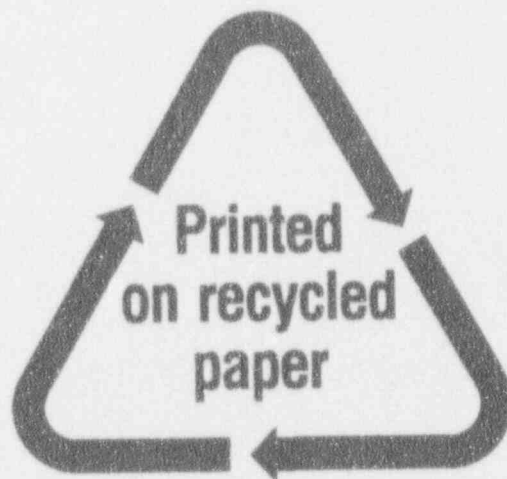

Federal Recycling Program

UNITED STATES
NUCLEAR REGULATORY COMMISSION
WASHINGTON, D.C. 20555-0001

SPECIAL FOURTH-CLASS RATE
POSTAGE AND FEES PAID
USNRC
PERMIT NO. G-67

OFFICIAL BUSINESS
PENALTY FOR PRIVATE USE, \$300

10 2055510001 1 JAN 1984
US NRC-000001
DIV 5015 & PUBLICATIONS SVCS
TRC-000-000000
D-011
WASHINGTON DC 20555