

AEOD/C104

REPORT ON THE
MILLSTONE UNIT 2 LOSS OF 125 V DC BUS
EVENT ON JANUARY 2, 1981

by the

OFFICE FOR ANALYSIS AND EVALUATION
OF OPERATIONAL DATA

November 1981

Prepared by: Matthew Chiramal
Eugene Imbro
Joan Giannelli

NOTE: This report documents results of studies completed to date by the Office for Analysis and Evaluation of Operational Data with regard to particular operating events. The findings and recommendations contained in this report are provided in support of other ongoing NRC activities concerning this event. Since the studies are ongoing, the report is not necessarily final, and the findings and recommendations do not represent the position or requirements of the responsible program office of the Nuclear Regulatory Commission.

A117

XA

8112010310

TABLE OF CONTENTS

	<u>Page</u>
EXECUTIVE SUMMARY	1
1.0 EVENT DESCRIPTION	3
2.0 EVALUATION OF THE EVENT AND LICENSEE'S CORRECTIVE ACTIONS . . .	8
2.1 Initiating Operator Error	8
2.2 Loss of the 125 V dc Bus.	10
2.3 Re-energization of 125 V dc Bus	11
2.4 "B" Diesel Generator Failure and Loss of Instrumentation Power Supplies.	12
2.5 Atmospheric Steam Dump Valves	13
2.6 Pressurizer Pressure Transient.	14
2.7 Pressurizer Spray System.	15
3.0 SUMMARY	16

Table

1. Sequence of Events On January 2, 1981	18
--	----

Figures

1. 125 V DC Emergency and 120 V AC Vital System
2. Millstone Unit 2 Simplified 1 Line Diagram
3. Simplified Schematics, Final Trip and Fast-Transfer
4. Simplified Schematics, Diesel Engine Failure Relays
5. Simplified Schematics, Millstone Unit 2 Primary Coolant Piping

REPORT ON THE
MILLSTONE UNIT 2 LOSS OF 125 V DC BUS EVENT

ON JANUARY 2, 1981

EXECUTIVE SUMMARY

An event occurred at Millstone 2 involving the loss of one station 125V dc bus due to operator error. A review of the event was undertaken by AEOD since it involved several incidents as follows:

- (1) Partial loss of normal offsite power,
- (2) Complete loss of control room annunciators,
- (3) Inoperability of both emergency diesel generators (one of them due to an independent failure),
- (4) Loss of several indicators in the control room, and
- (5) Ineffective pressurizer spray through the normal spray system.

Our evaluation of the event did not identify any safety concerns or the need for any further actions by the NRC other than those being considered in the generic safety task A-30, "Adequacy of Safety-Related DC Power Systems" and the Unresolved Safety Issue A-44, "Station Blackout." There are, however, certain lessons to be learned from the event that should be identified to the licensees for their consideration and information. These are:

- (1) The need to revise procedures of operating plants to address the recovery from a loss of a dc bus event by including the effects of re-energization of the lost bus;
- (2) The need to inform plant operators of problems that could be encountered when diesel generators are running in an emergency mode, and the need to add corrective actions in appropriate procedures to counter these problems;

- (3) The need to make plant operators aware that during partial pump operation certain pump combinations may exist which will not provide adequate spray flow to the pressurizer;
- (4) The need to familiarize plant operators with the potential for non-equilibrium pressurizer behavior when normal spray flow is unavailable;
and
- (5) The need to familiarize operators with core conditions that produce significant quantities of non-condensibles.

1.0 EVENT DESCRIPTION

Initial Conditions: Reactor at 100% power, turbine output - 884 MWe. (see Table 1 for sequence of events.)

The event was initiated by a plant equipment operator while performing his shift duties. Instead of operating a 125 V dc system ground detector switch, he mistakenly used the adjacent control switch and opened breaker D0103 which de-energized the "A" facility 125 V dc bus 201A (see Figure 1). Loss of the dc bus caused the opening of four (of a total eight) reactor trip circuit breakers (TCBs) which tripped the reactor. The loss of the dc bus also caused complete loss of all control room annunciators and started the "A" facility diesel generator. The operators noticed the trip by observing CEA inward motion (the four TCBs that opened were without indication because of loss of dc voltage, and the other four were indicated closed).

The reactor trip should have caused a turbine trip and consequent generator lockout. However, since the trip relay in the turbine EHC system receives its power from dc bus 201A, the automatic turbine trip did not occur. Approximately 29 seconds after the loss of the dc bus, the control room operator operated the master trip button on the EHC system panel. This caused a turbine trip, since the 24 V dc power required was available from the permanent magnet generator on the turbine shaft. The turbine stop valves closed, but the generator remained tied to the 345 KV system.

On a turbine trip, the station auxiliary loads would normally fast-transfer from the normal station service transformer (NSST) to the reserve station

service transformer (RSST) (see Figure 2). This is accomplished by means of tripping lockout relay 94TG and energizing automatic transfer relays 83X1 and 83X2. Automatic trip of the main generator breakers is facilitated by relay 94MGI which operates when all four turbine stop valves are closed.

During the event, however, only relay 94TG, which is connected to the "B" facility 125 V dc system, operated on the turbine trip from the 24 V dc logic. Relays 83X1 and 83X2, which are connected to the "A" facility 125V dc, did not operate. Contacts of the 94TG relay normally trip the four NSST breakers (two 6900 V bus breakers and two 4160 V bus breakers).

The two breakers whose control power is supplied by the "B" facility dc bus tripped and de-energized 6900 V bus 25B and 4160 V buses 24B and 24D. The two breakers whose control power is supplied by the "A" facility dc bus did not trip since no control power was available. Therefore, buses 25A (6900 V) and 24A and 24C (4160 V) remained connected to the main generator and the 345 KV switchyard through the NSST. The main generator breakers 9T-2 and 8T-2 in the switchyard remained closed because trip lockout relay 94MGI is also connected to the "A" facility 125 V dc bus.^{1/}

Since relays 83X1 and 83X2 did not operate (see Figure 3), the RSST supply breakers for buses 24D and 25B did not receive a close signal. With 4160 V bus 24D remaining de-energized, the emergency safeguards actuation system (ESAS) detected a loss of normal power (LNP), which caused load shedding

^{1/} Millstone 2 has a back-up electric reverse power relay connected to the "B" facility 125 V dc bus. This relay has a time delay and will disconnect the main generator from the 345 KW switchyard 30 seconds after reverse power is sensed. The reverse power relay is set to actuate when the power flow from switchyard is slightly less than the windage and friction losses in the turbine generator unit. (The friction and windage losses are a fraction of a percent of generator rated power.) Therefore, as a result of the energy stored in the turbine after a trip, the timeframe for actuation of the reverse power relay will be in the order of minutes after the turbine stop valves closed.

and isolation of bus 24D. The "B" emergency diesel generator (13U) automatically started and energized that bus. Buses 24B and 25B remained de-energized. The loss of the "A" dc bus also caused a "black start" of the "A" emergency diesel generator (12U), since the air supply solenoid valves that supply engine starting air are designed to open upon loss of power (i.e., de-energized to open). Since dc power was not available, no field flashing occurred and output breakers remained inoperable.

Approximately 51 seconds following the initiation of the event, the "A" dc bus was re-energized (the operator who had caused the event had been in communication with the control room operator and was directed to reclose the breaker).

NSST supply breakers of buses 24A and 25A tripped and the buses fast-transferred to the RSST on operation of relay 83X1 and the fast-transfer logic. Relay 83X2 operation caused RSST supply breaker of 6900 V bus 25B to close attempting to energize all its connected motors (two reactor coolant pumps and one condensate pump) - this caused the breaker to trip on overcurrent.

Relay 94MGI also operated and tripped the generator output breakers in the switchyard. The main steam isolation valves closed upon re-energization of the dc bus due to the control schemes of the air supply and vent solenoid valves in the valve actuator. Closure of MSIVs caused the tripping of both main feed pumps. Auxiliary feed pumps were manually started, supplying both steam generators.

"A" emergency diesel generator (EDG) failure-to-start relay (SFR) energized upon re-energization of the dc bus. This in turn energized the diesel shutdown relay (SDR) which stopped the engine (See Figure 4). On loss of dc control power and subsequent re-energization of the dc bus the SDR could be energized by operation of either the loss of dc power relays (CR-1 & CR-2) or the failure-to-start relay (SFR). Once tripped, local

About nine minutes into the event, "B" EDG tripped and de-energized bus 24D. The EDG was declared inoperable due to a service water leak that sprayed the machine. After reviewing available data, the licensee concluded that the salt water spray had caused malfunction of the governor control, which had caused the engine to run down in speed. The two-out-of-three low lube oil pressure trip had consequently tripped the engine.

It was also concluded that the loss of several instrumentation power supplies connected to the diesel generator bus was caused by the operation of the input fuses in the transformer of the power supplies. This was due to the low frequency caused by the slowing of the diesel generator. The loss of the power supplies caused the loss of several indicators in the control room.

On loss of the "B" EDG, the control room operator connected bus 24D to the RSST after overriding the undervoltage signal. It was noted at this time that several indications were not available (including auxiliary feedwater flow to the No. 1 SG, main steam header pressure, make-up tank level, charging pump pressure, etc.). One to two hours later, all fuses were replaced and the instrumentation restored. Loss of this instrumentation hampered operator actions during the recovery operation.

One-half hour following the reactor trip, the pressurizer level returned to 40%, its programmed value at hot zero power. The pressurizer pressure was restored to 2250 psia 45 minutes following the reactor trip by the pressurizer heaters. While in the hot shutdown condition, the atmospheric dump valves (ADVs) were automatically controlling reactor coolant average temperature to 541°F, nine degrees above the normal zero power T_{av} of 532°F

and the operator was trying to control pressurizer pressure by spraying with the normal spray system. However, only two reactor coolant pumps, P40A and P40C, were operating because the RSST supply breaker for the 6900 V bus 25B had tripped on overcurrent. The operators assumed this two-pump combination provided effective pressurizer spray since, as shown in Figure 5, one of the two lines to the common spray header comes from the cold leg at the P40A reactor coolant pump discharge. However, the operators were having difficulty controlling the pressure and therefore assumed non-condensibles were present in the pressurizer. Subsequent review of initial plant startup test data has shown that this two-pump combination results in no significant pressurizer spray flow.

Reactor coolant average temperature decreased when the ADVs opened, resulting in a decrease in pressurizer level and pressure. The decrease in pressurizer pressure caused the liquid to flash resulting in an increase in the steam mass. When the ADVs closed, the reactor coolant average temperature and the pressurizer level increased, compressing a larger steam mass. Since the two cycles of opening and closing of the ADVs immediately preceding the lifting of the PORVs caused the pressurizer pressure and level to drop a successively lower value, the mass of steam increased with each cycle. Due to the quiescent liquid surface, the heat transfer from the steam to the pressurizer liquid was small. In addition, since the spray flow was inadequate and the heat transfer to the walls is small, minimal condensation occurred. The increase in pressurizer level caused the steam mass to be compressed, nearly isentropically, which resulted in an increase in pressure and temperature of the steam. The isentropic compression caused the initially saturated steam to become superheated rather than condense, leading the operators to believe that the abnormal pressure response was caused by the presence of non-condensable gases in the pressurizer.

Since the cycling of the ADVs caused the mass of steam to increase, the pressurizer level swings caused the pressure to reach higher peaks in each successive cycle. When the pressure increased to 2380 psia, approximately two hours and 15 minutes after the reactor trip, the power operated relief valves (PORVs) opened briefly. The operators then began to use the auxiliary spray and the pressurizer pressure was successfully lowered. A plant cooldown to cold shutdown conditions was then begun. During the operation of the PORVs the temperature in the discharge line and the quench tank parameters increased as expected. However, the acoustic valve monitoring system (AVMS) did not respond. Subsequent verification by the licensee (by manually opening a PORV) indicated the AVMS was operable. Since the AVMS is designed with a 2.4 second time delay, it was concluded by the licensee that AVMS did not actuate because of the extremely short duration that the relief valves were open.

2.0 EVALUATION OF THE EVENT AND LICENSEE'S CORRECTIVE ACTIONS

2.1 Initiating Operator Error

Although the ground detector switch and the bus breaker switch are adjacent to each other, they are of different shapes and styles. Further, the breaker control switch has a plastic hinged cover to prevent inadvertent operation. The licensee has concluded that any further physical protection would hamper quick operation of the breakers. The licensee's corrective actions will provide permanent breaker identification labels. The licensee also plans to review the plant equipment operator rounds to identify other similar situations.

During our visit to the plant we inspected the control switch location at the local panel. We consider the licensee's analysis of the situation complete and adequate.

2.2 Loss of the 125 V dc Bus

On loss of the "A" facility dc bus the system operated as designed, although there were several items that were not foreseen. The licensee has revised his emergency procedure for loss of a main dc bus to reflect the information gained during the transient and the subsequent investigation.

- (a) Annunciators - All control room annunciators are powered from "A" facility dc bus 201A. The licensee will install redundant annunciator power supplies.

- (b) Emergency Diesel Generator - The diesel generator control scheme is such that on loss of dc voltage the diesel engine will "black start." The licensee's conclusion, which was also confirmed by Fairbanks Morse (the manufacturer), is that the diesel will start and come up to speed on the manual governor. In this condition, the only trip remaining is the mechanical overspeed protection. Since control voltage is lost, no field flashing will occur and the output breaker will not be operable. The licensee has revised his procedures to instruct the operators to manually close the starting air supply valves and trip the engine locally upon loss of dc voltage. These actions will conserve the diesel starting air supply for later use when dc control power is restored. The diesel engine is a Fairbanks Morse unit and the problem encountered here could be generic in nature.

The details of this experience should be fed back to other licensees for information and application as necessary. Further, the licensees of operating reactors should be made aware of the fact that the loss of a dc bus could lead to a "quiet" plant trip due to the possibility of loss of all control room annunciators.

- (c) Turbine Trip, Generator Trip and Loss of Normal Power - Loss of a dc bus at the plant could prevent automatic trip of the turbine and generator, as it did during this event. Licensee has revised emergency procedures to trip the turbine and generator manually and to assure that the non-affected diesel generator automatically starts and energizes its bus. This means that on the loss of a main dc bus, only the non-affected diesel generator is relied on to supply power; all offsite sources are isolated manually.

The licensee has initiated a study of the turbine and generator trip schemes and the NSST to RSST fast-transfer schemes to evaluate the need for redundant relays and power supplies so that these functions would occur with one dc bus de-energized; i.e., with one dc bus lost, normal offsite power would be automatically supplied to station auxiliaries associated with the other dc bus.

Although, the effects of the loss of a dc bus may be unique to a particular plant design, several aspects of it are applicable to all operating plants. Hence, the details of this experience should be disseminated for information and review.

2.3 Re-energization of 125 V dc Bus

Several unexpected events occurred upon re-energization of the lost dc bus:

- (a) Diesel Generator - The "A" diesel generator, that had "black started," was automatically tripped due to the actuation of the failure-to-start relay. To restart the diesel after this would require local reset action. The licensee considers the loss of a dc bus a single failure that would cause the loss of one train of redundant equipment; hence, re-energization of the dc bus and consequent events have no further safety consequence. When implemented, the licensee's revised procedures (to trip the DG and close the air valves) will assure that the DG is available again should dc power be restored. It is noted that even with dc power restored, the revised procedure does not assure the availability of the DG without additional operator action. We believe that the licensee's procedure should include a requirement to reset the diesel engine control when the dc bus is re-energized.
- (b) Reserve Station Transformer - On re-energization of the "A" dc bus and actuation of the fast-transfer scheme, the RSST attempted to pickup all the loads of 6900 V ac bus 25B that had de-energized earlier. This attempt to start two reactor coolant pumps and a condensate pump caused an overcurrent trip of the bus supply breaker. To prevent such occurrences revised procedures now require manual load shed of all affected buses upon loss of a dc bus.
- (c) Main Steam Isolation Valve - The control logic is designed to close the MSIVs upon re-energization of a lost dc bus.

This is due to the effect of providing a control circuit that would permit MSIV closure during an accident with one dc bus de-energized. A review of the schematics supplied by the licensee shows that the MSIVs will not close on loss of one division of dc control power; however, upon re-energization the MSIVs will close. Operator action is required to reopen the valves.

The re-energization of the lost dc bus caused several unexpected events. Generally, procedures available at operating plants have not considered the steps to be taken upon re-energization. Depending on the time duration of the loss, the recovery steps may vary. Based on the experience of this event we consider that all licensees should be alerted to the need to analyze their systems and to provide detailed procedures to handle the loss and subsequent re-energization of a major dc bus.

2.4 "B" Diesel Generator Failure and Loss of Instrumentation Power Supplies

During the event, loss of normal power on the "B" facility 4160 V bus 24D resulted in the automatic start of "B" diesel generator and energization of bus 24D. In such an emergency mode of operation, the only engine trips available are engine overspeed, generator differential current and a two-out-of-three low lube oil pressure trip. When the service water leak developed, and sprayed the diesel engine, it apparently caused the engine control system to malfunction, resulting in a minimum speed/no fuel control position. With the diesel generator still tied to bus 24D and supplying load requirements, this malfunction caused low speed of the engine and the two-out-of-three low lube oil pressure trip. During this transient, high volts per hertz conditions also existed at the diesel generator bus and loads which caused various instrumentation fuses to blow.

The licensee's short-term corrective actions included replacing the affected governor connector, repairing the leak in the service water piping, and cleaning and drying electrical components in the sprayed area. Long-term commitments include the evaluation of the need for spray protection of the diesel generator, determination of the cause of the leak, and a review of the qualification requirements for the governor connector assembly.. The actions taken by the licensee are deemed adequate.

However, it is our opinion that operators should be made more aware of the problems that could be encountered while the diesel generator is running in an emergency mode (with most of the normal engine trips bypassed) and that procedures should be provided for handling contingencies under such modes of operation. The problems to be considered are the development of conditions that could lead to damage or failure of safety equipment supplied by the diesel generator; examples are generator overvoltage, generator undervoltage, and generator underfrequency. Under such conditions, depending on the plant situation, the diesel generator may be shut down to prevent damage to safety equipment.

2. 5 Atmospheric Steam Dump Valves

During this event these valves automatically controlled reactor coolant temperature to approximately 541°F. Since this is 9°F above the normal hot standby temperature, it appears that the ADV controller was set too high. The licensee will revise the operating procedures to indicate that the reactor coolant average temperature should be maintained at 532°F. We consider this action adequate.

2.6 Pressurizer Pressure Transient

As discussed previously, the 6900 V bus 25B supply breaker tripped on overcurrent when the "A" facility 125 V dc power was restored. Consequently, since reactor coolant pumps P40B and P40D are powered by the 25B bus, these pumps were stopped and forced circulation was being provided by pumps P40A and P40C. As can be seen from Figure 5, the pressurizer spray is taken from the discharge side of pumps P40A and P40B in the reactor coolant system loop with the surge line. Therefore, since spray lines are taken from only two cold legs the spray flow available with two pumps operating will vary depending on the two-pump combination running.

In this instance, the operators apparently failed to realize that with only P40A and P40C running the spray flow available was not sufficient to be effective in pressure control. The subsequent unexpected pressurizer behavior and the appearance of "hardness" caused by the superheating of the steam led the operators to believe non-condensibles were present in the pressurizer.

Although a similar pressurizer behavior would have occurred if non-condensibles were present, there was no apparent basis for the operators to assume the presence of non-condensibles, since all the actions following the reactor trip, such as establishing auxiliary flow, were accomplished in a routine manner. However, the loss of instrumentation (caused by the "B" diesel generator speed control problem) could have led the operators to overestimate the severity of the event. In retrospect, had bus 25B been re-energized and pumps P40B and P40D been started to re-establish spray flow, no anomalous pressurizer behavior would have occurred.

Although the event did not impact on the health and safety of the public it did indicate a need for increased operator awareness of lack of spray flow during certain combinations of two reactor coolant pump operation. In addition, the event also showed a lack of understanding of the non-equilibrium behavior of the pressurizer and the fact that significant core damage is necessary to produce non-condensibles in the amount required to cause the pressurizer pressure response indicated.

The licensee has revised the plant operating procedures to specify the pump combinations which should be used to achieve an effective pressurizer spray. A caution has been added to warn the operators that pump combinations other than those listed may lead to inadequate spray flow and the impression of system "hardness," i.e., non-condensibles present. The licensee is also conducting a generic review of all plant startup test data to determine other important operational data. In addition, the non-equilibrium pressurizer behavior and the core conditions necessary to produce large amounts of non-condensibles have been reviewed with the operators. We consider this action adequate.

2.7 Pressurizer Spray System

The plant technical specifications place a limit on the allowable temperature differential between the pressurizer steam space and the incoming spray water. The basis for this limitation is to eliminate the potential for thermal fatigue in the spray nozzle and the associated piping. At Millstone 2, this limit is 350°F. When the auxiliary spray was initiated on January 2, 1981, a maximum temperature difference of approximately 550°F resulted. This was due to the water which had been sitting in the auxiliary spray line prior to the event being swept into the pressurizer. Following a review of the original stress analysis it was concluded that the thermal transient did not compromise the structural integrity of the pressurizer spray nozzle nor the auxiliary

spray system piping, considering the thermal fatigue and fracture toughness design limitations. However, it was recommended that a detailed stress analysis be performed. The plant procedures were also revised to emphasize the potential for thermal shock and the resultant desirability to use a pump combination which will deliver adequate spray flow and minimize the need to use the auxiliary spray system.

3.0 SUMMARY

The event at Millstone 2 involved the following related and unrelated failures.

- (a) Loss of "A" 125 V dc bus and related failures,
- (b) Loss of "B" diesel generator and related failures, and
- (c) Operational problems due to the RCS pump configuration running causing lack of pressurizer spray (related to 1 and 2).

The event did not include any safety concerns other than those included in Generic Task A-30 and USI A-44. The actions taken by the licensee are adequate and the analysis and investigation conducted were very good.

The following generic concerns should be referred to NRR/IE for their consideration:

- (a) The need to revise procedures of operating plants to address the recovery from a loss of a dc bus event by including steps to be taken on re-energization of the bus.
- (b) The need to inform plant operators of problems that could be encountered when diesel generators are running in an emergency mode, and to add corrective actions in appropriate procedures to counter such problems.

- (c) The need to make plant operators aware that during partial pump operation certain pump combinations may exist which will not provide adequate spray flow to the pressurizer.
- (d) The need to familiarize plant operators with the potential for non-equilibrium pressurizer behavior when normal spray flow is unavailable.
- (e) The need to familiarize operators with core conditions that produce significant quantities of non-condensibles.

The issuance of an IE Circular covering the details of this event and the identified concerns is recommended.

Table 1

SEQUENCE OF EVENTS ON JANUARY 2, 1981

0050- The 125 volt dc bus 201A was de-energized, resulting in a reactor trip.
0051

Approximately 30 seconds later, the turbine was tripped from main control board C07. This resulted in the closure of the turbine stop valves and de-energization of 6900 V bus 25B and 4160 V busses 24B and 24D. On the partial loss of normal power (LNP) diesel generator 13U ("B" facility) started and energized bus 24D. Fifty seconds after the reactor trip, bus 201A was re-energized by closing breaker D0103 resulting in a generator trip and the fast-transfer of 6900 V bus 25A and 4160 V busses 24A and 24C to the reserve station service transformer. The reserve station service transformer feeder breaker to bus 25B momentarily closed and then tripped open on overcurrent. Diesel generator 12U ("A" facility) also tripped when bus 201A was re-energized.

For supporting information on the sequence of reactor, turbine and generator trip see Attachment 1. Also, on re-energization of bus 201A, the main steam isolation valves shut, thereby tripping both main feed pumps. The electric auxiliary feed pumps were started and feed initiated to both steam generators.

0100 The 13U diesel generator tripped and de-energized bus 24D. The load shed signal was overridden and buses 24B and 24D re-energized from the reserve station service transformer. The diesel generator was declared inoperable due to a service water leak which sprayed the machine and caused the trip.

It was noted that despite energization of 4160 V bus 24D, many indications were not available. Included were auxiliary feedwater flow rate to #1 steam generator, main steam header pressure, condensate

storage and surge tank levels, primary make-up water tank level, all computer indications and functions, boric acid storage tank level, charging pump pressure and flow and Terry turbine steam supply pressure. These indications were restored when the blown fuses were replaced, one to two hours later.

0100- Reactor coolant system temperature and pressure were controlled in hot
0300 standby while completing the recovery from the loss of dc. Operations were hampered by the loss of the instruments noted above and operation of only two reactor coolant pumps. Since spray was not as effective as the operator expected, he controlled pressurizer pressure using pressurizer level changes. This resulted in cruder control than normal. Reactor coolant system temperature was maintained using the atmospheric dumps with little problem.

0305 Pressurizer pressure increased to approximately 2380 psia, and both power operated relief valves opened for a short period and reclosed. The downstream pipe temperature indicators and quench tank parameters responded but the open duration was not sufficient to trigger the acoustic valve monitors. The auxiliary spray valve was used to lower pressurizer pressure.

0600 Commenced cooldown to cold shutdown.

125 VD EMERGENCY AND 120 VAC VITAL SYSTEM

REV. 0	DATE	6/14/74
DESIGNED BY	DATE	6/14/74
OPER. FORM	DATE	2945C
RECEIVED	DATE	3002A

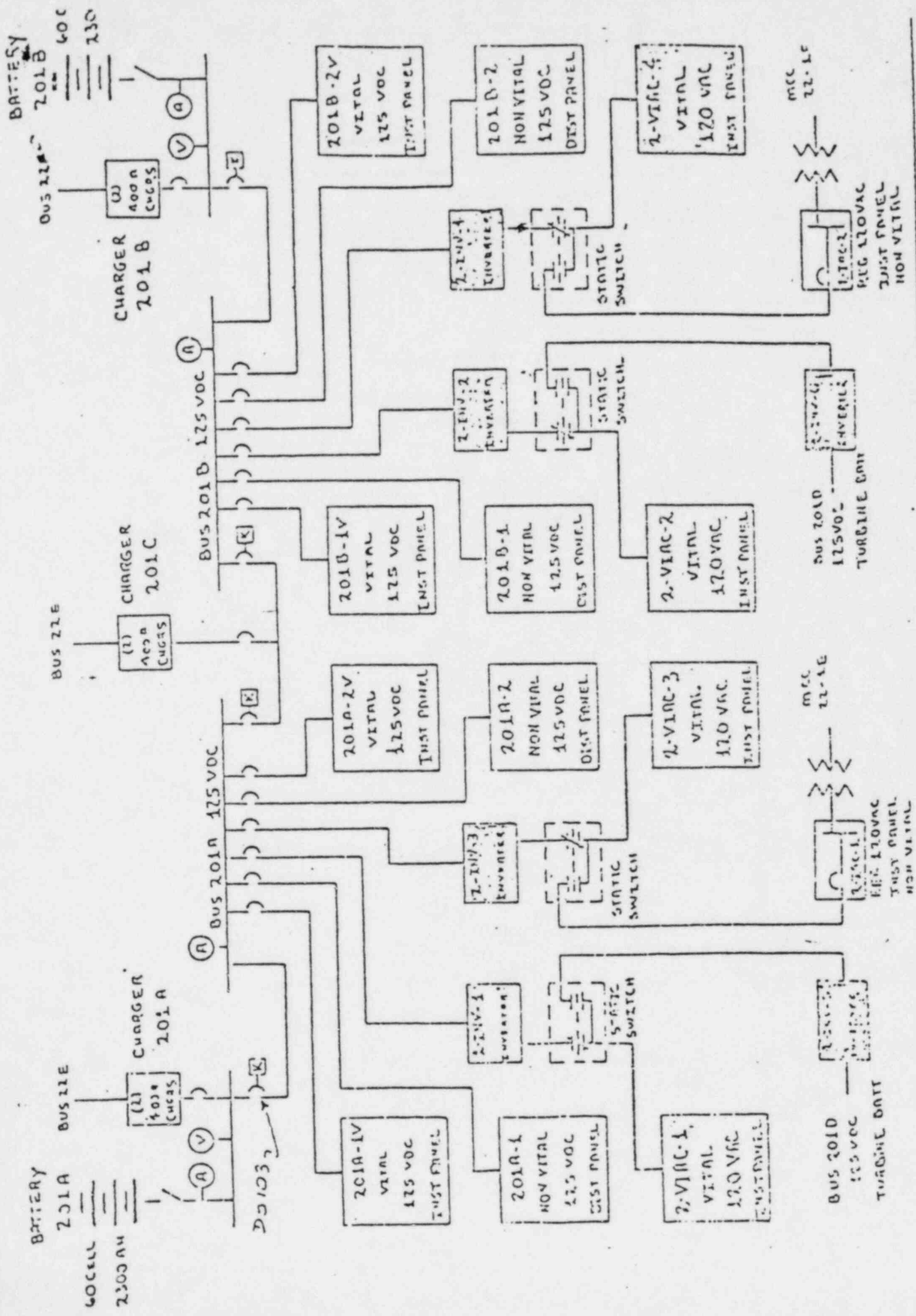

FIGURE 1

MILLSTONE UNIT 2
SIMPLIFIED I LINE DIAGRAM

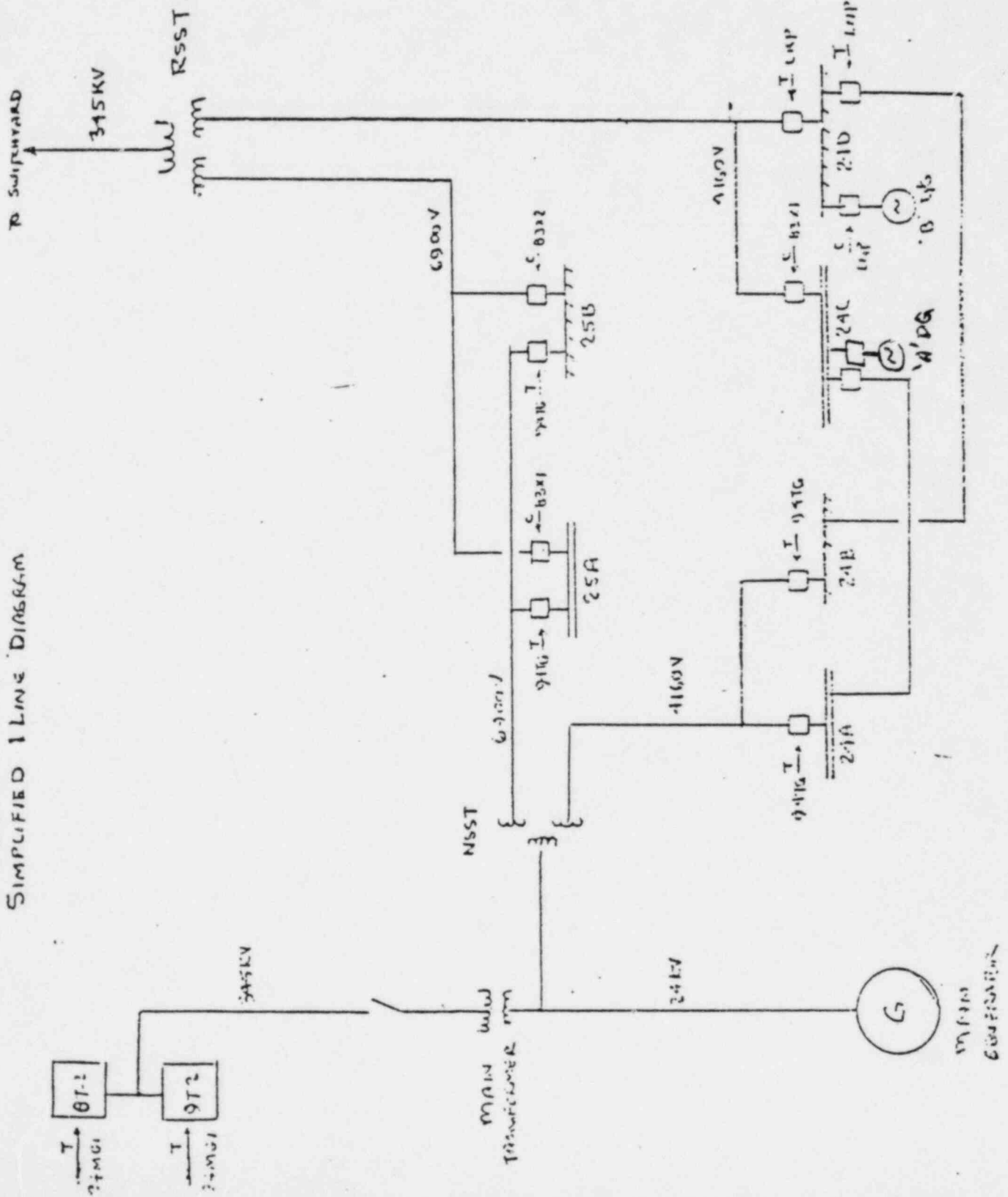

FIGURE - 2

SIMPLIFIED SCHEMATICS
 FINAL TRIP AND FAST TRANSFER

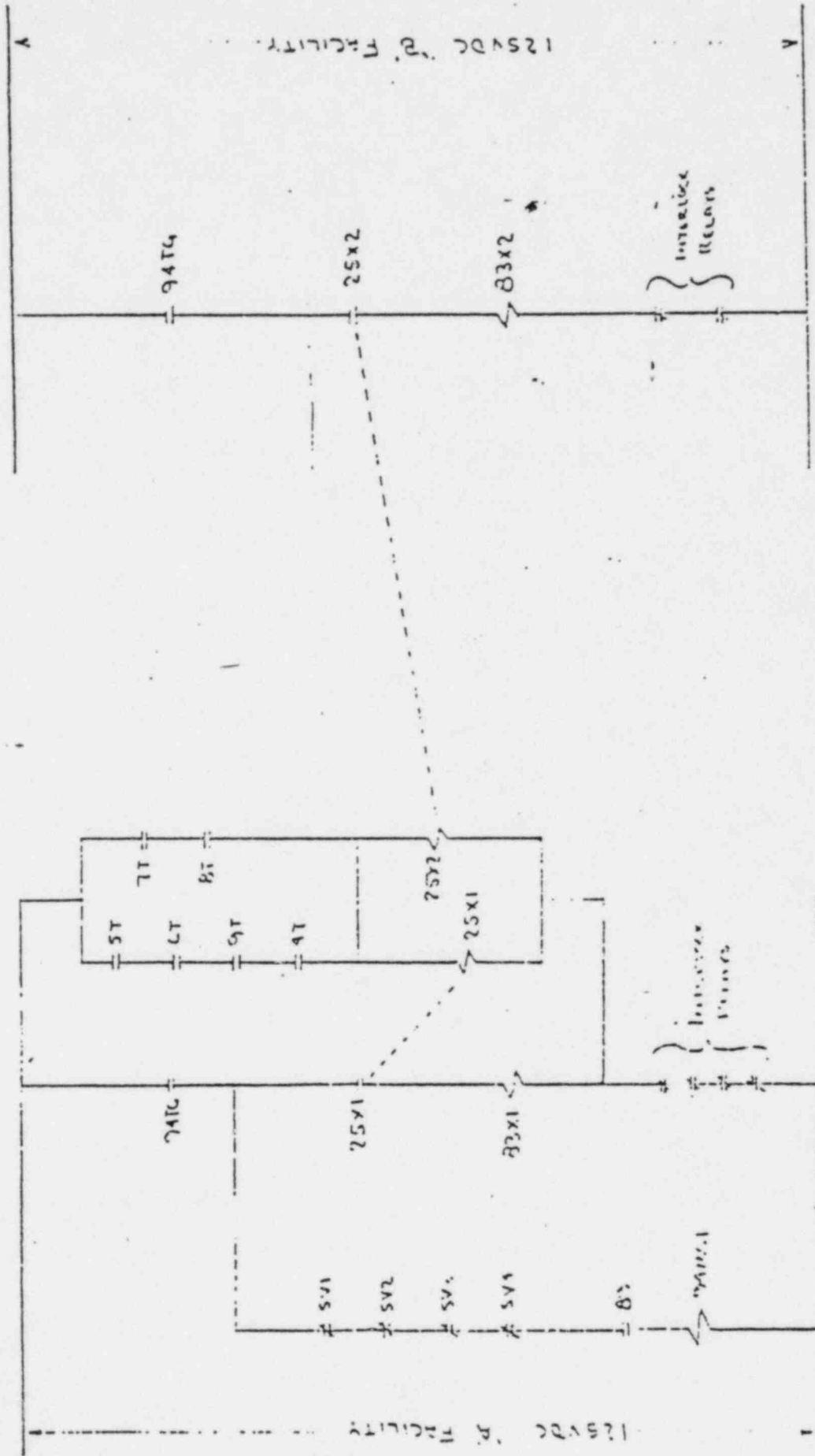
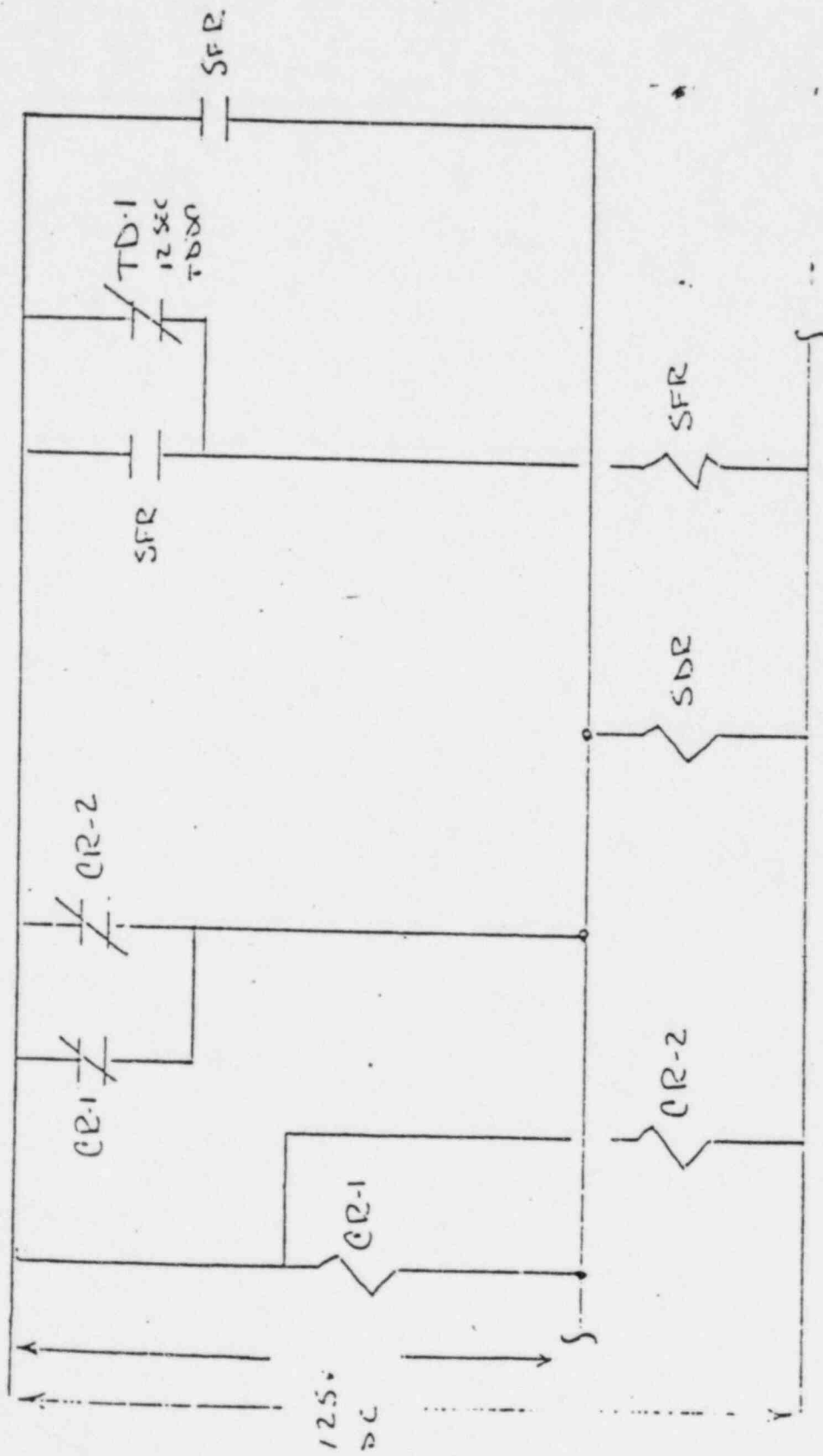

FIGURE - 3



SIMPLIFIED SCHEMATICS
DIESEL ENGINE FAILURE RELAYS

FIGURE - 4

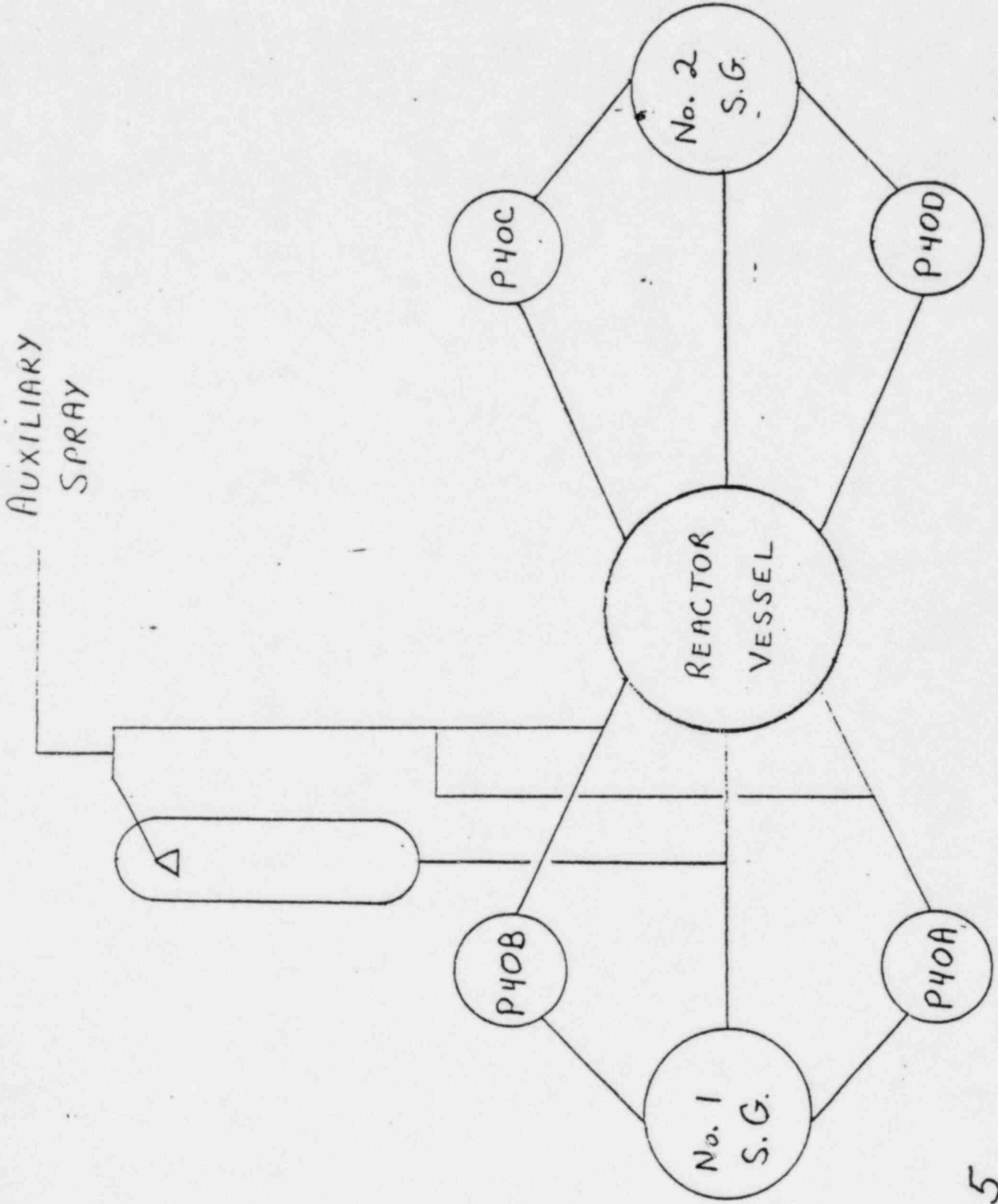

FIGURE 5

SIMPLIFIED SCHEMATICS, MILLSTONE UNIT 2 PRIMARY COOLANT PIPING