

U.S. NUCLEAR REGULATORY COMMISSION
DOCKET NO. 50-261
LICENSE NO. DPR-23

**SAFE-SHUTDOWN CAPABILITY
ASSESSMENT
AND
PROPOSED MODIFICATIONS**

10 CFR 50, APPENDIX R, SECTION
III G

H. B. ROBINSON UNIT NO. 2

**CAROLINA POWER & LIGHT
COMPANY**

March 1982

CONTENTS

<u>SECTION</u>	<u>TITLE</u>
1.0	Introduction
2.0	Methodology--10CFR50, Appendix R, Section III G Assessment
3.0	Rationale for Providing an Alternative/Dedicated Shutdown Capability (10CFR50, Appendix R, Section III G(3))
4.0	Associated Circuit Review
5.0	Summary Table Which Identifies the Means of Establishing Compliance with 10CFR50, Appendix R, Section III G and Schedule for Modifications
6.0	Modifications Planned to Establish Compliance with 10CFR50, Appendix R, Section III G(2) and (3)
7.0	H. B. Robinson Unit No. 2 Fire Zones--Reactor and Auxiliary Buildings (NUS Drawing No. 8726-M-4000)
8.0	Responses to Questions Comprising NRC Request For Information Dated February 20, 1981

1.0 INTRODUCTION

This document provides information describing the safe-shutdown capabilities for H. B. Robinson Unit No. 2 (HBR 2). The capabilities include the existing hot-standby operating features (installed under previous plant modifications), the planned upgrade of hot-standby features, and the planned implementation of cold-shutdown features. Sections 2.0 through 8.0 describe these features, provide assurance of the adequacy of the features, describe the process by which they were identified, and define the plant modifications planned to achieve compliance with 10 CFR 50, Appendix R, Section III G.

Section 2.0 describes, in a procedural format, the course of action that was followed in evaluating the plant safe-shutdown capabilities in light of 10 CFR 50, Appendix R. Through this process, areas of compliance with Appendix R were defined, areas requiring modification were identified, and conceptual designs were developed.

Section 3.0 describes the rationale for selecting the alternative/dedicated shutdown approach (i.e., electing to comply with Appendix R, Section III G(3)) for HBR 2.

Section 4.0 describes the process employed in identifying, analyzing, and (if required) resolving "associated circuit" problems as addressed by Appendix R.

Section 5.0 is a summary table which denotes, by plant fire zone, the scheduled modifications planned for implementation to establish compliance with Section III G(3) of Appendix R. Exemptions noted are provided in a separate document.

Section 6.0 provides a listing of the modifications identified in Section 5.0, with a synopsis of the plant hardware impact of each modification.

Section 7.0 contains NUS drawing number 8726-M-4000, which provides the location of all fire zones in the reactor and auxiliary buildings. (Not shown on this drawing is the service water pump area intake structure, which is physically remote from the reactor and auxiliary buildings).

Section 8.0 contains the responses to questions comprising the NRC Request For Information dated February 20, 1981. The responses, which are keyed to the original

questions, are identified as Enclosure 1, Questions 8(a) through (l), and Enclosure 2, Questions 1 and 2.

2.0 METHODOLOGY--10CFR50, APPENDIX R SECTION III G

2.1 Scope

This section reflects the procedures used to review the fire protection of the safe shutdown capability provided to meet the requirements of Appendix R to 10CFR50.

The following efforts were identified as required:

1. Identify shutdown systems required to achieve cold shutdown.
2. Identify associated circuit interface areas (both electrical and physical proximity). Review spurious operation of the RCS high-low pressure boundary valves.
3. Identify conceptual designs to provide equipment and wiring capability for the dedicated or normal shutdown systems considering a fire in any zone.

2.2 Review of Systems Required to Achieve Hot Standby and Cold Shutdown

- 2.2.1 FSAR and P&IDs were reviewed to identify the systems required to achieve hot standby and cold shutdown conditions.
- 2.2.2 Cable routing paths by fire zone were identified for the normal shutdown equipment and for the dedicated hot standby equipment as installed. Plant cable drawings, hot standby cable installation drawings, plant staff information, and field trips to the plant were used as information sources.
- 2.2.3 The instrumentation required for shutdown of the plant to cold shutdown status was identified by reviewing plant operating procedures and system descriptions.

- 2.2.4 Power availability, for each item of shutdown equipment, was identified by reviewing the normal and alternative power sources.
- 2.2.5 A review by plant fire zone for the possible effects of a loss of each fire zone was accomplished. The review determined which equipment and/or power source would be unavailable and identified what alternate equipment was available to provide the required function.
- 2.2.6 An interim report was issued to summarize the findings of this portion of the study. A listing of the systems and equipment which were deemed as necessary to provide the functions required for cold shutdown was provided. The cable routing for each equipment item identified as part of the dedicated/alternative system was shown. The location of each equipment item was presented and the equipment alternates were listed considering a fire in each plant fire zone. A summarized listing of the problem areas to achieving cold shutdown was provided. This report was controlled as described by the procedures referenced in Section 2.6 and delivered to CP&L engineering and plant staffs for review and comment.

2.3 Associated Circuit Interface Review

- 2.3.1 A review of the possible inadvertent operation of equipment on a system-by-system basis was conducted. The possible effects of associated circuits on achieving the safe shutdown of the plant was identified. Plant wiring information by fire zone was utilized in conjunction with control wiring diagrams and switchgear and motor control center connection diagrams to expose possible effects of a fire in any single fire zone.
- 2.3.2 The results of spurious operation for each component were reviewed to determine if a resultant LOCA was possible.
- 2.3.3 If two or more redundant components were identified which could provide protection from a possible LOCA event, the cable routing for the components, both power and control, was then reviewed to determine if wiring for redundant components was routed through common fire zones.

2.3.4 For hot standby, the possible effects of associated circuit failures (worst case effects always presumed) were identified.

2.3.5 An interim report was issued to summarize the findings of this portion of the study. A tabular listing of associated circuits for each safe shutdown component was provided along with the power supply and control power, wiring by fire zone, and the isolation of available circuits and fire zones common to normal safe shutdown and alternative equipment. Also included were modifications identified to preclude the effects of associated circuit failures and fault isolation requirements on a component-by-component basis. The report was controlled as described by the procedures identified in Section 2.6 and delivered to CP&L engineering and plant staffs for review and comment.

2.4 Effects of Transient Combustibles

2.4.1 A plant site visit with a fire protection consultant was conducted and an inspection of each plant fire zone containing safe shutdown equipment was conducted. This visit resulted in comments regarding possible effects from transient combustibles at various points through the plant.

2.4.2 Particular plant areas required for cold shutdown such as the RHR pit and pipe alley areas were reviewed for possible fire effects. Combustible surveys and fire effects previously provided by the Fire Protection Program Review APCS 9.5-1, H. B. Robinson Unit No. 2, CP&L, January 1, 1977, were utilized to determine fire hazards.

2.5 Conceptual Designs for Dedicated/Alternative Shutdown Systems

2.5.1 The results tabulated by the previous interim reports plus comments received as a result of the review of these reports were summarized.

2.5.2 Based upon the previous interim reports and fire hazard analysis, a dedicated/alternative shutdown system was conceptually designed. The functions required, the equipment to provide the functions, and the instruments to monitor the functions were identified. Control panel locations,

power supply locations, and cable routings independent of the normal system equipment and cables were identified.

- 2.5.3 A report was issued which documented, by block diagram, the equipment controls, power sources, switching networks, and possible cable routings. A shutdown scheme based upon the utilization of the previous hot standby safe shutdown equipment was expanded to include cold shutdown capability. This report was controlled as described by the procedures referenced in Section 2.6 and delivered to CP&L engineering and plant staffs for review and comment.
- 2.5.4 Comments from the review of this report on conceptual designs were considered and an additional summary was prepared for the possible effects on safe shutdown for the case where safety-related systems remained energized and under operator control.

2.6 Quality Assurance and Control

A quality assurance plan was issued to ensure the correctness and completeness of the documentation utilized in this review study.

3.0 RATIONALE FOR PROVIDING AN ALTERNATIVE/DEDICATED SHUTDOWN CAPABILITY (10CFR50, APPENDIX R, SECTION III G(3))

The separation criteria applied in developing the original HBR plant design were not consistent with the separation requirements of 10CFR50, Appendix R. Consequently, an evaluation was required to determine whether to extensively reroute existing circuits to establish adequate separation or to provide an alternative/dedicated shutdown capability.

It was determined that both shutdown-related equipment trains (cables) were in close proximity at many points throughout the plant, making it impractical to fully establish train separation in accordance with 10CFR50, Appendix R, Section III G(1) or III G(2). The obstacles encountered were:

- Inability to establish 20-ft. separation in most plant areas.
- Impracticality of installing three-hour-rated fire barriers in most areas (potentially severe impact on operations, maintenance, or HVAC functions).
- Impracticality of installing fixed fire suppression systems in many plant areas (congested equipment areas and/or potential equipment damage as a result of system actuation).
- Particular plant physical impact of separating circuits and power feeds associated with the plant emergency diesel generators. In order to separate the diesel equipment trains and provide for continuous availability of shutdown power (assuming loss of offsite power), extensive rerouting of 480V bus duct and conduits would be required.
- Particular problem areas included the control room, cable spreading room/relay room, battery room, and emergency switchgear room. Virtually all existing shutdown-related control and instrumentation circuits interfaced with one or more of these areas, and the highly congested equipment and raceway installations made it infeasible to establish adequate train separation within the areas. Because many of these circuits are safety related and all of these circuits were required to interface with the control room,

it was not feasible to provide alternative routing outside of the existing fire areas.

- These considerations dictated that an alternative control location, using a dedicated control panel, be provided to allow for shutdown operation in the event of a fire in any of the above areas.
- The possibility of loss of off-site power concurrent with a fire in one of several selected fire areas necessitated the installation of a dedicated DS power generation and distribution system.

In summation, the safe-shutdown capability provided at HBR represents a combination of alternative and dedicated shutdown concepts as defined by 10CFR50, Appendix R. As a result, new modifications will be designed to meet the requirements of Section III G(3) of 10CFR50, Appendix R, with a limited number to meet Section III G(1) and III G(2).

4.0 ASSOCIATED CIRCUIT REVIEW

The problem of associated circuits within this plant, which has limited physical separation of existing safety related components, is resolved by effectively creating a separate shutdown train. The separate shutdown equipment is powered from an independent power source. Control is provided by a dedicated control station which is remote from the normal control location. Cabling of the interconnect wiring is accomplished by utilizing alternate cable routing paths and isolating devices for electrical isolation from normal systems power and control circuits. All alternative/dedicated shutdown related circuits are routed in separate conduit containing only alternative/dedicated shutdown cables. Where common cable routing is encountered, fire barrier protection and fire suppression is provided. The reference material provided in the response to Question 1-D, of Enclosure 2 of the February 20, 1981 NRC request for information identifies the equipment and wiring in fire zones where associated circuits are encountered.

A tabulation of these common areas and the proposed protection is provided here for clarification.

<u>FIRE ZONE</u>	<u>COMMON CIRCUITRY</u>	<u>PROTECTION PROVIDED</u>
4	Charging pumps B&C wiring to E1&E2 buses	Coordinated circuit breaker protection isolates buses when required. Alternative pumps (S.I.) provide charging capability after reduction of RC system pressure.
5	Circuits to E1, E2, and the dedicated shutdown (DS) bus	The low volume of fixed combustibles present in this area plus the distance between the safety related circuits and the alternative shutdown circuits provide protection. A fire barrier between component cooling pumps has been provided and all alternative/dedicated shutdown cables are routed in separate conduit. See exemption request.

<u>FIRE ZONE</u>	<u>COMMON CIRCUITRY</u>	<u>PROTECTION PROVIDED</u>
12	Control circuits for dedicated shutdown system and power circuits for normal system	Dedicated circuits will be routed in conduit and provided with one-hour-rated fire barrier and automatic fire suppression (water spray) system.
13	Power and control circuits for both normal and dedicated shutdown systems	A fire in this zone could involve dedicated shutdown system power and control circuits and power circuits associated with E1 and E2. Breaker coordination will provide protection for E1 and E2 buses, thus allowing normal shutdown system operation. S.I. pumps provide charging capability.
24	Control and power circuits for both normal and dedicated shutdown systems	One-hour-rated fire barriers and automatic fire suppression provided.
28	Control and power circuits for both normal and dedicated shutdown systems	Fire barrier provided for alternative/dedicated circuits; due to low volume of combustibles present automatic fire suppression is not required. See exemption request.

5.0 SUMMARY TABLE OF MEANS OF ESTABLISHING COMPLIANCE WITH 10CFR50,
APPENDIX R, SECTION III G

The plant safe-shutdown capabilities were assessed for each fire zone; a fire was postulated in each zone, and the ability to achieve (cold) shutdown using the remaining plant equipment (unaffected by fire in that zone) was evaluated.

The results of this assessment are summarized on the attached table, which provides the following information for each fire zone:

- Whether the existing safe-shutdown features comply with Appendix R, Section III G (1, 2, or 3).
- If compliance has not yet been established, but will be achieved under the provisions of III G (1) or III G (2), the projected implementation date is given.
- If compliance has not yet been established, but will be achieved under the provisions of III G (3), the required modifications are identified (modification numbers are keyed to the listing of modifications in Section 6.0), and the projected implementation date is given.
- Areas in which exemptions from the requirements of Appendix R are justified are noted (see Exemption Requests) and areas having no safe-shutdown impact or required modifications are identified.

COMPLIANCE WITH APPENDIX R CRITERIA

Zones	Complies with III G	III G.1 or G.2		III G.3		Exemption Requested
		Mod. Req.	Date	Mod. Req.*	Date	
1	Yes	-	-	-	-	-
2	Yes	-	-	-	-	-
3	Yes	-	-	-	-	-
4	Yes	-	-	-	-	-
5	No	Yes	Note 1	16	Note 2	Yes
6	NA	-	-	-	-	-
7	NA	-	-	-	-	-
8	NA	-	-	-	-	-
9	No	No	-	7,9,10,13 15,18	Note 2	-
10	No	No	-	9,16,18	Note 2	-
11	No	No	-	2,3,6	Note 2	-
12	No	Yes	Note 1	2,3,5,19,20	Note 2	-
13	No	No	-	2,21	Note 2	-
14	NA	-	-	-	-	-
15	NA	-	-	-	-	-
16	No	No	-	1,3,4,7,8 18,22	Note 2	-
17	NA	-	-	-	-	-
18	NA	-	-	-	-	-
19	No	No	-	1-22	Note 2	-
20	No	No	-	1-22	Note 2	-
21	No	No	-	2	Note 2	-
22	No	No	-	1,3-20,22	Note 2	-
23	No	No	-	2,9,10,17,22	Note 2	-
24	No	No	-	7,9,10,12, 13,15,17,18	Note 2	-
25	No	No	-	13	Note 2	-
26	NA	-	-	-	-	-
27	No	Yes	Note 2	1	Note 2	Yes
28	No	Yes	Note 1	13,15-18	Note 2	Yes
SWP	No	Yes	12/1/82	No	-	Yes

LEGEND: Nos. 1-22 indicate the number of the modification descriptions (see Section 6.0)

NA - Not applicable (No safe shutdown equipment in the fire zone)

SWP - Service Water Pump Area

NOTES: 1 Planned for implementation during 1983 refueling outage.

2 Planned for implementation during 1984 refueling outage.

*Modifications identified require NRC approval.

6.0 MODIFICATIONS PLANNED TO ESTABLISH COMPLIANCE WITH 10CFR50, APPENDIX R, SECTION III.G(3)

In order to establish compliance with 10CFR50, Appendix R, under the provisions of Section III.G(3), the following modifications are planned:

1. Provide an additional switchgear section to expand the existing DS bus. Breakers for station air compressor, pressurizer heaters (control group) and RHR pump are required.
2. Abandon the existing power connections to the primary air compressor and the pressurizer heater control group; reconnect these loads to the expanded 480V DS bus. Pressurizer heater routing to be relocated to south cable vault. Provide alternate control at the charging pump room shutdown panel for the pressurizer heaters.
3. Install a dedicated 480V motor control center (MCC-DS) in the 4-KV switchgear room to support safe shutdown motor loads.
4. Provide the capability for the transfer of control and power circuits serving valves V1-8A, V2-14A, and V6-12D from MCC-6 to MCC-DS. Controls for these valves will remain on the existing turbine deck and charging pump room shutdown panels. Requires the addition of a transfer switch panel in fire zone 13.
5. Provide the capability for the transfer of the steam-driven auxiliary feed-water pump oil bearing pump from MCC-6 to MCC-DS. Provide alternate control from the charging pump room shutdown panel. Requires the addition of a transfer switch panel in fire zone 5.
6. Provide the capability for the transfer of the auxiliary building cooling unit fan from MCC-5 to MCC-DS.
7. Provide the capability for the transfer of isolation valves 535 and 536 from MCC-6 to MCC-DS at a transfer switch panel added in fire zone 5. Provide alternate control at the charging pump room shutdown panel.

Monitor valve position at the charging pump room shutdown panel for PCV 456 and 455C using independent power and cabling.

8. Replace the existing charging pump room panel with a new set of panels to accommodate additional controls and instrumentation.
9. Install dedicated temperature instrumentation for letdown relief line temperature with indication at the charging pump room shutdown panel (alternative to TE 141).
10. Provide dedicated level instrumentation for the pressurizer relief tank with indication at the charging pump room shutdown panel. Cable will be routed through the south cable vault.
11. Disable power and control (during normal plant operation) to valves 860A and B to prevent inadvertent operation. Provide valve position monitoring circuits, with indication in the control room.
12. Disable power and control (during normal plant operation) to valve 750. Provide a valve position monitoring circuit with indication in the control room.
13. Provide disconnect means for solenoid valves associated with reactor head vent and pressurizer vent lines.
14. Install dedicated level instrumentation for the volume control tank, with indication at the charging pump room shutdown panel.
15. Provide alternate control from the charging pump room shutdown panel for cold shutdown equipment normally operated from the control room (valves 200A, 460A, and 311).
16. Provide alternate control from the turbine deck shutdown panel for cold shutdown equipment normally operated from the control room (valves V1-8B, V1-8C, V2-14B, and V2-14C). Requires the addition of a transfer switch panel in fire zone 13.

17. Install dedicated instrumentation with indication at the charging pump room shutdown panel to provide cold shutdown information for RCS temperature (hot and cold leg), volume control tank level, RHR flow, and in-core temperature (utilizing existing in-core sensors).
18. Modify letdown system valves 460B, 204A, and 204B to enable manual control for air-operated valves; install manual air pilot valves to permit letdown valve control without solenoid actuation.
19. Modify the turbine deck shutdown panel to provide controls and indication for Loop B and C auxiliary feedwater turbine steam inlet valves and feedwater outlet valves. Install remaining RCS Loop B and C temperature monitors.
20. Provide the capability for the transfer of control and power circuits serving boric acid pump A, boric acid tank heater A, and associated heat tracing from MCC-5 to MCC-DS. Provide alternate controls at the charging pump room shutdown panel.
21. Perform an analysis of the MCC-6 control circuits routed through fire zone 13; verify that each circuit is protected by an effective isolation device (e.g., fuse) to prevent potential fire-induced damage to MCC-6 control circuits.
22. Install a dedicated 125V DC power supply (fed from the DS 480V distribution panel) for use with alternative/dedicated shutdown DC loads.

7.0 H. B. ROBINSON UNIT NO. 2 FIRE ZONES - REACTOR AND AUXILIARY
BUILDINGS (NUS DRAWING NO. 8726-M-4000)

The drawing presented in this section provides a plan of the plant and identifies each fire zone for the plant.

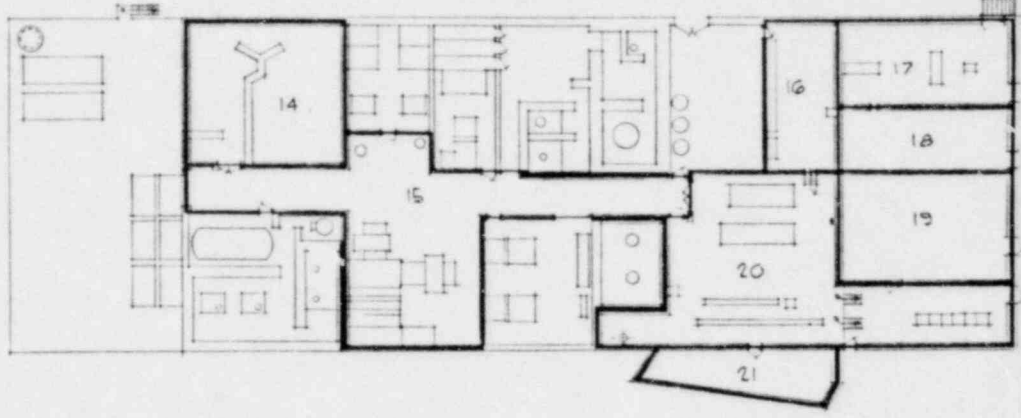

AUXILIARY BUILDING FLOOR EL. 242-0 N 246-0

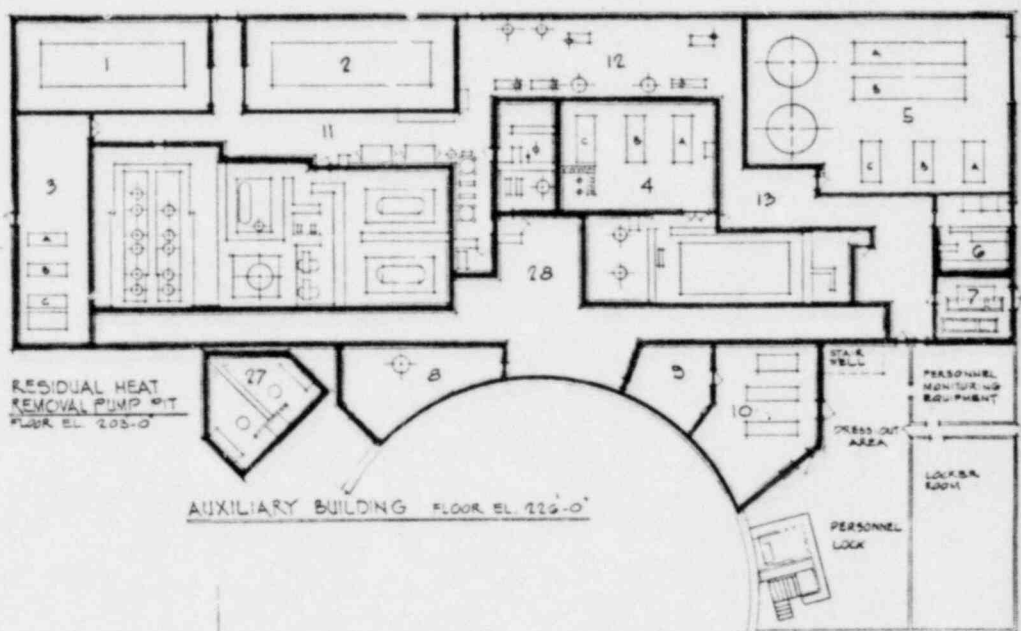

RESIDUAL HEAT REMOVAL PUMP PIT FLOOR EL. 205-0

AUXILIARY BUILDING FLOOR EL. 226-0

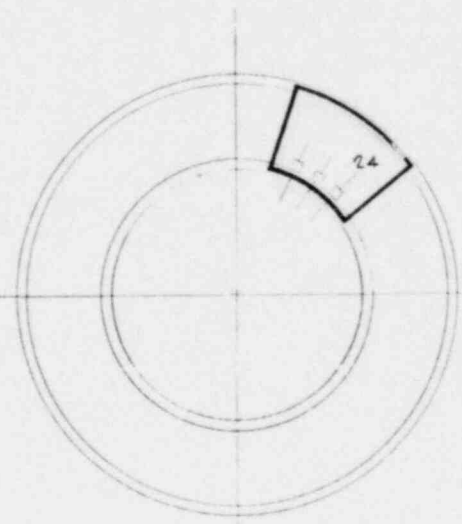

REACTOR BLDG. FLOOR EL. 219-0 ELECTRICAL PENETRATION AREA

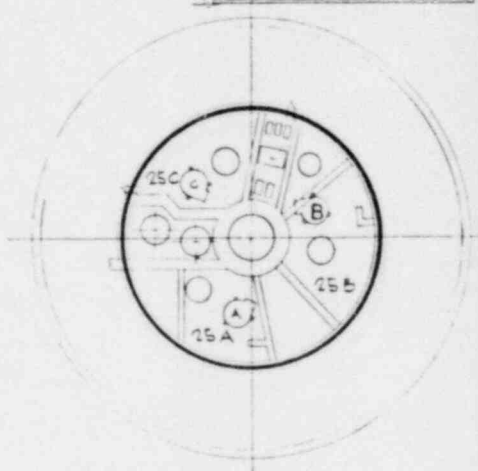

REACTOR BLDG. FLOOR EL. 251-0 REACTOR COOLANT PUMP BAYS

REVISIONS	
NO.	DESCRIPTION
A	ISSUED FOR CLIENT REVIEW 7/18/82

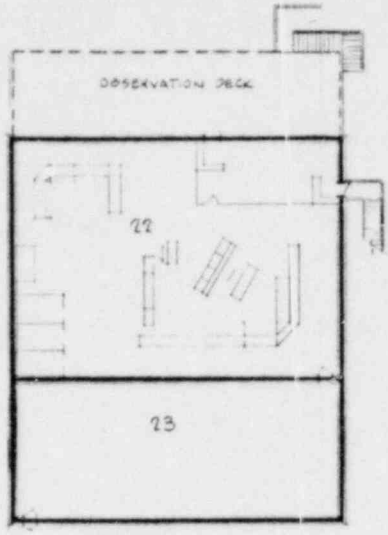
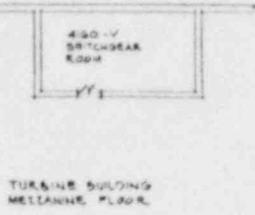

CONTROL ROOM FLOOR EL. 254'-0"

LEGEND:

ZONE	DESCRIPTION
1	DIESEL GENERATOR ROOM B
2	DIESEL GENERATOR ROOM A
3	SAFETY INJECTION PUMP ROOM
4	CHARGING PUMP ROOM
5	COMPONENT COOLING PUMP ROOM
6	HOT LAB/COUNTING ROOM
7	AUXILIARY FEEDPATER PUMP ROOM
8	BORON INJECTION TANK ROOM
9	NORTH CABLE VAULT
10	SOUTH CABLE VAULT
11	HALLWAY-DIESEL GENERATORS/MCC-S
12	HALLWAY-AIR COMPRESSORS
13	HALLWAY-COMPONENT COOLING/CHARGING ROOMS
14	WASTE HANDLING ROOM
15	HALLWAY-HVAC EQUIPMENT
16	BATTERY ROOM
17	HVAC EQUIPMENT ROOM
18	FORMER UNIT-1 CABLE SPREADING ROOM
19	RELAY COMPUTER AND UNIT-2 CABLE SPREADING ROOM
20	EMERGENCY SWITCHGEAR ROOM
21	ROD CONTROL ROOM
22	CONTROL ROOM
23	RELAY (HAGAN) ROOM
24	CONTAINMENT ELECTRICAL PENETRATION AREA
25	REACTOR COOLANT PUMP BAYS (A, B, C)
26	CONTAINMENT HVAC (FILTER) UNITS
27	RESIDUAL HEAT REMOVAL PUMP PIT
28	PIPE ALLEY

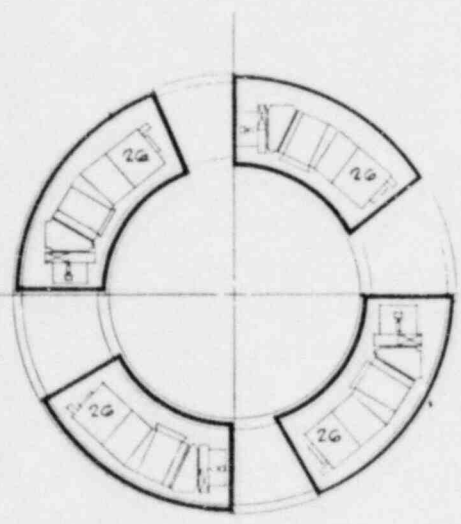

ISSUED FOR CLIENT REVIEW

DESIGN: Carolina Power & Light CHECKED: [Signature] DATE: 7/18/82 DRAWN BY: [Signature] PROJECT NO.: 8726-M-4000	CAROLINA POWER & LIGHT COMPANY HB ROBINSON STEAM ELECTRIC PLANT UNIT No. 2 - FIRE ZONES AUXILIARY & REACTOR BUILDINGS NUS 8726-M-4000 ROCKVILLE, MD
--	---

8.0 RESPONSES TO QUESTIONS COMPRISING NRC REQUEST FOR INFORMATION
DATED FEBRUARY 20, 1981

The following NRC positions and answers to the questions presented for each position are provided here as they reflect the proposed design modifications for the H. B. Robinson Unit 2.

NRC Positions From Enclosure 1 of the Letter

- 8(a) Provide a description of the systems or portions thereof used to provide the shutdown capability and modifications required to achieve the alternate shutdown capability if required.

RESPONSE

The functional and hardware requirements for achieving a hot-standby condition are tabulated in the H. B. Robinson Unit No. 2 Fire Protection Program Review (APCSB 9.5.1), dated January 1, 1977. The requirements which are directed at achieving and maintaining a cold shutdown condition, are summarized on Table 1.

In the original plant configuration, fires occurring in some areas could impair the use of any or all of this equipment, primarily through destruction of power and control cables. Consequently, provisions have been made for the transfer of power and/or the control of select components to alternative sources to mitigate the consequences of a severe fire in these plant areas (i.e., control room, cable spreading room, emergency switchgear room, or battery room). The hot-standby capability is in basic accordance with Appendix R requirements and this capability is to be modified to include cold shutdown capability.

Figure 1, sheets 1 through 6, presents simplified piping and instrument diagrams of the major functional elements of the alternate shutdown capability; not all features associated with the shutdown capability are shown on the figure. The modification, as described herein, is intended only to ensure the operability of those systems and components needed to achieve a cold shutdown condition. The modification impacts the following existing and plant features.

- Steam-driven feedwater pump and steam supply valves
- Power-operated relief valves
- Component cooling pump A
- Service water pump D and associated valves
- Charging pump A
- Residual heat removal pump A

- Remote shutdown control panels (charging pump room and turbine deck)
- Dedicated 480V switchgear and motor control center
- Dedicated diesel generator
- Dedicated AC and DC power supplies
- Dedicated shutdown instrumentation (primary and secondary systems)
- Instrument air compressor
- Pressurizer heaters (control group)

Simplified schematic diagrams and descriptive summaries are provided for the above features. These diagrams and summaries are based on the reference design drawings listed on Table 2, which are available for review upon request.

Steam-Driven Feedwater Pump Shutoff Valves

A transfer switch panel located in the Auxiliary Building enables the transfer of power and control for the steam-driven feedwater pump (FWP) shutoff valves V1-8A and V2-14A from the existing remote control signals to local control from the turbine deck panel. Simplified control diagrams for valves V1-8A and V2-14A are presented by Figures 2 and 3, respectively. Valves V1-8B, V1-8C, V2-14B, and V2-14C will be modified in an identical manner for cold shutdown operation. The modification does not change the existing control voltage or power source alignment with the valves. The transfer to local control is annunciated in the control room.

Power-Operated Relief Valves

The turbine deck control panel also provides for disabling the existing remote control of steam generator power-operated relief valves RV1-1, RV1-2, and RV1-3; Figure 10 is a simplified diagram of the control transfer. When transferred to local control, the valves can be operated by using the existing valve controllers located on the turbine deck. The transfer to local control is annunciated in the control room.

Component Cooling Pump A

A transfer switch is provided on the charging pump room control panel to disable the existing remote control of component cooling pump (CCP) A and to transfer control of the pump to a local switch on the panel. Figure 4 is a simplified diagram

of the control transfer scheme. The modification does not change the existing control voltage or power source alignment (480V bus DS) with the pump. The transfer to local control is annunciated in the control room.

Service Water Pump D

The normal supply for service water pump (SWP) D is 480V bus E2, with control from the plant control room. To provide a power supply and controls independent of the control, cable spreading, and emergency switchgear rooms, manual circuit breakers 1 and 2 have been installed as shown on Figure 5. When properly aligned, these breakers provide an alternate power supply and control station for SWP D. Alternative control is accomplished from the charging pump room panel. The breakers are provided with a Kirk key interlock, with breaker 1 normally closed, breaker 2 normally open (the status of breaker 2, through an auxiliary contact, is annunciated in the control room). The Kirk key interlock is a single key system, and the respective breaker must be tripped before the key can be removed. Consequently, simultaneous closure of both breakers is impossible. Service water discharge valve V6-12D, which isolates the SWP D from the service water header, will be modified so that it is powered through local circuit breakers with a mechanical interlock as shown on Figure 6. The valve is normally powered from MCC-6 but the Kirk key breaker allows power from the dedicated MCC to be supplied to the local breaker. Thus, power train isolation is maintained and valve operation is available from the auxiliary shutdown power connections.

In the event of a control room, cable spreading room, or emergency switchgear room fire, breaker 1 is tripped and breaker 2 is closed. Service water pump D is then fed by the dedicated power supply and is controlled from the auxiliary panel in the charging pump room. In this configuration, operation of SWP D is independent of the control room, cable spreading room, and emergency switchgear rooms, and is unaffected by any fire in these areas. Similarly, operation of service water discharge valve V6-12D in the "alternative shutdown" mode is unaffected by fires in the control room, cable spreading room, and emergency switchgear room.

Charging Pump A

Alternate controls, independent of the control, cable spreading, and emergency switchgear rooms, have been provided for charging pump A. Since the normal power supply for this pump (480V bus DS) is outside the emergency switchgear room, an alternate power source is not required.

The alternate controls for charging pump A, consisting of a control transfer switch and pushbutton control switches, are located on the charging pump room control panel. As shown on Figure 7, the pushbutton control switches are electrically functional only when the control transfer switch is in the "local" position. With the control transfer switch in the "local" position, operation of charging pump A is not affected by any fire in the control, cable spreading, or emergency switchgear rooms.

Pressurizer Heaters (Control Group)

Alternate controls, independent of the control, cable spreading, and emergency switchgear rooms, will be provided for these heaters. The heaters will be powered from the 480V bus DS, therefore, an alternate power source will not be required.

The alternate controls will be located in the charging pump room and a control transfer switch similar to the charging pump A supplied to provide isolation from normal circuits and annunciate remote control to the control room.

Emergency DC Power Supply/Dedicated Shutdown Instrumentation

The modification provides an alternate DC control voltage source to the emergency switchgear. Dedicated distribution panel A provides an alternate DC control voltage source to 4kV buses 1 and 2 via interconnections with bus 1 cubicle 7 and to 480V buses 1 and 2A. The transfer to the alternate 125 VDC control voltage source is annunciated in the control room. In addition, a UPS (uninterruptible power supply) is located outside of the emergency switchgear room, in the 4KV switchgear room. The UPS supports dedicated shutdown instrumentation which is located in the charging

pump room control panel. The dedicated shutdown instrumentation will provide the following local displays at the charging pump room panel:

- Reactor coolant temperature (3 loops, both hot and cold leg) (2 loops are new)
- Nuclear instrumentation (source-range)
- Steam generator 1 level
- Steam generator 2 level
- Steam generator 3 level
- Pressurizer relief tank level (new)
- Pressurizer level
- Pressurizer pressure
- Pressurizer relief line power operated valves 455c and 456 position display.
- Volume control tank level (new)
- RHR flow (new)
- RHR relief line temperature (new)
- Letdown relief line temperature monitor (new)
- Incore temperature display (new)

Additional instrumentation displays will be provided at the turbine deck control panel to enable auxiliary feedwater pump and steam dump control. Displays are as follows:

- Steam generator levels 1, 2 and 3
- Pressurizer level and pressure
- Condensate storage tank level
- Reactor coolant system temperatures (3 loops hot and cold leg) (2 loops are new)

In the event of a fire in the battery room (or cable spreading room) coincident with a loss of offsite power, a complete loss of site DC power may be experienced. The main consequence of this failure would be the inability to operate circuit breakers to align alternate power sources (most breakers are DC-operated).

To mitigate the consequences of this potential situation a backup onsite power supply is provided to power the shutdown-related loads through 480V bus DS. The breakers supplying the shutdown loads will be either manually operated or electrically (AC)

operated. The onsite power supply and the associated switchgear and appurtenances have been designed and procured to non-seismic Category I criteria, and are not designed to meet single-failure criteria.

Cable routing for the DC power and the previously mentioned dedicated instrument loop is or will be independent of the zones containing normal plant instrumentation wiring. At the sensor installation lead dress will provide as much physical separation as possible to avoid common fire effects.

Instrument Air - Primary Air Compressor

Instrument air is not required for hot-standby operation; however, the continued availability of instrument air will be ensured by providing power and local control to the air compressor located in the turbine building. Power will be from the DS bus and power and control cables will not be routed into the auxiliary building. Operation of the letdown system for cold shutdown boration will utilize this air supply.

Miscellaneous Motor-Operated Valves and Pump Motors

Several motor-operated valves and pumps (required for safe shutdown) will be provided with alternative controls and status indication on the charging pump room panel. These controls will be implemented in a manner similar to that described for the steam-driven auxiliary feedwater pump steam supply valve. All controls will be activated by means of transfer switches, which will disable the existing (control room) controls and transfer control of the valves to the dedicated shutdown panel in the charging pump room. Activation of these transfer switches will be annunciated in the control room. The transfer switches will be mounted in two cabinets, one in fire zone 13 for train A related components and one in fire zone 5 for train B related components. Appropriate separation between safety-related power systems and nonsafety-related circuits shall be provided and is depicted on Figure 8 for a typical valve to indicate separation and control schemes. Isolation circuits shall be employed to prevent fault transfer including hot shorts between the control room, cable spreading room and the transfer switch area.

Components to be provided with alternative controls include the following:

- Pressurizer relief tank isolation valves 535 and 536
- Pressurizer spray control valve 311
- Steam-driven auxiliary feedwater pump-oil bearing pump
- Boric acid pump A
- Boric acid heat trace A
- Boric acid tank heater A
- Auxiliary building HVAC input fan HVS-1
- Letdown line isolation valve 460A
- Orifice valve 200A
- Pressurizer heaters (control group)

RHR Pump

Residual heat removal pump A will be utilized to provide the decay heat removal necessary to achieve and maintain cold shutdown. Power for the pump and its associated cooler fan unit is to remain connected to emergency bus E1. In the event that a fire in fire zone 28, the emergency switchgear room, or the control room is encountered, alternative power feeds from a predesignated breaker at the dedicated shutdown bus will be installed. Cables and procedures to accomplish the interconnections will be available at the site and the reconnection will be accomplished while the plant remains in the stable hot-standby mode. Routing of cables shall be outside the auxiliary building with a direct connection to the dedicated shutdown bus.

Safe-Shutdown Electrical Distribution System

The 480V dedicated shutdown bus will have the nonsafety-related shutdown loads (charging pump A, component cooling pump A, pressurizer heaters, and primary air compressor) permanently connected to the bus. This bus is normally fed from offsite power, but can be connected to the dedicated diesel generator from the diesel generator control panel, located in the turbine deck switchgear room. A motor control center will be located in the turbine deck switchgear room and will provide power to the shutdown valves and small motor pumps as shown on Figure 11. These loads will include feedwater valves V1-8A, V1-8B, V1-8C, V2-14A, V2-14B, V2-14C;

the service water valve V6-12D; the pressurizer relief line block valves V535 and V536; the oil bearing pump for the steam driven feedwater pump; the boric acid pump A, Tank A heater and associated heat trace, and the auxiliary building inlet HVAC fan. Instrumentation power (120 VAC) is supplied by an uninterruptible power supply which is normally powered from the dedicated 480V bus. All circuit breakers on the 480V DS bus (with the exception of the feeder breakers) are provided with AC control power from the DS bus itself. The feeder breakers are operated using the 48V DC battery system associated with the uninterruptible power supply.

Repair Procedures for Cold Shutdown

In addition to the above described repair procedures for the RHR pumps, repair procedures also may be written to install emergency (temporary) cables for other cold shutdown equipment.

At the present time, the modifications associated with establishing a dedicated cold shutdown capability are at the conceptual design stage, consequently, detailed design drawings of cold shutdown cable and conduit routing have not yet been developed.

For the cold shutdown modifications listed in Section 6.0 and described in this section, portions of the proposed cable runs may be identified during the detailed design phase to be installed as part of a cable repair procedure that will require only pulling and termination of the cable.

Modifications will be made to the extent that cable repair procedures can be written such that repairs can be made within 72 hours. Cables and procedures to accomplish the cable pulling and the terminations will be available at the site.

Table 1
Functional and Hardware Requirements for Achieving and
Maintaining Cold Shutdown Conditions

<u>Plant Functional Requirements</u>	<u>Equipment Functional Requirements</u>	<u>Minimum Equipment Requirements</u>
Monitor and control primary system inventory and pressure	Monitor RCS inventory	One wide-range pressurizer level indicator
	Inject borated makeup water	One charging pump and injection path or one SI pump and injection path
	Provide borated makeup water source	Boric acid pump and tank or RWST (manual valve alignment)
	Monitor RCS pressure	One wide-range pressure indicator
	Control pressure- increase	One charging pump and injection path or one SI pump and injection path
	Control pressure- decrease	One charging pump and pressurizer auxiliary spray line
Remove decay heat by:		
a) Feedwater addi- tion to the steam genera- tors with steam venting to atmosphere	Provides feedwater	One steam-driven pump and associ- ated valves and oil bearing pumps
	Monitor condensate tank level	One tank level monitor
	Monitor steam generator level	One wide-range level indicator per loop

Table 1
 Functional and Hardware Requirements for Achieving and
 Maintaining Cold Shutdown Conditions (Continued)

<u>Plant Functional Requirements</u>	<u>Equipment Functional Requirements</u>	<u>Minimum Equipment Requirements</u>
	Vent main steam to atmosphere	Three main steam PORVs and positioners
	Monitor RCS temperature	Temperature sen- sors and associ- ated instrumen- tation for hot and cold leg indication from each loop
b) Decay heat removal to cold shutdown	Remove residual heat	One RHR pump, heat exchanger and as- sociated valve train
Verify reactor is subcritical	Monitor RCS boron concentration or startup range neutron flux to ensure that subcriticality is maintained	One sample cooler HX and valve train or the dedicated system neutron monitor channel
Auxiliary services required by the components that directly perform the above functions	Component cooling	One pump with HX and associated valve train
	Service water	One pump and associated valve train
	4160-Vac and 480-Vac power distribution	480-V bus DS, 480-V DS MCC, DS diesel generator, and 4kV Bus 3 (if offsite power is available)

Table 1
 Functional and Hardware Requirements for Achieving and
 Maintaining Cold Shutdown Conditions (Continued)

<u>Plant Functional Requirements</u>	<u>Equipment Functional Requirements</u>	<u>Minimum Equipment Requirements</u>
	120-Vac power distribution	Dedicated shut- down 120-Vac unin- terruptible power supply
	125-Vdc power distribution	DC power supplies from dedicated shutdown power
	RHR pump area cooling, charging, pump cooler	One cooler per system
Auxiliary services provided for operator convenience	Instrument air	One compressor

TABLE 2

REFERENCE DRAWINGS - PARTIAL LISTING

<u>Drawing Number</u>	<u>Revision</u>	<u>Title</u>
5137-E-6100		Control Wiring Diagram for Service Water Pump D
SH. 1	2	
2	2	
3	3	
4	4	
5137-E-6101		Control Wiring Diagram for Steam-Driven FWP Steam Shutoff Valve V1-8A
SH. 1	4	
2	4	
3	2	
5137-E-6109	6	Interconnection Diagram, Annunciator DSA
5137-E-6110	5	Interconnection Diagram, Annunciator DSB
5137-E-6115		Control Wiring Diagram for Steam-Driven FWP Shutoff Valve V2-14A
SH. 1	3	
2	4	
3	5	
5137-E-6116		Control Wiring Diagram for Service Water Discharge Valve V6-12D
SH. 1	2	
2	4	
3	5	
5137-E-6211		Interconnection Diagram, Charging Pump Room Control Panel
SH. 1	5	
3	3	

TABLE 2 (Cont'd)

REFERENCE DRAWINGS - PARTIAL LISTING

<u>Drawing Number</u>	<u>Revision</u>	<u>Title</u>
5137-E-6212		Interconnection Diagram, Turbine Deck Panel
SH. 1	3	
2	3	
3	4	
4	3	
5137-E-6213		Interconnection Diagram, Local/Remote CB Panels
SH. 7	4	
17	5	
23	5	
5137-E-6215		Interconnection Diagram, Emergency DC Power Supply System
SH. 1	5	
2	6	
5137-E-6216		Interconnection Diagram, Dedicated Shutdown Instrumentation
SH. 1	7	
2	1	
5137-E-6217	5	Alternate Power Connection Diagram, MCC-5
5137-E-6218	2	Interconnection Diagram, Remote Transfer Switch Panel, V1-8A
5137-E-6219	2	Interconnection Diagram, Remote Transfer Switch Panel, V2-14A

TABLE 2 (Cont'd)

REFERENCE DRAWINGS - PARTIAL LISTING

<u>Drawing Number</u>	<u>Revision</u>	<u>Title</u>
5137-E-6220		Interconnection Diagram, Steam Dump Control
SH. 1	1	System
2	5	
5137-E-6311		
SH. 1	7	Reactor Auxiliary Building Ground Floor - Conduits
2	7	Reactor Auxiliary Building Upper Floor - Conduits
3	7	Charging Pump Room - Conduits
4	8	Turbine Generator Area Switchgear Room - Conduits
5	8	Mezzanine Deck - Conduits
6	6	Control Room - Conduits
7	3	Reactor Building - Conduits
5137-E-6313		Charging Pump Room Control Panel Layout
SH. 1	7	
2	1	
3	0	
5137-E-6314		Turbine Deck Control Panel Layout
SH. 1	6	
2	1	
5137-E-6318	5	Mimic Bus Panel Layout
5137-E-6319		Transfer Switch Panel V1-8A and V2-14A
SH. 1	3	
2	0	

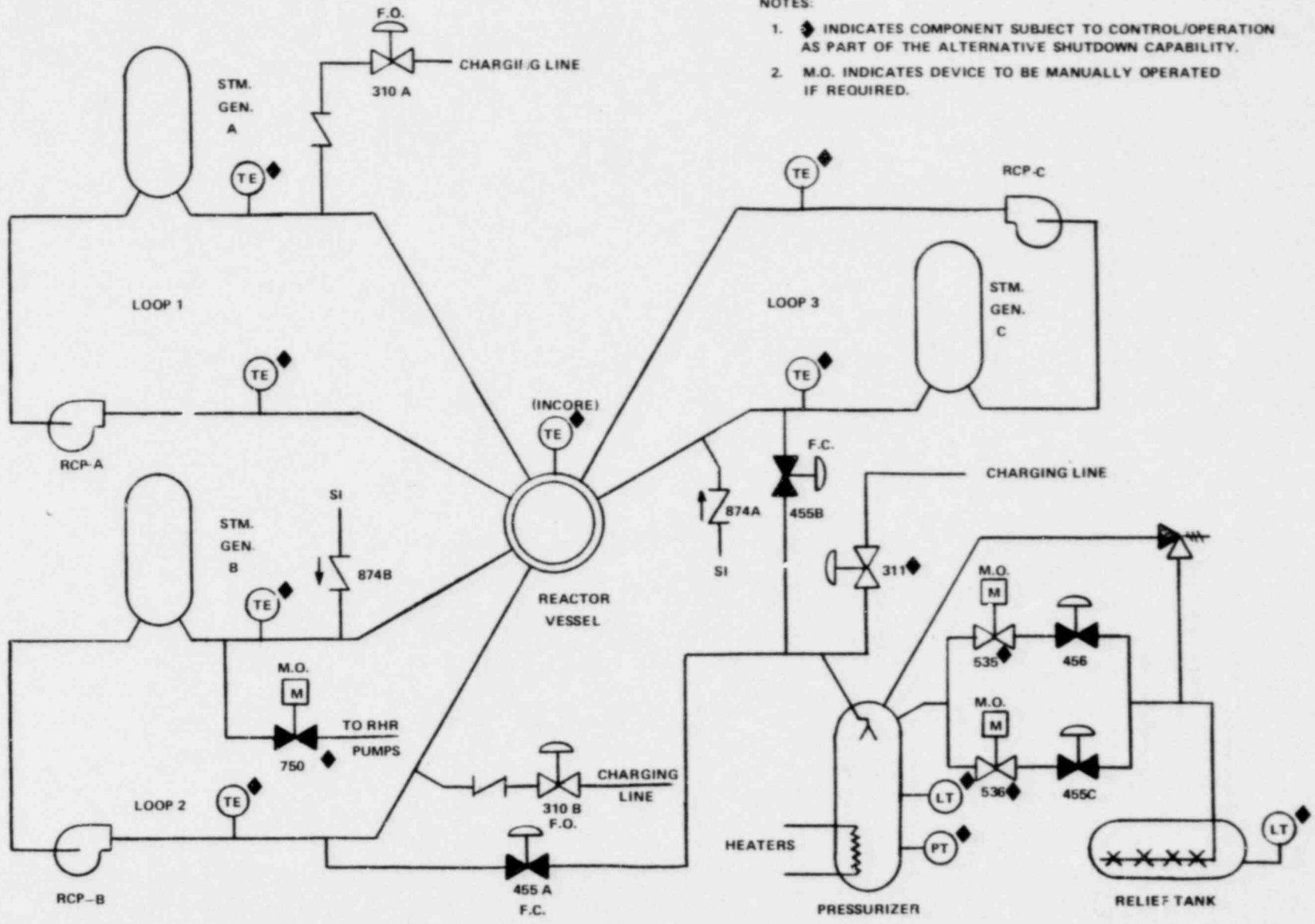

NOTES:

1. INDICATES COMPONENT SUBJECT TO CONTROL/OPERATION AS PART OF THE ALTERNATIVE SHUTDOWN CAPABILITY.
2. M.O. INDICATES DEVICE TO BE MANUALLY OPERATED IF REQUIRED.

REACTOR COOLANT SYSTEM
 FIGURE 1, SHEET 1

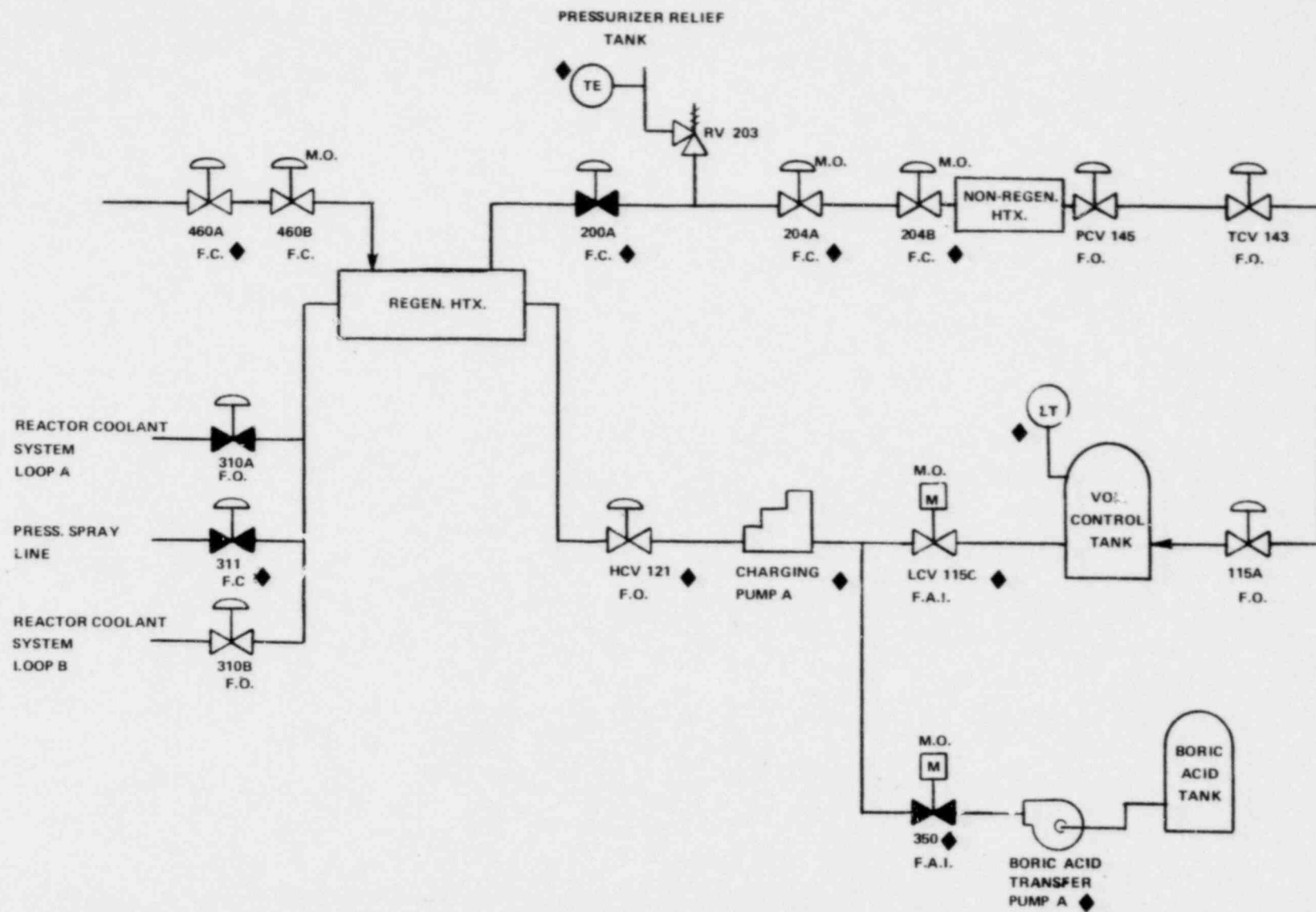

LETDOWN AND CHARGING SYSTEMS
 FIGURE 1, SHEET 2

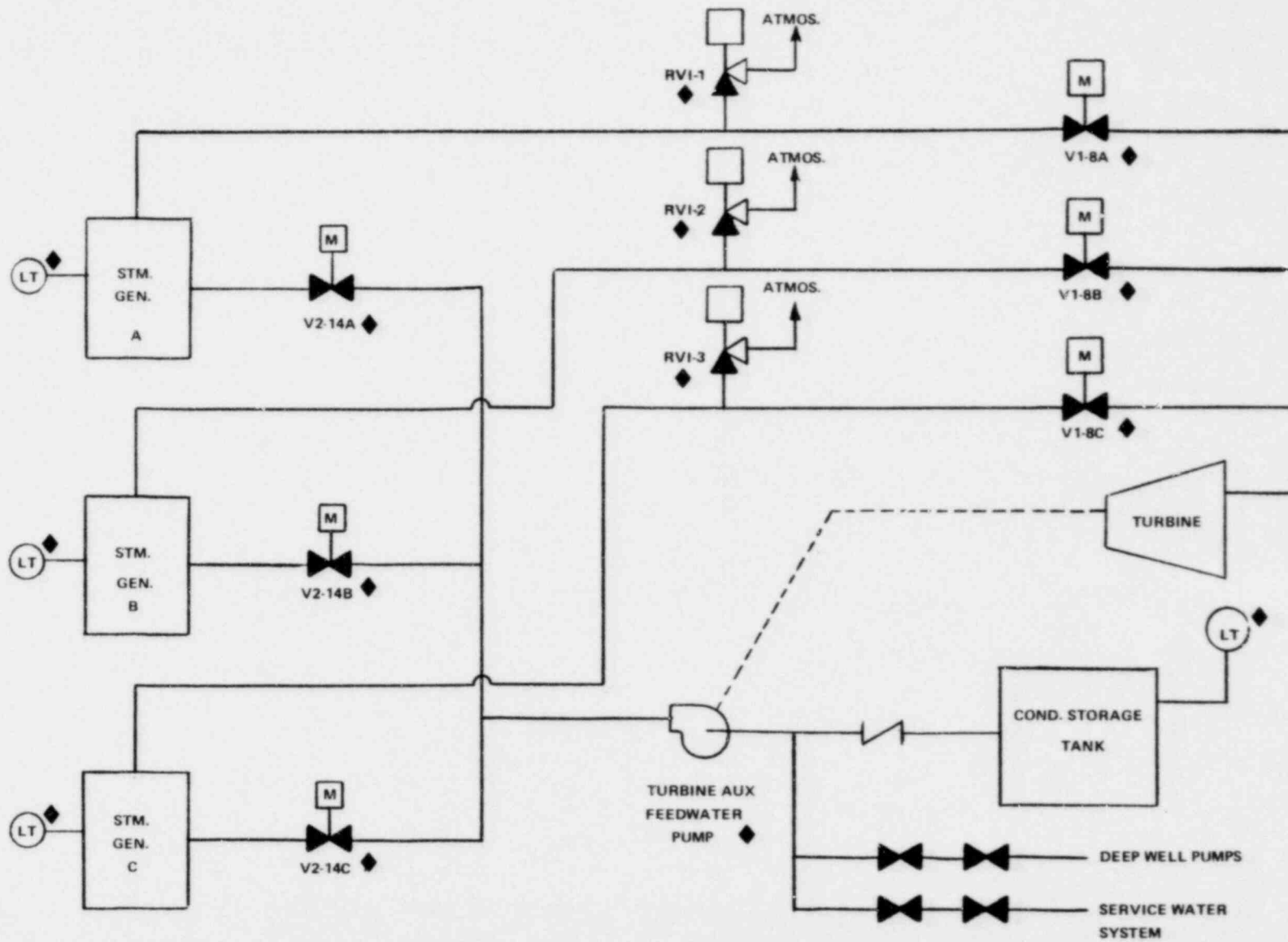

FEEDWATER, CONDENSATE AND STEAM EXTRACTION SYSTEMS
 FIGURE 1, SHEET 3

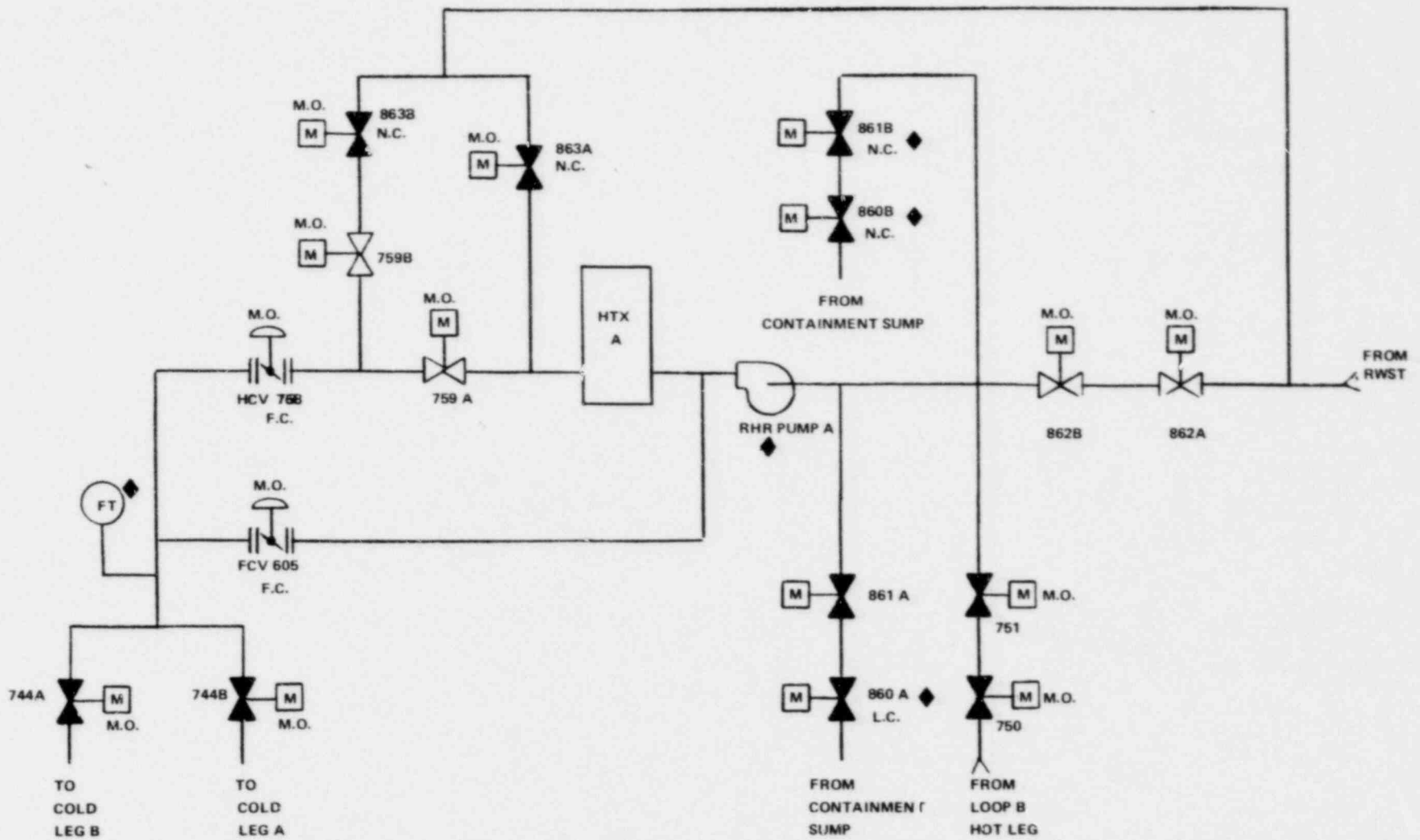

RESIDUAL HEAT REMOVAL SYSTEM
 FIGURE 1, SHEET 4

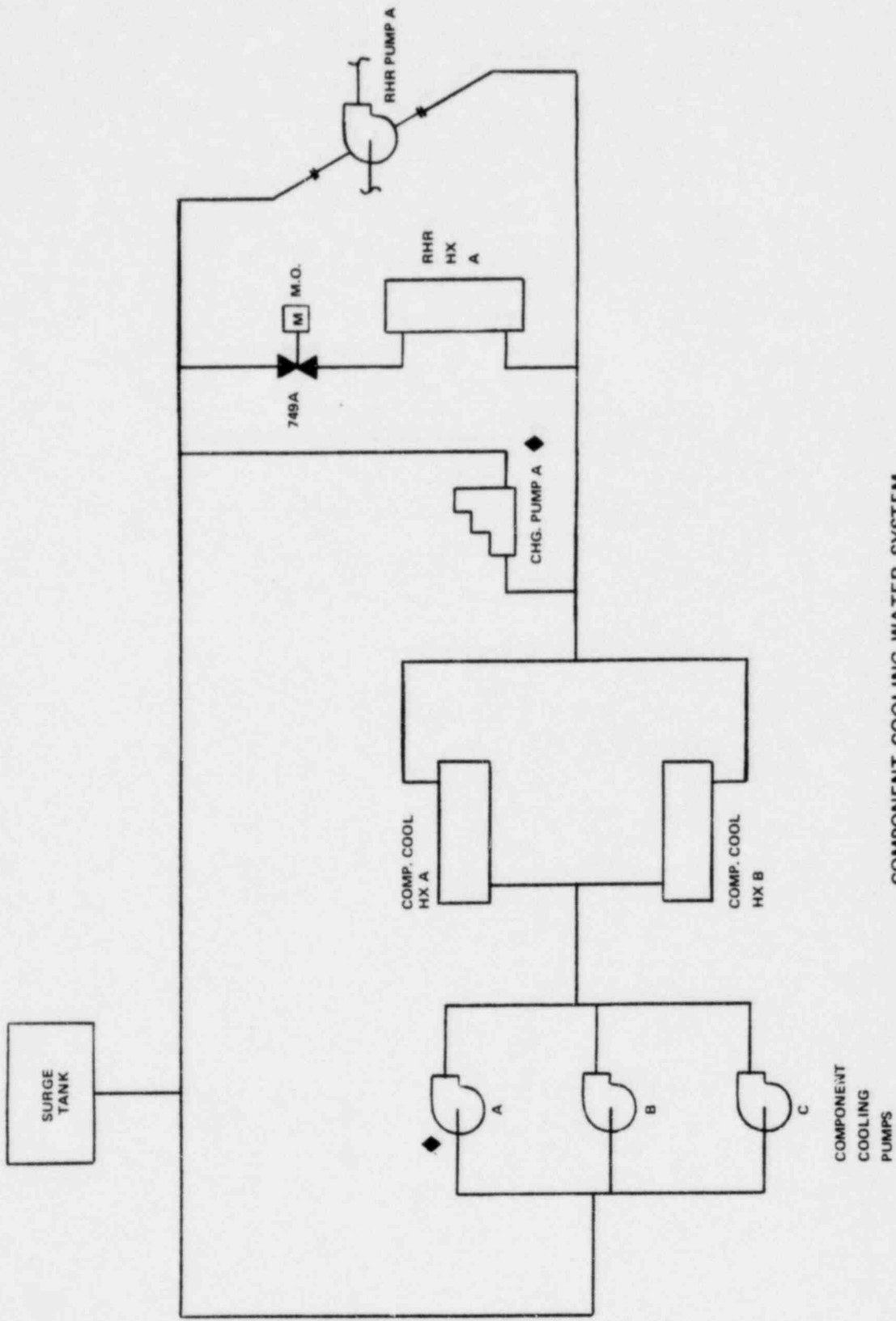

COMPONENT COOLING WATER SYSTEM
 FIGURE 1, SHEET 5

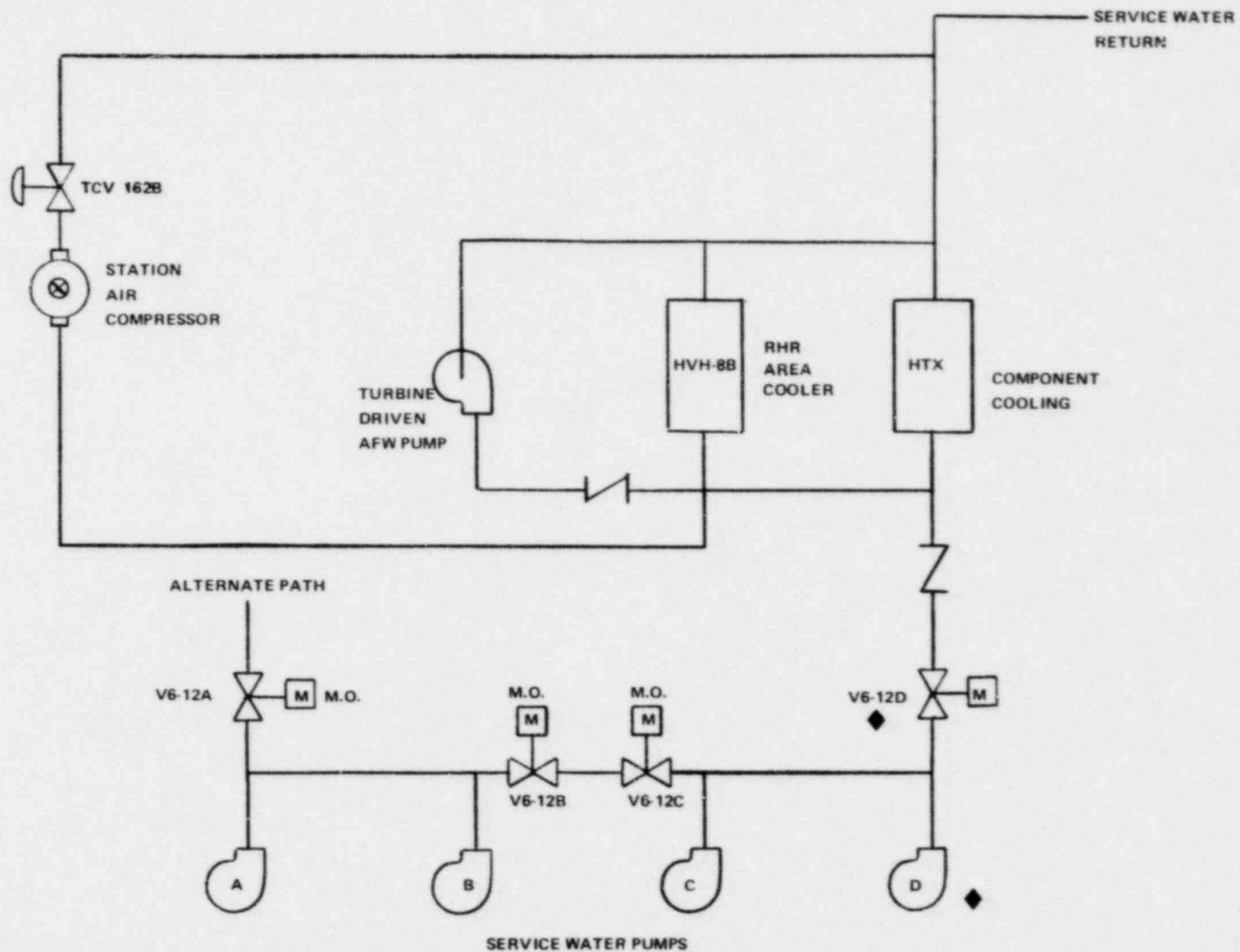

SERVICE WATER SYSTEM
 FIGURE 1, SHEET 6

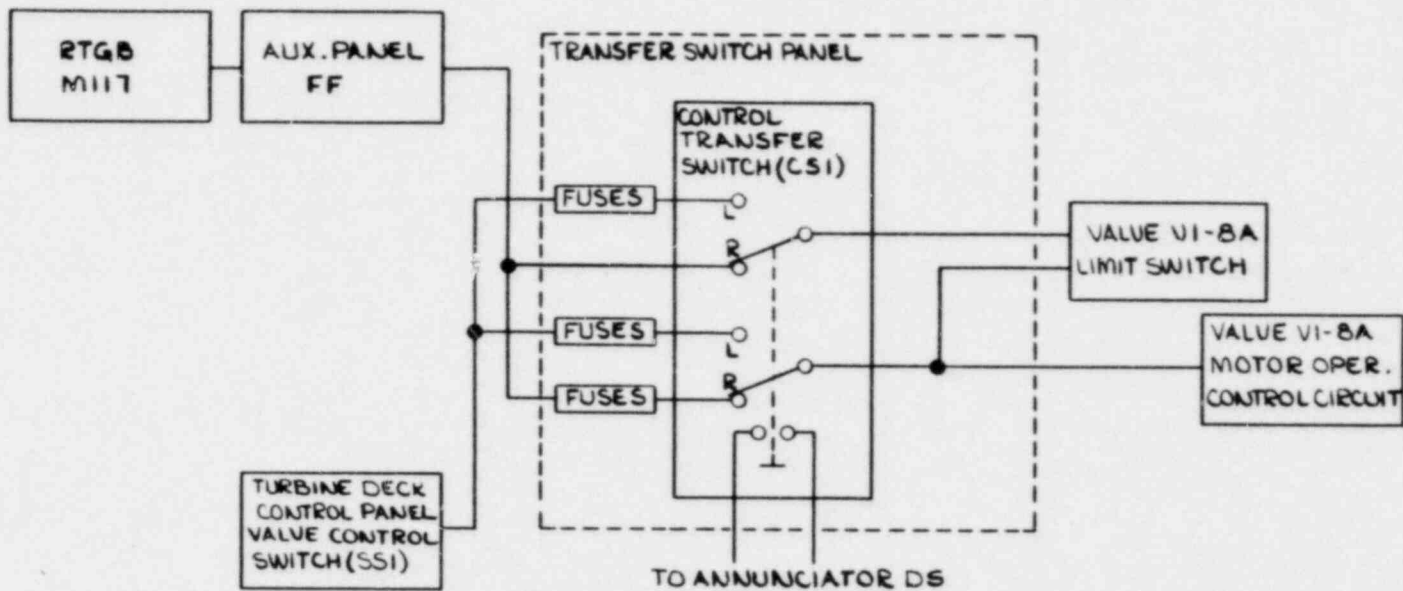

NOTES

1. SWITCH CSI IS SHOWN IN REMOTE CONTROL POSITION.
2. REFER TO NUS DRAWING 5137-E-6101, -6109, -6218, -6314 & -6318.

FIGURE 2
STEAM DRIVEN FWP STEAM SHUTOFF VALVE V1-8A

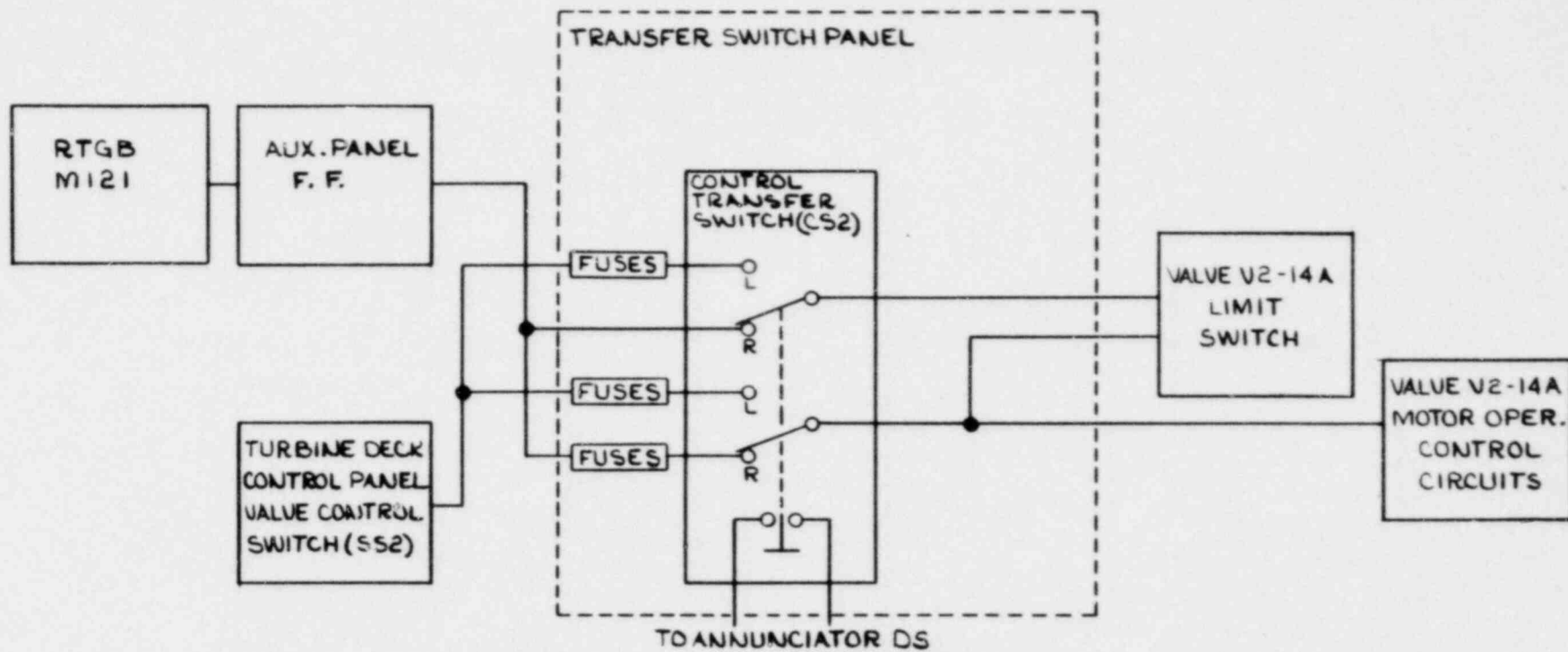

NOTES

1. SWITCH CS2 SHOWN IN REMOTE CONTROL POSITION.
2. REFER TO NUS DRAWINGS 5137-E-6109, -6115, -6219, -6314 & -6319.

FIGURE 3
STEAM DRIVEN FWP STEAM SHUTOFF VALVE V2-14A

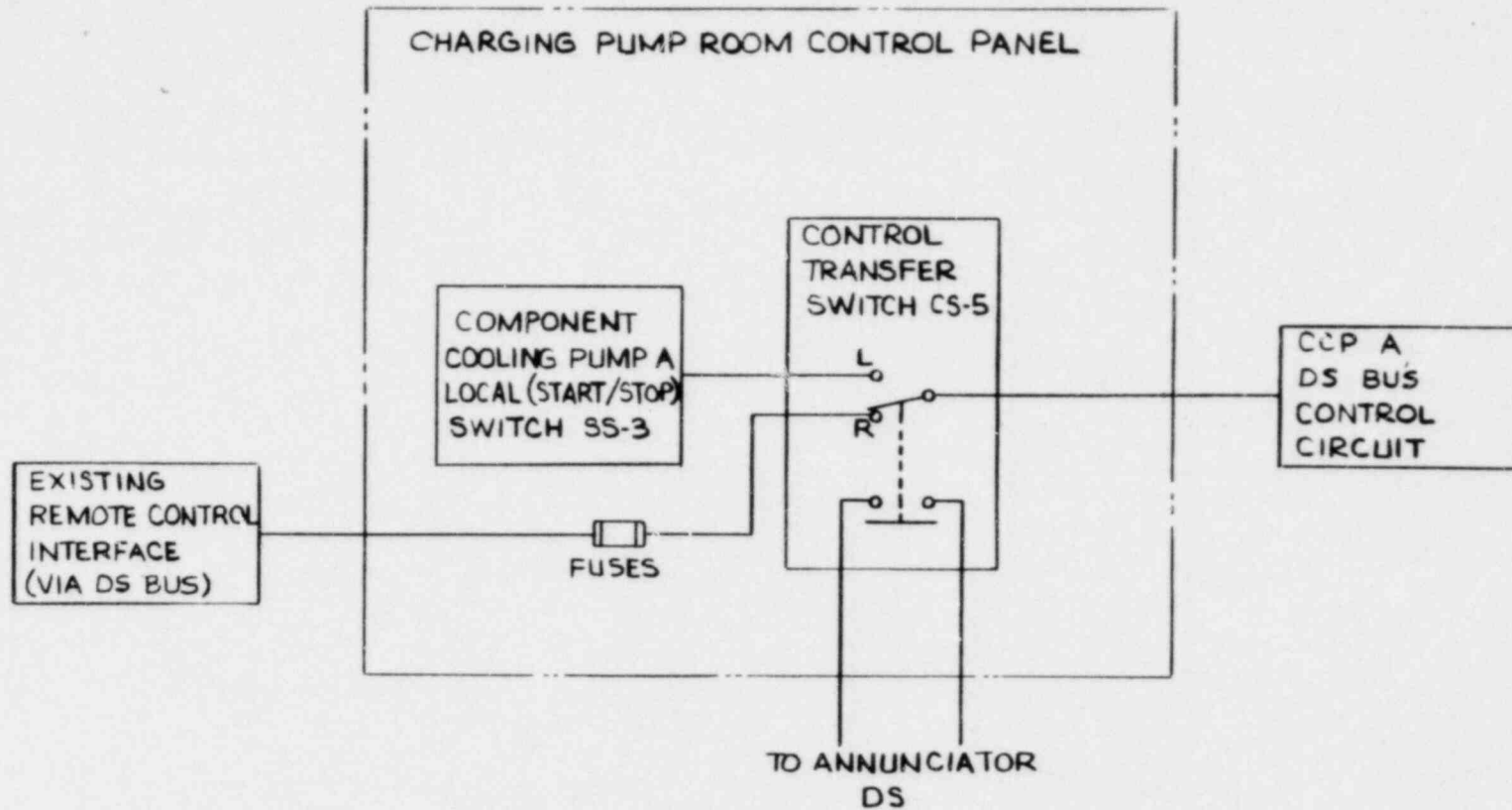

NOTES:

1. SWITCH CS-5 SHOWN IN REMOTE CONTROL POSITION
2. REFERENCE: NUS DRAWINGS 5137-E-6110, 5137-E-6211, AND 5137-E-6313

FIGURE 4
COMPONENT COOLING PUMP 'A' CONTROL TRANSFER.

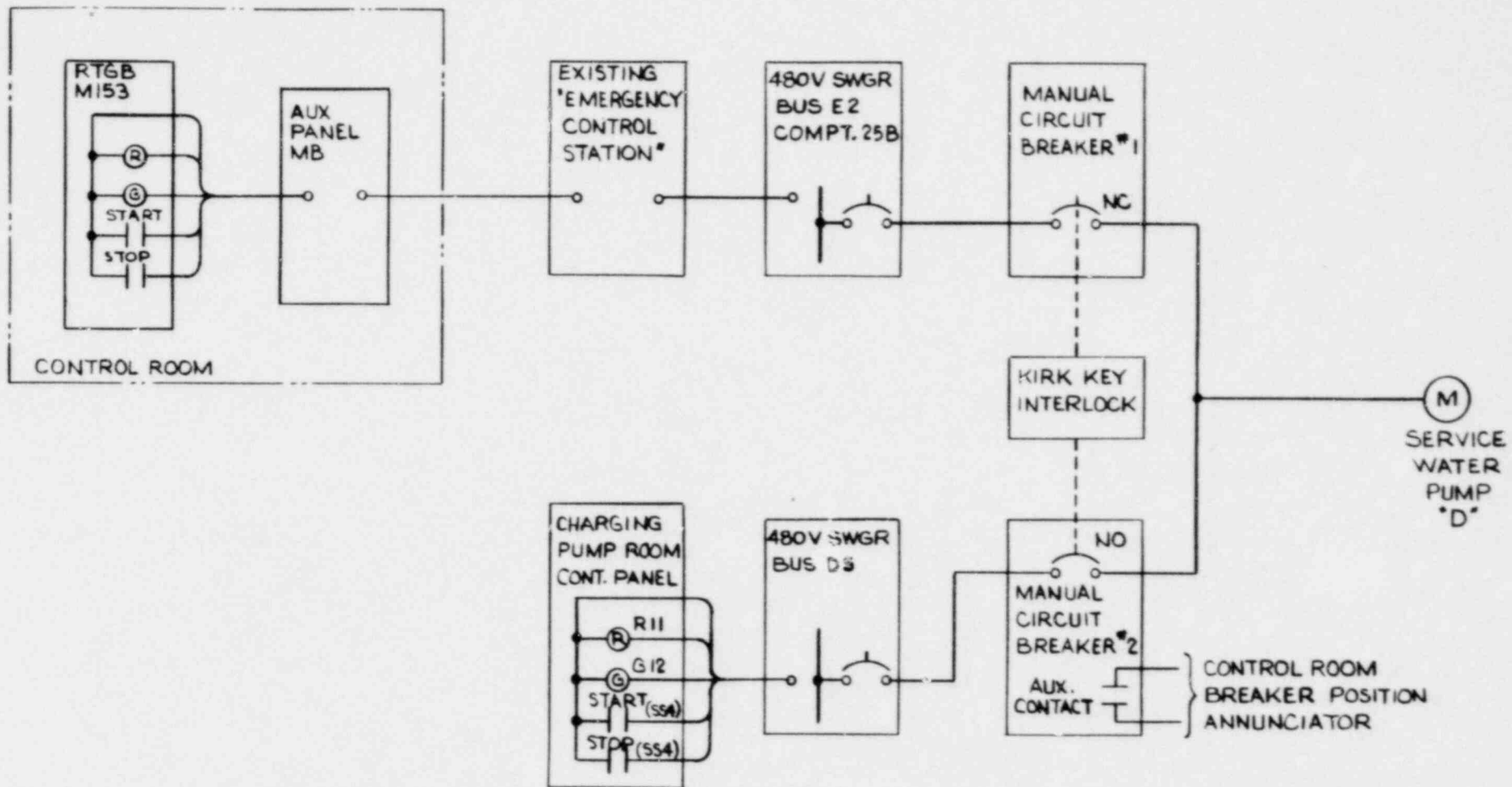

NOTE:

1. REFER TO NUS DWG 5137-E-6000, SHT. 1-4 FOR WIRING DETAILS

FIGURE 5
SERVICE WATER PUMP 'D'

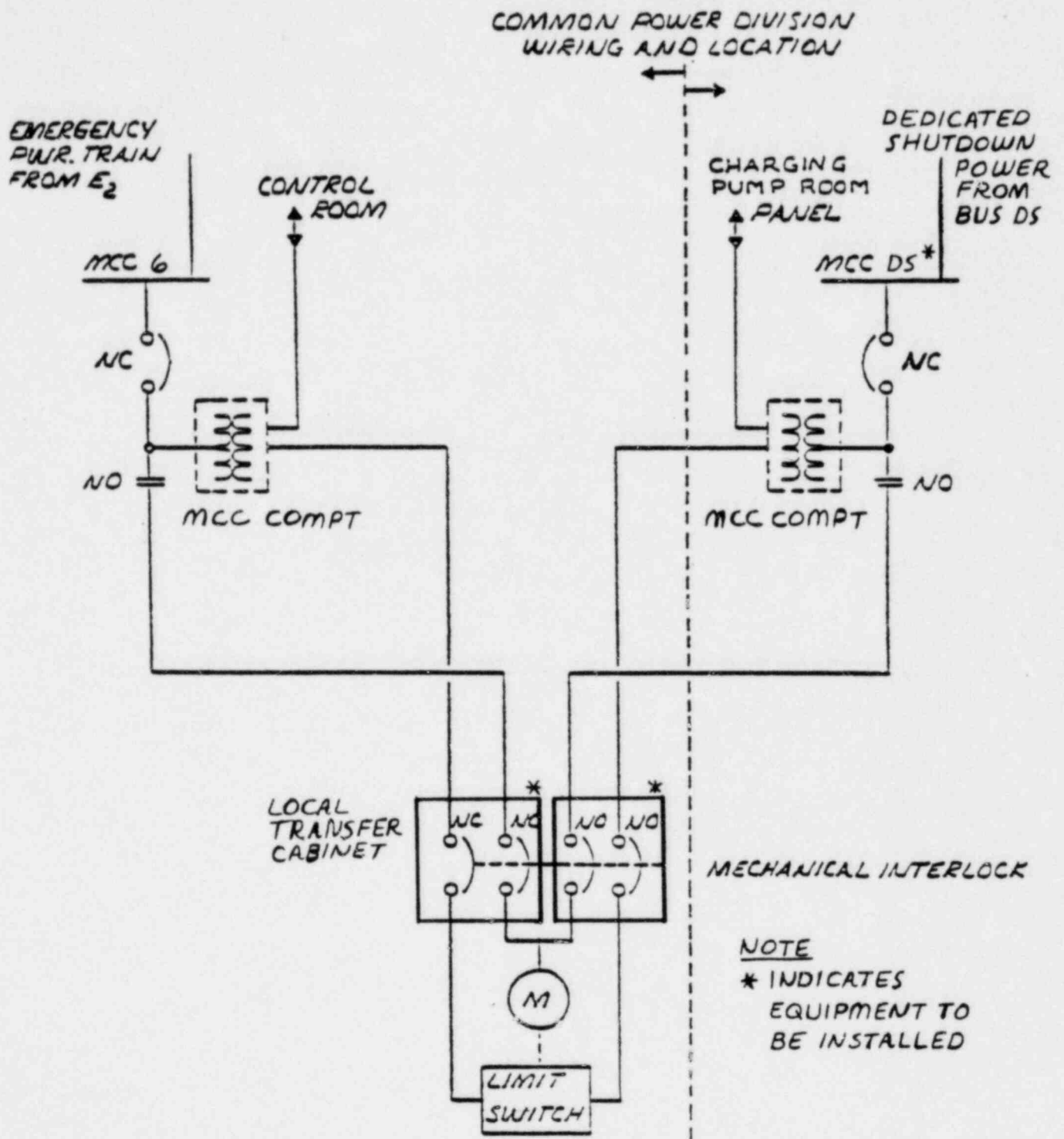
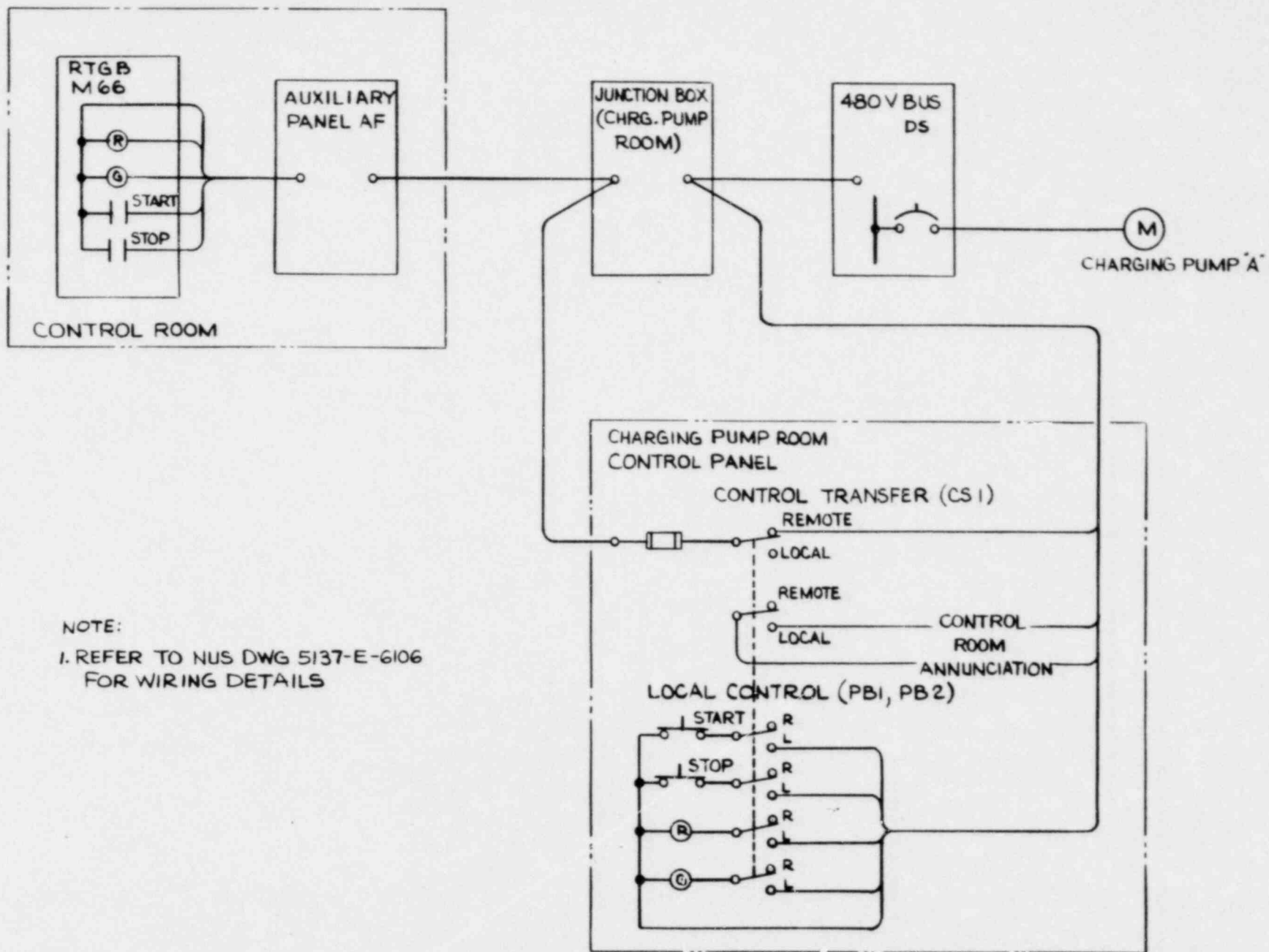

FIGURE 6
SERVICE WATER DISCHARGE VALVE V6-12D



NOTE:
 1. REFER TO NUS DWG 5137-E-6106
 FOR WIRING DETAILS

FIGURE 7
 CHARGING PUMP 'A'

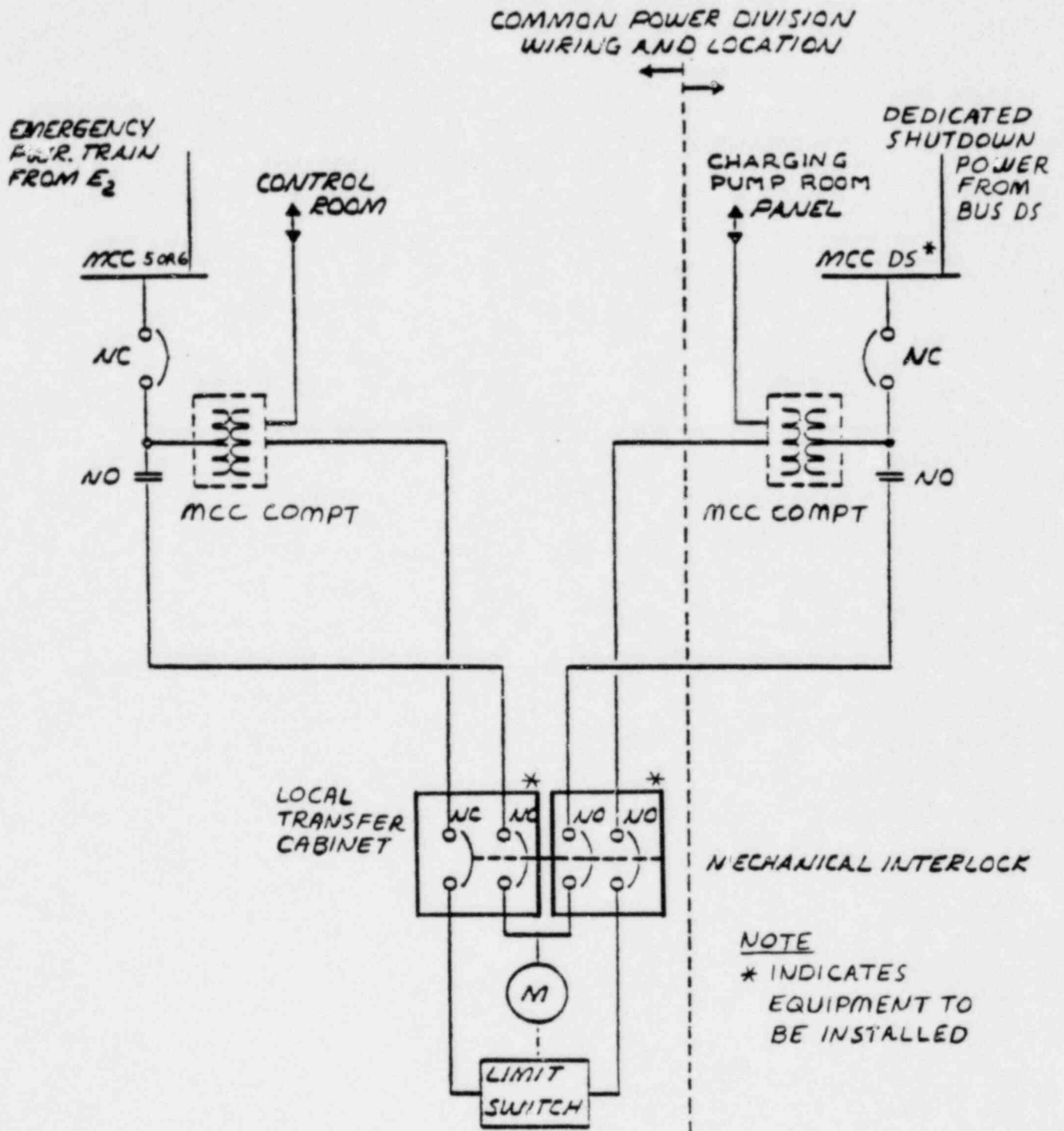
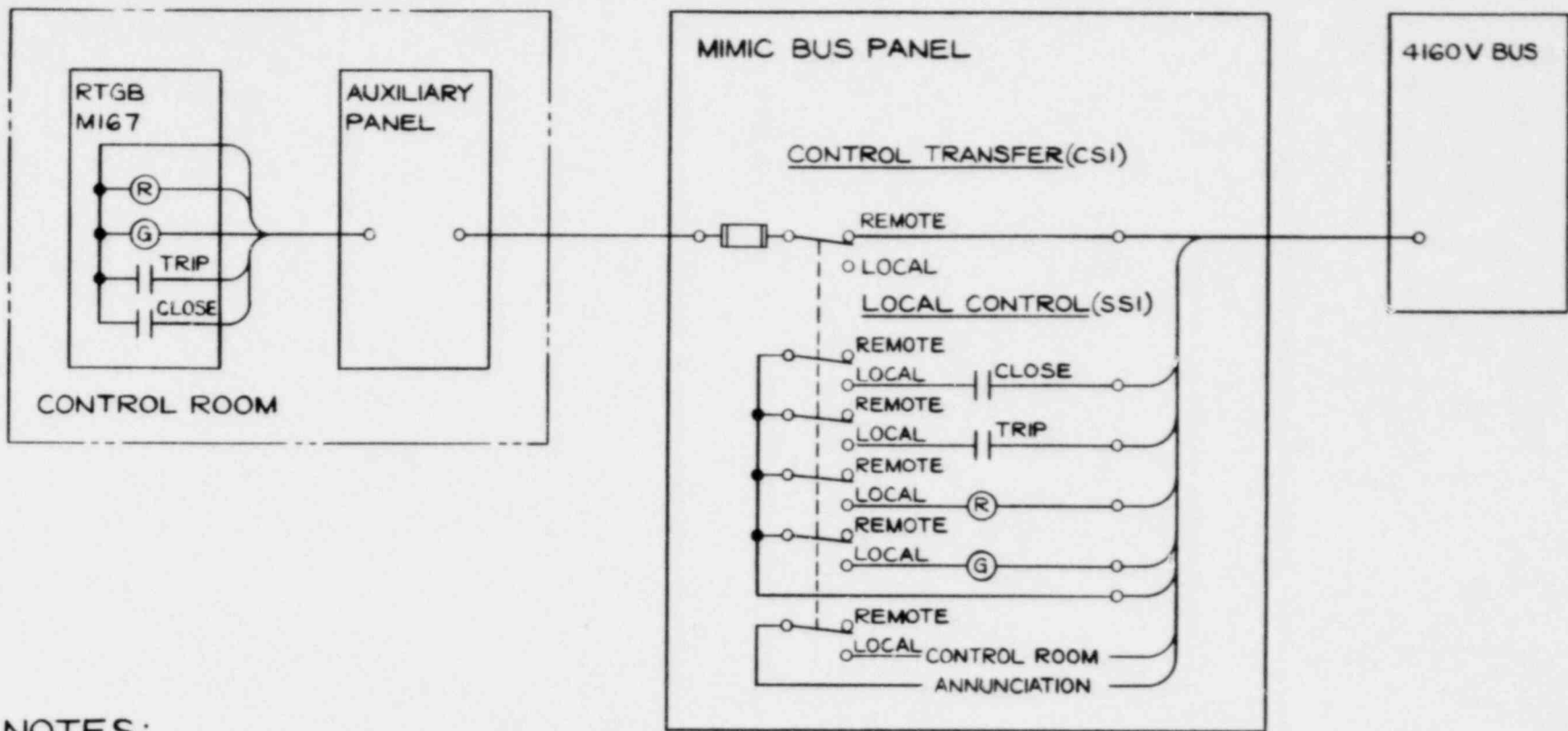

FIGURE 8
TYPICAL VALVE CONTROL MODIFICATION



NOTES:

1. THIS SCHEMATIC IS TYPICAL FOR BREAKER CONTROLS ON THE MIMIC BUS PANEL, AND APPLIES TO THE FOLLOWING BREAKERS:

2. REFER TO NUS DWG. 5137-E-6213 FOR WIRING DETAILS.

<u>CIRCUIT BREAKER</u>
4160V BUS 3, CUB. 17
480V BUS 3, CUB. 16B
480V BUS 3, CUB. 15B
4160V BUS 3, CUB. 15
4160V BUS 3, CUB. 19

<u>MIMIC BUS PANEL CONT. SWS.</u>
CS 3 SS 3
CS 12 SS 12
CS 10 SS 10
CS 7 SS 7
CS 13 SS 13

FIGURE 9
TYPICAL MIMIC PANEL BREAKER CONTROLS

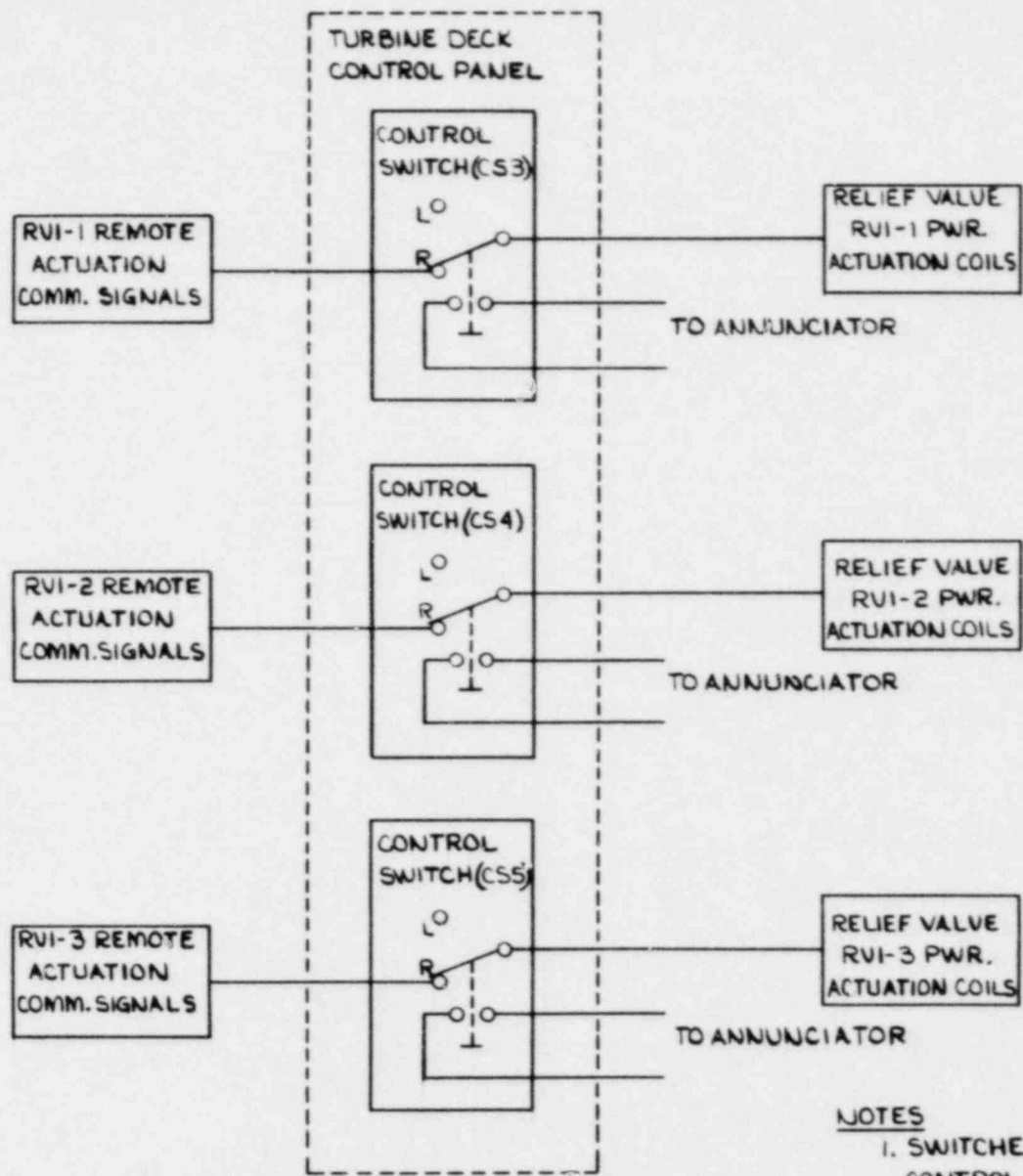

NOTES

1. SWITCHES SHOWN IN REMOTE CONTROL POSITION.
2. REFER TO NUS DRAWING 5137-E-6109, -6220 & -6314.

FIGURE 10
STEAM DUMP VALVE CONTROL

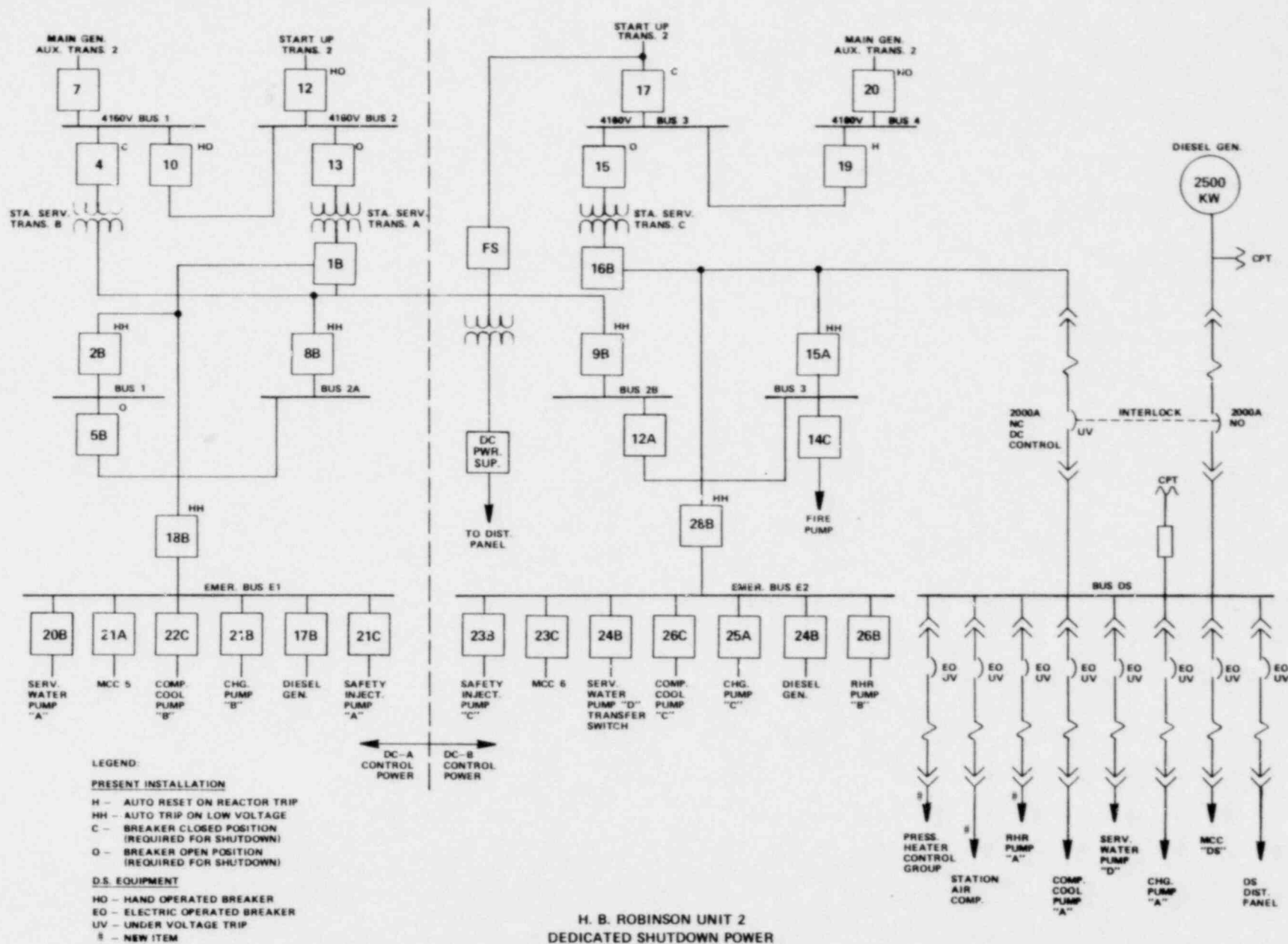

FIGURE 11
Sheet 1 of 2

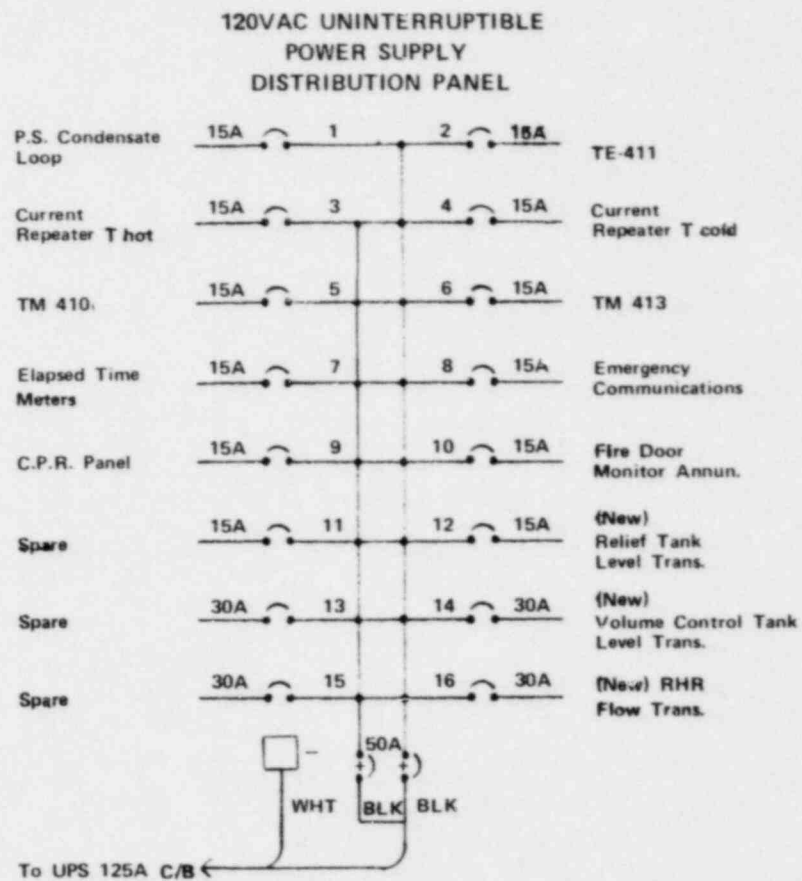
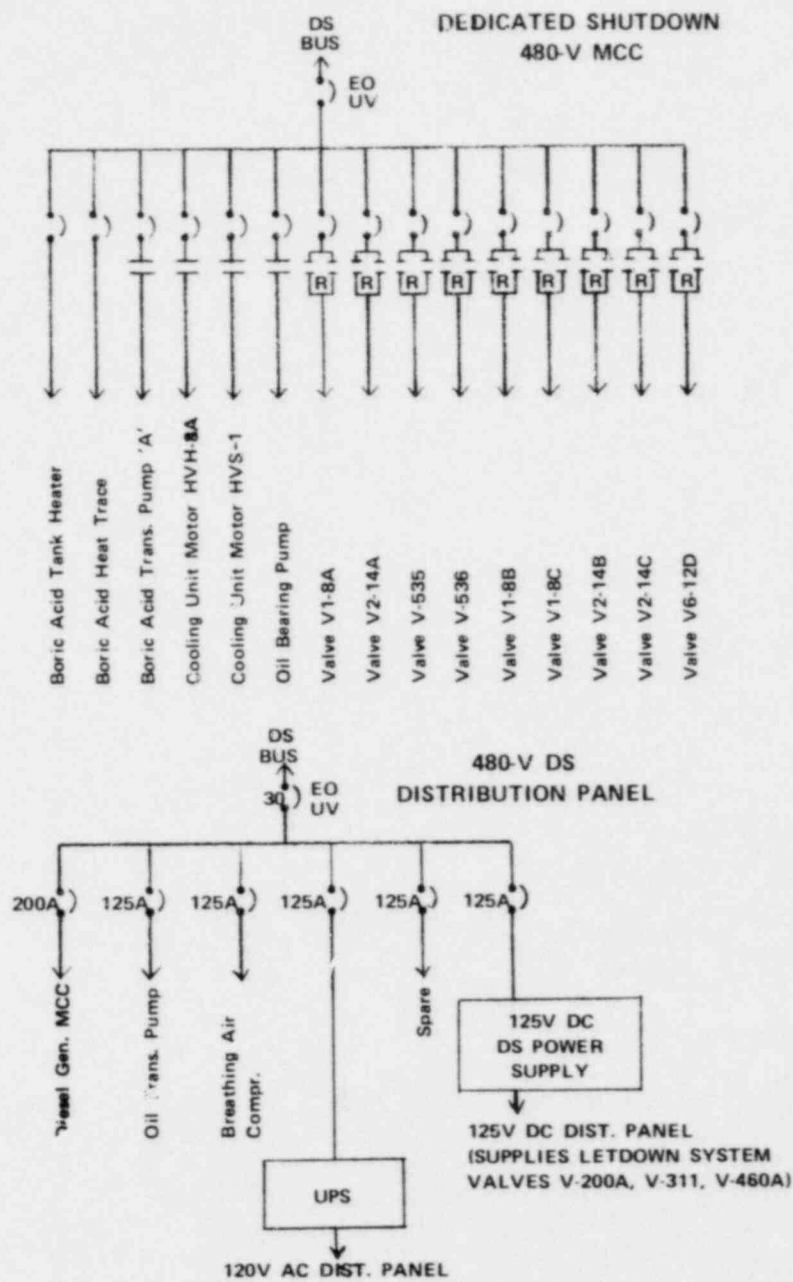

FIGURE 11
Sheet 2 of 2

8(b) System design by drawings which show normal and alternate shutdown control and power circuits, location of components, and that wiring which is in the area and the wiring which is out of the area that required the alternate system.

Hot Standby Capability

A description of the systems used to provide normal and alternative shutdown capabilities is given in the response to question 8(a).

All new components that provide power or control capabilities for the dedicated shutdown system hot standby capability have been located so that alternate power sources or control stations will not be affected by a fire that could damage the normal shutdown systems. In addition, all conduits and cable for the dedicated shutdown systems have generally been routed through areas that will not be affected by fires that could damage systems normally required for shutdown.

Where it was not possible to route redundant cables through separate fire areas (e.g., inside containment), alternative separation provisions in accordance with 10CFR50, Appendix R, Section III G have been installed to provide equivalent separation.

In some cases existing power and control cables for the normal shutdown equipment have also been rerouted to avoid hazardous areas. All new cable has been installed in rigid steel conduit routed through areas remote from cables presently used for the normal shutdown systems.

The location of all new control panels and equipment and the routing of all new wiring and conduits required for the dedicated shutdown system hot standby capability are shown in detail on NUS Drawing 5137-E-6311, Sheets 1 through 7.

Table 3 is a matrix that summarizes the location of all cables involved in the existing dedicated shutdown system and identifies the fire zones through which the cables for each system are routed. (Actual cable/conduit routing details are provided in the design documentation listed on Table 2.) Although Table 3 describes equipment associated with the existing hot standby capability, several items shown on the table have not yet been installed. These modifications, which are identified in the "Remarks" column as MR - Modification Required, are presently at the conceptual design stage and will

be implemented concurrently with the cold shutdown modifications. The cable routing guidelines provided by Table 3 will be used in developing the actual cable/conduit routing design.

Cold Shutdown Capability

At the present time, the modifications associated with establishing a dedicated cold shutdown capability are at the conceptual design stage. Consequently, detailed design drawings of cold shutdown cable and conduit routing have not yet been developed. However, Table 4 is a matrix that identifies the proposed routing for cold-shutdown cables. (See page A-8, Repair Procedures for Cold Shutdown.)

The proposed cable routes have been selected in accordance with the same criteria used in the development of the existing hot-standby capability. Where practicable, circuits serving redundant shutdown-related functions will be routed through separate fire areas; where this level of separation cannot be achieved, alternative measures (as espoused in 10CFR50, Appendix R, Section III G, or their equivalent) will be applied to ensure that adequate separation is maintained.

Table 3
Location of Hot Standby Equipment and Cabling by Fire Zone

Safe Shutdown Component	4	3	6	8	9	10	11	12	13	15	15	17	19	20	22	23	24	25	26	27	28	TB	WH	OS	IS	Remarks		
<u>Letdown System</u>																												
(Valve positions indicated for loss of air)																												
<u>Valves</u>																												
LCV460A					C					C			C	C	C	C	C	X/C			C						FC	
LCV460B						C				C			C	C	C	C	C	X/C			C						FC	
200A,B,C					C					C			C	C	C	C	C	X/C			C						FC	
204A,B										C			C	C	C	C					X/C						FC	
PCV145										C			C	C	C	C					X/C						FO	
TCV143										C			C	C	C	C					X/C						FO	
LCV115A	X/C									C			C	C	C	C					X/C						FO	
<u>Charging System</u>																												
(Valve positions indicated for loss of air)																												
<u>Charging Pump A</u>																												
<u>Valves</u>																												
LCV115C	X/P/C																				P/C	P/C	P/C					
HCV121									C	C			C	C	C	C					X/C						FAI	
350									C	C			C	C	C	C					X/C						FO	
310A					C					C			C	C	C	C	C	X/C									MO	
310B						C				C			C	C	C	C	C	X/C									FO	
Pressurizer Pressure	C/P									C								C	X/C		C	P	C/P				FO	
Pressurizer Level	C/P									C								C	X/C		C	P	C/P					
<u>Feedwater System</u>																												
<u>Steam Driven FWP</u>																												
Aux. Oil Pump																						X/P					MR	
<u>Valves</u>																												
V2-14 A											P	P										X/P/C	P					
RV1-1																						X/C					MO, Gas Power	
RV1-2																						X/C					MO, Gas Power	
RV1-3																						X/C					MO, Gas Power	
V1-8A												P	P								X/C/P			P				
Loop Temp Th HLA	C					C/P											C	X/C	C	C/P	P							
Loop Temp Tc HCA	C					C/P											C	X/C	C	C/P	P							
Condensate Tank Level	C																						C/P	C/P				
Steam Gen. Levels 1,2,3	C					C											C	X/C	C	C/P	P							
<u>Comp. Cooling Water Sys.</u>																												
Comp Cool Water Pump A	C	P									C	C										P/C		C				
Comp Cool HXB		X																										
Comp Cool Surge Tank		X																										
<u>Service Water System</u>																												
Service Water Pump D	C	P/C									C	C										C	P/C	C	P/C	P/C		
Valve																												
V6-12D		P									P	P										C	X/C	C				

Table 3
Location of Hot Standby Equipment and Cabling by Fire Zone (Continued)

Safe Shutdown Component	4	5	6	8	9	10	11	12	13	15	16	17	19	20	22	23	24	25	26	27	28	TB	WH	OS	IS	Remarks	
Neutron Mon NPI	C					X/P											C				C	P					
<u>HVAC System</u>																											
HVS-1 Fan							P/C	P/C		X/P	P				C												MR
<u>Instrument Air System</u>																											
Primary Air Comp																						X/P					MR
Valve PCV 1716				X																							NO
<u>Power Supplies</u>																											
DS-Bus																						X/P			P		
MCC-5		P					X/P	P	P												P	P	P	P			
MCC-DS		P												X/P								P/C					MR, Pwr. from DS bus.

Legend:

- MO = Manual operation - i.e., valve override
- MR = Modification required to provide routing as listed
- P = Power cables
- C = Control or instrument cables
- X = Location of equipment
- TB = Turbine building
- WH = Waste holding tank area
- OS = Outside of auxiliary building
- IS = Intake structure area
- FC = Fail closed
- FO = Fail open
- FAI = Fail as is

Table 4
Location of Cold Shutdown Equipment and Cabling by Fire Zone

Safe Shutdown Component	4	5	6	8	9	10	11	12	13	15	16	17	19	20	27	23	24	25	26	27	28	TB	WH	OS	15	Remarks	
<u>Letdown System</u>																											
<u>Valves</u>																											
LCV460A						P											P	X/P			P						MR, FC
LCV460B																		X									MO, FC
200A						P											P	X/P			P						MR, FC
204A, B																					X						MO, FC
PCV145																					X						FO
TCV143																					X						FO
LCV115A																					X						FO
Non-Regen. HX																											
Vol. Control Tank Lv 535,536	C																										
	C					P/C											P/C	X/P/C			P/C						MR
<u>Charging System</u>																											
Charging Pump A		X/P/C																				P/C	P/C	P/C			
Boric Acid Pump A		C	X/P																								MR
Regen. Hx.																		X									
Boric Acid Heat Tank & Trace A						P					P/C																MR
<u>Valves</u>																											
LCV115C		X																									MO
HCV121				X/C																							MO
311		C				C			P/C								P/C	X/C			C	C					MR
310A																		X									MO
310B																		X									MO
350		X/C																									MO
865A																		X									MO
865B																		X									MO
865C																		X									MO
Pressurizer Pressure	C/P						C										C	X/C			C	P	C/P				
Pressurizer Level	C/P						C										C	X/C			C	P	C/P				MR
Pressurizer Heaters	C					P			C								P	P/X			P	C/P	C				MR
<u>Feedwater System</u>																											
Steam Driven FWP																							X/P				MR
Aux. Oil Pump																											
<u>Valves</u>																											
V2-14 A, B		P						P	P	P													X/P/C				MO
V2-6 A, B																							X/P				MO
RV1-1																							X				MO
RV1-2																							X				MO
RV1-3																							X				MO
V1-8A									C	P													X/P/C		P		
V1-8B, C			P/C																				X/P/C				MR
Loop Temp Th HLB, HLC	C									C/P							C	X/C	C		C/P	P					MR

Table 4
Location of Cold Shutdown Equipment and Cabling by Fire Zone (Continued)

Safe Shutdown Component	4	5	6	8	9	10	11	12	13	15	16	17	19	20	22	23	24	25	26	27	28	TB	WH	OS	IS	Remarks	
Neutron Mon NPI	C					X/P											C				C	P					
<u>HVAC System</u>																											
HVS-1 Fan		P/C								X/P	P												P				MR
<u>Instrument Air System</u>																											
Primary Air Comp.																							X/P				MR
<u>Valve</u>																											
PCV 1716				X																							MO
<u>Power Supplies</u>																											
MCC-DS																							X/P				MR
DS-Bus																							X/P		P		MR

Legend:

- MO = Manual operation - i.e., valve override
- MR = Modification required to provide routing as listed
- F = Power cables
- C = Control or instrument cables
- X = Location of equipment
- TB = Turbine building
- WH = Waste holding tank
- OS = Outside of auxiliary building
- IS = Intake structure
- FO = Fail open
- FC = Fail closed
- FAI = Fail as is

- 8(c) Demonstrate that changes to safety systems will not degrade safety systems (e.g., new isolation switches and control switches should meet design criteria and standards in FSAR for electrical equipment in the system that the switch is to be installed; cabinets that the switches are to be mounted in should also meet the same criteria (FSAR) as other safety related cabinets and panels; to avoid inadvertent isolation from the Control Room, the isolation switches should be key-locked, or alarmed in the Control Room if in the "local" or "isolated" position; periodic checks should be made to verify switch is in the proper position for normal operation; and a single transfer switch or other new device should not be a source for a single failure to cause loss of redundant safety systems).

RESPONSE

The engineered safety feature systems were designed in accordance with the applicable General Design Criteria (GDC) effective in 1968. The reactor protection system was also designed in accordance with applicable GDCs and IEEE 279, "Proposed Criteria for Nuclear Power Plant Protection Systems," August 1968. No regulatory guides were available for incorporation into the original design criteria for the engineered safety features.

The dedicated shutdown (hot standby and cold shutdown) system modification does not impact the physical integrity of any safety-related system components. The only interfaces with the existing reactor coolant system pressure boundary are for the installation of new instrument lines for new dedicated shutdown system instrumentation. The modification does not impact the system process and the dedicated shutdown system will continue to meet all of the original mechanical and operational design criteria.

The electrical portion of the modification complies with the original design criteria for engineered safety features as defined by applicable GDCs effective in 1968. The modification provides for:

Separation of Redundant Circuits

Where safety-related circuits have been modified, new wiring and components have been installed and the Control Panel is to be wired such that the separation requirements of Regulatory Guide 1.75 Rev. 2 are met. The basis for the modification (fire hazards analysis) dictates that power and control wiring for selected components (e.g., one charging pump, one service water pump) be rerouted so that cables serving redundant pumps do not pass through common fire areas.

Fault Isolation for Safety-Related Circuits and Power Supplies

Electrical isolation is provided to ensure that external faults (fire-induced) will not degrade existing or new safety-related electrical systems (see responses to items 8e and g).

Separation of Safety and Non-Safety-Related Circuits

Isolation devices and/or physical separation are provided to ensure that failures in non-safety-related circuits will not jeopardize adjacent safety-related circuits (see responses to items 8b, d, and e).

Annunciation in Main Control Room on Bypass or Assumption of Local Control

For those components provided with a "control transfer" feature, auxiliary contacts on each control transfer switch are used to provide annunciation (in the control room) when the component is switched out of its "remote control" mode.

This annunciation feature has been implemented for all auxiliary shutdown components having remote/local control capabilities.

Interlocks and Administrative Controls to Limit the Consequence of Faulted Conditions

Electromechanical key interlocks on selected circuit breakers prevent the inadvertent cross-connection or simultaneous faulting of redundant power supplies.

Seismic Installation in Safety-Related Areas or Safety-Related Cabinets

Interfaces with existing safety-related cabinets and new safety-related cabinets (e.g., charging pump room panel, transfer switch panels) and their included components have been designed to remain functional through a safe shutdown earthquake (SSE).

Single-Failure Criterion

All new safety-related components and safety-related interfaces are designed so that no single failure can cause the loss of redundant safety systems. The modifications affect only one train of redundant equipment (e.g., one charging pump, one component cooling pump). The failure of any one of these equipment trains will not initiate the failure of the redundant train; electrical and physical separation of the redundant trains have not been degraded as a result of the modification.

Cold-Shutdown Capability

The above criteria will be applied in the development of the detailed design for the cold-shutdown modification, to ensure that any additional hardware changes do not degrade existing safety-related systems.

- 8(d) Demonstrate that wiring, including power sources for the control circuit and equipment operation for the alternate shutdown method, is independent of equipment wiring in the area to be avoided.

RESPONSE

As discussed in the response to Question 8(a), the intent of the alternative/dedicated shutdown modification is to ensure the operability of at least one train of components, in the event of a fire in any single fire zone, to perform all functions required to achieve cold shutdown conditions. Several fire zones have been identified as "critical" in that cables for redundant shutdown-related components are routed through these areas. Consequently, a severe fire in one of these areas may incapacitate redundant equipment trains by destroying power and control cables or by damaging power supplies (switchgear, motor control centers, or batteries). The critical areas include the control room, cable spreading room, emergency switchgear room, and battery room.

All cables serving alternative shutdown components are routed so as to avoid these areas. In addition, the alternative shutdown cables are routed so as to avoid routing redundant cables (serving the normal and alternative device) through the same fire zone wherever possible. Where redundant circuits must be routed through the same fire zone, and adequate spatial separation cannot be achieved, separation in the form of rated fire barriers will be provided or it will be shown that other equipment is available for safe shutdown.

Power sources (480 VAC, 125 VDC, 120 VAC) for shutdown and cooldown operation are located so that the normal and alternative sources are not exposed to common fire hazards. The normal (safety-related) 125 VDC and 120 VAC sources are located in the battery room and emergency switchgear room. The dedicated 125 VDC and 120 VAC sources are located in the 4 KV switchgear room of the turbine building which is physically remote from the battery and emergency switchgear rooms. The dedicated shutdown 480-VAC bus and motor control center are also located in the 4 KV switchgear room of the turbine building. Routing of cables connected to these power sources will be in accordance with the separation criteria previously described. Cable routing by fire zone is provided on Table 3 and Table 4 in the response to Question 8(b).

8(e) Demonstrate that alternate shutdown power sources, including all breakers, have isolation devices in control circuits that are routed through the area to be avoided, even if the breaker is to be operated manually.

RESPONSE

Detailed control wiring diagrams for existing and modified plant equipment involved in the alternative shutdown system are listed on Table 2. The following paragraphs discuss the methods used to isolate power and control circuits of the alternative shutdown equipment from those used for normal shutdown.

Steam-Driven Feedwater Pump Shutoff Valves V1-8A and V2-14A

Figures 2 and 3 are simplified control diagrams for these two valves. Transfer switches have been provided on a panel in the auxiliary building to transfer control of the valves to a control panel located on the turbine deck. When the transfer switches are moved to the "local" position all control circuits for these valves routed to the main control room or to auxiliary panel "FF" are effectively isolated from the alternative control circuits.

In the event that a fire or other event causes a short circuit in the normal (remote) control circuits before the transfer switches are operated, the fuses in these circuits will open before damage can occur in the alternate control circuit. These isolation fuses are coordinated with the fuses in the valve motor operator control circuits to ensure that the control power supply fuses do not open due to faults in the remote control cables. Additional fuses have been provided in the transfer switch panel to ensure that the motor operator control circuits are not damaged by faults in the local control circuits at the turbine deck control panel.

As part of the cold shutdown modification, the alternative shutdown controls for valves V1-8A and V2-14A will be modified to establish a configuration similar to that shown on Figure 8. This arrangement will permit the transfer of power and control for these valves from MCC-5 to the alternative shutdown power source and control panel in the event of a fire. The isolation features will not be degraded by this modification; the magnetic contactors and local transfer switches, along with isolators

(fuses) in control circuits, will ensure that the valve control circuits are not damaged prior to assuming control at the appropriate shutdown panel.

The control/power modification as described conceptually for V1-8A will also be implemented for the following cold-shutdown-related components:

- Feedwater pump valves V1-8B, V1-8C, V2-14B, and V2-14C
- Letdown system valve LCV-460A
- Boric acid pump A
- Boric acid heat tracing A
- Boric acid tank A heater
- Pressurizer relief line block valves V535 & V536
- Aux. pressurizer spray line valve 311
- Letdown line orifice valve 200A
- Aux. feedwater pump (turbine) oil bearing pump
- Auxiliary building inlet fan unit HVS-1

Component Cooling Pump A

Figure 4 is a simplified control diagram for component cooling pump A, showing the isolation devices for the control circuits. (Component cooling pump A has been permanently assigned to DS bus.) The transfer switch and fuses located in the charging pump room panel effectively isolate all circuits required for local control in the event of damage to existing controls in the main control room or the associated cables. The fuses are coordinated with control fuses at the circuit breaker to ensure that the breaker controls remain operative in the event of a fault in the remote control circuits.

Pressurizer Heaters (Control Group)

The pressurizer heater control group will be permanently assigned to the DS bus and will utilize control transfer features similar to those described for the component cooling Pump A. Alternative control will be located at the charging pump room shutdown panel.

Service Water Pump D

Figure 5 is a simplified control diagram for service water pump D. Manual circuit breakers 1 and 2 have been provided with interlocks to ensure that faults in the normal power supply will not affect the availability of the alternative power supply system for this pump. The alternative control for this pump is located in the charging pump room control panel and is completely separate from the normal control system; therefore, isolation devices are not required for the remote controls.

Service Water Discharge Valve V6-12D

Figure 6 shows the control system modification for valve V6-12D. The normal supply for this valve operator is from MCC-6 and control from the main Control Room. The alternative power source and control location will be from DS-MCC with a control switch at the charging pump room panel. Isolation of the circuits will be accomplished by means of the magnetic contactors in MCC-6 and DS-MCC and the transfer switches which are located inside the auxiliary building. In addition, cables for the normal and alternative control circuits are routed in areas remote from each other.

Charging Pump A

Figure 7 is a simplified control diagram for the existing control circuits for this pump. When the transfer switches are placed in the "Local" position all control circuits for this pump which is routed to the main control room are effectively isolated from the alternative control circuits. Coordinated fuses in the remote control circuits will isolate faulted parts of these remote control circuits from the alternative controls before the manual transfer is accomplished.

4KV and 480V Switchgear

The responses to questions 8a and 8k describe the methods for providing power to the shutdown loads from the dedicated shutdown bus. Those breakers controlling the supply of offsite power to the shutdown loads (DS bus) are connected to a "local-remote" breaker control panel located in the 4KV switchgear room. Figure 9 gives a typical breaker control configuration for this panel. The control power cable from the cable spreading room runs through a "quick-blow" fuse in the control panel.

The breaker to be operated is outfitted with a "slo-blow" fuse. In the event of a short in the normal control power cable, the "quick-blow" fuse would blow prior to the "slo-blow" fuse in the breaker. Thus the breaker could still be operated by switching the breaker "local-remote" switch to the "local" position. This switching is annunciated in the Control Room.

Residual Heat Removal Pump A and HVH-8B Cooler

In the event of a severe fire that damages power or control cables associated with RHR pump A, repair procedures will be effected to install temporary cables between a spare breaker on the DS bus to the RHR pump A and HVH-8B. The breaker on the DS bus will then be closed manually to apply power to the pump and cooler. Consequently, the alternative feeder is completely independent of the normal power and controls, and isolation devices are not required.

8(f) Demonstrate that licensee procedure(s) have been developed which describe the tasks to be performed to effect the shutdown method. A summary of these procedures should be reviewed by the staff.

RESPONSE

At the present time, the alternative/dedicated shutdown system is configured to provide a hot-standby operation capability. Plant shutdown operation utilizing the dedicated shutdown features is accomplished in accordance with emergency procedure (EI-18). Copies of these procedures are maintained at the Robinson Plant for NRC review and inspection.

Following completion of the cold-shutdown modification, these procedures will be upgraded to provide for the operation of additional shutdown-related equipment.

- 8(g) Demonstrate that spare fuses are available for control circuits where these fuses may be required in supplying power to control circuits used for the shutdown method and may be blown by the effects of a cable spreading room fire. The spare fuses should be located convenient to the existing fuses. The shutdown procedures should inform the operator to check these fuses.

RESPONSE

The response to question 8(e) details which equipment necessary for the operation of the dedicated shutdown system, is fused to prevent loss of all control capability due to the effects of a fire in the cable spreading room, control room, or relay room. Spare fuses will be located inside each dedicated shutdown control or switching panel and inside each breaker necessary to provide power for the alternative shutdown system. The status of all shutdown equipment (e.g., valve position, breaker position) will be indicated visually by lights on the dedicated shutdown control panels. A blown fuse common to both the normal and dedicated shutdown control power supplies (such as in a 480V breaker) would be indicated by a failure of the affected valve, breaker or pump to operate from the local control panel. Operating procedures for the dedicated shutdown system contain instructions to the operator to inspect, and if necessary, replace the appropriate fuse(s). These emergency operating procedures will be available at the Robinson Plant for NRC inspection.

- 8(h) Demonstrate that the manpower required to perform the shutdown functions using the procedures of (f) as well as to provide fire brigade members to fight the fire is available as required by the fire brigade technical specifications.

RESPONSE

As stated in Technical Specifications 6.2.2f, "A Plant Fire Brigade of at least 5 members shall be maintained on site at all times. This excludes 3 members of the minimum shift crew necessary for safe shutdown of the plant. . . ." These requirements will provide sufficient personnel to take the plant to hot standby as is presently provided with the existing dedicated shutdown equipment.

If additional manpower is required to go to cold shutdown from hot standby, credit will be taken for availability of off-site personnel from other shifts.

Following completion of the modifications required to meet Appendix R and preparation/revision of operating procedures, manpower requirements will be assessed and revisions as necessary will be made to the Technical Specification.

- 8(i) Demonstrate that adequate acceptance tests are performed. These should verify that: equipment operates from the local control station when the transfer or isolation switch is placed in the "local" position and that the equipment cannot be operated from the control room; and that equipment operates from the control room but cannot be operated at the local control station when the transfer or isolation switch is in the "remote" position.

RESPONSE

Acceptance test procedures are developed as an integral part of the plant modification packages under which the dedicated shutdown modifications are implemented. New equipment is not placed in operation, nor is (existing) modified equipment returned to operation prior to successful completion, review, and sign-off of an approved acceptance test procedure.

The procedures are designed to fully demonstrate the alternative/dedicated shutdown capabilities as follows:

- Verify operability of shutdown-related equipment from both normal and alternative shutdown controls.
- Verify operability of interlocks between normal and alternative shutdown controls.
- Verify operability of equipment status lights and annunciators.
- Verify operability of control and power transfer circuits.
- Verify operability of dedicated shutdown power sources.
- Verify operability and accuracy of dedicated shutdown instrumentation.

Completed acceptance test procedures are retained with the original plant modification packages, and are available at the Robinson Plant for NRC inspection.

- 8(j) Technical Specifications of the surveillance requirements and limiting conditions for operation for that equipment not already covered by existing Tech. Specs. For example, if new isolation and control switches are added to the service water system, the existing Tech. Specs. surveillance requirements on the service water system should add a statement similar to the following: "Every third pump test should also verify that the pump starts from the alternate shutdown station after moving all service water isolation switches to the local control position."

RESPONSE

On December 2, 1980, CP&L submitted a technical specification change request reflecting changes and additions to the plant as a result of dedicated shutdown system modifications that would take the plant to hot standby. These specifications have not been approved at this time. Following completion of the detailed design of the changes required to meet Appendix R, CP&L will amend the previous submittal with appropriate changes.

- 8(k) Demonstrate that the systems available are adequate to perform the necessary shutdown functions. The functions required should be based on previous analyses, if possible (e.g., in the FSAR, such as a loss of normal a.c. power or shutdown on a Group I isolation (BWR)). The equipment required for the alternate capability should be the same or equivalent to that relied on in the above analyses.

RESPONSE

The operational functions required to achieve and maintain a shutdown condition are identified on Table 1 in the response to Question 8(a). These functions correspond to those listed in Section 14.1.12 of the H. B. Robinson Unit 2 FSAR. The referenced section of the FSAR discusses the functions required for a shutdown following a loss of AC power; the same functions would be required for shutdown following a postulated fire. The operability of the shutdown functions for both hot standby and cold shutdown cases presume that offsite power is not available, but dedicated diesel provides power for the functions identified here.

The functions required for shutdown and the adequacy of the equipment provided to perform these functions are discussed below.

Monitor and Control Primary System Coolant Inventory

The Chemical and Volume Control System is provided with 3 charging pumps. As stated in Section 9.2.2 of the FSAR, one charging pump is adequate to provide full charging flow and the reactor coolant pump seal water supply during normal seal leakage. For this reason, the operability of one charging pump (A) was ensured by rerouting power and control circuits, and by providing an alternate control location (charging pump room panel).

In order to monitor primary coolant level and primary coolant system pressure, one channel each of pressurizer level and pressurizer pressure instrumentation have been provided on the charging pump room panel and turbine deck panel. By providing one dedicated channel for each parameter, primary coolant conditions can be adequately monitored. Consequently, instrument lines, electrical cables, and power sources have been provided for the operation of this instrumentation.

Remove Decay Heat by Means of Feedwater Addition to the Steam Generators, With Atmospheric Venting of Steam

Section 14.1.12 of the FSAR describes an acceptable method of decay heat removal using the secondary system. The auxiliary feedwater pump (steam-driven) is utilized for steam generator feedwater, because the analysis of FSAR Section 14.1.12 postulated a loss of AC power.

To effectively utilize the secondary system for decay heat removal, two steam generators must be fed; level instrumentation for all three steam generators has been provided at both local shutdown panels.

The referenced FSAR analysis takes credit for operation of the steam generator safety relief valves and power-operated relief valves in order to vent steam to the atmosphere. To ensure the availability of full steam-venting capability, the control circuits for the power-operated relief valves (3) were modified to allow local control.

Monitor Reactor Coolant Neutron Level To Assure That Subcriticality Is Maintained

While maintaining a hot-standby condition, reactor coolant neutron level can be adequately monitored by one startup range neutron channel. A dedicated instrument channel, connected to an existing detector, has been installed in the south cable vault. Reactor coolant sampling provides an alternative means of monitoring RCS neutron monitor level.

Required Auxiliary Services

Component Cooling Water:

As stated in Section 9.3 of the FSAR, one component cooling loop (pump and heat exchanger) will provide cooling for all components in the auxiliary and containment buildings. Consequently, the operability of one pump (A) has been ensured by rerouting of power and control cables and provision of an alternate (local) control capability.

Service Water:

To ensure the operability of one service water pump (D) and its associated discharge valve (V6-12D), power and control cables have been provided. Only one pumping train has been modified, because the cooling requirements are assumed to be lower than those specified in the FSAR (i.e., it is assumed that a LOCA does not occur coincident with the postulated fire). Although cooldown time is extended with reduced service water capacity, one pump will provide sufficient flow to permit cooldown operation.

Decay Heat Removal to Cold Shutdown Conditions

In order to bring the unit to cold shutdown conditions, operation of at least one RHR equipment train (pump, heat exchanger, valve train) is required. As described in Section 9.3 of the FSAR, each RHR train is capable of removing decay heat and operation of one train is adequate to achieve cold shutdown conditions (FSAR Section 9.3.1).

To ensure the operability of the RHR decay heat removal function, fire protection features will be installed to ensure the availability of one pump following a fire in the pit. As described in the response to Question 8(a), power for this pump will be available from the dedicated shutdown bus. Valve alignment will be accomplished by manual operation and system operation will be provided by manual adjustment. A dedicated channel of RHR flow instrumentation will provide flow indication on the shutdown panel in the charging pump room.

480-V AC 125-V DC Electrical Power

Refer to the response to Question 8(a). The power system includes the following:

- Redistribution of shutdown related loads to a dedicated system (DS) 480V switchgear bus. This bus is normally fed from offsite power but can be switched over (at turbine deck) to receive power from the dedicated diesel generator.

- Establishment of dedicated DC and AC power sources. A dedicated 125 VDC source will be used for operation of selected circuit breakers and valve control circuits while a UPS will supply 120-V AC source for shutdown-related instrumentation.

The switchgear allocation and DC power supply capacity associated with the dedicated shutdown diesel generator power feed have been sized to support the shutdown-related loads. The adequacy of the power supplies is supported by design calculations. No loads other than the equipment essential to shutdown operation are connected to the dedicated buses.

NRC Positions as Presented in Enclosure 2 of the Letter

1. Section III.G of Appendix R to 10 CFR Part 50 requires cabling for or associated with redundant safe shutdown systems necessary to achieve and maintain hot shutdown conditions be separated by fire barriers having a three-hour fire rating or equivalent protection (see Section III.G.2 of Appendix R). Therefore, if option III.G.3 is chosen for the protection of shutdown capability cabling required for or associated with the alternative method of hot shutdown for each fire area, must be physically separated by the equivalent of a three-hour rated fire barrier from the fire area.

In evaluating alternative shutdown methods, associated circuits are circuits that could prevent operation or cause maloperation of the alternative train which is used to achieve and maintain hot shutdown condition due to fire induced hot shorts, open circuits or shorts to ground.

Safety-related and nonsafety-related cables that are associated with the equipment and cables of the alternative, or dedicated method of shutdown are those that have a separation from the fire area less than that required by Section III.G.2 of Appendix R to 10 CFR 50 and have either (1) a common power source with the alternate shutdown equipment and the power source is not electrically protected from the post-fire shutdown circuit of concern by coordinated circuit breakers, fuses or similar devices, (2) a connection to circuits of equipment whose spurious operation will adversely affect the shutdown capability, e.g., RHR/RCS Isolation Valves, or (3) a common enclosure, e.g., raceway, panel, junction box, with alternative shutdown cables and are not electrically protected from the post-fire shutdown circuits of concern by circuit breakers, fuses or similar devices.

For each fire area where an alternative or dedicated shutdown method, in accordance with Section III.G.3 of Appendix R to 10 CFR Part 50, is provided by proposed modifications, the following information is required to demonstrate that associated

circuits will not prevent operation or cause maloperation of the alternative or dedicated shutdown method:

- A. Provide a table that lists all equipment including instrumentation and support system equipment that are required by the alternative or dedicated method of achieving and maintaining hot shutdown.

RESPONSE

This information requested is enclosed in this submittal as Table 1 in the response to Enclosure 1, Question 8(a), which provides a listing of the functions and components required for achieving and maintaining cold shutdown using the alternative shutdown mode.

- B. For each alternative shutdown equipment listed in 1.A above, provide a table that lists the essential cables (instrumentation, control, and power) that are located in the fire area.

RESPONSE

As stated in the response to Enclosure 1, Question 8(b), the dedicated shutdown modification has been completed for the hot-standby capability and the cable routings are identified on the drawings listed on Table 2. The equipment and instrumentation to be utilized for alternative shutdown (both hot-standby and cold shutdown) are listed on Tables 3 and 4. Although the cable routings for the cold shutdown related cables are conceptual at this time, Table 4 identifies the principal zones that will be occupied by the alternative/dedicated shutdown cables.

The routing of these circuits, coupled with other plant modifications, will eliminate the exposure to common high-hazard fire areas or will provide adequate spatial separation or rated fire barriers between cables serving normal and alternative devices.

The fire protection concept provided for both the hot-standby and cold shutdown system cables is to provide electrical separation by employing a dedicated power source and spatial separation by utilizing alternative fire zone routing. Where separate fire

zones are not available, appropriate fire barrier separation in accordance with 10 CFR 50 Appendix R, Section III G requirements are provided.

- C. Provide a table that lists safety-related and nonsafety-related cables associated with the equipment and cables constituting the alternative or dedicated method of shutdown that are located in the fire area.

RESPONSE

The enclosed Table 5 provides a listing of the alternative shutdown components, their power connection, wiring by fire zone, type of electrical isolation provided, and the common fire zones shared by normal shutdown equipment and wiring. The alternative shutdown circuits are currently installed for hot-standby and will be routed for cold shutdown in separate conduit, with appropriate electrical isolation at any of the alternative shutdown/normal shutdown circuit interfaces. By establishing complete physical separation with fire barriers and isolation in this manner, the cables employed for the alternative shutdown equipment are not classified as associated circuits to other normal plant circuits.

- D. Show that fire-induced failures of the cables listed in B and C above will not prevent operation or cause maloperation of the alternative or dedicated shutdown method.

RESPONSE

Any fire-induced failures of normal control and power circuits or circuits associated with the alternative shutdown cables, power supplies, or equipment will not adversely affect the shutdown operation, as a result of the following design criteria:

- I. When operating in the alternative shutdown mode, essential components will utilize AC and DC power supplies that are independent of the normal distribution systems. Only circuits required for safe-shutdown operation interface with these power sources; failures of any circuits associated with the normal distribution system will have no effect on the alternative shutdown circuits.

2. Circuits required for the alternative shutdown operation will be rerouted as indicated to avoid high-hazard fire zones occupied by normal shutdown circuits. Circuits will be rerouted in conduit, which will contain only alternative shutdown circuits. Consequently, the alternative shutdown circuits will be routed independently of all other plant circuits.
3. All interfaces between normal and alternative shutdown circuits will be provided with electrical isolation. The isolation concepts are described in the response to Question 8(e) of Enclosure 1.
 - E. For each cable listed in 1.B above, provide detailed electrical schematic drawings that show how each cable is isolated from the fire area.

RESPONSE

The dedicated shutdown system modification is not yet at the detailed design stage for cold shutdown capability; consequently, detailed electrical schematic drawings are not available. However, the isolation concepts that will be applied for the alternative shutdown cables are described in the response to Question 8(e) of Enclosure 1. Hot-standby modifications completed to date are described by the reference drawings listed on Table 2. Copies of these drawings are available as a separate enclosure. The conceptual schematic/block diagram illustrating the isolation concepts is presented as Figure 8 (see response to Question 8(e) of Enclosure 1). This diagram identifies the principal isolation components and their locations. Although Figure 8 only illustrates the isolation scheme for a motor-operated valve, the same concepts will be applied to protect alternative/dedicated shutdown circuits for pumps, circuit breakers, and other components, as required.

NRC Position

2. The residual heat removal system is generally a low pressure system that interfaces with the high pressure primary coolant system. To preclude a LOCA through this interface, we require compliance with the recommendations of Branch Technical Position RSB 5-1. Thus, this interface most likely consists of two redundant and independent motor-operated valves. These two motor-operated valves and

their associated cable may be subject to a single fire hazard. It is our concern that this single fire could cause the two valves to open resulting in a fire-initiated LOCA through the subject high-low pressure interface. To assure that this interface and other high-low pressure interfaces are adequately protected from the effects of a single fire, we require the following information:

- A. Identify each high-low pressure interface that uses redundant electrically controlled devices (such as two series motor operated valves) to isolate or preclude rupture of any primary coolant boundary.

RESPONSE

The following interfaces with the primary coolant system utilize redundant electrically controlled devices to isolate the pressure boundary:

1. Residual heat removal system suction line valves V-750 and V-751 comprise a motor-operated valve pair (in series).
2. Pressurizer PORVs and associated motor-operated block valves: PCV-455C/V-536, PCV-456/V-535
3. Chemical and volume control system letdown line utilizes multiple air-operated valves (fail closed on loss of air) and valves V-460A and 460B are a motor-operated valve pair (in series).
4. Reactor head vent discharge line to containment or quench tank has solenoid valves 572 and 571 respectively in series with solenoid valves 567 and 568 which are in parallel. The pressurizer vent utilizes the same solenoid valves 572 and 571 in series with solenoid valves 569 and 570 which are in parallel.

- B. Identify the device's essential cabling (power and control) and describe the cable routing (by fire area) from source to termination.

RESPONSE

1. Residual Heat Removal System - Valves V-750, V-751

The control circuits for these valves have common routing in the control room, cable spread room, emergency switchgear room, auxiliary building hallway pipe alley, cable vault, and containment cable penetration and routing areas. The power circuits have common routing in the auxiliary building pipe alley, cable vault and containment cable penetration areas.

2. Pressurizer PORVs PCV-455C, PCV-456C and Block Valves V-535, V-536

The control power circuits for the PORVs and block valves have common routing in the control room, cable spreading room, emergency switchgear room, auxiliary building pipe alley, cable vault and containment cable penetration areas.

3. Chemical and Volume Control System Letdown Line

The valves associated with this system have essentially the same routing as described in (2) above.

4. Reactor Head Vent and Pressurizer Vent Liners

The valves associated with these systems have essentially the same routing as described in (2) above.

- C. Identify each location where the identified cables are separated by less than a wall having a 3-hour fire rating from cables for the redundant device.

RESPONSE

Cables associated with the redundant RHR, pressurizer PORV and block, letdown, and vent system valve pairs are routed through a number of common fire zones. Where redundant cables are routed through common zones, they are generally not separated by a 3-hour-fire barrier. The areas of exposure to common fire hazards for each redundant valve pair are possible in each of the fire areas identified in (2-B) above.

- D. For the areas identified in item 2c above (if any), provide the bases and justification as to the acceptability of the existing design or any proposed modifications.

RESPONSE

1. RHR Valves V-750 and 751

The RHR function is not required to achieve hot-standby; consequently, there is no requirement (based on time response restrictions) to control the RHR system from a central shutdown control panel. The RHR may be aligned using manual operation of valves (V-750 and 751) that are normally operated using electrical actuators.

It is recognized that rerouting of redundant circuits to avoid common fire zones or installation of barriers will not provide the required separation in all areas. The zone containing the valves will necessarily remain a vulnerable location, because of the physical proximity of the redundant valves, exposing cables, and valve actuators to a common fire hazard. As a result, the circuits for one valve in the pair will be modified so that AC power is removed under normal plant operating conditions. By removing AC power, no postulated fire-induced circuit faults can cause the normally closed valve to spuriously open.

2. Pressurizer PORVs and Block Valves (V-536, PCV-455C, V-535, and PCV-456)

The pressurizer relief block valves (V-535, V-536) are operated as normally open, motor operated valves. In the event that the associated PORV is spuriously opened by a fire-induced event, the block valve would require AC power to close the relief path. Removal of power and/or loss of air supply will cause PORVs to fail closed. The physical proximity of the valves, and exposure (of cables and actuators) to common fire hazards makes manual operation unreliable in the event of a fire in a critical fire zone. In addition, the motor-operated block valves are generally inaccessible for direct manual operation. To ensure that both pressurizer relief paths can be secured when required, the following modifications will be made:

- Reroute critical actuation circuits for valves 535 and 536 in separate conduit (downstream of disconnect switches) as required to avoid exposure

to potential fire-induced "hot shorts" to other circuits. In addition, a transfer switch scheme will provide power from the DS-MCC when normal plant power is unavailable.

- Provide remote status (position) indicators for both PORVs on the charging pump room panel.
- Provide for remote control of valves 535 and 536 for primary system pressure reduction at the dedicated shutdown panel in the charging pump room. These actuation circuits will be activated through a control transfer switch, and will be normally de-energized. The criteria and approach to ensure control circuit isolation will be as described for Question 1-8(e).

3. Letdown Orifice Valves V-200A, V-200B, V-200C, and Letdown Line Valves V-460A, V-460B, V-204A, and V-204B

The letdown system valves are designed to fail closed on loss of instrument air or control power. However, in the event of a fire in a critical fire zone, any or all of these valves may be spuriously actuated. If one or more of the letdown orifice isolation valves (V-200A, V-200B, V-200C) is spuriously opened while V-204A and V-204B are closed, a release may occur through RV-203. To control this possible release isolation valve 460A will be provided with alternative power and control by utilizing a transfer switch scheme. Valve 200A, a letdown orifice valve will also be provided with alternative power and control. The following modifications to the V-200A and V-460A actuation circuits will be made:

- Provide remote control switches (at the charging pump room shutdown panel) to permit control of valves V-460A and V-200A for shutdown to cold shutdown. Control circuit isolation described in 1-8(e) will be provided.
- Provide transfer of power from normal plant power to dedicated power source using a transfer switch scheme to ensure isolation, annunciation, etc.

- Reroute critical actuation circuits for valves V-200A and V-460A in separate conduit (downstream of disconnect switches) as required to avoid exposure to potential fire-induced "hot shorts" to other circuits.
- Manual operation of remaining letdown valves to an open condition will be conducted prior to beginning cooldown to cold shutdown status from the hot-standby condition.

Table 5. Alternative Shutdown Equipment Associated Circuits

<u>Dedicated Shutdown Component</u>	<u>Power Supply & Control Power</u>	<u>Wiring by Fire Zone</u>	<u>Isolation Provided</u>	<u>Alternate Equipment/Wiring Common Zones</u>
<u>Letdown System</u>				
Valves				
LCV 460A	DP	Zones 24,10,28,4,TB	Switch to new controller--DS power	28,24
LCV 460B	MO	NA	Disconnect from power panel	NA
200A	DP	Zones 25,24,10,28,4,TB,13	Switch power to DS bus	25,24,28
204A and B	MO	NA	Disconnect from power panel	NA
PCV 145	MO	NA	Disconnect from power panel	NA
TCV 143	MO	NA	Disconnect from power panel	NA
LCV 115A	MO	NA	Disconnect from power panel	NA
Vol. control tank Level sensor/ind. 535,536	DP	Zones 4,15,TB	Power from DS bus	15
	DP	Zones 25,24,10,28,4,13	Power from DS bus	25,24,28,13
<u>Steam & Feedwater Systems</u>				
Steam driven FWP Aux. oil pump	DP	Zone TB	Power from DS bus, control-at TB	NA
Valves				
V2-14A	DP#	Zone TB	Switch disconnect from MCC 10 to DS bus	NA
V2-14B	DP	Zone TB	Switch disconnect from MCC 9 to DS bus	NA
V2-14C	DP	Zone TB	Switch disconnect from MCC 9 to DS bus	NA
V2-6A,B,C	MO	NA	Disconnect from MCC 10,9,9	NA
FCV 478	MO	NA	Disconnect from power panel	NA
FCV 479	MO	NA	Disconnect from power panel	NA
FCV 488	MO	NA	Disconnect from power panel	NA
FCV 489	MO	NA	Disconnect from power panel	NA
FCV 498	MO	NA	Disconnect from power panel	NA
FCV 499	MO	NA	Disconnect from power panel	NA
RV1-1	DP#	Zone TB	Switch disconnect at turbine deck panel	NA
RV1-2	DP#	Zone TB	Switch disconnect at turbine deck panel	NA
RV1-3	DP#	Zone TB	Switch disconnect at turbine deck panel	NA
V1-8A	DP#	Zone TB	Switch MCC 5 to DS bus	NA
V1-8B	DP	Zone TB	Switch MCC 6 to DS bus	NA
V1-8C	DP	Zone TB	Switch MCC 6 to DS bus	NA
RCS-Hot & Cold Leg Temp Loop 1	DP##	Zones 25,24,10,28,TB	Power from DS bus	25,24,28
RCS-Hot & Cold Leg Temp Loop 2	DP	Zones 25,24,10,28,TB	Power from DS bus	25,24,28
RCS-Hot & Cold Leg Temp Loop 3	DP	Zones 25,24,10,28,TB	Power from DS bus	25,24,28
Condensate Tank Level	DP#	Zones 4,28,TE	Power from DS bus	NA
Steam Gen. Level No. 1	DP#	Zones 24,25,10,4,28,TB	Power from DS bus	25,24,28
Steam Gen. Level No. 2	DP#	Zones 24,25,10,4,28,TB	Power from DS bus	25,24,28
Steam Gen. Level No. 3	DP#	Zones 24,25,10,4,28,TB	Power from DS bus	25,24,28

Table 5. Alternative Shutdown Equipment Associated Circuits (Continued)

<u>Dedicated Shutdown Component</u>	<u>Power Supply & Control Power</u>	<u>Wiring by Fire Zone</u>	<u>Isolation Provided</u>	<u>Alternate Equipment/Wiring Common Zones</u>
<u>Charging System</u>				
Charging Pump A	DP#	Zones 4,28,WH,TB	Isolated to control room by fuses power supplied by DS bus	NA
Boric Acid Pump A	DP	Zones 5,13,4,TB	Switch power from EI to DS bus	NA
Boric Acid Heat Trace A	DP	Zones 5,TB,13	Switch power from MCC 5 to DS bus	NA
Boric Acid Tank A Htr.	DP	Zones 5,TB,13	Switch power from MCC 5 to DS bus	NA
<u>Valves</u>				
LCV 115C	MO	NA	Disconnect from power panel	NA
HCV 121	MO	NA	Disconnect from power panel	NA
HCV 110	MO	NA	Disconnect from power panel	NA
311	DP	Zones 4,28,10,24,25,13	Switch from power panel to DS power	28,24,25
310 A&B	MO	NA	Disconnect from power panel	NA
FCV 113A	MO	NA	Disconnect from power panel	NA
865 A&BLC	MO	NA	Disconnect from power panel	NA
350	MO	NA	Disconnect from MCC 5	NA
Pressurizer Pressure	DP#	Zones 25,24,10,28,4	Power from DS bus	25,24,28
Pressurizer Level	DP#	Zones 25,24,10,28,4	Power from DS bus	25,24,28
Pressurizer Heater Group	DP	Zones 25,24,TB,9,13,28	Power from DS bus	24,24
Incore Temp. Mon. Sys.	DP	Zones 25,24,10,28,4	Power from DS bus; readout in chg. pump room	NA
<u>RHR System</u>				
RHR Pump A	DP	Zones 27,TB	Power from DS bus	27
<u>Valves</u>				
863A&B	MO	NA	Disconnect power at MCC 5 & 6	NA
HCV 758	MO	NA	Local air power	NA
861 A&B	MO	NA	Disconnect from MCC 5 & 6	NA
860 A&B	MO	NA	Disconnect	NA
750	MO	NA	Disconnect from MCC 5	NA
751	MO	NA	Disconnect from MCC 6	NA
862A	MO	NA	Disconnect from MCC 5	NA
864B	MO	NA	Disconnect from MCC 5	NA
744A	MO	NA	Disconnect from MCC 5	NA
759A	MO	NA	Disconnect from MCC 5	NA
FCV 605	MO	NA	Local air power	NA
RHR Flow	DP	Zones 28,4,TB	Power from DS bus; readout in chg. pump room	28
<u>Reactivity Monitor</u>				
Neutron Mon. NPI	DP#	Zones 4,10,28,TB,24,25	Power from DS bus; located Zone 10; readout in chg. pump room.	24,25,28

Table 5. Alternative Shutdown Equipment Associated Circuits (Continued)

<u>Dedicated Shutdown Component</u>	<u>Power Supply & Control Power</u>	<u>Wiring by Fire Zone</u>	<u>Isolation Provided</u>	<u>Alternate Equipment/Wiring Common Zones</u>
<u>Component Cooling</u>				
<u>Water System</u>				
Pump A	DP#	Zones 4,5,12,TB	Isolated to control room by fuses; power from DS bus	5
Valve 749A	MO	NA	Disconnect from MCC 5	NA
<u>Service Water System</u>				
Pump D	DP#	Zones 4,5,12,28,TB,IS	Isolated to control room by fuses; power from DS bus	12,IS
Valve V6-12D	DP##	Zones 5,12,28,TB,WH	Isolated to control room by fuses	12,IS
<u>Instrument Air System</u>				
Primary Air Compressor	DP	Zone TB	Control from TB	NA
Valve PCV 1716	MO	NA	Disconnect from power panel	NA
<u>HVAC System</u>				
HVH-8A Fan - RHR PT	DP	Zone 27	Rewire if required	NA
HVS-1 Fan - Aux bldg	DP	Zones 15,16,TB	Switch from MCC 5 to DS bus	15
<u>Plant Power</u>				
DS-Bus	DP#	Zone TB	Power from DS diesel generator	NA

Legend

DP - Dedicated shutdown power
MO - Manual operation
NA - Not applicable
DS - Dedicated shutdown
TB - Turbine building
IS - Intake structure
- Hot shutdown modification completed
- Hot shutdown modification completed but change will be made.