



**Commonwealth Edison**  
One First National Plaza, Chicago, Illinois  
Address Reply to: Post Office Box 767  
Chicago, Illinois 60690

February 4, 1982

Mr. A. Schwencer, Chief  
Licensing Branch #2  
Division of Licensing  
U. S. Nuclear Regulatory Commission  
Washington, DC 20555



Subject: LaSalle County Station Unit 1  
Start-Up Test Schedule  
NRC Docket No. 50-373

Dear Mr. Schwencer:

The purpose of this letter is to provide a copy of the LaSalle County Station Unit 1 Startup Test Schedule as requested by Mr. A. Bournia during a meeting in your offices on January 22, 1982. Also included is a power vs time plot which depicts the startup program.

If there are any further questions on this matter, please contact this office.

Very truly yours,

C. E. Sargent  
Nuclear Licensing Administrator

lm

Enclosures

cc: NRC Resident Inspector - LSCS

3398N

*Boo!*  
*5/1/1*

LSCS 1

STARTUP PROGRAM

Power vs Time

1-18-82

CES  
FM  
ROB

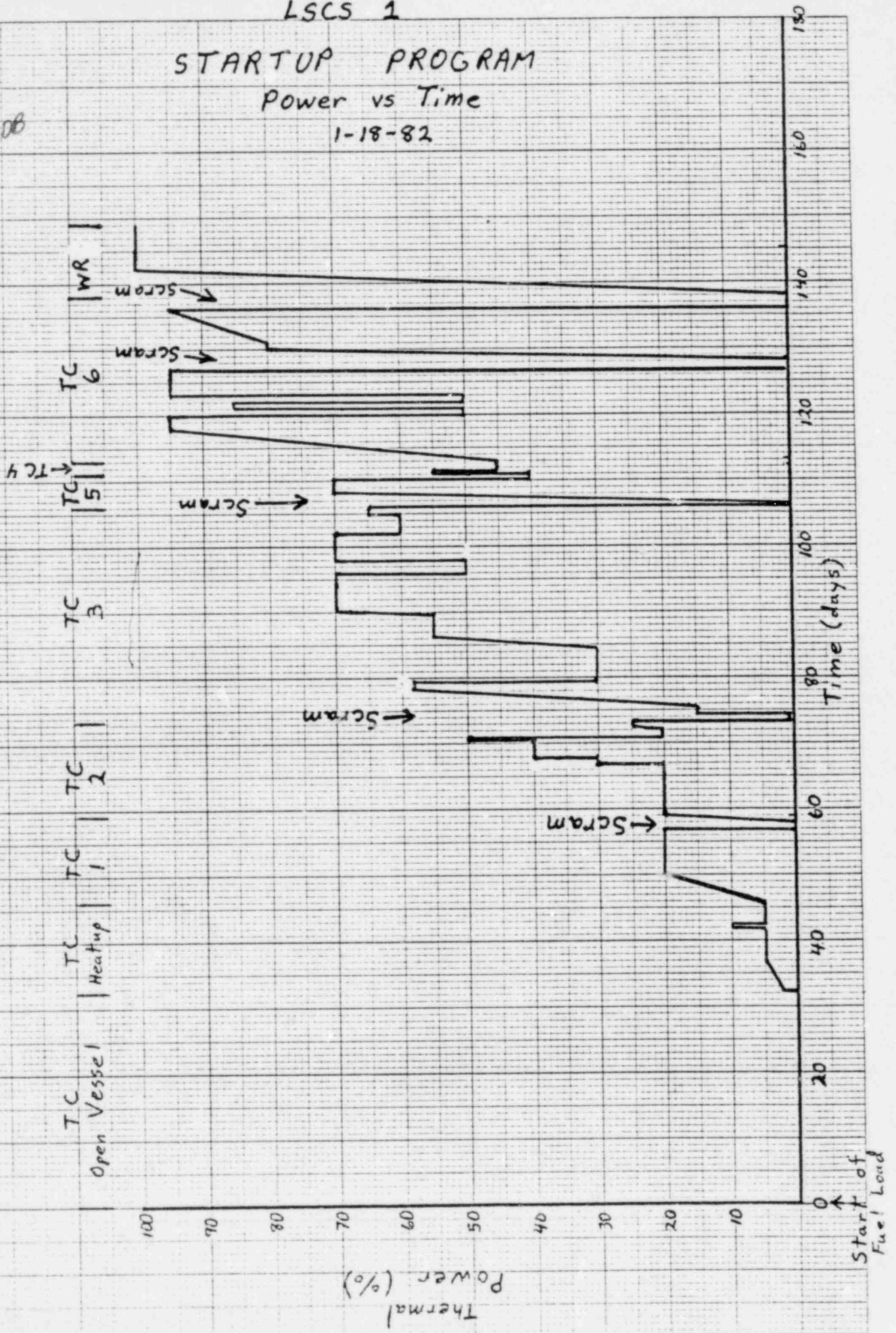

THE STARTUP TEST SCHEDULE INDICATES THE ANTICIPATED TEST SEQUENCE. THE ACTUAL TESTING SCHEDULE CAN VARY FROM THE ANTICIPATED SCHEDULE DUE TO EQUIPMENT PROBLEMS OR OTHER CONSIDERATIONS.

ESTIMATED TIME REQUIREMENTS FOR EACH STARTUP TEST ASSUME CONTINUOUS TESTING DURING THREE EIGHT HOUR SHIFTS PER DAY, 7 DAYS PER WEEK. NO ALLOWANCE HAS BEEN MADE FOR PERIODS OF TIME DURING WHICH NO TESTING IS PERFORMED UNLESS REQUIRED BY A SPECIFIC TEST'S PREREQUISITES (EG. STF-14). TIMES SHOWN ALSO ASSUME TROUBLE-FREE TESTING (IE. NO DELAYS DUE TO MECHANICAL FAILURE OR SYSTEM PERFORMANCE DEFICIENCIES).

```
*****  
* CHANGES TO THIS SCHEDULE AND *  
* TO THE TEST TIME REQUIREMENTS *  
* ARE ANTICIPATED AS TESTING *  
* PROGRESSES *  
*****
```

### SYMBOLS



TEST SEQUENCE NUMBER

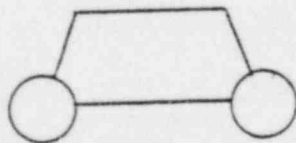

INDICATES TESTS TO BE PERFORMED IN CONJUNCTION WITH EACH OTHER

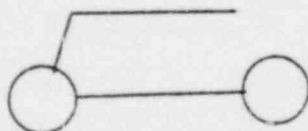

INDICATES TESTS TO BE PERFORMED SIMULTANEOUSLY FOR CONVENIENCE

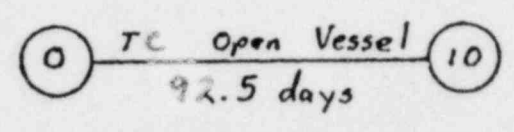
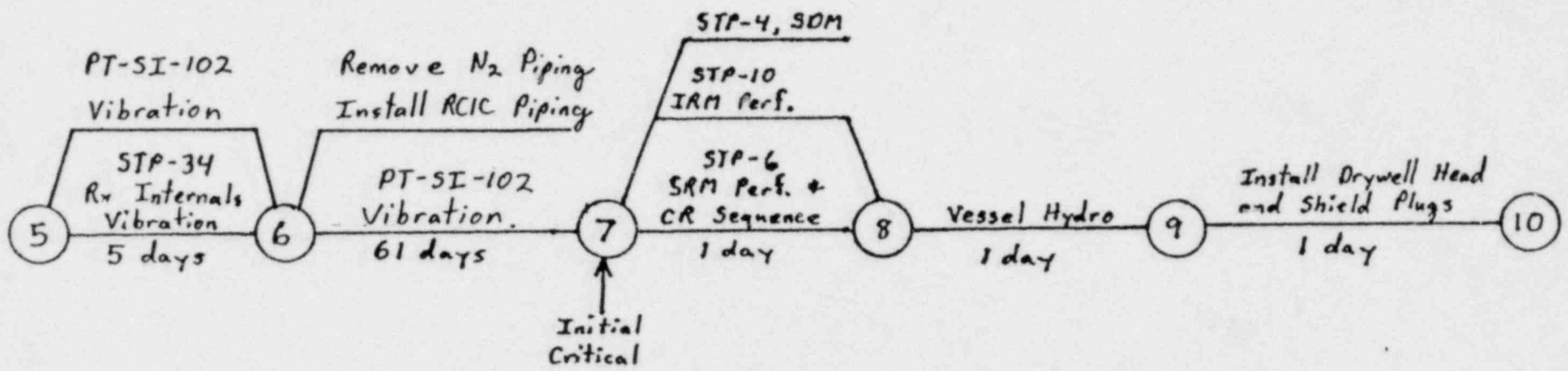
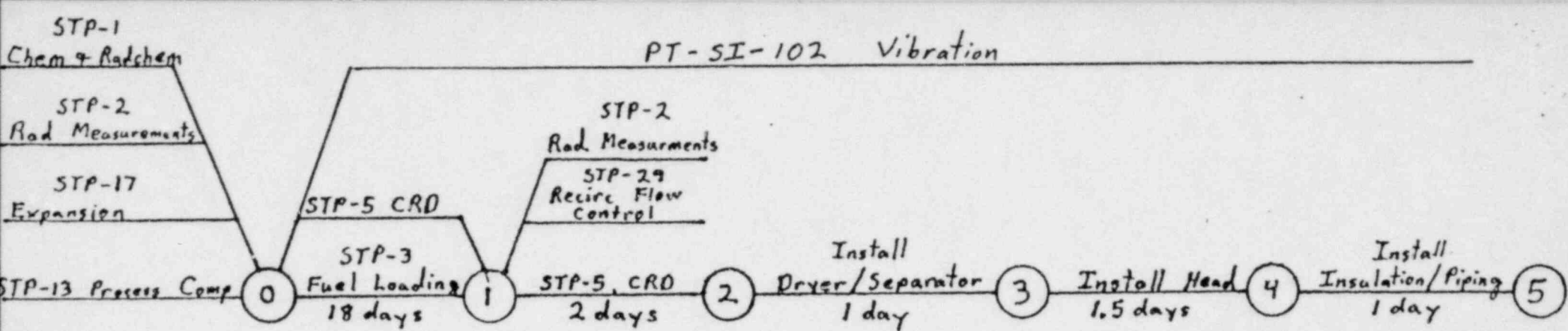

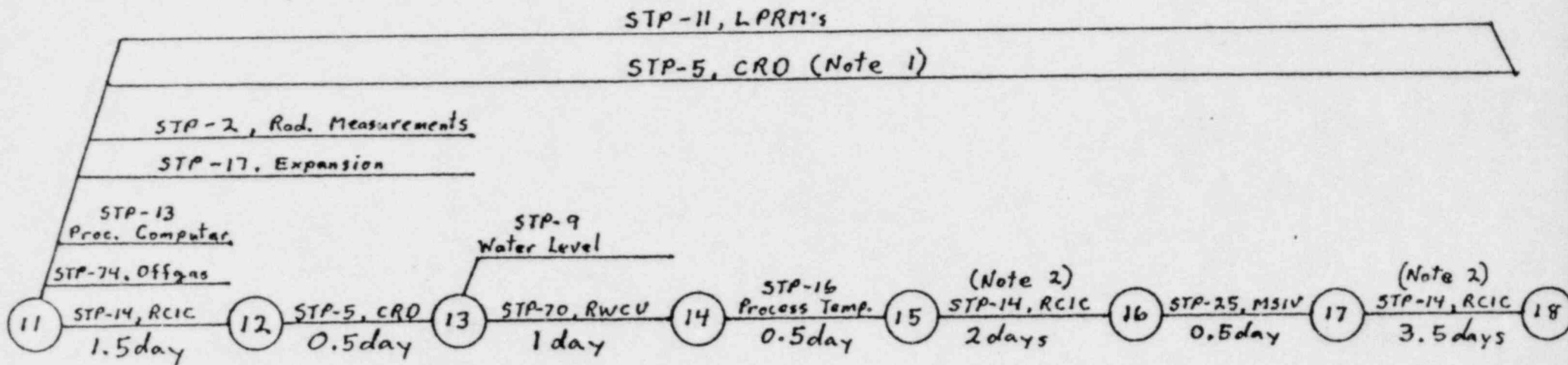
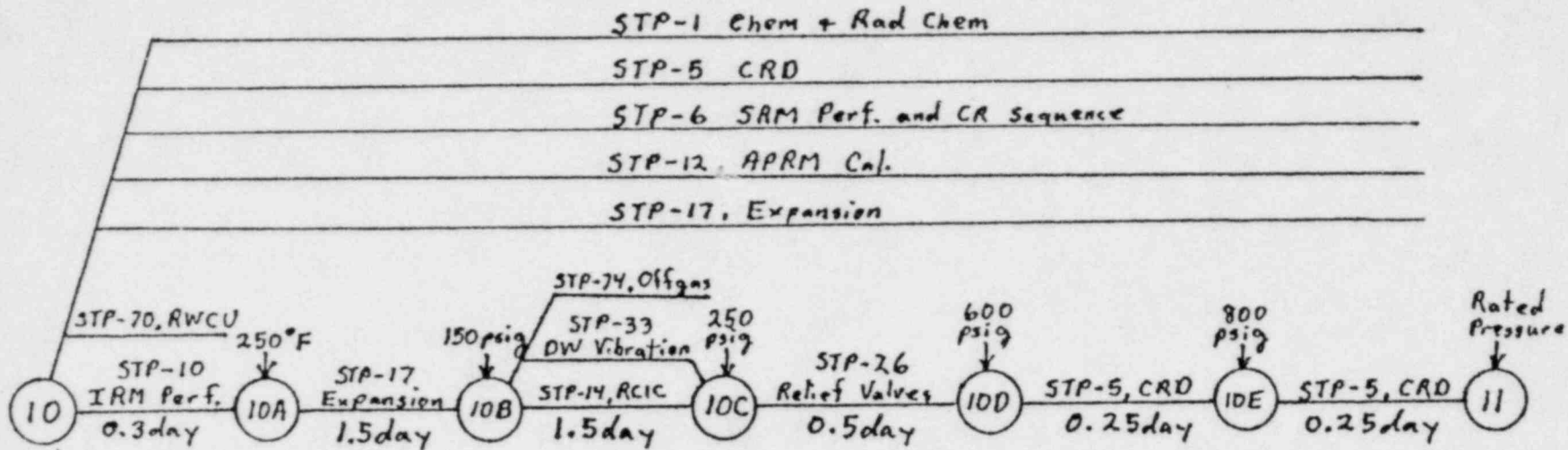

Note 1: Requires operation in 4 different control rod sequences

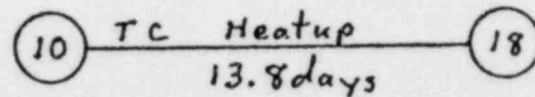

Note 2: A minimum of 3 days of no RCIC operation must be established prior to this test.

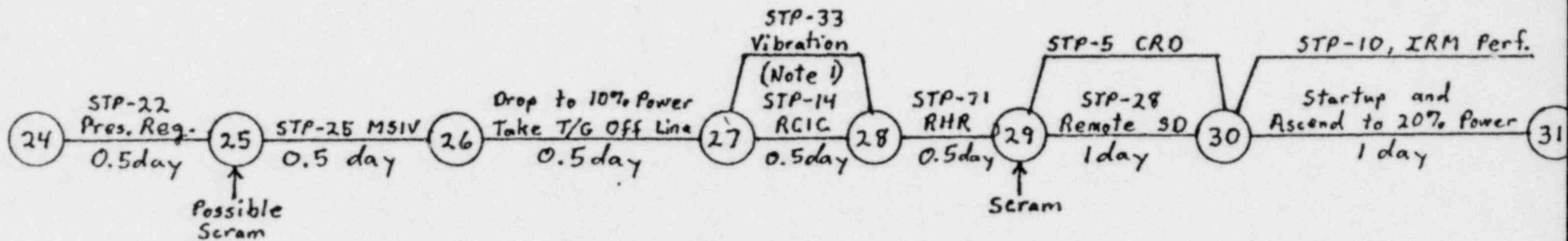
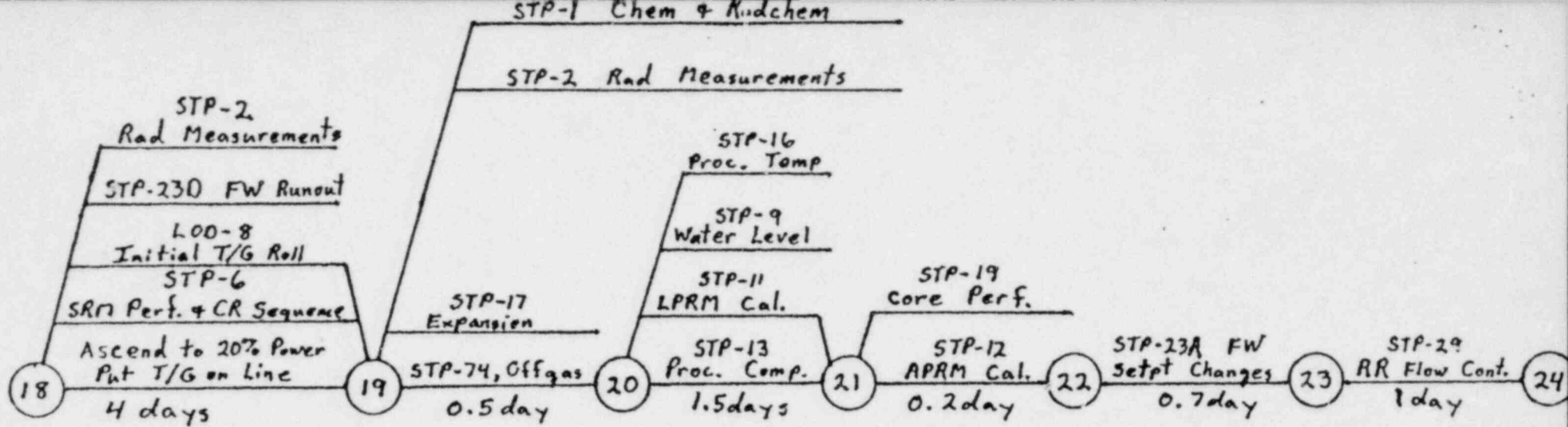

Note 1: A minimum of 3 days of no RCIC operation must be established prior to performing this test.

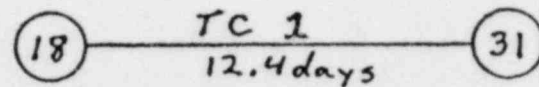

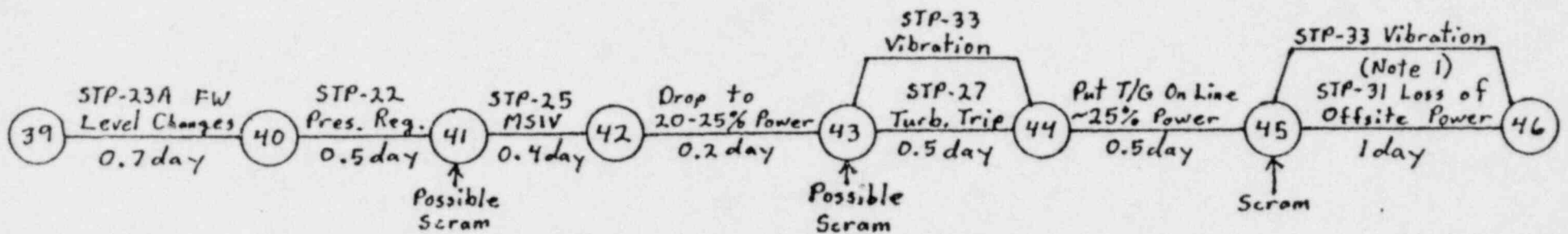
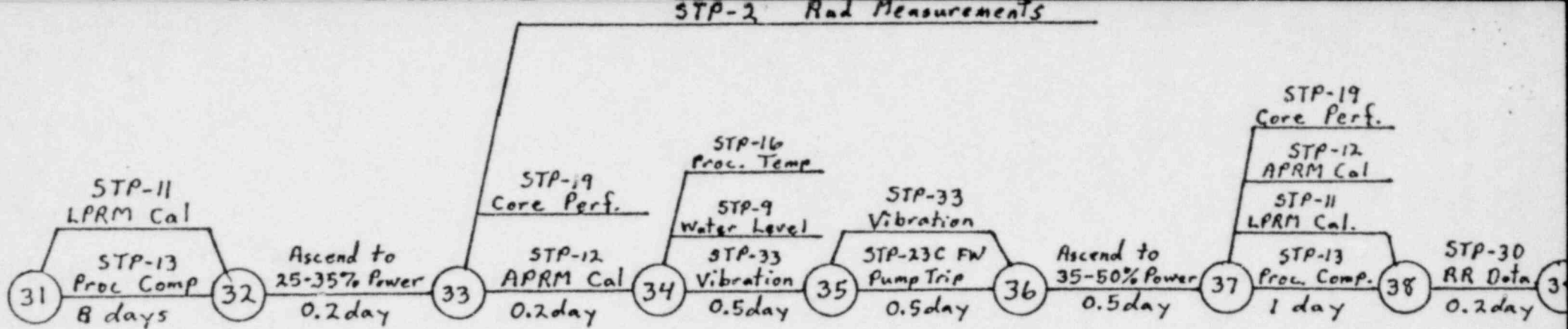

Note 1: T/G must be on line at  $\geq 10\%$  load for  $\geq 3$  hr prior to this test.

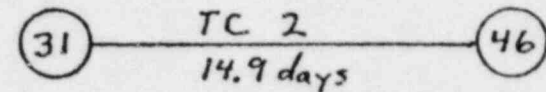

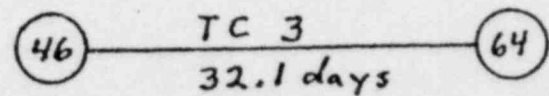
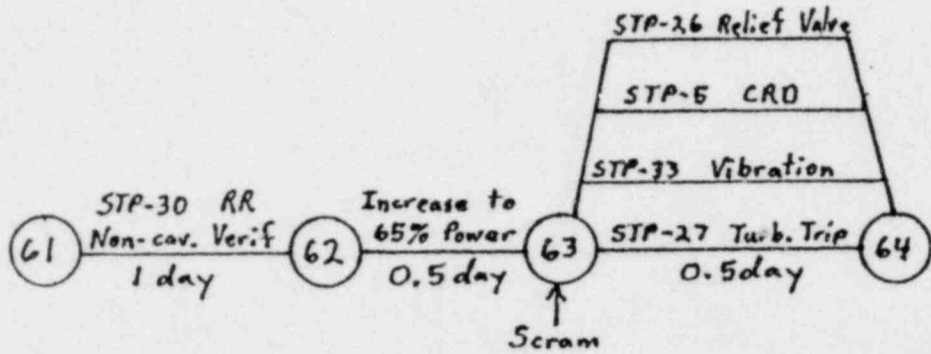
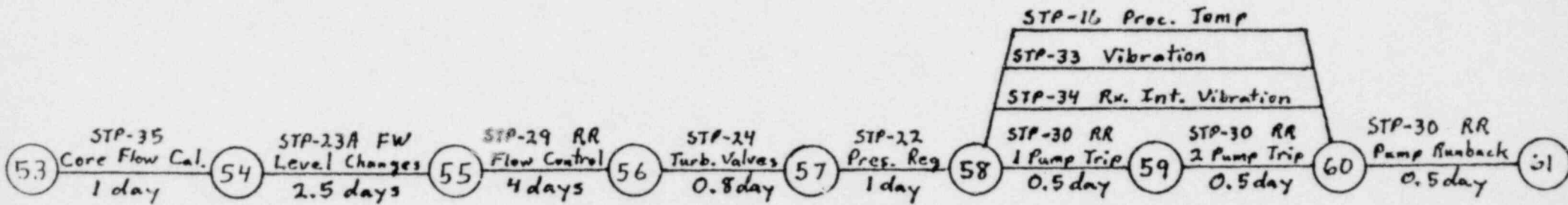
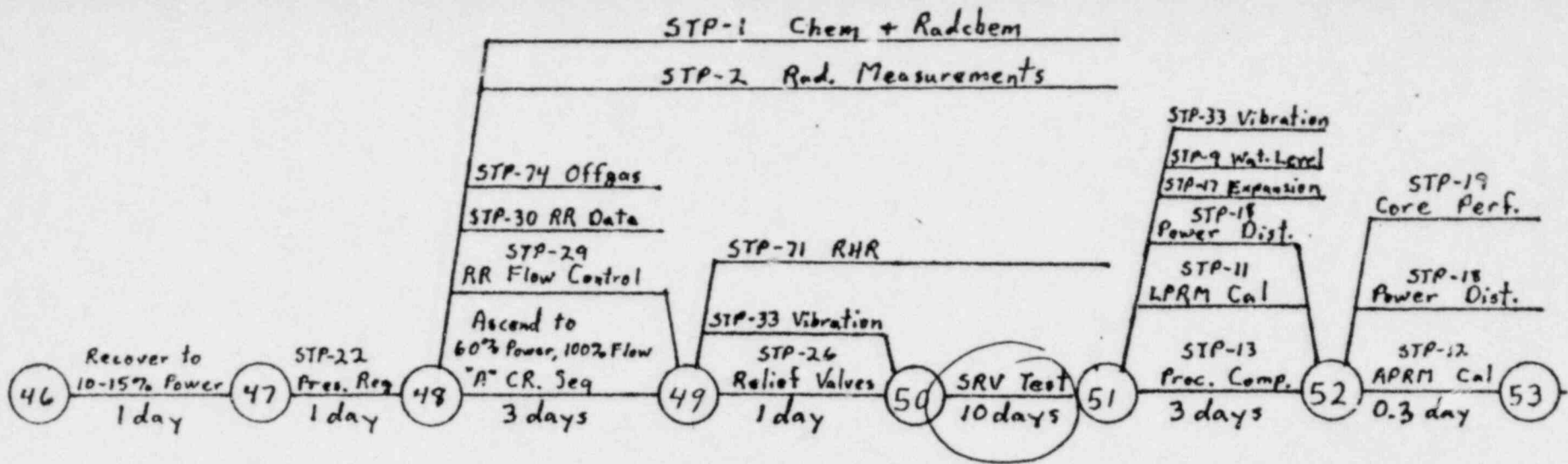



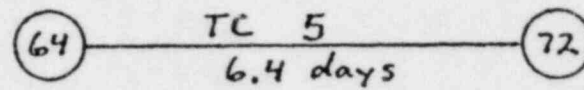
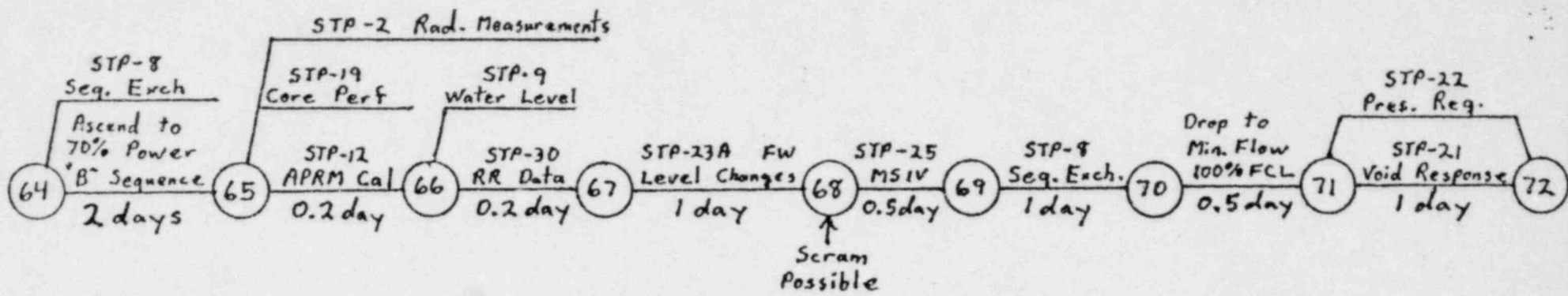

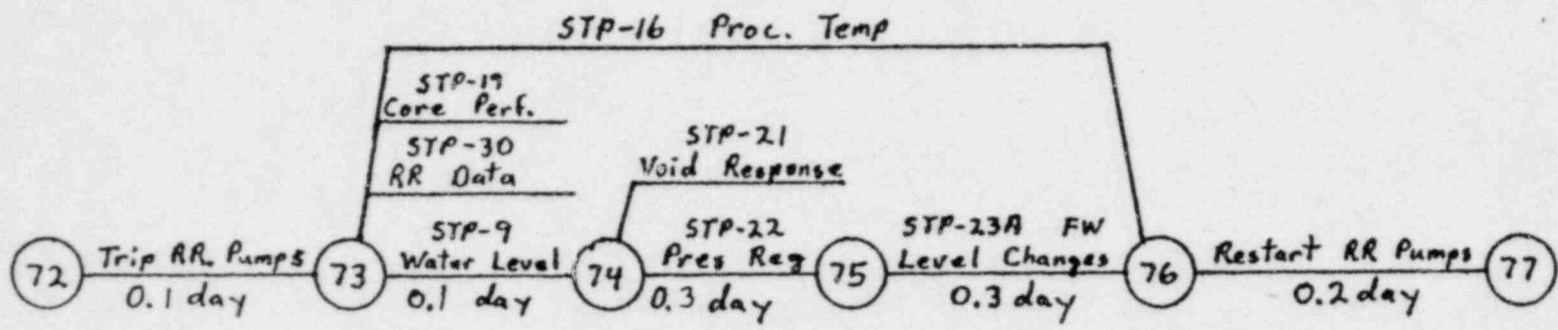

**CAUTION**

Tech Specs do not allow the Recirc Pumps to be tripped for more than 24 hours.

