



March 17, 1993
LD-93-047

Docket No. 52-002

Attn: Document Control Desk
U.S. Nuclear Regulatory Commission
Washington, D.C. 20555

Subject: System 80+™ Inservice Testing of Pumps and Valves

Dear Sirs:

Enclosed with this letter are the summary of inservice testing requirements and listings of the pumps and valves to be tested. This information is currently being printed for CESSAR-DC and it is ABB-CE's understanding that this information should enable this issue to be closed.

If you have any questions, please call me or Mr. Stan Ritterbusch at (203) 285 5208.

Very truly yours,

COMBUSTION ENGINEERING, INC.

C. B. Brinkman
Acting Director
Nuclear Systems Licensing

CBB/ser

cc: J. Trotter (EPR1)
T. Wambach (NRC)
P. Lang (DOE)

250032 ABB Combustion Engineering Nuclear Power

Combustion Engineering, Inc.
9303260154 930317
FBR ADDCK 0520002
A PDR

1000 Prospect Hill Road
Post Office Box 500
Westborough, MA 01581

Telephone (203) 688-1911
Fax (203) 285-9512
Telex 98297 COMBEN WSOB

D032

DSER Open Item 3.9.6-1

Revised 3/17/93

The staff requires that a schedule for the IST program for equipment and components be submitted for review.

Proposed Open Item 3.9.6-1 Resolution

All pumps and valves requiring in-service testing in accordance with ASME Code requirements will be included in CESSAR-DC Table 3.9-15, as attached. The table includes testing requirements of each component and the frequency at which testing will be performed. Additionally, typical testing configurations will be included in CESSAR-DC Figure 3.9-16, as attached.

In the design of critical reactor vessel internals components which are subject to fatigue, the stress analysis is performed utilizing the design fatigue curve of Figure I-9-2 of Section III of the ASME Boiler and Pressure Vessel Code. A cumulative usage factor of less than one is used as the limiting criterion.

As indicated in the preceding sections, the stress and fatigue limits for reactor internals components are obtained from the ASME Code. Allowable deformation limits are established as 80% of the loss-of-function deflection limits. These limits provide adequate safety factors assuring that so long as calculated stresses, usage factors, or deformations do not exceed these limits, the design is conservative.

3.9.6 IN-SERVICE TESTING OF PUMPS AND VALVES

The in-service^{1.5} testing program for Code Class 1, 2 and 3 pumps and valves ~~will be~~ developed in accordance with the requirements of Section XI of the ASME B&PV Code. This program is implemented to assess operational readiness during preservice and in-service inspection. The inservice testing program in coordination with the System 80+ design ~~will utilize~~ provisions and features such that minimal departure from ASME B&PV Code, Section XI, Subsections IWP and IWV requirements result.

3.9.6.1 In-service Testing of Pumps

In-service testing of pumps is limited to those Code Class 2 and 3 pumps which are required to perform a specific function in shutting down a reactor or in mitigating the consequences of an accident, and that are provided with an emergency power source. ~~The required hydraulic and mechanical parameters will be measured by the methods and with frequency prescribed in Subsection IWP of ASME Section XI. The pump test plan and schedule are included in the technical specifications.~~

DELETE AND ADD INSERT 1

In addition to Section XI of the ASME B & PV Code, the following provisions will be included as a part of the pump test plan for the pumps specified above:

- A. Full flow testing of these Class 2 and 3 pumps on a quarterly basis.
- B. Pump suction pressure while pump is operating will be a standard test parameter in addition to static suction pressure (pump shut down).
- C. Guidance for ensuring minimal pump miniflow operation while testing.

D. A Pump Maintenance Plan which will ensure the trending of all safety related pump test parameters. This program will also provide a link between trended results and plant engineers responsible for pump operability and reliability so that problems may be identified and further analysis may be instituted. The Plan will also establish a pump disassembly/inspection program based upon:

1. Historical performance of the pump to identify pumps which are prone to degradation/wear.
2. Analysis of trends of pump test parameters.
3. Analysis of pump components, such as "O-Rings," which are subject to aging.

3.9.6.2 In-service Testing of Valves

In-service testing of valves is limited to those Code Class 1, 2 and 3 valves which are required to perform a specific function in shutting down a reactor or in mitigating the consequences of an accident. ~~The required hydraulic and mechanical parameters will be measured by the methods and with frequency prescribed in Subsection IV of ASME Section XI. The test plan and schedule are included in the technical specifications.~~

In addition to Section XI of the ASME B & PV Code, the following provisions will be included as a part of the valve test plan for the valves specified above:

- A. Determination of the optimal test frequency of valves from a regulatory, design, vendor and engineering practicality standpoint.
- B. Programmatic use of appropriate non-intrusive diagnostic check valve testing technologies.
- C. For those valves which must operate under differential pressure to perform their safety function, tests are to be performed on an appropriate schedule in a manner which best replicates the postulated differential pressure.
- D. Categorization and appropriate testing of the following classes of Category A valves:
 1. Pressure isolation valves - valves that provide isolation of a pressure differential from one part of a system to another or between systems.

CESSAR-DC Attachment (Refer to page 3.9-64)

INSERT 1:

All pumps requiring in-service testing in accordance with Section XI of the ASME B&PV Code are listed in Table 3.9-15 which includes testing requirements for each pump and the frequency at which testing will be performed. Typical testing configurations to support in-service testing of the pumps are shown in Figure 3.9-16 and referenced in Table 3.9-15 where applicable.

CESSAR-DC Attachment (Refer to page 3.9-64a)

INSERT 2:

All valves requiring in-service testing in accordance with Section XI of the ASME B&PV Code are listed in Table 3.9-15 which includes testing requirements for each valve and the frequency at which testing will be performed. Typical testing configurations to support in-service testing of the valves are shown in Figure 3.9-16 and referenced in Table 3.9-15 where applicable.

TABLE 3.9-15

INSERVICE TESTING SAFETY-RELATED PUMPS AND VALVES

<u>PUMP</u>	<u>SAFETY CLASS</u>	(h) <u>TEST PARAMETER</u>	<u>TEST FREQ</u>	(i) <u>TEST CONFIG.</u>	<u>CESSAR-DC FIGURE NO.</u>
CCW PUMP 1A	3	DP, PS, PO, Q, V	3 mo.	16	9.2.2-1.1
CCW PUMP 1B	3	DP, PS, PO, Q, V	3 mo.	16	9.2.2-1.1
CCW PUMP 2A	3	DP, PS, PO, Q, V	3 mo.	16	9.2.2-1.7
CCW PUMP 2B	3	DP, PS, PO, Q, V	3 mo.	16	9.2.2-1.7
MD EFW PUMP 1	3	DP, PS, PO, Q, V	3 mo.	16	10.4.9-1.1
TD EFW PUMP 1	3	N, DP, PS, PO, Q, V	3 mo.	16	10.4.9-1.1
MD EFW PUMP 2	3	DP, PS, PO, Q, V	3 mo.	16	10.4.9-1.1
TD EFW PUMP 2	3	N, DP, PS, PO, Q, V	3 mo.	16	10.4.9-1.1
SI PUMP 1	2	DP, PS, PO, Q, V	3 mo.	16	6.3.2-1A
SI PUMP 2	2	DP, PS, PO, Q, V	3 mo.	16	6.3.2-1B
SI PUMP 3	2	DP, PS, PO, Q, V	3 mo.	16	6.3.2-1A
SI PUMP 4	2	DP, PS, PO, Q, V	3 mo.	16	6.3.2-1B
SC PUMP 1	2	DP, PS, PO, Q, V	3 mo.	16	6.3.2-1A
SC PUMP 2	2	DP, PS, PO, Q, V	3 mo.	16	6.3.2-1B
CS PUMP 1	2	DP, PS, PO, Q, V	3 mo.	16	6.3.2-1A
CS PUMP 2	2	DP, PS, PO, Q, V	3 mo.	16	6.3.2-1B
SSW PUMP 1A	3	DP, PS, PO, Q, V	3 mo.	17	9.2.1-1.1
SSW PUMP 1B	3	DP, PS, PO, Q, V	3 mo.	17	9.2.1-1.1
SSW PUMP 2A	3	DP, PS, PO, Q, V	3 mo.	17	9.2.1-1.3
SSW PUMP 2B	3	DP, PS, PO, Q, V	3 mo.	17	9.2.1-1.3
ECW PUMP 1A	3	DP, PS, PO, Q, V	3 mo.	16	9.2.9-1.1
ECW PUMP 1B	3	DP, PS, PO, Q, V	3 mo.	16	9.2.9-1.1
ECW PUMP 2A	3	DP, PS, PO, Q, V	3 mo.	16	9.2.9-1.5
ECW PUMP 2B	3	DP, PS, PO, Q, V	3 mo.	16	9.2.9-1.5
DG BUILDING SUMP PUMP 1A	3	DP, Q, V	2 yr.	17	9.5.9-1
DG BUILDING SUMP PUMP 1B	3	DP, Q, V	2 yr.	17	9.5.9-1
DG BUILDING SUMP PUMP 2A	3	DP, Q, V	2 yr.	17	9.5.9-1
DG BUILDING SUMP PUMP 2B	3	DP, Q, V	2 yr.	17	9.5.9-1
RB SUBSPHERE QUAD A SUMP PUMP 1	3	DP, Q, V	2 yr.	17	9.3.3-2.1
RB SUBSPHERE QUAD A SUMP PUMP 2	3	DP, Q, V	2 yr.	17	9.3.3-2.1
RB SUBSPHERE QUAD B SUMP PUMP 1	3	DP, Q, V	2 yr.	17	9.3.3-2.2
RB SUBSPHERE QUAD B SUMP PUMP 2	3	DP, Q, V	2 yr.	17	9.3.3-2.2
RB SUBSPHERE QUAD C SUMP PUMP 1	3	DP, Q, V	2 yr.	17	9.3.3-2.1
RB SUBSPHERE QUAD C SUMP PUMP 2	3	DP, Q, V	2 yr.	17	9.3.3-2.1
RB SUBSPHERE QUAD D SUMP PUMP 1	3	DP, Q, V	2 yr.	17	9.3.3-2.2
RB SUBSPHERE QUAD D SUMP PUMP 2	3	DP, Q, V	2 yr.	17	9.3.3-2.2
CHARGING PUMP 1	3	DP, PS, PO, Q, V	3 mo.	16	9.3.4-1.2
CHARGING PUMP 2	3	DP, PS, PO, Q, V	3 mo.	16	9.3.4-1.2

TABLE 3.9-15 (Continued)

INSERVICE TESTING SAFETY-RELATED PUMPS AND VALVES

<u>VALVE NO.</u>	<u>VALVE DESCRIPTION</u>	<u>(a) VALVE TYPE</u>	<u>(b) VALVE ACT.</u>	<u>(c) SAFETY CLASS</u>	<u>(d) CODE CAT.</u>	<u>(e) VALVE FUNCT</u>	<u>(f) TEST REQD</u>	<u>(g) TEST FREQ</u>	<u>(i) TEST CONFIG.</u>	<u>CESSAR-DC FIG. NO.</u>
CC-100	CCW HX 1A BYPASS CTRL	GL	AD	3	B		S	3 mo.		9.2.2-1.1
CC-100	CCW HX 1A BYPASS CTRL	GL	AD	3	B		MT	3 mo.		9.2.2-1.1
CC-100	CCW HX 1A BYPASS CTRL	GL	AD	3	B		FS	3 mo.		9.2.2-1.1
CC-100	CCW HX 1A BYPASS CTRL	GL	AD	3	B		LPV	2 yr.		9.2.2-1.1
CC-101	CCW HX 1B BYPASS CTRL	GL	AD	3	B		S	3 mo.		9.2.2-1.1
CC-101	CCW HX 1B BYPASS CTRL	GL	AD	3	B		MT	3 mo.		9.2.2-1.1
CC-101	CCW HX 1B BYPASS CTRL	GL	AD	3	B		FS	3 mo.		9.2.2-1.1
CC-101	CCW HX 1B BYPASS CTRL	GL	AD	3	B		LPV	2 yr.		9.2.2-1.1
CC-102	NON-ESS. SPLY HDR 1 ISOL	BF	AD	3	B		S	CS(3)		9.2.2-1.1
CC-102	NON-ESS. SPLY HDR 1 ISOL	BF	AD	3	B		MT	CS(3)		9.2.2-1.1
CC-102	NON-ESS. SPLY HDR 1 ISOL	BF	AD	3	B		FS	CS(3)		9.2.2-1.1
CC-102	NON-ESS. SPLY HDR 1 ISOL	BF	AD	3	B		LPV	2 yr.		9.2.2-1.1
CC-103	NON-ESS. RTN HDR 1 ISOL	BF	AD	3	B		S	CS(3)		9.2.2-1.1
CC-103	NON-ESS. RTN HDR 1 ISOL	BF	AD	3	B		MT	CS(3)		9.2.2-1.1
CC-103	NON-ESS. RTN HDR 1 ISOL	BF	AD	3	B		FS	CS(3)		9.2.2-1.1
CC-103	NON-ESS. RTN HDR 1 ISOL	BF	AD	3	B		LPV	2 yr.		9.2.2-1.1
CC-106	CCW HX 1A INLET ISOL	BF	EL	3	B		S	3 mo.		9.2.2-1.1
CC-106	CCW HX 1A INLET ISOL	BF	EL	3	B		MT	3 mo.		9.2.2-1.1
CC-106	CCW HX 1A INLET ISOL	BF	EL	3	B		LPV	2 yr.		9.2.2-1.1
CC-107	CCW HX 1B INLET ISOL	BF	EL	3	B		S	3 mo.		9.2.2-1.1
CC-107	CCW HX 1B INLET ISOL	BF	EL	3	B		MT	3 mo.		9.2.2-1.1
CC-107	CCW HX 1B INLET ISOL	BF	EL	3	B		LPV	2 yr.		9.2.2-1.1
CC-108	CCW HX 1A OUTLET ISOL	BF	EL	3	B		S	3 mo.		9.2.2-1.1
CC-108	CCW HX 1A OUTLET ISOL	BF	EL	3	B		MT	3 mo.		9.2.2-1.1
CC-108	CCW HX 1A OUTLET ISOL	BF	EL	3	B		LPV	2 yr.		9.2.2-1.1
CC-109	CCW HX 1B OUTLET ISOL	BF	EL	3	B		S	3 mo.		9.2.2-1.1
CC-109	CCW HX 1B OUTLET ISOL	BF	EL	3	B		MT	3 mo.		9.2.2-1.1
CC-109	CCW HX 1B OUTLET ISOL	BF	EL	3	B		LPV	2 yr.		9.2.2-1.1
CC-110	SCS HX 1 CONTROL	GL	AD	3	B		S	3 mo.		9.2.2-1.2
CC-110	SCS HX 1 CONTROL	GL	AD	3	B		MT	3 mo.		9.2.2-1.2
CC-110	SCS HX 1 CONTROL	GL	AD	3	B		FS	3 mo.		9.2.2-1.2
CC-110	SCS HX 1 CONTROL	GL	AD	3	B		LPV	2 yr.		9.2.2-1.2

TABLE 3.9-15 (Continued)

INSERVICE TESTING SAFETY-RELATED PUMPS AND VALVES

VALVE NO.	VALVE DESCRIPTION	(a) VALVE TYPE	(b) VALVE ACT.	(c) SAFETY CLASS.	(d) CODE CAT.	(e) VALVE FUNCT.	(f) TEST REQ.	(g) TEST FREQ.	(i) TEST CONFIG.	CESSAR-DC FIG. NO.
CC-111	SCS HX 1 OUTLET ISOL	BF	EL	3	B		S	3 mo.		9.2.2-1.2
CC-111	SCS HX 1 OUTLET ISOL	BF	EL	3	B		MT	3 mo.		9.2.2-1.2
CC-111	SCS HX 1 OUTLET ISOL	BF	EL	3	B		LPV	2 Yr.		9.2.2-1.2
CC-111	SCS HX 1 OUTLET ISOL	BF	EL	3	B		DDP	EL	8	9.2.2-1.2
CC-112	SFP HX 1 CONTROL	GL	AD	3	B		S	3 mo.		9.2.2-1.2
CC-112	SFP HX 1 CONTROL	GL	AD	3	B		MT	3 mo.		9.2.2-1.2
CC-112	SFP HX 1 CONTROL	GL	AD	3	B		FS	3 mo.		9.2.2-1.2
CC-112	SFP HX 1 CONTROL	GL	AD	3	B		LPV	2 Yr.		9.2.2-1.2
CC-113	SFP HX 1 OUTLET ISOL	BF	EL	3	B		S	3 mo.		9.2.2-1.2
CC-113	SFP HX 1 OUTLET ISOL	BF	EL	3	B		MT	3 mo.		9.2.2-1.2
CC-113	SFP HX 1 OUTLET ISOL	BF	EL	3	B		LPV	2 Yr.		9.2.2-1.2
CC-113	SFP HX 1 OUTLET ISOL	BF	EL	3	B		DDP	EL	8	9.2.2-1.2
CC-114	CS HX 1 OUTLET ISOL	BF	EL	3	B		S	3 mo.		9.2.2-1.2
CC-114	CS HX 1 OUTLET ISOL	BF	EL	3	B		MT	3 mo.		9.2.2-1.2
CC-114	CS HX 1 OUTLET ISOL	BF	EL	3	B		LPV	2 Yr.		9.2.2-1.2
CC-114	CS HX 1 OUTLET ISOL	BF	EL	3	B		DDP	5 Yr.	8	9.2.2-1.2
CC-122	NON-ESS. SPLY HDR 1 ISOL	BF	AD	3	B		S	CS(3)		9.2.2-1.1
CC-122	NON-ESS. SPLY HDR 1 ISOL	BF	AD	3	B		MT	CS(3)		9.2.2-1.1
CC-122	NON-ESS. SPLY HDR 1 ISOL	BF	AD	3	B		FS	CS(3)		9.2.2-1.1
CC-122	NON-ESS. SPLY HDR 1 ISOL	BF	AD	3	B		LPV	2 Yr.		9.2.2-1.1
CC-123	NON-ESS. RTN HDR 1 ISOL	BF	AD	3	B		S	CS(3)		9.2.2-1.1
CC-123	NON-ESS. RTN HDR 1 ISOL	BF	AD	3	B		MT	CS(3)		9.2.2-1.1
CC-123	NON-ESS. RTN HDR 1 ISOL	BF	AD	3	B		FS	CS(3)		9.2.2-1.1
CC-123	NON-ESS. RTN HDR 1 ISOL	BF	AD	3	B		LPV	2 Yr.		9.2.2-1.1
CC-130	CCW SUPPLY TO RCP 1A,1B	BF	EL	2	A		S	CS(1)		9.2.2-1.5
CC-130	CCW SUPPLY TO RCP 1A,1B	BF	EL	2	A		MT	CS(1)		9.2.2-1.5
CC-130	CCW SUPPLY TO RCP 1A,1B	BF	EL	2	A		LPV	2 Yr.		9.2.2-1.5
CC-130	CCW SUPPLY TO RCP 1A,1B	BF	EL	2	A	CI	LT	2 Yr.	2	9.2.2-1.5
CC-130	CCW SUPPLY TO RCP 1A,1B	BF	EL	2	A		DDP	5 Yr.	2	9.2.2-1.5
CC-1302	CCW PUMP 1A DISCHARGE	CK	SA	3	C		S	3 mo.	11	9.2.2-1.1
CC-1302	CCW PUMP 1A DISCHARGE	CK	SA	3	C		RF	3 mo.	9	9.2.2-1.1
CC-1303	CCW PUMP 1B DISCHARGE	CK	SA	3	C		S	3 mo.	11	9.2.2-1.1
CC-1303	CCW PUMP 1B DISCHARGE	CK	SA	3	C		RF	3 mo.	9	9.2.2-1.1

TABLE 3.9-15 (Continued)

INSERVICE TESTING SAFETY-RELATED PUMPS AND VALVES

<u>VALVE NO.</u>	<u>VALVE DESCRIPTION</u>	<u>(a) VALVE TYPE</u>	<u>(b) VALVE ACT.</u>	<u>(c) SAFETY CLASS</u>	<u>(d) CODE CAT</u>	<u>(e) VALVE FUNCT</u>	<u>(f) TEST REQD</u>	<u>(g) TEST FREQ</u>	<u>(i) TEST CONFIG</u>	<u>CESSAR-DC FIG. NO.</u>
CC-131	CCW SUPPLY TO RCP 1A,1B	BF	EL	2	A		S	CS(1)		9.2.2-1.5
CC-131	CCW SUPPLY TO RCP 1A,1B	BF	EL	2	A		MT	CS(1)		9.2.2-1.5
CC-131	CCW SUPPLY TO RCP 1A,1B	BF	EL	2	A		LPV	2 yr.		9.2.2-1.5
CC-131	CCW SUPPLY TO RCP 1A,1B	BF	EL	2	A	CI	LT	2 yr.	2	9.2.2-1.5
CC-132B	MAKEUP TO CCW SURGE TANK 1 FROM SSWS	CK	SA	3	C		S	3 mo.	14	9.2.2-1.1
CC-132B	MAKEUP TO CCW SURGE TANK 1 FROM SSWS	CK	SA	3	C		RF	3 mo.	9	9.2.2-1.1
CC-136	CCW RETURN FROM RCP 1A,1B	BF	EL	2	A		S	CS(1)		9.2.2-1.5
CC-136	CCW RETURN FROM RCP 1A,1B	BF	EL	2	A		MT	CS(1)		9.2.2-1.5
CC-136	CCW RETURN FROM RCP 1A,1B	BF	EL	2	A		LPV	2 yr.		9.2.2-1.5
CC-136	CCW RETURN FROM RCP 1A,1B	BF	EL	2	A	CI	LT	2 yr.	3	9.2.2-1.5
CC-136	CCW RETURN FROM RCP 1A,1B	BF	EL	2	A		DDP	5 yr.	3	9.2.2-1.5
CC-137	CCW RETURN FROM RCP 1A,1B	BF	EL	2	A		S	CS(1)		9.2.2-1.5
CC-137	CCW RETURN FROM RCP 1A,1B	BF	EL	2	A		MT	CS(1)		9.2.2-1.5
CC-137	CCW RETURN FROM RCP 1A,1B	BF	EL	2	A		LPV	2 yr.		9.2.2-1.5
CC-137	CCW RETURN FROM RCP 1A,1B	BF	EL	2	A	CI	LT	2 yr.	3	9.2.2-1.5
CC-137	CCW RETURN FROM RCP 1A,1B	BF	EL	2	A		DDP	5 yr.	3	9.2.2-1.5
CC-1507	CCW SUPPLY TO RCP 1A,1B	CK	SA	2	A/C		S	CS(2)	11	9.2.2-1.5
CC-1507	CCW SUPPLY TO RCP 1A,1B	CK	SA	2	A/C	CI	LT	2 yr.	2	9.2.2-1.5
CC-1548	CCW RETURN FROM RCP 1A,1B	CK	SA	2	A/C		S	RO(2)	12	9.2.2-1.5
CC-1548	CCW RETURN FROM RCP 1A,1B	CK	SA	2	A/C	CI	LT	2 yr.	3	9.2.2-1.5
CC-200	CCW HX 2A BYPASS CTRL	GL	AD	3	B		S	3 mo.		9.2.2-1.7
CC-200	CCW HX 2A BYPASS CTRL	GL	AD	3	B		MT	3 mo.		9.2.2-1.7
CC-200	CCW HX 2A BYPASS CTRL	GL	AD	3	B		FS	3 mo.		9.2.2-1.7
CC-200	CCW HX 2A BYPASS CTRL	GL	AD	3	B		LPV	2 yr.		9.2.2-1.7
CC-201	CCW HX 2B BYPASS CTRL	GL	AD	3	B		S	3 mo.		9.2.2-1.7
CC-201	CCW HX 2B BYPASS CTRL	GL	AD	3	B		MT	3 mo.		9.2.2-1.7
CC-201	CCW HX 2B BYPASS CTRL	GL	AD	3	B		FS	3 mo.		9.2.2-1.7
CC-201	CCW HX 2B BYPASS CTRL	GL	AD	3	B		LPV	2 yr.		9.2.2-1.7
CC-202	NON-ESS. SPLY HDR 2 ISOL	BF	AD	3	B		S	CS(3)		9.2.2-1.7
CC-202	NON-ESS. SPLY HDR 2 ISOL	BF	AD	3	B		MT	CS(3)		9.2.2-1.7
CC-202	NON-ESS. SPLY HDR 2 ISOL	BF	AD	3	B		FS	CS(3)		9.2.2-1.7
CC-202	NON-ESS. SPLY HDR 2 ISOL	BF	AD	3	B		LPV	2 yr.		9.2.2-1.7

TABLE 3.9-15 (Continued)

INSERVICE TESTING SAFETY-RELATED PUMPS AND VALVES

VALVE NO.	VALVE DESCRIPTION	(a) VALVE TYPE	(b) VALVE ACT.	(c) SAFETY CLASS	(d) CODE CAT.	(e) VALVE FUNC.	(f) TEST REQ.	(g) TEST FREQ.	(h) TEST CONFIG.	CESSAR-DC FIG. NO.
CC-203	NON-ESS. RTN HDR 2 ISOL	BF	AD	3	B	S	S	CS(3)		9.2.2-1.7
CC-203	NON-ESS. RTN HDR 2 ISOL	BF	AD	3	B	MT	MT	CS(3)		9.2.2-1.7
CC-203	NON-ESS. RTN HDR 2 ISOL	BF	AD	3	B	FS	FS	CS(3)		9.2.2-1.7
CC-203	NON-ESS. RTN HDR 2 ISOL	BF	AD	3	B	LPV	LPV	2 Yr.		9.2.2-1.7
CC-206	CCW HX 2A INLET ISOL	BF	EL	3	B	S	S	3 mo.		9.2.2-1.7
CC-206	CCW HX 2A INLET ISOL	BF	EL	3	B	MT	MT	3 mo.		9.2.2-1.7
CC-206	CCW HX 2A INLET ISOL	BF	EL	3	B	LPV	LPV	2 Yr.		9.2.2-1.7
CC-207	CCW HX 2B INLET ISOL	BF	EL	3	B	S	S	3 mo.		9.2.2-1.7
CC-207	CCW HX 2B INLET ISOL	BF	EL	3	B	MT	MT	3 mo.		9.2.2-1.7
CC-207	CCW HX 2B INLET ISOL	BF	EL	3	B	LPV	LPV	2 Yr.		9.2.2-1.7
CC-208	CCW HX 2A OUTLET ISOL	BF	EL	3	B	S	S	3 mo.		9.2.2-1.7
CC-208	CCW HX 2A OUTLET ISOL	BF	EL	3	B	MT	MT	3 mo.		9.2.2-1.7
CC-208	CCW HX 2A OUTLET ISOL	BF	EL	3	B	LPV	LPV	2 Yr.		9.2.2-1.7
CC-209	CCW HX 2B OUTLET ISOL	BF	EL	3	B	S	S	3 mo.		9.2.2-1.7
CC-209	CCW HX 2B OUTLET ISOL	BF	EL	3	B	MT	MT	3 mo.		9.2.2-1.7
CC-209	CCW HX 2B OUTLET ISOL	BF	EL	3	B	LPV	LPV	2 Yr.		9.2.2-1.7
CC-210	SCS HX 2 CONTROL	GL	AD	3	B	S	S	3 mo.		9.2.2-1.8
CC-210	SCS HX 2 CONTROL	GL	AD	3	B	MT	MT	3 mo.		9.2.2-1.8
CC-210	SCS HX 2 CONTROL	GL	AD	3	B	FS	FS	3 mo.		9.2.2-1.8
CC-210	SCS HX 2 CONTROL	GL	AD	3	B	LPV	LPV	2 Yr.		9.2.2-1.8
CC-211	SCS HX 2 OUTLET ISOL	BF	EL	3	B	S	S	3 mo.		9.2.2-1.8
CC-211	SCS HX 2 OUTLET ISOL	BF	EL	3	B	MT	MT	3 mo.		9.2.2-1.8
CC-211	SCS HX 2 OUTLET ISOL	BF	EL	3	B	LPV	LPV	2 Yr.		9.2.2-1.8
CC-211	SCS HX 2 OUTLET ISOL	BF	EL	3	B	DDP	DDP	EL	B	9.2.2-1.8
CC-212	SFP HX 2 CONTROL	GL	AD	3	B	S	S	3 mo.		9.2.2-1.8
CC-212	SFP HX 2 CONTROL	GL	AD	3	B	MT	MT	3 mo.		9.2.2-1.8
CC-212	SFP HX 2 CONTROL	GL	AD	3	B	FS	FS	3 mo.		9.2.2-1.8
CC-212	SFP HX 2 CONTROL	GL	AD	3	B	LPV	LPV	2 Yr.		9.2.2-1.8
CC-213	SFP HX 2 OUTLET ISOL	BF	EL	3	B	S	S	3 mo.		9.2.2-1.8
CC-213	SFP HX 2 OUTLET ISOL	BF	EL	3	B	MT	MT	3 mo.		9.2.2-1.8
CC-213	SFP HX 2 OUTLET ISOL	BF	EL	3	B	LPV	LPV	2 Yr.		9.2.2-1.8
CC-213	SFP HX 2 OUTLET ISOL	BF	EL	3	B	DDP	DDP	EL	B	9.2.2-1.8

TABLE 3.9-15 (Continued)

INSERVICE TESTING SAFETY-RELATED PUMPS AND VALVES

VALVE NO.	VALVE DESCRIPTION	(a) VALVE TYPE	(b) VALVE ACT.	(c) SAFETY CLASS	(d) CODE CAT.	(e) VALVE FUNCT.	(f) TEST READ	(g) TEST FREQ.	(h) TEST CONFIG.	CESSAR-DC FIG. NO.
CC-214	CS HX 2 OUTLET ISOL	BF	EL	3	B		S	3 mo.		9.2.2-1.8
CC-214	CS HX 2 OUTLET ISOL	BF	EL	3	B		MT	3 mo.		9.2.2-1.8
CC-214	CS HX 2 OUTLET ISOL	BF	EL	3	B		LPV	2 yr.		9.2.2-1.8
CC-214	CS HX 2 OUTLET ISOL	BF	EL	3	B		DDP	5 yr.	8	9.2.2-1.8
CC-222	NON-ESS. SPLY HDR 2 ISOL	BF	AD	3	B		S	CS(3)		9.2.2-1.7
CC-222	NON-ESS. SPLY HDR 2 ISOL	BF	AD	3	B		MT	CS(3)		9.2.2-1.7
CC-222	NON-ESS. SPLY HDR 2 ISOL	BF	AD	3	B		FS	CS(3)		9.2.2-1.7
CC-222	NON-ESS. SPLY HDR 2 ISOL	BF	AD	3	B		LPV	2 yr.		9.2.2-1.7
CC-223	NON-ESS. RTN HDR 2 ISOL	BF	AD	3	B		S	CS(3)		9.2.2-1.7
CC-223	NON-ESS. RTN HDR 2 ISOL	BF	AD	3	B		MT	CS(3)		9.2.2-1.7
CC-223	NON-ESS. RTN HDR 2 ISOL	BF	AD	3	B		FS	CS(3)		9.2.2-1.7
CC-223	NON-ESS. RTN HDR 2 ISOL	BF	AD	3	B		LPV	2 yr.		9.2.2-1.7
CC-230	CCW SUPPLY TO RCP 2A,2B	BF	EL	2	A		S	CS(1)		9.2.2-1.11
CC-230	CCW SUPPLY TO RCP 2A,2B	BF	EL	2	A		MT	CS(1)		9.2.2-1.11
CC-230	CCW SUPPLY TO RCP 2A,2B	BF	EL	2	A		LPV	2 yr.		9.2.2-1.11
CC-230	CCW SUPPLY TO RCP 2A,2B	BF	EL	2	A	CI	LT	2 yr.	2	9.2.2-1.11
CC-230	CCW SUPPLY TO RCP 2A,2B	BF	EL	2	A		DDP	5 yr.	2	9.2.2-1.11
CC-2302	CCW PUMP 2A DISCHARGE	CK	SA	3	C		S	3 mo.	11	9.2.2-1.7
CC-2302	CCW PUMP 2A DISCHARGE	CK	SA	3	C		RF	3 mo.	9	9.2.2-1.7
CC-2303	CCW PUMP 2B DISCHARGE	CK	SA	3	C		S	3 mo.	11	9.2.2-1.7
CC-2303	CCW PUMP 2B DISCHARGE	CK	SA	3	C		RF	3 mo.	9	9.2.2-1.7
CC-231	CCW SUPPLY TO RCP 2A,2B	BF	EL	2	A		S	CS(1)		9.2.2-1.11
CC-231	CCW SUPPLY TO RCP 2A,2B	BF	EL	2	A		MT	CS(1)		9.2.2-1.11
CC-231	CCW SUPPLY TO RCP 2A,2B	BF	EL	2	A		LPV	2 yr.		9.2.2-1.11
CC-231	CCW SUPPLY TO RCP 2A,2B	BF	EL	2	A	CI	LT	2 yr.	2	9.2.2-1.11
CC-2328	MAKEUP TO CCW SURGE TANK 2 FROM SSWS	CK	SA	3	C		S	3 mo.	14	9.2.2-1.7
CC-2328	MAKEUP TO CCW SURGE TANK 2 FROM SSWS	CK	SA	3	C		RF	3 mo.	9	9.2.2-1.7
CC-236	CCW RETURN FROM RCP 2A,2B	BF	EL	2	A		S	CS(1)		9.2.2-1.11
CC-236	CCW RETURN FROM RCP 2A,2B	BF	EL	2	A		MT	CS(1)		9.2.2-1.11
CC-236	CCW RETURN FROM RCP 2A,2B	BF	EL	2	A		LPV	2 yr.		9.2.2-1.11
CC-236	CCW RETURN FROM RCP 2A,2B	BF	EL	2	A	CI	LT	2 yr.	3	9.2.2-1.11
CC-236	CCW RETURN FROM RCP 2A,2B	BF	EL	2	A		DDP	5 yr.	3	9.2.2-1.11

TABLE 3.9-15 (Continued)

INSERVICE TESTING SAFETY-RELATED PUMPS AND VALVES

VALVE NO.	VALVE DESCRIPTION	(a) VALVE TYPE	(b) VALVE ACT.	(c) SAFETY CLASS	(d) CODE CAT	(e) VALVE FUNCT	(f) TEST REQD	(g) TEST FREQ	(i) TEST CONFIG	CESSAR-DC FIG. NO.
CC-237	CCW RETURN FROM RCP 2A,2B	BF	EL	2	A		S	CS(1)		9.2.2-1.11
CC-237	CCW RETURN FROM RCP 2A,2B	BF	EL	2	A		MT	CS(1)		9.2.2-1.11
CC-237	CCW RETURN FROM RCP 2A,2B	BF	EL	2	A		LPV	2 yr.		9.2.2-1.11
CC-237	CCW RETURN FROM RCP 2A,2B	BF	EL	2	A	CI	LT	2 yr.	3	9.2.2-1.11
CC-237	CCW RETURN FROM RCP 2A,2B	BF	EL	2	A		DDP	5 yr.	3	9.2.2-1.11
CC-240	CCW SPLY TO LETDOWN HX	BF	EL	2	A		S	CS(4)		9.2.2-1.14
CC-240	CCW SPLY TO LETDOWN HX	BF	EL	2	A		MT	CS(4)		9.2.2-1.14
CC-240	CCW SPLY TO LETDOWN HX	BF	EL	2	A		LPV	2 yr.		9.2.2-1.14
CC-240	CCW SPLY TO LETDOWN HX	BF	EL	2	A	CI	LT	2 yr.	2	9.2.2-1.14
CC-240	CCW SPLY TO LETDOWN HX	BF	EL	2	A		DDP	5 yr.	2	9.2.2-1.14
CC-241	CCW SPLY TO LETDOWN HX	BF	EL	2	A		S	CS(4)		9.2.2-1.14
CC-241	CCW SPLY TO LETDOWN HX	BF	EL	2	A		MT	CS(4)		9.2.2-1.14
CC-241	CCW SPLY TO LETDOWN HX	BF	EL	2	A		LPV	2 yr.		9.2.2-1.14
CC-241	CCW SPLY TO LETDOWN HX	BF	EL	2	A	CI	LT	2 yr.	2	9.2.2-1.14
CC-242	CCW RTN FROM LETDOWN HX	BF	EL	2	A		S	CS(4)		9.2.2-1.14
CC-242	CCW RTN FROM LETDOWN HX	BF	EL	2	A		MT	CS(4)		9.2.2-1.14
CC-242	CCW RTN FROM LETDOWN HX	BF	EL	2	A		LPV	2 yr.		9.2.2-1.14
CC-242	CCW RTN FROM LETDOWN HX	BF	EL	2	A	CI	LT	2 yr.	3	9.2.2-1.14
CC-242	CCW RTN FROM LETDOWN HX	BF	EL	2	A		DDP	5 yr.	3	9.2.2-1.14
CC-243	CCW RTN FROM LETDOWN HX	BF	EL	2	A		S	CS(4)		9.2.2-1.14
CC-243	CCW RTN FROM LETDOWN HX	BF	EL	2	A		MT	CS(4)		9.2.2-1.14
CC-243	CCW RTN FROM LETDOWN HX	BF	EL	2	A		LPV	2 yr.		9.2.2-1.14
CC-243	CCW RTN FROM LETDOWN HX	BF	EL	2	A	CI	LT	2 yr.	3	9.2.2-1.14
CC-243	CCW RTN FROM LETDOWN HX	BF	EL	2	A		DDP	5 yr.	3	9.2.2-1.14
CC-2507	CCW SUPPLY TO RCP 2A,2B	CK	SA	2	A/C		S	CS(2)	11	9.2.2-1.11
CC-2507	CCW SUPPLY TO RCP 2A,2B	CK	SA	2	A/C	CI	LT	2 yr.	2	9.2.2-1.11
CC-2548	CCW RETURN FROM RCP 2A,2B	CK	SA	2	A/C		S	RO(2)	12	9.2.2-1.11
CC-2548	CCW RETURN FROM RCP 2A,2B	CK	SA	2	A/C	CI	LT	2 yr.	3	9.2.2-1.11
CC-2622	CCW SPLY TO LETDOWN HX	CK	SA	2	A/C		S	CS(5)	11	9.2.2-1.14
CC-2622	CCW SPLY TO LETDOWN HX	CK	SA	2	A/C	CI	LT	2 yr.	2	9.2.2-1.14
CC-2628	CCW RTN FROM LETDOWN HX	CK	SA	2	A/C		S	RO(5)	13	9.2.2-1.14
CC-2628	CCW RTN FROM LETDOWN HX	CK	SA	2	A/C	CI	LT	2 yr.	3	9.2.2-1.14

TABLE 3.9-15 (Continued)

INSERVICE TESTING SAFETY-RELATED PUMPS AND VALVES

<u>VALVE NO.</u>	<u>VALVE DESCRIPTION</u>	<u>(a) VALVE TYPE</u>	<u>(b) VALVE ACT.</u>	<u>(c) SAFETY CLASS</u>	<u>(d) CODE CAT.</u>	<u>(e) VALVE FUNCT</u>	<u>(f) TEST REQD</u>	<u>(g) TEST FREQ</u>	<u>(h) TEST CONFIG.</u>	<u>CESSAR-DC FIG. NO.</u>
CH-255	SEAL INJ. CONT. ISOL	GL	EL	2	A		S	CS(6)		9.3.4-1.1
CH-255	SEAL INJ. CONT. ISOL	GL	EL	2	A		MT	CS(6)		9.3.4-1.1
CH-255	SEAL INJ. CONT. ISOL	GL	EL	2	A		LPV	2 yr.		9.3.4-1.1
CH-255	SEAL INJ. CONT. ISOL	GL	EL	2	A	CI	LT	2 yr.	1	9.3.4-1.1
CH-255	SEAL INJ. CONT. ISOL	GL	EL	2	A		DDP	5 yr.	1	9.3.4-1.1
CH-304	SHUTDOWN PURIF. TO LD HX	CK	SA	2	A/C	P,CI,IV	LT	2 yr.	1	9.3.4-1.1
CH-307	SHUTDOWN PURIF. TO LD HX	GT	M	2	A	P,CI,IV	LT	2 yr.	1	9.3.4-1.1
CH-494	RESIN SLUICE SUPPLY HDR TO RDT	CK	SA	2	A/C		S	3 mo.	12	9.3.4-1.3
CH-494	RESIN SLUICE SUPPLY HDR TO RDT	CK	SA	2	A/C	CI	LT	2 yr.	1	9.3.4-1.3
CH-505	RCP SEAL RETURN	GL	AD	2	A		S	CS(7)		9.3.4-1.2
CH-505	RCP SEAL RETURN	GL	AD	2	A		MT	CS(7)		9.3.4-1.2
CH-505	RCP SEAL RETURN	GL	AD	2	A		FS	CS(7)		9.3.4-1.2
CH-505	RCP SEAL RETURN	GL	AD	2	A		LPV	2 yr.		9.3.4-1.2
CH-505	RCP SEAL RETURN	GL	AD	2	A	CI	LT	2 yr.	4	9.3.4-1.2
CH-505	RCP SEAL RETURN	GL	AD	2	A		DDP	5 yr.	4	9.3.4-1.2
CH-506	RCP SEAL RETURN	GL	AD	2	A		S	CS(7)		9.3.4-1.2
CH-506	RCP SEAL RETURN	GL	AD	2	A		MT	CS(7)		9.3.4-1.2
CH-506	RCP SEAL RETURN	GL	AD	2	A		FS	CS(7)		9.3.4-1.2
CH-506	RCP SEAL RETURN	GL	AD	2	A		LPV	2 yr.		9.3.4-1.2
CH-506	RCP SEAL RETURN	GL	AD	2	A	CI	LT	2 yr.	4	9.3.4-1.2
CH-506	RCP SEAL RETURN	GL	AD	2	A		DDP	5 yr.	4	9.3.4-1.2
CH-515	LOOP 2B LETDOWN ISOL	GL	AD	1	A		S	CS(8)		9.3.4-1.1
CH-515	LOOP 2B LETDOWN ISOL	GL	AD	1	A		MT	CS(8)		9.3.4-1.1
CH-515	LOOP 2B LETDOWN ISOL	GL	AD	1	A		FS	CS(8)		9.3.4-1.1
CH-515	LOOP 2B LETDOWN ISOL	GL	AD	1	A		LPV	2 yr.		9.3.4-1.1
CH-515	LOOP 2B LETDOWN ISOL	GL	AD	1	A		DDP	5 yr.	4	9.3.4-1.1
CH-516	LP 2B LETDOWN CONT. ISOL	GL	AD	1	A		S	CS(8)		9.3.4-1.1
CH-516	LP 2B LETDOWN CONT. ISOL	GL	AD	1	A		MT	CS(8)		9.3.4-1.1
CH-516	LP 2B LETDOWN CONT. ISOL	GL	AD	1	A		FS	CS(8)		9.3.4-1.1
CH-516	LP 2B LETDOWN CONT. ISOL	GL	AD	1	A		LPV	2 yr.		9.3.4-1.1
CH-516	LP 2B LETDOWN CONT. ISOL	GL	AD	1	A	CI	LT	2 yr.	4	9.3.4-1.1
CH-516	LP 2B LETDOWN CONT. ISOL	GL	AD	1	A		DDP	5 yr.	4	9.3.4-1.1
CH-523	LP 2B LETDOWN CONT. ISOL	GL	AD	2	A		S	CS(8)		9.3.4-1.1

TABLE 3.9-15 (Continued)

INSERVICE TESTING SAFETY-RELATED PUMPS AND VALVES

VALVE NO.	VALVE DESCRIPTION	(a) VALVE TYPE	(b) VALVE ACT.	(c) SAFETY CLASS	(d) CODE CAT	(e) VALVE FUNCT	(f) TEST REQD	(g) TEST FREQ	(h) TEST CONFIG.	CESSAR-DC FIG. NO.
CH-523	LP 2B LETDOWN CONT. ISOL	GL	AD	2	A		MT	CS(8)		9.3.4-1.1
CH-523	LP 2B LETDOWN CONT. ISOL	GL	AD	2	A		FS	CS(8)		9.3.4-1.1
CH-523	LP 2B LETDOWN CONT. ISOL	GL	AD	2	A		LPV	2 YR.	4	9.3.4-1.1
CH-523	LP 2B LETDOWN CONT. ISOL	GL	AD	2	A	CI	LT	2 YR.	4	9.3.4-1.1
CH-523	LP 2B LETDOWN CONT. ISOL	GL	AD	2	A		DDP	5 YR.	4	9.3.4-1.1
CH-524	CVCS CHARGING LINE ISOL.	GL	EL	2	A		S	CS(9)		9.3.4-1.1
CH-524	CVCS CHARGING LINE ISOL.	GL	EL	2	A		MT	CS(9)		9.3.4-1.1
CH-524	CVCS CHARGING LINE ISOL.	GL	EL	2	A		LPV	2 YR.		9.3.4-1.1
CH-524	CVCS CHARGING LINE ISOL.	GL	EL	2	A	CI	LT	2 YR.	1	9.3.4-1.1
CH-524	CVCS CHARGING LINE ISOL.	GL	EL	2	A		DDP	5 YR.	1	9.3.4-1.1
CH-560	RDT DISCHARGE ISOL.	GL	AD	2	A		S	3 MO.		9.3.4-1.3
CH-560	RDT DISCHARGE ISOL.	GL	AD	2	A		MT	3 MO.		9.3.4-1.3
CH-560	RDT DISCHARGE ISOL.	GL	AD	2	A		FS	3 MO.		9.3.4-1.3
CH-560	RDT DISCHARGE ISOL.	GL	AD	2	A		LPV	2 YR.		9.3.4-1.3
CH-560	RDT DISCHARGE ISOL.	GL	AD	2	A	CI	LT	2 YR.	4	9.3.4-1.3
CH-561	RDT DISCHARGE ISOL.	GL	AD	2	A		S	3 MO.		9.3.4-1.3
CH-561	RDT DISCHARGE ISOL.	GL	AD	2	A		MT	3 MO.		9.3.4-1.3
CH-561	RDT DISCHARGE ISOL.	GL	AD	2	A		FS	3 MO.		9.3.4-1.3
CH-561	RDT DISCHARGE ISOL.	GL	AD	2	A		LPV	2 YR.		9.3.4-1.3
CH-561	RDT DISCHARGE ISOL.	GL	AD	2	A	CI	LT	2 YR.	4	9.3.4-1.3
CH-580	RESIN SLUICE SUPPLY HDR TO RDT ISOL	GL	AD	2	A		S	3 MO.		9.3.4-1.3
CH-580	RESIN SLUICE SUPPLY HDR TO RDT ISOL	GL	AD	2	A		MT	3 MO.		9.3.4-1.3
CH-580	RESIN SLUICE SUPPLY HDR TO RDT ISOL	GL	AD	2	A		FS	3 MO.		9.3.4-1.3
CH-580	RESIN SLUICE SUPPLY HDR TO RDT ISOL	GL	AD	2	A		LPV	2 YR.		9.3.4-1.3
CH-580	RESIN SLUICE SUPPLY HDR TO RDT ISOL	GL	AD	2	A	CI	LT	2 YR.	4	9.3.4-1.3
CH-705	CHARGING PUMP 2 DISCHARGE	CK	SA	3	C		S	3 MO.	11	9.3.4-1.2
CH-705	CHARGING PUMP 2 DISCHARGE	CK	SA	3	C		RF	3 MO.	9	9.3.4-1.2
CH-719	CHARGING PUMP 1 DISCHARGE	CK	SA	3	C		S	3 MO.	11	9.3.4-1.2
CH-719	CHARGING PUMP 1 DISCHARGE	CK	SA	3	C		RF	3 MO.	9	9.3.4-1.2
CH-747	CVCS CHARGING LINE	CK	SA	2	A/C		S	CS(10)	12	9.3.4-1.1
CH-747	CVCS CHARGING LINE	CK	SA	2	A/C	CI	LT	2 YR.	1	9.3.4-1.1
CH-835	SEAL INJ. CONT. ISOL	CK	SA	2	A/C		S	CS(11)	11	9.3.4-1.1
CH-835	SEAL INJ. CONT. ISOL	CK	SA	2	A/C	CI	LT	2 YR.	1	9.3.4-1.1

TABLE 3.9-15 (Continued)

INSERVICE TESTING SAFETY-RELATED PUMPS AND VALVES

<u>VALVE NO.</u>	<u>VALVE DESCRIPTION</u>	<u>(a) VALVE TYPE</u>	<u>(b) VALVE ACT</u>	<u>(c) SAFETY CLASS</u>	<u>(d) CODE CAT</u>	<u>(e) VALVE FUNCT</u>	<u>(f) TEST REQD</u>	<u>(g) TEST FREQ</u>	<u>(i) TEST CONFIG</u>	<u>CESSAR-DC FIG. NO.</u>
DF-130	FO DAY TANK 1 LEVEL CTRL	GL	AD	3	B	S		3 mo.		9.5.4-1.1
DF-130	FO DAY TANK 1 LEVEL CTRL	GL	AD	3	B	MT		3 mo.		9.5.4-1.1
DF-130	FO DAY TANK 1 LEVEL CTRL	GL	AD	3	B	FS		3 mo.		9.5.4-1.1
DF-130	FO DAY TANK 1 LEVEL CTRL	GL	AD	3	B	LPV		2 yr.		9.5.4-1.1
DF-230	FO DAY TANK 2 LEVEL CTRL	GL	AD	3	B	S		3 mo.		9.5.4-1.2
DF-230	FO DAY TANK 2 LEVEL CTRL	GL	AD	3	B	MT		3 mo.		9.5.4-1.2
DF-230	FO DAY TANK 2 LEVEL CTRL	GL	AD	3	B	FS		3 mo.		9.5.4-1.2
DF-230	FO DAY TANK 2 LEVEL CTRL	GL	AD	3	B	LPV		2 yr.		9.5.4-1.2
DS-110	START AIR RCVR 1A INLET	CK	SA	3	A/C	S		3 mo.	15	9.5.6-1.1
DS-110	START AIR RCVR 1A INLET	CK	SA	3	A/C	LT		2 yr.	9	9.5.6-1.1
DS-112	START AIR RCVR 1A OUTLET	CK	SA	3	C	S		3 mo.	15	9.5.6-1.1
DS-113	SA SPLY TO ENG CTRL PNL 1	CK	SA	3	A/C	S		3 mo.	15	9.5.6-1.1
DS-113	SA SPLY TO ENG CTRL PNL 1	CK	SA	3	A/C	LT		2 yr.	9	9.5.6-1.1
DS-115	DGE 1 SA LEFT BANK INLET	GT	S	3	B	S		3 mo.		9.5.6-1.1
DS-115	DGE 1 SA LEFT BANK INLET	GT	S	3	B	MT		3 mo.		9.5.6-1.1
DS-115	DGE 1 SA LEFT BANK INLET	GT	S	3	B	FS		3 mo.		9.5.6-1.1
DS-115	DGE 1 SA LEFT BANK INLET	GT	S	3	B	LPV		2 yr.		9.5.6-1.1
DS-116	DGE 1 SA LEFT BANK INLET	GT	S	3	B	S		3 mo.		9.5.6-1.1
DS-116	DGE 1 SA LEFT BANK INLET	GT	S	3	B	MT		3 mo.		9.5.6-1.1
DS-116	DGE 1 SA LEFT BANK INLET	GT	S	3	B	FS		3 mo.		9.5.6-1.1
DS-116	DGE 1 SA LEFT BANK INLET	GT	S	3	B	LPV		2 yr.		9.5.6-1.1
DS-117	DGE 1 SA LEFT BANK INLET	CK	SA	3	C	S		CS(35)	15	9.5.6-1.1
DS-118	DGE 1 SA LEFT BANK INLET	CK	SA	3	C	S		CS(35)	15	9.5.6-1.1
DS-120	START AIR RCVR 1B INLET	CK	SA	3	A/C	S		3 mo.	15	9.5.6-1.1
DS-120	START AIR RCVR 1B INLET	CK	SA	3	A/C	LT		2 yr.	9	9.5.6-1.1
DS-122	START AIR RCVR 1B OUTLET	CK	SA	3	C	S		3 mo.	15	9.5.6-1.1
DS-123	SA SPLY TO ENG CTRL PNL 1	CK	SA	3	A/C	S		3 mo.	15	9.5.6-1.1
DS-123	SA SPLY TO ENG CTRL PNL 1	CK	SA	3	A/C	LT		2 yr.	9	9.5.6-1.1
DS-125	DGE 1 SA RIGHT BANK INLET	GT	S	3	B	S		3 mo.		9.5.6-1.1

TABLE 3.9-15 (Continued)

INSERVICE TESTING SAFETY-RELATED PUMPS AND VALVES

VALVE NO.	VALVE DESCRIPTION	(a) VALVE TYPE	(b) VALVE ACT.	(c) SAFETY CLASS.	(d) CODE CAT.	(e) VALVE FUNCT.	(f) TEST REQD.	(g) TEST FREQ.	(i) TEST CONFIG.	CESSAR-DC FIG. NO.
DS-125	DGE 1 SA RIGHT BANK INLET	GT	S	3	B		MT	3 mo.		9.5.6-1.1
DS-125	DGE 1 SA RIGHT BANK INLET	GT	S	3	B		FS	3 mo.		9.5.6-1.1
DS-125	DGE 1 SA RIGHT BANK INLET	GT	S	3	B		LPV	2 yr.		9.5.6-1.1
DS-126	DGE 1 SA RIGHT BANK INLET	GT	S	3	B		S	3 mo.		9.5.6-1.1
DS-126	DGE 1 SA RIGHT BANK INLET	GT	S	3	B		MT	3 mo.		9.5.6-1.1
DS-126	DGE 1 SA RIGHT BANK INLET	GT	S	3	B		FS	3 mo.		9.5.6-1.1
DS-126	DGE 1 SA RIGHT BANK INLET	GT	S	3	B		LPV	2 yr.		9.5.6-1.1
DS-127	DGE 1 SA RIGHT BANK INLET	CK	SA	3	C		S	CS(35)	15	9.5.6-1.1
DS-128	DGE 1 SA RIGHT BANK INLET	CK	SA	3	C		S	CS(35)	15	9.5.6-1.1
DS-210	START AIR RCVR 2A INLET	CK	SA	3	A/C		S	3 mo.	15	9.5.6-1.1
DS-210	START AIR RCVR 2A INLET	CK	SA	3	A/C		LT	2 yr.	9	9.5.6-1.1
DS-212	START AIR RCVR 2A OUTLET	CK	SA	3	C		S	3 mo.	15	9.5.6-1.1
DS-213	SA SPLY TO ENG CTRL PNL 2	CK	SA	3	A/C		S	3 mo.	15	9.5.6-1.1
DS-213	SA SPLY TO ENG CTRL PNL 2	CK	SA	3	A/C		LT	2 yr.	9	9.5.6-1.1
DS-215	DGE 2 SA LEFT BANK INLET	GT	S	3	B		S	3 mo.		9.5.6-1.2
DS-215	DGE 2 SA LEFT BANK INLET	GT	S	3	B		MT	3 mo.		9.5.6-1.2
DS-215	DGE 2 SA LEFT BANK INLET	GT	S	3	B		FS	3 mo.		9.5.6-1.2
DS-215	DGE 2 SA LEFT BANK INLET	GT	S	3	B		LPV	2 yr.		9.5.6-1.2
DS-216	DGE 2 SA LEFT BANK INLET	GT	S	3	B		S	3 mo.		9.5.6-1.2
DS-216	DGE 2 SA LEFT BANK INLET	GT	S	3	B		MT	3 mo.		9.5.6-1.2
DF-216	DGE 2 SA LEFT BANK INLET	GT	S	3	B		FS	3 mo.		9.5.6-1.2
DS-216	DGE 2 SA LEFT BANK INLET	GT	S	3	B		LPV	2 yr.		9.5.6-1.2
DS-217	DGE 2 SA LEFT BANK INLET	CK	SA	3	C		S	CS(35)	15	9.5.6-1.2
DS-218	DGE 2 SA LEFT BANK INLET	CK	SA	3	C		S	CS(35)	15	9.5.6-1.2
DS-220	START AIR RCVR 2B INLET	CK	SA	3	A/C		S	3 mo.	15	9.5.6-1.1
DS-220	START AIR RCVR 2B INLET	CK	SA	3	A/C		LT	2 yr.	9	9.5.6-1.1
DS-222	START AIR RCVR 2B OUTLET	CK	SA	3	C		S	3 mo.	15	9.5.6-1.1
DS-223	SA SPLY TO ENG CTRL PNL 2	CK	SA	3	A/C		S	3 mo.	15	9.5.6-1.1

TABLE 3.9-15 (Continued)

INSERVICE TESTING SAFETY-RELATED PUMPS AND VALVES

<u>VALVE NO.</u>	<u>VALVE DESCRIPTION</u>	<u>(a) VALVE TYPE</u>	<u>(b) VALVE ACT.</u>	<u>(c) SAFETY CLASS</u>	<u>(d) CODE CAT</u>	<u>(e) VALVE FUNCT</u>	<u>(f) TEST RECD</u>	<u>(g) TEST FREQ</u>	<u>(i) TEST CONFIG.</u>	<u>CESSAR-DC FIG. NO.</u>
DS-223	SA SPLY TO ENG CTRL PNL 2	CK	SA	3	A/C		LT	2 Yr.	9	9.5.6-1.1
DS-225	DGE 2 SA RIGHT BANK INLET	GT	S	3	B		S	3 mo.		9.5.6-1.2
DS-225	DGE 2 SA RIGHT BANK INLET	GT	S	3	B		MT	3 mo.		9.5.6-1.2
DS-225	DGE 2 SA RIGHT BANK INLET	GT	S	3	B		FS	3 mo.		9.5.6-1.2
DS-225	DGE 2 SA RIGHT BANK INLET	GT	S	3	B		LPV	2 Yr.		9.5.6-1.2
DS-226	DGE 2 SA RIGHT BANK INLET	GT	S	3	B		S	3 mo.		9.5.6-1.2
DS-226	DGE 2 SA RIGHT BANK INLET	GT	S	3	B		MT	3 mo.		9.5.6-1.2
DS-226	DGE 2 SA RIGHT BANK INLET	GT	S	3	B		FS	3 mo.		9.5.6-1.2
DS-226	DGE 2 SA RIGHT BANK INLET	GT	S	3	B		LPV	2 Yr.		9.5.6-1.2
DS-227	DGE 2 SA RIGHT BANK INLET	CK	SA	3	C		S	CS (35)	15	9.5.6-1.2
DS-228	DGE 2 SA RIGHT BANK INLET	CK	SA	3	C		S	CS (35)	15	9.5.6-1.2
EF-100	SD EPW PUMP #1 SG ISOL.	GT	EL	2	B		S	3 mo.		10.4.9-1.1
EF-100	SD EPW PUMP #1 SG ISOL.	GT	EL	2	B		MT	3 mo.		10.4.9-1.1
EF-100	SD EPW PUMP #1 SG ISOL.	GT	EL	2	B		LPV	2 Yr.		10.4.9-1.1
EF-100	SD EPW PUMP #1 SG ISOL.	GT	EL	2	B		DDP	5 Yr.		10.4.9-1.1
EF-101	SD EPW PUMP #2 SG ISOL.	GT	EL	2	B		S	3 mo.		10.4.9-1.1
EF-101	SD EPW PUMP #2 SG ISOL.	GT	EL	2	B		MT	3 mo.		10.4.9-1.1
EF-101	SD EPW PUMP #2 SG ISOL.	GT	EL	2	B		LPV	2 Yr.		10.4.9-1.1
EF-101	SD EPW PUMP #2 SG ISOL.	GT	EL	2	B		DDP	5 Yr.		10.4.9-1.1
EF-102	MD EPW PUMP #1 SG ISOL.	GT	EL	2	B		S	3 mo.		10.4.9-1.1
EF-102	MD EPW PUMP #1 SG ISOL.	GT	EL	2	B		MT	3 mo.		10.4.9-1.1
EF-102	MD EPW PUMP #1 SG ISOL.	GT	EL	2	B		LPV	2 Yr.		10.4.9-1.1
EF-102	MD EPW PUMP #1 SG ISOL.	GT	EL	2	B		DDP	5 Yr.		10.4.9-1.1
EF-103	MD EPW PUMP #2 SG ISOL.	GT	EL	2	B		S	3 mo.		10.4.9-1.1
EF-103	MD EPW PUMP #2 SG ISOL.	GT	EL	2	B		MT	3 mo.		10.4.9-1.1
EF-103	MD EPW PUMP #2 SG ISOL.	GT	EL	2	B		LPV	2 Yr.		10.4.9-1.1
EF-103	MD EPW PUMP #2 SG ISOL.	GT	EL	2	B		DDP	5 Yr.		10.4.9-1.1
EF-104	SD EPW PUMP #1 FLOW CTRL	GL	EL	3	B		S	3 mo.		10.4.9-1.1
EF-104	SD EPW PUMP #1 FLOW CTRL	GL	EL	3	B		MT	3 mo.		10.4.9-1.1
EF-104	SD EPW PUMP #1 FLOW CTRL	GL	EL	3	B		LPV	2 Yr.		10.4.9-1.1
EF-104	SD EPW PUMP #1 FLOW CTRL	GL	EL	3	B		DDP	5 Yr.		10.4.9-1.1

TABLE 3.9-15 (Continued)

INSERVICE TESTING SAFETY-RELATED PUMPS AND VALVES

VALVE NO.	VALVE DESCRIPTION	(a) VALVE TYPE	(b) VALVE ACT.	(c) SAFETY CLASS	(d) CODE CAT	(e) VALVE FUNCT	(f) TEST READ	(g) TEST FREQ	(h) TEST CONFIG.	CESSAR-DC FIG. NO.
EF-105	SD EFW PUMP #2 FLOW CTRL	GL	EL	3	B	B	S	3 MO.		10.4.9-1.1
EF-105	SD EFW PUMP #2 FLOW CTRL	GL	EL	3	B	B	MT	3 MO.		10.4.9-1.1
EF-105	SD EFW PUMP #2 FLOW CTRL	GL	EL	3	B	B	LPV	2 YR.	8	10.4.9-1.1
EF-105	SD EFW PUMP #2 FLOW CTRL	GL	EL	3	B	B	DDP	5 YR.		10.4.9-1.1
EF-106	MD EFW PUMP #1 FLOW CTRL	GL	EL	3	B	B	S	3 MO.		10.4.9-1.1
EF-106	MD EFW PUMP #1 FLOW CTRL	GL	EL	3	B	B	MT	3 MO.		10.4.9-1.1
EF-106	MD EFW PUMP #1 FLOW CTRL	GL	EL	3	B	B	LPV	2 YR.	9	10.4.9-1.1
EF-106	MD EFW PUMP #1 FLOW CTRL	GL	EL	3	B	B	DDP	5 YR.		10.4.9-1.1
EF-107	MD EFW PUMP #2 FLOW CTRL	GL	EL	3	B	B	S	3 MO.		10.4.9-1.1
EF-107	MD EFW PUMP #2 FLOW CTRL	GL	EL	3	B	B	MT	3 MO.		10.4.9-1.1
EF-107	MD EFW PUMP #2 FLOW CTRL	GL	EL	3	B	B	LPV	2 YR.	8	10.4.9-1.1
EF-107	MD EFW PUMP #2 FLOW CTRL	GL	EL	3	B	B	DDP	5 YR.		10.4.9-1.1
EF-108	EFW PUMP #1 STEAM SUPPLY	GT	AD	2	B	B	S	3 MO.		10.4.9-1.2
EF-108	EFW PUMP #1 STEAM SUPPLY	GT	AD	2	B	B	MT	3 MO.		10.4.9-1.2
EF-108	EFW PUMP #1 STEAM SUPPLY	GT	AD	2	B	B	FS	3 MO.		10.4.9-1.2
EF-108	EFW PUMP #1 STEAM SUPPLY	GT	AD	2	B	B	LPV	2 YR.		10.4.9-1.2
EF-109	EFW PUMP #2 STEAM SUPPLY	GT	AD	2	B	B	S	3 MO.		10.4.9-1.2
EF-109	EFW PUMP #2 STEAM SUPPLY	GT	AD	2	B	B	MT	3 MO.		10.4.9-1.2
EF-109	EFW PUMP #2 STEAM SUPPLY	GT	AD	2	B	B	FS	3 MO.		10.4.9-1.2
EF-109	EFW PUMP #2 STEAM SUPPLY	GT	AD	2	B	B	LPV	2 YR.		10.4.9-1.2
EF-110	EFW PUMP #1 CONTINUOUS STM DR.	GT	EL	2	B	B	S	3 MO.		10.4.9-1.2
EF-110	EFW PUMP #1 CONTINUOUS STM DR.	GT	EL	2	B	B	MT	3 MO.		10.4.9-1.2
EF-110	EFW PUMP #1 CONTINUOUS STM DR.	GT	EL	2	B	B	LPV	2 YR.		10.4.9-1.2
EF-111	EFW PUMP #2 CONTINUOUS STM DR.	GT	EL	2	B	B	S	3 MO.		10.4.9-1.2
EF-111	EFW PUMP #2 CONTINUOUS STM DR.	GT	EL	2	B	B	MT	3 MO.		10.4.9-1.2
EF-111	EFW PUMP #2 CONTINUOUS STM DR.	GT	EL	2	B	B	LPV	2 YR.		10.4.9-1.2
EF-112	EFW PUMP #1 STM BYPASS	GT	AD	2	B	B	S	3 MO.		10.4.9-1.2
EF-112	EFW PUMP #1 STM BYPASS	GT	AD	2	B	B	MT	3 MO.		10.4.9-1.2
EF-112	EFW PUMP #1 STM BYPASS	GT	AD	2	B	B	FS	3 MO.		10.4.9-1.2
EF-112	EFW PUMP #1 STM BYPASS	GT	AD	2	B	B	LPV	2 YR.		10.4.9-1.2
EF-113	EFW PUMP #2 STM BYPASS	GT	AD	2	B	B	S	3 MO.		10.4.9-1.2
EF-113	EFW PUMP #2 STM BYPASS	GT	AD	2	B	B	MT	3 MO.		10.4.9-1.2
EF-113	EFW PUMP #2 STM BYPASS	GT	AD	2	B	B	FS	3 MO.		10.4.9-1.2

TABLE 3.9-15 (Continued)

INSERVICE TESTING SAFETY-RELATED PUMPS AND VALVES

<u>VALVE NO.</u>	<u>VALVE DESCRIPTION</u>	<u>(a) VALVE TYPE</u>	<u>(b) VALVE ACT</u>	<u>(c) SAFETY CLASS</u>	<u>(d) CODE CAT</u>	<u>(e) VALVE FUNCT</u>	<u>(f) TEST REQD</u>	<u>(g) TEST TEST FREQ</u>	<u>(i) TEST TEST CONFIG</u>	<u>CESSAR-DC FIG. NO.</u>
EF-113	EFW PUMP #2 STM BYPASS	GT	AD	2	B		LPV	2 yr.		10.4.9-1.2
EF-200	SD EFW PUMP #1 SG ISOL.	CK	SA	2	C		S	CS(12)	12	10.4.9-1.1
EF-200	SD EFW PUMP #1 SG ISOL.	CK	SA	2	C		RF	CS(12)	9	10.4.9-1.1
EF-201	SD EFW PUMP #2 SG ISOL.	CK	SA	2	C		S	CS(12)	12	10.4.9-1.1
EF-201	SD EFW PUMP #2 SG ISOL.	CK	SA	2	C		RF	CS(12)	9	10.4.9-1.1
EF-202	MD EFW PUMP #1 SG ISOL.	CK	SA	2	C		S	CS(12)	12	10.4.9-1.1
EF-202	MD EFW PUMP #1 SG ISOL.	CK	SA	2	C		RF	CS(12)	9	10.4.9-1.1
EF-203	MD EFW PUMP #2 SG ISOL.	CK	SA	2	C		S	CS(12)	12	10.4.9-1.1
EF-203	MD EFW PUMP #2 SG ISOL.	CK	SA	2	C		RF	CS(12)	9	10.4.9-1.1
EF-204	SD EFW PUMP #1 DISCHARGE	CK	SA	3	C		S	CS(12)	11	10.4.9-1.1
EF-204	SD EFW PUMP #1 DISCHARGE	CK	SA	3	C		RF	CS(12)	9	10.4.9-1.1
EF-205	SD EFW PUMP #2 DISCHARGE	CK	SA	3	C		S	CS(12)	11	10.4.9-1.1
EF-205	SD EFW PUMP #2 DISCHARGE	CK	SA	3	C		RF	CS(12)	9	10.4.9-1.1
EF-206	MD EFW PUMP #1 DISCHARGE	CK	SA	3	C		S	CS(12)	11	10.4.9-1.1
EF-206	MD EFW PUMP #1 DISCHARGE	CK	SA	3	C		RF	CS(12)	9	10.4.9-1.1
EF-207	MD EFW PUMP #2 DISCHARGE	CK	SA	3	C		S	CS(12)	11	10.4.9-1.1
EF-207	MD EFW PUMP #2 DISCHARGE	CK	SA	3	C		RF	CS(12)	9	10.4.9-1.1
PC-257	REFUELING CAV CLEANUP SCTN	PK	M	2	A	P, CI	LT	2 yr.	4	9.1-3
PC-258	REFUELING CAV CLEANUP SCTN	PK	M	2	A	P, CI	LT	2 yr.	4	9.1-3
PC-291	REFUELING CAV CLEANUP RTN	PK	M	2	A	P, CI	LT	2 yr.	4	9.1-3
PC-292	REFUELING CAV CLEANUP RTN	PK	M	2	A	P, CI	LT	2 yr.	4	9.1-3
RC-406	RAPID DEPRESSURIZATION VALVE	GL	EL	1	A		S	CS(13)		5.1.2-3
RC-406	RAPID DEPRESSURIZATION VALVE	GL	EL	1	A		MT	CS(13)		5.1.2-3
RC-406	RAPID DEPRESSURIZATION VALVE	GL	EL	1	A		LPV	2 yr.		5.1.2-3
RC-407	RAPID DEPRESSURIZATION VALVE	GL	EL	1	A		S	CS(13)		5.1.2-3
RC-407	RAPID DEPRESSURIZATION VALVE	GL	EL	1	A		MT	CS(13)		5.1.2-3
RC-407	RAPID DEPRESSURIZATION VALVE	GL	EL	1	A		LPV	2 yr.		5.1.2-3

TABLE 3.9-15 (Continued)

INSERVICE TESTING SAFETY-RELATED PUMPS AND VALVES

<u>VALVE NO.</u>	<u>VALVE DESCRIPTION</u>	<u>(a) VALVE TYPE</u>	<u>(b) VALVE ACT</u>	<u>(c) SAFETY CLASS</u>	<u>(d) CODE CAT</u>	<u>(e) VALVE FUNCT</u>	<u>(f) TEST REQD</u>	<u>(g) TEST FREQ</u>	<u>(i) TEST CONFIG.</u>	<u>CESSAR-DC FIG. NO.</u>
RC-408	RAPID DEPRESSURIZATION VALVE	GT	EL	1	A		S	CS(13)		5.1.2-3
RC-408	RAPID DEPRESSURIZATION VALVE	GT	EL	1	A		MT	CS(13)		5.1.2-3
RC-408	RAPID DEPRESSURIZATION VALVE	GT	EL	1	A		LPV	2 yr.		5.1.2-3
RC-409	RAPID DEPRESSURIZATION VALVE	GT	EL	1	A		S	CS(13)		5.1.2-3
RC-409	RAPID DEPRESSURIZATION VALVE	GT	EL	1	A		MT	CS(13)		5.1.2-3
RC-409	RAPID DEPRESSURIZATION VALVE	GT	EL	1	A		LPV	2 yr.		5.1.2-3
RC-410	PRESSURIZER GAS VENT VALVE	GL	S	1	A		S	CS(14)		5.1.2-3
RC-410	PRESSURIZER GAS VENT VALVE	GL	S	1	A		MT	CS(14)		5.1.2-3
RC-410	PRESSURIZER GAS VENT VALVE	GL	S	1	A		FS	CS(14)		5.1.2-3
RC-410	PRESSURIZER GAS VENT VALVE	GL	S	1	A		LPV	2 yr.		5.1.2-3
RC-411	PRESSURIZER GAS VENT VALVE	GL	S	1	A		S	CS(14)		5.1.2-3
RC-411	PRESSURIZER GAS VENT VALVE	GL	S	1	A		MT	CS(14)		5.1.2-3
RC-411	PRESSURIZER GAS VENT VALVE	GL	S	1	A		FS	CS(14)		5.1.2-3
RC-411	PRESSURIZER GAS VENT VALVE	GL	S	1	A		LPV	2 yr.		5.1.2-3
RC-412	PRESSURIZER GAS VENT VALVE	GL	S	1	A		S	CS(14)		5.1.2-3
RC-412	PRESSURIZER GAS VENT VALVE	GL	S	1	A		MT	CS(14)		5.1.2-3
RC-412	PRESSURIZER GAS VENT VALVE	GL	S	1	A		FS	CS(14)		5.1.2-3
RC-412	PRESSURIZER GAS VENT VALVE	GL	S	1	A		LPV	2 yr.		5.1.2-3
RC-413	PRESSURIZER GAS VENT VALVE	GL	S	1	A		S	CS(14)		5.1.2-3
RC-413	PRESSURIZER GAS VENT VALVE	GL	S	1	A		MT	CS(14)		5.1.2-3
RC-413	PRESSURIZER GAS VENT VALVE	GL	S	1	A		FS	CS(14)		5.1.2-3
RC-413	PRESSURIZER GAS VENT VALVE	GL	S	1	A		LPV	2 yr.		5.1.2-3
RC-414	REACTOR VESSEL GAS VENT VALVE	GL	S	1	A		S	CS(14)		5.1.2-3
RC-414	REACTOR VESSEL GAS VENT VALVE	GL	S	1	A		MT	CS(14)		5.1.2-3
RC-414	REACTOR VESSEL GAS VENT VALVE	GL	S	1	A		FS	CS(14)		5.1.2-3
RC-414	REACTOR VESSEL GAS VENT VALVE	GL	S	1	A		LPV	2 yr.		5.1.2-3
RC-415	REACTOR VESSEL GAS VENT VALVE	GL	S	1	A		S	CS(14)		5.1.2-3
RC-415	REACTOR VESSEL GAS VENT VALVE	GL	S	1	A		MT	CS(14)		5.1.2-3
RC-415	REACTOR VESSEL GAS VENT VALVE	GL	S	1	A		FS	CS(14)		5.1.2-3
RC-415	REACTOR VESSEL GAS VENT VALVE	GL	S	1	A		LPV	2 yr.		5.1.2-3
RC-416	REACTOR VESSEL GAS VENT VALVE	GL	S	1	A		S	CS(14)		5.1.2-3
RC-416	REACTOR VESSEL GAS VENT VALVE	GL	S	1	A		MT	CS(14)		5.1.2-3
RC-416	REACTOR VESSEL GAS VENT VALVE	GL	S	1	A		FS	CS(14)		5.1.2-3

TABLE 3.9-15 (Continued)

INSERVICE TESTING SAFETY-RELATED PUMPS AND VALVES

VALVE NO.	VALVE DESCRIPTION	(a)	(b)	(c)	(d)	(e)	(f)	(g)	(i)	CESSAR-DC FIG. NO.
		VALVE TYPE	VALVE ACT.	SAFETY CLASS.	CODE CAT.	VALVE FUNCT.	TEST REQD.	TEST FREQ.	TEST CONFIG.	
RC-416	REACTOR VESSEL GAS VENT VALVE	GL	S	1	A		LPV	2 YR.		5.1.2-3
RC-417	REACTOR VESSEL GAS VENT VALVE	GL	S	1	A		S	CS(14)		5.1.2-3
RC-417	REACTOR VESSEL GAS VENT VALVE	GL	S	1	A		MT	CS(14)		5.1.2-3
RC-417	REACTOR VESSEL GAS VENT VALVE	GL	S	1	A		FS	CS(14)		5.1.2-3
PC-417	REACTOR VESSEL GAS VENT VALVE	GL	S	1	A		LPV	2 YR.		5.1.2-3
RC-418	RCGV DISCHARGE TO RDT	GL	S	2	B		S	3 MO.		5.1.2-3
RC-418	RCGV DISCHARGE TO RDT	GL	S	2	B		MT	3 MO.		5.1.2-3
RC-418	RCGV DISCHARGE TO RDT	GL	S	2	B		FS	3 MO.		5.1.2-3
RC-418	RCGV DISCHARGE TO RDT	GL	S	2	B		LPV	2 YR.		5.1.2-3
RC-419	RCGV DISCHARGE TO IRWST	GL	S	2	B		S	3 MO.		5.1.2-3
RC-419	RCGV DISCHARGE TO IRWST	GL	S	2	B		MT	3 MO.		5.1.2-3
RC-419	RCGV DISCHARGE TO IRWST	GL	S	2	B		FS	3 MO.		5.1.2-3
RC-419	RCGV DISCHARGE TO IRWST	GL	S	2	B		LPV	2 YR.		5.1.2-3
SC-204	SG 1 COLD LEG SAMPLE	GL	S	2	B		S	3 MO.		---
SC-204	SG 1 COLD LEG SAMPLE	GL	S	2	B		MT	3 MO.		---
SC-204	SG 1 COLD LEG SAMPLE	GL	S	2	B		FS	3 MO.		---
SC-204	SG 1 COLD LEG SAMPLE	GL	S	2	B		LPV	2 YR.		---
SC-211	SG 1 HOT LEG SAMPLE	GL	S	2	B		S	3 MO.		---
SC-211	SG 1 HOT LEG SAMPLE	GL	S	2	B		MT	3 MO.		---
SC-211	SG 1 HOT LEG SAMPLE	GL	S	2	B		FS	3 MO.		---
SC-211	SG 1 HOT LEG SAMPLE	GL	S	2	B		LPV	2 YR.		---
SC-219	SG 1 COLD LEG SAMPLE	GL	S	2	B		S	3 MO.		---
SC-219	SG 1 COLD LEG SAMPLE	GL	S	2	B		MT	3 MO.		---
SC-219	SG 1 COLD LEG SAMPLE	GL	S	2	B		FS	3 MO.		---
SC-219	SG 1 COLD LEG SAMPLE	GL	S	2	B		LPV	2 YR.		---
SC-220	SG 1 DOWNCOMER SAMPLE	GL	S	2	B		S	3 MO.		---
SC-220	SG 1 DOWNCOMER SAMPLE	GL	S	2	B		MT	3 MO.		---
SC-220	SG 1 DOWNCOMER SAMPLE	GL	S	2	B		FS	3 MO.		---
SC-220	SG 1 DOWNCOMER SAMPLE	GL	S	2	B		LPV	2 YR.		---
SC-221	SG 1 DOWNCOMER SAMPLE	GL	S	2	B		S	3 MO.		---
SC-221	SG 1 DOWNCOMER SAMPLE	GL	S	2	B		MT	3 MO.		---
SC-221	SG 1 DOWNCOMER SAMPLE	GL	S	2	B		FS	3 MO.		---
SC-221	SG 1 DOWNCOMER SAMPLE	GL	S	2	B		LPV	2 YR.		---

TABLE 3.9-15 (Continued)

INSERVICE TESTING SAFETY-RELATED PUMPS AND VALVES

VALVE NO.	VALVE DESCRIPTION	(a) VALVE TYPE	(b) VALVE ACT.	(c) SAFETY CLASS	(d) CODE CAT.	(e) VALVE FUNCT.	(f) TEST REQD.	(g) TEST FREQ.	(h) TEST CONFIG.	CESSAR-DC FIG. NO.
SC-222	SG 2 COLD LEG SAMPLE	GL	S	2	B		S	3 MO.		----
SC-222	SG 2 COLD LEG SAMPLE	GL	S	2	B		MT	3 MO.		----
SC-222	SG 2 COLD LEG SAMPLE	GL	S	2	B		FS	3 MO.		----
SC-222	SG 2 COLD LEG SAMPLE	GL	S	2	B		LPV	2 YR.		----
SC-223	SG 2 COLD LEG SAMPLE	GL	S	2	B		S	3 MO.		----
SC-223	SG 2 COLD LEG SAMPLE	GL	S	2	B		MT	3 MO.		----
SC-223	SG 2 COLD LEG SAMPLE	GL	S	2	B		FS	3 MO.		----
SC-223	SG 2 COLD LEG SAMPLE	GL	S	2	B		LPV	2 YR.		----
SC-224	SG 2 HOT LEG SAMPLE	GL	S	2	B		S	3 MO.		----
SC-224	SG 2 HOT LEG SAMPLE	GL	S	2	B		MT	3 MO.		----
SC-224	SG 2 HOT LEG SAMPLE	GL	S	2	B		FS	3 MO.		----
SC-224	SG 2 HOT LEG SAMPLE	GL	S	2	B		LPV	2 YR.		----
SC-225	SG 2 HOT LEG SAMPLE	GL	S	2	B		S	3 MO.		----
SC-225	SG 2 HOT LEG SAMPLE	GL	S	2	B		MT	3 MO.		----
SC-225	SG 2 HOT LEG SAMPLE	GL	S	2	B		FS	3 MO.		----
SC-225	SG 2 HOT LEG SAMPLE	GL	S	2	B		LPV	2 YR.		----
SC-226	SG 2 DOWNCOMER SAMPLE	GL	S	2	B		S	3 MO.		----
SC-226	SG 2 DOWNCOMER SAMPLE	GL	S	2	B		MT	3 MO.		----
SC-226	SG 2 DOWNCOMER SAMPLE	GL	S	2	B		FS	3 MO.		----
SC-226	SG 2 DOWNCOMER SAMPLE	GL	S	2	B		LPV	2 YR.		----
SC-227	SG 2 DOWNCOMER SAMPLE	GL	S	2	B		S	3 MO.		----
SC-227	SG 2 DOWNCOMER SAMPLE	GL	S	2	B		MT	3 MO.		----
SC-227	SG 2 DOWNCOMER SAMPLE	GL	S	2	B		FS	3 MO.		----
SC-227	SG 2 DOWNCOMER SAMPLE	GL	S	2	B		LPV	2 YR.		----
SC-228	SG 1 HOT LEG SAMPLE	GL	S	2	B		S	3 MO.		----
SC-228	SG 1 HOT LEG SAMPLE	GL	S	2	B		MT	3 MO.		----
SC-228	SG 1 HOT LEG SAMPLE	GL	S	2	B		FS	3 MO.		----
SC-228	SG 1 HOT LEG SAMPLE	GL	S	2	B		LPV	2 YR.		----
SG-130	SG 1 MAIN FW DOWNCOMER ISOLATION	GT	P	2	B		S	CS(15)		10.1-2
SG-130	SG 1 MAIN FW DOWNCOMER ISOLATION	GT	P	2	B		MT	CS(15)		10.1-2
SG-130	SG 1 MAIN FW DOWNCOMER ISOLATION	GT	P	2	B		FS	CS(15)		10.1-2
SG-130	SG 1 MAIN FW DOWNCOMER ISOLATION	GT	P	2	B		LPV	2 YR.		10.1-2
SG-132	SG 1 MAIN FW ECONOMIZER ISOLATION	GT	P	2	B		S	CS(15)		10.1-2

TABLE 3.9-15 (Continued)

INSERVICE TESTING SAFETY-RELATED PUMPS AND VALVES

VALVE NO.	VALVE DESCRIPTION	(a) VALVE TYPE	(b) VALVE ACT.	(c) SAFETY CLASS	(d) CODE CAT.	(e) VALVE FUNCT.	(f) TEST REQD.	(g) TEST FREQ.	(h) TEST CONFIG.	CESSAR-DC FIG. NO.
SG-132	SG 1 MAIN FW ECONOMIZER ISOLATION	GT	P	2	B		MT	CS(15)		10.1-2
SG-132	SG 1 MAIN FW ECONOMIZER ISOLATION	GT	P	2	B		FS	CS(15)		10.1-2
SG-132	SG 1 MAIN FW ECONOMIZER ISOLATION	GT	P	2	B		LPV	2 YR.		10.1-2
SG-135	SG 2 MAIN FW DOWNCOMER ISOLATION	GT	P	2	B		S	CS(15)		10.1-2
SG-135	SG 2 MAIN FW DOWNCOMER ISOLATION	GT	P	2	B		MT	CS(15)		10.1-2
SG-135	SG 2 MAIN FW DOWNCOMER ISOLATION	GT	P	2	B		FS	CS(15)		10.1-2
SG-135	SG 2 MAIN FW DOWNCOMER ISOLATION	GT	P	2	B		LPV	2 YR.		10.1-2
SG-137	SG 2 MAIN FW ECONOMIZER ISOLATION	GT	P	2	B		S	CS(15)		10.1-2
SG-137	SG 2 MAIN FW ECONOMIZER ISOLATION	GT	P	2	B		MT	CS(15)		10.1-2
SG-137	SG 2 MAIN FW ECONOMIZER ISOLATION	GT	P	2	B		FS	CS(15)		10.1-2
SG-137	SG 2 MAIN FW ECONOMIZER ISOLATION	GT	P	2	B		LPV	2 YR.		10.1-2
SG-140	SG 1 MAIN STEAM ISOL	GT	EH	2	B		S	QC(16)		10.1-2
SG-140	SG 1 MAIN STEAM ISOL	GT	EH	2	B		MT	CS(16)		10.1-2
SG-140	SG 1 MAIN STEAM ISOL	GT	EH	2	B		FS	CS(16)		10.1-2
SG-140	SG 1 MAIN STEAM ISOL	GT	EH	2	B		LPV	2 YR.		10.1-2
SG-141	SG 2 MAIN STEAM ISOL	GT	EH	2	B		S	QC(16)		10.1-2
SG-141	SG 2 MAIN STEAM ISOL	GT	EH	2	B		MT	CS(16)		10.1-2
SG-141	SG 2 MAIN STEAM ISOL	GT	EH	2	B		FS	CS(16)		10.1-2
SG-141	SG 2 MAIN STEAM ISOL	GT	EH	2	B		LPV	2 YR.		10.1-2
SG-150	SG 1 MAIN STEAM ISOL	GT	EH	2	B		S	QC(16)		10.1-2
SG-150	SG 1 MAIN STEAM ISOL	GT	EH	2	B		MT	CS(16)		10.1-2
SG-150	SG 1 MAIN STEAM ISOL	GT	EH	2	B		FS	CS(16)		10.1-2
SG-150	SG 1 MAIN STEAM ISOL	GT	EH	2	B		LPV	2 YR.		10.1-2
SG-151	SG 2 MAIN STEAM ISOL	GT	EH	2	B		S	QC(16)		10.1-2
SG-151	SG 2 MAIN STEAM ISOL	GT	EH	2	B		MT	CS(16)		10.1-2
SG-151	SG 2 MAIN STEAM ISOL	GT	EH	2	B		FS	CS(16)		10.1-2
SG-151	SG 2 MAIN STEAM ISOL	GT	EH	2	B		LPV	2 YR.		10.1-2
SG-169	SG 1 MSIV BYPASS	GT	P	2	B		S	3 MO.		10.1-2
SG-169	SG 1 MSIV BYPASS	GT	P	2	B		MT	3 MO.		10.1-2
SG-169	SG 1 MSIV BYPASS	GT	P	2	B		FS	3 MO.		10.1-2
SG-169	SG 1 MSIV BYPASS	GT	P	2	B		LPV	2 YR.		10.1-2
SG-172	SG 1 MAIN FW DOWNCOMER ISOLATION	GT	P	2	B		S	CS(15)		10.1-2
SG-172	SG 1 MAIN FW DOWNCOMER ISOLATION	GT	P	2	B		MT	CS(15)		10.1-2

TABLE 3.9-15 (Continued)

INSERVICE TESTING SAFETY-RELATED PUMPS AND VALVES

VALVE NO.	VALVE DESCRIPTION	(a) VALVE TYPE	(b) VALVE ACT.	(c) SAFETY CLASS	(d) CODE CAT	(e) VALVE FUNCT	(f) TEST REQD	(g) TEST FREQ	(h) TEST CONFIG	CESSAR-DC FIG. NO.
SG-172	SG 1 MAIN FW DOWNCOMER ISOLATION	GT	P	2	B		FS	CS(15)	(1)	10.1-2
SG-172	SG 1 MAIN FW DOWNCOMER ISOLATION	GT	P	2	B		LPV	2 Yr.		10.1-2
SG-174	SG 1 MAIN FW ECONOMIZER ISOLATION	GT	P	2	B		S	CS(15)		10.1-2
SG-174	SG 1 MAIN FW ECONOMIZER ISOLATION	GT	P	2	B		MT	CS(15)		10.1-2
SG-174	SG 1 MAIN FW ECONOMIZER ISOLATION	GT	P	2	B		FS	CS(15)		10.1-2
SG-174	SG 1 MAIN FW ECONOMIZER ISOLATION	GT	P	2	B		LPV	2 Yr.		10.1-2
SG-175	SG 2 MAIN FW DOWNCOMER ISOLATION	GT	P	2	B		S	CS(15)		10.1-2
SG-175	SG 2 MAIN FW DOWNCOMER ISOLATION	GT	P	2	B		MT	CS(15)		10.1-2
SG-175	SG 2 MAIN FW DOWNCOMER ISOLATION	GT	P	2	B		FS	CS(15)		10.1-2
SG-175	SG 2 MAIN FW DOWNCOMER ISOLATION	GT	P	2	B		LPV	2 Yr.		10.1-2
SG-177	SG 2 MAIN FW ECONOMIZER ISOLATION	GT	P	2	B		S	CS(15)		10.1-2
SG-177	SG 2 MAIN FW ECONOMIZER ISOLATION	GT	P	2	C		MT	CS(15)		10.1-2
SG-177	SG 2 MAIN FW ECONOMIZER ISOLATION	GT	P	2	B		FS	CS(15)		10.1-2
SG-177	SG 2 MAIN FW ECONOMIZER ISOLATION	GT	P	2	B		LPV	2 Yr.		10.1-2
SG-178	SG 1 ATMOS. DUMP VALVE	GL	S	2	B		S	3 mo.		10.3.2-1
SG-178	SG 1 ATMOS. DUMP VALVE	GL	S	2	B		MT	3 mo.		10.3.2-1
SG-178	SG 1 ATMOS. DUMP VALVE	GL	S	2	B		FS	3 mo.		10.3.2-1
SG-178	SG 1 ATMOS. DUMP VALVE	GL	S	2	B		LPV	2 Yr.		10.3.2-1
SG-179	SG 2 ATMOS. DUMP VALVE	GL	S	2	B		S	3 mo.		10.3.2-1
SG-179	SG 2 ATMOS. DUMP VALVE	GL	S	2	B		MT	3 mo.		10.3.2-1
SG-179	SG 2 ATMOS. DUMP VALVE	GL	S	2	B		FS	3 mo.		10.3.2-1
SG-179	SG 2 ATMOS. DUMP VALVE	GL	S	2	B		LPV	2 Yr.		10.3.2-1
SG-183	SG 2 MSIV BYPASS	GT	P	2	B		S	3 mo.		10.1-2
SG-183	SG 2 MSIV BYPASS	GT	P	2	B		MT	3 mo.		10.1-2
SG-183	SG 2 MSIV BYPASS	GT	P	2	B		FS	3 mo.		10.1-2
SG-183	SG 2 MSIV BYPASS	GT	P	2	B		LPV	2 Yr.		10.1-2
SG-184	SG 1 ATMOS. DUMP VALVE	GL	S	2	B		S	3 mo.		10.3.2-1
SG-184	SG 1 ATMOS. DUMP VALVE	GL	S	2	B		MT	3 mo.		10.3.2-1
SG-184	SG 1 ATMOS. DUMP VALVE	GL	S	2	B		FS	3 mo.		10.3.2-1
SG-184	SG 1 ATMOS. DUMP VALVE	GL	S	2	B		LPV	2 Yr.		10.3.2-1
SG-185	SG 2 ATMOS. DUMP VALVE	GL	S	2	B		S	3 mo.		10.3.2-1
SG-185	SG 2 ATMOS. DUMP VALVE	GL	S	2	B		MT	3 mo.		10.3.2-1
SG-185	SG 2 ATMOS. DUMP VALVE	GL	S	2	B		FS	3 mo.		10.3.2-1

TABLE 3.9-15 (Continued)

INSERVICE TESTING SAFETY-RELATED PUMPS AND VALVES

VALVE NO.	VALVE DESCRIPTION	(a) VALVE TYPE	(b) VALVE ACT.	(c) SAFETY CLASS	(d) CODE CAT.	(e) VALVE FUNCT.	(f) TEST RECD.	(g) TEST FREQ.	(h) TEST CONFIG.	CESSAR-DC FIG. NO.
SG-185	SG 2 ATMOS. DUMP VALVE	GL	S	2	B		LEV	2 YR.		10.3.2-1
SI-100	SIS DIV 1 MINIFLOW-IRWST	CK	SA	2	C		S	3 mo.	12	6.3.2-1A
SI-101	SIS DIV 2 MINIFLOW-IRWST	CK	SA	2	C		S	3 mo.	12	6.3.2-1B
SI-113	SI PUMP #4 DISCHARGE	CK	SA	2	A/C		S	RO(18)	12	6.3.2-1C
SI-113	SI PUMP #4 DISCHARGE	CK	SA	2	A/C	CI	LT	2 YR.	1	6.3.2-1C
SI-123	SI PUMP #2 DISCHARGE	CK	SA	2	C		S	CS(19)	12	6.3.2-1C
SI-133	SI PUMP #3 DISCHARGE	CK	SA	2	A/C		S	RO(18)	12	6.3.2-1C
SI-133	SI PUMP #3 DISCHARGE	CK	SA	2	A/C	CI	LT	2 YR.	1	6.3.2-1C
SI-143	SI PUMP #4 DISCHARGE	CK	SA	2	C		S	CS(19)	12	6.3.2-1C
SI-157	CS PUMP #1 SUCTION	CK	SA	2	C		S	3 mo.	11	6.3.2-1A
SI-158	CS PUMP #2 SUCTION	CK	SA	2	C		S	3 mo.	11	6.3.2-1B
SI-164	CS PUMP #1 DISCHARGE	CK	SA	2	A/C		S	RO(20)	12	6.3.2-1C
SI-164	CS PUMP #1 DISCHARGE	CK	SA	2	A/C	CI	LT	2 YR.	1	6.3.2-1C
SI-165	CS PUMP #2 DISCHARGE	CK	SA	2	A/C		S	RO(20)	12	6.3.2-1C
SI-165	CS PUMP #2 DISCHARGE	CK	SA	2	A/C	CI	LT	2 YR.	1	6.3.2-1C
SI-168	SCS TRAIN 2 DISCHARGE	CK	SA	2	C		S	CS(19)	12	6.3.2-1C
SI-178	SCS TRAIN 1 DISCHARGE	CK	SA	2	C		S	CS(19)	12	6.3.2-1C
SI-215	SI TANK 4 DISCHARGE	CK	SA	1	A/C		S	RR(21)	14	6.3.2-1C
SI-215	SI TANK 4 DISCHARGE	CK	SA	1	A/C	BV	LT	2 YR.	10	6.3.2-1C
SI-217	DVI NOZZLE 2B	CK	SA	1	A/C		S	RO(22)	12	6.3.2-1C
SI-217	DVI NOZZLE 2B	CK	SA	1	A/C	BV	LT	2 YR.	10	6.3.2-1C
SI-225	SI TANK 2 DISCHARGE	CK	SA	1	A/C		S	RR(21)	14	6.3.2-1C
SI-225	SI TANK 2 DISCHARGE	CK	SA	1	A/C	BV	LT	2 YR.	10	6.3.2-1C
SI-227	DVI NOZZLE 1B	CK	SA	1	A/C		S	CS(22)	12	6.3.2-1C
SI-227	DVI NOZZLE 1B	CK	SA	1	A/C	BV	LT	2 YR.	10	6.3.2-1C

TABLE 3.9-15 (Continued)

INSERVICE TESTING SAFETY-RELATED PUMPS AND VALVES

VALVE NO.	VALVE DESCRIPTION	(a) VALVE TYPE	(b) VALVE ACT.	(c) SAFETY CLASS	(d) CODE CAT.	(e) VALVE FUNCT.	(f) TEST REQD.	(g) TEST FREQ.	(h) TEST CONFIG.	CESSAR-DC FIG. NO.
SI-235	SI TANK 3 DISCHARGE	CK	SA	1	A/C	BV	S	RR(21) 2 YR.	14	6.3.2-1C
SI-235	SI TANK 3 DISCHARGE	CK	SA	1	A/C	BV	LT		10	6.3.2-1C
SI-237	DVI NOZZLE 2A	CK	SA	1	A/C	BV	S	RO(22) 2 YR.	12	6.3.2-1C
SI-237	DVI NOZZLE 2A	CK	SA	1	A/C	BV	LT		10	6.3.2-1C
SI-245	SI TANK 1 DISCHARGE	CK	SA	1	A/C	BV	S	RR(21) 2 YR.	14	6.3.2-1C
SI-245	SI TANK 1 DISCHARGE	CK	SA	1	A/C	BV	LT		10	6.3.2-1C
SI-247	DVI NOZZLE 1A	CK	SA	1	A/C	BV	S	CS(22) 2 YR.	12	6.3.2-1C
SI-247	DVI NOZZLE 1A	CK	SA	1	A/C	BV	LT		10	6.3.2-1C
SI-293	SIT FILL LINE ISOL	GL	M	2	A	CI.F	LT	2 YR.	4	6.3.2-1B
SI-300	DIV 1 SC/CS PUMP TEST LINE	GT	EL	2	B		S	3 MO.		6.3.2-1A
SI-300	DIV 1 SC/CS PUMP TEST LINE	GT	EL	2	B		MT	3 MO.		6.3.2-1A
SI-300	DIV 1 SC/CS PUMP TEST LINE	GT	EL	2	B		LPV	2 YR.		6.3.2-1A
SI-301	DIV 2 SC/CS PUMP TEST LINE	GT	EL	2	B		S	3 MO.		6.3.2-1B
SI-301	DIV 2 SC/CS PUMP TEST LINE	GT	EL	2	B		MT	3 MO.		6.3.2-1B
SI-301	DIV 2 SC/CS PUMP TEST LINE	GT	EL	2	B		LPV	2 YR.		6.3.2-1B
SI-302	SI DIV 1 MINIFLOW ISOL	GT	EL	2	B		S	RO(23) 2 YR.		6.3.2-1A
SI-302	SI DIV 1 MINIFLOW ISOL	GT	EL	2	B		MT	RO(23) 2 YR.		6.3.2-1A
SI-302	SI DIV 1 MINIFLOW ISOL	GT	EL	2	B		LPV	2 YR.		6.3.2-1A
SI-303	SI DIV 2 MINIFLOW ISOL	GT	EL	2	B		S	RO(23) 2 YR.		6.3.2-1B
SI-303	SI DIV 2 MINIFLOW ISOL	GT	EL	2	B		MT	RO(23) 2 YR.		6.3.2-1B
SI-303	SI DIV 2 MINIFLOW ISOL	GT	EL	2	B		LPV	2 YR.		6.3.2-1B
SI-304	CS & SI PUMP 1 SCTN ISOL	GT	EL	2	B		S	CS(24) 2 YR.		6.3.2-1A
SI-304	CS & SI PUMP 1 SCTN ISOL	GT	EL	2	B		MT	CS(24) 2 YR.		6.3.2-1A
SI-304	CS & SI PUMP 1 SCTN ISOL	GT	EL	2	B		LPV	2 YR.		6.3.2-1A
SI-305	CS & SI PUMP 2 SCTN ISOL	GT	EL	2	B		S	CS(24) 2 YR.		6.3.2-1B
SI-305	CS & SI PUMP 2 SCTN ISOL	GT	EL	2	B		MT	CS(24) 2 YR.		6.3.2-1B
SI-305	CS & SI PUMP 2 SCTN ISOL	GT	EL	2	B		LPV	2 YR.		6.3.2-1B
SI-308	SI PUMP 3 SCTN ISOL	GT	EL	2	B		S	CS(24) 2 YR.		6.3.2-1A
SI-308	SI PUMP 3 SCTN ISOL	GT	EL	2	B		MT	CS(24) 2 YR.		6.3.2-1A
SI-308	SI PUMP 3 SCTN ISOL	GT	EL	2	B		LPV	2 YR.		6.3.2-1A

TABLE 3.9-15 (Continued)

IN-SERVICE TESTING SAFETY-RELATED PUMPS AND VALVES

VALVE NO.	VALVE DESCRIPTION	(a) VALVE TYPE	(b) VALVE ACT.	(c) SAFETY CLASS	(d) CODE CAT	(e) VALVE FUNCT	(f) TEST REQD	(g) TEST FREQ	(h) TEST CONFIG	CESSAR-DC FIG. NO.
SI-309	SI PUMP 4 SCIN ISOL	GT	EL	2	B		S	CS(24)		6.3.2-1B
SI-309	SI PUMP 4 SCIN ISOL	GT	EL	2	B		MT	CS(24)		6.3.2-1B
SI-309	SI PUMP 4 SCIN ISOL	GT	EL	2	B		LPV	2 Yr.		6.3.2-1B
SI-310	SC HX #1 OUTLET ISOL.	GL	EL	2	B		S	3 mo.		6.3.2-1A
SI-310	SC HX #1 OUTLET ISOL.	GL	EL	2	B		MT	3 mo.		6.3.2-1A
SI-310	SC HX #1 OUTLET ISOL.	GL	EL	2	B		LPV	2 Yr.		6.3.2-1A
SI-310	SC HX #1 OUTLET ISOL.	GL	EL	2	B		DDP	5 Yr.	8	6.3.2-1A
SI-311	SC HX #2 OUTLET ISOL	GL	EL	2	B		S	3 mo.		6.3.2-1B
SI-311	SC HX #2 OUTLET ISOL	GL	EL	2	B		MT	3 mo.		6.3.2-1B
SI-311	SC HX #2 OUTLET ISOL	GL	EL	2	B		LPV	2 Yr.		6.3.2-1B
SI-311	SC HX #2 OUTLET ISOL	GL	EL	2	B		DDP	5 Yr.	8	6.3.2-1B
SI-312	SC HX #1 BYPASS	GL	EL	2	B		S	3 mo.		6.3.2-1A
SI-312	SC HX #1 BYPASS	GL	EL	2	B		MT	3 mo.		6.3.2-1A
SI-312	SC HX #1 BYPASS	GL	EL	2	B		LPV	2 Yr.		6.3.2-1A
SI-312	SC HX #1 BYPASS	GL	EL	2	B		DDP	5 Yr.	8	6.3.2-1A
SI-313	SC HX #2 BYPASS	GL	EL	2	B		S	3 mo.		6.3.2-1B
SI-313	SC HX #2 BYPASS	GL	EL	2	B		MT	3 mo.		6.3.2-1B
SI-313	SC HX #2 BYPASS	GL	EL	2	B		LPV	2 Yr.		6.3.2-1B
SI-313	SC HX #2 BYPASS	GL	EI	2	B		DDP	5 Yr.	8	6.3.2-1B
SI-321	HOT LEG INJ LP 1 ISOL	GL	EL	2	A		S	3 mo.		6.3.2-1C
SI-321	HOT LEG INJ LP 1 ISOL	GL	EL	2	A		MT	3 mo.		6.3.2-1C
SI-321	HOT LEG INJ LP 1 ISOL	GL	EL	2	A		LPV	2 Yr.		6.3.2-1C
SI-321	HOT LEG INJ LP 1 ISOL	GL	EL	2	A	CI	LT	2 Yr.	1	6.3.2-1C
SI-321	HOT LEG INJ LP 1 ISOL	GL	EL	2	A		DDP	5 Yr.	1	6.3.2-1C
SI-322	TRAIN 1 SI TANK FILL	GL	AD	1	A		S	3 mo.		6.3.2-1C
SI-322	TRAIN 1 SI TANK FILL	GL	AD	1	A		MT	3 mo.		6.3.2-1C
SI-322	TRAIN 1 SI TANK FILL	GL	AD	1	A		FS	3 mo.		6.3.2-1C
SI-322	TRAIN 1 SI TANK FILL	GL	AD	1	A		LPV	2 Yr.		6.3.2-1C
SI-322	TRAIN 1 SI TANK FILL	GL	AD	1	A	BV	LT	2 Yr.	10	6.3.2-1C
SI-331	HOT LEG INJ LP 2 ISOL	GL	EL	2	A		S	3 mo.		6.3.2-1C
SI-331	HOT LEG INJ LP 2 ISOL	GL	EL	2	A		MT	3 mo.		6.3.2-1C
SI-331	HOT LEG INJ LP 2 ISOL	GL	EL	2	A		LPV	2 Yr.		6.3.2-1C
SI-331	HOT LEG INJ LP 2 ISOL	GL	EL	2	A	CI	LT	2 Yr.	1	6.3.2-1C
SI-331	HOT LEG INJ LP 2 ISOL	GL	EL	2	A		DDP	5 Yr.	1	6.3.2-1C

TABLE 3.9-15 (Continued)

INSERVICE TESTING SAFETY-RELATED PUMPS AND VALVES

VALVE NO.	VALVE DESCRIPTION	(a) VALVE TYPE	(b) VALVE ACT.	(c) SAFETY CLASS	(d) CODE CAT.	(e) VALVE FUNCT.	(f) TEST RECD	(g) TEST FRQ	(i) TEST CONFIG.	CESSAR-DC FIG. NO.
SI-332	TRAIN 2 SI TANK FILL	GL	AD	1	A		S	3 mo.		6.3.2-1C
SI-332	TRAIN 2 SI TANK FILL	GL	AD	1	A		MT	3 mo.		6.3.2-1C
SI-332	TRAIN 2 SI TANK FILL	GL	AD	1	A		FS	3 mo.		6.3.2-1C
SI-332	TRAIN 2 SI TANK FILL	GL	AD	1	A		LPV	2 yr.		6.3.2-1C
SI-332	TRAIN 2 SI TANK FILL	GL	AD	1	A	BV	LT	2 yr.	10	6.3.2-1C
SI-390	HVT SPILLWAY ISOLATION	GT	EL	2	B		S	CS(40)		6.8-4
SI-390	HVT SPILLWAY ISOLATION	GT	EL	2	B		MT	CS(40)		6.8-4
SI-390	HVT SPILLWAY ISOLATION	GT	EL	2	B		LPV	2 yr.		6.8-4
SI-391	HVT SPILLWAY ISOLATION	GT	EL	2	B		S	CS(40)		6.8-4
SI-391	HVT SPILLWAY ISOLATION	GT	EL	2	B		MT	CS(40)		6.8-4
SI-391	HVT SPILLWAY ISOLATION	GT	EL	2	B		LPV	2 yr.		6.8-4
SI-392	HVT SPILLWAY ISOLATION	GT	EL	2	B		S	CS(40)		6.8-4
SI-392	HVT SPILLWAY ISOLATION	GT	EL	2	B		MT	CS(40)		6.8-4
SI-392	HVT SPILLWAY ISOLATION	GT	EL	2	B		LPV	2 yr.		6.8-4
SI-393	HVT SPILLWAY ISOLATION	GT	EL	2	B		S	CS(40)		6.8-4
SI-393	HVT SPILLWAY ISOLATION	GT	EL	2	B		MT	CS(40)		6.8-4
SI-393	HVT SPILLWAY ISOLATION	GT	EL	2	B		LPV	2 yr.		6.8-4
SI-394	REACTOR CAVITY SPILLWAY ISOLATION	GT	EL	2	B		S	3 mo.		6.8-4
SI-394	REACTOR CAVITY SPILLWAY ISOLATION	GT	EL	2	B		MT	3 mo.		5.8-4
SI-394	REACTOR CAVITY SPILLWAY ISOLATION	GT	EL	2	B		LPV	2 yr.		6.8-4
SI-395	REACTOR CAVITY SPILLWAY ISOLATION	GT	EL	2	B		S	3 mo.		6.8-4
SI-395	REACTOR CAVITY SPILLWAY ISOLATION	GT	EL	2	B		MT	3 mo.		6.8-4
SI-395	REACTOR CAVITY SPILLWAY ISOLATION	GT	EL	2	B		LPV	2 yr.		6.8-4
SI-404	SI PUMP #1 DISCHARGE	CK	SA	2	C		S	RO(18)	11	6.3.2-1A
SI-405	SI PUMP #2 DISCHARGE	CK	SA	2	C		S	RO(18)	11	6.3.2-1B
SI-424	SI PUMP #1 MINIFLOW	CK	SA	2	C		S	3 mo.	11	6.3.2-1A
SI-424	SI PUMP #1 MINIFLOW	CK	SA	2	C		RF	CS(25)	9	6.3.2-1A
SI-426	SI PUMP #2 MINIFLOW	CK	SA	2	C		S	3 mo.	11	6.3.2-1B
SI-426	SI PUMP #2 MINIFLOW	CK	SA	2	C		RF	CS(25)	9	6.3.2-1B
SI-434	SI PUMP #3 DISCHARGE	CK	SA	2	C		S	RO(18)	11	6.3.2-1A

TABLE 3.9-15 (Continued)

INSERVICE TESTING SAFETY-RELATED PUMPS AND VALVES

<u>VALVE NO.</u>	<u>VALVE DESCRIPTION</u>	<u>(a) VALVE TYPE</u>	<u>(b) VALVE ACT.</u>	<u>(c) SAFETY CLASS</u>	<u>(d) CODE CAT</u>	<u>(e) VALVE FUNCT</u>	<u>(f) TEST REQD</u>	<u>(g) TEST FREQ</u>	<u>(i) TEST CONFIG.</u>	<u>CESSAR-DC FIG. NO.</u>
SI-446	SI PUMP #4 DISCHARGE	CK	SA	2	C		S	RO(18)	11	6.3.2-1B
SI-448	SI PUMP #4 MINIFLOW	CK	SA	2	C		S	3 mo.	11	6.3.2-1B
SI-448	SI PUMP #4 MINIFLOW	CK	SA	2	C		RF	CS(25)	9	6.3.2-1B
SI-451	SI PUMP #3 MINIFLOW	CK	SA	2	C		S	3 mo.	11	6.3.2-1A
SI-451	SI PUMP #3 MINIFLOW	CK	SA	2	C		RF	CS(25)	9	6.3.2-1A
SI-484	CS PUMP #2 DISCHARGE	CK	SA	2	C		S	3 mo.	12	6.3.2-1B
SI-484	CS PUMP #2 DISCHARGE	CK	SA	2	C		RF	CS(17)	9	6.3.2-1B
SI-485	CS PUMP #1 DISCHARGE	CK	SA	2	C		S	3 mo.	12	6.3.2-1A
SI-485	CS PUMP #1 DISCHARGE	CK	SA	2	C		RF	CS(17)	9	6.3.2-1A
SI-522	HOT LEG INJ LP1	CK	SA	1	A/C		S	RO(18)	12	6.3.2-1C
SI-522	HOT LEG INJ LP1	CK	SA	1	A/C	BV	LT	2 yr.	10	6.3.2-1C
SI-523	HOT LEG INJ LP1	CK	SA	1	A/C		S	RO(18)	12	6.3.2-1C
SI-523	HOT LEG INJ LP1	CK	SA	1	A/C	BV, CI	LT	2 yr.	1	6.3.2-1C
SI-532	HOT LEG INJ LP2	CK	SA	1	A/C		S	RO(18)	12	6.3.2-1C
SI-532	HOT LEG INJ LP2	CK	SA	1	A/C	BV	LT	2 yr.	10	6.3.2-1C
SI-533	HOT LEG INJ LP2	CK	SA	1	A/C		S	RO(18)	12	6.3.2-1C
SI-533	HOT LEG INJ LP2	CK	SA	1	A/C	BV, CI	LT	2 yr.	1	6.3.2-1C
SI-540	SI PUMP #4 DISCHARGE	CK	SA	1	A/C		S	RO(18)	12	6.3.2-1C
SI-540	SI PUMP #4 DISCHARGE	CK	SA	1	A/C	BV	LT	2 yr.	10	6.3.2-1C
SI-541	SI PUMP #2 DISCHARGE	CK	SA	1	A/C		S	CS(27)	12	6.3.2-1C
SI-541	SI PUMP #2 DISCHARGE	CK	SA	1	A/C	BV	LT	2 yr.	10	6.3.2-1C
SI-542	SI PUMP #3 DISCHARGE	CK	SA	1	A/C		S	RO(18)	12	6.3.2-1C
SI-542	SI PUMP #3 DISCHARGE	CK	SA	1	A/C	BV	LT	2 yr.	10	6.3.2-1C
SI-543	SI PUMP #1 DISCHARGE	CK	SA	1	A/C		S	CS(27)	12	6.3.2-1C
SI-543	SI PUMP #1 DISCHARGE	CK	SA	1	A/C	BV	LT	2 yr.	10	6.3.2-1C
SI-568	SC PUMP #1 DISCHARGE	CK	SA	2	C		S	3 mo.	11	6.3.2-1A
SI-568	SC PUMP #1 DISCHARGE	CK	SA	2	C		RF	RO(17)	9	6.3.2-1A

TABLE 3.9-15 (Continued)

INSERVICE TESTING SAFETY-RELATED PUMPS AND VALVES

VALVE NO.	VALVE DESCRIPTION	(a) VALVE TYPE	(b) VALVE ACT.	(c) SAFETY CLASS	(d) CODE CAT	(e) VALVE FUNCT	(f) TEST RECD	(g) TEST FREQ	(i) TEST CONFIG	CESSAR-DC FIG. NO.
SI-569	SC PUMP #2 DISCHARGE	CK	SA	2	C	S	S	3 mo.	11	6.3.2-1B
SI-569	SC PUMP #2 DISCHARGE	CK	SA	2	C	RF	RF	RO (17)	9	6.3.2-1B
SI-600	SCS TRAIN 2 DISCHARGE	GL	EL	2	A	S	S	3 mo.		6.3.2-1C
SI-600	SCS TRAIN 2 DISCHARGE	GL	EL	2	A	MT	MT	3 mo.		6.3.2-1C
SI-600	SCS TRAIN 2 DISCHARGE	GL	EL	2	A	LPV	LPV	2 yr.		6.3.2-1C
SI-600	SCS TRAIN 2 DISCHARGE	GL	EL	2	A	DDP	DDP	5 yr.	8	6.3.2-1C
SI-601	SCS TRAIN 1 DISCHARGE	GL	EL	2	A	S	S	3 mo.		6.3.2-1C
SI-601	SCS TRAIN 1 DISCHARGE	GL	EL	2	A	MT	MT	3 mo.		6.3.2-1C
SI-601	SCS TRAIN 1 DISCHARGE	GL	EL	2	A	LPV	LPV	2 yr.		6.3.2-1C
SI-601	SCS TRAIN 1 DISCHARGE	GL	EL	2	A	DDP	DDP	5 yr.	8	6.3.2-1C
SI-602	SI LINE 2 THROTTLE	GL	EL	2	A	S	S	3 mo.		6.3.2-1C
SI-602	SI LINE 2 THROTTLE	GL	EL	2	A	MT	MT	3 mo.		6.3.2-1C
SI-602	SI LINE 2 THROTTLE	GL	EL	2	A	LPV	LPV	2 yr.		6.3.2-1C
SI-602	SI LINE 2 THROTTLE	GL	EL	2	A	DDP	DDP	5 yr.	8	6.3.2-1C
SI-603	SI LINE 1 THROTTLE	GL	EL	2	A	S	S	3 mo.		6.3.2-1C
SI-603	SI LINE 1 THROTTLE	GL	EL	2	A	MT	MT	3 mo.		6.3.2-1C
SI-603	SI LINE 1 THROTTLE	GL	EL	2	A	LPV	LPV	2 yr.		6.3.2-1C
SI-603	SI LINE 1 THROTTLE	GL	EL	2	A	DDP	DDP	5 yr.	8	6.3.2-1C
SI-604	HOT LEG INJ LP1 ISOL	GT	EL	2	B	S	S	CS (41)		6.3.2-1A
SI-604	HOT LEG INJ LP1 ISOL	GT	EL	2	B	MT	MT	CS (41)		6.3.2-1A
SI-604	HOT LEG INJ LP1 ISOL	GT	EL	2	B	LPV	LPV	2 yr.		6.3.2-1A
SI-604	HOT LEG INJ LP1 ISOL	GT	EL	2	B	DDP	DDP	5 yr.	8	6.3.2-1A
SI-609	HOT LEG INJ LP2 ISOL	GT	EL	2	B	S	S	CS (41)		6.3.2-1B
SI-609	HOT LEG INJ LP2 ISOL	GT	EL	2	B	MT	MT	CS (41)		6.3.2-1B
SI-609	HOT LEG INJ LP2 ISOL	GT	EL	2	B	LPV	LPV	2 yr.		6.3.2-1B
SI-609	HOT LEG INJ LP2 ISOL	GT	EL	2	B	DDP	DDP	5 yr.	8	6.3.2-1B
SI-611	SIT #4 FILL LINE	GL	AD	2	B	S	S	3 mo.		6.3.2-1C
SI-611	SIT #4 FILL LINE	GL	AD	2	B	MT	MT	3 mo.		6.3.2-1C
SI-611	SIT #4 FILL LINE	GL	AD	2	B	FS	FS	3 mo.		6.3.2-1C
SI-611	SIT #4 FILL LINE	GL	AD	2	B	LPV	LPV	2 yr.		6.3.2-1C
SI-614	SIT #4 DICHARGE ISOL	GT	EL	1	B	S	S	CS (28)		6.3.2-1C
SI-614	SIT #4 DICHARGE ISOL	GT	EL	1	B	MT	MT	CS (28)		6.3.2-1C
SI-614	SIT #4 DICHARGE ISOL	GT	EL	1	B	LPV	LPV	2 yr.		6.3.2-1C

TABLE 3.9-15 (Continued)

INSERVICE TESTING SAFETY-RELATED PUMPS AND VALVES

VALVE NO.	VALVE DESCRIPTION	(a) VALVE TYPE	(b) VALVE ACT	(c) SAFETY CLASS	(d) CODE CAT	(e) VALVE FUNCT	(f) TEST REQD	(g) TEST FREQ	(h) TEST CONFIG	CESSAR-DC FIG. NO.
SI-616	SI PUMP #4 DISCHARGE	GL	EL	2	A		S	3 mo.		6.3.2-1C
SI-616	SI PUMP #4 DISCHARGE	GL	EL	2	A		MT	3 mo.		6.3.2-1C
SI-616	SI PUMP #4 DISCHARGE	GL	EL	2	A		LPV	2 yr.		6.3.2-1C
SI-616	SI PUMP #4 DISCHARGE	GL	EL	2	A	CI	LT	2 yr.	1	6.3.2-1C
SI-616	SI PUMP #4 DISCHARGE	GL	EL	2	A		DDP	5 yr.	1	6.3.2-1C
SI-618	SI LINE 4 LEAKAGE RETURN	GL	AD	1	A		S	3 mo.		6.3.2-1C
SI-618	SI LINE 4 LEAKAGE RETURN	GL	AD	1	A		MT	3 mo.		6.3.2-1C
SI-618	SI LINE 4 LEAKAGE RETURN	GL	AD	1	A		FS	3 mo.		6.3.2-1C
SI-618	SI LINE 4 LEAKAGE RETURN	GL	AD	1	A		LPV	2 yr.		6.3.2-1C
SI-618	SI LINE 4 LEAKAGE RETURN	GL	AD	1	A	BV	LT	2 yr.	10	6.3.2-1C
SI-621	SIT #2 FILL LINE	GL	AD	2	B		S	3 mo.		6.3.2-1C
SI-621	SIT #2 FILL LINE	GL	AD	2	B		MT	3 mo.		6.3.2-1C
SI-621	SIT #2 FILL LINE	GL	AD	2	B		FS	3 mo.		6.3.2-1C
SI-621	SIT #2 FILL LINE	GL	AD	2	B		LPV	2 yr.		6.3.2-1C
SI-624	SIT #2 DICHARGE ISOL	GT	EL	1	B		S	CS(28)		6.3.2-1C
SI-624	SIT #2 DICHARGE ISOL	GT	EL	1	B		MT	CS(28)		6.3.2-1C
SI-624	SIT #2 DICHARGE ISOL	GT	EL	1	B		LPV	2 yr.		6.3.2-1C
SI-626	SI PUMP #2 DISCHARGE	GL	EL	2	A		S	3 mo.		6.3.2-1C
SI-626	SI PUMP #2 DISCHARGE	GL	EL	2	A		MT	3 mo.		6.3.2-1C
SI-626	SI PUMP #2 DISCHARGE	GL	EL	2	A		LPV	2 yr.		6.3.2-1C
SI-626	SI PUMP #2 DISCHARGE	GL	EL	2	A		DDP	5 yr.	8	6.3.2-1C
SI-628	SI LINE 2 LEAKAGE RETURN	GL	AD	1	A		S	3 mo.		6.3.2-1C
SI-628	SI LINE 2 LEAKAGE RETURN	GL	AD	1	A		MT	3 mo.		6.3.2-1C
SI-628	SI LINE 2 LEAKAGE RETURN	GL	AD	1	A		FS	3 mo.		6.3.2-1C
SI-628	SI LINE 2 LEAKAGE RETURN	GL	AD	1	A		LPV	2 yr.		6.3.2-1C
SI-628	SI LINE 2 LEAKAGE RETURN	GL	AD	1	A	BV	LT	2 yr.	10	6.3.2-1C
SI-631	SIT #3 FILL LINE	GL	AD	2	B		S	3 mo.		6.3.2-1C
SI-631	SIT #3 FILL LINE	GL	AD	2	B		MT	3 mo.		6.3.2-1C
SI-631	SIT #3 FILL LINE	GL	AD	2	B		FS	3 mo.		6.3.2-1C
SI-631	SIT #3 FILL LINE	GL	AD	2	B		LPV	2 yr.		6.3.2-1C
SI-634	SIT #3 DICHARGE ISOL	GT	EL	1	B		S	CS(28)		6.3.2-1C
SI-634	SIT #3 DICHARGE ISOL	GT	EL	1	B		MT	CS(28)		6.3.2-1C
SI-634	SIT #3 DICHARGE ISOL	GT	EL	1	B		LPV	2 yr.		6.3.2-1C

TABLE 3.9-15 (Continued)

INSERVICE TESTING SAFETY-RELATED PUMPS AND VALVES

VALVE NO.	VALVE DESCRIPTION	(a) VALVE TYPE	(b) VALVE ACT.	(c) SAFETY CLASS	(d) CODE CAT	(e) VALVE FUNCT.	(f) TEST RECD	(g) TEST FREQ.	(h) TEST CONFIG.	CENRAP-DC FIG. NO.
SI-636	SI PUMP #3 DISCHARGE	GL	EL	2	A		S	3 MO.		6.3.2-1C
SI-636	SI PUMP #3 DISCHARGE	GL	EL	2	A		MT	3 MO.		6.3.2-1C
SI-636	SI PUMP #3 DISCHARGE	GL	EL	2	A		LPV	2 YR.		6.3.2-1C
SI-636	SI PUMP #3 DISCHARGE	GL	EL	2	A	CI	LPV	2 YR.	1	6.3.2-1C
SI-636	SI PUMP #3 DISCHARGE	GL	EL	2	A		DDP	5 YR.	1	6.3.2-1C
SI-638	SI LINE 3 LEAKAGE RETURN	GL	AD	1	A		S	3 MO.		6.3.2-1C
SI-638	SI LINE 3 LEAKAGE RETURN	GL	AD	1	A		MT	3 MO.		6.3.2-1C
SI-638	SI LINE 3 LEAKAGE RETURN	GL	AD	1	A		FS	3 MO.		6.3.2-1C
SI-638	SI LINE 3 LEAKAGE RETURN	GL	AD	1	A		LPV	2 YR.		6.3.2-1C
SI-638	SI LINE 3 LEAKAGE RETURN	GL	AD	1	A	BV	LT	2 YR.	10	6.3.2-1C
SI-641	SIT #1 FILL LINE	GL	AD	2	B		S	3 MO.		6.3.2-1C
SI-641	SIT #1 FILL LINE	GL	AD	2	B		MT	3 MO.		6.3.2-1C
SI-641	SIT #1 FILL LINE	GL	AD	2	B		FS	3 MO.		6.3.2-1C
SI-641	SIT #1 FILL LINE	GL	AD	2	B		LPV	2 YR.		6.3.2-1C
SI-644	SIT #1 DACHARGE ISOL.	GT	EL	1	B		S	CS(28)		6.3.2-1C
SI-644	SIT #1 DICHARGE ISOL.	GT	EL	1	B		MT	CS(28)		6.3.2-1C
SI-644	SIT #1 DICHARGE ISOL.	GT	EL	1	B		LPV	2 YR.		6.3.2-1C
SI-646	SI PUMP #1 DISCHARGE	GL	EL	2	B		S	3 MO.		6.3.2-1C
SI-646	SI PUMP #1 DISCHARGE	GL	EL	2	B		MT	3 MO.		6.3.2-1C
SI-646	SI PUMP #1 DISCHARGE	GL	EL	2	B		LPV	2 YR.		6.3.2-1C
SI-646	SI PUMP #1 DISCHARGE	GL	EL	2	B		DDP	5 YR.	8	6.3.2-1C
SI-648	SI LINE 1 LEAKAGE RETURN	GL	AD	1	A		S	3 MO.		6.3.2-1C
SI-648	SI LINE 1 LEAKAGE RETURN	GL	AD	1	A		MT	3 MO.		6.3.2-1C
SI-648	SI LINE 1 LEAKAGE RETURN	GL	AD	1	A		FS	3 MO.		6.3.2-1C
SI-648	SI LINE 1 LEAKAGE RETURN	GL	AD	1	A		LPV	2 YR.		6.3.2-1C
SI-648	SI LINE 1 LEAKAGE RETURN	GL	AD	1	A	BV	LT	2 YR.	10	6.3.2-1C
SI-651	SC PUMP #1 SUCTION	GT	EL	1	A		S	CS(29)		6.3.2-1C
SI-651	SC PUMP #1 SUCTION	GT	EL	1	A		MT	CS(29)		6.3.2-1C
SI-651	SC PUMP #1 SUCTION	GT	EL	1	A		LPV	2 YR.		6.3.2-1C
SI-651	SC PUMP #1 SUCTION	GT	EL	1	A	BV	LT	2 YR.	10	6.3.2-1C
SI-651	SC PUMP #1 SUCTION	GT	EL	1	A		DDP	E1	8	6.3.2-1C
SI-652	SC PUMP #2 SUCTION	GT	EL	1	A		S	CS(29)		6.3.2-1C
SI-652	SC PUMP #2 SUCTION	GT	EL	1	A		MT	CS(29)		6.3.2-1C
SI-652	SC PUMP #2 SUCTION	GT	EL	1	A		LPV	2 YR.		6.3.2-1C

TABLE 3.9-15 (Continued)

INSERVICE TUSTING SAFETY-RELATED PUMPS AND VALVES

VALVE NO.	VALVE DESCRIPTION	(a) VALVE TYPE	(b) VALVE ACT	(c) SAFETY CLASS	(d) CODE CAT	(e) VALVE FUNCT	(f) TEST REQD	(g) TEST FREQ	(i) TEST CONFIG	CESSAR-DC FIG. NO.
SI-652	SC PUMP #2 SUCTION	GT	EL	1	A	BV	LT	2 Yr.	10	6.3.2-1C
SI-652	SC PUMP #2 SUCTION	GT	EL	1	A		DDP	E1	8	6.3.2-1C
SI-653	SC PUMP #1 SUCTION	GT	EL	1	A		S	CS(29)		6.3.2-1C
SI-653	SC PUMP #1 SUCTION	GT	EL	1	A		MT	CS(29)		6.3.2-1C
SI-653	SC PUMP #1 SUCTION	GT	EL	1	A		LPV	2 Yr.		6.3.2-1C
SI-653	SC PUMP #1 SUCTION	GT	EL	1	A	BV	LT	2 Yr.	10	6.3.2-1C
SI-653	SC PUMP #1 SUCTION	GT	EL	1	A		DDP	E1	8	6.3.2-1C
SI-654	SC PUMP #2 SUCTION	GT	EL	1	A		S	CS(29)		6.3.2-1C
SI-654	SC PUMP #2 SUCTION	GT	EL	1	A		MT	CS(29)		6.3.2-1C
SI-654	SC PUMP #2 SUCTION	GT	EL	1	A		LPV	2 Yr.		6.3.2-1C
SI-654	SC PUMP #2 SUCTION	GT	EL	1	A	BV	LT	2 Yr.	10	6.3.2-1C
SI-654	SC PUMP #2 SUCTION	GT	EL	1	A		DDP	E1	8	6.3.2-1C
SI-655	SC PUMP #1 SUCTION	GT	EL	2	A		S	CS(29)		6.3.2-1C
SI-655	SC PUMP #1 SUCTION	GT	EL	2	A		MT	CS(29)		6.3.2-1C
SI-655	SC PUMP #1 SUCTION	GT	EL	2	A		LPV	2 Yr.		6.3.2-1C
SI-655	SC PUMP #1 SUCTION	GT	EL	2	A		DDP	E1	8	6.3.2-1C
SI-656	SC PUMP #2 SUCTION	GT	EL	2	A		S	CS(29)		6.3.2-1C
SI-656	SC PUMP #2 SUCTION	GT	EL	2	A		MF	CS(29)		6.3.2-1C
SI-656	SC PUMP #2 SUCTION	GT	EL	2	A		LPV	2 Yr.		6.3.2-1C
SI-656	SC PUMP #2 SUCTION	GT	EL	2	A		DDP	E1	8	6.3.2-1C
SI-671	CS PUMP #2 DISCHARGE	GT	EL	2	A		S	3 mo.		6.3.2-1B
SI-671	CS PUMP #2 DISCHARGE	GT	EL	2	A		MT	3 mo.		6.3.2-1B
SI-671	CS PUMP #2 DISCHARGE	GT	EL	2	A	CI	LPV	2 Yr.	1	6.3.2-1B
SI-671	CS PUMP #2 DISCHARGE	GT	EL	2	A		LT	2 Yr.		6.3.2-1B
SI-672	CS PUMP #1 DISCHARGE	GT	EL	2	A		S	3 mo.		6.3.2-1A
SI-672	CS PUMP #1 DISCHARGE	GT	EL	2	A		MT	3 mo.		6.3.2-1A
SI-672	CS PUMP #1 DISCHARGE	GT	EL	2	A		LPV	2 Yr.		6.3.2-1A
SI-672	CS PUMP #1 DISCHARGE	GT	EL	2	A	CI	LT	2 Yr.	1	6.3.2-1A
SI-682	SIT FILL LINE CONT. ISOL	GL	AD	2	A		S	3 mo.		6.3.2-1C
SI-682	SIT FILL LINE CONT. ISOL	GL	AD	2	A		MT	3 mo.		6.3.2-1C
SI-682	SIT FILL LINE CONT. ISOL	GL	AD	2	A		FS	3 mo.		6.3.2-1C
SI-682	SIT FILL LINE CONT. ISOL	GL	AD	2	A		LPV	2 Yr.		6.3.2-1C
SI-682	SIT FILL LINE CONT. ISOL	GL	AD	2	A	CI	LT	2 Yr.	4	6.3.2-1C

TABLE 3.9-15 (Continued)

INSERVICE TESTING SAFETY-RELATED PUMPS AND VALVES

VALVE NO.	VALVE DESCRIPTION	(a) VALVE TYPE	(b) VALVE ACT.	(c) SAFETY CLASS	(d) CODE CAT	(e) VALVE FUNCT	(f) TEST RECD	(g) TEST FREQ	(i) TEST CONFIG	CESSAR-DC FIG. NO.
SI-690	SCS TRAIN 2 WARMUP ISOL	GL	EL	2	A		S	3 MO.		6.3.2-1C
SI-690	SCS TRAIN 2 WARMUP ISOL	GL	EL	2	A		MT	3 MO.		6.3.2-1C
SI-690	SCS TRAIN 2 WARMUP ISOL	GL	EL	2	A		LPV	2 YI.	8	6.3.2-1C
SI-690	SCS TRAIN 2 WARMUP ISOL	GL	EL	2	A		DDP	EI		6.3.2-1C
SI-691	SCS TRAIN 1 WARMUP ISOL.	GL	EL	2	A		S	3 MO.		6.3.2-1C
SI-691	SCS TRAIN 1 WARMUP ISOL.	GL	EL	2	A		MT	3 MO.		6.3.2-1C
SI-691	SCS TRAIN 1 WARMUP ISOL.	GL	EL	2	A		LPV	2 YI.	8	6.3.2-1C
SI-691	SCS TRAIN 1 WARMUP ISOL.	GL	EL	2	A		DDP	EI		6.3.2-1C
SS-200	HOT LEG SAMPLE	GL	S	2	A		S	3 MO.		
SS-200	HOT LEG SAMPLE	GL	S	2	A		MT	3 MO.		
SS-200	HOT LEG SAMPLE	GL	S	2	A		FS	3 MO.		
SS-200	HOT LEG SAMPLE	GL	S	2	A		LPV	2 YI.	4	
SS-200	HOT LEG SAMPLE	GL	S	2	A	CI	LT	2 YI.		
SS-201	PRESSURIZER LIQUID SAMPLE	GL	S	2	A		S	3 MO.		
SS-201	PRESSURIZER LIQUID SAMPLE	GL	S	2	A		MT	3 MO.		
SS-201	PRESSURIZER LIQUID SAMPLE	GL	S	2	A		FS	3 MO.		
SS-201	PRESSURIZER LIQUID SAMPLE	GL	S	2	A		LPV	2 YI.	4	
SS-201	PRESSURIZER LIQUID SAMPLE	GL	S	2	A	CI	LT	2 YI.		
SS-202	PRESSURIZER STEAM SPACE SAMPLE	GL	S	2	A		S	3 MO.		
SS-202	PRESSURIZER STEAM SPACE SAMPLE	GL	S	2	A		MT	3 MO.		
SS-202	PRESSURIZER STEAM SPACE SAMPLE	GL	S	2	A		FS	3 MO.		
SS-202	PRESSURIZER STEAM SPACE SAMPLE	GL	S	2	A		LPV	2 YI.	4	
SS-202	PRESSURIZER STEAM SPACE SAMPLE	GL	S	2	A	CI	LT	2 YI.		
SS-203	HOT LEG SAMPLE	GL	S	2	A		S	3 MO.		
SS-203	HOT LEG SAMPLE	GL	S	2	A		MT	3 MO.		
SS-203	HOT LEG SAMPLE	GL	S	2	A		FS	3 MO.		
SS-203	HOT LEG SAMPLE	GL	S	2	A		LPV	2 YI.	4	
SS-203	HOT LEG SAMPLE	GL	S	2	A	CI	LT	2 YI.		
SS-204	PRESSURIZER LIQUID SAMPLE	GL	S	2	A		S	3 MO.		
SS-204	PRESSURIZER LIQUID SAMPLE	GL	S	2	A		MT	3 MO.		
SS-204	PRESSURIZER LIQUID SAMPLE	GL	S	2	A		FS	3 MO.		
SS-204	PRESSURIZER LIQUID SAMPLE	GL	S	2	A		LPV	2 YI.	4	
SS-204	PRESSURIZER LIQUID SAMPLE	GL	S	2	A	CI	LT	2 YI.		
SS-205	PRESSURIZER STEAM SPACE SAMPLE	GL	S	2	A		S	3 MO.		

TABLE 3.9-15 (Continued)

INSERVICE TESTING SAFETY-RELATED PUMPS AND VALVES

VALVE NO.	VALVE DESCRIPTION	(a) VALVE TYPE	(b) VALVE ACT.	(c) SAFETY CLASS	(d) CODE (AT)	(e) VALVE FUNCT.	(f) TEST REQD.	(g) TEST FREQ.	(h) TEST CONFIG.	CESSAR-DC FIG. NO.
SS-205	PRESSURIZER STEAM SPACE SAMPLE	GL	S	2	A		MT	3 MO.		---
SS-205	PRESSURIZER STEAM SPACE SAMPLE	GL	S	2	A		FS	3 MO.		---
SS-205	PRESSURIZER STEAM SPACE SAMPLE	GL	S	2	A		LPV	2 YR.	4	---
SS-205	PRESSURIZER STEAM SPACE SAMPLE	GL	S	2	A	CI	LT	2 YR.		---
SS-208	HOLDUP VOLUME TANK SAMPLE	GL	S	2	A		S	3 MO.		---
SS-208	HOLDUP VOLUME TANK SAMPLE	GL	S	2	A		MT	3 MO.		---
SS-208	HOLDUP VOLUME TANK SAMPLE	GL	S	2	A		FS	3 MO.		---
SS-208	HOLDUP VOLUME TANK SAMPLE	GL	S	2	A		LPV	2 YR.	4	---
SS-208	HOLDUP VOLUME TANK SAMPLE	GL	S	2	A	CI	LT	2 YR.		---
SS-210	HOLDUP VOLUME TANK SAMPLE	GL	S	2	A		S	3 MO.		---
SS-210	HOLDUP VOLUME TANK SAMPLE	GL	S	2	A		MT	3 MO.		---
SS-210	HOLDUP VOLUME TANK SAMPLE	GL	S	2	A		FS	3 MO.		---
SS-210	HOLDUP VOLUME TANK SAMPLE	GL	S	2	A		LPV	2 YR.	4	---
SS-210	HOLDUP VOLUME TANK SAMPLE	GL	S	2	A	CI	LT	2 YR.		---
SS-211	HOLDUP VOLUME TANK SAMPLE	GL	S	2	A		S	3 MO.		---
SS-211	HOLDUP VOLUME TANK SAMPLE	GL	S	2	A		MT	3 MO.		---
SS-211	HOLDUP VOLUME TANK SAMPLE	GL	S	2	A		FS	3 MO.		---
SS-211	HOLDUP VOLUME TANK SAMPLE	GL	S	2	A		LPV	2 YR.	4	---
SS-211	HOLDUP VOLUME TANK SAMPLE	GL	S	2	A	CI	LT	2 YR.		---
SW-100	SSW STRAINER 1A BACKWASH	PL	EL	3	B		S	3 MO.		9.2.1-1.1
SW-100	SSW STRAINER 1A BACKWASH	PL	EL	3	B		MT	3 MO.		9.2.1-1.1
SW-100	SSW STRAINER 1A BACKWASH	PL	EL	3	B		LPV	2 YR.		9.2.1-1.1
SW-101	SSW STRAINER 1B BACKWASH	PL	EL	3	B		S	3 MO.		9.2.1-1.1
SW-101	SSW STRAINER 1B BACKWASH	PL	EL	3	B		MT	3 MO.		9.2.1-1.1
SW-101	SSW STRAINER 1B BACKWASH	PL	EL	3	B		LPV	2 YR.		9.2.1-1.1
SW-102	SSW STRAINER 1A BACKWASH	PL	EL	3	B		S	3 MO.		9.2.1-1.1
SW-102	SSW STRAINER 1A BACKWASH	PL	EL	3	B		MT	3 MO.		9.2.1-1.1
SW-102	SSW STRAINER 1A BACKWASH	PL	EL	3	B		LPV	2 YR.		9.2.1-1.1
SW-103	SSW STRAINER 1B BACKWASH	PL	EL	3	B		S	3 MO.		9.2.1-1.1
SW-103	SSW STRAINER 1B BACKWASH	PL	EL	3	B		MT	3 MO.		9.2.1-1.1
SW-103	SSW STRAINER 1B BACKWASH	PL	EL	3	B		LPV	2 YR.		9.2.1-1.1
SW-104	SSW STRAINER 1A BACKWASH	PL	EL	3	B		S	3 MO.		9.2.1-1.1
SW-104	SSW STRAINER 1A BACKWASH	PL	EL	3	B		MT	3 MO.		9.2.1-1.1

TABLE 3.9-15 (Continued)

INSERVICE TESTING SAFETY-RELATED PUMPS AND VALVES

<u>VALVE NO.</u>	<u>VALVE DESCRIPTION</u>	<u>(a) VALVE TYPE</u>	<u>(b) VALVE ACT</u>	<u>(c) SAFETY CLASS</u>	<u>(d) CODE CAT</u>	<u>(e) VALVE FUNCT</u>	<u>(f) TEST REQD</u>	<u>(g) TEST FREQ</u>	<u>(i) TEST CONFIG.</u>	<u>CESSAR-DC FIG. NO.</u>
SW-104	SSW STRAINER 1A BACKWASH	PL	EL	3	B		LPV	2 yr.		9.2.1-1.1
SW-105	SSW STRAINER 1B BACKWASH	PL	EL	3	B		S	3 mo.		9.2.1-1.1
SW-105	SSW STRAINER 1B BACKWASH	PL	EL	3	B		MT	3 mo.		9.2.1-1.1
SW-105	SSW STRAINER 1B BACKWASH	PL	EL	3	B		LPV	2 yr.		9.2.1-1.1
SW-106	SSW STRAINER 1A BACKWASH	PL	EL	3	B		S	3 mo.		9.2.1-1.1
SW-106	SSW STRAINER 1A BACKWASH	PL	EL	3	B		MT	3 mo.		9.2.1-1.1
SW-106	SSW STRAINER 1A BACKWASH	PL	EL	3	B		LPV	2 yr.		9.2.1-1.1
SW-107	SSW STRAINER 1B BACKWASH	PL	EL	3	B		S	3 mo.		9.2.1-1.1
SW-107	SSW STRAINER 1B BACKWASH	PL	EL	3	B		MT	3 mo.		9.2.1-1.1
SW-107	SSW STRAINER 1B BACKWASH	PL	EL	3	B		LPV	2 yr.		9.2.1-1.1
SW-108	SSW STRAINER 1A BACKWASH	PL	EL	3	B		S	3 mo.		9.2.1-1.1
SW-108	SSW STRAINER 1A BACKWASH	PL	EL	3	B		MT	3 mo.		9.2.1-1.1
SW-108	SSW STRAINER 1A BACKWASH	PL	EL	3	B		LPV	2 yr.		9.2.1-1.1
SW-109	SSW STRAINER 1B BACKWASH	PL	EL	3	B		S	3 mo.		9.2.1-1.1
SW-109	SSW STRAINER 1B BACKWASH	PL	EL	3	B		MT	3 mo.		9.2.1-1.1
SW-109	SSW STRAINER 1B BACKWASH	PL	EL	3	B		LPV	2 yr.		9.2.1-1.1
SW-110	SSW STRAINER 1A BACKWASH	PL	EL	3	B		S	3 mo.		9.2.1-1.1
SW-110	SSW STRAINER 1A BACKWASH	PL	EL	3	B		MT	3 mo.		9.2.1-1.1
SW-110	SSW STRAINER 1A BACKWASH	PL	EL	3	B		LPV	2 yr.		9.2.1-1.1
SW-111	SSW STRAINER 1B BACKWASH	PL	EL	3	B		S	3 mo.		9.2.1-1.1
SW-111	SSW STRAINER 1B BACKWASH	PL	EL	3	B		MT	3 mo.		9.2.1-1.1
SW-111	SSW STRAINER 1B BACKWASH	PL	EL	3	B		LPV	2 yr.		9.2.1-1.1
SW-120	CCW HX 1A INLET ISOL	BF	EL	3	B		S	3 mo.		9.2.1-1.2
SW-120	CCW HX 1A INLET ISOL	BF	EL	3	B		MT	3 mo.		9.2.1-1.2
SW-120	CCW HX 1A INLET ISOL	BF	EL	3	B		LPV	2 yr.		9.2.1-1.2
SW-121	CCW HX 1B INLET ISOL	BF	EL	3	B		S	3 mo.		9.2.1-1.2
SW-121	CCW HX 1B INLET ISOL	BF	EL	3	B		MT	3 mo.		9.2.1-1.2
SW-121	CCW HX 1B INLET ISOL	BF	EL	3	B		LPV	2 yr.		9.2.1-1.2
SW-122	CCW HX 1A OUTLET ISOL	BF	EL	3	B		S	3 mo.		9.2.1-1.2
SW-122	CCW HX 1A OUTLET ISOL	BF	EL	3	B		MT	3 mo.		9.2.1-1.2
SW-122	CCW HX 1A OUTLET ISOL	BF	EL	3	B		LPV	2 yr.		9.2.1-1.2

TABLE 3.9-15 (Continued)

INSERVICE TESTING SAFETY-RELATED PUMPS AND VALVES

<u>VALVE NO.</u>	<u>VALVE DESCRIPTION</u>	<u>(a) VALVE TYPE</u>	<u>(b) VALVE ACT</u>	<u>(c) SAFETY CLASS</u>	<u>(d) CODE CAT</u>	<u>(e) VALVE FUNCT</u>	<u>(f) TEST REQD</u>	<u>(g) TEST FFREQ</u>	<u>(i) TEST CONFIG.</u>	<u>CESSAR-DC FIG. NO.</u>
SW-123	CCW HX 1B OUTLET ISOL	BF	EL	3	B	S	3 mo.		9.2.1-1.2	
SW-123	CCW HX 1B OUTLET ISOL	BF	EL	3	B	MT	3 mo.		9.2.1-1.2	
SW-123	CCW HX 1B OUTLET ISOL	BF	EL	3	B	LPV	2 yr.		9.2.1-1.2	
SW-1302	SSW PUMP 1A DISCHARGE	CK	SA	3	C	S	3 mo.	11	9.2.1-1.1	
SW-1302	SSW PUMP 1A DISCHARGE	CK	SA	3	C	RF	3 mo.	9	9.2.1-1.1	
SW-1303	SSW PUMP 1B DISCHARGE	CK	SA	3	C	S	3 mo.	11	9.2.1-1.1	
SW-1303	SSW PUMP 1B DISCHARGE	CK	SA	3	C	RF	3 mo.	9	9.2.1-1.1	
SW-200	SSW STRAINER 2A BACKWASH	PL	EL	3	B	S	3 mo.		9.2.1-1.3	
SW-200	SSW STRAINER 2A BACKWASH	PL	EL	3	B	MT	3 mo.		9.2.1-1.3	
SW-200	SSW STRAINER 2A BACKWASH	PL	EL	3	B	LPV	2 yr.		9.2.1-1.3	
SW-201	SSW STRAINER 2B BACKWASH	PL	EL	3	B	S	3 mo.		9.2.1-1.3	
SW-201	SSW STRAINER 2B BACKWASH	PL	EL	3	B	MT	3 mo.		9.2.1-1.3	
SW-201	SSW STRAINER 2B BACKWASH	PL	EL	3	B	LPV	2 yr.		9.2.1-1.3	
SW-202	SSW STRAINER 2A BACKWASH	PL	EL	3	B	S	3 mo.		9.2.1-1.3	
SW-202	SSW STRAINER 2A BACKWASH	PL	EL	3	B	MT	3 mo.		9.2.1-1.3	
SW-202	SSW STRAINER 2A BACKWASH	PL	EL	3	B	LPV	2 yr.		9.2.1-1.3	
SW-203	SSW STRAINER 2B BACKWASH	PL	EL	3	B	S	3 mo.		9.2.1-1.3	
SW-203	SSW STRAINER 2B BACKWASH	PL	EL	3	B	MT	3 mo.		9.2.1-1.3	
SW-203	SSW STRAINER 2B BACKWASH	PL	EL	3	B	LPV	2 yr.		9.2.1-1.3	
SW-204	SSW STRAINER 2A BACKWASH	PL	EL	3	B	S	3 mo.		9.2.1-1.3	
SW-204	SSW STRAINER 2A BACKWASH	PL	EL	3	B	MT	3 mo.		9.2.1-1.3	
SW-204	SSW STRAINER 2A BACKWASH	PL	EL	3	B	LPV	2 yr.		9.2.1-1.3	
SW-205	SSW STRAINER 2B BACKWASH	PL	EL	3	B	S	3 mo.		9.2.1-1.3	
SW-205	SSW STRAINER 2B BACKWASH	PL	EL	3	B	MT	3 mo.		9.2.1-1.3	
SW-205	SSW STRAINER 2B BACKWASH	PL	EL	3	B	LPV	2 yr.		9.2.1-1.3	
SW-206	SSW STRAINER 2A BACKWASH	PL	EL	3	B	S	3 mo.		9.2.1-1.3	
SW-206	SSW STRAINER 2A BACKWASH	PL	EL	3	B	MT	3 mo.		9.2.1-1.3	
SW-206	SSW STRAINER 2A BACKWASH	PL	EL	3	B	LPV	2 yr.		9.2.1-1.3	
SW-207	SSW STRAINER 2B BACKWASH	PL	EL	3	B	S	3 mo.		9.2.1-1.3	
SW-207	SSW STRAINER 2B BACKWASH	PL	EL	3	B	MT	3 mo.		9.2.1-1.3	
SW-207	SSW STRAINER 2B BACKWASH	PL	EL	3	B	LPV	2 yr.		9.2.1-1.3	

TABLE 3.9-15 (Continued)

INSERVICE TESTING SAFETY-RELATED PUMPS AND VALVES

VALVE NO.	VALVE DESCRIPTION	(a) VALVE TYPE	(b) VALVE ACT	(c) SAFETY CLASS	(d) CODE CAT	(e) VALVE FUNCT	(f) TEST REQD	(g) TEST FREQ	(i) TEST CONFIG.	CESSAR-DC FIG. NO.
SW-208	SSW STRAINER 2A BACKWASH	PL	EL	3	B		S	3 mo.		9.2.1-1.3
SW-208	SSW STRAINER 2A BACKWASH	PL	EL	3	B		MT	3 mo.		9.2.1-1.3
SW-208	SSW STRAINER 2A BACKWASH	PL	EL	3	B		LPV	2 yr.		9.2.1-1.3
SW-209	SSW STRAINER 2B BACKWASH	PL	EL	3	B		S	3 mo.		9.2.1-1.3
SW-209	SSW STRAINER 2B BACKWASH	PL	EL	3	B		MT	3 mo.		9.2.1-1.3
SW-209	SSW STRAINER 2B BACKWASH	PL	EL	3	B		LPV	2 yr.		9.2.1-1.3
SW-210	SSW STRAINER 2A BACKWASH	PL	EL	3	B		S	3 mo.		9.2.1-1.3
SW-210	SSW STRAINER 2A BACKWASH	PL	EL	3	B		MT	3 mo.		9.2.1-1.3
SW-210	SSW STRAINER 2A BACKWASH	PL	EL	3	B		LPV	2 yr.		9.2.1-1.3
SW-211	SSW STRAINER 2B BACKWASH	PL	EL	3	B		S	3 mo.		9.2.1-1.3
SW-211	SSW STRAINER 2B BACKWASH	PL	EL	3	B		MT	3 mo.		9.2.1-1.3
SW-211	SSW STRAINER 2B BACKWASH	PL	EL	3	B		LPV	2 yr.		9.2.1-1.3
SW-220	CCW HX 2A INLET ISOL	BF	EL	3	B		S	3 mo.		9.2.1-1.4
SW-220	CCW HX 2A INLET ISOL	BF	EL	3	B		MT	3 mo.		9.2.1-1.4
SW-220	CCW HX 2A INLET ISOL	BF	EL	3	B		LPV	2 yr.		9.2.1-1.4
SW-221	CCW HX 2B INLET ISOL	BF	EL	3	B		S	3 mo.		9.2.1-1.4
SW-221	CCW HX 2B INLET ISOL	BF	EL	3	B		MT	3 mo.		9.2.1-1.4
SW-221	CCW HX 2B INLET ISOL	BF	EL	3	B		LPV	2 yr.		9.2.1-1.4
SW-222	CCW HX 2A OUTLET ISOL	BF	EL	3	B		S	3 mo.		9.2.1-1.4
SW-222	CCW HX 2A OUTLET ISOL	BF	EL	3	B		MT	3 mo.		9.2.1-1.4
SW-222	CCW HX 2A OUTLET ISOL	BF	EL	3	B		LPV	2 yr.		9.2.1-1.4
SW-223	CCW HX 2B OUTLET ISOL	BF	EL	3	B		S	3 mo.		9.2.1-1.4
SW-223	CCW HX 2B OUTLET ISOL	BF	EL	3	B		MT	3 mo.		9.2.1-1.4
SW-223	CCW HX 2B OUTLET ISOL	BF	EL	3	B		LPV	2 yr.		9.2.1-1.4
SW-2302	SSW PUMP 2A DISCHARGE	CK	SA	3	C		S	3 mo.	11	9.2.1-1.3
SW-2302	SSW PUMP 2A DISCHARGE	CK	SA	3	C		RF	3 mo.	9	9.2.1-1.3
SW-2303	SSW PUMP 2B DISCHARGE	CK	SA	3	C		S	3 mo.	11	9.2.1-1.3
SW-2303	SSW PUMP 2B DISCHARGE	CK	SA	3	C		RF	3 mo.	9	9.2.1-1.3
XX-001	BREATHING AIR SUPPLY	GT	EL	2	A		S	3 mo.		---
XX-001	BREATHING AIR SUPPLY	GT	EL	2	A		MT	3 mo.		---
XX-001	BREATHING AIR SUPPLY	GT	EL	2	A		LPV	2 yr.		---

TABLE 3.9-15 (Continued)

INSERVICE TESTING SAFETY-RELATED PUMPS AND VALVES

<u>VALVE NO.</u>	<u>VALVE DESCRIPTION</u>	<u>(a) VALVE TYPE</u>	<u>(b) VALVE ACT</u>	<u>(c) SAFETY CLASS</u>	<u>(d) CODE CAT</u>	<u>(e) VALVE FUNCT</u>	<u>(f) TEST REQD</u>	<u>(g) TEST FREQ</u>	<u>(h) TEST CONFIG.</u>	<u>CESSAR-DC FIG. NO.</u>
XX-001	BREATHING AIR SUPPLY	GT	EL	2	A	CI	LT	2 yr.	1	---
XX-002	BREATHING AIR SUPPLY	CK	SA	2	A/C		S	3 mo.	14	---
XX-002	BREATHING AIR SUPPLY	CK	SA	2	A/C	CI	LT	2 yr.	1	---
XX-003	STATION AIR SUPPLY	GT	EL	2	A		S	3 mo.		---
XX-003	STATION AIR SUPPLY	GT	EL	2	A		MT	3 mo.		---
XX-003	STATION AIR SUPPLY	GT	EL	2	A		LPV	2 yr.		---
XX-003	STATION AIR SUPPLY	GT	EL	2	A	CI	LT	2 yr.	1	---
XX-004	STATION AIR SUPPLY	CK	SA	2	A/C		S	3 mo.	14	---
XX-004	STATION AIR SUPPLY	CK	SA	2	A/C	CI	LT	2 yr.	1	---
XX-005	DIV 1 INSTR. AIR SUPPLY	GT	EL	2	A		S	3 mo.		9.3.1-1.2
XX-005	DIV 1 INSTR. AIR SUPPLY	GT	EL	2	A		MT	3 mo.		9.3.1-1.2
XX-005	DIV 1 INSTR. AIR SUPPLY	GT	EL	2	A		LPV	2 yr.		9.3.1-1.2
XX-005	DIV 1 INSTR. AIR SUPPLY	GT	EL	2	A	CI	LT	2 yr.	1	9.3.1-1.2
XX-006	DIV 1 INSTR. AIR SUPPLY	CK	SA	2	A/C		S	3 mo.	14	9.3.1-1.2
XX-006	DIV 1 INSTR. AIR SUPPLY	CK	SA	2	A/C	CI	LT	2 yr.	1	9.3.1-1.2
XX-007	DIV 2 INSTR. AIR SUPPLY	GT	EL	2	A		S	3 mo.		9.3.1-1.2
XX-007	DIV 2 INSTR. AIR SUPPLY	GT	EL	2	A		MT	3 mo.		9.3.1-1.2
XX-007	DIV 2 INSTR. AIR SUPPLY	GT	EL	2	A		LPV	2 yr.		9.3.1-1.2
XX-007	DIV 2 INSTR. AIR SUPPLY	GT	EL	2	A	CI	LT	2 yr.	1	9.3.1-1.2
XX-008	DIV 2 INSTR. AIR SUPPLY	CK	SA	2	A/C		S	3 mo.	14	9.3.1-1.2
XX-008	DIV 2 INSTR. AIR SUPPLY	CK	SA	2	A/C	CI	LT	2 yr.	1	9.3.1-1.2
XX-010	HIGH VOL CONT PURGE SPLY 1	BF	AD	2	A		S	CS(30)		9.4.6
XX-010	HIGH VOL CONT PURGE SPLY 1	BF	AD	2	A		MT	CS(30)		9.4.6
XX-010	HIGH VOL CONT PURGE SPLY 1	BF	AD	2	A		FS	CS(30)		9.4.6
XX-010	HIGH VOL CONT PURGE SPLY 1	BF	AD	2	A		LPV	2 yr.		9.4.6
XX-010	HIGH VOL CONT PURGE SPLY 1	BF	AD	2	A	CI	LT	2 yr.	5	9.4.6
XX-011	HIGH VOL CONT PURGE SPLY 1	BF	AD	2	A		S	CS(30)		9.4.6
XX-011	HIGH VOL CONT PURGE SPLY 1	BF	AD	2	A		MT	CS(30)		9.4.6
XX-011	HIGH VOL CONT PURGE SPLY 1	BF	AD	2	A		FS	CS(30)		9.4.6
XX-011	HIGH VOL CONT PURGE SPLY 1	BF	AD	2	A		LPV	2 yr.		9.4.6
XX-011	HIGH VOL CONT PURGE SPLY 1	BF	AD	2	A	CI	LT	2 yr.	5	9.4.6

TABLE 3.9-15 (Continued)

INSERVICE TESTING SAFETY-RELATED PUMPS AND VALVES

VALVE NO.	VALVE DESCRIPTION	(a) VALVE TYPE	(b) VALVE ACT	(c) SAFETY CLASS	(d) CODE CAT	(e) VALVE FUNCT	(f) TEST REQD	(g) TEST FREQ	(h) TEST CONFIG	CESSAR-DC FIG. NO.
XX-012	HIGH VOL CONT PURGE SPLY 2	BF	AD	2	A		S	CS(30)		9.4.6
XX-012	HIGH VOL CONT PURGE SPLY 2	BF	AD	2	A		MT	CS(30)		9.4.6
XX-012	HIGH VOL CONT PURGE SPLY 2	BF	AD	2	A		FS	CS(30)		9.4.6
XX-012	HIGH VOL CONT PURGE SPLY 2	BF	AD	2	A		LPV	2 yr.		9.4.6
XX-012	HIGH VOL CONT PURGE SPLY 2	BF	AD	2	A	CI	LT	2 yr.	5	9.4.6
XX-013	HIGH VOL CONT PURGE SPLY 2	BF	AD	2	A		S	CS(30)		9.4.6
XX-013	HIGH VOL CONT PURGE SPLY 2	BF	AD	2	A		MT	CS(30)		9.4.6
XX-013	HIGH VOL CONT PURGE SPLY 2	BF	AD	2	A		FS	CS(30)		9.4.6
XX-013	HIGH VOL CONT PURGE SPLY 2	BF	AD	2	A		LPV	2 yr.		9.4.6
XX-013	HIGH VOL CONT PURGE SPLY 2	BF	AD	2	A	CI	LT	2 yr.	5	9.4.6
XX-014	HIGH VOL CONT PURGE EXHST 1	BF	AD	2	A		S	CS(30)		9.4.6
XX-014	HIGH VOL CONT PURGE EXHST 1	BF	AD	2	A		MT	CS(30)		9.4.6
XX-014	HIGH VOL CONT PURGE EXHST 1	BF	AD	2	A		FS	CS(30)		9.4.6
XX-014	HIGH VOL CONT PURGE EXHST 1	BF	AD	2	A		LPV	2 yr.		9.4.6
XX-014	HIGH VOL CONT PURGE EXHST 1	BF	AD	2	A	CI	LT	2 yr.	5	9.4.6
XX-015	HIGH VOL CONT PURGE EXHST 1	BF	AD	2	A		S	CS(30)		9.4.6
XX-015	HIGH VOL CONT PURGE EXHST 1	BF	AD	2	A		MT	CS(30)		9.4.6
XX-015	HIGH VOL CONT PURGE EXHST 1	BF	AD	2	A		FS	CS(30)		9.4.6
XX-015	HIGH VOL CONT PURGE EXHST 1	BF	AD	2	A		LPV	2 yr.		9.4.6
XX-015	HIGH VOL CONT PURGE EXHST 1	BF	AD	2	A	CI	LT	2 yr.	5	9.4.6
XX-016	HIGH VOL CONT PURGE EXHST 2	BF	AD	2	A		S	CS(30)		9.4.6
XX-016	HIGH VOL CONT PURGE EXHST 2	BF	AD	2	A		MT	CS(30)		9.4.6
XX-016	HIGH VOL CONT PURGE EXHST 2	BF	AD	2	A		FS	CS(30)		9.4.6
XX-016	HIGH VOL CONT PURGE EXHST 2	BF	AD	2	A		LPV	2 yr.		9.4.6
XX-016	HIGH VOL CONT PURGE EXHST 2	BF	AD	2	A	CI	LT	2 yr.	5	9.4.6
XX-017	HIGH VOL CONT PURGE EXHST 2	BF	AD	2	A		S	CS(30)		9.4.6
XX-017	HIGH VOL CONT PURGE EXHST 2	BF	AD	2	A		MT	CS(30)		9.4.6
XX-017	HIGH VOL CONT PURGE EXHST 2	BF	AD	2	A		FS	CS(30)		9.4.6
XX-017	HIGH VOL CONT PURGE EXHST 2	BF	AD	2	A		LPV	2 yr.		9.4.6
XX-017	HIGH VOL CONT PURGE EXHST 2	BF	AD	2	A	CI	LT	2 yr.	5	9.4.6
XX-018	LOW VOL CONT PURGE SPLY	BF	AD	2	A		S	3 mo.		9.4.6
XX-018	LOW VOL CONT PURGE SPLY	BF	AD	2	A		MT	3 mo.		9.4.6
XX-018	LOW VOL CONT PURGE SPLY	BF	AD	2	A		FS	3 mo.		9.4.6
XX-018	LOW VOL CONT PURGE SPLY	BF	AD	2	A		LPV	2 yr.		9.4.6
XX-018	LOW VOL CONT PURGE SPLY	BF	AD	2	A	CI	LT	2 yr.	1	9.4.6

TABLE 3.9-15 (Continued)

INSERVICE TESTING SAFETY-RELATED PUMPS AND VALVES

VALVE NO.	VALVE DESCRIPTION	(a) VALVE TYPE	(b) VALVE ACT.	(c) SAFETY CLASS	(d) CODE CAT.	(e) VALVE FUNCT.	(f) TEST REQD.	(g) TEST FREQ.	(h) TEST CONFIG.	CESSAR-DC FIG. NO.
XX-019	LOW VOL CONT PURGE SPLY	CK	SA	2	A/C	S	S	3 mo.	12	9.4.6
XX-019	LOW VOL CONT PURGE SPLY	CK	SA	2	A/C	LT	LT	2 yr.	1	9.4.6
XX-020	LOW VOL CONT PURGE EXHST	BF	AD	2	A	S	S	3 mo.		9.4.6
XX-020	LOW VOL CONT PURGE EXHST	BF	AD	2	A	MT	MT	3 mo.		9.4.6
XX-020	LOW VOL CONT PURGE EXHST	BF	AD	2	A	FS	FS	3 mo.		9.4.6
XX-020	LOW VOL CONT PURGE EXHST	BF	AD	2	A	LPV	LPV	2 yr.		9.4.6
XX-020	LOW VOL CONT PURGE EXHST	BF	AD	2	A	LT	LT	2 yr.	4	9.4.6
XX-021	LOW VOL CONT PURGE EXHST	BF	AD	2	A	S	S	3 mo.		9.4.6
XX-021	LOW VOL CONT PURGE EXHST	BF	AD	2	A	MT	MT	3 mo.		9.4.6
XX-021	LOW VOL CONT PURGE EXHST	BF	AD	2	A	FS	FS	3 mo.		9.4.6
XX-021	LOW VOL CONT PURGE EXHST	BF	AD	2	A	LPV	LPV	2 yr.		9.4.6
XX-021	LOW VOL CONT PURGE EXHST	BF	AD	2	A	LT	LT	2 yr.	4	9.4.6
XX-030	SG 1 COMBINED BLOWDOWN	GT	EL	2	B	S	S	3 mo.		10.4.8-1
XX-030	SG 1 COMBINED BLOWDOWN	GT	EL	2	B	MT	MT	3 mo.		10.4.8-1
XX-030	SG 1 COMBINED BLOWDOWN	GT	EL	2	B	LPV	LPV	2 yr.		10.4.8-1
XX-030	SG 1 COMBINED BLOWDOWN	GT	EL	2	B	DDP	DDP	5 yr.	8	10.4.8-1
XX-031	SG 1 COMBINED BLOWDOWN	GT	EL	2	B	S	S	3 mo.		10.4.8-1
XX-031	SG 1 COMBINED BLOWDOWN	GT	EL	2	B	MT	MT	3 mo.		10.4.8-1
XX-031	SG 1 COMBINED BLOWDOWN	GT	EL	2	B	LPV	LPV	2 yr.		10.4.8-1
XX-031	SG 1 COMBINED BLOWDOWN	GT	EL	2	B	DDP	DDP	5 yr.	8	10.4.8-1
XX-032	SG 1 COMBINED BLOWDOWN	CK	SA	2	C	S	S	RO (26)	13	10.4.8-1
XX-033	SG 2 COMBINED BLOWDOWN	GT	EL	2	B	S	S	3 mo.		10.4.8-1
XX-033	SG 2 COMBINED BLOWDOWN	GT	EL	2	B	MT	MT	3 mo.		10.4.8-1
XX-033	SG 2 COMBINED BLOWDOWN	GT	EL	2	B	LPV	LPV	2 yr.		10.4.8-1
XX-033	SG 2 COMBINED BLOWDOWN	GT	EL	2	B	DDP	DDP	5 yr.	8	10.4.8-1
XX-034	SG 2 COMBINED BLOWDOWN	GT	EL	2	B	S	S	3 mo.		10.4.8-1
XX-034	SG 2 COMBINED BLOWDOWN	GT	EL	2	B	MT	MT	3 mo.		10.4.8-1
XX-034	SG 2 COMBINED BLOWDOWN	GT	EL	2	B	LPV	LPV	2 yr.		10.4.8-1
XX-034	SG 2 COMBINED BLOWDOWN	GT	EL	2	B	DDP	DDP	5 yr.	8	10.4.8-1
XX-035	SG 2 COMBINED BLOWDOWN	CK	SA	2	C	S	S	RO (26)	13	10.4.8-1
XX-040	FIRE WATER SUPPLY	GT	EL	2	A	S	S	3 mo.		---
XX-040	FIRE WATER SUPPLY	GT	EL	2	A	MT	MT	3 mo.		---

TABLE 3.9-15 (Continued)

INSERVICE TESTING SAFETY-RELATED PUMPS AND VALVES

VALVE NO.	VALVE DESCRIPTION	(a) VALVE TYPE	(b) VALVE ACT	(c) SAFETY CLASS	(d) CODE CAT	(e) VALVE FUNCT	(f) TEST RECD	(g) TEST FREQ	(i) TEST CONFIG.	CESSAR-DC FIG. NO.
XX-040	FIRE WATER SUPPLY	GT	EL	2	A		LPV	2 YI.		---
XX-040	FIRE WATER SUPPLY	GT	EL	2	A	CI	LT	2 YI.	1	---
XX-040	FIRE WATER SUPPLY	GT	EL	2	A		DDP	5 YI.	1	---
XX-041	FIRE WATER SUPPLY	CK	SA	2	A/C		S	RO(36)	12	---
XX-041	FIRE WATER SUPPLY	CK	SA	2	A/C	CI	LT	2 YI.	1	---
XX-050	CONT RAD MONITOR SAMPLE INLET	GL	S	2	A		S	3 MO.		---
XX-050	CONT RAD MONITOR SAMPLE INLET	GL	S	2	A		MT	3 MO.		---
XX-050	CONT RAD MONITOR SAMPLE INLET	GL	S	2	A		FS	3 MO.		---
XX-050	CONT RAD MONITOR SAMPLE INLET	GL	S	2	A		LPV	2 YI.		---
XX-050	CONT RAD MONITOR SAMPLE INLET	GL	S	2	A	CI	LT	2 YI.	4	---
XX-050	CONT RAD MONITOR SAMPLE INLET	GL	S	2	A		DDP	5 YI.	4	---
XX-051	CONT RAD MONITOR SAMPLE INLET	GL	S	2	A		S	1 MO.		---
XX-051	CONT RAD MONITOR SAMPLE INLET	GL	S	2	A		MT	MO.		---
XX-051	CONT RAD MONITOR SAMPLE INLET	GL	S	2	A		FS	3 MO.		---
XX-051	CONT RAD MONITOR SAMPLE INLET	GL	S	2	A		LPV	2 YI.		---
XX-051	CONT RAD MONITOR SAMPLE INLET	GL	S	2	A	CI	LT	2 YI.	4	---
XX-051	CONT RAD MONITOR SAMPLE INLET	GL	S	2	A		DDP	5 YI.	4	---
XX-052	CONT RAD MONITOR SAMPLE OUTLET	GL	S	2	A		S	3 MO.		---
XX-052	CONT RAD MONITOR SAMPLE OUTLET	GL	S	2	A		MT	3 MO.		---
XX-052	CONT RAD MONITOR SAMPLE OUTLET	GL	S	2	A		FS	3 MO.		---
XX-052	CONT RAD MONITOR SAMPLE OUTLET	GL	S	2	A		LPV	2 YI.		---
XX-052	CONT RAD MONITOR SAMPLE OUTLET	GL	S	2	A	CI	LT	2 YI.	4	---
XX-052	CONT RAD MONITOR SAMPLE OUTLET	GL	S	2	A		DDP	5 YI.	4	---
XX-053	CONT RAD MONITOR SAMPLE OUTLET	GL	S	2	A		S	3 MO.		---
XX-053	CONT RAD MONITOR SAMPLE OUTLET	GL	S	2	A		MT	3 MO.		---
XX-053	CONT RAD MONITOR SAMPLE OUTLET	GL	S	2	A		FS	3 MO.		---
XX-053	CONT RAD MONITOR SAMPLE OUTLET	GL	S	2	A		LPV	2 YI.		---
XX-053	CONT RAD MONITOR SAMPLE OUTLET	GL	S	2	A	CI	LT	2 YI.	4	---
XX-053	CONT RAD MONITOR SAMPLE OUTLET	GL	S	2	A		DDP	5 YI.	4	---
XX-060	ILRT PRESSURE SENSING	GL	M	2	A	P, CI	LT	2 YI.	4	---
XX-061	ILRT PRESSURE SENSING	GL	M	2	A	P, CI	LT	2 YI.	4	---
XX-070	DENIN WATER SUPPLY	GT	EL	2	A		S	3 MO.		---
XX-070	DENIN WATER SUPPLY	GT	EL	2	A		MT	3 MO.		---

TABLE 3.9-15 (Continued)

INSERVICE TESTING SAFETY-RELATED PUMPS AND VALVES

VALVE NO.	VALVE DESCRIPTION	(a) VALVE TYPE	(b) VALVE ACT	(c) SAFETY CLASS	(d) CODE CAT	(e) VALVE FUNCT	(f) TEST REQD	(g) TEST FREQ	(i) TEST CONFIG.	CESSAR-DC FIG. NO.
XX-070	DEMIN WATER SUPPLY	GT	EL	2	A		LPV	2 yr.		---
XX-070	DEMIN WATER SUPPLY	GT	EL	2	A	CI	LT	2 yr.	1	---
XX-071	DEMIN WATER SUPPLY	CK	SA	2	A/C		S	RO(37)	15	---
XX-071	DEMIN WATER SUPPLY	CK	SA	2	A/C	CI	LT	2 yr.	1	---
XX-080	NITROGEN SUPPLY	GT	EL	2	A		S	3 mo.		---
XX-080	NITROGEN SUPPLY	GT	EL	2	A		MT	3 mo.		---
XX-080	NITROGEN SUPPLY	GT	EL	2	A		LPV	2 yr.		---
XX-080	NITROGEN SUPPLY	GT	EL	2	A	CI	LT	2 yr.	1	---
XX-081	NITROGEN SUPPLY	CK	SA	2	A/C		S	3 mo.	14	---
XX-081	NITROGEN SUPPLY	CK	SA	2	A/C	CI	LT	2 yr.	1	---
XX-090	ILRT PRESSURIZATION LINE	GL	M	2	A	P, CI	LT	2 yr.	6	---
XX-100	RCP OIL FILL LINE	GT	EL	2	A		S	3 mo.		---
XX-100	RCP OIL FILL LINE	GT	EL	2	A		MT	3 mo.		---
XX-100	RCP OIL FILL LINE	GT	EL	2	A		LPV	2 yr.		---
XX-100	RCP OIL FILL LINE	GT	EL	2	A	CI	LT	2 yr.	4	---
XX-101	RCP OIL FILL LINE	GT	EL	2	A		S	3 mo.		---
XX-101	RCP OIL FILL LINE	GT	EL	2	A		MT	3 mo.		---
XX-101	RCP OIL FILL LINE	GT	EL	2	A		LPV	2 yr.		---
XX-101	RCP OIL FILL LINE	GT	EL	2	A	CI	LT	2 yr.	4	---
XX-110	CONT SUMP PUMP DISCH	GT	AD	2	A		S	3 mo.		9.3.3-1
XX-110	CONT SUMP PUMP DISCH	GT	AD	2	A		MT	3 mo.		9.3.3-1
XX-110	CONT SUMP PUMP DISCH	GT	AD	2	A		LPV	2 yr.		9.3.3-1
XX-110	CONT SUMP PUMP DISCH	GT	AD	2	A	CI	LT	2 yr.	3	9.3.3-1
XX-111	CONT SUMP PUMP DISCH	GT	AD	2	A		S	3 mo.		9.3.3-1
XX-111	CONT SUMP PUMP DISCH	GT	AD	2	A		MT	3 mo.		9.3.3-1
XX-111	CONT SUMP PUMP DISCH	GT	AD	2	A		LPV	2 yr.		9.3.3-1
XX-111	CONT SUMP PUMP DISCH	GT	AD	2	A	CI	LT	2 yr.	3	9.3.3-1
XX-112	CONT SUMP PUMP DISCH	CK	SA	2	A/C		S	RO(26)	13	---
XX-112	CONT SUMP PUMP DISCH	CK	SA	2	A/C	CI	LT	2 yr.	3	---
XX-120	RDT GAS SPACE TO GWMS	GL	EL	2	A		S	3 mo.		---
XX-120	RDT GAS SPACE TO GWMS	GL	EL	2	A		MT	3 mo.		---

TABLE 3.9-15 (Continued)

INSERVICE TESTING SAFETY-RELATED PUMPS AND VALVES

VALVE NO.	VALVE DESCRIPTION	(a) VALVE TYPE	(b) VALVE ACT	(c) SAFETY CLASS	(d) CODE CAT	(e) VALVE FUNCT	(f) TEST REQD	(g) TEST FREQ	(i) TEST CONFIG.	CESSAR-DC FIG. NO.
XX-120	RDT GAS SPACE TO GWMS	GL	EL	2	A		LPV	2 yr.		---
XX-120	RDT GAS SPACE TO GWMS	GL	EL	2	A	CI	LT	2 yr.	4	---
XX-121	RDT GAS SPACE TO GWMS	GL	EL	2	A		S	3 mo.		---
XX-121	RDT GAS SPACE TO GWMS	GL	EL	2	A		MT	3 mo.		---
XX-121	RDT GAS SPACE TO GWMS	GL	EL	2	A		LPV	2 yr.		---
XX-121	RDT GAS SPACE TO GWMS	GL	EL	2	A	CI	LT	2 yr.	4	---
XX-130	DECONTAMINATION LINE	GL	M	2	A	P, CI	LT	2 yr.	4	---
XX-131	DECONTAMINATION LINE	GL	M	2	A	P, CI	LT	2 yr.	4	---
XX-150	SG 1 WET LAYUP RECIRC	CK	SA	2	C		RF	CS(31)	9	---
XX-151	SG 2 WET LAYUP RECIRC	CK	SA	2	C		RF	CS(31)	9	---
XX-160	CONT. VENT. UNITS DRAIN HEADER	GT	EL	2	A		S	3 mo.		---
XX-160	CONT. VENT. UNITS DRAIN HEADER	GT	EL	2	A		MT	3 mo.		---
XX-160	CONT. VENT. UNITS DRAIN HEADER	GT	EL	2	A		LPV	2 yr.		---
XX-160	CONT. VENT. UNITS DRAIN HEADER	GT	EL	2	A	CI	LT	2 yr.	3	---
XX-161	CONT. VENT. UNITS DRAIN HEADER	GT	EL	2	A		S	3 mo.		---
XX-161	CONT. VENT. UNITS DRAIN HEADER	GT	EL	2	A		MT	3 mo.		---
XX-161	CONT. VENT. UNITS DRAIN HEADER	GT	EL	2	A		LPV	2 yr.		---
XX-161	CONT. VENT. UNITS DRAIN HEADER	GT	EL	2	A	CI	LT	2 yr.	3	---
XX-162	CONT. VENT. UNITS DRAIN HEADER	CK	SA	2	A/C		S	RO(26)	13	---
XX-162	CONT. VENT. UNITS DRAIN HEADER	CK	SA	2	A/C	CI	LT	2 yr.	3	---
XX-170	PAL 1 EQUALIZATION LINE	CK	SA	2	A/C		S	6 mo(38)	15	---
XX-170	PAL 1 EQUALIZATION LINE	CK	SA	2	A/C	CI	LT	2 yr.	7	---
XX-171	PAL 1 EQUALIZATION LINE	CK	SA	2	A/C		S	6 mo(38)	15	---
XX-171	PAL 1 EQUALIZATION LINE	CK	SA	2	A/C	CI	LT	2 yr.	7	---
XX-172	PAL 2 EQUALIZATION LINE	CK	SA	2	A/C		S	6 mo(38)	15	---
XX-172	PAL 2 EQUALIZATION LINE	CK	SA	2	A/C	CI	LT	2 yr.	7	---
XX-173	PAL 2 EQUALIZATION LINE	CK	SA	2	A/C		S	6 mo(38)	15	---
XX-173	PAL 2 EQUALIZATION LINE	CK	SA	2	A/C	CI	LT	2 yr.	7	---

TABLE 3.9-15 (Continued)

INSERVICE TESTING SAFETY-RELATED PUMPS AND VALVES

VALVE NO.	VALVE DESCRIPTION	(a) VALVE TYPE	(b) VALVE ACT.	(c) SAFETY CLASS	(d) CODE CAT.	(e) VALVE FUNCT.	(f) TEST REQD.	(g) TEST FREQ.	(h) TEST CONFIG.	CESSAR-DC FIG. NO.
XX-180	ECW EXP TANK 1 N ₁ SUPPLY	CK	SA	3	C		RF	3 mo.	9	9.2.9-1.1
XX-181	ECW EXP TANK 1 N ₂ SUPPLY	CK	SA	3	C		RF	3 mo.	9	9.2.9-1.1
XX-182	ECW EXP TANK 1 SSWS M/U	CK	SA	3	C		S	3 mo.	14	9.2.9-1.1
XX-182	ECW EXP TANK 1 SSWS M/U	CK	SA	3	C		RF	3 mo.	9	9.2.9-1.1
XX-183	ECW EXP TANK 1 SSWS M/U	CK	SA	3	C		S	3 mo.	14	9.2.9-1.1
XX-183	ECW EXP TANK 1 SSWS M/U	CK	SA	3	C		RF	3 mo.	9	9.2.9-1.1
XX-184	ECW EXP TANK 1 DWMS M/U	CK	SA	3	C		RF	3 mo.	9	9.2.9-1.1
XX-185	ECW EXP TANK 1 DWMS M/U	CK	SA	3	C		RF	3 mo.	9	9.2.9-1.1
XX-186	ECW PUMP 1A DISCHARGE	CK	SA	3	C		S	3 mo.	11	9.2.9-1.1
XX-186	ECW PUMP 1A DISCHARGE	CK	SA	3	C		RF	3 mo.	9	9.2.9-1.1
XX-187	ECW PUMP 1B DISCHARGE	CK	SA	3	C		S	3 mo.	11	9.2.9-1.1
XX-187	ECW PUMP 1B DISCHARGE	CK	SA	3	C		RF	3 mo.	9	9.2.9-1.1
XX-188	ECW EXP TANK 2 N ₁ SUPPLY	CK	SA	3	C		RF	3 mo.	9	9.2.9-1.5
XX-189	ECW EXP TANK 2 N ₂ SUPPLY	CK	SA	3	C		RF	3 mo.	9	9.2.9-1.5
XX-190	ECW EXP TANK 2 SSWS M/U	CK	SA	3	C		S	3 mo.	14	9.2.9-1.5
XX-190	ECW EXP TANK 2 SSWS M/U	CK	SA	3	C		RF	3 mo.	9	9.2.9-1.5
XX-191	ECW EXP TANK 2 SSWS M/U	CK	SA	3	C		S	3 mo.	14	9.2.9-1.5
XX-191	ECW EXP TANK 2 SSWS M/U	CK	SA	3	C		RF	3 mo.	9	9.2.9-1.5
XX-192	ECW EXP TANK 2 DWMS M/U	CK	SA	3	C		RF	3 mo.	9	9.2.9-1.5
XX-193	ECW EXP TANK 2 DWMS M/U	CK	SA	3	C		RF	3 mo.	9	9.2.9-1.5
XX-194	ECW PUMP 2A DISCHARGE	CK	SA	3	C		S	3 mo.	11	9.2.9-1.5
XX-194	ECW PUMP 2A DISCHARGE	CK	SA	3	C		RF	3 mo.	9	9.2.9-1.5
XX-195	ECW PUMP 2B DISCHARGE	CK	SA	3	C		S	3 mo.	11	9.2.9-1.5
XX-195	ECW PUMP 2B DISCHARGE	CK	SA	3	C		RF	3 mo.	9	9.2.9-1.5
XX-196	NCW CONT SUPPLY DIV 1	BF	AD	2	A		S	CS (32)		9.2.9-1.12

TABLE 3.9-15 (Continued)

INSERVICE TESTING SAFETY-RELATED PUMPS AND VALVES

<u>VALVE NO.</u>	<u>VALVE DESCRIPTION</u>	<u>(a) VALVE TYPE</u>	<u>(b) VALVE ACT.</u>	<u>(c) SAFETY CLASS</u>	<u>(d) CODE CAT.</u>	<u>(e) VALVE FUNCT</u>	<u>(f) TEST REQD</u>	<u>(g) TEST FREQ</u>	<u>(i) TEST CONFIG.</u>	<u>CESSAR-DC FIG. NO.</u>
XX-196	NCW CONT SUPPLY DIV 1	BF	AD	2	A		MT	CS(32)		9.2.9-1.12
XX-196	NCW CONT SUPPLY DIV 1	BF	AD	2	A		FS	CS(32)		9.2.9-1.12
XX-196	NCW CONT SUPPLY DIV 1	BF	AD	2	A		LPV	2 yr.		9.2.9-1.12
XX-196	NCW CONT SUPPLY DIV 1	BF	AD	2	A	CI	LT	2 yr.	1	9.2.9-1.12
XX-197	NCW CONT SUPPLY DIV 1	CK	SA	2	A/C		S	CS(39)	12	9.2.9-1.12
XX-197	NCW CONT SUPPLY DIV 1	CK	SA	2	A/C	CI	LT	2 yr.	1	9.2.9-1.12
XX-198	NCW CONT RETURN DIV 1	BF	AD	2	A		S	CS(32)		9.2.9-1.12
XX-198	NCW CONT RETURN DIV 1	BF	AD	2	A		MT	CS(32)		9.2.9-1.12
XX-198	NCW CONT RETURN DIV 1	BF	AD	2	A		FS	CS(32)		9.2.9-1.12
XX-198	NCW CONT RETURN DIV 1	BF	AD	2	A		LPV	2 yr.		9.2.9-1.12
XX-198	NCW CONT RETURN DIV 1	BF	AD	2	A	CI	LT	2 yr.	3	9.2.9-1.12
XX-199	NCW CONT RETURN DIV 1	BF	AD	2	A		S	CS(32)		9.2.9-1.12
XX-199	NCW CONT RETURN DIV 1	BF	AD	2	A		MT	CS(32)		9.2.9-1.12
XX-199	NCW CONT RETURN DIV 1	BF	AD	2	A		FS	CS(32)		9.2.9-1.12
XX-199	NCW CONT RETURN DIV 1	BF	AD	2	A		LPV	2 yr.		9.2.9-1.12
XX-199	NCW CONT RETURN DIV 1	BF	AD	2	A	CI	LT	2 yr.	3	9.2.9-1.12
XX-200	NCW CONT RETURN DIV 1	CK	SA	2	A/C		S	RO(26)	12	9.2.9-1.12
XX-200	NCW CONT RETURN DIV 1	CK	SA	2	A/C	CI	LT	2 yr.	3	9.2.9-1.12
XX-201	NCW CONT SUPPLY DIV 2	BF	AD	2	A		S	CS(32)		9.2.9-1.16
XX-201	NCW CONT SUPPLY DIV 2	BF	AD	2	A		MT	CS(32)		9.2.9-1.16
XX-201	NCW CONT SUPPLY DIV 2	BF	AD	2	A		FS	CS(32)		9.2.9-1.16
XX-201	NCW CONT SUPPLY DIV 2	BF	AD	2	A		LPV	2 yr.		9.2.9-1.16
XX-201	NCW CONT SUPPLY DIV 2	BF	AD	2	A	CI	LT	2 yr.	1	9.2.9-1.16
XX-202	NCW CONT SUPPLY DIV 2	CK	SA	2	A/C		S	CS(39)	12	9.2.9-1.16
XX-202	NCW CONT SUPPLY DIV 2	CK	SA	2	A/C	CI	LT	2 yr.	1	9.2.9-1.16
XX-203	NCW CONT RETURN DIV 2	BF	AD	2	A		S	CS(32)		9.2.9-1.16
XX-203	NCW CONT RETURN DIV 2	BF	AD	2	A		MT	CS(32)		9.2.9-1.16
XX-203	NCW CONT RETURN DIV 2	BF	AD	2	A		FS	CS(32)		9.2.9-1.16
XX-203	NCW CONT RETURN DIV 2	BF	AD	2	A		LPV	2 yr.		9.2.9-1.16
XX-203	NCW CONT RETURN DIV 2	BF	AD	2	A	CI	LT	2 yr.	3	9.2.9-1.16
XX-204	NCW CONT RETURN DIV 2	BF	AD	2	A		S	CS(32)		9.2.9-1.16
XX-204	NCW CONT RETURN DIV 2	BF	AD	2	A		MT	CS(32)		9.2.9-1.16

TABLE 3.9-15 (Continued)

INSERVICE TESTING SAFETY-RELATED PUMPS AND VALVES

VALVE NO.	VALVE DESCRIPTION	(a) VALVE TYPE	(b) VALVE ACT.	(c) SAFETY CLASS	(d) CODE CAT.	(e) VALVE FUNCT.	(f) TEST REQD.	(g) TEST FREQ.	(h) TEST CONFIG.	CESSAR-DC FIG. NO.
XX-204	NCW CONT RETURN DIV 2	BF	AD	2	A		FS	CS(32)		9.2.9-1.16
XX-204	NCW CONT RETURN DIV 2	BF	AD	2	A		LPV	2 YF.		9.2.9-1.16
XX-204	NCW CONT RETURN DIV 2	BF	AD	2	A	CI	LT	2 YF.	3	9.2.9-1.16
XX-205	NCW CONT RETURN DIV 2	CK	SA	2	A/C		S	RO(26)	12	9.2.9-1.16
XX-205	NCW CONT RETURN DIV 2	CK	SA	2	A/C	CI	LT	2 YF.	3	9.2.9-1.16
XX-210	CS PUMP RM 1 BACKWATER VALVE	CK	SA	3	C		S	RO(33)	15	9.3.3-2.1
XX-210	CS PUMP RM 1 BACKWATER VALVE	CK	SA	3	C		RF	RO(33)	9A	9.3.3-2.1
XX-211	CS HX ROOM 1 BACKWATER VALVE	CK	SA	3	C		S	RO(33)	15	9.3.3-2.1
XX-211	CS HX ROOM 1 BACKWATER VALVE	CK	SA	3	C		RF	RO(33)	9A	9.3.3-2.1
XX-212	SI PUMP RM 1 BACKWATER VALVE	CK	SA	3	C		S	RO(33)	15	9.3.3-2.1
XX-212	SI PUMP RM 1 BACKWATER VALVE	CK	SA	3	C		RF	RO(33)	9A	9.3.3-2.1
XX-213	SC HX ROOM 1 BACKWATER VALVE	CK	SA	3	C		S	RO(33)	15	9.3.3-2.1
XX-213	SC HX ROOM 1 BACKWATER VALVE	CK	SA	3	C		RF	RO(33)	9A	9.3.3-2.1
XX-214	SC PUMP RM 1 BACKWATER VALVE	CK	SA	3	C		S	RO(33)	15	9.3.3-2.1
XX-214	SC PUMP RM 1 BACKWATER VALVE	CK	SA	3	C		RF	RO(33)	9A	9.3.3-2.1
XX-215	SI PUMP RM 3 BACKWATER VALVE	CK	SA	3	C		S	RO(33)	15	9.3.3-2.1
XX-215	SI PUMP RM 3 BACKWATER VALVE	CK	SA	3	C		RF	RO(33)	9A	9.3.3-2.1
XX-216	CS PUMP RM 2 BACKWATER VALVE	CK	SA	3	C		S	RO(33)	15	9.3.3-2.2
XX-216	CS PUMP RM 2 BACKWATER VALVE	CK	SA	3	C		RF	RO(33)	9A	9.3.3-2.2
XX-217	CS HX ROOM 2 BACKWATER VALVE	CK	SA	3	C		S	RO(33)	15	9.3.3-2.2
XX-217	CS HX ROOM 2 BACKWATER VALVE	CK	SA	3	C		RF	RO(33)	9A	9.3.3-2.2
XX-218	SI PUMP RM 2 BACKWATER VALVE	CK	SA	3	C		S	RO(33)	15	9.3.3-2.2
XX-218	SI PUMP RM 2 BACKWATER VALVE	CK	SA	3	C		RF	RO(33)	9A	9.3.3-2.2
XX-219	SC HX ROOM 2 BACKWATER VALVE	CK	SA	3	C		S	RO(33)	15	9.3.3-2.2
XX-219	SC HX ROOM 2 BACKWATER VALVE	CK	SA	3	C		RF	RO(33)	9A	9.3.3-2.2
XX-220	SC PUMP RM 2 BACKWATER VALVE	CK	SA	3	C		S	RO(33)	15	9.3.3-2.2
XX-220	SC PUMP RM 2 BACKWATER VALVE	CK	SA	3	C		RF	RO(33)	9A	9.3.3-2.2
XX-221	SI PUMP RM 4 BACKWATER VALVE	CK	SA	3	C		S	RO(33)	15	9.3.3-2.2

TABLE 3.9-15 (Continued)

INSERVICE TESTING SAFETY-RELATED PUMPS AND VALVES

<u>VALVE NO.</u>	<u>VALVE DESCRIPTION</u>	<u>(a) VALVE TYPE</u>	<u>(b) VALVE ACT</u>	<u>(c) SAFETY CLASS</u>	<u>(d) CODE CAT</u>	<u>(e) VALVE FUNCT</u>	<u>(f) TEST REQD</u>	<u>(g) TEST FREQ</u>	<u>(i) TEST CONFIG.</u>	<u>CESSAR-DC FIG. NO.</u>
XX-221	SI PUMP RM 4 BACKWATER VALVE	CK	SA	3	C		RF	RO(33)	9A	9.3.3-2.2
XX-222	DIV 1 EPW PUMP RMS BACKWATER VALVE	CK	SA	3	C		S	RO(33)	15	9.3.3-3.1
XX-222	DIV 1 EPW PUMP RMS BACKWATER VALVE	CK	SA	3	C		RF	RO(33)	9A	9.3.3-3.1
XX-223	DIV 1 CCW PUMP RMS BACKWATER VALVE	CK	SA	3	C		S	RO(33)	15	9.3.3-3.1
XX-223	DIV 1 CCW PUMP RMS BACKWATER VALVE	CK	SA	3	C		RF	RO(33)	9A	9.3.3-3.1
XX-224	DIV 2 EPW PUMP RMS BACKWATER VALVE	CK	SA	3	C		S	RO(33)	15	9.3.3-3.2
XX-224	DIV 2 EPW PUMP RMS BACKWATER VALVE	CK	SA	3	C		RF	RO(33)	9A	9.3.3-3.2
XX-225	DIV 2 CCW PUMP RMS BACKWATER VALVE	CK	SA	3	C		S	RO(33)	15	9.3.3-3.2
XX-225	DIV 2 CCW PUMP RMS BACKWATER VALVE	CK	SA	3	C		RF	RO(33)	9A	9.3.3-3.2
XX-230	RB SUB. QUAD A SUMP PUMP 1 DISCH	CK	SA	3	C		S	RO(34)	14	9.3.3-2.1
XX-230	RB SUB. QUAD A SUMP PUMP 1 DISCH	CK	SA	3	C		RF	RO(34)	9	9.3.3-2.1
XX-231	RB SUB. QUAD A SUMP PUMP 2 DISCH	CK	SA	3	C		S	RO(34)	14	9.3.3-2.1
XX-231	RB SUB. QUAD A SUMP PUMP 2 DISCH	CK	SA	3	C		RF	RO(34)	9	9.3.3-2.1
XX-232	RB SUB. QUAD B SUMP PUMP 1 DISCH	CK	SA	3	C		S	RO(34)	14	9.3.3-2.2
XX-232	RB SUB. QUAD B SUMP PUMP 1 DISCH	CK	SA	3	C		RF	RO(34)	9	9.3.3-2.2
XX-233	RB SUB. QUAD B SUMP PUMP 2 DISCH	CK	SA	3	C		S	RO(34)	14	9.3.3-2.2
XX-233	RB SUB. QUAD B SUMP PUMP 2 DISCH	CK	SA	3	C		RF	RO(34)	9	9.3.3-2.2
XX-234	RB SUB. QUAD C SUMP PUMP 1 DISCH	CK	SA	3	C		S	RO(34)	14	9.3.3-2.1
XX-234	RB SUB. QUAD C SUMP PUMP 1 DISCH	CK	SA	3	C		RF	RO(34)	9	9.3.3-2.1
XX-235	RB SUB. QUAD C SUMP PUMP 2 DISCH	CK	SA	3	C		S	RO(34)	14	9.3.3-2.1
XX-235	RB SUB. QUAD C SUMP PUMP 2 DISCH	CK	SA	3	C		RF	RO(34)	9	9.3.3-2.1
XX-236	RB SUB. QUAD D SUMP PUMP 1 DISCH	CK	SA	3	C		S	RO(34)	14	9.3.3-2.2
XX-236	RB SUB. QUAD D SUMP PUMP 1 DISCH	CK	SA	3	C		RF	RO(34)	9	9.3.3-2.2
XX-237	RB SUB. QUAD D SUMP PUMP 2 DISCH	CK	SA	3	C		S	RO(34)	14	9.3.3-2.2
XX-237	RB SUB. QUAD D SUMP PUMP 2 DISCH	CK	SA	3	C		RF	RO(34)	9	9.3.3-2.2
XX-240	DG BLDG SUMP PUMP 1A DISCH	CK	SA	3	C		S	RO(34)	14	9.5.9-1
XX-240	DG BLDG SUMP PUMP 1A DISCH	CK	SA	3	C		RF	RO(34)	9	9.5.9-1

TABLE 3.9-15 (Continued)

INSERVICE TESTING SAFETY-RELATED PUMPS AND VALVES

VALVE NO.	VALVE DESCRIPTION	(a) VALVE TYPE	(b) VALVE ACT.	(c) SAFETY CLASS	(d) CODE CAT.	(e) VALVE FUNCT.	(f) TEST REQ.	(g) TEST FRQ.	(h) TEST CONFIG.	CESSAR-DC FIG. NO.
XX-241	DG BLDG SUMP PUMP 1B DISCH	CK	SA	3	C		S	RO (34)	14	9.5.9-1
XX-241	DG BLDG SUMP PUMP 1B DISCH	CK	SA	3	C		RF	RO (34)	9	9.5.9-1
XX-242	DG BLDG SUMP PUMP 2A DISCH	CK	SA	3	C		S	RO (34)	14	9.5.9-1
XX-242	DG BLDG SUMP PUMP 2A DISCH	CK	SA	3	C		RF	RO (34)	9	9.5.9-1
XX-243	DG BLDG SUMP PUMP 2B DISCH	CK	SA	3	C		S	RO (34)	14	9.5.9-1
XX-243	DG BLDG SUMP PUMP 2B DISCH	CK	SA	3	C		RF	RO (34)	9	9.5.9-1
XX-250	DIV 1 CHRS SUCTION	GL	EL	2	A		S	3 MO.		6.2.5-1
XX-250	DIV 1 CHRS SUCTION	GL	EL	2	A		MT	3 MO.		6.2.5-1
XX-250	DIV 1 CHRS SUCTION	GL	EL	2	A		LPV	2 YR.		6.2.5-1
XX-250	DIV 1 CHRS SUCTION	GL	EL	2	A	CI	LT	2 YR.	4	6.2.5-1
XX-250	DIV 1 CHRS SUCTION	GL	EL	2	A		DDP	5 YR.	4	6.2.5-1
XX-251	DIV 1 CHRS SUCTION	GL	EL	2	A		S	3 MO.		6.2.5-1
XX-251	DIV 1 CHRS SUCTION	GL	EL	2	A		MT	3 MO.		6.2.5-1
XX-251	DIV 1 CHRS SUCTION	GL	EL	2	A		LPV	2 YR.		6.2.5-1
XX-251	DIV 1 CHRS SUCTION	GL	EL	2	A	CI	LT	2 YR.	4	6.2.5-1
XX-251	DIV 1 CHRS SUCTION	GL	EL	2	A		DDP	5 YR.	4	6.2.5-1
XX-252	DIV 2 CHRS SUCTION	GL	EL	2	A		S	3 MO.		6.2.5-1
XX-252	DIV 2 CHRS SUCTION	GL	EL	2	A		MT	3 MO.		6.2.5-1
XX-252	DIV 2 CHRS SUCTION	GL	EL	2	A		LPV	2 YR.		6.2.5-1
XX-252	DIV 2 CHRS SUCTION	GL	EL	2	A	CI	LT	2 YR.	4	6.2.5-1
XX-252	DIV 2 CHRS SUCTION	GL	EL	2	A		DDP	5 YR.	4	6.2.5-1
XX-253	DIV 2 CHRS SUCTION	GL	EL	2	A		S	3 MO.		6.2.5-1
XX-253	DIV 2 CHRS SUCTION	GL	EL	2	A		MT	3 MO.		6.2.5-1
XX-253	DIV 2 CHRS SUCTION	GL	EL	2	A		LPV	2 YR.		6.2.5-1
XX-253	DIV 2 CHRS SUCTION	GL	EL	2	A	CI	LT	2 YR.	4	6.2.5-1
XX-253	DIV 2 CHRS SUCTION	GL	EL	2	A		DDP	5 YR.	4	6.2.5-1
XX-254	DIV 1 CHRS DISCH	GL	EL	2	A		S	3 MO.		6.2.5-1
XX-254	DIV 1 CHRS DISCH	GL	EL	2	A		MT	3 MO.		6.2.5-1
XX-254	DIV 1 CHRS DISCH	GL	EL	2	A		LPV	2 YR.		6.2.5-1
XX-254	DIV 1 CHRS DISCH	GL	EL	2	A	CI	LT	2 YR.	4	6.2.5-1
XX-254	DIV 1 CHRS DISCH	GL	EL	2	A		DDP	5 YR.	4	6.2.5-1
XX-255	DIV 1 CHRS DISCH	CK	SA	2	A/C		S	3 MO.	14	6.2.5-1
XX-255	DIV 1 CHRS DISCH	CK	SA	2	A/C		LT	2 YR.	1	6.2.5-1

TABLE 3.9-15 (Continued)

INSERVICE TESTING SAFETY-RELATED PUMPS AND VALVES

VALVE NO.	VALVE DESCRIPTION	(a) VALVE TYPE	(b) VACUUM ACT.	(c) SAFETY CLASS.	(d) CODE CAT.	(e) VALVE FUNCT.	(f) TEST REQD.	(g) TEST FREQ.	(h) TEST CONFIG.	CESSAR-DC FIG. NO.
XX-256	DIV 2 CHRS DISCH	GL	EL	2	A		S	3 mo.		6.2.5-1
XX-256	DIV 2 CHRS DISCH	GL	EL	2	A		MT	3 mo.		6.2.5-1
XX-256	DIV 2 CHRS DISCH	GL	EL	2	A	CI	LPV	2 yr.	1	6.2.5-1
XX-256	DIV 2 CHRS DISCH	GL	EL	2	A		LT	2 yr.		6.2.5-1
XX-256	DIV 2 CHRS DISCH	GL	EL	2	A		DDP	5 yr.	1	6.2.5-1
XX-257	DIV 2 CHRS DISCH	CK	SA	2	A/C		S	3 mo.	14	6.2.5-1
XX-257	DIV 2 CHRS DISCH	CK	SA	2	A/C	CI	LT	2 yr.	1	6.2.5-1
XX-258	DIV 1 CHRS INDIV. SUCTION	GL	EL	2	B		S	3 mo.		6.2.5-1
XX-258	DIV 1 CHRS INDIV. SUCTION	GL	EL	2	B		MT	3 mo.		6.2.5-1
XX-258	DIV 1 CHRS INDIV. SUCTION	GL	EL	2	B		LPV	2 yr.		6.2.5-1
XX-258	DIV 1 CHRS INDIV. SUCTION	GL	EL	2	B		DDP	5 yr.	1	6.2.5-1
XX-259	DIV 1 CHRS INDIV. SUCTION	GL	EL	2	B		S	3 mo.		6.2.5-1
XX-259	DIV 1 CHRS INDIV. SUCTION	GL	EL	2	B		MT	3 mo.		6.2.5-1
XX-259	DIV 1 CHRS INDIV. SUCTION	GL	EL	2	B		LPV	2 yr.		6.2.5-1
XX-259	DIV 1 CHRS INDIV. SUCTION	GL	EL	2	B		DDP	5 yr.	1	6.2.5-1
XX-260	DIV 1 CHRS INDIV. SUCTION	GL	EL	2	B		S	3 mo.		6.2.5-1
XX-260	DIV 1 CHRS INDIV. SUCTION	GL	EL	2	B		MT	3 mo.		6.2.5-1
XX-260	DIV 1 CHRS INDIV. SUCTION	GL	EL	2	B		LPV	2 yr.		6.2.5-1
XX-260	DIV 1 CHRS INDIV. SUCTION	GL	EL	2	B		DDP	5 yr.	1	6.2.5-1
XX-261	DIV 2 CHRS INDIV. SUCTION	GL	EL	2	B		S	3 mo.		6.2.5-1
XX-261	DIV 2 CHRS INDIV. SUCTION	GL	EL	2	B		MT	3 mo.		6.2.5-1
XX-261	DIV 2 CHRS INDIV. SUCTION	GL	EL	2	B		LPV	2 yr.		6.2.5-1
XX-261	DIV 2 CHRS INDIV. SUCTION	GL	EL	2	B		DDP	5 yr.	1	6.2.5-1
XX-262	DIV 2 CHRS INDIV. SUCTION	GL	EL	2	B		S	3 mo.		6.2.5-1
XX-262	DIV 2 CHRS INDIV. SUCTION	GL	EL	2	B		MT	3 mo.		6.2.5-1
XX-262	DIV 2 CHRS INDIV. SUCTION	GL	EL	2	B		LPV	2 yr.		6.2.5-1
XX-262	DIV 2 CHRS INDIV. SUCTION	GL	EL	2	B		DDP	5 yr.	1	6.2.5-1
XX-263	DIV 2 CHRS INDIV. SUCTION	GL	EL	2	B		S	3 mo.		6.2.5-1
XX-263	DIV 2 CHRS INDIV. SUCTION	GL	EL	2	B		MT	3 mo.		6.2.5-1
XX-263	DIV 2 CHRS INDIV. SUCTION	GL	EL	2	B		LPV	2 yr.		6.2.5-1
XX-263	DIV 2 CHRS INDIV. SUCTION	GL	EL	2	B		DDP	5 yr.	1	6.2.5-1
XX-264	DIV 1 RECOMBINER INLET ISOL	GL	EL	2	B		S	3 mo.		6.2.5-1
XX-264	DIV 1 RECOMBINER INLET ISOL	GL	EL	2	B		MT	3 mo.		6.2.5-1

TABLE 3.9-15 (Continued)

INSERVICE TESTING SAFETY-RELATED PUMPS AND VALVES

VALVE NO.	VALVE DESCRIPTION	(a) VALVE TYPE	(b) VALVE ACT.	(c) SAFETY CLASS	(d) CODE CAT.	(e) VALVE FUNCT.	(f) TEST REQD.	(g) TEST FREQ.	(i) TEST CONFIG.	CESSAR-DC FIG. NO.
XX-264	DIV 1 RECOMBINER INLET ISOL	GL	EL	2	B		LPV	2 Yr.		6.2.5-1
XX-264	DIV 1 RECOMBINER INLET ISOL	GL	EL	2	B		DDP	5 Yr.	8	6.2.5-1
XX-265	DIV 1 RECOMBINER INLET ISOL	GL	EL	2	B		S	3 mo.		6.2.5-1
XX-265	DIV 1 RECOMBINER INLET ISOL	GL	EL	2	B		MT	3 mo.		6.2.5-1
XX-265	DIV 1 RECOMBINER INLET ISOL	GL	EL	2	B		LPV	2 Yr.		6.2.5-1
XX-265	DIV 1 RECOMBINER INLET ISOL	GL	EL	2	B		DDP	5 Yr.	8	6.2.5-1
XX-266	DIV 2 RECOMBINER INLET ISOL	GL	EL	2	B		S	3 mo.		6.2.5-1
XX-266	DIV 2 RECOMBINER INLET ISOL	GL	EL	2	B		MT	3 mo.		6.2.5-1
XX-266	DIV 2 RECOMBINER INLET ISOL	GL	EL	2	B		LPV	2 Yr.		6.2.5-1
XX-266	DIV 2 RECOMBINER INLET ISOL	GL	EL	2	B		DDP	5 Yr.	8	6.2.5-1
XX-267	DIV 2 RECOMBINER INLET ISOL	GL	EL	2	B		S	3 mo.		6.2.5-1
XX-267	DIV 2 RECOMBINER INLET ISOL	GL	EL	2	B		MT	3 mo.		6.2.5-1
XX-267	DIV 2 RECOMBINER INLET ISOL	GL	EL	2	B		LPV	2 Yr.		6.2.5-1
XX-267	DIV 2 RECOMBINER INLET ISOL	GL	EL	2	B		DDP	5 Yr.	8	6.2.5-1
XX-268	DIV 1 RECOMBINER OUTLET ISOL	GL	EL	2	B		S	3 mo.		6.2.5-1
XX-268	DIV 1 RECOMBINER OUTLET ISOL	GL	EL	2	B		MT	3 mo.		6.2.5-1
XX-268	DIV 1 RECOMBINER OUTLET ISOL	GL	EL	2	B		LPV	2 Yr.		6.2.5-1
XX-268	DIV 1 RECOMBINER OUTLET ISOL	GL	EL	2	B		DDP	5 Yr.	8	6.2.5-1
XX-269	DIV 1 RECOMBINER OUTLET	CK	SA	2	C		S	3 mo.	14	6.2.5-1
XX-270	DIV 2 RECOMBINER OUTLET ISOL	GL	EL	2	B		S	3 mo.		6.2.5-1
XX-270	DIV 2 RECOMBINER OUTLET ISOL	GL	EL	2	B		MT	3 mo.		6.2.5-1
XX-270	DIV 2 RECOMBINER OUTLET ISOL	GL	EL	2	B		LPV	2 Yr.		6.2.5-1
XX-270	DIV 2 RECOMBINER OUTLET ISOL	GL	EL	2	B		DDP	5 Yr.	8	6.2.5-1
XX-271	DIV 2 RECOMBINER OUTLET	CK	SA	2	C		S	3 mo.	14	6.2.5-1
XX-272	DIV 1 H ₂ CALIBRATION SUPPLY	GL	EL	2	B		S	3 mo.		6.2.5-1
XX-272	DIV 1 H ₂ CALIBRATION SUPPLY	GL	EL	2	B		MT	3 mo.		6.2.5-1
XX-272	DIV 1 H ₂ CALIBRATION SUPPLY	GL	EL	2	B		LPV	2 Yr.		6.2.5-1
XX-272	DIV 1 H ₂ CALIBRATION SUPPLY	GL	EL	2	B		DDP	5 Yr.	8	6.2.5-1
XX-273	DIV 2 H ₂ CALIBRATION SUPPLY	GL	EL	2	B		S	3 mo.		6.2.5-1
XX-273	DIV 2 H ₂ CALIBRATION SUPPLY	GL	EL	2	B		MT	3 mo.		6.2.5-1
XX-273	DIV 2 H ₂ CALIBRATION SUPPLY	GL	EL	2	B		LPV	2 Yr.		6.2.5-1
XX-273	DIV 2 H ₂ CALIBRATION SUPPLY	GL	EL	2	B		DDP	5 Yr.	8	6.2.5-1

TABLE 3.9-15 (Continued)

INSERVICE TESTING SAFETY-RELATED FUNDS AND VALVES

VALVE NO.	VALVE DESCRIPTION	(a) VALVE TYPE	(b) VALVE ACT.	(c) SAFETY CLASS.	(d) CODE CAT.	(e) VALVE FUNCT.	(f) TEST REQD.	(g) TEST FREQ.	(i) TEST CONFIG.	CESSAR-DC FIG. NO.
XX-274	DIV 1 NITROGEN SUPPLY	GL	S	2	B		S	3 MO.		6.2.5-1
XX-274	DIV 1 NITROGEN SUPPLY	GL	S	2	B		MT	3 MO.		6.2.5-1
XX-274	DIV 1 NITROGEN SUPPLY	GL	S	2	B		LPV	2 YR.		6.2.5-1
XX-275	DIV 2 NITROGEN SUPPLY	GL	S	2	B		S	3 MO.		6.2.5-1
XX-275	DIV 2 NITROGEN SUPPLY	GL	S	2	B		MT	3 MO.		6.2.5-1
XX-275	DIV 2 NITROGEN SUPPLY	GL	S	2	B		LPV	2 YR.		6.2.5-1
XX-276	DIV 1 ANALYZER INLET FROM RECOMB.	GL	S	2	B	SPLY	S	3 MO.		6.2.5-1
XX-276	DIV 1 ANALYZER INLET FROM RECOMB.	GL	S	2	B	SPLY	MT	3 MO.		6.2.5-1
XX-276	DIV 1 ANALYZER INLET FROM RECOMB.	GL	S	2	B	SPLY	LPV	2 YR.		6.2.5-1
XX-277	DIV 2 ANALYZER INLET FROM RECOMB.	GL	S	2	B	SPLY	S	3 MO.		6.2.5-1
XX-277	DIV 2 ANALYZER INLET FROM RECOMB.	GL	S	2	B	SPLY	MT	3 MO.		6.2.5-1
XX-277	DIV 2 ANALYZER INLET FROM RECOMB.	GL	S	2	B	SPLY	LPV	2 YR.		6.2.5-1
XX-278	DIV 1 ANALYZER INLET FROM RECOMB.	GL	S	2	B	DISCH	S	3 MO.		6.2.5-1
XX-278	DIV 1 ANALYZER INLET FROM RECOMB.	GL	S	2	B	DISCH	MT	3 MO.		6.2.5-1
XX-278	DIV 1 ANALYZER INLET FROM RECOMB.	GL	S	2	B	DISCH	LPV	2 YR.		6.2.5-1
XX-279	DIV 2 ANALYZER INLET FROM RECOMB.	GL	S	2	B	DISCH	S	3 MO.		6.2.5-1
XX-279	DIV 2 ANALYZER INLET FROM RECOMB.	GL	S	2	B	DISCH	MT	3 MO.		6.2.5-1
XX-279	DIV 2 ANALYZER INLET FROM RECOMB.	GL	S	2	B	DISCH	LPV	2 YR.		6.2.5-1
XX-280	DIV 1 ANALYZER OUTLET	GL	S	2	B		S	3 MO.		6.2.5-1
XX-280	DIV 1 ANALYZER OUTLET	GL	S	2	B		MT	3 MO.		6.2.5-1
XX-280	DIV 1 ANALYZER OUTLET	GL	S	2	B		LPV	2 YR.		6.2.5-1
XX-281	DIV 2 ANALYZER OUTLET	GL	S	2	B		S	3 MO.		6.2.5-1
XX-281	DIV 2 ANALYZER OUTLET	GL	S	2	B		MT	3 MO.		6.2.5-1
XX-281	DIV 2 ANALYZER OUTLET	GL	S	2	B		LPV	2 YR.		6.2.5-1
XX-282	DIV 1 CHRS PURGE TO ANNULUS	GL	EL	2	B		S	3 MO.		6.2.5-1
XX-282	DIV 1 CHRS PURGE TO ANNULUS	GL	EL	2	B		MT	3 MO.		6.2.5-1
XX-282	DIV 1 CHRS PURGE TO ANNULUS	GL	EL	2	B		LPV	2 YR.		6.2.5-1
XX-282	DIV 1 CHRS PURGE TO ANNULUS	GL	EL	2	B		DDP	5 YR.	8	6.2.5-1
XX-283	DIV 2 CHRS PURGE TO ANNULUS	GL	EL	2	B		S	3 MO.		6.2.5-1
XX-283	DIV 2 CHRS PURGE TO ANNULUS	GL	EL	2	B		MT	3 MO.		6.2.5-1
XX-283	DIV 2 CHRS PURGE TO ANNULUS	GL	EL	2	B		LPV	2 YR.		6.2.5-1
XX-283	DIV 2 CHRS PURGE TO ANNULUS	GL	EL	2	B		DDP	5 YR.	8	6.2.5-1

TABLE 3.9-15 (Continued)

INSERVICE TESTING SAFETY-RELATED PUMPS AND VALVES

<u>VALVE NO.</u>	<u>VALVE DESCRIPTION</u>	<u>(a) VALVE TYPE</u>	<u>(b) VALVE ACT.</u>	<u>(c) SAFETY CLASS</u>	<u>(d) CODE CAT</u>	<u>(e) VALVE FUNCT</u>	<u>(f) TEST REQD</u>	<u>(g) TEST FREQ</u>	<u>(h) TEST CONFIG.</u>	<u>CESSAR-DC FIG. NO.</u>
XX-284	DIV 1 CHRS BYPASS ISOL	GL	EL	2	B		S	3 mo.		6.2.5-1
XX-284	DIV 1 CHRS BYPASS ISOL	GL	EL	2	B		MT	3 mo.		6.2.5-1
XX-284	DIV 1 CHRS BYPASS ISOL	GL	EL	2	B		LPV	2 yr.		6.2.5-1
XX-284	DIV 1 CHRS BYPASS ISOL	GL	EL	2	B		DDP	5 yr.	8	6.2.5-1
XX-285	DIV 2 CHRS BYPASS ISOL	GL	EL	2	B		S	3 mo.		6.2.5-1
XX-285	DIV 2 CHRS BYPASS ISOL	GL	EL	2	B		MT	3 mo.		6.2.5-1
XX-285	DIV 2 CHRS BYPASS ISOL	GL	EL	2	B		LPV	2 yr.		6.2.5-1
XX-285	DIV 2 CHRS BYPASS ISOL	GL	EL	2	B		DDP	5 yr.	8	6.2.5-1

TABLE 3.9-15 (Continued)

INSERVICE TESTING SAFETY-RELATED PUMPS AND VALVES

NOTES:

- (a) Valve Type: GL - Globe BK - Butterfly
 GT - Gate PK - Packless
 CK - Check PL - Plug
- (b) Valve Actuator: EL - Electric motor S - Solenoid
 SA - Self actuating EH - Electro-hydraulic
 AD - Air diaphragm P - Piston
 M - Manual
- (c) ASME Safety Classification as defined in CESSAR-DC, Subsection 3.2.2.
- (d) Valve ASME Code Category A, B, C, or D as defined in ASME OM-10, OMA 1988, Subsection 1.4.
- (e) Valve Function: BV - Reactor Coolant Pressure Boundary Isolation (CESSAR-DC Subsection 5.2)
 CI - Containment Isolation (CESSAR-DC, Subsection 6.2.4)
 P - Passive valves as defined by ASME OM-10, OMA 1988, Subsection 1.3 are denoted by a P in this column. All other valves are active valves.
- (f) Required Valve Tests per ASME OM-10, OMA 1988:
 LT - Valve Leakage Rate Test (per OM-10, OMA 1988)
 Subsection 4.2.2.2 for valves with function CI in (e) above.
 Subsection 4.2.2.3 for valves with function BV in (e) above.
 LPV - Valve Position Verification (ASME OM-10, OMA 1988, Subsection 4.1)
 S - Valve Stroke Exercise:
 Category A or B (ASME OM-10, OMA 1988, Subsection 4.2.1)
 Category C (ASME OM-10, OMA 1988, Subsection 4.3)
 RF - Reverse Flow Exercise for Category C valves (ASME OM-10, OMA 1988, Subsection 4.3)
 MT - Valve Stroke Time Test of Category A or B power operated valves (ASME OM-10, OMA 1988, Subsection 4.2.1.4)
 FS - Valve Test for fail-safe actuation of Category A or B valves (ASME OM-10, OMA 1988, Subsection 4.2.1.6)
 DDP - Design Differential Pressure Stroke Test (per NRC Generic Letter 89-10). Performing this test also fulfills the requirements of the valve stroke exercise (S) test above.

TABLE 3.9-15 (Continued)

INSERVICE TESTING SAFETY-RELATED PUMPS AND VALVES

- (g) Pump or valve test exclusions, alternatives, and frequency per ASME Code OM-6 and OM-10. For valves whose test frequency exceed the normal frequency, see the note (as indicated in parenthesis beside the test frequency) for additional information.

CS - Cold Shutdown

The following condition applies for all testing performed during cold shutdown:

For cold shutdowns less than 48 hours, valve testing does not have to be performed. However, for cold shutdowns expected to exceed 48 hours, valve testing will commence as soon as possible, but no later than 48 hours after reaching cold shutdown. Valve testing will proceed in a normal manner until all testing is complete or the plant is ready to return to power. A completion of all valve testing is not a prerequisite to return to power. Any testing not completed by the end of one cold shutdown will be performed during subsequent cold shutdowns, starting from the last test performed at the previous cold shutdown. In case of frequent shutdowns, testing will not be performed more often than once every three months.

RO - Refueling Outage

RR - Partially stroke valve at or when proceeding to/starting up from cold shutdown. Fully stroke valve during each refueling outage. Some valves may require mechanical exercising or disassembly during each refueling outage to verify operability.

QC - Partially stroke valve every three months. Fully stroke valve during cold shutdown.

E1 - Valve operates in the course of plant operation at a frequency which satisfies test requirements. Additional exercising not required provided the test parameters are analyzed and recorded at an operational interval not exceeding the test interval requirement.

Category A or B (ASME OM-10, Subsection 4.2.1.5)

Category C (ASME OM-10, Subsection 4.3.2.3)

- (h) Pump Test Parameters as defined in ASME OM-6, Subsection 5.2:

N - Speed	V - Vibration
DP - Differential Pressure	PS - Static Suction Pressure
Q - Flow Rate	PO - Operating Suction Pressure

- (i) Typical test configurations for pumps and valves requiring special valve arrangements and/or test connections are shown in CESSAR-DC Figure 3.9-16.

TABLE 3.9-15 (Continued)

INSERVICE TESTING SAFETY-RELATED PUMPS AND VALVES

- (1) Valves: CC-130, CC-131, CC-136, CC-137, CC-230, CC-231, CC-236, CC-237

During normal operations, these valves are open to supply/return cooling water to/from the Reactor Coolant Pump (RCP) support coolers. Failure of these valves in the closed position could lead to pump damage or failure and force a unit shutdown. Therefore, these valves will be tested during cold shutdown when the RCP's are not operating.

- (2) Valves: CC-1507, CC-1548, CC-2507, CC-2548

These valves function as both containment isolation valves and relief valves. Testing of these valves requires isolating cooling water flow to the RCP support coolers which is not practical during normal operations as stated in (1) above. Therefore, testing of these valves must be performed when the RCP's are not operating. Valves CC-1507 and CC-2507 pass flow in the same direction as the main supply line, and testing can be performed by closing valves CC-131 and CC-231 and verifying flow downstream of the check valves. Therefore, these valves will be tested during cold shutdown. However, valves CC-1548 and CC-2548 pass flow in the opposite direction of the return flow. Full flow stroke testing of these valves requires the use of test connections. Therefore, these valves will be tested during refueling when isolating the CCW return flow is acceptable and valves are easily accessible.

- (3) Valves: CC-102, CC-103, CC-122, CC-123, CC-202, CC-203, CC-222, CC-223

These valves close on receipt of a Safety Injection Actuation Signal to isolate the non-essential component cooling water (CCW) loops. The non-essential cooling loops provide cooling of the Non-essential Chillers. As stated in (32), both divisions of Non-essential Chilled Water (NCW) need to be maintained in operation to provide the heat sink for containment cooling which precludes closure of these valves during normal operations. The non-essential cooling loop in Division 2 also supplies cooling water to the letdown heat exchanger which cools the letdown flow from the Reactor Coolant System (RCS). On high letdown temperature, letdown flow is minimized. Closing the Division 2 valves during normal operations could cause a sudden decrease in letdown flow which could result unnecessary RCS transients. More importantly, failure to cool the high temperature letdown flow leaving the regenerative heat exchanger can lead to cavitation at the letdown orifices which has been known to cause line failure. Therefore, these valves will be tested during cold shutdown.

- (4) Valves: CC-240, CC-241, CC-242, CC-243

These valves isolate cooling water to/from the letdown heat exchanger and close on a Containment Isolation Actuation Signal. For reasons stated in (3) above, testing these valves during normal operations is not practical. Therefore, these valves will be tested during cold shutdown.

- (5) Valves: CC-2622, CC-2628

These valves function as both containment isolation valves and relief valves. Testing requires isolating cooling flow to the letdown heat exchanger. As stated in (3) above, this is not practical during normal operations. The arrangement of these valves is the same as valves described in (2). Therefore, the same test frequencies will apply. Valve CC-2622 will be tested during cold shutdown and CC-2628 will be tested during refueling.

TABLE 3.9-15 (Continued)

INSERVICE TESTING SAFETY-RELATED PUMPS AND VALVES

- (6) Valves: CH-255

This valve isolates seal injection water to the RCP seals. Valve closure during normal operations with the RCP's operating would result in damage to pump seals. Therefore, this valve will be tested during cold shutdown when the RCP's are not operating.

- (7) Valves: CH-505, CH-506

These valves close on receipt of a Containment Spray Actuation Signal to isolate the RCP seal return line. During normal operations, these valves are open to maintain seal injection flow across the RCP seals. Closure of these valves during normal operations would inhibit seal water flow across the RCP seals which would result in damage to the pump seals. Therefore, these valves will be tested during cold shutdown when the RCP's are not operating.

- (8) Valves: CH-515, CH-516, CH-523

These valves are normally open to pass letdown flow from the RCS to the Chemical and Volume Control System (CVCS). Stroking these valves during normal operations could result in unnecessary RCS transients. In addition, these valves experience high stresses when cycled due to the high pressure environment in which they operate. Repeated cycling of the valves at this high pressure could severely affect valve integrity over the expected operating life of the valves. In addition, failure of these valves in the closed position could result in a loss of pressurizer level control forcing a unit shutdown. Therefore, these valves will be tested during cold shutdown when the effects of valve operation are minimized.

- (9) Valves: CH-524

This valve functions as a containment isolation valve and isolates charging flow to the RCS. During normal operations, this charging flow is used to cool the letdown flow in the regenerative heat exchanger and to provide makeup to the RCS. For reasons stated in (3), it is not practical to test this valve during normal operations. In addition, failure of this valve in the closed position could result in a loss of pressurizer level control forcing a unit shutdown. Therefore, this valve will be tested during cold shutdown.

- (10) Valves: CH-747

This valve functions as a containment isolation valve. Testing requires that charging flow be isolated. As stated in (9) above, this is not practical during normal operations. Therefore, this valve will be tested during cold shutdown.

- (11) Valves: CH-835

This valve functions as a containment isolation valve. Testing requires that seal injection to the RCP's be isolated. As stated in (6), this is not practical during normal operations. Therefore, this valve will be tested during cold shutdown.

- (12) Valves: EF-200, EF-201, EF-202, EF-203, EF-204, EF-205, EF-206, EF-207

When Emergency Feedwater System (EFWS) operation is required, these valves

TABLE 3.9-15 (Continued)

INSERVICE TESTING SAFETY-RELATED PUMPS AND VALVES

must open to provide flow to the steam generators (SG's). Testing of these valves requires EPW injection into the SG's which is not practical during normal operations due to the effects of thermal shock to the SG feedwater nozzles and potential overcooling of the RCS. Testing during cold shutdown is not desirable due to the SG's being in wet layup conditions. Therefore, these valves will be tested following cold shutdown prior to entering mode 2 which allows normal SG water levels to be established and the system aligned for standby readiness.

- (13) Valves: RC-406, RC-407, RC-408, RC-409

These valves must be capable of opening to provide the assured means for depressurizing the RCS. These valves are closed during normal operations. Opening these valves during normal operations increases the potential for a loss-of-coolant-accident (LOCA) since only one valve would be closed to maintain the RCS pressure boundary. Therefore, these valves will be tested during cold shutdown.

- (14) Valves: RC-410, RC-411, RC-412, RC-413, RC-414, RC-415, RC-416, RC-417

These valves must be capable of opening to vent non-condensable gases from the reactor vessel/pressurizer during a severe accident. These valves are closed during normal operations. Opening these valves during normal operations increases the potential for a LOCA since only one valve would be closed to maintain the RCS pressure boundary. Although a third normally closed valve is located downstream of these valves, it is not designed to provide the RCS pressure boundary function. Therefore, these valves will be tested during cold shutdown.

- (15) Valves: SG-130, SG-132, SG-135, SG-137, SG-172, SG-174, SG-175, SG-177

These valves isolate main feedwater to the SG's upon receipt of a Main Steam Isolation Signal (MSIS). Closure of these valves during normal operations would isolate feedwater to the SG's which may result in a severe transient in the SG and a unit trip. Therefore, these valves will be tested during cold shutdown.

- (16) Valves: SG-140, SG-141, SG-150, SG-151

These valves isolate the main steam lines upon receipt of a MSIS. Closure of these valves during normal operations may cause severe transients in the main steam lines and result in a unit trip. These valves may be partially stroked during normal operations; however, tests requiring full valve closure will be performed during cold shutdown.

- (17) Valves: SI-484, SI-485, SI-568, SI-569

These valves must close to prevent reverse flow when either the SC pumps are used to provide containment spray or the CS pumps are used to provide shutdown cooling flow. These valves are tested by operating either the SC or CS pump in a division, opening the discharge crossover isolation valve between the two systems, and isolating the suction of the off-line pump. Closure of the check valve on reverse flow in the discharge of the off-line pump is verified by monitoring pressure increase upstream of the valve. This alignment is not practical during normal operations since both trains of SC and CS must be operable. Therefore, these valves will be tested during cold shutdown.

TABLE 3.9-15 (Continued)

INTERVICE TESTING SAFETY-RELATED PUMPS AND VALVES

- (18) Valves: SI-113, SI-133, SI-404, SI-405, SI-434, SI-446, SI-522, SI-523,
SI-532, SI-533, SI-540, SI-542

These valves must open to pass flow from the Safety Injection (SI) pumps to the RCS. These valves cannot be stroked during normal operations since the only full flow flowpath discharges to the RCS. SI pump discharge pressure is not sufficient to overcome normal RCS operating pressure. These valves cannot be stroked during cold shutdown since this may result in low temperature overpressurization (LTOP) of the RCS. Therefore, these valves will be tested during refueling.

- (19) Valves: SI-123, SI-143, SI-168, SI-178

These valves must open to provide flow from SI pumps 1 and 2 or the Shutdown Cooling (SC) pumps to the RCS. These valves cannot be stroked during normal operations since the only full flow flowpath discharges to the RCS. Neither the SI or SC pump discharge pressure is sufficient to overcome normal RCS operating pressure. Therefore, these valves will be stroked open when SC is initiated to proceed to cold shutdown and will be verified to close when SC pumps are stopped during unit startup from cold shutdown.

- (20) Valves: SI-164, SI-165

These valves are required to open to pass flow from the Containment Spray (CS) pumps to the containment atmosphere. Under no circumstances can these valves be stroked open with flow since this would result in spraying down containment. Therefore, these valves will either be mechanically exercised or disassembled during refueling to verify operability.

- (21) Valves: SI-215, SI-225, SI-235, SI-245

These valves must open to pass flow from the SI tanks to the RCS. During normal operations SI tank pressure is insufficient to overcome normal RCS operating pressure. Therefore, these valves will be partially stroked when proceeding to/starting up from cold shutdown. To verify full stroke capability, these valves will either be mechanically exercised or disassembled during refueling. If diagnostic testing can determine the minimum flow required to fully open these valves, verification of this minimum flow will be sufficient to demonstrate valve operability.

- (22) Valves: SI-217, SI-227, SI-237, SI-247

These valves must open to pass flow from the safety injection/shutdown cooling lines and the SI tanks to the RCS. The discharge pressure from either of these sources is insufficient to overcome normal RCS operating pressure. Therefore, valves SI-227 and SI-247 will be stroked upon initiation of SC when proceeding to cold shutdown. Testing of valves SI-217 and SI-237 requires operation of the SI pumps. This is not practical during cold shutdown as stated in (18). Therefore, these valves will be tested during refueling.

- (23) Valves: SI-302, SI-303

These valves must be open to maintain a minimum flow path for the SI pumps. In addition, these valves must be capable of closing to perform their containment isolation function even though they would normally remain open during an accident. Testing these valves requires removing

TABLE 3.9-15 (Continued)

INSERVICE TESTING SAFETY-RELATED PUMPS AND VALVES

power to both SI pumps in the valve's respective division to ensure pumps cannot be operated at no flow conditions. Technical Specifications only allows both pumps in a single division to be inoperable during refueling. Therefore, these valves will be tested during refueling.

- (24) Valves: SI-304, SI-305, SI-308, SI-309

These valves must open to align the suction of the SI and CS pumps to the IRWST. In addition, these valves must be capable of closing to perform their containment isolation function even though they would normally remain open during an accident. Technical Specifications do not permit testing these valves during normal operations since all four SI pumps and both CS pumps must be operable. Therefore, these valves will be tested during cold shutdown.

- (25) Valves: SI-424, SI-426, SI-448, SI-451

These valves must close if their associated SI pump is not operating. Testing these valves requires isolating the associated SI pump while operating the other SI pump in the division. Since all four SI pumps are required to be operable during normal operations, these valves will be tested during cold shutdown.

- (26) Valves: XX-032, XX-035, XX-112, XX-162, XX-200, XX-205

These valves function as both containment isolation valves and relief valves. These valves have the same test requirements and arrangements as the valves in the CCW return lines described in (2). Therefore, the same test frequencies will apply for the same reasons given in (2). These valves will be tested during refueling.

- (27) Valves: SI-541, SI-543

These valves must open to pass flow from the SI or SC pumps to the RCS. The only full flow flowpath for testing these valves discharges to the RCS. Neither the SI or SC pump discharge pressure is sufficient to overcome normal RCS operating pressure. Therefore, these valves will be tested upon initiation of SC pumps when proceeding to cold shutdown.

- (28) Valves: SI-614, SI-624, SI-634, SI-644

These valves must be open to pass flow from the SI tanks to the RCS. Technical Specifications do not permit testing these valves during normal operations since all four SI tanks must be operable. Normal shutdown/startup procedures require these valves to be closed when proceeding to cold shutdown and to be opened when starting up from cold shutdown. Testing of these valves will be performed at this time.

- (29) Valves: SI-651, SI-652, SI-653, SI-654, SI-655, SI-656

These valves must open to align the SC pump suction to the RCS. These valves are interlocked such that they cannot be opened when RCS pressure is above the operating pressure of the SCS. Therefore, these valves cannot be tested during normal operations. Testing will be performed during cold shutdown when valves can be manipulated.

- (30) Valves: XX-010, XX-011, XX-012, XX-013, XX-014, XX-015, XX-016, XX-017

TABLE 3.9-15 (Continued)

INSERVICE TESTING SAFETY-RELATED PUMPS AND VALVES

These valve must close on receipt of a CIAS to perform their containment isolation function. During normal operations, these valves are closed and Technical Specifications do not permit opening. Therefore, these valves will be tested during cold shutdown.

- (31) Valves: XX-150,XX-151

These valves must close on reverse flow in the SG wet layup recirculation line to perform their containment isolation function. The recirculation lines are isolated during normal operations and are only used when the SG's are in wet layup conditions such as during cold shutdown. Therefore, these valves will be tested during cold shutdown when the recirculation system is stopped.

- (32) Valves: XX-196,XX-198,XX-199,XX-201,XX-203,XX-204

These valves must close on receipt of a CSAS. During normal operations, these valves are open to provide chilled water to the containment and CEDM coolers. To maintain containment air temperatures within limits, three of the containment coolers are required to operate with the fourth unit in standby. Testing these valves during normal operations requires isolating chilled water to two of the four containment coolers which is not practical. Therefore, these valves will be tested during cold shutdown.

- (33) Valves: XX-210,XX-211,XX-212,XX-213,XX-214,XX-215,XX-216,XX-217,
XX-218,XX-219,XX-220,XX-221,XX-222,XX-223,XX-224,XX-225

These valves must close to prevent reverse flow from the various sumps to safety related equipment rooms which drain to the sumps. Typically, the sumps have some type of grating or cover over them such that access to the valves for testing is not practical during normal operations. Therefore, these valves will be tested during refueling.

- (34) Valves: XX-230,XX-231,XX-232,XX-233,XX-234,XX-235,XX-236,XX-237
XX-240,XX-241,XX-242,XX-243

These valves must open to pass flow from the discharge of safety related sump pumps. These valves must also be capable of closing to prevent recirculating the discharge from an operating sump pump through the redundant pump which may not be operating. Testing these valves requires operating the sump pumps. Typically, the sumps do not contain a sufficient volume of water to allow sump pump operation. Per OM-6, the pumps are only required to be tested once every two years. Therefore, these valves will be tested during refueling along with sump pumps.

- (35) Valves: DS-117,DS-118,DS-127,DS-128,DS-217,DS-218,DS-227,DS-228

These valves must open to pass starting air flow from the air receivers to the diesels. Testing requires isolating one of the starting air receivers from the diesel which is not permitted during normal operations. Therefore, these valves will be tested during cold shutdown.

- (36) Valves: XX-041

The fire water header inside containment is maintained dry during normal operations. Stroking this valve would require admitting water into the header which must then be drained. Therefore, this valve will be tested during refueling when time and accessibility permit.

TABLE 3.9-15 (Continued)

INSERVICE TESTING SAFETY-RELATED PUMPS AND VALVES

(37) Valves: XX-071

Demineralized water is not normally in use during power operations, therefore this valve cannot be stroked. Valve testing will be performed during refueling when demineralized water usage permits sufficient flow for stroking the valve.

(38) Valves: XX-170,XX-171,XX-172,XX-173

The personnel air locks are tested every six months. As part of that testing, the equalization line check valves will be tested.

(39) Valves: XX-197,XX-202

These valves function as both containment isolation valves and relief valves. These valves have the same arrangement as valves in the CCW supply lines described in (2). Since isolation of NCW is not permitted during normal operations as stated in (32), these valves will be tested during cold shutdown.

(40) Valves: SI-390,SI-391,SI-392,SI-393

These valves must open in a severe accident to allow water in the IRWST to flood the reactor cavity to cover core debris. To test these valves, manual valves upstream must be closed to prevent flow of water from the IRWST to the Holdup Volume Tank when these valves are opened. Closing the manual valves is not practical during operations since they require containment entry. Therefore, these valves will be tested during cold shutdown.

(41) Valves: SI-604,SI-609

These valves must be capable of opening to provide borated water to the RCS hot legs for long term cooling following a large break LOCA. Technical Specifications require these valves to be closed with power removed during normal operations. Therefore, these valves will be tested during cold shutdown when power can be restored to the valve operators.

TYPICAL INSERVICE TESTING CONNECTIONS

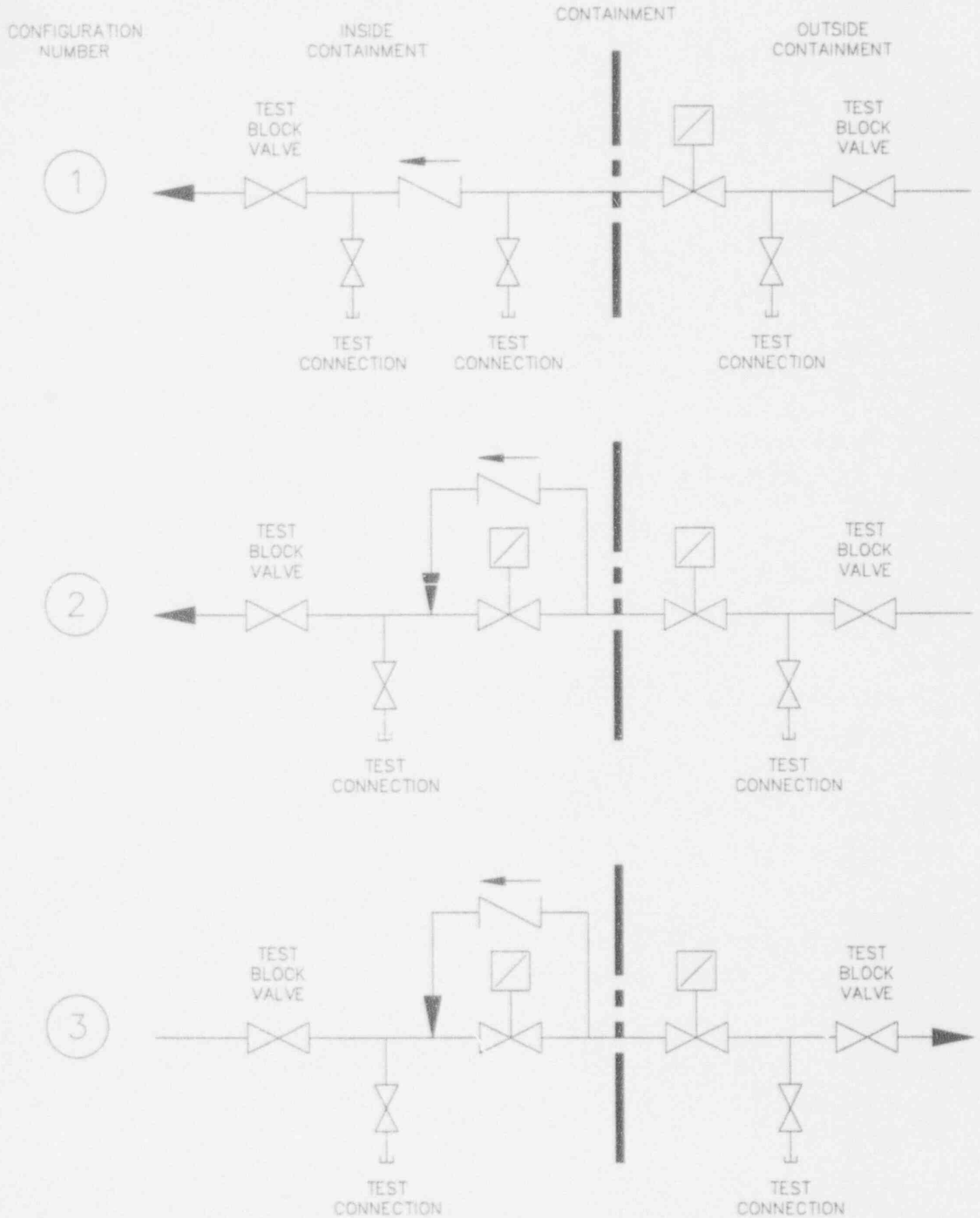

FIGURE 3.9-16
SHEET 1 OF 6

TYPICAL INSERVICE TESTING CONNECTIONS

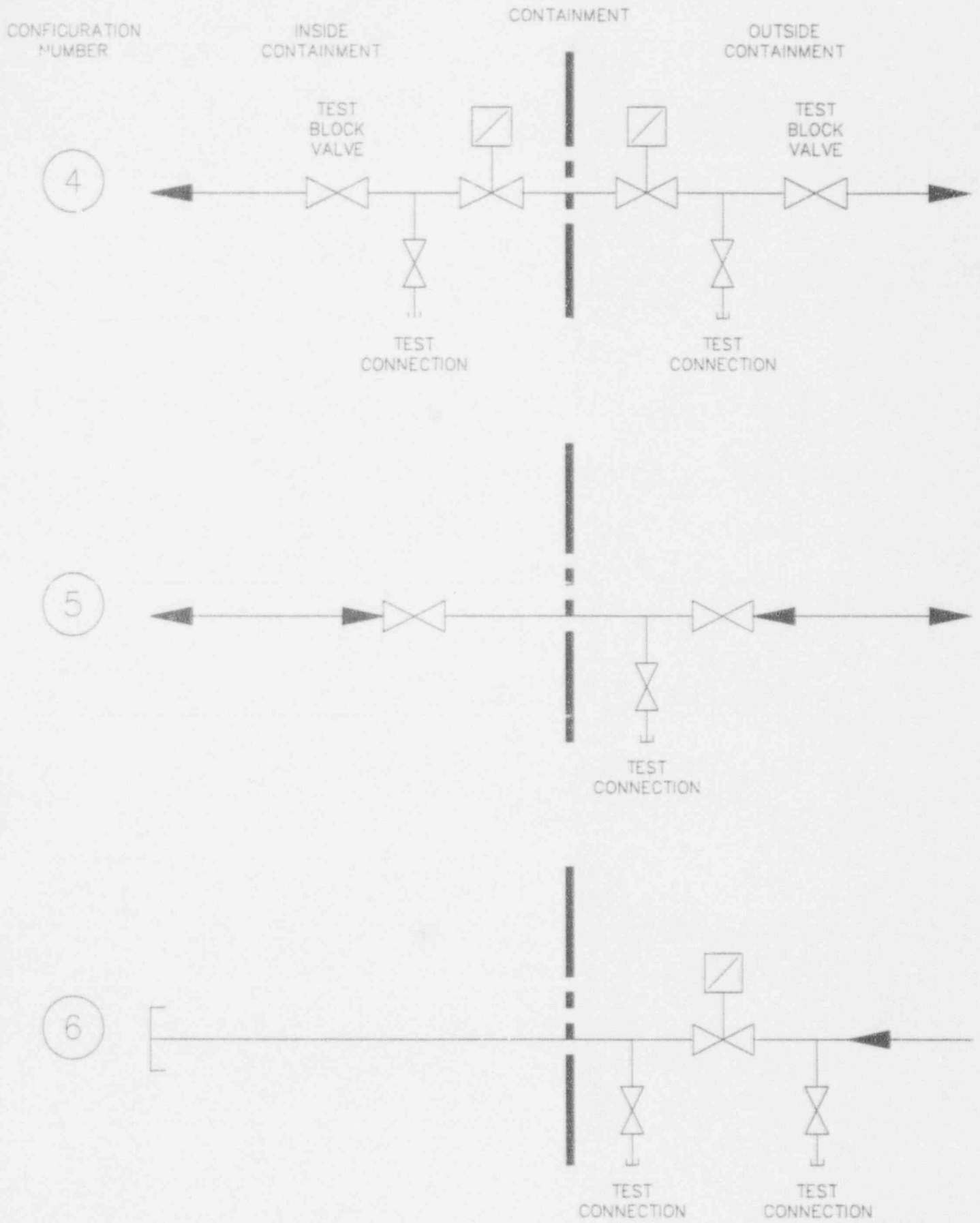
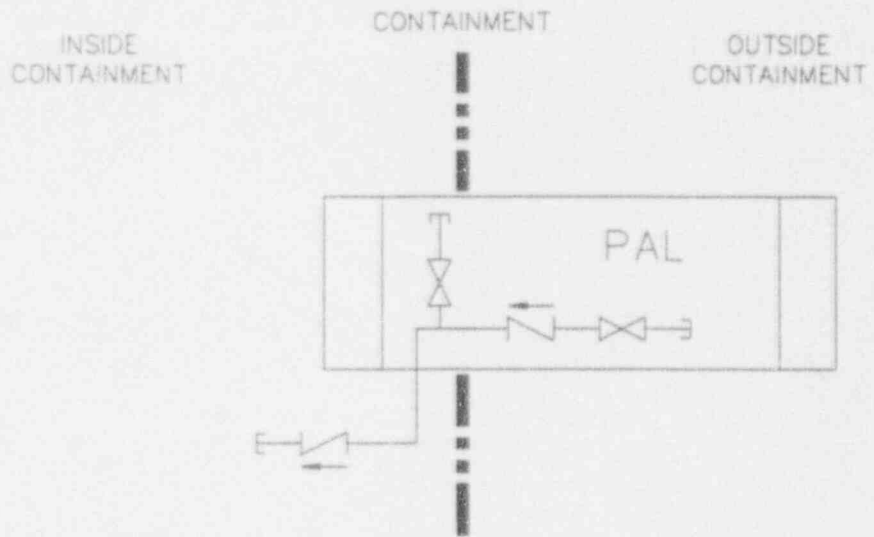

FIGURE 3.9-16
SHEET 2 OF 6

TYPICAL INSERVICE TESTING CONNECTIONS

CONFIGURATION
NUMBER

7



8

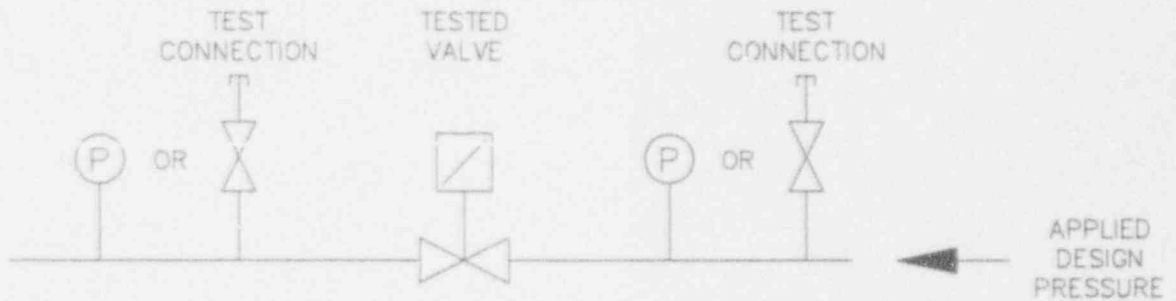

9

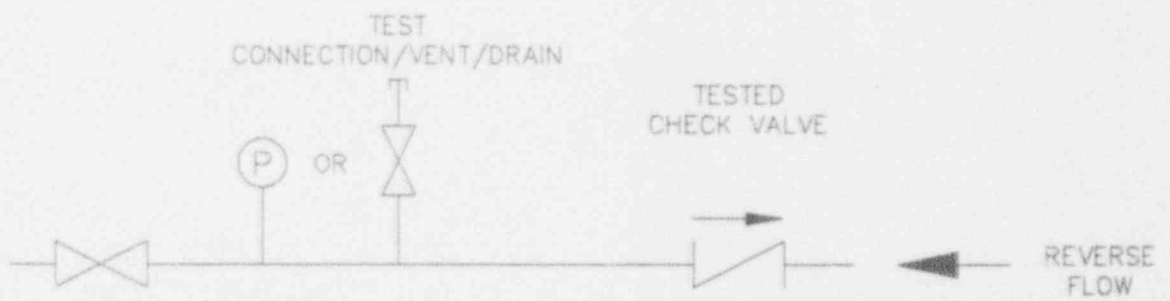

9A

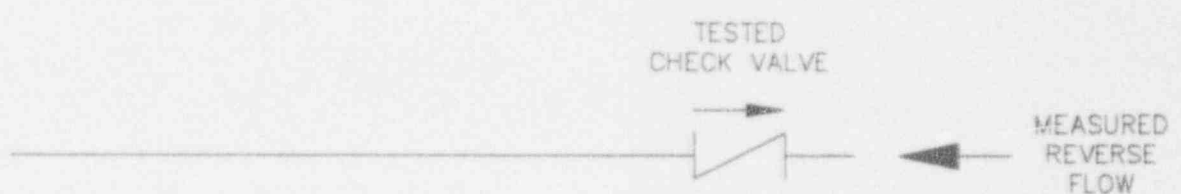

TYPICAL INSERVICE TESTING CONNECTIONS

CONFIGURATION
NUMBER

10

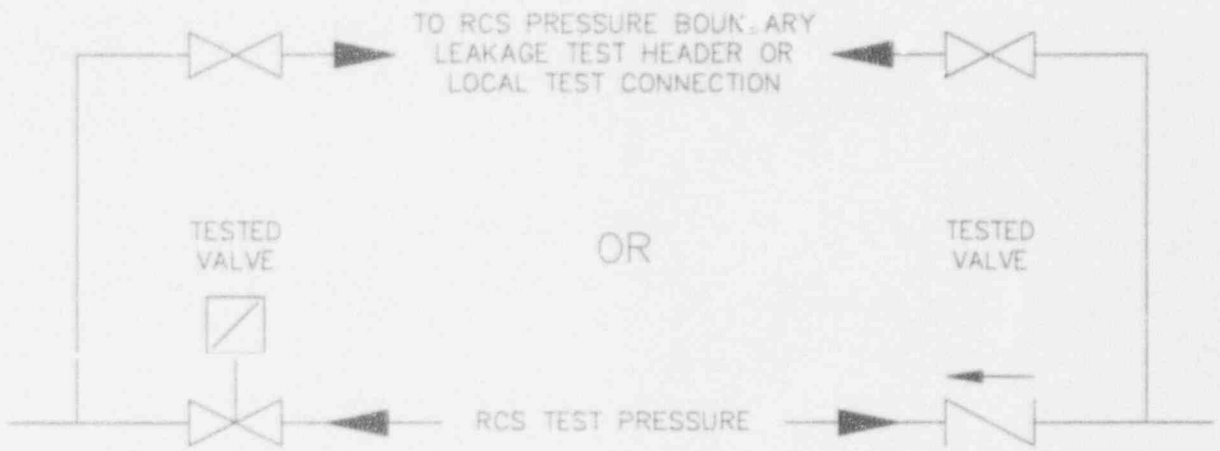

11

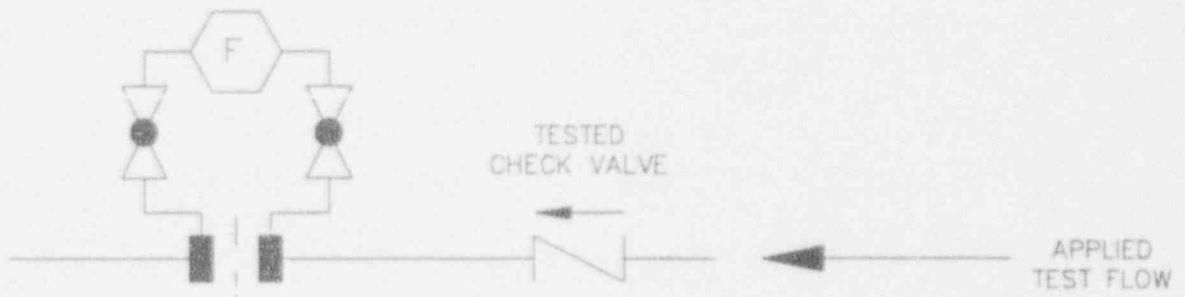

12

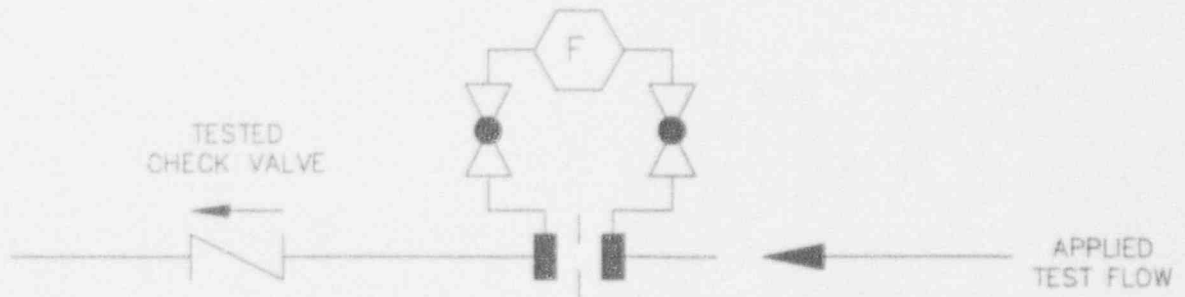

TYPICAL INSERVICE TESTING CONNECTIONS

CONFIGURATION
NUMBER

13

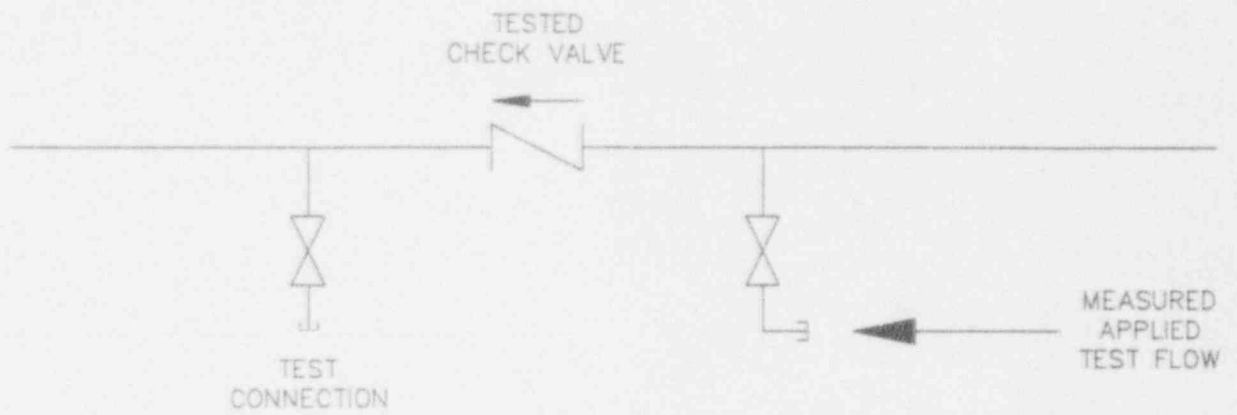

14

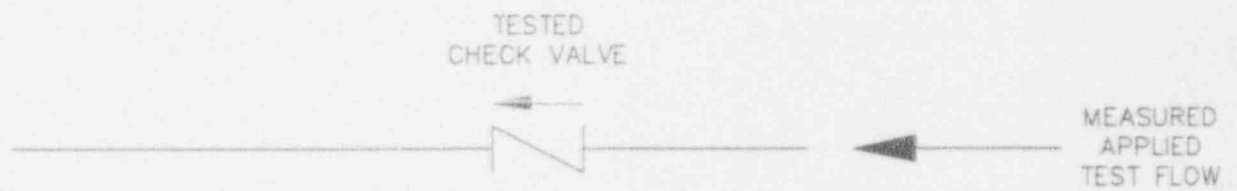

15

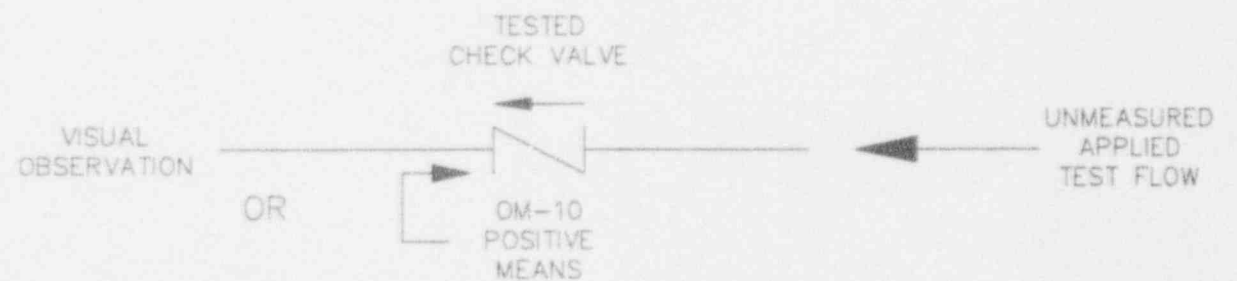

TYPICAL INSERVICE TESTING CONNECTIONS

CONFIGURATION
NUMBER

16

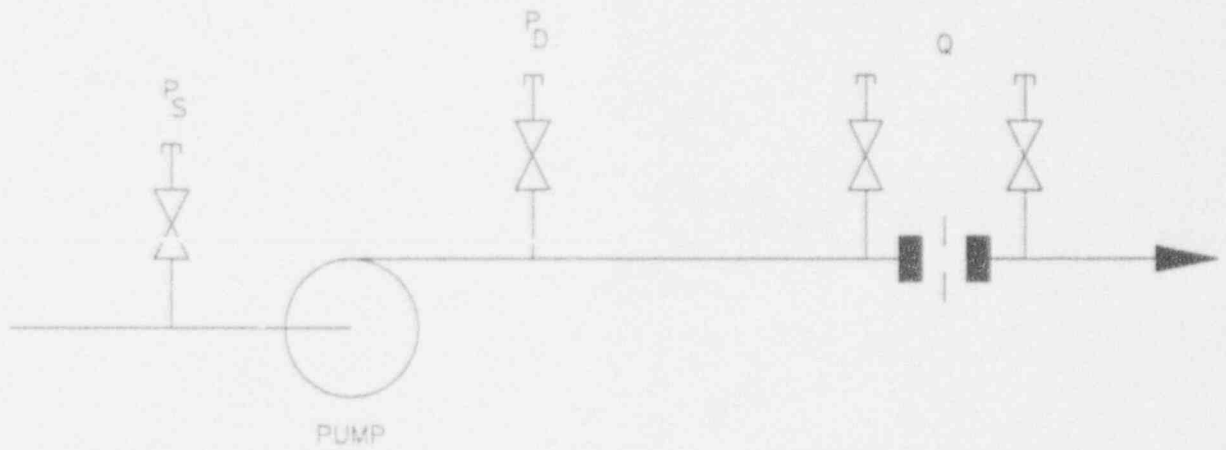

17

