

INSERVICE INSPECTION  
PROGRAM SUMMARY MANUAL

PALO VERDE  
NUCLEAR GENERATING STATION  
UNIT 3

ARIZONA PUBLIC SERVICE COMPANY  
P.O. Box 52034  
Phoenix, AZ 85072

PVNGS  
4 miles south  
Wintersburg, Az 85343

PREPARED BY: R. Brown DATE: 7-29-92

REVIEWED BY: JAH DATE: 7-29-92

ANII CONCURRENCE: Robt S. Foster DATE: 7-29-92

APPROVED BY:  
ENGINEERING MANAGER [Signature] DATE: 8/10/92

COMMERCIAL  
SERVICE DATE: 01/08/88

PROGRAM NO: ISI-3  
REVISION NO: 1

REV. 1  
12-23-91

TABLE OF CONTENTS

1.0	Summary . . . . .	1-1
2.0	Code Applicability. . . . .	1-1
3.0	Description . . . . .	1-2
3.1	Scope. . . . .	1-2
3.2	System Boundaries. . . . .	1-2
3.3	Accessibility. . . . .	1-3
3.4	Examination Techniques . . . . .	1-3
3.5	Inspection Intervals . . . . .	1-3
3.6	Examination Categories . . . . .	1-4
3.7	Evaluation and Repair. . . . .	1-4
3.8	System Pressure Tests. . . . .	1-4
3.9	Augmented High Energy Piping . . . . .	1-4
3.10	Exemptions . . . . .	1-5
3.11	Code Cases . . . . .	1-5
3.12	Definition of Terms. . . . .	1-6
4.0	ASME Class 1 Examination Summary. . . . .	4-1
	Index. . . . .	4-2
5.0	ASME Class 2 Examination Summary. . . . .	5-1
	Index. . . . .	5-2
6.0	ASME Class 3 Examination Summary. . . . .	6-1
	Index. . . . .	6-2
7.0	Augmented High Energy Piping. . . . .	7-1
8.0	RHR, ECCS, and CHR Piping . . . . .	8-1
9.0	Requests for Relief . . . . .	9-1
	Index. . . . .	9-2
10.0	ISI Boundary Drawings . . . . .	10-1
11.0	Zone Drawings . . . . .	11-1
	Index. . . . .	11-2



RECORD OF REVISIONS

<u>PAGE NUMBER</u>	<u>REVISION</u>
Cover	1
i thru iii	1
1-1 thru 1-5	1
4-1 thru 4-2	0
Table 1-1 page 1 of 2	1
1-1 page 2 of 2	0
1-2 page 1 of 2	1
1-2 page 2 of 2	0
1-3 page 1 of 2	1
1-3 page 2 of 2	0
1-4	1
1-5 page 1 of 2	0
1-5 page 2 of 2	1
1-6 page 1 and 2 of 3	1
1-6 page 3 of 3	0
1-7 page 1 of 4	1
1-7 page 2 thru 4 of 4	0
1-8	1
1-9 page 1 thru 3 of 5	1
1-9 page 4 and 5 of 5	0
1-10	0
1-12 page 1 and 2 of 2	0
1-13	1
1-14	0
1-15	1
1-16	0
1-IWF page 1 thru 3 of 3	1
1-RCP	0
5-1 and 5-2	0
Table 2-1 page 1 thru 2 of 3	0
2-1 page 3 of 3	1
2-2 page 1 and 2 of 2	1

Table 2-3 page 1 thru 3 of 4	1
2-3 page 4 of 4	0
2-4	0
2-5 page 1 thru 3 of 4	1
2-5 page 4 of 4	0
2-6	1
2-7	1
2-IWF page 1 thru 6 of 6	1
6-1 and 6-2	0
Table 3-1 page 1 of 2	0
3-1 page 2 of 2	1
3-IWF	0
7-1	0
Table 2-AHE page 1 and 3 of 3	0
2-AHE page 2 of 3	1
8-1	0
Table 2-CFR page 1 thru 6 of 6	1
9-1	0
9-2	1
Relief Request 1 thru 8	1
10-1	0
10-2	1
11-1 thru 11-4	1
Zone Drawings	(see Dwg)

PALO VERDE  
NUCLEAR GENERATING STATION  
UNIT 3  
INSERVICE INSPECTION - PROGRAM SUMMARY

1.0 SUMMARY

This document contains a detailed description of the Inservice Inspection Program for Palo Verde Nuclear Generating Station (PVNGS), Unit 3. This program conforms to the requirements of 10 CFR 50.55a(g) and the PVNGS Technical Specifications. In addition, the information is presented in a form consistent with applicable requirements of Standard Review Plan Sections 5.2.4 and 6.6, and the recommendations contained in NRC letter dated July 17, 1981, from Mr. R.L. Tedesco, NRC, to E.E. Van Brunt, Jr. APS, "Guidance for Preparing Preservice and Inservice Inspection Programs and Relief Requests-Palo Verde Nuclear Generating Units 1, 2 and 3".

The revision is being prepared to include changes resulting from the NRC review and acceptance of Revision 0, see NRC letter dated October 21, 1987, from E.A. Licitra, NRC, to E.E. Van Brunt, Jr., ANPP, "Inservice Inspection Programs - Palo Verde Units 1, 2 & 3". The major changes in this revision are to establish a common interval date for all units, to update the Requests for Relief, to include the Zone Drawings, and to make small changes and corrections noted during the initial use of the program.

2.0 CODE APPLICABILITY

Based on paragraph 10 CFR 50.55a(b)(2) that was published 12 months prior to the date March 25, 1987 of issuance of the operating license, the 1983 Edition through and including the Summer 1983 Addenda of ASME Section XI was utilized to prepare this program. However, in accordance with NRC Letter dated October 21, 1987, to Mr. E. E. Van Brunt, Jr. allowing the three units to be under the same Edition and Addenda, the 1980 Edition through and including the Winter 1981 Addenda was utilized for the first 10 year program in order to maintain consistency with Units 1 and 2. In addition, and in accordance with paragraph 10 CFR 50.55a(b)(2)(iv)(A), the extent of Class 2 piping welds for the PVNGS Safety Injection System: Reactor Residual Heat Removal (RHR), Emergency Core Cooling System (ECCS), and Containment Heat Removal (CHR), was determined in accordance with the 1974 Edition through and including the Summer 1975 Addenda of ASME Section XI.

This program will be updated for each inspection interval to conform with the requirements of the latest edition and addenda of the ASME Section XI Code referenced in paragraph (b) of 10 CFR 50.55a. When a code-required examination is considered to be impractical, because of plant design or other conditions, a request for relief from that requirement will be prepared and included in the program at the beginning of that inspection interval (Section 9.0). If a code-required examination is identified to be impractical during the course of an inspection and the code required percentages are not met, a request for relief will be prepared and submitted with the next revision to the program.

### 3.0 DESCRIPTION

#### 3.1 SCOPE

3.1.1 This Inservice Inspection Program Summary includes all applicable nondestructive examinations required by ASME Section XI and those identified in the PVNGS Technical Specifications as identified below:

1. Examination of ASME Class 1, 2, and 3 pressure retaining components and their supports.
2. Examination of the Reactor Coolant Pump Flywheels in accordance with PVNGS Technical Specifications Section 3/4.4.9.
3. Augmented high energy piping examination in accordance with PVNGS UFSAR Section 6.6.8.
4. Augmented examinations of CHR, RHR, and ECCS piping in accordance with 10 CFR 50.55a.
5. Special examinations to satisfy other commitments or concerns that are based on operating experiences, USNRC Circulars, Information Notices, Bulletins, Combustion Engineering Bulletins, INPO Reports, etc. These examinations are scheduled throughout this program and reference the applicable notification documents.

3.1.2 Those items that would generally be included in an Inservice Inspection Program, but are not included are identified below:

1. The inservice testing of snubbers will be performed in accordance with the PVNGS Technical Specifications Section 3/4.7.9.

Note: Request for Relief #1 in Section 9.0.

2. The pump and valve testing program is contained and submitted under a separate cover.

#### 3.2 SYSTEM BOUNDARIES

A complete set of Inservice Boundary drawings was included in Section 10.0 of Revision 0 of the Unit 1 Program, see Letter ANPP-33266-EEVB/KLM, dated August 26, 1985, from E.E. Van Brunt, Jr., ANPP, to George W. Knighton, NRC, "Palo Verde Nuclear Generating Station (PVNGS) Unit 1 Docket Nos. STN 50-528 (License No. NPF-41) Initial Inservice Inspection Program-PVNGS Unit 1". There have been no significant changes since those drawings were submitted; therefore, a new set is not being submitted with this revision. Please refer to these drawings for definition of the ASME Class 1, 2, and 3 systems; components; and boundaries scheduled for examinations and pressure testing. A set of some drawings was requested to be submitted to the NRC for a thorough review of Revision 0. A copy of these are now included in Section 11.0.

### 3.3 ACCESSIBILITY

The preservice examinations were performed with examination techniques, both automated and manual, similar to those planned for use during Inservice Inspection. The examination limitations noted during the preservice examinations were documented in requests for relief submitted with the preservice examination program. There have been no additional code limitations noted during the formulation of this program other than those contained in the Request for Relief Section.

All items that are scheduled for examination will be examined to the extent practical. In addition, any code limitations that are noted during the examinations will be documented in the summary reports that are prepared after each outage.

### 3.4 EXAMINATION TECHNIQUES

The three types of examinations utilized to perform Inservice Inspections, along with the actual nondestructive examination technique, are identified in the legend below:

VT - Visual

S - Surface

VOL - Volumetric

VT - 1 (General Condition)

VT - 2 (Leakage)

VT - 3 (Structural Condition)

VT - 4 (Operability)

PT - Liquid Penetrant

MT - Magnetic Particle

ET - Eddy Current

UT - Ultrasonic

RT - Radiography

All the above nondestructive examination techniques will be performed using specific techniques and procedures that are identified in ASME Section XI, or alternative examinations that are demonstrated to be equivalent or superior to those identified.

### 3.5 INSPECTION INTERVALS

The Inservice Inspection Program was prepared in accordance with Program B of ASME Section XI. The initial 10 year inspection interval and corresponding inspection periods are defined below:

First Inspection Interval:	1-8-88 to 1-10-98
Period One :	1-8-88 to 5-10-91
Period Two :	5-11-91 to 9-10-94
Period Three :	9-11-94 to 1-10-98

These dates have been modified to a common interval start date for all three PVNGS units. This is in accordance with NRC letter dated October 21, 1987, from E.A. Licitra, NRC, to E.E. Van Brunt, Jr., ANPP, "Inservice Inspection Programs Palo Verde, Units 1, 2, and 3" to allow the three units to be under the same ASME Section XI edition and addenda. It should be noted that the intervals/periods may change between units to allow for extended outage durations per IWA-2400 of ASME Section XI. The Unit 3 interval has been increased by 9 months and 23 days due to the extended duration of the first re-fueling outage.

### 3.6 EXAMINATION CATEGORIES

The examination categories of ASME Section XI were utilized to develop this program for all systems, components, and supports. The Program summary tables contained in Sections 4.0 and 5.0 are organized by examination category for ASME Class 1 and 2 systems, respectively. For each examination category, these tables identify the system, line number, nondestructive examination method, total number of items, required examination amount for each inspection period, and running percentage. For ASME Class 3 systems, the examination categories are identified in Section 6.0.

### 3.7 EVALUATION AND REPAIR

The evaluation of all examination results will be performed in accordance with ASME Section XI Articles IWA and IWB-3000. In addition, all applicable repairs and replacements will be performed in accordance with ASME Section XI Articles IWA, IWB, IWC, IWD, and IWF-4000 and 7000. Pressure tests will be performed only on welded repairs or replacements, in accordance with IWA-4000 and 5000. Both the evaluations and repair or replacement will be performed in accordance with the 1980 Edition through and including the Winter 1981 Addenda of ASME Section XI, or later editions and addenda of ASME Section XI referenced in 10 CFR 50. All repairs and replacements will be documented in accordance with the Work Control program, and are maintained at Palo Verde for review.

### 3.8 SYSTEM PRESSURE TESTS

System pressure tests will be performed in accordance with ASME Section XI and as identified in Sections 4.0, 5.0, and 6.0 for ASME Class 1, 2, and 3, respectively. These tables also identify the type of pressure test, test frequency, any applicable requests for relief, and references the appropriate ASME Section XI Article for each of the ASME Code Classes.

### 3.9 AUGMENTED HIGH ENERGY PIPING

Based on the PVNGS UFSAR, an augmented examination is required for protection against postulated pipe failures. This augmented examination program includes the following high energy piping systems located between the containment penetration and the main steam support structural wall:

- Main Steam
- Feedwater
- Steam Generator Blowdown
- Downcomer Feedwater

The summary tables in Section 7.0 identify each system, along with the required examination amounts and frequencies. As shown by this table, a volumetric examination of all longitudinal and circumferential welds is scheduled. These welds will be examined to the maximum extent practical. Any limitations to the examination will be included and documented on the examination report prepared in accordance with ASME Section XI.

### 3.10 EXEMPTIONS

The exemption criteria identified in the 1980 Edition through and including the Winter 1981 Addenda of ASME Section XI was utilized for all ASME Class 1, 2, and 3 components and systems. This includes the PVNGS Safety Injection System (RHR, ECCS, and CHR systems) piping and components, even though 10 CFR 50.55a requires the 1974 Edition through and including the 1975 Summer Addenda be utilized. It was concluded after a detailed review that the exemption criteria identified in the Winter 1981 Addenda was more conservative in every case than those identified in the Summer 1975 Addenda, and more examinations would therefore be performed on safety injection systems piping and components.

A thorough review of all the systems and components was performed in accordance with the above exemptions and a complete set of color coded Inservice Inspection Boundary drawings was prepared. These drawings are maintained at the PVNGS site for review.

### 3.11 CODE CASES

ASME Section XI Code Case acceptability will be based on Regulatory Guide 1.147.

DEFINITION OF TERMS

AHE:	Augmented High Energy
ANII:	Authorized Nuclear Inservice Inspector
ANPP:	Arizona Nuclear Power Project
APS:	Arizona Public Service
ASME:	American Society of Mechanical Engineers
Aux:	Auxiliary
BWR:	Boiling Water Reactor
CE:	Combustion Engineering
CEDM:	Control Element Drive Mechanism
CFR:	Code of Federal Regulations
CH:	Charging
CHR:	Containment Heat Removal
Circ:	Circumferential
CL:	Cold Leg
CRD:	Control Rod Drive
CS:	Containment Spray
CSP:	Containment Spray Pump
DWG:	Drawing
ECCS:	Emergency Core Cooling System
FW:	Feedwater
HL:	Hot Leg
HPSI:	High Pressure Safety Injection
Hx:	Heat Exchanger
ICI:	In Core Instrumentation
IEB:	Inspection and Enforcement Bulletin
IEIN:	Inspection and Enforcement Information Notice
Inj:	Injection
INPO:	Institute for Nuclear Power Operations
ISI:	Inservice Inspection
LPSI:	Low Pressure Safety Injection
MSSS:	Main Steam Support Structure
NDE:	Nondestructive Examination
NRC:	Nuclear Regulatory Commission
PDV:	Pressure Differential Valve
PSV:	Pressurizer Safety Valve
PWR:	Pressurized Water Reactor



Definition of Terms continued

— PVNGS:	Palo Verde Nuclear Generating Station
PZR:	Pressurizer
RC:	Reactor Coolant
RCP:	Reactor Coolant Pump
Reg.:	Regulatory
REV:	Revision
RR:	Reactor Residual Heat Removal
Recirc:	Recirculation
RCS:	Reactor Coolant System
RPV:	Reactor Pressure Vessel
RVLMS:	Reactor Vessel Level Monitoring System
REM:	Roentgen Equivalent Man
SDCHX:	Shutdown Cooling Heat Exchanger
SD:	Shutdown
SER:	Significant Event Report
SG:	Steam Generator
SI:	Safety Injection
SN:	Serial Number
T:	Thickness
Tech. Spec:	Technical Specification
UFSAR:	Updated Final Safety Analysis Report
USNRC:	United States Nuclear Regulatory Commission
UV:	Multivariable Control Valve
V:	Valve

SECTION 4.0  
ASME CLASS 1  
EXAMINATION SUMMARY

## INDEX

<u>TABLE</u>		<u>EXAM CATEGORIES</u>
1-1	B-A,	Pressure Retaining Welds in Reactor Vessel
1-2	B-B,	Pressure Retaining Welds in Vessels Other Than Reactor Vessels
1-3	B-D,	Full Penetration Welds of Nozzles in Vessels - Inspection Program B
1-4	B-E,	Pressure Retaining Partial Penetration Welds in Vessels
1-5	B-F,	Pressure Retaining Dissimilar Metal Welds
1-6	B-G-1,	Pressure Retaining Bolting, Greater Than 2 in. in Diameter
1-7	B-G-2,	Pressure Retaining bolting, 2 in. and Less in Diameter
1-8	B-H,	Integral Attachments for Vessels
1-9	B-J,	Pressure Retaining Welds in Piping
1-10	B-K-1,	Integral Attachments for Piping, Pumps and Valves
1-12	B-L-1 & B-M-1, B-L-2 & B-M-2,	Pressure Retaining Welds in Pump Casings and Valve Bodies and Pump Casings and Valve Bodies
1-13	B-N-1, B-N-2, B-N-3,	Interior of Reactor Vessel Integrally Welded Core Support Structures and Interior Attachments to Reactor Vessels Removable Core Support Structures
1-14	B-O,	Pressure Retaining Welds in Control Rod Housing
1-15	B-P,	All Pressure Retaining Components
1-16	B-Q,	Steam Generator Tubing
1-IWF	F-A, F-B, F-C,	Plate and Shell Type Supports Linear Type Supports Component Standard Support
1-RCP	N/A,	Reactor Coolant Pump Flywheel Examinations Reg. Guide 1.14

ASME ITEM NO.	ZONE-COMPONENT OR SYSTEM	IDENTIFICATION	DESCRIPTION LINE NO., OR SERIAL NO.	NDE METHOD	TOTAL ITEMS	EXAMINATION AMOUNT	INSPECTION PERIOD	RUNNING %	REMARKS AND RELIEF REQUESTS
B 100	EXAM CATEGORY B-A, PRESSURE RETAINING WELDS IN REACTOR VESSEL								
110	SHELL WELDS CIRCUMFERENTIAL 1- Reactor Vessel	Butt Welds	SN 65173	Voi	3 **	0	One	0	
111						0	Two	0	
						3	Three	100	
112	LONGITUDINAL 1- Reactor Vessel	Butt Welds	SN 65173	Voi	9 **	0	One	0	
						0	Two	0	
						9	Three	100	
120	HEAD WELDS CIRCUMFERENTIAL	None							
121									
122	AXIAL 1- Reactor Vessel Bottom Head	Butt Weld	SN 65173	Voi	1	0	One	0	AUTOMATED EXAM CORE BARREL REMOVED. EXAMINE ENTIRE ACCESSIBLE LENGTH
						0	Two	0	
						1	Three	100	
	2- Closure Head	Butt Weld	SN 65173	Voi	1	33%	One	33	EXAMINE ENTIRE ACCESSIBLE LENGTH
						33%	Two	66	
						34%	Three	100	
130	SHELL-TO-FLANGE WELD 1- Reactor Vessel	Butt Weld	SN 65173	Voi	1	50% *	One	50	* EXAM FROM FLANGE MATHG SURFACE
						10%	Two	50	
						100% **	Three	100	
140	HEAD-TO-FLANGE WELD 2- Closure Head	Butt Weld	SN 65173	Voi, S	1	33%	One	33	** AUTOMATED EXAM CORE BARREL REMOVED.
						33%	Two	66	
						34%	Three	100	

# APS

## PALO VERDE NUCLEAR GENERATING STATION 10 YEAR INTERVAL - EXAMINATION SUMMARY

### ASME CLASS I

ASME ITEM NO.	ZONE-COMPONENT OR SYSTEM	IDENTIFICATION	DESCRIPTION LINE NO., OR SERIAL NO.	NDE METHOD	TOTAL ITEMS	EXAMINATION AMOUNT	INSPECTION PERIOD	RUNNING %	REMARKS AND RELIEF REQUESTS
150 151	REPAIR WELDS BELTLINE REGION	None							

# APS PALO VERDE NUCLEAR GENERATING STATION

## 10 YEAR INTERVAL - EXAMINATION SUMMARY

### ASME CLASS 1

TABLE 1-2  
PAGE 1 OF 2

ASME ITEM NO.	ZONE-COMPONENT OR SYSTEM	IDENTIFICATION	DESCRIPTION LINE NO., OR SERIAL NO.	NDE METHOD	TOTAL ITEMS	EXAMINATION AMOUNT	INSPECTION PERIOD	RUNNING %	REMARKS AND RELIEF REQUESTS
B 200	EXAM CATEGORY B-B, PRESSURE RETAINING WELDS IN VESSELS OTHER THAN REACTOR VESSELS								
210	PRESSURIZER SHELL TO HEAD WELDS								*1 FOOT MIN. OF EACH LONGITUDINAL WELD THAT INTERSECTS THE SCHED- ULED CIRC. WELDS WILL BE EXAMINED.
211	CIRCUMFERENTIAL AND * LONGITUDINAL	Butt Weld	SN 65373	Vot	1	33%	One	33	
212						33%	Two	66	
						34%	Three	100	
	5- Pressurizer Shell to bottom Head	Butt Weld	SN 65373	Vot	1	33%	One	33	
	5- Pressurizer Shell to Top Head	Butt Weld	SN 65373	Vot	1	33%	Two	66	
						34%	Three	100	
220	HEAD WELDS	None	-	-	-	-	-	-	
221	CIRCUMFERENTIAL	None	-	-	-	-	-	-	
222	MERIDIONAL	None	-	-	-	-	-	-	
230	STEAM GENERATORS HEAD WELDS								
231	CIRCUMFERENTIAL								
	3- Steam Generator 1	Butt Welds	SN 65273-1	Vot	4	1	One	25	**STAY- CYLINDER EXAMS
						1	Two	50	
						2 **	Three	100	
	4- Steam Generator 2	Butt Welds	SN 65273-2	Vot	4	1	One	25	**STAY CYLINDER EXAMS
						1	Two	50	
						2 **	Three	100	

REV. 1  
12-23-91

ASME ITEM NO.	ZONE-COMPONENT OR SYSTEM	IDENTIFICATION	DESCRIPTION LINE NO., OR SERIAL NO.	NDE METHOD	TOTAL ITEMS	EXAMINATION AMOUNT	INSPECTION PERIOD	RUNNING %	REMARKS AND RELIEF REQUESTS
232	MERIDIONAL 3- Steam Generator 1	Burr Welds	SN 65273-1	Vel	6	4 1 1	One Two Three	66 83 100	
	4- Steam Generator 2	Burr Welds	SN 65273-2	Vel	6	0 5 1	One Two Three	83 100	
240	TUBESHEET TO HEAD 3- Steam Generator 1	Burr Welds	SN 65273-1	Vel	2	1 0 1 *	One Two Three	50 50 100	*STAY- CYLINDER EXAMS
	4- Steam Generator 2	Burr Welds	SN 65273-2	Vel	2	0 1 1 *	One Two Three	50 50 100	
250	HEAT EXCHANGERS	None	-	-	-	-	-	-	
251	HEAD WELDS	None	-	-	-	-	-	-	
252	CIRCUMFERENTIAL	None	-	-	-	-	-	-	
253	MERIDIONAL	None	-	-	-	-	-	-	
260	LONGITUDINAL TUBESHEET TO SHELL	None	-	-	-	-	-	-	
261	(OR HEAD) WELDS TUBESHEET TO SHELL	None	-	-	-	-	-	-	

# APS

## PALO VERDE NUCLEAR GENERATING STATION 10 YEAR INTERVAL - EXAMINATION SUMMARY

### ASME CLASS 1

TABLE 1-3  
PAGE 1 OF 2

ASME ITEM NO.	ZONE-COMPONENT OR SYSTEM	IDENTIFICATION	DESCRIPTION LINE NO., OR SERIAL NO.	NDE METHOD	TOTAL ITEMS	EXAMINATION AMOUNT	INSPECTION PERIOD	RUNNING %	REMARKS AND RELIEF REQUESTS
B 300	EXAM CATEGORY B-D: FULL PENETRATION WELDS OF NOZZLES IN VESSELS-INSPECTION PROGRAM B								
390 & 3100	REACTOR VESSEL NOZZLE-TO-VESSEL WELDS AND NOZZLE INSIDE RADIUS SECTION								
	1- Reactor Vessel	Outlets - 2 Inlets - 4	SN 65173	Vol	6	2 0 4 *	One Two Three	33 33 100	*AUTOMATED EXAMS FROM SHELL SIDE WITH CORE BARREL REMOVED
3110 & 3120	PRESSURIZER NOZZLE-TO-VESSEL WELDS AND NOZZLE INSIDE RADIUS SECTION								
	5- Pressurizer	Surge - 1 Spray - 1 Safeties - 4	SN 65373	Vol	6	2 2 2	One Two Three	33 66 100	
3130 & 3140	STEAM GENERATORS NOZZLE-TO-VESSEL WELDS AND NOZZLE INSIDE RADIUS SECTION								
	3- Steam Generator 1	Inlet - 1 Outlet - 2	SN 65273-1	Vol	3	1 1 1	One Two Three	33 66 100	
	4- Steam Generator 2	Inlet - 1 Outlet - 2	SN 65273-2	Vol	3	1 1 1	One Two Three	33 66 100	

REV. 1  
12-23-91



ASME ITEM NO.	ZONE-COMPONENT OR SYSTEM	IDENTIFICATION	DESCRIPTION LINE NO., OR SERIAL NO.	NDE METHOD	TOTAL ITEMS	EXAMINATION AMOUNT	INSPECTION PERIOD	RUNNING %	REMARKS AND RELIEF REQUESTS
3150	HEAT EXCHANGERS NOZZLE TO VESSEL WELDS AND NOZZLE INSIDE RAJBUS SECTION	None							
A		None							
3160		None							

**APS**PALO VERDE NUCLEAR GENERATING STATION  
10 YEAR INTERVAL - EXAMINATION SUMMARY

## ASME CLASS 1

TABLE 1-4  
PAGE 1 OF 1

ASME ITEM NO.	ZONE-COMPONENT OR SYSTEM	IDENTIFICATION	DESCRIPTION LINE NO., OR SERIAL NO.	NDE METHOD	TOTAL ITEMS	EXAMINATION AMOUNT	INSPECTION PERIOD	RUNNING %	REMARKS AND RELIEF REQUESTS
B 400	EXAM CATEGORY B-E PRESSURE RETAINING PARTIAL PENETRATION WELDS IN VESSELS								ALL EXAMS PERFORMED IN CONJUNCTION WITH EXAM CATEGORY B-P
410	PARTIAL PENETRATION WELDS								
411	VESSEL NOZZLES	None							
412	CONTROL ROD DRIVE NOZZLES								
	Reactor Vessel Closure Head	CEDM Nozzles	SN 65173	VT-2	97	8 8 9	One Two Three	8 16 26	
413	INSTRUMENT NOZZLES								
	Reactor Vessel	Bottom Head	SN 65173	VT-2	61	5 5 6	One Two Three	8 16 26	
420	PRESSURIZER HEATER PENETRATION WELDS	Bottom Head	SN65373	VT-2*	36	3 3 3	One Two Three	8 17 26	* A SUPPLEMENTAL VT-2 EXAM WILL BE PERFORMED ON ALL STANDPIPE AND HEATER NOZZLES EACH REFUELING OUTAGE. (SEE CE INFO BULLETIN 89-06)

REV. 1  
12-23-91

ASME ITEM NO.	ZONE-COMPONENT OR SYSTEM	IDENTIFICATION	DESCRIPTION LINE NO., OR SERIAL NO.	NDE METHOD	TOTAL ITEMS	EXAMINATION AMOUNT	INSPECTION PERIOD	RUNNING %	REMARKS AND RELIEF REQUESTS
B 900	EXAM CATEGORY B/E, PRESSURE RETAINING DISSIMILAR METAL WELDS								
510	REACTOR VESSEL NOMINAL PIPE SIZE ≥ 4 IN. NOZZLE TO SAFE END BUTT WELDS	None							
520	NOMINAL PIPE SIZE < 4 IN. NOZZLE TO SAFE END BUTT WELDS	None							
530	NOZZLE TO SAFE END SOCKET WELDS	None							
540	PRESSURIZER NOMINAL PIPE SIZE ≥ 4 IN. NOZZLE TO SAFE END BUTT WELDS								
	20-Surge 29-Spray* 31-Safeties (4)	Butt Welds Butt Welds Butt Welds	RC-28-12" RC-18-4" RC-1-6" RC-3-6" RC-5-6" RC-7-6"	S, Vel	6	2 2 2	One Two Three	33 66 100	* RT SUP. ELEMENTAL EXAM FOR THERMAL SLEEVE INTEGRITY (NOTE BEEN 82.09)
550	NOMINAL PIPE SIZE < 4 IN. NOZZLE TO SAFE END BUTT WELDS	None							
560	NOZZLE TO SAFE END SOCKET WELDS	None							
570	STEAM GENERATOR NOMINAL PIPE SIZE ≥ 4 IN. NOZZLE TO SAFE END BUTT WELDS	None							
580	NOMINAL PIPE SIZE < 4 IN. NOZZLE TO SAFE END BUTT WELDS	None							

# APS

## PALO VERDE NUCLEAR GENERATING STATION 10 YEAR INTERVAL - EXAMINATION SUMMARY

### ASME CLASS 1

TABLE 1-5  
PAGE 2 OF 2

ASME ITEM NO.	ZONE-COMPONENT OR SYSTEM	IDENTIFICATION	DESCRIPTION LINE NO., OR SERIAL NO.	NDE METHOD	TOTAL ITEMS	EXAMINATION AMOUNT	INSPECTION PERIOD	RUNNING %	REMARKS AND RELIEF REQUESTS
590	NOZZLE TO SAFE END SOCKET WELDS	None	-	-	-	-	-	-	
5100	HEAT EXCHANGERS NOMINAL PIPE SIZE ≥ 4 IN. NOZZLE TO SAFE END BUTT WELDS	None	-	-	-	-	-	-	
5110	NOMINAL PIPE SIZE < 4 IN. NOZZLE TO SAFE END BUTT WELDS	None	-	-	-	-	-	-	
5120	NOZZLE TO SAFE END SOCKET WELDS	None	-	-	-	-	-	-	
5130	PIPING NOMINAL PIPE SIZE ≥ 4 IN. DISSIMILAR METAL BUTT WELDS								ITEMS B5.130 & B5.140 SYSTEMS COMBINED FOR PERCENTAGE
	20-Pressurizer Surge	Butt Weld	RC-28-12"	S, Vol	1	1	Three	-	
	21-Shutdown Cooling Loop 1	Butt Weld	RC-51-16"	S, Vol	1	1	One	-	
	22-Shutdown Cooling Loop 2	Butt Weld	RC-68-16"	S, Vol	1	1	Two	-	
	23-Safety Injection 1A	Butt Weld	SI-207-14"	S, Vol	1	1	One	-	
	24-Safety Injection 1B	Butt Weld	SI-223-14"	S, Vol	1	1	Three	-	
	25-Safety Injection 2A	Butt Weld	SI-160-14"	S, Vol	1	1	Two	-	
	26-Safety Injection 2B	Butt Weld	SI-179-14"	S, Vol	1	1	Three	-	
5140	NOMINAL PIPE SIZE < 4 IN. DISSIMILAR METAL BUTT WELDS								
	27-Pressurizer Spray 1A	Butt Weld	RC-62-3"	S	1	1	One	-	
	28-Pressurizer Spray 1B	Butt Weld	RC-17-3"	S	1	1	Two	-	
	32-Drain Line 1A	Butt Weld	RC-60-2"	S	1	1	One	29	
	33-Drain Line 1B	Butt Weld	RC-58-2"	S	1	1	Two	-	
	34-Drain Line 2A	Butt Weld	RC-96-2"	S	1	1	Three	-	
	36-Lowdown Line	Butt Weld	RC-91-2"	S	1	1	Three	100	
	37-Charging Line*	Butt Weld	CH-5-3"	S	1	1	Two	64	
5150	DISSIMILAR METAL SOCKET WELDS	None	-	-	-	-	-	-	*RT SUPPLE- MENTAL EXAM FOR THERMAL SLEEVE INTEGRITY (NOTE IBEN 82-09)

REV. 1  
12-23-91

ASME ITEM NO.	ZONE-COMPONENT OR SYSTEM	IDENTIFICATION	DESCRIPTION LINE NO., OR SERIAL NO.	NDE METHOD	TOTAL ITEMS	EXAMINATION AMOUNT	INSPECTION PERIOD	RUNNING %	REMARKS AND RELIEF REQUESTS
600	EXAM CATEGORY B-G-1: PRESSURE RETAINING ROLLING GREATER THAN 1 IN. IN DIAMETER REACTOR VESSEL CLOSURE HEAD NUTS	Nuts	7.237" x 7.91"	S	54	18 18 18	One Two Three	33 66 100	
620	CLOSURE STUDS, IN FLANGE	None*							*STUDS WILL BE REMOVED FOR EXAMI- NATION
630	CLOSURE STUDS, WHEN REMOVED	Studs	7.380" x 76.37"	S, M6	54	18 18 18	One Two Three	33 66 100	
640	THREADS IN FLANGE	Flange Ligaments	SN 65173	M6	54	0 0 54	One Two Three	0 0 100	
650	CLOSURE WASHERS, BUSHINGS	Washers	7.50" x 1.27"	VT-1	54	18 18 18	One Two Three	33 66 100	
660	PRESSURIZER	None							
670	BOLTS AND STUDS FLANGE SURFACE, WHEN CONNECTION DISAS- SEMBLED	None							
680	NUTS, BUSHINGS, AND WASHERS	None							

# APS PALO VERDE NUCLEAR GENERATING STATION

## 10 YEAR INTERVAL - EXAMINATION SUMMARY

### ASME CLASS 1

TABLE 1-6  
PAGE 2 OF 3

ASME ITEM NO.	ZONE-COMPONENT OR SYSTEM	IDENTIFICATION	DESCRIPTION LINE NO., OR SERIAL NO.	NDE METHOD	TOTAL ITEMS	EXAMINATION AMOUNT	INSPECTION PERIOD	RUNNING %	REMARKS AND RELIEF REQUESTS
690	STEAM GENERATORS BOLTS AND STUDS	None	-	-	-	-	-	-	
6100	FLANGE SURFACE, WHEN CONNECTION DISAS- SEMBLED	None	-	-	-	-	-	-	
6110	NUTS, BUSHINGS, AND WASHERS	None	-	-	-	-	-	-	
6120	HEAT EXCHANGERS BOLTS AND STUDS	None	-	-	-	-	-	-	
6130	FLANGE SURFACE, WHEN CONNECTION DISAS- SEMBLED	None	-	-	-	-	-	-	
6140	NUTS, BUSHINGS, AND WASHERS	None	-	-	-	-	-	-	
6150	PIPING BOLTS AND STUDS	None	-	-	-	-	-	-	
6160	FLANGE SURFACE, WHEN CONNECTION DISAS- SEMBLED	None	-	-	-	-	-	-	
6170	NUTS, BUSHINGS, AND WASHERS	None	-	-	-	-	-	-	
6180	PUMPS BOLTS AND STUDS**								
	16-Reactor Coolant Pump 1A	Flange Studs	4.33" x 32.87"	Vol*	16	5 5 6	One Two Three	31 62 100	*A SUPPLEMENTAL VT-1 EXAM WILL BE PERFORMED 100% PER REFUELING OUTAGE (SEE IEBN 80-27) **SUPPLEMENTED BY VISUAL (EACH REMOVAL) AND SUR- FACE (AT 5 YEAR INTERVALS) EXAMS WHEN REMOVED (SEE IEB 82-02)
	17-Reactor Coolant Pump 1B	Flange Studs	4.33" x 32.87"	Vol*	16	5 5 6	One Two Three	31 62 100	
	18-Reactor Coolant Pump 2A	Flange Studs	4.33" x 32.87"	Vol*	16	5 5 6	One Two Three	31 62 100	
	19-Reactor Coolant Pump 2B	Flange Studs	4.33" x 32.87"	Vol*	16	5 5 6	One Two Three	31 62 100	

REV 1  
12-23-91

ASME ITEM NO.	ZONE-COMPONENT OR SYSTEM	IDENTIFICATION	DESCRIPTION LINE NO., OR SERIAL NO.	NDE METHOD	TOTAL ITEMS	EXAMINATION AMOUNT	INSPECTION PERIOD	RUNNING %	REMARKS AND RELIEF REQUESTS	
6190	<u>FLANGE SURFACE, WHEN CONNECTION DISASSEMBLED</u>  16, 17, 18 and 19- Reactor Coolant Pumps 1A, 1B, 2A, 2B	Flange Surface	CASING SN 1A - 1259 1B - 1261 2A - 1260 2B - 1262	VT-1	16 per pump	*	One Two Three	*	*100% EXAM WHEN DISASSEMBLED (THERE ARE NO BUSHINGS IN THE PUMP FLANGES) **THE CLAMPING RING WILL BE EXAMINED (THERE ARE NO WASHERS)	
6200	<u>NUTS, BUSHINGS AND WASHERS**</u>  16-Reactor Coolant Pump 1A	Nuts & Clamping Ring	4.528" x 7.283"	VT-1	16	5 5 6	One Two Three	31 62 100		
	17-Reactor Coolant Pump 1B	Nuts & Clamping Ring	4.528" x 7.283"	VT-1	16	5 5 6	One Two Three	31 62 100		
	18-Reactor Coolant Pump 2A	Nuts & Clamping Ring	4.528" x 7.283"	VT-1	16	5 5 6	One Two Three	31 62 100		
	19-Reactor Coolant Pump 2B	Nuts & Clamping Ring	4.528" x 7.283"	VT-1	16	5 5 6	One Two Three	31 62 100		
6210	<u>VALVES</u> <u>BOLTS AND STUDS</u>	None	-	-	-	-	-	-		
6220	<u>FLANGE SURFACE, WHEN CONNECTION DISASSEMBLED</u>	None	-	-	-	-	-	-		
6230	<u>NUTS, BUSHINGS, AND WASHERS</u>	None	-	-	-	-	-	-		



**PALO VERDE NUCLEAR GENERATING STATION  
10 YEAR INTERVAL - EXAMINATION SUMMARY**

**ASME CLASS 1**

TABLE 1-7  
PAGE 1 OF 4

ASME ITEM NO.	ZONE-COMPONENT OR SYSTEM	IDENTIFICATION	DESCRIPTION LINE NO., OR SERIAL NO.	NDE METHOD	TOTAL ITEMS	EXAMINATION AMOUNT	INSPECTION PERIOD	RUNNING %	REMARKS AND RELIEF REQUESTS
B 700	<u>EXAM. CATEGORY B-G-2, PRESSURE RETAINING BOLTING 2 IN. AND LESS IN DIAMETER</u>								
710	REACTOR VESSEL BOLTS, STUDS AND NUTS	None							
720	PRESSURIZER BOLTS, STUDS AND NUTS								
	5- PZR Manway	Studs & nuts	1.5" x 14.5"	VT-1	* 20 pairs	20 20 20	One Two Three	100 100 100	*STUDS ONLY, SUPPLEMENTED BY VISUAL (EACH REMOVAL) AND SURFACE (AT 5 YEAR INTERVALS) EXAMS WHEN REMOVED (SEE IIB 82-02)
730	<u>STEAM GENERATORS BOLTS, STUDS AND NUTS</u>								
	3- Steam Generator 1 Cold Leg and Hot Leg Manways	Studs & Nuts	1.5" x 14.5"	VT-1	* 40 Pairs	40 40 40	One Two Three	100 100 100	
	4- Steam Generator 2 Cold Leg and Hot Leg Manways	Studs & Nuts	1.5" x 14.5"	VT	* 40 Pairs	40 40 40	One Two Three	100 100 100	
740	<u>HEAT EXCHANGERS</u>	None							
750	<u>PIPING BOLTS, STUDS AND NUTS</u>								
	31-PZR Safeties	Flange Flange Flange Flange	RC-1-6" RC-3-6" LC-5-6" RC-7-6"	VT-1	* 4	1 1 2	One Two Three	25 50 100	
	37-Charging Line	Flange	CH-5-3"	VT-1	1	1 0 0	One Two Three	100 100 100	

REV. 1  
12-23-91



ASME ITEM NO.	ZONE-COMPONENT OR SYSTEM	IDENTIFICATION	DESCRIPTION LINE NO., OR SERIAL NO.	NDE METHOD	TOTAL ITEMS	EXAMINATION AMOUNT	INSPECTION PERIOD	RUNNING %	REMARKS AND RELIEF REQUESTS				
160	PUMPS BOLTS, STUDS AND NUTS	16-Reactor Coolant Pump 1A Seal Cover Bolting	Seal Cover	1.5" x 8.27"	VT-1	16	5	One	31				
			Studs & Nuts					5	Two	62			
								6	Three	100			
		17-Reactor Coolant Pump 1B Seal Cover Bolting	Seal Cover	1.5" x 8.27"	VT-1	16	5	One	31				
			Studs & Nuts					5	Two	62			
								6	Three	100			
		18-Reactor Coolant Pump 2A Seal Cover Bolting	Seal Cover	1.5" x 8.27"	VT-1	16	5	One	31				
			Studs & Nuts					5	Two	62			
								6	Three	100			
		19-Reactor Coolant Pump 2B Seal Cover Bolting	Seal Cover	1.5" x 8.27"	VT-1	16	5	One	31				
			Studs & Nuts					5	Two	62			
								6	Three	100			
		770	VALVES BOLTS, STUDS AND NUTS	21-SD Cooling Looping 1	UV-651	RC-051-16"	VT-1	2	1	One	50		
					UV-653					SI-240-16"	0	Two	50
											1	Three	100
22-SD Cooling Loop 2	UV-652			RC-068-16"	VT-1	2	1	One	50				
	UV-654							SI-193-16"	1	Two	100		
									0	Three	100		
23-SI Loop 1A	V-235			SI-207-14"	VT-1	4	1	One	25				
	UV-634			SI-207-14"				2	Two	75			
	V-237			SI-207-14"				1	Three	100			
	V-542			SI-203-12"									
24-SI Loop 1B	V-245			SI-223-14"	VT-1	4	1	One	25				
	UV-644			SI-223-14"				2	Two	75			
	V-247			SI-223-14"				1	Three	100			
	V-543			SI-221-12"									
25-SI Loop 2A	V-215			SI-160-14"	VT-1	4	1	One	25				
	UV-614	SI-160-14"	1	Two				50					
	V-217	SI-160-14"	2	Three				100					
	V-540	SI-156-12"											

**APS**PALO VERDE NUCLEAR GENERATING STATION  
10 YEAR INTERVAL - EXAMINATION SUMMARY

## ASME CLASS 1

TABLE 1-7  
PAGE 5 OF 4

ASME ITEM NO.	ZONE-COMPONENT OR SYSTEM	IDENTIFICATION	DESCRIPTION LINE NO., OR SERIAL NO.	NDE METHOD	TOTAL ITEMS	EXAMINATION AMOUNT	INSPECTION PERIOD	RUNNING %	REMARKS AND RELIEF REQUESTS
770	CONTINUED								
	26-SI Loop 2B	V.225 UV-624 V.227 V.541	SI-179-14" SI-179-14" SI-179-14" SI-175-12"	VT-1	4	1 2 1	One Two Three	25 75 100	
	27-PZR Spray Loop 1A	V.240 PV-100E V.243	RC-62-3" RC-62-3" RC-16-3"	VT-1	3	0 1 2	One Two Three	0 33 100	
	28-PZR Spray Loop 1B	V.241 PV-100F V.242	RC-17-3" RC-17-3" RC-18-3"	VT-1	3	2 1 0	One Two Three	66 100 100	
	29-Combined PZR Spray	V.244	RC-18-4"	VT-1	1	0 0 1	One Two Three	0 0 100	
	31-PZR Safeties	PSV-209 PSV-201 PSV-202 PSV-203	RC-1-6" RC-3-6" RC-5-6" RC-7-6"	VT-1	4	1 1 2	One Two Three	25 50 100	
	32-Drain Line Loop 1A	V.334 V.234	RC-60-2" RC-60-2"	VT-1	2	2 0 0	One Two Three	100 100 100	
	33-Drain Line Loop 1B	V.335 V.235	RC-58-2" RC-58-2"	VT-1	2	0 2 0	One Two Three	0 100 100	
	34-Drain Line Loop 2A	V.333 V.233	RC-96-2" RC-96-2"	VT-1	2	0 2 0	One Two Three	0 100 100	
	35-Drain Line Loop 2B	V.332 V.232	RC-89-2" RC-89-2"	VT-1	2	0 0 2	One Two Three	0 0 100	
	36-Letdown Line	UV-515 UV-516	RC-91-2" CH-1-2"	VT-1	2	0 0 2	One Two Three	0 0 100	
	37-Charging Line	PDV-240	CH-5-3"	VT-1	1	1 0 0	One Two Three	100 100 100	

# APS PALO VERDE NUCLEAR GENERATING STATION 10 YEAR INTERVAL - EXAMINATION SUMMARY

## ASME CLASS 1

TABLE 1-7  
PAGE 4 OF 4

ASME ITEM NO.	ZONE-COMPONENT OR SYSTEM	IDENTIFICATION	DESCRIPTION LINE NO., OR SERIAL NO.	NDE METHOD	TOTAL ITEMS	EXAMINATION AMOUNT	INSPECTION PERIOD	RUNNING %	REMARKS AND RELIEF REQUESTS
770	CONTINUED								
	38-Loop 1 Drain	V-215 V-216	RC-70-2" RC-70-2"	VT-1	2	1 0 1	One Two Three	50 50 100	
	39-HPSI Supply Loop 1	V-523 V-522 V-957	SI-248-3" SI-248-3" SI-248-3"	VT-1	3	1 2 0	One Two Three	33 100 100	
	40-HPSI Supply Loop 2	V-533 V-532 V-958	SI-199-3" SI-199-3" SI-199-3"	VT-1	3	0 1 2	One Two Three	0 33 100	
780	CRD HOUSINGS BOLTS, STUDS, AND NUTS								
	2- Closure Head RVLMS Locations	Muron Clamps	CEDM 92 CEDM 96	VT-1	2	1 0 1	One Two Three	50 50 100	

ASME ITEM NO.	ZONE-COMPONENT OR SYSTEM	IDENTIFICATION	DESCRIPTION LISE NO., OP SERIAL NO.	NDE METHOD	TOTAL ITEMS	EXAMINATION AMOUNT	INSPECTION PERIOD	RUNNING %	REMARKS AND RELIEF REQUESTS
B 800	EXAM CATEGORY B-H, INTEGRAL ATTACH- MENTS FOR VESSELS	None							
810	REACTOR VESSEL INTEGRALLY WELDED ATTACHMENTS								
820	PRESSURIZER INTEGRALLY WELDED ATTACHMENTS								
	5. Pressurizer	Support Skirt	SN 65273	S, Vol	1	33% 33% 34%	One Two Three	33 66 100	
830	STEAM GENERATOR, INTEGRALLY WELDED ATTACHMENTS								
	3. Steam Generator 1	Support Skirt	SN 65273-1	Vol	1	33% * 34%	One Two Three	33* * 100*	* MULTIPLE VESSELS, EXAMINATIONS TOTAL 100% SUPPORT SKIRT WELD IN 1 STEAM GENERATOR.
	4. Steam Generator 2	Support Skirt	SN 65273-2	Vol	1	* 33% *	One Two Three	* 66 *	
840	HEAT EXCHANGERS INTEGRALLY WELDED ATTACHMENTS	None							

# APS PALO VERDE NUCLEAR GENERATING STATION

## 10 YEAR INTERVAL - EXAMINATION SUMMARY

### ASME CLASS 1

TABLE 1-9  
PAGE 1 OF 5

ASME ITEM NO.	ZONE-COMPONENT OR SYSTEM	IDENTIFICATION	DESCRIPTION LINE NO., OR SERIAL NO.	NDE METHOD	TOTAL ITEMS	EXAMINATION AMOUNT	INSPECTION PERIOD	RUNNING %	REMARKS AND RELIEF REQUESTS
B 900	EXAM CATEGORY B-J PRESSURE RETAINING WELDS IN PIPING								
910	NOMINAL PIPE SIZE ≥ 4 IN.								
911	CIRCUMFERENTIAL AND								* THE LESSER OF 12" OR 1 PIPE DIAMETER LENGTH FROM SCHEDULED CIRC WELD INTERSECTION WILL BE EXAMINED
912	*LONGITUDINAL WELDS								
	6- RCS Primary Piping	HL 1 HL 2 CL 1A to RCP CL 1B to RCP CL 2A to RCP CL 2B to RCP CL 1A to RPV CL 1B to RPV CL 2A to RPV CL 2B to RPV	RC-32-42" ID RC-63-42" ID RC-33-30" ID RC-30-30" ID RC-73-30" ID RC-84-30" ID RC-34-30" ID RC-31-30" ID RC-79-30" ID RC-93-30" ID	S, Vol	62	7 6 9	One Two Three	11 21 35	AUTOMATED EXAM OF NOZZLE TO EXTENSION AND EXTENSION TO PIPE WELDS
	20-PZR Surge Line	Butt Welds	RC-28-12"	S, Vol	11	1 0 2	One Two Three	9 9 27	
	21-SD Cooling Loop 1	Butt Welds	RC-51-16" SI-240-16"	S, Vol	21	2 2 2	One Two Three	10 19 29	
	22-SD Cooling Loop 2	Butt Welds	RC-68-16" SI-193-16"	S, Vol	19	2 2 3	One Two Three	11 21 37	
	23-SI Loop 1A	Butt Welds	SI-207-14" SI-203-12"	S, Vol	18	3 0 2	One Two Three	17 17 28	

REV 1  
12-23-91



**PALO VERDE NUCLEAR GENERATING STATION  
10 YEAR INTERVAL - EXAMINATION SUMMARY**

**ASME CLASS 1**

ASME ITEM NO.	ZONE-COMPONENT OR SYSTEM	IDENTIFICATION	DESCRIPTION LINE NO., OR SERIAL NO.	NDE METHOD	TOTAL ITEMS	EXAMINATION AMOUNT	INSPECTION PERIOD	RUNNING %	REMARKS AND RELIEF REQUESTS
911 & 912	CONTINUED								
	24-SI Loop 1B	Butt Welds	SI-223-14" SI-221-12"	S, Vol	17	0 3 2	One Two Three	0 18 29	
	25-S <sub>1</sub> Loop 2A	Butt Welds	SI-160-14" SI-156-12"	S, Vol	21	2 3 1	One Two Three	10 24 29	
	26-SI Loop 2B	Butt Welds	SI-179-14" SI-175-12"	S, Vol	17	2 1 2	One Two Three	12 18 29	
	28 & 29- PZR Spray Loop 1B and Combined	Butt Welds	RC-18-4"	S, Vol	15	2 1 2	One Two Three	13 18 33	
	31-PZR Saferies	Butt Welds	RC-1-6" RC-3-6" RC-5-6" RC-7-6"	S, Vol	12	1 2 2	One Two Three	8 25 42	
	36-Letdown Line Delay Coil	Butt Welds	RC-91-16"	S, Vol	4	0 1 0	One Two Three	0 25 25	
920	<u>NOMINAL PIPE SIZE &lt; 4 IN.</u>								* THE LESSER OF 12" OR 1 PIPE DIAMETER LENGTH FROM SCHEDULED CIRC WELD INTERSECTION WILL BE EXAMINED
921 & 922	<u>CIRCUMFERENTIAL AND *LONGITUDINAL WELDS</u>								
	27-PZR Spray Loop 1A	Butt Welds	RC-62-3" RC-16-3"	S	39	3 3 4	One Two Three	8 15 26	
	28-PZR Spray Loop 1B	Butt Welds	RC-17-3" RC-18-3"	S	36	4 3 3	One Two Three	11 19 28	

# APS

## PALO VERDE NUCLEAR GENERATING STATION 10 YEAR INTERVAL - EXAMINATION SUMMARY

### ASME CLASS 1

TABLE 1-9  
PAGE 3 OF 5

ASME ITEM NO.	ZONE-COMPONENT OR SYSTEM	IDENTIFICATION	DESCRIPTION LINE NO., OR SERIAL NO.	NDE METHOD	TOTAL ITEMS	EXAMINATION AMOUNT	INSPECTION PERIOD	RUNNING %	REMARKS AND RELIEF REQUESTS
921 & 922	CONTINUED								* VOL EXAM OF 2 WELDS AND BASE-METAL DOWN-STREAM OF V431 PER IEB 88-08.
	30-Aux PZR spray	Butt Welds	CH-009-2" CH-520-2" CH-521-2"	S	11	2	One*	18	
						2	Two	36	
						0	Three	36	
	32-Drain Line Loop 1A	Butt Welds	RC-60-2"	S	5	2	One	40	
						0	Two	40	
						0	Three	40	
	33-Drain Line Loop 1B	Butt Welds	RC-58-2"	S	5	0	One	0	
						2	Two	40	
						0	Three	40	
	34-Drain Line Loop 2A	Butt Welds	RC-96-2"	S	5	0	One	0	
						0	Two	0	
2						Three	40		
35-Drain Line Loop 2B	Butt Welds	RC-89-2"	S	5	0	One	0		
					0	Two	0		
					2	Three	40		
36-Letdown Line	Butt Welds	RC-91-2"	S	70	4	One	6		
					6	Two	14		
					8	Three	26		
37-Charging Line	Butt Welds	CH-5-3"	S	60	5	One	8		
					6	Two	18		
					6	Three	28		
38-Drain Line Loop 1	Butt Welds	RC-70-2"	S	4	0	One	0		
					1	Two	25		
					0	Three	25		
39-HPSI Supply Loop 1	Butt Welds	SI-248-3"	S	36	2	One	6		
					3	Two	14		
					4	Three	25		
40-HPSI Supply Loop 2	Butt Welds	SI-199-3"	S	24	3	One	13		
					2	Two	21		
					2	Three	29		

REV 1  
12-23-91



# APS PALO VERDE NUCLEAR GENERATING STATION

## 10 YEAR INTERVAL - EXAMINATION SUMMARY

### ASME CLASS 1

TABLE 1-9  
PAGE 4 OF 5

ASME ITEM NO.	ZONE-COMPONENT OR SYSTEM	IDENTIFICATION	DESCRIPTION LINE NO., OR SERIAL NO.	NDE METHOD	TOTAL ITEMS	EXAMINATION AMOUNT	INSPECTION PERIOD	RUNNING %	REMARKS AND RELIEF REQUESTS
930	BRANCH PIPE CONNECTION WELDS								
931	NOMINAL PIPE SIZE ≥ 4 IN.								ITEM B9.31, SYSTEMS COMBINED FOR PERCENTAGE
	6- RCS Primary Piping	Surge	RC-32-42" ID	S, Vol	1	1	Three		
		SD Cooling 1	RC-32-42" ID	S, Vol	1	0	-	-	
		SD Cooling 2	RC-63-42" ID	S, Vol	1	0	-	-	
		SI 1A	RC-34-30" ID	S, Vol	1	1	One	14	
		SI 1B	RC-31-30" ID	S, Vol	1	1	Three	-	
		SI 1C	RC-79-30" ID	S, Vol	1	1	Two	29	
		SI 1D	RC-93-30" ID	S, Vol	1	1	Three	71	
932	NOMINAL PIPE SIZE < 4 IN.								ITEM B9.32, SYSTEMS COMBINED FOR PERCENTAGE
	6- RCS Primary Piping	Drain 1A	RC-33-30" ID	S	1	1	One	-	
		PZR Spray 1A	RC-34-30" ID	S	1	0	-	-	
		Drain 1B	RC-36-30" ID	S	1	0	-	-	
		PZR Spray 1B	RC-31-30" ID	S	1	0	-	-	
		Drain 2A	RC-73-30" ID	S	1	0	-	-	
		Charging	RC-79-30" ID	S	1	1	Two	-	
		Letdown	RC-84-30" ID	S	1	1	Three	42	
	21-SD Cooling Loop 1	2" Drain	RC-051-16"	S	2	0	One	-	
		3" HPSI				0	Two	-	
						0	Three	-	
	22-SD Cooling Loop 2	3" HPSI	RC-068-16"	S	1	1	One	14	
						0	Two	-	
						0	Three	-	
	36-Letdown Line	2" Delay Coil	RC-091-16"	S	4	0	One	-	
						2	Two	36	
						0	Three	-	
940	SOCKET WELDS								
	32-Drain Line Loop 1A	Socket Welds	RC-060-2"	S	3	1	One	33	
						0	Two	33	
						0	Three	33	
	33-Drain Line Loop 1B	Socket Welds	RC-058-2"	S	3	0	One	0	
						1	Two	33	
						0	Three	33	





**PALO VERDE NUCLEAR GENERATING STATION  
10 YEAR INTERVAL - EXAMINATION SUMMARY**

**ASME CLASS 1**

TABLE 1-9  
PAGE 5 OF 5

ASME ITEM NO.	ZONE-COMPONENT OR SYSTEM	IDENTIFICATION	DESCRIPTION LINE NO., OR SERIAL NO.	NDE METHOD	TOTAL ITEMS	EXAMINATION AMOUNT	INSPECTION PERIOD	RUNNING %	REMARKS AND RELIEF REQUESTS
940	<u>CONTINUED</u>								
	34-Drain Line Loop 2A	Socket Welds	RC-096-2"	S	3	0 1 0	One Two Three	0 33 33	
	35-Drain Line Loop 2B	Socket Welds	RC-089-2"	S	3	0 0 1	One Two Three	0 0 33	
	38-Drain Line Loop 1	Socket Welds	RC-070-2"	S	3	1 0 0	One Two Three	33 33 33	

# APS PALO VERDE NUCLEAR GENERATING STATION

## 10 YEAR INTERVAL - EXAMINATION SUMMARY

### ASME CLASS 1

TABLE 1-10  
PAGE 1 OF 1

ASME ITEM NO.	ZONE-COMPONENT OR SYSTEM	IDENTIFICATION	DESCRIPTION LINE NO., OR SERIAL NO.	NDE METHOD	TOTAL ITEMS	EXAMINATION AMOUNT	INSPECTION PERIOD	RUNNING %	REMARKS AND RELIEF REQUESTS
B 1000	EXAM CATEGORY B-E-1, INTEGRAL ATTACHMENTS FOR PIPING, PUMPS, AND VALVES								
1010	PIPING INTEGRALLY WELDED ATTACHMENTS								ITEM B10.10 COMBINED FOR PERCENTAGE
	22-SD Cooling Loop 2	Lugs	SI-193-16"	S	1	1	Two		
	24-SI Loop 1B	Stanchion	SI-223-14"	S	1	1	Three		
	25-SI loop 2A	Stanchion	SI-160-14"	S	1	1	Three	100	
	26-SI Loop 2B	Stanchion	SI-179-14"	S	1	1	One		
	36-Letdown Line	Lugs	RC-091-16"	S	2	1 1	One Two	33 66	
1020	PUMPS INTEGRALLY WELDED ATTACHMENTS	None	-	-	-	-	-	-	
1030	VALVES INTEGRALLY WELDED ATTACHMENTS	None	-	-	-	-	-	-	

# APS

## PALO VERDE NUCLEAR GENERATING STATION 10 YEAR INTERVAL - EXAMINATION SUMMARY

### ASME CLASS 1

TABLE 1-12  
PAGE 1 OF 2

ASME ITEM NO.	ZONE-COMPONENT OR SYSTEM	IDENTIFICATION	DESCRIPTION LINE NO., OR SERIAL NO.	NDE METHOD	TOTAL ITEMS	EXAMINATION AMOUNT	INSPECTION PERIOD	RUNNING %	REMARKS AND RELIEF REQUESTS
B 1200	EXAM CATEGORY B-L-1, B-M-1; PRESSURE RETAINING WELDS IN PUMP CASINGS AND VALVE BODIES; EXAM CATEGORY B-L-2, B-M-2; PUMP CASINGS AND VALVE BODIES								
	PUMPS								
1210	PUMP CASING WELDS	None	-	-	-	-	-	-	
1220	PUMP CASINGS								
	16-RC Pump 1A	Internal	1259	VT-3	4	Examine the Internal Surfaces in 1 Pump	*	100	* BY THE END OF THE INTERVAL
	17-RC Pump 1B	Surfaces	1261						
	18-RC Pump 2A		1260						
	19-RC Pump 2B		1262						
	VALVES								
1230	VALVES, NOMINAL PIPE SIZE < 4 IN. VALVE BODY WELDS	None	-	-	-	-	-	-	
1240	VALVES, NOMINAL PIPE SIZE ≥ 4 IN. VALVE BODY WELDS								
	Borg Warner Gate Valves Utilizing Forged Construction	UV-651 UV-653 UV-652 UV-654 UV-634 UV-644 UV-614 UV-624	RC-51-16" SI-240-16" RC-68-16" SI-193-16" SI-207-14" SI-223-14" SI-160-14" SI-179-14"	Vol	8	Examine the Weld in 1 Valve	*	100	* BY THE END OF THE INTERVAL



**PALO VERDE NUCLEAR GENERATING STATION  
10 YEAR INTERVAL - EXAMINATION SUMMARY**

**ASME CLASS 1**

TABLE 1-12  
PAGE 2 OF 2

ASME ITEM NO.	ZONE-COMPONENT OR SYSTEM	IDENTIFICATION	DESCRIPTION LINE NO., OR SERIAL NO.	NDE METHOD	TOTAL ITEMS	EXAMINATION AMOUNT	INSPECTION PERIOD	RUNNING %	REMARKS AND RELIEF REQUESTS
1240	<u>CONTINUED</u>								
	Borg Warner Check Valve Utilizing Forged Construction	V-244	RC-18-4"	Vol	1	1	*	100	* BY THE END OF THE INTERVAL
	Dresser Pressure Safety Valves Utilizing Forged Construction	PSV-200 PSV-201 PSV-202 PSV-203	RC-1-6" RC-3-6" RC-5-6" RC-7-6"	Vol	4	Examine the Weld in 1 Valve	*	100	
1250	<u>VALVE BODY EXCEEDING 4 IN. NOMINAL PIPE SIZE</u>								
	Borg Warner Gate Valves Utilizing Forged Construction	UV-631 UV-633 UV-632 UV-634 UV-644 UV-614 UV-624	RC-51-16" SI-240-16" RC-68-16" SI-193-16" SI-207-14" SI-223-14" SI-160-14" SI-179-14"	VT-3	8	Examine the Internal Surfaces of 1 Valve	*	100	
	Borg Warner Check Valves Utilizing Forged Construction	V-235 V-237 V-542 V-245 V-247 V-543 V-215 V-217 V-540 V-225 V-227 V-541	SI-207-14" SI-207-14" SI-203-12" SI-223-14" SI-223-14" SI-221-12" SI-160-14" SI-160-14" SI-156-12" SI-179-14" SI-179-14" SI-175-12"	VT-3	12	Examine the Internal Surfaces of 1 Valve	*	100	
	Dresser Pressure Safety Valves Utilizing Forged Construction	PSV-200 PSV-201 PSV-202 PSV-203	RC-1-6" RC-3-6" RC-5-6" RC-7-6"	VT-3	4	Examine the Internal Surfaces of 1 Valve	*	100	

# APS

## PALO VERDE NUCLEAR GENERATING STATION 10 YEAR INTERVAL - EXAMINATION SUMMARY

### ASME CLASS 1

TABLE 1-13  
PAGE 1 OF 1

ASME ITEM NO.	ZONE-COMPONENT OR SYSTEM	IDENTIFICATION	DESCRIPTION LINE NO., OR SERIAL NO.	NDE METHOD	TOTAL ITEMS	EXAMINATION AMOUNT	INSPECTION PERIOD	RUNNING %	REMARKS AND RELIEF REQUESTS
B 1300	EXAM CATEGORY B-N-1; INTERIOR OF REACTOR VESSEL; B-N-2, INTEGRALLY WELDED CORE SUPPORT STRUCTURES AND INTERIOR ATTACHMENTS TO REACTOR VESSELS; B-N-3, REMOVABLE CORE SUPPORT STRUCTURES								
1310	REACTOR VESSEL VESSEL INTERIOR  1- Reactor Vessel			VT-3	Accessible Areas	33% 33% 34%	*One *Two *Three	33 66 100	*EXAMINE AT 1st REFUELING OUTAGE, AND SUBSEQUENTLY AT 3-YEAR INTERVALS
1320	REACTOR VESSEL (BWR) INTERIOR ATTACHMENTS	N/A							
1321	CORE SUPPORT STRUCTURE	N/A							
1322									
1330	INTERIOR ATTACHMENTS WITHIN BELTLINE REGION	None							
1331	INTERIOR ATTACHMENTS BEYOND BELTLINE REGION			VT-3	Accessible Welds	100%	**	100	** BY THE END OF THE INTERVAL
1332	CORE SUPPORT STRUCTURE			VT-3	Accessible Surfaces	100%	**	100	

REV 1  
12-23-91

# APS

## PALO VERDE NUCLEAR GENERATING STATION 10 YEAR INTERVAL - EXAMINATION SUMMARY

### ASME CLASS 1

TABLE 1-14  
PAGE 1 OF 1

ASME ITEM NO.	ZONE-COMPONENT OR SYSTEM	IDENTIFICATION	DESCRIPTION LINE NO., OR SERIAL NO.	NDE METHOD	TOTAL ITEMS	EXAMINATION AMOUNT	INSPECTION PERIOD	RUNNING %	REMARKS AND RELIEF REQUESTS
B 1400	EXAM CATEGORY B-O; PRESSURE RETAINING WELDS IN CONTROL ROD HOUSINGS								
1410	REACTOR VESSEL WELDS IN CRD HOUSING								ITEM B14.10 COMBINED FOR PERCENTAGE
	2- Reactor Vessel Closure Head CEDM Housings	Lower Housing Welds	Housings #66 - #97	Vol	97 *	0 0 0	One Two Three	- - -	*32 PERIPHERAL (126 TOTAL WELDS)
	2- Reactor Vessel Closure Heads CEDM Housings	Upper Housing Welds	Housings #66 - #97	Vol	97 *	2 2 3	One Two Three	- - -	** INCLUDES 2 RVLMS TRANSITION HUBS.
	2- Reactor Vessel/Tube Housing Closure Heads CEDM Housings	Housings ** Lower Weld	Vol #66 - #97	97	* 2	One 2 3	3 Two Three	- 6 11	
	2- Reactor Vessel Closure Heads CEDM Housings	Tube Housing Upper Weld	Housings #66 - #97	Vol	97 *	0 0 0	One Two Three	- - -	

# APS

## PALO VERDE NUCLEAR GENERATING STATION 10 YEAR INTERVAL - EXAMINATION SUMMARY

### ASME CLASS 1

TABLE 1-15  
PAGE 1 OF 1

ASME ITEM NO.	ZONE-COMPONENT OR SYSTEM	IDENTIFICATION	DESCRIPTION LINE NO., OR SERIAL NO.	NDE METHOD	TOTAL ITEMS	EXAMINATION AMOUNT	INSPECTION PERIOD	RUNNING %	REMARKS AND RELIEF REQUESTS
B 1500	<u>EXAMINATION CATEGORY</u> B-P. ALL PRESSURE RETAINING COMPONENTS								
	<u>SYSTEM LEAKAGE TEST</u>								
1510	Reactor Vessel	Pressure		VT-2		Entire Pressure retaining boundary IWA-5000 IWB-5000	*	100	* EACH REFUELING OUTAGE
1520	Pressurizer	Retaining			***				
1530	Steam Generators	Boundary							
1540	Heat Exchangers								
1550	Piping								
1560	Pumps								
1570	Valves								
	<u>SYSTEM HYDRO-TEST</u>								
1511	Reactor Vessel	Pressure		VT-2		Entire Pressure retaining boundary IWA-5000 IWB-5000	**	100	** BY THE END OF THE INTERVAL
1521	Pressurizer	Retaining							
1531	Steam Generators	Boundary							
1541	Heat Exchangers								
1551	Piping								
1561	Pumps								
1571	Valves								*** PERFORM WALKDOWN AT THE BEGINNING OF EACH REFUELING OUTAGE FOR GENERIC LETTER 88-05. IN ADDITION, WALKDOWNS SHOULD ALSO BE PERFORMED FOR SHUTDOWNS FOLLOWING OPERATION LONGER THAN APPROXIMATELY 6 MONTHS IN MODE 1 OR 2.

REV. 1  
12-23-91





# APS

## PALO VERDE NUCLEAR GENERATING STATION 10 YEAR INTERVAL - EXAMINATION SUMMARY

### ASME CLASS 1

TABLE 1-IWF  
PAGE 1 OF 3

ASME ITEM NO.	ZONE-COMPONENT OR SYSTEM	IDENTIFICATION	DESCRIPTION LINE NO., OR SERIAL NO.	NDE METHOD	TOTAL ITEMS	EXAMINATION AMOUNT	INSPECTION PERIOD	RUNNING %	REMARKS AND RELIEF REQUESTS
* F 110 F 120 F 130 F 140 F 210 F 220 F 230 F 240 F 310 F 320 F 330 F 340 F 350	EXAM CATEGORY F-A, PLATE AND SHELL TYPE SUPPORTS and EXAM CATEGORY F-B, LINEAR TYPE SUPPORTS and EXAM CATEGORY F-C, COMPONENT STANDARD SUPPORTS								REQUEST FOR RELIEF #1 & #3  * INCLUDES EXAM ITEMS IDENTIFIED AS APPLICABLE.  ** NDE METHOD INCLUDES VT-4 EXAMS, WHERE APPLICABLE.
	1- Reactor Vessel	Support Columns	SN 65173	** VT-3	4	0 *** 0 0	One Two Three	0 0 0	*** REQUEST FOR RELIEF #6.
	3- Steam Generator 1	Support Skirt	SN 65273-1	VT-3	1	1 0 0	One Two Three	100 100 100	
	4- Steam Generator-2	Support Skirt	SN 65273-2	VT-3	1	0 1 0	One Two Three	- 100 100	
	5- Pressurizer	Support Skirt	SN 65373	VT-3	1	0 0 1	One Two Three	- - 100	
	16-Reactor Coolant Pump 1A	Vertical and Lateral Supports	SN 1111-1A	VT-3	10	2 4 4	One Two Three	20 60 100	
	17-Reactor Coolant Pump 1B	Vertical and Lateral Supports	SN 1111-1B	VT-3	10	2 4 4	One Two Three	20 60 100	
	18-Reactor Coolant Pump 2A	Vertical and Lateral Supports	SN 1111-2A	VT-3	10	4 2 4	One Two Three	40 60 100	
	19-Reactor Coolant Pump 2B	Vertical and Lateral Supports	SN 1111-2B	VT-3	10	4 2 4	One Two Three	40 60 100	

REV. 1  
12-23-91

# APS PALO VERDE NUCLEAR GENERATING STATION 10 YEAR INTERVAL - EXAMINATION SUMMARY

## ASME CLASS 1

TABLE 1-IWF  
PAGE 2 OF 3

ASME ITEM NO.	ZONE-COMPONENT OR SYSTEM	IDENTIFICATION	DESCRIPTION LINE NO., OR SERIAL NO.	NDE METHOD	TOTAL ITEMS	EXAMINATION AMOUNT	INSPECTION PERIOD	RUNNING %	REMARKS AND RELIEF REQUESTS
F 110	CONTINUED								
F 120									
F 130									
F 140	20-PZR Surge Line	Supports	RC-28-12"	VT-3	7	2	One	29	
F 210						2	Two	58	
F 220						3	Three	100	
F 230	21-SD Cooling Loop 1	Supports	RC-51-16" SI-240-16"	VT-3	22	7	One	32	
F 240						7	Two	64	
F 310						8	Three	100	
F 320	22-SD Cooling Loop 2	Supports (1-B10.10)	RC-68-16" SI-193-16"	VT-3	13	4	One	31	
F 330						5	Two	69	
F 340						4	Three	100	
F 350	23-SI Loop 1A	Supports	SI-207-14" SI-203-12"	VT-3	6	1	One	17	
						2	Two	50	
						3	Three	100	
	24-SI Loop 1B	Supports (1-B10.10)	SI-223-14" SI-221-12"	VT-3	8	2	One	25	
						2	Two	50	
						4	Three	100	
	25-SI Loop 2A	Supports (1-B10.10)	SI-160-14" SI-156-12"	VT-3	7	2	One	29	
						3	Two	71	
						2	Three	100	
	26-SI Loop 2B	Supports (1-B10.10)	SI-179-14" SI-175-12"	VT-3	8	3	One	38	
						3	Two	75	
						2	Three	100	
	27-PZR Spray Loop 1A	Supports	RC-62-3" RC-16-3"	VT-3	26	9	One	35	
						9	Two	69	
						8	Three	100	
	28-PZR Spray Loop 1B	Supports	RC-17-3" RC-18-3" RC-18-4"	VT-3	28	9	One	32	
						8	Two	61	
						11	Three	100	
	29-PZR Spray Loop 1B and Combined	Supports	RC-18-4"	VT-3	3	2	One	67	
						1	Two	100	
						0	Three	100	
	30-Aux PZR Spray	Supports	CH-521-2"	VT-3	2	0	One	-	
						0	Two	-	
						2	Three	100	

REV. 1  
12-23-91

# APS PALO VERDE NUCLEAR GENERATING STATION 10 YEAR INTERVAL - EXAMINATION SUMMARY

## ASME CLASS 1

TABLE 1-IWF  
PAGE 3 OF 3

ASME ITEM NO.	ZONE-COMPONENT OR SYSTEM	IDENTIFICATION	DESCRIPTION LINE NO., OR SERIAL NO.	NDE METHOD	TOTAL ITEMS	EXAMINATION AMOUNT	INSPECTION PERIOD	RUNNING %	REMARKS AND RELIEF REQUESTS
F 110	CONTINUED								
F 120									
F 130	32-Drain Line	Supports	RC-60-2"	VT-3	2	2	One	100	
F 140	Loop 1A					0	Two	100	
F 210						0	Three	100	
F 220									
F 230	33-Drain Line	Supports	RC-58-2"	VT-3	2	0	One	-	
F 240	Loop 1B					2	Two	100	
F 310						0	Three	100	
F 320									
F 330	34-Drain Line	Supports	RC-96-2"	VT-3	2	0	One	-	
F 340	Loop 2A					2	Two	100	
F 350						0	Three	100	
	35-Drain Line	Supports	RC-89-2"	VT-3	2	0	One	-	
	Loop 2B					0	Two	-	
						2	Three	100	
	36-Letdown Line	Supports (2-B10.10)	RC-91-2" CH-001-2"	VT-3	30	9	One	30	
						10	Two	63	
						11	Three	100	
	37-Charging Line	Supports	CH-5-3"	VT-3	43	14	One	33	
						14	Two	65	
						15	Three	100	
	38-Drain Line	Supports	RC-70-2"	VT-3	2	0	One	0	
	Loop 1					0	Two	0	
						2	Three	100	
	39-HPSI Supply	Supports	SI-248-3"	VT-3	14	4	One	29	
	Loop 1					5	Two	62	
						5	Three	100	
	40-HPSI Supply	Supports	SI-199-3"	VT-3	9	3	One	33	
	Loop 2					4	Two	77	
						2	Three	100	
N/A	Snobobs: IWF-5000 All inservice testing requirements will be performed in accordance with PVNGS Technical Specifications								REQUEST FOR RELIEF #1.

REV 1  
12-23-91

# APS

## PALO VERDE NUCLEAR GENERATING STATION 10 YEAR INTERVAL - EXAMINATION SUMMARY

### ASME CLASS 1

TABLE 1-RCP  
PAGE 1 OF 1

ASME ITEM NO.	ZONE-COMPONENT OR SYSTEM	IDENTIFICATION	DESCRIPTION LINE NO., OR SERIAL NO.	NDE METHOD	TOTAL ITEMS	EXAMINATION AMOUNT	INSPECTION PERIOD	RUNNING %	REMARKS AND RELIEF REQUESTS
N/A	<u>REACTOR COOLANT PUMP FLYWHEEL EXAMINATIONS</u>  <u>REG. GUIDE 1.14.</u>  16, 17, 18 and 19 Reactor Coolant Pumps 1A, 1B, 2A and 2B Flywheels	Flywheels		Vol*  S, Vol**	4  4	4  4	One Two  Three	100 100  100	REFERENCE PVNGS TECHNICAL SPECIFICATION 4.4.9  * AN ULTRASONIC EXAMINATION WILL BE PERFORMED OF OF THE AREAS OF HIGHER STRESS CONCENTRATION AT THE BORE AND KEYWAYS.  ** A SURFACE EXAM OF ALL EXPOSED SURFACES AND A COMPLETE ULTRASONIC EXAM TO THE EXTENT PRACTICAL WILL BE PERFORMED.

SECTION 5.0  
ASME CLASS 2  
EXAMINATION SUMMARY

## INDEX

TABLE		EXAM CATEGORY
2-1	C-A,	Pressure Retaining Welds in Pressure Vessels
2-2	C-B,	Pressure Retaining Nozzle Welds in Vessels
2-3	C-C,	Integral Attachments for Vessels, Piping, Pumps, and Valves
2-4	C-D,	Pressure Retaining Bolting Greater than 2 in. in Diameter
2-5	C-F,	Pressure Retaining Welds in Piping
2-6	C-G,	Pressure Retaining Welds in Pumps and Valves
2-7	C-H,	All Pressure Retaining Components
2-IWF	F-A, F-B, F-C,	Plates and Shell Type Supports Linear Type Supports Component Standard Supports

ASME ITEM NO.	ZONE-COMPONENT OR SYSTEM	IDENTIFICATION	DESCRIPTION LINE NO., OR SERIAL NO.	NDE METHOD	TOTAL ITEMS	EXAMINATION AMOUNT	INSPECTION PERIOD	RUNNING %	REMARKS AND RELIEF REQUESTS
C100	EXAM. CATEGORY C.A. PRESSURE RETAINING WELDS IN PRESSURE VESSELS.								
110	STEAM GENERATORS SHELL CIRCUMFERENCE TIAL WELDS 41- Steam Generator 1 42- Steam Generator 2	Shell to Conical Welds Shell to Conical Welds	SN-65273-1 SN-65273-2	Vol Vol	2 2	1* 0 0 0 0 1**	One Two Three One Two Three	50 - - - - 100	MULTIPLE VESSELS PERCENTAGE COMBINED *50% EACH WELD **80% EACH WELD
120	HEAD CIRCUMFERENCE TIAL WELDS 41- Steam Generator 1 42- Steam Generator 2	Head to Shell Weld Head to Shell Weld	SN-65273-1 SN-65273-2	Vol Vol	1 1	50% 0 0 0 0 50%	One Two Three One Two Three	50 - - - - 100	
130	TUBESHEET TO SHELL WELD 41- Steam Generator 1 42- Steam Generator 2	Outside Shell and Stay Cylinder Outside Shell and Stay Cylinder	SN-65273-1 SN-65273-2	Vol Vol	2 2	50%* 0 0 0 0 1**	One Two Three One Two Three	25 - - - - 90 100	*OUTSIDE SHELL WELDS **STAY CYLINDER EXAM

**APS**PALO VERDE NUCLEAR GENERATING STATION  
10 YEAR INTERVAL - EXAMINATION SUMMARY

ASME CLASS 2

TABLE 2-1  
PAGE 2 OF 3

ASME ITEM NO.	ZONE-COMPONENT OR SYSTEM	IDENTIFICATION	DESCRIPTION LINE NO., OR SERIAL NO.	NDE METHOD	TOTAL ITEMS	EXAMINATION AMOUNT	INSPECTION PERIOD	RUNNING %	REMARKS AND RELIEF REQUESTS
110	REGENERATIVE HEAT EXCHANGER SHELL CIRCUMFERENTIAL WELDS							1	SINGLE VESSEL
	68-Regenerative Heat Exchanger	Butt Welds	SN-79314	Vol	3	1 1 1	One Two Three	33 66 100	
120	HEAD CIRCUMFERENTIAL WELDS								
	68-Regenerative Heat Exchanger	Head to Shell	SN-79314	Vol	2	1 0 1	One Two Three	50 50 100	
130	TUBESHEET-TO-SHELL WELDS								
	68-Regenerative Heat Exchanger	Butt Welds	SN-79314	Vol	4	0 2 2	One Two Three	0 50 100	
110	LETDOWN HEAT EXCHANGER SHELL CIRCUMFERENTIAL WELDS								SINGLE VESSEL
	69-Letdown Heat Exchanger	Shell to Flange	SN-N2376	Vol	1	50% 0 50%	One Two Three	50 50 100	
120	HEAD CIRCUMFERENTIAL WELDS	None							
130	TUBESHEET-TO-SHELL WELD								
	69-Letdown Heat Exchanger	Butt Weld	SN-N2376	Vol	1	50% 0 50%	One Two Three	50 50 100	



# APS PALO VERDE NUCLEAR GENERATING STATION 10 YEAR INTERVAL - EXAMINATION SUMMARY

## ASME CLASS 2

TABLE 2-1  
PAGE 3 OF 3

ASME ITEM NO.	ZONE-COMPONENT OR SYSTEM	IDENTIFICATION	DESCRIPTION LINE NO., OR SERIAL NO.	NDE METHOD	TOTAL ITEMS	EXAMINATION AMOUNT	INSPECTION PERIOD	RUNNING %	REMARKS AND RELIEF REQUESTS
	SHUTDOWN COOLING HEAT EXCHANGERS								MULTIPLE VESSELS PERCENTAGE COMBINED
110	SHELL CIRCUMFERENTIAL WELDS								
	84-SD Cooling Heat Exchanger 1	Shell to Flange	SN-18345	Vol	1	0 50% 0	One Two Three	- 50 50	
	87-SD Cooling Heat Exchanger 2	Shell to Flange	SN-18346	Vol	1	0 0 50%	One Two Three	- - 100	
120	HEAD CIRCUMFERENTIAL WELDS	None	-	-	-	-	-	-	
130	TUBESHEET-TO-SHELL WELD								
	84-SD Cooling Heat Exchanger 1	Butt Weld	SN-18345	Vol	1	0 50% 0	One Two Three	- 50 50	
	87-SD Cooling Heat Exchanger 2	Butt Weld	SN-18346	Vol	1	0 0 50%	One Two Three	- - 100	

REV 1  
12-23-91

# APS

## PALO VERDE NUCLEAR GENERATING STATION 10 YEAR INTERVAL - EXAMINATION SUMMARY

### ASME CLASS 2

TABLE 2-2  
PAGE 1 OF 2

ASME ITEM NO.	ZONE-COMPONENT OR SYSTEM	IDENTIFICATION	DESCRIPTION LINE NO., OR SERIAL NO.	NDE METHOD	TOTAL ITEMS	EXAMINATION AMOUNT	INSPECTION PERIOD	RUNNING %	REMARKS AND RELIEF REQUESTS
C200	EXAM CATEGORY C-B: PRESSURE RETAINING NOZZLE WELDS IN VESSELS								
210	NOZZLE IN VESSELS ≤ 1/2 IN NOMINAL THICKNESS	None							
230	NOZZLES WITHOUT REINFORCING PLATE IN VESSELS > 1/2 IN NOMINAL THICKNESS								
221 & 222	NOZZLE-TO-SHELL (OR HEAD) WELDS AND NOZZLE INSIDE RADIUS SECTION								INSIDE RADIUS ON PIPING ONLY GREATER THAN 12" DIAMETER MULTIPLE VESSELS PERCENTAGE COMBINED
	41- Steam Generator 1	Nozzle to Vessel Welds	SN-65273-1	S,Vol	7	1 0 2	One Two Three	29 - 100	
	42- Steam Generator 2	Nozzle to Vessel Welds	SN-65273-2	S,Vol	7	1 2 1	One Two Three	- 57 -	
	84-SD Cooling Heat Exchanger 1	Nozzle to Shell Welds	SN-18345	S,Vol	2	0 1 0	One Two Three	- 50 -	MULTIPLE VESSELS PERCENTAGE COMBINED
	87-SD Cooling Heat Exchanger 2	Nozzle to Shell Welds	SN-18346	S,Vol	2	0 0 1	One Two Three	- - 100	

REV. 1  
12-23-91

ASME ITEM NO.	ZONE-COMPONENT OR SYSTEM	IDENTIFICATION	DESCRIPTION LINE NO., OR SERIAL NO.	NDE METHOD	TOTAL ITEMS	EXAMINATION AMOUNT	INSPECTION PERIOD	RUNNING %	REMARKS AND RELIEF REQUESTS
230	NOZZLES WITH REINFORCING PLATE IN VESSELS > 1/2 IN. NOMINAL THICKNESS								
231	REINFORCING PLATE WELDS TO NOZZLE AND VESSEL	None							
232	NOZZLE TO SHELL (OR HEAD) WELDS	None							
	INSIDE OF VESSEL ACCESSIBLE	None							
	INSIDE OF VESSEL INACCESSIBLE	None							



**PALO VERDE NUCLEAR GENERATING STATION  
10 YEAR INTERVAL - EXAMINATION SUMMARY**

**ASME CLASS 2**

ASME ITEM NO.	ZONE-COMPONENT OR SYSTEM	IDENTIFICATION	DESCRIPTION LINE NO., OR SERIAL NO.	NDE METHOD	TOTAL ITEMS	EXAMINATION AMOUNT	INSPECTION PERIOD	RUNNING %	REMARKS AND RELIEF REQUESTS
C300	EXAM CATEGORY C-C, INTEGRAL ATTACHMENTS FOR VESSELS, PIPING PUMPS AND VALVES								
310	PRESSURE VESSELS INTEGRALLY WELDED ATTACHMENTS								
	41- Steam Generator 1	2- Snubber Lugs	SN-65273-1	S	2	1 0 0	One Two Three	50 - -	MULTIPLE VESSELS- PERCENTAGE COMBINED
	42- Steam Generator 2	2- Snubber Lugs	SN-65273-2	S	2	0 1 0	One Two Three	- 100 -	
	68- Regenerative Heat Exchanger	2- Supports	SN-79314	S	2	0 1 1	One Two Three	- 50 100	SINGLE VESSEL
320	PIPING INTEGRALLY WELDED ATTACHMENTS								
	43- Main Steam SG-1 90° Inside Cont.	Attachments	SG-36	S	6	1 1 4	One Two Three	16 33 100	
	44- Main Steam SG-1 270° Inside Cont.	Attachments	SG-33	S	5	0 3 2	One Two Three	- 60 100	
	45- Main Steam SG-2 270° Inside Cont.	Attachments	SG-42	S	5	3 1 1	One Two Three	60 80 100	
	46- Main Steam SG-2 90° Inside Cont.	Attachments	SG-45	S	5	0 2 3	One Two Three	- 40 100	

REV. 1  
12-23-91

# APS PALO VERDE NUCLEAR GENERATING STATION

## 10 YEAR INTERVAL - EXAMINATION SUMMARY

### ASME CLASS 2

TABLE 2-3  
PAGE 2 OF 4

ASME ITEM NO.	ZONE-COMPONENT OR SYSTEM	IDENTIFICATION	DESCRIPTION LINE NO., OR SERIAL NO.	NDE METHOD	TOTAL ITEMS	EXAMINATION AMOUNT	INSPECTION PERIOD	RUNNING %	REMARKS AND RELIEF REQUESTS
320	CONTINUED								
	54-Feedwater SG-1 Inside Cont.	Attachments	SG-002	S	1	0 0 1	One Two Three	- - 100	
	55-Feedwater SG-2 Inside Cont.	Attachments	SG-005	S	2	1 0 1	One Two Three	50 50 100	
	62-Aux. Feedwater SG-1	Attachments	AF-018	S	1	0 1 0	One Two Three	- 100 100	
	64-Blowdown SG-1 Inside Cont.	Attachments	SG-39 SG-53	S	5	3 1 1	One Two Three	60 80 100	
	65-Blowdown SG-2 Inside Cont.	Attachments	SG-48 SG-52	S	7	2 3 2	One Two Three	29 71 100	
	71-LPSI Room A Discharge	Attachments	SI-87	S	1	1	One	-	SI SYSTEM % 'S COMBINED
	76-CS Room A Suction	Attachments	SI-9	S	1	1 1	One Three	-	
	77-CS Room A Discharge	Attachments	SI-79	S	1	1	Three	-	
	80-CS Room B Discharge	Attachments	SI-119	S	1	1	Three	-	
	82-SDCHX Room A	Attachments	SI-78	S	1	1	Three	-	
	83-SDCHX Room A	Attachments	SI-70 SI-87 SI-90	S	4	2 2	Two Three	-	
	86-SDCHX Room B	Attachments	SI-72	S	2	2	Three	-	
	88-East Wrap	Attachments	SI-72	S	1	1	One	-	
	89-East Wrap	Attachments	SI-194	S	1	1	One	-	

REV 1  
12-23-91

# APS PALO VERDE NUCLEAR GENERATING STATION 10 YEAR INTERVAL - EXAMINATION SUMMARY

## ASME CLASS 2

TABLE 2-3  
PAGE 1 OF 4

ASME ITEM NO.	ZONE-COMPONENT OR SYSTEM	IDENTIFICATION	DESCRIPTION LINE NO., OR SERIAL NO.	NDE METHOD	TOTAL ITEMS	EXAMINATION AMOUNT	INSPECTION PERIOD	RUNNING %	REMARKS AND RELIEF REQUESTS
320	CONTINUED								
	91-Weat Wrap	Attachments	SI-70	S	4	4	One	-	
	92-Weat Wrap	Attachments	SI-239 SI-241	S	3	1 2	One Two	- -	
	93-Weat Wrap	Attachments	SI-89	S	1	1	Two	-	
	94-SI A & 88'	Attachments	SI-70	S	2	2	Two	-	
	95-SI B & 88'	Attachments	SI-194	S	1	1	Three	-	
	96-SI LPSI 1A	Attachments	SI-202	S	1	1	Three	-	
	99-SI LPSI 2B	Attachments	SI-174	S	1	1	Two	-	
	100-SI LPSI A	Attachments	SI-7 SI-369	S	2	1 1	One Two	- -	
	101-SI LPSI B	Attachments	SI-30	S	1	1	Three	-	
	Total Safety Injection			S	29	10 9 10	One Two Three	34 66 100	
330	PUMPS INTEGRALLY WELDED ATTACHMENTS								
	72-4 LPSI Pump Loop 1	Attachment Lugs	SN 0876-44	S	3	2 1	One Two Three	66 100 100	
	75-4 LPSI Pump Loop 2	Attachment Lugs	SN 0876-45	S	3	0 1 2	One Two Three	- 33 100	
	78-Containment Spray Pump Loop 1	Attachment Lugs	SN 0876-46	S	3	2 1 0	One Two Three	66 100 100	

REV 1  
12-23-91

ASME ITEM NO.	ZONE-COMPONENT OR SYSTEM	IDENTIFICATION	DESCRIPTION LINE NO., OR SERIAL NO.	NDE METHOD	TOTAL ITEMS	EXAMINATION AMOUNT	INSPECTION PERIOD	RUNNING %	REMARKS AND RELIEF REQUESTS
330	CONTINUED 81 Containment Sporry Pump Loop 2	Attachments Logs	SN 0876-47	S	3	0 1 2	One Two Three	100	
340	VALVES INTEGRALLY WELDED ATTACHMENTS	None							

**APS****PALO VERDE NUCLEAR GENERATING STATION  
10 YEAR INTERVAL - EXAMINATION SUMMARY****ASME CLASS 2**TABLE 2.4  
PAGE 1 OF 1

ASME ITEM NO.	ZONE-COMPONENT OR SYSTEM	IDENTIFICATION	DESCRIPTION LINE NO., OR SERIAL NO.	NDE METHOD	TOTAL ITEMS	EXAMINATION AMOUNT	INSPECTION PERIOD	RUNNING %	REMARKS AND RELIEF REQUESTS
C400	EXAM CATEGORY C-D: PRESSURE RETAINING BOLTING EXCEEDING 2 IN. IN DIAMETER								
410	PRESSURE VESSELS BOLTS AND STUDS	None	-	-	-	-	-	-	
420	PIPING BOLTS AND STUDS	None	-	-	-	-	-	-	
430	PUMPS BOLTS AND STUDS	None	-	-	-	-	-	-	
440	VALVES BOLTS AND STUDS								
	47-Main Steam SG-1 270° MSSS	Bonnet Bolts	UV-170	Vol	20	20	One	(25)	ITEM C440 COMBINED FOR PERCENTAGE
	48-Main Steam SG-1 90° MSSS	Bonnet Bolts	UV-180	Vol	20	20	One	(25)	
	49-Main Steam SG-2 270° MSSS	Bonnet Bolts	UV-171	Vol	20	20	Three	(100)	
	50-Main Steam SG-2 90° MSSS	Bonnet Bolts	UV-181	Vol	20	20	Three	(100)	
	56-Feedwater SG-1 MSSS	Bonnet Bolts	UV-132 UV-174	Vol Vol	20 20	20 20	Two Two	(50) (50)	
	57-Feedwater SG-2 MSSS	Bonnet Bolts	UV-137 UV-177	Vol Vol	20 20	20 20	Three Three	(100) (100)	



ASME ITEM NO.	ZONE-COMPONENT OR SYSTEM	IDENTIFICATION	DESCRIPTION LINE NO., OR SERIAL NO.	NDE METHOD	TOTAL ITEMS	EXAMINATION AMOUNT	INSPECTION PERIOD	RUNNING %	REMARKS AND RELIEF REQUESTS
C500	EXAMINATION CATEGORY C/E PRESSURE RETAINING WELDS IN PIPING								
510	PIPING WELDS 5/12 IN NOMINAL WALL THICKNESS CIRCUMFERENTIAL AND LONGITUDINAL WELDS	Butt Welds	SG-81-6" SG-83-6"	S S	14 14	** **			BHR, CHR, & ECUS SYSTEMS ARE SCHEDULED PER 19 CFR 50 REQUIREMENTS AND ARE IDENTIFIED IN TABLE 2-CTR
511 & 512	33-Steams to Aux. Feedwater System	Butt Welds	SG-8-6" SG-8-8"	S*** S	3 23	1 2 (5) 0 (5)	One Two Three	4 12 12	**2.5T MIN. FROM EACH SCHEDULED CIRC. WELD INTERSECTION WILL BE EXAMINED
	38-Aux. and Downcomer Feedwater SG 1 Inside Containment	Butt Welds	SG-11-6" SG-11-8"	S*** S	3 23	1 3 (5) 1 (5)	One Two Three	4 15 19	**REQUIREMENTS IDENTIFIED IN TABLE 2-AHE ***AN AUGMENTED(40)
520	PIPING WELDS > 1/2 IN NOMINAL WALL THICKNESS CIRCUMFERENTIAL AND LONGITUDINAL WELDS	Butt Welds	SG-36-28"	S, Vol	19	3 0 2	One Two Three	16 16 26	***AN AUGMENTED(40) VOL EXAMINATION WILL BE PERFORMED EACH PERIOD (SEE IEB 79-13 AND SER 83-07)
521 & 522	43>Main Steam SG-1 90" Inside Cont.	Butt Welds	SG-33-28"	S, Vol	21	3 1 2	One Two Three	14 19 29	**2.5TMIN FROM EACH SCHEDULED CIRC. WELD INTERSECTION WILL BE EXAMINED
	44>Main Steam SG-1 270" Inside Cont.	Butt Welds							

# APS PALO VERDE NUCLEAR GENERATING STATION

## 10 YEAR INTERVAL - EXAMINATION SUMMARY

### ASME CLASS 2

TABLE 2-5  
PAGE 2 OF 4

ASME ITEM NO.	ZONE-COMPONENT OR SYSTEM	IDENTIFICATION	DESCRIPTION LINE NO., OR SERIAL NO.	NDE METHOD	TOTAL ITEMS	EXAMINATION AMOUNT	INSPECTION PERIOD	RUNNING %	REMARKS AND RELIEF REQUESTS
521	CONTINUED								
522	45-Main Steam SG-2 270° Inside Cont.	Butt Welds	SG-42-28"	S,Vol	19	0	One	-	
2						Two	11		
3						Three	26		
	46-Main Steam SG-2 90° Inside Cont.	Butt Welds	SG-45-28"	S,Vol	21	2	One	10	
2						Two	19		
1						Three	24		
	47-Main Steam SG-1 270° MSSS	Butt Welds	SG-206-28"	S,Vol	4	*	-	-	
			SG-206-12"	S,Vol	2	*	-	-	
			SG-206-6"	S,Vol	5	*	-	-	
	48-Main Steam SG-1 90° MSSS	Butt Welds	SG-207-28"	S,Vol	4	*	-	-	
			SG-207-12"	S,Vol	2	*	-	-	
			SG-207-6"	S,Vol	5	*	-	-	
	49-Main Steam SG-2 270° MSSS	Butt Welds	SG-208-28"	S,Vol	4	*	-	-	*REQUIREMENTS IDENTIFIED IN TABLE 2-AHE
			SG-208-12"	S,Vol	2	*	-	-	
			SG-208-6"	S,Vol	5	*	-	-	
	50-Main Steam SG-2 90° MSSS	Butt Welds	SG-209-28"	S,Vol	4	*	-	-	
			SG-209-12"	S,Vol	2	*	-	-	
			SG-209-6"	S,Vol	5	*	-	-	
	51-Atmosphere Dump SG-1	Butt Welds	SG-59-12"	S,Vol	13	*	-	-	
			SG-70-12"	S,Vol	16	*	-	-	
	52-Atmosphere Dump SG-2	Butt Welds	SG-84-12"	S,Vol	16	*	-	-	
			SG-103-12"	S,Vol	13	*	-	-	
	54-Foodwater SG-1 Inside Cont.	Butt Welds	SG-2-24"	S,Vol	30	5	One	9	
			SG-2-16"	S,Vol	4	5	Two	18	
			SG-2-14"	S,Vol	10	6	Three	28	
			SG-13-16"	S,Vol	3	-	-	-	
			SG-13-14"	S,Vol	10	-	-	-	
	55-Foodwater SG-2 Inside Cont.	Butt Welds	SG-5-24"	S,Vol	30	5	One	9	
			SG-5-16"	S,Vol	3	5	Two	18	
			SG-5-14"	S,Vol	10	5	Three	27	
			SG-14-16"	S,Vol	3	-	-	-	
			SG-14-14"	S,Vol	10	-	-	-	

REV 1  
12-23-91

# APS PALO VERDE NUCLEAR GENERATING STATION 10 YEAR INTERVAL - EXAMINATION SUMMARY

## ASME CLASS 2

TABLE 2-5  
PAGE 3 OF 4

ASME ITEM NO.	ZONE-COMPONENT OR SYSTEM	IDENTIFICATION	DESCRIPTION LINE NO., OR SERIAL NO.	NDE METHOD	TOTAL ITEMS	EXAMINATION AMOUNT	INSPECTION PERIOD	RUNNING %	REMARKS AND RELIEF REQUESTS
521 522	CONTINUED								
	56-Feedwater SG-1 MSSS	Butt Welds	SG-20'-24" SG-202-24"	S,Vol S,Vol	2 2	* *	-	-	
	57-Feedwater SG-2 MSSS	Butt Welds	SG-204-24" SG-205-24"	S,Vol S,Vol	2 2	* *	-	-	*REQUIREMENTS IDENTIFIED IN TABLE 2-AHE
	58-Aux. and Downcomer Feedwater SG-1 Inside Containment	Butt Welds	SG-8-6" AF-4-6"	S,Vol S,Vol	1 12**	3 0 2	One Two Three	23 23 38	**INCLUDES 1 DISSIMILAR WELD
	59-Aux. and Downcomer Feedwater SG-2 Inside Containment	Butt Welds	SG-11-6" AF-6-6"	S,Vol S,Vol	1 12**	2 2 1	One Two Three	15 31 38	
	60-Downcomer Feedwater SG-1 MSSS	Butt Welds	SG-200-8" SG-008-8"	S,Vol	2 4	* -	-	-	
	61-Downcomer Feedwater SG-2 MSSS	Butt Welds	SG-203-8" SG-11-8"	S,Vol	2 4	* -	-	-	
	62-Aux. Feedwater SG-1 N. NS	Butt Welds	AF-4-6" AF-18-6"	S,Vol S,Vol	7 11	1 2 2	One Two Three	6 17 28	
	63-Aux. Feedwater SG-2 MSSS	Butt Welds	AF-6-6" AF-16-6"	S,Vol S,Vol	13 3	1 2 2	One Two Three	6 19 31	
	64-Blowdown SG-1 Inside Cont.	Butt Welds	SG-39-6" SG-53-6"	S,Vol S,Vol	34 13	2 4 4	One Two Three	4 13 21	
	65-Blowdown SG-2 Inside Cont.	Butt Welds	SG-48-6" SG-52-6"	S,Vol S,Vol	34 14	4 3 4	One Two Three	8 15 23	

REV. 1  
12-23-91

ASME ITEM NO.	ZONE-COMPONENT OR SYSTEM	IDENTIFICATION	DESCRIPTION LINE NO., OR SERIAL NO.	NDE METHOD	TOTAL ITEMS	EXAMINATION AMOUNT	INSPECTION PERIOD	RUNNING %	REMARKS AND RELIEF REQUESTS
521	CONTINUED 66-Blowdown SG-1 MSSS	Butt Welds	SG-39-6"	S, Vel	2	*		1	*REQUIREMENTS IDENTIFIED IN TABLE 2-AHE
522									
530	67-Blowdown SG-2 PIPE BRANCH CONNECTIONS > 4 IN. NOMINAL PIPE SIZE CIRCUMFERENTIAL AND **LONGITUDINAL WELDS 47-Main Steam SG-1 270° MSSS 48-Main Steam SG-1 90° MSSS 49-Main Steam SG-2 270° MSSS 50-Main Steam SG-2 90° MSSS	Butt Welds	SG-48-6"	S, Vel	2	*			**2.5T MIN FROM EACH SCHEDULED BRANCH WELD INTERSECTION WILL BE EXAMINED
531									
532									
532									
		Sweepoints	SG-206-28"	S	7	*			*REQUIREMENTS IDENTIFIED IN TABLE 2-AHE
		Sweepoints	SG-207-28"	S	8	*			
		Sweepoints	SG-208-28"	S	8	*			
		Sweepoints	SG-209-28"	S	7	*			

# APS PALO VERDE NUCLEAR GENERATING STATION 10 YEAR INTERVAL - EXAMINATION SUMMARY

## ASME CLASS 2

TABLE 2.6  
PAGE 1 OF 1

ASME ITEM NO.	ZONE-COMPONENT OR SYSTEM	IDENTIFICATION	DESCRIPTION LINE NO., OR SERIAL NO.	NDE METHOD	TOTAL ITEMS	EXAMINATION AMOUNT	INSPECTION PERIOD	RUNNING %	REMARKS AND RELIEF REQUESTS
C600	EXAM CATEGORY C-G: PRESSURE RETAINING WELDS IN PUMPS AND VALVES							1	
610	PUMPS PUMP CASING WELDS	None							
620	VALVES VALVE BODY WELDS								
	Dresser, 6" x 10" Pressure Safety Main Steam Valves	Zone 47 Zone 48 Zone 49 Zone 50	SG-206-28" SG-207-28" SG-208-28" SG-209-28"	S S S S	5 5 5 5	Examine the weld in 1 valve	*	100	*BY THE END OF THE INTERVAL
	Borg Warner, 16" Gate Valves LPSI Pump Suction	Zone 92 Zone 89	SI-241-16" SI-194-16"	S S	1 1	Examine the weld in 1 valve	*	100	
	Borg Warner, 6" Gate Valves SDCHX Outlet	Zone 83 Zone 86	SI-131-6" SI-131-6"	S S	1 1	Examine the weld in 1 valve	*	100	

REV. 1  
12-23-91



# APS PALO VERDE NUCLEAR GENERATING STATION 10 YEAR INTERVAL - EXAMINATION SUMMARY

## ASME CLASS 2

TABLE 2-7  
PAGE 1 OF 1

ASME ITEM NO.	ZONE-COMPONENT OR SYSTEM	IDENTIFICATION	DESCRIPTION LINE NO., OR SERIAL NO.	NDE METHOD	TOTAL ITEMS	EXAMINATION AMOUNT	INSPECTION PERIOD	RUNNING %	REMARKS AND RELIEF REQUESTS
C700	EXAM CATEGORY C-H: ALL PRESSURE RETAINING COMPONENTS							1	
	SYSTEM FUNCTIONAL TESTS ***								
710	Pressure Vessels	Pressure		VT-2		Entire Pressure retaining boundary IWA-5000 IWC-5000	*	100	*EACH INSPECTION PERIOD
730	Piping	Retaining							
750	Pumps	Boundary							
770	Valves								
	SYSTEM HYDRO TESTS								
720	Pressure Vessels	Pressure		VT-2		Entire Pressure retaining boundary IWA-5000 IWC-5000	**	100	**EACH INSPECTION INTERVAL
740	Piping	Retaining							
760	Pumps	Boundary							
780	Valves								
									***REQUEST FOR RELIEF # 7

REV. 1  
12-23-91

# APS

## PALO VERDE NUCLEAR GENERATING STATION 10 YEAR INTERVAL - EXAMINATION SUMMARY

### ASME CLASS 2

TABLE 2-IWF  
PAGE 1 OF 6

ASME ITEM NO.	ZONE-COMPONENT OR SYSTEM	IDENTIFICATION	DESCRIPTION LINE NO., OR SERIAL NO.	NDE METHOD	TOTAL ITEMS	EXAMINATION AMOUNT	INSPECTION PERIOD	RUNNING %	REMARKS AND RELIEF REQUESTS
* F110 F120 F130 F140 F210 F220 F230 F240 F310 F320 F330 F340 F350	EXAM CATEGORY E-A: PLATE AND SHELL TYPE SUPPORTS and EXAM CATEGORY E-B: LINEAR TYPE SUPPORTS and EXAM CATEGORY E-C: COMPONENT STANDARD SUPPORTS			**				1	REQUEST FOR RELIEF #1&3  *INCLUDES EXAM ITEMS IDENTIFIED, AS APPLI- CABLE **NDE METHOD INCLUDES VT-4 EXAMS, WHERE APPLICABLE
	41-Steain Generator 1	2-Snubbers	SN-65273-1	VT-3	2	2 0 0	One Two Three	100 100 100	
	42-Steain Generator 2	2-Snubbers	SN-65273-2	VT-3	2	0 2 0	One Two Three	- 100 100	
	43-Main Steam SG-1 Inside Containment	Supports	SG-36	VT-3	9	3 2 4	One Two Three	33 56 100	
	44-Main Steam SG-1 Inside Containment	Supports	SG-33	VT-3	10	2 5 3	One Two Three	20 70 100	
	45-Main Steam SG-2 Inside Containment	Supports	SG-42	VT-3	9	3 3 3	One Two Three	33 67 100	
	46-Main Steam SG-2 Inside Containment	Supports	SG-45	VT-3	10	2 5 3	One Two Three	20 70 100	
	47-Main Steam SG-1 270° MSSS	Supports	SG-206	VT-3	1	1 0 0	One Two Three	100 100 100	
	48-Main Steam SG-1 90° MSSS	Supports	SG-207	VT-3	1	0 1 0	One Two Three	- 100 100	
	49-Main Steam SG-2 270° MSSS	Supports	SG-208	VT-3	1	0 0 1	One Two Three	- - 100	

REV 1  
12-23-91

**APS**PALO VERDE NUCLEAR GENERATING STATION  
10 YEAR INTERVAL - EXAMINATION SUMMARY

## ASME CLASS 2

TABLE 2-IWF  
PAGE 2 OF 6

ASME ITEM NO.	ZONE-COMPONENT OR SYSTEM	IDENTIFICATION	DESCRIPTION LINE NO., OR SERIAL NO.	NDE METHOD	TOTAL ITEMS	EXAMINATION AMOUNT	INSPECTION PERIOD	RUNNING %	REMARKS AND RELIEF REQUESTS
F110	CONTINUED								
F120	50-Main Steam SG-2	Supports	SG-209	VT-3	1	0	One	-	
F130	90° MSSS					0	Two	-	
F140						1	Three	100	
F210									
F220	51-Atmosphere Dump	Supports	SG-59	VT-3	2	1	One	50	
F230	SG-1		SG-70			1	Two	100	
F240						0	Three	100	
F310									
F320	52-Atmosphere Dump	Supports	SG-84	VT-3	2	0	One	-	
F330	SG-2		SG-103			0	Two	-	
F340						2	Three	100	
F350									
	53-Steam to Aux. Feedwater System	Supports	SG-81	VT-3	8	4	One	50	
			SG-83			2	Two	75	
						2	Three	100	
	54-Feedwater SG-1 Inside Cont.	Supports	SG-2	VT-3	20	7	One	35	
			SG-13			7	Two	70	
						6	Three	100	
	55-Feedwater SG-2 Inside Cont.	Supports	SG-5	VT-3	19	8	One	42	
			SG-14			7	Two	79	
						4	Three	100	
	56-Feedwater SG-1 MSSS	Supports	SG-202	VT-3	1	0	One	-	
						1	Two	100	
						0	Three	100	
	57-Feedwater SG-2 MSSS	Supports	SG-205	VT-3	1	0	One	-	
						0	Two	-	
						1	Three	100	
	58-Aux. and Downcomer Feedwater SG-1 Inside Cont.	Supports	SG-8	VT-3	22	7	One	32	
			AF-4			7	Two	64	
						8	Three	100	
	59-Aux. and Downcomer Feedwater SG-2 Inside Cont.	Supports	SG-11	VT-3	22	6	One	27	
			AF-6			6	Two	55	
						10	Three	100	
	60-Downcomer Feedwater SG-1 MSSS	Supports	SG-200	VT-3	3	1	One	33	
						0	Two	33	
						2	Three	100	
	61-Downcomer Feedwater SG-2 MSSS	Supports	SG-203	VT-3	3	0	One	-	
						2	Two	66	
						1	Three	100	

REV. 1  
12-23-91



# APS PALO VERDE NUCLEAR GENERATING STATION

## 10 YEAR INTERVAL - EXAMINATION SUMMARY

### ASME CLASS 2

TABLE 2-IWF  
PAGE 3 OF 6

ASME ITEM NO.	ZONE-COMPONENT OR SYSTEM	IDENTIFICATION	DESCRIPTION LINE NO., OR SERIAL NO.	NDE METHOD	TOTAL ITEMS	EXAMINATION AMOUNT	INSPECTION PERIOD	RUNNING %	REMARKS AND RELIEF REQUESTS
F110	CONTINUED								
F120								1	
F130									
F140	62-Aux. Feedwater SG-1 MSSS	Supports	AF-4	VT-3	4	1	One	25	
F210			AF-18			1	Two	50	
F220						2	Three	100	
F230									
F240	63-Aux. Feedwater SG-2 MSSS	Supports	AF-6	VT-3	5	2	One	40	
F310			AF-16			2	Two	80	
F320						1	Three	100	
F330									
F340	64-Blowdown SG-1 Inside Cont.	Supports	SG-39	VT-3	35	11	One	31	
F350			SG-53			12	Two	66	
						12	Three	100	
	65-Blowdown SG-2 Inside Cont.	Supports	SG-48	VT-3	34	10	One	29	
			SG-52			11	Two	62	
						13	Three	100	
	68-Regenerative Heat Exchanger	Supports	SN-79314	VT-3	2	0	One	-	
						1	Two	50	
						1	Three	100	
	70-LPSI Pump A Suction	Supports	SI-67	VT-3	5	1	One	-	All SI (ZONES 70 THRU 101) COM- BINED FOR PER- CENTAGE.
			SI-241			4	Three	-	
			SI-307						
	71-LPSI Pump A Discharge	Supports	SI-78	VT-3	6	1	One	-	
			SI-87			5	Two	-	
	72-LPSI Pump A	Supports	SN-0876-44	VT-3	3**	2	One	-	**3 PUMP SUPPORTS
						1	Two	-	
	73-LPSI Pump B Suction	Supports	SI-34	VT-3	5	1	Two	-	
			SI-194			4	Three	-	
			SI-308						
	74-LPSI Pump B Discharge	Supports	SI-129	VT-3	6	6	Three	-	

REV. 1  
12-23-91



**PALO VERDE NUCLEAR GENERATING STATION  
10 YEAR INTERVAL - EXAMINATION SUMMARY**

**ASME CLASS 2**

ASME ITEM NO.	ZONE-COMPONENT OR SYSTEM	IDENTIFICATION	DESCRIPTION LINE NO., OR SERIAL NO.	NDE METHOD	TOTAL ITEMS	EXAMINATION AMOUNT	INSPECTION PERIOD	RUNNING %	REMARKS AND RELIEF REQUESTS
F110	CONTINUED								
F120									
F130									
F140	75-LPSI Pump B	Supports	SN-0876-45	VT-3	3**	1	Two	-	
F210						2	Three	-	
F220									
F230									
F240	76-Containment Spray	Supports	SI-9	VT-3	5	1	One	-	**3 PUMP SUPPORTS
F310	Pump A Suction		SI-67			4	Three	-	
F320			SI-78					-	
F330									
F340	77-Containment Spray	Supports	SI-79	VT-3	10	4	One	-	
F350	Pump A Discharge		SI-82			3	Two	-	
						3	Three	-	
	78-Containment Spray	Supports	SN-0876-46	VT-3	3**	2	One	-	
	Pump A					1	Two	-	
	79-Containment Spray	Supports	SI-33	VT-3	8	3	One	-	
	Pump B Suction		SI-34			2	Two	-	
			SI-123			3	Three	-	
	80-Containment Spray	Supports	SI-119	VT-3	10	3	One	-	
	Pump B Discharge		SI-147			4	Two	-	
						3	Three	-	
	81-Containment Spray	Supports	SN-0876-47	VT-3	3**	1	Two	-	
	Pump B					2	Three	-	
	82-Shutdown Cooling A	Supports	SI-79	VT-3	3	2	One	-	
			SI-78			1	Three	-	
	83-Shutdown Cooling A	Supports	SI-70	VT-3	19	4	One	-	
			SI-87			3	Two	-	
			SI-90			12	Three	-	
			SI-89					-	
			SI-82					-	
	85-Shutdown Cooling B	Supports	SI-119	VT-3	9	3	One	-	
			SI-123			6	Two	-	
	86-Shutdown Cooling B	Supports	SI-72	VT-3	26	3	One	-	
			SI-134			7	Two	-	
			SI-147			16	Three	-	
			SI-135					-	
			SI-129					-	

REV 1  
12-23-91

# APS PALO VERDE NUCLEAR GENERATING STATION

## 10 YEAR INTERVAL - EXAMINATION SUMMARY

### ASME CLASS 2

TABLE 2-IWF  
PAGE 5 OF 6

ASME ITEM NO.	ZONE-COMPONENT OR SYSTEM	IDENTIFICATION	DESCRIPTION LINE NO., OR SERIAL NO.	NDE METHOD	TOTAL ITEMS	EXAMINATION AMOUNT	INSPECTION PERIOD	RUNNING %	REMARKS AND RELIEF REQUESTS
F110	CONTINUED								
F120	88-Safety Injection	Supports	SI-72	VT-3	14	8	One	-	
F130			SI-73			6	Three		
F140	89-Safety Injection	Supports	SI-173 SI-194	VT-3	5	4	One	-	
F210						1	Three		
F220									
F230	90-Safety Injection	Supports	SI-134	VT-3	2	2	Two	-	
F240									
F310	91-Safety Injection	Supports	SI-70 SI-71	VT-3	10	7	One	-	
F320						2	Two		
F330						1	Three		
F340	92-Safety Injection	Supports	SI-2 SI-239 SI-241	VT-3	12	5	One	-	
F350						5	Two		
						2	Three		
	93-Safety Injection	Supports	SI-89	VT-3	4	2	Two	-	
						2	Three		
	94-Safety Injection	Supports	SI-70 SI-89 SI-241	VT-3	13	3	One	-	
						7	Two		
						5	Three		
	95-Safety Injection	Supports	SI-72 SI-134 SI-194	VT-3	18	6	One	-	
						10	Two		
						2	Three		
	96-LPSI 1A	Supports	SI-202	VT-3	18	3	One	-	
						8	Two		
						7	Three		
	97-LPSI 1B	Supports	SI-230	VT-3	27	10	One	-	
						7	Two		
						10	Three		
	98-LPSI 2A	Supports	SI-155	VT-3	7	2	One	-	
						5	Two		
	99-LPSI 2B	Supports	SI-174	VT-3	10	5	Two	-	
						5	Three		

REV. 1  
12-23-91

**APS****PALO VERDE NUCLEAR GENERATING STATION  
10 YEAR INTERVAL - EXAMINATION SUMMARY****ASME CLASS 2**TABLE 2.1WF  
PAGE 6 OF 6

ASME ITEM NO.	ZONE-COMPONENT OR SYSTEM	IDENTIFICATION	DESCRIPTION LINE NO., OR SERIAL NO.	NDE METHOD	TOTAL ITEMS	EXAMINATION AMOUNT	INSPECTION PERIOD	RUNNING %	REMARKS AND RELIEF REQUESTS
F110	CONTINUED								
F120									
F130	100-LPSI A Suction	Supports	SI-7	VT-3	3	2	One	-	
F140			SI-241			1	Two	-	
F210			SI-369						
F220									
F230	101-LPSI B Suction	Supports	SI-30	VT-3	8	8	Three	-	
F240			SI-194						
F310			SI-368						
F320									
F330	SI SYSTEMS				277	79	One	29	
F340	ZONES (70-101)					89	Two	61	
F350	TOTALS					109	Three	100	

REV 1  
12-23-91

SECTION 6.0  
ASME CLASS 3  
EXAMINATION SUMMARY

## INDEX

TABLE		EXA*1 CATEGORY
3-1	D-A, D-B,	Systems in Support of Reactor Shutdown Function Systems in Support of Emergency Core Cooling, Containment Heat Removal, Atmosphere Cleanup, and Reactor Heat Removal
	D-C,	Systems in Support of Residual Heat Removal from Spent Fuel Storage Pool
3-IWF	F-A, F-B, F-C,	Plate and Shell Type Supports Linear Type Supports Component Standard Supports

ASME ITEM NO.	ZONE-COMPONENT OR SYSTEM	IDENTIFICATION	DESCRIPTION LINE NO., OR SERIAL NO.	NDE METHOD	TOTAL ITEMS	EXAMINATION AMOUNT	INSPECTION PERIOD	RUNNING %	REMARKS AND RELIEF REQUESTS
D120 thru D160	EXAMINATION CATEGORY D.A. SYSTEMS IN SUP. PORT OF REACTOR SHUTDOWN FUNCTION AND					ASME CLASS 3 SYSTEMS ARE IDENTIFIED ON THE ISI BOUNDARY DRAWINGS CONTAINED IN SECTION 10.0.			
D220 thru D260	EXAMINATION CATEGORY D.B. SYSTEMS IN SUP. PORT OF EMERGENCY CORE COOLING CONTAINMENT HEAT REMOVAL, ATMOSPHERE CLEANUP, AND REACTOR RESIDUAL HEAT REMOVAL AND								
D320 thru D360	EXAMINATION CATEGORY D.C. SYSTEMS IN SUP. PORT OF RESIDUAL HEAT REMOVAL FROM SPENT FUEL STORAGE POOL								
	All Class 3 Systems (Except Auxiliary Feedwater)	Integrally Welded Attachments	All lines greater than 4" nominal pipe size	VT-3	All	100%	Each inspection interval	100%	
	Auxiliary Feedwater Systems	Integrally Welded Attachments	All lines	VT-3	All	100%	Each inspection interval	100%	REQUEST FOR RELIEF #1 & #3

ASME ITEM NO.	ZONE-COMPONENT OR SYSTEM	IDENTIFICATION	DESCRIPTION LINE NO., OR SERIAL NO.	NDE METHOD	TOTAL ITEMS	EXAMINATION AMOUNT	INSPECTION PERIOD	RUNNING %	REMARKS AND RELIEF REQUESTS
	EXAMINATION CATEGORY D-A. SYSTEMS IN SUP- PORT OF REACTOR SHUTDOWN FUNCTION A, Q EXAMINATION CATEGORY D-B. SYSTEMS IN SUP- PORT OF EMERGENCY CORE COOLING, CON- TAINMENT HEAT RE- MOVAL, ATMOSPHERE CLEANUP, AND REAC- TOR RESIDUAL HEAT REMOVAL AND EXAMINATION CATEGORY D-C. SYSTEMS IN SUP- PORT OF RESIDUAL HEAT REMOVAL FROM SPENT FUEL STORAGE POOL.								
D110 D210 D310	SYSTEM INSERVICE OR FUNCTIONAL TESTS *** Pressure Retaining Components	Pressure Retaining Boundary		VT-2		Entire Pres- sure Retain- ing Boundary TWA-5000 TWD-5000	*	100	*EACH INSPECTION PERIOD.
D110 D210 D310	SYSTEM HYDRO-TESTS Pressure Retaining Components	Pressure Retaining Boundary		VT-2		Entire Pres- sure Retain- ing Boundary TWA-5000 TWD-5000	**	100	**EACH INSPECTION INTERVAL  ***REQUEST FOR RELIEF # 7&8



ASME ITEM NO.	ZONE-COMPONENT OR SYSTEM	IDENTIFICATION	DESCRIPTION LINE NO., OR SERIAL NO.	NDE METHOD	TOTAL ITEMS	EXAMINATION AMOUNT	INSPECTION PERIOD	RUNNING %	REMARKS AND RELIEF REQUESTS
F110 F120 F130 F140 F210 F220 F230 F240 F310 F320 F330 F340 F350	EXAM CATEGORY F.A. PLATE AND SHELL TYPE SUPPORTS AND EXAM CATEGORY F.B. LINEAR TYPE SUPPORTS AND EXAM CATEGORY F.C. COMPONENT STANDARD SUPPORTS			**					*INCLUDES EXAM ITEMS IDENTIFIED, AS APPL. CABLE.  **NDE METHOD INCLUDES VT-4 EXAMS, WHERE APP. LICABLE.  REQUEST FOR RELIEF # 1&3
	All Class 3 Systems (Except Auxiliary Feedwater)	Support Components	All lines greater than 4" nominal pipe size	VT-3	All	100%	Each Inspection Interval	100%	
	Auxiliary Feedwater Systems	Support Components	All lines	VT-3	All	100%	Each Inspection Interval	100%	

SECTION 7.0  
AUGMENTED HIGH  
ENERGY PIPING

# APS

## PALO VERDE NUCLEAR GENERATING STATION 10 YEAR INTERVAL - EXAMINATION SUMMARY

### ASME CLASS 2

TABLE 2-AHE  
PAGE 1 OF 3

ASME ITEM NO.	ZONE-COMPONENT OR SYSTEM	IDENTIFICATION	DESCRIPTION LINE NO., OR SERIAL NO.	NDE METHOD	TOTAL ITEMS	EXAMINATION AMOUNT	INSPECTION PERIOD	RUNNING %	REMARKS AND RELIEF REQUESTS
510	AUGMENTED EXAMINATIONS OF HIGH ENERGY PIPING				(*)				(*IDENTIFIES THE NUMBER OF WELDS THAT ARE NOT ASME CLASSIFIED
511	PIPING WELDS ≤ 1/2 IN. NOMINAL WALL THICKNESS								**NONE
512	CIRCUMFERENTIAL AND **LONGITUDINAL WELDS								
	51-Bypass UV-180	Butt Welds 4" x .337"	SG-95-4"	S, Vol	(20)	0 20 0	One Two Three	- 100 100	
	52-Bypass UV-171	Butt Welds 4" x .337"	SG-100-4"	S, Vol	(20)	0 0 20	One Two Three	- - 100	
	53-Steam to Aux. Feedwater	Butt Welds 6" x .432"	SG-81-6" SG-83-6"	S, Vol S, Vol	14 14	10 9 9	One Two Three	36 68 100	
520	PIPING WELDS > 1/2 IN. NOMINAL WALL THICKNESS								
521	CIRCUMFERENTIAL AND **LONGITUDINAL WELDS								*100% OF ALL INTERSECTING LONGITUDINAL WELDS WELL BE EXAMINED
522	47-Main Steam SG-1 270° MSSS	Butt Welds	SG-206-28" SG-206-12" SG-206-6"	S, Vol S, Vol S, Vol	4(1) 2 5	12 0 0	One Two Three	100 100 100	
	48-Main Steam SG-1 90° MSSS	Butt Welds	SG-207-28" SG-207-12" SG-207-6"	S, Vol S, Vol S, Vol	4(1) 2 5	0 12 0	One Two Three	- 100 100	
	49-Main Steam SG-2 270° MSSS	Butt Welds	SG-208-28" SG-208-12" SG-208-6"	S, Vol S, Vol S, Vol	4(1) 2 5	0 0 12	One Two Three	- - 100	

# APS PALO VERDE NUCLEAR GENERATING STATION

## 10 YEAR INTERVAL - EXAMINATION SUMMARY

### ASME CLASS 2

TABLE 2-AHE  
PAGE 2 OF 3

ASME ITEM NO.	ZONE-COMPONENT OR SYSTEM	IDENTIFICATION	DESCRIPTION LINE NO., OR SERIAL NO.	NDE METHOD	TOTAL ITEMS	EXAMINATION AMOUNT	INSPECTION PERIOD	RUNNING %	REMARKS AND RELIEF REQUESTS
521	CONTINUED								
522	50-Main Steam SG-2 90" MSSS	Butt Welds	SG-209-28"	S, Vol	4(1)	0	One	-	
			SG-209-12"	S, Vol	2	0	Two	-	
			SG-209-6"	S, Vol	5	12	Three	100	
	51-Atmospheric Dump SG-1	Butt Welds 12" x .844"	SG-59-12"	S, Vol	13	13	One	45	
			SG-70-12"	S, Vol	16	16	Two	100	
						0	Three	100	
	52-Atmospheric Dump SG-2	Butt Welds 12" x .844"	SG-84-12"	S, Vol	16	0	One	-	
			SG-103-12"	S, Vol	13	0	Two	-	
						29	Three	100	
	56-Feedwater SG-1 MSSS	Butt Welds	SG-201-24"	S, Vol	2	4	One	67	
			SG-202-24"	S, Vol	2	2	Two	100	
			SG-224-24"	S, Vol	(2)	0	Three	100	
	57-Feedwater SG-2 MSSS	Butt Welds	SG-204-24"	S, Vol	2	0	One	-	
			SG-205-24"	S, Vol	2	0	Two	-	
			SG-225-24"	S, Vol	(2)	6	Three	100	
	60-Downcomer Feed- water SG-1 MSSS	Butt Welds 8" x .719"	SG-200-R"	S, Vol	2(8)	9	One	64	
			SG-8-8"	S, Vol	4	5	Two	100	
						0	Three	100	
	61-Downcomer Feed- water SG-2 MSSS	Butt Welds 8" x .719"	SG-203-8"	S, Vol	2(8)	0	One	-	
			SG-11-8"	S, Vol	4	5	Two	36	
						9	Three	100	
	66-Blowdown SG-1 MSSS	Butt Welds	SG-39-6"	S, Vol	2(13)	9	One	69	
						6	Two	100	
						0	Three	100	
	67-Blowdown SG-2 MSSS	Butt Welds	SG-48-6"	S, Vol	2(10)	0	One	-	
						6	Two	50	
						6	Three	100	
530	Pipe Branch Connections								
531	Circumferential and								
532	*Longitudinal Welds								
	47-Main Steam SG-1 270" MSSS	Sweepolets	SG-206-28"	S, Vol	7	7	One	100	*SCHEDULED UNDER C5.21 AND C5.22
						0	Two	100	
						0	Three	100	

REV. 1  
12-23-91



**PALO VERDE NUCLEAR GENERATING STATION  
10 YEAR INTERVAL - EXAMINATION SUMMARY**

**ASME CLASS 2**

ASME ITEM NO.	ZONE-COMPONENT OR SYSTEM	IDENTIFICATION	DESCRIPTION LINE NO., OR SERIAL NO.	NDE METHOD	TOTAL ITEMS	EXAMINATION AMOUNT	INSPECTION PERIOD	RUNNING %	REMARKS AND RELIEF REQUESTS
531 532	CONTINUED								
	48-Main Steam SG-1 90° MSSS	Sweepolets	SG-207-28"	S, Vol	8(1)	0 9 0	One Two Three	- 100 100	
	49-Main Steam SG-2 270° MSSS	Sweepolets	SG-208-28"	S, Vol	8(1)	0 0 2	One Two Three	- - 100	
	50-Main Steam SG-2 90° MSSS	Sweepolets	SG-209-28"	S, Vol	7	0 0 7	One Two Three	- - 100	

SECTION 8.0

RHR, ECCS, AND CHR PIPING

# APS

## PALO VERDE NUCLEAR GENERATING STATION 10 YEAR INTERVAL - EXAMINATION SUMMARY (RHR, ECCS, and CHR SYSTEMS)

### ASME CLASS 2

TABLE 2-CPB  
PAGE 1 OF 6

ASME ITEM NO.	ZONE-COMPONENT OR SYSTEM	IDENTIFICATION	DESCRIPTION LINE NO., OR SERIAL NO.	NDE METHOD	TOTAL ITEMS	EXAM AMOUNT		INSPECTION PERIOD	(40 YR) 10 YR %	REMARKS AND RELIEF REQUESTS
						40 YR	10 YR			
CS00	Exam Category C-1* Pressure Retaining Welds in Piping	Note 2		Note 1				Note 3		
510	Piping Welds ≤ 1/2" nominal wall thickness									
511	Circumferential and									
512	** Longitudinal welds  (75 category C-F)									
	70 & 73 LPSI Pump Room A & B Suction	Butt Welds 14" x 0.312"	SI-307 SI-308	S, Vol S, Vol	(48) 6 6	(24) 3 3	 3 4 3	One Two Three	***	***Category CS.10 systems are combined for percentages
		16" x 0.312"	SI-67 SI-34	S, Vol S, Vol	5 5	3 2				
		18" x 0.312"	SI-241 SI-194	S, Vol S, Vol	3 3	2 1				
		20" x 0.375"	SI-307 SI-308	S, Vol S, Vol	10 10	5 5				
	71 & 74 LPSI Pump Room A & B Discharge	Butt Welds 8" x 0.322"	SI-87 SI-129	S, Vol S, Vol	(55) 2 2	(28) 1 1	 3 3 2	One Two Three		
		10" x 0.365"	SI-78 SI-123 SI-87 SI-129	S, Vol S, Vol S, Vol S, Vol	3 3 23 22	1 2 12 11				
	76 & 79 CS Pump Room A & B Suction	Butt Welds 10" x 0.365	SI-78 SI-123	S, Vol S, Vol	(47) 2 2	(24) 1 1	 2 2 2	One Two Three		
		14" x 0.312"	SI-009 SI-33	S, Vol S, Vol	4 4	2 2				
		14" x 0.312"	SI-67 SI-34	S, Vol S, Vol	7 7	4 3				
		16" x 0.312"	SI-67 SI-34	S, Vol S, Vol	2 2	1 1				
		18" x 0.312"	SI-9 SI-33	S, Vol S, Vol	9 8	5 4				

REV. 1  
12-23-91

# APS

## PALO VERDE NUCLEAR GENERATING STATION 10 YEAR INTERVAL - EXAMINATION SUMMARY (RHR, ECCS, and CHR SYSTEMS)

### ASME CLASS 2

TABLE 2-CFR  
PAGE 2 OF 6

ASME ITEM NO.	ZONE-COMPONENT OR SYSTEM	IDENTIFICATION	DESCRIPTION LINE NO., OR SERIAL NO.	NDE METHOD	TOTAL ITEMS	EXAM AMOUNT		INSPECTION PERIOD	(40 YR) 10 YR %	REMARKS AND RELIEF REQUESTS
						40 YR	10 YR			
511 512	CONTINUED									
	77 & 80 Containment Spray Pump Room A & B Discharge	Butt Welds 8" x 0.322"	SI-79 SI-119	S, Vol S, Vol	(67) 1 1	(34) 1 0	3 4 4	One Two Three		
		10" x 0.365"	SI-79 SI-119	S, Vol S, Vol	28 27	14 14				
		10" x 0.365"	SI-82 SI-147	S, Vol S, Vol	5 5	3 2				
	82 & 85 Shutdown Cooling Heat Exchanger Inlets Room A & B	Butt Welds 10" x 0.365"	SI-078 SI-123	S, Vol S, Vol	(46) 9 10	(24) 5 5	2 4 1	One Two Three		
		10" X 0.365"	SI-79 SI-119	S, Vol S, Vol	9 9	4 5				
		20" x 0.500"	SI-078 SI-123	S, Vol S, Vol	4 5	2 3				
	83 & 86 Shutdown Cooling Heat Exchanger Outlets Room A & B	Butt Welds 6" x 0.280"	SI-131 SI-131	S, Vol S, Vol	(117) 4 4	(59) 2 2	6 3 9	One Two Three		
		10" X 0.365"	SI-82 SI-147	S, Vol S, Vol	5 3	3 1				
		10" X 0.365"	SI-87 SI-129	S, Vol S, Vol	12 7	6 4				
		10" X 0.365"	SI-89 SI-134	S, Vol S, Vol	12 14	6 7				
		14" x 0.375"	SI-90 SI-135	S, Vol S, Vol	10 10	5 5				
		16" x 0.375"	SI-70 SI-72	S, Vol S, Vol	4 4	2 2				

REV 1  
12-23-91



# APS

## PALO VERDE NUCLEAR GENERATING STATION 10 YEAR INTERVAL - EXAMINATION SUMMARY (RHR, ECCS, and CHR SYSTEMS)

### ASME CLASS 2

TABLE 2-CFR  
PAGE 3 OF 6

ASME ITEM NO.	ZONE-COMPONENT OR SYSTEM	IDENTIFICATION	DESCRIPTION LINE NO., OR SERIAL NO.	NDE METHOD	TOTAL ITEMS	EXAM AMOUNT		INSPECTION PERIOD	(40 YR) 10 YR %	REMARKS AND RELIEF REQUESTS
						40 YR	10 YR			
511 512	CONTINUED									
		20" x 0.500"	SI-70 SI-72	S, Vol S, Vol	14 14	7 7				
	88 & 91 Safety Injection East and West Wraps	Butt Welds 10" x 0.365"	SI-172 SI-71	S, Vol S, Vol	(52) 4 2	(16) 2 1	3 2 0	One Two Three		
		12" x 0.375"	SI-72 SI-73 SI-70 SI-71	S, Vol S, Vol S, Vol S, Vol	17 6 9 8	4 2 2 2				
		20" x 0.500"	SI-72 SI-70	S, Vol S, Vol	3 3	1 2				
	89 & 92 Shutdown Cooling Suction East and West Wraps	Butt Welds 10" x 0.250" **10" x 0.365"	SI-173 SI-239	S, Vol S, Vol	(64) 11 10	(33) 6 5	5 1 2	One Two Three		**One Weld per line
		12" x 0.250"	SI-38 SI-2	S, Vol S, Vol	4 10	2 5				
		16" x 0.312"	SI-194 SI-241 SI-173	S, Vol S, Vol S, Vol	8 11 2	4 6 1				
		18" x 0.312"	SI-194 SI-241	S, Vol S, Vol	3 5	1 3				

REV 1  
12-23-91

# APS

## PALO VERDE NUCLEAR GENERATING STATION 10 YEAR INTERVAL - EXAMINATION SUMMARY (RHR, ECCS, and CHR SYSTEMS)

### ASME CLASS 2

TABLE 2-CFR  
PAGE 4 OF 6

ASME ITEM NO.	ZONE-COMPONENT OR SYSTEM	IDENTIFICATION	DESCRIPTION LINE NO., OR SERIAL NO.	NDE METHOD	TOTAL ITEMS	EXAM AMOUNT		INSPECTION PERIOD	(40 YR) 10 YR %	REMARKS AND RELIEF REQUESTS
						0 YR	10 YR			
511 512	CONTINUED									
	95 & 93 Safety Injection East & West Wrap	Butt Welds 8" x 0.322"	SI-134 SI-89	S,Vol S,Vol	(24) 2 2	(12) 1 1	0 4 0	One Two Three		
		10" x 0.365"	SI-134 SI-89	S,Vol S,Vol	5 11	3 5				
		24" x 0.375"	SI-30 SI-7	S,Vol S,Vol	2 2	1 1				
	94 & 95 Safety Injection Train A & B	Butt Welds 10" x 0.365"	SI-89 SI-134	S,Vol S,Vol	(73) 10 9	(37) 5 5	2 0 2	One Two Three		
		18" x 0.312"	SI-194 SI-241	S,Vol S,Vol	19 18	10 9				
		20" x 0.500"	SI-70 SI-72	S,Vol S,Vol	12 5	6 2				
	100 & 101 LPSI Section Inside Containment	Butt Welds 10" x 0.250" **6" x 0.280"	SI-369 SI-368	S,Vol S,Vol	(41) 10 17	(21) 5 9	1 2 4	One Two Three		**One Weld per line.
		16" x 0.312"	SI-241 SI-194	S,Vol S,Vol	3 7	2 3				
		24" x 0.375"	SI-7 SI-30	S,Vol S,Vol	2 2	1 1				
	Category CS10 Systems Total				(634)	(312)	30 29 29	One Two Three	(100) 10 19 28	

REV. 1  
12-23-91

ASME ITEM NO.	ZONE-COMPONENT OR SYSTEM	IDENTIFICATION	DESCRIPTION LINE NO., OR SERIAL NO.	NDE METHOD	TOTAL ITEMS	EXAM AMOUNT		INSPECTION PERIOD	(40 YR) 10 YR %	REMARKS AND RELIEF REQUESTS
						40 YR	10 YR			
520	Piping Welds Over 1/2" nominal wall thickness									
521	Circumferential and **Longitudinal welds (*75 category C-F)				(33)	(8)				**2.5T min. from each scheduled circ. weld intersection will be examined.
522		88 & 91 LPSI Header To Loop-West Wrap	12" x 1.125"	SI-72 & 155 SI-73 & 174 SI-70 & 202 SI-71 & 220	S,Wel S,Wel S,Wel S,Wel	8 8 9 8	2 2 2 2	1 0 0	One Two Three	*** ***Category C520 systems are combined for percentages.
	90 & 93 Safety Injection-East & West Wrap	Butt Welds 24" x 0.562"	SI-308 SI-307	S,Wel S,Wel	(4) 2 2	(2) 1 1	0 1 0	One Two Three		
	96, 97, 98, 99 LPSI Header to Primary Loops Inside Containment	Butt Welds 12" x 1.125"  12" x 1.312"	SI-202 SI-220 SI-155 SI-174 SI-202 SI-220 SI-155 SI-174	S,Wel S,Wel S,Wel S,Wel S,Wel S,Wel S,Wel S,Wel	(108) 4 4 4 2 22 33 21 18	(28) 1 1 1 1 6 8 5 5	2 3 3	One Two Three		
	100 & 101 LPSI Section Inside Containment	Butt Welds 16" x 1.594"	SI-241 SI-194	S,Wel S,Wel	(4) 2 2	(2) 1 1	0 0 0	One Two Three		
	Category C520 Systems Total				(149)	(40)	3 4 3	One Two Three	(100) 8 18 25	
530	Pipe Branch Connections									**2.5T min. from each weld intersection will be examined.
531	Circumferential and *Longitudinal Welds									
532		82 & 85 SDCHX Inlets Room A & B	Sweep - 4 20" x 10"	SI-78 SI-123	S S	(4) 2 2	(2) 1 1	1 0 0	One Two Three	** **Category C530 systems are combined for percentages.



**PALO VERDE NUCLEAR GENERATING STATION**  
**10 YEAR INTERVAL - EXAMINATION SUMMARY**  
 (RHR, ECCS, and CHR SYSTEMS)

**ASME CLASS 2**

ASME ITEM NO.	ZONE-COMPONENT OR SYSTEM	IDENTIFICATION	DESCRIPTION LINE NO., OR SERIAL NO.	NDE METHOD	TOTAL ITEMS	EXAM AMOUNT		INSPECTION PERIOD	(40 YR) 10 YR %	REMARKS AND RELIEF REQUESTS
						40 YR	10 YR			
530	CONTINUED									
531	83 & 86 SDCHX Outlet Room A & B	Sweepolets			(8)	(4)				
		20" x 6"	SL-70	S	4	2	0	One		
		20" x 10"	SL-72	S	4	2	0	Two		
532	88 & 91 Safety Injection-East & West Wrap	20" x 14"				1		Three		
		Sweepolets			(2)	(1)				
		20" x 12"	SL-70	S	1	1	1	One		
	89 & 92 Safety Injection		SL-72	S	1	0	0	Two		
							0	Three		
	Category C530 Systems Total	Sweepolets	SL-194	S	1	1	0	One	(100)	
			18" x 12"	SL-241	S	1	0	0	Two	25
							0	Three	25	
					(16)	(8)	2	One	38	
							1	Three		

REV 1  
 12-23-91

SECTION 9.0  
REQUEST FOR RELIEF

RELIEF REQUEST  
INDEX

<u>NUMBER</u>	<u>DESCRIPTION</u>
1.	Hydraulic and Mechanical Snubbers will be tested in accordance with PVNGS Technical Specifications.
2.	Withdrawn
3.	Insulation will not be removed for visual examinations or welded or mechanical attachments.
4.	Level III Personnel will be recertified by examination every 5 years.
5.	Withdrawn
6.	Reactor Vessel Support Visual Examination.
7.	Class 2 and 3 Systems Pressure Test.
8.	Class 3 System Pressure Test

RELIEF REQUEST NO. 1

COMPONENT OR ITEM	CODE CLASS	PROGRAM TABLE	CODE ITEM	EXAM CATEGORY
HYDRAULIC AND MECHANICAL SNUBBERS	1	1-IWF	N/A	N/A
	2	2-IWF	N/A	N/A
	3	3-IWF	N/A	N/A

#### CODE REQUIREMENT

Perform inservice functional testing of hydraulic and mechanical snubbers in accordance with IWF-5000

#### BASIS

A detailed and comprehensive testing program for snubbers is contained in the PVNGS Technical Specifications.

#### 9.3 ALTERNATE EXAMINATION

The requirements for testing snubbers will be in accordance with the PVNGS Technical Specifications, Section 4.7.9.

#### SCHEDULE FOR IMPLEMENTATION

First Ten Year Inspection Interval

#### APPROVAL

NRC letter dated October 21, 1987, from E.A. Licitra, NRC, to E.E. Van Brunt, Jr., "Inservice Inspection Programs Palo Verde, Unit 1, 2, & 3".

RELIEF REQUEST NO. 2

COMPONENT OR ITEM	CODE CLASS	PROGRAM TABLE	CODE ITEM	EXAM CATEGORY
NOZZLE INSIDE RADIUS SECTIONS				
PRESSURIZER	1	1-3	B3.120	B-D
STEAM GENERATOR	1	1-3	B3.140	B-D
STEAM GENERATOR	2	2-2	C2.22	C-B
SHUT DOWN COOLING HEAT EXCHANGERS	2	2-2	C2.22	C-B

WITHDRAWN

9-4

REV 1  
12-23-91



RELIEF REQUEST NO. 3

COMPONENT OR ITEM	CODE CLASS	PROGRAM TABLE	CODE ITEM	EXAM CATEGORY
SUPPORT COMPONENTS	1	1-IWF	ALL ITEMS	F-A, F-B & F-C
	2	2-IWF		F-A, F-B & F-C
	3	3-IWF		F-A, F-B & F-C
INTEGRAL ATTACHMENTS	3	3-1		D-A, D-B & D-C

#### CODE REQUIREMENT

Perform visual examinations (VT-3) of the mechanical or welded attachments to the pressure retaining component on insulated systems.

#### BASIS

The visual examinations of the mechanical or welded attachments will be performed to the extent practical. The insulation will not be removed to perform these examinations. It has been our experience that any loss of support capability or adequate restraint can usually be detected through the examination of uninsulated portions of the support, the accessible portions of the attachments through the insulation gaps, and/or the surrounding insulation.

#### ALTERNATE EXAMINATION

The mechanical and welded attachments will be visually examined to the extent practical. The insulation will be removed from around the support attachment for further examinations whenever an abnormality is detected.

#### SCHEDULE FOR IMPLEMENTATION

First Ten Year Inspection Interval

#### APPROVAL

NRC letter dated October 21, 1987, from E.A. Licita, NRC, to E.E. Van Brunt, Jr., "Inservice Inspection Programs Palo Verde, Unit 1, 2, & 3".

REV. 1  
12-23-91

RELIEF REQUEST NO. 4

COMPONENT OR ITEM	CODE CLASS	PROGRAM TABLE	CODE ITEM	EXAM CATEGORY
N/A	N/A	N/A	N/A	N/A

#### CODE REQUIREMENT

All Level III personnel shall be recertified by examination on a triennial basis (TWA-2300(a)(1)).

#### BASIS

The 1985 Edition of Section XI and the 1983 Edition thru Summer 1983 Addenda of ASME III (Latest Edition and Addenda referenced in 10 CFR 55.55a) requires Level III personnel to be recertified every 5 years.

9-6

#### ALTERNATE EXAMINATION

All Level III personnel shall be recertified by examination every 5 years.

#### SCHEDULE FOR IMPLEMENTATION

First Ten Year Inspection Interval

#### APPROVAL

NRC letter dated October 21, 1987, from E.A. Licita, NRC, to E.E. Van Brunt, Jr., "Inservice Inspection Programs Palo Verde, Unit 1, 2, & 3".

REV. 1  
12-23-91

RELIEF REQUEST NO. 5

COMPONENT OR ITEM	CODE CLASS	PROGRAM TABLE	CODE ITEM	EXAM CATEGORY
N/A	N/A	N/A	N/A	N/A

WITHDRAWN

RELIEF REQUEST NO. 6

COMPONENT OR ITEM	CODE CLASS	PROGRAM TABLE	CODE ITEM	EXAM CATEGORY
Reactor Vessel Supports	1	1-IWF	F2.10 F2.20 F2.30 F2.40	F-B

#### CODE REQUIREMENT

Perform visual examination (VT-3) of the Reactor Vessel Supports

#### BASIS

The visual examination of the reactor vessel supports will not be performed. The supports are inaccessible from the refueling cavity seal ring area for either direct or remote visual examination. Examination from the ICI chase below the vessel would require extensive scaffolding to be erected in order to get up to the support pedestal and the exam would still be severely limited due to accessibility between the reactor vessel and the cavity. The performance of this visual would require extremely large amounts of time, effort, expense, and radiation exposure (expected to be 3 man rem per support based on surveys taken in Unit 3 during first refueling outage).

#### ALTERNATE EXAMINATION

No alternate examination is proposed.

#### SCHEDULE FOR IMPLEMENTATION

First Ten Year Inspection Interval.

#### APPROVAL

Pending NRC approval.

9-8

REV 1  
12-23-91

RELIEF REQUEST NO. 7				
COMPONENT OR ITEM	CODE CLASS	PROGRAM TABLE	CODE ITEM	EXAM CATEGORY
PRESSURE RETAINING COMPONENTS	2	2-7	C710	C-H
	3	3-1	C730	D-A
			C750	D-B
			C770	D-C
			D110	
			D210	
			D310	

#### CODE REQUIREMENT

Perform System Functional (class 2) and System Inservice (class 3) pressure test in accordance with IWA-5000, IWC-5000, IWD-5000.

#### 9.9 BASIS

This relief is applicable only to portions of piping systems that are classified ASME due to penetration of containment building liner plate. For the applicable class 2 systems the piping upstream and downstream of containment isolation is classified non-ASME. The class 3 system is applicable to the fuel transfer tube (containment to fuel bldg.).

#### ALTERNATE EXAMINATION

The applicable containment piping penetrations and fuel transfer tube are routinely subjected to surveillance testing. This testing consists of integrated leak rate testing and/or local leak rate testing.

#### SCHEDULE FOR IMPLEMENTATION

First Ten Year Inspection Interval.

#### APPROVAL

Pending NRC approval.

RELIEF REQUEST NO. 8

COMPONENT OR ITEM	CODE CLASS	PROGRAM TABLE	CODE ITEM	EXAM CATEGORY
PRESSURE RETAINING COMPONENTS	3	3-1	D2.10	D-B

CODE REQUIREMENT

Perform System Inservice Pressure Test in accordance with IWA-5000 and IWD-5000

BASIS

The 1986 Edition of Section XI Code (which is included in the latest Edition referenced in the current 10 CFR 50.55a) requires a Functional Pressure Test be performed on systems in support of Emergency Core Cooling, Containment Heat Removal, Atmospheric Cleanup, and Reactor Residual Heat Removal.

9-10

ALTERNATE EXAMINATION

Perform a Functional Pressure Test on Class 3 Pressure Retaining Components within systems not normally operating while the Unit is Inservice.

SCHEDULE FOR IMPLEMENTATION

First Ten Year Inspection Interval.

APPROVAL

Pending NRC Approval.

SECTION 10.0  
ISI  
BOUNDRY DRAWINGS



NOTE: See ISI Drawings for Unit 1 ISI Program, Letter ANPP-33266-EEVB/KLM, dated August 26, 1985, from E.E. Van Brunt, Jr., ANPP, to George W. Knighton, NRC, "Palo Verde Nuclear Generating Station (PVNGS) Unit 1 Docket Nos. STN 50-528 (License No. NPF-41) Initial Inservice Inspection Program-PVNGS Unit 1".



SECTION 11.0  
ZONE DRAWINGS

ZONE DRAWING INDEX

Drawing Number	Revision	Drawing Title	Code Class
Zone 1	0	Reactor Vessel	1
Zone 2	0	Closure Head	1
Zone 3	0	Steam Generator 1	1
Zone 4	0	Steam Generator 2	1
Zone 5	0	Pressurizer	1
Zone 6	0	RCS Primary Piping	1
Zone 7-15	NOT	USED	1
Zone 16	0	Reactor Coolant Pump 1A	1
Zone 17	0	Reactor Coolant Pump 1B	1
Zone 18	0	Reactor Coolant Pump 2A	1
Zone 19	0	Reactor Coolant Pump 2B	1
Zone 20	0	Pressurizer Surge	1
Zone 21	0	Shutdown Cooling Loop 1	1
Zone 22	0	Shutdown Cooling Loop 2	1
Zone 23	0	Safety Injection 1A	1
Zone 24	0	Safety Injection 1B	1
Zone 25	0	Safety Injection 2A	1
Zone 26	0	Safety Injection 2B	1
Zone 27	0	Pressurizer Spray 1A	1
Zone 28	0	Pressurizer Spray 1B	1
Zone 29	0	Combined Pressurizer Spray	1
Zone 30	0	Aux. Pressurizer Spray	1
Zone 31	0	Pressurizer Safeties	1
Zone 32	0	Drain Line 1A	1
Zone 33	0	Drain Line 1B	1
Zone 34	0	Drain Line 2A	1
Zone 35	0	Drain Line 2B	1
Zone 36	0	Letdown Line	1
Zone 37	0	Charging Line	1
Zone 38	0	Drain Line Loop 1	1
Zone 39	0	HPSI Long Term Recirc 1	1
Zone 40	0	HPSI Long Term Recirc 2	1
Zone 41	0	Steam Generator 1	2
Zone 42	0	Steam Generator 2	2
Zone 43	0	Main Steam SG 1 East	2
Zone 44	0	Main Steam SG 1 West	2
Zone 45	0	Main Steam SG 2 East	2
Zone 46	0	Main Steam SG 2 West	2
Zone 47	0	Main Steam SG 1 West	2
Zone 48	0	Main Steam SG 1 East	2
Zone 49	0	Main Steam SG 2 East	2
Zone 50	0	Main Steam SG 2 West	2
Zone 51	0	Atmospheric Dump No. 1	2
Zone 52	0	Atmospheric Dump No. 2	2

ZONE DRAWING INDEX (Cont'd)

Drawing Number	Revision	Drawing Title	Code Class
Zone 53	0	Steam to Aux Feedwater System	2
Zone 54	0	Feedwater SG No. 1	2
Zone 55	0	Feedwater SG No. 2	2
Zone 56	0	Feedwater SG No. 1	2
Zone 57	0	Feedwater SG No. 2	2
Zone 58	0	Aux & Downcomer Feedwater SG 1	2
Zone 59	0	Aux & Downcomer Feedwater SG 2	2
Zone 60	0	Downcomer Feedwater SG 1	2
Zone 61	0	Downcomer Feedwater SG 2	2
Zone 62	0	Auxiliary Feedwater SG 1	2
Zone 63	0	Auxiliary Feedwater SG 2	2
Zone 64	0	Blowdown SG 1	2
Zone 65	0	Blowdown SG 2	2
Zone 66	0	Blowdown SG 1	2
Zone 67	0	Blowdown SG 2	2
Zone 68	0	Regenerative Heat Exchanger	2
Zone 69	0	Letdown Heat Exchanger	2
Zone 70	0	LPSI Pump Room A Suction	2
Zone 71	0	LPSI Pump Room A Discharge	2
Zone 72	0	LPSI Pump A	2
Zone 73	0	LPSI Pump Room B Suction	2
Zone 74	0	LPSI Pump Room B Discharge	2
Zone 75	0	LPSI Pump B	2
Zone 76	0	Containment Spray Pump Room A Suction	2
Zone 77	0	Containment Spray Pump Room A Discharge	2
Zone 78	0	Containment Spray Pump A	2
Zone 79	0	Containment Spray Pump Room B Suction	2
Zone 80	0	Containment Spray Pump Room B Discharge	2
Zone 81	0	Containment Spray Pump B	2
Zone 82	0	Shutdown Cooling Heat Exchanger Room A	2
Zone 83	0	Shutdown Cooling Heat Exchanger Room A	2
Zone 84	0	Shutdown Cooling Heat Exchanger Room A	2
Zone 85	0	Shutdown Cooling Heat Exchanger Room B	2
Zone 86	0	Shutdown Cooling Heat Exchanger Room B	2
Zone 87	0	Shutdown Cooling Heat Exchanger B	2

ZONE DRAWING INDEX (Cont'd)

Drawing Number	Revision	Drawing Title	Code Class
Zone 88	0	East Wrap	2
Zone 89	0	East Wrap	2
Zone 90	0	East Wrap	2
Zone 91	0	West Wrap	2
Zone 92	0	West Wrap	2
Zone 93	0	West Wrap	2
Zone 94	0	A Train Misc. Pipe Chases & 88' Pipe Tunnel	2
Zone 95	0	B Train Misc. Pipe Chases & 88' Pipe Tunnel	2
Zone 96	0	Containment LPSI Header to Loop 1A	2
Zone 97	0	Containment LPSI Header to Loop 1B	2
Zone 98	0	Containment LPSI Header to Loop 2A	2
Zone 99	0	Containment LPSI Header to Loop 2B	2
Zone 100	0	Containment LPSI Train A Suction	2
Zone 101	0	Containment LPSI Train B Suction	2

**NOTES:**

TAG NO. 3MPLER01  
 SERIAL NO. 45173 (LE)  
 N. O. NO. 22654

REFERENCE DWG.  
 N001-3-01-15 AND 17  
 N001-3-01-41 AND 61  
 N001-3-01-72

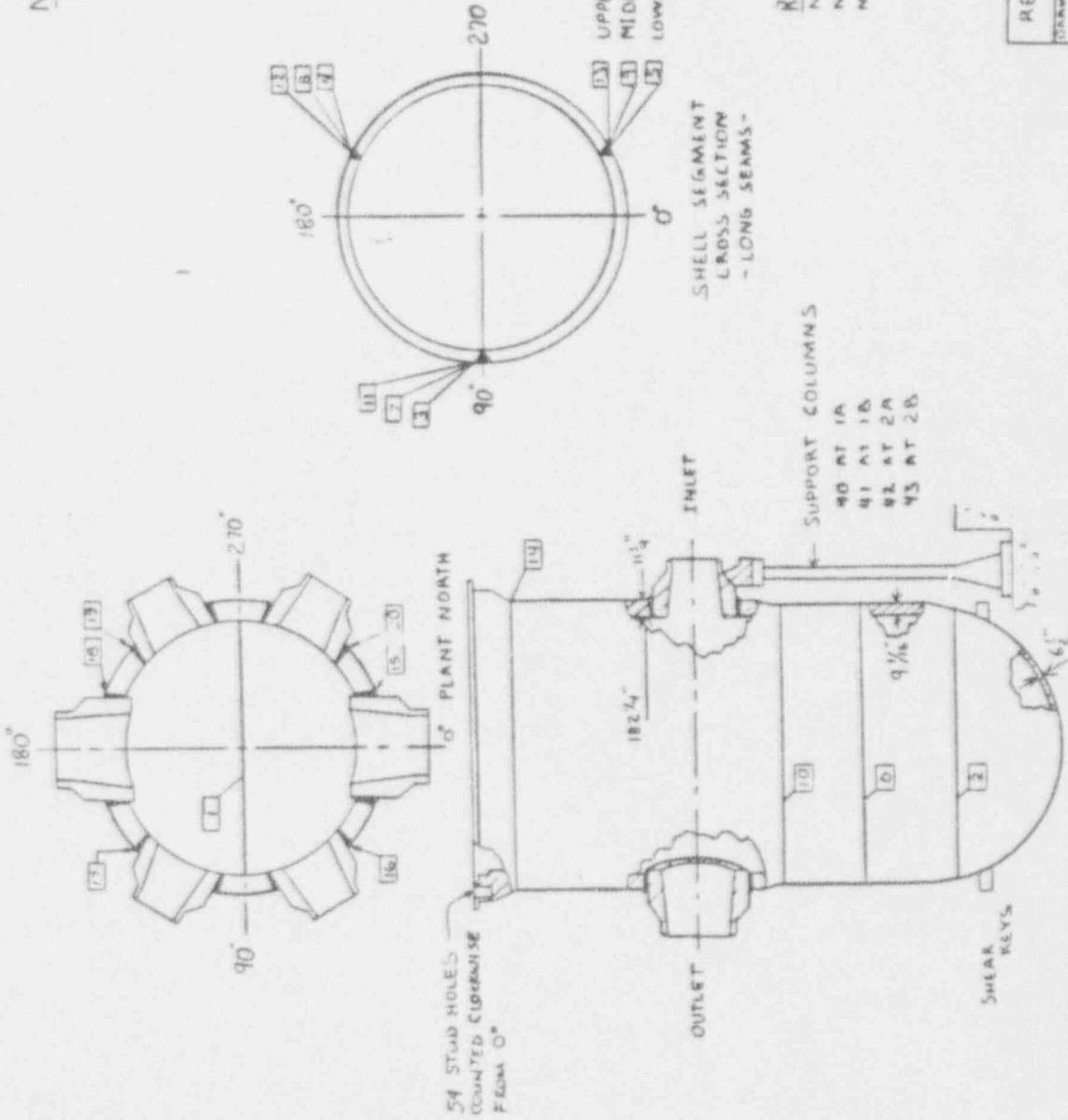

REV 0	UNIT # 3 ZONE 1
DESIGNED BY D. P. HANSEN	TITLE REACTOR VESSEL
CHECKED BY J. B. TRIPLETT	

**NOTES:**

- 1 ITEM NO. - LEDM NO
- 2 TAG NO. 3MARE03
- 3 SERIAL NO. 45173 (E E)
- 4 P. B. NO. 22655
- 5 THIS CLAMP CONTAINS 9 STUDS AND 80 STUDS

**REFERENCE DWGS:**

- N001-3-01-20 AND 25
- N001-3-01-121 AND 213

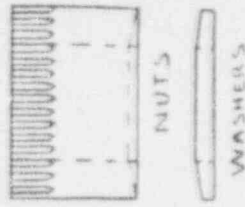

CLOSURE HEAD STUDS # 1 THRU # 54

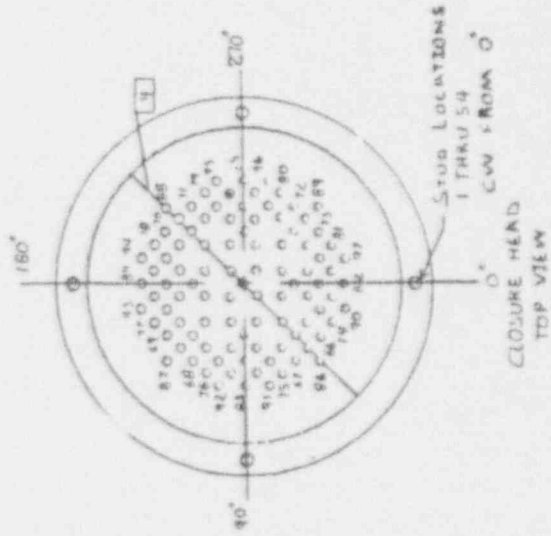
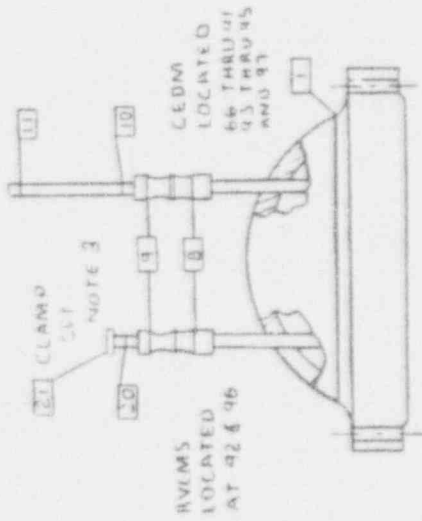
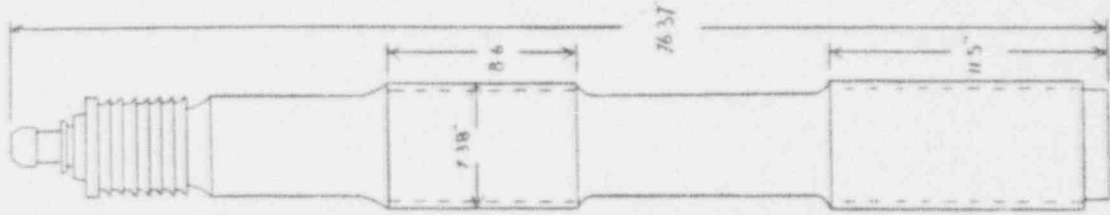

REV 0	UNIT #3 ZONE 2
DRAWN BY D. B. HATHORN	TITLE CLOSURE HEAD
CHECKED BY J. B. SCHENKER	

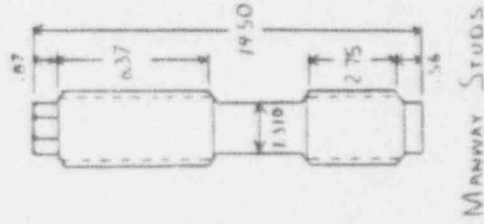
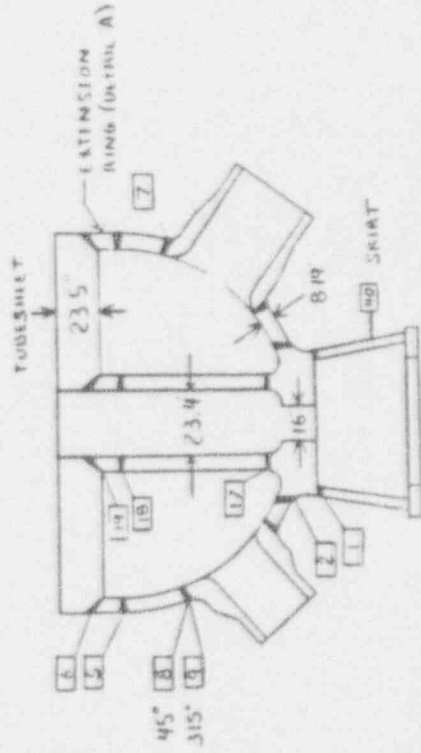
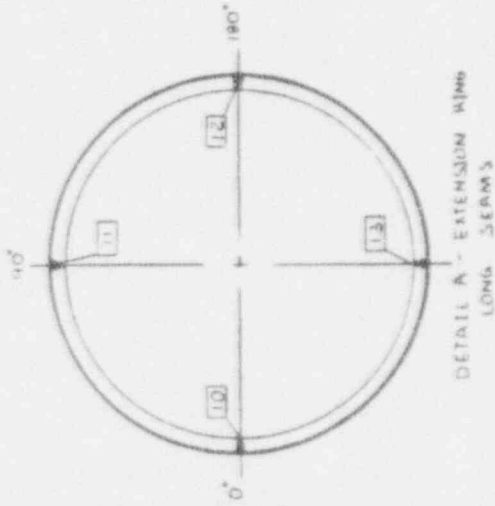
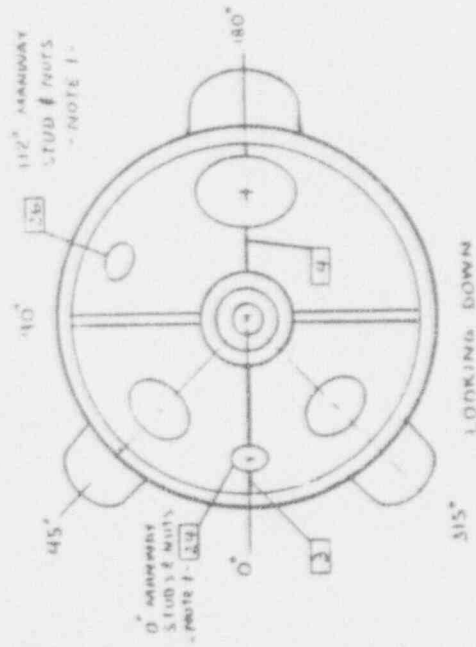

**NOTES:**

- 1) STUD LOCATION IS # 1 TO 6 GOING CW TO # 20
- 2) YOGA NO. 3MRE001A SERIAL NO. 65273-1(C) N.D. NO. 22860

**REFERENCE DWGS.**

- N001-6-03-9 AND 10
- N001-6-03-53
- N001-6-03-239 AND 313

REV 0	UNIT 3 ZONE 3
DESIGNED BY U. S. HANSEN	TITLE STEAM GENERATOR # 1
CHECKED BY TOS	

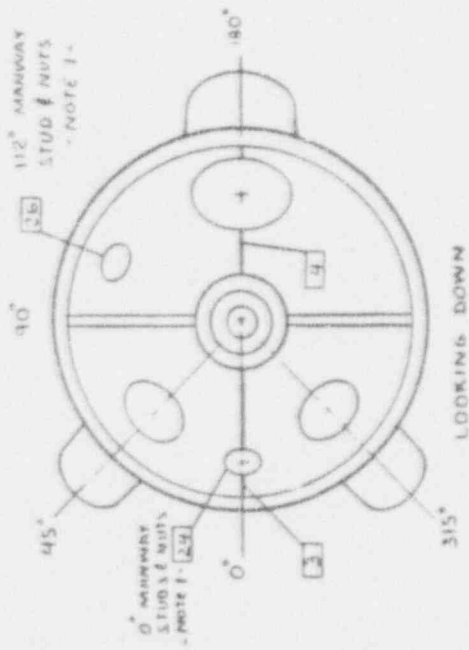

LOOKING DOWN

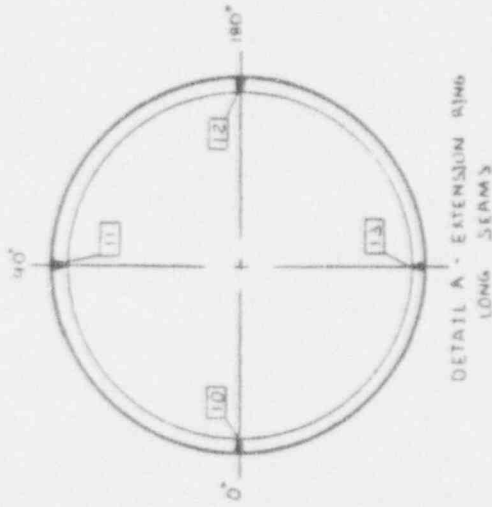

DETAIL A - EXTENSION RING LONG SEAMS

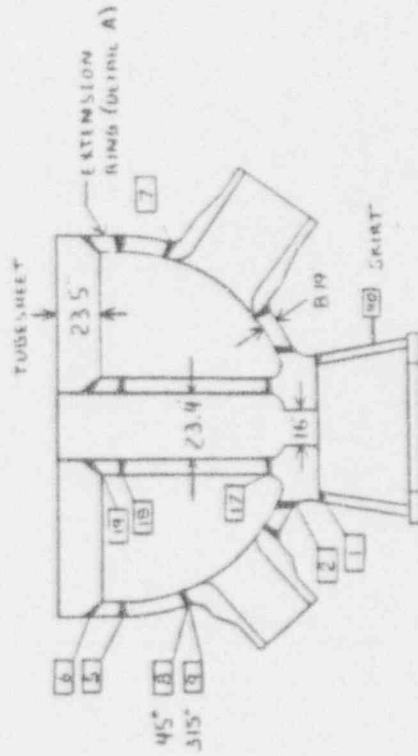

CHANNEL HEAD CROSS SECTION

**NOTES:**  
 1) STUD LOCATION IS #1 TDC  
 GOING CW TO #20  
 2) TAG NO. 3MKCEEO18  
 SERIAL NO. 65273-2 (CE)  
 N.D. NO. 22864

REFERENCE DWGS.

- N001-6.03-9 AND 10
- N001-6.03-53
- N001-6.03-259 AND 313

MANWAY STUDS

REV 0	DWG	UNIT 3 ZONE 4
DRAWN BY U. S. HANSEN	TITLE	STEAM GENERATOR # 2
CHECKED BY TBS		



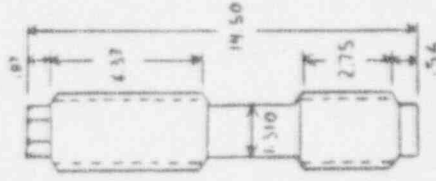
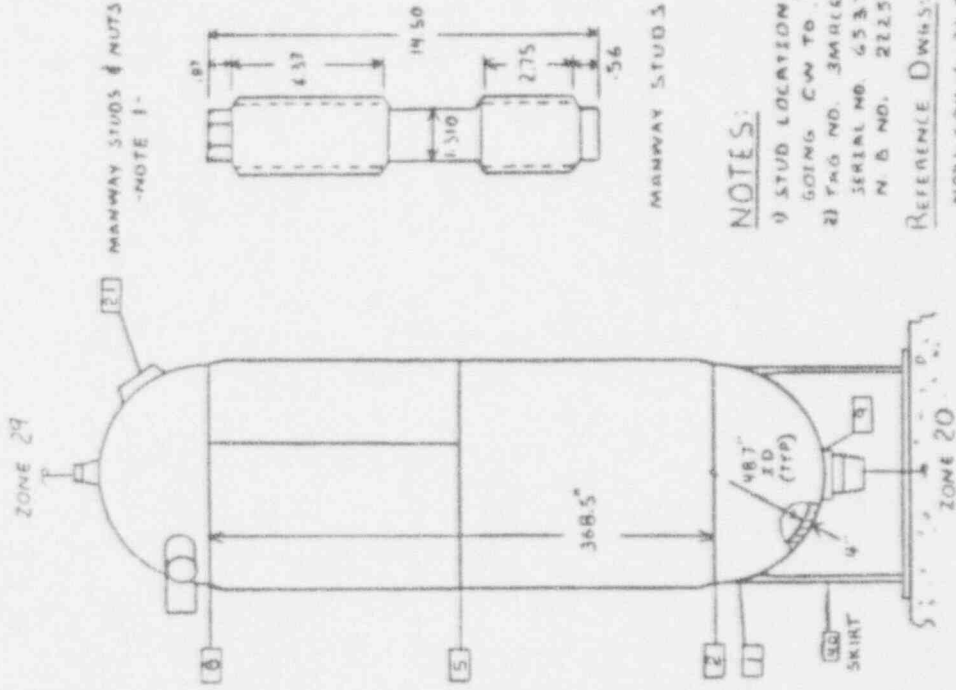
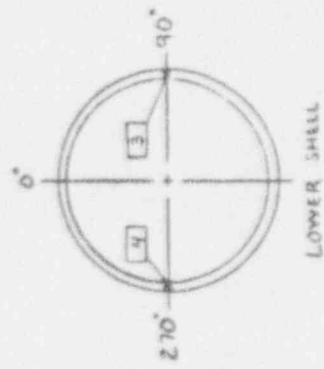
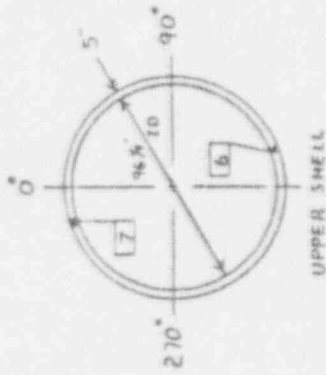
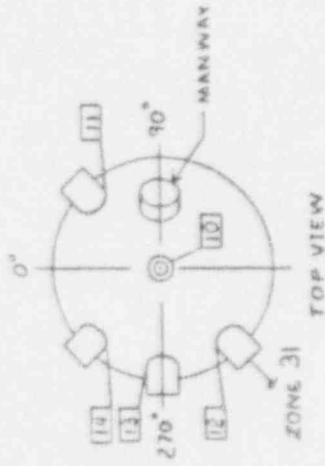

**NOTES:**  
 1) STUD LOCATION IS #, TDC  
 GOING CW TO # 20  
 2) TAG NO. 3MRCE502  
 SERIAL NO. 45375 (44)  
 N. B. NO. 22254

REFERENCE DWGS:  
 N001-6.0U-6, 31 AND 90

DWG	UNIT #3 ZONE 5
REV 0	TITLE
DRAWN BY D. S. HANSEN	PRESSURIZER
CHECKED BY JRS	

NOTES:

- 1 PIPE LONGSEAMS AT 3.00 AND 9.00 POSITIONS
- 2 ELBOW LONGSEAMS AT LONG AND SHORT RADII.

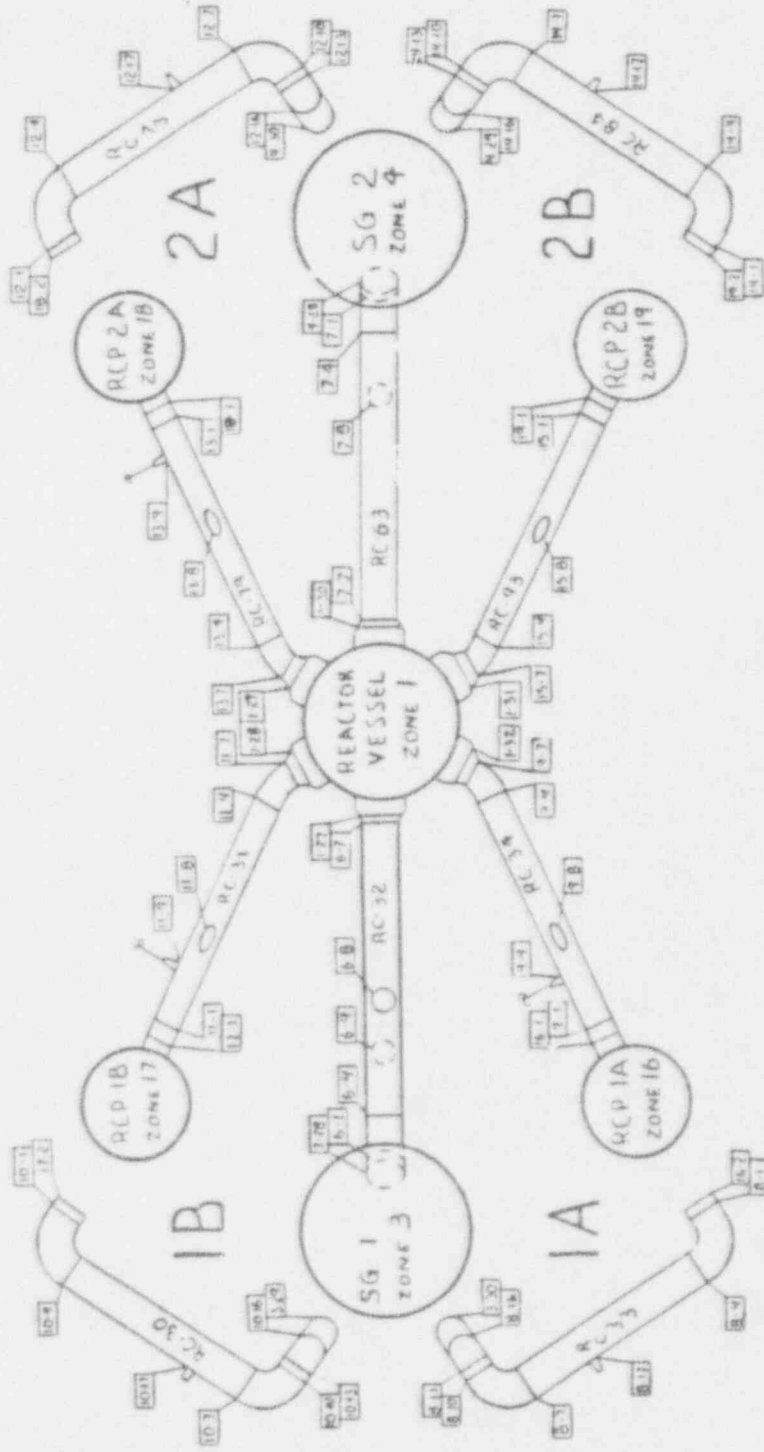

REFERENCE DRAWINGS:

- 13-0-226 103
- MOD 1-6-07-85 AND 112
- MOD 1-6-01-90 THRU 94
- MOD 1-6-01-96 THRU 100

REV 0	DATE	UNIT 3 ZONE 6
DRAWN BY JBS		TITLE: RCS
CHECKED BY		PRIMARY PIPING

**NOTES:**

- 1) STUD LOCATIONS C/W FROM DISCHARGE  $\frac{1}{4}$ "
- 2) TAG NO. 3MRCEP01A  
SERIAL NO IIII-A (C-E)  
M.B. NO. 23461

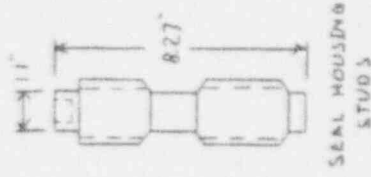
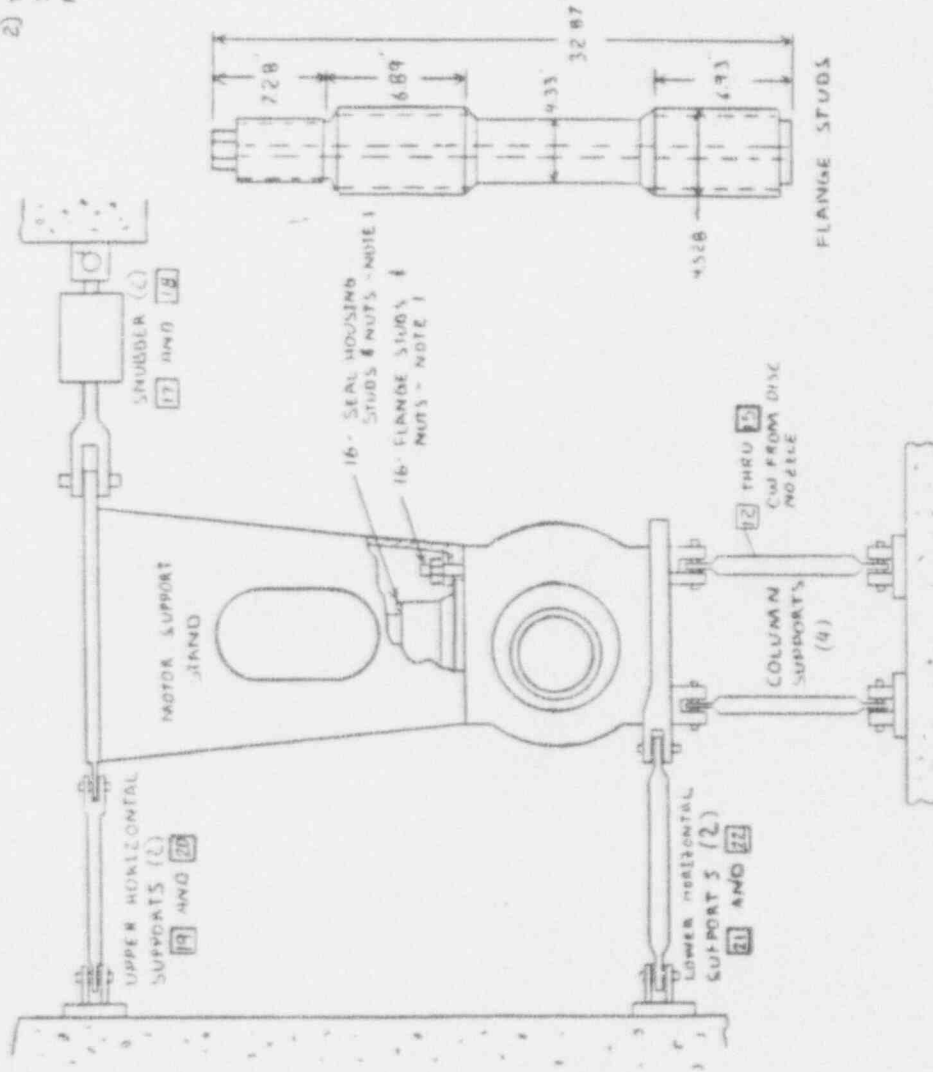

**REFERENCE DWGS:**

- M001 - 6-02-41B
- M001 - 6-02-42D THRU 423
- M001 - 6-02-101 & 105

REV 0	DWG	UNIT 3 ZONE 16
DESIGN BY D. S. HANSEN	TITLE REACTOR COOLANT PUMP 1A	
CHECKED BY JBS		

NOTES:

- 1) STUD LOCATIONS C.W FROM DISCHARGE &
- 2) TAG NO. SPACERONS SERIAL NO IIII-18 (C-E) N.O. NO. 25362

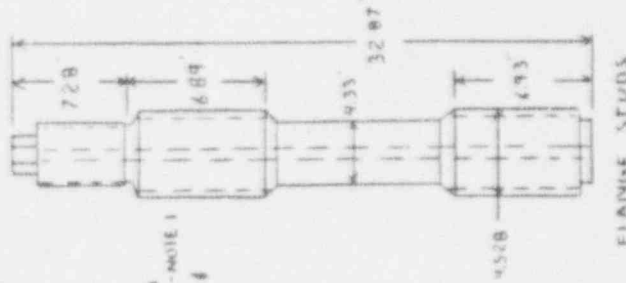
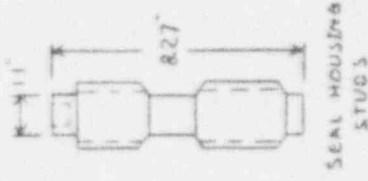
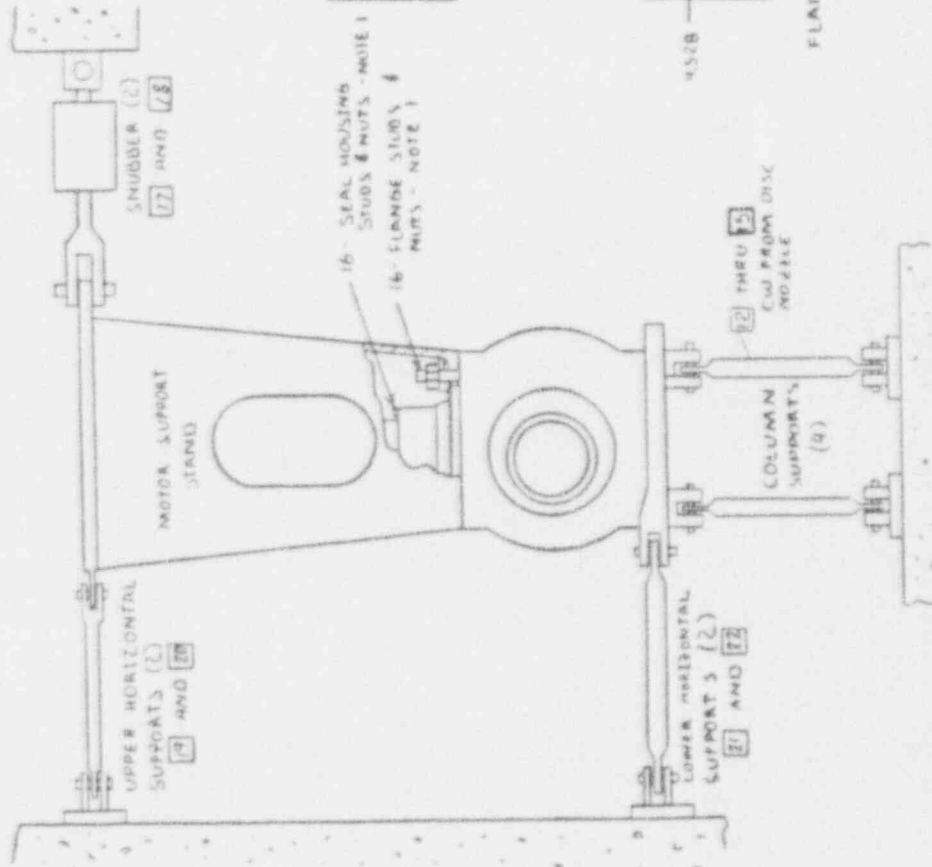

REFERENCE DWGS.  
 M001 - 6.02 - 418  
 M001 - 6.02 - 420 THRU 423  
 M001 - 6.02 - 107 & 108

REV 0	UNIT 3 ZONE 17
DESIGNED BY D. S. HANSEN	TITLE REACTOR COOLANT PUMP 18
CHECKED BY TBS	

**NOTES:**

- 1) STUD LOCATION S C.W FROM DISCHARGE  $\phi$
- 2) TAG NO. 3MRCEP001C  
SERIAL NO. 1111-2A (K-E)  
M.B. NO. 23463

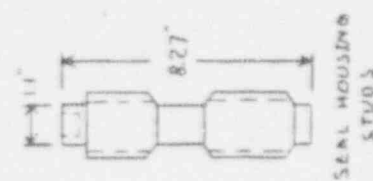
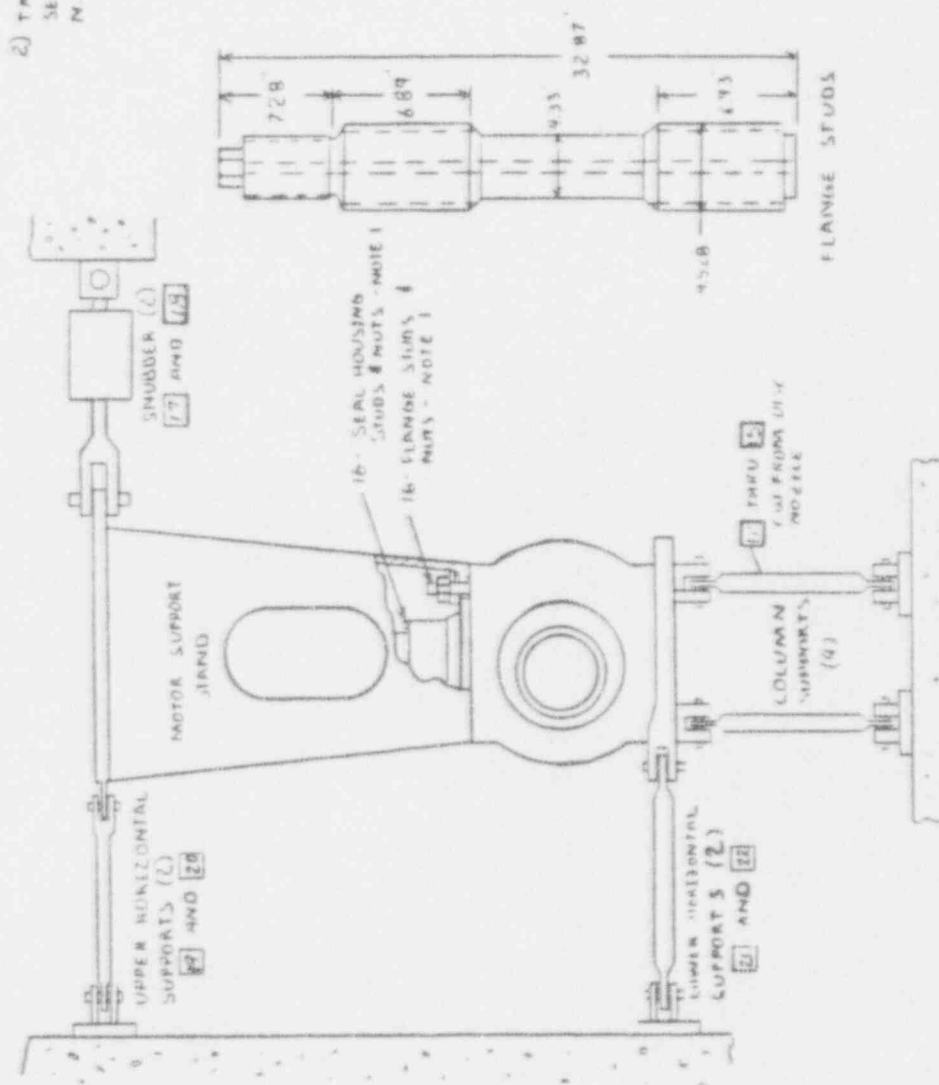

**REFERENCE DRAWINGS:**  
 N001 - 6-02-418  
 N001 - 6-02-420 THRU 423  
 N001 - 6-02-101 & 105

REV 0	UNIT 3 ZONE 1B
DESIGNED BY C. D. HANSEN	TITLE REACTOR COOLANT PUMP 2A
CHECKED BY TBS	

**NOTES:**

- 1) STUD LOCATIONS C/W FROM DISCHARGE
- 2) TAG NO. 3MRCPE01P  
SERIAL NO. 1111-28 (C-E)  
M.O. NO. 23464

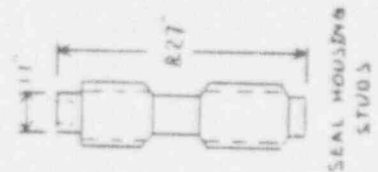
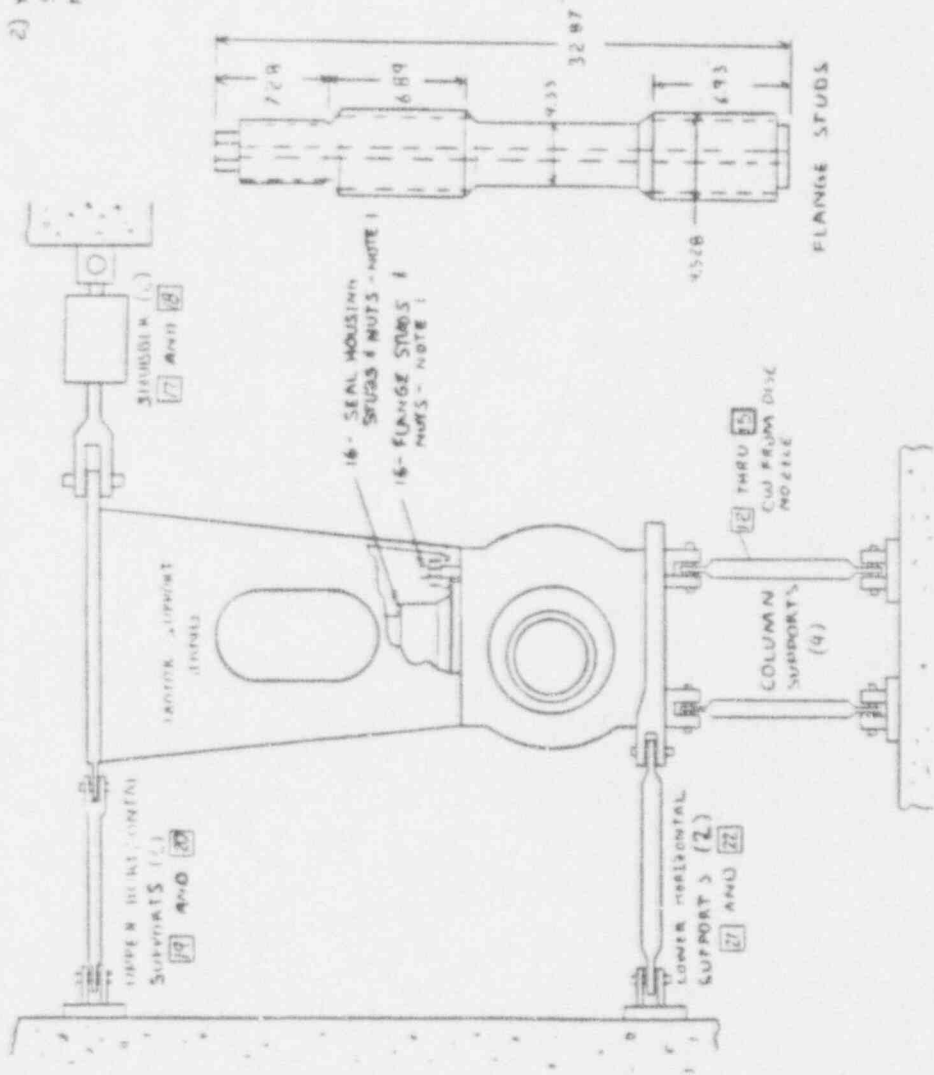

**REFERENCE DWGS.**  
 N001 - 6-02-418  
 N002 - 6-02-420 THRU 423  
 N003 - 4-02-107 & 108

REV 0	UWG	UNIT 3 ZONE 19
DESIGNED BY 31 D. HANSEN		TITLE REACTOR COOLANT PUMP 28
CHECKED BY JBS		

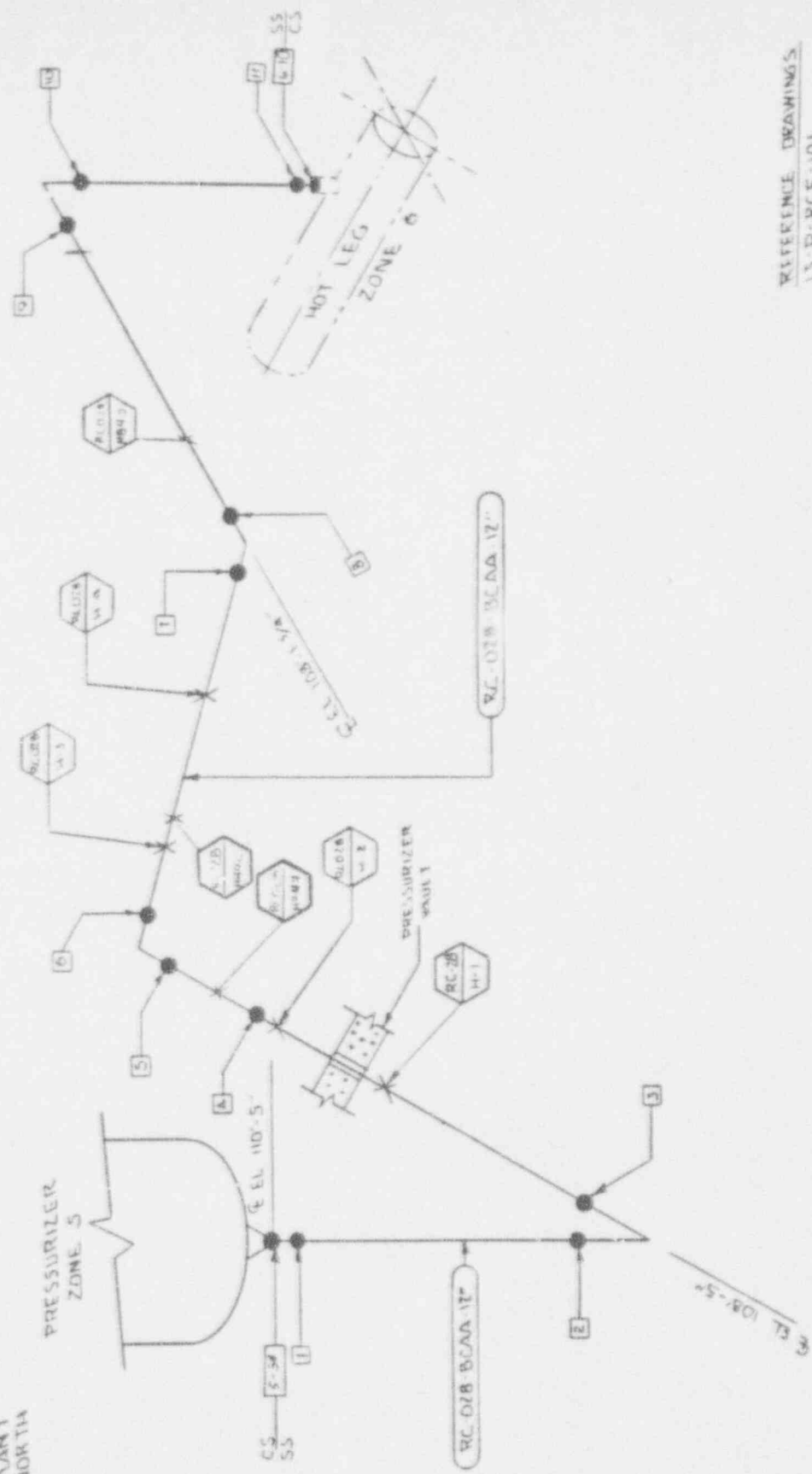

REFERENCE DRAWINGS  
13-P-RCF-101

REV. 1	UNIT 3 ZONE 20
REV. 2	RESURFACER SURGE
REV. 3	
REV. 4	
REV. 5	
REV. 6	
REV. 7	
REV. 8	
REV. 9	
REV. 10	
REV. 11	
REV. 12	
REV. 13	
REV. 14	
REV. 15	
REV. 16	
REV. 17	
REV. 18	
REV. 19	
REV. 20	
REV. 21	
REV. 22	
REV. 23	
REV. 24	
REV. 25	
REV. 26	
REV. 27	
REV. 28	
REV. 29	
REV. 30	
REV. 31	
REV. 32	
REV. 33	
REV. 34	
REV. 35	
REV. 36	
REV. 37	
REV. 38	
REV. 39	
REV. 40	
REV. 41	
REV. 42	
REV. 43	
REV. 44	
REV. 45	
REV. 46	
REV. 47	
REV. 48	
REV. 49	
REV. 50	
REV. 51	
REV. 52	
REV. 53	
REV. 54	
REV. 55	
REV. 56	
REV. 57	
REV. 58	
REV. 59	
REV. 60	
REV. 61	
REV. 62	
REV. 63	
REV. 64	
REV. 65	
REV. 66	
REV. 67	
REV. 68	
REV. 69	
REV. 70	
REV. 71	
REV. 72	
REV. 73	
REV. 74	
REV. 75	
REV. 76	
REV. 77	
REV. 78	
REV. 79	
REV. 80	
REV. 81	
REV. 82	
REV. 83	
REV. 84	
REV. 85	
REV. 86	
REV. 87	
REV. 88	
REV. 89	
REV. 90	
REV. 91	
REV. 92	
REV. 93	
REV. 94	
REV. 95	
REV. 96	
REV. 97	
REV. 98	
REV. 99	
REV. 100	

REFERENCE DRAWINGS:

23-P-SIF-105

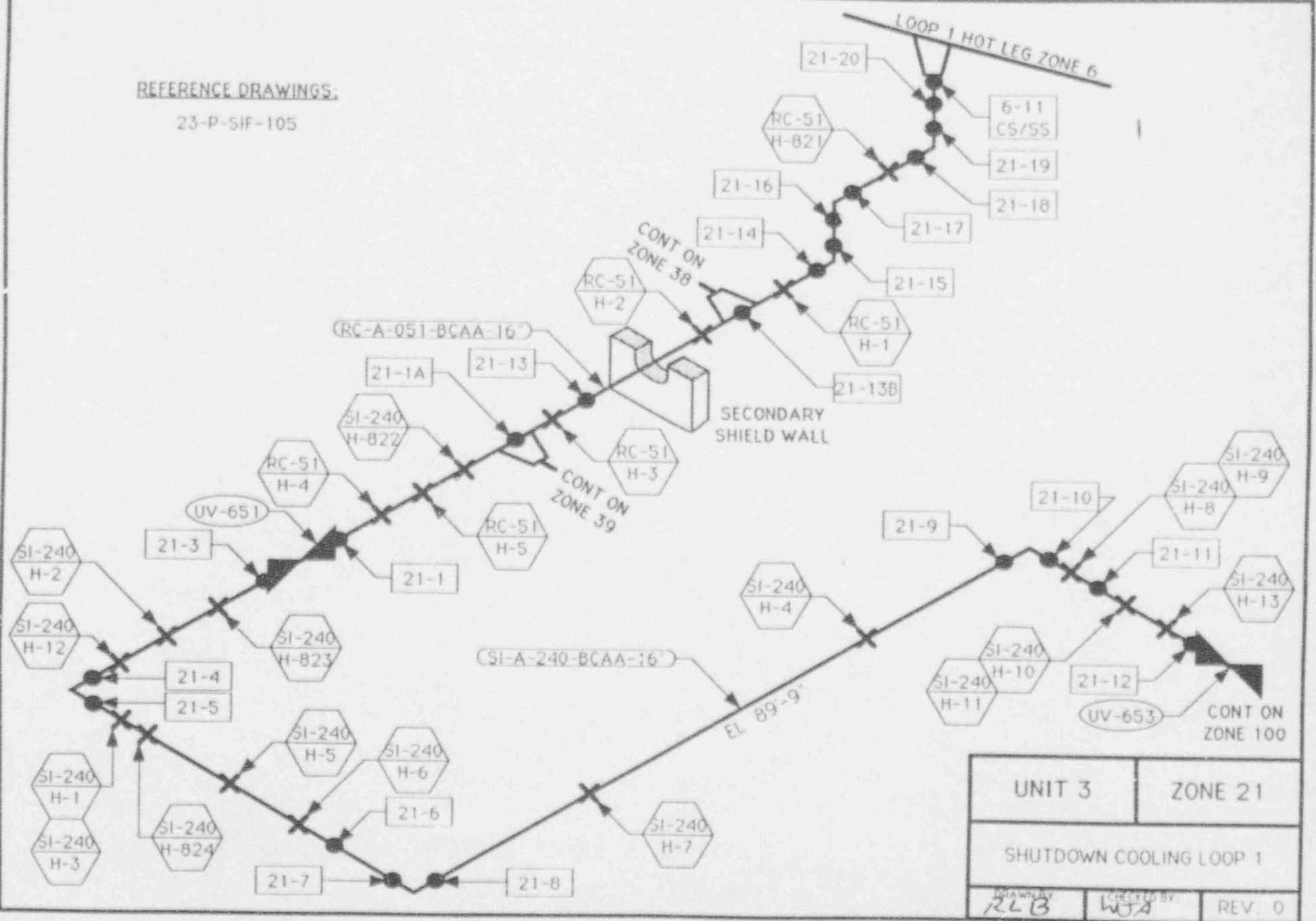

UNIT 3	ZONE 21
SHUTDOWN COOLING LOOP 1	
DRAWN BY RZB	CHECKED BY WJA
REV. 0	



REFERENCE DRAWINGS:

23-P-SIF-105

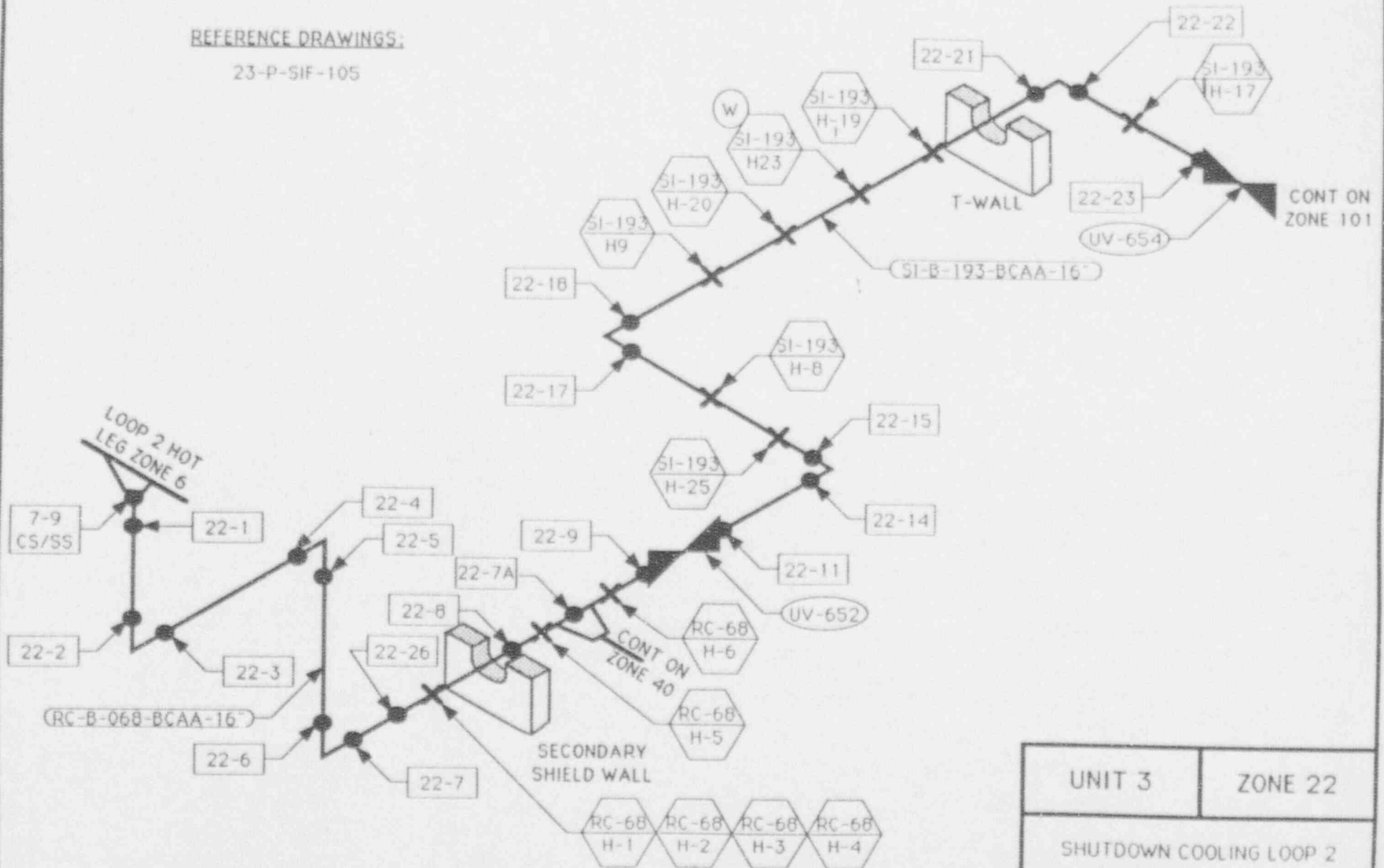

UNIT 3	ZONE 22
SHUTDOWN COOLING LOOP 2	
DRAWN BY RLB	CHECKED BY WJA
	REV. 0

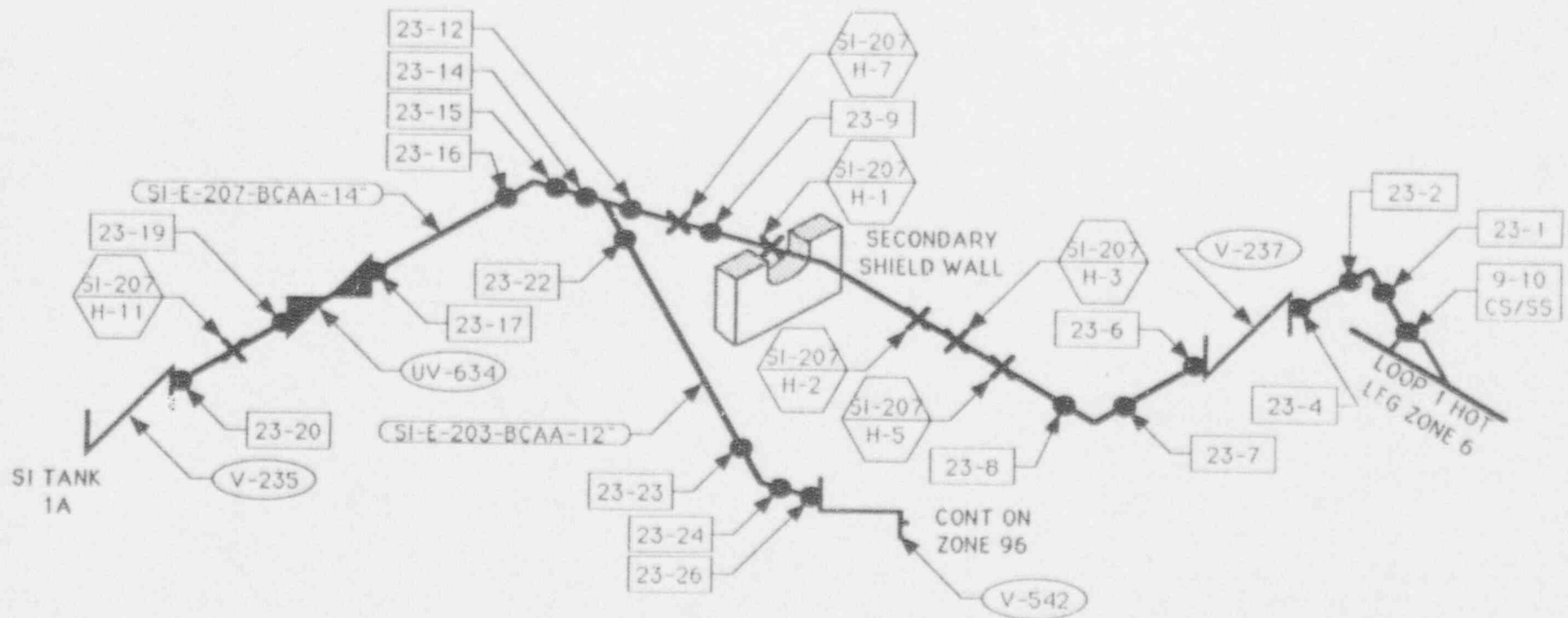

REFERENCE DRAWINGS:

13-P-SIF-103

UNIT 3	ZONE 23
SAFETY INJECTION 1A	
DRAWN BY ZLB	CHECKED BY WJA
	REV. 0

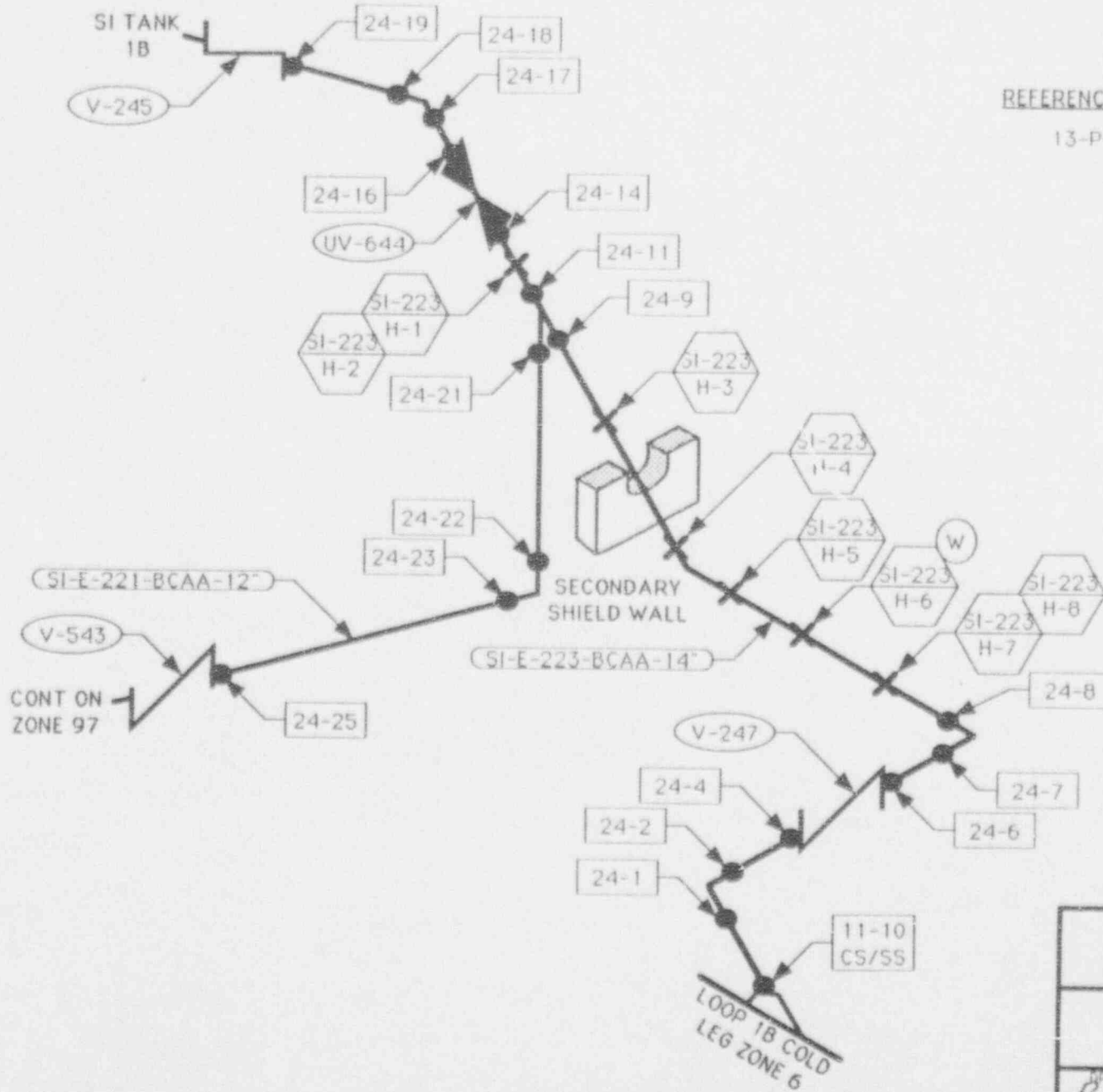

REFERENCE DRAWINGS:

13-P-SIF-103

UNIT 3	ZONE 24
SAFETY INJECTION 1B	
DRAWN BY RLB	CHECKED BY WSA
REV. 0	

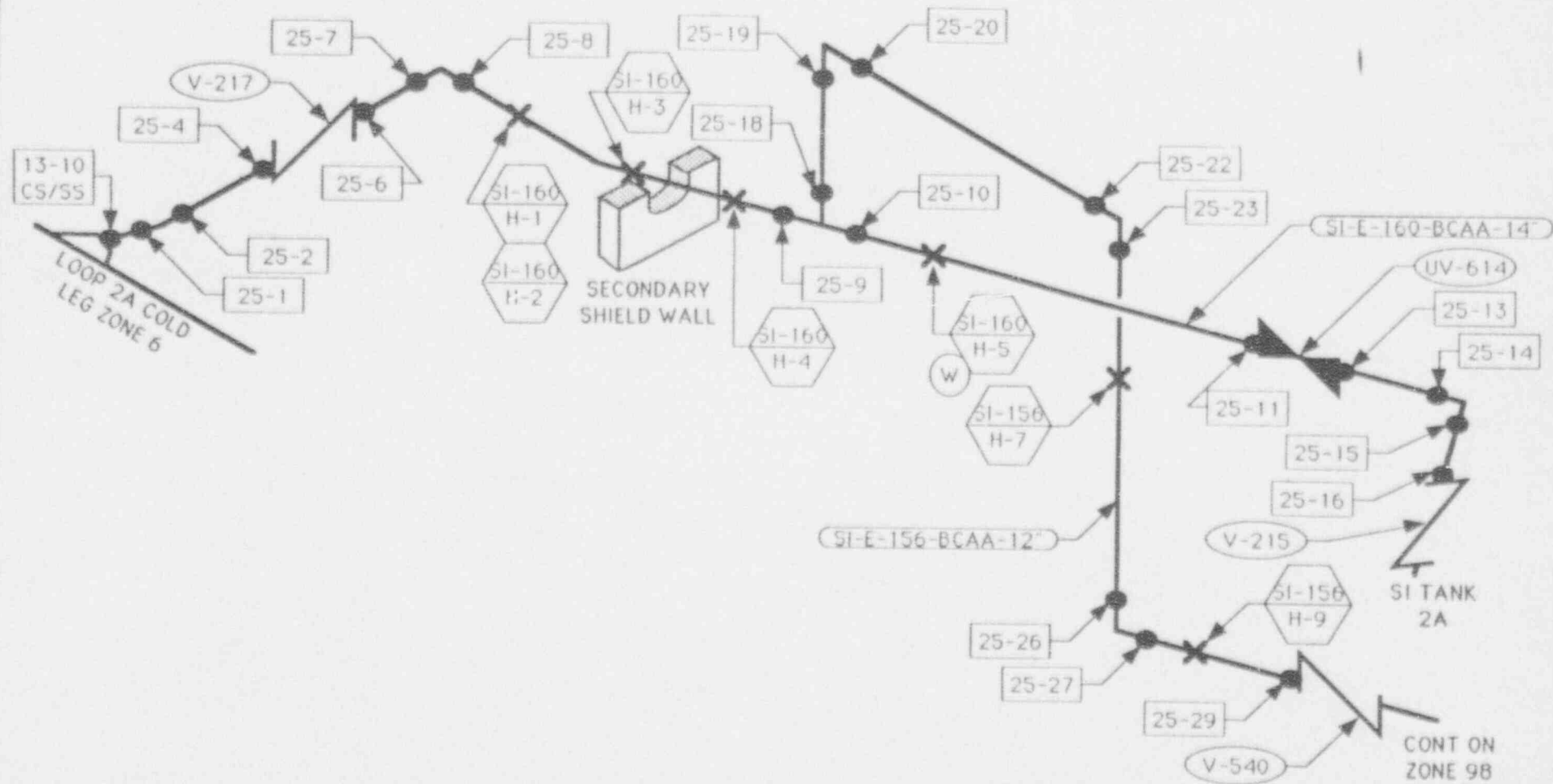

REFERENCE DRAWINGS:

13-P-SIF-136

UNIT 3	ZONE 25
SAFETY INJECTION 2A	
DRAWN BY RLB	CHECKED BY WSA
REV. 0	

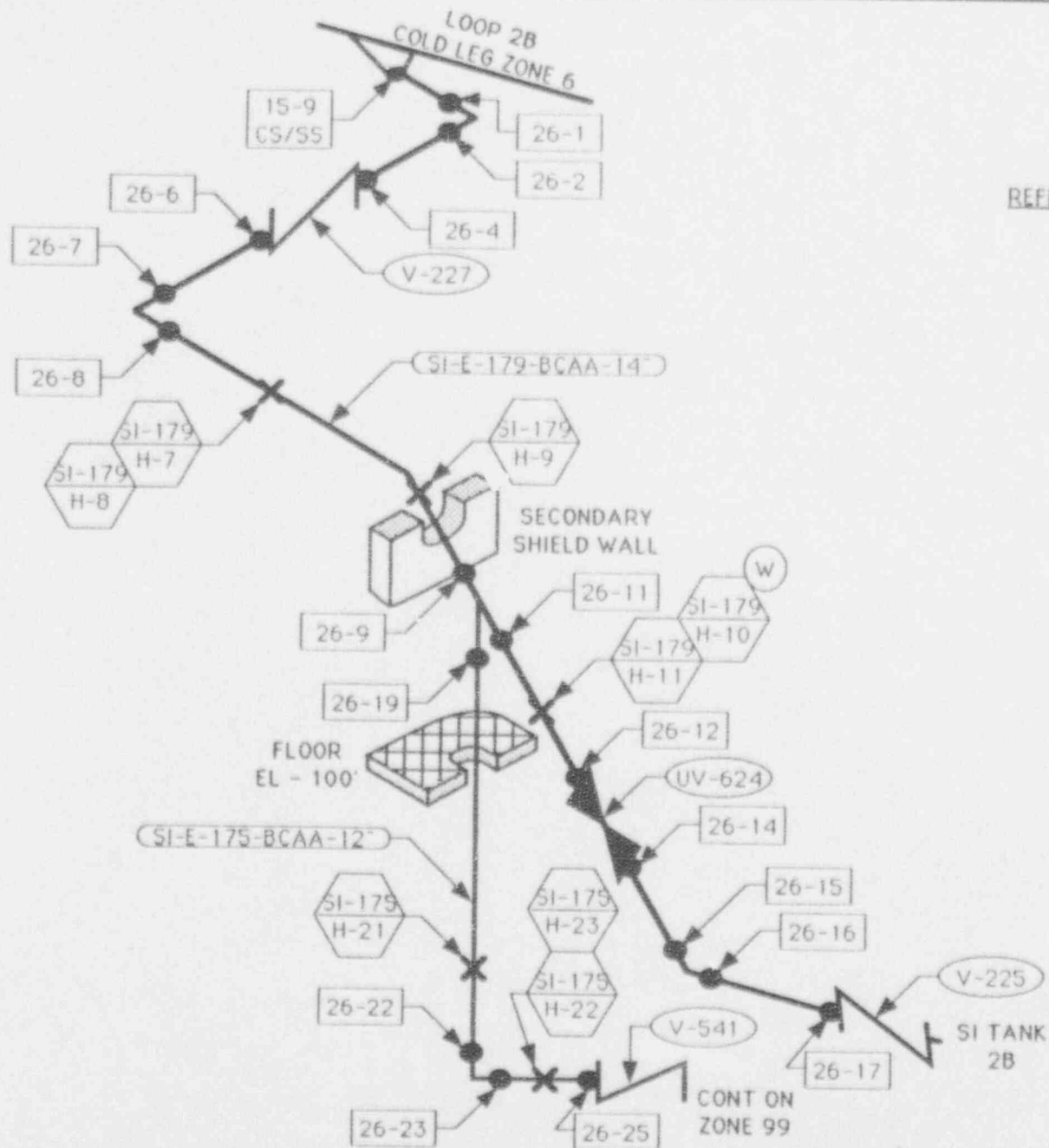

REFERENCE DRAWINGS:

13-P-SIF-136

UNIT 3	ZONE 26
SAFETY INJECTION 2B	
DRAWN BY RLB	CHECKED BY WJA
	REV 0

REFERENCE DRAWING  
 U.S.P. REF. 01 REV. 5

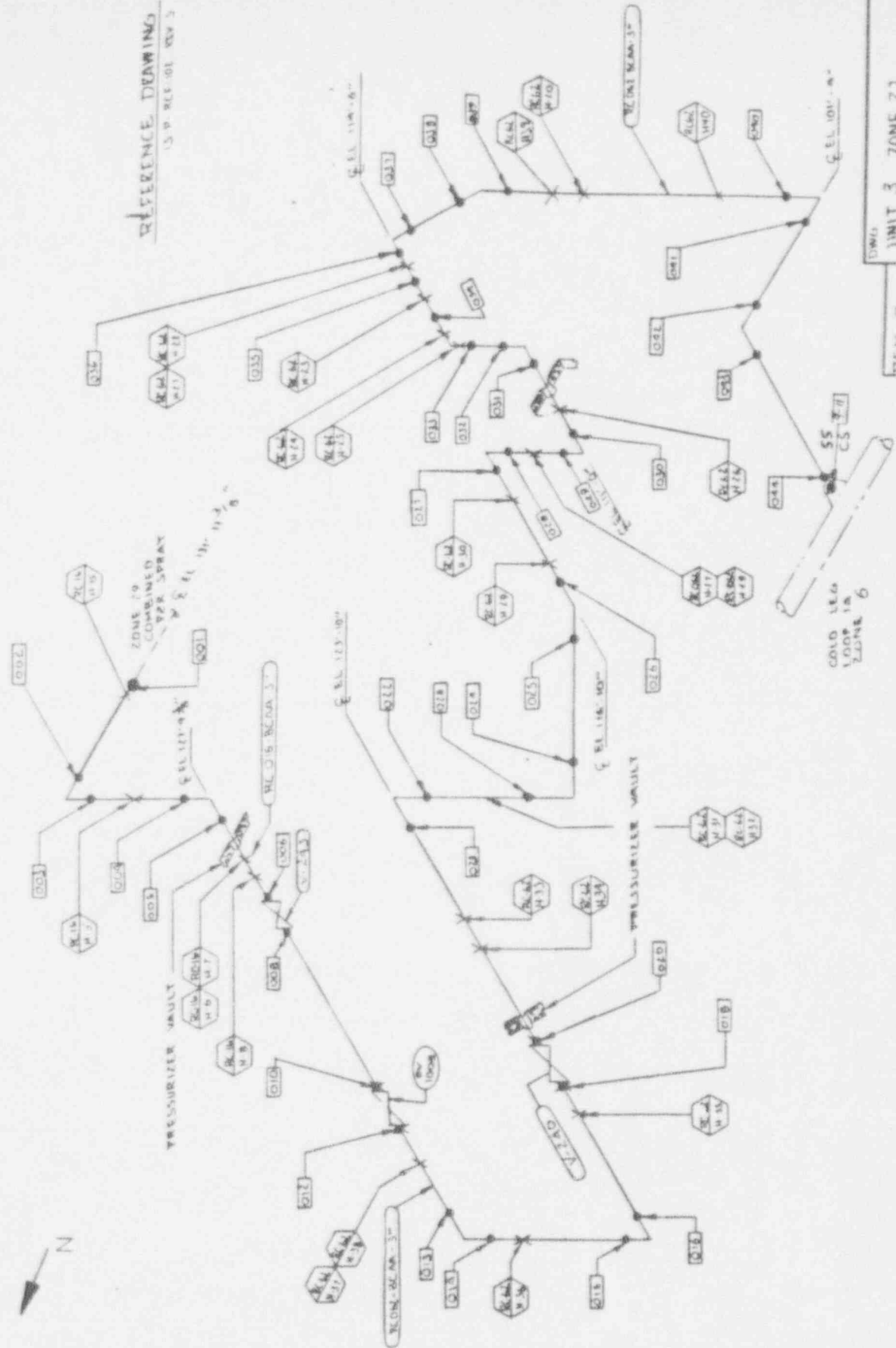

REV. 0	UNIT 3 ZONE 21
DRAWN BY: J. HOLLE	TITLE: PRESSURIZER SPRAY /A
CHECKED BY: TBS	



ZONE 75 COMBINED  
AIR SUPPLY

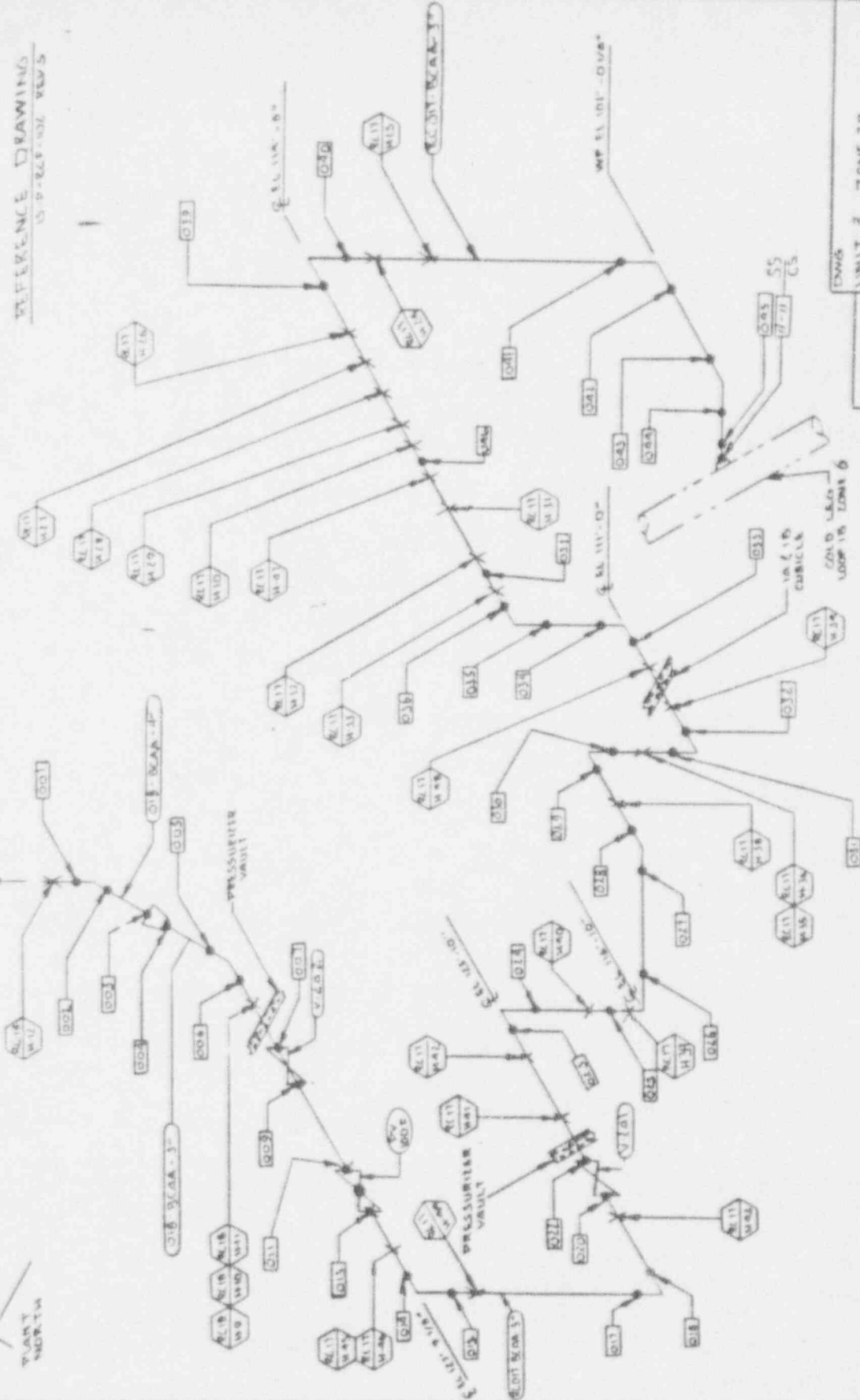

REFERENCE DRAWING  
15-D-624-031 REV 5

REV. 0	UNIT 3 ZONE 28
DRAWN BY: J. HOLLER	TITLE PRESSURIZER SPRAY 1B
CHECKED BY: TBS	

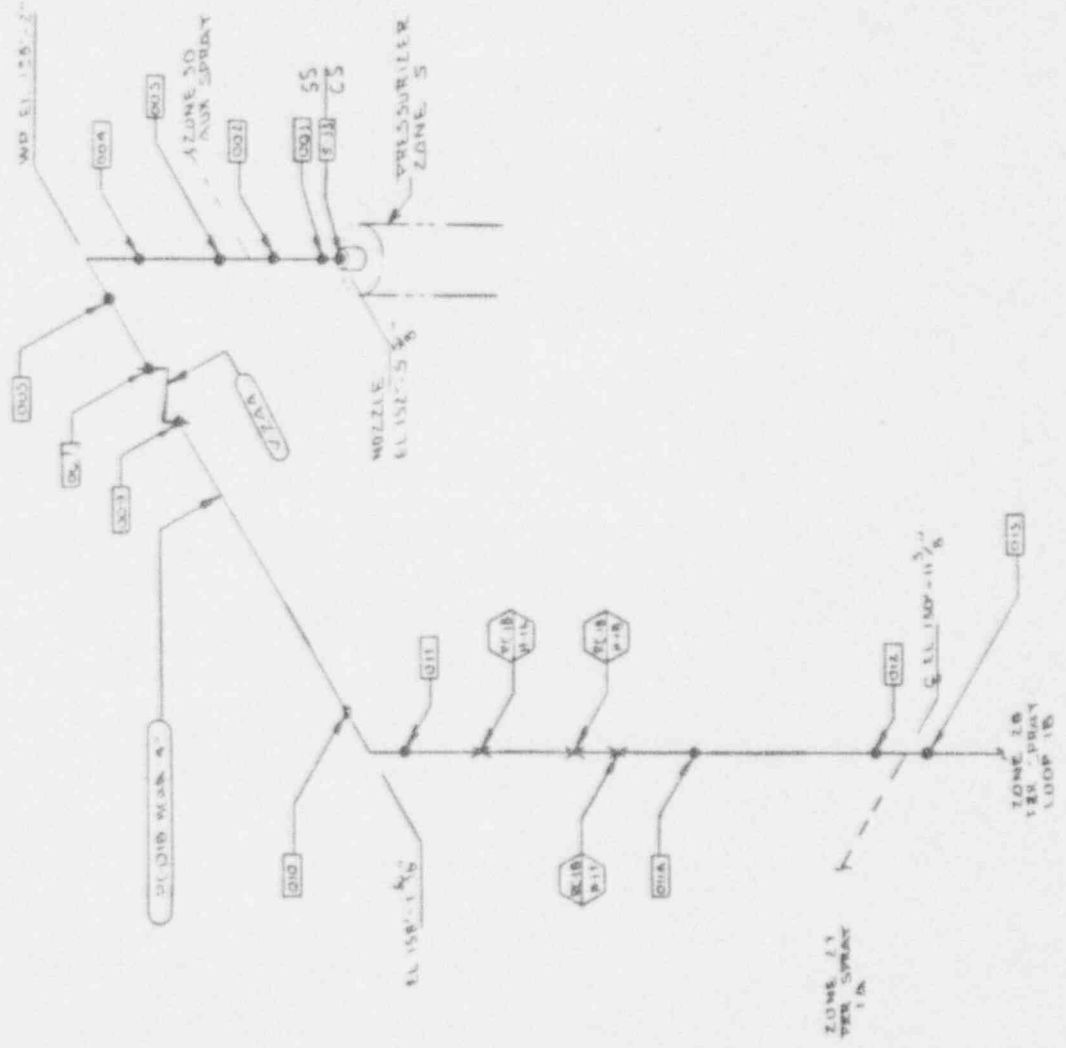

REFERENCE DRAWING  
 13-P-REL-001-REV 5

REV: 0	UNIT 3	ZONE 2 9
DRAWN BY: J.DOLLER	TITLE COMBINED PRESSURIZER SPRAY	
CHECKED BY: JBS		



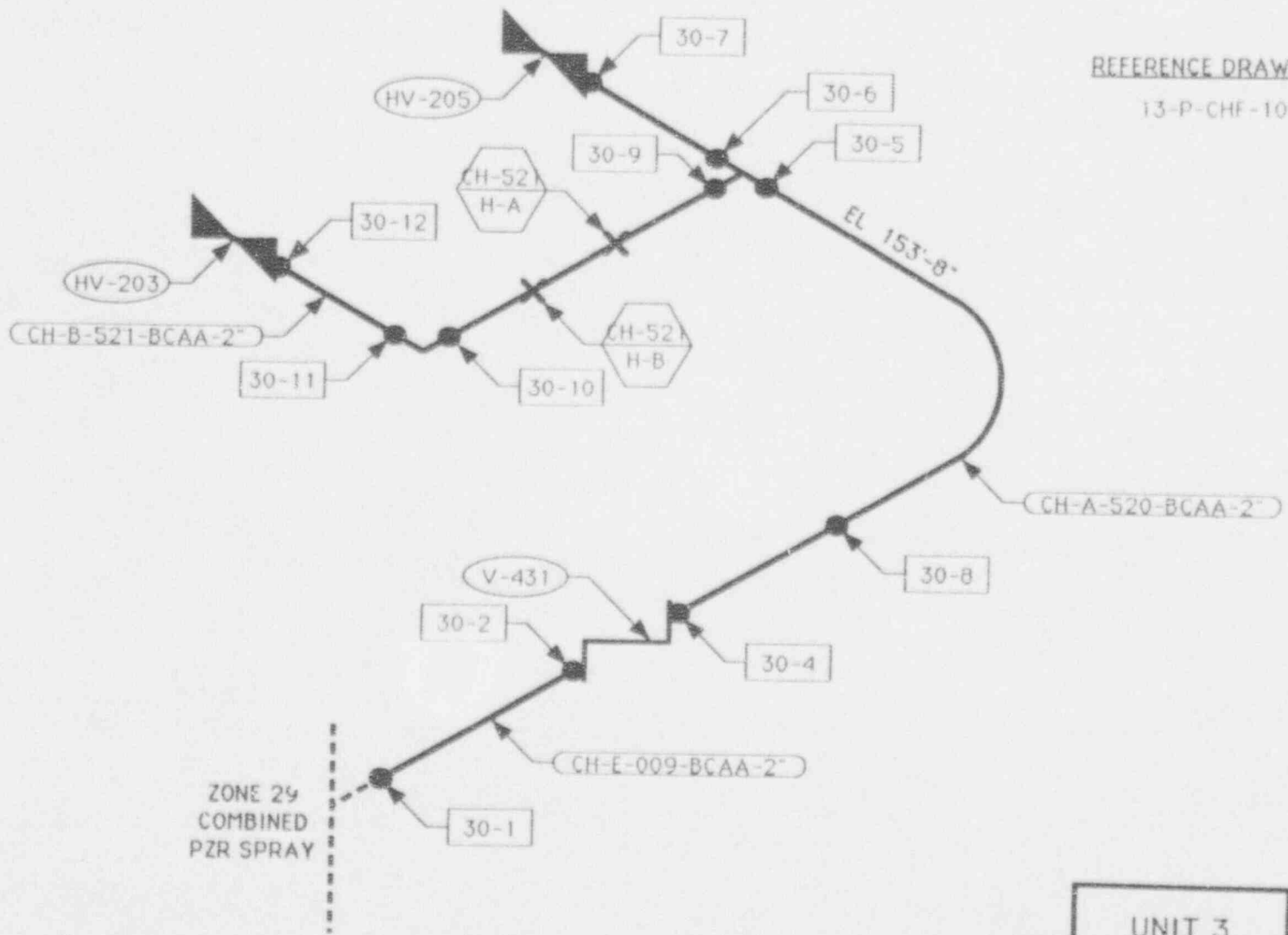

REFERENCE DRAWINGS:  
13-P-CHF-107

UNIT 3	ZONE 30
AUX PRESSURIZER SPRAY	
DRAWN BY RLB	CHECKED BY WSA
	REV. 0

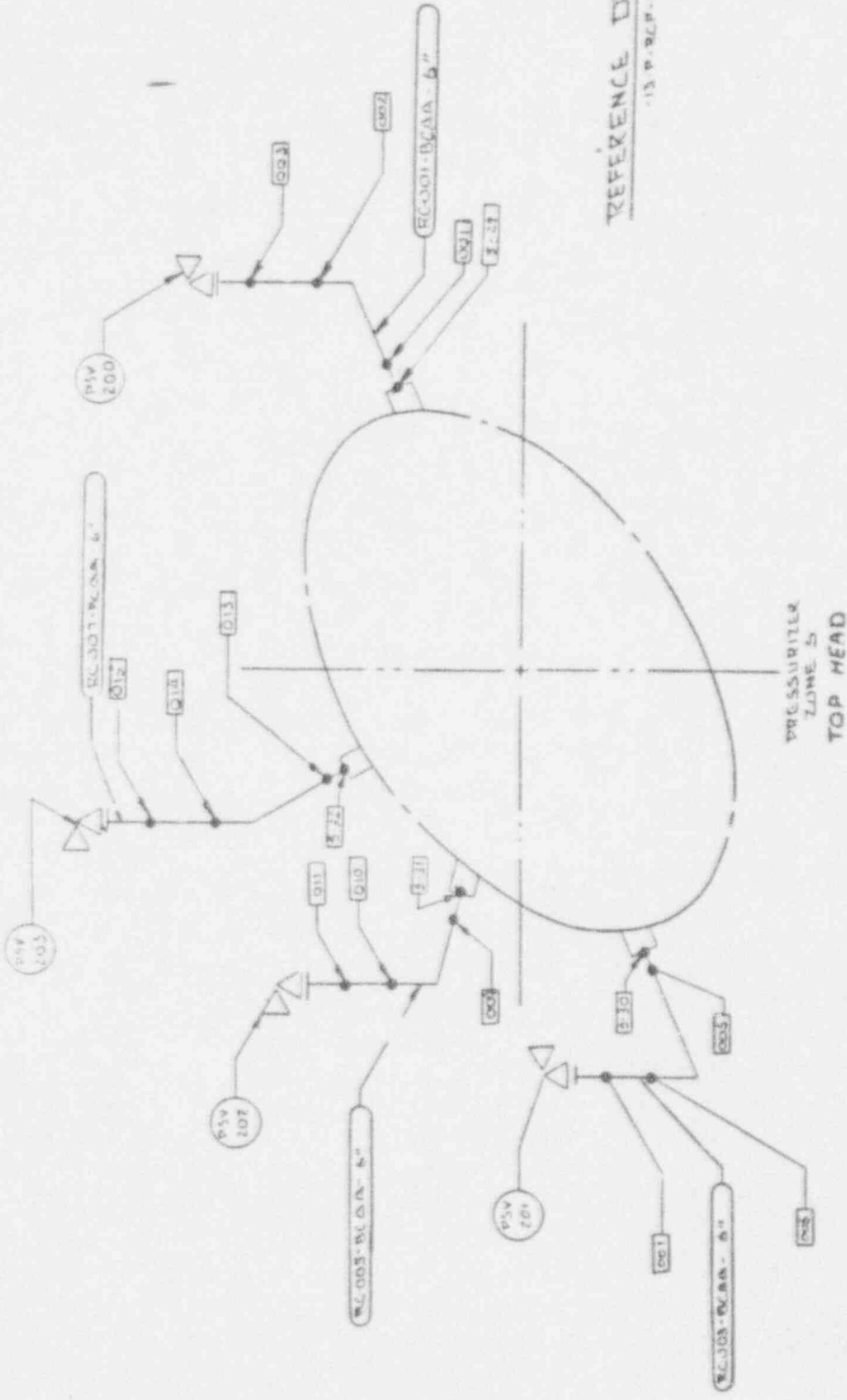

REFERENCE DRAWING  
 -13 P-RCP-11A REV A

NOTE:  
 Ø-2" X 1/8" STUDS / FLANGE

REV 0	UNIT 3 ZONE 31
DESIGNED BY: J. MULLER	TITLE PRESSURIZER SAFETIES
CHECKED BY: JBS	

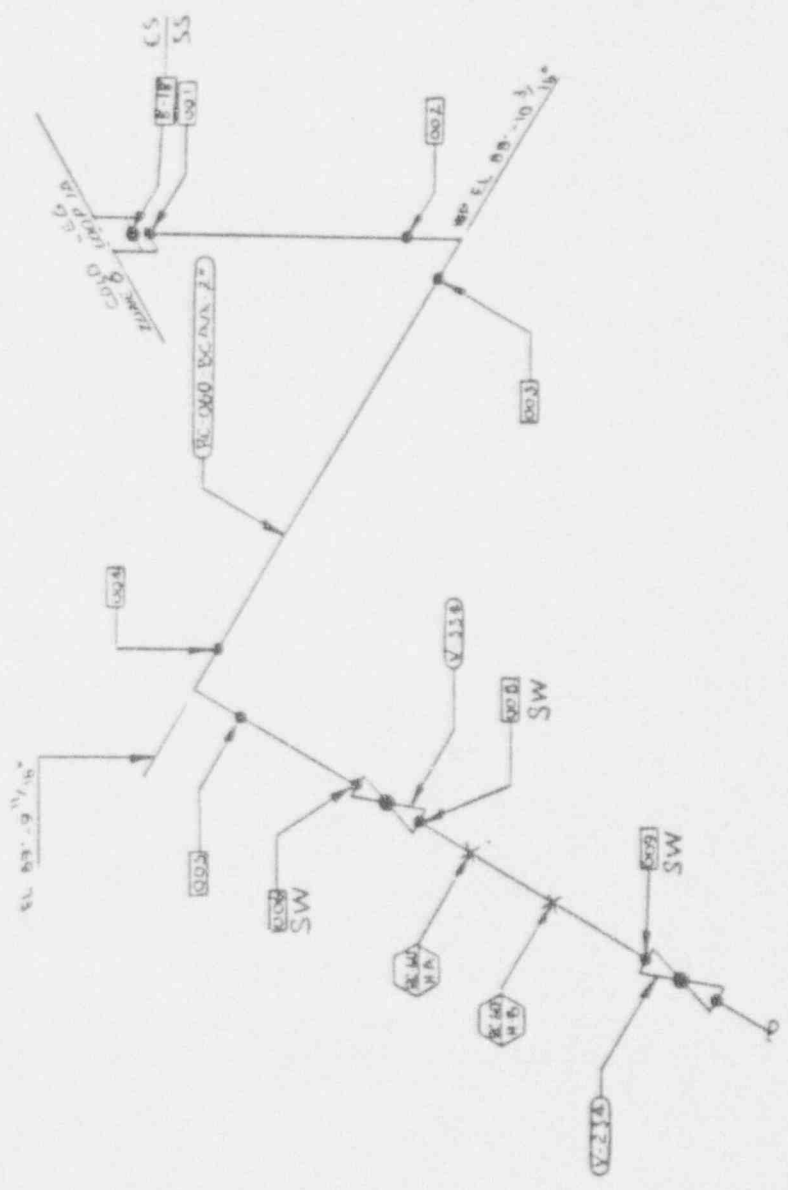

REFERENCE DRAWING  
13 P-CMF-110 REV 3

NOTE:  
SW = SOCKET WELD

REV. 0	LONG.
DRAWN BY: J. HOLLER	UNIT 3 ZONE 32
CHECKED BY: JBS	FILE
	DRAIN LINE 1A







REFERENCE DWG  
13 C.M.F-142

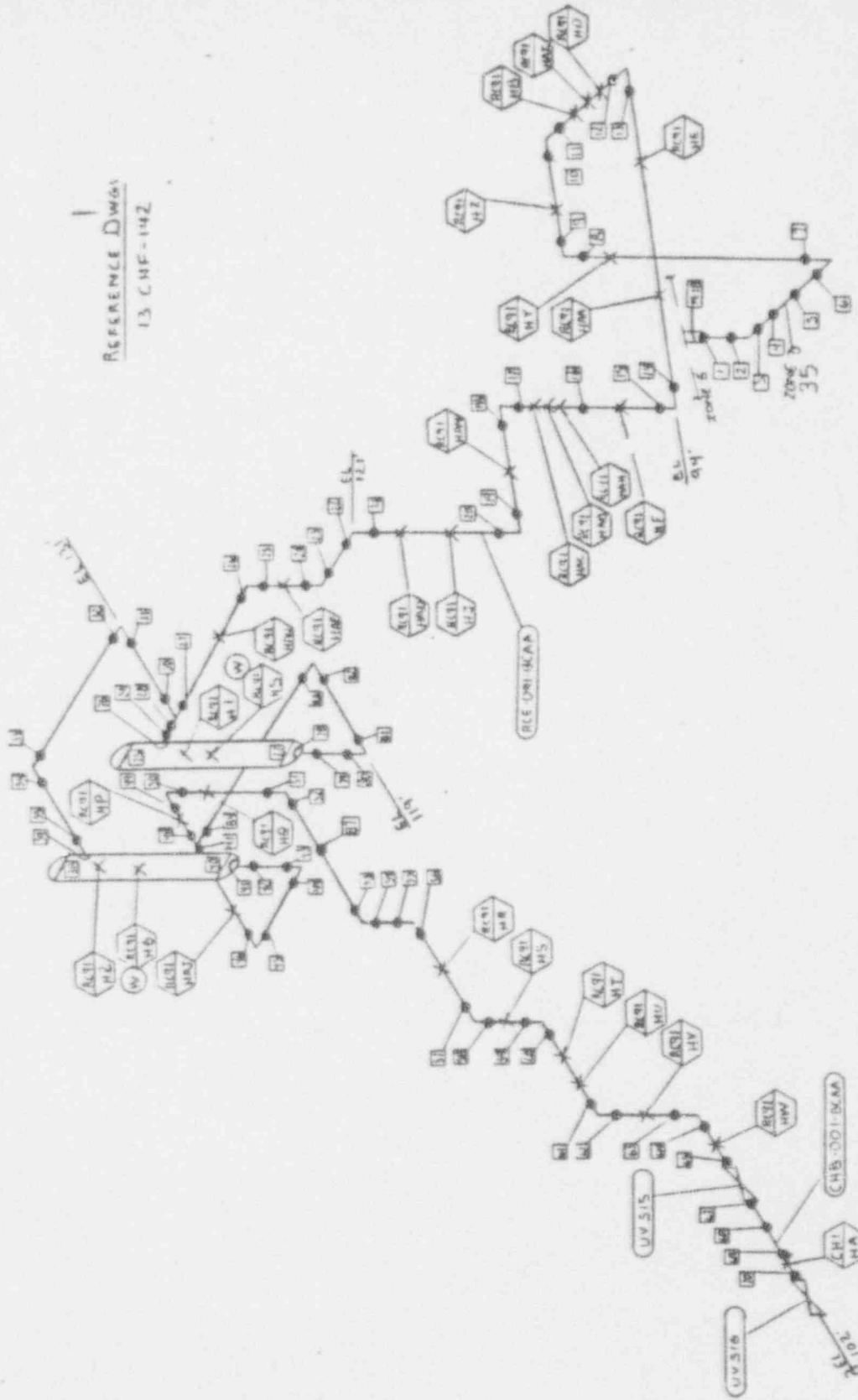

DESIG	UNIT 3 ZONE 36
REV 0	TITLE LETDOWN LINE
DRAWN BY D. J. HANSEN	
CHECKED BY JUS	

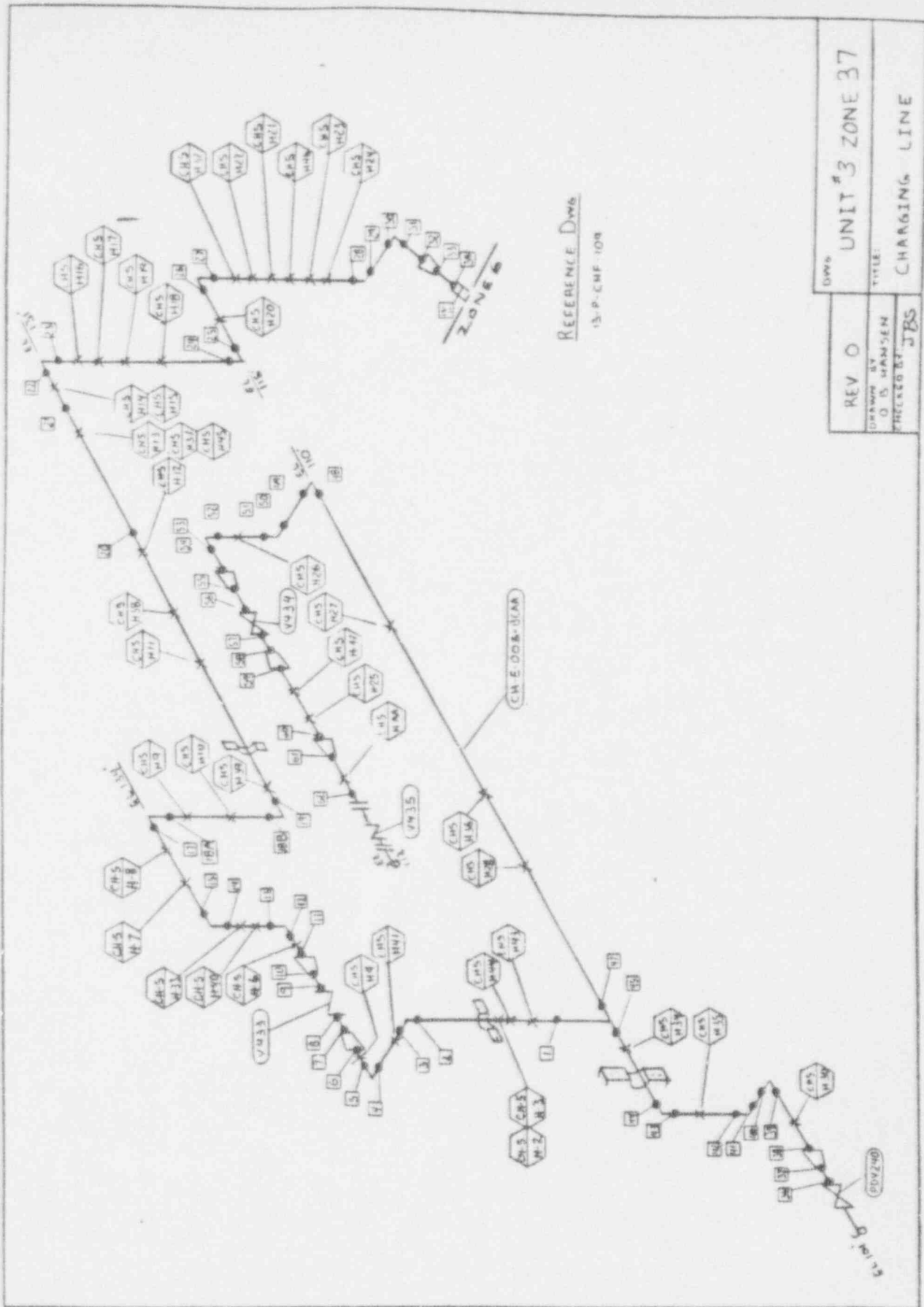

REFERENCE DWG  
13-P-CMF-108

REV 0	DWGS	UNIT 3 ZONE 37
DRAWN BY O. S. HANSEN	TITLE:	CHARGING LINE
CHECKED BY JBS		



REFERENCE DRAWINGS:

23-P-51F-105

NOTE:

SW = SOCKET WELD

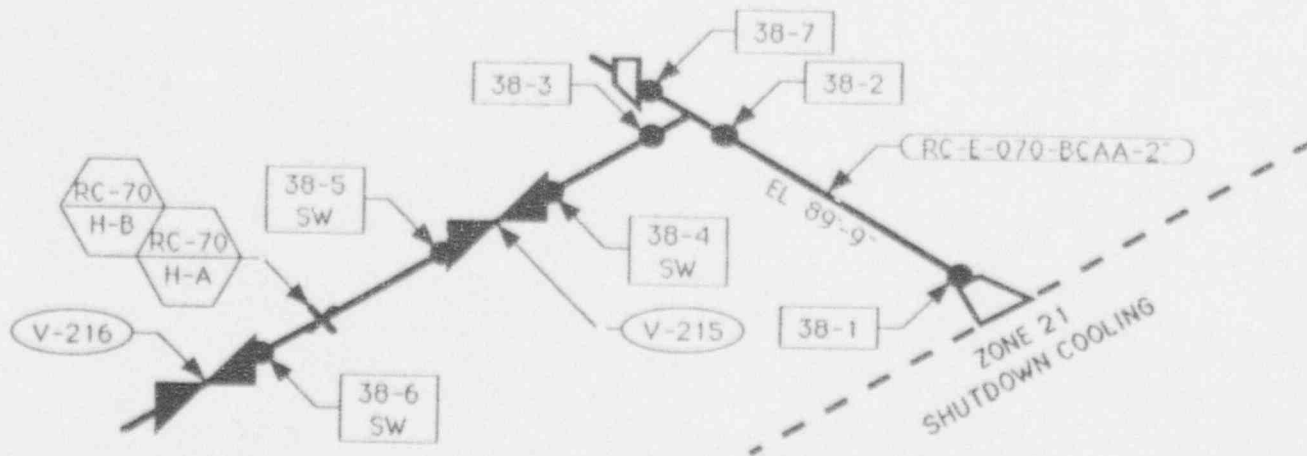

UNIT 3	ZONE 38
DRAIN LINE LOOP 1	
DRAWN BY RLB	CHECKED BY WJA
REV. 0	

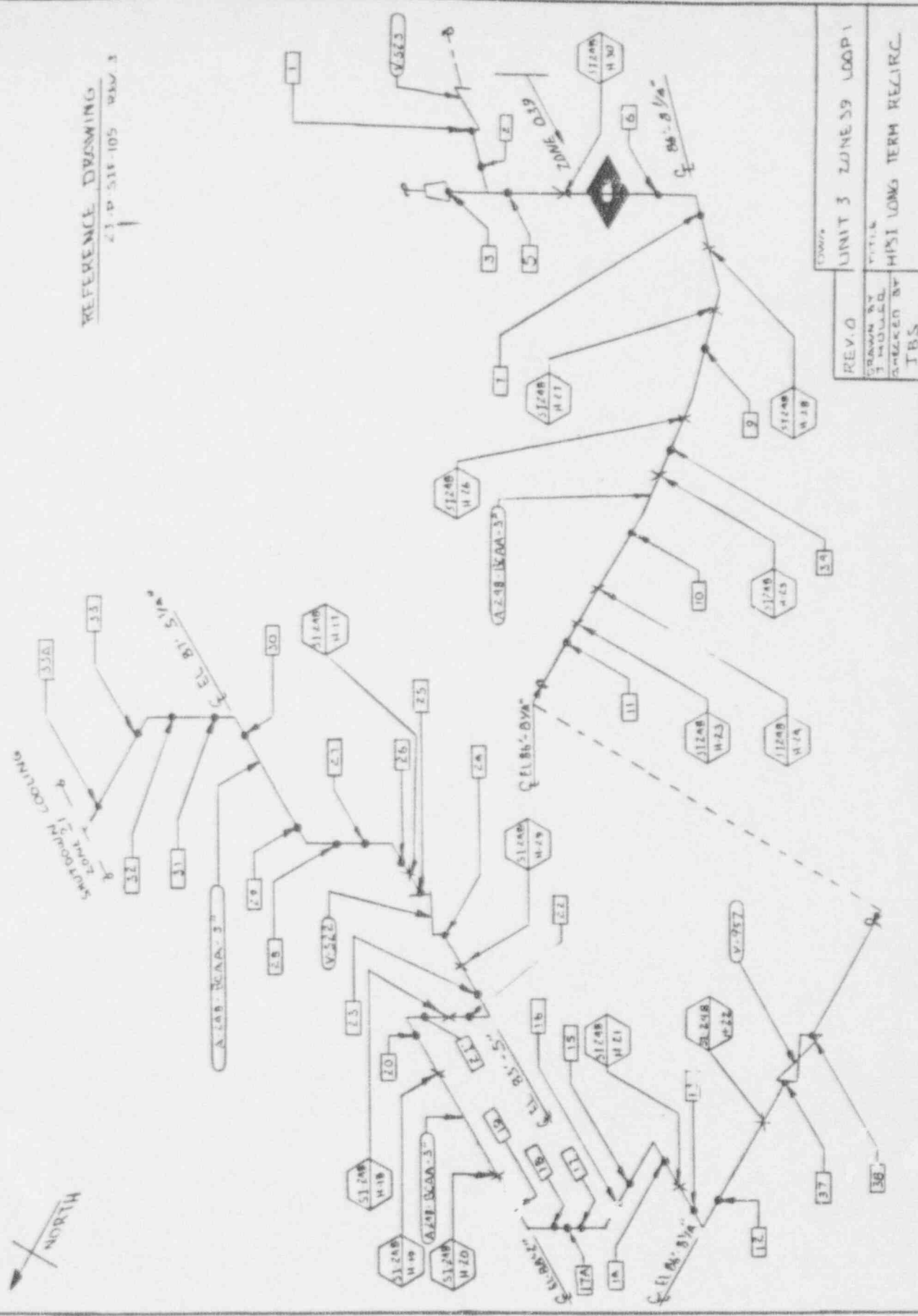

REFERENCE DRAWING  
 2.3.10-518-105 REV. 3



REV. 0	UNIT 3 ZONE 39 LOOP 1
DRAWN BY	T.T.H.
CHECKED BY	HPSI LONG TERM REPAIR
IBS	



SHUTDOWN LOADING  
2 - ZONE 22

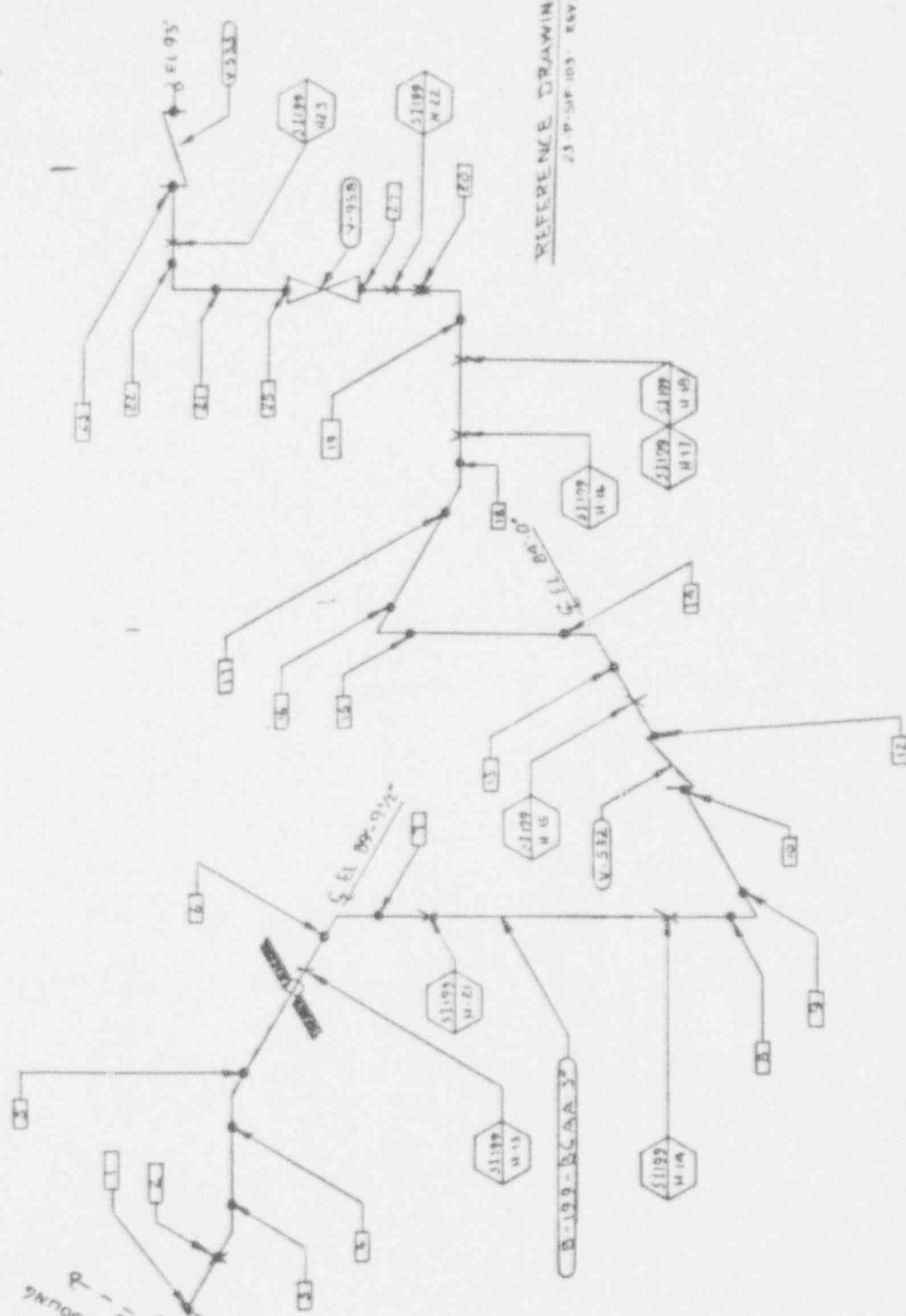

REFERENCE DRAWING  
23 P-SIF 103 REV3

REV. 0	UNIT 3 ZONE 40
DRAWN BY CHECKED BY DATE	TITLE MPSI LONG TERM RELIRC2

NOTES:  
 1) STUDS AT 1/2 OF HOY LEG  
 2) STUDS ARE 16-1.5" X 9"  
 3) STUDS ARE 16-1" X 6"  
 4) TAG NO. 3MACEE01A  
 SERIAL NO. 65273-1 (C-E)  
 N.S. NO. 22860

REFERENCE DWGS:  
 M001-6-03-9 AND 10  
 M001-6-03-103  
 M001-6-03-339

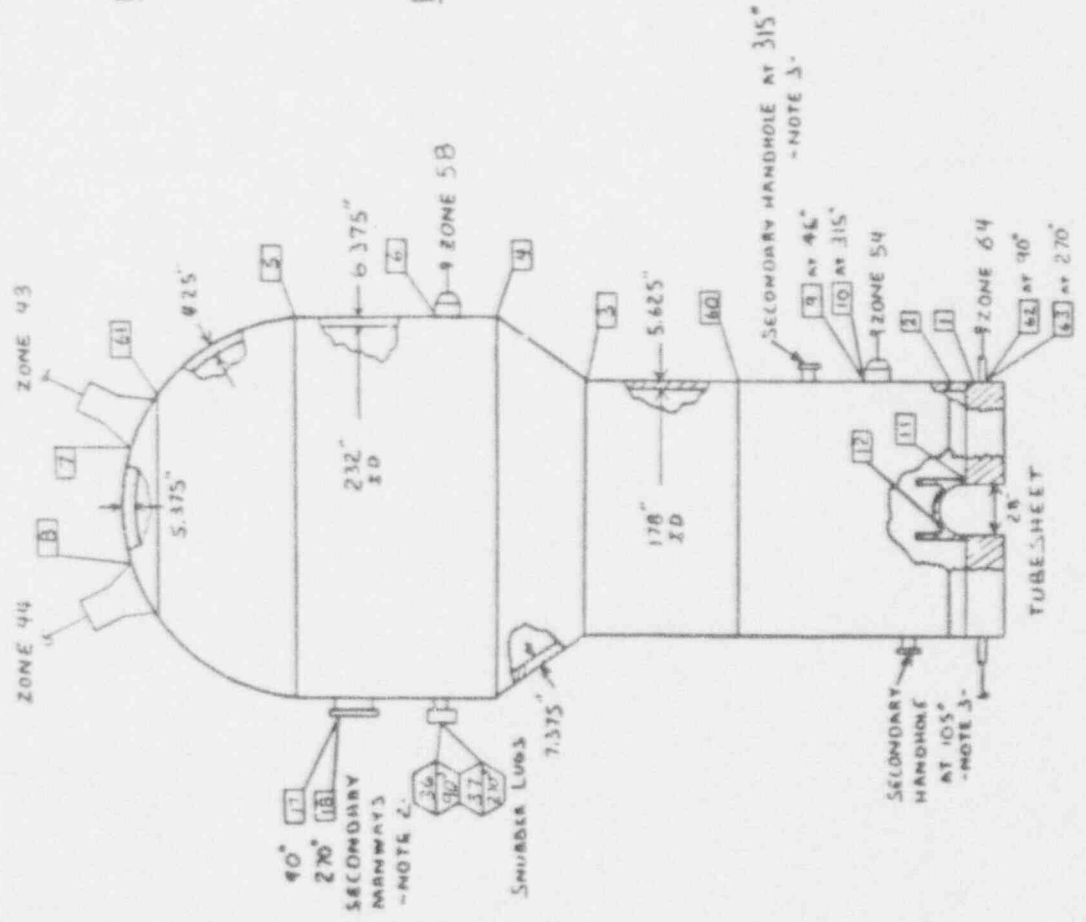

REV 0	DWG	UNIT #3 ZONE 41
Drawn by D. O. HANSEN		TITLE STEAM GENERATOR I
Checked by JBS		

NOTES:

- 1) 0" IS AT 1/4 OF HOT LEG
- 2) STUDS ARE 16-1.5" x 9"
- 3) STUDS ARE 16-1" x 6"
- 4) TAG NO. 3MRCEE/118
- SERIAL NO. 65273-2 (C-E)
- N.B. NO. 22861

REFERENCE DWGS:

- MO01-6-03-9 AND 10
- MO01-6-03-103
- MO01-6-03-139

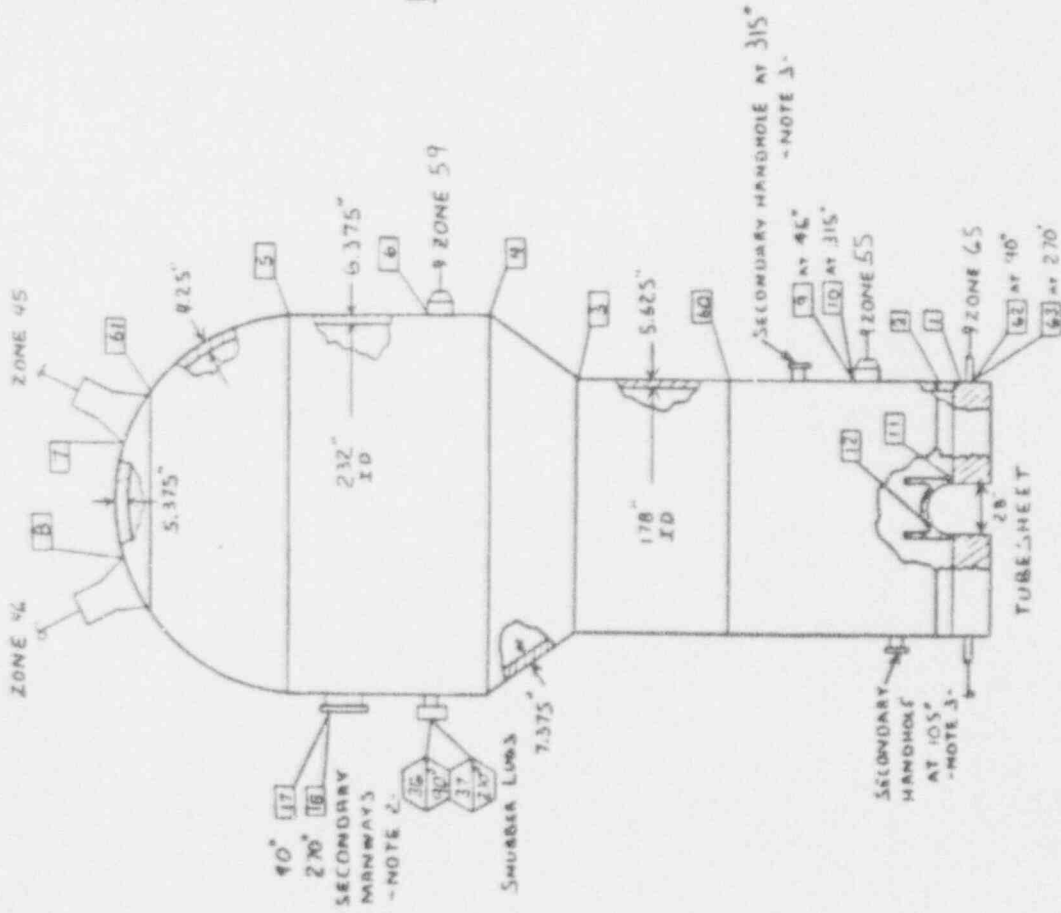

REV 0	DWG	UNIT #3 ZONE 42
DESIGN BY D. B. HANSEN		TITLE STEAM GENERATOR 2
ENGINEER BY JRS		

LINE	DIR/SW	ESOW	YD
36	52° 42'	1	2
36	28° 41' 25"	2	30

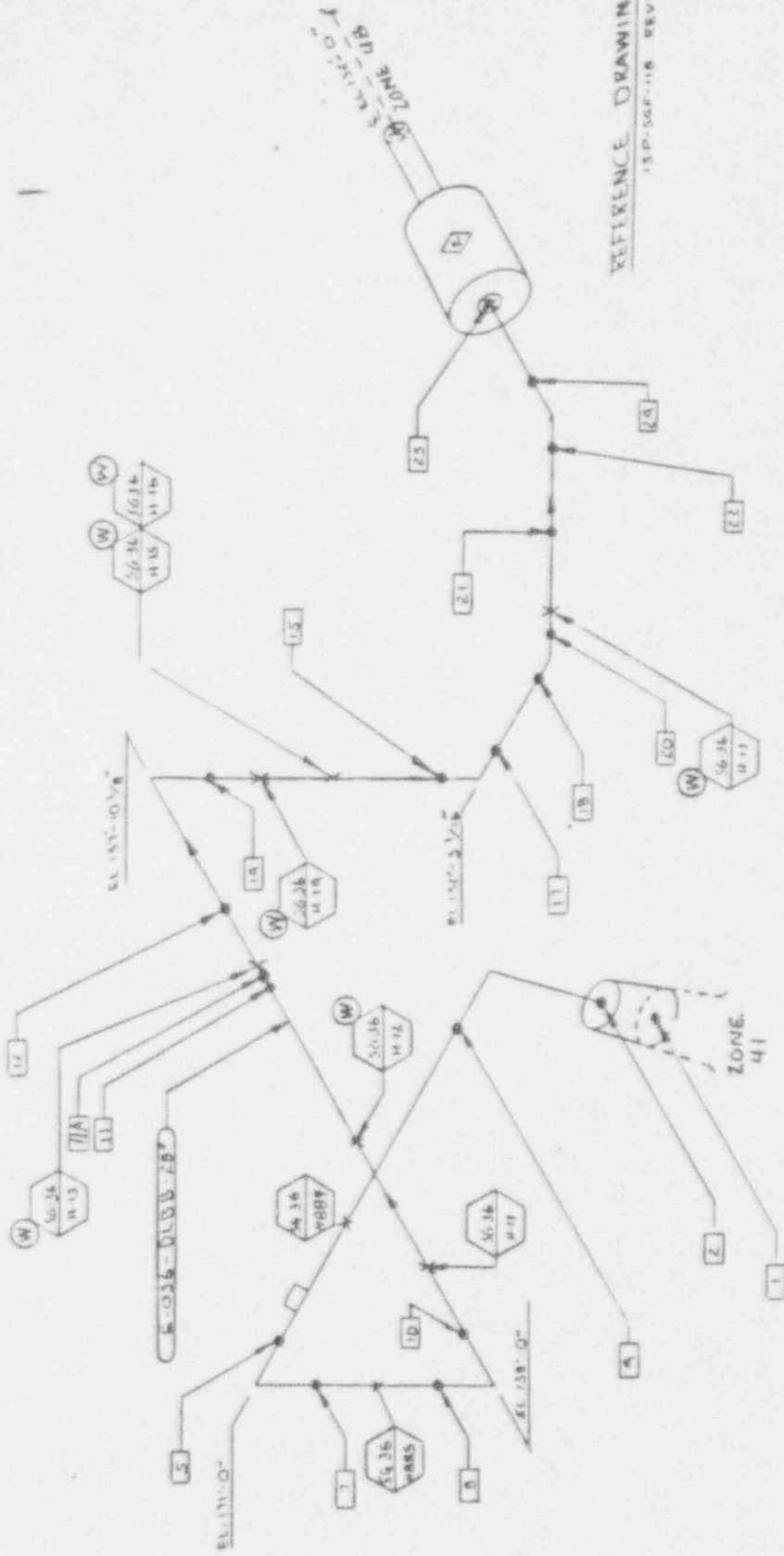

REFERENCE DRAWING  
15P-SGF-118 REV 4

REV. 0	DATE	BY	CHKD	TITLE
				UNIT 3 ZONE 4-5
				MAIN STEAM
				SG 1 EAST





LINE	DATE/SCALE	BY	TO
33	3/28/20	1	2
33	2/28/13	2	30

REFERENCE DRAWING  
 15-P-50P-118 REV A

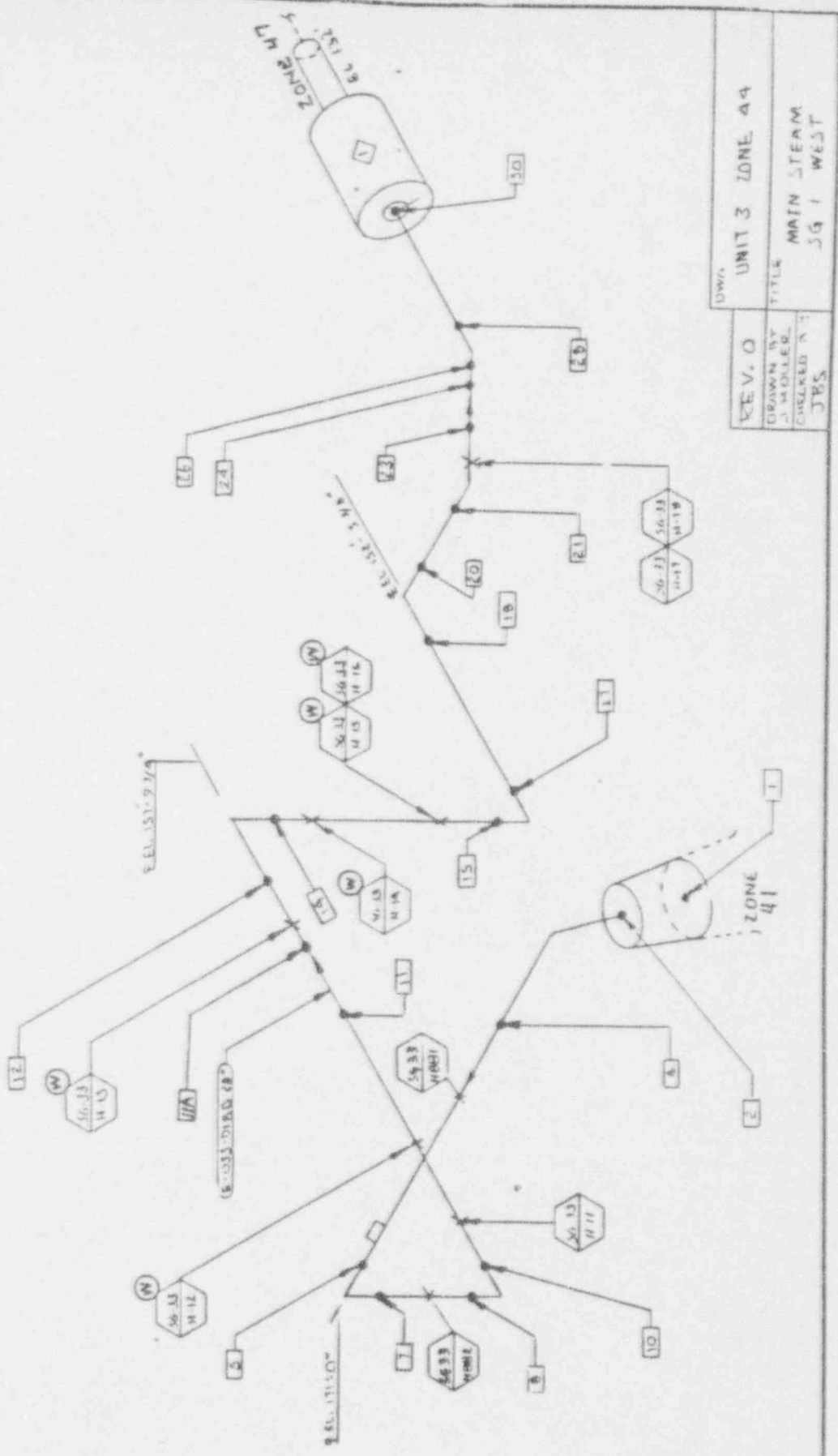

REV. 0	DWG. UNIT 3 ZONE 49
DRAWN BY J. HOLLER	TITLE MAIN STEAM
CHECKED BY JBS	591 WEST

LINE NO	TYPE	FROM	TO
AL	2"	1	2
AL	2 1/2" x 1.25"	2	2.5



REFERENCE DRAWING  
13-D-568-118 REV A

ZONE 42

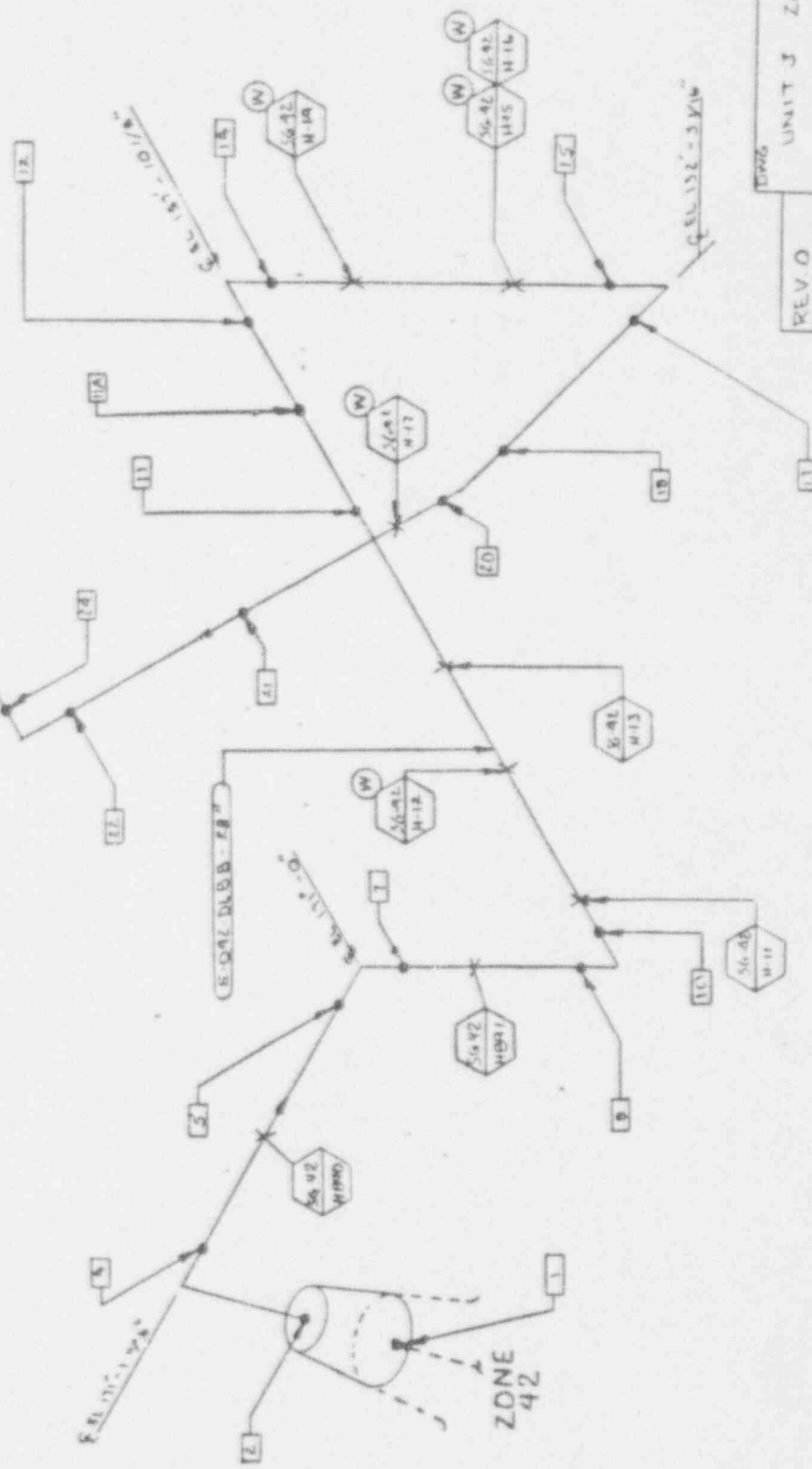
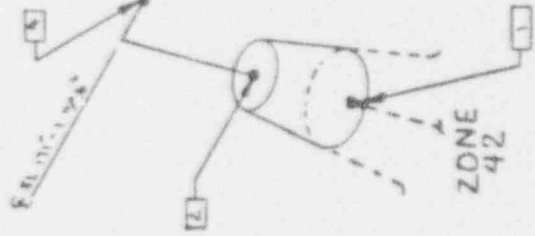

REV 0	UNIT J	ZONE 45
DRAWN BY D. MOLLER	TITLE MAIN STEAM	
CHECKED BY JRS	SO 2 EAST	



LINE #	DIA/SAM	FROM	TO
4-5	32" X 2"	1	2
4-5	28" X 1.25"	7	2-8

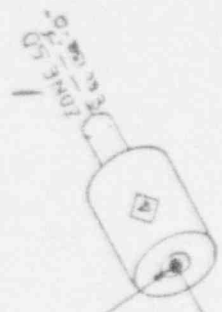

REFERENCE DRAWING  
13-V-56F-118 REV A

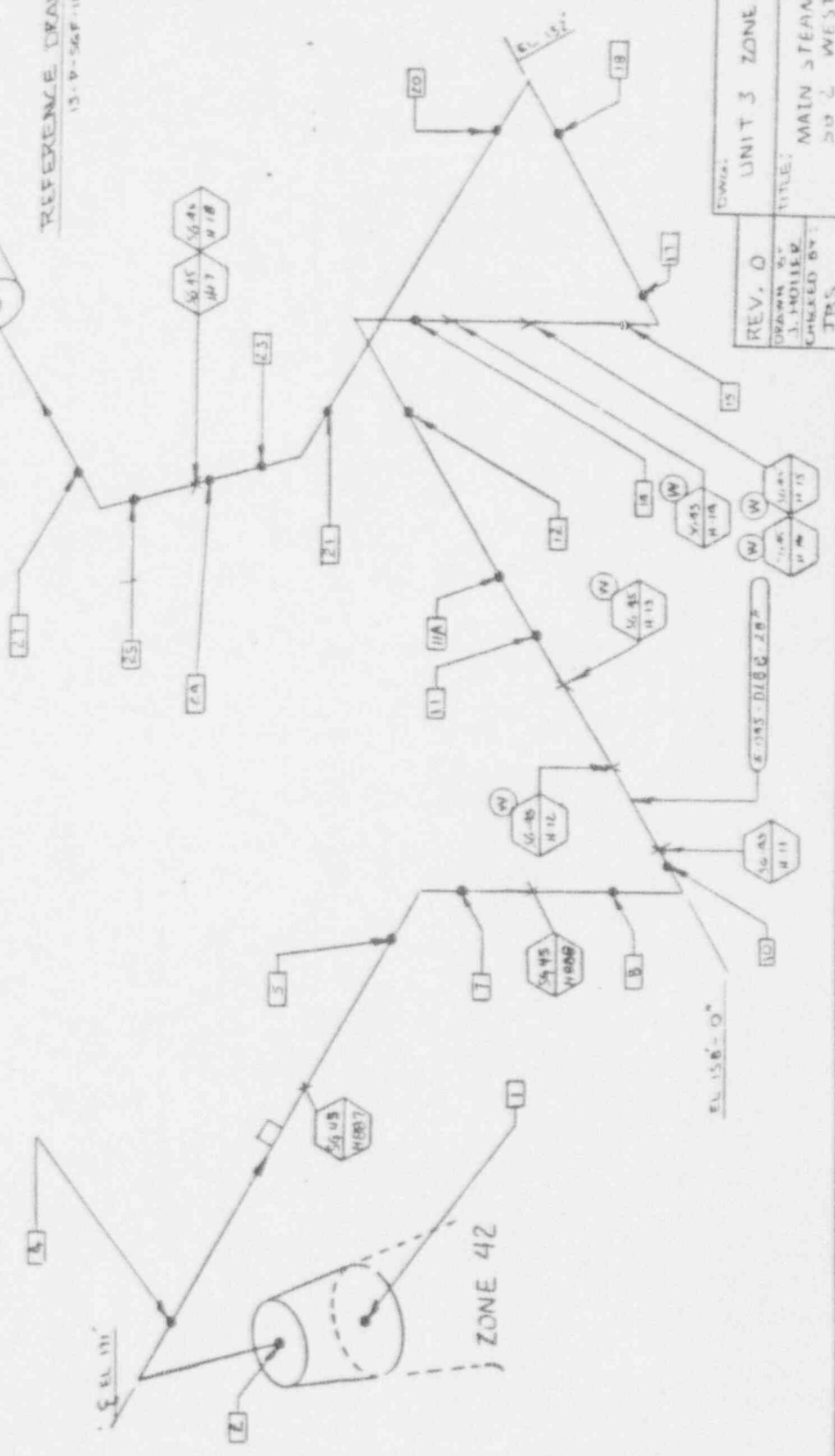

REV. 0	UNIT 3 ZONE A6
DRAWN BY: J. HOLLIS	TITLE: MAIN STEAM
CHECKED BY: JBS	NO. 2 WEST

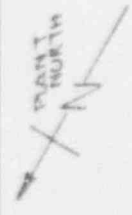

LINE #	DIA/SCH	FROM	TO
206	18" X 1.125"	30	30
206	6" X 1.5"	A	20
206	12" X .884"	28	29

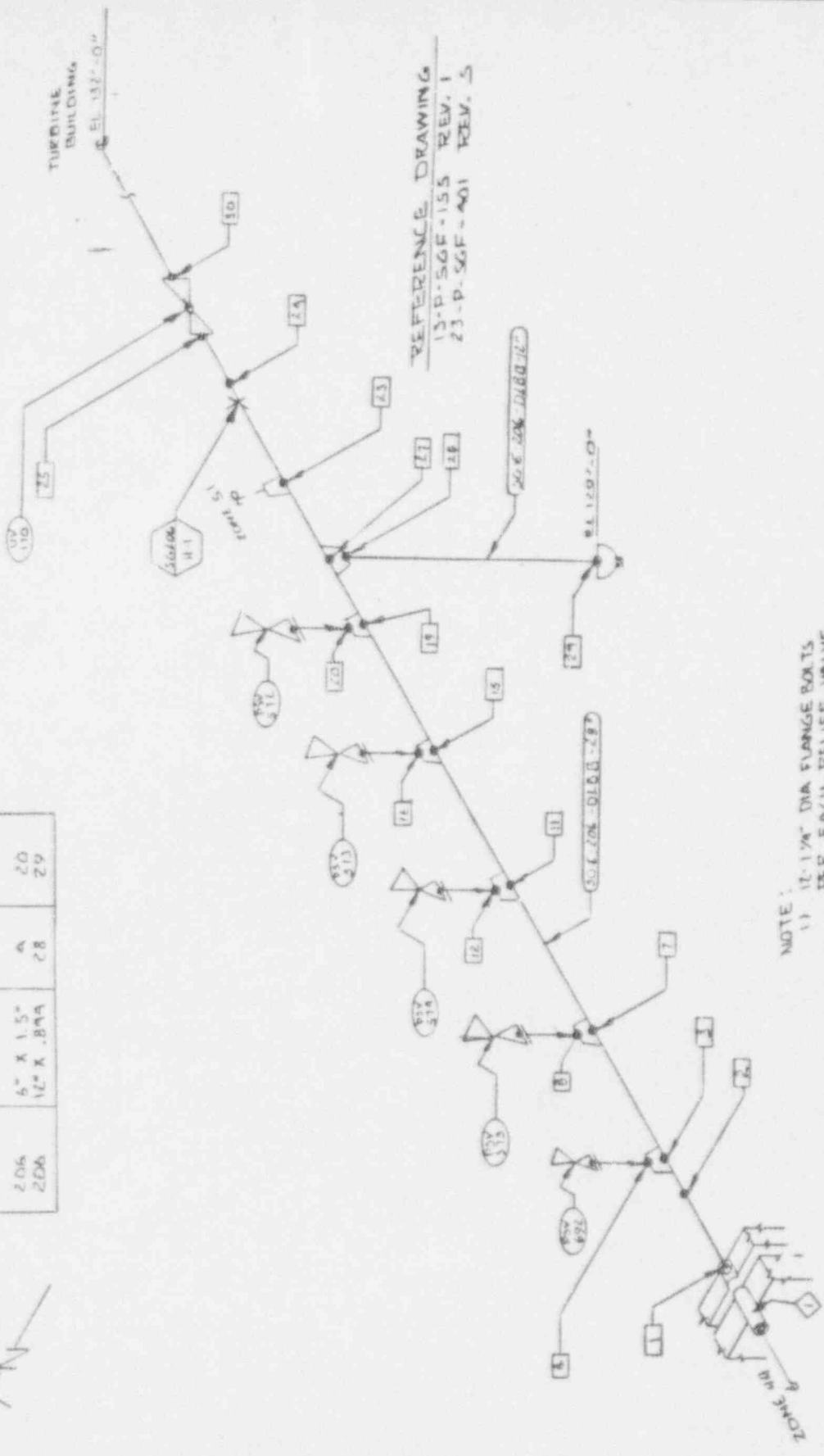

REFERENCE DRAWING  
 13-P-SGF-155 REV. 1  
 23-P-SGF-401 REV. 5

NOTE:  
 1) 12-1/4" DIA FLANGE BOLTS PER EACH RELIEF VALVE.  
 2) MSIV 20-2 1/4" MSIV TO BONNET BOLTS

REV	DATE	BY	CHKD BY	APP'D BY
0		J. HOLLER		
				JRS

DWG UNIT 3 ZONE 47  
 TITLE MAIN STEAM  
 5/G #1 (WEST)

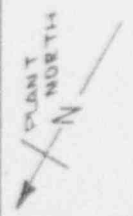

LINE #	DIR / DIM	FROM	TO
207	28" X 1.15"	1	30
207	6" X 1.5"	A	20
207	12" X .844"	28	29

TURBINE BUILDING  
ELEV. 124'-0"

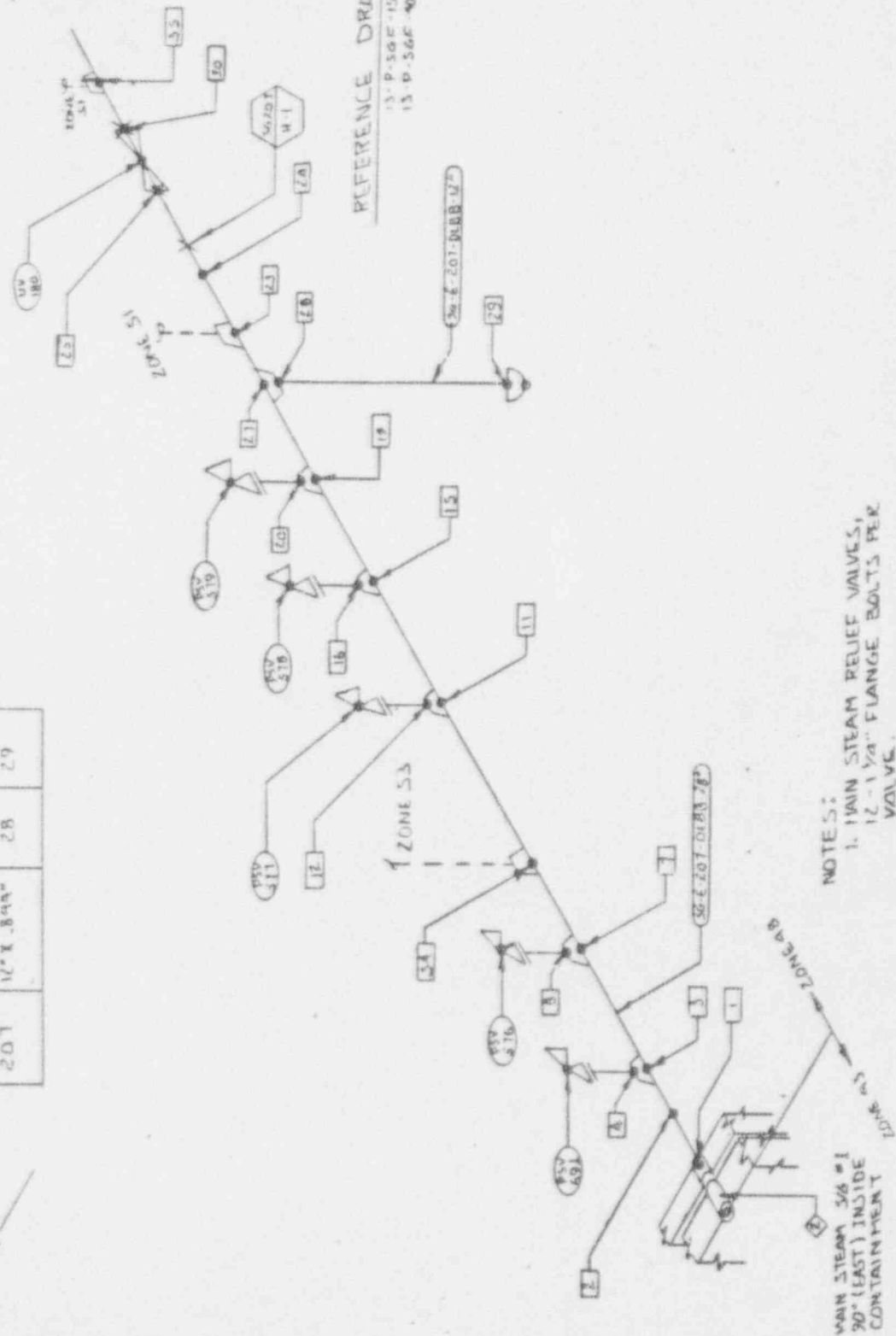

REFERENCE DRAWING  
13-P-566-155 REV 1  
13-P-566-401 REV 5

- NOTES:
1. MAIN STEAM RELIEF VALVES, 12 - 1 1/2" FLANGE BOLTS PER VALVE.
  2. MS-TV, 20 - 2 1/4" BODY TO BONNET BOLTS.

MAIN STEAM 5/8" I  
90° (EAST) INSIDE  
CONTAINMENT

REV.	BY	TITLE	DWG
0	J. HOLLER	UNIT 3 ZONE 4D	
		MAIN STEAM	
		5/8" I EAST	
		CHECKED BY	
		T.S.S.	

LINE #	DIA / SCH	FROM	TO
208	28" X 1.15"	1	30
208	6" X 1.5"	A	20
208	12" X .044"	28	29

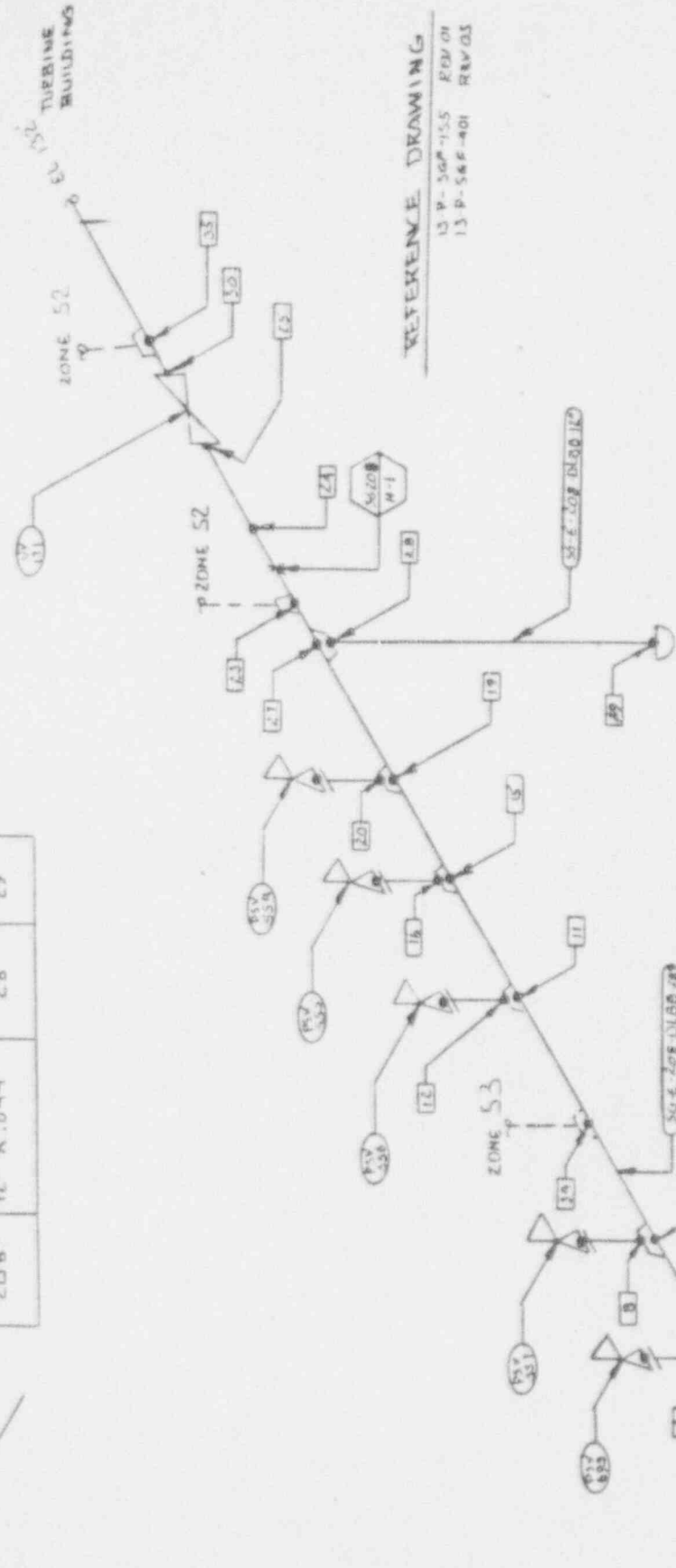
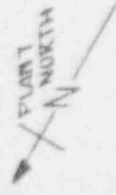

REFERENCE DRAWING  
 13-P-50P-155 REV 01  
 13-P-50P-401 REV 03

NOTE:  
 1. MAIN STEAM RELIEF VALVE.  
 12-1/4" FLANGE BOLTS PER VAL.  
 2. MSIV, 20-2 1/4" BODY TO BONNET BOLTS

REV. 0	DWG. UNIT 3 ZONE 49
DRAWN BY J. HOLLER	TITLE: MAIN STEAM
CHECKED BY JBS	S/G 2 (EAST)





LINE #	DIA/SCH	FROM	TO
SG-59	12" x .844"	1	51
SG-70	12" x .844"	37	49
SG-95	4" x .337"	65	76

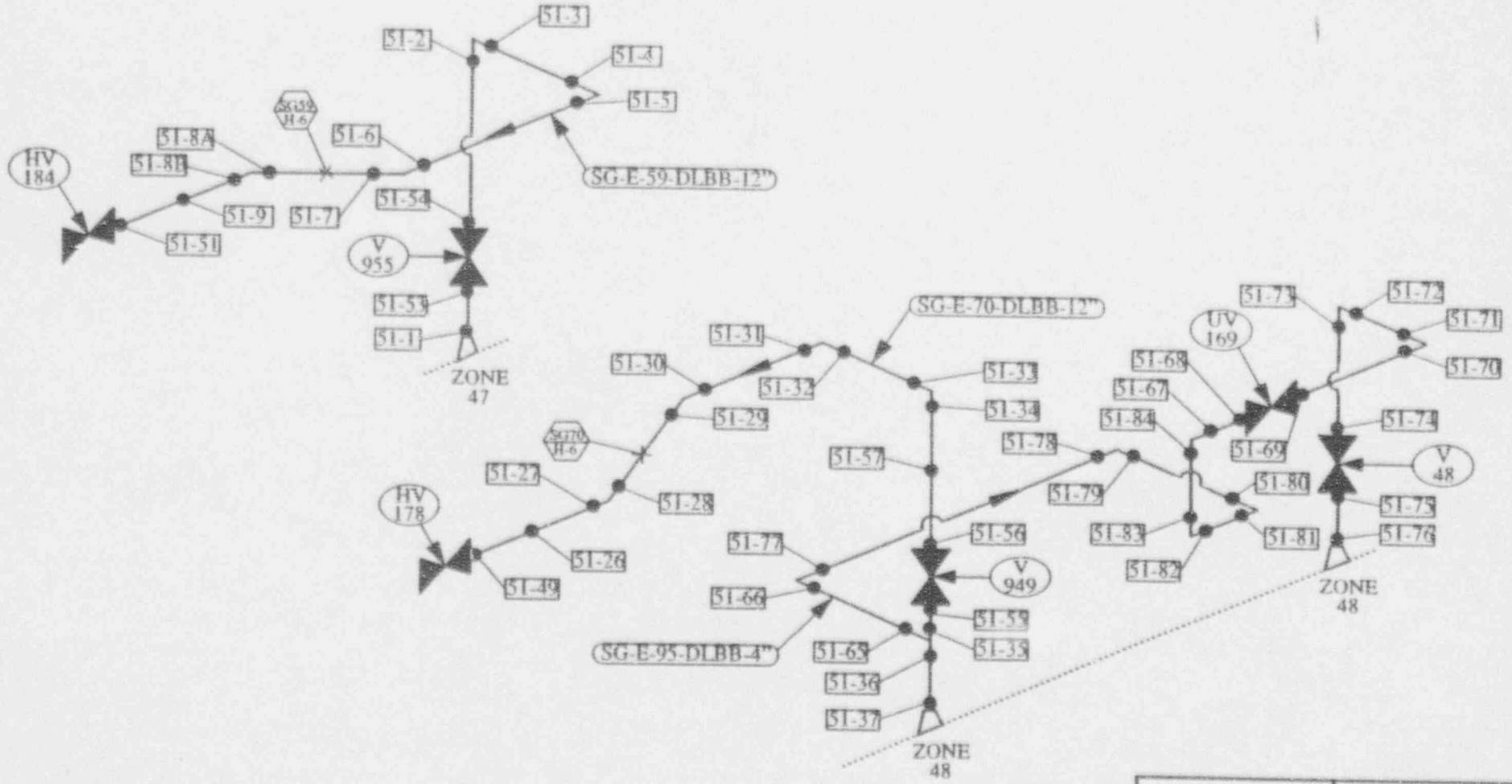

REFERENCE DRAWINGS  
13-P-SGF-158

UNIT 3	ZONE 51
ATMOSPHERIC DUMP # 1	
DRAWN BY <i>RLB</i>	CHECKED BY <i>WB</i>
REV. 0	



LINE #	DIA/SCH	FROM	TO
SG-103	12" x .844"	1	50
SG-84	12" x .844"	38	52
SG-100	4" x .337"	65	76

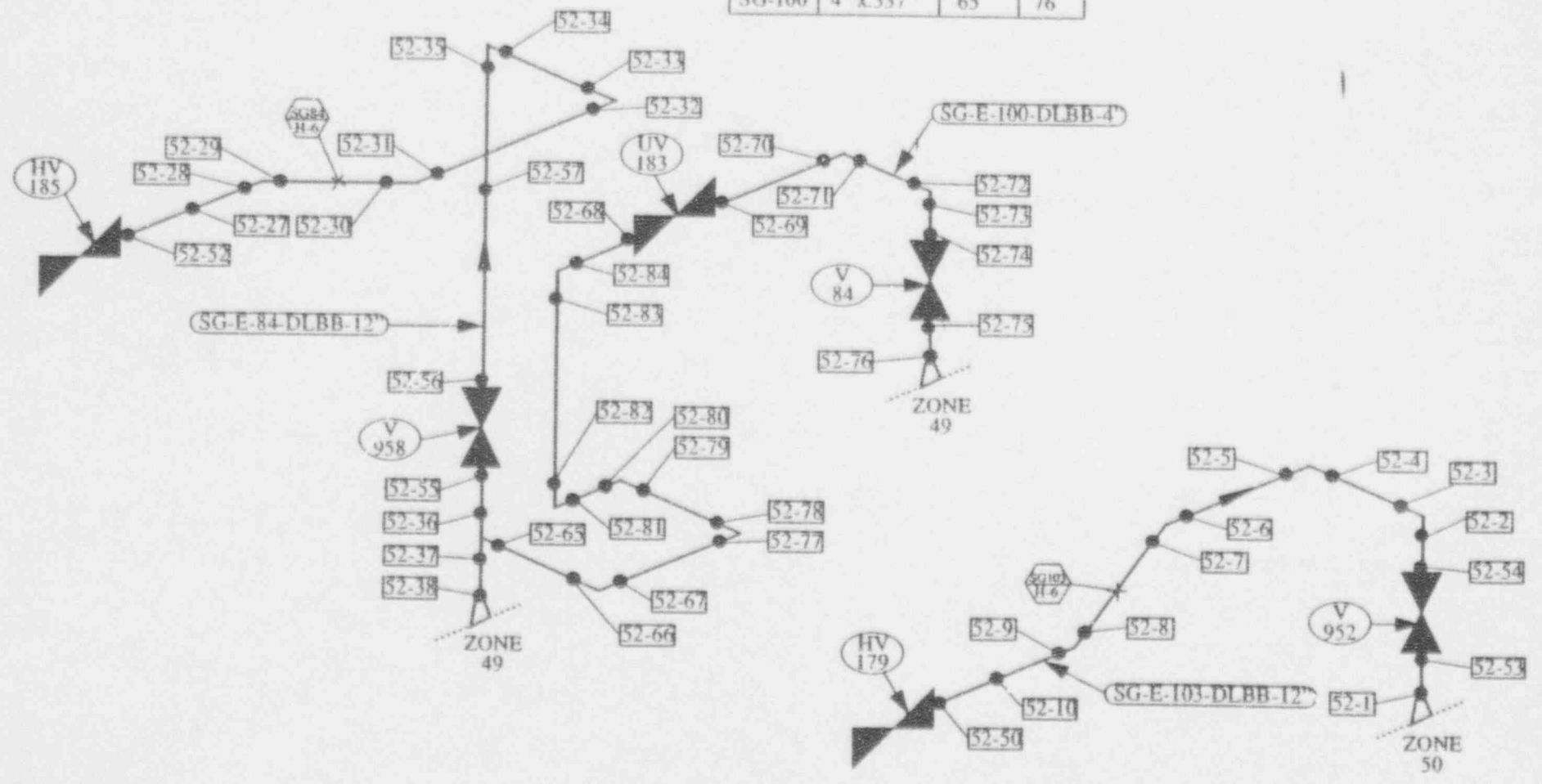

REFERENCE DRAWINGS  
13-P-SGF-158

UNIT 3	ZONE 52
ATMOSPHERIC DUMP # 2	
DESIGNED BY RLB	CHECKED BY CTB
REV. 0	

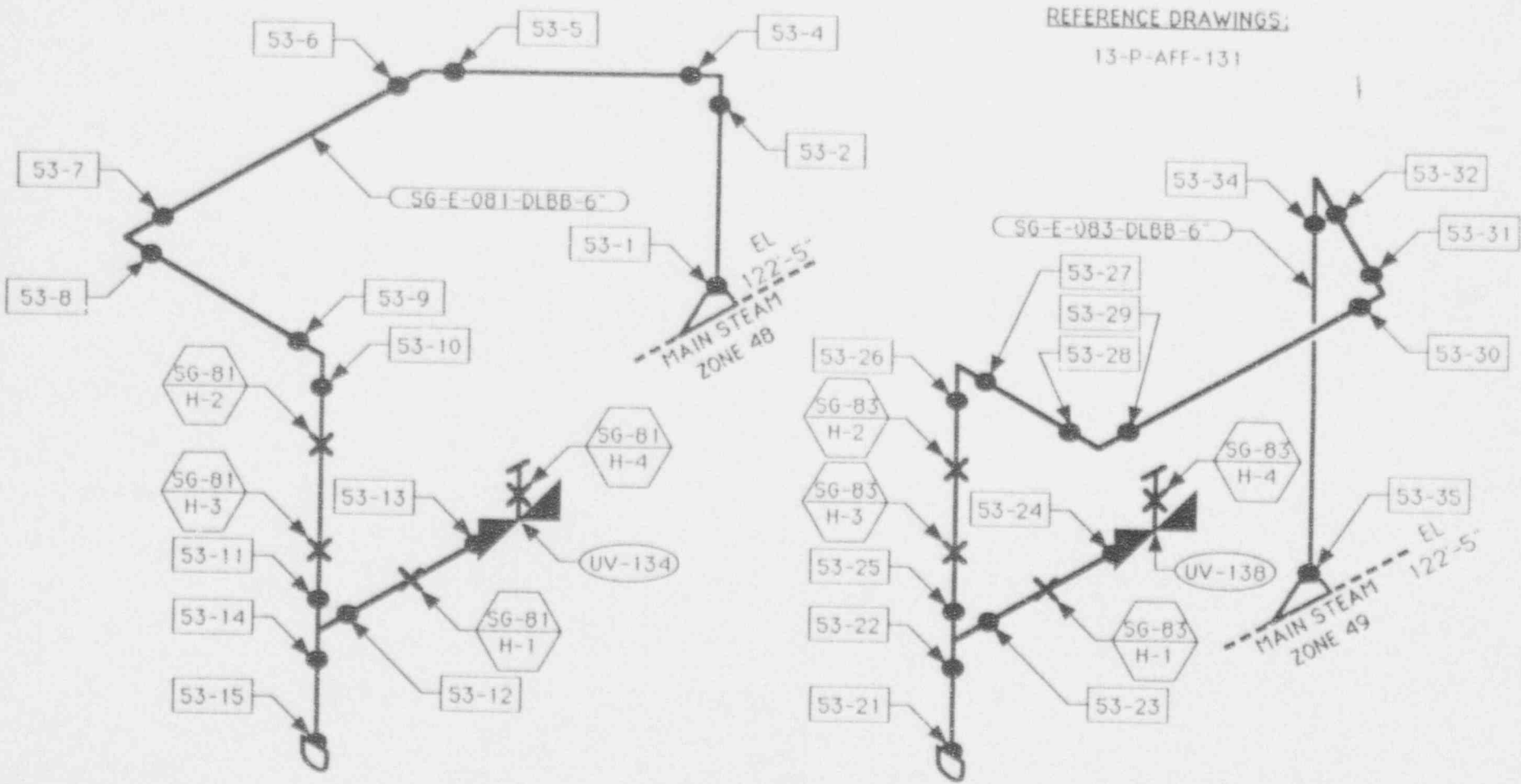

LINE #	DIA X SCH	FROM	TO
SG-081	6" X 0.432"	53-1	53-15
SG-083	6" X 0.432"	53-21	53-35

UNIT 3	ZONE 53
STEAM TO AUX FEEDWATER SYSTEM	
DRAWN BY <i>RLB</i>	CHECKED BY <i>WJA</i>
REV. 0	



LLINE	DIA./SCH	FROM	TO
2	14" x .938	15	24
2	16" x .844	25A	26
2	16" x 1.175	41-38	-
2	24" x 1.218	13,27	40
13	14" x .938	1	10
13	16" x .844	11A	12
13	16" x 1.175	41-39	-

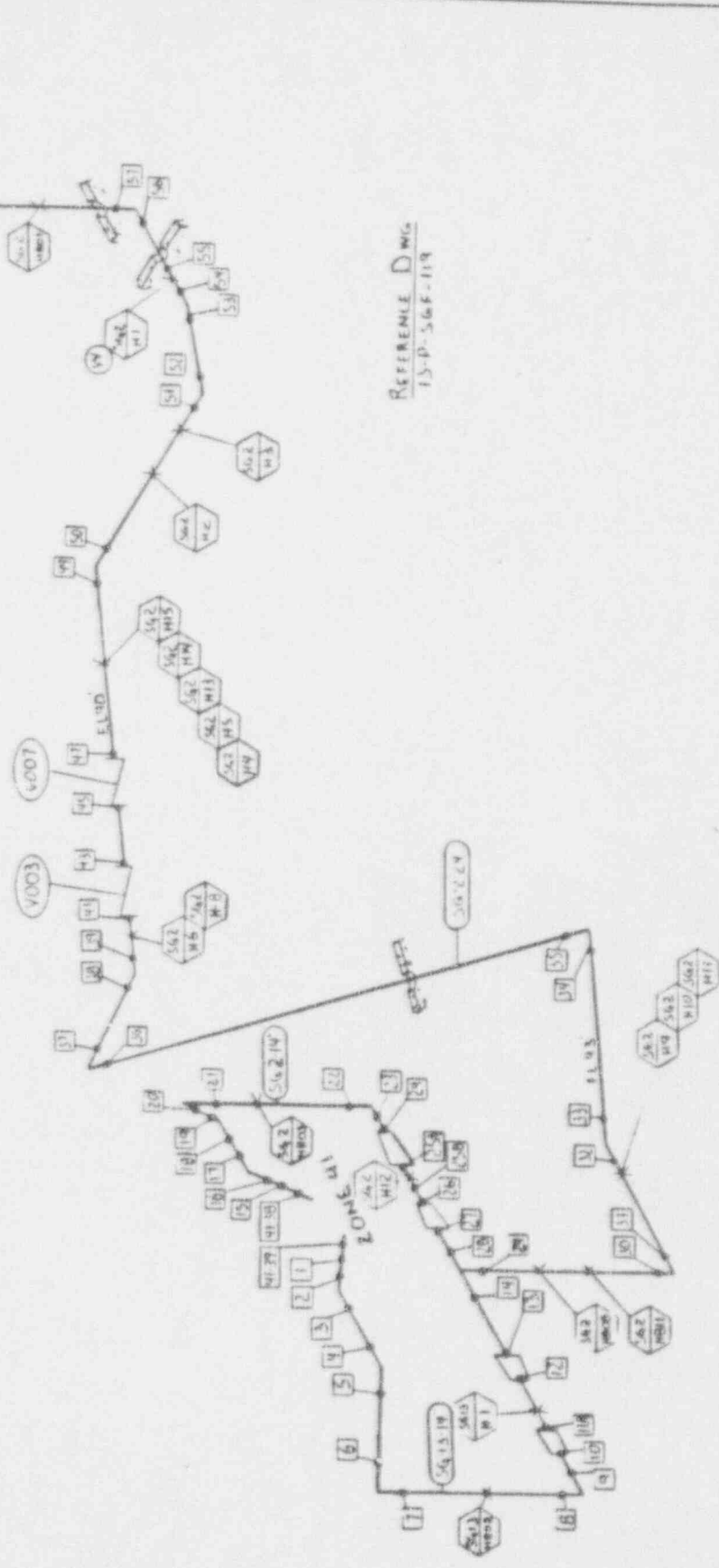

REFERENCE DWG  
13-P-568-119

REV. 0	DWG UNIT 3 ZONE 54
DRAWN BY D.D. HANSEN	TITLE FEEDWATER 56 MD. 1
CHECKED BY TBS	

REFERENCE DWG  
13-P-56F-114

LINE	DIA./SCH.	FROM	TO
5	14" X 1.38"	15	24
5	16" X 1.844"	25	26
5	16" X 1.75"	42, 38	-
5	24" X 1.218"	13, 27	40
14	14" X 1.38"	1	10
14	16" X 1.844"	11	12
14	16" X 1.75"	42, 37	-

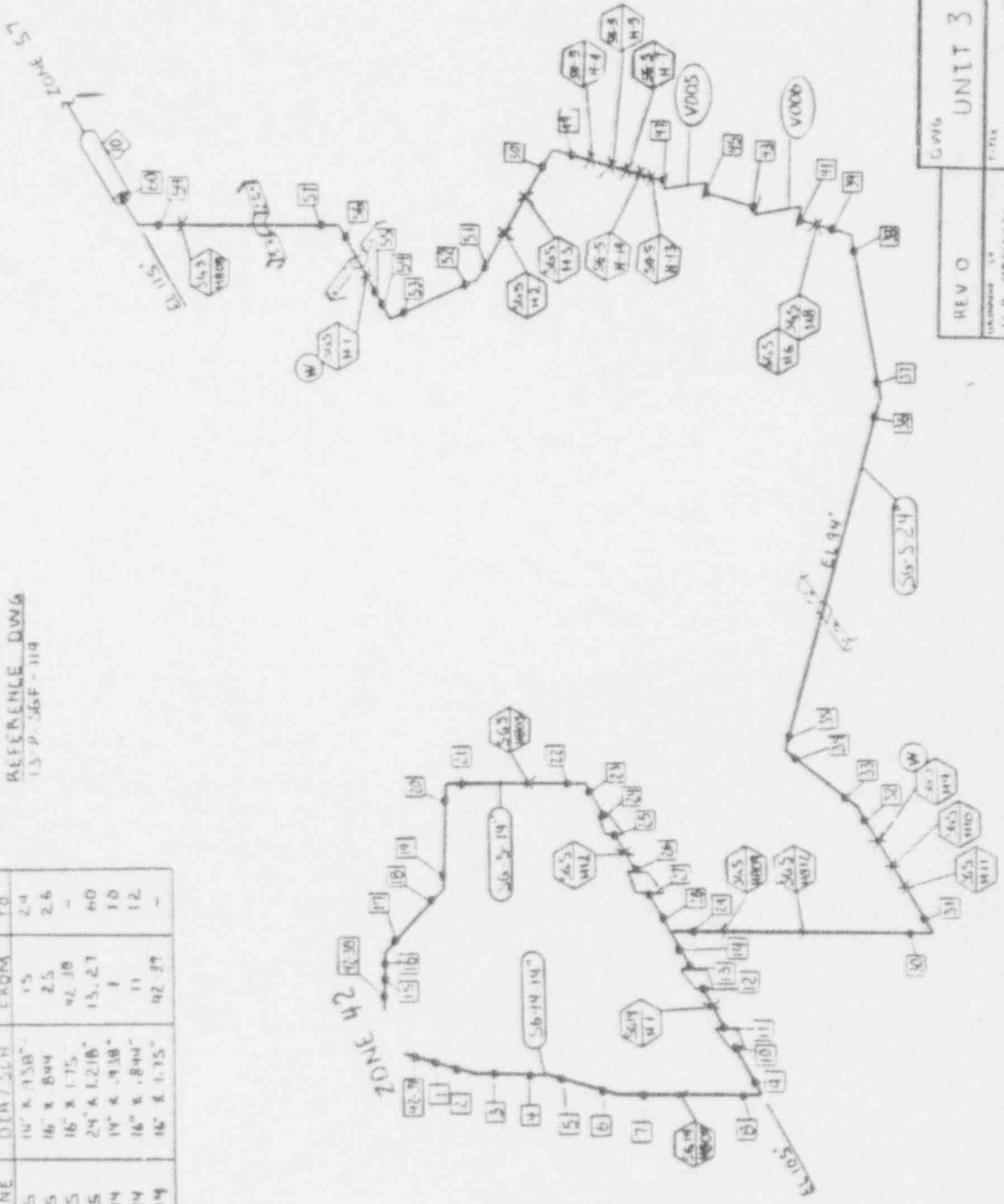

REV 0	CW/6	UNIT 3 ZONE 55
DESIGNED BY D. S. HATHORN	CHECKED BY JBS	FEEDWATER SG ND 2

LINE #	DIA/SCH	FROM	TO
202	24" x 1.531"	1	4
201	24" x 1.812"	6	7
224	24" x 1.812"	9	13
224	24" x 3.00"	12	-

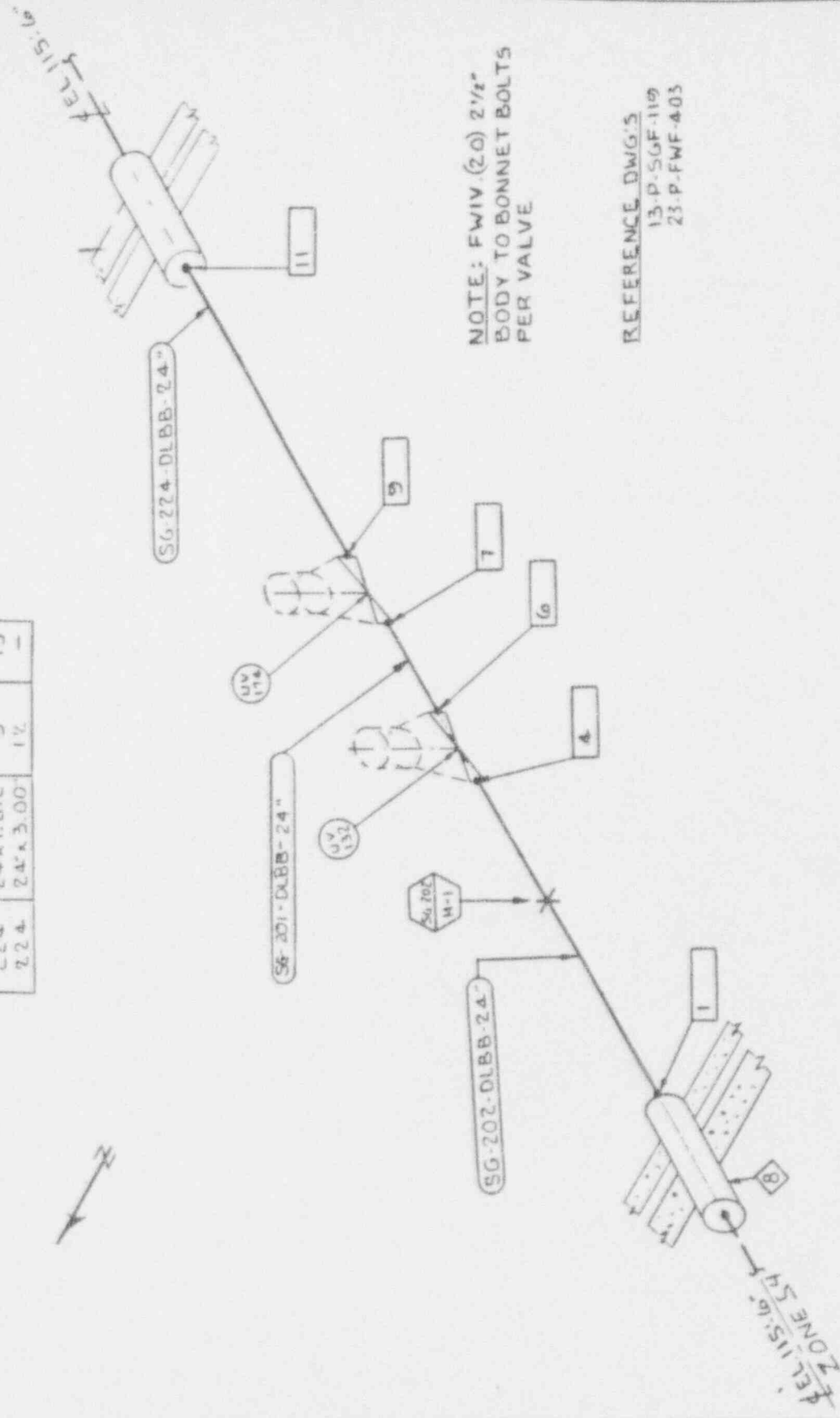

NOTE: FWIV (20) 2 1/2" BODY TO BONNET BOLTS PER VALVE

REFERENCE DWG'S  
13-P-SGF-119  
23-P-FWF-403

REV. 0	DWG	UNIT # 3 ZONE 516
DRAWN BY P. CURGIO		TITLE: FEEDWATER
CHECKED BY JBS		STEAM GENERATOR # 1

LINE #	DIA/SCH	FROM	TO
205	24" x 1.531	1	4
204	24" x 1.812	6	7
225	24" x 1.812	9	13
225	24" x 3.00	12	-

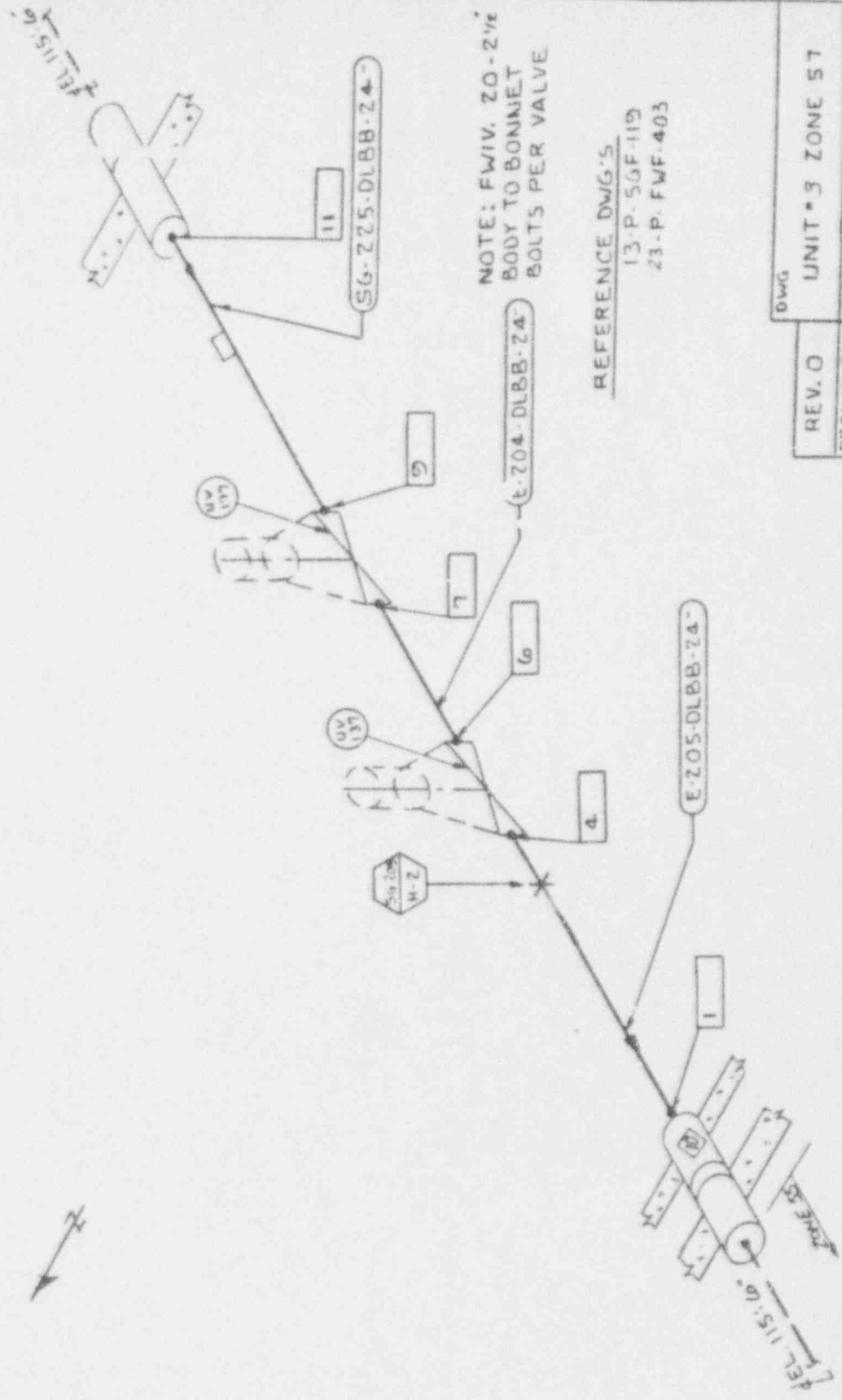

NOTE: FWIV, 20-2 1/2"  
 BODY TO BONNET  
 BOLTS PER VALVE

REFERENCE DWG'S  
 13-P. 56F-119  
 23-P. FWF-403

REV. 0	UNIT # 3 ZONE 57
DRAWN BY R. CURCIO	TITLE FEEDWATER STEAM GENERATOR # 2
CHECKED BY JRS	

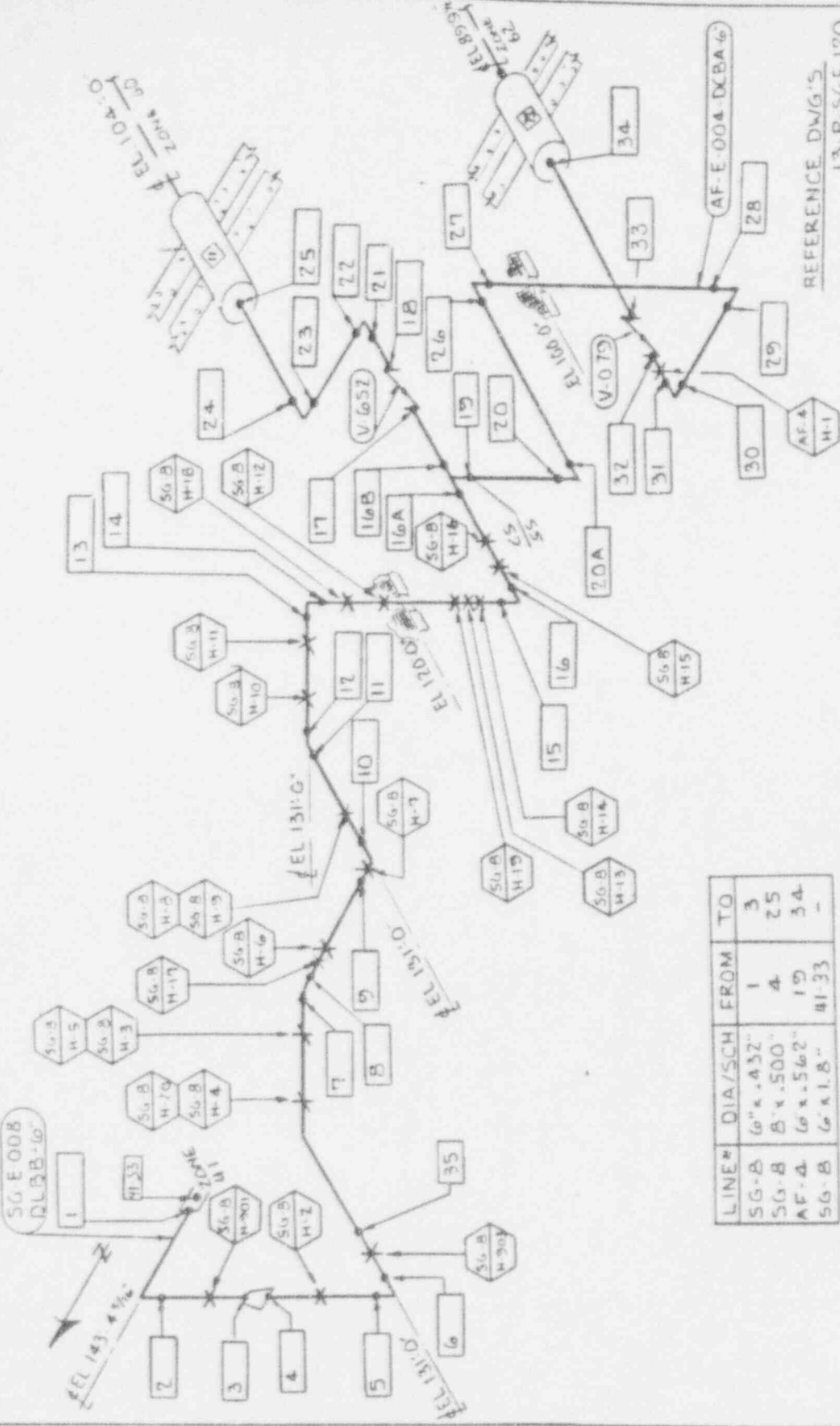

LINE#	DIA/SCH	FROM	TO
SG-B	6" x .432"	1	3
SG-B	8" x .500"	4	25
AF-4	6" x .562"	19	34
SG-B	6" x 1.8"	41-33	-

REFERENCE DWG'S  
13-P-56F-120

REV. 0	DWG: UNIT # 3 ZONE 5B
DRAWN BY R. CURCIO	TITLE AUXILIARY DOWNCOMER
CHECKED BY JBS	FEEDWATER STEAM GEN. # 1

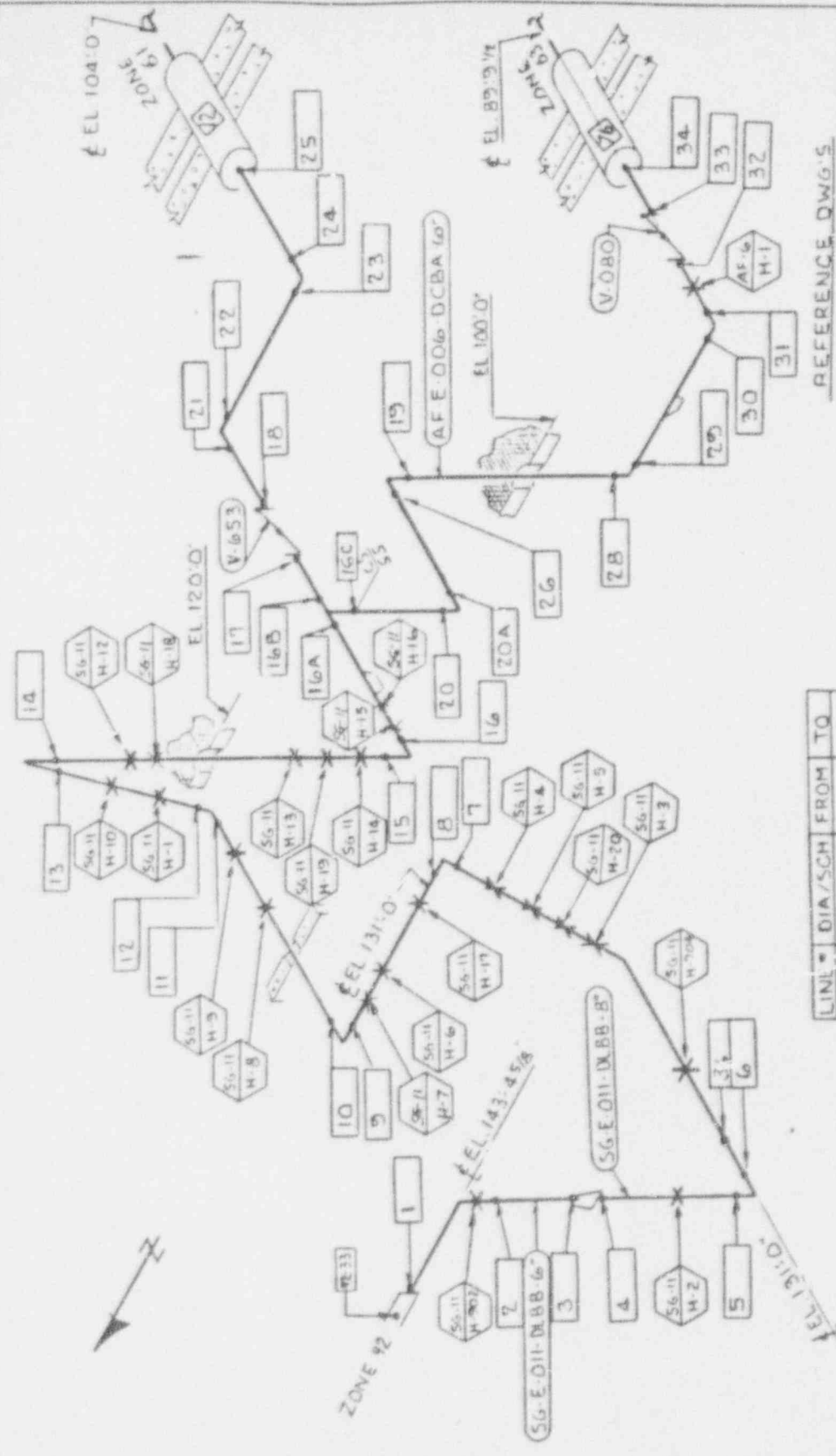

REFERENCE DWG'S  
13-P-50F-170 REV. 2

LINE #	DIA/SCH	FROM	TO
SG-11	6" x .432"	1	3
SG-11	8" x .500"	4	25
AF-6	6" x .562"	16	34
SG-11	6" x 1.8"	42-33	-

REV. 0	DWG	UNIT # 3	ZONE 59
DRAWN BY R. CURCIO			TITLE AUX/DOWNCOMER
CHECKED BY JBS			FEEDWATER STEAM GEN # 2

LINE #	DIA/SCH	FROM	TO
56-200	8" x .119"	2	12
56-8	8" x .119"	14	17

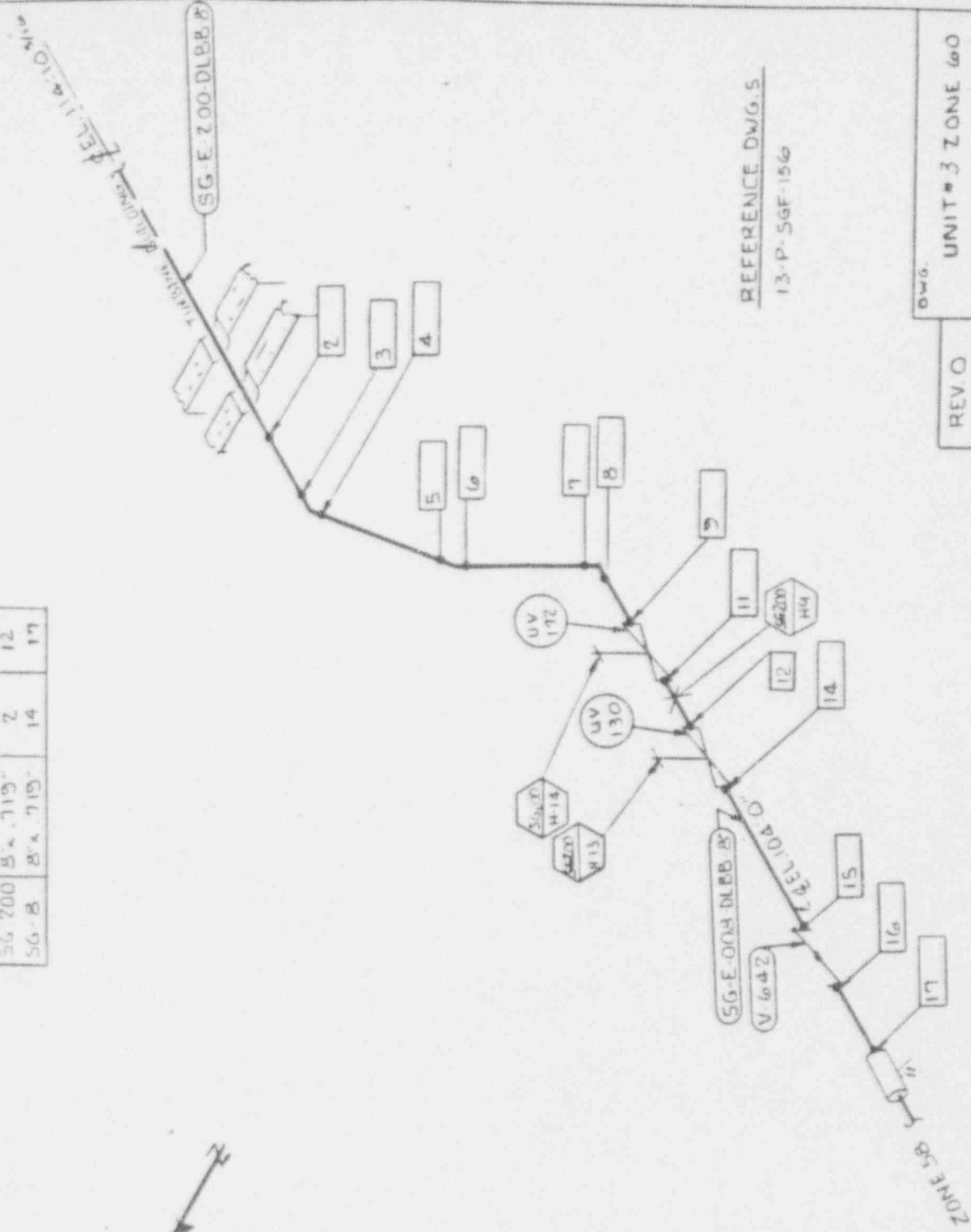

REFERENCE DWG. 5  
13-P-SGF-156

REV. 0	DWG.	UNIT # 3 ZONE 60
DESIGNED BY R. CURCIO	TITLE DOWNCOMER	
CHECKED BY JBS	FEEDWATER STM GEN # 1	

LINE #	DIA/SCH	FROM	TO
56-203	R. 7.119	2	12
56-11	B. 7.119	14	17

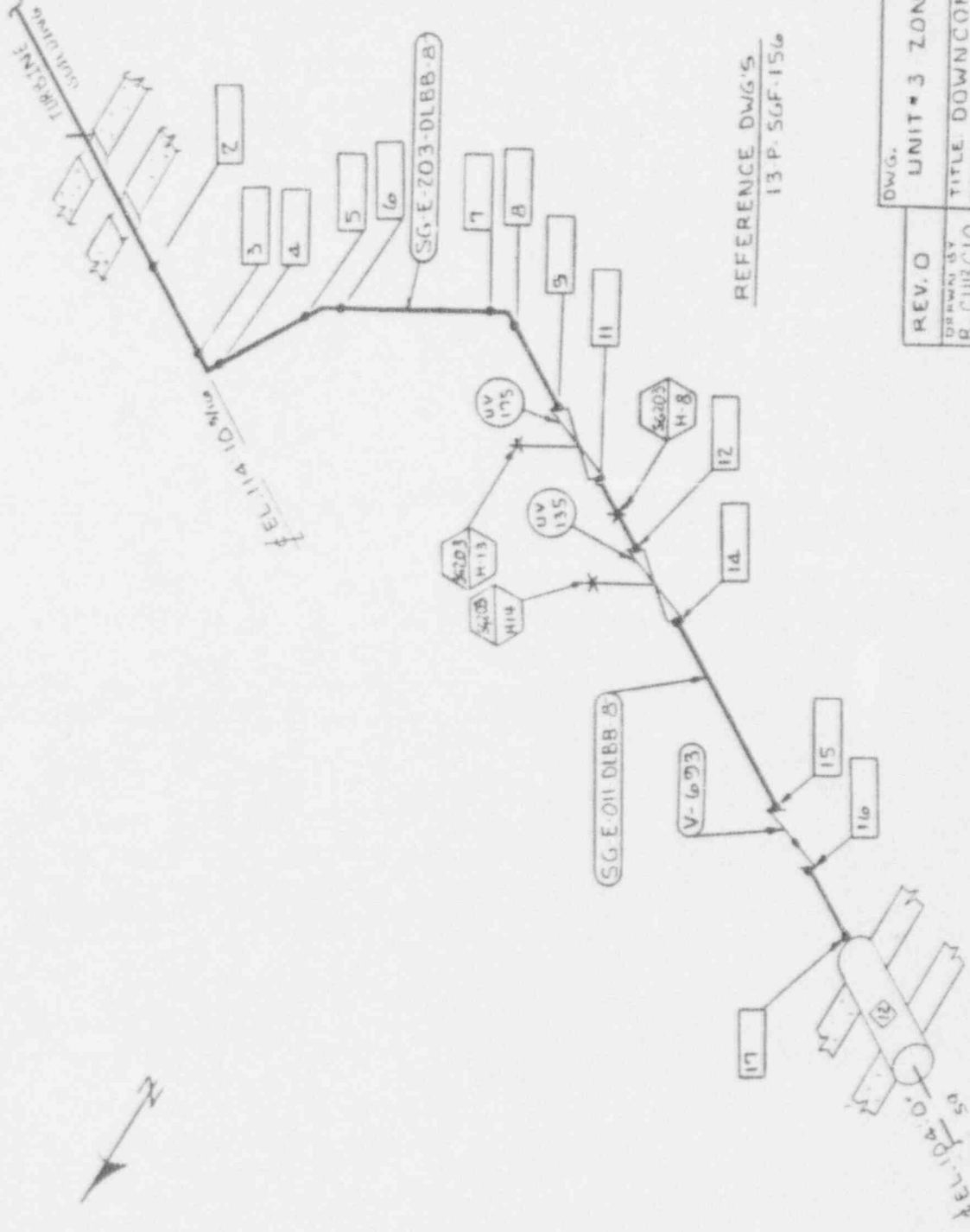

REFERENCE DWG'S  
13 P. SGF-156

REV. O	DWG.
UNIT # 3 ZONE 61	
TITLE: DOWNCOMER	
FEEDWATER STM GEN # 2	
DESIGNED BY R. CURCIO	
CHECKED BY J.B.	



LINE #	DIA/SCH	FROM	TO
AF-18	6" x 562"	4	14
AF-4	6" x 562"	18	24

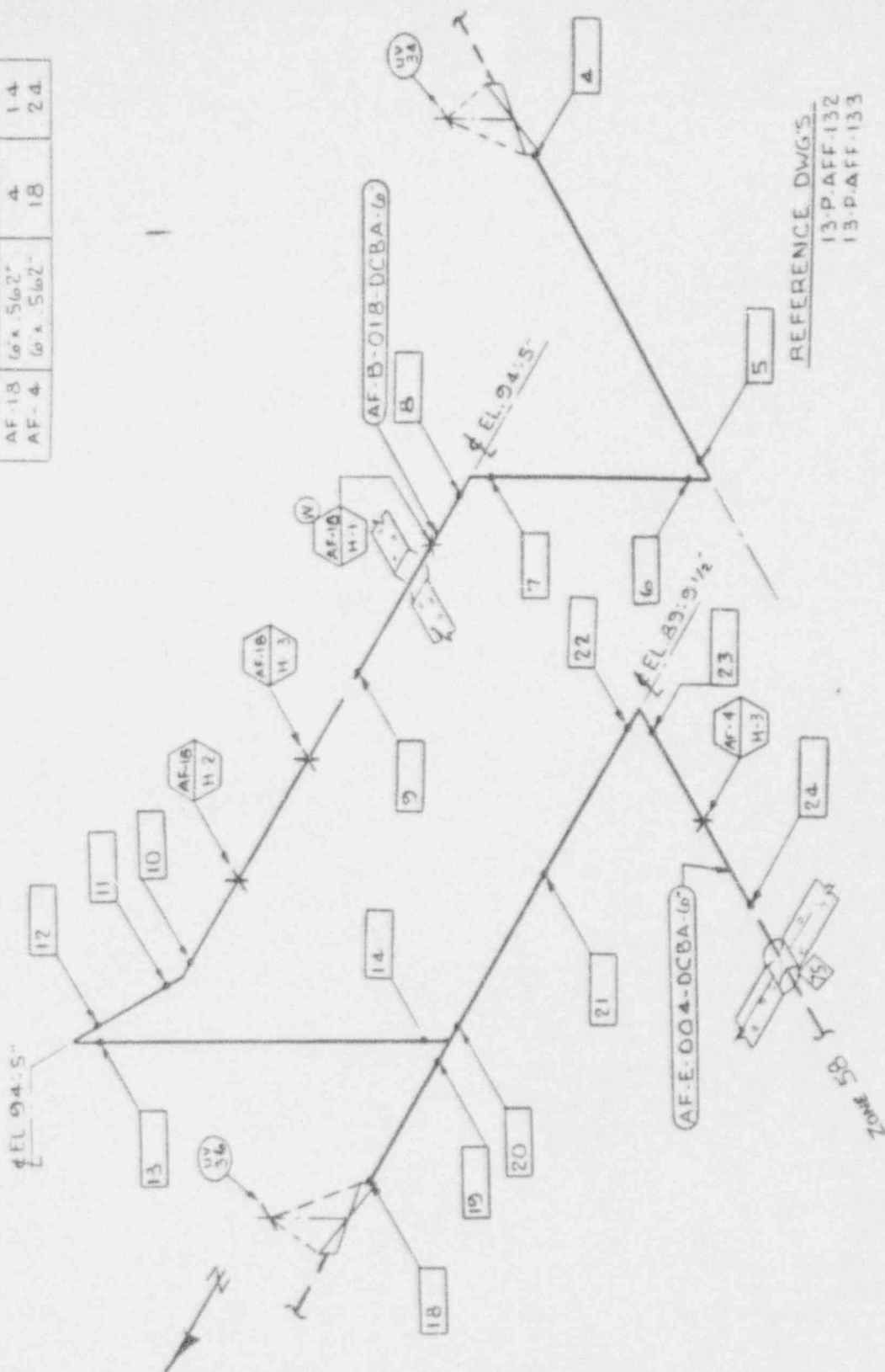

REFERENCE DWG'S:  
 13-P-AFF-132  
 13-P-AFF-133

REV.	DATE	BY	CHECKED BY	DWG.
0		R. CURCIO	TR3	UNIT # 3 ZONE 62 TITLE: AUXILIARY FEEDWATER STEAM GENERATOR # 1

LINE #	DIA / SCH	FROM	TO
AF-16	6 x 562"	18	19
AF-6	6 x 562"	4	30

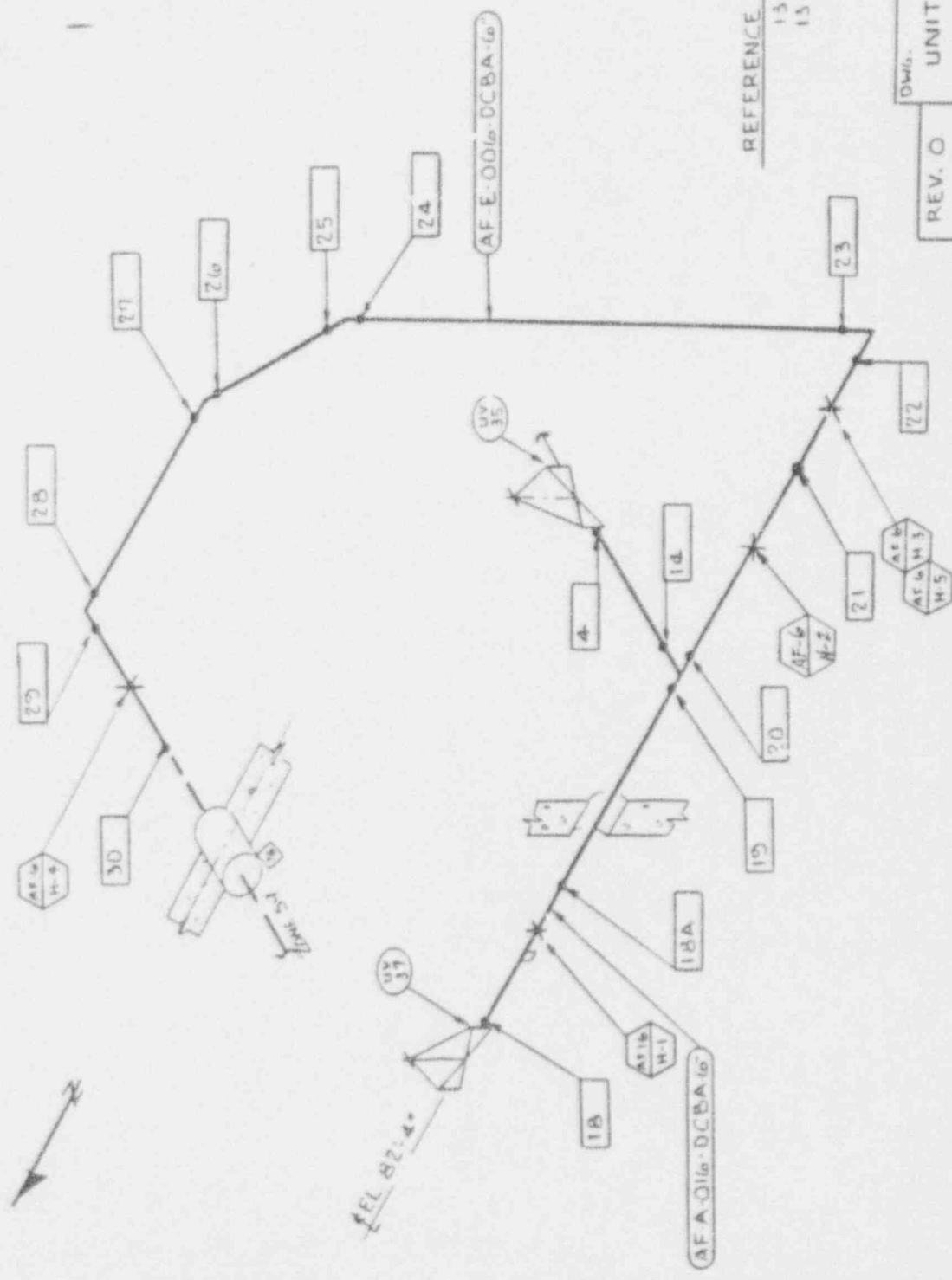

REFERENCE DWG'S  
 13-P-AFF-132  
 13-P-AFF-133

REV. O	DWG.	UNIT # 3 ZONE 605
1	R. CUK C10	TITLE AUXILIARY FEEDWATER
2	UNGENA 001	STEAM GENERATOR # 2
3	JBS	

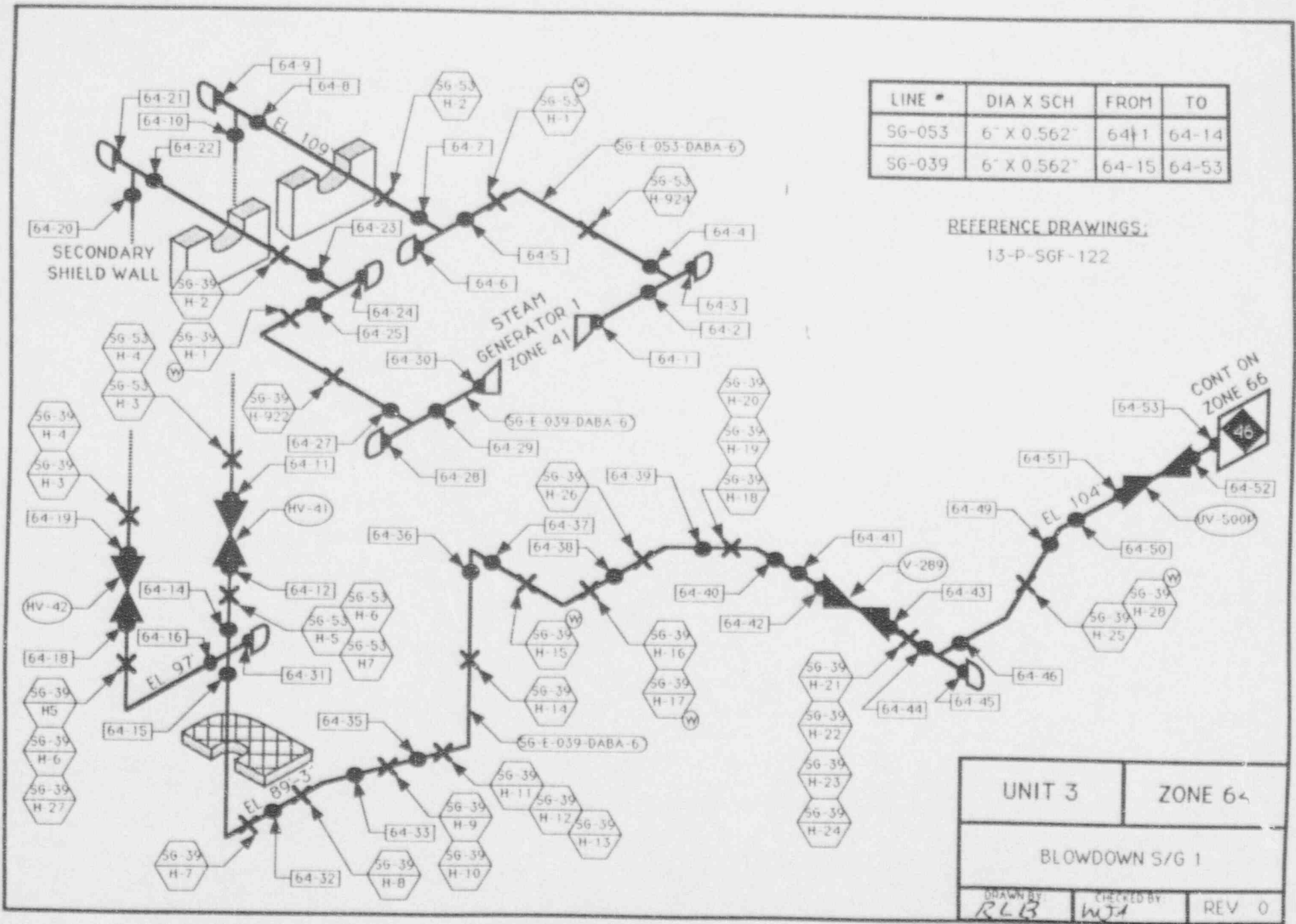

LINE #	DIA X SCH	FROM	TO
SG-053	6" X 0.562"	64-1	64-14
SG-039	6" X 0.562"	64-15	64-53

REFERENCE DRAWINGS:  
13-P-SGF-122

UNIT 3	ZONE 64
BLOWDOWN S/G 1	
DRAWN BY RLB	CHECKED BY WJL
REV 0	

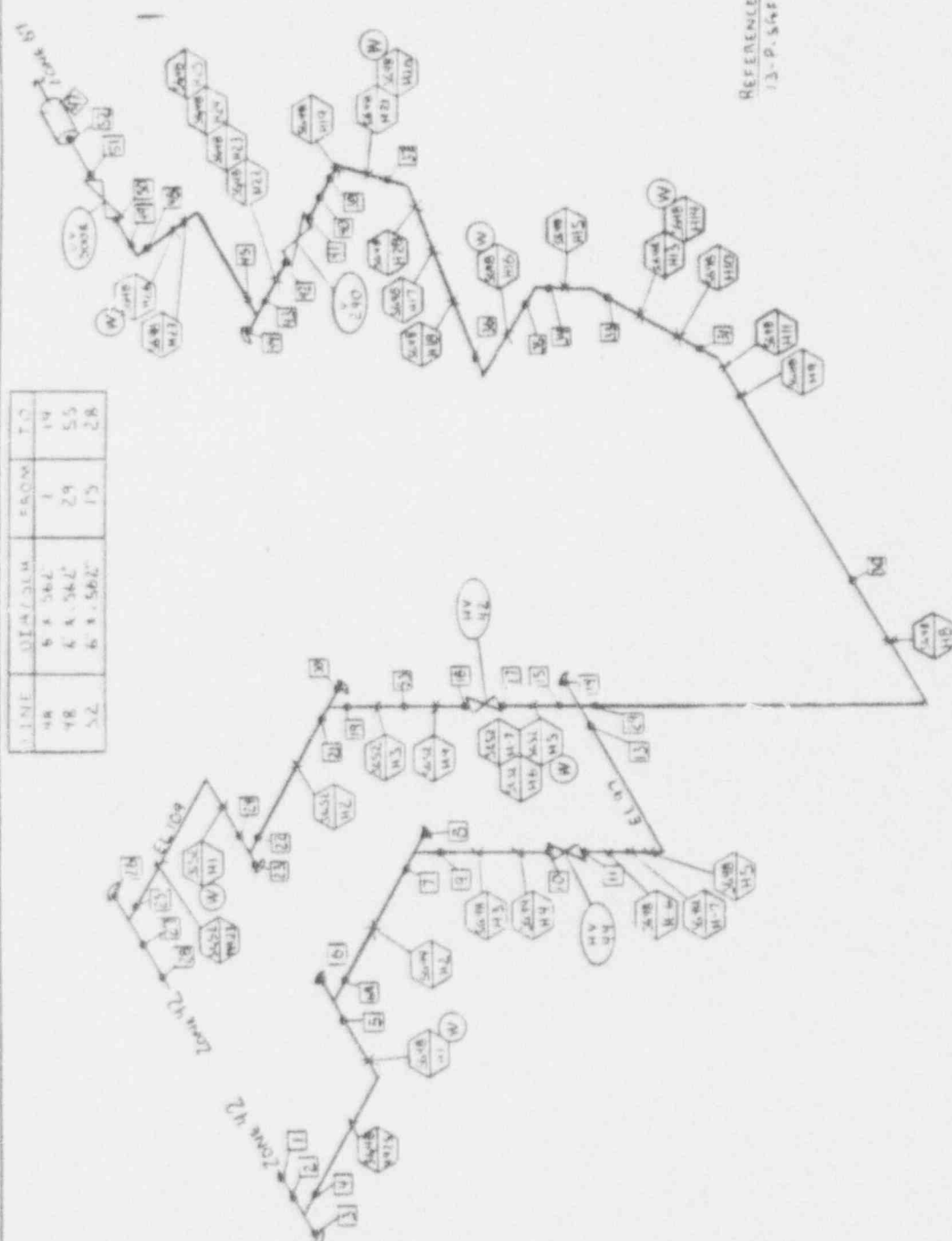

REFERENCE DWG  
13-P.54F.140

LINE	VIADUCT	FROM	T.O
18	5 X 562"	1	19
18	6 X 562"	29	55
52	6 X 562"	15	28

REV 0	UNIT 3 ZONE 65
DRAWN BY C. J. HARMAN	DATE 7/65
CHECKED BY JES	

BLOWDOWN 5/6 2

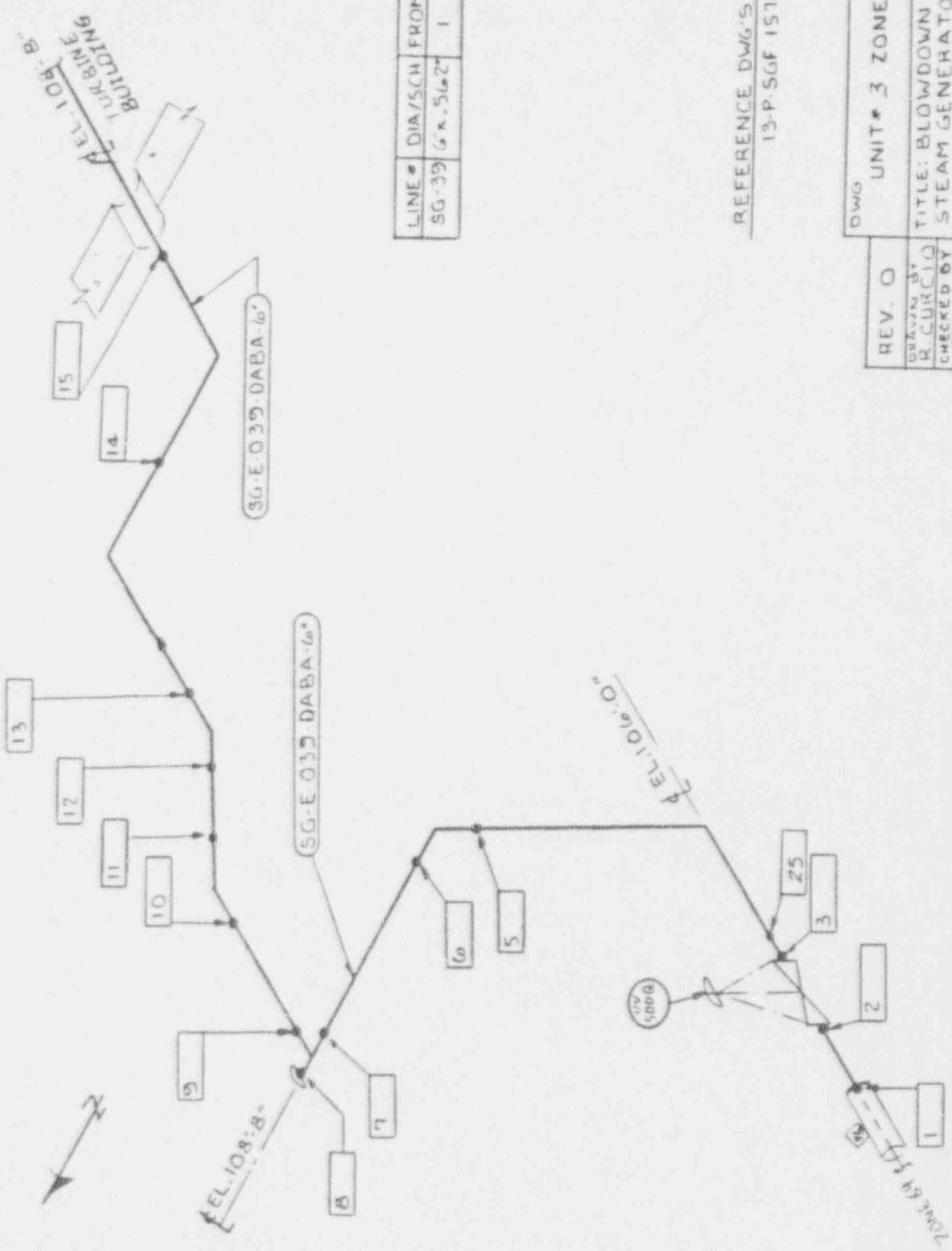

LINE #	DIA/SCH	FROM	TO
SG-39	6 x 56.2"	1	15

REFERENCE DWG'S  
13-P-56F 157

REV.	BY	DATE	DWG	UNIT #	ZONE	6x6
0	R. CURCIO			3		
	TP2					

TITLE: BLOWDOWN  
STEAM GENERATOR #1



ZONE 3A

LINE #	DIA/ISCH	FROM	TO
5G-48	φ 4.562"	1	12

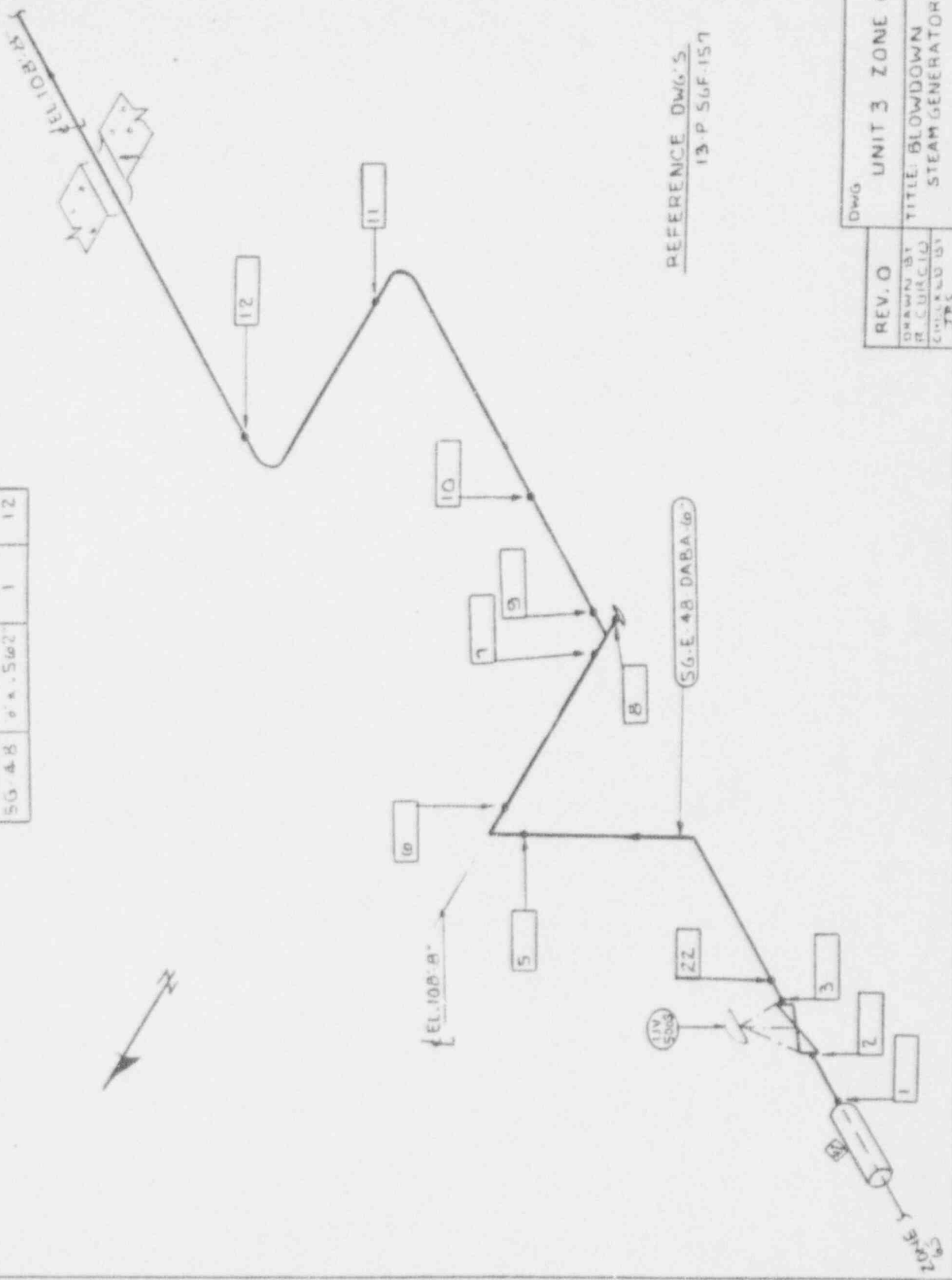

REFERENCE DWG'S  
13-P 56F-157

REV. 0	DWG
DRAWN BY R. CURCIO CHECKED BY JRS	UNIT 3 ZONE 67 TITLE: BLOWDOWN STEAM GENERATOR #2

NOTES:

TAG NO. 3MCHEEDI  
SERIAL NO 73319 AMETER  
N O NO 430

REFERENCE DWGS:

N001-703-1  
N001-703-48 THRU 50

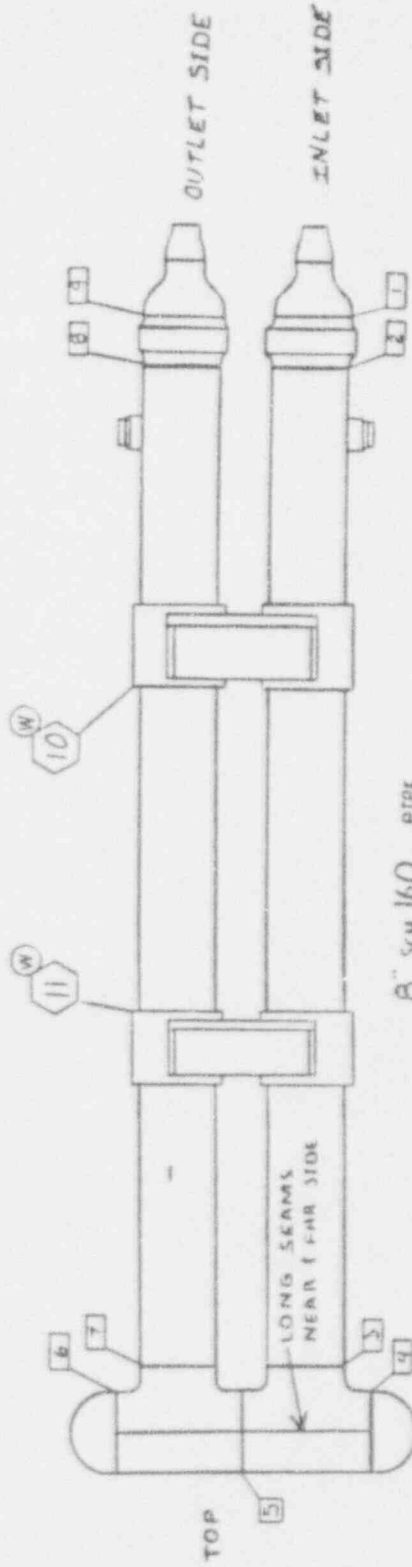

REV 0	DWG
DESIGNED BY D. S. HANSEN	TITLE UNIT 3 ZONE 68
DRAWN BY JBS	REGENERATIVE HEAT EXCHANGER

NOTES:

TAG NO. 3MLHNE02 |  
SERIAL NO. N2376 (RICHMOND ENGR)  
M.B. NO 78454

REFERENCE DRAWINGS:

N001-703-26  
N001-703-27  
N001-703-28  
N001-703-29

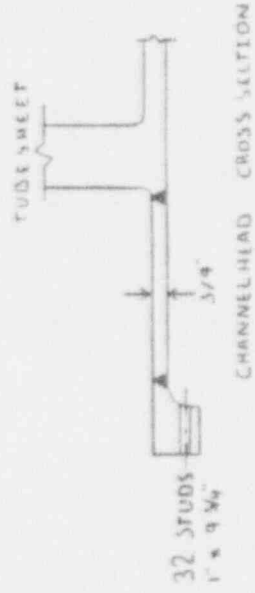

DWG.	UNIT 3 ZONE 69
REV. 0	TITLE: LETDOWN HEAT EXCHANGER
DESIGNED BY D.B. HANSEN	
CHECKED BY JBS	



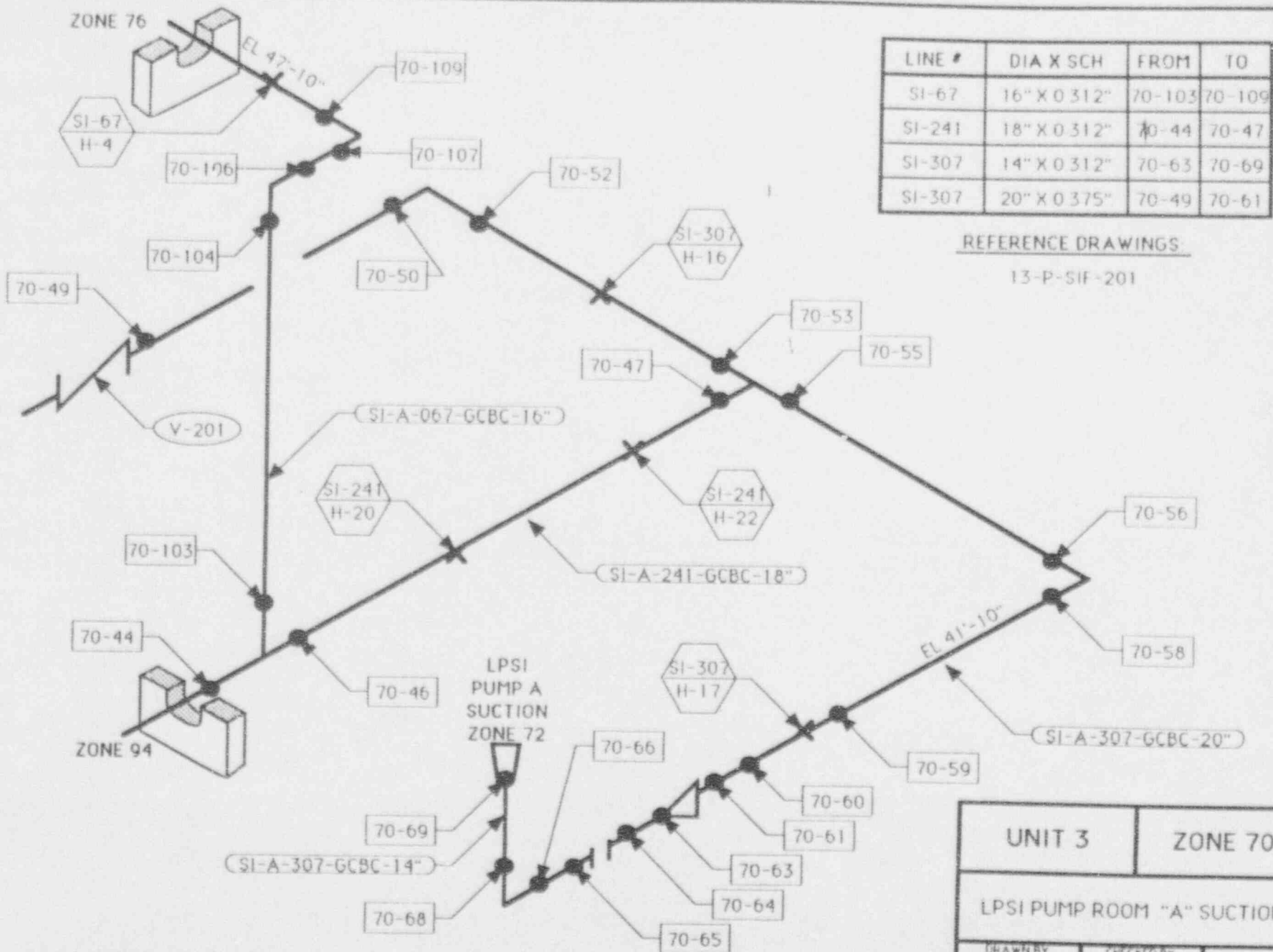

LINE #	DIA X SCH	FROM	TO
SI-67	16" X 0.312"	70-103	70-109
SI-241	18" X 0.312"	70-44	70-47
SI-307	14" X 0.312"	70-63	70-69
SI-307	20" X 0.375"	70-49	70-61

REFERENCE DRAWINGS:

13-P-SIF-201

UNIT 3		ZONE 70	
LPSI PUMP ROOM "A" SUCTION			
DRAWN BY <i>[Signature]</i>	CHECKED BY <i>[Signature]</i>	REV 0	

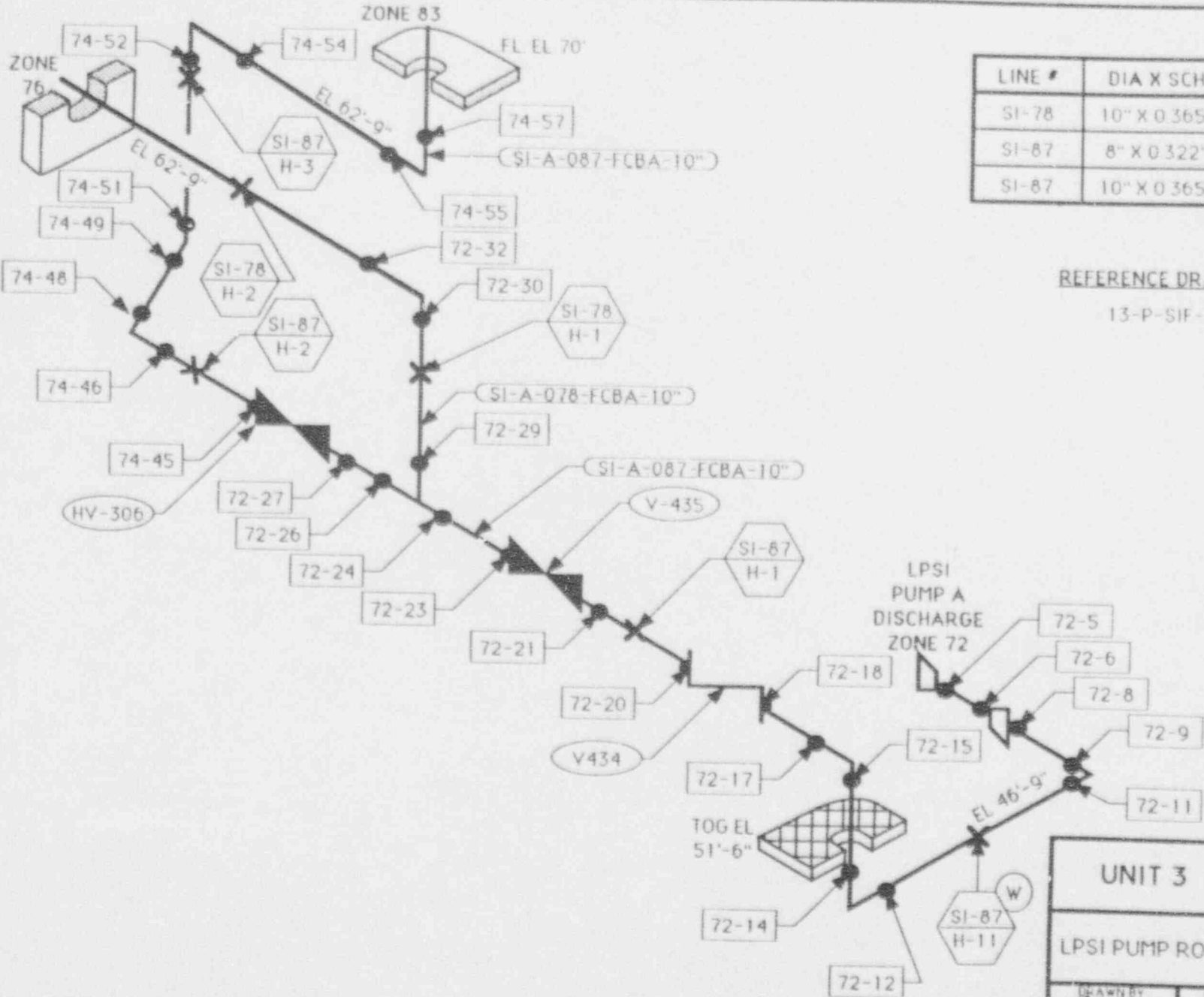

LINE #	DIA X SCH	FROM	TO
SI-78	10" X 0.365"	72-29	72-32
SI-87	8" X 0.322"	72-5	72-6
SI-87	10" X 0.365"	72-8	74-57

REFERENCE DRAWINGS:  
13-P-SIF-207

UNIT 3	ZONE 71
LPSI PUMP ROOM "A" DISCHARGE	
DRAWN BY <i>JBC</i>	CHECKED BY <i>DBH</i>
REV 0	

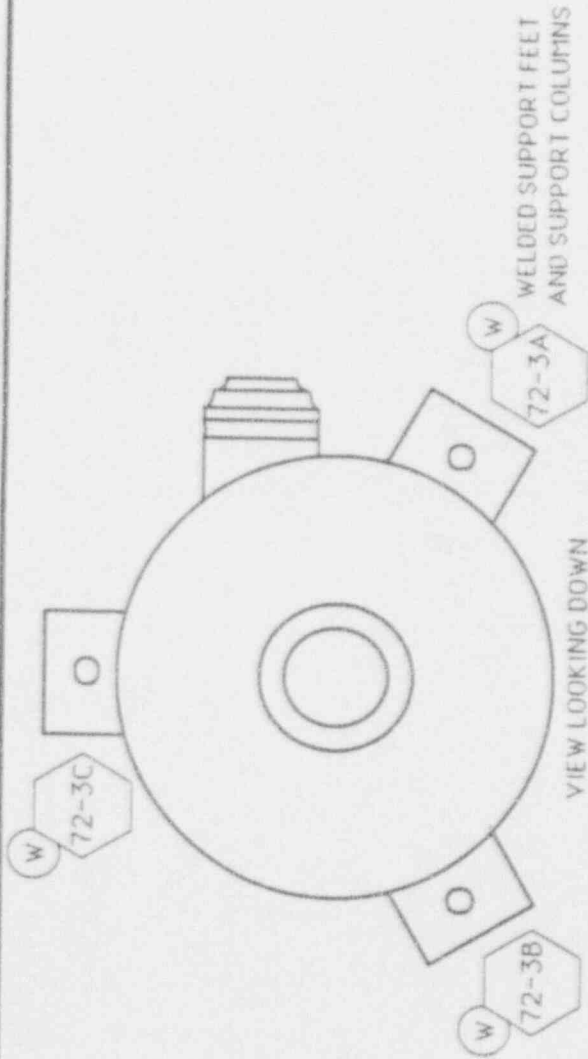

NOTES.

- 1) TAG NUMBER: 3MSIAP01
- 2) SERIAL NUMBER: 0876-44 INGERSOLL RAND
- 3) NATIONAL BOARD NUMBER: 523

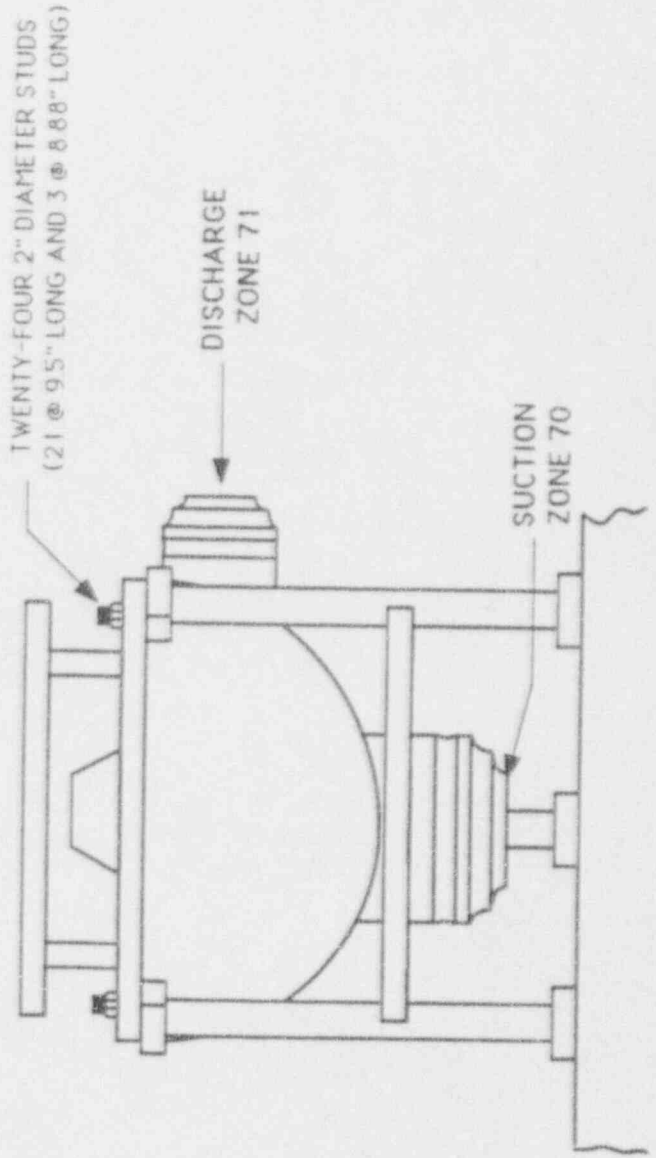

REFERENCE DRAWINGS:

- N001-1101-36
- N001-1101-50

UNIT 3	ZONE 72
LPSI PUMP A	
DESIGNED BY <i>DBB</i>	CHECKED BY <i>DBH</i>
	REV 0

LINE #	DIA X SCH	FROM	TO
SI-308	14" X 0.312"	71-63	71-69
SI-308	20" X 0.375"	71-49	71-61
SI-194	18" X 0.312"	71-44	71-47
SI-34	16" X 0.312"	71-105	71-111

REFERENCE DRAWINGS:

13-P-SIF-202

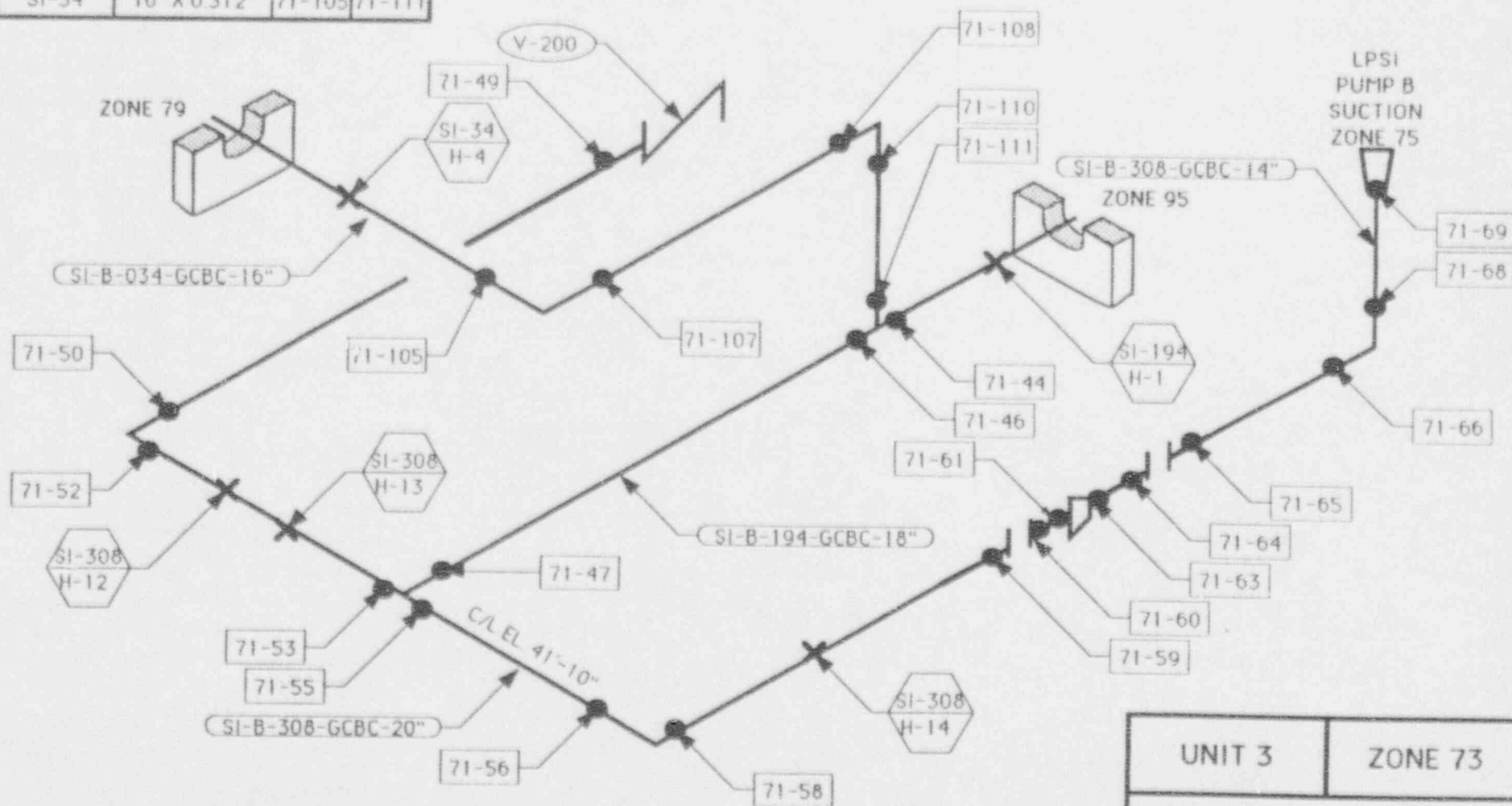

UNIT 3	ZONE 73
LPSI PUMP ROOM "B" SUCTION	
DRAWN BY <i>[Signature]</i>	CHECKED BY <i>[Signature]</i>
	REV 0

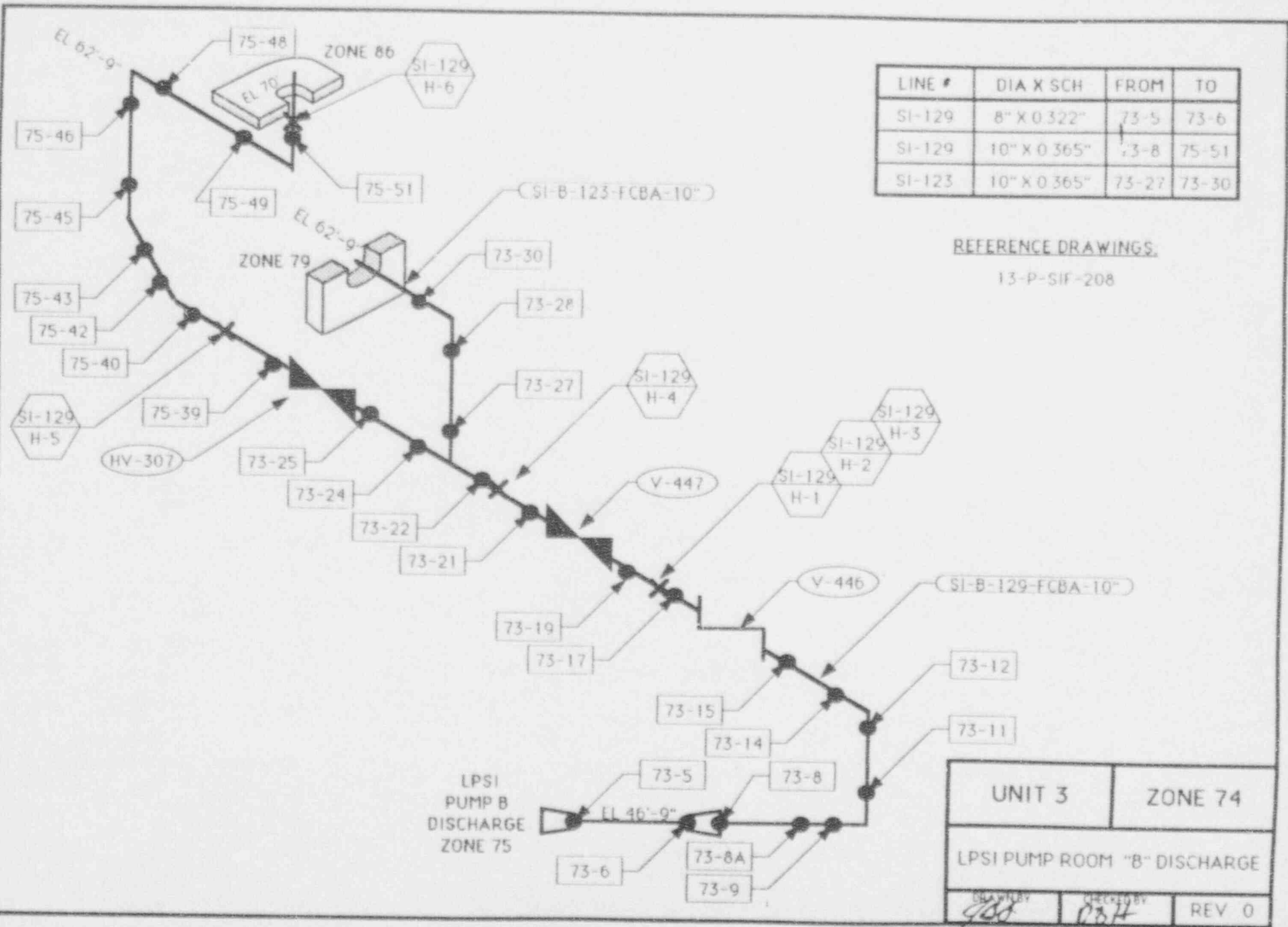

LINE #	DIA X SCH	FROM	TO
SI-129	8" X 0.322"	73-5	73-6
SI-129	10" X 0.365"	73-8	75-51
SI-123	10" X 0.365"	73-27	73-30

REFERENCE DRAWINGS:  
13-P-SIF-208

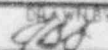
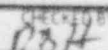
UNIT 3	ZONE 74
LPSI PUMP ROOM "B" DISCHARGE	
<small>DRAWN BY</small> 	<small>CHECKED BY</small> 
REV 0	

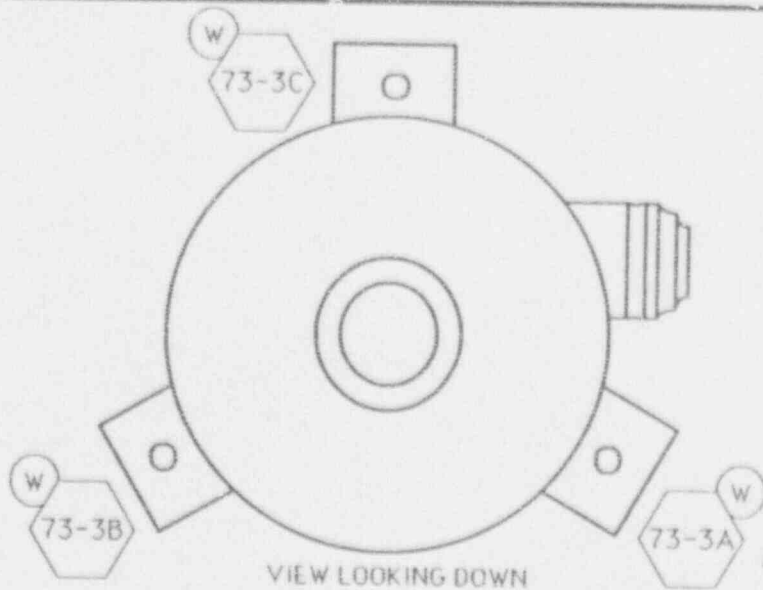

VIEW LOOKING DOWN

WELDED SUPPORT FEET  
AND SUPPORT COLUMNS

NOTES.

- 1) TAG NUMBER: 3MSIBP01
- 2) SERIAL NUMBER: 0876-45 INGERSOLL RAND
- 3) NATIONAL BOARD NUMBER: 524

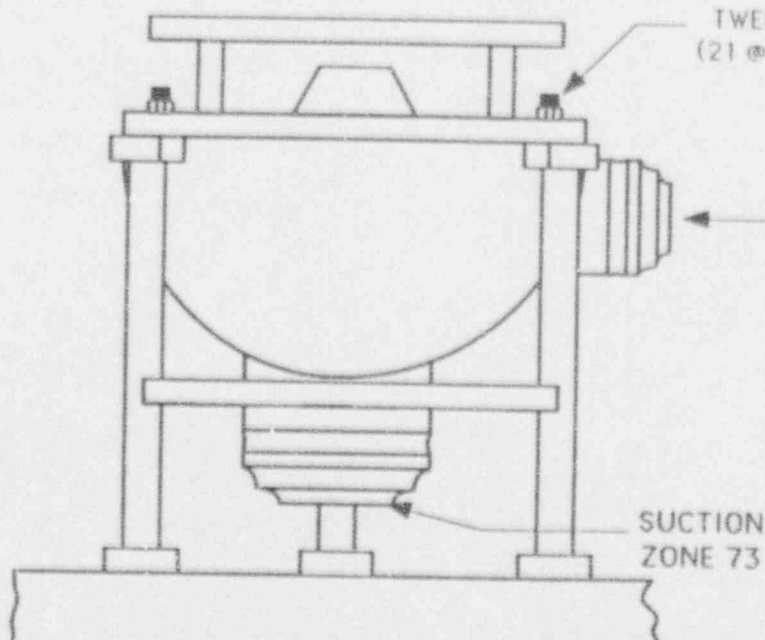

TWENTY-FOUR 2" DIAMETER STUDS  
(21 @ 95" LONG AND 7 @ 8.88" LONG)

DISCHARGE  
ZONE 74

SUCTION  
ZONE 73

REFERENCE DRAWINGS:

N001-11.01-36  
N001-11.01-50

UNIT 3	ZONE 75
LPSI PUMP B	
DRAWN BY <i>DBH</i>	CHECKED BY <i>DBH</i>
	REV 0

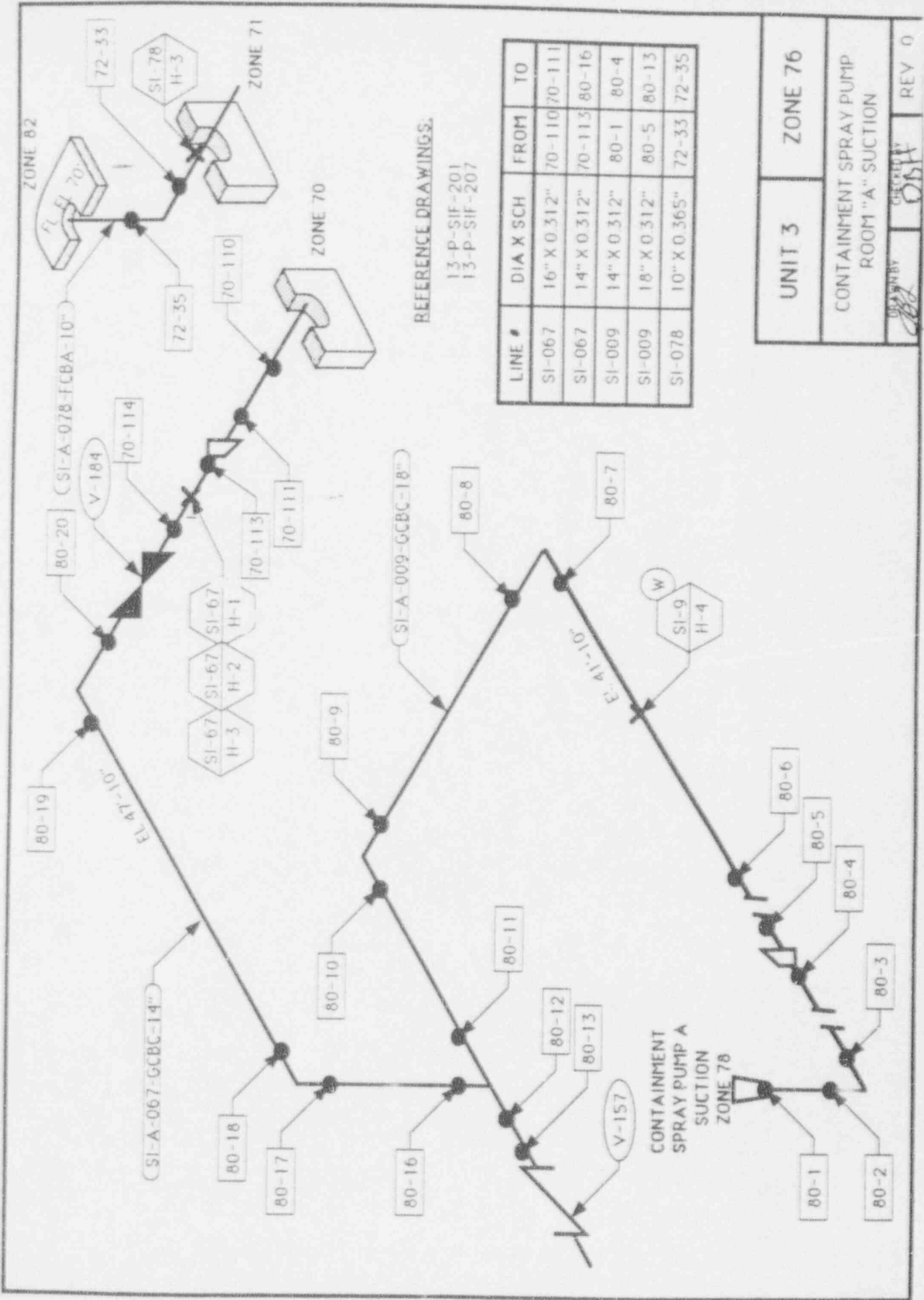

REFERENCE DRAWINGS.

13-P-SIF-201  
13-P-SIF-207

LINE #	DIA X SCH	FROM	TO
SI-067	16" X 0.312"	70-110	70-111
SI-067	14" X 0.312"	70-113	80-16
SI-009	14" X 0.312"	80-1	80-4
SI-009	18" X 0.312"	80-5	80-13
SI-078	10" X 0.365"	72-33	72-35

UNIT 3	ZONE 76
CONTAINMENT SPRAY PUMP ROOM "A" SUCTION	
DESIGNED BY <i>[Signature]</i>	CHECKED BY <i>[Signature]</i>
	REV 0



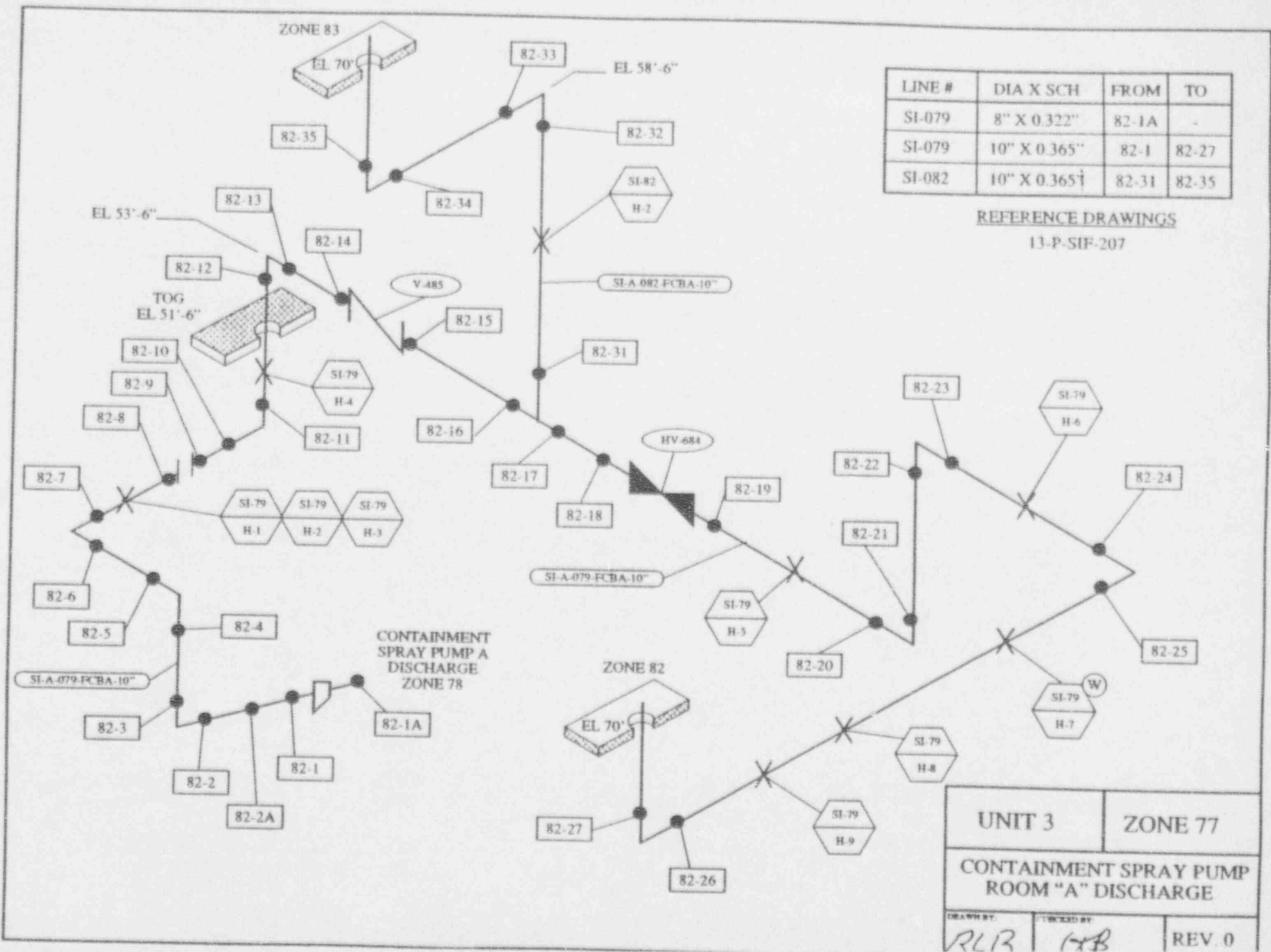

LINE #	DIA X SCH	FROM	TO
SI-079	8" X 0.322"	82-1A	-
SI-079	10" X 0.365"	82-1	82-27
SI-082	10" X 0.365"	82-31	82-35

REFERENCE DRAWINGS  
13-P-SIF-207

UNIT 3	ZONE 77
CONTAINMENT SPRAY PUMP ROOM "A" DISCHARGE	
DRAWN BY: RLR	CHECKED BY: HAB
REV. 0	



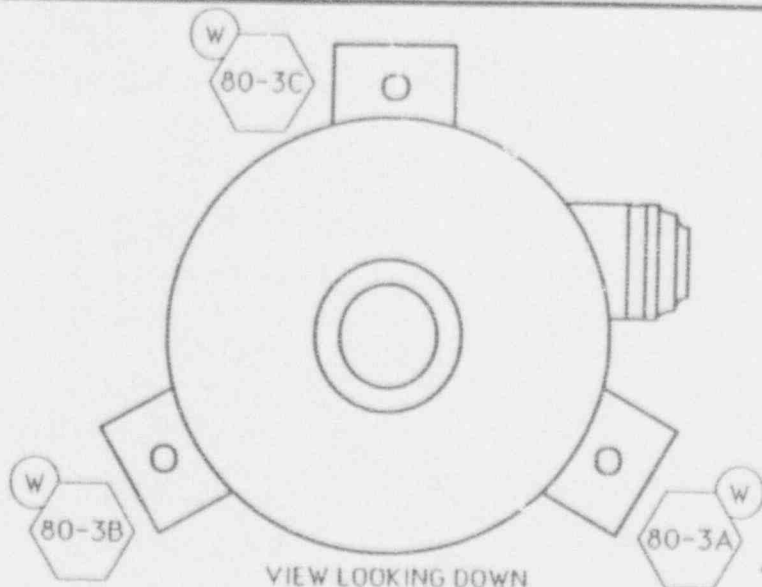

VIEW LOOKING DOWN

WELDED SUPPORT FEET  
AND SUPPORT COLUMNS

**NOTES:**

- 1) TAG NUMBER: 3MSIAP03
- 2) SERIAL NUMBER: 0876-46 INGERSOL RAND
- 3) NATIONAL BOARD NUMBER: 521

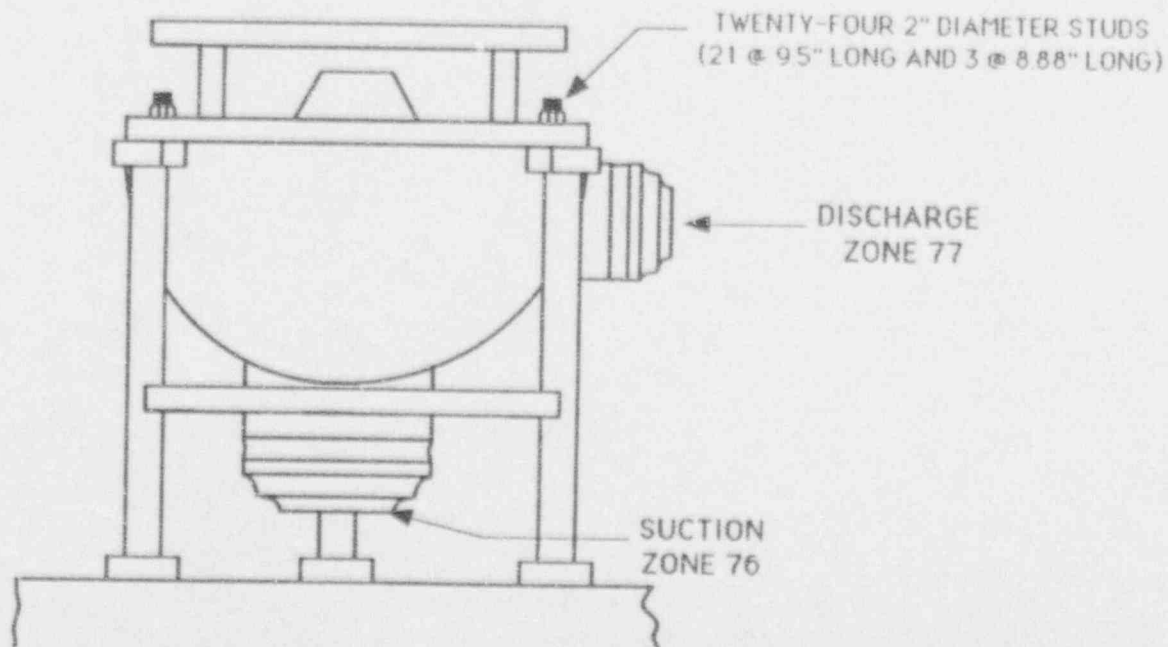

TWENTY-FOUR 2" DIAMETER STUDS  
(21 @ 95" LONG AND 3 @ 8.88" LONG)

DISCHARGE  
ZONE 77

SUCTION  
ZONE 76

REFERENCE DRAWINGS:

N001-1101-36

UNIT 3	ZONE 78
CONTAINMENT SPRAY PUMP A	
DRAWN BY <i>JES</i>	CHECKED BY <i>DBH</i>
	REV 0

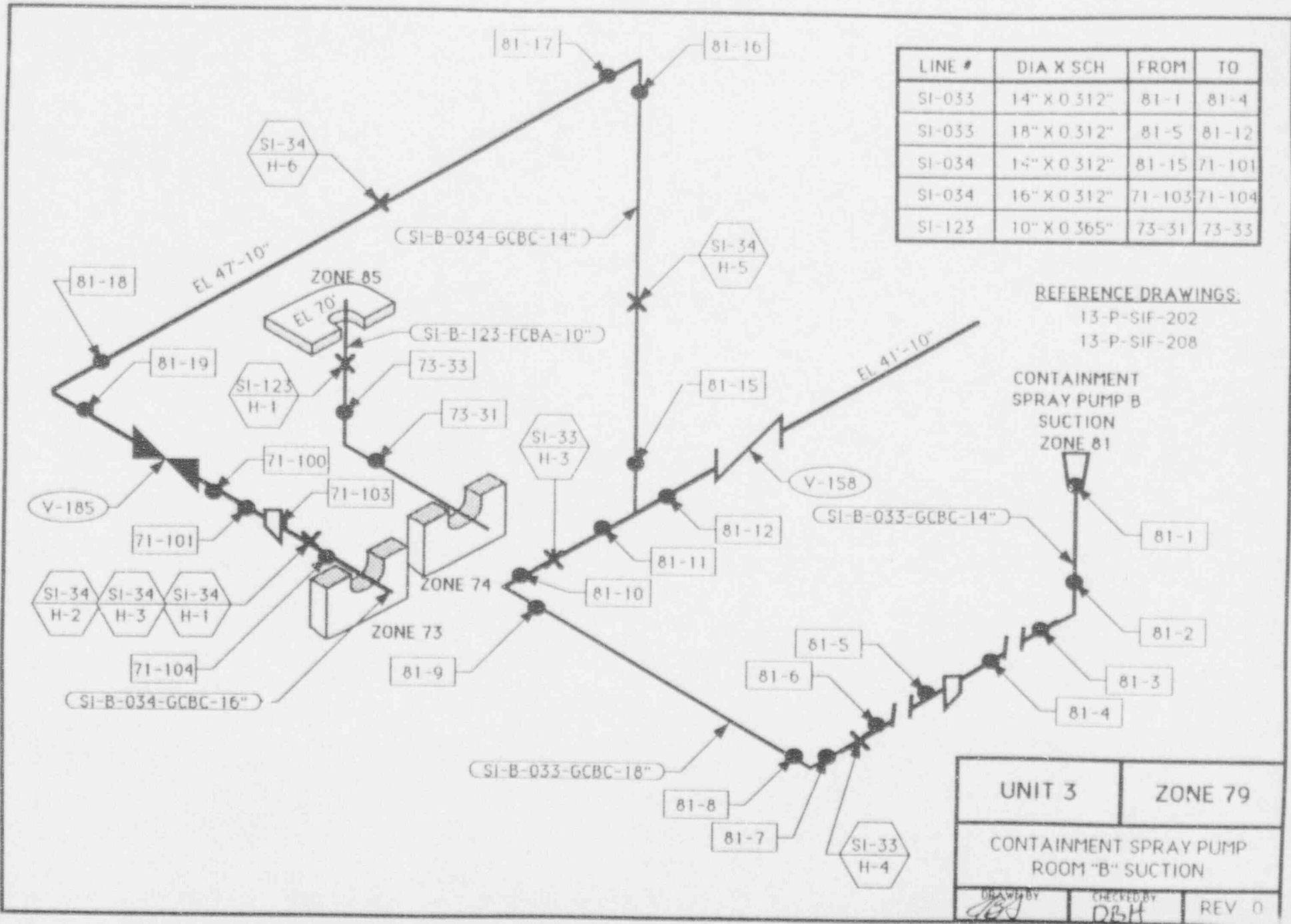

LINE #	DIA X SCH	FROM	TO
SI-033	14" X 0.312"	81-1	81-4
SI-033	18" X 0.312"	81-5	81-12
SI-034	14" X 0.312"	81-15	71-101
SI-034	16" X 0.312"	71-103	71-104
SI-123	10" X 0.365"	73-31	73-33

REFERENCE DRAWINGS:  
 13-P-SIF-202  
 13-P-SIF-208

CONTAINMENT  
 SPRAY PUMP B  
 SUCTION  
 ZONE 81

UNIT 3	ZONE 79
CONTAINMENT SPRAY PUMP ROOM "B" SUCTION	
DRAWN BY <i>[Signature]</i>	CHECKED BY DBH
	REV 0

CONT ON  
ZONE 86

LINE #	DIA X SCH	FROM	TO
SI-119	8" X 0.322"	83-1A	-
SI-119	10" X 0.365"	83-1	83-26
SI-147	10" X 0.365"	83-30	83-34

REFERENCE DRAWINGS:

13-P-SIF-208

CONT ON  
ZONE 85

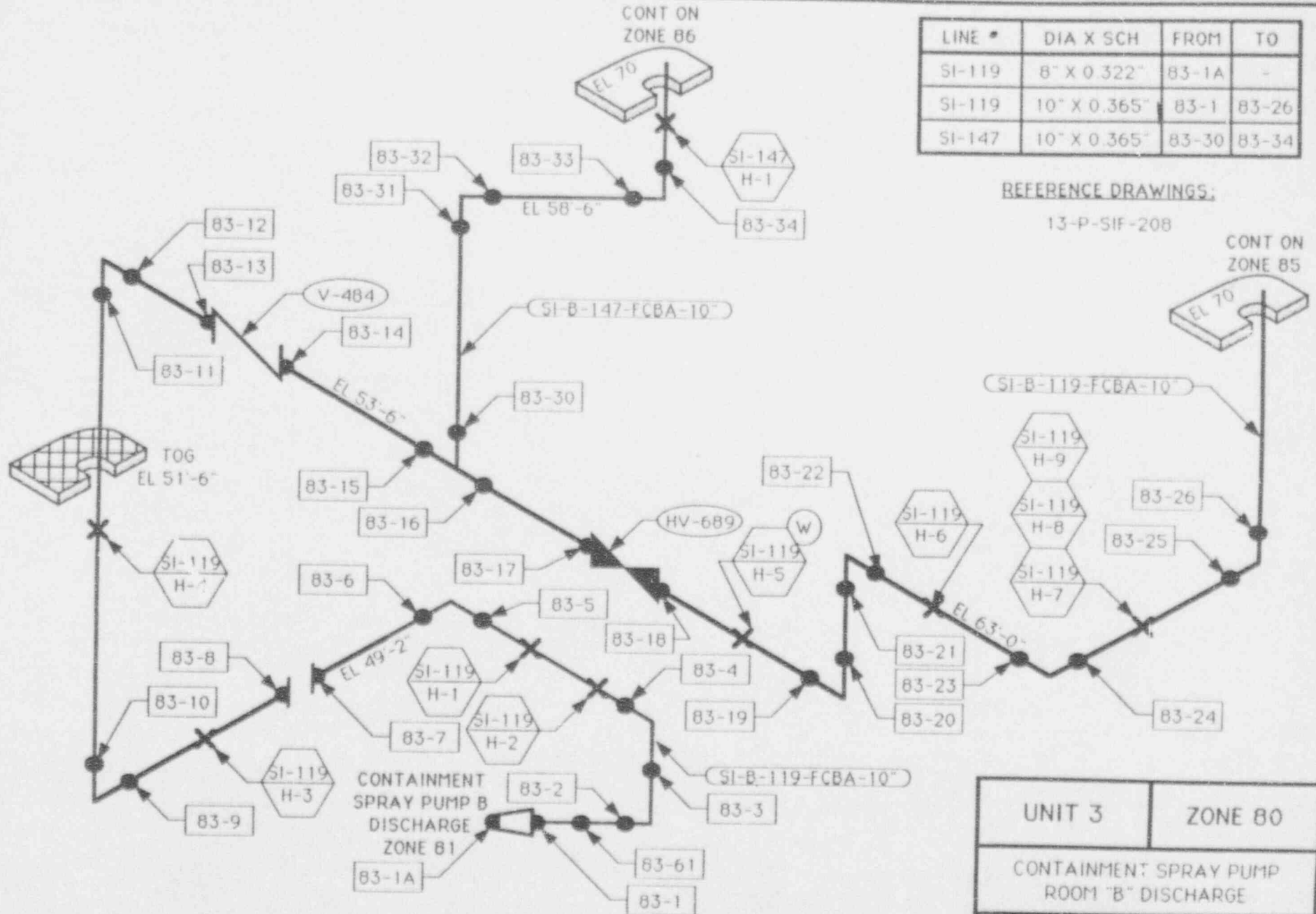

UNIT 3	ZONE 80
CONTAINMENT SPRAY PUMP ROOM "B" DISCHARGE	
DRAWN BY RLB	CHECKED BY WJA
	REV. 0

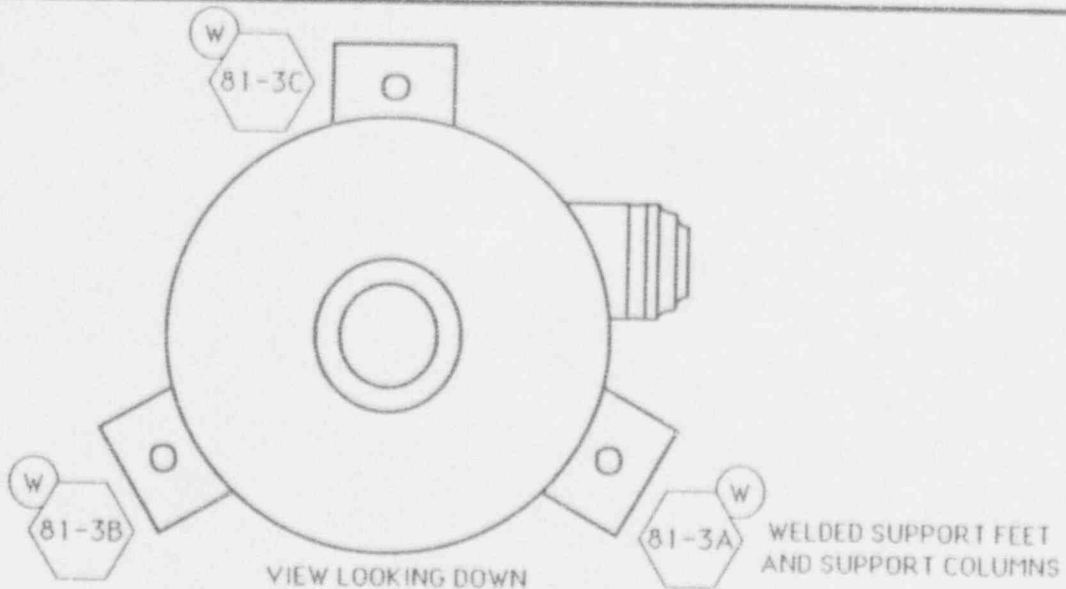

NOTES:

- 1) TAG NUMBER: 3MSIBPO3
- 2) SERIAL NUMBER: 0876-47 INGERSOL RAND
- 3) NATIONAL BOARD NUMBER: 522

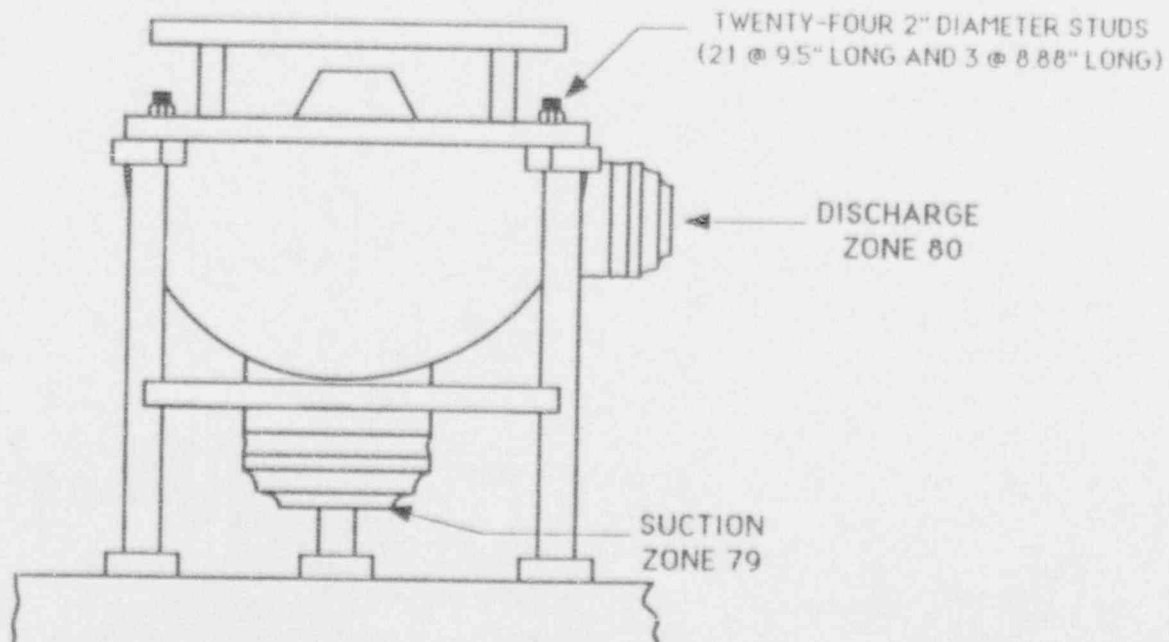

REFERENCE DRAWINGS:

N001-11.01-36

UNIT 3	ZONE 81
CONTAINMENT SPRAY PUMP B	
DRAWN BY <i>DBH</i>	CHECKED BY <i>DBH</i>
	REV 0



**REFERENCE DRAWINGS:**

- 13-P-SIF-201
- 13-P-SIF-203
- 13-P-SIF-207

LINE #	DIA X SCH	FROM	TO
SI-070	20" X 0.500"	74-1	74-19
SI-070	16" X 0.375"	74-21	74-25
SI-070	20" X 0.500"	74-27	74-75
SI-082	10" X 0.365"	82-36	82-40
SI-087	10" X 0.365"	74-58	74-74
SI-089	10" X 0.365"	74-77	74-87
SI-089	10" X 0.365"	82-41	82-44
SI-090	14" X 0.375"	74-105	74-118
SI-131	6" X 0.280"	74-97	74-100

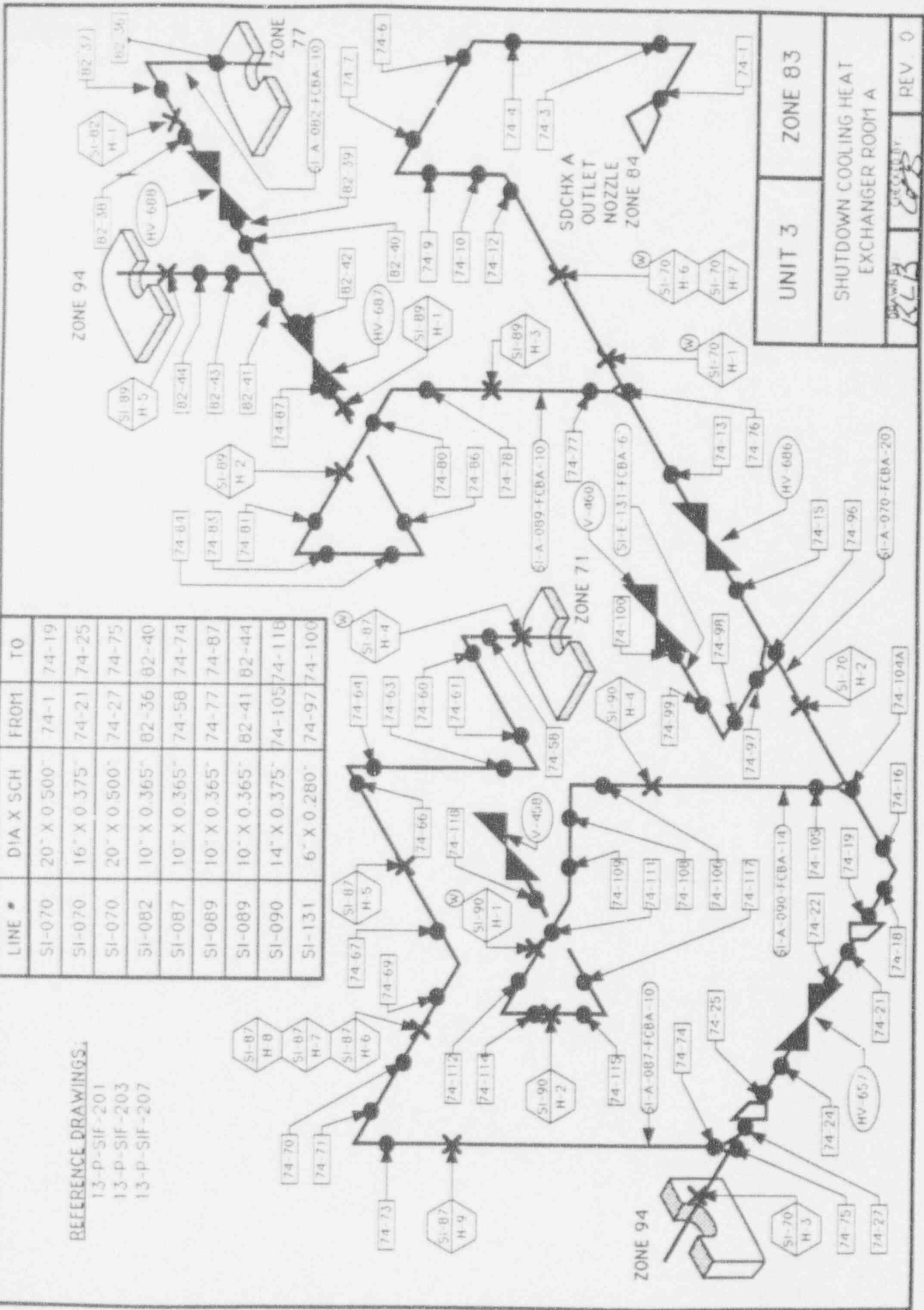

UNIT 3

ZONE 83

SHUTDOWN COOLING HEAT EXCHANGER ROOM 1A

REV 0

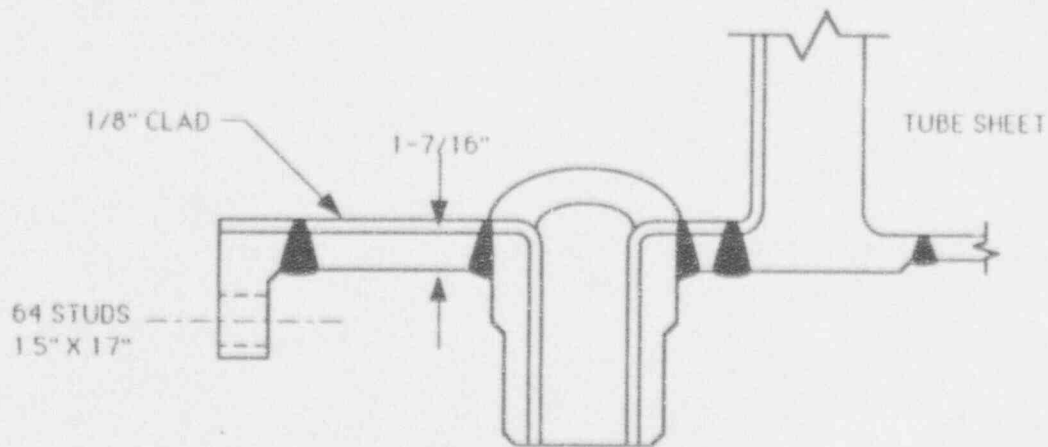

CHANNEL HEAD CROSS SECTION

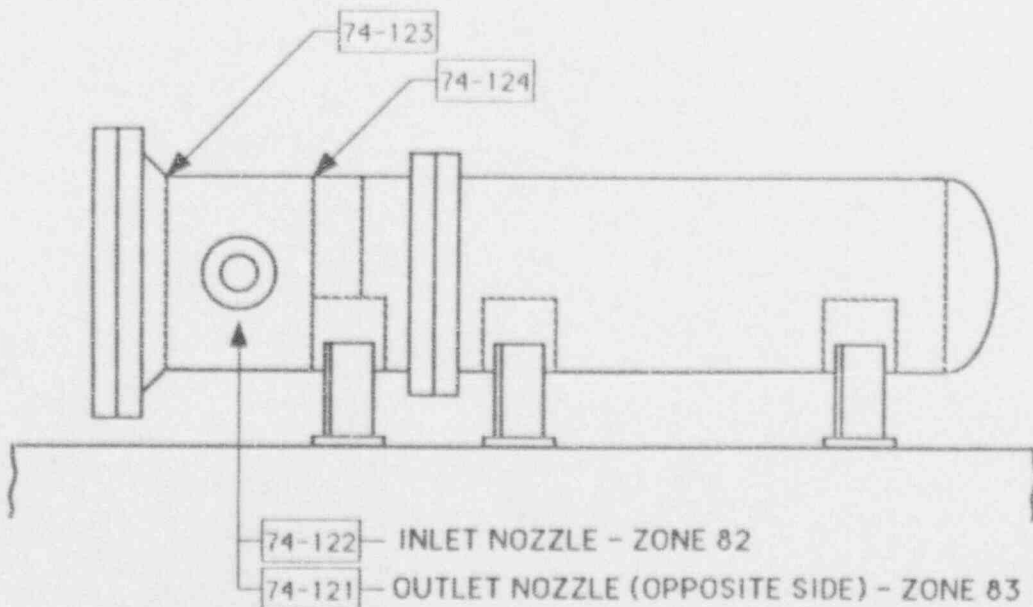

NOTES:

- 1) TAG NUMBER: 3MSIAE01
- 2) SERIAL NUMBER: S-18345  
(ENGR & FABRICATORS)
- 3) NATIONAL BOARD NUMBER: 1532

REFERENCE DRAWINGS:

- N001-703-20  
N001-703-25

UNIT 3	ZONE 84
SHUTDOWN COOLING HEAT EXCHANGER A	
DRAWN BY <i>[Signature]</i>	CHECKED BY DBH
	REV 0



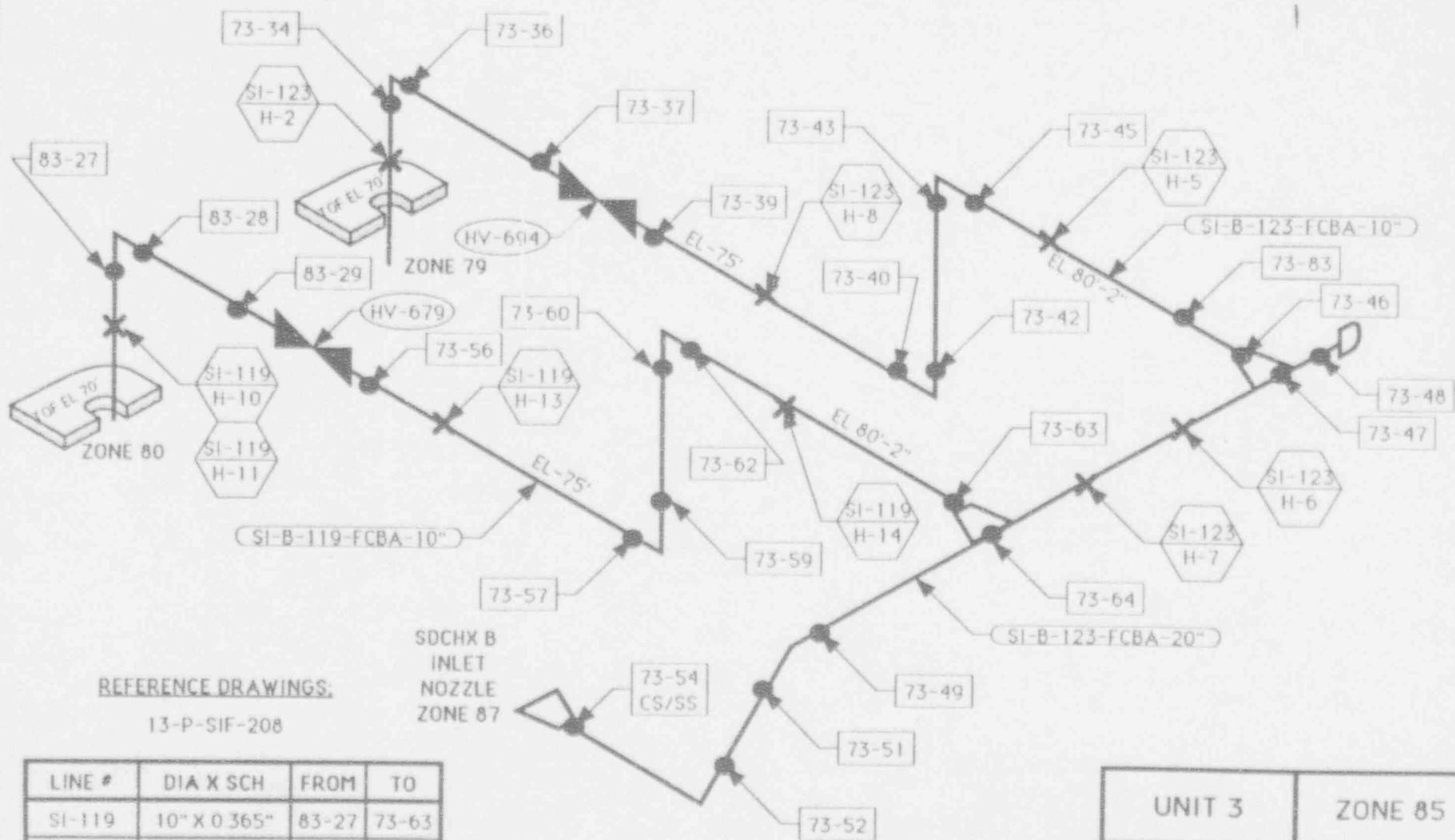

REFERENCE DRAWINGS:

13-P-SIF-208

LINE #	DIA X SCH	FROM	TO
SI-119	10" X 0.365"	83-27	73-63
SI-123	10" X 0.365"	73-34	73-46
SI-123	20" X 0.500"	73-48	73-54

UNIT 3	ZONE 85
SHUTDOWN COOLING HEAT EXCHANGER ROOM B	
DRAWN BY <i>[Signature]</i>	CHECKED BY <i>[Signature]</i>
REV 0	



LINE #	DIA X SCH	FROM	TO
SI-072	20" X 0.500"	75-1	75-17
SI-072	16" X 0.375"	75-19	75-23
SI-072	20" X 0.500"	75-25	75-26
SI-129	10" X 0.365"	75-53	75-61
SI-131	6" X 0.280"	75-81	75-84
SI-134	10" X 0.365"	75-62	75-72
SI-134	10" X 0.365"	83-38	83-43
SI-135	14" X 0.375"	75-87	75-100
SI-147	10" X 0.365"	83-35	83-37

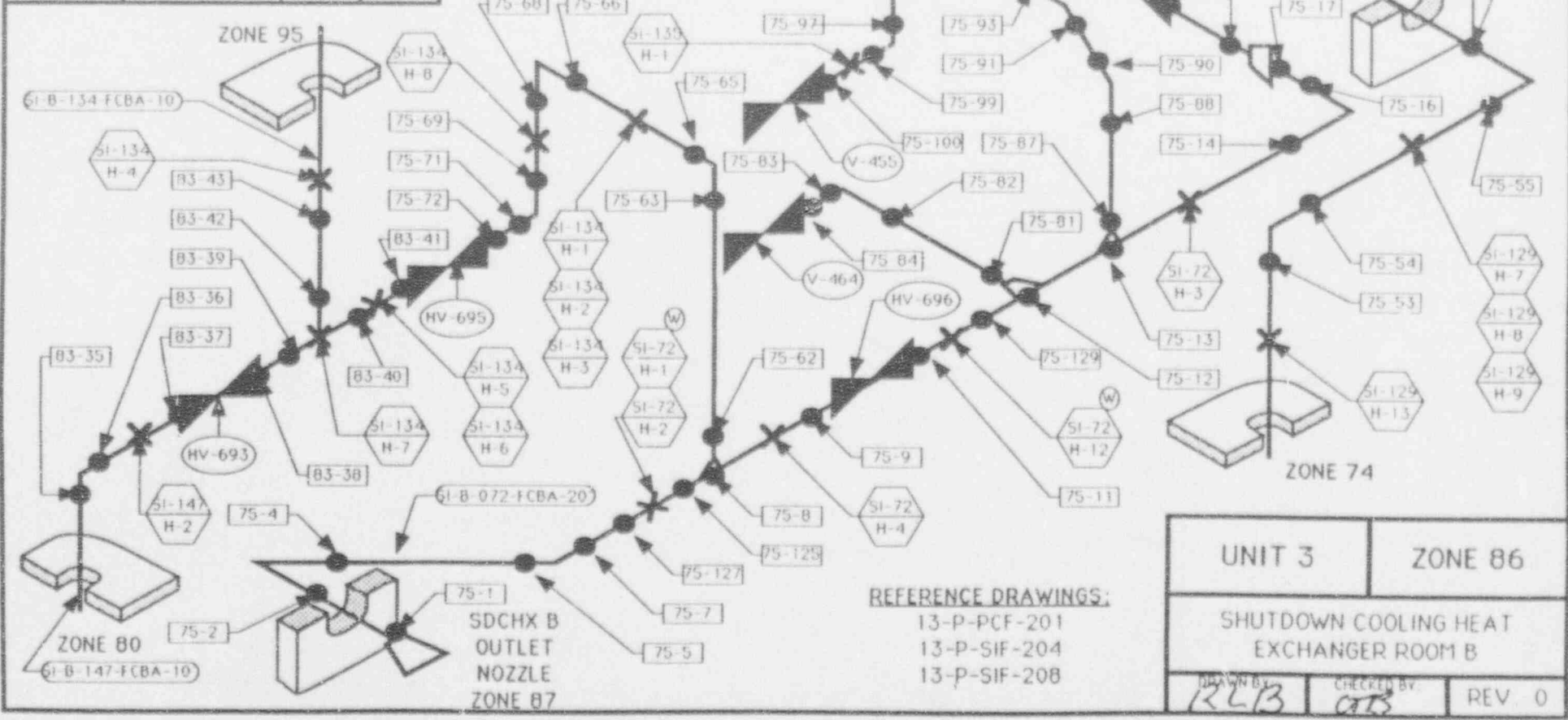

REFERENCE DRAWINGS:  
 13-P-PCF-201  
 13-P-SIF-204  
 13-P-SIF-208

UNIT 3	ZONE 86
SHUTDOWN COOLING HEAT EXCHANGER ROOM B	
DRAWN BY <i>RLB</i>	CHECKED BY <i>ATS</i>
	REV 0

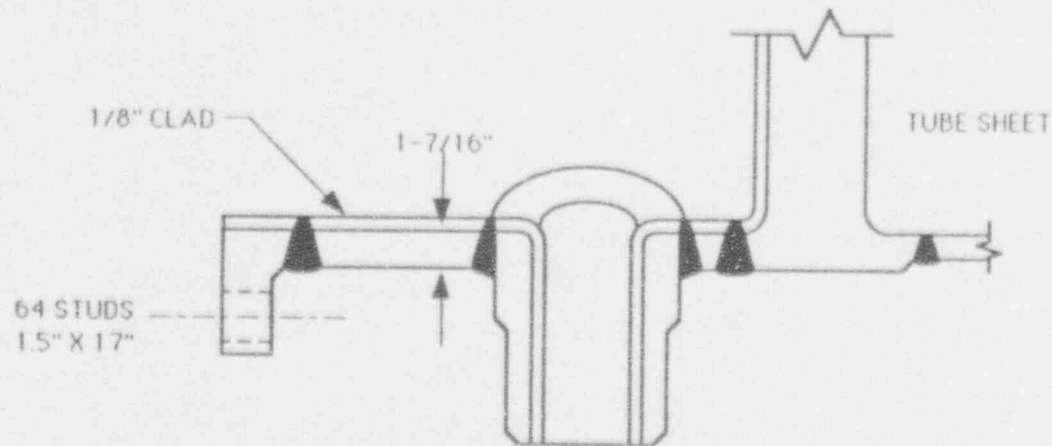

CHANNEL HEAD CROSS SECTION

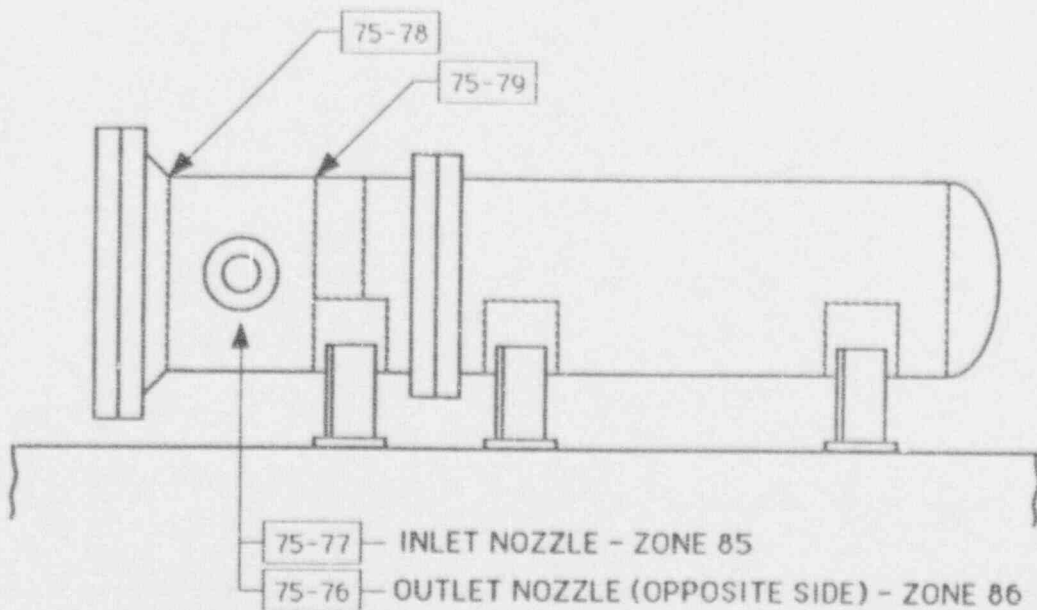

NOTES:

- 1) TAG NUMBER: 3MS10E01
- 2) SERIAL NUMBER: S-18346  
(ENGR & FABRICATORS)
- 3) NATIONAL BOARD NUMBER: 1599

REFERENCE DRAWINGS:

- N001-703-20  
N001-703-25

UNIT 3	ZONE 87
SHUTDOWN COOLING HEAT EXCHANGER B	
DRAWN BY <i>[Signature]</i>	CHECKED BY SBH
	REV. 0

LINE #	DIA X SCH	FROM	TO
SI-072	12" X 0.375"	78-2	78-11
SI-072	12" X 1.125"	78-13	78-14
SI-072	20" X 0.500"	75-35	75-38
SI-073	12" X 0.375"	79-1	79-11
SI-073	12" X 1.125"	79-13	79-14
SI-155	12" X 1.125"	78-16	78-21
SI-172	10" X 0.365"	78-10C	78-10D
SI-174	12" X 1.125"	79-16	79-21

REFERENCE DRAWINGS:  
13-P-SIF-208

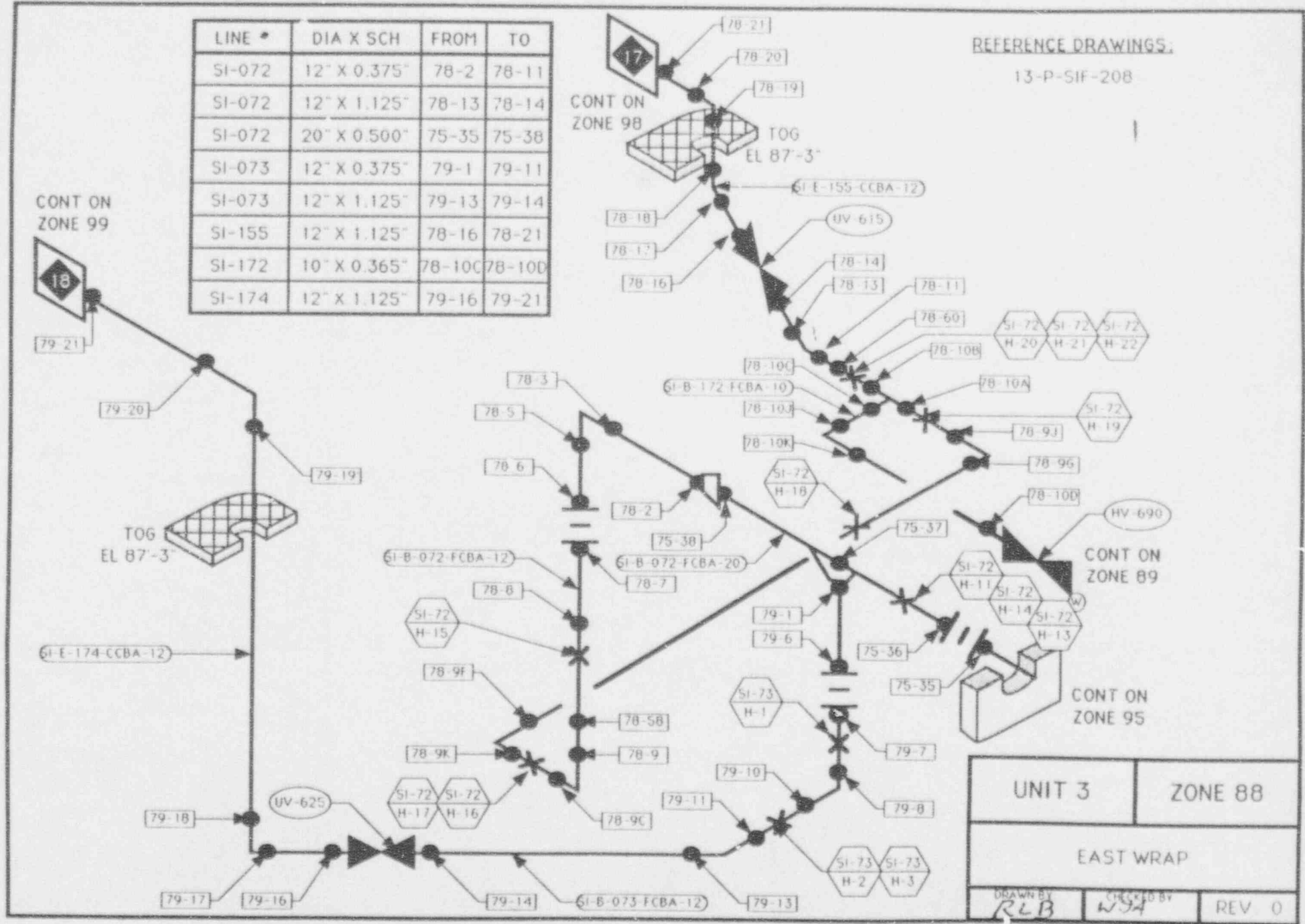

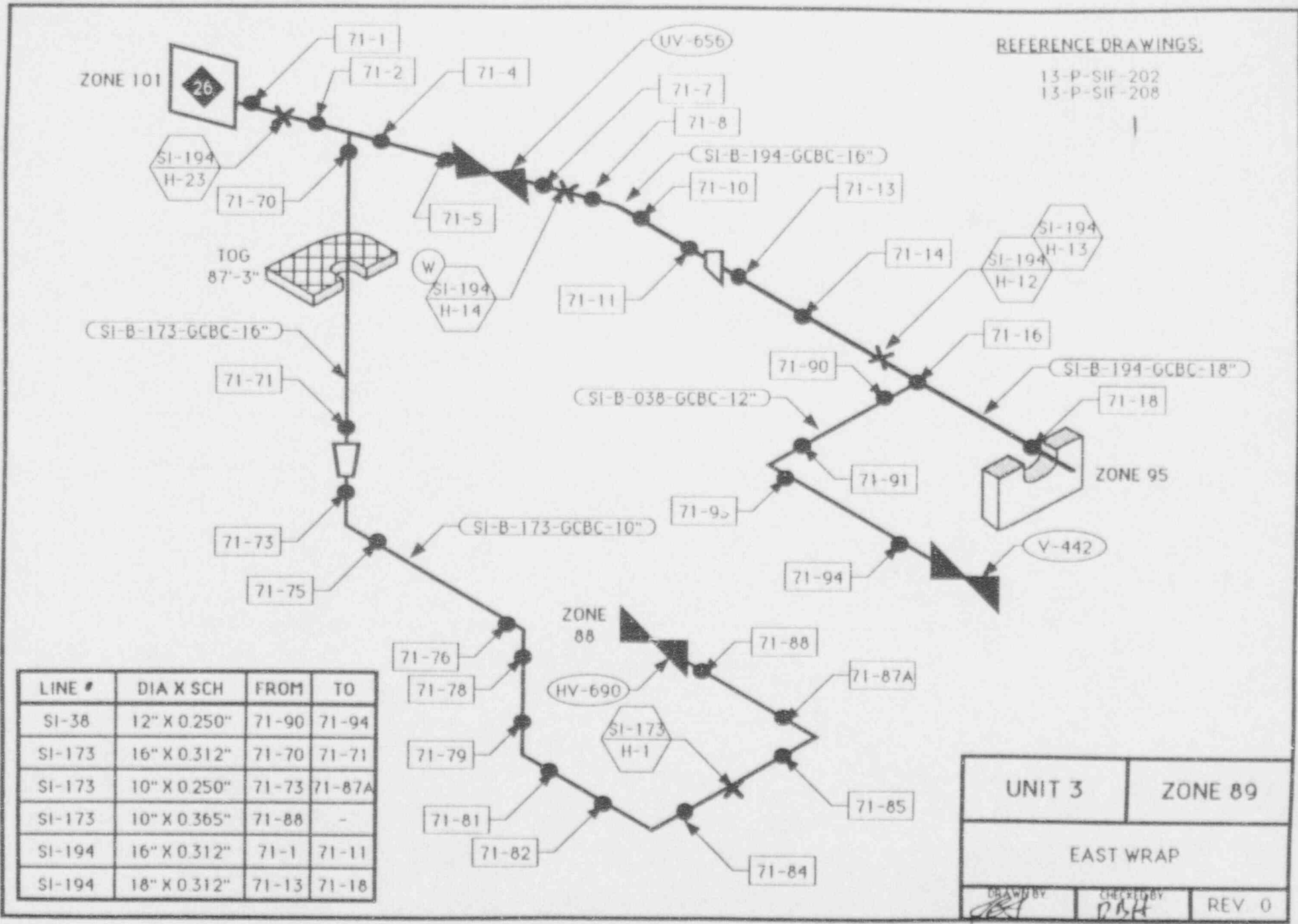

REFERENCE DRAWINGS:

13-P-SIF-202  
13-P-SIF-208

LINE #	DIA X SCH	FROM	TO
SI-38	12" X 0.250"	71-90	71-94
SI-173	16" X 0.312"	71-70	71-71
SI-173	10" X 0.250"	71-73	71-87A
SI-173	10" X 0.365"	71-88	-
SI-194	16" X 0.312"	71-1	71-11
SI-194	18" X 0.312"	71-13	71-18

UNIT 3	ZONE 89
EAST WRAP	
DRAWN BY <i>[Signature]</i>	CHECKED BY <i>[Signature]</i>
	REV 0

LINE #	DIA X SCH	FROM	TO
SI-030	24" X 0.375"	85-6	85-8
SI-134	10" X 0.365"	83-53	83-57
SI-134	8" X 0.322"	83-58	83-59
SI-308	24" X 0.562"	85-9	85-11

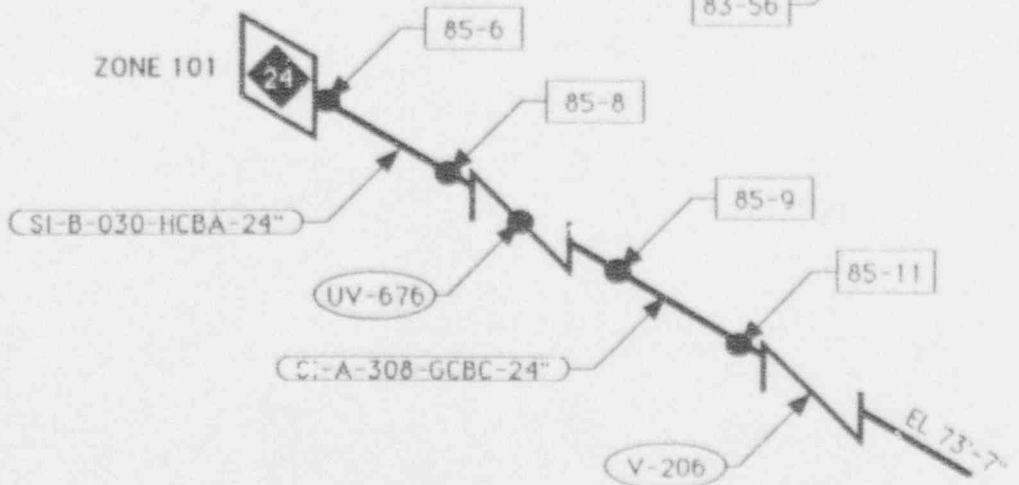
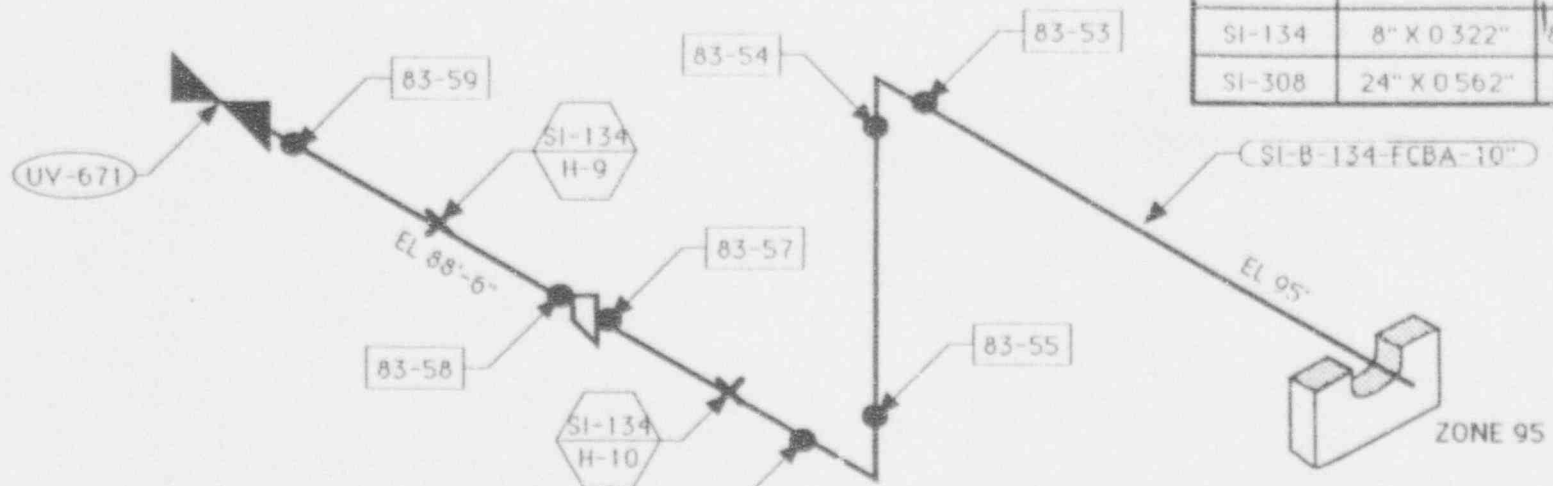

REFERENCE DRAWINGS:  
 13-P-SIF-202  
 13-P-SIF-208

UNIT 3	ZONE 90	
EAST WRAP		
DRAWN BY <i>JBT</i>	CHECKED BY <i>QBH</i>	REV 0

LINE #	DIA X SCH	FROM	TO
SI-070	20" X 0.500"	74-42	74-44
SI-070	12" X 0.375"	76-2	76-13
SI-070	12" X 1.125"	76-52	76-14
SI-071	12" X 0.375"	74-103	77-11
SI-071	12" X 1.125"	77-13	77-14
SI-071	10" X 0.365"	77-10C	77-10D
SI-202	12" X 1.125"	76-16	76-21
SI-220	12" X 1.125"	77-16	77-21

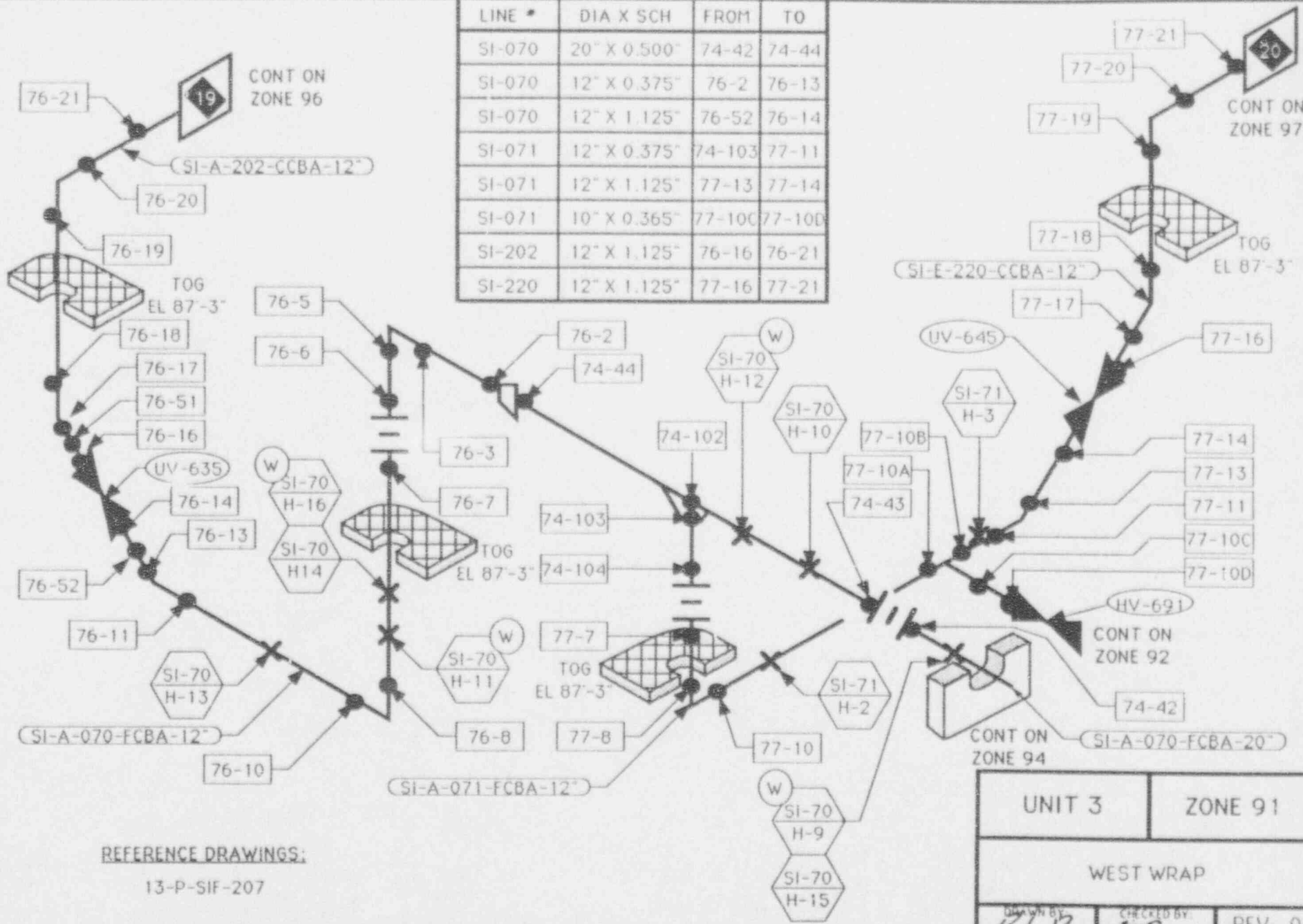

REFERENCE DRAWINGS:  
13-P-SIF-207

UNIT 3	ZONE 91
WEST WRAP	
DRAWN BY RLB	CHECKED BY MB
REV. 0	



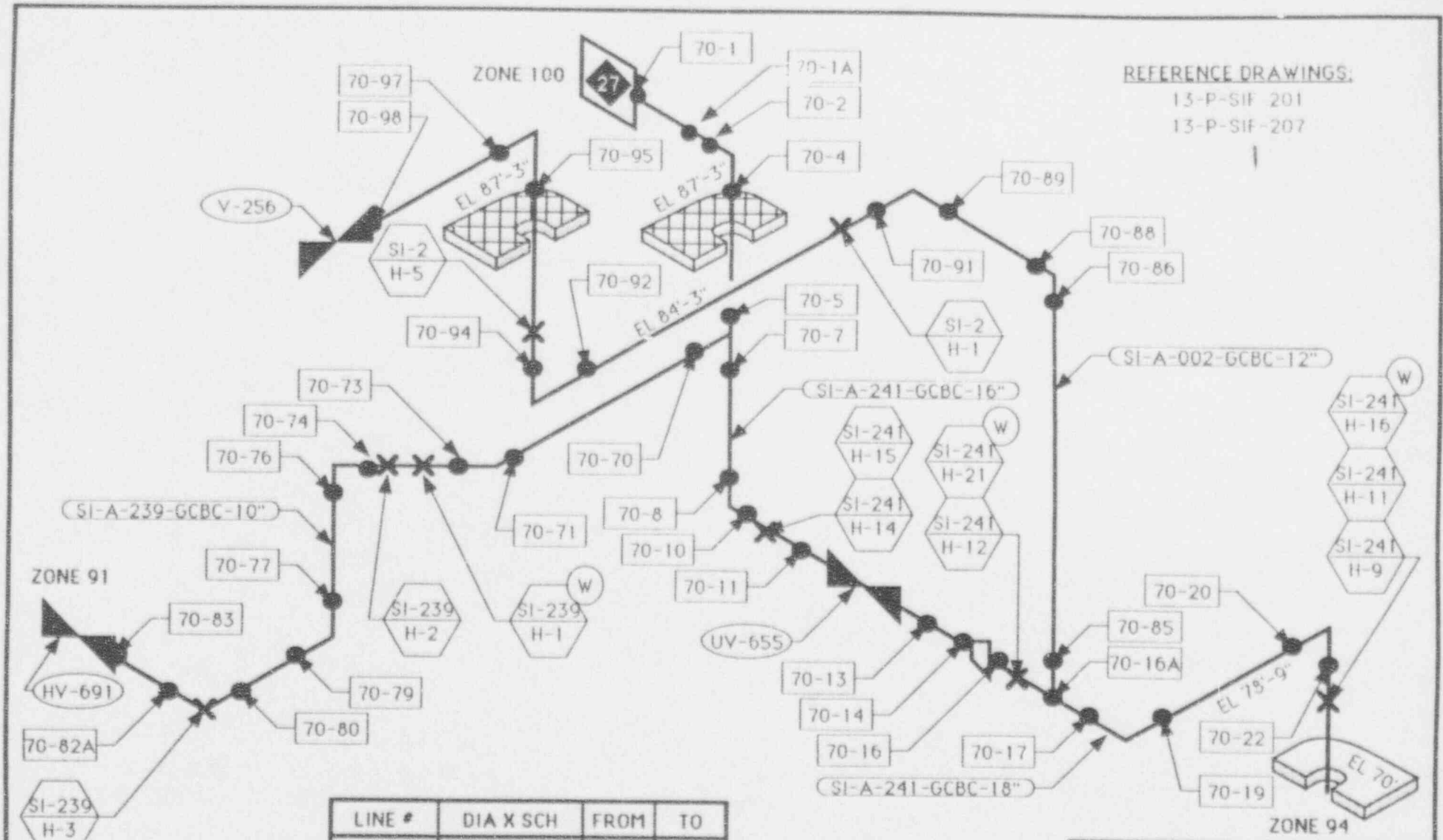

REFERENCE DRAWINGS:  
 13-P-SIF 201  
 13-P-SIF-207

LINE #	DIA X SCH	FROM	TO
SI-002	12" X 0.250"	70-85	70-98
SI-239	10" X 0.250"	70-70	70-82A
SI-239	10" X 0.365"	70-83	-
SI-241	16" X 0.312"	70-1	70-14
SI-241	18" X 0.312"	70-16	70-22

UNIT 3	ZONE 92
WEST WRAP	
DRAWN BY <i>[Signature]</i>	CHECKED BY <i>[Signature]</i>
	REV 0

LINE #	DIA X SCH	FROM	TO
SI-089	8" X 0.322"	82-66	82-67
SI-089	10" X 0.365"	82-55	82-65
SI-007	24" X 0.375"	84-6	84-8
SI-307	24" X 0.562"	84-9	84-11

REFERENCE DRAWINGS:

13-P-SIF-201  
13-P-SIF-207

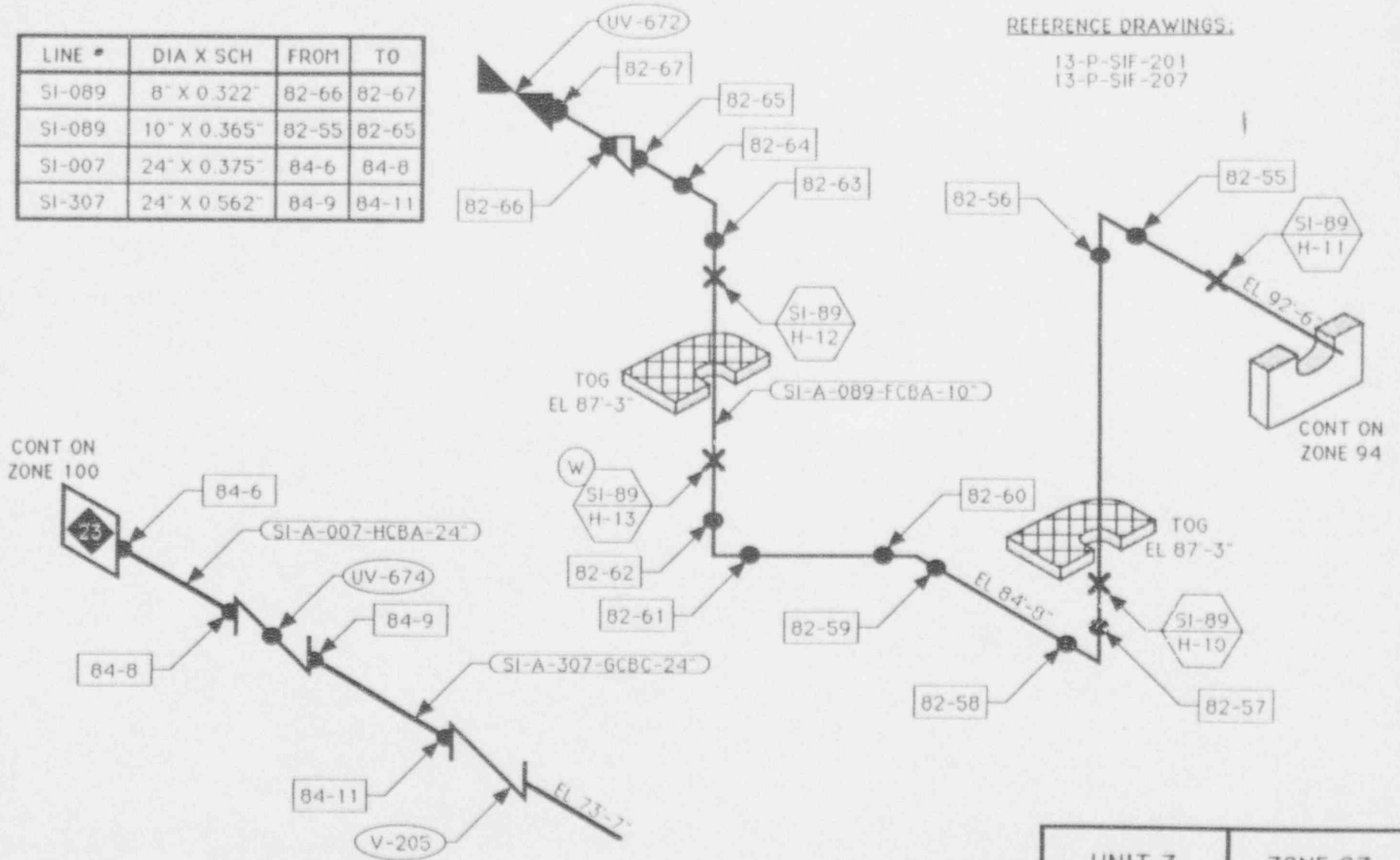

CONT ON  
ZONE 100

CONT ON  
ZONE 94

UNIT 3	ZONE 93
WEST WRAP	
DRAWN BY <i>RLB</i>	CHECKED BY <i>WJA</i>
	REV. 0



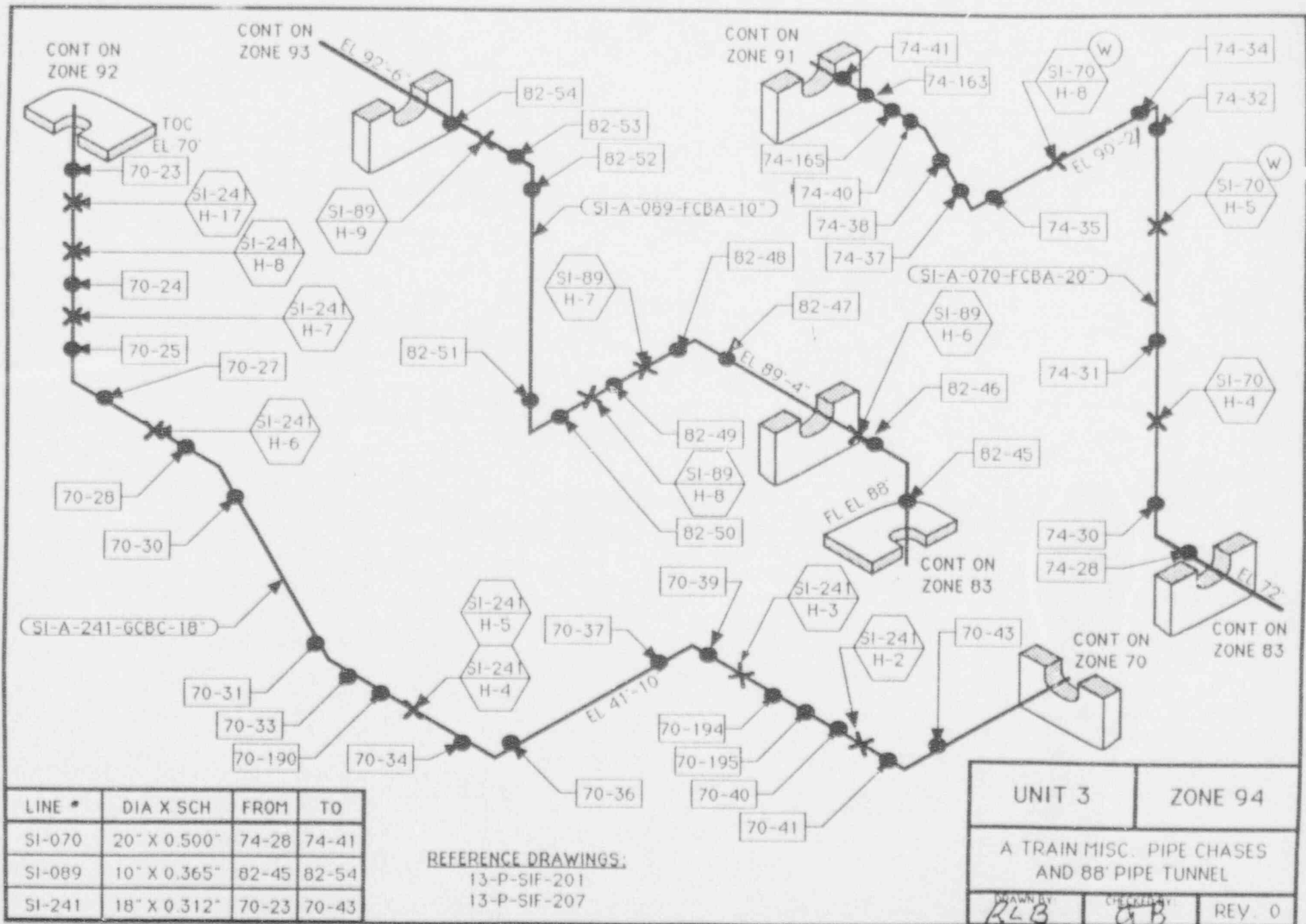

LINE #	DIA X SCH	FROM	TO
SI-070	20" X 0.500"	74-28	74-41
SI-089	10" X 0.365"	82-45	82-54
SI-241	18" X 0.312"	70-23	70-43

REFERENCE DRAWINGS:  
 13-P-SIF-201  
 13-P-SIF-207

UNIT 3	ZONE 94
A TRAIN MISC. PIPE CHASES AND 88' PIPE TUNNEL	
DRAWN BY RLB	CHECKED BY G.B.
REV 0	

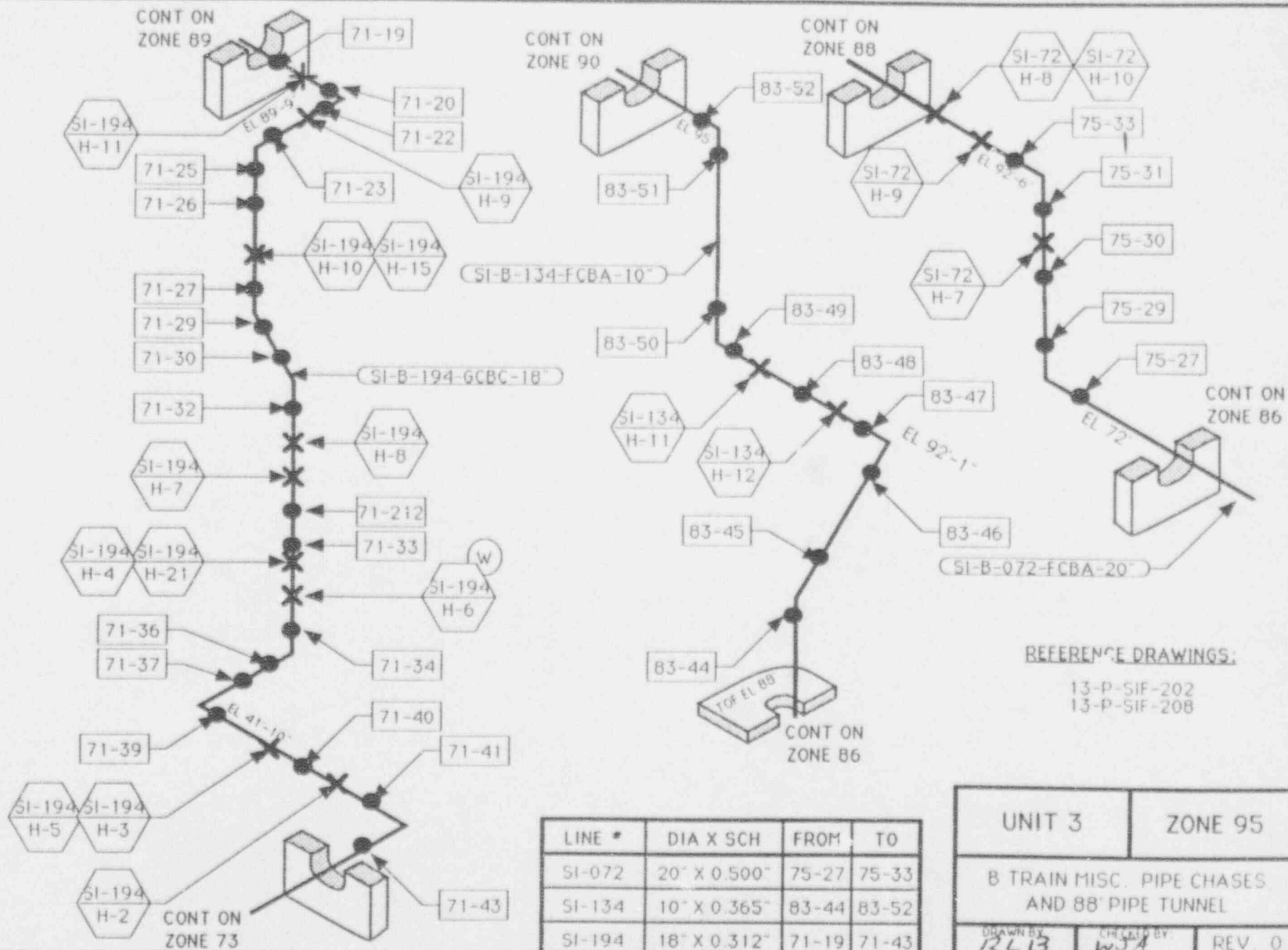

LINE #	DIA X SCH	FROM	TO
SI-072	20" X 0.500"	75-27	75-33
SI-134	10" X 0.365"	83-44	83-52
SI-194	18" X 0.312"	71-19	71-43

**REFERENCE DRAWINGS:**

- 13-P-SIF-202
- 13-P-SIF-208

UNIT 3		ZONE 95	
B TRAIN MISC. PIPE CHASES AND 88' PIPE TUNNEL			
DRAWN BY <i>RLB</i>	CHECKED BY <i>WJA</i>	REV. 0	

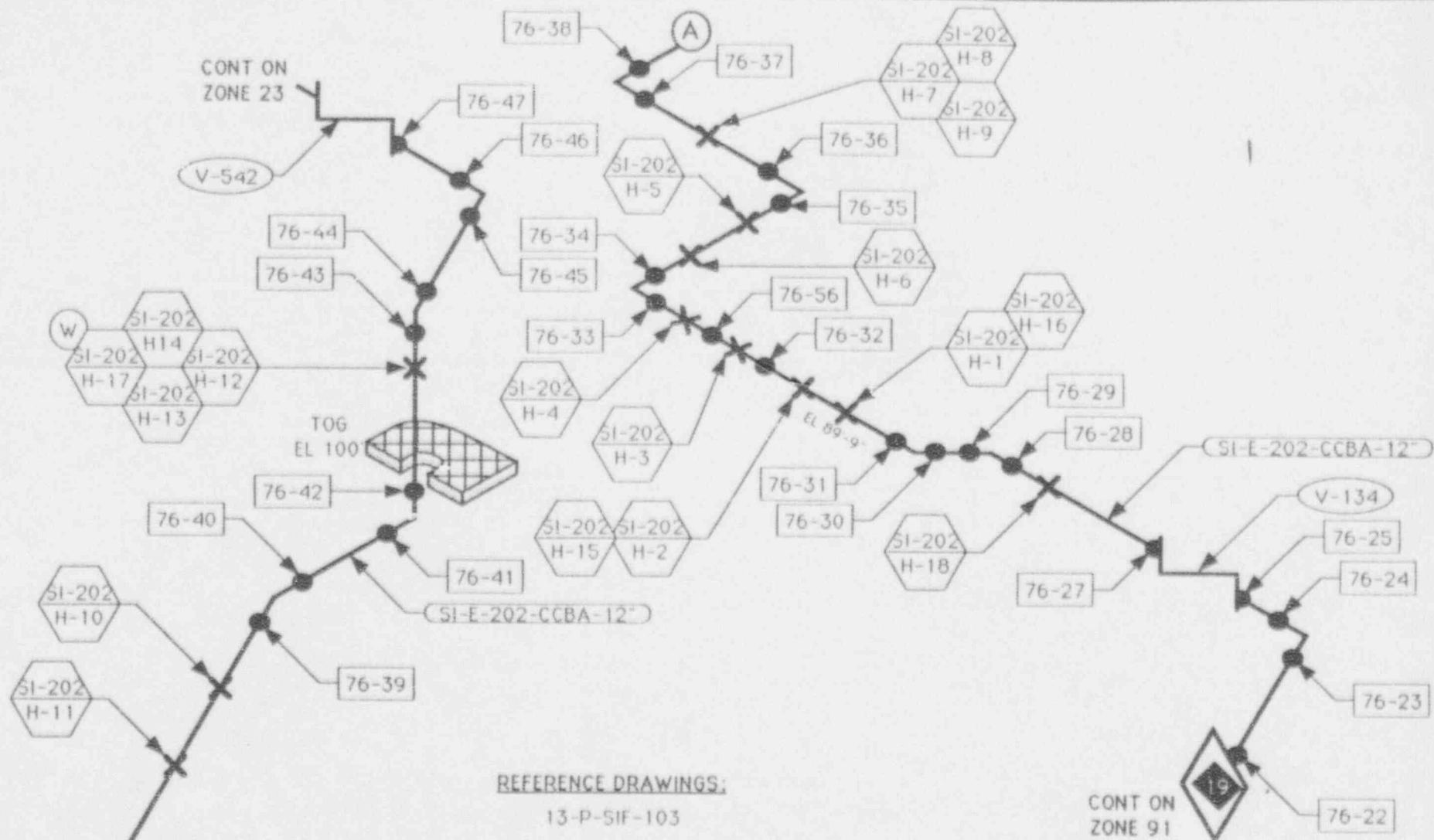

REFERENCE DRAWINGS:

13-P-SIF-103

LINE #	DIA X SCH	FROM	TO
SI-202	12" X 1.125	76-22	76-25
SI-202	12" X 1.312"	76-27	76-47

CONT ON  
ZONE 91

UNIT 3	ZONE 96
CONTAINMENT LPSI HEADER TO LOOP 1A	
DRAWN BY <i>RLB</i>	CHECKED BY <i>WJA</i>
	REV. 0

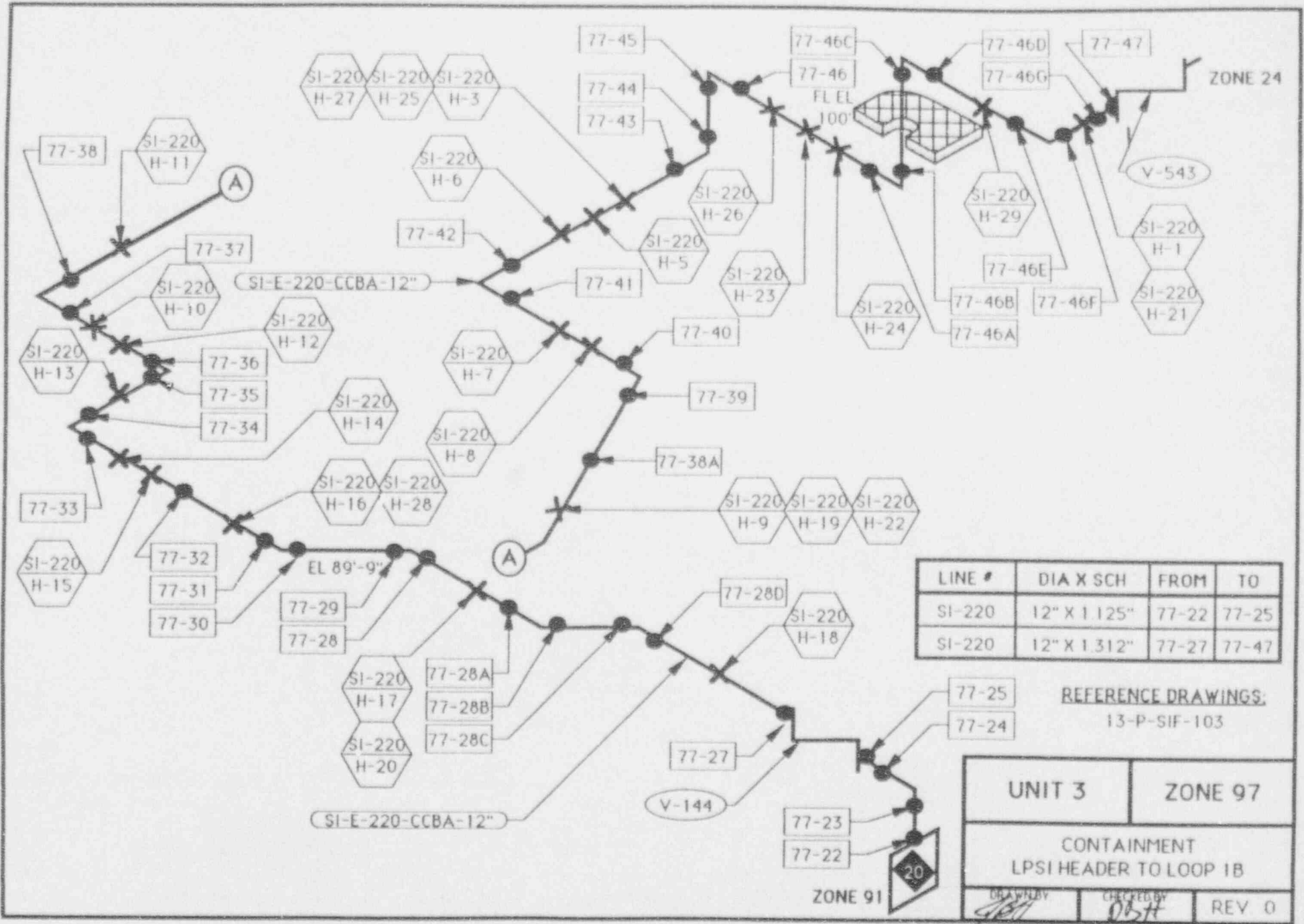

LINE #	DIA X SCH	FROM	TO
SI-220	12" X 1 1/2"	77-22	77-25
SI-220	12" X 1 3/4"	77-27	77-47

REFERENCE DRAWINGS:  
13-P-SIF-103

UNIT 3	ZONE 97
CONTAINMENT LPSI HEADER TO LOOP 1B	
DRAWN BY <i>481</i>	CHECKED BY <i>05H</i>
REV 0	

ZONE 91

ZONE 24

SI-E-220-CCBA-12"

EL 89'-9"

SI-E-220-CCBA-12"

20



LINE #	DIA X SCH	FROM	TO
SI-155	12" X 1.125"	78-22	78-25
SI-155	12" X 1.312"	78-27	78-47

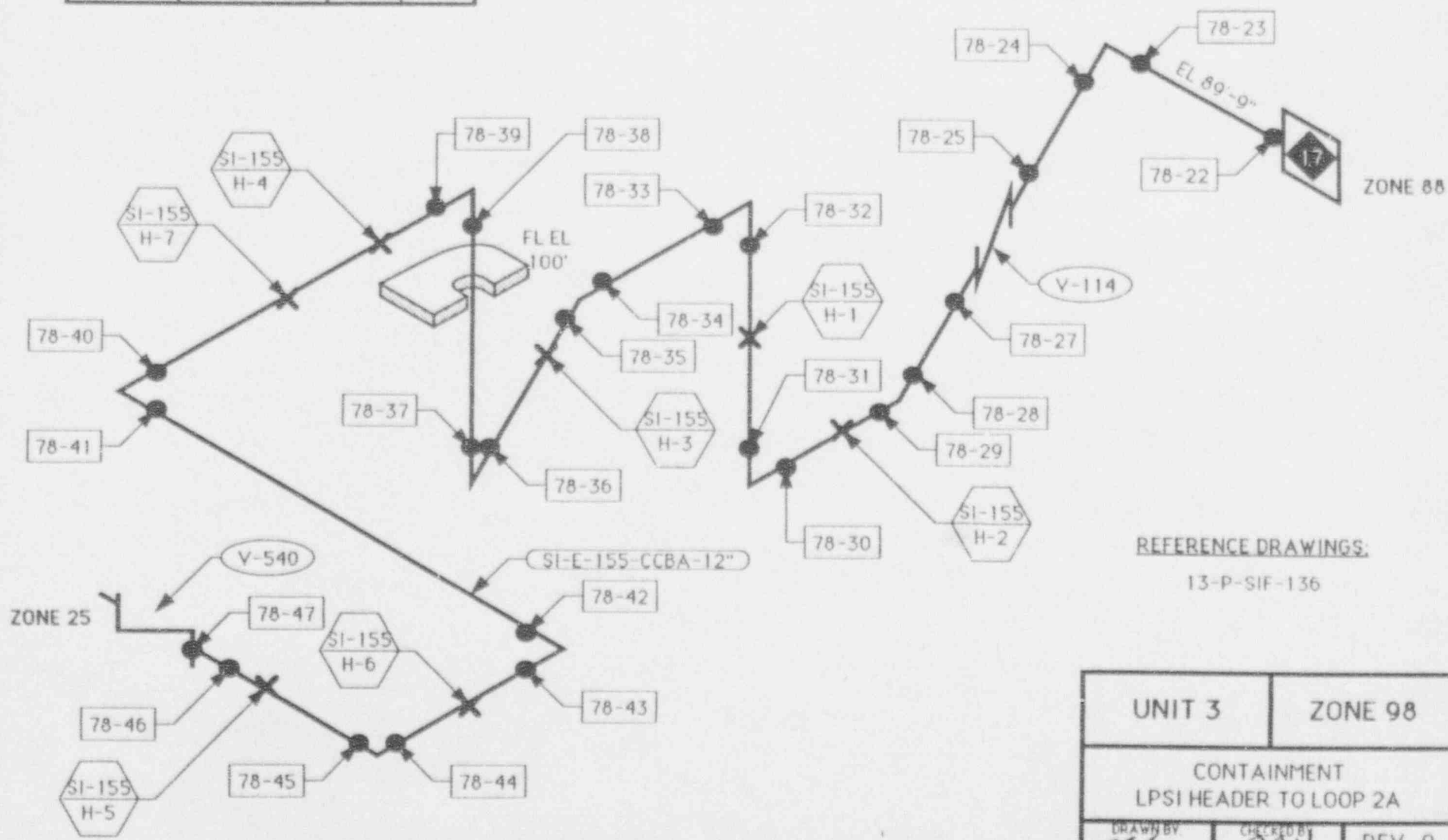

REFERENCE DRAWINGS:

13-P-SIF-136

UNIT 3	ZONE 98
CONTAINMENT LPSI HEADER TO LOOP 2A	
DRAWN BY <i>[Signature]</i>	CHECKED BY <i>[Signature]</i>
	REV 0

LINE #	DIA X SCH	FROM	TO
SI-174	12" X 1.125"	79-23	79-25
SI-174	12" X 1.312"	79-27	79-47

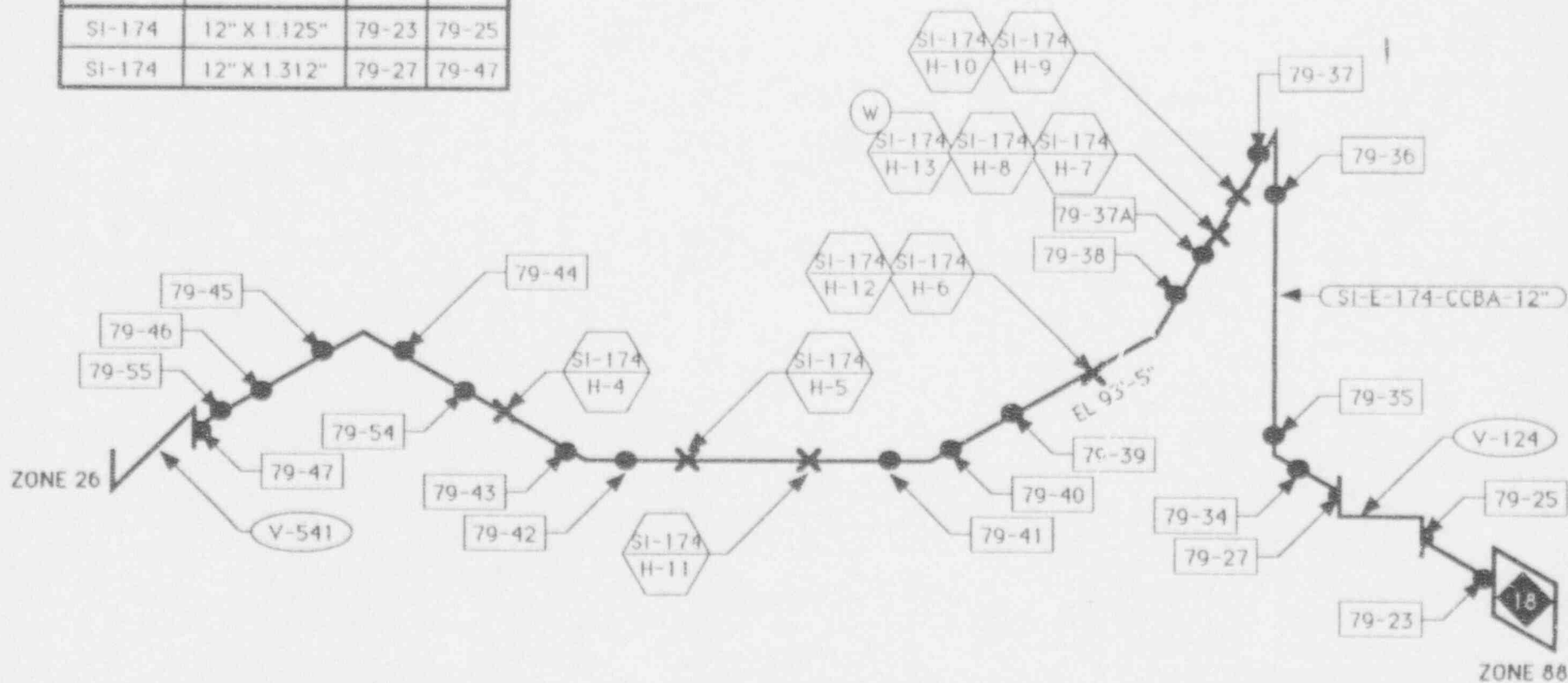

REFERENCE DRAWINGS:

13-P-SIF-136

UNIT 3	ZONE 99	
CONTAINMENT LPSI HEADER TO LOOP 2B		
DRAWN BY <i>[Signature]</i>	CHECKED BY <i>[Signature]</i>	REV 0

LINE #	DIA X SCH	FROM	TO
SI-007	24" X 0.375"	84-2	84-3
SI-241	16" X 0.312"	70-116	70-119
SI-241	16" X 1.594"	70-120	70-121
SI-369	10" X 0.250"	70-122	70-132
SI-369	6" X 0.280"	70-134	-

REFERENCE DRAWINGS:

- 23-P-SIF-105
- 13-P-SIF-151
- 13-P-ZCG-112

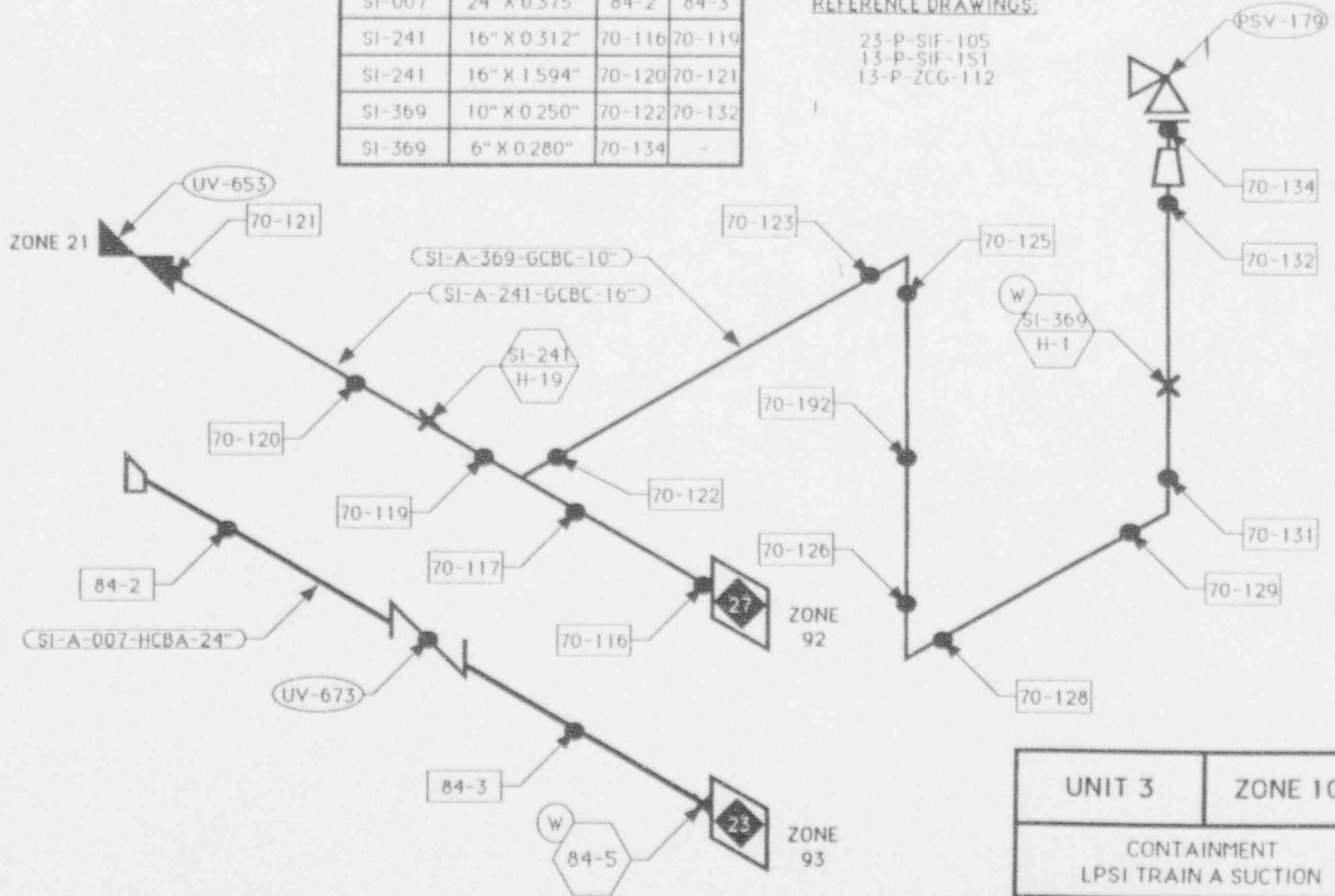

UNIT 3	ZONE 100
CONTAINMENT LPSI TRAIN A SUCTION	
DRAWN BY <i>JET</i>	CHECKED BY <i>DBH</i>
	REV 0

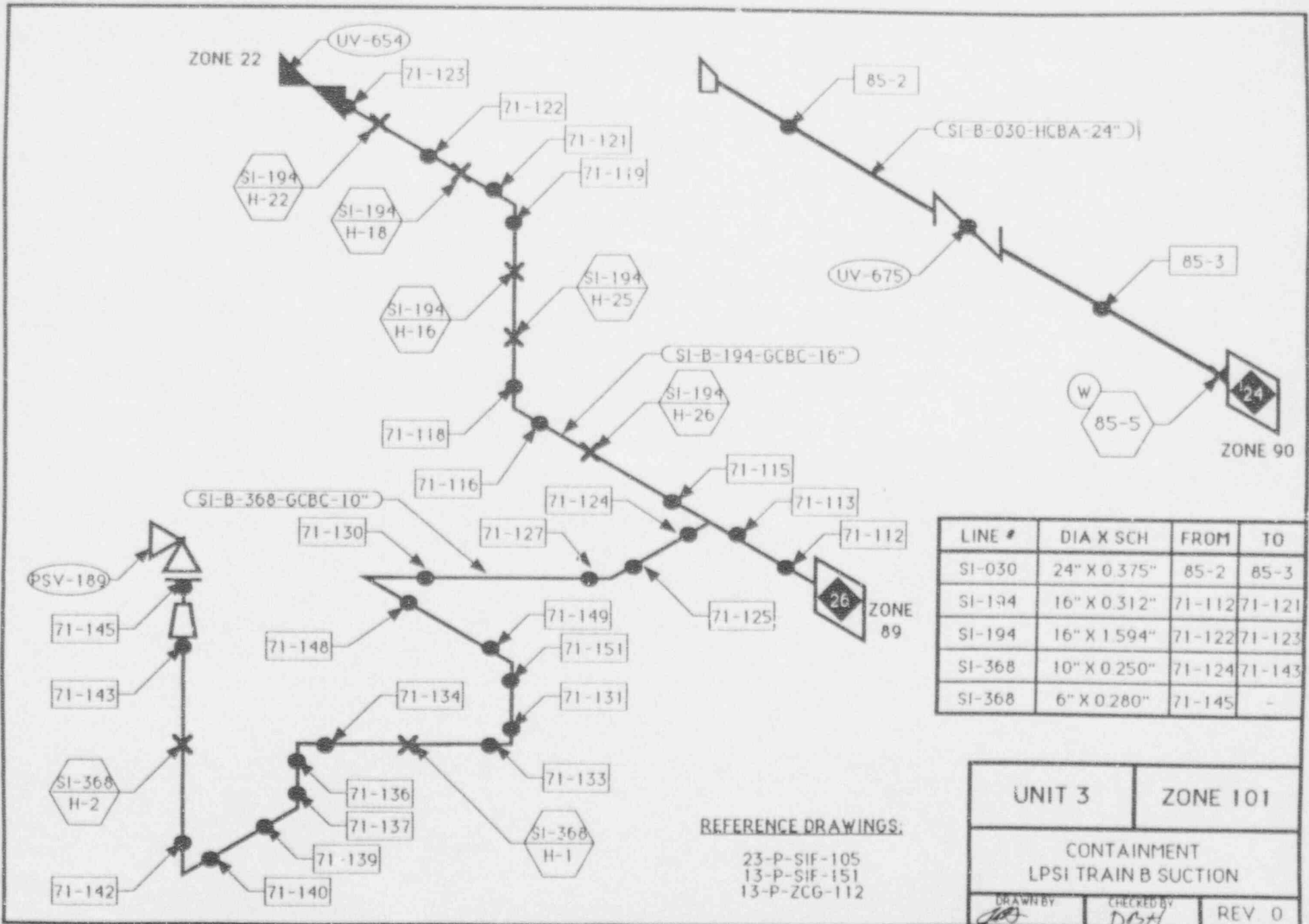

LINE #	DIA X SCH	FROM	TO
SI-030	24" X 0.375"	85-2	85-3
SI-194	16" X 0.312"	71-112	71-121
SI-194	16" X 1.594"	71-122	71-123
SI-368	10" X 0.250"	71-124	71-143
SI-368	6" X 0.280"	71-145	-

REFERENCE DRAWINGS:

- 23-P-SIF-105
- 13-P-SIF-151
- 13-P-ZCG-112

UNIT 3		ZONE 101	
CONTAINMENT LPSI TRAIN B SUCTION			
DRAWN BY <i>[Signature]</i>	CHECKED BY <i>[Signature]</i>	REV 0	



