

SUMMARY DOCUMENT:  
ASSESSMENT OF ANTICIPATED IMPACTS OF  
CONSTRUCTION AND OPERATION OF  
SEABROOK STATION ON THE  
ESTUARINE, COASTAL AND OFFSHORE WATERS  
HAMPTON - SEABROOK, NEW HAMPSHIRE

Prepared for  
PUBLIC SERVICE COMPANY OF NEW HAMPSHIRE  
Manchester, New Hampshire

by  
NORMANDEAU ASSOCIATES, INC.  
Bedford, New Hampshire

December 1977

8111240902 811118  
PDR ADOCK 05000443  
C PDR



**NORMANDEAU ASSOCIATES, INC.**  
Nashua Road • Bedford, New Hampshire 03102

#### ACKNOWLEDGEMENTS

Normandeau Associates, Inc. acknowledges the assistance of Yankee Atomic Electric Company and Alden Research Laboratories, Worcester Polytechnic Institute in preparation of Section 3.

## TABLE OF CONTENTS

		PAGE
1.0	INTRODUCTION . . . . .	1.0-1
2.0	DESCRIPTION OF EXISTING ENVIRONMENT . . . . .	2.0-1
2.1	INTRODUCTION AND GENERAL OVERVIEW. . . . .	2.0-1
2.1.1	Physical Setting . . . . .	2.0-1
2.1.2	Hydrographic Setting . . . . .	2.0-6
2.1.3	Biological Setting . . . . .	2.0-15
2.2	HYDROGRAPHIC ENVIRONMENT . . . . .	2.0-20
2.2.1	Currents . . . . .	2.0-20
2.2.1.1	Observations and Measurements from Fixed Points (Eulerian Method) . . . . .	2.0-20
2.2.1.2	Observation and Measurement of Current Trajectories (Lagrangian Method) . . . . .	2.0-28
2.2.2	Atmospheric Influences . . . . .	2.0-34
2.2.2.1	Prevailing Winds . . . . .	2.0-34
2.2.2.2	Storms . . . . .	2.0-35
2.2.3	Tides . . . . .	2.0-37
2.2.4	Water Temperatures . . . . .	2.0-38
2.2.4.1	Ambient Variability. . . . .	2.0-38
2.2.4.2	Mean Vertical Profiles . . . . .	2.0-48
2.2.5	Salinity . . . . .	2.0-48
2.2.5.1	Ambient Variability. . . . .	2.0-50
2.2.5.2	Mean Vertical Profiles . . . . .	2.0-52
2.2.6	Seasonal Water Mass Classification . . . . .	2.0-55
2.2.7	Dissolved Oxygen . . . . .	2.0-62

	PAGE
2.2.8	Sedimentological Conditions . . . . . 2.0-62
2.2.8.1	Sea-Floor Stability . . . . . 2.0-62
2.2.8.2	Suspended Sediments . . . . . 2.0-64
2.2.9	Hampton Harbor Estuary. . . . . 2.0-65
2.2.9.1	Sedimentological Conditons . . . . . 2.0-65 at the Inlet
2.2.9.2	Turbidity . . . . . 2.0-65
2.2.9.3	Tidal Hydraulics. . . . . 2.0-66
2.2.9.4	Patterns of Tidal Flow. . . . . 2.0-67
2.2.9.5	Probability of Estuarine Entry of Coastwise Drifting. . . . . 2.0-70
2.3	MARINE COMMUNITIES. . . . . 2.0-72
2.3.1	Introduction. . . . . 2.0-72
2.3.2	Plankton. . . . . 2.0-73
2.3.2.1	Phytoplankton . . . . . 2.0-73
2.3.2.2	Invertebrate Zooplankton. . . . . 2.0-76
2.3.2.3	Ichthyoplankton . . . . . 2.0-80
2.3.3	Benthos . . . . . 2.0-82
2.3.3.1	Benthic Faunal Communities. . . . . 2.0-82
2.3.3.2	Benthic Macroalgal Community. . . . . 2.0-89
2.3.4	Nekton . . . . . 2.0-89
2.3.4.1	Invertebrates . . . . . 2.0-92
2.3.4.2	Finfish Community . . . . . 2.0-92
3.0	CHARACTERISTICS OF THE PROPOSED CIRCULATING WATER SYSTEM. . . . . 3.0-1
3.1	INTRODUCTION AND GENERAL SYSTEM DESCRIPTION . . . . 3.0-1

	PAGE
3.2	GENERAL INSTRUCTIONS. . . . . 3.0-2
3.3	INTAKE SYSTEM. . . . . 3.0-6
3.4	DISCHARGE SYSTEM. . . . . 3.0-8
3.4.1	Thermal Discharge Performance Under Normal Operations. . . . . 3.0-8
3.4.2	Dilution of Ambient Water. . . . . 3.0-17
3.4.3	Farfield Thermal Plume Characteristics . . . . . 3.0-18
3.5	BIOFOULING CONTROL . . . . . 3.0-26
3.5.1	Circulating Water System and Service Water System . . . . . 3.0-26
3.5.2	Intake System. . . . . 3.0-27
3.5.3	The Thermal Effects of Backflushing. . . . . 3.0-28
3.5.4	Pumphouse to Condenser . . . . . 3.0-30
3.5.5	Condenser. . . . . 3.0-31
3.5.6	Service Water System . . . . . 3.0-31
4.0	REPRESENTATIVE IMPORTANT SPECIES (RIS) . . . . . 4.0-1
4.1	CRITERIA FOR SELECTION . . . . . 4.0-1
4.2	SELECTED SPECIES . . . . . 4.0-3
4.2.1	Diatom, <i>Skeletonema costatum</i> . . . . . 4.0-3
4.2.2	Red Tide Alga, <i>Gonyaulax tamarensis</i> . . . . . 4.0-4
4.2.3	Irish Moss, <i>Chondrus crispus</i> . . . . . 4.0-4
4.2.4	Copepod, <i>Eurytemora herdmani</i> . . . . . 4.0-4
4.2.5	Ocean Quahog, <i>Arctica islandica</i> . . . . . 4.0-4
4.2.6	Razor Clam, <i>Ensis directus</i> . . . . . 4.0-5
4.2.7	Soft-shelled Clam, <i>Mya arenaria</i> . . . . . 4.0-5
4.2.8	Mussel, <i>Mytilus edulis</i> . . . . . 4.0-6
4.2.9	American lobster, <i>Homarus americanus</i> . . . . . 4.0-6
4.2.10	Alewife, <i>Alosa pseudoharengus</i> . . . . . 4.0-6

	PAGE
4.2.11	Menhaden, <i>Brevoortia tyrannus</i> . . . . . 4.0-7
4.2.12	Coho Salmon, <i>Oncorhynchus kisutch</i> . . . . . 4.0-7
4.2.13	Smelt, <i>Osmerus mordax</i> . . . . . 4.0-7
4.2.14	Pollock, <i>Pollachius virens</i> . . . . . 4.0-8
4.2.15	Flounder, <i>Pseudopleuronectes americanus</i> . . . . . 4.0-8
4.2.16	Mackerel, <i>Scomber scombrus</i> . . . . . 4.0-8
5.0	IMPACT ANALYSIS . . . . . 5.0-1
5.1	BACKGROUND AND HISTORICAL INFORMATION . . . . . 5.0-1
5.1.1	introduction. . . . . 5.0-1
5.1.2	<i>Skeletonema costatum</i> . . . . . 5.0-1
5.1.3	<i>Gonyaulax tamarensis</i> . . . . . 5.0-6
5.1.4	<i>Chondrus crispus</i> . . . . . 5.0-9
5.1.5	<i>Eurytemora herdmani</i> . . . . . 5.0-13
5.1.6	<i>Arctica islandica</i> . . . . . 5.0-13
5.1.7	<i>Ensis directus</i> . . . . . 5.0-19
5.1.8	<i>Mya arenaria</i> . . . . . 5.0-23
5.1.9	<i>Mytilus edulis</i> . . . . . 5.0-27
5.1.10	<i>Homarus americanus</i> . . . . . 5.0-30
5.1.11	<i>Alosa pseudoharengus</i> . . . . . 5.0-34
5.1.12	<i>Brevoortia tyrannus</i> . . . . . 5.0-34
5.1.13	<i>Oncorhynchus kisutch</i> . . . . . 5.0-40
5.1.14	<i>Osmerus mordax</i> . . . . . 5.0-40
5.1.15	<i>Pollachius virens</i> . . . . . 5.0-47
5.1.16	<i>Pseudopleuronectes americanus</i> . . . . . 5.0-47
5.1.17	<i>Scomber scombrus</i> . . . . . 5.0-53
5.2	CONSTRUCTION EFFECTS. . . . . 5.0-58

	PAGE
5.3	IMPACTS DUE TO PLANT OPERATION. . . . . 5.0-59
5.3.1	Plume Entrainment . . . . . 5.0-59
5.3.1.1	Indirect Effects of Brief Exposure. . . . . 5.0-60
5.3.1.2	Sublethal Effects of Prolonged Plume Exposure . . . . 5.0-62
5.3.1.3	Demonstrations of Thermal Impact on Representative Species . . . . . 5.0-64
5.3.2	Entrapment. . . . . 5.0-67
5.3.3	Passage Through the Cooling Water System: Pumped Entrainment . . . . . 5.0-73
5.3.4	Backflushing. . . . . 5.0-73
5.4	TOTAL IMPACT. . . . . 5.0-78
6.0	GLOSSARY OF PERTINENT BIOLOGICAL AND HYDROGRAPHIC TERMS . . . . . 6.0-1
7.0	LITERATURE CITED. . . . . 7.0-1
8.0	APPENDIX . . . . . 8.0-1

## LIST OF FIGURES

		PAGE
2.1-1.	Location map of the Gulf of Maine (From PSNH, 1973). . . . .	2.0-2
2.1-2.	Location map of New Hampshire coastal waters with NAI Seabrook Station study area off Hampton Beach. . . . .	2.0-4
2.1-3.	Location map of Hampton Harbor estuary . . . . .	2.0-5
2.1-4.	Substrate types in intake and discharge areas off Hampton Beach, New Hampshire . . . . .	2.0-7
2.1-5.	Map of Northwestern Atlantic coast showing general circulation patterns. (From Sutcliffe, Loucks and Drinkwater, 1975). . . . .	2.0-8
2.1-6.	Seasonal variations in circulation patterns of surface waters in the Gulf of Maine. (From Bumpus and Lauzier, 1965) . . . . .	2.0-10
2.1-7.	Location map showing NAI moorings with current meters and temperature monitors in coastal waters off Hampton Beach, New Hampshire . . . . .	2.0-13
2.1-8.	Diagram showing hydrographic studies which have been conducted off Hampton Beach, New Hampshire, from 1972 to date. . . . .	2.0-14
2.1-9.	Diagram showing biological studies which have been conducted in the vicinity of Hampton Beach, New Hampshire from 1969 to date . . . . .	2.0-17
2.2-1.	Examples of main types of current flows observed in coastal waters off Hampton Beach, New Hampshire . . . . .	2.0-21
2.2-2.	Tabulation of monthly percentage of observed current flow types for coastal waters off Hampton Beach, New Hampshire, from 1973 through 1976 . . . . .	2.0-23
2.2-3.	Plot of daily net drift of longshore (north-south) components averaged over 3-day periods from mid- depth current meters off Hampton Beach, New Hamp- shire, 1973 through 1976 . . . . .	2.0-30



	PAGE
2.2-4	Net-drift trajectories of drift bottles (top) and sea-bed drifters (bottom) released by NAI during September 1972, January 1973 and June 1973. . . . . 2.0-32
2.2-5.	Diagrammatic representation of low-pressure systems and accompanying wind patterns from storms moving up off the coast and up the St. Lawrence River valley illustrating effects on coastal flows in the western Gulf of Maine . . . . . 2.0-36
2.2-6.	Plot of high-water and low-water tide heights in the Hampton Harbor estuary during a typical lunar month from July 28 to August 25, 1973 . . . . . 2.0-39
2.2-7.	Monthly temperature observations at the discharge site (Mooring 12) for near-surface and near-bottom waters from 1975 slack-water surveys (both low water, LW and high water, HW) . . . . . 2.0-41
2.2-8.	Representative summertime hourly average temperature data from the discharge site, the offshore intake site and the Hampton Harbor estuary from August 17 to 31, 1976 . . . . . 2.0-43
2.2-9.	Representative wintertime hourly average temperature data from the discharge site, the offshore intake site and the Hampton Harbor estuary from January 17 to 31, 1976. . . . . 2.0-45
2.2-10.	Surface water temperatures (F) in Hampton Harbor estuary and adjacent coastal waters on June 19, 1975, from slack-water survey at high water (left) and low water (right) . . . . . 2.0-47
2.2-11.	Typical mean temperature profiles from coastal waters off Hampton Beach, New Hampshire, during 1975. 2.0-49
2.2-12.	Surface salinities ( $^{\circ}/_{\infty}$ ) in Hampton Harbor estuary and adjacent coastal waters on September 29, 1975, from slack-water survey at high water (left) and low water (right) . . . . . 2.0-51
2.2-13.	Surface salinities ( $^{\circ}/_{\infty}$ ) in Hampton Harbor estuary and adjacent coastal waters on December 16, 1975, from plankton cruise measurements . . . . . 2.0-53
2.2-14.	Typical mean salinity profiles from coastal waters off Hampton Beach, New Hampshire, during 1975 . . . . . 2.0-54

2.2-15.	Annual cycle of temperature and salinity variations in near-surface waters off the coast of New Hampshire and in the western Gulf of Maine . . . . .	2.0-56
2.2-16.	Annual cycle of temperature and salinity variations in near-bottom waters off the coast of New Hampshire and in the western Gulf of Maine . . . . .	2.0-57
2.2-17.	Annual cycle of water mass types based on temperature and salinity variations in waters off the New Hampshire coast and in the western Gulf of Maine .	2.0-58
2.2-18.	Monthly dissolved oxygen and percentage saturation observations at the discharge site (Mooring 12) for near-surface and near-bottom waters from 1975 slack-water surveys (both low water, LW and high water, HW). . . . .	2.0-63
2.2-19.	Diagrammatic representation of typical flow patterns into and out of Hampton Harbor estuary over the course of a tidal cycle; ebb tide (top) and flood tide (bottom). . . . .	2.0-68
3.1-1.	Map view of Seabrook Station circulating water system . . . . .	3.0-3
3.2-1.	Profile of Seabrook Station circulating water system . . . . .	3.0-5
3.3-1.	Diagram showing proposed velocity cap for Seabrook station. . . . .	3.0-7
3.4-1.	Diagram showing proposed Seabrook Station diffuser configuration. . . . .	3.0-9
3.4-2.	Predicted tidal average surface temperatures from Seabrook Station operation . . . . .	3.0-11
3.4-3.	Predicted tidal average vertical temperature structure from Seabrook Station operation. . . . .	3.0-12
3.4-4.	Predicted hourly surface temperatures from Seabrook Station operation. . . . .	3.0-13
3.4-5.	Predicted hourly vertical temperatures from Seabrook Station operation (first half of tidal cycle). . . . .	3.0-14
3.4-6.	Predicted hourly vertical temperatures from Seabrook Station operation (second half of tidal cycle) . . . . .	3.0-15

3.4-7.	Predicted hourly surface temperatures from Seabrook Station operation. . . . .	3.0-16
3.4-8.	Predicted far-field surface temperature isotherms under weak ambient southward currents and average heat transfer. . . . .	3.0-20
3.4-9.	Predicted far-field surface temperature isotherms under weak ambient northward currents and average heat transfer. . . . .	3.0-21
3.4-10.	Predicted far-field surface temperature isotherms under weak ambient northward currents and low heat transfer. . . . .	3.0-22
3.4-11.	Predicted far-field surface temperature isotherms under weak ambient northward currents and high heat transfer. . . . .	3.0-23
3.4-12.	Predicted far-field surface temperature isotherms under moderate ambient northward currents and average heat transfer. . . . .	3.0-24
5.1-1.	Example of selected species relative temporal abundance and thermal characteristic display . . . . .	5.0-2
5.1-2	Diatom, <i>Skeletonema costatum</i> , relative temporal abundance and thermal characteristics. . . . .	5.0-3
5.1-3.	Distribution of the diatom, <i>Skeletonema costatum</i> , in the Western Atlantic Ocean. . . . .	5.0-4
5.1-4.	History of PSP toxicity levels in <i>Mytilus edulis</i> and <i>Mya arenaria</i> from Hampton Harbor Estuary, NH and Essex Estuary, MA. Data courtesy of: New Hampshire Division of Public Health and Massachusetts Department of Public Health, Lawrence Experimental Station. . . . .	5.0-7
5.1-5.	Distribution of the red tide alga, <i>Gonyaulax tamarensis</i> in the Western Atlantic Ocean . . . . .	5.0-8
5.1-6.	Red tide alga, <i>Gonyaulax tamarensis</i> , relative temporal abundance and thermal characteristics . . . . .	5.0-10
5.1-7.	Distribution of Irish Moss, <i>Chondrus crispus</i> , in the Western Atlantic Ocean . . . . .	5.0-11

	PAGE
5.1-8. Irish Moss ( <i>Chondrus crispus</i> ) relative temporal abundance and thermal characteristics. . . . .	5.0-12
5.1-9. Distribution of the copepod, <i>Eurytemora herdmani</i> in the Western Atlantic Ocean. . . . .	5.0-14
5.1-10. Copepod, <i>Eurytemora herdmani</i> , relative temporal abundance and thermal characteristics. . . . .	5.0-16
5.1-11. Distribution of Mahogany quahog, <i>Arctica islandica</i> in the Western Atlantic Ocean. . . . .	5.0-17
5.1-12. Mahogany clam (ocean quahog), <i>Arctica islandica</i> , relative temporal abundance and thermal characteristics . . . . .	5.0-20
5.1-13. Jack-knife clam, <i>Ensis directus</i> , relative temporal abundance and thermal characteristics. . . . .	5.0-21
5.1-14. Distribution of the Razor clam, <i>Ensis directus</i> , in the Western Atlantic Ocean . . . . .	5.0-22
5.1-15. Distribution of soft-shell clam, <i>Mya arenaria</i> , in the Western Atlantic Ocean . . . . .	5.0-24
5.1-16. Soft-shell clam, <i>Mya arenaria</i> , relative temporal abundance and thermal characteristics. . . . .	5.0-25
5.1-17. Distribution of Blue mussel, <i>Mytilus edulis</i> in the Western Atlantic Ocean . . . . .	5.0-28
5.1-18. Blue Mussel, <i>Mytilus edulis</i> , relative temporal abundance and thermal characteristics. . . . .	5.0-29
5.1-19. Distribution of lobster, <i>Homarus americanus</i> in the Western Atlantic Ocean . . . . .	5.0-31
5.1-20. American lobster, <i>Homarus americanus</i> , relative temporal abundance and thermal characteristics . . . .	5.0-33
5.1-21. Distribution of Alewife, <i>Alosa pseudoharengus</i> in the Western Atlantic Ocean. . . . .	5.0-35
5.1-22. Alewife, <i>Alosa pseudoharengus</i> , relative temporal abundance and thermal characteristics. . . . .	5.0-37
5.1-23. Distribution of Menhaden, <i>Brevoortia tyrannus</i> in the Western Atlantic Ocean . . . . .	5.0-38

	PAGE
5.1-24. Atlantic menhaden, <i>Brevoortia tyrannus</i> , relative temporal abundance and thermal characteristics . . .	5.0-41
5.1-25. Distribution of Coho salmon, <i>Oncorhynchus kisutch</i> in the Western Atlantic Ocean. . . . .	5.0-42
5.1-26. Coho salmon, <i>Oncorhynchus kisutch</i> , relative temporal abundance and thermal characteristics. . . . .	5.0-43
5.1-27. Distribution of Rainbow smelt, <i>Osmerus mordax</i> in the Western Atlantic Ocean . . . . .	5.0-44
5.1-28. Rainbow smelt, <i>Osmerus mordax</i> , relative temporal abundance and thermal characteristics. . . . .	5.0-46
5.1-29. Distribution of Pollock, <i>Pollachius virens</i> , in the Western Atlantic Ocean . . . . .	5.0-48
5.1-30. Pollock, <i>Pollachius virens</i> , relative temporal abundance and thermal characteristics. . . . .	5.0-50
5.1-31. Distribution of Winter flounder, <i>Pseudopleuronectes americanus</i> , in the Western Atlantic Ocean . .	5.0-51
5.1-32. Winter flounder, <i>Pseudopleuronectes americanus</i> , relative temporal abundance and thermal characteristics . . . . .	5.0-52
5.1-33. Distribution of Atlantic mackerel, <i>Scomber scombrus</i> in the Western Atlantic Ocean . . . . .	5.0-56
5.1-34. Atlantic mackerel, <i>Scomber scombrus</i> , relative temporal abundance and thermal characteristics . . .	5.0-57
5.3-1. Seabrook Station backflush plume entrained volume. .	5.0-76

LIST OF TABLES

	PAGE
2.2-1. DISTRIBUTION OF CURRENT-FLOW TYPES IN COASTAL WATERS SEAWARD OF THE OUTER SUNK ROCKS OFF HAMPTON BEACH, N.H. . . . .	2.0-74
2.2-2. AMBIENT TEMPERATURE DIFFERENCES (F) BETWEEN ROCKS AREA AND INTAKE SITES DURING PERIODS OF HIGHEST OBSERVED ANNUAL TEMPERATURES IN 1973, 1975 AND 1976 . . . . .	2.0-46
2.2-3. TEMPERATURE AND SALINITY CHARACTERISTICS OF COASTAL WATER-MASS TYPES OF THE WESTERN GULF OF MAINE. . . . .	2.0-59
2.3-1. RELATIVE REPRESENTATION OF NET PHYTOPLANKTON IN THE VICINITY OF HAMPTON BEACH, NEW HAMPSHIRE . . .	2.0-75
2.3-2. RELATIVE REPRESENTATION OF HOLOPLANKTERS IN THE VICINITY OF HAMPTON BEACH, NEW HAMPSHIRE. . . . .	2.0-77
2.3-3. RELATIVE REPRESENTATION OF MEROPLANKTERS IN THE VICINITY OF HAMPTON BEACH, NEW HAMPSHIRE. . . . .	2.0-79
2.3-4. SPECIES RANK FOR ICHTHYOPLANKTON BASED ON CATCH IN MIDWATER PLANKTON TOWS . . . . .	2.0-81
2.3-5. SUBTIDAL HARD SUBSTRATE SPECIES IN THE VICINITY OF THE PROPOSED INTAKE AND DISCHARGE SITES, NUMBERED ACCORDING TO RANK ORDER OF ABUNDANCE . . . .	2.0-83
2.3-6. SUBTIDAL COBBLE SUBSTRATE DOMINANT SPECIES IN THE VICINITY OF THE PROPOSED INTAKE AND DISCHARGE SITES. NUMBERED ACCORDING TO RANK ORDER OF ABUNDANCE . . . . .	2.0-84
2.3-7. SUBTIDAL SAND SUBSTRATE SPECIES IN THE VICINITY OF THE PROPOSED INTAKE AND DISCHARGE SITES, NUMBERED ACCORDING TO RANK ORDER OF ABUNDANCE. . . . .	2.0-85

	PAGE
2.3-8. INTERTIDAL HARD SUBSTRATE DOMINANT SPECIES AT HIGH (+8.5 FT), MID (+4.2 FT) AND LOW (0 FT) TIDAL LEVELS IN THE VICINITY OF THE PROPOSED INTAKE AND DISCHARGE SITES. . . . .	2.0-87
2.3-9. INTERTIDAL SAND SUBSTRATE DOMINANT SPECIES AT HIGH (+8.3 FT), MID (+4.2 FT) AND LOW (0 FT) TIDAL LEVELS IN THE VICINITY OF THE PROPOSED INTAKE AND DISCHARGE SITES. . . . .	2.0-88
2.3-10. COMMON MEIOFAUNA INVERTEBRATE TAXA FOUND IN OCEANIC AND ESTUARINE SOFT SUBSTRATE SAMPLES AND/OR IN <i>CORALLINA OFFICIANALIS</i> HOLDFASTS . . . . .	2.0-90
2.3-11. COMMON HARPACTICOID COPEPOD SPECIES FOUND IN OCEANIC SOFT SUBSTRATE SAMPLES AND/OR IN <i>CORALLINA OFFICIANALIS</i> HOLDFASTS . . . . .	2.0-90
2.3-12. DISTRIBUTION OF MACROALGAE IN THE OFFSHORE COASTAL HAMPTON-SEABROOK STUDY AREA IN 1975-1976, ASSOCIATED SPECIES NOTED IN PARENTHESES. . . . .	2.0-91
2.3-13. SEABROOK FINFISH ECOLOGICAL CATEGORIZATION . . . . .	2.0-93
2.3-14. SPECIES RANK OF BOTTOM FISHES BASED ON OTTER TRAWL CATCH. . . . .	2.0-94
2.3-15. SPECIES RANK OF PELAGIC FISHES BASED ON GILL NET CATCH. . . . .	2.0-96
3.4-1. AREAS ENCLOSED BY ISOTHERMS. . . . .	3.0-19
3.4-2. SURFACE HEAT TRANSFER COEFFICIENTS . . . . .	3.0-25
4.1-1. CHECKLIST OF REPRESENTATIVE SPECIES AND RATIONALE. . . . .	4.0-2
5.1-1. TEMPORAL DISTRIBUTION OF <i>SKELETONEMA COSTATUM</i> ( $10^3$ CELLS $M^3$ ) OFF HAMPTON BEACH, NEW HAMPSHIRE. . . . .	5.0-5
5.1-2. TEMPORAL DISTRIBUTION OF <i>EURYTEMORA HERDMANI</i> (INDIVIDUALS/ $M^3$ ). . . . .	5.0-15
5.1-3. TEMPORAL DISTRIBUTION OF JUVENILE <i>ARCTICA ISLANDICA</i> (INDIVIDUALS/ $M^2$ ) IN THE VICINITY OF HAMPTON BEACH, NH . . . . .	5.0-18
5.1-4. ABUNDANCE OF <i>M. ARENARIA</i> ADULTS (> 25 mm) IN HAMPTON-SEABROOK ESTUARY, NOVEMBER SURVEYS . . . . .	5.0-26

	PAGE
5.1-5. ABUNDANCE OF <i>M. ARENARIA</i> LARVAE (140-320 $\mu\text{m}$ ) IN NEW HAMPSHIRE COASTAL WATERS. . . . .	5.0-26
5.1-6. ABUNDANCE OF <i>M. ARENARIA</i> SPAT (1 TO 25 mm) IN HAMPTON-SEABROOK ESTUARY, NOVEMBER SURVEYS. . . . .	5.0-26
5.1-7. TEMPORAL DISTRIBUTION OF <i>MYTILUS EDULIS</i> SPAT FROM "OUTER SUNK ROCKS" OFF HAMPTON BEACH, NH . . . . .	5.0-27
5.1-8. TEMPORAL CHANGES IN <i>HOMARUS AMERICANUS</i> LEGAL CATCH PER EFFORT FOR 15 STRINGS IN THE VICINITY OF HAMPTON BEACH, NH . . . . .	5.0-32
5.1-9. ABUNDANCE OF LOBSTER, <i>HOMARUS AMERICANUS</i> LARVAE IN "NEUSTON" TOWS OFF HAMPTON BEACH, NEW HAMPSHIRE IN 1973 (INDIVIDUALS PER 100 $\text{M}^3$ ). . . . .	5.0-32
5.1-10. TEMPORAL DISTRIBUTION OF ALEWIFE, <i>ALOSA PSEUDO-HARENGUS</i> , IN NEW HAMPSHIRE COASTAL WATERS . . . . .	5.0-36
5.1-11. TEMPORAL DISTRIBUTION OF MENHADEN, <i>BREVOORTIA TYRANNUS</i> , IN NEW HAMPSHIRE COASTAL WATERS . . . . .	5.0-39
5.1-12. TEMPORAL DISTRIBUTION OF RAINBOW SMELT, <i>OSMERUS MORDAX</i> , IN NEW HAMPSHIRE COASTAL WATERS . . . . .	5.0-45
5.1-13. TEMPORAL DISTRIBUTION OF POLLOCK, <i>POLLACHIUS VIRENS</i> , IN NEW HAMPSHIRE COASTAL WATERS . . . . .	5.0-49
5.1-14. TEMPORAL DISTRIBUTION OF WINTER FLOUNDER, <i>PSEUDO-PLEURONECTES AMERICANUS</i> , IN NEW HAMPSHIRE COASTAL WATERS. . . . .	5.0-54
5.1-15. TEMPORAL DISTRIBUTION OF ATLANTIC MACKEREL, <i>SCOMBER SCOMBRUS</i> . . . . .	5.0-55
5.3-1. INDIRECT EFFECTS OF THERMAL PLUME ENTRAINMENT . . . . .	5.0-60
5.3-2. SUBLETHAL EFFECTS OF DELIBERATE PROLONGED EXPOSURE TO THERMAL PLUME CONDITIONS . . . . .	5.0-63
5.3-3. QUANTITATIVE ASSESSMENT OF RELATIVE IMPACT DUE TO PLUME ENTRAINMENT . . . . .	5.0-66
5.3-4. NORMAL SWIMMING VELOCITIES OF SELECTED FINFISH SPECIES . . . . .	5.0-71
5.3-5. QUANTITATIVE ASSESSMENT OF RELATIVE IMPACT DUE TO PASSAGE THROUGH THE COOLING WATER SYSTEM. . . . .	5.0-74



5.3-6.	IMPACT OF SUBLETHAL EXPOSURE TO CRITICAL PORTION OF THE THERMAL PLUME DURING ONE COMPLETE BACKFLUSHING OPERATION, SEABROOK STATION. . . . .	5.0-75
5.4-1.	STRESSES ON REPRESENTATIVE IMPORTANT SPECIES BY SEABROOK STATION COOLING WATER SYSTEM (NUMERICAL VALUES APPLY TO YEARS OF MAXIMUM LOCAL ABUNDANCE). . .	5.0-79
5.4-2.	ESTIMATED AGE RELATED SURVIVORSHIP OF SOFT-SHELL CLAMS, <i>MYA ARENARIA</i> (NAI, 1977b) . . . . .	5.0-82
5.4-3.	ESTIMATES OF POTENTIAL LOSS BY AGE GROUP . . . . .	5.0-85

SUMMARY DOCUMENT: ASSESSMENT OF ANTICIPATED IMPACTS OF  
CONSTRUCTION AND OPERATION OF SEABROOK STATION  
ON THE ESTUARINE, COASTAL AND OFFSHORE WATERS,  
HAMPTON-SEABROOK, NEW HAMPSHIRE

1.0 INTRODUCTION

The purpose of this document is to summarize all pertinent work that has been accomplished to date with respect to assessment of possible impacts on the marine ecosystem of the construction and operation of Seabrook Nuclear Station. It includes the cumulative data and results of baseline studies, continuous environmental monitoring programs, and special studies conducted since the station's original conception in 1968 (studies began in 1969). A wide spectrum of subjects are covered, with the emphasis on the general, but encompassing areas of biological, hydrographic and hydrothermal studies necessary to describe, detail, and analyze this highly variable and previously poorly or unstudied ecosystem. This document specifically includes a lengthy analysis of the station's potential for impacting selected representative important species, a method which has been decreed by the relevant regulatory statutes to be one means of determining overall environmental impact on a given ecosystem.

As with any reporting effort where studies are in some manner still ongoing, some results in this document may become outdated; one should keep this in mind when seeking information or endeavoring to utilize data or results from this report. Subsequent reports to those cited in this document, when they become available, will certainly be of further value when making impact assessments.

## 2.0 DESCRIPTION OF EXISTING ENVIRONMENT

### 2.1 INTRODUCTION AND GENERAL OVERVIEW

Since June 1969 Normandeau Associates, Inc. (NAI) has been conducting baseline biological, hydrographic and sedimentological studies for the Public Service Company of New Hampshire's (PSNH) Seabrook Station Project. These studies of a portion of the western Gulf of Maine, the coastal waters off Hampton Beach, New Hampshire, and Hampton Harbor estuary, have been designed primarily to determine temporal and spatial distribution of dominant fauna and flora; general seasonal structure of plankton, benthic, and finfish communities; and annual variability of ambient water currents, temperature, salinity, density, dissolved oxygen, tides, net circulation patterns and winds. These studies, which represent one of the most comprehensive preoperational monitoring programs conducted for a proposed oceanside power plant, have substantiated data previously collected by other workers, and in addition, have added much valuable new information.

#### 2.1.1 Physical Setting

The site for the Seabrook Station along the southeastern coast of New Hampshire is fronted by a portion of the western North Atlantic Ocean known as the Gulf of Maine. This water body is proposed to be both the primary source of cooling water for the power plant as well as the receiving water mass for its heated effluent.

The Gulf of Maine (Figure 2.1-1) forms a roughly rectangular embayment about 175 n mi across from west to east and 100 n mi from south to north. It stretches from Cape Cod and Nantucket Island, Massachusetts, northeastward along roughly 525 n mi of shoreline (excluding bays and inlets) to Cape Sable, Nova Scotia. It is bordered to the south by two shallow banks areas, Georges Bank and Browns Bank, which apparently restrict water circulation with the North Atlantic

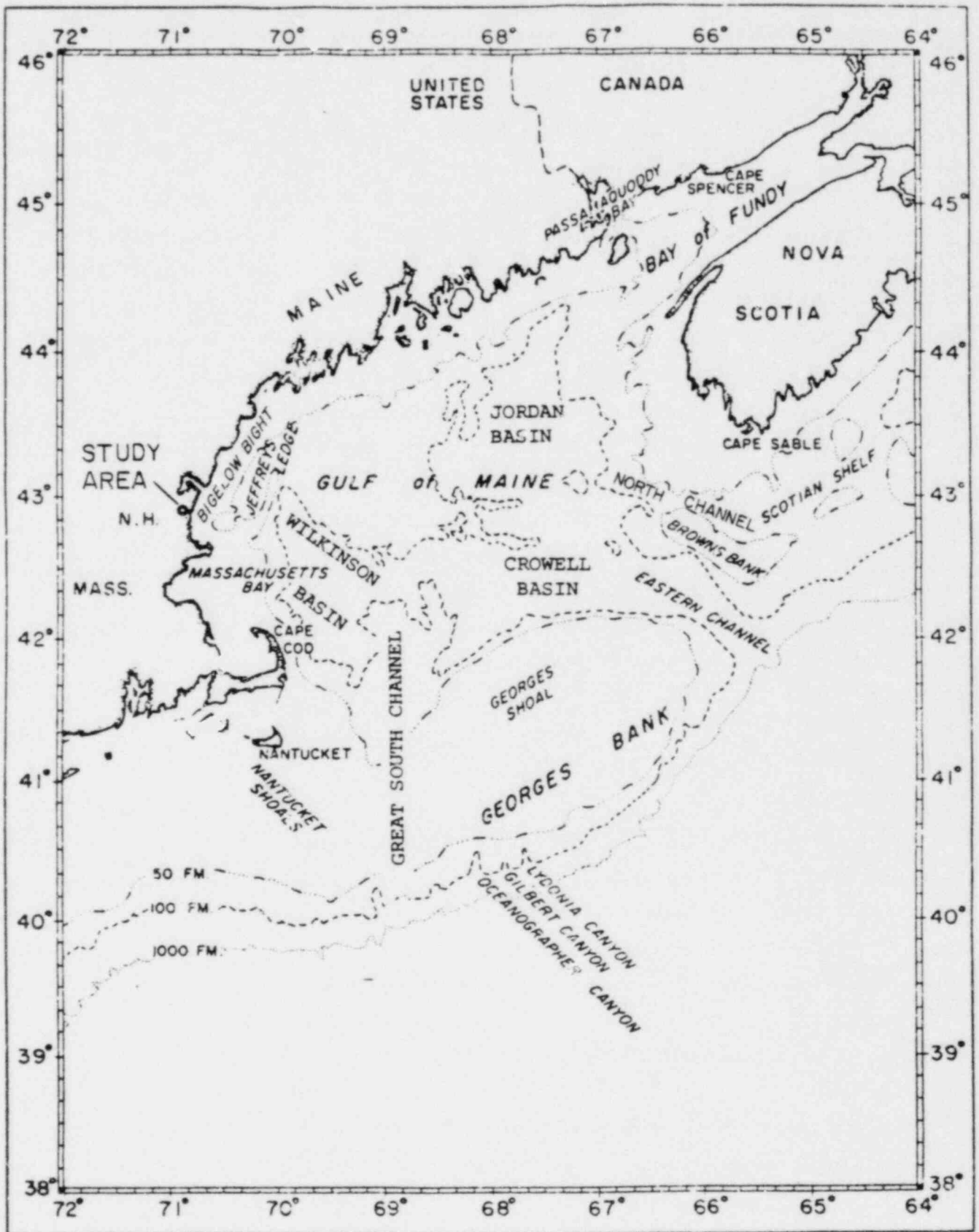

Figure 2.1-1. Location map of the Gulf of Maine (from PSNH, 1973).

and essentially enclose the Gulf as a coastal sea. The Gulf of Maine comprises an estimated surface area of about  $4.9 \times 10^4 \text{ m}^2$  and a volume of approximately  $10^{15}$  gallons (excluding the Bay of Fundy).

No way!  
Must be miles

The Gulf of Maine has generally irregular bottom topography with numerous banks and sinks. A narrow, gently sloping shelf up to 13 n mi wide rings much of its periphery; but the Gulf is dominated by three deep basins: Wilkinson Basin, located in the western half of the Gulf (maximum depth about 930 ft); Jordan Basin, in the northeastern portion (about 810 ft deep); and Crowell Basin, in the southeastern section (about 1,240 ft deep; Figure 2.1-1). The seaward edge of the Gulf consists of a nearly continuous series of shallow sills extending from Nantucket to Cape Sable: Georges Bank which is between 90 and 210 ft deep, but in places is almost out of water at low tide; and Browns Bank which is between 100 and 300 ft deep. There are three narrow passages which breach this sill, connecting the deeper basins of the Gulf to the open ocean: Great South Channel between Nantucket and Georges Bank (about 210 ft deep); the Eastern Channel between Georges Bank and Browns Bank (about 680 ft deep); and the Northern Channel separating Browns Bank and the mainland of Nova Scotia (about 420 ft deep).

The western Gulf of Maine adjacent to the coast of New Hampshire, known as Bigelow Bight, is dominated by two deep basins: Jeffreys Basin, which is about 600 ft deep; and Scantum Basin, which is about 420 ft deep (Figure 2.1-2). A broad gently-sloping shelf area with numerous local bottom irregularities, especially in the vicinity of the Isles of Shoals, lies between these basins and the coast. On the seaward side, these basins are somewhat separated from the main Gulf by a shallow rise known as Jeffreys Ledge.

The site for Seabrook Station is on the southern New Hampshire coast adjacent to Hampton Harbor (or Hampton-Seabrook) estuary (Figure 2.1-3). This estuary and associated marsh, which has an area of approximately 3,800 acres, is part of the general uplift pattern of a

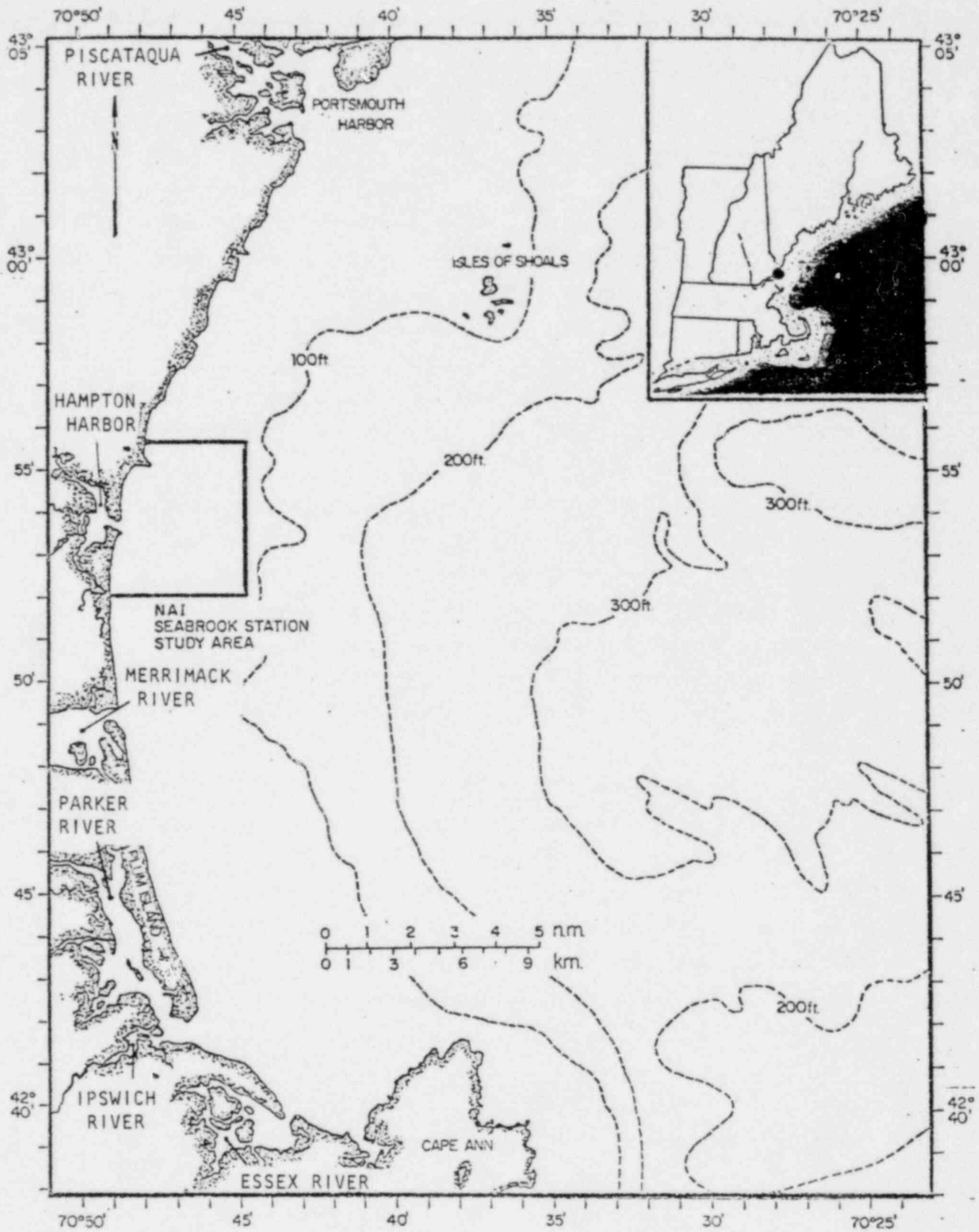

Figure 2.1-2. Location map of New Hampshire coastal waters with NAI Seabrook Station study area off Hampton Beach.

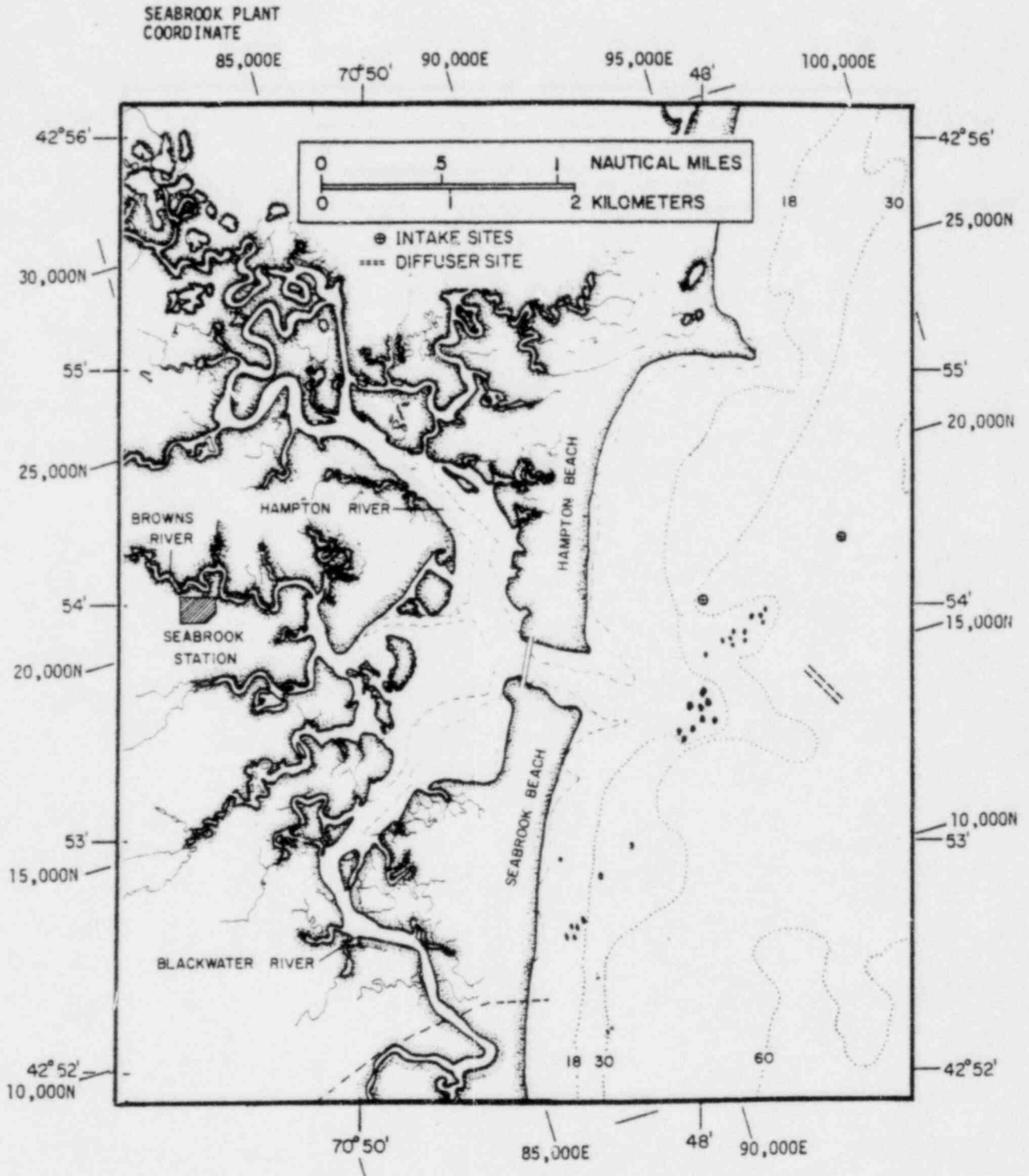

Figure 2.1-3. Location map of Hampton Harbor estuary.

previously submerged coastal plain bordered on its outer perimeter by a barrier beach.

The Hampton-Seabrook marsh/estuary is sectioned by several tidal rivers. Although there is a discernible watershed, the attendant runoff is not particularly significant. The several streams and their branches serve primarily as tidal streams directing the inward and outward flow of saline water twice daily.

The substrate of the adjacent offshore area where the cooling system intake and discharge is proposed to be located is extremely heterogeneous but composed of three basic types: rock-ledge, cobble (rocks less than 6 inches in diameter), and sand (Figure 2.1-4).

#### 2.1.2 Hydrographic Setting

The general circulation pattern of the western portion of the Atlantic, which includes the Gulf of Maine, has been documented by NAI studies, as well as by other workers such as Bigelow, 1927; Day, 1958; Bumpus and Lauzier, 1965; Graham, 1970a; and Bumpus, 1973. The waters on the Scotian Shelf, known as the Nova Scotia current (Bigelow, 1927) are a mixture of Gulf of St. Lawrence water, residual Labrador current water, and more saline waters from offshore called Slope Water (McLellan, 1954). These waters (Figure 2.1-5) generally flow southwesterly, parallel to the Atlantic coast of Nova Scotia, rounding the tip of Nova Scotia and entering the Gulf of Maine (Sutcliffe, Loucks and Drinkwater, 1975).

These circulation studies have shown that the flow of water in the Gulf is strongly influenced by the tides, and at most locations, the tidal currents comprise the greater part of the total water movement. However, this tidal movement is superimposed on a more general counter-clockwise scheme of net, non-tidal circulation (Gulf of Maine gyre) which undergoes an annual cycle. This flow pattern is due to the inter-





Figure 2.1-4. Substrate types in intake and discharge areas off Hampton Beach, New Hampshire.

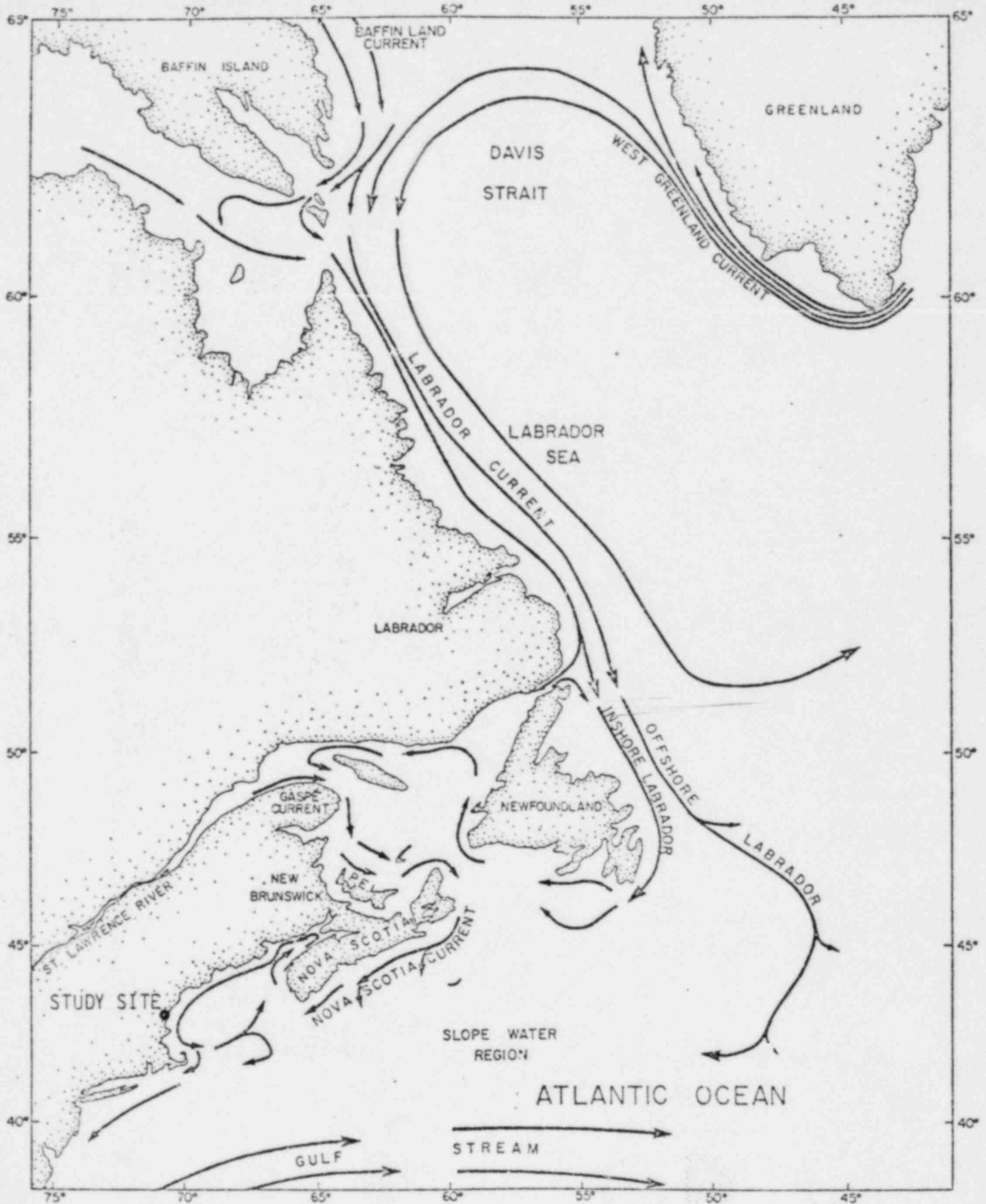

Figure 2.1-5. Map of Northwestern Atlantic coast showing general circulation patterns. (From Sutcliffe, Loucks and Drinkwater, 1975.)

action of many influences which include: (1) freshwater runoff, (2) winds, (3) bathymetry, and (4) Coriolis effect.

According to Bumpus and Lauzier (1965), the chief wintertime characteristic of the circulation in the Gulf of Maine is an indraft of waters from off Cape Sable, across Browns Bank and the eastern Gulf into the Bay of Fundy (Figure 2.1-1). Along the western coastal regions, a southerly flow develops which continues past Cape Cod and out through Great South Channel. Between the indraft into the Bay of Fundy and the southerly flow along the western side of the Gulf, several irregular eddies develop by February. A well-developed area of divergence north of Georges Bank is also present by this time of the winter. In the early spring, freshwater runoff is discharged from coastal estuaries, helping to set in motion an eddy which rapidly develops into a huge counterclockwise gyre encompassing the entire Gulf of Maine by the end of May (Figure 2.1-6). As during the winter, there is an indraft into the gyre from the Scotia Shelf and Georges Bank. In the eastern Gulf the drift may be northward into the Bay of Fundy or westward along the coast of Maine. The less-saline waters of the western side of the Bay of Fundy join this westward flow and the net southward flows off the New Hampshire coast past Cape Ann. Flows continue southward past Massachusetts Bay, diverting into the Bay, into Cape Cod Bay, or continuing out past Cape Cod. From there they continue southwestward into Nantucket Sound or eastward onto Georges Bank. Drift-bottles released by NAI along the New Hampshire coast in late spring of 1973, 1974, and 1975, at the time of year when the flow reaches its peak, have been carried southward and then eastward across the Gulf to Nova Scotia in as little as 70 to 90 days. In the summer the pattern of the spring gyre persists, but its drift rate gradually decreases (Figure 2.1-6). Finally, by late fall and early winter, the southern side of the Gulf's counterclockwise flow breaks down into a southerly drift across George's Bank and the annual cycle is completed.

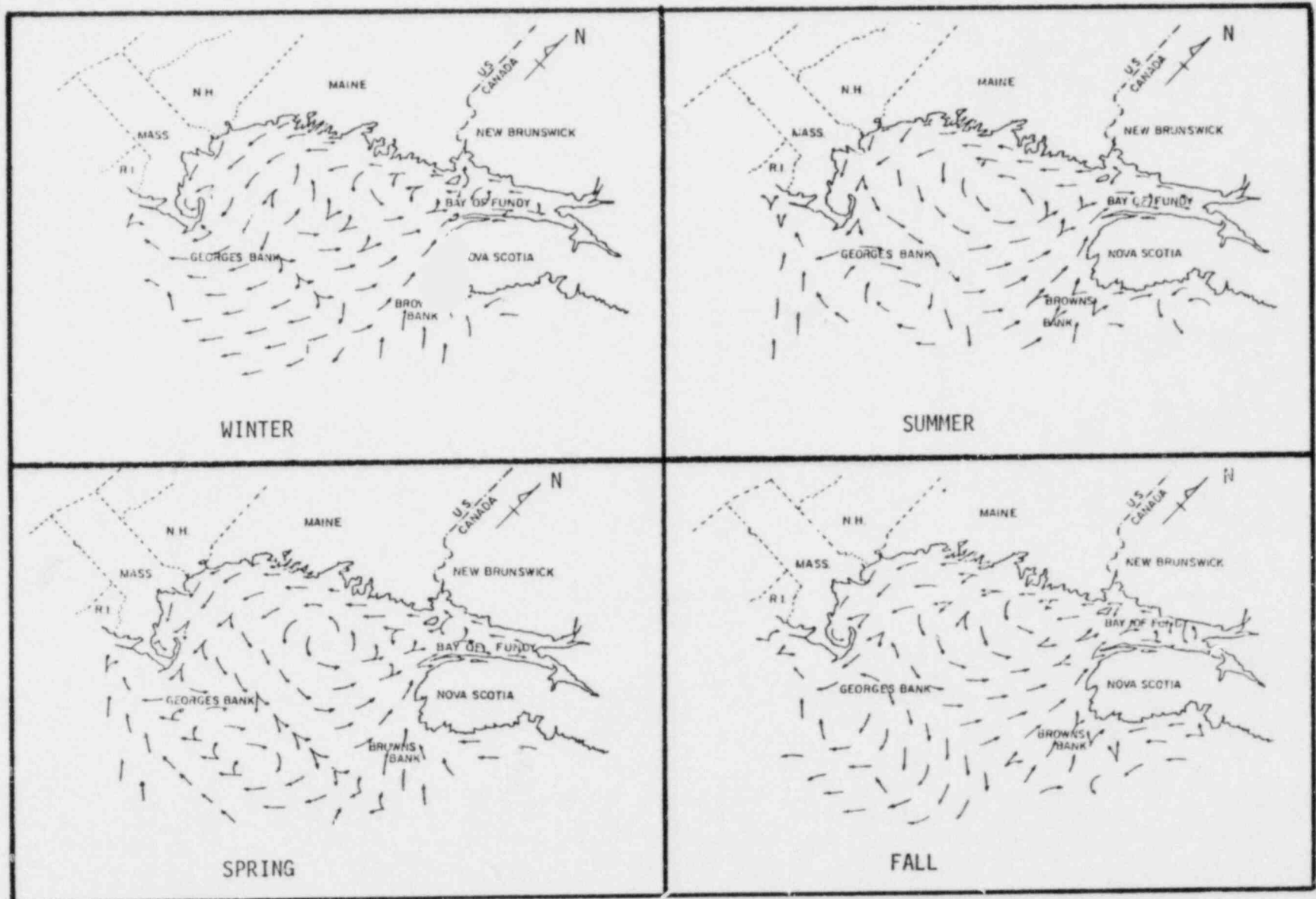

Figure 2.1-6. Seasonal variations in circulation patterns of surface waters in the Gulf of Maine (from Bumpus and Lauzier, 1965).

The study area off the New Hampshire coast represents a small segment of the coastal shelf zone of the Gulf of Maine in the North Atlantic Estuarine Zone (U.S. Fish and Wildlife Service, 1970). Graham (1970a) has defined this coastal water as lying within 13 n mi of the coast and at depths less than 328 ft extending from the mouth of the Bay of Fundy to Cape Cod. These coastal waters represent an area of mixing between water entering the Gulf of Maine via the Northern and Eastern Channels (Figure 2.1-2) and freshwater discharge, which varies seasonally, but is about 24 mi<sup>3</sup> annually (Emery and Uchupi, 1972). In general near-bottom waters from the Northeast Channel have a salinity of about 34.0 ‰ (Bigelow, 1927) and an annual temperature range of about 39.2 to 48.2 F (Colton and Stoddard, 1973).

The distribution of temperature and salinity of the waters in the Gulf of Maine has been studied by Bigelow (1927), Colton et al. (1968), Colton and Stoddard (1972) and TRIGOM (1974). Graham (1970a, 1970b) has studied the coastal waters of the Gulf of Maine from Cape Ann, Massachusetts, to Machias Bay, Maine. Surface-water temperature and salinity within a 16.2 n mi radius of the Merrimack River was studied by Ford (1947). Other hydrographic studies in these waters include: Wiseman (LSU, 1969 unpublished personal communication), EG and G (1972), Manohar-Maharaj and Beardsley (1973), NAI (1974a), Cox (1975) and NAI (1976f).

From 1969 through 1972 NAI conducted preliminary hydrographic surveys emphasizing summertime conditions in the Hampton Harbor estuary (NAI, 1971). Starting in September 1972 and continuing through to the present, NAI's extensive studies (1975b, 1975f and 1977a) have included the following:

- I. Continuous Monitoring of Oceanographic and Meteorological Parameters from Fixed Points:
  - A. Mooring Deployment: More than 30 different specially designed mooring systems to serve as instrumentation platforms have been deployed on a year-round basis.

- B. Current Measurements: For nearly 4-1/2 years continuous water current speed and direction measurements have been obtained from the various offshore moorings (Figure 2.1-7 compiling a data base, exceeding 30 current-meter mooring years (Figure 2.1-8).
- C. Temperature Measurements: For nearly 4-1/2 years continuous water temperature measurements have been obtained from the various offshore moorings as well as from around the Inner and Outer Sunk Rocks and the Hampton Harbor estuary, documenting nearly 25 temperature monitoring years of data;
- D. Tide Elevation Measurements: For nearly 4-1/2 years tide elevation has been monitored continuously in the Hampton Harbor estuary;
- E. Wind Measurements: For nearly 4-1/2 years wind speed and direction have been monitored continuously in Hampton Beach State Park.

## II. Oceanographic Cruises:

- A. Plankton Cruises: Essentially monthly oceanographic cruises to survey plankton distribution, hydrographic parameters, and net circulation patterns (drifter releases) in the western Gulf of Maine out to almost 25 n mi offshore;
- B. Slack Water Surveys: Monthly to semi-monthly hydrographic surveys to document low-water and high-water "slack" distributions of ambient temperature, salinity, density and dissolved oxygen at stations in Hampton Harbor and offshore around the various proposed intake and discharge sites;
- C. Special Temperature Studies: Over a 1-year period intensive temperature surveys (including *in situ* monitoring and tide-pool measurements) were made around the Inner and Outer Sunk Rocks off the mouth of Hampton Harbor;

## III. Anchor Station Studies:

Periodic surveys over a tidal cycle at selected stations to document ambient currents, temperature, salinity, density and dissolved oxygen frequently included *in situ* streamer observations and drogue studies;

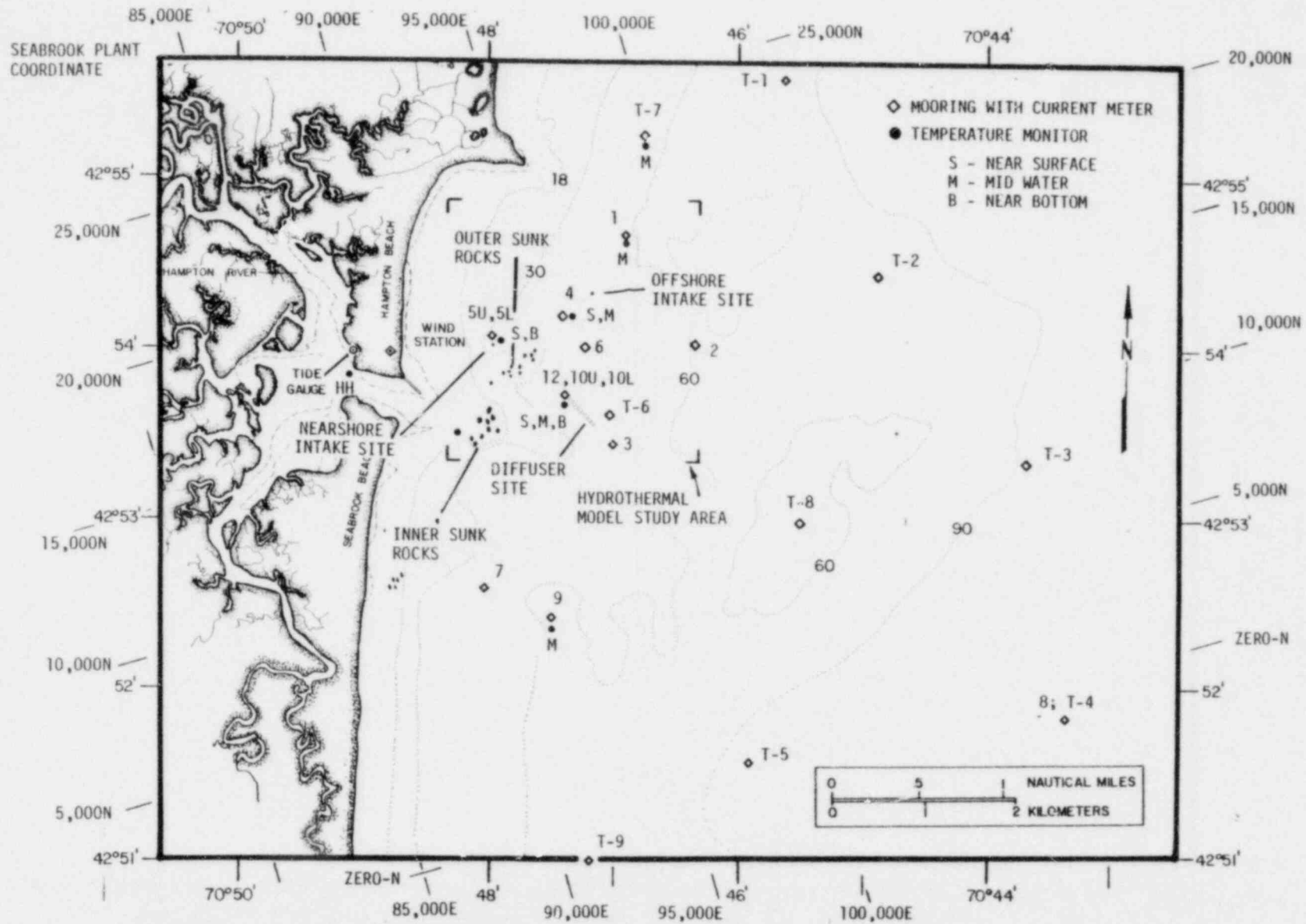

Figure 2.1-7. Location map showing NAI moorings with current meters and temperature monitors in coastal waters off Hampton Beach, New Hampshire.

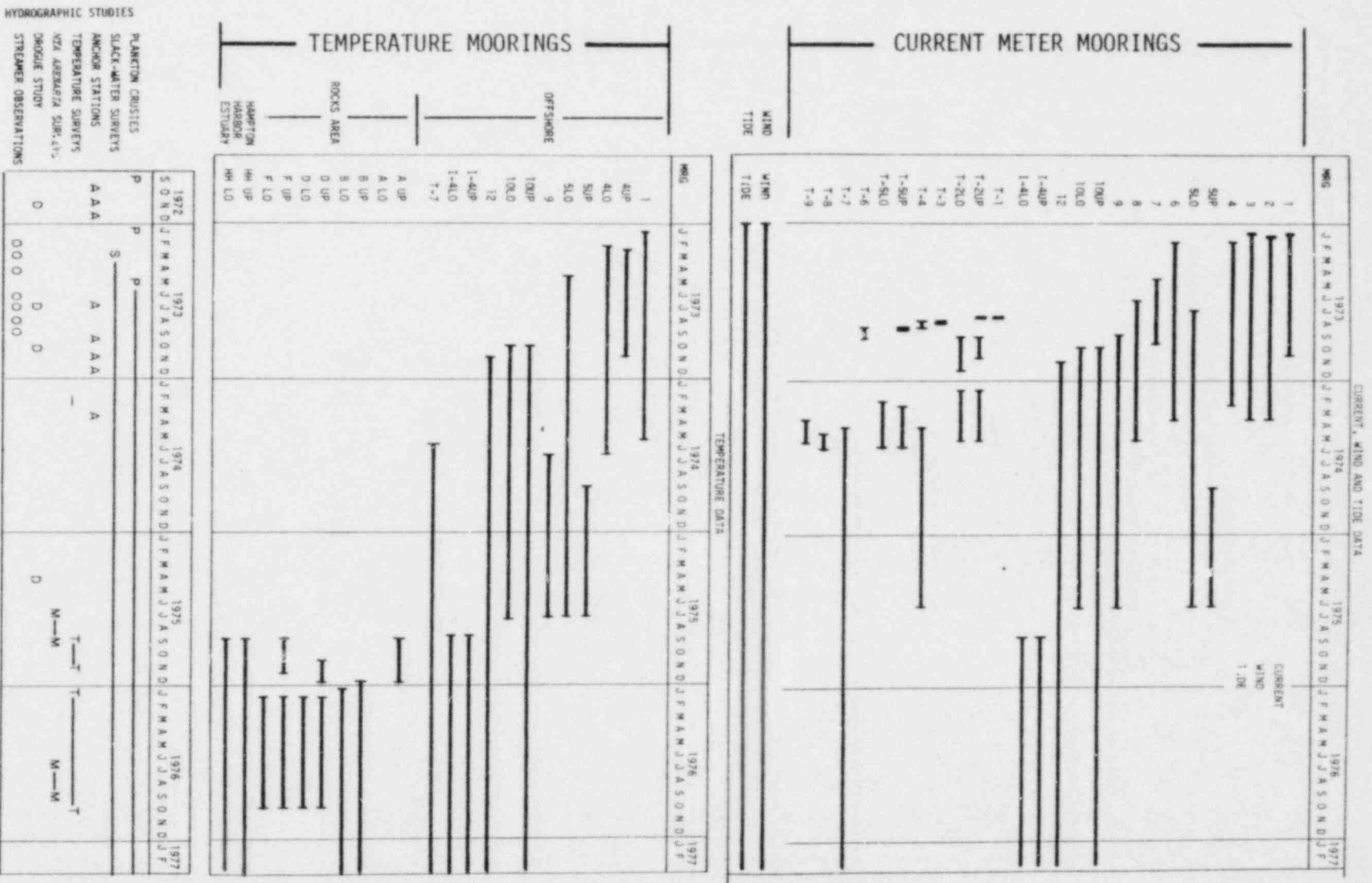

Figure 2.1-8. Diagram showing hydrographic studies which have been conducted off Hampton Beach, New Hampshire, from 1972 to date.



#### IV. Drifter Studies:

More than 4 years of drifter releases including some 12,000 drift bottles and nearly 15,000 drogue and sea-bed drifters with an overall recovery of about 25 to 40% depending upon the drifter type; included a special study to determine the probability of coastal waters entering the Hampton Harbor estuary and neighboring estuaries as a function of distance and depth offshore (NAI, 1975b);

#### V. Sedimentological Studies:

- A. Sediment Stakes: Monthly height measurements of stakes jettied into the sea floor were used to document long-term, net-sediment erosion and/or deposition;
- B. Sediment Trap: This device was used to document seasonal aspects of near-bottom suspended sediment transport at the nearshore intake site;
- C. Turbidity Survey: Two special surveys were conducted to measure ambient turbidity levels in Hampton Harbor estuary under "typical" and "post-storm" conditions.

#### 2.1.3 Biological Setting

Biogeographically, the New Hampshire nearshore zone is approximately at the midpoint in the Nova Scotian Marine Province which extends from Nova Scotia south to Cape Cod. Generally, the marine organisms resident in the Hampton-Seabrook area are also found throughout the province.

The fauna and flora of this province are relatively well known and the following studies provide information concerning spatial and temporal distribution of dominant species in each category:

- I. Finfish: Bigelow and Schroeder (1953), TRIGOM (1974);
- II. Benthos: TRIGOM (1974), Parker (1975);

- III. Macroalgae: Lamb and Zimmerman (1964), Mann (1972), Mathieson, Hehre and Reynolds (1977):
- IV. Plankton: Bigelow (1926), Gran and Braarud (1935), Fish and Johnson (1937), Lillick (1940), Sherman (1965, 1966, 1968, 1970).
- V. Intertidal: TRIGOM (1974), Menge (1976), Gosner (1971).

Biological studies for Seabrook Station began in the summer of 1969. Initial studies (NAI, 1970, 1971, 1972a-h) focused on the biota of Hampton-Seabrook estuary since it was originally proposed that the cooling system intake be located in the estuary. When the concept of an offshore site was adopted in 1972, studies of the nearshore biota were initiated, and have continued through to the present (Figure 2.1-9). These studies have included the following:

- I. Soft-shell Clam, *Mya arenaria*
  - A. Adult Surveys: Beginning in 1969, and continuing from 1971 to the present, five major clam flats in Hampton Seabrook Estuary have been sampled annually in November, to document variability in the standing stock of harvestable clams. In addition, one of the flats (designated as No. 2) has been sampled quarterly;
  - B. Spat Surveys: Concurrent with the adult surveys, samples of newly settled young (1 to 25 mm long) have been obtained. Beginning in early 1976, the spat program was expanded to include five other nearby northern New England estuaries.
  - C. Planktonic Larvae Tows: Beginning in 1969 and continuing to the present, plankton pump samples have been analyzed during the warmer months to determine spatial and temporal abundance of the pelagic larvae.
  - D. Larviculture: A special laboratory study was undertaken in 1975 to confirm larval identification. *Mya arenaria* and a distantly related species, *Hiatella* sp. were spawned and the eggs reared to the settling (pediveliger) stage.

	1969		1970		1971		1972		1973		1974		1975		1976		1977		
	J	J	J	J	J	J	J	J	J	J	J	J	J	J	J	J	J	J	
SOFT-SHELL CLAM																			SOFT-SHELL CLAM
ADULT	---					---		---	---	---	---	---	---	---	---	---	---	---	ADULT
SPAT						---	---	---	---	---	---	---	---	---	---	---	---	---	SPAT
LARVAE	---		---		---		---		---		---		---		---		---		LARVAE
FINFISH																			FINFISH
TRAWL									---	---	---	---	---	---	---	---	---	---	TRAWL
GILL NET							---	---	---	---	---	---	---	---	---	---	---	---	GILL NET
SEINE	---								---	---	---	---	---	---	---	---	---	---	SEINE
PLANKTON																			PLANKTON
ZOOPLANKTON			---	---	---	---	---	---	---	---	---	---	---	---	---	---	---	---	ZOOPLANKTON
PHYTOPLANKTON			---	---	---	---	---	---	---	---	---	---	---	---	---	---	---	---	PHYTOPLANKTON
ICHTHYOPLANKTON	---				---		---		---		---		---		---		---		ICHTHYOPLANKTON
BENTHOS																			BENTHOS
SUBTIDAL							---	---					---	---	---	---	---	---	SUBTIDAL
INTERTIDAL													---	---	---	---	---	---	INTERTIDAL
ESTUARINE													---	---	---	---	---	---	ESTUARINE
METOFAUNA													---	---	---	---	---	---	METOFAUNA
SETTLING COMMUNITY													---	---	---	---	---	---	SETTLING COMMUNITY
MACROALGAE																			MACROALGAE
INTERTIDAL	---												---	---	---	---	---	---	INTERTIDAL
SUBTIDAL							---	---	---	---	---	---	---	---	---	---	---	---	SUBTIDAL
GROWTH STUDIES													---	---	---	---	---	---	GROWTH STUDIES
LOBSTER (ADULT)							---	---	---	---	---	---	---	---	---	---	---	---	LOBSTER (ADULT)
(LARVAE)							---	---	---	---	---	---	---	---	---	---	---	---	(LARVAE)

Figure 2.1-9. Diagram showing biological studies which have been conducted in the vicinity of Hampton Beach, New Hampshire from 1969 to date.

## II. Finfish

- A. Otter Trawls: Replicate 10-15 min tows have been conducted monthly from 1974 to the present, and twice monthly in 1973, along transects offshore from Hampton Beach.
- B. Gill Nets: Offshore from Hampton Beach, 48 or 72 hour sets have been carried out approximately monthly, from 1974 to the present, and twice monthly in 1973.
- C. Beach Seines: Collections have been made from April through November using seine casts in the shallower reaches of Hampton-Seabrook estuary, twice monthly in 1973 and monthly from 1974 to the present.
- D. Ichthyoplankton Collections: Oblique tows using one meter diameter 505  $\mu$ m and, occasionally, 333  $\mu$ m mesh nets have been conducted approximately twice monthly in 1973, and monthly from 1974 to the present.

## III. Phytoplankton and Invertebrate Zooplankton

- A. Pumps: Submersible electric pumps have been used since 1972 to study spatial and temporal variability of phytoplankton and microzooplankton on a monthly basis (twice monthly during the warmer months of 1973). The pumps were also used to obtain water samples for plant nutrient, chlorophyll a, and carbon<sup>14</sup> uptake analysis.
- B. Net tows: Oblique tows using 333  $\mu$ m and, occasionally, 505  $\mu$ m mesh nets, 60 cm in diameter, mounted in a twin "bongo" frame, have been employed on approximately a monthly basis since 1973, to investigate temporal and horizontal variability of macrozooplankton. In 1973, sampling was twice monthly and ranged over a particularly wide area of Bigelow Bight, out to almost 25 n mi from the Seabrook Station site.

## IV. Benthos

- A. Subtidal Fauna: For the past two years, surveys have been conducted quarterly at 15 subtidal stations in the vicinity of the proposed intake and discharge site, and at four stations in Hampton-Seabrook Estuary, to determine community structure. Surveys of offshore subtidal benthos were also conducted in the summers of 1969, 1972 and 1974.

- B. Intertidal Fauna: Destructive (dredge) and non-destructive samples have been taken since the spring of 1975 on a quarterly basis from three intertidal elevations on rock ledge habitat off Hampton Beach. Concurrently, destructive sampling has also been carried out at four intertidal stations in Hampton-Seabrook Estuary.
- C. Meiofauna: Since the summer of 1975, replicate cores to sample meiofauna (tiny interstitial organisms) have been collected quarterly at five subtidal stations off Hampton Beach and four intertidal stations in Hampton-Seabrook Estuary, in order to describe temporal and spatial distribution of dominant organisms.
- D. Macroalgae: Growth rate, vertical distribution of biomass, and reproductive cycles of two dominant macroalgae species: irish moss, *Chondrus crispus*; and kelp, *Laminaria saccharina*, have been monitored monthly since the summer of 1975.

V. Lobster, *Homarus americanus*

- A. Trapping Studies: Since 1972, a string of 15 to 30 lobster pots in the vicinity of the proposed discharge site has been tended by an experienced lobsterman approximately once every three days, from June through November. Records are kept for computing catch per effort.
- B. Planktonic Larvae: During the summer of 1973, replicate 15 minute tows were conducted monthly along five transects offshore from Hampton Beach, using a one-meter diameter 505  $\mu$ m mesh net equipped to tow breaking the water surface.

VI. Biofouling:

Short-term settlement of biofouling organisms and long-term community structure has been monitored for two years in the estuary, and offshore, with the use of submerged artificial substrates.

The most recent of these studies have been incorporated into the preoperational monitoring program; further description of this program and location of sample sites is given in Section 6.0.

## 2.2 HYDROGRAPHIC ENVIRONMENT

### 2.2.1 Currents

Currents are large-scale water movements which occur everywhere in the ocean. The forces causing major ocean currents come primarily from winds and from unequal heating and cooling of ocean waters. Both are the result of unequal heating of the earth's surface. Ocean currents contribute to the heat transport from tropics to poles, thereby partially equalizing earth-surface temperatures (Gross, 1972). Because the Gulf of Maine is a coastal ocean lying over the continental shelf, it is especially susceptible to wind influence. Winds blowing over the surface of the water set surface waters in motion, which may in turn cause storm surges, coastal currents, or upwelling. Secondly, winds generate waves which affect the coastal ocean through their actions on shorelines and mixing of surface waters. A consistent feature of coastal processes is their compressed time scale as compared with the same processes in the open ocean. The shallowness of coastal waters, such as off Hampton Beach, allows rapid heating, cooling, evaporation, dilution, or movement as an overall pattern of periodic abrupt change in contrast to the more uniform conditions of the deep ocean (Gross, 1972).

#### 2.2.1.1 Observations and Measurements from Fixed Points (Eulerian Method)

##### I. PRINCIPAL FLOW PATTERNS

The coastal waters off Hampton Beach are very dynamic and some current flow is always present because of the combined effects of tide, wind stress, net drift and other hydrographic and meteorological dynamics. In terms of the resultant flow patterns, six principal variants may be described (Figure 2.2-1). These are basically derived from the superimposition of persistent, steady-state, flow on the ebb and flood of tidal circulation. Weak Tidal Flow is quite variable but has a tendency

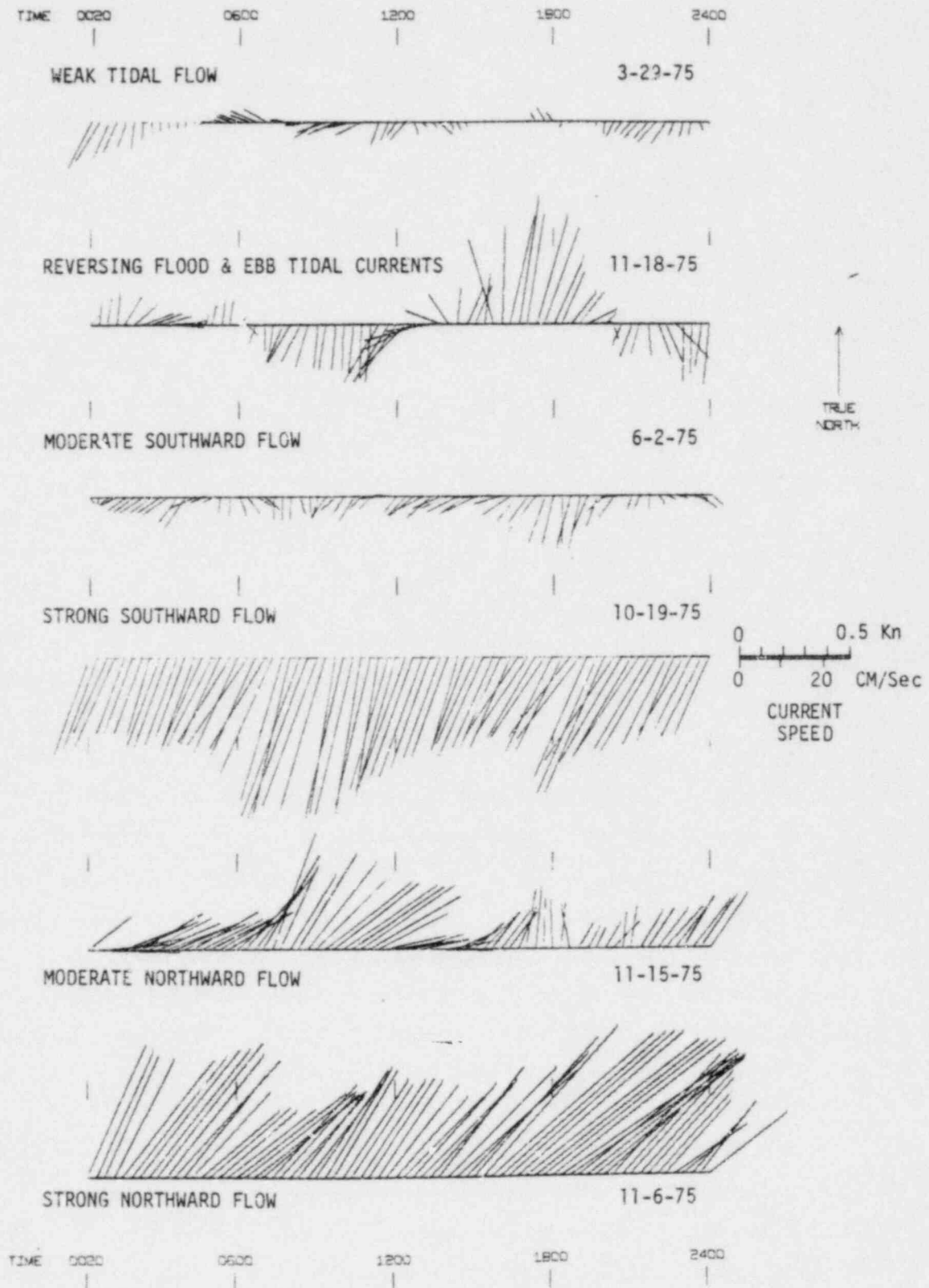

Figure 2.2-1. Examples of main types of current flows observed in coastal waters off Hampton Beach, New Hampshire.

toward periodic reversals in direction. Strong expression of Reversing Flood and Ebb Tidal Currents on a regular 6 to 7 hr basis occurs when there is very little effective steady-state motion. Moderate or Strong North/South Flow occurs when steady-state flow completely overwhelms tidal reversal.

Classified as described above, coastal current-meter flow data from moorings seaward of the Outer Sunk Rocks exhibit the frequencies given in Figure 2.2-2 and Table 2.2-1. The most common type of flow in these waters was transient or tidal flows, which comprised almost one-half (41%) of the 4-yr (1437 day) study period from January 24, 1973 to December 31, 1976 (Table 2.2-1). The most frequent flows of this type were reversing flood- and ebb-tidal currents, comprising 20.7% overall. Weak tidal flows made up the remaining 19.7% overall.

The steady-state flows toward the south and the north were about equally distributed (28.6% overall for the former and 31.1% overall for the latter). The southerly flows along the coast, which occurred roughly one fourth of the year, were generally the result of northeasterly storms and occasional periods of northwesterly winds. Such flows essentially masked out the tidal currents and frequently persisted unabated for days at a time. Moderate southward flows of about 0.2 to 0.3 kn comprised 19.7% overall. Strong flows, which occasionally reached 1.0 kn comprised 8.8% overall. Correspondingly, the northward flows generally occurred during the remaining fourth of the year in conjunction with strong south-to-southwest winds or as possible seiching in the western Gulf of Maine following storm surges. Moderate northward flows comprised 26.0% overall, whereas strong flows were 5.1% overall (Table 2.2-1).

The coastal waters frequently demonstrate a two-layer flow system reinforced by ambient stratification of temperature, and salinity (see Section 2.2.6). During the spring, summer and early fall, the upper portion of the water column is warmer and less saline than waters at depth because of radiational heating and runoff. In the late fall



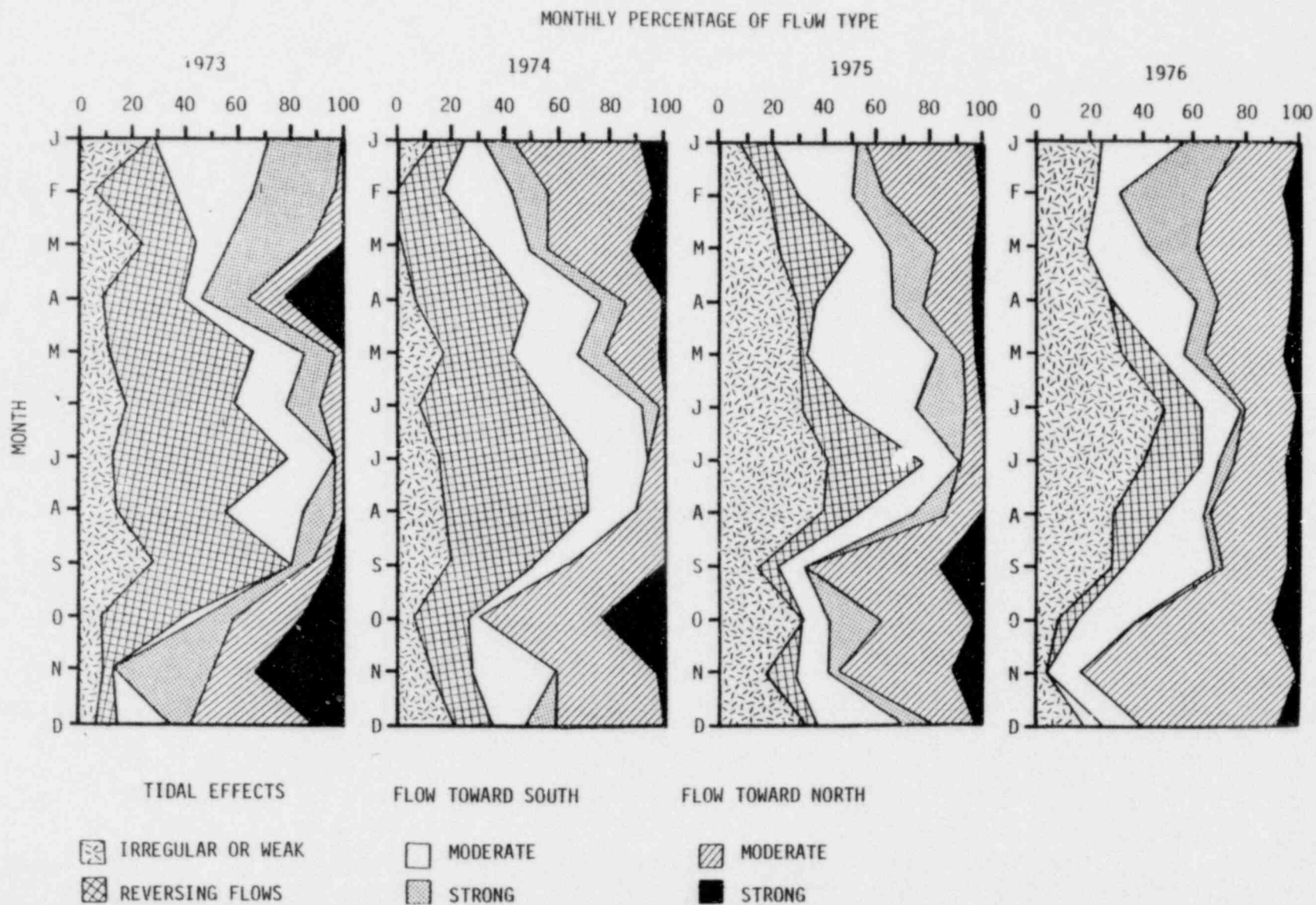

Figure 2.2-2. Tabulation of monthly percentage of observed current flow types for coastal waters off Hampton Beach, New Hampshire, from 1973 through 1976.

TABLE 2.2-1. DISTRIBUTION OF CURRENT-FLOW TYPES IN COASTAL WATERS SEAWARD OF THE OUTER SUNK ROCKS OFF HAMPTON BEACH, N.H.

MONTH	NO. OF DAYS IN MONTH	NUMBER OF DAYS PER MONTH (PERCENTAGE)					
		TRANSIENT FLOW		STEADY-STATE FLOW			
		TIDAL EFFECTS		FLOW TOWARD THE SOUTH		FLOW TOWARD THE NORTH	
		WEAK TIDAL FLOW	REVERSING FLOOD AND EBB TIDAL CURRENTS	MODERATE ABOUT 0.2-0.3 KN	STRONG GENERALLY >0.3 KN	MODERATE ABOUT 0.2-0.3 KN	STRONG GENERALLY >0.3 KN
<b>1973</b>							
January	7	2.0 (28.6)	0.0 (0.0)	3.0 (42.8)	2.0 (28.6)	0.0 (0.0)	0.0 (0.0)
February	28	2.0 (7.1)	8.0 (28.6)	9.0 (32.1)	8.0 (28.6)	1.0 (3.6)	0.0 (0.0)
March	31	9.0 (29.0)	6.0 (19.4)	3.5 (11.3)	10.0 (32.2)	3.5 (11.3)	0.0 (0.0)
April	30	3.0 (10.0)	9.0 (30.0)	2.0 (6.7)	5.5 (18.3)	4.0 (13.3)	6.5 (21.7)
May	31	4.0 (12.9)	16.5 (53.2)	6.0 (19.4)	4.0 (12.9)	0.5 (1.6)	0.0 (0.0)
June	30	6.0 (20.0)	12.0 (40.0)	5.5 (18.3)	4.0 (13.3)	2.5 (8.3)	0.0 (0.0)
July	31	4.5 (14.5)	20.0 (64.5)	6.0 (19.4)	0.0 (0.0)	0.5 (1.6)	0.0 (0.0)
August	31	4.5 (14.5)	13.0 (41.9)	9.0 (29.0)	3.0 (9.7)	1.5 (4.8)	0.0 (0.0)
September	30	8.5 (28.3)	16.0 (53.3)	0.0 (0.0)	2.0 (6.7)	2.5 (8.3)	1.0 (3.3)
October	31	3.0 (9.7)	9.5 (30.6)	2.0 (6.4)	4.0 (12.9)	7.5 (24.2)	5.0 (16.1)
November	30	0.5 (1.7)	3.5 (11.7)	0.5 (1.7)	0.0 (0.0)	15.5 (51.7)	10.0 (33.3)
December	31	2.5 (8.1)	3.0 (9.7)	5.5 (17.7)	2.5 (8.1)	14.0 (45.2)	3.5 (11.3)
TOTAL DAYS	341	48.5 (14.2)	116.5 (34.2)	52.0 (15.2)	45.0 (13.2)	53.0 (15.5)	26.0 (7.6)
PERCENT BY TYPE		(48.4)		(28.4)		(23.1)	
<b>1974</b>							
January	31	4.0 (12.9)	3.5 (11.3)	2.5 (8.1)	3.5 (11.3)	14.5 (46.8)	3.0 (9.7)
February	28	0.0 (0.0)	5.0 (17.8)	7.0 (25.0)	4.0 (14.3)	11.0 (39.3)	1.0 (3.6)
March	31	0.5 (1.6)	10.0 (32.2)	4.5 (14.5)	2.5 (8.1)	9.5 (30.6)	4.0 (12.9)
April	30	2.0 (6.7)	12.5 (41.7)	8.5 (28.3)	3.0 (10.0)	4.0 (13.3)	0.0 (0.0)
May	31	5.5 (17.7)	8.0 (25.8)	7.5 (24.2)	3.0 (9.7)	6.0 (19.4)	1.0 (3.2)
June	30	2.5 (8.3)	14.5 (48.3)	10.5 (35.0)	2.0 (6.7)	0.5 (1.7)	0.0 (0.0)
July	31	5.0 (16.1)	17.0 (54.8)	7.0 (22.6)	0.0 (0.0)	2.0 (6.4)	0.0 (0.0)
August	31	5.5 (17.7)	14.5 (46.5)	5.5 (17.7)	0.0 (0.0)	3.5 (11.3)	0.0 (0.0)
September	30	6.0 (20.0)	9.0 (30.0)	4.5 (15.0)	0.0 (0.0)	10.5 (35.0)	0.0 (0.0)
October	31	2.0 (6.4)	6.5 (21.0)	1.0 (3.2)	0.0 (0.0)	14.5 (46.8)	7.0 (22.6)
November	30	4.0 (13.3)	4.5 (15.0)	9.5 (31.7)	0.0 (0.0)	11.0 (36.7)	1.0 (3.3)
December	31	6.5 (21.0)	4.5 (14.5)	3.5 (11.3)	3.5 (11.3)	13.0 (41.9)	0.0 (0.0)
TOTAL DAYS	365	43.5 (11.9)	111.5 (30.5)	71.5 (19.6)	21.5 (5.9)	100.0 (27.4)	17.0 (4.6)
PERCENT BY TYPE		(42.4)		(25.5)		(32.0)	
<b>1975</b>							
January	31	3.0 (9.7)	3.5 (11.3)	10.0 (32.2)	1.0 (3.2)	12.5 (40.3)	1.0 (3.2)
February	28	5.5 (19.6)	3.0 (10.7)	6.0 (21.4)	3.0 (10.7)	10.5 (37.5)	0.0 (0.0)
March	31	7.0 (22.6)	9.0 (29.0)	4.0 (12.9)	5.5 (17.7)	4.5 (14.5)	1.0 (3.2)
April	30	9.0 (30.0)	2.0 (6.7)	8.5 (28.3)	4.0 (13.3)	5.5 (18.3)	1.0 (3.3)
May	31	9.5 (30.6)	1.0 (3.2)	15.5 (50.0)	3.0 (9.7)	1.0 (3.2)	1.0 (3.2)
June	30	9.5 (31.7)	5.0 (16.7)	8.0 (26.7)	5.5 (18.3)	2.0 (6.7)	0.0 (0.0)
July	31	12.5 (40.3)	4.0 (12.9)	7.0 (22.6)	1.5 (4.8)	4.5 (14.5)	0.0 (0.0)
August	31	12.0 (38.7)	4.0 (12.9)	7.0 (22.6)	1.5 (4.8)	4.5 (14.5)	0.0 (0.0)
September	30	4.5 (15.0)	2.5 (8.3)	3.0 (10.0)	0.0 (0.0)	15.0 (50.0)	5.0 (16.7)
October	31	9.5 (30.6)	0.0 (0.0)	3.5 (11.3)	6.0 (19.4)	11.0 (35.5)	1.0 (3.2)
November	30	5.5 (18.3)	3.0 (10.0)	4.0 (13.3)	1.0 (3.3)	13.0 (43.3)	3.5 (11.7)
December	31	10.5 (33.9)	1.0 (3.2)	10.5 (33.9)	3.0 (9.7)	5.5 (17.7)	0.5 (1.6)
TOTAL DAYS	365	98.5 (27.0)	45.0 (12.3)	84.0 (23.0)	35.5 (9.7)	88.0 (24.1)	14.0 (3.8)
PERCENT BY TYPE		(79.3)		(32.7)		(27.9)	
<b>1976</b>							
January	31	7.5 (24.2)	0.0 (0.0)	9.5 (30.6)	6.5 (21.0)	7.5 (24.2)	0.0 (0.0)
February	29	6.5 (22.4)	0.0 (0.0)	5.5 (19.0)	5.5 (19.0)	9.5 (32.8)	2.0 (6.9)
March	31	5.5 (17.7)	0.0 (0.0)	7.5 (24.2)	5.5 (17.7)	11.5 (37.1)	1.0 (3.2)
April	30	8.5 (28.3)	0.0 (0.0)	9.5 (31.7)	2.5 (8.3)	8.5 (28.3)	1.0 (3.3)
May	31	10.0 (32.2)	4.0 (12.9)	3.5 (11.3)	2.0 (6.4)	9.5 (30.6)	2.0 (6.4)
June	30	14.5 (48.3)	4.0 (13.3)	4.5 (15.0)	0.5 (1.7)	6.5 (21.7)	0.0 (0.0)
July	31	12.5 (40.3)	6.5 (21.0)	2.5 (8.1)	1.5 (4.8)	6.0 (19.4)	2.0 (6.4)
August	31	9.0 (29.0)	5.0 (16.1)	5.5 (17.7)	0.5 (1.6)	9.5 (30.6)	1.5 (4.8)
September	30	8.5 (28.3)	1.0 (3.3)	11.0 (36.7)	0.5 (1.7)	7.5 (25.0)	1.5 (5.0)
October	31	2.5 (8.1)	2.0 (6.4)	7.5 (24.2)	0.0 (0.0)	15.5 (50.0)	3.5 (11.3)
November	30	1.5 (5.0)	0.0 (0.0)	4.0 (13.3)	0.0 (0.0)	24.5 (81.7)	0.0 (0.0)
December	31	6.0 (19.4)	1.5 (4.8)	5.5 (17.7)	0.0 (0.0)	15.5 (50.0)	2.5 (8.1)
TOTAL DAYS	366	92.5 (25.3)	24.0 (6.6)	76.0 (20.8)	25.0 (6.8)	131.5 (35.9)	17.0 (4.6)
PERCENT BY TYPE		31.8		27.6		40.6	
<b>SUMMARY: 1973 TO 1976</b>							
TOTAL DAYS =	1437	283.0	297.0	283.5	127.0	373.5	73.0
PERCENT		(19.7)	(20.7)	(19.7)	(8.8)	(26.0)	(5.1)
PERCENT BY TYPE		(40.4)		(28.6)		(31.1)	

the waters are more homogeneous from surface to bottom, whereas, in the winter the upper part of the water column is actually slightly colder than at depth because of radiational cooling. This stratification creates a shear-plane at depth within the water column and enables the winds to drive the near-surface waters downwind whenever the winds have been strong and persistent enough. This is the basic phenomenon which accounts for the steady-state flows either southward or northward. The flow at depth frequently is reversed from that of the near-surface layer in apparent compensation.

Spectral analysis of representative current-meter data over a range of frequency periods from about 120 hrs to less than 6 hrs indicates that three main frequency components are present in flow patterns off Hampton Beach, New Hampshire: (1) a very low frequency storm component and possible lunar-cycle effect with a periodicity of 80 to 120 hrs, (2) a strong tidal component at about 12 hrs, and (3) a weak secondary component at 6 to 7 hrs which may be related to irregular tidal flows (NAI, 1975f).

In the summertime the shallow current meters show both a well-developed storm component and a tidal component, indicating that the upper part of the water column is alternately affected by wind-driven near-surface flows and the tides. At mid-depth current meters, the storm component is less evident, the tidal component is dominant, and the secondary component is more pronounced. Near bottom the flows are almost completely tidal with some secondary component, indicating that near-bottom waters are below the depth to which storm effects generally extend in the summer.

During the winter, only storms and 12-hr tidal components are generally observed. The shallower current meters are generally dominated by storm flows with very weak tidal components. Near-bottom waters show a stronger tidal component with a weak secondary 7 to 8-hr component, but still tend to be dominated by the storm conditions. During winter, the tidal effects are almost completely masked out by

storms and possibly lunar-cycle effects. Cross-covariance analysis of current and wind data has shown that near-surface currents lag several hours behind wind shifts.

## II. SEASONAL FLOW

Currents observed during the fall months are generally toward the north and northeast at mean speeds of 0.17 to 0.44 kn; apparently, these are largely caused by southwest winds and breakdown in the flow of the Gulf of Maine gyre. Flows in other directions are generally about 0.10 to 0.19 kn with some higher mean speeds toward the southwest (up to 0.22 kn). Distinct shearing along the thermocline between the upper and lower portions of the water column has been observed at both the discharge site and the nearshore intake site. Near-bottom mean speeds are higher in the fall than are typically observed during the summer. Thus, near-surface currents tend to follow the wind; whereas, flows at depth tend to parallel the coast under more tidal influence or move shoreward as a possible compensatory flow.

In general during the winter months, winds and storms play a dominant role in coastal circulation of the waters off Hampton Beach, New Hampshire and in the western Gulf of Maine. A prevalent flow toward the north or northeast at mean speeds of 0.13 to 0.20 kn prevails at the shallower depths. These flows are nearly balanced by south-to-southwesterly currents averaging 0.19 to 0.23 kn. At the nearshore intake site weaker currents and more evenly distributed flows, with a slight prevalence for southwesterly directions, are indicated by the data. Tidal effects are also usually more apparent at this location than at other moorings, possibly because of channeling effects between Outer Sunk Rocks and Hampton Beach. Currents at depth are generally progressively weaker than near-surface flows. Near-bottom flows at the diffuser site are apparently affected by the bottom topography and a northwesterly compensatory flow toward shore (NAI, 1975f). Offshore at Mooring T-4 the southerly flows are usually more dominant than at near-shore moorings, but mean current speeds are about the same.

During the spring months, storms generally continue to play an important role in coastal circulation with the tides beginning to show more of an influence, especially during periods of calm weather. The predominant flows in the spring are generally toward the south and southwest quadrants, at about the same mean speeds (about 0.15 to 0.29 kn) as equivalent flows during the preceding winter months. Northward currents are nearly as common as in the winter, but their mean speeds are faster (0.10 to 0.28 kn). This bimodal pattern is primarily the result of combined effects of northeasterly and southwesterly storm winds, which drive nearshore waters either southward or northward along the coast respectively. At the nearshore intake sites, flows are generally strongly bimodal to the north and southwest, reflecting the topographic effect of the Outer Sunk Rocks on local flow patterns.

The influence of tides during the calmer atmospheric periods between storms is evidenced by nearly-equal flow distributions in various directions. Flows at the proposed discharge site often show pronounced shearing. Highest current speeds are usually observed near the surface; mean speeds of 0.29 kn southward and 0.28 kn northward have been recorded. At depth, the diffuser site has shown weaker mean speeds (about 0.23 kn southward and 0.16 kn northward). An anomalous northward component has been noted at depth in apparent compensation for the prevailing offshore winds and local effects of adjacent bedrock topography on the sea floor. Offshore at Mooring T-4, the southerly flows were more dominant and even stronger than nearshore (mean speeds of 0.25 to 0.30 kn).

During the summer months storms are less frequent and less intense, enabling tidal effects to become more apparent. During the summer months flows are generally weak and variable in all directions (about 0.10 to 0.15 kn) because of increased dominance of tidal effects. Occasional northeast storms during the summer accounted for the strong southwestward component at many of the moorings (mean speeds of 0.17 to 0.29 kn). During the summer observed current speeds weaker than 0.05 kn occurred more frequently than at any other time of the year.

During periods when tides predominated, flows alternated between northward flood and southward ebb, but there is generally a net residual drift of several nautical miles per day southward along the coast as part of the counterclockwise Gulf of Maine gyre. At the proposed discharge site, flows have shown considerable variation from one depth to another. Near surface northeasterly and southwesterly flows have been nearly balanced; only during 10% of the summer were speeds below 0.05 kn. At mid-depth, flow was more southerly with 15% of the speeds below 0.05 kn. Near bottom 63% of the flows were less than 0.05 kn with currents predominantly toward the northwest and southeast, similar to trends observed during the spring. Offshore at Mooring T-4 the strong south-to-southwesterly currents, observed during the spring persist throughout the summer season.

#### 2.2.1.2 Observation and Measurement of Current Trajectories (Lagrangian Method)

##### 1. DAILY NET DRIFT

Calculations of daily net drift or water-mass displacement along the coast (24-hr vector average based on actual 20-min observations of current speed and direction) further demonstrate the dynamic nature of the waters off Hampton Beach. Regardless of actual flow type (i.e., weak tidal flow, reversing flood and ebb-tidal currents, moderate or strong southward flows, and moderate or strong northward flows), the coastal currents are such that for any given day there is always some net residual non-tidal drift. Thus, nearshore flows may generally be conceptualized as somewhat discrete entities, often moving alternatively northward and southward independently from water masses further off shore which have greater freedom of motion in the east/west plane.

Daily net-drift data (longshore or north-south components averaged over 3-day periods for ease in presentation) collected from mid-depth current meters off Hampton Beach during 1973 through 1976 are

summarized in Figure 2.2-3. Data from the summer season, when tidal flows are most prevalent (Figure 2.2-2) and entrainment impacts of power plant operation potentially the greatest, show typical net drift rates of at least 1 to 2 n mi per day with numerous periods of much greater net drifts. Periods of large net drift are in apparent response to storm effects. Although conditions from year to year have varied slightly, a general summertime pattern has been observed in all 4 years. During both June and July of all 4 years, predominant net drift was southward except for about 4 to 5 days of northward drift. In August 1973 there was very little northward drift, in August 1974 about 5 to 6 days, and in August 1975 and 1976 about 10 to 12 days. During September 1973 and 1976 there was about 6 to 8 days of northward net drift, in 1974 about 21 days, and in 1975 about 27 days, showing conditions have varied somewhat from one summer to another.

These data document short periods of relatively small net drift over several days at times which occur periodically during the summer season. As these data show, such quiescent periods are interrupted by periods of strong flow, lasting for days at a time and resulting in large-scale net displacement of nearshore waters.

## II. DRIFTER RELEASES

For more than 4 years NAI has studied residual net non-tidal drift and circulation patterns in the western Gulf of Maine by means of year-round drifter releases. Since September 1972 drift bottles have been used to document near-surface flows out to 23 n mi offshore, whereas near-bottom flows have been studied by means of sea-bed drifters. Through September 1976 NAI released nearly 12,000 drift bottles and approximately 15,000 drogue and seabed drifters, with an overall recovery of about 25 to 40% depending upon the drifter type.

The results of the NAI studies (1975b and 1975f) show that most of the recoveries have been between Cape Ann and southern Maine,

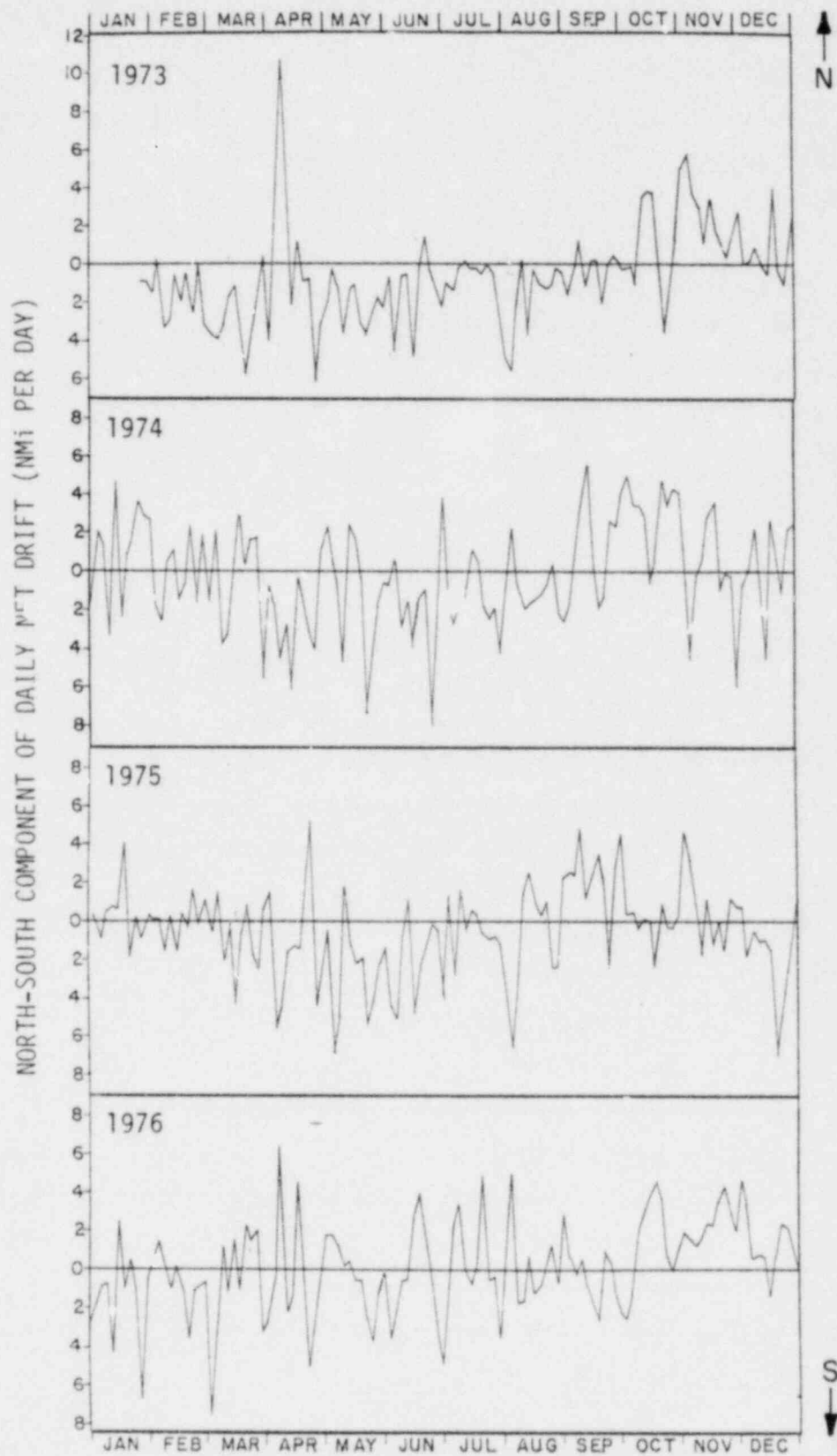

Figure 2.2-3. Plot of daily net drift of longshore (north-south) components averaged over 3-day periods from mid-depth current meters off Hampton Beach, New Hampshire, 1973 through 1976.



with the remainder in Maine, in Massachusetts Bay, and on Cape Cod. Furthest recoveries to the north and east have been along the coast of Nova Scotia (two recent returns have been from the Azores Islands and the Shetland Islands). Westernmost recoveries have been from Fire Island on Long Island, New York, and Watch Hill, Rhode Island. Numerous recoveries have been made on Martha's Vineyard and Nantucket with a few returns from Block Island, the Cuttyhunk Islands, and Buzzards Bay.

Typical seasonal drift patterns are documented as follows (Figure 2.2-4): "summer" season (June 1973), "fall" season (September 1972), and "winter" season (January 1973)\*. Monthly recovery percentages for the NAI studies have run from about 10 to 50 percent, depending upon the actual release (NAI, 1975f).

The drift bottles were typically carried southward and offshore, out past Cape Ann, by the flow of the Gulf of Maine gyre. Bottles released from the more-seaward stations had the lowest recovery percentages and frequently traveled the longest distances, but typically had higher non-tidal net drift ratios than the more-landward stations. Near-surface flows of the drift bottles were generally 1 to 3 n mi per day or at least ten times faster than the near-bottom flows of the seabed drifters (usually 0.1 n mi per day or less).

In contrast, sea-bed drifters released out to about 5 to 6 n mi offshore almost always had a southwestward component toward shore. This flow pattern was probably because of compensatory flow of saline waters intruding landward at depth below less-dense, seaward-moving surface layers. These flows may also be related to the effects of

---

\* Recoveries outside of the study area are coded as follows:

- "MB" for Massachusetts Bay and Cape Cod Bay
- "CC" for the outer or Atlantic coast of Cape Cod including Nantucket Sound and Buzzards Bay
- "RI" for Rhode Island
- "NY" for New York
- "NS" for Nova Scotia and the other Maritime Provinces of Canada

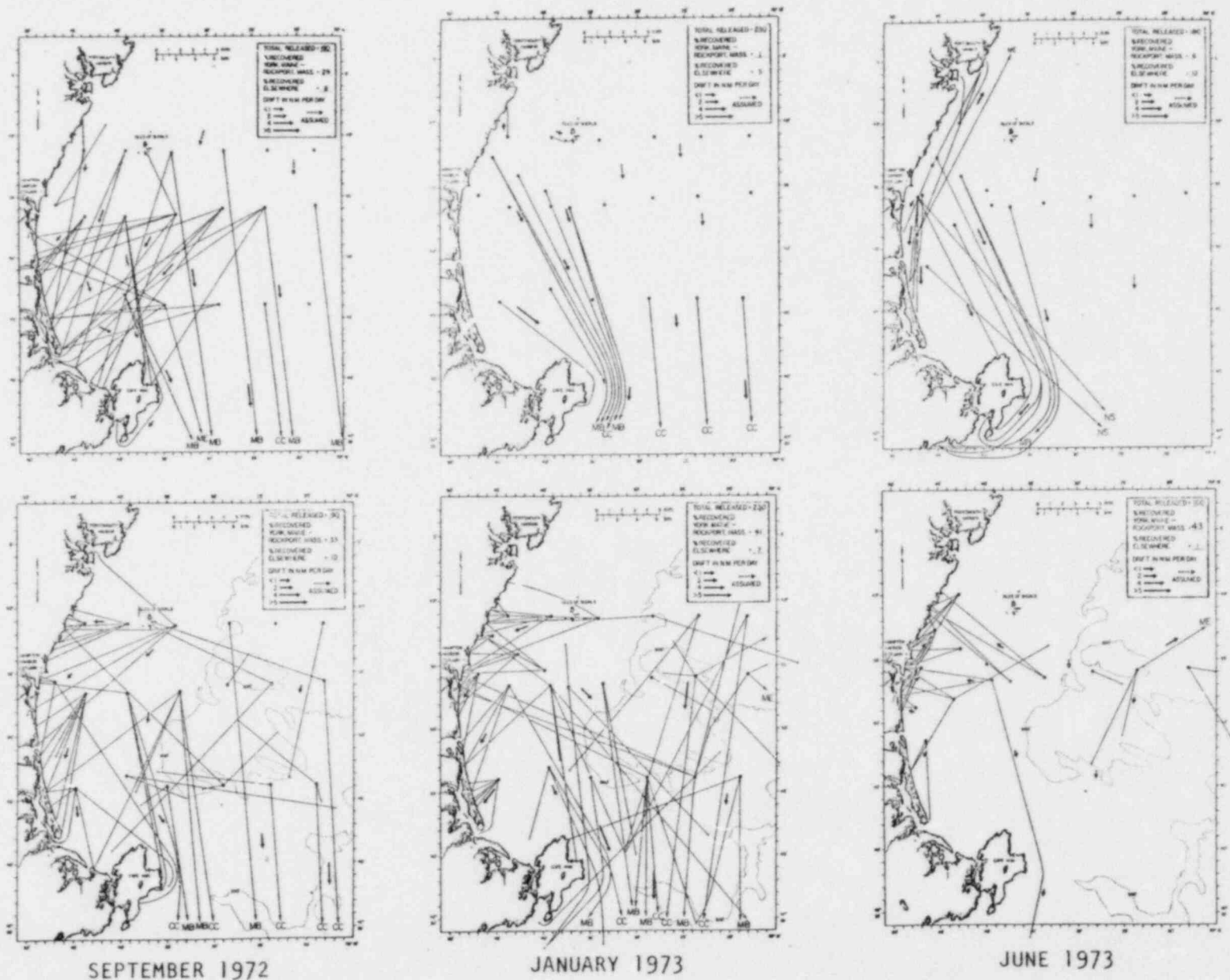

DRIFT BOTTLES

SEA-BED DRIFTERS

Figure 2.2-4. Net-drift trajectories of drift bottles (top) and sea-bed drifters (bottom) released by NAI during September 1972, January 1973 and June 1973.

northeast storms. Further seaward of this distance out beyond about 6 to 8 n mi, the near-bottom waters tended to move up-slope out of Scantum Basin and southward past Cape Ann into Massachusetts Bay. Some drifters were carried up onto Jeffreys Ledge, while others appear to have been carried through the deep channel off Cape Ann. Some of the variation in bottom drift is due to irregularities in bottom topography. Although sea-bed drifters are widely used to examine nearbottom flows (Bumpus, 1965), it should be noted that they are subject to entanglement in seaweed, rocks or bottom debris as they drift along and thus probably underestimate the true drift rate.

The general drift patterns of nearshore drifter releases show close corroboration with mean-flow data from the NAI current-meter moorings. During the summertime there is a tendency for waters at depth (deeper than about 10 to 20 ft) to have a southwesterly net-drift component of flow onshore, as apparent compensation for the prevailing south-to-southeasterly offshore netdrift of near-surface flows. These near-surface flows appear to parallel the coast or to be more southeasterly offshore, except under conditions of short-term opposing wind stress when the flows may be northward or northeastward. In general, the further offshore one goes, the faster the non-tidal net-drift rate becomes.

Thus the NAI drifter and current-meter data corroborate the findings of previous workers and document that, during much of the year, the Gulf of Maine gyre and associated hydrographic phenomena result in net southerly flows along the New Hampshire coast and in the western Gulf of Maine. These flows become part of the huge counterclockwise circulation pattern which encompasses the entire Gulf. Occasional periods of northerly flow were observed, generally following periods of southwesterly winds or representing possible seiching in the western Gulf after the passage of intense northeast storms and low-pressure systems. The instances of northerly flow during the winter season also point to possible breakdown of the Gulf of Maine gyre into several localized eddies at that time of year (Csanady, 1974). Surface flow was generally at least 10 times faster than near-bottom flow. The surface

flow was usually southward and offshore, out past Cape Ann, whereas the seabed drifters showed bottom flow almost always with a southwestern component toward shore. This is probably due to the dominance of north-east storms, which appear to drive much of the bottom flow, and also to the compensation flow of saline waters intruding landward at depth below seaward moving surface layers. Drifters released out to about 5 to 6 n mi offshore generally strand between York, Maine and Cape Ann; but seaward of this area, the higher number of distant returns and significantly lower recovery percentages document the dominance of the Gulf of Maine gyre flowing southward toward Cape Cod.

## 2.2.2 Atmospheric Influences

### 2.2.2.1 Prevailing Winds

Winds play an important role in near-surface water-mass transport, especially close to shore. Local wind data, which have been collected continuously by NAI from January 1973 to date at Hampton Beach State Park (location map, Figure 2.1-3), and wind data collected at the Seabrook plant site (PSNH, 1973) have documented that prevailing winds are from the west and northwest; but that highest speeds have generally been from the northeast. Rose diagrams from the fall and winter season, when offshore waters are typically unstratified, show a prevalence of winds from the northwest with secondary peaks from the southwest and northeast. Rose diagrams from the spring and summer season, when offshore waters are typically stratified, show that winds common at this time of year are generally light and variable with less tendency for any preferential directions. As during the winter, strongest winds are from the northeast in conjunction with "northeaster" storms.

When prevailing winds move near-surface waters away from the coast, subsurface waters move upward to replace them in a process called "upwelling". This phenomenon has been documented in the western Gulf of Maine by NAI (1975f), Hartwell (1975), Kangas and Hufford (1974), Graham

(1970a), and Longard and Banks (1952). This appears to be an important process for bringing nutrients into the more-productive nearshore areas. Likewise when winds are onshore, the opposite process of "downwelling" or plunging of coastal waters seaward along the bottom can occur (NAI, 1975f). Strongest wind effects always accompany northeast storms. During these storms near-surface waters are often carried southward at speeds of up to 1.0 kn or greater.

#### 2.2.2.2 Storms

Based on all of the NAI current-meter data which have been collected from off Hampton Beach, it appears that storms and associated winds play a key role in the large-scale water-mass displacement of the western Gulf of Maine and appear to help drive the general counterclockwise circulation of the Gulf of Maine gyre. In general, low-pressure systems moving across the region cause the stormiest conditions and the most-significant wind-stress effects in nearshore waters (Beardsley and Butman, 1974). Two basic patterns have been observed over the years.

The first pattern is when a low-pressure system moves slowly northeastward up the Atlantic coast, some 50 to 100 n mi offshore, over Georges Bank and past the Maritime provinces out to sea (Figure 2.2-5). The counterclockwise wind circulation of such storms means that winds from the north or northeast blow from across the Gulf of Maine, "lashing" the coast as a typical "nor'easter" or northeast storm. Such storms have long been recognized as the most influential to this coast, especially from the viewpoint of beach erosion (Hayes and Boothroyd, 1969), and seem to consistently result in strong southward flows along the coast (Hartwell, 1976).

The second pattern is when a low-pressure system moves slowly northeastward over the Great Lakes, up the St. Lawrence River valley, and over eastern Canada out to sea (Figure 2.2-5). In this instance the winds in the Gulf of Maine are from the southwest or south on the oppo-

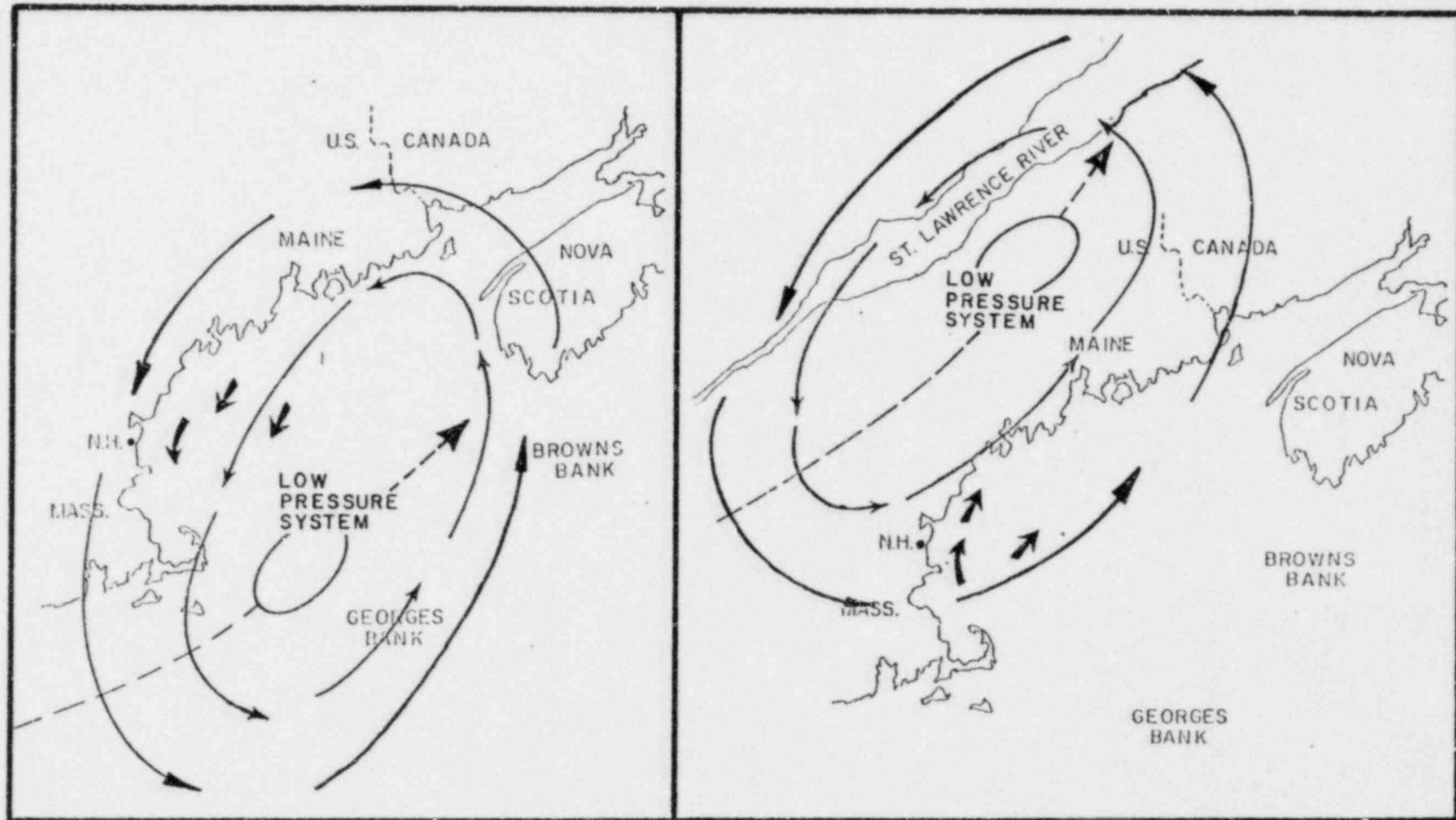

Figure 2.2-5. Diagrammatic representation of low-pressure systems and accompanying wind patterns from storms moving up off the coast and up the St. Lawrence River valley illustrating effects on coastal flows in the western Gulf of Maine.

site side of the storm's counterclockwise circulation pattern, typically resulting in northward flows along the coast.

In either case, nearshore waters seem to respond very quickly to the storm winds, probably owing to the relative shallowness along the coast. Frequently, ambient coastal flows may be 180° opposite to the storm-generated currents. For a period of a day or two these opposite nearshore and offshore flows may continue; but eventually the storm effects become dominant (provided the storm has been strong and persistent enough) and both nearshore and offshore flows become coupled, flowing in the same direction (Figure 2.2-5). Once the storm passes, the nearshore waters are again the first to return to more-normal conditions (Hartwell, 1976 and NAI, 1977a).

Thus storms and accompanying winds, especially those of low pressure systems, play an important role (along with tides and net residual drift patterns) in coastal water-mass dynamics of the western Gulf of Maine and the rest of the Gulf as well. In general, nearshore waters respond rapidly to wind changes, frequently within a matter of hours as was documented in NAI (1975f). This phenomenon creates coastal jets or pulses of flow which frequently dominate coastal circulation. Such coastal jets have been described by Csanady (1972) in Lake Ontario (a freshwater body which is somewhat smaller than the Gulf of Maine) and Scott and Csanady (1976) in their studies of nearshore currents off Long Island. Thus if wind stress has been strong and persistent enough, such jets expand seaward, causing nearshore and offshore water masses to become "coupled". As was seen in some of these examples, shearing is also important and flows at times can be quite complex.

### 2.2.3 Tides

Tides which have been measured continuously in Hampton Harbor estuary at the Hampton Beach Marina (location map, Figure 2.1-3) from January 1973 to date, have showed close agreement with the National

Oceanic and Atmospheric Administration-National Ocean Survey (NOAA-NOS) tide-table predictions (NOAA-NOS, 1976). In general, the mean tide range is about 8.3 ft. Spring tides have ranged as high as 12.5 ft; whereas, neap tides have ranged as low as 6.0 ft. Under storm conditions abnormally high tides are often observed. In general, these tides are of the mixed, semidiurnal type with a small (1 to 2 ft) diurnal inequality which is most pronounced during spring tides (Figure 2.2-6). The change in tide height (high or low water) and tidal-current direction generally occurs 15 to 30 min earlier offshore than inside Hampton Harbor. Measurements of tide height and times of high and low water at the mouth of the estuary in August 1974 showed that recorded heights at the Hampton Beach Marina were as much as 6 in. higher and occurred 3 to 10 min later than on the coast (NAI, 1975a).

#### 2.2.4 Water Temperature

##### 2.2.4.1 Ambient Variability

Large temperature changes occur in shallow, partially isolated waters of coastal oceans such as the Gulf of Maine. These variations are well beyond anything found in the open ocean. Winds, for instance, affect water temperatures to a marked degree. On the Atlantic coast, winds coming from the continent are much warmer than the ocean in summer, and much colder in winter, therefore exerting substantial influence on coastal-water temperatures. Furthermore, such winds are dry, having lost much of their moisture through precipitation. Thus these winds usually cause extensive evaporation when they blow across coastal waters (Gross, 1972). Off Hampton Beach the highest surface water temperatures are generally in the mid 60's °F but temperatures as high as 76 F have been measured. Lowest surface-water temperatures are controlled by the point of initial freezing of seawater, which generally is about 28.4 F depending on the surface-water salinity. In winter, sea ice frequently forms, especially in Hampton Harbor and other small estuaries where cooling is rapid due to the large surface area and small volume of water present.



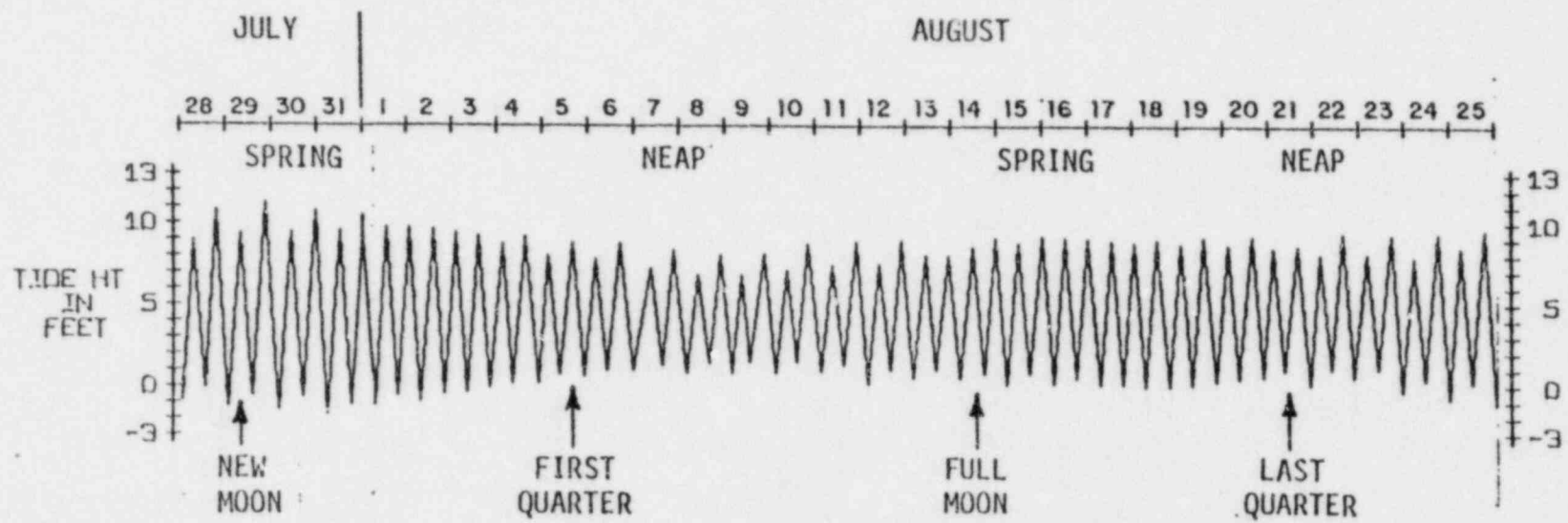

Figure 2.2-6. Plot of high-water and low-water tide heights in the Hampton Harbor estuary during a typical lunar month from July 28 to August 25, 1973.

The coastal waters off Hampton Beach and in the western Gulf of Maine out to at least 9 mi or more offshore undergo an annual cycle which is representative of the natural variability of coastal waters, caused by factors such as: tides, winds, solar radiation, waves, storms, upwelling or downwelling, rainfall, evaporation and estuarine thermal plumes.

Temperature measurements from the monthly plankton cruises have documented far-field conditions to the north and south of Hampton Beach. Near-surface measurements have showed a tendency for the temperatures further offshore to be slightly warmer than those along the coast during most of the year. However, in the summer, the estuarine stations and stations close to shore were generally warmer. These patterns are primarily the result of radiational warming in the estuary and shallow coastal waters during the summer and radiational cooling during the winter.

Measurements made at the discharge site (Mooring 12) during a typical year for near surface and near bottom at high water and at low water (Figure 2.2-7) illustrate the tendency for near-surface temperatures to be colder at low water during the winter months, because of cooled ebb-tidal waters flushing from Hampton Harbor and adjacent estuaries. Correspondingly, near-surface temperatures are warmer at low water during the summer months, because offshore waters are cooler than the warmed ebb-tidal plumes from Hampton Harbor and adjacent estuaries. Thus on the flooding tide during the winter, near-surface waters tend to become warmer, and during the summer they tend to become colder, as water from further offshore displaces water closer to shore; the converse is true on the ebbing tide. Near-bottom waters show less variability; but, there is a tendency for low-water conditions to be slightly warmer than high-water conditions. Highest mean near-bottom temperatures were observed during September, lagging behind highest surface temperatures because of the presence of the thermocline.

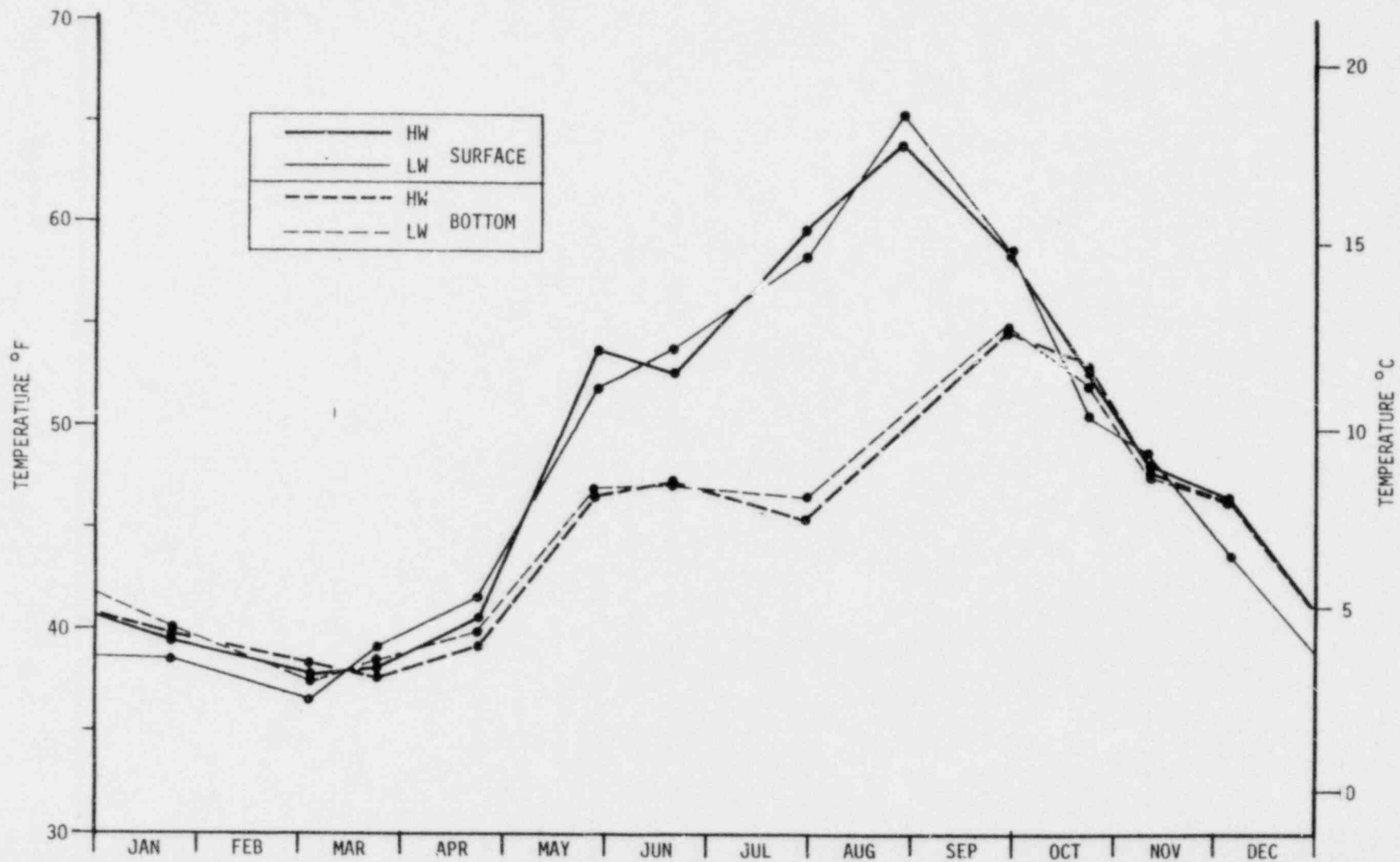

Figure 2.2-7. Monthly temperature observations at the discharge site (Mooring 12) for near-surface and near-bottom waters from 1975 slack-water surveys (both low water, LW and high water, HW).

Warming of surface waters during the day readily occurs, especially in areas such as Hampton Harbor, which are protected from winds and waves. This variation occurs despite the large heat capacity of water and the ability of the Gulf of Maine to mix the additional heat to considerable depths beneath the ocean surface. In the absence of other influences, surface water temperatures are generally highest in mid-afternoon and lowest at dawn. At midnight the water column is nearly isothermal. Cooling continues throughout the night so that by dawn, the surface water is cooler than the waters at depth. After the sun rises, the surface layer is warmed; by noon the surface layer is distinctly warmer than waters immediately below the surface. Warming continues until late afternoon, when the surface temperature is highest. Later, the surface layer begins to cool and is slightly cooler at dusk. During the night, the surface waters cool until the water column is again isothermal around midnight (Gross, 1972).

Tides cause temperature changes in coastal waters by moving water masses of different temperatures and by causing vertical movements of waters. Tidally induced temperature changes are especially noticeable in shallow areas such as the Hampton Harbor estuary. In such salt marshes, water temperatures are highest on a summer day after the water has flooded the marsh. The water is warmed by contact with the warm marsh sediments and directly by absorption of solar radiation. Thus water coming out of the estuary on a summer day is often in excess of 12 F degrees warmer than offshore waters. Likewise when the tide rises, bringing coastal waters into the estuary, it is much colder than the water that flowed out several hours earlier (Gross, 1972).

Variations in hourly average temperatures further illustrate the dynamic nature of these waters. Examples of typical mid-summer data (August 17 to 31, 1976) from offshore moorings, moorings in the Rocks area, and Hampton Harbor estuary show changes of at least 2 to 6 F within 1 hr, 5 to 12 F within a tidal cycle (12.8 hrs) and 5 to 13 F over a day (Figure 2.2-8). Even during the winter, such as January 17 to 31, 1976, rapid fluctuations over short periods of time have been



observed at all of the NAI moorings (Figure 2.2-9). Data from the rest of the year show comparable variability (NAI, 1977).

To further document the ambient variability of the waters around the Inner and Outer Sunk Rocks, where concern has been raised that backflushed thermal plumes could have an impact, late-summer measurements of water temperatures in tide pools have showed ambient  $\Delta t$ 's of at least 2 to 7 F in September. Similarly, data taken from continuous monitors closest to the Rocks area at the time of highest annual temperatures have showed ambient temperature differences (ambient bottom versus Rocks area) of 2 to 18 F from either the nearshore or offshore intake sites (Table 2.2-2). In general, highest daily temperatures occur during the ebbing tide and around low water in response to flushing of the warm ebb-tidal plume out of Hampton Harbor estuary (see example from June 19, 1975 in Figure 2.2-10). Ambient variability around the Rocks is much greater than anticipated temperature rises from plant operation, or even from the several hours of a typical backflushing operation. Furthermore, at the times of maximum temperature rises at the Rocks, flows most often are seaward which would tend to carry any backflushed waters away from the Rocks and minimize additional temperature effects. Such variability is due to the continuous complex interaction of factors such as: discharge of local estuaries, runoff, precipitation, winds, tides, storms, currents, upwelling, downwelling, turbulence, and the estuarine thermal plume.

The projected temperature rises from operation of the Seabrook Station circulating water system of 4 to 5 F or less within the mixing zone are expected to be the same order of magnitude as or less than presently existing ambient variability. Once in operation it appears likely that, as the plant's thermal plume dissipates its heat to the atmosphere and is mixed by ambient currents, its far-field latent temperature will be almost impossible to separate from ambient variability. Indeed the temperature data which have been collected over the more than 4 years of intensive studies show that the BTU output of naturally heated waters from Hampton Harbor estuary on a typical summer

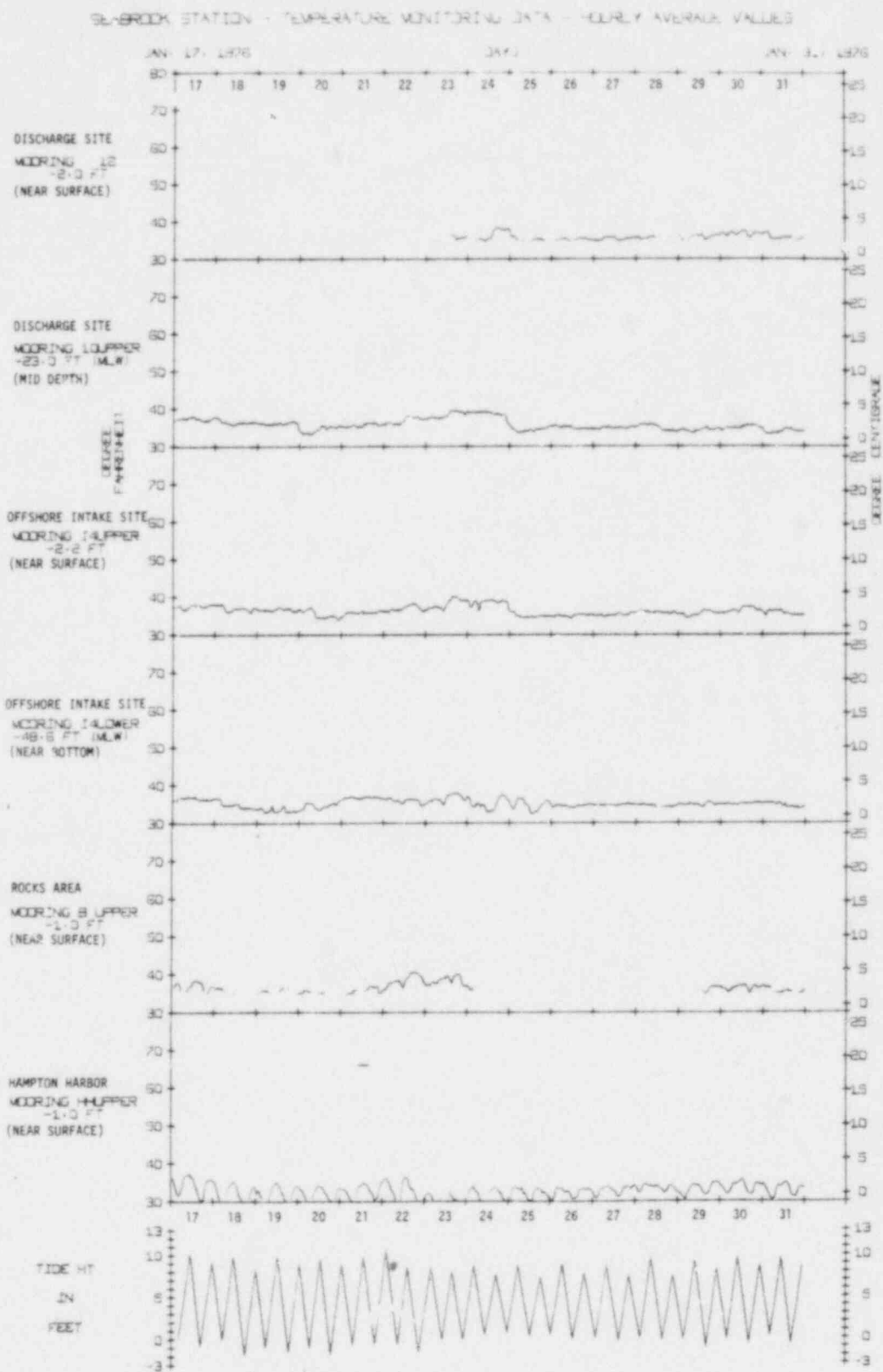

Figure 2.2-9. Representative wintertime hourly average temperature data from the discharge site, the offshore intake site and the Hampton Harbor estuary from January 17 to 31, 1976.

TABLE 2.2-2. AMBIENT TEMPERATURE DIFFERENCES (F) BETWEEN ROCKS AREA AND INTAKE SITES DURING PERIOD OF HIGHEST OBSERVED ANNUAL TEMPERATURES IN 1973, 1974, 1975 AND 1976.

DATE	ROCKS AREA <sup>1</sup> APPROXIMATE DAILY MAXIMUM SURFACE TEMPERATURE	NEARSHORE INTAKE SITE <sup>2</sup>		OFFSHORE INTAKE SITE <sup>3</sup>	
		APPROXIMATE DAILY MAXIMUM NEAR BOTTOM TEMPERATURE	TEMPERATURE DIFFERENCE RELATIVE TO ROCKS AREA	APPROXIMATE DAILY MAXIMUM NEAR BOTTOM TEMPERATURE	TEMPERATURE DIFFERENCE RELATIVE TO ROCKS AREA
8-26-73	66.0 *	50.2	15.8	57.0	9.0
8-27-73	67.0	51.2	15.8	58.0	9.0
8-28-73	66.0	53.2	12.8	58.2	7.8
8-29-73	67.2	55.2	12.0	60.2	7.0
8-30-73	67.5	55.2	12.3	58.2	9.3
8-31-73	70.0	57.0	13.0	57.5	12.5
9-01-73	72.0	56.0	16.0	56.0	16.0
9-02-73	75.5	59.8	15.7	58.1	17.4
9-03-73	74.5	58.0	16.5	59.0	15.5
9-04-73	76.0	59.5	16.5	58.2	17.8
9-05-73	73.0	65.5	7.5	62.0	11.0
9-06-73	71.5	58.2	13.3	59.0	12.5
9-07-73	72.0	51.0	21.0	54.0	18.0
9-08-73	70.0	51.0	19.0	53.2	16.8
9-09-73	65.0	51.0	14.0	52.5	12.5
9-10-73	66.0	51.0	15.0	52.0	14.0
8-12-74	63.0	55.8	7.2	55.0	8.0
8-11-74	63.7	57.8	5.9	52.6	11.1
8-14-74	64.9	58.8	6.1	55.9	9.0
8-15-74	64.8	60.0	4.8	54.3	10.5
8-16-74	65.2	57.9	7.3	53.6	11.6
8-17-74	63.9	52.1	11.8	51.9	12.0
8-18-74	63.9	51.5	12.4	52.0	11.9
8-19-74	65.0	53.3	11.7	52.0	13.0
8-20-74	66.8	60.0	6.8	54.0	12.8
8-21-74	65.5	60.7	4.8	53.0	12.5
8-22-74	65.7	58.8	6.9	53.5	12.2
8-23-74	66.0	57.0	9.0	52.0	14.0
8-24-74	65.9	57.8	8.1	52.5	13.4
8-25-74	66.0	60.0	6.0	53.0	13.0
8-26-74	65.5	61.9	3.6	54.5	11.0
8-27-74	63.0	58.1	4.9	54.1	8.9
8-09-75	65.5				
8-10-75	66.4				
8-11-75	68.0				
8-12-75	67.6	63.6	4.0	55.9	11.7
8-13-75	68.9				
8-14-75	67.0				
8-15-75	68.3				
8-16-75	68.0				
8-17-75	68.0				
8-18-75	67.2				
8-19-75	65.7	61.2	4.5	56.1	9.6
8-20-75	64.6				
8-21-75	54.3				
8-22-75	62.8				
8-23-75	64.8				
8-24-75	65.7				
8-25-75	60.8				
8-26-75	61.5	57.5	4.0	51.8	9.7
8-20-76	65.2	60.8	4.4	57.1	8.1
8-21-76	67.6	61.0	6.6	55.8	11.8
8-22-76	69.5	61.9	7.6	56.0	13.5
8-23-76	69.5	61.6	7.9	54.1	15.4
8-24-76	69.1	66.9	2.2	59.4	9.7
8-25-76	69.4	67.5	1.9	55.3	14.1
8-26-76	69.9	66.0	3.9	55.9	14.0
8-27-76	68.7	64.7	4.0	53.5	15.2
8-28-76	66.5	57.9	8.6	50.3	16.2
8-29-76	62.8	54.3	8.5	49.4	13.4
8-30-76	57.6	54.7	2.9	49.8	7.8

## \* DATA SOURCES

	1	2	3
1973	Mooring 4 upper	Mooring 5 lower	Mooring 1
1974	Mooring 12	Mooring 5 lower	Mooring 10 lower
1975	Mooring 12	Beckman Profile	Beckman Profile
1976	Mean of moorings B, D and F	Mooring 10 upper	Mooring I-4 lower



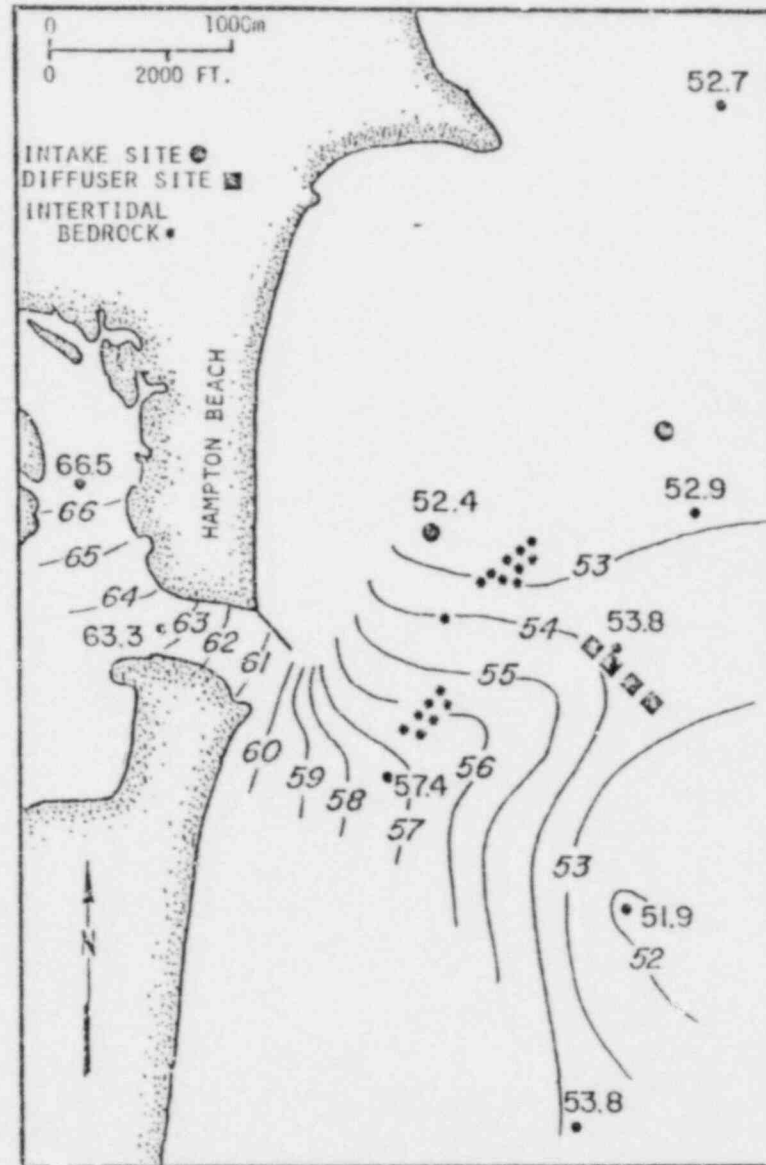
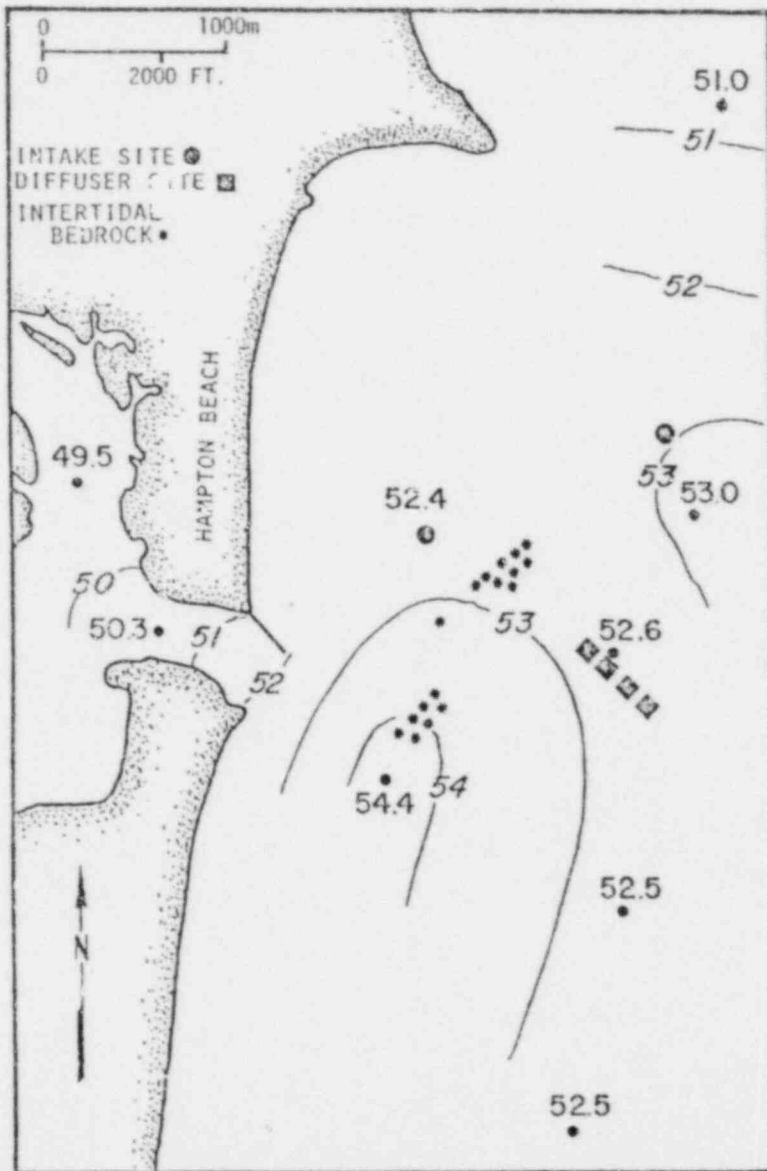

Figure 2.2-10. Surface water temperatures (F) in Hampton Harbor estuary and adjacent coastal waters on June 19, 1975, from slack-water survey at high water (left) and low water (right).

day can be at least two to three times the equivalent amount of waste which Seabrook Station would discharge in the same time period.

#### 2.2.4.2 Mean Vertical Profiles

Mean temperature profiles from offshore slackwater survey stations during 1975 are illustrated in Figure 2.2-11. Starting in November and December with essentially homogeneous thermal conditions from near surface to near bottom averaging around 46.4 to 48.2 F, temperatures dropped sharply in the early winter. Coldest temperatures occurred during February, lagging about 30 days behind the minimum atmospheric temperature observed during the year. At this time there was also some thermal inversion of coastal waters, wherein the near-surface temperatures were several degrees F colder than those at depth because of radiational cooling.

From the isothermal conditions in March, the water column showed a gradual warming trend as the spring season progressed (Figure 2.2-11). By May and June the development of the seasonal thermocline was well along. By mid-summer the coastal waters showed a strong thermal stratification with a variation of 13.3 to 14.0 F between near-surface and near-bottom depths. Maximum near-surface temperatures occurred during August, lagging about 30 days behind the maximum atmospheric temperatures observed during the year. During September and early October, the stratification broke down rapidly and temperatures became more homogeneous from near surface to near bottom.

#### 2.2.5 Salinity

Salinity extremes occur in coastal waters where excess fresh water discharged from the continents is mixed back into the ocean. Typically isohalines tend to parallel the ocean boundaries, reflecting dilution along the coast and greater net evaporation further out to sea (Gross, 1973).

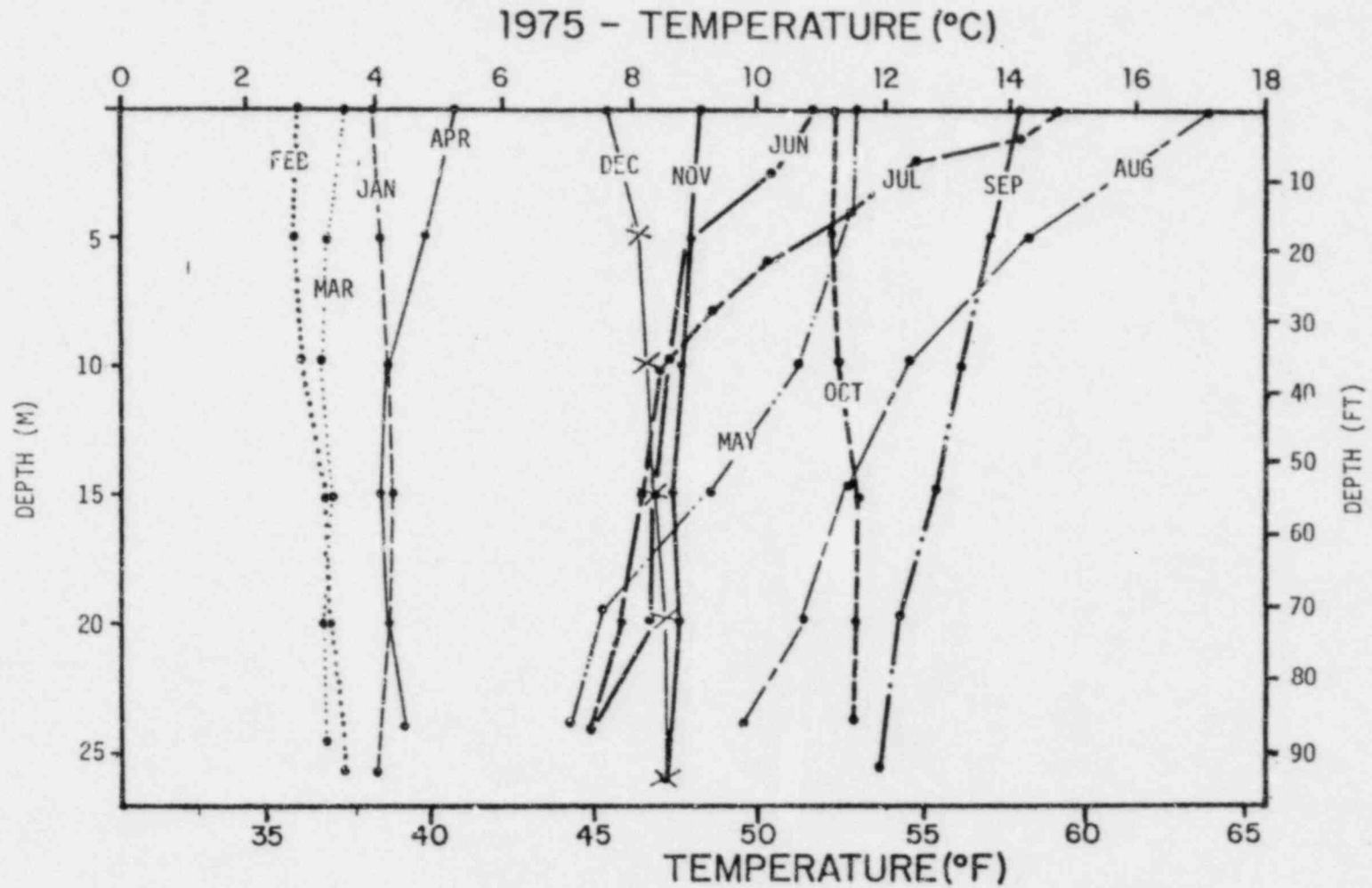

Figure 2.2-11. Typical mean temperature profiles from coastal waters off Hampton Beach, New Hampshire, during 1975.

In general, water entering the Gulf of Maine is either:

1. Runoff from the continents,
2. Rainfall, or
3. Northwest Atlantic water (salinity about 34 ‰; Bigelow, 1927).

The fresh water is mixed with salt water in estuaries before it reaches the Gulf of Maine proper or falls as rain across the Gulf. The salinity of this estuarine water varies considerably, depending primarily upon the size of the drainage basin. The largest source of freshwater runoff in this portion of the western Gulf of Maine is the Merrimack River (Manohar-Maharaj and Beardsley, 1973). Next largest is the Great Bay System (including the Piscataqua River) followed by the Hampton Harbor estuary; other nearby sources include the Parker River estuary, and Essex River estuary (Figure 2.1-2). These estuaries typically release waters as fresh as 20 ‰, causing a well-defined coastal halocline during much of the year. Offshore these waters become diluted with the 34 ‰ waters from the Northwest Atlantic.

#### 2.2.5.1 Ambient Variability

Near-surface measurements from slack-water surveys have showed offshore salinities to be generally quite uniform; however, in Hampton Harbor estuary, values down as low as 20.9 ‰ have been observed (for example September 29, 1975; Figure 2.2-12). These surveys have documented salinity variations of as much as 10 ‰ within the estuary over a single tidal cycle; more typical variations were 2 to 6 ‰ between tidal cycles (NAI, 1977).

Salinity measurements from the monthly plankton cruises have documented far-field conditions to the north and south of Hampton Beach. As with the slack-water survey data, near-surface measurements have showed lowest salinities generally in Hampton Harbor or off the mouth of

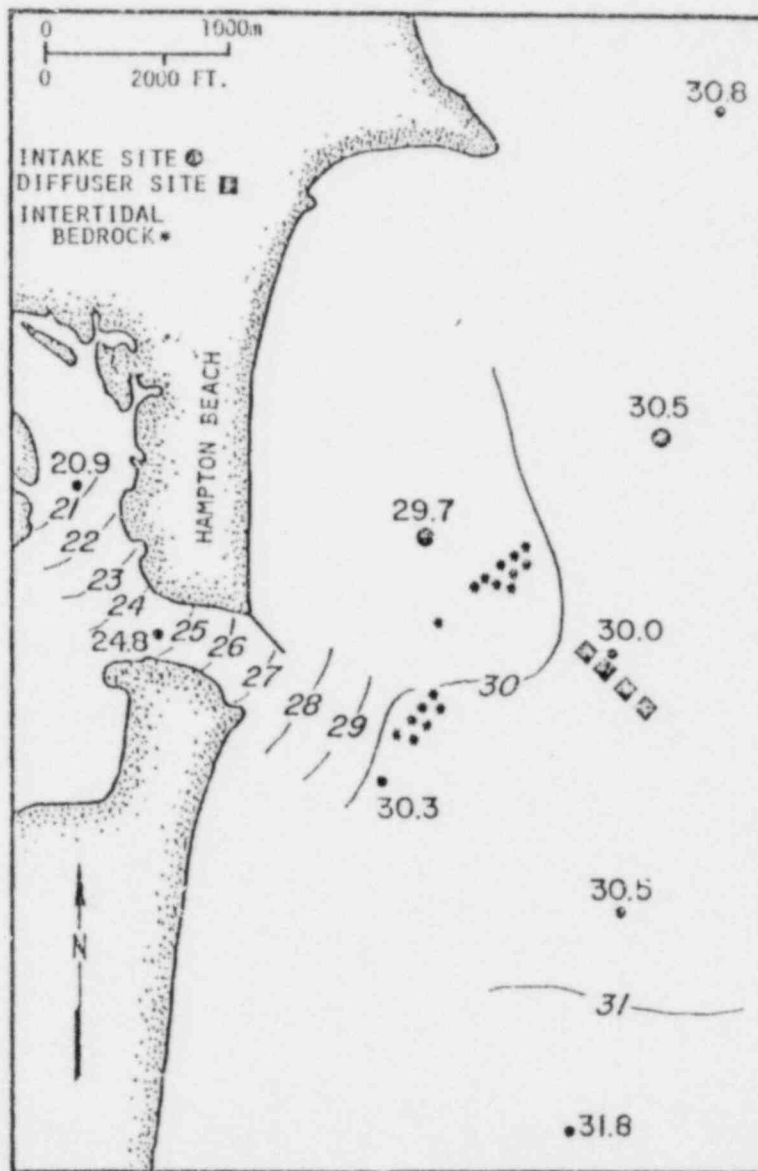
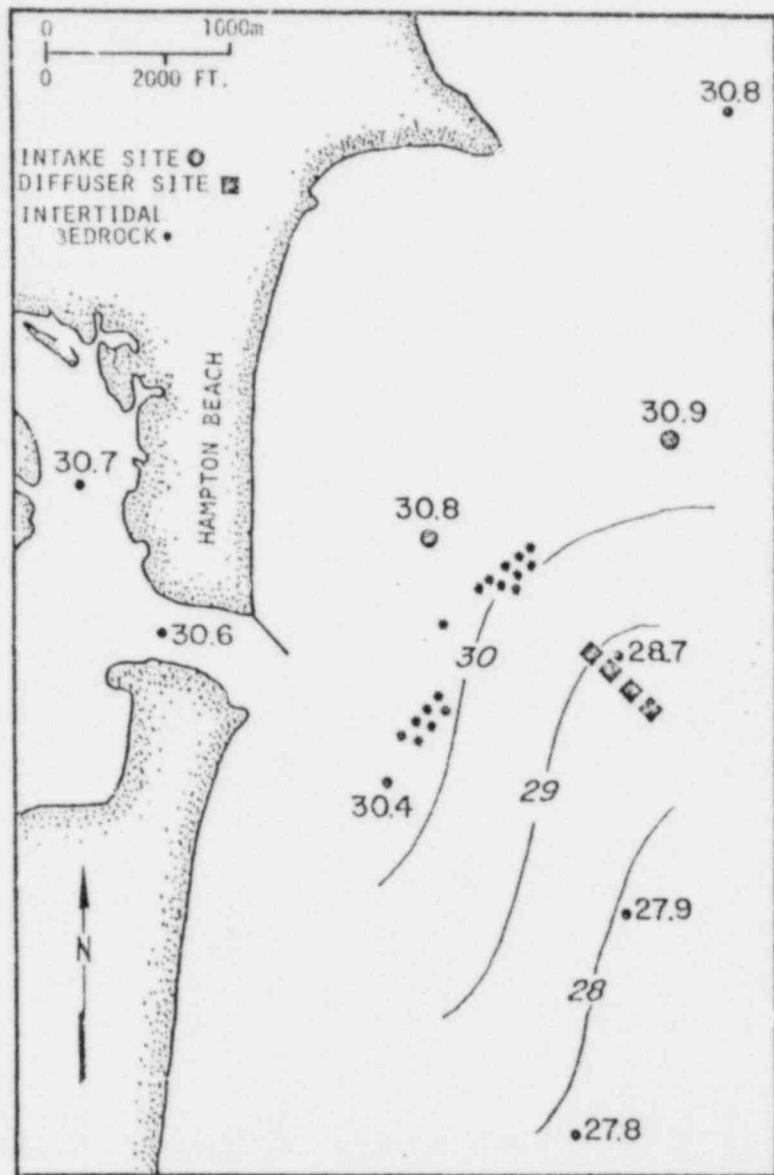

Figure 2.2-12. Surface salinities (‰) in Hampton Harbor estuary and adjacent coastal waters on September 29, 1975, from slack-water survey at high water (left) and low water (right).

the Merrimack River estuary (for example December 16, 1975 in Figure 2.2-13). Salinities at stations off Hampton Beach were generally homogeneous.

Typical measurements made at the discharge site (Mooring 12) during 1975 for near surface and near bottom at high water and low water show that mean values for near surface were around 31 to 32 ‰ with lowest values during the fall (28.5 ‰ in late September and 29.7 ‰ in mid November). Near-bottom salinities were slightly higher and much less variable, ranging from 31.0 to 32.8 ‰. In general lowest salinities were observed at low water, reflecting the influence of the ebb-tidal flows from Hampton Harbor and adjacent estuaries (NAI, 1975f).

#### 2.2.5.2 Mean Vertical Profiles

Mean salinity profiles from offshore slack-water survey stations during 1975 further illustrate this annual cycle (Figure 2.2-14). In December the water was essentially isohaline from near surface to near bottom, averaging around 31.6 to 32.0 ‰. Salinities increased during the winter with near-surface values always being less than those at depth. During March, April, and May, near-surface salinities dropped sharply to 30.0 ‰ and lower, forming a distinct halocline. This reflected the typical spring runoff of fresh water into the western Gulf of Maine. During the summer months, salinities increased again but the halocline was less evident. In September, October and November, increased runoff reestablished the halocline again, showing surface-to-bottom variations of up to 2.0 ‰ (Figure 2.2-14). In the late fall the onset of more-intense winter storms, in the absence of the seasonal thermocline and decreased runoff, brought increased vertical mixing and return to the isohaline conditions of December.

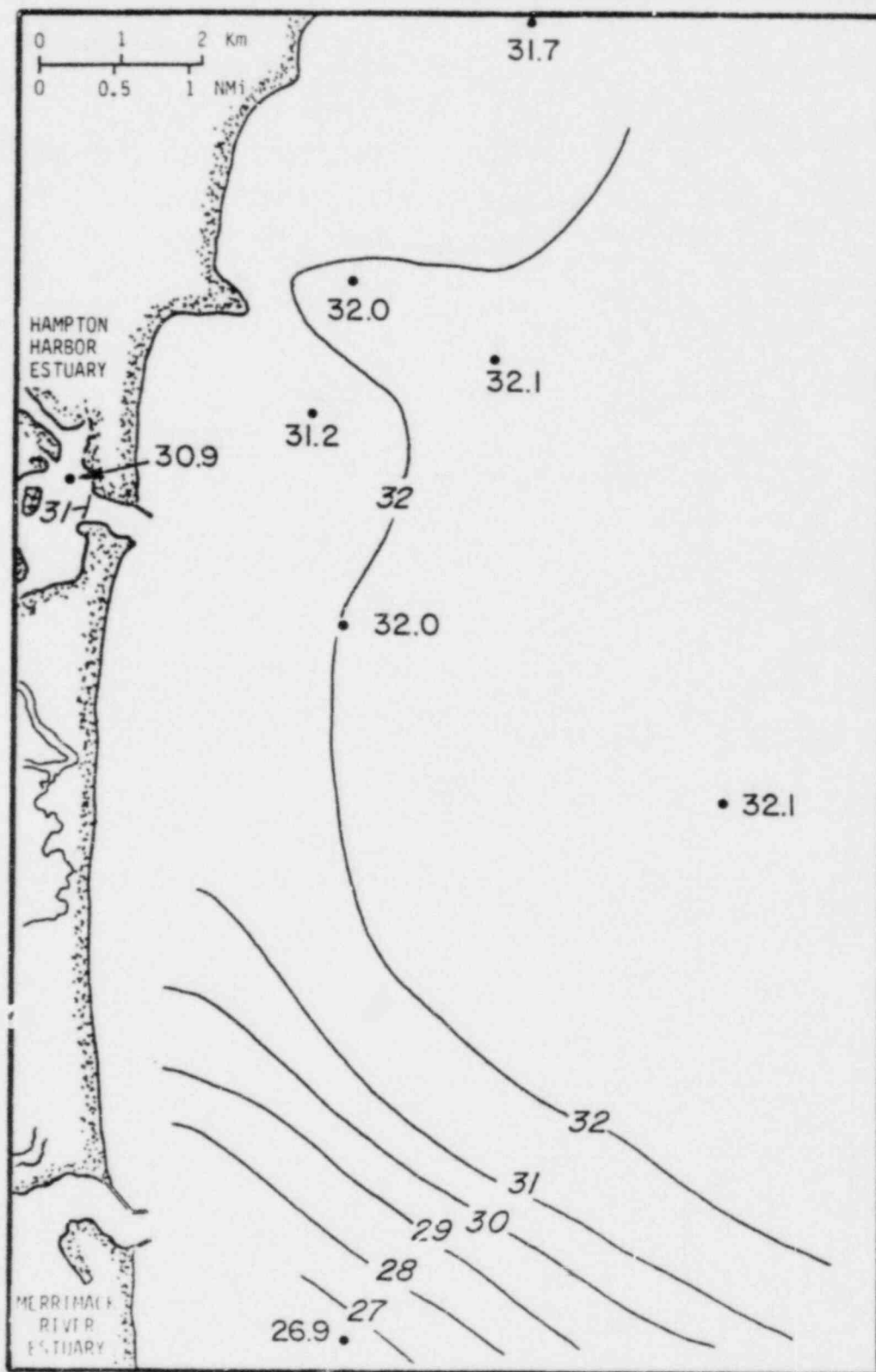

Figure 2.2-13. Surface salinities ( $^{\circ}/_{\infty}$ ) in Hampton Harbor estuary and adjacent coastal waters on December 16, 1975, from plankton cruise measurements.

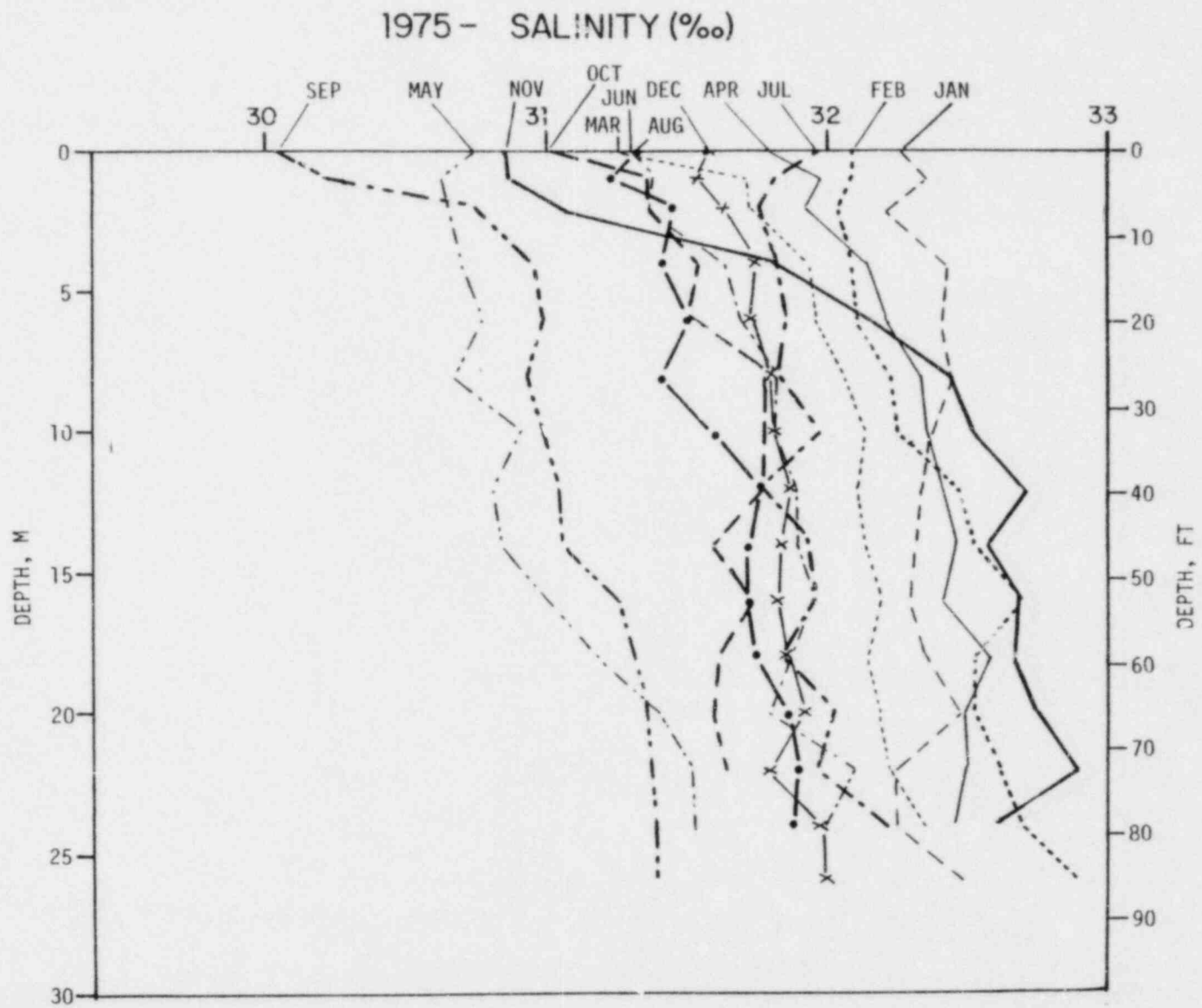

Figure 2.2-14. Typical mean salinity profiles from coastal waters off Hampton Beach, New Hampshire, during 1975.



## 2.2.6 Seasonal Water Mass Classification

During the spring, summer and early fall, the upper portion of the water column is warmer and less saline than waters at depth because of radiational heating and runoff. In the late fall the waters are more homogeneous from surface to bottom, whereas, in the winter the upper part of the water column is actually slightly colder than at depth because of radiational cooling.

This annual progression or cycle is primarily manifested in the ambient variations in temperature and salinity which help to define six distinct water masses over the course of the year as follows (Figures 2.2-15 to 17 and Table 2.2-3):

### I. DECEMBER WATER MASS

Beginning in December, waters in the study area typically show a vertical homogeneity from near surface to near bottom. Temperatures range from 40.6 to 44.5 F (4.8 to 7.0 C) and salinities average from 31.1 to 33.2 ‰. This vertical uniformity probably results from atmospheric cooling and vertical mixing of the water column associated with breakdown of the seasonal thermocline, shallowing of the halocline and increased intensity of major storms as the winter season begins.

### II. WINTER WATER MASS

From January through March both near-surface and near-bottom waters undergo pronounced cooling down to 41.0 to 35.6 F. Through much of the winter, near-surface temperatures are slightly cooler than those of near-bottom waters, resulting in a weak reversed or negative thermal stratification. Coldest temperatures generally occur during January and February, lagging about 30 days behind the minimum atmospheric temperatures observed during the year. Salinities remain about the same as in

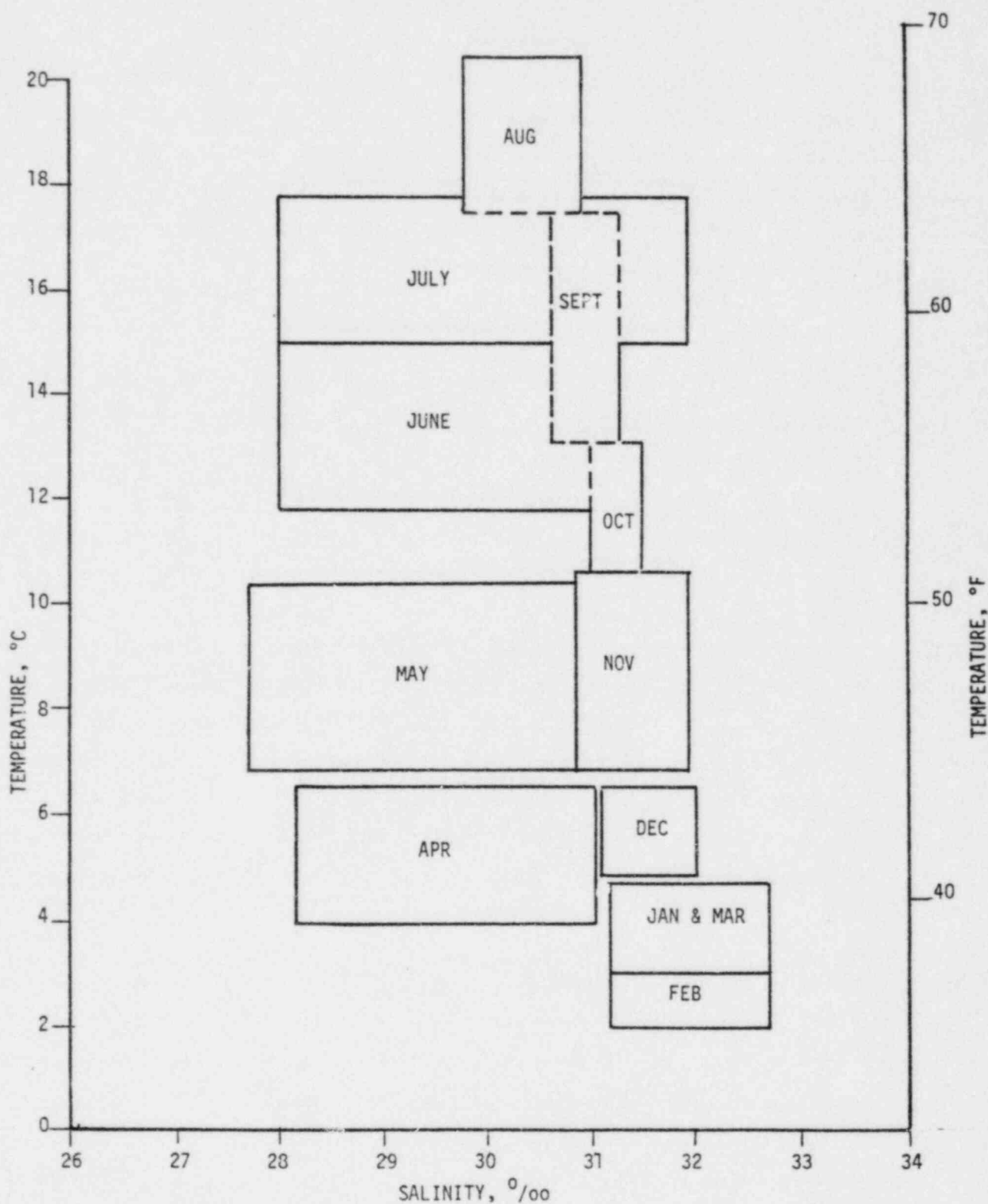

Figure 2.2-15. Annual cycle of temperature and salinity variations in near-surface waters off the coast of New Hampshire and in the western Gulf of Maine.

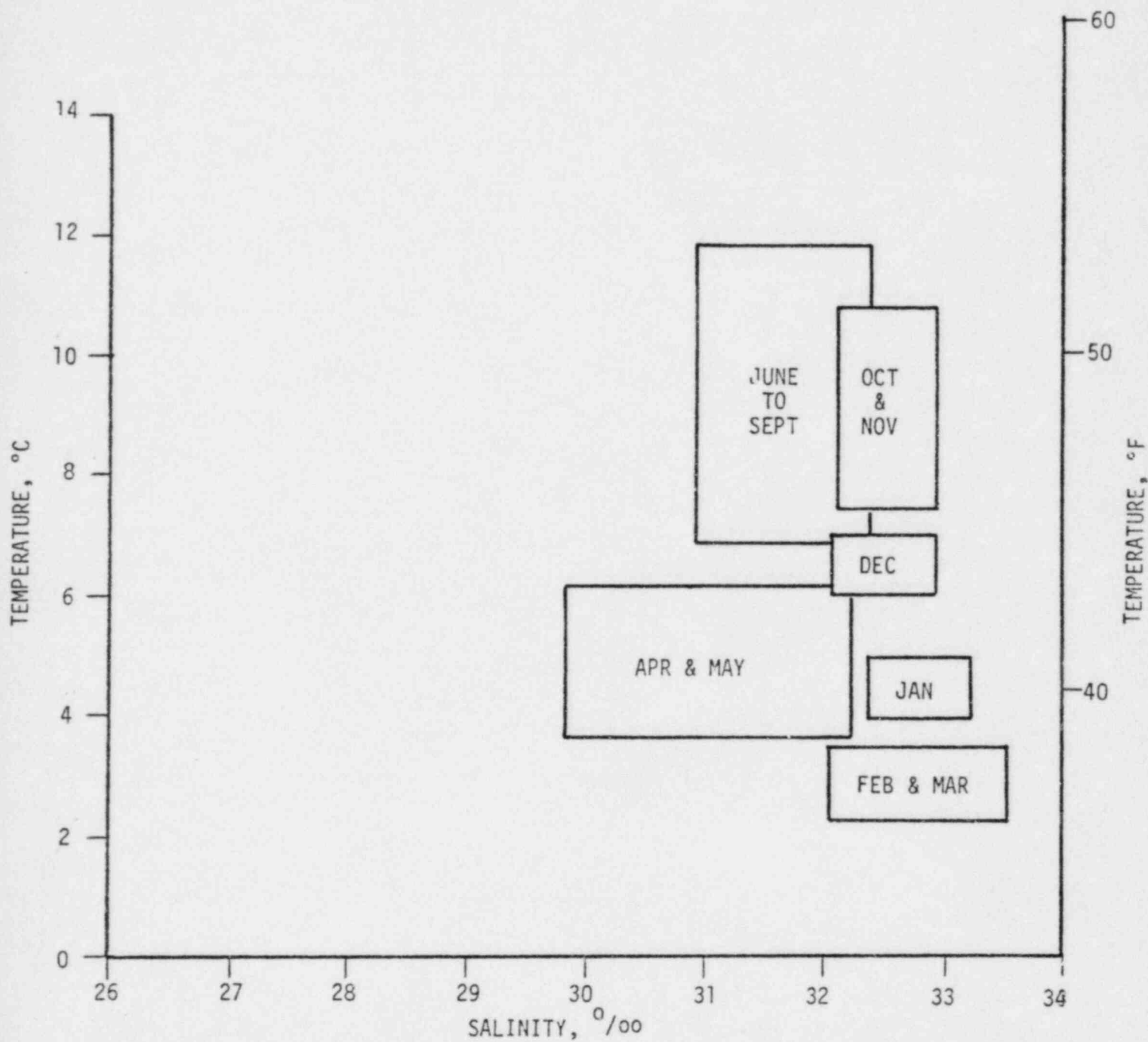

Figure 2.2-16. Annual cycle of temperature and salinity variations in near-bottom waters off the coast of New Hampshire and in the western Gulf of Maine.

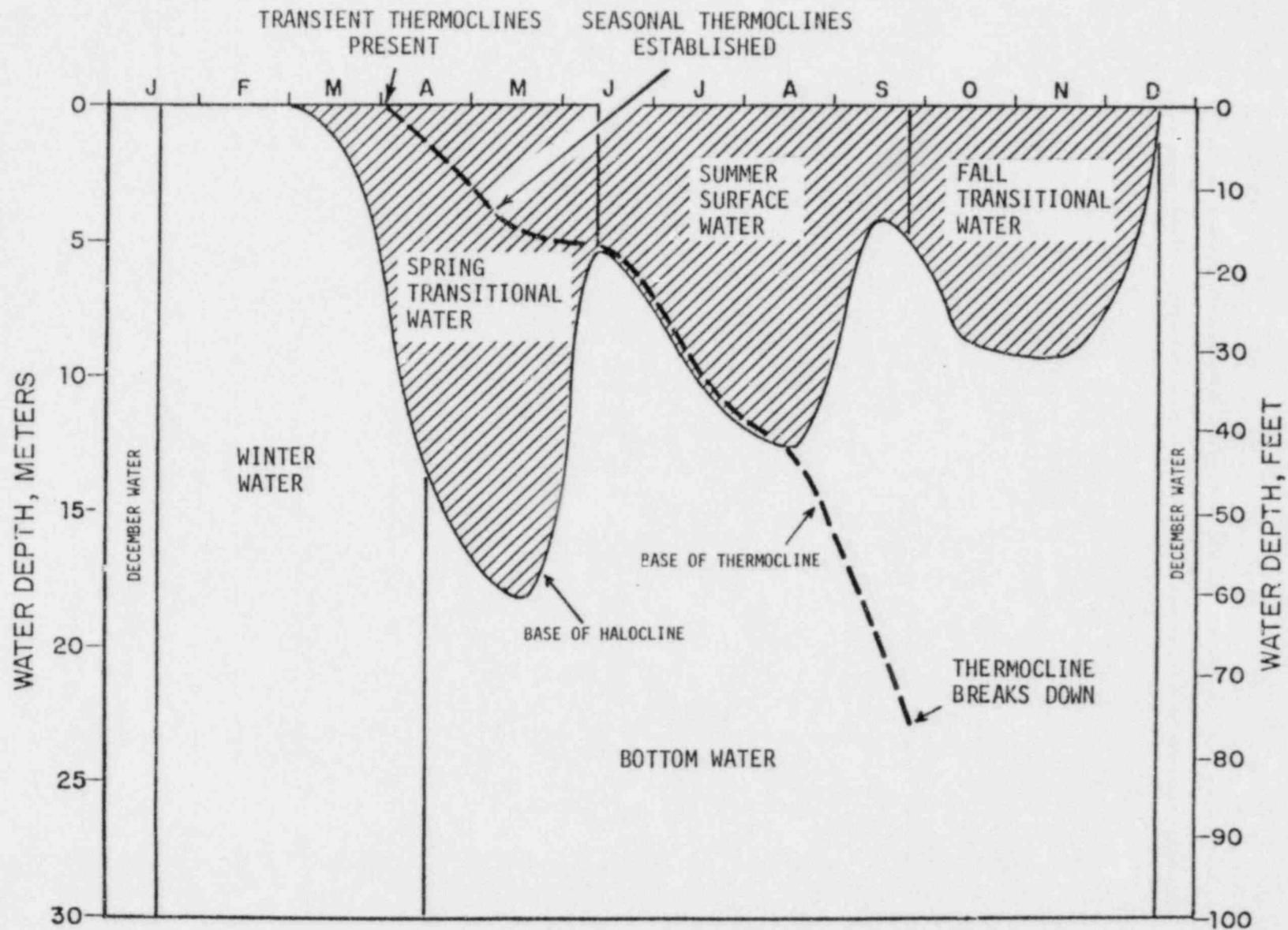

Figure 2.2-17. Annual cycle of water mass types based on temperature and salinity variations in waters off the New Hampshire coast and in the western Gulf of Maine.

TABLE 2.2-3. TEMPERATURE AND SALINITY CHARACTERISTICS OF COASTAL WATER-MASS TYPES OF THE WESTERN GULF OF MAINE.

WATER MASS	TEMPERATURE RANGE		SALINITY RANGE ‰
	F	C	
December Water	40.6-44.6	4.8- 7.0	31.1-33.2
Winter Water (January to March)	35.6-41.0	2.0- 5.0	31.1-33.6
Spring Transitional Water (March to June)	39.2-50.5	4.0-10.3	27.7-31.0
Summer Surface Water (June to September)	53.2-68.5	11.8-20.3	28.0-32.0
Bottom Water (April and May)	38.5-43.2	3.6- 6.2	29.9-32.2
(June to September)	44.2-53.2	6.8-11.8	30.9-32.4
(October to November)	45.3-51.4	7.4-10.8	32.2-32.9
Fall Transitional Water (September to November)	44.2-55.4	6.8-13.0	30.8-32.0

the December Water Mass (31.1 to 33.5 ‰). Thus at this time of the year, coastal waters are well-mixed both horizontally and vertically.

### III. SPRING TRANSITIONAL WATER MASS

Freshwater runoff, coupled with atmospheric heating and decrease in storm frequency, causes major changes in the temperature and salinity characteristics of the near-surface waters whereas only minor effects are observed in the deeper waters. In March, the development of the surface layer is typically initiated by an increase in freshwater runoff which lowers salinity in the surface waters and promotes stabilization of the water column. The characteristics of the Winter Water Mass are maintained in the deep water as the Transitional Water Mass develops. In early April, atmospheric warming promotes development of the annual thermocline. Initially, the depth of the thermocline coincides with the depth of the halocline, suggesting that the warming of the surface waters occurs after the surface layer has been established by river runoff. The gradually rising temperatures average 39.2 to 50.5 F with highest values in June. Salinities show a marked decrease from those of the Winter Water Mass, down to 27.7 to 31.0 ‰. This results from spring runoff and leads to the development of a sharp halocline which typically is most pronounced during May. During periods of high estuarine discharge, salinities also tend to show a gradient perpendicular to the shoreline; i.e., salinities increase with increasing distance offshore.

### IV. SUMMER SURFACE WATER MASS

During late spring near-surface salinities begin to increase again after the peak spring runoff has passed. By June the thermocline and halocline coincide again and the Summer Surface Water Mass becomes established. Temperatures show a sharp increase over those of the Spring Transitional Water Mass (53.2 to 68.5 F). Maximum tempera-

tures generally occur during August, lagging about 30 days behind the maximum atmospheric temperatures observed during the year. Salinities show an average rise of about 1 ‰ over those of the Spring Transitional Water Mass (up to 28.0 to 32.0 ‰). This salinity increase is primarily due to decreased freshwater discharge to the Gulf of Maine and increased evaporation. By late summer the thermocline continues to deepen; whereas, the halocline gets shallower again.

#### V. BOTTOM WATER MASS

The Bottom Water Mass is observed from April through November but typically can be divided into three phases which correspond closely to the various Surface Water Masses. April and May typically show a warming trend (38.5 to 43.2 F) and moderate salinities (29.9 to 32.2 ‰). From June to September temperatures increase to 44.2 to 53.2 F but salinities remain about the same (30.9 to 32.4 ‰). During October and November temperatures decrease again (51.4 to 45.3 F); whereas, salinities increase to 32.2 to 32.9 ‰.

#### VI. FALL TRANSITIONAL WATER MASS

Development of this water mass generally occurs when the halocline is reestablished by a secondary pulse of freshwater discharge into the Gulf of Maine. By this time of the year, the progressive breakdown of the thermocline is brought on by increased major storm activity and vertical mixing. Temperatures decrease from 55.4 to 44.2 F and salinities decrease to 30.8 to 32.0 ‰ (Table 2.2-3). By November there is no thermal stratification and the halocline becomes shallower again. By December maximum homogeneity is evident throughout the water column with no distinguishable surface layer. Thus, the development and maintenance of the surface layer is a result of low salinity water being discharged from the estuaries, rather than the presence of a thermocline. The freshened surface layer persists in the fall, even though there was a lack of thermal stratification.

## 2.2.7 Dissolved Oxygen

The monthly slack-water surveys and plankton cruises have documented the dissolved oxygen conditions in coastal waters. For example, measurements made at the discharge site (Mooring 12) during 1975 for near surface and near bottom at high water and low water are presented in Figure 2.2-18. Highest values were observed during the late winter, spring and early summer (about 9.0 to 11.6 mg/l); whereas lowest values occurred during the fall (down to 7.0 mg/l in November). No consistent pattern was observed between tidal stage or water depth, suggesting that dissolved oxygen follows a seasonal cycle related to planktonic photosynthesis, temperature and salinity; but at any given time of year, it is essentially homogeneously distributed.

The percentage saturation of dissolved oxygen for Mooring 12 over the same time period is also summarized in Figure 2.2-18. During the winter and spring, concentrations gradually rose from about 90% to around 105%. Over the summer, near-surface waters were highly super-saturated (up to 120%); whereas, near-bottom waters were generally undersaturated (down to 90%). Lowest concentrations were in November (near bottom down to 75%). Again no consistent difference between tidal stage or water depth values was observed.

## 2.2.8 Sedimentological Conditions

### 2.2.8.1 Sea-Floor Stability

Measurements of the exposed heights of paired sediment stakes at eight locations off Hampton Beach have provided data on relative bottom stability and possible sediment transport over more than three years of monthly observations (NAI, 1975f and 1977a). All of the sediment stakes have documented numerous erosional and depositional cycles of up to 9 in. or 22.9 cm but these have generally resulted in little net change at most locations. The most pronounced changes have been asso-



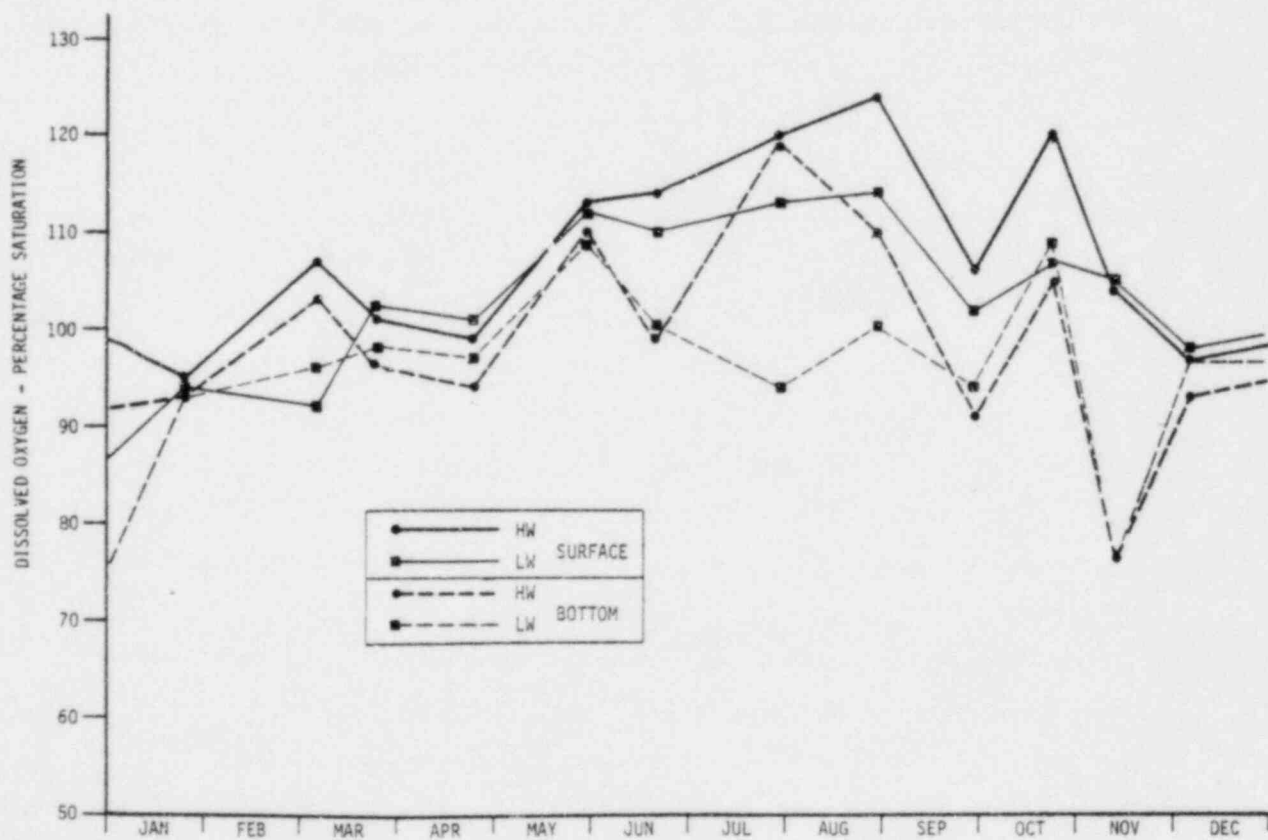
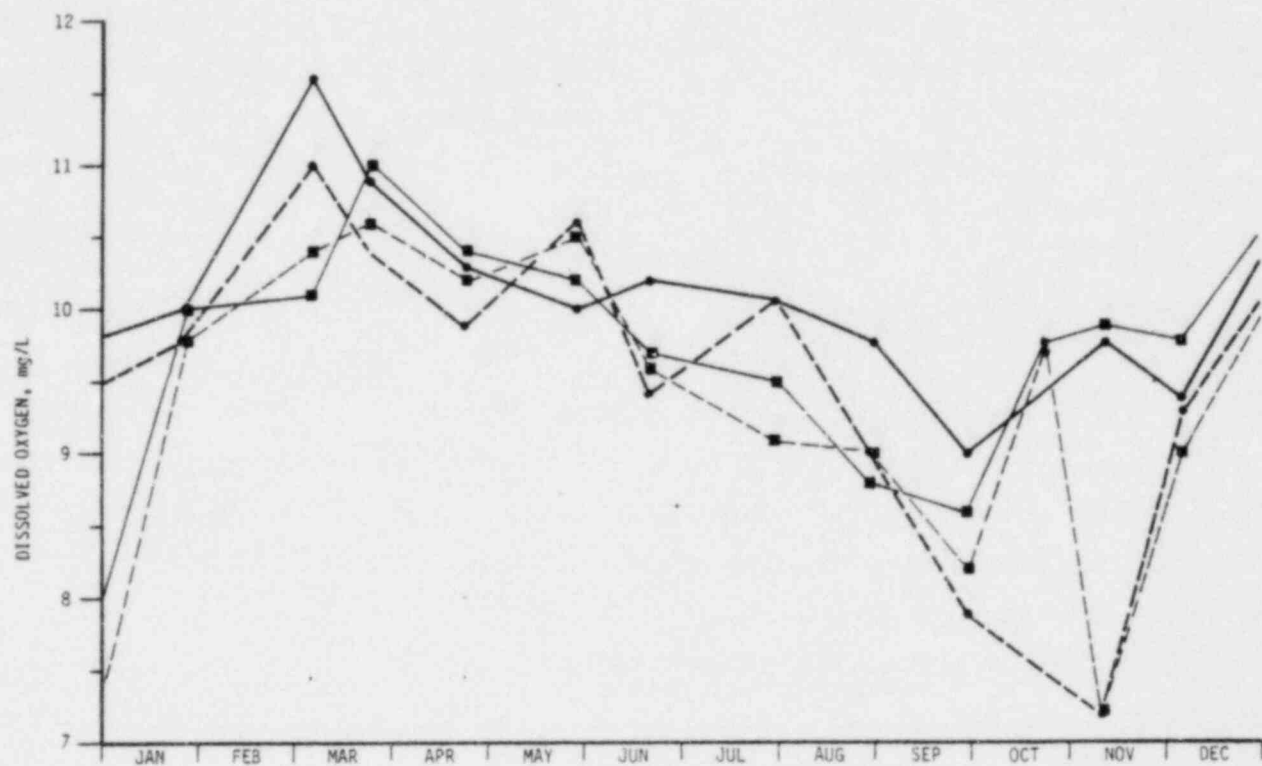

Figure 2.2-18. Monthly dissolved oxygen and percentage saturation observations at the discharge site (Mooring 12) for near-surface and near-bottom waters from 1975 slack-water surveys (both low water, LW and high water, HW).

ciated with northeast storms when strong near-bottom currents and large waves affect the sea floor; however, the storm effects are compensated by transport processes which tend to accumulate sediment under non-storm conditions. Thus the sea floor off Hampton Beach appears to be in a state of dynamic equilibrium.

#### 2.2.8.2 Suspended Sediments

The suspended load of particulate matter in offshore waters is largely the result of: discharge of suspended sediments from freshwater runoff; resuspension of tidal-flat sediments by wind, wave activity, and subsequent seaward transport out of estuaries; and biological growth. Total particulate concentrations off the New Hampshire coast from the mouth of the Piscataqua River to the 500-ft contour in Jefferys Basin, as measured during 1971 and 1972, showed large fluctuations; but in general, the winter months had the highest concentrations and the summer months the lowest (Ward, 1972). Highest organic concentrations were often seen during increases in total particulate concentrations, excluding the phytoplankton blooms, indicating that the increase in particulate concentrations can be largely attributed to inorganic sources. Generally about 35% of the total particulate matter was of an organic source.

According to Shevenell (1974), turbidity in the coastal shelf waters is characterized by a near-surface zone and a near-bottom zone of increased turbidity during times of density stratification in the water column. When this density stratification broke down, an offshore gradient in turbidity was observed. The dispersion of sediment-rich estuarine waters into the coastal shelf waters was controlled by the density gradient between the two water masses. Data on light transmission showed near-surface and near-bottom turbid zones during most of the year with a middle zone which had much less suspended material. From these data, it appears that the surface turbid layer is primarily due to phytoplankton and to a lesser extent to particulate matter from estua-

rine discharge. This latter component was not readily noticeable during the summer months. The bottom turbid zone is primarily due to re-suspension of bottom sediments by scouring associated with water currents and long-period wave action.

## 2.2.9 Hampton Harbor Estuary

### 2.2.9.1 Sedimentological Conditions at the Inlet

The Hampton Harbor estuary inlet was subject to northward and southward migration in response to coastal storms; but in the early 1930's, it was stabilized at its present location with breakwaters constructed by the U.S. Army Corps of Engineers. Depths in the main channel are somewhat variable due to shifting sands, storm effects, and periodic maintenance dredging. In general it is about 20 to 30-ft deep (at MLW) at the Route 1A Highway Bridge and shoals considerably a short distance to the east to about 6-ft deep (at MLW) in the main navigation channel. The shallow 3 to 4-ft deep (at MLW) sand bar or "sill" stretching from the northern breakwater to the Inner Sunk Rocks is formed by sand eroded from Hampton Beach and transported southward by the littoral longshore drift, especially during storms. This channel requires routine dredging every year to keep it open.

### 2.2.9.2 Turbidity

During the fall of 1975 NAI conducted a special study to determine ambient turbidity levels in Hampton Harbor estuary under varying oceanographic and meteorologic conditions (NAI, 1976e). The mean turbidity reading in the main harbor near the proposed barge landing site on September 17, 1975 under normal or relatively "calm" conditions was 1.43 FTU's (Formazin Turbidity Units). After the northeast storm of October 18 to 21, 1975, the mean turbidity was 3.92 FTU's, an increase of 2.73 times. Likewise, the control station in the Blackwater

River showed post-storm turbidity 1.86 times that of calm conditions. However, near the proposed plant site south of the Browns River, turbidities (as high as 36.0 FTU, measured with the Hach turbidimeter) showed no relationship at all to storm events.

Results of this study showed that there was generally a two- to three-fold increase over "calm"-condition turbidity levels in Hampton Harbor estuary following a coastal storm lasting several days. In general, turbidity appears to be inversely related to the stage of tide. During high tide, turbidity levels are lower, possibly due to the influence of less-turbid offshore water; whereas, at low tide turbidity levels tend to increase. This relationship was most apparent at the Browns River site. Ambient turbidity levels as high as 36 FTU's and 72 mg/l total non-filterable residue were measured within the upper reaches of the estuary. During stormy periods especially in the winter, elevated turbidity levels such as these have been seen to persist for weeks at a time both in Hampton Harbor and offshore.

### 2.2.9.3 Tidal Hydraulics

Under natural conditions, current speeds at the estuary inlet range from about zero to as much as 2 to 3 kn on spring tides; maximum flow through the inlet may reach nearly  $18.0 \times 10^6$  gal/min (gpm) or more than 40,100 ft<sup>3</sup>/sec (cfs). The average flow on a typical flooding tide is about  $9.8 \times 10^6$  gpm or 21,835 cfs. Over a period of 12 hrs and 30 min, under typical conditions, about  $3.7 \times 10^9$  gal of water first enters and then leaves the estuary on one flood and ebb tide cycle. At low-water slack tide, a mean of approximately  $500 \times 10^6$  gal of water is estimated to remain in the estuary. Thus, the total average flood tide volume of the estuary is approximately  $4.2 \times 10^9$  gal. Expressed on a percentage basis, about 88% of the estuary volume leaves and returns on each ebb and flood tide cycle. At low-water slack tide, the estuarine residual is approximately 12% that of the total volume of the basin. Only about 6% of the ebb tidal plume returns to the estuary on the next tidal cycle (EBASCO, 1969).

#### 2.2.9.4 Patterns of Tidal Flow

As has been previously described, there is a pronounced seasonal variability between the waters of the Hampton Harbor estuary and the adjacent ocean waters of the western Gulf of Maine. In the summer, the estuarine waters are generally warmer and fresher than the ambient ocean waters offshore because of solar radiation and land runoff. In the winter, the estuarine waters are generally colder than offshore waters due to solar insolation, but are still fresher because of land runoff. The general circulation and flow pattern of these waters can be summarized as follows (Figure 2.2-19):

##### I. EBB TIDE

During ebb tide, in the absence of storms and wind-stress effects, coastal waters off Hampton Beach seaward of the Outer Sunk Rocks generally flow southward or southwestward parallel to the coast at about 0.2 to 0.3 kn. Storms and periods of high winds may cause strong wind-driven flows that can mask these weak southerly ebb-tidal currents, resulting in sustained northerly or southerly flows that can persist for days.

Ebb-tidal currents from the estuary flow through the inlet (slightly southeastward), reaching speeds in excess of 2 to 3 kns due to the constriction caused by the breakwaters. The sill to the north of the inlet causes most of the water flushing out of the estuary to flow through the dredged navigation channel and southeastward, where it generally forms a distinct near-surface plume in the offshore ambient ocean waters. As noted previously, this plume is comprised of less-dense warm and fresh water during the summer and less-dense fresh and cold water during the winter. Some of the estuarine water flows northward across the sill toward the Outer Sunk Rocks, but it is a small portion of the total ebb-tidal prism. Current flows at the proposed nearshore intake site are generally weak (0.1 to 0.15 kn) and toward the northeast during this phase of the tide.



## II. LOW WATER

Because of the natural tidal lag in coastal waters, low water and the changing of the tide generally occur about 15 to 30 min earlier offshore than in the estuary. Offshore tidal currents weaken as the tide changes, going through a series of rotary directional changes but rarely becoming "slack" for very long. Cold, salty ocean water begins to flood landward into the estuary at depth, while the fresher estuarine water is still ebbing seaward near the surface. Slack-water occurs at slightly different times from place to place within the estuary, but generally lasts only about 15 to 20 min.

## III. FLOOD TIDE

Once the tide changes offshore seaward of the Outer Sunk Rocks, flood-tidal currents generally flow northward parallel to the coast. As noted previously, these tidal currents are generally only observed when atmospheric conditions are calm, in the absence of storms and wind-stress effects. Near the mouth of the estuary, ocean water flooding northward along the coast at depth begins to intrude into the estuary along the bottom of the channel, turning sharply toward the northwest as it moves landward through the inlet. Near-surface flows in the residual ebb-tidal plume south of the Inner Sunk Rocks are generally weak and variable. At the proposed nearshore intake site, weak tidal currents begin to flow toward the southwest as the tide changes.

By mid-tide, the entire water column is flooding strongly toward the northwest into the mouth of the inlet. There is also a well-developed flow southward across the sill and into the estuary. At this stage of the tide, flows are northward at the proposed discharge site at about 0.15 to 0.25 kn and southwestward at the proposed nearshore intake site at about 0.1 to 0.15 kn.

By late-flood tide, the strong landward flows of up to about 1 kn toward the estuary begin to slacken. Although some of the waters

from the residual ebb-tidal plume have been carried back into the estuary, most of the water has actually been drawn from depth at the harbor mouth.

#### IV. HIGH WATER

As during low water, the period of high water and any attendant "slack" current condition generally occurs about 15 to 30 min earlier offshore than in the estuary. Near-surface waters from the estuary begin to ebb seaward, while flood-tidal currents at depth continue to intrude landward.

#### V. ENTRAINMENT EFFECTS

A relatively small portion of the ebb-tidal plume flushed out of the estuary would move northward where it would be subjected to entrainment by the proposed nearshore intake for the Seabrook Station. During the flood-tide, proportionately more water entering the estuary would be subjected to entrainment; but it is still only a small portion of the total flood-tidal prism of the estuary. No entrainment of water destined to enter the estuary would occur at the offshore intake site because of the site's distance offshore and depth.

##### 2.2.9.5 Probability of Estuarine Entry of Coastwise Drifting Organisms

During the summer of 1975 NAI conducted several special studies to provide additional information on the potential entrainment impact of either of the proposed Seabrook Station intakes on the planktonic organisms found in the coastal waters off Hampton Beach (NAI, 1975b). The larvae of the soft-shelled clam, *Mya arenaria*, which are available in the near-shore waters for recruitment to the various estuaries along the coast of the western Gulf of Maine were of special concern.



A drifter study was conducted to evaluate, on a probabilistic basis, the percentage of water contributed to the tidal prism of Hampton Harbor estuary or neighboring estuaries from various positions and depths offshore. Groups of three types of drifters were released approximately weekly at low water (and occasionally at high water) from June 4 through September 23, 1975 to study the months that the planktonic larvae of *M. arenaria* are generally in the water column. Drifter-release stations were approximately 1500 ft (0.25 n mi) apart on east-west transects through the proposed intake and diffuser sites out to 3 n mi offshore. These drifters, which were used to examine net-flow patterns at various levels in the water column, included: (1) drift bottles which moved with the near-surface currents; (2) 15-ft and 30-ft Brooke drifters which were carried by currents at depth in the water column; and (3) sea-bed drifters which moved along the sea floor. Of the 13,240 drifters which were released, more than 32% had been recovered as of October 31, 1975.

Concurrent to two of the drifter-release surveys (July 23 and August 6), subsurface dye releases were made at a depth of about -30 ft (or 9.1 m) below MLW at the offshore intake site. These releases showed the same general flow patterns as the drifters and demonstrated the two-layer flow pattern and southerly net-drift of these coastal waters which is especially apparent during the summer months.

In addition, extensive weekly sampling for *M. arenaria* larvae was conducted along with the drifter releases from July 7 through September 23. With the drifter recovery percentages as the basic hydrographic input and the observed *M. arenaria* densities observed along the intake (I) transect as the basic biological input, possible estuarine recruitment from any intake location out to 3 n mi offshore was examined for the conditions of peak *M. arenaria* densities in the water column. In this way it was possible to estimate the numbers of *M. arenaria* larvae, as a function of distance offshore and depth, which could have been carried into the Hampton Harbor estuary or any other estuary.

The results of these special studies demonstrate that no unique current streamline persists between any of the transect release points and any estuary. Although projected entrainment of *M. arenaria* larvae which might have otherwise entered Hampton Harbor would be low anywhere along the Intake Transect; from the drifter releases, the off-shore intake site appears to be one where such entrainment losses would be minimized relative to sites either further offshore or closer to shore. For a continuation of discussion of entrainment impacts see biological section 5.3.

## 2.3 MARINE COMMUNITIES

### 2.3.1 Introduction

In general, marine plants and animals are highly evolved but comparatively simple organized forms, reflecting an evolutionary history of more than 600 million years. The distribution and habits of marine biota are distinctly different from those of terrestrial biota, primarily due to: 1) the buoyancy of water, and 2) the lack of deep penetration of light (to 15 m or less in coastal areas, depending on the amount of suspended matter). The predominant plant life are algae, taking the form of either tiny cells or massive fronds of simply organized tissues (the "seaweeds"). The richness of animal life in the sea is well known. Of the nineteen or so widely recognized animal phyla, all except one or two are found in the sea; five of the phyla (Brachiopoda, Chaetognatha, Phoronida, Pogonophora, Echinodermata) are exclusively marine. The three most highly evolved groups (Mollusca, Arthropoda, Chordata) are well represented.

Although the greatest density and variety of sea life is to be found nearest the continents, even these coastal areas are not evenly populated. Pelagic organisms (those which drift or swim freely in the ocean) are directly, or indirectly through food requirements, required to follow the movements of water masses. Benthic (bottom-dwelling)

organisms are typically strongly associated with a particular substrate type, such as rock or sand.

Sea organisms are often considered to be delicate and fragile, however, in their home environment, they are, to the contrary, rugged and resilient. Most have prodigious powers of repopulation so that the loss of even a great many individuals may be of little consequence to the population at large. Of the many marine species which have survived epochal change (ice ages, continental drift, magnetic field reversals, etc.), there are few which lack considerable defenses against fluctuating environmental conditions.

In the following sections, those marine organism assemblages, represented in the general vicinity of sites to be used for Seabrook Station cooling water intake and discharge structures, are described. The categories in which they are treated reflect their distribution and habits (i.e. plankton, benthos, and nekton).

### 2.3.2 Plankton

#### 2.3.2.1 Phytoplankton

Phytoplankton are the microscopic primary producers of the sea. They exist either as single cells or as groups of cells. As primary producers, they fix solar energy into chemical energy and, thus constitute the base of the marine food web. Phytoplankton serve directly as food for herring-like fishes, including alewife and menhaden. The movement and distribution of plankton are primarily dependent upon ocean currents. They are not capable of making sustained swimming movements against a current.

## I. NET PHYTOPLANKTON

The phytoplankton are best known from net collections. Net phytoplankton typically undergo periods of peak abundance in late spring and, again, in fall. These "blooms" are closely tied to availability of light and plant nutrients (e.g., phosphorus and nitrogen compounds), which are, in turn, generally associated with seasonal patterns of thermal stratification and destratification (mixing) of the water column.

The net phytoplankton in the study area are overwhelmingly dominated by diatom species; for example, of approximately 115 species or genera identified from net phytoplankton collections in 1975-76, 96 were diatoms. Large, armored dinoflagellates make up the next most important group; there were nine dinoflagellate species in 1975-76 collections. These two groups predominate in net collections not necessarily because they are more numerous or represent the greater portion of the biomass, but because they are large and have spiny structures, or form chains, so that they are easily caught. Diatoms and armored dinoflagellates are also relatively easy to preserve and their distinctive structures (which retard sinking) make good recognition characters.

Table 2.3-1 ranks the more abundant net phytoplankton in the vicinity of the proposed intake and discharge site. It is readily apparent that the genus *Chaetoceros* (all the members of which are chain-formers and have long spines) predominates. *Thalassiosira*, and sometimes *Detonula confervacea*, have also been numerically important, particularly during the early spring. The two *Ceratium* species are mid-summer to fall dominants, while *Rhizosolenia alata* is strictly a fall dominant. The temporal abundance and distribution of *Skeletonema costatum* is discussed in Section 5.1.2.

TABLE 2.3-1. RELATIVE REPRESENTATION OF NET PHYTOPLANKTON IN THE VICINITY OF HAMPTON BEACH, NEW HAMPSHIRE.

SPECIES	ABUNDANCE RANK		
	1975-76	1974-75	1972-73
<i>Chaetoceros debilis</i> (B)	1	1	1
<i>Chaetoceros furcellatus</i> (B)	2	ND*	ND*
<i>Chaetoceros compressus</i> (B)	3	ND*	ND*
<i>Thalassiosira nordenskioldi</i> (B)	4	5	4
<i>Chaetoceros lacinosus</i> (B)	5	ND*	ND*
<i>Chaetoceros affinis</i> (B)	6	2	ND*
<i>Chaetoceros brevis</i> (B)	7	ND*	ND*
<i>Chaetoceros</i> spp. (B)	3	ND*	2*
<i>Chaetoceros diadema</i> (B)	9	ND*	ND*
<i>Rhizosolenia alata</i> (B)	10	10	ND
<i>Nitzschia seriata</i> (B)	11	ND	ND
<i>Chaetoceros decipiens</i> (B)	12	8	ND*
<i>Skeletonema costatum</i> (B)	13	4	3
<i>Ceratium tripos</i> (D)	16	ND	23
<i>Detonula confervacea</i> (B)	18	6	ND
<i>Ceratium longipes</i> (D)	21	7	11

B = Diatom

D = Dinoflagellate

ND = No Data

\* = systematic separation of *Chaetoceros* spp  
varied from year to year

## II. NANOPLANKTON

The term nanoplankton is used to describe that fraction of the plankton which passes through a fine mesh net (mesh size: 50 to 65  $\mu\text{m}$ ). The size range has never been precisely defined, and depends largely on the author. Organisms which comprise this category represent a wide variety of taxa, some of which are difficult to distinguish because of their small size and general lack of recognition characters. Nevertheless the nanoplankton often represent a considerable portion of the biomass (especially in summer) and contribute significantly to measures of primary production (e.g., Carbon 14 uptake).

Certain nanoplankters, such as the flagellates *Isochrysis galbana* and *Monochrysis lutheri* are staples in the diet of cultured bivalve molluscs; others such as *Gonyaulax tamarensis* are toxic. In addition, certain "net" phytoplankters will escape to the nanoplankton when cell size has substantially diminished. These cell diminutions are the result of sequential divisions and will occur until the organism produces an auxospore, which then forms into a full-sized cell, allowing the process to begin all over again.

### 2.3.2.2 Invertebrate Zooplankton

#### I. Holoplankton

Holoplankters are animal organisms which spend their entire life cycle drifting in the water column. From the standpoint of numerical abundance, usually the same 8 to 12 species of copepod crustaceans characteristically comprise 60 to 90% of all planktonic animals in the New Hampshire coastal area. Most of these ubiquitous copepod species belong to the calanoid (i.e., *Calanus*-like) group. Of the 13 most abundant holoplankters in the vicinity of the proposed cooling-water intake and discharge site, nine are calanoids. The thirteenth species on the list, *Tortanus discaudatus*, is a carnivorous copepod; all other species listed in Table 2.3-2 are herbivores or omnivores.

TABLE 2.3-2. RELATIVE REPRESENTATION OF HOLOPLANKTERS  
IN THE VICINITY OF HAMPTON BEACH, NEW HAMPSHIRE

SPECIES	ABUNDANCE RANK			
	1975-76	1974-75	1973-74	1972-73
<i>Oithona similis</i> (Cy)	1	1	1	1
<i>Pseudocalanus minutus</i> (Ca)	2	3	3	6
<i>Microsetella norvegica</i> (H)	3	ND	ND	9
<i>Centropages typicus</i> (Ca)	4	2	4	5
<i>Temora longicornis</i> (Ca)	5	8	6	4
<i>Calanus finmarchicus</i> (Ca)	6	4	10	10
<i>Eurytemora herdmanni</i> (Ca)	7	7	2	3
<i>Evadne</i> spp. (Cl)	8	6	8	2
<i>Acartia longiremis</i> (Ca)	9	ND	ND	ND
<i>Podon</i> spp. (Cl)	10	9	7	ND
<i>Acartia tonsa</i> (Ca)	11	5	5	ND
<i>Metridia lucens</i> (Ca)	12	ND	ND	ND
<i>Tortanus discaudatus</i> (Ca)	13	10	9	ND

Ca = Calanoid copepod  
 Cy = Cyclopoid copepod  
 H = Harpacticoid copepod  
 Cl = Cladoceran  
 ND = No Data

Among the various other holoplanktonic groups only the herbivorous cladocerans ("water fleas") rank with the copepods in numerical importance. Other, less numerous, members of the holoplankton include: 1) predators, such as, *Sagitta* spp. ("arrow worms"), *Aurelia aurita* (the "moon jelly") and ctenophores ("comb jellies"), and 2) the largest-bodied animal group associated with the zooplankton, the euphausiids ("krill") which are a key component in the diet of marine birds and mammals, as well as many economically important finfish.

## II. MEROPLANKTON

This category refers to animal organisms which are planktonic only during the early life stages. Included are embryos and larval stages of most benthic animals (see Section 2.3.3). The eggs and larvae of finfish are also included in this category of plankton. However, they are collectively termed ichthyoplankton (see Section 2.3.2.3). Table 2.3-3 presents the more abundant groupings in order of numerical importance. Particular significance is attached to the larvae of economically important bivalve molluscs, such as: the soft-shelled clam, *Mya arenaria*; mussel, *Mytilus edulis* and the sea scallop, *Placopecten magellanicus*. Larvae of *M. edulis* numerically dominate the bivalve group. Brachyuran (crab) larvae are occasionally numerically important. Crab zoea of the common rock crab, *Cancer irroratus* frequently occur in large numbers in early summer plankton collections.

## III. TYCHOPLANKTON

The tychoplankton consists of organisms which temporarily inhabit the water column when they are swept from the sea bottom by storm surges or actively migrate up into the water column to feed (usually at night). Mysids (e.g., *Neomysis americana*), cumaceans (e.g. *Diastylis polita*), isopods, amphipods, and certain decapods, such as the sand shrimp, *Crangon septemspinosa* comprise this often overlooked plank-



TABLE 2.3-3. RELATIVE REPRESENTATION OF MEROPLANKTERS IN THE VICINITY OF HAMPTON BEACH, NEW HAMPSHIRE.

TAXONOMIC GROUPINGS	ABUNDANCE RANK	
	1975-76	1972-73
Bivalve veligers	1	1
Gastropod veligers	2	2
Polychaete larvae	3	4
Cirriped (barnacle) nauplii	4	3
Echinoderm larvae	5	7
Cirriped (barnacle) cyprids	6	5
Gastropod eggs	7	ND
Polychaete trochophores	8	6
Bryozoan cyphonautes larvae	9	ND
Epicaridean larvae	10	ND

ND = No Data

ton category. Because of their relatively large body size, the tycho-plankton may add substantially to the biomass and numbers of other plankton groups on an intermittent basis.

#### 2.3.2.3 Ichthyoplankton

Fish eggs generally demonstrate a definite seasonal pattern in New Hampshire coastal waters, with high densities during spring and early summer and low densities during winter. While fish eggs representing approximately 14 species have been collected in the nearshore zone since 1972, five species generally account for over 90% of the total (Table 2.3-4). Cunner eggs, by far the most abundant type, are dominant during June and July. Other summer dominants include eggs of American plaice, hake, fourbeard rockling and mackerel. During fall and winter the most abundant eggs are those of the cod/haddock complex, and those of pollock. Spring dominants include American plaice, cunner, cod/haddock and rockling eggs.

Fish larvae are present in approximately equal numbers throughout the year except for low densities in early fall. Although 33 larval species have been collected, seven of these generally account for over 90% of the total number of larvae. Sand lance larvae, which are abundant during winter and early spring, are usually the most abundant type (Table 2.3-4). Other spring dominants include seasnail, American plaice, radiated shanny, and winter flounder larvae. Summer dominants are larvae of cunner, witch flounder, and fourbeard rockling. Larvae collected in late fall and early winter are almost exclusively those of herring and pollock.

Periods of egg or larvae maximum density for each species are relatively short-lived and timing of these periods varies slightly from year to year. Thus sampling events may coincide with peak density of a particular species one year, but not other years. This accounts for the variability in rank among years shown in Table 2.3-4, and, although this

TABLE 2.3-4. SPECIES RANK FOR ICHTHYOPLANKTON BASED ON CATCH IN MIDWATER PLANKTON TOWS.

SPECIES	COMMON NAMES	1975-1976		1974-1975	1973-1974
		RANK	% OF TOTAL	RANK	RANK
<b>EGGS</b>					
<i>Labridae/Limanda</i>	Cunner/yellowtail flounder	1	59	1	1
<i>Hippoglossoides platessoides</i>	American plaice	2	13	6	7
<i>Gadus/Melanogrammus</i>	Cod/haddock	3	10	5	4
<i>Urophycis</i> spp.	Hake	4	6	3	2
<i>Enchelyopus cimbrius</i>	Fourbeard rockling	5	5	4	6
<i>Scophthalmus aquosus</i>	Windowpane	6	2	7	5
<i>Scomber scombrus</i>	Mackerel	7	1	2	3
<b>LARVAE</b>		RANK	% OF TOTAL	RANK	RANK
<i>Ammodytes americanus</i>	Sand lance	1	37	1	3
<i>Clupea harengus</i>	Atlantic Herring	2	16	9	11
<i>Tautogolabrus adspersus</i>	Cunner	3	8	2	4
<i>Liparis</i>	Seasnail	4	8	3	1
<i>Hippoglossoides platessoides</i>	American plaice	5	8	7	ND
<i>Enchelyopus cimbrius</i>	Fourbeard rockling	6	5	4	5
<i>Glyptocephalus cysoglossus</i>	Witch flounder	7	4	15	13
<i>Pollachius virens</i>	Pollack	8	2	5	2

ND = No Data

rank may vary from year to year, the species discussed above are the dominant ichthyoplankton species in New Hampshire coastal waters.

### 2.3.3 Benthos

#### 2.3.3.1 Benthic Faunal Communities

##### I. SUBTIDAL COMMUNITY

The area of the proposed Seabrook Nuclear Station discharge and intake structures is composed of three basic substrate types: rock-ledge, cobble (rocks less than 6" in diameter) and sand (see Figure 2.1-4). The distribution and composition of the benthic faunal communities is determined primarily by substrate type and secondarily by depth. This substrate heterogeneity is a major component of the natural variability found within the shallow subtidal benthic communities along the New Hampshire coast.

The rock ledge and cobble substrate areas are a mosaic of rocks, ledge, gravel and sand, each with an associated faunal assemblage. Those species considered hard substrate (rock-ledge, cobble) dominant fauna, form a ubiquitous group of epifaunal species associated with hard substrate to at least 80 feet below mean low water (Tables 2.3-5 and 2.3-6). In addition to the large ubiquitous group of dominant fauna there are smaller hard substrate species groups distributed within narrower depth ranges.

The faunal composition on subtidal sand substrate areas is determined primarily by the grain size of the sediments. Generally the sand substrate areas are composed of fine sand, moderately to well sorted. However, there are small patches of gravel with a 2 to 4 inch overlayer of sand located in the area of the proposed intake. Each of these substrates has an associated faunal group (Table 2.3-7).

TABLE 2.3-5. SUBTIDAL HARD SUBSTRATE SPECIES IN THE VICINITY OF THE PROPOSED INTAKE AND DISCHARGE SITES, NUMBERED ACCORDING TO RANK ORDER OF ABUNDANCE.

	1975-1976	APRIL 1975	AUGUST 1974	SUMMER 1972
<i>Spirorbis spirillum</i> ✓	1	1	1	9
Mytilidae spat	2	6	4	NC
<i>Lacuna vincta</i>	3	2	7	5
<i>Pontogeneia inermis</i> ✓	4	4	2	29
<i>Jassa falcata</i>	5	NC	11	3
<i>Ischyrocerus anguipes</i>	6	3	10	NC
<i>Balanus balanus</i> ✓	7	NC	9	31
<i>Hiatella</i> spp. ✓	8	NC	6	32
<i>Spirorbis borealis</i> ✓	9	8	17	NC
<i>Caprella septentrionalis</i>	10	NC	5	22
<i>Idotea phosphorea</i>	11	NC	15	4
<i>Molgula</i> sp.	12	11	8	2
<i>Pleusymetes glaber</i>	13	10	NC	50
<i>Asterias</i> spp. ✓	14	5	3	1

NC = None Collected

TABLE 2.3-6. SUBTIDAL COBBLE SUBSTRATE DOMINANT SPECIES IN THE VICINITY OF THE PROPOSED INTAKE AND DISCHARGE SITES. NUMBERED ACCORDING TO RANK ORDER OF ABUNDANCE.

	75-76	AUGUST 74
<i>Unciola irrorata</i>	1	4
<i>Hiatella</i> spp. ✓	2	NC
<i>Cerastoderma pinnulatum</i>	3	21
<i>Leptocheirus pinguis</i>	4	20
<i>Spirorbis spirillum</i> ✓	5	9
<i>Euchone rubrocincta</i>	6	NC
<i>Corophium crassicorne</i>	7	NC
<i>Pontogeneia inermis</i> ✓	8	15
<i>Euclymene collaris</i>	9	NC
<i>Spirorbis borealis</i> ✓	10	NC
<i>Asterias</i> spp. ✓	11	22
<i>Balanus balanus</i> ✓	12	25
<i>Tonicella ruler</i>	13	3
<i>Strongylocentrotus droebachiensis</i>	14	8
<i>Tharyx</i> spp.	15	

NC = Not Collected

TABLE 2.3-7. SUBTIDAL SAND SUBSTRATE SPECIES IN THE VICINITY OF THE PROPOSED INTAKE AND DISCHARGE SITES, NUMBERED ACCORDING TO RANK ORDER OF ABUNDANCE.

	1975-1976	SUMMER 1975	APRIL 1975
<i>Acanthohaustorius millsi</i>	1	NC	NC
<i>Tellina agilis</i>	2	3	NC
<i>Protohaustorius deichmannae</i>	3	NC	NC
<i>Psammonyx nobilis</i>	4	5	NC
<i>Echinarachnius parma</i>	5	4	7
<i>Spirorbis spirillum</i>	6	NC	NC
<i>Leptocuma minor</i>	7	NC	NC
<i>Clymenella torquata</i>	8	2	NC
<i>Spisula solidissima</i>	9	NC	NC
<i>Stenelais limicola</i>	10	11	NC
<i>Unciola irrorata</i>	11	NC	NC
<i>Arctica islandica</i>	12	7	2
<i>Diastylis polita</i>	13	NC	9
Mytilidae	14	NC	NC
<i>Aricidea</i> spp.	15	NC	10
<i>Edwardia elegans</i>	16	1	3
<i>Spiophanes bombyx</i>	17	13	5
<i>Pontogeneia inermis</i>	18	NC	8
<i>Tharyx</i> sp.	19	NC	NC
<i>Eucylmene collaris</i>	20	NC	4
<i>Jassa falcata</i>	21	NC	NC
<i>Myriochele heeri</i>	22	NC	1
<i>Ischyrocerus anguipes</i>	23	NC	NC
<i>Scoloplos fragilis</i>	NC	NC	6
<i>Siliqua costata</i>	NC	6	NC
<i>Ensis directus</i>	NC	9	NC

NC = Not Collected

The variability in the density of individual species and the number of species is due to breeding cycles and recruitment periods and the emmigration and immigration of major fish and crustacean predators into and out of the area. Spawning and recruitment occur during all seasons of the year, primarily during the spring with a moderate decrease in numbers per species during the summer and fall. The major predators (lobsters, crabs, cunner, pollock, cod, winter flounder) are generally present in high abundances during the spring and summer months. During the winter, fewer species spawn and recruit and most of the major predators leave the area. In general, the biological activity within the benthic community is correlated to water temperature trends, activity decreases as the water temperature decreases during November and increases as the water temperature increases during March-April.

## II. INTERTIDAL

The distribution and composition of the intertidal benthic faunal communities is determined primarily by substrate type and secondarily by adaptation to those physical parameters associated with tidal height, i.e. length of immersion, fluctuations of water temperature and salinity and wave action. In general, densities and numbers of species decrease on both hard and sand substrates with increasing distance above mean low water (Tables 2.3-4 and 2.3-10). Seasonal fluctuations in the number of species and density of individual species is determined by the breeding and recruitment cycles of the dominant species and by physical removal due to wave and storm activity.

## III. MEIOFAUNA

Meiofauna are benthic animals which pass through a 1 mm mesh screen but are retained at 63  $\mu$ m. Studies of these key organisms in the energy cycle, in the vicinity of the proposed cooling-water intake and discharge site, began in 1975. So far, a total of 29 taxonomic group-



TABLE 2.3-8. INTERTIDAL HARD SUBSTRATE DOMINANT SPECIES AT HIGH (+8.5 FT), MID (+4.2 FT) AND LOW (0 FT) TIDAL LEVELS IN THE VICINITY OF THE PROPOSED INTAKE AND DISCHARGE SITES.

HIGH	JUNE 1976	MARCH 1976	DECEMBER 1975	SEPTEMBER 1975
<i>Littorina littorea</i>	1	4		1
<i>Littorina obtusata</i>	2	1		
Mytilidae spat		3		
<i>Balanus balanoides</i>		2		
<i>Mytilus edulis</i>	4			
<i>Gammarus angulosus</i>	5			
<i>Carcinus maenas</i>	3			

MID	JUNE 1976	MARCH 1976	DECEMBER 1975	SEPTEMBER 1975
<i>Balanus balanoides</i>	1	1	1	1
<i>Hyale nilssoni</i>	4	6	6	2
Mytilidae spat	2	3	2	3
<i>Littorina obtusata</i>	3	2	3	4
Oligochaete	5	7	5	5
<i>Littorina littorea</i>	6	4	4	6
<i>Probursa veneris</i>				7
<i>Jaera marina</i>	7			8
<i>Nucella lapillus</i>	8			9
<i>Gammarus oceanicus</i>				10
<i>Hiatella</i> spp.			7	
<i>Littorina saxatilis</i>			8	
<i>Fabricia sabella</i>		5		
<i>Mysella planulata</i>	9			

TABLE 2.3-9. INTERTIDAL SAND SUBSTRATE DOMINANT SPECIES AT HIGH (+8.3 FT), MID (+4.2 FT) AND LOW (0 FT) TIDAL LEVELS IN THE VICINITY OF THE PROPOSED INTAKE AND DISCHARGE SITES.

MID	JUNE 1976	MARCH 1976	DECEMBER 1975	SEPTEMBER 1975
<i>Scolelepis squamatus</i>	1	1		
<i>Nereis diversicolor-virens</i>		2		
Mytilidae spat		3		

LOW	JUNE 1976	MARCH 1976	DECEMBER 1975	SEPTEMBER 1975
<i>Oligochaeta</i>				1
<i>Scolelepis squamatus</i>				2
<i>Amphiporeia virginiana</i>				3
<i>Lacuna vineta</i>			1	
<i>Caprella septentrionalis</i>			2	
<i>Jassa falcata</i>			3	
<i>Idotea phosphorea</i>			4	
<i>Ischyrochrus anguipes</i>			5	
<i>Jaera marina</i>			6	
<i>Caprella andreae</i>			7	

ings have been identified, the major categories of which are shown in Table 2.3-10. The *Corallina officianalis* to which the table refers is a very common crustose algae whose holdfasts offer a great variety of microhabitats to these tiny animals. Among the major organism categories, the harpacticoid copepods (Table 2.3-11) are particularly noteworthy as they are a major component in the diet of many ground feeding fish.

#### 2.3.3.2 Benthic Macroalgal Community

The benthic macroalgal community on rocky substrates in the offshore coastal Hampton-Seabrook study area (Table 2.3-12) consists of several dominant perennial species with the intermittent occurrence of certain annuals. The major associations are distributed vertically in overlapping bands, their distribution depending primarily on their particular light requirements and secondarily on their temperature and submersion requirements. Standing crop and numbers of taxa also show a vertical orientation with maximum values distributed around MLW. Because of their perennial nature, the major algal associations along with their standing crop and numbers of taxa remain generally constant over time; fluctuations are due to the occurrence of annual species and periods of maximum growth and recruitment of all species.

#### 2.3.4 Nekton

Nekton are large bodied organisms capable of directing their own body movements over long distances; this contrasts with the plankton which have a limited capability of directing their movements independently from drifting water masses.

TABLE 2.3-10. COMMON MEIOFAUNA INVERTEBRATE TAXA FOUND IN OCEANIC AND ESTUARINE SOFT SUBSTRATE SAMPLES AND/OR IN *CORALLINA OFFICIANALIS* HOLDFASTS.

Nematoda  
 Harpacticoida  
 Bivalvia  
 Polychaeta  
 Ostracoda  
 Gastrotricha  
 Halacaridae  
 Turbellaria  
 Tardigrada  
 Archiannelida

TABLE 2.3-11. COMMON HARPACTICOID COPEPOD SPECIES FOUND IN OCEANIC SOFT SUBSTRATE SAMPLES AND/OR IN *CORALLINA OFFICIANALIS* HOLDFASTS.

*Thompsonula hyaenae*  
*Halectinosoma neofactum*  
*Halectinosoma* sp. 1  
*Pseudobradya* sp. 1  
*Dactylopodia vu garis*  
*Paralaophonte macera*  
*Parastenhelia spinosa*  
*Tachidius discipes*  
*Rhizothrix minuta*  
*Amphiascus minutus*

TABLE 2.3-12. DISTRIBUTION OF MACROALGAE IN THE OFFSHORE COASTAL HAMPTON-SEABROOK STUDY AREA IN 1975-1976; ASSOCIATED SPECIES NOTED IN PARENTHESES

Depth from MLW	(m)	+2.6	+1.3	0	-5.2	-6.1	-9.1	-10.7	-12.2	-15.2	-18.3	-24.4
	(ft)	+8.5	+4.2	0	-17	-20	-30	-35	-40	-50	-60	-80
Number of taxa		21	31	42* (25)	34	34	31	25	26	24	23	15
Mean standing crop (gms dry wt m <sup>2</sup> )		17	2171	583* (3547)	596	790	244	162	117	72	30	6

MACROALGAL ASSOCIATION

Species dominant  
(algae type - common name)

*Fucus* spp. *Ascophyllum nodosum*  
(Brown -- "rock" algae)

*Chondrus crispus*  
(red -- "Irish moss")

*Desmarestia* spp.  
(brown -- none)

*Laminaria* spp.  
(brown -- "kelp")

*Phyllophora*  
(red -- none)

Crustose corallines  
(red -- none)

*Agarum cribosum*/brown -- kelp  
*Antithamnion* spp. (red -- none)

*Rhodophyllis dichotoma*  
(red -- none)

\* Depends on community dominants.

VERTICAL DISTRIBUTION

(Primary associated species)

(Certain annual species)

(Certain perennial species including crustose forms)

(*Gigartina* above MLW)

(*Corallina* below MLW)

(Certain annual species)

(3 kelp species)

(*Phycodrys*, *Ptilota* & other perennial reds)

(Primarily 6 species)

(Species distributed by depth)

(only taxa)

(Only species)

#### 2.3.4.1 Invertebrates

Two diverse invertebrate groups are important representatives in the nekton: the caridean crustaceans (i.e. shrimp or prawns) and the cephalopod molluscs (i.e. squid). The prawn group is represented in the vicinity of the intake and discharge site by such commercially important species as *Pandalus borealis* and *Dichelopandalus* sp. while important species of local squid are predominantly of the genus *Loligo*. All of these species are carnivores.

#### 2.3.4.2 Finfish Community

Approximately 70 species of finfish have been identified in New Hampshire coastal waters since monitoring studies began in 1972 (NAI, 1974c, 1975b, 1977a). The finfish community can generally be categorized into bottom fish, near-bottom browsers, and pelagic fish, although, as is shown in Table 2.3-13, these categories may overlap for certain species.

Based on results of three years of trawl data (Table 2.3-14), the most abundant fish in the trawl catches were yellowtail flounder (*Limanda ferruginea*), smelt (*Osmerus mordax*), cod (*Gadus morhua*), winter flounder (*Pseudopleuronectes americanus*), longhorn sculpin (*Myoxocephalus octodecemspinosus*), skates (*Raja* spp.) and oceanpout (*Macrozoares americanus*). Observations by SCUBA divers on rocky substrate areas, inaccessible by trawl, indicate that cunner (*Tautoglabrus adspersus*), pollock (*Pollachius virens*) and radiated shanny (*Ulvaria subbifurcata*) are also common members of the bottom or near-bottom community. In fact, density estimates of cunner by divers indicate that it is probably the most abundant fish species in the near-shore area. Of these species, yellowtail, cod, winter flounder, windowpane, longhorn sculpins, skates, and radiated shanny are permanent residents of the nearshore area. Although cunner are also permanent residents of the area, they are only active from April through December. Individuals overwinter

TABLE 2.3-13. SEABROOK FINFISH ECOLOGICAL CATEGORIZATION.

BOTTOM FISH	NEAR BOTTOM & BROWSERS	PELAGIC PLANKTIVORES & PREDATORS
Winter flounder Yellowtail Smooth flounder Atlantic halibut American plaice Windowpane Fourspot flounder Summer flounder Red hake White hake Spotted hake Radiated shanny Skates (Small, Big, Winter)	Cunner Tautog Scup Banded rudderfish  Pollock  Black sea bass Atlantic cod Tomcod  Sand shark	Atlantic mackerel Bluefish Blueback herring Alewife Striped bass  Rainbow smelt Atlantic menhaden Atlantic herring  Atlantic silversides
Rock gunnel Grubby Longhorn sculpin Shorthorn sculpin	    	
	Silver hake Smooth dogfish Spiny dogfish	
Atlantic sturgeon Atlantic wolffish American sand lance Cusk Lumpfish Fourbeard rockling Witch flounder Sea snail Goosefish Snakeblenny Ocean pout		
Sea raven Striped sea robin	Haddock	

TABLE 2.3-14. SPECIES RANK OF BOTTOM FISHES BASED ON OTTER TRAWL CATCH.

SPECIES	COMMON NAME	1975-1976		1974-1975	1973-1974
		RANK	% OF TOTAL	RANK	RANK
<i>Limanda ferruginea</i>	Yellowtail flounder	1	38	2	1
<i>Osmerus mordax</i>	Rainbow smelt	2	17	1	2
<i>Urophycis</i> spp.	Hake	3	16	4	8
<i>Gadus morhua</i>	Cod	4	5	5	3
<i>Merluccius bilinearis</i>	Silver hake	5	5	11	18
<i>Myoxocephalus octodecemspinosus</i>	Longhorn sculpin	6	4	8	6
<i>Pseudopleuronectes americanus</i>	Winter flounder	7	3	3	4
<i>Macrozoarces americanus</i>	Oceanpout	8	2	9	14
<i>Raja erinacea</i>	Little skate	9	2	7	7
<i>Scophthalmus aquosus</i>	Windowpane	10	2	6	5



deep in rock crevices in a torpid non-feeding state. Smelt are also common near bottom during the winter months.

Based on gill net catch, the most abundant pelagic fish species are Atlantic herring (*Clupea harengus*), pollock (*Pollachius virens*), blueback herring (*Alosa aestivalis*), mackerel (*Scomber scombrus*), menhaden (*Brevoortia tyrannus*), alewife (*Alosa pseudoharengus*), and at least during 1976, silver hake (*Merluccius bilinearis*) (Table 2.3-15). All are migratory species which utilize New Hampshire coastal waters only on a seasonal basis. Herring are abundant from late fall through early summer, but are absent in summer; pollock are abundant from early spring through fall, but are absent in winter. Blueback herring, alewife, and mackerel generally occur only during late spring and early fall, but mackerel may also occur during mid-summer. Silver hake occur from spring through late fall, but are absent during August when temperature is highest.

Surveys of sportfishermen conducted from 1973 through 1976 indicate similar species composition and seasonality with winter flounder, the species most often caught.

TABLE 2.3-15. SPECIES RANK OF PELAGIC FISHES BASED ON GILL NET CATCH.

SPECIES	COMMON NAME	1975-1976		1974-1975	1973-1974
		RANK	% OF TOTAL	RANK	RANK
<i>Clupea harengus</i>	Atlantic herring	1	54	19	8
<i>Merluccius bilinearis</i>	Silver hake	2	12	ND	10
<i>Alosa aestivalis</i>	Blueback herring	3	9	ND	6
<i>Pollachius virens</i>	Pollock	4	7	1	1
<i>Alosa pseudoharengus</i>	Alewife	5	5	15	9
<i>Scomber scombrus</i>	Mackerel	6	4	9	3
<i>Osmerus mordax</i>	Rainbow smelt	7	2	ND	7
<i>Brevoortia tyrannus</i>	Menhaden	8	2	10	5
<i>Gadus morhua</i>	Cod	9	2	2	2
<i>Urophycis</i> spp.	Hake	10	1	12	ND

ND = No Data

\* Both *Alosa* spp. included in *A. pseudoharengus* category.

### 3.0 CHARACTERISTICS OF THE PROPOSED CIRCULATING WATER SYSTEM

#### 3.1 INTRODUCTION AND GENERAL SYSTEM DESCRIPTION

Seabrook Station as well as any electric steam-generating station requires cooling water to condense steam into water after the steam has passed through the turbines which drive the electric generators. The steam condensate is then pumped back into the steam generator to continue the power cycle. The condenser cooling water does not come in direct contact with the reactor systems. The major change which occurs in the condenser cooling water is the addition of heat by which spent steam is condensed. Also, as described in Chapter 3 of the Seabrook Environmental Report (PSNH, 1973), small quantities of certain chemicals and wastes are introduced into the circulating water and discharged in highly diluted concentrations.

Seabrook Station has been designed with a "once-through" condenser cooling-water system. "Once-through" means that the condenser cooling water is taken from a natural water body (the ocean, in this case) into the plant at ambient temperature, passed through the heat exchange system (main condensers and service water heat exchangers), and then discharged back into the ocean at an increased temperature. This increase in temperature is often referred to as the condenser temperature rise or delta-T ( $\Delta T$ ).

Steam-electric power production requires that a certain amount of heat must be removed from the spent steam to condense it to water to be returned by pumping to the steam generation cycle. For Seabrook Station with both units operating, the quantity of heat which must be removed is about  $16 \times 10^9$  BTU/hr. Removal of waste heat from the steam generation cycle can be accomplished by one of two means - either limiting the amount of cooling-water flow and having a high condenser temperature rise ( $\Delta T$ ), or having a larger circulating cooling-water flow and lower  $\Delta T$ . To minimize pumped entrainment impacts, Seabrook Station has been designed with a high  $\Delta T$  and a "minimal" cooling-water flow. The resulting temperature rise for Seabrook Station is 39 F with a

nominal circulating cooling-water requirement of  $1822 \text{ ft}^3/\text{sec}$  (cfs). A meaningful comparison to put this flow rate into perspective can be made with the flow rate of the Merrimack River, which at Lowell, Massachusetts has annual discharge/or flow rate of 7164 cfs. On the other hand, the tidal prism (the amount of water which enters and leaves on a 12.8 hr tidal cycle) for Hampton Harbor is on the average  $470 \times 10^6 \text{ ft}^3$  or  $3.5 \times 10^9$  gal, which represents an average flow rate of approximately 20,400 cfs.

Cooling water for the Seabrook Station is drawn from and discharged back into the Gulf of Maine east of Hampton Harbor at locations shown on Figure 3.1-1.

The hydrological and biological description of this body of water including its natural temperature patterns is presented in Section 2.

This heat dissipation system has been selected for the Seabrook Station on the basis of environmental and engineering considerations. It is designed to provide the necessary cooling and heat dissipation function, as well as to protect the balanced indigenous marine ecosystem and to represent the best technology available for offshore intake and discharge structures. Specific objectives in the selection of this heat rejection system were the protection of the estuarine ecosystem and especially the existing clam flats; protection of indigenous and migratory marine life; and finally, ensuring that the selected system of heat dissipation would not provide hazards or impediments to highway, railroad, ship or air traffic in the region.

### 3.2 GENERAL SPECIFICATIONS

The quantity of heat dissipated by each unit is approximately  $8 \times 10^9$  BTU/hr for condenser cooling during full-load normal operation. For this purpose, the quantity of ocean water provided is 390,000 gallons per minute (gpm) per unit for condenser cooling, plus an additional flow

This page intentionally left blank.

of 22,000 gpm per unit for the service water heat exchanger. Consequently, the nominal total flow is 412,000 gpm per unit or 824,000 gpm for both units. Because there is no consumptive use of cooling water, the amount returned to the ocean at the point of discharge is 412,000 gpm per unit or 824,000 gpm for both units. This flow amount is maintained during normal operation throughout the year. All cooling water is drawn from the ocean at a location about 7,000 ft offshore of Hampton Beach, as shown on Figures 3.1-1 and 3.2-1. This water flows through a 19-ft inside diameter (I.D.) tunnel about 17,160 ft (3.25 mi) long and into the pumphouse located at the plant site. The time of travel through the intake tunnel at the nominal rated flow capacity of 824,000 gpm is about 44 min at a velocity of approximately 7.2 ft/sec (fps). Upon entering the pumphouse, the velocity decreases to allow for debris screening before entering the pumps.

One main condenser is provided for each unit. The circulating water temperature is raised 39 F as it passes through the condenser. Time of travel through the condenser is about 16 sec at the specified flow of 390,000 gpm per unit. Having passed through the condensers, the cooling water flows approximately 16,500 ft (3.12 mi) through another 19-ft I.D. tunnel to the submerged offshore diffuser. Travel time through the discharge lines for 824,000 gpm flow is 37 min at approximately 7.2 fps.

A cross-sectional profile of both the intake and discharge systems is shown in Figure 3.2-1. Each tunnel is constructed with a 0.5 percent slope toward the land to allow for gravity flow of water seepage toward the plant during construction and, if necessary, during dewatering of the tunnel. The intake and discharge tunnels have centerline elevations of -175 and -163 ft below mean sea level (MSL) respectively at the ocean end. Centerline elevations at the plant for the intake and discharge tunnels are -248 and -250 ft (MSL) respectively. Each tunnel is connected to the surface at the plant by vertical riser shafts.

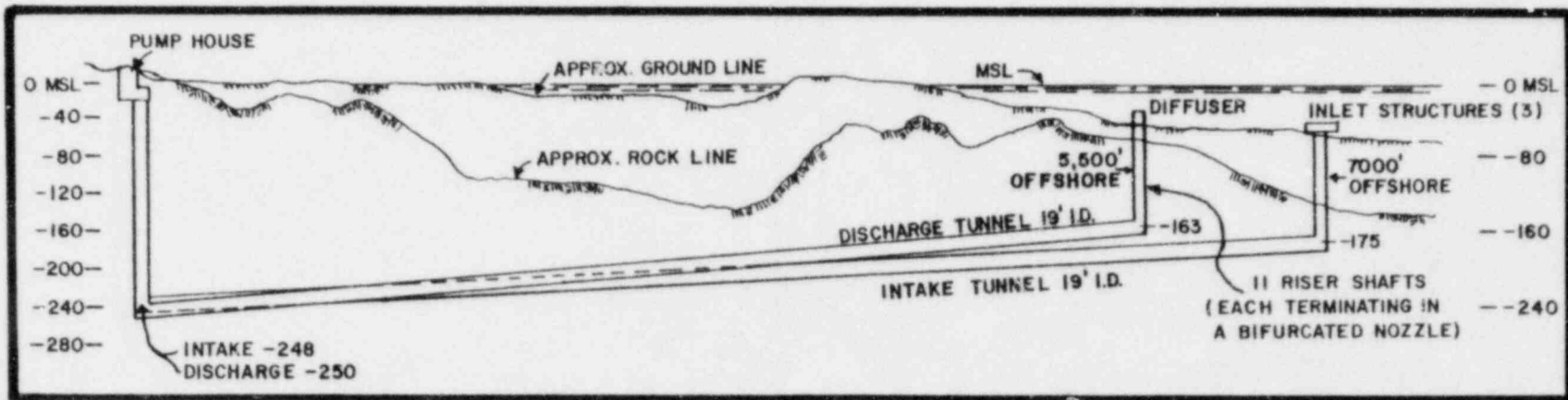

NOTE: THIS DRAWING NOT TO SCALE

Figure 3.2-1. Profile of Seabrook Station circulating water system.

### 3.3 INTAKE SYSTEM

The intake system consists of three offshore inlets submerged about 110 ft apart on the sea floor, three 10-ft I.D. riser shafts, the 19-ft I.D. intake tunnel, and a pumphouse located at the plant.

The inlet structures are located approximately 7,000 ft east of Hampton Beach where the water depth is about 58 ft (MSL). Cooling water enters each inlet structure through a "velocity cap" which is below mid-depth in the water column and which has an opening between 10 and 17 ft off the bottom. Figure 3.3-1 shows the plan and elevation details of the inlet structures. The inlet structures are concrete and the tunnel system is concrete lined. All exterior surfaces of the intake structures will be coated with an anti-biofouling material to prevent attachment and growth of organisms which would encourage grazing by fish.

Experience with offshore inlet structures along the coast of California indicates that a horizontal inflow current has much less potential for fish entrapment than a vertical current (Weight, 1958; Downs and Meddock, 1974; Schuler and Larson, 1974; 1975). A horizontal inflow direction is maintained about an inlet structure by means of the previously mentioned "velocity cap" (Figure 3.3-1). This is a combination of a flat plate positioned just above the opening to the vertical inlet shaft and a flange at the top of the vertical inlet shaft of the same diameter as the "cap". The "velocity cap" allows inflowing water to enter the gap between the cap and the flange from only a horizontal direction. The nominal inflow velocity at the outer edge of the Seabrook Station "velocity cap" is 1.0 fps.

The top of the 19-foot I.D. intake tunnel is at a depth of about -165 ft (MSL) and is connected to each intake structure by a 10-ft I.D. "riser shaft". The route of the intake tunnel is shown in Figure 3.1-1. The pumphouse located at the site contains six circulating water pumps. Each pump is rated for 130,000 gpm flow at an 80-ft pumping head. Also contained in the pumphouse structure are vertical traveling screens, a large forebay and appropriate hydraulic equipment such as valves and stoplogs.



PLAN VIEWS

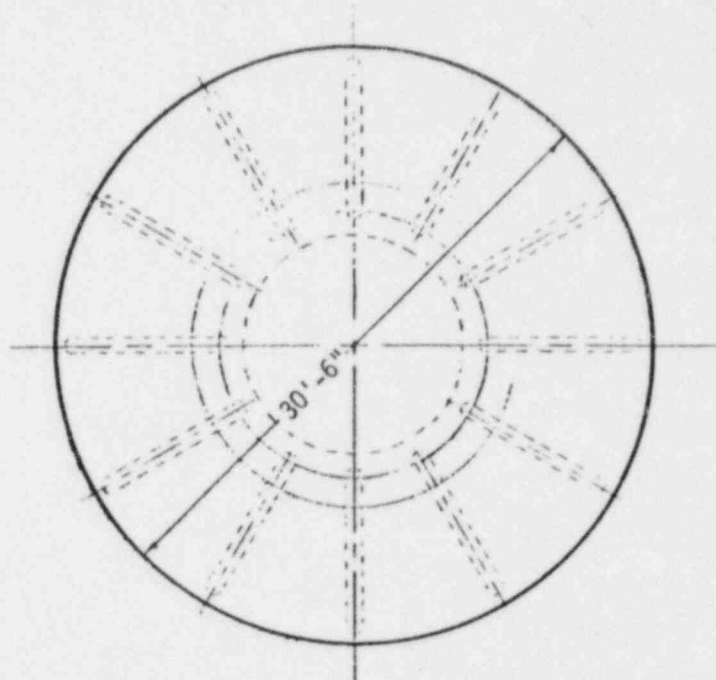
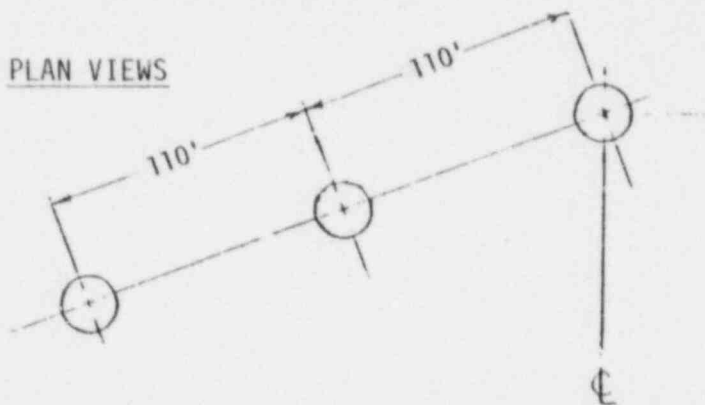

CROSS-SECTIONALS

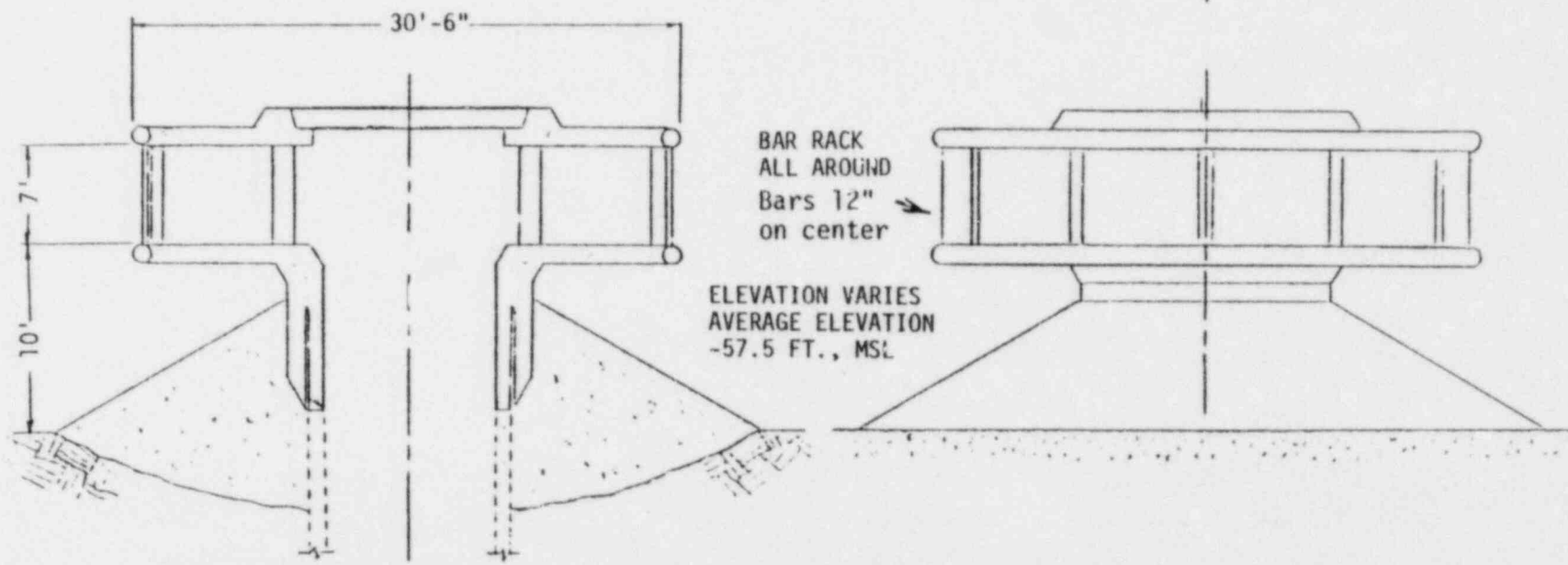

Figure 3.3-1. Diagram showing proposed velocity cap for Seabrook Station and plan view for riser shafts at the offshore intake location.

### 3.4 DISCHARGE SYSTEM

This discharge system consists of a 19-ft I.D. discharge tunnel and 11 vertical riser shafts, each 4.5 ft in diameter, which terminate in two 2.65-ft I.D. nozzles on each riser shaft. The riser shafts and nozzles constitute the 22-port submerged multiport diffuser which is located in approximately 50 to 60 ft of water. Each nozzle is approximately 7 to 10 ft above the sea floor. Both the discharge tunnel and riser shafts are concrete lined. The proposed diffuser design is shown in Figure 3.4-1.

Cooling water is discharged in a generally eastward direction through the multiport diffuser, beginning at a location approximately 5500 ft due east of the Hampton Harbor inlet. The 11 riser shafts which form the multiport diffuser are aligned in the northwest-southeast direction. The spacing between the riser shafts is about 100 ft and the multiport diffuser is about 1000-ft long. The normal travel time from the plant to the first point of discharge is approximately 37 min. Discharge velocity during normal operation is 15 fps.

During the backflushing operation (see Section 3.5) the discharge tunnel and multiport diffuser act as the intake system, since the flow direction is reversed. The backflush flow rate drops to approximately half the normal operational rate as noted above, and therefore, the velocity entering the diffuser nozzles is also cut in half to about 7.5 fps.

#### 3.4.1 Thermal Discharge Performance Under Normal Operations

Extensive hydrothermal model testing was performed at Alden Research Laboratories (ARL) of Worcester Polytechnic Institute to determine a suitable design for the submerged multiport diffuser (ARL, 1974). Tests were conducted to evaluate the behavior of the discharge during a series of representative current conditions (eight were selected)

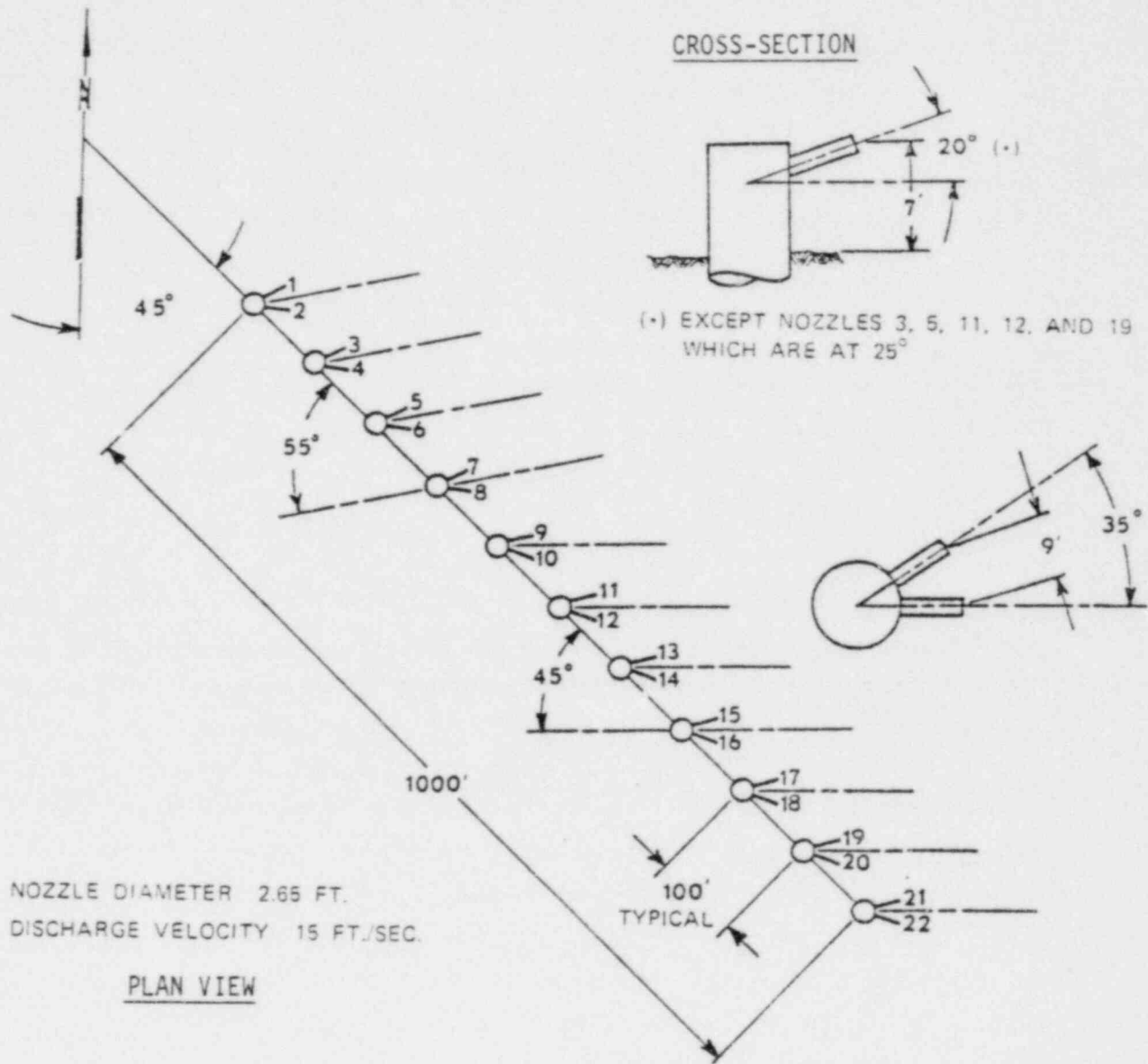
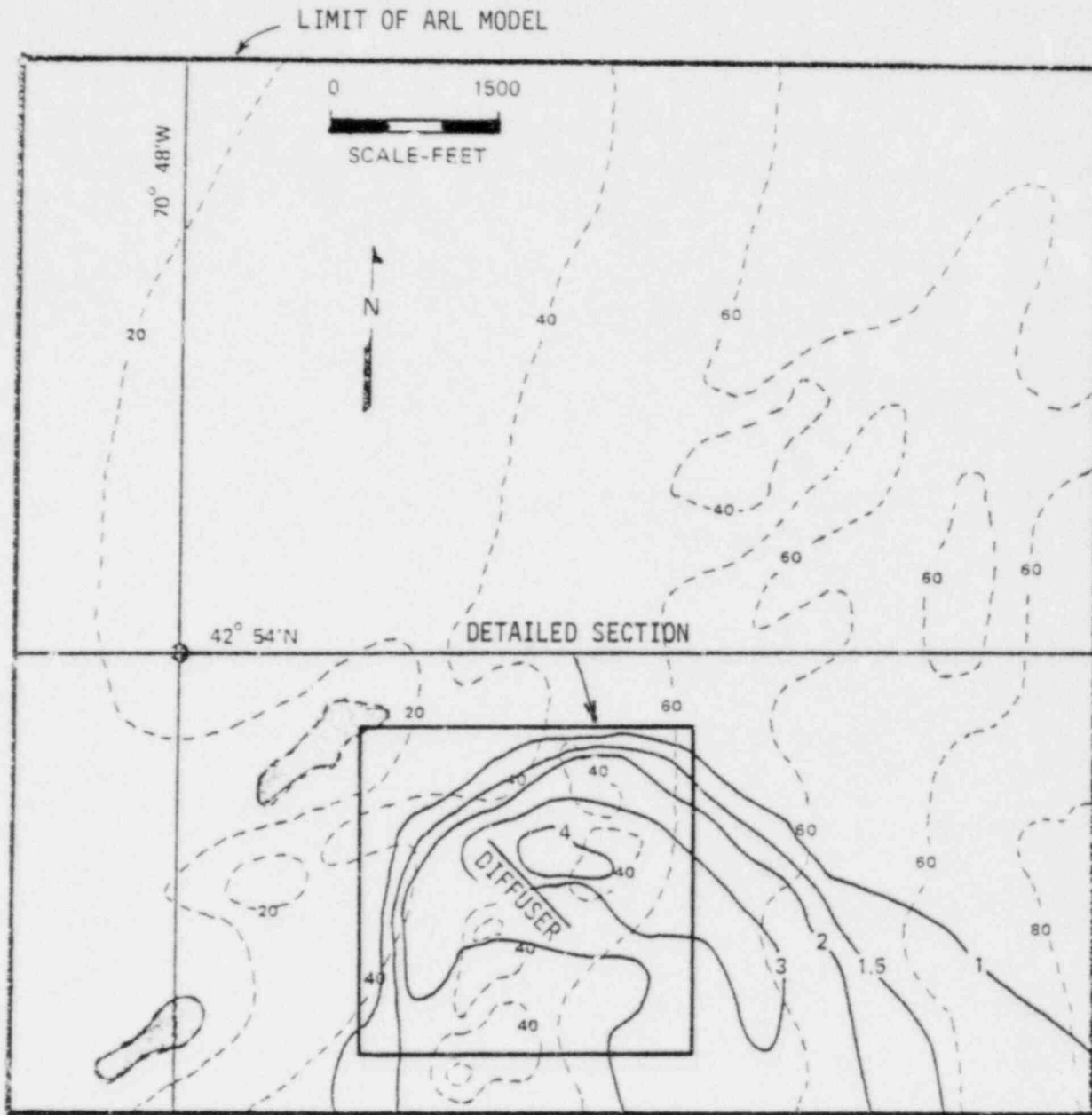

Figure 3.4-1. Diagram showing proposed Seabrook Station diffuser configuration.

in a 1 to 115 uniform Froude scale model. The thermal discharge criteria established by the Environmental Protection Agency (EPA) specifies a surface maximum temperature increase no higher than 5 F. By virtue of the 15 fps discharge velocity from the multiport diffuser located in water depths of more than 50 ft and diffuser nozzle orientation and design, the maximum surface temperature increase above ambient temperatures is only 5 F. This occurs infrequently, and even then, only over a small surface area. The Seabrook Station discharge design results in a 5 F surface maximum temperature rise, even though the initial temperature rise at the discharge point (diffuser nozzle) is 39 F. This result is remarkable when a survey of other New England coastal power plants reveals surface maximum temperature rises of 20 F and many as high as 28 and 29 F. Even the proposed Pilgrim Unit II has a maximum surface temperature rise of 20 F.

Since the thermal plume resulting from normal station discharge was designed to achieve a surface maximum temperature no greater than 5 F above normal ambient water temperature, a high rate of temperature reduction must occur. The high rate of temperature reduction occurs in a very short distance from the diffuser. Within about 32 seconds, the temperature is reduced from 39 F to 5 F above ambient. The volume of water raised to temperatures in excess of the 5 F surface temperature rise is small -- about 3 acre feet.

Near-field isotherms for the backflush case are presented in Appendix A for the hydrothermal "worst case" results (winter conditions, non-stratified, 100 percent plant heat rejection). Figures 3.4-2 through 3.4-7 represent the normal discharge operation for the worst case winter current with the station at full load.



CYCLE NO.	<u>1NS.15</u>	DIFFUSER CONFIGURATION	<u>230</u>
AMBIENT TEMPERATURE (°F)	<u>43.32</u>	FLOW RATE (CFS)	<u>1822</u>
TEST NO.	<u>178</u>	INTAKE TEMPERATURE (°F)	<u>43.32</u>
TEST DATE	<u>2/12/75</u>	PLANT ΔT (°F)	<u>40.2</u>

Figure 3.4-2. Predicted tidal average surface temperature differentials ( $\Delta T$  in degrees F) from Seabrook Station operation, based on ARL modeling studies. Depth isobaths are in ft below MSL.

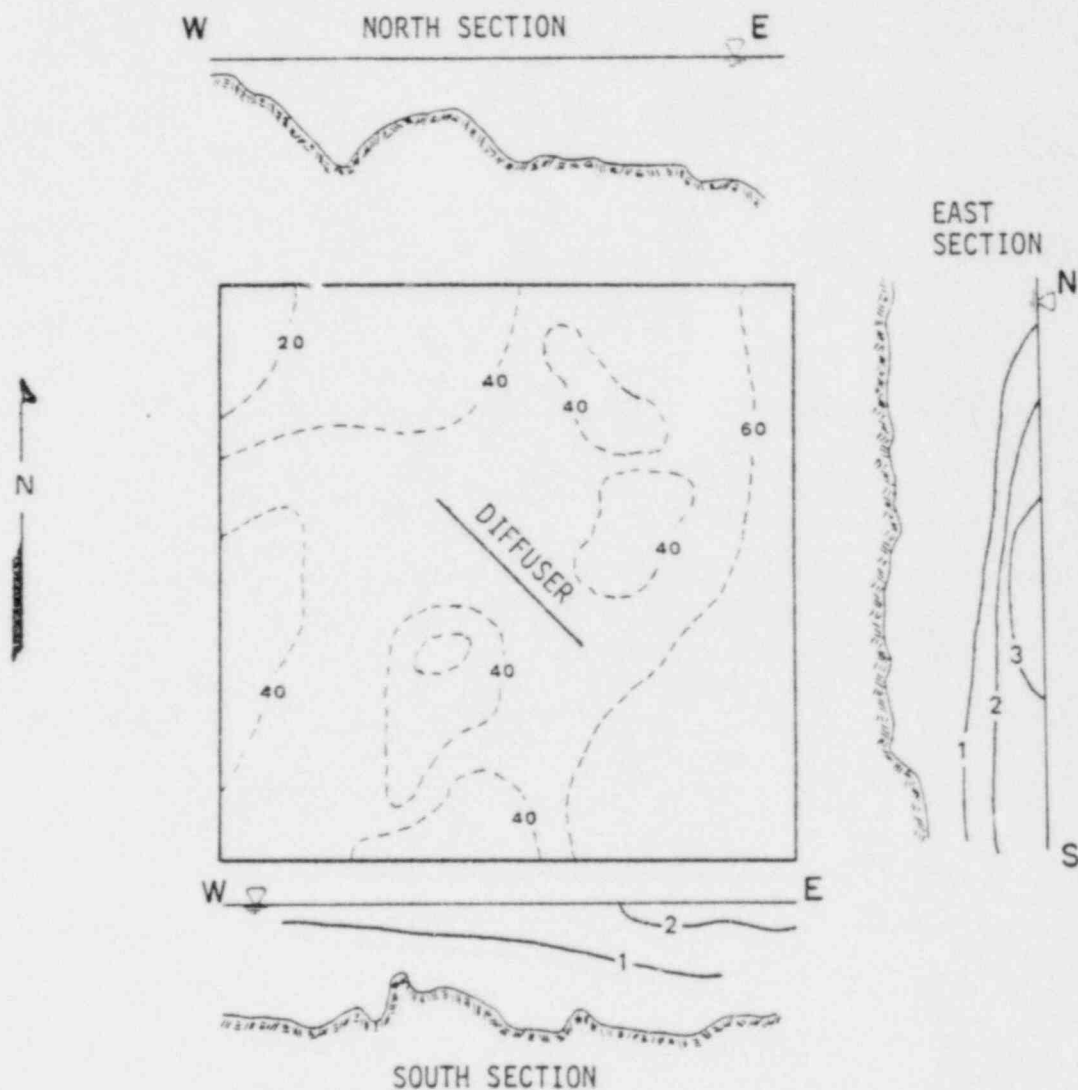
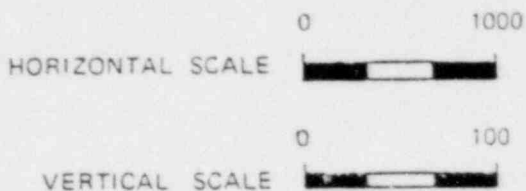

TEST NO. 178  
 TEST DATE 2/12/75  
 DIFFUSER 23D

Depth isobaths in ft below MSL

Figure 3.4-3. Detailed section of ARL modeling showing predicted tidal average vertical temperature differential ( T in degrees F) structure from Seabrook Station operation. (Refer to Figure 3.4-2 for perspective of area this figure covers.)

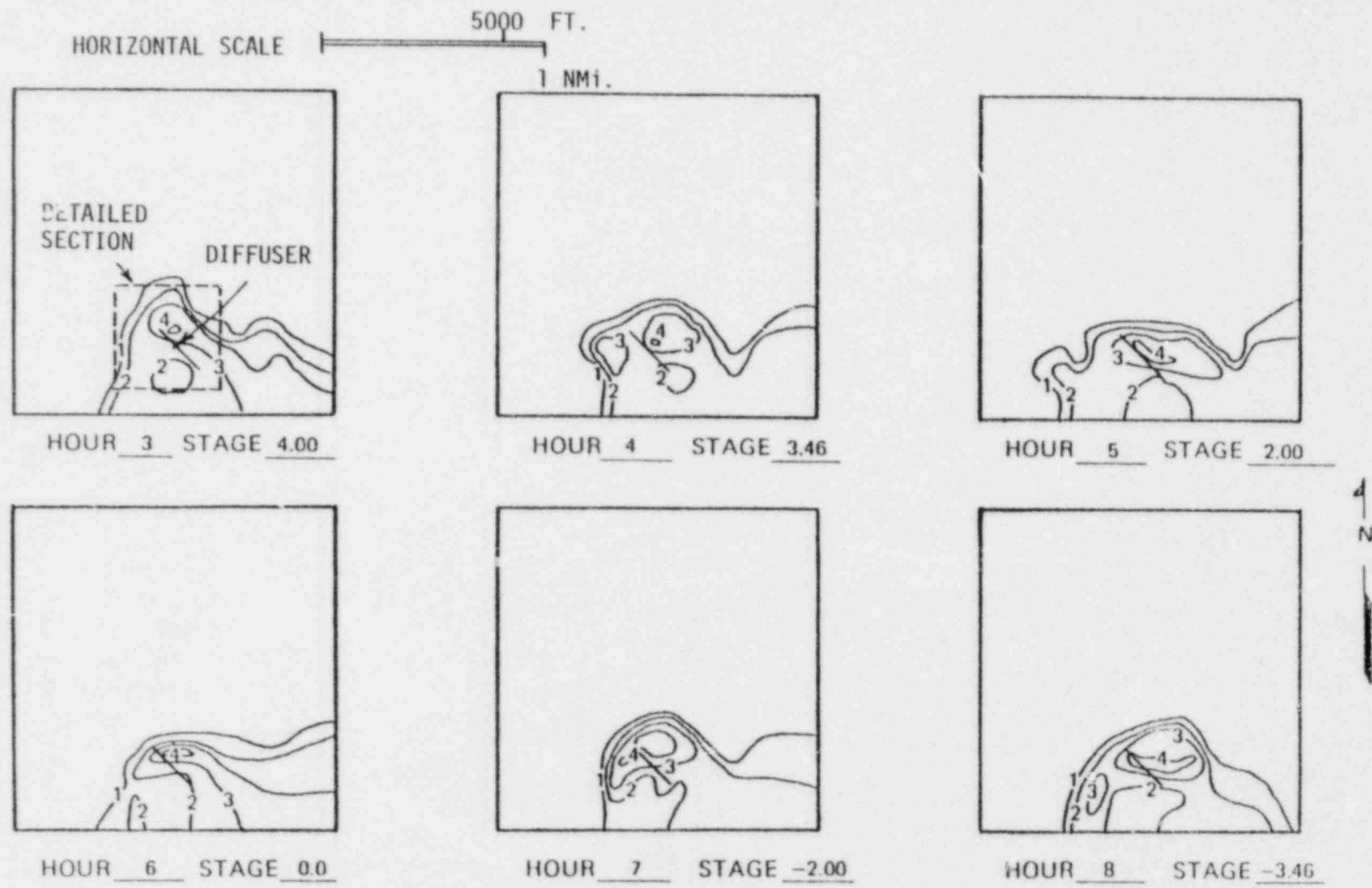

Figure 3.4-4. Predicted hourly surface temperature differential ( T in degrees F) from Seabrook Station operation.

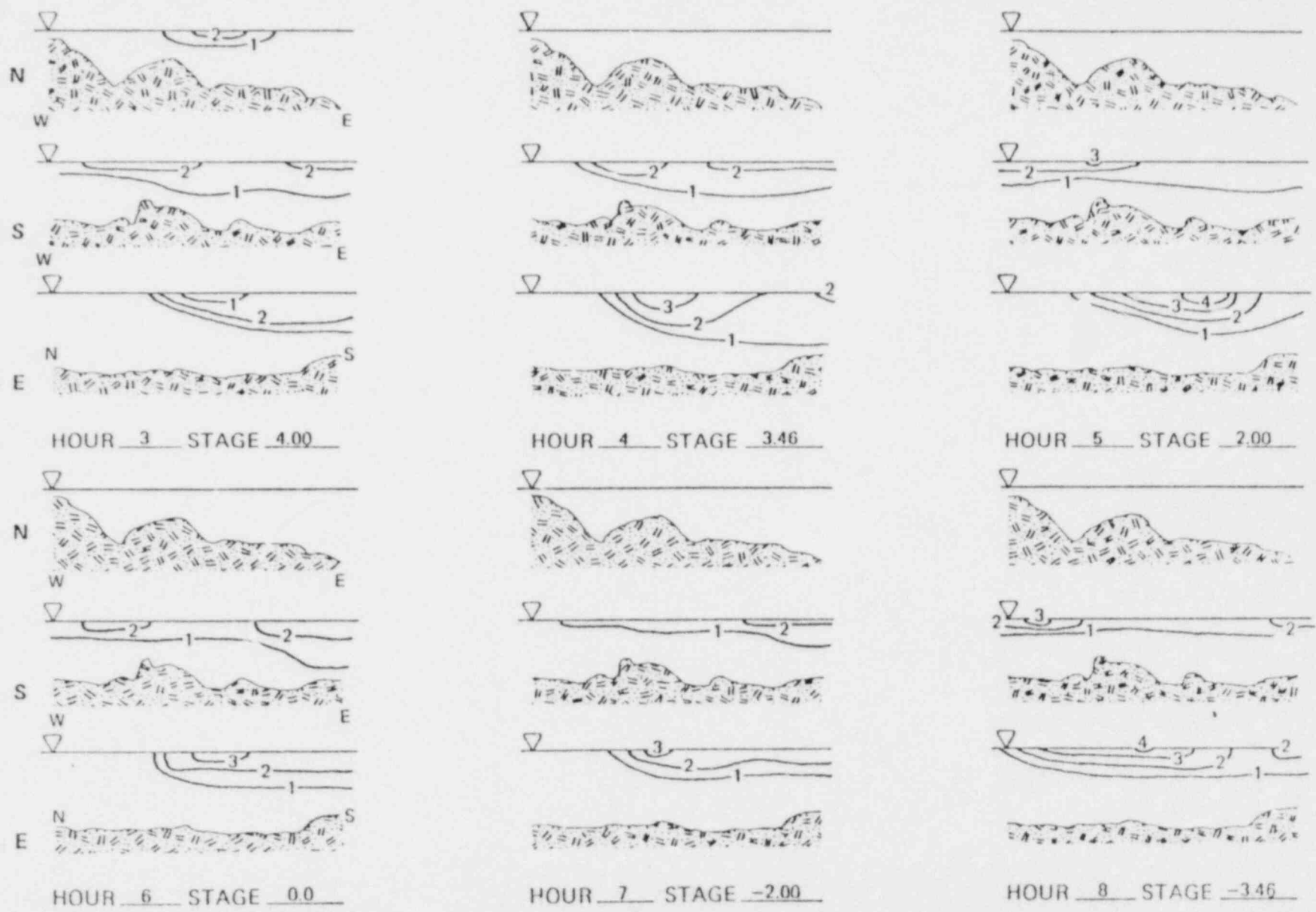

Figure 3.4-5. Detailed sections showing predicted hourly vertical temperature differential ( $\Delta T$  in degrees F) from Seabrook Station operation. (first half of tidal cycle).



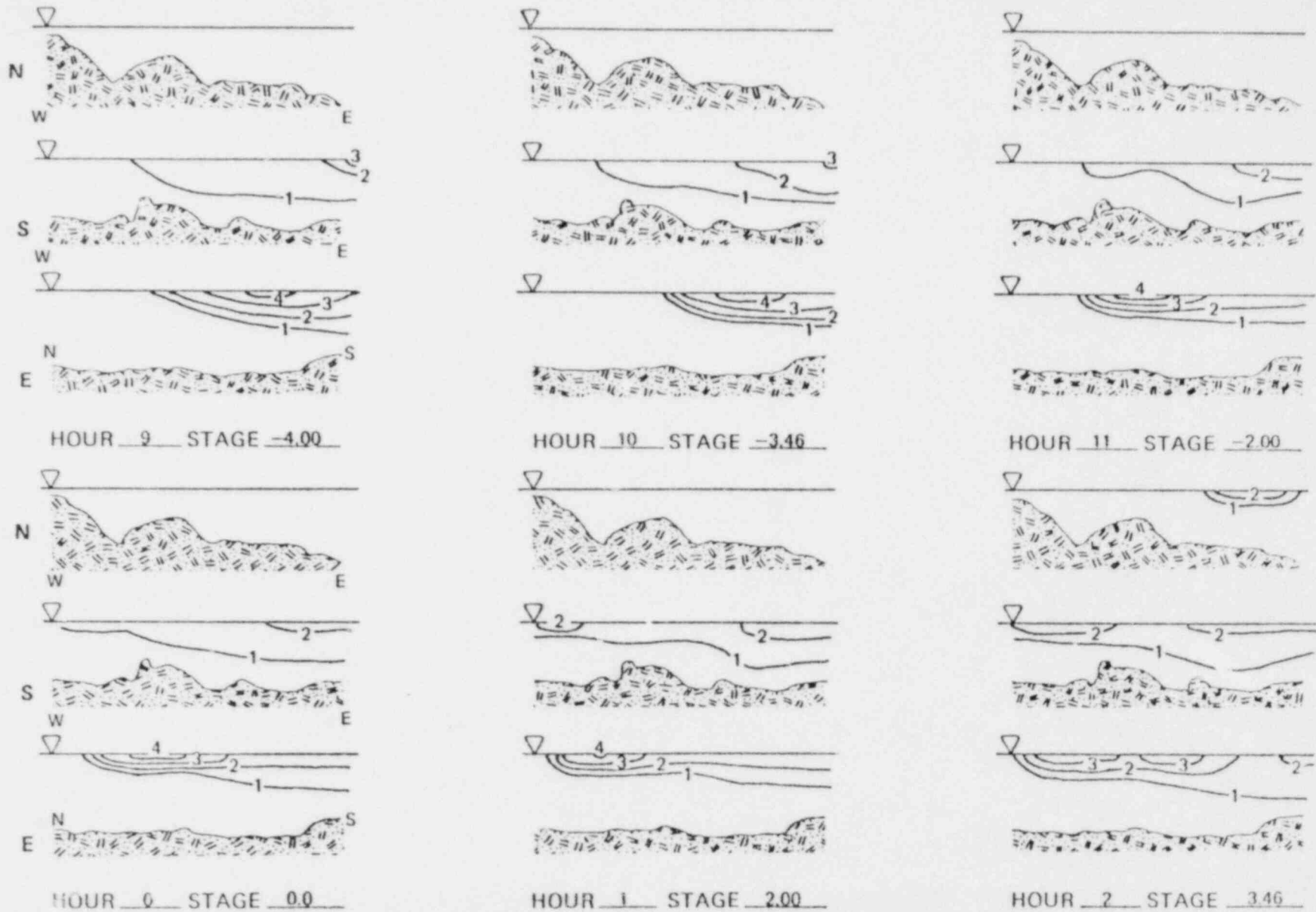

Figure 3.4-6. Detailed sections showing predicted hourly vertical temperature differential ( $\Delta T$  in degrees F) from Seabrook Station operation. (second half of tidal cycle).

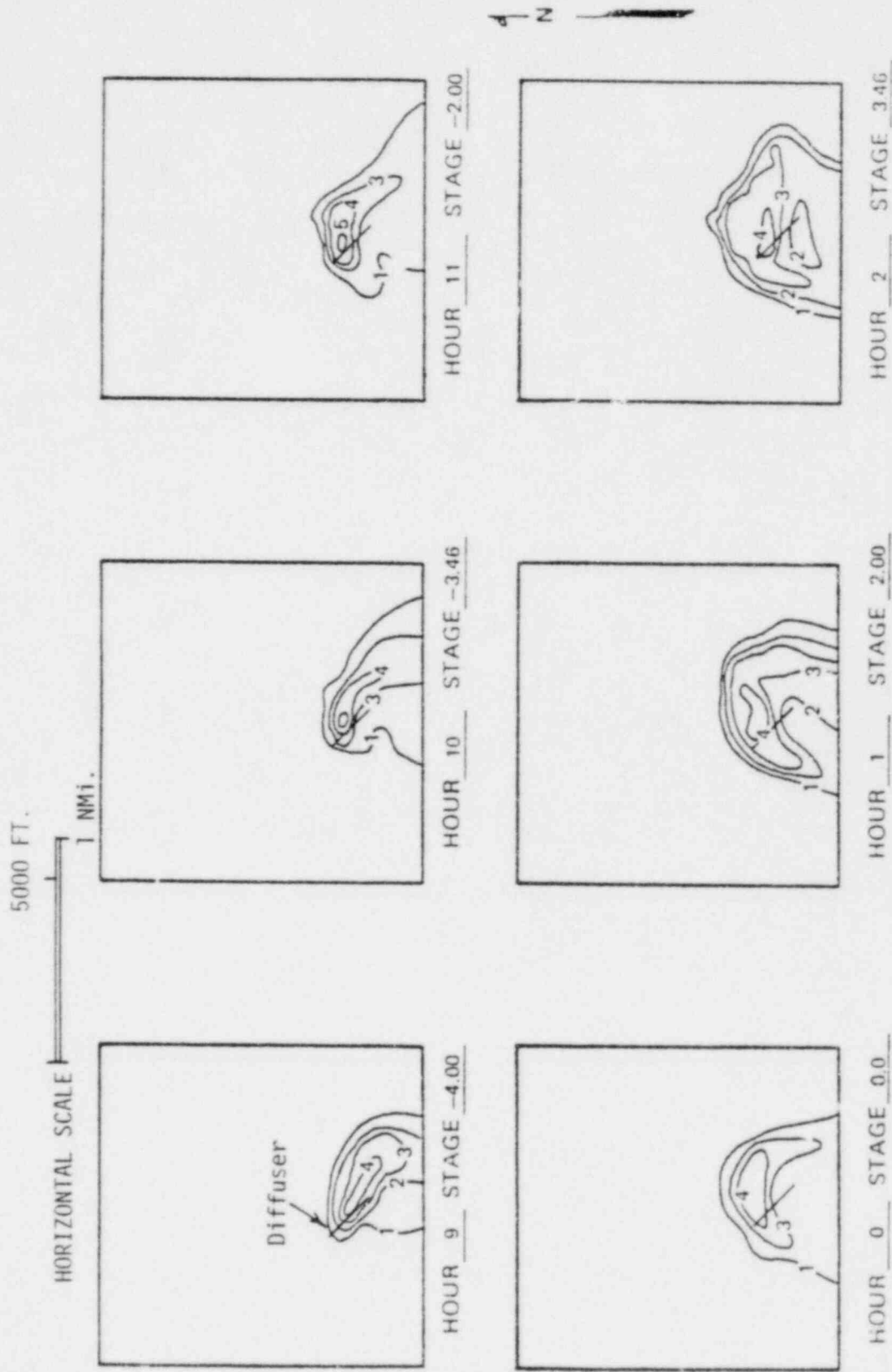

Figure 3.4-7. Predicted hourly surface temperature differentials ( $\Delta T$  in degrees F) from Seabrook Station operation.

### 3.4.2 Dilution of Ambient Water

The diffuser performance discussed above can only be achieved with mixing of ambient water into the discharged water because decrease in temperature is proportional to volumetric dilution. Dilution is generally defined as the initial temperature rise divided by the temperature rise of interest. An example of this is  $39/5 = 7.9$  for the dilution of the thermal plume from the origin to the point where the plume reaches the surface.

Dilution values are important since the dilution factor indicates the amount of ambient water required to achieve a given temperature rise.

$$\text{If dilution is defined as } D = \frac{\Delta T_i}{\Delta T_F} \quad (1)$$

$$\text{and } Q_i \Delta T_i = Q_2 \Delta T_F \quad (2)$$

$$\text{where } Q_2 = Q_i + Q_A \quad (3)$$

$$\text{then } Q_2 = \frac{Q_i \Delta T_i}{\Delta T_F} \quad \text{or}$$

$$Q_i + Q_A = \frac{Q_i \Delta T_i}{\Delta T_F}$$

$$\text{and } Q_A = Q_i \frac{\Delta T_i}{\Delta T_F} - Q_i$$

$$\text{so that } Q_A = Q_i (D-1) \quad (4)$$

- For
- $T_i$  = initial temperature rise
  - $T_F$  = temperature rise of interest
  - $Q_i$  = plant cooling-water flow
  - $Q_A$  = ambient water entrained into the plume
  - $Q_2$  = combined flow in the discharge plume at the point of interest

Equation (4) above shows that the amount of ambient receiving water entrained into a thermal plume is the dilution value at any temperature minus one, times the initial plant flow.

Equation (2) represents the conservation of heat equation in the near field and is applicable to the thermal plume of any power plant operating with a "once-through" cooling water system. Thus for operating at a steady-state condition, the amount of receiving water required to dilute the discharge to a given temperature is constant. This is true regardless of the discharge nozzle configuration.

#### 3.4.3 Far-Field Thermal Plume Characteristics

A detailed analytical study of the far-field thermal plume behavior is presented in ARL, 1975. This far-field study was structured as a parametric analysis of the thermal discharge under widely varying ambient conditions.

Far-field thermal performance of the discharge is primarily dependent on two ambient parameters: ocean currents (magnitude and direction) and surface heat transfer coefficient. Surface heat transfer coefficient is primarily a function of wind speed, relative humidity,

water temperature, and air temperature.

The parameters included in the Seabrook far-field study and reproduced here are taken from Table 1 of ARL, 1975.

TABLE 3.4-1. AREAS ENCLOSED BY ISOTHERMS

AMBIENT CURRENT SPEED (kn)	DIRECTION TOWARD (°TRUE)	TRANSFER COEFFICIENT (BTU/ft <sup>2</sup> /dayF)	ISOTHERM AREAS ACRES ENCLOSED	
			1.5 F	2.0 F
0.15	170	150	4,700	900
0.15	30	150	5,000	1,200
0.15	30	100	7,200	1,700
0.15	30	250	3,200	800
0.40	30	150	2,800	300

Surface isotherm plots related to the parameters given in the above table are provided in Figures 3.4-8 through 3.4-12.

The purpose of a parametric study such as this one is to determine the far-field plume sensitivity to variation in the parameters utilized in the study. It is clearly evident from Table 3.4-1 that isotherm areas show the greatest dependence on ambient current speed and surface heat loss coefficient. However, it is important to note that the far-field plume is a high inertia, slow-acting system, reacting very slowly to changes in ambient conditions. Therefore, average monthly values of the various dependent input parameters are representative for use in predicting thermal plume performance in the Gulf of Maine.

In order to assess the thermal impact of the far-field thermal plume from the parametric study, representative values of the significant dependent parameters must be determined before results can be obtained from the table.

*Handwritten note:* Heat is one of the 2 parameters shown that affect the isotherm area.

*Handwritten note:* what table?

*Handwritten note:* The purpose above gives conclusions from Table 3.4-1. It refers to this table.

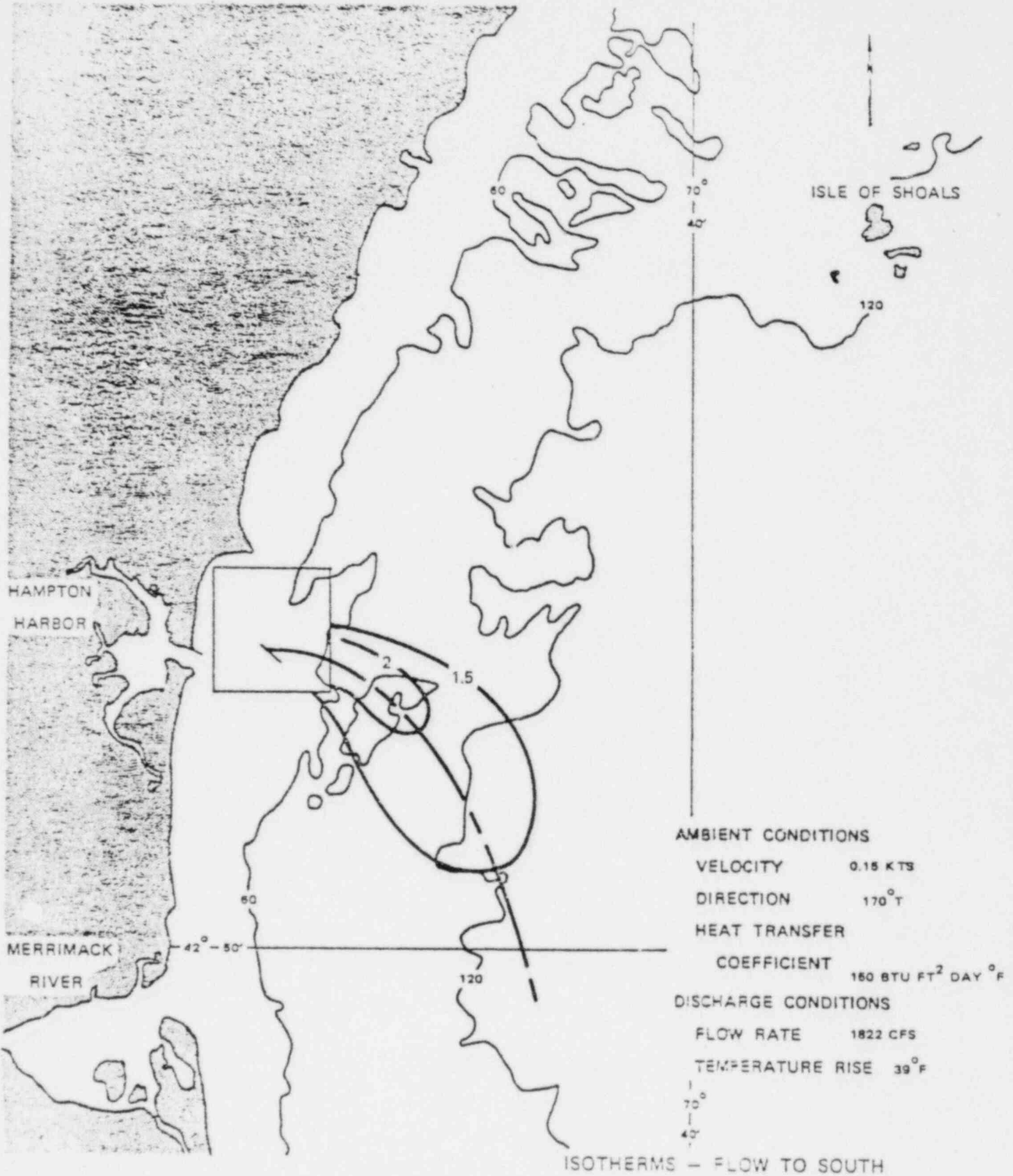

Figure 3.4-8. Predicted far-field surface temperature isotherms (in  $\Delta T$  degrees F) under weak ambient southward currents and average heat transfer.

0 10,000  
  
 PROTOTYPE-FEET

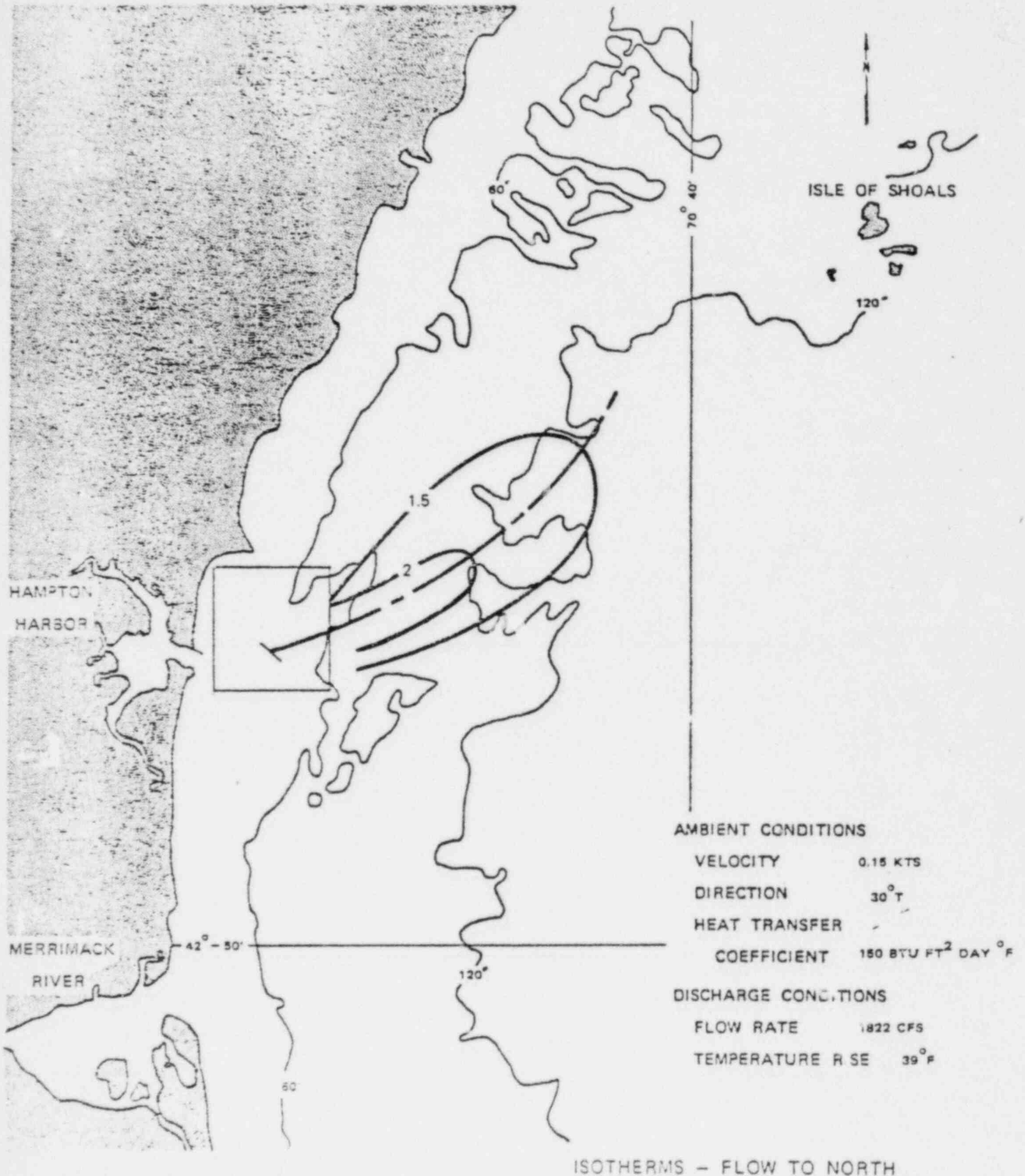
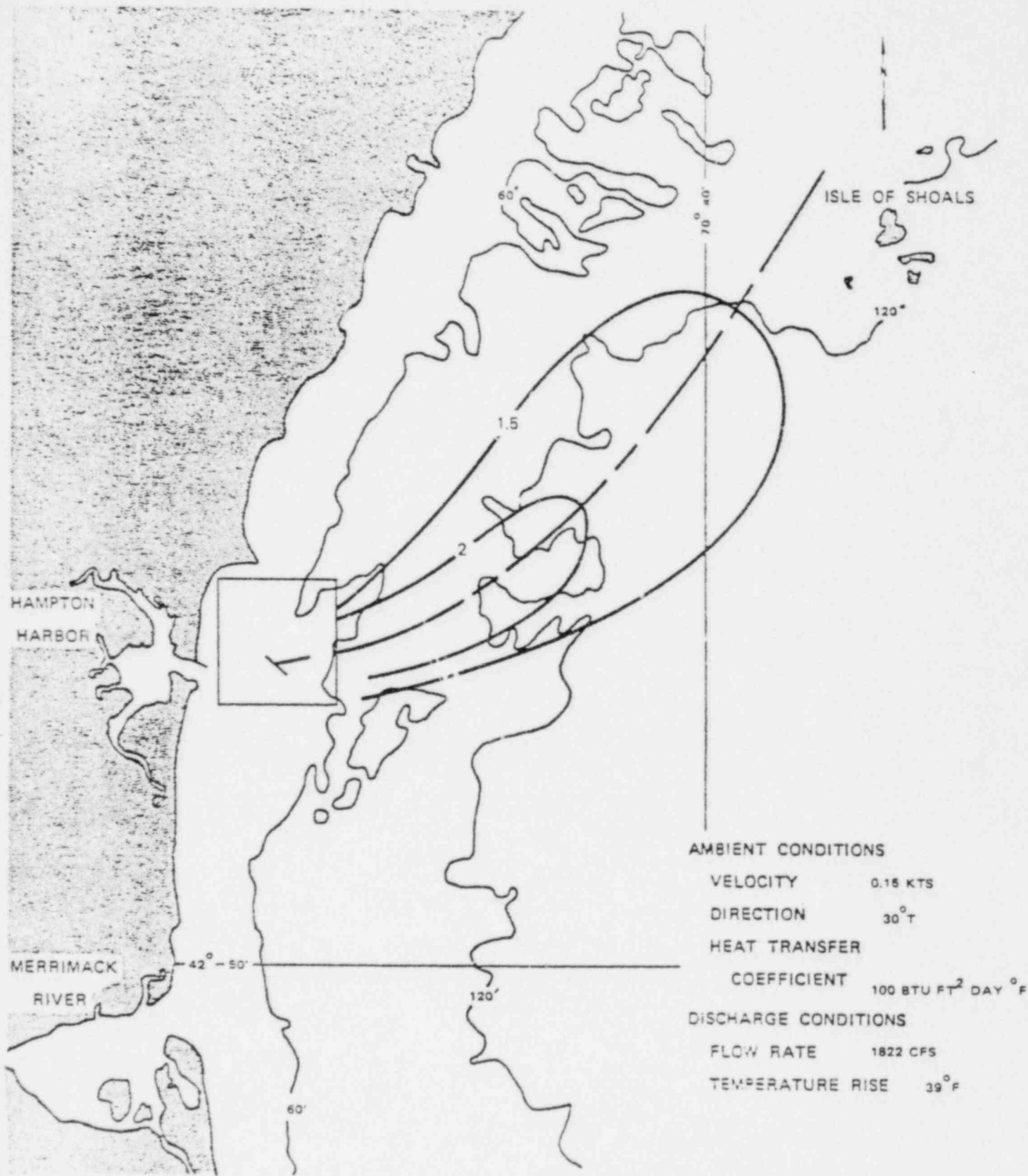

Figure 3.4-9. Predicted far-field surface temperature isotherms (in  $\Delta T$  degrees F) under weak ambient northward currents and average heat transfer..



ISOTHERMS - FLOW TO NORTH

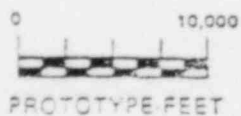

Figure 3.4-10. Predicted far-field surface temperature isotherms (in  $\Delta T$  degrees F) under weak ambient northward currents and low heat transfer.



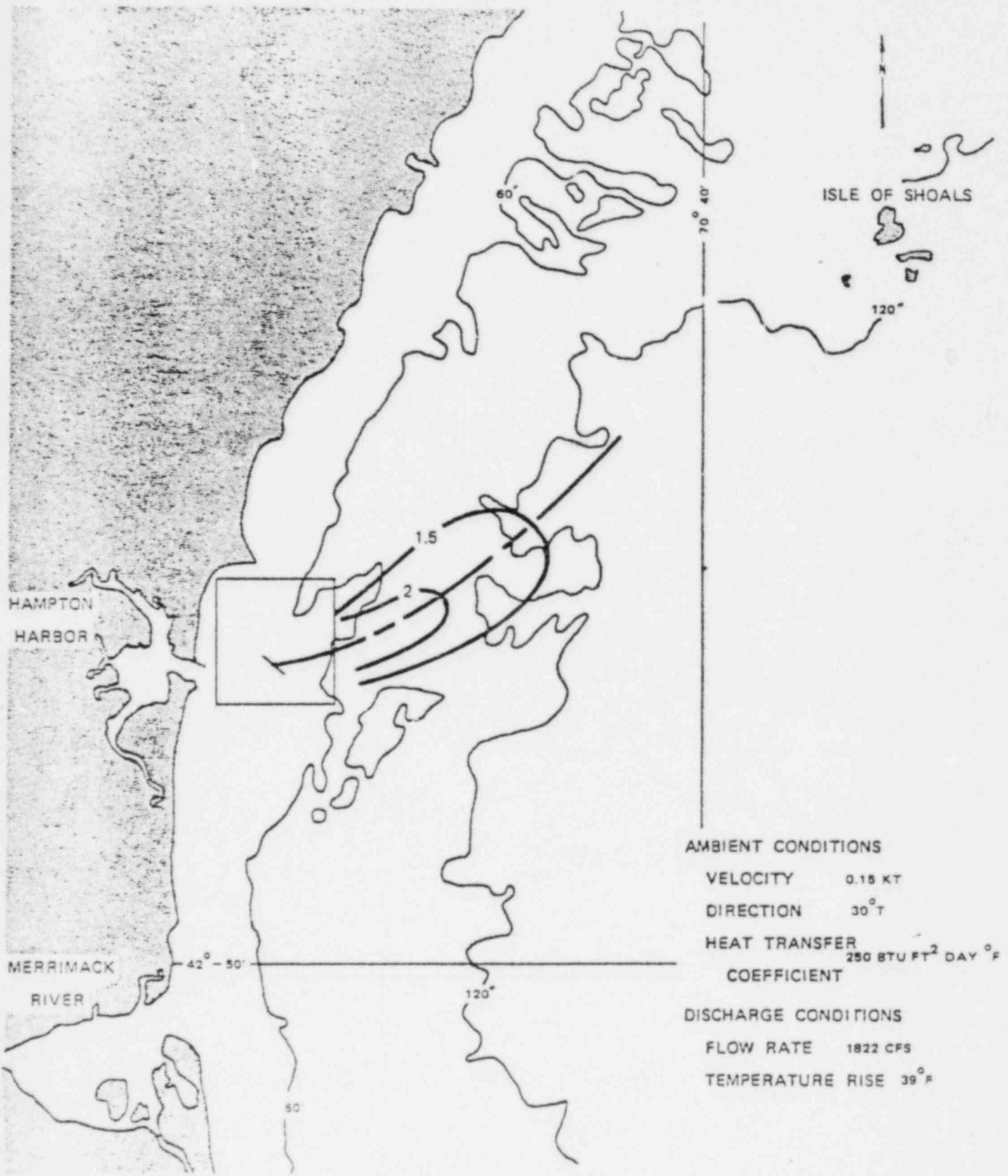
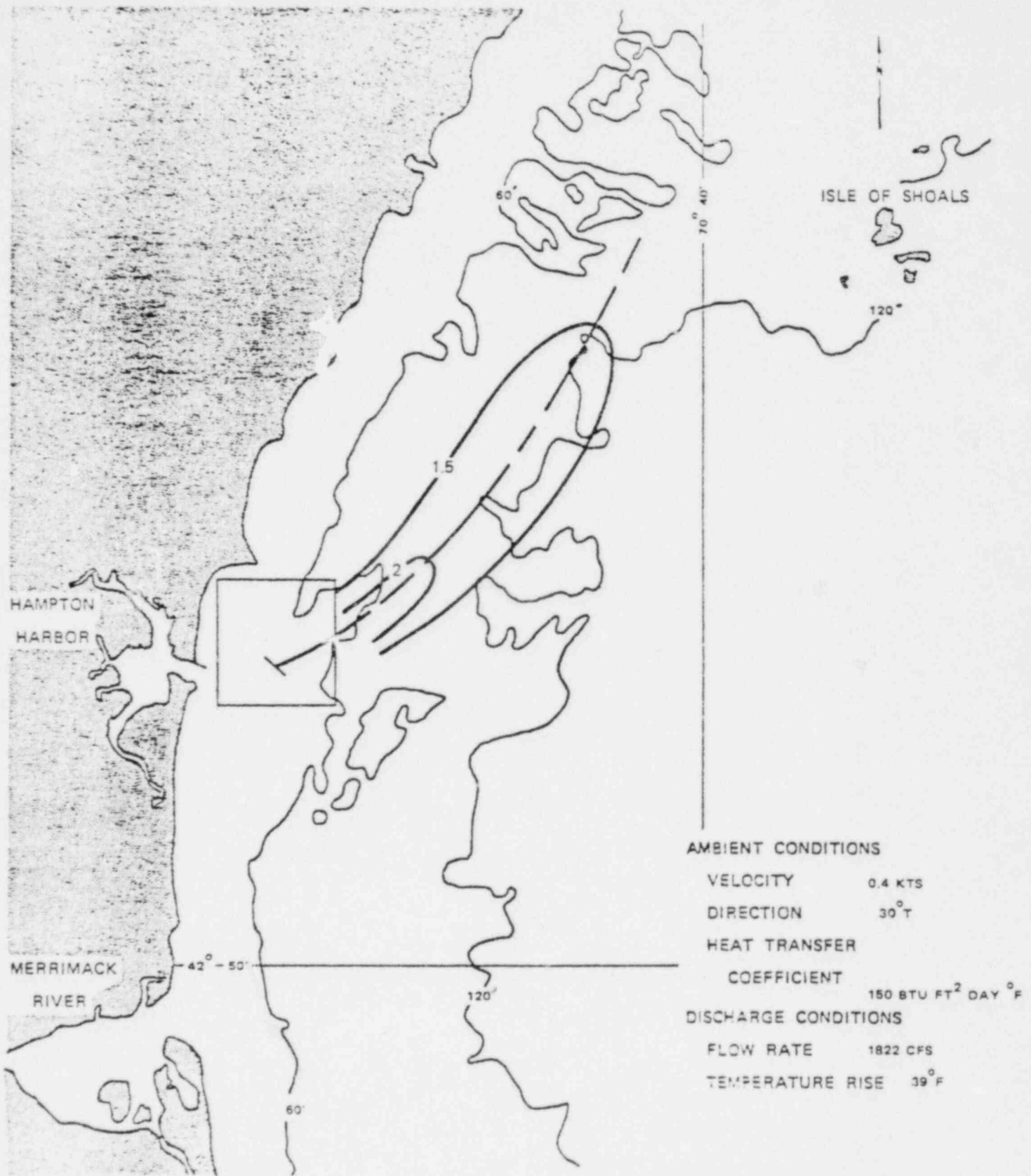

Figure 3.4-11. Predicted far-field surface temperature isotherms (in  $\Delta T$  degrees F) under weak ambient northward currents and high heat transfer.



ISOTHERMS - FLOW TO NORTH

Figure 3.4-12. Predicted far-field surface temperature isotherms (in  $\Delta T$  degrees F) under moderate ambient northward currents and average heat transfer.

Surface heat loss coefficients for the offshore study area were determined using methods developed by Ryan and Harleman (1973). Calculated monthly values of the surface heat transfer coefficient are provided in Table 3.4-2 below.

TABLE 3.4-2. SURFACE HEAT TRANSFER COEFFICIENTS

<u>MONTH</u>	<u>BTU/FT<sup>2</sup>/DAY/F</u>
Jan	155
Feb	164
Mar	162
Apr	163
May	157
Jun	155
Jul	178
Aug	186
Sep	202
Oct	191
Nov	163
Dec	158
ANNUAL MEAN	166

As can be seen from Table 3.4-2, the smallest monthly surface heat loss coefficient occurs in January and June, while the largest occurs in September with a mean annual value of 166 BTU/ft<sup>2</sup>/day/F.

Based on the parameters provided in Tables 3.4-1 and 3.4-2, it is possible to select the most realistic plume conditions from the far-field parametric analysis of ARL (1975). The most representative far-field surface plume size is, therefore, expected to be between that found on Figures 3.4-9 and 3.4-12. The 1.5 F isotherm would be found between 4.3 and 5.3 mi from the Isles of Shoals. However, the position of the plume could be expected as shown in Figure 3.4-8, with about the same frequency. This may be seen in Table 2.2-1 of Section 2. The further eastward the plume extends, the more it becomes caught in the Gulf of Maine gyre, eventually becoming a component of this net southward-drifting water mass.

Based on the information provided in Tables 3.4-1 and 3.4-2, Figures 3.4-10 and 3.4-11 are not representative of the far-field thermal plume and are provided only to demonstrate the sensitivity of the far-field plume to variations in parameters that were included in the analysis.

### 3.5 BIOFOULING CONTROL

#### 3.5.1 Circulating Water System and Service Water System

The intake portions of the circulating water and service water systems from the ocean inlets to the condensers are subject to the settlement and growth of marine fouling organisms. These organisms must not be allowed to accumulate in the cooling-water system. Growth of attached marine organisms progressively impedes flow, eventually reaching a point where adequate cooling water could not be obtained by the pumping system. To maintain the cooling system in an operational condition, it is absolutely necessary to effectively control biofouling. The discharge sections of the circulating water system, downstream of the condensers, are not subject to marine biofouling because the normal discharge temperature is high enough to preclude settlement and growth of fouling organisms.

For the purpose of biofouling control, the circulating and service water system can be considered in four sections:

- a. The intake portion from offshore ocean intakes to the pumphouse,
- b. The circulating water pumphouse to condensers,
- c. The condensers, and
- d. The service water system.

### 3.5.2 Intake System

In the intake section from the offshore ocean inlets to the intake transition structure adjacent to the pumphouse, biofouling control is accomplished by periodically reversing the cooling-water flow in the intake and discharge tunnels. This is accomplished by means of an appropriate on-site valving arrangement. To assure fouling protection during the period between initial tunnel flooding and plant operation, the tunnel lining may be initially painted with antifouling paint.

The backflushing mode of operation is used to add heated water to the intake tunnel and thermally shock any organism, primarily mussels, which might have settled and been growing in the tunnel. Without this mode of operation, organisms could multiply and grow to an extent that they would constrict the intake and severely affect plant operation.

Backflushing of the system for biofouling control is accomplished by redirecting circulating water flow within the plant. In order for heat treatment to be effective, a temperature of 120 F must be reached and maintained for a period of approximately 2 hrs. In order to achieve the increase in discharge temperature, the station flow rate must be reduced by approximately one half, generally requiring a power level reduction as well. Since the flow is reduced by one half, the travel time of reheated water through the tunnel is about twice normal or approximately 92 min. Thus, a minimum of 1.5 hrs is required before approximately 120 F water reaches all parts of the intake tunnel, and an additional 1.5 hrs (minimum) is required to bring the system back to normal temperature and re-reverse flow after the heat treatment period. The total time for the entire backflush cycle is approximately 6 hrs.

### 3.5.3 The Thermal Effects of Backflushing

In the development of thermal backflushing procedures, two fundamental design criteria were considered: effective time-temperature regimes for biofouling control, and limiting the backflush plume thermal effect on the Inner and Outer Sunk Rocks so as to not exceed naturally occurring ambient temperature fluctuations.

With respect to the first design criteria, it has been determined from experience at other power plants on the New England coast and applicable information from the literature that to achieve effective biofouling control, it is necessary to maintain a temperature of 120 F continuously for a period of no less than 2 hrs at a frequency of once every 2 weeks during the warmer months (April to November). Therefore, the circulating water system has been designed for flow reversal and raising and maintenance of 120 F in the intake tunnel for 2 hrs. From an operational viewpoint, the total time in the backflush mode will be approximately 6 hrs but the 120 F temperature will only be maintained for approximately 2 hrs.

A series of hydrothermal model tests have been conducted at ARL to determine the characteristics of the backflushing plume. The model used for these tests was a densimetric Froude model with a uniform scale of 1 to 115. Scale models of the actual inlet structures were tested in this model at scale flows corresponding to the actual time, temperature, and flow relationships which occur during backflushing.

For these tests, various current patterns which have been observed by NAI to occur in the vicinity of the proposed intake sites were simulated. In addition, the effect of tide level was also simulated. For the purpose of evaluating possible "worst case" conditions, the phasing of the backflush thermal discharge from the intakes with the selected simulated ambient currents was chosen to ensure that the plume is discharged under the most likely situations to cause advection of the plume onto the Inner and Outer Sunk Rocks.

Typical results of these tests are presented in Appendix A. The backflush thermal plume behavior for the proposed intake location is shown in these figures. The test cases shown in these figures correspond to a backflushing procedure which complies with the first design criteria, in that each case produces a temperature of 120 F at any given point inside the intake tunnel for a continuous period of 2 hrs.

Thermal plume results as shown in Appendix A indicate that the thermal impact on the Outer Sunk Rocks averages less than 1 F during the backflush cycle for the three types of representative current conditions tested. The maximum temperature increase on the Outer Sunk Rocks is about 3 F and lasts for periods of about 1 hr during only one of the ambient current conditions tested. Thermal impact on the Inner Sunk Rocks is expected to be even less.

Having thus determined the thermal backflush plume characteristics, it is necessary to consider these results in the perspective of ambient temperature fluctuations in the vicinity of the Inner and Outer Sunk Rocks. A detailed description of such fluctuations is presented in Section 2.2.4.1.

Based upon the ambient temperature fluctuations observed as compared to the results of the backflush model tests, it can be seen that the backflush plume from the proposed intake location will not exceed the naturally occurring temperature fluctuations on the Rocks.

Moreover, based on the data presented in Section 2.2.4.1 and Appendix A, it can be seen that maximum temperatures at the Rocks during the summer generally occurs during ebb tide or at low-water slack. During this period, the thermal plume as a result of backflush operation would also be traveling away from the estuary and the Rocks. When the tide turns and the thermal plume is directed towards the Rocks, normally cooler ambient ocean water would flood over them. Thus, if the backwash plume is also carried onto the Rocks, the temperature increase associated with Seabrook

Station backflush plume cannot add to the ambient temperature maximums which are greater than temperature increases induced by backflushing.

#### 3.5.4 Pumphouse to Condenser

Biofouling control in the pumphouse and on-site intake pipes is accomplished by intermittent chlorination and the application of an anti-fouling coating. The active chlorine which is provided by the injection of sodium hypochlorite at upstream feed points, is intended to discourage the settlement and growth of mussels and barnacles. Accumulation of these organisms could limit the circulating water flow by increasing the effective roughness of the pipes; and, if allowed to grow too large, could also plug condenser tubes after detachment from the pipe surfaces.

Chlorination treatment will conform to EPA Effluent Guidelines (40CFR, Part 423). Consequently, it is proposed that sodium hypochlorite be injected for a maximum of 2 hrs per day on each unit. The dosage is adjusted to restrict the average level of the equivalent free residual chlorine at the discharge to 0.2 mg/l over the 2-hr period (maximum 0.5 mg/l). The actual feed rate will depend on the chlorine reaction or decay rate in seawater.

The equivalent free residual chlorine decays rapidly from condenser inlet to ocean discharge point as a result of prolonged exposure to elevated temperatures. Approximately a 2.5 min. flow or contact time occurs between the pumphouse and condensers, and an additional 37 min is required for heated discharge water to flow from the discharge transition structure near the pumphouse to the ocean discharge at the diffuser.

The intake flume, pumphouse and on-shore intake pipes will be periodically dewatered for inspection. Based on experience at other plants, it is anticipated that every second year the surfaces may require scraping and painting with anti-fouling paint.



### 3.5.5 Condenser

The sodium hypochlorite injected into the cooling water also prevents the accumulation of slime-forming organisms in the condenser tubes. Whereas, the control of marine growth in the pipes and tunnels is required essentially only during the warmer months, the control of slime is required all year round. Therefore, the chlorine dosage described above is injected throughout the year. If slime were allowed to grow in the condenser, the heat transfer efficiency could be reduced to unacceptable levels and plant output would be significantly reduced.

### 3.5.6 Service Water System

Biofouling may have to be controlled in the service water system by continuous low-level chlorination. To accomplish this, sodium hypochlorite would be continuously injected in the service water pumphouse. No other completely effective biofouling control measure is presently available for this system; it is impossible to dewater and paint the inside surfaces of the service water piping because it is relatively small in diameter and inaccessible. Intermit+ent chlorination at the levels proposed for the main circulating water flow is unlikely to be effective if not augmented by periodic application of anti-fouling paint. Heat treatment at temperatures anticipated for the main circulating water system, as previously described (Section 3.5.2), cannot be tolerated in the service water system due to temperature limitations within the system and anything short of the time-temperature regime proposed for the circulating water system would not be an effective biofouling control. Continuous low-level chlorination, however, is known to be effective for biofouling control and consequently may be proposed at some future date for the service water system. Considering that the same factors of prolonged exposure to elevated temperatures apply within the service water system and that the flow of the service water system is less than 6% of the total cooling water flow, equivalent free residual chlorine levels would be unmeasurable with presently available on-site monitoring methodology after the service water stream is added to the main condenser discharge.

#### 4.0 REPRESENTATIVE IMPORTANT SPECIES (RIS)

##### 4.1 CRITERIA FOR SELECTION

Selection of representative important species (RIS) was accomplished in accordance with guidelines set forth in the manual: 316(a) Technical Guidance -- Thermal Discharges (DRAFT), September 30, 1974. The following biotic categories were recognized in this guidance manual:

- 1) Macroinvertebrates
- 2) Finfish
- 3) Thermally sensitive species
- 4) Economically important species
- 5) Community dominants (e.g. high biomass, high numerical abundance, habitat formers)
- 6) Nuisance species

This document also called attention to the need to consider the trophic status (i.e. role in the transfer of energy and nutrients) of the organism.

The final list, containing a total of 16 species (Table 4.1-1), was adopted by Region I EPA. The emphasis appears to have been placed on organisms which are recognizable to the public: most have direct economic significance. Seven of the 16 species are finfish, all of which are commercial and/or sport species. Of the six invertebrate animals selected, five have at least potential direct economic importance, with four of the selectees being relatively larger bodied bivalve molluscs. Three of the chosen species are primary producers (photosynthetic), one of which has direct economic potential, (*Chondrus crispus*) and another posing a direct economic threat (*Gonyaulax tamarensis*).

TABLE 4.1-1. CHECKLIST OF REPRESENTATIVE SPECIES AND RATIONALE.

	Diatom <i>Sk. coetatum</i>	Red tide <i>G. tamarensis</i>	Irish moss <i>C. crispus</i>	Copepod <i>E. herdmani</i>	Clam <i>A. islandica</i>	Clam <i>E. directus</i>	Clam <i>M. arenaria</i>	Mussel <i>M. edulis</i>	Lobster <i>H. americanus</i>	Alewife <i>A. pseudoharengus</i>	Menhaden <i>B. tyrannus</i>	Salmon <i>O. kisutch</i>	Smelt <i>O. mordax</i>	Pollock <i>F. vitreus</i>	Flounder <i>F. americanus</i>	Mackerel <i>S. scombrus</i>
Community Dominant			X				X	X						X	X	
Oceanic Coastal (Neritic)	X	X	X	X	X	X	X	X	X	X	X	X	X	X	X	X
Pelagic	X	X		X	l	l	l	l	l	X	X	X	X	X	l	X
Benthic			X		X	X	X	X	X						X	
Rocky substrate			X					X							X	
Sandy Substrate					X	X	X	X	X						X	
Intertidal																
Subtidal			X		X	X	X	X	X						X	
Trophic level																
Primary Producer	X	X	X		X	X	X	X		l	l					
Herbivore				X	X	X	X	X				X	X	X	X	X
Carnivore									X		X					
Omnivore										X	X				X	X
Source of Impact																
Plume Entrainment	P	P	P	P	P,l	P,l	P,l	P	P,l	P,l	P,l			P,l	P,l	P,l
Entrapment										A	P	P	A	A	P	P
Plant Passage	P	P		P	A,l	A,l	A,l	A,l	A,l	A,l	P,l		A	A,l	P,l	P,l

X = Category applies

l = Category applies only to early life stages

P = Possible impact \*

A = Certain impact \*

\* Definition of impact as used here

Lists of threatened and endangered species (e.g., U.S. Dept. of Interior, Fish and Wildlife Service 1975; Boullengier, 1974) were consulted to evaluate whether there were any threatened or endangered species which should be included as representative important species. Since there were no species mentioned on these lists that have been collected in the study area, it was concluded that more of these species should be included among the representative important species.

Discussions of individual RIS do, however, identify those species which may be considered thermally "sensitive", in the sense that they are likely to exhibit a negative response to heat. Brief mention is also made of predator-prey relationships and the extent to which some of the more unfamiliar organisms have been objects of previous scientific study.

Although discussions of non-RIS members of the marine communities described in Section 2.3 is rather scant in the following sections, they have not been neglected or overlooked. Various ongoing preoperational programs (See Section 6.0) investigate the diversity, abundance, and distribution of a wide range of organisms, of which the discussions in Section 2.3 are representative.

## 4.2 SELECTED SPECIES

### 4.2.1 Diatom, *Skeletonema costatum*

*Skeletonema* is a diatom of potential food value to herbivorous zooplankters, and is commonly represented in phytoplankton collections from coastal New Hampshire. Its biology has been well studied in areas south of Cape Cod (e.g. in Long Island Sound and Narragansett Bay where it is characteristically the dominant species of late winter and spring phytoplankton blooms).

#### 4.2.2 Red Tide Alga, *Gonyaulax tamarensis*

This dinoflagellate has recently become a nuisance organism of major economic importance in northern New England because it produces an endotoxin which accumulates in clams and mussels and causes paralytic shellfish poisoning (PSP) when these molluscs are ingested. Several studies on environmental requirements for growth have begun as a result of the threat to public health.

#### 4.2.3 Irish Moss, *Chondrus crispus*

Irish moss is an important source of carrageenan (stabilizer in food products and industrial uses) and therefore is of potential economic importance. At present, there is no commercial harvest of Irish moss in New Hampshire coastal waters, although it is extremely abundant at mean low water and can be regarded as a habitat former in this zone. Considerable knowledge of the biology of this plant is available; of particular interest are parallel studies ongoing at Pilgrim Station in Massachusetts.

#### 4.2.4 Copepod, *Eurytemora herdmani*

The copepod *E. herdmani* is a representative of the herbivorous zooplankton and a potential food item for larger, carnivorous zooplankters and larval finfish. The species is common in net and pump samples from coastal New Hampshire. The biology of this species is reasonably well known, and indicates relative sensitivity to temperature extremes.

#### 4.2.5 Ocean Quahog, *Arctica islandica*

The ocean quahog, or mahogany clam, has formed the basis of a commercial fishery only since the late 1940's. Currently, this clam is

harvested only south of Cape Cod where it lives in very deep water (46 feet or more). Substantial, but commercially unimportant, patches are scattered in the vicinity of the proposed intake and discharge sites. Many aspects of the biology of this species have not been fully investigated, although it is well known that the animal is extremely intolerant of warm water.

#### 4.2.6 Razor Clam, *Ensis directus*

The jack-knife or razor clam is valued as a seafood delicacy, but supports only a minor commercial fishery. No razor clams are harvested commercially in New Hampshire waters. Quantitative sampling to obtain estimates of abundance and distribution are costly. Thermal requirement and other aspects of the environmental biology of this species is poorly known. This species was added to the list upon the advice of the EPA region I staff.

#### 4.2.7 Soft-shelled Clam, *Mya arenaria*

From the outset, the soft-shelled clam has been a principal subject of study in connection with Seabrook Station. Hampton Seabrook Estuary is the site of much of the recreational clam digging activity in the state of New Hampshire. In recent years, however, these soft-shelled clam stocks have been severely depleted. Neighboring states of Massachusetts and Maine have well established commercial fisheries for this species. With regard to power plant operation, the main concern is with the entrainment of planktonic larvae which have been found to be closely associated with coastal water masses in New Hampshire and adjacent states' territorial waters.

#### 4.2.8 Mussel, *Mytilus edulis*

The blue, or edible, mussel may be regarded with ambivalence; on the one hand, it is a species of great potential as a shell fishery (Mytiliculture has been practiced for centuries in Europe); on the other hand, it is also a principal fouling organism, outranking the barnacles, *Balanus* spp., north of Cape Cod. The characteristic "mussel bars" or banks constitute a major habitat feature of many sheltered coves and embayments, including Hampton Harbor. These "mussel bars" at times limit the habitat of the soft-shelled clam by encroaching on otherwise favorable habitat. *Mytilus edulis* is one of the most extensively studied of any marine organism.

#### 4.2.9 American Lobster, *Homarus americanus*

The American lobster is familiar, if only as a cooked seafood item. The species is distributed over much of the continental shelf, although the traditional New England fishery is almost entirely restricted to nearshore areas. Despite widespread intensive fishing, juvenile lobsters, less than legal size, are fairly common in the immediate vicinity of the proposed cooling-water intake and discharge sites for Seabrook Station. Basically, the species occupies a top carnivore and scavenger position and is epibenthic (dwelling on top of the sea bottom).

#### 4.2.10 Alewife, *Alosa pseudoharengus*

The alewife is a clupeoid (i.e. herring-like) fish which spawns in fresh water. The nearest spawning areas are the Taylor and Hampton Rivers which empty into Hampton-Seabrook Estuary. Juveniles are commonly caught in gill nets set in inshore areas in the vicinity of the intake and discharge site for Seabrook station. Adults are commercially important, with uses ranging from pet food and fish meal, to the more traditional salting or curing. The species is also used by fishermen as bait for gamefish. Alewives feed chiefly on zooplankton; the fry, in turn are eaten by predaceous fish, such as the striped bass, and perhaps the coho salmon (Scarola, 1973).

#### 4.2.11 Menhaden, *Brevoortia tyrannus*

The Atlantic menhaden is a migratory clupeoid species whose recent appearance off the New Hampshire coast during the warmer months has coincided with climatic warming trends in seawater temperatures. From Cape Cod southward, the species' pernicious habit of crowding into embayments has led to several "fish kill" incidents at operating New England electric generating stations. The species has commercial value primarily as a source of "fish meal". Menhaden feed on phytoplankton and microzooplankton. They are preyed on by striped bass, and especially, bluefish.

#### 4.2.12 Coho Salmon, *Oncorhynchus kisutch*

The coho salmon is native to the Pacific northwest, but was introduced into New Hampshire waters beginning in 1969 in an attempt to establish a salmon sport fishery. Some success has been achieved with the return of sea-run adults reared from eggs and released as fry from New Hampshire hatcheries. It appears that the successful establishment of a naturally reproducing stock will require several more years of assistance from artificial rearing. It was added to the list upon advice of EPA Region I staff.

#### 4.2.13 Smelt, *Osmerus mordax*

The rainbow smelt is a marine fish, which, returns to fresh-water in the early spring to spawn. This species is a popular sport fish and a delicacy. It also constitutes a major prey item for salmonids and other game fish. Commercial catches are made throughout the Great Bay estuarine complex. While there are scant data on thermal requirements of this species, its seasonal and spatial distribution indicates a preference for colder water as well as an affinity for nearshore areas.



#### 4.2.14 Pollack, *Pollachius virens*

Pollack are gadoid (i.e. cod-like) fish which are commercially important and very abundant. In fresh, frozen or canned seafood products, pollock substitute for cod as well as an even scarcer close relative, the haddock. In the vicinity of the proposed cooling-water intake and discharge area, young pollock are among the most common midwater fish. Pollock are voracious carnivores, feeding largely on smaller finfish and pelagic crustaceans.

#### 4.2.15 Flounder, *Pseudopleuronectes americanus*

The winter, or blackback, flounder is a nearshore bottom-dwelling flatfish of both commercial and recreational importance. It is one of the most abundant species in the vicinity of the intake and discharge sites, and is the mainstay of the local recreational fishing industry (i.e. boat rentals, bait and tackle sales, etc.). Winter flounder are fairly nonselective in their feeding habits, consuming a variety of benthic organisms. The ecology and population biology of this species, has been the subject of several scientific studies.

#### 4.2.16 Mackerel, *Scomber scombrus*

The Atlantic mackerel is both a commercial and a sport species, popular as a seafood delicacy. The commercial fishery has historically been subject to great fluctuations. Prey of the mackerel are almost exclusively pelagic, and include both planktonic and nektonic organisms. The thermal requirements of this species are relatively well known and indicate a cold water preference.

## 5.0 IMPACT ANALYSIS

### 5.1 BACKGROUND AND HISTORICAL INFORMATION

#### 5.1.1 Introduction

Material for the following discussions was extracted from numerous literature review articles, plus a search by computer of more than a quarter of a million publications and reports on thermal effects in various bibliographic data bases. Quantitative information pertinent to thermal requirements of specific representative important species was compiled in graphical displays (See explanatory Figure 5.1-1). Along with thermal characteristics data these graphical displays depict: 1) daily maximum surface water temperatures from three years of records (November 1973 through October 1976) in the vicinity of the proposed intake and discharge sites, and 2) the general pattern of temporal abundance. Where quantitative data were available concerning population densities of planktonic stages, a maximum density value (in individuals per 100 m<sup>3</sup>) was given for the month of peak abundance.

#### 5.1.2 *Skeletonema costatum*

*Skeletonema* is a centric, chain-forming diatom. Like other phytoplankters, it experiences extensive seasonal population fluctuations (e.g. "blooms") and exhibits the "patchy" spatial distribution characteristic of plankton in general. *Skeletonema* has a relatively broad temperature tolerance (Figure 5.1-2) and is found throughout the North Atlantic, with an affinity for near coastal areas (Figure 5.1-3).

At times this species has been an important representative of the phytoplankton community in New Hampshire Coastal waters, particularly in late summer; record densities for recent years seem to have occurred in the summer of 1973 (Table 5.1-1). Since 1973, absolute peak densities appear to have diminished and the seasonal peak split between

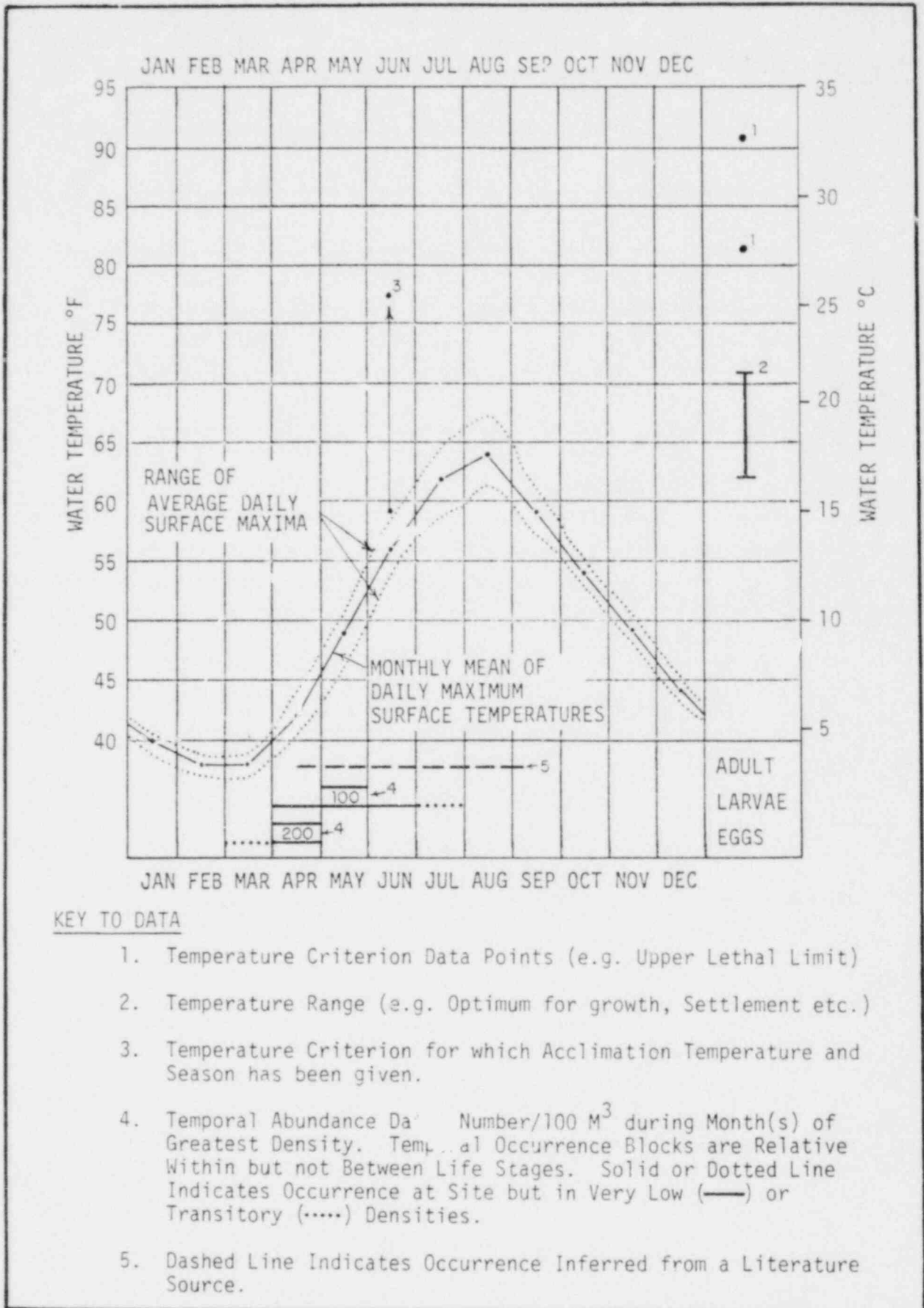
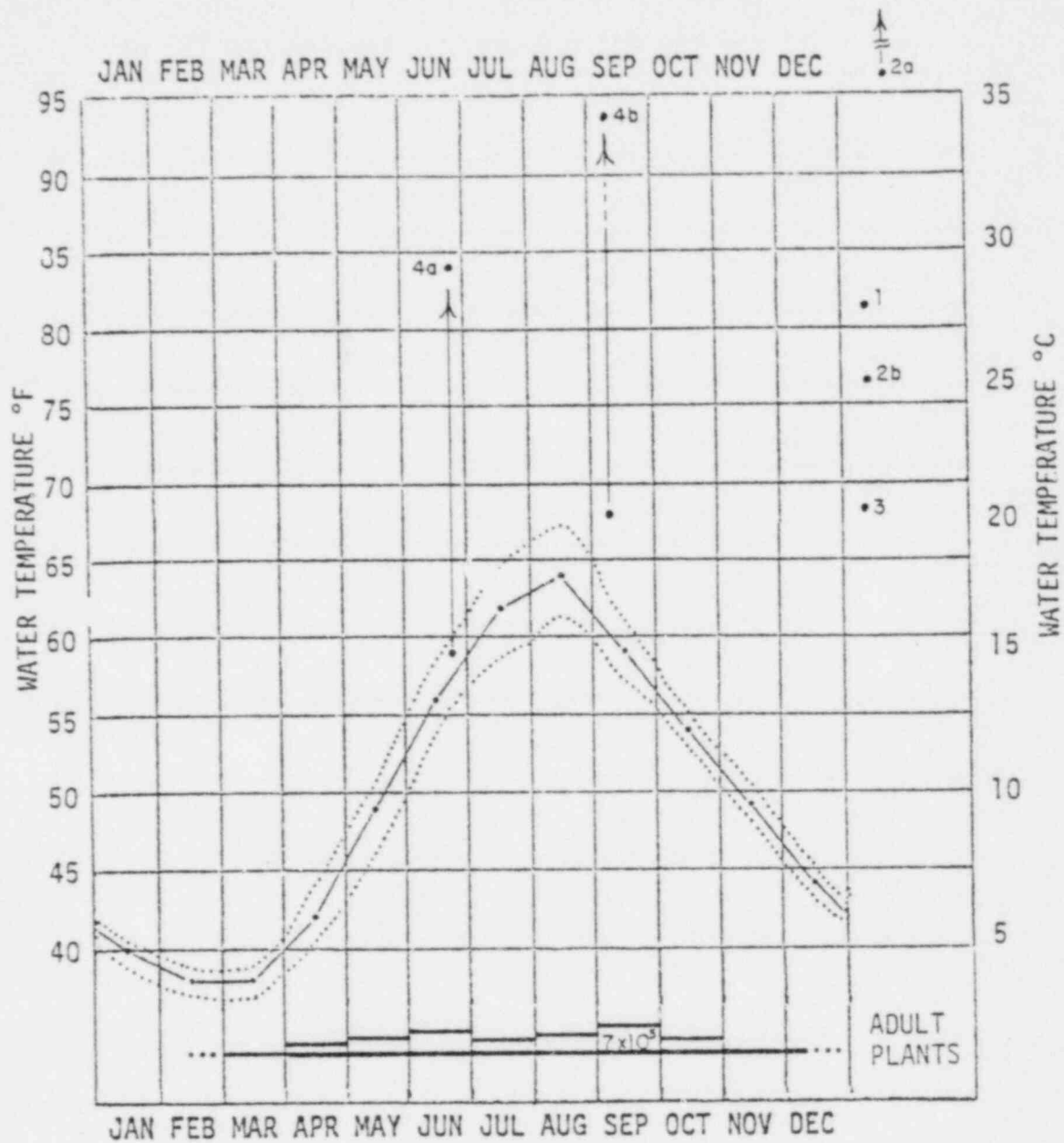

Figure 5.1-1. Example of Selected Species Relative Temporal Abundance and Thermal Characteristics Display.



1. Upper Threshold of No Thermal Stress (Jitts et al., 1964)
- 2a. Maximum Temperature Range for Survival, 99-104° (Curl and Macleod, 1961; Matsue, 1954)
- b. Optimum for Growth and Photosynthesis (Curl and Macleod, 1961)
3. Upper Temperature Limit for Optimum Growth and Photosynthesis (Jorgensen, 1968)
- 4a. Cells Withstand 25.2° Δt, Acclimated to 59° (Crippen, 1974)
- b. Significant Mortality 25.2° Δt, Acclimated to 68°.

Figure 5.1-2. Diatom, *Skeletonema costatum*, relative temporal abundance and thermal characteristics

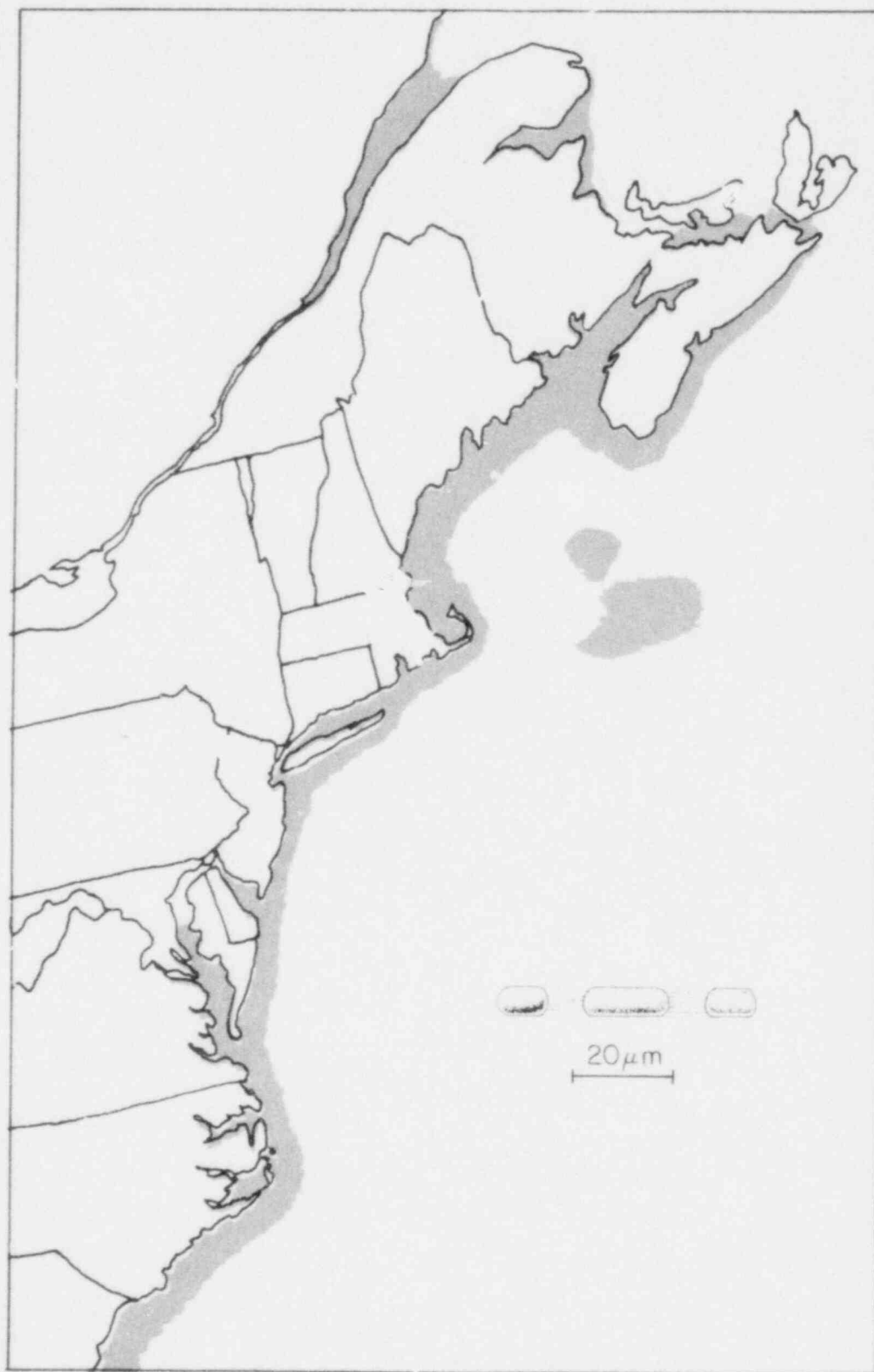

Figure 5.1-3. Distribution of the diatom, *Skeletonema costatum* in the Western Atlantic Ocean.

TABLE 5.1-1. TEMPORAL DISTRIBUTION OF *SKELETONEMA COSTATUM*  
 ( $10^3$  CELLS  $M^{-3}$ ) OFF HAMPTON BEACH, NEW HAMPSHIRE.

	JAN	FEB	MAR	APR	MAY	JUN	JUL	AUG	SEP	OCT	NOV	DEC
1976	0.0	5.7	0.0	27	22	135	0.0	0.0	5.7	9.7		
1975	0.0	28	38	457	0.0	ND	0.0	17.5	1624	17.9	114	1.3
1974	0.0	23	5.1	215	37	5.7	ND	50	1702	17.5	10.5	3.4
1973	ND	ND	0.8	ND	0.0	504	3536	13,043	0.0	164	111	0.0
1972	ND	ND	ND	0.0	0.0	ND	2164	1,040	ND	4.9	ND	.04

ND = No Data

late spring and early fall. The observed changes in distribution and abundance may reflect competitive responses of other phytoplankters to climatic changes in sea temperature. Zero values (Table 5.1-1) should not be interpreted as a complete absence of this species but as an indication that: 1) *Skeletonema* cells and chains were small enough to pass through the net, or 2) patches of *Skeletonema* were relatively small and widely dispersed.

Water column stability and residence time in lighted waters are important factors in the maintenance of growth in this and other phytoplankton species. *Skeletonema* has been found to require relatively high levels of vitamin B-12 (Guillard and Cassie 1963; Droop 1955) and iron chelate (Ryther and Kramer, 1961) characteristic of coastal waters. With plenty of nutrients, optimal temperatures and light, *Skeletonema* may divide up to three times a day in laboratory culture (Smayda, 1973). However, reproduction under field conditions has been estimated at between .03 and .63 divisions per day (NAI, 1974d).

### 5.1.3 *Gonyaulax tamarensis*

This tiny (36  $\mu\text{m}$ ) dinoflagellate is ultimately responsible for paralytic shellfish poisoning (PSP) in humans and animals. The poisoning results from eating filter feeding molluscs (e.g. clams and mussels) which have accumulated the poison by feeding during *G. tamarensis* blooms. The first major PSP outbreak of recent times in northern New England occurred in July 1972; since that time, smaller episodes of PSP have occurred each year, typically in May-June and in August-September (Figure 5.1-4). The repeated minor outbreaks appear to be the aftermath of the initial (1972) incident. Until 1972, blooms of toxic proportions in the Gulf of Maine were confined to eastern Canada (Figure 5.1-5). High toxicities in shellfish have been an annual phenomenon in the Bay of Fundy (Prakash, et al., 1971; Hartwell, 1975).

One key to the local persistence of this nuisance species appears to be the ability to form cysts whenever growth conditions, e.g.

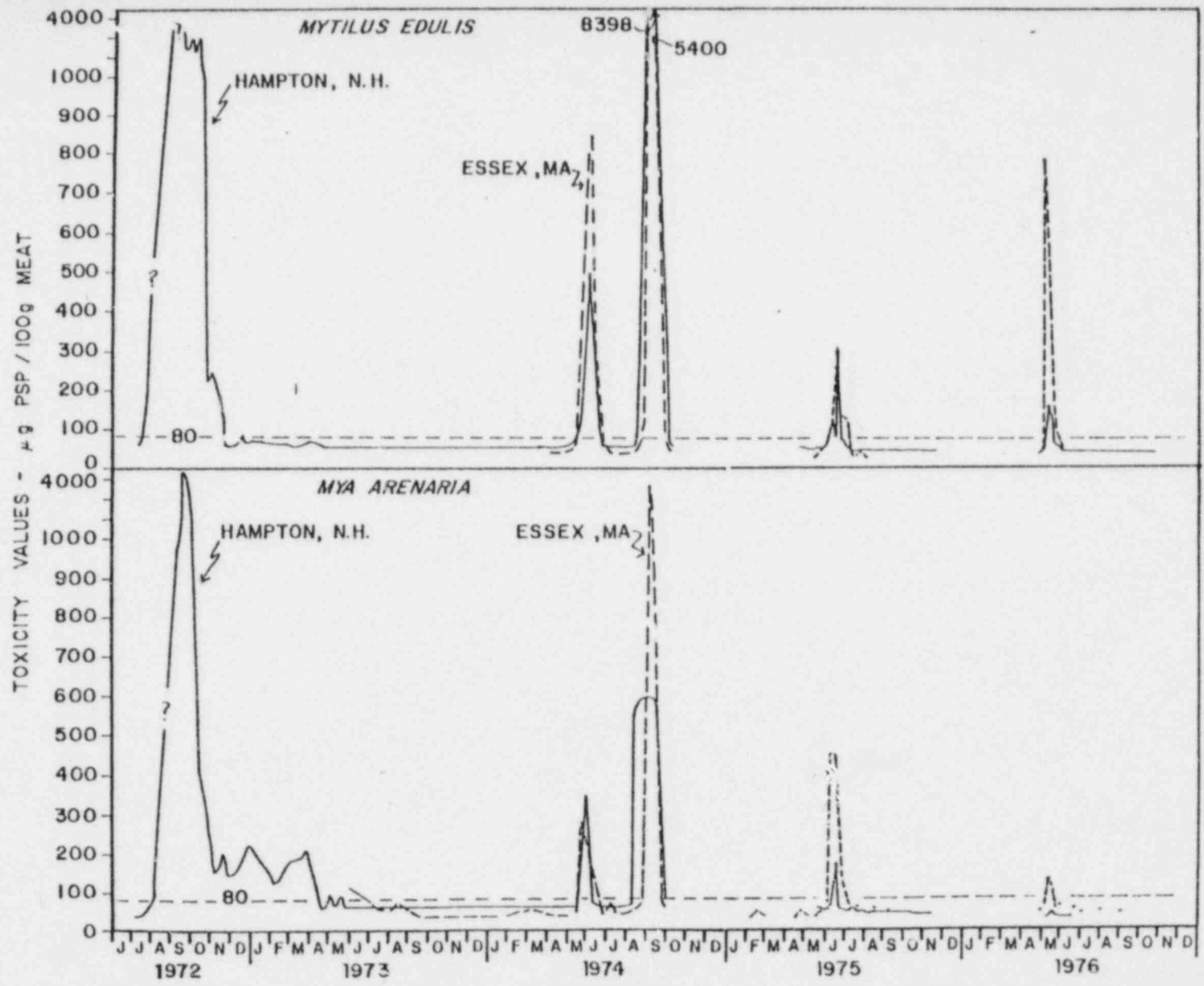

Figure 5.1-4. History of PSP toxicity levels in *Mytilus edulis* and *Mya arenaria* from Hampton Harbor Estuary, NH and Essex Estuary, Massachusetts. Data courtesy of: New Hampshire Division of Public Health and Massachusetts Department of Public Health, Lawrence Experimental Station.



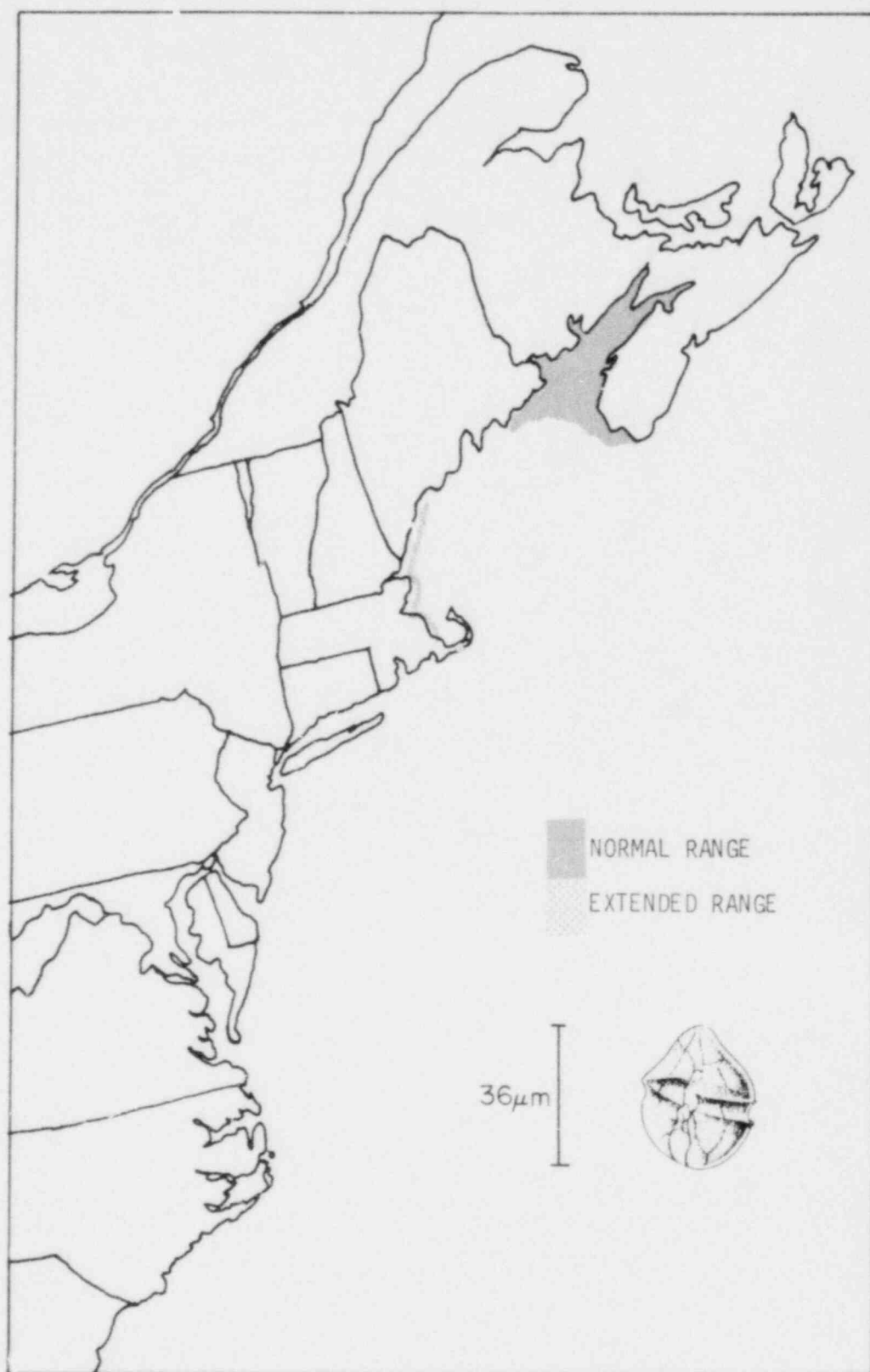

Figure 5.1-5. Distribution of the red tide alga, *Gonyaulax tamarensis* in the Western Atlantic Ocean.

temperature, (Figure 5.1-6) are unfavorable; these cysts then lie dormant until favorable conditions (light, temperature, nutrients) reoccur.

#### 5.1.4 Chondrus crispus

Irish moss is a perennial red alga distributed from New Jersey to Labrador (Figure 5.1-7), with densest populations occurring in the Gulf of Maine. It is considered a eurythermal species, tolerant of a wide range of temperatures (Figure 5.1-8). *Chondrus* grows best on stable horizontal surfaces, such as ledge and boulders, with its primary abundance from mean low water to -33 ft; in this zone it is a dominant species. Because of substrate availability, dense populations extend to 2 ft above mean low water at the Outer Sunk Rocks, but are generally restricted to the sublittoral at Great Boar's Head.

Densities in the vicinity of the intake and discharge site averaged slightly more than 400 gms/m<sup>2</sup>, dry weight (range: 248-562 gms/m<sup>2</sup>) at mean low water and 16 ft in quarterly samples from 1975-76. Biomass tends to reach a maximum in late summer, and a minimum in winter (due to erosion with little growth replacement). *Chondrus* plants reproduce sexually from late summer to late fall-early winter and again in the spring.

Although physiological studies have indicated that 68°F is about optimal for photosynthesis in mature plants, high photosynthetic rates occur over a very wide temperature range. Interaction with light intensity is an essential consideration. The sporeling stage is by far the most sensitive, with temperatures as low as 75°F decreasing growth and survival (Figure 5.1-8).

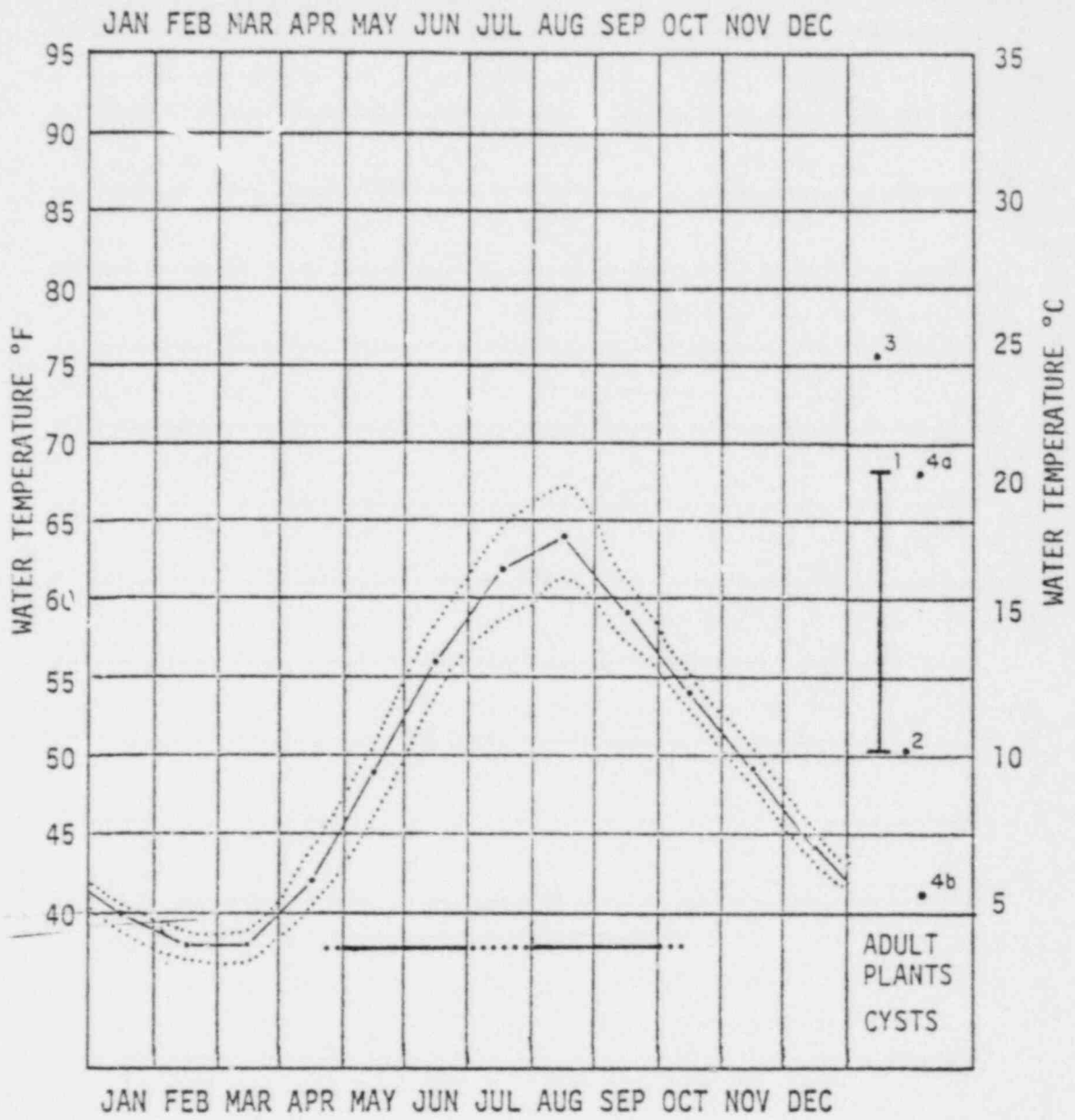

- 1. Optimum Temperature Range for Growth (Loeblich and Loeblich, 1974)
- 2. Critical Determinant for Development of Blooms (Massachusetts DEH, 1973)
- 3. Approximate Upper Limit of Growth; Organism Encysts (Yentsh et al., 1974)
- 4a. Optimum Temperature for Growth (Cole et al., 1975)
- b. Approximate Lower Limit of Growth; Organism Encysts

Figure 5.1-6. Red tide alga, *Gonyaulax tamarensis*, relative temporal abundance and thermal characteristics.

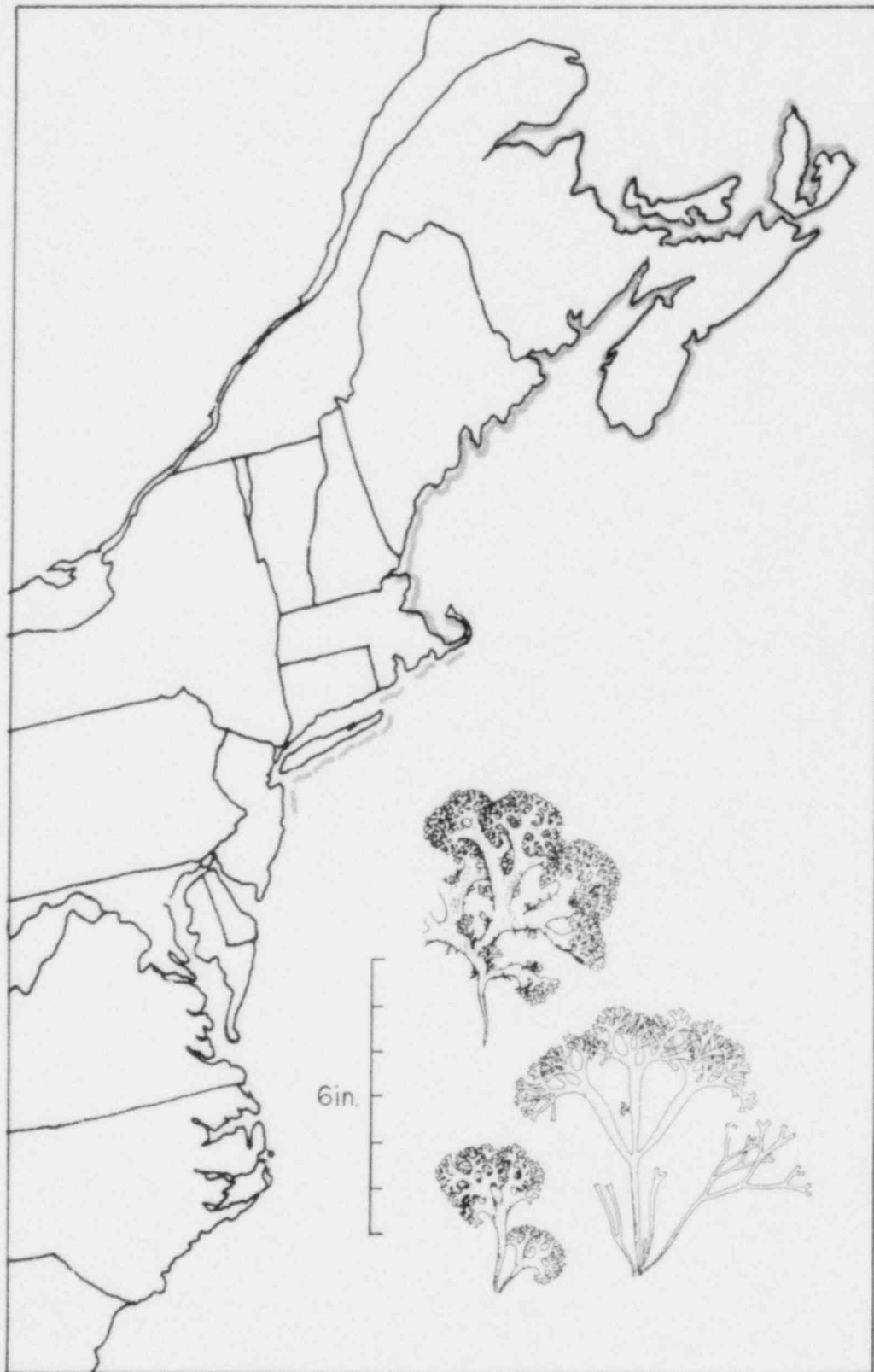
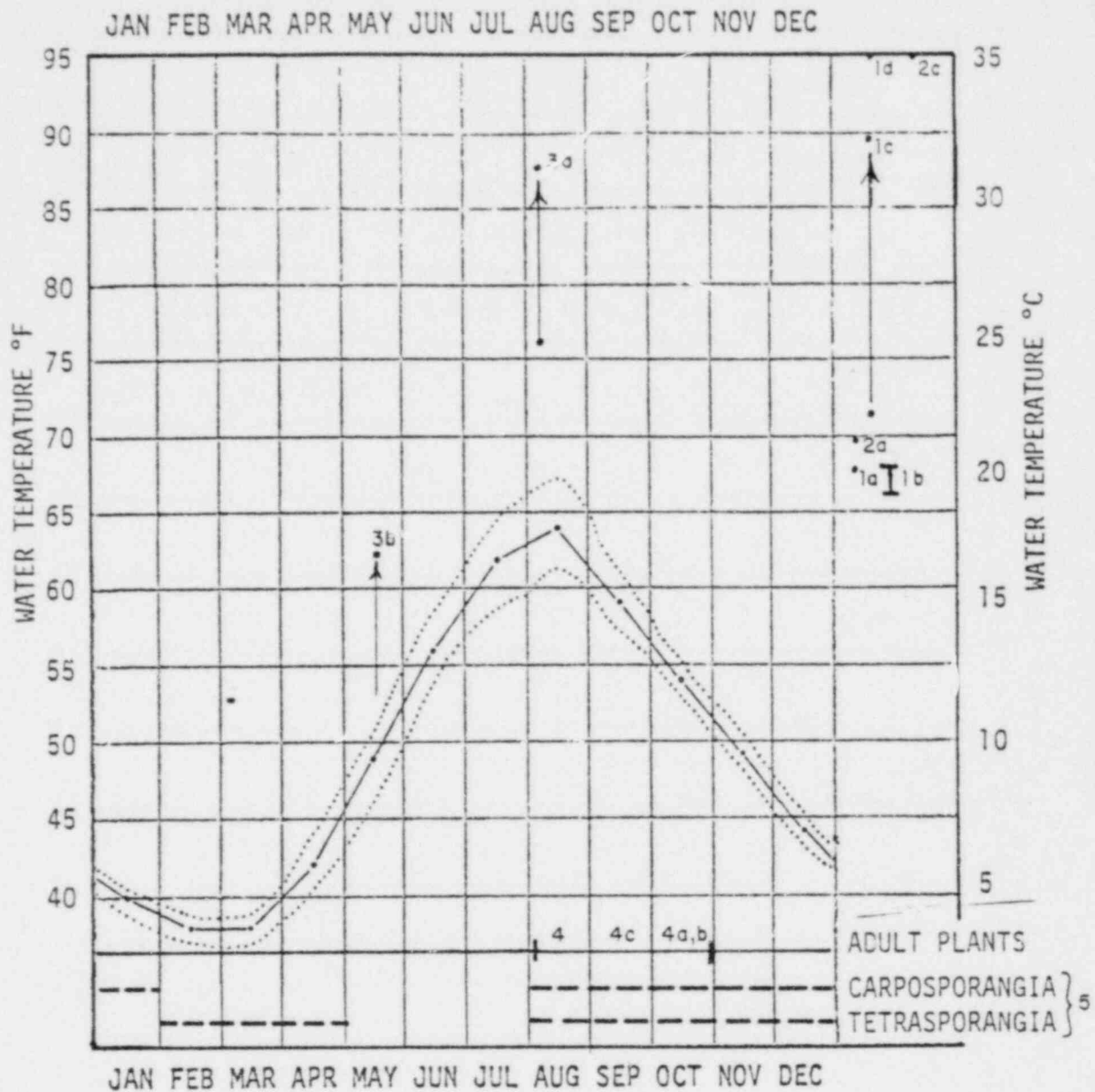

Figure 5.1-7. Distribution of Irish Moss, *Chondrus crispus* in the Western Atlantic Ocean.



- 1a. Optimum Temperature for Photosynthesis (Mathieson and Prince, 1973)
- b. Optimum Range for Growth of Sporelings
- c. Sharply Increasing Respiration Rate; P/R Ratio Declining
- d. Thermal Damage Indicated
- 2a. Optimum Temperature for Growth of Sporelings (Prince, 1971)
- b. 100% Mortality of Tetraspores and Carpospores after 410 Days
- c. 100% Mortality of Tetraspores and Carpospores after 6 Minutes
- 3a. Threshold Beyond which Photosynthesis Declines Sharply, Summer Material } (Mathieson and Norall, 1975)
- b. Threshold Beyond which Photosynthesis Declines Sharply, Winter Material }
4. Period of Maximum Growth and Abundance (Biomass); (NAI, 1976; Mathieson and Burns (1975))
  - a. up to 686 gms/m<sup>2</sup> at MLW at outer Sunken Rocks (NAI, 1976)
  - b. up to 562 gms/m<sup>2</sup> at -6m at Outer Sunken Rocks (NAI, 1976)
  - c. Maximum Growth (NAI, 1976) (Prince and Kingsbury, 1973)
5. Primary Reproductive Periods (NAI, 1976; Mathieson and Burns, 1971)

Figure 5.1-8. Irish moss (*Chondrus crispus*) relative temporal abundance and thermal characteristics.

#### 5.1.5 Eurytemora herdmani

This calanoid copepod, is cold temperate in distribution (Figure 5.1-9), with a strong affinity for coastal waters, especially harbors and embayments. Very few individuals have been found more than 10-12 miles seaward from the New Hampshire coast (NAI, 1974d). For the past three years collections in the vicinity of the intake and discharge sites have shown that the species may be present at almost anytime of the year, with maximum population densities usually occurring in the summer months (Table 5.1-2). Most of the over wintering *E. herdmani* are immature forms. *Eurytemora* has a generation time of about 70 days at 34°F, which decreases to 20 days at 57°F; above 66°F there is no successful reproduction (Katona, 1970). Other thermal response data are given in Figure 5.1-10.

#### 5.1.6 Arctica islandica

The ocean quahog (Figure 5.1-11) is the sole surviving member of an entire mollusc family (Arcticidae) the other members of which became extinct with the last ice age. In addition to its commercial size, its extremely short siphons restrict it to the top few centimeters of sediment, making it economical to dredge. The present center of the commercial fishery in New England is Rhode Island; however, the state of Maine has recently become interested in the commercial possibilities of this species off its own shores.

Adult densities of 1 or 2 individuals per m<sup>2</sup> have been determined for New Hampshire waters. Also, specimens were readily obtained, particularly in winter, for a study of reproductive cycles (NAI, 1977a). However, it appears doubtful that there are sufficient concentrations of adults to sustain a viable fishery (Spurr and Seamans, 1975). Data on juvenile *A. islandica*, collected during benthic surveys in the vicinity of intake and discharge sites over the past five years, are presented in Table 5.1-3.

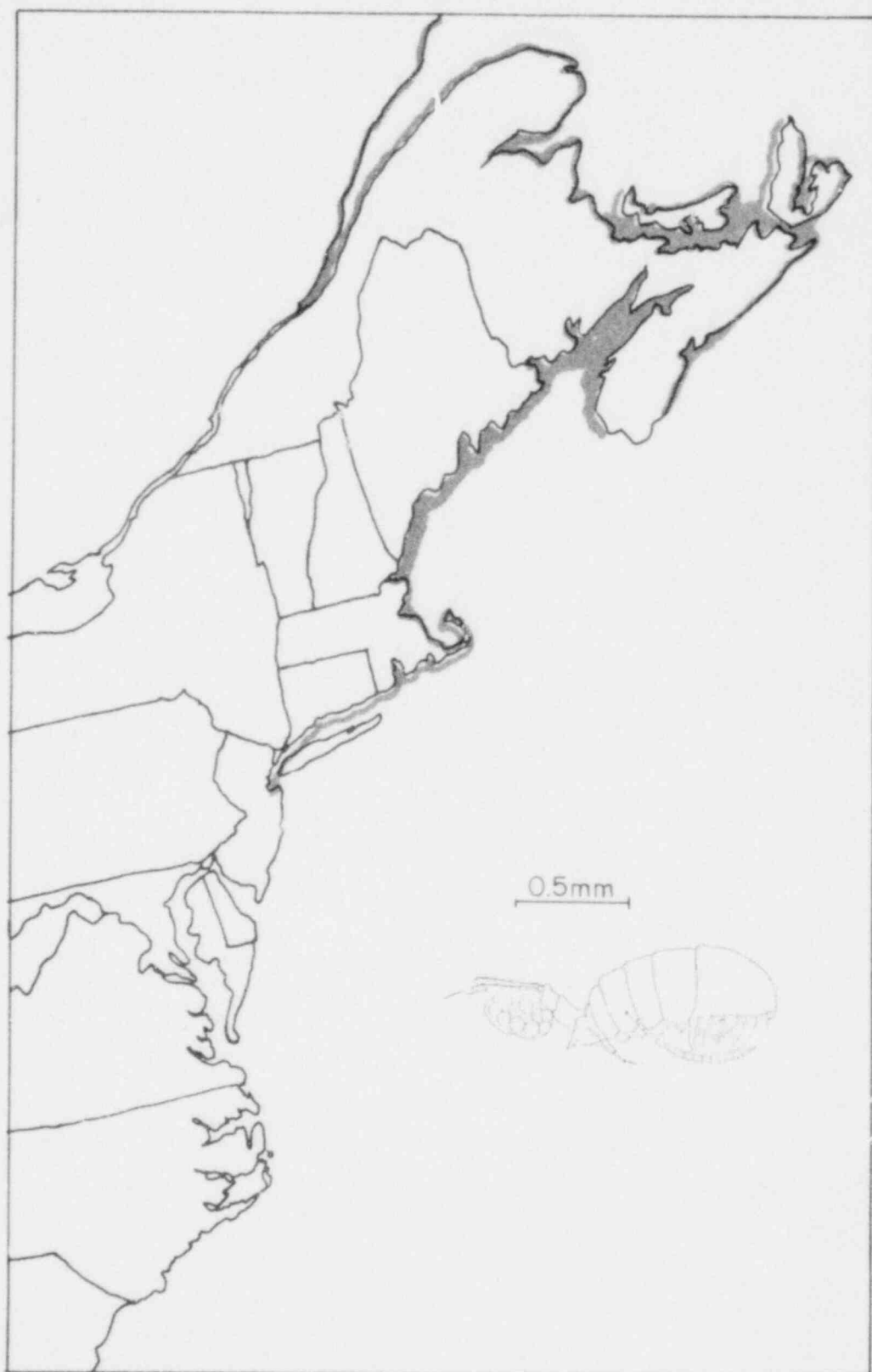

Figure 5.1-9. Distribution of the copepod, *Eurytemora herdmani* in the Western Atlantic Ocean.

TABLE 5.1-2. TEMPORAL DISTRIBUTION OF *EURYTEMORA HERDMANI* (INDIVIDUALS/m<sup>3</sup>).

## ADULTS

	Jan	Feb	Mar	Apr	May	Jun	Jul	Aug	Sept	Oct	Nov	Dec
1976	0	0.4	1.5	0.3	9.4	302						
1975	0	9.5	1.4	0	45	ND	7.3	1.6	2.7	1.0	0.2	0.1
1974	0	0	0	0	5	1040	0	0	0	0	0	0
1973	ND	ND	1	ND	1270	880	850	250	0	0	0	0
1972	ND	ND	ND	4	148	ND	872	507	ND	24	ND	0

## JUVENILES (COPEPODITES &amp; NAUPLII)

1976	3.5	3.3	0	1.5	1.6	1095						
1975	ND	ND	ND	ND	ND	ND	15	83	26	0	0	13
1974	3.5	0	0	0	0	ND	ND	ND	ND	ND	ND	ND
1973	ND	ND	ND	ND	600	2570	350	90	0	0	30	100

ND = No Data



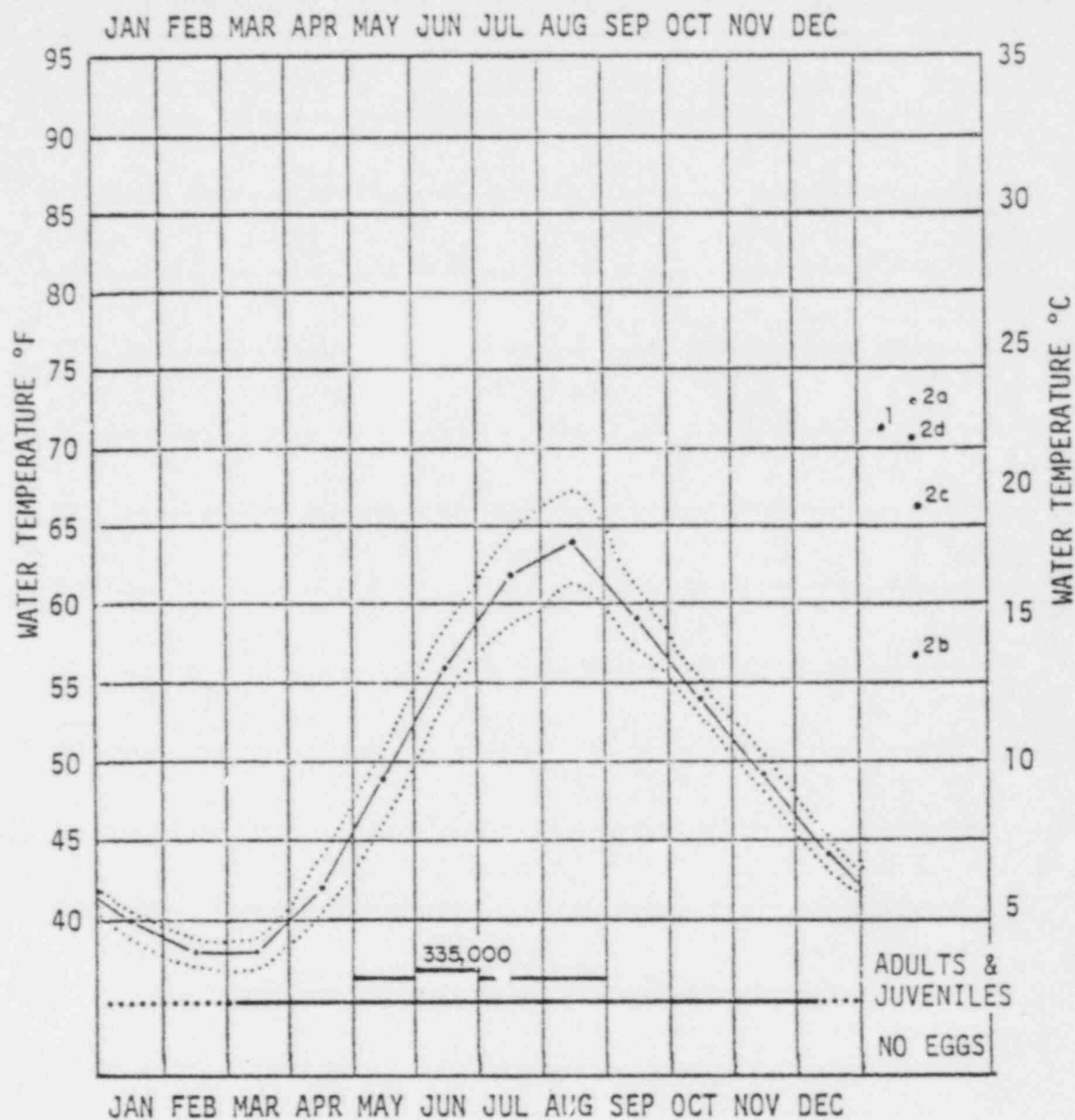

1. Maximum temperature for adult survival (Gonzalez, 1973)
- 2a. Maximum 24-48 hr temperature tolerance (Katona, 1970)
- b. Growth optimum
- c. Maximum temperature for reproduction and development
- d. Aberrant swimming behavior observed

Figure 5.1-10. Copepod, *Eurytemora hermani*, relative temporal abundance and thermal characteristics.

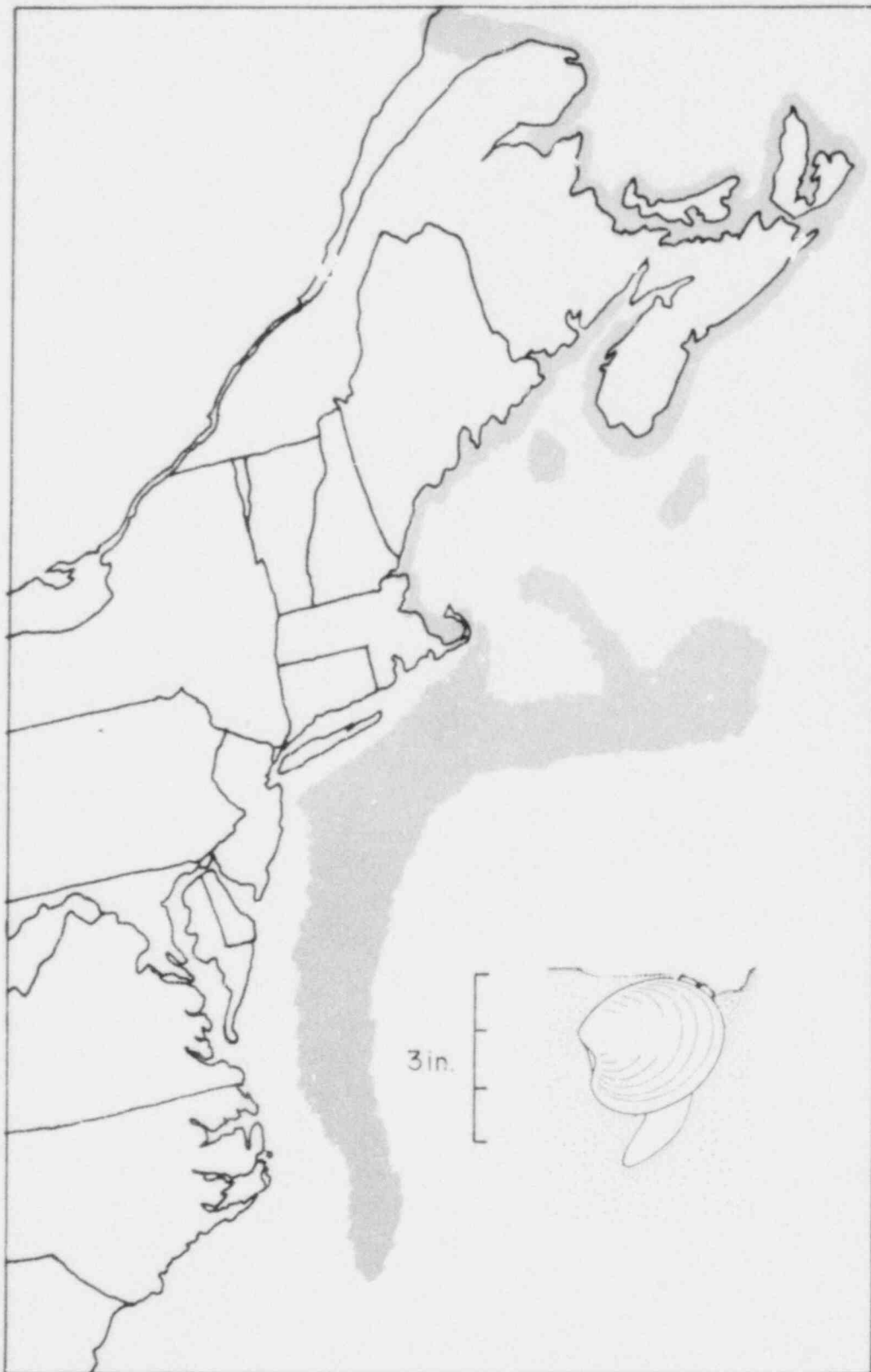

Figure 5.1-11. Distribution of Mahogany quahog, *Arctica islandica* in the Western Atlantic Ocean.

TABLE 5.1-3. TEMPORAL DISTRIBUTION OF JUVENILE *ARCTICA ISLANDICA*  
(INDIVIDUALS/M<sup>2</sup>) IN THE VICINITY OF HAMPTON BEACH, NH.

	JAN	FEB	MAR	APR	MAY	JUN	JUL.	AUG	SEP	OCT	NOV	DEC
1976	54.4	NC	NC	9.0	NC	NC	NC	NC	NC	NC	NC	NC
1975	NC	NC	NC	NC	196.8	NC	10.2	NC	NC	5.8	NC	NC
1974	NC	NC	NC	NC	NC	NC	2.0	NC	NC	NC	NC	NC
1973	NC	NC	NC	NC	NC	NC	NC	NC	NC	NC	NC	NC
1972	NC	NC	NC	NC	NC	NC	5.5	NC	NC	NC	NC	NC

NC = No Collections made

Spawning apparently commences in late June-early July in both Rhode Island and New Hampshire waters (Loosanoff, 1953; NAI, 1977) and continues into October. With a length of larval life of about 60 days (Landers, 1976) this would place the period when larvae appear in the water column at between late August to December. As recognition characters have yet to be established for *A. islandica* larvae, the occurrence of the larvae in relatively low numbers in plankton collections from this period can only be tentatively acknowledged.

Data on thermal requirements for this species is scant. Unpublished observations (Savage, University of Rhode Island) show that the animal is surprisingly active at temperatures below 32°F. On the other hand, adults of this species barely tolerate seawater at room temperature (Figure 5.1-12).

#### 5.1.7 *Ensis directus*

The jack-knife, or razor, clam is well known for its burrowing ability which contributes to its resistance to being removed from its substrate. The typical habitat for this species is sandy embankments near mean low water. Some samples from the vicinity of the proposed intake and discharge sites have been found to contain juveniles, particularly in summer, with densities in the range of three to four individuals per  $m^2$ . The presence of adults in the area has also been established by NAI diver observations. In subtidal NH waters adult densities were determined at 2 to 6 individuals per  $m^2$  (Spurr and Seamans, 1975). However, because of the propensity to resist capture, even by a venturi suction dredge, these values probably underestimate the true population density existing under favorable substrate conditions.

Investigations of thermal response have not been conducted, although the experimental temperatures under which Castagna and Chanley (1973) carried out their burrowing experiments, may approximate an optimum (see Figure 5.1-13). Considering the similar geographic distribution (Figure 5.1-14), thermal tolerance of the razor clam probably differs little from that of the soft-shell clam, *Mya arenaria*.

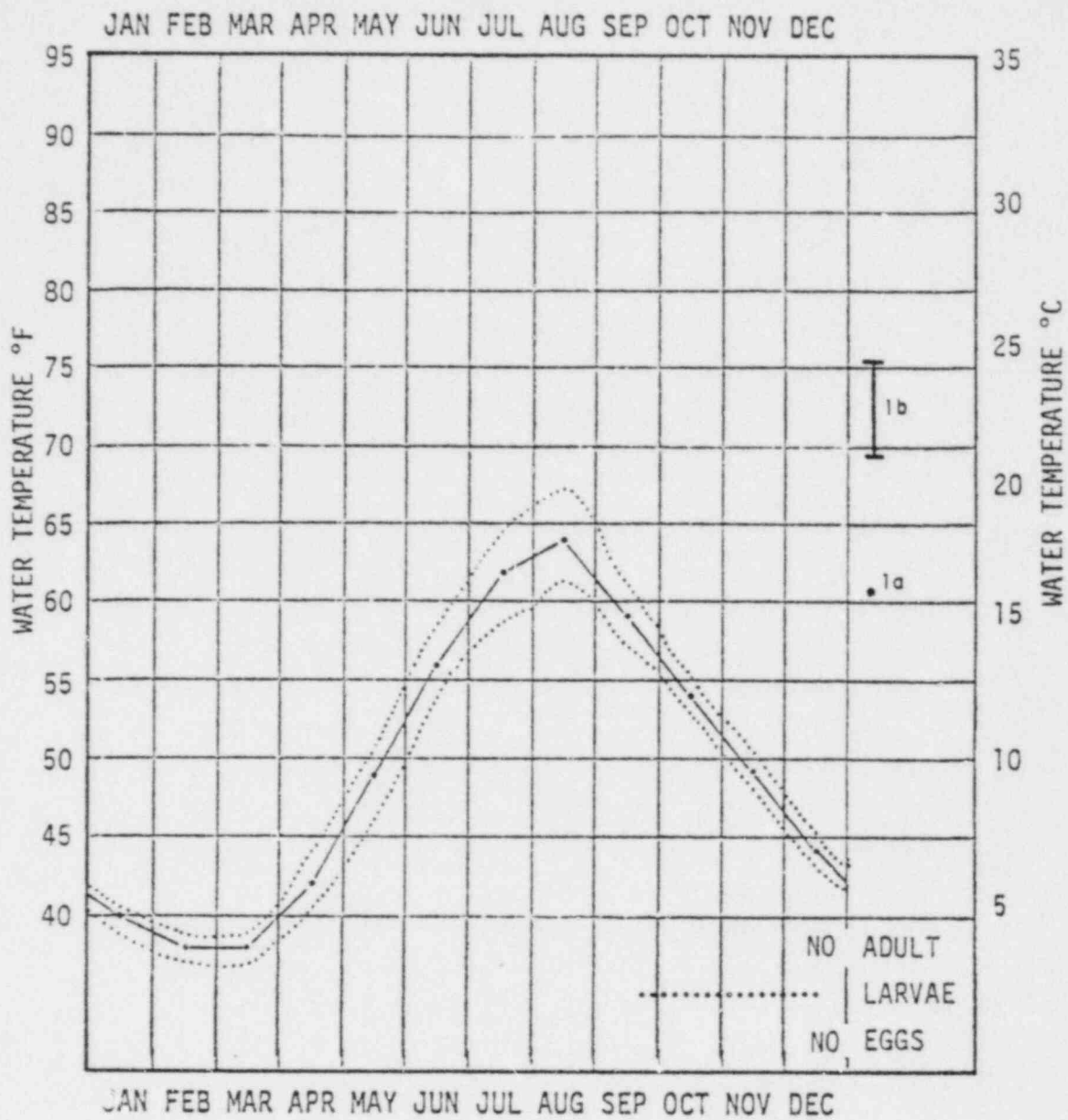

- 1a. Approximate Temperature at which Adult Shows Symptoms of Thermal Stress (Savage; unpublished data)  
 b. Upper Thermal Tolerance Range; Adult.

Figure 5.1-12. Mahogany clam (ocean quahog), *Arctica islandica*, relative temporal abundance and thermal characteristics.

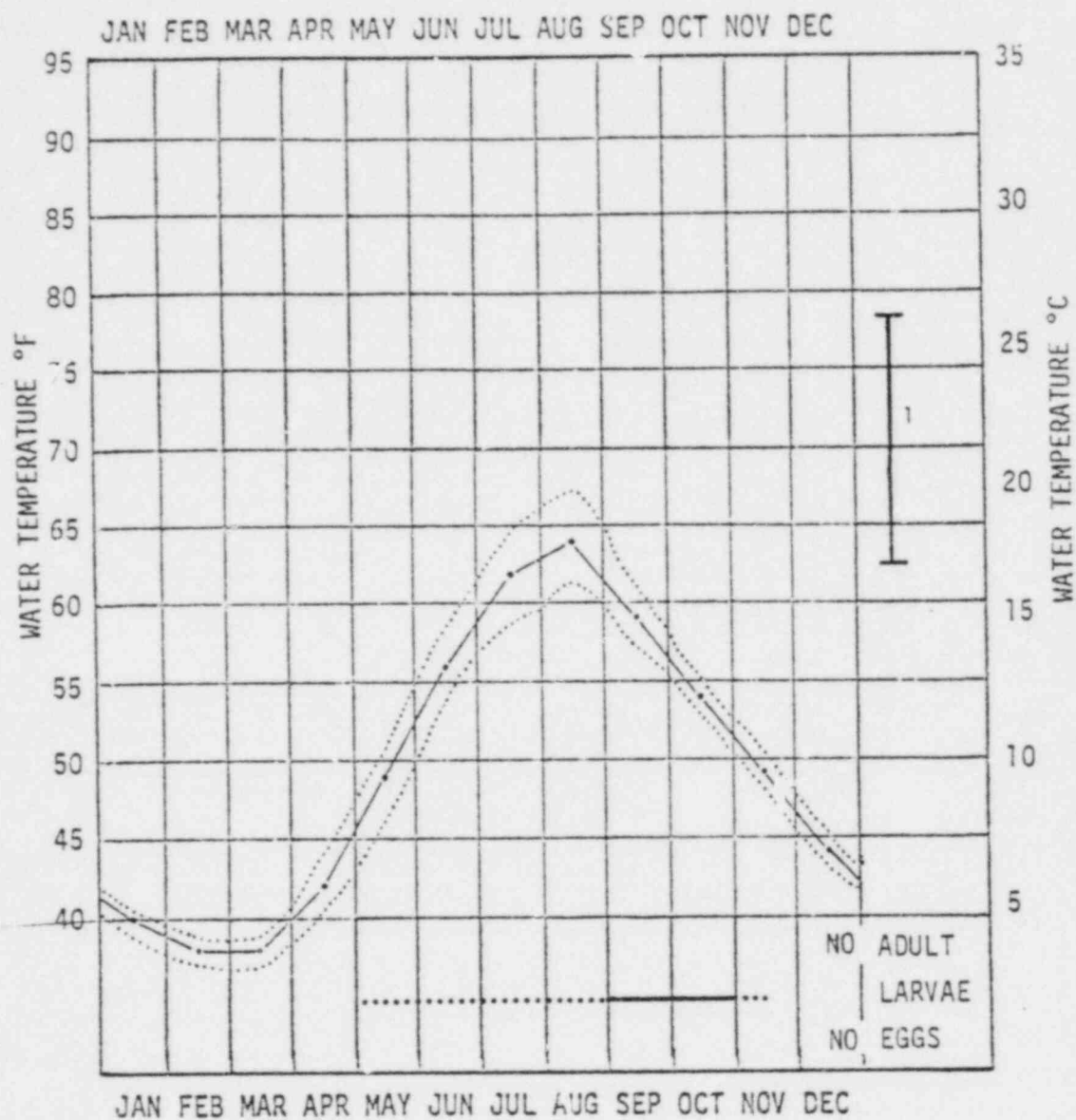

1. Experimental Temperature Range Adult Reburrows (Costagna and Chanley, 1973)

Figure 5.1-13. Jack-knife clam, *Ensis directus*, relative temporal abundance and thermal characteristics.

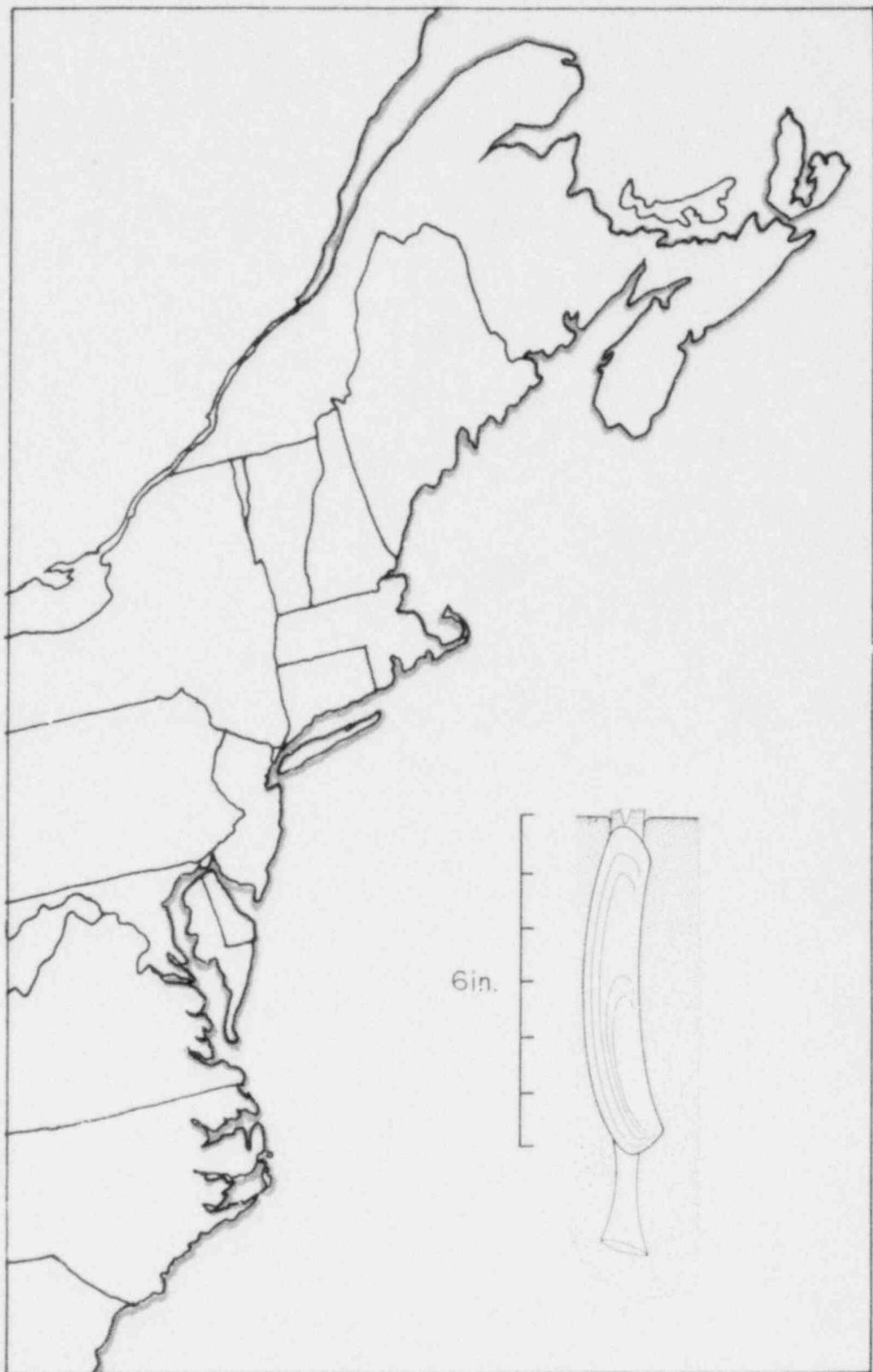

Figure 5.1-14. Distribution of Razor clam, *Ensis directus* in the Western Atlantic Ocean.

The planktonic larvae are strikingly distinct from other bivalve species (Sullivan, 1948); relatively large numbers occur particularly in September-October plankton samples and are another indication that substantial numbers of adult razor clams exist in the local area. The small amount of numerical data available for *E. directus* larvae suggests that population densities are about of the same order of magnitude as for *Mya arenaria* larvae (see 5.1.3, below).

#### 5.1.8 *Mya arenaria*

The soft-shelled clam (Figure 5.1-15) is a prominent inhabitant of sandy tidal flats in rivers and harbors where it is easily dug. Thermal tolerance characteristics are presented in Figure 5.1-16. Six years of surveying the clam flats in Hampton-Seabrook Estuary have shown the population to have greatly diminished (Table 5.1-4). Replenishment of the depleted stocks depends primarily on recruitment of larvae spawned in adjacent clam propagation areas (i.e. estuaries of northern Massachusetts and southern Maine). The larvae are washed out of the parent estuary with the ebbing tide to drift up and down the coast with the currents. Dispersal is such that population densities diminish with distance offshore. When considered over the entire season of sustained abundance (Table 5.1-5) the term "neritic band" has been used to suggest the much higher probability of encountering relatively dense "patches" of larvae moving close to shore as opposed to further at sea.

On flooding tides, a small portion of the drifting larvae are subducted into the narrow inlet leading to Hampton Harbor. Those that are mature enough (larger than 240  $\mu\text{m}$ , or approximately 25 to 30 days old) will: 1) attach to sand grains, or other substrate, 2) undergo metamorphosis, and 3) eventually settle into temporary burrows as "spat". Data presented in Table 5.1-6 suggest that spat sets have varied greatly over the past six years, with the most recent set being the heaviest of all. Comparison of Tables 5.1-5 and 5.1-6 suggests that larval density in coastal waters is not the sole determinant of spatfall success.



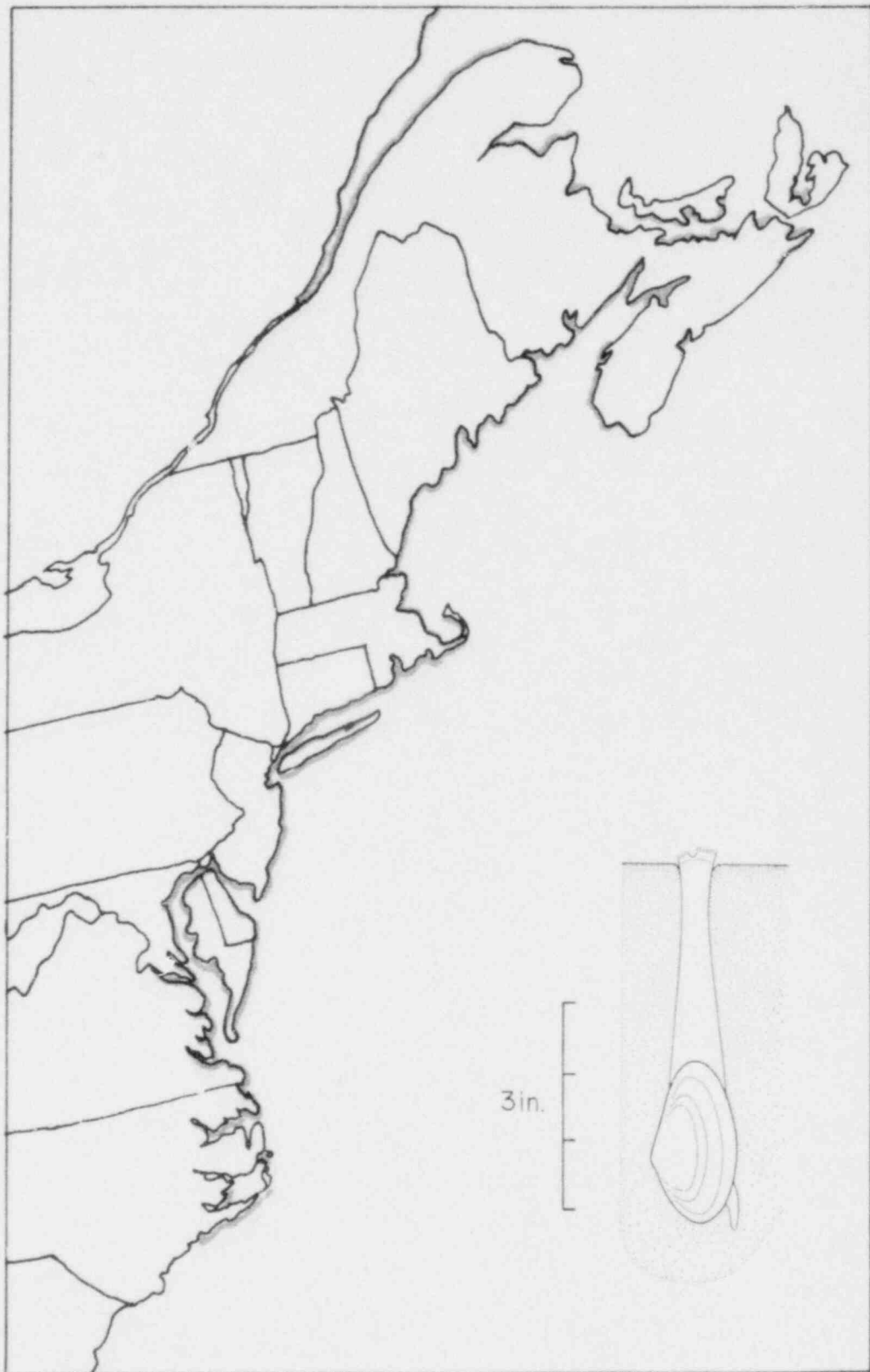
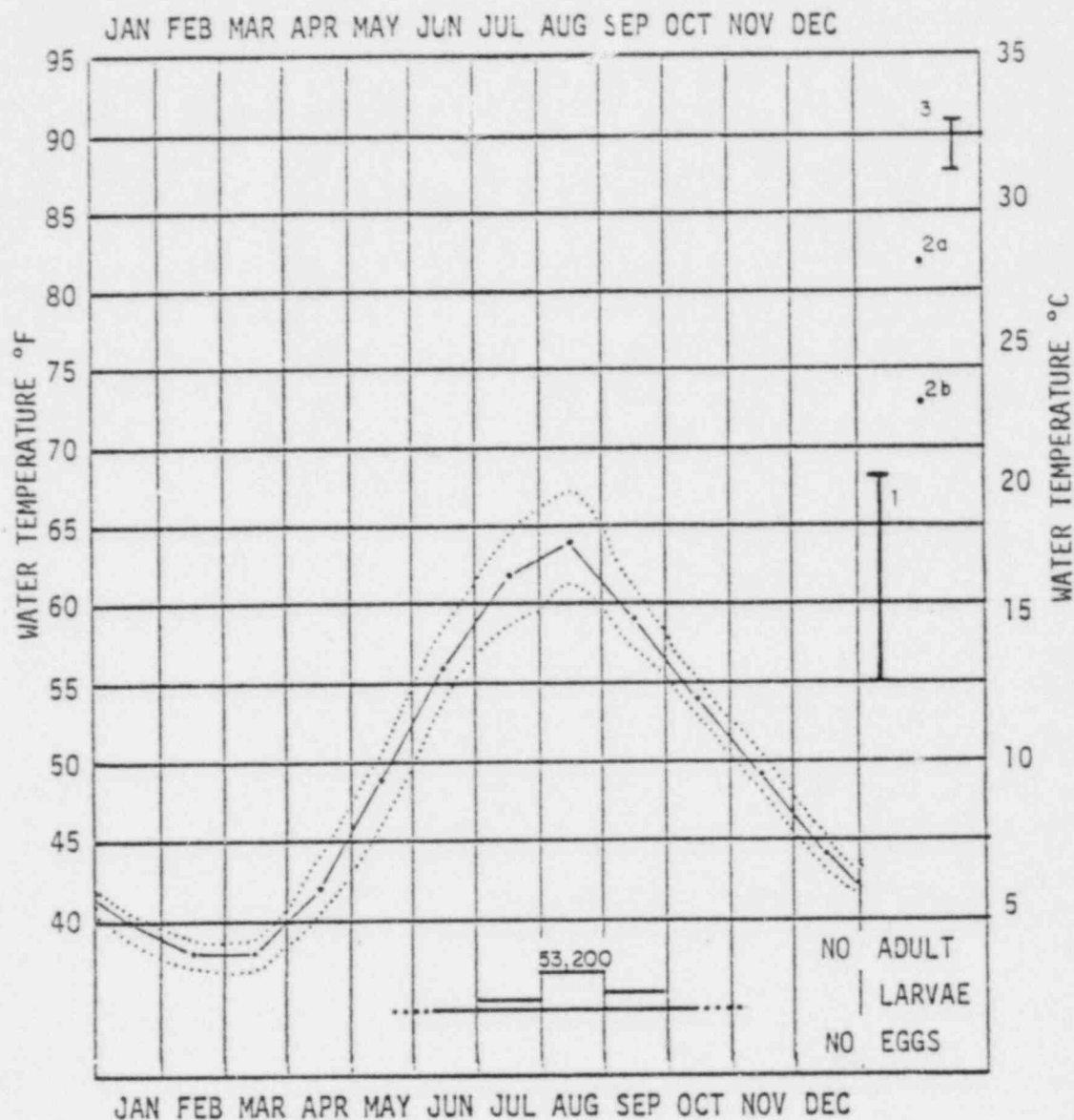

Figure 5.1-15. Distribution of soft shell clam, *Mya arenaria* in the Western Atlantic Ocean.



1. Temperature Range for Normal Reproduction (Ropes and Stickney 1965)
- 2a. Thermal Maximum for Larval Survival (Stickney, 1964) reared through metamorphosis (approx. 14 days)
- b. Upper Limit of Thermal Optimum for Larval Survival (Stickney, 1964) reared through metamorphosis (approx 14 days)
3. 24 hr Median Temperature Tolerance for Adults (Kennedy and Mihursky, 1971)

Figure 5.1-16. Soft-shell clam, *Mya arenaria*, relative temporal abundance and thermal characteristics.

TABLE 5.1-4. ABUNDANCE OF *M. ARENARIA* ADULTS (> 25 mm)  
IN HAMPTON-SEABROOK ESTUARY, NOVEMBER SURVEYS.

<u>Year</u>	<u>Mean Population Density</u> (ft <sup>2</sup> )	<u>Standing Stock</u> (Bushels per acre)
1971	10.4	84 ± 18
1972	8.4	58 ± 18
1973	3.8	41 ± 18
1974	4.1	56 ± 9
1975	1.0	34 ± 4
1976	0.3	12 ± 3

TABLE 5.1-5. ABUNDANCE OF *M. ARENARIA* LARVAE (140-320µm)  
IN NEW HAMPSHIRE COASTAL WATERS.

<u>Year</u>	<u>Season of Sustained Abundance</u>	<u>Mean Density</u> (m <sup>3</sup> )
1974	16 - July - 5 Sept.; 51 days	69
1975	16 - Aug. - 14 Oct.; 59 days	532
1976	27 - Jul. - 27 Sept.; 62 days	244

TABLE 5.1-6. ABUNDANCE OF *M. ARENARIA* SPAT (1 TO 25 mm)  
IN HAMPTON-SEABROOK ESTUARY, NOVEMBER SURVEYS.

<u>Year</u>	<u>Mean Population Density</u> (ft. <sup>2</sup> )
1971	92
1972	130
1973	47
1974	2
1975	37
1976	762

5.1.9 Mytilus edulis

The blue mussel (Figure 5.1-17) attaches to almost any hard surface, from the intertidal well into the subtidal zone. On rocky outcroppings in the vicinity of the proposed discharge and intake site, adult densities rarely exceed 30 individuals per m<sup>2</sup> and are often much less dense because of the effect of wave action. During storms portions of the outer and inner sunk rocks are sometimes totally denuded of these animals with the focus of the damage at the low water mark. Lower down, in the subtidal zone, competition for food and space occurs between *M. edulis* and the horse mussel, *Modiolus modiolus*.

Juvenile settlement appears to occur throughout most of the year (Table 5.1-7) and, therefore, may provide a more sensitive indication of cooling water system impact than adult densities:

TABLE 5.1-7. TEMPORAL DISTRIBUTION OF *MYTILUS EDULIS* SPAT FROM "OUTER SUNK ROCKS" OFF HAMPTON BEACH, NH.

DATE	MEAN DENSITY (M <sup>3</sup> )
September 1975	3,443
December 1975	9,832
March 1976	3,183
June 1976	20,886

Thermal requirements for spat settlement are included with other thermal tolerance data in Figure 5.1-18.

The principal blue mussel habitat in the local area is in Hampton Harbor, where extensive intertidal mussel banks are regarded with some displeasure because of recent encroachment on potential soft-shell clam propagation areas. In the past, there has been some (unsuccessful) attempt to limit this encroachment. A few mussels are taken from the banks for human consumption, particularly by Canadian visitors.

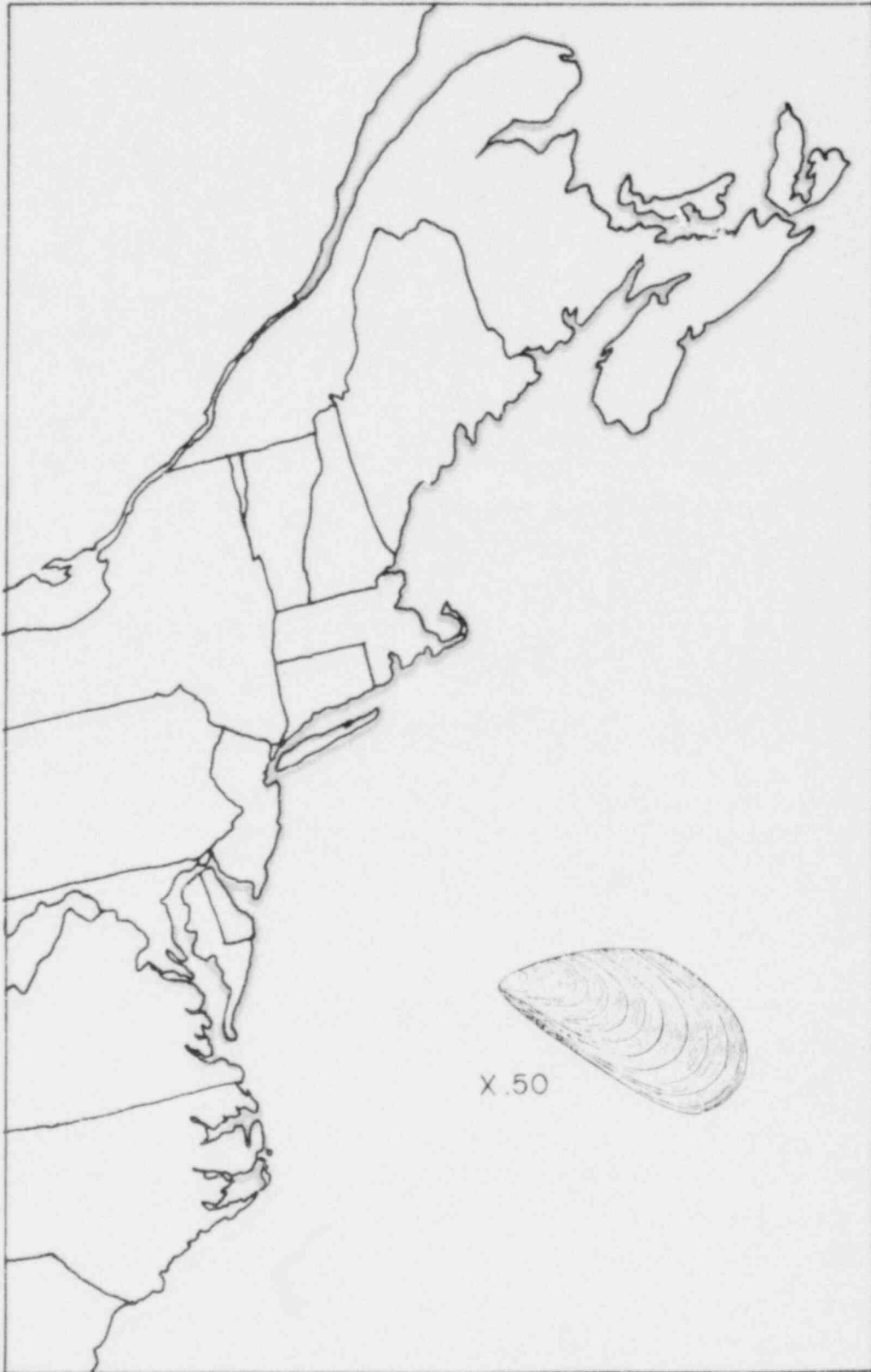
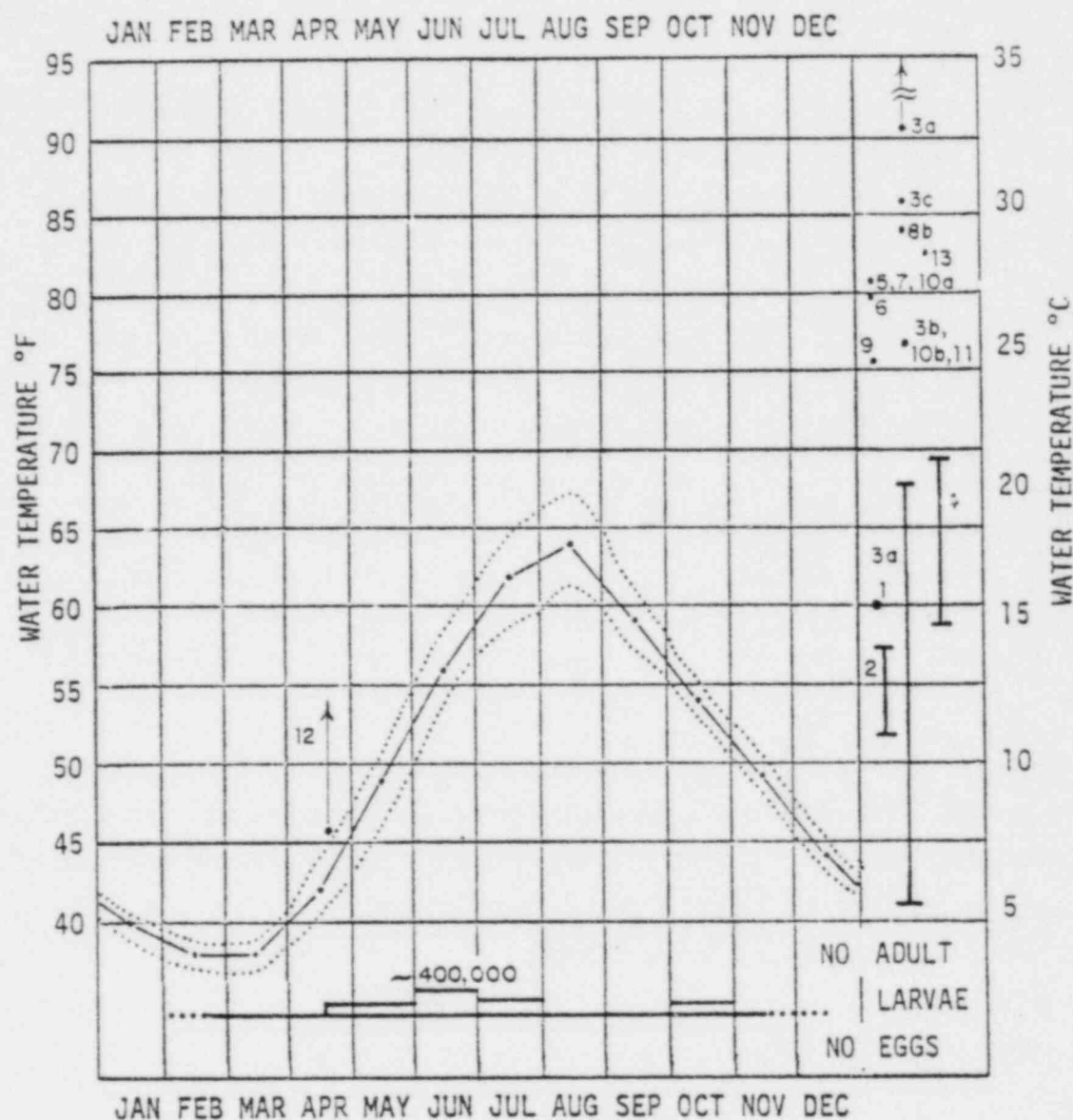

Figure 5.1-17. Distribution of Blue mussel, *Mytilus edulis* in the Western Atlantic Ocean.



1. Minimal Spawning Temperature (Engle and Loosanoff, 1944)
2. Optimal Temperature Range for Larvae Survival and Growth (Lough, 1974)
- 3a. Temperature Range for Larvae Survival (Brenko and Calabrese, 1969) tested for 16-17 days
- b. Erratic Survival of Larvae Observed
- c. Temperature at which 100% Mortality of Larvae Observed
4. Temperature Range for Settlement of Pediveliger Larvae (Engle and Loosanoff, 1944)
5. Intolerance of Juvenile Mussels Found (Gonzalez, 1973)
6. Temperature Limit for Southern Boundary (Hutchins, 1947)
7. Temperature Limit for Natural Range (Read and Cumming, 1967)
- 8a. Average Lethal Point for *Mytilus*: 105.4°F (Henderson, 1929)
- b. 24-hr Median Temperature Tolerance
9. Adults Susceptible to Predation (Pearce, 1969)
- 10a. Temperature where Mortality of Adults Reported (Gonzalez, 1973)
- b. Temperature for Cessation of feeding
11. Water Filtration Capacity Affected (Widdows, 1973)
12. Rapid Rise in Temperature Reported to Induce Spawning (Wilson and Seed, 1974)
13. Upper Incipient Lethal Temperature (Wallis, 1975)

Figure 5.1-18. Blue Mussel, *Mytilus edulis*, relative temporal abundance and thermal characteristics.

5.1.10 Homarus americanus

The American lobster (Figure 5.1-19) at one time was an extremely common bottom dwelling invertebrate, but has been extensively overfished for more than a century. Despite this fact, the continued demands for this species as a seafood delicacy have kept the fishing effort relatively constant. The primary commercial means of capture is to set traps ("lobster pots") into which the animals are lured by bait or the opportunity to seek shelter. In 1975, the latest year for which such statistics were available, approximately 23,400 pots were operating in New Hampshire waters and produced a total of 480 thousand pounds of whole lobsters. Catch data from the immediate vicinity of the proposed cooling water discharge site indicate relative stability in catch per effort over the past five years (Table 5.1-8).

Temperature is an important environmental factor for all stages in the life of the lobster (Figure 5.1-20). Extrusion of the eggs from the female's body, breeding, hatching, and molting of the adults are all stimulated by seasonal warming of water temperature. In northern New England, a fully mature female lobster lays between 7000 and 23,000 eggs, and usually carries them for a year or more (Squires, 1970). The first few larval stages are planktonic, with a strong affinity for the top few centimeters of the surface waters. Lobster larvae are rarely collected except in ("neuston") nets designed to sample the water surface.

Available evidence suggests that coastal New Hampshire is not an important spawning area for *H. americanus*. Adults are legal for harvest at a carapace length of 3 1/8 inches, when only a small proportion have become sexually mature. Less than 2% of all the females recovered from the vicinity of the discharge site have been egg bearers, compared to an average of 23% offshore (Skud and Perkins, 1969). Results of the 1973 lobster larvae survey (Table 5.1-9) showed that most of the larvae collected were in the fourth or fifth stage of development suggesting that these older larvae were drifting into the area from more distant breeding grounds.

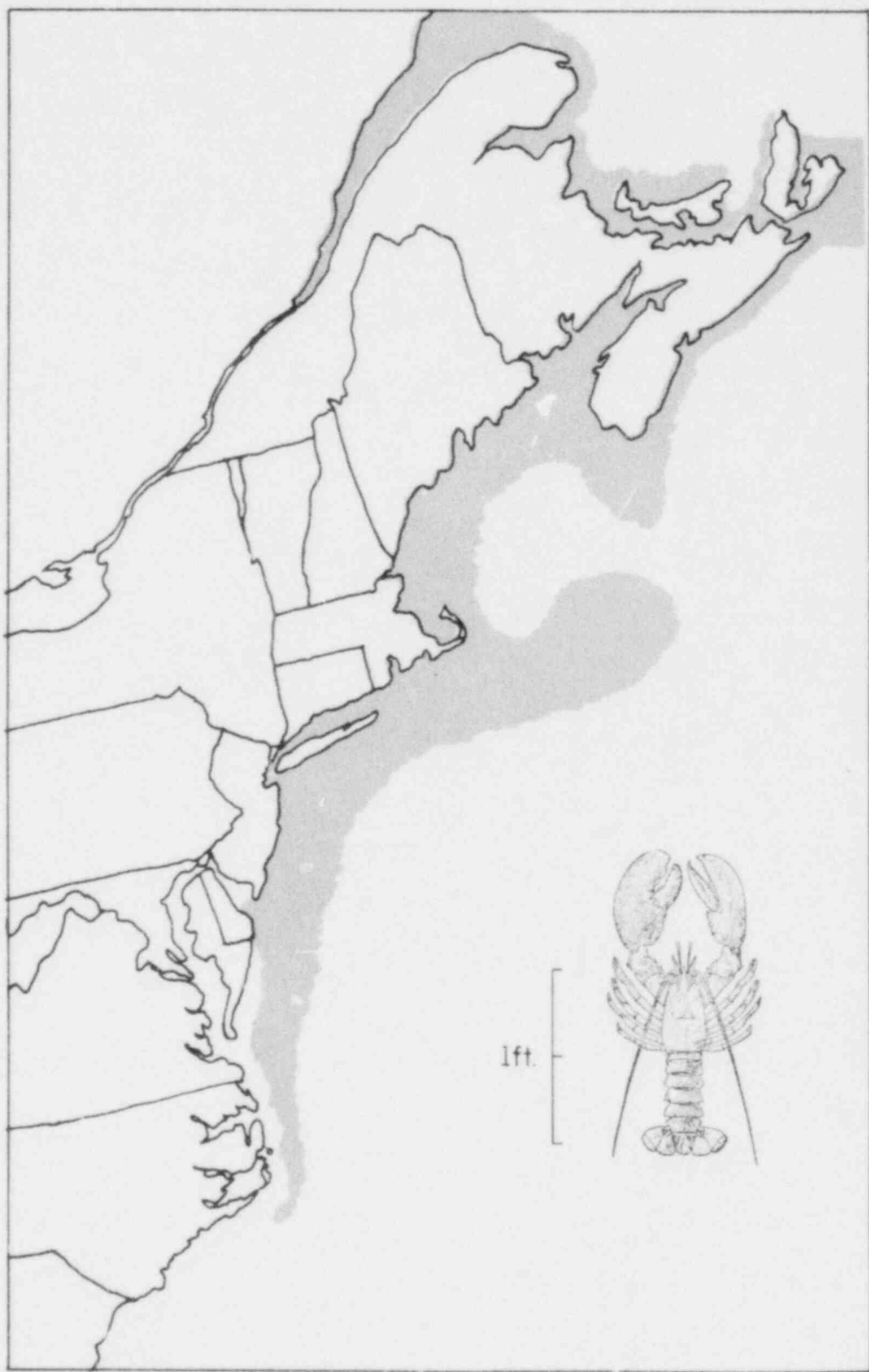

Figure 5.1-19. Distribution of lobster, *Homarus americanus* in the Western Atlantic Ocean.



TABLE 5.1-8. TEMPORAL CHANGES IN *HOMARUS AMERICANUS* LEGAL CATCH PER EFFORT FOR 15 POT STRINGS IN THE VICINITY OF HAMPTON BEACH, NH.

	JUNE	JUL	AUG	SEP	OCT	NOV
1976	3.42	8.64	10.02	8.04	10.48	10.04
1975	3.00	5.71	9.50	8.46	10.25	10.77
1974	2.49 <sup>a</sup>	6.67	9.42	12.76	9.71	13.35
1973 <sup>a</sup>	5.00	4.00	8.93	6.85	12.46	6.92
1972 <sup>a</sup>	6.18	4.00	5.87	14.43	8.86	5.09

<sup>a</sup>Values do not include lobsters in the 3 1/8 to 3 1/4 range of carapace length

TABLE 5.1-9. ABUNDANCE OF LOBSTER, *HOMARUS AMERICANUS* LARVAE, IN "NEUSTON" TOWS OFF HAMPTON BEACH, NEW HAMPSHIRE IN 1973 (INDIVIDUALS PER 100 M<sup>3</sup>).

<u>MAY</u>	<u>JUN</u>	<u>JUL</u>	<u>AUG</u>	<u>SEP</u>	<u>OCT</u>
0.0	0.0	1.9	6.0	0.8	0.0

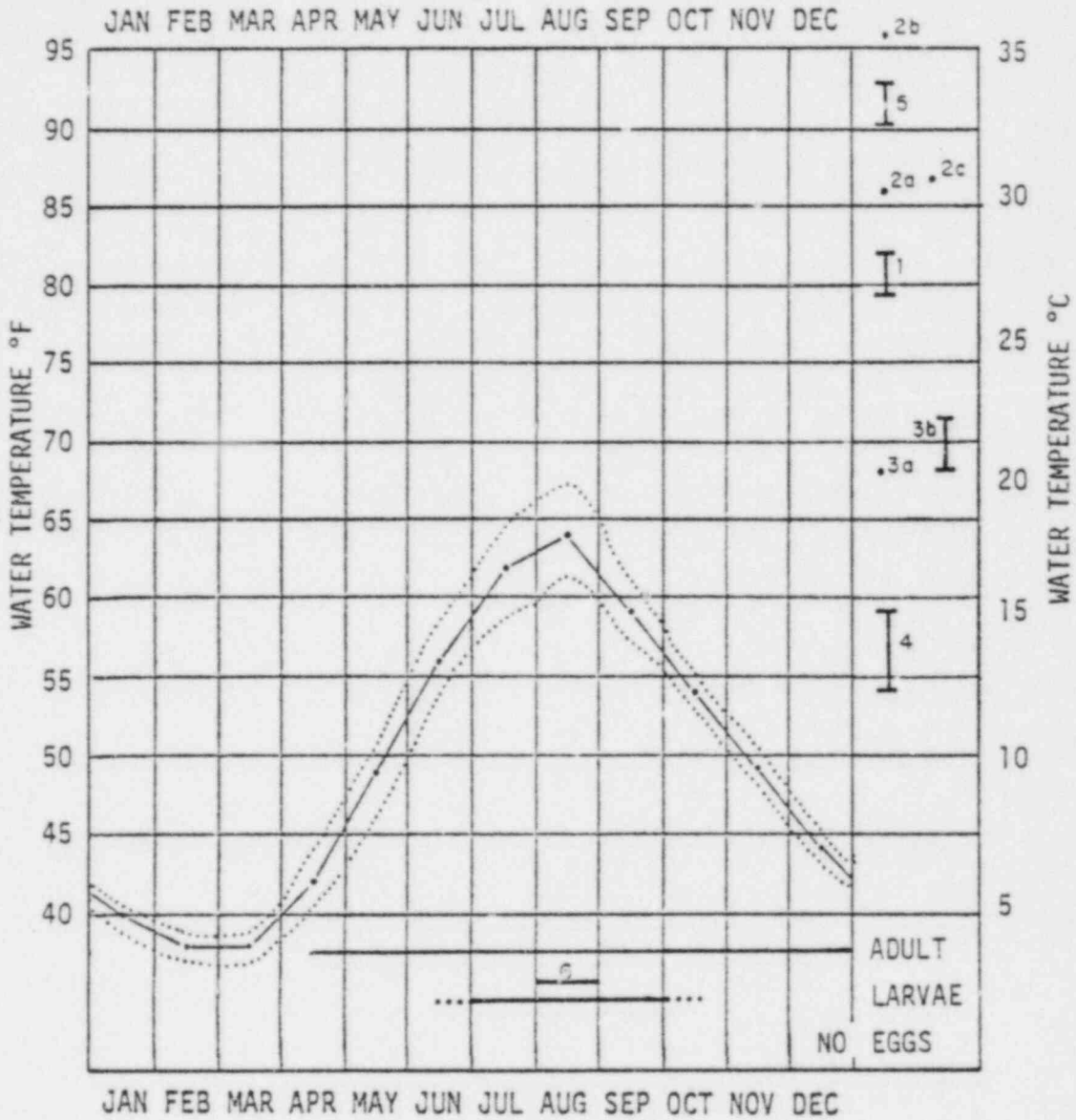

1. 48 hr Median Temperature Tolerance Range, Adults (McLeese, 1956)
- 2a. Eggs Reared to Hatching (Perkins, 1972)
- b. Maximum Survival Temperature, 20-30 min Exposure, Larval Stages 1 through 4
- c. 6 hr Median Temperature Limit, All Larval Stages
- 3a. Optimum Temperature for Growth of Adults (Sastry, pers comm)
- b. Optimum Temperature Range for Larvae
4. Temperature Range of Normal Reproduction (Sherman and Lewis, 1967; Wilder, 1953)
5. Lethal Temperature Tolerance Limit, Larval Stages 3-5 (Huntsman, 1924)

Figure 5.1-20. American lobster, *Homarus americanus*, relative temporal abundance and thermal characteristics.

5.1.11 *Alosa pseudoharengus*

The alewife (Figure 5.1-21) is an anadromous (freshwater spawning) clupeoid fish which forms extensive schools far at sea. Adults are rarely encountered inshore except during the spawning season (April-May). However, small schools of juveniles often frequent the inshore area (Table 5.1-10) usually associated with a look-alike relative, the blueback herring, *Alosa aestivalis*. Eggs (surface adhering in stream beds) and larvae (fresh water) have not been taken in ichthyoplankton collections in the vicinity of the intake and discharge sites.

In freshwater lakes, extensive mortalities have been reported to occur in summer (Graham, 1956). Many of the thermal response characteristics depicted in Figure 5.1-22 pertain to investigations on "landlocked" alewives.

5.1.12 *Brevoortia tyrannus*

The Atlantic menhaden (Figure 5.1-23) is a warm temperate clupeoid which usually migrates into New Hampshire coastal waters in small numbers in May or June (Table 5.1-11). In 1976, these fish appeared somewhat earlier, possibly because of the unusually early spring in that year.

South of Cape Cod, where the species are more abundant, the particular affinity for warm water has led to difficulties in connection with thermal discharge plumes. Mass mortalities occasionally occur when the fish are densely packed into a closely confined space, such as a marina basin or cooling canal. These "fish kills" appear to be associated with greatly reduced dissolved oxygen concentrations, fish oxygen requirements being high and oxygen solubility being low at temperatures which the fish prefer. Where thermal discharge plumes may be abruptly encountered, mortalities may also be augmented by formation of gas emboli in the fish's body fluids ("gas bubble disease"). The probability of such fish kills occurring in New Hampshire offshore waters is remote because of: 1) the lack of confinement, especially in the vicinity of the proposed discharge site, and 2) the relatively small population densities typical of New Hampshire menhaden "runs".

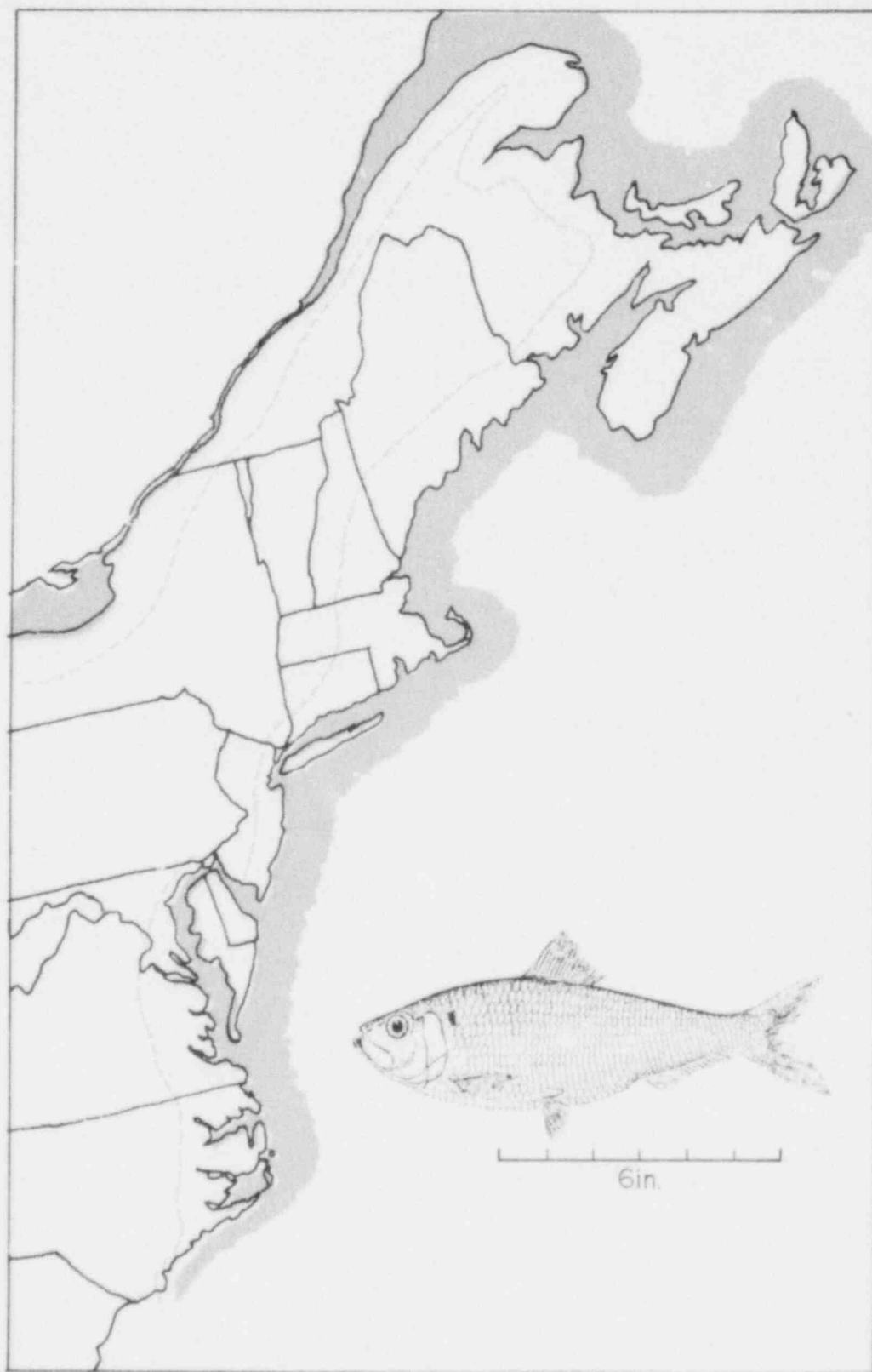

Figure 5.1-21. Distribution of Alewife, *Alosa pseudoharengus* in the Western Atlantic Ocean.

TABLE 5.1-10. TEMPORAL DISTRIBUTION OF ALEWIFE, *ALOSA PSEUDOHARENGUS*, IN NEW HAMPSHIRE COASTAL WATERS.

EGG AND LARVAL DENSITY (#/m<sup>3</sup>)

	Jan	Feb	Mar	Apr	May	Jun	Jul	Aug	Sep	Oct	Nov	Dec
1976 eggs	ND	0	0	0	0	0						
larvae	ND	0	0	0	0	0						
1975 eggs	0	0	0	0	0	ND	0	0	0	0.002	0	0
larvae	0	0	0	0	0	ND	0.099	0	0	0	0	0
1974 eggs	0	0	0	0	ND	1.9	0	0	0	0	0	0
larvae	0	0	0	0	ND	0.008	2.17	0	0.185	0.006	0	0
1973 eggs	ND	ND	ND	ND	0	0	0	0	0	0	0	0
larvae	0	ND	ND	ND	0	0	0.02	0.03	0.01	.005	0	0

ADULT DENSITY  
(NUMBER PER 1000 SQUARE FEET OF GILL NET/DAY)

1976	0	0	0	0.05	0.72	0	0	0.28	0.02	0	0	0
1975	0	0	0.08	0.25	0	ND	0	0.37	0	2.62	0.07	0
1974	0	0	0	0	0	0	0	0	0	0	0	0
1973	ND	ND	ND	ND	0	0	0	0	0	0	0	0
1972	ND	ND	ND	ND	ND	0	ND	0	0	0	ND	ND

ND = no data

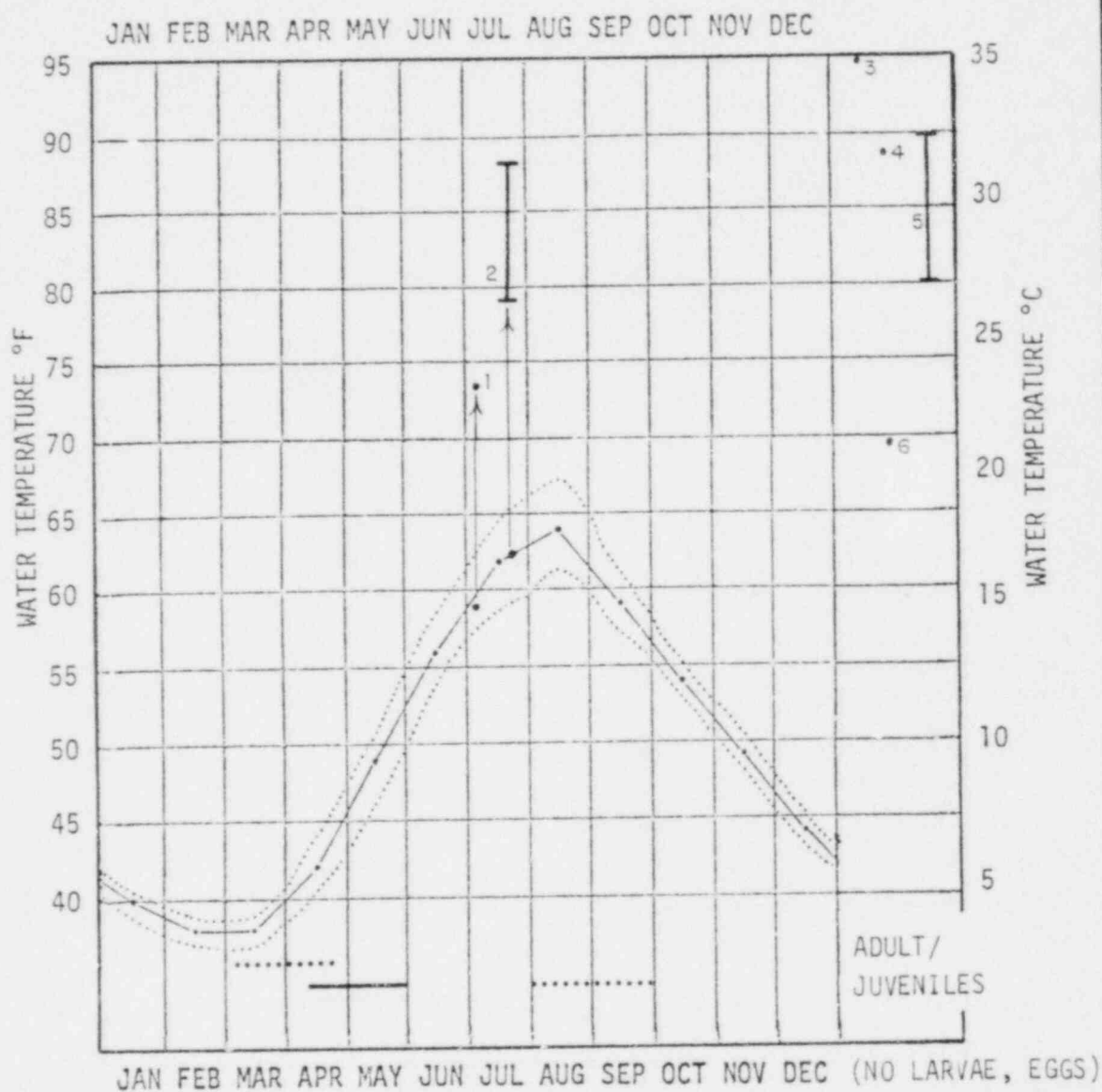

1. 90 Hour Tolerance Limit After Acclimation to 59° (Altman and Dittmer, 1966; citing work by Graham, 1956) FW
2. Acute Lethal Temperature Range, Adults Acclimated to 62.6° (Stanley, 1973) FW
3. Able to Withstand Brief Exposure for Feeding (Dorfman and Westman, 1970) FW
4. Upper Lethal Temperature for Adults (Huntsman, 1946)
5. Upper Lethal Temperature Range for Adults (Trembley, 1960) FW
6. Temperature Above Which Upstream Migration Ceases (Cooper, 1961)

FW = Study performed on fresh water acclimated subjects

Figure 5.1-22. Alewife, *Alosa pseudoharengus*, relative temporal abundance and thermal characteristics.

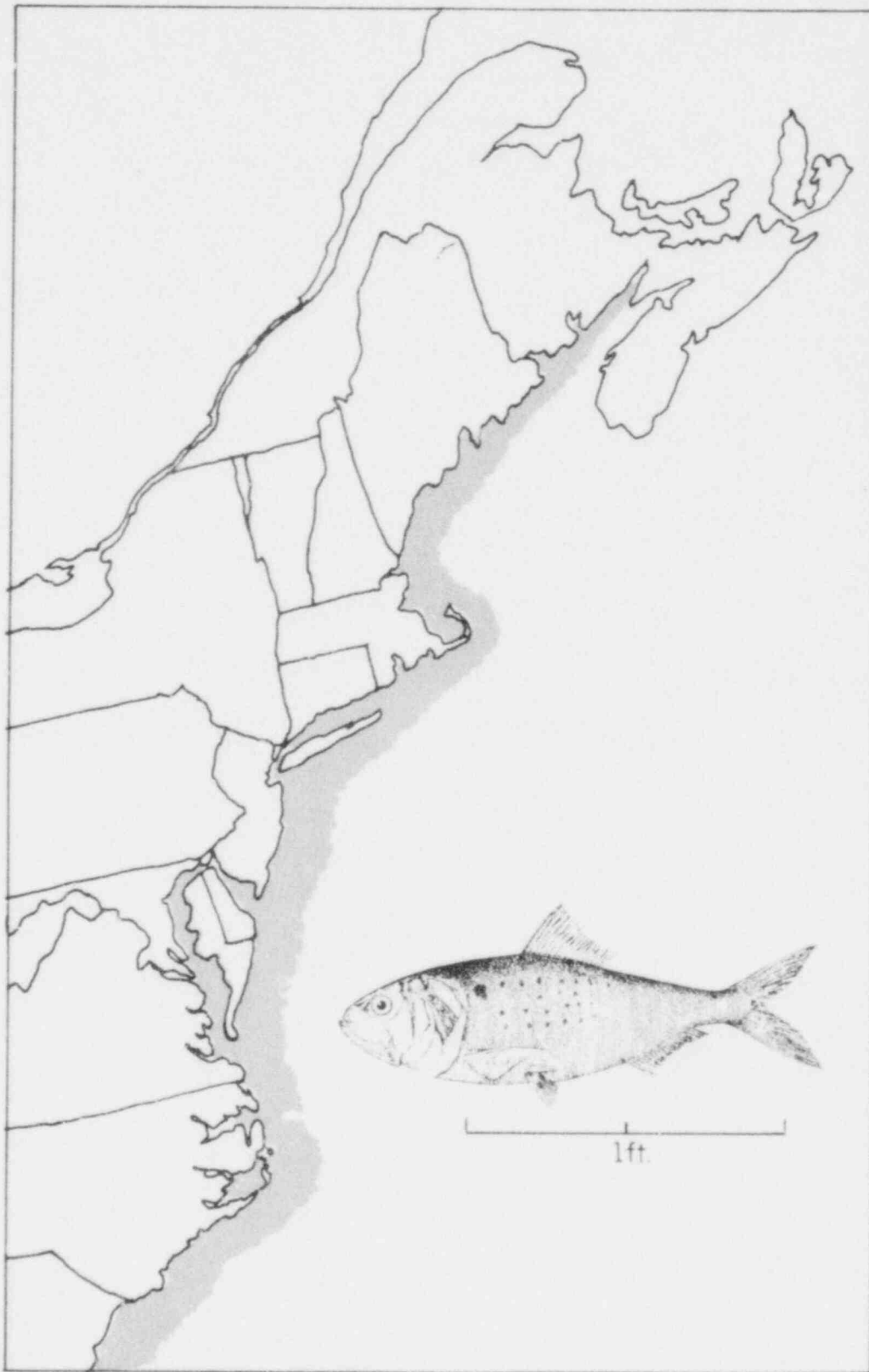

Figure 5.1-23. Distribution of Menhaden, *Brevoortia tyrannus* in the Western Atlantic Ocean.

TABLE 5.1-11. TEMPORAL DISTRIBUTION OF MENHADEN, *BREVOORTIA TYRANNUS*, IN NEW HAMPSHIRE COASTAL WATERS.

EGG AND LARVAL DENSITY (#/m<sup>3</sup>)

	Jan	Feb	Mar	Apr	May	Jun	Jul	Aug	Sep	Oct	Nov	Dec
1976 eggs	ND	0	0	0	0	0						
larvae	ND	0	0	0	0	0						
1975 eggs	0	0	0	0	0	ND	0	0	0	0.002	0	0
larvae	0	0	0	0	0	ND	0.099	0	0	0	0	0
1974 eggs	0	0	0	0	ND	1.9	0	0	0	0	0	0
larvae	0	0	0	0	ND	0.008	2.17	0	0.185	0.006	0	0
1973 eggs	ND	ND	ND	ND	0	0	0	0	0	0	0	0
larvae	0	ND	ND	ND	0	0	0.20	0.03	0.01	.005	0	0

ADULT DENSITY  
(NUMBER PER 1000 SQUARE FEET OF GILL NET/DAY)

1976	0	0	0.02	0.02	0.05	0.12	0.02	0.02	0.02	0.03	0.02	0
1975	0	0	0	0	0	ND	0	0	0	1.13	0.02	0
1974	0	0	0	0	ND	0.17	0.25	0.67	0	0	0.02	0
1973	ND	ND	ND	0	0	0	6.98	0.05	0.05	0	0.10	0
1972	ND	ND	ND	ND	ND	0.56	ND	0	0	0	ND	ND

ND = no data



New Hampshire is very near the extreme northward limit of the reproductive range of this species (Bigelow and Schroeder, 1953); thus only occasional local spawning activity is suggested by the data presented in Table 5.1-11. Particulars concerning menhaden thermal tolerance are presented in Figure 5.1-24.

#### 5.1.13 Oncorhynchus kisutch

The coho salmon is an introduced west coast marine fish (Figure 5.1-25) that spawns in fresh water. The young spend about one year in fresh water before descending to the sea (Scarola, 1973). Sexually mature individuals return after spending two years at sea (sometimes after only one year for "precocious" males). In New Hampshire the peak of the spawning run usually occurs in October (Scarola, 1973). Coho salmon have not been captured in the vicinity of the proposed intake and discharge sites; however, in November 1976, four juveniles (length: approximately 12 inches) were taken in Hampton-Seabrook estuary with a beach seine. Information on thermal requirements for this species is summarized in Figure 5.1-26.

#### 5.1.14 Osmerus mordax

In marine waters (Figure 5.1-27) the rainbow smelt rarely strays more than a mile or two from shore. With the coming of colder temperatures in the fall, these fish gather in harbors and embayments in preparation for the spring spawning run to gravel bottomed fresh water streams. Data presented in Table 5.1-12 are consistent with this behavior in that catches are demonstrably higher during colder months. Eggs are adhesive and are, therefore, not encountered in marine waters; the larvae are only nominally encountered (Table 5.1-12).

Smelt prefer colder water (43-46°F; see also Figure 5.1-28) which partially explains why the catch in the vicinity of the proposed intake and discharge sites come mainly from near-bottom waters.

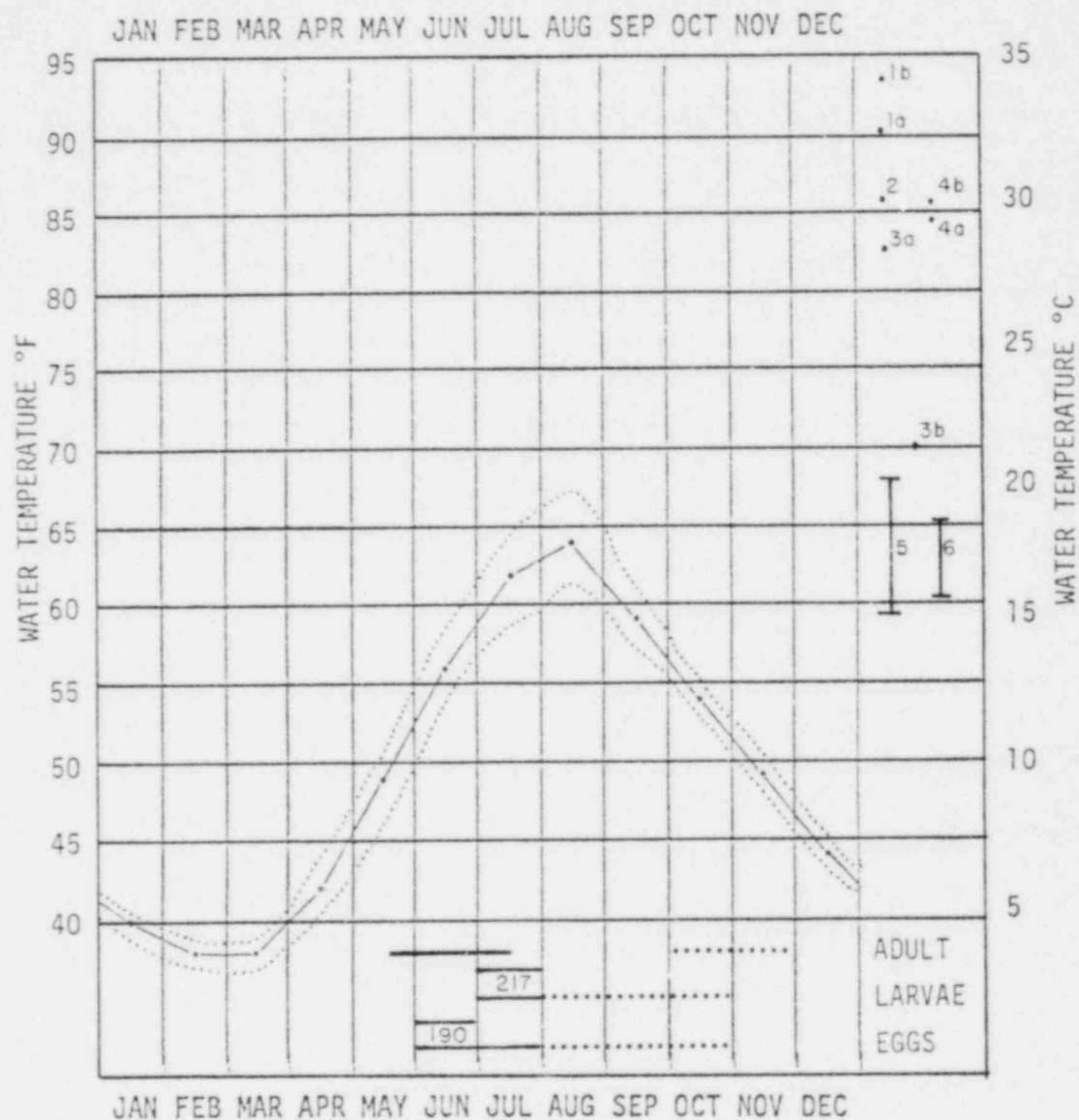

- 1a. Maximum Summer Survival for Yearlings and Adults Acclimated to 72° (Lewis and Hettler, 1968)
- b. Maximum Summer Survival and Development of Larvae
2. 24 hr Median Temperature Tolerance, Adults (Battelle Columbus, 1972)
- 3a. Avoidance Temperature, Juveniles Acclimated to 72° (Meldrim and Gift, 1971)
- b. Preferred Temperature
- 4a. Critical Thermal Maximum for Juveniles Acclimated to 59° (Hoss et al., 1974)
- b. Critical Thermal Maximum for Larvae Acclimated to 59°
5. Preferred Temperature Range (Reintjes, 1969; Citing Work Done by Goode, 1879)
6. Temperature Range at Which Larvae are Most Abundant (Kendall and Reintjes, 1975)

Figure 5.1-24. Atlantic menhaden, *Brevoortia tyrannus*, relative temporal abundance and thermal characteristics.

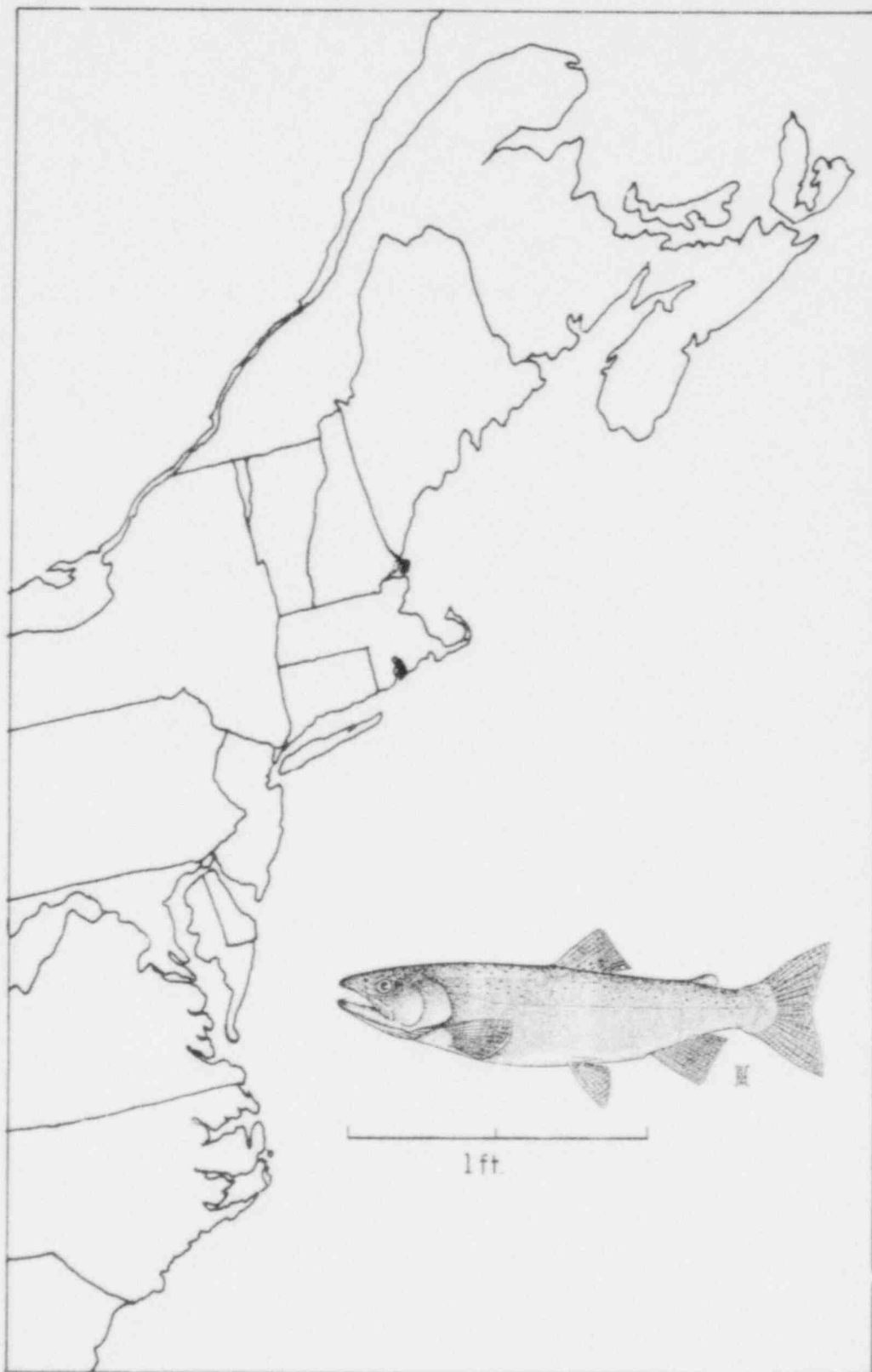
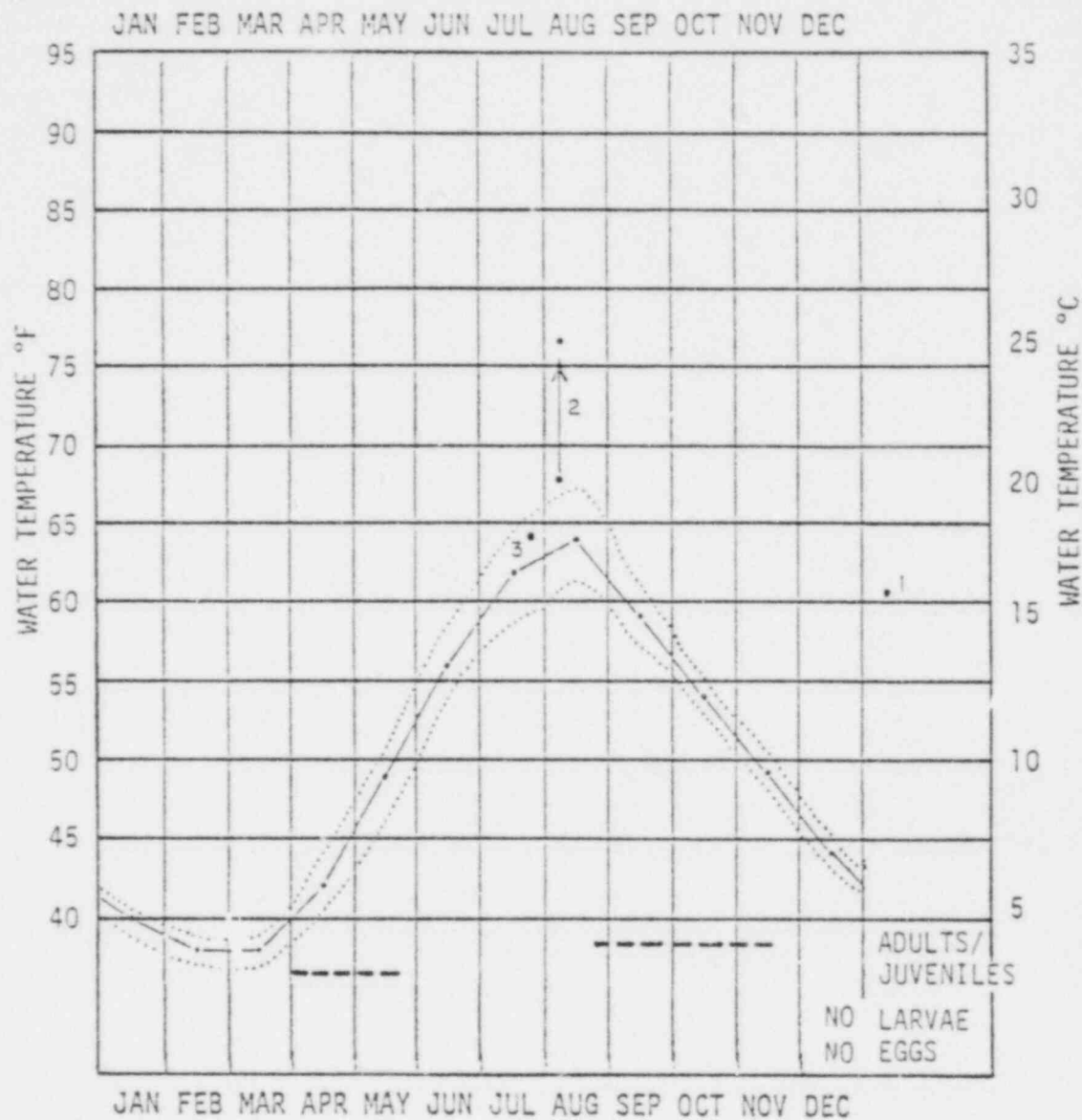

Figure 5.1-25. Distribution of Coho salmon, *Oncorhynchus kisutch* in the Western Atlantic Ocean.



1. Surface Temperature Above Which Returning Spawners are Blocked (Joyner, 1973)
2. Upper Lethal Temperature Tolerance Limit of Juveniles Acclimated to 68° (Brett, 1952)
3. Remain in Warmest Water Until Temperature is Exceeded (Engel & Magnusson, 1976)

Figure 5.1-26. Coho salmon, *Oncorhynchus kisutch*, relative temporal abundance and thermal characteristics.

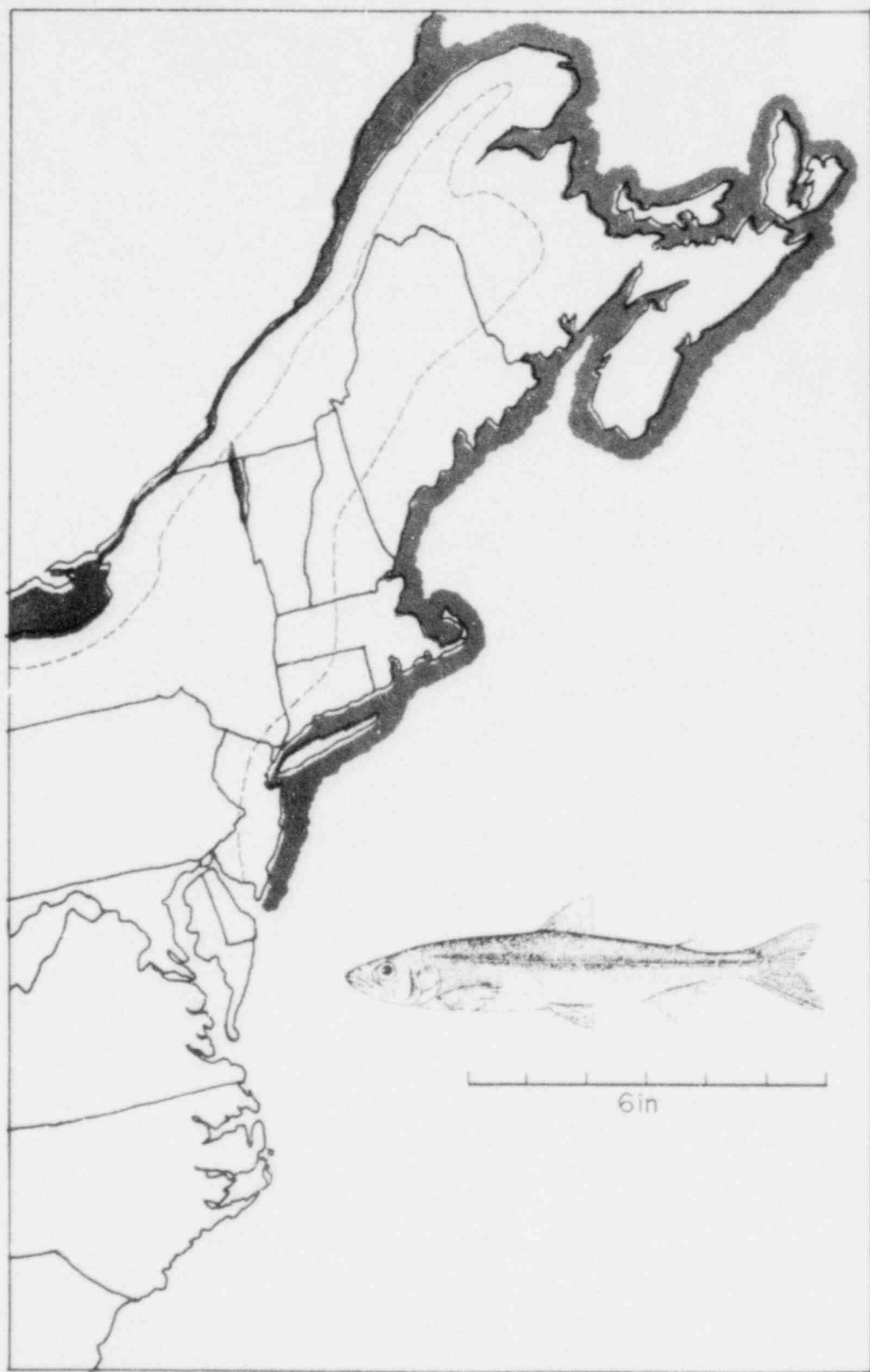

Figure 5.1-27. Distribution of Rainbow smelt, *Osmerus mordax* in the Western Atlantic Ocean.

TABLE 5.1-12. TEMPORAL DISTRIBUTION OF RAINBOW SMELT, *OSMERUS MORDAX* IN NEW HAMPSHIRE COASTAL WATERS.LARVAL DENSITY (#/m<sup>3</sup>)

	Jan	Feb	Mar	Apr	May	Jun	Jul	Aug	Sep	Oct	Nov	Dec
1976 Larvae	0	0	0	0	0.010	0	ND	ND	ND	ND	ND	ND
1975 Larvae	0	0	0	0	0.025	ND	0	0	0	0	0	0
1974 Larvae	0	0	0	0.04	ND	0	0	0	0	0	0	0
1973 Larvae	0	ND	ND	ND	0.06	0.02	0	P	0	0	0	0

ADULT DENSITY  
(#/10 MIN TOW)

1976	19.5	22.9	45.6	9.4	0	0.10	0	0	0	0	0	1.17
1975	29.1	5.6	22.0	8.8	0	ND	1.7	0	0	0	0.1	0
1974	5.0	3.2	6.4	11.4	0.9	0	0	0.5	2.8	0	14.6	38.5
1973	ND	ND	ND	ND	0.45	0.55	1.2	0.7	0.5	10.3	42.5	21.9

ND = no data

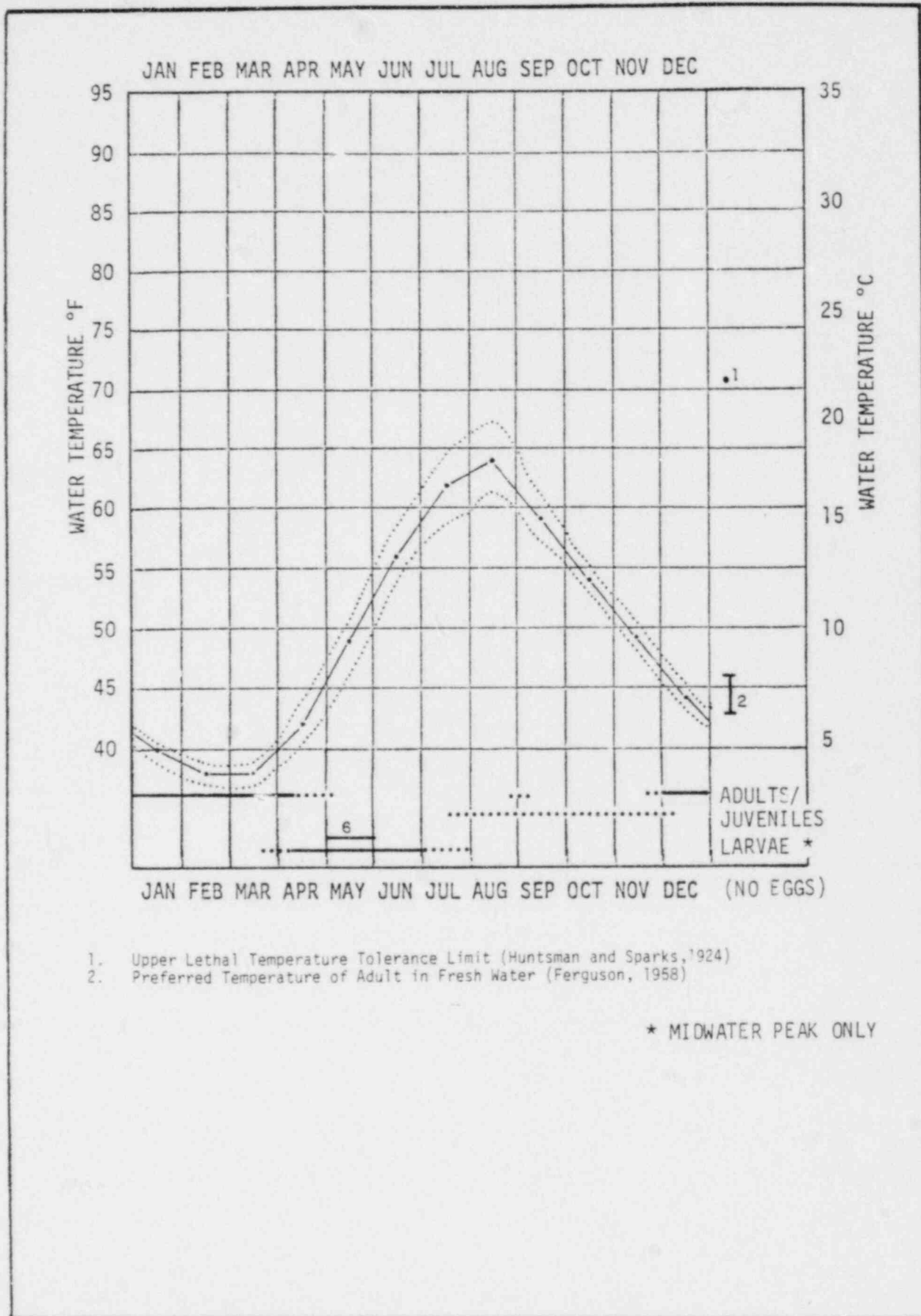

Figure 5.1-28. Rainbow smelt, *Osmerus mordax*, relative temporal abundance and thermal characteristics.

5.1.15 *Pollockius virens*

Tagging studies have shown that pollock (Figure 5.1-29) move over great distances (Leim and Scott, 1966). It is likely that the nearest center of spawning activity is immediately to the south and west, from the Isles of Shoals to Cape Ann (Steele, 1963). Pollock eggs are found in the area of the proposed intake and discharge site during the spawning period (November to January) but never in great abundance (Table 5.1-13). Perhaps this is because the general circulation in the Gulf of Maine is toward the south (see: Section 2.1.2).

Pollock captured in the vicinity of the intake and discharge sites are nearly all juveniles, seldom more than 16 inches in length. This suggests that immature fish may remain for sometime in inshore "nursery" areas, while mature fish presumably move quickly back to the open sea after spawning.

Pollock are cold water fish, although little knowledge of specific thermal requirements is available. What little is known is depicted in Figure 5.1-16.

5.1.16 *Pseudopleuronectes americanus*

Winter flounder inhabit soft muddy to moderately hard bottom in depths generally ranging from six to 120 feet, although some fish have been found as deep as 300 feet (Leim and Scott, 1966). Throughout most of the range (Figure 5.1-31) populations are relatively localized. In southern parts of its range this flounder is abundant near shore only when temperatures are generally below approximately 60°F (see Figure 5.1-32). Favorable inshore temperatures usually occur in the south only in the winter months; hence, the name, "winter" flounder.

Winter flounder spawn in shallow water in late winter to spring. Eggs are demersal and adhesive; thus, they are not encountered



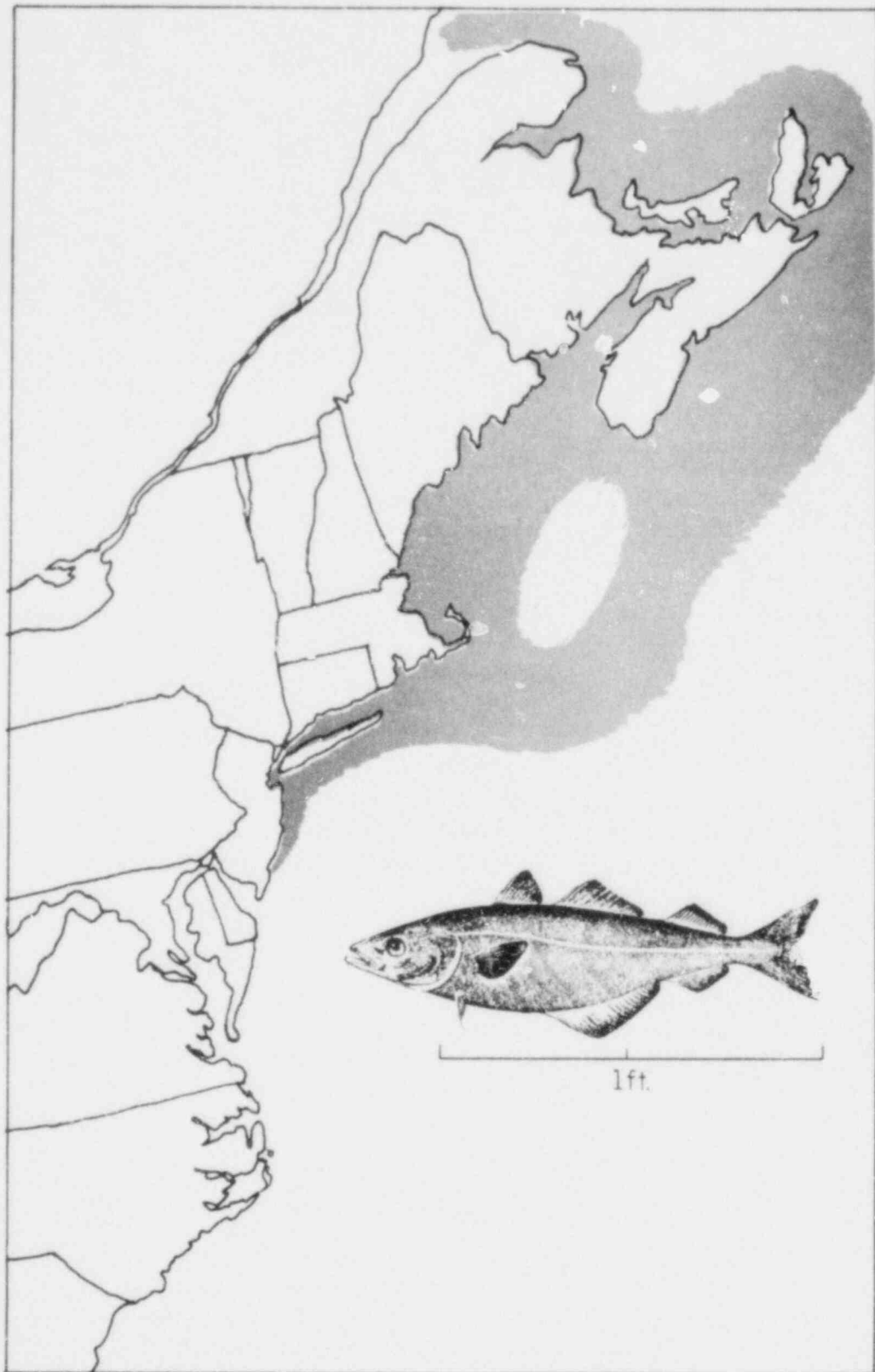

Figure 5.1-29. Distribution of Pollock, *Pollachius virens* in the Western Atlantic Ocean.

TABLE 5.1-13. TEMPORAL DISTRIBUTION OF POLLOCK, *POLLACHIUS VIRENS*,  
IN NEW HAMPSHIRE COASTAL WATERS.

EGG AND LARVAL DENSITY (#/m<sup>3</sup>)

	Jan	Feb	Mar	Apr	May	Jun	Jul	Aug	Sep	Oct	Nov	Dec
1976 eggs	ND	0.012	0.002	0.018	0.054	0.036						
larvae	ND	0.046	0.002	0	0.010	0.002						
1975 eggs	0.115	0.03	0	0	0	ND	0	0	0	0.012	0.084	0.045
larvae	0.05	0.295	0.024	0	0	ND	0.002	0	0	0	0.052	0.237
1974 eggs	0.78	0.005	0	0	ND	0	0	0	0	0	0.115	0.04
larvae	0.50	0.02	0.03	0	ND	0	0	0	0	0	0.09	0.425
1973 eggs	ND	ND	ND	ND	0	0	0	0	0.005	0.28	0.09	0.75
larvae	(1)	ND	ND	ND	0	0	0	0	0	0	0.01	0.05

ADULT DENSITY  
(#/1000 SQ. FT OF GILL NET/DAY)

1976	0	0	0.02	0.02	0.05	0.12	0.02	0.02	0.02	0.03	0.02	0
1975	0	0	0	0	0	ND	0	0	0	1.13	0.02	0
1974	0	0	0	0	ND	0.17	0.25	0.67	0	0	0	0
1973	ND	ND	ND	0	0	0	6.98	0.05	0.05	0	0.10	0
1972	ND	ND	ND	ND	ND	0.56	ND	0	0	0	ND	nd

ND = no data

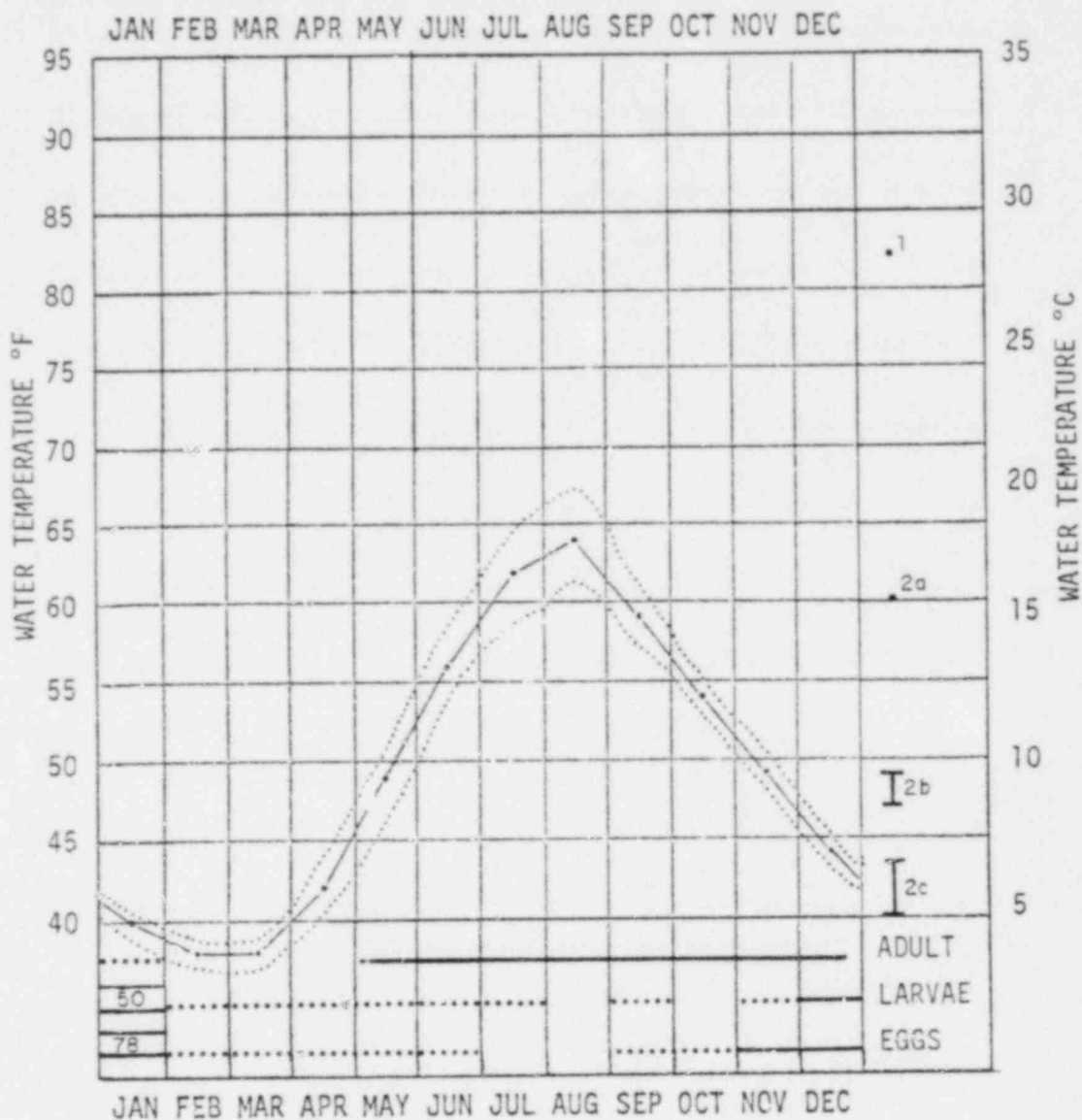

1. Survives for Short Periods (Britton, 1924)
- 2a. Usual Avoidance Temperature (Bigelow and Schroeder, 1953)
- b. Temperature Range Required to Induce Spawning
- c. Temperature for Optimum Egg Production

Figure 5.1-30. Pollock, *Pollachius virens*, relative temporal abundance and thermal characteristics.

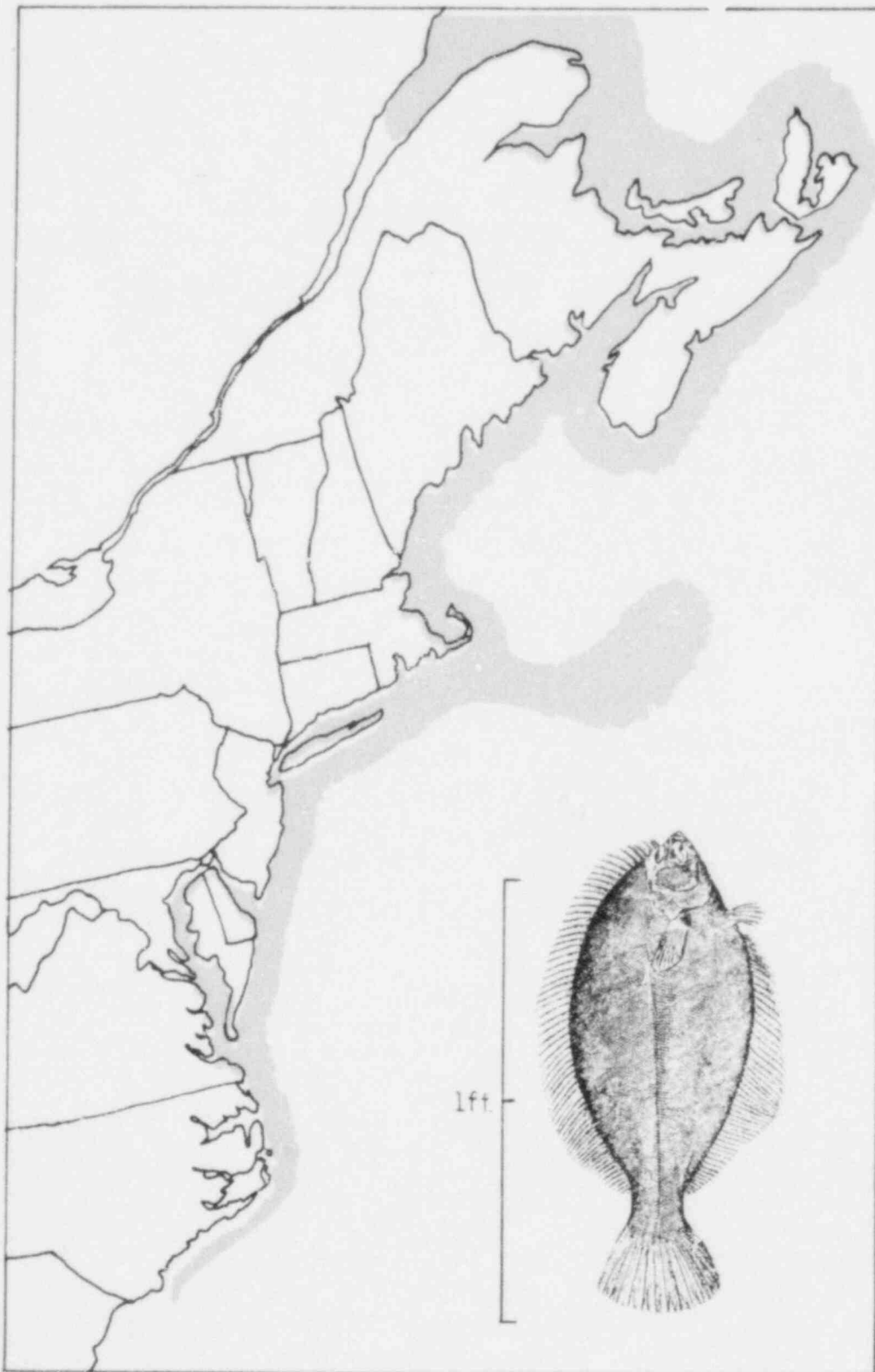
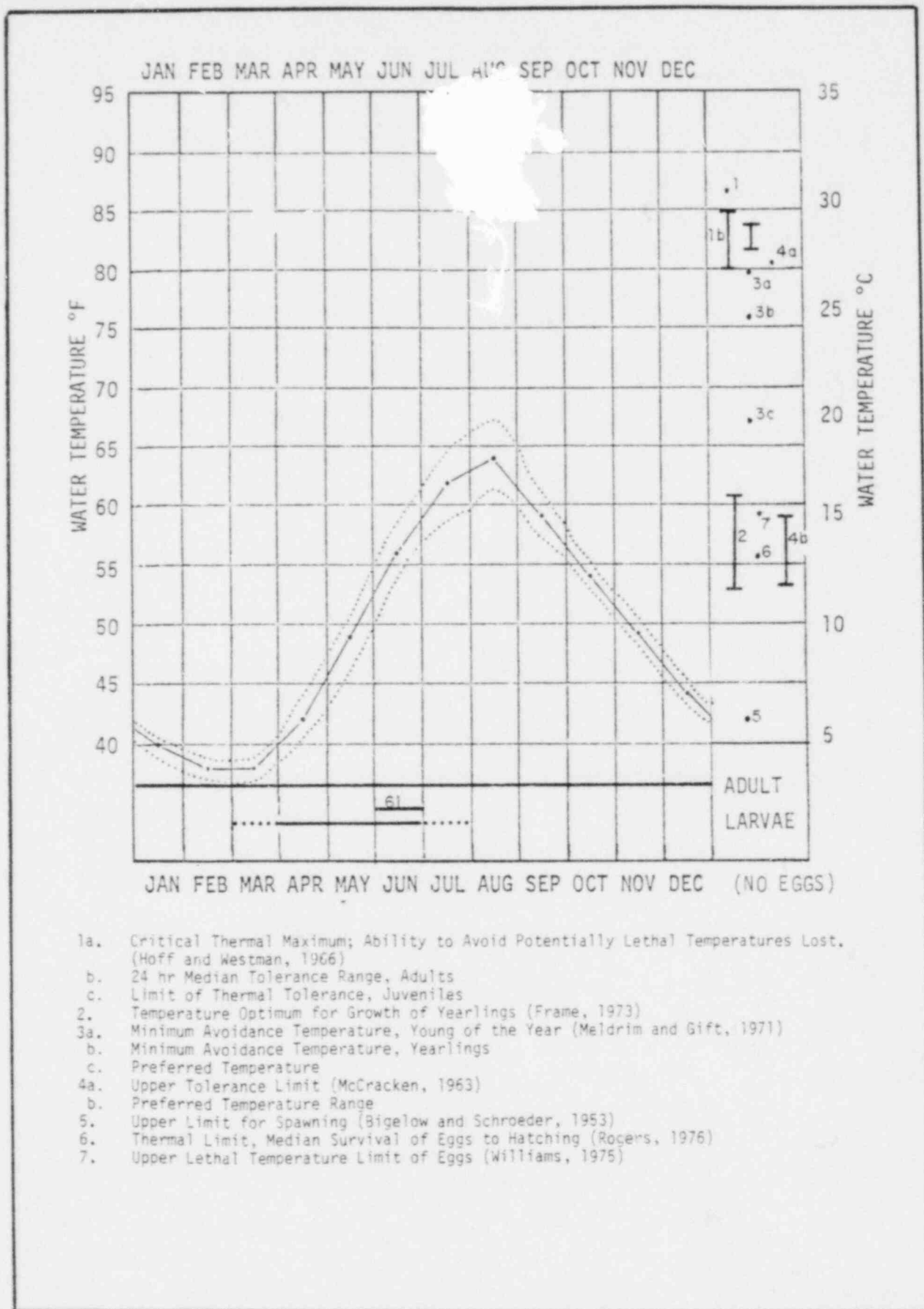

Figure 5.1-31. Distribution of Winter flounder, *Pseudopleuronectes americanus*, in the Western Atlantic Ocean.



- 1a. Critical Thermal Maximum; Ability to Avoid Potentially Lethal Temperatures Lost. (Hoff and Westman, 1966)
- b. 24 hr Median Tolerance Range, Adults
- c. Limit of Thermal Tolerance, Juveniles
2. Temperature Optimum for Growth of Yearlings (Frame, 1973)
- 3a. Minimum Avoidance Temperature, Young of the Year (Meldrim and Gift, 1971)
- b. Minimum Avoidance Temperature, Yearlings
- c. Preferred Temperature
- 4a. Upper Tolerance Limit (McCracken, 1963)
- b. Preferred Temperature Range
5. Upper Limit for Spawning (Bigelow and Schroeder, 1953)
6. Thermal Limit, Median Survival of Eggs to Hatching (Rogers, 1976)
7. Upper Lethal Temperature Limit of Eggs (Williams, 1975)

Figure 5.1-32. Winter flounder, *Pseudopleuronectes americanus*, relative temporal abundance and thermal characteristics.

in ichthyoplankton collections. Distribution of the larvae and adults in the vicinity of the proposed intake and discharge sites is shown in Table 5.1-14.

#### 5.1.17 *Scomber scombrus*

The Atlantic mackerel is a pelagic fish of the open sea, and one of the most active and migratory species (Figure 5.1-33). In winter, mackerel move into the moderately deep water of the outer continental shelf; in spring, there is a general inshore and northeastward migration (Leim and Scott, 1966). Spawning occurs in late spring to early summer, with the area from the Chesapeake Capes to Massachusetts Bay constituting the most important spawning area (Sette, 1943); other important spawning areas are well to the north of Nova Scotia (Sparks, 1929). In New Hampshire waters, both adults and early life stages (i.e. eggs and larvae) have been taken during the reported spawning period (Table 5.1-15). Somewhat smaller numbers of adults have also been collected at the time of fall withdrawal to winter quarters.

According to Bigelow and Schroeder (1953), mackerel "...shed their eggs wherever their wandering habits have chanced to lead them when the sexual products ripen." Also, "...mackerel vary so widely in abundance over periods of years that the precise localities of greatest egg production may be expected to vary from year to year depending on the local concentrations of fish". The wide year-to-year variations in egg abundance shown in Table 5.1-15 are consistent with these statements of Bigelow and Schroeder (1953).

The scarcity of eggs in August collections is consistent with data presented in Figure 5.1-34 which imply that late summer temperatures in nearshore New Hampshire waters are marginal for normal development. Furthermore, there is some indication from the spatial distribution of mackerel eggs and larvae (NAI, 1974d) that spawning is more intense further offshore (i.e. two to three miles from the proposed cooling water intake and discharge sites).

TABLE 5.1-14. TEMPORAL DISTRIBUTION OF WINTER FLOUNDER, *PSEUDO-  
PLEURONECTES AMERICANUS*, IN NEW HAMPSHIRE COASTAL  
WATERS.

LARVAL DENSITY (#/m<sup>3</sup>)

	Jan	Feb	Mar	Apr	May	Jun	Jul	Aug	Sept	Oct	Nov	Dec
1976 larvae	ND	0	0.005	0.088	0.130	0.009						
1975 larvae	0	0	0	0	0.012	ND	0.002	0	0	0	0	0
1974 larvae	0	0	0.02	0.02	ND	0	0	0	0	0	0	0
1973 larvae	0	ND	ND	ND	0.46	0.61	0.02	0	0	0	0	0

ADULT DENSITY  
(#/10 MIN TOW)

1976	0.50	1.33	1.18	0.67	1.67	4.20	2.00	4.50	6.42	3.25	2.92	2.92
1975	0	4.83	0	1.67	0	ND	1.91	0.58	2.75	1.58	1.50	0.67
1974	1.50	1.90	0.25	1.50	1.30	1.33	0.50	2.83	0	3.00	0.50	0.67
1973	ND	ND	ND	ND	0.40	2.30	4.05	2.80	4.25	3.30	0.95	0.50

ND = no data

TABLE 5.1-15. TEMPORAL DISTRIBUTION OF ATLANTIC MACKEREL, *SCOMBER SCOMBRUS*.EGG AND LARVAL DENSITY (#/m<sup>3</sup>)

		Jan	Feb	Mar	Apr	May	Jun	Jul	Aug	Sep	Oct	Nov	Dec
1976	Eggs	ND	0	0	0	0.016	0.784	ND	ND	ND	ND	ND	ND
	Larvae	ND	0	0	0	0	0.023	ND	ND	ND	ND	ND	ND
1975	Eggs	0	0	0	0	0	ND	0.007	0	0	0	0	0
	Larvae	0	0	0	0	0	ND	0	0	0	0	0	0
1973	Eggs	0	0	0	0	ND	37.55	0.41	0	0	0	0	0
	Larvae	0	0	0	0	ND	0.69	15.50	0	0	0	0	0

ADULT DENSITY  
(#/1000 SQ. FT GILL NET/DAY)

1976	0	0	0	0	0.02	0.79	0.60	3.59	3.75	0.38	0.25	0.49
1975	0	0	0	0	0	ND	1.39	0	0	0.37	0.49	0
1974	0	0	0	0	0	0	0.17	0.58	0	0	0.33	0
1973	ND	ND	ND	0	0.10	2.08	1.46	1.46	0.36	0.99	0.68	0.05
1972	ND	ND	ND	ND	ND	0.56	ND	0	1.04	0.42	ND	ND

ND = No Data





Figure 5.1-33. Distribution of Atlantic mackerel, *Scomber scombrus* in the Western Atlantic Ocean.

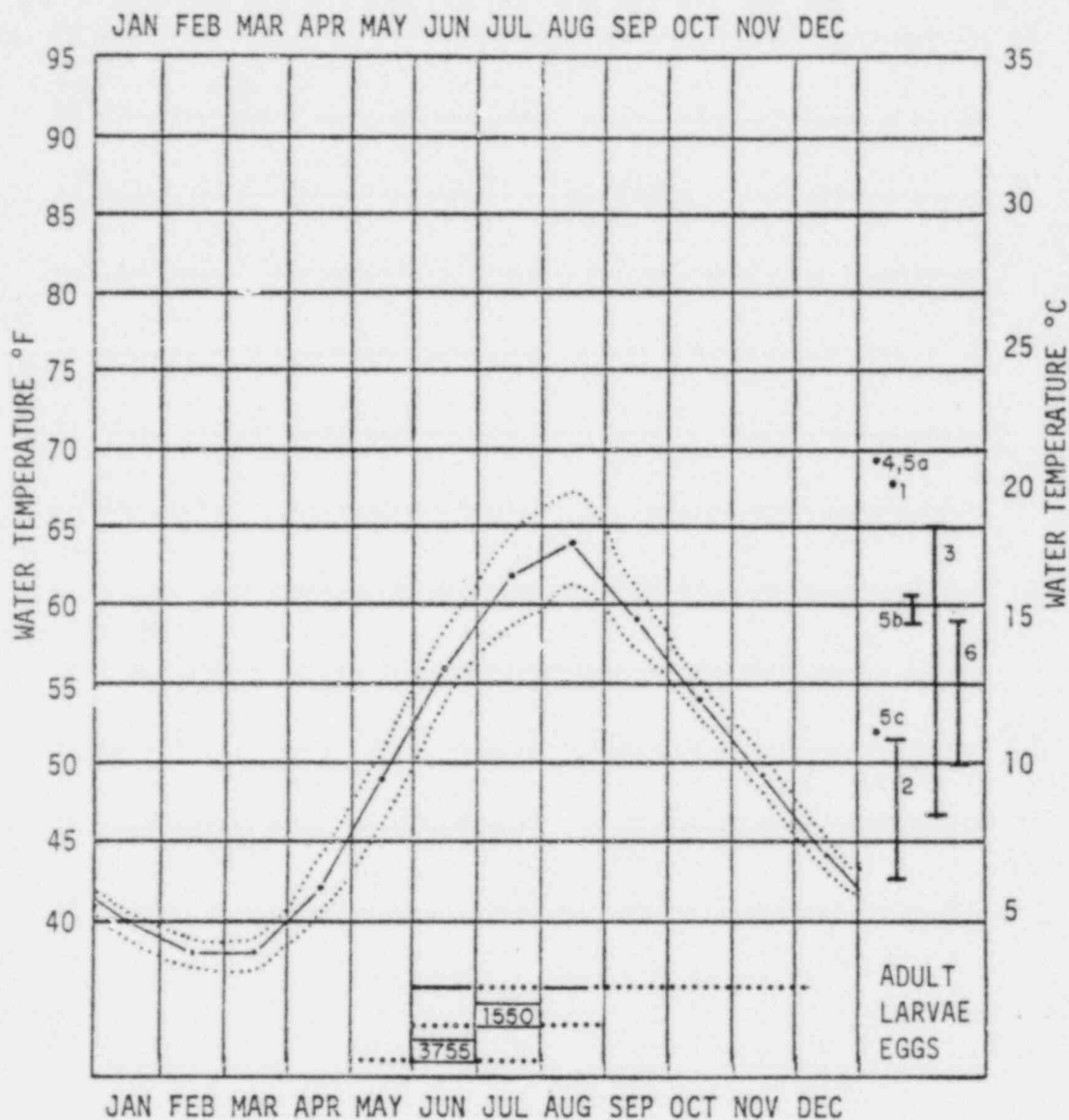

1. Highest Temperature Where Found (Bigelow and Schroeder, 1953)
2. Most Intensive Spawning Temperature Range (Sette, 1943)
3. Normal Development Temperature Range for Eggs (Bigelow and Schroeder, 1953)
4. Upper Tolerance Limit to Embryo (Altman and Dittmer, 1966; Cite Work Done by Moore (1940))
- 5a. Upper Lethal Temperature Tolerance Limit of Embryo (Worley, 1933)
- 5b. Optimum Temperature of Embryo
- 5c. Lower Lethal Temperature Tolerance Limit of Embryo
6. Spawning Temperature Range (Heia and Laevastu, 1962)

Figure 5.1-34. Atlantic mackerel, *Scomber scombrus*, relative temporal abundance and thermal characteristics.

## 5.2 CONSTRUCTION EFFECTS

Impact of intake and discharge construction on nearshore marine communities will be local and, generally, temporary although construction will result in the destruction of small areas of habitat at each location.

The intake site is located near the outer edge of a large soft-substrate area, and is composed of mixed sand and gravel (Figure 2.3-1). Dominant invertebrate species include the amphipod *Acanthohaustorius millis*, *Protohaustorius deichmannae*, and *Pontogeneia inermis* the bivalve *Tellina agilis*, the tubicolous polychaete *Myriochele heeri*, and the burrowing anemone *Edwardsia elegans* (NAI, 1975i). *Ensis directus* and juvenile *Arctica islandica*, both representative important species, occur in low numbers at the intake site; fairly dense patches are located closer to shore. Many species of bottom dwelling finfish also occur near the intake site, and one of these, the winter flounder, is a representative important species.

The discharge site is located in a hard substrate area that varies between large rocks and exposed ledge (see Figure 2.1-4). Dominant invertebrate species include polychaete worms in the genus *Spirorbis*, the amphipod *Pontogeneia inermis*, the barnacle *Balanus balanus*, the bivalves *Hiatella arctica* and *Modiolus modiolus*, the gastropod *Lacuna vineta*, the starfish *Asterias sp.*, and a representative important species, the lobster, *Homarus americanus*. Dominant macroalgae include *Phyllophora truncata*, *Ajarum cribrosum*, *Phycodrys rubens*, *Corallina officinalis*, and *Ptilota serrata* (NAI, 1975g, 1977a). The most abundant finfish in the discharge area is the cunner, but pelagic species such as pollock, mackerel and alewife, all representative important species, also utilize the region during certain times of the year (NAI, 1977a).

Impacts on these species during construction of either the intake or discharge will be temporary. During excavation of the approximately one-tenth acre area for the intake structure, most benthic

species will probably be destroyed. It is unlikely that *Arctica islandica*, *Ensis directus*, or any other infaunal species located in the immediate construction area will survive excavation, and construction of the intake area will also permanently destroy a small area of habitat for these species. Finfish species such as winter flounder, obviously, will be displaced and temporarily excluded from the immediate area of construction. Similar destruction of habitat will occur during construction of the discharge, and attached organisms in the approximately one-third acre area will be destroyed. Motile forms such as lobsters, crabs, and finfish will be displaced and temporarily excluded.

It is also conceivable that an increase in suspended materials derived from sediments disturbed during construction at either location may affect benthic communities beyond the immediate construction area. However, the nearshore zone is already subject to marked fluctuations (see Section 2.2.8) in turbidity due to storm activity and organisms living in the area are well adapted to such perturbations.

It is extremely important to realize that all species found in the construction areas are widely distributed throughout coastal waters in the Gulf of Maine and in most cases over a much wider area (NAI, 1975a, b; 1977). The total area disturbed by construction (less than one-half acre) is so small compared with general distributions of potentially affected species that the effects of this temporary disturbance for local marine populations will be negligible.

### 5.3 IMPACTS DUE TO PLANT OPERATION

#### 5.3.1 Plume Entrainment

Thermal plume entrainment, in contrast with plant passage (pumped entrainment) discussed below, is essentially a hydraulic phenomenon, involving the drawing of water from a receiving water body into a

discharging stream. Thus, the plume consists of a mixture of the original thermal effluent, plus the entrained receiving water. Organisms drawn into the effluent stream along with the receiving water experience relatively brief temperature surges before being cooled to near-ambient temperatures by the entrainment of more receiving water.

Discussion of the impact of plume exposure is organized, below, under three headings: 1) the possibility of indirect effects resulting from brief exposure, 2) sublethal symptoms of prolonged exposure, and 3) impact of passive plume entrainment at various stages in the life histories of selected aquatic species. The last section is treated in the greatest detail, and includes a quantitative assessment of impact on early life stages.

#### 5.3.1.1 Indirect Effects of Brief Exposure

Indirect effects are here defined as latent or time-delay effects which produce a response in some organ or life stage other than the one exposed or which are related to heat exposure by a chain or sequence, of intermediary processes. This topic does not include a discussion of symptoms in, or responses of, the exposed organisms or life stage, as these are discussed in the sections to follow. Such indirect effects as have been identified from the literature have been listed in Table 5.3-1:

TABLE 5.3-1. INDIRECT EFFECTS OF THERMAL PLUME ENTRAINMENT

1. Loss of egg buoyancy, leading to sinking;
2. Morphological abnormalities (deformities) in the larvae resulting from exposure of the egg;
3. Depletion of food resources caused by heat induced species composition shifts.

The list is very short because heat is not a substance (like a biocide, for example) which can accumulate and be passed up the food chain, but a property which is readily passed off to a cooler body (thermodynamics). Neither can one compare heat to extremely short-wave electromagnetic radiation (from ultraviolet light to gamma rays). For the most part, effects of heat are recognizable immediately; excess heat alters (ultimately inactivates) cell chemistry, but (unlike short-wave electromagnetic radiation) has never been known to produce a toxic reaction product.

Of the three items on the list of indirect effects, the first is mentioned (without documented evidence) by only one authority (deSylva, 1969) and relates to the fact that the heated plume is less dense than the underlying cooler water; hence, the loss of (positive) buoyancy in the eggs. The consequences of the sinking are presumed by deSylva (1969) to be: (1) encounter with bottom waters of poorer quality (oxygen depletion, toxic products of decomposition, etc.) and (2) attenuation of incident light below levels required for normal development. Neither consequence appears appropriate under the conditions which prevail off Hampton Beach. Furthermore, it is unlikely that the egg would sink very deeply before encountering ambient densities, whereupon the sinking rate would assume natural proportions. Attenuation of incident light (which is naturally subject to widely erratic fluctuations, in any case) would seem to be of marginal effect, especially considering the offsetting benefits in terms of reduced visibility to potential predators.

The second item on the list considers the effect of early heat exposure on subsequent (unexposed) developmental stages. Both deSylva (1969) and Kinne (1970) cite evidence for this, but only one primary source (Battle, 1929) appears to deal with sudden brief exposure of the type experienced during plume entrainment. While the hypothesis that this response can be generalized for all aquatic organisms seems tentatively acceptable, the point to be made from the experiments performed is that the temperature elevations required to produce this latent

effect closely approach those which produce direct responses in the organisms affected. Thus, a simple solution can be found in being slightly on the conservative side with regard to assigning heat tolerance limits, as will be discussed further in Section 5.3.1.3.

The final item on the list is also mentioned by several authors (deSylva, 1969; Kinne, 1970; Miller and Beck 1975) and pertains to presumed (heat induced) changes in local faunal assemblages, which result in replacement of native prey (food) organisms by less edible species with greater tolerance of cooling-water system impact. Imbedded in this hypothesis is a chain of assumptions each of which demand proof. Suffice it to say here, however, that, with regard to the Seabrook Station cooling system design, any argument advancing such an idea would be particularly weak because of the measures which have been taken, namely: location of the intake in offshore waters and employment of a multiport diffuser (see Section 3.1) to protect coastal faunal assemblages against any displacement on a broad scale. It should be emphasized, that in the literature search, it was found that the overwhelming majority of the investigations pertained to impacts associated with a closely confined system, such as a lake, estuary, river or embayment; few studies have dealt with such an unconfined system as is represented by the area proposed for discharging cooling water from Seabrook Station.

#### 5.3.1.2 Sublethal Effects of Prolonged Plume Exposure

Effects of prolonged exposure treated here emphasize those which develop as a result of strongly swimming organisms (finfish, shrimp, squid, etc.) deliberately choosing to remain in the thermal plume. The situation is analogous to a person working in the sun on a hot summer day. In fact, the first three effects listed in Table 5.3-2 are directly akin to symptoms of heat stroke and heat exhaustion that might strike the summer sun laborer, unless he seeks protection. Apparently both fish and men are about equally likely (or unlikely) to seek relief. At least one study (Spigarelli; 1975) showed that, although the

TABLE 5.3-2. SUBLETHAL EFFECTS OF DELIBERATE PROLONGED EXPOSURE TO THERMAL PLUME CONDITIONS. (FROM de SYLVA, 1964 and KINNE, 1970).

1. Increased metabolism (e.g., respiration, heart beat, enzymatic activity, feeding and other body functions)
2. Increased sensitivity to other physiological stress (synergisms)
3. Neurological responses (dulling of reaction to stimuli, disorientation, etc.)
4. Shortening of duration of early life stages (e.g. early metamorphosis)
5. Out-of-phase reproduction and development
6. Morphometric changes (e.g. smaller body size at comparable growth stage)
7. Decreased growth rate and body mass
8. Inactivation of thermally labile enzymes and processes dependent thereon (e.g. those which control melanism -- the lightening and darkening of body pigments)
9. Increased incidence of disease/parasitism



fish tended to concentrate in the thermal plume, individual stays were brief.

Again, it should be emphasized that information concerning deliberate selection of above ambient thermal conditions derives from closely confined areas where plumes are, more or less, in stationary equilibrium. That such behavior will be evident at all off Hampton Beach, with Seabrook Station in operation, is pure conjecture at this point. The potentially impacted area is subject to strong action of wind and waves, not to mention tidal rotation of the currents (see Section 3.3). It is expected that even the most persistent swimming organisms will have to periodically relocate themselves in the plume, thereby unavoidably encountering near ambient conditions for considerable amounts of time. Kinne (1970) and others (Miller and Beck 1975; Wolfson, 1974) have concluded that the intermittent nature of this heat exposure will considerably reduce the chance of developing symptoms and effects listed in Table 5.3-2.

#### 5.3.1.3 Demonstrations of Thermal Impact on Representative Species

Data presented in graphical displays (Section 5.1) were evaluated to determine an "impact threshold" temperature for larvae (and eggs, where appropriate) of the 9 animal species that have potentially entrainable planktonic stages. The "impact threshold" temperature was defined as the lowest temperature at which any detrimental effect (including sublethal effects) could conceivably occur given the brevity of exposure experienced during thermal plume entrainment. For a few of these species (notably the pollock, *Pollachius virens*) values were selected largely on the basis of intuitive reasoning (e.g., seasonal distribution of the larvae or eggs). On the other hand, for most species (particularly, menhaden and winter flounder), the nature of the available data made selection of threshold temperatures rather clear.

The month of maximum impact was simply the month in which peak larval (egg) abundance usually occurred (Section 5.1). The critical  $\Delta t$  ( $^{\circ}\text{F}$ ) was determined by subtracting from the "impact threshold temperature" the monthly mean of daily water temperature maxima (Table 5.3-3) for the month of maximum impact.

Computing the number of individuals "critically" exposed to the heat of the discharged water was accomplished using data on life stage numerical density (Section 5.1). Volume-rate of entrainment, to the point at which the plume will have cooled below the critical  $\Delta t$  ( $^{\circ}\text{F}$ ) was estimated using the following formula:

$$Q_e = \frac{Q_d \times (\Delta t_i - \Delta t_c)}{\Delta t_c}$$

where:

$Q_e$  = volume rate of entrainment ( $\text{m}^3$  per day) to the critical  $\Delta t$  ( $^{\circ}\text{F}$ ) isotherm

$Q_d$  = volume rate of discharge at the diffuser port (equal to intake hydraulic loading,  $4.66 \times 10^6 \text{ m}^3$  per day)

$\Delta t_i$  = initial  $\Delta t$  at the diffuser port ( $39^{\circ}\text{F}$ )

$\Delta t_c$  = critical  $\Delta t$ , from column 5, Table 5.3-3.

Entrainment volume rates ( $Q_e$ ) are given for each of the nine species in column 6, Table 5.3-3. Estimation of the number of organisms hypothetically entrained in the "critical" portion of the plume (columns 7 and 8, Table 5.3-3) was accomplished simply by multiplying organism numerical density (per  $\text{m}^3$ ) by  $Q_e$ .

The numbers indicated in Columns 7 and 8, Table 5.3-3 are extremely conservative and should not be construed to imply direct mortalities. At least two studies (Hubbs and Bryan, 1974; Schubel, 1974) made it clear that fish eggs are unlikely to be killed outright by exposure to heated discharges. Similarly, copepods and bivalve larvae acute mortalities have been shown to be insignificant (NAI, 1976 a), given the brevity of the exposure. Maximum exposure times (column 9, Table 5.3-3) were obtained from physical and analytical models of the

TABLE 5.3-3. QUANTITATIVE ASSESSMENT OF RELATIVE IMPACT DUE TO DISCHARGE PLUME ENTRAINMENT.

SPECIES	LIFE STAGE (1)	IMPACT THRESHOLD TEMPERATURE (°F) (2)	MONTH OF MAX. ABUNDANCE (3)	MONTHLY MEAN OF MAX. SURF. TEMPERATURE (4)	CRITICAL ΔT °F (5)	ENTRAINMENT VOLUME RATE (Q <sub>e</sub> ) (10 <sup>6</sup> m <sup>3</sup> /day) (6)	MAXIMUM NO. OF INDIVIDUAL EXPOSED TO CRITICAL PORTION OF THERMAL PLUME		MAXIMUM EXPOSURE TIME (SECONDS) (9)
							ACUTE (MILLIONS/DAY) (7)	ANNUAL (BILLIONS) (8)	
Copepod, <i>Eurytemora herdmani</i>	Adults	68	Jun	56	12	10.48	35,100	2166.	4.0
	Juveniles								
Mussel, <i>Mytilus edulis</i>	Larvae	69	Jun	56	13	9.32	37,280	3635.	3.4
Clam, <i>Mya arenaria</i>	Larvae	79	Aug	64	15	7.46	1,179	133	2.6
Lobster, <i>Homarus americanus</i>	Larvae	86	Aug	64	22	3.60	0.21	.009	1.5
Smelt, <i>Osmerus mordax</i>	Larvae	64	May	49	15	7.46	0.45	.018	2.6
Flounder, <i>Pseudopleuronectes americanus</i>	Larvae	78	Jun	56	22	3.60	2.2	.122	1.5
Menhaden, <i>Brevoortia tyrannus</i>	Eggs	75	Jun	56	19	4.91	9.33	.280	1.8
	Larvae	83	Jul	62	21	4.00	8.68	.284	1.6
Pollock, <i>Pollachius virens</i>	Eggs	59	Nov	49	10	13.51	10.5	.770 <sup>1</sup>	6.0
	Larvae	49	Jan	40	9	15.53	7.76	.412	8.0
Mackerel, <i>Scomber scombrus</i>	Eggs	65	Jun	56	9	15.53	583.	17.7 <sup>2</sup>	8.0
	Larvae	68	Jul	62	6	25.63	397.	12.4	30.0

<sup>1</sup> equivalent to the production of 3422 average females (Bigelow and Schroeder, 1953)

<sup>2</sup> applied only in years when local waters serve as important breeding grounds (see section 5.1); equivalent to the production of 39 thousand average females (Bigelow and Schroeder, 1953)

proposed Seabrook Station cooling water discharge system based on homogeneous conditions for a very low ambient current velocity; therefore the values represent conditions which tend to overestimate the limits of the thermal plume.

The influence of the thermal plume on intertidal organisms, particularly those attached to the Outer and Inner Sunk Rocks must also be considered as part of the plume entrainment issue. The sporeling stage of *Chondrus crispus* may be considered a thermally sensitive intertidal indicator. The critical  $\Delta t$  for *Chondrus* sporelings is evaluated to be +7°F (Section 5.1.4). Hydrothermal model tests, conducted by Alden Research Laboratories to predict thermal plume behavior, both under normal operating conditions and during backflushing, show the worst case to be encroachment of the +4°F isotherm upon these rocks. Therefore it is not anticipated that intertidal impact of the thermal plume will be detectable.

On the other hand, there is some indication (Section 5.1.9) that elevating the temperature of the water surrounding the sunk rocks by 2 or 3°F may be detrimental to the settlement of pediveliger larvae of *Mytilus edulis* for brief periods during summer. A few hydrological model scenarios show that optimum temperatures for settlement may be exceeded when ambient sea surface temperatures exceed approximately 67-69°F.

### 5.3.2 Entrapment

Nektonic organisms too large to pass through the condenser cooling system, such as squid and finfish, may be drawn into the intake structure and trapped or impinged upon the plant's traveling screens. Any living organism thus entrapped or impinged is susceptible to injury and, ultimately, death unless escape is possible. Since the Seabrook Station cooling water system configuration with widely separated intake and pump house locations generally precludes incorporation of an effective escape mechanism, the task of mitigating ad-

verse impingement and entrapment effects is best achieved by designing an intake structure with a low probability of entrapping nektonic animals.

The design of an intake structure that adequately safeguards the environment involves several steps. Guidance for such a procedure is available in the "Development Document for Proposed Best Technology Available for Minimizing Adverse Environmental Impact of Cooling Water Intake Structures" U.S.E.P.A., 1973). According to this document the "best technology available" for a cooling-water intake is one that minimizes the impacts of entrainment and entrapment.

The first step to reduce the potential magnitude of potential entrapment and impingement impacts is to gather sufficient information on the characteristics of the biological community to be protected. For Seabrook Station, studies of the temporal and spatial distribution and abundance of the nekton have been under way for over five years. Particular emphasis has been placed on identifying the location of fish spawning grounds, migratory pathways, nursery areas and other similarly critical areas. Natural water temperatures have been measured nearly continuously in these waters for over four years. Information has been gathered on fish swimming capabilities for many local species of importance. All of these study findings have been useful in locating and designing a cooling-water intake structure reflecting the best technology available for minimizing adverse effects. Based on this knowledge of the marine environment offshore from Hampton, the basic criteria set forth by the U.S. EPA for an acceptable intake location are met in that the area may be characterized as follows: (1) No rare or endangered species are found in the area; (2) the area does not serve as a principal migratory pathway for important commercial and game-fish species; (3) the area does not serve as a principal spawning or nursery area for any important commercial or game fish; and (4) the area is not biologically dissimilar from other New Hampshire coastal waters. Furthermore and very important, the intake structure will draw water essentially from just below the mid-level of the water column, the level of lowest fish abundance.

After fixing the location, the design was optimized. The proposed intake structure design incorporates a velocity cap to allow horizontal water entry. Experience with the velocity cap at other power plants has shown that entrapment is sharply reduced, as fish sense horizontal currents better than vertical currents and thereby are better able to avoid possible capture.

The velocity cap intake concept originated in California when in 1957 Southern California Edison Company sought means of minimizing fish entrapment at their then proposed Huntington Beach Steam Station. This station is located on the coast and draws its water from offshore, as will Seabrook. Offshore intakes in California, prior to this date, were of the simple standpipe type and had an essentially vertical intake flow. At times, existing stations such as the El Segundo and Redondo Beach plants were known to entrap relatively large quantities of fish. Studies were initiated in an effort to improve this situation. These studies were essentially of the laboratory type involving physical modeling of different intake structures and included testing with live fish, and are reported in detail by Weight (1958).

Weight's (1958) investigation disclosed that fish generally reacted poorly, or not at all, to vertical current vectors, but did perceive and orient to a horizontal current and, thus, were in a better position to avoid entrapment. From this finding developed the concept of a velocity cap which could be placed over the existing standpipe intakes, thereby converting the approach currents to horizontal. Since this was a laboratory study with scale models and small fish, the next step was to apply the velocity cap principle to full-scale testing.

Based on the laboratory results, a velocity cap was designed and installed at El Segundo Station. Comparison of fish entrapment figures before and after installation revealed that the velocity cap reduced the numbers of fish entrapped up to 90%. As a result of this proven effectiveness, similar caps were retrofitted at all Southern California Edison Stations with ocean intakes and were incorporated into

all new designs. The concept was also adopted by the Los Angeles Department of Water and Power for their Scattergood Station. As further testimony to the device's effectiveness, entrapment rates at Scattergood increased an order of magnitude when the cap was lost for a short time as a result of a storm.

Subsequently, additional scale model studies have been conducted in California, as reported by Downs and Meddock (1973) and Schuler and Larson (1975). These authors concluded: (1) Velocity-capped offshore intake structures offer significantly more protection to fishes than do uncapped structures. This is simply a confirmation of Weight's (1958) results; (2) When approach velocity is reduced for a given velocity cap the numbers of fish entrapped decreases. With a control velocity cap intake at 2.5 ft/sec, the percent reduction from control for various test caps of lower velocity ranged for one test fish species (anchovy, *Engraulis mordax*) from 70% at 2.0 ft/sec to 6% at 0.5 ft/sec. Two other test species (white croaker, *Genyonemus lineatus*; and walleye surfperch, *Hyperprosopon argenteum*) showed comparable values -- 67% at 2.0 ft/sec and 24% at 1.0 ft/sec; (3) Existing caps were found to have a non-uniform approach velocity from top to bottom of the annular opening, with much higher current speeds at the lower lip. Consequently, it was near this lower edge where most fish were drawn in. To correct this, caps were modified to extend both caps and lower lips horizontally from the standpipe (the so-called "T" structure). This modified design was tested against earlier caps and was shown to take 30% to 40% less fish. Further experimentation with this improved structure showed a definite velocity effect. The mean percent of fish entrapped, relative to a 2.5 ft/sec control, ranged from 12% at 1.5 ft/sec to 57% at 2.0 ft/sec; (4) drawing from the "T" structure concept, a circular modified structure, with an extended horizontal riser (see Figure 3.3-1) was designed and tested against both the "T" structure and the conventional cap currently in use. The circular modified cap was as effective as the "T" structure while offering certain engineering advantages. In comparison with the conventional cap, the circular modified structure took 30% to 40% fewer fish; (5) for both engineering and fish protection reasons, the circular modified structure with an approach velocity of 1.5 ft/sec was considered.

The design of the Seabrook intake structure incorporates all of the entrapment-mitigating features illuminated by the California laboratory and operating plant experiences. The intake will incorporate a circular velocity cap located approximately just below mid-depth. This depth was selected because studies to date (NAI, 1975h) have shown it to be the area of the water column least-frequented by fishes; it will be above the area utilized by demersal forms and below that generally used by the surface-oriented, pelagic migratory forms. Threshold velocities at the outer margin of the cap orifices will be uniformly about one ft/sec. As the following table (5.3-4) illustrates, this is well below both the burst and sustainable swim speeds typical of local finfishes:

TABLE 5.3-4. NORMAL AND BURST SWIMMING VELOCITIES OF SELECTED FINFISH SPECIES.

<u>SPECIES</u>	<u>SUSTAINED VELOCITY</u>	<u>BURST VELOCITY</u>	<u>SOURCE(S)</u>
<i>Clupea harengus</i>	2-4 ft/sec		(Blaxter & Dickson, 1959; Brawn, 1960; Boyar, 1961)
<i>Morone saxatilis</i>	2 ft/sec		(Kerr, 1953; Tatham, 1970; Bibko et al., 1972)
<i>Pollachius virens</i>	2 ft/sec	6 ft/sec	(Blaxter & Dickson, 1959)
<i>Brevoortia tyrannus</i>	2 ft/sec	4 ft/sec	(field observations Millstone Station)
<i>Scomber scombrus</i>	6 ft/sec	10 ft/sec	(Blaxter & Dickson, 1959)
<i>Gadus morhua</i>	2.5 ft/sec	7 ft/sec	(Blaxter & Dickson, 1959; Beamish, 1966)
<i>Pseudopleuronectes americanus</i>	2 ft/sec	4 ft/sec	(Beamish, 1966)

Most fishes should therefore have no trouble detecting, orienting to, and escaping the low-velocity horizontal currents which will typify the Seabrook intake structure.



In addition to incorporating the design features found to be effective through West Coast powerplant intake experiences, an additional measure has been included in the Seabrook design to further reduce entrapment potential. Based on knowledge of the resident ichthyofauna, it appeared that the cunner (*Tautoglabrus adspersus*), could be relatively susceptible to entrapment because of its feeding habit; cunner browse hard-substrate attached forms (e.g., barnacles and blue mussels). To eliminate the potential attractiveness of an invertebrate covered structure to cunner, the exterior surfaces of the intake structures will be covered with an antifouling material (see Section 3.5.4).

As a final consideration, various regulatory agencies have adopted a position favoring the Seabrook-type velocity cap intake structure for coastal cooling systems. The U.S. Atomic Energy Commission funded a review of powerplant intake structure designs and their environmental acceptability. This study was conducted by the Hanford Engineering Development Laboratory, a subsidiary of Westinghouse Electric Corporation, and resulted in a report entitled, "A Review of Thermal Power Plant Intake Structure Designs and Related Environmental Considerations" (Sonnichen, et al., 1973). One of the conclusions reached was that for offshore intakes, "use velocity caps, or accept lower intake velocities". This is an especially significant conclusion in that the velocity caps reviewed had approach velocities greater than 2.5 ft/sec. It implies that velocity caps are unlike conventional shoreline intakes or standpipes, and that they can successfully operate with approach velocities greater than those typically recommended for intakes without caps. Similarly, the U.S. Environmental Protection Agency (USEPA, 1973) concluded that:

"...The 'velocity cap' intake can be recommended to be considered for all offshore vertical intakes since it would add relatively little to the cost of the intake, and has been shown to be generally effective in reducing fish intake to these systems..."

These regulatory agency findings substantiate previously established conclusions that the Seabrook Station intake structure design represents an environmentally acceptable device which will minimize the adverse effects of impingement and entrapment on the indigenous nekton.

### 5.3.3 Passage Through the Cooling-Water System; Pumped Entrainment

Mortalities attributable to mechanical and hydraulic stress on organisms pumped through electric generating station cooling-water systems have been documented (McLean, 1973; Bunting, 1974; Davies and Jensen, 1974). Combined with the heat stress (up to +39 F  $\Delta t$ ) it is reasonable to assume that few, if any, RIS individuals would survive passage. Thus, assessment of losses due to pumped passage need only account for expected population densities ( $m^3$ ) and the hydraulic loading (approximately  $4.66 \times 10^6 m^3/day^1$ ), ignoring the distinctions in RIS thermal tolerances. Results of his approach are shown in Table 5.3-5.

### 5.3.4 Backflushing

Estimations of impact on nine representative, important animal species, having planktonic stages, which have the potential for being exposed to the backflushing plume, are presented in Table 5.3-6. The format is identical to that discussed above (Section 5.3.1.3). Critical entrainment volumes given in Table 5.3-6 were obtained from physical and analytical models of the proposed Seabrook Station cooling-water system as it is expected to operate during backflushing (Figure 5.3-1). The volumes listed in Table 5.3-6 were calculated with the assumption that the backflush cycle will discharge 120 F water for 6 hours when in reality 120 F water will be discharged for 2 hours to accomplish biofouling control (see Section 3.5.2). Although this assumption simplifies the calculations, it does result in an overestimation of volume entrained at 120 F and therefore of thermal impact of the backflush plume. In other words, it is a "worst case" estimate.

TABLE 5.3-5. QUANTITATIVE ASSESSMENT OF RELATIVE IMPACT DUE TO PASSAGE THROUGH THE COOLING - WATER SYSTEM.

	MAXIMUM NO. OF INDIVIDUALS PASSING THROUGH PLANT	
	ACUTE (MILLIONS/DAY)	ANNUAL (BILLIONS)
Copepod, <i>Eurytemora herdmani</i> adults and juveniles	15,611	963
Mussel, <i>Mytilus edulis</i> larvae	18,640	1817
Clam, <i>Mya arenaria</i> larvae	736	83
Lobster, <i>Homarus americanus</i> larvae	0.28	.012
Smelt, <i>Osmerus mordax</i> larvae	0.28	.011
Flounder, <i>Pseudopleuronectes americanus</i> larvae	2.8	.158
Menhaden, <i>Brevoortia tyrannus</i> (Eggs)	8.9	.266
(Larvae)	10.1	.331
Pollock, <i>Pollachius virens</i> (Eggs)	3.6	.266
(Larvae)	2.3	.124
Mackerel, <i>Scomber scombrus</i> (Eggs)	175.0	5.31
(Larvae)	72.2	2.26

TABLE 5.3-6. IMPACT OF SUBLETHAL EXPOSURE TO CRITICAL PORTION OF THE THERMAL PLUME DURING ONE COMPLETE BACKFLUSHING OPERATION, SEABROOK STATION.

Species	Stage	Critical Entrainment Vol. ( $\times 10^6$ m <sup>3</sup> )	Max. observed Orgsm. Density (No./m <sup>3</sup> )	Maximum No. Individuals Exposed	Overall Impact
Copepod <i>Eurytemora herdmani</i>	Adults and juveniles	5.22	3350	17.5 billion	negligible, RP
Mussel <i>Mytilus edulis</i>	Larvae	4.75	4000	19.0 billion	negligible, RP
Clam <i>Mya arenaria</i>	Larvae	4.05	2500	10.1 billion	negligible, RP, H
Lobster <i>Homarus americanus</i>	Larvae	2.65	0.06	159 thousand	negligible, NB, H
Smelt <i>Osmerus mordax</i>	Larvae	4.05	0.06	243 thousand	negligible, NB, S
Flounder <i>Pseudopleuronectes americanus</i>	Larvae	2.65	0.61	1.62 million	negligible, S, H
Menhaden <i>Brevoortia tyrannus</i>	Eggs Larvae	3.08 2.75	1.90 2.17	5.85 million 5.97 million	negligible, NB, S negligible, NB, S
Pollock <i>Pollachius virens</i>	Eggs Larvae	6.44 7.25	0.78 0.50	5.02 million 3.62 million	negligible, S, H negligible, S, H
Mackerel <i>Scomber scombrus</i>	Eggs Larvae	7.25 11.34	37.6 15.5	273 million 176 million	negligible, S, H negligible, S, H

RP = high population potential; H = potential losses insignificant compared to direct fishing pressures; NB = local area not important as a breeding ground; S = potential loss insignificant compared to natural mortality (i.e. starvation, predation and disease)

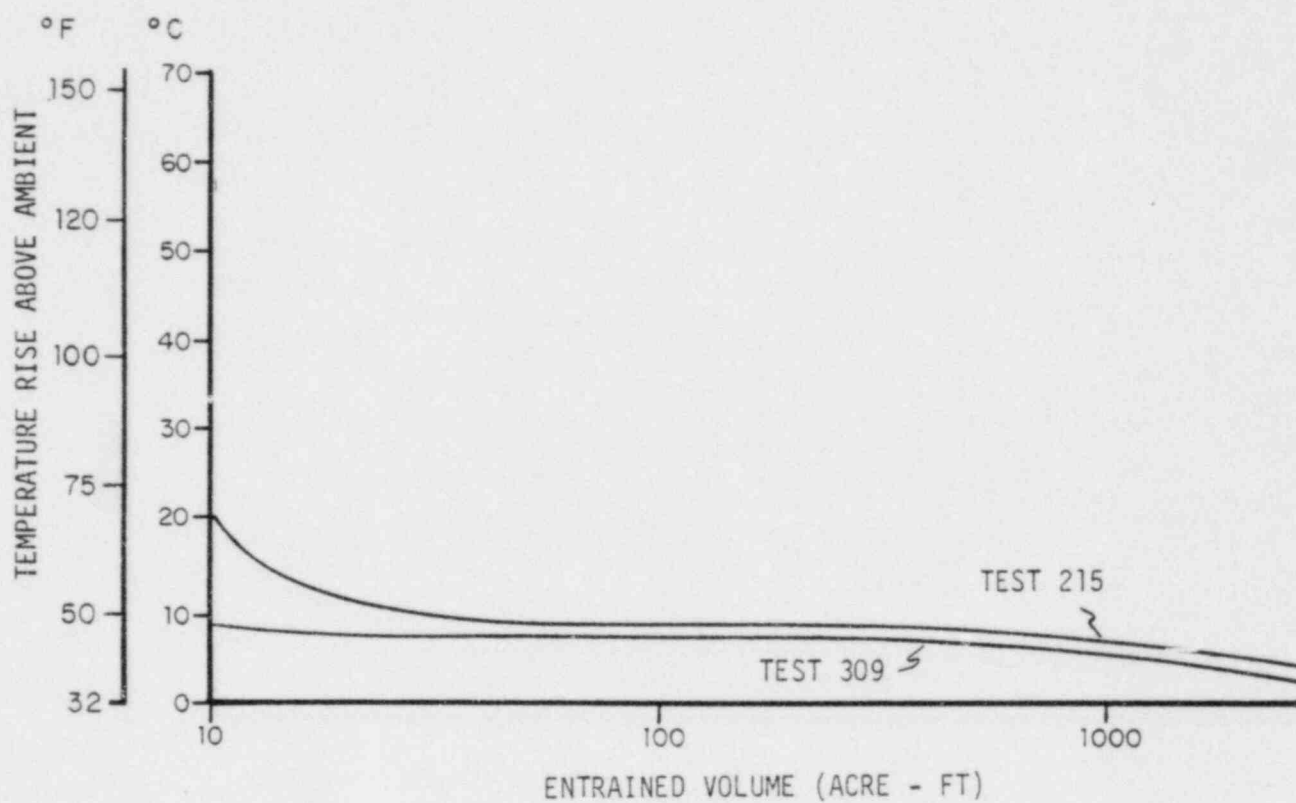

Figure 5.3-1. Seabrook Station backflush plume entrained volume. (worst case)  
Test 215 at 100% power level.  
Test 309 at 63% power level.

Estimation of the number of organisms theoretically entrained in the "critical" portion of the plume (Table 5.3-6) was accomplished by multiplying the organism's maximum density (per  $m^3$ ) by critical entrainment volume, as in Section 5.3.1.3. These numbers are extremely conservative, given the brevity of exposure (e.g., 41 seconds to  $\Delta t \geq +10$  F), and should not be construed to imply direct mortalities. As previously stated in Section 5.3.1.3 Hubbs and Bryan (1974), and Schubel (1974) have shown that fish eggs, in particular, are unlikely to be killed outright by exposure to typical heated discharges. Similarly, acute mortalities of copepods and bivalve mollusc larvae exposed to discharge plumelike conditions have been shown not to differ significantly from controls (NAI, 1976a). (In this thermal bioassay, planktonic organisms were exposed to a temperature that decreased from a  $\Delta t$  of 5 F in approximately 30 seconds. The animals were subsequently held at  $\Delta t$  of 5 F for approximately 1 hour).

Table 5.3-6 shows maximum potential exposures for one complete backflushing operation. Given the proposed schedule of two backflushings per month during the principal fouling season (approximately April through October), and no more than one backflushing per month during the colder months, it is unlikely that backflushing will have an impact on the life cycle of any one species more than 2 to 3 times annually due to the relatively short planktonic period of meroplanktonic species. Certainly, there would be only a single yearly episode of the magnitude presented in Table 5.3-6; in most instances, the chance that the impact would be as great as suggested in Table 5.3-6, in any given year, is less than likely. In the case of the mackerel, for example, egg and larval densities have been an order of magnitude or more below the densities given in Table 5.3-6, in five years out of the six studied.

Considering such variables as 1) the size and area occupied by the reproducing stock; 2) natural causes of mortality, such as starvation, predation, and disease; and 3) fishing pressures to which several of the species are subjected, periodic backflushing on the indicated schedule will have only negligible impact on plankton. Natural mortalities of between 5% and 11% of the total New Hampshire coastal population per day have been

estimated for the copepod, *Eurytemora herdmani* (NAI, 1974e) and for the larvae of finfish closely related to some of the representative important species considered here: Gadoid fish (Jones and Hall, 1973) and plaice (Cushing and Harris, 1973). These natural mortalities occur not just in the vicinity of the backflushing plume but over vast areas of the ocean. In the case of the pollock, for example, backflushing plume exposure would be equivalent to the natural daily death rate in 1/10 square mile of ocean, according to population simulation model results (Jones and Hall, 1973).

#### 5.4 TOTAL IMPACT

A summary of the foregoing discussions is presented in Table 5.4-1. Such numerical assessments as are presented here are meant to provide some measure of the relative sensitivity of the RIS to thermal effects, they are not intended as predictions. Due to the use of conservative assumptions throughout this exercise, these numbers undoubtedly overestimate the true impact.

Consideration of entrapment impact applies only to larger bodied RIS, the American lobster and the seven representative finfish species. Since the intake structure will stand 8 to 10 feet above the sea floor, entrapment of lobsters and other demersal forms, e.g., flounder is not an important consideration. Expected finfish entrapment impacts have been discussed in Section 5.3.2. Although there is no feasible means of putting entrapment impact into quantitative terms until Seabrook Station is in operation, it has been pointed out (Section 5.3.2) that the intake structure will incorporate certain design features expected to be very effective in minimizing entrapment potential.

In the case of plant passage (pumped entrainment) projected numerical impact is expected to be largely lethal. However, in the case of thermal plume exposure, negative impacts, if they occur, are expected to be largely sublethal and/or indirect (for example, temporarily dimin-

TABLE 5.4-1. STRESSES ON REPRESENTATIVE IMPORTANT SPECIES BY SEABROOK STATION COOLING-WATER SYSTEM (NUMERICAL VALUES APPLY TO YEARS OF MAXIMUM LOCAL ABUNDANCE).

Species	Plant Operation			Cooling Water System Construction ref. Section 5.2	Overall Response Expected
	Entrapment (large-bodied forms) ref. Section 5.3.2	Plant Passage (small-bodied forms) ref. Section 5.3.3	Thermal Plume Impacts* (normal oper.) ref. Section 5.3.1		
1 Diatom, <i>Skeletonema costatum</i>	not applicable	impact not negative; high natural division rate; possible growth stim.	impact not neg.; potential local stim. growth	not applicable	None
2 Red tide alga <i>Gonyaulax tamarensis</i>	not applicable	impact not negative; potential for pos. response due to local upwelling	impact not neg.; potential local stim. growth	not applicable	not possible to assess stimulatory effects
3 Irish moss <i>Chondrus crispus</i>	not applicable	no appreciable impact; passage of spores only (N)	no neg. impact; possible stim. unreasonable growth	not applicable	None
4 Copepod <i>Eurytemora borchmani</i>	not applicable	Adults & juveniles; 96.3 billion annually (N) short generation times	Adults & juveniles; 2.2 trillion ann (N, S) short generation times	not applicable	None
5 Ocean quahog <i>Arctica islandica</i>	not applicable	roughly 1/5 magnitude as for soft-shelled clam	roughly 1/5 magnitude as for soft-shelled clam	0.1 acre potential habitat removed (L, R)	high repopulation potential (N)
6 Razor clam <i>Ensis directus</i>	not applicable	roughly the same magnitude as for soft-shelled clam	roughly the same magnitude as for soft-shelled clam	0.1 acre potential habitat removed (L, R)	extremely high repopulation potential (N)
7 Soft-shelled clam <i>Mya arenaria</i>	not applicable	83 billion larvae annually (N)	133 billion larvae annually (N, S)	not applicable	extremely high repopulation potential (N) 1
8 Mussel <i>Mytilus edulis</i>	not applicable	1.8 trillion larvae annually (N)	3.6 trillion larvae ann. (N, S) aquat settlement interrupted 69*	not applicable	extremely high repopulation potential (N)
9 Lobster <i>Homarus americanus</i>	extremely unlikely due to height of intake structure	12 million larvae annually (N)	9 million larvae ann. (N, S)	neg. impact transient when compl. may impr. habitat	(N)-rel. little local breed. loss sec. 5.3.1, 10
10 Alouate <i>Alosa pseudoharengus</i>	potential problem with juveniles minimized by vel. cap (N)	not applicable; anadromous	adults & juveniles only (N, S)	transitory, nuisance only	(N) <sup>2</sup> - none for early life stages
11 Menhaden <i>Brevoortia tyrannus</i>	minor potential problem with juveniles minimized by velocity cap (N)	larvae: 331 million annually (N) eggs: 266 million annually	larvae: 290 million ann. (N, S) eggs: 206 million ann.	transitory, nuisance only	(N) <sup>2</sup>
12 Coho salmon <i>Oncorhynchus kisutch</i>	minor potential problem with juveniles minimized by velocity cap (N)	not applicable; anadromous	juveniles only (N, S)	transitory, nuisance only	None <sup>2</sup> , (N) for juveniles
13 Smelt <i>Osmerus mordax</i>	potential problem minimized by velocity cap (N)	larvae: 11 million annually (N) eggs: none anadromous	larvae: 10 million annually (N, S) eggs: none anadromous	transitory, nuisance only	(N) <sup>2</sup>
14 Pollack <i>Pollachius virens</i>	potential problem minimized by velocity cap (N)	larvae: 124 million annually (N) eggs: 266 million annually	larvae: 412 million annually eggs: 770 million annually	transitory, nuisance only	(N) <sup>2</sup>
15 Winter flounder <i>Pseudopleuronectes americanus</i>	very minor potential problem minimized by height of intake structure (N)	larvae: 158 million annually (N) eggs: none (demersal)	larvae: 122 million annually (N, S) eggs: none (demersal)	comp. displacement over 5-10 acres (L, R)	(N) <sup>2</sup>
16 Rockerel <i>Scorpaenopsis</i>	very minor potential problem minimized by velocity cap (N)	larvae: 2.3 billion annually (N) eggs: 5.3 billion annually	larvae: 12 billion ann. (N, S) eggs: 10 billion ann.	transitory, nuisance only	(N) <sup>2</sup> , 3

\* This does not include quantitative estimates of exposure to the backflushing plume since this was calculated on a "per exposure" basis and varies with species. Consideration of backflush plume impact is not expected to significantly alter overall response expected, (see Table 5.3-6 and discussion).

(N) = negligible impact on population at large  
 (S) = exposure to sublethal effects only  
 (L) = localized impact or displacement

1 Estimates based on 1976 data. Low equivalent to less than 580 bushels; approximately 1% of estimated 1976 harvest.

2 see text (section 5.4) for explanation

3 numbers shown here represent very high local egg production, which occurs only when fertile adults are in transit during early summer.



ished ability to feed or escape predation). Even so, exposure to critical plume temperatures will be so brief (less than 10 seconds except in the case of mackerel larvae; see Table 5.3.3), that it is extremely likely that the numbers grossly exaggerate incipient mortality due to encounter with either the normal discharge or backflushing plume.

Comments in the extreme right hand column of Table 5.4-1, entitled: "Overall response expected", are based on speculations concerning those life phases or processes which would most likely represent the RIS response. In the case of the phytoplankter, *Skeletonema costatum*, inactivation of algal cells passing through the plant may be offset by a stimulatory effect, and possibly a competitive advantage conveyed during winter, from the dissipated heat of the thermal plume. Therefore the "overall" response is assessed as neutral. A similar argument applies to the red tide alga, *Gonyaulax tamarensis*, except that the effect of local upwelling on this species is as yet unclear. Only spores of Irish moss, *Chondrus crispus*, will pass through the cooling system. Where the dissipated heat from the thermal plume comes in contact with the attached plants, some unseasonable growth may be supported. Again, as in the case of *Skeletonema*, any potential detrimental or beneficial effects are expected to be effectively neutralized by other extrinsic factors (such as available light) which strongly control the growth and survival of plant species.

Among the animal species the situation is even more complex. Heat from the dissipated plume, however, is not expected to convey any advantage to the species listed in Table 5.4-1. Holoplanktonic species, represented by the copepod, *Eurytemora herdmani*, will be entrained at all life stages. The potential effects of power plant operation on such holoplankters should be mitigated by their enormous recovery rate, which is due primarily to a short breeding time and a widely dispersed breeding stock.

Bivalve molluscs, represented in Table 5.4-1 by four species, are potentially vulnerable primarily at the pelagic larval stage. Although

literally billions of larvae will be consumed, it is necessary to understand that because of evolved compensatory mechanisms for natural mortality due to starvation and predation, etc., only a tiny fraction of this projected loss of planktonic larvae will be realized in adult populations.

Because of the extent and intensity of the population studies which have taken place, and because this species is as vulnerable to adverse impact as any found locally, the soft-shelled clam, *Mya arenaria*, has been selected as an example of the "worst case" of total impact to meroplanktonic species. In the following discussion, an attempt is made to translate into the equivalent number of harvestable clams the number of planktonic larvae exposed to: 1) passage through the plant cooling system (pumped entrainment), 2) temperatures in the discharge plume greater than the critical  $\Delta t$  (15 F) and 3) temperatures in the backflushing plume greater than the critical  $\Delta t$ . This approach conservatively assumes that all clam larvae exposed to a critical  $\Delta t$  will be killed which, as discussed above is unlikely to be the case for any species.

Using data obtained during six years of surveys (NAI, 1977c), spat survival ratios (Table 5.4-2) were estimated by approximating the areas under size-frequency modes assumed to represent certain year-classes. Modes assigned to particular year-classes in succeeding survey years were compared. Percentage of area remaining from the previous year's modal area was taken to be an estimate of per annum survivorship. Values presented in Table 5.4-2 represent a composite of individual year-class survivorship from the umboned larval stage to young-of-the-year spat involved, relating the seasonal total larval population existing off the coast of northern Massachusetts, New Hampshire and southern Maine (estimated to be 1 to 2 trillion in 1975; NAI, 1977c) to the total standing crop of newly settled spat within the same region (estimated as 2 to 4 billion in early 1976; NAI, 1977c).

TABLE 5.4-2. ESTIMATED AGE RELATED SURVIVORSHIP OF SOFT-SHELL CLAMS, *MYA ARENARIA* (NAI, 1977b).

<u>AGE SPAN</u>	<u>SURVIVAL RATIO</u>
Umboned larva to young-of-the-year	0.002 = $S_1$
Young-of-the-year to yearling	0.022 = $S_2$
Yearling to 2 yr old	0.265 = $S_3$
2 yr old to 3 yr old	0.275 = $S_4$
3 yr old to 4 yr old	0.200 = $S_5$
4 yr old to 5 yr old	0.152 = $S_6$

To compute adult equivalency of larval loss, the estimated number of larvae entrained ( $N_L$ ) was multiplied by cumulative survivorship (i.e., the product of survival ratios for each life stage,  $S_1$ ,  $S_2$ ,  $S_3$ , etc.); the result is the number of adult clams ( $N_A$ ) that represent the presumed total entrainment loss, assuming no density dependent limiting factors operating on the adult clam population.

In calculating the number of larvae that would pass through the cooling system (pumped entrainment), 1976 data have been used throughout. The 1976 data indicate that the mean number of larvae passing the proposed intake site, from 28 June to 19 October, was  $158/m^3/day$ . Given that the hydraulic consumption of the plant, at maximum capacity, is approximately  $54 m^3/sec$  or  $4.66 \times 10^6 m^3/day$ , the daily passage of *M. arenaria* larvae would be  $736 \times 10^6$ . Over the entire 113 day period of study (extending beyond the season of sustained abundance), this amounts to approximately 83 billion umboned larvae conservatively assumed to be fatalities had Seabrook Station been operating at full capacity throughout the summer of 1976.

Similarly, it may be shown that, at a discharge plume entrainment volume rate of  $7.46 \times 10^6 m^3/day$  (Table 5.3-3), the daily entrainment of *M. arenaria* larvae would be  $1179 \times 10^6$ ; thus 133 billion larvae would have come in contact with "critical" discharge plume temperatures during the 1976 season.

If it is assumed that the backflushing operation occurs three times during the soft-shell clam's peak density of  $2500/m^3$ , then it follows from Table 5.3-6 that approximately  $30 \times 10^9$  larvae will be briefly exposed to a critical  $\Delta t$  or higher each year.

In computing the equivalent impact of pumped encrainment of larval clams in terms of yearling clams (shell length approximately 20 to 37 mm), the following survival ratios must be included: 1) umboned stage (point at which  $N_L$  is established) to young of the year ( $S_1$ ) and 2) young of the year to yearling ( $S_2$ ). Thus, the equation:

$$N_A = S_1 S_2 N_L$$

is solved as:

$$N_A = 0.002 \times 0.022 \times 83 \times 10^9 = 3,652,000$$

According to tables provided in Belding (1931) it would take approximately 250 clams averaging 32 mm in shell length to fill a quart measure. Thus, the potential resource loss would be equivalent to 14,600 quarts (456 bushels) of yearling clams.

Similar calculations were performed for two year old clams. In this case, survival from the end of the first year to the end of the second year of settlement must be factored into cumulative survivorship. Thus:

$$\begin{aligned} N_A &= S_1 S_2 S_3 N_L \\ &= 0.002 \times 0.022 \times 0.265 \times 83 \times 10^9 = 967,780 \end{aligned}$$

It would take approximately 92 clams of this age (average shell length: 44 mm) to fill a quart measure (Belding, 1931); thus, the potential resource loss would be equivalent to approximately 10,520 quarts (329 bushels) of clams.

Table 5.4-3 summarizes the results of equivalency computations for age groups up to 5 years. Assuming that this potential loss averaged across each of the five age groups, fairly represents the potential loss to New England clam diggers, then the loss of 196 bushels per year due to pumped entrainment, 314 bushels per year due to plume entrainment, and 70 bushels per year due to backflushing, for a total of 580 bushels, is offered as a conservative assessment.

It has been estimated (NAI, 1977c) that there are approximately 2500 acres of clam flats, in southern Maine, New Hampshire and northern Massachusetts within the potential influence of Seabrook Station. Hampton-Seabrook estuary is estimated to have approximately 175 acres of clam flats. If these flats are assumed to be equally affected, then approximately 7% of this loss (totalling approximately 40 bushels) can be assessed against Hampton-Seabrook estuary.

It becomes readily apparent that, based on these conservative calculations, potential soft-shell clam resource losses due to operation of Seabrook Station can hardly be expected to be notable. In 1975-1976, clam diggers apparently removed approximately 3600 bushels from Hampton-Seabrook flats, despite the drastically reduced stock (NAI, 1977c). The annual loss to the Hampton-Seabrook flats attributed to operating Seabrook Station, by the above calculations, amounts to only 1% of this harvest rate.

Lobsters, *Homarus americanus*, are heavily overfished inshore throughout northern New England so that the principal impairment of stock replacement is the taking of adult animals which would otherwise breed and propagate young. The relatively few larvae which do enter New Hampshire waters are sparsely and unevenly distributed so that even the large quantities of sea water to be used by Seabrook Station for cooling will entrain relatively few of them.

TABLE 5.4-3. ESTIMATES OF POTENTIAL LOSS BY AGE GROUP.

AGE (YRS)	SHELL LENGTH (MM)	TOTAL NUMBER (N <sub>A</sub> )	DRY MEASURE QUARTS	EQUIVALENT BUSHEL
a. Plant Passage (Pumped Entrainment)				
1	20-37	3,652,000	14,600	456
2	37-52	967,780	10,520	329
3	46-60	266,140	4,670	146
4	53-64	53,230	1,280	40
5	59-67	8,090	253	8
				Average 196
b. Discharge Plume Entrainment (Normal Operation) *				
1	20-32	5,843,200	23,260	730
2	37-52	1,548,000	16,800	526
3	46-60	425,800	7,470	234
4	53-64	85,170	2,050	64
5	59-67	12,900	405	13
				Average 314
c. Backflushing *				
1	20-37	1,320,000	5,280	165
2	37-52	348,000	3,783	118
3	46-60	93,000	1,632	51
4	53-64	18,000	433	14
5	59-67	2,700	84	3
				Average 70
				Overall Total 580 †

\* Estimates are doubly conservative, given that the brevity of discharge and backflush plume exposures above critical temperatures will be unlikely to result in 100% mortality.

† As discussed in the text (Section 5.4), approximately 7% of this loss or 40 bushels is assessed against Hampton-Seabrook estuary which represents approximately 1% of the 1976 annual harvest rate.

Of the seven finfish species included among the representative important species, three of them (alewife, salmon and smelt) are anadromous, meaning that the reproductive products and the very young fry will essentially be absent from the vicinity of the offshore cooling water system. In addition the winter flounder has demersal eggs, which preclude their being entrained by a near midwater level intake system. Important breeding areas of the menhaden, which is only a warm water visitor to the area, are well to the south of Cape Cod. Mackerel breed while in migratory transit, and thus only infrequently utilize New Hampshire waters as a breeding ground.

Perhaps a "worst case" of impact from the cooling water system on a finfish species would involve pollock which are reported to have an important spawning area nearby (Section 5.1.15). If the highly conservative numerical values given in Table 5.4-1 are taken to be additive it cannot be conceived that total larval losses could possibly exceed 536 million in a single year. As previously cited (Section 5.3.4), Jones and Hall (1973) have developed a simulation model for the growth and death of haddock larvae (a species taxonomically related to pollock) which indicates a death rate of 10% per day. A similar modeling effort by Cushing and Harris (1973) showed a mortality rate of 5% per day (80% per month) at larval densities between 1 and 5 per  $m^3$ . These natural losses, which are projected to occur primarily due to starvation, would amount to 50 million larvae lost per square mile per day using the Jones and Hall (1973) approach, or approximately one larvae for every 8  $m^3$  of seawater using the Cushing and Harris (1973) method. Considering the amount of seawater in the immediate vicinity of Seabrook Station (New Hampshire territorial waters, to 3-mile limit, enclose approximately 54 square miles of ocean) it appears that natural causes may bring about the destruction of more finfish larvae in one day than Seabrook Station would destroy in one year.

It seems reasonable to conclude that, in evaluating the total effect of all hazards to marine life, construction and operation of Seabrook Station can be expected to play a relatively minor role. The

prospect of negative impact by this powerplant on indigenous plant and animal communities is greatly diminished given the perspective of natural causes of mortality. The major challenges to population survival, namely: widespread dispersal of early life stages beyond areas presently suited to adult development, starvation, predation and disease have been met and overcome long ago in the evolutionary history of the marine organisms now inhabiting the area in question.

In addition to the inherent capability of these populations to compensate for stresses, the design of the cooling water system has incorporated several features which should further mitigate the impact on indigenous populations resulting from operation of the Seakrook Station. These features include:

1. Minimization of cooling water volume in order to limit the number of planktonic organisms subjected to pumped entrainment;
2. Use of a diffuser on the discharge to expedite the cooling of the heated discharge water and limit the areal extent of water with temperatures greater than a  $\Delta t$  of 5 F;
3. Location of the discharge structure over a mile offshore in water greater than 50 feet deep in order to assure greater cooling of heated discharge water before it reaches the surface and to minimize the potential of the heated plume impinging upon intertidal area on shore;
4. Location of the intake structure over a mile offshore, 10-17 feet off the bottom in water greater than 50 feet deep to minimize entrapment of demersal species and surface-oriented migratory fish as well as buoyant fish eggs, in addition to permitting zones-of-passage for migratory fish both inshore and offshore of the intake location;



5. Use of a circular velocity cap and low intake approach velocities (1 foot per sec) to minimize fish entrapment;
6. Use of anti-biofouling material on intake structures to minimize entrapment of "grazing" fish species.

## 6.0 GLOSSARY OF PERTINENT BIOLOGICAL AND HYDROGRAPHIC TERMS

acclimation	habituation or adjustment to altered environmental factors (e.g., temperature)
algae	several groups of simple aquatic plants, attached to surfaces (e.g., seaweeds) or floating freely in the water column (phytoplankton)
anadromous	ascending rivers from the sea, at certain seasons, in order to breed in fresh water
aquaculture	the farming of fish, shellfish, algae and other aquatic organisms
aquatic	growing or living in, or frequenting, water
Arthropoda	a phylum consisting of animals with articulated bodies and limbs. The more important classes of this phylum are the insects, arachnids (spiders) and crustaceans
assimilation	the uptake of food or other materials for incorporation as new biomass
association	(ecologically) a subunit of community organization identified by its major organisms
assemblage	(ecologically) a group of organisms occurring together with no implied interdependence
benthic	pertaining to the subaquatic bottom
benthos	aquatic organisms living on or in the bottom strata or substrata (sediments) of a water body <ol style="list-style-type: none"> <li>1. epibenthos (epifauna): pertaining to organisms crawling over the bottom (starfish, crabs, etc.)</li> <li>2. infauna: pertaining to organisms burrowed within the bottom substrate (clams, worms, etc.)</li> <li>3. meiofauna: tiny benthos which pass through a 1 mm screen but are retained on a 0.062 mm screen (e.g., harpacticoid copepods, nematodes)</li> </ol>

4. macrobenthos (macroinvertebrates): larger bodied forms, including all benthic organisms of direct economic value to man
- bioassay a test, conducted in the laboratory or natural environment (*in situ*), in which organisms are used to detect or measure the presence or effect of one or more substances or conditions, i.e., toxic chemicals or conditions
- biota the living part of a system (flora and fauna)
- biotic community plant and animal populations occupying a given area, with a demonstrated interdependence (e.g., predators and prey together)
- Brachiopoda a group of animals having bivalve shells within which is a pair of microscopic, tentacle-bearing "arms" used in feeding
- Chaetognatha a group of small, free-swimming marine worms having movable, curved jaws (chaetae) on either side of the mouth
- Chordata a phylum of animals which have, at some stage of development, a "notochord" (longitudinal elastic supporting rod), a dorsally situated central nervous system, and gill clefts. All vertebrates, and some marine invertebrates (such as the acorn worms, tunicates, etc.) are members of this phylum
- Coriolis effect an apparent force which accounts for the effect of the earth's spin on particles moving over the face of the earth; in the Northern Hemisphere the apparent deflection is to the right
- crustacean (class:Crustacea) includes the crabs, crayfish, lobsters and shrimps; characterized by a hard outer shell (carapace) over the head and mid-body (thorax)
- demersal living near the sea floor
- densimetric Froude Model a laboratory based model in which one or more nondimensional numbers represent physical factors such as pressure gradients, gravity and/or friction, movement of fluid systems. The adjective "densimetric" refers to a concern with the fluid's density. William Froude was a pioneer in fluid mechanics

deposit (detrital) feeding	a feeding process whereby food organisms and organic debris are gleaned from settled matter resting on, or in, the bottom sediments
detritus	any fine particulate debris, usually of organic origin
diatoms	single celled microscopic plants forming a major component of plankton; with cell walls of silica
Dinoflagellate	unicellular organisms, roughly ovoid but asymmetrical, some possessing covering plates of cellulose (thus the term "armored") and typically possessing a flagella; may or may not be photosynthetic
downwelling	a downward movement of surface water generally caused by converging currents or as a result of a water mass becoming more dense than the surrounding water
ebb current	the tidal withdrawal of water from an estuary or away from shore
Echinodermata	a marine animal phylum consisting of the starfishes, sea urchins and their allies
ecosystem	all the organisms in a community plus the associated environmental or abiotic (i.e., physicochemical) factors
embolus (plural:emboli)	any foreign or abnormal particle circulating in the blood, as a bubble of air, a blood clot, etc.
endemic	native to a specific geographic area
entrainment (plume or momentum)	the hydraulic incorporation and passage of ambient waters and organisms into and through a discharge plume
entrainment (pumped)	the uptake of planktonic organisms in the water by an intake structure and their passage through the entire circuit of the circulating water system
entrapment	the uptake of macroscopic organisms, mainly finfish, which will not pass completely through the circulating water cooling system but be impinged on the screening or filtering devices prior to entering the plant

estuary	a semi-enclosed, tidal body of saline or brackish water with free connection to the sea; often the lower reaches of a river which flows into the ocean
euphotic zone	the layer of water which receives sufficient sunlight to sustain surplus photosynthetic production above respiration needs
exotics	nonendemic species; not native but introduced
fauna	animal life (entire group of animals of an area)
filter (suspension) feeding	a feeding process employed by many aquatic organisms whereby small food organisms are gleaned from the water column in which they are suspended
flood current	the tidal current associated with increase in tidal height with the direction of movement toward shore or upstream into an estuary
flora	plant life (entire group of plants of an area)
food chain	the transfer of energy from one organism to the next (e.g., plants → grazing animals → carnivore → top carnivore)
food cycle	production, consumption and decomposition of food and the energy relationships involved
food web	a group of interrelated food chains
fouling organism	an organism that attaches to the surface of a continuously or periodically submerged object
Froude Scale Model	see densimetric Froude Model
genus (plural:genera)	a group of species so closely related as to share the first part of a scientific name
gyre	a circular or spiral form, usually applied to closed or semi-enclosed current systems
halocline	a sharp or marked vertical salinity gradient (follows same definition as thermocline)
high-water	the upper limit of the surface water level reached by the rising tide; also called high tide
indicator species	an organism of a particular species which constitutes an important link in the biotic community such that it represents the fate of the community with respect to impact of changed environmental conditions

indigenous	native
intertidal	shoreline zone between extremes of high and low tides
isohaline	pertaining to or indicating equality of salinity at a given time or place
isothermal	pertaining to or indicating equality of temperature at a given time or place
knot	a unit of speed equal to 1 n mi/hr or approximately 51 cm/sec
larva	independent, active, immature stage of an animal which is quite unlike the adult in appearance
light compensation level	depth at which production by photosynthesis just balances respiration (O <sub>2</sub> /CO <sub>2</sub> ); delineates the lower limit of the euphotic zone
littoral	shallow shore region, extending to the limit of occupancy by attached (benthic) plants (e.g., seaweeds); also intertidal zone (see also light compensation level and euphotic zone)
longshore drift	a flow of water roughly parallel to the shore and constituting a relatively uniform drift in the water just seaward of the surf zone
low pressure system	a storm system with counterclockwise atmospheric circulation characterized by a low or relatively low barometric pressure
low water	the lowest limit of the surface-water level reached by the ebbing tide; also called low tide
lunar month	the average time between successive new, or full, moons; equal to 29 days 12 hours 44 minutes.
mariculture	(see aquaculture); the cultivation of marine (sea) life
mean low water	mean value of the lowest level reached by both daily ebbing tides; for western North Atlantic locations it is "zero" depth
meiofauna	see: benthos
metabolism	process by which an organism builds and breaks down (cytoplasmic) compounds within itself; the sum of chemical changes by which energy is provided for vital processes, and for the formation and destruction of living tissue

mollusc	(phylum:Mollusca) includes clams and oysters (bivalves), octopi, squids and snails; having a soft segmented body and a hard, calcareous shell, which is external except in squids, octopi, cuttlefishes, etc.
motile	capable of movement, not fixed or sessile
nanoplankton	almost submicroscopic plankton (5 to 60 micrometers in size), not ordinarily collected by typical plankton nets
neap tide	lowest range of tidal excursion, occurring near the times of the first and last quarter of the moon
nekton	free swimming aquatic organisms, including finfish, squid and the larger shrimps
neritic	shallow water marine environment; the open waters near a coastline over the continental shelf
neuston	organisms's living in a thin surface film layer of a water body
niche	a concept which combines an organism's habitat and functional role in the community
northeaster	a storm characterized by strong, moisture laden, winds from the northeast quadrant
organism	any living individual, plant or animal
pelagic	pertaining to the open ocean, where organisms spend most of their time floating or swimming freely; not in contact with the bottom regardless of whether the water is shallow or deep
periphyton (aufwuchs)	any organism attached or clinging to plant surfaces under water; more specifically, attached submacroscopic and microscopic algae, insect larvae, etc.
photosynthesis	the formation of carbohydrates from carbon dioxide and water in the presence of chlorophyll using sunlight as an energy source
phototropism	a stimulus reaction or orientation response to light
Phoronidea	a marine animal phylum consisting of a few species only; they are rather small, worm-like and sedentary except for the free swimming larva

plankter	planktonic organism
plankton	macroscopic and microscopic organisms passively drifting or weakly swimming in natural waters
	<ol style="list-style-type: none"> <li>1. phytoplankton: plant plankton (i.e., diatoms, etc.)</li> <li>2. zooplankton: animal plankton (i.e., copepods, etc.)</li> <li>3. meroplankton: temporary plankton, mainly eggs and larvae; seasonal occurrence</li> <li>4. holoplankton: organisms with complete life cycle in the plankton</li> <li>5. ichthyoplankton: finfish eggs and larvae</li> <li>6. tychoplankton: bottom dwelling, organisms briefly carried up or occasionally actively swimming into the pelagic zone (e.g., mysid shrimp)</li> </ol>
plankton bloom	a sudden rapid increase to an enormous number of individual phytoplankters under certain conditions
Pogonophora	a marine animal phylum consisting of a few species of worm-like tube dwelling organisms
primary productivity	rate at which energy is incorporated into organic carbon compounds by photosynthesizing organisms (chiefly green plants)
productivity	rate at which energy is incorporated as fixed carbon into living tissue by organisms at any trophic level
red tide	discoloration of surface waters, most frequently in coastal zones, caused by large concentrations of microorganisms, particularly dinoflagellates in the plankton; may be toxic to some organisms
respiration	the chemical and osmotic processes by which an organism incorporates oxygen and gives off carbon dioxide formed by oxidation in the tissues; the reversal of the photosynthetic process
rheotaxis	a stimulation or orientation response in which water currents are the directive factor



salinity	a measure of the quantity of dissolved salts in seawater; formally defined as the total amount of dissolved solids in seawater in parts per thousand (o/oo) by weight
sedentary	(ecologically) usually, attached to some substratum, non-motile
seiche	a standing wave oscillation of an enclosed or semi-enclosed water body that continues, pendulum-fashion, after the cessation of the originating force, which may have been atmospheric, seismic, or tide-induced
sessile	having lost the ability to move, attached or stationary
shellfish	a popular term, including both molluscs and crustaceans (clams, lobsters, etc.)
spat	the larvae of young bivalve molluscs (i.e., clams, mussels, oysters, etc.) just after setting.
species	a group of organisms that possess one or more distinctive characteristics in common, and can interbreed, reproducing these characteristics in the offspring
sporeling	a tiny plant form which develops following germination of the spore (reproductive body of primitive plants)
spring tide	tide of increased range which occurs about every two weeks when the moon is new or full
succession	a sequential process of community change with time; interactions between preceding (early colonizing) organisms and the environment, create a situation which favors a succeeding organism or organisms. The theoretical endpoint is "climax" growth
synergism (-istic)	cooperative action of discrete factors such that the resultant effect is greater than the sum of the two factors taken independently (e.g., as in the mixing of two drugs)

thermocline	the layer of water in which there is a sharp or marked temperature change over a small increase in depth; this usually occurs in summer and occupies a mid-depth position, causing a physical (density) isolation of surface and bottom waters
tidal flat	flat land areas which are covered and uncovered by the rise and fall of the tides
trophic level	one of the several successive levels of nourishment in a food chain or web; photosynthetic plants occupy the first level, and the animals which graze upon them, the second level
tropism	a directed movement in response to a stimulus
turbidity	reduced water clarity resulting from the presence of suspended matter; water is considered turbid when its load of suspended matter is visibly conspicuous, waters contain some suspended matter and, therefore, are turbid to some degree
turnover	in production, the rate at which something is used up, and replaced
upwelling	the process by which water rises from a lower to a higher depth, usually as a result of divergence, or surface water moving offshore to be replaced by inflowing bottom water
viable	capable of living
vitality	reproductive success; capacity to live and develop

## LITERATURE CITED

- Alden Research Laboratory. 1974. Hydrothermal Studies of Diffuser Discharge in the Coastal Environment: Seabrook Station. Prepared for Public Service Company of New Hampshire and United Engineers and Constructors, Inc. Report No. 86-74/M252F, August 1974.
- Alden Research Laboratory. 1975. Dynamics of Offshore Buoyant Plumes Produced by a Submerged Diffuser Far Field Analytical Model for the Seabrook Station. Prepared for Public Service Company of New Hampshire and Yankee Atomic Electric Company. Report No. 30-75/M296AF, March 1975.
- Alden Research Laboratory. 1976a. Hydraulic Studies of the Seabrook Screenwell for Public Service Company of New Hampshire and United Engineers and Constructors, Inc. Report No. 94-76/M302F, August 1976.
- Alden Research Laboratory. 1976b. Experimental Study of Discharge Structures Public Service Company of New Hampshire Seabrook Station, Units 1 and 2. Prepared for Yankee Atomic Electric Company. Report No. 130-76/M296CF, November 1976.
- Alden Research Laboratory. 1976c. Experimental Study of Intake Structures Public Service Company of New Hampshire Seabrook Station, Units 1 and 2. Prepared for Yankee Atomic Electric Company. Report No. 131-76/M296DF, November 1976.
- Altman, P. L. and D. S. Dittmer (eds.). 1966. Environmental Biology. Fed. Proc., Fed. Amer. Soc. Exper. Biol. Bethesda, MD. 25:1-694.
- Atomic Energy Commission. 1974. Draft Environmental Statement Seabrook Station Units 1 and 2, Public Service Company of New Hampshire. Docket Nos. 50-443 and 50-444.
- Battelle Columbus Laboratories. 1972. Pilgrim Nuclear Studies. Benthic Survey and Bioassay Studies to Commonwealth of Massachusetts. Division of Marine Fisheries. Report No. 14399.
- Beamish, F. W. H. 1966. Swimming endurance of some Northwest Atlantic fishes. J. Fish. Res. Bd. Can. 23(3).
- Beardsley, R. C. and B. Butman. 1974. Circulation on the New England Continental Shelf: Response to Strong Winter Storms. Geophysical Research Letters. V. 1, No. 4. pp. 181-184.

- Belding, D. L. 1931. The soft-shelled clam fishery of Massachusetts. Commonwealth of Mass., Dept. of Natural Resources. Mar. Fish. Ser. 1. 65 pp.
- Bibko, P.N., L. Wirtenan, L and P.E. Kueser 1972. Preliminary studies on the effects of air bubbles and intense illumination on the swimming behavior of the striped bass (*Morone saxatilis*) and the gizzard shad (*Dorosoma cepedianum*) Unpubl. Rpt. Westinghouse Environmental Systems
- Bigelow, H. B. 1926. Plankton of the offshore waters of the Gulf of Maine. U.S. Bur. Fish. Bull. 40:1-509.
- Bigelow, H. B. 1927. Physical oceanography of the Gulf of Maine. Bull. of the U.S. Bur. of Fish. 40:511-1027.
- Bigelow, H. B. and W. C. Schroeder. 1953. Fishes of the Gulf of Maine. U.S. Fish and Wildl. Serv. Fish. Bull. 53(4):1-577.
- Blax' J. H. S. and W. Dickson. 1959. Observations on swimming speeds of fish. J. Conseil. Intl. Explor. Mer. 24:472-479.
- Boullengier, R. M. 1974. Report on endangered and threatened species including those species deserving special consideration in New Hampshire and Vermont. U.S. Fish and Wildlife Service, Concord, N.H. 40 pp.
- Boyer, H.C. 1961. Swimming speed of immature Atlantic herring in reference to the Passamaguoddy Tidal Project. Trans. Am. Fisheries Soc., 90 (1):21-26
- Brenko, M. and A. Calabrese. 1969. The combined effects of salinity and temperature on larvae of the mussel, *Mytilus edulis*. Mar. Biol. 4(3):224-226.
- Brett, J. R. 1952. Temperature tolerance in young Pacific salmon, (Genus *Oncorhynchus*). J. Fish. Res. Bd. Can. 9(6):265-323.
- Britton, S. W. 1924. The effects of extreme temperature on fishes. Amer. Jour. Physiol. 67:411-421.
- Brawn, V.M. 1960. Underwater television observations of the swimming speed and behavior of captive herring. J. Fish. Res. Bd. Canada 17(5):689-698.
- Bumpus, D. F. 1973. A description of the circulation on the continental shelf of the east coast of the United States. p. 111-157 in Progress in Oceanography. V. 6. Permagon Press.
- Bumpus, D. F. and L. M. Lauzier. 1965. Surface circulation on the continental shelf off eastern North America between Newfoundland and Florida. Am. Geograph. Soc., Serial Atlas of the Marine Environment Folio 7. 22 pp
- Bunting, O. L. 1974. Zooplankton: Thermal regulation and stress. in B. J. Gallagher (ed.), Energy Production and Thermal Effects. Ann Arbor Science. Ann Arbor, Michigan. pp. 50-55.

- Castagna, M. and P. Chanley. Salinity tolerance of some marine bivalves from inshore and estuarine environments in Virginia waters on the western mid-Atlantic coast. *Malacologia*. 12:47-
- Cole, E.J., C.M. Yentsch, C.S. Yentsch and M. Salvaggio. 1975. Some of the growth characteristics of *Gonyaulax tamerensis* isolated from the Gulf of Maine. *Environmental Letters*. 9(2):153-166.
- Colton, J. B., R. R. Marak, S. Nickerson and R. R. Stoddard. 1968. Physical, chemical and biological observations on the continental shelf, Nova Scotia to Long Island, 1964-1966. U.S. Fish Wildl. Serv. Data Rept. 23, microfiche. 1 p.
- Colton, J. B. and R. R. Stoddard. 1972. Average monthly sea-water temperatures, Nova Scotia to Long Island, 1940-1959. *Amer. Geog. Soc., Folio 21*. 2 p. Appendix, 10 plates.
- Colton, J. B. and R. R. Stoddard. 1973. Bottom water temperatures on the continental shelf, Nova Scotia to New Jersey. U.S. Dept. Comm., NOAA Tech. Rep. NMES. 376-55 p.
- Cooper, R. A. 1961. Early life history and spawning migration of the alewife, *Alosa pseudoharengus*. M. Sc. Thesis, University of Rhode Island, Kingston, RI. 58 pp.
- Cox, G. V. 1975. Environmental site assessment for a Massachusetts Bay deepwater oil terminal. in Proceedings Offshore Technology Conference, May 5-8, 1975. Paper OTC 2382.
- Crippen, R. W. 1974. Some thermal effects of a simulated entrainment regime on marine plankton. Ph.D. Thesis, University of Maine, Orono, ME.
- Csanady, G. T. 1972. The coastal boundary layer in Lake Ontario. Part I: The spring regime. *Jour. Phys. Oceanog.* V. 4. pp. 415-453.
- Csanady, G. T. 1974. Barotropic currents over the continental shelf. *Jour. Phys. Oceanog.* 4:357-371.
- Curl, H. and G. C. McLeod. 1961. The physiological ecology of a marine diatom, *Skeletonema costatum* (Grev.) Cleve. *J. Mar. Res.* 19:70-88.
- Cushing, D. H. and J. G. K. Harris. 1973. Stock and recruitment and the problem of density-dependence. *Rapp. Proc. Verb. Cons. Perm. Int. Expl. Mer.* 164:142-155.
- Davies, R. M. and L. D. Jensen. Effects of entrainment of zooplankton at three mid-Atlantic power plants. Electric Power Research Inst. Report No. 10. 75 pp.
- Day, C. G. 1958. Surface circulation in the Gulf of Maine as deduced from drift bottles. U.S. Fish Wildl. Serv. Fish. Bull. 58:443-472.
- deSylva, D. P. 1969. Theoretical considerations of the effects of heated effluents on marine fishes. in: Biological Aspects of Thermal Pollution, P. A. Krenkel and F. L. Parker (eds.). Proc. Nat. Symp. Thermal Pollution, Portland, Oregon, June 3-5, 1968. Vanderbilt University Press. pp. 229-293.

- Dorfman, D. and J. Westman. 1970. Responses of some anadromous fishes to varied oxygen concentrations and increased temperatures. New Jersey Water Resources Research Institute.
- Downs, D. D. and K. R. Meddock. 1974. Engineering application of fish behavior studies in the design of intake systems for coastal generating stations. Paper delivered to Amer. Soc. of Chem. Eng. Conference, January 1974.
- Droop, M. R. 1955. A pelagic diatom requiring Cobalamin. *J. Mar. Biol. Assoc. U.K.* 34:229-231.
- EBASCO Services, Inc. 1969. Thermal discharge application report, circulating water system, Seabrook Station Unit No. 1. A report to Public Service Company of New Hampshire. October 1969. New York, NY.
- EG and G. 1972. The first report of a study to forecast nuclear power plant effects on coastal zones: EG and G Environmental Services, Waltham, Massachusetts. 392 pp.
- Emery, K. O. and E. Uchupi. 1972. Western North Atlantic Ocean: topography, rocks structure, water, life and sediments. *Amer. Assoc. Petr. Geol. Memoir.* 17:532 pp.
- Engel, S. and J. J. Magnuson. 1976. Vertical and horizontal distributions of coho salmon (*Oncorhynchus kisutch*), yellow perch (*Perca flavescens*) and cisco (*Coregonus artedii*) in Palette Lake, Wisconsin. *J. Fish. Res. Bd. Can.* 33:2710-2715.
- Engle, J. B. and V. L. Loosanoff. 1944. On season of attachment of larvae of *Mytilus edulis*. *Ecol.* 25(4):433-440.
- EPA, 316(a). Technical Guidance - Thermal Discharges (Draft), September 30, 1974.
- Ferguson, R. G. 1958. The preferred temperature of fish and their midsummer distribution in temperate lakes and streams. *J. Fish. Res. Bd. Can.* 15:607-624.
- Fish, C. J. and M. W. Johnson. 1937. The biology of the zooplankton population in the Bay of Fundy and Gulf of Maine with special reference to productivity and distribution. *J. Biol. Bd. Canada.* 3:189-322.
- Ford, W. L. 1947. Hydrography of the Western Atlantic: the distribution of the Merrimack River effluent in Ipswich Bay. Tech. Rpt. No. 3. Woods Hole Oceanographic Institution, Woods Hole, MA. 23 pp.

- Frame, D. W. 1973. Conversion efficiency and survival of young winter flounder, *Pseudopleuronectes americanus*, under experimental conditions. *Trans. Amer. Fish. Soc.* 102(3):614-616.
- Gonzales, J. G. 1973. Seasonal variation in the responses of estuarine populations to heated water in the vicinity of a stream generating plant. Ph.D. Thesis, University of Rhode Island, Kingston, RI. 142 pp.
- Gosner, K. L. 1971. Guide to identification of marine and estuarine invertebrates. Wiley-Interscience, New York. 693 pp.
- Graham, J. J. 1956. Observations on the alewife, *Pomolobus pseudo-harengus* (Wilson), in fresh water. *Univ. Toronto Studies Biol. Series No. 62. Publ. Ontario Fish. Res. Lab. No. 74.* 43 pp.
- Graham, J. J. 1970a. Coastal currents in the western Gulf of Maine. *Int. Conf. Atl. Fish. Res. Bull.* 7:19-31.
- Graham, J. J. 1970b. Temperature, salinity and transparency observations. Coastal Gulf of Maine, 1962-1965. U.S. Fish Wildl. Serv. Data Report 42.
- Gran, H. H. and T. Braarud. 1935. A quantitative study of the phytoplankton in the Bay of Fundy and the Gulf of Maine. *J. Biol. Bd. Canada.* 1:279-467.
- Gross, M. G. 1972. Oceanography: A view of the earth. Prentice-Hall, Inc., Englewood Cliffs, N.J. 581 pp.
- Guillard, R. L. and V. Cassie. 1963. Minimum cyanocobalamin requirements of some marine centric diatoms. *Limnol. Oceanogr.* 8(2): 161-165.
- Hartwell, A. D. 1975. Hydrographic features affecting the distribution and movement of toxic dinoflagellates in the western Gulf of Maine. pp. 47-68 in: Proc. of the 1st Int. Conf. on Toxic Dinoflagellate Blooms, Nov. 4-6, 1974, Boston, Mass. Mass. Science & Tech. Found. in Wakefield, Mass. 641 pp.
- Hartwell, A. D. 1976. Effects of storms on coastal currents of the western Gulf of Maine (abs.). *EOS Trans. AGU V. 57, No. 4:261.* (presented at American Geophysical Union Spring Annual Meeting, Washington, D.C., April 1976).
- Hayes, M. O. and J. E. Boothroyd. 1969. Storms as modifying agents in the coastal environment. p. 245-265 in: Coastal Research Group, Univ. of Mass., 1969, Coastal Environments, N.E. Mass. and N.H., Field Trip Guidebook: Eastern Section of Soc. of Econ. Paleo. and Min. Field trip, May 1969. 462 pp.

- Hela, I. and T. Laevastu. 1962. Fisheries Hydrography. Fishing News (books) LTD., London.
- Henderson, J. T. 1929. Lethal temperatures of Lamellibranchiata. *Contr. Can. Biol. Fish. N.S.* 4(25):397-411.
- Hoff, J. G. and J. R. Westman. 1966. The temperature tolerance of three species of marine fishes. *J. Mar. Res.* 24(2):131-140.
- Hoss, D. E., W. F. Hettler and L. C. Coston. 1974. Effects of thermal shock on larval estuarine fish - ecological implications with respect to entrainment in power plant cooling systems. *Proc. Int. Symp. on the Early Life History of Fish. Oban (UK). 17 May 1973.* J.H.S. Blaxter (ed.), Springer-Verlag, Berlin. pp. 357-371.
- Hubbs, C. and C. Bryan. 1974. Effect of parental temperature experience on thermal tolerance of eggs of *Menidia audens*. *Proc. Int. Symp. on the Early Life History of Fish. Oban (UK). 17 May 1973.* J.H.S. Blaxter (ed.), Springer-Verlag, Berlin. pp. 431-435.
- Huntsman, A. G. 1924. Limiting factors for some marine animals. Resistance of larval lobsters to extremes of temperature. *Contr. Can. Biol. Fish. N.S.* 2(5):89-94.
- Huntsman, A. G. 1946. Heat stroke in Canadian maritime stream fishes. *J. Fish. Res. Bd. Can.* 6:476-482.
- Huntsman, A. G. and M. I. Sparks. 1924. Limiting factors for marine animals. Relative resistance to high temperatures. *Contr. Can. Biol. Fish. N.S.* 2(6):97-114.
- Hutchins, L. W. 1947. The bases for temperature zonation in geographical distribution. *Ecol. Monogr.* 17(3):325-335.
- Jitts, H. R., C. D. McAllister, K. Stephens and J. D. H. Strickland. 1964. Cell division rates of some marine phytoplankters as a function of light and temperature. *J. Fish. Res. Bd. Can.* 21: 139-157.
- Jones, R. and W. Hall. 1973. A simulation model for studying the population dynamics of some fish species. in: The Mathematical Theory of the Dynamics of Biological Populations. M.S. Bartlett and R. Horns (eds.). Academic Press, London. pp. 35-39.
- Jorgensen, E. 1968. The adaptation of plankton algae. III. Results of the temperature adaptation of *Skeletonema costatum*. *Physiol. Planta.* 21:423-427.
- Joyner, T. 1973. Part III: Effect of the ocean environment on the high seas distribution of salmon. *Mar. Fish. Rev.* 35:4-



- Kangas, R. E. and G. L. Hufford. 1974. An upwelling rate for Massachusetts Bay. *J. Geophys. Res.* 79:2231-2236.
- Katona, S. K. 1970. Growth characteristics of the copepods, *Eurytemora affinis* and *E. herdmani* in laboratory culture. *Helgo. Wiss. Meeresunters.* 20:373-384.
- Kendell, A. W. and J. W. Reintjes, Jr. 1975. Geographic and hydrographic distribution of Atlantic menhaden eggs and larvae along the middle Atlantic coast from RV DOLPHIN cruises, 1965-1966. NOAA, NMFS. *Fish. Bull.* 73(2):317-335.
- Kennedy, V. S. and J. A. Mihursky. 1971. Upper temperature tolerances of some estuarine bivalves. *Ches. Sci.* 12(4):193-204.
- Kerr, J. E. 1953. Studies on fish preservation at the Contra Costa stream plant of the Pacific Gas & Electric Company. *Calif. Fish. Bull.* 92. 66 pp.
- Kinne, O. 1970. Temperature. in: *Marine Ecology*, O. Kinne (ed.), Wiley, New York. 1(pt. 1):321-616.
- Lamb, I. M. and H. M. Zimmerman. Marine vegetation of Cape Ann, Essex County, Mass. *Rhodora.* 66:217-254.
- Landers, W. S. 1976. Reproduction and early development of the ocean quahog, *Arctica islandica*, in the laboratory. *The Nautilus.* 90(2):88-92.
- Leim, A. H. and W. B. Scott. 1966. Fishes of the Atlantic Coast of Canada. *Fish. Res. Bd. Can. Bull. No. 155.* 435 pp.
- Lewis, R. M. and W. F. Hettler, Jr. 1968. Effect of temperature and salinity on the survival of young Atlantic menhaden, *Brevoortia tyrannus*. *Trans. Amer. Fish. Soc.* 97(4):344-349.
- Lillick, L. C. 1940. Phytoplankton and planktonic protozoa of the offshore waters of the Gulf of Maine. II: Qualitative composition of the planktonic flora. *Trans. Amer. Phil. Soc.* 31(3):193-239.
- Loeblich, L. A. and A. R. Loeblich, III. 1974. The dinoflagellate causing New England red tides: scanning electron microscopy and physiology. *Jour. Phycol.* 10:3-
- Longard, J. R. and R. E. Banks. 1952. Wind-induced vertical movement of water on an open coast. *EOS Trans. AGU* 33:377.
- Loosanoff, V. L. 1953. Reproductive cycle in *Cyprina islandica*. *Biol. Bull.* 104(2):146-155.

- Lough, R. G. 1974. A reevaluation of the combined effects of temperature and salinity on survival and growth of *Mytilus edulis* larvae using responded surface technique. Proc. Nat. Shellfish. Assoc. 64:73-76.
- Mann, K. H. 1972. Ecol. energetics of the seaweed zone in a marine bay on the Atlantic coast of Canada. I: Zonation and biomass of seaweeds. Mar. Biol. 12:1-10.
- Manohar-Maharaj, V. and R. C. Beardsley. 1973. Spring runoff into Massachusetts Bay, 1973. MIT Sea Grant Program Report No. MITSG 74-9, Cambridge, Mass. 103 pp.
- Massachusetts Division of Environmental Health. 1973. The red tide - a public-health emergency. New England Jour. Med. 288:1126-
- Mathieson, A. C. and R. L. Burns. 1975. Ecological Studies of economic red algae. V: Growth and reproduction of natural and harvested populations of *Chondrus crispus* Stackhouse in New Hampshire. J. Exp. Mar. Biol. Ecol. 17:137-156.
- Mathieson, A. C., E. J. Hehre and N. B. Reynolds. 1977 (in press). Invest. of New England marine algae. I: Floristic and descriptive ecol. study of the marine algae at Jaffrey Point. Nova Hedwigia.
- Mathieson, A. C. and T. Norall. 1975. Physiological studies of subtidal red algae. J. Exp. Mar. Biol. Ecol. 20:237-247.
- Mathieson, A. C. and J. S. Prince. 1973. Ecology of *Chondrus crispus* Stackhouse. Proc. N.S. Inst. Sci. 27(suppl).
- Matsue, Y. 1954. On the culture of the marine diatom *Skeletonema costatum* (Grev.) Cleve. in: Review of Fisheries Science in Japan. Jap. Soc. Adv. Sci., Tokyo. 41 pp.
- McCracken, F. D. 1963. Seasonal movements of the winter flounder, *Pseudopleuronectes americanus* (Walbaum) on the Atlantic coast. J. Fish. Res. Bd. Can. 20(2):551-586.
- McLean, R. I. 1970. Chlorine and temperature stress on estuarine invertebrates. Jour. Water Poll. Contr. Fed. 45(5):837-841.
- McLeese, D. W. 1956. Effects of temperature, salinity and oxygen on the survival of the American lobster. J. Fish. Res. Bd. Can. 13(2):247-272.
- McLellan, H. J. 1954. Temperature-salinity relations and mixing on the Scotian shelf. J. Fish. Res. Bd. Canada. 11(4):419-430.
- Meldrum, J. W. and J. J. Gift. 1971. Temperature preference, avoidance and shock experiments with estuarine fishes. Ichthyological Assoc., Inc., Ithaca (NY). Bull. 7.

- Menge, B. A. 1976. Organization of the New England rocky intertidal community: role of predation, competition and environmental heterogeneity. *Ecol. Mono.* 46(2):355-393.
- Miller, D. C. and A. D. Beck. 1975. Development and application of criteria for marine cooling waters. in: *Environmental Effects of Cooling Systems at Nuclear Power Plants.* Proc. Intl. Atomic Energy Agency, Vienna, Aus. pp. 639-657.
- National Oceanic and Atmospheric Administration-National Ocean Survey. 1976. *Tide Tables.* U.S. Dept. Comm., Washington, D.C. 290 pp.
- Normandeau Associates, Inc. 1971. *Seabrook Ecological Study: Phase I 1969-1970, Hampton-Seabrook Estuary, New Hampshire.* Prepared for Public Service Company of New Hampshire. 313 pp.
- Normandeau Associates, Inc. 1972a. *Seabrook Ecological Study: Phase II 1970-1971, Hampton-Seabrook Estuary, New Hampshire.*
- Normandeau Associates, Inc. 1972b. *Seabrook Ecological Study 1971. Soft-shelled clam spat density.* Technical Report III-1.
- Normandeau Associates, Inc. 1972c. *Seabrook Ecological Study 1971. An assessment of zooplankton abundance and exchange, Hampton-Seabrook Estuary and nearby offshore waters.* Technical Report III-2.
- Normandeau Associates, Inc. 1972d. *Seabrook Ecological Study 1971. Soft-shelled clam density.* Technical Report III-3.
- Normandeau Associates, Inc. 1972e. *Seabrook Ecological Study 1971. Marsh disturbance study.* Technical Report III-4.
- Normandeau Associates, Inc. 1972f. *Seabrook Ecological Study 1971. Primary productivity in Hampton-Seabrook Estuary.* Technical Report III-5.
- Normandeau Associates, Inc. 1972g. *Seabrook Ecological Study 1971. Day/night zooplankton study.* Technical Report III-6.
- Normandeau Associates, Inc. 1972h. *Seabrook Ecological Study 1971. Fish larvae and eggs of the Hampton-Seabrook Estuary.* Technical Report III-7.
- Normandeau Associates, Inc. 1972i. *Seabrook Ecological Study 1971. Soft-shelled clam (*Mya arenaria*) larvae studies.* Technical Report III-8.
- Normandeau Associates, Inc. 1972j. *Seabrook Ecological Study 1971. Preliminary Bioassay of marsh peat extract.*
- Normandeau Associates, Inc. 1973a. *Seabrook Ecological Study 1972. Effects of extract of saltmarsh substrate on the survival of selected marine fish and invertebrates.* Technical Report IV-1.

- Normandeau Associates, Inc. 1973b. Seabrook Ecological Study 1972. Studies on the soft-shelled clam, *Mya arenaria*, in the Hampton-Seabrook estuary, New Hampshire. Technical Report IV-2.
- Normandeau Associates, Inc. 1973c. Seabrook Ecological Study 1972. Occurrence of adult and larval finfish in tidal and oceanic waters at Hampton-Seabrook estuary, New Hampshire. Technical Report IV-3.
- Normandeau Associates, Inc. 1973d. Seabrook Ecological Study 1972. Plankton distribution in the vicinity of Hampton-Seabrook, New Hampshire. Technical Report IV-4.
- Normandeau Associates, Inc. 1973e. Seabrook Ecological Study 1972. The benthos of the area offshore Hampton and Seabrook Beaches, New Hampshire. Technical Report IV-5.
- Normandeau Associates, Inc. 1974a. Preliminary assessment of possible environmental impacts of the proposed Olympic offshore docking terminals and pipeline. For Frederick R. Harris, Inc., Great Neck, New York. 174 pp.
- Normandeau Associates, Inc. 1974b. Seabrook Ecological Study 1973. Studies on the American lobster, *Homarus americanus*, in the vicinity of Hampton Beach, New Hampshire. Technical Report V-1.
- Normandeau Associates, Inc. 1974c. Seabrook Ecological Study 1973. Studies on the soft-shelled clam, *Mya arenaria*, in the Hampton-Seabrook estuary, New Hampshire. Technical Report V-2.
- Normandeau Associates, Inc. 1974d. Seabrook Ecological Study 1973. Finfish ecology investigations at the Hampton-Seabrook estuary, New Hampshire and adjoining coastal waters, 1973-1974. Technical Report V-3.
- Normandeau Associates, Inc. 1974e. Seabrook Ecological Study 1973. The impact of entrainment by the Seabrook Station. Technical Report V-4.
- Normandeau Associates, Inc. 1975a. *Mya arenaria* confirmational study. September 1975.
- Normandeau Associates, Inc. 1975b. Seabrook Ecological Study 1974. Probability of coastal waters entering the Hampton Harbor estuary and neighboring estuaries as a function of distance offshore. Technical Report VI-9.
- Normandeau Associates, Inc. 1975c. Seabrook Ecological Study 1974. Spatial and temporal distribution of the larvae of the soft-shelled clam, *Mya arenaria*, in the Hampton-Seabrook estuary and nearby offshore waters. Technical Report VI-1.

- Normandeau Associates, Inc. 1975d. Seabrook Ecological Study 1974. Studies of American lobster, *Homarus americanus*, catches in the vicinity of Hampton Beach, New Hampshire. Technical Report VI-4.
- Normandeau Associates, Inc. 1975e. Seabrook Ecological Study 1974. Studies on the soft-shelled clam, *Mya arenaria*, in the Hampton-Seabrook estuary, New Hampshire. Technical Report VI-3.
- Normandeau Associates, Inc. 1975f. Seabrook Ecological Study 1974. Summary report of hydrographic studies off Hampton Beach, New Hampshire, including the Hampton Harbor estuary and the western Gulf of Maine: September 1972 to March 1975. Technical Report VI-8.
- Normandeau Associates, Inc. 1975g. Seabrook Ecological Study 1974. The benthos inhabiting the area of the proposed Seabrook Station discharge. Technical Report VI-5. October 1975.
- Normandeau Associates, Inc. 1975h. Seabrook Ecological Study 1974. Vertical distribution and abundance of finfish in the area of the proposed Seabrook Station intake. Technical Report VI-2.
- Normandeau Associates, Inc. 1975i. Seabrook Environmental Studies. Plankton monitoring 1974-1975. Technical Report VI-6.
- Normandeau Associates, Inc. 1975j. The benthos inhabiting the area of the proposed location of the Seabrook Station intake.
- Normandeau Associates, Inc. 1976a. Assessment of thermal plume mortality attributable to Seabrook Station cooling water discharge off Hampton Beach, New Hampshire. May 1976.
- Normandeau Associates, Inc. 1976b. New Haven Harbor Station Ecological Monitoring Studies. Acute toxicity studies. Prepared for The United Illuminating Company, New Haven, CT.
- Normandeau Associates, Inc. 1976c. Seabrook Ecological Studies 1975. Finfish ecology investigations at the Hampton-Seabrook estuary, New Hampshire and adjoining coastal waters. Technical Report VI-7. February 1976.
- Normandeau Associates, Inc. 1976d. Spatial and temporal distribution of the larvae of the soft-shelled clam, *Mya arenaria*, in the New Hampshire coastal waters, 1975. Technical Report VI-10.
- Normandeau Associates, Inc. 1976e. Turbidity levels in the Hampton Harbor estuary under both "calm" conditions and "post-storm" conditions. Prepared for Public Service Company of New Hampshire. 13 pp.
- Normandeau Associates, Inc. 1976f. Candidate Environmental Impact Statement for Project P152 Dredging Portsmouth Naval Shipyard, Portsmouth, N.H. Contract No. N62472-76-C-1069.

- Normandeau Associates, Inc. 1977a. Annual summary report for 1975 hydrographic studies off Hampton Beach, New Hampshire. Technical Report VII-2; prepared for Public Service Company of New Hampshire. 250 pp.
- Normandeau Associates, Inc. 1977b. Seabrook Ecological Studies 1975-1976. Annual Report.
- Normandeau Associates, Inc. 1977c. Seabrook Ecological Studies 1975-1976. Studies on the soft-shelled clam, *Mya arenaria*, in the vicinity of Hampton-Seabrook estuary, New Hampshire.
- Normandeau Associates, Inc. 1977d. Seabrook Ecological Studies 1975-1976. Studies ... benthos
- Parkash, A., J.C. Medcof and A.D. Tennant, 1971. Paralytic shellfish poisoning in eastern Canada. Fish. Res. Bd. Can. Bull. 177. 88 pp.
- Parker, R. H. 1975. The study of benthic communities: a model and review. Elsevier Scientific Pub. Co., Amsterdam. 279 pp.
- Pearce, J. B. 1969. Thermal addition and the benthos. Cape Cod Canal. Ches. Sci. 10(3-4):227-233.
- Perkins, H. C. 1972. Developmental rates at various temperatures of embryos of the northern lobsters (*Homarus americanus*, Milne-Edwards). Fish. Bull. 70:95-
- Perkins, H. C. 197?. The effects of high water temperatures on the survival of larvae of the northern lobster (*Homarus americanus*, Milne-Edwards) under certain experimental conditions. Mimeo Report, Nat. Mar. Fish. Serv. Biol. Lab. West Boothbay Harbor, Maine.
- Prince, J. S. 1971. An ecological study of the marine red algae *Chondrus crispus* in the waters off Plymouth, Massachusetts. Ph.D. Thesis, Cornell University, Ithaca, NY.
- Prince, J. S. and J. M. Kingsbury. 1973. The ecology of *Chondrus crispus* at Plymouth, Massachusetts. II: Field Studies. Amer. J. Bot. 60(10):964-975. III: Effect of elevated temperature on growth and survival. Biol. Bull. 145:580-588.
- Public Service Company of New Hampshire. 1973. Seabrook Station Environmental Report Prepared for the Atomic Energy Commission.
- Public Service Company of New Hampshire. 1974. Selection of representative important species pursuant to 316(a) of the Federal Water Pollution Control Act, Amendments of 1972. 44 pp.
- Read, K. R. H. and K. B. Cumming. 1967. Thermal tolerance of bivalve molluscs, *Modiolus modiolus* (L.), *Mytilus edulis* (L.) and *Brachiodontes demissus* (Dillwyn). Comp. Biochem. Physiol. 22(1): 149-155.

- Reintjes, J. W. 1969. Synopsis of biological data on Atlantic menhaden, *Brevoortia tyrannus*. U.S. Fish. Wildl. Serv. Circ. No. 320. 30 pp.
- Rogers, C. A. 1976. Effects of temperature and salinity on the survival of winter flounder embryos. U.S. Nat. Mar. Fish. Serv. Fish. Bull. 74(1):52-58.
- Ropes, J. W. and A. P. Stickney. 1965. Reproductive cycle of *Mya arenaria* in New England. Biol. Bull. 128:315-327.
- Ryan, P. J. and D. R. F. Harleman. 1973. "An Analytical and Experimental Study of Transient Cooling Pond Behavior", R. M. Parson's Laboratory for Water Resources and Hydrodynamics, Department of Civil Engineering, Massachusetts Institute of Technology, T.R.-161, 1973.
- Ryther, J. H. and D. D. Kramer. 1961. Relative iron requirement of zone coastal and offshore plankton algae. Ecology 42(2):444-446.
- Sastry, A. N. 1974. Personal communication. University of Rhode Island, Narragansett, RI.
- Savage, N. B. 1971. Unpublished data on thermal effects on *Arctica islandica*. University of Rhode Island and U.S. EPA Nat. Mar. Wtr. Qual. Lab., Narragansett (RI).
- Scarola, J. F. 1973. Freshwater fishes of New Hampshire. N.H. Fish and Game Dept. Div. Inland & Marine Fish. 131 pp.
- Schubel, J. R. 1974. Effects of exposure to time-excess temperature histories typically experienced at power plants on hatching success of fish eggs. Estuar. Coast. Mar. Sci. 2(2):105-116.
- Schuler, V. J. and L. E. Larson. 1974. Experimental studies evaluating aspects of fish behavior as parameters in the design of generating station intake systems. Paper delivered to the Amer. Soc. Chem. Eng. Conference. January 1974.
- Schuler, V. J. and L. E. Larson. 1975. Improved fish protection at intake systems. Jour. Env. Eng. Div. ASCE. 101(EEG), 897-910.
- Scott, J. T. and G. T. Csanady. 1976. Nearshore currents off Long Island. Jour. Geophy. Research. V. 81, No. 30. pp. 5401-5409.
- Sette, O. 1943. Biology of the Atlantic mackerel (*Scomber scombrus*) of North America. Part 1: Early life history including growth, draft and mortality of eggs and larval populations. U.S. Fish. Wildl. Serv. Fish. Bull. 50:149-237.

- Sherman, D. and R. D. Lewis. 1967. Seasonal occurrence of larval lobsters in coastal waters of central Maine. Proc. Nat. Shellfish Assoc. 57:27-30.
- Sherman, K. 1965. Seasonal and areal distribution of Gulf of Maine coastal zooplankton, 1963. Int. Comm. Northwest Atl. Fish. Spec. Publ. 6:611-624.
- Sherman, K. 1966. Seasonal and areal distribution of zooplankton in coastal waters of the Gulf of Maine, 1964. U.S. Fish. Wildl. Serv. Spec. Sci. Rep. Fish 530. 11 pp.
- Sherman, K. 1968. Seasonal and areal distribution of zooplankton in coastal waters of the Gulf of Maine, 1965 and 1966. U.S. Fish. Wildl. Serv. Spec. Sci. Rep. Fish. 562. 11 pp.
- Sherman, K. 1970. Seasonal and areal distribution of zooplankton in coastal waters of the Gulf of Maine, 1967 and 1968. U.S. Fish. Wildl. Serv. Spec. Sci. Rep. Fish. 594. 8 pp.
- Shevenell, T. C. 1974. Distribution and dispersal of particulate matter in a temperate coastal shelf environment. Proceedings of Symposium on Interrelationships of Estuarine and Continental Shelf Sedimentation, July 9-14. Bordeaux, France. pp. 87-94.
- Skud, B. E. and H. C. Perkins. 1969. Size composition, sex ratio, and size at maturity of offshore northern lobsters. U.S. Fish. Wildl. Serv., Spec. Sci. Rept. Fish. No. 598.
- Smayda, T. J. 1973. The growth of *Skeletonema costatum* during a winter-spring bloom in Narragansett Bay. Norwegian J. Bot. 20:219-247.
- Smith, B. W. 1974. Thermal effects upon some of the indigenous biota in the waters offshore Hampton, New Hampshire: A search of the literature. Public Service Company of New Hampshire. 43 pp.
- Smith, R. L. 1973. Upwelling. in: R. G. Pirie (ed.), Oceanography: Contemporary Readings in Ocean Sciences. Oxford Univ. Press, New York. pp. 126-147.
- Sonnichan, J.C. Jr., B.W. Bentley, G.F. Bailey and R.F. Nakatoni. A review of thermal power plant intake structure designs and related environmental considerations. Hanford Engineering Development Laboratory, Richland, Washington. Prepared for the U.S. Atomic Energy Commission. 1973.
- Sparks, M. I. 1929. The spawning and development of mackerel on the outer coast of Nova Scotia. Contrib. Can. Biol. Fish. N.S. 4(28): 443-452.
- Spigarelli, S. A. 1975. Behavioral responses of Lake Michigan fishes to a nuclear power plant discharge. in: Environmental Effects of Cooling Systems at Nuclear Power Plants. Proc. Intl. Atomic Energy Agency, Vienna, Aus. pp. 479-498.



- Spurr, E.W. and R.G. Seamans, Jr. 1975 (?). An investigation of the subtidal clam resources of New Hampshire, Project Compl. report 3-226R. State of NH & N.O.A.A. 8pp.
- Squires, H. J. 1970. Lobster (*Homarus americanus*) fishery and ecology in Port au Port Bay, Newfoundland, 1960-1965. Proc. Nat. Shellf. Assoc. 60:22-37.
- Stanley, J. G. 1973. Mucus and freshwater osmoregulation in anadromous fishes and relationships to mortalities in the alewife. Wisconsin Dept. Nat. Res. Madison (Wisc.), and NOAA. Rockville, MD.
- Steele, O. H. 1963. Pollock, *Pollachius virens* (L) in the Bay of Fundy. J. Fish. Res. Bd. Can. 20(5):1267-1314.
- Stickney, A. P. 1964. Salinity, temperature and food requirements of soft-shell clam larvae in laboratory culture. Ecology 45(2):283-291.
- Strahler, A. N. and A. H. Strahler. 1973. Environmental Geoscience. Hamilton Publishing Co., Santa Barbara, Calif. pp. 85-112.
- Sullivan, C. M. 1948. Bivalve larvae of Malpeque Bay, P.E.I. Fish. Res. Bd. Can. Bull. No. 77. 36 pp.
- Sutcliffe, W. H., R. H. Louks and K. F. Drinkwater. 1975. Coastal circulation and physical oceanography. Paper presented at International Commission for the Northwest Atlantic Fisheries, June 1975. 33 pp.
- Sverdrup, H. H., M. W. Johnson and R. A. Fleming. 1942. The oceans: their physics, chemistry and general biology. Prentice-Hall, Inc., New York, New York. 1087 pp.
- Tatham, T. R. 1970. Swimming speed of the white perch *Morone americana*, striped bass, *Morone saxatilis* and other estuarine fishes. Tech. Rpt. prepared by Ichthyological Assoc. for Consolidated Edison Co., New York, Inc.
- Tremblay, F. J. 1960. Research project on effects of condenser discharge water on aquatic life, 1956-1959. Inst. Res., Lehigh Univ. approximately 160 pp.
- TRIGOM. 1974. A socio-economic and environmental inventory of the North Atlantic region. V. I. Prepared for BLM Marine Minerals Div., by the Research Institute of the Gulf of Maine, So. Portland, Maine.
- U.S. Dept. of Interior, Fish and Wildlife Service. 1975. Endangered species of the United States. Federal Register V. 40 No. 188.
- U.S. Environmental Protection Agency. 1975. A summary of thermal effects for United States estuarine and coastal biota. in: EPA/NRC/FWS 316(a) Technical Guidance Manual and Guide for thermal effects sections of nuclear power plant environmental impact statements. Appendix II. pp. 24-50.

- U.S. Environmental Protection Agency. 1976. Development document for best technology available for the location, design construction and capacity of cooling water intake structures for minimizing adverse environmental impact. 150pp.
- U.S. Fish and Wildlife Service. 1970. National estuary study. V. 2: 303 pp.
- U.S. Fish and Wildlife Service. 1975. A first step towards standardizing biological data requirements for the EPA/NRC Memorandum of Understanding. (Draft Guidance Manual), National Power Plant Team, Ann Arbor, MI.
- Wallis, R. L. 1975. Thermal tolerance of *Mytilus edulis* of eastern Australia. Mar. Biol. 30(3):183-191.
- Ward, L. G. 1972. Seasonal variations in suspended sediments and hydrographic parameters in the waters of coastal New Hampshire. (unpublished progress report), University of New Hampshire, Durham, New Hampshire. 29 pp.
- Weight, R. H. 1958. Ocean cooling water system for 800 MW power station. J. Power Div. Proc. Amer. Soc. Civil Eng. Paper 1888:1-22.
- Widdows, J. 1973. Effect of temperature and food on the heart beat, ventilation rate and oxygen uptake of *Mytilus edulis*. Mar. Biol. 20(4):269-276.
- Wilder, D. J. 1953. The growth rate of the American lobster, *Homarus americanus*. J. Fish. Res. Bd. Can. 10(7):371-412.
- Williams, G. C. 1975. Viable embryogenesis of the winter flounder, *Pseudopleuronectes americanus*. Mar. Biol. 33(1):71-74.
- Wilson, J. H. and R. Seed. 1974. Reproduction in *Mytilus edulis* L. (Mollusca:Bivalvia) in Carlingford Lough, Northern Ireland. Ir. Fish. Invest. Ser. B. 15:1-
- Wolfson, A. A. 1974. Some effects of increased temperature on the settlements and development of a marine community in the laboratory. Univ. Calif. San Diego. Sea Grant Publ. 39.
- Worley, L. G. 1933. Development of the egg of the mackerel at different constant temperatures. J. Gen. Physiol. 16:841-857.
- Yentch, C. S. et al. 1974. Influence of temperature on the photosynthetic efficiency in natural populations of marine phytoplankton. in: Symposium on Thermal Ecology, J.W. Gibbons and R. R. Sharitz (eds.). Tech. Info. Ctr., Oak Ridge, Tenn. pp. 508-

SECTION 8.0

APPENDIX

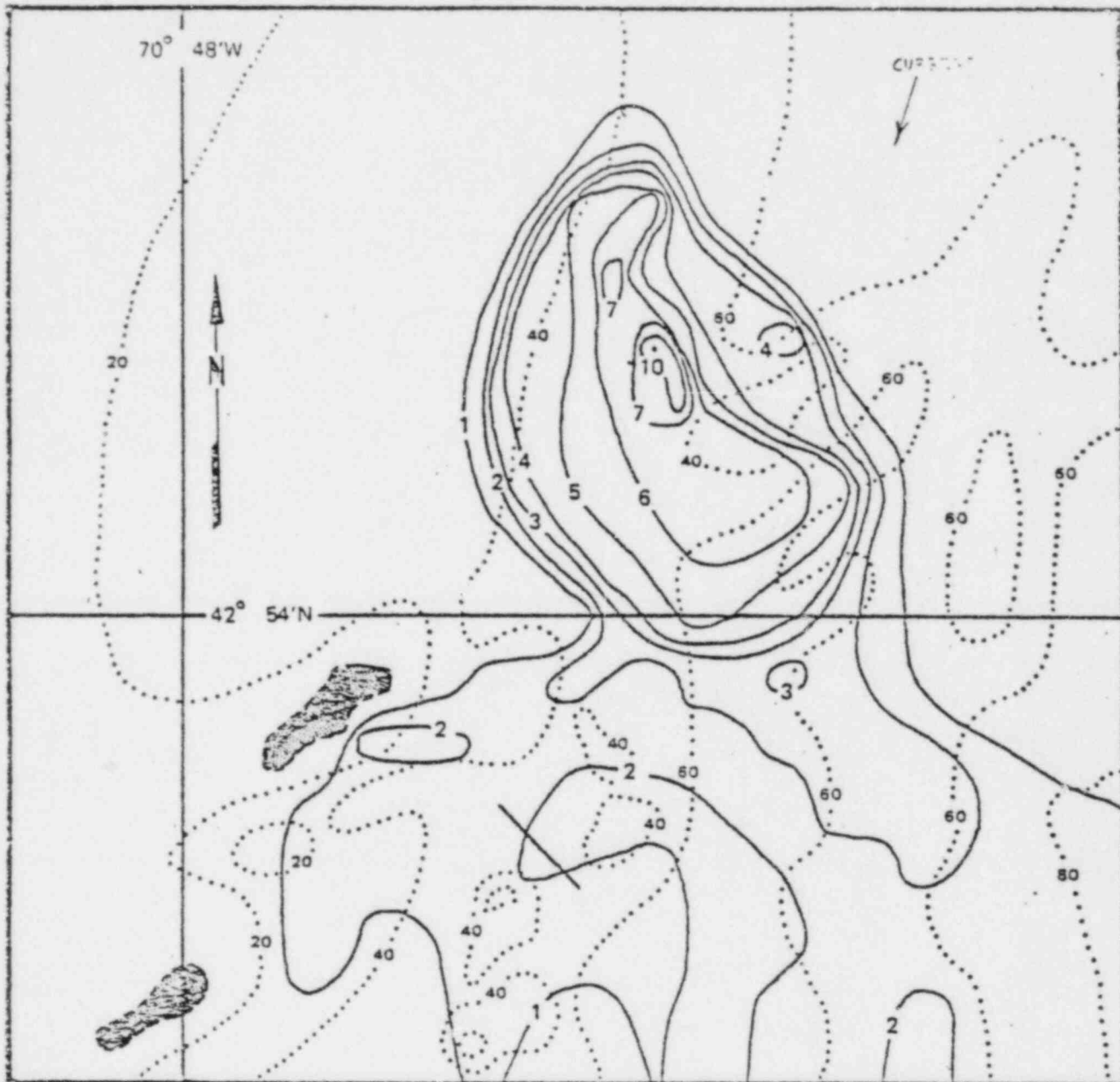

TIME 1.0 hrs.      CURRENT DIRECTION N-S      INTAKE FLOW 1822 cfs  
 TIDE M/W      CURRENT VELOCITY 0.15 kts      INTAKE  $\Delta T$  63.5 F  
 MODEL AMBIENT 69.5 F      PROTOTYPE AMBIENT 41.0 F      POWER LEVEL 100%  
 TEST NO. 212      INTAKE "A"      TEST DATE 6/3/75

SURFACE ISOTHERMS - BACKFLUSHING ( 3 INTAKES )

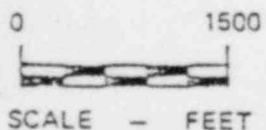

SEABROOK HYDROTHERMAL MODEL STUDY  
 PUBLIC SERVICE COMPANY OF NEW HAMPSHIRE  
 YANKEE ATOMIC ELECTRIC COMPANY

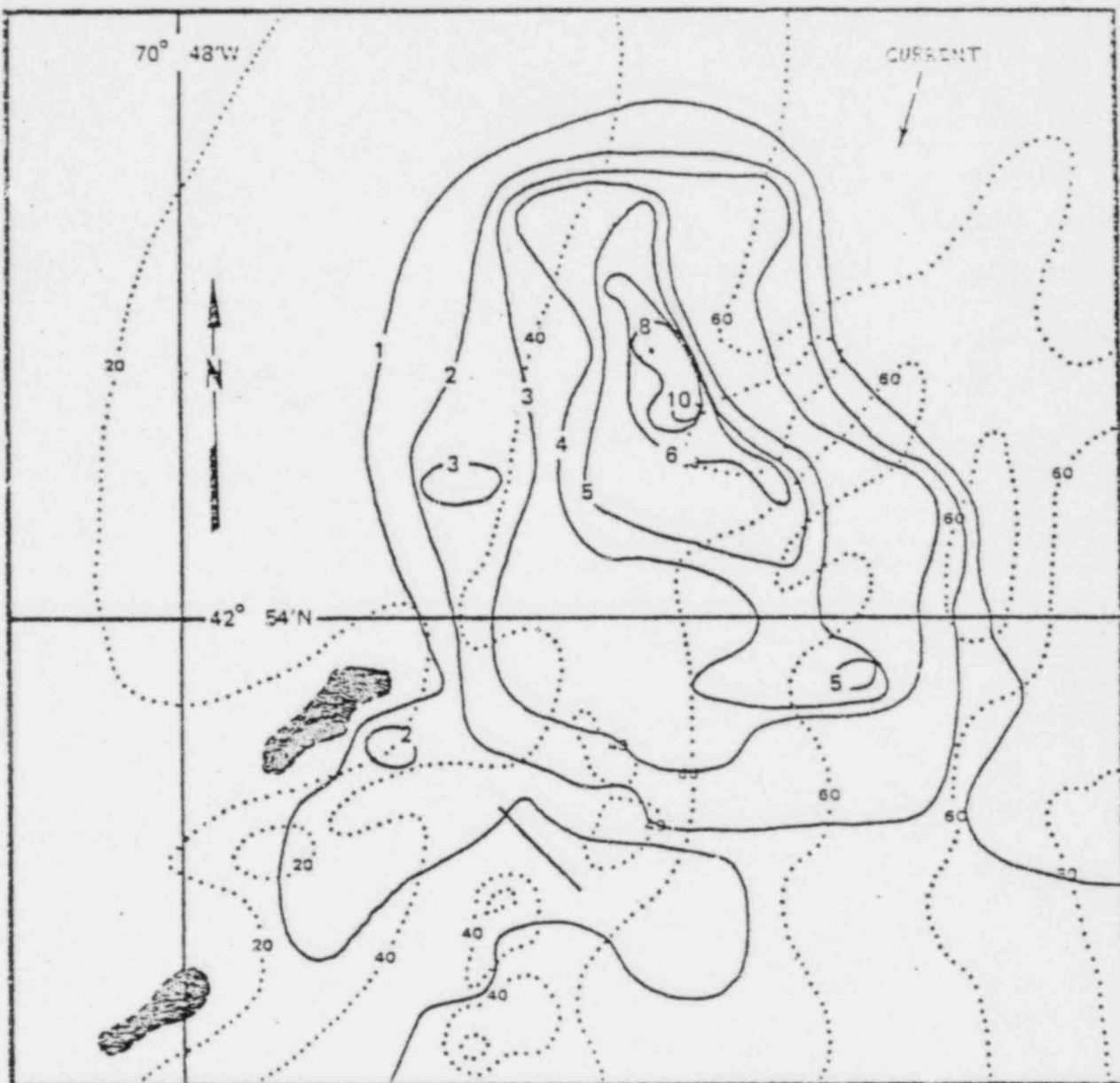

TIME 2.0 hrs.      CURRENT DIRECTION N-S      INTAKE FLOW 869 cfs  
 TIDE M/W      CURRENT VELOCITY 0.15 kts      INTAKE  $\Delta T$  72.6 F  
 MODEL AMBIENT 69.5 F      PROTOTYPE AMBIENT 41.0 F      POWER LEVEL 100%  
 TEST NO. 212      INTAKE "A"      TEST DATE 6/3/75

SURFACE ISOTHERMS - BACKFLUSHING ( 3 INTAKES )

0                      1500  
  
 SCALE - FEET

SEABROOK HYDROTHERMAL MODEL STUDY  
 PUBLIC SERVICE COMPANY OF NEW HAMPSHIRE  
 YANKEE ATOMIC ELECTRIC COMPANY

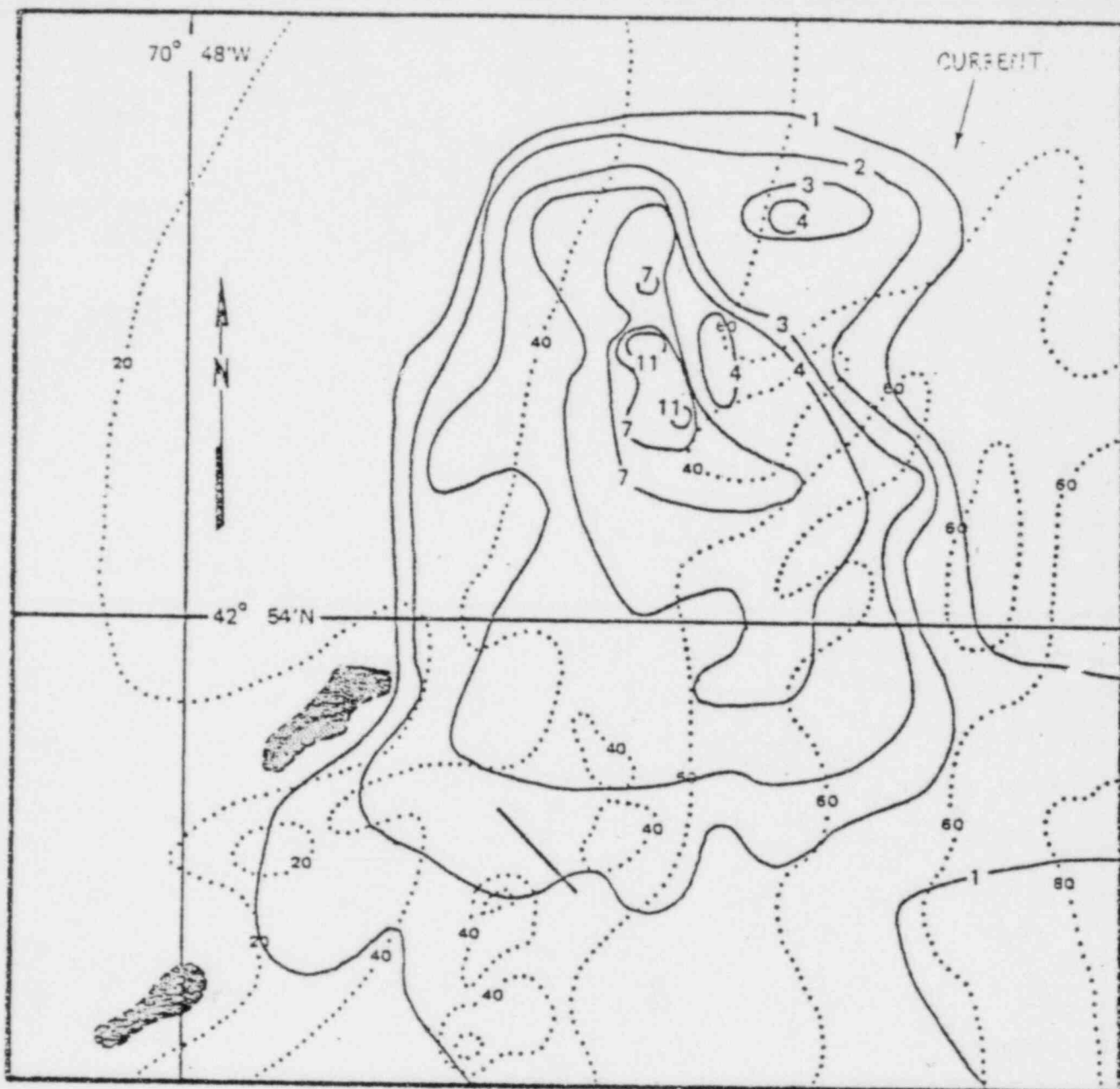

TIME <u>3.0</u> hrs.	CURRENT DIRECTION <u>N-S</u>	INTAKE FLOW <u>869</u> cfs
TIDE <u>M/S</u>	CURRENT VELOCITY <u>0.15</u> kts	INTAKE $\Delta T$ <u>81.2</u> F
MODEL AMBIENT <u>69.5</u> F	PROTOTYPE AMBIENT <u>41.0</u> F	POWER LEVEL <u>100%</u>
TEST NO. <u>212</u>	INTAKE "A"	TEST DATE <u>6/3/75</u>

SURFACE ISOTHERMS - BACKFLUSHING ( 3 INTAKES )

SEABROOK HYDROTHERMAL MODEL STUDY  
 PUBLIC SERVICE COMPANY OF NEW HAMPSHIRE  
 YANKEE ATOMIC ELECTRIC COMPANY

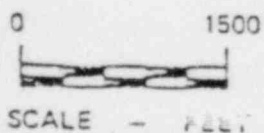

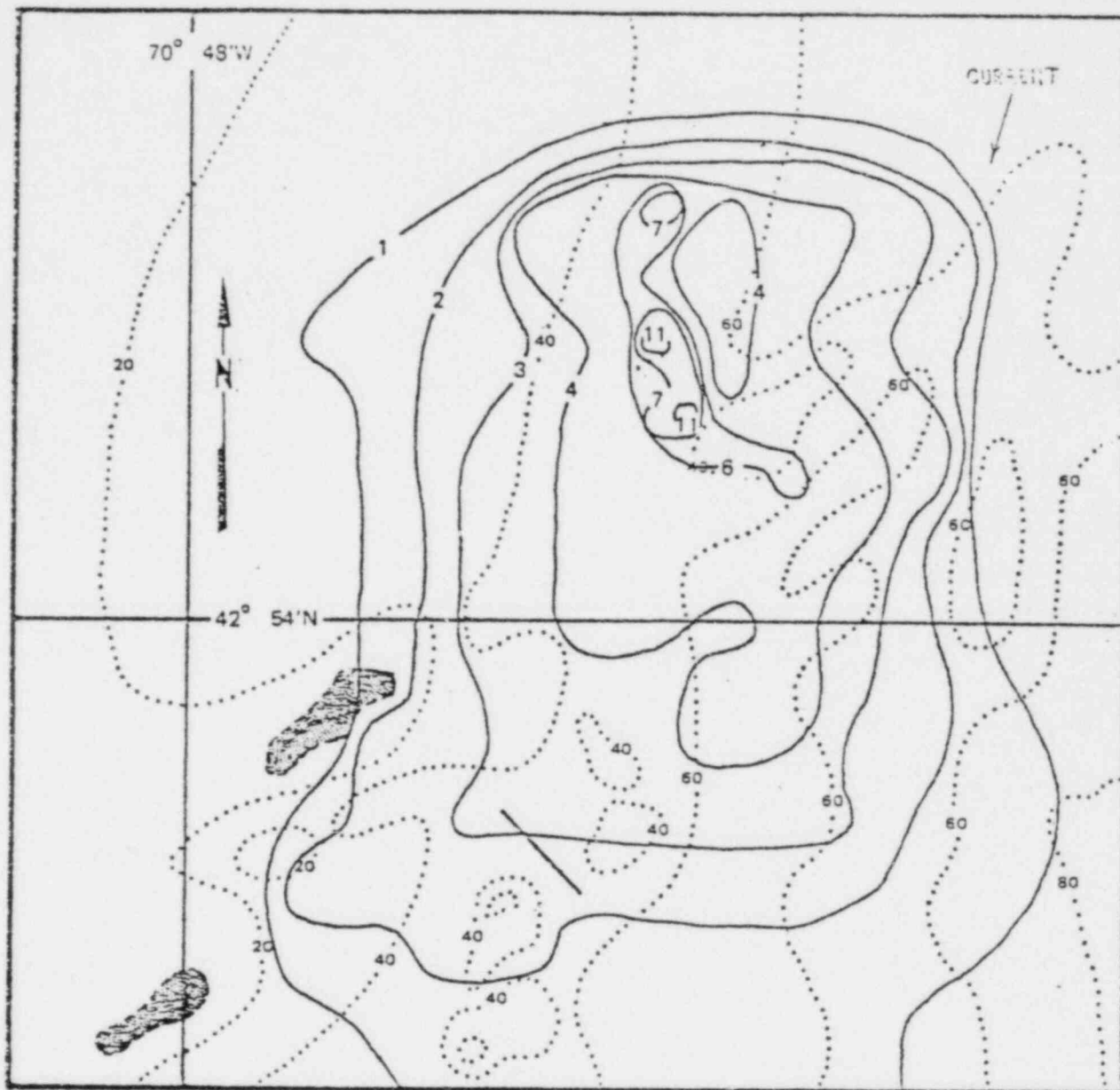

TIME <u>4.0 hrs.</u>	CURRENT DIRECTION <u>N-S</u>	INTAKE FLOW <u>869</u> cfs
TIDE <u>M/W</u>	CURRENT VELOCITY <u>0.15</u> kts	INTAKE $\Delta T$ <u>81.4 F</u>
MODEL AMBIENT <u>69.5 F</u>	PROTOTYPE AMBIENT <u>41.0 F</u>	POWER LEVEL <u>100%</u>
TEST NO. <u>212</u>	INTAKE "A"	TEST DATE <u>6/3/75</u>

SURFACE ISOTHERMS - BACKFLUSHING ( 3 INTAKES )

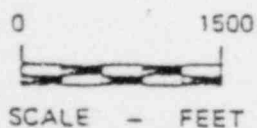

SEABROOK HYDROTHERMAL MODEL STUDY  
PUBLIC SERVICE COMPANY OF NEW HAMPSHIRE  
YANKEE ATOMIC ELECTRIC COMPANY

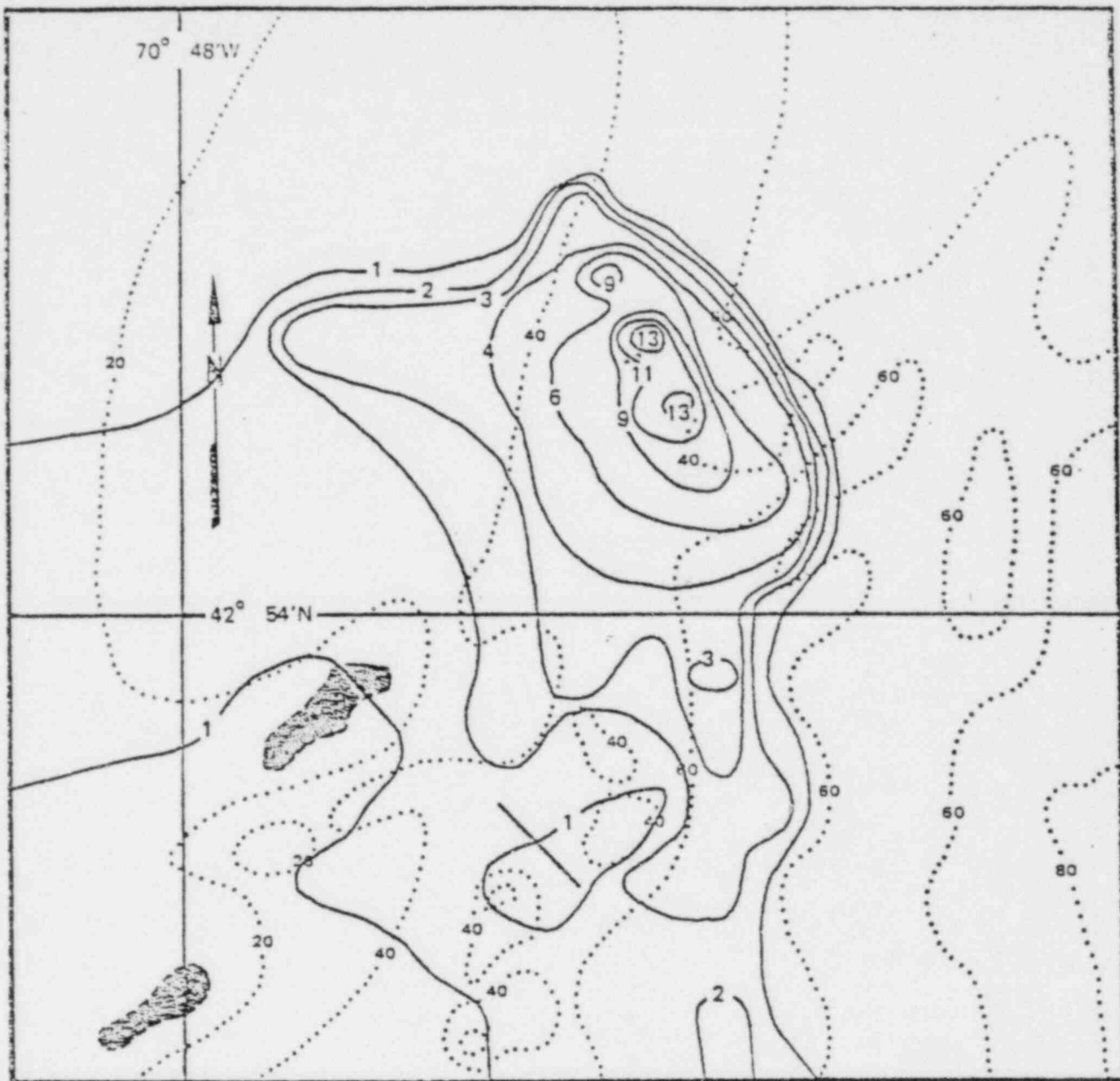

TIME 5.0 hrs.      CURRENT DIRECTION NE-SW      INTAKE FLOW 1822 cfs  
 TIDE L/W      CURRENT VELOCITY 0.2 kts      INTAKE  $\Delta T$  80.5 F  
 MODEL AMBIENT 69.3 F      PROTOTYPE AMBIENT 41.0 F      POWER LEVEL 100 %  
 TEST NO. 211      INTAKE "A"      TEST DATE 6-3-75

SURFACE ISOTHERMS - BACKFLUSHING ( 3 INTAKES )

SEABROOK HYDROTHERMAL MODEL STUDY  
 PUBLIC SERVICE COMPANY OF NEW HAMPSHIRE  
 YANKEE ATOMIC ELECTRIC COMPANY

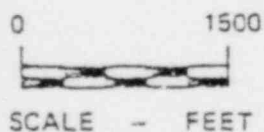



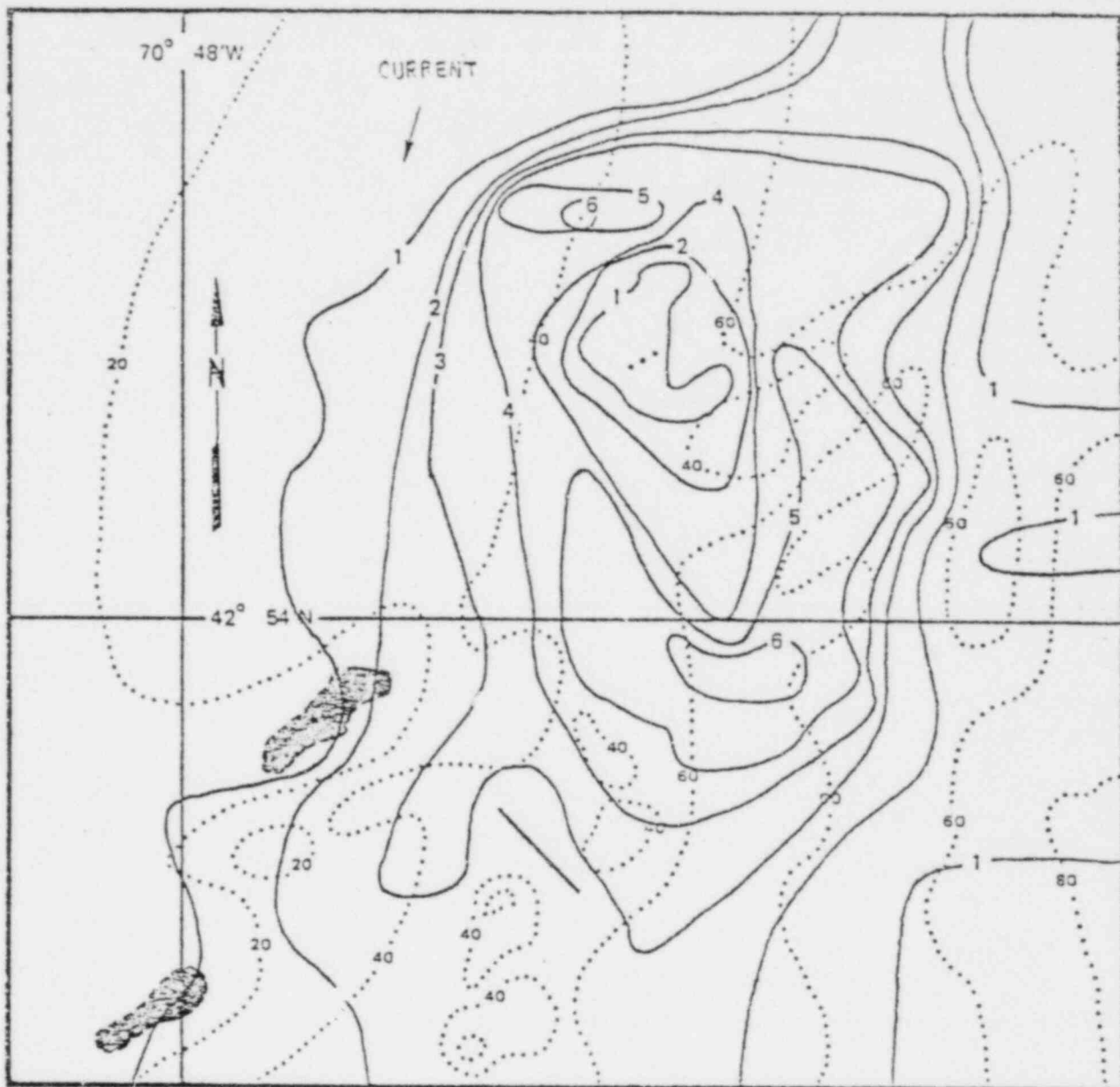

TIME 6.0 hrs.      CURRENT DIRECTION N-S      INTAKE FLOW 1322 cfs  
 TIDE M/W      CURRENT VELOCITY 0.15 kts      INTAKE  $\Delta T$  .1 F  
 MODEL AMBIENT 69.5 F      PROTOTYPE AMBIENT 41.0 F      POWER LEVEL 100%  
 TEST NO. 212      INTAKE "A"      TEST DATE 6/3/75

SURFACE ISOTHERMS - BACKFLUSHING ( 3 INTAKES )



SEABROOK HYDROTHERMAL MODEL STUDY  
 PUBLIC SERVICE COMPANY OF NEW HAMPSHIRE  
 YANKEE ATOMIC ELECTRIC COMPANY

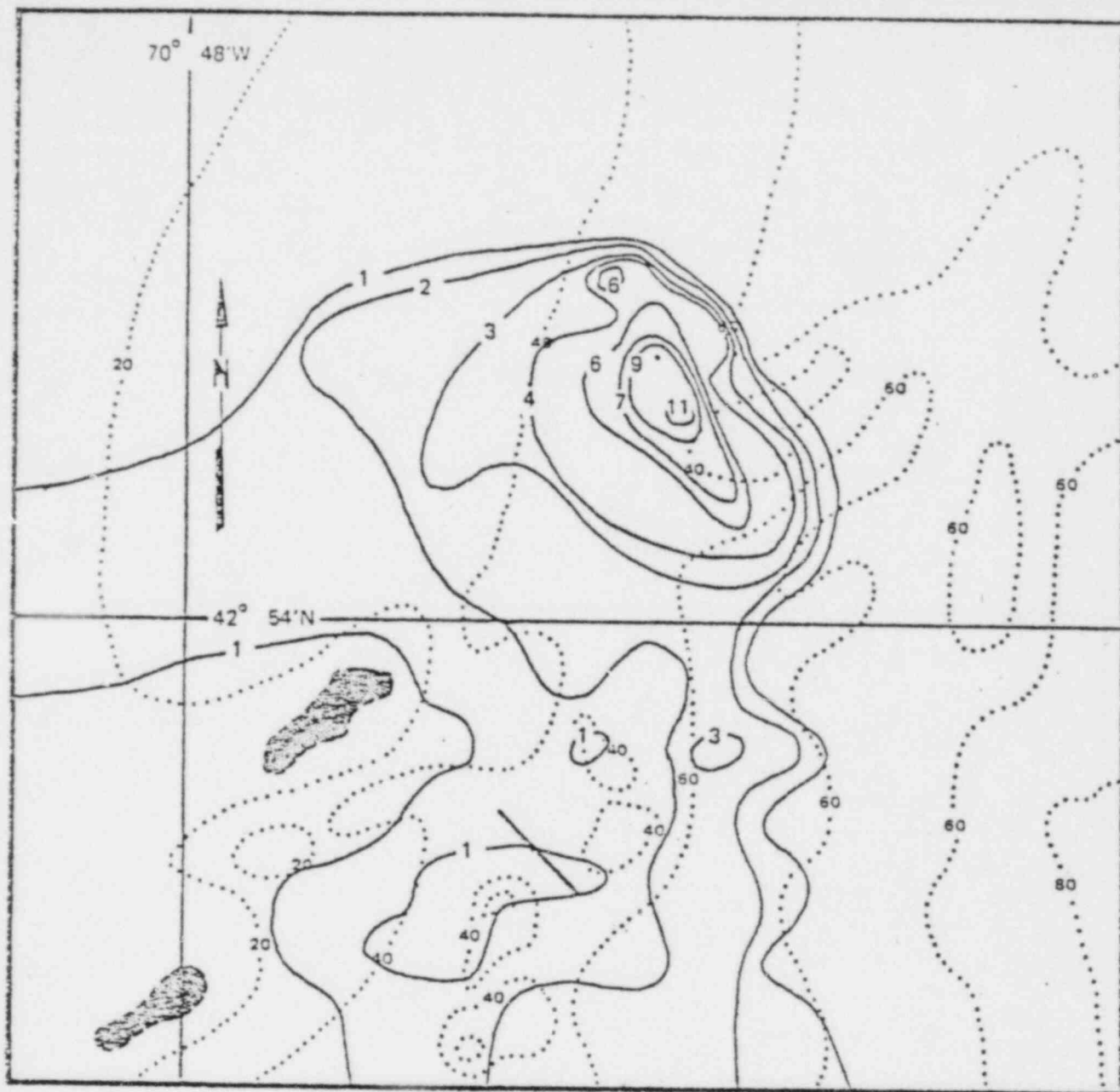

TIME 3.0 hrs.      CURRENT DIRECTION NE-SW      INTAKE FLOW 869 cfs  
 TIDE L/W      CURRENT VELOCITY 0.2 kts      INTAKE  $\Delta T$  78.0 F  
 MODEL AMBIENT 69.3 F      PROTOTYPE AMBIENT 41.0 F      POWER LEVEL 100 %  
 TEST NO. 211      INTAKE "A"      TEST DATE 6-3-75

SURFACE ISOTHERMS -- BACKFLUSHING ( 3 INTAKES )

0      1500  
  
 SCALE - FEET

SEABROOK HYDROTHERMAL MODEL STUDY  
 PUBLIC SERVICE COMPANY OF NEW HAMPSHIRE  
 YANKEE ATOMIC ELECTRIC COMPANY

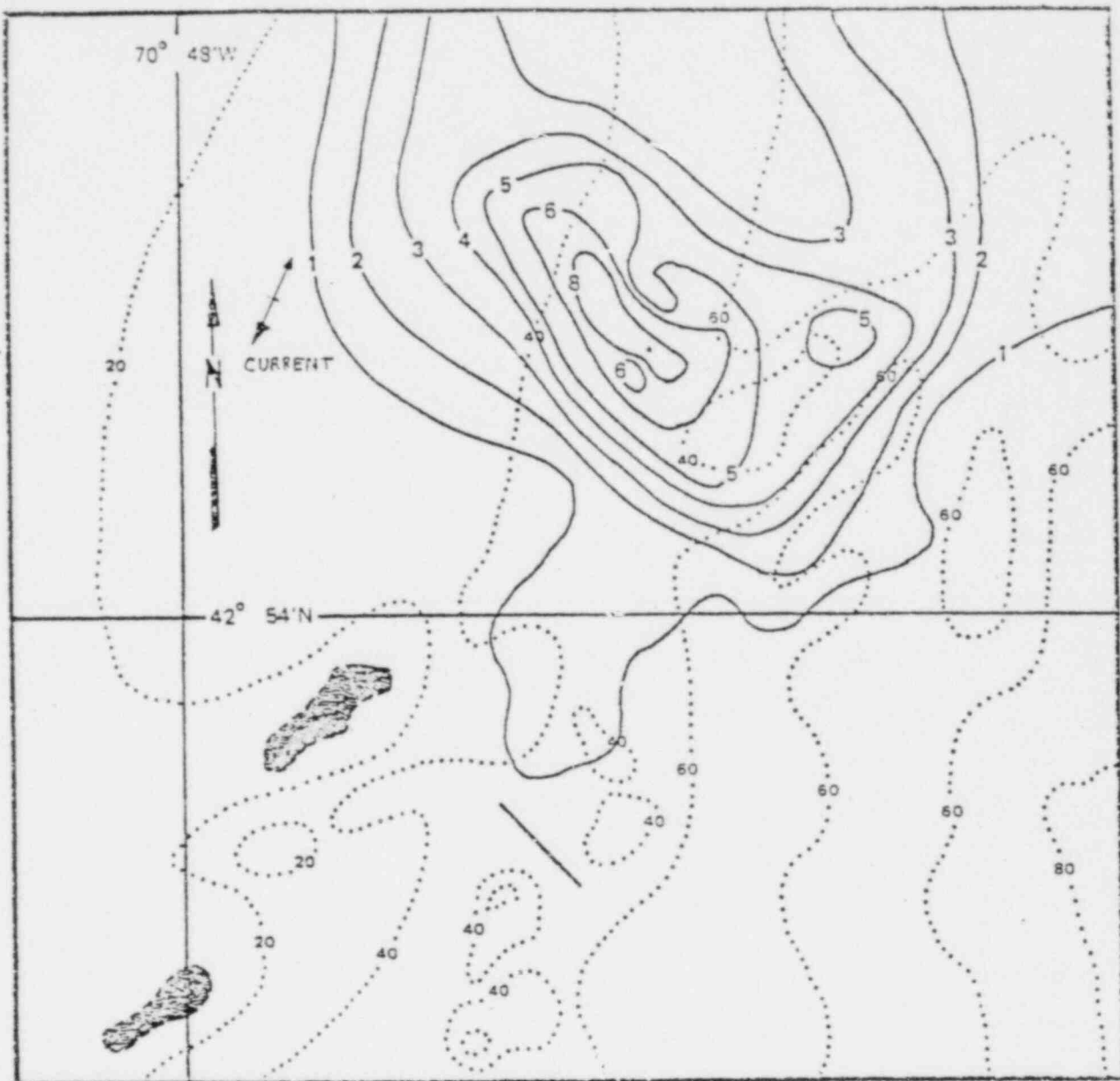

TIME 2.0 hrs.      CURRENT DIRECTION cycle 4      INTAKE FLOW 869 cfs  
 TIDE \_\_\_\_\_      CURRENT VELOCITY \_\_\_\_\_ kts      INTAKE  $\Delta T$  68.2 F  
 MODEL AMBIENT 69.0 F      PROTOTYPE AMBIENT 41.0 F      POWER LEVEL 100%  
 TEST NO. 215      INTAKE "A"      TEST DATE 6/5/75

SURFACE ISOTHERMS - BACKFLUSHING ( 3 INTAKES )



SEABROOK HYDROTHERMAL MODEL STUDY  
 PUBLIC SERVICE COMPANY OF NEW HAMPSHIRE  
 YANKEE ATOMIC ELECTRIC COMPANY

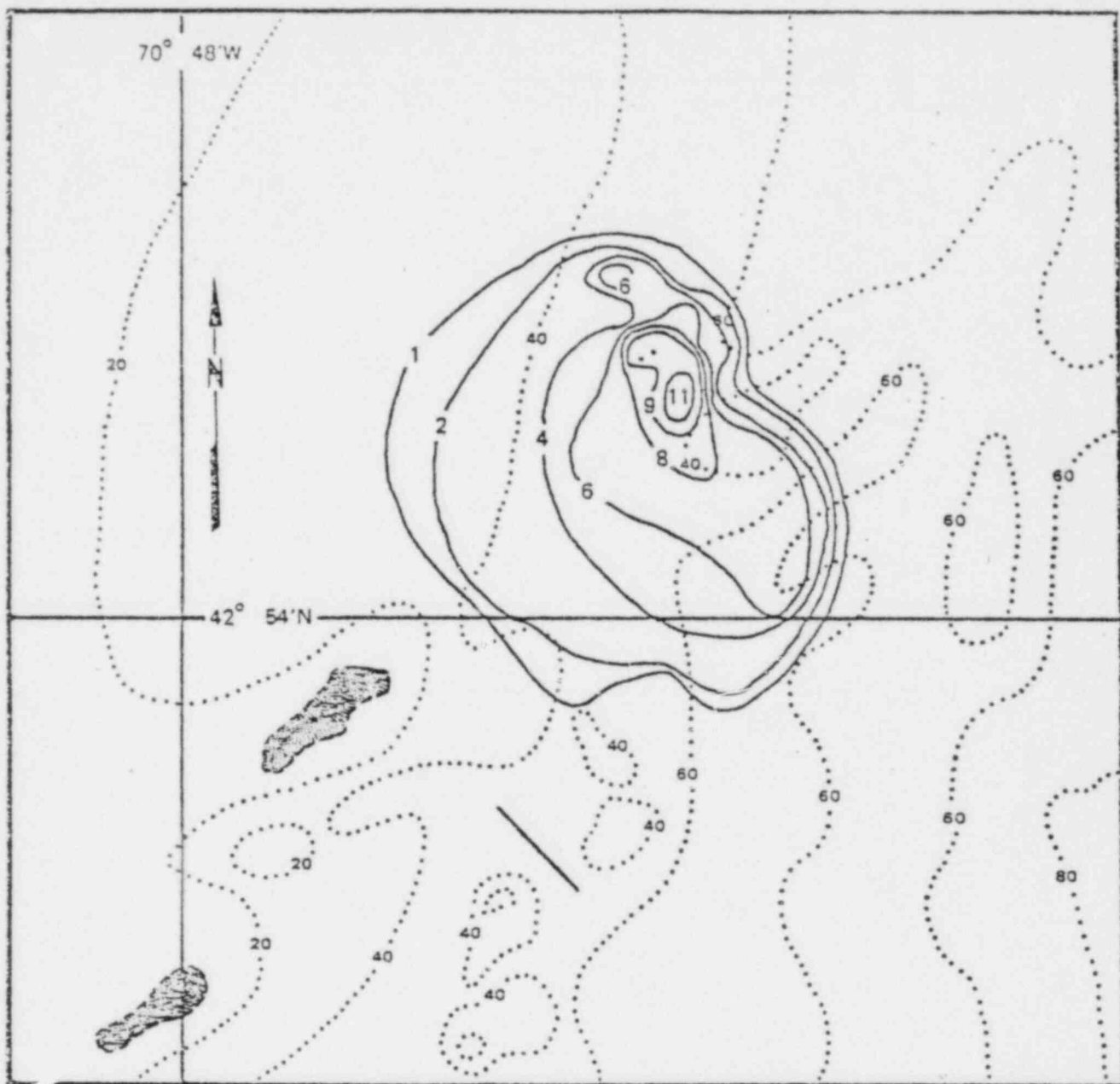

TIME <u>1.0</u> hrs.	CURRENT DIRECTION <u>NE-SW</u>	INTAKE FLOW <u>1822</u> cfs
TIDE <u>L/W</u>	CURRENT VELOCITY <u>0.2</u> kts	INTAKE $\Delta T$ <u>63.5</u> F
MODEL AMBIENT <u>69.3</u> F	PROTOTYPE AMBIENT <u>41.0</u> F	POWER LEVEL <u>100</u> %
TEST NO. <u>211</u>	INTAKE "A"	TEST DATE <u>6-3-75</u>

SURFACE ISOTHERMS - BACKFLUSHING ( 3 INTAKES )

SEABROOK HYDROTHERMAL MODEL STUDY  
PUBLIC SERVICE COMPANY OF NEW HAMPSHIRE  
YANKEE ATOMIC ELECTRIC COMPANY



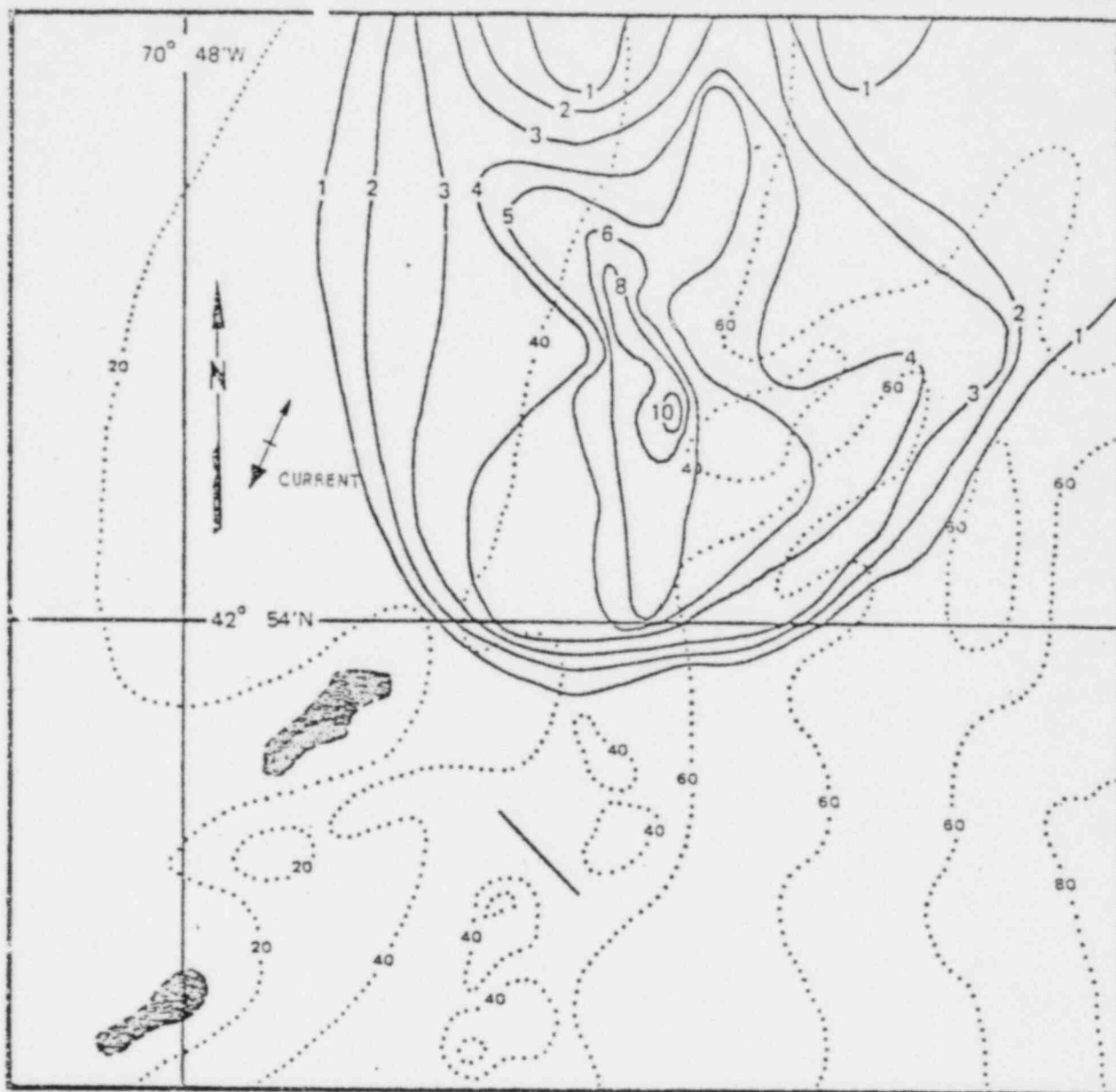

TIME 4.0 hrs.      CURRENT DIRECTION Cycle 4      INTAKE FLOW 869 cfs  
 TIDE \_\_\_\_\_      CURRENT VELOCITY \_\_\_\_\_ kts      INTAKE  $\Delta T$  83.4 F  
 MODEL AMBIENT 69.0 F      PROTOTYPE AMBIENT 41.0 F      POWER LEVEL 100%  
 TEST NO. 215      INTAKE "A"      TEST DATE 6/5/75

SURFACE ISOTHERMS - BACKFLUSHING ( 3 INTAKES )

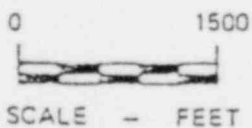

SEABROOK HYDROTHERMAL MODEL STUDY  
 PUBLIC SERVICE COMPANY OF NEW HAMPSHIRE  
 YANKEE ATOMIC ELECTRIC COMPANY

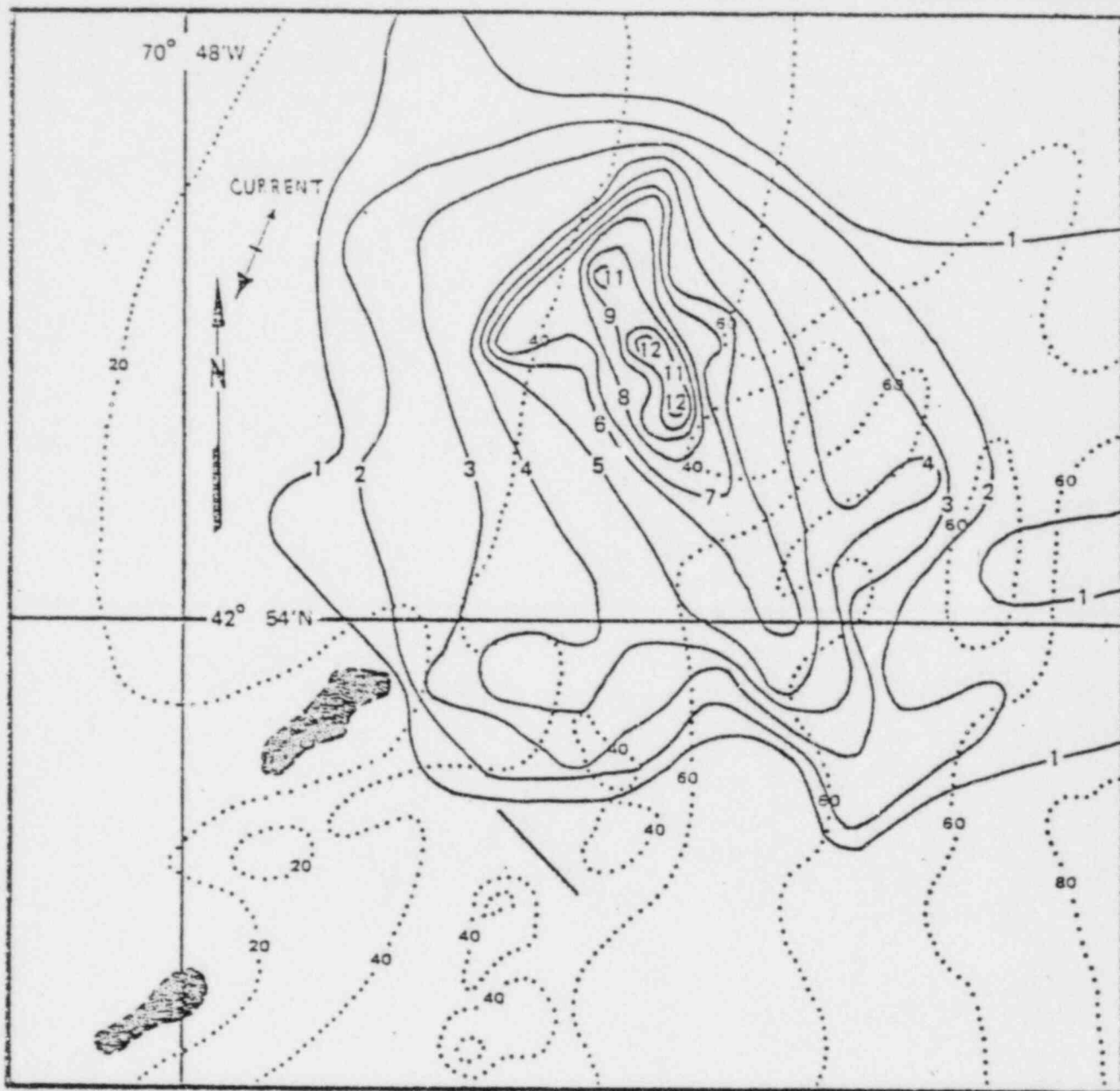

TIME 5.0 hrs.      CURRENT DIRECTION Cycle 4      INTAKE FLOW 1822 cfs  
 TIDE \_\_\_\_\_      CURRENT VELOCITY \_\_\_\_\_ kts      INTAKE  $\Delta T$  72.0 F  
 MODEL AMBIENT 69.0 F      PROTOTYPE AMBIENT 41.0 F      POWER LEVEL 100%  
 TEST NO. 215      INTAKE "A"      TEST DATE 6/5/75

SURFACE ISOTHERMS - BACKFLUSHING ( 3 INTAKES )

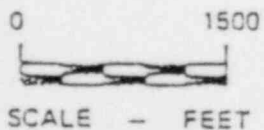

SEABROOK HYDROTHERMAL MODEL STUDY  
 PUBLIC SERVICE COMPANY OF NEW HAMPSHIRE  
 YANKEE ATOMIC ELECTRIC COMPANY

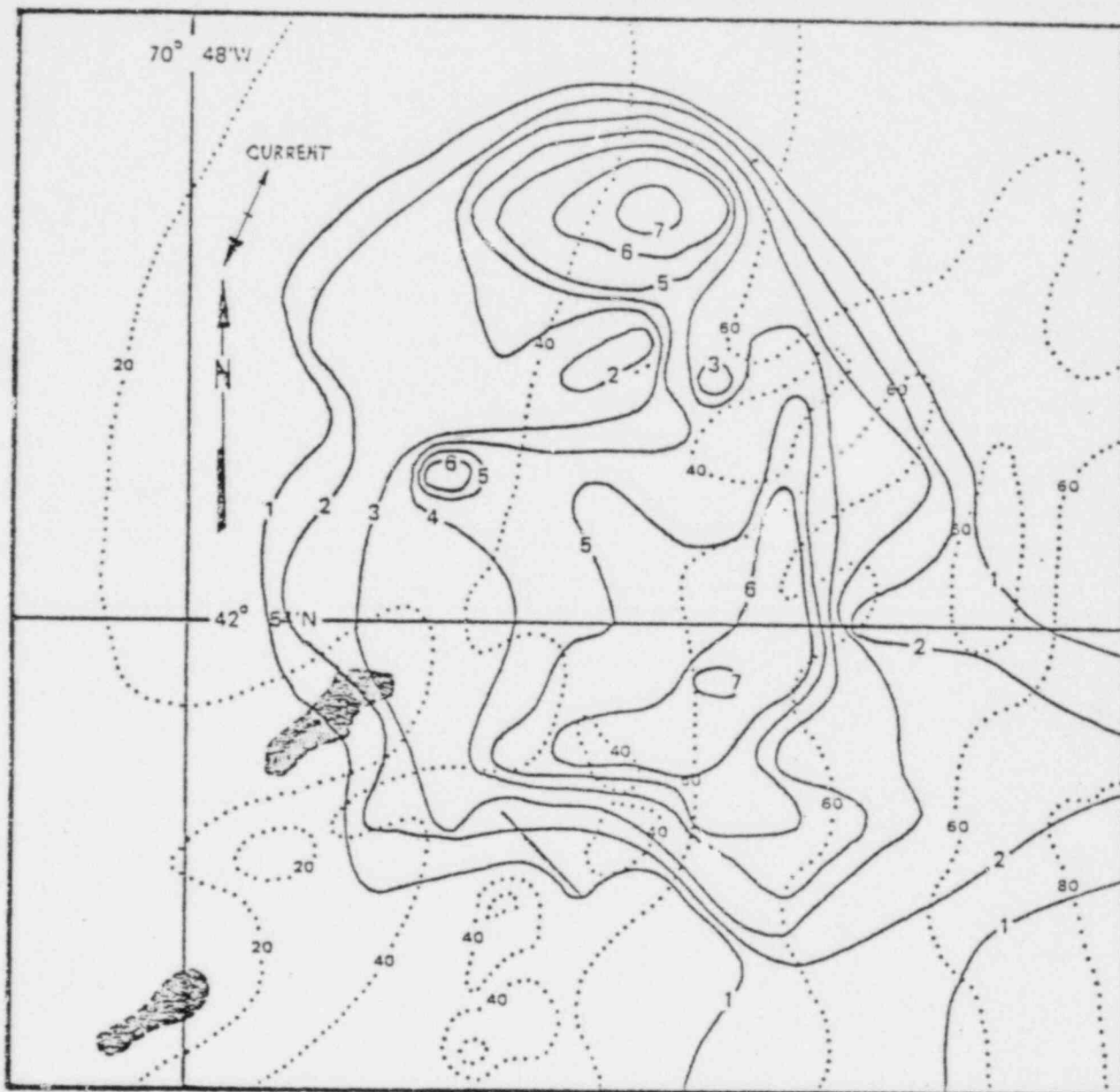

TIME 6.8 hrs.      CURRENT DIRECTION Cycle 4      INTAKE FLOW -1822 cfs  
 TIDE \_\_\_\_\_      CURRENT VELOCITY \_\_\_\_\_ kts      INTAKE  $\Delta T$  -1 F  
 MODEL AMBIENT 69.0 F      PROTOTYPE AMBIENT 41.0 F      POWER LEVEL 100%  
 TEST NO. 215      INTAKE "A"      TEST DATE 6/5/75

SURFACE ISOTHERMS - BACKFLUSHING ( 3 INTAKES )

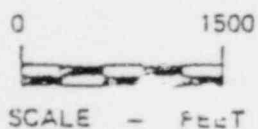

SEABROOK HYDROTHERMAL MODEL STUDY  
 PUBLIC SERVICE COMPANY OF NEW HAMPSHIRE  
 YANKEE ATOMIC ELECTRIC COMPANY

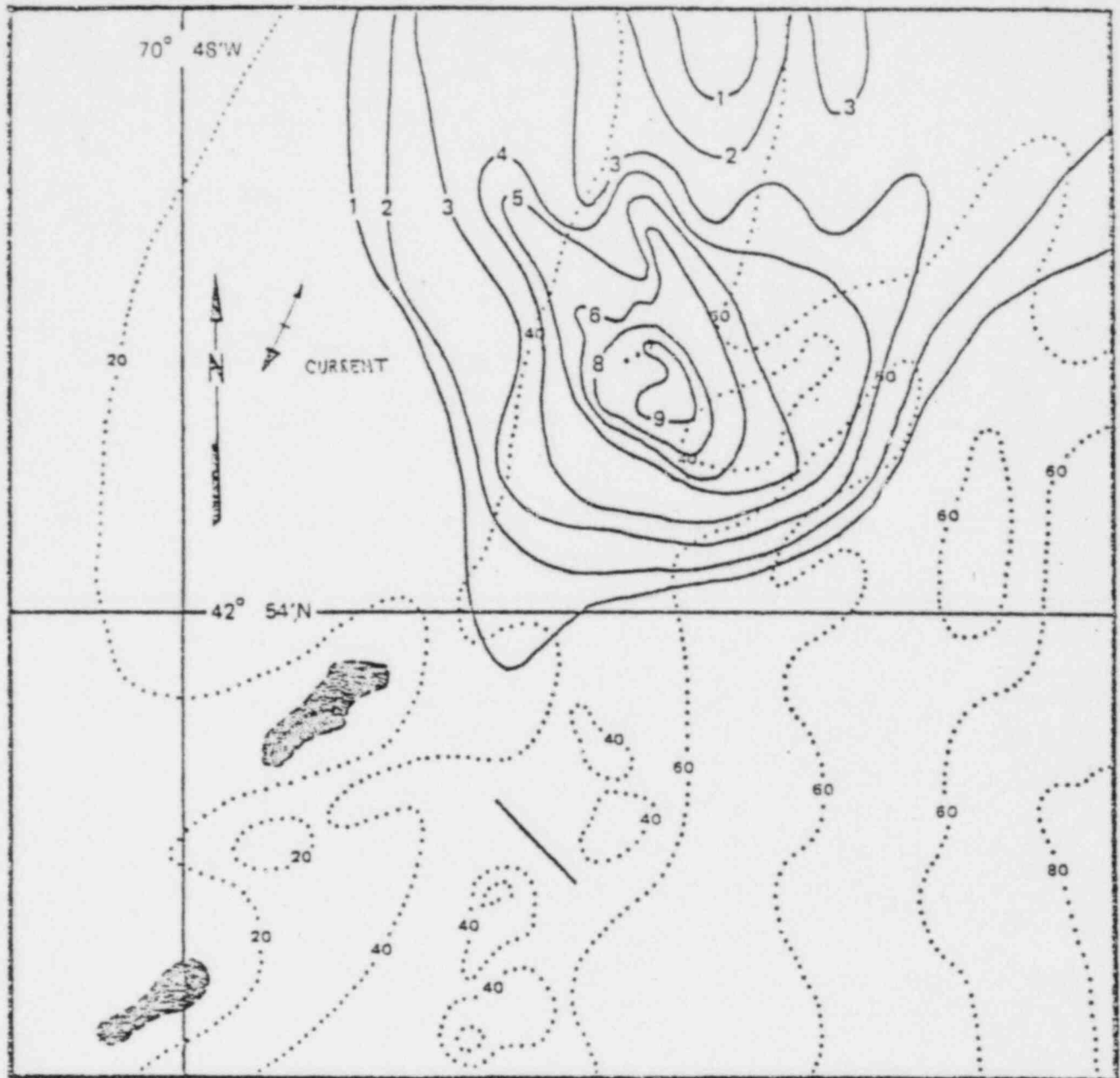

TIME 3.0 hrs.      CURRENT DIRECTION cycle 4      INTAKE FLOW 869 cfs  
 TIDE \_\_\_\_\_      CURRENT VELOCITY \_\_\_\_\_ kts      INTAKE  $\Delta T$  81.4 F  
 MODEL AMBIENT 69.0 F      PROTOTYPE AMBIENT 41.0 F      POWER LEVEL 100%  
 TEST NO. 215      INTAKE "A"      TEST DATE 6/5/75

SURFACE ISOTHERMS - BACKFLUSHING ( 3 INTAKES )

SEABROOK HYDROTHERMAL MODEL STUDY  
 PUBLIC SERVICE COMPANY OF NEW HAMPSHIRE  
 YANKEE ATOMIC ELECTRIC COMPANY

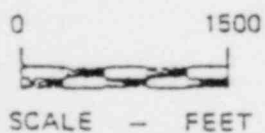



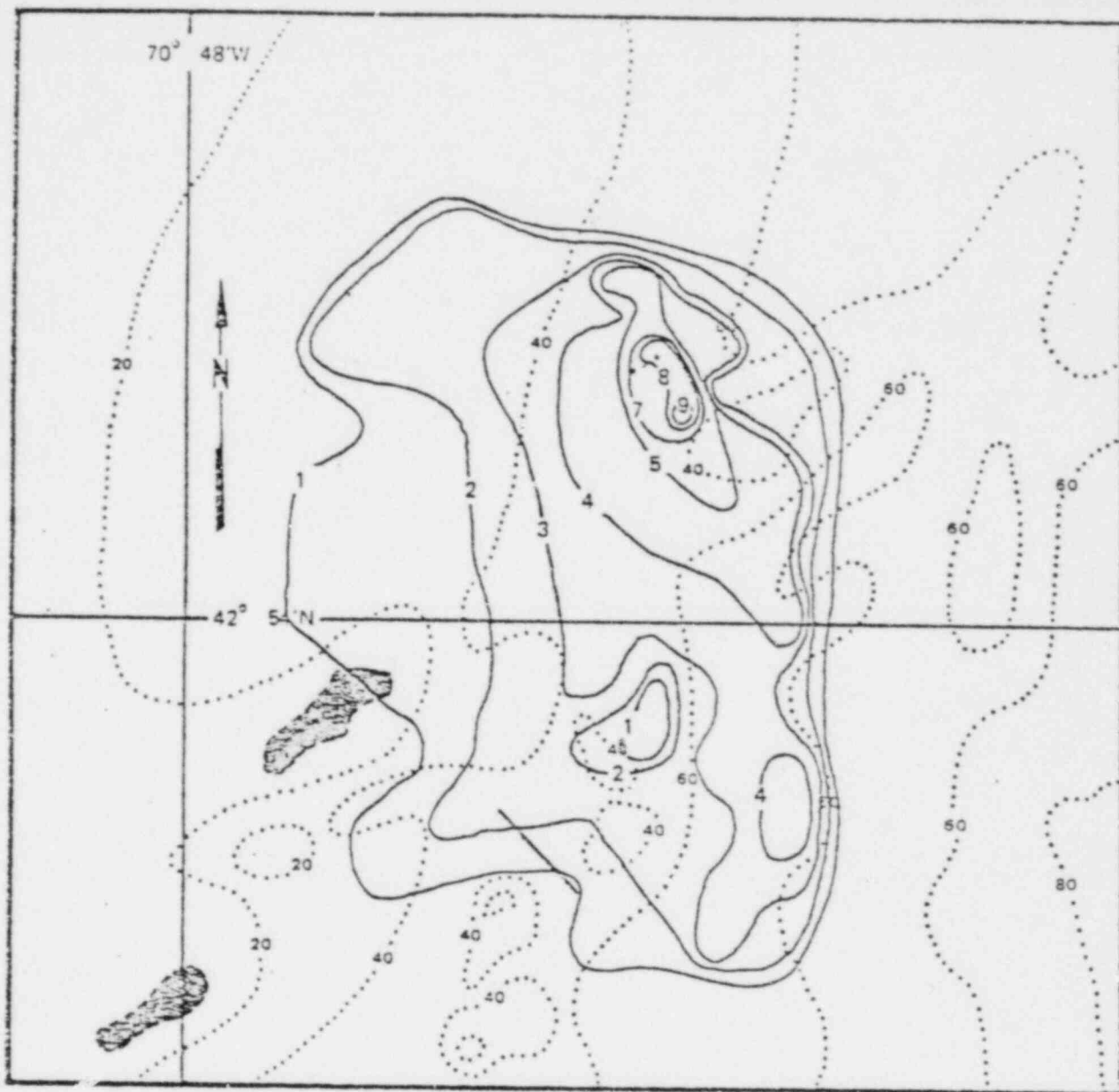

TIME 2.0 hrs.      CURRENT DIRECTION NE-SW      INTAKE FLOW 869 cfs  
 TIDE L/W      CURRENT VELOCITY 0.2 kts      INTAKE  $\Delta T$  64.6 F  
 MODEL AMBIENT 69.3 F      PROTOTYPE AMBIENT 41.0 F      POWER LEVEL 100 %  
 TEST NO. 211      INTAKE "A"      TEST DATE 6-3-75

SURFACE ISOTHERMS - BACKFLUSHING ( 3 INTAKES )

0      1500  
  
 SCALE - FEET

SEABROOK HYDROTHERMAL MODEL STUDY  
 PUBLIC SERVICE COMPANY OF NEW HAMPSHIRE  
 YANKEE ATOMIC ELECTRIC COMPANY

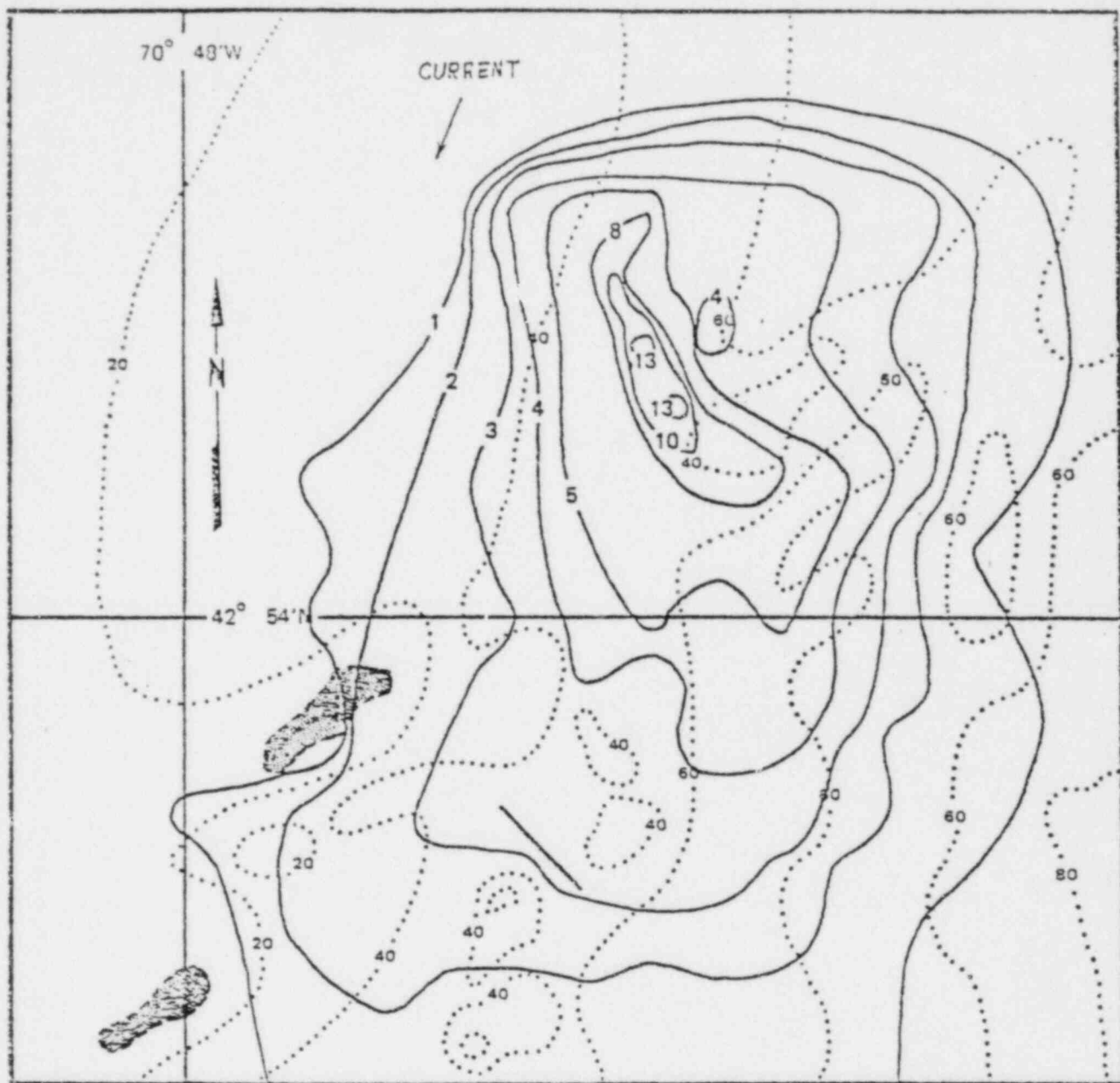

TIME 5.0 hrs.      CURRENT DIRECTION N-S      INTAKE FLOW 1822 cfs  
 TIDE M/W      CURRENT VELOCITY 0.15 kts      INTAKE  $\Delta T$  76.7 F  
 MODEL AMBIENT 69.5 F      PROTOTYPE AMBIENT 41.0 F      POWER LEVEL 100%  
 TEST NO. 212      INTAKE "A"      TEST DATE 6/3/75

SURFACE ISOTHERMS -- BACKFLUSHING ( 3 INTAKES )

SEABROOK HYDROTHERMAL MODEL STUDY  
 PUBLIC SERVICE COMPANY OF NEW HAMPSHIRE  
 YANKEE ATOMIC ELECTRIC COMPANY

0      1500  
  
 SCALE - FEET

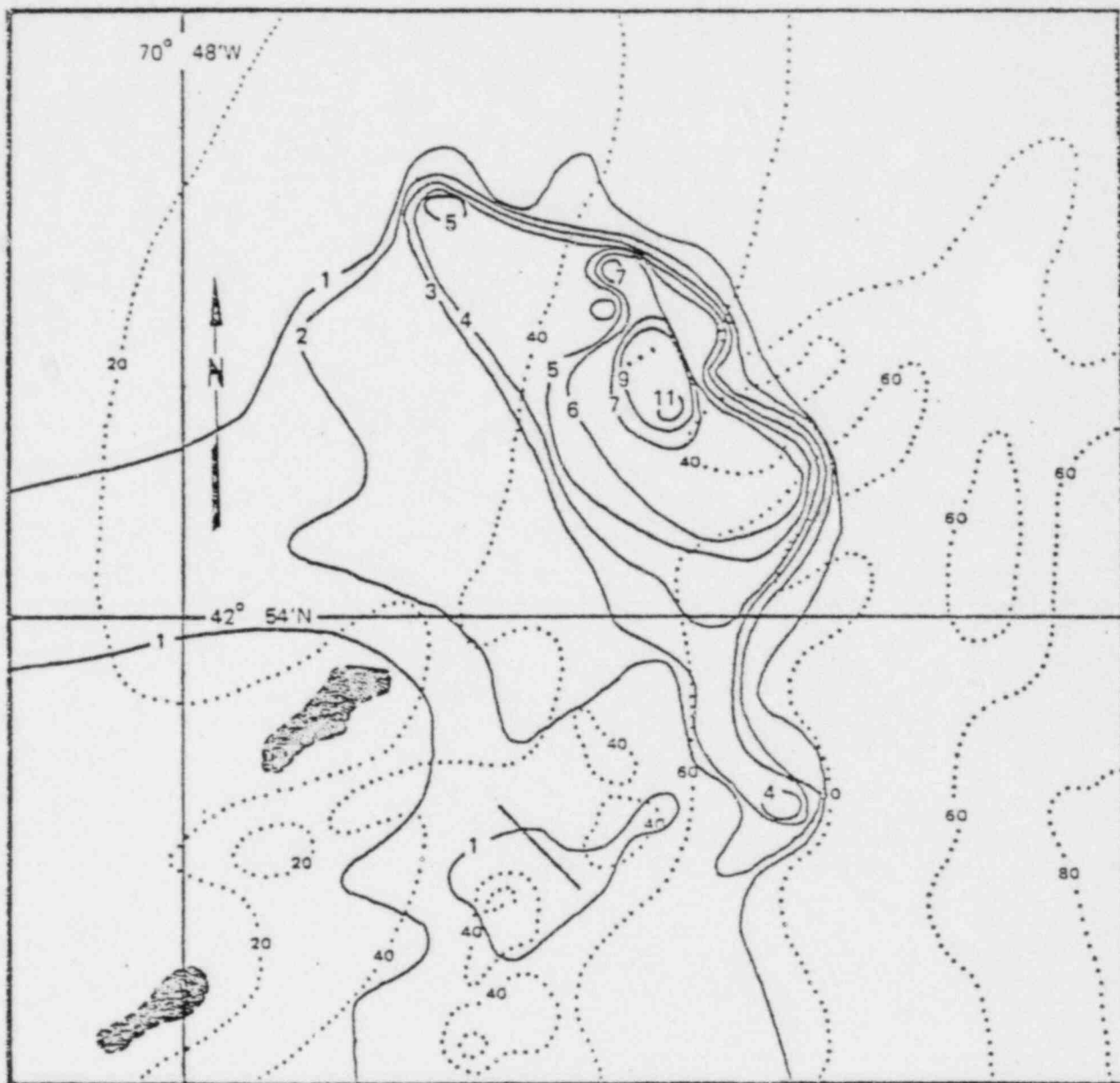

TIME 4.0 hrs.      CURRENT DIRECTION NE-SW      INTAKE FLOW 869 cfs  
 TIDE L/W      CURRENT VELOCITY 0.2 kts      INTAKE  $\Delta T$  81.2 F  
 MODEL AMBIENT 69.3 F      PROTOTYPE AMBIENT 41.0 F      POWER LEVEL 100 %  
 TEST NO. 211      INTAKE "A"      TEST DATE 6-3-75

SURFACE ISOTHERMS - BACKFLUSHING ( 3 INTAKES )

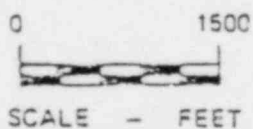

SEABROOK HYDROTHERMAL MODEL STUDY  
 PUBLIC SERVICE COMPANY OF NEW HAMPSHIRE  
 YANKEE ATOMIC ELECTRIC COMPANY

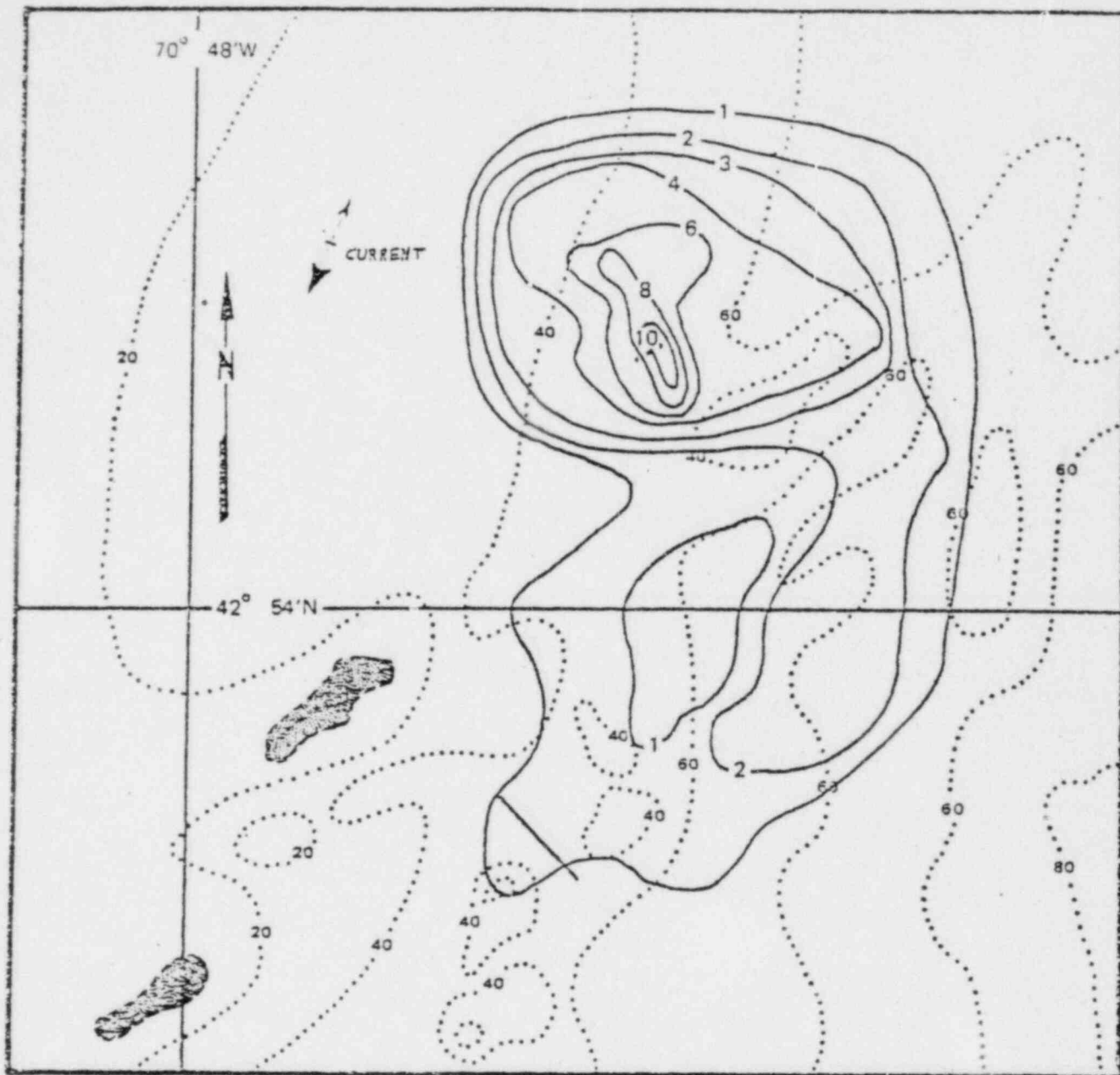

TIME 1.0 hrs.      CURRENT DIRECTION cycle 4      INTAKE FLOW 1822 cfs  
 TIDE \_\_\_\_\_      CURRENT VELOCITY \_\_\_\_\_ kts      INTAKE  $\Delta T$  61.8 F  
 MODEL AMBIENT 69.0 F      PROTOTYPE AMBIENT 41.0 F      POWER LEVEL 100%  
 TEST NO. 215      INTAKE "A"      TEST DATE 6/5/75

SURFACE ISOTHERMS - BACKFLUSHING ( 3 INTAKES )

SEABROOK HYDROTHERMAL MODEL STUDY  
 PUBLIC SERVICE COMPANY OF NEW HAMPSHIRE  
 YANKEE ATOMIC ELECTRIC COMPANY



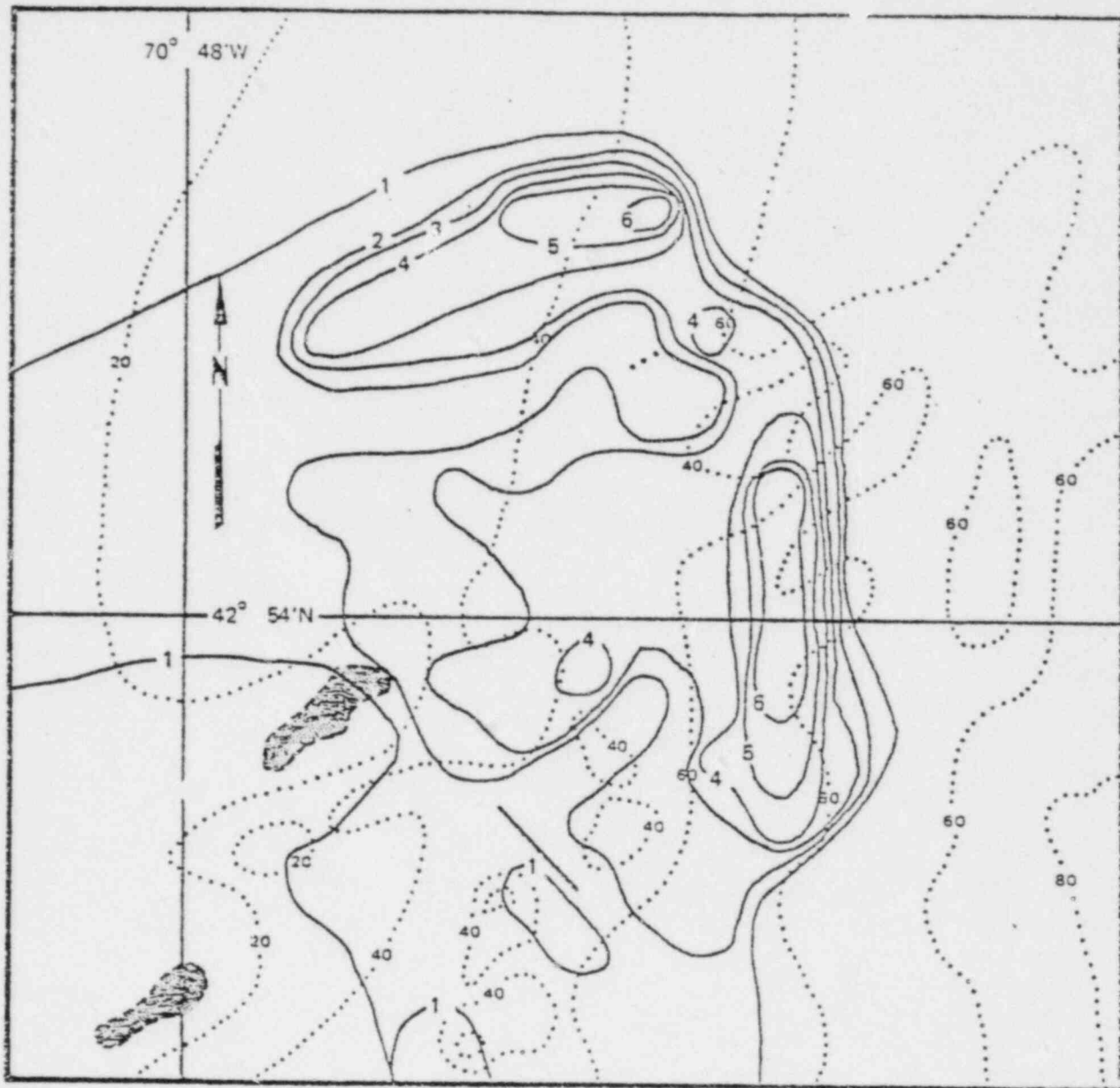

TIME 6.0 hrs.      CURRENT DIRECTION NE-SW      INTAKE FLOW -1822 cfs  
 TIDE L/W      CURRENT VELOCITY 0.2 kts      INTAKE  $\Delta T$  .1 F  
 MODEL AMBIENT 69.3 F      PROTOTYPE AMBIENT 41.0 F      POWER LEVEL 100 %  
 TEST NO. 211      INTAKE "A"      TEST DATE 6-3-75

SURFACE ISOTHERMS - BACKFLOW ( 3 INTAKES )

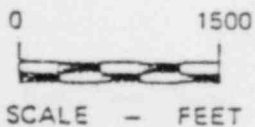

SEABROOK HYDROTHERMAL MODEL STUDY  
 PUBLIC SERVICE COMPANY OF NEW HAMPSHIRE  
 YANKEE ATOMIC ELECTRIC COMPANY