

THIS DOCUMENT CONTAINS
POOR QUALITY PAGES

1980 Annual Report

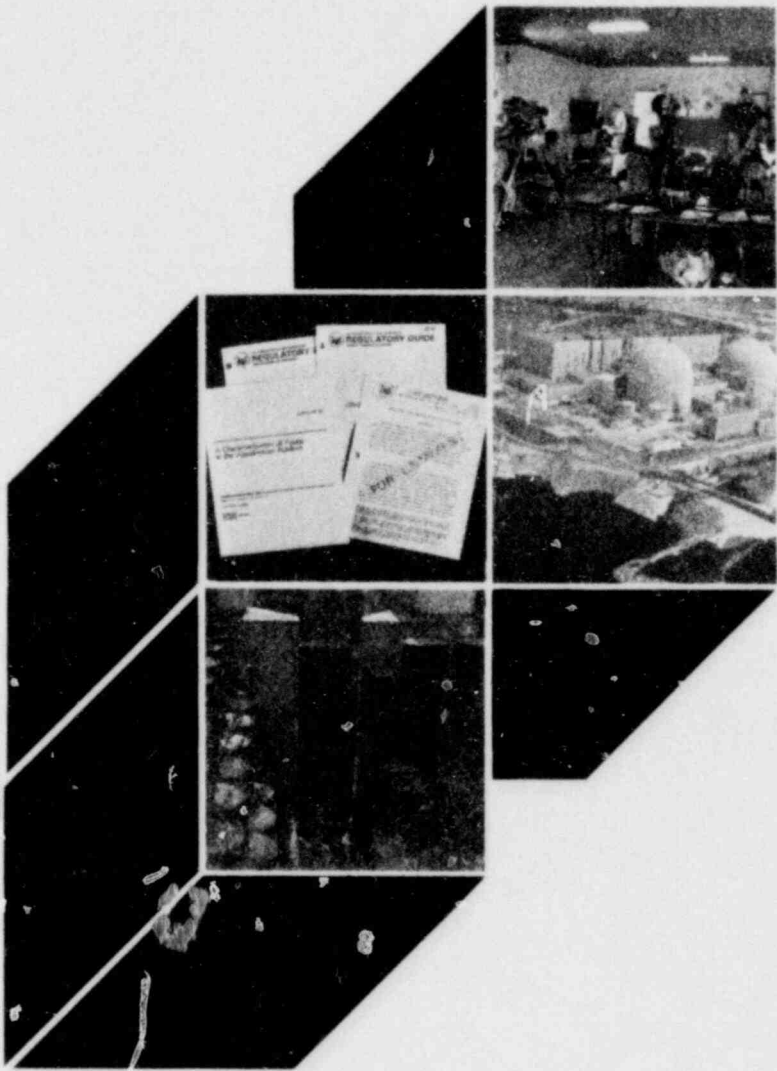

U.S. NUCLEAR
REGULATORY COMMISSION

8105040098

Table of Contents

Chapter 1—OVERVIEW

| | |
|---|----|
| POLICY, PLANNING AND OUTLOOK | 1 |
| Defining a Safety Goal | 2 |
| RESHAPING THE AGENCY | 2 |
| The Commission and EDO | 3 |
| Staff Reorganizations | 3 |
| REACTOR REGULATION | 3 |
| The Status of Licensing | 3 |
| Reviews of Operating Reactors | 5 |
| Rulemaking Actions | 6 |
| TMI-2 Accident Aftermath | 6 |
| Emergency Preparedness | 10 |
| New Focus on Operating Experience | 11 |
| OTHER MAJOR PROGRAMS | 11 |
| Inspection and Enforcement Activities | 11 |
| Research | 12 |
| Waste Management | 12 |
| Materials and Transportation | 13 |
| Domestic Safeguards | 13 |
| International Activities | 14 |

Chapter 2—AFTERMATH OF THE ACCIDENT AT THREE MILE ISLAND

| | |
|--|----|
| STATUS OF THE TMI-2 FACILITY | 15 |
| Decontamination of Water—EPICOR II | 15 |
| Decontamination of Atmosphere | 16 |
| Reactor Building Entry | 17 |
| Programmatic Environmental Impact Statement | 17 |
| Advisory Panel on TMI Cleanup | 17 |
| NRC Policy Statement on State Requirements at TMI | 18 |
| Six TMI Workers Incur Radiation Overexposure | 19 |
| SPECIAL REPORTS ON THREE MILE ISLAND | 19 |
| Psychological Stress Resulting from the TMI Accident | 19 |
| Socioeconomic Impacts of the TMI Accident | 19 |
| Impact of Three Mile Island on Biota | 20 |
| Groundwater Monitoring at TMI | 20 |
| NRC Special Inquiry Group | 22 |
| Special Senate Investigation Report | 23 |
| GAO Report to Congress on TMI | 24 |
| Potential Impact of Bankruptcy of TMI Licensee | 24 |

Chapter 3—EMERGENCY PREPAREDNESS

| | |
|---|----|
| Upgrading Licensee Emergency Preparedness | 27 |
| NRC's Emergency Preparedness Organization..... | 28 |
| NRC/FEMA Relationship..... | 29 |
| Development of Guidance, Criteria and Regulations | 29 |
| Emergency Planning Zones Concept | 30 |
| Prompt Notification..... | 31 |
| Emergency Response Facilities..... | 31 |
| Policy on Potassium Iodide..... | 33 |
| Emergency Preparedness Exercises..... | 33 |
| NRC Incident Response..... | 33 |

Chapter 4—REACTOR REGULATION

| | |
|---|----|
| STATUS OF LICENSING | 37 |
| ADVANCED NUCLEAR POWER REACTORS..... | 41 |
| REACTOR SAFETY ISSUES..... | 42 |
| UNRESOLVED SAFETY ISSUES | 42 |
| Identification of New Issues..... | 42 |
| Progress Reports | 45 |
| Water Hammer..... | 45 |
| Asymmetric Blowdown Loads on the Reactor Coolant System..... | 46 |
| PWR Steam Generator Tube Integrity | 46 |
| BWR Mark I and Mark II Pressure Suppression Containments..... | 49 |
| Anticipated Transients Without Scram..... | 50 |
| BWR Nozzle Cracking..... | 51 |
| Reactor Vessel Material Toughness..... | 51 |
| Fracture Toughness and Potential for Lamellar Tearing of Component Supports..... | 52 |
| Systems Interactions in Nuclear Power Plants | 52 |
| Environmental Qualification of Safety-Related Electrical Equipment..... | 53 |
| Control of Heavy Loads Near Spent Fuel..... | 54 |
| Seismic Design Criteria..... | 54 |
| Pipe Cracks at Boiling Water Reactors | 55 |
| Containment Emergency Sump Reliability..... | 56 |
| Station Blackout | 56 |
| OTHER TECHNICAL ISSUES | 57 |
| Qualification of Safety-Related Equipment..... | 57 |
| PWR Pipe Cracking..... | 58 |
| Turbine Disk Cracking..... | 58 |
| Fire Protection..... | 60 |
| Decontamination of Dresden Facility | 60 |
| Control Rod Failure at Browns Ferry..... | 61 |
| IMPROVING THE LICENSING PROCESS..... | 61 |
| REORGANIZATION OF NRR..... | 61 |
| Human Factors..... | 62 |
| Systems Interaction Branch..... | 65 |
| PREPARATION AND IMPLEMENTATION OF THE TMI ACTION PLAN | 66 |
| OTHER LICENSING CONCERNS..... | 68 |
| Consideration of Serious Accidents at Nuclear Power Plants..... | 68 |
| Reliability Evaluation Programs..... | 69 |
| Quality Assurance | 69 |
| Standard Review Plans..... | 70 |
| Siting of Nuclear Power Plants | 70 |
| Future Need for Electric Generating Facilities..... | 71 |
| Interim Hydrogen Control..... | 72 |
| Socioeconomic Impacts of the Construction and Operation of Nuclear Power Plants..... | 72 |

| | |
|--|----|
| PROTECTING THE ENVIRONMENT | 73 |
| The IFEU Report | 73 |
| Pathogenic Amoebae from Cooling Systems | 74 |
| Terrestrial and Aquatic Impacts | 75 |
| ANTITRUST ACTIVITIES | 76 |
| INDEMNITY AND FINANCIAL PROTECTION | 77 |
| The Price-Anderson System | 77 |
| Financial Protection for Three Mile Island | 78 |
| Indemnification of Storage of Spent Fuel at Distant Reactor Locations | 78 |
| Determination of an Extraordinary Nuclear Occurrence | 78 |
| Indemnity Operations | 78 |
| Insurance Premium Refund | 79 |
| ADVISORY COMMITTEE ON REACTOR SAFEGUARDS | 79 |

Chapter 5—OPERATING EXPERIENCE

| | |
|--|----|
| New Notification Rule | 81 |
| ABNORMAL OCCURRENCES—FISCAL YEAR 1980 | 82 |
| Update on Abnormal Occurrences from Fiscal Year 1979 | 82 |
| Plutonium Inhaled at Fuel Cycle Facility | 84 |
| Radiography Firm Irradiates Adjacent Business Offices | 84 |
| Crystal River Incident—Loss of Instrumentation | 85 |
| Decay Heat Removal Capability Lost at Davis-Besse | 87 |
| Partial Scram System Failure at Browns Ferry Unit 3 | 88 |
| Agreement State Abnormal Occurrences | 90 |
| OFFICE FOR ANALYSIS AND EVALUATION OF OPERATIONAL DATA | 90 |
| AEOD ACTIVITIES DURING 1980 | 92 |
| AEOD TECHNICAL STUDIES | 93 |
| Partial Scram System Failure at Browns Ferry Unit 3 | 93 |
| Loss of Component Cooling Water to All Reactor Coolant Pumps | 96 |
| Asiatic Clams Jam System | 97 |
| Loss of Off-Site Power at Arkansas Nuclear One | 99 |
| Water Hammer in LWR Piping Systems | 99 |

Chapter 6—MATERIALS REGULATION AND TRANSPORTATION

| | |
|---|-----|
| FUEL CYCLE ACTIONS | 101 |
| SURVEYS OF FUEL CYCLE | 101 |
| Improved Radon Estimates | 102 |
| Appeal Board Hearing on Radon | 103 |
| Updating Values in Table S-3 | 103 |
| Nuclear Fuel Cycle Evaluations | 104 |
| SPENT FUEL STORAGE ACTIONS | 104 |
| Movements Between Reactors | 104 |
| Away-From-Reactor Storage | 104 |
| ADVANCED FUEL ACTIVITIES | 105 |
| OTHER FUEL CYCLE ACTIVITIES | 105 |
| Radiological Contingency Planning | 105 |
| Implementation of 40 CFR Part 190 | 105 |
| Evaluating Sites for Radioactivity | 106 |
| Ammonium Nitrate Waste | 106 |
| West Valley, N.Y., Facility | 106 |
| TRANSPORTATION OF RADIOACTIVE MATERIALS | 107 |
| Low-Level Waste Shipments | 107 |
| Irradiated Fuel Packaging Actions | 107 |
| Safety of Transportation Workers | 107 |

| | |
|---|-----|
| GAO Report..... | 108 |
| Transportation in Urban Areas..... | 108 |
| Power Reactor Wastes..... | 108 |
| Emergency Response Planning..... | 108 |
| Routing of Shipments..... | 109 |
| Packaging Standards..... | 109 |
| International Standards..... | 110 |
| BYPRODUCT MATERIAL LICENSING..... | 110 |
| INDUSTRIAL LICENSING..... | 110 |
| Industrial Radiography..... | 110 |
| Gauging Devices..... | 111 |
| Gas Chromatography..... | 111 |
| Well Logging..... | 111 |
| Consumer Products..... | 112 |
| MEDICAL LICENSING..... | 112 |
| Laboratory Tests..... | 112 |
| Nuclear Medicine Procedures..... | 112 |
| Treatment with Sealed Sources..... | 112 |
| Advisory Committee on the Medical Uses of Isotopes..... | 113 |
| Reducing Occupational Exposure..... | 113 |
| Other Actions in Medical Area..... | 114 |

Chapter 7—DOMESTIC SAFEGUARDS

| | |
|---|-----|
| Scope of NRC Programs..... | 115 |
| STATUS OF SAFEGUARDS IN 1980..... | 115 |
| Fuel Cycle Facilities..... | 115 |
| Transportation Activities..... | 117 |
| Reactor Safeguards..... | 120 |
| Contingency Planning and Threat Assessment..... | 122 |
| SAFEGUARDS REGULATORY ACTIVITIES AND ISSUES..... | 122 |
| Physical Security..... | 122 |
| Material Control and Accounting..... | 123 |
| SAFEGUARDS RESEARCH AND TECHNICAL ASSISTANCE..... | 124 |

Chapter 8—WASTE MANAGEMENT

| | |
|--|-----|
| Overview of 1980 Activity..... | 127 |
| Internal Coordination..... | 127 |
| HIGH-LEVEL WASTE PROGRAM..... | 128 |
| Regulatory Development..... | 128 |
| Regulatory Guides..... | 129 |
| Reviewing DOE Site Investigations..... | 129 |
| Other Interagency Efforts..... | 130 |
| Waste Confidence Hearing..... | 130 |
| REGULATING LOW-LEVEL WASTE..... | 131 |
| Regulatory Development..... | 131 |
| Licensing Activities..... | 132 |
| Assistance to Agreement States..... | 132 |
| REGULATING URANIUM RECOVERY AND MILL TAILINGS..... | 132 |
| Licensing Activities..... | 132 |
| Regulatory Development..... | 133 |
| Technical Assistance to Agreement States..... | 133 |
| Remedial Action at Inactive Sites..... | 133 |

Chapter 9—INSPECTION AND ENFORCEMENT

| | |
|--|-----|
| THE INSPECTION PROGRAM | 135 |
| Reporting Defects and Noncompliance | 136 |
| Types of Inspections..... | 136 |
| Licensee, Contractor, and Vendor Inspection Program..... | 137 |
| Performance Appraisal Program..... | 137 |
| Independent Measurement/Verification Program..... | 138 |
| Impact of TMI on Inspection Program..... | 139 |
| Resident Inspector Program..... | 139 |
| Operations Inspection Program Upgraded..... | 140 |
| Direct Radiation Monitoring Network Established..... | 141 |
| Bulletins, Circulars, and Information Notices..... | 143 |
| Increase in Response Activities..... | 144 |
| ENFORCEMENT ACTIONS..... | 144 |
| New Enforcement Policy Proposed..... | 144 |
| INVESTIGATIONS..... | 145 |
| Three Mile Island..... | 146 |
| Marble Hill Nuclear Generating Station..... | 146 |
| The South Texas Project..... | 147 |

Chapter 10—COOPERATION WITH THE STATES

| | |
|--|-----|
| STATE AGREEMENTS PROGRAM | 161 |
| Review of State Regulatory Programs | 161 |
| Adequacy and Compatibility Findings..... | 161 |
| NRC Technical Assistance to States..... | 162 |
| Training Offered by NRC..... | 163 |
| Annual Agreement States Meeting..... | 163 |
| Agreement States and Uranium Mill Tailings..... | 164 |
| Abnormal Occurrence in Agreement States..... | 164 |
| EMERGENCY PREPAREDNESS | 164 |
| Training Program for States..... | 164 |
| Planning Guidance to States..... | 164 |
| LIAISON AND COOPERATIVE ACTIVITIES | 165 |
| Transportation Surveillance | 165 |
| Memoranda of Understanding..... | 165 |
| State Liaison Officers | 165 |
| National/State Organizations | 166 |
| Conference of Radiation Control Program Directors..... | 166 |
| Notification of Waste Shipments..... | 166 |

Chapter 11—INTERNATIONAL COOPERATION

| | |
|---|-----|
| INFORMATION EXCHANGES | 167 |
| BILATERAL ARRANGEMENTS | 167 |
| Exchanging Operating Data | 168 |
| Foreign Visitors and Assignments..... | 168 |
| RESEARCH AGREEMENTS | 169 |
| COOPERATION WITH INTERNATIONAL ORGANIZATIONS..... | 169 |
| IAEA Nuclear Safety Program..... | 169 |
| Technical Assistance Through IAEA | 170 |
| Cooperation with the OECD..... | 171 |
| EXPORT/IMPORT ACTIONS AND NONPROLIFERATION EFFORTS..... | 171 |
| EXPORT LICENSING ACTIONS..... | 171 |
| Tarapur (India) Exports..... | 171 |
| Philippines Reactor Project | 171 |

| | |
|--|------------|
| Environmental Effects of Exports..... | 172 |
| NONPROLIFERATION EFFORTS..... | 173 |
| Agreements for Cooperation..... | 173 |
| Retransfers for Reprocessing..... | 173 |
| Nuclear Fuel Cycle Evaluations..... | 173 |
| NRC Role in Nonproliferation Policy..... | 174 |
| INTERNATIONAL SAFEGUARDS..... | 175 |
| US/IAEA Safeguards Agreement..... | 176 |
| Export Licensing Information Needs..... | 176 |
| Support of International Safeguards..... | 176 |
| Foreign Physical Protection..... | 177 |
| Other Activities..... | 177 |

Chapter 12—STANDARDS DEVELOPMENT

| | |
|--|------------|
| CONCERNS OF HIGH PRIORITY..... | 179 |
| POWER REACTOR STANDARDS..... | 181 |
| Operators' Licenses..... | 181 |
| Nuclear Power Plant Simulation..... | 181 |
| Quality Assurance..... | 181 |
| Degraded Core Considerations..... | 182 |
| Reporting Reactor Operational Events..... | 182 |
| Surveillance and Inservice Inspection..... | 183 |
| Reactor Containment..... | 183 |
| System and Component Criteria..... | 183 |
| Protection Against Fire..... | 183 |
| Anticipated Transients Without Scram..... | 184 |
| Electrical Qualification Testing..... | 184 |
| Electric Systems and Components..... | 184 |
| Systems Interaction..... | 184 |
| Classification of Electrical Systems..... | 184 |
| Safety Analysis Reports..... | 185 |
| Reporting Defects and Noncompliances..... | 185 |
| FUEL CYCLE PLANT STANDARDS..... | 185 |
| Decommissioning..... | 185 |
| Spent Fuel Storage..... | 185 |
| Nuclear Criticality Safety..... | 185 |
| Plant Safety..... | 185 |
| Waste Management..... | 185 |
| SITING STANDARDS..... | 186 |
| Site Safety..... | 186 |
| Emergency Planning..... | 187 |
| Environmental Protection..... | 187 |
| RADIOLOGICAL HEALTH STANDARDS..... | 188 |
| Low-Level Radiation Effects..... | 188 |
| Nuclear Medicine..... | 188 |
| OCCUPATIONAL HEALTH STANDARDS..... | 188 |
| Reducing Occupational Exposures..... | 188 |
| Implementing EPA Guidance..... | 189 |
| Testing for Personnel Dosimetry..... | 189 |
| Industrial Radiography Safety..... | 190 |
| Respiratory Protection..... | 190 |
| Personnel Monitoring Reports..... | 191 |
| Bioassays..... | 191 |
| Instructing Workers on Radiation Risks..... | 192 |
| Health Protection at Uranium Mills..... | 192 |
| Worker Exposure to Neutrons..... | 192 |
| Radiation Surveys at Manufacturing Plants..... | 192 |
| Conferences During Inspections..... | 193 |
| Calibration of Air Sampling Instruments..... | 193 |
| Medical Institutions..... | 193 |

| | |
|---|-----|
| Gamma Irradiators..... | 193 |
| SAFEGUARD STANDARDS..... | 193 |
| Physical Protection..... | 193 |
| Material Control and Accounting..... | 194 |
| RADIOISOTOPES IN INDUSTRY..... | 194 |
| Thoriated Welding Electrodes..... | 194 |
| Smoke Detectors..... | 194 |
| Contaminated Smelted Alloys..... | 195 |
| Well-Logging Sources..... | 195 |
| Plutonium-Powered Cardiac Pacemakers..... | 195 |
| Licensing Matters..... | 195 |
| NATIONAL STANDARDS PROGRAM..... | 195 |
| IAEA REACTOR SAFETY STANDARDS..... | 196 |

Chapter 13—NUCLEAR REGULATORY RESEARCH

| | |
|--|-----|
| WATER REACTOR SAFETY RESEARCH..... | 197 |
| SYSTEMS ENGINEERING..... | 197 |
| Integral Systems Tests..... | 198 |
| Separate Effects Experiments..... | 199 |
| FUEL BEHAVIOR RESEARCH..... | 202 |
| Cladding Experiments..... | 202 |
| In-Reactor Testing..... | 203 |
| Fuel Behavior Codes..... | 203 |
| Hydrogen Program..... | 203 |
| Fuel Meltdown/Fission Product Release and Transport..... | 203 |
| COMPUTER CODES..... | 205 |
| Code Improvement..... | 205 |
| Code Assessment..... | 205 |
| Code Application..... | 206 |
| RESEARCH SUPPORT..... | 206 |
| Instrumentation, Control and Power Systems Research..... | 206 |
| Operational Safety Research..... | 207 |
| Technical Support..... | 207 |
| ADVANCED TECHNOLOGY SAFETY RESEARCH..... | 207 |
| HIGH TEMPERATURE GAS-COOLED REACTORS..... | 208 |
| LIQUID METAL FAST BREEDER REACTORS..... | 208 |
| Analysis Program..... | 208 |
| Accident Energetics..... | 209 |
| Aerosol Release and Transport..... | 209 |
| Systems Integrity..... | 209 |
| TMI-2 POST-ACCIDENT EXAMINATIONS..... | 210 |
| GENERAL REACTOR SAFETY RESEARCH..... | 210 |
| SITE SAFETY RESEARCH..... | 210 |
| Geology and Seismology..... | 210 |
| Meteorology and Hydrology..... | 211 |
| METALLURGY AND MATERIALS RESEARCH..... | 211 |
| Fracture Mechanics..... | 211 |
| Operating Environmental Effects..... | 212 |
| Nondestructive Examination..... | 212 |
| MECHANICAL ENGINEERING RESEARCH..... | 213 |
| Seismic Safety Margins Research Program..... | 213 |
| Nonlinear System Modeling..... | 213 |
| Piping Benchmarks..... | 213 |
| Load Combinations Research Program..... | 213 |
| Heißdampfreaktor (HDR)..... | 214 |
| Snubber Design Application and Testing Project..... | 214 |
| Safety and Relief Valves..... | 214 |
| STRUCTURAL ENGINEERING RESEARCH..... | 214 |
| Structural Response..... | 214 |
| Seismic Shear Transfer..... | 215 |

| | |
|--|-----|
| Seismic Design Criteria | 215 |
| Soil-Structure Interaction | 215 |
| FUEL CYCLE, ENVIRONMENTAL AND WASTE MANAGEMENT RESEARCH... | 215 |
| FUEL CYCLE RESEARCH | 215 |
| Facility Safety Research | 215 |
| Effluent Control Research | 215 |
| Transportation Safety Research | 215 |
| Decommissioning Research | 216 |
| SITING AND ENVIRONMENTAL RESEARCH | 216 |
| Radiation Dosimetry | 216 |
| Socioeconomic Impacts and Regional Siting | 216 |
| Ecological Impact Studies | 217 |
| Emergency Preparedness | 217 |
| WASTE MANAGEMENT RESEARCH | 217 |
| High Level Waste Research | 217 |
| Low Level Waste Research | 217 |
| Uranium Recovery Research Program | 218 |
| SYSTEMS AND RELIABILITY RESEARCH | 218 |
| REACTOR SYSTEMS ANALYSIS AND LICENSING SUPPORT | 218 |
| REACTOR ACCIDENT CONSEQUENCES ANALYSIS | 219 |
| METHODOLOGY DEVELOPMENT | 219 |
| FUEL CYCLE RISK ASSESSMENT | 220 |
| RESEARCH TO IMPROVE REACTOR SAFETY | 220 |
| Alternate Containment Concepts | 220 |
| Alternate Decay Heat Removal Systems | 220 |
| Advanced Display and Diagnostic Systems | 220 |
| Advanced Instrumentation | 221 |
| Plant Systems Analysis | 221 |

Chapter 14—COMMUNICATING WITH THE PUBLIC

| | |
|---|-----|
| MAKING DOCUMENTS AVAILABLE | 223 |
| NRC's PUBLIC INFORMATION PROGRAM | 226 |
| HANDLING DIFFERING OPINIONS | 227 |
| CONGRESSIONAL OVERSIGHT | 227 |
| REPORTS TO CONGRESS | 229 |
| PUBLIC PARTICIPATION IN NRC PROCEEDINGS | 230 |

Chapter 15—PROCEEDINGS AND LITIGATION

| | |
|--|-----|
| ATOMIC SAFETY AND LICENSING BOARDS | 233 |
| Three Mile Island Hearings | 234 |
| Other Highlights | 235 |
| ATOMIC SAFETY AND LICENSING APPEAL BOARDS | 235 |
| Health and Safety Questions | 236 |
| Environmental Issues | 236 |
| Intervention and Procedural Issues | 237 |
| Authority Over Staff | 237 |
| Board Composition and Procedures | 238 |
| COMMISSION DECISIONS | 238 |
| St. Lucie Antitrust | 238 |
| ENO Decision—Three Mile Island | 238 |
| Diablo Canyon—Physical Security | 239 |
| Sterling Power Project | 239 |
| Waste Confidence Rulemaking | 239 |
| Marble Hill Hearing Request | 240 |
| Criteria for Antitrust Significant Changes Finding | 240 |

| | |
|---------------------------------------|-----|
| Atlantic Research Civil Penalty | 240 |
| South Texas Project | 241 |
| JUDICIAL REVIEW | 242 |
| Pending Cases | 242 |
| Closed Cases..... | 248 |

Chapter 16—ADMINISTRATION AND MANAGEMENT

| | |
|---|-----|
| Personnel and Organization | 251 |
| Commission and Office Director Appointments | 251 |
| Organizational Changes..... | 252 |
| President's Reorganization Plan | 252 |
| EMPLOYEE-MANAGEMENT RELATIONS | 253 |
| Incentive Awards Program..... | 253 |
| Union Activity..... | 254 |
| Equal Employment Opportunity | 254 |
| INSPECTION AND AUDIT | 255 |
| Implementation of TMI Lessons Learned..... | 255 |
| Resident Inspector Program..... | 255 |
| Former Reactor Inspection Program | 255 |
| License Fee Management Program | 256 |
| Reactor Safety Research Plan | 256 |
| Flow of a Licensee Event Report | 256 |
| Internal Information Flow..... | 256 |
| FUNDING AND BUDGET MATTERS..... | 256 |
| Project Management..... | 257 |
| Contracting and Reimbursable Work | 257 |
| INFORMATION RETRIEVAL SYSTEM..... | 258 |
| PHYSICAL FACILITIES..... | 258 |
| NRC LICENSE FEES | 259 |
| COST OF OL ISSUANCES | 260 |

APPENDICES:

| | |
|--|-----|
| Appendix 1—NRC ORGANIZATION | 263 |
| Appendix 2—NRC COMMITTEES AND BOARDS | 267 |
| Appendix 3—PUBLIC DOCUMENT ROOMS | 270 |
| Appendix 4—REGULATIONS AND AMENDMENTS..... | 276 |
| Appendix 5—REGULATORY GUIDES | 283 |
| Appendix 6—NUCLEAR ELECTRIC GENERATING UNITS IN OPERATION UNDER CONSTRUCTION OR PLANNED | 285 |
| Appendix 7—STATUS OF TMI ACTION PLAN ITEMS..... | 296 |
| | |
| Index | 300 |

Statutory Reporting Requirements Addressed

ENERGY REORGANIZATION ACT OF 1974, AS AMENDED

Section 307(c) directs the Commission to include in its Annual Report statements and descriptions concerning:

“...the short-range and long-range goals, priorities, and plans of the Commission as they relate to the benefits, costs, and risks of nuclear power.” (See Chapter 1 for overall statement. Specific goals concerning nuclear power reactors are also discussed in Chapters 2 and 4; emergency preparedness in Chapter 3; operating experience in Chapter 5; fuel cycle in Chapter 6; safeguards in Chapter 7; wastes in Chapter 8; inspection and enforcement in Chapter 9; nuclear nonproliferation in Chapter 11; standards in Chapter 12; and research and risk assessment in Chapter 13.)

“...the Commission’s activities and findings in the following areas—

- “(1) insuring the safe design of nuclear power plants and other licensed facilities. . .” (For reactors, see Chapters 2, 4, 12 and 13; materials facilities, devices and transportation packages, Chapters 6, 12 and 13; waste facilities, Chapters 6 and 12.)
- “(2) investigating abnormal occurrences and defects in nuclear power plants and other licensed facilities. . .” (See Chapters 2, 3, 4 and 5.)
- “(3) safeguarding special nuclear materials at all stages of the nuclear fuel cycle. . .” (See Chapters 7, 12 and 13.)
- “(4) investigating suspected, attempted, or actual thefts of special nuclear materials in the licensed sector and developing contingency plans for dealing with such incidents. . .” (Chapters 7, 9 and 12.)
- “(5) insuring the safe, permanent disposal of high-level radioactive wastes through the licensing of nuclear activities and facilities. . .” (See Chapter 8.)
- “(6) protecting the public against the hazards of low-level radioactive emissions from licensed nuclear activities and facilities. . .” (See Chapters 2, 4, 6 and 12.)

Section 205 requires development of “a long term plan for projects for the development of new or improved safety systems for nuclear power plants” and an annual updating of the plan. (See Chapter 13.)

Section 209 requires the Commission to include in each Annual Report a chapter describing the status of NRC’s domestic safeguards program. (See Chapter 7.)

Section 210 directs the Commission to submit “a plan providing for the specification and analysis of unresolved safety issues relating to nuclear reactors,” and to include progress reports in the Annual Report thereafter concerning corrective actions. (See Chapter 4.)

NUCLEAR NONPROLIFERATION ACT OF 1978

Section 602 requires annual reports by the Commission and the Department of Energy to “include views and recommendations regarding the policies and actions of the United States to prevent proliferation which are the statutory responsibility of those agencies. . .” (See Chapter 11.)

ATOMIC ENERGY ACT OF 1954, AS AMENDED

Section 170i directs the Commission to report annually on indemnity operations implementing the Price-Anderson Act which provides a system to pay public liability claims in the event of a nuclear incident. (See Chapter 4.)

PUBLIC LAW 96-295

Section 303 directs the Commission to report annually a statement of—

- “(1) the direct and indirect costs to the Commission for the issuance of any license or permit and for the inspection of any facility; and
- “(2) the fees paid to the Commission for the issuance of any license or permit for the inspection of any facility.” (See Chapter 16.)



1 Overview

This is the sixth Annual Report of the U.S. Nuclear Regulatory Commission. It is submitted to the President for transmittal to the Congress as required by Section 307(c) of the Energy Reorganization Act of 1974.

The report describes the major programs, actions and plans of the NRC during fiscal year 1980 in carrying out its statutory responsibilities for regulating civilian nuclear activities so that the public health and safety are protected. This introductory chapter presents an overview of NRC activity, provides updating on significant events and actions occurring after the end of fiscal year 1980 through December 31, and briefly describes major Commission policies and plans for 1981.

The major product of the agency during 1980 was the formulation and refinement of the TMI Action Plan, initiated in late 1979 to revamp NRC regulatory and licensing functions on a timely basis, consistent with the urgent need for setting priorities and moving quickly to improve safety measures. Developing and implementing the Action Plan has been an all-consuming project of many elements of the staff and has received the close attention of the Commission. The studies and investigations into the causes of the TMI accident and the needs for corrective actions produced more than one thousand recommendations.

The Action Plan (NUREG-0660) consolidates the many recommendations into discrete, scheduled tasks relating to specific changes (or studies of possible future changes) in regulatory requirements and NRC organization and procedures. It presents a sequence of actions aimed at an orderly and controlled improvement in safety. The Action Plan is the program plan for the future and also documents the actions taken by the NRC during the period since the accident. (See Chapter 4.)

POLICY, PLANNING AND OUTLOOK

In reappraising its priorities, the Commission developed and issued in May 1980 a Policy, Planning, and Program Guidance (PPPG) document to provide direction to the staff on the general policies and objectives of the agency and to provide guidance for developing appropriate resource needs for fiscal years 1982 through 1986. (See *1979 NRC Annual Report*, pp. 1-2.) This document was used to shape NRC programs and prepare the recently completed budget request for fiscal years 1982-1984 as well as to provide policy guidance for fiscal years 1980 and 1981.

Policies stated in the PPPG to be followed in achieving adequate protection of public health and safety, and in developing NRC programs and plans, are:

- Priority will be given to NRC activities expected to have the greatest effect on reducing risks to the public health and safety.
- NRC will require careful consideration of the benefits and costs of alternative ways to achieve regulatory objectives.
- Consideration of costs is appropriate in deciding alternative methods for achieving a given level of risk.
- NRC will consider the public health and safety implications of not operating a nuclear facility as well as the potential radiological or other hazards associated with its operation.
- NRC will emphasize prompt and vigorous enforcement in dealing with licensees who are unable or unwilling to comply with NRC requirements.
- Licensees who cannot achieve an adequate level of protection will not be permitted to operate.

- NRC will not license or permit the continued operation of a facility unless it is confident that, after termination of the operating license, there will be adequate protection of future generations from potential hazards of the decommissioned facility itself and from wastes associated with it.
- Licensee initiatives to provide a higher level of public protection than the minimum NRC level will be encouraged and supported.
- Maintenance of radiation exposures as low as reasonably achievable under normal conditions is a fundamental objective.
- NRC will emphasize measures to minimize the consequences of possible accidents, theft or diversion of nuclear materials, and sabotage or other illegal acts.
- The NRC waste management program is critical to the success of an urgent national task, and will be organized and planned to be consistent with the President's policy on waste management.
- The focus of NRC research will be on assisting in determining adequate levels of public health and safety protection and exploring ways to achieve improved protection levels. It should not include research that should be supported exclusively by the private sector.

The PPPG document expands on the general policy statements, giving detailed planning guidance in such areas as priorities in reactor regulation, achieving greater NRC presence at major licensed facilities, improving emergency response capabilities, and developing improved siting criteria for nuclear plants. This document is being updated for use in developing programs and budget estimates for fiscal years 1983-1987.

Defining a Safety Goal

The basic question in safety regulation is "How safe is safe enough?" While an answer was not forthcoming from any of the major investigations into the TMI accident, the need for a more precise definition of what is an adequate level of protection for the public health and safety has become more urgent.*

*In the final session of the 96th Congress, the Senate passed S.2358, an NRC authorization bill for fiscal year 1981, which would require NRC, after notice and opportunity for public hearing, to develop a safety goal for reactor regulation. There was no corresponding action by the House of Representatives.

The Commission's Policy, Planning, and Program Guidance document commits the NRC to developing a safety goal but society must ultimately provide the answer as to what is acceptable. This commitment is as follows:

"As the agency responsible for nuclear regulation, the NRC must play the fundamental role leading to the proper determination of what is an adequate level of protection. The NRC must bring its management and technical expertise to bear in assuring that the regulated industry achieves and maintains that protection." (See *1979 NRC Annual Report*, pp. 9-10.) The PPPG also states that some basic NRC goals are to define more clearly the level of protection that the Commission believes is adequate based on statutes, public input, and NRC's subjective and quantitative evaluations; to increase efforts to describe to the public the risks of nuclear activities and the uncertainties in judgments of risks; and to seek public advice on the acceptability of these risks.

The Commission initially stated its intention to develop a safety policy statement in its transmittal of comments to the President's Office of Science and Technology Policy in November 1979 concerning the President's Commission report on the TMI accident. The project subsequently became a part of the implementation of the TMI Action Plan.

In October 1980, the Commission approved a plan (NUREG-0735) formulated by the staff for developing a safety goal for nuclear power plants. The year-long project involves a search and review of all literature on the subject, contacts and discussions with many public and private organizations, groups and individuals, and analysis and research. While the basic principle of a safety goal may be stated simply as the establishment of a general degree of safety to govern applicable regulations and licensing actions, the development of such a goal is subject to a number of complications. These include gaps in knowledge as to what the risks are, differing philosophical perspectives as to what criteria should be used to define when a risk is "acceptable," issues involving economic and equity considerations, and techniques to make interpretations where there is uncertainty. A preliminary policy statement and supporting information are expected to be published early in calendar year 1981 for public comment. They will serve as the main focus of several regional workshops.

RESHAPING THE AGENCY

Organizational and procedural changes to support the reordering of priorities, particularly those

responding to the TMI accident, continued throughout 1980 and are still in progress.

The Commission and EDO

The President's Reorganization Plan No. 1 of 1980, responding to recommendations of the Kemeny Commission's report on the TMI accident, cleared the Congress in June and became effective on October 1, 1980. Its thrust is to strengthen the authority of the NRC Chairman relative to the Commission and of the Executive Director for Operations (EDO) relative to the program staff.

The Commission retains responsibility for policy formulation, rulemaking, and orders and adjudication.

The Chairman carries out all other Commission functions and is the official spokesman and the principal executive officer of the Commission. In the latter capacity, the Chairman directs and delegates to the EDO responsibility for all administrative functions, distribution of business, preparation of reorganization proposals and budget estimates, allocation of funds, and personnel matters other than those affecting the five major program offices and certain other offices reporting to the Commission. The Chairman has the responsibility, which may be delegated to another Commissioner, for responding to a nuclear emergency.

The EDO reports to the Chairman on all matters. The directors of all five program offices (including the Offices of Nuclear Reactor Regulation, Nuclear Regulatory Research, and Nuclear Material Safety and Safeguards, which formerly reported to the Commission through the EDO) now report to the EDO. The heads of Commission-level offices (except Public Affairs and Congressional Affairs, which report to the Chairman) continue to report directly to the Commission. The EDO keeps the Commission fully and currently informed through the Chairman, and all Commissioners have equal access to all agency information.

Actions are continuing to fully implement the President's Reorganization Plan, including modification of practices, delegations of authority, and reviews of relevant documents for possible revisions.

Staff Reorganizations

Adjustments in the allocation of resources were extensive throughout the agency, particularly in the licensing and inspection areas. Notable among the organizational changes in the NRC staff during 1980 were:

- Creation of a new Office for Analysis and Evaluation of Operational Data, approved by the Commission in July 1979 and effected during fiscal year 1980. This Office is engaged in analyzing and evaluating operational safety data associated with all NRC-licensed activities and communicating the lessons of operating experience to all appropriate parties (see Chapter 5).
- Creation within the Office of Nuclear Reactor Regulation (NRR) of a number of new elements, as well as consolidation and reorientation of staff activities within existing organizational components (see Chapter 4). A major move was the establishment of a Division of Human Factors Safety to concentrate wholly on the benefits and problems represented by the human element in nuclear operations. The division is concerned with such person-related considerations as control room design, operation procedures, operator and managerial competence, operator testing and licensing criteria. Also, NRR established a Three Mile Island Program Office to direct its activities associated with cleanup operations at the TMI site.
- Assignment of responsibility for managing all NRC activities related to emergency preparedness to a new Emergency Preparedness Program Office (EPPO), initially comprising two components: a licensing branch to review emergency plans of applicants for reactor plant licenses and the evaluations performed by the Federal Emergency Management Agency of State and local emergency plans, and a development branch responsible for developing and evaluating policy recommendations and regulatory requirements in this area, as well as developing emergency planning and preparedness guidance and technical support for EPPO. In November 1980, as part of a general reorganization of the Office of Inspection and Enforcement, the emergency preparedness function was transferred to that office and redesignated the Division of Emergency Preparedness. A third component was added to manage the NRC's incident response operations and planning efforts. (See Chapter 3.)

REACTOR REGULATION

The Status of Licensing

After the TMI accident, the Commission decided that power reactor licensing should be halted until substantial completion of the assessment of the

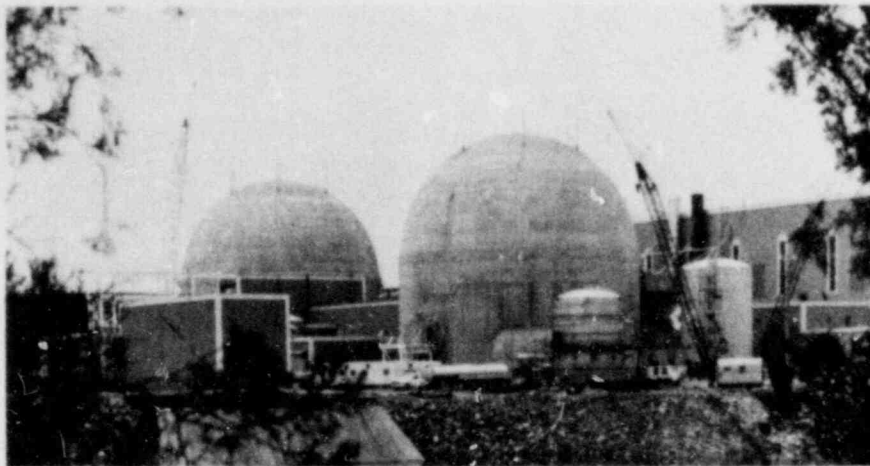

Virginia Electric & Power Co.'s North Anna Power Station near Mineral, Va. North Anna Unit 2 was the first power reactor to be licensed for full power operation since the TMI-2 accident in March 1979. The facility was licensed in August 1980 after the licensee conducted an exercise to demonstrate the adequacy of its emergency plan and overall emergency preparedness at the facility (see Chapter 3).

accident and initiation of comprehensive improvements in the operation and regulation of nuclear plants. Policy guidance issued in November 1979 specified that no licensing board decisions authorizing issuance of a construction permit, limited work authorization or operating license should be issued except after further order of the Commission itself. In particular, the Commission noted that it would "be providing case-by-case guidance on changes in regulatory policies."

During the pause in licensing, the recommendations of several groups investigating the lessons learned from the TMI accident became available. These were incorporated into a "TMI Action Plan" (NUREG-0660, May 1980). In response to further Commission guidance on operating licenses, "TMI-Related Requirement for New Operating Licenses" (NUREG-0694) was published in June. This was superseded by NUREG-0737, "Clarification of TMI Action Plan Requirements," adopted on October 28, 1980, which sets forth requirements for new operating licenses that should be "necessary and sufficient for responding" to the TMI accident. Approved requirements and schedules for operating plants were also issued. It should be noted that some actions to improve the safety of operating plants were judged necessary immediately after the accident and could not be delayed until the Action Plan was developed, although they were subsequently included in the Plan. Many of these immediate actions, after approval by the Commission, have already been taken by licensees and others are scheduled in NUREG-0737 to be completed in the near future.

The licensing pause ended on February 29, 1980, with the Commission's approval of a fuel loading and low-power testing license for Sequoyah Unit 1 in Tennessee, followed by similar licenses for North Anna 2 in Virginia and Salem 2 in New Jersey, in April; and for Farley 2 in Alabama in October.

Full-power licenses were issued for North Anna 2 in August and for Sequoyah 1 in September. Several other plants were nearing completion or had been completed during the year, of which two were seeking low-power operating licenses. No construction permits have been issued since the TMI accident; however, the staff was developing plans in December for completing reviews of several applications. The Commission has issued for public comment NUREG-0718, "Proposed Licensing Requirements for Pending Applications for Construction Permits and Manufacturing License," preparatory to determining policy for proceeding with these applications. During fiscal year 1981 the NRC expects to issue a final version of this report which will identify for pending applicants the necessary and sufficient TMI-related requirements for construction permits.

In House of Representatives Report No. 96-1093 (dealing with the NRC appropriation for fiscal year 1981), the Appropriations Committee's Subcommittee on Energy and Water Development directed the Commission to provide monthly reports on the status of its efforts to carry out its licensing and regulatory duties and to improve the management of its resources. The first such report, covering the period from the time of the NRC's testimony before the committee in April 1980 through mid-November, was forwarded in November. An updated report was transmitted in December.

The TMI accident required reprogramming in fiscal year 1980 of resources in the Office of Nuclear Reactor Regulation (NRR) from the review of reactor construction permits and operating licenses to higher priority activities in the TMI Action Plan. The catch-up phase in which NRR is now engaged involves additional in-depth reviews for application of TMI-related requirements. Resource priorities in licensing reviews are being given to the review of near-term operating license applications in order to

minimize unnecessary regulatory-related delays in fuel loading schedules. As of the end of 1980, construction was expected to be completed on nine nuclear power plant units over the next two years before the NRC can complete actions on operating license applications for these plants. The resulting delays in issuance of operating licenses, due mainly to hearing activities, are estimated in the range of four to 12 months—or perhaps longer if the adjudicatory process involves resolution of complex and controversial issues.

During the fiscal year, utilities requested withdrawal of construction application permits for nine units and an early site review application for two units and terminated plans for two others. In October and November, utilities requested the withdrawal of construction permit applications for three other units, and announced cancellation of two additional units that were under construction.

As of December 31, 1980, a total of 163 nuclear power reactors were under NRC regulatory purview, with an aggregate generating capacity of about 157,000 electrical megawatts, as follows:

- 68 licensed to operate (excluding 3 shut down indefinitely: Three Mile Island 2, Humboldt Bay and Dresden 1).
- 2 licensed for low-power testing.
- 82 for which construction permits have been granted (excluding 2 denied certification by the N.Y. State Siting Board: Jamesport 1 and 2).
- 11 under construction permit review (excluding 1 indefinitely postponed: Clinch River; and 2 denied certification by the N.Y. State Siting Board: New Haven 1 and 2).

Reviews of Operating Reactors

During fiscal year 1980, approximately 1,900 reactor licensing actions (amendments of operating licenses) were reviewed and processed. In fiscal year 1981, about 2,500 are expected to be completed. Section 110 of Public Law 96-295, the fiscal year 1980 NRC Authorization Act which became law in June, requires the NRC to develop, submit to Congress, and implement a comprehensive plan for the systematic safety evaluation of all currently operating nuclear power plants. A detailed plan to implement the requirements of P.L. 96-295 is being developed and a status report is expected to be issued for public comment in the Spring of 1981. Under a staff proposal, the ongoing Systematic Evaluation Program (SEP), begun in 1977, would be integrated into the new plan. In the SEP, 11 older licensed operating reactors are being reviewed in light of current licensing criteria to determine the

need for backfitting. It is currently scheduled for completion in 1982.

During 1980 the Commission began to examine whether additional protection requirements should be imposed on certain reactors located near densely populated areas. In February 1980, the Commission issued a Confirmatory Order for the Zion (Illinois) and Indian Point (New York) plants—each facility comprising two units—requiring certain plant modifications, including means for providing protection from radiological releases in the event of a core-melt accident. The licensees are performing risk assessments to demonstrate that the aggregate public risk from these facilities is not greater than that predicted for the reference pressurized water reactor analyzed in the Reactor Safety Study (WASH-1400). In May 1980, the NRC requested the applicant for the Limerick plant, under construction in Pennsylvania, to make a preliminary risk assessment taking into account significant design differences between its facility and the reference boiling water reactor in the Reactor Safety Study. The licensees' studies will be reviewed by the staff to determine if these facilities need to be modified.

In another action, affecting all operating power reactors in the United States, the NRC in October ordered amendment of technical specifications of operating licenses to require the environmental qualification, and documentation therefor, of all safety-related electrical equipment. The modifications require the licensees to:

- By December 1, 1980, have available at a central location complete and auditable records describing the qualification method used in sufficient detail to document the degree of compliance with NRC requirements.
- Assure by June 30, 1982, that the reactor safety-related electrical equipment be qualified to meet NRC requirements for withstanding service environments including extreme heat, steam, and radiation that might result from loss-of-coolant or main-steam-line-break accidents inside containments or high-energy-line breaks inside or outside containments.

The staff's action stemmed from a Commission Memorandum and Order of May 23, 1980, dealing with its reconsideration of a November 1977 petition from the Union of Concerned Scientists which sought action regarding fire protection and protection of electrical equipment from accident environments. (See *1978 NRC Annual Report*, pp. 32-34 and 121-124.) Also, the final rule on fire protection programs for operating nuclear power plants was issued in November (45 *Federal Register* 76602). It provides for upgrading fire protection at plants licensed to operate prior to January 1, 1979, by requiring the resolution of certain generic issues in fire protection safety.

By the end of 1980, the NRC had completed plans for a major program to assure that equipment in nuclear power facilities is qualified to perform its function under conditions that would exist in a serious accident. New rules are in preparation to address environmental qualification of equipment. During 1981, NRC will publish safety evaluation reports detailing actions which licensees must complete and the acceptability of installed equipment. In addition, related regulatory guides will be reviewed for updating.

Rulemaking Actions

Several noteworthy rulemaking actions have been completed or are in process that have significant implications for power reactor licensing in the future.

A major rulemaking to upgrade emergency planning around power reactors, completed in August, is described in Chapter 5. The final rule which became effective in November provides, among other things, that no new operating license will be granted unless the NRC can make a favorable finding that the integration of on-site and off-site emergency planning gives reasonable assurance that adequate protection measures can and will be taken in the event of a radiological emergency.

Another important action was the publication in the *Federal Register* in July of an advance notice of rulemaking on revision of siting criteria, based on a task force study begun in August 1978 and the Commission's consideration of its recommendations. Public comments were requested on proposed broad goals such as (1) establishing site approval requirements independent of plant-specific safety features to compensate for unfavorable site characteristics; (2) taking into consideration in siting the risk associated with accidents beyond the design basis (i.e., Class 9 accidents) by establishing population density and distribution criteria; and (3) requiring that sites selected will minimize the risk from energy generation. The new siting criteria, which would not apply to construction permit applications on file before October 1979, will be consistent with the provisions in the fiscal year 1980 NRC Authorization Act (P.L. 96-295) directing NRC to develop demographic requirements for siting. (See Chapter 4, "Siting of Nuclear Power Plants," and Chapter 12, "Siting Standards.")

During fiscal year 1981, a proposed rule on demographic criteria for nuclear power plant sites and a draft environmental impact statement supporting the proposed rule will be issued for comment.

The NRC policy regarding consideration of severe accidents of very low probability (referred to collectively as Class 9 accidents, following a classification scheme proposed by the former Atomic Energy

Commission in 1971) was reversed on June 13, 1980, with issuance of a Commission statement of interim policy on "Nuclear Power Plant Accident Considerations Under the National Environmental Policy Act of 1969." This policy cancelled the categorization of accidents, thereby eliminating the term "Class 9," and adopted the position that future environmental impact statements issued regarding major licensing decisions will consider the site-specific environmental impacts attributable to all accident sequences that lead to release of radioactive materials, including sequences that can result in inadequate cooling and melting of the reactor core.

On October 2 the Commission published an advance notice of long-term rulemaking in the *Federal Register* regarding the possibility of regulatory changes to require design of nuclear power plants to cope with accidents more serious than those currently considered in the safety analysis reports. The need to reexamine current practices was pointed up by the fact that the TMI accident resulted in core damage more severe than that considered for the design basis event in safety analyses of nuclear plants. At the same time, the Commission published a proposed interim rule requiring measures to protect against degraded core cooling conditions. (See Chapters 4 and 12.) In 1981, NRC will coordinate the degraded core cooling rulemaking activity with other related rules (minimum engineered safety features, siting, and emergency planning.)

TMI-2 Accident Aftermath

Investigations. The accident at TMI-2 and response to it by the NRC, the Administration, the Congress and others, up through the issuance of the report of the President's Commission on October 30, 1979, and the President's response to recommendations in that report on December 7, 1979, were covered in detail in the *1979 NRC Annual Report*. Subsequently, the Special Inquiry Group established by the Commission to assess independently the implications of the accident issued its report in January 1980, and a Special Senate Investigation report was published in July. (See Chapter 2 in this Annual Report.) The recommendations in these reports that were not duplicative of those from other studies have been taken into account in NRC actions and plans.

The Special Inquiry Group took hundreds of depositions under oath, conducted close to a thousand interviews, and studied the depositions and interviews produced by earlier investigations. Prominent among its major recommendations was the proposal that the NRC be replaced by an Executive Branch agency headed by a single administrator, an

idea which the President's Commission on the TMI accident had also put forward in its report of October 1979. A number of other changes in structure and emphasis within the NRC were advocated by the group, notably an overhaul of the licensing process, greater attention to operator training and operating experience, a policy of remote siting for new reactor plants, and greater application of human factors engineering.

The Special Senate Investigation of the TMI accident dealt with several specific questions regarding events at TMI during the period of the accident, as well as with causes and consequences of those events. A conclusion of the investigation was that whenever there is uncertainty as to whether a reactor core is covered or uncovered (as there was at TMI), that fact in itself calls for a serious consideration of the need to evacuate the population around the plant. Finding no evidence of willful concealment of plant conditions on anyone's part, the investigation concluded that human error was the principal contributor to the severity of the accident. The root causes of the accident, however, included deficient training, faulty design, inadequate procedures, insufficient attention to human factors, and other problems. The investigation report ascribed ultimate responsibility for the accident to the utility, the reactor vendor, the architect-engineering firm that built the plant, and the NRC.

President's Oversight Committee. By Executive Order 12202 of March 18, 1980, President Carter established a Nuclear Oversight Committee to advise on the progress of Federal and State authorities and the nuclear power industry in improving the safety of nuclear power and implementing the approved recommendations of the President's Commission on the Accident at Three Mile Island.

The five members of the Oversight Committee, announced by the President on May 7, 1980, were: Bruce Babbitt, Governor of Arizona; John Deutch,

professor of chemistry at Massachusetts Institute of Technology; Marvin L. Goldberger, physicist and president of California Institute of Technology; Patrick E. Haggerty, president and chief executive officer of Texas Instruments until his retirement in 1976*; and Harold W. Lewis, professor of physics at the University of California at Santa Barbara. Governor Babbitt was designated to serve as chairman of the Committee.

The Oversight Committee met in public session during the latter half of 1980. Members of the NRC staff testified at several meetings. In response to a request of the President's Office, the Committee provided an interim report to the President by letter of September 26, 1980, on its evaluation of the NRC TMI Action Plan. (See Chapter 4 for discussion of the Action Plan.)

Cleanup Phase. Since the time the damaged TMI-2 reactor was brought to a stable condition in April 1979, the attention of the licensee, the industry, the NRC and other interested parties and agencies has been devoted to the immense task of decontaminating the facility and other problems arising from the cleanup activities. These activities are being closely monitored by NRC staff detailed to the site for the duration of the cleanup.

During 1980, most of the radioactivity from several hundred thousand gallons of contaminated water accumulated in the auxiliary and fuel-handling buildings was removed by processing through a three-stage demineralization system which the Commission authorized the licensee to use in October 1979. The decontaminated water is being held in storage tanks at the site. The radioactive spent resins

*Mr. Haggerty died in October. Although seriously ill when the interim report was submitted to the President, he participated in its preparation and approved its content. The President had not appointed a replacement at the time this annual report went to press.

The Commission receives the report on the accident at Three Mile Island Unit 2 from its Special Inquiry Group in January 1980. The independent review was directed by Mitchell Rogovin (upper left center of photo).



used in processing are contained within steel liners placed in massive concrete structures. Alternatives for final disposition of the decontaminated water and the liners are under study. The more highly contaminated water in the reactor containment building has not yet been processed.

To permit personnel entry into the reactor building—an important step to assess radiation levels and equipment damage preparatory to planning decontamination and defueling—it was necessary to remove a large volume of radioactive krypton-85 gas that had been released into the containment during the accident. After issuing an environmental assessment of alternatives which took into account hundreds of public comments, the Commission authorized the licensee to purge the building atmosphere in a controlled manner. This operation was carried out safely from June 28 to July 11, 1980, under detailed procedures approved by the NRC staff. The first personnel entry into the containment was made on July 23.

Lawsuits were brought against the NRC in June seeking an injunction against the venting of krypton-85 from the TMI-2 reactor building. Injunctive relief was denied. The cases were consolidated before the District of Columbia Circuit Court of Appeals, which, on November 19, declared that the Commission's refusal to hold hearings in connection with its approval of purging the TMI containment was illegal. (*Sholly v. NRC*—see Chapter 15, "Judicial Review.") The Court held that even where a license amendment involves "no significant hazards considerations," any interested person who requests a hearing is entitled by Section 189(a) of the Atomic Energy Act to a hearing before the amendment becomes effective. Since the decision has serious implications for the expeditious handling of hundreds of license amendments for which the NRC has generally found "no significant hazards considerations"—such as changes to conform to revised regulations, or to reflect routine fuel reloadings—the Commission is seeking a rehearing *en banc* of the case, and may seek legislative relief. The Court stayed its mandate in this case through February 10, 1981, to allow for consideration of the petition for rehearing. This means that the NRC is not required to follow the *Sholly* decision until the stay expires or, if an extension of the stay is granted, until appeals of this decision are finally resolved.

At the Commission's direction, the staff prepared a draft programmatic environmental impact statement concerning the overall program of decontamination of TMI-2 and disposal of the resultant radioactive waste. The statement (NUREG-0683), issued for public comment in August, concluded that methods exist or can be adapted to carry out the cleanup operations with minimal releases of radioac-

tivity to the environment. More than 30 public meetings have been held in Pennsylvania and Maryland to discuss this statement. A final statement reflecting the consideration of comments will be issued in early 1981. During the comment period, the Commission established a 12-member advisory panel for consultation on major stages of the cleanup. It is chaired by the Chairman of the Dauphin County (Pa.) Commissioners and includes other State and local government officials from the area as well as independent technical experts and representatives of intervenor groups. (The establishment of the advisory panel was included in H.R. 6628, the fiscal year 1981 authorization bill considered but not passed by the 96th Congress.)

Licensee's Financial Problems. Because the high cost projected for the lengthy decontamination and recovery program required at TMI-2 could conceivably force the licensee into bankruptcy under current conditions before the cleanup is completed, the NRC staff explored this possibility and potential consequences in a report to the Commission which was published in November.

The plant owners are Metropolitan Edison Co. (Met Ed), the licensee, which owns 50 percent of the facility; Pennsylvania Electric Co., which owns 25 percent; and the Jersey Central Power & Light Co., which also owns 25 percent. These utilities are wholly owned subsidiaries of General Public Utilities (GPU) of New Jersey.

The TMI owner estimated the total cost would range from \$690 million to \$1.15 billion, and the NRC staff assumed a cost of \$900 million (1980 dollars) in making its assessment. The plant was insured for \$300 million and this amount is expected to be expended by the end of 1981, leaving a balance of \$600 million needed to complete the cleanup for which the licensee has not identified the source. Fixed costs of maintaining and operating the power station are running at \$150 million a year, and the plant has not been permitted to be part of the rate base of any of the three GPU utilities. In September, Met Ed reduced its overall work force at the site (mainly contract personnel) by 20 percent upon denial by the State public utility commission of an emergency rate increase which, in turn, resulted in a tightening of credit from the banking consortium providing short-term credit to the utility.

On September 23 the licensee, seeking a stay of a Pennsylvania Public Utility Commission order not to use revenues for the cleanup that were not provided by insurance, took the position that it could not comply with the order without violating Federal law requiring compliance with NRC directives. The Nuclear Regulatory Commission issued a policy statement declaring that it "will not excuse (the TMI licensee) from compliance with any order, regulation

or other requirements by the Commission" which serve the purpose of protecting public health and safety or the environment.

Consultants to the NRC staff in the financial study felt that the events that could cause or avoid bankruptcy are within the control of three forces: the State public utility commissions in Pennsylvania and New Jersey, which could approve rate increases; the banks, which could continue to provide credit to the owners; and the NRC, which could approve the restart of TMI Unit 1. (The restart of Unit 1, which was shut down for refueling at the time of the accident, is now the subject of a hearing before an Atomic Safety and Licensing Board.) Alternatively, to forestall bankruptcy, the Federal government could provide loan guarantees or grants, or establish a system for assessing other utilities or the nuclear industry.

In the event of default, a Federal agency could engage a contractor to do the work, or take over the plant and complete the cleanup itself. Either alternative would require substantial Congressional funding.

The chief recommendation of the staff report was that the NRC encourage the Executive Branch to initiate discussions among State and Federal agencies and the financial community concerning the ability of

the licensee to continue and follow through on the cleanup.

GPU Tort Act Claim. On December 8, GPU filed with the Commission a \$4 billion administrative claim under the Federal Tort Claims Act for property damage resulting from the TMI-2 accident. The claim alleges that the NRC induced Met Ed, the licensee, to rely on the Commission to warn it of defects in equipment, analyses, procedures and training affecting the operation of TMI-2 of which the NRC was, or should have been aware. Met Ed also alleges that it relied upon the NRC to review with due care the equipment, analyses, procedures and training for plant operation submitted to the NRC by nuclear equipment vendors and nuclear plant licensees.

The Commission has until June 8, 1981 to decide on GPU's claim. If no decision is reached by that time, the claim is considered denied. In this event, or if the claim is in fact partially or totally denied by the NRC, GPU can file suit in an Federal district court. (28 U.S. C. 2675.)



NRC's advisory panel for the decontamination of TMI-2 held its first meeting on November 12, 1980, in Harrisburg. The seven of the 12 members or their representatives who were present are, left to right: Jean Kahr, Susquehanna Valley Alliance; Thomas Cochran, Natural Resources Defense Council; Joel Roth, chairman of the TMI Alert Organization; Robert

Reid, mayor of Middletown, Pa.; Panel Chairman John E. Minnich, chairman of the Dauphin County (Pa.) Commissioners; Clifford Jones, Pennsylvania Department of Environmental Resources; and Craig Williamson, representing the Office of the Governor of Pennsylvania.

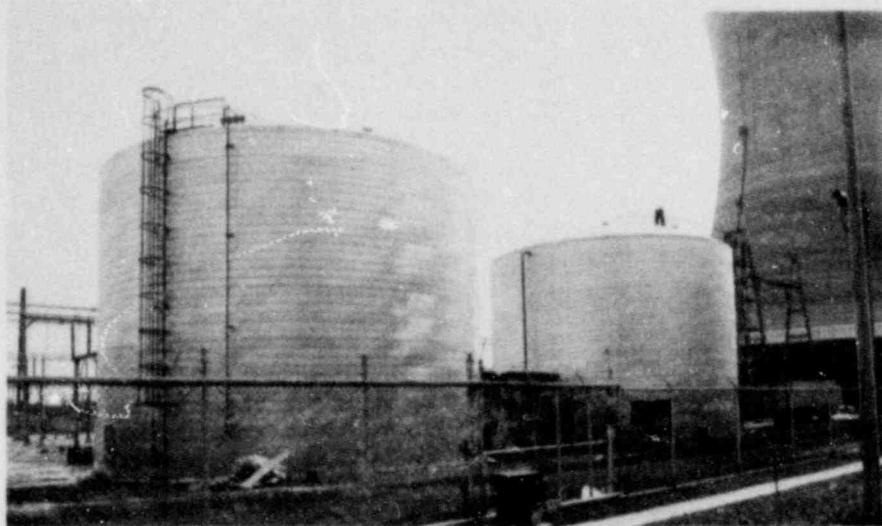

Work on these two 500,000-gallon tanks neared completion at the end of 1980 as the licensee developed plans to decontaminate some 700,000 gallons of radioactive water in the basement of the reactor containment building and provide for storage on site pending decisions on final disposal of the processed water.

Emergency Preparedness

The deficiencies in emergency preparedness evidenced during the TMI accident is continuing to receive high priority. (See Chapter 3.) In mid-1979, the NRC began a formal reconsideration and revision of the nature and purpose of emergency preparedness in areas near nuclear power facilities. These efforts were accelerated in 1980, concentrating first on promptly improving preparedness at all operating nuclear power plants and those nearing the operating license stage.

On December 7, 1979, President Carter assigned the lead responsibility for assisting State and local governments in developing emergency plans for nuclear power plants to the Federal Emergency Management Agency (FEMA), and the NRC detailed the emergency preparedness staff of its Office of State Programs to FEMA for an extended period in 1980 to help with the program. Two Memoranda of Understanding between the agencies were negotiated concerning (1) their respective roles in emergency plans and preparedness and (2) incident response. Under the first, FEMA will, among other tasks, determine whether State and local plans are adequate and feasible, be responsible for training State and local officials in emergency preparedness, and define interagency assignments and procedures in the coordination of emergency planning and response. The NRC responsibilities under this agreement are to assess the adequacy and feasibility of its licensees' emergency plans, review the FEMA determinations as to State and local plans, and to decide whether the overall state preparedness at a site has any licensing or regulatory implications (such as warranting issuance of a license or indicating a need for temporary shutdown). The second memorandum

covered NRC/FEMA cooperation and responsibilities in responding to emergencies, and defined their respective roles in some detail.

NRC's final rule on emergency planning which became effective on November 3, 1980, provides, among other things, that no new operating license will be granted without a favorable NRC finding that the integration of on-site and off-site emergency planning gives reasonable assurance that adequate protective measures can and will be taken in the event of a radiological emergency.

The combination of the TMI lessons learned and the review of in-place programs has led to the development and issuance during the year of several criteria and guidance documents on emergency planning. One identifies conditions requiring notification of authorities by plant operators. Another gives interim guidance jointly from NRC and FEMA for use by licensees and State and local governments in preparing and evaluating response plans and preparedness. A third document presents functional criteria for proposed licensee emergency support facilities. Among such facilities would be computer connections (Nuclear Data Link) between operating nuclear facilities and the NRC Operations Center to provide capability for monitoring key safety parameters in the plants.

The Commission issued two reports to Congress in September—one on NRC emergency communications, and the other describing the Nuclear Data Link concept. A report on the overall status of emergency response planning for nuclear power plants, directed by Section 109 of Public Law 96-295, will be transmitted to the Congress in early 1981.

New Focus on Operating Experience

The NRC's response to recommendations from major TMI studies urging a new emphasis and thoroughness in applying the lessons of operating experience found expression in several ways, including certain organizational changes: the creation of a new office—the Office for Analysis and Evaluation of Operational Data (see Chapter 5) and the creation within the Office of Nuclear Reactor Regulation of an Operating Experience Evaluation Branch (see Chapter 4). Also of particular note was the adoption, in February 1980, of a new notification rule under which licensees are required to notify the NRC Operations Center in the Office of Inspection and Enforcement within one hour of certain specified safety-significant events.

Among the abnormal events reported to the NRC by licensees during 1980 were the following:

Loss of Instrumentation at Crystal River. An electrical short-circuit at the Crystal River facility in Florida in February 1980 brought about a partial loss of power to instrumentation associated with automatic control systems and some control board indicators. It was nearly seven hours before the situation was stabilized, leaving some 43,000 gallons of reactor coolant on the floor of the containment building. Although there was no impact on the general public or plant employees, these instrumentation failures were significant, and the NRC created a "B&W Reactor Transient Response Task Force" to assess the generic aspects of these kinds of events.

Partial Scram Failure at Browns Ferry. The Tennessee Valley Authority reported that a total of 76 control rods in the Unit 3 reactor of its Browns Ferry facility (a boiling water reactor) failed to insert fully into position to shut down the reactor. Eventually the rods were properly positioned, after four separate attempts to do so, and no damage occurred.

This type of failure could have resulted in substantial fuel damage. An NRC study team was formed and appropriate bulletins and orders were issued by NRC to all other licensees for boiling water reactors.

Indian Point Unit 2 Leakage. Upon entry of containment on October 17, 1980, plant personnel observed leaking fan coolers. Nearly 100,000 gallons of service water had leaked into the containment. The licensee concluded that about nine feet of the reactor vessel had been submerged while operating. The plant is currently in an extended outage which is expected to last until April 1981 to place the heat exchanging sections of the five fan coolers. Prior to restart, the licensee will be required to perform an

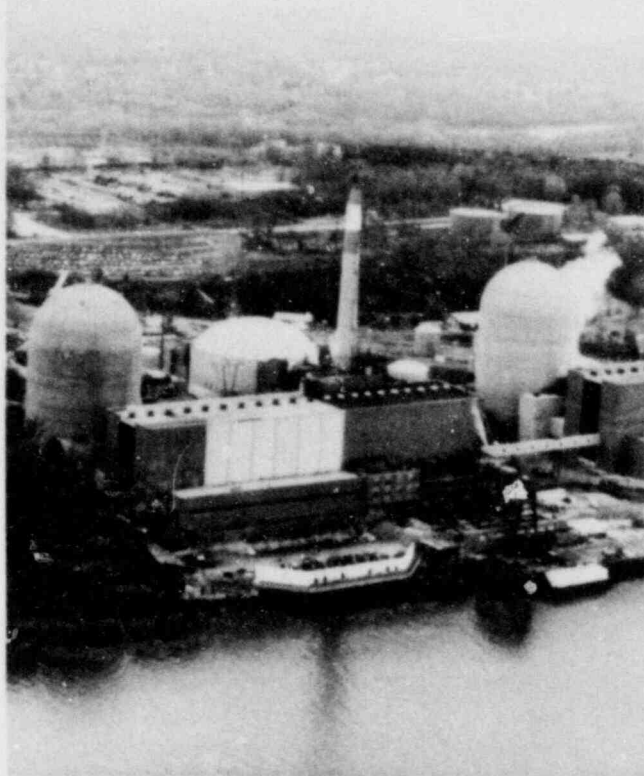

Indian Point Station in New York. The inoperative Unit 1 is at center, flanked by Unit 2 on the left and Unit 3 at right.

analysis of the reactor vessel and submit it to the NRC for review. A bulletin has been issued by the Office of Inspection and Enforcement to assure that all plants take the necessary actions to prevent such an occurrence.

Several other salient operational events are discussed in Chapter 5, as are all events defined as "Abnormal Occurrences" and reported quarterly to the Congress, from the last quarter of fiscal year 1979 through the third quarter of fiscal year 1980.

OTHER MAJOR PROGRAMS

Inspection and Enforcement Activities

Substantial development and significant change were introduced into the NRC inspection and enforcement program during fiscal year 1980. Resident inspectors were deployed at all sites with power reactors in operation or in preoperational testing, as well as at 18 sites with reactor facilities under construction. As of September 30, 1980, there were

136 resident inspectors at 76 different sites. The inspection activity at operating reactor sites and at plants under construction was improved and intensified. Special team appraisals of health physics programs were conducted at the operating plants.

A significant portion of the inspection effort at operating power reactors was directed toward verification of licensees' implementation and completion of actions specified in the TMI Action Plan. License applicants and those receiving licenses during the report period were especially affected, as routine inspections were augmented by inspections to verify compliance with requirements delineated in the TMI Action Plan. The plan has also brought about changes in the construction inspection program, with special attention to such matters as quality assurance, on-site design, and review of "as-built" structures and systems.

The imposition of 49 civil penalties on licensees during the report period totaled about \$1.4 million. In other enforcement actions, the NRC issued 26 "cease and desist" or similar orders, and approximately 100 bulletins and other notices alerting licensees to safety-related matters. More than 5,400 licensee inspections and 125 investigations were conducted during the period.

By legislation enacted in June 1980, the limit on an NRC fine for a single violation was raised from \$5,000 to as much as \$100,000 per day with no ceiling on the total fine for any 30-day period. The Commission included the NRC's plans for implementing its increased civil penalty authority in its Proposed General Statement of Policy and Procedure for Enforcement Actions, published for public comment in October 1980. Comments received will be considered in refining the policy in rulemaking during 1981. The policy is in interim effect, and emphasizes the use of stronger enforcement measures to assure that, in the long term, noncompliance is more expensive to licensees than compliance. Emphasis is also placed on prohibiting operations by licensees who cannot achieve and maintain adequate levels of protection for the public and their workers.

Research

The new priorities brought about by the TMI accident had a far-reaching impact on NRC's safety research programs in 1980 and plans for the future (See Chapter 13.) The Loss-of-Fluid Test (LOFT) and Semiscale facilities in Idaho, for example, previously had been used almost exclusively to study phenomena associated with large-break accidents involving sudden losses of reactor coolant. By mid-1980, both programs had been largely reoriented to the conduct of small-break experiments to increase

knowledge on solving problems such as those that occurred at TMI. In the coming year, the unique features of LOFT will be used for realistic studies of advanced control room concepts and man/machine interactions under the stressful conditions of actual loss-of-coolant accidents. A task force study of LOFT will be submitted to the Commission early in 1981 to assist in deciding on the future plans for this facility.

Other research activities were redirected, as well. Some placed greater concentration on severe accident phenomena in the context of health and socio-economic effects. Others involve transient simulations of the late phases of loss-of-coolant accidents, again reflecting the lessons of TMI. Overall, NRC's water reactor safety research program in 1980 underwent a distinct shift from the theoretical or generic emphasis of previous years to the examination of pragmatic safety questions that had arisen from more recent operating experience.

The other major change in research activity in 1980 was a new emphasis given to probabilistic risk assessment as a potential tool for use in licensing decisions. The research staff section previously handling this activity was enlarged, given division status, and set to evaluating a variety of accident sequences with the goal of developing improved reliability models for operating reactors. The first phase of the evaluation, involving study of the Crystal River plant, was nearly complete by the end of the year.

During 1980 the research staff drafted a long-range research plan and circulated the draft to other program offices for comment. In 1981 the final version of the plan is to be submitted to the Commission for its approval.

Waste Management

In February of 1980, President Carter announced a comprehensive radioactive waste management program based on recommendations of the Interagency Review Group on Radioactive Waste Management, of which the NRC had been a non-voting member. Included in the President's program was a proposal for legislation to extend NRC licensing authority over all DOE transuranic waste disposal facilities and any new DOE sites for commercial low-level waste disposal. Legislation was enacted in December 1980 which assigned responsibility to provide disposal capacity for low-level commercial wastes generated within the boundaries of a State to that State. Such wastes may, under the Low-level Radioactive Waste Policy Act—and pursuant to conditions provided under the Atomic Energy Act—be disposed of within a State, somewhere in the region under multi-State compacts. Such compacts must be approved by Congress and reviewed every five years.

The regulations for high-level waste repositories (10 CFR Part 60) were considered by the Commission during the report period, and the licensing procedures were published as a proposed rule in December 1979. Draft technical criteria for the regulation of geological disposal were prepared by the staff and were published in an advance notice of proposed rulemaking in May 1980. The final rule on procedures is scheduled for issuance in early 1980.

Staff activity related to the NRC Waste Confidence rulemaking continued during the fiscal year. In this proceeding, the Commission seeks to generically assess the current degree of assurance that radioactive wastes can be safely disposed of, and to determine whether radioactive wastes can be safely stored on-site past the expiration of existing facility licenses until off-site disposal or storage is available. (See Chapter 15, "Commission Decisions.")

In October 1980, the NRC released the Final Generic Environmental Impact Statement (GEIS) on Uranium Milling, along with regulations on mill tailings. These regulations are presently being challenged in court (see Chapter 15, "Judicial Review").

(See Chapter 8 for discussion of all aspects of waste management activity during the report period.)

Materials and Transportation

Growth within the NRC's fuel cycle program is centered in byproduct material (radioisotopes) licensing, which comprises the bulk of the annual processing of some 5,000 to 6,000 applications for new licenses, license amendments and license renewals involving materials. These represent primarily medical, industrial and academic users.

Fuel cycle actions in 1980 include completion of a program of measuring radon releases from uranium mining and milling operations and development of new radon estimates for the environmental impact fuel cycle rule (Table S-3 of 10 CFR Part 51), the conduct of 183 transportation package design certification reviews, approval of about 350 quality assurance programs for radioactive material transportation activities, and continuation of the review of terminated licenses issued by the former Atomic Energy Commission to identify possible contaminated sites.

In November, the NRC issued a rule (10 CFR Part 72), effective in December, setting forth licensing requirements for storage of spent fuel in independent installations. The staff is reevaluating, in light of the new regulation, an application for the renewal of General Electric Company's license to receive spent fuel for storage at its Morris (Illinois) Operation. This proposal is being contested by the State and other intervenors.

The NRC continued an accelerated inspection schedule at all three existing commercial low-level waste burial sites in Washington, Nevada, and South Carolina to assist in examining shipments for compliance with all applicable regulations.

In October, the NRC made available to State governors a report showing approved routes through 33 States for the shipment of spent reactor fuel. In December, the Commission published proposed regulation revisions that would require licensees to notify governors in advance of shipment of spent fuel or potentially hazardous nuclear wastes, in response to a requirement in Section 301 of P.L. 96-295. A draft assessment of environmental impacts resulting from transportation of radioactive material through urban areas was published in 1980, and a draft generic environmental impact statement is being prepared.

In view of the number of incidents where personnel have been accidentally exposed to radiations from radiography sources, the staff plans to issue in mid-1981 a report on significant radiography incidents.

NRC studies to develop an information base on the technology, safety, and costs of decommissioning various nuclear facilities in advance of rulemaking have been largely completed. A draft generic environmental impact statement on decommissioning will be published early in 1981, to be followed by a policy statement in mid-1981 and subsequent proposed amendments to the appropriate rules.

Domestic Safeguards

A number of developments in the area of domestic safeguards during fiscal year 1980 include the following:

The new Safeguards Upgrade Rule—strengthening physical security requirements to protect against a larger, more sophisticated threat at any facilities possessing, using, or transporting five formula kilograms of SSNM—became effective in March 1980 and is expected to be implemented during 1981 and 1982. (See Chapter 7.)

During the report period the NRC transmitted to the Congress the final three reports documenting results of the staff's 18-month program of comprehensive evaluations of safeguards at licensed facilities which possessed formula quantities of SSNM during fiscal year 1980. All required permanent improvements were completed in that period.

Several important changes in requirements for the protection of licensed spent fuel shipments became effective in July 1980, including: (1) the transit of heavily populated areas is no longer embargoed; (2)

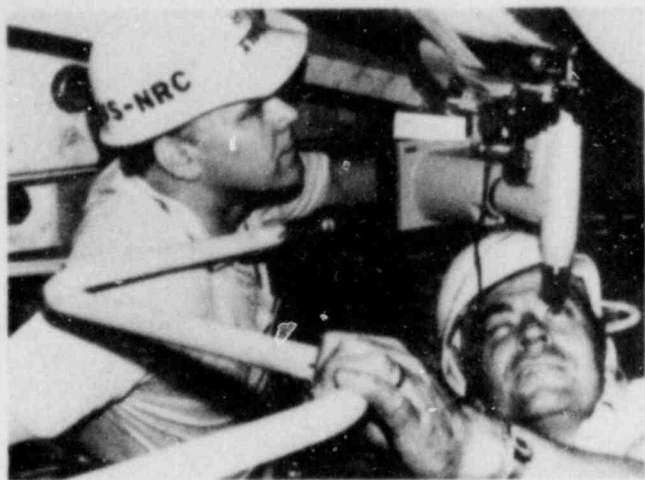

NRC resident inspector assists metallurgical consultant in performing a microscopic examination of the grain structure of heat-treated steel piping at main steam line penetration in reactor containment building of Washington Nuclear Project No. 2.

if a shipment passes through or near a heavily populated area, additional protective measures are required; (3) about 60 cities have been added to the list of heavily populated urbanized areas; and (4) vessels in port, either unloading spent fuel or passing through, are required to be protected by armed guards.

International Activities

The NRC's activities in the international sphere continue to expand. (See Chapter 11.) Arrangements for exchange of nuclear safety information were concluded with Finland and the Philippines, bringing to 19 the total of such bilateral compacts at the end of 1980. Negotiations with six other countries are underway. Expansion of these agreements and other efforts will help ensure the inclusion of radiological incident information from other nations in the NRC's information bank, thereby supporting the evaluation of operational experience to further safety.

During fiscal year 1980, the NRC issued 462 nuclear export licenses, of which 89 were for major exports, and 127 amendments to existing licenses. The NRC consulted with Executive Branch agencies on seven Agreements for Cooperation with other countries, a nuclear technology export, nine requests to transfer U.S.-supplied nuclear fuel for reprocess-

ing, and about 100 exports of nuclear-related commodities licensed by the Department of Commerce.

In the export licensing area, the Commission confronted controversial and difficult issues in 1980, particularly with respect to applications for reload nuclear fuel for India's Tarapur reactors and for replacement component hardware for these facilities. The Commission was of the unanimous view that the license applications did not satisfy the applicable criteria set forth in the Atomic Energy Act and, in May, referred the applications to the President as provided by the Act. Subsequently, President Carter determined that "withholding the exports... would be seriously prejudicial to the achievement of United States non-proliferation objectives and would otherwise jeopardize the common defense and security..." After issuance of Executive Order 11218 in June, authorizing the exports, the matter was subject to a 60-day Congressional review period as provided by law. A resolution disapproving the two proposed fuel exports passed the House, but was narrowly rejected by the Senate. The fuel under one license was shipped in October; the second shipment will await further consideration by the Executive Branch and consultation with the Congress. The component exports have also been approved.

The Commission continues to be concerned over the adequacy of International Atomic Energy Agency (IAEA) safeguards applied to nuclear exports and NRC's need for more detailed information on safeguards implementation abroad. The NRC has continued efforts with the Executive Branch to assist the IAEA in strengthening international safeguards. Regarding the voluntary U.S. offer to permit application of IAEA safeguards to U.S. civil nuclear facilities, the NRC published implementing regulations in July following the Senate's unanimous vote of its advice and consent to ratification of the U.S./IAEA agreement as a treaty. The agreement entered into force on December 9, and the implementing regulations became effective on December 24. During 1981, NRC staff will work with affected licensees, the Executive Branch, and the IAEA in developing facility-specific safeguards agreements for those facilities selected by the IAEA for inspection, and in initiating the reports required under the U.S./IAEA Safeguards Agreement.

With respect to NRC's consultative role on nuclear export matters under the purview of the Executive Branch, as provided by law, the Commission continues to believe that retransfer requests involving reprocessing are difficult to assess in the absence of a coherent overall policy.

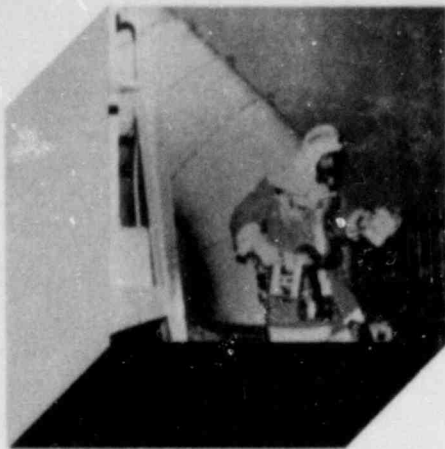

2

Aftermath of the Accident at Three Mile Island

The second chapter of the *1979 NRC Annual Report* (pp. 11-62) gave a detailed account of the events of March 28, 1979, and the period immediately thereafter at the Three Mile Island Nuclear Station in Pennsylvania. That treatment covered major phases of the accident and responses to it on the part of the NRC, the Administration, the Congress and others, up through the issuance of the report of the President's Commission on the Accident at Three Mile Island (Kemeny Commission) on October 30, 1979, and concluding with the President's response to the recommendations of that report, issued on December 7, 1979.

The present chapter attempts to update the specific situation at Three Mile Island through the current report period (ended September 30, 1980) and also to take cognizance of generic aspects of the TMI aftermath, as reflected in the findings and recommendations of reports issued since the President's Commission finished its work, and in policies and requirements developed by NRC in the wake of TMI. The aggregate of tasks which correspond to recommendations of the various TMI investigators and which the NRC has committed itself to undertake is designated the TMI Action Plan. This plan comprises over 150 separate tasks in a number of broad categories and embraces a time frame extending more than five years into the future. Some portions of the plan are touched upon in this chapter, but a fuller discussion of its implications for NRC licensing activities in general will be found in Chapter 4. A tabulation of each of the tasks in the plan can be found in Appendix 7.

The chapter is made up of two sections and discusses the following subject areas: the events and actions that have taken place at the TMI-2 facility from the time of the last annual report to the end of fiscal year 1980, with an assessment of the environmental and socioeconomic impact of the TMI

accident after 18 months; a discussion of the findings and recommendations contained in certain TMI investigative reports issued during the current report period, dealing with causes, effects and lessons, and also actions associated with decontamination and cleanup at TMI-2.

STATUS OF THE TMI-2 FACILITY

On the afternoon of April 27, 1979, the reactor coolant pump which had been providing the flow through the core of the TMI-2 reactor and bearing away the decay heat for removal through a steam generator was intentionally shut down and natural circulation cooling was achieved. The reactor was thus brought to a stable condition which could be sustained without dependence on the functioning of electrically activated equipment.

Decontamination of Water—EPICOR II

After the accident, about 450,000 gallons of contaminated water with intermediate levels of radioactivity (i.e., concentrations between one and 100 microcuries-per-milliliter) were held in various tanks and sumps in the auxiliary and fuel-handling buildings at TMI-2. In addition, contaminated water from system leakage, flushing and draining was accumulating at the rate of about 400 gallons-per-day. To decontaminate this water, the licensee for TMI proposed to install a three-stage demineralization system called EPICOR-II, which uses resins to adsorb radioactivity. Following the NRC Memorandum and Order of October 16, 1979, which directed that the EPICOR-II system be used, the licensee began processing the contaminated water at an average rate of

10 gallons-per-minute. As of August 1980, about 500,000 gallons of water (including some recycling) had been processed and about 55,000 curies of radioactivity removed. The processed water contains concentration levels of less than 0.00001 microcuries-per-milliliter, except for tritium. The latter is not affected by the processing and remains at a concentration of about 0.2 microcuries-per-milliliter.

The decontaminated water is being held in storage tanks at the site. The spent resins are dewatered and stored in steel liners, which are placed in massive concrete structures with concrete walls four feet thick and 15-ton concrete caps over each cell. The structures provide environmental protection and radiation shielding which allows personnel to work alongside and on top of the cells. (See the *1979 NRC Annual Report*, pp. 22-24.) Alternatives for the final disposition of the processed water and of the liners were being evaluated at the close of the report period. The more highly contaminated water in the reactor containment building had not yet been processed at that time.

Decontamination of Atmosphere

Before workers could begin the job of cleaning up the containment building, maintaining instruments and equipment, and eventually removing the damaged fuel from the reactor core, the radioactive gas krypton-85 which had been released into the reactor building during the accident had to be removed. Although the gas was only thinly diffused throughout the building atmosphere (in a concentration of about one microcurie-per-milliliter), it nevertheless posed a danger to personnel who would have to work in the building for prolonged periods. In February 1980, two incidents occurred involving small inadvertent releases of krypton-85: one was associated with the leak of up to 1,000 gallons of primary coolant from the makeup system to the TMI-2 auxiliary building on February 11, and the other on the following day, when a small leak went undetected for about 17 hours. These releases represented a psychological health hazard calling for timely decontamination of the plant.

In March 1980, the NRC staff issued for public comment a draft environmental assessment of a



Storage area at Three Mile Island for "spent" ion-exchange resin liners containing radioactive material removed from the contaminated water in the auxiliary building tanks at the TMI-2 site. One modular storage structure is shown at left center of photo, while construction of a new facility next to it is under-

way. The facilities have 4-foot thick concrete walls and hold concrete-shielded, galvanized corrugated steel cylinders in which the spent resin liners are placed. Shipment of liners from the site will depend on approval of a disposal facility and availability of shipping casks.

number of alternatives for the decontamination of the reactor building atmosphere. Approximately 800 responses were received from various Federal, State and local agencies and officials, as well as from non-governmental organizations and private individuals. Following appropriate revisions, responding to the comments received, and additional reviews and analyses by NRC staff, the "Final Environmental Assessment for Decontamination of the Three Mile Island Unit 2 Reactor Building Atmosphere" (NUREG-0662) was issued in May 1980. The statement discussed several alternatives and the potential environmental impacts associated with each.

Having reviewed the staff assessment and recommendations, together with the comments of the public, the Governor of Pennsylvania, and many others, the Commission issued a Memorandum and Order which authorized the licensee to clean the reactor building atmosphere by means of a controlled purge or release of contaminated air through filter systems. On the same day, the Commission issued a modification of the TMI operating license setting off-site dose limits for the purge.

The purging operation was carried out under detailed procedures approved by the NRC staff; it began on June 28, 1980, and by July 11 was essentially complete. Measurements showed that about 43,000 curies of krypton-85 was released during this period. Samples from the release flow were analyzed to ascertain the presence of radionuclides other than krypton, and the amounts were determined to be insignificant. During the entire operation, members of the NRC staff were on-site to monitor the licensee's activities. In addition, off-site radiation monitoring programs were conducted by the licensee, the NRC, the Environmental Protection Agency, the Department of Environmental Resources of the Commonwealth of Pennsylvania, and also by private individuals—through the Community Radiation Monitoring Program set up by the Department of Energy and the Commonwealth of Pennsylvania. The maximum cumulative radiation dose and the maximum dose rate measured at off-site locations were a fraction of the limits allowed under NRC regulations.

Reactor Building Entry

Personnel entry into the reactor building at TMI-2 was an important first step toward acquiring technical data by which to assess radiation levels and equipment damage and plan for decontamination and defueling. On July 23, 1980, after completion of the purging of krypton-85, two engineers in the employ of the licensee entered the reactor building through an airlock. They were wearing protective clothing and carried self-supply air-breathing apparatus. The ini-

tial entry lasted for 20 minutes; the engineers took 29 photos and six radiation swipes, and made a general survey of the area for beta and gamma radiation.

A second entry was made on August 15, 1980, by four workers; two of them stayed for 20 minutes and the others for 40 minutes. All were physically exhausted by working at temperatures of 85° to 90°F inside the building while wearing several layers of protective clothing and full-face respirators. The team managed to energize the building's lights. They observed that the sump water was murky with floating debris, and that electric wiring had become so brittle it crumbled when touched. A standard black telephone had partially melted. A 55-gallon drum with the top cover still attached was crushed. Numerous rusted surfaces were observed, but the reactor head appeared to be in good condition.

Programmatic Environmental Impact Statement

Responding to a directive of the Commission issued on November 21, 1979, the NRC staff prepared a draft programmatic environmental impact statement dealing with the decontamination and disposal of radioactive waste resulting from the TMI accident. The statement (NUREG-0683) was released for public comment on August 14, 1980. It discussed four fundamental activities necessary to the cleanup: treatment of radioactive liquids; decontamination of the building and equipment; removal of fuel and decontamination of the coolant system; and packaging, handling, storing and transporting nuclear waste. The statement addresses the principal environmental impacts that can be expected to occur as a consequence of cleanup activities, including occupational and off-site radiation doses and resultant health effects, socioeconomic effects, and the effects of psychological stress (see "Special Reports on TMI," below). Off-site doses of radiation from normal cleanup operations were considered, together with those from postulated accidents. The NRC staff concluded that methods exist or can be adapted to perform the cleanup operations at TMI with minimal releases of radioactivity to the environment. It was anticipated that the Final Programmatic Environmental Impact Statement—incorporating comments from other agencies of government and from the public as well as responses to those comments by the NRC staff—would be ready for issuance by early 1981, following an extensive comment period.

Advisory Panel on TMI Cleanup

While the draft environmental statement on the TMI cleanup was out for comment, the NRC



A milestone in the post-accident cleanup at TMI-2 was reached on July 23, 1980, with the first entry into the reactor building since the accident on March 28, 1979. The licensee's personnel are shown in protective clothing with communications and radiation detection equipment as they prepare to enter the inner door of the personnel access hatch.

announced the creation of a 12-member advisory panel to consult with the Commission and give advice on major stages of the cleanup. The panel was headed by the Chairman of the Dauphin County (Pa.) Commissioners, and includes other officials from State and local government, scientists and citizens from the area. NRC Chairman John F. Ahearne, in making the announcement, noted that "the NRC Special Task Force on the Three Mile Island Cleanup recommended that the Commission develop a formal means to obtain input and views from the residents of the Three Mile Island area on the cleanup plans. Subsequently . . . provision was made for the establishment of a Three Mile Island

Advisory Panel . . . We believe this group can provide the Commission with valuable counsel on the actions to be proposed and taken by the NRC regarding cleanup of Three Mile Island Unit 2."

NRC Policy Statement on State Requirements at TMI

On September 23, 1980, the TMI licensee sought a temporary stay of a cease and desist order of the Pennsylvania Public Utility Commission under which the licensee was ordered not to use revenues for cleanup and restoration at TMI-2 which were not

provided by insurance. The licensee took the position that it could not comply with the State Commission's order without violating Federal law requiring it to comply with directives of the NRC. The NRC's policy statement declared: "This Commission strongly emphasizes that all the health, safety and environmental requirements applicable to TMI 2 must be fully complied with by the TMI licensee. In the event of any such conflict [between an order of the State's Public Utility Commission and an NRC requirement], . . . NRC requirements must supersede State agency requirements that result in a lesser degree of protection to the public. In short, the Commission will not excuse [the TMI licensee] from compliance with any order, regulation or other requirements by the Commission" which serves the purpose of protecting public health and safety or the environment.

Six TMI Workers Incur Radiation Overexposure

During the very early phases of post-accident activities at TMI, an accidental overexposure to radiation affecting six individuals took place. On August 29, 1979, the six men entered a room in the TMI-2 fuel-handling building to inspect and tighten leaking valves preparatory to decontamination of the area. Reactor coolant water, highly contaminated from the March 28 accident, was leaking from the valves. The radiation survey instrument used by the workers showed a gamma dose rate in the room of 10-15 rem-per-hour in general and, in one small zone, of 25 rem-per-hour. It was decided that the time limit on the presence of each worker in the radiation area was four minutes. What the survey instrument failed to disclose was the beta radiation rates in the room, which were running as high as 2500 rem-per-hour.

It was later ascertained that the workers had received doses in excess of regulatory limits from the beta radiation. The doses were as high as 166 rem to the whole body, in one instance, and 161 rem in another. No indication of medically significant effects in the personnel was identified by medical examination. The causes of the accident were determined to be inadequate instrumentation for radiation detection and a failure to require adequately protective clothing for the workers. Corrective action was taken under NRC direction.

SPECIAL REPORTS ON THREE MILE ISLAND

The 1979 NRC Annual Report carried detailed treatment of the major investigations into the TMI-2

accident available during 1979 (see Chapter 2 of that report). Following are discussions of the findings and recommendations coming out of continuing research into the causes and consequences of the accident, from the final reports of major investigative bodies issued in 1980, and from an inquiry into financial problems related to the TMI cleanup.

Psychological Stress Resulting from The Three Mile Island Accident

One of the significant findings of NRC research into TMI-2 was the lingering psychological stress which the accident imposed. Recognizing that psychological and emotional distress would probably be present in the community during the long period of decontamination and cleanup, the NRC staff, in collaboration with consulting psychologists, developed a program to delineate the nature and level of such stress. The first product of this collaboration was a discussion of stress in the final environmental assessment for decontamination of the TMI reactor building atmosphere, published in May 1980 for public comment. In that document, the staff concluded that atmospheric purging of krypton-85 from the TMI containment would result in less psychological impact than alternative decontamination procedures. The staff acknowledged, however, that this recommendation would be unpopular with a segment of the local community. Preliminary observation by the consultants during the venting operation indicated that the more expeditiously the purging operation was conducted, the lower the stress induced by the activity would be.

The complete process of decontamination was addressed in the draft programmatic environmental impact statement on decontamination of TMI, published in August 1980. The conclusion set forth in that issuance was that, although low levels of stress would persist during the cleanup period, no long-term psychological effects on the majority of the community should be expected. Moreover, the general level of stress associated with decontamination subsequent to the purging of the containment atmosphere would be well below that already experienced by residents during the accident.

Socioeconomic Impacts of the TMI Accident

As part of its documentation of post-accident effects at TMI, the NRC developed a research program on the socioeconomic impact on the area. The first element of this program took the form of a telephone survey covering 1,500 households within 55 miles of TMI and seeking information on the activi-

ties of household members during and after the accident, their attitudes toward TMI and nuclear power in general, their demographic characteristics, and both the short-term and continuing socioeconomic effects of the accident. This survey constitutes the broadest and most detailed of the studies undertaken in the wake of the TMI accident, as of the end of fiscal year 1980. The survey results were published in October 1979 in a preliminary report, "Three Mile Island Telephone Survey" (NUREG/CR-1093).

The survey results disclosed that the impact of the TMI accident affected large numbers of people, both socially and economically, and that some effects continued long after the accident. The magnitude of public anxiety during the period of the accident can be gauged by the fact that 144,000 persons living within 15 miles of the plant temporarily left their homes, some of them for as long as two months. Those who relocated travelled an average distance of 100 miles, to a total of 21 States. These evacuees stayed mainly with friends and relatives. The economic cost of the accident for evacuated and non-evacuated households was estimated to be \$18 million—including relocation costs, lost pay and other income losses, and other expenses. The emotional stress (see discussion above, under "Psychological Stress") was such as to disrupt the social routines of residents and to cause a large number of them to consider moving out of the area.

To study the short-run impact of the accident on the real estate market, the NRC contracted with the Institute for Research on Land and Water Resources at the Pennsylvania State University in April 1980. The specific objective of the contracted study is the isolation—through the use of statistical and non-statistical techniques—of the accident's impact on real estate prices, number of sales, delay in sales, and changes in mortgaging policies. Research design incorporating a sample of all single family houses and lot sales from 1975 through 1979, for an area within 25 miles of TMI and for three control areas, has been prepared. The researchers also expected to interview a number of mortgage lenders, realtors, and developers. Results of the study were expected in late 1980.

A second report, expanding upon the telephone survey, was prepared with the cooperation of the Governor of Pennsylvania's Office of Policy and Planning and published in January 1980. It is entitled "The Social and Economic Effects of the Accident at Three Mile Island: Findings to Date" (NUREG/CR-1215). The report deals with impacts of the accident on the regional economy, the business community, local government agencies, churches, schools, hospitals, prisons, and homes for the elderly. It also appraises the impacts on agriculture and tourism, both economic sectors adversely

affected in the short run by the accident. Finally, the report estimates the long-term effects of the accident on persons, business firms, the value of real estate, and political institutions.

Impact of Three Mile Island on Biota

A number of residents near the TMI power plant maintained that there was a causal connection between the operation of the facility—and the accident there—and problems in the region with the health of animals and plants. The NRC staff investigated the claims, with participation by a veterinarian from the Environmental Protection Agency, a radiobiologist from the Argonne National Laboratory, and a veterinarian from the Pennsylvania Department of Agriculture. Their findings, published as an NRC technical report (NUREG-0738), indicated that, while some local residents were in fact having problems with animals and plants, no causal connection could be established between events at TMI and those problems.

With respect to recreational fishing on the Susquehanna River near TMI, comparisons were drawn up between the period after the accident and the period of 1974-1978. The monthly levels of fishing activity were found to be about average during 1979, but harvests, and indices of harvest success, were at record low levels for five months following the accident, though they improved with time until normal levels were attained again in the sixth month. The depressed harvests did not result from degraded water quality or other ecological or radiological causes attributable to the accident, but rather from the fact that many local anglers did not retain their catch, or retained less than normal, because of their concern about the quality of the fish after the accident. The gradual recovery of retained fish harvests followed the same general pattern as the decreasing perception of threat and concern with radioactive emissions among the local populace.

Groundwater Monitoring at TMI

Because of the potential for leaking of radioactive water from TMI into the groundwater and subsequently into the Susquehanna River, the NRC staff requested that the TMI licensee install a series of monitoring wells around the auxiliary and reactor buildings. The wells were completed and monitoring begun in early 1980. Initial tests showed tritium levels below the maximum permissible concentrations, but several readings were higher than normally occurring background levels. The latter fact caused some concern, because if a leak from the reactor

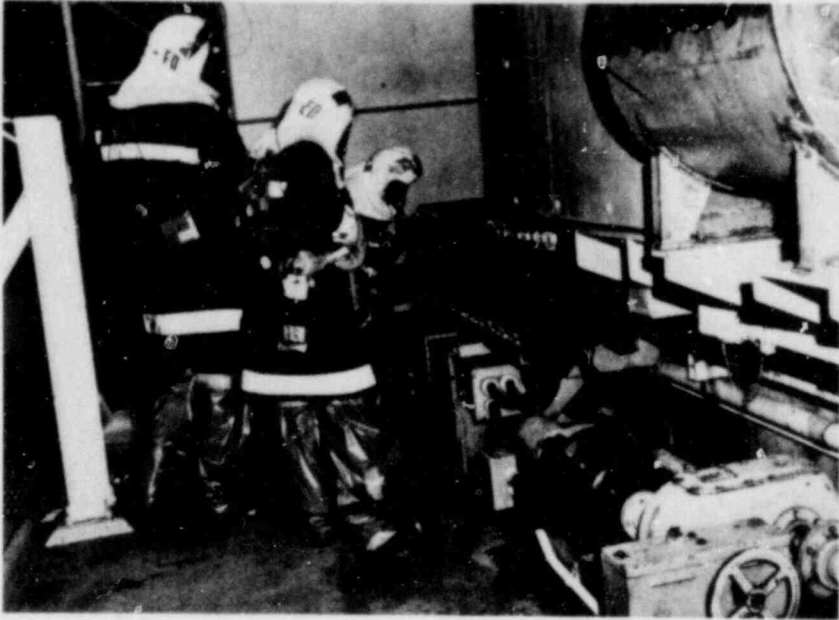

Metropolitan Edison personnel are shown carrying out a radiation mapping program inside the containment building of TMI-2. The levels of radiation are recorded on a building floor

plan. This necessary step preparatory to developing a comprehensive plan for decontamination began in the summer of 1980.

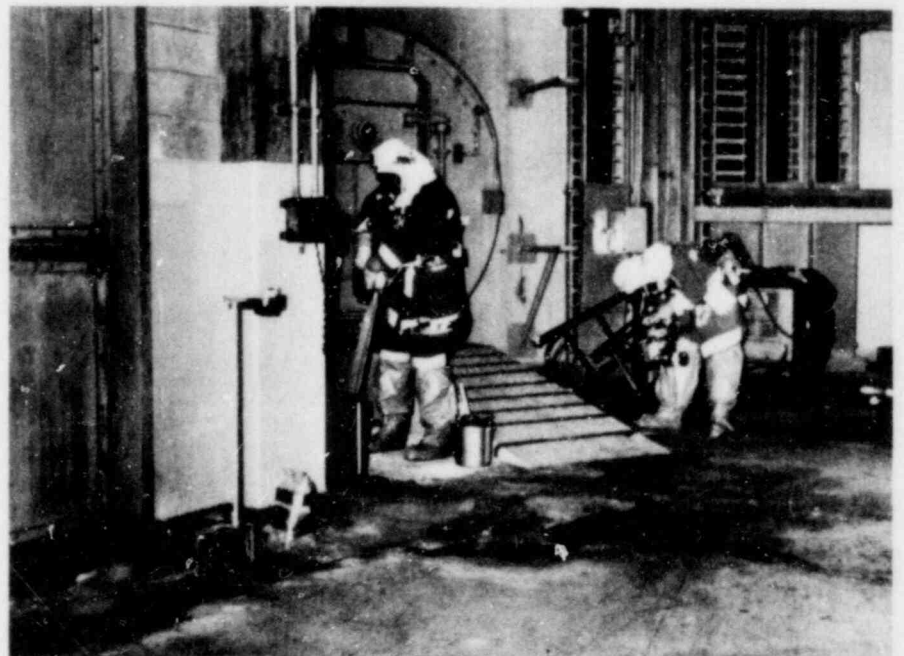

building had occurred, the first radionuclide to be detected in the groundwater would most likely be tritium.

The NRC staff then requested a program of monitoring, sampling, analysis, and testing to determine the actual cause of the high tritium readings. After several months of testing, no significant increases were observed, and it was decided that the likeliest cause of the concentration first detected was a leak from the borated water storage tank, and not from the reactor building.

The program has been continued and expanded to provide a close monitor of groundwater quality on the island and to identify any further contamination of the groundwater at the TMI site.

NRC Special Inquiry Group

Within weeks of the accident at Three Mile Island, the Nuclear Regulatory Commission decided to establish a Special Inquiry Group to carry out, under independent directorship, a thorough analysis of the causes and assessment of the implications of the accident. Although the work of the group was not intended to be a duplication of the efforts of the President's Commission (see Chapter 2 of the *1979 NRC Annual Report*) or any other investigative body, there was a good deal of overlap between its coverage and that of the President's Commission, including a number of similar or identical recommendations in the final reports of both.

In mid-June of 1979, the Commission contracted with the law firm of Rogovin, Stern, and Huge to have the firm assume directorship of the group and responsibility for its work. Most of the people eventually assembled to assist in the inquiry were drawn from the NRC professional staff, carefully screened to avoid any conflict of interest. A number of technical consultants in the areas of accident investigation and safety management were also engaged to assist in the inquiry, as were some lawyers with investigative experience. Also contributing to the study—mainly by providing specialized technical expertise—were some of the national laboratories of the Department of Energy, the National Academy of Public Administration (in the area of emergency response), and a private firm experienced in human factors engineering.

In the course of the inquiry, the group took about 270 formal depositions under oath, including those of the five NRC commissioners, dozens of other NRC officials, the management of the company licensed to operate the TMI facility and of the company which made the reactor, control room personnel from TMI, and persons responsible for emergency preparedness at the State and county levels of government. Besides these formal statements, the group carried out on the order of a thousand inter-

views not under oath. In addition, the group had access to the transcripts of interviews and depositions taken by the President's Commission, other NRC investigators, and others.

Finally, in an effort to optimize the quality of the finished report and to guard against inadvertent bias on the part of NRC staff participating in the inquiry or from any other source, the judgments of 21 outside experts were solicited both during the planning stage and while the report was in final preparation. These consultants—associated with universities, national laboratories, industry, and public-interest groups—were selected with a view to eliciting informed judgment from a broad spectrum of interests and approaches.

The results of the special inquiry were published in January 1980 under the title, "Three Mile Island - A Report to the Commissioners and to the Public" (NUREG-CR/1250, Vols. I and II). A summary of the principal conclusions and recommendations offered in that report follows.

Findings and Recommendations. Many of the conclusions and recommendations of the NRC Special Inquiry Group were, as noted, closely congruent with those of the President's Commission on the Accident at Three Mile Island, which were made public in October of 1979, and with those of other studies, including those of NRC offices. A major proposal of both the President's Commission and the Special Inquiry Group was that the NRC be replaced by an executive branch agency headed by a single administrator, based on the conviction that the TMI accident had demonstrated that authority was too diffuse in a five-member commission for quick, clear and effective decision-making in an emergency. The recommendation was not adopted in the Administration's reorganization plan for the NRC, though the office of the Chairman was, under that plan, greatly strengthened with respect to managerial prerogatives and emergency powers.

A fundamental finding of the group was that the TMI accident did not expose hardware problems so much as it revealed management deficiencies both in the nuclear power industry and the NRC. Of the latter, the group affirmed that "the Commission is incapable, in its present configuration, of managing a comprehensive national safety program . . . adequate to ensure the public health and safety." The group ascribed an "attitude of complacency" to both industry and the NRC prior to TMI, but took note of the fact that the "defense-in-depth" concept did in fact serve to protect the public health and safety during and after the accident, and that "less attention than is deserved will be given to what 'went right'" at TMI. The group's technical analyses showed that the accident "did not result in radioactive release levels that posed any threat to public health, even in the long run."

Among the changes prescribed by the group in response to lessons learned at TMI were these:

- A shift in resources within NRC from the sphere of reviewing facility design to the monitoring of actual operating reactors, with new emphases on the evaluation of operating experience and inspection of operating reactors.
- A strengthening of on-site technical capability and utility management at reactor sites, with new emphasis on reactor-operator training, together with new NRC requirements regarding the qualifications of supervisors of reactor operations.
- A policy of remote siting for new reactor plants and clear definition of a minimum evacuation planning zone for existing plants, with upgraded emergency planning. Plants that could not meet the criteria for the minimum zone were to be closed unless (1) additional safety systems for mitigation of accidents were installed, or (2) the President determined that their operation was vital to national interests.
- Increased use of quantitative risk assessment methods in the NRC licensing process.
- Greater application of human factors engineering, including better instrumentation display and overall design of the control room.
- An overhaul of the NRC licensing process, increased standardization, increased use of rule-making procedures, and funding for intervenors in the licensing hearings.

The group also called for renewed efforts to educate the public concerning the risks and benefits associated with nuclear power generation, as compared with those deriving from other kinds of power plants, and with such risks as a continued dependence on foreign oil imports.

Without attempting to decide "how safe is safe enough," the group concluded that the "generation of nuclear power can never be risk-free. It will inevitably present certain risks. . . ." Their report affirmed that the defense-in-depth concept and other strengths in the reactor safety system do not detract from the urgent need to make changes "where important weaknesses have been revealed."

Special Senate Investigation Report

The report of the Special Senate Investigation of the TMI accident—undertaken at the behest of the Subcommittee on Nuclear Regulation of the Senate Committee on Environment and Public Works—was published in July 1980. The investigation focused on three discrete aspects of the TMI accident:

- (1) Events of the first day, especially with respect to what the utility management and the NRC officials knew and did not know about the condition of the reactor core and the implications of their knowledge or lack of it for decisions on evacuating the population or taking other protective action.
- (2) Cleanup activities at the TMI site, including safety, legal, financial and social problems associated with those activities.
- (3) Events prior to the initiation of the TMI accident which may have contributed to the severity of the outcome of that accident.

Regarding the first area of inquiry, the investigation sought to answer the question of whether the known condition of the plant during the early hours of the accident warranted a precautionary evacuation of the surrounding community, and of whether there was willful concealment of the true situation by plant operators and managers. Noting that by 8:30 a.m. on March 28, 1979—some four hours into the accident, the reactor core had been uncovered for a prolonged period, the investigators cited the uncertainty of the operating personnel at the site as a fact which "should itself be deemed a plant condition" sufficient to warrant consideration of a precautionary evacuation. As to whether the utility official in charge of emergency planning and response was also uncertain about the condition of the core, the investigators found that factual record unclear. They concluded that if the official had been unsure, and had understood his proper role in recommending protective actions, he should have advised State officials to consider a precautionary evacuation of the population in close proximity to the plant. The report concluded that the utility management was remiss in not clearly communicating its uncertainty on the morning of the first day to the NRC and to the State, and, for their part, the NRC and the State were remiss in not pursuing the matter and ascertaining the condition of the reactor and the plant, including the uncertainty about whether the core was covered. Although the factual record is not clear, the lesson is, according to the report: it is that when there is prolonged and substantial uncertainty about whether a reactor core is covered or uncovered, the affected State should consider the need for evacuation of the population near the reactor plant.

On the subject of willful concealment, the investigators found that the evidence reviewed by them does not disclose any intentional concealment by the utility on the first day of the TMI accident. Conflicting statements were made as to whether the utility official in charge of emergency operations was made aware of major evidence of an uncovered and severely damaged core, but the investigators affirmed that the weight of the evidence does not support a

judgment that there was intentional concealment of such information by the utility. In that respect, the Senate investigation finding resembled that of the President's Commission and the NRC Special Inquiry Group, with the conclusion that human error was the principal contributor to the severity of the accident. The Senate report added the caveat that it would be "inappropriate and unfair" simply to blame control room personnel for the accident at TMI-2. The utility, the reactor vendor, the architect-engineering firm that built the plant, and the NRC all share responsibility for the deficiencies that together constitute the underlying cause of the accident—in operator training, control room design, instrumentation and equipment, and in emergency procedures. The investigators also found insufficient attention on the part of the industry and the NRC to the importance of human factors in the designing and operating of nuclear facilities. Such factors, they proposed, were so serious that they had consequences equivalent to those that could be brought about by major mechanical failures or design defects.

Beyond the human factors, the investigation identified some major weaknesses in the design of the facility that made it difficult to understand and deal with the off-normal condition and concluded that TMI control room personnel did not have the benefit of guidance based on similar accidents in the past because neither the reactor vendor nor the NRC had carried out an effective review of potentially recurring problems.

Because of the many measures taken since the accident which are responsive to these deficiencies, and because of continuing policy studies by its investigative staff, the Subcommittee did not put forward specific recommendations at the time the report was made public.

GAO Report to Congress on TMI

The General Accounting Office issued its report to the Congress on the TMI-2 accident on September 9, 1980, in a document entitled "Three Mile Island: The Most Studied Nuclear Accident in History." Some of the principal findings and judgments set forth in that report are discussed below.

- The "defense-in-depth" concept—resulting in multiple backup systems for safety-related equipment and successive protective barriers to mitigate the impact of any accident—caused the NRC to ignore signs of certain design or operating weaknesses in nuclear power plants. The NRC tended to assume that if an important system failed and plant operators did not know how to deal with the situation, the plant would automatically correct the problem or shut itself down safely. For the same reason, emergency

planning by State and local government had not been made mandatory.

- Management direction provided by NRC was particularly deficient.
- The President's reorganization plan for NRC, greatly expanding the role and authority of the Chairman but leaving the Commissioners responsible for setting policy, will, if properly carried out, offer the opportunity for an effective management structure. The GAO endorses this reorganization.
- While the NRC has taken or planned action responsive to most of the recommendations offered in major investigations of TMI, it has made little progress in establishing goals and criteria which describe what level of safety is enough. The GAO endorses the directive of the Senate Committee on Environment and Public Works (in the draft authorizing legislation for NRC for fiscal year 1981) that a safety goal for nuclear reactor regulation be developed by June of 1981. Only the NRC knows its own licensing capabilities and limitations, and it alone will be responsible for meeting the safety goal, so the NRC—subject to review by the Congress—should be responsible for establishing it.
- The NRC appears to have recognized past inadequacies and to be taking corrective action.
- The NRC seems to have recognized the value of probabilistic risk assessment and to be moving in the right direction.
- The GAO endorses action by the President to set up a special oversight group to follow the implementation of TMI-related recommendations.

Potential Impact of Bankruptcy of TMI Licensee

In a report to the Commission by the NRC Director of Nuclear Reactor Regulation (NRR) in September 1980, the possibility and potential consequences of bankruptcy on the part of the TMI licensee were explored at length. The TMI power plant is owned by the Metropolitan Edison Company (Met Ed) and Penelec Company in Pennsylvania, and the Jersey Central Company in New Jersey. Met Ed is the licensee for TMI and owns 50 percent of the facility; the other two utilities own 25 percent each. Shares in the holding company for these utilities, General Public Utilities, Inc. (GPU), are publicly held.

At the end of the report period, the TMI-2 reactor was in stable shutdown condition and decontamination and cleanup operations were under way. The key phases in decontamination and defueling—which

must be carried out, regardless of economic or other considerations—are these: (1) reactor core cooling; (2) decontamination of auxiliary and fuel-handling buildings; (3) decontamination of the containment and reactor coolant system; (4) reactor inspection and defueling; (5) radioactive waste processing; (6) solid radioactive waste management; (7) construction of needed support facilities; and (8) installation of radiological controls. Work in most of these areas was in progress by September 1980.

The cost of these operations was estimated in fiscal year 1980 by the TMI owner to range from \$690 million to \$1,150 million. In making its assessment, the NRC staff has assumed a cost of \$900 million. The plant was insured for \$300 million, and it is expected that this sum will have been expended by the end of 1981. The NRC concern is that the source of the \$600 million balance necessary to carry out the cleanup of TMI-2 has not been identified by the licensee. Since the fixed costs of maintaining and operating the TMI power station are running \$150 million per year (including servicing the debt and preferred stock and depreciation cost), and the plant is not part of the rate base for any of the three utilities of GPU, bankruptcy of the TMI owners before a cleanup is accomplished has to be considered a possibility. In September 1980, Med Ed reduced its overall work force by 20 percent (mainly contract personnel) after it was denied an emergency rate increase, resulting in a tightening of credit from the banking consortium providing short term credit to the utility. It was estimated that this action could extend the recovery period for Unit 2 into 1986.

The NRR report noted that experts on the subject do not regard bankruptcy as a desirable solution for a company in GPU's situation. The problems which have led to financial distress, the need to buy power from outside and the costs of cleaning up TMI-2, are going to continue, and there is no way to predict how much of the licensee's funds would go to creditors and how much to cleanup activities. The consultants felt that the events which could precipitate bankruptcy for the TMI owners are within the control of three forces: State public utility commissions in Pennsylvania and New Jersey, the consortium of banks providing credit to the owners, and the NRC.

If the State public utility commissions provide rate increases adequate to cover cleanup, the banks continue to extend short-term credit, and the NRC licenses the restart of TMI-1, then bankruptcy could be avoided. Alternatively, the Federal government can extend financial assistance in the form of loan guarantees or grants, or can establish a system for assessing other utilities or the nuclear industry the costs of cleaning up TMI-2. That action could also enable the TMI owners to avoid bankruptcy.

Should a default take place, however, action would have to be taken to protect the public health and safety and maintain TMI-2 in a safe condition while completing decontamination.

Two possible approaches to dealing with licensee default were considered by the staff: (1) a Federal agency would engage a contractor—possibly the TMI owners, or a Federal or State agency—to do the work; or (2) a Federal agency would, by whatever means, take over the plant and complete the cleanup itself. The first approach is feasible, but only with substantial funding by Congress. With regard to the second approach, it is doubtful that any Federal agency has either the personnel to take over the cleanup operation or the funding—although it might, with sufficient Congressional authorization and funding, hire the needed personnel. In addition, the staff concluded that, except in a situation of extreme importance for the health and safety of the public, direct NRC involvement in and assumption of cleanup activities are not clearly authorized under existing law (and are without precedent in the exercise of regulatory functions). The NRC does have statutory authority to revoke licenses, take possession of special nuclear material, and operate a facility; and it has the final say as to who may assume the responsibility of a licensee.

Finally, the chief recommendation of the staff was that the NRC encourage the Executive Branch to initiate discussions among State and Federal agencies and representatives of the financial community with regard to the financial ability of the licensee to continue cleanup. Such discussions would help disclose common goals in the public interest and help define what each party involved is trying to accomplish and is willing to accept.



3

Emergency Preparedness

Protection of the health and safety of the public requires emergency preparedness both on and off the sites of nuclear plants as well as proper siting and engineered design features of the plants themselves. Results of the accident at TMI made it clear that the protection provided by siting and engineered safety design features must be bolstered by the ability to take protective measures during the course of an accident. The accident also clearly demonstrated that on-site conditions and actions, even if they do not cause significant off-site radiological consequences, can affect the way the various State and local entities react to protect the public from any dangers associated with the accident.

In June 1979, the NRC began a formal reconsideration and revision of the role of emergency preparedness in areas around nuclear power facilities. This chapter briefly describes the NRC's accelerated efforts in the emergency preparedness and response area during 1979-1980 which, by year-end, were centralized in one office. A comprehensive report on the status of emergency response planning and preparedness around nuclear plants will be sent to the Congress in early 1981, as directed by Section 109 of Public Law 96-295.

Upgrading Licensee Emergency Preparedness

An action plan for promptly improving emergency preparedness at all operating nuclear power plants and those plants scheduled to apply for an operating license in the near term was implemented in July 1979. The plan identified the elements required for upgrading licensee emergency preparedness for accidents, including the integration of emergency planning and preparedness by responsible agencies both on-site and off-site. The NRC formed review teams and developed a schedule of site visits giving

priority to those sites in areas of relatively high population and those scheduled for operating licenses within the next year. Regional meetings were held in August 1979 to brief licensees, State and local officials, and the public on the interim emergency planning and preparedness acceptance criteria, site visit schedules, and the schedule of upgraded emergency plans.

The review team effort concentrated not only on improving licensee emergency preparedness, but also on the capability of off-site agencies to take appropriate emergency actions, and improvement of working relationships and communications among all concerned. Existing emergency plans were reviewed prior to the site visit, and informal visits with State and local officials were held by the team leader before the meeting with the licensees.

Technical meetings were held with the licensee during each visit to discuss existing emergency plans, to identify the areas requiring improvement, and to communicate new upgraded criteria. Local and State authorities as well as the general public were invited to attend. Technical meetings were also held between the NRC reviewers and local and State authorities.

A primary function of the review teams during each site visit was to meet with the public at a location near the nuclear facility to receive comments and views. The public meetings were generally held in the evening in order to get maximum attendance and, in almost all cases, the meetings were well covered by the local press and television media.

Initial site visits began in September 1979 with a visit to the Three Mile Island site, and were completed in July 1980 with a visit to the Summer Nuclear Power Plant in South Carolina. In all, during fiscal year 1980, the review teams visited 72 operational nuclear power units and 6 units scheduled for operating licenses within about one year. The teams traveled to 52 geographical locations.

NRC's Emergency Preparedness Organization

Significant changes were made during fiscal year 1980 in organization and responsibilities for radiological emergency response planning and preparedness, both within and outside the NRC. On December 7, 1979, responding to the President's Commission's report on the Three Mile Island Accident, President Carter assigned the Federal Emergency Management Agency (FEMA) lead responsibility for assisting State and local governments in developing emergency response plans in support of nuclear power plants, a function formerly performed by the NRC. (See 1979 Annual Report, p. 62.) To help FEMA implement its program, the NRC detailed the emergency preparedness staff of its Office of State Programs to FEMA for an extended period during 1980. While the function of training State and local government personnel was included in the transfer of responsibilities to FEMA, the NRC, by agreement, continued to fund radiological response training

through fiscal year 1980, involving courses for several hundred personnel during the year (see Chapter 10).

Organization changes within the NRC are described below.

In April 1980, the Office of Nuclear Reactor Regulation (NRR) was reorganized and the responsibility for managing and directing all NRC actions related to emergency preparedness was assigned to the newly-formed Emergency Preparedness Program Office (EPPO). Two branches were created in EPPO. The Emergency Preparedness Licensing Branch was given the responsibility for reviewing and evaluating emergency plans associated with the applications for nuclear reactor facilities and reviewing the emergency preparedness evaluations of State and local emergency plans performed by the Federal Emergency Management Agency (FEMA). The Emergency Preparedness Development Branch was given the responsibility for developing and evaluating policy recommendations and regulatory requirements for emergency preparedness, developing emergency planning and preparedness guidance and technical

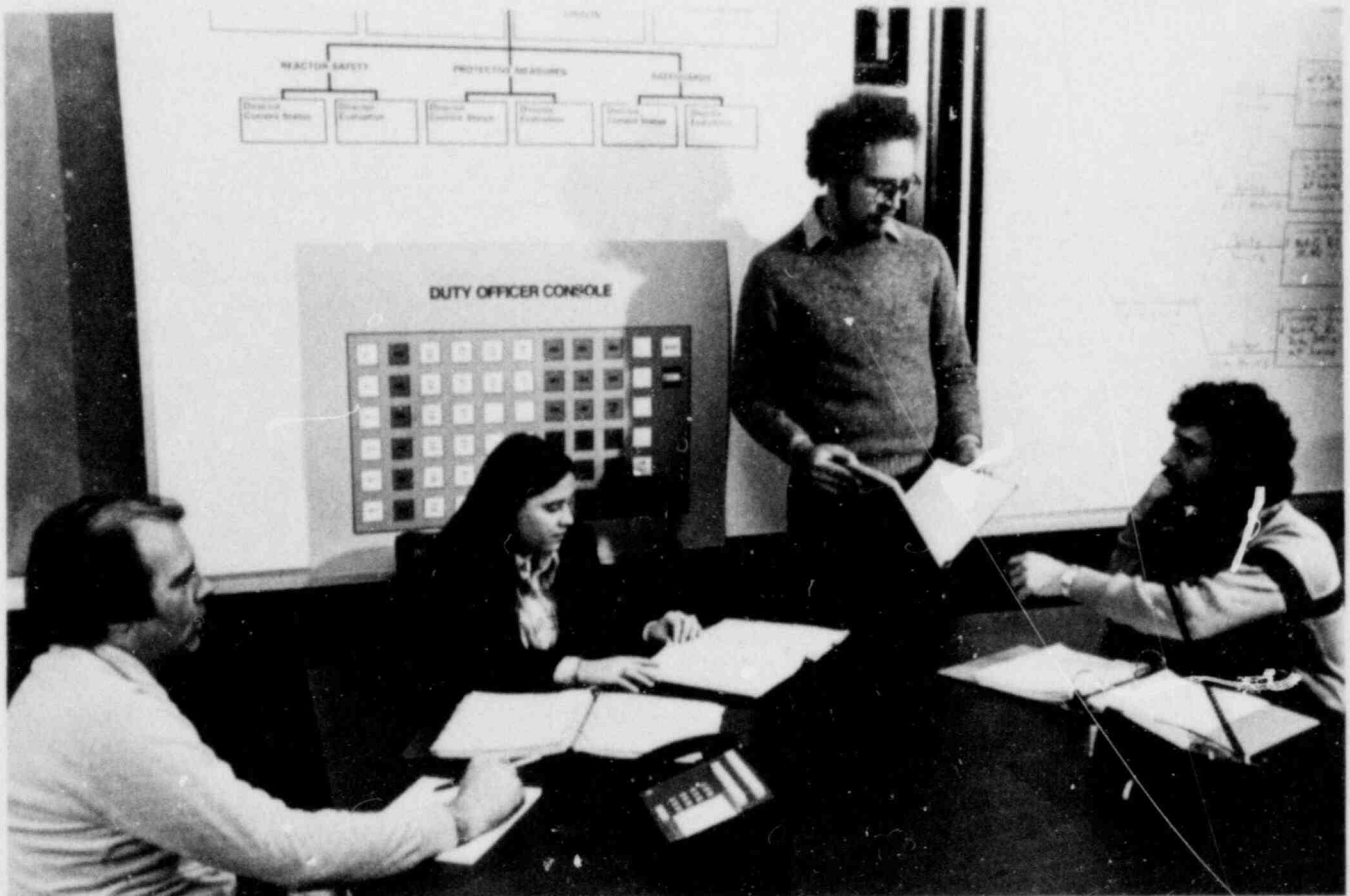

Changes in the NRC's emergency preparedness organization during 1980 included consolidation of major functions and improvements in the layout of the agency's Operations Center.

Members of the Office of Inspection and Enforcement's Incident Response Branch are shown participating in a test of communications in the Center's executive team room.

publications, and providing technical support for the Eppo. A total of 29 professionals and staff was authorized for Eppo in fiscal year 1980.

In November 1980, the emergency preparedness function was transferred from NRR to the Office of Inspection and Enforcement and redesignated the Division of Emergency Preparedness. A third component, the Incident Response Branch, was created to manage the NRC's incident response operations and planning efforts.

NRC/FEMA Relationship

During 1980, the NRC and FEMA negotiated two Memoranda of Understanding (MOU) laying out the agencies' roles—one covering emergency plans and preparedness, and the other on incident response. The first MOU, which became effective January 14, 1980, superseded some aspects of previous agreements between the NRC and other Federal agencies whose functions were assigned to FEMA on April 1, 1979. This MOU was signed in final form on November 4, 1980. Specifically, FEMA's responsibilities relating to those of the NRC are to:

- Make findings and determinations as to whether State and local emergency plans are adequate.
- Verify that State and local emergency plans are capable of being implemented (e.g., adequacy and maintenance of procedures, training, resources, staffing levels and qualification, and equipment).
- Assume responsibility for emergency preparedness training of State and local officials.
- Develop and issue updated interagency assignments that delineate respective agency capabilities and responsibilities and define procedures for coordination and direction for emergency planning and response.

The NRC's responsibilities for emergency preparedness identified in the MOU are to:

- Assess licensee emergency plans for adequacy.
- Verify that licensee emergency plans are adequately implemented (e.g., adequacy and maintenance of procedures, training, resources, staffing levels and qualifications, and equipment).
- Review the FEMA findings and determination on the adequacy and capability of State and local plans.
- Make decisions on the overall state of emergency preparedness (i.e., integration of the licensee's emergency preparedness as determined by the NRC and of the State/local governments as determined by FEMA and

reviewed by NRC) and issue operating licenses or initiate the shutdown of operating reactors.

The NRC and FEMA also executed a separate MOU on incident response activities which became effective on October 22, 1980. This MOU covers NRC/FEMA cooperation and responsibilities in response to emergencies. It defines in some detail the relationships between the two agencies in responding to a potential or actual radiological emergency and clarifies the assistance that can be provided by one agency to the other in carrying out their respective responsibilities for protection of the public.

In addition, FEMA has prepared a proposed rule regarding "Review and Approval of State Radiological Emergency Plans and Preparedness." (44 FR 42342, dated June 24, 1980.) According to the proposed rule, FEMA will approve State and local emergency plans and preparedness, and issue findings and determinations with respect to the adequacy of such plans and the capabilities of State and local governments to effectively implement them. These findings and determinations will be provided to the NRC for use in its licensing process.

Development of Guidance, Criteria and Regulations

A substantial body of guidance and criteria has been developed by the NRC for the use of licensees as well as State and local agencies in upgrading their emergency plans and preparedness. This guidance and criteria, including a new NRC rule on emergency planning, reflects a number of the recommendations made in the TMI Lessons Learned Report, the President's Commission report, and the NRC Special Inquiry Group report. The principal documents issued by the NRC are:

- (1) "Draft Emergency Action Level Guidelines for Nuclear Power Plants" (NUREG-0610), was published on September 19, 1979, for interim use and comment. This document identified four classes of Emergency Action Levels, each with examples of initiating conditions: Notification of Unusual Event, Alert, Site Emergency, and General Emergency. With this guidance, requirements were established for rapid identification and uniform classification of accidents together with prompt notification of off-site authorities by plant operators. This guidance appears in final form as an appendix to NUREG-0654, Revision 1.
- (2) "Criteria for Preparation and Evaluation of Radiological Emergency Response Plans and

Preparedness in Support of Nuclear Power Plants" (NUREG-0654) (FEMA-REP-1), published in January 1980 for interim use and comment, compiles previously published guidance as a joint effort by NRC and FEMA. It provides common references and guidance for State and local agencies, licensees, the NRC, FEMA, and other Federal agencies in developing and improving State and local government and licensee emergency plans and preparedness. Revision 1 of NUREG-0654/FEMA-REP-1 was published in November 1980 as final FEMA and NRC guidance.

- (3) *Final Rule on Emergency Planning.* In June 1979, the NRC began a formal reconsideration of the role of emergency planning in ensuring the continued protection of the public health and safety in areas around nuclear power facilities. On December 19, 1979, the NRC published in the *Federal Register* proposed amendments to its regulations for public comment. During the comment period, in January 1980, the NRC conducted four regional workshops with State and local officials, utility representatives, and the public on the proposed amendments. The information from these workshops, more than 200 public comment letters, and two petitions for rulemaking were considered in developing the final rule. In addition, the Commission was briefed on June 25, 1980, by three panels of public commenters, one each comprised of representatives from the industry, State and local governments, and public interest groups.

The final rule was published in the *Federal Register* on August 1980, (45 FR 55402) to become effective November 3, 1980. It provides that no new operating license will be granted unless the NRC can make a favorable finding that the integration of on-site and off-site emergency planning provides reasonable assurance that adequate protective measures can and will be taken in the event of a radiological emergency. In the case of an operating reactor, if, after April 1, 1981, it is determined that there are such deficiencies that a favorable NRC finding is not warranted and if the deficiencies are not corrected within four months of that determination, the Commission will determine expeditiously whether the reactor should be shut down or whether some other enforcement action is appropriate. In any case where the Commission believes that the public health, safety or interest so requires, the

plant will be required to shut down immediately. Licensees, however, will have an opportunity to demonstrate to the satisfaction of the Commission that deficiencies in emergency plans are not significant for the plant in question, that adequate interim compensating actions have been or will be taken promptly, or that there are compelling reasons to permit plant operation. Emergency planning considerations must be extended to two zones, one consisting of an area of about 10 miles in radius for exposure to the radioactive plume that might result from a nuclear power reactor accident and the other an area of about 10 miles and the EPZ for the ingestion exposure pathway has a radius of about 50 miles in radius for food that might become contaminated. This Emergency Planning Zone concept is discussed below.

Additionally, the final rule sets forth 16 emergency planning standards which must be met for on-site and off-site emergency plans within the emergency planning zones. Assessments by the NRC and FEMA of the on-site and off-site emergency plans will be made with respect to these planning standards.

- (4) *"Functional Criteria for Emergency Response Facilities"* (NUREG-0696), was issued for public comment on August 15, 1980. The proposed facilities include a Technical Support Center and an Emergency Operations Facility for the management, assessment, support and coordination of accident situations. Also included with these facilities would be a Safety Parameter Display System which would monitor the safety status of the plant and a Nuclear Data Link which would transmit critical plant variables to the NRC headquarters and regional offices. The emergency response facilities are discussed below.

Emergency Planning Zones Concept

Based on the recommendations of an NRC and EPA Task Force Report on Emergency Planning (NUREG-0396/EPA-520/1-78-016), two Emergency Planning Zones (EPZs) are to be established around each light water nuclear power plant. The EPZ for the plume exposure pathway has a radius of about 50 miles. (The diagram shows the concept of Emergency Planning Zones.) Predetermined protective action plans are required to be established for the EPZs. The exact size and shape of each EPZ will be decided by emergency planning officials after they

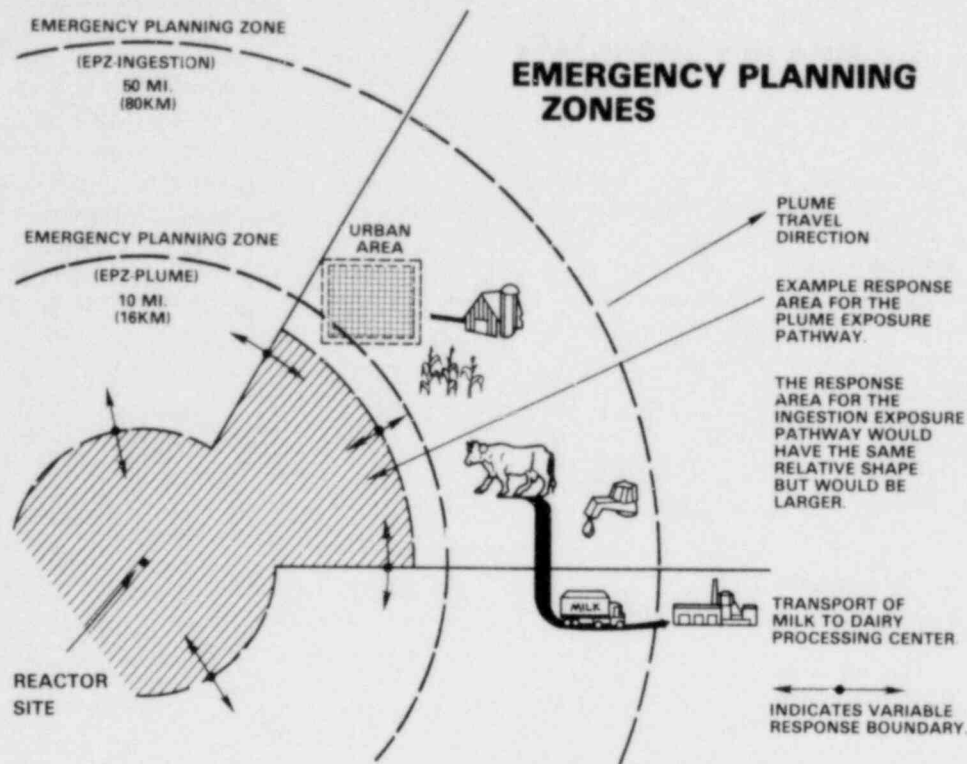

consider the specific conditions at each site. These distances are considered large enough to provide a response base which would support activity outside the Emergency Planning Zone should this ever be needed.

Small, light-water-cooled power reactors (less than 250 MWt) and the Ft. St. Vrain gas-cooled reactor may have smaller EPZs of about 5 and 30 miles, respectively, based on the lower potential hazard from these facilities due to lower radionuclide inventory and generally longer times involved for release of significant amounts of activity in the event of an accident.

Prompt Notification

A licensee is required, by the new NRC rule on emergency planning to have the capability to notify responsible State and local governmental agencies within 15 minutes after declaring an emergency. In addition, the licensee is to demonstrate that State and local officials have the capability to make a public notification decision promptly on being informed by the licensee of an emergency condition. Administrative and physical means are to be established by July 1, 1981, for prompt alerting and notification of response organizations and the public within the plume exposure pathway Emergency Planning Zone. The design objective is to have the capability to

essentially complete the initial notification of the public within the 10-mile EPZ within about 15 minutes.

Emergency Response Facilities

The TMI accident investigations identified the need for extensive improvements in emergency preparedness at nuclear power plants. Among areas identified as needing action are establishment of organizations to manage and control activities both on and off-site during emergency situations; the facilities for these organizations; the availability of information needed to assess and manage the situation; and the provisions for disseminating accurate and timely information, warnings, and instructions to local and State agencies, the affected population, and the public in general. Criteria for providing emergency response facilities were developed by the staff and issued for public comment in NUREG-0696, "Functional Criteria for Emergency Response Facilities" (August 1980). These facilities are:

Technical Support Center. The Technical Support Center (TSC) is an emergency response facility located in close proximity to the control room with the necessary displays and data available for senior plant management personnel and technical personnel

to support the control room operations personnel during emergency situations. The facility will meet the same habitability requirements as the control room and have the capability to analyze plant conditions. In addition, the TSC will perform the functions of the Emergency Operations Facility (EOF) (described below) for providing radiological and environmental information to the State and local governments and to the NRC until the EOF is activated.

Emergency Operations Facility. The Emergency Operations Facility (EOF) is a facility near the plant for management of overall emergency response and coordination of radiological assessments. It may also be used for management of recovery operations. While the TSC function is centered on management of the plant in the mitigation of accidents, the EOF is designed to provide assistance in the decision-making process to protect the public health and safety and to control radiological monitoring teams and facilities on-site and off-site. The EOF will evaluate potential or actual radioactivity releases from the plant and any environmental consequences and, therefore, must have adequate radiological,

meteorological and plant systems information to perform these functions. The EOF will be utilized by the licensee to coordinate its emergency response activities with those of local, State, and Federal emergency response organizations, including the NRC and FEMA.

Safety Parameter Display System. The Safety Parameter Display System (SPDS) would provide a display of plant parameters from which the safety status of operation may be assessed in the control room, TSC, and EOF. The primary function of the SPDS is to help operating personnel in the control room make quick assessments of plant safety status. Duplication of the SPDS displays in the TSC and EOF would improve the exchange of information between these facilities and the control room and assist management in the decision making process. The SPDS would be operated during normal operations and during all classes of emergencies.

Nuclear Data Link. The Nuclear Data Link (NDL) would be a data transmission system designed to send a specified set of variables from the plant to the NRC Operations Center in Bethesda, Md. Its purpose is to provide management personnel

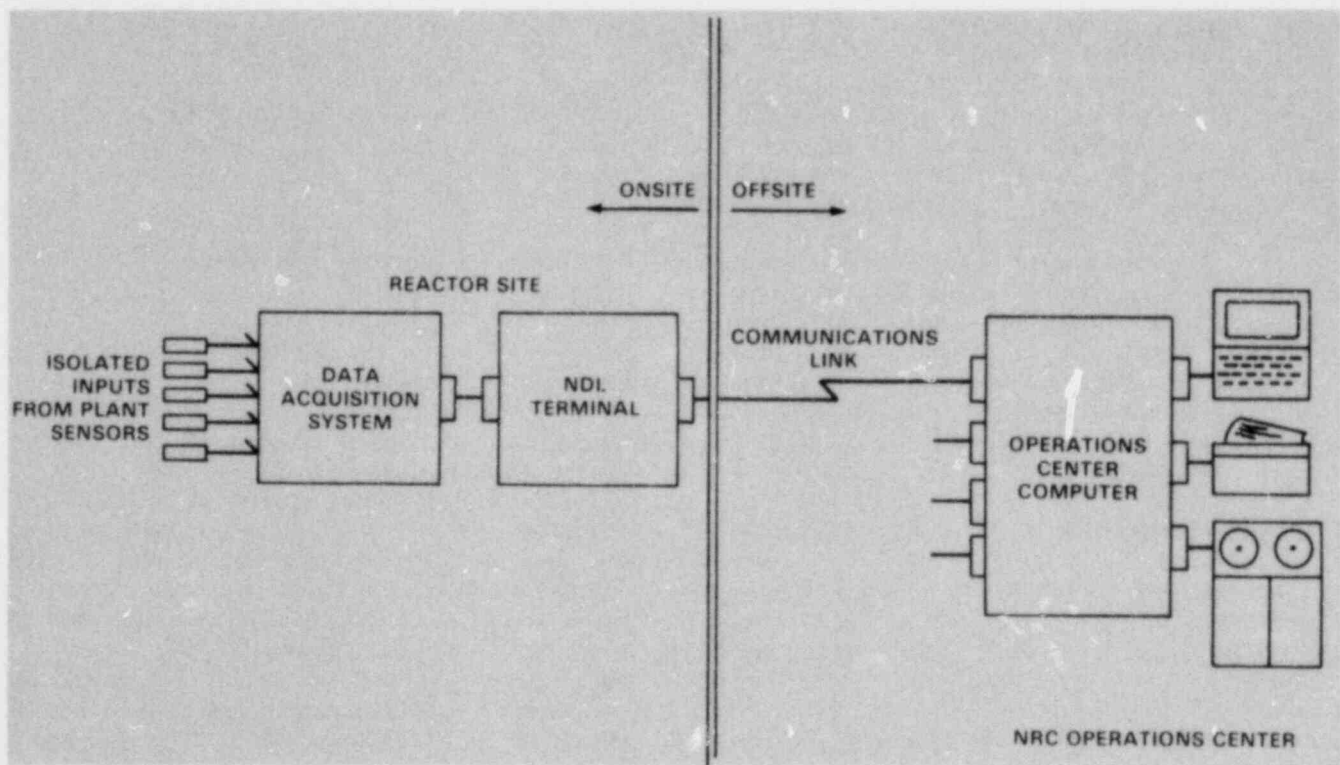

The proposed Nuclear Data Link (NDL) system consists of a data acquisition system and an NDL terminal (both located on-site), and an Operations Center system at NRC headquarters. The NDL would process and transmit certain reactor process variables and radiological and site meteorological data from each operating nuclear power plant to the NRC Operations Center. The Center's subsystem would include a general-purpose com-

puter capable of receiving data from any plant, and which may be used to maintain a file of current data from each reactor site. Video data terminals, printers, magnetic memory storage, and miscellaneous peripheral (including display of numerical and graphic representations of data) would comprise the balance of the equipment at the NRC Operations Center.

at NRC headquarters with timely, reliable and accurate plant systems, meteorological and radiological information. When an incident occurs, the NRC must be prepared to provide advice and support to the nuclear facility operator, off-site State and local authorities and other Federal officials. NRC management must be able to make independent assessments of the actions taken by the licensee and off-site authorities to protect the public health and safety. In addition, the NRC is responsible for keeping Federal, State and local officials and the general public informed about the technical and radiological aspects of the incident and subsequent emergency response activities. The NDL data also would help NRC headquarters personnel provide timely support to regional NRC personnel at the plant site.

In all emergency situations, the NRC's major role will be to monitor the situation and advise protective actions, but will not extend to any manipulation of nuclear facility controls. However, in extreme cases, the NRC may direct that certain operations be performed at the nuclear facility. Any such direction would come from the NRC Director of Site Operations after his arrival at the site and from NRC headquarters prior to that time.

Policy on Potassium Iodide

A major concern following a severe nuclear power plant accident is protection of the public from radioiodine which may be released. Although all plants have engineered safeguards to prevent escape of radioiodine, a protective measure exists that can be used even if the safeguards fail. This protective measure is orally administered stable potassium iodide (KI). The thyroid gland concentrates and uses iodine in its normal metabolic processes but it cannot distinguish between stable iodine or radioiodine. Administration of the stable iodine will saturate the thyroid and prevent uptake of radioiodine.

The use of potassium iodide, however, is not without controversy. Although most studies indicate it is relatively harmless and the risk of using it appears to be small, some reports indicate there may be significantly higher risk among certain segments of the population. Until these risks are evaluated, the NRC believes that interim measures to encourage its use should be taken at least under controlled conditions. Therefore, the staff recommended that the Commission adopt an interim policy encouraging the stockpiling of KI for site personnel, offsite emergency personnel, and offsite institutions (e.g., hospitals or prisons) within about 10 miles where immediate evacuation may not be feasible or would be very difficult. The staff also recommended that FEMA concur in this interim policy and be requested to study the feasibility of establishing a national stockpile of KI and developing a distribution plan for the

general public. Questions have been raised as to whether the amount of radioactive iodine released in gaseous form from a reactor core damaged in an accident has been overestimated, and this is currently under intensive study.

Emergency Preparedness Exercises

In determining the adequacy of an emergency plan and the overall emergency preparedness at a nuclear power facility, it is necessary to conduct an integrated exercise that involves all the major response organizations. Such an exercise was required prior to issuing an operating license to Virginia Electric and Power Co. (VEPCO) for Unit 2 of the North Anna Nuclear Power Facility, the first facility to be licensed for full power operation since the TMI accident in March 1979. This exercise was conducted on August 16, 1980, and involved VEPCO, the State of Virginia radiological emergency response organization, the local authorities, and FEMA.

In the exercise, there were simulations of on-site releases of radioactivity, site evacuation, an injured contaminated person, a fire on-site, and radioactive monitoring on and off-site. Radiological monitoring from VEPCO's emergency response organization was used within a 10-mile radius of the facility, local authorities dispatched fire equipment and personnel in response to the notification of the fire and a local rescue squad was dispatched in response to the notification of the injured person. Site evacuation was tested by actually moving groups of persons along a prescribed route to a radiological monitoring and control center where they were monitored for any contamination.

The exercise by the VEPCO emergency response organization was observed and evaluated by NRC personnel. The State and local authorities, emergency response organizations were evaluated by FEMA personnel. A similar integrated joint exercise was conducted around the site of Tennessee Valley Authorities Sequoyah Nuclear Power Plant prior to issuance of an operating license for Unit 1 of that facility.

NRC Incident Response

The past year has been one of evaluation, analysis and major improvements for the NRC Incident Response Program. The staff has been enhanced and, commensurate with this, an emphasis on effective organizational structure and approach has been undertaken in order to improve the overall NRC response organization.

Emergency Preparedness from the Operations Center perspective concerns three main functional

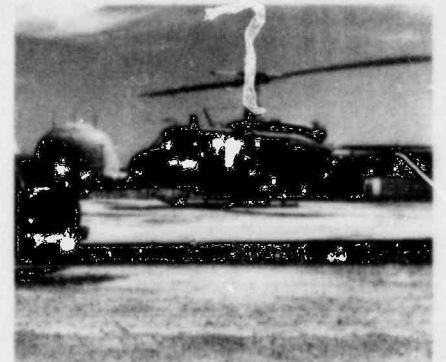
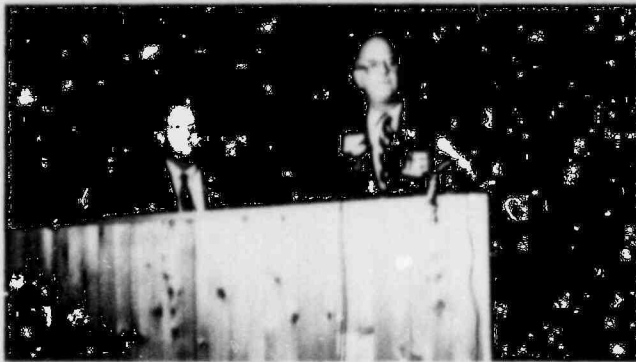
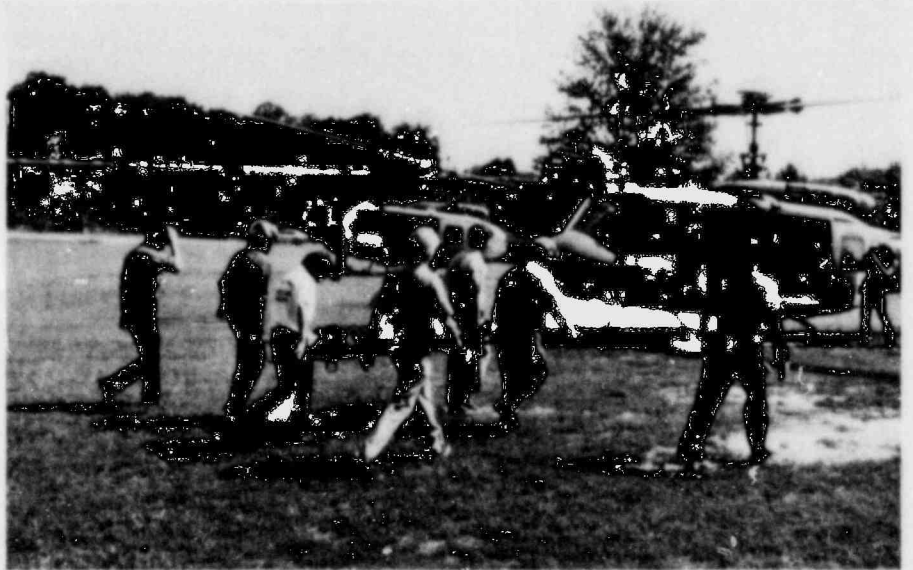

On August 16, 1980, an emergency preparedness exercise was conducted at the Virginia Electric and Power Company's (VEPCO) North Anna Power Facility in Louisa County, Va., to assess VEPCO's ability to respond to a radiological emergency. The eight-hour exercise—which involved VEPCO, the State of Virginia radiological emergency response organization, and local authorities—began early in the morning with a mock chain reaction of mechanical malfunctions and escalated to a general state of emergency with a simulated meltdown of the reactor core. The test culminated in the simulated evacuation of 15,000 people from five surrounding counties.

Some scenes from the day's activities are shown above. They include, beginning at the top left and reading clockwise, the following:

—The Civil Air Patrol sets up radiation monitoring devices at designated locations within a 10-mile radius of the facility.

—Officials keep the media informed of events and activities within the plant and of evacuation progress within the five-county area.

—Volunteer evacuees arrive at the Louisa High School. School buses were dispatched along established routes as part of the overall plan, as soon as a state of general emergency was declared.

—An "injured and contaminated" VEPCO employee is carried from Louisa County Emergency Evacuation Center at the Louisa High School to a waiting National Guard helicopter.

—Virginia Governor John Dalton arrives at the North Anna site in a National Guard helicopter to attend a press conference.

—VEPCO President William Berry (behind microphone) and Governor Dalton explain the significance of the preparedness exercise to the media.

areas. The Operations Center staff has undertaken the task of developing systematic analyses concerning the role of NRC as an agency as well as the roles of individuals within the agency responding to actual or potential nuclear power related emergencies. A similar approach has been undertaken regarding communication requirements specifically involving people, procedures, information, facilities, and equipment. Lastly, all of the recommendations associated with these developments are being exercised, coordinated and modified where needed.

During the year, the NRC Incident Response Plan (NUREG-0728, September 1980) was developed by the staff to coordinate the agency's emergency response program. The main tasks now include interfacing with other external and internal response organizations to develop a consistent approach to nuclear emergency planning. This effort has been initiated, as seen in the NRC input to the FEMA National Contingency and Federal Radiological Response Plans currently being developed.

Communication improvements are perhaps the most visible measure of the ongoing emergency response effort. In this area many interim improvements have been addressed since the TMI accident and many recommendations are being assessed for the future. A report to Congress "NRC Emergency Communications" (NUREG-0729, September 1980), addresses this issue. Individual role responsibilities have been addressed in the NRC Incident

Response Plan and procedures regarding them either have been or are being developed. Information needs are continuously assessed and significant resources have been committed to improving this area. A report to Congress on the Acquisition of Reactor Data for the NRC Operations Center (NUREG-0730, September 1980) reviews the major staff efforts to develop the Nuclear Data Link (NDL) concept. In addition, other informational needs have been formulated and are currently being developed, such as a program for producing a nuclear facility 10-mile radius emergency planning map. All of the developments in this area are pointed toward better organizational communication and a resulting efficient emergency response.

Facilities and equipment have been evaluated in terms of functional needs and individual interaction, and have represented the most tangible improvements to date. In addition to the Emergency Notification System, already employed, the installation of the Health Physics Network communication link for transmission of radiological data is a prime example of this type of improvement. An analysis of space requirements in relation to a better planned response organization has resulted in improvement in the physical layout of the Operations Center.

All of these areas have been and will continue to be tested during actual radiological emergencies and artificial scenarios as part of a systematic exercise program for NRC's emergency response.

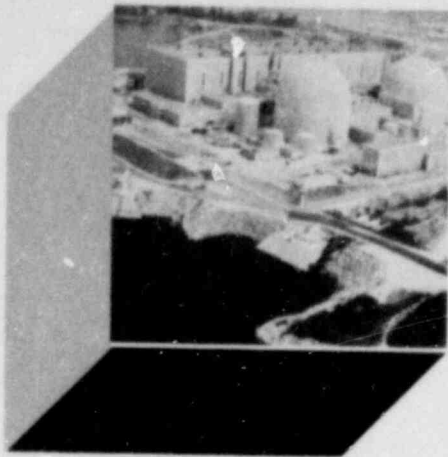

4

Reactor Regulation

The licensing of nuclear power plants is a basic NRC activity, centered in the Office of Nuclear Reactor Regulation (NRR) where each proposed nuclear reactor facility is reviewed by a staff of professionals drawn from a broad spectrum of engineering and scientific disciplines. The objectives, functions and structure of NRR were profoundly affected by the accident at Three Mile Island in March 1979 and its aftermath (see the *1979 NRC Annual Report*, Chapters 2 and 3). The implications of that event and subsequent analyses of it bore directly on NRR responsibilities and procedures, in such areas as overall plant design, control room design and instrumentation, operator training and licensing, emergency planning (see Chapter 3), and others.

This chapter covers NRR activities during fiscal year 1980, a period of broad and intense mobilization within NRR to meet its commitments to respond to the lessons of TMI. The chapter is made up of the following major sections: licensing activity during fiscal 1980; reactor safety issues (including a progress report on "Unresolved Safety Issues"); improvements in licensing and regulation (including reorganization of NRR and adoption of the TMI Action Plan); environmental issues arising during the report period; antitrust activities; indemnity and financial report; and activities of the Advisory Committee on Reactor Safeguards.

Status of Licensing

After the accident at Three Mile Island Unit 2 on March 28, 1979, no construction permits or operating licenses were issued by the Office of Nuclear Reactor Regulation for the remainder of 1979. On

October 10, 1979, the Commission published an Interim Statement of Policy and Procedure in the Federal Register stating that "... new construction permits, limited work authorizations, or operating licenses for any nuclear power reactors shall be issued only after action of the Commission itself." During fiscal year 1980, four applications for low-power operating licenses (authorizing fuel loading and low-power testing at a reactor power level up to 5 percent of full power) and two applications for full-power operating licenses came before the Commission. After consideration by the Commissioners, licenses were issued to the plants listed in Table 1.

The highest priority in the reactor licensing activities of NRR, apart from those associated with operating reactors, is given to operating-license (OL) reviews of applicants holding construction permits (CPs), especially near-term applications. A number of applicants whose plants are approaching completion, however, are likely to experience some delay between completion and a licensing decision by the NRC. This is due mainly to the prolonged dislocation of staff and resources to deal with the aftermath of the TMI-2 accident and to the time required for review and hearings associated with contested applications.

During the pause in licensing activities, the recommendations of several groups established to investigate the lessons learned from TMI-2 became available. The short-term recommendations of the TMI-2 Lessons Learned Task Force of the NRC were implemented and reviewed by the staff in the first quarter of 1980. Evaluation reports were written for each nuclear power plant and issued by April 1980. The recommendations were met by all licensees.

Recommendations from the various investigatory groups were correlated and incorporated into a TMI Action Plan (NUREG-0660) published in May 1980.

THE LICENSING PROCESS

Obtaining an NRC construction permit—or a limited work authorization, pending a decision on issuance of a construction permit—is the first objective of a utility or other company seeking to operate a nuclear power reactor or other nuclear facility under NRC license. The process is set in motion with the filing and acceptance of the application, generally comprising ten or more large volumes of material covering both safety and environmental factors, in accordance with NRC requirements and guidance. The second phase consists of safety, environmental, safeguards and antitrust reviews undertaken by the NRC staff. Third, a safety review is conducted by the independent Advisory Committee on Reactor Safeguards (ACRS); this review is required by law. Fourth, a mandatory public hearing is conducted by a three-member Atomic Safety and Licensing Board (ASLB), which then makes an initial decision as to whether the permit should be granted. This decision is subject to appeal to an Atomic Safety and Licensing Appeal Board (ASLAB) and could ultimately go to the Commissioners for final NRC decision. The law provides for appeal beyond the Commission in the Federal courts.

As soon as an initial application is accepted, or "docketed," by the NRC, a notice of that fact is published in the *Federal Register*, and copies of the application are furnished to appropriate State and local authorities and to a local public document room (LPDR) established in the vicinity of the proposed site, as well as to the NRC-PDR in Washington, D.C. At the same time, a notice of a public hearing is published in the *Federal Register* and local newspapers which provides 30 days for members of the public to petition to intervene in the proceeding. Such petitions are entertained and adjudicated by the ASLB appointed to the case, with rights of appeal by the petitioner to the ASLAB.

The NRC staff's safety, safeguards, environmental and antitrust reviews proceed in parallel. With the guidance of the Standard Format (Regulatory Guide 1.70), the applicant for a construction permit lays out the proposed nuclear plant design in a Preliminary Safety Analysis Report (PSAR). If and when this report has been made sufficiently complete to warrant review, the application is docketed and NRC staff evaluations begin. Even prior to submission of the report, NRC staff conducts a substantive review and inspection of the applicant's quality assurance program covering design and procurement. The safety review is performed by NRC staff in accordance with the Standard Review Plan for Light-Water-Cooled Reactors, initially published in September 1975 and updated periodically. This plan states the acceptance criteria used in evaluating the various systems, components and structures important to safety and in assessing the proposed site, and it describes the procedures used in performing the safety review.

The NRC staff examines the applicant's PSAR to determine whether the plant design is safe and consistent with NRC rules and regulations; whether valid methods of calculation were employed and accurately carried out; whether the applicant has conducted his analysis and evaluation in sufficient depth and breadth to support staff approval with respect to safety. When the staff is satisfied that the acceptance criteria of the Standard Review Plan have been met by the applicant's preliminary report, a Safety Evaluation Report is prepared by the staff summarizing the results of their review regarding the anticipated effects of the proposed facility on the public health and safety.

Following publication of the staff Safety Evaluation Report, the ACRS completes its review and meets with staff and applicant. The ACRS then prepares a letter report to the Chairman of the

NRC presenting the results of its independent evaluation and recommending whether or not a construction permit should be issued. The staff issues a supplement to the Safety Evaluation Report incorporating any changes or actions adopted as a result of ACRS recommendations. A public hearing can then be held, generally in a community near the proposed site, on safety aspects of the licensing decision.

In appropriate cases, NRC may grant a Limited Work Authorization to an applicant in advance of the final decision on the construction permit in order to allow certain work to begin at the site, saving as much as seven months time. The authorization will not be given, however, until NRC staff has completed environmental impact and site suitability reviews and the appointed ASLB has conducted a public hearing on environmental impact and site suitability with a favorable finding. To realize the desired saving of time, the applicant must submit the environmental portion of the application early.

The environmental review begins with a review of the applicant's Environmental Report (ER) for acceptability. Assuming the ER is sufficiently complete to warrant review, it is docketed and an analysis of the consequences to the environment of the construction and operation of the proposed facility at the proposed site is begun. Upon completion of this analysis, a Draft Environmental Statement is published and distributed with specific requests for review and comment by Federal, State and local agencies, other interested parties and members of the public. All of their comments are then taken into account in the preparation of a Final Environmental Statement. Both the draft and the final statements are made available to the public at the time of respective publication. During this same time period NRC is conducting an analysis and preparing a report on site suitability aspects of the proposed licensing action. Upon completion of these activities, a public hearing, with the appointed ASLB presiding, may be conducted on environmental and site suitability aspects of the proposed licensing action (or a single hearing on both safety and environmental matters may be held, if that is indicated).

The antitrust reviews of license applications are carried out by the NRC and the Attorney General in advance of, or currently with, other licensing reviews. If an antitrust hearing is required, it is held separately from those on safety and environmental aspects.

About two or three years before construction of the plant is scheduled to complete, the applicant files an application for an operating license. A process similar to that for the construction permit is followed. The application is filed, NRC staff and the ACRS review it, a Safety Evaluation Report and an updated Environmental Statement are issued. A public hearing is not mandatory at this stage, but one may be held if requested by affected members of the public or at the initiative of the Commission. Each license for operation of a nuclear reactor contains technical specifications which set forth the particular safety and environmental protection measures to be imposed upon the facility and the conditions that must be met for the facility to operate.

Once licensed, a nuclear facility remains under NRC surveillance and undergoes periodic inspections throughout its operating life. In cases where the NRC finds that substantial, additional protection is necessary for the public health and safety or the common defense and security, the NRC may require "backfitting" of a licensed plant, that is, the addition, elimination or modification of structures, systems or components of the plant.

In accordance with further Commission guidance for power reactor operating licenses published in the *Federal Register* on June 20, 1980, the requirements deriving from the TMI-2 accident were set forth in NUREG-0694, entitled "TMI-Related Requirements for New Operating Licenses."

Four types of TMI-related requirements and actions for new operating licenses were approved by the Commission: (1) those required to be completed by a license applicant prior to receiving a fuel-loading and low-power testing license, (2) those required to be completed by a license applicant prior to receiving a license to operate at appreciable power levels up to full power, (3) those the NRC will take prior to issuing a fuel-loading and low-power testing or a full-power operating license, and (4) those required to be completed by a licensee prior to a specified date. A clarification of the implications of NUREG-0694 was subsequently issued, as NUREG-0737; other requirements are expected to be issued in the future as work progresses in accordance with the TMI Action Plan.

In addition to the plants which received licenses in 1980, several other plants were nearing completion or had completed construction during the year. Two of these facilities—McGuire 1 (N.C.) and Diablo Canyon (Cal.)—were also seeking low-power operating licenses. The staff is reviewing these applications against the new requirements in NUREG-0694. The low-power operating license for Diablo Canyon is presently pending before the Atomic Safety and Licensing Board, and board consideration may also be necessary for the McGuire facility.

During the pause in licensing, the staff also neared completion of their review of several applications for construction permits. These facilities include Black Fox (Okla.), Allens Creek (Tex.), Pilgrim Unit 2 (Mass.), Perkins (N.C.), and Pebble Springs (Ore.). Before these plants can receive construction permits they must meet new requirements resulting from the accident at Three Mile Island. The Commission has issued for comment "Proposed Licensing Requirements for Pending Applications for Construction Permits and Manufacturing License (NUREG-0718)." After the comment period, the Commission will review the proposed requirements and determine the policy for proceeding with pending construction permit and manufacturing license applications.

At the time of the accident at Unit 2 of the Three Mile Island Nuclear Station, Unit 1 was shut down for refueling. Unit 1 is essentially identical to Unit 2 and is owned and operated by the same licensee. During the period immediately after the accident, the licensee was instructed by the NRC staff not to resume operation of Unit 1 pending approval by the Nuclear Regulatory Commission. On July 2, 1979, the Commission ordered that the facility remain shut down until further order of the Commission and that a hearing must precede restart. Commission Orders of August 9, 1979, and March 6, 1980, specified the issues to be considered in that hearing. A report issued in June 1980, NUREG-0680, provided an evaluation of the licensee's compliance with items in Order of August 9, 1979. The hearing by the Atomic Safety and Licensing Board began in October 1980. The board was instructed to proceed expeditiously in

Table 1. Nuclear Power Plant Licensing Action—Fiscal Year 1980*

| LOW-POWER OPERATING LICENSES | | | |
|--|-----------------|--------------------|---------------------------|
| <i>Applicant</i> | <i>Facility</i> | <i>Date Issued</i> | <i>Location</i> |
| Tennessee Valley Authority | Sequoyah 1 | 02/29/80 | Hamilton County, Tenn. |
| Virginia Electric & Power Co. | North Anna 2 | 04/11/80 | Louisa County, Va. |
| Public Service Electric & Gas Co., et al. | Salem 2 | 04/18/80 | Salem County, N.J. |
| Alabama Power Co. | Farley 2 | 09/04/80 | Houston County, Ala. |
| FULL-POWER OPERATING LICENSES | | | |
| Virginia Electric & Power Co. | North Anna 2 | 08/21/80 | Louisa County, Va. |
| Tennessee Valley Authority | Sequoyah 1 | 09/17/80 | Hamilton County, Tenn. |

*No Limited Work Authorizations or Construction Permits for nuclear power plants were issued during fiscal year 1980.

conducting a fair and thorough hearing and in arriving at a recommendation for a decision by the Commission regarding restart of Unit 1.

In February 1980, the Commission issued a Confirmatory Order for the Zion (Ill.) and Indian Point (N.Y.) plants (high population sites) requiring extraordinary interim measures until design changes are decided upon for protection from radiological releases in the event of a core-melt accident. The licensees are performing a rigorous risk study of these plants to demonstrate that the aggregate public risk from these facilities is not greater than that predicted for the reference PWR plant in the Reactor Safety Study (WASH-1400). In May 1980, the applicant for the Limerick plant (under construction at a high population site) was requested to perform a preliminary risk study taking into account significant design differences between its facility and the reference BWR plant in the Reactor Safety Study. These risk studies, scheduled to be completed in the fall of 1980, will be reviewed by the staff to determine if additional requirements need to be implemented at these facilities.

Experience from the emergency response role of the NRC in the Three Mile Island accident, as well as conclusions of task forces responsible for followup activities, indicate that a more rapid response for technical activities can be achieved through the use of interdisciplinary full-time technical support teams dedicated to this purpose. As a result, in the reorganization of the Office of Nuclear Reactor Regulation

(NRR), an Operating Reactors Assessment Branch was created to provide such support in the processing of licensing actions, to perform initial evaluation of unanticipated events, to define needed assistance from other NRR groups, and to be responsible for technical coordination of all post-TMI safety requirements.

The Three Mile Island accident and its aftermath permitted little if any attention by the NRC staff to furthering the program for standardization of the design of nuclear power plants. With the ebbing of the need for emergency actions, the staff is re-examining the standardization program with particular attention to impacts on the program resulting from Three Mile Island. To date, 13 Preliminary Design approvals (PDAs) for standardized designs of nuclear steam supply systems or balance-of-plant have been issued with a validity period of three years. Some of these were extended for an additional two years. The NRC staff is currently considering new guidelines regarding PDA extensions and, in the interim, is extending for six months the PDAs that are about to expire.

The Systematic Evaluation Program is concerned with the review of 11 older licensed operating reactors in the light of current licensing criteria and determining where there is need for change. The program has identified several significant safety topics, for example, (1) environmental qualification of safety-related equipment, (2) identification of systems required for the safe shutdown of a plant and deficiencies in those systems, (3) identification of significant site hazards such as floods and tornadoes,

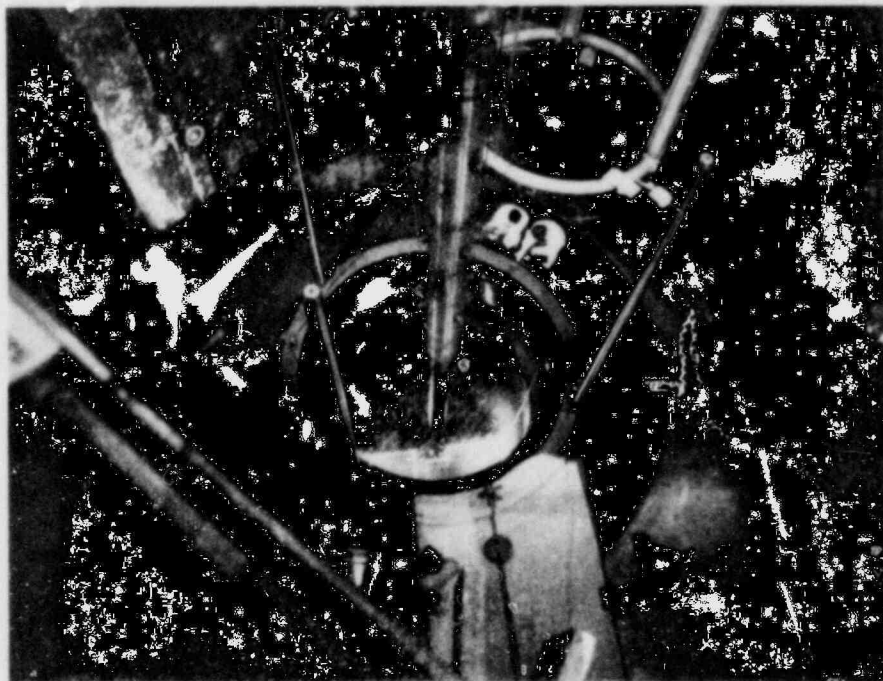

Nuclear fuel is loaded into the reactor of Virginia Electric & Power Co.'s North Anna Power Station's Unit 2, the first power reactor issued a full-power operating license since the Three Mile Island accident in March 1979.

and (4) re-evaluation of seismic design criteria. An integrated assessment will be performed for each facility, and recommendations will be made regarding requirements for retrofitting. That assessment has been started for the Palisades Nuclear Power Station (Mich.) and is expected to be completed early in 1981. Completion of assessments for all 11 of the older plants is currently scheduled for mid-1982.

Public Law 96-295 of June 30, 1980, requires the NRC to develop, submit to Congress, and implement a comprehensive plan for the systematic safety evaluation of all currently operating nuclear power plants. A plan for complying with this requirement is being worked out. The law provides that the plan shall include, among other data, the identification of each current rule and regulation which the NRC considers to be of particular significance to the protection of public health and safety; determination of the extent to which each plant currently operating complies with these rules and regulations; identification of all generic safety issues for which technical solutions have been developed and determination of which of these solutions have been developed and determination of which of these solutions should be incorporated into NRC rules and regulations; and a schedule for developing a technical solution for the remaining generic safety issues.

Applications for Permits Withdrawn. No new applications for NRC construction permits for nuclear power plants have been received since 1978. During fiscal year 1980, utilities requested withdrawal of applications for construction permits for the following nuclear power plants: Erie Units 1 and 2 (Ohio), Greenwood Units 2 and 3 (Mich.) Haven (Wis.), North Coast (P.R.), Sterling (N.Y.), and Sundersert Unit 1 and 2 (Cal.). An application for an early site review for Douglas Point Units 1 and 2 (Md.) was also withdrawn. Notice of a decision to terminate plans to construct Davis-Besse Units 2 and 3 (Ohio) was received. In the last quarter of 1980, utilities requested withdrawal of applications for construction permits for Greene county (N.Y.) and for New Haven Units 1 and 2 (N.Y.), and announced cancellation of the construction of Forked River (N.J.), North Anna Unit 4 (Va.), and Montague Units 1 and 2 (Mass.).

ADVANCED NUCLEAR POWER REACTORS

According to the policy enunciated by President Carter on April 7, 1977, the commercial reprocessing

and recycling of plutonium produced in nuclear power reactors would be indefinitely postponed and high priority given to consideration of alternative designs, deferring the time when breeder reactors could be commercialized. Thus the status of the staff review of the Clinch River Breeder Reactor remained inactive throughout the year. During the report period, the NRC completed its participation in the review and assessment of a variety of reactor types and fuel cycles being considered by the Department of Energy as part of the Nonproliferation Alternative Systems Assessment Program. A new revision to the Preliminary Safety and Environmental Information Document was published, along with a final draft of a report on Nuclear Proliferation and Civilian Nuclear Power.

The Fast Flux Test Facility. This facility provides an intense field of fast neutrons for irradiating fuels and materials in connection with advanced reactor research and development. It is located near Richland, Wash., and is owned by the Department of Energy. It is not subject to licensing by the NRC, but an NRC staff safety review was performed under an interagency agreement. Initiation of fuel loading started in November 1979, and the facility achieved initial criticality on February 9, 1980. Prior to full-power operation, scheduled for the end of 1980, a series of tests were planned to determine whether natural circulation of the coolant is a viable method of removing decay heat as predicted by analyses.

Fort St. Vrain. This facility is a 330-MWe high-temperature gas-cooled reactor operated by the Public Service Company of Colorado near Platteville, Colo. The power level is restricted to 70 percent of initially rated power pending resolution of several items concerning accident reanalysis, fluctuation of power and temperature, and analysis of depressurization following a permanent loss of forced circulation. A group of utilities has shown interest in an advanced high-temperature gas-cooled reactor, and NRC review of design and safety criteria has started.

The Floating Nuclear Power Plant. This power plant concept utilizes a conventional pressurized light-water reactor mounted on a floating platform and sited at offshore or near-shore sites in the ocean or in estuaries and rivers. Offshore Power Systems, a subsidiary of Westinghouse Electric Corporation, filed an application with the NRC in 1973 for a license to manufacture up to eight identical floating nuclear power plants at Blount Island near Jacksonville, Fla. Public hearings on safety and environmental issues have been held. Further reviews of issues related to the Three Mile Island accident are planned.

Reactor Safety Issues

The following section comprises two categories of reactor safety issues: (1) the Unresolved Safety Issues, on which an annual report to the Congress is mandated by statute, and (2) Other Technical Issues, which are problems and concerns other than Unresolved Safety Issues but related to the safe operation of licensed facilities.

UNRESOLVED SAFETY ISSUES

Section 210 of the Energy Reorganization Act of 1974, as amended, requires, among other things, that the annual report of the Commission to the President and the Congress shall include progress reports on those items previously identified as "Unresolved Safety Issues." The initial identification of these issues is described in the NRC report to Congress entitled "NRC Program for the Resolution of Generic Issues Related to Nuclear Power Plants" (NUREG-0410, January 1978). Subsequently, a report on "Task Action Plans for Unresolved Safety Issues Related to Nuclear Power Plants" was published (NUREG-0649, February 1980). Previous NRC annual reports and this present report describe NRC's progress in resolving the issues.

Seven of the tasks associated with previously identified issues have now been reported as complete. Each of the seven tasks with the number of the report which provides the technical resolution and the status of implementation thereof at the operating plants, is presented in Table 2. Because of the diversion of many NRR staff personnel to deal with the TMI accident in 1979, no new Unresolved Safety Issues were identified in last year's annual report. Four new issues have been designated "Unresolved Safety Issues" and these are discussed among other issues covered in this section. The discussion represents the first systematic review of new candidate issues since the publication of NUREG-0410; it was undertaken by the Generic Issues Branch in the Division of Safety Technology, established under the April 1980 reorganization of NRR to provide full-time, dedicated task management of active unresolved safety issues.

Identification of New Issues

Pursuant to the NRC staff's continuing responsibility to identify Unresolved Safety Issues, a systematic review has been performed of all candidate issues from the Three Mile Island investigations and other sources. The issues considered derived from a large number of recommendations and concerns from three principal sources—the TMI Action Plan, ACRS letters and reports since January 1979, and the NRC staff. Many were disclosed by analysis of operating experience.

Table 2: Unresolved Safety Issues for Which a Final Technical Resolution Has Been Completed

| <i>Title</i> | <i>Date Completed</i> | <i>Report Published</i> | <i>Implementation Status</i> |
|---|-----------------------|-------------------------|---|
| A-2 Asymmetric Blowdown Loads | Nov. 1980 | NUREG-0609 | Licensee responses under review |
| A-6 Mark I Short Term Program | Dec. 1977 | NUREG-0408 | Complete |
| A-7 Mark I Long Term Program | July 1980 | NUREG-0661 | Implementation voluntarily initiated by the affected utilities has been confirmed by Commission order |
| A-10 Boiling Water Reactor Nozzle Cracking | Nov. 1980 | NUREG-0619 | Letter to licensees requiring implementation of the findings in NUREG-0612 issued on Dec. 22, 1980 |
| A-26 Reactor Vessel Pressure Transient Protection | Sept. 1978 | NUREG-0224 | Complete |
| A-36 Control of Heavy Loads Near Spent Fuel | July 1980 | NUREG-0612 | Letter to licensees requesting implementation of the findings in NUREG-0612 issued on Dec. 22, 1980. |
| A-42 Pipe Cracks in Boiling Water Reactors | July 1980 | NUREG-0313 Revision 1 | An implementation letter to each licensee is in preparation. |

The evaluation process used to determine which of the candidate safety issues would be designated as Unresolved Safety Issues consisted of two steps, an initial screening and an evaluation of safety importance. In the initial screening an issue was eliminated from further consideration if it met one or more of the following criteria.

- (1) The safety issue is not related to nuclear power plant safety, e.g., transportation of radioactive materials.
- (2) A staff position on the issue has been developed or is expected to be developed within six months.
- (3) The issue is not generic.
- (4) The issue is only indirectly related to nuclear power plant safety, e.g., recommended changes in the licensing process, NRC organization, etc.
- (5) Definition of the issue requires long-term confirmatory or exploratory research.
- (6) The issue is related to one already being addressed as an Unresolved Safety Issue and can reasonably be or already is included in the current program.
- (7) The issue requires a policy decision rather than a technical solution.
- (8) The issue is related to safety improvements where existing protection is adequate.
- (9) The issue involves programmatic matters involving implementation of issue resolutions already achieved.
- (10) The issue includes collection of related issues in lieu of focused critical issues.

Each of the candidate issues resulting from the initial screening was subjected to a systematic review to judge whether it was a potentially significant safety deficiency or would result in a potentially significant safety improvement. Comments and recommendations were provided by the Advisory Committee on Reactor Safeguards, NRC's Office for Analysis and Evaluation of Operational Data, and the NRC's Office of Policy Evaluation.

As a result of this selection, screening, and evaluation process—and based upon a determination of the Commission—the four issues listed below were designated as new Unresolved Safety Issues:

- (1) Shutdown Decay Heat Removal Requirements (Task A-45).

- (2) Seismic Qualification of Equipment in Operating Plants (Task A-46).
- (3) Safety Implications of Control Systems (Task A-47).
- (4) Hydrogen Control Measures and Effects of Hydrogen Burns on Safety Equipment (Task A-48).

The NRC Staff is currently in the process of developing Task Action Plans which will include schedules for resolving these issues. The following is a brief description of each of these new issues.

Shutdown Decay Heat Removal Requirements (Task A-45). Following a reactor shutdown, the radioactive decay of the fission products continues to produce heat (decay heat) which must be removed from the primary system. The principal means for removing this heat in a pressurized water reactor (PWR)—in the absence of a large loss-of-coolant accident—is through the steam generators to the secondary side of the plant. Although many improvements to the steam generator auxiliary feedwater system were required by the NRC following the TMI-2 accident, providing an alternative means of heat removal would substantially increase the plant's capability to deal with a broader spectrum of transients and accidents and, therefore, could significantly reduce the overall risk to the public. Consequently, this Unresolved Safety Issue will investigate alternative means of decay heat removal in PWR plants, using existing equipment where possible. This study will consist of a generic systems evaluation and will result in recommendations regarding the desirability of, and possible design requirements for, an alternative decay heat removal method (other than that normally associated with the steam generator and secondary system). This Unresolved Safety Issue will also investigate the need and possible design requirements for improving the reliability of decay heat removal capacity in boiling water reactors.

Seismic Qualification of Equipment in Operating Plants (Task A-46). The design criteria and methods for the seismic qualification of mechanical and electrical equipment in nuclear power plants have undergone significant change during the course of the commercial nuclear power program. Consequently, the margins of safety provided in existing equipment to resist seismically induced loads and perform the intended safety functions may vary considerably. The seismic qualification of the equipment in operating plants must, therefore, be reassessed to ensure the ability to bring the plant to a safe shutdown condition when subject to a seismic event. The objective of this Unresolved Safety Issue is to estab-

**Table 3. Schedule for Resolution and Implementation of
Unresolved Safety Issues**
(as of Sept. 30, 1980)

| <i>Task No.</i> | <i>Unresolved Safety Issue</i> | <i>Schedule for Issuing Draft Staff Report in 1978 NRC Annual Report</i> | <i>Schedule for Issuing Draft Staff Report as of Jan. 1, 1981</i> | <i>Schedule for Issuing Final Staff Report as of Jan. 1, 1981</i> | <i>Implementation</i> |
|-----------------|--|--|---|---|-----------------------|
| A-1 | Water Hammer | 1980 | June 1981 | May 1982 | |
| A-2 | Asymmetric Blowdown Loads | Early 1979 | | Completed Nov. 1980 | In Process |
| A-3 | PWR Steam Generator Tube Integrity | Early 1980 | Feb. 1981 | May 1981 | |
| A-4 | PWR Steam Generator Tube Integrity | Early 1980 | Feb. 1981 | May 1981 | |
| A-5 | PWR Steam Generator Tube Integrity | Early 1980 | Feb. 1981 | May 1981 | |
| A-7 | BWR Mark I and II Pressure Suppression Containments | Oct. 1979 | | Completed July 1980 | 1982 |
| A-8 | BWR Mark I and II Pressure Suppression Containments | Oct. 1980 | March 1981 | Sept. 1981 | |
| A-39 | BWR Mark I and II Pressure Suppression Containments | Oct. 1979 | May 1981 | Nov. 1981 | |
| A-9 | Anticipated Transients Without Scram | Early 1979 | | | |
| A-10 | BWR Nozzle Cracking | Late 1979 | May 1980 | Completed Nov. 1980 | In Process |
| A-11 | Reactor Vessel Material Toughness | July 1979 | | Proposed for Rulemaking Dec. 1980 | |
| A-12 | Steam Generator and Reactor Vessel Supports | August 1979 | Nov. 1979 | May 1981 | |
| A-17 | Systems Interactions | Phase I—Sept. 1979. Phase II— Sept. 1980 | | May 1981 | |
| A-24 | Qualification of Class IE Safety-Related Equipment | 1979 | | March 1981 | In Process |
| A-36 | Control of Heavy Loads Near Spent Fuel | Early 1979 | | Completed July 1980 | 1982 |
| A-40 | Seismic Design Criteria | Phase I—1979 Phase II—1981 | Dec. 1980 | | |
| A-42 | Pipe Cracks in Boiling Water Reactors | Not Scheduled | | Completed July 1980 | 1981* |
| A-43 | Containment Emergency Sump | Not Scheduled | June 1983 | Sept. 1983 | |
| A-44 | Station Blackout | Not Scheduled | March 1982 | Oct. 1982 | |

*To Initiate Surveillance

lish an explicit set of guidelines that could be used to judge the adequacy of the seismic qualification of mechanical and electrical equipment at all operating plants, in lieu of attempting to backfit current design criteria for new plants. This guidance will concern equipment required to safely shut down the plant, as well as equipment whose function is not required for safe shutdown, but whose failure could result in adverse conditions which might impair shutdown functions.

Safety Implications of Control Systems (Task A-47). This issue concerns the potential for accidents or transients being made more severe as a result of control system failures or malfunctions. These failures or malfunctions may occur independently or as a result of the accident or transient under consideration and would be in addition to any control system failure that may have initiated the event. Although it is generally believed that control system failures are not likely to result in loss of safety functions which could lead to serious events or result in conditions that safety systems are not able to deal with, in-depth studies have not been performed to support this belief. The potential for an accident that would affect a particular control system—and the effects of the control system failures—will differ from plant to plant. Therefore, it is not likely that it will be possible to develop generic answers to these concerns, but rather plant-specific reviews will be required. The purpose of the Unresolved Safety Issue is to define generic criteria that may be used for plant-specific reviews. A specific subtask of this issue will be to study the steam generator overfill transient in PWRs and the reactor overfill transient in BWRs to determine and define the need for preventive and/or mitigative design measures to accommodate this transient.

Hydrogen Control Measures and Effects of Hydrogen Burns on Safety Equipment (Task A-48). Postulated reactor accidents which result in a degraded or melted core can entail the generation and release to the containment of large quantities of hydrogen. The hydrogen is formed from the reaction of the zirconium fuel cladding with steam at high temperatures and/or by radiolysis of water. Experience gained from the TMI-2 accident indicates that it may be desirable to require more specific design provisions for handling larger hydrogen releases than currently required by the regulations—particularly for smaller, low pressure containment designs.

This issue will call for the investigation of means to predict the quantity and release rate of hydrogen following degraded core accidents and various means to deal with large releases to the containment, such as by inerting of the containment or controlled burning. The potential effects of proposed hydrogen control measures on safety, including the effects of hydrogen burns on safety-related equipment, will also be investigated.

Progress Reports

Progress reports for each of the Unresolved Safety Issues under active consideration during 1980, shown in Table 3, are provided below. (For background on earlier phases of each of these issues, see the 1979 NRC Annual Report, pp. 65-86.) Final reports for five additional Unresolved Safety Issues were issued during 1980 (A-2, A-7, A-10, A-36 and A-42). Draft NRC staff reports providing a technical resolution have been issued for comment for Task A-9, "Anticipated Transients Without Scram for Light Water Reactors," and Task A-12, "Fracture Toughness and Potential for Lamellar Tearing of PWR Steam Generator and Reactor Coolant Pump Supports." The reports describe the technical studies conducted by the NRC staff or its contractors and the safety conclusions that constitute the NRC staff's resolution of each of the issues. Public and industry comment is being solicited and considered on each of these reports. The final report will include a summary and assessment of all of the comments received.

The present schedule for the completion of work on each of the Unresolved Safety Issues is given in Table 3. Important elements in the implementation of these tasks are: (1) the provision of a public comment period following the issuance of the staff's technical resolution, followed by discussion and disposition of the comments received in a final report; (2) provision for the incorporation of the technical resolution into the NRC's Regulations, Standard Review Plan, Regulatory Guides or other official guidance; and (3) provision for application of the technical resolution to operating plants.

Water Hammer

Water hammer events are intense pressure pulses in fluid systems (such as commonly experienced when rapidly closing a water faucet), and they often occur in nuclear power plant fluid systems. In the past few years, over 200 incidents involving water hammer in nuclear power reactors have been reported. The phenomenon occurs in various fluid systems and for various reasons—e.g., the rapid condensation of steam pockets, steam-driven slugs of water, pump startup with partially empty lines, or rapid valve motions. While no water hammer incident has resulted in the release of radioactivity outside of a plant, the concern is that water hammer could result in the failure of a pipe in the reactor coolant system or disable a system required to cool the plant after a reactor shutdown.

Seven technical reports on water hammer were issued by NRC contractors during 1979 and three

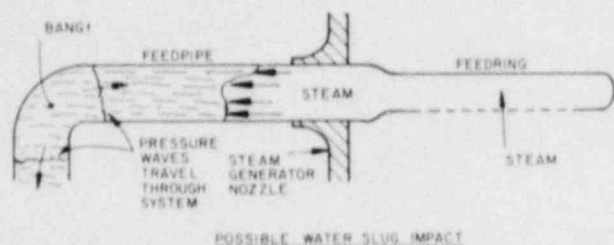
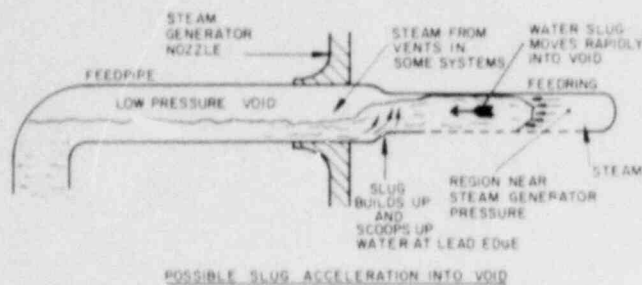

In a steam-generator water hammer, the water slug, which may be traveling at tens or even hundreds of feet per second, impacts on the water filling the upstream side of the pipe, sending hydraulic pressure waves through the system which may cause damage to piping.

additional draft technical reports were issued during 1980. Work was initiated in late 1980 on an NRC report which will summarize the findings of all studies and actions taken as part of Task A-1. This report will present staff recommendations for final resolution of the water hammer issue. This NUREG report is currently scheduled to be issued in mid-1982.

Asymmetric Blowdown Loads On the Reactor Coolant System

In the very unlikely event of a rupture of the primary coolant piping in light water reactors, large non-uniformly distributed loads would be imposed upon the reactor vessel, reactor vessel internals, and other components in the reactor coolant system. Plant modifications to ensure that the postulated loads are accommodated have been implemented late in the construction stage of several plants and have been proposed and are under staff review for some operating plants. For plants still under operating license review, the NRC staff requires the plant-specific analyses and any necessary plant modifications be completed prior to issuance of an operating license. The staff also reviewed and approved topical reports from the vendors of pressurized water reactors (PWRs), explaining their generic approaches to the calculation of the asymmetric loads in a loss-of-coolant accident.

The NRC staff's resolution of this issue is described in a report, "Asymmetric Blowdown Loads on PWR Primary Systems: Resolution of Generic Task Action Plan A-2" (NUREG-0609, December 1980). This report provides acceptance criteria and guidelines for use in plant-specific analyses. Such analyses were requested of all licensees with operating PWRs in January 1978, and an evaluation of its plant's capacity to sustain asymmetric loads was received from each. These were undergoing staff review at the end of fiscal year 1980. Asymmetric blowdown loads are expected to have lesser safety significance in boiling water reactors (BWRs), which operate at much lower pressure than the pressurized water reactors. A plan for resolving the matter for BWR plants will be developed by the NRC staff and carried out separately from the PWR issue.

PWR Steam Generator Tube Integrity

In plants employing pressurized water reactors, the primary coolant is kept under pressure sufficient to prevent boiling. This high-pressure water passes through tubes around which water circulates in a secondary system where steam is produced to drive the turbine generators. The assembly in which the heat transfer takes place is the steam generator. The tubes within it are an integral part of the primary coolant boundary, keeping the radioactive primary coolant in a closed system, isolated from the environment. Maintenance of steam generator tube integrity is a primary concern, both during normal operation or during an accident. Discussions of specific problems associated with steam generator tube integrity occurring at operating reactors were provided in two reports: "Operating Experience with Recirculation Steam Generators" (NUREG-0523, January 1979) and "Operating Experience with Once Through Steam Generators" (NUREG-0571, March 1980).

The significant developments in Westinghouse steam generators since July 1979 were the following:

- Steam generators inspections at Point Beach Unit 1 (Wis.) during August and October 1979 indicated extensive caustic-induced, intergranular attack and stress corrosion cracking of the steam generator tubes in the tube/tubesheet crevices. Because of concerns regarding the apparent high rate of tube degradation, the large number of tubes affected, and the detectability of cracking of tubes in the tubesheet crevices, the unit is currently operating under restrictions imposed by Orders dated November 30, 1979 and April 4, 1980. The results of required inspection in March and August 1980 indicated that the tubesheet crevice degradation phenomenon is still active, although the number

PWR STEAM GENERATOR

Caustic-induced intergranular attack and stress-corrosion cracking within the crevices between the tubes and the tube-sheet in steam generators for pressurized water reactors emerged as a significant operational problem at a number of units during the past year.

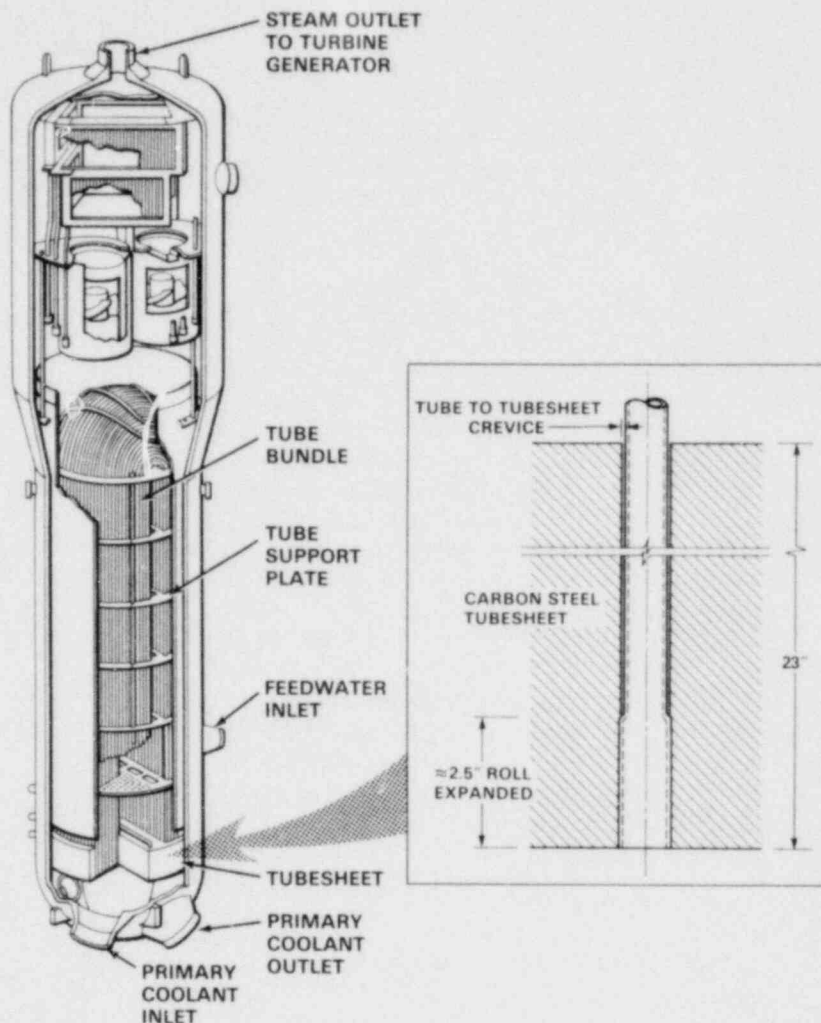

of newly defective tubes found during these inspections was significantly smaller than in previous inspections. The need for confirming, by Order, the licensee's plans to perform another steam generator inspection during its scheduled refueling outage in November 1980 was under consideration by the staff at the close of the report period.

- Five units (Point Beach Units 1 and 2, H. B. Robinson Unit 2 (S.C.), R. E. Ginna (N.Y.), and Prairie Island Unit 1 (Minn.), incurred inservice steam generator leaks due to the tube-sheet crevice phenomenon since August 1979. Two additional units, Prairie Island Unit 2 and San Onofre Unit 1 (Cal.), are also known to

have experienced the tubesheet crevice phenomenon. In comparison to Point Beach Unit 1, the numbers of affected tubes identified at these other units to date are considerably smaller, in some cases amounting to only one or two tubes.

- San Onofre Unit 1 has been shut down since a steam generator leak occurrence on April 7, 1980, attributable to at least five defective tubes. Multifrequency eddy current examinations and laboratory examinations of tube specimens removed from the plant indicated the leaking tubes to be among approximately 1,000 tubes with extensive caustic-induced, intergranular attack and circumferential cracking at the top of the tubesheet elevation. The licensee has ini-

tiated a repair program to install sleeves in all steam generator tubes within the zone of the tube bundle where this phenomenon is occurring. The program is intended as a long-term corrective action.

- Trojan Unit 1 (Ore.) and Farley Unit 1 (Ala.) were shut down on October 12, 1979 and June 13, 1980, respectively, because of steam generator leaks occurring in the U-bend region of Row-1 tubes. Similar defects, which occasioned only slight leakage and did not lead to plant shutdown, were observed at North Anna Unit 1 (Va.) during the December 1979 refueling outage. These U-bend leaks are not denting-related, but the definite cause is uncertain and their safety significance is presently under staff review. In cooperation with the Portland General Electric Company, the Westinghouse Corporation has initiated an intensive program of laboratory examination and analysis of tube specimens removed from the Trojan steam generators. Besides seeking to establish the cause and significance of these defects, the examination will employ non-destructive methods to identify tubes which may eventually develop such defects.
- On October 2, 1979, Prairie Island Unit 1 underwent a steam generator tube rupture leading to a primary-to-secondary leak of 400 gallons-per-minute. The reactor was brought to a cold shutdown in a routine manner following the emergency procedures for such an event. Subsequent inspection revealed that the tube rupture was caused by mechanical wear of the tube by a foreign object leading eventually to a pressure burst. The foreign object was later identified as a spring, jammed by the flow-blocking device; it is believed that the spring was part of sludge removal equipment and was inadvertently left in the steam generator during a previous outage.
- The January 1980 inspection of the Prairie Island Unit 2 steam generators resulted in the finding of 132 tubes with wall-thinning indications. A laboratory analysis of the tube specimen removed from the unit indicates that the tube wall thinning was corrosion-induced, possibly related to resin carryover from the condensate polisher. The corrosion mechanism is still under investigation.
- During the first refueling and steam generator inspection outage at North Anna Unit 1 in Sep-

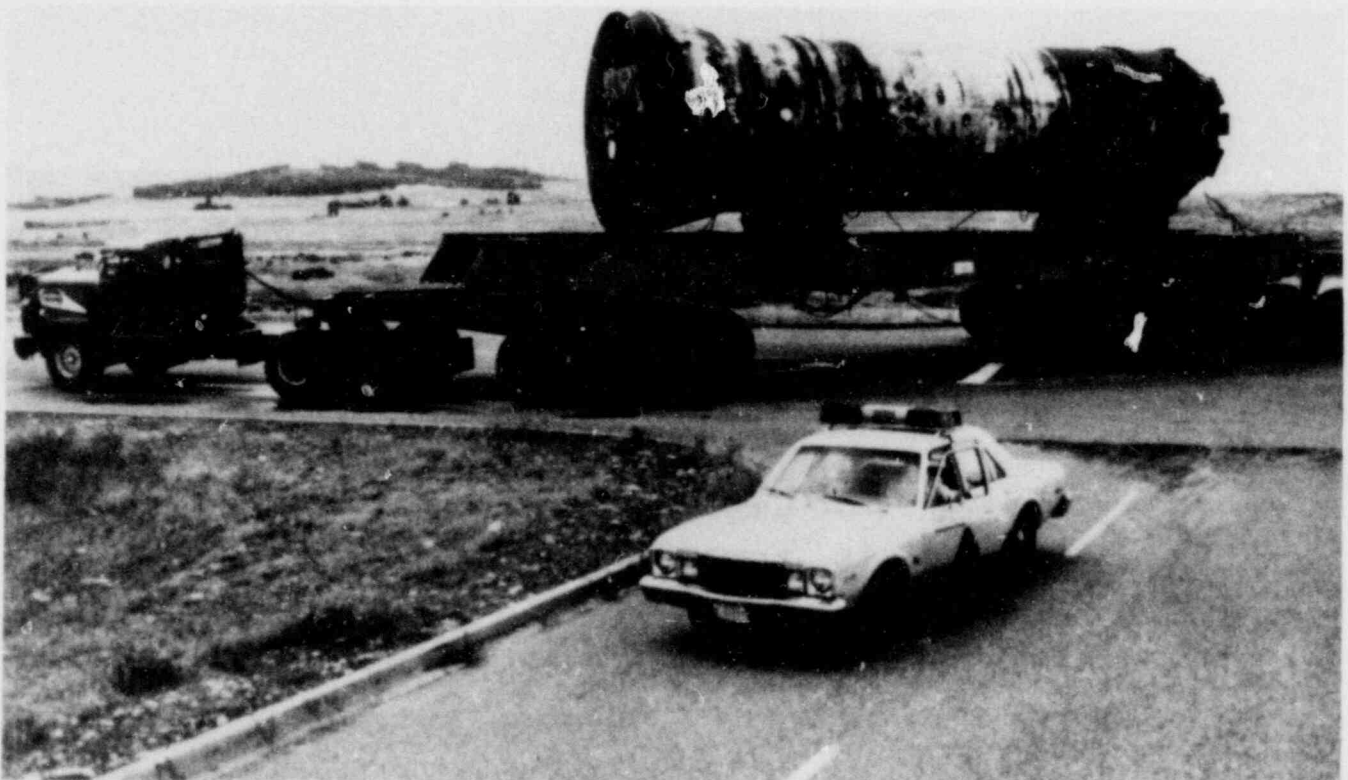

In April and May 1980, a corroded steam generator from the Surry Nuclear Power Station was shipped by truck (shown here)

across country and by barge up the Columbia River to the Battelle Pacific Northwest Laboratory for research on tube integrity.

tember 1979, support plate/tube intersection corrosion cracking—and/or possible support-plate-ligament cracking—was detected. The latter is indicative of an early stage of denting. (Tube-denting is discussed in the NRC Annual Reports of 1978 and 1979). A review of the plant-chemistry data indicated that a major discharge of resins from the condensate polisher into the steam generators occurred in February 1979. The resins are believed to have decomposed in the steam generator operating environment, producing sulfuric acid. This, in turn, led to magnetite formation within the support plate crevices. A program of boric acid treatment was implemented in an attempt to stop further magnetite formation.

- Replacement of the Surry Unit 2 (Va.) steam generators has been completed, and replacement of the Surry Unit 1 steam generators began in September 1980. Replacement is also planned at Turkey Point Units 3 and 4 (Fla.) subject to a hearing ordered by the Atomic Safety and Licensing Board. In the interim and prior to replacement, these units (which are extensively degraded by denting) are operating under restrictions imposed by the NRC.

Steam generator inspections at Combustion Engineering units since August 1979 have not revealed any new significant developments. At Palisades (Mich.), where significant wastage had been observed up to 1976, the results of the September 1979 steam generator inspection indicate that the wastage phenomenon has essentially been arrested.

Significant developments regarding Babcock and Wilcox steam generators since August 1979 included the following:

- Steam generator inspections performed at Oconee Unit 1 (S.C.) during the November 1979 refueling outage resulted in the removal from service, by plugging, of approximately 80 tubes. The tube degradations were generally attributed to "liquid impingement" erosion, affecting both on- and off-lane tubes.
- Oconee Unit 3 was shut down on June 15, 1980, with a steam generator leak. Subsequent inspection revealed the leak in a lane tube with a fatigue-induced, 300° circumferential crack at the upper tubesheet. Similar fatigue cracks have been observed previously at all three Oconee units. (The lane-tube degradation was reported previously in NRC Annual Reports of 1978 and 1979).

Plant technical specifications require routine inservice inspection of steam generators to be performed every 12 to 24 months. The NRC has imposed license conditions on plants with severely

degraded steam generators to increase the required frequency of inspection. The conditions also require that, following inspection of steam generators and completion of any necessary repair programs by the licensees, the NRC must approve or concur in the restart of each severely affected facility. Safe operation is assured by the imposition of strict conditions, including the plugging of affected tubes and restricting of allowable leak rates during operation.

While the NRC continues to closely monitor and evaluate the acceptability for continued operation of plants experiencing steam generator tube problems, it is proceeding with three generic tasks in the NRC program for the resolution of generic issues. Specifically involved are Generic Tasks A-3, A-4, and A-5, addressed to the problems of Westinghouse, Combustion Engineering, and Babcock and Wilcox steam generators, respectively. (A description of these Task Action Plans was provided in the 1979 NRC Annual Report, p. 70). The approach taken in the Task Action Plan is to integrate technical studies in the three areas of systems analyses, inservice inspection, and tube integrity in order to establish improved criteria by which to ensure safe and reliable steam generator operation. These studies have been completed and a draft report will be issued for public comment.

BWR Mark I and Mark II Pressure Suppression Containments

Boiling water reactor (BWR) pressure-suppression containment systems, principally designed by the General Electric Company, are engineered to utilize a large mass of water (suppression pool) as a heat sink which will condense the steam and absorb the energy released from the reactor primary system in the event of postulated accidents or transients. The absorption of excessive energy by the stored water reduces the pressure in the containment and that, in turn, reduces the driving force that might lead to a release of fission products to the environment that may have escaped into the containment building from the primary system.

During the course of large-scale testing for an advanced design pressure-suppression containment (Mark III) and during in-plant testing of facilities with the Mark I containment design, new suppression pool hydrodynamic loads were identified which had not been explicitly considered in the original design basis for Mark I and Mark II plants. These additional loads result from the dynamic effects of air and steam being rapidly forced into the suppression pool during a loss-of-coolant accident (LOCA) or a safety relief valve discharge from the primary system.

The NRC staff has identified and initiated a number of generic tasks to review and evaluate the

results of the industry programs and to develop criteria for licensing actions on individual plants using the Mark I and Mark II containment designs. Task A-6 was completed with the issuance of the "Mark I Containment Short-Term Program Safety Evaluation Report" (NUREG-0408, December 1977). In that report, the NRC concluded that an adequate margin of safety had been demonstrated for the most probable hydrodynamic loads induced by a design-basis LOCA, such that the licensed Mark I BWR facilities may continue operation without undue risk to the health and safety of the public while the Long-Term Program is being conducted.

Task A-7 was concluded with the issuance of the "Mark I Containment Long-Term Program Safety Evaluation Report" (NUREG-0661, July 1980). This report describes the results of the NRC's review of the proposed generic hydrodynamic load definition and structural assessment techniques and the NRC Acceptance Criteria for the subsequent plant-unique assessments. The plant-unique assessments are currently underway and most of the affected utilities have performed several of the known plant modifications in order to expedite the resolution of this issue. The Acceptance Criteria are to be formally issued to the Mark I licensees with schedules for completion of all of the plant modifications needed to conform to those criteria. Based on the NRC's review of the proposed modification schedules, the implementation of the Mark I Long-Term Program is expected to be completed in 1982.

Task A-8 deals with the "Mark II Containment Program." The Mark II Owner's Group developed a program consisting of a number of analytical and experimental tasks to support their pool, dynamic-loads application methods. They divided the overall program into two parts: a Lead-Plant Program and a Long-Term Program. The Lead-Plant Program was essentially completed with the publication of a report on "Mark II Containment Lead Plant Program Load Evaluation and Acceptance Criteria" (NUREG-0487, October 1978).

As a result of new full-scale test data that became available early in 1980, questions were raised regarding the acceptability of the lead-plant chugging and condensation oscillation loads. Following the Mark II owners analysis of this new test data, new loads were presented in July 1980. The staff plans to issue their evaluation of these loads in December 1980 in the form of a letter report.

The Mark II owners plan to issue several key reports in October 1980 wherein several new Long-Term Program loads will be proposed. The staff recently issued Revision 3 to the A-8 Action Plan, which scheduled an evaluation in late 1980 of these loads. This is to be followed by a safety evaluation report in March 1981.

Under Generic Task A-39, "Determination of Safety Relief Valve Pool Dynamic Loads and Temperature Limits for BWR Containment," the NRC staff is evaluating the results of industry experimental and analytical programs for Mark I, II, and III containment designs. The results of Generic Task A-39 will be an integral part of the final acceptability of these designs. The portions of this generic task related to the Mark I design have been completed and reported in "Safety Evaluation Report: Mark I Containment, Long-Term Program: Resolution of Generic Technical Activity A-7" (NUREG-0661, July 1980). The portions related to Mark II and Mark III are currently scheduled to be completed in November 1980 and May 1981, respectively.

Anticipated Transients Without Scram

Nuclear Plants have safety and control systems to limit the consequences of abnormal operating conditions. During the life of a nuclear power unit, "anticipated transients" are, by definition, abnormal operating conditions likely to occur one or more times. These are conditions such as a loss of power to recirculation pumps, the loss of off-site power, the tripping of the turbine generator set, and the like. In some such cases, a rapid shutdown of the nuclear reaction—initiating a "scram"—is an important safety measure. If there were a potentially severe transient, and the reactor shutdown system did not function as designed, then an "anticipated-transient-without-scram," or ATWS, would have occurred.

ATWS safety issues have been under study by the AEC, NRC and the nuclear industry for a number of years. Details on the safety significance of ATWS and actions taken by NRC and industry prior to 1980 in response to its safety issues may be found in the *1979 NRC Annual Report*, p. 73.

The NRC staff, in December 1978, proposed a combination of preventive and mitigative means of providing improved protection from ATWS events in a report, "Anticipated Transients Without Scram for Light Water Reactors" (NUREG-0460).

Volume 4 of NUREG-0460, issued for comment in March 1980, presented staff review of industry responses to the alternatives proposed in Volume 3. The staff received comments from industry and from the NRC Advisory Committee on Reactor Safeguards and submitted a recommendation for rule-making for Commission consideration on September 4, 1980.

(During the report period, an incident took place at the Browns Ferry Nuclear Plant Unit 2 (Ala.) involving the failure of the reactor to scram completely. The event is discussed at length in Chapter 5, under "Abnormal Occurrences" and "AEOD Technical Studies.")

BWR Nozzle Cracking

Over the past several years, inspections at 22 of the 23 boiling water reactor (BWR) plants licensed for operation in the United States have disclosed some degree of cracking in the feedwater nozzles of the reactor vessel at 18 facilities. The one remaining facility has not yet accumulated significant operating time and has, therefore, not yet been inspected. The feedwater nozzles are an integral part of the primary pressure boundary of the reactor coolant system and the second barrier (after the fuel cladding) to the release of radioactive fission products. All of the repaired BWR feedwater nozzles met the ASME pressure vessel code limits and, therefore, no immediate action was necessary. The cracking is potentially serious, however, because it could lead to a reduction in safety margins during repair work and result in considerable shutdown time.

The reactor vendor (the General Electric Company) and the NRC have concluded from their separate studies that the cracks are initiated by rapid fluctuations in water temperature on the inside surface of the nozzles during periods of low feedwater temperature when flow may also be unsteady and perhaps intermittent. The cracks then grow deeper as a result of operational startup and shutdown cycles or other operationally induced transients. The stainless steel cladding exhibited less resistance to crack initiation than the underlying low-alloy steel. The affected licensees have increased inspections of the nozzles and are closely monitoring the situation, pending long-term solution.

In a closely related area, the NRC was informed in March 1977 by the General Electric Company that a crack had been found in the nozzle of the control rod drive (CRD), return-line in a reactor vessel. The CRD return-line nozzles are the openings in BWR pressure vessels through which the high pressure water in excess of that needed to operate and cool the CRDs is returned to the pressure vessel. The cracks resembled those found in the feedwater nozzles and seemed to be the result of the same kind of cyclic thermal stresses that were causing feedwater nozzle cracks.

In 1977 the NRC staff efforts related to the resolution of these two similar issues regarding nozzle cracking in boiling water reactors were consolidated into a single staff effort, Generic Task A-10.

The NRC draft report, "BWR Feedwater Nozzle and Control Rod Drive Return Line Nozzle Cracking" (NUREG-0619, April 1980), incorporates guidance for operating reactors and plants under licensing review. Public comment on this report was invited in May 1980. Public comments were received and incorporated where applicable. A meeting was held in September 1980 to discuss the remaining issue requiring near-term action, that of the efficacy of

proposed inservice thermal sleeve-seal, leakage-detection systems. The final report, "BWR Feedwater Nozzle and Control Rod Drive Return Line Nozzle Cracking" (NUREG-0619), incorporates changes made as the result of public comments and includes a summary of NRC's responses to all comments received.

The resolution of questions regarding the future selection of improved inservice inspection techniques (for crack detection) and frequency of inspection has been separated from the generic task while major industry investigations continue (including thermal cracking in a full-size nozzle mockup to be used in ultrasonic evaluation). A supplement to the NRC staff report cited above may be necessary upon completion of these studies. In the meantime, stringent inspection requirements, based mainly upon dye-penetrant testing, are still in force. All licensee efforts (such as system and operational changes to lengthen the time prior to crack initiation and to slow crack growth) are taken into account in the determination of inspection techniques and criteria.

Plant-specific implementation of the generic licensing positions developed under this task (with the exception of future inservice inspection questions) has begun.

Reactor Vessel Material Toughness

Nuclear reactor pressure vessels are required to have adequate margin against fracture in the presence of relatively large postulated flaws. This requirement is imposed for conservatism even though extensive, periodic inservice inspection programs provide protection against the presence of such flaws.

For the service time and operating conditions typical of current operating plants, reactor vessel fracture toughness provides adequate margins of safety against vessel failure. Further, for most plants the vessel material properties are such that adequate fracture toughness can be maintained over the life of the plants. However, results from a reactor vessel surveillance program indicate that up to 20 older operating pressurized water reactor pressure vessels were fabricated with materials that will have marginal toughness after comparatively short periods of operation. This issue of "Reactor Vessel Material Toughness" has been designated as Task A-11.

A program intended to provide an engineering analysis of reactor pressure vessel beltline regions based on elastic-plastic fracture mechanics concepts was established in late 1978 by the U.S. Department of Energy, with management by Sandia Laboratories. The work was completed in early 1980 but failed to reach the goal of developing a viable analysis method. This resulted in a delay of about one year for the completion of Task A-11. Currently, the

development of useful formulations, advanced material properties and engineering verification is being accomplished by the NRC through several technical assistance contracts with active NRC staff participation. The engineering method will account for radiation-induced material degradation.

Since the publication of the 1979 NRC Annual Report, the following has been accomplished:

- (1) The newly developed elastic-plastic fracture test method for routine determination of fracture toughness was employed to provide data from irradiated specimens of pressure vessel steels.
- (2) Advanced elastic-plastic fracture mechanics concepts were developed and the results published.
- (3) Elastic-plastic fracture mechanics methods were employed to develop formulas for predicting fracture of pressure vessels with both surface and through-wall cracks in the cylindrical shell regions.
- (4) A team of recognized experts in the several engineering disciplines involved in Task A-11 was assembled and is working actively under several NRC contracts to evaluate the "J-integral" and "tearing modulus" concepts with respect to reactor pressure vessel applications and revision of existing codes and standards.

Task A-11 is now scheduled to be completed by December 31, 1980, with the issuance of a NUREG report. This delayed completion date remains well in advance of the latest acceptable date to assure that adequate fracture toughness is maintained in those older reactor vessels that will have lower toughness with the passage of time.

Fracture Toughness and Potential for Lamellar Tearing of Component Supports

During the course of the licensing review for a specific pressurized water reactor (PWR), a number of questions were raised as to (1) the adequacy of the fracture toughness properties of the material used to fabricate the reactor coolant pump supports and steam generator supports, and (2) the potential for failure due to lamellar tearing of these same supports. Because materials and designs similar to those of the PWR originally reviewed have been used in other plants, review of this issue was designated as generic Task A-12. This review has recently been expanded to include other PWR supports and the supports of cooling water reactors as well.

Definitive acceptance criteria regarding fracture toughness of all support materials and resistance to stress-corrosion cracking of high-strength support

materials were forwarded to licensees and applicants in letters dated May 19 and 20, 1980. Because of negative responses, the NRC staff convened a meeting with licensees, applicants, and other industry representatives in August 1980. The outcome of the meeting was tentative NRC staff acceptance of a program sponsored by industry through the Electric Power Research Institute for resolution of issues regarding fracture toughness and stress corrosion. The NRC staff established the following specific criteria for the industry-sponsored program to be acceptable:

- (1) Fracture toughness values must be confirmed.
- (2) Plant-specific geometries must be included in the calculations.
- (3) Residual stresses must be included.
- (4) Methods of determining initial flow size must be clearly defined, and pickup or modeling must be used to demonstrate reliability of non-destructive examination methods.
- (5) A probability of failure argument as the sole means of proving acceptability of high strength materials will not be accepted.

In addition, the NRC staff required that the proposed alternative program be presented to the staff by the end of 1980. This program, if found acceptable by the NRC staff, may then be utilized by licensees and applicants. Failure to do this will result in the staff's imposition of its original criteria, modified to incorporate comments deemed applicable.

Lamellar tearing, the second aspect of the problem, is a cracking phenomenon which occurs beneath welds and is principally found in rolled steel plate fabrications. The results of an extensive survey by a consultant to the staff revealed that, although lamellar tearing is a common occurrence in structural steel construction, virtually no inservice failures attributable to lamellar tearing are known. Nonetheless, additional research is being planned to provide a more definitive and complete evaluation of the importance of lamellar tearing to the structural integrity of nuclear power plant support systems. This research will be a follow-on effort to Generic Task A-12. The Electric Research Institute has been asked to fund and manage the desired research.

Systems Interaction In Nuclear Power Plants

In November 1974, the Advisory Committee on Reactor Safeguards requested that the staff give attention to the evaluation of safety systems from a multidisciplinary point of view in order to identify potentially undesirable interactions between plant systems. The concern arises because the design and

analysis of systems is frequently assigned to specialists whose focus could lead them to overlook adverse interactions between systems. Task A-17 was initiated to provide an independent investigation of systems required to perform safety functions in order to assess the degree to which the current review procedures take potential systems interactions into account. This investigation has been conducted by Sandia Laboratories under contract assistance to the NRC.

The contractor effort on Phase I of the task began in May 1978 and was completed in March 1980, seeking to identify areas where interactions are possible between systems which could negate or seriously degrade the performance of safety functions. The investigation, conducted by means of "fault tree" analyses, identified the way in which NRC review procedures account for these interactions; it was completed during 1979.

A contractor report was published under the title, "Final Report - Phase I: Systems Interaction Methodology Applications Program" (NUREG/CR-1321, April 1980). Another report providing the NRC staff's conclusions based on the contractor's work was scheduled to be issued in April 1980. However, the Three Mile Island Unit 2 accident caused the NRC staff to consider reorienting the Task A-17 Phase I effort so as to include improved treatment of such matters as operator actions, design errors, and maintenance procedures. It was decided not to disrupt the Phase I effort, which was nearing completion, but rather to consider expanding the Phase II effort to include treatment of TMI-2 related issues.

On February 20, 1980, the NRC staff and its contractor presented the results of the Phase I investigation to the Subcommittee on Plant Arrangements of the Advisory Committee on Reactor Safeguards. While the subcommittee encouraged the NRC staff to continue its investigation using the more disciplined and formal methods of analyses, it nevertheless recommended that the NRC staff provide a demonstration of the efficacy of the "fault tree" method of analysis used in Phase I before extending the investigation to include the treatment of other matters. The NRC staff has been unsuccessful in attempting to demonstrate the efficacy of the fault tree method of analysis for revealing potential systems interactions. Whether the fault tree method of Phase I is practical by itself or needs to be supplemented, or perhaps replaced, by alternative methods needs to be determined. For this reason, the NRC staff's conclusions based on the contractor's work and the scoping of Phase II follow-on work have both been delayed from the forecasted completion date of April 1980. The NRC staff now plans to define a way to demonstrate the analytical method and issue a report on the demonstration by November 1981, and from that base the NRC staff plans to define the scope of Phase II follow-on studies by March 1982.

Concurrent with this effort on Task A-17, the NRC staff and utility applicants and licensees are performing investigations of systems interaction using alternative methods. One method, which will be conducted at the Indian Point Unit 3 plant, employs "failure modes and effects analyses" together with a compartment-by-compartment examination of a plant. Another method which has been performed by the applicant at the Diablo Canyon plant evaluates the overall effect on the plant safety system function of failure of nonseismic equipment, components and structures because of earthquake. This study is now being reviewed by the NRC staff and the ACRS. The staff concluded that there is reasonable assurance that there are no systems interactions from a seismic initiator that can adversely affect safety.

Following the accident at Three Mile Island and as a consequence of the recommendations of the President's Commission on the Accident at Three Mile Island, the NRC Office of Nuclear Reactor Regulation was reorganized to give greater emphasis to integrated review of plant systems.

Environmental Qualification of Safety-Related Electrical Equipment

Safety systems are installed at nuclear plants to mitigate the consequences of postulated accidents. Certain of these postulated accidents could create severe environmental conditions inside the containment, such as high temperature, humidity, pressure, and radiation levels. The most serious such accident would be a high-energy pipe break in the reactor coolant system piping or in a main steam line. In order to assure that electrical equipment in safety systems will perform its function under accident conditions, the NRC requires that such equipment be qualified to perform in the environment associated with the accident. The process of clarifying the criteria has given rise to certain questions regarding the adequacy of qualification tests and analyses. Generic Task A-24 was established to address this question for those plants which received a Construction Permit Safety Evaluation Report after July 1974.

IEEE Standard No. 323 for Qualifying Class IE Equipment for Nuclear Power Generating Stations and its ancillary standards have provided the focal point for the development of environmental qualification requirements in recent years. These standards set forth basic requirements for environmental qualification of electrical equipment and provide varying degrees of detail for implementation of these requirements.

The staff requires in part that, for newer plants (specifically those for which a construction permit

(CP) safety evaluation report (SER) was issued after July 1, 1974), the methods and programs developed to qualify safety-related equipment should conform to the requirements of IEEE 323-1974 and that this standard be used as a guide in evaluating these qualification programs. For plants for which a construction permit SER was issued prior to July 1, 1974, the staff has required that the qualification programs be developed in conformance with the guidelines established in IEEE 323-1971: "IEEE Trial-Use Standard: General Guide for Qualifying Class IE Electrical Equipment for Nuclear Power Generating Stations." This requirement has been applied on a case-by-case basis to older plants that have been, or are currently, undergoing an operating license review. On May 23, 1980, the NRC issued an order establishing criteria to be used for the environmental qualification of safety-related electric equipment. This act resulted in orders for modification of license to all reactor licensees, on August 29 and October 24, 1980.

Several aspects of equipment qualification are being pursued at this time by the NRC staff and the nuclear industry on a generic basis, in order to achieve a more uniform implementation of requirements established in IEEE 323-1974. One such activity is a continuing process of revising and upgrading industry standards by providing more detailed guidelines for implementing the basic requirements. A part of Generic Task A-24 is the development of NRC staff positions which address selected areas of the qualification issue. These positions are applicable to plants that are, or will be, in the CP or OL review process and that are required to satisfy the requirements set forth in either the 1971 or 1974 version of the IEEE-323 standard. A report was issued on "Interim Staff Position on Environmental Qualification of Safety-Related Electrical Equipment" (NUREG-0588, December 1979). The final version of NUREG-0588 incorporating public comments is scheduled to be issued in March 1981.

Supplemental reports may be issued reflecting any changes in these interim positions which might result from the continuing investigations of the Three Mile Island Unit 2 accident, the staff's review of the responses to Bulletin 79-01 on operating plants, and the resolution of several issues that are currently being pursued by the NRC and the nuclear industry such as aging effects, sequential vs. simultaneous testing, etc. Other efforts under Generic Task A-24, such as the review methods used for environmental qualification of safety-related electrical equipment, were eliminated from the scope of the generic activity. The staff will perform this as part of operating license reviews. Task A-24 will be completed with the issuance of the final version of NUREG-0588. Several ongoing staff actions related to electrical equipment at operating plants are discussed below, under "Other Technical Issues."

Control of Heavy Loads Near Spent Fuel

Overhead cranes are used to lift heavy objects, sometimes in the vicinity of spent fuel, in both PWRs and BWRs. If a heavy object, such as a spent fuel shipping cask or shielding block, were to fall or tip onto spent fuel in the storage pool or in the reactor core during refueling, there could be a release of radioactivity to the environment. The NRC staff's review of this safety issue was designated as Generic Task A-36. The objective of the task was to develop criteria which would reduce the possibility that heavy loads might cause unacceptable damage to irradiated fuel in a storage pool or in the reactor core.

In July 1980 a report, "Control of Heavy Loads at Nuclear Power Plants" (NUREG-0612), was issued providing resolution of this issue. The report describes the staff's review and provides the criteria that should be satisfied to assure safe handling of heavy loads. The report also provides the basis for revisions to the Standard Review Plan (SRP) and Regulatory Guides—to be used both in future reviews of new plants and for implementing additional requirements and procedures in operating plants.

Although the criteria provided in NUREG-0612 are generic, implementation of these criteria will depend upon plant design characteristics and specific procedures in effect at each particular plant, therefore requiring a plant-by-plant review. Accordingly, letters are being sent to each licensee requesting an evaluation of its facility according to the criteria in NUREG-0612, a description of modifications and changes to be made to satisfy NUREG-0612, and a schedule for effecting changes and modifications with the objective of completing these by March 1983. This licensee information will be required by March 1981, and will be reviewed by the staff with contractor technical assistance. Staff reviews of information pertaining to the control of heavy loads at Indian Point Units 2 and 3, Three Mile Island Unit 1, and Zion Units 1 and 2 are already under way and changes to Standard Review Plans and Regulatory Guides will be made to incorporate the criteria of NUREG-0612.

Seismic Design Criteria

NRC regulations require that nuclear power plant structures, systems and components important to safety be designed to withstand the effects of natural phenomena such as earthquakes. There are a number of plants with construction permits and operating licenses issued before current regulations were in place. For this reason, the seismic designs of various plants are being reviewed again to assure that they represent no undue risk to the public. Generic Task

Overhead systems are used for the handling of heavy loads in nuclear power plants. Photo shows a typical polar crane in a pressurized water reactor containment building for handling such loads as the reactor vessel head, upper vessel internals, vessel service platform, and reactor coolant pumps. Generic Task A-36 addresses criteria to help reduce the possibility of unacceptable damage to irradiated fuel in a storage pool or in the reactor from the handling of heavy loads.

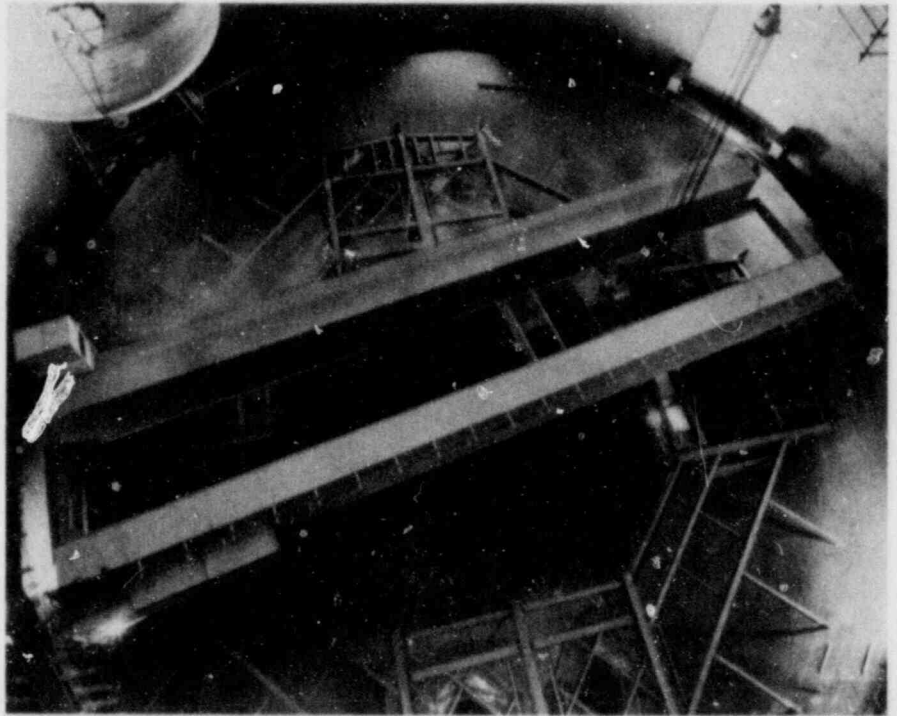

A-40 is a compendium of short-term efforts to support the re-evaluation of the seismic design of operating reactors and to support licensing activities in general.

Phase I includes a number of studies related to the response to earthquakes of structures, systems, and components. These studies, performed under NRC-sponsored contracts, were completed by October 1979. Reviews of study results are underway. The results will support the effort on seismic reevaluation of operating plants, particularly in the area of site-specific definition of seismic input. Reports on site-specific response spectra were published as part of Phase I. A report with recommendations for NRC seismic design criteria was also published and revised drafts of related sections of the Standard Review Plan and Regulatory Guides were completed.

Phase II of Task A-40 includes several subtasks pertaining to numerical modeling of earthquakes at the source, analysis of near-source ground motion, and attenuation of high-frequency ground motion. Subtask studies by NRC contractors are scheduled for completion by the end of 1980. An analysis of near-source ground motion and the state-of-the-art review of earthquake source modeling has been published in a report, "State-of-the-Art Study Concerning Near-Field Earthquake Ground Motion" (NUREG/CR-1340, August 1980). Review and implementation of the results of these studies in terms of recommended revisions to the Standard Review Plan and Regulatory Guides are scheduled for March 1981.

Pipe Cracks at Boiling Water Reactors

Pipe cracking has occurred in the heat-affected zones of welds in primary system piping in boiling-water reactors (BWRs) since the mid-1960s. The major problem is recognized to be intergranular stress corrosion cracking (IGSCC) of austenitic stainless steel components that have been made susceptible to this failure mode by being "sensitized," either by welding or by post-weld heat treatment. Although the likelihood is extremely low that IGSCC-induced cracks will propagate far enough to create a significant hazard to the public, the occurrence of such cracks is undesirable and measures to minimize IGSCC in BWR piping systems are indicated to improve overall plant reliability.

A "Technical Report on Material Selection and Processing Guidelines for BWR Coolant Pressure Boundary Piping" (NUREG-0313, Revision 1) was issued in October 1979. The report sets forth the NRC staff's revised guidelines for reducing IGSCC susceptibility of BWR piping. The guidelines describe a number of preventive and corrective measures acceptable to the NRC, including guidelines for: (1) corrosion-resistant metals for installation in BWR piping, (2) methods of testing, (3) processing techniques, (4) augmented inservice inspection, and (5) leak detection. The report also included recommendations for developmental work to provide future improvements in limiting the extent of IGSCC or detecting it when it occurs.

All comments were evaluated and several modifications to the report were made to accommodate

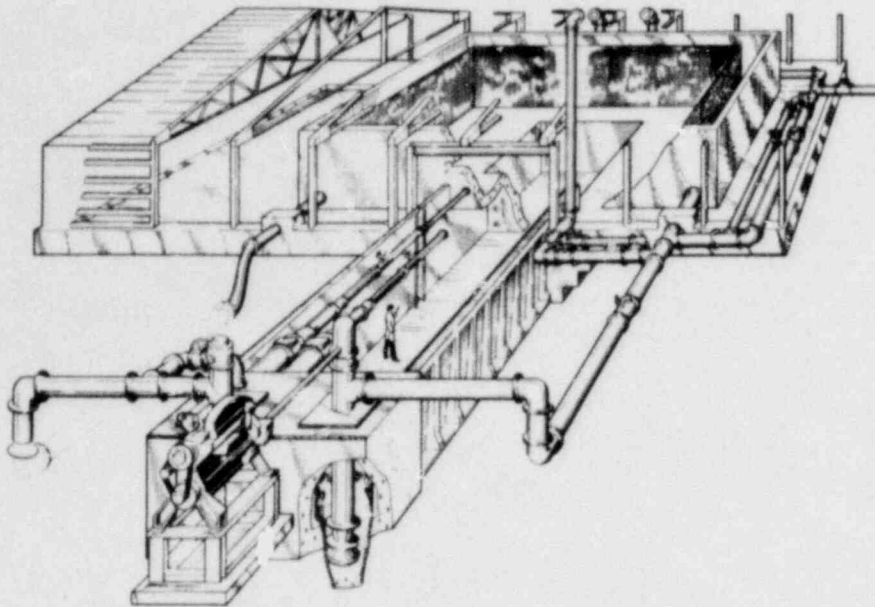

Perspective view of the test facility for containment emergency sumps at the Alden Research Laboratory in Worcester, Mass. Experiments on sump hydraulics are scheduled for 1981 as a part of Generic Task A-43.

those comments of significance to safety. The final NUREG-0313, Revision 1, was published in July 1980 and this constitutes the completion of the generic technical activity A-42. The staff is now in the process of implementing its position established in the NUREG report.

Containment Emergency Sump Reliability

Following a postulated loss-of-coolant accident (LOCA), such as a break in the reactor coolant system piping, the water flowing from the break would be collected in the emergency sump at the low point in the containment. This water would later be recirculated through the reactor system by the emergency core cooling system (ECCS) pumps to maintain adequate core cooling. This water would also be circulated through the containment spray system to remove heat and fission products from the containment. Loss of the ability to draw water from the emergency sump could therefore disable the emergency core cooling and containment spray systems.

Action on this issue has been designated as Task A-43. A Task Action Plan was under development in March 1979 when it was disrupted by the Three Mile Island Unit 2 accident. The Task Action Plan is now being re-evaluated, consistent with NRR's redefined needs. Activities being pursued include: (1) sump hydraulic studies at the Alden Research Laboratory, and (2) assessment of insulation utilized in PWR containments.

A DOE-funded program requested by NRC has been contracted to the Sandia Laboratories. The associated research is being performed by the Alden Research Laboratory to obtain engineering data on

full-scale sump hydraulics behavior to determine: (1) the interrelationships and importance of sump geometric design parameters on sump hydraulic performance, particularly their susceptibility to induced vortices which could entrain air into the recirculation lines and reduce pump performance, and (2) to determine the effectiveness of vortex suppression devices.

The Alden Laboratory has successfully concluded the shakedown testing of the experimental facility. The experiments will be made during the fiscal year 1981 and the data analysis and reporting of results by Sandia are targeted for completion about April 1982.

In addition to the sump hydraulics aspects, a representative plant survey to establish the types of insulation employed within reactor containments is nearing completion. Preliminary findings indicate that the predominant insulation employed is a metallic foil type. These findings, along with a review of typical operating plants will be used to reassess the potential for LOCA-generated debris to block containment sumps. A reassessment is expected by June 1981.

Station Blackout

In keeping with the "defense-in-depth" safety strategy, electrical power essential to the effective performance of certain safety systems at nuclear power plants must be supplied by at least two independent redundant sources called "divisions." For example, the systems used to remove decay heat to cool the reactor core following a reactor shutdown are among the safety systems which must have uninterrupted electric power supply to meet safety

requirements. Each independent division for supplying electricity to safety systems includes an off-site alternating current (a.c.) power connection, an on-site standby emergency a.c. power supply (usually one or more diesel-electric generators), and on-site direct current (d.c.) sources.

The issue of station blackout involves a study of whether or not nuclear power plants should be designed to accommodate a complete loss of all a.c. power (i.e., a loss of off-site sources and all on-site emergency diesel sources). Loss of all a.c. power for an extended time in pressurized water reactors, accompanied by loss of all of the auxiliary feedwater pumps, could result in a failure to adequately cool the reactor core, with potentially serious core melt or core-degradation consequences. Usually one of two redundant pumps is a steam-turbine-driven pump that is not dependent on a.c. power for activation or operation. However, if all of the auxiliary feedwater pumps are dependent on a.c. power to function, then a loss of all a.c. power for an extended period could, of itself, result in a failure to cool the reactor core sufficiently to avert serious consequences. Although this is a low probability event sequence, it could be a significant contributor to the overall risk of core melt accidents. The latter would entail major economic losses and also increase the risks (depending yet on the integrity of the containment structure) to the property and safety of the off-site population as well as occupational workers on-site.

Current NRC safety regulations require as a minimum that diverse power drives be provided for the redundant auxiliary feedwater pumps. As noted above, this is normally accomplished by utilizing one or more a.c. power electric motor driven pumps and one or more redundant steam turbine driven pumps. One concern is the design adequacy of plants licensed prior to adoption of the current requirements.

The task action plan (A-44) for resolving these issues was approved in July 1980, with a scheduled completion date of October 1982. The resolution of the issue will involve extensive use of reliability and risk assessment studies. This includes a detailed analysis of a.c. power supply reliability, an evaluation of potential accident sequence probabilities and consequences, and plant response analysis. In the current program, emphasis is being placed on quantification of reliability of a.c. power supplies and, if necessary, developing requirements to assure a high reliability. A contract has been placed with the Oak Ridge National Laboratory for technical assistance in the a.c. power reliability and accident sequence analysis tasks. Also, preliminary plant response analysis for several station blackout accident scenarios are under way within NRC.

The first effort scheduled for completion in the program involves the reassessment and documenta-

tion of a preliminary survey conducted in 1979. The intent of this survey was to identify any operating plants having an exceptionally high probability of station blackout accidents. This preliminary effort found that there were no currently operating plants of unusually high susceptibility to a severe core damage accident resulting from a station blackout. To take better account of analytical uncertainties, it was decided to refine the survey. The updated assessment is scheduled to be completed in fiscal year 1981.

(The station blackout problem was pivotal in an appeal board hearing on the licensing of the St. Lucie Unit 1 nuclear facility (Fla.), held during the report period. The board imposed conditions designed to improve the ability of utility personnel to deal with loss-of-power situations. See Chapter 15.)

OTHER TECHNICAL ISSUES

Qualification of Safety-Related Equipment

In view of the evolution in equipment qualification requirements and review procedures, questions have arisen as to the quality of installed equipment, especially in older operating facilities. The concern is not necessarily that the equipment is not of good quality, but rather that the quality has not been demonstrated and documented in accordance with current standards.

In November 1977, the Union of Concerned Scientists (UCS) petitioned for an upgrading of the environmental qualification requirements for electrical equipment in operating facilities to current standards. This petition ultimately led to the Commission's Memorandum and Order of May 23, 1980 (CLI-80-21) which provides guidance and directives to resolve this matter.

The staff has developed a plan to implement the Commission's Order and to develop and carry out procedures for the review of the qualification of mechanical as well as electrical equipment. The objective of the plan is to provide a systematic approach to assuring that all safety-related equipment in both operating and new facilities is properly qualified. To facilitate the implementation of this plan, a new Equipment Qualification Branch has been established within the Division of Engineering of NRR.

The Equipment Qualification Program consists of four principal parts:

- Environmental Qualification Reviews and Implementation
- Seismic and Dynamic Qualification Reviews and Implementation
- Equipment Qualification Standards Development

- Review and Implementation of Equipment Qualification Test Programs

Overall coordination of the Equipment Qualification Program will be provided by NRR with the Equipment Qualification Branch acting as the lead branch. The Office of Inspection and Enforcement will participate in the reviews of licensee submittals and vendor test programs, perform inspections of equipment at the various sites and direct the activities associated with the accreditation of testing laboratories and the independent testing of selected equipment. The Office of Standards Development will be responsible for developing a rule and associated regulatory guides addressing NRC requirements regarding equipment qualification. Finally, the Office of Nuclear Regulatory Research will develop and execute research programs to provide technical information for the Equipment Qualification Program.

In addition to coordinating the overall Equipment Qualification Program, NRR will review licensee submittals, develop an equipment qualification data bank, develop standard qualification criteria, and perform the necessary licensing activities associated with the program. NRR will review and monitor the equipment testing programs conducted both by industry and testing laboratories on behalf of the NRC to assure the objectives of the Equipment Qualification Program are being met.

PWR Pipe Cracking

Since 1975, the NRC has completed three studies to investigate and assess the causes and safety significance of cracking found in various Light Water Reactor (LWR) piping systems. (See NRC annual reports for 1975, 1978 and 1979.)

During 1979, several instances of cracking in feedwater piping in pressurized-water reactors together with reported cases of intergranular stress corrosion cracking at Three Mile Island Unit 1, led to the establishment of the PWR Pipe Crack study group. In May 1980, the group completed a report, "Investigation and Evaluation of Cracking Incidents in Piping in Pressurized Water Reactors," NUREG-0691.

The major efforts of the study group focused on three questions: (1) the causes and safety significance of pipe cracks in PWR safety-related systems, (2) the ability of current in-service inspection (ISI) and leak detection techniques to detect these cracks and the effectiveness of current inspection programs, and (3) recommendations for both upgrading the licensing process for plants in the operating license (OL) and construction permit (CP) stages and for implementation of new criteria on operating plants.

The study group identified four distinct classes of degraded PWR piping: (1) small-diameter lines that have broken in service from fatigue loads, (2)

austenitic stainless steel lines in PWR systems that have a service history of leakage caused by intergranular stress corrosion, (3) feedwater lines that have partial/through-wall cracks (in one instance there was a leaking crack) that resulted from inservice thermal fatigue loadings, and (4) lines where service experience indicates a history of both cracking and water hammer or dynamic loading.

To assess the safety significance of these cracking mechanisms, the group performed simplified generic scoping analyses for the affected piping systems and evaluated actions that have been or could be taken to ensure that adequate safety margins are maintained for degraded piping. The group concluded that augmented inspection and pipe replacement or repair when defects are found are effective measures to ensure adequate safety margins for feedwater lines with thermal fatigue cracks and for stainless steel secondary system lines with stress corrosion cracking. These actions currently are being implemented by the staff. The study group also identified one instance where a large dynamic loading may produce potentially unacceptable accident consequences. Although the group believes that large dynamic loads are rare events and that failure from dynamic loading is unlikely, the potential for excessive dynamic loading should be investigated further as part of NRC Generic Task Action Plan A-1, "Water Hammer." Finally, the results of simplified generic scoping analyses performed by the group indicate that small-line breaks observed in two systems may degrade the function of the systems below that assumed in the FSAR for certain postulated accident conditions. The group believes that further plant-specific scoping and more detailed analyses should be conducted to better define the safety implications of small-lines breaks. Should these analyses indicate unacceptable degradation of system function, remedial measures should be taken to preclude small-line breaks in affected systems.

The study group also identified areas where inservice inspection for thermal fatigue cracking and intergranular stress corrosion cracking could be improved generally. The group further concluded that leak detection practices are generally adequate; however, it was suggested that more sensitive leak detection methods might be desirable outside containment for accident and some transients conditions.

Specific recommendations for implementation of the study group's findings for operating plants and plants under construction are included in the study group report.

Turbine Disc Cracking

Late in 1979, representatives of the Westinghouse Electric Corporation met with Westinghouse turbine

PWR FEEDWATER LINE CRACKING
ILLUSTRATION OF HOW THERMAL STRESSES ARE GENERATED

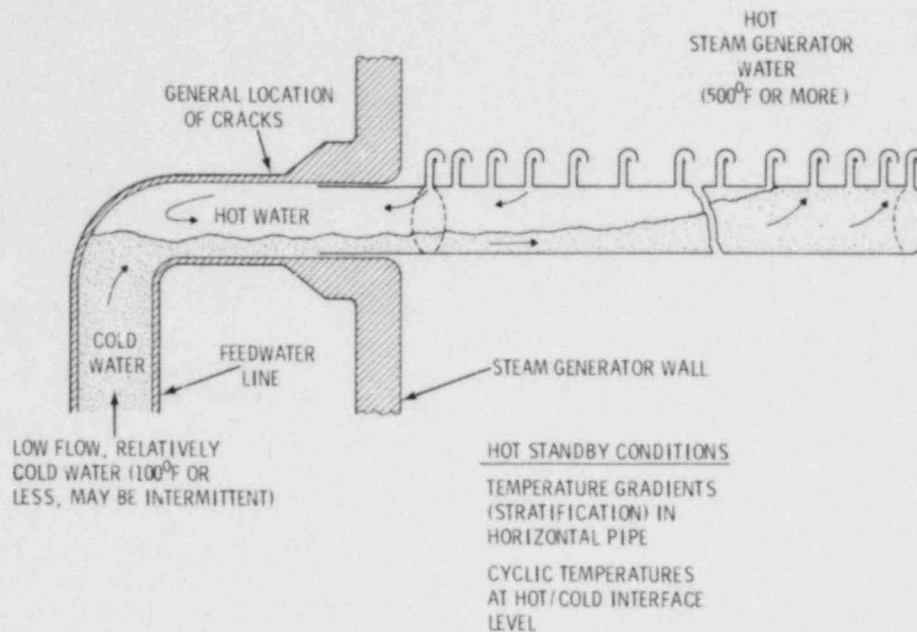

owners to discuss several problems, especially the recently discovered cracking of "shrunk-on" turbine discs. Westinghouse urged owners of 19 plants to inspect their turbines by spring of 1980, and the utilities agreed to do so.

Westinghouse met with the NRC staff at Bethesda, Md., on December 17, 1979, to convey the information it had and discuss inspection results. Westinghouse also offered the staff criteria for permitting continued operation of turbines with known or postulated cracks. These criteria, having been modified by the staff, were felt to constitute a conservative basis for operation under existing inspection schedules. All turbines considered to require inspection in the near term were inspected by the end of the report period. The staff will continue to evaluate inspection results, repairs, and the calculational procedures used by these licensees to justify continued operation of turbines.

During the course of this investigation, a turbine disc failure occurred at Yankee Nuclear Power Station (Mass.). The preliminary analysis indicates that the cause was stress corrosion cracking. The crack depths actually found were in agreement with the staff's "worst-case" predication model and very close to the calculated critical flaw depth.

The staff also met several times with General Electric Company's Turbine Division personnel regarding the possibility that their turbines may also be subject to cracking. Detailed technical information has been

provided to the staff, and we are currently evaluating this information. Approximately eight General Electric turbines have already been inspected, and although some minor "water cutting" has been noticed, no cracks have been found to date.

At the present time, it is not known what the exact conditions are that cause turbine disc cracking. It is known that caustic soda and some acids will cause cracking of turbine disc steels, but laboratory and field tests also have shown that, under the right conditions, cracks can be initiated and propagated by pure steam or high-temperature water. It is also known from laboratory tests that, under some conditions, a significant period of incubation is needed to initiate a crack, whereas under other conditions, cracks will start to grow as soon as service conditions are applied. These realities make it impossible to predict crack growth rates and sizes in operating equipment. Instead, an attempt is made to predict what the worst case is likely to be.

Extensive studies by the British who experienced wide-spread turbine disc cracking in the early 1970's found that disc material and heat treatment, keyway and bore designs, temperature of operation, and, to some degree, steam chemistry were major factors. NRC staff, having plotted the depths of cracks found to date and total operating hours to discovery of a crack, found cracking to be a function of operating temperature and material yield strength. The rate of growth of cracks increases with the temperature. It

also increases with the yield strength, probably because steel of higher yield strength is more susceptible to cracking and is selected to accommodate higher design stresses.

The staff is in the process of defining inspection requirements which involve procedures for predicting maximum postulated crack sizes and methods for calculating the size of cracks that could cause disc failure. These calculations must be performed for each turbine, and for each individual disc considered subject to cracking, since each disc has a unique combination of material and operating parameters.

Fire Protection

Following the fire at the Brown's Ferry Plant in March 1975, the NRC initiated a review of the fire protection programs for all operating plants and for plants not yet operational. Improved guidelines have been developed and the minimum requirements for specific aspects of fire protection for operating plants were added as Appendix R to 10 CFR Part 50.

The fire protection program reviews have been completed for the 70 licensed power plants, and most modifications to improve plant capabilities have been made. The remainder of the modifications are to be completed by late 1982, except for modifications to provide dedicated shutdown systems. Replication tests which demonstrate the performance of fire protection features which have been approved by the NRC as meeting NRC regulations are also being performed. In addition, an audit program to review the

fire protection at operating plants at three year intervals is being developed.

On November 4, 1977, the Union of Concerned Scientists (UCS) filed a Petition for Emergency and Remedial Action. Part of this petition dealt with fire protection concerns at plants under construction and at operating plants. The Commission issued an order on April 13, 1978 denying the UCS petition on the basis that plants under construction or in operation are in compliance with General Design Criterion 3—Fire Protection. On May 2, 1978, the UCS submitted a petition requesting Commission reconsideration. The Commission issued an order on May 23, 1980, again denying the UCS petition on the basis that the NRC's fire protection program provides reasonable assurance that the public health and safety is being adequately protected during the time necessary for corrective action.

Decontamination of Dresden Facility

Commonwealth Edison Company (CECo) has proposed to decontaminate the primary cooling system of the Dresden Nuclear Power Station Unit 1 (D1). This represents the first major effort in the U.S. to decontaminate the entire primary coolant system of a reactor for the purpose of reducing occupational exposures during subsequent operation. CECo has completed construction of all of the support facilities needed to carry out the decontamination and has submitted information required by the NRC staff concerning testing programs, preservice inspection of

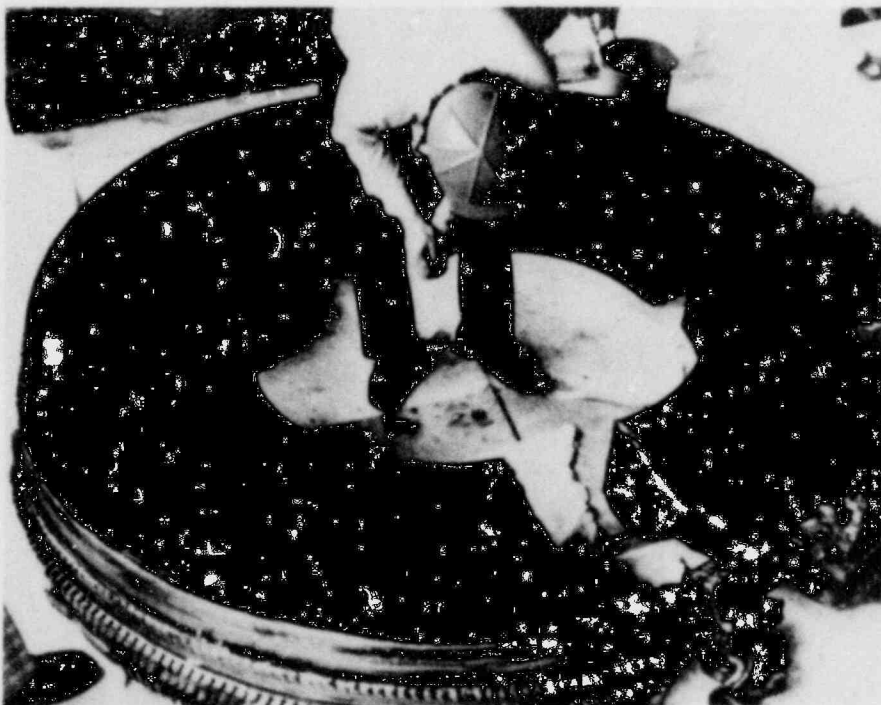

A turbine disc that failed at the Yankee Nuclear Power Station, Rowe, Mass., in January 1980. Preliminary analysis indicated the cause was stress corrosion cracking.

primary coolant boundary, and post-cleaning surveillance programs. A draft Environmental Impact Statement was issued by the NRC in May 1980 for public comment, and the final Statement was published in October 1980.

Solvent wastes generated during the decontamination project will be solidified in 55-gallon drums. The solidification system combines the radioactive liquid waste with a solution of vinyl ester resin binder, catalyst, and promoter to produce a product for packaging and eventual off-site shipment to a licensed disposal facility. Because of concern about the impact of chelating agents in the waste on other waste in the burial ground, the NRC has required that the waste be buried at an arid disposal site, i.e., the Beatty, Nev., or Hanford, Wash., commercial waste disposal sites.

Control Rod Failure at Browns Ferry

The failure of 76 control rods to insert fully into position during a routine manual "scram" at Browns Ferry Unit 3 constituted a major off-normal occurrence in fiscal year 1980 and raised an important technical issue. This incident is discussed in detail in Chapter 5, under "Abnormal Occurrences" and also under "AEOD Technical Studies."

Improving the Licensing Process

REORGANIZATION OF NRR

A major reorganization of the NRC Office of Nuclear Reactor Regulation (NRR) was undertaken in April 1980. This reorganization was intended to facilitate management of the expected workload over the next few years, to provide for the most effective implementation of changes and improvements recommended by the various Three Mile Island accident investigators, and, in general, to use NRR resources in the most effective and efficient way.

The new organization is set forth in the diagram below. Some of its major features are as follows:

- (1) The new Division of Human Factors Safety is devoted totally to the people-oriented aspects of safety, the benefits and hazards of the human element in nuclear operations.
- (2) All project managers are consolidated into a single Division of Licensing, in a move which expands and reinforces their authority

and responsibility. The basic technical disciplines have also been drawn together into two sectors—the Division of Engineering and the Division of Systems Integration. This eliminates the previous segregation of expertise between the plants in operation and those under licensing review. More effective interchange and application of requirements and experience between these two areas are expected to result.

- (3) The Division of Safety Technology is dedicated to the timely development of solutions to generic safety issues and also to certain managerial and procedural improvements evolving from the TMI accident.
- (4) The organization as a whole is geared to provide an interdisciplinary systems approach to licensing reviews, operating problems and generic issues.
- (5) An interdisciplinary team approach is employed in managing selected projects and programs.
- (6) Better uniformity and continuity of policies and personnel between pre- and post-licensing phases is realized, since there is no need to transfer a plant from one division to another when the plant becomes operational.

The 1980 reorganization of NRR also included establishment of a Research and Standards Coordination Branch to coordinate NRR programs with those of the Office of Nuclear Regulatory Research and the Office of Standards Development. A major area requiring extensive coordination and one which will have a large impact on licensing regulations and procedures is the rulemaking proceedings dealing with reactor siting, emergency planning, degraded core cooling, engineered safety features, and alternative sites.

Also a part of the reorganization of the Office of Nuclear Reactor Regulation (NRR) was the forma-

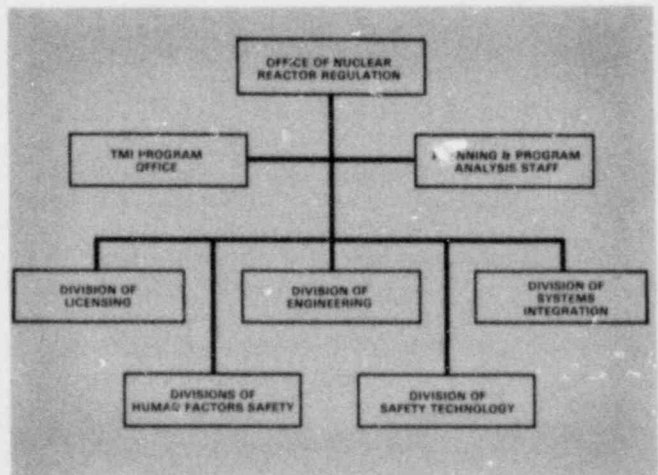

tion of the Reliability and Risk Assessment Branch to coordinate licensing activities in NRR involved with application of probabilistic risk assessment techniques. The use of these was given new impetus in the aftermath of the TMI-2 accident as a means for identifying significant contributors to risk that could be overlooked in applying the design basis currently in use in the licensing of nuclear power plants.

Recognizing the importance of reactor plant experience to the licensing process, the NRR has also created an Operating Experience Evaluation Branch (OEEB), which is dedicated to the systematic review and evaluation of reactor operations. When incidents are identified as having possible safety implications, the OEEB will recommend appropriate additional staff review and evaluation or may perform its own independent review. The OEEB maintains active contact with the Office for Analysis and Evaluation of Operational Data, project managers and other NRC staff elements.

Human Factors

One of the findings common to the various reports on the accident at Three Mile Island Unit 2 was the inadequacy of consideration of human factors in the design, operation and regulation of nuclear power plants. When the Office of Nuclear Reactor Regulation was reorganized in April 1980, a new Division of Human Factors Safety was established to provide a focal point for increased emphasis on the people-oriented aspects of safety. This new Division deals with safety-related aspects of the man-machine interface, plant procedures and tests, qualifications and licensing of persons in certain functions, and the organization and management of the plant and the corporate staff as a whole. Most of the Division's early effort went into the review of plants which were to be ready for an operating license in the near future.

Control Room Design Reviews. The TMI Action Plan states that all licensees and applicants for operating licenses will be required to conduct a detailed control room design review in order to identify and correct design deficiencies. This detailed review is expected to take about a year. Applicants for operating licenses who are unable to complete this review prior to issuance of a license are required to make preliminary assessments of their control rooms to identify significant human factors and instrumentation problems and establish a schedule for correcting deficiencies. These applicants will also be required to complete the more detailed control room reviews on the same schedule as other licensees with operating plants.

To audit the preliminary assessments, NRC has formed teams of engineers and human factors spe-

cialists to conduct on-site reviews of human factors in control room design for plants which are in late stages of construction and are candidates for a near term operating license. The human factors design review consists of an evaluation of the layout of the control room; the arrangement and layout of important and essential controls, displays and instrumentation; the adequacy of the alarm system (audio and visual); the effects of lighting and noise on the operators responses; the effectiveness of the communication systems; and other topics of human factors that may have an adverse effect on the control room operators.

Following each site visit, a safety evaluation report is prepared to point out human engineering deficiencies which might lead to an operator error. The most serious deficiencies must be rectified by the licensee prior to issuance of a full-power operating license.

By the end of fiscal year 1980, site visits had been conducted at the following plants: Sequoyah 1 (Tenn.); North Anna 2 (Va.); Salem 2 (N.J.); Diablo Canyon 1 (Cal.); McGuire 1 (N.C.); Farley 2 (Ala.); San Onofre 2 (Cal.); Summer (S.C.); and LaSalle 1 (Ill.).

In August 1980, NUREG-CR 1580, a draft report entitled "Human Engineering Guide to Control Room Evaluations," was issued for public comment. This draft was prepared under contract by the Essex Corporation to provide guidance for detailed control room reviews. It is anticipated that comments and internal NRC recommendations can be resolved so that the final guidelines can be issued early in 1981. Each applicant for an operating license and each operating plant licensee will be required to use these guidelines as the basis for a detailed control room review.

Review of Emergency Procedures. The objective of the procedures review as defined in the NRC TMI Action Plan (NUREG-0660) is to improve the quality of procedures so as to provide greater assurance that the operators' actions are technically correct and that procedures are explicit and easily understood under normal, transient and accident conditions.

The NRC Bulletins and Orders Task Force for TMI required technical changes to be made to specific operating plants and emergency procedures at all operating plants. The primary purpose of these changes was to improve procedures related to prevention and mitigation of accidents. Since the completion of this effort NRC has taken action to assure immediate improvement of selected emergency operating procedures for near-term operating license applicants. Specific actions taken include (1) in-depth reviews of selected emergency procedures (Steam Generator Tube Rupture, Inadequate Core Cooling, Small-Break LOCA, Loss of Feedwater); (2) meeting with vendors to discuss analyses and

NRC teams of engineers and human factors specialists conduct on-site reviews of control room design at plants in late stages of construction or nearing the operating license stage. Here, NRC personnel inspect control room panel at Farley Nuclear Plant Unit 2 near Dothan, Ala.

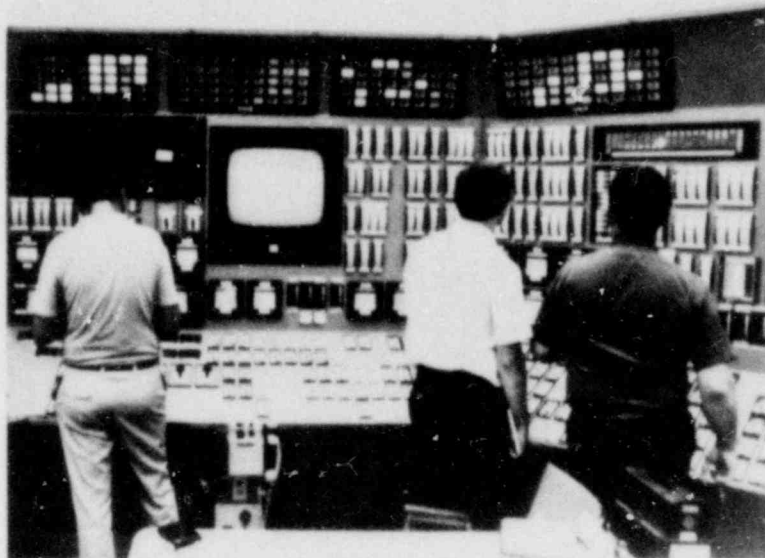

guidelines; (3) meeting with the applicant to discuss procedure evaluation; (4) observation of a simulator walk-through of selected procedures with shift crews; (5) observation of a plant walk-through for one of the selected procedures; and (6) evaluations of the adequacy of all the emergency procedures for mitigating transients and accidents based on the review of the selected procedures. Review of the North Anna, Farley, Sequoyah and Salem plants has been completed and the reviews of McGuire, Diablo Canyon, and Summer plants are in progress. Pacific Northwest Laboratory is providing technical assistance in reviewing procedures of plants being evaluated for operating licenses.

The Babcock & Wilcox Company and General Electric Owners Group have committed to the development of "symptom-oriented" procedures and have submitted draft guidelines. This approach permits the plant operators to respond to symptoms whether or not the nature of the initiating event has been identified and is thus an improvement over the current event-oriented procedures which require the operators to diagnose the event prior to taking action. The symptom-based guidelines developed by the General Electric Owners Group have been reviewed and approved for trial implementation at the LaSalle Nuclear Station to be operated by the Commonwealth Edison Company in Illinois. Combustion Engineering and Westinghouse will be submitting upgraded guidelines based on analyses that go beyond the current regulatory requirements for transient and accident mitigation, in early 1981.

Based on the experience gained in the review of emergency procedures for plants currently being licensed, the staff, with the assistance of technical

consultants, will develop criteria for the preparation of improved procedures. The criteria will include consideration of the human factors aspects of plant procedures as well as technical adequacy. These criteria, scheduled for completion in 1981, will be used in connection with a long range program for upgrading safety related procedures at all plants.

Initial Test Programs. The TMI Action Plan requires applicants for operating licenses to perform a set of low-power tests to appraise and increase the capabilities of shift crews to operate facilities in a safe and competent manner and to assure training in responding to plant changes and off-normal events. Operators of facilities nearing operating license decision are required to develop and implement intensified training exercises during the low-power testing programs. As of the end of the report period, the test programs were completed at North Anna 2, Sequoyah, and Salem 2. Five more plants, one BWR and four PWRs, were expected to perform the low-power tests before the end of 1980.

Technical Competence of Utility Licensees. During 1980, in accordance with the TMI Action Plan, the NRR staff developed guidelines to be used on an interim basis for evaluating the management qualifications, structure and technical resources of utilities operating or having applied for license to operate nuclear power plants. An early version of the draft guidelines was completed in February 1980 and was used by NRC's reviewing teams in their evaluation of the management and technical support resources of utilities with application nearing an operating license decision. Comments aimed at improving the draft document were received from various parties.

Based on these comments and on its own experience, NRR modified the guidelines and published them for public and industry comment and for interim use (NUREG-0731, "Guidelines for Utility Management Structure and Technical Resources").

An early effort by Basic Energy Technology Associates, Inc., resulted in a report entitled "Power Plant Staffing" (NUREG/CR-1280), prepared for NRC under contract, which was issued for public comment in April 1980. Another contractor produced a report entitled "Utility Management and Technical Resources" (NUREG/CR-1656), setting forth some guidelines related to utility management and technical resources, and this was issued for comment.

The Action Plan calls for Commission-approved guidelines to be issued as requirements to all licensees of operating plants and applicants for operating licenses in the early part of 1981. Licensees of operating plants are to review their organizational structures and their technical resources in light of these requirements, make revisions as necessary, and submit to the NRC, by mid-1981, descriptions of their training and staffing activities. Applicants for operating licenses will be reviewed for conformance to the Commission-approved requirements as part of the normal review process.

Interim Criteria for Shift Staffing. Pending completion of the long-term development of criteria for shift staffing and administrative controls, in accordance with the TMI Action Plan, the NRC staff developed interim criteria setting forth shift staffing requirements for operating plants. These were issued in a letter, dated July 31, 1980, to all licensees of operating plants, applicants for operating licenses and holders of construction permits. The major change conveyed by this letter was a requirement that an additional senior reactor operator be assigned on each shift, other than during cold shutdown conditions. The letter also set forth the policy that overtime is not to be routinely used to compensate for an inadequate number of licensed personnel, and that, in any case, overtime was not to exceed the limits established in the letter.

Shift Technical Advisor. In accordance with the TMI Action Plan, NRC has required, since January 1980, that for the short-term a shift technical advisor who has some engineering expertise and training in plant dynamic response be on duty on each shift of an operating plant to serve as advisor to the shift supervisor. By January 1, 1981, licensees of all operating plants were required to have advisors who had completed the engineering course work and training requirements prescribed by NRC. This requirement for maintaining a technical advisor on duty on all shifts, in addition to the licensed operators, was imposed because it was considered a neces-

sary method for improving a plant operating staff's capabilities for diagnosing and responding to off-normal conditions.

Operator Licensing. The following revised criteria were established during fiscal year 1980 regarding qualifications of reactor operators:

- The experience requirement associated with qualification for a senior operator's examination was changed from four years of power plant experience of which one must be nuclear to four years of which two must be nuclear. Responsible experience is defined as that experience gained as a control room operator or plant staff engineer.
- Instructors must take a senior operator examination and must be enrolled in requalification programs.
- Facility certifications regarding an applicant's qualifications, previously signed by plant management, must be signed by highest level of corporate management.
- NRC examinations will include these new topics: "Principles of Heat Transfer and Fluid Mechanics" (operator exam) and "Theory of Fluids and Thermodynamics" (senior operator exam); time limits will be imposed: nine hours for the operator exam and seven hours for the senior operator exam; the minimum passing grade will be raised from 70 percent to 80 percent overall and 70 percent in each category of the test. Waivers of the oral portion of the senior operator examination for individuals who hold operator licenses will not be granted routinely, as they were in the past. All examination results will be released to facility management rather than only the results of those who had failed the examination, as was done previously.
- In requalification programs, the content will be expanded to include the new test topics; the minimum passing grade will be raised from 70 percent to 80 percent overall and 70 percent in each category; the programs will be expanded to include mandatory control manipulations during both normal and abnormal operating conditions.

Rule changes have been proposed that will include the following long range criteria and/or requirements:

- (1) Additional formal education requirements for senior operators and shift supervisors.
- (2) More NRC involvement in the requalification programs, including the administration of examinations.
- (3) More extensive use of simulators in initial training programs and requalification programs.

An ad hoc committee consisting of three professors of nuclear engineering and a senior nuclear engineer from the Oak Ridge National Laboratory, all part-time examiners in the Operator Licensing Branch of NRR, was appointed to develop procedures and criteria for accreditation of training instructors. In addition, the entire operator licensing program, including selection procedures, training programs, licensing procedures, and qualifications and training of examiners was to be evaluated by an independent contractor in a study scheduled for completion on November 30, 1980. The recommendations of these two studies will be weighed in the rulemaking proceedings.

Finally, the operator licensing program is being expanded. Plans are being made to establish licensing offices at Chicago, Oak Ridge National Laboratory in Tennessee, and the Energy Technology Engineering Center in Canoga Park, Cal.

During fiscal year 1980, the NRC issued 297 new operator licenses, 233 renewals, and 21 amendments, bringing the number of operator licenses in effect on September 30, 1980, to 1,158. During the same period, 245 new licenses, 589 renewals and 51 amendments were issued for senior operators, bringing the total to 1,488 in effect.

Systems Interaction Branch

One of the objectives of the TMI Action Plan is to improve consideration of the effects of systems interaction on nuclear power plant safety. A Systems Interaction Branch was established as part of the reorganization of the NRC Office of Nuclear Reactor Regulation in April 1980. Its chief functions are to

develop the methods that can identify and evaluate significant systems interactions in light water reactor plants. This methodology will provide the basis for regulatory guidance to be used by the staff and industry in forthcoming evaluations of selected light water reactor plants.

A major activity of the branch has been the evaluation of Pacific Gas and Electric Company's (PG&E's) systems interaction program for seismically-induced events for their Diablo Canyon Nuclear Plant. The Diablo Canyon program was developed as a result of discussions with a subcommittee of the Advisory Committee on Reactor Safeguards in November 1979. The objective of PG&E's program was to establish confidence that, if and when subjected to severe seismic events from the Hosgri fault, the structures, systems, and components important to safety shall not be prevented from performing their intended safety functions because of interactions with non-safety-related structures, systems, or components which have failed under the seismic shock. In addition, safety-related structures, systems, and components must not lose the redundancy required to compensate for single failures as a result of such interaction, and this capability was also tested.

PG&E used the "walkdown method" to postulate systems interactions for Diablo Canyon. Safety-related structures, systems and components were defined as "targets," and non-safety-related structures, systems and components were defined as "sources." Interactions between sources and targets were postulated by an interdisciplinary team of engineers during systematic, inplant walkdowns of target equipment using previously-established criteria. PG&E's program has resulted in the postula-

The first NRC examiners' conference to be held since the Three Mile Island accident was convened in late 1980 at Bethesda, Md., headquarters to implement a revamped program for the training, examining and licensing of power reactor operators.



tion of a substantial number of interactions. Approximately one-third of the total number of interactions postulated were ultimately resolved by plant modifications. The staff and the Advisory Committee on Reactor Safeguards have concluded from their reviews that PG&E's program is acceptable. The Diablo Canyon systems interaction studies must be completed prior to full-power operation.

Contracts have been made with Lawrence Livermore Laboratory, Brookhaven National Laboratory, and Battelle Memorial Institute to provide technical assistance in the definition of systematic methods suitable for analyzing systems interactions in nuclear power plants and subsequent establishment of regulatory guidance for use by the staff and industry. A state-of-the-art evaluation of systematic methods for near-term use is targeted for completion in December 1980. Issuances of interim and final regulatory guidance are expected in September 1981 and September 1982, respectively. The interim guidance is expected to recommend that systems interactions in nuclear power plants be evaluated using a combination of methods including (1) lessons learned from nuclear power plant operating experience; (2) walk-downs similar to those used by PG&E at Diablo Canyon; and (3) analytical techniques such as failure modes and effects analysis, event-tree analysis, fault-tree analysis, and dependency diagrams.

(While the Systems Interaction Branch is not responsible for the resolution of the systems interaction concern cited earlier under "Unresolved Safety Issues," its members participate in the work undertaken to that end.)

PREPARATION AND IMPLEMENTATION OF THE TMI ACTION PLAN

Since the accident at Three Mile Island on March 28, 1978, there has been an abundance of studies and investigations of the causes underlying the accident and recommendations for corrective actions. Primary among them are investigations by committees of both houses of the Congress, the President's Commission on the Accident at Three Mile Island, the NRC Special Inquiry Group, the NRC Advisory Committee on Reactor Safeguards, the TMI Lessons-Learned Task Force and the Bulletins and Orders Task Force of the NRC Office of Nuclear Reactor Regulation, and the Special Review Group of the NRC Office of Inspection and Enforcement. Others who have undertaken serious studies of the accident include a number of State groups, individual utilities, and new industry organizations, such as the Atomic Industrial Forum Policy Committee on

Follow-up to the Three Mile Island Accident; the Nuclear Safety Analysis Center, operated for the electric utility industry by the Electric Power Research Institute; and the Institute for Nuclear Power Operations.

In late 1979, the NRC initiated the development of a TMI Action Plan to organize its regulatory and licensing functions on a timely basis, consistent with the urgent need for setting priorities and moving quickly to improve safety measures. The obvious starting point in developing the Action Plan was consideration of the recommendations from the primary investigative studies cited above. In the aggregate, the recommendations from these studies numbered over a thousand. Although the various groups, for the most part, reached similar conclusions, they organized and stated their recommendations in accordance with their particular perspectives. The plan, as developed, contains approximately 175 discrete actions organized into the following five chapters, each covering a broad subject area: Operational Safety; Siting and Design; Emergency Preparedness and Radiation Effects; Regulatory Practices and Procedures; and NRC Policy, Organization and Management. (See Appendix 7 for a listing of the tasks subsumed under the five chapters, indicating the progress realized thus far on each and the scheduled date of completion.)

The Action Plan serves to consolidate and define the many general recommendations from the official investigations into a set of discrete, scheduled tasks that specify changes (or studies of possible future changes) in regulatory requirements and the organization and procedures of NRC. The actions in the plan have been assigned the appropriate priority and schedule for implementation. The various NRC offices have estimated the resource requirements and schedules for NRC and the industry to accomplish each of the actions. All of this information is provided in the final version of the report issued in May 1980: "NRC Action Plan Developed as a Result of the TMI-2 Accident" (NUREG-0660, Vols. 1 and 2). NUREG-0737, "Clarification of TMI Action Plan Requirements," which was issued to licensees on October 31, 1980, specified the implementation schedules, applicability, method of implementation review, submittal dates and clarification of technical positions. NUREG-0737 represents a subset of NUREG-0660 for only those items which have been approved by the Commission to date.

The Action Plan is a roadmap for both short and longer range actions. It catalogues, as well, the many decisions and actions already taken by the NRC in the year since the accident. For example, the NRC took a number of immediate steps to improve the safety of operating nuclear power plants in the first few days and weeks after the accident which were judged to be necessary and could not be delayed

until the comprehensive plan was developed. These steps were described in a series of Bulletins and Orders to the licensees of operating plants that provided up-to-the-minute interpretations of the sequence of events leading up to the TMI accident and required specific changes at all operating plants to guard against repetitions of such events. A few months later, approximately 30 short-term requirements were issued by the NRC on the basis of lessons learned from the accident. These were implemented in two stages, between January 1, 1980 and January 1, 1981, by all operating plant licensees. All of the immediate and short-term actions were documented in the Action Plan so that they could be coordinated and accounted for during the development of the longer term requirements that are also reflected in the plan. (See *1979 NRC Annual Report*, pp. 22-34.)

In developing the Action Plan, the various recommendations and possible actions of the principal investigations were assessed and either adopted, rejected or modified. While decisions as to whether to include specific items in the plan were based primarily on their congruence with recommendations of the principal investigations, decisions on the priority and resources to be afforded the various actions in the plan were based primarily on their relative risk-reduction potential. The Action Plan presents a sequence of actions that will bring about a gradual, orderly and controlled improvement in safety as each action is completed and the initial immediate actions are replaced or supplemented by longer term, more stable improvements.

Operational Safety. The actions in the plan directed toward the goal of increasing operational safety have two supporting objectives. The first is to improve the operation of the plant so that the number of events that could lead to accidents is reduced. The second is to improve the ability of the operating staff to recognize such events and take appropriate corrective actions. The first objective, preventing the causes of accidents, is addressed through improvements in the selection and training of not only the reactor operators, but all reactor plant personnel, and through improvements in utility management techniques and capabilities. Specific improvements are required in the content and level of training courses, in the use of plant simulators, in operating procedures, and in the design of the controls and instrument displays in the control room. These improvements reduce the incidence of accident situations and also increase the ability of the operating staff to arrest an accident before any serious consequences result. Improvements in the evaluation of operating experience and the auditing of day-to-day plant operations are also to be instituted to help the plant technical support staff and management in preventing accidents.

Siting and Design. Although there was general agreement that reactor operations merited primary emphasis, the upgrading of current plant designs was also identified in studies of the accident as a safety increment not to be overlooked. The TMI-2 accident re-emphasized the importance of high system reliability—even though there were no significant equipment failures other than that of the relief valve on the pressurizer. Therefore, the Action Plan contains requirements for the assessment of the reliability of some of the engineered safety features (e.g., auxiliary feedwater, emergency core cooling, containment isolation, and decay-heat removal, including natural circulation) and an overall assessment of accident probabilities and consequences using simplified reliability analyses for all plants. These analyses are directed toward identifying and correcting specific weaknesses in current designs.

The Action Plan also calls for study of the desirability of additional requirements and safety systems to reduce the risk from accidents in which there is significant melting or "degradation" of the core, such as occurred during the accident at TMI. For example, the plan includes continuation of the NRC work of changing its siting requirements to re-establish distance between population centers and reactors as a safety feature in itself. The plan also contains interim improvements and rulemaking on the capability of nuclear power plants to mitigate the consequences of accidents in which the core is severely damaged and a long-term study of the possibilities for mitigating accidents. The interim improvements include reducing the possible leakage of highly radioactive material, improving shielding to permit access to important areas, providing better means of sampling the reactor coolant and containment atmosphere, adding or increasing the range of instruments so that accident conditions can be monitored, and providing the operating staff with training in the capability and use of the currently installed systems.

Of major concern during the accident at TMI was the quantity of hydrogen released, which was much greater than the amount that is required to be considered under the current NRC rules. The plan includes an interim rulemaking action to consider the need for interim hydrogen control features for small containment structures, where the potential for ignition of hydrogen is the greatest, and other interim consequence mitigation features for accidents involving core damage.

Emergency Planning. In addition to the weaknesses in operational safety and system design, the investigators of the TMI accident generally agreed that the state of planning and preparedness for emergencies at nuclear power plants was inadequate. This condition was apparently the result of several factors: the low priority assigned to emer-

gency planning by NRC and its licensees; a poor definition of the NRC role in emergencies; and insufficient coordination between licensees, NRC, and the other Federal, State and local agencies involved. A major improvement accomplished soon after the accident was the centralization of emergency planning and response in a single federal agency—the Federal Emergency Management Agency (FEMA). Immediate actions in the Action Plan include better facilities for on-site personnel handling emergencies, improvements in the organization of personnel for handling emergencies, the improvement of emergency plans for off-site action by the utility and by State and local governments, and improvement in the emergency response capability of the NRC. The accident at TMI-2 also increased awareness of the importance of informing the public during and before emergencies, and actions are provided for in the plan to increase understanding among the news media and public of how nuclear plants operate, what radiation is and what effect it has on health, and what protective actions will be provided during emergencies.

The investigations of the accident have also shown the need for better protection of the public from radiation, by means of improved monitoring of radioactive effluents from plants, better radioanalytical measurements and more rapid estimation of off-site doses, and control of the release of radioactivity into the hydrosphere. A consistent and mutually supportive set of actions to address these areas is included in the Action Plan. The investigations have also shown the need to improve radiation protection of workers, particularly under accident conditions. Thus, the plan calls for improvements in radiation-protection plans, health-physics operations, in-plant radiation monitoring, and the habitability of control rooms; all of them are intended to keep the exposures of workers during both normal operations and accidents as low as reasonably achievable.

(See Chapter 3 for detailed discussion of emergency preparedness and NRC-FEMA relationships.)

Upgrading NRC Procedures, Programs and Policies. In addition to the areas discussed above, which primarily address requirements for licensees, the self-examination by NRC that followed the accident identified necessary improvements in the regulation of nuclear power plants. One area of improvement is the formulation, issuance, and enforcement of NRC requirements. Better rulemaking procedures, periodic re-evaluation of rules, and more efficient means of issuing requirements are under development. Authority for increased civil penalties has been obtained, and currently available sanctions are to be more effectively applied. Training of inspectors is also being improved.

Another area of improvement is in the early identification, assessment, and resolution of safety issues.

Research on the quantification of safety goals, a program to resolve generic issues, and a better means of resolving issues relating to plants under construction are closely associated actions included in the Action Plan. Studies are also included to determine what actions, if any, should be taken regarding the possible effects on safety of economic factors such as Internal Revenue Service and Public Utility Commission rules, the ongoing systematic assessment of the safety of operating reactors, and the extension of the lessons learned from TMI to other areas regulated by NRC. The plan also contains actions to be taken by the Commission to revise present policies, procedures, and organization to more effectively accomplish the mission of the agency. Among these actions are the articulation of a safety goal or safety policy objective, evaluation of the licensing process to reduce delays while assuring time for reasonable review and appeal, facilitation of public participation, and examination of the Commission's role in safety regulation. The need for legislation to modify the Commission's authority and procedures during emergency situations will be studied. Also included are studies of the role, functions and organizations of the Commission and the offices so as to increase the application of human factors principles and integrated systems engineering, increase the effectiveness of inspection and enforcement, increase the effectiveness of advisory committees, such as the ACRS, increase staff technical capabilities, and more effectively identify and assess safety issues.

OTHER LICENSING CONCERNS

Consideration of Serious Accidents At Nuclear Power Plants

On June 13, 1980, the Nuclear Regulatory Commission published a Statement of Interim Policy on "Nuclear Power Plant Accident Considerations Under the National Environmental Policy Act of 1969." This represented a revision of previous policy concerning requirements of the Act, especially with respect to the consequences of the more severe kinds of accidents of very low probability that are physically possible. Such accidents had been commonly referred to as "Class 9" accidents (following a classification scheme proposed by the former Atomic Energy Commission in 1979).

In its statement, the NRC adopted the position that future Environmental Impact Statements—issued in connection with major licensing decisions for nuclear power plants—shall include considerations of the site-specific environmental impacts attributable to accidents resulting in releases of

radioactive materials, including those which can result in inadequate cooling of reactor fuel and melting of the reactor core. Attention is to be given both the probabilities and the range of possible consequences of such accidents.

Reliability Evaluation Programs

There is abundant evidence from recent experience that quantitative reliability or risk assessment is a valuable tool for the regulation of nuclear reactors. Analysis of this type can provide great insight into the relative safety significance of reactor plant systems and design features and is valuable in assessing the merits of prospective changes in such systems and features. An Interim Reliability Evaluation Program (IREP) has been established by the NRC for a pilot study of a single plant (Crystal River Unit 3) followed by a scaled-up study of four plants. Included are analyses of single and multiple failures, unavailability due to testing and maintenance, and operator errors. Initiating events will include a wide range of transients and loss-of-coolant accidents. When a standardized evaluation methodology is available, it will be applied to all nuclear power plants in a National Reliability Evaluation Program (NREP), to be initiated in fiscal year 1982 and to require several years to complete.

Quality Assurance

The application of disciplined engineering practices and thorough management and programmatic controls to the design, fabrication, construction, and operation of nuclear power plants is essential to the protection of public health and safety and of the environment. Quality Assurance (QA) provides this necessary discipline and control. Through a QA program that meets NRC requirements, all organizations performing work that is ultimately related to the safety of plant operation are required to conduct that work in a preplanned and documented manner; to independently verify the adequacy of completed work; to provide records that will confirm the acceptability of work and manufactured items; and to assure that all individuals involved with the work are properly trained and qualified to carry out their responsibilities.

Each NRC licensee is held responsible for assuring that its nuclear power plants are built and operated safely in conformance with the NRC regulations. In addition, the NRC has several specific QA responsibilities. First, it has the responsibility for developing the criteria and guides for judging the acceptability of nuclear power plant QA programs. Second, it has a responsibility for reviewing the descriptions of QA

programs of each licensee and its principal contractors to assure that sufficient management and program control exist. Finally, NRC inspects selected activities to determine that the QA programs are being implemented effectively.

Where QA programs are found deficient, the NRC requires appropriate upgrading. In those cases where the QA program is not being properly implemented, the NRC uses enforcement authority as necessary to achieve proper implementation. Further, if a generic QA problem develops, improvements in QA programs are required industry wide.

Examples where deficiencies were found in QA program implementation and where enforcement action by the Office of Inspection and Enforcement was taken are the Marble Hill and South Texas projects. NRC staff review of the QA deficiencies identified at the construction sites revealed that improvements were needed in the overall management, both organizationally and in the experience level of personnel; in the staffing level of supervisory and inspection personnel; in the qualification and training of inspection personnel; and in specific QA controls for nonconformance, corrective action, and stop-work authority. With full resolution of these deficiencies, full construction activities will be permitted to resume.

As one of the results of the TMI accident, it was decided that the quality assurance programs for several nuclear plants should be re-evaluated and upgraded as necessary, primarily because of their location in high population density areas. The plants selected for re-evaluation are Three Mile Island Unit 1 (awaiting restart), Zion Units 1 and 2, and Indian Point Units 2 and 3. Upgrading of these programs will be accomplished by increasing the scope of structures systems and components to be included under the QA program, improving the effectiveness and responsiveness of the QA organization and personnel through better organizational relationships, increased staffing and qualification levels, and greater involvement of the QA function in all operational activities.

Through the NRC topical report program, the industry had widely adopted standardized QA programs which obviate the need for a new review on each new project. As of the end of fiscal year 1980, a total of 36 topical reports on quality assurance from manufacturers of nuclear steam supply systems, architect-engineering firms, constructors, and utilities have been found acceptable by the NRC; other reports are under review.

NRC is engaged in activities, as part of the topical report program, that are intended to minimize or eliminate the need for redundant audits of suppliers without reducing the confidence that work is proceeding satisfactorily in accordance with regulations. NRC has already reviewed and found accept-

able topical reports submitted by the Coordinating Agency for Supplier Evaluation (CASE) and by the American Institute of Steel Construction (AISC) that are intended to achieve these objectives. NRC is in the process of reviewing a topical report describing the ASME certification and inspection program which, if found acceptable, could also be endorsed as a "third party" audit program. Successful completion of this effort should further reduce the need for pre-award audits and for yearly programmatic audits by purchasers.

In light of the TMI accident, and as a result of problems in implementing quality assurance programs at construction sites, the criteria for determining an acceptable QA program are actively under review and evaluation to identify areas where further improvements can be made—both with respect to the capabilities and qualifications of individuals performing quality affecting activities, and to the criteria for determining those items which fall under the control of the QA program.

Standard Review Plans

A program was initiated in 1980 to revise all Standard Review Plans. The two main objectives of the program are: (1) to ensure that the compliance of an applicant with each regulation is explicitly determined and clearly documented, and (2) to incorporate the new and revised regulatory positions that have resulted from consideration of the TMI accident. The program is planned for completion in the spring of 1981.

Siting of Nuclear Power Plants

In August 1978, the Nuclear Regulatory Commission directed the staff to develop a general policy statement on nuclear power reactor siting. A Siting Policy Task Force formed for that purpose submitted its report to the Commission in August 1979, setting forth the following broad goals pursuant to a firm, clear siting policy:

- (1) To strengthen siting as a factor in defense-in-depth by establishing requirements for site approval that are independent of plant design consideration. The present policy of permitting plant design features to compensate for unfavorable site characteristics has resulted in improved designs, but has tended to de-emphasize site isolation.
- (2) To take into consideration in siting the risk associated with accidents beyond the design basis (Class 9) by establishing population density and distribution criteria. Plant design

improvements have reduced the probability and consequences of design basis accidents, but there remains the residual risk from accidents not considered in the design basis. Although this risk cannot be completely reduced to zero, it can be significantly reduced by selective siting.

- (3) To require that sites selected will minimize the risk from energy generation. The selected sites should be among the best available in the region where new generating capacity is needed. Siting requirements should be stringent enough to limit the residual risk of reactor operation but not so stringent as to eliminate the nuclear option from large regions of the country. This is because energy generation from any source has its associated risk, with risks from some energy sources being greater than that of the nuclear option.

On July 29, 1980, the Nuclear Regulatory Commission published in the *Federal Register* an advance notice of rulemaking on Revision of Reactor Siting Criteria. The notice solicited comments on the goals given above and also on seven of nine recommendations of the Siting Policy Task Force and on alternatives. Consideration of two of the recommendations was deferred. (See *1979 NRC Annual Report*, pp.108-110 for details.) Among the recommendations were proposals to change the way protection is provided for accidents by incorporating a fixed exclusion and protective action distance and population density and distribution criteria; to require consideration of the potential hazards posed by man-made activities and natural characteristics of sites by establishing minimum standoff distances; to require a reasonable assurance that interdictive measures are possible to limit groundwater contamination resulting from Class 9 accidents within the immediate vicinity of the site; to include consideration of postlicensing changes in off-site activities; to continue the current approach relative to site selection from a safety viewpoint, but to select sites so that there are no unfavorable characteristics requiring unique or unusual design to compensate for site inadequacies; to specify that site approval be established at the earliest decision point in the review and provide criteria that would have to be satisfied for this decision to be subsequently reopened in the licensing process; and to provide that a final decision disapproving a proposed site by a State agency whose approval is fundamental to the project would be sufficient basis for NRC to terminate review.

Public Law 96-295 of June 30, 1980, authorizing appropriations to the NRC for fiscal year 1980 directed the NRC to develop and promulgate regulations establishing demographic requirements for siting of utilization facilities. Those regulations are to

specify demographic criteria for facility siting, including maximum population density and population distribution for zones surrounding the facility without regard to any design, engineering, or other differences among such facilities. The regulations shall take into account the feasibility of all actions outside the facility which may be necessary to protect public health and safety in the event of any accidental release of radioactive material from the facility which may endanger public health or safety. After promulgation of the regulations, no construction permit may be issued for a utilization facility unless it complies with these requirements, except that they do not apply to any facility for which an application for a construction permit was filed on or before October 1, 1979.

Siting Studies. The NRC has initiated a contract with the Sandia Laboratories to provide a technical basis for the formulation of demographic criteria for facility siting.

A study has also been made for the NRC by Pacific Northwest Laboratories on the level of available information that is sufficient for comparing the environmental and socioeconomic features of candidate sites for nuclear power stations and for guiding plant design, baseline surveys, and operational practices. The results were published in November 1979 in a report entitled "The Use of Reconnaissance Level Information for Environmental Assessment" (NUREG/CR-0990).

The NRC staff compiled and issued in October 1979 a report entitled "Demographic Statistics Pertaining to Nuclear Power Reactor Sites" (NUREG-0348). It provides population statistics for the environs of 145 nuclear sites and contains information to aid in the evaluation of population trends and general patterns. An updated version is planned when data from the 1980 census become available.

The process of early site review adopted by the NRC in 1977 is being used to evaluate alternative sites for a proposed nuclear power station in Carroll County, Ill. In this connection, the previous NRC experience with studies of alternative sites in the case of Seabrook (N.H.) and Pilgrim 2 (Mass.) has been valuable.

A method has been developed for comparative evaluation of seismic hazards at different sites in the eastern United States. Earthquake mechanisms are not sufficiently understood in that region to permit direct modeling for earthquake prediction. A probabilistic methodology has been formulated for the NRC under a contract with the Lawrence Livermore Laboratory and a subcontract with the TERA Corporation and has been published in report NUREG/CR-1582. This method supplements historical data with expert interpretation and judgment.

Interagency Cooperation. The NRC participates as a permanent member of the Interagency Work Group on Historic and Archeological Preservation. During the report period, the NRC provided its first Preliminary Case Report to the Advisory Council on Historic Preservation concerning the potential alteration of the Port Hudson National Historic Landmark in Louisiana by widening a corridor for transmission lines associated with the River Bend Power Station.

NRC staff members served as chairman and secretary of the Hydrology Committee of the Water Resources Council during 1979-80. Activities of the Committee included investigation of techniques to estimate flood-flow frequency for ungaged watersheds, assessment of low-flow prediction methods, reassessment of groundwater study requirements, update of statistical methods for stream flow determination, and evaluation of hurricane surge techniques. The NRC is also a member of the National Water Data Exchange, a nationwide program managed by the United States Geological Survey to improve water data acquisition and access. The NRC is participating in the Interagency Committee on Dam Safety, formed to assist in the development and implementation of the President's "Federal Guidelines for Dam Safety" published in June 1979.

By an Executive Order issued in May 1977, the President called upon Federal agencies to consider any contemplated action affecting the nation's floodplains as an opportunity to reduce the impact of floods on human safety, health, and welfare and to restore and preserve the natural and beneficial value of the floodplains. During the report period, the NRC staff, in consultation with the Federal Interagency Panel on Floodplain Management, developed procedures for reviewing reactor sites consistent with the intent of the Executive Order, for those cases in which an Environmental Impact Statement had already been issued. During 1980, the staff undertook the evaluation of several such reactor sites with a view to improving floodplain management. Most sites for nuclear power plants require placement of some type of facilities in floodplains, such as auxiliary buildings, pipelines, and roadways associated with cooling-water intake and discharge structures. Usually they are small in size, relative to the floodplain cross-section's area, and do not interfere significantly with its flood-handling capability. If significant impacts are identified, it is generally required that structures be relocated or redesigned or that other measures be taken to minimize impact on and preserve the floodplain.

Future Need for Electric Generating Facilities

Analysis of the future need for electric generating facilities, independent of analyses by electric utilities,

has been conducted for the NRC by the Oak Ridge National Laboratory, where an econometric model for forecasting demand for electric energy has been under development for several years. Research completed prior to 1980 provided a capability of projecting such demand through the year 1990 by State and by major consuming sectors (residential, commercial, and industrial). In 1980 the model was extended to utility service areas and was published, together with the results for six representative utilities (NUREG/CR-1147). A step was taken toward disaggregating the industrial sector to subindustry groups, and a model for 15 such groups was published (NUREG/CR-1139). Finally, a model was developed for forecasting peak and minimum loads and load duration curves, and its application to 20 utility systems was published (NUREG/CR-1256).

Interim Hydrogen Control

The accident at Three Mile Island involved a large amount of metal-water reaction in the core with resulting hydrogen generation well in excess of the amounts specified in NRC regulations. A rulemaking proceeding on the subject of degraded cores and hydrogen management has been initiated by the Commission. Pending this proceeding, interim action is needed to require the inerting of small containments, i.e., all Mark I and Mark II containments for boiling water reactor plants, and to study possible improvements in the hydrogen management capability of intermediate-sized containments with relatively low design pressures, i.e., the ice condenser and Mark III containments. A proposed interim rule requiring measures to protect against degraded core conditions was published in the *Federal Register* on October 2, 1980.

In the course of the Commission's licensing of the Sequoyah plant, an ice condenser containment plant, the Tennessee Valley Authority (TVA) proposed an "interim distributed ignition system" as its approach to improving hydrogen management capability. This involved the placement of about 30 high temperature glow plugs at selected locations inside the containment. The object of this system is to burn any hydrogen that develops from various postulated degraded core accidents before the hydrogen concentration inside containment rises to harmful levels. The Commission decided that the Sequoyah Unit 1 full power license should be conditioned to require the TVA to demonstrate adequate hydrogen control for the near term and that such adequacy must be confirmed by the Commission for operation to continue beyond January 31, 1982. In the meantime, development analyses and tests designed to validate the proposed ignition system were to be sponsored by TVA and the NRC. Requirements for mitigating

the effects of hydrogen in the other ice condenser plants and Mark III containment plants were in preparation at the close of the report period.

Socioeconomic Impacts of the Construction and Operation of Nuclear Power Plants

An evaluation of the change in the esthetic and scenic values of an area resulting from the construction and operation of a nuclear plant is most significant when considering a choice between the relatively unobtrusive mechanical-draft cooling towers and the much larger but more economical natural-draft towers. A contract was made by the NRC with the Pacific Northwest Laboratories for the purpose of developing analytical tools for predicting dollar costs of the relative visual esthetic change attributable to the alternative cooling tower types. The researchers elicited responses from individuals shown a pair of landscapes (photographs of actual landscapes with the two types of towers and a variety of plumes issuing from them, added artificially) and then asked a series of questions intended to determine the respondents' willingness-to-pay and willingness-to-accept compensation for changes in the visual quality of the landscape. A diversity of background and attitude in the sampling was provided for.

The conclusion of the study was that a natural draft cooling tower will cause a statistically significant visual-esthetic impact on a community, compared to a mechanical draft tower. Willingness to pay for a mechanical draft tower, so as to avoid a natural draft tower, ranged from nothing to \$10-per-month for the average household, depending on site-specific conditions. These results and a detailed description of the methodology employed are reported in "The Visual Impact of Alternative Closed Cycle Cooling Systems" (NUREG/CR-0989), published in April 1980.

As with other industrial facilities constructed in rural communities, the process of building a nuclear power station involves a large number of incoming construction workers, and their household requirements and probable residential location are important elements in anticipating demands on local public services and housing. NRC staff initiated contract research with the contractor cited above and the Human Affairs Research Center in Seattle, Wash., to develop analytical tools for predicting the number of workers who will move to the area to work at a given construction site; the socioeconomic and demographic characteristics of the immigrating workers; the number of workers who will relocate their families; the prospect of these workers remaining in the area; the residential location pattern of the immigrating workers; and the type of housing that these



The visual/aesthetic impact of mechanical-draft cooling towers versus various types of natural-draft cooling towers is illustrated

by artificial additions to a photograph of a potential nuclear power plant site.

workers are likely to select. Research findings and a series of reports on the matter were expected by the end of 1980.

To generalize on the socioeconomic impacts related to the siting, construction, and operation of nuclear power stations, the NRC entered into a contract with Mountain West Research, Inc., of Tempe, Ariz. This study encompasses two phases, to be completed in 1981. The first is a study of 12 nuclear plant sites to determine the probable effects of a nuclear power plant on the economy, demography, housing and settlement patterns, government and public services, social structure, and the general public at each one. A concluding effort will be devoted to an evaluation of the significance of the probable impacts. It will be based on an analysis of impacts on discrete social groups and on a comparison of the objective evaluations of the project with perceived effects. During the report period, a detailed metho-

dological approach had been reported, the Calvert Cliffs (Md.) and Peach Bottom (Pa.) draft case studies had been prepared, and draft reports were nearing completion for D.C. Cook (Mich.), Nine Mile Point (N.Y.), Fitzpatrick (N.Y.), Diablo Canyon (Cal.), Rancho Seco (Cal.), Surry (Va.) and Three Mile Island (Pa.) facilities. Work on the case study phase should be completed by early 1981.

Protecting the Environment

The IFEU Report

The staff has reviewed a report known formally as the "Radioecological Assessment of the Wyhl Nuclear Power Plant," and informally as the "IFEU

Report." The report was written by a private group of individuals at the University of Heidelberg, West Germany, who are affiliated with an organization called the Institute for Energy and Environmental Research (IFEU is the German acronym). Although the report has been referred to as the "Heidelberg Report" in the past, the authors have not been authorized to use the name of the University of Heidelberg. The IFEU report presents an assessment of the environmental radiological impact of a proposed pressurized-water reactor to be built near Wyhl, West Germany.

The assessment is based largely on mathematical models that are used to calculate doses to humans in the area surrounding a reactor site and describe the movement of radioactive materials in the environment. These are the same mathematical models that are used by the NRC to calculate doses to ensure that any radiation exposure resulting from reactor operations is far below national and international recommended "safe" levels.

The NRC staff reviewed the IFEU Report because the report implied that the NRC may be substantially underestimating doses to individuals living near nuclear power plants by using incorrect values for parameters in the mathematical models. Although the IFEU Report assessment is based largely on environmental models described in four NRC Regulatory Guides, the NRC staff's review of the report indicates that the IFEU authors used values for some model parameters that are too high.

As a result, the IFEU Report estimated doses to the public by some pathways that are up to 10,000 times higher than the doses calculated using the NRC values for those parameters.

The NRC staff's review concluded that the IFEU Report does not provide any substantial evidence that the NRC significantly underestimates doses. This conclusion is based on: (1) measured effluent releases at reactors operating in the U.S., which are much less than those used in the IFEU report, (2) measured environmental concentrations near reactors operating in the U.S., which are much lower than those calculated in the IFEU report, and (3) a detailed review of the literature regarding critical parameters employed in the models in question, which does not support the values used in the IFEU report.

The results of the staff review have been published in draft form for public comment, both as a main report for the technical community (NUREG-0663) and as a summary report for general public information. The final report is expected in 1981.

Pathogenic Amoebae from Cooling Systems

The association between water pollution—in the forms of thermal, organic, and bacterial

enrichment—and the outbreak of disease in people coming into contact with such water has long been recognized. Within the past 10 years, however, these factors have come to be particularly associated with proliferation of free living pathogenic amoebae of the genera *Naegleria* and *Acanthamoeba*. Among diseases attributed to these organisms are chronic meningoencephalitis, pneumonitis, various intestinal disorders, serious eye infections, and primary amoebic meningoencephalitis (PAME), a rapidly progressive disease difficult to diagnose and, once established in its victim, nearly always fatal.

Reports of the isolation of pathogenic strains of *N. fowleri* from thermally enriched water bodies receiving power plant effluents prompted the Office of Nuclear Reactor Regulation to initiate a study of the extent of distribution of thermophilic amoebae in cooling systems of electric power stations. The study, undertaken by Oak Ridge National Laboratory, focused on seven power stations (six fossil, one nuclear); this study confirmed the presence of pathogenic *Naegleria* at three plants, including the nuclear plant (Dresden). A separate study in the fall of 1979 revealed the presence of the amoebae, in very high numbers, at the Prairie Island Nuclear Generating Plant in Red Wing, Minn.

There have been no reported cases of meningoencephalitis reported among power plant personnel to date and the assessment by the Minnesota Department of Health is that a public health risk does not exist at the Prairie Island plant. However, the presence of the amoebae in plant cooling system waters does represent a potential occupational health hazard. The seriousness of the disease and the confirmed presence of the pathogen at several plants resulted in the issuance of a circular in January 1980 by the Office of Inspection and Enforcement warning all licensees with closed cycle cooling systems of the potential occupational health hazard and recommending appropriate action.

A special chlorination program was instituted at the Prairie Island plant in November 1979, following issuance of an Environmental Impact Appraisal and Environmental Technical Specification change by the Office of Nuclear Reactor Regulation. After fish were removed from the plant cooling system, sodium hypochlorite was added to the circulating water until the free available chlorine concentration rose to above 2.0 milligrams-per-liter. This concentration was maintained for six hours. Destruction of both the free amoeba and its encysted form was expected. Extensive monitoring of liquid effluents and chlorinated cooling tower drift and the dechlorination of plant blowdown were conducted to both minimize and fully document the environmental effects of the eradication program. Results indicate that the program was successful in reducing the number of amoebae by two to three orders of magnitude.

There are currently no known one-time actions that will result in the permanent reduction of the number of these organisms to levels below those associated with occupational or public health hazards. Where the organisms are found to occur in large numbers, periodic control programs like the one used at Prairie Island will be relied upon to reduce risks to plant workers and the public. Continued investigations of these and other organisms, such as Legionnaires' Disease Bacterium, will actively be supported by NRC.

Terrestrial and Aquatic Impacts

Right-of-way Management. An environmental impact assessment of proposed transmission lines connected to nuclear facilities is undertaken as part of the staff's review responsibilities under the National Environmental Policy Act (NEPA). The lands beneath those transmission lines, the "rights-of-way," can provide a valuable environmental benefit to fish and wildlife resources, when properly managed. A cooperative effort between the U.S. Fish and Wildlife Service, the NRC and several other concerned Federal agencies resulted in the publication of a three-volume manual specifying a step-by-step approach to right-of-way management. This publication presents management strategies that may enhance fish and wildlife resources, are cost-effective, and also assure electric transmission reliability. The manual is currently being used by the staff as an aid in its NEPA assessment of environmental alternatives to proposed transmission system designs and route selections.

Cooling Tower Drift. Current techniques for monitoring drift and drift damage from cooling towers involve time-consuming and expensive sampling and chemical analyses of plant and soils. In an effort to reduce the need for these, the NRC undertook a three-year investigative program to determine the utility of various remote sensing techniques in the detection and monitoring of salt stress on vegetation. Predictive drift modeling was used to select areas which should be monitored around salt- or brackish-water cooling towers. Experimental vegetative plots with controlled salt-mist applications were used to study the relationships between salt deposition, salt stress symptom development, and detectability of the salt stress using remote sensors. Remote sensing techniques were also tested around operating cooling towers. False color infrared (FCIR) aerial photographs gave the best results of the methods tested and areas of salt stress were found to be identifiable in the photographs. A standard environmental technical specification has been developed, based on FCIR aerial photography, which eliminates the need for the sampling and chemical analyses.

Shad Stuck on Intake Screens. During 1980, the staff continued its investigation into the causes and effects of impingement by threadfin shad on cooling water intake screens at power plants sited on southeastern U.S. reservoirs. The threadfin shad is an important species because of its status as the food base for valuable sport and commercial fish species in many southeastern reservoirs. The threadfin shad is not native to these reservoirs, having been introduced by State and Federal fisheries resource managers. The species is highly susceptible to impingement on cooling water intake screens, especially during winter months, when the lower water temperature causes disorientation and death from cold shock. Results obtained during 1980 confirm previous findings that power plant intakes are acting as efficient samplers of the natural fluctuations in threadfin shad populations and of their response to the temperature extremes encountered in southeastern reservoirs.

Bluegill Sunfish Deformed. During 1979 and 1980, the incidence of abnormalities in bluegill sunfish from Lake Robinson in South Carolina showed a marked increase. The abnormalities—mainly deformed gills and irregularly shaped mouths—may be causing a reduction in the bluegill population in the lake. The problem appears to be linked with high concentrations of the metals, copper and zinc, which have been recorded in Lake Robinson sediments and water and in the livers of bluegill. Lake Robinson provides cooling water and receives discharges from H. B. Robinson Unit 1 (fossil fueled) and Unit 2 (nuclear fueled). The lake, which was formed by impoundment of Black Creek, has waters of low pH value (acidic) due to drainage of swamp soils. This condition may be the cause of the accelerated corrosion of the plant's condenser tubes. The licensee plans to replace the currently installed condenser tubes with stainless steel tubes. Meanwhile, biological studies are going on to find the cause of and to define the stage at which the abnormality appears in the bluegill. The NRC staff will coordinate its review of the study results with the State of South Carolina and the Environmental Protection Agency.

Measuring Impact on Fisheries. Considering the multitude of simulation models purporting to measure the effect of power station operation on fish populations, the NRC contracted with the College of Fisheries at the University of Washington to compare existing models and provide the NRC staff with guidance in using them. The result was a report entitled "Process Notebook for Aquatic Ecosystem Simulation" (NUREG/CR-1182), published in January 1980. A related study evaluated the potential usefulness of existing fisheries management techniques in impact assessment. Conducted at the Battelle Pacific Northwest Laboratories, the study

resulted in the publication of "Evaluation of Catch-Per-Unit-Effort Indices Used in Aquatic Monitoring—Programs at Nuclear Power-Plant-Sites" (NUREG/CR-1598). This report provides the staff with appropriate guidance for the establishment of fisheries sampling programs at nuclear power stations conducted in support of license applications. A final year of study has been contracted with Battelle to provide the staff with guidance in the evaluation of the data resulting from such monitoring programs.

Monitoring Impact on Biota. The operating license for a nuclear power plant requires that the licensee perform monitoring programs to assure that plant operation does not have a significant deleterious impact on the biota in the vicinity. Extensive reviews have been made of the environmental data compiled at four operating plants which have completed five or more years of monitoring. These reviews have shown that the impacts predicted in the preoperational environmental impact statements were reasonable and adequate in comparison with those actually observed during operation. These findings will provide useful information for the siting and design of future power plants located on water-bodies near those reviewed. The reviews will also provide



Threadfin shad collected from the intake screen of the cooling water system at Unit 1 of the Arkansas Nuclear One plant. Impingement of this species is a problem experienced at plants sited on southeastern U.S. reservoirs.

operational experience to sharpen general impact assessment and prediction.

Antitrust Activities

As required by law since December 1970, the NRC has conducted precicensing antitrust reviews of all applications for nuclear power plants and certain other commercial nuclear facilities. These reviews assure that the issuance of a particular license will neither create nor maintain a situation inconsistent with the antitrust laws. The NRC holds a hearing whenever one is recommended by the Attorney General and also considers whether antitrust issues raised by the NRC staff or intervenors should be subject to a hearing. Remedies to antitrust problems usually take the form of conditions attached to licenses. Such license conditions may result either from hearings or from non-hearing negotiated settlements.

Antitrust hearings are held separately from those on environment, health and radiological safety matters. So that antitrust reviews do not delay NRC licensing decisions, applicants are required to submit specified antitrust information to the NRC at least nine months, but not earlier than 36 months, before other parts of the construction permit applications are filed for acceptance review. Additionally, NRC performs antitrust reviews prior to issuing operating licenses to determine whether significant changes in applicants' activities have occurred since the construction permit antitrust reviews which would necessitate an antitrust hearing.

Since the inception of NRC's antitrust program, 90 initial construction permit antitrust reviews have been performed and one is pending. Based on these reviews, the Department of Justice recommended 17 for hearing, 24 for "no hearing" because applicants agreed to antitrust license conditions, and 49 for "no hearing," without need for conditions. In addition to these reviews, NRC has reviewed and sought advice from the Department of Justice in 41 cases in which additional applicants are seeking part ownership participation in nuclear plants for which the initial applications had been reviewed previously. No hearings have been recommended for these additional applicants.

The NRC has also sought the Attorney General's advice for two applications for operating licenses where the Commission determined that significant changes in the applicants' activities have occurred. The Attorney General recommended hearings in both cases. Additionally, the NRC staff has completed operating license reviews of 13 applications in which it found no significant changes to have occurred and is currently reviewing fourteen others.

In its antitrust program, NRC has reviewed over 170 private, public and cooperative utilities, which accounted for approximately 84 percent of total kilowatt hour sales in the United States in 1977. The NRC has reviewed 72 of the top 100 utilities, ranked by kilowatt hour sales, in the the United States.

Significant developments have occurred during fiscal year 1980 in several antitrust proceedings. These developments include the following:

- In June 1978, the NRC issued a Notice of Violation to the Cleveland Electric Illuminating Company (CEI) regarding alleged noncompliance with antitrust conditions imposed on the Davis-Besse Unit 1 and the Perry Units 1 and 2 licenses, pertaining to transmission services for the city of Cleveland, Ohio. CEI denied the allegations and requested that the NRC impose a civil penalty on CEI for failing to comply with its antitrust license conditions. On May 13, 1980, the NRC staff ordered, and CEI filed, an agreed upon transmission service tariff with the Federal Energy Regulatory Commission (FERC). That tariff satisfied the NRC staff's objections set forth in the Notice of Violation. The matter is subject to a compliance conference at the FERC to work out language differences between a FERC tariff and the NRC-ordered tariff now on file. The Justice Department's request for a civil penalty is pending before the Commission.
- On June 28, 1978, the Commission ordered an antitrust hearing with respect to Florida Power and Light Company's application to construct and operate the St. Lucie, Unit 2, Nuclear Power Plant. The Commission decision was in response to a late petition to intervene and request for a hearing filed by the Municipal Utilities Association and several Florida cities. A settlement proposal has been submitted to the licensing board for approval and implementation. All parties have not agreed to the settlement and the potential for a hearing remained at the close of the report period.
- In 1978, the Attorney General advised the Commission that "significant changes" had occurred since the construction permit antitrust reviews for both the South Texas and Comanche Peak facilities. Consequently, the Attorney General recommended hearings in both cases. Settlement license conditions have been successfully negotiated among the applicants, the Justice Department, and the NRC staff and have been submitted to the licensing board for approval. Opposition to the settlement conditions has been voiced by an intervenor in south Texas and the board is considering that opposition.
- Discovery has been progressing in the antitrust proceeding for Pacific Gas and Electric

Company's application for its Stanislaus nuclear power plant.

- In May 1979, certain Mississippi municipal electric utilities requested that the NRC staff institute an enforcement proceeding against the Mississippi Power and Light Company (MP&L) for alleged violations of MP&L's Grand Gulf anti-trust license conditions. Following investigation, the NRC staff issued a Notice of Violation with license conditions pertaining to transmission service, access to the Grand Gulf nuclear facility and selling wholesale power. MP&L responded by denying any violations but offering to settle the issues. All interested parties are pursuing settlement negotiations.

Indemnity and Financial Protection

The Price-Anderson System

NRC regulations implementing the Price-Anderson Act provide a three-layered system for the payment of public liability claims for personal injury or property damage that may result from a nuclear incident. The first layer of this system requires all licensees of commercial nuclear power plants rated at 100 electrical megawatts or more to provide proof of financial protection in an amount equal to the maximum liability insurance available from private sources. Currently, this amount is \$160 million.

The second layer provides a mechanism—payment of a retrospective premium—whereby the utility industry would share liability for any damages exceeding \$160 million that result from a nuclear incident. In the event of a nuclear incident causing damages exceeding \$160 million, each licensee of a commercial reactor rated at 100 electrical megawatts or more would be assessed a prorated share of damages of up to the statutory maximum of \$5 million per reactor per incident. Presently, the secondary financial protection layer amounts to \$355 million (i.e., 71 power reactors rated in excess of 100 MW(e) licensed to operate X \$5 million-per-reactor).

The third layer, Government indemnity, provides the difference between the \$560 million limit of liability and the sum of the first and second layers. Currently, the third layer comes to \$45 million. Government indemnity for reactors will be phased out when the sum of the first and second layers provides liability coverage of \$560 million. Under the current level of primary financial protection required by the Commission, this will occur when 80 com-

mercial reactors have been licensed. After that point, the limit of liability for a single nuclear incident would increase without limit in increments of \$5 million for each new commercial reactor licensed.

Financial Protection For Three Mile Island

On May 1, 1979, the two nuclear energy liability insurance pools (American Nuclear Insurers and Mutual Atomic Energy Liability Underwriters) informed the NRC and the licensee for Three Mile Island (TMI) that, because of the accident of March 28, 1979, the pools were unwilling to make \$160 million in nuclear liability insurance available for the TMI site, despite the licensee's request for the increase from \$140 million. The first layer of financial protection under Price-Anderson had risen from \$140 to \$160 million as of January 1, 1979. The insurance pools were unwilling to make \$160 million in nuclear liability insurance available for the TMI site because of their desire to clearly limit their potential liability for claims and claims expenses arising out of the March 28 accident to \$140 million.

The Commission notified the licensee for TMI that it would be necessary for it to demonstrate compliance with NRC regulations by providing to the Commission evidence that \$160 million in primary financial protection for both Units 1 and 2 was in place as of May 1, 1979. The insurance pools proposed an endorsement that would provide \$140 million in primary insurance for TMI Units 1 and 2, with an added \$20 million coverage for Unit 1. The added coverage would only apply at Unit 2, however, if a new accident at Unit 2 were to be declared an "extraordinary nuclear occurrence" under definitions set forth in the Atomic Energy Act of 1954 and in NRC regulations. The insurance pools insisted on this proviso to ensure that the added \$20 million insurance could not be used to satisfy public liability claims associated with the March 28, 1979 accident.

In a related area, the indemnity agreement executed by the licensee and the NRC requires that, in the event that payments made by insurers under a policy representing the first layer of Price-Anderson reduce the aggregate limit of the policy, the licensee must apply to its insurers for reinstatement of the amount of such payments. The TMI licensee requested reinstatement of approximately \$1.3 million already paid out for claims arising out of the March 28, 1979 accident.

Indemnification of Storage of Spent Fuel At Distant Reactor Locations

On January 8, 1979, the Commission published a notice in the *Federal Register* (44 FR 1751) request-

ing public comment on specific requests by two utilities, Duke Power Company and Commonwealth Edison Company, to store spent fuel at a reactor site different from the one where it was generated and to have this fuel indemnified. Commonwealth Edison has since requested that the NRC defer action on its application. Sixteen comment letters were received and evaluated by the staff. Duke proposes to store some of the fuel irradiated at its Oconee (S.C.) facility at its McGuire reactor site (N.C.) under its materials license, which presently authorizes only the storage of unirradiated fuel at the latter locale. The staff has recommended that the Commission extend indemnity coverage to the Oconee irradiated fuel to be stored at the McGuire reactor. The staff proposes that the licensee provide financial protection equal to the maximum amount of primary insurance available from the private insurers, and also participate in the industry retrospective insurance system (the "second layer" under Price-Anderson) as a condition to receiving government indemnity at the McGuire plant.

Determination of an Extraordinary Nuclear Occurrence

On July 23, 1979, the Nuclear Regulatory Commission published a notice in the *Federal Register* (44 FR 43128) that the Commission was undertaking a determination as to whether the March 28, 1979, accident at the Three Mile Island Unit 2 reactor (TMI-2) constituted an "extraordinary nuclear occurrence" (ENO) as defined in NRC regulations, 10 CFR Part 140, subsections 140.84 and 140.85. In late December 1979, a staff panel appointed by the Commission to evaluate public comments and other relevant data completed its work and reported to the Commission. The panel recommended that the Commission find that the Three Mile Island accident did not constitute an ENO as defined in the Commission's regulations. The Commission accepted the panel's recommendation and on April 16, 1980, determined that the TMI accident did not constitute an "extraordinary nuclear occurrence." Consequently, defendants in Three Mile Island lawsuits are not required to waive certain traditional defenses available to them and claimants have the same rights that they would normally have under existing negligence law.

Indemnity Operations

As of September 30, 1980, 137 indemnity agreements with NRC licensees were in effect. Indemnity fees collected by the NRC from October 1, 1979, through September 30, 1980, totaled \$1,014,105.

Total fees collected since the inception of the program are \$21,027,359. Future collection of indemnity fees will continue to decrease as the indemnity program is phased out for commercial reactor licensees. No payments have been made under the NRC's indemnity agreement with licensees during the 23 years of the program's existence.

Insurance Premium Refund

The two private nuclear energy liability insurance pools (American Nuclear Insurers and the Mutual Atomic Energy Liability Underwriters) paid their policyholders the fourteenth annual refund of premium reserves under their Industry Credit Rating Plan. Under the plan, a portion of the annual premiums is set aside as a reserve for either payment of losses or ultimate return to policyholders. The amount of the reserve available for refund is determined on the basis of loss experience of all policyholders over the preceding 10-year period. Refunds paid in 1980 totaled \$849,941, which is approximately 20.1 percent of all premiums paid on the nuclear liability insurance policies issued in 1970 and covers the period 1970-1980. The refunds represent 27.9 percent of the premiums placed in reserve in 1970.

Advisory Committee On Reactor Safeguards

The Advisory Committee on Reactor Safeguards (ACRS) is a panel of advisors statutorily established to review construction permit and operating license applications for nuclear power reactors and other nuclear facilities and to report its findings to the Nuclear Regulatory Commission (NRC). The Committee is unique in that there exists no comparable body composed of acknowledged experts in the field of nuclear reactor safety and related fields whose Congressional mandate is to provide the Commission with independent advice in this area. ACRS reports are also made part of the public record.

Besides reviewing license applications, the Committee provides advice to the Commission on a wide variety of safety-related issues such as the adequacy of proposed reactor safety standards, reactor safety research, specific technical issues of a topical nature, and the safety of operating power reactors. Topical reviews are performed by the Committee upon request by the NRC Commissioners or upon its own initiative. Upon request by the Department of Energy (DOE), the Committee reviews and provides

reports with regard to the possible hazards of DOE nuclear activities and facilities. An expansion of the Committee's statutory responsibilities (Public Law 95-209) also requires Committee review of the NRC's Reactor Safety Research Program and submission of an annual report to the Congress regarding its adequacy.

The Nuclear Regulatory Commission, on the basis of the technical review functions outlined in the statutory mission of the Committee, appoints ACRS members from the scientific and engineering disciplines guided by three particular criteria: outstanding scientific and technical ability, balanced and mature judgment, and willingness to devote the time required (approximately 130 days each year) to the demanding work involved.

There has been a conscious effort to obtain members trained in both nuclear and the nonnuclear disciplines who have had experience in the various fields needed to evaluate proposed construction and operation of nuclear power plants and related facilities.

In fiscal year 1980, both the President's Commission on TMI (Kemeny Commission) and the NRC Special Inquiry Group recommended an expanded and strengthened role for the ACRS in the regulatory process, accompanied by a strengthening of the ACRS staff to perform independent technical analysis. Action has been taken in several areas to strengthen ACRS involvement in the regulatory process, including the identification and preparation of safety-related rules. The Committee is presently involved in two NRC rulemaking procedures related to the disposal of radioactive waste materials.

During fiscal year 1980, the Committee prepared the following special reports to the Congress and Congressional Oversight Committees:

- The Committee's Annual Report to the Congress, Review and Evaluation of the Nuclear Regulatory Commission Safety Research Program for fiscal year 1981 (NUREG-0657). The 1981 report focused on implications of the Three Mile Island accident and new directions in research. Particular attention was also given to systems engineering code development, fuel behavior, reactor environmental effects, waste management, safeguards, risk assessment and improved reactor safety, among others.
- Report to Honorable Morris K. Udall, Chairman, House Committee on Interior and Insular Affairs, on the development of a hybrid power reactor design with plant features to maximize safety.
- Report to Chairman Udall on the consistency of actual component failure experience with the failure rate projected in the Reactor Safety Study (WASH-1400) and the probabilistic analysis of

selected events at the Davis Besse (Ohio) and Rancho Seco (Cal.) nuclear power plants.

- ACRS response to Chairman Udall's request for comments on the proposed NRC supplemental budget request for fiscal year 1980.
- With regard to specific nuclear power plant activity in fiscal year 1980—other than that at Three Mile Island—the Committee reviewed and prepared reports on the NRC Systems Interaction Study for Indian Point Unit 3 (New York); interim low power operation of the Sequoyah Nuclear Plant Unit 1 (Tenn.); extended operation of the Shippingport Light Water Breeder Reactor (Pa.); and full power operation of the Sequoyah Nuclear Plant Units 1 & 2.

During this reporting period the Committee was especially active in the preparation of special reports for the NRC on a variety of issues. Thirty special reports to the NRC were prepared as compared to 19 in fiscal year 1979. Of these 30, eight were directly related to the TMI-2 accident and the action plans that followed; seven were related to inquiries, investigations and reorganizations generated by TMI-2, and 16 were related to generic nuclear safety issues such as:

- Qualification of radioactive waste system operating personnel.
- Proposed acceptance criteria for the Mark I Containment Long-Term program.
- Report of the Siting Policy Task Force.
- Reports on NUREG-0460, Anticipated Transients Without Scram, and on NUREG-0667, "Transient Response of B&W Reactors."

In addition to these 30 reports to the full NRC, the Committee prepared nine special reports for individual Commissioners on several issues, primarily related to TMI-2 and the regulatory policy changes

which followed. Of particular interest in this area were ACRS reports on the comparative risk to the public resulting from operation of nuclear power plants compared to other forms of energy generation and other technological activities of society.

At the request of the NRC, the Committee also reviewed the proposed NRC Safety Research Budget for 1982 and provided its comments in time for the Commissioners to be able to take them into account in their review of the budget.

Advice to the NRC was provided on eight proposed regulatory criteria and guides relating to such matters as:

- Qualification of QA program personnel.
- Proposed emergency planning rule.
- Instruments for assessing light water reactor and environs conditions following an accident.
- Testing of air locks.
- Revised clad swelling and rupture model.

The Committee was also involved, during the latter part of the year, in the development of acceptable quantitative risk criteria for the regulation of nuclear facilities—including consideration of serious core damage as the result of a major accident.

In performing the reviews and preparing the reports referenced above, the ACRS held 12 full committee meetings. In addition, 94 subcommittee and working group meetings were held, and a total of four site facility visits were made.

The ACRS Chairman, Vice Chairman, three Committee members and the ACRS Executive Director visited nuclear reactor facilities in Germany and France and met with the German Reactor Safety Committee and the comparable French advisory body, the Groupe Permanent Reactor. The RSK reciprocated with a return visit to ACRS, NRC and U.S. nuclear facilities in September 1980.

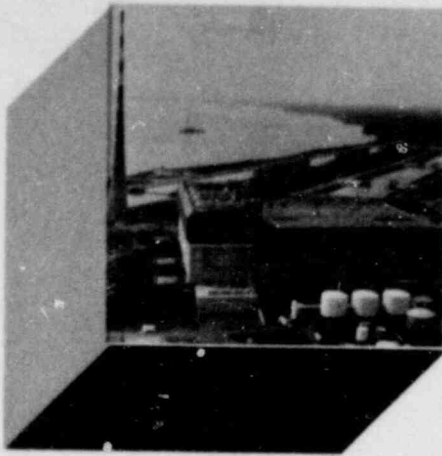

5

Operating Experience

The causes and consequences of a wide variety of abnormal events in nuclear power plants have long been the subject of research within and outside of NRC, and many preventive and mitigative measures are derived from experimental activity (see Chapter 13). But the study of actual operating experience is also invaluable to the discovery of latent vulnerabilities in nuclear generating plants and other nuclear facilities, and of unforeseen cause-effect connections between events. It is well known that the Three Mile Island accident exposed a number of areas which merited much closer attention than they had received—control room design and instrumentation, operator training, emergency planning, etc. On a lesser scale, even relatively inconsequential incidents often contain a clue and carry a warning as to a possible hazard not previously perceived and, in any case, constitute a lapse in control of operations that must be recorded, reported, understood and remedied.

All NRC licensees are required to report unplanned events in their operations which do or could have safety significance. Licensee Event Reports are evaluated by several NRC offices, as indicated below and throughout the chapter. Some of these may merit treatment as "abnormal occurrences" (see discussion below) and/or may present generic problems calling for study as "unresolved safety issues," such as those cited in the preceding chapter. This chapter deals with the more significant operating experience of specific NRC licensees during fiscal year 1980 and activities associated with understanding the causes and implications of off-normal events and acting on that knowledge. (The Unresolved Safety Issues discussed in Chapter 4 are generic concerns mainly derived from operating experience.)

New Notification Rule

The Office of Inspection and Enforcement (IE) has the responsibility for the immediate NRC response to abnormal events in nuclear power plants. In order to facilitate timely NRC responses, more stringent notification requirements were placed on operating reactor facilities in February 1980 with the publication of 10 CFR 50.72 as an immediately effective rule. The rule requires notification from licensees to the NRC operations Center within one hour of certain significant events, via a dedicated direct telephone line. The major events covered in the rule include unplanned reactor shutdown, unplanned or unmonitored releases of radioactivity, the exceeding of any Technical Specification Safety Limit, and manual or automatic actuation of engineered safety feature or protective system. An immediate assessment of each event reported under the rule is made to determine safety significance and the need for NRC follow-up action. This assessment is made by the headquarters staff of IE and the Regional Duty Officers who are on duty 24 hours each day, with the support, when needed, of other NRC components. Each event reported under the new rule is subsequently reviewed to determine (1) the adequacy of short term corrective action, (2) the need for possible generic action at other nuclear plants or further action by the reporting facility, and (3) the identification of events appropriate for classification as Abnormal Occurrences (see section following).

IE routinely communicates information received on significant events to other NRC offices and, when appropriate, to other power plant licensees regarding potential generic problems that may have been reported. The latter communications take the form of Information Notices, Circulars and Bulletins (see Chapter 9).

ABNORMAL OCCURRENCES—FISCAL YEAR 1980

As required by law, the NRC reports to the Congress, in each calendar quarter, any "abnormal occurrence" that has taken place in a facility or in the course of an activity licensed by the NRC. An "abnormal occurrence" is defined in Section 208 of the Energy Reorganization Act of 1974 as "an unscheduled incident or event which the Commission determines is significant from the standpoint of public health or safety."

Because of the broad scope of regulation and the conservative margins and prohibitions incorporated into it, a large number of deviations from regulations are reported each year by NRC licensees. In making the decision that a given incident among the thousands reported is or is not an abnormal occurrence, the NRC applies a criterion first promulgated in a policy statement issued February 24, 1977 (42 FR 10950), which provides that an incident or event which involves a "major reduction in the degree of protection of the public health or safety" shall be deemed an abnormal occurrence. The policy statement declares that such an event "would involve a moderate or more severe impact on the public health or safety and could include but need not be limited to:

- "(1) Moderate exposure to, or release of, radioactive materials licensed by or otherwise regulated by the Commission;
- "(2) Major degradation of essential safety-related equipment; or
- "(3) Major deficiencies in design, construction, use of, or management controls for licensed facilities or material."

Update on Abnormal Occurrences From Fiscal Year 1979

The quarterly report to the Congress on abnormal occurrences for the period July-September 1979 was not published in time for inclusion in the *1979 NRC Annual Report*. A brief discussion of the occurrences covered in the quarterly report follows.

Valves Left Open for Over a Year. While preparing to test two valves in a bypass line at the Palisades Nuclear Power Station (Mich.), plant personnel found that both were locked in the open position when they should have been locked closed.

An investigation disclosed that the valves might have been improperly positioned from April 1978 when a test of the bypass line filters was performed.

The situation came to light in September 1979. The plant had operated at power for most of the intervening period.

The fact that the valves had been open for this extended period did not of itself have an adverse effect on public health, but if an accident had occurred involving fuel damage and primary coolant had been released into the containment while the valves were open, a significant release of radioactive material from the containment would have occurred. Moreover, there is no instrumentation to show that such a release was taking place because of open valves in the bypass line around the main containment purge valve. (The bypass system was designed to permit the venting of hydrogen from the containment during the period following an accident that had led to the formation of hydrogen.)

The main reason for this potentially serious condition to have arisen and gone undetected was a lapse in the development of procedures for ensuring containment integrity. The checklist used to perform a valve line-up associated with each startup of the reactor after cold shutdown did not include a check on the valves in question. Another procedure also overlooked the importance of the final positioning of these valves.

Following corrective action by the licensee—including review and revision of procedures and checklists—the NRC staff determined that the potential public hazard represented by the long-overlooked situation at the plant had been high and, in November of 1979, proposed the imposition of civil penalties in the amount of \$450,000 for the prolonged violation of containment integrity at the facility.

Dam Fails at Uranium Mill. An impoundment dam for uranium mill tailings at the United Nuclear Church Rock Uranium Mill near Gallup, N.M., failed on July 16, 1979, and both tailings solution and solids poured through the break into a catchment area below the dam. Subsequently the catchment embankment was also breached and the solution flowed into an arroyo and on into the Rio Puerco River, which flows through Gallup. The break eventually allowed about 100 million gallons of tailings solution and 1,100 tons of solid (sand) to flow out of the impoundment before it was closed. The tailings solution travelled down the river and was not dissipated until, it was estimated, it had carried 30 miles into Arizona.

This facility is owned by the United Nuclear Corporation and licensed by the State of New Mexico under the NRC Agreement States program. At the time of the incident, the mill tailings were also under general license of the NRC. The dam failure did not

Site of break in a uranium mill tailings impoundment near Gallup, N.M., on July 16, 1979. The dam break allowed some 100 million gallons of tailings solution and 1,100 tons of sand to flow into the Rio Puerco River.



present an immediate radiation health hazard to the public, but the tailings solution was sufficiently acidic to cause chemical burns if ingested or in contact with skin, and chemical contamination of groundwater was a long-term concern.

It was determined that two causes could be identified as contributing to the dam failure: the way the dam was constructed, and an operator's failure to maintain a buffer of mill tailings between the dam and the tailings solution. The dam construction was such that it permitted differential settlement leading to cracks in the embankment. The failure to maintain a buffer between the solution and the dam allowed tailings water to penetrate and weaken the embankment.

On the day of the dam failure, the State of New Mexico ordered termination of operations of the facility and an investigation. In October 1979, the NRC staff issued an order concurring in the identification of causes proposed by the licensee and allowing limited generation and storage of tailings for a limited time under certain special precautions. Direct

NRC regulatory authority over tailings in Agreement States was subsequently removed by Act of Congress, amending the Act discussed on page 151 and 152 of the *1979 NRC Annual Report*. The order of the State of New Mexico remained in effect, however, and imposed essentially the same terms and conditions as had the NRC order.

Unresolved Inventory Difference at Nuclear Fuel Plant. An inventory difference between the amount of highly enriched uranium physically on hand and the amount accounted for in its records was reported by the licensee, Nuclear Fuel Services, Inc., to the NRC in September 1979. The inventory difference, which was in excess of the limit specified in the license, was found at the fuel fabrication facility in Erwin, Tenn. The licensee was unable to account for the highly enriched uranium processed at the plant between June 18 and August 14, 1979. A re-inventory was done and reported on in November 1979, but the results were inconclusive. An NRC Inventory Verification Team confirmed the re-inventory results. Because of the possibility that the

material was stolen, both the NRC and the Federal Bureau of Investigation carried out investigations but could find no factual information to support the inference that theft had occurred, or to refute the inference that it had. The inventory difference could have been the result of imprecise measurement and accounting practices, but theft could not be ruled out.

The licensee was ordered by the NRC to halt further introduction of feed material on the day the difference was reported and to start an extensive inventory. On January 17, 1980, the Commission voted to permit a resumption of operations at the plant, after verification by NRC staff that the licensee had carried out improvements in the accounting, internal control, and physical security systems. The NRC required a substantial upgrading of measures protecting against theft of special nuclear material at the facility, better surveillance and control over personnel with access to the material, and improved search procedures.

The following are the Abnormal Occurrences reported by the NRC to the Congress for the first three quarters of fiscal year 1981. (One Abnormal Occurrence took place at the Three Mile Island nuclear plant and is discussed in Chapter 2.) The quarterly report for the last quarter of the report period, July-September 1980, was not available for coverage in the *1980 NRC Annual Report*.

Plutonium Inhaled At Fuel Cycle Facility

This accident took place in the Parks Township Plutonium Facility, operated by the Babcock & Wilcox Company in Pennsylvania. On November 16, 1979, a technician was engaged in repairing a power blender used in association with the processing of plutonium by means of a "glovebox." After about half an hour's activity, another technician discovered elevated levels of alpha radiation in the area, and the technician doing the repair work immediately checked his shoes and clothing and found contamination of the latter. Several other workers in the area also detected contamination of shoes and clothing, and all were evacuated.

Of the 15 people working in the area, 12 showed some evidence of plutonium contamination, but apparently only the person working on the blender had received an excessive dose, and only he was believed to have incurred a deposit of plutonium in the lung. The deposition was determined to range between 40 and 50 nanocuries by an *in vivo* detection method carried out at the University of Pittsburgh.

Later assessment by the Los Alamos Scientific Laboratory, however, showed a lung burden of 10 to 15 nanocuries of plutonium, plus about three nanocuries of americium-241. The discrepancy was under study at the close of the report period. If the deposition was in fact 50 nanocuries, the total dose to the lung would be about 100 rem, 95 percent of which will take place within six years. It would constitute one of the three largest plutonium burdens ever sustained by a worker in facilities licensed by NRC.

The exposure was caused by a seal failure in the equipment in the work area. The seal was repaired and a secondary seal installed. The NRC required that a continuous air monitor and audible alarm system be provided at this and all other licensed facilities processing plutonium. The affected technician was placed under medical supervision. There was no release of radioactive material off-site.

Radiography Firm Irradiates Adjacent Business Offices

The licensee radiography company conducted its activities both in the field, usually at construction sites, and also in a garage which was part of its property in Farmington Hills, Mich. The garage work was mainly radiographic inspection of sample welds prepared as part of the qualification tests for welders. Two adjoining business offices shared a common wall with the garage.

The radiation emanating from the iridium-192 source used in the garage operations carried through to the two business establishments. The licensee had not performed radiation surveys or surveillance in these unrestricted areas and had not notified the owners or employees in the offices when radiographic operations were being performed. Responding to allegations of a former employee of the licensee, the NRC investigated and determined that, from a study of the work records of the licensee, the maximum exposure received by any employee of the business office alongside the garage was three rem over a 23-month period. It was estimated that 10 persons received more than 0.5 rem in a calendar year and that 36 received lesser doses. These exposures were not expected to produce medically discernible results.

An order suspending the radiography firm's license was issued by NRC on February 29, 1980, and the company was required to show cause why the license should not be revoked. On May 19, 1980, the license was revoked. NRC met with the employees of the adjacent businesses to review the results of the NRC investigation, and a medical consultant went over the data and implications of the radiation exposures.

Crystal River Incident— Loss of Instrumentation

This event bore a number of similarities to the accident at Three Mile Island (TMI). It took place at the Crystal River Unit 3, located in Citrus County, Fla., which employs a pressurized water reactor designed by Babcock & Wilcox (B&W), as did the Three Mile Island Unit 2.

On February 26, 1980, an electrical malfunction resulted in the partial loss of power to some "non-nuclear" instrumentation (NNI), affecting automatic plant control systems and certain control board indicators—such as those showing temperature, pressure and flow in the reactor coolant system, the pressure and level in the steam generators, and pressurizer level. The short-circuit caused the relief valve on the pressurizer to open (as it had at TMI) and also a spray valve, and it resulted in false control signals to the Integrated Control System (ICS), the most significant of which brought about a reduction in feedwater flow to the steam generators. A false signal also caused the ICS to withdraw the control rods and increase power output in the reactor (later terminated automatically).

The reduction in feedwater flow lowered the heat removal rate to a point where temperature and pressure in the reactor coolant system began to rise. The reactor shut down automatically when coolant pressure reached a pre-set ceiling and the coolant system was then depressurized. At this point, a high-pressure injection system—bringing a new supply of coolant to the reactor under high pressure—was activated automatically, in response to the loss of coolant through the relief valve and the drop in coolant pressure following reactor shutdown. The reactor coolant pumps were secured by the operators, in accordance with emergency procedures. When an alarm indicated that the level in the coolant drain tank had risen, meaning that coolant was going out of the system, the operators closed the pressurizer relief block valve. However, the operators correctly decided *not* to terminate the high pressure injection, in contrast to the action taken at TMI. The decision was taken on grounds that there was insufficient information available to justify cutting off the added flow of coolant. The continued flow of coolant into the system caused it to fill "solid" (with water), including the pressurizer, at the top of which a steam bubble is normally maintained. The coolant pressure also increased, to the point where a safety valve lifted and water spilled through it and through the reactor coolant drain tank rupture disk into the containment building.

About 20 minutes after the short-circuit occurred, power was restored to the NNI. At that time, the pressurizer was filled solid with water, the reactor

coolant pressurizer was an above normal 2,400 pounds-per-square-inch, the temperature at a coolant outlet was an above normal 556°F, one of the two steam generators was "dry" (without feedwater flow), and the reactor core was being cooled by high pressure injection as well as by natural circulation through the other steam generator. With the power restored to the instrumentation, the operators throttled high pressure injection to reduce the flow of water through the open safety valve into the reactor building; they also re-established the water level in the dry steam generator.

Forty-one minutes into the accident, the licensee declared a "class B" emergency. All non-essential personnel were evacuated from the site and appropriate agencies notified. After an hour and a half, the operators achieved control of coolant pressure using the normal makeup and letdown flows, the coolant temperature was under control, and the core was being cooled by natural circulation. At three and three-fourths hours from the onset of the accident, a steam bubble was re-established at the top of the pressurizer, and at six and three-fourths hours, two reactor coolant pumps were restarted. The reactor was then stable and under control, but there were 43,000 gallons of reactor coolant on the floor of the containment building.

The amount of radioactivity released to the environment during this period was within regulatory limits. Inside the containment the radiation level went as high as 50 rem-per-hour early in the event, but declined rapidly thereafter. The spilled coolant was later reprocessed for in-plant use.

Although there was no impact on the general public or on plant employees, these failures in the non-nuclear instrumentation system were significant, especially inasmuch as the NNI has not been considered safety-related and has not been subjected to the reliability and quality assurance criteria and assessment that safety-related systems are. Of particular concern to the NRC is the apparent lack in B&W nuclear power plants of sufficient design requirements related to the interface between the nuclear steam supply system (the reactor, steam generators and associated equipment) and the balance-of-plant, especially feedwater supply to the steam generators.

The initiating cause of the event was found to be a misalignment of a "voltage buffer card" which shorted out; the short-circuit later cleared itself by burning through the foil on a printed circuit card. Power supply failures to NNI or ICS, leading to reactor shutdown, relief-valve actuation and other off-normal conditions, have taken place in B&W plants for an extensive period. Since December 1974, a total of 29 NNI-ICS power failures at B&W plants have been identified, of which 21 caused reactor

shutdown, 17 involved relief-valve actuation, and four resulted in the startup of high pressure injection. Feedwater transients occurred in 19 of these cases. Three ICS failures also took place which did not result in reactor shutdown, and five power failures were recorded which happened when the reactor was shut down for other reasons. Most of these incidents involved reactor shutdown, usually the result of a feedwater transient (as in the Crystal River event described). The data seem to support the conclusion that when an NNI-ICS failure does occur, a severe feedwater transient leading to reactor shutdown and actuation of high pressure injection is very likely to result.

Following the accident of February 26, 1980, the licensee for the affected facility took these corrective steps:

- Complete testing and inspection of the NNI system.
- Installation of redundant electrical channels to indicators of 23 key plant parameters.
- Comprehensive operator training in effectively responding to NNI-ICS failures.
- Installation of a "positive position" indicator for the pressurizer relief valve and two safety valves in the reactor coolant system.

- Modification of NNI power supply to improve reliability.
- Evaluation of NNI power supply reliability, in response to an NRC bulletin.
- Modification of the control circuitry for the relief valve and spray valves to assure that they will not open in the event of a loss of NNI power.

On being notified of the situation at Crystal River, the NRC activated emergency response centers both in the region and at its headquarters and dispatched regional teams to the site to monitor and assess events as they transpired. Some days later, the NRC convened a meeting at its headquarters with all licensees operating reactors designed by B&W to explore the implications of the Crystal River event and the history of similar events at their facilities and to discuss corrective actions. On March 12, 1980, a B&W Reactor Transient Response Task Force was created within NRC to assess the generic aspects of the kinds of events experienced at B&W plants, and its findings were published in May 1980 in a report entitled "Transient Response of Babcock & Wilcox-Designed Reactors" (NUREG-0667). That document, as had several earlier NRC staff reports, concerns itself with the apparent sensitivity of the B&W plants to transients involving over-cooling and under-cooling con-

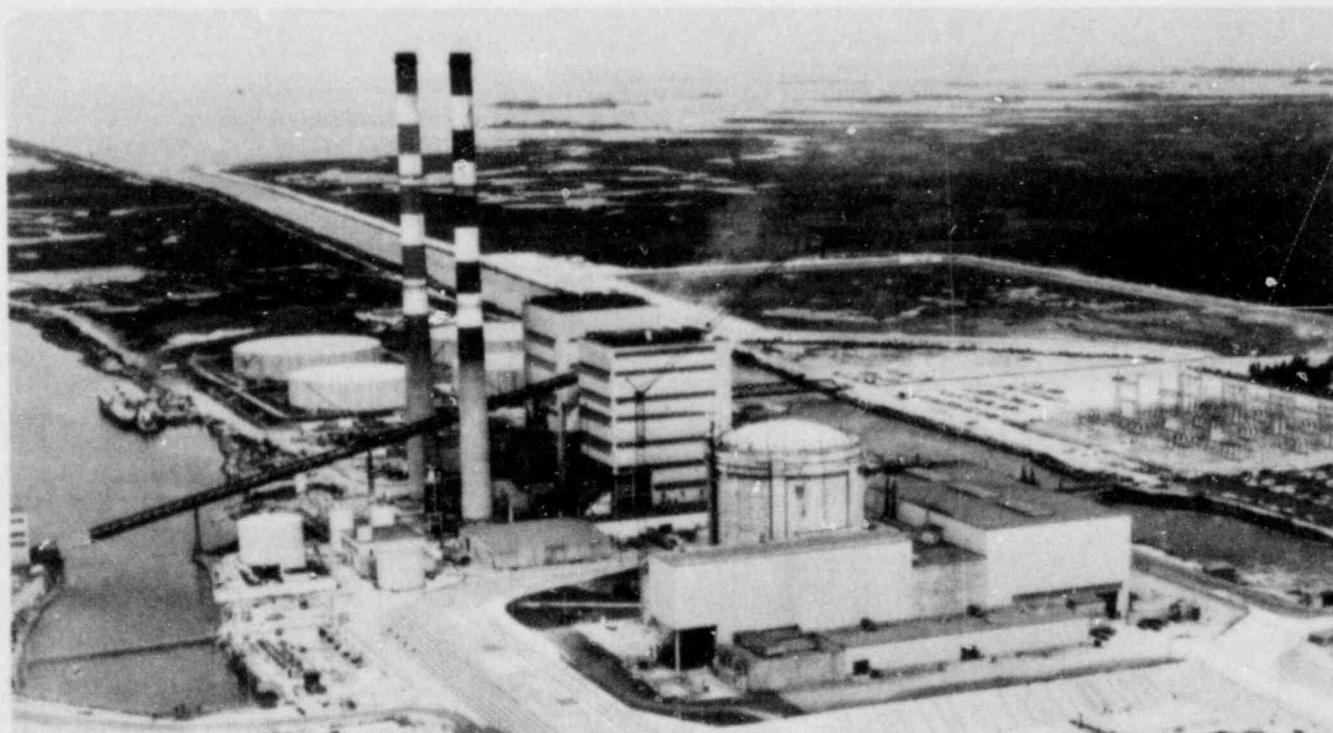

An event during 1980 at the Florida Power Corporation's Crystal River Plant Unit 3 resembled in some respects the problems encountered in the accident at Three Mile Island. Unit 3, in

foreground above, is sited alongside two coal-fired electric generating units.

ditions, small break loss-of-coolant accidents, and the consequences of malfunctions and failures of the NNI and ICS. Of particular concern in the past had been the realization that certain anticipated transients or unplanned occurrences could lead to frequent challenges to the engineered safety features of a plant, e.g., the activation of emergency core cooling systems. Some reduction of this sensitivity had been effected at the time of the Crystal River event, but the latter showed that the subject clearly required further, deeper study.

At the close of the report period, the body of requirements placed upon B&W plant operators consisted of those developed by the Lessons Learned Task Force and the Bulletins and Orders Task Force following the TMI accident, the actions set forth in the TMI Action Plan of May 1980 (see Chapter 2), and an NRC Bulletin (79-27) associated with an incident at the Oconee Nuclear Station Unit 3 (S.C.) on November 10, 1979, when a loss of NNI resulted in a partial loss of indicator information in the control room. In March of 1980, licensees for B&W nuclear power plants were asked by NRC to communicate the actions they had taken in light of the Crystal River event, and the licensee for that facility was specifically asked to set forth its assessment of the event in the context of all post-TMI requirements cited above. That response was forthcoming on March 12, 1980, and the NRC Director of Nuclear Reactor Regulation issued a Confirmatory Order on April 14 to the respondent based on the latter's commitments and on expected improvements—a reduction of the likelihood of a power loss of the kind experienced in February 1980, and upgrading of the ability of operating personnel to respond to this kind of transient. Similar orders were issued to all licensees for B&W facilities.

While further study of the problems is carried out by NRC and the industry and close surveillance of susceptible plants is maintained, the implementation of the task force requirements deriving from study of the TMI accident will move forward.

Decay Heat Removal Capability Lost at Davis-Besse

On April 19, 1980, the Toledo Edison Company reported a temporary loss of the capability for removing decay heat at the Davis-Besse Unit 1 nuclear power plant. The plant is located in Ottawa County, Ohio, and employs a pressurized water reactor designed by Babcock & Wilcox. The incident occurred when the facility was shut down for refueling and maintenance, which had begun on April 8. On April 19, two of the four essential instrument buses were lost, resulting in the loss of decay heat

removal capability for about two and one-half hours. The loss happened with the reactor coolant system temperature at 90°F, the decay heat being removed through loop number two, the vessel head "detensioned" with bolts in place, the reactor coolant level slightly below the vessel-head flanges, and the manway covers removed on top of the steam generators.

With the plant in a refueling outage, there were a number of systems and components out of service for maintenance and/or testing—such as the containment spray system, the high pressure injection system, decay heat loop number one, and certain instrument buses. Probably as the result of mechanical vibration or accidental bumping by construction workers, a "feeder breaker" in a switchgear bus was tripped. The breaker affected an electrical circuit which was the single energizing source for two channels of the safety features actuation system (SFAS). The loss of power to the two SFAS channels set off a chain of automatic events that ultimately affected decay heat loop number two, the operating loop. About two minutes after the breaker tripped, an operator manually stopped decay heat removal pump number two to prevent damage to the pump from loss of suction. Consequently the capability to remove decay heat from Unit 1 was lost for about two and one-half hours, the time needed to check out and realign the systems and vent air from decay heat loop number two (number one was being prepared for maintenance work and was not available).

When decay heat removal was lost, reactor coolant temperature rose from 90°F to about 170°F, a level still considerably below that at which fuel damage could result. There were no off-site releases of radioactivity and no injuries to personnel during this period, although the internal communications system was without power for 33 minutes. The resultant problems in communication between the control room and other parts of the plant may have contributed to the delay in restoring decay heat removal capability.

The foregoing describes one out of a total of 10 separate incidents which took place at the Davis-Besse plant and which affected or involved the decay heat removal systems. The other incidents, which involved briefer time-frames than that above, are noted below, in chronological order.

April 18—capability for decay heat removal was lost for 29 minutes when, with the reactor in cold shutdown, the single decay heat pump in operation was tripped.

May 28—a decay heat isolation valve was inadvertently closed, resulting in the loss of decay heat removal for about two minutes.

May 31—the control room operator stopped the decay heat pump when the flow meter indication for the decay heat loop dropped off-scale; it was later discovered that a mechanic had taken the flow meter out of service for testing without informing the control room.

June 14—an inadvertent SFAS actuation resulted in a loss of decay heat removal flow for about two minutes; when borated water level dropped to the low-level limit, an SFAS actuation closed the borated tank isolation valves causing a loss of suction to the decay heat pump.

July 10—because of procedural error, power to the flow control valve was lost and decay heat removal flow was reduced to 2,000 gallons-per-minute for a period of 51 seconds (the minimum required flow is 2,800 gallons-per-minute); the power was lost when an SFAS channel was de-energized for maintenance work on a bus.

July 24—a blown fuse caused the decay heat isolation valve to close, resulting in a loss of decay heat removal for about 50 minutes, until manual bypass valves were opened.

July 24—after the preceding condition was corrected, another decay heat isolation valve was inadvertently closed, causing loss of decay heat removal for about two minutes; improper maintenance procedure was the cause.

August 8—the same isolation valve as cited in the preceding was inadvertently closed, resulting in a loss of decay heat removal for about three minutes; again, maintenance error was the cause.

August 13—the same isolation valve as cited in the last two items was inadvertently closed and decay heat removal was lost for about five minutes; maintenance work brought about an automatic tripping of the valve.

The two major factors underlying these events were the extensive maintenance work going on during this period and the lack of adequate administrative control to prevent or at least ameliorate the consequences of the incidents. Besides the short term measures taken by the licensee in response to the April 19 occurrence, the following long term corrective steps were taken, in accordance with a bulletin (80-12) of the NRC Office of Inspection and Enforcement.

- Revision of procedures to include alternative methods for providing water to the reactor core and improved monitoring of core temperature.
- Added guidance provided for the venting of the decay heat removal system when air is drawn into it.
- Revision of procedures related to emergency sump isolation valves.
- Revision of procedures related to electrical power supply, minimizing the possibility of a loss of power to two instrument channels at the same time.
- Special procedures drawn up related to the availability of the redundant decay heat system and pre-conditions to its being taken out of service.

Pressurized water reactors are most susceptible to a loss of the capability for decay heat removal when steam generators or other means of removing decay heat are not readily available, a situation which often occurs during refueling activities or when concurrent maintenance work is taking place. The bulletin noted above was issued to all licensees for these kinds of facilities on May 9, 1980, calling for a review at each one of all operating events associated with loss of decay heat removal capability, especially those similar to the Davis-Besse experience of April 19, and a close examination of procedures and equipment by which such events can be prevented or mitigated.

Partial Scram System Failure At Browns Ferry Unit 3

On June 28, 1980, an incident at the Browns Ferry Nuclear Power Plant—a facility owned and operated by the Tennessee Valley Authority—was reported to the NRC involving the failure of 76 control rods to insert fully into position to shut down the reactor at Unit 3. A routine manual "scram" or reactor shutdown was undertaken with the reactor operating at about 35 percent of full power, and 76 of a total of 185 control rods did not respond fully to the manual activation intended to insert them into the reactor core and close down the fission process. All but one of the 76 rods were on a side of the core where the power level was registering 2 percent or less. A second manual attempt to insert the rods left 59 less than fully inserted, and a third effort two minutes later still left 49 less than fully inserted. Six minutes after that, an automatic scram occurred and all the rods inserted fully when the scram discharge level bypass switch was reset from "bypass" to "normal" and there was a high water level in the scram discharge instrument volume. The core coolant flow, temperature and pressure remained normal throughout the event.

Essentially, the control rod drives which withdraw and insert the control rods in a boiling water reactor (BWR) designed by the General Electric Company (as are those at Browns Ferry) are water-driven pistons. During a scram, a relatively high pressure is applied to the bottom of the piston. When an outlet valve opens to relieve the pressure at the top of the piston, the rod is driven rapidly up into the reactor

The Tennessee Valley Authority's three-unit Browns Ferry Nuclear Power Plant, located on Wheeler Lake near Decatur, Ala. The three reactor units are housed in the reactor buildings in foreground. The six forced-draft condenser water cooling towers required for the station (two towers for each unit) are shown in background.



core. The water discharged in this process from the 185 control rods is collected in two sets of interconnected pipes (four 6-in. pipes on each side of the reactor) called the "scram discharge volume" or SDV. Normally these pipes are continually drained and ready to receive discharge water whenever a scram takes place.

At the Browns Ferry Unit 3, there are two separate SDVs for the two halves of the reactor core. On the east side—where all but one of the failed rods were located—the SDV was apparently partially full of water when the incident occurred, leaving insufficient room for the discharge of water through the outlet valve when scram was initiated. When pressure equalized above and below the rods being inserted into the core, the rods stopped moving. After each attempt to achieve a total scram, the operator reset the signal which allowed water to drain from the SDV and thus allowed the rods to move further each time. Finally, on the fourth attempt, enough water had drained to allow the rods to go all the way in.

The event did not constitute a danger to the general public or to plant employees, nor did it occasion any release of radioactivity to the environment or damage to the reactor fuel. This kind of event, however, could result in significant fuel damage under other circumstances than obtained at the time. (See discussion of causal factors underlying this occurrence under "Office for Analysis and Evaluation of Operating Data," below.)

The NRC Region II office dispatched a core physics specialist to assist the two NRC resident inspec-

tors at Browns Ferry and later a team was organized at the site which included the Region II Director and personnel from NRC headquarters. On July 3, a bulletin from the Office of Inspection and Enforcement (IE Bulletin 80-17) directed all other BWR licensees to perform prompt inspections of the SDV for their facilities, carry out two scrams within 20 days to confirm operability of the SDV, review emergency procedures to assure that appropriate requirements related to control rod failure were included, and conduct training that would acquaint their personnel with the type of problem experienced at Browns Ferry Unit 3.

On July 18, 1980, a supplement to the bulletin was issued to BWR licensees calling for an analysis of their SDVs, revision of procedures on the initiation of standby liquid control systems, specification of actions to be taken by operators if water is found in the SDV, daily monitoring of the SDV pending installation of a continuous monitor, and the study of designs to improve the venting of the SDV.

Licensee testing done under the initial bulletin revealed a number of anomalies at a number of BWR facilities related to the SDV and scrambling operations.

A second supplement to the bulletin of July 3 was issued on July 22, requiring BWR licensees to provide a vent path from the SDV directly to the building atmosphere without an intervening component other than the vent valve. A third supplement, issued on August 22, required BWR licensees to put procedures in effect within five days which would prescribe an immediate manual scram under certain

conditions—low control air pressure, multiple rod drift-in alarms, a marked change in the number of control rods with high temperature alarms. Procedures were also to be adopted which would require functional testing of relevant alarms and switches after each scram.

Agreement State Abnormal Occurrences

Beginning in 1977, the Commission directed that abnormal occurrences taking place at facilities licensed for operation by an Agreement State should be included in the quarterly report to the Congress. The criterion applied in deciding that an event at a facility operated by an Agreement State licensee is an abnormal occurrence is the same as that applied to NRC licensees.

Following are discussions of abnormal occurrences reported from Agreement States and treated in quarterly reports by NRC to the Congress during the last quarter of fiscal year 1979 and the first three quarters of fiscal year 1980.

Two Overexposures Reported in Fourth Quarter of 1979. Covered in the report to the Congress for the period July-September 1979, which was issued too late for inclusion in the *1979 NRC Annual Report*, were two incidents of radiation overexposure reported as abnormal occurrences by Agreement States. One of these happened in July 1979 near St. James, La., when a radiographer retrieved a 100-curie radiation source with his hands. It was estimated that his right hand had received a dose of 3,000 to 10,000 rem and that he received a whole body dose less than 20 rem. The Louisiana Nuclear Energy Division cited the licensee for violations and issued appropriate warnings to all radiography licensees in its jurisdiction.

In August 1979, an incident at the Dow Chemical Company's facility in Freeport, Tex., was reported, involving a radiographer's assistant who picked up a radioactive assembly which had fallen from a camera and taken it to his supervisor. The latter was in a truck dark room at the time, so the assistant waited about two minutes after knocking before the radiographer opened the door, saw the source and knocked it from his assistant's hand. The State of Texas estimates that the assistant received a whole body dose from 200 to 300 rem. The licensee was cited for seven items of noncompliance.

Overexposure of Hot Cell Operator. This incident took place at the licensee's operation in Baton Rouge, La., and involved the handling of a shipment of radioactive pellets of iridium-192. A container with several hundred unencapsulated pellets was

unloaded at the licensee's facility on August 30, 1979, in a "hot cell" operation using remote manipulators. When he was unable to replace the top of the container by remote means, the worker doing the unloading finally entered the hot cell and replaced it by hand.

It was not until September 7, 1979, that the licensee employee began to experience symptoms of the overexposure. On that day, he first noticed swelling in his fingers. When the condition worsened, with blistering of several fingers and the thumbs of both hands, the employee was examined in a hospital in New Orleans, La., on September 12. The diagnosis on this occasion was that the worker had an allergy to nickel. Because of the nature of his employment, however, he was also examined at Oak Ridge, Tenn., on September 21, when a scan was performed and cytogenetic tests conducted. The result of this examination was the conclusion that the worker had received a dose of between 2,500 and 3,000 rads to the thumb and three fingers of the right hand and thumb and two fingers of the left. At the time the occurrence was reported to the Congress, the individual was back on the job, apparently recovered.

The Louisiana Nuclear Division cited the licensee for a violation because of the overexposure to the employee. A review of the licensee's hot cell operation and employee training indicated that the employee had been instructed not to handle a shipping container other than by remote manipulation. The State nuclear authority recommended that the licensee provide an operating manual for its hot cell operators.

Office for Analysis and Evaluation of Operational Data

In 1978, the General Accounting Office undertook an evaluation of the NRC's program for collecting, assessing and disseminating operating information and concluded in its report of January 1979: "... the NRC does not know if it is promptly finding and identifying all potential safety-related problems." The GAO reviewers found that the NRC program was neither systematic nor documented and that organizational responsibilities within the program were not defined. These findings and recommendations associated with them were being studied by NRC staff when the Three Mile Island accident took place in March 1979.

The numerous and intensive investigations of that event served to reinforce the judgment that an effec-

tive and comprehensive operational data assessment program was essential for the NRC to fulfill its mission and that the existing program, despite some proven usefulness, was not adequate. The reality that emerged from these studies was that the large number of Licensee Event Reports received by NRC every day (10 to 15), frequently incomplete and inherently difficult to interpret in cause-effect terms or to apply to other than the affected facility, had overwhelmed the capacity of the NRC or the industry to assimilate the lessons of experience. (The Licensee Event Report (LER) is a report to NRC by a licensee of any unexpected occurrence in its operation that has actual or potential safety significance.) Adding to the problem of processing LERs adequately was, the GAO concluded, the lack of any systematic coordination either among the NRC components dealing with operating data or between the NRC and industry, with the result that each organizational element faced the whole job of gathering and assessing operational information and promulgating its interpretations of it on its own.

In the wake of Three Mile Island, a major commitment has been made on the part of the NRC, the nuclear industry as a whole and individual licensees to extract the safety-related lessons to be found in operating experience and to communicate and apply them throughout the industry. An integral and important part of the NRC effort to do so was the creation of a new Office for Analysis and Evaluation of Operational Data (AEOD). The creation of the office was approved by the Commission in July 1979, and other offices of NRC were also directed to set up organizational components for analyzing operating experience. Several branches were established within the Office of Nuclear Reactor Regulation to evaluate operating experience; an Events Analysis Section was created in the Office of Inspection and Enforcement to assess the immediate safety implications of operating events; and the Office of Nuclear Regulatory Research greatly expanded its examination and use of operational data within the Division of Systems and Reliability Research. The Office of Management and Program Analysis, the Office of International Programs, and the Office of Standards Development are also deeply involved with the collection and appraisal of operational data.

The AEOD was created to analyze and evaluate operational safety data associated with all NRC-licensed activities and to feed back the lessons of experience in order to improve safety in all licensed operations. It was also intended that the new office should assume an oversight/peer-review role with respect to the overall NRC program and serve as NRC's focal point for interaction with outside organizations dedicated to operational data analysis. AEOD was officially established in October 1979 and a per-

manent director for it was appointed in January 1980. The Office conducts its own data acquisition—including on-site investigation wherever indicated—and all operational events are screened by the Office for safety-significant problems. The events are also scrutinized with a view to spotting emerging trends and patterns with safety significance. Engineering evaluations and in-depth analyses are initiated into events or trends identified by AEOD as significant or potentially significant for safe operation. If immediate action is warranted, an AEOD recommendation therefor is transmitted to other NRC offices. The Office also coordinates activities within NRC dealing with operational safety data and with such outside organizations as the Institute of Nuclear Power Operations and the Nuclear Safety Analysis Center, (both industry groups), and the Advisory Committee on Reactor Safeguards (see Chapter 4).

The sequence of screening, characterizing, and evaluating reported power reactor operating data as performed by AEOD is shown in the accompanying chart. The sequence—when fully developed and implemented—will apply to all LERs received by NRC and to other selected information handled by the Office. The basic steps are as follows:

- (1) Operational data received by AEOD, assembled into review packages, and assigned to selected engineers for screening.
- (2) Data are screened to determine if the situation described represents a potential risk to the public sufficient to warrant immediate engineering evaluation and possible case study review.
- (3) Data are coded in a computer-readable format which will permit subsequent computerized searches for specific aspects of each situation.
- (4) Data are assigned by computer to the AEOD Power Reactor Watch List—a listing of critical or unusual situations which warrant close attention because of their potential for jeopardizing public health and safety.
- (5) Each watch list situation is monitored by an AEOD engineer to assure that every entry is collated with historical data and assessed in terms of pertinent operational experience.
- (6) Engineering evaluations are performed to examine the implications of operating experience for certain watchlist situations and for immediately significant events (from step #2) to determine if intensive analysis and evaluation as a case study is indicated.

(7) In-depth case studies are performed to determine the level of safety concern and, if needed, to support recommendations for corrective actions.

(8) Findings and recommendations are communicated to the appropriate NRC office for action.

ANALYSIS AND EVALUATION PROGRAM

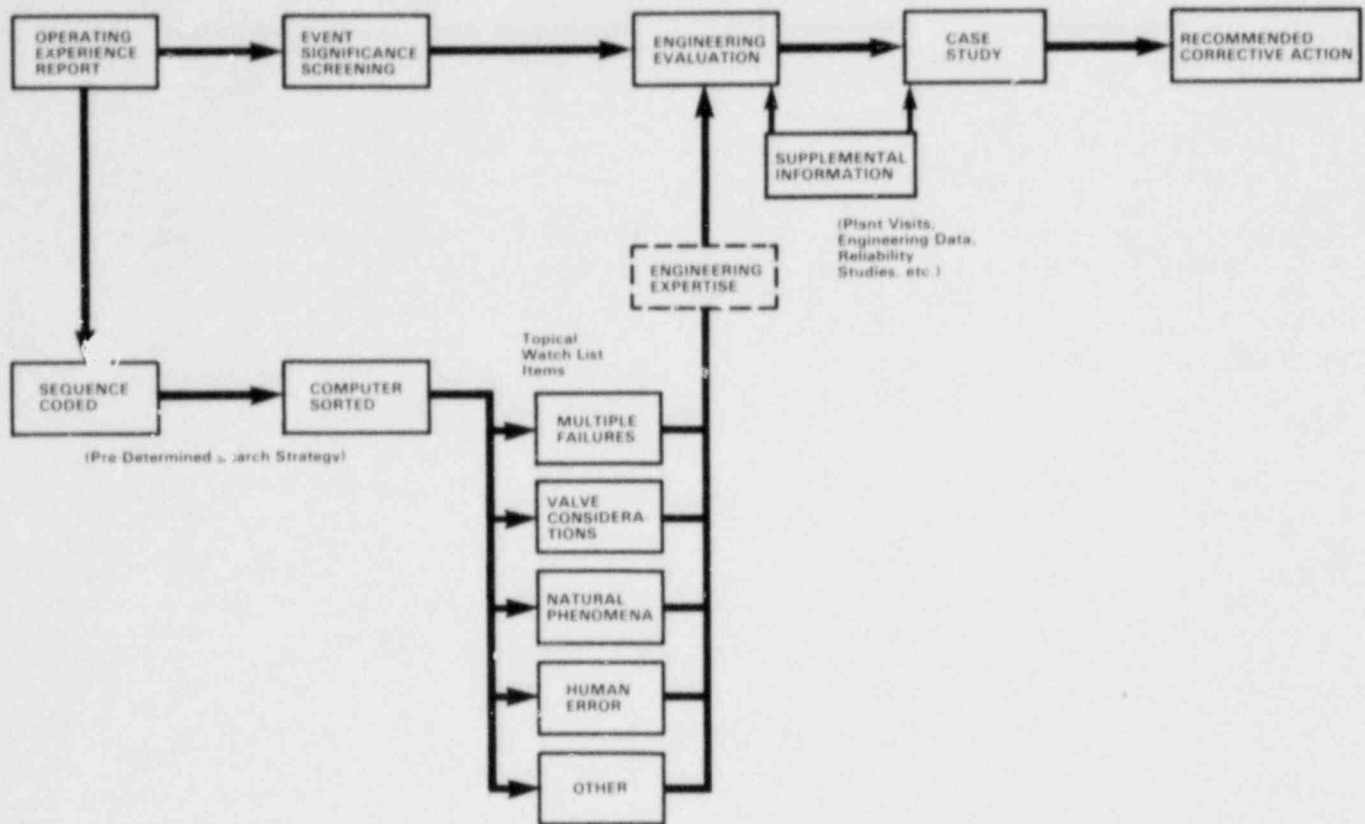

AEOD ACTIVITIES DURING 1980

In early 1980, AEOD implemented its program for the screening of each Licensee Event Report (LER). During the report period, AEOD conducted frequent engineering evaluations of operational events and potential generic operational problems to develop additional information and insight into an event and to determine if a detailed case study analysis was warranted. As a result of these evaluations and other considerations, AEOD initiated 18 case studies during 1980. A number of these were completed and the resulting reports included recommendations for follow-on actions by other NRC offices. Summaries of several individual case studies are presented in the following section.

AEOD has also initiated efforts to improve the reporting, collection, storage, and retrieval of opera-

tional experience. These activities include an assessment of the merits of combining the NRC Licensee Event Report (LER) system and the industry-government Nuclear Plant Reliability Data System (NPRDS) into an integrated operational experience reporting system.

AEOD has also begun work on a new program for storing the description of an event in a manner that can be efficiently searched and sorted by computer. This sequence coding and search procedure will greatly improve the NRC's ability to search the operational experience data base for events with specific complex characteristics or interrelationships.

Finally, AEOD has served as the focal point for establishing a systematic operational data assessment program within the NRC and for the development of a working relationship between the NRC and various industry groups such as the Institute of Nuclear Power Operations (INPO), as noted above.

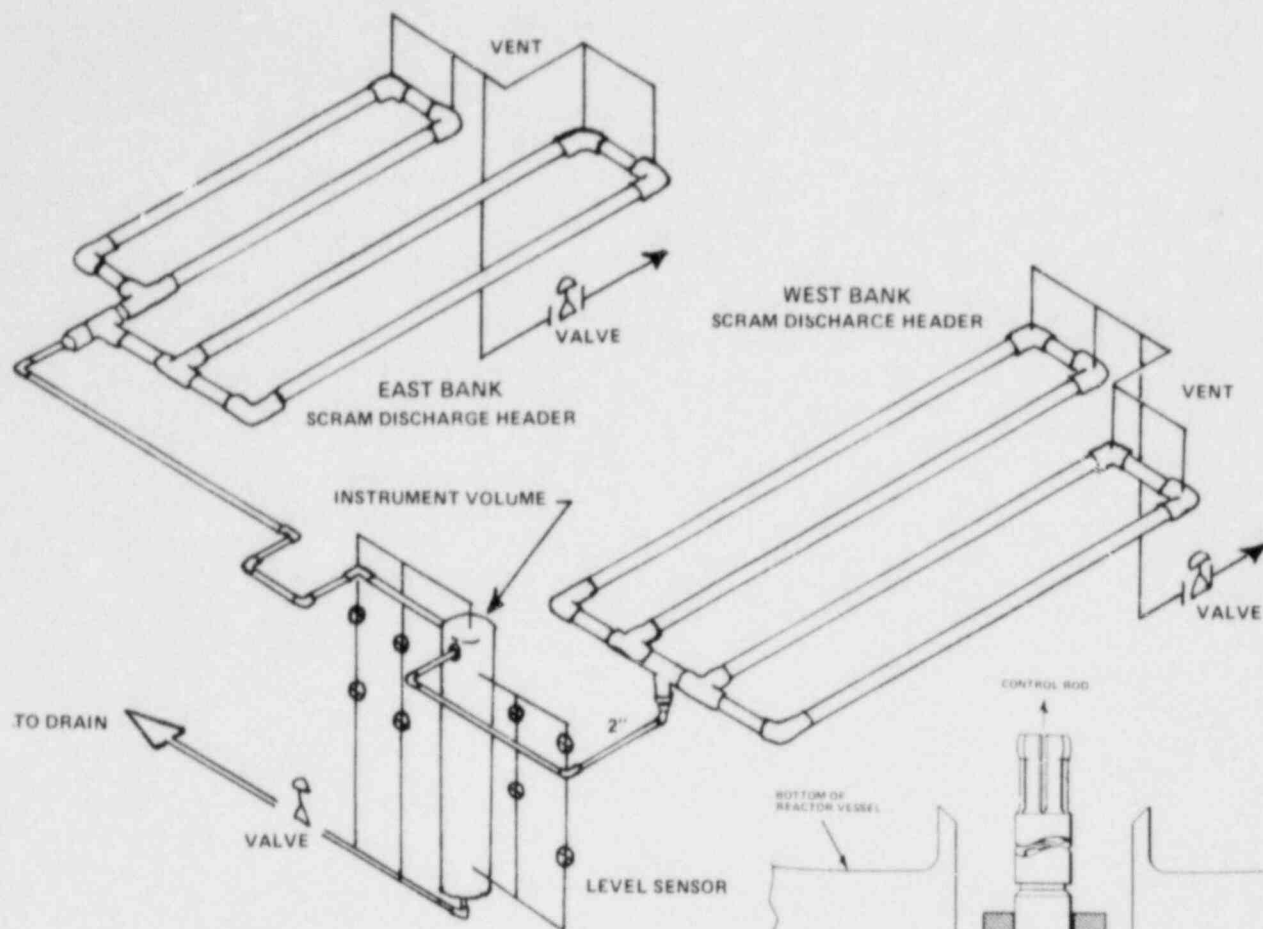

AEOD TECHNICAL STUDIES— SELECT MAJOR CASES

Partial Scram System Failure At Browns Ferry Unit 3

Browns Ferry Unit No. 3 experienced a partial failure of its scram system on June 28, 1980, while shutting down for a scheduled feedwater system maintenance. The failure occurred when the control room operating personnel initiated a manual scram at low power which was the next step in the normal shutdown process. Upon scram actuation, all of the control rods on the west side of the core inserted properly. However, most of the rods on the east side of the core failed to fully insert, stopping at positions ranging from 00 to 46 (48 corresponds to fully withdrawn) with an average insertion of about 20 positions. In all, four reactor scrams over a period of 14

At top of page is a simplified diagram showing a control rod drive mechanism for a boiling water reactor such as Browns Ferry Unit 3, where 76 of a total of 185 control rods failed to fully insert when called upon to do so in June 1980. The partial failure of the scram system was caused by the presence of water in the east bank of the scram discharge volume (SDV) header.

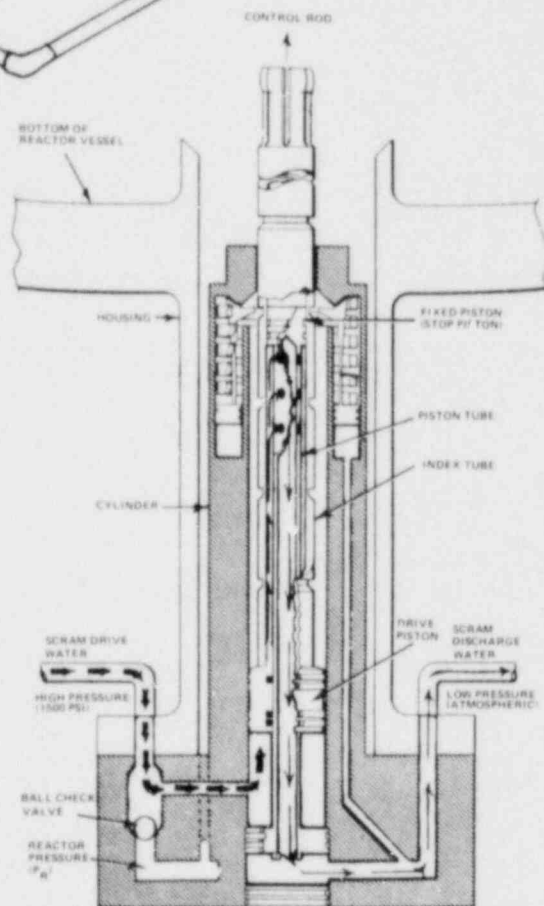

Immediately above is an isometric view of the SDV which is a set of pipes located on each side of the reactor, designed to be continuously drained so that it can receive discharge water if a scram should occur. As a result of the Browns Ferry event, all BWR licensees were required to take actions to prevent occurrence of an event of this nature.

minutes were required to complete full insertion of the east side control rods. (See discussion under "Abnormal Occurrences—Fiscal Year 1980," above.)

Shortly after the Browns Ferry 3 event, AEOD initiated an independent investigation of the Browns Ferry 3 scram system design and operation, including special scram system tests and inspections which were performed at the plant site during the days immediately following the event. The principal purpose of this independent assessment was to determine the lessons learned and recommend corrective actions to prevent recurrence. The review focused on the scram system design and the adequacy of the design features which protect against the loss of scram capability and provide containment isolation.

The AEOD assessment of the Browns Ferry 3 (BF-3) partial scram failure, documented in a report dated July 30, 1980, concluded that the cause of the partial loss of scram capability was the presence of water in the east scram discharge header. The report also identified possible fundamental deficiencies in vent and drain arrangements for the scram discharge volume/scram instrument volume. These deficiencies cast doubt upon the ability of the scram discharge volume protection and isolation features to adequately perform their intended functions. In light of these deficiencies, the report recommended corrective action. The recommended changes went beyond the immediate short-term corrective actions which were taken at Browns Ferry and at other BWRs as a result of IE Bulletin 80-17 and its supplements.

The principal findings from the AEOD study are summarized below.

- Even with unobstructed venting and draining conditions, the BF-3 scram instrument volume (SIV) high level scram function did not and could not have provided protection against the undetected accumulation of water in the east scram discharge volume (SDV) header, with attendant loss of the east bank scram capability.
- A single blockage in the west header SDV vent or drain line coupled with the east side difficulties could have resulted in an undetected accumulation of water in both the east and west headers which could have disabled the scram capability of all control rods.
- With the BF-3 SDV/SIV design, a blockage in the SDV drain path can cause a partial loss of scram capability and disable the protection function installed to assure detection and automatic corrective action.
- Numerous actual and potential mechanisms existed for introducing and retaining water in the SDV with no accumulation in the SIV.
- The BF-3 SDV/SIV design arrangement resulted in the automatic high level scram safety function being adversely influenced by the nonsafety-related reactor building clean radioactive waste drain system.
- The BF-3 partial scram failure event, together with events at other BWRs, showed that the float-type water level monitoring instruments had a significant degree of unreliability.
- If a scram condition exists which cannot be bypassed in "shutdown" or "refuel" mode, then failure of either of the non-redundant SDV vent or SIV drain valves to close could result in an unisolatable blowdown of reactor coolant outside primary containment.
- The emergency operating instructions at BF-3 did not include a procedure or guidance for the operator to follow in the event of a partial or complete scram failure.

As a result of these findings, AEOD recommended the following changes to the scram system design and operating basis:

- The SIV high level scram function should be made independent of the SDV vent and drain arrangement. AEOD recommended that the SIV tank be placed directly under the low end of the 6" SDV header and that the top of the SIV tank be connected to the bottom of the SDV header by a short, vertical 6" diameter pipe (rather than the long 2" diameter horizontal pipe which existed at BF-3). This arrangement would assure water spillage from the SDV directly into the SIV tank containing the level monitoring instruments. Furthermore, this arrangement would not depend on venting or draining phenomena which are sensitive to blockages. AEOD also recommended that all plants provide separate SIV tanks; one for each SDV header. Separate SIVs, in immediate proximity to their respective headers, would assure proper water spillage into the SIVs and would provide adequate redundancy for protection against a total loss of scram capability.
- Diversity should be added to SIV water level monitoring instruments for SIV high level scram function. Monitoring techniques such as differential pressure cells, ultrasonic detection, or conductivity probes should be considered for this purpose.
- All vent and drain paths from the SDV and SIV should be equipped with redundant, automatic isolation valves.
- Emergency operating procedures and operator training should be provided for both partial and complete scram failures.

AEOD concluded that the Browns Ferry Unit 3 partial scram failure demonstrated that the BWR scram system was susceptible to loss-of-scram capability while operating at power and that the loss could remain undetected by the operator and unprotected by the reactor protection system.

In addition to its study of the Browns Ferry 3 partial scram failure, AEOD continued its investigation of the BWR scram system by examining the potential for unacceptable interaction between the control rod drive system and the control air system. From this study, AEOD raised a concern about the adverse effect of a slow loss of control air pressure. For such an event (which had been reported in several LERs) scram outlet valve leakage increases, a condition which can result in rapid filling of the SDV without full insertion of control rods, thereby preventing an automatic scram. The concern focused on the SDV fill rate, the time available for operator action, and the alarms and indications in the control room to guide his actions. Prompted by this concern, Supplement 3 to IE Bulletin 80-17 was issued which required specific immediate short-term remedial actions by BWR licensees to compensate for inadequacy of the scram protection system.

AEOD also analyzed the interim equipment and procedures installed at Browns Ferry Units 1, 2 and 3 in response to IE Bulletin 80-17 and its Supplements, together with the original safety-grade protection equipment installed when the plant was originally built. The analysis focused on assuring continued safe operation pending completion of the recommended scram system modifications. AEOD documented this assessment in a report issued in September 1980.

The principal findings of the September study are summarized below:

- The composite system which was installed following the BF-3 event, and which utilized ultrasonic water detection equipment and special procedures in conjunction with previously installed instrumentation and procedures, did not restore the level of scram protection capability thought to be assured in the original design. However, except for degraded control air pressure, the composite system provided adequate assurance for the interim that water accumulation in the Scram Discharge Volume, which could result in a loss of scram capability, would be reliably detected and adequately responded to by the operator.
- Degraded control air pressure could result in scram outlet valve leakage to the SDV which would require operator action within a few minutes to manually scram the reactor before scram capability would be lost. Degraded control air pressure may also initiate a plant transient which would require a scram. Such an event would be accompanied by numerous control room alarms and indications which could distract the operator from a prompt manual scram actuation. Installed instrumentation did not appear to adequately assure sufficient time for operator diagnosis and actions for this event.
- Operating experience indicated that a significant number of reactor scrams attributed to loss of control air pressure had already occurred. These provided evidence that rapid filling of the SDV was a credible event.

The principal recommendations made by AEOD were:

- An immediate manual scram should be required based on control room indication of degraded

In its study of the partial scram system failure at Browns Ferry, the Office for Analysis and Evaluation of Operational Data identified fundamental deficiencies in the vent and drain arrangements for the scram discharge volume/scram instrument volume (SDV/SIV). Shown is a schematic of the scram hydraulic system in scammed valve lineup.

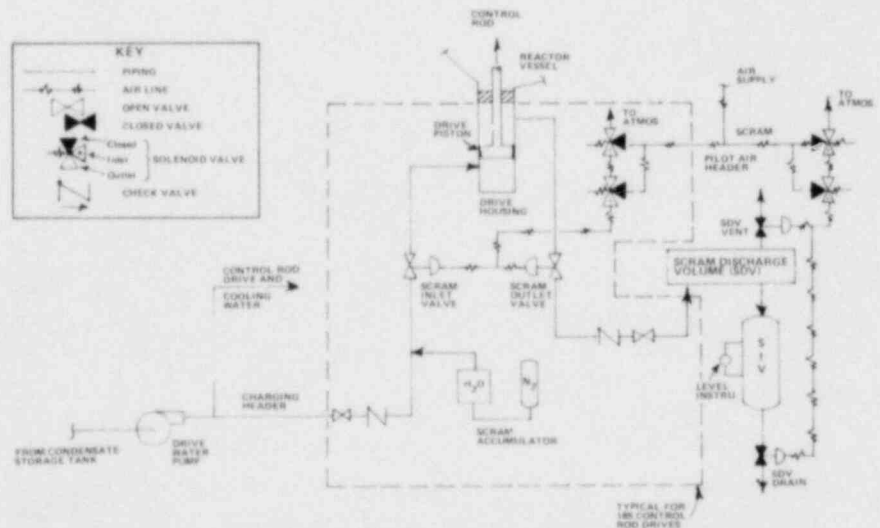

control air pressure. Review of licensee proposals should include consideration of the available pressure indications, and procedures to assure that other alarms and indications do not divert operator attention from this priority action.

- Redundant air header pressure instrumentation should be provided in the control room. To aid the operator in quickly focusing his attention on the need for protective action, a distinctive alarm for degraded air pressure should be provided.
- Because of the possibility that a currently unidentified water source could result in water accumulation in the SDV, it would be prudent to monitor the ultrasonic system alarm output in the control room and require an immediate verification of a sustained alarm by operator monitoring of the equipment. Operability and calibration checks of the system should be continued on a schedule of once per shift.

AEOD concluded that satisfying the intent of these recommendations was necessary to assure that the affected BWRs could be safely operated during the interim period prior to completion of the long term modifications to the scram system.

Loss of Component Cooling Water To All Reactor Coolant Pumps

The incident under study began at 2:26 a.m. on June 11, 1980, at the St. Lucie Power Plant (Fla.). While the reactor was operating at full power, one of the two containment isolation valves in the component cooling water (CCW) return line from the reactor coolant pumps (RCPs) closed, causing a

simultaneous loss of CCW to all RCPs. After an unsuccessful attempt to reopen the CCW return valve, the reactor was manually shut down, or tripped. The RCPs were tripped within two minutes of the reactor trip. After the RCPs were tripped, the operators "jogged" one of the RCPs to aid in establishing plant cooldown on natural circulation, the normal means of cooling the plant under these conditions. CCW was re-established to the RCPs at 3:50 a.m. by jumpering an air supply to the CCW return valve to reopen it. However, the RCPs were not re-started because the shaft seals had exceeded the manufacturer's recommended lower seal cavity temperature limit of 250°F.

During the period from 6:01 a.m. to 6:30 a.m., the Reactor Coolant System (RCS) pressure was lowered from 1,140 pounds-per-square-inch (psi) to 690 psi. At 6:13 a.m., pressurizer level oscillations were observed when the charging pumps were aligned to the auxiliary spray connection in the pressurizer. As the charging pump flow was alternated between the auxiliary spray connection and the normal charging connection in the cold leg, it was observed that the pressurizer level would increase when the charging pumps were in the spray mode and decrease when in the normal charging mode. This behavior is indicative of void formation somewhere in the RCS other than the pressurizer. It now appears that the void, or steam bubble, was formed in the reactor vessel head, since there is essentially no flow through this region of the reactor vessel during natural circulation to effect its cooldown. Since the steam bubble in the reactor vessel head was not affecting the natural circulation flow, the cooldown continued. At 12:27 p.m., the Low Pressure Safety Injection (LPSI) Pump 1A was started to take the RCS and pressurizer solid and to raise the RCS pressure, in order to



This aerial photo of the St. Lucie Nuclear Power Station in Florida shows the reconstructed derrick which was blown down by Hurricane David in September 1979. Two buildings under construction as part of Unit 2 of the plant were damaged by the derrick's collapse. Unit 1, at right, has been in commercial operation since 1976.

Subsequently procedures were adopted to monitor in real time the progress of severe natural phenomena such as hurricanes, floods and seismic events. The monitoring equipment consists of a set of teletype receivers connected to each of the five regional warning circuits of the National Weather Service and a National Digital Facsimile System (DIFAX) unit which receives weather maps and charts from the National Weather Service. The usefulness of the system was proved in the monitoring by NRC staff in August 1980 of Hurricane Allen's progress through the Gulf of Mexico until its landfall near Brownsville, Tex.

maintain an adequate subcooling margin in the RCS. At 2:32 p.m., a bubble was drawn in the pressurizer. The RCS behaved normally indicating that the steam bubble in the reactor vessel head was no longer present.

AEOD initiated a study of this natural circulation cooldown shortly after it occurred. The principal findings of that study follow.

- The rapid depressurization of the RCS resulted in a plant condition that was not anticipated by the plant operators.
- The jogging of the RCP to aid in the establishment of natural circulation appears to have been unnecessary. Although it caused no problem it did increase the potential for seal failure.
- The formation of the steam bubble in the reactor vessel did not inhibit natural circulation flow.
- A rapid depressurization could be a problem for a Babcock & Wilcox plant, particularly if it is being cooled down on natural circulation on one steam generator. Once a bubble forms in the inactive hot leg—either because of flashing in the “candy-cane” or vapor expanding out of the reactor vessel—natural circulation could be precluded in the inactive loop. Once formed, it is thermodynamically impossible to condense the bubble by repressurization if the process is adiabatic. The steam bubble can only be condensed by cooling of the bubble, which may be a relatively slow process because of the hot walls of the RCS piping.
- The CCW is supplied to the RCPs in such a manner that a single failure can stop cooling flow to all RCP seals. The loss of CCW to the RCP seals may cause degradation of the RCS pressure boundary even if the RCPs are stopped.

As a result of the findings described above, AEOD recommended the following.

- Operator training be expanded to emphasize plant behavior during the establishment of natural circulation. This would preclude unnecessary concern or unnecessary starting of RCPs.
- Operator training be expanded to allow operators to quickly recognize the symptoms of formation of a void in the RCS (other than in the pressurizer).
- Procedures be developed to guide the operators in responding to a bubble formed in the reactor vessel head.
- Cooldown procedures during natural circulation be expanded to specify a non-mandatory rate of depressurization which, if adhered to, would

avoid formation of a bubble in the reactor vessel head.

- Consideration be given to the potential for the formation or accumulation of steam in the “candy-cane” of the B&W reactors, particularly in the inactive loop, when natural circulation cooldown is being accomplished with a single steam generator.
- Consideration be given to providing a supply of cooling water to the RCPs that will not be totally disabled by a single failure.
- Consideration be given to providing a means to measure temperature in the reactor vessel head.

As a result of the investigation, AEOD concluded that the primary significance of the June 11, 1980, natural circulation cooldown is that the formation of the steam bubble in the reactor head was unexpected by the plant operators and was not immediately recognized by them. These facts could have led to the operators' taking improper corrective action, although this did not happen at St. Lucie. However, operator training needs to be expanded so that the formation of a steam bubble in the reactor head can be promptly recognized by the operators during a rapid depressurization that occurs during a natural circulation cooldown. Although further investigation is necessary, the voiding of the reactor vessel head does not represent an immediate safety concern. However, it is a plant condition that clearly should be avoided, if possible. Formation of a steam bubble in the reactor vessel head did not in any way impede natural circulation and the reactor was brought to a cold shutdown condition in an orderly manner.

Asiatic Clams Jam System

On September 4, 1980, Arkansas Nuclear One (ANO), Unit 2 was shut down after failing to meet the minimum service water flow-rate through the containment air coolers specified in the Technical Specifications. An investigation by the licensee revealed that Asiatic clams had gotten into the service water system, grown and caused a flow blockage.

The Tennessee Valley Authority first experienced fouling caused by these clams in the condensers and service water systems at its Shawnee Steam Plant in 1957. Asiatic clams were also found at the Browns Ferry Nuclear Plant (Ala.) in October 1974 just a few months after it went into commercial operation. The Asiatic clam has spread across the Tennessee Valley region and is found at virtually all of TVA's steam-electric and hydroelectric generating stations.

Because of the potential for similar occurrences at other operating stations, AEOD instituted its investigation of the event to be pursued along with NRR's investigation. The primary concern is that the clams

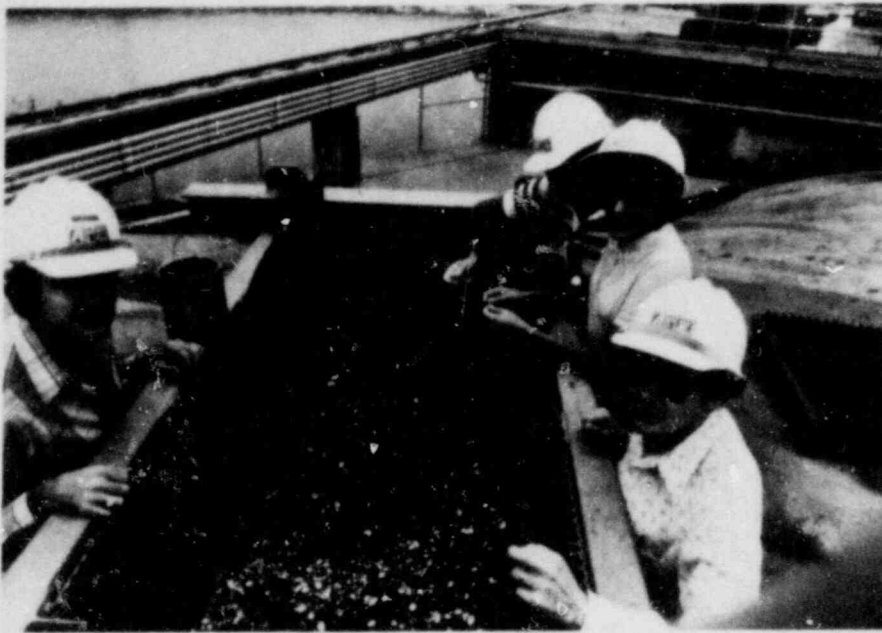

Employees of Arkansas Power & Light Co., at Unit 2 of the Arkansas Nuclear One station, near Russellville, are shown with thousands of Asiatic clams being removed from the intake bay of the plant's cooling water system. The unit had to be shut down because of inadequate flow of service water through the containment air coolers. The freshwater clams, attracted by the slightly warmer water, had gotten into the system, grown and caused the blockage. First discovered in the United States on the West Coast in 1938, the clams have spread rapidly into at least 33 States, and have been found at virtually all of the Tennessee Valley Authority's generating stations.

are a potential mechanism for common mode failure which could cut off the flow of cooling water to safety-related equipment. Because of this concern, a visit was made to the ANO plant and a preliminary report was issued by AEOD on October 21, 1980. The report discussed the flow blockage found in the ANO service water system, made recommendations for better surveillance, and requested that licensees gather and convey information regarding operating experience with fouling of cooling water systems.

The Asiatic clam is a non-native bivalve (two hinged shells) mollusc, *Corbicula* species. It was first found in the United States in 1938, on the northern shore of the Columbia river near Knappton, Wash. Since that time, the clams have rapidly spread across the country and are now reported in at least 33 States. The species in question is found in fresh water.

These freshwater clams are hermaphroditic, so even the presence of a single Asiatic clam in a cooling water system can lead to infestation. The adult clam reportedly releases larvae ranging in size from 200-240 microns. These reach sexual maturity within the first year. The peak spawning seasons occur when the water temperature is between 62°F and 75°F, typically in May and again in September at ANO and Browns Ferry. One adult clam can release many thousands of larvae in one season at a rate of 300-400 per day during the peak. The clams have a life expectancy of two-to-four years, can grow up to 60 mm in length and have proven to be very hardy.

Studies performed on these clams have shown them to be resistant to chlorination, and the chlorination procedures presently followed at nuclear power plants appear to be ineffective in their control.

They have also shown an amazing ability to survive even when removed from the water. One study reported that under favorable temperature and humidity conditions some clams survived for over 26 days when left in air. On the other hand, they have shown a much greater sensitivity to heat. It has been demonstrated that 100 percent mortality can be expected after exposing these clams to 120°F water for two minutes. At ANO the service water systems of both units were flushed with 170°F water for approximately one-half hour.

When the low service water flow in the ANO Unit 2 containment air coolers was found, the licensee disassembled the service water piping at the coolers. Clams were found in the three-inch supply piping at the inlet to the coolers and in the cooler inlet water-boxes. Some of the clams were alive but most of the debris was made up of shells. The size of the clams was about 16 mm (approximately 5/8 inch). The service water, taken from the reservoir at ANO, is filtered before it is pumped through the system. The strainers on the service water pump discharges were examined and found to be intact. Since these strainers are 3/16 inch mesh, much smaller than some of the shells found, it indicates that clams have been growing in the system.

Following the discovery of the Asiatic clams in the containment coolers of Unit 2, the licensee examined other equipment cooled by service water in both Unit 1 and Unit 2. In Unit 2, clam shells were also found in the seal water coolers of the containment spray and the low pressure safety injection pumps. Clams were found in some Auxiliary Building room coolers and in the Auxiliary Cooling Water System which serves non-safety related equipment. In Unit

1, clams were found only in two of the four containment air cooler inlet headers and waterboxes. Further investigation revealed that the service water strainer for these two coolers was broken. The licensee concluded that the clams did not grow in the system but were swept in through the broken strainer. Since there is no flow instrumentation on the Unit 1 coolers, these clams were not discovered during surveillance testing.

In view of the serious problems that could be caused by the clams, AEOD recommended in its report to NRR and IE that consideration be given to the installation of flow instrumentation for each essential component supplied with service water where such instrumentation does not already exist. It was also recommended that this flow indication be periodically monitored and included in the surveillance requirements specified in the plant Technical Specifications. In addition, AEOD requested that information be gathered from the licensees regarding any operating experience involving the fouling of cooling water systems and ascertaining whether biological monitoring has ever revealed the presence of clams, mussels or other potentially troublesome marine growth in either the source or receiving water-body at their plants. This information will assist AEOD in the continuing study of the scope and magnitude of this problem which may affect a number of operating reactors. It is clear from the study done to date that insufficient information exists on the life cycle and control of Asiatic clams.

Loss of Off-site Power At Arkansas Nuclear One

As a result of tornados in the Russellville, Ark. area on April 7, 1980, both units at Arkansas Nuclear One experienced a loss of off-site power. Since both units were operating initially at nearly 100 percent power, a study was initiated by AEOD to compare the natural circulation response of the Babcock and Wilcox Nuclear Steam Supply System (NSSS) in Unit 1 to the Combustion Engineering NSSS in Unit 2. Both units experienced a loss of off-site power after tornado damage to off-site transmission towers which resulted in the loss of four of the five lines providing power to the station. Although the remaining line provided power to the station switchyard, a failure in the bus tie auto-transformer circuitry isolated this off-site power source from both units. The on-site emergency diesel generators energized the essential buses and both units began to cool down by natural circulation as expected.

Each unit experienced equipment performance anomalies during the initial phase of the event. The High Pressure Injection (HPI) System was actuated

manually by Unit 1 operators in response to the decreasing system pressure and pressurizer level caused by the shrinkage of the reactor coolant system which follows a reactor trip. One of the four HPI isolation valves failed to open. On Unit 2, the emergency feedwater flow was interrupted momentarily because of the loss of pump suction caused by feedwater suction flashing.

Neither malfunction adversely affected the recovery of either unit during the transient. Sustained operation of the HPI system required Unit 1 operators to cycle the pressurizer electromagnetic relief valve to reduce system pressure. In addition, the valve was cycled several times to ascertain that the system was not solid (i.e., that there was no loss of the steam bubble in the pressurizer).

The AEOD analyses and evaluation of the event and of the natural circulation response of each unit identified procedural and design deficiencies. The most important findings include: the lack of regulatory requirements for the station switchyard to function following a single failure; improper emergency feedwater pump suction alignment which resulted in loss of feedwater flow; improper alignment of manual selector and mode switches which resulted in loss of the process and trend computer; lack of regulatory recordkeeping requirements for operator actions, alarms, and system conditions needed for post-transient analyses; continued unavailability of the unit 2 turbine-driven emergency feedwater train; and lack of uniform natural circulation criteria and operator understanding and recognition of natural circulation conditions. A number of recommendations regarding corrective actions were made by AEOD to the Office of Nuclear Reactor Regulation.

Water Hammer in LWR Piping Systems

Throughout the history of nuclear power plants, licensees of operating reactors have reported a large number of water hammer events during commercial operation. The term water hammer is applied to those changes of flow condition that could result in significant hydrodynamic loadings caused by the operation of a fluid system. Most of these reported events have resulted in damage to piping supports and restraints, and, in a few cases, equipment failures. (See Chapter 4, "Unresolved Safety Issues.")

In 1977, the NRC staff established a water hammer review group which initiated a review of reported water hammer events and of the potential for occurrence of water hammer in all fluid systems that could have an impact on plant safety. The objectives of the review were to identify the causes of water hammer events that could affect reactor safety and to recommend actions needed to reduce the

likelihood of such events. Since these NRC review efforts began, several NRC reports on water hammer have been published and recommendations have been made and implemented to reduce the potential for damaging steam generator water hammers. For other types of water hammer, NRC has proposed a series of task action plans to continue its investigation.

Because of the continuing incidence of water hammer and its potential impact on the operation of certain safety systems, the Office for Analysis and Evaluation of Operational Data (AEOD) has initiated an independent review of the water hammer events that have occurred in LWRs. The objective is to review all available water hammer events, especially those events which are new or have not yet been considered by the NRC water hammer review group.

A summary list, in order of significance, of those events that are important to the operation of safety systems is being prepared. The list will be used to develop recommendations to the water hammer review group on the priority of their investigation for different water hammer events.

In addition, AEOD will identify scenarios (e.g., basic initiating mechanisms, design features, operating procedures, anticipated transients, and single failures) that could result in water hammer events. The effort includes detailed review of system operation and thorough analysis of particular events. This independent AEOD effort on water hammer review will result in recommendations on possible design or procedural changes to prevent the occurrence or minimize the consequences of the potential water hammers.

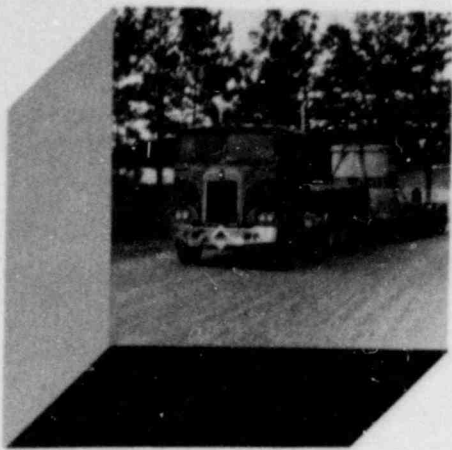

6

Materials Regulation and Transportation

Regulation of the possession, use and disposition of nuclear materials is administered by the NRC's Office of Nuclear Material Safety and Safeguards through three major programs: the fuel cycle and material safety program, including transportation, discussed below; the safeguards program (including the safeguarding of facilities), discussed in Chapter 7; and the waste management program (including uranium recovery operations), discussed in Chapter 8.

The fuel cycle and material safety activities covered in this chapter include licensing and other regulatory actions concerned with (1) purification and conversion of uranium ore concentrates (after mining and milling) to uranium hexafluoride, (2) conversion of the uranium hexafluoride (after enrichment in Government-owned diffusion plants) to ceramic uranium dioxide pellets and their fabrication into fuel for light water nuclear reactors, (3) production of naval reactor fuel, (4) storage of spent reactor fuel, (5) transportation of all types of nuclear materials, and (6) production and use of reactor-produced radioisotopes ("byproduct material").

Among actions in these areas during fiscal year 1980, the NRC:

- Completed 26 major and 69 minor licensing actions dealing with uranium fuel.
- Acted on 4,614 applications for new byproduct material licenses and amendments and renewals of existing licenses, and completed 133 evaluations of sealed sources and devices containing radioactive materials.
- Completed 183 transportation package design certification reviews, and approved 349 quality assurance programs for radioactive material transportation activities.
- Conducted 44 post-licensing visits to observe the operations of materials licensees.

- Continued the review and analyses of terminated AEC materials licenses to identify possible contaminated sites, and identified suspect sites for further evaluation.
- Completed a program of measuring radon releases from uranium mining and milling operations and developed new radon estimates for the environment impact fuel cycle rule (Table S-3 of 10 CFR Part 51). The staff also supported appeal board hearings on radon environmental impacts.
- Completed a pilot program of regionalizing material licensing and developed plans for expanding this concept.

In other actions, the fuel cycle and material safety staff prepared an emergency response plan to support overall NRC effort in this area, defined proposed radiological contingency planning requirements for fuel cycle and material licensees, and issued orders implementing Environmental Protection Agency radiation protection standards for the uranium fuel cycle (40 CFR 190).

Fuel Cycle Actions

SURVEYS OF FUEL CYCLE

The environmental impacts of construction and operation of fuel cycle plants of every type are analyzed and evaluated in detail by the NRC as part of the process for licensing such plants. In connection with the licensing of reactors, the NRC also considers the cumulative environmental effects of the entire fuel cycle from fuel production to the disposal of the spent fuel and radioactive wastes. In

MATERIALS LICENSES REGULATED BY NRC

(AS OF JULY 31, 1980)

| | |
|--------------------------|--------------|
| BYPRODUCT MATERIAL | 7,784 |
| Medical | 2,625 |
| Academic | 377 |
| Industrial | 4,894 |
| Civil Defense | 88 |
| SOURCE MATERIAL | 312 |
| SPECIAL NUCLEAR MATERIAL | 539 |
| EXPORT | 14 |
| IMPORT | 4 |
| TRANSPORTATION | 6 |
| Total | 8,658 |

this consideration of cumulative environmental impacts of the uranium fuel cycle, there has been controversy, including litigation, over the effects of the naturally radioactive gas radon-222, resulting from the radioactive decay of natural uranium, which is released in mining and milling operations. In 1980 the environmental effects of radon-222 were the subject of major efforts in research, in impact assessments, and in licensing proceedings.

In a related matter, a petition was submitted by the States of Wisconsin and New York to include the economic costs of radioactive waste disposal in the environmental impacts of the nuclear fuel cycle. The Commission was divided, on a 2-2 vote, as to whether to grant the petition. This effectively denied the petition.

To facilitate informed public participation in the consideration of environmental impacts of the fuel cycle, the Commission directed the staff to prepare a narrative explanation of the impacts presented in Table S-3 of the regulation of 10 CFR 51.20. The narrative, which was submitted to the Commission for approval in September 1980, describes the environmental impacts of the uranium fuel cycle, explains which fuel cycle plants are the major contributors, identifies the operations which cause the impacts, and describes the calculated health effects among the U.S. population.

Improved Radon Estimates

Research projects that had been in progress for two years were completed in 1980 with the publication of reports on radon-222 emissions from uranium mining in both open-pit and underground mines and

completion of the Final Generic Environmental Impact Statement (GEIS) on Uranium Milling. (This statement, designated NUREG-0706, was published in October 1980. See Chapter 1.) Under NRC contracts, Battelle Pacific Northwest Laboratory measured the radon released to the atmosphere from open-pit mining operations in Wyoming and underground mines in New Mexico. These mines account for about 65 percent of the uranium output from open-pit mines and 63 percent of the output from underground mines in the United States. Similar measurements of radon releases from an open-pit mine in a different type of rock in New Mexico, performed by the Argonne National Laboratory under another NRC contract, were lower than those in the Wyoming sandstone ore bodies. The research will continue with further investigations of the New Mexico mine rock formation's permeability to radon diffusion and of the radon measurements obtained by different types of measuring apparatus.

The extensive radon emission measurements were documented in technical reports in which new esti-



Argonne National Laboratory designed and built special equipment to monitor radon-222, a naturally radioactive gas from the radioactive decay of natural uranium released in mining and milling operations. Data collected by the continuous radon emission monitor (shown in foreground) and by more conventional instruments (background) which measure temperature, wind direction and velocity, and atmospheric pressure, are used in impact assessments and research projects.

A high-lift on the floor of an open pit mine removes the crumbly sandstone overburden to expose uranium ore. At this depth, the uranium can be detected easily with a Geiger counter. The vein of uranium ore will be marked for excavation and transport to the mill for processing.

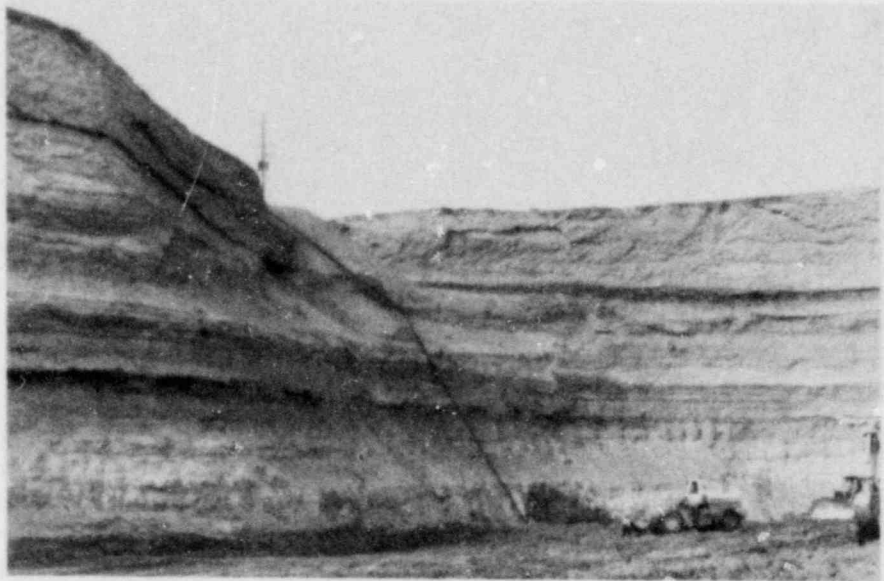

mates were presented for the total quantity released in mining uranium for fueling a typical nuclear power plant. The estimates showed that these releases do not add significantly to the natural radon content of the air (less than 0.5%).

The new estimates of releases from uranium mining were added to new estimates of releases from uranium milling to develop a revised estimate of total radon releases from the entire nuclear fuel cycle, and a technical report (NUREG-0805) was prepared for publication as a reference document for rulemaking action. Preparations were made for a rulemaking proceeding to amend the NRC regulations in 10 CFR 51.20 to incorporate the new radon estimate. The new value will include the revised estimates given in the GEIS on uranium milling, and is expected to resolve litigation problems in reactor licensing cases involving controversy over radon's environmental impacts.

Appeal Board Hearing on Radon

In February 1980, an appeal board hearing was held to resolve the radon issue in connection with several reactor licensing cases. The cases had been combined into a single hearing by mutual agreement of the parties, since all dealt with the same questions relating to radon.

The new radon environmental impact estimates from Battelle's measurements at uranium mines and from the GEIS on uranium milling were introduced in the hearing and witnesses were cross-examined by the parties. After the appeal board's decision, expected in early fiscal year 1981, the amendment to incorporate new, overall radon estimates into 10 CFR 51.20 will be developed.

Updating Values in Table S-3

A draft report was submitted by the NRC's contractor, the NUS Corporation, to update the "Environmental Survey of the Uranium Fuel Cycle" which was published in 1974 to provide reference data for Table S-3 in the NRC regulation 10 CFR 51.20. While the draft report was in preparation, there were regulatory developments which precluded completion of the project on the schedule originally planned. In particular, the changes being made in the waste management criteria and regulations for both high-level and low-level radioactive wastes will not be firmly established until about the end of 1981. Also, the environmental impact estimates for spent fuel reprocessing were based on the Barnwell Nuclear Fuel Plant which has not been licensed for operation and may never be used for commercial fuel reprocessing. Plans for a new fuel reprocessing plant had been developed by Exxon Nuclear Co., but NRC review of the license application was discontinued without prejudice in 1978 because of the national policy against reprocessing. Thus, at present, there is no firm basis for more up-to-date estimates of the environmental impacts of the back end of the fuel cycle.

The staff considered the merits of updating only the portions of Table S-3 dealing with the front end of the fuel cycle. However, the contractor's report of updated values for these operations shows no significant changes from present Table S-3 values except in the case of radon-222, for which a separate amendment is already planned. The staff thus concluded that completion of even a limited update at this time is not justified, especially since no issues other than radon are being raised in reactor licensing proceedings with respect to the present Table S-3.

Nuclear Fuel Cycle Evaluations

The final reports of the International Nuclear Fuel Cycle Evaluation (INFCE) and the Nonproliferation Alternative Systems Assessment Program (NASAP), in which NRC staff participated, were published early in 1980. (See also Chapter 11.) The INFCE report noted that nations facing shortages of energy raw materials, including uranium fuel, may choose to reprocess spent fuel and to recycle uranium and plutonium as a means of stretching their energy resources. International interest emphasizes regional centers in which spent fuel reprocessing and new fuel fabrication would be performed in facilities which minimize the transportation of recovered plutonium in order to strengthen the safeguarding of this material.

NASAP reports on alternative reactor and fuel cycle systems showed no alternative which clearly improved or facilitated the pursuit of nonproliferation objectives. The Carter Administration advised the Commission in July 1980 that nothing in the INFCE reports or other events since the original nuclear policy statement in 1977 had altered the Administration's view that the U.S. "should defer indefinitely the commercial reprocessing and recycling of plutonium produced in U.S. nuclear power programs."

NUCLEAR FUEL CYCLE FACILITIES

| TYPE | APPLICATIONS | |
|---|--------------|-----------|
| | OPERATING | FILED |
| Uranium Mills* | 21 | 9 |
| UF ₆ Production Plants | 2 | 0 |
| Enriched Uranium Fuel Processing and Fabrication Plants | 16 | 0 |
| Plutonium Fuel Processing and Fabrication Plants | 6*** | 1** |
| Fuel Reprocessing Plants | 0 | 2** |
| Irradiated Fuel Storage Facilities | 2 | 1*** |
| Waste Burial Grounds* | 3 | 1 |
| Enrichment Plants | 0 | 0 |
| TOTAL | 50 | 14 |

*Some of the Mills and Waste Burial Grounds are Under Agreement State License

**Firm Plans Affected by Pu-Recycle Question (Applications for these Commercial facilities terminated by NRC)

***Pilot Plant, Experimental or R&D Facilities

****Does not include Standardized Design or Trans-shipment Projects

Congressional Inquiries Regarding GESMO. The public hearing on the "Generic Environmental Statement on the Use of Recycled Plutonium in Mixed Oxide Fuel in LWRs" (GESMO) was terminated in 1977 following the Administration's announcement of the U.S. policy against reprocessing and recycle of plutonium. (See 1977 Annual Report, pp. 45-46, and 1978 Annual Report, pp. 72-73.) In 1980, a number of Congressional inquiries were made to the NRC about reinstating the GESMO proceeding to prepare for U.S. reprocessing and recycle programs. Several bills were introduced in the Congress to require the Commission to reopen consideration of this matter. None of these proposals was enacted.

The Commission published a *Federal Register* notice on August 13, 1980, seeking public comments on (1) whether the Commission should reopen the GESMO proceeding; (2) what action, if any the Commission should take related to commercial reprocessing; and (3) whether the Commission should consider any other actions related to this subject.

SPENT FUEL STORAGE ACTIONS

The need for storage of spent nuclear fuel continues to stimulate actions by nuclear power plant licensees to increase capacities of storage pools at reactor sites and to ship irradiated fuel from sites with filled pools to others where room is available. Interest also continues in proposals for off-site facilities dedicated to spent fuel storage.

Movements Between Reactors

An evidentiary hearing continued through 1980 before an atomic safety and licensing board on Duke Power Company's application for the transfer of spent fuel from its Oconee Nuclear Station, Seneca, S.C., to the McGuire Nuclear Station in North Carolina, which is not yet in operation. This application was contested by two intervenors: Carolina Environmental Study Group and Natural Resources Defense Council. The hearing record was closed in April, and the NRC staff's proposed findings were filed on June 17, 1980. Duke's application was rejected by the board in its initial decision filed on October 31, 1980. The applicant has elected to appeal the board's decision and has filed exceptions to it. NRC staff has also elected to appeal this decision and filed exceptions to it on November 10, 1980.

Away-From-Reactor Storage

Since 1972, the General Electric Co. has been storing spent fuel at its Midwest Fuel Recovery Plant (now renamed the Morris Operation) at Morris, Ill.

In February 1979, the licensee submitted a timely application for renewal of its materials license. Petitions for leave to intervene in the license renewal proceeding were filed by the Illinois attorney general and a group of individuals. An atomic safety and licensing board appointed to conduct a hearing admitted the petitioners as intervenors in the proceeding after a special prehearing conference in February 1980.

As part of its review, the staff issued an Environmental Impact Appraisal in June 1980, which concluded that the proposed licensing action will not significantly affect the quality of the human environment and that there will be no significant environmental impact from the proposed action.

In November 1980, prior to the issuance of the staff's Safety Evaluation Report, the Commission promulgated a new rule, 10 CFR Part 72, entitled "Licensing Requirements for the Storage of Spent Fuel in an Independent Spent Fuel Storage Installation," to become effective in December 1980. The Commission directed that the Morris Operation license renewal matter should proceed pursuant to Part 72. At the end of 1980, the staff was reevaluating the licensee's submissions in light of the new regulation.

ADVANCED FUEL ACTIVITIES

The NRC staff continued to evaluate the integrity and safety of six plutonium processing and fuel fabrication plants that are licensed to possess and process five kilograms or more of unencapsulated plutonium. The objective is to improve, to the extent practicable, the capabilities of these facilities to withstand the effects of adverse natural phenomena and to protect the health and safety of the public (see 1979 NRC Annual Report, p. 124).

The analysis of plant capability includes site characterization with regard to seismology/geology, surface hydrology, normal and severe weather meteorology, and the structural capacity to withstand severe seismic and meteorologic events. Analysis of risk to the public involves source term estimation, meteorological dispersion, demography, ecology, and radiological impact.

Three of the six plants have been completely analyzed and summary documents have been issued which describe the effects of damage to the facilities from natural phenomena (NUREG-0547, regarding the Babcock and Wilcox facility at Parks Township, Pa.; NUREG-0621, concerning Westinghouse's facility at Cheswick, Pa.; and NUREG-0722 describing the Exxon Mixed Oxide Fabrication Plant at Richland, Wash.). NUREG-0547 and NUREG-0621 were issued in 1979. NUREG-0722 was issued in 1980.

The analysis of the General Electric facility at the Vallecitos Nuclear Center at Pleasanton, Calif., was completed in 1980 and the pertinent summary is in preparation. Analyses of the remaining two plants is expected to be completed in 1981.

OTHER FUEL CYCLE ACTIVITIES

Radiological Contingency Planning

During the year, NRC initiated a program to assure that its fuel cycle and major materials licensees have contingency plans for proper response to radiation emergencies. Such plans are needed to assure that (1) plants are properly configured to limit releases of radioactive materials and radiation exposures in the event of an accident, (2) a capability exists for measuring and assessing the significance of accidental releases, (3) appropriate emergency equipment and procedures are provided on-site to protect workers against radiation hazards that might be encountered following an accident, (4) notifications will be promptly made off-site to Federal, State and local government agencies, and (5) that necessary recovery actions will be taken in a timely fashion to return a plant to a safe condition following an accident. Steps are being taken to require licensees to submit information describing plant systems important to safety; characterizing classes of credible emergency situations that might occur, and specifying radiological contingency measures for each class; describing authorities and responsibilities of key individuals and groups; and describing equipment and facilities designated for use during radiation emergencies. (See also Chapter 3.)

Implementation of 40 CFR Part 190

On January 13, 1977, the Environmental Protection Agency issued regulations setting forth environmental radiation protection standards for the uranium fuel cycle (40 CFR Part 190). These regulations became effective for uranium fuel cycle plants (except for uranium mills) on December 1, 1979. In essence, the regulations require that radioactivity in planned effluent releases, radon and its daughters excepted, from fuel cycle plants be limited so that no member of the public will receive an annual dose equivalent of more than 25 millirems to the whole body, 75 millirems to the thyroid or 25 millirems to any other organ.

The NRC, as the "Regulatory Agency" defined in 40 CFR Part 190, is responsible for assuring that uranium fuel cycle plants licensed by the Commission meet the requirements of the new environmental radiation protection standards. To assure compliance, the licenses of all plants subject to the new

regulations were conditioned to limit the concentration of radioactivity in the environment so that the dose equivalents would not be exceeded.

Evaluating Sites for Radioactivity

The NRC continued to be active in evaluating sites of former radioactive material operations in order that corrective action can be taken wherever required to protect the public.

Formerly Licensed Sites. In response to an earlier General Accounting Office inquiry concerning potential radiation safety problems at sites previously operated under AEC licenses, the NRC has been examining the files of licenses terminated before 1965 to ascertain that proper decontamination has been carried out.

The Oak Ridge National Laboratory and the NRC staff have completed the evaluation of docket files for old source and special nuclear material licenses. Less than 60 sites were identified which require further evaluation by the NRC. The evaluation of docket files for old byproduct materials licenses has been started by Oak Ridge National Laboratory. Several thousand old dockets will be examined under this part of the program, and the effort will be completed in early 1981.

Known Contaminated Sites. NRC has awarded a contract for radiological surveys of known contaminated sites including the West Lake Landfill in St. Louis County, Missouri, and Reed-Keppler Park, West Chicago, Illinois, where radioactive materials were buried in the past. The surveys will define the location and quantities of material present and serve as the basis for determining what corrective actions may be needed.

Ammonium Nitrate Waste

An application has been received from Kerr-McGee Nuclear Corporation for an amendment to its UF_6 plant license which would permit the unrestricted use of raffinate containing ammonium nitrate as a commercial fertilizer. Tested raffinate has been used for a number of years under experimental conditions as a fertilizer on Kerr-McGee owned land at the UF_6 plant site. Prior to making a decision on the requested amendment, both an environmental assessment and a safety analysis of the proposed use will be prepared.

West Valley, N.Y., Facility

The West Valley Demonstration Project Act (P.L. 96-368, signed by the President on October 1, 1980) authorizes the Department of Energy (DOE) to undertake a high-level waste solidification project at the West Valley site. The Act required DOE consultation with NRC in carrying out the project. In anticipation of the legislation, DOE had started work on an environmental impact statement that will address the alternatives for disposing of the high-level liquid waste stored at the shut down reprocessing plant located at West Valley.

During the past year, the General Accounting Office (GAO) investigated and reported on the West Valley problem. The GAO recommended that the Federal and State governments work together to decide the future disposition of the site.

As part of its continuing assessment of the safety conditions associated with the high-level waste storage system at West Valley, the NRC staff through its contractor, Rockwell Hanford Operations, has initiated an inspection and evaluation program of the problems involved. The program will use state-of-the-art technology which includes photographic

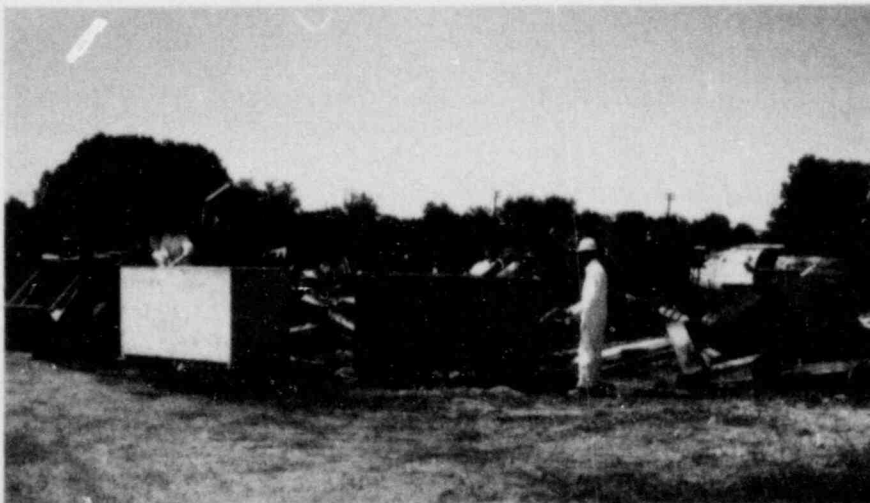

Radiation specialists scan the site of a former nuclear materials production plant operated by the Kerr-McGee Corporation at West Chicago, Ill. The survey will locate sources of radioactivity and amounts of radioactive material remaining since shutdown of the plant in 1973, and a decontamination plan will be established.

inspections of accessible portions of tanks and vaults, ultrasonic inspections of tank walls for thickness and detection of small defects, waste-soil interaction studies, and heat transfer analyses for various possible waste configurations. The program is expected to continue through fiscal year 1983.

The staff also continued to assess the effects of severe natural phenomena on the dormant facility at West Valley. Analysis of the effects of a major earthquake on the acid high-level liquid waste tanks has demonstrated that no undue risk to the health and safety of the public would be posed by such an event. Analysis of the effects of severe tornadoes on the reprocessing plant building is nearing completion.

Transportation of Radioactive Materials

Transportation of radioactive materials is regulated at the Federal level mainly by the NRC and the Department of Transportation (DOT). NRC sets the standards for "Type B" packages (those whose content of radioactive materials requires that they be safely retained in their containers under both normal and accident conditions) and for packages containing fissile material. NRC also makes independent evaluations of package designs submitted by applicants and serves as a technical advisor to DOT.

Package designs used by contractors for the Department of Energy (DOE) are reviewed and approved by that agency; however, the NRC has been reviewing such package designs as submitted by DOE. These NRC reviews are not binding on the DOE, but an NRC approval permits commercial licensees to use these packages.

Since late 1979, NRC has specifically subjected its own licensees to DOT regulatory requirements for shipments of radioactive materials. This program has resulted in an overall increase in the Federal capability for inspection and enforcement of nuclear shipment requirements and also has created an increased awareness on the part of shippers of the need for compliance. During 1980, the NRC processed a number of civil penalty enforcement actions against NRC licensees for violations of transport regulatory requirements.

Low-Level Waste Shipments

In 1980, assistance was provided to the State of Washington at the low-level waste disposal facility located on the Hanford Reservation. NRC personnel assisted Washington State inspectors in examining arriving shipments of low-level waste to determine if the shipments were in compliance with all applicable

regulations. This effort was part of the NRC's response to the Governor of Washington that actions would be taken to ensure that Federal regulations on low-level waste shipments are met.

In February 1980, the NRC assisted the State of Nevada in hosting a meeting on low-level waste attended by representatives of waste carriers, generators, brokers, burial ground operators, and Federal and State regulators. The aim of the meeting was to identify and discuss problems in the low-level waste area. (See Chapter 10 for further details.) NRC continued an accelerated inspection schedule of three to five days per month at all three commercial low-level waste burial sites located in Washington, Nevada and South Carolina.

The American National Standards Institute Subcommittee on Transportation of Radioactive Waste (with NRC participation) completed its final draft of a standard for the packaging of aqueous radioactive wastes for transportation from nuclear power plants. It will require that liquid wastes be solidified and filter cartridges be encapsulated prior to shipment, and that a high-quality container be used.

Irradiated Fuel Packaging Actions

In April 1979, NRC issued an Order to Show Cause (immediately effective), prohibiting the use of the Model No. NFS-4 package pending satisfaction of specific requirements to measure and report any deviations of existing packagings from the Commission-approved design (see *1979 NRC Annual Report*, pages 127 and 128). Of the seven packagings fabricated, three have been returned to service, two were found to deviate from the approved design, and two were not submitted to the NRC for reinstatement consideration. The NRC received and at year-end was reviewing an application which addresses the effect of the observed deviations on the ability of the packaging to meet the performance requirements of 10 CFR Part 71.

Packaging designs using thick, solid steel walls for containment and gamma shielding have been submitted to the NRC for review (see *1979 NRC Annual Report*, page 128). The Model No. TN-12, submitted by Transnuclear, Inc., has been withdrawn for marketing reasons. The Model No. NAC-3K, submitted by Nuclear Assurance Corp., was still under review at the end of November 1980. A major factor in this review is determination of fracture toughness for thick steel forgings.

Safety of Transportation Workers

During 1980, work continued on a study of radiation exposure of transportation workers handling large numbers of radioactive material packages. The

study is examining procedures used at carriers' facilities for handling radioactive materials packages and will determine exposures received by transport workers. Information obtained in the study will be used to prepare a recommendation to DOT on what further measures may be necessary to control radiation exposures in selected portions of the transportation industry. A report will be published in 1981.

During fiscal year 1980, the NRC/DOT-sponsored State Surveillance Program on Transportation of Radioactive Material was continued. In July 1980, a report on the status of the program was published. (See Chapter 10.)

GAO Report

In May 1979, the General Accounting Office (GAO) issued a report entitled "Federal Actions Are Needed to Improve Safety and Security of Nuclear Materials Transportation." One GAO recommendation was that the NRC amend its regulations that require receivers of radioactive materials packages to promptly monitor the surface contamination and external radiation levels of the package. The GAO recommended that the monitoring requirement be extended to include additional packages not previously covered in the regulation. The purpose of the regulation is to provide a means for rapid detection of a package that had either leaked in transit or had a substantial reduction in shielding integrity. Rapid detection of such a problem would allow remedial action to be taken to either reduce the exposure or mitigate the effects of exposure on transport workers and the general public. The NRC is examining the package monitoring rule to determine if changes are necessary.

The GAO also recommended that NRC and DOT reduce permissible contamination levels for packages and vehicles to levels compatible with what industry can reasonably achieve. In March 1980, in response to this recommendation, the NRC initiated a study for permissible levels of surface contamination for packages of radioactive material. The study is evaluating the health benefits and economic costs associated with lowering the permissible contamination levels. The results will be used to determine appropriate contamination limits based on the relative costs and health benefits of lowering contamination levels. The study is expected to be completed in 1981.

Transportation in Urban Areas

During 1980, Sandia Laboratories, under contract to the NRC, continued its work to assess the environmental impacts resulting from the transportation of radioactive materials through urban areas, and submitted several reports. The study has been

examining the impacts resulting from incident-free transport, vehicular accidents during transport, and from other abnormal situations. In performing this study, Sandia developed computer models to account for the special features of the urban environment. The results of these calculations are given in a draft environmental assessment, NUREG/CR-0743, published in July 1980. Two additional contractor reports by Rice University and the University of Texas, and Battelle Human Affairs Research Center (NUREG/CR-0742 and -0744, also published in July 1980) assess social impacts. These studies, which were issued for public comment, will form the basis for a draft generic environmental impact statement on the transportation of radioactive material in urban areas which NRC expects to publish in fiscal year 1981.

Power Reactor Wastes

In 1980, an effort was undertaken to update the NRC's (then AEC) 1972 report, WASH-1238, "Environmental Survey of Transportation of Radioactive Material to and from Nuclear Power Plants." The update will assess the effects of numerous changes that have taken place since 1972 such as the lack of spent fuel reprocessing, higher fuel burnups, and spent fuel storage. In addition, the updating analyses will determine the characteristics of radioactive materials shipments to and from nuclear power plants in order to calculate radiological health impacts.

Emergency Response Planning

In 1980, the NRC published a survey of current State radiological emergency response capabilities for transportation-related incidents. The NRC will use the information from the report in its role regarding radiological incident planning, emergency response training, and other activities assisting State and local governments.

The NRC began work in 1980, with EPA participation, to develop a model program for response to transportation-related radiological incidents which can be used by State and local governments. The results of the survey and the model program will be used to develop cost-effective guidance for State and local governments in upgrading their emergency response capabilities.

In 1980, a committee of the American National Standards Institute continued to develop an industry standard on emergency response for highway transportation accidents involving radioactive materials. The committee includes representatives from industry, State governments, the NRC, and other Federal agencies. The standard will provide guidance to car-

riers and shippers on items to be considered in emergency response planning and on procedures to be used by their personnel immediately following a highway accident involving truckload quantities of radioactive material.

Other activities related to emergency response capabilities for radiological transportation accidents included:

- In July 1980, the NRC published a final report, NUREG-0535, "Review and Assessment of Package Requirements (Yellowcake) and Emergency Response to Transportation Accidents" (see 1979 NRC Annual Report, page 127). In this report, an NRC/DOT study group recommends that carriers and shippers write response plans.
- The NRC issued a report prepared under contract by Indiana University entitled, "Survey of Current State Radiological Emergency Response Capabilities for Transportation Related Incidents" (see 1979 NRC Annual Report, page 129). The report concludes that the States vary significantly in the extent in which they plan for emergency response; however, some areas are identified in which uniform standards, guidelines, or NRC technical assistance may be worthwhile.
- The NRC is participating jointly with the Federal Emergency Management Agency (FEMA) and four other agencies to provide guidance and training to State and local governments.
- The NRC has initiated a program to improve transportation-related incident/accident reporting.

(See also Chapter 3, "Emergency Preparedness.")

Routing of Shipments

Under its Memorandum of Understanding with DOT, NRC is to provide technical advice and assistance to that agency. NRC advice relative to DOT's proposed rulemaking on the routing of radioactive material shipments was to require routing of shipments in a manner that will minimize total annual health impact, including nonradiological impacts. A technical analysis shows that, for typical transportation routing alternatives, nonradiological impacts associated with transportation accidents far outweigh the corresponding radiological impacts. All impacts would be minimized by the use of interstate highways which entail the shortest travel time to the destination.

Pre-Shipment Notification. At the end of fiscal year 1980, the NRC staff was completing for Commission consideration proposed amendments to 10 CFR Parts 71 and 73 that would require licensees to notify governors in advance when shipments of spent



Flatbed truck transports a sealed container of contaminated resins to a waste disposal site. The resins, used to clean contaminated water at nuclear power plants, are housed in steel cylinders and placed inside sealed canisters for the trip. Transport packaging for this type of radioactive material must be approved by the NRC.

nuclear fuel or potentially hazardous nuclear wastes will be passing through their States.

The revisions to the regulations would implement Section 301 of Public Law 96-295, enacted on June 30, 1980, which requires the NRC to "promulgate regulations providing for timely notification to the governor of any State prior to the transport of nuclear waste, including spent nuclear fuel, to, through, or across the boundaries of such State." The notification is not required for shipments determined by the Commission not to pose a potentially significant hazard to the public health and safety.

Packaging Standards

In February 1980, the NRC issued a revision to Guide 7.9, which identifies the information to be provided in an application for the approval of packaging for shipping Type B, large quantity, and fissile radioactive material and presents a uniform format for presenting the information.

In August 1979, the NRC published for public comment a revision to 10 CFR Part 71, "Packaging of Radioactive Material for Transportation and Transportation of Radioactive Material Under Certain Conditions." This revision of the NRC transportation regulations would make them more compatible with those of the International Atomic Energy

Agency (IAEA) and thus with those of most major nuclear nations of the world. Comments were received from 26 persons which included support for the proposal, technical comments urging changes to the proposal, and a plea for uniformity among NRC, IAEA, and DOT regulations.

International Standards

In 1983, the IAEA will issue a revision of its Safety Series No. 6, "Regulations for the Safe Transport of Radioactive Materials." NRC participated with DOT in 1980 meetings of IAEA to establish technical recommendations for the revision and to work on the first draft revision of the rules. Public comments will be solicited on this first draft revision, with redrafting scheduled for March 1982.

Byproduct Material Licensing

Reactor-produced radionuclides are used extensively throughout the United States for civilian and military industrial applications, basic and applied research, the manufacture of consumer products, civil defense activities, academic studies, and medical

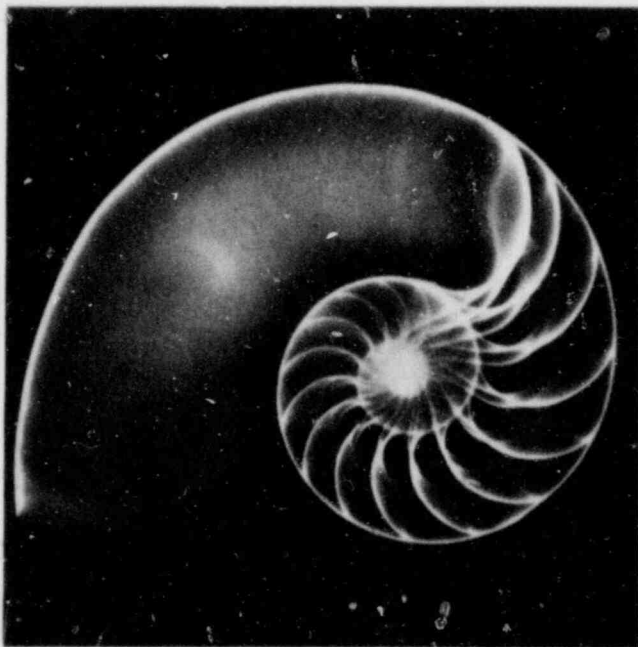

NRC and Agreement States regulate the industrial and basic research applications of radiography. Just as the exquisite structural detail of the chambered nautilus is shown in this radiograph produced by an encapsulated neutron source, so too are structural defects in metal castings and welds detected by radiography using gamma radiation sources.

diagnosis, treatment and research. The NRC's evaluation and licensing program is designed to assure that these activities will not endanger public health and safety.

The NRC administers 8,700 material licenses. The agency took 4,614 licensing actions during fiscal year 1980, of which 721 were on applications for new licenses, 3,008 concerned license amendments, and 885 were license renewals. In addition to the 8,700 NRC material licenses, 12,100 licenses are administered by 26 States which have assumed authority over certain materials under regulatory agreements with the NRC, as part of the Agreement States Program (see Chapter 10).

A two-year Pilot Regionalization Licensing Program was completed in NRC Region III (Glen Ellyn, Illinois) during the year. The principal conclusion was that better service to applicants and licensees can be provided by a regionalized material licensing program. Based on results of the pilot program, NRC plans to continue decentralized material licensing in Region III and to establish a similar program in Region I (King of Prussia, Pennsylvania) in January 1981.

INDUSTRIAL LICENSING

Industrial Radiography

Radiography, the process of imaging with radiation for the nondestructive testing of material, is widely used in a variety of industrial applications and basic research. Radiation passes through the object to be examined and the object's image is recorded on film. The amount of darkening of the film depends on the density of the object being radiographed. Encapsulated gamma radiation sources are widely used in radiography for determining structural defects in metallic castings and welds. Encapsulated neutron sources are also used to produce radiographs of hydrogenous materials. Occasionally, beta emitters are used to examine thin films and low density materials. Industrial radiography utilizing large gamma sources is potentially one of the more dangerous activities regulated by the NRC.

Regulatory actions to improve safety during fiscal year 1980 included:

- An NRC order on November 21, 1979, for all licensees using sealed sources of one specific model to withdraw them from use and store them until appropriate design modifications are made. This action was taken because of a high rate of failure of this particular source model (5 failed sources out of 20 distributed by the manufacturer) over the past four years.

- Amendments of the regulation 10 CFR Part 34, effective March 3, 1980, to codify several safety requirements that had in the past been accomplished through the licensing process. Some of the significant provisions are: (1) a requirement for management audits of the performance of radiographers every three months, (2) a requirement that a physical radiation survey be made after each radiographic exposure, and (3) a requirement that permanent radiographic facilities be equipped with independent visible and audible alarms.

Gauging Devices

Approximately 2,000 of the material licensing actions completed by the NRC in fiscal year 1980 dealt with portable and fixed gauging devices. Of these, the most common types licensed were thickness gauges, level gauges and moisture density gauges. A simple type of thickness gauge may be described as a device consisting of a radiation detector with a radiation level indicator. The object being measured passes between the radiation source and the detector. The amount of radiation passing through the object and reaching the detector is proportional to the density and thickness of the object and is observed on the indicator. When only one surface of an object is available for measurement, gauges utilizing backscatter and x-ray fluorescence are sometimes used. A few examples of the measurements made with radioisotopes gauges are the thickness of paper products, fluid levels in oil and chemical tanks, moisture and density at construction sites, and in manufactured items such as satellites and missiles. These devices are designed to minimize radiation hazards associated with their use so that minimal training and experience are required for their use.

Gas Chromatography

Second only to the number of licenses issued for gauging devices were those issued for low-energy beta sources used in gas chromatography devices. Gas chromatography is one of the most useful methods available for identifying individual constituents in substances. A simple explanation of gas chromatography is as follows: the substance to be analyzed is converted to a gaseous form and temporally separated in a column containing an absorbing medium. As the various gaseous components of the substance to be analyzed move through an ionized atmosphere created by the beta radiation source in a detector cell, the fluctuations in electrical current are recorded and from this chemists are able to identify and measure each component. Gas



Nuclear techniques are used extensively in exploring for new energy sources. Improved well-logging techniques, using sealed radioactive sources or tracing instruments, provide geologists, engineers and drilling contractors with precise information about subsurface conditions which indicate the presence of oil or gas. Such information helped to make this off-shore oil well operational.

chromatography is used to determine the components present in complex mixtures such as petroleum products, smog and cigarette smoke. It is also used extensively in biological and medical research to identify the components of complex proteins and enzymes.

Well Logging

Nuclear techniques are widely used in exploration for oil, gas, coal and mineral deposits. Few scientific endeavors have undergone more constant and sweeping change than the well logging industry. What was originally little more than a correlation tool for the geologist, has become an indispensable data source for the log analyst, the geologist, the engineer, the geophysicist, and the well drilling contractor. The "log" is a continuous recording of the value of physical parameters as a function of depth in a drilled hole. The instrument package, i.e., well logging tool (the "probe" or "sonde") is lowered to the bottom of the drilled hole at the end of a cable. The cable or "wire line" transmits power to the sonde and data signals to the surface. In the case of nuclear logs, the

sonde may contain sealed gamma or neutron sources, or may contain detection instrumentation to trace the positions of uncontained radioactive tracer materials previously placed in the well in drilling fluid, cement, etc.

Today's logging programs still supply data for subsurface structural mapping, but they also define the lithology, identify the productive zones, accurately mirror their depth and thickness, and permit a valid quantitative and qualitative interpretation of reservoir characteristics and content. Originally developed for the detection of hydrocarbons, today's logging systems extend to the location and evaluation of coal and mineral deposits as well.

The NRC and the Agreement States license a large number of service companies to possess radiation sources for use in their oil and gas well logging operations as well as mineral well logging in thousands of new and previously drilled wells.

Consumer Products

A large number of consumer products containing small quantities of radioactive materials have been evaluated and authorized for manufacture and distribution. Among those reviewed and approved in 1980 were backlit tritium watches, static eliminators, smoke detectors, false teeth, tritium exit signs and ceramic table ware and tile. The NRC authorizes the distribution of such products if careful evaluation indicates they will present a minimal risk to public health and safety. An environmental impact statement is under preparation to assess the impact of consumer products containing radioactive materials and to establish new NRC policy for regulation of consumer products.

During the year, NRC amended 10 CFR Part 32, effective on January 1, 1980, to require that the outside of each smoke detector and the point of sale package be labeled with sufficient information to inform prospective purchasers that the device contains radioactive material, and to identify the radioactive material and activity contained in the smoke detector.

MEDICAL LICENSING

The NRC issues licenses to hospitals and physicians for the use of radioactive materials in diagnosing and treating patients. The facilities, personnel, program controls and equipment described in each application are carefully reviewed to ensure the safety of the public, patients and occupationally exposed workers. Reviews must be conducted on a timely basis so as to avoid delays in providing essential medical services.

Laboratory Tests

Radioisotope tracers are added to laboratory samples to measure drug concentrations, hormone levels, toxic substances, etc. This procedure is known as radioimmunoassay. Some 75 to 90 million laboratory tests involve the use of radioactive material for medical diagnosis each year in the United States.

Nuclear Medicine Procedures

Drug labeled with radioisotopes are known as radiopharmaceuticals. Patients receive these materials by injection, inhalation or oral administration. Physicians use specialized detecting equipment to visualize the distribution of a radioactive drug within an organ system. Using this technology, it is possible to locate tumors and blood clots, measure physiological function, and monitor the effectiveness of treatment. Stronger doses of radiopharmaceuticals are administered therapeutically to treat hyperactive thyroid conditions and certain forms of cancer. An estimated 15 to 20 million such nuclear medicine procedures are performed in this country annually.

Treatment with Sealed Sources

Sealed sources that produce high radiation fields are used in teletherapy units to treat cancer. The teletherapy unit provides shielding and collimation to direct the radiation beam to the affected part of the patient's body. Much smaller sealed sources are designed to be implanted directly into the tumor area. This procedure, known as brachytherapy, limits the radiation field to the affected area and spares healthy tissue from radiation damage. NRC licenses the use of these sources in the same manner that it licenses nuclear medicine procedures. In addition, NRC (or an Agreement State, as appropriate) reviews the design and construction of each sealed source and teletherapy unit to ensure radiation safety and source integrity under stress.

Order to Monitor Teletherapy Units. On May 7, 1980, prompted by reports of teletherapy equipment malfunctions, the NRC issued an order to all teletherapy licensees concerning safety procedures. The malfunctions involved faulty shutters that failed to stop the radiation beam and equipment that gave improper indication of the beam status. If not detected and corrected immediately, these malfunctions have the potential for causing excessive (even lethal) radiation exposures to operating personnel and patients. NRC ordered licensees to equip each teletherapy room with a commercially available device that continually monitors the status of the radiation beam and provides a visible signal to the teletherapy operator. NRC is also pursuing corrective action with the teletherapy manufacturers.

Advisory Committee on the Medical Uses of Isotopes

NRC utilizes an advisory committee of physicians and medical physics specialists from the public sector to provide guidance on medical licensing issues. The NRC staff conducted public meetings of this Committee on January 18 and August 18, 1980. After hearing comments from interested organizations and members of the public, the Committee:

- Recommended increasing NRC's training and experience requirements for physicians who use licensed material in nuclear medicine procedures.
- Approved new application forms that require better documentation of physician training and experience.

- Examined several medical specialty board certification programs to determine whether they might be accepted by NRC as evidence of adequate training and experience.
- Made a formal recommendation to the Commissioners concerning the use of iodine-131 for therapeutic treatment of cardiac dysfunction.
- Provided advice on drafting a rule to permit licensees greater flexibility in disposing of laboratory test vials and animal carcasses containing tracer levels of tritium and carbon-14. A proposed rule was published on October 8, 1980.

Reducing Occupational Exposure

In addition to observing the statutory limits for personnel radiation exposure, NRC licensees should

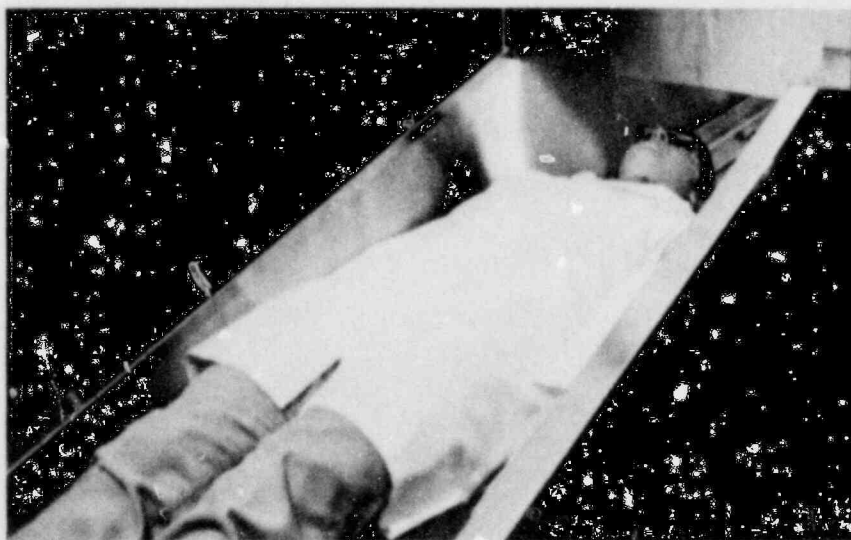

Some organizations dealing with radioisotopes employ mobile counting laboratories to monitor employees who work with radioactive materials on a regular basis. A radiation worker is

shown above in the whole-body counter of such a laboratory housed in the trailer of a truck (inset).

also keep exposure "as low as is reasonably achievable"(ALARA). This concept takes into account the state of technology and the economics of making improvements in relation to the benefit of reduced exposure. NRC now requires that medical licensees submit formal ALARA programs and has developed a model program that licensees may adopt in order to eliminate an additional paperwork burden.

Based upon experience gained from developing the medical ALARA program, NRC is now preparing requirements for formal ALARA programs in the academic and industrial licensing areas. Such programs ensure that licensees continuously examine

personnel exposure and make improvements to reduce exposure wherever feasible.

Other Actions in Medical Area

In other 1980 actions improving safety in the medical area, the NRC: (1) issued a final rule requiring licensees to report to NRC certain misadministrations of radioactive material to patients; (2) published a final rule requiring testing of a widely-used radionuclide, technetium-99m, for the presence of a contaminant, molybdenum-99; and (3) amended its regulations to delete the authorization for physicians and pharmacists to use medicinals containing source material (e.g., uranium or thorium).



7

Domestic Safeguards

In accordance with Section 209 of the Energy Reorganization Act of 1974, as amended, the Nuclear Regulatory Commission includes in each Annual Report to Congress a chapter describing the status of NRC's domestic safeguards program for the protection of certain nuclear materials and facilities. This chapter discusses safeguards provided for licensed facilities and activities during fiscal year 1980, covering the general areas of (1) scope of NRC safeguards efforts, (2) the status and effectiveness of safeguards, (3) safeguards policy issues and regulatory actions, (4) research and technical assistance, and (5) NRC safeguards management.

(The status of safeguards during fiscal year 1979 was discussed in the *1979 NRC Annual Report*, pp. 133-144.)

Scope of NRC Programs

The Atomic Energy Act of 1954 and the Energy Reorganization Act of 1974 direct the NRC to regulate the safeguards provided by its licensees for certain nuclear facilities and activities. With the objective of assuring protection of the public health and safety and the national defense and security, the NRC designs and enforces measures to deter, prevent, and respond to (1) unauthorized possession, theft, diversion, or use of special nuclear material; and (2) sabotage of nuclear facilities.

Safeguards for fuel cycle facilities emphasize protection against theft or diversion of "formula quantities" of strategic special nuclear material (SSNM), while power reactor safeguards concentrate on protection against radiological sabotage.

As in fiscal year 1979, NRC safeguards regulation during 1980 covered 19 "Category I" fuel cycle facilities, selected transportation activities, 70 power reactors licensed for commercial operation, and 71

non-power reactors (for research, testing, training or the production of radioisotopes). The 19 Category I fuel cycle facilities are authorized to possess formula quantities of SSNM, which includes uranium-235 (contained in uranium enriched to 20 percent or more in the U-235 isotope), uranium-233, or plutonium. A "formula quantity" is 5,000 grams or more of SSNM as computed by the formula: grams = (grams U-235) + 2.5 (grams U-233 + grams plutonium).

The selected transportation activities mentioned above involve shipments of spent fuel or formula quantities of licensed SSNM, amounting to about 10 per month.

STATUS OF SAFEGUARDS IN 1980

Fuel Cycle Facilities

A new rule requiring licensees of facilities that possess formula quantities of SSNM to protect against a larger, more sophisticated external threat, and internal conspiracies (instead of a single insider) became effective in March 1980 ("Physical Protection Upgrade Rule," 44 FR 68184). The additional requirements include primarily:

- Increased hardening and penetration resistance of access control points, alarm stations and SSNM storage vaults.
- A dedicated, more heavily armed on-site response force.
- A higher level of redundancy and diversity of intrusion alarms, communications, personnel search techniques and material control measures.

Of the 19 facilities authorized to possess formula quantities of SSNM, only six have actual holdings

that will require the submission of physical protection plans to meet the requirements of the new rule. The remaining facilities have either reduced their holdings to quantities of lesser significance, are in the process of decommissioning, or have self-protecting material (external radiation dose rate is greater than 100 rems per hour at three feet) which is exempt from the new requirements. The six facility plans and three shipper/carrier plans were received for review and approval during fiscal year 1980.

As described in the 1979 Annual Report, the Nuclear Fuel Services (NFS) highly enriched uranium facility at Erwin, Tenn., resumed production operations in January 1980. For the previous four months, the facility had been shut down in conjunction with an investigation into an inventory difference that was reported in September 1979. Production was allowed to continue following the implementation of new safeguards measures designed to protect against the theft of SSNM by collusive acts and to improve the

accountability for highly enriched uranium. In addition, the limits for inventory differences requiring a special reinventory or plant shutdown were made less restrictive in view of the Commission's recognition of the vital defense nature of the NFS facility, as well as the uncertainty involved in the measurement of nuclear materials in the complex chemical process. While the investigation reconciled a part of the inventory difference, the discrepancy was not reduced to a level that would be expected solely as a result of measurement uncertainty. Nevertheless, the investigation did not discover any fact (other than the presence of the inventory difference) to indicate that SSNM had been stolen. However, that possibility could not be ruled out.

In February 1980, the Natural Resources Defense Council requested a hearing concerning the Commission's decision to allow a resumption of operations at NFS as an NRC-licensed facility. (A hearing was scheduled for early fiscal year 1981.)

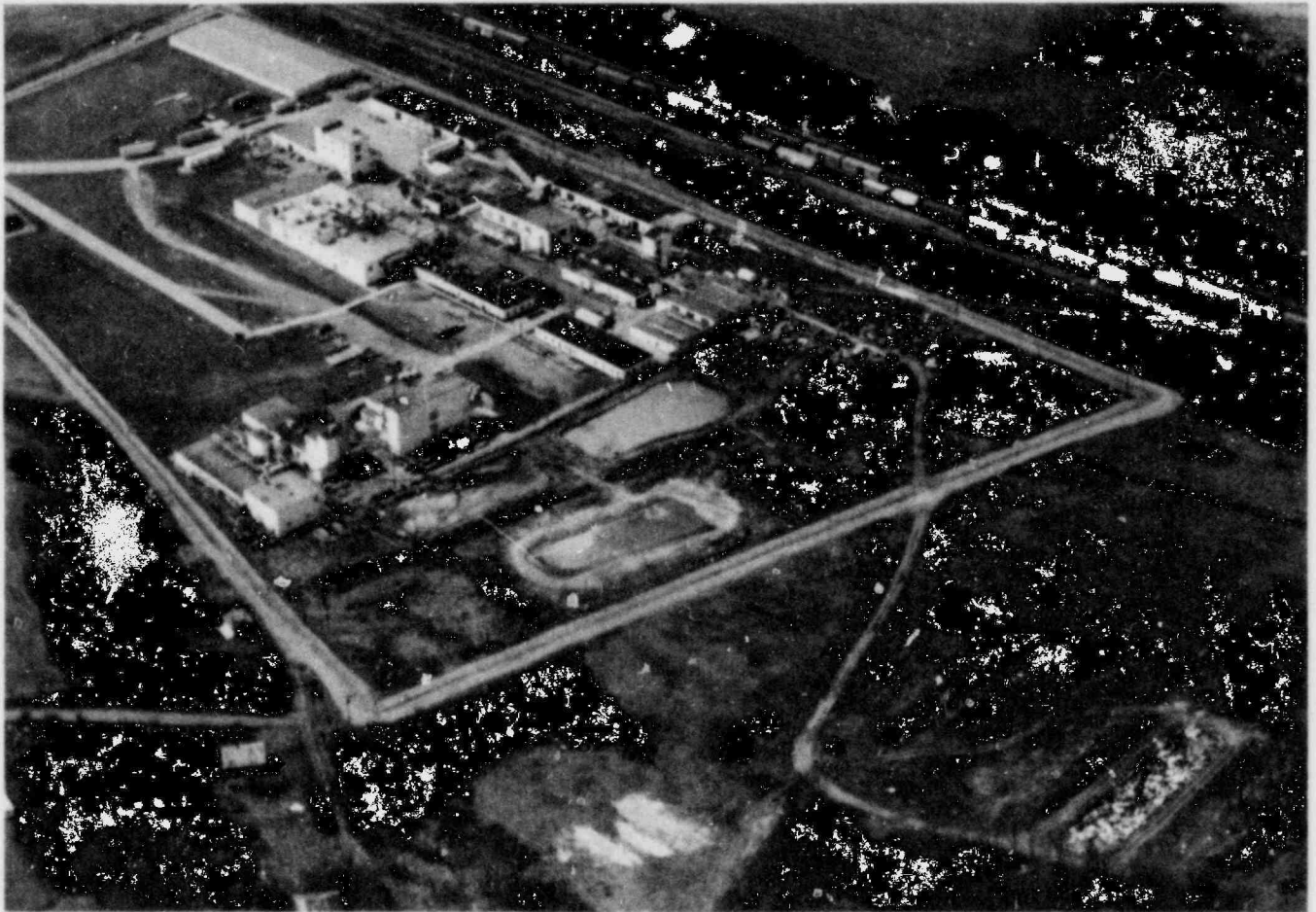

Aerial view of the Nuclear Fuel Services high-enriched uranium plant at Erwin, Tenn., which resumed operations in January 1980 following a three-month shutdown to investigate

and reconcile inventory differences. Production began again after required improvements were made in both physical protection and material controls and accounting procedures.

NRC inspects both import and export shipments of special nuclear material at its point of entry or departure. This photo shows NRC inspectors and transport security personnel during the transfer of a shipment of plutonium from a cargo plane to a truck which will take the plutonium to a nuclear facility in the United States.



Category II and III* fuel cycle licensees that possess, use or transport less than a formula quantity of special nuclear material (SNM) are now subject to the requirements of 10 CFR 73.67, "Licensee Fixed Site and In-Transit Requirements for the Physical Protection of Special Nuclear Material of Moderate and Low Strategic Significance." In fiscal year 1980, twenty-four of these licensees submitted fixed-site plans and 16 submitted transportation plans for review by the NRC in response to these new requirements.

During fiscal year 1980, NRC transmitted to Congress the final three reports documenting results of the staff's 18-month program of comprehensive evaluations of safeguards at licensed facilities which possessed formula quantities of SSNM during that period. Preliminary results of these evaluations were summarized in the 1979 Annual Report. By the end of fiscal year 1979, required corrective actions for all facilities had been identified, and interim measures required by NRC had been put into effect in those cases where permanent improvements had not yet been completed. During fiscal year 1980, all required permanent improvements were completed.

In July 1980, the NRC staff completed additional vulnerability assessments at a plutonium storage

facility, a spent fuel storage facility, and a spent fuel and high-level waste storage facility. Two field teams examined each facility with respect to (1) vulnerability to external assault and (2) vulnerability to an insider. The teams assessed the vulnerability of each facility relative to the design basis threat for radiological sabotage, published in 10 CFR 73.1. As a result, a number of improvements were made in the safeguards systems at each site during the year.

Inspection and Enforcement at Fuel Cycle Facilities. NRC inspection and enforcement activity at fuel cycle facilities during fiscal year 1980 included 7,916 hours of on-site inspection at 12 facilities authorized to possess formula quantities of unirradiated SSNM in an unsealed form. These inspections revealed 44 items of noncompliance with safeguards requirements (see Table 1). A pilot program to aid in determining the significance of one or more noncompliances on the effectiveness of the safeguards system has been developed. The preliminary results of this program are being evaluated.

Transportation Activities

Spent Fuel Shipments. The NRC revised requirements for the protection of licensed spent fuel shipments, effective July 3, 1980 (10 CFR 73.37, "Requirements for Physical Protection of Irradiated Reactor Fuel in Transit"). The changes to an interim rule issued in July 1979 (see 1979 Annual Report, p. 135) were based primarily on public comments and the experience gained during the first year of approving spent fuel transport routes.

*Category II material includes between 1 kg and 5 kg of highly enriched uranium, between 500 grams and 2 kg of plutonium, and 10 kg or more of uranium enriched between 10 percent and 20 percent. Category III material includes between 15 grams and 1 kg of highly enriched uranium, between 15 grams and 500 grams of plutonium, less than 10 kg of uranium enriched between 10 percent and 20 percent, and 10 kg or more of uranium enriched to less than 10 percent.

Table 1. Safeguards Inspections at Fuel Cycle Facilities During FY 1980^a

| <i>Facilities Authorized to Possess Formula Quantities</i> | <i>Number of Safeguards Inspections</i> | <i>Number of Inspection Manhours</i> | <i>Number of Items of Noncompliance</i> | <i>Percent of Unannounced Inspections</i> |
|--|---|--------------------------------------|---|---|
| Babcock & Wilcox, Apollo, Pa. | 26 | 887 | 5 | 46 |
| Babcock & Wilcox, Leechburg, Pa. | 18 | 475 | 6 | 44 |
| Babcock & Wilcox, Lynchburg Research Center, Lynchburg, Va. ^b | 0 | 0 | 0 | 0 |
| Babcock & Wilcox, Naval Nuclear Fuels Division, Lynchburg, Va. | 13 | 572 | 2 | 76 |
| Exxon Nuclear, Richland, Wash. | 5 | 258 | 1 | 80 |
| General Atomic, San Diego, Calif. | 10 | 1,064 | 0 | 60 |
| General Electric, Vallecitos, Calif. | 3 | 64 | 0 | 67 |
| Kerr McGee Nuclear, Crescent, Okla. ^b | 2 | 43 | 2 | 100 |
| Nuclear Fuel Services, Erwin, Tenn. | 21 | 1,328 | 12 | 81 |
| Rockwell International, Canogo Park, Calif. | 8 | 699 | 4 | 75 |
| Texas Instruments, North Attleboro, Mass. | 9 | 407 | 4 | 100 |
| United Nuclear, Montville, Conn. | 15 | 839 | 3 | 80 |
| United Nuclear Wood River Junction, R.I. | 10 | 705 | 0 | 90 |
| Westinghouse Plutonium Fuel Development Laboratory, Cheswick, Pa. | 12 | 475 | 5 | 75 |
| TOTALS | 152 | 7,916 | 44 | 70 |

^aBased on information on file as of November 5, 1980.

^bThese facilities are either not operating or not holding formula quantities in unirradiated form.

The revised interim rule contains four important changes: (1) transit of heavily populated areas is no longer embargoed; (2) if a shipment passes through or near a heavily populated area, additional protective measures are required, e.g., two escort vehicles, one in the lead and one in the rear each occupied by an armed guard; (3) approximately 60 cities are added to the heavily populated urbanized area list;

and (4) vessels in port, either unloading spent fuel or passing through, are required to be protected by armed guards. The staff is now reviewing a recently published Department of Transportation rule on routing of radioactive material shipments to determine the applicability of DOT's routing criteria to spent fuel.

During fiscal year 1980, NRC approved 29 routes over which 126 spent fuel shipments were made.

Table 2. Transportation Safeguards Inspection During FY 1980*

| Type | Number of Shipments | Number of Inspections | Number of Inspection Manhours** | Number of Items of Noncompliance | Percent of Unannounced Inspections |
|------------------------------------|---------------------|-----------------------|---------------------------------|----------------------------------|------------------------------------|
| Strategic Special Nuclear Material | 5 | 5 | 1,784 | 0 | 0 |
| Irradiated Fuel | 126 | 86 | 480 | 0 | 0 |

*Based on information on file as of 11/5/80.

**Actual data not on file. Manhours listed are estimates based on previous experience.

Except for several short delays caused by mechanical problems (corrected at the scene or nearest truck stop), there were no incidents or accidents involving these shipments.

SSNM Shipments. Five shipments of formula quantities of SSNM (Category I nuclear materials) were made during the report period—three domestic and two for export purposes.

The requirements for more stringent security measures to protect Category I materials shipments (10 CFR 73.25, "Performance Capabilities for Physical Protection of Strategic Special Nuclear Material in Transit" and 10 CFR 73.26, "Transportation Physical Protection Systems, Subsystems, Components, and Procedures") became effective on March 25, 1980; however, these provisions will not be implemented fully until March 1981. Accordingly no shipments under the revised requirements were made in fiscal year 1980. As noted above, three companies have submitted transportation protection plans for review and approval in response to these new requirements.

Shipment Route Surveys. NRC safeguards teams conduct field surveys of transportation routes proposed for shipment of spent fuel or significant amounts of SSNM. During these surveys, the staff gathers information for NRC contingency planning as well as route licensing approval considerations. The teams coordinate with local law enforcement agencies along the way to increase their awareness and knowledge of the shipments and to identify local law enforcement contacts who can be called upon for assistance, if needed.

During fiscal year 1980, the NRC teams surveyed one route for shipment of SSNM and 23 routes for shipment of spent fuel. They collected data in the field, traveled approximately 11,000 road miles through 32 states, and met with some 250 local and State law enforcement agency representatives along

the way. To help familiarize law enforcement officials with details concerning nuclear shipments, the NRC staff prepared a brochure entitled "Information Package on Spent Nuclear Fuel Shipments for Law Enforcement Agencies." More than 2,000 copies of the brochures have been distributed.

As a by-product of the NRC staff surveys, licensees transporting nuclear materials also receive route profile data which describe appropriate law enforcement contacts and communications to be used by nuclear material carriers to obtain assistance if needed.

Other New Requirements for Category I Material. NRC issued a general license to carriers and persons who transport or make arrangements for transportation of Category I materials and for carriers who transport spent fuel. This change establishes regulatory authority for NRC inspection of such shipments and holds the carriers responsible for compliance with protection requirements.



A specially designed tractor-trailer used to transport special nuclear materials stops at a weigh station near a heavily populated area. One of the two required escort vehicles is shown at left.

Shipments of Categories II and III Material.

About 15 shipments of Category II material were made during fiscal year 1980. (Shipments of Category III materials are not monitored and recorded on a continuing basis.)

New requirements for the physical protection of Category II/III shipments (10 CFR 73.67, "Licensee Fixed Site and In-Transit Requirements for the Physical Protection of Special Nuclear Material of Moderate and Low Strategic Significance") became effective during the year, with implementation required by September 21, 1980. In response, 16 licensees submitted transportation protection plans for review and approval, of which about half had been approved by the end of the fiscal year.

Transport Inspection and Enforcement. During the year, NRC determined the adequacy of transportation safeguards both by licensing evaluation of physical protection plans for materials in-transit and by inspection of selected shipments. Inspections covered all domestic shipments and the domestic segments of import and export shipments of formula quantities of SSNM. Such inspections included all in-transit portions, intermodal transfers and periods of temporary storage. Of 126 shipments of irradiated fuel, both domestic and imports, made in 1980, 86 were inspected at the point of origin or the point of destination. No items of noncompliance with transportation safeguards requirements were noted. (See Table 2 for a summary of transportation inspection activity.)

Reactor Safeguards

Status of Safeguards at Power Reactors. NRC requirements for physical security at power reactor facilities were, for the most part, unchanged during fiscal year 1980. The adequacy of safeguards at such facilities was determined through the licensing process and the ongoing reactor safeguards inspection program.

Power reactor licensees have security programs in effect that are based on NRC-approved security plans

prepared in response to 10 CFR 73.55, "Requirements for Physical Protection of Licensed Activities in Nuclear Power Reactors against Radiological Sabotage." As indicated in the *1979 NRC Annual Report*, the implementation of certain defensive measures against potential sabotage by personnel working inside the facility has been deferred by the Commission until further evaluations of need and possible alternative measures are completed. These evaluations are still underway. On a related matter, the Commission has requested the staff to prepare a proposed rule for public comment that would require the establishment of an industry-operated program for determining the trustworthiness of personnel authorized for entry to nuclear power plants.

There continue to be delays at certain facilities in the installation and operation of specific security equipment, thereby requiring the use of approved temporary measures pending final system implementation. The use of such temporary measures, such as additional security personnel, does not relieve an individual licensee from its commitment to complete and operate all of the final security systems and procedures described in the security plans. To ensure timely completion of the outstanding items on final system implementation, the NRC drafted an action plan towards the end of the year.

The NRC staff has been developing techniques and plans for a program of assessing vulnerability at operating power reactors. Efforts during the report period included a "paper exercise" involving a Standardized Nuclear Unit Power Plant Systems (SNUPPS) hypothetical reactor facility and two tests of the detailed assessment methodology at an operating reactor. The staff plans to begin the program during fiscal 1981, scheduling vulnerability assessments for those operating power reactors which have fully implemented NRC-approved physical protection plans and have demonstrated subsequent satisfactory compliance with them.

Status of Safeguards at Non-Power Reactors. All licensed non-power reactors have operative security plans as required by 10 CFR 73.40 ("Physical Pro-

Table 3. Reactor Safeguards Inspections During FY 1980*

| Facility | Number of Safeguards Inspections/Visits | Number of Inspection Manhours | Number of Items of Noncompliance | Percent of Unannounced Inspection |
|---------------|---|-------------------------------|----------------------------------|-----------------------------------|
| Power Reactor | 235 | 10,878 | 322 | 92% |
| Non-Power | 55 | 928 | 04 | 89% |

*Based on information on file as of 11/5/80.

tection: General Requirements at Fixed Sites") for protection against sabotage. In addition, licensees possessing less than formula quantities of SSNM have submitted security plans in accordance with the requirements of 10 CFR 73.67 ("Licensee Fixed Site and In-Transit Requirements for the Physical Protection of Special Nuclear Material of Moderate and Low Strategic Significance") for review and approval by the NRC. The new requirements include:

- Storage and use of nuclear material only in controlled access areas.
- Monitoring of controlled access areas to detect unauthorized activities.
- Screening of individuals granted unescorted access.
- Response procedures to deal with safeguards contingencies.
- In-transit protection.

Many non-power reactor facilities that possess formula quantities of SSNM are either reducing holdings or extending operating schedules to ensure that

the SSNM is irradiated to the self-protecting level. As a result, less than six non-power reactors are expected to have formula quantities of SSNM beyond the end of fiscal year 1980. These facilities will be required to meet the specific requirements of both 10 CFR 73.67 and 10 CFR 73.60 ("Additional Requirements for the Physical Protection of Special Nuclear Material at Non-Power Reactors").

Inspection and Enforcement at Reactors. NRC inspection and enforcement activities at reactors provide a means for judging the effectiveness of safeguards. In addition, NRC has developed a pilot program to aid in determining the effect that a non-compliance, or combination of noncompliances, would have on the effectiveness of the physical protection safeguards system. The NRC expended 10,878 hours in on-site safeguards inspections at power reactors, and 928 hours at non-power reactors and research facilities. These inspections revealed 326 items of noncompliance with safeguards requirements (see Table 3).

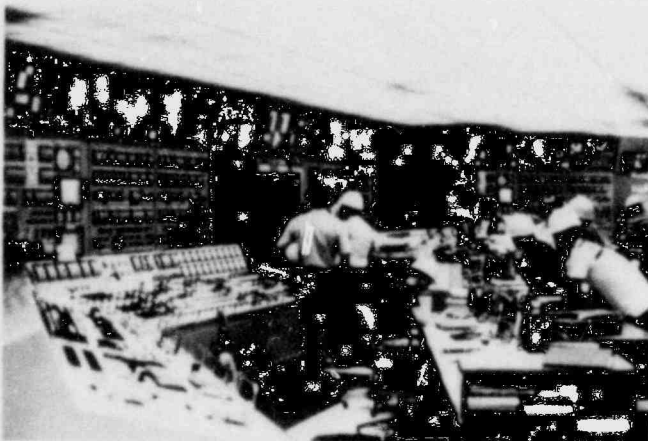

Nearly 11,000 hours of NRC staff time was devoted to safeguards inspections at nuclear power reactors in 1980. Shown here, clockwise from upper left, are NRC inspectors and plant personnel (1) analyzing a control room layout, (2) checking the

access to an auxiliary feedwater pipe system tunnel, (3) examining the auxiliary feedwater pumps, and (4) examining and testing the radiation monitors at an exit.

Contingency Planning and Threat Assessment

Safeguards contingency plans are developed to deal with threats, thefts and sabotage relating to special nuclear materials and nuclear facilities. In support of the NRC contingency planning effort, memoranda of understanding were concluded in fiscal year 1980 with the National Security Agency, the Federal Aviation Administration, and the Bureau of Alcohol, Tobacco and Firearms. These memoranda formalize procedures for information exchange and coordinated response actions.

As reported last year, the NRC staff during fiscal year 1979 reviewed and approved safeguards contingency plans developed by each of the 19 fuel cycle facility licensees authorized to have formula quantities of SSNM. All operating power reactor facilities have prepared safeguards contingency plans and upgraded guard qualification and training plans. About half of the contingency plans and 25 percent of the guard training and qualification plans for power reactors have been approved by the NRC and are in the process of being implemented. Action on the remainder will be completed during fiscal year 1981.

In July 1980, the NRC staff published NUREG-0703, "Potential Threat to Licensed Nuclear Activities from Insiders (Insider Study)." This report presents data on the characteristics of malevolent insiders as revealed in case studies of theft and sabotage in government and industry. As part of its continuing threat assessment effort, the staff also updated NUREG-0525, "Safeguards Summary Event List" (September 1980), which provides data on nine categories of safeguards-related events involving licensed nuclear materials and facilities.

The "Communicated Threat Credibility Project" continues to provide multidisciplinary tools for investigating the credibility of communicated threats and for providing advice to the Department of Energy, the NRC, the Federal Bureau of Investigation, and other appropriate agencies during an actual or perceived emergency from nuclear extortion threats.

SAFEGUARDS REGULATORY ACTIVITIES AND ISSUES

During fiscal year 1980, the NRC continued to develop and adopt regulations designed to improve nuclear safeguards. Resolving several major safeguards issues constituted an important part of NRC's activities. Efforts to deal with additional unresolved safeguards issues must continue into 1981 and beyond.

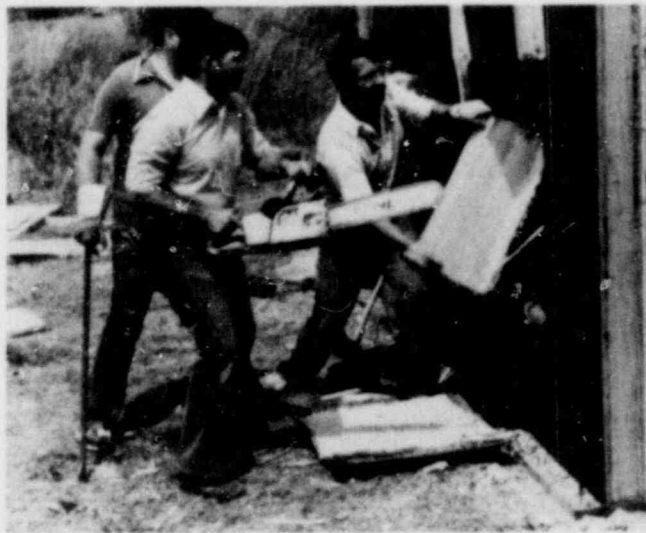

In support of the new requirements set forth in NRC's Physical Upgrade Rule, the Army Materiel Systems and Analysis Activity at Aberdeen Proving Grounds, Md., conducted a research program aimed at developing cost-effective barrier systems. The U.S. Army personnel shown here are testing the penetration resistance of a hardened barrier.

Physical Security

The new Safeguards Upgrade Rule, which strengthened physical security requirements for any facilities possessing, using, or transporting five formula kilograms of strategic special nuclear material, became effective in March 1980. Licensees are expected to achieve full implementation by the fall of 1981. To assist licensees in understanding and fulfilling the performance standards set forth in the new rule, the Commission established a Licensee Safeguards Guidance Group. This group received from licensees over 30 inquiries of a generic nature. After conducting informal discussions at the licensee sites and NRC headquarters, the group issued bulletins responding to these inquiries.

Work continued on how best to apply the new rules to university and industry research reactors in light of the unique characteristics of this segment of the nuclear community. Although NRC staff has concluded that research reactors presently are adequately safeguarded, the study of the practicality of giving safeguards credit for certain fuel and reactor design features and radiation levels of irradiated fuel had not been completed by the end of the fiscal year.

Another important problem expected to be resolved in fiscal year 1981 relates to the regulation upgrading power reactor physical security safeguards. When first issued in 1977, the rule called for conducting either a physical or an instrument search for the detection of prohibited material. The Commis-

sion was petitioned to eliminate the possible interpretation of "physical search" as requiring a "pat-down" search. The Commission plans to issue final requirements for entry searches in early fiscal year 1981. The Commission also intends to issue revised requirements for access controls to vital areas within power reactor facilities.

In 1980, the new physical protection requirements for SNM in less than five formula kilogram quantities (Category II and Category III materials) were implemented. These regulations, published in July 1979, made the U.S. rules consistent with International Atomic Energy Agency (IAEA) standards. In early 1980, an amendment to these rules was published for public comment. This amendment would give NRC authority to delay a shipment of less than five formula kilograms of SNM to prevent two or more shipments which in the aggregate would amount to five formula kilograms or greater from being in transit at the same time. This rule is expected to become effective in 1981.

Requirements of the new interim rule for spent fuel shipments were discussed earlier in this chapter. The staff must now reassess the need for changes based on the results of ongoing research. It is expected that the interim rule will be revised or rescinded in 1982 following analysis of the research results.

Transient shipments of formula quantities of SSNM continue to be a matter of concern. A transient shipment is one that temporarily uses U.S. facilities while moving from one foreign country to another. NRC has prepared a regulation that would require protection of such shipments, which usually are carried by an aircraft transiting a U.S. airport.

Regarding transient shipments of spent fuel, the NRC has begun to analyze the alternatives involved in providing safeguards protection and possible regulatory changes to implement such protection.

The NRC also is continuing efforts to estimate the potential hazards of sabotage (or theft, if that should occur) at high-level nuclear waste storage sites. Conceivably, the radioactive dispersal hazards might be similar to those resulting from sabotage of spent fuel. The staff is also continuing to analyze the alternatives involved in transporting wastes resulting from the Three Mile Island nuclear power plant accident to disposal sites. The results of these analyses will enable the staff to determine what safeguards measures, if any, should be required for nuclear waste activities.

In the area of security force qualifications, the NRC is preparing revisions to its requirements that will ensure careful verification of employment data for security force applicants, calling attention to the fact that there are criminal sanctions for the falsification of such data.

Material Control and Accounting

For years the NRC has used reports of inventory differences that exceed certain limits to signal accountability problems or out-of-control processing situations. However, since inventory differences are based on periodic plantwide inventories, they do not provide a timely indication of loss of material. Moreover, the causes of unusual or excessive inventory differences are not always clear, even after extensive investigation. Therefore, the NRC staff is examining several alternatives to relying on inventory difference as a primary indicator of accounting problems.

In July 1980, NRC issued its sixth report on inventory accounting differences at NRC-licensed facilities (NUREG-0430, Volume 1, No. 5, "Licensed Fuel Facility Status Report"), covering the last six months of calendar year 1979. The report noted that, while inventory differences had occurred, investigations by both licensees and NRC had not established that significant quantities of special nuclear material had been stolen.

The staff is continuing development of a major rule aimed at improving the level of safeguards assurance provided by material control and accounting systems. The goals are to provide more timely material control and accounting indicators which can be resolved more clearly, and which will better identify the accountability problems within a licensee's plant. The rule will also significantly upgrade protec-



Drivers and armed guards for a truck shipment of special nuclear material are briefed as they await offloading at a user facility. NRC supervises guard and driver training as part of its program to assure that special nuclear materials are protected throughout all phases of transport.

tion against insider collusion and will establish standards of training and qualification for material control and accounting personnel. A draft rule, which had been expected to be completed by year-end, is now planned for issuance early in fiscal year 1981.

NRC/IAEA Interaction. In 1980, the U.S./IAEA Safeguards Agreement was ratified as a treaty. This Agreement will be implemented when the U.S. notifies the IAEA that its statutory and constitutional requirements for entry into force have been met. In July 1980, the Commission published in final form the new regulations required to facilitate the application of IAEA safeguards under this treaty in the eligible licensed U.S. nuclear industry. (See Chapter 11 for detailed discussion of international safeguards.)

Classification of Safeguards Information. In fiscal year 1980, NRC instituted a program for the classification of safeguards information produced and held by licensees possessing a formula quantity of non-self-protecting SSNM (the Category I facilities and transportation organizations moving such material). The Classified Safeguards Program is based on Executive Order 12065, "National Security Information," the Atomic Energy Act of 1954, as amended, and 10 CFR Parts 25 and 95, "Access to and Protection of National Security Information and Restricted Data."

Under the program, certain information on material control and accountability, physical protection at fixed sites, and in-transit protection of special nuclear material can be classified. The program also covers safeguards analyses that indicate vulnerabilities and plans for protecting formula quantities of SSNM, and certain safeguards communications-related information and procedures.

Information would only be classified if its disclosure would significantly assist a malevolent individual or group in acquiring or using SSNM. Specific identification of classifiable information is given in the appendices to 10 CFR Part 95.

SAFEGUARDS RESEARCH AND TECHNICAL ASSISTANCE

The NRC safeguards contractual program includes both research projects (long-term, comprehensive efforts) and technical assistance projects (short-term efforts supporting operational assignments). In fiscal year 1980, about \$11 million was spent on safeguards research and technical assistance. Approximately \$4 million of the total was spent on research projects and the remaining \$7 million on technical assistance projects. The Commission reviewed and approved all safeguards contracts exceeding \$20,000 in funding.

Fiscal year 1980 research projects that have contributed to or are expected to improve safeguards programs are as follows:

- The "*Effectiveness Evaluation Methods for Fixed-Site Physical Protection*" project. Generic fault-tree techniques have been improved and extensively used to identify vital areas within about 24 pressurized water reactor and boiling water reactor sites during 1980, and have proved to be an effective aid in licensing and evaluating power reactors. Once the vital areas are identified, a second method, the Safeguards Automated Facility Evaluation (SAFE), can be used to indicate general weaknesses in the site security system in preventing unauthorized access to the identified areas. This was improved during the year and was selectively applied to various reactor plants. A third method, Safeguards Network Analysis Procedure (SNAP), is used to apply the results of SAFE to pinpoint specific weaknesses in the safeguards system. SNAP has undergone some NRC user suitability testing and is expected to help in physical security field evaluations of operating fuel cycle facilities.
- The "*Effectiveness Evaluation Methods for Material Control and Accounting*" project. Two computerized evaluation methods, called Structured Assessment Approach (SAA) and Safeguard Vulnerability Analysis Program, were developed and currently are being tested. They will be used in assessing the effectiveness of material control and accounting safeguards at fuel cycle facilities. SAA assists in analyzing the vulnerability of a facility to both insider and outsider adversaries with authorized and unauthorized access and extensive capabilities. This project has also developed the Aggregated System Model to aid in the development of the Material Control and Accounting Upgrade Rule.
- The "*Application and Development Facility*" has been established for the user offices to test and apply the computerized methods developed by the safeguards research program. This facility, which has been operating since January 1980, contains a micro-computer and associated hardware that permit a safeguards analyst to use the computer programs directly.
- The research on "*Nuclear Power Plant Design Concepts for Sabotage Protection*" continued through fiscal year 1980. Design alternatives and damage control measures for nuclear power plants were studied in order to improve their inherent protection against sabotage. A recent

typical plant design* was selected and characterized to provide a baseline against which the effectiveness and impact of proposed changes could be measured. Some promising design alterations as well as methods to mitigate damage were thoroughly analyzed. The results have been reviewed and selected features have been identified for more comprehensive investigation.

- The "*Inspection Methods for Physical Protection*" project will provide NRC regional inspectors with new and improved methods and procedures for conducting physical protection compliance inspections. These will be used to determine whether licensed nuclear facilities or transportation activities are operated and conducted in compliance with the licensee's approved security plans and NRC regulations.
- The "*Safeguards for Proliferation Resistant Fuel Cycles*" study will provide a basis for future NRC regulatory policy if alternative fuel cycles are developed and constructed by the domestic nuclear industry.

*The Standardized Nuclear Unit Power Plant System is a system identified by Bechtel Corporation. It takes advantage of standardized engineering and installation practices for the purpose of simplifying licensing and acceptance reviews.

- The "*Spent Fuel Cask Vulnerability Program*" is designed to assess potential releases of radioactivity from specified explosive attacks on spent fuel casks and their irradiated fuel contents. This program includes scale model experiments using actual irradiated fuel. The information will be used by the licensing staff in its ongoing efforts to confirm and/or modify current safeguards regulations protecting spent fuel shipments.

The safeguards technical assistance program includes projects which are conducted by the major program offices to support their operational missions. These projects ranged from helping to establish a technical basis for determining safeguards requirements for high-level waste repositories to providing assistance in developing the technical basis for NRC's material control and accounting upgrade rule.

Each of the major program offices with safeguards interest participates in the planning and implementing of NRC's domestic safeguards contractual program. The Safeguards Technical Assistance and Research Coordinating (STAR) Group, which has members from each cognizant office, provides inter-office coordination for the program. The STAR Group processed 49 research and technical assistance projects during fiscal year 1980.

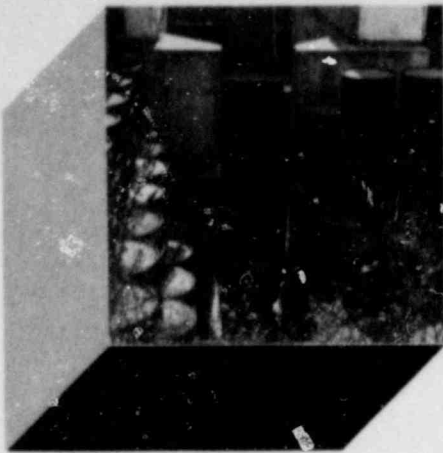

8

Waste Management

The NRC's nuclear waste management activities are directed by the Office of Nuclear Material Safety and Safeguards (NMSS). These functions, which cover the regulation of all NRC licensed source, byproduct and special nuclear material waste and uranium mill tailings, include the following:

- Developing the criteria and framework for regulating high-level waste management, including the technical bases for licensing, and licensing actions on proposals for high-level waste commercial repositories.
- Licensing and regulating low-level waste disposal facilities and providing the technical support for such regulation.
- Licensing and regulating uranium recovery facilities and associated mill tailings. These operations include uranium mills, heap-leaching facilities, ore-buying stations, solution mining (insitu), and byproduct uranium recovery.

The interim storage of spent nuclear reactor fuel and transportation of all forms of radioactive waste are discussed in Chapter 6.

Overview of 1980 Activity

In 1980, the NRC staff worked on regulations to ensure that methods for disposing of radioactive waste meet the Commission's goal for safe disposal. To accomplish this goal, each of the three waste management program areas focused on licensing and regulatory improvements.

During the year, the NRC released, in two parts, a regulation for high-level waste repositories (10 CFR Part 60). The proposed procedural portion was published in the Federal Register as a proposed rule (44 FR 7048). In May 1980, the technical criteria for

regulating geologic disposal was published as an advance notice of proposed rulemaking (45 FR 31393). The staff also prepared a draft of the regulatory guide on format and content of site characterization reports.

In addition, the NRC completed models for assessing radionuclide transport in bedded salt, continued preparing a draft Site Characterization Report Review Plan for DOE site characterization reports, and worked on an assessment of the extent to which the Department of Energy's programs were directed at developing the information required to comply with NRC's proposed high-level waste regulations.

In the low-level waste disposal area, the NRC concentrated on developing comprehensive licensing criteria. In 1981, the staff expects to issue drafts of the low-level waste regulation (10 CFR Part 61) and its environmental impact statement. Supporting regulatory guides are also being drafted.

In the uranium recovery program, the NRC continued to improve the regulatory basis for licensing decisions, and to take actions to ensure that uranium recovery operations are properly conducted to protect the public and the environment. A total of 52 licenses were issued, renewed, or amended, and 21 project reviews were conducted to assist Agreement States. In addition, regulations related to uranium mill tailings (amendment to 10 CFR Part 40) were issued in final form (45 FR 65521), and the supporting final Generic Environmental Impact Statement on Uranium Milling was issued in October 1980 (45 FR 67177). Supporting regulatory guides for the uranium milling industry are also being developed.

Internal Coordination

The Waste Management Review Group, (formed in May 1979) consists of representatives of the major

NATIONAL WASTE MANAGEMENT PLAN

On February 12, 1980, President Carter announced a comprehensive radioactive waste management program based on recommendations issuing from the Interagency Review Group on Radioactive Waste Management (IRG) which made its final report in March 1979. (The NRC, as an independent regulatory agency, participated as a non-voting member of the IRG. See 1978 Annual Report, pp. 93-94 and 1979 Annual Report, pp. 146-147.) The President's program includes the following elements:

- The Department of Energy (DOE), as lead agency in the Executive Branch for management and disposal of radioactive wastes, will prepare a National Plan for Nuclear Waste Management with the cooperation of other relevant Federal agencies. It is anticipated that a draft will be issued in 1980 for public and Congressional review.
- Creation of a 19-member State Planning Council consisting of 15 governors and other elected officials, and four members of executive departments and agencies, to work with the Executive Branch and Congress on waste management decisions and actions.
- Adoption of an interim planning strategy for high-level wastes which relies on mined geologic repositories capable of accepting both waste from reprocessing and unreprocessed commercial spent fuel. The program focuses on locating and characterizing four to five potentially suitable sites and selection of one or more by 1985 for licensing and operation by the mid-1990's.
- Legislation will be sought to extend NRC licensing authority over all DOE transuranic waste disposal facilities and any new DOE sites for commercial low-level waste disposal.
- DOE will assist States in efforts to establish a reliable commercial low-level radioactive waste disposal system.
- EPA will consult with the NRC to resolve issues of overlapping jurisdiction and the two agencies should seek to improve and expedite regulatory actions.
- The President urged the Nuclear Regulatory Commission to conduct in a timely and thorough manner its proceeding to determine whether or not it has confidence that wastes produced by nuclear power reactors can and will be disposed of safely.

Proposed legislation dealing with a number of elements in the President's program was before the Congress as fiscal year 1980 ended.

NRC program offices. The group is responsible for coordinating all NRC waste management technical assistance and research projects. The group assists the Director of NMSS in making in-depth technical evaluations, eliminating duplication or overlap, and reviewing documentation for procurement methods. In 1980, the group reviewed 75 technical assistance projects, and also examined approximately 100 descriptive summaries for fiscal year 1981 technical assistance projects. In 1980, the group also initiated the development of procedures to achieve consistency and integration of total NRC waste management efforts.

Another coordinating activity of the NRC waste management program in 1980 was the presentation of the waste management program and budget to the advisory Committee on Reactor Safeguards (ACRS). In February 1980, the ACRS reported favorably to Congress on the research aspects of the program (NUREG-0557).

HIGH-LEVEL WASTE PROGRAM

Regulatory Development

In 1980 the NRC made significant progress in developing regulations for the management of high-level radioactive waste and supporting guidance in the form of staff technical directives and regulatory guides.

The proposed regulation (10 CFR Part 60) for licensing the disposal by DOE of high-level wastes in geological repositories has been developed in two parts. The first section, setting forth proposed procedures, was published for public comment in December 1979 (44 FR 7048). It contains general provisions, license information, State participation procedures and specifications for reports, tests, and inspections and enforcement. These procedures call for a four-stage review process with opportunity for public participation at each stage.

In May 1980, the technical portion of 10 CFR Part 60 was published as an advance notice of proposed rulemaking (45 FR 31393). It contains requirements for ownership, siting design, waste packaging, retrieval of waste, and monitoring. The advance notice informs the public of the technical criteria being considered and allows the opportunity for reply. In 1981, the procedural portion of the regulation will be published as a final rule, and the technical sections will also be published for public comment as a proposed rule. An environmental impact appraisal for the technical criteria is being prepared.

As a part of the rulemaking process, the NRC has obtained peer reviews of the technical rule by

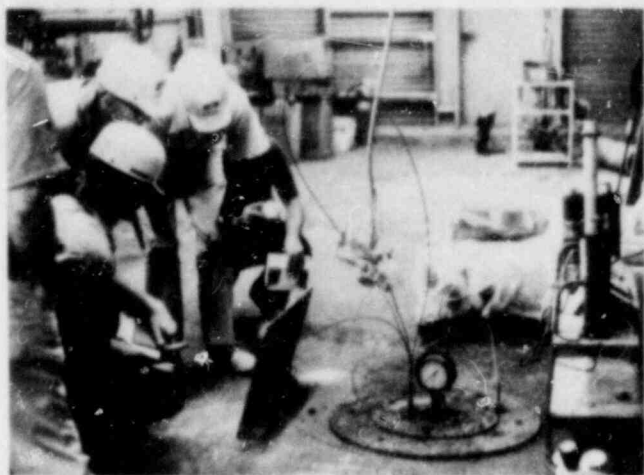

High level waste specialists from the NRC staff traveled to numerous locations where the Department of Energy is studying geologic settings which may be suitable for waste-repository sites. The photo above shows NRC and DOE staffers 500 feet below ground in a salt dome as they examine instrumentation to measure brine migration. This visit, to the Avery Island Salt Mine in Louisiana, was one of several stops made by the NRC team during an extended tour of the Mississippi-Louisiana-Texas Gulf Interior Salt Dome region in September 1980. A similar visit had been made earlier, in July, to the Hanford, Washington area. At right is a section of caprock core taken from a salt dome for use in studying the porosity and permeability of this unit, the dissolution history of the dome, and other characteristics important in considerations of waste-repository suitability. Samples such as this were taken from several salt domes examined as part of the DOE program.

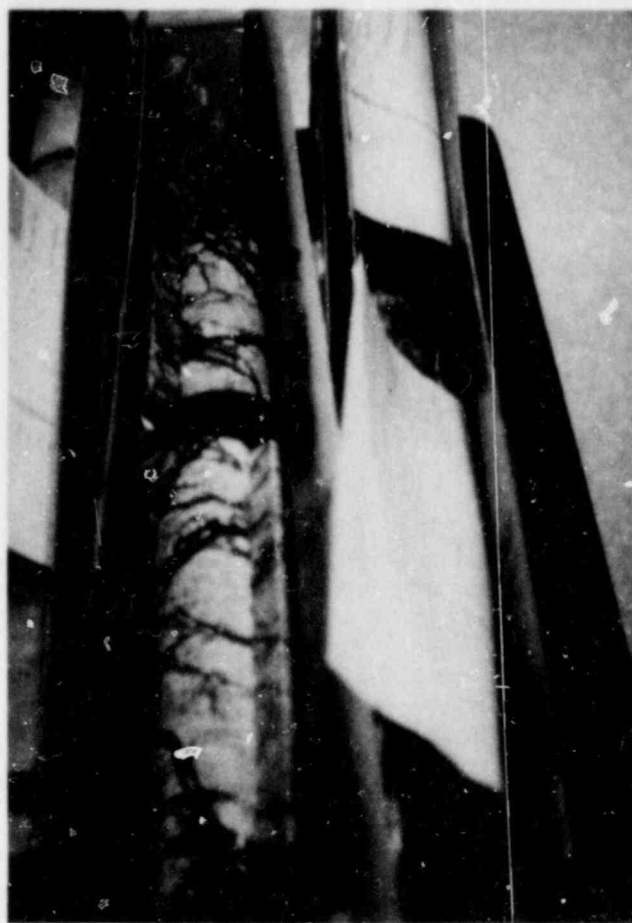

environmental, industrial, academic, and public interest representatives. These peer reviews were conducted by the University of Arizona; the Keystone Institute of Keystone, Colo.; and the Resolve Institute of Palo Alto, Calif.

Regulatory Guides

Also under development are regulatory guides specifying the information needed to support an application for a high-level repository, including Site Characterization Reports, Environmental Reports, and Safety Analysis Reports. During the year, NRC worked on a draft of the Standard Format and Content Guide for the Site Characterization Report. This guide, scheduled for completion in 1981, describes the information needed to identify siting issues, determine the status of each issue, and present plans for resolution of issues, if necessary. It also specifies information required on how areas were selected for characterization, on alternative sites that are being

considered, the technical data necessary to describe the site, conceptual design of the underground facility, waste form and emplacement environment, and performance analysis. The NRC will provide additional guidance to DOE in regulatory guides being developed for the Environmental Report and Safety Analysis Report.

Technical Directives. Another form of regulatory guidance regarding a high-level waste repository application is provided by technical directives which represent a staff position on a major issue. These staff recommendations may subsequently be incorporated into a regulatory guide. In 1980, the Waste Management staff issued technical directives to DOE on the resolution of issues related to site characterization and geochemical research. Additional directives are planned on waste form and packaging, performance assessment, siting, and repository design.

Reviewing DOE Site Investigations

In 1980, the NRC performed several reviews of DOE's site screening activities. The NRC is continuing to review and comment on the site screening

geological investigations at Hanford, Wash., and at the Gulf Interior Salt Domes. In 1981, reviews will be extended to other sites in various geological media.

In its program of upgrading site characterization review capability, the NRC is continuing to develop radionuclide transport models for domed salt, bedded salt, basalt, welded tuff, and granite. During the year, Sandia Laboratories transferred to the NRC staff a porous flow model, called the Sandia Waste Isolation Flow and Transport Model (SWIFT). This model will be used to evaluate radionuclide transport in bedded salt and possibly in domed salt. The NRC is also fashioning a fracture flow model, which will be used to evaluate radionuclide transport in basalt, granite, and other fractured media. The NRC also is developing, under contract, modeling capability for both the repository environment and biosphere transport of radionuclides. In 1981, these models will be transferred to the NRC staff for evaluation.

In a continuing assessment of the national high-level waste program, the NRC will advise DOE on its development of a generic environmental impact statement on commercially generated radioactive waste as well as an environmental impact statement concerning defense high-level waste. (See 1979 Annual Report, pp. 148-149.)

Other Interagency Efforts

During 1980, the NRC was associated with a variety of interagency programs dealing with high-level waste management.

One such effort is the Earth Science Technical Plan, on which the NRC provided comments. The plan was developed by DOE and the U.S. Geological Survey to formally organize the individual earth-science research tasks directed toward a geologic repository for radioactive waste. As a commenting agency, the NRC will give technical assistance and review the plan.

Review is continuing of the standard for disposal of high-level radioactive waste being developed by the Environmental Protection Agency (EPA), which is responsible for standards to protect against radiation in the general environment. The NRC will implement the final standard for repositories of high-level waste. During 1980, the staffs of the NRC and EPA conferred frequently on regulatory development, and consultation will continue on the evolving standards affecting NRC programs.

During the report period, the NRC reviewed the efforts of the Materials Characterization Board, a DOE-funded organization which is developing leaching tests. The NRC will continue to comment on the technical activities of the Board.

Another major activity in NRC's interagency high-level waste management program is its review of DOE's activities in the West Valley project in New York.

The West Valley Demonstration Project Act (P.L. 96-368, signed by the President, October 1, 1980) authorizes DOE to undertake the solidification and disposal of the liquid high-level waste stored at the site of the spent fuel reprocessing plant formerly operated by Nuclear Fuel Services, Inc., at West Valley, N.Y. The law requires DOE to consult with the NRC in carrying out the project. The NRC staff will continue to coordinate with DOE activities, giving specific attention to what waste forms would be acceptable for receipt in a high-level waste repository. NRC staff will also review and comment on any documents developed by DOE in its environmental review activities at the West Valley site. (See Chapter 6, Materials Regulation.)

Waste Confidence Hearing

In 1980, NRC staff work continued in the NRC Waste Confidence rulemaking (PR-50, 51). The rulemaking, which began in October 1979, was initiated



by the Commission in order to generically assess the current degree of assurance that radioactive wastes can be safely disposed of, to determine when such disposal or off-site storage will be available, and to determine whether radioactive wastes can be safely stored on-site past the expiration of existing facility licenses until off-site disposal or storage is available.

After the first prehearing conference in January 1980, the presiding officer determined that the proceeding would deal only with disposal of spent fuel and not with high-level reprocessing waste, and that issues concerning transportation are beyond the scope of the hearing. The NRC staff has provided a large number of documents for participants' use to assure that the record is complete and all technical issues are explored in the proceeding. (See "Commission Decisions" in Chapter 15 for further discussion.)

The storage and transportation of spent nuclear fuel are discussed in Chapter 6.

REGULATING LOW-LEVEL WASTE

Regulatory Development

In 1980, the NRC continued to develop regulatory tools to provide comprehensive standards for low-level wastes. Because present Commission regulations are not specifically tailored for regulation of disposal sites for low-level waste, the staff concentrated on three major projects: a regulation for a low-level waste disposal site (10 CFR Part 61), a supporting environmental impact statement, and amplifying regulatory guides.

In February 1980, the NRC notified the public of the availability of a preliminary draft of 10 CFR Part 61 which outlines licensing procedures, performance objectives, and technical criteria for disposal of low-level waste into a land facility (45 FR 13104).

The first part of the draft regulation deals with administrative and procedural requirements, such as definitions, general application requirements, and financial qualifications of an applicant. The second part of the regulation deals with technical aspects and sets out overall performance objectives and requirements for waste form and content, site characteristics, design and operations, monitoring, closure, and post-operational surveillance.

The final section would outline specific limitations applying to individual disposal methods.

The NRC plans to formally issue the draft regulation and draft environmental impact statement in 1981. Amendments and supplements to the environmental impact statement addressing low specific activity/high volume waste and high specific activity/low volume waste for disposal in other than shallow land burial and intermediate land burial will also be published at a later date.

The draft of the regulation (10 CFR 61) has been circulated for informal public comments, and the Commission has received a variety of written responses. To provide a broad base of early input from State, industry, and public groups, four regional workshops on the draft regulation were held in Atlanta (April 21-22), Denver (July 14-15), Chicago (July 17-18), and Boston (November 6-7). Workshop recommendations have been submitted to NRC and these, as well as other comments will be considered by the NRC staff in the development of the Proposed Part 61 regulation and of the environmental impact statement.

The NRC is continuing research and other work to develop regulatory guides for the low-level waste regulation. The staff is currently drafting guides for the low-level waste application contents, waste classification, site selection, and site closure and funding. To improve the basis of regulatory development, the NRC is funding research efforts in the areas of modeling, waste classification, volume reduction, and treatment of liquid low-level wastes.

Bulldozers work to cover a portion of a containment trench into which low level waste containers have been dumped. When the entire trench has been filled in this manner, a temporary marker indicating the dimensions and content of the trench will be erected. This marker will be replaced by a permanent one as soon as the cover earth has settled and the area has been grassed over. (The four photos present one continuous vista.)

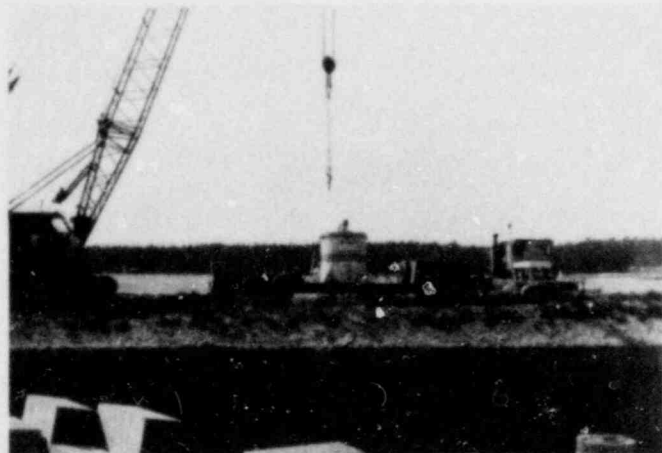

Licensing Activities

In 1980, the staff continued to assess health, safety, and environmental aspects of NRC-licensed low-level waste disposal facilities. The NRC completed its safety review for renewal of a license for disposal of special nuclear materials at Richland, Wash., in November 1979, and continued safety reviews for renewal of a similar license at Barnwell, S.C.

At the Sheffield, Ill., low-level waste burial site, the NRC continued to analyze the health, safety, and environmental aspects of the decommissioning of the Nuclear Engineering Co.'s (NECO) facility which has been operating under NRC license. (See *1979 NRC Annual Report*, pp. 149-150.) In the proceeding before an Atomic Safety and Licensing Board, the NRC staff filed suggested conditions for site closure and stabilization with the board after a prehearing conference in June 1980. NECO is monitoring and maintaining the site while the legal proceedings are being resolved.

The NRC is continuing research in support of low-level waste disposal licensing activities, including environmental assessments of sites, long-term erosion, hydrology, and trench cap studies. New research and technical assistance projects are underway to address new and unique problems in waste disposal posed by the Three Mile Island (TMI) accident.

Regional imbalance for low-level waste sites continued in 1980 because only one applicant in Kansas, an Agreement State, sought a license. At one time, six sites were licensed to operate in Illinois, Kentucky, New York, Nevada, South Carolina, and Washington, but only three are now operating. Of these, the Beatty, Nev., and Hanford, Wash., sites were both closed on occasion by the States during the past year. Furthermore, the third operating facility at Barnwell, S.C., is reducing by 50 percent the amount of waste it will receive during 1980-81. The governors of Washington, Nevada, and South Carolina have stressed the need for new sites to handle regional disposal needs and expressed the hope that other states will join in addressing the problem.

Assistance to Agreement States

The NRC continues to furnish technical advice to Agreement States regarding low-level waste licensing activities. In May 1980, the NRC staff assisted Kansas in review of the Southwest Nuclear Co.'s application for the use of a salt mine at Lyons, Kansas for the retrievable storage of low-level radioactive material. If requested, the NRC will also provide Kansas with an environmental assessment of the site.

In July 1980, the NRC advised Nevada regarding the application of the Nuclear Engineering Co. for

renewal of its license for the low-level waste burial site at Beatty, Nev. South Carolina received NRC technical assistance in 1980 to develop the scope and nature of assistance for a formal agreement. The State of Washington was assisted in its review of a license renewal application for the Richland low-level waste disposal site.

The NRC will continue to work with the States to upgrade requirements at existing disposal sites, and is conducting research to give Agreement States a better technical basis for making regulatory decisions.

REGULATING URANIUM RECOVERY AND MILL TAILINGS

Licensing Activities

The NRC is responsible for assuring that uranium recovery facilities are constructed, operated, and decommissioned in a manner that will protect the public health and safety and the environment. The NRC places a high priority on assuring that operating mills are brought into compliance with the EPA's new radiation standards (40 CFR 190) and with NRC regulations developed as a result of the Uranium Mill Tailings Radiation Control Act of 1978, as amended (UMTRCA).

During 1980, the NRC staff completed work on 2 new uranium recovery licenses, 4 license renewals, 12 major amendments for facility modifications, 2 amendments to licenses required by EPA standards, 9 license amendments caused by inspection and enforcement activities, and 23 minor and administrative amendments. In addition, 21 technical assistance projects were provided to Agreement State programs. At year-end, there were 15 uranium mills, 9 heap leach/ore-buying stations/byproduct recovery facilities, 13 research and development solution mining operations, and 2 commercial solution mining activities authorized under NRC license.

During the year, the NRC worked with State and industry officials on a problem at the Irigaray Uranium Solution Mining Project in Wyoming, which is an NRC licensee. In April 1980, an NRC order was issued to the licensee to suspend production because of evidence of uncontrolled vertical excursions of leaching solutions. The licensee was required to provide geologic and hydrologic data demonstrating that control of the mining process and restoration of the groundwater are achievable in the proposed mine field areas. The NRC is still studying the advisability of continued operations and what additional license conditions may be warranted.

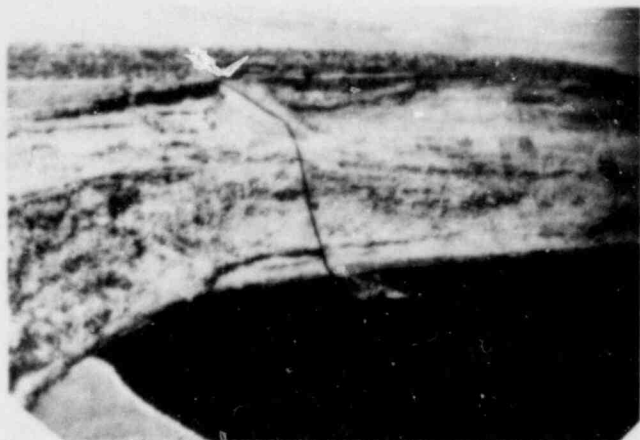

A mined-out pit is used as a mill tailings pond at the Union Carbide uranium mill in Gas Hills, Wyo. At left, the tailings are sent directly from the mill to the clay-lined pond by means of a slurry. At right, the water from the pond is pumped back up



to the mill for use in the milling operation to convert raw uranium ore to "yellowcake" (U_3O_8), a uranium concentrate used as feed material for further conversion to uranium hexafluoride and ultimate refinement for reactor fuel or other uses.

Regulatory Development

In 1980, the NRC continued efforts to upgrade regulations for uranium recovery operations and associated tailings. In October, the NRC released the final Generic Environmental Impact Statement (GEIS) on Uranium Milling (NUREG-0706) along with regulations on mill tailings, which constitute minimum national standards. The regulations, which focus primarily on tailings disposal as mandated by UMTRCA, also specify broad criteria for mill operations and decommissioning. Development of the final GEIS included a benefit-cost analysis of a wide range of alternatives for controlling emissions from uranium mills and for uranium mill tailings disposal impacts to populations nearby and far from mills, where the short- and long-term consequences were considered. Public comments on the final GEIS and on the associated regulations were received in written form, and at public meetings in Denver, Colo., and Albuquerque, N.M. These public comments were addressed in the final GEIS.

The regulations on uranium milling are cast primarily in the form of broad performance objectives. The NRC is developing regulatory guides to provide more specific information on how to meet these performance objectives. Some 20 additional guides will be needed to more fully implement controls dealing with uranium recovery and mill tailings management. Work on these guides was initiated in 1980, and will continue for several years.

A draft guide on standard format and content of license applications (including environmental reports) for in situ uranium extraction was issued in July 1980.

Technical Assistance to Agreement States

The UMTRCA established a number of new requirements affecting the NRC Agreement States program. In its technical assistance program, the NRC assures that Agreement State criteria used to license and regulate uranium recovery operations are compatible with criteria for similar operations under NRC jurisdiction. Under UMTRCA and implementing regulations, the Agreement State role remains a substantial one. (See also Chapter 10.)

The NRC provided technical assistance in 1980 to California, Colorado, Arizona, New Mexico, Oregon, Texas, and Washington in the licensing and regulation of uranium recovery operations. This included 21 project reviews, covering uranium mills, heap-leach operations, solution-mining operations, and research and development activities.

The NRC also continued to provide assistance to New Mexico in its assessment of the Church Rock tailings impoundment area where a dam failure released large quantities of radioactively contaminated water and sediment in July 1979. (See 1979 Annual Report pp. 146-152.) NRC staff worked with State officials to analyze the effects on contaminated areas downstream from the Church Rock area and to verify cleanup. The NRC also helped prepare a draft report on the incident (Survey of Radionuclide Distributions Resulting from the Church Rock, New Mexico Uranium Mill Tailings Pond Dam Failure).

Remedial Action at Inactive Sites

The NRC continued to carry out the mandate of Title I of the UMTRCA which requires review of

DOE's remedial action program at inactive tailing sites and other former ore processing areas. The Commission provides reviews, concurrences, and licensing actions during the remedial process. The NRC reviewed the initial phases of several DOE actions in 1980, and worked out with DOE a detailed plan for subsequent interaction between the agencies.

In conformance with a provision in the fiscal year 1980 Supplemental Appropriations and Recission Bill Report (No. 96-829), the NRC staff has developed,

in consultation with the State of South Dakota, EPA, the Department of Housing and Urban Development, and the Tennessee Valley Authority (TVA) an Edgemont Cleanup Action Program. The project involves cleanup of tailings located off-site from a defunct uranium mill formerly operated at Edgemont, S.D., and now owned by TVA. During 1980, NRC initiated preliminary work necessary for off-site tailings cleanup, which is scheduled to begin in 1981.



9

Inspection and Enforcement

During 1980 the NRC made significant changes to improve its inspection programs for both operating power reactors and reactors under construction, completed stationing NRC resident inspectors at the sites of all operating nuclear power plants and many others under construction, and developed a proposed enforcement policy which in part reflects implementation of a substantially increased civil penalty authority enacted by the Congress.

Salient actions and developments during Fiscal Year 1980 included:

- Deployment of inspectors to all sites with power reactors in operation or preoperational testing, and at 18 sites with reactors under construction, bringing the total full time resident inspection force to 136 inspectors at 76 sites by September 30, 1980.
- Major changes in the operating reactor program to emphasize direct inspection efforts for better assessment and verification of licensee management control, operational safety, and conformance with regulatory requirements.
- Similar improvements in certain inspection activities at reactors in the construction stage stressing independent verification testing and inspection for added assurance that important safety-related equipment will function in an accident environment.
- Initiation of special team appraisals of the adequacy and effectiveness of licensees' health physics programs at operating power reactor sites.
- Start of a major program to independently measure radiation levels around all operating power reactors, involving about 50 thermoluminescent dosimeters per site at distances out to 10 miles.
- Imposition of 49 civil penalties on licensees totaling almost \$1.4 million and issuance of 26 orders to "cease and desist" operations or to

modify, suspend, or revoke licenses for noncompliance with NRC requirements.

- Enactment of legislation increasing by twenty-fold the amount of a fine that NRC can levy for a licensee violation. NRC developed a proposed new enforcement policy which, in part, implements this authority, and placed it into interim use as fiscal year 1980 ended.
- Issuance of approximately 100 bulletins and other notices alerting licensees to safety-related matters, and conduct of 5,416 licensee inspections and 126 investigations.

THE INSPECTION PROGRAM

The Inspection and Enforcement Program is directed by NRC's Office of Inspection and Enforcement (IE), with a headquarters staff located in Bethesda, Maryland, and a field staff deployed in NRC's five regional offices located in or near Philadelphia, Atlanta, Chicago, Dallas, and San Francisco. The IE staff was increased from 730 to 846 in fiscal year 1980, and about 81 percent of the total staff is assigned to the regions. A total of 5,416 inspections of all types were conducted during fiscal year 1980 (see Table 1).

The objectives of inspections are to:

- Determine whether licensees are complying with NRC requirements.
- Identify conditions that may adversely affect public health and safety, the common defense and security, the environment or the safeguarding of nuclear materials and facilities.
- Provide information to assist in developing a basis for issuance, denial, or amendment of an authorization, permit, or license.

Table 1. Inspections Conducted in Fiscal Year 1980

| <i>Program</i> | <i>Number of Licenses</i> | <i>Number of Inspections</i> |
|----------------------------|---------------------------|------------------------------|
| Power Reactor Construction | 109 | 1,531 |
| Operating Power Reactors | 77 | 1,600 |
| Other Reactors | 84 | 36 |
| Fuel Facilities | 38 | 106 |
| Materials | 8,681 | 1,419 |
| Vendors | 300 | 213 |
| Safeguards | 239 | 461 |

- Determine whether licensees and their contractors and suppliers have implemented adequate quality assurance programs.

When an inspection or investigation discloses events or conditions that present a potential or actual threat to public health and safety, the environment, or the safeguarding of nuclear materials and facilities, the NRC takes prompt action and routinely communicates relevant information to other parts of government, licensees, and the public.

As the result of a task group study of significant and recurring construction problems, NRC has modified the construction inspection program to provide additional emphasis on earlier construction activities, the prevention or earlier identification of construction deficiencies, the effectiveness of quality assurance and quality control implementation, and independent measurement/verification activities by inspectors. Twenty-eight major modifications were made to the construction inspection program during fiscal year 1980 to accomplish this activity. (Some of the matters covered by this task group overlapped with some of the TMI Action Plan items relating to construction inspection.)

Reporting Defects and Noncompliance

Individual directors or responsible officers of firms involved in the nuclear industry are required by NRC regulation 10 CFR Part 21 to report noncompliance with NRC regulations or the existence of defects that could create a substantial health and safety hazard. The regulation, which implements Section 206 of the Energy Reorganization Act of 1974, as amended, became fully effective on January 6, 1978.

About 125 Part 21 reports were received by the NRC during fiscal year 1980, and were reviewed to assess the reported deficiency, the adequacy of the proposed corrective action, and the possibility of generic problems. NRC inspectors seek to ensure that appropriate followup actions are taken.

In April 1980, the NRC proposed a civil penalty of \$100,000—the first of its kind—against the Babcock & Wilcox Co. (B&W) for failure to provide for reporting as required by 10 CFR Part 21. NRC concluded that B&W, the reactor manufacturer for the Three Mile Island plant, did not have an effective system for collection, review and evaluation, and reporting of important safety information, and that information available to B&W before the TMI-2 accident should have been reported in accordance with Part 21.

The NRC has initiated a systematic recording and screening system for construction deficiency reports (10 CFR 50.55(e)), with evaluation for possible generic aspects. These reports from construction permit holders inform the NRC of deficiencies found in design or construction which, if not corrected, could adversely affect operational safety.

Types of Inspections

NRC's inspections are of two basic types: routine and reactive. In routine inspections, NRC inspectors determine whether licensees are complying with their licenses and technical specifications and with the regulations. This effort includes direct observation and verification of licensee activities, and reviewing procedures, checking records, interviewing people, and, where appropriate, making direct measurements. Plans for making more direct measurements are being implemented. Reactive inspections are conducted in response to information received by NRC regarding conditions or events affecting licensed facilities or material under NRC jurisdiction. Such information may come from routine NRC inspections; from an applicant, licensee, contractor, or supplier; or from licensee employees or other members of the public.

Inspections cover the entire range of NRC licensed activities. Reactor-related inspections cover all phases of nuclear power plants (preconstruction ac-

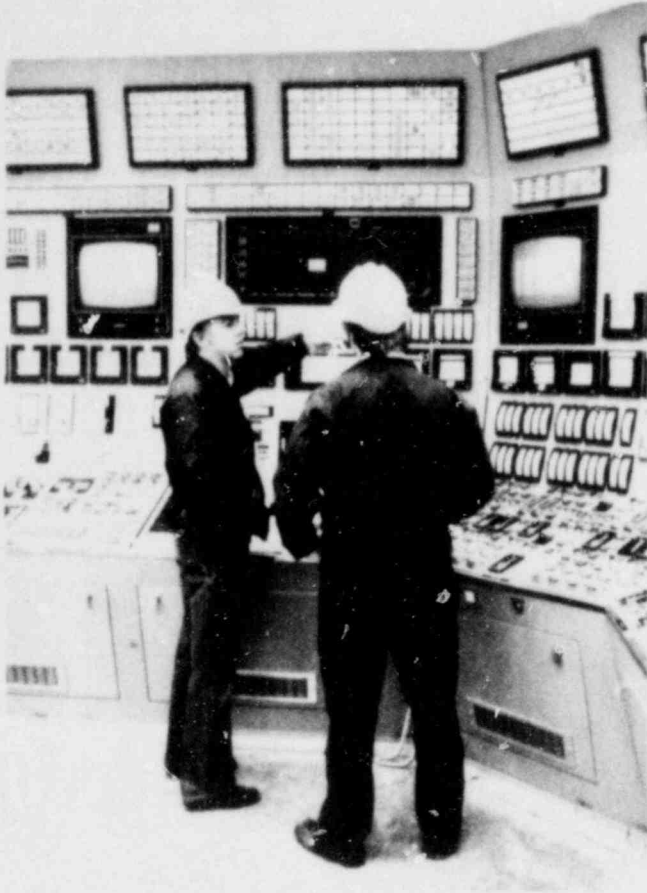

NRC inspections at Duke Power Co.'s McGuire Nuclear Station in North Carolina, where Unit 1 is in the final stages of construction. Inspectors are shown (left) checking control room

tivities, construction, preoperational testing and startup, operation, shutdown, and decommissioning) and similar phases of research and test reactors. In addition, NRC inspects the quality assurance programs of contractors and vendors who supply safety-related equipment, components, and services to power reactors under construction or in operation. NRC also inspects fuel facility and materials and safeguards activities to ensure compliance with applicable NRC regulations and license conditions.

Licensee, Contractor, and Vendor Inspection Program

About half the work associated with constructing a nuclear facility is accomplished offsite, including overall design and the fabrication of components of safety-related systems. Inspections of nuclear steam system suppliers, architect-engineers and vendors of safety-related components are performed by NRC's Licensee, Contractor, and Vendor Inspection Branch (LCVIB) inspectors, located in the Region IV (Dallas) office. Approximately 50 percent of the inspec-

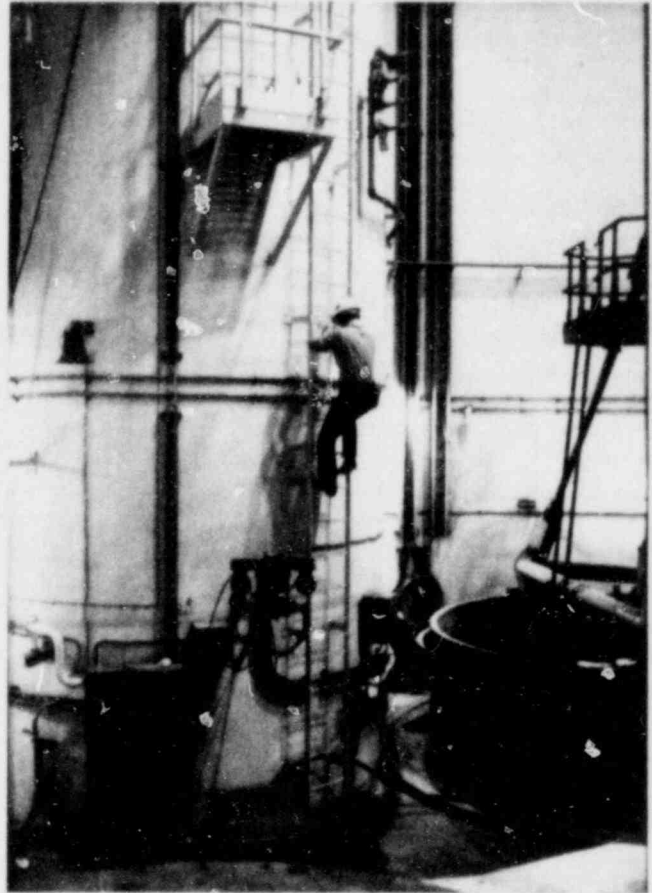

instrumentation and (right) descending to the containment floor following a check of the pressurizer cubicle.

tions involve component fabrication or design-related problems.

During fiscal year 1980, a modest shift in inspection emphasis was accomplished in the LCVIB. Activities experiencing change included:

- Performing more reactive inspections.
- Redirecting emphasis toward the inspection of technical activities performed by contractors.
- Followup on Part 21 Reports, Bulletins, and Circular issues.
- Inspecting and witnessing environmental qualification of electrical, instrumentation, and control equipment.
- Inspecting design and analytical work performed by licensee contractors.

Performance Appraisal Program

Three licensee management appraisal inspections were completed in fiscal year 1980, and some 20 such inspections are scheduled for fiscal year 1981.

An annual report addressing the performance appraisal findings identified in 1979 was issued in 1980. This report and the 1980 inspection findings will be used in the Systematic Assessment of Licensee Performance reviews conducted by NRC management.

Independent Measurement/Verification Program

IE continued to increase its efforts during 1980 with independent measurement/verification of licensee and contractor activities during the construction phase. Contractors have been used periodically to perform independent non-destructive examinations. In August 1980, a contractor was selected to perform destructive testing and analysis of selected materials used in safety-related structures and systems. During 1980, seven such tests were completed or in progress.

In 1980, programs and procedures were completed for independent nondestructive examination by NRC Regional Office personnel. A mobile facility has been purchased by NRC Region I for this use.

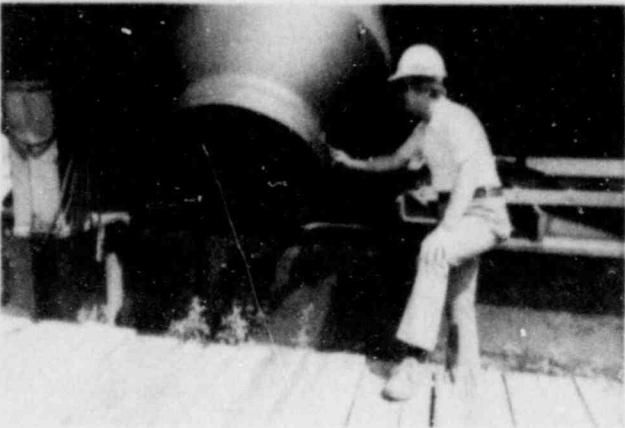

Inspections during construction of Duke Power Co.'s two units at its Catawba Nuclear Station site in South Carolina. Shown clockwise, from top left, are inspections of a pipe weld reinforcement, pipe fittings, reactor pressure vessel head con-

Environmental Qualification Program. A comprehensive, independent verification testing and inspection program for environmentally qualified equipment is being developed and implemented to verify the adequacy of equipment for those plants currently under construction.

The program is designed to provide in-depth coverage of carefully selected equipment and a more general type of coverage for other environmentally qualified equipment installed in safety-related systems. The total environmental qualification problem is being addressed: in the short term through direct NRC involvement to yield immediate results, and in the long term through standardization activities that will improve the industry's control over the qualification process.

The major activities in the environmental qualification program for which IE maintains a lead responsibility include:

- Conducting independent verification tests on selected equipment.
- Performing in-depth inspections and witnessing selected qualification tests performed by or for the applicant or licensee.

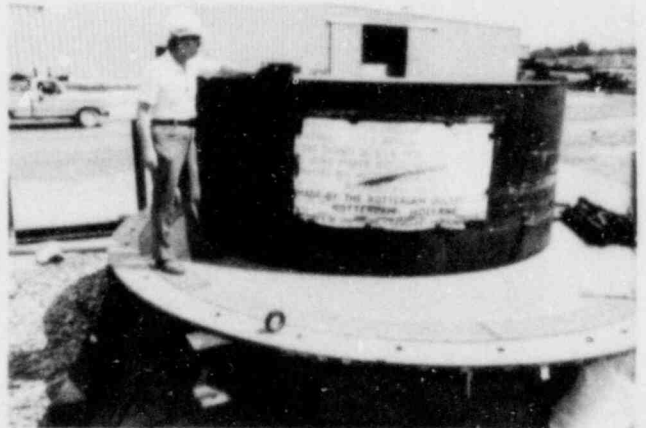
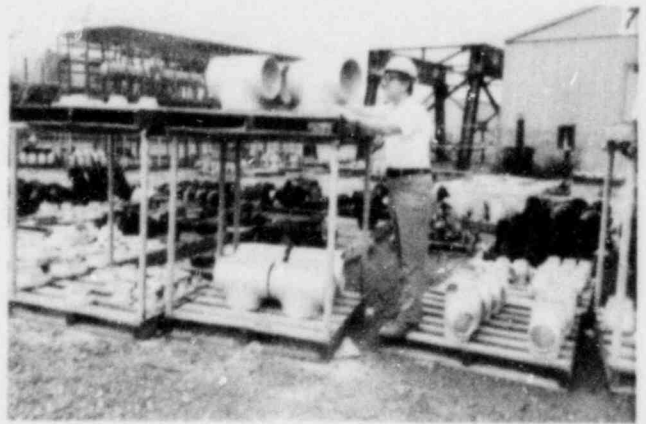

tainer, and a reactor vessel nozzle. NRC also conducts off-site inspections of nuclear steam system suppliers, architect-engineers, and vendors of safety-related components for nuclear power plants.

- Initiation of a third-party laboratory accreditation program.

Impact of TMI on Inspection Program

A significant portion of the inspection effort at operating power reactors was directed toward verification of licensee's implementation and completion of actions specified in the TMI Action Plan, NUREG-0660. Particularly impacted were the inspection programs for license applicants and those receiving licenses during the period covered by this report. Although inspection effort is routinely increased for those facilities nearing the operating license stage, specific inspection emphasis was focused on the first facilities to come up for operating license approval since the TMI accident. In addition to routine inspection activities required to demonstrate the adequacy of licensee programs to safely operate the facility and the licensee's conformance to regulatory requirements, further inspections were required to verify compliance with requirements imposed as a result of the accident and specifically delineated in the TMI Action Plan.

Appropriate changes to the construction inspection program have been generally based on TMI Action Plan items. These changes pertain to quality assurance and quality control inspection activities, on-site design, review of as-built structures and systems, and increased independent measurements. Most of these changes are increasing the scope of the routine construction inspection program. This increase is occurring at a time when deferral or deletion of portions of the routine inspection program are already taking place due to increased reactive effort.

Radiation Protection Programs. The TMI accident and the resultant problems identified in radiation protection have underscored a need for special efforts to assure that nuclear power reactor facilities have adequate radiation protection programs. In January 1980, IE initiated special team appraisals of the health physics programs at operating power reactor sites. The immediate objective was to perform a comprehensive evaluation of the overall adequacy and effectiveness of power reactor licensees' total health physics programs. Whereas the routine inspection program had been more compliance-oriented and led to the inspection of health physics program by discrete subject areas, the new appraisal program was structured to afford an integrated look at the total program. The teams included not only health physicists from within the NRC, but also professionals from outside the agency to provide an extra dimension of perspective to the appraisals.

A second objective of the program is to identify generic problems and improve NRC requirements and guidance. Licensees are being informed in the appraisal reports that they will be required to develop and implement radiation protection plans. Each licensee must include in the radiation protection plan sufficient measures to provide lasting corrective action for significant weaknesses identified during the special appraisal of the current health physics program. The onsite appraisals will be completed in early 1981. Completion of the implementation inspections for the new radiation protection plans will extend into 1982.

Resident Inspector Program

During the report period, the NRC rapidly implemented its program to station inspectors full time at the sites of nuclear power reactors. The first such assignments were made in 1978; 60 inspectors were assigned to 45 sites by the end of 1979, and deployment continued at a rapid pace through 1980. As of June 1980, at least one senior inspector had been assigned to each of the 47 sites with an operating reactor, with some allotted two inspectors. Additional inspectors were assigned to 28 other sites with power reactors undergoing construction or testing.

By September 30, 1980, a total of 136 inspectors were assigned to 76 sites: 47 sites with operational reactors, 11 other sites with power reactors in preoperational testing, and 18 sites where power reactors were being constructed. (See Table 2 for sites added during fiscal year 1980.)

NRC resident inspectors also are assigned to one fuel facility (Nuclear Fuel Services, Erwin, Tenn.) and one low-level waste facility (Nuclear Engineering Co., Richland, Wash.). At the end of fiscal year 1980, the resident inspector position was discontinued at the B&W fuel facility in Apollo, Pa., which is undergoing decommissioning.

The resident inspector is NRC's continuing presence on-site. These inspectors are well versed in their site's characteristics, technology, procedures, and personnel. As NRC's "eyes and ears," they monitor day-to-day activities and licensee performance. They are responsible for followup on NRC bulletins, circulars, and information notices relating to that site, and for assuring that the licensee meets commitments in response to NRC enforcement actions. They are available to respond to events, both onsite and in the local area, providing a reliable and knowledgeable contact to monitor and communicate about activities taken to assure the public health and safety. With the assistance of Region-based inspec-

Table 2. Sites Manned by Resident Inspectors During 1980

| <i>Facility</i> | <i>Location</i> | <i>Licensee</i> |
|---|----------------------|--------------------------------------|
| Big Rock Point Nuclear Plant | Big Rock Point, Mich | Consumers Power Co. |
| Catawba Nuclear Plant | Lake Wylie, S.C. | Duke Power Co. |
| Clinton Nuclear Power Plant | Clinton, Ill. | Illinois Power Co. |
| Cocper Nuclear Station | Brownville, Neb. | Nebraska Public Power District |
| Crystal River Plant Unit 1 | Red Level, Fla. | Florida Power Corp. |
| Duane Arnold Energy Center | Pala, Iowa Unit 1 | Iowa Electric Light |
| Enrico Fermi Atomic Power Plant Unit 2 | Lagoona Beach, Mich. | Detroit Edison Co. |
| James A. FitzPatrick Nuclear Power Plant | Scriba, N.Y. | Power Authority of the State of N.Y. |
| Fort Calhoun Station Unit 1 | Fort Calhoun, Neb. | Omaha Public Power District |
| R. E. Ginna Nuclear Power Plant Unit 1 | Ontario, N.Y. | Rochester Gas & Electric Co. |
| Grand Gulf Nuclear Station | Port Gibson, Miss. | Mississippi Power & Light Co. |
| Haddam Neck Generating Station | Haddam Neck, Conn. | Connecticut Yankee Atomic Power Co. |
| Shearon Harris Plant | Bonsal, N.C. | Carolina Power & Light Co. |
| Hope Creek Generating Station | Salem, N.J. | Public Service Electric & Gas Co. |
| Kewaunee Nuclear Power Plant | Carlton, Wisc. | Wisconsin Public Service Corp. |
| Genoa Nuclear Generating Station (LaCrosse) | Genoa, Wisc. | Dairyland Power Corp. |
| Maine Yankee Atomic Power Plant | Wiscasset, Maine | Maine Yankee Atomic Power Co. |

tors, they perform a scheduled program of inspection into all aspects of plant construction, testing, and operation that have a significant bearing on assuring the public health and safety, protecting the environment, and safeguarding nuclear materials and nuclear facilities. They participate in preparing enforcement actions and in periodic assessments of licensee performance. They often represent the NRC before local and State governments, the local press and broadcast media, civic groups, and in responding to inquiries from the public.

The NRC will continue to assign one or more resident inspectors to sites with power reactors in operation or in preoperational testing. Most sites will have two inspectors. The NRC also assigns one resident inspector to each site where nuclear plant construction is well advanced or where problems are evident in earlier stages of construction.

Operations Inspection Program Upgraded

A major change in the operating reactor inspection program was made in February 1980 to meet agency commitments to maximize the direct inspection efforts at those sites with resident inspectors. The program revisions, which coincided with the assignment of resident inspectors at most operating power reactor sites, emphasizes inspector direct observation, verification and assessment of licensee activities, and interviews and discussions by inspectors with licensee personnel. The enhanced direct inspection effort is expected to provide a better assessment of the licensee's management control program and whether the facility is being operated safely and in conformance with the regulatory requirements. By year-end, positive feedback from the program was already being received regarding instances where the resident

| | | |
|--|--------------------------|---------------------------------------|
| Wm. B. McGuire Nuclear Station | Cowans Ford Dam, N.C. | Duke Power Co. |
| Monticello Nuclear Generating Plant | Monticello, Minn. | Northern States Power Co. |
| Nine Mile Point Nuclear Station | Scriba, N.Y. | Niagara Mohawk Power Co. |
| Oyster Creek Nuclear Power Plant Unit 1 | Toms River, N.J. | Jersey Central Power & Light Co. |
| Perry Nuclear Power Plant | Perry, Ohio | Cleveland Electric Illuminating Co. |
| Phipps Bend | Plant Phipps Bend, Tenn. | Tennessee Valley Authority |
| Pilgrim Station | Plymouth, Mass. | Boston Edison Co. |
| Point Beach Nuclear Plant | Two Creeks, Wisc. | Wisconsin Electric Power Co. |
| River Bend Station | St. Francisville, La. | Gulf States Utilities Co. |
| H. B. Robinson S.E. Plant Unit 2 | Hartsville, S.C. | Carolina Power & Light Co. |
| St. Lucie Plant | Ft. Pierce, Fla. | Florida Power & Light Co. |
| Three Mile Island Nuclear Station | Middletown, Pa. | Metropolitan Edison Co. |
| Vermont Yankee Generating Station | Vernon, Vt. | Vermont Yankee Nuclear Power Corp. |
| Washington Nuclear 1, 4 | Richland, Wash. | Washington Public Power Supply System |
| Washington Nuclear 3, 5 | Satsop, Wash. | Washington Public Power Supply Steam |
| Waterford Steam Electric Station | Taft, La. | Louisiana Power & Light Co. |
| Wolf Creek | Burlington, Kans. | Kansas Gas & Electric Co. |
| Yankee Nuclear Power Station | Rowe, Mass. | Yankee Atomic Electric Co. |
| Nuclear Engineering Co. (Waste Facility) | Richland, Wash. | Nuclear Engineering Co. |

inspector not only detected potential safety problems, but also assured that the situations were properly corrected. The revised program also provides guidance for coordination of the resident inspector's inspection activities with those of the regional based inspectors.

Studies are underway to further increase the effectiveness and safety efficiency of the operating reactor inspection program. In April 1980, Sandia Laboratories completed for IE a study, "Development of a Checklist for Evaluating Maintenance, Test, and Calibration Procedures Used at Nuclear Power Plants," (NUREG/CR-1368). Results of this study along with its companion document, "Procedures Evaluation Checklist for Maintenance, Test, and Calibration Procedures," (NUREG-CR-1369) are being reviewed by IE for incorporation into the inspection program.

A similar study regarding methods for inspector evaluation of emergency procedures at nuclear power plants is being directed by Sandia Laboratories for IE.

Direct Radiation Monitoring Network Established

Another major program undertaken by NRC during fiscal year 1980 is the measurement of the radiation levels in the environment around nuclear power plants. This program is being conducted around 49 nuclear power plant sites, which include all operating reactors and three reactors scheduled for operating license decisions in the near future. As other reactors approach the operational stage, their sites will be added to the program. Thermoluminescent dosimeters (TLDs) are used to measure the cumulative direct



Changes in the inspection program are increasing the scope of NRC's construction inspections. Here, in earlier stages of construction at Public Service Electric & Gas Co.'s Hope Creek Station in New Jersey, clockwise from upper left, an inspector observes compaction of backfill soil, examines Cadweld in structural reinforcement bars, checks sand-cone soil density tests, and notes repairs being made on voids and honeycombing in concrete.

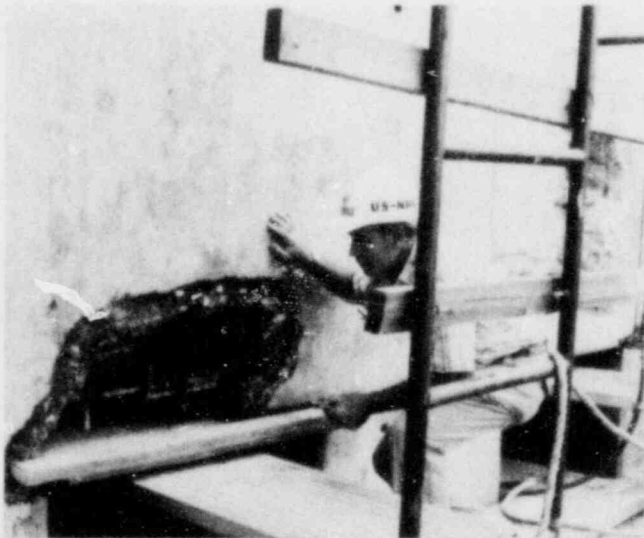
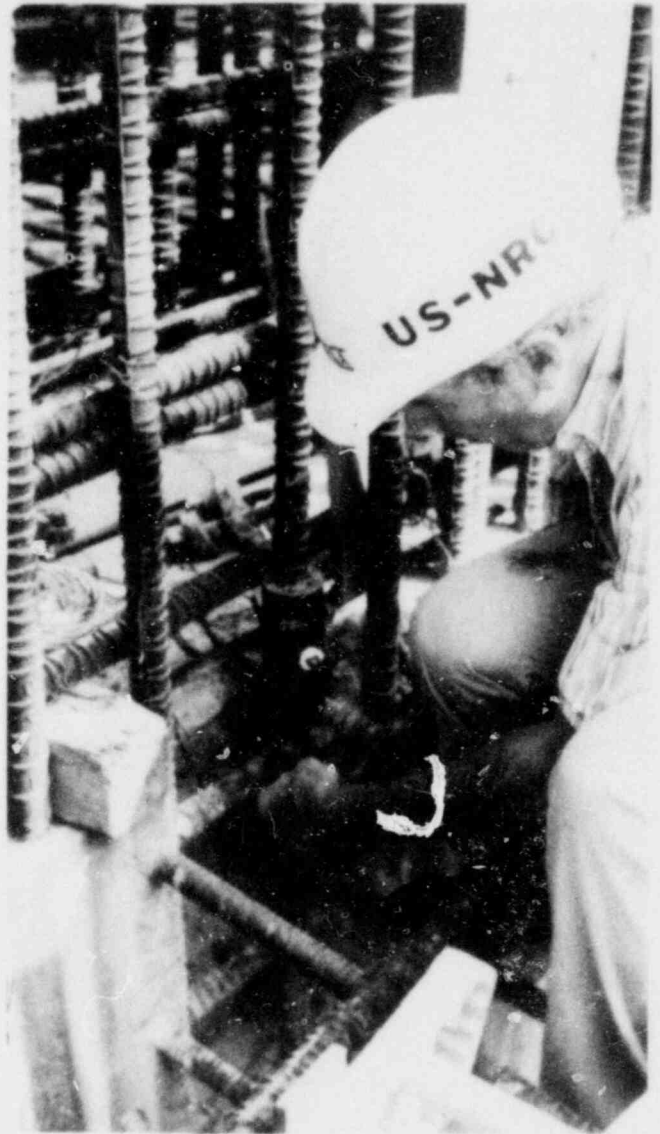

radiation levels at the point of location. Approximately 50 TLDs have been installed at each site, covering all sectors of the compass, population centers, and high public interest locations out to a distance of about 10 miles.

The purposes of the program are to (1) provide an independent verification of the accuracy of the licensee's environmental direct radiation measurements, (2) measure the ambient radiation levels in the vicinity of operating plants for use in assessing population doses resulting from routine operation, and (3) provide a continuously maintained network of TLDs that can be used for timely assessment of cumulative environmental doses under accident conditions.

The program is a cooperative effort with States in which the reactor sites are located. The States, under contract to NRC, pick up and exchange TLDs and ship them to the NRC Region I office for processing.

Bulletins, Circulars, and Information Notices

During 1980, IE continued to issue Bulletins, Circulars, and Information Notices at a rate comparable to 1979.

The IE Bulletin is used to notify licensees of specific actions to be taken, and usually requires a report to the NRC on such actions. The Bulletin addresses matters of concern or events related to reactor safety, material safeguards, radiological safety or environmental protection.

Bulletins usually, although not always, require the action on a one-time only basis. They are not intended to substitute for new or revised license conditions or requirements. If a licensee refuses to perform an action set forth in the Bulletin, the requirement for the action may be imposed on the licensee by an Order. During 1980, 18 Orders were issued to licensees in followup to inadequate or untimely responses to Bulletin 79-27, which related to "Loss of Nonclass I-E Instrumentation and Control Power Bus During Operation."

Particular considerations which might require the issuance of a Bulletin include events in which the safety significance is of such a magnitude as to result in an immediate impact on all of a certain type of licensee. Other considerations include events having a potential generic problem impact and where the event requires action by a particular class of license or permit holder. When appropriate, IE obtains comments from the Institute for Nuclear Power Operations, nuclear steam system suppliers, and vendors before issuing bulletins. This procedure has proved to be effective in obtaining faster and better focused responses from licensees.



In addition to the program of installing fixed thermoluminescent dosimeters to measure radiation levels around nuclear power plants, the NRC maintains mobile laboratories that can be driven to sites for confirmatory radiation measurements. Here, radiation specialists from NRC's Region III office check a computer-based gamma spectrometer and other equipment before routine measurements at the Dresden Nuclear Power Station in Illinois.

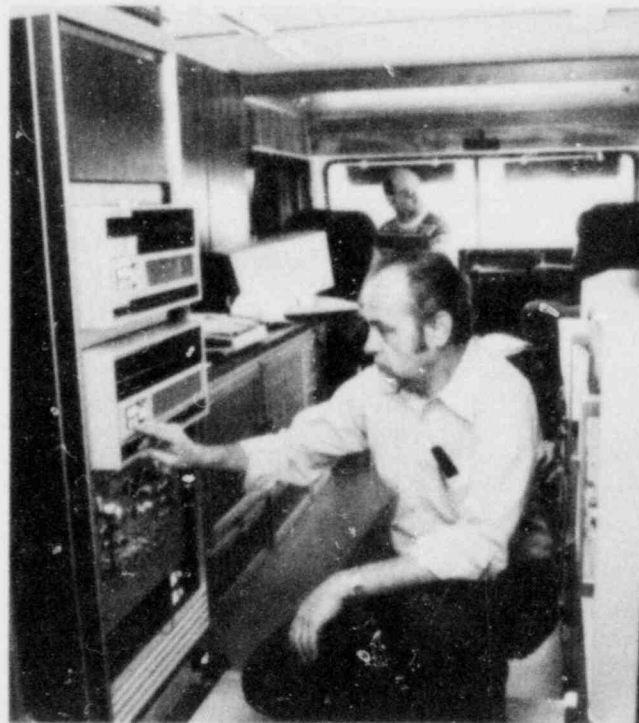

The IE Circular is used to notify licensees of actions which the NRC recommends be taken. These matters are generally of lesser significance than those addressed by a Bulletin, and a written response by the licensee is not required. The licensees may or may not initiate the recommended action. However, if further analysis and/or information regarding the matter indicates increased significance, it may result in the issuance of a Bulletin.

The Information Notice is used for rapid transmittal of information applicable or potentially applicable to license and permit holders. The information may or may not have been completely analyzed by NRC. It does not require acknowledgement or response, but licensees are advised to take appropriate action if the information applies to their facility. The concerns which might require issuance of an Information Notice include those for which a Bulletin or Circular may be applicable, but for which significance of the event or condition does not warrant issuance of a Bulletin or Circular. (The types of conditions addressed by Bulletins, Circulars, and Information Notices are indicated in the complete listing of the issuances for 1979 in the 1979 Annual Report, pp. 160-165.)

Increase in Response Activities

The amount of effort expended by IE personnel in reactive inspections, investigations, and related work continued to increase during 1980. Unplanned reactive effort required at some construction sites has caused some postponements of routine inspection activities. Much of this effort was spent in inspecting, investigating, and following up allegations, Part 21 reports, Bulletins, Circulars, and Information Notices.

During 1980, IE increased and reorganized its staff to assign engineers exclusively to follow events at operating reactors. Their efforts are concentrated on reactors designed by individual nuclear steam system suppliers in a manner to bring greater expertise to bear on events, resulting in prompt notification of the NRC Operations Center. They also review licensee event reports, inspection reports, and day-to-day events. Additional engineering analysis capability has also been added to provide support for specialty problems.

The NRC Operations Center, focal point for NRC's initial response to significant incidents involving NRC-licensed activities, was substantially upgraded in 1980. The 2,000-square-foot center, which is manned continuously by qualified senior engineers, was activated four times during fiscal year 1980: twice as a part of NRC drills and twice in response to incidents at nuclear power plants. (See Chapter 3 for details.)

ENFORCEMENT ACTIONS

The regulatory program is designed to assure that licensees perform in accordance with NRC regulations, licenses and permits, and with applicable sections of Federal statutes. NRC is empowered to take enforcement action when licensees are not satisfying these requirements or are conducting operations in a way that might endanger the public health and safety or the environment, or adversely affect the common defense and security.

Enforcement action requires the licensee to correct the particular problems and establish measures to preclude recurrence—including deficiencies in the quality assurance program if such deficiencies allowed the problem to occur, continue, or reoccur.

The severity of NRC enforcement actions varies with the seriousness of the matter and the licensee's previous compliance record. Several levels of NRC actions are provided:

- Written Notices of Violation are provided for instances of noncompliance with NRC requirements.
- Civil penalties are considered for licensees who evidence significant or repetitive items of noncompliance, particularly when a Notice of Violation has not been effective. Civil penalties may also be imposed for particularly significant first-of-a-kind violations.
- Orders to "cease and desist" operations, or for modification, suspension, or revocation of licenses, are used to deal with licensees who do not respond to civil penalties or to deal with violations that constitute a significant threat to public health and safety or to the common defense and security. In the latter case, an order may be made effective immediately.

During fiscal year 1980, the NRC imposed 49 civil penalties on licensees totaling about \$1.4 million (see Table 3), and issued 26 orders to "cease and desist" operations or to modify, suspend, or revoke licenses for noncompliance with NRC requirements (see Table 4).

New Enforcement Policy Proposed

Public Law 96-295, enacted in June 1980, amended the Atomic Energy Act of 1954 to give the Com-

NRC REGIONAL OFFICES AND COMMERCIAL NUCLEAR POWER REACTORS IN THE UNITED STATES

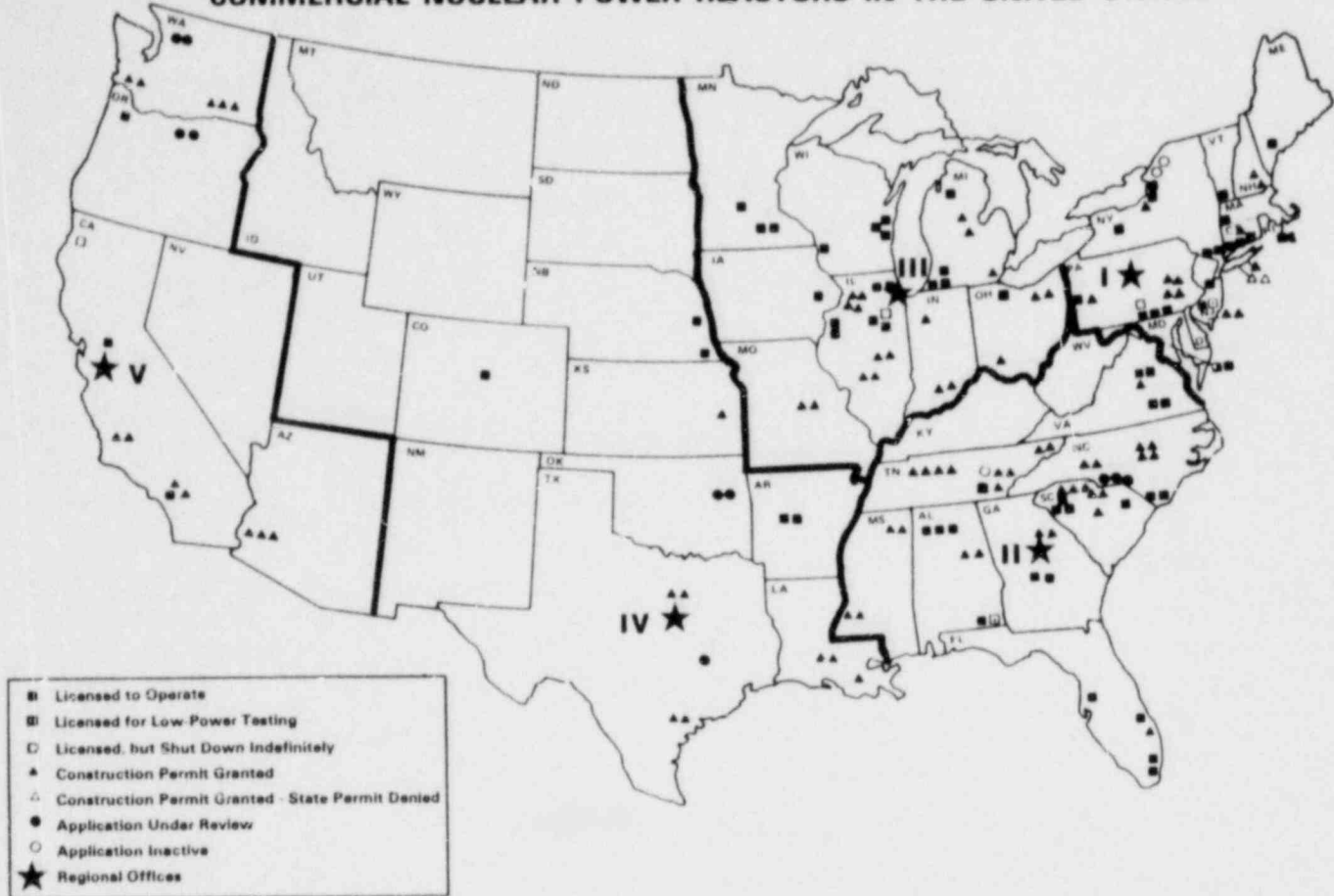

mission authority to impose fines as high as \$100,000 for each violation of NRC requirements, and with no ceiling on the total fine for any 30-day period. The previous limit for a single violation was \$5,000, with a ceiling of \$25,000 for all violations during any 30-day period.

On October 7, 1980, the Commission published in the *Federal Register* (45 FR 66754) for interim use and public comment a Proposed General Statement of Policy and Procedure for Enforcement Actions which, in part, addresses the agency's plans for implementing the higher civil penalty authority. The proposed policy emphasizes prompt and vigorous enforcement and assurance that a licensee will not benefit by violating NRC regulations. This involves the use of stronger enforcement measures to assure, in the long term, that noncompliance is more expensive than compliance. Emphasis is also placed on prohibiting operations by licensees who cannot achieve and maintain adequate levels of protection.

The proposed policy provides a range of enforcement actions from more severe, when essential

health and safety-related requirements have been violated, to less severe when the violations involve requirements of only minor safety or environmental significance.

The NRC staff scheduled a series of one-day meetings at five metropolitan locations throughout the country in December to explain the proposed policy and obtain public comment before the final version is codified in NRC regulations.

INVESTIGATIONS

An important adjunct to NRC's inspection effort is the investigative program which covers not only in-depth probes or irregularities revealed during inspections, but also investigations of incidents, accidents, allegations, or any unusual circumstances occurring at or related to NRC-licensed facilities or activities. A heightened public awareness and interest in nuclear power has resulted in an increase in the

number of allegations received by NRC. Each allegation must be carefully investigated to determine its possible impact upon the public health and safety.

Investigations are conducted by experienced investigative personnel located in each of the five NRC regional offices. Investigators are assigned to the immediate staff of the regional director, both to emphasize the importance of the investigative program and to provide better support to the various functional branches in the region. Since NRC investigations are usually technical in nature and may involve several scientific or engineering disciplines, the investigator frequently works with and coordinates the activities of technical personnel who may be assigned to provide assistance. Investigators also maintain close liaison with Federal, State, and local law enforcement agencies and work closely with them on investigations of mutual interest. Within the past year, IE investigators have conducted investigations into diverse allegations ranging from the falsification of records relied upon by NRC to the willful violation of NRC rules, regulations, and license conditions. One series of major investigations resulted in the imposition of civil penalties totalling \$100,000.

Oversight of the NRC investigations program is exercised by a small investigative staff located at headquarters. During fiscal year 1980, IE personnel conducted 126 investigations, of which 83 were

prompted by allegations dealing with reactor construction or operational events at licensed facilities. Other investigations dealt with allegations or events involving loss or theft of licensed material, overexposures, sabotage, and matters of general public interest.

Significant special investigations conducted during the year are described below.

Three Mile Island

An investigation was initiated upon receipt of a report that a reporter for the *Guide*, a weekly newspaper in the Harrisburg, Pa., area, had assumed another person's identity and was hired to work as a site protection officer at the Three Mile Island (TMI) facility. The imposter worked as a watchperson at the site from December 17, 1979 until January 31, 1980, at which time he revealed his true identity to the licensee and indicated his intention to write a series of articles regarding alleged security deficiencies at the site.

Six specific allegations, pertaining primarily to access controls, were made by the imposter. The subsequent investigation revealed four infractions, three concerning access controls and one concerning testing and maintenance of search equipment. The licensee was cited for these infractions.

Marble Hill Nuclear Generating Station

The Marble Hill Nuclear Generating Station of Public Service of Indiana is located in southeastern Indiana. The site is approximately 9 miles northeast of Milton, Kentucky.

Beginning in April 1979, a series of noncompliances associated with concrete construction were identified by IE inspectors. In June, allegations related to concrete construction were made by a former worker at the site. The licensee agreed to stop safety-related concrete work until certain quality assurance actions were completed to the NRC's satisfaction.

In July 1979, the National Board of Boiler and Pressure Vessel Inspectors reported several deficiencies at the site (not related to concrete) and recommended suspension of the utility's American Society of Mechanical Engineers Owner's Certificate for apparent Code violations of Section III, Division 1, of the ASME Boiler and Pressure Vessel Code. As a result of further investigation by IE inspectors, who identified construction management problems, an Order confirming the suspension of all safety-related construction work at the site was issued on August 14, 1979.



"Honeycombing" in concrete at the Marble Hill Nuclear Generating Station in Indiana was one of a number of construction deficiencies which led to an NRC-ordered suspension of work on safety-related construction for several months.

A public meeting was conducted by the NRC on August 19, 1980, in Bay City, Texas to receive information and views in connection with enforcement action against the Houston Lighting & Power Co. regarding quality control matters at the South Texas Project.

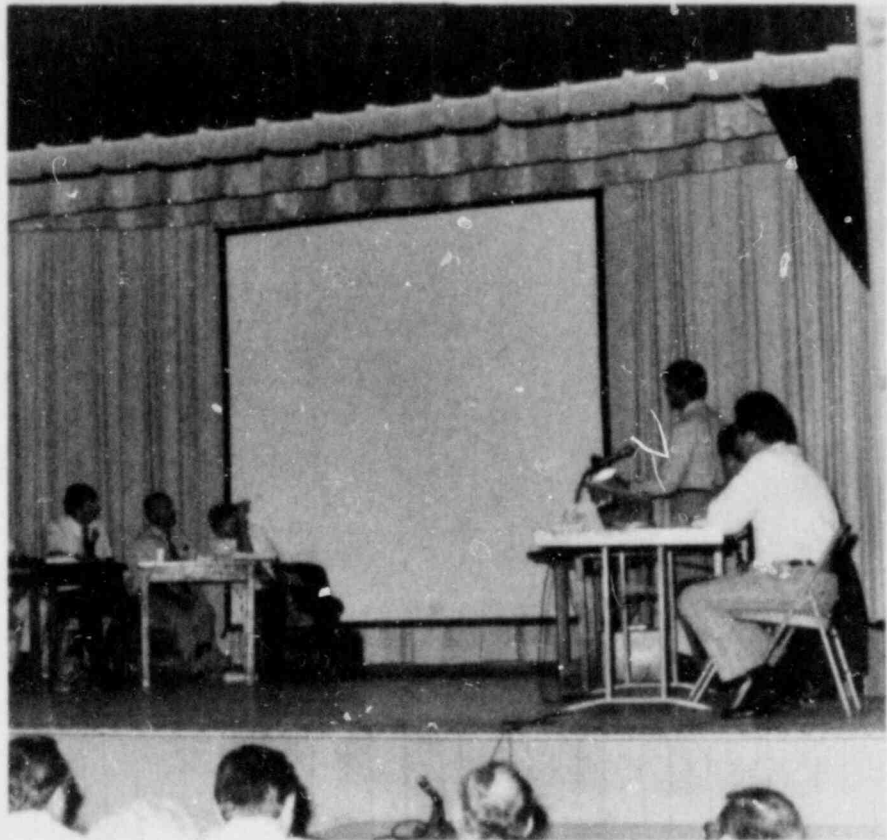

In February 1980, the licensee responded to the nine specific items of the Order and submitted a description of the revised quality assurance program. In March, a public meeting was held near the site to review the program submitted. In May, the IE staff documented the status of the project and the actions necessary in the future as various milestones are reached. Later in May, a Graduated Rescission of the Order was issued which provides for a gradual, step-wise restart of construction as the licensee completed various activities. The adequacy of the activities covered by each step are to be verified by IE inspectors prior to the next step.

Two independent structural concrete consultants have been employed to assist the NRC in the technical assessment of the in-place structures, the need for repairs, and the adequacy of corrective actions. A considerable amount of inspection/verification remains to be completed prior to resolving the safety issues and completing the enforcement action.

The South Texas Project

The South Texas Project is being managed by Houston Lighting and Power Company under joint ownership with the City of Austin, the City of San Antonio, and the Central Power and Light Company. The project is located in Matagorda County near the

south central coast on the Gulf of Mexico about 10 miles south of Bay City, Texas.

Early in 1977, the first of a series of allegations concerning harassment and intimidation of quality control inspectors at the site was made. IE investigation of these and other allegations resulted in no findings to substantiate the allegations. Since the allegations persisted into 1978, an NRC management meeting was held in August of 1978 with the licensee. This meeting reviewed the allegations and the NRC concerns relative to the implementation of the licensee's quality assurance program. In the spring of 1979, an allegation was received by the FBI regarding a possible conspiracy to defraud the United States. After an FBI investigation, the United States Attorney's Office having jurisdiction declined prosecution.

Several Immediate Action letters were issued to Houston Lighting & Power Co. in 1978 and 1979 which documented agreements between the NRC and the licensee. Each of these letters addressed safety issues related to plant construction.

In November 1979, another series of allegations were received which addressed threats, harassment, and intimidation of quality control personnel. As a result of a special IE team investigation extending over a period of 4 months, 22 noncompliances were identified. On April 30, 1980, a Notice of Violation with a \$100,000 civil penalty and a Show Cause Ord-

er were issued. These documents noted that there had been instances of harassment, intimidation, and threat which potentially could reduce the effectiveness of the quality assurance program. On May 23, 1980, the licensee submitted a document admitting the violations and paid the civil penalty. On July 28, 1980, the licensee submitted a response to the Order

to Show Cause which addressed the 10 major items in the Order.

As a result of the need for further technical information and to satisfy one of the points in the Order, the NRC conducted a public meeting in Bay City, Texas on August 19, 1980. The enforcement action is still in process. (See Chapter 15, under "Commission Decisions.")

Table 3. Civil Penalties Imposed During Fiscal Year 1980

| <i>Licensee</i> | <i>Amount</i> | <i>Reason</i> |
|--|---|---|
| Niagara Mohawk Power Corp. Syracuse, N.Y. (Nine Mile Point Unit 1) | \$18,000 (Reported as pending in FY 1979) | Noncompliance items in the physical security area. Order imposing penalty issued. Licensee paid the \$18,000 penalty. |
| United Nuclear Corp. Wood River Junction, R.I. (Fuel Processor) | \$11,250 (Proposed fine was \$15,750 in FY 1979) | Noncompliance items in the physical security area. Order imposing a mitigated penalty of \$11,250. Licensee paid the \$11,250 penalty. |
| University of Wisconsin Madison, Wis. (Academic Broad License) | \$1,800 (Proposed fine was \$2,300 in FY 1979) | Inadequate training of personnel, failure to evaluate internal exposures of personnel and releases of airborne material to unrestricted areas. Order imposing a mitigated penalty of \$1,800 issued. Licensee paid the \$1,800 penalty. |
| Virginia Electric & Power Co. Richmond, Va. (Surry Unit 2) | \$15,000 (Reported as pending in FY 1979) | Whole body exposure of an individual and failure to follow procedures. Order imposed penalty of \$15,000 which was paid by licensee. |
| Nuclear Pharmacy, Inc. Milwaukee, Wis. (Radiopharmaceutical Distributor) | \$24,000 (Proposed in FY 1979) | Distribution of radioactive material not intended for human use to medical licensees, relabeling and misrepresenting the material as suitable for human use. Matter under review in Department of Justice. Civil penalty action deferred. |
| Diagnostic Isotopes Bloomfield, N.J. (Radiopharmaceutical Distributor) | \$8,000 | Extremity exposures of personnel, failure to report exposures to the NRC, inadequate surveys, and inadequate instruction of personnel. Order issued imposing a mitigated penalty of \$8,000 which the licensee paid. |
| Boston Edison Co. Boston, Mass. (Pilgrim Station) | \$5,000 | Noncompliance item in the physical security area. Order issued imposing the \$5,000 penalty which the licensee paid. |
| Metropolitan Edison Co. Reading, Pa. (Three Mile Island Unit 2) | \$155,000 | Noncompliance items relating to the Three Mile Island Unit 2 accident. Order issued imposing the \$155,000 penalty which the licensee paid. |
| Consumers Power Co. Jackson, Mich. (Palisades Nuclear Power Station) | \$450,000 | Operation of Palisades reactor for extended period with containment integrity violated. Order imposing \$450,000 penalty issued. At the licensee's request a hearing is being held. |
| Duquesne Light Co. Pittsburgh, Pa. (Beaver Valley Unit 1) | \$5,000 | Operation of the reactor with a part of the emergency core cooling system unavailable for automatic start. Licensee paid the \$5,000 penalty. |

| <i>Licensee</i> | <i>Amount</i> | <i>Reason</i> |
|--|---------------|--|
| Connecticut Yankee Atomic Power Co. Hartford, Conn. Haddam Neck Generating Station) | \$27,500 | Noncompliance items in radiological health and safety area. Licensee paid the \$27,500 penalty. |
| Tennessee Valley Authority Chattanooga, Tenn. (Browns Ferry Unit 3) | \$29,000 | Breakdown in management and procedural controls in the area of maintenance and reporting activities. Licensee paid the \$29,000 penalty. |
| Eastern Testing & Inspection, Inc. Pennsauken, N.J. (Radiographer) | \$6,900 | Noncompliance items relating to loss of an iridium-192 source. Original proposed fine of \$8,400 mitigated to \$6,900, which licensee is paying in 12 installments. |
| Atomic Disposal Co. Tinley Park, Ill. (Waste Handler) | \$500 | Possession of radioactive waste in excess of authorized 6-month limit. Order issued imposing \$500 penalty which licensee paid. |
| Boston Edison Co. Boston, Mass. (Pilgrim Station) | \$5,000 | Noncompliance item related to shipment of radioactive waste. Licensee paid the \$5,000 penalty. |
| Portland General Electric Co. Portland, Ore. (Trojan Nuclear Plant) | \$5,000 | Noncompliance items in the physical security area. Proposed fine was \$13,000, however; licensee paid \$5,000 which was accepted as adequate based on licensee's statements. |
| Nuclear Pharmacy, Inc. (Elfreth Alley Apothecary) Philadelphia, Pa. (Radiopharmaceutical Distributor) | \$4,000 | Noncompliance items related to extremity exposure of individual. Licensee paid the \$4,000 penalty. |
| University of Chicago Chicago, Illinois | \$2,100 | Noncompliance items related to whole body and extremity exposures of an individual. Proposed fine of \$2,400 mitigated to \$2,100, which the licensee paid. |
| Alexandria Hospital Alexandria, Va. | \$2,100 | Noncompliance items related to material false statements in a license renewal application. Order issued imposing Penalty of \$2,100 which the licensee paid. |
| Rockford Memorial Hospital Rockford, Ill. | \$2,400 | Noncompliance items related to loss of iridium-192 implant seeds. Licensee paid the \$2,400 penalty. |
| Public Service Electric & Gas Co. Newark, N.J. area. (Salem Nuclear Generating Station) | \$23,000 | Noncompliance items in the physical security Licensee paid the \$23,000 penalty. |
| Sacramento Municipal Utility District Sacramento, Calif. (Rancho Seco Nuclear Generating Station) | \$25,000 | Noncompliance items relating to the operation of the Rancho Seco reactor with certain portions of the emergency core cooling system in degraded condition. Licensee paid the \$25,000 penalty. |
| Union Carbide Corporation Tuxedo, N.Y. | \$1,000 | Noncompliance items related to the shipment of radioactive waste. Proposed penalty of \$3,000 mitigated to \$1,000 which the licensee paid. |

Table 3. Civil Penalties Imposed During Fiscal Year 1980

(continued)

| <i>Licensee</i> | <i>Amount</i> | <i>Reason</i> |
|--|-----------------------|---|
| Smith Kline & French Laboratories Philadelphia, Pa. | \$5,000 | Noncompliance items related to the shipment of radio- active waste. Licensee paid the \$5,000 penalty. |
| The Babcock & Wilcox Co. Lynchburg, Va. (Vendor) | \$100,000 | Noncompliance items related to failure to report information on potential safety problems that could have helped prevent or reduce severity of the Three Mile Island accident. The Babcock & Wilcox Co. paid the \$100,000 penalty. |
| Houston Lighting & Power Co. Houston, Texas (South Texas Units 1 and 2) | \$100,000 | Noncompliance items related to failures of the licensee and a contractor to control all activities affecting the safety-related functions in the quality control program. The licensee paid the \$100,000 penalty. |
| Vermont Yankee Nuclear Power Corp. Westboro, Mass. (Vermont Yankee Generating Station) | \$4,000 | Noncompliance item related to transportation of radio- active material. Licensee paid the \$4,000 penalty. |
| Providence Hospital Anchorage, Alaska | \$1,500 | Noncompliance items related to the loss of iridium-192 implant seeds. Order issued imposing mitigated penalty of \$1,500 (originally proposed at \$1,700), which was paid. |
| Virginia Electric & Power Co. Richmond, Va. (Surry Units 1 and 2) | \$8,000 | Noncompliance items related to transportation of radioactive waste material. Licensee paid the \$8,000 penalty. |
| Carolina Power & Light Co. Raleigh, N.C. (Brunswick Units 1 and 2) | \$24,000 | Noncompliance items related to an unmonitored, uncontrolled release of airborne radioactive material to the environment. Licensee paid the \$24,000 penalty. |
| Washington Public Power Supply System Richland, Wash. (Washington Nuclear Project 2) | \$59,500 (Pending) | Noncompliance items in the quality assurance program. |
| Tennessee Valley Authority Chattanooga, Tenn. (Browns Ferry Plant) | \$5,000 | Noncompliance item relating to transportation of radioactive waste material. Licensee paid the \$5,000 penalty. |
| Georgia Power Co. Atlanta, Ga. (Hatch Units 1 and 2) | \$4,000 | Noncompliance item relating to transportation of radio- active waste material. Licensee paid the penalty. |
| Toledo Edison Co. Toledo, Ohio (Davis-Besse Unit 3) | \$13,000 | Noncompliance items relating to the exposure of two individuals. Licensee paid the \$13,000 penalty. |
| Commonwealth Edison Co. Chicago, Ill. (Quad-Cities Units 1 and 2) | \$4,000 | Noncompliance item relating to the transportation of radioactive material. Licensee paid the \$4,000 penalty. |
| Superior Industrial X-Ray Co. Blue Island, Ill. (Radiographer) | \$9,800 (Pending) | Noncompliance items relating to a radiographic exposure device being left unattended. |

| <i>Licensee</i> | <i>Amount</i> | <i>Reason</i> |
|--|-----------------------|--|
| Nuclear Pharmacy, Inc. Chicago, Ill. (Radiopharmaceutical Supplier) | \$5,700 | Noncompliance items relating to the exposure of an individual. Licensee paid \$4,200. The case is pending. |
| Teldyne Isotopes, Inc. Westwood, N.J. (Radioactive Supplier) | \$3,000 | Noncompliance items relating to transportation Materials of radioactive waste material. Licensee paid the penalty. |
| Jersey Central Power & Light Co. Morristown, N.J. (Oyster Creek Unit 1) | \$21,000 | Noncompliance items in the health and safety areas. Licensee paid the \$21,000 penalty. |
| Boston Edison Co. Boston, Mass. (Pilgrim Station) | \$13,000 (Pending) | Noncompliance items involving failure to follow procedures. |
| Carolina Power & Light Co. Raleigh, N.C. (Brunswick Units 1 and 2) | \$89,000 | Noncompliance items relating to the improper disposition of licensed radioactive material. Licensee paid the penalty. |
| Baltimore Gas & Electric Co. Baltimore, Md. (Calvert Cliffs Units 1 and 2) | \$21,000 | Noncompliance items relating to failure to follow procedures and also items in the physical security area. Licensee paid the \$21,000 penalty. |
| Minneapolis Mining and Manufacturing Co. St. Paul, Minn. (Radioactive Material Supplier) | \$2,000 (Pending) | Noncompliance items relating to the transportation of radioactive waste material. |
| Metropolitan Edison Co. Reading, Pa. (Three Mile Island Unit 2) | \$9,000 (Pending) | Noncompliance items relating to the transportation of radioactive waste material. Licensee paid \$5,000. The case is pending. |
| Power Authority of the State of New York New York, N.Y. (James A. Fitzpatrick Nuclear Power Plant) | \$48,000 (Pending) | Noncompliance items in the physical security area. |
| Power Authority of the State of New York New York, N.Y. (Indian Point Unit 3) | \$12,000 (Pending) | Noncompliance items relating to whole body and extremity exposures of personnel. |
| Magnaflux Corp. Chicago, Ill. (Radiographer) | \$2,000 | Noncompliance item relating to loss of radiographic exposure device during transportation. Licensee paid the \$2,000 penalty. |
| Consumers Power Co. Jackson, Mich. (Palisades Nuclear Power Station) | \$16,000 | Noncompliance items relating to failure to follow operating procedures. Licensee paid the \$16,000 penalty. |
| Atomic Disposal Co. Tinley Park, Ill. (Waste Material) | \$2,000 (Pending) | Noncompliance items relating to transportation of radioactive waste material. |
| Charles Zimmerman, M.D. Paterson, N.J. | \$1,250 | Noncompliance items relating to the loss of radioactive material. The licensee paid the \$1,250 penalty. |

Table 3. Civil Penalties Imposed During Fiscal Year 1980*(continued)*

| <i>Licensee</i> | <i>Amount</i> | <i>Reason</i> |
|---|---------------|--|
| Consumers Power Co. Jackson, Mich. (Radiography Licensee) | \$5,000 | Noncompliance items relating to whole body exposure of individual. The licensee paid the \$5,000 penalty. |
| Michael Reese Hospital and Medical Center Chicago, Ill. | \$300 | Noncompliance item relating to procurement of radioactive material from a supplier not authorized to distribute material for human use. Licensee paid the \$300 Penalty. |
| New England Nuclear Corp. Boston, Mass. | \$2,000 | Noncompliance item relating to transportation of waste material. Licensee paid the \$2,000 penalty. |
| Nuclear Metals, Inc. Concord, Mass. | \$2,000 | Noncompliance item relating to transportation of waste material. |

Table 4. Enforcement Orders Issued by IE in Fiscal Year 1980*

| <i>Licensee</i> | <i>Date</i> | <i>Reason</i> |
|---|-------------|---|
| Consumers Power Co. Jackson, Mich. (Palisades Nuclear Power Station) | 11/9/79 | Order modifying license, effective immediately. <i>Reason:</i> To require that appropriate review of checklists and procedures be performed to assure that engineered safety features are in compliance with the limiting condition for operation requirements in the Technical Specifications. |
| Duquesne Light Co. Pittsburgh, Pa. (Beaver Valley Unit 1) | 12/5/79 | Order modifying license, effective immediately. <i>Reason:</i> To require that the licensee's administrative control of licensed activities involving operating and maintaining safety equipment verify availability of all required equipment when a counterpart is removed from an operable status. |
| Consumers Power Co. Jackson, Mich. Midland Units 1 and 2 | 12/6/79 | Order modifying construction permits. <i>Reason:</i> Issued jointly by the Offices of Inspection and Enforcement and Nuclear Reactor Regulation directing that the construction permits for Midland Units 1 and 2 be modified to prohibit further work on the placement, compaction, or excavation of fill material under and around certain safety-related structures and systems until a construction permit amendment has been applied for and granted by NRC. The licensee requested a hearing in the matter, which is pending. |
| Tennessee Valley Authority Chattanooga, Tenn. (Browns Ferry Units 1, 2, & 3) | 1/4/80 | Order modifying license, effective immediately. <i>Reason:</i> To require that appropriate review of administrative controls and procedures for maintenance activities, including procedures for removal and replacement of containment penetration closures, be performed to assure that the limiting conditions for operation of the facility are not defeated by maintenance or other activities. |

| <i>Licensee</i> | <i>Date</i> | <i>Reason</i> |
|---|-------------|--|
| Gorsira X-Ray, Inc. Farmington Hills, Mich. (Non-Licensee) | 2/28/80 | Order to Cease and Desist. <i>Reason:</i> The firm was conducting field radiography without an NRC license. |
| American X-Ray & Inspection, Inc. Farmington Hills, Mich. (Radiographer) | 2/28/80 | Order to Show Cause, and Order Suspending License. <i>Reason:</i> Unsafe radiation safety protection practices. Transfer of NRC license and material to a non-licensee. |
| | 5/19/80 | Order revoking license. <i>Reason:</i> Licensee did not respond to the 2/28/80 order within the specified 25 days. |
| Toledo Edison Co. Toledo, Ohio (Davis Besse Unit 1) | 3/5/80 | Order modifying license, effective immediately. <i>Reason:</i> Changes in the plant operating staff were required to provide reasonable assurance that the facility can be safely operated under emergency conditions. |
| Public Service Electric & Gas Co. Newark, N.J. (Salem Unit 1) | 3/20/80 | Order modifying license, effective immediately. <i>Reason:</i> Problems in the physical security area. |
| Sacramento Municipal Utility District Sacramento, Calif. (Rancho Seco Nuclear Station) | 4/1/80 | Order modifying license, effective immediately. <i>Reason:</i> Inadequate control Generating of procedures and operating activities. |
| Tennessee Valley Authority Chattanooga, Tenn. Browns Ferry Units 1, 2, & 3 and Sequoyah Unit 1 | 4/4/80 | Confirmatory Order. <i>Reason:</i> To formalize commitments from the licensee to respond to IE Bulletin 79-27. |
| Virginia Electric & Power Co. Richmond, Va. (North Anna Units 1 and 2; Surry Units 1 and 2) | 4/4/80 | Confirmatory Order. <i>Reason:</i> Same as above. |
| Georgia Power Company Atlanta, Ga. (Hatch Units 1 and 2) | 4/4/80 | Confirmatory Order. <i>Reason:</i> Same as above. |
| Public Service Electric & Gas Co. Newark, N.J. (Salem Units 1 and 2) | 4/4/80 | Confirmatory Order. <i>Reason:</i> Same as above. |
| Power Authority of the State of New York New York, N.Y. (Indian Point Unit 3) | 4/4/80 | Confirmatory Order. <i>Reason:</i> Same as above. |
| Consolidated Edison Co. New York, N.Y. (Indian Point Unit 2) | 4/4/80 | Confirmatory Order. <i>Reason:</i> To formalize commitments from the licensee to respond to IE Bulletin 79-27. |
| Jersey Central Power & Light New York, N.Y. (Indian Point Unit 2) | 4/4/80 | Confirmatory Order. <i>Reason:</i> Same as above. |
| Yankee Atomic Electric Co. Westboro, Mass. (Yankee Nuclear Power Station) | 4/4/80 | Confirmatory Order. <i>Reason:</i> Same as above. |

Table 4. Enforcement Orders Issued by IE in Fiscal Year 1980*
(continued)

| <i>Licensee</i> | <i>Date</i> | <i>Reason</i> |
|---|-------------|---|
| Public Service Co. of Colorado Denver, Colo. (Fort St. Vrain Nuclear Generating Station) | 4/4/80 | Confirmatory Order. <i>Reason:</i> Same as above |
| Southern California Edison Co. Rosemead, Calif. (San Onofre Unit 1) | 4/4/80 | Confirmatory Order. <i>Reason:</i> Same as above |
| Consumers Power Co. Jackson, Mich. (Palisades Station) | 4/22/80 | Confirmatory Order. <i>Reason:</i> Same as above. |
| Houston Lighting & Power Co. Houston, Texas (South Texas Projects Units 1 & 2) | 4/30/80 | Order to Show Cause (Effective Immediately) <i>Reason:</i> To require licensee to show cause why safety-related construction activities should not be stopped within 90 days of the Order and remain stopped until certain reviews of program were made and information submitted to the NRC. |
| Public Service Co. of Indiana Plainfield, Ind. (Marble Hill Units 1 and 2) | 5/15/80 | Graduated Rescission of Order dated August 15, 1979. <i>Reason:</i> To assure that the licensee's corrective actions are implemented and effective and that construction activities at the Marble Hill site are resumed in a graduated, stepwise fashion with review by the NRC at appropriate stages. |
| Jersey Central Power & Light Co. Morristown, N.J. (Oyster Creek Unit 1) | 7/8/80 | Order to modify license, effective immediately. <i>Reason:</i> To modify license to assure the utiliza- tion of only qualified technicians in activities important to the protection of workers. |

*Numerous enforcement orders have also been issued by the NRC Offices of Nuclear Reactor Regulation and Nuclear Material Safety and Safeguards.

Table 5. IF Bulletins, Circulars, and Information Notices Issued During Fiscal Year 1980

IE BULLETINS

| <i>Bulletin No.</i> | <i>Date Issued</i> | <i>Subject</i> | <i>Issued To</i> |
|------------------------|--------------------|---|---|
| 79-25 | 11/1/79 | Failures of Westinghouse BFD Relays in Safety-Related Systems | Power Facilities with OLs of CPs |
| 79-26 | 11/19/79 | Boron Loss from BWR Control Blades | BWR Facilities with CP and all Power Reactor Facilities with OLs or CPs |
| 79-27 | 11/30/79 | Loss of Non-Class-I-E Instrumentation and Control Power System Bus During Operation | Power Facilities with OLs or CPs |
| 79-28 | 12/5/79 | Possible Malfunction of Namco Model EA 180 Limit Switches at Elevated Temperatures | All Power Facilities with OLs or CPs |
| 80-01 | 1/11/80 | Operability of Ads Valve Pneumatic Supply | BWR reactors with OLs |
| 80-02 | 1/21/80 | Inadequate Quality Assurance for Nuclear Supplied Equipment | BWR reactors with OLs or CPs |
| 80-03 | 1/31/80 | Loss of charcoal from standard Type II, 2 inch, Tray Adsorber Cells | Power reactors with OLs or CPs |
| 80-04 | 2/7/80 | Analysis of a PWR Main Steam Line Break with continued feedwater addition | All power reactors with OLs or CPs |
| 80-05 | 3/7/80 | Vacuum condition resulting in damage to chemical volume control system (CVCS) hold-up tanks | PWR's with OLs or CPs |
| 80-06 | 3/12/80 | Engineered safety feature (ESF) reset controls | All power reactors with OLs or CPs |
| 79-GSA | 4/4/80 | Longitudinal weld defects in ASME SA-312 type 304 stainless steel pipe | All power reactors with OLs or CPs |
| 80-07 | 4/2/80 | BWR Jet Pump Assembly Failure | All GE BWR's with OLs or CPs |
| 80-07 Supplement No. 1 | 5/12/80 | BWR Jet Pump Assembly Failure | All GE BWR's with OLs or CPs |
| 80-08 | 4/4/80 | Examination of Containment Lines Penetration Welds | All Power Reactors with OLs or CPs |
| 80-09 | 4/15/80 | Hydramotor Actuator Deficiencies | All Power Reactors with OLs or CPs |
| 80-10 | 5/2/80 | Contamination of nonradioactive System and Resulting Potential for unmonitored, uncontrolled release to environment | All Power Reactors with OLs or CPs |
| 80-11 | 5/6/80 | Masonry Wall Design | All Power Reactors with OLs or CPs |
| 80-12 | 5/9/80 | Decoy Heat Removal System Operability | PWR's with OLs or CPs |
| 80-13 | 5/12/80 | Cracking in Core Spray Spargers | BWR's with OLs or CPs |
| 80-14 | 6/11/80 | Degradation of Scram Discharge Volume Capability | BWR's with OLs or CPs |

**Table 5. IE Bulletins, Circulars, and Information Notices Issued
During Fiscal Year 1980**

(continued)

IE BULLETINS

| <i>Bulletin No.</i> | <i>Date Issued</i> | <i>Subject</i> | <i>Issued To</i> |
|------------------------|--------------------|---|--|
| 80-15 | 6/17/80 | Possible Loss of Emergency Notification System (ENS) With Loss of Off-Site Power | All Nuclear Power & Fuel Facility with OLs |
| 80-16 | 6/26/80 | Potential Misapplication of Rosemount Inc. Model 1151 and 1152 Pressure Transmitters with either "A" or "D" output codes and IE Circular No. 80-16, operational deficiencies in Rosemount Model 510DU Trip Units and Model 1152 Pressure Transmitters | All Power Reactors with OLs or CPs |
| 80-17 | 7/3/80 | Failure of Control Rods to Insert During a Scram at a BWR | All BWR Reactors with OLs or CPs |
| 80-17 Supplement No. 1 | 7/18/80 | Failure of Control Rods to Insert During a Scram at a BWR | All BWR Reactors with OLs or CPs |
| 80-17 Supplement No. 2 | 7/21/80 | Failure of Control Rods to Insert During a Scram at a BWR | All BWR Reactors with OLs or CPs |
| 80-18 | 7/22/80 | Maintenance of Adequate Minimum Flow thru Centrifugal Charging Pumps Following Secondary Side High Energy Line Rupture | All PWR Reactors with OLs or CPs |
| 80-19 | 7/30/80 | Failure of Mercury-Wetted Matrix Relays in Reactor Protective System of Operating Nuclear Power Plants Designed by Combustion Engineering | All Nuclear Reactors with OLs or CPs |
| 80-19 Revision 1 | 8/13/80 | Failure of Mercury-Wetted Matrix Relays in Reactor Protective System of Operating Nuclear Power Plants Designed by Combustion Engineering | All Nuclear Reactors with OLs or CPs |
| 80-20 | 7/30/80 | Failure of Westinghouse Type W-2 Spring Return to Neutral Control Switches | All Nuclear Reactors with OLs or CPs |

CIRCULARS

| <i>Circular No.</i> | <i>Date Issued</i> | <i>Subject</i> | <i>Issued To</i> |
|---------------------|--------------------|--|-------------------------------------|
| 79-21 | 10/17/79 | Prevention of Unplanned Releases of Radioactivity | Power Reactors with OLs and CPs |
| 79-22 | 11/15/79 | Stroke Times for Power Operated Relief Valves | Power Reactors with OLs and CPs |
| 79-23 | 11/19/79 | Motor Starters and Contractors Failed to Operate | All Power Reactors with OLs and CPs |
| 79-24 | 11/23/79 | Proper Installation and Calibration of Core Spray Pipe Break Detection Equipment on BWRs | All Power Reactors with OLs and CPs |

| <i>Circular No.</i> | <i>Date Issued</i> | <i>Subject</i> | <i>Issued To</i> |
|---------------------|--------------------|--|-------------------------------------|
| 79-25 | 12/14/79 | Shock Arrestor Strut Assembly Interference | Power Reactors with CPs |
| 80-01 | 1/11/80 | Service advice for GE Induction Disc Relays | Power Reactors with OLs or CPs |
| 79-25a | 1/28/80 | Shock Arrestor Strut Assembly Interference | Power Reactors with OLs or CPs |
| 80-02 | 1/28/80 | Nuclear Power Plant Staff Work Hours | Power & Non-Power Reactors with OLs |
| 80-03 | 3/5/80 | Protection from Toxic Gas Hazards | Power Reactors with OLs |
| 80-04 | 3/13/80 | Securing of Threaded Locking Devices on Safety-Related Equipment | Power Reactors with OLs or CPs |
| 80-05 | 3/27/80 | Emergency Diesel-generator Lubricating oil Addition and Onsite Supply | Power Reactors with OLs or CPs |
| 80-06 | 3/27/80 | Control and Accountability Systems for Implant Therapy Sources | Selected Medical License |
| 80-07 | 4/2/80 | Problems with HPCI Turbine Oil Systems | Power Reactors with OLs or CPs |
| 80-08 | 4/15/80 | BWR Technical Specification Inconsistency RPS Response Time | GE BWRs with OLs |
| 80-09 | 4/24/80 | Problems with Plant Internal Communications Systems | All Reactors with OLs or CPs |
| 80-10 | 4/24/80 | Failure to Maintain Environmental Qualification of Equipment | All Reactors with OLs or CPs |
| 80-11 | 5/9/80 | Emergency Diesel Generator Lube Oil Cooler Failures | All Reactors with OLs or CPs |
| 80-12 | 5/12/80 | Valve-Shaft-to-Actuator Key May Fall out of Place when Mounted Below Horizontal Axis | All Reactors with OLs or CPs |
| 80-13 | 5/23/80 | Grid Strap Damage in Westinghouse Fuel Assemblies | All Reactors with OLs or CPs |
| 80-14 | 6/17/80 | Radioactive Contamination of Plant Demineralized Water System and Resultant Internal Contamination of Personnel | CPs and Fuel Cycle Licensees |
| 80-15 | 6/20/80 | Loss of Reactor Coolant Pump Cooling and Natural Circulation Cooledown | Power Reactors with OLs or CPs |
| 80-16 | 6/26/80 | Potential Misapplication of Rosemount, Inc., Models 1151 and 1152 Pressure Transmitters with either "A" or "D" Output Codes and IE Circular No. 80-16, Operational Deficiencies in Rosemount Model 510DU Trip Units and Model 1152 Pressure Transmitters | All Reactors with OLs or CPs |
| 80-17 | 7/21/80 | Fuel Pin Damage Due to Water Jet From Baffle Plate Corner | PWR's with OLs or CPs |
| 80-18 | 8/18/80 | 10 CFR 50.59 Safety Evaluations for Changes to Radioactive Waste Treatment Systems | All Power Reactors with OLs or CPs |
| 80-19 | 8/18/80 | Noncompliance with License Requirements for Medical Licensees | All Medical Licensees |

**Table 5. IE Bulletins, Circulars, and Information Notices Issued
During Fiscal Year 1980**
(continued)

| INFORMATION NOTICES | | | |
|----------------------------|--------------------|---|---|
| <i>Information Notice</i> | <i>Date Issued</i> | <i>Subject</i> | <i>Issued To</i> |
| 79-25 | 10/1/79 | Reactor Trips at Turkey Point Units 3 and 4 | All Power Facilities with OLs or CPs |
| 79-26 | 11/1/79 | Breach of Containment Integrity | All Power Facilities with OLs or CPs |
| 79-27 | 11/16/79 | Steam Generator Tube Ruptures at Two PWR Facilities | All Power Facilities with OLs or CPs |
| 79-28 | 11/16/79 | Overloading of Structural Elements Due to Pipe Support Loads | All Power Facilities with OLs or CPs |
| 79-29 | 11/16/79 | Loss of Nonsafety-Related Reactor Coolant System Instrumentation During Operation | |
| 79-30 | 12/6/79 | Reporting of Defects and Noncompliance, 10 CFR Part 21 | All Power Reactor Facilities Holding OLs or CPs |
| 79-31 | 12/11/79 | Use of Incorrect Amplified Response Spectra (ARS) | All Power Reactors with OLs or CPs |
| 79-32 | 12/18/79 | Separation of Electrical Cables for HPCI and ADS | All Reactors with OLs or CPs |
| 79-33 | 12/11/79 | Improper Closure of Primary Containment Access Hatches | All Reactors with OLs or CPs |
| 79-25 | 10/1/79 | Reactor Trips at Turkey Point Units 3 and 4 | All Power Facilities with OLs or CPs |
| 79-26 | 11/1/79 | Breach of Containment Integrity | All Power Facilities with OLs or CPs |
| 79-27 | 11/16/79 | Steam Generator Tube Ruptures at Two PWR Facilities | All Power Facilities with OLs or CPs |
| 79-28 | 11/16/79 | Overloading of Structural Elements Due to Pipe Support Loads | All Power Facilities with OLs or CPs |
| 79-29 | 11/16/79 | Loss of Nonsafety-Related Reactor Coolant System Instrumentation During Operation | |
| 79-30 | 12/6/79 | Reporting of Defects and Noncompliance, 10 CFR Part 21 | All Power Reactor Facilities Holding OLs or CPs |
| 79-31 | 12/11/79 | Use of Incorrect Amplified Response Spectra (ARS) | All Power Reactors with OLs or CPs |
| 79-32 | 12/18/79 | Separation of Electrical Cables for HPCI and ADS | All Reactors with OLs or CPs |
| 79-33 | 12/11/79 | Improper Closure of Primary Containment Access Hatches | All Reactors with OLs or CPs |
| <i>Information Notice</i> | <i>Date Issued</i> | <i>Subject</i> | <i>Issued To</i> |
| 79-34 | 12/26/79 | Inadequate Design of Safety-Related Heat Exchangers | All Reactors with OLs or CPs |
| 79-35 | 12/27/79 | Control of Maintenance and Essential Equipment | All Reactors with OLs or CPs |
| 79-36 | 12/28/79 | Computer Code Defect in Stress Analysis of Piping Elbow | All Reactors with OLs or CPs |

INFORMATION NOTICES

| <i>Information Notice</i> | <i>Date Issued</i> | <i>Subject</i> | <i>Issued To</i> |
|---------------------------|--------------------|---|--|
| 79-37 | 12/28/79 | Cracking in Low Pressure Turbine Discs | All Reactors with OLs or CPs |
| 80-01 | 1/2/80 | Fuel Handling Events | All Reactors with OLs or CPs |
| 80-02 | 1/24/80 | 8x8R Water Rod Lower End Plug Wear | All BWRs with OLs or CPs |
| 80-03 | 1/28/80 | Main Turbine Electrohydraulic Control System | All Reactors with OLs or CPs |
| 80-04 | 2/1/80 | BWR Fuel Exposure in Excess of Limits | All BWRs with OLs or CPs |
| 80-05 | 2/5/80 | Chloride Contamination of Safety Related Piping and Components | All Reactor with OLs or CPs |
| 80-06 | 2/26/80 | Notification of Significant Events: Reactors with OLs | |
| 80-06 Supplement | 7/28/80 | Notification of Significant Events at Operating Power Reactor | Reactors with OLs |
| 80-07 | 2/29/80 | Pump Shaft Fatigue Cracking | Light Water Reactor Facilities with OLs |
| 80-08 | 2/29/80 | The States Company Sliding Link Electrical Terminal Block | Power Reactor with OLs or CPs |
| 80-09 | 3/4/80 | Possible Occupational Health Hazard Associated with Closed Cooling Systems for Operating Power Reactors | Power Reactors with OLs or CPs |
| 80-10 | 3/7/80 | Partial Loss of Non-Nuclear Instrument System Power Supply During Operation | Power Reactor with OLs or CPs |
| 80-11 | 3/10/80 | Generic Problems with Asco Valves In Nuclear Applications Including Fire Protection Systems | Reactors with OLs or CPs Full Fab and Processing Fac |
| 80-12 | 3/27/80 | Instrument Failure Causes Opening of Prox and Block Valve | Power Reactors with OLs and CPs |
| 80-13 | 3/28/80 | General Electric Type SBM Control Switches—Defective Cam Followers | Light Water Reactor with OLs and CPs |
| 80-14 | 3/31/80 | Safety Suggestions from Employees | Power Reactors with OLs or CPs |
| 80-15 | 4/18/80 | Axial Longitudinal Oriented Cracking in Piping | Light Water Reactor with OLs or CPs |
| 80-16 | 4/28/80 | Shaft Seal Packing Causes Binding in Main Steam Swing Check & | All Power Reactors with OLs or CPs |
| 80-17 | 4/30/80 | Potential Hazards Associated with Interchangeable Parts on Radiographic Equipment | Radiography Licenses |
| 80-18 | 5/1/80 | Possible Weapons Smuggling Pouch | Power Reactors with OLs and Fuel Fabrication and Processing Facilities |
| 80-19 | 5/5/80 | Niosh Recall of Recirculating—Mode (Closed Circuit) Self-contained Breathing Apparatus (Rebreathers) | Power Reactors with OLs, Research Reactors, Full Cycle Facilities and Priority 1's |
| 80-20 | 5/8/80 | Loss of Decay Heat Removal Capability at Davis-Besse Unit 1 While in a Refueling Mode | Light Water Reactors with OLs or CPs |
| 80-21 | 5/15/80 | Anchorage and Support of Safety-Related Electrical Equipment | Power Reactors with OLs or CPs |

**Table 5. IE Bulletins, Circulars, and Information Notices Issued
During Fiscal Year 1980**
(continued)

| <i>Information Notice</i> | <i>Date Issued</i> | <i>Subject</i> | <i>Issued To</i> |
|---------------------------|--------------------|--|-------------------------------------|
| 80-22 | 5/22/80 | Breakdown in Contamination Control Program | All Power Reactors with OLs or CPs |
| 80-23 | 5/28/80 | Loss of Suction to Emergency Feedwater Pumps | Power Reactors with OLs or CPs |
| 80-24 | 5/30/80 | Low-Level Radioactive Waste Burial Criteria | All Licensees |
| 80-25 | 5/30/80 | Transportation of Pyrophoric Uranium | Selected Source Material Licensees |
| 80-26 | 6/9/80 | Evaluation of Contractor QA Program | All Part 50 Licensees |
| 80-27 | 6/10/80 | Degradation of Reactor Coolant Pump Studs | PWRs with OLs or CPs |
| 80-28 | 6/11/80 | Prompt Reporting of Required Information to NRC | All Reactors with OLs or CPs |
| 80-29 | 8/7/80 | Broken Studs on Terry Turbine Steam Inlet Flange | All Light Water Reactors OLs or CPs |

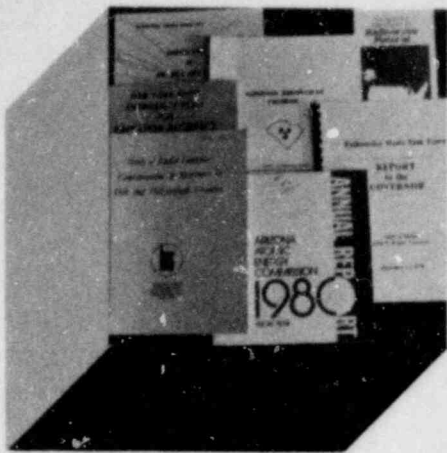

10

Cooperation with the States

Regulatory activities involving NRC contacts with regional, State and local agencies involve many of the agency's staff offices, as well as the Commission itself. Principal focus for NRC/State interactions remained with the Office of State Programs, although the transfer in 1980 of some emergency planning functions and the augmentation of regional liaison activities considerably altered the makeup of that office.

In addition to such organizational/functional changes, 1980 was marked by a resurgent interest in and activity under the Agreement States program, heightened levels of cooperation in the field of waste disposal, and the initiation of new training programs for State personnel.

Highlights: The State of Rhode Island became the 26th Agreement State on January 1, 1980. Seven States indicated their interest in regulating uranium mill tailings by applying for Federal grants to expand and improve programs. There were several closings or restrictions imposed at the three low-level radioactive waste burial sites operated in Agreement States. NRC initiated an in-depth uranium licensing and inspection course for State personnel. The criteria for the review of Agreement State radiation control programs were revised and published as a proposed policy statement. Memoranda of Understanding were negotiated with the State of Oregon. Regional meetings were held with State Liaison Officers in NRC regions IV and V, and staffing of Regional State Liaison Offices in all five NRC regions was completed. These activities are discussed below.

STATE AGREEMENTS PROGRAM

The Nuclear Regulatory Commission enters into agreements providing for the assumption by qualified

States of regulatory responsibility over byproduct and source material and small quantities of special nuclear material. At the end of 1980, 26 Agreement States were exercising regulatory authority over some 12,000 nuclear material licenses: Alabama, Arizona, Arkansas, California, Colorado, Florida, Georgia, Idaho, Kansas, Kentucky, Louisiana, Maryland, Mississippi, Nebraska, Nevada, New Hampshire, New Mexico, New York, North Carolina, North Dakota, Oregon, Rhode Island, South Carolina, Tennessee, Texas and Washington.

Review of State Regulatory Programs

The NRC conducts a formal periodic review of each Agreement State's radiation control program to determine whether it is adequate to protect the public health and safety and is compatible with NRC's regulatory program. The annual reviews assess the State's organization, administration, staffing, regulations, licensing, and compliance functions for the program. During 1980, 29 such program reviews and two follow-up reviews were conducted. Field evaluations of State inspectors are also made by NRC reviewers. NRC staff members accompanied State inspectors at a number of licensed facilities, including a State-licensed uranium mill, and two State phosphate operations with uranium extraction circuits.

Adequacy and Compatibility Findings

The two follow-up reviews resulted from earlier NRC findings of significant program deficiencies in the California and Florida programs because of recurring high inspection backlogs and staff shortages. The 1980 reviews found both States' radiation control

AGREEMENT STATE PROGRAM

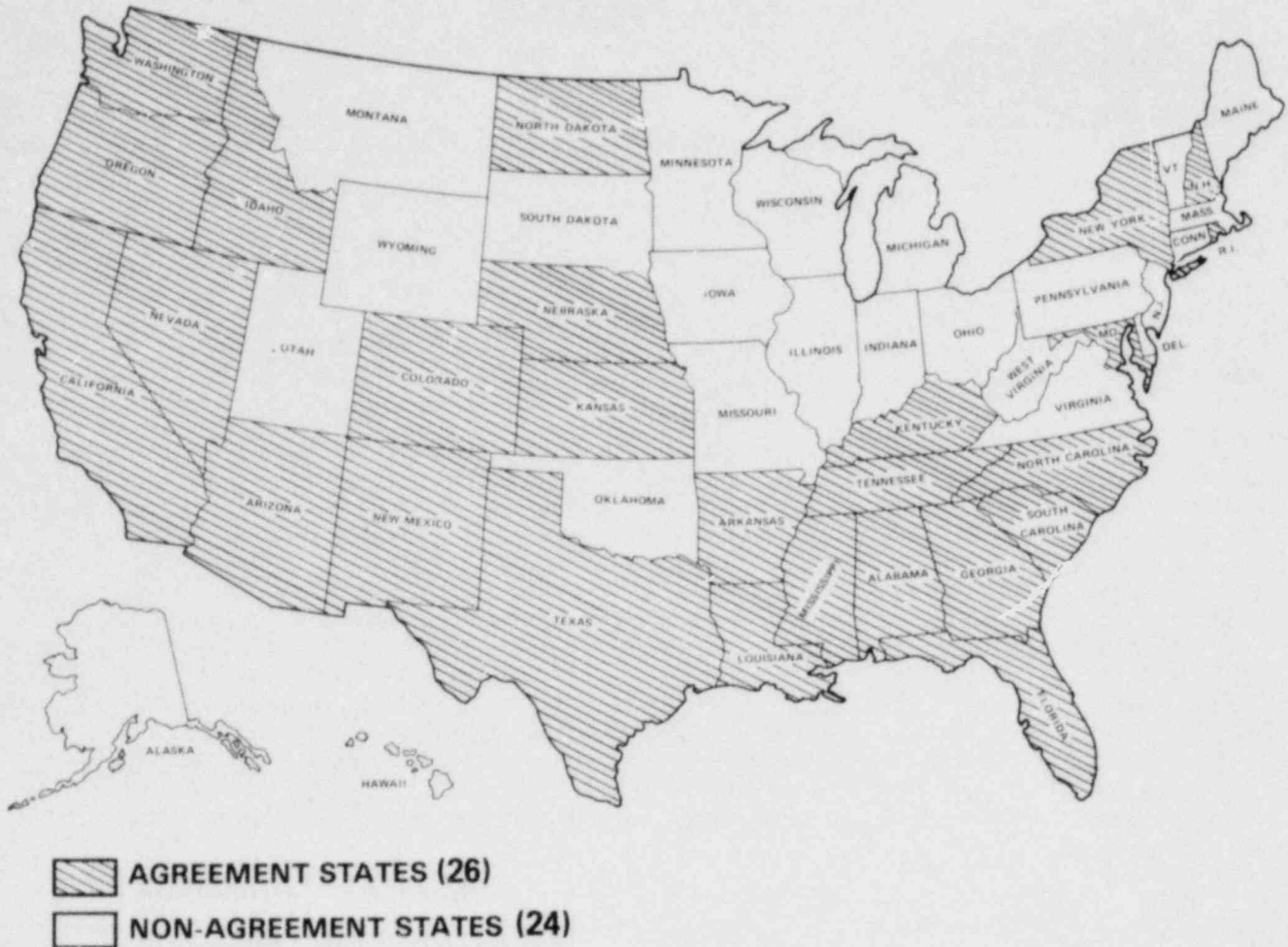

programs had been corrected and were adequate and compatible.

With respect to the compatibility of Agreement State programs with NRC regulatory programs, the programs of 24 States were found compatible in 1979, but a compatibility finding for the State of Nevada could not be made because it had not adopted regulations equivalent to those of the NRC dealing with requirements for notices, instructions, and reports by licensees to workers (10 CFR Part 19 of the NRC's regulations). Early in 1980, Nevada formally adopted these regulations and the Nevada program was considered compatible at that time.

The Rhode Island agreement was negotiated during calendar year 1979 and its program was found to be adequate and compatible, with the result that Rhode Island became the 26th Agreement State on January 1, 1980. Thus, early in 1980, all 26 Agreement States were deemed to have adequate and compatible radiation control programs.

NRC Technical Assistance to States

NRC continued to provide technical assistance to the Agreement States in 1980 in the handling of major licensing actions, health physics matters, environmental analyses, review of proposed regulations, and guidance for inspection and enforcement actions. NRC is assisting Kansas, for example, with the review of a proposed low-level radioactive waste disposal license (see Chapter 8).

At the request of Nevada and Washington, NRC inspectors were assigned temporarily to low-level radioactive waste burial sites in those States to assist in inspecting shipments (see Chapter 6). Arizona, California, Colorado, New Mexico, Oregon, Texas, and Washington received NRC assistance connected with uranium milling operations (see Chapter 8).

The NRC and South Carolina signed a Statement of Cooperation on June 19, 1980 whereby NRC will

NUCLEAR MATERIALS LICENSES IN EFFECT

1961, 1965, 1970, 1975-1979

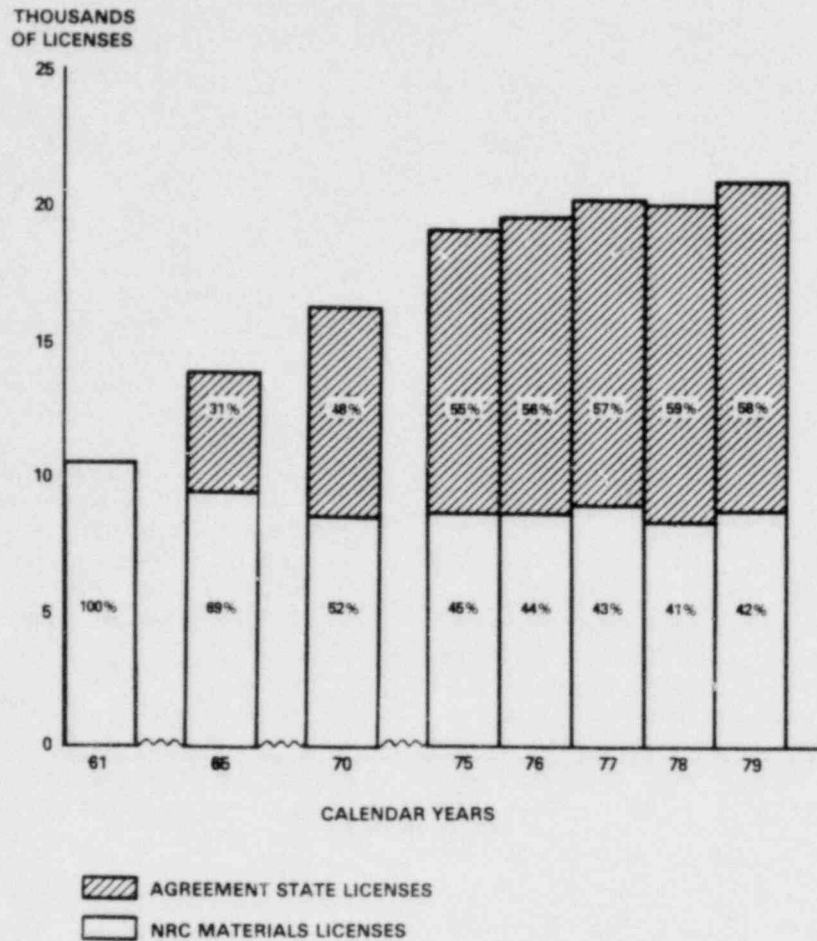

assist with an environmental assessment for the low-level waste burial site at Barnwell.

Training Offered by NRC

State regulatory personnel have regularly attended NRC-sponsored courses to upgrade technical and administrative skills. The training is available to both Agreement and non-Agreement State personnel at no cost. Training courses presented in 1980 included the following: Industrial Radiography, Baton Rouge, Louisiana; Medical Uses of Radionuclides, Memorial Sloan Kettering Cancer Center in New York; Health Physics and Radiation Protection, Oak Ridge Associated Universities; Inspection Procedures, NRC Region III Office; Calibration of Teletherapy Machines, M.D. Anderson Hospital in Houston, Texas; Orientation in Regulatory Practices, NRC Headquarters; Gas and Oil Well-Logging for Regula-

tory Personnel, Houston, Texas; Radiation Protection Engineering, Oak Ridge Associated Universities; Uranium Mill Licensing and Inspection Procedures; and a special program, Licensing of Inspection Procedures for Uranium Extraction Circuits associated with Phosphate Processing Plants, for personnel from Florida, Louisiana, and Idaho. In all, 185 State personnel received 385 student-weeks of training during the year.

Annual Agreement States Meeting

The annual meeting of radiation control program directors for the Agreement States was held in October 1979, at NRC Headquarters. Discussion topics included emergency response, transportation of radioactive material, waste management, regulation of uranium mills, environmental reviews, occupational radiation protection and specific problems involving radioactive materials. In addition, the NRC

review criteria for evaluating Agreement State programs were discussed. Recommendations by State representatives at the meeting included: opposition to dual (Federal and State) licensing of uranium mill tailings, loan of environmental surveillance equipment to the States, development of model State emergency response plans, continuation of the level and quality of the training program for State personnel, definition of NRC's policy on the proliferation of nuclear burial sites, development of radioactive waste definitions, and review and comparison of the Agreement States and Federal salary structures.

Agreement States and Uranium Mill Tailings

The Uranium Mill Tailings Radiation Control Act of 1978 (UMTRCA) requires Agreement States that wish to continue regulating uranium mills and tailings after November 8, 1981 to adopt Federal technical standards and procedures, including the preparation of written environmental analyses, and to provide opportunities for hearings and public participation in the processing of license applications for these facilities. The Agreement States regulate more than half of the active uranium mills and have abandoned tailings piles within their borders. In conformance with the legislation, NRC will negotiate amendments to the agreements with States that wish to continue uranium mill regulation. The 1978 act also authorized NRC's first grant program, under which NRC has awarded a total of \$500,000 to the States of California, Colorado, Nevada, New Mexico, Oregon, Texas, and Washington to help them develop regulatory programs that meet the new requirements. On April 15, 1980, Arizona relinquished to NRC its authority over uranium mills and mill tailings, at the request of the State's governor and under the terms of the Atomic Energy Act of 1954, as amended.

NRC training for State personnel on the licensing of uranium mills during 1980 included two 2-week courses on licensing and inspection of mills and a 2-day seminar on bioassay related to uranium mining and milling. Two special on-the-job training programs covering phosphate plants with uranium circuits were conducted during the year for representatives from Florida, Louisiana, and Idaho.

Abnormal Occurrence in Agreement States

Only one abnormal occurrence in an Agreement State was reported to the Congress in 1980. It occurred in Louisiana when a hot cell operator received a radiation dose that produced blistering of several fingers and thumbs of both hands. The operator had removed iridium-192 pellets from the

shipping capsule in a hot cell and, subsequently, entered the hot cell to replace the cap on the shipping capsule by hand and received the radiation exposure. The shipping capsule was estimated to have contained 12 curies of iridium-192 contamination. The individual has returned to work. (See also Chapter 5.)

EMERGENCY PREPAREDNESS

On December 7, 1979, responding to the report of the President's Commission on Three Mile Island, President Carter directed that the Federal Emergency Management Agency (FEMA) should take the lead agency responsibility, formerly assigned to NRC, for working with State and local governments to develop their radiological emergency response plans. (See *1979 NRC Annual Report*, p. 62.) Accordingly, the NRC and FEMA entered into a Memorandum of Understanding (MOU) to delineate responsibilities in radiological emergency preparedness. (For a detailed discussion of the MOU and other emergency preparedness activities, see Chapter 3.)

Training Program for States

Under the MOU transferring the review and training functions to FEMA, NRC continued funding training activities until the end of fiscal year 1980, and this resulted in 16 courses on radiological emergency response operations for about 400 students, 8 courses on radiological accident assessment for about 200 students and 2 planning courses for about 100 students during the year.

Planning Guidance to States

Until this year, the NRC had been using NUREG-75/111, "Guide and Checklist for Development and Evaluation of State and Local Government Radiological Emergency Response Plans in Support of Fixed Nuclear Facilities," as a guide for developing and evaluating State and local radiological emergency response plans. During fiscal year 1980, this was replaced with another document, NUREG-0654/FEMA-REP-1, "Criteria for Preparation and Evaluation of Radiological Emergency Response Plans and Preparedness in Support of Nuclear Power Plants," which combines State/local requirements and licensee requirements. (See Chapter 3 for additional details.)

In January 1980, NRC held four regional workshops to review with State officials NRC's emer-

gency planning rule. These workshops were attended by State legislators as well as energy policy, siting, civil defense, and radiation control officials. (See Chapter 3).

LIAISON AND COOPERATIVE ACTIVITIES

Transportation Surveillance

During 1980, eight States were involved in the joint NRC/Department of Transportation program for the surveillance of radioactive materials transported into, within, or through their borders. Georgia, Illinois, Michigan, and South Carolina completed three years of monitoring. The second year results of the Illinois program (for the period June 1978 to June 1979), the Michigan program (September 1978 to August 1979), and the South Carolina program (October 1978 to September 1979) were published as NUREG/CR-1193, -1194, and -1434, respectively, and the first year results of the Kentucky program (September 1978 to December 1979) were published as NUREG/CR-1671. Washington and Florida completed their first year programs in September 1980. Maryland began its program in June 1980, and Nevada began in September 1980.

The program contributes valuable data concerning the transportation of radioactive materials in the

respective States, promotes familiarity with Federal and State regulations on the part of shippers, carriers, and State personnel, and results in closer adherence to regulations for safeguarding the health and safety of transportation workers and the general public. This year, the emphasis for future programs began to shift from surveillance to enforcement to further insure that radioactive materials are transported safely.

Memoranda of Understanding

In the past four years, NRC has entered into Memoranda of Understanding with States under which the parties pledge cooperation in areas of mutual interest. Some of these have dealt with specific matters of the quality of water discharged from NRC-licensed facilities. Others have been more general. In 1980, NRC and Oregon signed a general memorandum and two sub-agreements, one covering the protection of security information and the other the coordination of NRC and Oregon resident inspector programs at the Trojan Nuclear Power Station.

State Liaison Officers

The governors of all States have now appointed liaison officers to maintain direct communication

NRC Chairman John Ahearne addresses representatives of the States at a national meeting of liaison officers to the NRC, held at headquarters in Bethesda, Md., in December 1980.





A meeting of NRC's State liaison officers from the regional offices was held in late 1980. All five NRC regional offices are now staffed with liaison personnel for closer contacts with the States.

with NRC so that at the end of 1980 there were 51 State liaison officers to the NRC (including the Commonwealth of Puerto Rico). In November 1979, a Regional State Liaison Officer meeting was held in NRC Region IV, and another in Region V in March 1980, to acquaint the States with regional office operations and to discuss such issues as transportation and management of radioactive wastes, uranium mills and tailings, and emergency planning. A national meeting of State liaison officers for the 50 States was planned for early December 1980.

NRC expanded its Regional State Liaison Officer Program to include all five regional offices in 1980, to improve NRC's ability to respond to State interests and to better accommodate State interests in NRC decision-making.

National/State Organizations

Throughout 1980, NRC continued working with regional bodies such as the Western Interstate Energy Board and Southern States Energy Board, and with such organizations as the National Governors' Association, National Conference of State Legislatures, National Association of Attorneys General, National Association of Counties, and National Association of Regulatory Utility Commissioners. NRC staff members also met with State legislators during the year. Most such meetings dealt with NRC programs on radioactive waste management and radiological emergency response planning. In several instances NRC witnesses presented testimony before State legislative committees on such matters as radioactive waste disposal, transportation, emergency response planning, nuclear power plant siting and decommissioning.

Conference of Radiation Control Program Directors

The NRC in 1980, together with the Bureau of Radiological Health of the Department of Health and Human Services and the Office of Radiation Programs of the Environmental Protection Agency, continued to provide financial and technical assistance to the Conference of Radiation Control Programs Directors, Inc., an organization of heads of State and municipal radiological health programs. (See p. 180, *1979 Annual Report*). Activities of the Interorganizational Committee for Radiological Emergency Response Planning and Preparedness, representing the Conference of Radiation Control Program Directors, the National Association of State Directors for Disaster Preparedness, and the U.S. Civil Defense Council, also continued to function in 1980.

Notification of Waste Shipments

NRC initially provided advance notification of radioactive waste shipments from Three Mile Island to Washington State's Hanford burial site and to South Carolina's Barnwell burial site to both en route and destination States. Later in 1980, the notifications were confined to Washington and South Carolina, as appropriate.

In response to Public Law 96-295, enacted in June 1980, the NRC at year-end was in the process of amending its regulations to require licensees to notify governors in advance when shipments of spent nuclear fuel or potentially hazardous nuclear wastes will be passing through their States. (See Chapter 6.)



11

International Cooperation

The NRC conducts a wide range of international activities, with a focus on nuclear safety and nonproliferation. This includes formal exchanges of information and cooperation with the regulatory bodies of 19 countries and several international organizations regarding civil radiological health and safety; nuclear export and import licensing and implementation of national policy to deter nuclear proliferation; and support of international nuclear safeguards.

During fiscal year 1980, the NRC:

- Executed arrangements with Finland and the Philippines for the exchange of nuclear safety information, bringing to 19 the total of such bilateral arrangements.
- Began or continued negotiations for information exchange arrangements with six other countries.
- Held policy and technical meetings with 500 visitors from 28 countries and five international organizations.
- Initiated a review of the many sources of foreign radiological incident information to determine the feasibility of including this information in NRC's data bank to support evaluation of operating experience from the safety point of view.
- Continued to support the International Atomic Energy Agency's technical safety assistance program which was expanded in scope and magnitude in 1979, largely as a result of U.S. initiatives.
- Adopted new amendments to NRC regulations to streamline the export licensing process.
- Issued 462 nuclear export licenses, of which 89 were for major exports, and 127 amendments to existing licenses.
- Continued to support domestic and international efforts to develop and operate the nuclear fuel cycle in ways that minimize the risk of nuclear proliferation.

Information Exchanges

BILATERAL ARRANGEMENTS

Since 1974, when the NRC's program of initiating regulatory information exchange and cooperation arrangements with other countries was formally begun, arrangements have been concluded with the following 19 countries: Belgium, Brazil, Denmark, Finland (September 1980), France, the Federal Republic of Germany, Greece, Iran (inactive), Israel, Italy, Japan, Korea, the Netherlands, the Philippines (April 1980), Spain, Sweden, Switzerland, Taiwan, and the United Kingdom. The NRC has, additionally, during 1980 either begun or continued cooperative arrangement negotiations with the regulatory authorities of Argentina, Canada, China, Egypt, Mexico, and Yugoslavia.

The objectives of these arrangements are to:

- (1) Establish a formal channel for prompt communications with foreign regulatory organizations on reactor safety problems.
- (2) Form a network for bilateral cooperation on nuclear safety, reactor safeguards, and environmental protection.
- (3) Provide assistance in improving nuclear health and safety practices of countries importing U.S. reactors and other equipment.

The arrangements typically call for the reciprocal exchange of regulatory information in the form of technical reports, correspondence, newsletters, meetings, training courses, and any other means agreed upon. In some cases, they also provide for cooperation in reactor safety research and temporary assignments of personnel to agency headquarters and lab-



Signing of agreement between the NRC and the Finnish Institute of Radiation Protection (IRP) took place in Helsinki on September 26, 1980. Seated, left to right, are U.S. Ambassador to Finland James Goodby, U.S. NRC commissioner Joseph Hendrie, IRP Director Antti Vuorinen, and IRP Assistant Director for Administration Jaakko Penttinen.

oratory programs under the sponsorship of both parties.

Arrangements are originally effective for five years, but may be extended by mutual written consent. Arrangements with Denmark, France, Spain, and Sweden were renewed for another five years during fiscal year 1980, and five more (those with the Federal Republic of Germany, Italy, Japan, Switzerland and the UK) were in the renewal process at year-end.

Exchanging Operating Data

A valuable lesson learned from the accident at Three Mile Island (TMI) was NRC's need to expand review and evaluation of operating incident data. Since approximately 40 percent of nuclear steam supply systems designed by U.S. firms are located in foreign countries, data from these reactors can provide a substantial input to the operating event data base. Under provisions of its bilateral regulatory arrangements with foreign countries, NRC is increasing efforts through correspondence, visits, and meetings to routinely and systematically exchange U.S. operating data for foreign data. In addition to these bilateral efforts, the NRC is participating in the Incident Reporting System of the OECD's Nuclear Energy Agency.

The NRC has contracted with the Nuclear Safety Information Center of the Oak Ridge National Laboratory to review the many sources of foreign

incident information and to determine the feasibility of including this information in NRC's automated data base. Results of this study are expected to assist in revising NRC's foreign operating information collection program.

Foreign Visitors and Assignments

During fiscal year 1980, the NRC held policy and technical meetings with large delegations and individual visitors from foreign countries and organizations totalling 500 persons from 28 countries and five international bodies. These included several two- to three-day discussions with foreign administrators of information and cooperation agreements with NRC as well as with their designated representatives regarding operational safety, safeguards, and environmental protection. Some visits included tours of U.S. nuclear facilities and national laboratories to observe NRC safety activities and safety research programs. Most of the visitors were from countries with which NRC has bilateral regulatory and safety research arrangements.

Numerous individual foreign reactor specialists were escorted to the TMI site for discussions with NRC and licensee representatives. In addition, six foreign regulatory personnel from five countries were assigned for six-month periods with the NRC operating personnel in Middletown, Pa., and with the licensee's staff at the site, to participate directly in the TMI recovery operations. Participants in fiscal

year 1980 were from Italy, Japan, Spain, Switzerland, and Taiwan. Ten other regulatory officials from France, Mexico, the Philippines, Spain, and Turkey participated in NRC programs to gain experience in the U.S. regulatory process and to contribute their expertise to various tasks for periods ranging from a month to a year.

Twenty foreign nationals from 13 countries attended a radiological emergency response operations training course held in Las Vegas, Nev., in October-November 1980. This course, which was conducted by a contractor of the Department of Energy's Nevada Operations Office, included field exercises involving the handling of various simulated nuclear accidents. The course was modeled after those held several times each year in Nevada under NRC sponsorship for U.S. State and local emergency response officials.

RESEARCH AGREEMENTS

In a very active year for international nuclear safety research, two agreements were renewed, and seven new cooperative agreements were concluded.

A broad research arrangement with the Commissariat à l'Énergie Atomique (CEA) and the Bundesminister für Forschung und Technologie (BMFT) of the Federal Republic of Germany was renewed for five years. The agreement for German participation in the NRC Loss-of-Fluid-Test (LOFT) program was renewed for an additional three years.

A major tripartite agreement was concluded in April 1980 among the NRC, BMFT, and the Japan Atomic Energy Research Institute (JAERI) to cooperate in coordinated analytical and experimental studies of the thermal hydraulic behavior of emergency core coolant during the refill and reflood phase of a LOCA in a pressurized water reactor. The performance of studies covered by this agreement requires funding of about \$70 million from each participant.

In May 1980, the NRC and the Power Reactor and Nuclear Fuel Development Corporation of Japan concluded an arrangement for NRC to complete a series of calculations of hypothetical core disruptive accidents using the SIMMER code in return for a cash payment.

Also in May, the NRC joined as a participant the Studsvik Demo-Ramp II international research project. This project is related to the investigation of the pellet/clad interaction failure mechanism in irradiated boiling water reactor fuel. The experiments are conducted at the R2 test reactor at Studsvik in Sweden. As a participant, the NRC provides a cash payment to the project.

On June 6, 1980, NRC concluded an agreement with the Netherlands Energy Research Foundation (ECN). It provides for the exchange of information and ECN's participation in the NRC Heavy Section Steel Technology and Aerosol Release and Transport programs, and for reciprocal activities by NRC in the Dutch Bros-Eposs and Aerosol programs.

Later in June, the NRC became a participant in the Marviken IV project which is studying jet behavior and effects of jet impingement forces on containment design. The experiments are performed at the Marviken reactor facility in Sweden. In return, the NRC extended for a two-year period the existing LOFT-NORHAV agreement with the Nordic countries represented by Denmark, Finland, Norway, and Sweden.

A research agreement was concluded with the French CEA providing for CEA's participation in the LOFT program for a period of three years. The CEA pays a cash fee for its participation. Brazil and Taiwan have also expressed an interest in participating in LOFT experiments in the future.

Finally, a tripartite agreement among Euratom, the Power Reactor and Nuclear Fuel Development Corporation (PNC) of Japan and the NRC went into force on November 14, 1980. This agreement provides for the acquisition of experimental data on the coolability of uranium dioxide fuel debris in liquid sodium at the U.S. Annular Core Research Reactor. Euratom and PNC will provide funds to support the experimental program.

COOPERATION WITH INTERNATIONAL ORGANIZATIONS

IAEA Nuclear Safety Program

The NRC continued to support the IAEA's expanded nuclear safety program which the member states approved after the accident at Three Mile Island Unit 2. Two NRC specialists were temporarily assigned to the IAEA staff at no financial cost to the IAEA, and other staff members served as consultants on improving safety assistance to developing countries and on IAEA's safety research role.

Work also continued in areas of long-standing collaboration, such as the IAEA nuclear power plant safety standards program. Several safety guides were completed in 1980, bringing the total to more than 20. NRC staff members also participated in meetings on waste management and transportation, including steps to perform a comprehensive review of IAEA's regulations for the safe transport of radioactive materials.

IAEA Stockholm Conference. A five-member delegation headed by Commissioner Hendrie attended the International Conference on Current Nuclear Power Plant Safety Issues in Stockholm in October 1980. The conference was proposed by the government of Sweden following the TMI accident as an opportunity for the international community to consider the meaning of the accident with respect to present and future use of nuclear power technology and national and international safety objectives.

Technical Assistance Through IAEA

The NRC, in cooperation with the IAEA Technical Assistance Program, continued to provide safety advice and assistance to regulatory authorities of countries embarking on nuclear power programs.

A number of Korean safety engineers made short-term visits to the NRC for training in the area of vendor inspection and safeguards, while two NRC engineers made short-term visits in August to discuss safety issues with the Korean Nuclear Regulatory Bureau and the Korean Atomic Energy Research Institute.

A PWR Fundamentals Course was conducted by NRC for the IAEA at the Brazilian National Nuclear Energy Commission (CNEN) in Rio de Janeiro, Brazil. Several CNEN staff members visited NRC head-

quarters and the regional office for short-term assignments in operator training, preoperational testing, nuclear steam supply systems, instrumentation and control and inspection procedures.

Numerous short-term missions were carried out by the NRC to assist the National Nuclear Safety and Safeguards Commission (CNSNS) of Mexico regarding containment, anticipated transients without scram, core analysis, and radiation protection. NRC also invited CNSNS staff members to participate in inspection training courses offered at headquarters in Bethesda. Short-term safety missions were also carried out by NRC staff members, on behalf of the IAEA, to the Democritos Research Reactor in Greece and the Krsko Nuclear Plant Site in Yugoslavia.

Also, the NRC has assigned an expert for one year as an IAEA adviser to Mexico to strengthen its nuclear regulatory program. A second NRC staff member has been made available for a nine-month IAEA assignment to advise Spanish regulatory authorities on the startup of their PWR reactor.

Training Courses Held. NRC staff members lectured in two IAEA courses conducted in 1980 by Argonne National Laboratory's Center for Educational Affairs. These courses covered the inspection of nuclear power plant construction and the regulation of nuclear power plants.

The NRC also provided lecturers for an IAEA course at the Karlsruhe Research Center in the Federal Republic of Germany.



NRC Executive Director for Operations William J. Dircks, right, greets Henri Malou, President of the Commission for Nuclear Power Plants, General Council, Member and Vice President of the French Parliament. The occasion was a visit of French parliamentarians in April 1980 to discuss the ramifications of the TMI accident and the future role of the NRC following the various investigations of that event.

Cooperation with the OECD

NRC is represented on several committees of the OECD's 24-country Nuclear Energy Agency. The principal focus of NRC's participation is the Committee on the Safety of Nuclear Installations (CSNI) and its Licensing Subcommittee. CSNI activities in 1980 included general exchanges of safety research and regulatory information, and specialized activities involving the review and comparison of computations and analyses related to key safety research and licensing questions, including emergency core cooling, containment responses, fuel-coolant interaction, fracture mechanisms and non-destructive testing of materials. In January 1980, the CSNI began a two-year trial of an improved program for the exchange of safety-significant information on reactor incidents occurring in the member countries.

NRC senior staff also participated in activities of the NEA standing committees on Radiation Protection and Public Health and on Waste Management, and on the NEA Ad Hoc Group on the Legal, Administrative and Financial Aspects of Long-Term Management of Radioactive Waste.

Export/Import Actions and Nonproliferation Efforts

EXPORT LICENSING ACTIONS

During the fiscal year ending September 30, 1980, the NRC issued 462 export licenses and 127 amendments to existing licenses. Of the 462 licenses issued, 89 were major licenses in three categories: special nuclear material, source material, and reactors. The 373 export licenses considered to be minor included 72 for small quantities of special nuclear material, 36 for source material, 65 for byproduct material, and 200 for components. (NRC also issued 31 import licenses, including amendments.)

Nineteen different nations received U.S. shipments of special nuclear material under major export licenses during the year. In addition, three nations received major quantities of source material, and two nations received a reactor facility. No licenses were issued during the period for the export of large quantities of plutonium.

Two particularly significant export license cases are discussed below.

Tarapur (India) Exports

The lengthy history of U.S.-India cooperation in connection with the supply of material and equip-

ment for the Tarapur Atomic Power Station (TAPS) is fully chronicled in the NRC Annual Reports for 1976, 1977, 1978, and 1979. In May 1980, the Commission was unable to find that license applications XSNM-1379 and XSNM-1569 for reload fuel for the Tarapur reactors and XCOM-0240, XCOM-0250, XCOM-0376, XCOM-0381 and XCOM-0395 for replacement component hardware for these reactors met the criteria for issuance set forth in Sections 109, 127, and 128 of the Atomic Energy Act of 1954, as amended (Commission Memorandum and Order CLI-80-18). Accordingly, the Commission referred the seven license applications to the President pursuant to procedures set forth in Section 126b(2) of the Act.

The Commission was of the unanimous view that Section 128 of the Act applied to the fuel export license applications and that India's failure to place all of its peaceful nuclear facilities under IAEA safeguards precluded NRC from making the finding required by Section 128a(1). Because of unique features in the U.S./India Agreement for Cooperation, the Commission was also unable, by unanimous vote, to find that the two fuel license applications satisfied the specific criteria in Section 127 of the Act or that the component license applications satisfied the criteria in Section 109 of the Act. By Executive Order 12218 of June 19, 1980, the President authorized the exports after determining (in accordance with Section 126b(2) of the Act) that "withholding the exports... would be seriously prejudicial to the achievement of United States non-proliferation objectives and would otherwise jeopardize the common defense and security...."

The exports were then subject to a 60-day Congressional review period as required by Section 126b(2) of the Atomic Energy Act, as amended. In September, a resolution disapproving both proposed fuel exports passed the House of Representatives by a vote of 298 to 98, but was rejected in the Senate by a vote of 48 to 46; consequently, the fuel under XSNM-1379 was shipped by Edlow International Co., as agent for the Government of India, in October. The second fuel shipment will only be made after further consideration by the Executive Branch and consultation with Congress. The component exports have also now been approved.

Philippines Reactor Project

On January 29, 1980, after reviewing all the submissions received pursuant to its order of October 19, 1979 (see 1979 Annual Report, p. 189), the Commission met in public session, during which it reached a preliminary consensus on the scope of its jurisdiction over health, safety, and environmental

Summary of Nuclear Export Licenses Issued During Fiscal Year 1980

| Country | MAJOR LICENSES ISSUED | | | | MINOR LICENSES ISSUED | | | |
|-----------------------|-----------------------|-----------|-----------|----------|-----------------------|-----------|-----------|------------|
| | Enriched Uranium | | Source | Power | Enriched | Source | Byproduct | Material & |
| | > 20% | < 20% | Material | Reactors | Uranium | Material | Material | Components |
| Canada | - | - | 2 | - | 5 | 4 | 5 | 22 |
| Euratom Community* | 8 | 23 | 8 | - | 22 | 16 | 11 | 72 |
| Japan | 4 | 26 | - | - | 21 | 5 | 12 | 24 |
| Korea | - | 2 | - | 1 | 2 | - | - | 5 |
| Philippines | - | - | - | 1 | - | - | 1 | 1 |
| Spain | - | 1 | - | - | 1 | - | 3 | 8 |
| Sweden | 1 | 3 | - | - | 3 | - | - | 3 |
| Switzerland | - | 3 | - | - | - | - | - | 1 |
| Taiwan | - | 3 | - | - | 3 | 1 | 1 | 8 |
| Yugoslavia | - | 1 | - | - | 2 | - | 1 | - |
| Others | - | - | 2 | - | 13 | 10 | 31 | 52 |
| TOTALS | 13 | 62 | 12 | 2 | 72 | 36 | 65 | 200 |

*The Netherlands, The Federal Republic of Germany, France, United Kingdom, Belgium, Denmark, Italy, Ireland, Luxembourg.

impacts abroad and decided to solicit additional public comments, specifically on the Philippines reactor export application. The Commission issued an order on February 8, 1980, requesting comments on (a) the health, safety, and environmental effects of the proposed exports upon the global commons and the territory of the United States and (b) the relationship of these effects to the common defense and security of the United States.

In response to the order, the NRC staff prepared a technical analysis which evaluated the potential radiological impacts upon the global commons that could result from operation of the plant. It concluded that neither routine releases nor releases from the most serious possible reactor accident, a core meltdown, would result in significant impacts on the global commons or the United States. On May 6, 1980, the Commission announced its final decision on the issues raised by the Philippines application. The Commission decided that, in reviewing reactor export applications in the future, it will consider only those health, safety, and environmental impacts which could affect the global commons or the territory of the United States.

Having determined that the Philippine application met the specific export licensing criteria of Section 127 of the Atomic Energy Act, as amended, and that the exports would not be "inimical to the common defense and security or public health and safety" of the United States, the Commission ordered the staff to issue the export license. Chairman Ahearne and Commissioner Bradford filed dissenting opinions.

Chairman Ahearne stated he agreed that, as a matter of law, the Commission was precluded from considering health, safety and environmental impacts on Philippine citizens, but that as a matter of policy he would have had the Commission examine impacts on U.S. interests abroad. He abstained from voting on the export license. Commissioner Bradford held that NEPA requires the Commission to consider impacts on U.S. military bases abroad, and that therefore the Commission should at least evaluate whether the proposed reactor design and the proposed site would be licensable in the U.S. He voted against issuance of the license.

The Commission's decision was challenged by intervenors in the U.S. Court of Appeals and was pending decision at year-end.

Environmental Effects of Exports

Pursuant to procedures established by Executive Order 12114, "Environmental Effects Abroad of Major Federal Actions," the NRC received from the Department of State during 1980 two environmental reviews of proposed nuclear reactor exports—one for the Philippines Nuclear Power Plant Unit 1, and another for the Korean Nuclear Power Plant Units 7 and 8. These "concise environmental documents" were made available to the Commission in connection with its deliberations on these two export cases.

While the NRC staff did not explicitly comment on either of these documents, it took note of the analyses contained in them and submitted its own technical analyses, performed by the Office of Nuclear Reactor Regulation, of the potential radiological impact on the global commons of both nuclear exports. These were forwarded to the Commission in conjunction with the staff's overall analysis of the Philippine and Korean export license applications.

The NRC, as a matter of policy, has agreed to perform independent case-by-case reviews of health, safety, and environmental implications of nuclear exports for the U.S. and the global commons, as well as to consider providing appropriate technical assistance to the Executive Branch, upon request, in the preparation of its environmental reviews.

NONPROLIFERATION EFFORTS

In addition to the NRC's direct export and import licensing activities, the Nuclear Nonproliferation Act of 1978 (NNPA) requires Executive Branch agencies to consult formally with NRC on nuclear export-related activities under their purview, including:

- Negotiation of new and revised Agreements for Cooperation with other countries (State Department and Department of Energy (DOE)).
- Nuclear technology exports (DOE).
- Government-to-government distribution of nuclear material (DOE).
- Negotiation of contracts for the supply of nuclear materials and equipment (including enrichment services to foreign recipients) (DOE).
- Consideration of requests to retransfer U.S.-supplied nuclear material and facilities (DOE).
- Consideration of requests to reprocess irradiated U.S.-supplied nuclear fuel (DOE).
- Other "suitable" arrangements as defined in Section 131 of the Atomic Energy Act of 1954, as amended.
- Exports of nuclear-related commodities by the Department of Commerce.

During the fiscal year ending September 30, 1980, the NRC consulted on items in these categories, including: 7 Agreements for Cooperation, 1 nuclear technology export, 9 reprocessing retransfer requests

and approximately 100 Department of Commerce-licensed nuclear-related exports.

Agreements for Cooperation

The renegotiation of agreements for nuclear cooperation, called for by the NNPA, continued in 1980. The key issues that were settled in the negotiations involved provisions regarding physical security, material accounting, and reciprocal approval rights concerning the storage, retransfer, and reprocessing of spent reactor fuel.

With the Department of State taking the lead role, after consultation with other U.S. agencies, including the NRC, agreements or amendments to agreements were concluded in 1980 with Canada, Indonesia, Colombia, Peru, Morocco, and the IAEA.

Retransfers for Reprocessing

The NRC continues to play an important advisory role in the review of requests involving retransfers of U.S.-supplied nuclear material to other countries for reprocessing. During fiscal year 1980, NRC reviewed nine cases involving such retransfers from Spain, Switzerland, Japan, and Sweden. The Commission also reviewed two retransfers, since passage of the NNPA, involving plutonium separated prior to enactment of the NNPA. The more significant of these retransfers involved the transfer of approximately 70.6 kilograms of Swiss plutonium for use in the super Phenix fast breeder reactor in France. The case was considered significant since it raised the issue of whether the end use—fuel for a fast breeder reactor—was in keeping with President Carter's policy of not encouraging the development of breeder technology. (The President subsequently approved the action.)

Nuclear Fuel Cycle Evaluations

The International Nuclear Fuel Cycle Evaluation (INFCE) in which NRC provided support on request to the U.S. delegation, was concluded in February 1980. The reports of the eight INFCE working groups and of the INFCE Technical Coordinating



Discussions of waste disposal problems and results of the International Nuclear Fuel Cycle Evaluation were conducted at NRC offices with representatives of the Federal Republic of Germany (FRG). Shown, left to right, are NRC Chairman John F. Ahearne; Richard Leberhorst, Chairman of the FRG Bundestag's Enquete-Commission on the Future of Nuclear Energy Politics; Dr. D. Faude, Karlsruhe Nuclear Research Center; and Stephan Von Welk, Scientific and Technological Counselor, FRG embassy.

Committee were received by the plenary conference which in turn submitted them to the governments of the 66 contributing countries. The reports are intended for use by the governments in developing their nuclear energy policies and in future international discussions concerning nuclear energy cooperation and safeguards.

Post-INFCE activities centered in the IAEA include: consultation intended to develop a system of international plutonium storage under IAEA auspices; a study of international spent fuel management; and a committee to look into ways in which the supply of nuclear technology, materials, and services among countries could be put on a more reliable basis.

NRC Role in Nonproliferation Policy

Under Section 602(a) of the Nuclear Nonproliferation Act, the Commission and DOE are required to include in their annual reports to Congress "views and recommendations regarding the policies and actions of the United States to prevent proliferation which are the statutory responsibility of these agencies..."

Recognizing that reliability of supply to countries adhering to effective nonproliferation policies is a key element of the U.S. effort to reduce proliferation concerns, the Commission has undertaken additional efforts to improve and expedite the export licensing process in a manner that will not compromise the adequacy of reviews to ensure that U.S. statutory requirements are met.

In June 1980, the NRC and the Department of Commerce adjusted their procedures regarding the types of nuclear components that fall under NRC's export licensing jurisdiction pursuant to Section 109 of the Atomic Energy Act of 1954, as amended. The Department of Commerce assumed export licensing authority over all "balance of plant" nuclear components, while the NRC retained licensing authority over those nuclear plant components which are "specially designed or prepared" for use in the nuclear reactor portion of a plant. The latter category includes (a) those items within or attached directly to the reactor vessel, (b) equipment which controls the level of power in the core, and (c) components which normally contain, or come in direct contact with, or control, the primary coolant of the reactor core.

Also, during 1980, in an effort to streamline the export licensing process, the following actions were taken:

- The Executive Branch and the NRC agreed that the Commission could approve, without referral to the Executive Branch, exports of single low-enriched uranium (LEU) reloads to certain countries having good nonproliferation credentials.
- The Commission delegated to the staff additional authority to issue export licenses without referral to the Commission, including approval of multiple LEU fuel reloads (five reloads or an initial core and three reloads) to certain major U.S. NPT trading partners. This should provide significant long-term assurance and enhanced perceptions abroad of the credentials of the U.S. as a reliable supplier of nuclear fuel to other countries, while at the same time maintaining appropriate nonproliferation controls.

- The NRC staff was authorized to approve, without Commission or Executive Branch review, annual amendments to existing multi-year LEU export licenses, provided there are no "material changed circumstances" in recipient country.
- In April 1980, the NRC published new amendments to 10 CFR Part 110 which established or expanded general licenses for source and byproduct material and for gram quantities of special nuclear material (SNM). In addition, the export of up to three grams of SNM may now be allowed without being subject to an agreement for cooperation.
- The Executive Branch and the NRC agreed that the Commission could approve, without referral to the Executive Branch, exports of dispersed tritium incorporated in timepieces.

In an effort to further expediting the licensing process, the NRC and the Executive Branch are considering additional amendments to Part 110. Among these proposed changes are (1) a new general license for up to 100 milligrams of SNM, (2) an increase in the source material general license from 1 to 10 kilograms, (3) an expansion of the byproduct material general license to include byproduct material with an atomic number greater than 83, and (4) new general licenses for the export of replacements for damaged

or defective fuel elements and for the export of LEU fuel samples. Various other proposals are being considered to expedite export licensing.

With respect to NRC's consultative role under Section 131 of the Atomic Energy Act of 1954, as amended, the Commission continues to believe that proposed retransfer and reprocessing requests are difficult to assess in the absence of a coherent overall policy.

The Commission also continues to be concerned over the issues of the adequacy of IAEA safeguards applied to nuclear exports and NRC needs for more detailed information concerning safeguards implementation abroad. During the year, the NRC worked closely with the Executive Branch in the continuing effort to improve international safeguards. (See discussion below.)

INTERNATIONAL SAFEGUARDS

International safeguards continued to draw substantial attention of the NRC in fiscal year 1980. In addition to responsibilities associated with the licensing of exports of nuclear materials and facilities, which result in NRC considering the implementation of international safeguards in recipient countries,



Members of the NRC's Advisory Committee on Reactor Safeguards (ACRS) and the comparable German Reactor Safety Committee (RSK) conducted exchange visits during 1980, including tours of nuclear facilities in each country. Shown at

ACRS offices are, left to right, ACRS Chairman Milton S. Plesset; Professor Hubertus Nickel and Armin Jahns, RSK; Dr. Klaus Gast, FRG Ministry of the Interior; and Professor Albert Ziegler, RSK.

NRC was involved during 1980 with the voluntary application of international safeguards at civil nuclear facilities in the U.S.

US/IAEA Safeguards Agreement

The NRC devoted further attention in 1980 to activities related to the voluntary U.S. offer to permit application of international safeguards by the International Atomic Energy Agency to civil nuclear facilities in the U.S. Under the U.S./IAEA Safeguards agreement, the U.S. will provide the IAEA with safeguards information about U.S. civil nuclear facilities "not of direct national security significance." From these, the IAEA will select a number of facilities for the implementation of safeguards inspections by IAEA inspectors and the reporting of accounting data. Implementation of the agreement will fulfill a 1967 Presidential offer to apply IAEA safeguards to U.S. civil nuclear facilities in order to demonstrate to other nations—particularly the developed nonnuclear weapons states—that the application of international safeguards would not result in commercial disadvantages. The United Kingdom and France, both nuclear weapons states, have made similar offers.

There were several major developments during 1980 towards bringing the U.S./IAEA agreement into force. On July 2, the Senate unanimously voted its advice and consent to ratification of the agreement as a treaty. On July 31, Part 75 of NRC's regulations, which implements the agreement with respect to NRC and Agreement State licensees, was published in final form. These regulations will become effective upon the agreement's entry into force and publication of notice thereof in the *Federal Register*. On August 4, a proposed eligible facility list of NRC and Agreement State facilities for application of IAEA safeguards was submitted to the Department of State for national security review by the Executive Branch. On August 20, the General Accounting Office (GAO) published in the *Federal Register* notice of receipt of the new and revised reporting forms and instructions which will be necessary for implementing the Agreement and invited public comments. GAO approval of the reporting forms and instructions is required before the Agreement can be put into force. NRC conducted two meetings with the licensed nuclear industry on September 22-24, 1980 and October 15-17, 1980, in Lexington, Kentucky and Denver, Colorado, respectively. These meetings were held to explain in detail the new and revised reporting forms and instructions.

Export Licensing Information Needs

As discussed in both the 1978 and 1979 Annual Reports, the NRC safeguards staff has identified its

needs for additional information on the implementation of international safeguards for use in reviewing export license applications. During fiscal year 1980, the NRC and the Department of State continued to explore approaches to meet the needs of the Commission which will be consistent with overall U.S. policy on international safeguards and the nonproliferation of nuclear weapons.

The IAEA Safeguards Implementation Report (SIR) for 1979, which NRC received in 1980, identified types of safeguards implementation problems that existed during calendar year 1979 and the corrective actions undertaken by the IAEA. Again, a number of the problems were unchanged from those identified in previous reports. The continuing resource constraints which the IAEA faces continues to be a cause for the persistence of these problems. These resource constraints include both a lack of inspection personnel and equipment, and the difficulties of expanding safeguards implementation apace with the rapidly growing number of nuclear facilities subject to safeguards. The IAEA has also experienced difficulties in the efficient use of the safeguards inspectorate.

Support of International Safeguards

During fiscal year 1980, NRC continued to work closely with the Executive Branch on a number of activities designed to assist the IAEA in strengthening international safeguards, including:

- Participation in DOE's Program for Technical Assistance to IAEA Safeguards. NRC's major contributions consisted of participation in the Technical Support Coordinating Committee, technical reviews of IAEA safeguards assistance projects, and the provision of experts without cost to the IAEA.
- Providing technical assistance to a foreign country in the development of its national system of material accounting and control, and the offer of similar assistance to other countries on request.
- Working with the IAEA and the Executive Branch to provide a training course in the U.S. for foreign officials who are responsible for establishing and managing their countries' national systems of material control and accounting.
- Participation in the U.S. Interagency Action Plan Working Group to strengthen IAEA safeguards.

Foreign Physical Protection

Training Courses Held. NRC staff members also lectured at the Second IAEA International Training Course on Physical Protection, sponsored by Sandia Laboratories, in November 1979. This course is primarily intended for representatives from countries in which the development and use of nuclear power is under way or planned for the near future and whose responsibilities include the preparation of regulations and the design and evaluation of physical protection systems.

Convention on Physical Protection. The Convention on the Physical Protection of Nuclear Materials, a U.S. initiative which is now a treaty, establishes the agreement of the international community on the appropriate levels of physical protection to be

accorded nuclear materials during transport, and facilitates international cooperation in the physical protection of all nuclear materials. The treaty was opened for signature in March 1980.

Other Activities

Other activities related to the areas of international safeguards and physical security of nuclear materials which NRC undertook during the year included:

- Participation in meetings, both in the U.S. and abroad, with foreign experts on international safeguards and physical security matters to exchange views and information.
- Assignment on a long-term basis of NRC safeguards technical experts to the IAEA staff in Vienna, Austria.

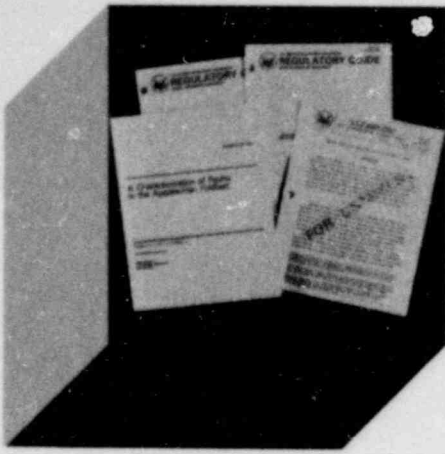

12

Standards Development

NRC standards are formulated to protect the public and nuclear industry workers from radiation, safeguard nuclear materials and facilities from theft and sabotage, and protect the quality of the environment in nuclear activities. Thus, the development of standards cuts across the range of the NRC's activities and requires close interaction between the Office of Standards Development and the agency's other program offices.

While many of the standards issued or worked on during fiscal year 1980 are discussed in this chapter, some are discussed elsewhere in this Annual Report under the topics to which they relate (e.g., transportation in Chapter 6, safeguards in Chapter 7, and waste management in Chapter 8).

CONCERNS OF HIGH PRIORITY

Issues of high priority in current standards development include the follo

Degraded Core Considerations. In October 1980, the NRC published a proposed interim rule related to hydrogen control and certain specific design and other requirements to mitigate the consequences of degraded-core accidents. The proposed interim rule was developed as a result of NRC evaluation of the TMI-2 accident. Also in October, the NRC published an advance notice of proposed long-term rulemaking in this area. (See discussion below under "Power Reactor Standards.")

Emergency Planning. A final rule upgrading emergency planning requirements for power reactors was published in August 1980. It requires applicants and licensees to submit licensee, State and local emergency plans in order for NRC to make a finding as to whether appropriate measures can be taken to

protect the public in the event of an emergency. (See discussion below under "Siting Standards.")

Siting Policy. NRC published an advance notice of proposed rulemaking in July 1980 to obtain preliminary public comments on power reactor siting policy. This begins a major rulemaking action that will result in updating of siting policy for reactors. (See discussion below under "Siting Standards.")

Anticipated Transients Without Scram (ATWS). An ATWS is an anticipated operational occurrence (transient) followed by failure of the reactor protection system to rapidly shut down (scram) the reactor following such transients by inserting sufficient negative reactivity using the control rods. The Commission is considering amending its regulations to require improvements in the design of light-water-cooled nuclear power plants to reduce the likelihood of failure of the protection system to rapidly shut down the reactor and to mitigate the consequences of such ATWS events. (See "Power Reactor Standards" below; also Chapter 4, under "Unresolved Safety Issues.")

Transportation. Sandia Laboratories continued to assess for NRC the environmental impacts resulting from the transportation of radioactive material through urban areas. Sandia's Draft Environmental Assessment, NUREG/CR-0743, was published in 1980, and the NRC staff began to prepare a draft generic environmental impact statement based on the Sandia assessment. The draft statement is expected to be published in fiscal year 1981. (See Chapter 6.)

Decommissioning. Reevaluation of NRC decommissioning policy is aimed at improving standards for all nuclear facilities. Major studies are nearing completion on the engineering methodology, radiation risks, and estimated costs of decommissioning light-

REGULATIONS AND GUIDES

NRC standards are primarily of two types:

- Regulations, setting forth in Title 10, Chapter I, of the Code of Federal Regulations requirements that must be met.
- Regulatory Guides, describing, primarily, methods acceptable to the NRC staff for implementing specific parts of the NRC's regulations.

When a new or amended regulation is proposed, it is normally published in the *Federal Register* to allow interested citizens time for comment before final adoption, in accordance with the Administrative Procedure Act. Following the public comment period, proposed regulations are revised, as appropriate, to reflect the comments received. If the regulation is adopted by the NRC, it is published in the *Federal Register* in final form with the date it becomes effective. After that publication, rules are codified for inclusion in the annual publication of the Code of Federal Regulations.

Some regulatory guides delineate techniques used by the staff to evaluate specific situations. Others provide guidance to applicants concerning the information needed by the staff in its review of applications for permits and licenses. Many NRC guides refer to or endorse national standards (also called "consensus standards" or voluntary standards) that are developed by recognized national organizations, often with NRC participation. NRC makes use of a national standard in the regulatory process only after an independent review of the standard has been made by the NRC staff and after public comment on NRC's planned use of the standard has been reviewed.

The NRC encourages comments and suggestions for improvements in regulatory guides and issues them for public comment in draft form before complete staff review and before an official NRC staff position has been established.

Copies of draft regulatory guides, together with their value/impact statements, are mailed for comment to many individuals and organizations. The value/impact statement indicates the objective of the guide, its expected effectiveness compared to alternative ways of achieving the objective, and expected impacts on other safety systems, NRC operations, other Government agencies, industry, and the public.

In order to reduce the burden on the taxpayer, the NRC has made arrangements with the U.S. Government Printing Office to become a consigned sales agent for certain NRC publications. Effective November 1, 1979, regulatory guides were included in this sales program. Draft guides, which are issued for public comment, continue to receive free distribution. Active guides are sold on a subscription or individual copy basis. Licensees of the NRC receive, at no cost, pertinent draft and active guides as they are issued.

Proposed and effective regulations published during fiscal year 1980 are summarized in Appendix 4. Draft and active regulatory guides issued, revised, or withdrawn are listed in Appendix 5.

water reactors and other nuclear facilities. A revised draft generic environmental impact statement, to be used in developing appropriate regulations, was nearing completion at the end of the fiscal year. (See discussion below under "Fuel Cycle Plant Standards.")

High-Level Radioactive Waste. Two major rule-making accomplishments concerning high-level waste management (10 CFR Part 60) occurred in this fiscal year. In December 1979, the NRC published a proposed rule giving procedural requirements for licensing high-level waste geologic repositories. In May 1980, an advance notice of proposed rulemaking was published on the technical criteria for licensing such facilities. The effective rule for the procedural requirements is expected to be issued in early 1981, late in 1980. (See "Fuel Cycle Plant Standards" below and Chapter 8.)

Spent Fuel Storage. An effective rule was published, effective in December 1980, on licensing requirements for the storage of spent fuel in an independent spent fuel storage installation. (See discussion below under "Fuel Cycle Plant Standards" and Chapter 6.)

Uranium Recovery and Extraction. Effective rule changes to establish specific uranium mill licensing requirements to implement the Uranium Mill Tailings Radiation Control Act of 1978 were published in the *Federal Register* on October 3, 1980. (See discussion below under "Fuel Cycle Plant Standards" and Chapter 8.)

Safeguards. Major safeguards standards efforts in fiscal year 1980 were focused on (1) developing regulations, guides, and technical reports for a material control and accounting capability that is both timely and sensitive with respect to inventory differences; (2) publishing the final rule to implement the US/IAEA Agreement; (3) publishing the final rule on the physical protection upgrade rule; (4) implementing a material access authorization program for fuel cycle facilities; and (5) developing requirements for an industry-run personnel screening program, including psychological evaluation and behavioral observation, to ensure continued reliability of personnel at power reactor sites. (See "Safeguards Standards" below and Chapter 7.)

Protection Against Fire. A proposed rule was published in the *Federal Register* in May 1980 that would require certain fire protection modifications at nuclear power plants operating prior to January 1, 1979. These modifications are considered minimum requirements to satisfy NRC regulations. (See "Power Reactor Standards" below.)

Radiological Health. Major 1980 NRC efforts concerning the effects of low-level ionizing radiation

included: (1) publication of an analysis of the feasibility of options for Federal epidemiological studies of populations exposed to low-level ionizing radiation (NUREG/CR-1728); (2) cooperation with the National Institute for Occupational Safety and Health to establish a radiation worker registry at the Three Mile Island Nuclear Station; and (3) work on a major revision of 10 CFR Part 20, NRC's principal radiation protection standards. (See discussion below under "Radiological Health Standards.")

Nuclear Medicine. A final rule was published on the reporting of medical misadministrations. This regulation requires physicians to report both inadequate and excessive diagnostic and therapeutic patient radiation exposure to the NRC and to the patient. (See "Radiological Health Standards" below.)

Accident Monitoring Instrumentation. Work continued on Revision 2 to Regulatory Guide 1.97. Substantial effort by ANS, including NRC staff participation, was directed at developing a consensus national standard that will be endorsed by this revision to the guide, which is expected to be issued early in fiscal year 1981. (See "Power Reactor Standards" below.)

POWER REACTOR STANDARDS

Operators' Licenses

Following the TMI-2 accident, concern over operator training led to steps to improve the NRC opera-

tor licensing process. The resulting proposed amendment to 10 CFR Part 55, "Operators' Licenses," was expected to be issued for public comment in late 1980. Changes will include requirements for (1) operator education, (2) operator simulator training that specifies the type of simulator to be used for training for specific plants, (3) operator understanding of the theory behind operation of a facility, (4) maintaining operator proficiency, and (5) NRC participation in requalification examinations.

Nuclear Power Plant Simulation

The results of a study performed by Oak Ridge National Laboratory and Memphis State University Center for Nuclear Studies on the feasibility of increasing the use of simulators in operator training have been used in the development of a draft guide, which was issued in July 1980. This draft guide endorses the American Nuclear Society's March 24, 1980 draft of ANS-3.5, "Nuclear Power Plant Simulators for Use in Operator Training," and describes a method acceptable to the NRC staff for specifying both the functional requirements of a simulator used for operator training and its similarity with its reference plant.

Quality Assurance

Quality assurance requirements for the design, construction, and operation of structures, systems, and components important to the safety of nuclear

A sealed steel cylinder is removed from its shipping container at the low-level waste disposal facility at Hanford, Wash. The NRC has worked with Federal and State agencies to develop standards for safely shipping and storing wastes.

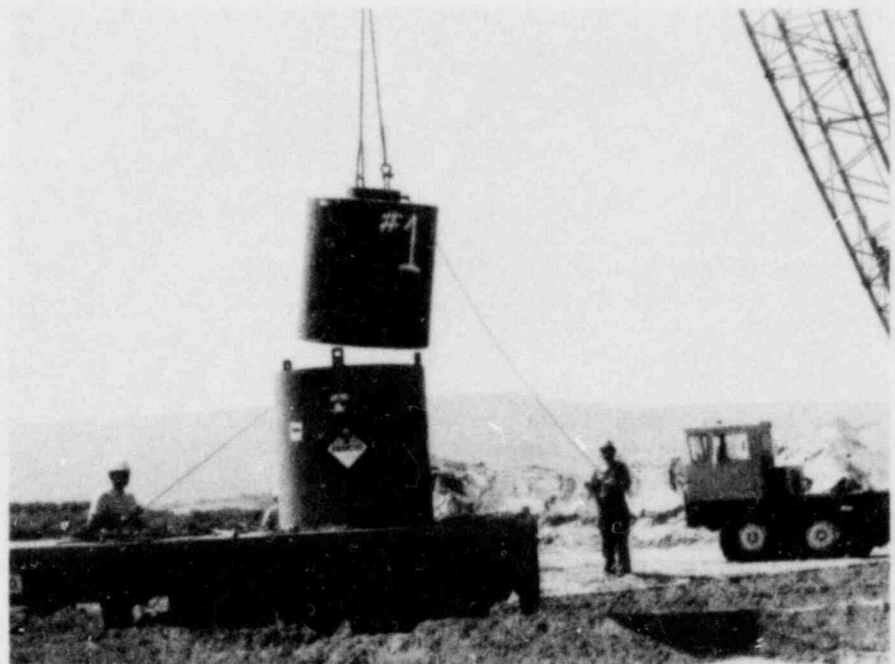



The NRC staff has been developing guidance on the use of nuclear power plant simulators in operator training. Photo shows the Browns Ferry Nuclear Plant simulator located at the

Tennessee Valley Authority's training center in Chattanooga, Tenn.

power plants are established in Appendix B to 10 CFR Part 50. During the past fiscal year, the NRC issued new and revised guides concerning the implementation of these requirements. In August 1980, Guide 1.146, on the qualification of audit personnel in quality assurance programs, was issued. In September 1980, Revision 1 to Guide 1.144, on auditing of quality assurance programs for nuclear power plants, was issued. In October 1980, proposed Revision 2 to Guide 1.8, on the qualifications and training of nuclear power plant personnel, was issued for a second public comment period to endorse the revised ANS-3.1 standard on this subject and to obtain public comment on the revised guidance.

In September 1980, Revision 1 to Guide 1.58, on the qualification of inspection, examination, and testing personnel for nuclear power plants, was issued. Since the issuance of the first proposed Revision 3 to Guide 1.33 on overall quality assurance program requirements for the operational phase of nuclear power plants, a substantial amount of guidance concerning the establishment of such a quality assurance program has been developed through assessment of the TMI-2 accident. In addition, the ANS-3.2 standard, "Administrative Controls and Quality Assurance Requirements for the Operation of Nuclear Power Plants," has been extensively revised to provide upgraded quality assurance program requirements. As a result of the incorporation of additional guidance into revisions of the ANS-3.2 standard and the guide, proposed Revision 3 to Guide 1.33 was scheduled to be issued in late 1980 for a second public comment period.

Degraded Core Considerations

The TMI-2 accident resulted in a severely damaged or degraded reactor core with the concomitant release of radioactive material to the primary coolant system and generation of hydrogen from fuel cladding/water reaction well in excess of the amounts required to be assumed for design purposes by current Commission regulations. Furthermore, the accident revealed limitations that existed in the design and operational aspects of the reactor system associated with mitigating the consequences of the accident and determining the status of the facility during and following the accident.

The NRC is initiating a long-term rulemaking to consider to what extent, if any, nuclear power plants should be designed to deal effectively with degraded-core and core-melt accidents and to mitigate the consequences thereof. An advance notice of proposed rulemaking was published in the *Federal Register* in October 1980 to solicit public comments on several questions related to the development of the long-term rule. The NRC has developed an interim rule to improve hydrogen management in some light-water reactor facilities and to provide specific design and other requirements to mitigate the consequences of accidents resulting in a degraded core. A notice of proposed rulemaking on this interim rule was also published in October 1980.

Reporting Reactor Operational Events

In February 1980, the NRC issued a rule to require the timely and accurate reporting of informa-

tion to the NRC by licensees following accidents or other significant events at operating nuclear power reactors. The need for such a rule was revealed as a result of the accident at TMI-2. Dedicated telephone lines have been installed for all operating power plants to the NRC to facilitate implementation of this requirement.

Surveillance and Inservice Inspection

Section 50.55a, "Rules and Standards," of 10 CFR Part 50 has been amended to incorporate, by reference, the 1978 edition of the American Society of Mechanical Engineers (ASME) Boiler and Pressure Vessel Code, Division 1 of Section XI, "Rules for Inservice Inspection of Nuclear Power Plants," with certain modifications, and Division 1 of Section III, "Nuclear Power Plant Components," as well as their addenda through summer of 1978. This will result in more flexibility for inservice inspection of pipe welds in facilities under construction and in operation and will avoid potential conflict between the code and the technical specifications concerning examination requirements for steam generator tubing. This regulation was also amended to clarify certain ambiguities in the requirements for inservice inspections.

Reactor Containment

A revision of Appendix J, "Primary Reactor Containment Leakage Testing for Water-Cooled Power Reactors," to 10 CFR Part 50 was issued in January 1980 for public comment and in September in effective form. This revision reflects experience gained with the local leak-testing program and represents an interim revision until a general revision of Appendix J is completed.

Concrete Containment and Structures. NRC endorsement of the ASME Boiler and Pressure Vessel Code's Section III, Division 2, "Code for Concrete Reactor Vessels and Containments," progressed another step with the issuance in November 1979 of proposed Revision 2 to Guide 1.136 on materials, construction, and testing of concrete containments. Acceptance of this national standard will make it possible to withdraw some existing regulatory guides on the subject.

System and Component Criteria

General Design Guidance. In May 1980, the staff issued Revision 16 to Guides 1.84 and 1.85 which list acceptable ASME Boiler and Pressure Vessel Code, Section III, Division 1 code cases, as well as

those code cases annulled or revised since the inception of these guides.

Several technical reports concerning decommissioning of light-water reactors were issued during the fiscal year. (See "Fuel Cycle Plant Standards" later in this chapter.)

Protection Against Fire

Resolution of the public comments on Guide 1.120, on fire protection guidelines for nuclear power plants, was interrupted in August 1979 when work was started on a fire protection rulemaking effort. A proposed rule was published for a 30-day public comment period in May 1980. It contained 17 separate

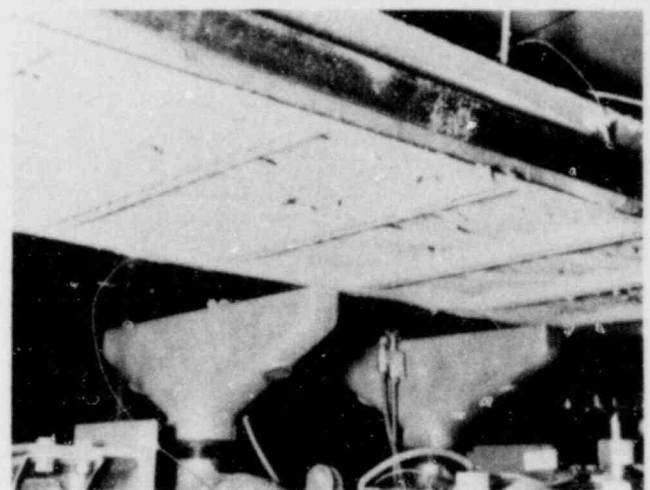
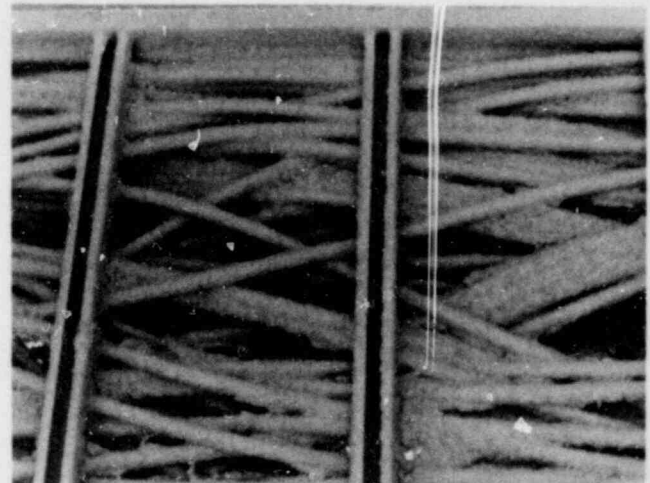

Sandia Laboratories has run many separate effects tests for NRC as part of the ongoing fire protection program. Photos show non-IEEE-383-approved cables arranged in cable tray configurations that could be typical of those found in older operating nuclear power plants. Upper photo, tray and cables are shown from below after coating with a flame-retardant material intended to slow down fire propagation. Above, the coated assembly is arranged for testing with two gas-fired ribbon-type burners installed below.

minimum fire protection requirements necessary for nuclear power facilities operating prior to January 1, 1979, to satisfy portions of General Design Criterion 3 of Appendix A to 10 CFR Part 50.

Anticipated Transients Without Scram

After several years of staff assessment, a proposed rule was developed and presented for Commission consideration in September 1980 on Anticipated Transients Without Scram (ATWS). The proposed rule would establish design requirements to reduce the likelihood of and/or mitigate the consequences of ATWS events. Public comments as well as the lessons learned from the Browns Ferry Unit 3 nuclear power plant incident, in which a large number of control rods failed to insert on manual scram, will be considered in the proposed ATWS rulemaking. A draft regulatory guide on acceptable evaluation models, mitigating system design criteria, and licensing requirements will also be issued. (See Chapters 4 and 5.)

Electrical Qualification Testing

Work continued on standards and guides for the qualification testing of electrical equipment used in nuclear power plants. Comments on a draft guide on qualification testing of cable penetration fire stops, issued in July 1979, will be assessed, along with research results, by NRC staff and the ACRS. Work is also underway to incorporate public and NRC staff comments into Revision 1 to Guide 1.131, on testing of cables and field splices, which was issued in 1979. Supporting research continues at Sandia Laboratories on radiation test source equivalence, synergistic efforts in environmental qualification, accelerated aging, and fires in cable tray assemblies. The NRC staff continued to participate with national standards committees in developing new, and updating existing, national qualification standards.

Electric Systems and Components

General Design Criterion 17, "Electric Power Systems," of Appendix A to 10 CFR Part 50 includes a requirement that the on-site electric power system have sufficient capacity and capability to ensure that (1) specified acceptable fuel design limits and design conditions of the reactor coolant pressure boundary are not exceeded as a result of anticipated operational occurrences and (2) the core is cooled and

containment integrity and other vital functions are maintained in the event of postulated accidents.

In December 1979, Revision 2 to Guide 1.9, on the selection, design, and qualification of diesel-generator units used as standby (on-site) electric power systems at nuclear power plants, was issued.

NRC staff participation continued on a national standards committee which is developing criteria for accident monitoring instrumentation. In this program, a draft standard, ANS-4.5, "Criteria for Accident Monitoring Functions in a Light-Water-Cooled Nuclear Power Generating Station," was developed and circulated for review. In addition, the NRC issued in December 1979 a proposed Revision 2 to Guide 1.97, on instrumentation for light-water-cooled nuclear power plants to assess plant and environs conditions during and following an accident, which endorses the draft ANS-4.5 standard.

Systems Interaction

As a result of contract work with Sandia Laboratories, a report, "Final Report—Phase 1, Systems Interaction Methodology Applications Program" (NUREG/CR-1321), was published in April 1980. It describes a method of reviewing nuclear power plant systems for potential interactions that is independent of the procedures used by the NRC in its Standard Review Plan (SRP). The method uses a computer code for evaluating the fault trees to identify potential system interactions. The document assesses the SRP to show where the potential interactions revealed by this independent method may not be specifically addressed by the SRP.

Classification of Electrical Systems

The Institute of Electrical and Electronics Engineers (IEEE), in collaboration with the NRC, is preparing a standard to provide a method for classifying instrumentation, control, and electrical equipment important to safety. While current practice in the design and licensing of nuclear power plants includes assigning electrical systems to either of two broad categories, "safety-related" or "non-safety-related," problems exist with this approach to classification. In order to address these problems, the IEEE and NRC are working together to develop a new standard which will provide a method for determining the degree of applicability of graded design requirements to these systems.

Preparation of the new standard will mean that systems important to safety, but previously considered "non-safety-related," will receive an appropriate degree of attention.

Safety Analysis Reports

In May 1980, the NRC published a rule that requires each nuclear power reactor licensee to submit periodically to the NRC revised pages for its Final Safety Analysis Report. These revised pages must indicate changes made to reflect information and analyses submitted to the NRC or prepared as a result of NRC requirements. This will result in an up-to-date reference document for use in recurring safety analyses performed by the licensee, the NRC, and other interested parties.

Reporting Defects and Noncompliances

The rule (10 CFR Part 21) requiring certain individuals to report to NRC defects that could create a substantial safety hazard, or failures to comply with regulations relating to substantial safety hazards, was amended in October 1979 to exclude commercial grade items from the scope of the rule until they are dedicated for a nuclear use. The Natural Resources Defense Council, Inc., has challenged the rule on various grounds in the United States Court of Appeals for the District of Columbia (Case 80-1328). The NRC brief was scheduled to be presented in this matter in October 1980. It is not anticipated that a decision will be rendered during 1980.

FUEL CYCLE PLANT STANDARDS

Decommissioning

Technical studies for the NRC are continuing at the Battelle Pacific Northwest Laboratories (PNL) to develop a decommissioning information base for light-water reactors and other nuclear facilities. This base will be used in developing appropriate regulations and guides. Four PNL reports (NUREG/CR-0569, on designing light-water reactors to facilitate decommissioning; NUREG/CR-0570, on low-level waste burial grounds; NUREG/CR-0772, on boiling water reactors; and NUREG/CR-1481, on financial strategies for nuclear power plant decommissioning) were published during fiscal year 1980. Another PNL report (NUREG/CR-1266, on uranium fuel fabrication plants) was nearing completion at year-end.

These PNL reports are part of a comprehensive reevaluation of NRC policy on decommissioning. Two NRC reports (NUREG-0436 (Revision 1, Supplement 1), on reevaluating NRC policy for decommissioning nuclear facilities, and NUREG-0590

(Revision 2), on regulation changes for decommissioning) were published during the report period. At year-end the staff was completing a major revision of an NRC report, "Draft GEIS on Decommissioning of Nuclear Facilities" (NUREG-0586), and preparation of a draft NRC report (Revision 2 to NUREG-0584, on assuring fund availability for decommissioning nuclear facilities).

Spent Fuel Storage

In November 1980, the NRC issued 10 CFR Part 72, "Licensing Requirements for the Storage of Spent Fuel in an Independent Spent Fuel Storage Installation," as an effective rule. Two contractor reports—NUREG/CR-0956, on the Morris operation, and NUREG/CR-1223, on dry storage of spent fuel—were published during the report period. A draft guide on standard format and content for the safety analysis report for an independent spent fuel storage installation (dry storage) was nearing completion at the end of the fiscal year. (See also Chapter 6.)

Nuclear Criticality Safety

A draft guide on nuclear criticality safety for pipe intersections containing aqueous solutions of enriched uranium nitrate was issued in January 1980, and the active guide was nearing completion at the end of the fiscal year. Also, a draft guide on nuclear criticality control and safety of homogeneous plutonium-uranium fuel mixtures outside reactors was nearing completion.

Plant Safety

A draft guide on standard format and content for the health and safety section of renewal applications for uranium fuel fabrication plants was issued in October 1980. This guide was the first of a group of documents to be developed to provide information for license renewal applications.

Waste Management

Fiscal year 1980 saw substantial standards effort in developing policy, rules, and supporting regulatory guides for the licensing of high-level and low-level radioactive waste management facilities and of uranium recovery operations, focusing on the control of mill tailings. Regulatory development in these areas is discussed in Chapter 8.



NRC is sponsoring a study of lightning characteristics to develop criteria for the design of lightning protection systems at nuclear power facilities. Even indirect lightning flashes close to computers and low-voltage equipment may induce spurious signals and generate unwanted or hazardous operations in systems controlled by such devices at these facilities.

SITING STANDARDS

NRC standards related to siting of nuclear facilities deal with site safety, emergency planning, and environmental considerations.

Site Safety

An important development in 1980 was the Commission's initiation of rulemaking on power reactor siting criteria with publication of an "Advance Notice of Rulemaking; Revision of Reactor Siting Criteria" (45 *Federal Register* 50350) on July 29. The notice discussed the recommendations of the "Report of the Siting Policy Task Force" (NUREG-0625, August 1979) together with some specific alternatives recommended by the NRC staff for consideration in the rulemaking. Public comments were requested on such issues as (1) elimination of the use of plant-specific safety features to compensate for unfavorable site characteristics, (2) whether siting criteria should be nationally uniform or regionally varying, (3) determination of demographic criteria, and (4) protection of power plants from off-site hazards.

Consistent with the fiscal year 1980 NRC Authorization Act, the new siting criteria will not be applied to construction permit applications on file before October 1979, will not preclude further nuclear siting in any region of the country, will be independent of variations in plant design, will specify demographic criteria including population density and distribution for zones surrounding the facility, and will take into account the feasibility of emergency actions in the event of an accidental release of radioactive material.

NRC site safety standards are rules and guides for assessing and mitigating adverse effects associated

with natural events such as earthquakes, floods, and extreme meteorological conditions and man's activities at and near nuclear sites.

In the hydrology area, Errata to Revision 2 to Guide 1.59, on design basis floods for nuclear power plants, was issued in August 1980. Three new ANSI standards which NRC helped develop were also issued: ANS-2.9, "Evaluation of Ground Water Supply for Nuclear Power Sites"; ANS-2.13, "Evaluation of Surface-Water Supplies for Nuclear Power Sites"; and ANS-2.17, "Evaluation of Radionuclide Transport in Ground Water for Nuclear Power Sites."

In the field of meteorology, a proposed Revision 1 to Guide 1.23, on meteorological programs at nuclear power plants, was issued in September 1980. Guide 1.145, on atmospheric dispersion models for potential accident consequence assessments at nuclear power plants, is being revised in response to public comments. NUREG/CR-1389, "Estimating Water Equivalent Snow Depth from Related Meteorological Variables," and NUREG/CR-1390, "Probability Estimates of Temperature Extremes for the Contiguous United States," were published in May 1980. NUREG/CR-1486, "Seasonal Variation of 10-Square-Mile Probable Maximum Precipitation Estimates, United States East of the 105th Meridian," was published in June 1980. Work is continuing on standards on atmospheric transport and dispersion of airborne effluents near structures, extreme windspeeds, extreme snow and ice accumulations, extreme temperatures, and hazards associated with lightning and dust and sand storms. A study of particulate transport, deposition, and resuspension has been initiated.

In the geology and seismology area, NUREG/CR-1621, "A Characterization of Faults in the Appalachian Foldbelt," was issued in October 1980.

Emergency Planning

A major rulemaking to upgrade emergency planning around nuclear power reactors was completed, with a final rule being published in August 1980 (45 *Federal Register* 55402). Major provisions of the final rule include requirements that (1) as a condition of receiving an operating license or continuing operations, applicants/licensees must submit their emergency plans and those of State and local agencies so that NRC can make a finding whether appropriate protective measures can be taken in the event of an emergency, (2) emergency planning considerations must extend to "Emergency Planning Zones," and (3) emergency plans must meet the standards specified in the regulation.

NRC will base its findings with respect to the State and local plans on a review of the Federal Emergency Management Agency (FEMA) findings as to whether they are adequate and capable of being implemented.

In developing the final rule, NRC took into account extensive comments from the public on an advance notice of proposed rulemaking, issued in July 1979, and on a proposed rule, issued in December 1979. Four workshops were held in various parts of the country in January 1980, where additional comments were obtained from State officials and members of the public. The staff analyses of the comments were published in NRC reports NUREG-0628, NUREG/CP-0011, and NUREG-0684. (See also Chapter 3.)

Environmental Protection

Environmental protection standards are concerned with the protection of the public and the environment from both radiological and nonradiological impacts of nuclear facilities. This includes assessment of the environmental impacts, control of effluents, and monitoring around the facilities.

A proposed rule on alternative site reviews of nuclear power plants was issued in April 1980. This rule would provide procedures and performance criteria for considering the National Environmental Policy Act in reviewing alternative sites.

Revision 1 to Guide 4.14, on radiological effluent and environmental monitoring at uranium mills, was published in April 1980, along with an associated report (NUREG/CR-1253) on measurement of background radiation around uranium mills.

Efforts continued in the areas of decommissioning nuclear facilities and disposal of radioactive waste. A final regulation was published to delete Section 20.304 of 10 CFR Part 20, which previously allowed



Representatives from NRC and FEMA, as well as from the Commonwealth of Virginia, joined in observing the day-long emergency preparedness exercise at the North Anna Nuclear Power Plant in Louisa County, Va. The exercise was required by NRC prior to issuance of an operating license for Unit 2.

licensees to bury small quantities of radionuclides without notifying NRC. Also published was a report on decommissioning, "Residual Radioactive Limits for Decommissioning" (NUREG-0613).

A substantive effort was devoted to environmental aspects of siting and emergency planning in support of the rulemaking activities described previously.

Interagency Coordination. Several aspects of siting and environmental protection involve close coordination with other Federal agencies.

Emergency planning involves close coordination with the FEMA. In January 1980, FEMA and NRC jointly published criteria for emergency plans (NUREG-0654) which were incorporated into the final emergency planning rule, published in August. NRC and FEMA will continue to work closely on emergency planning matters. (See Chapter 3.)

NRC has the responsibility for implementing both the Environmental Protection Agency's (EPA) guidance and generally applicable environmental standards for protection against radiation. During 1977, EPA published standards (40 CFR Part 190) that limit releases of radioactive material and resulting doses to the public from the operation of various nuclear facilities associated with the uranium fuel cycle. In April 1980, NRC published proposed regulations implementing 40 CFR Part 190 which were expected to be issued in final form late in 1980.

The Clean Air Act Amendments of 1977 include provisions for EPA to develop emission standards for radioactive materials from NRC-licensed facilities. As required by the Act, NRC and EPA staffs developed an agreement to minimize duplication of effort which was approved by the Commission in June 1980, and by EPA in October.

RADIOLOGICAL HEALTH STANDARDS

Low-Level Radiation Effects

The Epidemiology/Feasibility Planning Study, mandated by Public Law 95-601, was completed during the report period. It identifies the options for Federal epidemiology research and assesses the feasibility of these options. An interim progress report (NUREG/CR-1174) and the final report (NUREG/CR-1728) were issued during fiscal 1980.

NRC staff continued to participate in activities of the National Institutes of Health (NIH) Subcommittee on Proposed Studies at the Three Mile Island Nuclear Station and to provide information on radiation levels and doses received by persons at the site. NRC staff members also assisted the parent NIH-Interagency Committee on Radiation Research.

Significant progress was made in developing a TMI Radiation Worker Registry, initiated in 1979 in cooperation with the National Institute for Occupational Safety and Health (NIOSH). Continued progress is threatened by the licensee's financial problems. Work also progressed toward establishing an industry-wide radiation worker registry. These registries would contain information that would facilitate future radiation epidemiology studies.

A contract with Argonne National Laboratory to reanalyze a portion of the Tri-State Leukemia Study Data nears completion. The latest analyses of these data indicate serious flaws in controversial studies that estimated low-level radiation health effects based on the data from the study of patients in New York, Maryland, and Minnesota.

An advance notice of proposed rulemaking was published in an NRC effort to completely update and revise 10 CFR Part 20, NRC's principal radiation protection standards. Public comments have been reviewed and will be taken into account in considering occupational and general population radiation protection.

The NRC staff is participating in the activities of both the Radiation Policy Council, established by Executive Order on February 21, 1980, to coordinate Federal efforts in radiation protection, and the Interagency Radiation Research Committee, established by Executive Memorandum on the same date to coordinate Federal radiation research strategy. These bodies were established in response to recommendations of the Interagency Task Force on Ionizing Radiation Research to (1) improve the coordination of Federal research programs, (2) conduct a comprehensive review of these programs, and (3) establish a comprehensive program of research into the biological effects of low-level ionizing radiation.

The National Academy of Sciences Committee on

the Biological Effects of Ionizing Radiation (BEIR) published its third report (BEIR-III) in August 1980. Risk estimators published in the BEIR-I report of 1972 have been used for the NRC base to quantify the potential impacts of licensed activities that result in the exposure of humans to radiation. The BEIR-III report reevaluates the risk estimators used to predict potential health effects from exposures to low levels of x, beta, or gamma radiation. The NRC staff performed a preliminary review of the BEIR-III report to identify possible impacts on NRC regulatory actions. Perhaps the most important change in BEIR-III is the recommendation of a linear-quadratic model to express the relationship between low-level gamma whole-body exposures and radiation-induced cancers. Previously, a linear relationship had been recommended. Numerical changes in the risk estimators do not appear to be sufficient to warrant substantial changes in the methods used by the NRC staff to estimate health risks.

Nuclear Medicine

In fiscal year 1980, the NRC issued a final rule on medical misadministrations that requires the reporting to the NRC, and in certain instances to the patient, of diagnostic and therapeutic misadministrations in the medical use of NRC-licensed materials. Final rules were issued (1) requiring the measurement of a radioactive contaminant, molybdenum-99, in a diagnostic radiopharmaceutical and (2) removing the thorium-containing drug called Thorotrast from the general license category.

Significant progress was made on the preparation of a public information guide on the home care of radioiodine therapy patients and on a rule that would require licensees to measure radiopharmaceutical dosages before administration to patients.

OCCUPATIONAL HEALTH STANDARDS

Reducing Occupational Exposures

The NRC staff has recommended to the Commission an approach for applying the "as low as is reasonably achievable" (ALARA) concept to occupational radiation exposure control. The staff feels that the proposed approach would ensure inspectability and enforceability while avoiding disadvantages associated with strict optimization, i.e., "cost/benefit" determinations.

Under the approach, each affected NRC licensee would be required to develop and implement its own

individualized occupational ALARA program. Following any necessary negotiations between the licensee and the NRC staff, each program would be incorporated into the licensee's license. Accordingly, the program would have the force of a regulation.

The NRC staff's proposed criteria for judging each licensee's program are based on (1) the staff's opinion that, while the majority of the workers in NRC-licensed activities are adequately protected by their employers from radiation, improvements in protection for many other workers are needed and (2) the staff's objective that the radiation protection performance of all NRC licensees should be raised to the level provided by those considered to be the most safety conscious.

The staff has proposed ALARA program evaluation criteria that would require adoption of those safety measures that are known by experience to be both effective and reasonable in cost for specific types of licensees.

Implementing EPA Guidance

EPA was expected to issue for public comment in late 1980 a proposed revision of the radiation protection guidance for occupational exposure that was originally provided to Federal regulatory agencies in May 1960. Staff from NRC and other agencies served on an Interagency Advisory Working Group that made recommendations to EPA during the development of the revised guidance.

The NRC and the Department of Labor's Occupational Safety and Health Administration (OSHA) are expected to co-sponsor public hearings on the draft guidance. Based on comments and the record developed in the public meetings, the NRC and OSHA would then proceed with rulemaking actions to implement the revised guidance.

The guidance that is being developed by EPA is expected to reflect, to a considerable extent, the recommendations that have been set forth by the International Commission on Radiological Protection (ICRP) in ICRP Publication 26. These recommendations are of particular note because they include a procedure for summing the risk from the radiation that a person receives from sources that are deposited inside the body with that from radiation dose from sources outside the body. Such summation has not been previously required by NRC regulations both because of the difficult technical problems involved in establishing and implementing the methodology for summation and because the controls that are normally maintained over those radiation sources that might otherwise be deposited within the body prevent all but a very few individuals from experiencing significant exposure from such sources. When such exposures do occur, special evaluations

are required to take them into account in assessing the risks to any individuals so exposed.

Testing for Personnel Dosimetry

During the report period, the NRC staff continued to work on a program for the certification of firms which process personnel dosimetry devices that are used to measure the radiation dose received by work-

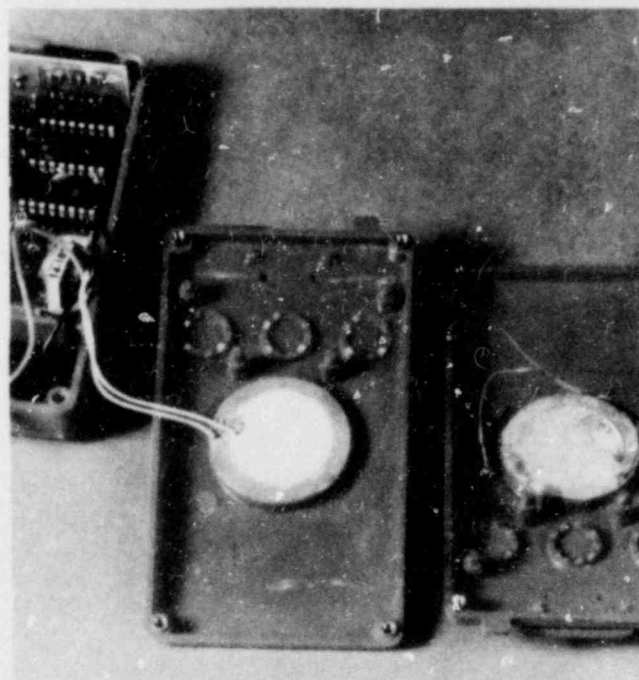
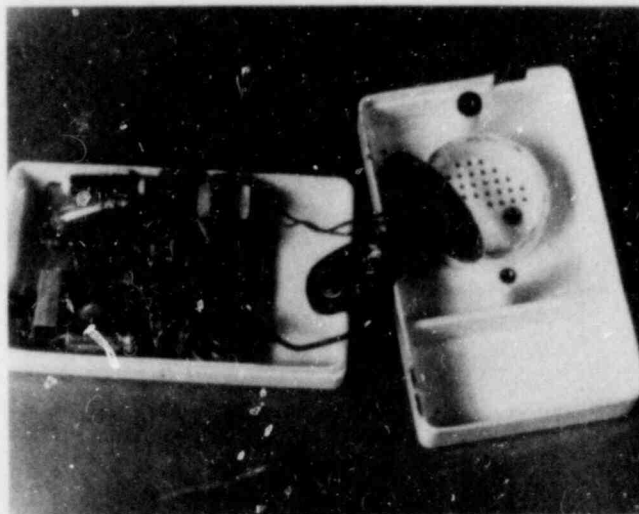

NRC is sponsoring tests of dosimeters which sound an alarm to the worker when high radiation doses are encountered. Upper photo shows dosimeter with a loose speaker caused by water dissolving the glue, and with a disconnected battery lead caused by dropping. Above, a ceramic speaker is shown damaged by dropping.

ers in NRC-licensed facilities. (See 1979 Annual Report, p. 210.) To obtain more accurate processing of dosimeters, the NRC staff is developing a proposed requirement that personnel dosimetry results be accepted only from those processors who shall have successfully passed certain prescribed accuracy tests. The test criteria would be adapted from a consensus standard developed by ANSI.

In March 1980, the NRC published an advance notice of rulemaking on certification of personnel dosimetry processors. The notice listed four alternatives for the operation of testing laboratories: (1) unspecified laboratory, (2) NRC-operated laboratory, (3) NRC-contracted laboratory, or (4) Federal Government (non-NRC)-operated laboratory. The notice invited public comment on how a test and certification program should be established and conducted.

In May 1980, the NRC staff held a two-day public meeting in Washington, D.C., to (1) discuss with processors, and others, methods of improving the consistency and accuracy of dosimetry results, (2) review the advance notice of rulemaking and the identified regulatory alternatives, (3) discuss elements of quality assurance programs, and (4) obtain comments.

The staff plans to conduct a third round of performance testing of dosimetry processors (see 1979 Annual Report for results of first two tests). During this final round, processors' performance would be tested and evaluated using the revised ANSI standard, which would provide the bases for the new amendments of 10 CFR Part 20. The results of a

third round of tests will enable the Commission to select the best criteria for performance testing.

Four reports on performance testing were published during fiscal year 1980: NUREG/CR-1063, NUREG/CR-1064, NUREG/CR-1304, and NUREG/CR-1593.

Industrial Radiography Safety

A petition for rulemaking to have the NRC license individual radiographers is under consideration. The petition states that safety in industrial radiography could be improved by making individual radiographers more directly responsible for their actions.

A safety training manual for industrial radiographers is under development and is scheduled for publication in fiscal year 1981.

Respiratory Protection

The NRC is continuing to develop the information necessary to ensure the adequacy of licensees' respiratory protection programs. In May 1980 the staff circulated an information notice to licensees regarding a recall by NIOSH of certain recirculating-mode self-contained breathing apparatus (SCBA) (Inspection and Enforcement Information Notice 80-19). The NRC staff helped in resolving problems with the use of such apparatus for reentry into the containment building of the damaged Three Mile Island Unit 2 reactor.



Respirator cartridges are tested against radioactive and nonradioactive iodine vapors in this experimental test apparatus at Los Alamos Scientific Laboratory (LASL). It was used to provide information on the use of respirators during early recovery operations after the TMI accident. The numbered sections are (1) airflow and humidity control, (2) radioiodine containment glovebox, (3) gas-chromatograph and methyl iodide samplers, (4) charcoal traps and detectors for radioiodine measurements, and (5) counting electronics and data logging.

A videotape and manual for training respirator users in proper respirator fitting methods, produced under a technical assistance contract with the Los Alamos Scientific Laboratory (LASL), were released for loan to the public in July 1980. Two additional videotapes of this type have been produced—one dealing with acceptable practices for using air-purifying respirators and the other describing acceptable practices for using atmosphere-supplying respirators. These tapes are expected to be made available to the public early in fiscal year 1981 upon completion of accompanying instructional manuals.

LASL continued under research contracts to evaluate respirator performance. Escape respirators and closed-circuit SCBA were tested in fiscal year 1980. Preparations were made to test the effectiveness of respirators under conditions of physiological stress, and work continued on criteria and test methods for certifying air-purifying respirators for use against radioiodines. In January 1980, a report was published on the evaluation and performance of open-circuit SCBA (NUREG/CR-1235). These data, along with additional information from LASL and other sources, will be used to update the NRC's guidance to licensees on acceptable respiratory protection programs.

During the year, NRC staff members participated in NIOSH's meetings on the future course of the national respirator test and certification program and served on the American National Standards Institute's (ANSI) Subcommittee for Respirator Test and Approval, the American Society for Testing Materials' committee for the quantitative fit testing of respirators, and the American Conference of Governmental Industrial Hygienists' respirator committee. LASL and NRC staff members presented a course for health physics recertification on respiratory protection in September 1980.

Personnel Monitoring Reports

In September 1978, the NRC published an amendment to its standards for protection against radiation (10 CFR Part 20) extending to all NRC licensees the requirement for annual statistical summary reports of workers' radiation exposures. Under the previous regulations, only four categories of licensees were required to submit annual statistical summary reports of monitored whole-body exposures, i.e., the number of people in each of 18 prescribed ranges of radiation exposure.

The amendment to 10 CFR Part 20 extended this statistical summary reporting requirement to all NRC specific licensees for a period of 2 years. The NRC staff is evaluating the data for 1978 and 1979 and considering whether to recommend extension or modification of the reporting requirement. The four



In this closed-circuit, self-contained breathing apparatus, air is supplied from the back-carried unit through one of the tubes to the mask. The exhaled air returns through the other tube to the back unit for cleaning, restoration to breathing quality and recirculation. LASL tests such respirators and makes recommendations to the NRC.

categories of licensees previously covered continue to be required to report in any event.

Bioassays

Guide 8.26, on bioassay programs and methods for fission and activation products, was issued in September 1980. For the most part, this guide adopts the recommendations of a recent standard issued by ANSI, which the NRC staff participated in developing. This guide supplements four previous guides that provided general information on acceptable methods in interpreting bioassay results and gave specific guidance on interpreting uranium bioassays.

During the past year, ANSI working group 2.5 of the Health Physics Society's Standards Committee drafted a standard for testing the performance and accuracy of bioassay analytical measurements. The NRC is planning to test this standard by contracting for a laboratory to send out biological samples containing known quantities of specific radionuclides to representative laboratories for analysis. When the results of these analyses are reported, both the performance capabilities at the laboratories and the

acceptability of the draft standard will be evaluated. These evaluations will be followed by the development of a test program to accredit laboratories that carry out bioassay measurements for the evaluation of internal exposures from radionuclides.

Instructing Workers on Radiation Risks

In May 1980, the NRC issued a draft guide on the instruction of workers concerning risks from occupational exposures to radiation. The guide, which is intended to be used during training in protection against radiation, has an appendix that lists a series of questions and answers about radiation risks. The questions were developed in discussions with nuclear workers.

It is expected that providing the workers with the best available information on radiation risks will allow them to make informed decisions concerning acceptance of these risks. Workers' good understanding of and proper respect for these risks provide the potential for improving their safety practices.

Health Protection at Uranium Mills

A memorandum of understanding to ensure consistency of regulatory actions was developed between the NRC and the Mine Safety and Health Administration (MSHA) of the Department of Labor. The Federal Mine Safety and Health Act of 1977 gives MSHA jurisdiction with respect to protection of uranium mill workers similar to that given NRC under the Atomic Energy Act of 1954, as amended. Draft guides on health physics surveys and on keeping occupational exposures as low as is reasonably achievable at uranium mills were published for comment in August 1980. The NRC staff is currently revising its guidance on bioassay at uranium mills. (See 1979 Annual Report, p. 212.)

Worker Exposure to Neutrons

The use of NTA film (a thick, photographic-type emulsion in which neutrons leave tracks) has come into question as an adequate dosimeter for monitoring workers' exposures to neutrons at pressurized-water reactors (PWRs). The NRC has contracted with the Battelle Pacific Northwest Laboratories (PNL) and the Rensselaer Polytechnic Institute (RPI) independently to examine this problem. PNL and RPI are conducting surveys both of the neutron spectra in work spaces at PWRs and of the responses of various types of dosimeters to such neutrons. The results of these studies indicate that NTA film is not an appropriate dosimeter for these neutrons because

it responds poorly to the neutrons of less than 0.7 MeV that constitute nearly all of the neutron dose in PWRs. Albedo dosimeters, which measure neutrons reflected from the body, provide better measurements of these neutron exposures because they exhibit the required sensitivity and respond to neutrons of low energy.

In light of this information, the NRC issued, in March 1980, proposed Revision 2 to Guide 8.14, on personnel neutron dosimeters. One purpose of this revision is to advise licensees of the inadequacy of NTA film for neutron dosimetry for routine operations at nuclear power plants. In revising the guide, NRC staff addressed the "state of technology" in personnel dosimeters for neutrons and provided guidance on acceptable methods for estimating workers' exposures to neutrons.

Radiation Surveys at Manufacturing Plants

Revision 1 to Guide 8.21, on health physics surveys for byproduct material at NRC-licensed processing and manufacturing plants, was issued in October 1979. This guide provides methods and procedures for establishing acceptable radiation survey programs in plants licensed by the NRC to manufacture products that contain or use byproduct radioactive

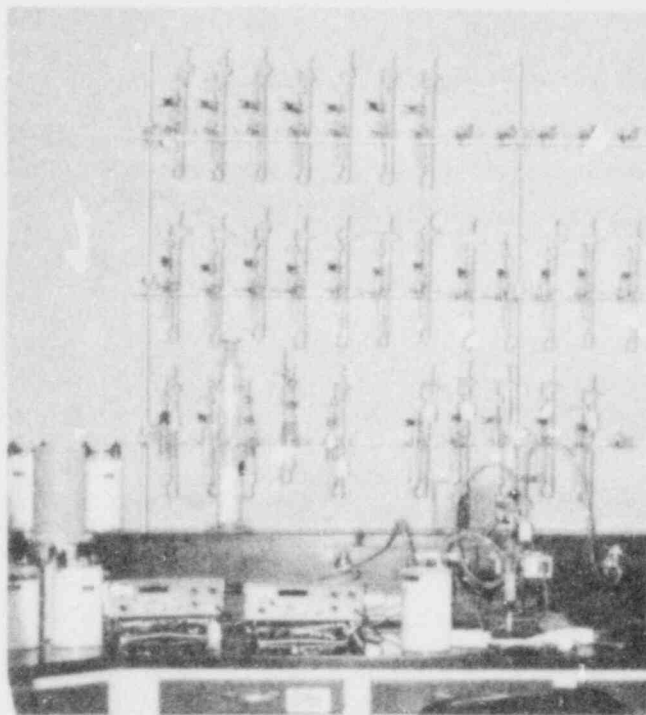

Equipment at the Mineral Exploration Company's Sweetwater Project in Wyoming used to measure the amount of uranium found in the urine of employees.

material. The guide should be useful to more than 1,000 licensees in establishing radiation safety survey programs for maintaining radiation exposures as low as is reasonably achievable.

Conferences During Inspections

In March 1980, the NRC published proposed amendments to its regulations on inspections (10 CFR Part 19) that would codify the existing practice of holding meetings with licensees during inspections. The proposed addition to § 19.14 would allow either the licensee or the NRC to invite workers or consultants to these meetings. It is expected that the provision for increased involvement of workers in discussions of radiological safety will facilitate the resolution of inspection findings.

Calibration of Air Sampling Instruments

In August 1980, Guide 8.25, on acceptable methods of calibrating air sampling instruments to more accurately determine the volume of air sampled, was issued. In addition, a frequency of calibration, an error limit, and documentation are specified. The guide is expected to improve licensees' air monitoring programs and estimates of workers' exposures to airborne radioactive material.

Medical Institutions

During the report period, two guides specific to occupational radiation protection in medical institutions were revised to take into account comments received on, and NRC regulatory experience with, the use of those guides as they were published in draft form in fiscal year 1979: Guide 8.23, on radiation surveys in medical institutions, and Guide 10.8, on medical licensing. Guide 10.8 explains the information to be submitted in an application for a license to use byproduct radioactive materials in diagnostic and therapeutic medical applications, provides a simpler form (NRC-313M) for completing the required entries, and provides acceptable methods and statements related to radiation safety and user qualifications. Revision 1 to Guide 10.8 was issued in October 1980; Revision 1 to Guide 8.23 was scheduled for issuance by year-end.

Guide 8.18 and a companion report (NUREG-0267), issued for comment in January 1978, have provided broad interim guidance and detailed information for establishing acceptable occupational radiation safety programs in medical institutions over the past two years. Since the subject areas of these documents overlap those of Guides 8.23 and 10.8, Guide

8.18 and NUREG-0267 will be revised to take into account public comments and changes in the related guides.

Gamma Irradiators

Guide 10.9 on the preparation of license applications for the use of gamma irradiators was issued in April 1980. It sets forth the information required for NRC review and action. The guide reflects the requirements for irradiators that became effective in 1978. (See 10 CFR Part 20).

SAFEGUARDS STANDARDS

The development of regulations for safeguarding special nuclear material and nuclear fuel cycle facilities against theft, diversion, or sabotage is addressed primarily in Chapter 7. Supporting regulatory guides and reports are discussed below.

Physical Protection

The NRC has developed and issued a number of regulatory guides in support of existing safeguards regulations and of the newly adopted rules for physical protection of special nuclear material (SNM) which are discussed in Chapter 7:

- (1) A draft guide, issued in October 1979, provides a logical scheme for determining when a safeguards event should be reported to the NRC and a partial list of the kinds of events that should be reported.
- (2) Guide 5.59, issued in January 1980, presents the standard format and content that is acceptable to the NRC staff for a licensee's physical security plan for protecting SNM of moderate or low strategic significance.
- (3) Guide 5.60, issued in April 1980, presents the standard format and content that is acceptable to the NRC staff for a licensee's plan for physical protection of strategic special nuclear material in transit.
- (4) Revision 1 to Guide 5.7, issued in May 1980, describes measures acceptable to the NRC staff for implementing entry/exit control requirements for protected areas, vital areas, and material access areas at facilities other than nuclear power plants.
- (5) Revision 1 to Guide 5.14, issued in May 1980, describes measures acceptable to the NRC staff for surveillance or observation of individuals within material access areas in

order to strengthen the safeguarding of strategic special nuclear material.

- (6) Revision 2 to Guide 5.44, issued in May 1980, describes six types of perimeter alarm systems for detecting intrusions into plants that use or process highly enriched uranium, uranium-233, or plutonium. This guide also sets forth criteria that are acceptable to the NRC staff for the systems' performance and use.
- (7) Revision 2 to Guide 5.52, issued in May 1980, presents the standard format and content that is acceptable to the NRC staff of a licensee's plan for the physical protection of strategic special nuclear material at fixed sites (other than nuclear power plants).
- (8) Guide 5.61, issued in June 1980, describes the intent and scope of the physical protection upgrade rule requirements for fixed sites.

In addition, several contractor reports were issued:

- NUREG/CR-0484, "Vehicle Access and Control Planning Document."
- NUREG/CR-0485, "Vehicle Access and Search Training Manual."
- NUREG/CR-0509, "Emergency Power Supplies for Physical Security Systems."
- NUREG/CR-1142, "Remote Response Mechanism."
- NUREG/CR-1327, "Security Lighting Planning Document for Nuclear Fixed Site Facilities."
- NUREG/CR-0543, "Central Alarm Station and Secondary Alarm Station Planning Document."
- NUREG/CR-0508, "Security Communication Systems for Nuclear Fixed Site Facilities."

Material Control and Accounting

The NRC issued two regulatory guides in support of existing requirements and the strengthened regulations being formulated for material control and accounting of SNM, discussed in Chapter 7:

- (1) Revision 1 to Guide 5.58, issued in February 1980, presents conditions and procedural approaches acceptable to the NRC staff for establishing and maintaining traceability of SNM control and accounting measurements.
- (2) Revision 1 to Guide 5.57, issued in June 1980, presents measures acceptable to the NRC staff for shipping and receiving control of strategic special nuclear material.

In addition, several contractor reports were issued:

- NUREG/CR-0772, "Auditing Measurement Control Programs."
- NUREG/CR-1102, "A Systematic Assessment of the Safeguards Regulations."
- NUREG/CR-1214, "The Controllable Unit Approach to Material Control: Application to a High Through-Put Mixed Oxide Process."
- NUREG/CR-0975, "Nondestructive Assay Confirmatory Assessment Experiments: Mixed Oxide."
- NUREG/CR-1017, "Vulnerability Analysis of a Mixed-Oxide Plant."
- NUREG/CR-1446, "Preparation of Working Reference Materials: Uranium Dioxide."
- NUREG/CR-0829, "A Measurement Control Program for Nuclear Material Accounting."
- NUREG/CR-0830, "Monitoring the Random Errors of Nuclear Material Measurements."
- NUREG/CR-1283, "Accounting Systems for Special Nuclear Material Control."
- NUREG/CR-1284, "Methods of Determining and Controlling Bias in Nuclear Material Accounting Measurements."
- NUREG/CR-1445, "Preparation of Working Reference Materials: Calcined Waste Recovery Products Containing Uranium or Plutonium."

RADIOISOTOPES IN INDUSTRY

Thoriated Welding Electrodes

In March 1980, the NRC issued a report on radiation doses from thorium contained in thoriated welding electrodes. The report, NUREG/CR-1039, presents estimates of potential radiation doses to welders and members of the general public during the use, distribution, and disposal of these electrodes. The conclusion that can be drawn from the results presented is that the use of thoriated welding electrodes does not constitute a significant health hazard. The report is one of a series to provide information for the NRC and the public on radiation doses associated with various products containing radioactive materials.

Smoke Detectors

In June 1980, the NRC issued new requirements for the labeling of smoke detectors. An estimated 35,000,000 smoke detectors have been distributed to homeowners and commercial and industrial users. These detectors contain small quantities of radioactive material, usually americium-241. The detectors

are distributed under specific licenses issued by the NRC, and users are exempt from NRC regulations. After January 1, 1981, the distributors will be required to label both the detectors and the boxes used in their retail sale. The new requirements are intended to: (a) inform prospective purchasers and other persons that the detectors contain radioactive material and (b) identify the radioactive material and quantity of radioactivity in each detector.

Contaminated Smelted Alloys

In October 1980, the NRC proposed amendments to exempt from licensing and regulatory requirements technetium-99 and low-enriched uranium (uranium whose isotope content is less than 20 percent uranium-235 by weight) as residual contamination in any smelted alloy. The NRC also proposed requirements for issuing specific licenses to persons desiring to smelt scrap or to initially transfer smelted alloys containing technetium-99 or low-enriched uranium as residual contamination. The exemption would allow the recycling of contaminated equipment and materials in an economic manner that would also conserve resources, rather than requiring the otherwise unnecessary controlled disposal of such contaminated equipment and materials as radioactive wastes.

Well-Logging Sources

A well-logging source is a tool containing radioactive material that can be lowered down a hole to identify the composition of different earth strata. On occasion these sources are irretrievably lost downwell. In 1980, the NRC began an assessment that will determine the risks involved in reopening a well containing an abandoned source with the subsequent release of radioactive material if the source were struck during drilling operations. This assessment will be an improvement over previous efforts in this area since it will examine the probabilities that a given well will be reentered and that an abandoned source will be located and damaged during redrilling operations. An estimate will also be made of the amount and particle size distribution of any radioactive material released to the biosphere. Results of the assessment will be used to determine if regulatory action is required.

Plutonium-Powered Cardiac Pacemakers

In October 1980, the NRC withdrew its 1977 proposed regulations for the routine use of plutonium-238 powered cardiac pacemakers. The proposed regulations would have established (1) general licenses

for the implantation, routine use, and recovery of plutonium-238 powered cardiac pacemakers that have been proved reliable and safe under investigational programs of actual use and (2) the requirements for issuance of specific licenses authorizing distribution of pacemakers for routine use under the general license.

The Commission's decision to withdraw the proposed regulations resulted from technological advances in nonnuclear power sources for pacemakers. These advances have resulted in the development of long-lived conventionally powered pacemakers that satisfy the 10-year design life objective that has been associated with the plutonium-238 powered pacemakers. The availability of the long-lived conventionally powered pacemakers, at a cost substantially less than the cost of the plutonium-238 pacemakers, has caused a reduction in the demand for the plutonium-238 pacemakers. Thus, there was no longer a need for the proposed regulations that were designed to keep track of large numbers of plutonium-238 pacemakers.

The NRC will continue under existing regulations to specifically license the use of plutonium-238 pacemakers. Accordingly, where it is desirable to select a pacemaker with the longest possible life, the patient and the patient's physician will have the option of selecting a plutonium-238 pacemaker.

Licensing Matters

In 1980, the NRC issued for public comment proposed Revision 1 to Guide 10.6 on the preparation of applications for the use of sealed sources and devices for the performance of industrial radiography. The revision addresses comments received on an earlier version of the guide and recent amendments to 10 CFR Part 34.

NATIONAL STANDARDS PROGRAM

The national standards program is conducted under the aegis of the American National Standards Institute (ANSI). ANSI acts as a clearinghouse to coordinate the work of standards development in the private sector.

The NRC staff is active in the national standards program, particularly with respect to setting priorities so that regulatory views are known regarding the standards that can be most useful in protecting the public health and safety. NRC participation is based on the need for national standards to define acceptable ways of implementing the NRC's basic safety regulations.

The actual drafting of standards is done by experts, most of whom are members of the pertinent technical and professional societies. Approximately 250 NRC staff members serve on working groups organized by technical and professional societies. These societies are listed in the accompanying table. National standards are used in the regulatory process only after independent review for suitability by the NRC staff and after public comments on their intended use have been solicited and considered.

IAEA REACTOR SAFETY STANDARDS

NRC has continued its lead role in organizing and carrying out U.S. participation in the IAEA program to develop safety codes of practice and safety guides for nuclear power plants. The NRC coordinates U.S. technical activities associated with this program. The codes and guides will provide a basis for national reg-

ulation by developing countries of the design, construction, and operation of nuclear power plants. NRC staff members continued to represent the United States on the IAEA Senior Advisory Group (SAG) that oversees the program and on the Technical Review Committees working in the five areas of primary interest: governmental organization, siting, design, operation, and quality assurance. The Director of the NRC's Office of Standards Development is the U.S. member of the SAG.

During 1980, the Senior Advisory Group, Technical Review Committees, and working groups under them drafted 4 new guides and completed 11 safety guides that were forwarded to the Director General of the IAEA with the recommendation that they be issued. About 50 of the approximately 58 safety guides planned to date have been drafted and are undergoing review. During the drafting process, the NRC standards staff coordinated the reviews within the U.S., soliciting comments from interested members of the public, industry, and other government agencies. (See also Chapter 11.)

SOCIETIES SPONSORING NUCLEAR STANDARDS DEVELOPMENT ACTIVITIES IN WHICH NRC STAFF MEMBERS PARTICIPATE

| | |
|---|---|
| American Association of Physicists in Medicine | American Welding Society |
| American Concrete Institute | Health Physics Society |
| American Conference of Governmental Industrial Hygienists | Institute of Electrical and Electronics Engineers |
| American Institute of Chemical Engineers | Institute of Nuclear Materials Management |
| American Institute of Steel Construction | Instrument Society of America |
| American Insurance Association | |
| American National Standards Institute | Metals Properties Council |
| American Nuclear Society | National Council of Radiation Protection and Measurements |
| American Society of Civil Engineers | National Fire Protection Association |
| American Society of Mechanical Engineers | National Sanitation Foundation |
| American Society for Nondestructive Testing | Society of Naval Architects and Marine Engineers |
| American Society for Testing and Materials | Welding Research Council |

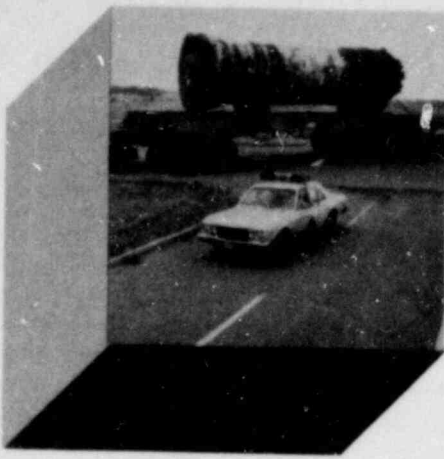

13

Nuclear Regulatory Research

During 1980, the redirection of research priorities generated by the accident at Three Mile Island resulted in new program, resource commitments and the internal organizational changes to accommodate them. As noted in the 1979 Annual Report, tests in loss-of-coolant test facilities such as LOFT and Semiscale, were largely redirected to the study of small breaks, addressing such TMI-related questions as whether reactor coolant pumps should remain running or be shut off during such transients. The Commission began looking at ways to better utilize the LOFT facility. Other facilities were being modified to conduct transient simulations of the late phases of LOCAs. Still other 1980 activities were geared to support NRC rulemakings, including one on degraded core cooling, to analyze new severe accident sequences and to assess health and other socioeconomic effects of severe accidents.

The importance of probabilistic risk assessment in providing information needed for licensing decisions led to the establishment of a new research division to evaluate a wide range of possible accident sequences and to develop improved reliability models for operating reactors. The first phase of the Interim Reliability Evaluation Program (IREP), which addressed the Crystal River plant, neared completion late in the year. Phase II of that program, initiated in September, will see the procedures developed in Phase I applied to four additional operating nuclear plants.

Code assessment and application work was directed largely toward the acquisition of new information on the progression and consequence of severe core damage in reactor and containment systems.

Increased attention was given to reactor operator qualification and training and to new evaluations of operators using reactor simulators. Similarly, evaluating the ability of instrumentation and electrical

equipment to withstand accident conditions was subjected to new scrutiny.

In fuel cycle and environmental research, new programs were initiated to improve the basis for evaluating consequences of major accidents in fuel cycle facilities, including fires, explosions, tornadoes, criticalities and equipment failures. Radiobiological research, to assist in emergency preparedness planning by assessing the consequences of radioiodine releases associated with reactor accidents. Increased emphasis was placed on research studying socioeconomic impacts of accidents on populations and environments.

Waste management research centered around transportation and storage, types of shipping containers, siting of disposal facilities and control of radioactive releases at disposal sites.

The sections of this chapter which follow describe, in some detail, these 1980 initiatives and changes, as well as NRC's many ongoing "workhorse" research programs to improve the safety of nuclear energy application, and efficiency of the licensing process.

Water Reactor Safety Research

SYSTEMS ENGINEERING

Systems engineering research provides integral-systems and separate effects experimental data as part of NRC's regulatory research support for the reactor licensing effort. Specific activities under these two experimental programs are discussed below.

Semiscale Mod-2A System

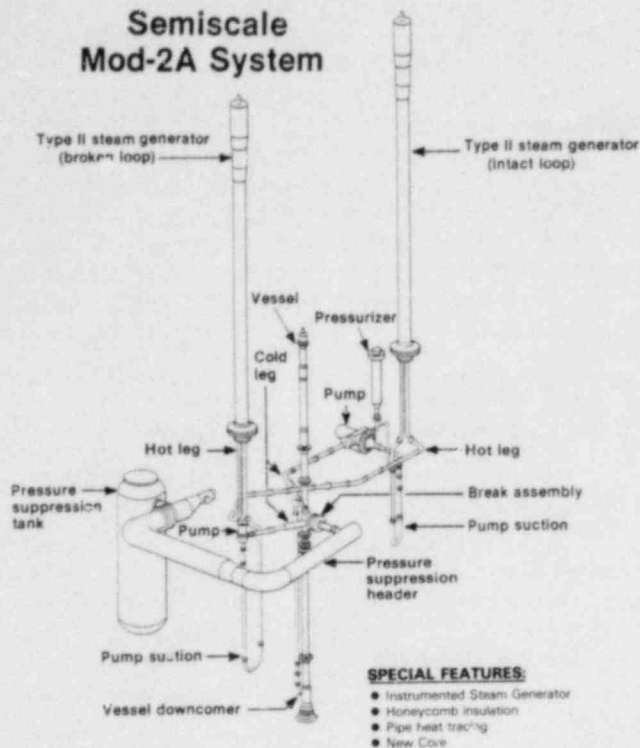

The Semiscale facility, a small-scale experimental system, is used to investigate the thermal and hydraulic processes expected to occur in a full-sized pressurized water reactor (PWR). To better simulate PWR activities, the facility has been reconfigured several times. In the Mod-2A system at the Idaho National Engineering Laboratory, the system components and subcomponents are arranged and scaled to assure proper liquid volume in the primary and secondary systems and are designed to control heat gain or loss. The components in the Mod-2A System are fully comparable in height and scale to those of a commercial Westinghouse reactor.

Integral Systems Tests

Loss-of-Fluid-Test (LOFT) Program. The LOFT program began as a program to provide experimental information to assess the analytical models used to evaluate the safety of commercial reactors and their emergency core cooling systems. LOFT has since been expanded to include the study of methods of controlling off-normal transients, of instrumentation for use in commercial reactors, and of diagnostic systems to aid reactor operators. Significant LOFT events in 1980 included five small-break accident tests involving loss of normal feedwater to help answer questions related to the small-break accident at Three Mile Island.

The first three small-break experiments were initiated in the same manner as earlier large-break loss-of-coolant (LOCA) experiments, that is, with the quick opening of blowdown valves representing a broken loop of a commercial reactor. The other two tests, initiated by opening valves in a pipe represent-

ing the intact loop of a commercial reactor, were designed to investigate the roles of reactor coolant pumps during the course of a small-break accident. One of the concerns raised by the Three Mile Island accident was whether the pumps should be stopped or allowed to continue operating in such cases. At the end of the year, the results from these experiments were being evaluated, not only as to phenomena revealed, but also against predictions of the tests required of the manufacturers of commercial reactors. The tests are revealing new information about TMI-type accidents and may suggest operator actions that would mitigate their consequences, largely due to improved control-room diagnostic instruments.

Representatives from Austria, the Federal Republic of Germany, Japan, the Netherlands, Switzerland, and Scandinavia continued to actively participate in the LOFT program.

Semiscale. The Semiscale test facility, initially assembled in the 1960's as a small, single-loop system containing simulated reactor components, has been reconfigured several times—each time with added detail to permit better simulation of PWR characteristics. Semiscale now consists of a pressure vessel with complete internals; an intact loop with an active steam generator, pump, and pressurizer; a broken loop with an active steam generator, pump, and rupture assembly; a pressure suppression system with a suppression tank, heater, and steam supply system; coolant injection accumulators for the intact and broken loop cold legs and an accumulator for the intact loop hot leg; and high and low pressure injection pumps for each loop. All major components and subcomponents are full height compared to a commercial Westinghouse reactor. The pressure vessel consists of an upper head that allows upper-head coolant injection, an upper plenum, a heated core region, a lower plenum and an external downcomer pipe and inlet annulus. The reactor core is simulated by an electrically heated core containing 25 heater rods. Total core power is two megawatts.

During 1980, Semiscale was used to:

- conduct LOFT counterpart tests to assist in the evaluation of scaling criteria and of behavior for small breaks. Semiscale provided good prediction of LOFT behavior, and differences from LOFT geometry did not significantly affect test results.
- conduct small-break audit tests to provide data needed to evaluate vendor and NRC small-break calculations. Qualitative behavior was predicted by the codes, and quantitative differences were identified and evaluated from the Semiscale tests.
- test Semiscale behavior in a variety of coolant-pump operating and shutdown conditions to pro-

vide a data base for use in resolving pump on/off issues in licensing reviews. The tests showed that continued pump operation caused less mass depletion in the cold-leg breaks, greater mass depletion in hot-leg breaks and that hot-leg breaks were less severe than cold-leg breaks. No data was found which dictated a change in the NRC requirements for pump operation during small-break accidents.

- perform preliminary station blackout tests. Information was obtained concerning facility behavior and the time required for the core to become uncovered.
- provide data for the U.S. and International Standard Problem Programs, formulated to help measure the ability of vendor and other codes to predict large and small break transients. A Semiscale experiment (S-07-10) provided the data-base for the comparison.
- determine and assess scaling criteria for small-break LOCAs. These experiments in Semiscale have shown that heat loss from the surface has been the most significant scaling problem, but the overall phenomena and timing of events during the transient are preserved. The heat loss problem was addressed in the hardware changes initiated at the end of the year.

The 1981 Semiscale program plan includes significant hardware changes to improve the facility. These will be designed to reduce heat loss, improve pump scaling, improve instrumentation, and, in general, to provide more representative behavior during small-break and transient tests in the facility. The test plan includes evaluations of natural convection in two phases (with and without inert gas); small break studies with and without upper head injection (UHI); simulation of the June 1980 St. Lucie shutdown transient, and initiation of transient test series, including further station blackout studies.

Separate Effects Experiments

Two-Loop Test Apparatus (TLTA). The TLTA, a scale model of a boiling water reactor featuring one full-size electrically simulated fuel bundle, is jointly sponsored by NRC, the Electric Power Research Institute (EPRI), and General Electric (GE). Since 1976, TLTA programs have evolved from separate effects heat transfer tests investigating the blowdown phase of a LOCA, to simulations of blowdown and coolant injection phases, as well as the early reflood phase. Thus, it now nearly qualifies as an integral systems test facility.

Testing completed in 1980 continued to show effective cooling of the bundle by emergency

coolants during the blowdown phase, and generally earlier bundle reflood than expected. Two small break tests produced data used to evaluate the calculation methods employed by BWR vendors to specify operator actions during small break accidents. Separate effects tests of heat transfer during periods when the bundle is uncovered were also conducted. At the end of the period, consideration was being given to upgrading the TLTA to permit better simulation of small break and other non-LOCA accidents and transients.

Steam-Water Mixing Tests. The effects of steam-water mixing on the penetration of core cooling water in models of PWR vessels have been studied for six years in the small 1/15 and 2/15 scale models at Battelle Columbus Laboratories in Ohio and at Creare, Inc. in New Hampshire. Final modeling, data analysis, and limited testing in a new 1/5 scale vessel were completed in 1980. Results continued to confirm the conservatism of models used in the licensing process, and to facilitate the planning and analysis of Upper Plenum Test Facility experiments in Germany. No additional work is planned in 1981 except documentation of results. (See "2D/3D Program" under "Research Support," later in this chapter.)

BWR Counter Current Flow Limit (CCFL) Refill/Reflood Program. This joint NRC, Electric Power Research Institute (EPRI), and General Electric Co. (GE) research program involves the Steam Sector Test Facility (SSTF), which is a full-scale model of a 30-degree sector of a boiling water reactor upper plenum. The purpose of the program is to investigate the distribution and penetration of cooling water sprayed over a core. (The penetration of cooling water into the core during high steam flow upwards through the core is called "counter current flow limit," or CCFL.) The parameters affecting CCFL are among the things being investigated in SSTF. To study spray cooling phenomena, a single heated rod bundle, a low-pressure version of the TLTA, discussed above. At year's end, the facility was being modified to conduct simulations of the late phases of a BWR LOCA transient. The modeling effort included in this program produced models for use in the first BWR version of the TRAC code. (See "Computer Code Improvements, Assessments and Applications.")

FLECHT-SEASET.* This NRC/Westinghouse/EPRI research program involves two major tasks and the facilities to investigate the reflood portion of a LOCA transient. Reflood heat transfer data is used in

*Full Length Emergency Cooling Heat Transfer Separate Effects and System Effects Tests.

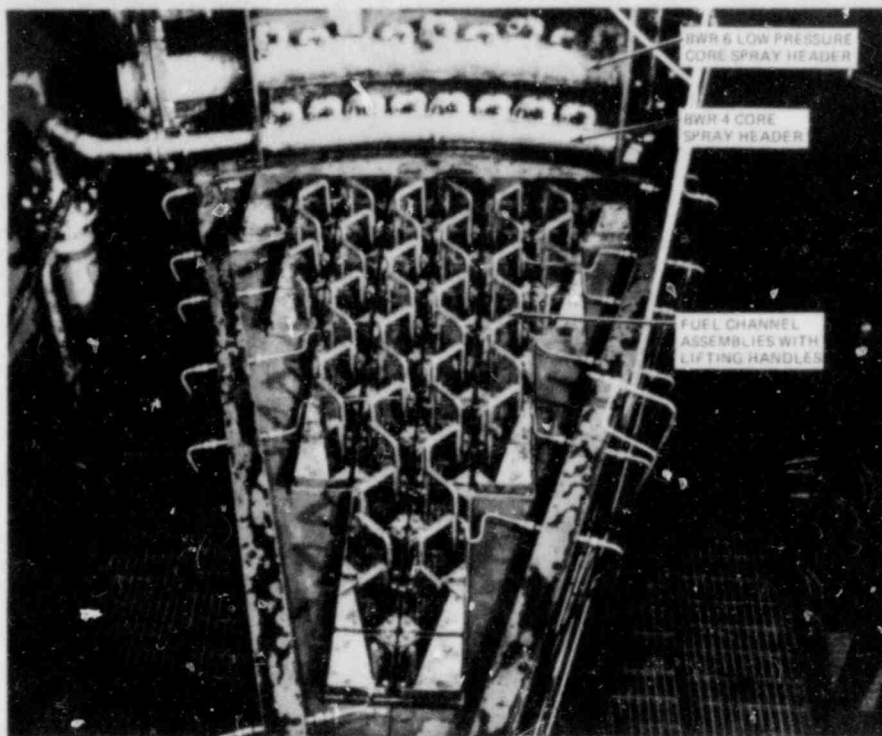

An important feature of the Sector Steam Test Facility in Lynn, Mass., is a full-scale model of a 30-degree sector of a boiling water reactor upper plenum. Experiments with this sector, which is shown here from the center of the core looking down and outward, include investigations of the distribution of cooling water sprayed over the top of a core and how the cooling water penetrates fuel bundles.

vendor licensing computer models, and reflood experiments are performed on bundles with flow blockage. Both tasks are in response to the requirements of 10 CFR Part 50, Appendix K. A 21-rod blocked-bundle test to study the flow blockage effort was in progress at the end of the period, with the planned use of significant blockage geometry from that test in 161-rod blocked bundle investigations of bypass and blockage effects. Construction of the test facility has begun. Also during the period, design was completed and construction begun on the Systems Effects Test facility, using a full-size 17 X 17 bundle with well-instrumented steam generators and other system components. These systems tests will include examinations of heat-transfer behavior during reflood, and single and two-phase flow natural circulation tests.

PWR Blowdown Heat Transfer (BDHT). As noted in the 1979 NRC Annual Report, the PWR-BDHT program was redirected after the Three Mile Island accident to experiments investigating uncovered bundle heat transfer in small-break accidents and to bring large LOCA-related experiments to conclusion. Some highlights in 1980 included high pressure (600-1200 psia) boiloff and reflood experiments, concluded in October, and experiments on heat transfer under transient blowdown conditions, concluded in August. Test data and analyses will be reported in 1981. Preliminary find-

more slowly than bundle refilling, and that cladding temperatures start to decrease as the bundle fills with water. These and other findings reported in 1980 are available in technical reports on the PWR blowdown heat transfer program.

Model Development. NRC research includes studies, using small-scale test facilities, of thermal-hydraulic LOCA phenomena. The object of each test is to provide accurate data for the development of the best-estimate models used in the safety codes that predict the thermal-hydraulics of postulated commercial reactor accidents.

Instrumentation Development. Since TMI, instrumentation for power plants has received increased attention. In 1980, liquid level indicators were developed and tested, and reactor vendors were contacted regarding the installation of these devices. In addition NRC began making arrangements with vendors to test vendor-developed liquid level indicators in NRC facilities such as TLTA and Semiscale. Other efforts for power plant application include instruments for detecting flow in the steam generators.

Most of the advanced instrumentation developed for NRC research programs reached the application stage in 1980. Argonne National Laboratory's Pulse Neutron Activation technique was applied to small-break, slow-flow natural circulation tests at the PKL test facility in Germany, and proved feasible for measuring low-speed liquid flow. A superheat probe, developed at Lehigh University, proved reliable for

measuring the temperature of "dry" (superheated) steam. The Laser Doppler technique, developed at SUNY-Stony Brook, has been used to measure liquid and vapor data which are important in instrument development for the international 2D/3D program. Holography has been used by Northwestern University to study condensation phenomena around core spray in more detail.

2D/3D Program. The NRC participates in the 2D/3D joint research program with Japan and Germany to study PWR reflood and refill during large- and small-break LOCAs, natural circulation, and blocked bundle behavior. NRC provides advanced instrumentation and analyses for these integral systems test facilities in Japan and Germany.

Small-break LOCA and natural circulation tests, based on 3D program recommendations in 1979, were conducted in the PKL Systems Effects Test (SET) Facility in Germany. Results show that a PWR can be adequately cooled by natural circulation of the primary system with steam content up to 28 percent. At higher percentages of steam, the circulation changes to a mode in which steam is condensed in the steam generators and the condensate drains back to the reactor vessel. Steam content up to 58 percent was covered in the test series, and even at these high percentages, the core was adequately cooled.

Preliminary analyses of large-break LOCA refill and reflood tests, conducted as part of the JAERI 3D program at the Japanese Cylindrical Core I Test Facility (CCTF), showed that the formation of steam did not restrict water flow during reflood even though liquid carried over into the outlet pipes, or "hot legs," and was vaporized in the steam generators. Also, the data show that a significant part of the water leaving the core was separated out in the upper plenum, leading to pool formation, fall-back of water into the core, and top-quenching of the fuel rods. Some of the coolant water injected into the cold leg did bypass the core, but not a significant amount.

A 2000-rod, two-dimensional (radial and axial) full-scale Japanese Slab Core I Test Facility (SCTF) is being constructed under the 3D program in Japan, and blocked bundle tests simulating a damaged core will be performed in 1981.

Under the 2D/3D program, a large number of two-phase flow instruments have been developed and fabricated for the JAERI and FRG test facilities. The Oak Ridge National Laboratory (ORNL) has developed small electrical probes for measuring velocity, film flow, and steam voids within the experimental core bundle and vessel. A unique drag-body design using a fuel element tie plate has also been developed and tested at ORNL. EG&G, Inc. has developed a new fluid distribution grid employing an



A series of reflooding experiments was completed in a joint NRC/Westinghouse/EPRI research program at the Full Length Emergency Cooling Heat Transfer facility to provide data on the amount of heat transferred from 12-foot-long fuel rods arranged to simulate a portion of a fuel rod array. This photo shows a 161-rod unblocked bundle which was used to investigate blockage geometry to allow comparisons with the core blockage data from the Cylindrical Core Test Facility in Japan.

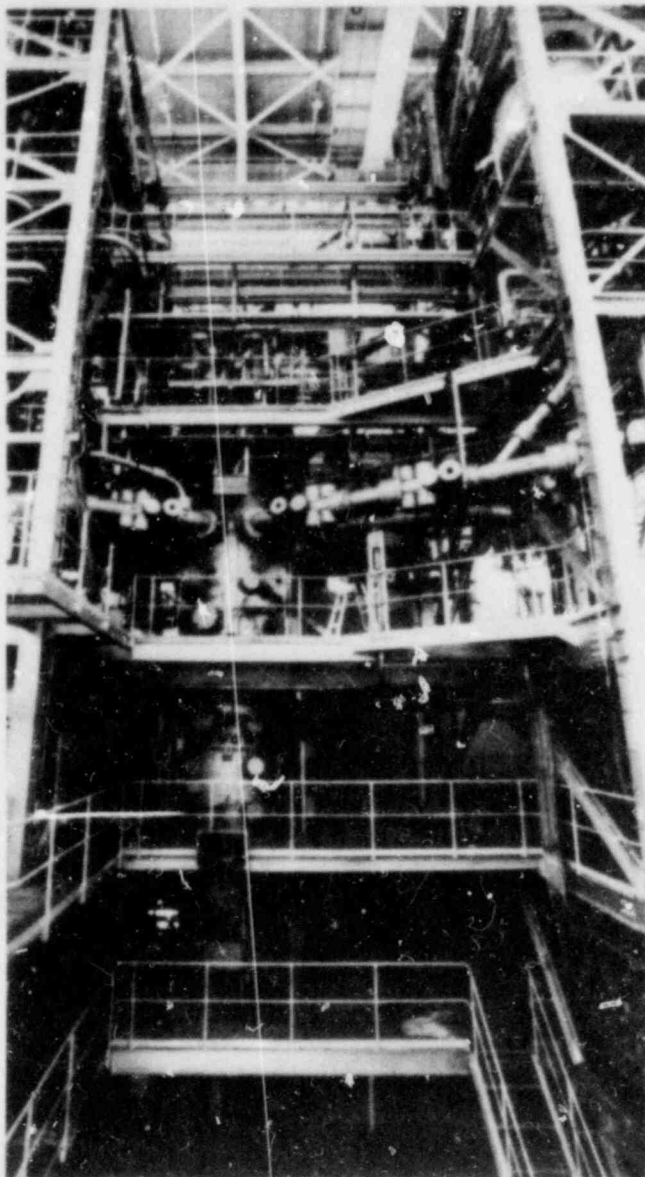

The Japanese Cylindrical Core Test Facility (CCTF) at the Japan Atomic Energy Research Institute (JAERI), Tokai, Japan, was built for PWR LOCA refill and reflood research and is being used to support the international 2D/3D test program. The CCTF models the full length and 1/21 of the volume of a large PWR nuclear plant, making it one of the world's largest test facilities for LOCA research.

optical probe and a cooled thermocouple bidirectional velocimeter as well as providing turbine flowmeters, gamma densitometers, drag discs, and conductivity probe liquid level detectors. The Los Alamos Scientific Laboratory (LASL) has developed a video-optical probe using a miniature TV camera for direct visual observation of special interest areas within the test vessel.

Scientists at Los Alamos continued their TRAC computer code calculations to assist JAERI and FRG

in the design of the 2D/3D facilities and provided post-test evaluations of PKL and CCTF test runs.

FUEL BEHAVIOR RESEARCH

This research program provides experimental data needed for the independent assessment of fuel behavior during accidents. Activities in 1980 again included cladding experiments, in-reactor testing, fuel meltdown and fission product transport tests, and fuel code development.

Cladding Experiments

Multirod Burst Test (MRBT) Program. The MRBT program at ORNL delineates the deformation behavior of unirradiated Zircaloy cladding under conditions postulated for loss-of-coolant accidents, and provides data used in assessing geometrical changes in the cladding and the flow channel restrictions that might result. Data from single-rod and multirod experiments include the effects of rod-to-rod interactions on ballooning and rupture behavior. Activities under the MRBT program continued essentially as reported in the 1979 Annual Report.

Accomplishments during 1980 have included new single-rod tests incorporating a heated shroud, the use of new shroud and fuel pin simulator temperature control systems, and the completion of a test with an 8 x 8-rod bundle in which the rods were confined by a reflective shroud. (The outer ring of rods provides both a good thermal boundary and a good deformation boundary for the inner 6 x 6 bundle.) In the latter test, sixty-three of the sixty-four rods burst at temperatures between 754° and 784°C, with a heating rate of 9.8°C/second. The test was conducted under conditions used for an earlier test, so that the effects of bundle size could be evaluated. Flow tests and cross-sectional analyses of bundle deformation are scheduled to be completed in 1981.

Mechanical Properties of Zircaloy. A University of Florida search for a fundamental equation relating true stress, true strain, and true strain rate in tensile deformation bore fruit in 1980 and the resulting equation has been applied to Zircaloy under various conditions and temperatures. At year's end, the equation and its constants (which vary with temperature) were being incorporated in computer code models to allow calculations of fuel rod ballooning and burst strains.

In-pile measurements by ORNL researchers of the creepdown of Zircaloy fuel cladding under typical PWR pressures and temperatures were completed in 1980 at the High Flux Reactor, Petten, The Netherlands. They showed that the creep rates under external pressures (as in real fuel rods) are at least four

times faster than rates calculated earlier from internally pressurized specimens.

The work at Argonne National Laboratory on improved criteria for assessing embrittlement damage to fuel rod cladding was completed in 1980 and published as NUREG/CR-1344. (See p.225, 1979 Annual Report.)

In-Reactor Testing

At the Power Burst Facility (PBF) in Idaho (See 1977 Annual Report, page 154.), experiments continued on possible power reactor accidents involving bursts of power due to control rod ejection, referred to as reactivity initiated accidents (RIA). (See p. 225, 1979 Annual Report.) Early RIA experiments resulted in more fuel swelling and cladding rupture than had been expected, and two subsequent tests, using bundles of fuel rods rather than the single-rod configuration tested earlier, raised questions about the test procedure or configuration that had been used. A 1980 test (RIA I-4), using nine previously irradiated fuel rods in a bundle, showed that the energy insertion limits given in NRC regulation 10 CFR 50 are probably realistic in limiting fuel rod damage. (Insertion limits relate to the sudden withdrawal of control rods.)

Comparisons of the LOCA behavior of unirradiated and irradiated fuel rods tested in the PBF at the end of 1979 (See p. 225, 1979 Annual Report) showed that irradiated rods tend to have more uniform circumferential strain during ballooning than unirradiated ones, and, thus, may produce somewhat larger ballooning strains, although these are not significantly greater than those observed in out-of-pile tests using electrically heated fuel rod simulators.

One of the questions about fuel behavior in a commercial reactor has been what happens to fuel rods when there is a disparity between the amount of power generated locally and the ability of the coolant flow to remove the heat it generates. During 1980, several tests in the PBF were conducted in both single-rod and 9-rod bundle configurations. The results show that the behavior is much more benign than previously thought.

Fuel Behavior Codes

In NRC's Fuel Rod Analysis Program (FRAP), fuel behavior information from the PBF, Halden, and LOFT programs is used in developing and assessing NRC fuel rod analysis codes, FRAPCON and FRAP-T. FRAPCON is used for the steady-state analysis of fuel rod response during normal reactor operation. FRAP-T is used for the transient analysis

of fuel rod response during off-normal reactor conditions. During 1980, models and correlations for the prediction of response to a LOCA were improved, giving FRAP-T a capability to predict, more accurately than before, temperatures, deformation, and possible failure of fuel rods during a LOCA. The NRC staff also used FRAP-T4 in 1979 for a series of non-LOCA fuel rod calculations, and plans to use both FRAP-T6 and FRAPCON-2 in FY 1981 for further fuel behavior studies. A report on the revised library of materials properties needed by the two codes was issued (NUREG/CR-0497, Rev. 1). Both FRAPCON-1 and FRAP-T5 were available at the National Energy Software Center (NESC) for distribution. The new version of FRAPCON (FRAPCON-2), which contains new mechanical and fuel relocation models, was completed and sent to the NESC in September 1980. FRAP-T6, with a new clad-ballooning model, is scheduled for completion in 1981.

Hydrogen Program

The TMI-2 accident highlighted the need for more information on hydrogen generation caused by the reaction of steam with overheated fuel cladding. The result was an investigation of techniques for measuring hydrogen under accident conditions, clarification of the flammability and detonability limits for hydrogen/air/steam mixtures, pressure-time histories of hydrogen combustion events, and on mitigating the effects of hydrogen combustion on safety equipment and containments. By the end of 1980, the program had produced a compendium of information describing the behavior of hydrogen in light water reactor accidents. In 1981, NRC will issue a study of mitigation methods (e.g., deliberate ignition, combustion quenching by Halon or suspended water fog) which could be applied to smaller containment systems. Plans for the future include experimental programs on the combustion properties of hydrogen/steam/air mixtures to help define the threat from hydrogen to containment and safety equipment in accidents.

Fuel Meltdown/Fission Product Release and Transport

Core-Melt Research. During 1980, the new experimental Large-Melt Facility (LMF), capable of melts up to 500 kg, was completed at Sandia Laboratories in New Mexico and began to investigate the consequences of explosive interactions when molten core materials contact water. Testing was initiated in an

intermediate scale (~25kg melt mass), fully instrumented test facility. Results are used to develop models for predicting the efficiency of the conversion of the thermal energy of the molten core into damaging mechanical loads on the reactor vessel and to determine whether steam explosions are credible threats to reactor containments. Related calculations indicate that such explosions are not likely to cause such massive failure of the reactor vessel that it would threaten the containment. However, the generation of small mass missiles, such as control rod drive assemblies, by the explosion might affect the containment.

Work was finished on Version 1 of the advanced computer code (CORCON) which models the phenomena which would occur if molten core material penetrates a reactor vessel and contacts concrete. This code and similar codes developed in the Federal Republic of Germany are used to predict the behavior of large-scale (200 kg melt mass) steel/concrete tests at Sandia Laboratories. The predictions will be compared to determine the adequacy of each code and to indicate where further model development is required.

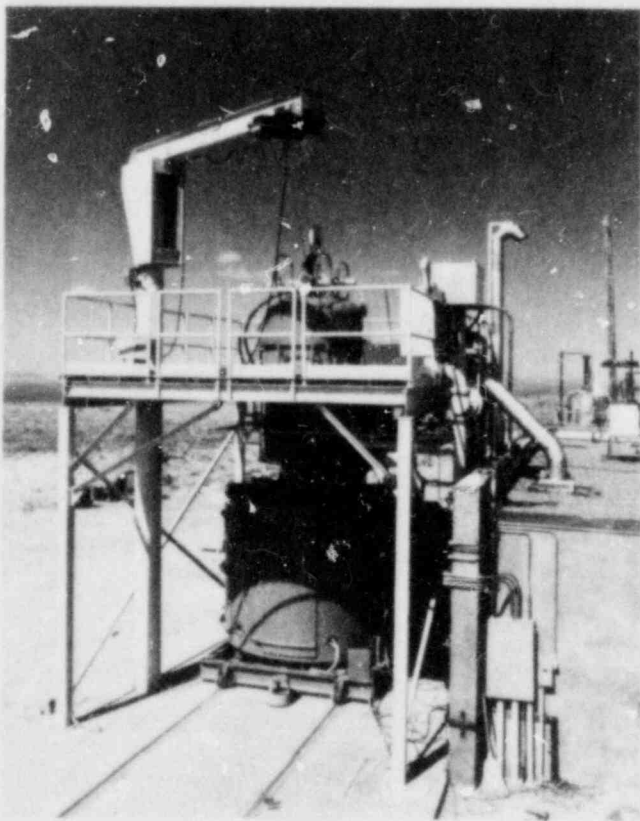

An experimental Large-Melt Facility (LMF) was constructed at Sandia Laboratories in 1980. The new LMF facility, capable of fuel melts of up to 500 kg, is used to investigate the explosive interaction of molten core materials and water.

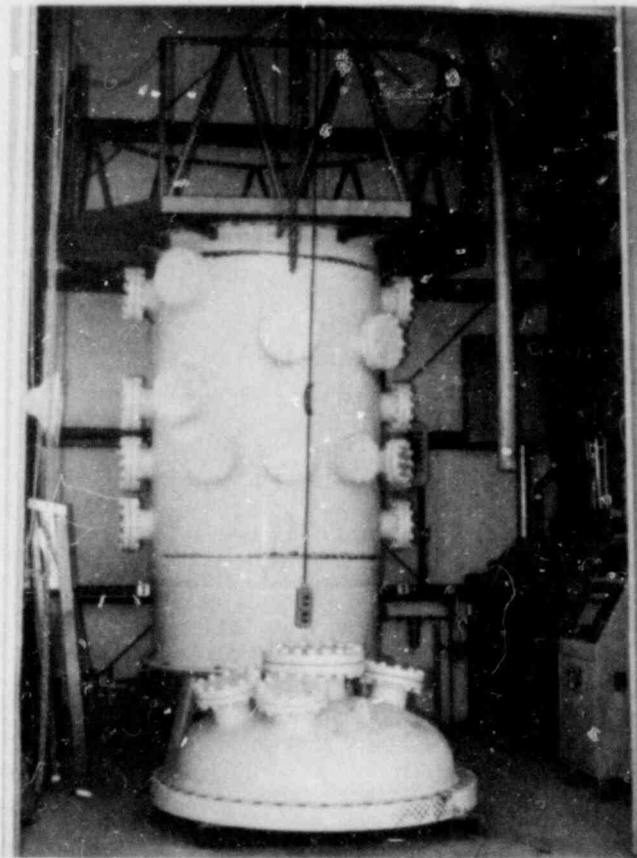

The Sandia Laboratories (N. Mex.) Steam Explosion Fully Instrumented Test chamber is used to assist in developing and validating the TRAP code, now nearing completion. The facility is shown here with the vessel head removed. Just to the right of the vessel is the induction melting power supply. Volume of the vessel is 5640 litres. Its inside diameter is about 1.5 meters. Height to the cat-walk is approximately 12 feet.

Fission Product Release and Transport. NRC programs initiated during 1980 included an investigation at the Naval Research Laboratory of radioiodine retention in activated charcoal filters and experiments at ORNL on the release of fission products in accidents involving core damage and fuel melting. In addition, the program at Battelle Columbus Laboratories (BCL) (see p. 226, 1979 Annual Report) to develop the TRAP-MELT fission product transport computer model was extended for three years, during which BCL will: (1) extend the TRAP-MELT code to predictions of fission product transport in containment buildings and reactor coolant systems, (2) incorporate detailed models for fission product release from the fuel, and (3) recommend experiments to verify the code.

Experimental programs at Sandia Laboratories and at BCL to provide basic data for development of the TRAP code, scheduled for completion next year, are providing key information in such areas as vapor pressures of important fission product chemicals,

deposition rates of fission products and chemical reactions of fission products in transport.

NRC participated in 1980 in the collection of fission product information as part of a joint government/private enterprise effort to evaluate safety data during decontamination and recovery of the TMI-2 plant.

COMPUTER CODES

Best-estimate systems codes, component codes, and evaluation model computer codes provide three basic methods for analyzing nuclear power plant safety. Best-estimate systems codes offer a way to apply the results from reactor safety research programs to evaluations of accidents since their scope encompasses whole-reactor coolant systems. Component codes consider only a specific portion of a reactor coolant system, but in greater detail. Evaluation model codes provide conservative (pessimistic assumptions) analyses for use in independent audits of licensing calculations. All of these, of course, are designed to assist in the resolution of licensing issues, and in 1980 those applications continued to increase as more was learned from the code improvement and assessment programs discussed below.

Code Improvement

RELAP-4/MOD 7, the best member in the RELAP-4 family of best-estimate codes, was completed in 1980 and made available to the public through the National Energy Software Center.

A more advanced code, TRAC-PD2, also completed and released, was a significant improvement over TRAC-PIA in both the code running time and the physical models describing core reflood and quenching. (The letters P and D in the code description stand for detailed (D) analyses of PWR (P) systems.) TRAC-BD1, also an outgrowth of TRAC-PIA, was completed in 1980, and was undergoing checkout at the end of the period prior to its release in 1981.

TRAC-PF1, a very fast-running code for analyses of PWR transients such as small break LOCAs was scheduled for release in 1980 (see p. 228, 1979 Annual Report); however, due to new work initiated in September 1980, its completion is now expected late in 1981. This code is being developed at LASL. Its BWR counterpart (TRAC-BF1), will be developed by INEL.

RELAP-5/MOD 1, a very fast-running, best-estimate code for one-dimensional analysis of PWR

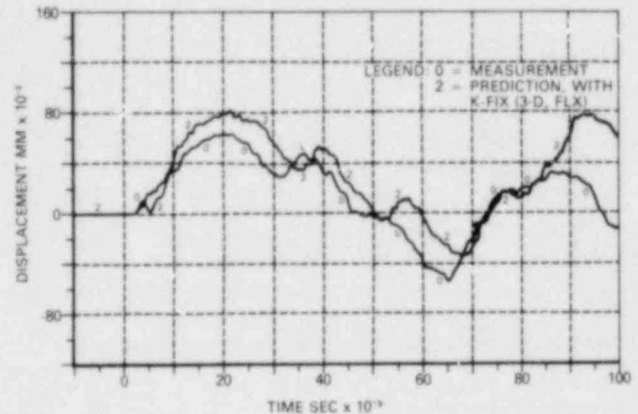

Comparison Between Experiment and Predictions for the Displacement

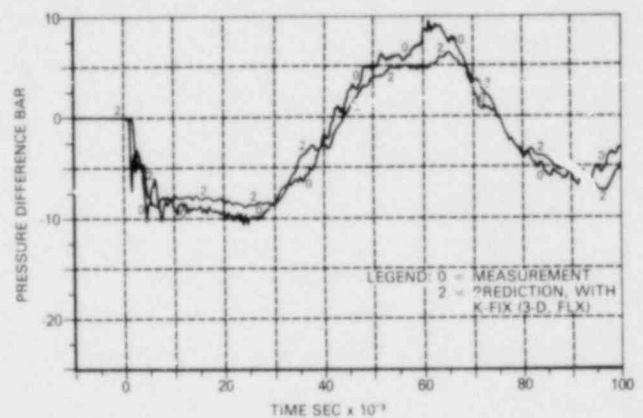

Comparison Between Experiment and Predictions for the Pressure Difference

Component computer codes are used to model the behavior of individual components of a reactor system. The K-FIX(3DFIX) component code developed at the Los Alamos Scientific Laboratory has been used to analyze the fluid-structure interaction on a reactor vessel core barrel immediately following a large pipe break. These diagrams show the differences between code-predicted and experimentally measured core-barrel displacement (above) and internal-external barrel pressure differences on a time scale shown in thousandths of a second.

accidents and transients, was in the checkout stage and slated for public release by the beginning of 1981.

RAMONA-III, (see 1979 Annual Report, p. 228), under systematic checkout during 1980, will be used for analyses of BWR transients involving detailed reactor kinetics effects.

COBRA/TRAC, aimed at analyses of PWR plants featuring upper head injection (see 1979 Annual Report, p. 228), was extensively checked out in 1980, and is expected to be released to the public early in 1981.

Code Assessment

Independent assessments of best-estimate systems codes provide information on the accuracy of predic-

tions of reactor response to various accidents or transients—information that is essential to the evaluation of margins of safety.

In an independent assessment of the TRAC-PIA code, completed in 1980, three DOE national laboratories identified the strengths and weaknesses of the code and the areas which require immediate attention. Improvements introduced in TRAC-PD2 drew heavily from this assessment. Independent assessments in 1981 will focus on TRAC-PD2 and RELAP-5.

Other codes, such as RELAP-4/MOD 7 and RAMONA-III, are assessed in the course of their application to various test predictions and through standard problem exercises developed under NRC sponsorship, or by U.S. industry and foreign governments.

Code Application

TRAC and RELAP-4 were used extensively in 1979 analyzing the TMI-2 incident (See p. 227, 1979 Annual Report). Some of that work continued during 1980. In 1980 TRAC (PIA and PD2 versions) was used in support of 2D/3D research, and both TRAC and RELAP codes were used in the Severe Accident Sequence Analysis (SASA) program, and in research programs at INEL.

RESEARCH SUPPORT

NRC Research Support in 1980 was expanded to accommodate an assessment of operational safety

problems associated with the TMI accident, as well as other operating reactor problems. The effort has been reorganized into Instrumentation, Control and Power Systems research and Operational Safety research.

Instrumentation, Control and Power Systems Research

Qualification Testing Evaluation (QTE). Tests at a new Loss-Of-Coolant QTE test facility at Sandia Laboratories in New Mexico were conducted on commercial nuclear power plant electrical connectors and terminal blocks. Studies defining the amount and types of radiation resulting from a design-basis LOCA were completed and used as a basis for licensing.

The "aging" of safety-related materials was investigated to predict the behavior of materials when exposed to heat and/or radiation. Experiments continued on electrical cables at Sandia laboratories under varying heat/radiation conditions and the effects of dose, dose-rate, and related phenomena were observed for many materials. This effort supports the development of methodologies for predicting the useful life of such materials in combined aging environments. Preliminary guidelines were prepared on the procedures to be used for "aging" experiments.

The evaluation of safety-related equipment from TMI-2 saw the completion of a study of the electrical (low-voltage) breakdown characteristics of terminal blocks during "clean," "humid," and "dirty" test

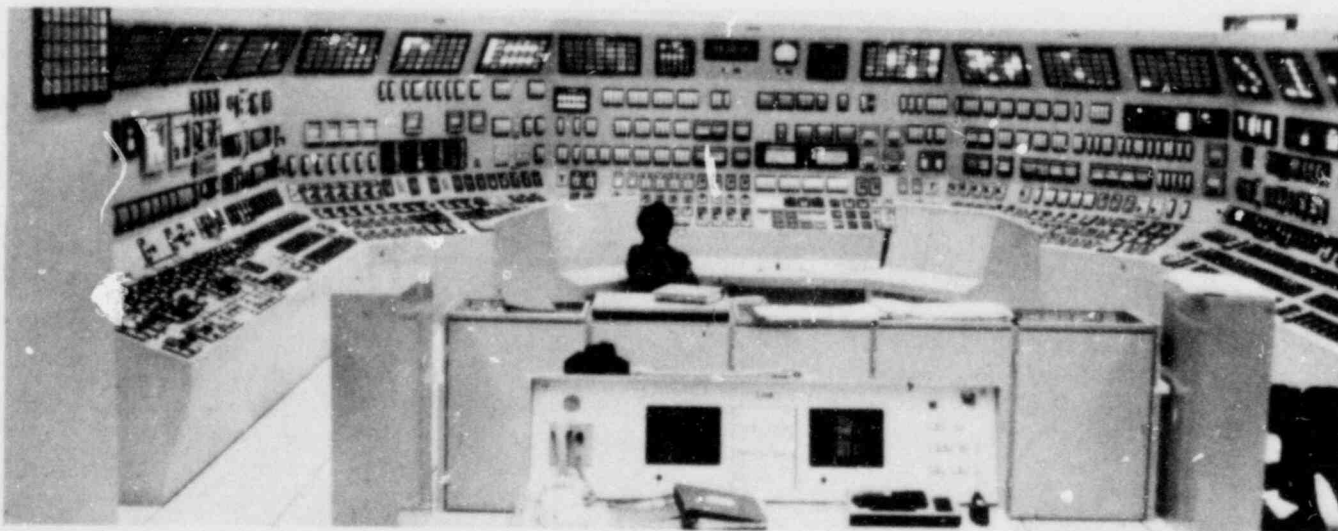

This control room simulator at the Tennessee Valley Authority's Sequoyah plant near Chattanooga is used to study operator time responses in emergencies. Results are correlated

with data from operating PWRs to develop predictive criteria for operator behavior.

conditions. The resulting statistics predict rather large probabilities for breakdown—as much as 10 percent for TMI-like environments and 30 percent for other LOCA environments.

Fire Protection. At the new Fire Suppression Test Facility at Sandia Laboratories in New Mexico, researchers completed check-out tests and initiated full-scale tests to study the effectiveness of Halon as a fire-suppression agent. Early results show it is effective on deep-seated cable tray fires if sufficient soak time is allowed. Tests using water and carbon dioxide were scheduled for 1981.

Plans for other full-scale fire tests involving plant mock-ups were initiated and the first two plants to be visited by NRC and laboratory personnel were selected. Some separate effects tests will be conducted early in 1981. In addition, small-scale floor/wall penetration seal fire tests were run to determine whether such tests can be used to complement full-scale tests.

Surveillance and Noise Diagnostics. Under the NRC research program at Oak Ridge, noise diagnostics techniques were used to correlate graphite block stack movements with temperature fluctuations and neutron signals from the Fort St. Vrain gas-cooled reactor in Colorado. It was possible to confirm that the individual stacks moved at random and infer the predominant direction of the movement.

A computer system for continuous on-line reactor surveillance, using noise diagnostics and pattern recognition, was installed at the Sequoyah Nuclear Power Station to obtain signature data on important PWR safety parameters.

A study was undertaken at ORNL in 1980 to see if the californium-252 source-driven neutron noise detector technique can be used to monitor light-water reactor subcriticality. This method has the potential of monitoring a damaged core when control rods cannot be moved to assure that safe shutdown margins are maintained.

Operational Safety Research

Human Factors. The first phase of a joint Memphis State University/ORNL review of the use of nuclear power plant simulators in operator training produced recommendations to improve simulator training procedures and to increase their use. The second phase of the study, to verify the fidelity of simulation, was initiated toward the end of the year. The control room simulator at TVA's Sequoyah plant was also the site of a study of operator time response during an abnormal occurrence. The study, conducted by General Physics Corporation, used timed action sequence measurements for several operator

crews during training or requalification activity. To correlate simulator results with plant data, Memphis State University began collecting and assessing time response data taken from operating PWR plant logs. Researchers at Oak Ridge will use the data from the two sources for the same malfunction to develop criteria covering operator response times.

Technical Support

Under the Technical Support Program, NRC shares sponsorship with the Department of Energy of the Nuclear Safety Information Center at Oak Ridge in Tennessee, and the National Energy Software Center at Argonne in Illinois.

Nuclear Safety Information Center The Nuclear Safety Information Center (NSIC) provides focal point for safety information on reactors and other nuclear facilities. In addition to the bimonthly review, *Nuclear Safety*, 10 reports were published in 1980. The NSIC provides support to numerous offices in NRC regarding review of Licensee Event Reports. Plants were announced during the year to transfer management responsibility for the NSIC from NRC's Office of Regulatory Research to its new Office for the Analysis and Evaluation of Operational Data at the end of 1981.

National Energy Software Center. The National Energy Software Center (NESC) at Argonne National Laboratory makes NRC-sponsored computer codes available to the public, U.S. government agencies, the Nuclear Energy Agency Data Bank in France, universities, and commercial organizations. On September 30, 1980, the NESC list of software packages available for distribution contained 43 items (codes) specifically sponsored by NRC.

Advanced Technology Safety Research

NRC's Advanced Safety Technology Research Program is an evaluation of the Advanced Reactor Safety Research effort of past years. Its scope covers all reactor types, with the objective of developing and applying advanced reactor safety research technology to problems involving the phenomenology and mitigation of severe accidents. The program focuses on Liquid Metal Fast Breeder reactors (LMFBR's) and

High Temperature Gas-Cooled reactor (HTGR's), and on the coordination of safety research in conjunction with TMI-2 cleanup.

HIGH TEMPERATURE GAS-COOLED REACTORS

Although the President's 1980 and 1981 budgets eliminated funds for gas-cooled reactor research, and plans had been made to curtail or discontinue some projects, Congress identified certain funds and specified that some programs were not to be terminated. Efforts were continued by NRC to allow the orderly termination of activities, and only a cadre of scientific talent was retained toward the possibility of a resumption of research. Under the guidelines for continuing skeletal activities, several programs of importance to the Fort Saint Vrain reactor continued at national laboratories. (See 1979 Annual Report, p. 233). These include metals and graphite programs at Brookhaven National Laboratory, transient analysis and structural evaluations at Los Alamos, systems evaluation and heat transfer testing at Oak Ridge, and development of graphite inspection techniques at Battelle Northwest.

LIQUID METAL FAST BREEDER REACTORS

Work in 1980 under the LMFBR Program consisted mainly of projects in Analysis, Accident Energetics, Aerosol Release and Transport, and Systems Integrity. These are summarized below:

Analysis Program

Argonne National Laboratory completed COMMIX-2, for analyzing reactor components, and BODYFIT-1, for the analysis of fuel rod bundles. Both are transient, three-dimensional thermal hydraulics codes. (See p. 234, 1979 Annual Report and pp. 200 and 201, 1978 Annual Report.) The BIFLO program, developed in 1980, provides a two-dimensional description of transient sodium boiling in an LMFBR subassembly by a code which runs fast enough to be used in calculations of accidents in which the core has melted. This code is now being benchmarked by comparison with more detailed codes such as COMMIX with experimental data such as that derived from the ORNL pin bundle experiments.

Work at Brookhaven National Laboratory continued in 1980 on the Super System Code (SSC), a series of computer codes simulating the thermohydraulic behavior of an entire nuclear power plant, including reactor core and heat-transport systems. The codes are designed to study operational and other system-wide transients, with emphasis on natural circulation events. They can be applied to many potential system designs and provide faster-than-real-time simulations, each version offering a specific set of capabilities.

The structure of SSC is basically a set of building blocks of models/components (e.g., core, pumps, pipes, heat exchangers). How these blocks are interconnected internally and what input one uses are essentially what differentiates one version of SSC from another. Thus, there is much overlap between versions and, to a large extent, any validation effort accomplished on one version of the code is applicable to others.

In addition to the SSC-L code (for loop-type LMFBRs), which has been available for three years, two other versions of SSC became operational during the year. These include SSC-P, applicable to pool-type LMFBRs, and SSC-W, applicable to pressurized water reactor systems. The SSC-L code and supporting documentation have now been made available to eight external users, including two foreign countries (West Germany and Japan). The users, in turn, have provided comments to improve and extend the code's capabilities.

Validation of the SSC in 1980 focused on: (1) pretest predictions of the Fast Flux Test Facility (FFTF) acceptance tests; (2) comparisons between SSC-L and IANUS (a Westinghouse proprietary code for FFTF transients) and (3) comparisons between SSC-L and DEMO (a Westinghouse code for Clinch River Breeder Reactor Project transients).

The Los Alamos Fuel Model (LAFM) has been integrated into a multipin thermal hydraulics computer code. This code system has the unique capability of performing coupled thermal-mechanical and hydraulic analyses in multirod geometry. The combined system represents a substantial improvement in the capability to predict and interpret experiments in which bundles of test fuel are taken to and beyond failure.

At Sandia Laboratories, major improvements to the containment analysis code CONTAIN (see p. 234, 1979 Annual Report) included analyses of aerosol and fission product behavior in containment atmospheres and two-phase thermodynamics and vapor-condensation mechanisms. At year's end,

work was underway to provide state-of-the-art models for molten fuel-concrete and sodium-concrete interactions, and to complete the generalization of the code for water reactors.

Sandia researchers also completed the first phase of an "Accident Delineation Study" which delineates accident sequences in an LMFBR. The next phase will attempt to quantify probabilities associated with various event sequences.

Accident Energetics

Brookhaven National Laboratory, worked on generic thermal-hydraulic technology important in assessing the consequences of severe accidents. Laboratory experiments and analyses were performed on the hydrodynamics and heat transfer, in boiling pools, with internal heat generation, and on liquid streaming and freezing in solid structures. A comprehensive review was issued on the thermal-hydraulic aspects of material motion in a severe LMFBR accident.

At Sandia Laboratories, planning continued for the Sandia Fuel Dynamics program (SANDY) which will use the Annular Core Research Reactor (ACRR) and the Coded Aperture Imaging System (CAIS) fuel motion diagnostics system to examine safety issues in the initiating phase of severe accidents. During 1980, two demonstration tests were successfully completed with the CAIS. The gas-driven flowing sodium loop design for these experiments also was completed.

A series of five experiments was performed in the ACRR to determine whether solid fuel disruption by fission gas release before fuel melting would reduce the energy release, and, hence, the consequences of the accident. Preliminary results of these joint (US-United Kingdom) experiments indicate this does not happen.

Prompt burst energetics experiments in the ACRR test reactor, to examine the mechanical damage potential of accidents in which a core melts and comes apart, supported previous indications that sodium vapor, not fuel vapor, is dominant under these conditions. A series of unique new experiments in the ACRR began during 1980 to examine freezing and streaming of molten fuel in solid structure. This determines whether a "sealed bottle" will form around the molten core during a severe accident—an important factor in determining accident consequences.

Aerosol Release and Transport

Tests were completed using the Nuclear Safety Pilot Plant (NSPP) at Oak Ridge, to scope the behavior of LMFBR nuclear aerosol uranium and

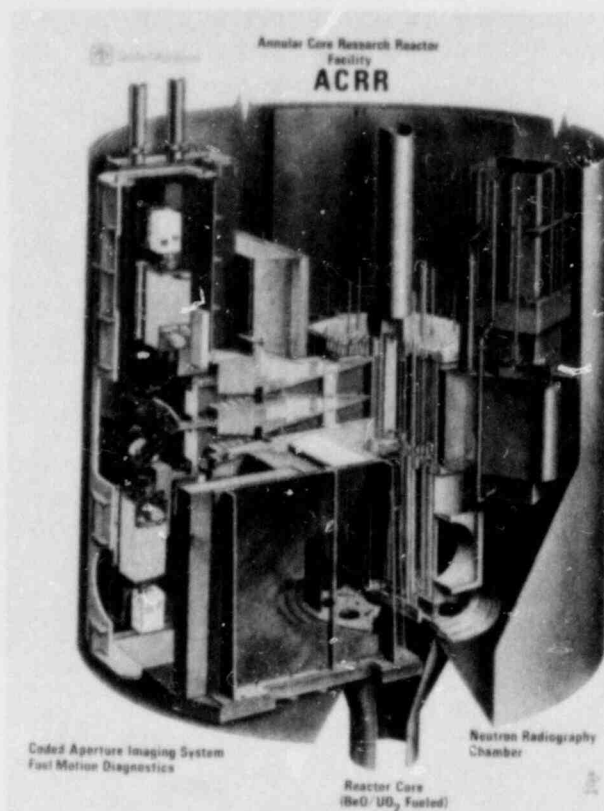

A new-type fuel-motion diagnostics system that uses coded-aperture-imaging of fission gamma rays from the test fuel has been developed and installed in the Annular Core Research Reactor (ACRR) at Sandia Laboratories. This system will be used to measure the motion of failed test fuel under severe accident conditions. Shown in cross section is a severe-accident experiment in the experiment cavity at the center of the ACRR reactor. The coded-aperture-imaging fuel-motion diagnostics system at the left can take pictures of the fuel movement inside the reactor core during a simulated accident.

sodium mixtures in secondary containments. The tests provide a data base for qualification of the HAAI M-3 computer code. HAARM-3 (see p. 235, 1979 Annual Report) is a Battelle Columbus Laboratories/University of Missouri code. As recommended by NRC's Advisory Committee on Reactor Safeguards, NSPP efforts have now been directed toward studies of more generic core-melt-generated aerosols applicable to both LWR and LMFBR reactors.

In another Oak Ridge study, electrical energy was used to produce high temperature, high pressure molten uranium oxide under water to study the transport characteristics under LMFBR-like conditions.

Systems Integrity

The fourth in a series of ACRR experiments on core debris coolability showed that debris beds in

near-boiling sodium dry out at much higher power levels than beds in colder sodium. It appears that cold sodium inhibits the formation of vertical channels in the bed which increase its coolability. Models developed from these ACRR experiments with sodium coolant were applied in TMI and Zion/Indian Point safety analyses.

Tests of molten fuel interactions with concrete to form a basis for validating computer models were conducted at Sandia. Results firmly established the two-stage characteristics of sodium interactions with concrete, and a model of the second stage was developed.

TMI-2 POST-ACCIDENT EXAMINATIONS

Early in 1980, the NRC asked the Department of Energy to cooperate in examining the damaged TMI-2 reactor and facilities during cleanup operations to gather data which may otherwise be lost. The NRC, DOE, the Electric Power Research Institute, and General Public Utilities entered into an agreement to cooperate in postaccident examinations.

The agreement established three principal groups to carry out the activities: a Joint Coordination Group to represent the senior management of each organization, a Technical Working Group of midlevel management personnel to oversee details of technical tasks, and a Technical Integration Office, located at TMI and staffed by DOE, to work with Metropolitan Edison and to contract for data retrieval and dissemination.

Initial planning and some early data gathering were completed in 1980. Cost-significant efforts outside the reactor will begin in 1981, and examinations of primary system internals and fuel will occur in subsequent years. Plans also were laid for international participation during 1981.

The technical tasks are divided as follows:

- Early Containment Penetration and Monitoring
- Instrumentation and Electrical Equipment Survivability
- Fission Product Transport, Deposition and Environmental Description
- Mechanical Components and Reactor Vessel
- Reactor Core Damage Assessment and Removal
- Spent Fuel Packaging, Shipment, Disposal and Examinations

General Reactor Safety Research

SITE SAFETY RESEARCH

NRC's Site Safety Research program is directed toward estimating the effects on nuclear facilities of earthquakes, floods, tornadoes, and other severe phenomena and understanding their distribution; and toward better understanding the meteorology affecting the dispersion of radionuclides in case of accidents.

Geology and Seismology

On July 27, 1980, a magnitude 5.1 earthquake occurred about 50 miles southeast of the Zimmer Nuclear Power Plant about 30 miles from Cincinnati. Within 12 hours, a team of seismologists from the University of Michigan was in the vicinity to record aftershocks, and within 48 hours, 5 groups sponsored by the NRC had installed 15 portable microearthquake seismographs to record aftershocks. A University of Kentucky seismologist coordinated the operation. In one month, more than 30 aftershocks were recorded, including three that could be felt. No damage occurred at the Zimmer plant; although a State of Kentucky seismicity map (USGS MAPMF-1144), indicates the center of the July 27 shock had the highest intensity of any known event within at least 100 km. Instrument records are provided by NRC-supported regional networks.

Other 1980 activities under this program included:

- Initiation of study of the seismological and volcanic hazards of the Pacific Northwest, the volcanic portion under an agreement with U.S. Geological Survey, and the seismological portion through a contractor seismograph network in the northern third of Oregon. The latter network will complement work in the State of Washington in monitoring the eruptions of Mt. St. Helens.
- Completion of a study (NUREG/CR-1217) of the seismic velocity structure beneath central Virginia to improve the capability to accurately locate earthquakes in that region. A preliminary reanalysis of earthquakes in the Giles County area of Virginia shows the earthquakes occurred along a single plane.

Meteorology and Hydrology

Emphasis in NRC meteorology research in 1980 shifted from the simple characterization of severe storms to the study of meteorological dispersion models and monitoring systems to determine atmospheric concentrations of radionuclides under accident conditions. The research involves evaluation of data from past controlled dispersion tests in different thermal stability conditions and terrain types. Significant projects initiated during the year included an evaluation of models for predicting airborne effluent concentrations during emergencies, using standardized data, and a compilation of the types of hardware and software needed for predictions of plume paths and concentrations.

METALLURGY AND MATERIALS RESEARCH

NRC's Metallurgy and Materials Research program may be also called the "Primary System Integrity Program" since it deals with the safety and serviceability of reactor pressure vessels, major piping and steam generator tubing—the components of a reactor's "primary system." The program includes studies of fracture mechanics for piping and pressure vessels, analyses of vessel integrity under heat shock or overpressure conditions and investigations into the whipping and crushing of broken pipes. Other studies involve the effects of radiation and coolant on steam generator tubes, stress corrosion on primary piping, and irradiation-induced loss of steel "toughness." Finally, the program includes studies of inservice inspection techniques to find flaws more easily and reliably, and of methods for continuous monitoring for that purpose. These activities are discussed below.

Fracture Mechanics

Elastic-Plastic Fracture Mechanics. Reactor vessel and piping steels are highly resistant to cracking and fracture, yet cracks do occur, usually caused by stress corrosion cracking and fatigue. Under normal operating conditions and at high temperatures, such cracks will grow slowly at a stable rate. In accidents, however, or when reactor temperatures are low but pressures high, cracks could grow rapidly and abruptly, leading possibly to a break in the vessel or pipes.

Validation of the "tearing instability" method for analyzing the stable cracking concept (See p. 229,

1979 Annual Report) continued in 1980 in tests with specimens several inches thick at the Naval Ship Research and Development Center in Maryland. At year's end the validation was being extended to tests on pipes up to eight inches in diameter. Those tests will be followed by tests on full-size pipes removed from nuclear service, which have large cracks induced by reactor operations.

Thermal Shock. By the end of 1980, the structural testing described in the 1979 annual report (see p. 229) was being completed to validate the analysis methods for the brittle (or fast) fractures which can occur when a vessel is subjected to cold water injection. In the sixth and penultimate test of that series at Oak Ridge, a large-diameter, thick-walled steel cylinder was used to confirm the results of the fifth test, in which the cracking from thermal shock was limited and stopped well short of wall penetration. Because the relation between vessel diameter and thickness, crack length, and test section length, are critically important, a final experiment is planned with a vessel having much thinner walls to more accurately model the effect of flexibility of the wall.

Crack Growth Rate. Despite the cases noted above, cracks usually extend very slowly in the harsh reactor environment, so their growth must be monitored and the cracks repaired when necessary. To gather research data, NRC organized an international cooperative effort on cyclic crack growth rate. Results from NRC-sponsored research at Westinghouse, have provided an experimental basis for revising crack growth rate curves in the 1980 Winter Addendum of the ASME Code, (Section XI, on Inservice Inspection), and those used in licensing estimates of the remaining safe life of a component.

Jet Forces from Broken Pipes. The impact of the water/steam (two-phase) jet on adjacent pipes and structures which would follow a pipe-break is the subject of NRC-sponsored studies at Sandia Laboratories aimed at upgrading the present code model characterizing the two-phase jet flow. By the end of 1980 Sandia had attained excellent validation of the model, adapted from existing NRC and other codes, using German and Swedish blowdown data. The resulting code will be used at the University of California (Berkeley), where another code is being developed to describe the actual motion and pipe whip of broken pipe systems. Validation of the pipe-whip code will be greatly enhanced in 1981 by experimental data from a new NRC program at Pacific Northwest Laboratory (PNL), as well as data obtained under a safety research exchange agreement with France.

Operating Environmental Effects

Irradiation Surveillance Dosimetry. To predict the progressive amount of embrittlement in a reactor vessel wall during its lifetime, surveillance capsules containing samples of vessel steel and neutron flux detectors are placed in all commercial reactors near the vessel walls. When removed and tested, the samples provide part of the basis for safe life estimates. Based on testing of the samples and flux detectors, an extrapolation is made of the steel condition in the vessel, using transport theory reactor physics codes. These can now be referenced to a benchmark test completed at Oak Ridge which provides for calibration of the calculations to within 15 percent, a significant improvement over present calculation accuracy. As the year ended, another irradiation experiment was underway at Oak Ridge to provide a reference benchmark for predicting embrittlement in reactor vessels—a further validation of the earlier prediction calculations.

Steam Generator Tube Integrity. Because service-defected steam generator tubes are needed

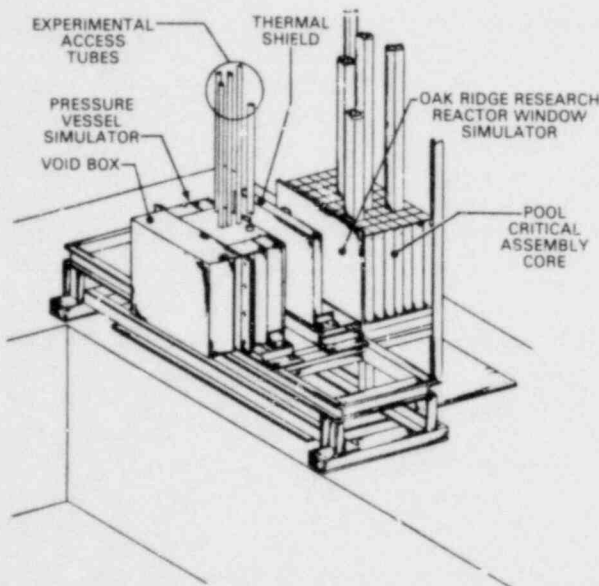

The continual bombarding by neutrons emitted from reactor fuel during operation causes embrittlement of the reactor vessel wall. To assess the significance of this progressive embrittlement, a benchmark test facility simulating a pressure vessel wall was established at the Oak Ridge National Laboratory. The results of the benchmark test, show close agreement between the measurements and calculations, and will help to establish reference benchmarks for reactor physics flux and spectrum calculations in the future.

for validation of tube integrity models (See p. 230, 1979 Annual Report), NRC moved a full-size steam generator, retired from service, from Surry, Virginia, to Richland, Washington where Battelle's Pacific Northwest Laboratory (PNL) is building research facility for studies on the generator. The first tests will be to validate inspection results by physical examination of the tubes, followed by burst testing to establish the margin of safety against operational failure. Subsequent tests will address the reasons for corrosion and cracking.

Environmentally Assisted Pipe Cracking. Changes in coolant chemistry (pH, temperature, etc.) from both normal and accident conditions can contribute to cracking of reactor pipes in combination with the other conditions, stresses and loads. In 1980, Argonne National Laboratory (ANL) completed a review of current pipe-cracking literature, to be published later, toward formulating a comprehensive new research program. The program will include confirmatory studies of both BWR and PWR pipe-cracking problems and proposed fixes, and will try to define cracking parameters.

Nondestructive Examination

Flaw Inspection by Ultrasonic Test. An improved ultrasonic testing (UT) method for inservice examination of components has been developed at the University of Michigan (See p. 196, 1978 Annual Report). It is called SAFT (Synthetic Aperture Focusing Technique), and it employs a computer to reconstruct three-dimensional images of flaws in a component based on multiple pulse-echo signals from a UT transducer. The method proved much better than earlier UT methods, and by year's end NRC had contracted with Southwest Research Institute (SWRI) to transfer the laboratory technology into usable field inspection equipment. SWRI constructed a SAFT-UT inspection system, with fixtures for pipe and vessel flaw inspection, and performed laboratory tests during 1980 before taking it out for field trials in 1981. Meanwhile, the University of Michigan is developing display systems that permit easier and more accurate identification of flaws to be made in the field, and is simplifying the computer processing of the multiple signals so that real-time flaw detection and evaluation also may be approached in the field.

Reliability of UT. Until these new UT developments become standard it will still be necessary to determine the reliability of current UT methods. Battelle's Pacific Northwest Laboratory is attempting to identify the variables important to UT inspections,

and to determine the critical ranges of those parameters, using flawed test samples, and inspections using different parameters and even different teams of inspectors. From these efforts, it is expected that the best inspection methods can be deduced. In 1980 PNL developed some preliminary recommendations for optimizing UT inspections. These recommendations will be refined in following years.

Eddy Current Test of Tubing. Inservice inspections of steam generator tubing are done using eddy current signals from small probes that pass through the tubes. Oak Ridge National Laboratory (ORNL) has been developing multifrequency test probes and instruments for several years, and in 1980 focused on the new problem of cracking in the crevice between the tube and the steam generator tube sheet and developed the probes and instruments to characterize such cracking. Late in 1980, staff members visited a reactor site to test the method.

Piping Sensitization Test. A unique nondestructive test, developed for NRC by General Electric (GE), at San Jose, is used to determine the degree of "sensitization" in stainless steel pipe welds. Sensitization is the term used to describe one element of stress corrosion in stainless steel—remove sensitized material and there is no cracking. GE's Electrochemical Potentiokinetic Reactivation (EPR) Test can be easily and quickly used in the field to earmark pipes and welds for more frequent ultrasonic inspections. The test is versatile. It is used as a quality control tool to assure that piping received from a mill is in proper metallurgical condition, and to validate the metallurgical condition of stainless steel welds in spent fuel storage racks. This research program was completed in 1980, and the laboratory technology transferred to the field. By the end of the year commercial test equipment was available.

MECHANICAL ENGINEERING RESEARCH

The Mechanical Engineering Research Program provides information on the engineering and structural behavior of systems, components, and equipment. It develops improved methods for evaluating the safety, operability, and structural integrity of these systems. These evaluations of margins of safety and probabilities of failure of safety-related plant features include a redefined view of what constitutes safety-related equipment. The major projects include the following:

Seismic Safety Margins Research Program (SSMRP)

SSMRP is a multi-discipline program to estimate conservatism in the seismic design criteria and to improve the requirements as needed. Accomplishments in 1980 included a probabilistic analysis methodology and development of event and fault trees for the Zion Nuclear Power Plant in Illinois, as well as state-of-the-art surveys in soil-structure interaction, structural response and mechanical subsystem response.

Nonlinear System Modeling

Improvements in a simplified computer code to analyze nonlinear systems led in 1980 to additional design charts describing the motion of mechanical equipment, including pumps and valves. Several studies also were conducted on the behavior of beams and structures subjected to severe vibrations. Reports on these tasks will be published in 1981. Vibration tests of a 6-inch nuclear valve were completed and the data correlated with the results of a 4-inch valve test. That test is described in NUREG/CR-1317, "Response of a Four-Inch Nuclear Power Plant Valve to Dynamic Excitation."

Piping Benchmarks

A report, NUREG/CR-1677, Volume I, "Piping Benchmark Problems, Dynamic Analysis of Uniform Support Motion Response Spectrum Method," published in 1980, presented benchmarks to validate computer programs used in the dynamic analysis of power plant piping systems. Piping codes which were developed or improved included modifications of the EPIPE code for linear elastic piping analysis to include a capability to account for independent support motion, and development of the PSAFE 1 and PSAFE 2 codes, for analysis in accord with the ASME Boiler and Pressure Vessel Code.

Load Combinations Research Program

The probability of simultaneous earthquakes causing a guillotine break in primary system piping was shown to be so small that consideration is being given to eliminating this load combination from the reactor design basis. Existing reactors may also be affected. At the end of 1980, a panel of experts was reviewing the process which led to these small probabilities to determine if it is an adequate basis for

licensing decisionmaking. NRC also is developing methods to combine dynamic responses from various loading conditions, and studies of a Mark II Safety Relief Valve line have shown it is feasible to use probabilistic concepts in selecting the load factors for the design of mechanical equipment.

Heissdampfreaktor (HDR)

The HDR is a decommissioned steam reactor in West Germany used to conduct reactor safety experiments. Blind predictions of the response of the HDR recirculation loop to motions generated by explosions adjacent to the facility in 1980, were made from data obtained at the HDR as part of a cooperative research program. NRC funded both the placement of accelerometers at support points and the computer predictions of recirculation loop response. The West Germans conducted the experiment and measured the recirculation loop response. Comparisons between the predictions and measurements should lead to better understanding of computer simulation predictions of piping system behavior.

Snubber Design Application and Testing Project

This project was initiated 1980 to evaluate existing seismic criteria for the mechanical and hydraulic snubbers on nuclear pipes and components, and the first activity—a broad-based industrial survey of current problems and needs—was completed. The results and those from two earlier snubbers sensitivity and single vs multiple snubber tests will be used to formulate the program test requirements.

Safety and Relief Valves

The TMI-2 accident highlighted a concern that pressurizer safety and relief valves of PWR plants, originally specified for steam service only, may have to pass water and two-phase mixtures in some circumstances. The PWR Owner's Group, through the Electric Power Research Institute (EPRI), initiated tests to ensure that the valves and associated systems will be qualified to meet all expected service conditions. NRC monitors this testing to identify codes and modeling techniques to confirm the adequacy of the valves. General Electric Company is formulating a similar test program on BWR valves for the BWR Owner's Group. NRC will also monitor those tests.

STRUCTURAL ENGINEERING RESEARCH

The Structural Engineering Research Program is aimed at assessing the ability of structures at nuclear plants to withstand routine operations, accidents and severe natural disturbances. New projects begun during 1980 deal with the safety margins of containments and other structures, dynamic testing methods for assessing safety, buckling loads for steel containments, engineering characterizations of seismic motion, benchmarking computer codes for structural engineering calculations, methods of combining loads for structural design, and flooding at nuclear sites. Other projects under this research program continued, as follows:

Structural Response

The methods used to perform dynamic analyses of nuclear plant structures were reviewed and a report,

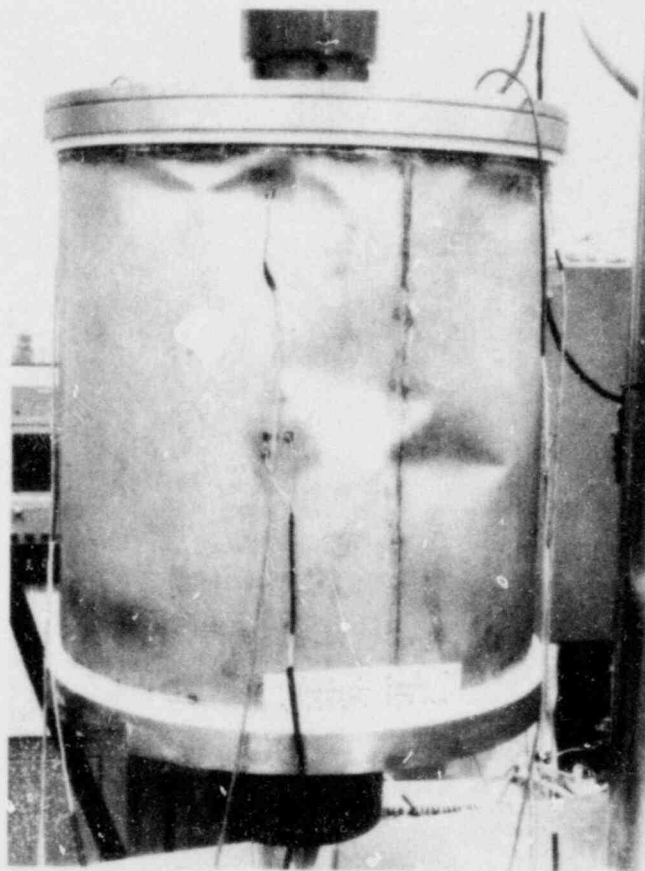

To establish safety margins for steel containments during routine operation or accident condition, the Los Alamos Scientific laboratory is performing buckling tests. Photo shows a steel containment that buckled in a preliminary high pressure test.

USNRC NUREG/CR-1423, "Structural Building Response Review," was published summarizing the state of the art and comparing the different methods.

Seismic Shear Transfer

Two reports were issued. One, NUREG/CR-1602, "Strength and Stiffness of Tensioned Reinforced Concrete Panels Subjected to Membrane Shear, Two-Way Reinforcing," examined the strength and stiffness degradation of containment wall panels subjected to cyclic loading. The other, NUREG/CR-1374, "Shear Transfer in Reinforced Concrete Containment Elements," described the first results of the experimental program to investigate shear transfer in a cracked containment vessel without diagonal reinforcement.

Seismic Design Criteria

A report, NUREG/CR-1161, "Recommended Revisions to Nuclear Regulatory Commission Seismic Design Criteria," suggested improvements in such areas as the specification of ground motion, soil-structure interaction effects, and the design of structures, equipment and components. (see Chapter 4, "Reactor Regulation".)

Soil-Structure Interaction

NRC investigations of methods to calculate the modifications in earthquake motion caused by heavy, rigid power plant structures resulted in publication of two reports: NUREG/CR-1717, "Soil-Structure Interaction Methods," a simplified computer code for licensing use in checking applicant submittals, and NUREG/CR-1780, "Soil-Structure Interaction: The Status of Current Analysis Methods and Research."

Fuel Cycle, Environmental, and Waste Management Research

FUEL CYCLE RESEARCH

Facility Safety Research

A new safety research program initiated in 1980 is developing analytical methods and experimental data to estimate the kinds and amounts and consequences

of radioactive releases from fuel cycle facilities in major accidents. The results will be summarized in a handbook on postulated accidents (including fires, explosions, tornados, criticalities, and equipment failures) as an aid to designers or license reviewers for such facilities.

Effluent Control Research

NRC's effluent control research provides data for evaluating licensee plans to control releases of radioactive materials at levels as low as reasonably achievable (ALARA).

An evaluation of the iodine absorption characteristics of six commercial grade charcoals used for effluent control in LWR's, completed in 1980, involved laboratory exposures of these charcoals to controlled quantities of ozone, SO₂, NO₂, CO, hydrocarbons, methane, and moisture for periods of one to nine months at three locations with significantly different exposure characteristics. The measured degradation of iodine absorption observed in these tests will be used to upgrade charcoal filter test and replacement requirements in LWRs.

The performance of effluent treatment systems at four operating LWR's (Zion, Fort Calhoun, Turkey Point, and Rancho Seco) were evaluated to determine the effectiveness of these systems in reducing public exposures. Based on this study, measurements were initiated at a fifth plant (Prairie Island) at the end of the year.

An evaluation of the effluent treatment systems of reactors undergoing decontamination, completed in 1980, included the costs of the treatment and other safety considerations related to decontamination.

The experiments at LASL on the performance of fuel cycle facility ventilation system components, such as filters and blowers, in tornado-pressure transients (see p. 238, 1979 Annual Report), are continuing. Analyses of the structural response of high efficiency filters to pressure differences such as are found in tornados was completed in 1980. These filters, produced by five different manufacturers, failed at pressure from 1.3 psi to 2.7 psi. Filter efficiency tests and tests of fans and damper tests under similar conditions are in progress.

Transportation Safety Research

Several transportation safety research projects completed in 1980 have led to a better understanding of the expected performance of radioactive material shipping containers during accidents. One project involved experiments to measure the release of small quantities of powdered material through small open-

ings in a failed containment vessel. A correlation based on air leak rates was developed which provides a realistic estimate of radioactive material release in various accident environments (temperature, impact, pressure, etc.).

A second project dealt with the ability of radioactive material shipping containers to withstand punctures in an accident. Some 60 puncture tests of stainless steel plates (representing shipping cask walls) were conducted. The resulting experimental data, together with the results of earlier studies will improve estimates of energies needed to puncture a container. Licensees also will be better able to meet NRC requirements in their shipping package designs. In addition, a new analytical model has been developed which will permit accurate estimates of the forces imposed on large shipping casks from the shocks and vibrations of normal rail transport. The model will improve assessments of cask tie-down features. The model was being validated at the end of the period against data from several 1978 rail coupling tests.

Decommissioning Research

Three projects in 1980 supported the development of standards and guides for the decommissioning of nuclear power reactors. In one project, samples of material from reactor vessels, vessel internals, and concrete shields were obtained to measure quantities of long-lived isotopes produced by the neutron activation of trace elements, information which may profoundly influence requirements for the safe disposal of such materials.

In the second project, samples from various areas in and around typical LWR plants were analyzed to determine the types and extent of radioactive contamination. At the end of the year, radiochemical analysis of samples from one shut-down reactor (Pathfinder), and one operating plant (Indian Point Unit 1) were being made.

The third decommissioning project is designed to measure the effectiveness of decontamination methods in reducing occupational exposures, off-site releases and radioactive waste volumes to assure that worker exposures are kept as low as reasonably achievable.

SITING AND ENVIRONMENTAL RESEARCH

Radiation Dosimetry

Two independent groups of investigators (Battelle PNL and Rensselaer Polytechnic Institute) measured

neutron energies, neutron flux, and radiation levels inside the containments of several operating plants, and compared them with readings from personnel dosimeters and dose rate instruments. This research led to revision of the NRC regulatory guide on personnel neutron dosimeters to provide for better worker protection. Another PNL project produced a new type of counter to measure small concentrations of plutonium in the human body.

Research at the University of California at Davis is assessing the potential consequences of radioiodine releases associated with reactor accidents. In 1980, measurements of the relative radiobiological effects of iodine isotopes 131 and 132 on rats and guinea pigs were made. The tests demonstrated that I-132 produced nine times greater radiological effect than equal dosage of I-131. A related study showed that fetal and weanling guinea pig thyroid glands are less radiosensitive than the thyroids of the adult, while neonatal thyroid glands are less sensitive.

New computer codes developed at ORNL to calculate Iodine-129 radiation doses to the population from nuclear facilities and for modeling the radionuclide transport through agricultural systems, were used by NRC in 1980 to calculate radiation doses from routine power plants releases.

Socioeconomic Impacts and Regional Siting

Studies of the social and economic effects of the accident at Three Mile Island included a telephone survey of 1,500 households in the area. Residents were asked to describe how the accident affected them. The most common response was that the accident had a short-term impact on those who were evacuated or who had lost time from work. The lack of adequate information provided to the public on the accident was cited as a source of stress. The information is used in hearings on reopening TMI and for future planning. NUREG/CR-1215 and NUREG/CR-1093 are reports on these studies.

A model was developed by economists at Oak Ridge to convert state-level electricity demand forecasts to forecasts for utility service areas and, thus, to improve forecast procedures in the licensing process, as called for under the National Environmental Policy Act of 1969 (NEPA). (NUREG/CR-1147)

A study by economists at PNL of the visual/aesthetic impact of closed cycle cooling systems (NUREG/CR-0980) resulted in a method for predicting, and expressing in dollars, the visual impact of natural versus mechanical draft towers on nearby populations. The information, also required by NEPA, is valuable to cost/benefit considerations in the licensing process.

Ecological Impact Studies

A two-dimensional simulation model was developed by Battelle for predicting the movement of sediments and radionuclides in the marine environments common to coastal and offshore nuclear plants. None of the earlier models adequately accounted for radionuclide transport in these environments. New models will be verified in further research.

Bioassays were completed by aquatic biologists at Battelle PNL on bluegill, rainbow trout, largemouth bass, and catfish to determine the effects of chlorine byproducts released in reactor cooling water to freshwater systems. Similarly, toxic effects of chlorine byproducts on little neck clams, oysters and Atlantic Menhaden were studied in marine systems.

In related studies at ORNL, dealing with the Indian Point nuclear complex, a model was developed to estimate mortality rates of Hudson River striped bass due to impingement and entrainment in power plant cooling water intakes. During 1980, estimates of the reduction in striped bass populations caused by losses at Indian Point were used in environmental hearings on that nuclear power station.

Emergency Preparedness

A prototype portable air sampler developed by Brookhaven National Laboratory as part of an NRC-Federal Emergency Management Agency-Department of Energy-Bureau of Radiological Health project has been used for all TMI iodine field measurements to date. In 1980, the instrument was evaluated by independent investigators at Idaho National Engineering Laboratory to assess the collection efficiency and performance of the air sampler under a complete range of simulated reactor accident conditions.

WASTE MANAGEMENT RESEARCH

NRC's waste management research program is designed to develop or improve predictive models and confirm basic data related to licensing decisions on high level waste repositories, shallow land burial sites, and uranium mill tailing operations.

High Level Waste Research

The emphasis of this research is toward establishing confidence that high level waste can be isolated

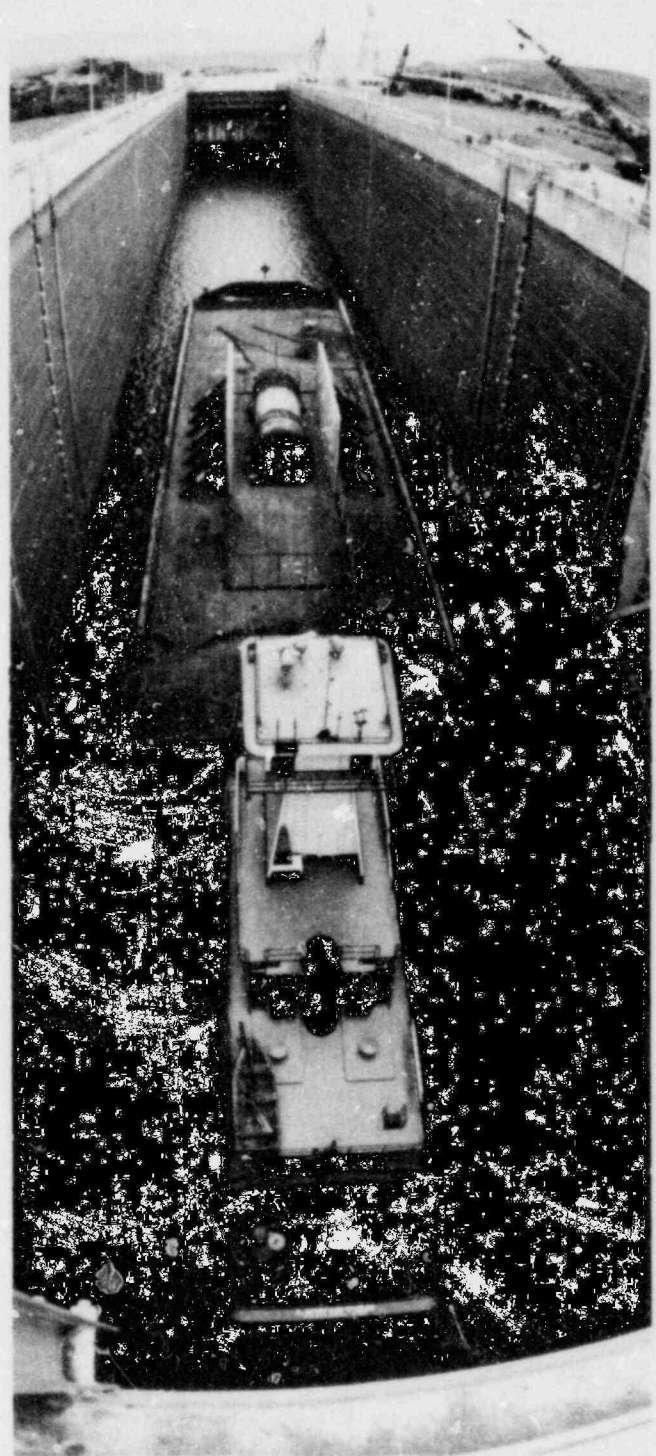

A corroded steam generator removed from one of the Surry Nuclear Power Station units in Virginia is shown passing through the Columbia River locks en route to the Battelle Pacific Northwest Laboratory in Richland, Wash. Before 1980, only mechanically defected tubing had been used in PNL's program to investigate the burst/collapse strength of flawed steam generator tubing. The service-defected tubing from this generator will be used to validate tube integrity computer models.

from the bioenvironment for long periods, most likely in deep geologic repositories. The program is divided into materials, geological and environmental sciences, and repository engineering and design assessment sub-programs.

Activity in the materials science program in 1980 continued to confirm experimentally the durability of matrices and packages for wastes, and to define the relationship between potential storage environments, such as salt, and the rates at which solidified wastes would leach into groundwater. The effects of variables such as temperature, pressure, groundwater chemistry and the chemistry of the storage medium on leach rates are being measured.

The geological and environmental science program is directed towards developing information on the rates at which radionuclides are transported in the environment. Experiments in 1980 tested methods for predicting the retention and movement of radioactive materials in soils and the flow of groundwater through fractured rock, characteristics which are important in assessing any proposed waste disposal site. Other studies deal with the use of indirect methods (i.e., radar, infrared, and magnetic measurements) to establish the geologic characteristics with minimal need.

The engineering and repository design includes research to assess safety considerations unique to a deep geologic repositories in providing long-term isolation of high level radioactive wastes.

Low Level Waste Research

The Low Level Waste Research Program is identifying better ways to predict and monitor the potential migration of radionuclides from waste disposal facilities and to evaluate alternatives to shallow land burial for low level wastes.

This program is measuring the migration of radioactivity at shallow land burial sites at Maxey Flats, Kentucky; West Valley, New York; and Sheffield, Illinois. Data are being applied to the development of better decommissioning and siting criteria. Liquid low level wastes which have been solidified prior to burial are also being tested for their stability and their capability to retain the radionuclides when immersed in water. Data developed in these programs already have contributed towards improved quality control requirements for wastes shipped for land burial.

Uranium Recovery Research Program

This research program focuses on measuring the effectiveness of methods to control the release of radioactive material from mills and mill tailings piles.

In 1980, the program included laboratory tests and computer modeling of radioisotope transport through groundwater systems, as well as tests on radon gas release from tailing piles and the retention of radon by various cover materials, such as clay. In addition, a study was begun to investigate the effectiveness of various erosion control techniques for tailings piles. Research results were documented in the following NRC publications: NUREG/CR-1495, "Assessment of Clay Liners for Tailings Pits at Morton Ranch, Wyoming;" NUREG/CR-1494, "Laboratory Assessment of Leachates and Permeability Changes in Clay Liners For Uranium Mill Tailings;" NUREG-1081, "Characterization of Uranium Tailings Cover Materials For Radon Flux Reduction."

Systems and Reliability Research

Formerly called "Risk Assessment Research," this program was expanded when the NRC reoriented its research programs in 1979 to reflect lessons learned from the TMI accident. It culminated in 1980 when the portion of the NRC organization responsible for risk assessment was enlarged and its name changed from Probabilistic Analysis Staff to Division of Systems and Reliability Research.

Activities in 1980 included the development of improved techniques to predict nuclear accident consequences; reactor risk and reliability assessment; fuel cycle risk assessment, and the development of statistical methods and data bases necessary for risk assessment. Special emphasis was given to the identification of serious accident precursors. A research evaluation of methods and data for predicting human error was also undertaken.

REACTOR SYSTEMS ANALYSIS AND LICENSING SUPPORT

NRC's use of risk assessment methods broadened in 1980. Activities included the reliability analyses of auxiliary feedwater systems in operating PWRs, and recommendations which can significantly improve reliability of systems. A technical program dealing with the unresolved safety issue of station blackout was initiated, and preliminary analyses, using probabilistic methods, were completed. A more thorough investigation is under way. Other 1980 projects included a value/impact analysis of the Standard

Review Plan used in reviewing license applications; special assistance on the Zion and Indian Point risk assessment studies; distribution in draft of a new computer code, called MARCH, which can analyze core meltdown phenomena; revision of probabilistic reliability assessments of direct current power supplies; completion of reports applying WASH-1400 methods to additional plants; and the screening of reactor operating experience to identify potential accident precursor sequences.

Funding was allocated in 1980 for a "Reactor Safety Study Methodology Applications Program" (RSSMAP) which applies WASH-1400 risk assessment methodology to the analysis of nuclear plants, each equipped by a different reactor vendor. Goals of the study are to compare those accident sequences which influence the calculated risk for a spectrum of reactor designs, identify design differences which significantly influence risk, and train new personnel in the field of risk assessment.

Work also began on the "Interim Reliability Evaluation Program" (IREP), designed to: 1) develop a method enabling one to identify for operating plants, those accident sequences which have a significant likelihood of occurrence, 2) expand NRC's capability to use probabilistic techniques, 3) provide tools to evaluate modifications to reduce the risk of specific accident sequences, and 4) broaden the perspective on risk to the public from operating reactors. Phase I of this program, a scoping analysis of Crystal River Unit 3, was initiated in November 1979, and was nearing completion at the end of 1980. Based on that phase, and on experience from RSSMAP and similar studies, Phase II, initiated in September 1980, will apply the procedures developed in Phase I and other studies to four operating plants. When completed, the methodology will be modified as required and then applied to all operating power facilities. In late 1981 NRC expects to publish results for each of the four plants studied. (NUREG/CR-1659, Volumes 1 through 4).

REACTOR ACCIDENT CONSEQUENCES ANALYSIS

Efforts to update the Calculations of Reactor Accident Consequences (CRAC) model and to develop a site-specific consequences model, continued in 1980 with sensitivity studies conducted to determine the significance of improvements in emergency response planning and meteorological dispersion modeling techniques. In conjunction with this effort, NRC also directed an international compari-

son of consequence models in a study sponsored by the OECD/NEA Committee on the Safety of Nuclear Installations.

Sandia Laboratories and the NRC staff completed a risk-based study (NUREG/CR-1433) on the cost/benefit of administering potassium-iodide as an emergency protective measure for reactor accidents.

In response to a petition regarding the Indian Point nuclear facilities, NRC conducted a study (NUREG-0715) comparing accident risks there with risks for other reactor sites and designs. This was an initial attempt to put in perspective the relationships between the reactor design, siting (population distribution), emergency response, and power level. The study highlighted the importance of reactor design as a factor in accident risk and in compensating for high population density.

METHODOLOGY DEVELOPMENT

NRC programs to develop methodology for probabilistic safety analysis and risk assessment continued in 1980 with a new emphasis on numerical risk criteria and on quantification of safety decisionmaking. Substantial progress was made on a survey of the use of numerical criteria in other fields, development of draft numerical criteria for nuclear reactor safety, and identifying analytical methods required to use such criteria. Other programs are being developed to model the risk implications of operating data, to evaluate ways to improve the single failure criterion by controlling dominant risk contributors, and to develop software for common-cause analysis.

NRC efforts to develop a methodology to estimate the frequency of large floods with the Flood Level Occurrence Evaluation (FLOE) code, and to evaluate the risk impact of floods in nuclear stations, continued.

Another program initiated in 1980 aims to develop probabilistic failure models for several inservice components of nuclear power plants such as piping and pressure vessels. Component failure data was compiled, mostly from the Licensee Event Report (LER) System and LER summary data were published for safety system valves, pumps, diesel generators, and control rod drives. Exploratory methodology for analysis of nuclear plant reliability data based on data gathered from plant maintenance logs, was developed and placed in a computer file for future analysis. Emphasis was on human error data analysis toward better understanding the man/machine interface and its impact on the availability of safety systems. A human factors handbook for use in evaluating engineered safety systems was prepared and at year's

end, human error rates were being analyzed toward quantifying (and modeling) human performance for a range of operating conditions. Together with Brookhaven National Laboratory and the IEEE, NRC sponsored a human factors workshop attended by 80 participants.

FUEL CYCLE RISK ASSESSMENT

NRC's development of methodologies to assess risks from nuclear fuel cycle activities, other than reactors continued in 1980, with emphasis on five main areas:

- Demonstration of the risk assessment methodology by application to a reference repository in bedded salt.
- Examination of the risk methodology and formulation of a plan to check the consistency and technical basis of developing NRC regulations, using the methodology, where appropriate.
- Documentation of the use of the risk assessment methodology in showing compliance/non-compliance with the Environmental Protection Agency's proposed Risk Assessment Standard for Waste Management.
- Refinement of simulation models to allow safety evaluation of a specific repository site.
- Plans to modify the methodology for bedded salt for application to basalt, domed salt, granite, and other media anticipated as candidates for a repository site. More than fifteen NUREG reports, user manuals, and technical articles were published.

Work began in 1980 on applying the risk methodology for high-level waste to spent fuel isolation in bedded salt, and preliminary comparisons were completed. An independent technical review of the published products of the risk methodology program was completed and report (NUREG/CR-1672) of the review was published. Preparation of a companion report responding to the review panel's critique will be initiated in 1981.

The Interoffice Waste Management Modeling Group (IWMG) (see p. 241, 1979 Annual Report) gained experience in waste isolation methodology from a series of problems exercised on the Sandia Waste Isolation Flow and Transport (SWIFT) model. Further analysis of SWIFT along with other models is planned for bedded salt and other geologic media in 1981. Draft program planning for the IWMG for the next two years closely follows the repository licensing schedule.

Research to Improve Reactor Safety

NRC's involvement in developing new safety concepts was addressed in 1978 and was moved ahead with the publication and partial implementation of NUREG-0438, "Plan for Research to Improve the Safety of Light-Water Nuclear Power Plants" (p. 242, 1979 Annual Report). Limited funds delayed significant progress, but work was initiated on alternate containment designs, decay heat removal systems, and improvements in the operator-machine interface. After TMI, a renewed interest developed in improving all aspects of reactor safety. Research previously considered confirmatory is now being re-examined to identify what could be learned about improving safety. Areas under study are described below with an indication of how research results might lead to improvements in safety. Some concepts are only practical for the construction of future nuclear power plants.

Alternate Containment Concepts

NRC has established the feasibility and risk reduction potential of vented, filtered containment and has generated several alternative design concepts. Molten-core retention devices are also being examined with emphasis on developing the functional requirements and design basis for such systems. The perceived benefit of alternate containment designs is to reduce the probability and magnitude of uncontrolled releases of radioactivity during severe accidents.

Alternate Decay Heat Removal Systems

NRC has developed design criteria and conceptual designs for an add-on decay heat removal system. This relatively simple, single-train system can improve safety by increasing the reliability of the decay heat removal function.

Advanced Display and Diagnostic Systems

Graphic display equipment installed in the LOFT control room and technical support center gives NRC practical experience in the design and use of improved operator-process communication systems.

This information will also help the NRC assess the need for and adequacy of improvements in the human-machine interface.

Advanced Instrumentation

NRC's need to verify the accuracy of computer calculations through experimentation has resulted in the development of instruments considerably more sophisticated than those in commercial use. The application of such instrumentation as liquid-level detectors and two-phase flow detectors may lead to improved safety through direct measurements of key variables as opposed to relying on derivation from other measurements.

Plant Systems Analysis

NRC is using probabilistic and deterministic methods to analyze the reliability of key plant systems. Recommendations have been provided for reducing the risk associated with the unavailability of these systems. For example, the reliability of PWR auxiliary feedwater systems was examined when the loss of main feedwater occurred with and without AC power. The studies indicated that relatively simple changes in design and procedures could significantly enhance system availability. (See NUREG-0611, "Generic Evaluation of Feedwater Transients and Small-Break Loss-of-Coolant Accidents in Westinghouse-Designed Operating Plants.")



14

Communicating With the Public

In a continuing atmosphere of intense public interest in nuclear energy, the NRC must see to it that all avenues of communication are kept open for issuing and receiving information concerning its regulatory activities. This means that NRC commissioners and staff members must respond to public needs for information, that their actions and decisions must be promptly and fully announced, that regulatory documents must be made accessible to the public, and that special efforts must be made to keep the Congress and other government agencies, foreign governments, public interest groups, the nuclear industry and the public at large informed of important developments in nuclear regulation.

In 1980, the NRC expanded the services offered through its Public Document Room, added a pilot Consumer Affairs program to its Public Affairs Office, and published a new and comprehensive policy statement to encourage and accommodate the expression within the staff of differing professional opinions. These and other 1980 activities in the field of communication are discussed below.

MAKING DOCUMENTS AVAILABLE

Public Document Room Services. NRC maintains a headquarters Public Document Room (PDR) at its offices at 1717 H Street, N.W., Washington, D.C., and satellite PDRs located near proposed or actual nuclear facility sites across the country. The local PDRs are maintained to provide detailed information of interest to each community concerning the nearby facility that has been licensed or is under NRC review. At the end of 1980, there were more than 150 local PDRs. (See Appendix 3 for a list of LPDRs.)

The headquarters PDR contains a large collection of technical, legal and administrative documents that

NRC receives or generates in fulfilling its regulatory responsibilities. The majority of these documents relate to the licensing and inspection of nuclear facilities and to the use, transport and disposal of nuclear materials. The holdings also include documents in such file categories as Commission correspondence, contracts, export and import licenses, rules and regulations, transcripts of Commission meetings, regulatory guides, agency generated reports and contractor technical reports. Unlike a library, the PDR does not maintain collections of published materials such as books, periodicals, monographs or general indexes.

The PDR responds to walk-in, letter and telephone requests for information and documents from any member of the public. Staff librarians who are highly knowledgeable in NRC documentation assist users in defining search strategies, explaining the use of reference tools and locating and retrieving documents in specific files.

A daily accession listing describing all incoming documents to the PDR and other types of document indexes are also available on site. In cases where existing indexes are not appropriate or where needed documentation cannot be easily drawn together, librarians perform on-line computer searches of the PDR bibliographic data base free of charge. This machine-readable data base contains descriptive citations for all records submitted to the facility after October 1978 and the principal licensing documents submitted prior to that date.

Any document in the collection may be viewed on-site and reproduced by a contract copying service for a fee. PDR staff will retrieve documents requested by letter or telephone and arrange for reproduction and mailing of requested material.

A statistical profile of the PDR during fiscal year 1980 indicated that the collection included about 972,000 documents, with an average of 365 new documents announced to the public each day. During an



The main NRC Public Document Room at Commission offices in Washington, D.C., contains a large collection of documents received or generated by the agency, and maintains facilities for computer search, microfiling and reproduction of such documents and records. During an average month in 1980, the PDR retrieved 6,900 files and microfiche in response to public requests, located 1,900 documents requested in letters, and serviced 750 users. More than 1.8 million pages and 23,000 microfiche cards were reproduced for the public.

average month, the PDR retrieved 6,900 files and microfiche in response to public requests, located 1,900 documents requested in letters from the public, and serviced 750 users. More than 1.8 million pages and 23,000 microfiche cards were reproduced for the public during the year.

Persons desiring to use or obtain additional information regarding the holdings, file organization, reference services and request procedures of the PDR may call (202) 634-3274 or write to the U.S. Nuclear Regulatory Commission, Public Document Room, Washington, DC 20555. A "Public Document Room User's Guide" is available upon request. In addition, guided tours of the facility and orientation/training for individuals or groups interested in using the facility can be arranged on an appointment basis.

Document Sales Program. To make NRC publications more readily available to the public, the Commission became a direct sales agent of the U.S. Government Printing Office in 1980. Under the program, customers can purchase available NRC publications by writing the NRC Sales Program, Washington, DC 20555, or by calling (301) 492-9530. Customers may pay by check or money order or can establish minimum \$50.00 deposit

accounts with the Superintendent of Documents, U.S. Government Printing Office, Washington, DC 20402. Before this program was established, obtaining documents generated by the NRC, its contractors, and licensees was a lengthy process. The new arrangement allows much more rapid response. In the first year of the NRC Sales Program, nearly 14,000 publications were sold, resulting in revenues exceeding \$127,000.

In addition to their availability at NRC Public Document Rooms, microfiche of publicly available documents related to nuclear power plant licensing and regulation may be purchased through a subscription program sponsored by the National Technical Information Service of the U.S. Department of Commerce in cooperation with the NRC. More than 2,000 microfiche are made available to subscribers each month in conjunction with the NRC's monthly "Title List of Documents Made Publicly Available." (See Chapter 16, "Administration and Management.")

An indexed compilation of regulatory and technical reports published from 1975 through 1978 was issued as NUREG-0304, Vol. 3, and an indexed compilation for 1979 that includes abstracts was published as NUREG-0304, Vol. 4.

Freedom of Information Act Releases. Like other government agencies, NRC is required to make its records available to members of the public under terms of the Freedom of Information Act (FOIA). Each year the number of FOIA requests received by NRC has increased. In fiscal year 1980, there were 650 requests, an increase of 150 over 1979. The subjects of the requests covered a wide range of public concerns, including issues of topical interest such as the Three Mile Island accident, operator training, transportation of nuclear wastes, and generic health and safety implications.

To make the information accessible to as many people as possible, NRC places documents released under the FOIA in its Washington, D.C., Public Document Room, and in cases where documents deal with a particular nuclear facility, in the Local Public Document Room serving that facility.

Records are withheld only if exempt under specific provisions of the FOIA. Examples are national security matters, trade secrets, legal work products, attorney-client advice, and personal privacy information. Wherever possible, withheld material is "portion-segregated," with only single words or phrases deleted.

Privacy Act Releases. Requests received by NRC for information to be released under terms of the Privacy Act of 1974 come mostly from NRC employees or from applicants for employment. The act provides that an individual is entitled to know what records an agency maintains under his or her name,



The number of NRC local public document rooms (LPDRs) expanded to more than 150 during 1980. These are typically located in libraries in towns or cities near actual or proposed nuclear facility sites. Shown above is the public library in Auburn, Neb., which houses the regulatory documents pertaining to the Cooper Nuclear Station. At right, the Penfield Library at the State University College in Oswego, N.Y., contains documents relating to the neighboring FitzPatrick Nuclear Power Plant, Nine Mile Point Nuclear Station, and the proposed Sterling Power Project. Below, the Somervell County Library in Glen Rose, Tex., moved from its original one-room location (left) to more spacious, renovated quarters (right). It is the LPDR for the Comanche Peak Nuclear Plant.



to seek access to them, and to have any errors corrected. The 21 Privacy Act requests received in 1980 sought various records included in personnel and security files, particularly documents pertaining to references furnished in connection with job applications or security checks.

NRC'S PUBLIC INFORMATION PROGRAM

In an effort to expand public awareness of, and participation in, agency activities, the NRC initiated a pilot program in Consumer Affairs. Two professional-level staff members were initially assigned to assist and advise the public about the agency's responsibilities and about the procedures for public involvement in its activities.

NRC press releases cover situations that range from the setting of a public hearing or workshop on proposed regulation changes to notification of specific applications for the building or operation of nuclear facilities. While the primary audience for these press releases is the news media, the scientific community, the industry and the general public may also receive them directly. NRC works frequently with news media representatives at both the local and national level, announcing key decisions of the Commission immediately by telephone or arranging interviews with members of the Commission and senior staff. Many important actions proposed or taken by the Commission also receive public notice through publication in the *Federal Register*.

"Government in the Sunshine." The Commission complies fully with the requirements of the

Sunshine Act of 1976 in its policies concerning public observation of, and access to, Commission deliberations. Staff papers and other documentation pertaining to the proposed issuance of export and import licenses, certain items of Commissioners' correspondence, and staff papers and associated visual materials discussed in public Commission meetings are all placed in the headquarters Public Document Room. The Commission permits radio and television coverage and tape recordings of Commission and licensing board meetings. An automatic telephone-answering service and a mailing list of interested persons are maintained to provide information daily concerning the scheduling of Commission meetings.

Commission regulations implementing the Sunshine Act (10 CFR Part 9, Subpart C) specify procedures for deciding whether to close a meeting, what records will be kept, and other administrative details. The law requires the Commission to open all of its meetings to public attendance unless one or more of 10 exemptions applies. The exemptions are designed to permit closed discussion of specified matters; however, transcripts, recordings or minutes must be made of most closed meetings, and these may be released to the public at a later date.

During 1980, the Commission conducted three-fourths of its meetings in open session. These sessions are attended by members of the public and are frequently covered by the press. Television coverage is not uncommon at sessions in which issues of significant public interest are discussed. The Commission has a continuing program for reviewing transcripts of closed meetings so they may be released to the public. Since enactment of the Sunshine Act, the Commission has released transcripts and/or minutes of 334 closed meetings.



In addition to conducting the majority of Commission meetings in open session under provisions of the Government in the Sunshine Act, the NRC opens most of its advisory committee meetings to the public. Shown here in open session in August 1980 is the Advisory Committee on the Medical Uses of Isotopes as it considered training and experience requirements for physicians who use NRC-licensed nuclear materials in medical procedures.

HANDLING DIFFERING OPINIONS

The NRC's long search for an effective way to assure that differing professional opinions are given proper consideration (See p. 223, 1978 Annual Report, and p. 250, 1979 Report) culminated during 1980 with the publication of a Commission policy statement and detailed instructions to all levels of the organization to implement the policy. Chapter 4125 of the NRC Manual, the official vehicle for promulgating permanent agency directives, directs all supervisors and managers to "maintain a working environment that encourages employees to make known their best professional judgments even though they may differ from prevailing staff view, disagree with a management decision or policy position, or take issue with proposed or established agency practice." It promises that "each differing opinion will be pursued to resolution" and that such opinions and the NRC responses to them will be made public. NRC employees are put on notice that it is not only their right but their duty "to make known their best professional judgments" and are given unqualified assurance that they will "be protected against retaliation in any form."

The detailed procedures set forth for the implementation of this policy define the responsibilities of the Executive Director for Operations, the directors of offices, immediate supervisors, and employees themselves. They include the establishment of a reporting system under the Office of Management and Program Analysis, and specific review procedures under a Special Review Panel. An appendix to the Manual Chapter describes alternatives for the channeling of differing opinions. The first is NRC's "Open Door Policy" which encourages employees to seek meetings with "any manager, including a Commissioner or the Chairman of the NRC." The second channel uses the independent Advisory Committee on Reactor Safeguards (ACRS), and the chapter provides detailed guidance on the role of the ACRS in commenting on and forwarding dissenting opinions.

The NRC strongly believes that both the agency and the public at large benefit from the expression of divergent views, and that the enunciated policy is a major step in the handling of such opinions and in the protections guaranteed to persons who articulate them.

CONGRESSIONAL OVERSIGHT

The number of hearings of the several Congressional committees exercising jurisdiction over NRC activities continued to increase in 1980. NRC witnesses testified a total of 44 times before 13 committees or subcommittees on such subjects as the

Three Mile Island accident, waste management and international affairs. The following list shows the date, committee, and subject of each hearing.

- 10/ 2/79—Senate Committee on Environment and Public Works, Subcommittee on Nuclear Regulation. (TMI Investigation)
- 10/ 3/79—Senate Committee on Environment and Public Works, Subcommittee on Nuclear Regulation. (TMI Investigation)
- 10/ 5/79—Senate Committee on Foreign Relations (U.S.-Australian Agreement for Cooperation)
- 10/11/79—House Committee on Foreign Affairs, Subcommittee on International Economic Policy and Trade. (U.S.-Australian Agreement for Cooperation)
- 10/22/79—House Committee on Interior and Insular Affairs, Subcommittee on Energy and the Environment. (Uranium Mill Tailings Disposal at Church Rock)
- 11/ 1/79—House Committee on Government Operations, Subcommittee on Environment, Energy and Natural Resources. (Emergency Preparedness at TMI)
- 11/ 5/79—House Committee on Interstate and Foreign Commerce, Subcommittee on Energy and Power. (Kemeny Commission Report on TMI)
- 11/ 7/79—House Committee on Science and Technology, Subcommittee on Energy Research and Production. (Low Level Radioactive Waste Disposal)
- 11/ 8/79—Senate Committee on Environment and Public Works, Subcommittee on Nuclear Regulation. (TMI Cleanup)
- 11/ 9/79—Senate Committee on Environment and Public Works, Subcommittee on Nuclear Regulation (TMI Cleanup)
- 11/14/79—House Committee on Science and Technology, Subcommittee on Energy Research and Production (Kemeny Report (TMI))
- 11/27/79—House Committee on Government Operations, Subcommittee on Environment, Energy and Natural Resources (Marble Hill Plant)
- 12/11/79—Senate Committee on Environment, and Public Works Subcommittee on Nuclear Regulation (Waste Management)
- 1/23/80—Senate Committee on Environment and Public Works, Subcommittee on Nuclear Regulation (Nuclear Waste)



The NRC participated in an exhibition, "You and the Federal Government: A Special Consumer Affair," sponsored by the U.S. Office of Consumer Affairs during National Consumer Education Week in October 1980. Some 2,500 members of the public attended the event in Washington where representatives of 35 agencies manned booths, distributed brochures and explained the functions and purposes of their organizations.

- 2/13/80—House Committee on Government Operations, Subcommittee on Environment, Energy and Natural Resources (Rogovin Report (TMI))
- 2/13/80—House Committee on Appropriations, Subcommittee on Energy and Water Development (FY 1980 Supplemental Appropriation)
- 2/13/80—Senate Committee on Governmental Affairs, Subcommittee on Energy, Nuclear Proliferation and Federal Services (Nuclear Waste Management Reorganization Act)
- 2/22/80—House Committee on Interstate and Foreign Commerce, Subcommittee on Energy and Power (FY 1981 Appropriation)
- 2/26/80—House Committee on Appropriations, Subcommittee on Energy and Water Development (FY 1981 Appropriation)
- 2/27/80—Senate Committee on Appropriations, Subcommittee on Energy and Water Development (FY 1981 Appropriation)
- 2/28/80—Senate Committee on Environment and Public Works, Subcommittee on Nuclear Regulation (FY 1981 Authorization)
- 3/ 7/80—House Committee on Interior and Insular Affairs, Subcommittee on Energy and the Environment (FY 1981 Authorization)
- 3/18/80—House Committee on Interior and Insular Affairs, Subcommittee on Energy and the Environment (FY 1981 Authorization)
- 3/24/80—Senate Committee on Environment and Public Works, Subcommittee on Nuclear Regulation (FY 1981 Authorization)
- 4/17/80—House Committee on Appropriations, Subcommittee on Energy and Water Development (FY 1981 Appropriations)
- 4/18/80—Senate Committee on Governmental Affairs (Reorganization Plan No. 1 of 1980)
- 5/ 2/80—Senate Committee on Environmental and Public Works (NRC Building Consolidation)
- 5/ 6/80—House Committee on Government Operations, Subcommittee on Legislation and National Security (Reorganization Plan No. 1 of 1980)
- 5/ 7/80—House Committee on Foreign Affairs, Subcommittee on International Economic Policy and Trade (Nuclear Exports)
- 5/22/80—House Committee on Interior and Insular Affairs, Subcommittee on Energy and the Environment (TMI Cleanup)
- 5/27/80—House Committee on Interior and Insular Affairs, Subcommittee on Energy and the Environment (Limerick Plant)
- 5/28/80—House Committee on Government Operations, Subcommittee on Environment, Energy and Natural Resources (Oyster Creek Plant)
- 5/29/80—House Committee on Government Operations, Subcommittee on Environ-

- ment, Energy and Natural Resources (Oyster Creek Plant)
- 5/29/80—House Committee on Science and Technology, Subcommittee on Energy Research and Protection (H.R. 7418—Demonstration Facilities for R&D Purposes)
- 5/29/80—House Committee on Public Works and Transportation, Subcommittee on Public Building and Grounds (NRC Building Consolidation)
- 6/18/80—Senate Committees on Foreign Relations and Governmental Affairs (Tarpur Exports)
- 6/19/80—House Committee on Science and Technology, Subcommittee on Energy Research and Protection (H.R. 7190—Light Water Nuclear Reactor Safety R&D)
- 7/ 2/80—House Committee on Government Operations, Subcommittee on Environment, Energy and Natural Resources (TMI)
- 7/22/80—Senate Committee Energy and Natural Resources, Subcommittee on Energy Research and Development (S. 2884—Nuclear Safety Research and Development Act of 1980)
- 7/25/80—House Committee on Interstate and Foreign Commerce, Subcommittee on Energy and Power (Waste Disposal)
- 7/28/80—House Committee on Interstate and Foreign Commerce, Subcommittee on Energy and Power (West Valley Site)
- 8/26/80—Senate Committee on Agriculture, Nutrition and Forestry, Subcommittee on Rural Development (Socioeconomic Effect of Waste Storage Facility)
- 9/23/80—House Committee on Interstate and Foreign Commerce, Subcommittee on Oversight and Investigations (South Texas Project)
- 10/ 7/80—House Committee on Government Operations, Subcommittee on Environment, Energy and Natural Resources (Ocean Dumping of Radioactive Material—Held in San Francisco, California)

REPORTS TO CONGRESS

The NRC keeps its oversight committees in the Congress fully and currently informed regarding

Commission activities. Information on significant developments is forwarded routinely to the appropriate committees, and special reports are issued in response to inquiries from committees and individual members of Congress.

Periodic reports to Congress or Congressional committees are required by law on the following matters:

- NRC Annual Report to the President, for his transmittal to the Congress on a fiscal year basis.
- Abnormal occurrences in regulated nuclear activities (quarterly).
- Indemnity activities under the Price-Anderson Act (annual; now incorporated in the NRC Annual Report).
- Administration of the Freedom of Information Act (annual).
- Implementation of the Government in the Sunshine Act (annual).
- Printing plant report (annual).
- Annual plant inventory (annual).
- Major organization components and numbers of employees (annual).
- Steps to meet provisions of Equal Opportunity Act (quarterly).
- Progress on resolving generic safety issues related to nuclear power plants (annual; incorporated in the NRC Annual Report).
- Updating of long-term research plan for projects to develop new or improved safety systems for nuclear power plants (annual; incorporated in the NRC Annual Report).
- Commission's views and recommendations on U.S. policies and actions to prevent proliferation (annual; incorporated in the NRC Annual Report).
- ACRS report concerning nuclear reactor safety research program (annual).
- Status of domestic safeguards matters during previous fiscal year (annual; incorporated in NRC Annual Report).
- Fuel cycle systems evaluation (semi-annual; annually in 1981 and 1982).
- Agency use of contracts, consultants, and national laboratories (annual).

GAO Reports. NRC issued a number of special reports to Congress as the result of studies by the General Accounting Office under its broad authority to assist Congress, its committees, and individual members in carrying out their legislative and oversight responsibilities.

An agency which is the subject of a GAO report recommending corrective actions is required by law

OPPORTUNITIES FOR FORMAL PUBLIC HEARINGS IN NRC PROCEEDINGS

| <i>Type of Proceeding</i> | <i>Opportunity for Hearing</i> | <i>Purpose of Hearing</i> | <i>Criteria for Granting Hearing</i> | <i>Unit Deciding To Hold Hearing</i> |
|---|---|--|--|--|
| RULEMAKING Proceeding | Prior to issuance of final rule. | To determine whether a proposed rule should be adopted. | At the discretion of the Commission. | Commission (which may decide to hold informal or "hybrid" hearing). |
| MANUFACTURING LICENSE Proceeding* | Mandatory hearing prior to issuance of manufacturing license. | To determine whether a license authorizing the manufacture of a production or utilization facility of a particular design should be issued. | Mandatory hearing on safety and environmental issues. | Mandatory hearing before Licensing Board. |
| CONSTRUCTION PERMIT Proceeding* | Mandatory hearing prior to issuance of construction permit. | To determine whether a particular production or utilization facility should be constructed at a particular site and, where indicated to resolve adverse anti-trust matters. | Mandatory hearing on safety and environmental issues; on anti-trust matters, upon request by interested persons or Attorney General or at discretion of Commission. | Mandatory hearing before Licensing Board. |
| OPERATING LICENSE Proceeding* | Prior to issuance of operating license. | To determine whether a particular production or utilization facility should be permitted to operate; antitrust review where significant changes have occurred since previous antitrust review. | Request by any person whose interest may be affected by proceeding who raises genuine issue of material fact, and at discretion of Commission; in addition, in the case of antitrust review, there must be determination by the Commission that significant changes have occurred. | Commission, Appeal Board or Licensing Board, as appropriate. |
| MATERIALS LICENSE Proceeding | Either prior to or after issuance of materials license. | To determine whether a particular materials license should be issued or remain in effect. | Request by any person whose interest will be affected by proceeding and at discretion of Commission. | Commission, Appeal Board, Licensing Board or Administrative Law Judge, as appropriate. |
| SHOW CAUSE Proceeding (to modify, suspend or revoke a license or for other appropriate action). | Prior to issuance of final Commission Order. | To determine appropriate action to be taken. | Upon demand by person cited in Show Cause Order or by request of other persons whose interest may be affected, upon making requisite factual showing. | Commission. |

*An opportunity for hearing is also provided prior to issuance of amendments to manufacturing licenses, construction permits, and operating licenses which involve significant hazards considerations. On November 19, 1980, the U.S. Court of Appeals for the D.C. Circuit decided in *Steven Sholly, et al., v. U.S. Nuclear Regulatory Commission* that the Commission may not issue a license amendment without a hearing even where there is no significant hazards consideration if there is a timely request for a hearing by an interested person. The mandate of the Court of Appeals has been stayed pending further consideration. (See chapter 1 under "TMI-2 Accident Aftermath" and Chapter 15 under "Judicial Review.")

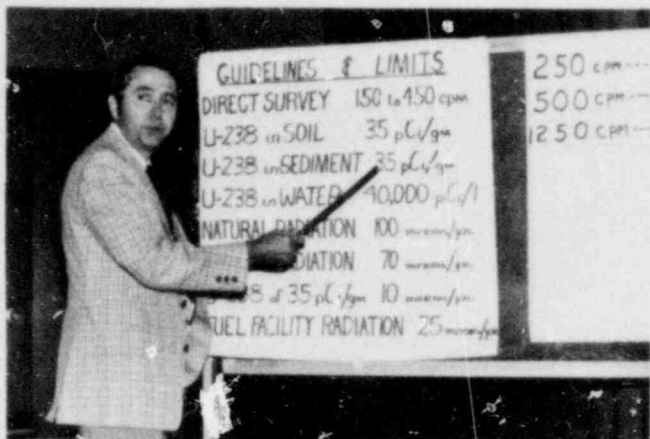

NRC staff members frequently participate in public meetings on matters of concern regarding licensee operations. Such a meeting was held in August 1980 in Ashtabula, Ohio, after a citizens' group alleged that excessive amounts of radioactive material was discharged into a stream from a facility of the RMI Co., an NRC licensee which fabricates uranium metal forms for



commercial firms and the Department of Energy. The chief of NRC Region III's Fuel Facility and Material Safety Branch reviews results of a survey that shows all environmental samples to be within NRC's guidelines except for a small area of sediment beneath the plant's discharge pipe into the stream. The company removed the sediment.

to report within 60 days to the Government Operations Committees of the House and Senate on steps taken or planned to implement the recommendations. During 1980, the GAO issued 11 reports covering various aspects of NRC activity. NRC responses to GAO recommendations are available in the main NRC Public Document Room in Washington, D.C. GAO reports issued during the year are:

- 10/ 2/79—"Emergency Preparedness Around the Rancho Seco Nuclear Powerplant: A Case Study."
- 10/10/79—"Nuclear Construction Times for the Second and Subsequent Plants at a Multi-Plant Site are Overstated."
- 11/15/79—"Placing Resident Inspectors at Nuclear Powerplant Sites: Is It Working?"
- 12/ 4/79—"Radiation Control Programs Provide Limited Protection."
- 1/15/80—"The Nuclear Regulatory Commission: More Aggressive Leadership is Needed."
- 3/31/80—"The Problem of Disposing of Nuclear Low-Level Waste: Where Do We Go From Here?"
- 4/ 1/80—"Existing Nuclear Sites Can Be Used For New Power Plant and Nuclear Waste Storage."
- 5/27/80—Letter Report to Senators Hart and Simpson—"Do NRC Plans Adequately Address Regulatory Deficiencies Highlighted by the TMI Accident?"
- 7/ 7/80—"Three Mile Island: The Financial Fallout."

8/18/80—Letter Report to Rep. Dingell: "Analysis of the Price-Anderson Act."

9/30/80—"Electricity Planning—"Today's Improvements Can Alter Tomorrow's Decisions."

PUBLIC PARTICIPATION IN NRC PROCEEDINGS

NRC regulations provide for formal participation by members of the public as parties in rulemaking, licensing and other proceedings.

Regulations also require that a public hearing on each application for a major nuclear facility construction permit be conducted by an Atomic Safety and Licensing Board (see Chapter 15). The hearing is announced well in advance in the *Federal Register* and is posted in a public document room near the proposed construction site, together with a copy of the application. Local newspapers also carry notice of the hearing. Interested persons or groups are invited to participate in the hearing by submitting a written statement, making an oral presentation, or petitioning the licensing board to become an "intervenor" in the proceeding with full participatory rights, including discovery and cross-examination of other participants. Intervenors participate in prehearing conferences with other interested parties for the exchange of information and identification of issues in contention.

If the licensing board disallows a petition, the petitioner may appeal to the Atomic Safety and Licensing Appeal Board (see Chapter 15). In some instances, the Commission may rule on a petition.

Ultimately, a petitioner may seek a ruling in the appropriate Federal Court of Appeals and the Supreme Court of the United States.

The same rights and procedures for public participation apply to hearings on applications for operating licenses, with the difference that such hearings are

not mandatory and need not take place unless requested by one or more interested parties.

To facilitate public participation, hearings of the licensing boards, with rare exceptions, are held in communities near each proposed facility site.

(See table describing NRC formal public hearings, above.)

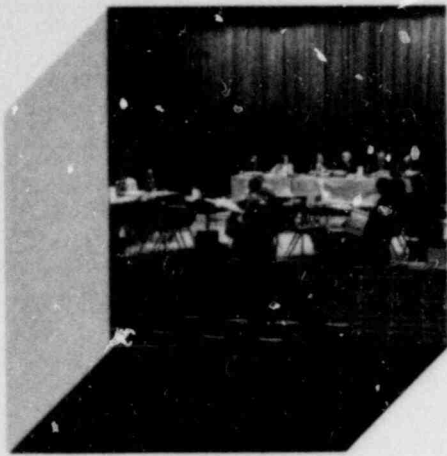

15

Proceedings and Litigation

Highlights of NRC adjudicatory activity during fiscal year 1980 are presented below, covering specifically activities of the Atomic Safety and Licensing Boards, the Atomic Safety and Licensing Appeal Boards, and significant decisions of the Commissioners. Brief accounts also are given of Federal court actions in which the NRC was a party or had an interest.

Delays continued in several facility license proceedings before licensing boards pending the NRC staff's evaluation and the boards' review of the Three Mile Island nuclear power plant accident. The Commission's November 1979 announcement that no licensing board decisions authorizing issuance of a construction permit, limited work authorization or operating license would be issued except after further order of the Commission itself, remained in effect. (See 1979 Annual Report, p. 255.) Subsequently, several operating licenses were authorized during the year by the Commission (see Chapter 4). In June 1980, the Commission issued a policy statement providing further guidance for the conduct of reactor operating license proceedings. This statement announced the intention in future actions on applications, to look to the list of "Requirements for New Operating Licenses" found in NUREG-0694 of June 1980 (superseded by NUREG-0737, "Clarification of TMI Action Plan Requirements," adopted on October 28, 1980) as setting forth requirements for new operating licenses which should be "necessary and sufficient for responding" to the TMI accident. Thus, current applications were to be judged against present regulations as supplemented by these TMI-related requirements. Insofar as certain provisions of NUREG-0694 seek to impose requirements beyond those necessary to show compliance with the regulations, "the (licensing and appeal) boards may entertain contentions asserting that the supplementation is unnecessary (in full or in part) and they may enter-

tain contentions that one or more of the supplementary requirements are not being complied with; they may not entertain contentions asserting that additional supplementation is required." (45 *Fed. Reg.* 41740.)

Thus, the policy statement allowed applicants for operating licenses to challenge in each adjudication the necessity for the supplementary requirements contained in NUREG-0694, while prohibiting intervenors from challenging their sufficiency.

On December 17, 1980, the Commission modified the June 20th policy to state that parties to an adjudication may challenge either the necessity for, or sufficiency of, supplementary TMI-related-requirements.

ATOMIC SAFETY AND LICENSING BOARDS

Atomic Safety and Licensing Boards perform the Commission's hearing function and render initial decisions on a variety of licensing and enforcement matters. Boards constitute the Commission's principal public forum, for it is here that individuals and organizations may voice their interests about a particular licensing or enforcement issue before an independent tribunal that will consider their concerns before rendering a decision.

The Atomic Energy Act of 1954 requires that a public hearing be held on every application for a construction permit for a nuclear power plant or related facility. An independent Atomic Safety and Licensing Board conducts this hearing. This board issues a decision on the application (known as an "Initial Decision") which, subject to the NRC's review and appellate procedures, may become the final NRC decision. The Act requires that a second opportunity

for hearing be provided before a license may be issued to operate a facility. A similar opportunity is provided before certain license amendments may be issued. Public participation is also invited in proceedings instituted by the NRC staff.

The Atomic Energy Act also requires that, prior to the issuance of a construction permit for a nuclear power plant or related facility, a determination be made by NRC as to whether the activities licensed by it would create or maintain a situation inconsistent with the antitrust laws. While the procedures for this review are more complex than those for other reviews, an opportunity to request a hearing before a licensing board is provided to those whose interests may be affected.

A licensing board consists of three members drawn from the membership of the Atomic Safety and Licensing Board Panel—a body of legal, technical, environmental, and other experts appointed by the Commission. As of September 30, 1980, the Panel included 13 permanent and 39 part-time members. Of these members, 17 are lawyers, 17 environmental scientists, 10 engineers, 6 physicists, 1 economist, and 1 chemist. (See Appendix 2 for names of members.) The Commission appoints members to the Panel based upon recognized experience, achievement, and independence in the appointee's field. Assignment of individuals to a licensing board depends on the kinds of issues involved in the proceeding before that board. Generally, a board consists of a lawyer-chairman, a nuclear engineer or reactor physicist, and an environmental scientist. However, antitrust problems are heard and decided by a board of three antitrust experts.

Aside from the hearing on antitrust matters, a hearing on a particular application may be divided into two phases—one concerning the health and safety and the common defense and security aspects of the application, as required by the Atomic Energy Act, and the other concerned with the environmental considerations required by the National Environmental Policy Act (NEPA). Separate initial decisions covering these matters may be issued.

As noted in last year's Annual Report, the Commission on November 5, 1979, announced that it was temporarily suspending its immediate effectiveness rule so that no construction permit, limited work authorization or operating license for a nuclear power reactor could issue without specific approval of the Commission itself. On June 16, 1980, the Commission issued a policy statement providing further guidance for power reactor operating licenses. Because of the necessity for the NRC staff to evaluate pending license applications in light of these evolving developments before taking a position in a hearing, licensing boards during fiscal year 1980 were unable to complete hearings and issue initial deci-

sions with respect to pending construction permit and operating license applications.

Three Mile Island Hearings

During the report period, boards have been concerned with a variety of license amendment and enforcement proceedings. Chief among these is the proceeding ordered by the Commission to determine whether Unit 1 of the Three Mile Island (TMI) Nuclear Station should be permitted to resume operation.

Following the accident at TMI Unit 2 on March 28, 1979, the Commission ordered that Unit 1 ("TMI-1") remain in cold shutdown until further order of the Commission itself subsequent to a hearing conducted by an Atomic Safety and Licensing Board to determine whether to permit restart of TMI-1 and, if so, under what conditions. In addition to the NRC staff and the licensee, Metropolitan Edison Co., there are 10 private intervening parties and four State and local government entities, including the Commonwealth of Pennsylvania and the Pennsylvania Public Utility Commission. After extensive discovery, specification of issues, and issuance of staff and licensee reports, the evidentiary hearing began in Harrisburg in October 1980. Although some 50 major contentions and a very large number of sub-contentions were accepted as issues in the proceeding, the excellent cooperation of most of the parties in specifying, reconsidering and consolidating contentions, in conjunction with the discovery process and the use of other prehearing procedures by the board (including the requirement that cross-examination plans be filed with the board), should result in a more efficient hearing than would normally be the case with the large numbers of parties and contentions.

Some of the issues are the management, technical and financial competence of the licensee, emergency planning, post-accident hydrogen control, interaction between Unit 2 and Unit 1, whether certain accident sequences previously categorized as Class 9 accidents should be considered, human factors engineering of control room design, analysis of the emergency feed-water system, qualification of equipment to withstand an accident environment and, overall, the sufficiency of the short-term and long-term actions proposed by the NRC staff to protect the health and safety of the public. At the end of fiscal year 1980, the Commission was still considering whether psychological stress should be dealt with as an issue in the proceeding.*

*On December 5, 1980, the Commission, by a 2-2 vote, determined that psychological stress should not be an issue in the proceeding. The Commission will however, reconsider its decision after the appointment of a fifth Commissioner.

The Three Mile Island accident has also led to the establishment of boards to deal with certain phases of the recovery operation at Unit 2. Thus, in authorizing the utility to decontaminate radioactive water at the site through the use of the EPICOR-II system, the Commission provided an opportunity for a hearing to be held on request by an interested person. Such a request was received and a board was established. The request was, however, withdrawn prior to hearing.

Similarly, a board was established to consider whether certain changes should be made in the technical specifications of the Unit 2 license which would better reflect the realities of the situation as it currently exists. A hearing on these matters should take place during the forthcoming year. That board was also empowered by the Commission to conduct any hearing that might be requested regarding the venting of krypton gas from the containment. Although a hearing was requested, that request was subsequently withdrawn.

In the wake of the accident, the Commission issued orders requiring certain modifications at other power reactors manufactured by the vendor of the TMI reactor to guard against a similar accident at another facility.

A hearing was requested and granted regarding application of the Order to the *Rancho Seco* (Calif.) facility. That hearing, in which the California Energy Commission was an active participant, was completed in May and a decision is expected in the forthcoming year. Principal issues included whether the containment should be modified to provide for controlled filtered venting, and engineering of the control room to take into account human factors.

Other Highlights

Highlights of non-TMI related matters during the year include the following.

In the *Trojan* (Ore.) proceeding, concerning certain modifications to the control building walls made necessary by the fact that the walls had been inadequately designed, a hearing was held in March and April 1980, and an initial decision issued in July. In that decision, the board imposed certain license conditions relating to the modifications and the method of carrying them out. At year-end the initial decision was before an appeal board with one of the imposed license conditions at issue.

In the *Vallecitos* (Calif.) proceeding, the board was compelled to decide whether a Congressman might violate certain Federal conflict of interest laws by participating in the proceeding in his official capacity. The board determined that the Congressman's good faith belief that he was representing the interests of his constituents through his participation, dictated

the conclusion that he was acting within the scope of his official duties.

During the report period, initial decisions were issued in the *Zion* (Ill.) and *Perkins* (N.C.) proceedings. In *Zion*, the board authorized expansion of the facility's spent fuel storage capacity, while in *Perkins* the board determined that there was no alternate site obviously superior to the chosen site. Authorization to begin construction at the *Perkins* site was withheld pending resolution of TMI-related issues.

In August 1980, the *Midland* (Mich.) antitrust board approved a settlement imposing license conditions that had been negotiated by Consumers Power Co. and the intervening utilities and approved by the NRC staff and Department of Justice. This formally brought to a close a proceeding that commenced in 1971 and was the subject of initial and appellate decisions on the merits of the controversy. At year-end, three other antitrust proceedings were in the prehearing stage.

ATOMIC SAFETY AND LICENSING APPEAL BOARDS

Atomic Safety and Licensing Appeal Boards, consisting of three members each, perform the Commission's review functions in facility licensing proceedings and in such others as the Commission may specify. Board membership for each proceeding is selected from among the members of the Atomic Safety and Licensing Appeal Panel by the Chairman of the Panel. (See Appendix 2 for membership of the Panel.)

Appeal boards entertain appeals from initial decisions of licensing boards and certain licensing board orders pertaining to petitions by members of the public seeking to intervene in NRC licensing proceedings. They also review initial decisions on their own initiative and sometimes consider questions on rulings referred by a licensing board while the proceeding before it is still in progress. Appeal boards occasionally conduct evidentiary hearings as part of their appellate review functions or as directed by the Commission. The appeal board is the highest level within the Nuclear Regulatory Commission at which a party may seek administrative review as a matter of right. Parties are permitted, however, to seek discretionary Commission review of certain appeal board rulings. The Commission also may itself decide to review an appeal board action. If the Commission does not review a decision, the decision of the appeal board becomes the final order of the Nuclear Regulatory Commission, subject to review in a Federal court of appeals.

Fiscal year 1980 was another active one for the appeal boards. During the year, the appeal boards



NRC licensing and appeal boards sometimes operate in somewhat makeshift circumstances to conduct public hearings near the plants or sites under consideration. Here, the Atomic Safety and Licensing Appeal Board considering seismic matters in the *Diablo Canyon* operating license proceeding conducts an evidentiary hearing in the Veterans Memorial Building auditorium at San Luis Obispo, Calif., in October 1980.

issued 50 decisions and orders which were included in *Nuclear Regulatory Commission Issuances*, the publication containing the adjudicatory issuances of the NRC. Numerous other unpublished orders, generally procedural in nature, were also issued by the appeal boards in the course of conducting the proceedings before them.

These appellate proceedings raised a variety of important legal, technical and other issues requiring appellate resolution. Some of the more significant decisions are highlighted below.

Health and Safety Questions

Safety questions were central to several appeal board decisions. In the *North Anna* (Va.) proceeding, an issue raised by an intervenor concerned the settlement of the land under the pumphouse which helps to provide service water for the plant. After conducting evidentiary hearings, the appeal board found that land settlement, while occurring, did not threaten the safe operation of the plant. Another issue, that concerning the plant's ability to withstand damage from missiles which might result if turbine blades broke while in operation, remained before the appeal board at year-end, awaiting the evaluation of recent experience involving other plants. The appeal board determined, however, that on the basis of current data, operation could be safely continued until Unit 1 is shut down for refueling and its turbine is inspected in early 1981.

In the *St. Lucie* (Fla.) proceeding, the principal question was whether the electrical system serving the plant was adequate to allow safe shutdown in emergency situations. On the basis of evidence

adduced at an evidentiary hearing which it conducted, the appeal board imposed certain conditions for the purpose of improving the ability of company personnel to deal with loss-of-power situations.

Black Fox (Okla.) involved the question whether the health effects of radioactive effluents released during normal plant operation at levels meeting the Commission's "as low as is reasonably achievable" requirements was litigable in individual licensing proceedings. The licensing board had allowed litigation to take place but found the health effects in this case to be negligible. The appeal board agreed with the licensing board's findings on the merits, but because the litigability issue could be significant in future proceedings, referred that question to the Commission. Subsequently, the Commission ruled that the health effects issue could be litigated in individual proceedings.

In *Diablo Canyon* (Calif.), an operating license proceeding, the appeal board reopened the issue of the plant's ability to withstand the effects of earthquakes. This was done to consider new data which developed after hearings on the operating license application with respect to seismic matters were concluded. Evidentiary hearings on this and another issue concerning the security plan for the plant are scheduled to be conducted in early fiscal year 1981.

Environmental Issues

The environmental and health effects of radon (Rn-222) releases produced in the mining and milling of uranium continued to require the attention of the appeal boards. As reported last year, because the question was common to a number of proceedings, several proceedings including that involving the

Peach Bottom (Pa.) plant, were consolidated for hearing. Evidentiary hearings were conducted by the three members of the appeal panel selected by the panel membership on the items still in dispute. A decision remains pending. (See also Chapter 6.)

In another proceeding involving an environmental issue, the question was whether an early site review required the preparation by the staff of a full-scale environmental impact statement. In the *Carroll County Site* (Ill.) early site review proceeding, the appeal board ruled that it did not. The basis for the ruling was that an early site proceeding is not "a major Federal action significantly affecting the quality of the human environment," inasmuch as it cannot authorize any work on the site that might produce environmental effects.

Another *North Anna* decision involved a proposed operating license amendment to increase the capacity of the plant's spent fuel pool. One of the many issues concerned the need to consider alternatives to the expansion of the spent fuel pool. The appeal board held that there is no requirement in NEPA to explore alternatives to a proposed action unless there is some basis for believing that the action might either have a significant environmental effect or give rise to a controversy over the allocation of resources. In this case, no such basis existed. The Commission denied a petition for review of the appeal board decision.

Intervention and Procedural Issues

During the year, the appeal boards dealt with a number of questions relating to the requirements that persons and organizations desiring to intervene in NRC proceedings must meet.

Allens Creek (Texas) involved the appeals of several persons who desired to intervene in this reactivated construction permit proceeding. Each had been denied permission because the time requirements for filing petitions or submitting contentions had not been met. The appeal board found the reasons given by the petitioners for their late actions inadequate, and upheld the denials. An important consideration in the appeal board's decision was that the petitioners had done little, if anything, to ascertain what was required of them to become a party to the proceeding and to discharge their obligations. In another decision involving the same plant, the appeal board held against a petitioner whose intervention petition was rejected by the licensing board. That person had sought to intervene on the ground that his planned investments in Houston real estate could be adversely affected by the construction and operation of the *Allens Creek* facility. In agreeing with the licensing board's action, the appeal board ruled that an interest which is purely economic in character is

insufficient to provide the basis for intervention in NRC licensing proceedings.

The *Allens Creek* proceeding was the source of still another appeal board decision on the subject of intervention. The question there was whether an intervenor's contention asserting, without detailing its factual basis, that building and operating a marine biomass farm was environmentally preferable to the *Allens Creek* plant, met the requirements for intervention. Relying on its 1973 *Grand Gulf* decision, the appeal board ruled that a petitioner need not, as a precondition to intervention, establish the existence of factual support for his contention.

In another proceeding involving an important procedural issue, the Governor of California sought to appeal a decision of the licensing board in which he had not participated as a party. In denying the Governor the right to appeal, the appeal board held in *Diablo Canyon* (Calif.) that because he had not assisted in the development of the record before the licensing board, he could not claim the right to appeal from that board's decision.

Sterling (N.Y.) dealt with an applicant's motion to terminate a construction permit proceeding while an appeal of the licensing board's decision authorizing the issuance of the permit was before the appeal board. The applicant had requested termination of the proceeding in the wake of a refusal by the State to issue a necessary "siting" certificate. The appeal board granted the request and ordered the construction permit revoked. *North Coast* (Puerto Rico) was another proceeding in which the question of termination was raised. There, the licensing board, upon a motion for dismissal of the proceeding by the intervenor, had ruled that absent a withdrawal request from the applicant, it lacked the authority to dismiss or deny a pending construction permit application without going through a hearing on the application even if it should clearly appear that the applicant had abandoned any intention to build the facility in question. In reversing that ruling, the appeal board noted that nothing in the Atomic Energy Act or in the Commission's Rules of Practice, relied on by the licensing board for its decision, contained any limitation upon the inherent authority of adjudicatory tribunals to dismiss those matters placed before them which have been mooted by supervening developments.

Authority Over Staff

The question of the licensing board's authority over the NRC staff came up for appeal board decision in *Shearon Harris* (N.C.). There, in conjunction with its authorization of a construction permit for the facility, the licensing board had ordered the staff to initiate action for a hearing when operating licenses

are sought for the plant in the future. On appeal by the staff, the appeal board ruled that licensing boards have no independent authority to initiate any form of adjudicatory proceeding. In lieu of that condition, the appeal board directed the staff not to issue a notice of hearing until it had taken certain steps relating to a preliminary assessment of the applicant's management capability to operate the facility. Subsequently, the Commission undertook review of the decision and ruled that licensing and appeal boards do not have the authority to direct the staff in the performance of its administrative functions—that the Commission itself has that authority. Consequently, the Commission reversed the appeal board's issuance of the instructions to the staff, but directed the staff to take the same measures which had been prescribed by the appeal board.

Board Composition and Procedures

Complaints against the composition of a licensing board and the conduct of prehearing discovery were the separate subjects in two appeal board decisions. In a show-cause proceeding involving the *La Crosse* (Wisc.) plant, a petitioner for intervention sought to disqualify the entire licensing board which had been assigned by the Commission to conduct it. The licensing board rejected the request and, following prescribed procedure, referred the matter to the appeal board. Upon consideration, the appeal board summarily affirmed the licensing board's decision, concluding that the request was patently without substance. In *Susquehanna* (Pa.), the appeal board dealt with the complaint of two intervenors on the manner in which pretrial discovery was being conducted in the operating license proceeding for the plant. The intervenors had alleged that the applicants and the NRC staff had abused the discovery procedures in order to block their effective participation and that the licensing board's rulings aided this abuse of the procedures. Upon review, the appeal board found that the complaints were not substantiated by the record. The intervenors have sought Commission review of the appeal board's decision. At year-end, the Commission had not ruled on their request.

Civil Penalty Proceedings

Atlantic Research Corporation (Va.) was a civil penalty proceeding. On an earlier occasion, the appeal board had ruled that, in circumstances where a license violation had occurred without any management culpability, no penalty should be assessed against the licensee. Subsequently, the Commission decided that a civil penalty may be imposed in the absence of management culpability and remanded

the proceeding to the appeal board for determination whether the proposed penalty should be mitigated. (see "Commission Decisions," below). The appeal board then set the amount at \$2,000, reducing it from the \$8,600 penalty that had been recommended by the Director of the Office of Inspection and Enforcement. The appeal board determined that the reduced amount would achieve the objective of focusing the attention of licensees upon the importance of scrupulous compliance by their employees with all regulatory requirements, while taking into account the mitigating factors present in this case.

In *Radiation Technology, Inc.* (N.J.), the appeal board upheld the assessment of \$4,050 in civil penalties against the byproduct materials licensee for eight license violations.

COMMISSION DECISIONS

Some of the Commission's more significant decisions during fiscal year 1980 are discussed below. The Commission's actions on export licensing cases are discussed in Chapter 11.

St. Lucie Antitrust

In this case involving Florida Power & Light Company's St. Lucie Plant, the Commission decided that, as a matter of discretion, it would not institute an antitrust proceeding under Section 105a of the Atomic Energy Act until a pending district court proceeding had been completed. The Commission's order, issued December 21, 1979, explained that two advantages were to be gained by awaiting the district court decision (remanded from the 5th Circuit Court of Appeals): (1) the Commission would be better able to decide what additional remedies, if any, were needed, and (2) the district court decision would assist in determining whether the threshold test for applying section 105a had been met.

Commissioner Bradford dissented, disagreeing both with the majority's view of the legislative history of Section 105a and with the majority's claimed advantages in awaiting a district court decision. Commissioner Bradford would have referred the issues raised by the 5th Circuit decision to the licensing board already presiding over a Section 105c proceeding for St. Lucie Unit 2 and Turkey Point Units 3 and 4.

ENO Decision—Three Mile Island

In a decision issued April 16, 1980, the Commission determined that the accident at Three Mile

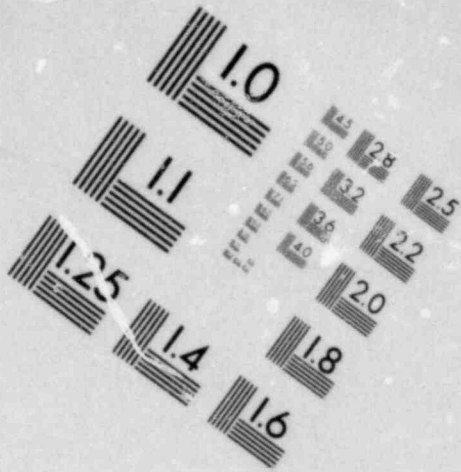
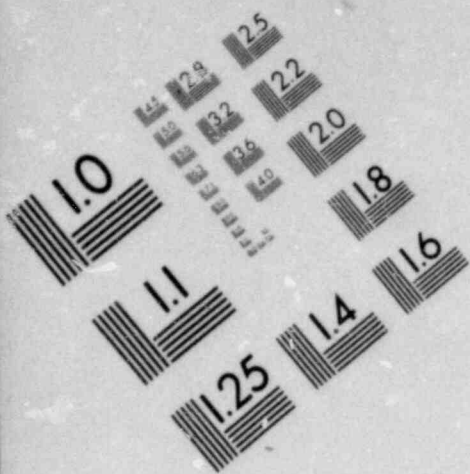

**IMAGE EVALUATION
TEST TARGET (MT-3)**

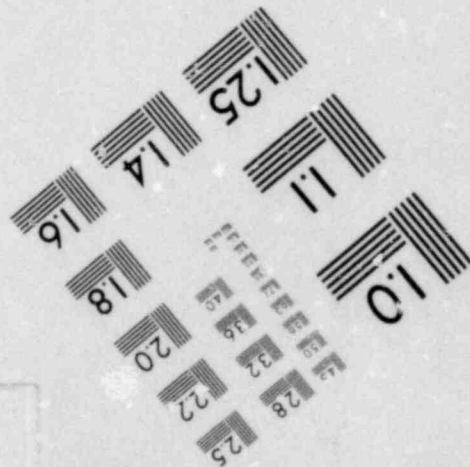
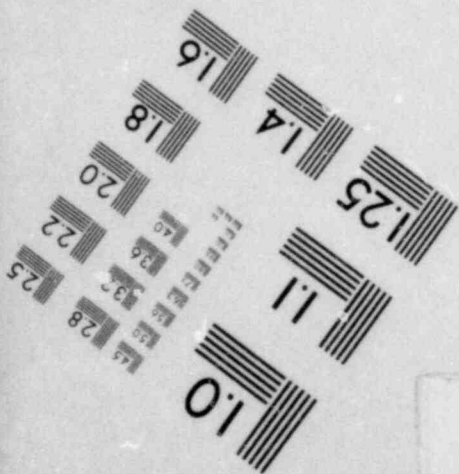
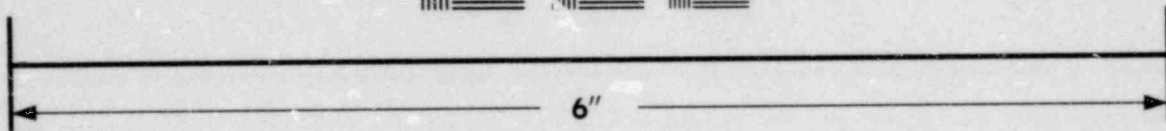

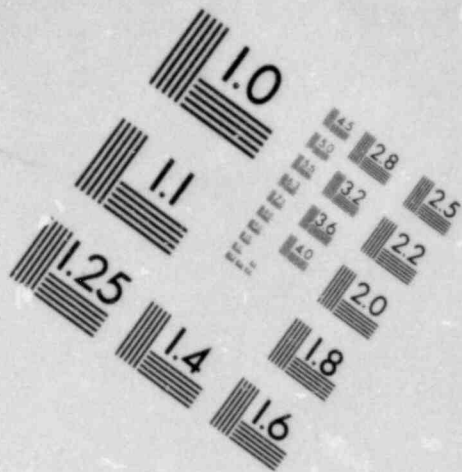
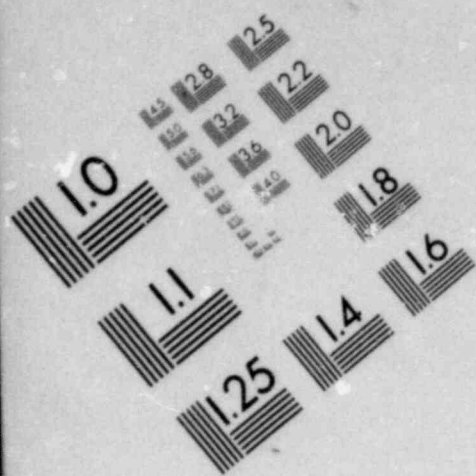
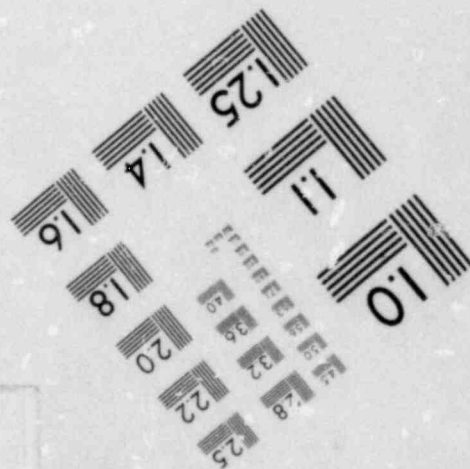
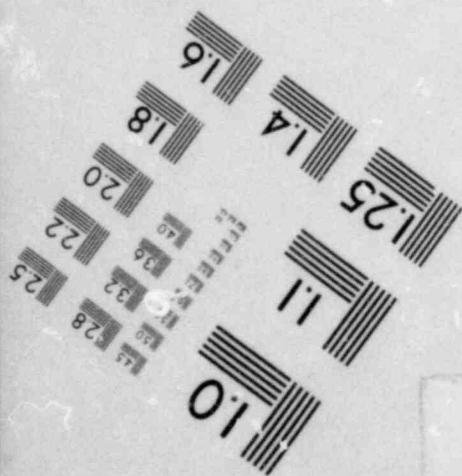
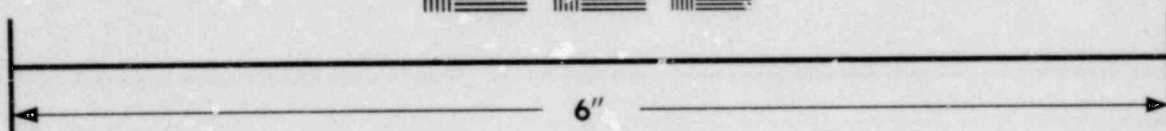
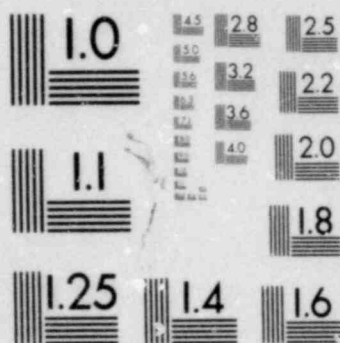

IMAGE EVALUATION
TEST TARGET (MT-3)



Island did not constitute an "extraordinary nuclear occurrence" (ENO) as that term is defined in the Price-Anderson Act and the Commission's regulations. (See 45 *Fed. Reg.* 27590, April 23, 1980.) The Commission found that the radiological releases associated with the accident did not meet Criterion I of the Commission's regulations, 10 CFR 140.84. The Commission made no explicit finding on Criterion II, dealing with offsite "damages," principally because it found this criterion could not be applied with any certainty to the facts of the Three Mile Island accident. Since both criteria must be met for an ENO to be found, the Commission determined that the accident at Three Mile Island was not an ENO. In brief, this meant that lawsuits associated with the accident would proceed under applicable State and Federal law rather than under certain strict liability sections of the Price-Anderson Act. (See also Chapter 4.)

Diablo Canyon—Physical Security

On June 12, 1980, the Commission issued an order directing that the applicant, Pacific Gas & Electric Co., allow counsel and expert witnesses for the intervenor, San Luis Obispo Mothers for Peace, to examine a "sanitized" version of the Diablo Canyon Nuclear Power Plant physical security plan. Under the terms of the Commission's order, these individuals would be required to execute an affidavit prohibiting them from publicly discussing or disseminating sensitive physical security information acquired through the NRC hearing process. The Commission noted that its regulations, namely 10 CFR 2.790, do contemplate that sensitive information may be turned over to intervenors in NRC proceedings under appropriate protective orders.

Sterling Power Project

On May 29, 1980, the Commission issued a memorandum and order in the proceeding on Rochester Gas & Electric Co.'s Sterling Project site which affirmed a decision by an Atomic Safety and Licensing Appeal Board. The appeal board had interpreted the Commission's "obviously superior" standard for choosing among alternative sites to require that an alternative site must be "clearly and substantially superior" for a licensing board to reject an applicant's proposed site. Commissioners Kennedy and Hendrie found that the general criteria contained in the appeal board's interpretation are consistent with the standard for comparing alternative sites established in the Commission's *Seabrook* decision and affirmed by the courts. Commissioner Gilinsky, in a separate opinion, agreed to affirm the

appeal board's interpretation because, as a practical matter, a licensing board can have the requisite degree of confidence to reject an applicant's proposed site only if an alternative site is substantially better.

Chairman Ahearne and Commissioner Bradford dissented on the grounds that the appeal board's interpretation of the "obviously superior" standard would require a licensing board to be confident that an alternative site is better by a large margin before rejecting an applicant's proposed site. Such a requirement, in the view of these Commissioners, is not contained in the "obviously superior" standard announced in *Seabrook*.

Waste Confidence Rulemaking

On October 25, 1979, the Commission announced initiation of a rulemaking proceeding to reassess its degree of confidence that high-level radioactive wastes produced by civilian nuclear facilities will be disposed of safely, and to determine when such disposal will be available and whether such wastes can be stored safely until safe disposal is available. The first prehearing conference was held on January 29, 1980. Subsequently, the presiding officer determined that the proceeding would deal only with the disposal of spent fuel and not with high-level reprocessed waste, and that safety issues regarding the transportation of spent nuclear fuel are beyond the scope of this proceeding. He also announced that approximately 130 core documents would be available for use by participants at the Department of Energy's (DOE) regional public document rooms, and that DOE would file its statement of position first to enable participants to focus their statements on significant facts and conclusions. DOE submitted its statement of position on April 15, 1980. Over 30 other participants have since filed statements of position.

On May 12, 1980, the Commission established a working group comprised of NRC personnel who will review the participants' submissions, identify issues in controversy, and assist in obtaining any further information required to assure the development of a complete record. Participants have since filed with the Commission cross-statements and suggestions for further procedures and additional areas of inquiry.

Marble Hill Hearing Request

The Commission denied a request for hearing filed by two public interest groups, the Sassafras Audubon Society (SAS) and the Knob and Valley Audubon Society (KVAS), regarding construction problems at the Marble Hill, Indiana, nuclear station. In a memorandum and order dated March 13, 1980, the Commission held that the petitioners lacked standing



NRC inspector examines "honeycombing" in containment concrete at the Marble Hill Nuclear Power Station, under construction in Indiana. Continuing construction deficiency problems led to a show cause order by NRC's Office of Inspection and Enforcement and corrective actions. (See Chapter 9 under "Investigations.")

to request a hearing on an order issued by the Director of the Office of Inspection and Enforcement, and declined to grant a hearing as a matter of discretion. The majority opinion found that petitioners did not meet judicial criteria for standing in that they requested relief beyond that already granted—shutdown of construction at the site—but did not actually complain of actions already taken by the Director. In a dissenting opinion, Commissioner Bradford outlined reasons why a discretionary hearing should have been granted. In a subsequent matter involving the application of the Marble Hill decision to a request for hearing on steam generator tube integrity at Point Beach Unit I (Wisconsin), Commissioners Bradford and Gilinsky disagreed strongly with the majority's conclusions about standing.

Criteria for Antitrust Significant Changes Finding

On June 30, 1980, the Commission responded to Central Electric Power Cooperative's petition for a finding that significant changes had occurred in the activities and proposed activities of applicants for an operating license at the Virgil C. Summer Nuclear Station in South Carolina. The Commission announced that it was requesting the assistance of

the Attorney General before finally deciding the matter; however, in so doing, it took the occasion tentatively to elaborate on the role and elements of the significant changes decision. The Commission chose this occasion, despite its atypicality, both because it was the first significant changes decision to come before the Commission in a contested posture and because it wished to provide guidance to the NRC staff, to whom it had recently delegated the authority to make this finding.

The Commission's order specified the following criteria for decision on significant changes:

- (1) Changes must have occurred "since the previous antitrust review." By that language it is meant since the previous *formal* review—at least the publication of the advice of the Attorney General, and extending to include a subsequent antitrust hearing.
- (2) Those changes must be "reasonably attributable to the licensee." This provision incorporates a fairness consideration, that licensees not be required to undergo a second antitrust review where they may not be held responsible or answerable for the changes in the competitive situation.
- (3) The changes must have "antitrust implications that would be likely to warrant Commission remedy." This criterion focuses on whether the situation, as changed, would be one warranting remedial action. To determine this, the Commission must take a hard look at the same matters that would be addressed after an affirmative significant changes decision. This is in the nature of a threshold test and requires prediction of answers to two questions: (a) whether an antitrust review would be likely to conclude that the situation as changed has negative antitrust implications, and (b) whether the Commission has available remedies. To make this determination the Commission requires the tentative views of the Attorney General on whether, in the event of an affirmative significant changes decision, a hearing would be required.

Parties and the Department of Justice were provided an opportunity to comment on this opinion.

Atlantic Research Civil Penalty

On March 14, 1980, the Commission overturned an appeal board decision holding that no civil penalty may be imposed under Section 234 of the Atomic Energy Act in the absence of specific licensee misfeasance, malfeasance, or non-feasance, or specific lack of licensee correction action. CLI-80-7, 11 NRC

413 (1980), reversing ALAB-542, 9 NRC 611 (1979). The appeal board had reasoned that without such a finding a civil penalty was punitive (as opposed to "remedial") and thus beyond the scope of Section 234. The Commission disagreed and vacated the appeal board decision, concluding that neither Section 234 nor its legislative history "compell[ed] the restriction the appeal board would place on the NRC's discretion to impose civil penalties...." 11 NRC at 419.

The Commission rejected the "punitive-remedial" dichotomy created by the appeal board as not useful in the NRC's statutory framework, since "[a]ll penalties are punitive in the view of the offender who pays them." *Id.* at 420. The Commission held that as long as there is a violation of Commission regulations, and the penalty is not "grossly disproportionate to the gravity of the offense," a civil penalty may be imposed. *Id.* at 421.

The Commission's decision outlined several important policy considerations. First, the Commission intended to provide an incentive for licensees to scrutinize their internal procedures for possible violations of Commission regulations. Second, the Commission emphasized that licensees would be held strictly responsible for safety. In the Commission's view, civil penalties provide one method for assuring licensee compliance with these policies.

Commissioner Hendrie concurred in the opinion, noting that the Commission's decision reflected its judgment, as a matter of regulatory policy, on the scope of its authority to impose civil penalties and that such authority was not without limit. Commissioner Kennedy dissented, finding the majority's view "so expansive as to exceed both our statutory mandate and the dictates of sound policy." *Id.* at

427. He concluded that the appeal board's approach was the more fair and reasonable regulatory policy.

The Commission remanded the case to the appeal board solely on the issue of mitigation. Upon further consideration, the appeal board mitigated the \$8,600 penalty to \$2,000. ALAB-594, 11 NRC 841 (June 2, 1980).

South Texas Project

The South Texas Project, for which Houston Lighting & Power Company holds a construction permit, has been the subject of 12 separate NRC investigations over a three-year period, involving conferences with the licensee, several prior items of noncompliance, a deviation, five immediate action letters, and recently substantiated allegations of harassment, intimidation and threats directed to quality assurance/quality control personnel and defects in the licensee's quality assurance/quality control program. These latest allegations, discovered as the result of an NRC investigation, formed the basis for an order to show cause why safety-related construction at the site should not be stopped until the licensee changes its procedures and operations. A fine of \$100,000 was also imposed. The licensee paid the fine and agreed to make widespread changes in its quality assurance/quality control program, the primary responsibility for which had previously been delegated to the licensee's contractor, Brown & Root, Inc. However, two local organizations requested a formal adjudicatory hearing on the show cause order. These organizations were intervenors in a presently-pending operating license adjudication for the South Texas plants, where the licensing board

NRC's Office of Inspection and Enforcement conducted a public meeting at Bay City, Texas, on August 19, 1980, to discuss quality control and management problems in construction of the Houston Lighting & Power Co.'s South Texas Nuclear Project. (See Chapter 9 under "Investigations.")

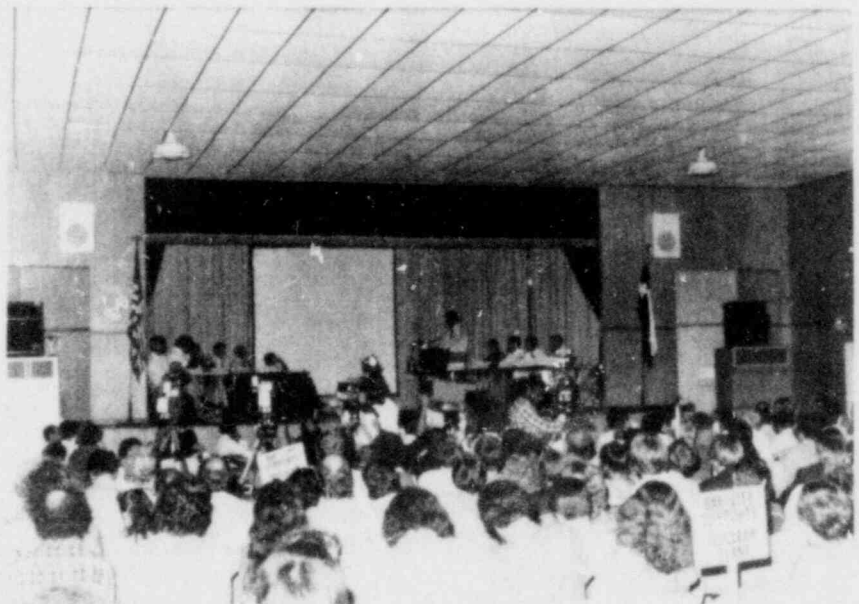

admitted their contentions of an inadequate quality assurance/quality control program.

On September 22, 1980, the Commission denied the request for the hearing on the show cause order on the grounds that the organizations were not entitled to a hearing as a matter of right and that a discretionary hearing on the order would not be an appropriate forum for a trial of the allegations. Instead, the Commission directed that the allegation be examined in the presently pending operating license proceeding, and that the licensing board issue an expedited, partial initial decision on the charges.

The Commission noted that despite a determination by the Director of Inspection and Enforcement in an enforcement action that a licensee has responded adequately to the concerns that formed the basis of a notice of violation or a show cause order, a licensing board in an operating license proceeding is not bound by this determination from making a decision which would further restrict, or even deny a license for, the operation of a facility. With reference to the licensee's previous approach to its quality assurance/quality control program, the Commission stated that either abdication of responsibility or abdication of knowledge on the part of a licensee or prospective licensee, whether during the construction or operation phase, can form an independent and sufficient basis for revoking a license or denying a license application on the grounds of lack of competence (i.e., technical) or character qualification under section 182a of the Atomic Energy Act. Additionally, after noting that the licensing board should also look into allegations of apparently false statements in the licensee's Final Safety Analysis Report, the Commission stated that false statements in documents submitted to the NRC may lead to denial of an initial license application or revocation of a license already held. In the interim, the Director of Inspection and Enforcement is closely monitoring the changes in operations that have been implemented or proposed by the licensee, and is assuring himself that construction can be recommenced. (See also Chapter 9.)

JUDICIAL REVIEW

Pending Cases

Sholly v. NRC (D.C. Cir., Nos. 80-1691, 80-1783 and 80-1784)

This lawsuit sought an injunction against the venting of krypton-85 from the TMI-2 reactor building. In orders dated June 26, June 27 and June 28, 1980, the D.C. Circuit denied the requests for injunctive relief. In a companion case seeking essentially the same relief, *PANE v. NRC* (3rd Cir., Nos. 80-1994

and 80-1995), the Third Circuit on July 10 transferred the cases to the D.C. Circuit for disposition. The cases were argued on the merits in September 1980. On November 19 the D.C. Circuit declared illegal the Commission's refusal to hold hearings in connection with its approval of venting the Three Mile Island containment of krypton early last summer. The D.C. Circuit held that even where a license amendment involves no significant hazards consideration, any interested person who requests a hearing is entitled by Section 189(a) of the Atomic Energy Act to a hearing before the amendment becomes effective. The court also held that the TMI-2 accident had essentially negated any operating authority in the TMI-2 license so that any action not authorized by the Commission's February 11 order establishing post-accident conditions for TMI-2 is a license amendment subject to Section 189(a) hearing requirements. (See Chapter 1.)

Susquehanna Valley Alliance v. Three Mile Island, 485 F. Supp. 81 (M.D. Pa.), *rev'd in part*, 619 F.2d 231 (3rd Cir.), *Cert. Pet. Pending sub nom. General Public Utilities Corp. v. Susquehanna Valley Alliance* (S.Ct. No. 80-382) (TMI)

The Susquehanna Valley Alliance brought this lawsuit on May 25, 1979, alleging that the Commission had approved the construction and operation of EPICOR-II, a demineralizing and filtration system designed to decontaminate intermediate-level radioactive waste water resulting from the TMI accident, and intended to allow discharge of the treated water into the Susquehanna River in violation of the Atomic Energy Act, the National Environmental Policy Act (NEPA), the Clean Water Act and various provisions of the United States Constitution. On that same day [and in response to a lawsuit raising virtually the same issues, *City of Lancaster v. NRC* (D.D.C., No. 79-1368)] the Commission issued a statement prohibiting the treatment or discharge of contaminated water, except for certain routine operational releases, until completion of an environmental assessment. On October 12, 1979, while the Commission was still considering EPICOR-II operation, the district court dismissed the complaint for lack of subject matter jurisdiction on the ground of SVA's failure to exhaust its administrative remedies. Thereafter, the Third Circuit reversed the dismissal of SVA's claims under NEPA, the Clean Water Act and the Constitution, but affirmed the dismissal of the Atomic Energy Act claim. A petition for writ of certiorari, filed by the utility, was pending at year-end.

Union of Concerned Scientists v. NRC (D.C. Cir. No. 80-1962)

On August 14, 1980, the UCS and five other organizations sought review in the D.C. Circuit of the Commission's statement of policy entitled

"Further Commission Guidance for Power Reactor Operating License," 45 *Fed. Reg.* 41738 (June 20, 1980). Petitioners contend that the policy statement unlawfully discriminates between parties to NRC adjudications by permitting applicants for operating licenses to challenge in each adjudication the necessity for the additional licensing requirements contained in NUREG-0694, while prohibiting intervenors from challenging their sufficiency. (In December, the Commission modified its June statement of policy. See beginning of this Chapter.)

Citizens Action for Safe Energy v. NRC (D.C. Cir. No. 80-1566)

This lawsuit, filed May 27, 1980, challenges the appeal board's decision in ALAB-587 which deferred for the present further consideration of Class 9 accidents in connection with the Black Fox plant. Petitioners contend that NEPA requires the Commission to prepare a supplemental environmental impact statement to consider the consequences of Class 9 accidents. Briefing was expected to be completed by December 1980.

Natural Resources Defense Council v. NRC (D.C. Cir. No. 80-1477) (Philippines)

On May 6, 1980, a number of environmental groups sued to set aside two Commission orders, the first of which had found that the export of a nuclear reactor and certain components to the Republic of the Philippines met all the applicable licensing criteria in the Atomic Energy Act of 1954, as amended by the Nuclear Non-Proliferation Act of 1978, and directed issuance of export licenses to the Westinghouse Electric Corp. In the second order the Commission declared that it would adhere to the policy reflected in its earlier licensing decisions and only consider those health, safety, and environmental impacts arising from exports of nuclear reactors that affect the territory of the United States or the global commons. The case was argued before the D.C. Circuit in September 1980, and is awaiting decision. On December 10, the court denied a motion to stay or prevent actual export of certain components pending a decision. (See Chapter 11 in this Annual Report and pp. 189 and 193, 1979 Annual Report.)

Natural Resources Defense Council v. NRC (D.C. Cir. No. 80-1328) (Part 21)

On March 24, 1980, NRDC Council sought review of a January 23, 1980 letter from the Chairman of the Nuclear Regulatory Commission denying its request that the Commission rescind certain amendments to 10 CFR Part 21. The Commission had adopted the amendments on October 19, 1978, without notice or comment, through the issuance of an immediately effective rule clarifying that items that are available in general commerce and which have no unique design requirements imposed for

nuclear application, are not within the scope of the Commission's rule pertaining to the reporting of defects in safety-related components. Briefing was completed in October 1980.

People of the State of Illinois v. NRC (D.C. Cir. No. 80-1163) (Bailly)

On February 7, 1980, the State of Illinois filed a lawsuit challenging the Commission's determination that the plan of the Northern Indiana Public Service Co. for installing foundation piles for the Bailly nuclear generating station in Indiana was not a design change requiring a construction permit amendment and a hearing as of right, and was not of such safety significance as to warrant a discretionary hearing. The Commission's decision noted that piling issues had appropriately been left for later resolution, and that the Advisory Committee on Reactor Safeguards had advised that the use of shorter pilings was not a significant design change from the standpoint of engineering. Briefing was completed in October 1980. (See 1979 Annual Report, pp. 261-272.)

Natural Resources Defense Council v. NRC (D.C. Cir. Nos. 80-1863 and 80-1864) (NFS Erwin)

These lawsuits filed July 28, 1980, seek review of two Commission orders involving the Nuclear Fuel Services' facility at Erwin, Tenn. In No. 80-1863, NRDC challenges an interlocutory Commission order that granted NRDC a hearing on a proposed license amendment for the NFS Erwin facility which was less adversary than petitioners sought. In No. 80-1864, NRDC challenges an immediately effective rule issued June 26, 1980, which amended the Commission's rules of procedures to incorporate the military function exception of the Administrative Procedure Act, and applied that adjudicatory exception to the ongoing license amendment proceeding for NFS Erwin. On September 29, 1980, the D.C. Circuit denied the Commission's motion to dismiss the rule challenge, stayed the rule pending appeal, and held the hearing case in abeyance.

Prairie Alliance v. NRC (C.D. III. No. 80-2095)

General Electric Co. v. NRC (D.D.C. No. 80-2659)

On May 7, 1980, the Prairie Alliance sued the NRC under the Freedom of Information Act (FOIA) to compel disclosure of the General Electric nuclear reactor study known as the Reed Report for its principal author. While that lawsuit was pending, on October 9, 1980, the Commission on a 2-2 vote was unable to muster a majority to claim any FOIA exemption for the report, and hence ordered its release. The General Electric Co. (G.E.) thereupon filed a complaint and a request for a temporary restraining order to enjoin release of the report and require its return to General Electric. Judge Aubrey Robinson ordered that G.E.'s case be transferred to

Federal district court in Illinois where the Prairie Alliance case had been filed, and enjoined the Commission from releasing the Reed Report pending disposition of the case by that court. A decision is expected in the first quarter of 1981.

Simmons v. Arkansas Power and Light Company and NRC (E.D. Ark., LR-80-C-263, on appeal, 8th Cir., No. 80-1633)

On May 30, 1980, plaintiffs Simmons, *et al.*, sued Arkansas Power and Light Co., the NRC, the State of Arkansas, and various State agencies seeking an injunction against operation of Arkansas Power & Light Unit 1, alleging that the emergency planning and preparedness program for the facility is inadequate. A hearing on the motion for preliminary injunction was held June 17-18, 1980. At the conclusion of plaintiffs' testimony and after argument on the motions to dismiss the lawsuit, Circuit Judge Arnold, sitting by designation, ruled from the bench that the constitutional claims were insubstantial, that there was no subject matter jurisdiction over the Federal statutory claims for plaintiffs' admitted failure to exhaust remedies under 10 CFR 2.206, and because exclusive judicial review over NRC actions is in the U.S. Courts of Appeals, the court lacked pendant jurisdiction over the State law claims. Plaintiffs have appealed that ruling to the Eighth Circuit, where briefing was completed in October.

Duke Power Co. v. NRC (D.C. Cir. No. 80-2253)

On October 10, 1980, Duke Power Co. filed a lawsuit challenging the Commission's final rule on radiological emergency planning issued August 11, 1980. 45 *Fed. Reg.* 55402. The utility indicated that it would also ask for Commission reconsideration of the rule and would defer pressing the lawsuit pending Commission disposition of the petition for reconsideration.

Kerr-McGee Nuclear Corp. v. NRC (10th Cir. No. 80-2043)

On October 3, 1980, Kerr-McGee petitioned the Tenth Circuit to review the Commission's uranium mill licensing requirements which were issued that day. 45 *Fed. Reg.* 65521-38. The complaint contends that the Commission's regulations imposed a substantial and unreasonable burden upon Kerr-McGee's uranium-processing operations.

Ft. Pierce Utilities Authority v. NRC (D.C. Cir. No. 80-1099)

On January 21, 1980, the Ft. Pierce Utilities Authority filed a lawsuit challenging the Commission's decision not to initiate at this time a Section 105a antitrust proceeding against the Florida Power & Light Company. The request had been prompted by a Fifth Circuit decision ruling that the Commission licensee had conspired with Florida

Power Corp. to divide the wholesale power market in Florida. The Commission reasoned that Section 105a was designed to supplement court ordered relief and that, until the Federal district court issued its decision, it was unclear what supplementary relief from the Commission might be necessary. Briefing was completed in July 1980.

Potomac Alliance v. NRC (D.C. Cir. No. 80-1862)

On August 28, 1980, the Potomac Alliance sought review of the appeal board's decision granting the Virginia Electric & Power Co. an operating license amendment to expand the capacity of its North Anna Unit 1 spent fuel pool. Petitioner claims that the Commission illegally failed to consider the environmental effects of storing spent fuel at the site after the plant's operating license has expired. The Commission's motion to dismiss the petition as untimely was denied on September 29, 1980.

Potomac Alliance v. NRC (D.C. Cir. No. 80-2122)

On September 18, 1980 the Potomac Alliance filed a lawsuit seeking to enjoin the repair of Virginia Electric & Power, Co.'s Surry Nuclear Power Station Unit 1 steam generators pending a more complete environmental impact statement. On October 3, the D.C. Circuit denied petitioner's request for an injunction. Repairs on the steam generators were begun on October 5.

Eason v. NRC (D.C. Cir. No. 80-1382)

This is an appeal from the February 6, 1980, decision of Judge Penn which dismissed plaintiff's FOIA request for a subscription to "Media Monitor." Judge Penn ruled that the FOIA did not encompass documents not yet in existence and that the Commission had not withheld any copies of the publication. The D.C. Circuit heard argument in the case on December 12, 1980.

Virginia Sunshine Alliance v. NRC (D.D.C. No. 80-2099)

On August 18, 1980, three groups brought suit to compel the Commission to release agency records concerning the details about routes for spent fuel shipments. The administrative request had pre-dated enactment on June 30, 1980, of a new Section 147 to the Atomic Energy Act. Consequently, the request was re-evaluated in light of the new criteria when the lawsuit was brought. On October 24, the Commission disclosed a number of documents to plaintiffs and filed an affidavit in court supporting the continued withholding of information covering communication dead zones, safe havens, and law enforcement response capabilities.

U.S. Nuclear Regulatory Commission v. Radiation Technology, Inc. (D.N.J. No. 80-2187)

On July 15, 1980, the Commission sued Radiation Technology, Inc., to collect civil penalties imposed

by the NRC under Section 234 of the Atomic Energy Act, for a series of infractions and deficiencies at defendant's Rockaway, New Jersey facility. A motion for summary judgment was in preparation at year-end.

Frisby, Kaiser and Clary v. IRS, NRC and MSPB (D.C. Cir. No. 80-1442)

This lawsuit was brought on April 18, 1980, by employees of two Federal Agencies who had been dismissed from government service. The Merit Systems Protection Board reopened the cases in light of the board's decision in *Wells v. Harris* (MSPB No. RR-80-3) for hearing officers to determine whether dismissal would have been proper under the standards for adverse actions of 5 U.S.C. Chapter 75, rather than under the Civil Service Reform Act of 1978 where an Office of Personnel Management-approved performance system had not yet been properly implemented. On reconsideration, the hearing officer upheld the removal of the NRC employee. Court proceedings have been held in abeyance pending completion of the administrative proceedings for the other two former employees.

International V.batim Reporters v. United States (Ct. Cl. No. 458-80)

On August 27, 1980, IVR sued the United States, claiming that the NRC illegally breached plaintiff's contract to provide stenographic reporting services. The Commission will counterclaim for excess procurement costs. Its position is that the reporting company failed to provide adequate reporting services.

People of the State of Illinois v. General Electric (N.D. Ill. No. 79-C-1427, appeal pending 8th Cir. No. 80-1962)

On April 11, 1979, the State of Illinois sued General Electric Co. (G.E.), the Commission, and the Department of Energy (DOE) over the G.E. Morris spent fuel storage facility. Illinois claimed that its Radioactive Waste Act violates the Illinois Constitution, is preempted by the Atomic Energy Act, and hence voids its perpetual care contract with G.E., and that DOE violated NEPA in not preparing an environmental impact statement (EIS) to accompany proposed legislation on the use of G.E. Morris as an away-from-reactor storage site. On December 18, 1979, Judge Will dismissed all but the EIS claim involving DOE; that latter claim was dismissed as moot on May 8, 1980, based on DOE's expressed intention to prepare a site-specific EIS before acquisition of Morris or any other facility once Congressional authorization was obtained. On June 27, 1980, Illinois appealed. Briefing was completed in October 1980.

Woliver v. NRC (D.D.C. No. 80-2627)

On October 15, 1980, this FOIA lawsuit was filed seeking a copy of a 1969 Sargent & Lundy Engineers' report to the Cincinnati Gas & Electric Co., "An Economic Evaluation of Alternatives." The Commission had denied the request for the report under Exemption 4 as proprietary.

Common Cause v. NRC (D.D.C. No. 80-2347)

On September 15, 1980, Common Cause filed a Government in the Sunshine Act lawsuit against the NRC claiming that the Commission's July 18, 1980, budget meeting was improperly closed to the public. Common Cause seeks a copy of the transcript of the meeting and an injunction requiring that like meetings in the future be held in open session. The Commission answered the complaint in November 1980.

Three Mile Island Litigation (M.D. Pa. No. 79-0432)

This is a consolidated complaint seeking money damages for personal injuries, property losses, and business losses alleged to have resulted from the Three Mile Island accident. On July 10, 1980, Judge Rambo ruled that the Federal district court properly had jurisdiction over the TMI litigation despite the fact that the Commission had determined that the accident did not constitute an extraordinary nuclear occurrence because the lawsuit in any event arises under Federal law; second, that the lawsuit could properly proceed as a class action as to the "economic harm" classes; and third, that insofar as personal injury claims were involved, class action treatment was proper only as to the alleged need for medical monitoring services. Judge Rambo specifically decided that claims of emotional distress flowing from the TMI accident were too diverse and personal to be adjudicated by the vehicle of a class action. The Commission is participating as a friend of the court in this lawsuit.

Friends of the Earth v. NRC (9th Cir. No. 79-7311)

This lawsuit sought review of the Commission's June 22, 1979, decision to restart the Rancho Seco Nuclear Unit 1 after completion of various TMI-related modifications. On July 5, 1979, the Ninth Circuit denied emergency relief, and on September 10, 1980, entered an order deferring action on the merits until completion of the ongoing licensing board hearing.

State of New York and People of the State of Illinois v. NRC (S.D.N.Y. 79 Civ. 4568)

This lawsuit follows similar suits by the State of New York which sought to stop the air shipment of plutonium pending preparation of an environmental impact statement. Those earlier requests for injunctive relief were rejected. See *State of New York v. NRC*, 550 F.2d 745 (2d Cir. 1977). The current

lawsuit challenges the adequacy of the NRC's environmental impact statement on the transportation of radioactive material (NUREG-0170), and is still in the early stages.

Upper Skagit Indian Tribe, Suak-Suiattle Indian Tribe and Swinomish Tribal Community v. NRC (D.C. Cir. No. 79-2277)

On October 26, 1979, three American Indian tribes petitioned the D.C. Circuit to review an appeal board decision denying their 3-1/2-year late petition to intervene in the Skagit construction permit proceeding. The court has held the petition in abeyance pending the outcome of the administrative proceedings. The case should soon be dismissed as moot since the utility no longer plans to build the plant at the Skagit site.

Peshlakai v. Duncan (D.D.C. No. 78-2416)

This lawsuit was brought on December 22, 1978, against a number of Federal agencies, primarily the Department of the Interior but also including NRC, claiming that government actions affecting the mining and milling of uranium violated NEPA because national, regional, and individual environmental impact statements had not been prepared on a multi-tudinous set of actions. The case is essentially the nuclear analogue of the *Kleppe* case which dealt with similar claims regarding coal exploration. Judge Harold H. Greene of the Federal district court saw it as such in a September 5, 1979, opinion which denied plaintiff's motion for a preliminary injunction to halt work at Mobil's pilot *in situ* plant project at Crown Point, N.M. Thereafter, on August 29, 1980, Judge Greene denied plaintiff's motion for partial summary judgment ruling that the regional environmental impact statement issue presented disputed material issues of fact, and hence was inappropriate for summary disposition.

John Abbotts v. NRC (D.D.C. No. 77-624)

On April 11, 1977, John Abbotts, the Public Interest Research Group, and the Natural Resources Defense Council brought an FOIA suit challenging the NRC decision to withhold certain safeguard documents. The dispute has since been narrowed to two small portions of two documents specifically contesting the proper classification of "baseline threat level" information. The court must now decide whether to review the documents *in camera* and whether there is a valid Exemption 1 claim by NRC.

Coalition for the Environment v. NRC (D.C. Cir. No. 77-1905) (Callaway)

Lloyd Harbor Study Group v. NRC (D.C. Cir. No. 73-2266) (Shoreham)

Nelson Aeschliman v. NRC (D.C. Cir. Nos. 73-1776 and 73-1867) (Midland)

Natural Resources Defense Council v. NRC (D.C. Cir. No. 74-1385) (Vermont Yankee)

These lawsuits challenge on uranium fuel cycle grounds ("Table S-3") the construction permits for Callaway, Shoreham, and Midland, and the Vermont Yankee operating license. Briefing in these cases is being held in abeyance pending the D.C. Circuit's decision in the fuel cycle rulemaking cases where the court heard argument in September 1980. See *Natural Resources Defense Council v. NRC* (D.C. Cir. Nos. 74-1586, 77-1448 and 79-2131) and *State of New York v. NRC* (D.C. Cir. No. 79-2110).

Natural Resources Defense Council v. NRC (D.C. Cir. Nos. 74-1586, 77-1448 and 79-2131) and

State of New York v. NRC (D.C. Cir. No. 79-2110)

These consolidated cases challenge three related versions of the Commission's uranium fuel cycle rule. The rule speaks to the fact that the environmental impact of operating a nuclear power reactor necessarily includes the impacts of off-site fuel cycle activities which support the plant. The rule sets out a table of values (Table S-3") to be used in individual licensing proceedings as a starting point for evaluating the contribution of fuel cycle activities to the environmental impact of light-water power reactors. The D.C. Circuit's consideration of these cases follows the Supreme Court's remand in *Vermont Yankee Nuclear Power Corp. v. NRDC*, 435 U.S. 519 (1978). Oral argument was heard in September 1980. The D.C. Circuit has held in abeyance a series of cases involving application of the S-3 rule to individual facilities pending its decision in the rulemaking cases. See *Lloyd Harbor Study Group v. NRC* (D.C. Cir. No. 73-2266) (Shoreham); *Nelson Aeschliman v. NRC* (D.C. Cir. No. 73-1776 and 73-1867) (Midland); *Natural Resources Defense Council v. NRC* (D.C. Cir. No. 74-1385) (Vermont Yankee); *Coalition for the Environment v. NRC* (D.C. Cir. No. 77-1905) (Callaway).

United States v. New York City (S.D.N.Y. No. 76 Civ. 273)

On January 15, 1976, the NRC, DOE, and the Department of Transportation (DOT) sought a judgment declaring a New York City Health Code provision dealing with the transportation of nuclear materials through the city to be inconsistent with the Federal statutory scheme governing the transportation of hazardous materials. The government's request for a preliminary injunction against enforcement of the Health Code provision was denied on January 30, 1976, in view of the absence of DOT regulations under the Hazardous Materials Transportation Act prohibiting such local ordinances. On April 4, 1978, DOT ruled that the New York City ordinance was not inconsistent with DOT's then existing statutory scheme and regulatory policy, but that a rulemaking would be held to consider what restrictions should be placed on local regulation of the routing of nuclear materials. The rulemaking has

not yet been completed and the lawsuit is still pending.

- State of New York v. NRC* (2d Cir. No. 75-4278)
Natural Resources Defense Council v. NRC (2d Cir. No. 75-427)
Allied General Nuclear Services v. NRDC (S.Ct. No. 76-653)
Commonwealth Edison Co. v. NRDC (S.Ct. No. 76-762)
Baltimore Gas & Electric Co. v. NRDC (S.Ct. No. 76-774)
Westinghouse Electric Corp. v. NRDC (S.Ct. No. 76-769)

These GESMO lawsuits have been pending before the Second Circuit ever since the Supreme Court on January 16, 1978, vacated the court of appeals decision in *Natural Resources Defense Council v. NRC*, 539 F.2d 824 (1976), and remanded the case to the Second Circuit "to consider the question of mootness." The court of appeals has not yet acted on NRC's request to dismiss the cases as moot.

West Michigan Environmental Action Council v. AEC (W.D. Mich. No. G-58-53)

Plaintiffs sought an injunction against the increased use of mixed-oxide fuel in Consumer Power's Big Rock Point power reactor. In June 1974 the court placed the case in abeyance pending the outcome of the GESMO proceeding. The utility has not pressed its application nor prepared the environmental report preliminary to pressing its application. Settlement attempts to have the lawsuit voluntarily dismissed without prejudice to bringing a new lawsuit should the utility activate its application have thus far been unsuccessful, and the case remains inactive on the court's docket.

Minnesota Environmental Control Citizen's Association, et al. v. AEC (D. Minn. No. 4-72-109)

Plaintiff, a citizen's association, sought to enjoin further development and operation of Northern States Power Co.'s Monticello and Prairie Island facilities on the ground that the Prairie Island construction permit and the Monticello provisional operating license were issued without preparation of an environmental impact statement. On June 28, 1972, the District Court issued an opinion refusing to enjoin the construction or provisional operation, but holding that before full operating permits for these facilities could be granted, a full NEPA review was required. The court retained jurisdiction over the matter to ensure that such a review was performed. During the past eight years, the Commission has undertaken this environmental review, and both licensing proceedings are nearing completion. When the administrative proceedings are completed, the NRC will move to dismiss this lawsuit.

Rosanna Kelly v. Hendrie, et al. (D.D.C. No. 79-1550)

On June 14, 1979, plaintiff filed a lawsuit alleging that she has suffered age and sex discrimination in her efforts to be promoted and has been retaliated against as a result of initiating EEO proceedings. Plaintiff seeks retroactive promotion and an injunction against discrimination. NRC's answer, filed in September 1979, denies the substantive allegations of her complaint. The court has deferred consideration of this case pending resolution at the administrative level. An EEOC hearing has been held, but the EEOC hearing examiner has not yet rendered an opinion.

Thot-Thompson v. McVeagh (D. Md. No. B-79-1703)

On August 16, 1979, plaintiff sued for damages alleged to be the result of certain statements defendant made. The NRC position is that the defendant was acting within the scope of his employment with NRC when he made the statements. The lawsuit was removed to Federal district court on September 13, 1979, and on August 18, 1980, the government's motion to dismiss was denied. The case is being handled through the Department of Justice and is at the discovery stage.

Kertis v. United States (W.D. Pa. No. 77-1259)

On November 4, 1977, plaintiff sued the United States to recover damages for the death of her husband who contracted leukemia after having been a worker in the Westinghouse Cheswick (Pa.) facility engaged in repair of Navy submarine pumps. Westinghouse held a byproduct license permitting it to possess a small amount of radioactive material incident to maintenance of Navy reactor components. A similar lawsuit was dismissed in 1976 as plaintiff was limited to workmen's compensation against Westinghouse under State law. The lawsuit is being handled by the Department of Justice.

Gentry v. United States (N.D. Ala. No. CA 79-L5181-NE)

This is a Federal Tort Claims Act lawsuit brought on September 14, 1979, by a former employee of Thiokol Corp. seeking money damages for exposure to radiation while working as a radiographer on government projects. On March 5, 1980, the court dismissed all defendants except the United States. A motion for summary judgment based on statute of limitations grounds was filed October 24, 1980, and is presently pending. The lawsuit is being defended by the Department of Justice.

Broudy v. United States (C.D. Calif. No. 79-02626 LEW (GX))

Punnett v. Carter (E.D. Pa. No. 79-29)

Skinner v. United States (N.D. Calif. No. CA-79-1231-WAI)

Hinkie v. United States (E.D. Pa. No. 79-2340)

Runnels v. United States (D. Hawaii NO. 79-0385)

These cases seek money damages for injuries suffered as a result of the atomic weapons testing program. The principal defendant in the suits is the United States and the cases are being defended by the Department of Justice. In *Skinner*, *Hinkie* and *Runnels*, the government has motions to dismiss pending. *Broudy* was dismissed on January 3, 1980, on the ground that no action will lie under the Federal Tort Claims Act for an injury which arises out of activity incident to military service. The case is now on appeal. In *Punnett*, plaintiff's motion for a preliminary injunction to compel the government to notify all soldiers formerly involved in the atomic testing program of potential risks of genetic damage was denied on March 30, 1979; the denial was later upheld by the Third Circuit.

Won-Door Corp. v. United States (Ct. Claims No. 109-79L)

Won Door sued the United States on March 20, 1979, for compensation for an alleged taking of its property by virtue of radon contamination from the adjoining Vitro uranium mill tailing site. The government answered denying a taking on June 11, 1979. On August 20, 1979, Judge Harkens stayed the proceeding at the request of the Department of Justice which is handling the defense of this action to allow for settlement negotiations. Negotiations are continuing.

Kepford v. NRC (D.C. Cir. Nos. 78-1160 and 78-2170)

In No. 78-1160, petitioner brought suit on February 27, 1978, to stay operation of the Three Mile Island Unit 2 facility, primarily because of claimed unacceptable health impacts from radon-222 releases attributable to the mining and milling of uranium to fuel the plant. On March 8, 1978, the D.C. Circuit denied the motion for a stay, and on March 22 the court held further review in abeyance pending completion of administrative proceedings. In No. 78-2170, petitioner brought suit on November 13, 1978, to review a September 15, 1978, Commission order affirming the appeal board's decision, ALAB-486, which authorized an operating license for TMI-2, but called for further hearings on the probability of a very heavy aircraft crash into the TMI-2 containment building. On May 11, 1979, the D.C. Circuit ordered the case held in abeyance pending completion of administrative proceedings.

Closed Cases

San Luis Obispo Mothers for Peace, et al. v. Hendrie (D.D.C., No. 80-2356)

Plaintiffs filed this lawsuit on September 16, 1980, seeking the disqualification of Commissioner Joseph M. Hendrie from any further participation in the proceedings on the pending operating license application for the Diablo Canyon Nuclear Plant in California. The basis for their claim is both allegedly improper *ex parte* contacts between the Commissioner and utility company officials and his purported involvement in the review of the Diablo Canyon license application during his tenure as a staff employee of the Atomic Energy Commission. On November 21, at the conclusion of oral argument, the case was dismissed for lack of jurisdiction. A formal order entered November 25 explained that final Commission licensing decisions were reviewable exclusively in the courts of appeals, that Commissioner Hendrie's refusal to disqualify himself was reviewable at the time of the Commission's final decision in the Diablo Canyon proceeding, and that plaintiffs had made no showing that Commissioner Hendrie's continued participation in the Diablo Canyon proceeding justified judicial interruption of the administrative process.

United States v. McGovern (M.D. Pa. No. 80-0560; on appeal 3rd Cir. No. 80-2128)

On June 2, 1980, the United States, on behalf of NRC, brought a subpoena enforcement action against five Metropolitan Edison employees as part of the Commission's ongoing investigation of the transfer of information from Met-Ed to the NRC on the first day of the Three Mile Island accident. Following two evidentiary hearings, Judge Rambo granted the Commission's motion to enforce the subpoenas on August 13, 1980. An appeal to the Third Circuit was dismissed on October 8, 1980, after the Third Circuit and Mr. Justice Brennan refused to stay enforcement of the subpoenas.

United States v. Henry (S.D. Ala. Misc. No. 80-0319-H)

On May 12, 1980, the United States, on behalf of NRC, brought a subpoena enforcement action against a former employee at the Marble Hill nuclear power plant as part of the Commission's investigation into the procedures followed in testing concrete used to construct the power plant. The case was withdrawn on June 23, 1980, when the employee agreed to respond to the subpoena.

Desrosiers v. NRC (E.D. Tenn. Civ. Action No. 1-80-36)

On February 12, 1980, Jim Desrosiers, individually and as Chairman of the Chattanooga for Safe Energy, brought suit to enjoin the NRC from issuing a low-power operating license for the Sequoyah nuclear power plant. On April 3, the district court dismissed the lawsuit for lack of jurisdiction.

Westinghouse Electric Corp. v. Hendrie (D.D.C., No. 79-2060, on appeal, D.C. Cir. No. 79-2069)

Westinghouse Electric Corp. v. Vance (D.D.C., No. 79-2110, on appeal, D.C. Cir. No. 79-2070)

Westinghouse sued the NRC and the Department of State, alleging unreasonable delay in the processing of its licenses to export a reactor and components to the Philippines. On August 30, Judge June Green denied the Westinghouse motion for injunction, and found that the NRC delay was not unreasonable given the important health and safety considerations implied by the application. Westinghouse appealed to the D.C. Circuit, but then withdrew its appeal.

Mississippi Power and Light Company, et al. v. NRC, et al. (15th Cir. No. 78-1565)

Nuclear Engineering Company v. NRC, et al. (5th Cir. No. 78-1871)

Chem-Nuclear Systems v. NRC, et al. (5th Cir. No. 78-2200)

A number of utilities sued the NRC on its February 9, 1978, license fee rule. The utilities alleged that NRC exceeded its statutory authority in setting the fees. They sought a declaration in the interim, and a refund of all fees collected under the rule and its 1973 predecessor. The Fifth Circuit affirmed the NRC schedule generally and as against each specific challenge on August 24, 1979. 601 F.2d 223. The Supreme Court denied *certiorari* on February 19, 1980. 100 S.Ct. 1066.

A.R. Martin-Trigona v. Department of Justice, et al. (S.D. Ill. No. 78-4006)

On January 30, 1978, plaintiff sued the Justice Department, Commonwealth Edison, and the NRC concerning the withholding under the FOIA of documents pertaining to the Quad-Cities nuclear power station. NRC is asserting Exemption 7 as grounds for withholding the documents. The court granted the motion to dismiss.

Detroit Edison Company v. NRC (6th Cir. No. 78-3187 and No. 78-3186)

On September 5, 1980, the Sixth Circuit affirmed the Commission's denial of Detroit Edison's petition for rulemaking to exclude transmission lines and other off-site construction from regulation by the Commission. The Court, following the reasoning in *Public Service Company of New Hampshire v. United States Nuclear Regulatory Commission*, 582 F.2d 77 (1st Cir.) *cert. denied*, 439 U.S. 1046 (1978), found that because the Atomic Energy Act provides the Commission jurisdiction over transmission lines, licenses can be conditioned to mitigate the environmental impacts of the routes of such lines. The court did not decide whether NEPA provides the Commission an independent source of substantive jurisdiction. On October 22, 1980, the court denied petitioners' motion for rehearing.

Akron, Canton & Youngstown R.R. v. ICC (6th Cir. No. 78-3425), *petition for cert. pending* (S.Ct. No. 79-1833)

On August 3, 1978, the eastern railroads sought review of an ICC decision ordering the railroads to publish tariffs for the carriage of spent fuel. On December 20, 1979, the Sixth Circuit affirmed the ICC decision, ruling that the railroads had a common carrier obligation to carry spent fuel. The court also decided that the ICC should defer to NRC and DOT for setting industry-wide safety standards for the carriage of radioactive materials, but that the ICC may allow individual carriers to make more stringent rules. 611 F.2d 1162. The railroads filed a petition for writ of *certiorari* on May 19, 1980, which is presently pending with the Supreme Court.

Radiation Technology v. NRC (D.N.J. No. 79-753)

Plaintiff sought money damages under the Federal Tort Claims Act for costs flowing from the suspension of his materials license. NRC's response alleged that counts 1 and 2 of the complaint were time-barred under the Tort Claims Act, and disputed the facts of the remaining claim. Judge Stern granted NRC's motion to dismiss counts 1 and 2 on statute of limitations grounds; the remaining claim was settled and subsequently dismissed by the court on February 25, 1980.

Ecology Action of Oswego, N.Y. v. NRC (D.C. Cir. No. 78-1855)

On March 12, 1980, the D.C. Circuit affirmed the appeal board's refusal to stay the Sterling nuclear power plant construction permit and refusal to enjoin Rochester Gas & Electric Co. from contracting for uranium to fuel the proposed plant pending Commission re-evaluation of the environmental impacts of the mining and milling of uranium. The petition for review of the appeal board's decision was filed August 25, 1978. The court agreed with NRC's argument that Ecology Action's assertion of irreparable injury from radon releases was contrary to the Congressional judgment contained in the Uranium Mill Tailings Radiation Control Act of 1978 that the risk from radon emissions can be limited to acceptable levels without stopping uranium mining and milling.

City of Lancaster v. NRC (D.D.C. No. 79-1368)

This lawsuit was brought May 21, 1979, seeking to enjoin use of the EPICOR-II demineralizer system and to enjoin discharge of accident-generated water from Three Mile Island Unit 2 into the Susquehanna River pending completion of an environmental impact statement and license amendment proceedings. The case was settled and dismissed with prejudice on February 28, 1980, the Commission having reiterated its intent to prepare a programmatic environmental impact statement and having agreed that no accident-generated wastewater will be discharged into the Susquehanna River until completion of that statement or such other environmental review as is contemplated by the Commission's November 21, 1979, policy statement, or until

December 31, 1981, whichever is earlier.

Commonwealth of Kentucky v. NRC (D.C. Cir. No. 78-1369)

On April 24, 1978, the Commonwealth of Kentucky sought review of ALAB-459, an appeal board decision which held that the Kentucky/Indiana border was the 1792 low water mark on the northwestern or Indiana side of the Ohio River. The issue arose when Kentucky claimed that the discharge pipe of the Marble Hill facility would be in Kentucky territory, and consequently that the Section 401(a)(1) Federal Water Pollution Control Act permit necessary for construction of the plant should have been obtained from Kentucky rather than Indiana. On April 18, 1980, the D.C. Circuit affirmed the appeal board finding conclusive a March 24, 1980 Supreme Court decision in the related case of *Kentucky v. Indiana* (S.Ct. No. 81 Original) which fixed the border as of the 1792 low water mark.

Friends of the Earth v. NRC, et al. (D.C. Calif. Div. No. C-80-0234-SW)

On January 30, 1980, Friends of the Earth (FOE) sued the NRC and the Pacific Gas and Electric Co. to compel the NRC to prepare a supplemental environmental statement to discuss the consequences of Class 9 accidents at Diablo Canyon. FOE argued that the TMI accident, various reports and recent analyses of accident probabilities such as the Lewis Report, GAO reports, etc., mean that the NRC can no longer categorically exclude detailed discussions of Class 9 events as "unforeseeable" for purposes of NEPA environmental analysis. NRC's motion to dismiss the lawsuit for lack of subject matter jurisdiction was granted September 26, 1980, on the ground that the licensing proceeding, when the identical issue is pending for decision, was still ongoing.

Honicker v. Hendrie (M.D. Tenn. Civ. No. 78-3371-NA-CV; on appeal 6th Cir. No. 79-1132, on petition for writ of *certiorari* S.Ct. No. 79-710)

Plaintiff sued the NRC for injunctive relief, alleging that the NRC had permitted nuclear power reactors and fuel cycle facilities to operate while underestimating the magnitude of adverse health consequences from the nuclear fuel cycle. Plaintiff sought revocation of all licenses and dismantling of all fuel cycle facilities. On February 19, 1980, the Supreme Court denied Ms. Honicker's petition for a writ of *certiorari* from the 6th Circuit decision which had affirmed the district court's dismissal of the case for lack of subject matter jurisdiction. See 465 F. Supp. 414 (M.D. Tenn.), *aff'd* 605 F.2d 556 (6th Cir.), *cert. denied* 100 S.Ct. 10015 (1980).

Virginia Sunshine Alliance v. NRC, et al. (D.D.C. No. 79-1989, on appeal, D.C. Cir. No. 79-2060)

On July 31, 1979, plaintiff sued to block the shipment of spent fuel from foreign research reactors through Portsmouth, Va., based on a claimed threat

of sabotage, and alleging that the route approval was given contrary to NEPA and NRC regulations. On August 3, 1980, District Court Judge Penn denied plaintiff's request to preliminarily enjoin spent fuel shipments through Norfolk, Va., finding that the Commission's new safeguards rule provided adequate protection against sabotage threats and that the Commission had taken a "hard look" at the sabotage issue in compliance with NEPA. An appeal from the denial of the injunction was voluntarily dismissed on October 14, 1980, and the district court case too was dropped on October 18, 1980.

Life of the Land v. Adams (D. Hawaii No. 79-0249)

Plaintiffs challenged the transport of two shipments of spent fuel from Japan through Hawaiian waters and the port of Honolulu, seeking preparation of an environmental impact statement and compliance with the Ports and Waterways Safety Act. The application for injunction on the first of these shipments was denied on June 7, 1979, and upheld by the Ninth Circuit on June 8, 1979. The governor closed the port to both shipments. One was permitted to refuel at Pearl Harbor on an emergency basis; the other refueled in non-Hawaiian waters. Because no more shipments were scheduled, the Justice Department filed a motion to dismiss on grounds the case was moot. On December 19, 1979, a voluntary dismissal was approved by the court.

Southern California Edison v. NRC (9th Cir. No. 79-7529)

On October 15, 1979, Southern California Edison Co. petitioned the Ninth Circuit to review the appeal board's June 15, 1979 decision, ALAB-550, which denied the company's motion to quash a subpoena the licensing board had issued in connection with antitrust proceedings on the Stanislaus nuclear power plant. The case was settled administratively and the lawsuit was voluntarily dismissed on May 14, 1980.

Duquesne Light Company v. NRC (3d Cir. Nos. 80-1295 and 80-1307)

Pennsylvania Power Company v. NRC (3d Cir. Nos. 80-1296 and 80-1310)

These petitions for review were filed on February 29, 1980, to review the appeal board's *Davis Besse* antitrust decision, ALAB-560, which had affirmed the licensing board ruling that construction and operation of the five nuclear power plants involved in this case would create and maintain a situation inconsistent with the antitrust laws. Specific license conditions were imposed to correct that situation. The utilities voluntarily withdrew their appeal and on October 8, 1980, the case was dismissed.



16

Administration and Management

At the end of fiscal year 1980, the NRC's full-time permanent personnel strength was 2,891. The agency obligated \$395.3 million during the year. NRC Headquarters activities remained dispersed in 10 buildings throughout the District of Columbia and Maryland. In May 1980, the Senate Committee on Environment and Public Works approved a resolution for construction of a Federally-owned building in Silver Spring, Md., to consolidate the NRC, and this resolution was still under review by the House Committee on Public Works and Transportation at year-end. As fiscal year 1981 began, the Commission was completing implementation of the President's Reorganization Plan No. 1 of 1980 which directed significant structural changes in the agency's leadership. These and other management and administrative support developments, including organization, personnel, and fiscal matters, are discussed below.

Personnel and Organization

For fiscal year 1980, Congress authorized 3,066 full-time permanent positions for the NRC, an increase of more than 6 percent above the fiscal year 1979 authorized level of 2,888. Almost 71 percent of NRC employees are located in the major program offices, about 20 percent are in program direction and administration, and the remainder are employed in the Commission staff and the independent advisory and adjudicatory bodies.

Of the 70 percent of NRC employees holding college degrees, more than 30 percent have masters degrees, over 5 percent have professional (mostly law) degrees, and over 13 percent have doctorates. Employees trained as scientists or engineers comprise more than half of the NRC's work force.

Commission and Office Director Appointments

The Commission continued at full five-member strength until June 30, 1980, when the term of Richard T. Kennedy expired. In early July 1980, President Carter nominated Dr. Albert Carnesale to the Commission. At the end of the fiscal year, this nomination had not been acted upon by the Senate. Commissioner John F. Ahearne continued to serve as Chairman, pending selection of a new Chairman from outside the agency as had been the announced intention of the President. (See 1979 NRC *Annual Report*, p. 62.)

The following changes took place in the principal staff:

- Lee V. Gossick, who had been Executive Director for Operations (EDO) since the NRC's inception, resigned in January 1980, and William J. Dircks, director of the Office of Nuclear Material Safety and Safeguards (NMSS), was named acting Executive Director, effective February 1.
- In September 1980, Mr Dircks was appointed Executive Director for Operations. At the same time, John G. Davis, who had been serving as acting director of NMSS since February, was appointed director of that office.
- In January 1980, Robert J. Budnitz was appointed director, Office of Nuclear Regulatory Research (RES), succeeding Saul Levine, who retired. In August 1980, Mr. Budnitz vacated that position and Thomas E. Murley was named acting director. (In November, after the end of the reporting period, Robert B. Minogue was appointed RES director, leaving his post as director, Office of Standards Development (SD),

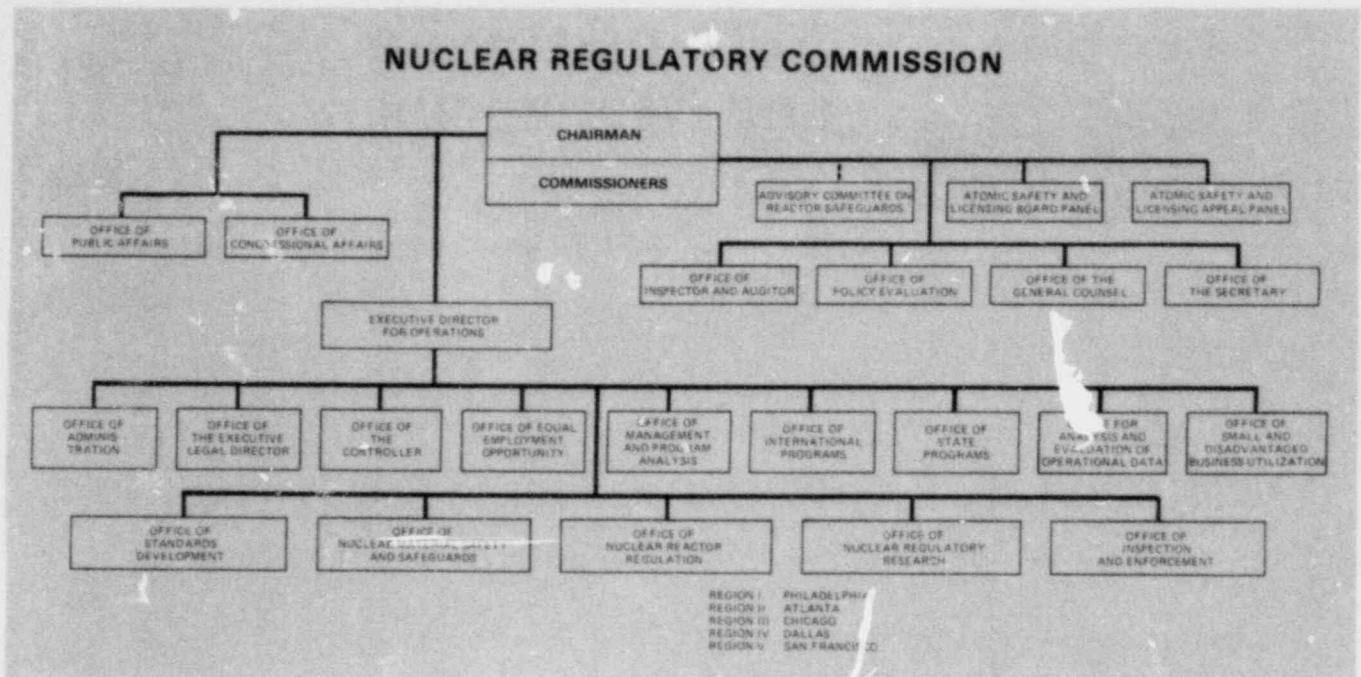

which was filled on an acting basis by Deputy Director Ray G. Smith.)

- In November 1979, Edward J. Hanrahan became director, Office of Policy Evaluation.
- In January 1980, Carlyle Michelson was named director of the recently established Office of Analysis and Evaluation of Operational Data.
- In August 1980, William B. Kerr was appointed director of the new Office of Small and Disadvantaged Business Utilization.
- In September 1980, G. Wayne Kerr was named director of the Office of State Programs after the departure of Robert G. Ryan.

The Advisory Committee on Reactor Safeguards designated Milton J. Plesset as its chairman for calendar year 1980.

Organizational Changes

Various changes in NRC organization, particularly those precipitated by the Three Mile Island (TMI) accident, continued throughout fiscal year 1980 or were initiated during the year.

President's Reorganization Plan

Of particular significance were actions taken to implement President Carter's Reorganization Plan No. 1 of 1980, which cleared the Congress in June and became effective on October 1. The plan, intended to correct structural deficiencies in NRC

leadership that had been identified by the various investigations following the TMI accident, generally calls for strengthening of the authority of the Chairman relative to the Commission and of the Executive Director for Operations relative to the program staff. The Commission retains responsibility for policy formulation, rulemaking, and orders and adjudication. The Chairman initiates personnel actions subject to Commission approval, for heads of offices reporting directly to the Commission, for the EDO, and for the heads of the five major program offices (NRR, NMSS, RES, IE, and SD). The EDO is to be consulted regarding actions affecting the program offices. Any Commissioner may initiate personnel actions for positions on the Advisory Committee on Reactor Safeguards, subject to Commission approval.

All other Commission functions are solely the Chairman's, who is the official spokesman (the Offices of Public Affairs and Congressional Affairs report to the Chairman) and the principal executive officer of the Commission. In the latter capacity, the Chairman directs and delegates to the EDO responsibility for all administrative functions; distribution of business; preparation of reorganization proposals and budget estimates; allocation of funds; and personnel matters other than those affecting the heads of offices mentioned above. The Chairman also has the responsibility, which may be delegated to another Commissioner, for responding to a nuclear emergency (see Chapter 3).

The EDO reports to the Chairman on all matters. The directors of all five program offices (including NRR, NMSS and RES, which formerly reported to the Commission through the EDO) now report to

the EDO. The heads of Commission-level offices (except PA and CA, which report to the Chairman) continue to report directly to the Commission. The EDO keeps the Commission fully and currently informed through the Chairman, and all Commissioners have equal access to all agency information.

At year-end, appropriate actions had been or were being taken to implement the President's Reorganization Plan, including modification of practices, delegations of authority, and initiation of reviews of relevant documents and procedures for possible revisions.

Staff Reorganizations. Numerous structural changes were made or initiated in some of the staff offices during the year, particularly those relating to reactor regulation and inspection and enforcement.

A major reorganization of NRR was implemented in April, designed to cope with the expected workload during the next few years and to reflect changes and improvements identified by the various TMI accident investigations. Features include establishment of a Division of Human Factors, strengthening of the Division of Safety Technology, and a consolidation of all project managers into a single Division of Project Management. (See Chapter 4.)

A reorganization of IE, involving both headquarters and regional offices, was in progress at the end of the fiscal year. It is designed to emphasize program development, enforcement, and appraisal of

licensee performance, and to place responsibility for the resident inspection program under one headquarters director. An important change was the centering of all NRC emergency preparedness activities in one office under the direction of IE, transferring responsibilities in this area from NRR and the Office of State Programs (see Chapter 3).

During the year, IE also relocated the BWR-PWR Technology Training Section, of its Career Management Branch from Bethesda, Md., to a new NRC Reactor Training Center in Chattanooga, Tenn.

A partial reorganization of RES took place in 1980. It included replacement of the Probabilistic Analysis Staff with a new Division of Systems and Reliability Research and establishment of the Operational Safety Research Branch and the Plant Instrumentation, Control and Power Systems Branch. A Chief Scientist position was also created.

EMPLOYEE-MANAGEMENT RELATIONS

Incentive Awards Program

NRC managers accelerated their use of incentive awards to recognize the performance of staff members at all levels during the past year and the

NRC EMPLOYMENT PROFILE

| | SEPTEMBER 30, 1979 | | | | SEPTEMBER 30, 1980 | | | |
|-----------|--------------------|----------|--------------|----------|--------------------|----------|--------------|----------|
| | MEN | | WOMEN | | MEN | | WOMEN | |
| | NON-MINORITY | MINORITY | NON-MINORITY | MINORITY | NON-MINORITY | MINORITY | NON-MINORITY | MINORITY |
| EXECUTIVE | 5 | 0 | 0 | 0 | 4 | 0 | 0 | 0 |
| SES | 185 | 3 | 2 | 0 | 180 | 3 | 2 | 0 |
| GS-18 | 0 | 0 | 0 | 0 | 0 | 0 | 0 | 0 |
| GS-17 | 4 | 0 | 1 | 0 | 4 | 0 | 1 | 0 |
| GS-16 | 11 | 0 | 1 | 0 | 18 | 0 | 1 | 0 |
| GS-15 | 452 | 24 | 9 | 0 | 506 | 24 | 10 | 0 |
| GS-14 | 526 | 53 | 19 | 2 | 575 | 63 | 22 | 4 |
| GS-13 | 262 | 31 | 26 | 8 | 310 | 36 | 33 | 9 |
| GS-12 | 129 | 14 | 43 | 9 | 139 | 16 | 54 | 10 |
| GS-11 | 62 | 16 | 47 | 14 | 54 | 9 | 57 | 12 |
| GS-1 - 10 | 69 | 24 | 465 | 142 | 68 | 22 | 461 | 144 |
| OTHER* | 22 | 9 | 2 | 0 | 22 | 10 | 3 | 0 |

* Employees whose salaries are set by wage board, scientific and technical schedule, or administrative determination.

numbers of awards increased sharply over fiscal year 1979. For example, the numbers of Special Achievement Awards granted increased 110 percent over the number granted in fiscal year 1979. Similarly, the numbers of High Quality Within-Grade Increases went up by 25 percent over fiscal year 1979.

Union Activity

Negotiations on Bargaining Agreement. On June 27, 1979, the National Treasury Employees Union (NTEU), the exclusive representative of all bargaining unit employees throughout the NRC, forwarded proposals for a comprehensive bargaining agreement covering the full range of policies and practices of the NRC's personnel management. A Management Negotiating Team representing office directors was assembled, and agency positions and counter-proposals on each of the Union's proposals have been formulated and approved by top management. Negotiations were commenced in January of 1980. As the fiscal year ended, the NTEU Bargaining Team and the NRC Management Negotiating Team had completed 51 bargaining sessions without agreeing on all of the issues. In October, the NTEU invoked the services of the Federal Mediation and Conciliation Service.

Third-Party Actions. During the year the NTEU vigorously pursued the right of the exclusive representative to contest management decisions in the various third-party forums which are available under law. For example, during the year, the Union filed 22 unfair labor practice charges against the agency and 69 grievances under the negotiated grievance procedure.

Equal Employment Opportunity

Progress Continues at GS-11 and Up. The overall NRC employment profile continued its gradual improvement during fiscal year 1980. On September 30, 1979, there were 174 minority persons and 181 women in grades GS-11 and above. At the end of fiscal year 1980, minority employment in those grades rose to 186—an increase of 7 percent over last year's figure—and women's employment in the same grades rose to 215, or 19 percent.

The NRC continued to submit quarterly reports to the Congress on women and minority persons hired and promoted, and on other actions designed to improve the agency's Equal Employment Opportunity (EEO) posture, with particular emphasis on grades GS-11 and above. Performance and career counseling services continued to provide assistance and support for employees, with an aim toward improving performance and job satisfaction.

Recruitment Emphasis. Recruiters visited 48 colleges and universities during the year to attract candidates for entry-level professional positions and the Cooperative Educational Program. Visits to 31 of these schools, which enrolled significant numbers of women and minority persons, resulted in formal applications, interviews, and attendance at various Job Fairs and/or Career Days which were sponsored by the university or student technical associations. Under the auspices of the Federal Equal Opportunity Recruitment Program, a talent bank was established for minority, women, and handicapped persons. A part of this activity emphasizes advertising in technical journals targeted for women, handicapped, and minority readers.

Special EEO Study. During 1980, the Commission became aware of issues of concern among some of its employees regarding equal employment opportunities at the NRC. After review of this matter by principal and concerned staff, it was agreed that an assessment be undertaken of the NRC's personnel policies and procedures and their possible impact on the EEO program. A private firm was contracted to perform the study and to recommend improvements in the EEO program should the assessment reveal any areas requiring management attention. At year-end, a random selection of employees had been interviewed regarding equal treatment of employees as well as applicants for employment of all races, ages, minority status, sexes, and the handicapped. A final report, based on quantitative and qualitative statistical analyses, is scheduled for completion in January 1981.

Federal Women's Programs. Throughout fiscal year 1980, the Federal Women's Program Advisory Committee continued meeting with FWP members and key office directors to discuss questions raised by female employees. Various training programs to enhance women's careers were made available to women employed at the NRC, including a one-day training program conducted by Federally Employed Women, Inc., (FEW) focusing on career development, leadership, and assertiveness communication techniques.

NRC women were represented during the year at several special women's functions, such as the White House Inter-Department Task Force on Women, the United Nations Mid-Decade for Women Conference, and an award ceremony honoring the first Federally employed woman to receive the Excalibur Award. NRC's FWP manager also spoke on the NRC Federal Women's Program during an FWP/FEW seminar at the Department of Energy.

NRC managers participated in a special Sexual Harassment Workshop designed to inform managers of their responsibilities under Equal Employment Opportunity Commission (EEOC) Guidelines on

As a part of NRC's Equal Employment Opportunity program of special ethnic observances, activities were carried out in February 1980 to acquaint NRC personnel with customs and traditions in the countries of the origin or ancestry of the more than 80 Asian-Americans employed in the agency.



Sexual Harassment, and of specific NRC policy on this matter.

Class Actions. Two class action complaints, filed by a single employee, are pending against the NRC alleging sex discrimination. The two complaints were filed separately in 1978 and 1979, and have been consolidated for processing by the EEOC. At the end of fiscal year 1980, attorneys for the class and for the NRC were engaged in pre-trial discovery to enable them to gain information relevant to the allegations in the complaint. Once this discovery process is completed, a hearing will be scheduled with the EEOC Complaints Examiner. This hearing is expected to take place in early 1981.

INSPECTION AND AUDIT

The Office of Inspector and Auditor (IA) conducts audits, investigations, and inspections to assure the effectiveness, efficiency, and integrity of NRC operations. Its responsibilities have included reviews of employee complaints and financial, compliance, and management audits, as well as liaison functions with the General Accounting Office and Department of Justice. Some of the more important IA activities are summarized below.

Implementation of TMI Lessons Learned

The accident at Three Mile Island (TMI) in March 1979 gave rise to a number of studies and investigations into what went wrong and why. To manage the numerous recommendations offered by these inquiries, NRC drafted an Action Plan which consolidated the recommendations and set priorities for implementation. (See Chapter 2.) On October 3,

1980, IA issued a report entitled, "Audit of the Implementation of NRR Related TMI Lessons Learned Concerning Utility Personnel Licensing and Training."

The report concludes that the overall Action Plan satisfies the intent of the many recommendations of the various accident TMI studies and brings them together in a coherent package for management action. Review of the implementation of lessons learned is continuing.

Resident Inspector Program

The second of two reports dealing with the NRC's resident inspector program was issued on December 21, 1979, which evaluates the overall implementation of the program. It identifies areas where program goals were being met or revised to accommodate both agency and inspector needs, and where further management attention was needed.

The report concludes that the program lacked high-level, centralized management, and that this hampered program implementation. The unresolved issues of (1) qualifications for resident inspectors, (2) the definition of the role of the resident inspectors, (3) the development of a career ladder for inspectors, (4) the reevaluation of resident inspection procedures, and (5) the administrative problems, are judged indicative of a general lack of management attention. The report recommends that a separate office be established to oversee all aspects of the resident inspector program, and makes other recommendations for improvement.

Former Reactor Inspection Program

A review of NRC's former reactor inspection program was conducted to assess the degree to which policies for inspecting commercial nuclear power

reactors were being successfully implemented. The subsequent "Information Report on the NRC's Former Reactor Inspection Program," issued July 31, 1980, deals principally with the power reactor inspection program before the emerging resident inspection program, and provides extensive material for comparison with the present resident inspector program. The report does not disclose any serious deficiencies in the inspection program areas examined. Generally, it concludes that the region-based reactor inspection program was well managed at the regional level, and that inspections were being performed at or near the proper time intervals. It also discloses a relatively high percentage of "not-clear" inspection steps for the operations phase inspections.

License Fee Management Program

An IA review of the license fee management program was performed to determine whether license fees were properly assessed and expeditiously collected. The resultant report, "Review of NRC's License Fee Management Program," was issued July 3, 1980. It concludes that the program was operating satisfactorily, and that reasonable effort was being made to assess and process fees for collection. There were a few areas, however, which warranted improvement such as procedures to expedite billing and processing of inspection fees and modifications to assure that inspection fees would be reasonable. The report recommends improvements in assessing, billing, processing, and collecting license fees.

Reactor Safety Research Plan

Public Law 95-209, dated December 13, 1977, required NRC to prepare a long-term plan to improve the safety of light-water nuclear power plants. A report issued June 11, 1980, assesses NRC's response to P.L. 95-209 and the status of the plan's implementation. This report, "Review of NRC's Plan for Research to Improve the Safety of Light Water Nuclear Power Plants," concludes that the plan was generally well prepared and responsive to the Congressional mandate. It further discloses that the plan did not contain a "long-term" assessment of research needs as required by the mandate, and that various problems with the Office of Management and Budget and Congressional Committees, coupled with internal difficulties, had impeded plan implementation. The report recommends, among other things, that the two research projects, Improved Methodology for Evaluating Research Topics and Scoping Studies, be performed in-house to the extent possible prior to contracting them out.

Flow of a Licensee Event Report

At the request of the Commission, IA conducted an inspection to determine the administrative flow of a licensee event report (LER) within NRC. The inspection surfaced problems in the distribution and administrative control of LERs. IA made recommendations to eliminate the deficiencies.

Internal Information Flow

At the request of the Commission, IA investigated reasons why information concerning a safety related incident at a foreign reactor had not been more expeditiously reported to the Commission by NRC staff members. The information concerned a power operated relief valve on a Westinghouse reactor, and was confirmatory data which supported subsequent NRC staff suspicions that a deficiency existed in the design of the emergency core cooling system in Westinghouse reactors. The incident occurred in 1974, but the investigation determined that information had not been received by NRC staff until April 26, 1979. No information was developed to indicate there were internal attempts to withhold information from the Commission. In fact, the information had been reviewed by some members of the NRC staff, but there had been no NRC policy identified which dealt with the handling of safety related information concerning foreign reactors.

FUNDING AND BUDGET MATTERS

NRC resource charts and financial statements appear at the end of this chapter. These charts show allocations of authorized personnel and funds to the various NRC activities carried out during fiscal year 1980, and to those projected for fiscal year 1981.

Personnel increases in fiscal year 1981 are predominantly influenced by the TMI accident of March 28, 1979. The largest increase in personnel for fiscal year 1981 is the Office of Inspection and Enforcement, including specific increases for inspection of reactors under construction, reactors in operation, fuel facilities, and materials licensees. Congressional approval has also been received to convert 146 full-time temporary positions to permanent positions in fiscal year 1981. In this regard, a comparability adjustment has been made in the fiscal year 1980 personnel figures presented earlier in this chapter to reflect this change.

The increase in funding for fiscal year 1981 is primarily concerned with incorporating lessons learned from the TMI accident and applying increased effort in the waste management area.

Project Management

During the year the EDO directed that project coordination and review procedures be examined to insure all projects receive careful review and consideration by appropriate levels of management.

New standardized criteria were set forth for placement of projects with other agencies as a source of capability other than the competitive procurement process. The procedure for placement of work with DOE was again reviewed; and a Senior Contract Review Board (SCRB) was established under the direction of the Commission to review all contractual actions of \$500,000 or more. The Board reviews proposed scopes of work, propriety of fiscal integrity, and appropriateness of projects in support in NRC requirements. This senior-level review also ensures that new contractual efforts do not duplicate other projects within the agency.

Lower level board reviews that have been in existence for some time—such as the Safeguards Technical Assistance and Research Review Group and the Waste Management Review Group—are still being performed in these technical areas with the SCRB reviewing the results. Finally, all new projects with annual obligations of \$1 million or more will be additionally reviewed by the Commission. This

overall review process ensures uniformity and objectivity in the NRC contractual program.

Contracting and Reimbursable Work

Most of the NRC's operating funds are expended in reimbursable arrangements with other agencies and contracts for confirmatory research and technical assistance in every major area of the agency's activity.

Some \$232 million was allocated to program support during fiscal year 1980, of which \$215.4 million went for reimbursable work performed for the NRC by other Federal agencies. The Department of Energy's share of this was approximately \$209 million for work performed in DOE's national laboratories and other facilities. This work included major research projects such as the Integrated Reliability Evaluation Program, and experiments at the Loss-of-Fluid Test (LOFT) Facility, the Power Burst Facility, and the Semiscale Facility. (Specific research programs are described in Chapter 13.)

Contracts with commercial firms for technical assistance, and research work (except work performed through DOE), as well as general purchases of all kinds, are administered through the Division of



A key element of NRC's internal word processing system is its Central Regulatory Electronic Stenographic System (CRESS), a two-shift (or "round-the-clock" when required) center that handles typing and revisions of most major NRC reports and documents. The information is stored for

retrieval/revision on diskettes and can be transmitted over telephone lines between the three CRESS sections in scattered NRC locations, as well as to the five regional offices and various laboratories and contractors. More than 250,000 pages of finished typing were prepared by CRESS during fiscal year 1980.

Contracts in the Office of Administration. Such contracts totaled approximately \$41.5 million during fiscal year 1980.

Activities to improve procurement practices during the year have focused on (1) promulgating contract close-out procedures, (2) implementing agency review of contractor invoices, (3) implementing contracting procedures relating to small and disadvantaged businesses (Public Law 95-507), (4) updating general provisions for cost reimbursement contracts, (5) completing the Procurement Handbook and procedures on contracting for consultant services, (6) drafting internal procedures for the contract information system, (7) promulgating the standard request for proposal (RFP) package, and (8) establishing procedures regarding receipt and safeguarding of bids and proposals.

INFORMATION RETRIEVAL SYSTEM

The NRC's computerized Automated Information Retrieval System provides the capabilities for indexing, storing, and retrieving documents received or generated by NRC. The information processing facility, located near NRC Headquarters in Bethesda, Md., houses the contractor staff of engineers, computer specialists, indexers, technical coders, and much of the equipment for the automation, transmission, and storage of documents. Essential elements of information are extracted from source documents and encoded to form a digital record for each document. The documents are then microfiched for storage and retrieval either at video-display terminals located in various NRC offices or through microfiche readers. All terminals are linked to the computer data base, permitting users to search for documents by a variety of data elements such as authors, date, recipient organization, etc.

The system also produces periodic indexes to documents in the data base, including title list reports, accession lists of documents placed in the NRC Public Document Room, and limited subject-search indexes for staff use. The monthly *Title List of Documents Made Publicly Available* is a comprehensive description and listing of docketed and nondocketed information received and generated by NRC. An abstract/index journal of formal NRC and contractor reports was initiated in 1980. This will be published periodically through 1980 and 1981 and evaluated as to its use as an information source for the scientific and technical community during 1981.

Terminals were scheduled to be installed in all five NRC regional offices by January 1981, providing access for the first time to the complete NRC information base.

Because of demands of groups investigating the TMI-2 accident (i.e., President's Commission, Congressional committees, and the NRC's indepen-

dent Special Inquiry Group), the system was tested under severe conditions during 1979 and 1980. In addition, the system contributed to the staff's efforts following the accident by providing searches, indexing, and microfiche. In all, the system staff processed approximately 20,000 TMI records. The complete listing of this effort appears in the three-volume *Title List of Publicly Available Documents on Three Mile Island Unit 2, Docket 50-320*, NRC report NUREG-0568, and a two-volume *Title List of Publicly Available Documents on TMI Unit 1, Docket 50-289*, NUREG-0631.

The demands for documentation and search capabilities prompted a rescheduling of major contract tasks to permit an accelerated backfit of power plant docket files into the data base, beginning with TMI, then proceeding with other B&W designed plants.

PHYSICAL FACILITIES

During fiscal year 1980, NRC housed approximately 2,600 headquarters employees in 10 buildings—one located in the District of Columbia and nine in the Maryland suburbs. Continuing efforts since 1977 by the NRC and the General Services Administration (GSA) to obtain Congressional approval for consolidation in a single facility resulted in positive steps during the year.

In February 1980, GSA submitted to the House Committee on Public Works and Transportation an amended "Report of Building Project Survey" which updated information submitted previously. In May, the Senate Environment and Public Works Committee approved a resolution for the construction of a Federally-owned building for NRC in Silver Spring, Md., at a cost not to exceed \$113,800,000. Since this proposal differs significantly from the one previously approved by the House Committee on Public Works and Transportation (see 1979 Annual Report, p. 279), it will require additional House action. Congressional approval also hinges on the lifting of the Senate Committee's moratorium on new Federal construction which was imposed in 1979.

This permanent solution to NRC's dispersal problem is at least six years away, assuming early Congressional approval. In April, space surveys and consultations with the Office of Management and Budget (OMB) resulted in OMB instructions to GSA to accomplish a partial, interim consolidation in two locations—one in the District of Columbia and the other in Bethesda, Md. This would accommodate about half of the agency at each location, vacating four outlying buildings, and would colocate selected critical units with the agency leadership.

In July 1980, under Congressional direction, the GAO initiated a review of NRC interim consolidation to determine if any other cost-effective options

are available. The GAO study found that the cost of the proposed interim consolidation could run as high as \$5.7 million, and that a less costly alternative could accomplish the same objectives. The alternative plan envisioned moving the Commissioners and their staffs to Bethesda and relocating other employees presently in Bethesda to the Matomic Building in downtown Washington. This, said the GAO, would put two-thirds of NRC's employees within a 15-minute walking distance of each other. In response, NRC held to the original OMB proposal, and stated that the GAO alternative would not satisfactorily address the present dispersal problem.

NRC LICENSE FEES

The practice of charging license fees was first adopted by the NRC (then AEC) in 1968, in accordance with provisions of the Independent Offices Appropriation Act of 1952 and with established Administration policy on recovery of user charges. In March 1974, the U.S. Supreme Court decided two cases which challenged the validity of annual fees for licenses assessed by the Federal Communications Commission and the Federal Power Commission under authority of the Independent Offices Appropriation Act. The Court ruled that the Act permitted an agency to assess fees only for special benefits rendered to identifiable persons as measured by the "value to the recipient" of the agency's service. As a result, the AEC discontinued its annual license fees and began to refund annual fees collected.

On March 23, 1978, the NRC adopted a revised schedule of license fees, which increased fees in several categories of applications and licenses and created additional categories of cost recovery for government services. These new categories included inspections, amendments, applications filed by vendors and architect-engineers for approval of standardized designs and renewals. All costs associated with generic licensing issues, research activities, standards development, State and international programs, export licensing, and contested licensing hearings

were excluded from recovery.

In the revised schedule, charges for facility and fuel cycle licenses, permits and approvals are based on actual costs (manpower and contractual) to the NRC of processing the licenses. Fees for most materials licenses are based on the average cost of processing the application for a particular category of license. The schedule includes fees for review of applications for standard design approvals from vendors and architect-engineers; utility applications referencing standard designs; license amendments; routine inspections; special projects and reviews; requests for approval of spent fuel casks and shipping containers; requests for approval of sealed sources and devices containing or utilizing byproduct, source, or special nuclear material; and licenses for the receipt and storage of spent nuclear fuel. In response to challenges by a number of licensees, the U.S. Court of Appeals for the Fifth Circuit issued an opinion in August 1979 upholding in all respects the NRC's 1978 schedule and guidelines for fees. (See 1979 Annual Report, p. 279.)

During fiscal year 1980, the NRC continued to collect fees for the processing of applications, permits, licenses, and approvals, and for routine health, safety, and safeguards inspections. Fees collected totaled \$12.5 million, of which \$2.2 million is held in a suspense account by the Department of the Treasury until action on the permit or license involved has been completed, at which time the actual costs of the action will be calculated. (See Table 1.) The total collected since fees were first imposed in 1968 through September 1980 is \$113.9 million. Of this total, \$6.5 million has been refunded to licensees as a result of the Supreme Court's 1974 decision against annual fees.

During fiscal year 1980, three operating licenses were issued which were subject to the actual costs requirement. Table 2 provides information relating costs of issuance and fees paid for these particular facilities. No construction permits were issued during the fiscal year.

Table 1. Fiscal Year 1980 License Fee Collections

| <i>Fees</i> | <i>Materials</i> | <i>Facilities</i> | <i>Totals</i> |
|---------------------|--------------------|--------------------|---------------------|
| Applications | \$ 165,000 | \$ 50,000 | \$ 215,000 |
| Construction Permit | - | - | - |
| Operating License | - | 1,630,000 | 1,630,000 |
| Amendments | 632,000 | 1,706,000 | 2,338,000 |
| Renewals | 230,000 | - | 230,000 |
| Inspection Fees | 2,210,000 | 5,765,000 | 7,975,000 |
| Special Projects | 16,000 | 118,000 | 134,000 |
| | <u>\$3,253,000</u> | <u>\$9,269,000</u> | <u>\$12,522,000</u> |

Table 2. Cost of OL Issuances During Fiscal Year 1980*
(in thousands of dollars)

| <u>Operating Licenses</u> | <u>Issue Date</u> | <u>Licensing Cost</u> | <u>Inspection Cost</u> | <u>Total Cost</u> | <u>Fees Paid</u> |
|---------------------------|-------------------|-----------------------|------------------------|-------------------|------------------|
| Sequoyah Unit 1 | 9/17/80 | \$1,940** | \$700 | \$2,640 | \$1,025 |
| North Anna Unit 2 | 10/17/80 | 870 | 480 | 1,350 | 303 |
| Salem Unit 2 | 4/18/80*** | | | | |

*No construction permits were issued in fiscal year 1980.

**NRC expects an additional \$100,000 will be spent on the ice condenser problem before Sequoyah is issued an unconditional license.

***A partial power license was issued to Salem 2 on April 18, 1980. Total Commission costs for the review will be determined when the full power license is issued.

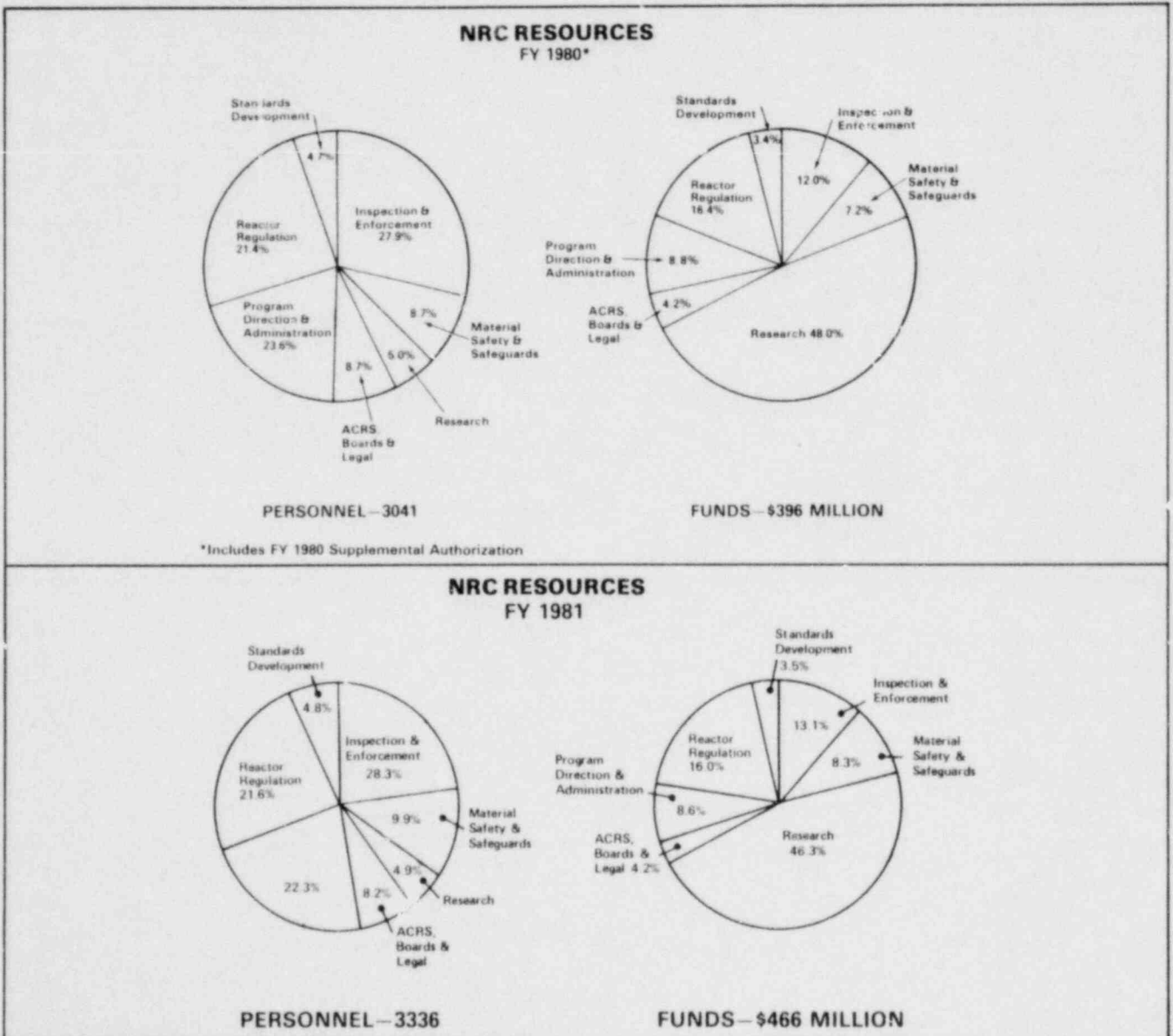

Fiscal Year 1979/1980 NRC Financial Statements

Balance Sheet (in thousands)

| | <i>September 30, 1980</i> | <i>September 30, 1979</i> |
|---|-------------------------------|-------------------------------|
| Assets | | |
| Cash: | | |
| Appropriated Funds in U.S. Treasury | \$ 168,468 | \$ 146,257 |
| Other (See Notes 1 and 3) | 4,414 | 10,426 |
| | <u>172,882</u> | <u>156,683</u> |
| Accounts Receivable: | | |
| Federal Agencies | 81 | 222 |
| Miscellaneous Receipts (Note 2) | 4,092 | 5,986 |
| Other | 248 | 272 |
| | <u>4,421</u> | <u>6,480</u> |
| Plant: | | |
| Completed Plant and Equipment | 9,446 | 7,462 |
| Less—Accumulated Depreciation | 1,978 | 1,314 |
| | <u>7,468</u> | <u>6,148</u> |
| Advances and Prepayments: | | |
| Federal Agencies | 160 | 171 |
| Other | 1,300 | 1,304 |
| | <u>1,460</u> | <u>1,475</u> |
| Total Assets | <u><u>\$ 186,231</u></u> | <u><u>\$ 170,786</u></u> |
| <hr/> | | |
| Liabilities and NRC Equity | | |
| | <i>September 30, 1980</i> | <i>September 30, 1979</i> |
| Liabilities: | | |
| Funds Held for Others (See Notes 1 and 3) | \$ 4,414 | \$ 10,426 |
| Accounts Payable and Accrued Expenses: | | |
| Federal Agencies | 57,623 | 42,884 |
| Other | 17,889 | 20,323 |
| Accrued Annual Leave of NRC Employees | 7,327 | 6,285 |
| Deferred Revenue (Note 3) | 2,892 | 1,330 |
| Total Liabilities | <u>90,145</u> | <u>81,248</u> |
| NRC Equity: Balance at October 1 | 89,538 | 75,924 |
| Additions: | | |
| Funds Appropriated—Net | 400,100 | 326,601 |
| | <u>489,638</u> | <u>402,525</u> |
| Deductions: | | |
| Net Cost of Operations | 372,032 | 305,865 |
| Funds Returned to U.S. Treasury (Note 2) | 21,520 | 7,122 |
| | <u>393,552</u> | <u>312,987</u> |
| Total NRC Equity | <u>96,086</u> | <u>89,538</u> |
| Total Liabilities and NRC Equity | <u><u>\$ 186,231</u></u> | <u><u>\$ 170,786</u></u> |

Note 1. As of September 30, 1980, includes \$1,328,427.44 of funds received under cooperative research agreements involving NRC, DOE, Federal Republic of Germany, Japan, Austria, the Netherlands, Belgium, and the United Kingdom. Included also is \$2,646,820.00 of funds received from deferred revenue billings. These funds will be refunded and/or recorded as earned revenue after the cost of processing the applicable application has been finalized and, accordingly, are not available for NRC use. (See Note 3.)

Note 2. These funds are not available for NRC use.

Note 3. On March 24, 1978, 10 CFR Part 1 was revised. Contained therein by category of license are maximum fee amounts to be paid by applicants at the time a facility or material license is issued. Also, after the review of the license application is complete (generally after license has been issued), the expenditures for professional manpower and appropriate support services are to be determined and the resultant fee assessed. In no event will the fee exceed the maximum fee for that license category which generally has been paid. This could involve the refunding of a significant portion of the initial amount paid. Therefore, the revenue is recorded in a deferred revenue account at the time of billing and is removed from this account and recorded in Funds Held for Others when the bill is paid. The balance in the Deferred Revenue account consists of deferred revenue on billings issued but not collected. (See Note 1.)

Note 4. Represents current year cost of plant and equipment acquisitions for use at DOE facilities.

Fiscal Year 1979/1980 Statement of Operations (in thousands)

| | <i>Fiscal Year 1980 (October 1, 1979, thru September 30, 1980)</i> | <i>Fiscal Year 1979 (October 1, 1978, thru September 30, 1979)</i> |
|---|--|--|
| Personnel Compensation | \$ 97,630 | \$ 85,351 |
| Personnel Benefits | 8,991 | 7,649 |
| Program Support | 229,216 | 181,950 |
| Administrative Support | 36,660 | 27,910 |
| Travel of Persons | 7,088 | 6,123 |
| Equipment (Technical) (See Note 4) | 8,558 | 6,545 |
| Construction (See Note 4) | - | 10 |
| Taxes and Indemnities | 28 | 3 |
| Refunds to Licensees | 1 | 180 |
| Representational Funds | 13 | 9 |
| Reimbursable Work | 169 | 367 |
| Increase in Annual Leave Accrual | 1,042 | 733 |
| Depreciation Expense | 696 | 547 |
| Equipment Write-offs and Adjustments | \$ 169 | \$ 26 |
| Total Cost of Operations | 390,261 | 317,403 |
| Less Revenues: | | |
| Reimbursable Work for Other Federal Agencies | 165 | 367 |
| Fees (deposited in U.S. Treasury as Miscellaneous Receipts (See Note 2): | | |
| Indemnity | 1,059 | 1,035 |
| Material License | 2,803 | 1,605 |
| Facility Licenses | 12,854 | 7,810 |
| Other | 1,348 | 137 |
| Total Revenue | 18,229 | 10,954 |
| Net Cost of Operations Before Prior Year Adjustments | 372,032 | 306,449 |
| Prior Year Adjustment | -0- | 584 |
| Net Cost of Operations | \$ 372,032 | \$ 295,865 |

U.S. Government Investment in the Nuclear Regulatory Commission (From January 19, 1975, through September 30, 1980—in thousands)

Appropriation Expenditures:

| | |
|--|------------------|
| Fiscal Year 1975 (January 19, 1975, through June 30, 1975) | \$ 52,792 |
| Fiscal Year 1976 (July 1, 1975, through September 30, 1976) | 226,248 |
| Fiscal Year 1977 (October 1, 1976, through September 30, 1977) | 230,559 |
| Fiscal Year 1978 (October 1, 1977, through September 30, 1978) | 270,877 |
| Fiscal Year 1979 (October 1, 1978, through September 30, 1979) | 309,493 |
| Fiscal Year 1980 (October 1, 1979, through September 30, 1980) | 377,889 |
| | 1,467,858 |
| Unexpended Balance of Appropriated Funds in U.S. Treasury, September 30, 1980 | 168,469 |
| Transfer of Refunds Receivable from Atomic Energy Commission, January 19, 1975—Total Funds Appropriated | 429 |
| | 1,636,756 |
| Less: | |
| Funds Returned to U.S. Treasury (See Note 2) | 72,262 |
| Assets and Liabilities Transferred from Other Federal Agencies without Reimbursement | 2,018 |
| Net Cost of Operations from January 19, 1975, through September 30, 1980 | 1,460,390 |
| Total Deductions | 1,540,670 |
| NRC Equity at September 30, 1980 as Shown on Balance Sheet | \$ 96,086 |

Appendix 1

NRC ORGANIZATION

(As of September 30, 1980)

COMMISSIONERS

John F. Ahearne, Chairman
 Victor Gilinsky
 Joseph M. Hendrie
 Peter A. Bradford
 Vacant

The Commission Staff

General Counsel, Leonard Bickwit
 Office of Policy Evaluation, Edward J. Hanrahan, Acting Director
 Office of Public Affairs, Joseph J. Fouchard, Director
 Office of Congressional Affairs, Carlton C. Kammerer, Director
 Office of Inspector and Auditor, James J. Cummings, Director
 Secretary of the Commission, Samuel J. Chilk

Other Offices

Advisory Committee on Reactor Safeguards, Milton S. Plesset, Chairman
 Atomic Safety & Licensing Board Panel, Robert M. Lazo, Acting Chairman*
 Atomic Safety & Licensing Appeal Panel, Alan S. Rosenthal, Chairman

EXECUTIVE DIRECTOR FOR OPERATIONS

Executive Director for Operations, William J. Dircks
 Deputy Executive Director for Operations, E. Kevin Cornell
 Assistant for Operations, Thomas A. Rehm

Program Offices

Office of Nuclear Reactor Regulation, Harold R. Denton, Director
 Office of Nuclear Material Safety and Safeguards, John G. Davis, Director
 Office of Nuclear Regulatory Research, Thomas E. Murley, Acting Director**
 Office of Standards Development, Robert B. Minogue, Director***
 Office of Inspection and Enforcement, Victor Stello, Jr., Director

Staff Offices

Office of Administration, Daniel J. Donoghue, Director
 Executive Legal Director, Howard K. Shapar
 Controller, Learned W. Barry
 Office of Equal Employment Opportunity, Edward E. Tucker, Director
 Office of Management and Program Analysis, Norman M. Haller, Director
 Office of International Programs, James R. Shea, Director
 Office of State Programs, G. Wayne Kerr, Director
 Office for Analysis and Evaluation of Operational Data, Carlyle Michelson, Director
 Office of Small and Disadvantaged Business Utilization, William B. Kerr, Director

Regional Offices

Region I Philadelphia, Pa., Boyce H. Grier, Director
 Region II Atlanta, Ga., James P. O'Reilly, Director
 Region III Chicago, Ill., James G. Keppler, Director
 Region IV Dallas, Texas, Karl V. Seyfrit, Director
 Region V San Francisco, Calif., Robert H. Engelken, Director

*B. Paul Cotter, Jr., was appointed Chairman of the ASLBP in November 1980.

**Robert B. Minogue was appointed Director of RES in November 1980.

***Ray G. Smith was appointed Acting Director of SD in November 1980.

The NRC is responsible for licensing and regulating nuclear facilities and materials and for conducting research in support of the licensing and regulatory process, as mandated by the Atomic Energy Act of 1954, as amended, the Energy Reorganization Act of 1974, as amended, and the Nuclear Nonproliferation Act of 1978; and in accordance with the National Environmental Policy Act of 1969, as amended, and other applicable statutes. These responsibilities include protecting public health and safety, protecting the environment, protecting and safeguarding materials and plants in the interest of national security; and assuring conformity with antitrust laws. Agency functions are performed through: standards-setting and rulemaking; technical reviews and studies; conduct of public hearings; issuance of authorizations, permits and licenses; inspection, investigation and enforcement; evaluation of operating experience, and confirmatory research. The Commission itself is composed of five members, appointed by the President and confirmed by the Senate, one of whom is designated by the President as Chairman. The Chairman is the principal executive officer and the official spokesman of the Commission.

The Executive Director for Operations directs and coordinates the Commission's operational and administrative activities among the program and support staff offices described below, and also coordinates the development of policy options for Commission consideration. The EDO reports directly to the Chairman.

The Office of Nuclear Reactor Regulation licenses nuclear power, test and research reactors under a two-phase process. A construction permit is granted before facility construction can begin and an operating license is issued before fuel can be loaded. NRR reviews license applications to assure that the proposed facility can be built and operated without undue risk to the health and safety of the public and with minimal impact on the environment. NRR monitors operating reactor facilities during their lifetime through decommissioning. NRR also reviews the financial responsibility of each applicant for a construction permit, confirms that each applicant is properly indemnified against accidents, and verifies that the applicant(s) is not in violation of antitrust laws.

The Office of Nuclear Material Safety and Safeguards is responsible for ensuring public health and safety, and protection of national security and environmental values in: the licensing and regulation of the possession, use and disposition of nuclear materials and the safeguarding of nuclear materials and facilities. The scope of its activities includes the processing, transport, storage and final disposal of nuclear materials. NMSS reviews and assesses safeguards against potential threats, thefts, and sabotage, and works closely with other NRC organizations in coordinating safety and safeguards programs and in recommending research, standards, and policy options necessary for their successful operation.

The Office of Nuclear Regulatory Research plans and implements research programs which are deemed necessary for the performance of the Commission's licensing and regulatory functions. These programs cover reactor safety areas such as materials behavior, site safety, systems engineering, and computer code development and

assessment. Research is also performed on safeguards, health effects associated with the nuclear fuel cycle, environmental impact of nuclear power, waste treatment and disposal, and transportation of radioactive materials.

The Office of Standards Development develops regulations, guides, and other standards needed for regulation of facilities and materials with respect to radiological health and safety and environmental protection, for materials safeguards and plant protection, and for antitrust review. The Office also coordinates NRC participation in national and international standards activities.

The Office of Inspection and Enforcement inspects nuclear facilities and materials licensees to determine whether facilities are constructed and operations are conducted in compliance with license provisions and Commission regulations, and to identify conditions that may adversely affect the protection of nuclear materials and facilities, the environment, or the health and safety of the public; inspects applicants and their facilities to provide a basis for recommending issuance or denial of licenses; investigates accidents, incidents, and allegations of improper actions that involve nuclear material and facilities; enforces NRC regulations and license provisions; and manages and directs all NRC actions related to emergency preparedness, including evaluation of State and local emergency plans performed by the Federal Emergency Management Agency (FEMA). IE, on behalf of NRC, manages and directs the Commission's five regional offices, located in Philadelphia, Pa., Atlanta, Ga., Chicago, Ill., Dallas, Texas, and San Francisco, Calif.

THE COMMISSION STAFF

The Office of the Secretary provides secretariat services for the conduct of Commission business and implementation of decisions, including planning meetings and recording deliberations, manages the staff paper system, monitors the status of actions, and maintains the Commission's official records. The office also processes institutional correspondence, controls the service of documents in adjudicatory and public proceedings, supervises the Washington, D.C. Public Document Room, administers the NRC historical program, and provides administrative support for the Commission.

The Office of General Counsel serves the Commission in a variety of legal capacities. The Office assists the Commission in the review of Appeal Board decisions, petitions seeking direct Commission relief, and rulemaking proceedings, and drafts legal documents necessary to carry out the Commission's decisions. The General Counsel provides a legal analysis of proposed legislation affecting the Commission's functions and assists in drafting legislation and preparing testimony. The General Counsel also represents the Commission in court proceedings, frequently in conjunction with the Department of Justice.

The Office of Policy Evaluation plans and manages activities involved in performance of an independent review of positions developed by the NRC staff which require policy determinations by the Commission. The

Office also conducts analyses and projects which are either self-generated or requested by the Commission.

The Office of Inspector and Auditor investigates to ascertain the integrity of all NRC operations; investigates allegations of NRC employee misconduct, equal employment and civil rights complaints, and claims for personal property loss or damage; conducts the NRC's internal audit activities; and hears individual employee concerns regarding Commission activities under the agency's "Open Door" policy. The office develops policies governing the Commission's financial and management audit program and is the agency contact with the General Accounting Office on this function. Refers criminal matters to the Department of Justice and maintains liaison with law enforcement agencies.

The Office of Public Affairs plans and administers NRC's program to inform the public of Commission policies, programs and activities and keeps NRC management informed of public affairs activities of interest to the Commission. OPA reports directly to the Chairman.

The Office of Congressional Affairs provides advice and assistance to the Commission and senior staff on congressional matters, coordinates NRC's congressional relations activities, and maintains liaison for the Commission with congressional committees and members of Congress. OCA reports directly to the Chairman.

SUPPORT STAFF

The Office of Administration directs the agency's programs for organization and personnel management; security and classification; technical information and document control; facilities and materials license fees; contracting and procurement; rules, proceedings and document services; data processing; management development and training; and other administrative housekeeping and special services.

The Office of the Controller develops and maintains the Commission's financial management program, including accounting, budgeting, pricing, contract finance, automatic data processing equipment acquisition, and accounting for capitalized property. Prepares reports necessary to the management of NRC funds. Maintains liaison with the General Accounting Office, Office of Management and Budget, Congressional Committees, other agencies, and industry. The Controller also prepares the NRC Five-Year Plan and performance resource evaluation studies.

The Office of the Executive Legal Director provides legal advice and services to the Executive Director for Operations and staff, including representation in administrative proceedings involving the licensing of nuclear facilities and materials, and the enforcement of license conditions and regulations; counseling with respect to safeguards matters, contracts, security, patents, administration, research, personnel, and the development of regulations to implement applicable Federal statutes.

The Office of Equal Employment Opportunity develops and recommends overall policy providing for equal employment opportunity, recommends improvements or

corrections to achieve this goal, and monitors the agency's affirmative action program.

The Office of International Programs plans and implements programs of international nuclear safety cooperation, creating and maintaining relationships with foreign regulatory agencies and international organizations; coordinates NRC export-import and international safeguards policies; issues export and import licenses; and coordinates responses by NRC to other agencies related to export-import actions and issues.

The Office of Management and Program Analysis provides NRC staff with management information and program analyses; identifies and analyzes major NRC policy, program and management issues and conducts long- and short-range planning to assist NRC operating officials; develops and implements management information and control systems and recommends policy on use of such systems for agency-wide applications; develops and implements application of sound statistical practices within NRC; and coordinates special information projects on overall NRC policies and programs.

The Office of State Programs directs programs relating to regulatory relationships with State governments and organizations and interstate bodies; and manages the NRC State Agreements program.

The Office for Analysis and Evaluation of Operational Data assures the proper analysis of operational data associated with all NRC-licensed activities and the feedback of such analyses to improve safety. The office identifies key analyses to be conducted, taking into account such factors as postulated accident sequences and data availability; selects appropriate analytical techniques and proposes data gathering mechanisms for data not currently available; conducts systematic safety analyses and evaluations of operational data to seek trends that would forecast a potential problem; develops recommendations to resolve problems revealed by operational data analyses and evaluations; provides analytical guidance to, accepts technical input from, and coordinates efforts of operational data analysis groups in other NRC offices; reviews overall NRC and industry response to assess implementation of recommended actions; and serves as focal point for interaction with the ACRS and industry groups involved in operational data analysis and evaluation.

The Office of Small and Disadvantaged Business Utilization develops and implements, in cooperation with the Director, Division of Contracts and Directors of other affected offices, specific policies and procedures to carry out the functions and duties of Sections 8 and 15 of the Small Business Act and Executive Order 12138, as they relate to the NRC. The office provides focus for NRC efforts to assist small business, small businesses owned by socially or economically disadvantaged individuals, women-owned businesses, and firms in labor surplus areas.

OTHER OFFICES

Advisory Committee on Reactor Safeguards. A statutory committee of 15 scientists and engineers advises the

Commission on the safety aspects of proposed and existing nuclear facilities and the adequacy of proposed reactor safety standards, and performs such other duties as the Commission may request

Atomic Safety and Licensing Board Panel. Three-member licensing boards drawn from the Panel—made up of lawyers and others with expertise in various technical fields—conduct public hearings and make such intermediate or final decisions as the Commission may authorize in proceedings to grant, suspend, revoke or amend NRC Licenses.

Atomic Safety and Licensing Appeal Panel. Three-member appeal boards selected from the Panel exercise the authority and perform the review functions which would otherwise be carried out by the Commission in licensing proceedings. ASLB decisions are reviewable by an appeal board, either in response to an appeal or on its own initiative. The appeal board's decision also is subject to review by the Commission on its initiative or in response to a petition for discretionary review.

Appendix 2

NRC Committees and Boards

Advisory Committee on Reactor Safeguards

The ACRS was made a statutory committee in 1957 by Section 29 of the Atomic Energy Act of 1954, as amended. The committee reviews safety studies and facility license applications referred to it in accordance with the Atomic Energy Act and the Energy Reorganization Act and makes reports thereon which are made part of the public record of the proceeding. The committee provides advice with respect to the hazards of new or existing nuclear facilities and the adequacy of related safety standards. The committee also performs such other additional duties as the Commission may request. The members are appointed for four-year terms by the Commission. The committee annually elects its own chairman and vice chairman. As of September 30, 1980 the members were:

- DR. MILTON S. PLESSET, *Chairman*, Professor, Department of Engineering Science—Emeritus, California Institute of Technology, Pasadena, Calif.
- DR. J. CARSON MARK, *Vice Chairman*, Retired Division Leader, Los Alamos Scientific Laboratory, Los Alamos, N.M.
- MYER BENDER, Director, Engineering Division, Oak Ridge National Laboratory, Oak Ridge, Tenn.
- DR. MAX W. CARBON, Professor and Chairman of Nuclear Engineering Department, University of Wisconsin, Madison, Wis.
- JESSE EBERSOLE, Retired Head Nuclear Engineer, Division of Engineering Design, Tennessee Valley Authority, Knoxville, Tenn.
- PROF. WILLIAM KERR, Professor of Nuclear Engineering, Director of Michigan Memorial-Phoenix Project, University of Michigan, Ann Arbor, Mich.
- DR. STEPHEN LAWROSKI, Senior Engineer, Chemical Engineering Division, Argonne National Laboratory, Argonne, Ill.
- DR. HAROLD W. LEWIS, Department of Physics, University of California, Santa Barbara, Calif.
- WILLIAM M. MATHIS, Retired Director, Planning, United Nuclear Industries, Inc., Richland, Wash.
- DR. DADE W. MOELLER, Chairman, Department of Environmental Health Sciences, School of Public Health, Harvard University, Boston, Mass.
- DR. DAVID OKRENT, Professor, School of Engineering and Applied Science, University of California, Los Angeles, Calif.
- JEREMIAH J. RAY, Retired Chief Electrical Engineer, Philadelphia Electric Company, Philadelphia, Pa.
- DR. PAUL G. SHEWMON, Professor, Chairman of Metallurgical Engineering Department, Ohio State University, Columbus, Ohio
- DR. CHESTER P. SIESS, Professor, Head of Civil Engineering Department, University of Illinois, Urbana, Ill.

Atomic Safety and Licensing Board Panel

Section 191 of the Atomic Energy Act of 1954 authorizes the Commission to establish one or more atomic safety and licensing boards, each comprised of three members, one of whom is to be qualified in the conduct of administrative proceedings and two of whom will have such technical or other qualifications as the Commission deems appropriate to the issues to be decided. The boards conduct such hearings as the Commission may direct and make such intermediate or final decisions as it may authorize in proceedings with respect to granting, suspending, revoking, or amending licenses or authorizations. The Atomic Safety and Licensing Board Panel (ASLBP) Office—with a permanent chairman who coordinates and supervises the ASLBP activities—serves as spokesman for the panel, and makes policy recommendations to the Commission concerning conduct of hearings and hearing procedures. Pursuant to subsection 201 (g)(1) of the Energy Reorganization Act of 1974, the functions performed by the licensing boards were specifically transferred to the Nuclear Regulatory Commission. As of September 30, 1980 the ASLBP was composed of the following members and professional staff ("*" denotes full-time ASLBP members and staff):

- ROBERT M. LAZO, Acting *Chairman*, ASLBP Attorney, U.S. Nuclear Regulatory Commission, Bethesda, Md.*
- DR. GEORGE C. ANDERSON, Department of Oceanography, University of Washington, Seattle, Wash.
- CHARLES BECHHOEFER, ASLAB Attorney, Bethesda, Md.*
- ELIZABETH S. BOWERS, ASLBP Attorney, Bethesda, Md.*
- JOHN H. BREBEL, Attorney with law firm of Alston, Miller & Gaines, Washington, D.C.
- GLENN O. BRIGH, ASLBP Engineer, Bethesda, Md.*
- DR. A. DIXON CALLIHAN, Retired Physicist, Union Carbide Corporation, Oak Ridge, Tenn.
- DR. E. LEONARD CHEATUM, Retired Director of Institute of Natural Resources, University of Georgia, Watkinsville, Ga.
- HUGH K. CLARK, Retired Attorney, E. I. duPont de Nemours & Company, Kennedyville, Md.
- DR. RICHARD F. COLE, ASLBP Environmental Scientist, Bethesda, Md.*
- DR. FREDERICK P. COWAN, Retired Physicist, Brookhaven National Laboratory, Boca Raton, Fla.
- VALENTINE B. DEALE, Attorney at Law, Washington, D.C.
- RALPH S. DECKER, Retired Engineer, U.S. Atomic Energy Commission, Cambridge, Md.
- DR. RONALD P. DE SYLVA, Professor, Biology and Living Resources, School of Marine and Atmospheric Science, University of Miami, Miami, Fla.
- MICHAEL A. DUGGAN, College of Business Adminis-

tration, University of Texas, Austin, Tex.

DR. GEORGE A. FERGUSON, Professor of Nuclear Engineering, Howard University, Washington, D.C.

DR. HARRY FOREMEN, Director, Center for Population Studies, University of Minnesota, Minneapolis, Minn.

JOHN H. FRYE, III, ASLBP Legal Counsel, Bethesda, Md.*

MICHAEL GLASER, Partner, law firm of Glaser and Fletcher, Washington, D.C.

JAMES P. GLEASON, ASLBP Attorney, Bethesda Md.

ANDREW C. GOODHOPE, Retired Administrative Law Judge, Federal Trade Commission, Wheaton, Md.

HERBERT GROSSMAN, ASLBP Attorney, Bethesda, Md.*

DR. CADET H. HAND, JR., Director, Bodega Marine Laboratory, University of California, Bodega Bay, Calif.

DR. DAVID L. HETRICK, Professor, Nuclear Engineering Department, University of Arizona, Tucson, Ariz.

ERNEST E. HILL, Engineer, Lawrence Livermore Laboratory, University of California, Livermore, Calif.

DR. ROBERT L. HOLTON, School of Oceanography, Oregon State University, Corvallis, Ore.

DR. FRANK F. HOOPER, Chairman, Resource Ecology Program, School of Natural Resources, University of Michigan, Ann Arbor, Mich.

ELIZABETH B. JOHNSON, Engineer, Oak Ridge National Laboratory, Oak Ridge, Tenn.

DR. WALTER H. JORDAN, Retired Senior Research Advisor & Physicist, Oak Ridge National Laboratory, Oak Ridge, Tenn.

DR. JERRY R. KLINE, ASLBP Environmental Scientist, Bethesda, Md.*

DR. JAMES C. LAMB, III, Department of Environmental Sciences & Engineering, University of North Carolina, Chapel Hill, N.C.

MARGARET M. LAURENCE, Partner, law firm of Laurence, Stokes and Neilan, Arlington, Va.

DR. J. V. LEEDS, JR., Professor, Environmental and Electrical Engineering, Rice University, Houston, Tex.

GUSTAVE A. LINENBERGER, ASLBP Physicist, Bethesda, Md.*

DR. LINDA W. LITTLE, Research Triangle Institute, Research Triangle Park, N.C. Department of Environmental Sciences & Engineering, University of North Carolina, Chapel Hill, N.C.

DR. M. STANLEY LIVINGSTON, Retired Associate Director, Atomic Energy Commission National Accelerator Laboratory, Santa Fe, N.M.

DR. EMMETH A. LUEBKE, ASLBP Physicist, Bethesda, Md.*

DR. WILLIAM E. MARTIN, Senior Ecologist, Battelle Memorial Institute, Columbus, Ohio

DR. KENNETH A. MCCOLLOM, Dean, Division of Engineering, Technology and Architecture, Oklahoma State University, Stillwater, Okla.

GARY L. MILHOLLIN, University of Wisconsin Law School, Madison, Wis.

MARSHALL E. MILLER, ASLBP Attorney, Bethesda, Md.*

DR. OSCAR H. PARIS, ASLBP Environmental Scientist, Bethesda, Md.*

DR. HUGH PAXTON, Los Alamos Scientific Laboratory, Los Alamos, N.M.

DR. PAUL W. PURDOM, Director, Environmental Studies Institute, Drexel University, Philadelphia, Pa.

DR. FORREST J. REMICK, Director, Institute of Science and Engineering, Pennsylvania State University, University Park, Pa.

DR. DAVID R. SCHINK, Department of Oceanography, Texas A&M University, College Station, Tex.

FREDERICK H. SHON, ASLBP Physicist, Bethesda, Md.*

IVAN W. SMITH, Administrative Law Judge, U.S. Nuclear Regulatory Commission, Bethesda, Md.*

DR. MARTIN J. STEINDLER, Chemist, Argonne National Laboratory, Argonne, Ill.

DR. QUENTIN J. STÖBER, Research Associate Professor, Fisheries Research Institute, University of Washington, Seattle, Wash.

JOSEPH F. TUBRIDY, Attorney at Law, Washington, D.C.

SEYMOUR WENNER, Retired Administrative Law Judge, Postal Rate Commission, Washington, D.C.

JOHN F. WOLF, Attorney, law firm of Lamensdorf, Leonard & Moore, Washington, D.C.

SHELDON J. WOLFE, ASLBP Attorney, Bethesda, Md.*

Atomic Safety and Licensing Appeal Panel

An Atomic Safety and Licensing Appeal Board, established effective September 18, 1969, was delegated the authority to perform the review function which would otherwise be performed by the Commission in proceedings on applications for licenses or authorizations in which the Commission had a direct financial interest, and in such other licensing proceedings as the Commission might specify.

In view of the increase in the number of proceedings subject to administrative appellate review, the Atomic Safety and Licensing Appeal Panel was established on October 25, 1972, from whose membership three member appeal boards could be designated for each proceeding in which the Commission had delegated its authority to an appeal board. At the same time, the Commission modified its rules to delegate authority to appeal boards in all proceedings involving the licensing of production and utilization facilities (for example, power reactors).

Pursuant to subsection 201 (g)(1) of the Energy Reorganization Act of 1974, the functions performed by appeal boards were specifically transferred to the Nuclear Regulatory Commission. The Commission appoints members to the Appeal Panel, and the Chairman of the panel (or, in his absence, the Vice Chairman) designates a three-member appeal board for each proceeding. The Commission retains review authority over decisions and actions of appeal boards. The appeal board panel, on September 30, 1980, was composed of the following full-time members and professional staff:

ALAN S. ROSENTHAL, Appeal Panel *Chairman*, U.S. Nuclear Regulatory Commission, Bethesda, Md.

DR. JOHN H. BUCK, Appeal Panel *Vice Chairman*, U.S. Nuclear Regulatory Commission, Bethesda, Md.

THOMAS S. MOORE, Appeal Panel Member, U.S. Nuclear Regulatory Commission, Bethesda, Md.

RICHARD S. SALZMAN, Appeal Panel Member, U.S. Nuclear Regulatory Commission, Bethesda, Md.

JOHN CHO, Counsel, Appeal Panel, U.S. Nuclear Regulatory Commission, Bethesda, Md.

CARDIS L. ALLEN, Technical Advisor, Appeal Panel, U.S. Nuclear Regulatory Commission, Bethesda, Md.

LINDA S. GILBERT, Legal Intern, Appeal Panel, U.S. Nuclear Regulatory Commission, Bethesda, Md.

ROBERT S. PERLIS, Legal Intern, Appeal Panel, U.S. Nuclear Regulatory Commission, Bethesda, Md.

During fiscal year, 1980, the Appeal Panel also included the following part-time members:

DR. LAWRENCE R. QUARLES, Dean Emeritus, School of Engineering and Applied Science, University of Virginia, Charlottesville, Va.

DR. W. REED JOHNSON, Professor of Nuclear Engineering, University of Virginia, Charlottesville, Va.

Advisory Committee on Medical Uses of Isotopes

The Advisory Committee on Medical Uses of Isotopes was established in July 1958. The ACMI, composed of qualified physicians and scientists, considers medical questions referred to it by the NRC staff, and renders expert opinion regarding medical uses of radioisotopes. The ACMI also advises the NRC staff, as requested, on matters of policy. Members are employed under yearly personal services contracts. The Deputy Director, Division of Fuel Cycle

and Material Safety, serves as Committee Chairman. As of September 30, 1980 the members were:

RICHARD E. CUNNINGHAM, Chairman, ACMI, Deputy Director, Division of Fuel Cycle and Material Safety, U.S. Nuclear Regulatory Commission, Silver Spring, Md.

DR. FRANK H. DE LAND, Chief, Nuclear Medicine Department, Veterans' Administration Hospital, Lexington, Ky.

DR. EDWARD W. WEBSTER, Director, Department of Radiation Physics, Massachusetts General Hospital, Boston, Mass.

DR. JOSEPH B. WORKMAN, Associate Professor of Radiology, Duke University Medical Center, Durham, N.C.

DR. VINCENT P. COLLINS, Medical Director, Houston Institute for Cancer Research, Diagnosis and Treatment, Houston, Tex.

DR. MELVIN L. GRIEM, Professor and Director, Chicago Tumor Institute, University of Chicago, Chicago, Ill.

DR. SALLY DENARDO, Director, Nuclear Hematology-Oncology, Department of Nuclear Medicine, University of California-Davis Medical Center, Sacramento, Ca.

DR. JACK GOODRICH, Radiology Associates of Erie, Hamot Medical Center, Erie, Pa.

DR. B. LEONARD HOLMAN, Chief, Clinical Nuclear Medicine, Department of Radiology, Peter Bent Brigham Hospital, Boston, Ma.

DR. DAVID H. WOODBURY, Director, Nuclear Medicine, Wayne County General Hospital, Eloise, Mi.

Appendix 3

Public Document Rooms

Most documents originated by NRC, or submitted to it for consideration, are placed in the Commission's Public Document Room at 1717 H Street, N.W., Washington, D.C., for public inspection. In addition, documents relating to licensing proceedings or licensed operation of specific facilities are made available in local public document rooms established in the vicinity of each proposed or existing nuclear facility. The locations of these local PDRs and the name of the facility for which documents are retained, are listed below. (NOTE: Updated listings of local PDRs may be obtained by writing to the Local Public Document Room Branch, Division of Rules and Records, U.S. Nuclear Regulatory Commission, Washington, D.C. 20555.)

ALABAMA

- Mrs. Maude S. Miller
Athens Public Library
South and Forrest
Athens, Ala. 35611
Browns Ferry Nuclear Plant
- Mr. Wayne Love
G. S. Houston Memorial Library
212 W. Burdeshaw Street
Dothan, Ala. 36303
Farley Nuclear Plant
- Mrs. Joanne Wyatt
Clanton Public Library
100 First Street
Clanton, Ala. 35045
Barton Nuclear Plant
- Mrs. Peggy McCutchen
Scottsboro Public Library
1002 South Broad Street
Scottsboro, Ala. 35768
Bellefonte Nuclear Plant
- Ms. Mary Ann Lovell
Prattville Public Library
220 Doster Road
Prattville, Ala. 36067
Alabama Nuclear Fuel Fabrication

ARIZONA

- Mrs. Mary Carlson
Phoenix Public Library
Science and Industry Section
12 East McDowell Road
Phoenix, Ariz. 85004
Palo Verde Nuclear Plant

ARKANSAS

- Mr. Vaughn
Arkansas Polytechnic College
Russellville, Ark. 72801
Arkansas Nuclear One

CALIFORNIA

- Mrs. Alice Rosenberger
Palo Verde Valley District Library
125 West Chanslorway

Blythe, Calif. 92255
Sundesert Nuclear Plant

- Mr. William B. Rohan
San Diego County Law Library
1105 Front Street
San Diego, Calif. 92101
Sundesert Nuclear Plant
- Mrs. Eileen Danforth
Mission Viejo Branch Library
24851 Chrisanta Drive
Mission Viejo, Calif. 92676
San Onofre Nuclear Plant
- Mr. Chi Su Kim
Documents and Maps Department
California Polytechnic State
University Library
San Luis Obispo, Calif. 93407
Diablo Canyon Nuclear Plant
- Mrs. Judy Klapprott
Humboldt County Library
636 F Street
Eureka, Calif. 95501
Humboldt Bay Nuclear Plant

- Mrs. Gabrielle Holmes
Business & Municipal Department
Sacramento City-County Library
828 I Street
Sacramento, Calif. 95814
Rancho Seco Nuclear Plant

- Stanislaus County Free Library
1500 I Street
Modesto, Calif. 95345
Stanislaus Nuclear Plant

- Nuclear Regulatory Commission,
Region V
Suite 202
1990 N. California Boulevard
Walnut Creek, Calif. 94596
GETR Vallecitos

- West Los Angeles Regional Library
11360 Santa Monica Boulevard
Los Angeles, Calif. 94596
UCLA Research Reactor

COLORADO

- Miss Ester Fromm
Greeley Public Library

City Complex Building
Greeley, Colo. 80631
Fort St. Vrain Nuclear Plant

- Mrs. Robin Satterwhit
Government Documents
Auraria Library
University of Colorado at Denver
Lawrence and 11th
Denver, Colo. 80204
Atlas Corp. Uranium Mill

CONNECTICUT

- Mr. Vincent Juliano
Waterford Public Library
Rope Ferry Road—Route 156
Waterford, Conn. 06385
Millstone Nuclear Plant
- Mrs. Phyllis Nathanson
Russell Library
119 Broad Street
Middletown, Conn. 06457
Haddam Neck Nuclear Plant

DELAWARE

- Mrs. Yvonne Puffer
Newark Free Library
750 East Delaware Avenue
Newark, Del. 19711
Summit Nuclear Plant

FLORIDA

- Ms. Sally Litton
Jacksonville Public Library
122 North Ocean Street
Jacksonville, Fla. 32204
Offshore Power Systems
Manufacturing Facility
- Mrs. R. Scott
Indian River Community College
Library
3209 Virginia Avenue
Ft. Pierce, Fla. 33450
St. Lucie Nuclear Plant
- Mrs. Bonsall
Crystal River Public Library
668 N.W. First

Crystal River, Fla. 32629
Crystal River Nuclear Plant

- Mrs. René Daily
Environmental and Urban
Affairs Library
Florida International University
Miami, Fla. 33199
Turkey Point Nuclear Plant
- Ms. Renee Pierce
Lily Lawrence Bow Library
212 Northwest First Avenue
Holmstead, Fla. 33030
Turkey Point Nuclear Plant
(Emergency Plan only)

GEORGIA

- Mrs. J. W. Borom
Burke County Library
Fourth Street
Waynesboro, Ga. 30830
Vogtle Nuclear Plant
- Ms. Annette Osborne
Appling County Public Library
301 City Hall Drive
Baxley, Ga. 31513
Hatch Nuclear Plant

ILLINOIS

- Mr. Ed Anderson
Illinois Valley Community College
Rural Route #1
Oglesby, Ill. 16348
LaSalle Nuclear Plant
- Mrs. Pam Wilson
Morris Public Library
604 Liberty Street
Morris, Ill. 60451
Dresden Nuclear Plant
Midwest Fuel Recovery Plant
- Mrs. Marie Hoschied
Moline Public Library
504 17th Street
Moline, Ill. 61255
Quad Cities Nuclear Plant
- Ms. Jo Ann Ellingson
Zion-Benton Public Library
2600 Emmaus Avenue
Zion, Ill. 60099
Zion Nuclear Plant
- Mrs. M. Evans
Vespasian Warner Public Library
120 West Johnson Street
Clinton, Ill. 61727
Clinton Nuclear Plant
- Ms. Kay Sauer
West Chicago Public Library
332 E. Washington Street
West Chicago, Ill. 60185
Rare Earth Facility
- Mrs. Penny O'Roarke
Byron Public Library

Third and Washington Streets
Byron, Ill. 61010
Byron Nuclear Plant

- Mr. Thomas Carter
Wilmington Township Public Library
201 S. Kankakee Street
Wilmington, Ill. 60481
Braidwood Nuclear Plant
- Savanna Township Public Library
326 Third Street
Savanna, Ill. 61074
Carroll Nuclear Plant
- Mr. Richard Gray
Rockford Public Library
215 N. Wyman Street
Rockford, Ill. 61103
Byron Nuclear Plant

INDIANA

- Ms. Michele Stipanovich
West Chester Township Public
Library
125 South Second Street
Chestertown, Ind. 46304
Bailly Nuclear Plant
- Ms. Carol Cowles
Madison-Jefferson County Public
Library
420 West Main Street
Madison, Ind. 47250
Marble Hill Nuclear Plant

IOWA

- Ms. Linda Hantey
Reference Service
Cedar Rapids Public Library
428 Third Avenue, S.E.
Cedar Rapids, Ia. 52401
Duane Arnold Nuclear Plant

KANSAS

- Mr. Jack Scott
Coffey County Courthouse
Burlington, Kans. 66839
Wolf Creek Nuclear Plant

KENTUCKY

- Mr. Clarence R. Graham
Louisville Free Public Library
4th and York Streets
Louisville, Ky. 40203
Marble Hill Nuclear Plant
- Ms. Beverly Bury
Campbell County Public Library
Alexandria Branch
400 West Main Street
Alexandria, Ky. 41001
Zimmer Nuclear Plant

LOUISIANA

- Mr. Ken Owen
University of New Orleans Library
Louisiana Collection, Lakefront
New Orleans, La. 70122
Waterford Nuclear Plant
- Mrs. Freeda Fisher
Audubon Library
West Feliciana Branch
Ferdinand Street
St. Francisville, La. 70775
- Mr. Jimmie H. Hoover
Government Documents Department
Louisiana State University
Baton Rouge, La. 70803
River Bend Nuclear Plant

MAINE

- Mrs. Barbara Shelton
Wiscasset Public Library
High Street
Wiscasset, Me. 04578
Maine Yankee Nuclear Plant

MARYLAND

- Mrs. Elizabeth Hart
Charles County Library
Garrett and Charles Streets
La Plata, Md. 20646
Douglas Point Nuclear Plant
- Mrs. Marie Barrett
Calvert County Library
Prince Frederick, Md. 20678
Calvert Cliffs Nuclear Plant
- Ms. Margaret Jacobs
Enoch Pratt Free Library
Business, Sciences & Technology
Department
Central Library
400 Cathedral Street
Baltimore, Md. 21201
TMI-1 Suspension Proceeding
(Transcripts only)

MASSACHUSETTS

- Mrs. Margaret Howland
Greenfield Community College
One College Drive
Greenfield, Mass. 01301
Yankee Rowe Nuclear Plant
- Ms. Ruth Chamberlain
Plymouth Public Library
North Street
Plymouth, Mass. 02360
Pilgrim Nuclear Plant
- The Carnegie Library
Avenue A
Turner Falls, Mass. 01376
Montague Nuclear Plant

MICHIGAN

- Mrs. Diana Shamp
Reference Department
Kalamazoo Public Library
315 South Rose Street
Kalamazoo, Mich. 49006
Palisades Nuclear Plant
- Mrs. Katherine Thomson
St. Clair County Library
210 McMorran Boulevard
Port Huron, Mich. 48060
Greenwood Nuclear Plant
- Mrs. M. B. Wallick
Charlevoix Public Library
107 Clinton Street
Charlevoix, Mich. 49720
Big Rock Point
- Mrs. Averill Packard
Grace Dow Memorial Library
1710 West St. Andrews Road
Midland, Mich. 48640
Midland Nuclear Plant
- Ms. Ann Stobbe
Maude Preston Palenske
Memorial Library
500 Market Street
St. Joseph, Mich. 49085
D. C. Cook Nuclear Plant
- Mrs. Sarah Peth
Reference Department
Monroe County Library System
3700 South Custer Road
Monroe, Mich. 48161
Fermi Nuclear Plant

MINNESOTA

- Mrs. Copeland
Environmental Conservation Library
Minneapolis Public Library
300 Nicollet Mall
Minneapolis, Minn. 55401
Monticello Nuclear Plant
Prairie Island Nuclear Plant

MISSOURI

- Mrs. Ladonna Justice
Fulton City Library
709 Market Street
Fulton, Mo. 65251
Callaway Nuclear Plant
- Mrs. Ranata Rotkowitz
Olin Library of Washington
University
Skinker & Lindell Boulevard
St. Louis, Mo. 63130
Callaway Nuclear Plant

MISSISSIPPI

- (Grand Gulf Plant PDR
being relocated.)

- Mr. William McMullin
Corinth Public Library
1023 Fillmore Street
Corinth, Miss. 38834
Yellow Creek Nuclear Plant

NEBRASKA

- Mr. Frank Gibson
W. Dale Clark Library
215 South 15th Street
Omaha, Neb. 68102
Ft. Calhoun Nuclear Plant
- Mrs. Loy Mowery
Auburn Public Library
118 15th Street
Auburn, Neb. 68305
Cooper Nuclear Plant

NEW HAMPSHIRE

- Miss Pamela Gjettem
Exeter Public Library
Front Street
Exeter, N.H. 03883
Seabrook Nuclear Plant

NEW JERSEY

- Mrs. Ginny Vail
Stockton State College Library
Pomona, N.J. 08240
Offshore Power Systems
Manufacturing Facility
- Miss Elizabeth Fogg
Salem Free Public Library
112 West Broadway
Salem, N.J. 08097
Salem Nuclear Plant
Hope Creek Nuclear Plant
- Mrs. Dolores Waddill
Ocean County Library
Brick Township Branch
401 Chambers Bridge Road
Brick, N.J. 08723
Oyster Creek Nuclear Plant
Forked River Nuclear Plant

NEW MEXICO

- Ms. Sandra Coleman
General Library, Reference
Department
University of New Mexico
Albuquerque, N.M. 87131
Waste Isolation Pilot Plant
- Ms. Ingrid Vollnhofner
New Mexico State Library
Box 1629

Santa Fe, N.M. 87503
Waste Isolation Pilot Plant

NEW YORK

- Documents Librarian
Penfield Library
State University College at Oswego
Oswego, N.Y. 13126
Nine Mile Point Nuclear Plant
FitzPatrick Nuclear Plant
New Haven Nuclear Plant
- Mrs. June Rogoff
Rochester Public Library
Business & Social Science Division
115 South Avenue
Rochester, N.Y. 14604
Ginna Nuclear Plant
- Mr. Oliver Swift
White Plains Public Library
100 Martine Avenue
White Plains, N.Y. 10601
Indian Point Nuclear Plant
- Mr. Peter Allison
New York University
70 Washington Sq. S.
New York, N.Y. 10012
(1979 and later material)
- Kathy McGowan
Shoreham-Wading River Public
Library
Route 25A
Shoreham, N.Y. 11786
Shoreham Nuclear Plant
- Mrs. E. Overton
Riverhead Free Library
330 Court Street
Riverhead, N.Y. 11901
Jamesport Nuclear Plant
- Mr. Stanley Zukowzki
Buffalo & Erie County Public
Library
Lafayette Square
Buffalo, N.Y. 14203
NFS Fuel Reprocessing Plant and
UF₆ Facility
- Ms. Marsha Russell
Town of Concord Public Library
23 North Buffalo Street
Springville, N.Y. 14141
NFS Fuel Reprocessing Plant and
UF₆ Facility
- Mr. Sol Becker
Public Health Library
New York City
Department of Health
125 Worth Street
New York, N.Y. 10012
Columbia University
Research Reactor
- Mrs. Dorothy Augustine
Catskill Public Library
One Franklin Street
Catskill, N.Y. 12414
Greene County Nuclear Plant
- Mr. Harold Ettelt
Columbia-Greene Community
College
P.O. Box 100

Hudson, N.Y. 12534
Greene County Nuclear Plant
(Transcripts only)

NORTH CAROLINA

- Ms. Dawn Hubbs
Atkins Library
University of North Carolina-
Charlotte
UNCC Station, N.C. 28223
McGuire Nuclear Plant
- Mr. Roy Dicks
Wake County Public Library
104 Fayetteville Street
Raleigh, N.C. 27601
Shearon Harris Nuclear Plant
- Mr. David G. Ferguson
Davie County Public Library
416 North Main Street
P.O. Box 158
Mocksville, N.C. 27028
Perkins Nuclear Plant
- Southport-Brunswick County Library
109 West Moore Street
Southport, N.C. 28461
Brunswick Nuclear Plant
- Mrs. Ann Laliotes
Franklin County Library
1026 Justice Street
Louisburg, N.C. 27549
Gulf Youngsville Fuel Fabrication
Facility

OHIO

- Mrs. Betty Waltman
Perry Public Library
3753 Main Street
Perry, Ohio 44081
Perry Nuclear Plant
- Mrs. Mary Mackzum
Clermont County Library
Third and Broadway Streets
Batavia, Ohio 45103
Zimmer Nuclear Plant
- Mr. Donald Fought
Ida Rupp Public Library
310 Madison Street
Port Clinton, Ohio 43451
Davis-Besse Nuclear Plant

OKLAHOMA

- Mr. Craig Buthoo
Tulsa City-County Library
400 Civic Center
Tulsa, Okla. 74102
Black Fox Nuclear Plant
- Mrs. O. J. Grosclaude
Sallisaw City Library

111 North Elm
Sallisaw, Okla. 74955
Sequoyah UF₆ Facility

- Mrs. Carol Robinson
Guthrie Public Library
201 North Division
Guthrie, Okla. 73044
Cimarron Pu Fabrication Plant
and Uranium Fuel Facility

OREGON

- Miss Carol VonDerAhe
City Hall, Records Office
Arlington, Ore. 97812
Pebble Springs Nuclear Plant
- Mr. Jim Takita
Multnomah County
Library
Social Science Dept.
801 S.W. 10th Ave.
Portland, Ore. 97205
Trojan Nuclear Plant

PENNSYLVANIA

- Mrs. Gail Frew
Reference Department
Osterhout Free Library
71 South Franklin Street
Wilkes-Barre, Pa. 18701
Susquehanna Nuclear Plant
- Pennsylvania State University
Central Pattee Library
Room 207
University Park, Pa. 16802
Susquehanna Nuclear Plant
(Transcripts only)
- Ms. Connie Webster
East Shore Area Branch Library
4501 Ethel Street
Harrisburg, Pa. 17109
Three Mile Island Nuclear Plant
(Transcripts only)
- Mr. Clifford Crowers
Free Library of Philadelphia
Government Publications Dept.
19th and Vine
Philadelphia, Pa. 19103
Three Mile Island Nuclear Plant
(Transcripts only)
- Ms. Elizabeth Harvey
Schlow Memorial Library
100 E. Beaver Avenue
State College, Pa. 16801
Three Mile Island Nuclear Plant
(Transcripts only)
- Mr. John Geschwindt
Government Publications Section
State Library of Pennsylvania
Education Building
Commonwealth and Walnut Street
Harrisburg, Pa. 17126
Peach Bottom Nuclear Plant
Three Mile Island Nuclear Plant
Fulton Nuclear Plant

- Mrs. Gordon Bauerle
Pottstown Public Library
500 High Street
Pottstown, Pa. 19464
Limerick Nuclear Plant
- Apollo Memorial Library
219 North Pennsylvania Avenue
Apollo, Pa. 15613
Apollo UF₆ and Pu Facilities
- Mrs. Catherine Brosky
Carnegie Library of Pittsburgh
4400 Forbes Avenue
Pittsburgh, Pa. 15213
Cheswick Fuel Development
Laboratories
- Mrs. Mary Columbo
B. F. Jones Memorial Library
663 Franklin Avenue
Aliquippa, Pa. 15001
Beaver Valley Nuclear Plant
Shippingport Light Water Breeder
Reactor

PUERTO RICO

- Mrs. Rosario Cabrera
Public Library, City Hall
Jose de Diego Avenue
P.O. Box 1086
Arecibo, P.R. 00612
North Coast Nuclear Plant
- Mrs. Amalia Ruiz De Porras
Erien Totti Public Library
College of Engineers, Architects
& Surveyors
Urb Roosevelt Development
Hato Rey, P.R. 00918
North Coast Nuclear Plant

RHODE ISLAND

- Mrs. Ann Crawford
Cross Mill Public Library
Old Post Road
Charlestown, R.I. 02831
Wood River Junction
- Mr. Thomas Reynolds
University of Rhode Island
University Library
Government Publications Office
Kingston, R.I. 02881
Wood River Junction

SOUTH CAROLINA

- Ms. Mary Mallaney
York County Library
325 South Oakland Avenue
Rock Hill, S.C. 29730
Catawba Nuclear Plant
- Mr. Ed Kilroy
Oconee County Library
501 W. Southbroad

Walhalla, S.C. 29691
Oconee Nuclear Plant

- Mrs. Peggy Cover
Clemson University Library
Science, Technology and
Agricultural Services
Clemson, S.C. 29631
Oconee Nuclear Plant
(Limited Documentation)
- Reference Department
Richland County Public Library
1400 Sumter Street
Columbia, S.C. 29201
Sumter Nuclear Plant
- Mrs. Allene Reep
Hartsville Memorial Library
Home and Fifth avenues
Hartsville, S.C. 29550
H. B. Robinson Nuclear Plant
- Mr. David Eden
Cherokee County Library
300 East Rutledge Avenue
Gaffney, S.C. 29340
Cherokee Nuclear Plant
- Mr. T. E. Richardson
County Office Building
Room 105
P.O. Box 443
Barnwell, S.C. 29812
Barnwell Fuel Plant
UF₆ Facility
Barnwell Fuel Storage Station
- Mr. Carl Stone
Anderson County Library
202 East Greenville Street
Anderson, S.C. 29621
Recycle Fuel Plant
- Mrs. Ellen Jenkins
Barnwell County Library
Hagood Avenue
Barnwell, S.C. 29812
Chem-Nuclear Plant

TENNESSEE

- Miss Kendall J. Cram
Tennessee State Library and Archives
403 Seventh Avenue, North
Nashville, Tenn. 37219
Hartsville Nuclear Plant
- Ms. Dorothy Dismuke
Oak Ridge Public Library
Civic Center
Oak Ridge, Tenn. 37830
Clinch River Breeder Plant
Exxon Nuclear Fuel Recovery
Center
- Mrs. Patricia Rugg
Lawson McGhee Public Library
500 West Church Street
Knoxville, Tenn. 37902
Clinch River Breeder Plant
Exxon Nuclear Fuel Recovery
Center
Fuel Fabrication Facility

- Mr. Wally Keasler
Chattanooga-Hamilton County
Bicentennial Library
1001 Broad Street
Chattanooga, Tenn. 37402
Sequoyah Nuclear Plant
Watts Bar Nuclear Plant
- Mr. T. Cal Hendrix
Kingsport Public Library
Broad and New Streets
Kingsport, Tenn. 37660
Phipps Bend Nuclear Plant
- Mr. H. E. Zittel
Oak Ridge National Laboratory
P.O. Box X
Oak Ridge, Tenn. 37830
Tyrone Nuclear Plant
(Transcripts only)

TEXAS

- Mr. John Hudson
University of Texas at Arlington
Arlington, Tex. 76019
Comanche Peak Nuclear Plant
(Limited Documentation)
- Ms. May Schmidt
Austin-Travis County Collection
Austin Public Library
810 Guadalupe Street
P.O. Box 2287
Austin, Tex. 78768
South Texas Nuclear Plant
- Matagorda County Courthouse
Matagorda County Law Library
P.O. Box 487
Bay City, Tex. 77414
South Texas Nuclear Plant
- Mr. James Sosa
San Antonio Public Library
Business, Science and Technology
Department
203 S. St. Mary Street
San Antonio, Tex. 78205
South Texas Nuclear Plant
(Inspection Reports Only)

- Mrs. Tim Whitworth
Somervell County Public Library
On The Square
P.O. Box 1417
Glen Rose, Tex. 76043
Comanche Peak Nuclear Plant
- Newton County Library
P.O. Box 657
Newton, Tex. 77034
Blue Hills Nuclear Plant
- Mrs. Kroesche
Sealy Public Library
201 Atchison Street
Sealy, Tex. 77474
Allens Creek Nuclear Plant

VERMONT

- Mrs. June Bryant
Brooks Memorial Library

224 Main Street
Brattleboro, Vt. 05301
Vermont Yankee Nuclear Plant

VIRGINIA

- Ms. Sandra Peterson
Swem Library
College of William & Mary
Williamsburg, Va. 23185
Surry Nuclear Plant
- Mr. Edward Kube
Board of Supervisors
Louisa County Courthouse
P.O. Box 27
Louisa, Va. 23093
North Anna Nuclear Plant
- Mr. Gregory Johnson
Alderman Library
Manuscripts Department
University of Virginia
Charlottesville, Va. 22901
North Anna Nuclear Plant

WASHINGTON

- Ms. D. E. Roberts
Richland Public Library
Swift and Northgate Streets
Richland, Wash. 99352
WPPSS 1, 2 and 4 Nuclear Plants
Skagit Nuclear Plant
Exxon Fuel Plants
- Mrs. Mary Ann Schafer
W. H. Abel Memorial Library
125 Main Street South
Montesano, Wash. 98563
WPPSS 3 and 5 Nuclear Plants

WISCONSIN

- Mrs. Jane Radloff
LaCrosse Public Library
800 Main Street
LaCrosse, Wis. 54601
LaCrosse BWR Nuclear Plant
- Elsie Heitkemper
Joseph Mann Library
1516 Sixteenth Street
Two Rivers, Wis. 54241
Point Beach Nuclear Plant
- Mr. Arthur M. Fish
Document Department, Library
University of Wisconsin
Stevens Point
Stevens Point, Wis. 54481
Point Beach Nuclear Plant
(Limited Documentation)
Wood Nuclear Plant

- Ms. Sue Grossheuch
Kewaunee Public Library
822 Juneau Street
Kewaunee, Wis. 54216
Kewaunee Nuclear Plant

- Mr. John Jax
University of Wisconsin
Stout Library
Menomonie, Wis. 54741
Tyrone Nuclear Plant

- Mr. Robert Fetvedt
University Library

University of Wisconsin—Eau Claire
Park and Garfield Avenues
Eau Claire, Wis. 54710
Tyrone Nuclear Plant
(Transcripts only)

- Mrs. Robert Goodrich
Durand Free Library
315 Second Avenue, West
Durand, Wis. 54736
Tyrone Nuclear Plant
(Transcripts only)

WYOMING

- Mrs. Carroll Highfill
Converse County Library
Douglas, Wyo. 82633
Highland Uranium Mill

- Mrs. Bess Sheller
Carbon County Public Library
Courthouse
Rawlins, Wyo. 82301
Shirley Basin Uranium Mill

Appendix 4

Regulations and Amendments—Fiscal Year 1980

The regulations of the Nuclear Regulatory Commission are contained in Title 10, Chapter 1, of the Code of Federal Regulations. Effective and proposed regulations concerning licensed activities, and certain policy statements relating hereto, which were published in the *Federal Register* during fiscal year 1980, are described briefly below.

REGULATIONS AND AMENDMENTS PUT INTO EFFECT

Domestic Licensing of Production and Utilization Facilities/Codes and Standards for Nuclear Powerplants—Part 50

On October 9, 1979, amendments to Part 50 were published, effective November 1, 1979, to update Sections III and XI of the ASME Code which are incorporated by reference into 10 CFR Part 50.

Licensing of Production and Utilization Facilities; Antitrust Review Procedures—Parts 2 and 50

On October 22, 1979, amendments to Parts 2 and 50 were published, effective immediately to reduce or eliminate the requirements for submission of antitrust information in certain "de minimis" instances and to clarify requirements for antitrust review of applications for licenses for class 103 facilities (commercial facilities) other than power reactors.

Rules of Practice for Domestic Licensing Proceedings; Petitions for Rule Making—Part 2

On October 25, 1979, amendments to Part 2 were published, effective November 26, 1979, requiring the petitioner to include a statement in support of the petition setting forth the specific issues involved, the petitioner's view regarding those issues, and relevant technical, scientific, or other data involved which are reasonably available to the petitioner.

Change of Office for Reporting Complaints of Misconduct—Part 0

On November 1, 1979, an amendment to Part 0 was published, effective immediately, to change the office to which complaints of fraud, graft, corruption, diversion of NRC assets, and misconduct of NRC employees are reported, from the Office of Administration to the Office of Inspector and Auditor.

Packaging of Radioactive Material for Transport and Transportation of Radioactive Material Under Certain Conditions; Shipment in Accordance with Department of Transportation Regulations—Part 71

On November 2, 1979, an amendment to Part 71 was published, effective December 3, 1979, to require all shipments of radioactive materials made by NRC licensees, other than shipments subject to the regulations of the U. S. Postal Service, to be made in accordance with the regulations of the U. S. Department of Transportation.

Telephone Number Changes for Regions III and V—Parts 20, 21, and 73

On November 5, 1979, amendments to Parts 20, 21, and 73 were published, effective immediately to show the new telephone numbers for Inspection and Enforcement Regional Offices in Glen Ellyn, Illinois, and Walnut Creek, California.

Domestic Licensing Proceedings; Modified Adjudicatory Procedures—Part 2

On November 9, 1979, amendments were published, effective immediately, to suspend 10 CFR 2.764 which is the rule of practice on issuance of licenses after adjudicatory decisions and to suspend the Statement of Policy on Conduct of Adjudicatory Procedures.

Physical Protection of Plants and Materials; Requirements for the Physical Protection of Nuclear Power Plants—Part 73

On November 16, 1979, an amendment to Part 73 was published, effective immediately, to change from November 1, 1979, to November 1, 1980, the implementation date when padlock searches of regular employees at nuclear power plants, the two-man rule procedures, and compartmentalization have to be implemented for protec-

tion against insider sabotage.

Review of Uncontested Matters by Adjudicatory Boards During Operating License Proceedings—Part 2

On November 23, 1979, an amendment to Part 2 was published, effective November 30, 1979, to provide that during an operating license proceeding, NRC adjudicatory boards may examine any serious matter not contested by the parties.

Physical Protection Upgrade Rule—Parts 70, 73, 150

On November 28, 1979 amendments to Parts 70, 73, and 150 were published in final form. The amendments are issued to strengthen the regulations for the physical protection of strategic special nuclear material, certain fuel cycle facilities, transportation and other activities involving significant quantities of strategic special nuclear material.

Guidelines for Enforcement of Transportation Rules—Part 71

On December 31, 1979, an amendment to Part 71 was published, to advise licensees of the guidelines the Office of Inspection and Enforcement will use to determine enforcement action in the area of transportation.

Licenses for Radiography and Radiation Safety Requirements for Radiographic Operations; Change of Reference—Part 34

On January 11, 1980, an amendment to Part 34 was published, effective March 3, 1980, changing a reference to Part 21 in Part 34. The change requires that radiographers receive instruction in the applicable sections of Part 21.

Rules of Practice for Domestic Licensing Proceedings—Part 2

On January 18, 1980, amendments to Part 2 were published, effective immediately, with request for comments. The Commission delegated to its Executive Director for Operations the authority to issue Orders to licensees during an emergency. This decision requires amendments to certain provisions of the NRC rules concerning the procedures for imposing requirements by Order. The amendments were adopted without notice of proposed rulemaking because it is a rule of agency organization, procedure, or practice.

Procedure for Resubmitting Requests for Waiver or Reduction of Fees Under the Freedom of Information Act—Part 9

On February 13, 1980, an amendment to Part 9 was published, effective immediately, revising "Subpart A—Freedom of Information Act Regulations" to make per-

manent the present procedure which allows persons who have been denied a fee waiver or reduction of fees under the Freedom of Information Act to resubmit requests for a waiver or reduction following receipt of the documents.

Commission Review of Export License Applications—Part 110

On February 20, 1980, an amendment to Part 110 was published, effective immediately, to revise regulations to narrow those classes of export applications which will require Commissioner review.

Immediate Reporting of Significant Events at Operating Nuclear Power Reactors—Parts 20 and 50

On February 29, 1980, amendments to Parts 20 and 50 were published, effective immediately to require timely and accurate information from licensees to NRC following significant events at operating nuclear power reactors.

Department of Energy Organization Act—Minor and Clarifying Amendments—1, 2, 20, 30, 40, 50, 70, 73, 140, 150

On March 5, 1980, minor and clarifying amendments to Parts 1, 2, 20, 30, 40, 50, 70, 73, 140, 150 were published, effective immediately, making changes in names and definitions to reflect the transfer of functions from the Energy Research and Development Administration to the Department of Energy made by the Department of Energy Organization Act.

Access to and Protection of National Security Information and Restricted Data—Parts 25 and 95

On March 5, 1980, Parts 25 and 95 were published, effective May 19, 1980, establishing procedures to facilitate licensee access to and protection of National Security Information and Restricted Data.

Privacy Act Regulations; Notice of Exemptions—Part 9

On March 18, 1980, an amendment to Part 9 was published, effective April 17, 1980, exempting from certain requirements of the Privacy Act of 1974 portions of a newly created system of records, "Document Control System, NRC-29" being published simultaneously.

Export and Import of Nuclear Equipment and Material; Export of certain Minor Quantities of Nuclear Material—Part 110

On March 21, 1980, amendments to Part 110 were published, effective April 21, 1980, to simplify licensing requirements for the export of certain quantities of nuclear material which do not have significance from a nuclear proliferation perspective.

Deletion of Reference to Panama Canal Zone; Minor Amendments—Parts 4, 20, 30, 40, 50, 55, 70, 110 and 150

On March 24, 1980, minor amendments to Parts 4, 20, 30, 40, 50, 55, 70, 110, and 150 were published, effective immediately, deleting all references to the Panama Canal Zone, reflecting the provisions of the Panama Canal Treaty of 1977 and the Panama Canal Defense Act of 1979.

Extension of Dates for Submitting and for Implementing Security Plans in Response to Requirements for the Physical Protection of Special Nuclear Material of Moderate and Low Strategic Significance—Part 73

On March 25, 1980, amendments to Part 73 were published, effective immediately, to extend the date for submitting physical security plans or amendments thereto in response to section 73.67 (c)(1) and (c)(2) of Part 73.

Packaging of Radioactive Material for Transport and Transportation of Radioactive Material Under Certain Conditions; Correction of U. S. Postal Service Regulation Reference—Part 71

On March 28, 1980, amendments to Part 71 were published, effective immediately, with the NRC correcting its regulatory references to U.S. Postal Service regulations governing the transportation of radioactive material by the U. S. Postal Service.

Nondiscrimination in Federally Assisted Commission Programs; Application to the Handicapped—Part 4

On March 6, 1980, amendments to Part 4 were published, effective May 20, 1980, to implement the requirements of section 504 of the Rehabilitation Act of 1973, as amended.

Filing of Confidential Statements of Employment and Financial Interests by NRC Employees—Part 0

On April 17, 1980, an amendment to Part 0 was published, effective immediately, regarding those NRC employees who are required to fill out confidential statements of employment and financial interests and the dates when these statements are due.

Periodic Updating of Final Safety Analysis Reports—Part 50

On May 9, 1980, an amendment to Part 50 was published, effective July 22, 1980, to require each person licensed to operate a nuclear power reactor to submit periodically to the Commission revised pages for its Final Safety Analysis Report (FSAR).

Misadministration Reporting Requirements— 35

On May 14, 1980, amendments to Part 35 were published, effective November 10, 1980, to require licensees to: (1) keep records of all misadministrations of radioactive material; (2) promptly report therapy misadministrations to the NRC, the referring physician, and the patient or the patient's responsible relative (or guardian); and (3) report diagnostic misadministration quarterly to NRC.

Physical Protection of Irradiated Reactor Fuel in Transit—Part 73

On June 3, 1980, amendments to Part 73 were published, effective July 3, 1980, amending the interim rule for the physical protection of irradiated reactor fuel (spent fuel) in transit resulting from public comments received and the experience gained during the several months the interim rule had been effective.

Deletion of Reference to Panama Canal Zone; Minor Amendments—Parts 95 and 140

On June 3, 1980 amendments to Parts 95 and 140 were published, effective immediately, deleting references to the Panama Canal Zone in Parts 95 and 140 to reflect the provisions of the Panama Canal Treaty of 1977 and the recently enacted Panama Canal Defense Act of 1979.

Specific Domestic Licenses to Manufacture or Transfer Certain Items Containing Byproduct Material—Part 32

On June 9, 1980, amendments to Part 32 were published, effective January 1, 1981 to provide new requirements for labeling of gas and aerosol detectors, including smoke detectors, and also for labeling the point-of-sale packaging for these detectors.

Testing of Radioisotope Generators—Parts 30 and 35

On June 19, 1980, amendments to Parts 30 and 35 were published effective September 2, 1980, to require medical licensees to test radioactive drugs for a contaminant called molybdenum-99. NRC is also imposing maximum limits for molybdenum-99 in these radioactive drugs.

Amendment to Provide Exception from Procedural Rules for Adjudications Involving Conduct of Military or Foreign Affairs Functions—Part 2

On July 3, 1980, an amendment to Part 2 was published, effective immediately, to provide an exception from those rules for adjudications involving the conduct of military or foreign affairs functions.

Access Authorization Fees for Nuclear Industry—Part 25

On July 3, 1980, an amendment to Part 25 was published, effective August 4, 1980, to establish a fee schedule to cover costs related to the processing of access

authorizations for personnel affected by 10 CFR Part 25, "Access Authorization for Licensee Personnel."

Access to and Protection of National Security Information Restricted Data; Extension of Effective Date—Parts 25 and 95

On July 3, 1980, amendments were made to Parts 25 and 95, effective October 1, 1980, to extend from May 1, 1980, to October 1, 1980, the effective dates of new 10 CFR Parts 25 and 95.

Rules of Practice for Domestic Licensing Proceedings—Part 2

On July 8, 1980, an amendment to Part 2 was published, effective immediately, to provide more realistic time limits for the Commission to review petitions and whether to review on its own initiative in such cases, a decision or action of the Atomic Safety and Licensing Appeal Board under 10 CFR 1.786.

Procedural Assistance in Adjudicatory Licensing Proceedings—Part 2

On July 25, 1980, amendments to Part 2 were published, effective immediately, to provide a one-year pilot program of procedural assistance in adjudicatory proceedings on applications for licenses and amendments thereto, except for antitrust proceedings, to parties other than the applicant.

Safeguards on Nuclear Material—Implementation of US/IAEA Agreement—Parts 40, 50, 70, 75, 150, and 170

On July 31, 1980, amendments were published to Parts 40, 50, 70, 75, 150 and 170, effective immediately, to enable the United States to implement the US/IAEA Safeguards Agreement with respect to licensed activities as soon as the Agreement enters into force.

Export and Import of Nuclear Equipment and Material; Commission Review of Export License Application—Part 110

On August 1, 1980, an amendment to Part 110 was published, effective immediately, to narrow and clarify those classes of export license applications which will require Commissioner review.

Emergency Planning—Parts 50 and 70

On August 19, 1980 amendments to Parts 50 and 70 were published. The Commission is upgrading its emergency planning regulations in order to assure that adequate protective measures can and will be taken in the event of a radiological emergency.

Emergency Planning; Negative Declaration; Finding of No Significant Impact for Effective Rule Changes—Part 50

On August 19, 1980 a notice on Part 50 was published stating that changes in the proposed rule concerning emergency planning will not have a significant impact on the human environment.

Deletion of Source Material Medicinals From the General License for Small Quantities of Source Material—Part 40

On August 20, 1980 NRC published an amendment to its licensing regulations by deleting the provision for general license authorization of the use of source material in humans by physicians, pharmacists, and other persons receiving source material in the form of medicinals or drugs.

REGULATIONS AND AMENDMENTS PROPOSED

Physical Protection of Plants and Materials; Reporting of Safeguards Events—Part 73

On October 22, 1979, proposed amendments to Part 73 were published for comment. The proposal would require licensees to report events which significantly threaten or lessen the effectiveness of their safeguards system. Concurrently, NRC issued a regulatory guide for comment which provided a procedure that could be used to determine whether an event is reportable, along with a partial list of events which should be considered reportable.

Storage and Disposal of Nuclear Waste—Parts 50 and 51

On October 25, 1979, a notice of proposed rulemaking was published to request comments from the public on a generic proceeding being conducted by NRC to reassess its degree of confidence that radioactive wastes produced by nuclear facilities will be safely disposed of, to determine when any such disposal will be available, and whether such wastes can be safely stored until safely disposed.

Specific Domestic Licenses to Manufacture or Transfer Certain Items Containing Byproduct Material

On November 30, 1979, proposed amendments to Part 32 were published for comment. NRC proposed new requirements for labeling the external surfaces of gas and aerosol detectors, including smoke detectors, as well as the point-of-sale packaging for these detectors.

Disposal of High-Level Radioactive Wastes in Geologic Repositories; Proposed Licensing Procedures

On December 6, 1979, proposed amendments to Parts 2, 19, 20, 21, 30, 40, 51, and 70, and a new Part 60 were

published for comment. The proposed rule set out was for licensing the receipt and disposal of high-level radioactive wastes at geologic repositories.

Privacy Act of 1974; New System of Records—NRC-35

On December 7, 1979, a notice proposing a new system of records was published for comment. It would establish a system of records subject to the Privacy Act, to be identified as NRC-35, "IE Household Move Survey."

Emergency Planning—Part 50

On December 19, 1979, proposed amendments to Part 50 were published for comment. The proposed rule addressed licensee, State and local government emergency preparedness, and the need to enhance protection of the public health and safety.

Transient Shipments of Strategic Special Nuclear Material

On January 8, 1980, proposed amendments to Parts 70 and 73 were published for comment. The proposed rule would withdraw the existing exemption from licensing requirements for carriers who possess formula quantities of strategic special nuclear material in the course of a transient shipment and require them to provide for a security system during stopovers at U. S. ports directly under the physical protection regulations of the NRC.

Domestic Licensing of Production and Utilization Facilities; Primary Reactor Containment Leakage Testing for Water-Cooled Power Reactors

On January 11, 1980, a proposed amendment to Part 50 was published for comment. The proposed rule sets out requirements for leak testing of containment building air locks in order to permit greater flexibility for such testing in the case of frequent use of the air locks.

Physical Protection of In-Transit Special Nuclear Material of Moderate Strategic Significance

On January 14, 1980, a proposed amendment to Part 73 was published for comment. The proposed rule would allow the NRC to delay shipment of certain quantities of Special Nuclear Material (SNM) of moderate strategic significance. The intent of the proposed rule is to prevent the concurrent shipment of two or more quantities of SNM of moderate strategic significance that, in total, would exceed a formula amount.

Change in Rules of Practice Governing Discipline in Adjudicatory Proceedings

On January 18, 1980, amendments to Part 2 were published for comment. The proposed rule is a result of an examination of Commission regulations regarding

representation and conduct of attorneys in adjudicatory proceedings. The proposed changes are, in general, clarifications of existing practice.

Rules of Practice

On January 23, 1980, amendments to Part 2 were published for comment. The proposed rule would permit NRC Atomic Safety and Licensing Boards to use special assistants to be drawn from the membership of the Atomic Safety and Licensing Board Panel. The special assistants would be allowed to participate as technical interrogators, alternate ASLB members, special masters, or consultants, thus facilitating the hearing process and improving the quality of the record produced.

Domestic Licensing of Production and Utilization Facilities; Operational Data Gathering

On January 30, 1980, an advance notice of proposed rule making was published for comment. The proposed rule would require that participation in the Nuclear Plant Reliability Data System (NPRDS) be mandatory for power reactor licensees.

Environmental Protection Regulations for Domestic Licensing and Related Regulatory Functions and Related Conforming Amendments

On March 3, 1980, a proposed rule was published for comment. The proposed rule would revise Part 51 to implement section 102(2) of the National Environmental Policy Act of 1969, as amended, in a manner which is consistent with NRC's domestic licensing and related regulatory authority. This proposal reflects the Commission's policy to take into account voluntarily, subject to certain conditions, the regulations of the Council on Environmental Quality implementing the procedural provisions of NEPA.

Licensing of Source Material: Deletion of Source Material Medicinals from the General License for Small Quantities of Source Material

On March 6, 1980, amendments to Part 40 were published for comment. The proposed rule would change the regulations by deleting the provision which authorizes the use of source material medicinals by physicians, pharmacists, and other persons receiving the source material in the form of medicinals or drugs. The proposed rule would prohibit any internal or external administration of source material, or the radiation therefrom, to human beings, except where authorized by an NRC specific license.

Protection of Employees Who Provide Information

On March 10, 1980, amendments to Parts 19, 30, 40, 50, 70, 71, and 150 were published for comment. The proposed rule would change the regulations to provide additional protection for employees who provide information to the Commission.

Domestic Licensing of Special Nuclear Material: General License Requirements for Any Person Who Possesses Irradiated Special Nuclear Material (SNM) In-Transit

On March 12, 1980, amendments to Part 70 were published for comment. The proposed rule would amend the regulations to issue a general license to any person who possesses irradiated reactor fuel in-transit.

Standards for Protection Against Radiation: Advance Notice of Proposed Rulemaking

On March 20, 1980, proposed amendments to Part 20 were published for comment. The amendments would bring NRC radiation protection standards into accord with current developments in radiation protection.

Information Conference During Inspection

On March 26, 1980, a proposed amendment to Part 19 was published for comment. The proposed rule would facilitate the exchange of information during and after inspections of licensed facilities and expedite the resolution of inspection findings.

No Significant Hazards Consideration

On March 28, 1980, proposed amendments to Parts 2 and 50 were published for comment. The proposed rule specifies criteria for determining whether a proposed amendment to an operating license or to a construction permit for a commercial or large production or utilization facility involves no significant hazards consideration.

Advance Notice of Proposed Rulemaking on Certification of Personnel Dosimetry Processors

On March 28, 1980, proposed amendments to Part 20 were published for comment. The proposed rule presents alternative courses of action to correct the existing situation (indicated by tests): a significant percentage of personnel dosimetry processors may not be performing with an appropriate degree of accuracy.

Licenses and Other Regulatory Services Under the Atomic Energy Act of 1954; Revision of Materials Fee Schedules

On March 31, 1980, proposed amendments to Part 170 were published for comment. The proposed rule adds a new fee Category 11.F to Section 170.31 for the schedule of fees on materials licenses and other regulatory services.

Licensing and Regulatory Policy Procedures for Environmental Protection; Alternative Site Reviews

On April 9, 1980, proposed amendments to Part 51 were published for comment. The proposed rule provides procedures and performance criteria for the review of alternative sites for nuclear power plants under the National Environmental Policy Act of 1969 (NEPA).

Environmental Radiation Protection Standards for Nuclear Power Operation

On April 17, 1980, proposed amendments to Part 20 were published for comment. The proposed rule incorporates the existing requirement for certain uranium fuel cycle licensees to comply with the Environmental Protection Agency's "Environmental Radiation Protection Standards for Nuclear Power Operation."

Technical Criteria for Regulating Geologic Disposal of High-Level Radioactive Waste

On May 13, 1980, an advance notice of proposed rulemaking was published for comment. The rule proposes licensing procedures for the disposal of high level radioactive wastes in geologic repositories.

Possible Amendments to "Immediate Effectiveness" Rule

On May 22, 1980, proposed amendments to Parts 2 and 50 were published for comment. The proposed rule sets out changes to the "Immediate Effectiveness" rule which provides that construction on a nuclear power plant can begin on the basis of an initial decision by an Atomic Safety and Licensing Board even though that decision is subject to further review within the Commission.

Fire Protection Program for Nuclear Power Plants Operating Prior to January 1, 1979

On May 29, 1980, a proposed amendment to Part 50 was published for comment. The proposed rule contains regulations to require certain minimum provisions for fire protection in operating nuclear power plants.

Licenses for Radiography and Radiation Safety Requirements for Radiographic Operations; Disposal of Records of Pocket Dosimeter Readings

On June 12, 1980, proposed amendments to Part 34 were published for comment. The proposed rule would amend the regulation to provide that pocket dosimeter records need be retained for only two years.

Miscellaneous Clarifying Amendments

On July 3, 1980, proposed amendments to Part 20 were published for comment. The proposed rule would clarify the text of several sections with the view of avoiding possible misinterpretations.

Domestic Licensing of Production and Utilization Facilities; Technical Specifications for Nuclear Power Reactors

On July 8, 1980, an advance notice of proposed rulemaking was published for comment. The notice requested comments on possible changes to regulations pertaining to technical specifications for nuclear power reactors.

Modification of the Policy and Regulatory Practice Governing the Siting of Nuclear Power Reactors

On July 29, 1980, an advance notice of rulemaking and revision of reactor siting criteria was published for com-

ment. NRC proposed the adoption of modified or additional regulations concerning the siting of nuclear power reactors.

Functional Criteria for Emergency Response Facilities—Part 50

On August 15, 1980 a proposed amendment to Part 50 was published for comment. The NRC staff is developing guidance for an acceptable method for providing the emergency response facilities needed to implement the plans for coping with emergencies that are required by §50.34 and Appendix E of 10 CFR Part 50.

Appendix 5

Regulatory Guides—Fiscal Year 1980

Regulatory guides describe and make available to the public methods acceptable to the NRC staff for implementing specific parts of the Commission's regulations and, in some cases, describe techniques used by the staff in evaluating specific problems or postulated accidents. Guides also may provide guidance to applicants concerning information needed by the staff in its review of applications for permits and licenses.

Comments and suggestions for improvements in guides are encouraged at all times, and guides will be revised, as appropriate, to accommodate comments and to reflect new information or experience. In an effort to provide for increased public participation in the regulatory process, the NRC now issues guides for public comment in draft form before the guides have received complete staff review and before an official NRC staff position has been established.

Regulatory guides may also be withdrawn when they are superseded by the Commission's regulations, when equivalent recommendations have been incorporated in applicable approved codes and standards, or when changes in methods and techniques have made them obsolete.

When guides are issued, revised, or withdrawn, notices are placed in the *Federal Register* and public announcements made.

In order to reduce the burden on the taxpayer, the NRC has made arrangements with the U.S. Government Printing Office to become a consigned sales agent for certain NRC publications including regulatory guides. Draft guides, which are issued for public comment, continue to receive free distribution. Active guides are sold on a subscription or individual copy basis. NRC licensees receive, at no cost, pertinent draft and active regulatory guides as they are issued.

The following guides were issued or revised (or withdrawn as noted) during the period October 1, 1979, to September 30, 1980.

Division 1—Power Reactor Guides

- 1.9 Selection, Design, and Qualification of Diesel-Generator Units Used as Standby (Onsite) Electric Power Systems at Nuclear Power Plants (Revision 2)
- 1.58 Qualification of Nuclear Power Plant Inspection, Examination, and Testing Personnel (Revision 1)
- 1.59 (Errata) Design Basis Floods for Nuclear Power Plants (Revision 2)
- 1.84 Design and Fabrication Code Case Acceptability

ASME Section III Division 1 (Revision 16)

- 1.85 Materials Code Case Acceptability ASME Section III Division 1 (Revision 16)
- 1.137 Fuel-Oil Systems for Standby Diesel Generators (Revision 1)
- 1.140 Design, Testing, and Maintenance Criteria for Normal Ventilation Exhaust System Air Filtration and Adsorption Units of Light-Water-Cooled Nuclear Power Plants (Revision 1)
- 1.143 Design Guidance for Radioactive Waste Management Systems, Structures, and Components Installed in Light-Water-Cooled Nuclear Power Plants (Revision 1)
- 1.144 Auditing of Quality Assurance Programs for Nuclear Power Plants (Revision 1)
- 1.146 Qualification of Quality Assurance Program Audit Personnel for Nuclear Power Plants

Division 2—Research and Test Reactor Guides

None

Division 3—Fuels and Materials Facilities Guides

None

Division 4—Environmental and Siting Guides

- 4.14 Radiological Effluent and Environmental Monitoring at Uranium Mills (Revision 1)

Division 5—Materials and Plant Protection Guides

- 5.7 Entry/Exit Control for Protected Areas, Vital Areas, and Material Access Areas (Revision 1)
- 5.14 Use of Observation (Visual Surveillance) Techniques in Material Access Areas (Revision 1)
- 5.44 Perimeter Intrusion Alarm Systems (Revision 7)
- 5.52 Standard Format and Content of a Licensee Physical Protection Plan for Strategic Special Nuclear Material at Fixed Sites (Other Than Nuclear Power Plants) (Revision 2)
- 5.57 Shipping and Receiving Control of Strategic Special Nuclear Material (Revision 1)
- 5.58 Considerations for Establishing Traceability of Spec-

ial Nuclear Material Accounting Measurements (Revision 1)

- 5.59 Standard Format and Content for a Licensee Physical Security Plan for the Protection of Special Nuclear Material of Moderate or Low Strategic Significance
- 5.60 Standard Format and Content of a Licensee Physical Protection Plan for Strategic Special Nuclear Material in Transit
- 5.61 Intent and Scope of the Physical Protection Upgrade Rule Requirements for Fixed Sites

Division 6—Product Guides

- 6.4 Classification of Containment Properties of Sealed Radioactive Sources (Revision 2)

Division 7—Transportation Guides

- 7.9 Standard Format and Content of Part 71 Applications for Approval of Packaging of Type B, Large Quantity, and Fissile Radioactive Material (Revision 1)

Division 8—Occupational Health Guides

- 8.21 Health Physics Surveys for Byproduct Material at NRC-Licensed Processing and Manufacturing Plants (Revision 1)
- 8.24 Health Physics Surveys During Enriched Uranium-235 Processing and Fuel Fabrication (Revision 1)
- 8.25 Calibration and Error Limits of Air Sampling Instruments for Total Volume of Air Sampled
- 8.26 Applications of Bioassay for Fission and Activation Products

Division 9—Antitrust and Financial Review Guides

None

Division 10—General Guides

- 10.9 Guide for the Preparation of Applications for Licenses for the Use of Gamma Irradiators

Draft Guides

Division 1

- RS 110-5 Nuclear Power Plant Simulators for Use in Operator Training

RS 917-4 Proposed Revision 2 to Guide 1.97, Instrumentation for Light-Water-Cooled Nuclear Power Plants to Assess Plant and Environs Conditions During and Following an Accident

SC 814-5 Proposed Revision 2 to Guide 1.136, Materials, Construction, and Testing of Concrete Containments (Articles CC-1000, -2000, and -4000 through -7000 of the "Code of Concrete Reactor Vessels and Containments")

SS 926-4 Proposed Revision 1 to Guide 1.23, Meteorological Programs in Support of Nuclear Power Plants

Division 3

FP 818-4 Standard Format and Content of License Applications, Including Environmental Reports, for In Situ Uranium Solution Extraction

FP 925-5 Nuclear Criticality Safety for Pipe Intersections Containing Aqueous Solutions of Enriched Uranyl Nitrate

Division 5

SG 901-4 Reporting of Safeguards Events

Division 7

TP 914-4 Measurement of Radiation Levels on Surfaces of Packages of Radioactive Materials

Division 8

OH 015-4 Proposed Revision 1 to Guide 8.12, Criticality Accident Alarm Systems

OH 710-4 Health Physics Surveys in Uranium Mills

OH 902-1 Instruction Concerning Risk from Occupational Radiation Exposure

OH 941-4 Information Relevant to Ensuring that Occupational Radiation Exposures at Uranium Mills Will Be As Low As Is Reasonably Achievable

OH 940-4 Proposed Revision 2 to Guide 8.14, Personnel Neutron Dosimeters

Division 10

TP 602-4 Proposed Revision 1 to Guide 10.6, Guide for the Preparation of Applications for Use of Sealed Sources and Devices for Performing Industrial Radiography

Appendix 6

Nuclear Electric Generating Units In Operation Or Under Construction

(As of November 25, 1980)

The following listing includes 163 nuclear power reactor electrical generating units which were in operation or under NRC review for construction permits in the United States as of November 25, 1980, representing a total capacity of approximately 157,000 MWe. TYPE is indicated by: BWR—boiling water reactor, PWR—pressurized water reactor, HTGR—high temperature gas-cooled reactor, and LMFBR—liquid metal cooled fast breeder reactor. STATUS is indicated by: OL—has operating license, CP—has construction permit, UR—under review for construction permit. The dates for operation are either actual or those scheduled by the utilities as of August 1980.

This listing includes 29 fewer units than a year ago, reflecting cancellations of plans for future facilities. In addition, delays in planned completion dates have been indicated during fiscal year 1980 for 76 other units. The reasons cited for delays and cancellations include (1) lower demand for electricity, (2) financial problems, (3) construction delays, (4) concerns for reactor safety, and (5) regulatory delays.

| Site | Plant | Capacity (Net MWe) | Type | Status | Utility | Commercial Operation |
|----------------|--|-----------------------|------|----------------------|----------------------------|-------------------------|
| ALABAMA | | | | | | |
| Decatur | Browns Ferry Nuclear Power Plant Unit 1 | 1,065 | BWR | OL 1973 | Tennessee Valley Authority | 1974 |
| Decatur | Browns Ferry Nuclear Power Plant Unit 2 | 1,065 | BWR | OL 1974 | Tennessee Valley Authority | 1975 |
| Decatur | Browns Ferry Nuclear Power Plant Unit 3 | 1,065 | BWR | OL 1976 | Tennessee Valley Authority | 1977 |
| Dothan | Joseph M. Farley Nuclear Plant Unit 1 | 829 | BWR | OL 1977 | Alabama Power Co. | 1978 |
| Dothan | Joseph M. Farley Nuclear Plant Unit 2 | 829 | PWR | OL 1980 ¹ | Alabama Power Co. | 1980 |
| Scottsboro | Bellefonte Nuclear Plant Unit 1 | 1,235 | PWR | CP 1974 | Tennessee Valley Authority | 1983 |
| Scottsboro | Bellefonte Nuclear Plant Unit 2 | 1,235 | PWR | CP 1974 | Tennessee Valley Authority | 1984 |
| ARIZONA | | | | | | |
| Winterburg | Palo Verde Nuclear Generating Station Unit 1 | 1,270 | PWR | CP 1976 | Arizona Public Service Co. | 1983 |
| Winterburg | Palo Verde Nuclear Generating Station Unit 2 | 1,270 | PWR | CP 1976 | Arizona Public Service Co. | 1984 |

¹Low power only.

| Site | Plant | Capacity (Net MWe) | Type | Status | Utility | Commercial Operation |
|------------------------------|--|-----------------------|------|---------|--|-------------------------|
| ARIZONA — (Continued) | | | | | | |
| Winterburg | Palo Verde Nuclear Generating Station Unit 3 | 1,270 | PWR | CP 1976 | Arizona Public Service Co. | 1986 |
| ARKANSAS | | | | | | |
| Russelville | Arkansas Nuclear One Unit 1 | 850 | PWR | OL 1974 | Arkansas Power & Light Co. | 1974 |
| Russelville | Arkansas Nuclear One Unit 2 | 912 | PWR | OL 1978 | Arkansas Power & Light Co. | 1980 |
| CALIFORNIA | | | | | | |
| Eureka | Humboldt Bay Power Plant Unit 3 ² | 65 | BWR | OL 1962 | Pacific Gas & Electric Co. | 1963 |
| San Clemente | San Onofre Nuclear Generating Station Unit 1 | 436 | PWR | OL 1967 | So. Calif. Ed. & San Diego Gas & Electric Co. | 1968 |
| San Clemente | San Onofre Nuclear Generating Station Unit 2 | 1,140 | PWR | CP 1973 | So. Calif. Ed. & San Diego Gas & Electric Co. | 1981 |
| San Clemente | San Onofre Nuclear Generating Station Unit 3 | 1,140 | PWR | CP 1973 | So. Calif. Ed. & San Diego Gas & Electric Co. | 1983 |
| Diablo Canyon | Diablo Canyon Nuclear Power Plant Unit 1 | 1,084 | PWR | CP 1968 | Pacific Gas & Electric Co. | 1981 |
| Diablo Canyon | Diablo Canyon Nuclear Power Plant Unit 2 | 1,106 | PWR | CP 1970 | Pacific Gas & Electric Co. | 1981 |
| Clay Station | Rancho Seco Nuclear Generating Station Unit 1 | 917 | PWR | OL 1974 | Sacramento Municipal Utility District | 1975 |
| COLORADO | | | | | | |
| Platteville | Fort St. Vrain Nuclear Generating Station | 330 | HTGR | OL 1973 | Public Service Co. of Colorado | 1979 |
| CONNECTICUT | | | | | | |
| Haddam Neck | Haddam Neck Generating Station | 575 | PWR | OL 1967 | Conn. Yankee Atomic Power Co. | 1968 |
| Waterford | Millstone Nuclear Power Station Unit 1 | 660 | BWR | OL 1970 | Northeast Nuclear Energy Co. | 1971 |
| Waterford | Millstone Nuclear Power Station Unit 2 | 830 | PWR | OL 1975 | Northeast Nuclear Energy Co. | 1975 |
| Waterford | Millstone Nuclear Power Station Unit 3 | 1,159 | PWR | CP 1974 | Northeast Nuclear Energy Co. | 1986 |
| FLORIDA | | | | | | |
| Florida City | Turkey Point Station Unit 3 | 693 | PWR | OL 1972 | Florida Power & Light Co. | 1972 |

²Shut down indefinitely

| Site | Plant | Capacity (Net MWe) | Type | Status | Utility | Commercial Operation |
|------------------------------|---|-----------------------|------|---------|--|-------------------------|
| FLORIDA — (Continued) | | | | | | |
| Florida City | Turkey Point Station Unit 4 | 693 | PWR | OL 1973 | Florida Power & Light Co. | 1973 |
| Red Level | Crystal River Plant Unit 3 | 825 | PWR | OL 1977 | Florida Power Corp. | 1977 |
| Ft. Pierce | St. Lucie Plant Unit 1 | 802 | PWR | OL 1976 | Florida Power & Light Co. | 1976 |
| Ft. Pierce | St. Lucie Plant Unit 2 | 842 | PWR | CP 1977 | Florida Power & Light Co. | 1983 |
| GEORGIA | | | | | | |
| Baxley | Edwin I. Hatch Plant Unit 1 | 786 | BWR | OL 1974 | Georgia Power Co. | 1975 |
| Baxley | Edwin I. Hatch Plant Unit 2 | 795 | BWR | OL 1978 | Georgia Power Co. | 1979 |
| Waynesboro | Alvin W. Vogtle, Jr. Plant Unit 1 | 1,100 | PWR | CP 1974 | Georgia Power Co. | 1985 |
| Waynesboro | Alvin W. Vogtle, Jr. Plant Unit 2 | 1,100 | PWR | CP 1974 | Georgia Power Co. | 1988 |
| ILLINOIS | | | | | | |
| Morris | Dresden Nuclear Power Station Unit 1 ² | 200 | BWR | OL 1959 | Commonwealth Edison Co. | 1960 |
| Morris | Dresden Nuclear Power Station Unit 2 | 794 | BWR | OL 1969 | Commonwealth Edison Co. | 1970 |
| Morris | Dresden Nuclear Power Station Unit 3 | 794 | BWR | OL 1971 | Commonwealth Edison Co. | 1971 |
| Zion | Zion Nuclear Plant Unit 1 | 1,040 | PWR | OL 1973 | Commonwealth Edison Co. | 1973 |
| Zion | Zion Nuclear Plant Unit 2 | 1,040 | PWR | OL 1973 | Commonwealth Edison Co. | 1974 |
| Cordova | Quad-Cities Station Unit 1 | 789 | BWR | OL 1972 | Comm. Ed. Co.- Iowa-Ill Gas & Elec. Co. | 1973 |
| Cordova | Quad-Cities Station Unit 2 | 789 | BWR | OL 1972 | Comm. Ed. Co.- Iowa-Ill Gas & Elec Co. | 1973 |
| Seneca | LaSalle County Nuclear Station Unit 1 | 1,078 | BWR | CP 1973 | Commonwealth Edison Co. | 1981 |
| Seneca | LaSalle County Nuclear Station Unit 2 | 1,078 | BWR | CP 1973 | Commonwealth Edison Co. | 1982 |
| Byron | Byron Station Unit 1 | 1,120 | PWR | CP 1975 | Commonwealth Edison Co. | 1983 |
| Byron | Byron Station Unit 2 | 1,120 | PWR | CP 1975 | Commonwealth Edison Co. | 1984 |
| Braidwood | Braidwood Unit 1 | 1,120 | PWR | CP 1975 | Commonwealth Edison Co. | 1985 |
| Braidwood | Braidwood Unit 2 | 1,120 | PWR | CP 1975 | Commonwealth Edison Co. | 1986 |
| Clinton | Clinton Nuclear Power Plant Unit 1 | 950 | BWR | CP 1976 | Illinois Power Co. | 1982 |
| Clinton | Clinton Nuclear Power Plant Unit 2 | 950 | BWR | CP 1976 | Illinois Power Co. | Indef. |

²Shut down indefinitely

| Site | Plant | Capacity (Net MWe) | Type | Status | Utility | Commercial Operation |
|----------------------|--|-----------------------|------|---------|--|-------------------------|
| INDIANA | | | | | | |
| Westchester Town | Bailly Generating Station | 660 | BWR | CP 1974 | Northern Indiana Public Service Co. | 1987 |
| Madison | Marble Hill Unit 1 | 1,130 | PWR | CP 1978 | Public Service of Indiana | 1986 |
| Madison | Marble Hill Unit 2 | 1,130 | PWR | CP 1978 | Public Service of Indiana | 1987 |
| IOWA | | | | | | |
| Pala | Duane Arnold Energy Center Unit 1 | 538 | BWR | OL 1974 | Iowa Elec. Light & Power Co. | 1975 |
| KANSAS | | | | | | |
| Burlington | Wolf Creek | 1,150 | PWR | CP 1977 | Kansas Gas & Elec. Co. | 1983 |
| LOUISIANA | | | | | | |
| Taft | Waterford Steam Electric Station | 1,165 | PWR | CP 1974 | Louisiana Power & Light Co. | 1982 |
| St. Francisville | River Bend Station Unit 1 | 934 | BWR | CP 1977 | Gulf States Utilities Co. | 1984 |
| St. Francisville | River Bend Station Unit 2 | 934 | BWR | CP 1977 | Gulf States Utilities Co. | Indef. |
| MAINE | | | | | | |
| Wiscasset | Maine Yankee Atomic Power | 790 | PWR | OL 1972 | Maine Yankee Atomic Power Co. | 1972 |
| MARYLAND | | | | | | |
| Lusby | Calvert Cliffs Nuclear Power Plant Unit 1 | 845 | PWR | OL 1974 | Baltimore Gas & Elec. Co. | 1975 |
| Lusby | Calvert Cliffs Nuclear Power Plant Unit 2 | 845 | PWR | OL 1976 | Baltimore Gas & Elec. Co. | 1977 |
| MASSACHUSETTS | | | | | | |
| Rowe | Yankee Nuclear Power Station | 175 | PWR | OL 1960 | Yankee Atomic Elec. Co. | 1961 |
| Plymouth | Pilgrim Station Unit 1 | 655 | BWR | OL 1972 | Boston Edison Co. | 1972 |
| Plymouth | Pilgrim Station Unit 2 | 1,180 | PWR | UR | Boston Edison Co. | Indef. |
| Turners Falls | Montague Unit 1 ³ | 1,150 | BWR | UR | Northeast Nuclear Energy Co. | Indef. |
| Turners Falls | Montague Unit 2 ³ | 1,150 | BWR | UR | Northeast Nuclear Energy Co. | Indef. |

³Indefinitely postponed.

| Site | Plant | Capacity (Net MWe) | Type | Status | Utility | Commercial Operation |
|--------------------|--|-----------------------|------|---------|--------------------------------|-------------------------|
| MICHIGAN | | | | | | |
| Big Rock Point | Big Rock Point Nuclear Plant | 72 | BWR | OL 1962 | Consumers Power Co. | 1963 |
| South Haven | Palisades Nuclear Power Station | 805 | PWR | OL 1971 | Consumers Power Co. | 1971 |
| Lagoona Beach | Enrico Fermi Atomic Power Plant Unit 2 | 1,123 | BWR | CP 1972 | Detroit Power Co. | 1982 |
| Bridgman | Donald C. Cook Plant Unit 1 | 1,054 | PWR | OL 1974 | Indiana & Michigan Elec. Co. | 1975 |
| Bridgman | Donald C. Cook Plant Unit 2 | 1,100 | PWR | OL 1977 | Indiana & Michigan Elec. Co. | 1978 |
| Midland | Midland Nuclear Power Plant Unit 1 | 492 | PWR | CP 1972 | Consumers Power Co. | 1984 |
| Midland | Midland Nuclear Power Plant Unit 2 | 818 | PWR | CP 1972 | Consumers Power Co. | 1983 |
| MINNESOTA | | | | | | |
| Monticello | Monticello Nuclear Generating Plant | 545 | BWR | OL 1970 | Northern States Power Co. | 1971 |
| Red Wing | Prairie Island Nuclear Generating Plant Unit 1 | 530 | PWR | OL 1973 | Northern States Power Co. | 1973 |
| Red Wing | Prairie Island Nuclear Generating Plant Unit 2 | 530 | PWR | OL 1974 | Northern States Power Co. | 1974 |
| MISSISSIPPI | | | | | | |
| Port Gibson | Grand Gulf Nuclear Station Unit 1 | 1,250 | BWR | CP 1974 | Mississippi Power & Light Co. | 1982 |
| Port Gibson | Grand Gulf Nuclear Station Unit 2 | 1,250 | BWR | CP 1974 | Mississippi Power & Light Co. | 1986 |
| Yellow Creek | Yellow Creek Unit 1 | 1,285 | PWR | CP 1978 | Tennessee Valley Authority | 1985 |
| Yellow Creek | Yellow Creek Unit 2 | 1,285 | PWR | CP 1978 | Tennessee Valley Authority | 1988 |
| MISSOURI | | | | | | |
| Fulton | Callaway Plant Unit 1 | 1,150 | PWR | CP 1976 | Union Electric Co. | 1982 |
| Fulton | Callaway Plant Unit 2 | 1,150 | PWR | CP 1976 | Union Electric Co. | 1987 |
| NEBRASKA | | | | | | |
| Fort Calhoun | Fort Calhoun Station Unit 1 | 457 | PWR | OL 1973 | Omaha Public Power District | 1973 |
| Brownville | Cooper Nuclear Station | 778 | BWR | OL 1974 | Nebraska Public Power District | 1974 |

| Site | Plant | Capacity (Net MWe) | Type | Status | Utility | Commercial Operation |
|----------------------|---|-----------------------|------|----------------------|---|-------------------------|
| NEW HAMPSHIRE | | | | | | |
| Seabrook | Seabrook Nuclear Station Unit 1 | 1,194 | PWR | CP 1976 | Public Service of N.H. | 1983 |
| Seabrook | Seabrook Nuclear Station Unit 2 | 1,194 | PWR | CP 1976 | Public Service of N.H. | 1985 |
| NEW JERSEY | | | | | | |
| Toms River | Oyster Creek Nuclear Power Plant Unit 1 | 650 | BWR | OL 1969 | Jersey Central Power & Light Co. | 1969 |
| Salem | Salem Nuclear Generating Station Unit 1 | 1,090 | PWR | OL 1976 | Public Service Elec. & Gas Co. | 1977 |
| Salem | Salem Nuclear Generating Station Unit 2 | 1,115 | PWR | OL 1980 ¹ | Public Service Elec. & Gas Co. | 1981 |
| Salem | Hope Creek Generating Station Unit 1 | 1,067 | BWR | CP 1974 | Public Service Elec. & Gas Co. | 1986 |
| Salem | Hope Creek Generating Station Unit 2 | 1,067 | BWR | CP 1974 | Public Service Elec. & Gas Co. | 1989 |
| NEW YORK | | | | | | |
| Indian Point | Indian Point Station Unit 2 | 873 | PWR | OL 1971 | Consolidated Edison Co. | 1973 |
| Indian Point | Indian Point Station Unit 3 | 965 | PWR | OL 1975 | Power Authority of the State of New York | 1976 |
| Scriba | Nine Mile Point Nuclear Station Unit 1 | 610 | BWR | OL 1969 | Niagara Mohawk Power Co. | 1969 |
| Scriba | Nine Mile Point Nuclear Station Unit 2 | 1,080 | BWR | OL 1969 | Niagara Mohawk Power Co. | 1986 |
| Ontario | R. E. Ginna Nuclear Power Plant Unit 1 | 490 | PWR | OL 1969 | Rochester Gas & Elec. Co. | 1970 |
| Brookhaven | Shoreham Nuclear Power Station | 854 | BWR | CP 1973 | Long Island Lighting Co. | 1983 |
| Scriba | James A. FitzPatrick Nuclear Power Plant | 821 | BWR | OL 1974 | Power Authority of the State of New York | 1975 |
| Long Island | Jamesport Unit 1 ⁴ | 1,150 | PWR | CP 1979 | Long Island Lighting Co. | 1988 |
| Long Island | Jamesport Unit 2 ⁴ | 1,150 | PWR | CP 1979 | Long Island Lighting Co. | 1990 |
| Oswego | New Haven 1 ⁴ | 1,250 | PWR | UR | N.Y. State Elec. & Gas Co. | Indef. |
| Oswego | New Haven 2 ⁴ | 1,250 | PWR | UR | N.Y. State Elec. & Gas Co. | Indef. |

¹Low power only.⁴Denied certification by New York State Siting Board.

| Site | Plant | Capacity (Net MWe) | Type | Status | Utility | Commercial Operation |
|-----------------------|--|-----------------------|------|-----------------|---|-------------------------|
| NORTH CAROLINA | | | | | | |
| Southport | Brunswick Steam Electric Plant Unit 2 | 821 | BWR | OL 1974 | Carolina Power & Light Co. | 1975 |
| Southport | Brunswick Steam Electric Plant Unit 1 | 821 | BWR | OL 1974 | Carolina Power & Light Co. | 1977 |
| Cowans Ford Dam | Wm. B. McGuire Nuclear Station Unit 1 | 1,180 | PWR | CP 1973 | Duke Power Co. | 1980 |
| Cowans Ford Dam | Wm. B. McGuire Nuclear Station Unit 2 | 1,180 | PWR | CP 1973 | Duke Power Co. | 1982 |
| Bonsal | Shearon Harris Plant Unit 1 | 915 | PWR | CP 1978 | Carolina Power & Light Co. | 1985 |
| Bonsal | Shearon Harris Plant Unit 2 | 915 | PWR | CP 1978 | Carolina Power & Light Co. | 1988 |
| Bonsal | Shearon Harris Plant Unit 3 | 915 | PWR | CP 1978 | Carolina Power & Light Co. | 1994 |
| Bonsal | Shearon Harris Plant Unit 4 | 915 | PWR | CP 1978 | Carolina Power & Light Co. | 1992 |
| Davie Co. | Perkins Nuclear Station Unit 1 | 1,280 | PWR | UR | Duke Power Co. | Indef. |
| Davie Co. | Perkins Nuclear Station Unit 2 | 1,280 | PWR | UR | Duke Power Co. | Indef. |
| Davie Co. | Perkins Nuclear Station Unit 3 | 1,280 | PWR | UR | Duke Power Co. | Indef. |
| OHIO | | | | | | |
| Oak Harbor | Davis-Besse Nuclear Power Station Unit 1 | 906 | PWR | OL 1977 | Toledo Edison-Cleveland Electric Illum. Co. | 1977 |
| Perry | Perry Nuclear Power Plant Unit 1 | 1,205 | BWR | CP 1977 | Toledo Edison-Cleveland Elec. Illum. Co. | 1984 |
| Perry | Perry Nuclear Power Plant Unit 2 | 1,205 | BWR | CP 1977 | Toledo Edison-Cleveland Elec. Illum. Co. | 1988 |
| Moscow | Wm. H. Zimmer Nuclear Power Station Unit 1 | 810 | BWR | CP 1972 | Cincinnati Gas & Elec. Co. | 1981 |
| OKLAHOMA | | | | | | |
| Inola | Black Fox Unit 1 | 1,150 | BWR | UR ⁵ | Public Service Co. of Oklahoma | 1985 |
| Inola | Black Fox Unit 2 | 1,150 | BWR | UR ⁵ | Public Service Co. of Oklahoma | 1988 |

⁵Limited work authorization issued

| Site | Plant | Capacity (Net MWe) | Type | Status | Utility | Commercial Operation |
|-----------------------|--|-----------------------|------|--------------|------------------------------------|-------------------------|
| OREGON | | | | | | |
| Prescott | Trojan Nuclear Plant Unit 1 | 1,130 | PWR | OL 1975 | Portland General Elec. Co. | 1976 |
| Arlington | Pebble Springs Unit 1 | 1,260 | PWR | UR | Portland General Elec. Co. | 1988 |
| Arlington | Pebble Springs Unit 2 | 1,260 | PWR | UR | Portland General Elec. Co. | 1990 |
| PENNSYLVANIA | | | | | | |
| Peach Bottom | Peach Bottom Atomic Power Station Unit 2 | 1,065 | BWR | OL 1973 | Philadelphia Elec. Co. | 1974 |
| Peach Bottom | Peach Bottom Atomic Power Station Unit 3 | 1,065 | BWR | OL 1974 | Philadelphia Elec. Co. | 1974 |
| Pottstown | Limerick Generating Station Unit 1 | 1,065 | BWR | CP 1974 | Philadelphia Elec. Co. | 1985 |
| Pottstown | Limerick Generating Station Unit 2 | 1,065 | BWR | CP 1974 | Philadelphia Elec. Co. | 1987 |
| Shippingport | Shippingport Atomic Power Unit 1 | 90 | PWR | ⁶ | Duquesne Light Co. & DOE | NA |
| Shippingport | Beaver Valley Power Station Unit 1 | 852 | PWR | OL 1976 | Duquesne Light Co. Ohio Edison Co. | 1976 |
| Shippingport | Beaver Valley Power Station Unit 2 | 852 | PWR | CP 1974 | Duquesne Light Co. Ohio Edison Co. | 1986 |
| Goldsboro | Three Mile Island Nuclear Station, Unit 1 | 819 | PWR | OL 1974 | Metropolitan Edison Co. | 1974 |
| Goldsboro | Three Mile Island Nuclear ² Station, Unit 2 | 906 | PWR | OL 1978 | Metropolitan Edison Co. | 1978 |
| Berwick | Susquehanna Steam Electric Station Unit 1 | 1,052 | BWR | CP 1973 | Pennsylvania Power & Light Co. | 1982 |
| Berwick | Susquehanna Steam Electric Station Unit 2 | 1,052 | BWR | CP 1973 | Pennsylvania Power & Light Co. | 1983 |
| SOUTH CAROLINA | | | | | | |
| Hartsville ville | H. B. Robinson S.E. Plant Unit 2 | 700 | PWR | OL 1970 | Carolina Power & Light Co. | 1971 |
| Seneca | Oconee Nuclear Station Unit 1 | 887 | PWR | OL 1973 | Duke Power Co. | 1973 |
| Seneca | Oconee Nuclear Station Unit 2 | 887 | PWR | OL 1973 | Duke Power Co. | 1974 |
| Seneca | Oconee Nuclear Station Unit 3 | 887 | PWR | OL 1974 | Duke Power Co. | 1974 |
| Broad River | Virgil C. Summer Nuclear Station Unit 1 | 900 | PWR | CP 1973 | So. Carolina Elec. & Gas Co. | 1981 |

⁶Operable but OL not required²Shut down indefinitely

| Site | Plant | Capacity (Net MWe) | Type | Status | Utility | Commercial Operation |
|-------------------------------------|--|-----------------------|-------|---------|---|-------------------------|
| SOUTH CAROLINA — (Continued) | | | | | | |
| Lake Wylie | Catawba Nuclear Station Unit 1 | 1,145 | PWR | CP 1975 | Duke Power Co. | 1983 |
| Lake Wylie | Catawba Nuclear Station Unit 2 | 1,145 | PWR | CP 1975 | Duke Power Co. | 1985 |
| Cherokee County | Cherokee Nuclear Station Unit 1 | 1,280 | PWR | CP 1977 | Duke Power Co. | 1990 |
| Cherokee County | Cherokee Nuclear Station Unit 2 | 1,280 | PWR | CP 1977 | Duke Power Co. | 1992 |
| Cherokee County | Cherokee Nuclear Station Unit 3 | 1,280 | PWR | CP 1977 | Duke Power Co. | Indef. |
| TENNESSEE | | | | | | |
| Daisy | Sequoyah Nuclear Power Plant Unit 1 | 1,140 | PWR | OL 1980 | Tennessee Valley Authority | 1980 |
| Daisy | Sequoyah Nuclear Power Plant Unit 2 | 1,140 | PWR | CP 1970 | Tennessee Valley Authority | 1981 |
| Spring City | Watts Bar Nuclear Plant Unit 1 | 1,165 | PWR | CP 1973 | Tennessee Valley Authority | 1981 |
| Spring City | Watts Bar Nuclear Plant Unit 2 | 1,165 | PWR | CP 1973 | Tennessee Valley Authority | 1982 |
| Oak Ridge | Clinch River Breeder Reactor Plant ³ | 350 | LMFBR | UR | U.S. Government | Indef. |
| Hartsville | TVA Plant A Unit 1 | 1,205 | BWR | CP 1977 | Tennessee Valley Authority | 1986 |
| Hartsville | TVA Plant A Unit 2 | 1,205 | BWR | CP 1977 | Tennessee Valley Authority | 1987 |
| Hartsville | TVA Plant B Unit 1 | 1,205 | BWR | CP 1977 | Tennessee Valley Authority | Indef. |
| Hartsville | TVA Plant B Unit 2 Authority | 1,205 | BWR | CP 1977 | Tennessee Valley | Indef. |
| Phipps Bend | Phipps Bend Unit 1 | 1,220 | BWR | CP 1978 | Tennessee Valley Authority | Indef. |
| Phipps Bend | Phipps Bend Unit 2 | 1,220 | BWR | CP 1978 | Tennessee Valley Authority | Indef. |
| TEXAS | | | | | | |
| Glen Rose | Commanche Peak Steam Electric Station Unit 1 | 1,150 | PWR | CP 1974 | Texas P&L, Dallas P&L, Texas Elec. Service | 1981 |

³Indefinitely postponed.

| Site | Plant | Capacity (Net MWe) | Type | Status | Utility | Commercial Operation |
|----------------------------|---|-----------------------|------|--------------|---|-------------------------|
| TEXAS — (Continued) | | | | | | |
| Glen Rose | Commanche Peak Steam Electric Station Unit 2 | 1,150 | PWR | CP 1974 | Texas P&L, Dallas P&L, Texas Elec. Service | 1983 |
| Wallis | Allens Creek Unit 1 | 1,150 | BWR | UR | Houston Lighting & Power Co. | 1987 |
| Bay City | South Texas Nuclear Project Unit 1 | 1,250 | PWR | CP 1975 | Houston Lighting & Power Co. | 1984 |
| Bay City | South Texas Nuclear Project Unit 2 | 1,250 | PWR | CP 1975 | Houston Lighting & Power Co. | 1986 |
| VERMONT | | | | | | |
| Vernon | Vermont Yankee Generating Station | 514 | BWR | OL 1972 | Vermont Yankee Nuclear Power Corp. | 1972 |
| VIRGINIA | | | | | | |
| Gravel Neck | Surry Power Station Unit 1 | 822 | PWR | OL 1972 | Va. Electric & Power Co. | 1972 |
| Gravel Neck | Surry Power Station Unit 2 | 822 | PWR | OL 1973 | Va. Electric & Power Co. | 1973 |
| Mineral | North Anna Power Station Unit 1 | 907 | PWR | OL 1976 | Va. Electric & Power Co. | 1978 |
| Mineral | North Anna Power Station Unit 2 | 907 | PWR | OL 1980 | Va. Electric & Power Co. | 1980 |
| Mineral | North Anna Power Station Unit 3 | 907 | PWR | CP 1974 | Va. Electric & Power Co. | 1987 |
| WASHINGTON | | | | | | |
| Richland | N-Reactor/WPPSS Steam | 850 | GR | ⁶ | Wash. Public Power Supply System | |
| Richland | WPPSS No. 1 (Hanford) | 1,267 | PWR | CP 1975 | Wash. Public Power Supply System | 1985 |
| Richland | WPPSS No. 2 (Hanford) | 1,103 | BWR | CP 1973 | Wash. Public Power Supply System | 1983 |
| Satsop | WPPSS No. 3 | 1,242 | PWR | CP 1978 | Wash. Public Power Supply System | 1986 |
| Richland | WPPSS No. 4 | 1,267 | PWR | CP 1978 | Wash. Public Power Supply System | 1986 |
| Satsop | WPPSS No. 5 | 1,242 | PWR | CP 1978 | Wash. Public Power Supply System | 1987 |
| Sedro Wooley | Skagit Nuclear Power Project Unit 1 | 1,277 | BWR | UR | Puget Sound Power & Light Co. | Indef. |

⁶Operable but OL not required.

| Site | Plant | Capacity (Net MWe) | Type | Status | Utility | Commercial Operation |
|---------------------------------|--|-----------------------|------|---------|----------------------------------|-------------------------|
| WASHINGTON — (Continued) | | | | | | |
| Sedro Wooley | Skagit Nuclear Power Project Unit 2 | 1,277 | BWR | UR | Puget Sound Power & Light Co. | Indef. |
| WISCONSIN | | | | | | |
| Genoa | Genoa Nuclear Generating Station (LaCrosse) | 50 | BWR | OL 1967 | Dairyland Power Coop. | 1969 |
| Two Creeks | Point Beach Nuclear Plant Unit 1 | 497 | PWR | OL 1970 | Wisconsin Michigan Power Co. | 1970 |
| Two Creeks | Point Beach Nuclear Plant Unit 2 | 497 | PWR | OL 1971 | Wisconsin Michigan Power Co. | 1972 |

Appendix 7

Status of TMI Action Plan Items

| ITEMS IMPLEMENTED DURING FY 1980 | | |
|----------------------------------|---|-------|
| | TITLE (LEAD OFFICE) | DATE |
| I.A.1.2 | Operational safety — Shift Supervisor admin. duties (NRR) | 01/80 |
| I.A.2.1 | Immediate upgrading of operator and Senior Operator training and qualifications (NRR) | 05/80 |
| I.A.3.1 | Revise scope and criteria for licensing exams (NRR) | 05/80 |
| I.B.2.1 | Revision of IE inspection program (IE) | 04/80 |
| I.C.2 | Shift and relief turnover procedures (NRR) | 01/80 |
| I.C.3 | Shift Supervisor responsibilities (NRR) | 01/80 |
| I.C.4 | Operating procedures — Control room access (NRR) | 01/80 |
| I.C.5 | Procedures for feedback of operating experience (NRR) | 01/80 |
| I.D.6 | Control room design — Technology transfer conference (RES) | 06/80 |
| I.E.1 | Establish Office for Analysis and Evaluation of Operational Data (AEOD) | 09/80 |
| I.E.2 | Program office — Operational data evaluation (AEOD) | 09/80 |
| II.E.3.1 | Decay heat removal — Reliability of power supplies for natural circulation (NRR) | 01/80 |
| II.G.1 | Power supplies for pressurizer relief valves, block valves, and level indications (NRR) | 05/80 |

THESE ACTION ITEMS WERE BEING WORKED ON AT THE END OF THE FY 1980 PERIOD:
TITLE (LEAD OFFICE)

| | |
|---------|--|
| I.A.1.1 | Operational safety — Shift technical advisor (NRR) |
| I.A.1.3 | Operational safety — Shift Manning (NRR) |
| I.A.1.4 | Operational safety — Long-term upgrading (SD) |
| I.A.2.2 | Training and qualification requirements for Operations personnel (NRR) |
| I.A.2.6 | Long-term upgrading of training and qualifications (SD) |
| I.A.3.2 | Operator licensing program changes (NRR) |
| I.A.3.4 | Licensing of additional Operations personnel (NRR) |
| I.A.4.1 | Training simulator improvements — Initial (NRR) |
| I.A.4.2 | Training simulator improvements — Long-term (SD) |
| I.A.4.3 | Feasibility study for procurement of training simulator (RES) |
| I.A.4.4 | Feasibility study to evaluate potential value of NRC engineering computer (RES) |
| I.B.1.1 | Management for Operations — Long-term improvements (NRR) |
| I.B.1.2 | Management for Operations — Evaluation for NTOL applicants (IE) |
| I.B.2.2 | Inspections at operating reactors — Resident inspector (IE) |
| I.B.2.3 | Inspections at operating reactors — Regional Evaluations (IE) |
| I.B.2.4 | Overview of licensee performance (IE) |
| I.C.1 | Short-term accident analysis and procedures revision (NRR) |
| I.C.6 | Procedures for verification of correct performance of operating activities (NRR) |
| I.C.7 | NSSS vendor review of operating procedures (NRR) |
| I.C.8 | Pilot monitoring of selected emergency procedures for NTOL applicants (NRR) |
| I.C.9 | Long-term plan for upgrading of procedures (NRR) |
| I.D.1 | Control room design reviews (NRR) |
| I.D.2 | Control Room Design — Plant safety parameter display console (NRR) |
| I.D.4 | Control room design standard (SD) |
| I.D.5 | Control room design — Improved instrumentation Research (RES) |
| I.E.3 | Operational safety data analysis (RES) |

- I.E.4 Coordination of licensee, industry, and regulatory programs (AEOD)
- I.E.6 Reporting requirements for analysis and dissemination of operating experience (AEOD)
- I.E.7 Information for analysis and dissemination of operating experience — Foreign sources (IP)
- I.E.8 Human error rate analysis (RES)
- I.F.1 Quality assurance — Expand QA list (SD)
- I.G.1 Training requirements — Preoperational and low-power testing (NRR)
- II.A.1 Siting policy reformulation (SD)
- II.B.1 Safety review consideration — Reactor coolant system vents (NRR)
- II.B.2 Safety review consideration — Plant shielding to provide post-accident access to vital areas (NRR)
- II.B.3 Safety review consideration — Post-accident sampling (NRR)
- II.B.4 Safety review consideration — Training to mitigate core damage (NRR)
- II.B.5 Safety review consideration — Research on phenomena associated with degraded core (RES)
- II.B.6 Safety review consideration — Risk reduction for operating reactors in high-population density areas (NRR)
- II.B.8 Safety review consideration — Rulemaking proceeding on degraded-core accidents (SD)
- II.C.1 Interim reliability evaluation program (IREP) (RES)
- II.C.2 Continuation of IREP (RES)
- II.C.3 Risk assessment — Systems interaction (NRR)
- II.D.1 Coolant system valves — Testing requirements (NRR)
- II.D.2 Coolant system valves — Research on test requirements (RES)
- II.D.3 Coolant system valves — Valve position indication (NRR)
- II.E.1.1 Auxiliary feedwater system evaluation (NRR)
- II.E.1.2 Auxiliary feedwater system automatic initiation and flow indication (NRR)
- II.E.1.3 Update standard review plan and develop regulatory guide (NRR)
- II.E.2.1 Reliance on the emergency core cooling system (ECCS) (NRR)
- II.E.2.2 Research on small break locas and anomalous transients (RES)
- II.E.3.2 Decay heat removal — Systems reliability (NRR)
- II.E.3.4 Decay heat removal — Alternate concepts research (RES)
- II.E.3.5 Decay heat removal — Regulatory guide (SD)
- II.E.4.1 Containment design — Dedicated penetrations (NRR)
- II.E.4.2 Containment design — Isolation dependability (NRR)
- II.E.4.4 Containment design — Purging (NRR)
- II.E.5.1 Design evaluation of B&W Reactors (NRR)
- II.E.5.2 B&W reactor transient response task force (NRR)
- II.F.1 Additional accident monitoring instrumentation (NRR)
- II.F.2 Identification of and recovery from conditions leading to inadequate core cooling (NRR)
- II.F.3 Instrumentation for monitoring accident conditions (Reg. Guide 1.97) (SD)
- II.F.5 Classification of instrumentation, control, and electrical equipment (SD)
- II.H.1 Maintain safety of TMI-2 and minimize environmental impact (NRR)
- II.H.2 Obtain technical data on the conditions inside the TMI-2 containment structure (RES)
- II.H.3 Evaluate and feedback information obtained from TMI (NRR)
- II.H.4 Determine impact of TMI on socioeconomic and real property values (RES)
- II.J.1.1 Establish a priority system for conducting vendor inspections (IE)
- II.J.1.2 Modify existing vendor inspection program (IE)
- II.J.2.1 Reorient construction inspection program (IE)
- II.J.2.2 Increase emphasis on independent measurement in the construction inspection program (IE)
- II.J.2.3 Assign resident inspectors to all construction sites (IE)
- II.J.3.1 Organization and staffing to oversee design and construction (NRR)
- II.J.4.1 Revise deficiency reporting requirements (IE)
- II.K.1 Measures to mitigate small-break locas and loss of feedwater accidents — IE bulletins (NRR)
- II.K.2 Commission orders on B&W plants to mitigate accidents (NRR)
- II.K.3 Final recommendations of B&O task force to
- III.A.1.1 Upgrade emergency preparedness (NRR)
- III.A.1.2 Upgrade licensee emergency support facilities (NRR)
- III.A.1.3 Maintain supplies of thyroid blocking agent (KI) (NRR)
- III.A.2.1 Amend 10 CFR 50 and Appendix E (to Part 50) (SD)
- III.A.2.2 Development of guidance and criteria (NRR)
- III.A.3.1 Emergency preparedness — NRC role in responding to nuclear emergencies (EDO)

| | |
|-----------|---|
| III.A.3.2 | Emergency preparedness — Improve operation centers (IE) |
| III.A.3.3 | Emergency preparedness — Communications (IE) |
| III.A.3.4 | Emergency preparedness — Nuclear data link (IE) |
| III.A.3.5 | Emergency preparedness — Training, drills, and tests (IE) |
| III.A.3.6 | Emergency preparedness — NRC and other agencies (EDO) |
| III.B.1 | Transfer of emergency preparedness responsibilities to FEMA (EDO) |
| III.B.2 | Implementation of NRC's and FEMA's responsibilities (EDO) |
| III.C.1 | Public information — Provide to news media and public (OPA) |
| III.C.2 | Public information — Provide training (OPA) |
| III.D.1.1 | Primary coolant sources outside the containment structure (NRR) |
| III.D.1.3 | Ventilation system and radioiodine adsorber criteria (NRR) |
| III.D.2.2 | Radioiodine, carbon-14, and tritium pathway dose analysis (NRR) |
| III.D.2.3 | Liquid pathway radiological control (NRR) |
| III.D.2.4 | Offsite dose measurements (IE) |
| III.D.2.6 | Independent radiological measurements (IE) |
| III.D.3.1 | Radiation protection plans (NRR) |
| III.D.3.2 | Health physics improvements (SD) |
| III.D.3.3 | Inplant radiation monitoring (NRR) |
| III.D.3.4 | Control room habitability (NRR) |
| III.D.3.5 | Radiation worker exposure data base (SD) |
| IV.A.1 | Seek legislative authority in enforcement process (OGC) |
| IV.A.2 | Revise enforcement policy (IE) |
| IV.D.1 | NRC staff training (ADM) |
| IV.D.1 | Expand research on quantification of safety decision-making (RES) |
| IV.F.2 | Plan for early resolution of safety issues (NRR) |
| IV.E.4 | Resolve generic issues by rulemaking (SD) |
| IV.E.5 | Assess currently operating reactors (NRR) |
| IV.F.1 | Increased IE security of power ascension test program (IE) |
| IV.F.2 | Evaluate the impacts of financial disincentives to the safety of nuclear power plants (NRR) |
| IV.H | NRC participation in the radiation policy council (SD) |

**THESE ITEMS FROM THE ACTION PLAN WERE NOT BEING WORKED ON AT THE END OF FY
1980:**

TITLE (LEAD OFFICE)

| | |
|----------|---|
| I.A.2.3 | Administration of training programs (NRR) |
| I.A.2.4 | NRR participation in inspector training (IE) |
| I.A.2.5 | Training and qualification of operating personnel — Plant drills (NRR) |
| I.A.2.7 | Accreditation of training institutions (NRR) |
| I.A.3.3 | Establish requirements for operator fitness (SD) |
| I.A.3.5 | Licensing of personnel — Statement of understanding with INPO and DOE (NRR) |
| I.B.1.3 | Management for Operations — Loss of safety function (SD) |
| I.D.3 | Control room design — Safety system status monitoring (NRR) |
| I.E.5 | Nuclear plant reliability data system (SD) |
| I.F.2 | Quality assurance — Develop more detailed QA criteria (SD) |
| I.G.2 | Scope of test program — Preoperational and low-power testing (NRR) |
| II.A.2 | Site evaluation of existing facilities (NRR) |
| II.B.7 | Safety review consideration — Analysis of hydrogen control (NRR) |
| II.C.4 | Risk assessment — Reliability engineering (NRR) |
| II.E.2.1 | Reliance on the Emergency Core Cooling System (ECCS) (NRR) |
| II.E.2.3 | Uncertainties in ECCS performance predictions (NRR) |
| II.E.3.3 | Coordinated study of shutdown heat removal requirements (NRR) |
| II.E.4.3 | Containment design — Integrity check (NRR) |
| II.E.6 | In situ testing of valves — Test adequacy study (NRR) |
| II.F.4 | Study of control and protection action design requirements (NRR) |
| II.J.1.3 | Increase regulatory control over present nonlicensees (IE) |
| II.J.1.4 | Assign resident inspectors to reactor vendors |
| II.J.3.2 | Management for design and construction — Issue Reg. Guide (SD) |

- III.D.1.2 Radioactive gas management (NRR)
- III.D.1.4 Radwaste system design features to aid in accident recovery and decontamination (NRR)
- III.D.2.1 Radiological monitoring of effluents (NRR)
- III.D.2.5 Offsite dose calculation manual (NRR)
- IV.B.1 Revise practices for issuance of instructions and information to licensees (IE)
- IV.C.1 Extend lessons learned from TMI to other NRC programs (NMSS)
- IV.E.3 Plan for resolving issues at construction permit stage (NRR)
- IV.G.1 Develop a public agenda for rulemaking (ADM)
- IV.G.2 Periodic and systematic reevaluation of existing rules (SD)
- IV.G.3 Improve rulemaking procedures (SD)
- IV.G.4 Study alternatives for improved rulemaking process (SD)

NOTE: Additional information on current status of the action plan items may be obtained from the TMI Action Plan Tracking System maintained by the Office of MPA.

**THESE ACTION ITEMS WERE DEVELOPED AS ITEMS IN WHICH
THE COMMISSION HAD LEAD RESPONSIBILITY:**

NRC POLICY, ORGANIZATION AND MANAGEMENT

- V.1 Develop NRC policy statement on safety
- V.2 Study elimination of nonsafety responsibilities
- V.3 Strengthen role of ACRS
- V.4 Study need for additional advisory committees
- V.5 Improve public and intervenor participation in hearing process
- V.6 Study construction-during-adjudication rules
- V.7 Study need for TMI-related legislation
- V.8 Study the need to establish an independent nuclear safety board
- V.9 Study the reform of the licensing process
- V.10 Study NRC top management structure and process
- V.11 Reexamine organization and functions of NRC offices
- V.12 Revise delegations of authority to staff
- V.13 Clarify and strengthen the respective roles of Chairman, Commission, and EDO
- V.14 Authority to delegate emergency response functions to a single commissioner
- V.15 Achieve single location—long-term
- V.16 Achieve single location—interim
- V.17 Reexamine commission role in adjudication

INDEX

- Abnormal event notification rule 81
- Abnormal occurrences 82-90
- Agreement States 90
 - dam failure 82, 83
 - highly enriched uranium inventory difference 83, 84
 - hot cell operator exposure 90
 - loss of decay heat removal capability 87, 88
 - loss of instrumentation 11, 85-87
 - open valves 82
 - partial scram system failure 88-90, 93-96
 - plutonium inhalation 84
 - radiographer overexposure 90
 - radiography firm license suspension 84
- Accident monitoring instrumentation 10, 32, 35, 180
- Accident probabilities 218-220
- see also Risk Assessment
- Adjudicatory activities 223-242
- Advanced reactors 41, 207-210
- Advisory Committee on the Medical Uses of Isotopes 113
- Advisory Committee on Reactor Safeguards 79, 80, 267
- Advisory Panel for TMI Cleanup 8, 9, 17, 18
- Aerosol research 209
- Agreement States—see State Agreements Program
- ALARA concept 187, 188, 215
- Ammonium nitrate waste disposal 106
- Anticipated Transients Without Scram (ATWS) 50, 51, 179, 183
- Antitrust activities 76, 77, 234, 238, 240
- Arkansas Nuclear One
- cooling system blockage 97-99
 - loss of offsite power 99
- Asiatic clams impede cooling 97-99
- Atomic Safety & Licensing Appeal Boards 235-238
- authority over staff 230, 237
 - civil penalty proceedings 238
 - environmental issues 236, 237
 - functions 235
 - health, safety questions 236
 - intervention, procedural issues 237
 - membership 268
- Atomic Safety and Licensing Boards 233-235
- authority over staff 237, 238
 - functions 233
 - highlights 235
 - membership 267
 - Midland proceeding 235
 - organization 234
 - Perkins proceeding 235
 - Trojan proceeding 235
 - Vallecitos proceeding 235
 - Zion proceeding 235
- ATWS
- see Anticipated Transients Without Scram
- Away-from-reactor spent fuel storage 104, 105
- Barnwell Nuclear Fuel Plant 103
- Bioassays 190
- Blowdown loading asymmetry 46
- Breeder reactors 41, 207, 209
- Browns Ferry Unit 3
- partial scram system failure 11, 50, 61, 88-90, 93-96
- Bulletins (I&E) 155, 156
- BWR's
- containments 49, 50
 - nozzle cracking 51
 - pipe cracks 55, 212
- Byproduct material licensing 110-114
- Cardiac pacemakers 194
- Church Rock Uranium Mill
- dam failure 82, 83
- Civil penalties 148-152, 238, 240, 241
- Class 9 accidents 6, 67-69, 234
- see also Meltdown research
- Classification of safeguards information 124
- Commission adjudicatory decisions 238-242
- Atlantic Research civil penalty 240
 - Diablo Canyon physical security 239
 - "Extraordinary Nuclear Occurrence" 238, 239
 - Marble Hill hearing request 240
 - South Texas Project 241, 142
 - St. Lucie antitrust 238
 - Sterling Power Project Site 239
 - Summer Nuclear Station antitrust 240
 - waste confidence rulemaking 239, 240
- Communicating with public 223-232
- Computer code development 203, 205, 206
- Congress
- hearings 227-229
 - NRC reporting 229, 231
- Construction permits (reactor) 41, 285-295
- Consumer affairs program 226
- Consumer products 112
- Containment design 46, 49, 50, 182, 215, 220, 239
- Convention on Physical Protection 177
- Cooling towers
- biological hazards 74, 75, 216
 - environmental impact 74, 75
- Core meltdown research 203-205, 209, 210
- Criticality safety 184
- Crystal River Unit 3
- loss of instrumentation 11, 85-87
 - risk assessment 69, 219
- Dam failure 82, 83
- Davis-Besse 1
- heat removal capability loss 87, 88
- Decommissioning 179, 180, 184, 216
- Decontamination activities 15-17, 60, 61
- Defect, noncompliance reporting 136, 184
- Degraded core cooling 6, 67-69, 179, 181
- Department of Energy
- export-related activities 173, 174
 - waste management 128-131, 133
- Diablo Canyon Nuclear Plant
- physical security 239
 - systems interaction program 65, 66
- Differing professional opinions 227
- Document sales program 224
- Domestic safeguards

- see Safeguards, domestic
- Dresden Nuclear Power Station
 - Unit 1 decontamination 60, 61
- Effluent control research 215
- Electrical Systems
 - classification 183
 - qualification 43, 45, 53, 54, 57, 58, 206, 207
- Embrittlement (radiation-induced) 212
- Emergency responses planning
 - communications 35
 - exercises 33, 34
 - FEMA role 28-30, 164, 186
 - foreign visitors 169
 - guidance, criteria, regulations 29, 30
 - iodine monitoring 217
 - licensee reviews 27
 - notification system 35
 - NRC facilities 31-33, 35
 - NRC Incident Response Program 33, 35
 - NRC Operations Center 144
 - NRC organization 3, 28, 29
 - NRC Technical Support Center 32
 - Nuclear materials transportation 108, 109
 - overview and update 10, 179
 - planning zones (EPZ's) 30, 31
 - potassium iodide policy 33
 - power reactors 62, 63, 67, 68
 - report to Congress 27
 - State role 164, 165
 - training 28, 169
 - upgrading 27
- Enforcement
 - bulletins, information notices 155-160
 - civil penalties 148-152
 - investigations 145-148, 241
 - orders 152-154
 - overview 135
 - policy 144, 145
- Environmental qualification of
 - electrical equipment 5, 53, 54, 83, 206, 207
- Environmental impacts
 - aquatic biota 75, 76
 - cooling tower drift 74, 75
 - materials licensing 105, 106
 - monitoring 75, 76
 - pathogenic amoebae 74, 75
 - power reactors 72-76
 - radiological 73, 74
 - socioeconomic impacts 72, 73, 216
 - TMI-2 accident 17, 19, 20
 - transmission lines 75
- Environmental protection
 - export licensing 172, 173
 - interagency coordination 186
 - research 216, 217
 - Wyhl ("IFEU") report 73, 74
- EPICOR-II operation 15, 16
- Equal Employment Opportunity Program 254
- Executive Director for Operations (NRC) 3
- Export, import licensing 14, 171-174
- "Extraordinary Nuclear Occurrence" (ENO) 78, 238, 239
- Farley Unit 1
 - steam generator degradation 48
- Fast Flux Test Facility 41
- Federal court actions 242-250
- Federal Emergency Management Agency (FEMA)
 - interagency coordination 186
 - memorandum of understanding 29
 - national contingency planning 35
 - role in radiological emergency 10, 28-30
- Federal Women's Programs 254
- Fire protection 5, 60, 182, 183, 207
- Fish abnormalities, impingement 75
- Fission-product transport research 204, 205, 209
- Floating nuclear power plants 41
- Floods 185, 219
- Fort St. Vrain reactor 41
- Fracture mechanics research 211
- Freedom of Information Act releases 224
- Fuel cycle evaluation 104, 173, 174
- Fuel cycle regulation
 - actions 13, 101
 - environmental surveys 101-104
 - evaluation 104, 173, 174
 - inspections 136
 - research 215, 216, 220
 - safeguarding 115-117
 - standards 184
- Fuels—see Nuclear fuels
- GAO reports
 - nuclear materials transportation 108
 - summary 229, 231
 - TMI-2 accident 24
- Gas chromatography 111
- Gas-cooled reactors 41, 207, 208
- Gauging devices 111
- General Electric Test Reactor 235
- General Public Utilities tort claim 9
- Generic reactor safety issues 42-61
- GESMO 104, 247
- GINNA nuclear power plant
 - steam generator degradation 47
- Groundwater monitoring 20, 22
- Health Physics Network 35
- Hearings public participation 230-232
- Heissdampferreaktor (HDR) 214
- High-level waste disposal 106, 107
- High-temperature gas-cooled reactors 208
- Human factors 62-65
 - staff reorganization 3
 - research 207, 219, 220
- Hydrogen control 45, 72, 203
- INFCE—see International Nuclear Fuel Cycle Evaluation
- Incident response plan 33, 35
- Indemnity operations 78, 79
- Indian Point 2
 - leaking fan coolers 11
- Industrial radiography 110, 111
- Inspections
 - assistance to states 162
 - bulletins, circulars 143, 144, 155-157
 - defects, noncompliance reporting 136, 184
 - information notes 143, 144, 158-160
 - number conducted 136
 - occupational safety 192
 - overviews 11, 12, 135
 - performance appraisal program 133, 138

- overview 13
- radiological contingency planning 105
- spent fuel storage 104, 105
- transportation 107-110
- Nuclear medicine 180, 187
- Nuclear Nonproliferation Act 173-175
- Nuclear Safety Information Center 207
- Nuclear reactor fuels
 - behavior 202-205
 - cladding experiments 202, 203
 - fabrication plants 105, 184
 - in-reactor testing 203
 - melt-down research 203-205, 209, 210
- Occupational health standards 187-192
- Oconee Units 1, 3
 - steam generator degradation 49
- OECD 171
- Office for Analysis and Evaluation of Operational Data (NRC)
 - activities 92
 - establishment 3, 11, 90-92
 - technical studies 93-100
- Operational data analysis 62, 90-100
- Operator licensing 64, 65
- Overview of report 1-14
- Palisades Nuclear Power Stations
 - open bypass valves 82
 - steam generator degradation 49
- Parks Township plutonium facility
 - plutonium exposure incident 84
- Physical security—see Safeguards, domestic
- Pipe cracking 55, 58, 212
- Plutonium processing plants 105
- Plutonium recycling 41, 104, 105
- Point Beach Units 1, 2
 - steam generator degradation 46, 47
- Policy, Planning, Program Guidance (PPPG) 1, 2
- Power reactors
 - abnormal event notification 81
 - abnormal occurrences 82-90
 - accident consequences 203, 219
 - advanced 41
 - Advisory Committee on Reactor Safeguards 79, 80
 - AFR spent fuel storage 104, 105
 - analysis of operational data 5, 6, 90-100
 - antitrust activities 76, 77
 - civil penalties 148-151
 - Class 9 accidents 6, 68, 69, 234
 - classification of electrical systems 183
 - construction permits 41, 285-295
 - control rod insertion failure 61
 - control room design 62
 - cooling tower impacts 74, 75
 - decontamination of Dresden facility 60, 61
 - degraded core cooling 6
 - effluent treatment systems 215
 - electrical demand forecasting 71, 72
 - emergency planning 62, 63, 67, 68
 - enforcement orders 152-154
 - environmental protection 72-76, 172, 173
 - exports 171-174
 - fire protection 5, 60
 - floating nuclear power plants 41
 - fuel transport between reactors 104
 - gas-cooled 41
 - human factors 62-65
 - hydrogen control 72, 203
 - improved safety research 220, 221
 - improving licensing process 61-73
 - indemnity, financial protection 77-79
 - inspections 136-142
 - investigations 146-148
 - irradiated fuel packaging 107
 - licensee technical competence 63, 64
 - licensing concerns 68-73
 - licensing status 3-5, 37, 39-41
 - low-power testing 63
 - monitoring network 141, 143
 - NRR reorganization 53, 61, 62-65
 - operating experience 11, 81-100
 - operating license applications 285
 - operating licenses issued 39, 285
 - operational safety 65
 - operator licensing 64, 65
 - pause in licensing 37, 39, 40
 - pipe cracking 55, 58
 - qualification of safety-related
 - equipment 43, 45, 53, 54, 57, 58, 206, 207
 - quality assurance 69, 70
 - radiological assessment 73, 74
 - regulatory priorities 1, 2
 - reliability evaluation 67
 - resident inspectors 140, 141
 - rulemaking actions 6
 - safeguards 120, 121
 - safety goal 2
 - safety parameter display 32
 - shift staffing 64
 - simulation 180, 181
 - siting 6, 67, 70, 71, 179, 185, 186, 210, 211, 215-217
 - standard review plans 70
 - standards 180-184
 - systems interactions 52, 53, 65, 66, 183
 - terrestrial, aquatic impacts 75, 76
 - TMI Action Plan 66-68
 - turbine disc cracking 58-60
 - unresolved safety issues 42-57
 - waste transportation 107, 108
 - see also Unresolved safety issues
- Prairie Island Unit 1
 - cooling system impact 74, 75
 - steam generator degradation 47, 48
- President's Commission on TMI-2 Accident 15
- President's Nuclear Oversight Committee 7
- President's Reorganization Plan No. 1 of 1980 3, 252, 253
- Pressure Vessel Embrittlement 212
- Price-Anderson Act 77, 78
- Privacy Act releases 224, 226
- Psychological stress of TMI-2 Accident 19
- Public Document Rooms 223-225, 270-275
- Public information program 226, 227
- Qualification of safety-related equipment 43, 45, 53, 54, 57, 58, 183
- Qualification testing research 206, 207
- Radiation dosimetry 216
- Radioactive wastes 127-134
 - ACRS review 128
 - Agreement States assistance 132, 133
 - DOE role 128-131, 133
 - high-level 127, 131, 217, 218
 - Interagency Review Group 12, 13, 127, 178
 - low-level 131, 132, 162, 163, 180, 218
 - National Waste Management Plan 128
 - overview 12, 13, 127
 - regulatory development 128, 129, 131, 184
 - research 217, 218

- shipments notification 166
- State role 128, 132
- uranium mill tailings 13, 102, 103, 132, 133
- waste confidence rulemaking 130, 131
- waste repository siting 129, 130
- Radiography incidents 84, 90, 164
- Radioiodine hazard 33, 217
- Radiological health standards 187-192
- Radiological emergencies—see Emergency response planning
- Radon impact estimates 102, 103
- Reactor licensing policy 37
- Reactor licensing process 38, 61, 62
- Regional siting 216
- Regulations, amendments (FY 80) 276-282
- Regulatory guides 283, 284
 - see also Standards development
- Relief valves 214
- Reprocessing exported fuel 173
- Research 197-221
 - advanced technology 207-210
 - aerosol release 209
 - breeders 207-209
 - cladding experiments 202, 203
 - computer codes 205, 206
 - containment 215, 220
 - core meltdown 203-205, 209, 210
 - decommissioning 216
 - ecological impact 217
 - effluent control 215
 - environmental 216, 217
 - fire protection 207
 - fission-product transport 204, 205, 209
 - fracture mechanics 213
 - fuel behavior 202-205
 - fuel cycle 215, 216, 220
 - geology 210
 - high-temperature gas-cooled reactors 208
 - hydrogen generation in accidents 203
 - human factors 207
 - instrumentation 220, 221
 - integral systems tests 198, 199
 - international agreements 169
 - liquid metal fast breeders 208-210
 - LOFT 198, 199
 - mechanical engineering 213, 214
 - meltdown experiments 203, 204, 209, 210
 - metallurgy, materials 211-213
 - meteorology 211
 - noise diagnostics 207
 - nondestructive testing 212, 213
 - overview 12, 197
 - pipe cracking 212
 - qualification testing evaluation 206, 207
 - radiation dosimetry 216
 - reactor accident consequences 219
 - reactor safety improvement 220, 221
 - regional siting 216
 - risk assessment 218-220
 - seismic safety 213, 215
 - seismology 210
 - separate effects experiments 199-202
 - site safety 210, 211
 - siting 216, 217
 - socioeconomic impacts 216
 - soil-structure interaction 215
 - steam generator tube integrity 212
 - structural engineering 214, 215
 - systems analysis 218, 219
 - systems engineering 197-202
 - TMI-2 post-accident examinations 210
 - transportation safety 215, 216
 - uranium recovery 218
 - waste management 217, 218
 - water reactor safety 197-202, 220, 221
- Respirators 189, 190
- Risk Assessment 1, 2, 5, 42, 43, 69, 218-220
- Robinson Unit ?
 - bluegill sunfish abnormalities 75
 - steam generator degradation 47
- S-3 table 13, 103
- Sabotage protection. see Safeguards, domestic
- Safeguards, domestic 115-125
 - fuel cycle facilities 115-117
 - information classification 124
 - inspection, enforcement 117-121, 136
 - material control and accounting 123, 124
 - overview 13, 14
 - physical security 122, 123
 - program scope 115
 - reactors 120, 121
 - research 124, 125
 - standards 192, 193
 - technical assistance 125
 - transportation 117-120, 123
- Safeguards, international
 - NRC/IAEA interaction 124
- Safeguards Technical Assistance and Research
 - coordinating group (STAR) 125
- Safety goal 2
- Safety valves 214
- Salem 2
 - low-power testing 63
- San Onofre Unit 1
 - steam generator degradation 47, 48
- Seismic design criteria 43, 44, 54, 55, 210, 213, 215
- Sequoyah
 - emergency preparedness 33
 - low-power testing 63
- Semiscale test facility 198, 199
- Siting policy 6, 70, 71, 179, 185, 186, 216
- Structural engineering research 214, 215
- Snubbers 214
- Socioeconomic impacts of TMI accident 19, 20
- South Texas Project 147, 148, 241, 242
- Special Inquiry Group report 18, 23, 24
- Special nuclear material
 - safeguards 115-120, 122, 124
- Special Inquiry Group report 18, 23, 24
- Special Senate Investigation of TMI-Accident 7, 23, 24
- Spent fuel shipments 117-119
- Spent fuel storage 13, 54, 78, 104, 105
- Standards development 179-195
 - air sampler calibration 192
 - ATWS 183
 - bioassays 190
 - concrete reactor vessels, containment 182
 - conferences during inspections 192
 - contaminated smelted alloys 194
 - decommissioning 184
 - degraded core cooling 181
 - emergency planning 186

- environmental protection 186
- EPA radiation guides 188
- fire protection 182, 183
- flooding 185
- fuel cycle plants 184
- fuel fabrication 184
- gamma irradiators 192
- high priority concerns 179, 180
- hydrology 185
- IAEA reactor safety standards 195
- industrial activities 189, 193, 194
- material control and accounting 193
- medical institutions 192
- meteorology 185
- National Standards Program 194, 195
- neutron exposure 191
- nuclear criticality safety 184
- nuclear medicine 187
- occupational health 187-192
- operators' licenses 180
- overview 179, 180
- personnel dosimetry, monitoring 188-190
- physical protection 192, 193
- plutonium-powered pacemakers 194
- power plant simulation 180, 181
- power reactors 180-184
- primary system surveillance 182
- qualification of electrical equipment 183
- quality assurance 180, 181
- radiation surveys 191, 192
- radiography safety 189, 194
- radiological health 187-192
- reactor containment integrity 182
- reporting operational events 181, 182
- respiratory protection 189
- safeguards 192, 193
- seismic 185
- siting 185, 186
- smoke detectors 193, 194
- spent fuel storage 184
- thoriated welding electrodes 193
- waste management 184
- well logging sources 194
- worker safety training 191
- State Agreements Program
 - abnormal occurrences 90, 164
 - adequacy, compatibility findings 161, 162
 - annual meeting 163, 164
 - low-level waste disposal 162, 163
 - NRC annual review 161
 - overview 161
 - radiation control programs 161, 162
 - technical assistance 132, 133, 162, 163
 - training State personnel 163
 - uranium mill operations 162
- States
 - emergency preparedness 27, 29-31, 164, 165
 - liaison officers 165, 166
 - memoranda of understanding 65
 - national associations 166
 - radiation control programs 161, 162, 166
 - radiological response training 164
 - regional organizations 166
 - transportation surveillance 165
 - waste shipments notification 109, 166
- Station blackout 56, 57
- Steam generator tube integrity 46-49, 212
- St. Lucie Power Plant
 - antitrust issue 238
 - loss of pump cooling water 96-97
 - station blackout issue 57
- Sterling Power Project site 239
- Summer Nuclear Station, antitrust issue 240
- Surry Units 1, 2
 - steam generator replacement 49
- Systematic Evaluation Program 5, 40, 41
- Thyroid blocking 33
- TMI Action Plan 1, 4, 12, 15, 37, 39, 66-68
- TMI-1
 - hearings 234
 - pipe cracking 58
- TMI-2
 - Advisory Panel on TMI Cleanup 8, 9, 17, 18
 - cleanup 7-10, 168-170, 189, 190
 - containment atmosphere decontamination 16, 17
 - costs of cleanup 25
 - decontamination 15-17, 21
 - effect on inspection program 139
 - environmental impact of accident 20
 - "Extraordinary Nuclear Occurrence" 78, 238, 239
 - financial protection 78
 - GAO report 24
 - groundwater monitoring 20, 22
 - hearings 234, 235
 - investigations, 6, 7, 22-24, 146, 255
 - iodine monitoring 2, 7
 - krypton-85 release 16, 17, 19
 - licensee financial state 8, 9, 24, 25
 - litigation 8, 9, 242, 245, 248, 249
 - NRC policy statement 18, 19
 - post-accident examination 210
 - programmatic environmental
 - impact statement (PEIS) 8, 17
 - psychological stress of accident 19
 - reactor building entry 17
 - respiratory protection 189, 190
 - socioeconomic impacts of accident 19, 20
 - Special Inquiry Group 22, 23
 - special reports 19-25
 - Special Senate Investigation 23, 24
 - status 15-19
 - water decontamination 15, 16
 - worker overexposure 19
- Transportation
 - emergency response planning 108, 109
 - GAO report 108
 - international standards 110
 - irradiated fuel packaging 107
 - low-level waste shipments 107, 180
 - overview 13, 14
 - packaging standards 109, 110
 - power reactor wastes 108
 - routing shipments 109
 - safeguards 117-120
 - safety research 215, 216
 - urban areas 108, 179
 - worker safety 107, 108
- Trojan Unit 1
 - steam generator degradation 48
 - turbine disc cracking 58-60
- Turkey Point Units 3, 4
 - steam generator replacement 49
- Unresolved safety issues 42-57
 - asymmetric blowdown loads 46
 - ATWS 50, 51, 183
 - BWR nozzle cracking 51
 - BWR pipe cracks 55
 - BWR pressure-suppression containments 49, 50
 - completed issues 42
 - containment emergency sump 56

- resident inspectors 139-141
- safeguards requirements 117-121
- types 136, 137
- Inspections and Auditing Activities 255, 256
 - former reactor inspection 255, 256
 - internal information flow 256
 - license event reports 256
 - license fee management 256
 - reactor safety research plan 256
 - resident inspector program evaluation 255
 - TMI lessons learned audit 255
- Instrumentation research 220, 221
- Insurance premium refunds 78
- Interagency Review Group on
 - Radioactive Waste Management 12, 13, 127, 128
- Interim Reliability Evaluation Program 69, 219
- International activities 167-177
 - agreements for cooperation 173
 - bilateral arrangements 167, 168
 - cooperation with IAEA, NEA (OECD) 169-171, 176
 - emergency response training 169
 - export licensing 171-173
 - foreign visitors 168
 - import licensing 171
 - international safeguards 175-177
 - nonproliferation efforts 173-175
 - operating data exchange 168
 - overview 14
 - Philippines reactor project 171, 172
 - physical protection training 177
 - regulatory information exchange 167, 168
 - research agreements 169
 - safeguards policy 176, 177
 - Tarapur exports 171
 - TMI-2 recovery 168, 169
 - training 170
- International Atomic Energy Agency (IAEA)
 - NRC technical assistance 170
 - nuclear safety program 169
 - post-INFCE activities 174
 - safeguards 14, 123
 - Stockholm Conference 170
 - training courses 170
 - transportation regulations 110
 - US/IAEA Safeguards Agreement 124, 176
- International Nuclear Fuel Cycle Evaluation 104, 173, 174
- Judicial review
 - closed cases 248-250
 - pending cases 242-248
- Kerr-McGee Nuclear Corporation
 - ammonium nitrate waste 106
- Legislative plans 128
- License fees 256, 259
- Licensee Event Reports (LER's) 91, 219, 256
- Licensing proceedings 230-242
- Limerick Generating Station
 - risk assessment 5
- Liquid Metal Fast Breeder Reactors (LMFBR) 208-210
- Litigation 242-250
- Loss-of-Fluid Test (LOFT) program 198, 199
- Loss of off-site power 99
- Loss of pump cooling 96, 97
- Low-level radiation effects 187
- Low-level wastes—see Radioactive wastes
- Marble Hill Nuclear Power Station
 - containment deficiency 239
 - hearing request 240
 - investigation 147, 148
- Material control and accounting 123, 124
- Materials research 211-213
- Medical licensing 112-114
- Meltdown research 203-205, 209, 210
- NASAP 104
- National Energy Software Center 207
- National Reliability Program 69
- National Standards Program 194, 195
- Neutron hazards 191
- Noise diagnostics 207
- Nondestructive testing 212, 213
- North Anna Power Facility
 - emergency response exercise 33, 34
 - steam generator degradation 48, 49
 - Unit 2 low-power testing 63
- Notification rule 81
- NRC administration, management 251-262
 - balance sheet 260
 - budget 256-258
 - class action complaints 255
 - Commission membership 251
 - Congressional oversight 227-229
 - consumer affairs program 226
 - contracting work 257, 258
 - cost of operating licenses 260
 - EEO 254-255
 - employee-management relations 253-255
 - Federal Women's Programs 254
 - financial statements 261, 262
 - handling differing opinions 227
 - headquarters consolidation 258, 259
 - incentive awards program 253, 254
 - information retrieval system 257, 258
 - inspection and audit 255, 256
 - license fees, collections 259
 - personnel 251
 - physical facilities 258, 259
 - principal staff changes 251, 252
 - project management review 257
 - recruitment 254
 - reports to Congress 229, 231
 - staff reorganizations 3, 253
 - statement of operations 262
 - union activity 254
- NRC basic policies 1, 2, 18, 19
- NRC-FEMA memorandum of understanding 10, 164
- NRC organization 3, 263-266
 - emergency response 28, 29, 32-35
 - NRR reorganization 11, 61, 62, 65
 - I&E functions 135, 136, 144
 - NMSS functions 127
- NRC resources 260
- Nuclear Data Link 10, 32, 35
- Nuclear Energy Agency (OECD) 171
- Nuclear Fuel Services (Erwin) 83, 84, 116
- Nuclear materials regulation 101-114
 - advanced nuclear fuels 105
 - byproduct materials 110-114
 - environmental protection 105, 106
 - evaluation of contaminated sites 106
 - fuel cycle surveys 101-104
 - high-level waste solidification 106, 107

- control system safety implications 45
- effects of hydrogen burns 45
- environmental qualification of
 - electrical equipment 53, 54
- heavy loads near spent fuel 54
- hydrogen control measures 45
- identification of issues 42, 43
- implementation of resolved issues 42, 44
- new issues 43, 45
- progress reports 45
- PWR vessel, steam generator support strength 52
- reactor vessel material toughness 51, 52
- schedule for resolution 44, 45
- seismic design criteria 54, 55
- seismic qualification in operating plants 43, 45
- shutdown decay heat removal 43
- station blackout 56, 57
- steam generator tube integrity 46-49
- systems interactions 52, 53
- water hammer 45, 46
- Uranium fuel cycle—see Fuel Cycle
- Uranium Mill Tailings Control Act 132, 133
- Uranium milling
 - dam failure 82, 83
 - GEIS 13, 102, 103, 133
 - inactive sites 133
 - radon release 102, 103
 - regulating 132, 133, 162, 164, 191
- Uranium mining
 - radon hazard 102, 103
- Waste Confidence Rulemaking 130, 131, 239, 240
- Waste Management—see Radioactive wastes
- Water hammer 45, 46, 99, 100
- Water reactor safety research 197-202, 220, 221
- West Valley (N.Y.) Facility
 - high-level waste disposal 106, 107, 130
- Wyhl ("IFEU") Report 73, 74
- Yankee Nuclear Power Station
 - turbine disc failure 59