

December 5, 1980

In reply, please
refer to LAC-7266

DOCKET NO. 50-409

Director of Nuclear Reactor Regulation
ATTN: Mr. Harold Denton, Director
Office of Nuclear Reactor Regulation
U. S. Nuclear Regulatory Commission
Washington, D. C. 20555

SUBJECT: DAIRYLAND POWER COOPERATIVE
LA CROSSE BOILING WATER REACTOR (LACBWR)
PROVISIONAL OPERATING LICENSE NO. DPR-45
ADDITIONAL INFORMATION - THREE MILE ISLAND
LESSONS LEARNED (NUREG-0578)

REFERENCE: (1) NUREG-0578, "TMI-2 Lessons Learned
Task Force Status Report and Short-
Term Recommendations," dated July 1979.

Gentlemen:

Enclosed in this submittal are the reports on the reviews of plant
transient and accident analyses required by NUREG-0578,
Section 2.1.9.

If you have any questions regarding this submittal, please contact
us.

Very truly yours,

DAIRYLAND POWER COOPERATIVE

Frank Linder

Frank Linder, General Manager

FL:LSG:abs

CC: J. Keppler, Reg. Dir., NRC-DRO III

Enclosures

REGISTRATION SERVICES
NRC
DISTRIBUTION DIVISION

DEC 11 AM 11 28

REGISTRATION SERVICES UNIT

8012120 225

P

SUMMARY OF ACCIDENT ANALYSES

This report contains analyses of all plant accidents considered in the LACBWR Safeguards Report, other than those recently submitted (LAC-6905, 6705, 6769.)

This report provides the accident portion of the analysis required by NUREG-0578, Section 2.1.9. The accidents considered in this report are:

- 1) Fuel Loading Accident
- 2) Power Failure
- 3) Control Rod Drive Mechanism Failure
- 4) Fuel Element Failure
- 5) Inadvertant Liquid Release
- 6) Inadvertant Airborne Stack Effluent

The event tree format is utilized in this presentation of accident analyses. The event trees are self-explanatory.

This report will not address the probability of occurrence of the above accidents. The actions which would occur following the above accidents are presented, as are possible consecutive failures. Operator actions necessary or incorrect are also included.

REFERENCES

1. LaCrosse Boiling Water Reactor Safeguards Report, August 1967.
2. LACBWR Environmental Report DPC-ED-3, Section 6, September 1972 (LAC-1360).
3. LACBWR Operating Manual.

I. FUEL LOADING ACCIDENT

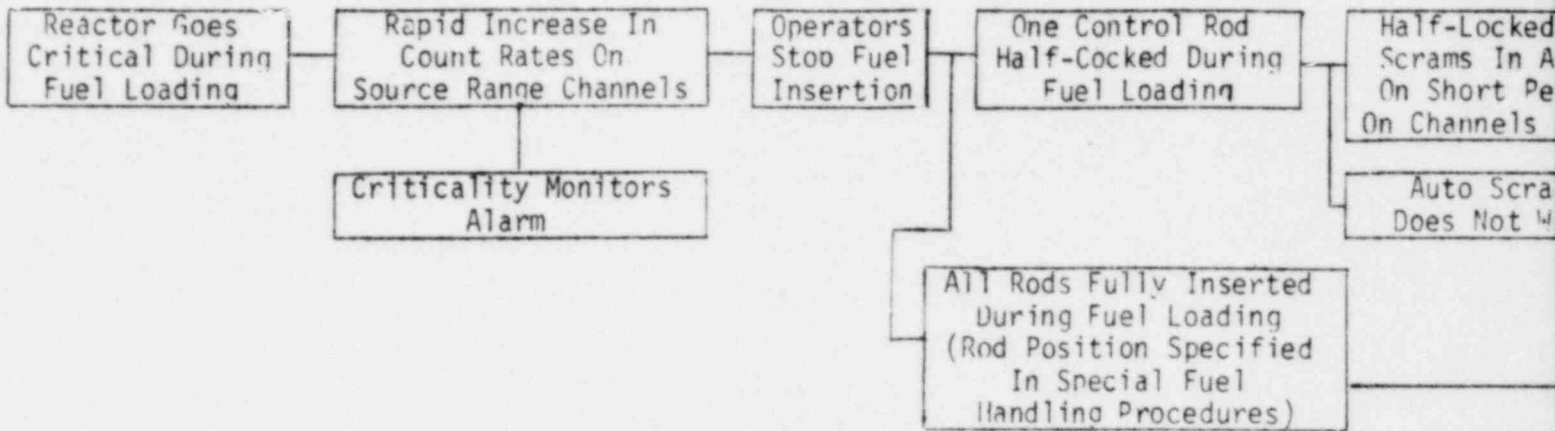

POOR ORIGINAL

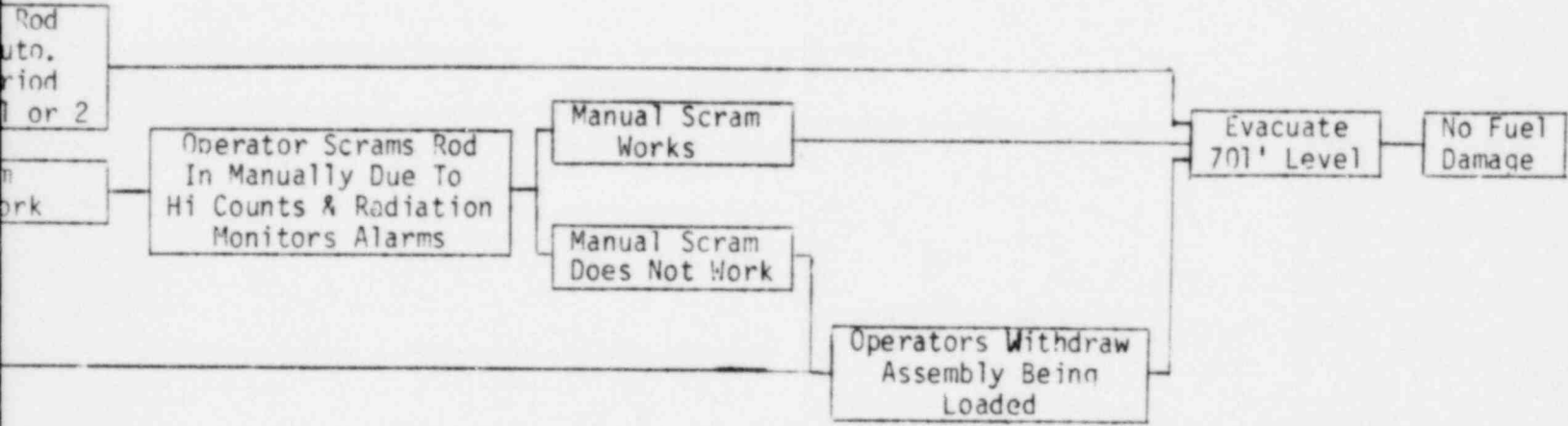

POOR ORIGINAL

II. POWER FAILURE

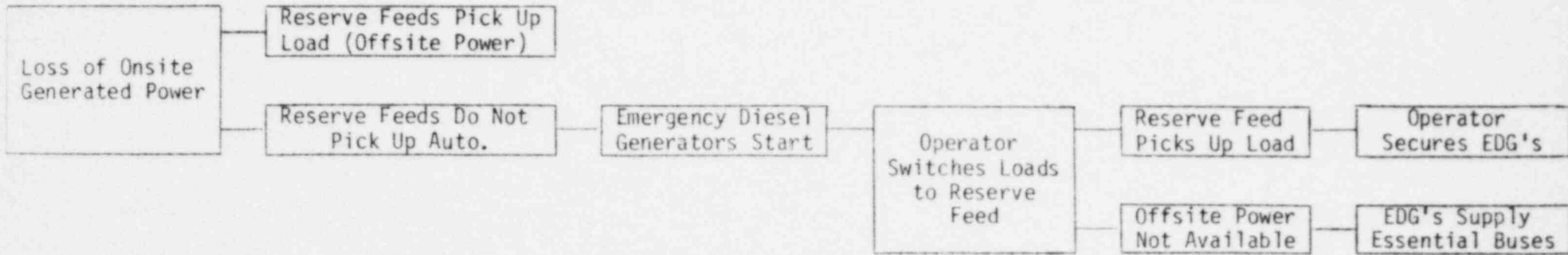

III. CONTROL ROD DRIVE MECHANISM FAILURE

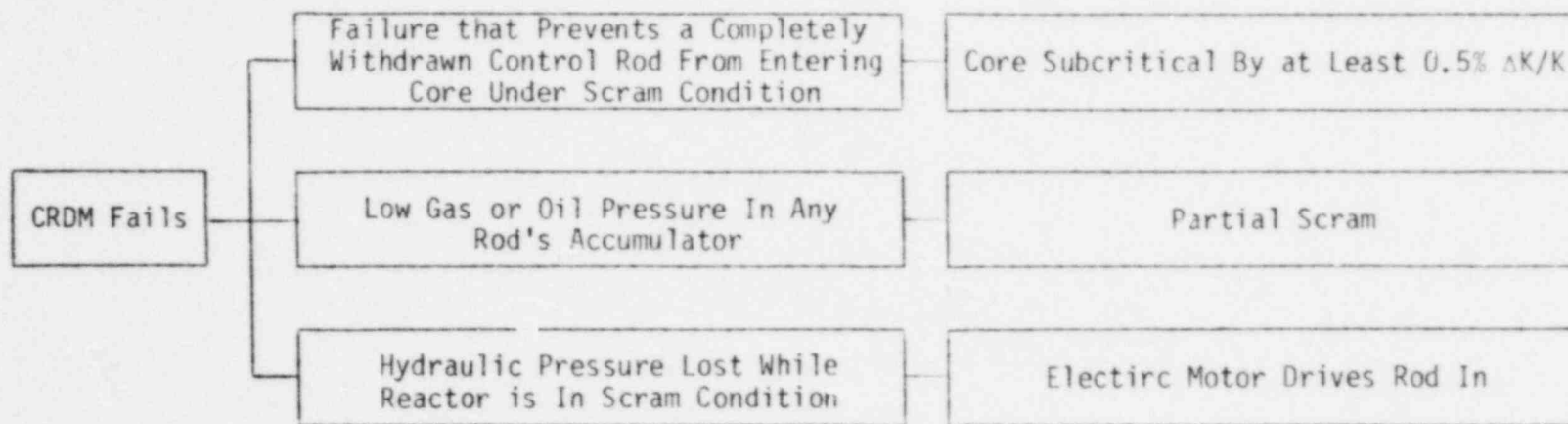

IV. FUEL ELEMENT FAILURE

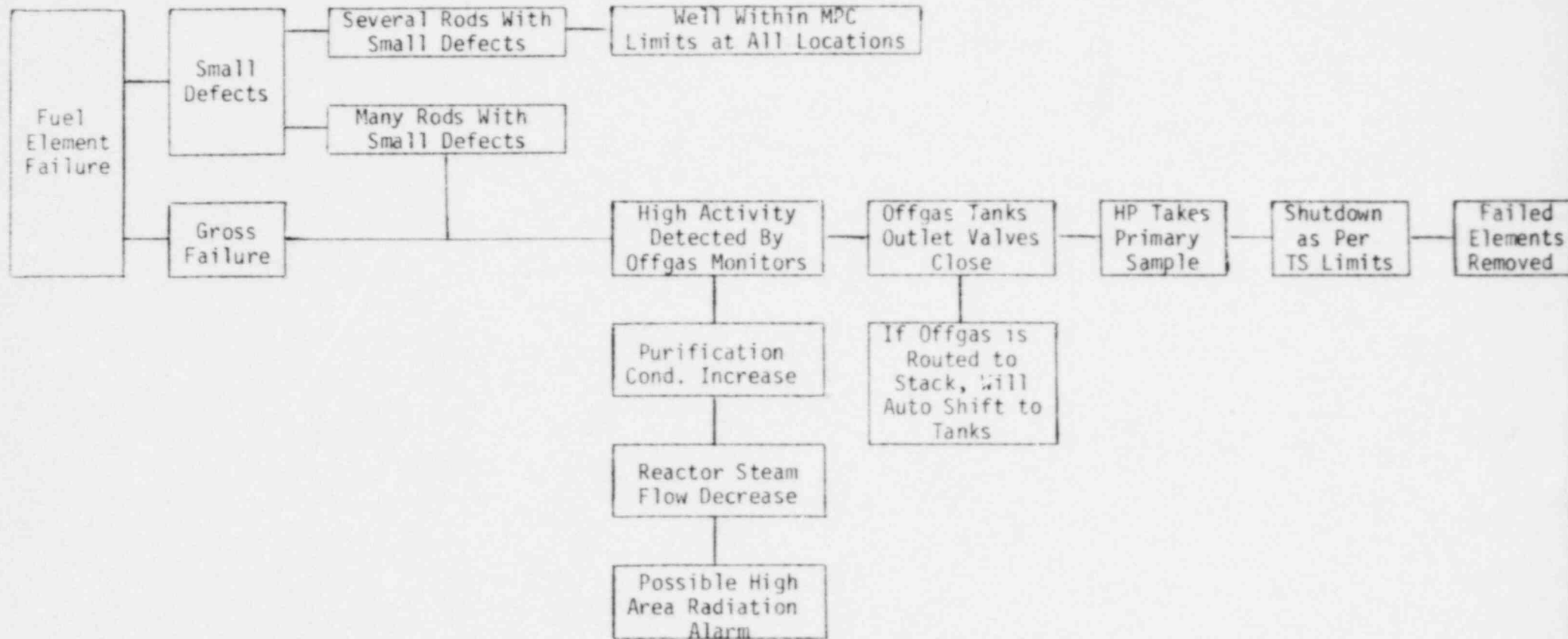

V. LIQUID WASTE DISCHARGE

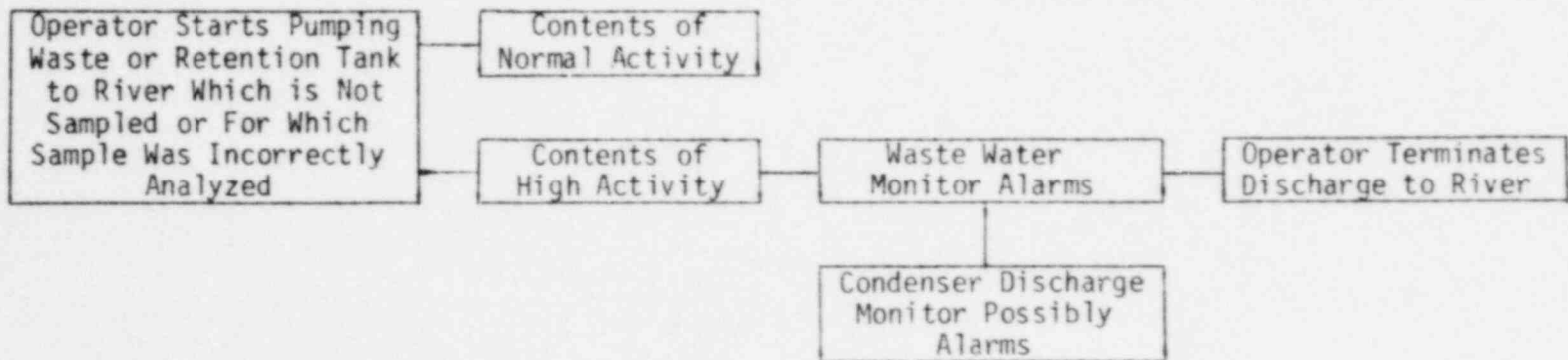

VI. INADVERTANT AIRBORNE STACK RELEASE

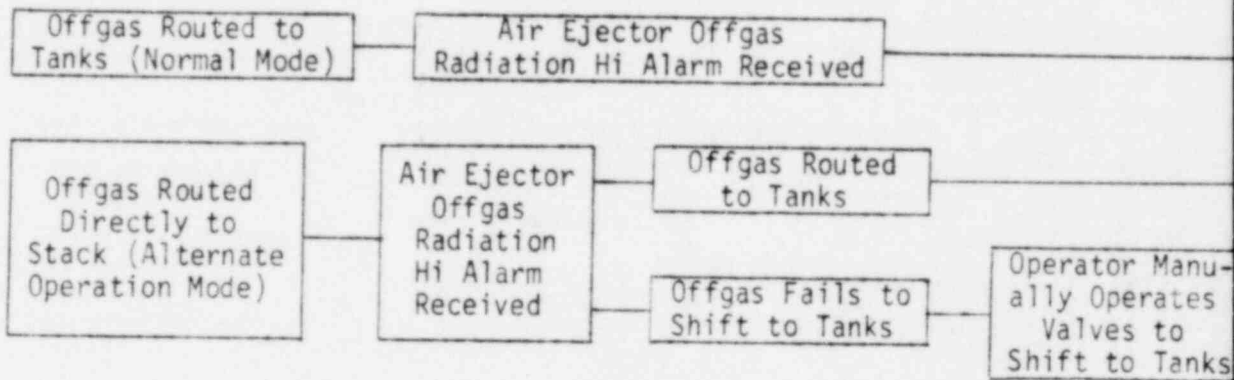

POOR ORIGINAL

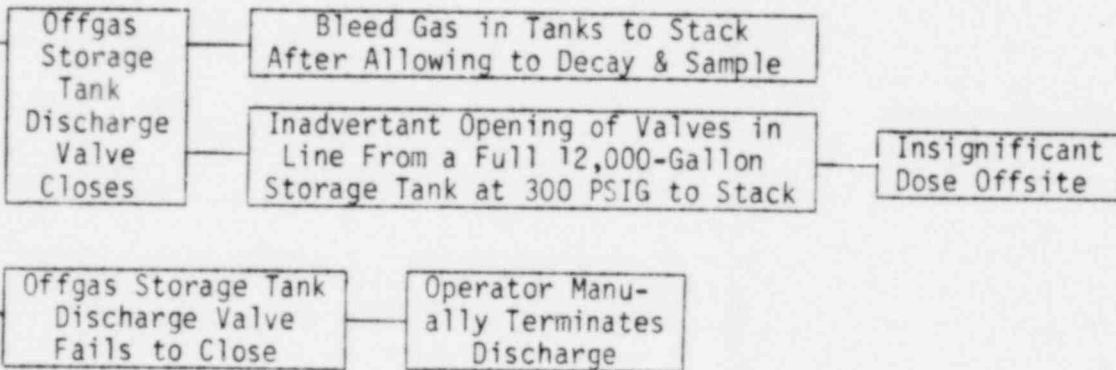

POOR ORIGINAL