

ATTACHMENT 1

PROPOSED TECHNICAL SPECIFICATION CHANGE

NORTH ANNA UNIT NO. 1

8009090 347

6.0 ADMINISTRATIVE CONTROLS

6.1 RESPONSIBILITY

6.1.1 The Station Manager shall be responsible for overall facility operation, ~~and shall delegate in writing the succession to this responsibility during his absence.~~ SEE ATTACHED PAGE

6.2 ORGANIZATION

OFFSITE

6.2.1 The offsite organization for facility management and technical support shall be as shown on Figure 6.2-1.

FACILITY STAFF

6.2.2 The Facility organization shall be as shown on Figure 6.2-2 and:

- a. Each on duty shift shall be composed of at least the minimum shift crew composition shown in Table 6.2-1.
- b. At least one licensed Operator shall be in the control room when fuel is in the reactor.
- c. At least two licensed Operators shall be present in the control room during reactor start-up, scheduled reactor shutdown and during recovery from reactor trips.
- d. An individual qualified in radiation protection procedures shall be on site when fuel is in the reactor.
- e. All CORE ALTERATIONS shall be directly supervised by either a licensed Senior Reactor Operator or Senior Reactor Operator Limited to Fuel Handling who has no other concurrent responsibilities during this operation.
- f. A Fire Brigade of at least 5 members shall be maintained onsite at all times*. The Fire Brigade shall not include the minimum shift crew shown in Table 6.2-1 or any personnel required for other essential functions during a fire emergency.

* Fire Brigade composition may be less than the minimum requirement for a period of time not to exceed 2 hours in order to accommodate unexpected absence of Fire Brigade members provided immediate action is taken to restore the Fire Brigade to within the minimum requirement.

In his absence, the Assistant Station Manager shall be responsible for overall facility operation. During the absence of both, the Station Manager shall delegate in writing the succession of this responsibility.

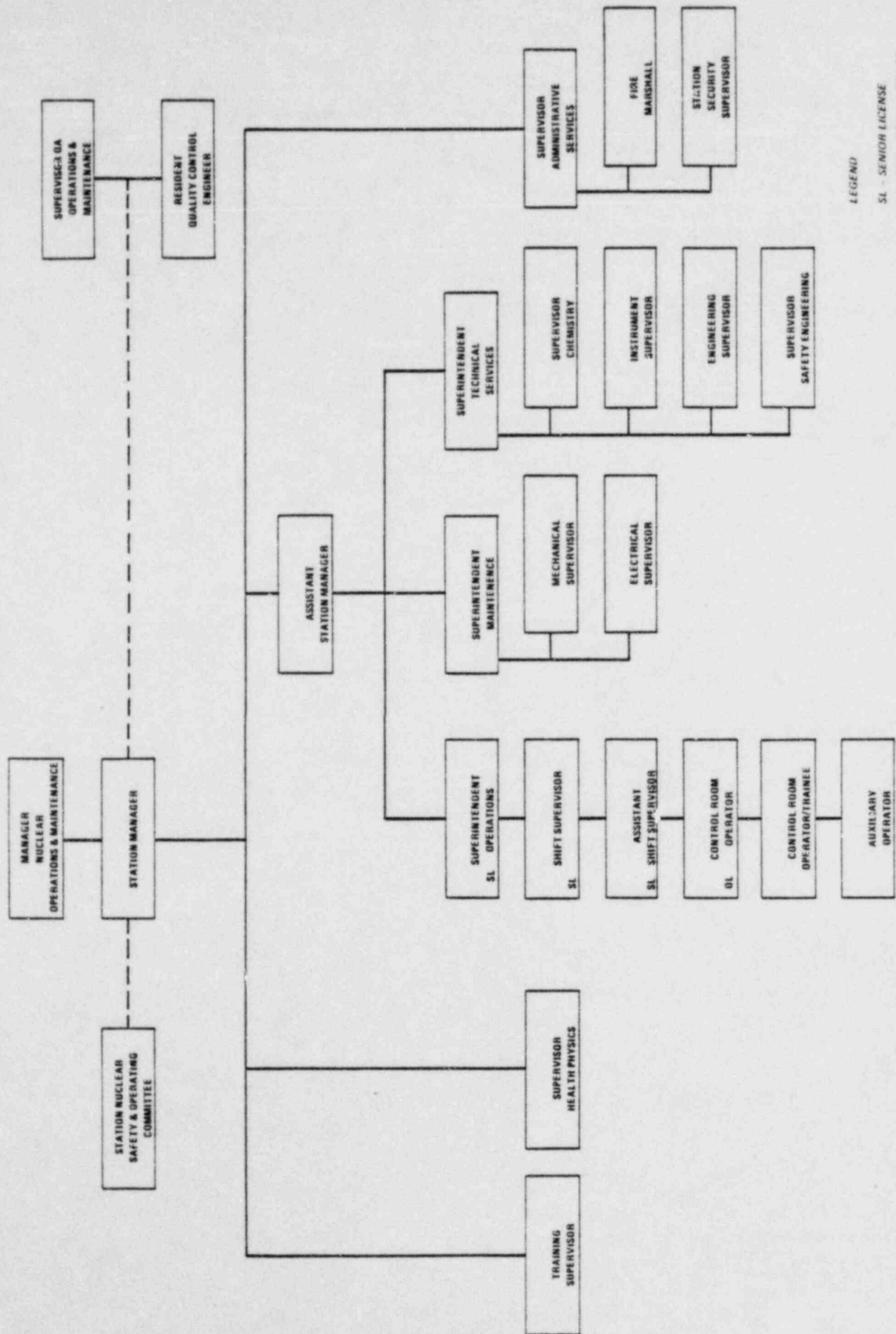

LEGEND
 SL - SENIOR LICENSE
 OL - OPERATOR'S LICENSE
 ... COMMUNICATIONS

Figure 6.2.2 Facility Organization - North Anna - Units 1 & 2

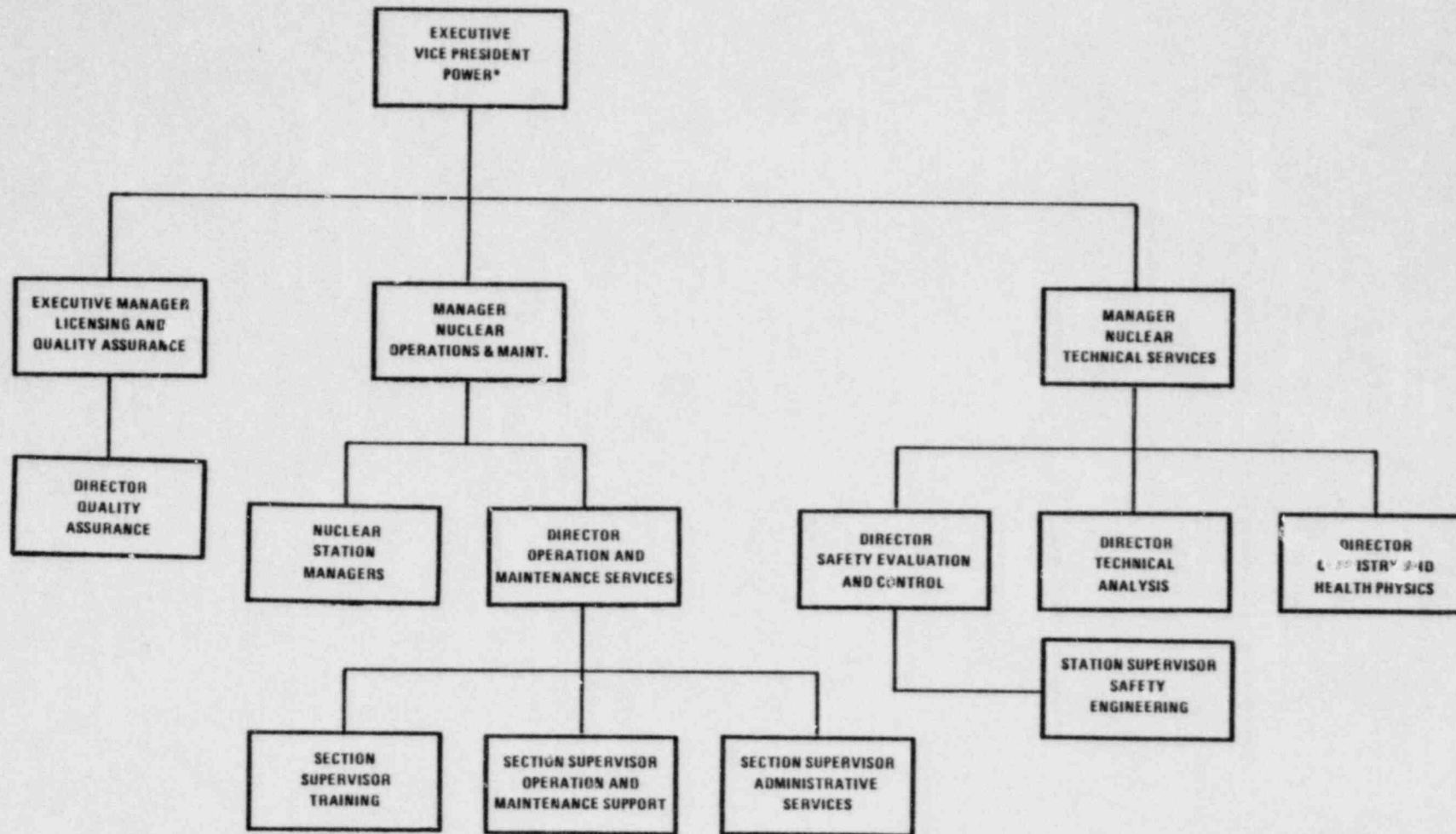

*RESPONSIBLE FOR CORPORATE FIRE PROTECTION PROGRAM

Offsite Organization for Facility Management and Technical Support

ADMINISTRATIVE CONTROLSMEETING FREQUENCY

6.5.1.4 The SNSOC shall meet at least once per calendar month and as convened by the SNSOC Chairman or his designated alternate.

QUORUM

6.5.1.5 A quorum of the SNSOC shall consist of the Chairman or Vice-Chairman and two members including alternates.

RESPONSIBILITIES

6.5.1.6 The SNSOC shall be responsible for:

- a. Review of 1) all procedures required by Specification 6.8.1 and changes thereto, 2) any other proposed procedures or changes thereto as determined by the Station Manager to affect nuclear safety.
- b. Review of all proposed tests and experiments that affect nuclear safety.
- c. Review of all proposed changes to Appendix "A" Technical Specifications.
- d. Review of all proposed changes or modifications to plant systems or equipment that affect nuclear safety.
- e. ^{Manager, Nuclear Operations and Maintenance} Investigation of all violations of the Technical Specifications including the preparation and forwarding of reports covering evaluation and recommendations to prevent recurrence to the ~~Director, Nuclear Operations and to the Chairman of the System Nuclear Safety and Operating Committee.~~ _{Director, Safety Evaluation and Control.}
- f. Review of events requiring 24 hour written notification to the Commission.
- g. Review of facility operations to detect potential nuclear safety hazards.

ADMINISTRATIVE CONTROLS

- h. Performance of special reviews, investigations or analyses and reports thereon as requested by the Chairman of the Station Nuclear Safety and Operating Committee.
- i. Review of the Plant Security Plan and implementing procedures and shall submit recommended changes to the Chairman of the Station Nuclear Safety and Operating Committee.
- j. Review of the Emergency Plan and implementing procedures and shall submit recommended changes to the Chairman of the Station Nuclear Safety and Operating Committee.

AUTHORITY

6.5.1.7 The SNSOC shall:

- a. Recommend to the Station Manager written approval or disapproval of items considered under 6.5.1.6(a) through (d) above.
- b. Render determinations in writing with regard to whether or not each item considered under 6.5.1.6(a) through (e) above constitutes an unreviewed safety question.
- c. Provide written notification within 24 hours to Manager, Nuclear Operations and Maintenance and the ~~Chairman of the System Nuclear Safety and Operating Committee~~ of disagreement between the SNSOC and the Station Manager; however, the Station Manager shall have responsibility for resolution of such disagreements pursuant to 6.1.1 above.

Director, Safety Evaluation and Control

RECORDS

6.5.1.8 The SNSOC shall maintain written minutes of each meeting and copies shall be provided to the Manager, Nuclear Operations and Maintenance and ~~Chairman of the System Nuclear Safety and Operating Committee.~~
the Director, Safety Evaluation and Control.

SAFETY EVALUATION AND CONTROL (SEC)

6.5.2 ~~SYSTEM NUCLEAR SAFETY AND OPERATING COMMITTEE (SyNSOC)~~

FUNCTION

SEC staff

6.5.2.1 The ~~SyNSOC~~ shall function to provide independent review and ~~audit~~ of designated activities in the areas of:

ADMINISTRATIVE CONTROLS

- a. Nuclear power plant operations
- b. Nuclear engineering
- c. Chemistry and radiochemistry
- d. Metallurgy
- e. Instrumentation and control
- f. Radiological safety
- g. Mechanical and electrical engineering
- h. ~~Quality assurance practices~~ Administrative controls and quality assurance practices
- i. Other appropriate fields associated with the unique characteristics of the nuclear power plant

COMPOSITION

~~6.5.2.2 The SyNSOC shall be composed of the Chairman and four other members. Membership shall be composed of the Managers or Directors of the Power Station Engineering, Fuel Resources, Nuclear Operations, and Licensing and Quality Assurance Departments or qualified designees from these departments and a sixth qualified member selected by the five other members. Members of the SyNSOC shall have an academic degree in an engineering or physical science field and, in addition, shall have a minimum of five years technical experience, of which a minimum of three years shall be in one or more areas given in Section 6.5.2.1.~~

ALTERNATES

~~6.5.2.3 All alternate members shall be appointed in writing by the SyNSOC Chairman to serve on a temporary basis.~~

CONSULTANTS

Director, Safety Evaluation and Control

6.5.2.4 Consultants shall be utilized as determined by the SyNSOC Chairman to provide expert advice to the SyNSOC.

SEC staff.

Composition

6.5.2.2 The SEC staff shall be composed of the Director, Safety Evaluation and Control and a minimum of three staff specialists. Each member of the SEC staff shall meet or exceed the minimum qualifications of ANSI N 18.1-1971.

ADMINISTRATIVE CONTROLS

MEETING FREQUENCY

~~6.5.2.5 The SyNSOC shall meet at least once per calendar quarter during the initial year of facility operation following fuel loading and at least once per six months thereafter.~~

QUORUM

~~6.5.2.6 A quorum of the SyNSOC shall consist of not less than a majority of the members or duly appointed alternates and shall be subject to the following constraints:~~

- ~~1. The Chairman or Vice Chairman shall be present for all meetings.~~
- ~~2. No more than a minority of the quorum shall have line responsibility for operation of the stations.~~
- ~~3. A motion carrying vote must consist of no less than three (3) votes.~~
- ~~4. No more than a minority of a quorum may be alternates.~~

REVIEW

SEC staff:

6.5.2.7 The following subjects shall be reviewed by the ~~SyNSOC~~:

- a. Written safety evaluations of changes in the stations as described in the Safety Analysis Report, changes in procedures as described in the Safety Analysis Report and tests or experiments not described in the Safety Analysis Report which are completed without prior NRC approval under the provisions of 10 CFR 50.59(a)(1). This review is to verify that such changes, tests or experiments did not involve a change in the technical specifications or an unreviewed safety question as defined in 10 CFR 50.59(a)(2) and is accomplished by review of minutes of the Station Nuclear Safety and Operating Committee and the design change program.
- b. Proposed changes in procedures, proposed changes in the station, or proposed tests or experiments, any of which may involve a change in the technical specifications or an unreviewed safety question as defined in 10 CFR 50.59(a)(2). Matters of this kind shall be referred to the ~~SyNSOC~~ by the Station Nuclear Safety and Operating Committee following its review prior to implementation.
SEC staff
- c. Changes in the technical specifications or license amendments relating to nuclear safety prior to implementation except in those cases where the change is identical to a previously reviewed proposed change.
- d. Violations and reportable occurrences such as:

 ADMINISTRATIVE CONTROLS

REVIEW (Cont'd)

1. Violations of applicable codes, regulations, orders, Technical Specifications, license requirements or internal procedures or instructions having safety significance;
2. Significant operating abnormalities or deviations from normal or expected performance of station safety-related structures, systems, or components; and
3. Reportable occurrences as defined in the station Technical Specifications, § 6.9.1.8.

Review of events covered under this paragraph shall include the results of any investigations made and recommendations resulting from such investigations to prevent or reduce the probability of recurrence of the event.

- e. Any other matter involving safe operation of the nuclear power stations which ~~a duly appointed subcommittee or committee member deems appropriate for consideration, or which is referred to the SyNSOC by the Station Nuclear Safety and Operating Committee.~~
SEC staff

AUDITS

~~6.5.2.8 Audits of station activities shall be performed under the cognizance of the SyNSOC. These audits shall encompass:~~

- ~~a. The conformance of facility operation to provisions contained within the Technical Specifications and applicable license conditions at least once per 12 months.~~
- ~~b. The performance, training and qualifications of the entire facility staff at least once per 12 months.~~
- ~~c. The results of actions taken to correct deficiencies occurring in facility equipment, structures, systems or method of operation that affect nuclear safety at least once per 6 months.~~
- ~~d. The performance of activities required by the Operational Quality Assurance Program to meet the criteria of Appendix "B", 10 CFR 50, at least once per 24 months.~~
- ~~e. The Station Emergency Plan and implementing procedures at least once per 24 months.~~
- ~~f. The Station Security Plan and implementing procedures at least once per 24 months.~~

ADMINISTRATIVE CONTROLS

- ~~g. Any other area of facility operation considered appropriate by the SyNSOC or the Executive Vice President-Power.~~
- ~~h. The Station Fire Protection Program and implementing procedures at least once per 24 months.~~
- ~~i. An independent fire protection and loss prevention program inspection and audit shall be performed at least once per 12 months utilizing either qualified offsite licensed personnel or an outside fire protection firm.~~
- ~~j. An inspection and audit of the fire protection and loss prevention program shall be performed by a qualified outside fire consultant at least once per 36 months.~~

AUTHORITY

SEC staff

Manager, Nuclear Technical Services

6.5.2.9 The SyNSOC shall report to and advise the Executive Manager ←
 Licensing and Quality Assurance, who shall advise the Executive Vice
 President - Power on those areas of responsibility specified in
 Section# 6.5.2.7. and 6.5.2.8.

in the SEC files and
 a summary shall be
 and

RECORDS

SEC

6.5.2.10 Records of SyNSOC activities shall be prepared, maintained and ←
 disseminated as indicated below within 14 working days of each meeting
 or following completion of the review or audit. each calendar month.

1. Executive Vice President-Power
2. Nuclear Power Station Managers
3. Manager, Nuclear Operations and Maintenance
4. ~~Members of the SyNSOC~~ Manager, Nuclear Technical Services
- 6.8. Others that the Chairman of the SyNSOC may designate.
 Director, Safety Evaluation and Control
5. Executive Manager, Licensing and Quality Assurance

6.5.3 Quality Assurance Department

Function

6.5.3.1 The Quality Assurance Department shall function to audit station activities. These audits shall encompass:

- a. The conformance of facility operation to provisions contained within the Technical Specifications and applicable license conditions at least once per calendar year.
- b. The performance, training and qualifications of the entire facility staff at least once per calendar year.
- c. The results of actions taken to correct deficiencies occurring in facility equipment, structures, systems or method of operation that affect nuclear safety at least twice per calendar year.
- d. The performance of activities required by the Operational Quality Assurance Program to meet the criteria of Appendix "B", 10 CFR 50, at least once per two calendar years.
- e. The Station Emergency Plan and implementing procedures at least once per two calendar years.
- f. The Station Security Plan and implementing procedures at least once per two calendar years.
- g. Any other area of facility operation considered appropriate by the Executive Manager-Licensing and Quality Assurance or the Executive Vice President-Power.
- h. The Station Fire Protection Program and implementing procedures at least once per two calendar years.
- i. An independent fire protection and loss prevention program inspection and audit shall be performed at least once per calendar year utilizing either qualified offsite licensee personnel or an outside fire protection firm.
- j. An inspection and audit of the fire protection and loss prevention program shall be performed by a qualified outside fire consultant at least once per three calendar years.

Authority

6.5.3.2 The Quality Assurance Department shall report to and advise the Executive Manager, Licensing and Quality Assurance, who shall advise the Executive Vice President-Power on those areas of responsibility specified in section 6.5.3.1.

Records

5.3.3 Records of the Quality Assurance Department audits shall be prepared and maintained in the department files. Audit reports shall be disseminated as indicated below:

1. Nuclear Power Station Manager
2. Manager - Nuclear Operations and Maintenance
3. Manager - Nuclear Technical Services
4. Supervisor - Quality Assurance, Operations and Maintenance
5. Supervisor of area audited
6. Nuclear Power Station Resident Quality Control Engineer

ADMINISTRATIVE CONTROLS

6.6 REPORTABLE OCCURRENCE ACTION

6.6.1 The following actions shall be taken for REPORTABLE OCCURRENCES:

- a. The Commission shall be notified and/or a report submitted pursuant to the requirements of Specification 6.9.
- b. Each REPORTABLE OCCURRENCE requiring 24 hour notification to the Commission shall be reviewed by the SNSOC and submitted to the ~~SyNSOC~~ and the Manager, Nuclear Operations and Maintenance.
SEC staff

6.7 SAFETY LIMIT VIOLATION

6.7.1 The following actions shall be taken in the event a Safety Limit is violated:

- a. The facility shall be placed in at least HOT STANDBY within one hour.
- b. The Safety Limit violation shall be reported to the Commission, the Manager, Nuclear Operations and Maintenance and to the ~~SyNSOC~~ within 24 hours.
SEC staff
- c. A Safety Limit Violation Report shall be prepared. The report shall be reviewed by the SNSOC. This report shall describe (1) applicable circumstances preceding the violation, (2) effects of the violation upon facility components, systems or structures, and (3) corrective action taken to prevent recurrence.
- d. The Safety Limit Violation Report shall be submitted to the Commission, the ~~SyNSOC~~ and the Manager, Nuclear Operations and Maintenance within 14 days of the violation.
SEC staff

ADMINISTRATIVE CONTROLS

- a. Records and drawing changes reflecting facility design modifications made to systems and equipment described in the Final Safety Analysis Report.
- b. Records of new and irradiated fuel inventory, fuel transfers and assembly burnup histories.
- c. Records of facility radiation and contamination surveys.
- d. Records of radiation exposure for all individuals entering radiation control areas.
- e. Records of gaseous and liquid radioactive material released to the environs.
- f. Records of transient or operational cycles for those facility components identified in Table 5.9-1.
- g. Records of reactor tests and experiments
- h. Records of training and qualification for current members of the plant staff.
- i. Records of in-service inspections performed pursuant to these Technical Specifications.
- j. Records of Quality Assurance activities required by the QA Manual.
- k. Records of reviews performed for changes made to procedures or equipment or reviews of tests and experiments pursuant to 10 CFR 50.59.
- l. Records of meetings of the SNSOC, and the ~~SyNSOC~~.
- m. SEE ATTACHED SHEET
- n. Records of secondary water sampling and water quality.

6.11 RADIATION PROTECTION PROGRAM

Procedures for personnel radiation protection shall be prepared consistent with the requirements of 10 CFR Part 20 and shall be approved, maintained and adhered to for all operations involving personnel radiation exposure.

m. Records of meetings of the System Nuclear Safety and Operating
Committee held prior to issuance of Amendment No. _____.

ATTACHMENT 2

PROPOSED TECHNICAL SPECIFICATION CHANGE

NORTH ANNA UNIT NO. 2

6.0 ADMINISTRATIVE CONTROLS

6.1 RESPONSIBILITY

6.1.1 The Station Manager shall be responsible for overall facility operation, ~~and shall delegate in writing the succession to this responsibility during his absence.~~ SEE ATTACHED PAGE

6.1.2 The Shift Supervisor (or during his absence from the Control Room, a designated individual) shall be responsible for the Control Room command function and shall be the only individual that may direct the licensed activities of licensed operators. A management directive to this effect, signed by the Executive Vice President, Power, shall be reissued to all station personnel on an annual basis.

6.2 ORGANIZATION

OFFSITE

6.2.1 The offsite organization for facility management and technical support shall be as shown on Figure 6.2-1.

FACILITY STAFF

6.2.2 The Facility organization shall be as shown on Figure 6.2-2 and:

- a. Each on duty shift shall be composed of at least the minimum shift crew composition shown in Table 6.2-1.
- b. At least one licensed Reactor Operator shall be in the control room when fuel is in the reactor. In addition, while the unit is in MODES 1, 2, 3 or 4, at least one licensed Senior Reactor Operator shall be in the Control Room.
- c. A health physics technician# shall be on site when fuel is in the reactor.
- d. All CORE ALTERATIONS shall be observed and directly supervised by either a licensed Senior Reactor Operator or Senior Reactor Operator Limited to Fuel Handling who has no other concurrent responsibilities during this operation.
- e. A site Fire Brigade of at least 5 members shall be maintained onsite at all times.# The Fire Brigade shall not include the minimum shift crew shown in Table 6.2-1 or any personnel required for other essential functions during a fire emergency.

#The health physics technician and Fire Brigade composition may be less than the minimum requirement for a period of time not to exceed 2 hours in order to accommodate unexpected absence provided immediate action is taken to fill the required positions.

In his absence, the Assistant Station Manager shall be responsible for overall facility operation. During the absence of both, the Station Manager shall delegate in writing the succession of this responsibility.

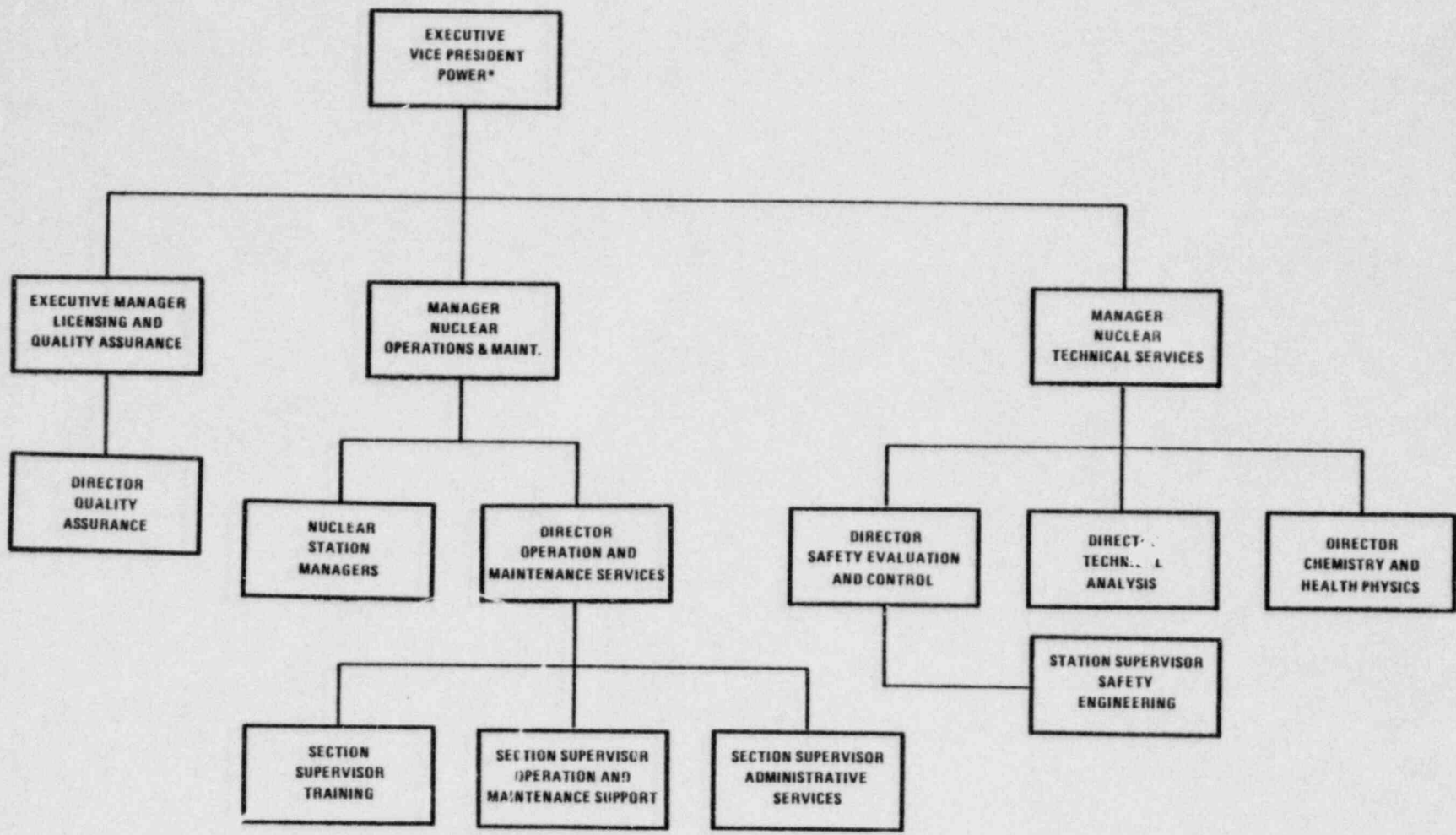

*RESPONSIBLE FOR CORPORATE FIRE PROTECTION PROGRAM

Offsite Organization for Facility Management and Technical Support

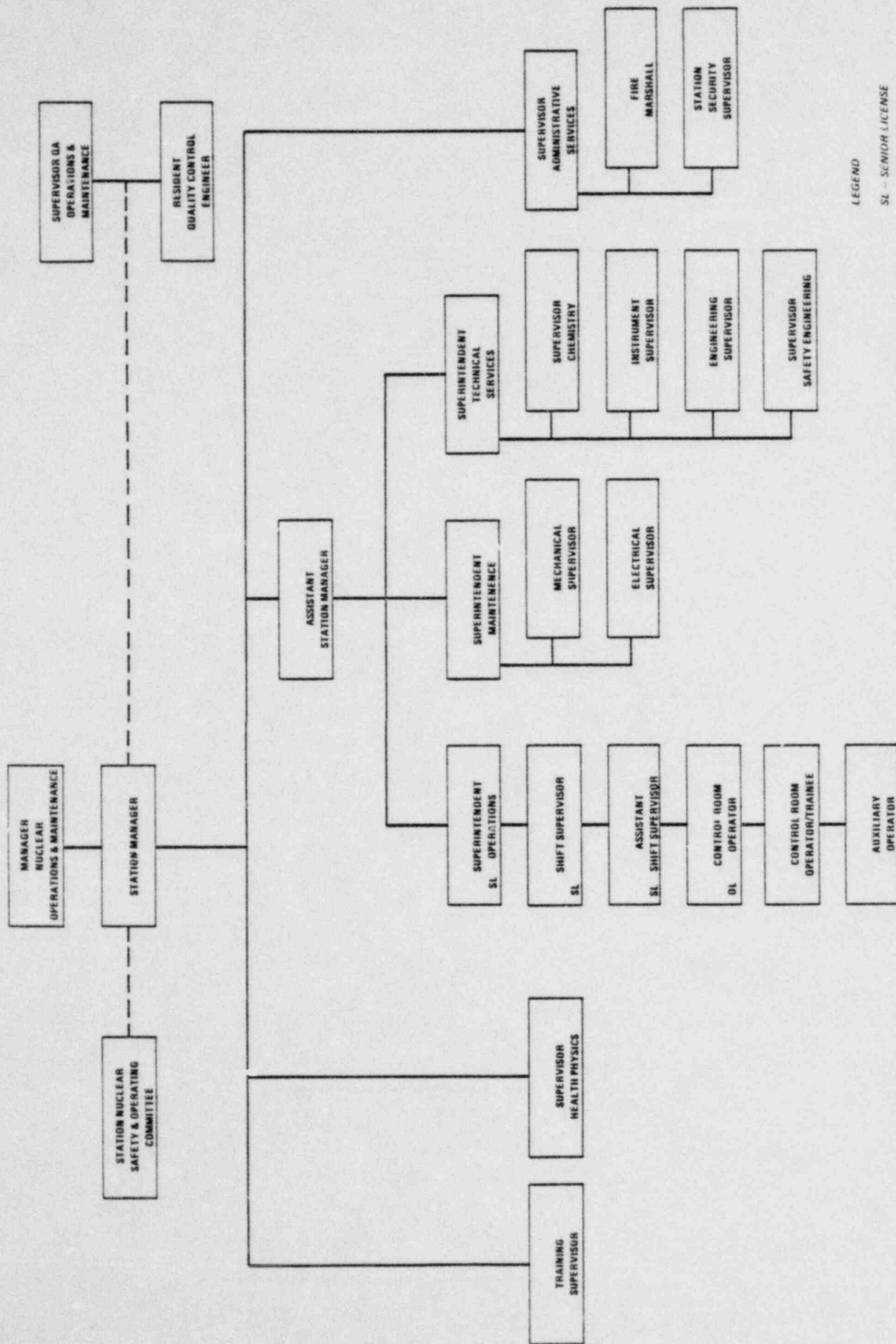

LEGEND
 SL - SENIOR LICENSE
 OL - OPERATOR'S LICENSE
 ... COMMUNICATIONS

Figure 6-2 Facility Organization - North Anna - Units 1 & 2

ADMINISTRATIVE CONTROLS

6.3 FACILITY STAFF QUALIFICATIONS

6.3.1 Each member of the facility staff shall meet or exceed the minimum qualifications of ANSI N18.1-1971 for comparable positions and the supplemental requirements specified in the March 28, 1980 NRC letter to all licenses, except for the Supervisor-Health Physics who shall meet or exceed the qualifications of Regulatory Guide 1.8, September 1975.

6.4 TRAINING

6.4.1 The Station Manager is responsible for ensuring that retraining and replacement training programs for the facility staff are maintained and that such programs meet or exceed the requirements and recommendations of Section 5.5 of ANSI N18.1-1971 and Appendix "A" of 10 CFR Part 55 and the supplemental requirements specified in the March 28, 1980 NRC letter to all licensees, and shall include familiarization with relevant industry operational experience identified by the ~~ISEG~~ SES.

6.5 REVIEW AND AUDIT

6.5.1 STATION NUCLEAR SAFETY AND OPERATING COMMITTEE (SNSOC)

FUNCTION

6.5.1.1 The SNSOC shall function to advise the Station Manager on all matters related to nuclear safety.

COMPOSITION

6.5.1.2 The SNSOC shall be composed of the:

- | | |
|----------------|--|
| Chairman: | Assistant Station Manager |
| Vice-Chairman: | Station Manager |
| Member: | → Superintendent - Operations |
| Member: | Superintendent - Maintenance |
| Member: | Superintendent - Technical Services |
| Member: | Superintendent - Operations |

ALTERNATES

6.5.1.3 All alternate members shall be appointed in writing by the SNSOC Chairman to serve on a temporary basis; however, no more than one alternates shall participate as a voting member in SNSOC activities at any one time.

ADMINISTRATIVE CONTROLS

MEETING FREQUENCY

6.5.1.4 The SNSOC shall meet at least once per calendar month and as convened by the SNSOC Chairman or his designated alternate.

QUORUM

6.5.1.5 A quorum of the SNSOC shall consist of the Chairman or Vice-Chairman and two members including alternates.

RESPONSIBILITIES

6.5.1.6 The SNSOC shall be responsible for:

- a. Review of 1) all procedures required by Specification 6.8.1 and changes thereto, 2) all programs required by Specification 6.8.4 and changes thereto, 3) any other proposed procedures or changes thereto as determined by the Station Manager to affect nuclear safety.
- b. Review of all proposed tests and experiments that affect nuclear safety.
- c. Review of all proposed changes to Appendix "A" Technical Specifications.
- d. Review of all proposed changes or modifications to plant systems or equipment that affect nuclear safety.
- e. Investigation of all violations of the Technical Specifications including the preparation and forwarding of reports covering evaluation and recommendations to prevent recurrence to the ~~Director, Nuclear Operations and to the Chairman of the System Nuclear Safety and Operating Committee.~~ ^{Manager, Nuclear Operations and Maintenance} Director, Safety Evaluation and Control.
- f. Review of events requiring 24-hour written notification to the Commission.
- g. Review of facility operations to detect potential nuclear safety hazards.
- h. Performance of special reviews, investigations or analyses and reports thereon as requested by the Chairman of the Station Nuclear Safety and Operating Committee.

ADMINISTRATIVE CONTROLS

- i. Review of the Plant Security Plan and implementing procedures and shall submit recommended changes to the Chairman of the Station Nuclear Safety and Operating Committee.
- j. Review of the Emergency Plan and implementing procedures and shall submit recommended changes to the Chairman of the Station Nuclear Safety and Operating Committee.

AUTHORITY

6.5.1.7 The SNSOC shall:

- a. Recommend to the Station Manager written approval or disapproval of items considered under 6.5.1.6(a) through (d) above.
- b. Render determinations in writing with regard to whether or not each item considered under 6.5.1.6(a) through (e) above constitutes an unreviewed safety question.
- c. Provide written notification within 24 hours to the Manager, Nuclear Operations and Maintenance and the ~~Chairman of the System Nuclear Safety and Operating Committee~~ of disagreement between the SNSOC and the Station Manager; however, the Station Manager shall have responsibility for resolution of such disagreements pursuant to 6.1.1 above.

→ Director, Safety Evaluation and Control

RECORDS

6.5.1.8 The SNSOC shall maintain written minutes of each meeting and copies shall be provided to the Manager, Nuclear Operations and Maintenance and ~~Chairman of the System Nuclear Safety and Operating Committee~~, the Director, Safety Evaluation and Control.

SAFETY EVALUATION AND CONTROL (SEC)

~~6.5.2 SYSTEM NUCLEAR SAFETY AND OPERATING COMMITTEE (SyNSOC)~~

FUNCTION

SEC staff

6.5.2.1 The ~~SyNSOC~~ shall function to provide independent review and ~~audit~~ of designated activities in the areas of:

- a. Nuclear power plant operations
- b. Nuclear engineering

ADMINISTRATIVE CONTROLS

- c. Chemistry and radiochemistry
- d. Metallurgy
- e. Instrumentation and control
- f. Radiological safety
- g. Mechanical and electrical engineering
- h. ~~Quality assurance practices~~ Administrative controls and quality assurance practices
- i. Other appropriate fields associated with the unique characteristics of the nuclear power plant.

COMPOSITION

SEE ATTACHED PAGE

~~6.5.2.2 The SyNSOC shall be composed of the Chairman and four other members. Membership shall be composed of the Managers or Directors of the Power Station Engineering, Fuel Resources, Nuclear Operations, and Licensing and Quality Assurance Departments or qualified designees from these departments and a sixth qualified member selected by the five other members. Members of the SyNSOC shall have an academic degree in an engineering or physical science field and, in addition, shall have a minimum of five years technical experience, of which a minimum of three years shall be in one or more areas given in Section 6.5.2.1.~~

ALTERNATES

~~6.5.2.3 All alternate members shall be appointed in writing by the SyNSOC Chairman to serve on a temporary basis.~~

CONSULTANTS

Director, Safety Evaluation and Control →

6.5.2.4 Consultants shall be utilized as determined by the SyNSOC Chairman to provide expert advice to the SyNSOC.

SEC staff.

MEETING FREQUENCY

~~6.5.2.5 The SyNSOC shall meet at least once per calendar quarter during the initial year of facility operation following fuel loading and at least once per six months thereafter.~~

Composition

6.5.2.2 The SEC staff shall be composed of the Director, Safety Evaluation and Control and a minimum of three staff specialists. Each member of the SEC staff shall meet or exceed the minimum qualifications of ANSi N 18.1-1971.

ADMINISTRATIVE CONTROLS

~~QUORUM~~

~~6.5.2.6 A quorum of the SyNSOC shall consist of not less than a majority of the members or duly appointed alternates and shall be subject to the following constraints:~~

- ~~1. The Chairman or Vice Chairman shall be present for all meetings.~~
- ~~2. No more than a minority of the quorum shall have line responsibility for operation of the stations.~~
- ~~3. A motion-carrying vote must consist of no less than three (3) votes.~~
- ~~4. No more than a minority of a quorum may be alternates.~~

REVIEW

6.5.2.7 The following subjects shall be reviewed by the ~~SyNSOC~~ SEC staff:

- a. Written safety evaluations of changes in the stations as described in the Safety Analysis Report, changes in procedures as described in the Safety Analysis Report and tests or experiments not described in the Safety Analysis Report which are completed without prior NRC approval under the provisions of 10 CFR 50.59(a)(1). This review is to verify that such changes, tests or experiments did not involve a change in the technical specifications or an unreviewed safety question as defined in 10 CFR 50.59(a)(2) and is accomplished by review of minutes of the Station Nuclear Safety and Operating Committee and the design change program.
- b. Proposed changes in procedures, proposed changes in the station, or proposed tests or experiments, any of which may involve a change in the technical specifications or an unreviewed safety question as defined in 10 CFR 50.59(a)(2). Matters of this kind shall be referred to the ~~SyNSOC~~ by the Station Nuclear Safety and Operating Committee following its ~~review~~ SEC staff review prior to implementation.
- c. Changes in the technical specifications or license amendments relating to nuclear safety prior to implementation except in those cases where the change is identical to a previously reviewed proposed change.

ADMINISTRATIVE CONTROLS

REVIEW (Cont'd)

- d. Violations and reportable occurrences such as:
1. Violations of applicable codes, regulations, orders, Technical Specifications, license requirements or internal procedures or instructions having safety significance;
 2. Significant operating abnormalities or deviations from normal or expected performance of station safety-related structures, systems, or components; and
 3. Reportable occurrences as defined in the station Technical Specifications ~~6.9.1.8.~~

Review of events covered under this paragraph shall include the results of any investigations made and recommendations resulting from such investigations to prevent or reduce the probability of recurrence of the event.

- e. Any other matter involving safe operation of the nuclear power stations which ~~a duly appointed subcommittee or committee member deems appropriate for consideration, or which is referred to the SyNSOC by the Station Nuclear Safety and Operating Committee.~~
SEC staff
- f. Reports and meeting minutes of the Station Nuclear Safety and Operating Committee.

AUDITS

~~6.5.2.8 Audits of station activities shall be performed under the cognizance of the SyNSOC. These audits shall encompass:~~

- ~~a. The conformance of facility operation to provisions contained within the Technical Specifications and applicable license conditions at least once per 12 months.~~
- ~~b. The performance, training and qualifications of the entire facility staff at least once per 12 months.~~
- ~~c. The results of actions taken to correct deficiencies occurring in facility equipment, structures, systems or method of operation that affect nuclear safety at least once per 6 months.~~

ADMINISTRATIVE CONTROLS

- ~~d. The performance of activities required by the Operational Quality Assurance Program to meet the criteria of Appendix "B", 10 CFR 50, at least once per 24 months.~~
- ~~e. The Station Emergency Plan and implementing procedures at least once per 24 months.~~
- ~~f. The Station Security Plan and implementing procedures at least once per 24 months.~~
- ~~g. Any other area of facility operation considered appropriate by the SyNSOC or the Executive Vice President-Power.~~
- ~~h. The Station Fire Protection Program and implementing procedures at least once per 24 months.~~
- ~~i. An independent fire protection and loss prevention program inspection and audit shall be performed at least once per 12 months utilizing either qualified offsite licensee personnel or an outside fire protection firm.~~
- ~~j. An inspection and audit of the fire protection and loss prevention program shall be performed by a qualified outside fire consultant at least once per 36 months.~~

AUTHORITY

SEC staff

Manager, Nuclear Technical Services

6.5.2.9 The SyNSOC shall report to and advise the ~~Executive Manager - Licensing and Quality Assurance~~, who shall advise the Executive Vice President - Power on those areas of responsibility specified in Sections 6.5.2.7 and 6.5.2.8 and review and approve the meeting minutes of the SyNSOC.

RECORDS

SEC

in the SEC files and a summary shall be

6.5.2.10 Records of SyNSOC activities shall be prepared, maintained, and disseminated as indicated below within 14 working days of each meeting or following completion of the review or audit, each calendar month.

1. Executive Vice President-Power
2. Nuclear Power Station Managers
3. Manager - Nuclear Operations and Maintenance
4. ~~Members of the SyNSOC~~ Manager - Nuclear Technical Services
6. ~~5.~~ Others that the Chairman of the SyNSOC may designate.
Director, Safety Evaluation and Control
5. Executive Manager - Licensing and Quality Assurance

6.5.3 Quality Assurance Department

Function

6.5.3.1 The Quality Assurance Department shall function to audit station activities. These audits shall encompass:

- a. The conformance of facility operation to provisions contained within the Technical Specifications and applicable license conditions at least once per calendar year.
- b. The performance, training and qualifications of the entire facility staff at least once per calendar year.
- c. The results of actions taken to correct deficiencies occurring in facility equipment, structures, systems or method of operation that affect nuclear safety at least twice per calendar year.
- d. The performance of activities required by the Operational Quality Assurance Program to meet the criteria of Appendix "B", 10 CFR 50, at least once per two calendar years.
- e. The Station Emergency Plan and implementing procedures at least once per two calendar years.
- f. The Station Security Plan and implementing procedures at least once per two calendar years.
- g. Any other area of facility operation considered appropriate by the Executive Manager-Licensing and Quality Assurance or the Executive Vice President-Power.
- h. The Station Fire Protection Program and implementing procedures at least once per two calendar years.
- i. An independent fire protection and loss prevention program inspection and audit shall be performed at least once per calendar year utilizing either qualified offsite licensee personnel or an outside fire protection firm.
- j. An inspection and audit of the fire protection and loss prevention program shall be performed by a qualified outside fire consultant at least once per three calendar years.

Authority

6.5.3.2 The Quality Assurance Department shall report to and advise the Executive Manager, Licensing and Quality Assurance, who shall advise the Executive Vice President-Power on those areas of responsibility specified in section 6.5.3.1.

Records

6.5.3.3 Records of the Quality Assurance Department audits shall be prepared and maintained in the department files. Audit reports shall be disseminated as indicated below:

1. Nuclear Power Station Manager
2. Manager - Nuclear Operations and Maintenance
3. Manager - Nuclear Technical Services
4. Supervisor - Quality Assurance, Operations and Maintenance
5. Supervisor of area audited
6. Nuclear Power Station Resident Quality Control Engineer

ADMINISTRATIVE CONTROLS

6.6 REPORTABLE OCCURRENCE ACTION

6.6.1 The following actions shall be taken for REPORTABLE OCCURRENCES:

- a. The Commission shall be notified and/or a report submitted pursuant to the requirements of Specification 6.9.
- b. Each REPORTABLE OCCURRENCE requiring 24 hour notification to the Commission shall be reviewed by the SNSOC and submitted to the ~~SyNSOC~~ and the Manager - Nuclear Operations and Maintenance.
SEC staff

6.7 SAFETY LIMIT VIOLATION

6.7.1 The following actions shall be taken in the event a Safety Limit is violated:

- a. The facility shall be placed in at least HOT STANDBY within one hour.
- b. The NRC Operations Center shall be notified by telephone as soon as possible and in all cases within one hour. The Manager, Nuclear Operations and Maintenance, and the ~~SyNSOC~~ shall be notified within 24 hours.
SEC staff
- c. A Safety Limit Violation Report shall be prepared. The report shall be reviewed by the SNSOC. This report shall describe (1) applicable circumstances preceding the violation, (2) effects of the violation upon facility components, systems or structures, and (3) corrective action taken to prevent recurrence.
- d. The Safety Limit Violation Report shall be submitted to the Commission, the ~~SyNSOC~~ and the Manager - Nuclear Operations and Maintenance within 14 days of the violation.
SEC staff

6.8 PROCEDURES & PROGRAMS

6.8.1 Written procedures shall be established, implemented and maintained covering the activities referenced below:

- a. The applicable procedures recommended in Appendix "A" of Regulatory Guide 1.33, Revision 2, February 1978.
- b. Refueling operations.

ADMINISTRATIVE CONTROLS

- l. Records of reviews performed for changes made to procedures or equipment or reviews of tests and experiments pursuant to 10 CFR 50.59.
- m. Records of meetings of the SNSOC, ~~and the SyNSOC.~~
- n. SEE ATTACHED PAGE
- o. Records of secondary water sampling and water quality.

6.11 RADIATION PROTECTION PROGRAM

Procedures for personnel radiation protection shall be prepared consistent with the requirements of 10 CFR Part 20 and shall be approved, maintained and adhered to for all operations involving personnel radiation exposure.

6.12 HIGH RADIATION AREA

6.12.1 In lieu of the "control device" or "alarm signal" required by paragraph 20.203(c)(2) of 10 CFR 20, each high radiation area in which the intensity of radiation is greater than 100 mrem/hr but less than 1000 mrem/hr shall be barricaded and conspicuously posted as a high radiation area and entrance thereto shall be controlled by requiring issuance of a Radiation Work Permit.* Any individual or group of individuals permitted to enter such areas shall be provided with or accompanied by one or more of the following:

- a. A radiation monitoring device which continuously indicates the radiation dose rate in the area.
- b. A radiation monitoring device which continuously integrates the radiation dose rate in the area and alarms when a preset integrated dose is received. Entry into such areas with this monitoring device may be made after the dose rate level in the area has been established and personnel have been made knowledgeable of them.
- c. An individual qualified in the protection procedures who is equipped with a radiation dose rate monitoring device. This individual shall be responsible for providing positive control over the activities within the area and shall perform periodic radiation surveillance at the frequency specified by the facility Health Physicist in the Radiation Work Permit.

* Health Physics personnel or personnel escorted by Health Physics personnel shall be exempt from the RWP issuance requirement during the performance of their assigned radiation protection duties, provide they comply with approved radiation protection procedures for entry in high radiation areas.

n. Records of meetings of the System Nuclear Safety and Operating
Committee held prior to issuance of Amendment No. _____.