

3.5 LIMITING CONDITION FOR OPERATION

4.5 SURVEILLANCE REQUIREMENT

active components of the LPCI Containment Cooling Subsystem and all active components of both Core Spray Subsystems and the diesel generators required for operation of such components if no external source of power were available, shall be operable.

~~4. From and after the date that a LPCI Subsystem is made inoperable for any reason, recirculation pumps, including the spray pumps, shall be made operable within 24 hours of the time the LPCI Subsystem is made inoperable. "Insert attached paragraphs 4.a and 4.b" here. The recirculation pumps shall be required for operation of such components if no external source of power were available, shall be operable.~~

4. When a LPCI Subsystem is made or found to be inoperable, the active components of the redundant LPCI Subsystem shall have been or shall be demonstrated to be operable within 24 hours (except the Recirculation System discharge valves).

5. All recirculation pump discharge valves and bypass valves shall be operable or closed prior to reactor startup.

5. a. All recirculation pump discharge and bypass valves shall be tested for operability during any period of reactor cold shutdown exceeding 48 hours, if operability tests have not been performed during the preceding 31 days.

6. If the requirements of Specification 3.5.A cannot be met, an orderly shutdown of the reactor shall be initiated and the reactor shall be in a cold shutdown condition with 24 hours.

b. Recirculation Pump discharge valves shall be tested to verify full open to full closed in 27 to 33 seconds each refueling outage.

B. Containment Spray Cooling Capability

1. Both containment cooling spray loops are required to be operable when the reactor water temperature is greater than 212°F except that a Containment

B. Containment Spray Cooling Capability

1. Surveillance of the drywell spray loops shall be performed as follows. During each five-year period, an air test shall be performed on the drywell spray headers and nozzles.

3.5.A.4

- a. From and after the date that a LPCI Subsystem is made or found to be inoperable due to failure of the associated UPS, reactor operation is permissible only during the succeeding thirty days, for the 1989/90 operating cycle, unless it is sooner made operable, provided that during that time the associated motor control center (89A or 89B) is powered from its respective maintenance tie, all active components of the other LPCI and the Containment Cooling Subsystem, the Core Spray Subsystems, and the emergency diesel generators shall be operable, the requirements of Specification 3.10.A.4 are met, and the 4160 volt tie line to the Vernon Hydro is the operable delayed access power source.

- b. From and after the date that a LPCI Subsystem is made or found to be inoperable for any reason, other than failure of the UPS during 1989/90 operating cycle, or Specification 3.5.A.4.a is not met, reactor operation is permissible only during the succeeding seven days unless it is sooner made operable, provided that during that time all active components of the other LPCI and the Containment Cooling Subsystem, the Core Spray Subsystems, and the diesel generators required for operation of such components if no external source of power were available, shall be operable.

ATTACHMENT 2

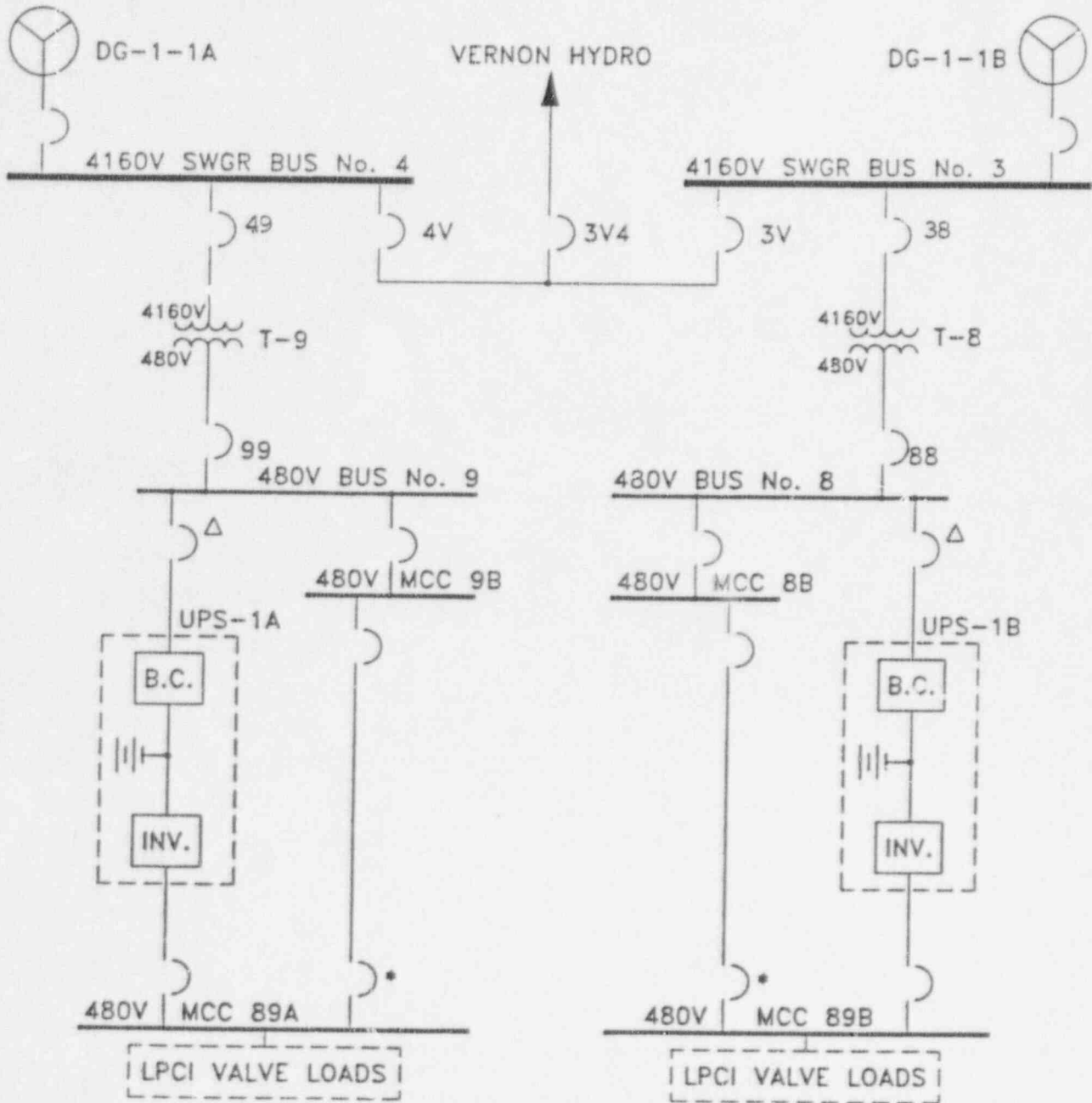

* NORMALLY OPEN (MAINTENANCE TIE)
 Δ TRIPS ON "CORE STANDBY COOLING SYSTEM" INITIATION SIGNAL