



UNITED STATES  
NUCLEAR REGULATORY COMMISSION  
WASHINGTON, D. C. 20555

May 15, 1980

LPDR

Docket No. 50-344

Mr. Charles Goodwin, Jr.  
Assistant Vice President  
Portland General Electric Company  
121 S. W. Salmon Street  
Portland, Oregon 97204

Dear Mr. Goodwin:

On December 28, 1979 the NRC Office of Inspection and Enforcement (IE) issued Information Notice No. 79-37 that discussed the discovery of cracks in the keyway and bore sections of discs in Westinghouse low-pressure turbines. A copy of this Information Notice with an errata sheet is enclosed. Subsequently, all licensee/users of low-pressure turbines manufactured by General Electric were invited to meet with the NRC staff and representatives of the vendor on January 9, 1980 to discuss the probability of disc cracking in these turbines. A summary of this meeting and the General Electric Company's presentation are also enclosed with this letter.

At the time of the January 9 meeting General Electric did not have any recent results of ultrasonic inspections of its low-pressure turbines. Since that date full UT inspections have been performed on six rotors at five nuclear power plants. Some indications in the keyway region have been reported in discs at three of these plants. General Electric personnel believe that these indications were caused by water erosion rather than by stress corrosion.

The staff desires to learn more about the underlying reasons for the indications found and the probable rate of growth of these indications and their effects on turbine disc integrity.

For this purpose we request that you provide the information sought in Enclosure 3 to this letter and address its safety significance. Under the provisions of 10 CFR 50.54(f) your response is requested within 30 days of the receipt of this letter. A copy of this letter is being telecopied to you, along with Enclosure 3.

It is my understanding that additional UT inspections are to be performed by General Electric in the near future. We encourage this action as being the only certain means of determining the integrity of turbine discs. We also recommend that if you have not already done so, you develop a schedule for performing a full UT inspection of at least one of your low-pressure turbines during the next major outage of your plant.

THIS DOCUMENT CONTAINS  
POOR QUALITY PAGES

8005300427

This request for generic information was approved by GAO under clearance number B-180225 (S79014); this clearance expires June 30, 1980.

Sincerely,

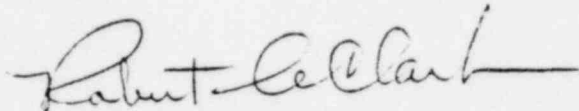
A handwritten signature in cursive script, appearing to read "Robert A. Clark". The signature is written in dark ink and is positioned above the typed name.

Robert A. Clark, Chief  
Operating Reactors Branch #3  
Division of Licensing

Enclosures:

1. Information Bulletin  
79-37
2. Meeting Summary
3. Information Requests

cc: See next page

Mr. Charles Goodwin, Jr.  
Portland General Electric Company

cc: Mr. J. W. Durham, Esquire  
Vice President and Corporate Counsel  
Portland General Electric Company  
121 S.W. Salmon Street  
Portland, Oregon 97204

Robert M. Hunt, Chairman  
Board of County Commissioners  
Columbia County  
St. Helens, Oregon 97501

Warren Hastings, Esquire  
Counsel for Portland General  
Electric Company  
121 S.W. Salmon Street  
Portland, Oregon 97204

Mr. Jack V. Lentsch, Manager  
Generation Licensing and Analysis  
Portland General Electric Company  
121 S.W. Salmon Street  
Portland, Oregon 97204

Columbia County Courthouse  
Law Library, Circuit Court Room  
St. Helens, Oregon 97501

Director, Oregon Department of Energy  
Labor and Industries Building, Room 111  
Salem, Oregon 97310

Richard M. Sandvik, Esquire  
Counsel for Oregon Energy Facility  
Siting Counsel and Oregon Department  
of Energy  
500 Pacific Building  
520 S.W. Yamhill  
Portland, Oregon 97204

Michael Malmros, Resident Inspector  
U. S. Nuclear Regulatory Commission  
Trojan Nuclear Plant  
P. O. Box 0  
Rainier, Oregon 97048

Mr. Donald W. Godard, Supervisor  
Siting and Regulation  
Oregon Department of Energy  
Labor and Industries Building, Room 111  
Salem, Oregon 97310

UNITED STATES  
NUCLEAR REGULATORY COMMISSION  
OFFICE OF INSPECTION AND ENFORCEMENT  
WASHINGTON, D.C. 20555

ISINS NO.: 6870  
Accession No.:  
7910250525

DUPLICATE

December 28, 1979

IE Information Notice No. 79-37

CRACKING IN LOW PRESSURE TURBINE DISCS

Description of Circumstances:

An anonymous letter was received by the Director of the Office of Inspection and Enforcement, on November 17, 1979 which alleged possible violation of Part 10 CFR 50.55e and/or 10 CFR 21 Regulations concerning reportability of recently discovered stress corrosion cracking in Westinghouse 1800 rpm low pressure turbine discs. Westinghouse had made a presentation on the turbine disc cracking to electric utility executives on October 30, 1979.

Telephone discussions between the NRC staff and Westinghouse's Turbine Division on November 20, 1979 established that cracking, attributed to stress corrosion phenomena, had been found in the keyway areas of several LP turbine discs at operating plants and that inservice inspection techniques (i.e., in situ ultrasonic examination) for crack detection have been developed and are being implemented in the field. The Office of Inspection and Enforcement was also notified on November 20, 1979 that during the current overhaul of Commonwealth Edison's Zion Unit 1 LP turbine, ultrasonic examination revealed embedded cracks located on the inlet side on the disc bore area where no cracks had been previously observed. Ultrasonic measurements indicate this disc bore cracking is of greater depth than the keyway cracks found to date. According to Westinghouse, these bore cracks have been metallurgically examined and preliminary findings show them not to be typical of classical stress corrosion cracking observed in the keyways. The probable cracking mechanism and impact on disc integrity is being further evaluated by Westinghouse.

A meeting was held on December 17, 1979 between the NRC staff, Westinghouse and utility representatives to discuss the disc cracking problem, repair alternatives, turbine missile evaluation, inspection techniques and plant inspection priorities. In response to the staff's request, Westinghouse provided the staff an updated report on December 21, 1979 regarding the current field inspection program that included a list of nuclear power plants already inspected, recommended inspection schedules and pertinent information related to LP turbines where cracks have been observed. Inspections to date have identified turbine disc cracks at Surry Unit 2, Point Beach Unit 2, Palisades, Indian Point Unit 3 and Zion Unit 1. All units except Point Beach Unit 2 will make repairs before the plants return to power. Point Beach returned to power on December 23, 1979 with a small crack in the No. 2 disc of LP Turbine No. 2. An analysis by Westinghouse indicated that the observed crack will not attain critical dimensions during 28 additional months of turbine operation. The NRC staff is evaluating the turbine inspection results and analysis by Westinghouse.

File # 7910250525

Westinghouse also notified the staff that extrapolation of information obtained from Indian Point Unit 3 inspection and analysis indicates that disc cracking could be significant at Indian Point Unit 2 and the turbines should be inspected sooner than the spring outage of 1980. The NRC staff is currently reviewing Consolidated Edison's plans for prompt evaluation of this potential problem at this unit.

Enclosure 1 lists the PWR plants having Westinghouse 1500/1800 rpm turbines. The AA category represents those turbines which appear to have the earliest need for inspection. With the exception of Yankee Rowe, Westinghouse has recommended to utilities that inspection of these machines be completed by the Spring 1980 outage period. The Rowe unit is uninspectable by the present ultrasonic techniques due to its design. Westinghouse has recommended the remaining machines of the Category A plants be inspected as their service periods approach five years or in the event significant corrosion problems become evident during this time. The NRC staff is currently reviewing the need for inspection of those PWR plants having other interfacing turbine designs shown in Enclosure 2. Changes to the forementioned inspection schedules proposed by Westinghouse may be necessary as new technical information becomes available.

From the information available to the NRC staff at this time it appears that cracking may be more generically widespread in turbine discs (e.g., keyways and bore areas) than previously observed. It is important to note that the UT inspections performed by Westinghouse thus far were essentially limited to the keyways (disc outlet) of selected discs whereas the Zion Unit 1 inspection results indicate that examination of the disc bore section must be taken into account. Also, Westinghouse is currently re-evaluating their previously estimated turbine missile energies based on recent missile test results from model symmetric and non-symmetric missile impact tests. Their preliminary findings, although subject to change, now indicate possible higher missile exit energies in some cases than previously expected.

This Information Notice is provided as an early notification of a possibly significant matter, the allegations and the generic safety implications of which are currently undergoing review by the NRC staff. It is expected that recipients will review the information applicable to their facilities. If NRC evaluations so indicate, further licensee actions may be requested or required. Embedded cracking in keyways and disc bore areas have been observed only in Westinghouse LP turbines thus far. However, the NRC staff believes that turbines of other manufacturers should be included in consideration of this problem.

No written response to this Information Notice is required. If you have any questions regarding this matter, please contact the Director of the appropriate NRC Regional Office.

Enclosures: As stated

Enclosure 1

CATEGORY AA

<u>UTILITY</u>	<u>STATION</u>	<u>UNIT</u>
Florida, P&L	Turkey Point	3
Consolidated ED.	Indian Point	2
PASNY	Indian Point	3
Arkansas P&L	Russellville	1
VEPCO	Surry	1
Carolina P&L	Robinson	2
So. Calif. Ed.	San Onofre	1
Yankee A.P.	Rowe	1
Wisc. Mich. Pwr.	Point Beach	1
Consumers Pwr.	Palisades	1
Commonwealth Ed.	Zion 1	1
Commonwealth Ed.	Zion 2	2
Florida P&L	Turkey Point	4
Nebraska PPD	Cooper	1
Wisc. Mich. Pwr.	Point Beach	2
Maine Yankee	Bailey Point	1
Rochester G&E	Ginna	1
Northern States	Prairie Island	1
Wisc. P.S.	Kewaunee	1

<u>CATEGORY A</u>		
<u>UTILITY</u>	<u>STATION</u>	<u>UNIT</u>
Alabama Power	Farley	1
Alabama Power	Farley	2
Baltimore G&L	Calvert Cliffs	2
Carolina P&L	Harris	1
Carolina P&L	Harris	2
Carolina P&L	Harris	3
Carolina P&L	Harris	4
Cincinnati G&E	Zimmer	1
Commonwealth Ed.	Byron	1
Commonwealth Ed.	Byron	2
Commonwealth Ed.	Braidwood	1
Commonwealth Ed.	Braidwood	2
Connecticut Yankee	Haddam Neck	1
Duke Power	McGuire	1
Duke Power	McGuire	2
Duquesne Lt.	Shippingport	1
Duquesne Lt.	Beaver Valley	1
Duquesne Lt.	Beaver Valley	2
Florida Power Corp.	Crystal River	3
Florida Power & Lt.	St. Lucie	1
Florida Power & Lt.	St. Lucie	2
Houston L&P	So. Texas	1
Houston L&P	So. Texas	2
Louisiana P&L	Waterford	3
Metropolitan Ed.	Three Mile Island	2
Northern States Pwr.	Prairie Island	2
Pub. Service E&G	Salem	1
Pub. Service E&G	Salem	2
Pacific G&E	Diablo Canyon	1
Pacific G&E	Diablo Canyon	2

CATEGORY A

<u>UTILITY</u>	<u>STATION</u>	<u>UNIT</u>
P.S. Indiana	Marble Hill	1
P.S. Indiana	Marble Hill	2
Puget Sound P&L	Skagit	1
SMUD.	Rancho Seco	1
TVA	Sequoyah	1
TVA	Sequoyah	2
TVA	Watts Bar	1
TVA	Watts Bar	2
VEPCO	North Anna	1
VEPCO	North Anna	2
VEPCO	North Anna	3
VEPCO	North Anna	4
VEPCO	North Anna	2
WPPSS	Hanford	2
WPPSS	WNPS	1
WPPSS	WNPS	3
WPPSS	WNPS	4
WPPSS	WNPS	5



## Enclosure 2

<u>UTILITY</u>	<u>STATION</u>	<u>UNIT</u>
Duke Power Co.	Oconee	1
Duke Power Co.	Oconee	2
Duke Power Co.	Oconee	3
OPPD	Ft. Calhoun	1
Baltimore Electric & Gas	Calvert Cliffs	1
Metropolitan Edison	Three Mile Island	1
Indiana & Michigan Electric	D.C. Cook	1
Indiana & Michigan Electric	D.C. Cook	2
Northeast Utilities	Millstone	2
Portland General Electric	Trojan	1
Toledo Edison	Davis Besse	1
Arkansas Power & Light	Arkansas Nuclear One	2
WPPSS	Hanford	1

Errata Sheet For  
IE Information Notice No. 79-37

Page 1, paragraph 2, line 9: Change "inlet" to "outlet"

Page 1, paragraph 3, lines 9 and 10: Change "Point Beach Unit 2" to  
"Point Beach Unit 1"

Page 1, paragraph 3, line 10: After Point Beach Unit 1 add an asterisk  
(\*") footnote and place a note at the bottom of the page as follows:  
"Wisconsin Electric Power Company orally notified the NRC project  
manager on November 5 that turbine disc cracking had been observed at  
Point Beach Unit 1."

Enclosure 1, line 4: Change "Russellville" to "ANO"

Enclosure 1, line 8: Change to read: "Yankee Atomic Electric, Yankee Rowe"

Enclosure 1, lines 9 and 15: Change "Wisc Mich Pwr" to "Wisc Elec Pwr"

Enclosure 1, line 16: Change to read "Maine Yankee Atomic Pwr, Maine Yankee"

Enclosure 1, page 3, line 13: Delete as redundant reference to North  
Anna 2

Dupe of 8003240560



UNITED STATES  
NUCLEAR REGULATORY COMMISSION  
WASHINGTON, D. C. 20555

FEBRUARY 21 1980

MEMORANDUM FOR: A. Schwencer, Chief  
Operating Reactors Branch #1, DOR

FROM: W. J. Ross, Project Manager  
Operating Reactors Branch #1, DOR

SUBJECT: MEETING WITH GENERAL ELECTRIC RELATED TO TURBINE DISC  
CRACKS

At the staff's request, representatives of General Electric met with the staff and licensee/user of G.E. turbines on January 9, 1980 to discuss the design of and operational experience of low pressure turbines. A list of attendees at the non-proprietary and proprietary sessions is attached.

In the non-proprietary session General Electric's personnel discussed the following topics: (a) turbine wheel (disc) integrity; (b) minimizing wheel (discs) bursts. Copies of the slides used in this presentation are attached in Enclosure 3.

Turbine Wheel Integrity

There has been no indication of cracks in the bore regions of G.E. low pressure turbine wheels. This experience includes the operation of 35 turbines at nuclear generating plants (22 BWRs-of which only three have actually been inspected) and 4000 wheels at 235 fossil units (percent of wheels inspected was not established at the meeting). A G.E. turbine has the following design characteristics:

- (1) 14 wheels or discs per rotor with 38" or 43" active length buckets or blades.
- (2) Rectangular axial keyway and circumferential locking ring minimize rotation of wheels on the turbine shaft (i.e. minimize stress).
- (3) Feedwater systems on nuclear plants are provided with full-flow demineralizer, (experience with fossil plants has been good even with poor water chemistry).

General Electric referenced a 1973 memorandum that postulated the probabilities of turbine missiles as follows:

*Dupe of 8005230770*

P ( $\leq 127\%$ normal turbine speed)	= $2.6 \times 10^{-7}$
P (runaway)	= $1.5 \times 10^{-7}$
P (lifetime total)	= $4.1 \times 10^{-7}$
P (annual average)	= $1.4 \times 10^{-8}$

General Electric continues to recommend that its users perform UT inspections of wheel bores at 6-year intervals. A satisfactory UT test has been developed for this purpose. To date the three UT tests that have been performed were on nuclear turbines that had averaged about 3 years of operating experience.

#### Minimizing Wheel Bursts

A brief review of actions taken by G.E. to eliminate the formation of cracks in turbine wheels was presented and included the following:

- 1) Forging process designed to eliminate internal cracks.
- 2) New wheels are inspected by visual, UT and magnetic particle techniques.
- 3) New wheels are tested at 120% operating speed.
- 4) Tolerance of defects caused by stress and corrosion maximized through choice of material.
- 5) Provision for UT testing of wheels after installation and use.

General Electric's personnel provided the following responses to questions from the audience.

1. Retention of a 6-year interval for inspection of turbines was justified by operating experience and crack growth rate studies.
2. Three G.E. turbines at nuclear plants (1 BWR and 2 PWR) have been inspected by UT and no indications observed. These turbines had seen about 3 years of service.
3. All wheels on turbines at nuclear sites are inspectable in sites (without removal from the turbine). Approximately 5 days are required to inspect one 14-wheel rotor. Four additional days would be needed to complete the inspection of a second rotor at the same site.
4. The length of a crack is postulated by G.E. to be 4 to 5 times the depth determined by UT.
5. Overspeed devices on G.E. turbines are testable under load and retain their protective capability during the test.

6. The G.E. representatives were not aware of any customer experience where overspeed emergency systems have ever been used.
7. Minimum defect size observable by UT as practiced by G.E. is as small as 30 mils in new wheels.
8. G.E. has little data related to chemical analysis of deposits in cracks because few have been observed. Chloride has been observed in pin cracks.
9. Comparisons of stress corrosion cracking between turbine discs (3.5% Ni Cr Mo V) and in 304 ss pipe are not appropriate because they have different fluids (water and steam) and different materials.
10. G.E.'s wheel keyways are not shielded from steam-flow chemicals (Westinghouse is considering such protection)
11. Thermal and vibrational stresses on turbine wheels are considered to be very small in comparison to design capability.
12. G.E. does not presently have specific teams of inspectors mobilized for inspecting turbines.

*William J. Ross*

William J. Ross, Project Manager  
Operating Reactors Branch #1  
Division Of Operating Reactors

Attachments:

Attendees  
Slides used in G.E. presentation

ATTENDEES

NRC

W. J. Ross  
R. E. Johnson  
M. L. Boyle  
A. Taboada  
J. J. Zudans  
W. P. Gammill  
K. G. Hoge  
T. Ippolito  
W. J. Collins  
E. G. Arndt  
I. A. Peltier  
K. M. Campe  
F. Clemenson  
C. D. Seller  
M. Wohl  
R. W. Klecker  
K. R. Wichman  
W. S. Hazelton  
V. Noonan

GENERAL ELECTRIC

R. S. Couchman  
D. P. Timo  
J. J. Hinchey  
W. J. Kaehler  
H. T. Watanase  
R. D. Brugge

ATTENDEES CONT'D

<u>NAME</u>	<u>UTILITY</u>
Paul Nastick	Bechtel Power Corporation
C. W. Hultman	NUPPS
J. E. McEwen	Portland General Electric
John Coombe	Stone and Webster
Richard G. Kriftner	American Electric Power
Paul H. Barton	Duke Power Company
Craig F. Nierode	Northern States Power Company
Otakar Jones	Westinghouse
James B. Lewis	Consumers Power Company
Robert L. Smith	Yankee Atomic Electric Company
Jim Knuber	Jersey Central Power and Light Company
Larry A. Johnson	Tennessee Valley Authority
Norman H. Gaffin	Philadelphia Electric Company
Martin J. McCormick, Jr.	Philadelphia Electric Company
L. Erik Titland	Baltimore Gas and Electric Company
Ronald O'Hara	Baltimore Gas and Electric Company
R. Niall M. Hunt	Baltimore Gas and Electric Company
R. G. Clisham	Baltimore Gas and Electric Company
S. F. Binderup	Omaha Public Power District
C. C. Seitz	Metropolitan Edison Company
P. K. Colvert	Commonwealth Edison Company
R. J. Tamminga	Commonwealth Edison Company
W. G. Clark, Jr.	Westinghouse
R. E. Warner	Westinghouse
V. S. Anderson	Westinghouse
B. B. Seth	Westinghouse
J. F. Etzweiler	American Electric Power

NUCLEAR STEAM TURBINE WHEEL RELIABILITY



## INTRODUCTION

This paper deals with shrunk-on bucket wheels used in steam turbines manufactured by the Large Steam Turbine-Generator Department of General Electric for use with nuclear reactor cycles. In particular, General Electric's efforts aimed at avoiding a wheel burst as the result of stress corrosion cracking are described. These efforts include steam purity recommendations, the use of optimum design, material selection and acceptance practices, and the introduction of a computerized in-service wheel bore ultrasonic test. In February, 1978, TIL-857 was issued outlining recommended in-service inspection practices for nuclear steam turbine rotors manufactured by General Electric. Recommendations include a complete ultrasonic examination of the shrunk-on wheel bores at about 6-year intervals.

## OVERVIEW

There are two possible mechanisms for initiating and/or growing cracks in nuclear wheels in service:

1. Stress Cycling
2. Stress Corrosion Cracking

The likelihood of initiating and/or growing a crack due to stress cycling associated with starts, stops, or load changes is small. Variations in stress amplitude resulting from operating transients are too low to produce significant crack growth, in the unlikely event that a defect exists in the wheel when it is placed in-service. The manner in which wheels are forged essentially precludes the possibility of producing an internal crack-like defect in the plane normal to the maximum stress (the axial-radial plane). Furthermore, in addition to a complete visual and magnetic particle inspection of all bore and external surfaces, all modern nuclear wheel forgings are subjected to a stringent 100% volumetric ultrasonic inspection at the time of manufacture. All nuclear wheels are spin tested during manufacture at 20% overspeed (although on some early units a few wheels without buckets attached), which further minimizes the probability of having an undetected crack or crack-like flaw with a critical size which would lead to spontaneous propagation at normal rotating speeds.

Thus, the major source of concern with respect to the in-service initiation and growth of cracks is that associated with stress corrosion. Although we have not observed stress corrosion (or other) cracking in the bores of any of our fossil or nuclear wheels made of modern materials, the possibility of initiation and propagation of a stress corrosion crack at the bore of a shrunk-on wheel cannot be entirely discounted. We and other turbine manufacturers have experienced stress corrosion cracks in the wheel dovetail region of integral rotors made of essentially the same material as that used in nuclear LP wheels. Recently, stress corrosion cracks were detected on the periphery of two modern GE shrunk-on wheels, operating in a fossil plant, which had been exposed to heavy caustic deposits. In addition, machines of both domestic and foreign design (not GE) have suffered cracks in the bore region of shrunk-on wheels, leading to wheel bursts in several cases.

A considerable number of steps have been taken to reduce the probability of a wheel burst due to stress corrosion cracking. Laboratory tests and service experience have indicated that consistent high levels of steam purity provides the best protection against stress corrosion cracking. Steam purity recommendations have been published in GEK-72281, attached. Modern wheels manufactured for nuclear

and fossil turbines are made from the highest quality vacuum poured NiCrMoV forgings which are heat treated to obtain an optimum combination of strength, ductility and toughness. Each forging must pass a stringent material acceptance procedure before being considered for use as a wheel. The procedure includes the non-destructive inspections previously discussed, along with laboratory tests to verify that material properties fall within specifications. Wheel geometries have been chosen to maintain the lowest level of operating stress.

Although a considerable effort has been made to maintain superior fracture toughness properties, and to minimize the likelihood for stress corrosion cracking, laboratory and field experiences indicate that the possibility for a wheel burst due to stress corrosion cracking cannot be discounted. For modern GE design nuclear shrunk-on wheels, the material crack size in the rim region which would lead to a wheel burst is very large, approaching the axial thickness of the wheels. Thus, such cracks, should they exist, would have a high probability of detection by surface inspections. This is not the case in the bore region where, because of higher stress levels, a crack could grow to a dangerous size prior to breaking through to an accessible surface. For this reason, G.E. has developed an ultrasonic test which searches for cracks at the wheel bore and keyway surfaces, along with material in the vicinity of the bore.

TIL-857, which was issued in February, 1978, outlines our recommendations for periodic inspection of General Electric steam turbine rotors operating in nuclear power plants. As described in TIL-857, we recommend that a complete magnetic particle inspection of the shrunk-on wheels should be performed during any outage when the turbine section is open. In addition, we recommend a more extensive test at about 6 year intervals, which should include an ultrasonic inspection of the shrunk-on wheels using the wheel bore ultrasonic test mentioned above.

A great amount of development work on stress corrosion cracking has been conducted, and our understanding of this phenomenon is much improved, although still inadequate to predict the precise time required for crack initiation and the rate of crack growth in a corrosive environment. It is therefore impossible to specify absolute "safe" inspection intervals to preclude the possibility of initiating and growing a crack to critical size between inspections. Recognizing this, we nevertheless believe that periodic inspections, as described in TIL-857, will greatly reduce the probability of a wheel burst.

The remainder of this report describes in greater detail the service experience of G.E. wheels in nuclear and fossil plants, along with the steps which have been taken to understand and reduce the chances for a wheel burst. Also included is a description of the wheel bore ultrasonic test, and the experimental program which helped to develop and verify the test capabilities.

#### SERVICE EXPERIENCE

At the present time, 42 (35 domestic) large steam turbine-generator units manufactured by G.E. are operating in nuclear power plants. The 1579 shrunk-on wheels in these units have accumulated over 9,000 wheel years of service without having experienced a failure. To date, 46 of these wheels have received an in-service wheel bore ultrasonic inspection with the result that no crack like indications have been found.

Of the large steam turbine generators operating in fossil plants, 235 G.E. units have shrunk-on wheels. This accounts for over 4000 wheels which have accumulated over 130,000 wheel years of service. To date, only one wheel failure has been experienced, and this occurred on a multiple stage Curtis design wheel which was made from an 1850°F austenitized CrMoV material. The wheel had been in-service for roughly 30 years and was scheduled for replacement. Metallurgical analysis of the fracture showed that cracks, probably caused by creep-rupture, initiated in pin bushing holes which extend radially from the bore surface. Unlike nuclear shrunk-on wheels which are used strictly in low temperature applications, this wheel operated at temperatures on the order of 900°F. The wheel fragments did not penetrate the turbine casing.

Fourteen shrunk-on wheels from two GE units, not manufactured from a modern NiCrMoV material, experienced stress corrosion cracking early in the 1950's. The cracks, which initiated in pin bushing holes, were detected within several years after the units went into service. (Nuclear wheels do not have pin-bushing holes.) An investigation revealed that a heavy build-up of deposits had formed on the turbine as a result of a large percentage of make-up water. To remove these deposits, the customer washed the turbine with a mild caustic solution. Caustic leaked into the pin holes, and concentrated during continued operation-resulting in the formation of stress corrosion cracks. The wheels were replaced and the units placed back into service.

Since this time, a total of 260 fossil wheels from 19 G.E. large steam turbines have received a full inspection. 166 of which were disassembled from the shafts while 94 have been inspected with the wheel bore ultrasonic test. Wheel disassembly was largely performed in conjunction with TIL-647, which called for unstacking particular built-up rotors to improve shaft and wheel geometry. While unstacked, the wheels were given a complete magnetic particle inspection of bore and peripheral surfaces. No cracks were found in these wheels. The wheel bore ultrasonic inspections performed to date on fossil wheels, resulted either from customer requests or from G.E. recommendations as the result of known steam chemistry upsets. No crack-like indications have been detected in bore or keyway regions. Recently, a magnetic particle examination revealed stress corrosion cracks on the periphery of two wheels operating in a fossil unit. This unit was found to have heavy deposits throughout, the chemical analysis of which revealed that they were largely formed by caustic deposition. Stress corrosion cracks were found on the wheels and at other locations in the high pressure and low pressure sections. Cracks on the wheel peripheries were found to be shallow. The ultrasonic inspection of the wheel bores and keyways revealed no indications, implying that if cracks existed, they were shallow.

Experience of other manufacturers with wheel stress corrosion cracking in nuclear units has received considerable attention in recent years. Perhaps the best documented is the British experience at the Hinkley Point A nuclear power station. In September, 1969, turbine generator No. 5 suffered a catastrophic wheel burst, which studies found to be the result of stress corrosion cracks reaching a critical size in the wheel keyway<sup>1,2</sup>. A detailed follow-up study by the CEGB revealed stress corrosion cracks in a considerable number of wheels having semi-circular keyways. The 3 CrMoV material used in many of these wheels was found to be temper embrittled and highly susceptible to stress corrosion cracking.

Bursts of large steam turbine wheels manufactured by other suppliers and operating in the United States are known to have occurred in fossil plants. Recent investigations have also revealed stress corrosion cracking in some nuclear steam turbine wheels.

#### LABORATORY PROGRAM

An extensive laboratory program has been underway to better quantify the resistance of wheel materials to stress corrosion cracking. The program has concentrated on relating mechanical, material and electrochemical parameters to the processes of crack initiation and growth. Most of the work to date has focused on caustic cracking, although other environments have been studied, including high purity water. Caustic appears to represent the greatest threat to G.E. wheels operating in nuclear and fossil power plants.

A considerable number of testing procedures have been utilized to investigate the resistance of NiCrMoV steels to stress corrosion cracking. Figure 1 shows results from dead weight load tests performed in caustic solutions under various conditions. Figure 2 illustrates the test apparatus with the environmental container removed so the smooth tensile type specimens can be observed. Scanning electron micrographs of a wheel material tested to failure in caustic are shown in Figure 3.

Quantitative measurements of the stress corrosion crack propagation rate in wheel alloys have been made using fracture mechanics type specimens (Figure 4). Generally, stress corrosion crack growth rates are depicted by plots of the type shown in Figure 5. The crack propagation rate is plotted versus the crack tip stress intensity factor, which is a function of the applied stress, the crack size and the geometry. A family of such curves are necessary to describe the variation of crack propagation rate with corrosion potential, temperature and caustic concentration.

Of particular interest are the threshold stress intensity ( $K_{th}$ ), the plateau or second stage, and the third stage of crack growth. The threshold stress intensity is the limit below which stress corrosion cracks will not propagate. The plateau or second stage is the region of relatively stable crack growth, over a range of stress intensity. Crack growth in region 3 is sharply accelerated as the crack tip stress intensity increases. Testing in the laboratory under controlled conditions has indicated that the threshold stress intensity in caustic is low, and in fact may be virtually non-existent. Figure 6 shows the typical range of stage 2 crack propagation rates versus temperature measured on wheel materials in 40% NaOH and maintained near the optimum corrosion potential to accelerate crack growth.

Corrosion potential has been found to be one of the most important parameters influencing the resistance of NiCrMoV wheel materials to caustic stress corrosion cracking. In the laboratory, corrosion potential can be controlled, thus providing a convenient means to run accelerated stress corrosion tests. Varying the potential from optimum, however, significantly reduces stress corrosion susceptibility. When uncontrolled, the free corrosion potential in caustic generally lies outside the range of maximum severity, except under transient conditions. Additional electrochemical studies have shown however that trace quantities of certain compounds, such as PbO, CuO and NaNO<sub>3</sub>, can influence the corrosion potential. It is possible that a critical quantity of trace compounds, if present in caustic deposits, will shift the potential towards an undesirable

region. Thus, this is a possible mechanism for explaining why fossil steam turbines, with caustic deposits, have not in all cases experienced stress corrosion cracking.

Tests have been performed to evaluate the potential for stress corrosion crack propagation in high purity water. Such an environment is reasonably typical of condensate in the wet stages of steam turbines operating in plants with BWR reactors. The tests have shown that although stress corrosion cracks can propagate in this environment, maximum rates of propagation have generally been lower, by a factor of 100 to 1000, than the maximum rates in 40% caustic. Similar results have been published by the British, who tested NiCrMoV materials both in water and "high quality" power plant steam.

#### GENERAL CONCLUSIONS

Based on laboratory test results and service experience, some general conclusions have been reached with regard to the potential for stress corrosion cracking in shrunk-on wheels.

1. Concentrated deposits, such as caustic, represent a significant threat to steam turbine components because of the possibility of developing stress corrosion cracks. The likelihood of cracks caused by caustic deposition is dependent on the corrosion potential, the temperature, the caustic concentration, the operating stress level, and the materials, and physical characteristics. Corrosion potential can be influenced by the presence of trace impurity compounds.
2. Stress corrosion resistance generally decreases as the material tensile strength increases.
3. There is considerable heat to heat scatter in resistance to stress corrosion cracking within a given material specification.
4. Modern large steam turbines require materials which cannot be made completely immune to stress corrosion cracking. Proper control of water chemistry remains the best way to guard against stress corrosion cracking.
5. Some stress corrosion cracking has been observed in NiCrMoV laboratory specimens exposed to pure water and wet steam environments. Maximum crack growth rates measured in these environments, however, are significantly less than those measured in more corrosive environments such as caustic. To date, G.E. service experience on steam turbine components manufactured from materials typical of modern wheel alloys has never linked stress corrosion cracking to pure steam or pure steam condensate. In all cases, stress corrosion cracks in these materials have been associated with concentrated caustic deposits. We believe, however, that at higher tensile strengths and/or at stress levels beyond those currently found in G.E. wheels, a significantly greater potential for stress corrosion cracking in relatively non-aggressive environments does exist.
6. Locally aggressive environments may develop in surface pits or in regions of the turbine where steam flow is restricted. Wheel keyways are regions where this can potentially occur.
7. In a contaminated steam environment cracks can grow by a stress corrosion mechanism, to critical size.

## STEAM PURITY

The need for good control of water chemistry in nuclear, as well as fossil fired steam turbine power plants, is generally recognized and the concentration of impurities in such systems is generally held to very low levels. Due to effective concentrating mechanisms operative in steam turbines, low levels of impurities can be transformed into concentrated solutions, however. There are three major concentrating mechanisms operative in a turbine, and they are briefly described below. Some of these mechanisms may be operative to a greater extent in PWR plants than in BWR plants.

### 1. Deposition from Superheated Steam

As steam expands through the turbine, the solubility of impurities in the steam decreases. Deposits form in the turbine when the concentration of impurities exceeds their solubility limit. The impurity concentration in a deposit can be far greater than its concentration in the steam. Concentrated caustic and chloride solutions are typical of deposits which can form by deposition from superheated steam. Deposits of this type form upstream of the Wilson line.

### 2. Acid Concentration at the Wilson Line

Turbine steam may also be contaminated with organic or inorganic acids. Unlike the situation for caustic and chloride described above, acids are very soluble in superheated steam and do not exceed their solubility. At the Wilson line, however, these acids become enriched in the first drops of water that are formed. This results in a situation in which low levels of acid in the steam can result in a concentrated acid solution at the early moisture region.

### 3. Evaporation and Drying

Another concentrating mechanism which occurs in steam turbines is the formation of concentrating solutions by the evaporation of water from dilute solutions. For example, during a cold start-up steam will condense on metallic surfaces which are at a lower temperature than the steam temperature. As the metallic part heats up, the moisture evaporates and practically all of the impurities are left. This concentrating mechanism is not a significant problem for parts with exposed surfaces because the impurities will be redissolved by the large volume of steam flow during operation. In stagnant areas, however, like the spaces between buckets and wheels or in the crevices between wheels and a shaft-) the solutions can concentrate and remain for long periods during operation.

Some of the incidents that can result in contamination of nuclear turbines are:

1. Use of cleaning fluids with unacceptable levels of caustic, chloride and sulfur for removing protective materials used during shipment.
2. Cleaning solutions used to remove deposits from the turbine or associated components.
3. Contaminated exhaust hood sprays used to control temperature in the low-pressure hoods during low load operation.

4. Improper operation and/or regeneration of feedwater demineralizers.
5. Contamination from condenser cooling water source because of condenser tube failures.

Stress corrosion cracking has been found in fossil steam turbine components from each of these causes but not generally where shrink on wheels has been effected. GEK-72281 outlines General Electric steam purity recommendations as applicable to the turbine-generator unit. Other requirements may be applicable to maintenance of auxiliary components such as reactor components, steam piping, etc.

#### WHEEL DESIGN AND MATERIAL SELECTION

Modern wheels manufactured by G.E. are made from vacuum poured NiCrMoV forgings which are heat treated to obtain the desired strength, ductility and toughness. The chemical composition and strength level of wheel forgings are chosen to best meet the service requirements of the wheel. To optimize stress corrosion resistance, tensile strengths are maintained at the lowest levels sufficient to adequately withstand operating stresses. Optimized material chemistry and processing results in wheel materials having superior toughness properties and thus superior resistance to brittle fracture.

In the bore region of shrunk-on wheels, induced stresses principally result from interference between the wheel and shaft, and the centrifugal forces of the buckets and wheel. Figure 7 shows the variation of tangential bore stress with rotational speed. The total stress, which is the sum of the shrink and centrifugal stresses is reasonably constant up to the speed at which shrink is lost. Centrifugal stresses have been minimized in General Electric wheels by optimizing the wheel shapes and mounting only one row of buckets on each wheel. Reducing centrifugal stresses lowers the magnitude of shaft-to-wheel interference necessary to maintain shrink at normal operating speed. Thermal stresses induced by steady state and transient steam conditions are generally small in comparison with shrink and centrifugal stresses.

In built-up rotors manufactured by G.E. and other manufacturers, shrunk-on wheels are keyed to the turbine shaft. This assures that even if shrink happens to be lost during transient operation, the wheels will not rotate relative to the shaft. Since keyways act as stress concentrators, local stresses in a wheel keyway are higher than nominal bore surface stresses. The magnitude of stress concentration is dependent on the size and shape of the keyway, which differs from manufacturer to manufacturer.

#### ULTRASONIC TEST DESCRIPTION

The wheel bore ultrasonic test searches for radial-axial cracks in the vicinity of the wheel bore and keyway of shrunk-on wheels (Figure 8). Due to the complex wheel geometry, every suitable wheel surface is used to ensure maximum inspection of the wheel bore and keyway. Tests are made from the wheel webs, hubs, and hub faces when accessible as shown in Figure 9, 10, and 11. Twin pitch-catch probes are used from the wheel webs and faces and a single probe technique is used from the wheel hubs. Various beam angles are used to project the ultrasonic beam

to the bore from the test surface in a way designed to detect radial axial defects. By varying the transducer positions in the manner of Figure 12, the axial length of the bore is tested. To obtain maximum coverage, each wheel may receive as many as forty individual scans with twenty in each opposing circumferential direction. On each scan, proper operation is monitored and sensitivity checks are made by measurement of the keyway signal amplitude.

Figure 13 shows a block diagram of the standard test setup. The rotor is rotated slowly within the casing using either the turning gear or an auxiliary turning device. Automated manipulator arms, which are mounted on the horizontal joint, position the transducers at precise locations and angles which have been pre-selected to provide the best assessment of each portion of the bore. If they are available, the test can also be performed with the rotor setup on power rolls. Ultrasonic data is processed by the computer and graphically displayed for operator review. Final results are stored on a magnetic disk for permanent retention.

While developing this procedure, it was found that score marks which are sometimes produced on wheel bores during the rotor assembly may produce disproportionately large ultrasonic indication amplitudes. A means of discriminating these signals from crack signals was obviously required. It was found that different test frequencies produced a more proportionate response to flaw size. Consequently, a dual frequency technique was adopted as shown in Figure 14.

#### DETECTION OF STRESS CORROSION CRACKS

Stress corrosion cracks have historically proved difficult to detect with ultrasonic means. The tightly closed, intergranular cracks are filled with corrodent and corrosion products and usually exhibit poor reflectivity for ultrasound. Although machined discontinuities were used in the early development of the test method, it was recognized that there was a need to establish the detectability on actual stress corrosion cracks of the size being sought.

An extensive program of producing stress corrosion cracks in full size wheels (Figure 15) and large ring specimens (Figure 16) was undertaken to verify the test method. Stresses near yield were generated by shrinking the wheels on to a stub shaft which was heated to further create an additional source of stress. The rings were stressed with a hydraulic jack. A 40% NaOH solution at 100°C was circulated through the wheel and ring keyways to produce stress corrosion cracks. The potential of the solution was controlled to accelerate corrosive attack.

To date, a total of three wheels and two large rings have been artificially cracked. The first wheel was exposed to 40% caustic for approximately one year and later broken open (Figure 17 and 18). Ultrasonic indication amplitudes equal to that of the keyway itself were observed from these cracks as shown in Figure 19 and 20. The deepest crack in this wheel was 1 1/4 inch (32 mm). Numerous smaller cracks with approximately 1/4" (6.4 mm) depth were also present near the axial end of the keyway and were detected from the wheel hub.

Another wheel was exposed with the objective of producing smaller cracks nearer to the detection limit of the ultrasonic test. After eight months of



exposure, ultrasonic tests of the wheel revealed significant cracking (Figure 21). A section containing the keyway was removed and magnetic particle tested (Figure 22) revealing an extensive network of cracks.

Smaller cracks were successfully induced in two ring shaped specimens. Again, the ultrasonic techniques detected these cracks which ranged in depth to a maximum 0.18 inches (4.6 mm) with an average depth of 0.040 inches (1 mm). Figure 23 is a metallographic section showing some of the cracks.

#### DISCUSSION AND SUMMARY

Shrunk-on wheels manufactured by General Electric have established an excellent record of trouble free service. Efforts to minimize operating stresses and optimized material properties undoubtedly contribute to this record. However, laboratory tests and field experience have demonstrated that wheel materials, operating at stress levels found in shrunk-on wheels, could develop stress corrosion cracks in-service. Cracks which might initiate in the bore region could propagate and, if left undetected, could result in a wheel burst. It therefore is prudent to inspect shrunk-on wheels periodically.

General Electric has developed an ultrasonic test, which can be performed with the wheels in place, and can inspect the critical bore and keyway regions. In February, 1978, TIL-857 was issued recommending inspection practices for 1500 and 1800 RPM nuclear turbine rotors. It was, and still is recommended, that a wheel sonic inspection of nuclear shrunk-on wheels should be performed at about six year intervals. This, in conjunction with maintaining steam purity levels, as recommended in GEK-72281, will significantly reduce the probability of a wheel burst.

## Reference

1. D. Kalderon, Steam Turbine Failure at Hinkley Point "A", Proc. Instn. Mech. Engrs., Vol. 186 31/72, 1972.
2. J.L. Gray, Investigation Into the Consequences of the Failure of a Turbine-Generator at Hinkley Point "A" Power Station, Proc. Instn. Mech. Engrs., Vol. 186 32/72, 1972.
3. T.G. McCord, B.W. Bussert, R.M. Curran, G.C. Gould, Stress Corrosion Cracking of Steam Turbine Materials, General Electric Report GER-2883, 1975.
4. F. Ammirato, G.C. Wheeler, Ultrasonic Inspection of In-Service Shrunk-On Turbine Wheels, General Electric Report 79MPL405, 1979.
5. B.W. Bussert, R.M. Curran, and G.C. Gould, The Effect of Water Chemistry on the Reliability of Modern Large Steam Turbines, General Electric Report GER-3086, 1978
6. T. Cowgill and K.E. Robbins, Understanding the Observed Effects of Erosion and Corrosion in Steam Turbines, Power, September, 1976.
7. R.M. Curran, B.R. Seguin, J.F. Quinlan, S. Toney, Stress Corrosion Cracking of Steam Turbine Materials, Southeastern Electric Exchange, Florida, April 21-22, 1969. (Proceedings were not published and reprints are no longer available).

### SCC DATA-LOAD VERSUS TIME TO FAILURE

40%, 212°F-950 mV (Vs. LAZARAN ELECTRODE)  
 28%, 150°F-950 mV (Vs. LAZARAN ELECTRODE)  
 28%, 150°F UNCONTROLLED POTENTIAL

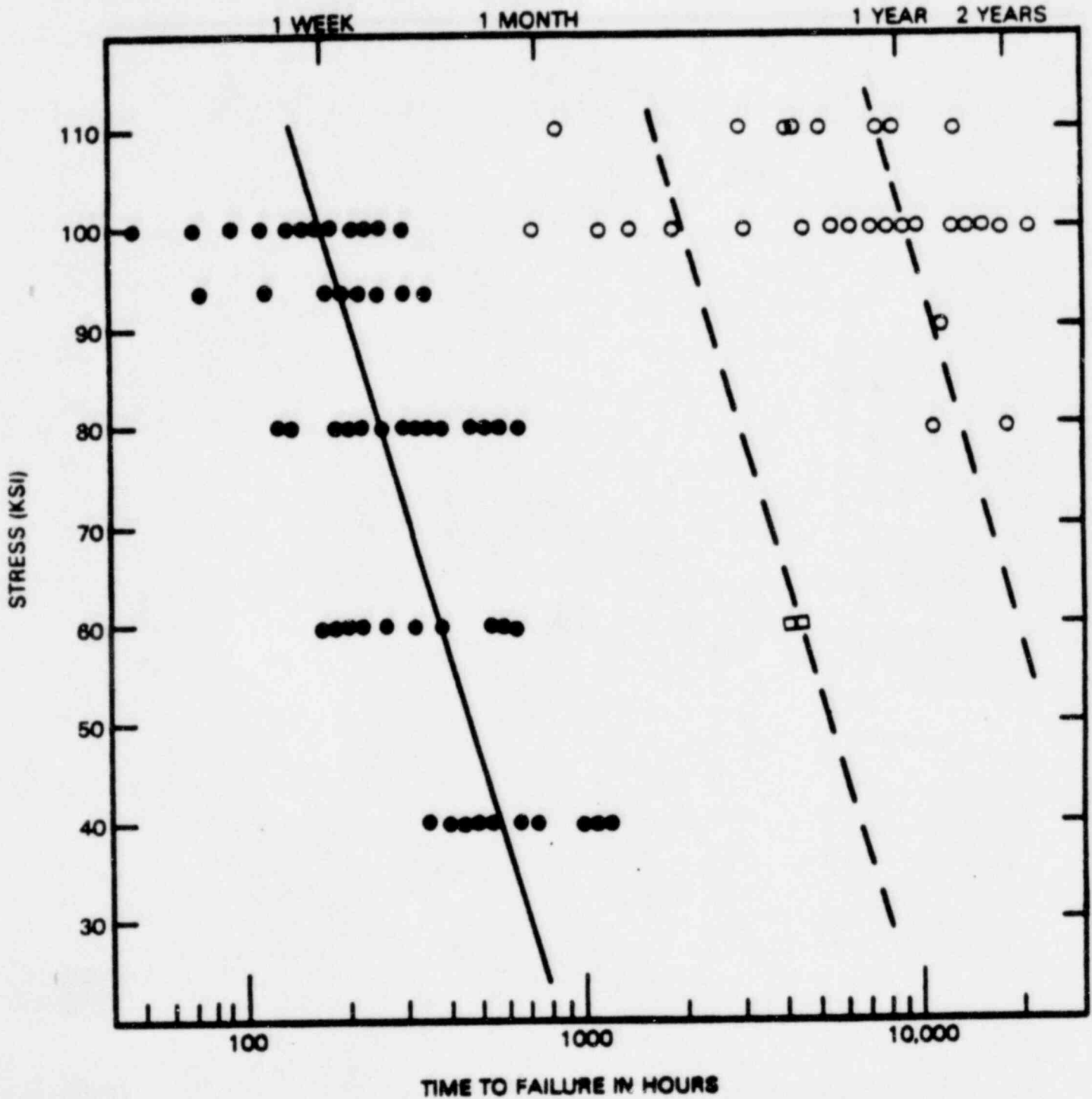

FIGURE 1: TIME TO FAILURE VERSUS APPLIED STRESS FOR WHEEL MATERIALS IN CAUSTIC. THE SOLID LINE IS THE LEAST SQUARES FIT TO THE 212°F, 40% CAUSTIC DATA. THE DOTTED LINES ARE DRAWN PARALLEL TO THE SOLID LINE AND ROUGHLY THROUGH THE MEAN FOR THE OTHER TWO CONDITIONS TO ILLUSTRATE THE EFFECT OF CHANGING CONDITIONS ON TIME TO FAILURE.

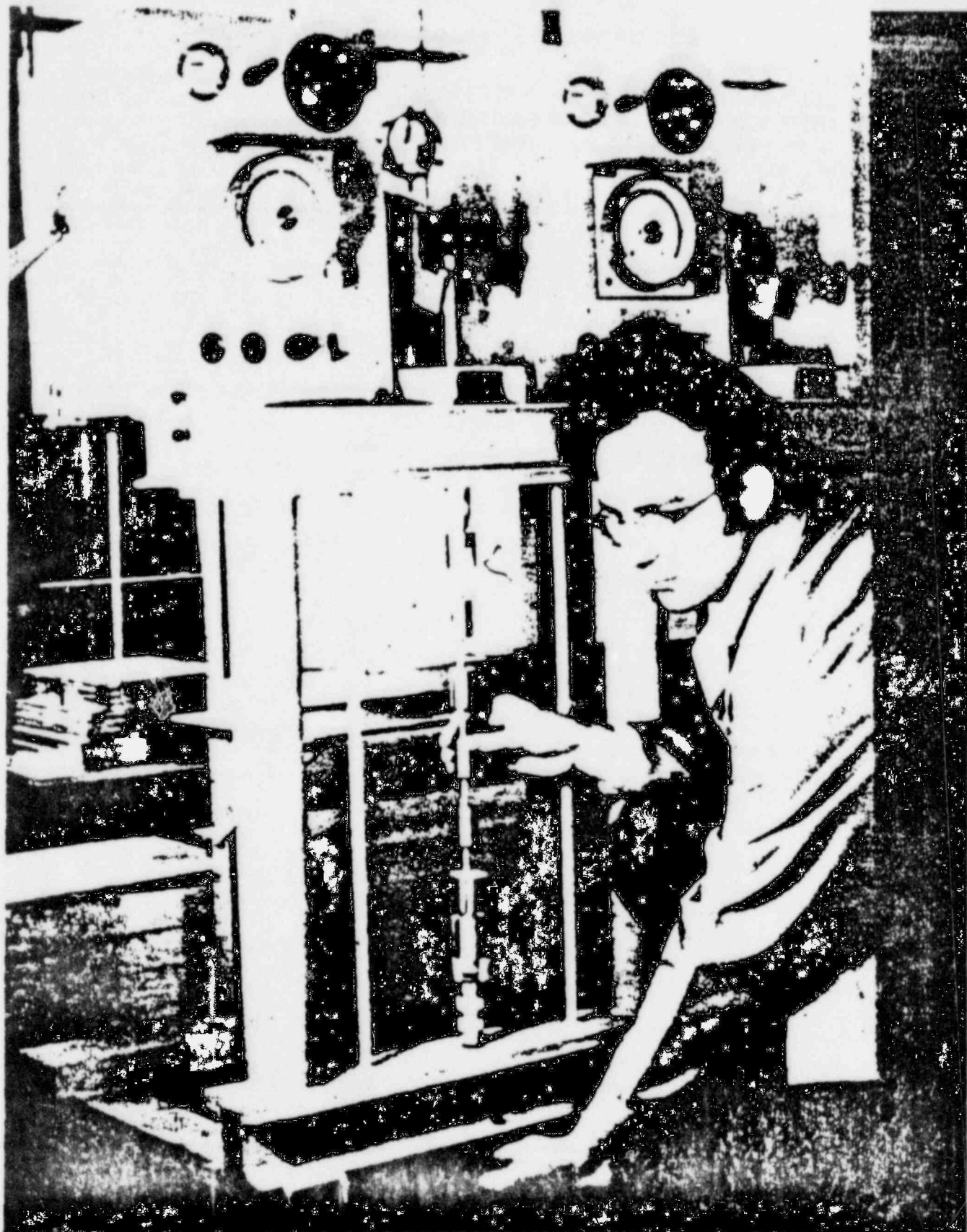
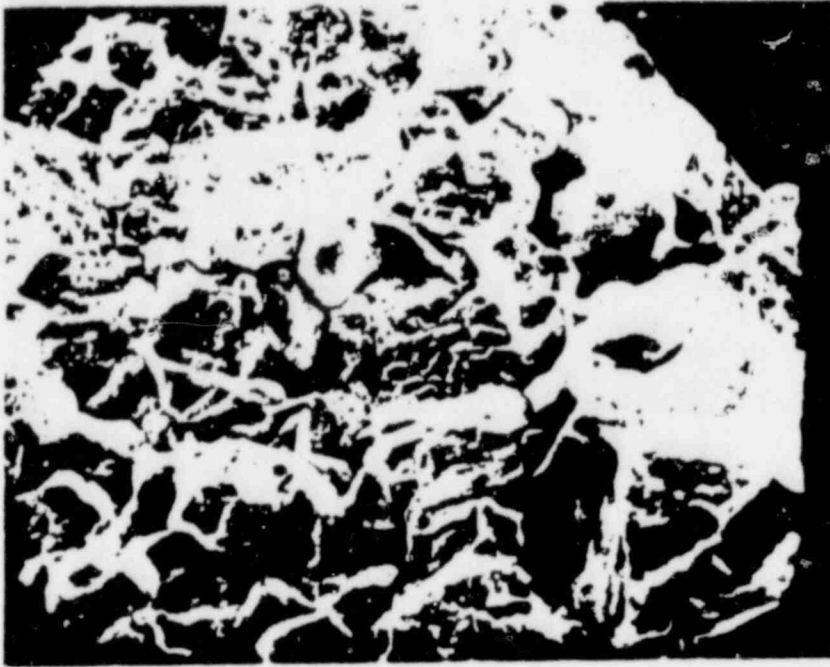
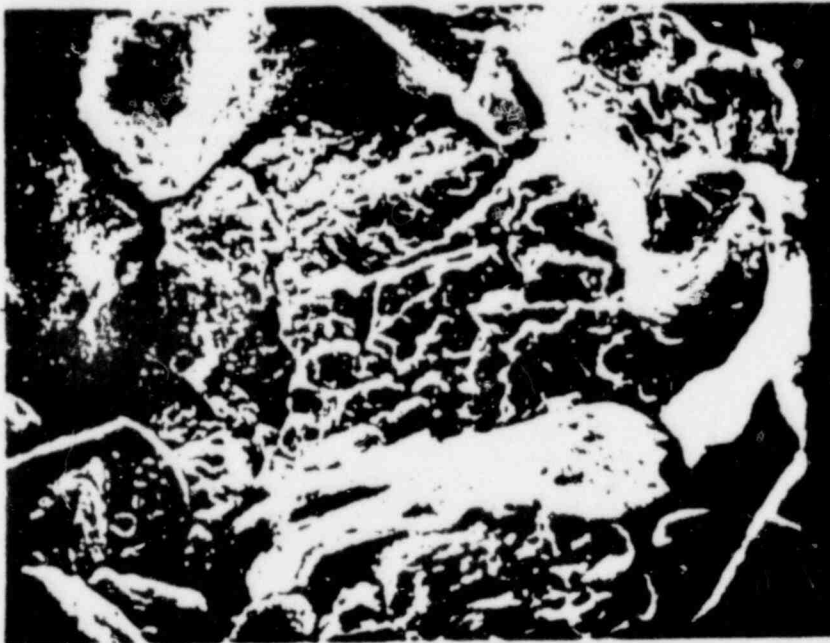

FIGURE 2 : APPARATUS USED FOR UNIAXIAL DEAD WEIGHT LOAD TESTING

## STRESS CORROSION FAILURE



(a) 200X



(b) 500X

Figure 3: Scanning electron micrographs of NiCrMoV sample. Micrograph (a) shows intergranular SCC near edge. Micrograph (b) shows transgranular tear at center of micrograph (a).

CRACK GROWTH SPECIMENS

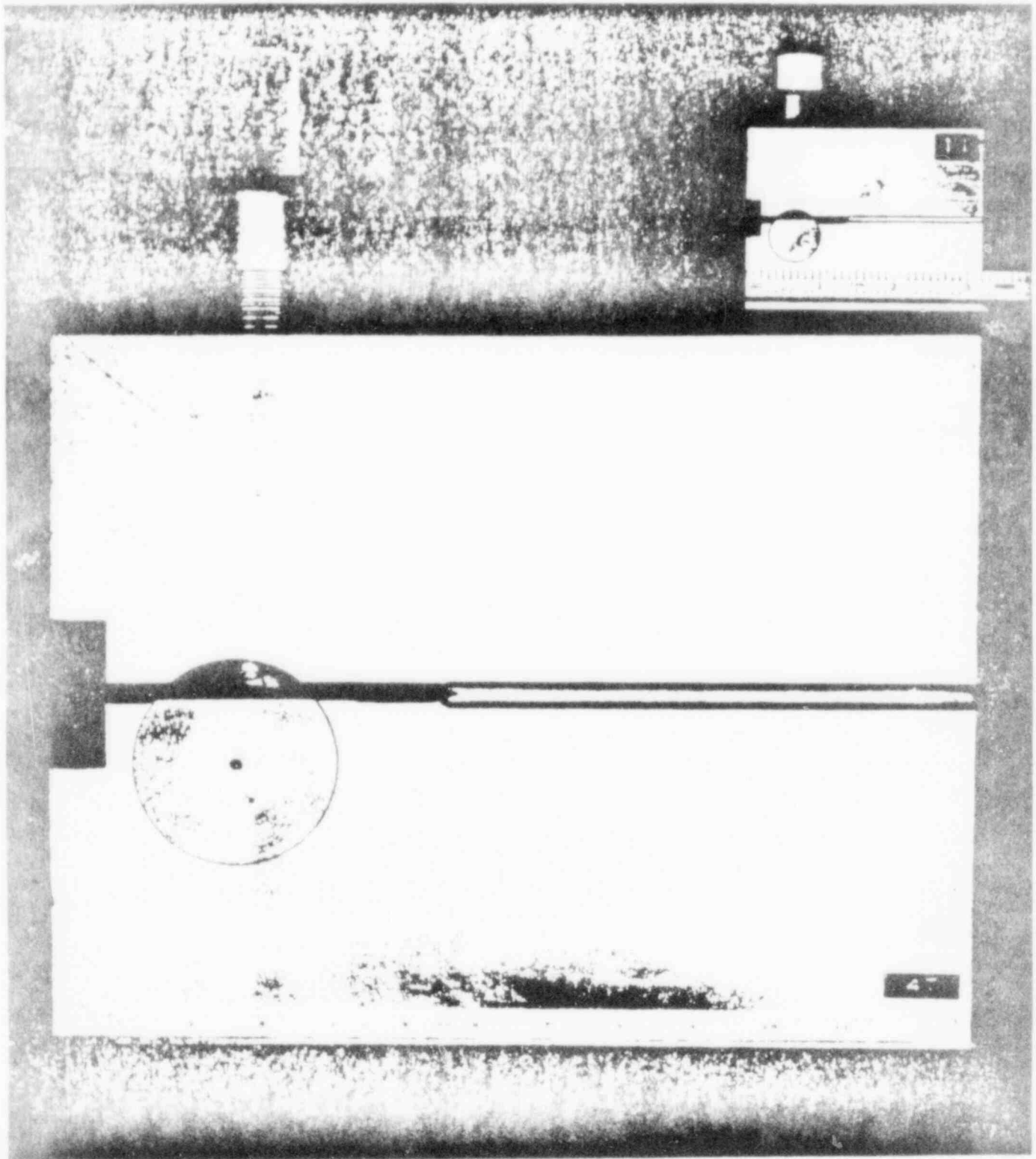

FIGURE 4 1T AND 4T MODIFIED WOL STRESS CORROSION CRACKING SPECIMEN

### STRESS CORROSION CRACK GROWTH CURVE

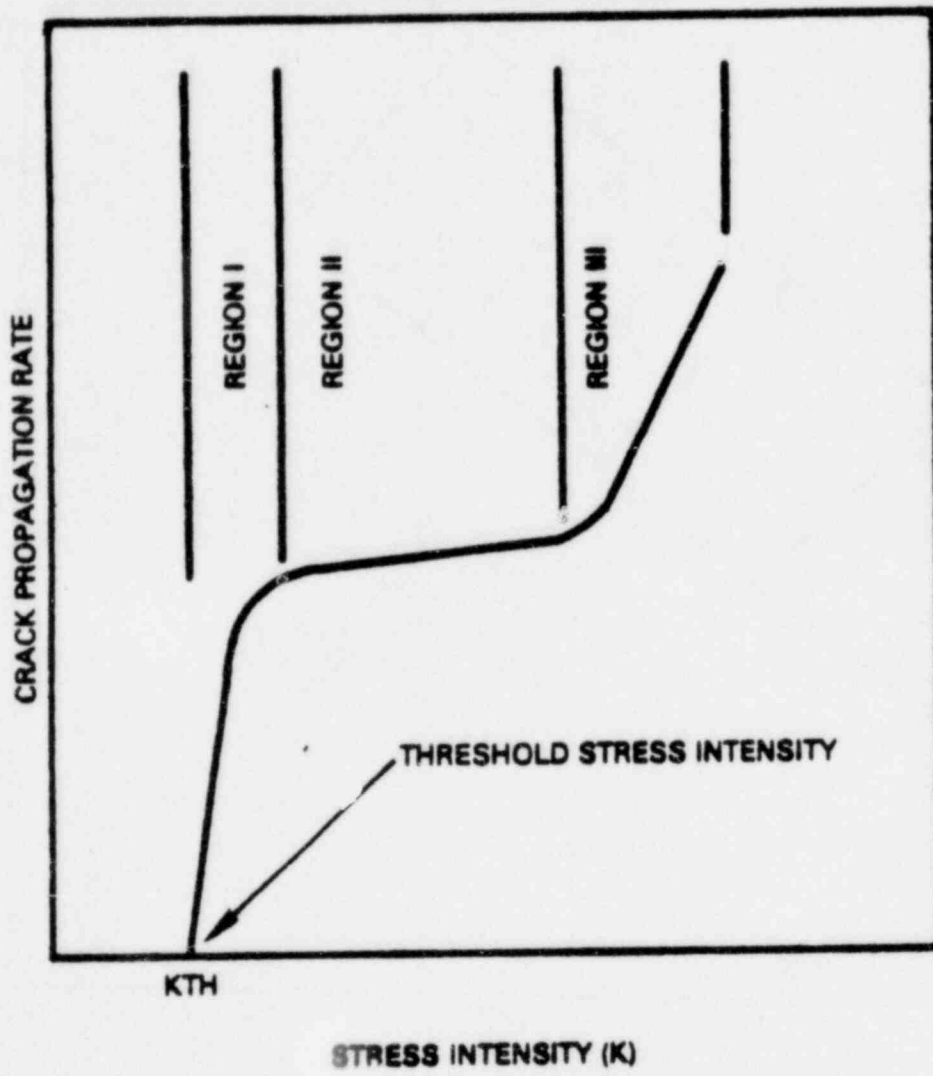

FIGURE 5: STRESS CORROSION CRACK GROWTH CURVE

# CRACK GROWTH RATE IN CAUSTIC

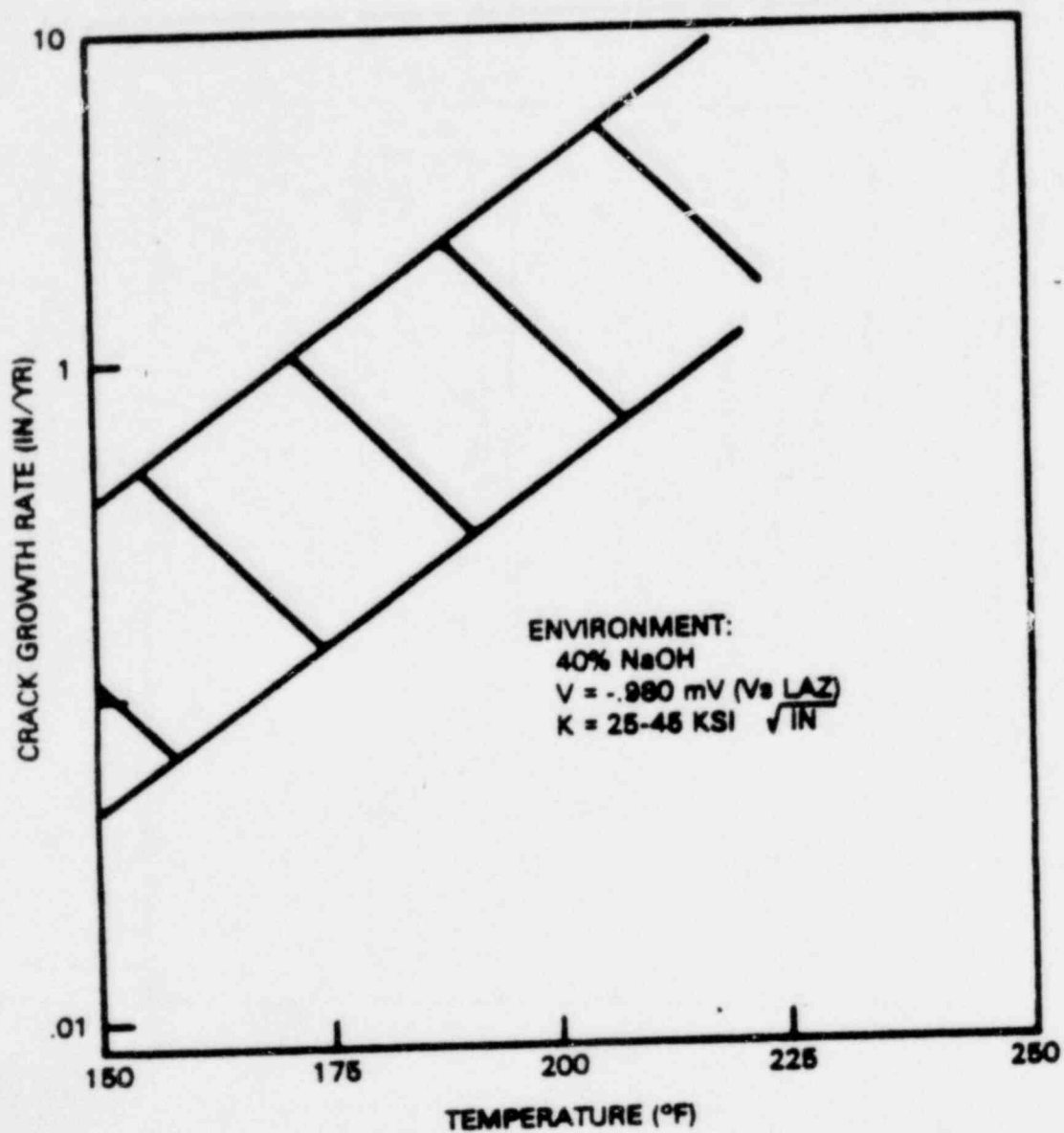

FIGURE 6: MEASURED STRESS CORROSION CRACK GROWTH RATE (REGION II) VERSUS TEMPERATURE FOR NiCrMoV WHEEL MATERIALS. CORROSION POTENTIAL MAINTAINED NEAR OPTIMUM.



## WHEEL BORE STRESS

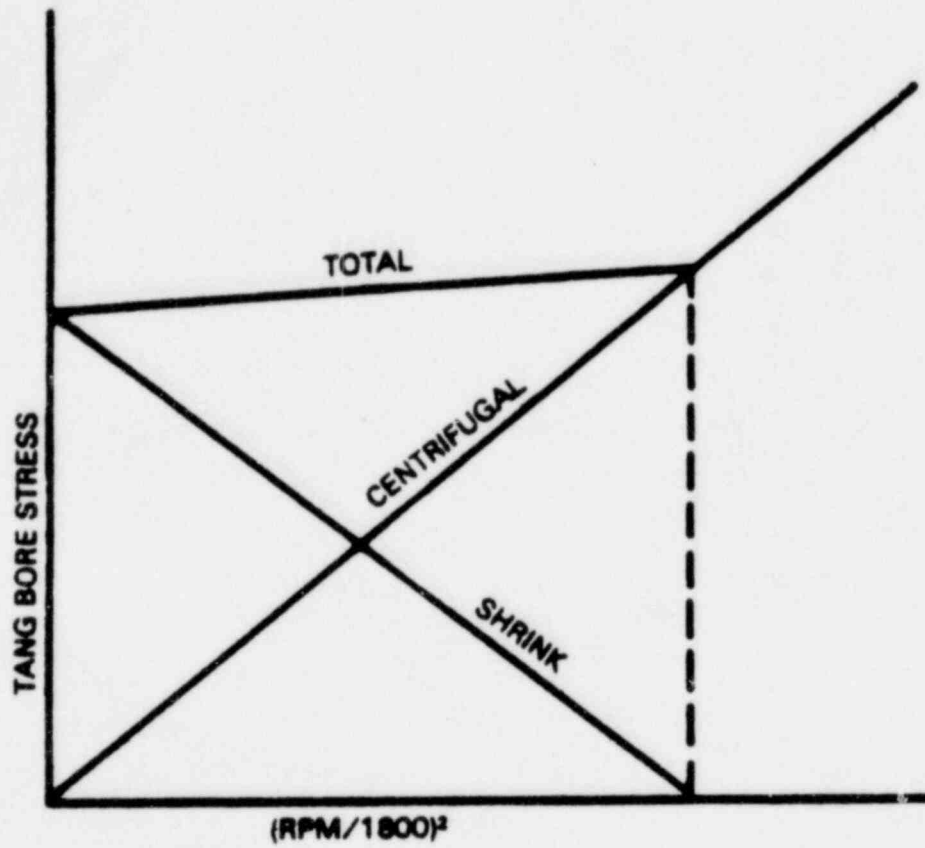

FIGURE 7: SHRUNK-ON WHEEL NOMINAL BORE STRESS

# PRINCIPLE OF SHEAR WAVE TEST FOR FLAWS IN THE RADIAL-AXIAL PLANE

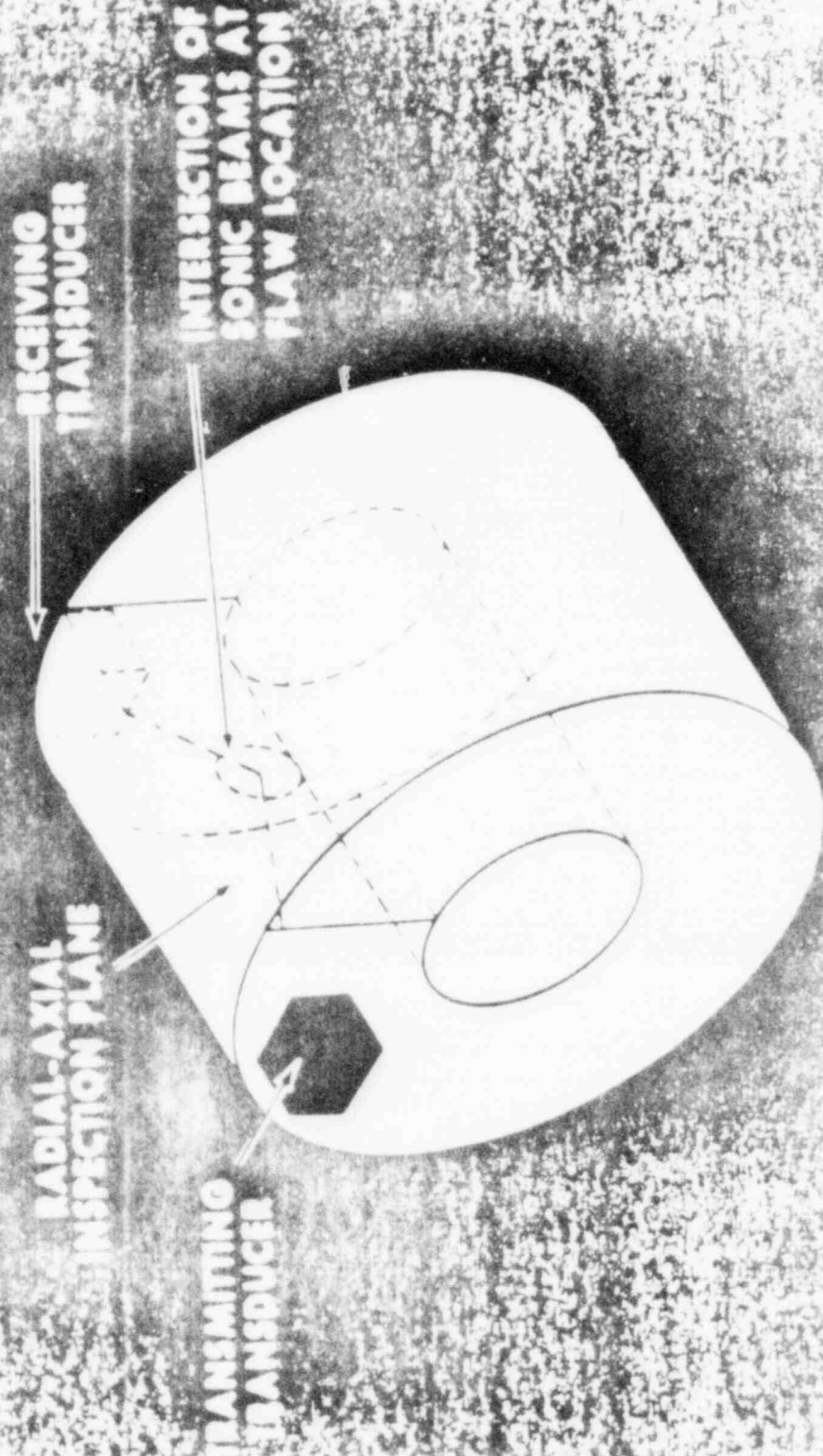

FIGURE 3

SHEAR WAVE TEST  
OF BUCKET WHEELS  
FOR AXIAL/RADIAL FLAWS

DUAL TRANSDUCERS  
FROM THE WEB

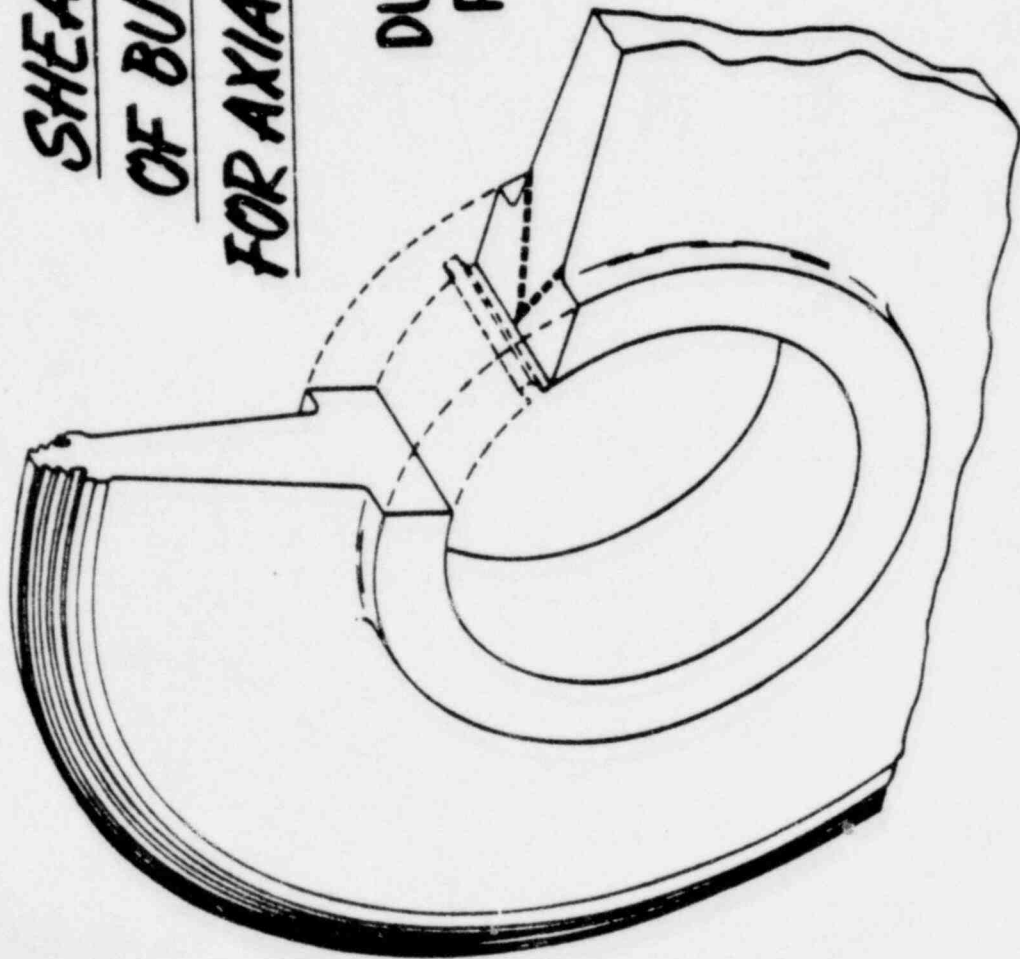

FIGURE 9

SHEAR WAVE TEST  
OF BUCKET WHEELS  
FOR AXIAL/RADIAL FLAWS

SINGLE TRANSDUCER  
FROM HUB O.D.

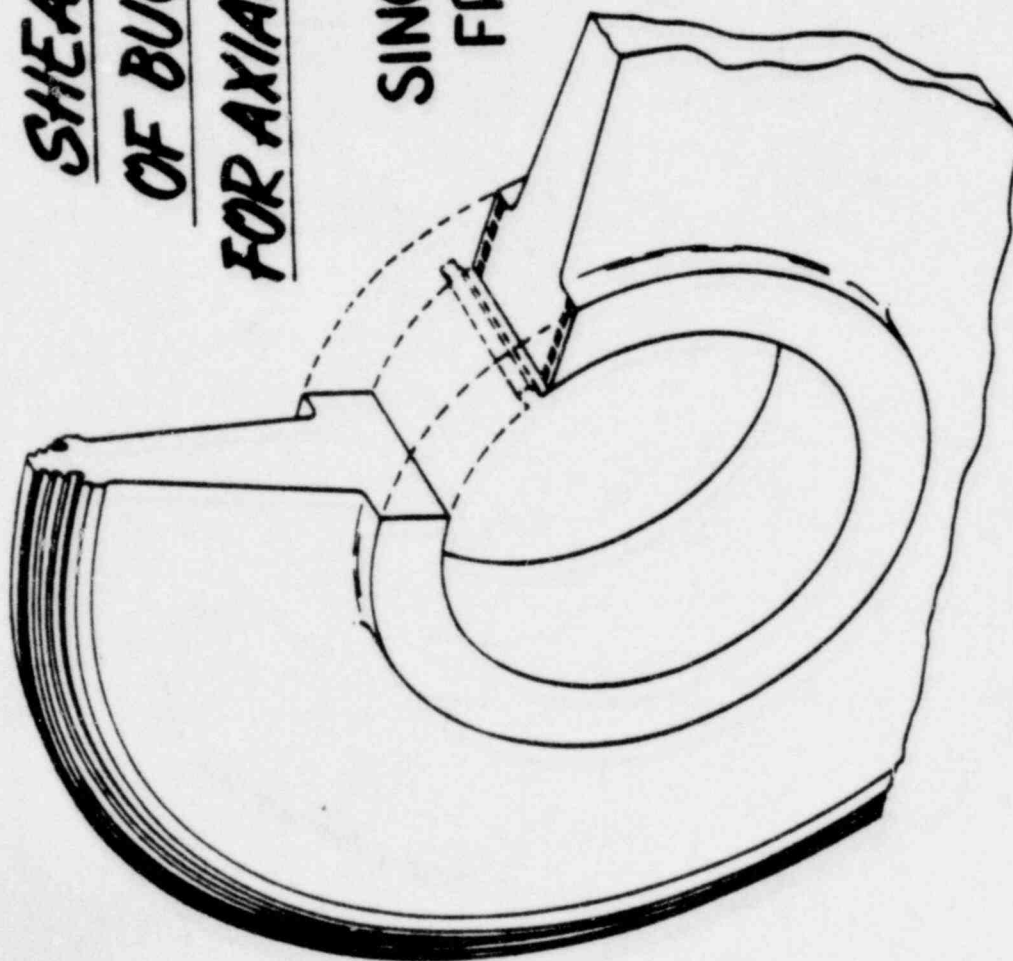
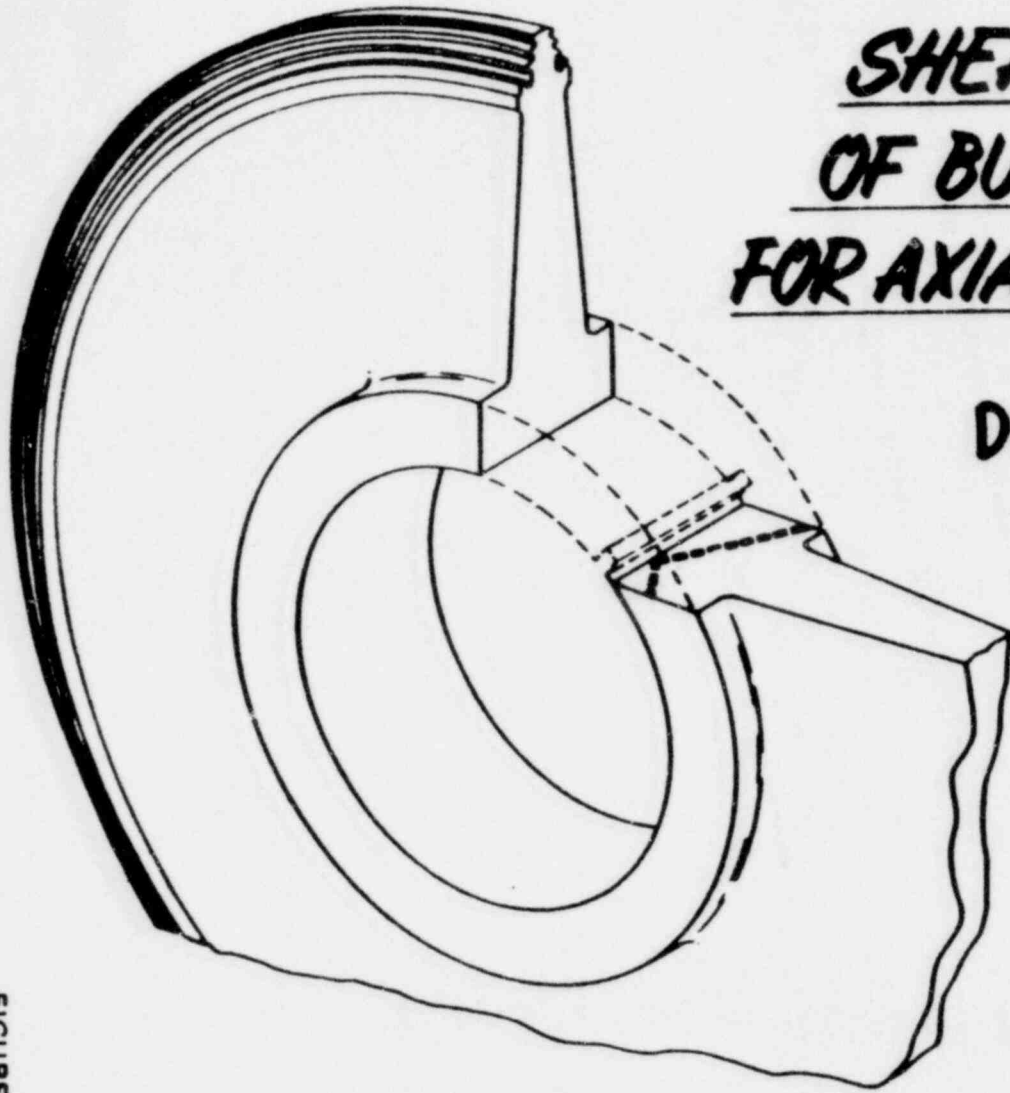

FIGURE 10

SHEAR WAVE TEST  
OF BUCKET WHEELS  
FOR AXIAL/RADIAL FLAWS

DUAL TRANSDUCERS  
FROM HUB FACE



**TRANSDUCER PLACEMENT FOR COVERAGE**

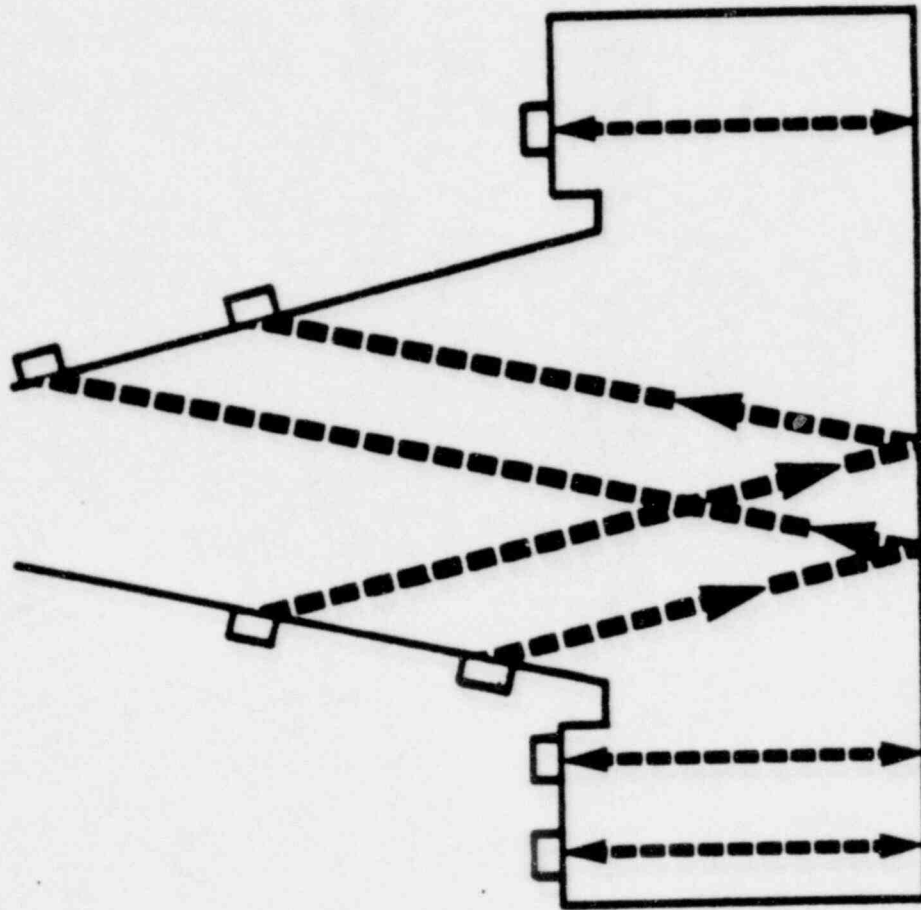
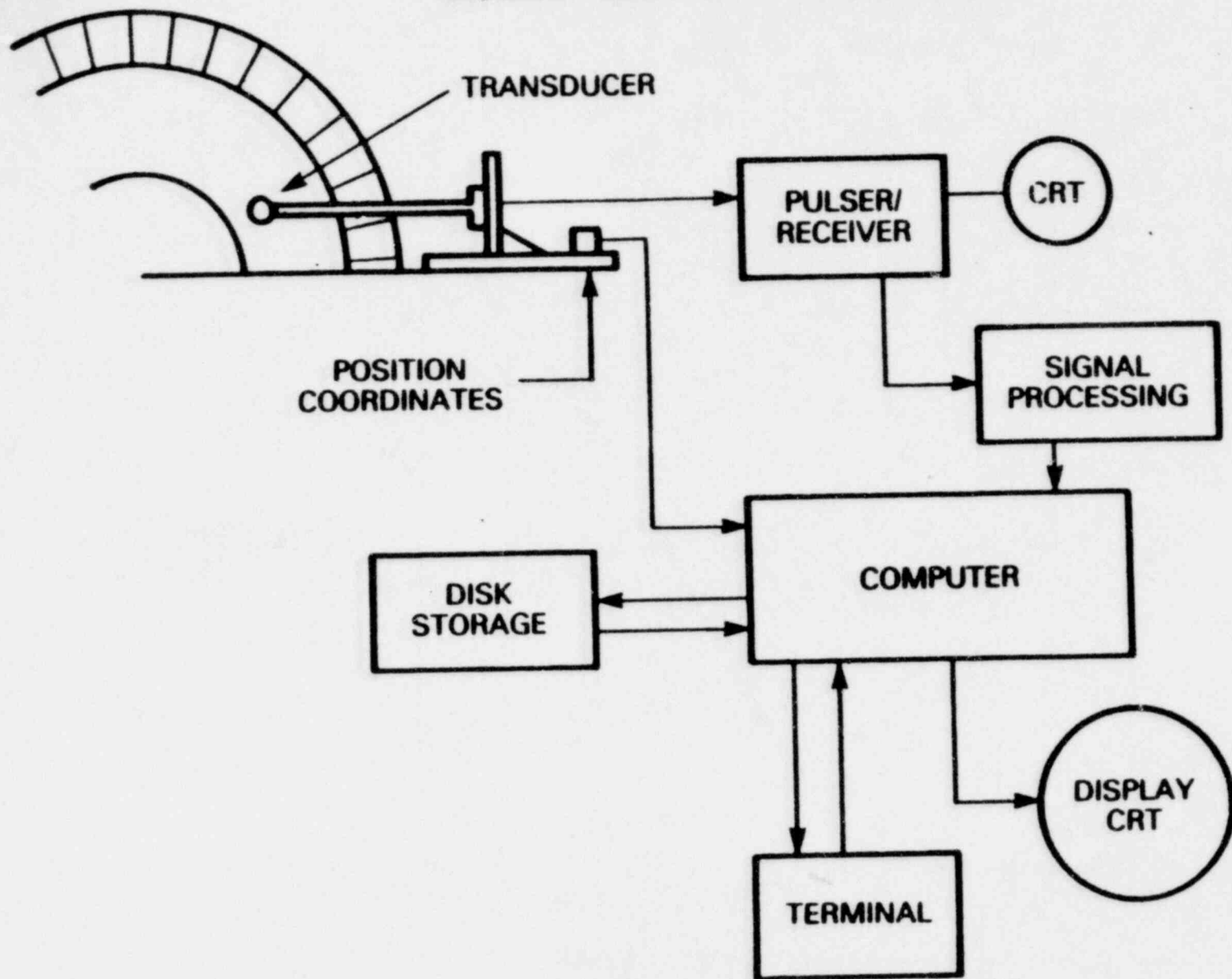

FIGURE 12

# WHEEL TEST BLOCK DIAGRAM



# LP WHEEL BORE TEST

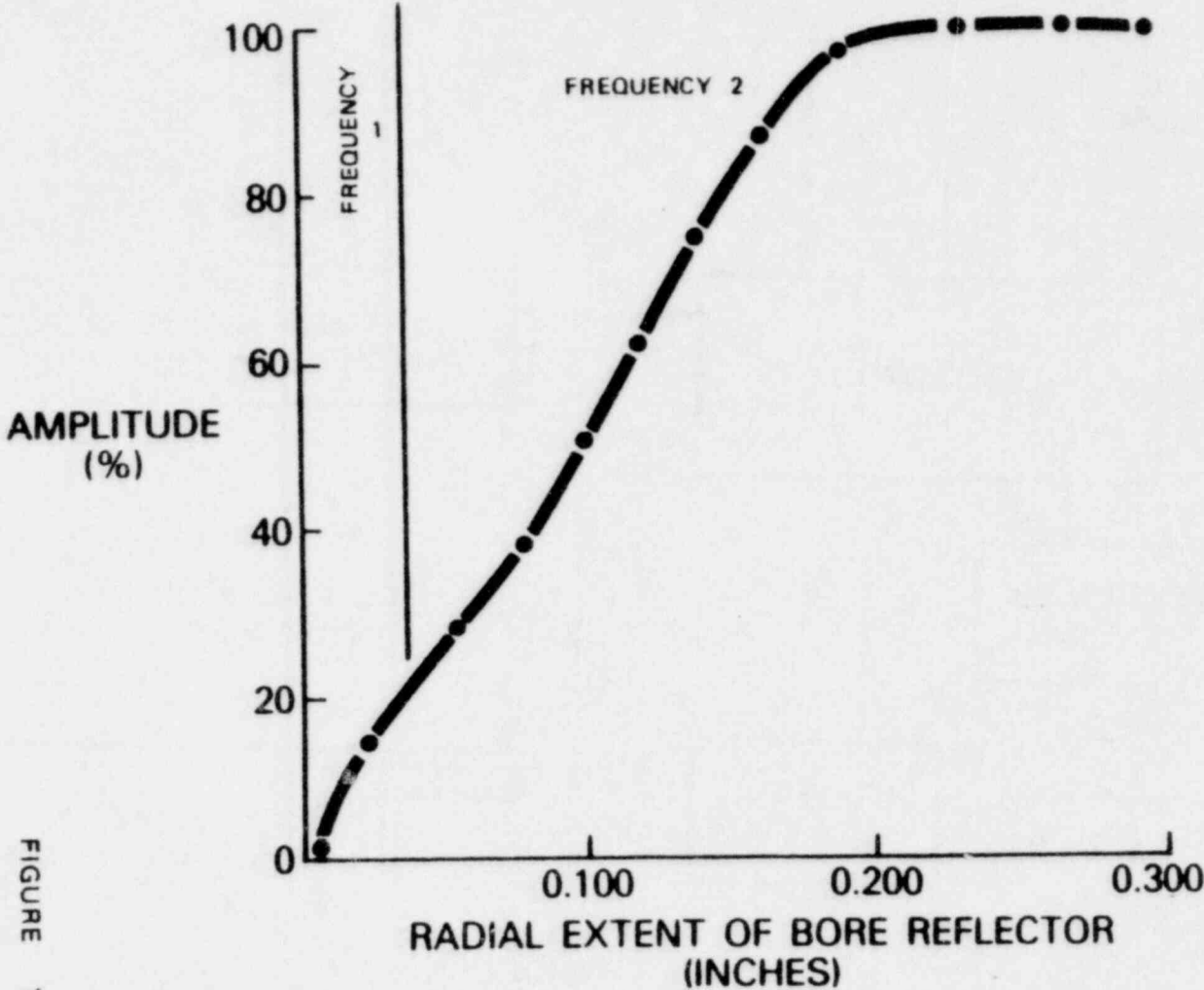

FIGURE 14



CRACKING A FULL SIZE WHEEL

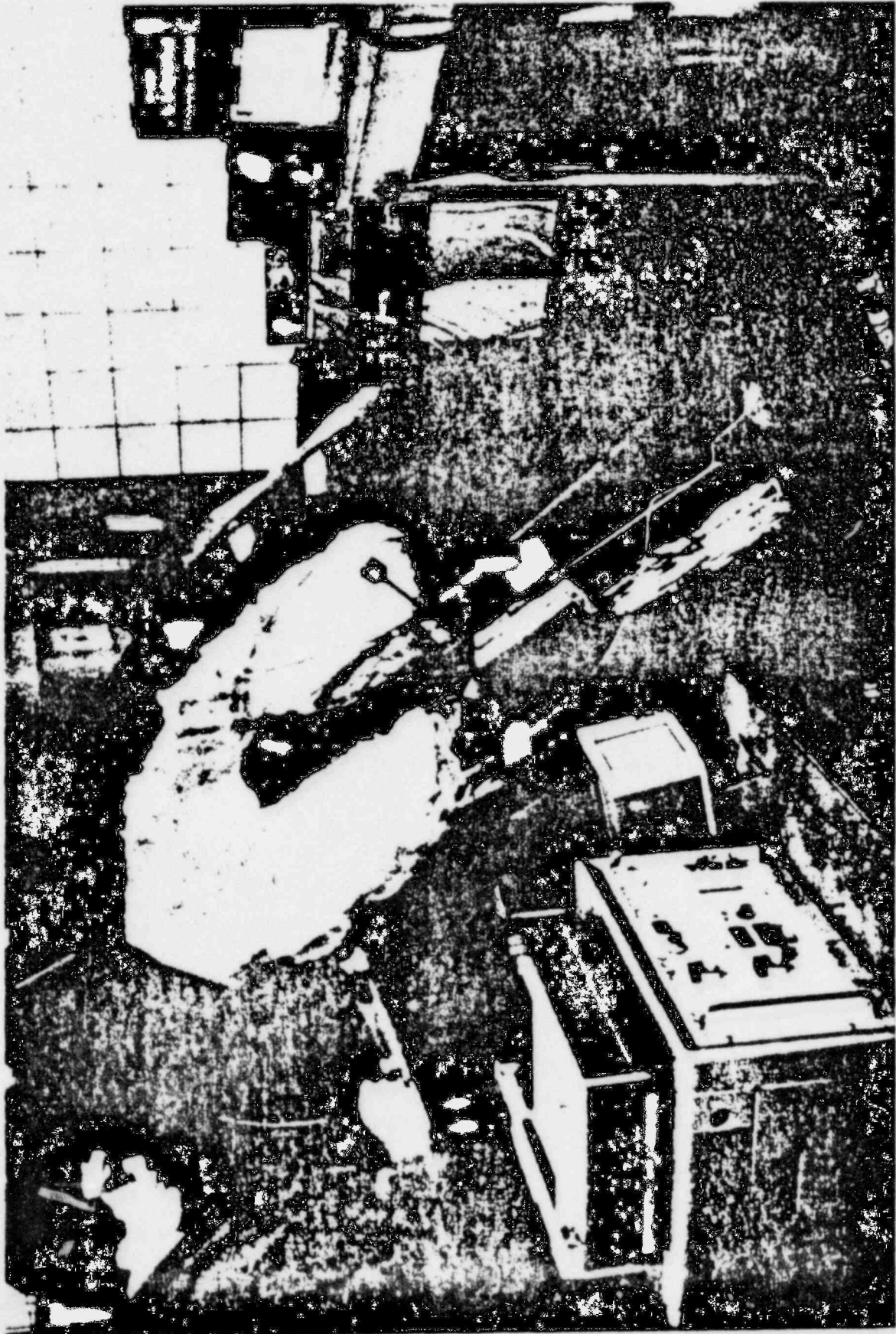

FIGURE 15

CRACKING A LARGE RING SPECIMEN

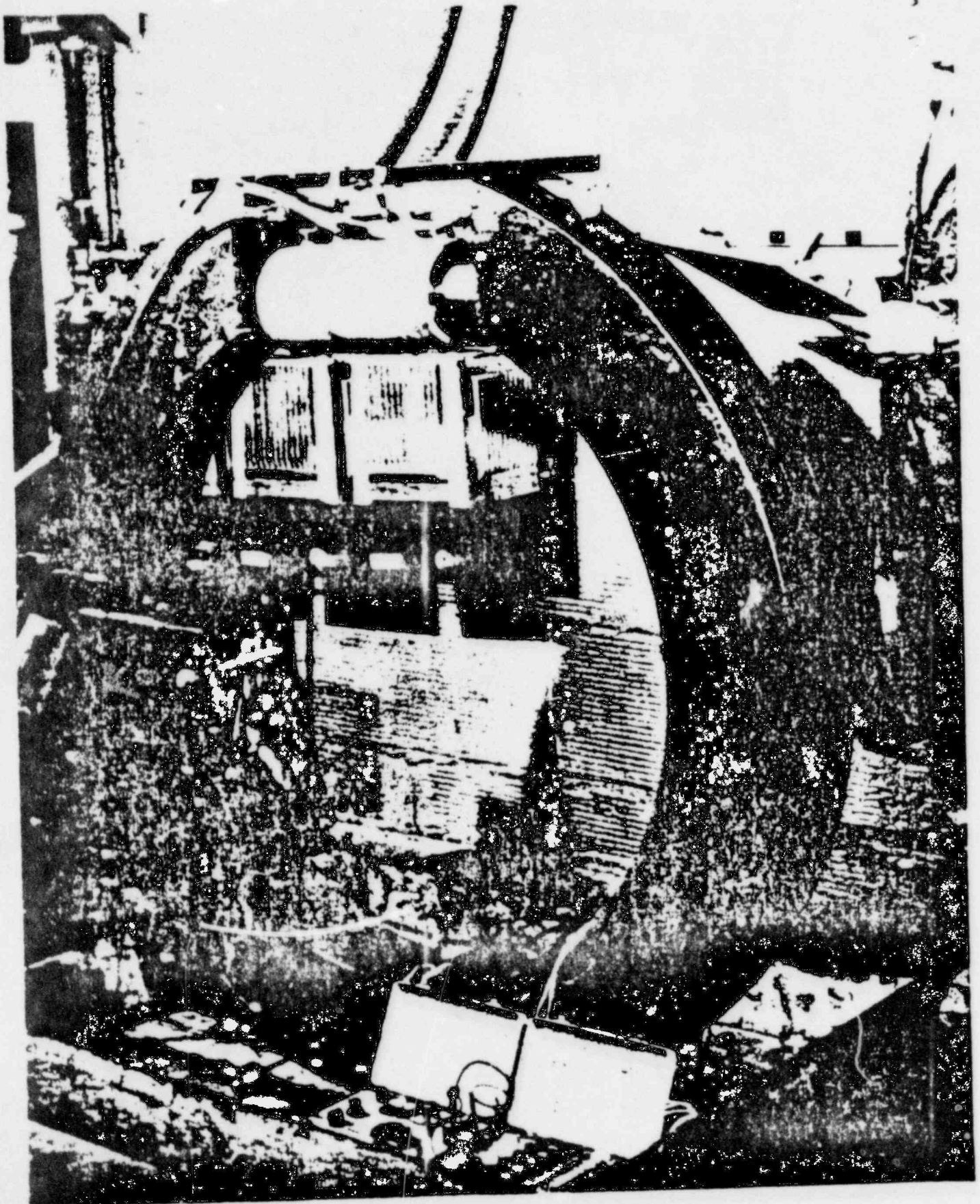

FIGURE 16

WHEEL CRACK EXPOSED

STRESS CORROSION  
CRACK

KEYWAY



1 2 3 4 5 6 7 8 9 10 11 12 13 14

FIGURE 17

STRESS CORROSION CRACK IN KEYWAY



FIGURE 18

45° PULSE-ECHO SHEAR WAVE  
FROM HUB O.D.

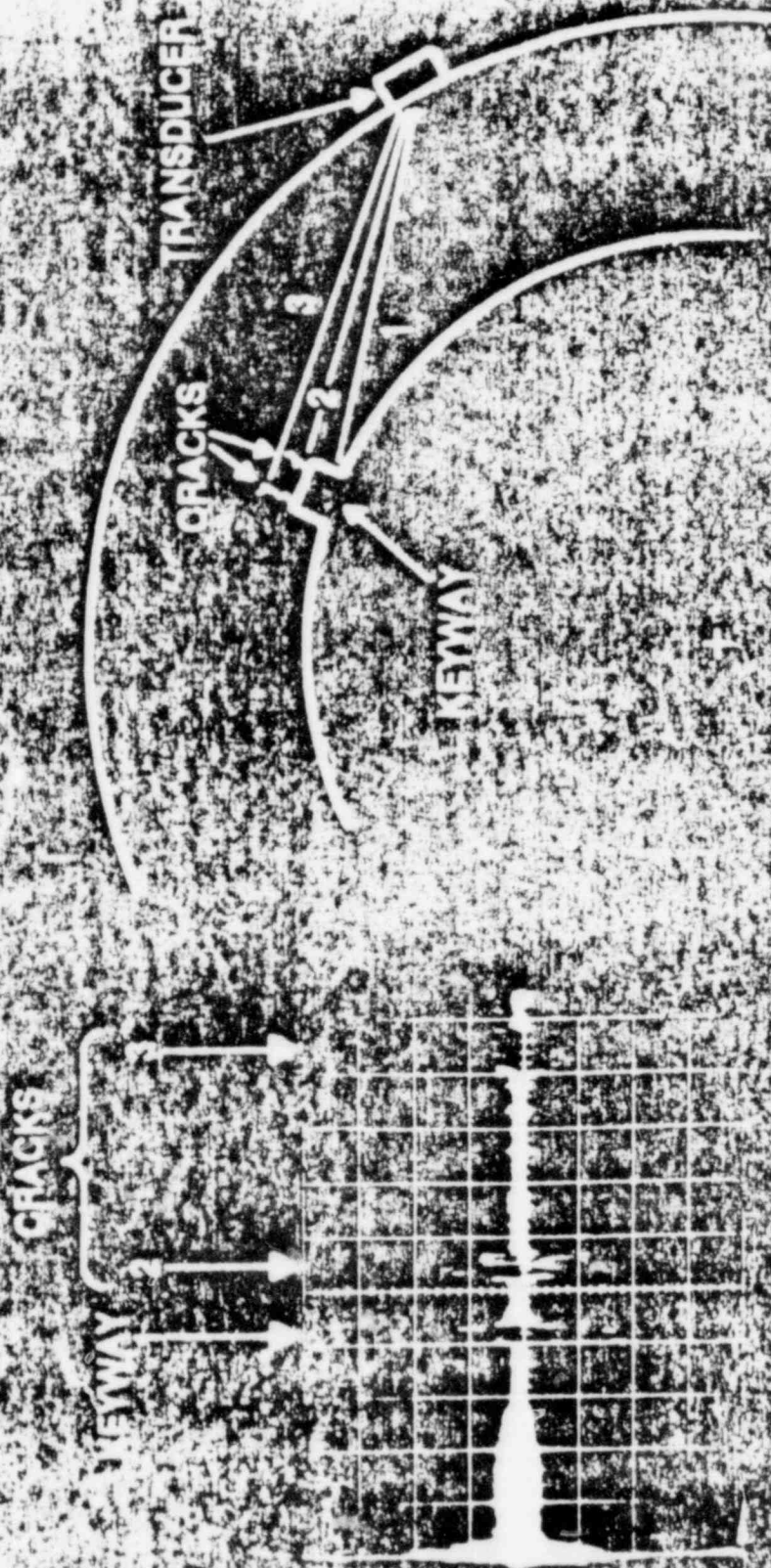

FIGURE 19

# 45° PITCH-CATCH FROM HUB FACE

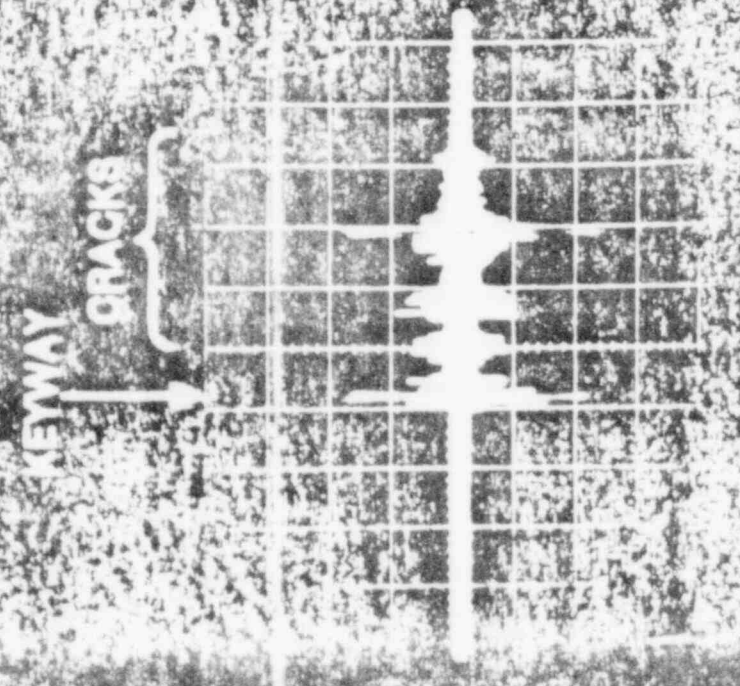
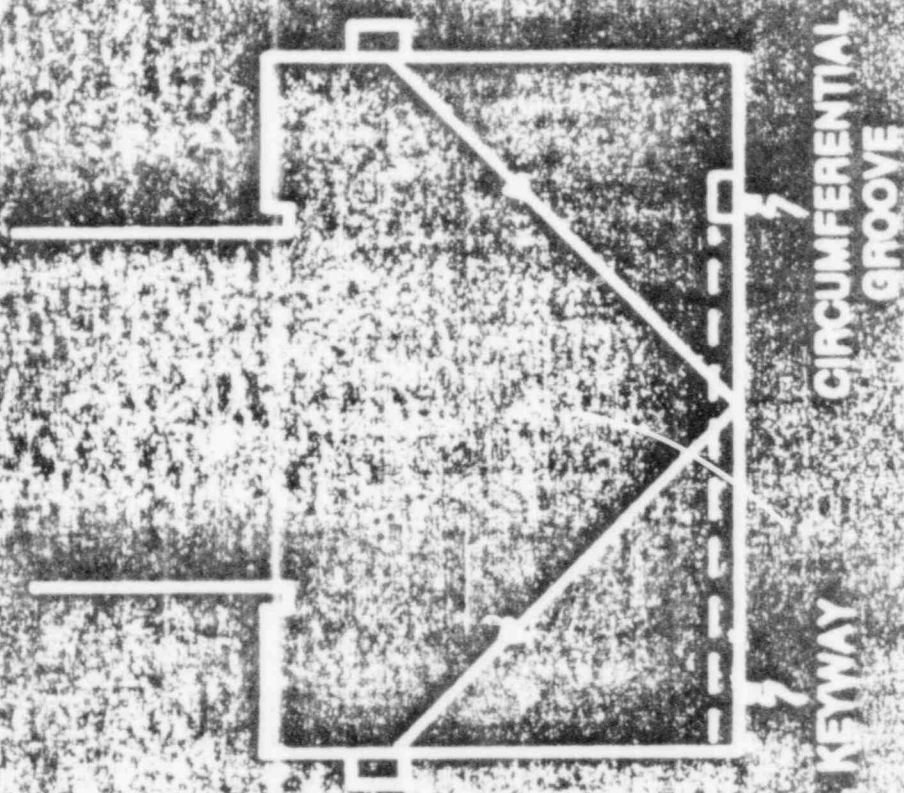
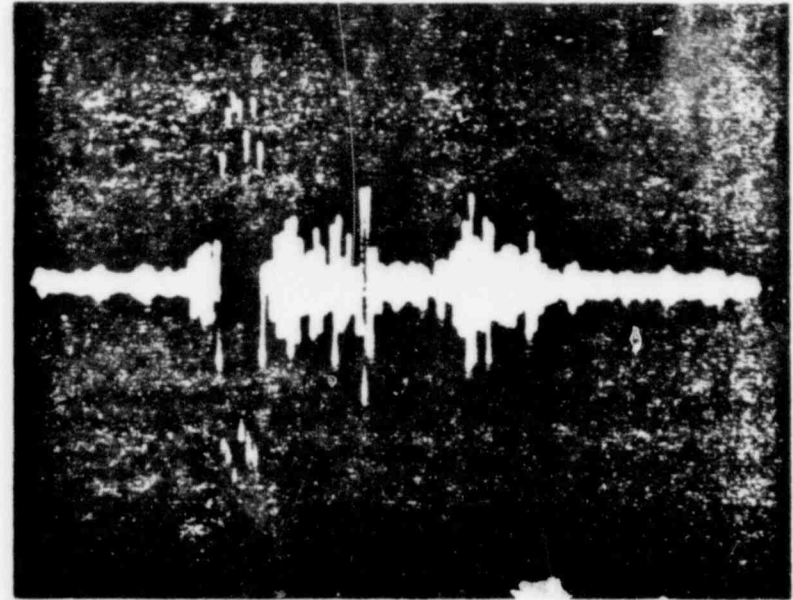

FIGURE 20

# WHEEL SPECIMEN

10/16/78  
CONDITION



BASE CONDITION

2/2/78

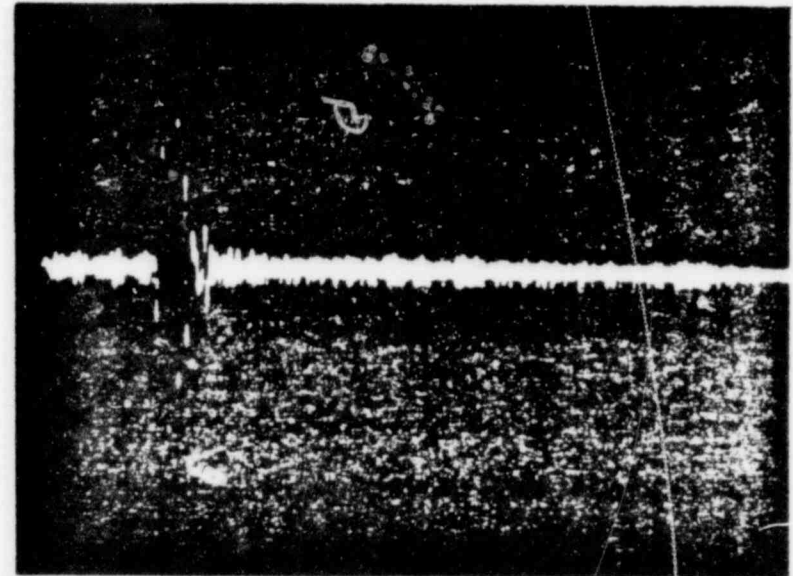

STRESS CORROSION CRACKS IN KEYWAY

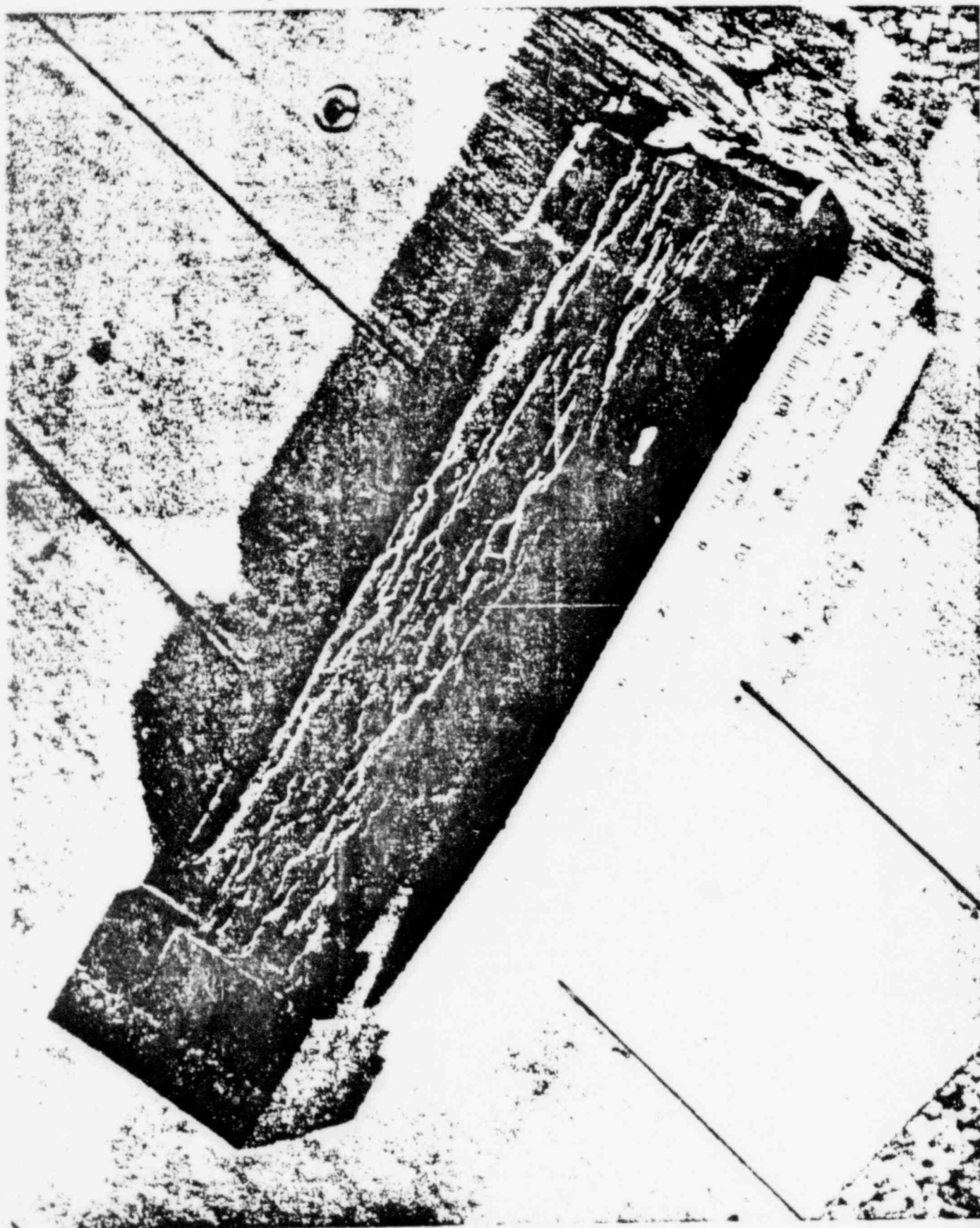
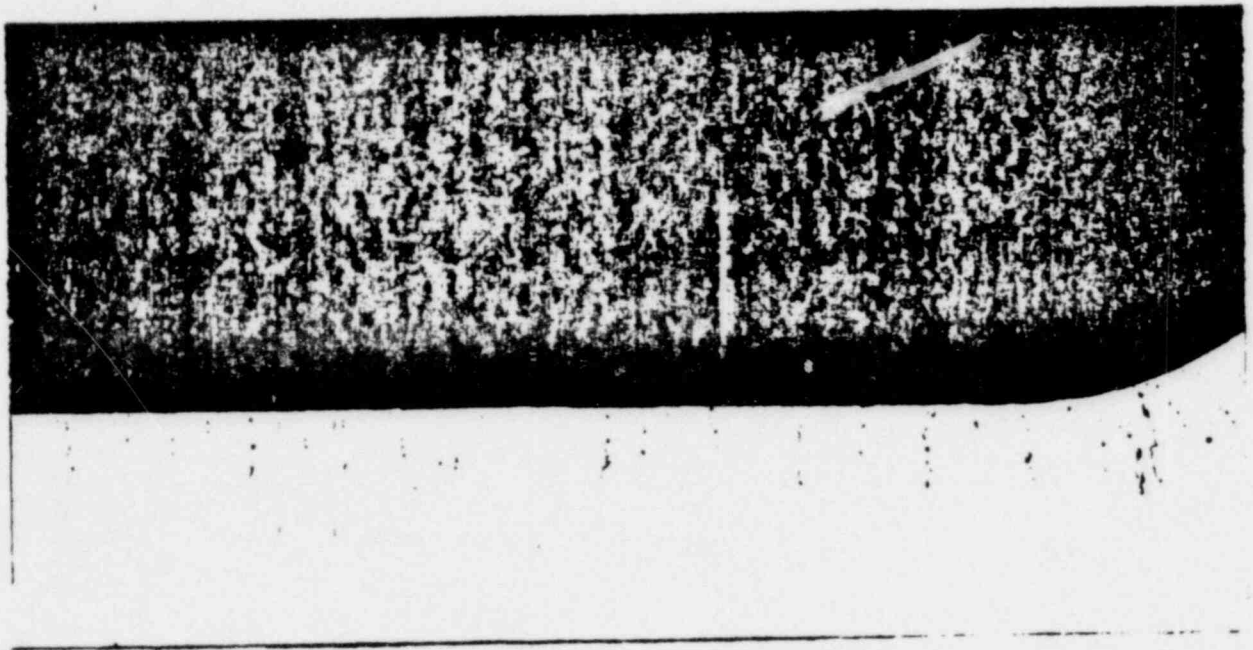

FIGURE 22



METALLOGRAPHIC SECTION OF CRACKS



$\overline{\hspace{1.5cm}}$   
1/16"

Figure 23 : Metallographic Section 8X As-Polished

SUMMARY OF TESTS TO BE PERFORMED

DAILY

SUMMARY OF TEST	SUMMARY OF ACTION FOLLOWING UNSUCCESSFUL TEST
<p>Fully close the main stop valves and combined valves by sequence testing at the EHC Test Panel.</p> <p>For details see "Flow Control" in Volume III.</p>	<p>Shut down immediately by unloading and then tripping from the EHC panel. DO NOT OPEN the generator breaker until ZERO or slightly NEGATIVE load has been reached. The cause of the problem should be corrected before restarting. In all cases of malfunction, the operator must make his decisions with a thorough knowledge of the system and act in the best interests of safe operation and minimizing potential damage to the turbine (e. g. Water Induction may be a problem if an open steam path exists to the turbine).</p>
<p>Test for movement of the extraction check valves provided with positive assist devices.</p> <p>For details, see "Extraction Check Valves" in Volume 1.</p>	<p>Isolate the extraction line immediately. For details, see "Extraction Check Valves", and investigate also per "Extraction Check Valves" in Volume 1.</p>
<p>Check the EHC fluid pump motor current.</p> <p>For details, see "Hydraulic Power Unit for Electro-Hydraulic Control Systems" in Volume 1.</p>	<p>Follow procedure in section IV-D of "Hydraulic Power Unit for Electro-Hydraulic Control Systems" in Volume 1. Take pump out of service and investigate if required.</p>
<p>Check the mechanical filter condition indicators on the EHC hydraulic pump suction strainers (and auxiliary pump strainer when applicable) and the pressure drop across the Fullers-Earth filters in the EHC hydraulic system to ensure that all filters are clean and functioning normally.</p> <p>For details, see "Hydraulic Power Unit for Electro-Hydraulic Control Systems" in Volume 1.</p>	<p>Change filter elements if any indicators or gauges show a change is required per section IV-C and IV-G of "Hydraulic Power Unit for Electro-Hydraulic Control Systems", in Volume 1.</p>

SUMMARY OF TESTS TO BE PERFORMED

WEEKLY

SUMMARY OF TEST	SUMMARY OF ACTION TO BE TAKEN ON AN UNSUCCESSFUL TEST
<p>Fully test <u>ALL</u> Main Turbine steam valves and <u>OBSERVE</u> the travel of the valve stems and linkages locally. It is recognized on nuclear fueled plants that it may not be practical to approach the valve during valve testing on a weekly basis due to the high radiation level. Nevertheless, each valve should be observed from a safe distance once a week, during valve testing, to check for changes in noise, vibration and other behavior.</p> <p>For details, see "Flow Control" in Volume III.</p>	<p>Shut down immediately by unloading and tripping from the EHC panel. DO NOT OPEN the generator breaker until ZERO or slightly NEGATIVE load has been reached. The cause of the problem should be corrected before restarting. In all cases of malfunction, the operator must make his decisions with a thorough knowledge of the system and act in the best interests of safe operation and minimizing potential damage to the turbine. (e.g., water induction may be a problem if an open steam path exists to the turbine).</p>
<p>Perform the Mechanical Overspeed trip test at the EHC Panel to test for operation of the Overspeed trip device and Mechanical Trip Valve.</p> <p>For details, see "Trip and Monitoring" in Volume III.</p>	<p>Unload the machine from the EHC panel. Open the generator breaker when ZERO or NEGATIVE load has been reached then perform the checks outlined in "Trip and Monitoring" in Volume III before shutting down to correct the problem.</p>
<p>Perform the Mechanical Trip Piston Test at the EHC panel to test for electrical activation of the trip mechanism.</p> <p>For details, see "Trip and Monitoring" in Volume III.</p>	<p>Unload the machine immediately (within one week if test on electrical trip is successful) from the EHC panel. Open the generator breaker when ZERO or slightly NEGATIVE load has been reached then perform the checks outlined in "Trip and Monitoring" in Volume III before shutting down to correct the problem.</p>
<p>Perform the Electrical Trip Test at the EHC panel to test for operation of the Electrical Trip Valve.</p> <p>For details, see "Trip and Monitoring" in Volume III.</p>	<p>Unload the machine immediately (within one week if test on mechanical trip piston is successful) from the EHC panel. Open the generator breaker when ZERO or slightly NEGATIVE load has been reached then perform the checks outlined in "Trip and Monitoring" in Volume III before shutting down to correct the problem.</p>
<p>Perform the "BACKUP OVERSPEED TRIP TEST" at the EHC panel to test the 2 out of 3 logic circuits.</p> <p>For details, see "Trip and Monitoring" in Volume III.</p>	<p>Go through the trouble shooting scheme in "Trip and Monitoring" in Volume III. Shut down should only be accomplished after unloading at the EHC panel. The generator breaker should <u>not</u> be opened with any load on the machine.</p>

GEK-46527A. PERIODIC OPERATIONAL TEST SUMMARY

SUMMARY OF TESTS TO BE PERFORMED  
WEEKLY (CONTINUED)

SUMMARY OF TEST	SUMMARY OF ACTION TO BE TAKEN ON AN UNSUCCESSFUL TEST
<p>Perform the Power load unbalance test at the EHC panel to check for correct operation.</p> <p>For details, see "Rate Sensitive Power load unbalance analog and logic circuits" in Volume III.</p>	<p>Reduce load to under 40% maximum unit load or go into the standby mode before replacing the power-load unbalance board with the factory spare per "Rate Sensitive power load unbalance analog and logic circuits" in Volume III. When in Standby, load should be limited to 50% of maximum unit load on units with trip anticipators and 80% of maximum load on units without trip anticipators. Individual units may have a higher permissible load. Consult with your General Electric Representative for this load point.</p>
<p>Test the Thrust Bearing Wear Detector for satisfactory trip points and operation.</p> <p>For details, see "Thrust Bearing Wear Detector Testing" and "Thrust Bearing Wear Detector" in Volume 1.</p>	<p>Investigate immediately and reset or repair within one week. While the device is out of service, avoid maximum load and switching in or out of feedwater heaters.</p> <p>For details, see "Thrust Bearing Wear Detector" in Volume 1.</p>
<p>Test automatic starting of ALL motor driven pumps by actuation of their pressure switches, and exercise each standby pump.</p> <p>For details, see "Automatic Pump Starting Weekly" in Volume 1.</p>	<p>Investigate and correct immediately malfunctions of all DC motor driven pumps. Investigate and correct within one week malfunctions of all AC motor driven pumps. For details, see "Automatic Pump Starting Weekly".</p>
<p>Test for alarm annunciation on the oil tank level gauge.</p> <p>For details, see "Oil Level Gauge Testing" in Volume 1.</p>	<p>Investigate immediately and repair within one week. Check oil level once per shift. Replenish to normal levels as necessary. For details see "Oil Level Gauge Testing".</p>
<p>Check the air gap on the silver brushes in the front standard for wear and wear rate.</p> <p>For details see "Removable shaft grounding device" in Volume 1.</p>	<p>Replace the silver brushes and/or operate per "Removable shaft grounding device" in Volume 1.</p>
<p>Perform the EVA test if early valving is provided.</p> <p>For details, see "Early Valve Actuation Analog and logic circuits" in Volume III.</p>	<p>Replace with the factory spare per "Early valve actuation analog and logic circuits" in Volume III.</p>
<p>Check that the air dryer on the hydraulic power unit has active desiccant.</p> <p>For details, see "Hydraulic Power Unit for Electrohydraulic Control Systems" in Volume 1.</p>	<p>Reactivate or change the desiccant immediately.</p>

IN-SERVICE INSPECTION  
OF  
1500 & 1800 RPM NUCLEAR TURBINE ROTORS

TIL-857

dated 2/17/78

PURPOSE

The purpose of this technical information letter is to give recommendations for inspecting all 1500 and 1800 RPM nuclear turbine rotors and, in particular, to announce the availability of a newly developed test for sonically inspecting shrunk-on turbine wheels. The mechanisms for initiating and/or growing cracks in nuclear shrunk-on wheels are also described, with particular reference to stress corrosion and recommendations for steam purity.

INTRODUCTION

Nearly all of the turbine-generators produced to date by the Large Steam Turbine-Generator Department for use with nuclear reactor cycles are tandem-compound units with a rotation speed of 1500 or 1800 RPM. These units are constructed with integral rotors (rotor machined from a single forging), and/or built-up rotors (shaft with shrunk-on wheels and couplings). In most nuclear turbines the HP rotor is of integral construction and the low pressure rotors are of built-up design, although there were a few early exceptions to this general configuration. The recommended inspections to be conducted on nuclear turbine rotors, the available inspection techniques, and the recommended intervals for such inspections are described below.

The Large Steam Turbine-Generator Department made plans several years ago to develop a means of inspecting the critical regions of shrunk-on nuclear turbine wheels without removing them from the turbine shaft. This development is now complete. We now have available the capability of ultrasonically inspecting for cracks in the vicinity of the keyway and the bore of nuclear wheels with the wheels in place. These critical regions have previously been impossible to inspect without removing wheels, using available nondestructive tests.

INTEGRAL ROTOR INSPECTION

We recommend that nuclear integral rotors be given a thorough external inspection at each outage when the rotor is exposed. This inspection should include a complete magnetic particle test of all external surfaces, including rotor, buckets, packings, journals, and couplings. Normal visual inspections should also be conducted at this time.

We recommend a more complete inspection of the rotor at approximately 10-year intervals. This should include magnetic particle and ultrasonic inspections from the rotor periphery and from the bore. A sonic test of the wheel dovetails on each stage should also be performed at this time.

BUILT-UP ROTOR INSPECTION

During any outage when a turbine section is open, the built-up rotor should also be given a thorough inspection. This inspection should include a complete magnetic particle test of all external surfaces, in-

BUILT-UP ROTOR INSPECTION - Continued

cluding shaft, wheels, buckets, packings, journals, couplings, and gears. Last stage erosion shields should be given a red dye inspection, and all finger dovetail pins should be sonically inspected.

We recommend a more extensive test at about 6-year intervals, including the ultrasonic inspection of tangential entry dovetails, and an ultrasonic inspection of the shrunk-on wheels. The inaccessible wheel bore and keyway surfaces, and the material in the vicinity of the bore, should be inspected using the recently developed ultrasonic test described in the following paragraphs.

The ultrasonic test of the bore and keyway regions must be conducted with the rotor being turned slowly at a constant speed. Specially designed ultrasonic transducers positioned on the hub and the web of the wheel are used to transmit ultrasound toward the bore. If a crack is present, a portion of the ultrasonic energy is reflected, either back to a dual transmitting/receiving crystal assembly, or to a receiver located at the appropriate location of the wheel. An analysis of the reflected signal is made to determine whether a crack is present. The material within 2 or 3 inches of the bore, including the keyway, is inspected by continuously varying the location of the transmitting and receiving crystals.

Rotor turning can be accomplished in some cases with the turning gear. In other cases it may be necessary to make special provisions or modifications to achieve the required speed. The exact speed requirement and related recommendations for the specific machine to be tested will be furnished prior to the outage. The turbine owner may wish to purchase a set of powered rolls. These could afford the added advantage of permitting the rotor to be tested away from the turbine, so that other maintenance can be accomplished concurrently. The I&SE Service Engineer can provide the functional description of such rolls.

The expected elapsed time for the wheel bore ultrasonic test is about five days for the first rotor and four days for each additional rotor inspection performed sequentially at the same site. This time does not include that required to prepare the wheels for the testing - cleaning the wheels, removing grease, rust, loose scale, etc., to permit close coupling between the ultrasonic transducers and the surface. The I&SE Service Engineer can discuss the required cleaning, and how it may be best accomplished.

The internal portion of the wheel away from the bore, which is not inspected during this test, is of much less concern. This is because a flaw of unacceptable size and location in the wheel, as manufactured, is unlikely. The manner in which the wheels are forged essentially precludes the possibility of producing an internal crack-like defect in the plane normal to the maximum stress (the axial-radial plane). Furthermore, all modern nuclear wheel forgings are subjected to a stringent 100% volumetric ultrasonic inspection at the time of manu-

BUILT-UP ROTOR INSPECTION - Continued

facture. All nuclear wheels are spin tested during manufacture at 20% overspeed, which further minimizes the probability of having an undetected crack or crack-like flaw with a critical size which would lead to spontaneous propagation at normal rotation speeds. Thus, the likelihood of a modern nuclear wheel entering service with an unacceptable defect is low. It therefore becomes more important to concentrate on the potential for the initiation and growth of cracks in service.

There are two possible mechanisms for initiating and/or growing cracks in nuclear wheels in service:

1. Stress Cycling.
2. Stress Corrosion Cracking.

The likelihood of initiating and/or growing a crack due to the stress cycling associated with starts, stops, or load changes is small. The variation in stress amplitude resulting from operating transients is too low to produce significant crack growth, in the unlikely event that a defect exists in the wheel when it is placed in service. Thus, the major source of concern with respect to the in-service initiation and growth of cracks is that associated with stress corrosion. Although we have not observed stress corrosion (or other) cracking in the bores of any of our fossil or nuclear wheels made of modern material, the possibility of initiation and propagation of a stress corrosion crack at the bore of a shrunk-on wheel cannot be entirely discounted. We and other turbine manufacturers have experienced stress corrosion cracks in the wheel dovetail region of integral rotors made of essentially the same material as that used in nuclear LP wheels. For modern GE design nuclear shrunk-on wheels, the material crack size in the rim region which would lead to wheel bursting is very large, approaching the axial thickness of the wheels. Thus, such cracks, should they exist, would have a high probability of detection by surface inspections. This is not the case in the bore region where, because of higher stress levels, a crack could grow to a dangerous size prior to breaking through to an accessible surface. The ultrasonic test permits the inspection of this region of the wheel.

A great amount of development work on stress corrosion cracking has been conducted, and our understanding of this phenomenon is much improved, although still inadequate to predict the precise time required for crack initiation and the rate of crack growth in a corrosive environment.

Stress corrosion crack initiation and growth is a complex process, influenced by many factors such as material properties, stress levels, environment, etc. and there is still considerable uncertainty about their interaction. Data generated to date show a great deal of scatter on

BUILT-UP ROTOR INSPECTION - Continued

both crack initiation times and growth rates, so that it is impossible to specify absolutely "safe" inspection intervals to preclude the possibility of initiating and growing a crack to critical size between inspections.

Recognizing that periodic inspections at reasonable intervals cannot provide absolute protection against a wheel burst, we nevertheless believe that such inspections will greatly reduce the probability of such occurrences. After having considered this and other factors, we conclude that inspection should be conducted at about 6-year intervals, as described above.

The inspections can be coordinated with reactor refueling schedules and/or sectionalized maintenance plans.

TURBINE STEAM PURITY

We believe the control of steam purity is the most positive way of protecting against stress corrosion cracking. Numerous studies have been made over the years to determine realistically achievable steam chemistry, and attempts have been made to relate impurity levels to the stress corrosion susceptibility of turbine materials. While much work remains to be done in this area, the attached instruction, GEK-63430, describes our judgment on the approach which we currently feel is workable and prudent.

We are not at present recommending a general inspection program for fossil turbine shroud-on wheels. We may recommend occasionally that certain wheels be inspected, depending on specific circumstances. Requests for inspecting fossil wheels will be honored to the extent of our inspection capacity, but priority will be given to nuclear wheels.

The information furnished in this technical information letter is offered by General Electric as a service to your organization. In view of this and since operation of your plant involves many factors not within our knowledge, and since operation is within your control and responsibility, it should be understood that General Electric accepts no liability in negligence or otherwise as a result of your application of this information.



# INSTRUCTIONS

GEK-72281



*(New Information, August 1979)*

## STEAM PURITY — STRESS CORROSION CRACKING

*dupe of  
8005230773*

*These instructions do not purport to cover all details or variations in equipment nor to provide for every possible contingency to be met in connection with installation, operation or maintenance. Should further information be desired or should particular problems arise which are not covered sufficiently for the purchaser's purposes, the matter should be referred to the General Electric Company.*

CONTENTS

	PAGE
I. GENERAL DESCRIPTION .....	3
II. OPERATIONAL RECOMMENDATIONS .....	3
A. Once-Through Steam Supply Systems .....	3
B. Drum Type Steam Supply Systems .....	3
C. Steam Purity Monitoring .....	4
III. MAINTENANCE RECOMMENDATIONS .....	5
A. Turbine Deposits .....	5

## I. GENERAL DESCRIPTION

Utilities have always controlled boiler water chemistry to prevent corrosion and deposits in the boiler, which can result in tube failures, and to prevent deposits in the turbine, which decrease unit output and lower efficiency. Sporadic instances of stress corrosion cracking (SCC) in turbines indicate that, in addition to steps to prevent boiler corrosion and turbine deposits, the water chemistry must be controlled to prevent the introduction of corrosive contaminants into the turbine which can cause SCC.

The most serious corrosive contaminants are caustic, chlorides, and sulfite (which decomposes into hydrogen sulfide). Due to powerful concentrating mechanisms operative in turbines and the aggressive nature of corrosive contaminants in high concentrations, it is necessary to restrict these contaminants to very low levels in the steam. The substitution of hydrazine for sodium sulfite as an oxygen scavenger has essentially eliminated problems due to sulfite. The elimination of chlorides and caustic is not as easy. Chlorides are almost always present in the condenser cooling water and condenser leaks permit chloride to enter the condensate stream. Caustic may be present intentionally from chemical additions to the boiler or unintentionally from improper operation and/or regeneration of condensate polishers or make up demineralizers.

The steam purity required to prevent corrosive deposits in utility turbines is not presently known. However, correlations between field service experience and utility water chemistry practices has enabled the General Electric Company to formulate steam purity guidelines that, if followed, are likely to avoid major SCC incidents. These guidelines are described in detail below.

## II. OPERATIONAL RECOMMENDATIONS

### A. Once-Through Steam Supply Systems

Minimizing the level of feedwater contaminants is extremely important for once-through type boilers since essentially all the impurities dissolved in the feedwater

remain dissolved in the steam and pass into the turbine. For these systems, the water purity input to the boiler is a good measure of the output steam purity. We conducted a water chemistry survey from 1975 to 1977 in which questionnaires and plant visits were used to assess current industry practices related to feedwater treatment, boiler water chemistry and steam purity measurements. The survey results from 50 once-through steam generators indicated that about 80% of the units continuously monitoring sodium and cation conductivity of the final feedwater achieve typical values of 3 ppb or less sodium and 0.2  $\mu\text{mho/cm}$  or less cation conductivity. In those units reported to have been operated within these limits, no major stress corrosion cracking incidents have occurred and only a minor amount of pitting corrosion has been observed.

In recognition that turbine operators need some margin on the feedwater chemistry limits to account for start-ups, shutdowns, and system upsets, we have adopted the following practical steam purity recommendations which should provide adequate protection from serious SCC incidents:

*It is recommended that: The steam purity be maintained at the lowest practical level of contaminants not to exceed 3.0 ppb Na and cation conductivity of 0.2  $\mu\text{mho/cm}$  during normal operations; during abnormal operation, for short periods not exceeding 100 hours per incident and accumulating 500 hours or less in a 12 month operating time, 6.0 ppb Na and 0.5  $\mu\text{mho/cm}$  should not be exceeded; and during emergency conditions for periods of 24 hours or less with accumulation not exceeding 100 hours in a 12 month operating time, 10.0 ppb and cation conductivity of 1.0  $\mu\text{mho/cm}$  should not be exceeded.*

### B. Drum Type Steam Supply Systems

A major difference between drum type units over once-through designs is the drum boiler's ability to separate dissolved solids from the steam due to the strong affinity of the solids for the liquid phase.

There is a much lower incidence of SCC on units operated with drum type boilers. Since these boilers generally are not well instrumented, it is not possible to relate this better performance to steam purity.

We would expect that drum boilers operated on the zero solids or all volatile treatment system would readily meet our recommended limits on sodium and cation conductivity listed above for once-through steam supply systems and these limits should be adhered to.

Some drum type boilers may be operated with a precision type control in which caustic is added to the boiler water to achieve the desired pH. Any carryover would result in the introduction of caustic, a very corrosive contaminant, into the turbine. In order to minimize corrosion damage to the turbine, drum boilers operated with precision control should deliver steam to the turbine that meets the sodium and cation conductivity limits recommended above for once-through systems.

For drum type units operated with the coordinated phosphate boiler water treatment, it is not evident what levels of sodium and cation conductivity are achievable in the steam. The lower incidence of serious corrosion damage for such units suggests that steam purity levels are comparable to those found for once-through boilers or that deposits containing corrosive contaminants are buffered by phosphates. Sodium phosphates are not believed to be corrosive to turbine materials. It is possible that the steam chemistry limitations on units using coordinated phosphates do not need to be as stringent as those recommended for once-through systems and industry programs need to be established to determine appropriate limits for units using this type of treatment. For these reasons we are not specifying steam purity limits for drum units using coordinated phosphate but we do recommend monitoring the steam purity, and careful attention to feedwater control.

### C. Steam Purity Monitoring

Most of the serious instances of turbine corrosion damage for both once-through and drum type boilers are associated with accidents or upset conditions. For example, in once-through systems, improper regeneration of deep bed polishers operated on the ammonia cycle can introduce caustic into the feedwater. In drum type systems, high drum levels, foaming, or defective steam separator baffles can significantly increase the amount of carryover. Operation of any boiler-turbine system with severe condenser leaks can eventually introduce chlorides into the turbine. Avoiding such instances requires constant attention to condenser leakage, demineralizer effluent purity, and steam purity.

The measurement of steam purity in units operated with drum type boilers is not as straightforward as for once-through types because of separation in the drum and the need for steam sampling.

Steam sampling techniques and instrumentation for drum boilers should be used to provide assurance against the type of chemical upsets described above.

Saturated steam sampling at the drum may be more readily accomplished than superheated steam sampling. Although the absolute values of steam purity measurements can be inaccurate because of nonrepresentative steam sampling, such steam purity monitoring is extremely useful in detecting trends or step changes in the chemical carryover.

To prevent the introduction of corrosive contaminants into the turbine we recommend that sodium and cation conductivity be monitored. Controlling the sodium to low levels insures that the corrosive compounds sodium hydroxide and sodium chloride are controlled. Limiting the cation conductivity is intended to provide a measure of protection against some of the other potentially corrosive contaminants. In the event that a reliable low level

chloride analyzer suitable for power plant use becomes available, we would strongly recommend its use for steam purity monitoring.

### III. MAINTENANCE RECOMMENDATIONS

#### A. Turbine Deposits

During turbine inspections the unit should be carefully inspected for deposits. Analyses of turbine deposits can provide an early warning that corrosive

contaminants have been introduced into the unit. These deposit analyses provide the information required for logical recommendations regarding the nondestructive examination of critical turbine components and for formulating corrective actions to eliminate the source of contaminants.

*We would recommend that turbine deposits be taken and analyzed during every inspection. The results should be reviewed with LSTG Engineering through Product Service.*

**GENERAL  ELECTRIC**

GENERAL ELECTRIC - DOMESTIC  
 NUCLEAR TURBINE-GENERATOR UNITS WITH G.E. BOILING WATER REACTORS  
 OPERATING OR UNDER CONSTRUCTION

<u>CUSTOMER</u>	<u>STATION/UNIT</u>	<u>RATING</u>	<u>TURBINE TYPE</u>	<u>STAGES REHEAT</u>	<u>SERVICE DATE</u>
Commonwealth Edison	Dresden 1	210	TC2F-38		4/15/60
Jersey Central Power & Light	Oyster Creek 1	641	TC6F-38	2	9/23/69
Niagara Mohawk Power	Nine Mile Pt 1	620	TC6F-38	2	11/9/69
Commonwealth Edison	Dresden 2	810	TC6F-38		4/13/70
Northeast Utilities	Millstone Pt 1	650	TC4F-43		11/29/70
Northern States Power	Monticello 1	543	TC4F-38		3/5/71
Commonwealth Edison	Dresden 3	810	TC6F-38		1/22/71
Commonwealth Edison	Quad Cities 1	810	TC6F-38		4/12/72
Commonwealth Edison	Quad Cities 2	810	TC6F-38		5/23/72
Boston Edison	Pilgrim 1	655	TC4F-43		7/19/72
Vermont Yankee	Vt. Nuc. Power 1	537	TC4F-38		9/20/72
Tennessee Valley Authority	Browns Ferry 1	1098	TC6F-43		10/15/73
Philadelphia Electric	Peachbottom 2	1098	TC6F-43		2/16/74
Iowa Electric Light & Power	Arnold 1	566	TC4F-38	2	5/19/74
Tennessee Valley Authority	Browns Ferry 2	1099	TC6F-43		8/28/74
Philadelphia Electric	Peachbottom 3	1098	TC6F-43		9/1/74
Georgia Power	Hatch 1	809	TC4F-43	2	11/11/74
PASNY	Fitzpatrick 1	850	TC4F-43	2	2/1/75
Carolina Power & Light	Brunswick 2	849	TC4F-43	2	4/29/75
Tennessee Valley Authority	Browns Ferry 3	1091	TC6F-43		9/12/76
Carolina Power & Light	Brunswick 1	849	TC4F-43	2	12/4/76
Georgia Power	Hatch 2	817	TC4F-43	2	9/22/78
Commonwealth Edison	LaSalle 1	1147	TC6F-38	2	Shipped
Pennsylvania Power & Light	Susquehanna 2	1085	TC6F-38		Shipped
Pennsylvania Power & Light	Susquehanna 1	1085	TC6F-38		Shipped
Commonwealth Edison	LaSalle 2	1147	TC6F-38	2	Shipped
Long Island Lighting	Shoreham 1	847	TC4F-43	2	Shipped
Cleveland Electric Illuminating	Perry 1	1253	TC6F-43	2	Shipped
Illinois Power	Clinton Power 1	985	TC4F-43	1	Shipped
Niagara Mohawk Power	Nine Mile Pt 2	1166	TC6F-38	1	Shipped
Gulf States Utilities	River Bend 1	998	TC4F-43	1	Shipped
Cleveland Electric Illuminating	Perry 2	1253	TC6F-43	2	To be shipped
Philadelphia Electric	Limerick 1	1092	TC6F-38		Shipped
Northern Indiana Public Service	Bally Nuclear 1	684	TC4F-38	2	To be shipped
Public Service Electric & Gas	Hope Creek 1	1118	TC6F-38		Shipped
Public Service Co. of Oklahoma	Black Fox 1	1180	TC6F-43		To be shipped
Gulf States Utilities	River Bend 2	998	TC4F-43	1	To be shipped
Public Service Electric & Gas	Hope Creek 2	1113	TC6F-38		Shipped
Public Service Co. of Oklahoma	Black Fox 2	1180	TC6F-43		To be shipped
Philadelphia Electric	Limerick 2	1092	TC6F-38		Shipped
Illinois Power	Clinton Power 2	985	TC4F-43	1	To be shipped

GENERAL ELECTRIC - DOMESTIC  
 NUCLEAR TURBINE-GENERATOR UNITS WITH PRESSURIZED WATER REACTORS  
 OPERATING OR UNDER CONSTRUCTION

<u>CUSTOMER</u>	<u>STATION/UNIT</u>	<u>RATING</u>	<u>TURBINE TYPE</u>	<u>STAGES REHEAT</u>	<u>REACTOR MFG</u>	<u>SERVICE DATE</u>
Washington Public Power	Hanford Sta 2	422	TC4F-43		GE	4/18/66
Washington Public Power	Hanford Sta 1	422	TC4F-43		GE	6/12/66
Duke Power	Oconee 1	887	TC6F-38	2	BW	5/6/73
Omaha Public Power District	Ft. Calhoun 1	481	TC4F-38		CE	8/25/73
Duke Power	Oconee 2	887	TC6F-38	2	BW	12/5/73
Baltimore Gas & Electric	Calvert 1	890	TC6F-38	2	CE	3/6/74
Metropolitan Edison	3 Mile Isle 1	837	TC6F-38		BW	6/19/74
Duke Power	Oconee 3	893	TC6F-38	2	BW	9/18/74
Indiana Michigan Electric	Cook 1	1089	TC4F-43	1	W	2/10/75
Northeast Utilities	Millstone Pt 2	881	TC4F-43	2	CE	11/9/75
Portland General Electric	Trojan 1	1178	TC6F-38	2	W	12/22/75
Toledo Edison	Davis-Besse 1	925	TC4F-43	2	BW	8/29/77
Arkansas Power & Light	Arkansas Nuc 2	943	TC4F-43	2	CE	12/26/78
South Carolina Electric & Gas	Summer 1	954	TC4F-43	1	W	Shipped
Consumers Power	Midland 2	852	TC4F-43	2	BW	Shipped
Duke Power	Catawba 1	1205	TC6F-43	2	W	Shipped
Public Service Co. of N.H.	Seabrook 1	1197	TC6F-43	1	W	Shipped
Consumers Power	Midland 1	905	TC2F-43	2	BW	Shipped
Union Electric	Callaway 1	1192	TC6F-38	2	W	Shipped
Arizona Public Service	Palo Verde 1	1359	TC6F-43	2	CE	Shipped
Kansas Gas & Electric	Wolf Creek 1	1192	TC6F-38	2	W	To be shipped
Duke Power	Catawba 2	1205	TC6F-43	2	W	To be shipped
Georgia Power	Vogtle 1	1157	TC6F-38	1	W	Shipped
Public Service Co. of N.Y.	Seabrook 2	1197	TC6F-43	1	W	To be shipped
Arizona Public Service	Palo Verde 2	1359	TC6F-43	2	CE	To be shipped
Monroester Gas & Electric	Sterling Nuc	1192	TC6F-38	2	W	To be shipped
Toledo Edison	Davis Besse 2	914	TC4F-43	2	BW	To be shipped
Northern States Power	Tyone 1	1192	TC6F-38	2	W	To be shipped
Arizona Public Service	Palo Verde 3	1359	TC6F-43	2	CE	To be shipped
Duke Power	Cherokee 1	1341	TC6F-43	2	CE	To be shipped
Tennessee Valley Authority	Yellow Creek 1	1339	TC6F-43	2	CE	To be shipped
Northeast Utilities	Millstone 3	1209	TC6F-43	1	W	Shipped
Tennessee Valley Authority	Yellow Creek 2	1339	TC6F-43	2	CE	To be shipped
Union Electric	Callaway 2	1192	TC6F-38	2	W	To be shipped
Toledo Edison	Davis Besse 3	914	TC4F-43	2	BW	To be shipped
Duke Power	Cherokee 2	1341	TC6F-43	2	CE	To be shipped
Long Island Lighting	Jamesport 1	1196	TC6F-43	1	W	To be shipped
Georgia Power	Vogtle 2	1157	TC6F-38	1	W	To be shipped
Duke Power	Cherokee 3	1341	TC6F-43	2	CE	To be shipped
Long Island Lighting	Jamesport 2	1196	TC6F-43	1	W	To be shipped



REQUEST FOR INFORMATION RELATED TO TURBINE DISCSSITE SPECIFIC GENERAL QUESTIONS - To Be Completed in 30 Days

- I. Provide the following information for each LP turbine:
  - A. Turbine type
  - B. Number of hours of operation for each LP turbine at time of last turbine inspection or if not inspected, postulated to turbine inspection
  - C. Number of turbine trips and overspeeds
  - D. For each disc:
    1. type of material including material specifications
    2. tensile properties data
    3. toughness properties data including Fracture Appearance Transition Temperature and Charpy upper steel energy and temperature
    4. keyway temperatures
    5. critical crack size and basis for the calculation
    6. calculated bore and keyway stress at operating design overspeed
    7. calculated  $K_{Ic}$  data
    8. minimum yield strength specified for each disc
- II. Provide details of the results of any completed inservice inspection of LP turbine rotors, including areas examined, since issuance of an operating license. For each indication detected, provide details of the location of the indication, its orientation, size, and postulated cause.
- III. Provide the nominal water chemistry conditions for each LP turbine and describe any condenser inleakages or other significant changes in water chemistry to this point in its operating life.
- IV. If your plant has not been inspected, describe your proposed schedule and approach to ensure that turbine cracking does not exist in your turbine.
- V. If your plant has been inspected and plans to return or has returned to power with cracks or other defects, provide your proposed schedule for the next turbine inspection and the basis for this inspection schedule, including postulated defect growth rate.
- VI. Indicate whether an analysis and evaluation regarding turbine missiles have been performed for your plant and provided to the staff. If such an analysis and evaluation has been performed and reported, please provide appropriate references to the available documentation. In the event that such studies have not been made, consideration should be given to scheduling such an action.

GENERIC QUESTIONS - To Be Completed in 30 Days

- I. Describe what quality control and inspection procedures are used for the disc bore and keyway areas.
- II. Provide details of the General Electric repair/replacement procedures for faulty discs.
- III. What immediate and long term actions are being taken by General Electric to minimize future "water cutting" problems with turbine discs? What actions are being recommended to utilities to minimize "water cutting" of discs?
- IV. Describe fabrication and heat treatment sequence for discs, including thermal exposure during shrinking operations.