

DUKE POWER COMPANY

POWER BUILDING

422 SOUTH CHURCH STREET, CHARLOTTE, N. C. 28242

WILLIAM O. PARKER, JR.
VICE PRESIDENT
STEAM PRODUCTION

October 7, 1976

TELEPHONE AREA 704
373-4083

Mr. Benard C. Rusche, Director
Office of Nuclear Reactor Regulation
U. S. Nuclear Regulatory Commission
Washington, D. C. 20555

Attention: Mr. A. Schwencer

RE: Oconee Nuclear Station
Docket Nos. 50-269, -270, -287

Dear Sir:

Your letter dated June 30, 1976 enclosed Amendments Nos. 27, 27 and 24 for Oconee Facility Operating Licenses DPR-38, -47, and -55 respectively. The accompanying supporting safety evaluation by the staff stated that the Licensee had advised that the emergency power path through the 230 kV switchyard had been seismically designed to withstand the 0.15g earthquake referenced to in the Oconee FSAR for Class I structures. Information identifying the details of the seismic design of this path were requested in sufficient time for staff review prior to the restart of Oconee 3 following the Fall, 1976 refueling outage.

The Oconee Nuclear Station Emergency Power System was designed before seismic design criteria for the overhead transmission path was required. It was our belief, however, that this system had been designed to the same criteria as other Class I structures. Since your request for supporting information was received three months ago, a review of existing documentation has been conducted to determine its acceptability to demonstrate the qualification of the path. Considerable effort has been expended in additional analyses and tests which have been considered necessary. Although these analyses are being completed as expeditiously as possible the complexity, diversity and vintage of the equipment comprising this path, and the short period of time which has transpired, has precluded completion of these tasks. Attached is a summary of the seismic qualifications of the path. Dates for completion of those analyses remaining and for the design of certain modifications necessary to assure the seismic integrity of the path are also provided. Supplemental reports will be submitted detailing the schedule for implementation of modifications as soon as their design effort is completed.

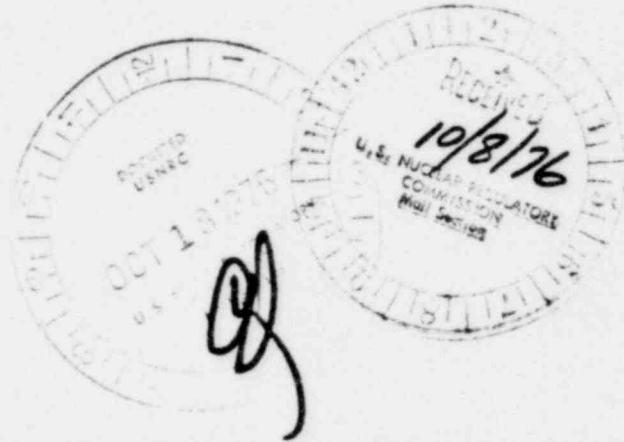

9792

7912060 680 P

Mr. Benard C. Rusche

Page 2

October 7, 1976

In view of the extremely low probability of a seismic event at the Oconee Nuclear Station and the relatively short period of time which will be necessary for the completion of additional analyses and modifications, it is considered that the health and safety of the public will not be affected by the continued operation of the Oconee Nuclear Station.

Very truly yours,

William O Parker Jr

William O. Parker, Jr.

MST:ge

KEOWEE OVERHEAD EMERGENCY POWER PATH
SEISMIC QUALIFICATION AND ANALYSIS
REQUEST FOR ADDITIONAL INFORMATION

The Keowee overhead emergency power path provides a highly reliable source of power to the Engineered Safeguards Systems of the Oconee Nuclear Station.

The Keowee overhead emergency power path consists of a transmission line from the Keowee main stepup transformer to the Oconee 230kV switchyard; one 230kV switchyard bus system including power circuit breakers, disconnect switches, and associated controls; and overhead lines from the Oconee 230kV switchyard to the Oconee startup transformers.

The Keowee overhead emergency power path interfaces with the Keowee main stepup transformer; 230kV switchyard power circuit breakers (numbers 8, 12, 15, 17, 21, 24, 26, 28, and 33); and the Oconee startup transformers (CT1, CT2, and CT3). This overhead emergency power path interfaces have the same seismic qualifications as the systems or equipment of the path itself.

The structures associated with the Keowee emergency overhead power path are Class 2 structures as defined by the Oconee Nuclear Station FSAR, Appendix 5A, Section 5A.1.2 and the PSAR Appendix 5A, Section 1.2.

Class 2 structures are designed in accordance with the structural design bases stated in the Oconee Nuclear Station FSAR, Section 5A.3 for normal operation and accident and seismic conditions. The seismic criteria used in the design of Class 2 structures is the same as the criteria specified for Class 1 structures in the Oconee Nuclear Station FSAR, Section 5A.2.

The structures and equipment comprising the Keowee overhead emergency power path are listed in Tables I and II, respectively.

The Keowee Overhead Emergency Power Path is shown in bold lines on Figure I.

The applicable criteria used in the design, fabrication, and installation of the structures and supports associated with the overhead emergency power path are found in the Oconee Nuclear Station FSAR, Section 5A.2. The applicable criteria for equipment associated with this power path are specified in the individual equipment specifications.

The seismic inputs and applicable loads and load combinations used in the testing and/or analysis of the structures and supports in the overhead emergency power path are covered in the Oconee Nuclear Station FSAR, Section 5A.2. For the seismic inputs used in the testing and/or analysis of equipment in the subject power path, refer to Table II.

Stress analyses using static loading conditions were used in the design and analysis of the structures and supports in the overhead emergency power path. These stress analyses used the maximum acceleration response value (i.e., the peak value of the response spectra curve corresponding to the appropriate damping factor) to calculate the static loads. The basis for this type analysis is given in the Oconee Nuclear Station FSAR, Section 2.6, and the PSAR, Supplement 1, Section 8.4.3(c). The design calculations for the above structures and supports are in the Duke Power Company Design Engineering Department files. The design and analysis methods, the design parameters, and the design limits used are shown in the calculations. For information regarding the equipment seismic qualification methods, refer to Table II.

The structures and supports for the overhead emergency power path are typical structural steel framing. The materials used and the design of the framing require no special fabrication or construction techniques other than accepted industry standards. There were no formal quality control procedures in effect for the procurement of material or the fabrication of Class 2 structures or supports. For equipment in the subject power path, any special materials or fabrication techniques required are stated in the individual equipment specification. There were no formal quality control procedures in effect for the procurement of equipment used in this power path. The equipment manufacturers were required to submit a statement indicating conformance with the equipment specification. Duke Power Company engineers also reviewed the manufacturers' designs, inspected equipment during various steps of manufacturing, and witnessed manufacturers' tests on the major equipment in the emergency power path.

Testing and inservice surveillance requirements are not applicable to the structures and supports of the overhead emergency power path. The equipment associated with this path is functionally tested monthly during the Emergency Power System Test (refer to the Oconee Nuclear Station Technical Specifications, Section 4.6). Additionally, all applicable equipment undergoes routine preventive maintenance in accordance with procedures established by Duke Power Company.

The Ocor 230kV switchyard strain structures are designed for allowable unit stresses in accordance with AISC Specifications (1963) with provisions for allowable stress increase of one-third for load combinations with 115 MPH wind. All strain structures are also designed for wind and

ice loads on conductors and shield wires in accordance with the National Electric Safety Code, Fourth Edition, for heavy loading (0.5 inches of radial ice and eight pounds wind at 0°F). The 230kV switchyard bus system (i.e., bus, bus supports, disconnect switches, lighting, arresters, etc.) are designed for 95 MPH winds. (Refer to the Oconee Nuclear Station FSAR, Section 5A.5).

Flood and tornado effects are not applicable to Class 2 structures. Flood studies (refer to the Oconee Nuclear Station FSAR, Section 2.4.3) show that Lake Keowee and Lake Jocassee are designed to contain and control floods such as to pose no risk to the Oconee Nuclear Station site.

Figure 1

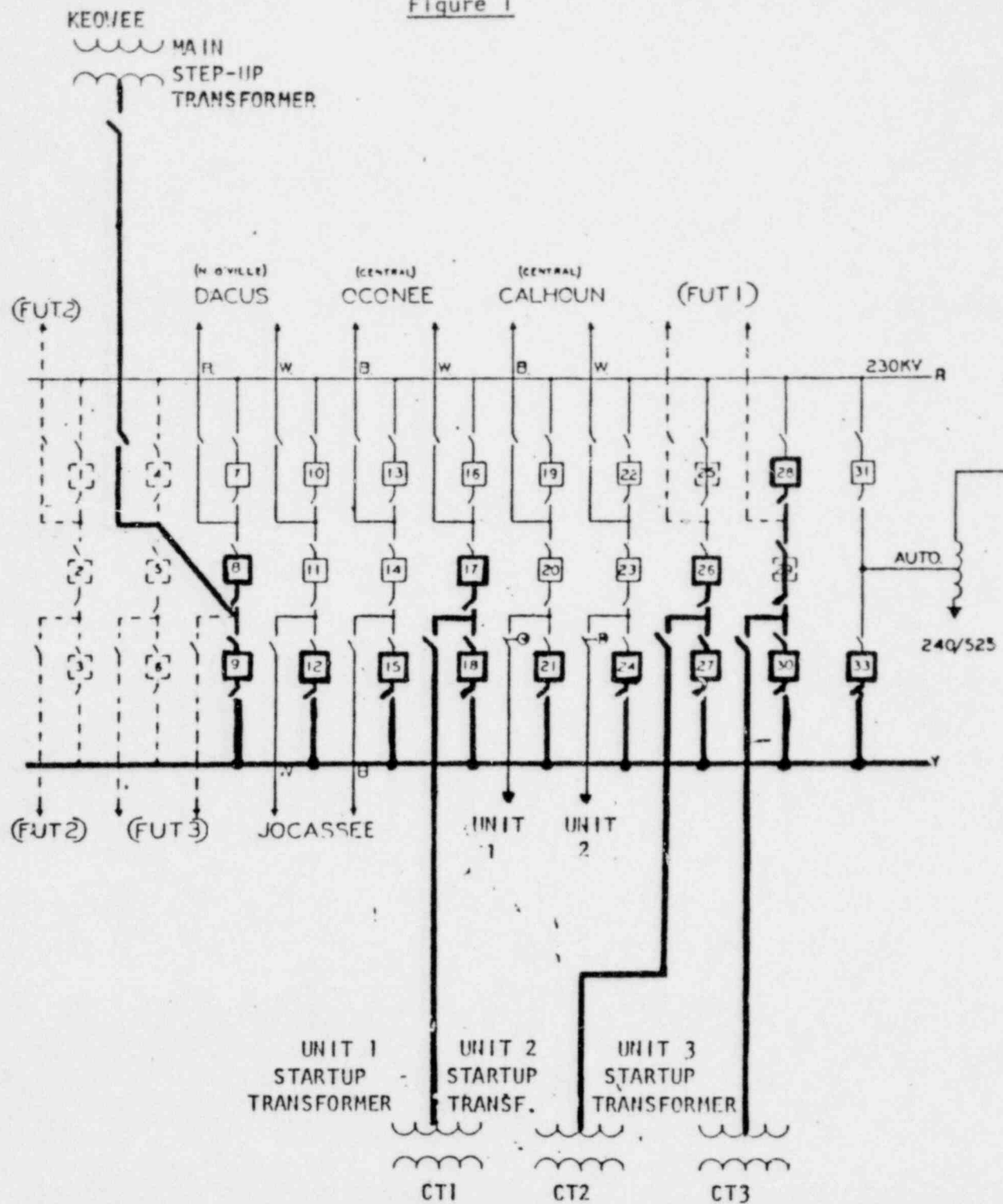

TABLE 1
KEOWEE-OCONEE OVERHEAD EMERGENCY
POWER PATH STRUCTURES QUALIFICATION SUMMARY

STRUCTURE	QUALIFIED	METHOD	BASIS FOR QUALIFICATION
1. Keewee Main Stepup Transformer Base	See Note 1	Analysis	0.15g Ground Motion
2. Oconee Startup Transformer Bases	See Note 2	Analysis	0.15g Ground Motion
3. Keewee 230KV Line Pulloff Structure	Yes	Analysis	0.15g Ground Motion
4. 230KV Transmission Line and Towers from Keewee to Oconee	See Note 3	Analysis	0.15g Ground Motion
5. Oconee 230KV Strain Structures	Yes	Analysis	0.15g Ground Motion
6. Oconee 230KV Swyd. Bus Support Structure	Yes	Analysis	0.15g Ground Motion
7. Oconee 230KV Swyd. Wave Trap Support Structure	Yes	Analysis	0.15g Ground Motion
8. Oconee 230KV Swyd. Lightning Arrestor Support Structure	Yes	Analysis	0.15g Ground Motion
9. Oconee 230KV Swyd. Coupling Capacitor Potential Devices (CCPD) Support Structure	See Note 4	Analysis	0.15g Ground Motion
10. Oconee 230KV Swyd. Disconnect Switch Support Structure	See Note 5	Analysis	0.15g Ground Motion
11. Oconee 230KV Swyd. PCB Support Structure	See Note 6	Analysis	0.15g Ground Motion
12. Oconee 230KV Swyd. Relay House	See Note 7	Analysis	0.15g Ground Motion
13. Oconee 230KV Swyd. Relay House Equipment Anchoring	See Note 7	Analysis	0.15g Ground Motion
14. 230KV Lines from Oconee 230KV Switchyard to Startup Transformers	Yes	Analysis	0.15g Ground Motion
15. Oconee Powerhouse 230KV Line and Shield Wire Pulloff Structures	Yes	Analysis	0.15g Ground Motion

- Note 1: Additional base restraints are to be added. Estimated scheduled completion for design of these modifications is December 1, 1976.
- Note 2: Additional base restraints to be added as results of analysis and design. Design modification completion is scheduled by November 1, 1976.
- Note 3: Analyses scheduled for completion November 1, 1976.
- Note 4: Those CCPD structures with bases located in fill-soil are qualified. Analysis is being conducted on those CCPD structures with bases located in original soil. Tests are scheduled to be completed by December 15, 1977.
- Note 5: Same as Note 4 except applicable to Disconnect Switch Support Structures.
- Note 6: Analysis scheduled for completion December 1, 1976.
- Note 7: The relay house structure is qualified. Modifications are to be made to cable trenches, concrete block walls, and the anchorage of some equipment. The completion of the design for these modifications is scheduled for February 1, 1977.

TABLE II
KEOWEE-OCONEE OVERHEAD EMERGENCY
POWER PATH EQUIPMENT SEISMIC QUALIFICATION SUMMARY

EQUIPMENT TYPE	IDENTIFICATION	QUALIFIED	METHOD	BASIS OF QUALIFICATION
1. Keowee Main Stepup Transformer	Transformer No. 1	Yes	Manufacturer Test/Analysis	0.36g
2. Oconee Startup Transformers	CT1, CT2, CT3	Yes	Manufacturer Test/Analysis	0.36g
3. 230KV Disconnect Switches		Yes	Manufacturer Test/Analysis	0.36g
4. Oconee 230KV Swyd. Bus Conductor System		See Note 1	Analysis	0.36g
5. 230KV Power Circuit Breakers (PCB's)	PCB Nos. 8, 9, 12, 15, 17, 18, 21, 24, 26, 27, 28, 30, 33	See Note 2	Test/Analysis	0.36g
6. 230KV Swyd. Coupling Capacitor Potential Devices		Yes	Manufacturer Test/Analysis	0.36g
7. 230KV Swyd. Lightning Arrestors		Yes	Manufacturer Test/Analysis	0.36g
8. 230KV Swyd. DC Distribution Centers	Nos. SY-DC1, SY-DC2	Yes	Test	0.36g
9. 230KV Swyd. DC Panelboards	Nos. DYA, DYB, DYC, DYD, DYE, DYF, DYG, DYH	Yes	Manufacturer Test	0.36g
10. 230KV Swyd. Control Power Batteries	Nos. SY-1, SY-2	Yes	Manufacturer Test	0.36g
11. 230KV Swyd. Battery Chargers	Nos. SY-1, SY-2, SY-S	Yes	Manufacturer Test	0.36g
12. 230KV Swyd. Relay House Lighting System		Yes	Analysis	0.36g

EQUIPMENT TYPE	IDENTIFICATION	QUALIFIED	METHOD	BASIS OF QUALIFICATION
13. 230KV Swyd. Relay Panels & Equipment		Note 3	Test/Analysis	0.36g
14. 230 KV Swyd. Relay House Roof Drain Pipe		See Note 4	Analysis	0.36g
15. 230KV Swyd. Relay House HVAC Duct		See Note 4	Analysis	0.36g
16. 230KV Swyd. Relay House Air Handling Unit		See Note 4	Analysis	0.36g

Note 1: Analysis incomplete. Scheduled to be completed by November 1, 1976.

Note 2: Analysis incomplete. Scheduled to be completed by March 1, 1977.

Note 3: Analysis incomplete. Scheduled to be completed by November 1, 1976.

Note 4: Minor field modifications are to be made. Schedule for modification design completion is November 1, 1976.