

APPENDIX I TABLE OF CONTENTS

APPENDIX I 10CFR50, APPENDIX I EVALUATION OF RADIOACTIVE RELEASES FROM
 POINT BEACH NUCLEAR PLANT (Historical) - - - - - I.1-1

I.1 INTRODUCTION (Historical) - - - - - I.1-1

 I.1.1 LIQUID RADIOACTIVE WASTE SYSTEM (Historical)- - - - - I.1-1

 I.1.2 GASEOUS RADIOACTIVE WASTE SYSTEM (Historical) - - - - - I.1-1

 I.1.3 SECONDARY SYSTEM WASTES (Historical) - - - - - I.1-1

 I.1.4 CHEMICAL AND VOLUME CONTROL SYSTEM (Historical) - - - - - I.1-2

 I.1.5 PLANT VENTILATION AND FILTRATION SYSTEMS (Historical)- - - - - I.1-2

 I.1.6 PREVIOUS RADIOACTIVE WASTE SYSTEM MODIFICATIONS (Historical) - - - - - I.1-2

 I.1.7 SUBSEQUENT CHANGES TO THE WASTEWATER EFFLUENT SYSTEM (Historical) - - I.1-3

 I.1.8 SUBSEQUENT CHANGES TO THE LIQUID RADIOACTIVE WASTE SYSTEM
 (Historical) - - - - - I.1-3

I.2 INFORMATION IN RESPONSE TO APPENDIX D OF DRAFT REGULATORY GUIDE 1.BB
 (Historical) - - - - - I.2-1

 I.2.1 General (Historical) - - - - - I.2-1

 I.2.2 Primary System (Historical) - - - - - I.2-2

 I.2.3 Secondary System (Historical) - - - - - I.2-2

 I.2.4 Liquid Waste Processing Systems (Historical) - - - - - I.2-3

 I.2.5 Gaseous Waste Processing System (Historical) - - - - - I.2-4

 I.2.6 Ventilation and Exhaust Systems (Historical) - - - - - I.2-6

 I.2.7 References (Historical) - - - - - I.2-8

I.3 CALCULATED SOURCE TERMS AND RELEASES OF GASEOUS AND LIQUID
 EFFLUENTS (Historical)- - - - - I.3-1

 I.3.1 ORIGINAL APPENDIX I EVALUATION (Historical) - - - - - I.3-1

 I.3.2 IMPACT OF UPRATED POWER OPERATIONS (Historical) - - - - - I.3-1

 I.3.3 REFERENCE (Historical)- - - - - I.3-1

I.4 METEOROLOGY (Historical) - - - - - I.4-1

 I.4.1 METEOROLOGICAL PROGRAM AT POINT BEACH NUCLEAR PLANT (Historical) - - - I.4-1

 I.4.2 DESCRIPTION OF X/Q AND D/Q MODELING PROCEDURES (Historical)- - - - - I.4-4

 I.4.3 CALCULATED X/Q AND D/Q VALUES FOR POINT BEACH NUCLEAR PLANT
 (Historical) - - - - - I.4-9

 I.4.4 REFERENCES (Historical) - - - - - I.4-9

I.5.0	HYDROLOGY (Historical)	I.5-1
I.5.1	DESCRIPTION OF DISCHARGE (Historical)	I.5-1
I.5.2	HYDROLOGICAL MODEL (Historical)	I.5-1
I.5.3	INPUT DATA (Historical)	I.5-3
I.5.4	REFERENCES (Historical)	I.5-3
I.6	SUPPLEMENTAL INFORMATION (Historical)	I.6-1
I.6.1	ENCLOSURE 1 (Historical)	I.6-1
I.6.2	ENCLOSURE 2 (Historical)	I.6-1
I.7	COMPARISONS OF REPORTED AND CALCULATED RELEASES OF RADIOACTIVITY (Historical)	I.7-1
I.7.1	GASEOUS RELEASES (Historical)	I.7-1
I.7.2	LIQUID RELEASES (Historical)	I.7-2
I.8	CALCULATIONS OF DOSES TO MAN (Historical)	I.8-1
I.8.1	DOSE MODELS - OFFSITE INDIVIDUALS (Historical)	I.8-1
I.8.2	DOSE MODELS - ONSITE INDIVIDUALS (Historical)	I.8-4
I.8.3	CALCULATED DOSES (Historical)	I.8-5
I.8.4	REFERENCES (Historical)	I.8-5
I.9	SUMMARY (Historical)	I.9-1
I.9.1	GASEOUS RELEASES (Historical)	I.9-1
I.9.2	LIQUID RELEASES (Historical)	I.9-1
I.9.3	IMPACT OF UPRATED POWER OPERATIONS (Historical)	I.9-2
I.9.4	REFERENCE (Historical)	I.9-2

I.1 10 CFR 50, APPENDIX I EVALUATION OF RADIOACTIVE RELEASES FROM POINT BEACH NUCLEAR PLANT

I.1 INTRODUCTION

[Appendix I to 10 CFR Part 50](#) of the Nuclear Regulatory Commission (NRC) regulations, published in May, 1975, sets forth numerical guidelines for design objectives and limiting conditions for operation to maintain releases of radioactive materials from light water reactors “as low as is reasonably achievable.” Section V.B of [Appendix I](#) requires the holders of permits or licenses for operation of light water reactors to submit information necessary to evaluate the means employed to meet the objectives of Appendix I. This appendix contains information for the evaluation in response to guidelines provided by the Commission in February, 1976.

Radioactive waste system and related systems are described in the FSAR, [Section 9.0](#) and [Section 11.0](#). In the initial plant design provisions were made for processing of all radioactive liquid and gaseous wastes prior to release via monitored pathways to the environment. Brief descriptions of the various systems and operation are as follows.

I.1.1 LIQUID RADIOACTIVE WASTE SYSTEM (See [Note 1](#))

All liquid radioactive wastes from controlled areas of the plant are collected in the liquid radioactive waste system waste holdup tank. These wastes are then processed by evaporation, as a minimum, and are released to the circulating water discharge on a batch basis. Each batch is analyzed prior to release. Filtration and demineralization equipment is available for further processing prior to release. Liquids are normally not recycled from this system.

I.1.2 GASEOUS RADIOACTIVE WASTE SYSTEM (See [Note 1](#))

Initial plant design incorporated a compressed gas decay tank system supplying cover gas for tanks containing un-degassed reactor coolant. Cover gas (primarily nitrogen) displaced by filling tanks and gas from chemical and volume control system gas strippers is compressed and stored in gas decay tanks. This gas is reused as cover gas when tanks are drained by processing or transfer of liquids. Periodically, gas must be released. The release is on a batch basis following a minimum decay time specified by Technical Specifications. Each batch is analyzed prior to release.

I.1.3 SECONDARY SYSTEM WASTES (See [Note 1](#))

Turbine building drains from both Units 1 and 2 are collected and routed to the effluent sump. Potable Water System Reverse Osmosis unit concentrate discharge and filter backwash are drained into the plant effluent sump. The façade sumps are normally pumped to the effluent sump. Sanitary wastes from the plant are routed to the plant sewage treatment system, which also discharges to the effluent sump. The effluent sump is pumped to the retention pond. The retention pond overflow effluent is normally released to a pathway subject to monitoring via radiation monitor RE-230 to the circulating water system. Capability for further processing of these wastes is not provided.

Initial plant design incorporated a flash tank for pressure reduction and cooling of the steam generator blowdown for each unit. The vent from each flash tank is routed to a plant ventilation exhaust. Liquid from the flash tank is routed to the circulating water discharge. Provisions are

also included for routing this liquid to the boric acid evaporators in the chemical and volume control system during periods of operation with significant primary-to-secondary leakage. Processed liquids are normally not recycled from this system.

I.1.4 CHEMICAL AND VOLUME CONTROL SYSTEM (See [Note 1](#))

The chemical and volume control system (CVCS) holdup tanks are shared between Units 1 and 2 and collect reactor coolant letdown for boron control and miscellaneous other reactor coolant drains. These liquids are then processed by ion exchange, gas stripping, filtration, and evaporation in the boron recovery portion of the CVCS. Boric acid evaporator condensate is collected and monitored on a batch basis prior to recycle to the reactor makeup water storage tank or release to the circulating water discharge. Concentrated boric acid is sent to the boric acid storage tanks or is solidified in cement and shipped offsite for burial. Evaporator condensate from this system is recycled as far as practicable for use as reactor makeup water.

I.1.5 PLANT VENTILATION AND FILTRATION SYSTEM (See [Note 1](#))

Ventilation air from buildings normally containing radioactive materials and equipment is exhausted through HEPA and/or carbon adsorber equipment depending on the potential for significant releases. Turbine building ventilation is exhausted through roof exhausters with no treatment.

Containment ventilation systems include HEPA and carbon adsorber equipment in internal recirculation systems and purge systems.

I.1.6 PREVIOUS RADIOACTIVE WASTE SYSTEM MODIFICATIONS (See [Note 1](#))

In 1971, Licensees completed conceptual designs of additional equipment to augment the initial plant systems and allow further reduction of radioactive releases from Point Beach Nuclear Plant. This additional equipment included treatment of air ejector offgas, larger evaporation equipment, gas stripping and decay processes, and cryogenic adsorption equipment for removal of long-lived noble gases from waste gas prior to release.

The additional evaporation equipment is used to process radioactive liquid waste and can be used to process steam generator blowdown from either unit. The capability for recycle of processed blowdown is also incorporated in these modifications. In addition, steam generator blowdown tank vent condensers are used to minimize potential gaseous releases.

Air ejector offgas from Units 1 and 2 passes through a delay duct for decay of short-lived isotopes and can be processed by a carbon adsorber prior to release.

Gas stripper equipment is used to maintain reactor coolant gas concentrations at low levels by stripping the letdown from each unit. Stripped gas from the gas strippers is sent to charcoal decay tanks shared by Units 1 and 2. Effluent from the charcoal decay tanks is normally recycled to Unit 1 and Unit 2 volume control tanks in the CVCS to minimize gaseous releases. If stripped gas is released, it can be processed for krypton removal in the cryogenic adsorption equipment prior to release. The adsorbed krypton is then stored in a gas decay tank.

I.1.7 SUBSEQUENT CHANGES TO THE WASTEWATER EFFLUENT SYSTEM

In 2002, conveyor type filters replaced the Retention Pond. A modification installed two filtration conveyors capable of processing 300 gpm each through a roll of paper media. These new filtration conveyers were installed to process the turbine hall sumps and the water treatment wastewell to provide assurance of compliance with the WPDES permit for total suspended solids. After the installation of the conveyers the turbine hall sump was rerouted to the conveyers and isolated as an input to the effluent sump. As part of the retirement of the retention pond, the wastewater stream from the plant effluent sump discharge was rerouted back into the plant and joined the common discharge piping downstream of the new filters, but upstream of RE-230, Wastewater effluent process monitor. The effluent sump was routed downstream of the filters because the inputs to the sump (sewage treatment plant effluent and potable water RO unit filter backwash and reject), meet the WPDES permit for solids without further treatment. The inputs into the effluent sump are routed past RE-230 prior to discharge.

A third filtration conveyer was installed to process the facade sump drains. The façade sumps were rerouted to a 30-gpm conveyor, and the filter media is checked for contamination prior to disposal. This limits the spread of contamination and will prevent cross contamination of normally clean systems.

The Retention Pond was subsequently capped and abandoned.

I.1.8 SUBSEQUENT CHANGES TO THE LIQUID RADIOACTIVE WASTE SYSTEM

A filtration/demineralization system has been added to the liquid radioactive waste system, and serves as the primary means of processing liquid radioactive waste. Wastes are processed and released to the circulating water discharge on a batch basis. Each batch is analyzed prior to release. If necessary, the processed liquid can be returned for reprocessing. The estimated liquid releases, based on use of the filtration/demineralization system, are listed in [Table 11.1-3](#).

Note 1. Description reflects plant design information when the Appendix I evaluation was performed. See other FSAR sections as applicable for current system descriptions.

I.2 INFORMATION IN RESPONSE TO APPENDIX D OF DRAFT REGULATORY GUIDE 1.BB

The information in this section was provided in response to Draft Regulatory Guide 1.BB (Reference 1) and referenced the FSAR where appropriate. In many instances, plant operating data were used, rather than design data in the FSAR, because these data were representative of expected plant operation. Adjustments in the assumptions contained in Reference 1 also were included where appropriate to account for shared systems and structures at Point Beach Nuclear Plant.

The information and data provided in this response are part of the evaluation demonstrating compliance with 10 CFR 50, Appendix I governing design (dose) objectives for radioactive effluents. Updates or changes to individual parameters are not to be made in the remaining sections (i.e., 2.0 – 9.0) unless a complete re-evaluation is to be performed. However, design or procedural changes that impact the calculation results or conclusion of this evaluation are to be updated in the appropriate sections of the evaluation. PBNP effluents are controlled, quantified, and evaluated pursuant to the programs required by the PBNP Offsite Dose Calculation Manual.

I.2.1 GENERAL

- a. Maximum core thermal power is 1518.5 MWt as stated in the FSAR, Table 3.2-1, and Operating Licenses DPR-24 and DPR-27.
- b. 1) The total calculated mass of uranium and plutonium in an equilibrium core is as follows:

	<u>Beginning Of Life</u>	<u>Middle Of Life</u>	<u>End Of Life</u>
Uranium (as U), lbs.	105,409	104,816	104,093
Plutonium (as Pu), lbs.	425	583	711

These values are based on an average burnup of 9300 MWD/MTU and operation at approximately 80 percent capacity factor.

- 2) Reload fuel is enriched to 3.1 weight percent uranium U²³⁵
- 3) There is no fissile plutonium in reload fuels at the present time.
- c. 1) The assumed plant capacity factor is 80 percent.
- 2) The assumed fuel defect level is 0.12 percent. The fuel cladding is Zircaloy.

- 3) Concentrations of fission, corrosion, and activation products in the primary and secondary coolant are given in [Table I.3-2](#) and [Table I.3-3](#), respectively, and are based on calculational methods recommended by [Reference 1](#).
- d. The quantity of tritium released in liquid and gaseous effluents is 610 and 610 curies per year, respectively, as calculated according to [Reference 1](#) assumptions. Tritium quantities released in liquid and gaseous effluents based on plant operating data are 859 and 110 curies per year, respectively.

I.2.2 PRIMARY SYSTEM

- a. The total calculated mass of primary coolant in the system (excluding the pressurizer and purification system) is 247,600 pounds per unit at full power. This value is based on volumes given in the FSAR, [Table 4.1-1](#) and [Table 4.1-3](#), with operation at T_{avg} of 570°F and a pressure of 2250 psig.
- b. The average primary coolant letdown rate to the purification system is 40 gallons per minute (19,800 pounds per hour) for each unit, based on information in the FSAR, [Table 9.3-2](#).
- c. The average flow rate through the cation demineralizers in the purification system is zero. Although initial design and operation included a cation demineralizer in series with a mixed bed demineralizer present plant operation normally utilizes only a single mixed bed demineralizer. Lithium control is accomplished with a mixed bed in H_3BO_3 form. This change was made necessary by the limited availability of lithium-7 hydroxide and lithium-7 form demineralizer resins.
- d. The average flow rate to the CVCS holdup tanks is approximately 1.1 gallons per minute (564 pounds per hour) for each unit, based on plant operating data for 1974 and 1975.

I.2.3 SECONDARY SYSTEM

- a. Each unit has two U-tube recirculating type steam generators. The carryover assumed in the evaluation is 0.20 percent for each steam generator based on plant measurements.
- b. The steam flow is 6.62×10^6 pounds per hour (3.31×10^6 pounds per hour per steam generator) based on the FSAR, [Table 4.1-4](#).
- c. The mass of steam in each steam generator at full power is 5,230 pounds, based on the FSAR, [Table 4.1-4](#), and steam conditions of 521°F and 821 psia.
- d. The mass of liquid in each steam generator at full power is 80,240 pounds based on the FSAR, [Table 4.1-4](#), and saturated conditions at 821 psia.
- e. The total mass of coolant in the secondary system at full power is 197,600 pounds (excluding the steam generators and the condenser hotwells) based on calculations from plant measurements.

- f. The primary to secondary leak rate assumed in the evaluation is 100 pounds per day for each unit.
- g. Each steam generator is provided with a blowdown connection located above the tubesheet. The blowdown is presently routed to a blowdown flash tank in each unit through throttling valves. The discharge from the flash tank is pumped through a filter to the plant circulating water discharge. Each blowdown flash tank is provided with a vent condenser cooled by service water. Modifications to the present system were made to allow heat recovery and processing of blowdown by [the filtration/demineralization system](#) if required prior to release.

During operation with significant primary to secondary leakage, steam generator blowdown can be processed at a reduced rate by [routing the affected steam generator\(s\) blowdown to the waste holdup tank and the filtration/demineralization system; which is shared by Units 1 and 2](#). The steam generator blowdown system is further discussed in the FSAR, [Section 10.1](#) and [Section 11.1](#).

Steam generator blowdown rates are normally on the order of 25 gallons per minute (12,500 pounds per hour) per steam generator. This is the average value used in the evaluation.

- h. Point Beach Nuclear Plant does not have provisions for condensate polishing demineralizers.

I.2.4 LIQUID WASTE PROCESSING SYSTEMS

- a. Information on sources of radioactive liquid wastes, flow rates, and expected radioactivity concentrations is provided in [Table I.2-1](#). These values are based on recommendations of [Reference 1](#), where appropriate, and on plant operating data. All liquid waste sources are calculated assuming plant operation for 365 days per year except for steam generator blowdown which is adjusted for an 80 percent capacity factor.

Since Point Beach Nuclear Plant is a two-unit plant with many shared systems and structures, it is not appropriate in all cases to double the values for a single unit as recommended by [Reference 1](#). In addition, because of the sharing, releases cannot be directly attributed to either Unit 1 or Unit 2 in most cases. Therefore, the information presented in [Table I.2-1](#) represents the total for Point Beach Nuclear Plant.

Values provided in [Reference 1](#), Table B-17, are used and are doubled for the two-unit plant except for the following items:

- 1) Laboratory drains are not doubled since there is a single laboratory for two units with drains directed to the liquid waste system.
- 2) Detergent wastes are not doubled since there is a single laundry for two units.
- 3) In addition to turbine building floor drains, additional secondary system waste is generated by continuous chemical analyzers in the secondary system. These have been added in addition to the turbine building floor drains value in [Reference 1](#).

- 4) Point Beach Nuclear Plant does not regenerate demineralizers in primary systems and no allowance is made for these wastes.
- 5) Evaporator condensate from the boric acid evaporators is recycled as reactor makeup water if the purity is within chemical specifications for makeup, however, releases from this source occur frequently. [Table I.2-1](#) includes this source as a separate category.

Comparison of plant released for 1974 and 1975 with values derived from [Table I.2-1](#) indicates good agreement. [Table I.2-1](#) is therefore used in the evaluation of releases.

Capacities of tanks and processing equipment used in calculating holdup times and decontamination factors for each processing step are provided in [Table I.2-2](#) and [Figure I.2-1](#), respectively.

Calculated liquid source terms by isotope and waste category are provided in [Table I.7-3](#). Calculated holdup times for each waste category are provided in [Table I.2-3](#). Observed operational liquid releases are provided in [Table I.7-6](#).

- b. Piping and instrument diagrams for radioactive waste systems and related systems are shown in the FSAR, [Figure 9.3-1](#) through [Figure 9.3-5](#), [Figure 10.1-1](#), [Figure 11.1-1](#) through [Figure 11.1-3](#), and [Figure 11.2-1](#) through [Figure 11.2-4](#). Process flow diagrams for the liquid waste system and the CVCS are presented in [Figure I.2-1](#) and [Figure I.2-2](#), respectively.

I.2.5 GASEOUS WASTE PROCESSING SYSTEM

- a. The volume of gas stripped from the primary coolant is approximately 78,000 cubic feet per year for each unit based upon a primary coolant hydrogen concentration of 35 cc per kilogram at standard conditions, a normal letdown flow of 40 gallons per minute, and two cold shutdowns per year for each unit.
- b. During normal operation, the primary coolant letdown flow for purification is continuously stripped, with stripped gas being routed to the gaseous radioactive waste processing system. The purified hydrogen from the charcoal decay tanks in the gaseous radioactive waste system is recycled to the volume control tanks as described in the FSAR, [Section 11.2](#).

Prior to a refueling shutdown or a cold shutdown requiring opening of the primary system, the primary system is stripped of dissolved gases. Under these conditions, the purified gas is routed to the volume control tank of the other unit.

The gaseous radioactive waste system incorporates a closed cover gas system with pressurized storage tanks which are used to store gas displaced during filling of the tanks in the CVCS and from operation of the gas strippers in the boron recovery portion of the CVCS. When tanks are emptied by processing, the stored gas is then recycled to fill the tank space. Periodically, gas inventory requires release of a portion of the stored gas. Present operation of the system utilizes four gas decay tanks in the cover gas system. The fourth tank can be used for storage of krypton from the cryogenic absorption equipment.

Each of the four usable gas decay tanks in the cover gas system has a volume of 525 cubic feet and a maximum operating pressure of 105 psig at ambient temperature. The total volume released from the tank at maximum pressure is approximately 3750 cubic feet at standard conditions. Plant radioactive release records indicate average release rates ranging from 2 to 15 cfm during batch releases.

- c. During normal operation, cover gas is routed between the CVCS holdup tanks and the gas decay tanks with small quantities of gas being produced from the gas strippers in the CVCS. The major source of gas is that produced by filling a CVCS holdup tank with letdown from the primary system during plant startup, load-follow operation, or boron dilution near the end of core life and from draining of the fuel transfer canal in the spent fuel pool. Normally, one gas decay tank is held in reserve to accommodate filling of one holdup tank. Releases are made as required to allow one gas decay tank to be held in reserve.

Minimum holdup time prior to release of a gas decay tank is 7 days as specified in Technical Specifications. Actual holdup times are significantly longer, based on plant experience on the order of one release per month.

Fill times for gas decay tanks are not predictable due to the variety of operating conditions which result in filling a tank and to the reuse of gas as cover gas. During letdown to the hold up tanks, the fill time is controlled by the maximum letdown rate of 80 gallons per minute. Under these conditions, the fill time is approximately 6 hours. During fuel transfer canal draining, the fill time is controlled by gas compressor capacity of 40 cubic feet per minute. Under these conditions, the fill time is approximately 1.5 hours.

Further discussion of the gaseous radioactive waste system is provided in the FSAR, [Section 11.2](#).

- d. HEPA filters are not provided downstream of the gas decay tanks.
- e. Stripped gas from the continuously operating letdown gas strippers (one per unit) is routed to 3 charcoal decay tanks connected in series. These 3 tanks, common to both units, each contain approximately 1000 pounds of charcoal. Total volume of each tank is 46 cubic feet and normal operating pressure is 75 psig at ambient temperature. The dynamic absorption coefficients (K) for krypton and xenon are 77.7 and 1,386 cm³/gm, respectively, at an operating pressure of 75 psig at 77°F. The dew point is 40°F. From Section 2.5.a, the operational flow rate is calculated at 0.37 cubic feet per minute at standard conditions for both units.

Stripped gas, mainly hydrogen, is normally routed from the charcoal decay tanks back to the reactor coolant system. Optional routing is to the cryogenic system for krypton removal or to the gas decay tanks in the cover gas system. An additional route to the auxiliary building vent exists but is not normally used.

- f. Piping and instrumentation diagrams for the gaseous radioactive waste system are given in the FSAR, [Figure 11.2-1](#), [Figure 11.2-2](#), and [Figure 11.2-3](#). A process flow diagram is presented in [Figure I.2-3](#).

I.2.6 VENTILATION AND EXHAUST SYSTEMS

- a. Areas of Point Beach Nuclear Plant which normally contain radioactive materials and which are provided with measures to reduce airborne radioactivity releases are shown in the FSAR, [Figure 11.4-1](#) through [Figure 11.4-8](#). Within these areas, the ventilation systems are designed so that flow is from areas of low potential for radioactive contamination to areas of higher potential. Piping and instrumentation diagrams for these ventilation systems are shown in [Figure I.2-4](#) and [Figure I.2-5](#). Areas of the plant which could contain low levels of radioactive contaminants with primary-to-secondary leakage, such as the turbine building, are not provided with HEPA or carbon adsorber equipment since releases from the areas are insignificant. A process flow diagram for all major ventilation systems is presented in [Figure I.2-3](#). Ventilation and exhaust systems are as follows:

1) Containment Ventilation

Each containment is provided with a containment purge system, an internal cleanup system, and a purge vent which exhausts above the containment facade. Purge exhaust (12,500 cubic feet per minute) is through roughing filters, HEPA filters, and carbon adsorbers. The internal cleanup system (5,000 cubic feet per minute) is provided with roughing filters, HEPA filters and carbon adsorbers. The cleanup system is not necessarily operated prior to each purge and therefore no credit is taken in the evaluation of releases via containment ventilation.

Pressure buildup in the containment as a result of instrument air leakage is vented continuously at a rate of approximately 10 cubic feet per minute via the containment air monitor. This effluent is routed to the containment purge filters prior to release via the purge vent.

The gas stripper building ventilation is routed to the Unit 2 purge vent at flow rates varying from 400 to 12,000 cubic feet per minute, depending on building air temperature. Operational measurements indicate that only about 2 percent of the total plant noble gas release is via this pathway. Capability exists for routing this ventilation air through the Unit 2 containment purge filtration equipment.

2) Auxiliary Building Ventilation

The auxiliary building ventilation includes ventilation air from service building controlled areas and is exhausted through the auxiliary building and the drumming area vents located above the Unit 1 containment facade.

The drumming area vent receives ventilation air from the drumming station in the auxiliary building, general areas of the auxiliary building above elevation 46' and spent fuel pool areas. Roughing and HEPA filters are provided for this exhaust.

The auxiliary building vent exhausts air from the service building, chemistry laboratory, general areas of the auxiliary building and cubicles containing radioactive equipment. The chemistry laboratory exhausts to the auxiliary building vent through roughing filters, HEPA filters and carbon adsorbers. Service building ventilation and general areas and

cubicles of the auxiliary building containing equipment with low potential for iodine releases are exhausted through roughing and HEPA filters. Areas of the auxiliary building with high potential for iodine releases are routed through roughing and HEPA filters to the auxiliary building vent with an optional route through carbon adsorbers and HEPA filters.

3) Turbine Building Ventilation

Units 1 and 2 share a combined turbine building. Outside air is provided at all levels of the building and is exhausted through 19 turbine building roof exhausters evenly spaced along the length of the turbine building roof.

4) Condenser Air Ejectors

Unit 1 and Unit 2 air ejectors discharge to a delay duct in the turbine building which provides a nominal one hour holdup prior to release via the auxiliary building vent. An optional route is through a carbon adsorber prior to the delay duct.

5) Radioactive Waste Gases

Releases of cover gas from gas decay tanks are directly to the auxiliary building vent at a controlled rate.

Stripped gas from the Unit 1 and Unit 2 gas strippers is normally routed through the charcoal decay tanks and back to the CVCS volume control tank for each unit. This gas may also be released directly to the auxiliary building vent. An optional route is to pass the charcoal decay tank effluent through cryogenic adsorption equipment prior to release. No credit for the cryogenic system is taken in calculating radioactive releases.

- b. Decontamination factors of 10 for iodines through carbon adsorbers and 100 for particulates through HEPA filters are assumed for the evaluation, consistent with recommendations in [Reference 1](#). All carbon adsorbers at Point Beach Nuclear Plant have a bed depth of 2 inches and a maximum face velocity of 40 feet per minute. Periodic testing of filtration equipment indicates decontamination factors at least equal to the above values. Credit is taken only for those filters which are normally in service.
- c. Calculated gaseous release rates for Point Beach Nuclear Plant are provided in [Table I.7 -1](#) and are based on methods recommended by [Reference 1](#). Observed operational gaseous releases for 1974 and 1975 are presented in [Table I.7-4](#) and [Table I.7-5](#).
- d. Release point descriptions are provided in [Table I.2-4](#). The release vents are the highest points of the plant. Where a range is given, the lower flow is assumed for the evaluation.

Each containment has a net free volume of 1,065,000 cubic feet. The containments are continuously vented to the containment purge filters via the containment monitoring system at a rate of approximately 10 cubic feet per minute.

Periodic venting of containment through the purge outlet valves with the unit at power was allowed during early plant operation. This practice is no longer allowed by plant Technical Specifications. However, for the purposes of the evaluation and based on plant

operation during 1974 and 1975, an average of 10 purges per year per unit is assumed during power operation and four purges per year per unit are assumed during shutdown. The average purge time is assumed to be 7 hours at a flow of 12,500 cubic feet per minute.

Since the containment cleanup system is not necessarily operated prior to each purge, no credit is taken for the system in evaluating releases from Point Beach Nuclear Plant.

I.2.7 REFERENCE

1. [Draft Regulatory Guide 1.BB, "Calculation of Releases of Radioactive Materials in Liquid and Gaseous Effluents From Pressurized Water Reactors \(PWR's\)," Sept. 1975.](#)

I.3 CALCULATED SOURCE TERMS AND RELEASES OF GASEOUS AND LIQUID EFFLUENTS

I.3.1 ORIGINAL APPENDIX I EVALUATION

The source terms (primary coolant and secondary side liquid and steam radioactivities) and the resulting radioactive releases (liquid and gaseous) are calculated using the basic assumptions and approaches recommended by [NRC Draft Regulatory Guide 1.BB](#).

The procedures used in this evaluation provide essentially the same mathematical treatments as the PWR-GALE code used by the NRC staff. Values of plant parameters are based on Point Beach Nuclear Plant design and operating data.

The plant design and operating data, draft regulatory guide reference plant parameters, and applicable ranges are shown in [Table I.3-1](#). Since the power level of 1518.5 MWt is outside the range given in [Table I.3-1](#), the NRC references of plant coolant activities shown in Table B of [Draft Regulatory Guide 1.BB](#) have been adjusted. [Table I.3-2](#) lists the resultant primary and secondary coolant radioactivity concentrations using these adjustment factors. [Table I.3-3](#) lists the total primary and secondary liquid activities calculated in a similar manner.

I.3.2 IMPACT OF UPDATED POWER OPERATIONS

The impact of a 17.6% power uprate (1811 MWT, including a 0.6% instrument uncertainty) on the annual liquid and gaseous releases were estimated in [Reference 1](#), using methodology and assumptions from NUREG-0017. The evaluation indicated an approximate 17.6% increase in the liquid effluent release concentrations compared to pre-uprate operations, as this activity is based on RCS activity possessing long half-lives (which increases in proportion to the power uprate percentage) and on waste volumes (which are essentially independent of power level within the applicability range on NUREG-0017). Tritium releases in liquid effluents increased proportionately to the power uprate.

Similarly for the gaseous releases, the impact of updated power on Kr-85 and tritium is limited to the increase in power level, 17.6%, taking into consideration a 0.6% uncertainty in the power level. Isotopes with shorter half-lives have increases slightly greater than the uprate percentage, estimated at 18.1 %. The other component of gaseous releases (i.e., iodines and particulates via the building ventilation systems), although increased, have a negligible impact on dose to the public. This is because the iodines and particulates category includes tritium, which is the controlling dose contributor.

I.3.3 REFERENCE

1. [Shaw Calculation 129187-M-0104](#), "Impact of EPU on Normal Operation Gaseous and Liquid Radioactive Effluent Releases," dated March 26, 2009.

I.4. METEOROLOGY

I.4.1 METEOROLOGICAL PROGRAM AT POINT BEACH NUCLEAR PLANT

The meteorological monitoring program at Point Beach Nuclear Plant was conducted in accordance with requirements in existence at the plant licensing stage. The data used in this evaluation was obtained during the 4/19/67 through 4/18/69 period. The meteorological tower is located approximately 2,000 feet south of the nearest reactor containment. Wind speed and wind direction at the 150-foot level (approximate height of the containments) were monitored by Belfort Type M wind instruments. The wind data were recorded on the Belfort recorder located in a shelter adjacent to the base of the tower and were reduced by visual (equal area) methods.

Atmospheric stability classes were determined by calculating hourly values of wind range, defined as the difference in azimuth between the maximum and minimum wind direction values during each hour. Hourly wind range values were then divided by a factor of 6, and a σ_{θ} versus Pasquill Stability Class relationship, now referenced in Regulatory Guide 1.23 (Reference 1), was applied to establish the stability class. Hourly average values of wind speed, wind direction, and atmospheric stability class were used to compute hourly X/Q and D/Q values.

Wind direction was recorded to the nearest degree. Wind speed was measured to the nearest mile per hour, while calms were determined by a calculational or computer threshold wind speed of 0.7 miles per hour and assigned to the last valid wind direction.

In order to calculate plume rise, ambient dry-bulb temperature is required. Since this parameter was not monitored at the site, monthly normals (1931-1960) at Kewaunee, Wisconsin (12 miles north) were used for each hour of the month considered.

a. Point Beach Meteorological Data

Table I.4-32 presents joint frequency distributions of wind speed and wind direction for each specific stability class, and all combined stability classes for the 4/19/67-4/18/69 onsite data period. Table I.4-33 presents similar distributions for each monthly period. A wind rose summary of Point Beach meteorology is presented in Table I.4-1.

b. Onsite Data Representativeness

Data obtained during the meteorological monitoring program at Point Beach Nuclear Plant is compared to that obtained from a program conducted at Haven, Wisconsin (approximately 30 miles south on the shore of Lake Michigan), during 1973 and 1974 as summarized in Table I.4-28. The latter program was designed in accordance with the guidance in Regulatory Guide 1.23. Table I.4-22, Table I.4-23, and Table I.4-24 provide a comparison of Haven and Point Beach data with that obtained at Milwaukee, Wisconsin, for concurrent and long-term periods.

National Weather Service data for General Mitchell Field, Milwaukee, Wisconsin, is presented in Table I.4-29 through Table I.4-31. The similarities between Point Beach and Haven are as expected since both sites are similar in surrounding terrain and both are located on the shore of Lake Michigan.

The following comparisons can be made from [Table I.4-22](#), [Table I.4-23](#), and [Table I.4-24](#):

Comparison A - Point Beach (1967-1969) to Haven (1973-1974)

Comparison B - Milwaukee (1967-1969) to Milwaukee (1973-1974)

Comparison C - Milwaukee (1967-1969) to Milwaukee (1956-1975)

Comparison A shows the similarities between Point Beach data and Haven data. Comparison B shows the overall similarity of the meteorological conditions that occurred during the 4/19/67-1/18/69 period with those conditions occurring during the 6/1/73-5/31/74 period. Comparison C shows the long-term data representativeness with climatology, using the 1/1/56-12/31/75 Milwaukee data base. For the 1/1/65-12/31/75 period, only 3-hour observations were recorded by the National Weather Service, however, this has no significant bearing on the comparisons, since a large data sample is used.

[Table I.4-22](#) shows stability class frequencies for the three sites and five data periods. Comparison A shows excellent similarity. The large preponderance of E, F, and G stabilities directly reflects the lake breeze phenomenon of undercutting cold air replacing warmer surface air, thus causing shallow pseudo-inversions. This is not present in the Milwaukee data, since the STAR ([Reference 2](#)) methodology is based on gross parameterization of incoming solar radiation and wind speed. "A" stabilities at this latitude are rare, since a solar angle of at least 60 degrees is required. Also, E, F and G stabilities can only occur at night. Thus, Milwaukee data cannot reflect the effect of the daytime lake breeze on the stability classifications. Comparison B shows good similarity in the overall meteorology for both the Point Beach and Haven data periods. Similarly, Comparison C indicates that both the 4/19/67-4/18/69, and the 6/1/73-5/31/74 periods are representative of the long-term climatology.

[Table I.4-23](#) shows the frequency distribution of wind direction by quadrant (and offshore/onshore breakdown) for the three sites and five data periods. Comparison A shows small anomalies in the ESE-S and WNW-N sectors, while Comparison B shows minor differences in the NNE-E sectors. These anomalies reflect small synoptic-scale meteorological differences. For example, during the 4/19/67-4/18/69 period, Milwaukee had 22.0 percent WNW-N winds, while Haven had 27.2 percent. Those figures reflect the larger frequency of northerly component winds with an increase in latitude north from Milwaukee. Comparison C shows long-term representativeness of both the Point Beach and Haven data periods.

[Table I.4-24](#) shows the average wind speed for each quadrant for the three sites and five data bases. Comparison A shows Point Beach somewhat windier than Haven, even though Comparison B indicates 6/1/73-5/31/74 to be the windier period. This is the result of the decreased friction of the earth's surface at the 150-foot Point Beach measurement, as opposed to the 10-meter Haven level, and the 20-foot Milwaukee level. Wind speed differences of this order can be found in year to year climatological variances. Comparison C shows overall similarity of both the Point Beach and Haven data periods with long-term climatology. [Table I.4-22](#), [Table I.4-23](#), and [Table I.4-24](#) show general representativeness of the Point Beach data to long-term climatology data from Milwaukee. [Table I.4-28](#)

through [Table I.4-32](#) present wind speed - wind direction point frequency distributions of the data used in the representativeness analysis.

It is concluded that the 4/19/67-4/18/69 Point Beach data are representative of the actual meteorology occurring at Point Beach, and also of the long-term climatology of the area. Since the present program produces representative meteorological data there is no basis for upgrading the program in accordance with [Reference 1](#).

c. Wet Deposition

[Table I.4-25](#) and [Table I.4-27](#) present precipitation-wind frequency distributions and intensity frequency distributions for National Weather Service Stations in the vicinity of Point Beach.

The onsite data period is represented by Green Bay (Austin Straubel Field), while the long-term climatology precipitation wind rose is represented by Milwaukee data. [Table I.4-27](#) shows that 90 percent of all precipitation falls at a rate of 0.09 inch/hour or less, and shows the lack of a well-defined rainy period within the growing and grazing season. [Table I.4-25](#) shows the precipitation to be generally well distributed with wind direction and wind speed. [Table I.4-26](#) shows that precipitation levels within a 50-mile vicinity of the site do not vary significantly. It is unlikely that significant wet deposition occurs near the Point Beach site. Thus, the D/Q analysis reflects dry deposition only.

d. Airflow Trajectory Regimes of Importance and Topography in the Vicinity of Point Beach

The Point Beach Nuclear Plant is situated near the shoreline of Lake Michigan in a relatively flat region of Wisconsin. Within a ten-mile radius of the plant, the scattered hills and knolls do not exceed 800 feet mean sea level (MSL) in any downwind sector. Plant grade is 606 feet MSL and major plant release points are at approximately 774 feet MSL. Based on the low relief of the surrounding terrain, airflow trajectory reversals caused by topographic obstacles are unlikely and, if they occur, are relatively insignificant. General topography within a 10-mile radius is shown in [Figure I.4-1](#). Maximum topographic elevation vs. distance by sector is illustrated in [Figure I.4-2](#).

Thunderstorm activity, squall lines and frontal passages are relatively infrequent in the vicinity of Point Beach, therefore, air flow reversals caused by their presence are minimal. These meteorological phenomena are generally short-lived and transitional and probably affect the overall local airflow less than one percent of the year. Based on the low frequency and short duration of these phenomena, as compared to an 8760-hour year, the overall effect on airflow reversals due to the phenomena are also relatively insignificant.

During the mid-spring to late-summer months (April through September), the lake is generally colder than the land. When the synoptic-scale meteorological conditions are weak and not very well established, a shallow flow from lake to land develops during the late morning to late afternoon hours. This airflow reversal phenomenon is called the "lake breeze." The lake breeze, when well established, can penetrate as much as 25 miles inland. Conservatively assuming the lake breeze prevails six hours (1100LST - 1700LST) each day

during the early spring through late summer (April through September) period, approximately 10 percent of the annual period would be subject to these conditions.

In order to conservatively account for airflow trajectory reversals with the Gaussian single-line trajectory model, the terrain correction factor, shown in Figure 2 of Regulatory Guide 1.111 (Reference 3) was applied to all X/Q and D/Q calculations. This factor assumes that the same air is advected four times over the same receptor location at distances of 1200 meters or less from the plant and approaches unity at greater distances. The terrain correction factor was conservatively applied to all occurrences, onshore or offshore winds, summer or winter, and day or night conditions. The application of Figure 2 terrain correction factors more than adequately compensates for the level of air trajectory reversals that would be experienced at PBNP.

I.4.2 DESCRIPTION OF X/Q AND D/Q MODELING PROCEDURES

In general, the methodology recommended by Reference 3 was used in the calculation of annual average and growing and grazing season average X/Q and D/Q values for the Point Beach site. Since there are a variety of release modes for the major release points, X/Q and D/Q must be evaluated for each operating condition. Six categories of release modes are defined and evaluated as follows:

Release Mode IA

This mode is the continuous exhaust of plant ventilation air through the auxiliary building vent. Since the exit velocity is high, this release is considered to be an elevated release subject to the constraints discussed in this section.

Release Mode IB

This mode is the periodic release of gas decay tank contents through the auxiliary building vent. The X/Q and D/Q values are evaluated for the gas decay tank release intervals and frequencies.

Release Mode IIA

This mode is the continuous release of 10 cubic feet per minute through each containment purge vent. Since exit velocities are negligible, the releases are considered ground level.

Release Model IIB

This mode is the periodic purge of containment through the containment purge vent. The exit velocities are high and the release is elevated. The X/Q and D/Q values are evaluated for the purge intervals and frequencies.

Release Mode IIC

This mode is the continuous release of gas stripper building ventilation through the Unit 2 containment purge vent. Exit velocities are variable and depend on building temperature; hence, the release is considered to be ground level.

Release Mode III

This mode is the continuous release of turbine building ventilation through the roof exhausters. The release is considered to be ground level.

A separate release mode was not defined for the drumming area vent, since the treatment assumed (HEPA) and the exit velocities and locations are essentially the same as that for the auxiliary building vent.

a. X/Q Model

The straight-line Gaussian diffusion model is used for X/Q calculations. Airflow reversals that are primarily caused by lake-breeze activity in the spring and summer months are conservatively accounted for by applying the correction factor ($\Omega(x)$) presented in Figure 2 of [Regulatory Guide 1.111](#). The following equation is utilized for annual average and grazing season average X/Q calculations:

$$\left[\frac{X}{Q}(x) \right]_{k1} = \frac{2.032}{N} \sum_{j=1}^{n1} \left[\frac{\Omega(x)}{x} \right]_k \left[\frac{E_t}{\bar{u}(\sigma_z^2(x)) + \frac{ch_b^2}{\pi}} + \frac{(1 - E_T) \exp\left(-\frac{1}{2} \left(\frac{he(x)}{\sigma_z} \right)^2\right)}{\bar{U}\sigma_z(x)} \right] \quad (1)$$

The entrainment coefficient (E_T) is a function of the ratio of exit velocity (U_e) to wind speed (u) for conditionally elevated release points. For stacks that are at least twice the height of a nearby structure, $E_T = 0$. For vent released occurring below the level of a nearby structure, 100 percent downwash is conservatively assumed ($E_T = 1$). For vent releases occurring between 1 and 2 times the height of a nearby structure, a “conditionally elevated” release is assumed, and the entrainment coefficient is defined as follows:

$$E_T = 0.0 \text{ when } U_e/\hat{u} > 5.0$$

$$E_T = 0.30 - 0.06 (U_e/\hat{u}) \text{ when } 1.5 < U_e/\hat{u} \leq 5.0 \quad (2)$$

$$E_T = 2.58 - 1.58 (U_e/\hat{u}) \text{ when } 1.0 < U_e/\hat{u} \leq 1.5$$

$$E_T = 1.0 \text{ when } U_e/\hat{u} \leq 1.0$$

The effective release height (h_e) is defined as:

$$h_e(x) = h_t + \Delta h(x) - [h_t(x) + h_a] \quad (3)$$

where Δh is the plume rise.

$$\text{To calculate plume rise, let } S = \frac{g d\theta}{T dz} \quad (4)$$

Then for A-D stabilities when $x < 10$ hr and for E-G stabilities when $x < 2.4 \hat{u}/S^{1/2}$, plume rise is given by:

$$\Delta h(x) = \frac{1.6}{\bar{u}} \left[\frac{gQH}{\pi C_p T} \right]^{1/3} (x)^{2/3} \quad (5)$$

For A-D stabilities, when $x \geq 10 h_r$, plume rise is given by:

$$\Delta h(x) = \frac{1.6}{\bar{u}} \frac{gQH}{\pi C_p T}^{1/3} (10h_r)^{2/3} \quad (6)$$

For E-G stabilities when $x \geq 2.4 \hat{u}/S^{1/2}$, plume rise is given by:

$$\delta h(x) = 2.9 \frac{gQH}{\pi C_p T \bar{u} S}^{1/3} \quad (7)$$

The topographic height ($h_t(x)$) is the actual height of the surface at the receptor point above plant grade. The aerodynamic downwash height correction (h_a) is defined by:

$$h_a = 3(1.5 - U_e/\bar{u})d \quad (8)$$

For cases where entrainment occurs, credit is taken for vertical plume expansion in the wake behind the release point building.

b. D/Q Model

Deposition is calculated as follows:

$$\left[\frac{D}{Q} \right]_{k1} = \left(\frac{\Omega(x)}{x} \right)_k \left(\frac{2\pi N}{16} \right)^{-1} \sum_{j=1}^{n_1} \left[n_1 \left(\frac{\delta}{Q} \right)_{Gk} E_t + \frac{1}{n_t} \sum_{i=1}^3 [1 - (E_t)_i] n_{i1} \left(\frac{\delta}{Q} \right)_{ik} \right] \quad (9)$$

Figure 7 of Reference 3 is used to determine ground release (entrained) relative deposition values, while Figures 8 through 10 of this [Regulatory Guide](#) are used to determine $[d_i(x)]_j$ values as a function of release height. Inspection of rainfall rate distributions at Austin Straubel Field in Green Bay, Wisconsin, for the 4/19/67-4/18/69 data period indicates that 90 percent of the hours with precipitation had totals of 0.09 inches or less. Therefore, it is unlikely that significant wet deposition occurs at the Point Beach site.

Dry deposition is calculated for elemental radioiodines and particulates only. The deposition rate for noble gases, tritium, carbon-14, and non-elemental radioiodines is too slow to allow accumulation at the distances considered in this evaluation. Although deposition and plume depletion occur simultaneously, the X/Q values are not reduced in order to remain conservative.

c. Methodology Employed For Intermittent Releases

The methodology employed in the calculation of intermittent release X/Q's and D/Q's is as follows and reflects current Site Analysis Branch practices:

1. One-hour sector-averaged X/Q values are calculated without terrain correction factors.
2. The 15% one-hour value is plotted at 1-hr. on log-log coordinates while the annual average value is plotted. At 8760 hours; a straight line is drawn, connecting the two points.
3. Log-log interpolation based on total ground intermittent release hours versus annual hours yields X/Q multiplier.
4. The multiplier is applied to annual average X/Q and D/Q values to obtain intermittent X/Q and D/Q values.

d. List of Symbols

1. Indices and Subscripts

i = index for elevated release stability group

j = index for number of hours

k = index for a particular receptor distance

l = index for a particular 22.5° sector

G = ground level

b = building

r = release

b = building

r = release

e = effective, exit

t = terrain

a = aerodynamic downwash

H = heat flux

P = pressure

2. Parameters

X/Q = relative concentration

D/Q = relative deposition rate

x = downwind (receptor) distance

$\Omega(x)$ = terrain correction factor

N = total number of valid data hours

\hat{u} = average wind speed

h_b = building height

$h_e(x)$ = effective release height

$\sigma_z(x)$ = vertical diffusion coefficient

U_e = exit velocity

h_r = release height

$\Delta h(x)$ = plume rise

h_t = topographic impaction height

h_a = aerodynamic downwash correction height adjustment

g = gravitational acceleration

Q_H = heat flux

C_p = specific heat at constant pressure

ρ = density of ambient air

T = ambient temperature

T_s = stack temperature

S = stability parameter

$d\Theta/dt$ = lapse rate of potential temperature

d = inner stack diameter

δ = relative deposition

n = number of valid data hours within a given sector

I.4.3 CALCULATED X/Q AND D/Q VALUE FOR POINT BEACH NUCLEAR PLANT

Table I.4-2 presents the highest offsite sector D/Q and X/Q values at the site boundary, nearest milk cow, milk goat, meat animal, resident, and vegetable garden. The annual period is represented by the 4/19/67-4/18/69 data period, while the grazing and/or growing season is approximated by the combination of the 4/19/67-10/18/67 and 4/19/68-10/18/68 periods. Table I.4-4 through Table I.4-13 list the X/Q values for each of the above key receptors, the shoreline receptors (if any), the population distances to 50 miles, and selected distances out to three miles, since two of the six release modes are conditionally elevated. Table I.4-14 through Table I.4-21 presents D/Q values for the same receptors and locations. Because the three former onsite residences have either been demolished or abandoned, the annual and grazing season X/Q and D/Q values at these locations (WNW sector at 1250 meters, NNW sector at 1880 and 1980 meters) provided in Table I.4-3 are historical.

I.4.4 REFERENCES

1. Regulatory Guide 1.23, "Onsite Meteorological Programs," February 1972.
2. STAR is a computer program used by the National Climatic Center, Asheville, N.C., to determine the probability of simultaneous occurrences of a specified wind speed, direction and stability class. STAR uses hourly records of this data over a long period of time to establish a climatological frequency matrix of wind speed, direction and stability class for a given site.
3. Regulatory Guide 1.111, "Methods of Estimating Atmospheric Transport and Dispersion of Gaseous Effluents in Routine Releases from Light-Water-Cooled Reactors," March 1976.

I.5 HYDROLOGY

I.5.1 DESCRIPTION OF DISCHARGE

The two Point Beach discharge flumes are each designed to accommodate discharge flows of 390,000 gpm. There is one flume for each unit. They are of similar design, one being the mirror image of the other.

Each flume is constructed of two rows of interlocked sheet pile sections. The shoreline (west) ends of the flumes are attached to the east pumphouse wall, perpendicular to the shoreline. Unit 1 flume extends into Lake Michigan in a SSE direction at an angle of 60 degrees to the shoreline. Unit 2 flume extends at the same angle in a NNE direction. Each flume is 35 feet wide at the lake end, 17 feet wide at the pumphouse and is 228 feet long. The floor of each flume consists of tremie concrete approximately two feet thick. The bottom depth below mean water level varies between 19 feet and 17 feet-9 inches. The flumes are protected along their sides from wave and ice action by steel spreaders between the piling and rubble stone placed along the outside of each piling row.

The Unit 1 flume has a 35 foot by 19 foot platform on the lake end which had been open to the public for fishing.

I.5.2 HYDROLOGY MODEL

The mathematical model used to calculate the lake dilution factor for Point Beach Nuclear Plant is based on methods suggested by Draft Regulatory Guide 1.EE (Reference 1). The plane source solution of the model can be obtained by integration of a point source solution over the source dimensions. For a steady point source discharge into a large lake of constant depth (d), a known steady longshore current (u), and straight shoreline the solution of the transport equation is:

$$x = \frac{W}{2\pi u \sigma_y \sigma_z} f(\sigma_z, z, z_s, d) f(\sigma_y, y, y_s) \quad (1)$$

$$f(\sigma_z, z, z_s, d) = \sum_{m=-\infty}^{\infty} \left\{ \exp\left[-\frac{(2md + z_s - z)^2}{2\sigma_z^2}\right] + \exp\left[-\frac{(2md - z_s - z)^2}{2\sigma_z^2}\right] \right\}$$

$$f(\sigma_y, y, y_s) = \exp\left[-\frac{(y_s - y)^2}{2\sigma_y^2}\right] + \exp\left[-\frac{(y_s + y)^2}{2\sigma_y^2}\right]$$

$$\sigma_y = \sqrt{\frac{2K_y X}{u}}, \quad \sigma_z = \sqrt{\frac{2K_z X}{u}}$$

Where:

x is the non-decaying concentration

K_y, K_z are the lateral and vertical turbulent diffusion coefficients

W is source strength

d is depth of the lake at the discharge point

X is distance in horizontal direction

h is the vertical depth of the discharge plume

In deriving Equation (1), it is assumed that:

(1) the discharge is located at the point $(0, Y_s, Z_s)$, i.e., at the origin of the x -axis and a distance Y_s from the shoreline and Z_s beneath the water surface; and,

(2) the longitudinal diffusion and time dependence in the dissolved constituent transport equation are negligible.

The solution of a plane source can be obtained by integration of Equation (1) over the source dimensions. It is assumed that the plane source has a width of b (in the Y -axis) and a depth of h (in the Z -axis). Integrating $f(\sigma_s, z, z_s, d)$ from z_s to $z_s + h$ with respect to z_s gives:

$$\int_{z_s}^{z_s+h} f(\sigma_s, z, z_s, d) dz_s = \sigma_z \sqrt{\frac{\pi}{2}} \sum_{m=-\infty}^{\infty} -A$$

Where:

$$A = -\operatorname{erf}\frac{(2md - z_s - z)}{\sqrt{2}\sigma_z} + \operatorname{erf}\frac{(2md + z_s + h - z)}{\sqrt{2}\sigma_z} + \operatorname{erf}\frac{(2md - z_s - z)}{\sqrt{2}\sigma_z} - \operatorname{erf}\frac{(2md + -z_s - h - z)}{\sqrt{2}\sigma_z}$$

Integrating $f(\sigma_y, y, y_s)$ from y_s to $y_s + b$ with respect to y_s gives:

$$\int_{y_s}^{(y_s+b)} f(\sigma_y, y, y_s) dy_s = \sigma_y \sqrt{\frac{\pi}{2}} B \quad (3)$$

Where:

$$B = -\operatorname{erf}\frac{(y_s - y)}{\sqrt{2}\sigma_y} + \operatorname{erf}\frac{(y_s + b - y)}{\sqrt{2}\sigma_y} - \operatorname{erf}\frac{(y_s + y)}{\sqrt{2}\sigma_y} + \operatorname{erf}\frac{(y_s + b + y)}{\sqrt{2}\sigma_y}$$

Therefore:

$$x = \frac{W}{2\pi u \sigma_y \sigma_z} \int_{z_s}^{z_s+h} f(\sigma_z, z, z_s, d) dz_s \int_{y_s}^{y_s+b} f(\sigma_y, y, y_s) dy_s$$

$$= \frac{W}{4u} \left(\sum_{m=-\infty}^{\infty} A \right) B \quad (4)$$

Where W is source strength per unit area.

The dilution factor, DF, is given by: $DF = W/(xQ)$ (5),

where Q is the volumetric discharge rate of the effluent.

I.5.3 INPUT DATA

Based on a paper by Paddock et. al. (Reference 2) the width of the plane source is estimated to be 1000 feet and the plane source is discharging 1000 feet offshore into a 0.4 feet per second current.

The lateral and vertical mixing coefficients are 900 cm²/sec (0.97 ft²/sec) and 2 cm²/sec (0.0022 ft²/sec), respectively. (Reference 3) From Equations (4) and (5), the centerline dilution factor 12 miles downstream at the Two Rivers, Wisconsin potable water intake is approximately 10 for a discharge rate of 644 cubic feet per second.

Field observations of flow patterns at Point Beach show the presence of reversing currents. (Reference 3, Reference 4) As indicated in Reference 1, when the directional distribution of currents is approximately bimodal, long-term dilution factors would be about twice those calculated from Equation (4). It is also noted that the dilution calculated by the above model is for a far field. Additional dilution arising from initial mixing in the near field (an additional dilution factor of 5) is also applied. The total dilution factor at the nearest water intake at Two Rivers, Wisconsin, is then calculated to be 100.

I.5.4 REFERENCES

1. Draft Regulatory Guide 1.EE (Working Paper), Methods for Estimating Aquatic Dispersion of Liquid Effluents from Routine Reactor Releases for the purpose of Implementing Appendix I, February, 1976.
2. Paddock, R. A., Policastro, A. J., Dunn, W. E., and Kyser, J. M., "Application of Prominent Near-Field Models for Heated Surface Discharge to Prototype Field Data on Lake Michigan," Energy and Envir. Systems Div., Argonne National Laboratory, paper presented at U.S. - Japan Seminar on Engineering and Environmental Aspects of Waste Heat Disposal, April 15-19, 1974, Tokyo, Japan.
3. Point Beach Nuclear Plant, "Non-Radiological Environmental Surveillance Program," Wisconsin Electric Power Company and Wisconsin Michigan Power Company, Annual Report No. 1, September 1972 through November 1973.
4. Point Beach Nuclear Plant, "Non-Radiological Environmental Surveillance Program," Wisconsin Electric Power Company and Wisconsin Michigan Power Company, Annual Report Nos. 2 and 3, November 1973 through October 1975.

I.6 SUPPLEMENTAL INFORMATION

By Enclosures 1 and 2 to a letter dated [February 17, 1976](#), the Nuclear Regulatory Commission requests that certain specific information be provided as part of the Appendix I evaluation. Requested information not provided elsewhere in the evaluation is presented in this section.

I.6.1 ENCLOSURE 1

“Guidance to Holders of Permits to Construct or Licenses to Operate Light-Water-Cooled Reactors for Which Application was Filed Prior to January 2, 1971, to Meet the Requirements of [Appendix I to 10 CFR Part 50](#).”

- a. Radioactive source terms used in the evaluation are consistent with the parameters and methodology set forth in [Regulatory Guide 1.BB](#) to the extent practicable. Any deviations from the Reg. Guide are noted. Descriptions of the applicable plant parameters and source term are provided in [Section I.2](#) and [Section I.3](#), respectively.
- b. Meteorological and Hydrological parameters used in the calculation of doses are consistent with Regulatory Guides 1.DD and 1.EE to the extent practicable. Meteorology and hydrology are discussed in further detail in [Section I.4](#). and [Section I.5](#), respectively.
- c. Dose calculations are consistent with [Regulatory Guide 1.109](#) to the extent practicable. Any deviations from [Regulatory Guide 1.109](#) are noted in the detailed discussion presented in [Section I.8](#).
- d. Operational liquid effluent release data is presented on an annual basis for 1974 and 1975 in [Table I.7-6](#). All liquid discharges are released through the discharge flumes via the circulating water system. Operational gaseous effluent release data is presented on an annual basis for 1974 and 1975 in [Table I.7-4](#). Operational gaseous effluent release data is presented on a monthly basis for 1974 and 1975 by release point in [Table I.7-5](#). A brief description of operating condition of each unit is noted for each month.
- e. Information requested in Enclosure 2 is provided in [Section 6.2](#).
- f. Proposed Technical Specifications reflecting the requirements of [Appendix I to 10 CFR Part 50](#) have been provided under separate cover.

I.6.2 ENCLOSURE 2

“Additional Information Needed from Holders of Permits or Licenses to Construct or Operate Light-Water-Cooled Reactors for Which Application was Filed Prior to January 2, 1971.”

- a. The information requested in Appendix D of [Regulatory Guide 1.BB](#) is provided as [Section I.2](#).
- b. Distances to the nearest site boundary are provided in [Table I.6-1](#). Distances to the nearest residence and nearest vegetable garden are presented in [Table I.6-2](#). Distances to the nearest milk cow, milk goat, and meat animal are given in [Table I.6-3](#).

In deriving these distances, it is assumed that every residence (farm or non-farm) has the

potential for having a vegetable garden. Since the land use in the vicinity of Point Beach Nuclear Plant is predominantly agricultural, the distance to the nearest milk or meat producing animal is assumed to be the distance to the nearest practicing farm having dwelling and a barn. However, it is assumed that land surrounding the site, owned by the Licensee and leased to local farmers, is unlikely to be used for pasture. Consistent with these assumptions, [Figure I.6-1](#) shows the locations of all farms and non-farm residences out to a distance of 3 miles for each radial sector.

- c. Based on considerations in Draft Regulatory Guide 1.DD, estimates of relative concentration (X/Q) and deposition (D/Q) appropriate for locations determined in item 2, above, are presented in [Table I.4-4 through Table I.4-21](#).
- d. A complete description of the meteorological program, data, models, and parameters is presented in [Section 4.0](#).
- e. [Regulatory Guide 1.23](#) did not exist during the design and licensing stages of Point Beach Nuclear Plant. The meteorological program and data are discussed in detail in [Section I.4.1](#).
- f. Meteorological data for the Point Beach site, discussion of representativeness, and description of meteorological monitoring instrumentation is presented in [Section I.4.](#). Since the present program produces representative meteorological data as discussed in [Section I.4.1.](#), there is no basis for upgrading the program in accordance with [Regulatory Guide 1.23](#).
- g. The lake breeze phenomenon is the only airflow trajectory regime of importance in the vicinity of Point Beach Nuclear Plant. A detailed discussion is presented in [Section I.4.1](#).
- h. A map showing detailed topographic features within a 10-mile radius of the plant is given in [Figure I.4-1](#). Plots of maximum topographic elevation versus distance for each sector are given in [Figure I.4-2](#).
- i. Intermittent gaseous releases at Point Beach Nuclear Plant occur from containment purges and gas decay tank releases. A summary of containment purge experience from January 1, 1974, to February 29, 1976, is presented in [Table I.6-4](#). Gas decay tank releases are summarized in [Table I.6-5](#).

I.7 COMPARISONS OF REPORTED AND CALCULATED RELEASES OF RADIOACTIVITY

I.7.1 GASEOUS RELEASES

Calculated annual gaseous releases are provided in [Table I.7 -1](#) and are based on the methods and assumptions in Draft [Regulatory Guide 1.BB](#). Reported Point Beach Nuclear Plant gaseous releases are provided for 1974 and 1975 by month in [Table I.7-5](#) and by year in [Table I.7-4](#).

a. Noble Gases

The calculated annual release of noble gases for the two-unit plant is 690 Curies per year. Comparing this value to the reported annual average releases of 27,000 Curies per year indicates disagreement by a factor of approximately 40. This disagreement is believed to be caused by a combination of radiation monitoring system background interference and assumptions in the model recommended by Draft [Regulatory Guide 1.BB](#) for calculation of releases.

The major release point for reported noble gas releases at Point Beach Nuclear Plant is the auxiliary building vent. This release point is monitored by a scintillation detector in the vent stack. The recorded output of this monitor is used to calculate total noble gas releases for the vent. The detector is shielded so small increases in ambient external background radiation levels will not increase the reported noble gas releases. Internal stack contamination or large increases in background radiation may increase the reported amount. Plant practice has been to account for these background changes where the duration and effects can be quantified, however, this cannot be done in all instances. As a result, reported releases of noble gases are conservatively high. Also, as a backup, a SPING pallet continuously draws samples off the vent stack.

The model recommended by Draft [Regulatory Guide 1.BB](#) accounts for noble gas releases from system leakage only via the leakage of undegassed liquids. Plant experience indicates that small leaks can occur from systems containing radioactive gases, such as the cover gas system. The radioactivity of these gases may be several orders of magnitude higher on a per volume basis than the noble gas radioactivity of undegassed liquids; hence a very small gaseous leak can result in significant noble gas releases. Since the model does not consider this potential the releases predicted by the model may not be compared to our experiences. A “gaseous leak” term for the model would be difficult to quantify since in most cases the volumetric leak rates of gaseous systems are so small that measurement is impracticable. Nevertheless, some allowance should be made for gaseous leaks to avoid setting design or operating objectives based on a release model which may not include all normal operating occurrences.

The reported releases are conservatively high because of the inclusion of a portion of radiation monitor background in determining noble gas releases while the calculated releases based on the model may be low because of the inability of the model to account for small gaseous leaks. Further refinements in both areas should result in calculated releases approaching actual plant releases.

Reference to [Table I.8-5](#) indicates that the dose based on calculated noble gas releases is approximately 0.03 millirems per year to the total body of an offsite individual. Adjusting this to the reported releases would result in a calculated dose on the order of 1 millirem per year. Both calculated doses are well within the design objective of 5 millirem per year.

b. Iodines

The calculated annual release of radioactive iodine for the plant is 0.3 Curies per year. This value compares favorably with reported iodine releases of 0.14 Curies per year on an annual average basis. The disagreement by a factor of 2 is not significant and may be the result of the lower fuel defect level during actual operation.

c. Particulates

The calculated annual release of particulate material for the plant is approximately 0.007 Curies per year while the reported releases for the plant are approximately 0.03 Curies per year on an annual average basis. The disagreement by a factor of approximately 4 arises primarily from higher than normal Cesium-138 during one month in the 1974 - 1975 period. Cesium-138 is a short-lived isotope not predicted by the model in Draft [Regulatory Guide 1.BB](#). Cesium-138 is of negligible dose significance and the factor of 4 disagreement is not significant.

d. Tritium

Calculated tritium releases based on Draft [Regulatory Guide 1.BB](#) are 610 Curies per year via gaseous pathways compared to reported releases of 110 Curies per year on an annual average basis. The disagreement by a factor of 6 is due to the assumption in Draft [Regulatory Guide 1.BB](#) that half the tritium produced is released in gaseous effluents. The difference is not significant since the dose significance of tritium is small.

I.7.2 LIQUID RELEASES

a. Gross Radioactivity (excluding tritium)

Calculated annual liquid releases are provided in [Table I.7-2](#) and [Table I.7-3](#). Reported Point Beach Nuclear Plant releases for 1974 and 1975 are provided in [Table I.7-6](#).

The calculated releases from Point Beach Nuclear Plant, excluding tritium and dissolved noble gases, are 3.2 Curies per year for the two unit plant, while the reported annual average is approximately 1 Curie per year for 1974 and 1975. The disagreement by approximately a factor of 3 is the result of the higher fuel defect assumptions and the 0.3 Curies for anticipated operational occurrences in the model recommended by Draft [Regulatory Guide 1.BB](#).

I.8 CALCULATIONS OF DOSES TO MAN

I.8.1 DOSE MODELS - OFFSITE INDIVIDUALS

Doses are calculated using the dose models contained in Regulatory Guide 1.109 ([Reference 1](#)) in the evaluation of potential doses to individuals in the vicinity of Point Beach Nuclear Plant. Pathways not considered in [Reference 1](#) or methods differing from [Reference 1](#) are described in the dose models and assumptions presented below.

Included in this evaluation are dose assessments of three pathway categories: 1) pathways associated with releases of liquid effluents to Lake Michigan, 2) the direct exposure from releases of noble gases to the atmosphere, and 3) pathways associated with radioiodines, particulates, carbon-14, and tritium releases to the atmosphere.

1. Liquid Effluents

A condenser circulating water flow rate of 644 cubic feet per second (290,000 gallons per minute) for the release streams is used in the calculation of all doses due to liquid effluents and is based on plant operating records for 1974 and 1975. All usage factors are taken from Table A-2 of [Reference 1](#) unless otherwise noted.

1. Swimming and Boating

For boating and swimming, the COHORT-II Monte Carlo Radiation Transport Code ([Reference 2](#)) has been used to calculate dose rates to boaters and swimmers. The gamma energy spectrum is based on the eighteen-group of the DLC-23/CASK library ([Reference 3](#)). The source radioactivity used for boating and swimming is the radioactivity in the discharge diluted by a factor of 5 to account for near-field dilution in the mixing zone.

The boating model assumes a disc source 50 feet in diameter with a thickness of 3 feet. Dose rates are calculated at points 1, 2, and 3 feet above the water to approximate the location of boaters. Attenuation by the boat is neglected.

The calculated dose rate is nearly constant at the three receptor points considered, indicating that the source model is essentially semi-infinite in this analysis. These dose rate levels are approximately half the submerged dose rates calculated for swimmers.

Usage factors for boating of 52 hours per year for teen and adult age groups and 29 hours per year for child are used as suggested by [Reference 1](#).

The Monte Carlo program is used to calculate the dose rate for swimming. A cylindrical source 10 feet in diameter is enclosed in an annular mass of water 20 feet in diameter. The source region was limited to the 10 feet diameter cylinder. The 20 feet diameter outer cylinder is added to include backscattering into the source region in the Monte Carlo analysis. A receptor point 2 feet below the surface is used. The calculated submerged dose rate is approximately twice the dose rate above the surface of the water.

The swimming pathway is not considered in [Reference 1](#). A usage factor of 100 hours per year is used for the adult and teen age groups. A usage factor of 56 hours per year is used for the child age group.

2. Ingestion of Potable Water

The Green Bay, Wisconsin, potable water intake is located in Lake Michigan approximately 13 miles north of the Point Beach site and the Two Rivers, Wisconsin, potable water intake is located approximately 12 miles south of the site. As part of intensive non-radiological environmental surveillance programs⁽⁴⁾ the lake current characteristics have been determined in the vicinity of the site. These studies indicate highly variable lake current direction; therefore, dilution factors at both intakes were evaluated and found to be approximately equal. Since the Two Rivers, Wisconsin, intake is nearest the site, this intake is considered in the evaluation; however, calculated ingestion doses would also be applicable to any individual using Green Bay, Wisconsin, potable water.

The calculational methods for determining lake dilution factors are described in [Section 5](#). A far-field dilution factor of 10 is calculated at the Two Rivers intake. Using a near-field dilution factor of 5 and a factor of 2 to account for variable current direction, the total dilution factor at the Two Rivers intake is 100. In addition to this dilution, a decay time of 44 hours is assumed (based on lake current measurements) and an additional 12 hours decay is assumed during transport of water through the purification plant. No credit is taken for removal of radioactivity by water treatment processes.

Ingestion of potable water is assumed to be 730 liters per year for adults and 510 liters per year for all other age groups.

3. Ingestion of Fish

For the maximum individual case, fish are assumed to be caught at the edge of the initial mixing zone. The appropriate mixing zone dilution factor is 5, as suggested by [Reference 1](#). A holdup time of 24 hours between catching and eating fish is assumed. The consumption of fish is assumed to be 21, 16, and 6.9 kilograms per year for an adult, teen and child, respectively.

4. Shoreline Recreation

A point 1500 meters south is the closest point to the site at which this pathway exists. A decay time of 3.4 hours is assumed and a total dilution factor of 878 at the shoreline is calculated in accordance with the models presented in [Section 5](#). Usage factors of 12, 67, and 14 hours per year are used for an adult, teen, and child, respectively. The shore width factor is assumed to be 0.

5. Ingestion of Invertebrates

Doses for ingestion of invertebrates are not calculated for Point Beach Nuclear Plant. There is no known fishery in the area for invertebrates.

6. Ingestion of Leafy Vegetables

For the maximum individual case, leafy vegetables are assumed to be irrigated from the potable water supply of the City of Two Rivers. The dilution factor is 100 and the consumption is 64, 42 and 26 kilograms per year for the adult, teen, and child, respectively. A holdup time of 24 hours is assumed between harvesting and eating leafy vegetables.

7. Ingestion of Stored Vegetables

For the maximum individual case, non-leafy stored vegetables are assumed to be irrigated from the Two Rivers potable water supply with a dilution factor of 100. The consumption is assumed to be 520, 630, and 520 kilograms per year for the adult, teen, and child, respectively. A holdup time of 60 days is assumed between harvesting and consumption.

8. Ingestion of Cow's Milk

For the maximum individual case, cow's milk is assumed to be produced at a farm which gets drinking and irrigation water from the potable water supply of the City of Two Rivers. A dilution factor of 100 is assumed. Consumption of cow's milk is assumed to be 310, 400, 330, and 330 liters per year for the adult, teen, child, and infant, respectively. A hold up time of 2 days is used between production and consumption.

9) Ingestion of Meat

Meat for the maximum individual is assumed to be produced from an animal at a farm which gets drinking and irrigation water from the potable water supply of Two Rivers. A dilution factor of 100 is assumed. The consumption is 110, 65, and 41 kilograms per year for the adult, teen, and child, respectively. A holdup time of 20 days is used between slaughter and consumption.

b. Gaseous Effluents

All dose pathways from gaseous releases are calculated using the methods and parameters described in [Reference 1](#). The following pathways are considered:

1. Noble Gas Releases

The maximum individual is assumed to be at the nearest residence in the south-southwest direction at a distance of 1460 meters for total body and beta skin doses. For gamma and beta air doses, the maximum individual is assumed to be at the site boundary in the south direction at a distance of 1270 meters. Annual average X/Q values are used.

2. Inhalation

The maximum individual is assumed to be at the nearest residence at a distance of 1460 meters in the south-southwest direction. Annual average X/Q values are applied for this location. Breathing rates of 7300, 5100, 2700, and 1900 m³/yr are assumed for the adult, teen, child, and infant, respectively.

3. Ingestion of Leafy Vegetables

For doses from ingestion of leafy vegetables, a garden is assumed to be at the nearest residence in the south-southwest direction at a distance of 1460 meters. Growing season X/Q's and deposition rates are applied based on a growing season of 6 months. Concentrations of tritium and carbon-14 in the vegetables are calculated using X/Q values as recommended in [Reference 1](#). The consumption is assumed to be the same as for the liquid pathway.

4. Ingestion of Stored Vegetables

Stored vegetables are grown at the same location as leafy vegetables and use the same X/Q's and deposition rates. Consumption of stored vegetables is assumed to be the same as for the liquid pathway.

5. Ingestion of Cow's Milk

A cow is assumed to be at the site boundary in the SSE direction at a distance of 1300 meters. A six month grazing season is assumed. Growing season X/Q's and deposition rates are applied. Concentrations of tritium and carbon-14 in the vegetation which the animal consumes are calculated using X/Q values as recommended in [Reference 1](#). The consumption of cow's milk is assumed to be the same as for the liquid pathway.

6. Ingestion of Goat's Milk

A milk goat is assumed to be at the same location as the milk cow. The X/Q's and deposition rates for the cow's milk pathway are used for this pathway. Consumption of goat's milk is assumed to be 310, 400, 330, and 330 liters per year for the adult, teen, child, and infant, respectively.

7. Ingestion of Meat

A meat animal is assumed to be at the same location as the milk cow. The X/Q's and deposition rates for the cow's milk pathway are used for this pathway. A six month grazing season is assumed. Consumption of meat is assumed to be the same as for the liquid pathways.

8. Standing on Contaminated Ground

The maximum individual is assumed to be in the south-southwest direction at a distance of 1460 meters. Annual deposition rates are applied for this location, and an occupancy and shielding factor of 0.7 is assumed.

I.8.2 DOSE MODELS - ONSITE INDIVIDUALS

Note: The following is historical because there are no longer any occupied residences within the site boundary.

Three occupied residences exist within the Point Beach Nuclear Plant site boundary which are owned by the Licensees and which are occupied only by families of plant employees. Since some (but not all) pathways exist for potential exposure of these individuals to releases from the plant, hypothetical doses have been calculated for onsite individuals in all age groups at the maximum location. No calculations are performed for ingestion of fresh or stored vegetables (liquid release pathway only), ingestion of cow or goat milk, and ingestion of meat since these pathways either cannot exist or are known not to exist for these individuals.

For the remainder of the potential pathways, the calculated doses are for individuals in the WNW sector at a distance of 1250 meters from the plant. Calculated doses for recreational activities such as fishing, swimming, and boating are identical to those for offsite individuals. Dose models for appropriate pathways are identical to those for offsite individuals except as modified by distance from release points.

I.8.3 CALCULATED DOSES

Calculated doses to offsite individuals are provided in [Table I.8-1](#) through [Table I.8-4](#) for radioiodine and particulates in gaseous effluents. Calculated doses to offsite individuals from liquid effluents are provided in [Table I.8-6](#) through [Table I.8-9](#). Calculated doses to offsite and onsite individuals from noble gas releases are provided in [Table I.8-5](#).

Calculated doses to onsite individuals for radioiodine and particulates in gaseous releases are provided in [Table I.8-10](#) through [Table I.8-13](#). Calculated doses to onsite individuals from liquid effluents can be obtained from [Table I.8-6](#) through [Table I.8-9](#) by summing the fish ingestion, swimming, boating and shoreline pathways.

The replacement of the Retention Pond by the conveyor-type filtration units does not have an adverse effect upon the calculated doses. Only the path has changed, with the function of the Retention Pond as a settling basin replaced by active filtration through the new equipment.

I.8.4 REFERENCES

1. [Regulatory Guide 1.109, "Calculation of Annual Doses to Man From Routine Releases of Reactor Effluents For The Purpose of Evaluating Compliance With 10 CFR Part 50, Appendix I," March, 1976, U. S. Nuclear Regulatory Commission, Washington, D.C.](#)
2. L. Soffer and L. Clemons, Jr., "COHORT-II-A Monte Carlo General Purpose Shielding Computer Code," CCC-198, Union Carbide Corporation, April, 1971.
3. G. W. Morrison, E. A. Straker, and R. H. Obegaarden, "A Coupled Neutron and Gamma-Ray Multigroup Cross Section Library For Use In Shielding Calculations," *Trans. American Nuclear Society*, 15, 535, 1972.
4. Point Beach Nuclear Plant "Non-Radiological Environmental Surveillance Program," Wisconsin Electric Power Company and Wisconsin Michigan Power Company, Annual Reports 1, 2 and 3 covering the period from November, 1972 through October, 1975.

I.9 SUMMARY

Calculations of radioactive releases and potential doses to individuals have been performed in accordance with models in Nuclear Regulatory Commission Regulatory Guides. The potential doses are calculated for each pathway through which exposure might be realized for various individuals. These pathways are then combined, as appropriate, to estimate the potential dose to a hypothetical individual exposed to all pathways. A comparison of calculated doses with the design objectives is given in [Table I.9-1](#) for offsite individuals and for onsite individuals. All calculated doses are within the design objectives and are as low as reasonably achievable.

I.9.1 GASEOUS RELEASES

Calculated gamma and beta air doses at the site boundary are 0.06 and 0.07 millirads per year, respectively, and are a small fraction of the design objectives of 10 and 20 millirads per year for gamma and beta dose rates.

Calculated total body and skin doses to an offsite individual are 0.03 and 0.06 millirems per year, respectively. These doses are a small fraction of the design objectives of 5 and 15 millirems per year to the total body and skin, respectively. Corresponding calculated doses to an onsite resident are 0.02 millirems per year total body, and 0.04 millirems per year to the skin. These calculated doses are also well within the design objectives.

The maximum calculated dose to any organ of an offsite individual from all pathways for radioiodine and particulates is 15 millirem per year to the thyroid and is equal to the design objective of 15 millirem per year. The maximum hypothetical individual for this case is an offsite infant residing at a distance of 1,460 meters in the south-southwest sector and ingesting 330 liters per year of goat's milk in addition to being exposed to radioactivity in air and on the ground. The calculated dose for the same infant ingesting an equivalent volume of cow's milk is 12 millirems per year. In either case, the design objective is met.

The calculated dose to any organ of an onsite resident is 0.82 millirems per year to the child thyroid. This calculated dose is well within the design objective of 15 millirems per year. Since all conservatively calculated doses from gaseous releases are within the design objectives it is concluded that gaseous waste processing systems and ventilation system filtration equipment at Point Beach Nuclear Plant will continue to maintain releases as low as reasonably achievable and further augmentation is not required.

I.9.2 LIQUID RELEASES

a. Calculated Doses

The highest calculated total body dose is 0.19 millirem per year for a hypothetical adult. Essentially all of this dose is calculated to be from eating fish living at the edge of the initial mixing zone in the surface plume near the plant. The calculated doses are well within the design objective of 5 millirem per year.

The highest calculated dose to any organ from liquid pathways is 0.26 millirem per year to the liver of an offsite teenage individual. The major portion of this dose is calculated to be from the same fish pathway as for the adult. This calculated dose is well within the design objective of 5 millirems per year.

b. Calculated Releases

Actual plant liquid releases for 1974 and 1975 average approximately 1 Curie per year and calculated releases are 3.2 Curies per year. These releases are well within the design objective of 5 Curies per year per reactor (10 Curies per year for the plant).

Because the doses and Curie releases via liquid pathways are much less than the design objectives there is no need to further augment liquid waste systems to continue to maintain releases as low as is reasonably achievable.

I.9.3 IMPACT OF UPATED POWER OPERATIONS

Scaling techniques, based on NUREG-0017, Revision 1 methodology, were used to assess the impact of core power uprate on radioactive gaseous and liquid effluents at PBNP.

As described in [Reference 1](#), the conservatively performed power uprate analysis used the plant core power operating history during the years 2002 to 2006, the reported liquid effluent and dose data during that period, NUREG-0017 equations and assumptions, and conservative methodology, to estimate the impact of operation at the analyzed uprate core power level of 1811 MWt on radioactive gaseous and liquid effluents, and normal operation off-site doses.

The licensed reactor core power level prior to 2003 was 1518.5 MWt. The core power was increased to 1540 MWt at the end of 2002. For the uprate condition, the system parameters used in the power uprate analysis reflected the flow rates and coolant masses at an analyzed core power level of 1811 MWt. For the pre-uprate condition, the evaluation used offsite doses based on an average 5 year set of organ and whole body doses calculated using data presented in the PBNP Annual Radioactive Effluent Release Reports for the years 2002 through 2006, taking into consideration the associated average annual core power level, extrapolated to 100 percent availability at the licensed power level.

Using the methodology and equations found in NUREG-0017, Revision 1, and based on a comparison of the change in power level and in plant coolant system parameters (e.g., reactor coolant mass, steam generator liquid mass, steam flow rate, reactor coolant letdown flow rate, flow rate to the cation demineralizer, letdown flow rate for boron control, steam generator blowdown flow rate, steam generator moisture carryover, etc.) for both pre-uprate and uprate conditions, the maximum potential percentage increase in coolant activity levels due to the uprate for each chemical group identified in NUREG-0017 was estimated.

To estimate an upper bound impact on off-site doses, the highest factor found for any chemical group pertinent to the release pathway was applied to the average doses previously determined as representative of operation at pre-uprate conditions. This approach was utilized to estimate the maximum potential increase in effluent doses due to the uprate, and demonstrate that the estimated off-site doses following the uprate, although increased, will continue to remain below the regulatory limits set by 10 CFR 50, Appendix I. [Reference 1](#) shows that based on operating history, the maximum estimated dose due to gaseous liquid radwaste effluents following power uprate will continue to remain significantly below the annual design objectives for gaseous and liquid radwaste effluents set by 10 CFR 50 Appendix I.

It is noted that actual gaseous and liquid effluent isotopic release and dose information are provided in the PBNP Annual Radioactive Effluent Release Reports.

I.9.4 REFERENCE

1. [Shaw Calculation 129187-M-0104](#), “Impact of EPU on Normal Operation Gaseous and Liquid Radioactive Effluent Releases,” dated March 26, 2009.

Table I.2-1 SOURCES AND EXPECTED RADIOACTIVITY OF LIQUID WASTES AT POINT BEACH NUCLEAR PLANT

<u>SOURCE</u>	<u>RATE</u> (gal/day)	<u>TOTAL</u> ⁽¹⁾ (gal/yr)	<u>EXPECTED FRACTION</u> ⁽²⁾ <u>OF PRIMARY COOLANT</u> <u>RADIOACTIVITY</u>	<u>EXPECTED FRACTION TO</u> <u>BE RELEASED</u>
<u>Primary System Waste</u>				
Containment Sumps	80	29,200	1.0	1.0
Auxiliary Building Drains	400	146,000	0.1	1.0
Laboratory Drains	400	146,000	0.002	1.0
Sampling Drains	70	25,550	1.0	1.0
Detergent Wastes	450	164,250	< 0.0001 Ci/yr	1.0
Miscellaneous	1,400	511,000	0.01	1.0
Anticipated Occurrences	-	4,000	0.30 Ci/yr	1.0
Total	2,800	1,026,000		
<u>Secondary System Waste</u>				
Turbine Building Floor Drains	14,400	5,250,000	Steam Condensate	1.0
Secondary System Sampling	5,000	1,820,000	Steam Condensate	1.0
Steam Generator Blowdown	144,000	42,050,000	0.1 x Steam Generator Blowdown	1.0
Total	163,400	49,120,000		
<u>Other</u>				
Letdown to CVCS Holdup Tanks	3,290	1,200,000	1.0	0.53

(1) Assumes 365 days per year for both Unit 1 and Unit 2 except for steam generator blowdown which is adjusted for 80 percent capacity factor.

(2) All fractions for primary system waste are related to degassed primary coolant concentrations and are prior to processing in radioactive liquid waste systems and related systems.

Table I.2-2 CAPACITIES USED IN CALCULATING HOLDUP TIMES FOR RADIOACTIVE LIQUIDS

<u>WASTE SOURCE</u>	<u>COMPONENT</u>	<u>TOTAL PROCESS RATE OR VOLUME</u>	<u>RATE OR VOLUME USED</u>
<u>Primary System Waste</u>	Waste Holdup Tank	21,000 gal.	8,400 gal.
	Waste Evaporator	35 gal./min.	35 gal./min.
	Waste Condensate Tanks	10,000 gal. each	8,000 gal.
	Waste Condensate Pumps	75 gal./min. each	150 gal./min.
<u>Other</u>			
Letdown to CVCS	Holdup Tanks	58,000 gal. each	69,600 ⁽¹⁾
Holdup Tanks	Boric Acid Evaporator	12.5 gal./min.	12.5 gal./min.
	Monitor Tanks	10,000 gal. each	8,000 gal.
	Monitor Tank Pumps	60 gal./min. each	120 gal./min.

(1) Based on sharing of three tanks by Units 1 and 2.

Table I.2-3 CALCULATED HOLDUP TIMES FOR COLLECTION, PROCESSING AND RELEASE

<u>SOURCE</u>	<u>CALCULATED HOLDUP TIME</u> ⁽¹⁾ (Days)
<u>Primary System</u>	
Containment Sumps	3.2
Auxiliary Building Drains	3.2
Laboratory Drains	3.2
Sampling Drains	3.2
Detergent Wastes	3.2
Miscellaneous	3.2
Anticipated Operational Occurrences	Not Applicable
<u>Secondary System</u>	
Turbine Building Floor Drains	30
Secondary System Sampling	30
Steam Generator Blowdown	Negligible
<u>Other</u>	
Letdown to CVCS Holdup Tanks	46.2 ⁽²⁾

(1) Calculated holdup times are based on methods recommended by Draft Regulatory Guide 1.BB.

(2) Based on sharing of three holdup tanks by Units 1 and 2.

Table I.2-4 POINT BEACH NUCLEAR PLANT RELEASE POINT DESCRIPTIONS

Sheet 1 of 3

Outside Design Temperature: -15°F (Winter) and 95°F (Summer)

1. UNIT 1 PURGE VENT

Diameter	= 36"
Flow	= 12,500 to 25,000 cfm for purging and 10 cfm for continuous venting.
Exit Velocity	= 20.1 to 40.2 miles per hour for purging.
Elevation	= 168' 0"
Height	= 142' 0" above finished grade 26' 0"
Location	= NE corner of Unit 1 facade
Facade Elevation	= 161' 6"
Design Temperatures:	
Operating	= 105°F (Winter) and 105°F (Summer)
Shutdown	= 50°F (Winter) and 105°F (Summer)
Adjacent Structures:	
N - Aux. Bldg. (el. 111' 9") and Unit 2 facade (el. 161' 6")	
E - Service Bldg. and Turbine Bldg. (el. 111' 9")	
S - None	
W - None	

2. UNIT 2 PURGE VENT

Diameter	= 36"
Flow	= 12,500 to 25,000 cfm for purging, 400 to 12,000 cfm for gas stripper bldg. ventilation, and 10 cfm for continuous venting.
Exit Velocity	= 20.1 to 40.2 miles per hour for purging and 0.6 to 19.3 miles per hour for gas stripper bldg. ventilation.
Elevation	= 168' 0"
Height	= 142' 0" above finished grade 26' 0"
Location	= SE corner of Unit 2 facade
Facade Elevation	= 161' 6"
Design Temperatures:	
Operating	= 105°F (Winter) and 105°F (Summer)
Shutdown	= 50°F (Winter) and 105°F (Summer)
Adjacent Structures:	
N - None	
E - Service Bldg. and Turbine Bldg. (el. 111' 9")	
S - Aux. Bldg. (el. 111' 9") and Unit 1 facade (el. 161' 6")	
W - None	

Table I.2-4 POINT BEACH NUCLEAR PLANT RELEASE POINT DESCRIPTIONS
Sheet 2 of 3

3. DRUMMING AREA VENT

Diameter	= 46"
Flow	= 43,100 cfm
Exit Velocity	= 42.4 miles per hour
Elevation	= 168' 0"
Height	= 142' 0" above finished grade 26' 0"
Location	= NW corner of Unit 1 facade
Facade Elevation	= 161' 6"
Design Temperatures:	= 65°F (Winter) and 85°F (Summer)
Adjacent Structures:	
	N - Aux. Bldg. (el. 111' 9") and Unit 2 facade (el. 161' 6")
	E - Service Bldg. and Turbine Bldg. (el. 111' 9")
	S - None
	W - None

4. AUXILIARY BUILDING VENT

Diameter	= 54"
Flow	= 61,400 cfm
Exit Velocity	= 43.9 miles per hour
Elevation	= 168' 0"
Height	= 142' 0" above finished grade of 26' 0"
Location	= SE corner of Unit 1 facade
Facade Elevation	= 161' 6"
Design Temperatures:	= 65°F (Winter) and 85°F (Summer)
Adjacent Structures:	
	N - Aux. Bldg. (el. 111' 9") and Unit 2 facade (el. 161' 6")
	E - Service Bldg. and Turbine Bldg. (el. 111' 9")
	S - None
	W - None

Table I.2-4 POINT BEACH NUCLEAR PLANT RELEASE POINT DESCRIPTIONS
Sheet 3 of 3

5. TURBINE BUILDING ROOF EXHAUSTERS (19)

Diameter	= NA	no credit taken for elevated
Flow	= 47,000 cfm each	-- release; ground release
Exit Velocity	= NA	assumed
Elevation	= Approximately 110'	(elevation of turbine building roof)
Height	= Approximately 84' above finished grade of 26' 0"	
Location	= Evenly spaced along a north-south line atop the turbine building	
Design Temperatures:	= 65°F (Winter) and 115°F (Summer)	
Adjacent Structures:		
N - None		
E - None		
S - None		
W - Facade Structures (el. 161' 6")		

Table I.3-1 COMPARISONS WITH PARAMETERS USED TO DESCRIBE THE REFERENCE PRESSURIZED WATER REACTOR WITH U-TUBE STEAM GENERATORS

<u>PARAMETER</u>	<u>SYMBOL</u>	<u>UNITS</u>	<u>NOMINAL VALUE</u>	<u>RANGE</u>		<u>PBNP VALUE</u>
				<u>MAXIMUM</u>	<u>MINIMUM</u>	
Thermal Power	P	MWt	3400	3800	3000	1518.5
Steam Flow Rate	FS	lbs/hr	1.5(7)	1.7(7)	1.3(7)	6.62(6)
Weight of water in reactor coolant system	SP	lbs	5.5(5)	6.0(5)	5.0(5)	2.75(5)
Weight of water in all steam generators	WS	lbs	4.5(5)	5.0(5)	4.0(5)	1.60(5)
Reactor coolant letdown flow (purification)	FD	- lbs/hr	3.7(4)	4.2(4)	3.2(4)	1.98(4)
Reactor coolant letdown flow (yearly average for boron control)	FB	lbs/hr	500	1000	250	564
Steam Generator blowdown flow (total)	FBD	lbs/hr				
Volatile			75,000	100,000	50,000	25,000
Fraction of radioactivity in blowdown stream which is not returned to the secondary coolant system	NBD	-	1.0	1.0	0.9	1.0
Flow through the purification system cation demineralizer	FA	lbs/hr	3700	7500	0.0	0.0
Ratio of condensate demineralizer flow rate to the total steam flow rate	NC	-				
Volatile			0.65	0.75	0.55	0.0
Ratio of the total amount of noble gases routed to gaseous radwaste from the purification system to the total amount of noble gases routed from the primary coolant system to the purification system (not including the boron recovery system)	Y	-	0.0	0.01	0.0	0.0 Kr-85 1.0 All Others

Table I.3-2 POINT BEACH NUCLEAR PLANT CALCULATED SOURCE TERM
 CONCENTRATIONS ($\mu\text{Ci/gm}$)
 Sheet 1 of 3

<u>Isotope</u>	<u>Reactor Coolant ($\mu\text{Ci/gm}$)</u>	<u>Steam Generator Liquid ($\mu\text{Ci/gm}$)</u>	<u>Steam Generator Steam ($\mu\text{Ci/gm}$)</u>
<u>NOBLE GASES</u>			
Kr-83m	1.7E-02	0.0	1.1E-08
Kr-85m	7.2E-02	0.0	4.6E-08
Kr-85	5.9E-02	0.0	3.8E-08
Kr-87	5.2E-02	0.0	3.1E-08
Kr-88	1.5E-01	0.0	9.3E-08
Kr-89	4.9E-03	0.0	3.1E-09
Xe-131m	4.3E-03	0.0	2.7E-09
Xe-133m	3.2E-02	0.0	2.0E-08
Xe-133	1.3E+00	0.0	8.2E-07
Xe-135m	1.3E-02	0.0	7.9E-09
Xe-135	1.7E-01	0.0	1.1E-07
Xe-137	8.9E-03	0.0	5.6E-09
Xe-138	4.3E-02	0.0	2.6E-08
<u>HALOGENS</u>			
Br-83	4.6E-03	2.2E-07	2.2E-09
Br-84	2.6E-03	2.5E-08	3.5E-10
Br-85	3.0E-04	5.6E-10	5.6E-12
I-130	1.9E-03	1.9E-07	1.9E-09
I-131	2.3E-01	2.7E-05	2.7E-07
I-132	9.6E-02	5.8E-06	5.8E-08
I-133	3.3E-01	3.8E-05	3.8E-07
I-134	4.6E-02	1.0E-06	1.0E-08
I-135	1.8E-01	1.4E-05	1.4E-07

Table I.3-2 POINT BEACH NUCLEAR PLANT CALCULATED SOURCE TERM
CONCENTRATIONS ($\mu\text{Ci/gm}$)
Sheet 2 of 3

CS, RB

Rb-86	7.6E-05	1.2E-08	1.2E-11
Rb-88	2.0E-01	1.7E-06	1.7E-09
Cs-134	2.2E-02	3.2E-06	3.2E-09
Cs-136	1.2E-02	1.8E-06	1.8E-09
Cs-137	1.6E-02	2.6E-06	2.6E-09

WATER ACTIVATION PRODUCTS

N-16	4.0E+01	2.8E-06	2.8E-06
------	---------	---------	---------

TRITIUM

H-3	1.0E+00	1.0E-03	1.0E-03
-----	---------	---------	---------

OTHER NUCLIDES

Cr-51	1.6E-03	2.5E-07	2.5E-10
Mn-54	2.6E-04	5.6E-08	5.6E-11
Fe-55	1.3E-03	2.3E-07	2.3E-10
Fe-59	8.3E-04	1.7E-07	1.7E-10
Co-58	1.3E-02	2.3E-06	2.3E-09
Co-60	1.7E-03	2.5E-07	2.5E-10
Sr-89	2.9E-04	5.7E-08	5.7E-12
Sr-90	8.3E-06	1.1E-09	1.1E-12
Sr-91	5.9E-04	1.5E-08	1.5E-11
Y-90	1.4E-05	1.1E-09	1.1E-12
Y-91m	3.7E-04	8.5E-09	8.5E-12
Y-91	1.7E-03	2.5E-07	2.5E-10
Y-93	1.2E-01	5.9E-09	5.9E-12
Zr-95	5.0E-05	1.1E-08	1.1E-11
Nb-95	4.1E-05	1.1E-08	1.1E-11
Mo-99	3.8E-01	2.0E-05	2.0E-08

Table I.3-2 POINT BEACH NUCLEAR PLANT CALCULATED SOURCE TERM
 CONCENTRATIONS ($\mu\text{Ci/gm}$)
 Sheet 3 of 3

Tc-99m	3.5E-01	1.8E-05	1.8E-08
Ru-103	3.7E-05	5.7E-09	5.7E-12
Ru-106	8.3E-06	1.1E-09	1.1E-12
Rh-103m	4.4E-05	5.7E-09	5.7E-12
Rh-106	9.9E-06	1.1E-09	1.1E-09
Te-125m	2.4E-05	1.7E-09	1.7E-12
Te-127m	2.3E-04	2.8E-08	2.8E-11
Te-127	7.7E-04	8.8E-08	8.8E-11
Te-129m	1.2E-03	1.7E-07	1.7E-10
Te-129	1.6E-03	1.7E-07	1.7E-10
Te-131m	2.2E-03	2.9E-07	2.9E-10
Te-131	1.1E-03	5.6E-08	5.6E-11
Te-132	2.3E-02	2.9E-06	2.9E-09
Ba-137m	1.6E-02	2.5E-06	2.5E-09
Ba-140	1.8E-04	2.8E-08	2.8E-11
La-140	1.3E-04	2.0E-08	2.0E-11
Ce-141	5.8E-05	1.1E-08	1.1E-11
Ce-143	3.5E-05	2.9E-09	2.9E-12
Ce-144	2.7E-05	5.6E-09	5.6E-12
Pr-143	4.2E-05	5.7E-09	5.7E-12
Pr-144	3.3E-05	5.6E-09	5.6E-12
Np-239	1.0E-03	1.7E-07	1.7E-10

Table I.3-3 POINT BEACH NUCLEAR PLANT CALCULATED SOURCE TERM ACTIVITIES (Ci)

Sheet 1 of 3

<u>Isotope</u>	<u>Reactor Coolant (Ci)</u>	<u>Steam Generators Liquid (Ci)</u>
<u>NOBLE GASES</u>		
Kr-83m	1.9E+00	0.0
Kr-85m	8.1E+00	0.0
Kr-85	6.7E+00	0.0
Kr-87	5.8E+00	0.0
Kr-88	1.7E+01	0.0
Kr-89	5.5E-01	0.0
Xe-131m	4.8E-01	0.0
Xe-133m	3.6E+00	0.0
Xe-133	1.5E+02	0.0
Xe-135m	1.4E+00	0.0
Xe-135	1.9E+01	0.0
Xe-137	1.0E+00	0.0
Xe-138	4.8E+00	0.0
<u>HALOGENS</u>		
Br-83	5.2E-01	1.6E-05
Br-84	2.9E-01	2.5E-06
Br-85	3.3E-02	4.1E-08
I-130	2.1E-01	1.4E-05
I-131	2.5E+01	2.0E-03
I-132	1.1E+01	4.3E-04
I-133	3.8E+01	2.8E-03
I-134	5.2E+00	7.5E-05
I-135	2.0E+01	1.0E-03
<u>CS, RB</u>		
Rb-86	8.6E-03	8.9E-07
Rb-88	2.2E+01	1.3E-04
Cs-134	2.5E+00	2.3E-04

Table I.3-3 POINT BEACH NUCLEAR PLANT CALCULATED SOURCE TERM ACTIVITIES (Ci)

Sheet 2 of 3

<u>Isotope</u>	<u>Reactor Coolant (Ci)</u>	<u>Steam Generators Liquid (Ci)</u>
<u>CS, RB</u>		
Cs-136	1.3E+00	1.3E-04
Cs-137	1.8E+00	1.9E-04
<u>WATER ACTIVATION PRODUCTS</u>		
N-16	4.5E+03	2.0E-04
<u>TRITIUM</u>		
H-3	1.1E-02	7.3E-02
<u>OTHER NUCLIDES</u>		
Cr-51	1.8E-01	1.9E-05
Mn-54	2.9E-02	4.1E-06
Fe-55	1.5E-01	1.6E-05
Fe-59	9.3E-02	1.2E-05
Co-58	1.5E+00	1.6E-04
Co-60	1.9E-01	1.9E-05
Sr-89	3.3E-02	4.1E-06
Sr-90	9.3E-04	8.2E-08
Sr-91	6.6E-02	1.1E-06
Y-90	1.6E-03	8.3E-08
Y-91m	4.2E-02	6.2E-07
Y-91	1.9E-01	1.9E-05
Y-93	1.3E-02	4.3E-07
Zr-95	5.6E-03	8.2E-07
Nb-95	4.7E-03	8.2E-07
Mo-99	4.3E+01	1.5E-03
Tc-99m	4.0E+01	1.3E-03
Ru-103	4.2E-03	4.1E-07

Table I.3-3 POINT BEACH NUCLEAR PLANT CALCULATED SOURCE TERM
ACTIVITIES (Ci)

Sheet 3 of 3

<u>Isotope</u>	<u>Reactor Coolant (Ci)</u>	<u>Steam Generators Liquid (Ci)</u>
<u>OTHER NUCLIDES</u>		
Ru-106	9.3E-04	8.2E-08
Rh-103m	5.0E-03	4.2E-07
Rh-106	1.1E-03	8.1E-08
Te-125m	2.7E-03	1.2E-07
Te-127m	2.6E-02	2.1E-06
Te-127	8.7E-02	6.4E-06
Te-129m	1.3E-01	1.2E-05
Te-129	1.8E-01	1.3E-05
Te-131m	2.4E-01	2.1E-05
Te-131	1.2E-01	4.1E-06
Te-132	2.6E+00	2.1E-04
Ba-137m	1.8E+00	1.8E-04
Ba-140	2.1E-02	2.1E-06
La-140	1.4E-02	1.5E-06
Ce-141	6.5E-03	8.2E-07
Ce-143	3.9E-03	2.1E-07
Ce-144	3.1E-03	4.1E-07
Pr-143	4.7E-03	4.1E-07
Pr-144	3.7E-03	4.1E-07
Np-239	1.1E-01	1.3E-05

Table I.4-1 POINT BEACH NUCLEAR PLANT ON-SITE WIND ROSE FOR 4/19/67 TO 4/18/69 (FREQUENCY PERCENT)

WINDS BLOWING FROM	<u>WIND SPEED CLASSIFICATIONS (MPH)</u>						<u>TOTAL</u>
	<u>1 - 3</u>	<u>4 - 7</u>	<u>8 - 12</u>	<u>13 - 18</u>	<u>19 - 24</u>	<u>25</u>	
N	0.56	1.42	2.93	3.16	1.11	0.66	9.84
NNE	0.31	0.85	1.89	1.77	0.94	0.72	6.49
NE	0.36	1.02	1.28	1.28	0.47	0.29	4.71
ENE	0.40	0.66	0.51	0.44	0.27	0.12	2.40
E	0.62	0.79	0.44	0.33	0.13	0.16	2.46
ESE	0.52	0.66	0.44	0.17	0.20	0.05	2.05
SE	0.51	1.02	0.81	0.61	0.31	0.27	3.52
SSE	0.37	0.83	1.37	0.82	0.57	0.25	4.21
S	0.48	1.25	2.63	2.13	1.04	0.53	8.06
SSW	0.40	1.30	4.27	4.45	1.73	0.39	12.54
SW	0.44	1.50	3.47	2.27	0.46	0.12	8.24
WSW	0.26	0.83	1.78	1.30	0.38	0.13	4.69
W	0.42	1.14	2.23	2.40	0.91	0.60	7.70
WNW	0.32	1.13	2.88	3.52	1.37	0.43	9.65
NW	0.29	1.05	2.72	2.47	0.45	0.15	7.13
NNW	0.19	0.76	2.12	1.60	0.59	0.14	5.40

Total Observations = 14,647

Percentage of Calms = 0.91

Table I.4-2 POINT BEACH NUCLEAR PLANT SUMMARY OF ANNUAL AND GRAZING SEASON X/Q's AND D/Q's FOR HIGHEST OFFSITE SECTORS

<u>Location</u>	<u>Release Mode</u>	<u>Type</u>	<u>Highest Sectors for Site Boundary & Animal Locations</u>						<u>Highest Sector for Nearest Resident & Vegetable Garden Location</u>					
			<u>S Sector (1,270m)</u>		<u>SSE Sector (1,300m)</u>		<u>SSW Sector (1,460m)</u>		<u>S Sector (1,270m)</u>		<u>SSE Sector (1,300m)</u>		<u>SSW Sector (1,460m)</u>	
			<u>X/Q</u> <u>x 10⁷</u>	<u>D/Q</u> <u>x 10⁹</u>	<u>X/Q</u> <u>x 10⁷</u>	<u>D/Q</u> <u>x 10⁹</u>	<u>X/Q</u> <u>x 10⁷</u>	<u>D/Q</u> <u>x 10⁹</u>	<u>X/Q</u> <u>x 10⁷</u>	<u>D/Q</u> <u>x 10⁹</u>	<u>X/Q</u> <u>x 10⁷</u>	<u>D/Q</u> <u>x 10⁹</u>	<u>X/Q</u> <u>x 10⁷</u>	<u>D/Q</u> <u>x 10⁹</u>
IA Auxiliary Building Vent	Continuous	Conditionally elevated	A GS	4.01 2.75	13.3 6.78	A GS	3.11 2.08	20.1 11.7	A GS	2.86 3.57	5.90 7.08			
IB Auxiliary Building Vent	Intermittent (during gas decay tank releases)	Conditionally elevated	A GS	9.43 7.34	31.3 18.1	A GS	9.36 8.44	60.5 47.5	A GS	8.05 9.00	16.6 17.8			
IIA Unit 1 and Unit 2 Purge Vent	Continuous 10 cfm Vent	Ground Level	A GS	60.7 51.9	47.9 34.1	A GS	19.5 13.1	24.6 14.7	A GS	23.9 28.0	21.8 26.3			
IIB Unit 1 and 2 Purge Vent	Intermittent (purge)	Conditionally elevated	A GS	27.0 22.1	47.6 33.2	A GS	16.7 12.4	50.0 37.9	A GS	19.1 20.7	29.1 30.1			
IIC Gas Stripper Building (through Unit 2 Purge Vent)	Continuous	Ground Level	A GS	60.7 51.9	47.9 34.1	A GS	19.5 13.1	24.6 14.7	A GS	23.9 28.0	21.8 26.3			
III Turbine Building Roof Exhausters	Continuous	Ground Level	A GS	70.4 60.8	47.9 34.1	A GS	21.0 14.1	24.6 14.7	A GS	26.6 31.4	21.8 26.3			

Notes: A = Annual Average; GS = Grazing or Growing Season, X/Q in sec/m³; D/Q in m⁻²

Table I.4-3 * POINT BEACH NUCLEAR PLANT ANNUAL GROWING SEASON X/Q's AND D/Q's FOR ONSITE RESIDENTS

Location	Release Mode		Type		WNW Sector (1,250 meters)		NNW Sector (1,880 meters)		NNW Sector (1,980 meters)		
					X/Q $\times 10^7$	D/Q $\times 10^9$	X/Q $\times 10^7$	D/Q $\times 10^9$	X/Q $\times 10^7$	D/Q $\times 10^9$	
IA Auxiliary Building Vent	Continuous	Conditionally elevated	A	0.732	3.91	A	1.49	3.90	A	1.40	3.39
			GS	0.857	5.37	GS	1.89	4.31	GS	1.78	3.75
IB Auxiliary Building Vent	Intermittent (during gas decay tank releases)	Conditionally elevated	A	4.05	21.7	A	6.55	17.1	A	6.25	15.1
			GS	4.31	27.2	GS	7.45	17.0	GS	7.11	15.0
IIA Unit 1 and Unit 2 Purge Vent	Continuous 10 cfm Vent	Ground Level	A	28.6	11.0	A	9.59	7.28	A	8.52	6.37
			GS	36.3	14.1	GS	13.1	9.18	GS	11.6	8.04
IIB Unit 1 and 2 Purge Vent	Intermittent (purge)	Conditionally elevated	A	11.9	23.9	A	9.82	15.7	A	9.19	14.0
			GS	12.8	28.8	GS	10.7	15.6	GS	10.1	14.0
IIC Gas Stripper Building (through Unit 2 Purge Vent)	Continuous	Ground Level	A	28.6	11.0	A	9.59	7.28	A	8.52	6.37
			GS	36.3	14.1	GS	13.1	9.18	GS	11.6	8.04
III Turbine Building Roof Exhausters	Continuous	Ground Level	A	32.4	11.0	A	10.6	7.28	A	9.38	6.37
			GS	40.9	14.1	GS	14.6	9.18	GS	12.9	8.07

Notes: A = Annual Average; GS = Growing Season, X/Q in sec/m^3 ; D/Q in m^{-2}

* This table is historical because onsite residences have either been demolished or abandoned.

Table I.4-4 POINT BEACH NUCLEAR PLANT AUXILIARY BUILDING VENT, CONTINUOUS ELEVATED RELEASE (IA)

DATA PERIOD: 4/19/67 - 4/18/69

Downwind Sector	Shoreline Boundary	Site Boundary	Nearest Residence	Nearest Farm	<u>X/Q (Sec/M³) at Various Receptor Distances (M)</u>															
					805	1,700	1,980	2,415	2,800	3,200	3,600	4,025	4,830	5,635	7,245	12,070	24,140	40,235	56,330	72,425
Order	E-07	E-07	E-07	E-07	E-07	E-07	E-07	E-07	E-07	E-07	E-07	E-07	E-07	E-07	E-08	E-08	E-08	E-09	E-09	E-09
SSE	3.37	3.11	1.84	3.11	3.74	2.19	1.78	1.34	1.08	0.896	0.754	0.640	0.483	0.380	2.53	1.16	0.464	2.41	1.56	1.12
S	N/A	4.01	1.67	4.01	5.90	2.88	2.47	2.02	1.74	1.52	1.35	1.19	1.01	0.882	6.41	3.40	1.60	9.13	6.26	4.71
SSW	N/A	3.17	2.86	2.22	4.09	2.65	2.46	2.12	1.78	1.52	1.31	1.13	0.869	0.697	4.87	2.22	1.02	5.55	3.69	2.72
SW	N/A	2.43	2.16	2.39	2.61	2.15	2.16	1.95	1.70	1.47	1.30	1.14	0.791	0.582	3.62	1.67	0.818	4.35	2.86	2.09
WSW	N/A	1.12	0.922	1.12	1.14	0.974	0.980	0.901	0.746	0.755	0.693	0.638	0.504	0.411	2.46	1.18	0.589	3.19	2.12	1.56
W	N/A	0.885	0.844	0.885	1.06	0.907	0.902	0.841	0.834	0.815	0.784	0.740	0.581	0.473	2.64	1.49	0.765	4.06	2.67	1.95
WNW	N/A	0.676	0.775	0.768	0.691	0.715	0.884	0.766	0.805	0.819	0.830	0.817	0.585	0.443	3.56	1.77	0.922	4.98	3.30	2.43
NW	N/A	1.03	0.884	0.915	1.78	1.15	1.05	0.910	0.906	0.890	0.876	0.857	0.830	0.788	5.35	2.01	1.01	5.43	3.61	2.65
NNW	2.96	1.37	1.09	1.37	2.81	1.69	1.40	1.13	1.02	0.961	0.913	0.861	0.792	0.725	4.82	2.16	0.863	4.56	2.99	2.18
N	12.0	0.938	0.836	N/A	4.97	2.94	2.41	1.84	1.49	1.23	1.04	0.944	0.828	0.745	5.86	3.05	1.17	6.00	3.87	2.79
NNE	55.4	N/A	N/A	N/A	7.61	3.78	3.12	2.43	2.01	1.69	1.45	1.26	0.985	0.802	5.72	2.93	1.30	7.21	4.87	3.62
NE	47.7	N/A	N/A	N/A	4.22	1.81	1.52	1.23	1.06	0.924	0.820	0.732	0.605	0.513	3.90	2.22	1.09	6.40	4.45	3.38
ENE	23.3	N/A	N/A	N/A	2.58	1.27	1.06	0.831	0.696	0.593	0.515	0.450	0.360	0.298	2.18	1.17	0.547	3.11	2.13	1.60
E	45.2	N/A	N/A	N/A	5.06	2.17	1.75	1.34	1.10	0.921	0.791	0.685	0.542	0.446	3.25	1.75	0.815	4.64	3.18	2.39
ESE	29.7	N/A	N/A	N/A	7.92	3.44	2.67	1.93	1.51	1.22	1.01	0.848	0.637	0.502	3.44	1.67	0.706	3.82	2.54	1.87
SE	11.0	N/A	N/A	N/A	6.22	2.68	2.07	1.48	1.16	0.928	0.766	0.639	0.477	0.374	2.54	1.23	0.514	2.78	1.85	1.37

Table I.4-5 POINT BEACH NUCLEAR PLANT GROWING/GRAZING SEASON X/Q AUXILIARY BUILDING VENT,
CONTINUOUS ELEVATED RELEASE (IA)

DATA PERIOD: 4/19/67-10/18/67
AND: 4/19/68-10/18/68

<u>X/Q (Sec/M³) at Various Receptor Distances (M)</u>																				
<u>Downwind Sector</u>	<u>Shoreline Boundary</u>	<u>Site Boundary</u>	<u>Nearest Residence</u>	<u>Nearest Farm</u>	<u>805</u>	<u>1,700</u>	<u>1,980</u>	<u>2,415</u>	<u>2,800</u>	<u>3,200</u>	<u>3,600</u>	<u>4,025</u>	<u>4,830</u>	<u>5,635</u>	<u>7,245</u>	<u>12,070</u>	<u>24,140</u>	<u>40,235</u>	<u>56,330</u>	<u>72,425</u>
<u>Order</u>	<u>E-07</u>	<u>E-07</u>	<u>E-07</u>	<u>E-07</u>	<u>E-07</u>	<u>E-07</u>	<u>E-07</u>	<u>E-07</u>	<u>E-07</u>	<u>E-07</u>	<u>E-07</u>	<u>E-07</u>	<u>E-07</u>	<u>E-07</u>	<u>E-08</u>	<u>E-08</u>	<u>E-08</u>	<u>E-09</u>	<u>E-09</u>	<u>E-09</u>
SSE	2.55	2.08	1.23	2.08	2.38	1.47	1.19	0.893	0.716	0.591	0.495	0.419	0.314	0.246	1.62	0.736	0.296	1.55	1.01	0.731
S	N/A	2.75	1.19	2.75	4.20	1.98	1.71	1.41	1.23	1.08	0.968	0.862	0.750	0.672	5.00	2.77	1.37	7.95	5.52	4.19
SSW	N/A	3.90	3.57	2.83	4.75	3.35	3.14	2.71	2.28	1.94	1.68	1.44	1.11	0.885	6.15	2.77	1.27	6.86	4.56	3.35
SW	N/A	3.29	2.96	3.26	3.17	2.93	2.96	2.69	2.35	2.04	1.80	1.58	1.10	0.808	5.01	2.31	1.15	6.10	4.02	2.93
WSW	N/A	1.29	1.22	1.29	1.11	1.20	1.27	1.21	1.02	1.06	0.989	0.922	0.737	0.604	3.62	1.75	0.888	4.84	3.22	2.37
W	N/A	0.937	1.06	0.937	0.870	1.08	1.11	1.07	1.09	1.08	1.06	1.01	0.803	0.658	3.66	2.10	1.11	5.93	3.90	2.85
WNW	N/A	0.858	1.06	1.05	0.686	0.922	1.19	1.05	1.13	1.16	1.18	1.17	0.834	0.628	5.02	2.45	1.21	6.42	4.22	3.08
NW	N/A	1.24	1.13	1.13	1.83	1.34	1.26	1.12	1.15	1.16	1.17	1.17	1.18	1.15	7.84	2.91	1.50	8.15	5.43	4.01
NNW	3.57	1.74	1.43	1.74	3.38	2.12	1.78	1.45	1.34	1.28	1.24	1.19	1.12	1.04	6.96	3.13	1.25	6.60	4.33	3.16
N	13.6	1.21	1.09	N/A	6.10	3.72	3.06	2.34	1.91	1.58	1.34	1.22	1.08	0.981	7.86	4.21	1.63	8.43	5.46	3.95
NNE	67.8	N/A	N/A	N/A	9.46	4.95	4.11	3.22	2.67	2.26	1.94	1.68	1.32	1.08	7.74	3.99	1.78	9.93	6.72	5.00
NE	53.9	N/A	N/A	N/A	4.95	2.11	1.76	1.42	1.22	1.07	0.946	0.844	0.698	0.593	4.52	2.61	1.31	7.69	5.37	4.09
ENE	29.4	N/A	N/A	N/A	3.25	1.55	1.27	0.988	0.819	0.692	0.596	0.518	0.410	0.337	2.45	1.30	0.604	3.43	2.35	1.77
E	33.2	N/A	N/A	N/A	4.13	1.73	1.38	1.03	0.834	0.691	0.586	0.502	0.390	0.316	2.26	1.19	0.556	3.19	2.19	1.66
ESE	16.3	N/A	N/A	N/A	5.38	2.13	1.63	1.16	0.914	0.739	0.616	0.521	0.398	0.319	2.25	1.17	0.535	3.02	2.07	1.55
SE	6.53	N/A	N/A	N/A	4.25	1.71	1.30	0.928	0.722	0.579	0.478	0.399	0.298	0.234	1.59	0.778	0.335	1.84	1.24	0.924

Table I.4-6 POINT BEACH NUCLEAR PLANT ANNUAL AVERAGE X/Q
AUXILIARY BUILDING VENT, INTERMITTENT ELEVATED RELEASE (IB)

Data Period: 4/19/67-4/18/69

X/Q (sec/m³) at Various Receptor Distances (m)

<u>Downwind Sector Order</u>	<u>Shoreline Boundary E-07</u>	<u>Site Boundary E-07</u>	<u>Nearest Residence E-07</u>	<u>Nearest Farm E-07</u>
SSE	9.83	9.36	6.61	9.36
S	N/A	9.43	5.25	9.43
SSW	N/A	8.41	8.05	7.58
SW	N/A	8.63	8.70	9.13
WSW	N/A	5.33	5.90	5.33
W	N/A	4.40	5.53	4.40
WNW	N/A	4.26	5.65	5.69
NW	N/A	5.40	5.14	5.10
NNW	11.56	6.15	5.46	6.15
N	30.07	3.61	3.53	N/A
NNE	106.	N/A	N/A	N/A
NE	129.	N/A	N/A	N/A
ENE	85.8	N/A	N/A	N/A
E	116.	N/A	N/A	N/A
ESE	63.4	N/A	N/A	N/A
SE	28.2	N/A	N/A	N/A

Table I.4-7 POINT BEACH NUCLEAR PLANT GROWING/GRAZING SEASON X/Q
AUXILIARY BUILDING VENT, INTERMITTENT ELEVATED RELEASE (IB)

4/19/67-10/18/67 AND 4/19/68-10/18/68

X/Q at Various Receptor Distances

<u>Downwind Sector Order</u>	<u>Shoreline Boundary E-07</u>	<u>Site Boundary E-07</u>	<u>Nearest Residence E-07</u>	<u>Nearest Farm E-07</u>
SSE	8.86	8.44	5.93	8.44
S	N/A	7.34	4.64	7.34
SSW	N/A	9.21	9.00	8.77
SW	N/A	10.1	10.1	10.7
WSW	N/A	5.72	7.03	5.72
W	N/A	4.72	6.60	4.72
WNW	N/A	4.72	6.66	6.81
NW	N/A	5.92	5.99	5.69
NNW	12.62	6.98	6.25	6.98
N	31.7	4.14	4.08	N/A
NNE	116	N/A	N/A	N/A
NE	142	N/A	N/A	N/A
ENE	96.0	N/A	N/A	N/A
E	103	N/A	N/A	N/A
ESE	48.3	N/A	N/A	N/A
SE	22.5	N/A	N/A	N/A

Table I.4-8 POINT BEACH NUCLEAR PLANT ANNUAL AVERAGE X/Q'S, UNIT 1 OR UNIT 2 CONTAINMENT PURGE VENT, CONTINUOUS GROUND LEVEL RELEASE (IIA) AND GAS STRIPPER BUILDING VIA UNIT 2 CONTAINMENT PURGE VENT, CONTINUOUS GROUND LEVEL RELEASE (IIC)

DATA PERIOD: 4/19/67-10/18/67

					<u>X/Q (Sec/M³) at Various Receptor Distances (M)</u>															
<u>Downwind Sector</u>	<u>Shoreline Boundary</u>	<u>Site Boundary</u>	<u>Nearest Residence</u>	<u>Nearest Farm</u>	<u>805</u>	<u>1,700</u>	<u>1,980</u>	<u>2,415</u>	<u>2,800</u>	<u>3,200</u>	<u>3,600</u>	<u>4,025</u>	<u>4,830</u>	<u>5,635</u>	<u>7,245</u>	<u>12,070</u>	<u>24,140</u>	<u>40,235</u>	<u>56,330</u>	<u>72,425</u>
<u>Order</u>	<u>E-07</u>	<u>E-07</u>	<u>E-07</u>	<u>E-07</u>	<u>E-07</u>	<u>E-07</u>	<u>E-07</u>	<u>E-07</u>	<u>E-07</u>	<u>E-07</u>	<u>E-07</u>	<u>E-07</u>	<u>E-07</u>	<u>E-07</u>	<u>E-08</u>	<u>E-08</u>	<u>E-08</u>	<u>E-09</u>	<u>E-09</u>	<u>E-09</u>
SSE	22.9	19.5	7.40	19.5	44.3	10.0	6.96	4.40	3.16	2.35	1.83	1.44	0.985	0.721	4.43	1.79	0.633	3.10	1.95	1.37
S	N/A	60.7	9.22	60.7	129.0	29.8	21.2	13.7	10.1	7.64	6.03	4.84	3.41	2.56	16.3	7.10	2.80	14.9	9.82	7.20
SSW	N/A	32.3	23.9	9.89	69.8	16.6	11.7	7.48	5.42	4.08	3.19	2.54	1.77	1.31	8.22	3.44	1.30	6.70	4.33	3.13
SW	N/A	15.7	8.45	11.7	51.7	12.0	8.45	5.41	3.92	2.95	2.31	1.84	1.28	0.947	5.94	2.49	0.941	4.85	3.14	2.27
WSW	N/A	17.5	5.02	17.5	41.1	9.43	6.63	4.24	3.08	2.32	1.81	1.44	1.00	0.745	4.68	1.97	0.749	3.87	2.51	1.82
W	N/A	20.5	5.97	20.5	46.2	10.7	7.50	4.81	3.49	2.63	2.06	1.64	1.14	0.846	5.31	2.24	0.851	4.40	2.85	2.06
WNW	N/A	14.9	7.21	6.55	58.1	13.5	9.50	6.11	4.44	3.35	2.62	2.09	1.46	1.08	6.83	2.90	1.11	5.74	3.73	2.71
NW	N/A	8.60	3.96	6.01	57.3	13.0	9.19	5.93	4.32	3.27	2.57	2.05	1.44	1.07	6.79	2.91	1.12	5.90	3.87	2.82
NNW	49.7	8.23	4.42	8.23	52.1	12.1	8.52	5.46	3.95	2.98	2.33	1.85	1.29	0.956	6.01	2.53	0.958	4.93	3.18	2.30
N	367.0	2.65	1.80	N/A	77.7	17.6	12.3	7.83	5.65	4.24	3.30	2.62	1.81	1.33	8.29	3.44	1.27	6.41	4.10	2.94
NNE	1,190.0	N/A	N/A	N/A	117.0	27.0	19.1	12.3	8.92	6.73	5.28	4.21	2.94	2.18	13.8	5.83	2.23	11.6	7.55	5.49
NE	1,540.0	N/A	N/A	N/A	108.0	24.9	17.7	11.4	8.36	6.34	5.00	4.00	2.81	2.10	13.4	5.79	2.26	12.0	7.87	5.76
ENE	796.0	N/A	N/A	N/A	57.6	13.1	9.27	5.97	4.35	3.29	2.58	2.06	1.44	1.07	6.77	2.89	1.11	5.81	3.80	2.77
E	1,150.	N/A	N/A	N/A	83.6	19.1	13.5	8.65	6.28	4.74	3.71	2.96	2.06	1.53	9.66	4.09	1.56	8.10	5.27	3.83
ESE	711.	N/A	N/A	N/A	77.7	17.2	12.0	7.64	5.52	4.14	3.23	2.56	1.77	1.31	8.17	3.42	1.27	6.48	4.18	3.01
SE	298.	N/A	N/A	N/A	62.6	13.7	9.60	6.12	4.42	3.32	2.59	2.06	1.42	1.05	6.57	2.76	1.03	5.29	3.42	2.48

Table I.4-9 POINT BEACH NUCLEAR PLANT GROWING/GRAZING SEASON X/Q'S, UNIT 1 OR UNIT 2 CONTAINMENT PURGE VENT, CONTINUOUS GROUND LEVEL RELEASE (IIA) AND GAS STRIPPER BUILDING VIA UNIT 2 CONTAINMENT PURGE VENT, CONTINUOUS GROUND LEVEL RELEASE (IIC)

DATA PERIOD: 4/19/67-10/18/67
AND 4/19/68-10/18/68

Downwind Sector	Shoreline Boundary	Site Boundary	Nearest Residence	Nearest Farm	<u>X/Q (Sec/M³) at Various Receptor Distances (M)</u>															
					805	1,700	1,980	2,415	2,800	3,200	3,600	4,025	4,830	5,635	7,245	12,070	24,140	40,235	56,330	72,425
Order	E-07	E-07	E-07	E-07	E-07	E-07	E-07	E-07	E-07	E-07	E-07	E-07	E-07	E-07	E-08	E-08	E-08	E-09	E-09	E-09
SSE	15.4	13.1	4.95	13.1	29.9	6.70	4.66	2.94	2.11	1.57	1.22	0.959	0.655	0.479	2.94	1.19	0.420	2.06	1.29	0.911
S	N/A	51.9	7.96	51.9	112	25.4	18.1	11.8	8.68	6.61	5.23	4.21	2.98	2.24	14.4	6.36	2.54	13.6	9.07	6.69
SSW	N/A	37.8	28.0	11.6	81.8	19.4	13.7	8.82	6.40	4.83	3.78	3.02	2.10	1.56	9.82	4.13	1.57	8.14	5.28	3.82
SW	N/A	21.8	11.7	16.2	72.1	16.7	11.7	7.52	5.45	4.11	3.22	2.56	1.78	1.32	8.30	3.49	1.32	6.84	4.43	3.21
WSW	N/A	26.4	7.58	26.4	61.8	14.2	10.0	6.42	4.56	3.51	2.75	2.19	1.52	1.13	7.12	3.01	1.14	5.92	3.84	2.78
W	N/A	30.1	8.75	30.1	68.1	15.6	11.0	7.04	5.11	3.85	3.01	2.40	1.67	1.24	7.80	3.30	1.25	6.49	4.21	3.05
WNW	N/A	19.0	9.12	8.28	73.3	M	12.1	7.72	5.59	4.21	3.29	2.62	1.82	1.35	8.47	3.57	1.34	6.89	4.45	3.21
NW	N/A	12.3	5.71	8.66	82.8	18.6	13.2	8.54	6.24	4.73	3.72	2.98	2.09	1.56	9.95	4.30	1.68	8.87	5.84	4.28
NNW	68.0	11.3	6.06	11.3	71.4	M	11.6	7.48	5.43	4.09	3.20	2.55	1.78	1.32	8.33	3.53	1.35	6.99	4.54	3.30
N	513	3.68	2.50	N/A	108	24.2	17.0	10.8	7.81	5.86	4.57	3.63	2.51	1.85	11.6	4.82	1.79	9.09	5.84	4.20
NNE	1,630	N/A	N/A	N/A	161	37.1	26.2	16.8	12.2	9.24	7.24	5.77	4.03	2.99	18.9	8.00	3.06	15.9	10.4	7.52
NE	1,850	N/A	N/A	N/A	127	29.2	20.7	13.5	9.85	7.48	5.90	4.73	3.33	2.50	15.9	6.93	2.72	14.5	9.54	6.99
ENE	894	N/A	N/A	N/A	64.3	14.5	10.3	6.62	4.82	3.65	2.86	2.29	1.60	1.19	7.54	3.23	1.24	6.54	4.29	3.13
E	822	N/A	N/A	N/A	58.8	13.2	9.28	5.98	4.35	3.29	2.58	2.06	1.44	1.07	6.77	2.89	1.11	5.81	3.80	2.77
ESE	620	N/A	N/A	N/A	64.2	14.1	9.94	6.39	4.64	3.50	2.75	2.19	1.53	1.14	7.18	3.07	1.18	6.16	4.04	2.95
SE	206	N/A	N/A	N/A	41.8	9.11	6.38	4.08	2.95	2.22	1.74	1.38	0.961	0.713	4.48	1.91	0.722	3.74	2.44	1.77

Table I.4-10 POINT BEACH NUCLEAR PLANT ANNUAL AVERAGE X/Q'S, UNIT 1 OR UNIT 2 CONTAINMENT PURGE VENT, INTERMITTENT RELEASE (IIB)

4/19/67-4/18/69

Downwind Sector	Shoreline Boundary	Site Boundary	Nearest Residence	Nearest Farm	X/Q (Sec/M ³) at Various Receptor Distances (M)									
					805	2,415	4,025	5,635	7,245	12,070	24,140	40,235	56,330	72,425
Order	E-07	E-07	E-07	E-07	E-07	E-07	E-07	E-07	E-08	E-08	E-08	E-09	E-09	E-09
SSE	18.6	16.7	9.60	16.7	11.8	2.20	0.890	0.492	3.16	1.37	0.528	2.69	1.72	1.23
S	N/A	27.0	8.96	27.0	24.8	4.64	2.11	1.37	9.42	4.62	2.04	11.3	7.62	5.67
SSW	N/A	22.9	19.1	12.8	17.0	3.91	1.68	0.951	6.31	2.74	1.16	6.13	4.02	2.93
SW	N/A	17.3	13.7	15.9	11.4	3.25	1.49	0.744	4.57	2.00	0.890	4.64	3.03	2.20
WSW	N/A	13.5	8.90	13.5	5.41	1.68	0.911	0.538	3.20	1.44	0.662	3.51	2.31	1.68
W	N/A	12.0	8.74	12.0	4.54	1.66	1.08	0.629	3.51	1.79	0.829	4.32	2.81	2.04
WNW	N/A	8.75	8.86	8.69	3.72	1.63	1.29	0.663	5.00	2.32	1.08	5.67	3.71	2.70
NW	N/A	9.41	7.24	7.84	7.93	1.91	1.29	0.982	6.41	2.45	1.11	5.85	3.85	2.81
NNW	27.9	9.04	7.10	9.04	9.61	1.97	1.19	0.871	5.61	2.43	0.937	4.86	3.15	2.28
N	135	4.28	3.85	N/A	16.5	2.96	1.29	0.915	6.87	3.33	1.25	6.34	4.06	2.92
NNE	461	N/A	N/A	N/A	28.6	4.63	1.94	1.12	7.60	3.61	1.53	8.29	5.53	4.08
NE	533	N/A	N/A	N/A	17.5	2.99	1.38	0.850	6.01	3.09	1.41	7.94	5.41	4.05
ENE	323	N/A	N/A	N/A	9.71	1.72	0.765	0.459	3.18	1.57	0.690	3.81	2.57	1.91
E	494	N/A	N/A	N/A	18.3	2.87	1.23	0.729	5.00	2.44	1.06	5.79	3.88	2.87
ESE	283	N/A	N/A	N/A	21.0	3.10	1.21	0.676	4.47	2.07	0.846	4.48	2.95	2.15
SE	110	N/A	N/A	N/A	14.9	2.33	0.915	0.511	3.37	1.56	0.634	3.37	2.22	1.63

Table I.4-11 POINT BEACH NUCLEAR PLANT GROWING/GRAZING SEASON X/Q'S, UNIT 1 OR UNIT 2 CONTAINMENT PURGE VENT, INTERMITTENT RELEASE (IIB)

4/19/67-10/18/67 AND 4/19/68-10/18/68

Downwind Sector	Shoreline Boundary	Site Boundary	Nearest Residence	Nearest Farm	X/Q (Sec/M ³) at Various Receptor Distances (M)									
					805	2,415	4,025	5,635	7,245	12,070	24,140	40,235	56,330	72,425
Order	E-07	E-07	E-07	E-07	E-07	E-07	E-07	E-07	E-08	E-08	E-08	E-09	E-09	E-09
SSE	13.7	12.4	7.23	12.4	6.58	1.29	0.532	0.298	1.93	0.855	0.336	1.73	1.11	0.794
S	N/A	22.1	7.07	22.1	17.6	3.06	1.47	1.01	7.19	3.70	1.71	9.68	6.63	4.98
SSW	N/A	24.8	20.7	13.9	20.1	4.64	2.00	1.14	7.56	3.28	1.40	7.42	4.88	3.56
SW	N/A	19.4	15.4	17.9	14.1	4.28	2.02	1.01	6.18	2.72	1.24	6.49	4.24	3.08
WSW	N/A	14.1	10.5	14.1	5.53	2.22	1.30	0.781	4.63	2.11	0.993	5.29	3.49	2.55
W	N/A	11.5	9.64	11.5	4.16	2.00	1.45	0.870	4.79	2.53	1.21	6.34	4.14	3.01
WNW	N/A	9.63	10.0	9.83	4.25	2.07	1.66	0.850	6.29	2.90	1.29	6.76	4.40	3.19
NW	N/A	10.0	8.06	8.41	8.81	2.26	1.73	1.42	9.35	3.52	1.65	8.78	5.80	4.26
NNW	30.0	9.93	7.99	9.93	11.2	2.48	1.61	1.22	7.89	3.42	1.33	6.92	4.51	3.28
N	140	4.78	4.46	N/A	18.7	3.59	1.61	1.18	9.17	4.62	1.74	8.94	5.76	4.15
NNE	473	N/A	N/A	N/A	33.8	5.79	2.50	1.47	10.0	4.84	2.07	11.3	7.54	5.57
NE	562	N/A	N/A	N/A	19.5	3.17	1.49	0.932	6.67	3.50	1.63	9.27	6.36	4.79
ENE	355	N/A	N/A	N/A	11.1	1.84	0.811	0.485	3.36	1.67	0.734	4.08	2.76	2.06
E	422	N/A	N/A	N/A	13.2	1.91	0.795	0.464	3.18	1.57	0.694	3.86	2.61	1.95
ESE	202	N/A	N/A	N/A	11.9	1.76	0.726	0.426	2.92	1.46	0.642	3.56	2.41	1.80
SE	76.6	N/A	N/A	N/A	8.62	1.33	0.527	0.297	1.98	0.939	0.396	2.16	1.44	1.07

Table I.4-12 POINT BEACH NUCLEAR PLANT ANNUAL AVERAGE X/Q'S, TURBINE BUILDING ROOF EXHAUSTERS, CONTINUOUS GROUND LEVEL RELEASE (III)

DATA PERIOD: 4/19/67-10/18/68

<u>X/Q (Sec/M³) at Various Receptor Distances (M)</u>																				
<u>Downwind Sector</u>	<u>Shoreline Boundary</u>	<u>Site Boundary</u>	<u>Nearest Residence</u>	<u>Nearest Farm</u>	<u>805</u>	<u>1,700</u>	<u>1,980</u>	<u>2,415</u>	<u>2,800</u>	<u>3,200</u>	<u>3,600</u>	<u>4,025</u>	<u>4,830</u>	<u>5,635</u>	<u>7,245</u>	<u>12,070</u>	<u>24,140</u>	<u>40,235</u>	<u>56,330</u>	<u>72,425</u>
<u>Order</u>	<u>E-07</u>	<u>E-07</u>	<u>E-07</u>	<u>E-07</u>	<u>E-07</u>	<u>E-07</u>	<u>E-07</u>	<u>E-07</u>	<u>E-07</u>	<u>E-07</u>	<u>E-07</u>	<u>E-07</u>	<u>E-07</u>	<u>E-07</u>	<u>E-08</u>	<u>E-08</u>	<u>E-08</u>	<u>E-09</u>	<u>E-09</u>	<u>E-09</u>
SSE	24.8	21.0	7.83	21.0	49.7	10.7	7.36	4.61	3.29	2.44	1.89	1.49	1.01	0.738	4.51	1.81	0.639	3.13	1.96	1.38
S	N/A	70.4	10.3	70.4	147	34.7	24.3	15.6	11.3	8.47	6.63	5.29	3.69	2.75	17.4	7.44	2.89	15.3	10.1	7.39
SSW	N/A	36.3	26.6	10.7	81.4	18.3	12.7	8.07	5.80	4.34	3.37	2.68	1.85	1.36	8.50	3.52	1.32	6.79	4.38	3.16
SW	N/A	17.5	9.27	13.0	59.3	13.3	9.27	5.87	4.21	3.15	2.45	1.94	1.34	0.990	6.17	2.56	0.959	4.93	3.19	2.30
WSW	N/A	19.7	5.49	19.7	46.9	10.5	7.31	4.63	3.32	2.48	1.93	1.53	1.06	0.782	4.88	2.03	0.765	3.94	2.55	1.85
W	N/A	23.1	6.55	23.1	52.9	11.9	8.28	5.24	3.76	2.82	2.19	1.74	1.20	0.887	5.54	2.31	0.870	4.48	2.90	2.10
WNW	N/A	16.8	7.94	7.19	66.5	15.2	10.6	6.70	4.82	3.61	2.81	2.23	1.54	1.14	7.14	2.99	1.13	5.86	3.80	2.76
NW	N/A	9.69	4.35	6.70	64.3	14.9	10.4	6.61	4.77	3.58	2.79	2.22	1.54	1.14	7.17	3.03	1.16	6.06	3.96	2.89
NNW	57.1	9.05	4.77	9.05	60.0	13.5	9.38	5.93	4.26	3.19	2.48	1.97	1.36	1.00	6.25	2.61	0.978	5.02	3.24	2.33
N	427	2.79	1.88	N/A	87.4	19.3	13.3	8.41	6.02	4.49	3.48	2.75	1.89	1.39	8.58	3.53	1.29	6.52	4.17	2.99
NNE	1,230	N/A	N/A	N/A	133	30.4	21.2	13.5	9.70	7.27	5.67	4.50	3.11	2.30	14.4	6.03	2.28	11.9	7.70	5.59
NE	1,560	N/A	N/A	N/A	122	28.8	20.1	12.9	9.29	6.98	5.46	4.35	3.03	2.25	14.2	6.05	2.33	12.3	8.07	5.90
ENE	813	N/A	N/A	N/A	64.7	14.9	10.4	6.63	4.77	3.58	2.79	2.22	1.54	1.14	7.13	3.01	1.14	5.96	3.89	2.83
E	1,180	N/A	N/A	N/A	94.4	21.5	15.0	9.50	6.84	5.12	3.99	3.17	2.19	1.62	10.1	4.23	1.60	8.29	5.38	3.91
ESE	773	N/A	N/A	N/A	86.1	19.0	13.2	8.30	5.95	4.43	3.44	2.72	1.87	1.38	8.52	3.53	1.30	6.63	4.27	3.08
SE	337	N/A	N/A	N/A	69.1	15.3	10.6	6.68	4.78	3.57	2.77	2.19	1.51	1.11	6.89	2.86	1.06	5.42	3.50	2.53

Table I.4-13 GROWING/GRAZING SEASON X/Q'S, TURBINE BUILDING ROOF EXHAUSTERS, CONTINUOUS GROUND LEVEL RELEASE (III)

DATA PERIOD: 4/19/67-10/18/67
AND: 4/19/68-10/18/68

<u>X/Q (Sec/M³) at Various Receptor Distances (M)</u>																				
<u>Downwind Sector</u>	<u>Shoreline Boundary</u>	<u>Site Boundary</u>	<u>Nearest Residence</u>	<u>Nearest Farm</u>	<u>805</u>	<u>1,700</u>	<u>1,980</u>	<u>2,415</u>	<u>2,800</u>	<u>3,200</u>	<u>3,600</u>	<u>4,025</u>	<u>4,830</u>	<u>5,635</u>	<u>7,245</u>	<u>12,070</u>	<u>24,140</u>	<u>40,235</u>	<u>56,330</u>	<u>72,425</u>
<u>Order</u>	<u>E-07</u>	<u>E-07</u>	<u>E-07</u>	<u>E-07</u>	<u>E-07</u>	<u>E-07</u>	<u>E-07</u>	<u>E-07</u>	<u>E-07</u>	<u>E-07</u>	<u>E-07</u>	<u>E-07</u>	<u>E-07</u>	<u>E-07</u>	<u>E-08</u>	<u>E-08</u>	<u>E-08</u>	<u>E-09</u>	<u>E-09</u>	<u>E-09</u>
SSE	16.6	14.1	5.24	14.1	33.4	7.14	4.92	3.08	2.20	1.63	1.26	0.990	0.673	0.491	3.00	1.20	0.424	2.08	1.30	0.919
S	N/A	60.8	9.03	60.8	125	30.2	21.2	13.6	9.87	7.45	5.84	4.67	3.26	2.44	15.5	6.71	2.64	14.1	9.35	6.88
SSW	N/A	42.7	31.4	12.7	95.0	21.7	15.1	9.58	6.89	5.16	4.02	3.19	2.21	1.63	10.2	4.24	1.60	8.28	5.36	3.88
SW	N/A	24.4	12.9	18.1	82.4	18.6	12.9	8.19	5.88	4.40	3.43	2.72	1.87	1.39	8.64	3.59	1.35	6.96	4.51	3.26
WSW	N/A	29.7	8.32	29.7	70.7	15.9	11.1	7.01	5.04	3.77	2.94	2.33	1.61	1.19	7.43	3.11	1.17	6.04	3.91	2.83
W	N/A	33.9	9.61	33.9	77.6	17.5	12.2	7.70	5.53	4.14	3.22	2.56	1.76	1.30	8.14	3.40	1.28	6.62	4.29	3.11
WNW	N/A	21.1	9.93	8.99	84.7	19.0	13.2	8.37	6.01	4.49	3.49	2.77	1.91	1.41	8.80	3.66	1.37	7.01	4.51	3.25
NW	N/A	14.1	6.35	9.75	92.3	21.6	15.1	9.62	6.95	5.22	4.08	3.25	2.26	1.68	10.6	4.50	1.73	9.14	6.01	4.39
NNW	78.2	12.5	6.58	12.5	82.1	18.6	12.9	8.18	5.88	4.40	3.43	2.72	1.88	1.39	8.70	3.64	1.38	7.13	4.63	3.35
N	593	3.88	2.62	N/A	120	26.7	18.5	11.7	8.37	6.25	4.85	3.84	2.63	1.94	12.0	4.96	1.83	9.26	5.94	4.27
NNE	1,690	N/A	N/A	N/A	183	41.8	29.1	18.5	13.3	9.97	7.77	6.17	4.27	3.16	19.8	8.27	3.13	16.3	10.6	7.67
NE	1,870	N/A	N/A	N/A	144	34.0	23.8	15.2	11.0	8.29	6.49	5.18	3.60	2.68	17.0	7.26	2.82	14.9	9.80	7.17
ENE	914	N/A	N/A	N/A	71.7	16.6	11.6	7.38	5.32	3.99	3.12	2.48	1.72	1.27	7.97	3.37	1.28	6.72	4.40	3.21
E	846	N/A	N/A	N/A	65.4	15.0	10.5	6.65	4.79	3.59	2.80	2.23	1.54	1.14	7.15	3.02	1.14	5.97	3.90	2.84
ESE	658	N/A	N/A	N/A	70.7	16.1	11.2	7.12	5.12	3.83	2.99	2.37	1.64	1.21	7.60	3.20	1.21	6.35	4.15	3.03
SE	228	N/A	N/A	N/A	46.2	10.3	7.14	4.51	3.23	2.42	1.88	1.49	1.03	0.758	4.72	1.98	0.744	3.85	2.50	1.81

Table I.4-14 POINT BEACH NUCLEAR PLANT ANNUAL AVERAGE D/Q'S, AUXILIARY BUILDING VENT, CONTINUOUS ELEVATED RELEASE (IA)

DATA PERIOD: 4/19/67-10/18/68

Downwind Sector	Shoreline Boundary	Site Boundary	Nearest Residence	Nearest Farm	D/Q (Sec/M ²) at Various Receptor Distances (m)															
					805	1,700	1,980	2,415	2,800	3,200	3,600	4,025	4,830	5,635	7,245	12,070	24,140	40,235	56,330	72,425
Order	E-09	E-09	E-09	E-09	E-09	E-09	E-09	E-09	E-09	E-09	E-09	E-10	E-10	E-10	E-10	E-10	E-11	E-11	E-11	E-12
SSE	24.0	20.1	6.95	20.1	46.9	9.85	6.48	3.80	2.58	1.84	1.37	10.4	6.78	4.81	2.89	1.12	3.61	1.45	0.758	4.63
S	N/A	13.3	1.48	13.3	29.4	6.10	4.04	2.40	1.65	1.19	0.905	7.13	5.12	4.19	3.48	2.12	9.36	3.80	1.89	11.0
SSW	N/A	8.07	5.90	2.12	18.7	3.88	2.57	1.53	1.05	0.760	0.580	4.58	3.30	2.72	2.28	1.40	6.23	2.53	1.25	7.27
SW	N/A	4.73	2.29	3.36	16.8	3.47	2.29	1.36	0.930	9.669	0.507	3.96	2.78	2.21	1.74	1.00	4.33	1.76	0.880	5.15
WSW	N/A	3.64	0.886	3.64	9.08	1.86	1.23	0.727	0.498	0.358	0.271	2.11	1.48	1.17	0.910	0.519	2.23	0.913	0.459	2.69
W	N/A	4.15	1.02	4.15	9.94	2.03	1.34	0.790	0.540	0.387	0.293	2.28	1.58	1.24	0.942	0.525	2.23	0.917	0.463	2.73
WNW	N/A	1.92	0.810	0.722	8.27	1.71	1.13	0.665	0.454	0.325	0.246	1.91	1.33	1.05	0.812	0.460	1.97	0.805	0.404	2.38
NW	N/A	1.71	0.672	1.11	13.5	2.80	1.85	1.09	0.747	0.536	0.405	3.16	2.20	1.73	1.33	0.753	3.21	1.31	0.657	3.85
NNW	23.6	3.26	1.55	3.26	24.6	5.15	3.39	1.99	1.36	0.968	0.725	5.57	3.73	2.76	1.86	0.887	3.41	1.38	0.700	4.16
N	153	1.57	1.00	N/A	69.5	14.7	9.64	5.66	3.84	2.73	2.03	15.5	10.1	7.15	4.29	1.67	5.37	2.14	1.12	6.80
NNE	219	N/A	N/A	N/A	63.6	13.4	8.82	5.20	3.54	2.53	1.90	14.6	9.91	7.47	5.25	2.65	10.5	4.24	2.13	12.6
NE	135	N/A	N/A	N/A	25.9	5.36	3.54	2.09	1.43	1.03	0.784	6.16	4.39	3.57	2.92	1.76	7.74	3.16	1.67	9.19
ENE	100	N/A	N/A	N/A	24.8	5.19	3.42	2.01	1.37	0.979	0.735	5.66	3.82	2.87	2.00	0.993	3.93	1.59	0.806	4.78
E	208	N/A	N/A	N/A	43.6	9.03	5.96	3.51	2.40	1.71	1.28	9.89	6.64	4.95	3.38	1.64	6.37	2.59	1.32	7.83
ESE	425	N/A	N/A	N/A	84.3	17.0	11.2	6.61	4.51	3.21	2.40	18.3	12.0	8.54	5.14	2.00	6.67	2.79	1.50	9.35
SE	229	N/A	N/A	N/A	63.5	12.6	8.30	4.90	3.34	2.39	1.79	13.7	8.94	6.36	3.82	1.48	4.96	2.12	1.16	7.29

Table I.4-15 POINT BEACH NUCLEAR PLANT GROWING/GRAZING SEASON D/Q'S, AUXILIARY BUILDING VENT, CONTINUOUS ELEVATED RELEASE (IA)

DATA PERIOD: 4/19/67-10/18/67
AND 4/19/68-10/18/68

<u>D/Q (Sec/M²) at Various Receptor Distances (m)</u>																				
<u>Downwind Sector</u>	<u>Shoreline Boundary</u>	<u>Site Boundary</u>	<u>Nearest Residence</u>	<u>Nearest Farm</u>	<u>805</u>	<u>1,700</u>	<u>1,980</u>	<u>2,415</u>	<u>2,800</u>	<u>3,200</u>	<u>3,600</u>	<u>4,025</u>	<u>4,830</u>	<u>5,635</u>	<u>7,245</u>	<u>12,070</u>	<u>24,140</u>	<u>40,235</u>	<u>56,330</u>	<u>72,425</u>
<u>Order</u>	<u>E-09</u>	<u>E-09</u>	<u>E-09</u>	<u>E-09</u>	<u>E-09</u>	<u>E-09</u>	<u>E-09</u>	<u>E-09</u>	<u>E-09</u>	<u>E-09</u>	<u>E-09</u>	<u>E-10</u>	<u>E-10</u>	<u>E-10</u>	<u>E-10</u>	<u>E-10</u>	<u>E-10</u>	<u>E-11</u>	<u>E-11</u>	<u>E-11</u>
SSE	14.1	11.7	4.06	11.7	27.7	5.76	3.79	2.22	1.51	1.07	0.801	6.10	3.98	2.83	1.71	0.668	2.19	0.891	0.470	2.88
S	N/A	6.78	0.766	6.78	15.2	3.11	2.06	1.23	0.849	0.618	0.476	3.81	2.87	2.49	2.28	1.51	6.95	2.84	1.41	8.16
SSW	N/A	9.65	7.08	2.53	22.2	4.65	3.08	1.82	1.25	0.903	0.688	5.43	3.92	3.23	2.73	1.69	7.50	3.04	1.51	8.74
SW	N/A	6.50	3.14	4.61	23.0	4.76	3.14	1.86	1.27	0.911	0.689	5.37	3.76	2.97	2.31	1.31	5.63	2.29	1.15	6.73
WSW	N/A	4.76	1.15	4.76	11.8	2.44	1.61	0.947	0.645	0.462	0.349	2.71	1.89	1.48	1.13	0.634	2.70	1.11	0.556	3.27
W	N/A	5.30	1.30	5.30	12.7	2.59	1.71	1.00	0.684	0.490	0.369	2.86	1.96	1.51	1.12	0.600	2.51	1.03	0.525	3.11
WNW	N/A	2.65	1.11	0.990	11.3	2.35	1.55	0.911	0.621	0.444	0.335	2.60	1.80	1.40	1.06	0.586	2.48	1.01	0.510	3.00
NW	N/A	1.94	0.762	1.26	15.5	3.19	2.10	1.24	0.847	0.608	0.460	3.59	2.52	2.01	1.58	0.916	3.97	1.63	0.817	4.80
NNW	26.2	3.60	1.71	3.60	27.3	5.69	3.75	2.21	1.50	1.07	0.806	6.21	4.20	3.17	2.23	1.12	4.48	1.82	0.923	5.47
N	194.	1.90	1.22	N/A	84.4	17.7	11.7	6.84	4.65	3.30	2.46	18.7	12.2	8.68	5.25	2.06	6.75	2.71	1.42	8.65
NNE	272.	N/A	N/A	N/A	80.4	16.9	11.1	6.56	4.47	3.20	2.40	18.5	12.5	9.45	6.67	3.38	13.5	5.44	2.74	16.2
NE	161.	N/A	N/A	N/A	29.8	6.11	4.04	2.39	1.74	1.18	0.895	7.03	5.02	4.07	3.34	2.01	8.87	3.63	1.81	10.6
ENE	122.	N/A	N/A	N/A	28.1	5.85	3.86	2.27	1.55	1.11	0.830	6.39	4.31	3.24	2.25	1.12	4.42	1.80	0.911	5.41
E	173.	N/A	N/A	N/A	32.6	6.68	4.41	2.60	1.77	1.27	0.951	7.32	4.91	3.65	2.47	1.18	4.59	1.88	0.967	5.79
ESE	298.	N/A	N/A	N/A	48.7	9.57	6.33	3.74	2.56	1.83	1.37	10.5	6.91	4.98	3.08	1.26	4.47	1.90	1.03	6.41
SE	151.	N/A	N/A	N/A	37.4	7.25	4.49	2.83	1.94	1.39	1.04	7.96	5.24	3.76	2.30	0.923	3.25	1.41	0.775	4.86

Table I.4-16 POINT BEACH NUCLEAR PLANT ANNUAL AVERAGE D/Q'S,
AUXILIARY BUILDING VENT, INTERMITTENT ELEVATED RELEASE (IB)

4/19/67-10/18/68

D/Q (m⁻²) at Various Receptor Distances (m)

<u>Downwind Sector Order</u>	<u>Shoreline Boundary E-09</u>	<u>Site Boundary E-09</u>	<u>Nearest Residence E-09</u>	<u>Nearest Farm E-09</u>
SSE	M	60.5	25.0	60.5
S	N/A	31.3	4.65	31.3
SSW	N/A	21.4	16.6	7.24
SW	N/A	16.8	9.22	12.8
WSW	N/A	17.3	5.67	17.3
W	N/A	20.6	6.69	20.6
WNW	N/A	12.1	5.91	5.35
NW	N/A	8.96	3.91	6.19
NNW	92.2	14.6	7.77	14.6
N	383	6.05	4.23	N/A
NNE	419	N/A	N/A	N/A
NE	364	N/A	N/A	N/A
ENE	368	N/A	N/A	N/A
E	534	N/A	N/A	N/A
ESE	907	N/A	N/A	N/A
SE	588	N/A	N/A	N/A

Table I.4-17 POINT BEACH NUCLEAR PLANT GROWING/GRAZING SEASON D/Q'S,
AUXILIARY BUILDING VENT, INTERMITTENT ELEVATED RELEASE (IB)

4/19/67-10/18/67 AND 4/19/68-10/18/68

D/Q (m⁻²) at Various Receptor Distances (m)

<u>Downwind Sector Order</u>	<u>Shoreline Boundary E-09</u>	<u>Site Boundary E-09</u>	<u>Nearest Residence E-09</u>	<u>Nearest Farm E-09</u>
SSE	M	47.5	19.6	47.5
S	N/A	18.1	2.98	18.1
SSW	N/A	22.2	17.8	7.84
SW	N/A	19.8	10.8	15.2
WSW	N/A	21.1	6.62	21.1
W	N/A	26.7	8.10	26.7
WNW	N/A	14.6	6.98	6.42
NW	N/A	9.26	4.04	6.34
NNW	92.6	14.5	7.47	14.5
N	452	6.51	4.57	N/A
NNE	464	N/A	N/A	N/A
NE	425	N/A	N/A	N/A
ENE	398	N/A	N/A	N/A
E	538	N/A	N/A	N/A
ESE	882	N/A	N/A	N/A
SE	521	N/A	N/A	N/A

Table I.4-18 POINT BEACH NUCLEAR PLANT ANNUAL AVERAGE D/Q'S, UNIT 1 OR UNIT 2 PURGE VENT, CONTINUOUS GROUND LEVEL RELEASE (IIA), GAS STRIPPER BUILDING VIA UNIT 2 PURGE VENT, CONTINUOUS GROUND LEVEL RELEASE (IIC), AND TURBINE BUILDING ROOF EXHAUSTERS, CONTINUOUS GROUND LEVEL RELEASE (III)

DATA PERIOD: 4/19/67-10/18/68

D/Q (Sec/M ²) at Various Receptor Distances (m)																				
Downwind Sector	Shoreline Boundary	Site Boundary	Nearest Residence	Nearest Farm	805	1,700	1,980	2,415	2,800	3,200	3,600	4,025	4,830	5,635	7,245	12,070	24,140	40,235	56,330	72,425
Order	E-09	E-09	E-09	E-09	E-09	E-09	E-09	E-09	E-09	E-09	E-09	E-10	E-10	E-10	E-10	E-10	E-11	E-11	E-11	E-12
SSE	29.3	24.6	8.72	24.6	60.2	12.1	8.17	4.94	3.42	2.47	1.86	1.43	9.33	6.56	3.76	1.28	3.35	1.25	0.650	3.96
S	N/A	47.9	5.63	47.9	110	22.1	14.9	9.01	6.24	4.50	3.39	2.60	17.0	12.0	6.86	2.34	6.12	2.29	1.19	7.24
SSW	N/A	30.4	21.8	8.18	72.7	14.6	9.86	5.96	4.13	2.98	2.24	1.72	11.3	7.92	4.54	1.55	4.05	1.51	0.785	4.78
SW	N/A	14.1	7.10	10.2	52.4	10.5	7.10	4.29	2.97	2.15	1.62	1.24	8.11	5.71	3.27	1.11	2.92	1.09	0.566	3.45
WSW	N/A	10.7	2.69	10.7	27.2	5.47	3.69	2.23	1.54	1.11	0.839	0.644	4.21	2.97	1.70	0.579	1.51	0.567	0.294	1.79
W	N/A	11.3	2.89	11.3	27.6	5.55	3.74	2.26	1.57	1.13	0.851	0.653	4.27	3.01	1.72	0.587	1.54	0.575	0.298	1.82
WNW	N/A	5.43	2.39	2.15	24.2	4.86	3.28	1.98	1.37	0.991	0.746	0.573	3.75	2.64	1.51	0.514	1.35	0.504	0.261	1.59
NW	N/A	4.95	2.02	3.28	39.5	7.93	5.35	3.23	2.24	1.62	1.22	0.934	6.11	4.30	2.46	0.839	2.20	0.822	0.426	2.60
NNW	44.7	6.13	3.03	6.13	47.0	9.45	6.37	3.85	2.67	1.93	1.45	1.11	7.28	5.12	2.93	1.00	2.62	0.979	0.508	3.09
N	458	2.16	1.38	N/A	89.7	18.0	12.2	7.35	5.09	3.67	2.77	2.12	13.9	9.78	5.60	1.91	4.99	1.87	0.969	5.90
NNE	1,360	N/A	N/A	N/A	139	28.0	18.9	11.4	7.90	5.70	4.29	3.29	21.5	15.2	8.68	2.96	7.74	2.90	1.50	9.15
NE	1,160	N/A	N/A	N/A	91.8	18.5	12.4	7.52	5.21	3.76	2.83	2.17	14.2	10.0	5.72	1.95	5.11	1.91	0.991	6.04
ENE	665	N/A	N/A	N/A	52.5	10.5	7.11	4.30	2.98	2.15	1.62	1.24	8.12	5.72	3.27	1.12	2.92	1.09	0.566	3.45
E	1,090	N/A	N/A	N/A	86.3	17.4	11.7	7.07	4.90	3.53	2.66	2.04	13.4	9.41	5.38	1.84	4.80	1.80	0.932	5.68
ESE	973	N/A	N/A	N/A	107	21.6	14.6	8.80	6.09	4.40	3.31	2.54	16.6	11.7	6.70	2.28	5.98	2.24	1.16	7.07
SE	385	N/A	N/A	N/A	79.5	16.0	10.8	6.52	4.51	3.26	2.45	1.88	12.3	8.66	4.96	1.69	4.43	1.66	0.859	5.23

Table I.4-19 POINT BEACH NUCLEAR PLANT GROWING/GRAZING SEASON D/Q'S, UNIT 1 OR UNIT 2 PURGE VENT, CONTINUOUS GROUND LEVEL RELEASE (IIA), GAS STRIPPER BUILDING VIA UNIT 2 PURGE VENT, CONTINUOUS GROUND LEVEL RELEASE (IIC), AND TURBINE BUILDING ROOF EXHAUSTERS, CONTINUOUS GROUND LEVEL RELEASE (III)

DATA PERIOD: 4/19/67-10/18/67
AND 4/19/68-10/18/68

<u>D/Q (Sec/M²) at Various Receptor Distances (m)</u>																				
<u>Downwind Sector</u>	<u>Shoreline Boundary</u>	<u>Site Boundary</u>	<u>Nearest Residence</u>	<u>Nearest Farm</u>	<u>805</u>	<u>1,700</u>	<u>1,980</u>	<u>2,415</u>	<u>2,800</u>	<u>3,200</u>	<u>3,600</u>	<u>4,025</u>	<u>4,830</u>	<u>5,635</u>	<u>7,245</u>	<u>12,070</u>	<u>24,140</u>	<u>40,235</u>	<u>56,330</u>	<u>72,425</u>
<u>Order</u>	<u>E-09</u>	<u>E-09</u>	<u>E-09</u>	<u>E-09</u>	<u>E-09</u>	<u>E-09</u>	<u>E-09</u>	<u>E-09</u>	<u>E-09</u>	<u>E-09</u>	<u>E-09</u>	<u>E-10</u>	<u>E-10</u>	<u>E-10</u>	<u>E-10</u>	<u>E-10</u>	<u>E-11</u>	<u>E-11</u>	<u>E-11</u>	<u>E-12</u>
SSE	17.5	14.7	5.22	14.7	36.0	7.25	4.89	2.95	2.05	1.48	1.11	8.53	5.58	3.93	2.25	0.767	2.01	0.751	0.389	2.37
S	N/A	34.1	4.01	34.1	78.3	15.7	10.6	6.41	4.44	3.21	2.41	18.5	12.1	8.53	4.88	1.66	4.36	1.63	0.845	5.15
SSW	N/A	36.6	26.3	9.86	87.6	17.6	11.9	7.18	4.97	3.59	2.70	20.7	13.6	9.55	5.47	1.86	4.88	1.82	0.946	5.76
SW	N/A	18.6	9.32	13.4	68.8	13.8	9.32	5.64	3.90	2.82	2.12	16.3	10.6	7.49	4.29	1.46	3.83	1.43	0.743	4.53
WSW	N/A	13.1	3.31	13.1	33.4	6.72	4.53	2.74	1.90	1.37	1.03	7.91	5.18	3.64	2.09	0.711	1.86	0.696	0.361	2.20
W	N/A	13.0	3.33	13.0	31.8	6.39	4.31	2.60	1.80	1.30	0.980	7.52	4.92	3.46	1.98	0.676	1.77	0.662	0.343	2.09
WNW	N/A	6.95	3.06	2.75	31.0	6.22	4.20	2.54	1.76	1.27	0.955	7.33	4.79	3.37	1.93	0.658	1.72	0.645	0.334	2.04
NW	N/A	6.05	2.46	4.01	48.2	9.68	6.53	3.95	2.73	1.97	1.49	11.4	7.45	5.25	3.00	1.02	2.68	1.00	0.520	3.17
NNW	56.3	7.73	3.82	7.73	59.3	11.9	8.04	4.86	3.36	2.43	1.83	14.0	9.18	6.46	3.70	1.26	3.30	1.23	0.640	3.90
N	567	2.67	1.71	N/A	111	22.3	15.0	9.10	6.30	4.55	3.42	26.3	17.2	12.1	6.92	2.36	6.18	2.31	1.20	7.30
NNE	1,740	N/A	N/A	N/A	178	35.8	24.1	14.6	10.1	7.28	5.49	42.1	27.5	19.4	11.1	3.78	9.90	3.70	1.92	11.7
NE	1,330	N/A	N/A	N/A	105	21.1	14.2	8.61	5.96	4.30	3.24	24.9	16.3	11.5	6.56	2.24	5.85	2.19	1.13	6.91
ENE	748	N/A	N/A	N/A	59.0	11.9	8.00	4.84	3.35	2.42	1.82	14.0	9.14	5.43	3.68	1.26	3.28	1.23	0.637	3.88
E	794	N/A	N/A	N/A	62.6	12.6	8.48	5.13	3.55	2.56	1.93	14.8	9.69	6.82	3.90	1.33	3.48	1.30	0.676	4.12
ESE	612	N/A	N/A	N/A	67.5	13.6	9.16	5.53	3.83	2.77	2.08	16.0	10.5	7.36	4.21	1.44	3.76	1.41	0.729	4.44
SE	240	N/A	N/A	N/A	49.7	9.99	6.73	4.07	2.82	2.03	1.53	11.8	7.69	5.41	3.10	1.06	2.76	1.03	0.536	3.27

Table I.4-20 POINT BEACH NUCLEAR PLANT ANNUAL AVERAGE D/Q'S, UNIT 1 OR UNIT 2 CONTAINMENT PURGE VENT, INTERMITTENT RELEASE (IIB)

4/19/67-4/18/69

D/Q (Sec/M ²) at Various Receptor Distances (m)														
Downwind Sector	Shoreline Boundary	Site Boundary	Nearest Residence	Nearest Farm	805	2,415	4,025	5,635	7,245	12,070	24,140	40,235	56,330	72,425
Order	E-09	E-09	E-09	E-09	E-09	E-09	E-10	E-10	E-10	E-10	E-11	E-11	E-11	E-11
SSE	M	50.0	21.0	50.0	49.4	4.01	11.2	5.20	3.09	1.17	3.61	1.43	0.745	0.454
S	N/A	47.6	7.43	47.6	56.2	4.59	13.4	6.77	4.60	2.19	8.28	3.30	1.66	0.977
SSW	N/A	39.3	29.1	12.9	40.6	3.33	9.67	4.81	3.18	1.46	5.33	2.11	1.06	0.626
SW	N/A	22.7	12.8	17.4	29.1	2.36	6.82	3.39	2.25	1.03	3.83	1.53	0.773	0.458
WSW	N/A	23.0	7.33	23.0	15.2	1.23	3.53	1.75	1.16	0.533	1.98	0.797	0.404	0.241
W	N/A	23.9	7.18	23.9	14.3	1.14	3.28	1.65	1.12	0.535	2.06	0.834	0.425	0.253
WNW	N/A	11.9	5.98	5.39	11.8	0.951	2.73	1.39	0.956	0.468	1.83	0.739	0.374	0.221
NW	N/A	10.5	4.81	7.15	21.4	1.73	4.99	2.49	1.66	0.774	2.90	1.16	0.589	0.350
NNW	83.5	13.6	7.53	13.6	30.1	2.44	6.96	3.37	2.14	0.923	3.24	1.29	0.659	0.394
N	572	5.58	3.89	N/A	72.5	5.90	16.6	7.70	4.60	1.75	5.45	2.15	1.11	0.677
NNE	1,128	N/A	N/A	N/A	86.1	7.03	20.2	9.82	6.31	2.76	9.75	3.86	1.96	1.16
NE	851	N/A	N/A	N/A	39.5	3.21	9.38	4.91	3.51	1.80	7.21	2.90	1.46	0.856
ENE	700	N/A	N/A	N/A	29.8	2.42	6.94	3.42	2.25	1.03	3.78	1.51	0.769	0.457
E	1,221	N/A	N/A	N/A	55.7	4.51	12.9	6.27	3.99	1.71	5.98	2.39	1.22	0.730
ESE	1,228	N/A	N/A	N/A	89.1	7.12	20.2	9.40	5.59	2.11	6.5	2.65	1.40	0.864
SE	600	N/A	N/A	N/A	66.7	5.26	14.8	6.90	4.09	1.54	4.86	2.00	1.08	0.671

Table I.4-21 POINT BEACH NUCLEAR PLANT GROWING/GRAZING SEASON D/Q'S, UNIT 1 OR UNIT 2 CONTAINMENT PURGE VENT, INTERMITTENT ELEVATED RELEASE (IIB)

4/19/67-10/18/68 AND 4/19/68-10/18/69

<u>D/Q (Sec/M²) at Various Receptor Distances (m)</u>														
<u>Downwind Sector</u>	<u>Shoreline Boundary</u>	<u>Site Boundary</u>	<u>Nearest Residence</u>	<u>Nearest Farm</u>	<u>805</u>	<u>2,415</u>	<u>4,025</u>	<u>5,635</u>	<u>7,245</u>	<u>12,070</u>	<u>24,140</u>	<u>40,235</u>	<u>56,330</u>	<u>72,425</u>
<u>Order</u>	<u>E-09</u>	<u>E-09</u>	<u>E-09</u>	<u>E-09</u>	<u>E-09</u>	<u>E-09</u>	<u>E-10</u>	<u>E-10</u>	<u>E-10</u>	<u>E-10</u>	<u>E-11</u>	<u>E-11</u>	<u>E-11</u>	<u>E-11</u>
SSE	M	37.9	15.9	37.9	28.9	2.33	6.51	3.02	1.81	0.691	2.19	0.877	0.461	0.282
S	N/A	33.2	5.02	33.2	32.4	2.64	7.80	4.12	2.98	1.55	6.24	2.51	1.26	0.736
SSW	N/A	40.4	30.1	13.2	45.7	3.75	10.9	5.48	3.70	1.74	6.54	2.60	1.30	0.766
SW	N/A	25.1	14.0	19.2	36.5	2.96	8.53	4.27	2.87	1.35	5.08	2.04	1.03	0.611
WSW	N/A	23.3	7.21	23.3	16.5	1.33	3.80	1.93	1.32	0.646	2.51	1.02	0.515	0.305
W	N/A	24.3	7.13	24.3	15.2	1.21	3.44	1.75	1.22	0.606	2.41	0.985	0.502	0.299
WNW	N/A	14.2	6.95	6.31	15.5	1.25	3.56	1.79	1.23	0.595	2.31	0.934	0.473	0.281
NW	N/A	10.1	4.58	6.83	22.6	1.82	5.26	2.69	1.88	0.935	3.69	1.49	0.755	0.447
NNW	86.5	13.6	7.43	13.6	33.9	2.74	7.85	3.87	2.54	1.16	4.27	1.71	0.871	0.519
N	617	6.03	4.27	N/A	87.7	7.11	19.9	9.27	5.57	2.15	6.81	2.70	1.41	0.856
NNE	1,088	N/A	N/A	N/A	104	8.47	24.2	11.9	7.77	3.49	12.7	5.05	2.55	15.2
NE	814	N/A	N/A	N/A	41.6	3.36	9.87	5.26	3.87	2.05	8.42	3.41	1.71	10.0
ENE	754	N/A	N/A	N/A	33.4	2.70	7.76	3.83	2.53	1.16	4.27	1.71	0.870	0.518
E	986	N/A	N/A	N/A	39.1	3.14	8.99	4.38	2.81	1.23	4.40	1.77	0.912	0.548
ESE	940	N/A	N/A	N/A	51.5	4.06	11.5	5.44	3.31	1.31	4.37	1.80	0.958	0.590
SE	465	N/A	N/A	N/A	39.3	3.04	8.61	4.04	2.44	0.949	3.17	1.34	0.726	0.452

Table I.4-22 POINT BEACH NUCLEAR PLANT PERCENTAGE FREQUENCY DISTRIBUTION OF PASQUILL STABILITY CLASS FOR POINT BEACH, HAVEN, AND MILWAUKEE

<u>LOCATION</u>	<u>VALID DATA HOURS</u>	<u>DATA PERIOD</u>	<u>PASQUILL STABILITY CLASS FREQUENCY PERCENTAGE</u>						
			<u>A</u>	<u>B</u>	<u>C</u>	<u>D</u>	<u>E</u>	<u>F</u>	<u>G</u>
POINT BEACH ⁽¹⁾	14,647	4/19/67- 4/18/69	0.87	1.37	9.39	35.02	34.55	11.67	7.13
HAVEN ⁽²⁾	7,968	6/1/73 - 5/31/74	1.91	1.50	2.35	34.63	37.83	14.02	7.76
MILWAUKEE ⁽³⁾	5,848 ⁽⁴⁾	4/19/67 - 4/18/69	0.17	2.89	8.96	69.90	8.81	6.24	4.04
MILWAUKEE ⁽³⁾	2,920 ⁽⁴⁾	6/1/73 - 5/31/74	0.00	1.10	7.23	74.37	9.67	5.72	1.82
MILWAUKEE ⁽³⁾	110,968 ⁽⁴⁾	1/1/56 - 12/31/75	0.08	2.28	8.09	68.75	10.03	7.13	3.65

Notes:

1. Stability Class determined by wind range.
2. Stability Class determined by Regulatory Guide 1.23 ΔT Classifications.
3. Stability Class determined by the STAR Program of the National Weather Service.
4. Observations recorded every third hour from 1/1/65 - 12/31/75.

Table I.4-23 POINT BEACH NUCLEAR PLANT PERCENTAGE FREQUENCY DISTRIBUTION OF WIND DIRECTION FOR POINT BEACH, HAVEN, AND MILWAUKEE

WIND FREQUENCY PERCENTAGE BY QUADRANT

<u>LOCATION</u>	<u>VALID DATA HOURS</u>	<u>DATA PERIOD</u>	<u>ONSHORE</u>		<u>OFFSHORE</u>		<u>CALM AND VARIABLE</u>
			<u>NNE - E</u>	<u>ESE - S</u>	<u>SSW - W</u>	<u>WNW - N</u>	
POINT BEACH ⁽¹⁾	14,647	4/19/67-4/18/69	16.06	17.84	33.17	32.02	0.91
HAVEN ⁽²⁾	7,968	6/1/73 - 5/31/74	16.97	21.99	33.36	27.18	0.50
MILWAUKEE ⁽³⁾	5,848 ⁽⁴⁾	4/19/67 - 4/18/69	17.93	21.84	35.51	22.00	2.72
MILWAUKEE ⁽³⁾	2,920 ⁽⁴⁾	6/1/73 - 5/31/74	14.69	23.01	34.45	25.86	1.99
MILWAUKEE ⁽³⁾	110,968 ⁽⁴⁾	1/1/56 - 12/31/75	17.54	22.17	34.23	24.12	1.94

Notes:

1. Monitored at the Point Beach Nuclear Plant.
2. Monitored at the Haven Site, according to Regulatory Guide 1.23 recommendations.
3. Observations taken at General Mitchell Field, a first-order National Weather Service Station.
4. Observations recorded every third hour from 1/1/65 - 12/31/75.

Table I.4-24 POINT BEACH NUCLEAR PLANT WIND SPEED BY QUADRANT FOR POINT BEACH, HAVEN, AND MILWAUKEE

<u>LOCATION</u>	<u>VALID DATA HOURS</u>	<u>DATA PERIOD</u>	<u>AVERAGE WIND SPEED BY QUADRANT (MPH)</u>			
			<u>ONSHORE</u>		<u>OFFSHORE</u>	
			<u>NNE - E</u>	<u>ESE - S</u>	<u>SSW - W</u>	<u>WNW - N</u>
POINT BEACH ⁽¹⁾	14,647	4/19/67-4/18/69	12.3	11.7	12.5	12.8
HAVEN ⁽²⁾	7,968	6/1/73 - 5/31/74	10.1	8.2	8.4	10.3
MILWAUKEE ⁽³⁾	5,848 ⁽⁴⁾	4/19/67 - 4/18/69	10.6	9.9	11.1	12.0
MILWAUKEE ⁽³⁾	2,920 ⁽⁴⁾	6/1/73 - 5/31/74	12.0	10.5	12.0	12.1
MILWAUKEE ⁽³⁾	110,968 ⁽⁴⁾	1/1/56 - 12/31/75	12.0	10.4	11.8	12.8

Notes:

1. Monitored at the Point Beach Nuclear Plant.
2. Monitored at the Haven Site, according to Regulatory Guide 1.23 recommendations.
3. Observations taken at General Mitchell Field, a first-order National Weather Service Station.
4. Observations recorded every third hour from 1/1/65 - 12/31/75.

Table I.4-25 POINT BEACH NUCLEAR PLANT WIND-PRECIPITATION (FREQUENCY PERCENT) SUMMARY FOR 1/1/56 - 12/31/75 AT MILWAUKEE

WINDS BLOWING FROM	PRECIPITATION OCCURING DURING WIND SPEED CLASSIFICATIONS (MPH)						TOTAL
	<u>1 - 3</u>	<u>4 - 7</u>	<u>8 - 12</u>	<u>13 - 18</u>	<u>19 - 24</u>	<u>≥ 25</u>	
N	.024	.087	.207	.393	.189	.199	1.020
NNE	.030	.128	.280	.441	.235	.117	1.231
NE	.026	.085	.169	.259	.102	.075	.716
ENE	.023	.041	.133	.180	.101	.035	.513
E	.032	.085	.147	.205	.059	.047	.575
ESE	.030	.091	.209	.229	.056	.021	.635
SE	.036	.099	.206	.223	.064	.033	.661
SSE	.043	.128	.268	.220	.054	.011	.724
S	.054	.174	.308	.256	.059	.011	.862
SSW	.033	.137	.257	.229	.060	.019	.735
SW	.030	.088	.176	.191	.054	.036	.575
WSW	.030	.096	.169	.200	.068	.041	.605
W	.038	.147	.225	.264	.091	.040	.805
WNW	.032	.138	.221	.320	.124	.030	.864
NW	.028	.078	.260	.296	.102	.030	.793
NNW	.028	.078	.260	.296	.102	.030	.793

TOTAL OBSERVATIONS = 110,960.

PRECIPITATION OCCURING DURING CALM WIND CONDITIONS = 0.086.

Table I.4-26 POINT BEACH NUCLEAR PLANT AVERAGE PRECIPITATION FOR WEATHER STATIONS IN THE VICINITY OF POINT BEACH NUCLEAR PLANT

STATION LOCATION	DISTANCE FROM PBNP (MILES)	PERIOD OF RECORD	AVERAGE PRECIPITATION (INCHES)											
			JAN	FEB	MAR	APR	MAY	JUN	JUL	AUG	SEP	OCT	NOV	DEC
Manitowoc	13 SSW	1863 - 1960	1.58	1.54	2.09	2.65	2.98	3.49	3.22	3.08	3.24	2.48	2.20	1.69
Kewaunee	12 N	1913 - 1960	1.44	1.36	1.59	2.51	3.08	3.26	2.94	2.78	3.09	2.04	2.27	1.45
Brillion	27 WSW	1924 - 1960	1.35	1.40	1.66	2.40	2.90	3.61	2.63	3.11	3.25	1.96	2.06	1.20
Green Bay	32 NW	1931 - 1960	1.15	1.08	1.34	2.46	3.06	3.36	2.71	2.75	2.92	1.91	1.91	1.18
Two Rivers	9 SSW	1951 - 1960	0.99	1.29	1.79	3.01	3.12	2.66	4.29	3.04	2.49	2.58	1.97	1.42

Annual Average Precipitations:

Manitowoc	30.24 inches
Kewaunee	27.81 inches
Brillion	27.53 inches
Green Bay	25.83 inches
Two Rivers	28.65 inches

Table I.4-27 POINT BEACH NUCLEAR PLANT MONTHLY PRECIPITATION TOTALS AND INTENSITY FREQUENCY DISTRIBUTIONS AT GREEN BAY, WISCONSIN APRIL 19, 1967 THROUGH APRIL 18, 1969

DATA PERIOD	TOTAL PRECIPITATION (INCHES)	HOURLY PRECIPITATION INTENSITY FREQUENCY						HOURS WITH PRECIPITATION
		TRACE	.01-.09	.10-.19	.20-.49	.50-.99	1.00 +	
4/19-4/30, 1967	0.27	46	10	0	0	0	0	56
5/1-5/31, 1967	2.45	36	37	8	0	0	0	81
6/1-6/30, 1967	8.47	46	62	12	4	3	1	128
7/1-7/31, 1967	1.96	23	11	5	0	1	0	40
8/1-8/31, 1967	2.43	32	22	7	2	0	0	63
9/1-9/30, 1967	0.46	21	20	0	0	0	0	41
10/1-10/31, 1967	4.71	63	78	9	2	0	0	152
11/1-11/30, 1967	1.66	86	42	4	0	0	0	132
12/1-12/31, 1967	1.17	105	37	2	0	0	0	144
1/1-1/31, 1968	0.94	151	45	0	0	0	0	196
2/1-2/29, 1968	0.45	126	32	0	0	0	0	158
3/1-3/31, 1968	0.97	49	22	1	1	0	0	73
4/1-4/30, 1968	4.84	69	61	12	5	0	0	147
5/1-5/31, 1968	3.10	80	44	7	3	0	0	134
6/1-6/30, 1968	6.97	51	68	11	8	1	0	139
7/1-7/31, 1968	2.00	18	16	7	2	0	0	43
8/1-8/31, 1968	2.66	29	16	3	3	1	0	52
9/1-9/30, 1968	3.31	54	37	3	5	0	0	99
10/1-10/31, 1968	1.01	35	21	3	0	0	0	59
11/1-11/30, 1968	1.01	97	50	0	0	0	0	147
12/1-12/31, 1968	2.69	165	108	0	0	0	0	273
1/1-1/31, 1969	2.60	130	86	1	0	0	0	217
2/1-2/28, 1969	0.04	64	4	0	0	0	0	68
3/1-3/31, 1969	1.04	84	40	2	0	0	0	126
4/1-4/18, 1969	<u>2.06</u>	<u>24</u>	<u>44</u>	<u>3</u>	<u>0</u>	<u>0</u>	<u>0</u>	<u>71</u>
Total	59.27	1,684	1,013	100	35	6	1	2,839
Percent of Total Hours		9.60	5.77	0.570	0.199	0.034	0.006	16.18

Table I.4-28 HAVEN JOINT FREQUENCY DISTRIBUTION ANNUAL SUMMARY 6/1/73 THROUGH 5/31/74

HAVEN SITE WIND - STABILITY SUMMARY STABILITY CLASS - A - METER WINDS, PERIOD 6/1/73 TO 5/31/74 NUMBER OF HOURLY OBSERVATIONS

WINDS FROM	WIND SPEED (MPH)						TOTAL
	1-3	4-7	8-12	13-18	19-24	25+	
N	1	0	1	0	0	0	2
NNE	0	0	10	3	7	0	20
NE	0	0	4	13	3	0	20
ENE	0	1	1	7	0	0	9
E	0	3	7	0	0	0	10
ESE	0	3	6	0	0	0	9
SE	0	1	12	0	0	0	13
SSE	0	0	1	3	0	0	4
S	0	0	3	0	0	0	3
SSW	0	1	0	2	0	0	3
SW	0	0	4	4	0	0	8
WSW	0	0	5	6	2	0	13
W	0	1	1	5	1	0	8
WNW	0	0	5	4	5	2	16
NW	0	1	4	3	1	0	9
NNW	0	0	3	2	0	0	5
TOTAL	1	11	67	52	19	2	152
Number of calm hours			0				
Number of variable directions			0				
Total number of observations			152				

Table I.4-28 (CONTINUED)

HAVEN SITE WIND - STABILITY SUMMARY STABILITY CLASS - B -
METER WINDS, PERIOD 6/1/73 TO 5/31/74, NUMBER OF HOURLY
OBSERVATIONS

WINDS FROM	WIND SPEED (MPH)						TOTAL
	1-3	4-7	8-12	13-18	19-24	25+	
N	0	1	1	3	2	0	7
NNE	0	0	2	1	3	0	6
NE	0	1	3	5	0	0	9
ENE	1	0	3	1	1	0	6
E	0	2	0	0	0	0	2
ESE	0	6	0	1	0	0	7
SE	1	1	2	1	0	0	5
SSE	0	0	5	0	0	0	5
S	0	2	0	1	0	0	3
SSW	0	1	2	0	0	0	3
SW	0	1	4	5	1	0	11
WSW	0	1	7	4	1	0	13
W	0	2	8	4	1	0	15
WNW	0	0	0	7	2	0	9
NW	0	0	4	3	0	0	7
NNW	0	3	4	4	0	0	11
TOTAL	2	21	45	40	11	0	119
Number of calm hours							0
Number of variable directions							0
Total number of observations							119

Table I.4-28 (CONTINUED)

HAVEN SITE WIND - STABILITY SUMMARY STABILITY CLASS - C -
METER WINDS, PERIOD 6/1/73 TO 5/31/74, NUMBER OF HOURLY
OBSERVATIONS

WINDS FROM	WIND SPEED (MPH)						TOTAL
	1-3	4-7	8-12	13-18	19-24	25+	
N	0	0	0	4	1	0	5
NNE	0	1	6	2	2	0	11
NE	0	3	6	7	3	2	21
ENE	0	3	5	1	1	0	10
E	0	1	6	2	0	0	9
ESE	0	5	3	1	0	0	9
SE	0	5	4	0	0	0	9
SSE	0	0	2	3	0	0	5
S	1	2	3	2	0	0	8
SSW	0	0	2	2	0	0	4
SW	0	0	6	5	2	0	13
WSW	1	2	5	5	2	0	15
W	0	3	5	11	2	0	21
WNW	0	1	5	12	6	0	24
NW	0	2	3	5	2	0	12
NNW	0	2	4	5	0	0	11
TOTAL	2	30	65	67	21	2	187
Number of calm hours							0
Number of variable directions							0
Total number of observations							187

Table I.4-28 (CONTINUED)

HAVEN SITE WIND - STABILITY SUMMARY STABILITY CLASS - D -
METER WINDS, PERIOD 6/1/73 TO 5/31/74, NUMBER OF HOURLY
OBSERVATIONS

WINDS FROM	WIND SPEED (MPH)						TOTAL
	1-3	4-7	8-12	13-18	19-24	25+	
N	6	28	41	49	14	6	144
NNE	1	16	57	51	22	3	150
NE	3	33	48	62	15	6	167
ENE	4	36	30	49	17	5	141
E	11	28	49	41	15	0	144
ESE	1	21	58	34	8	0	122
SE	2	39	75	32	3	0	151
SSE	0	30	86	16	0	0	132
S	7	28	58	24	1	0	118
SSW	2	51	68	31	4	0	156
SW	4	37	71	56	6	0	174
WSW	4	25	55	52	6	0	142
W	6	21	84	83	23	0	217
WNW	3	39	152	108	29	4	335
NW	4	38	103	82	13	0	240
NNW	6	27	99	83	8	0	223
TOTAL	64	497	1134	853	184	24	2756
Number of calm hours							2
Number of variable directions							2
Total number of observations							2760

Table I.4-28 (CONTINUED)

HAVEN SITE WIND - STABILITY SUMMARY STABILITY CLASS - E -
METER WINDS, PERIOD 6/1/73 TO 5/31/74, NUMBER OF HOURLY
OBSERVATIONS

WINDS FROM	WIND SPEED (MPH)						TOTAL
	1-3	4-7	8-12	13-18	19-24	25+	
N	15	53	61	37	1	1	168
NNE	10	52	74	38	2	2	178
NE	6	39	30	8	1	0	84
ENE	17	48	22	9	1	0	97
E	25	44	22	6	1	0	98
ESE	9	49	20	3	0	0	81
SE	11	54	55	25	0	0	145
SSE	23	80	111	39	4	0	257
S	31	124	93	20	3	0	271
SSW	29	117	72	25	2	0	245
SW	25	143	110	29	5	0	312
WSW	16	67	83	37	4	0	207
W	18	65	83	48	6	2	222
WNW	13	70	150	51	8	2	294
NW	8	59	89	30	0	0	186
NNW	7	33	83	32	4	0	159
TOTAL	263	1097	1158	437	42	7	3004
Number of calm hours							1
Number of variable directions							10
Total number of observations							3015

Table I.4-28 (CONTINUED)

HAVEN SITE WIND - STABILITY SUMMARY STABILITY CLASS - F -
METER WINDS, PERIOD 6/1/73 TO 5/31/74, NUMBER OF HOURLY
OBSERVATIONS

WINDS FROM	WIND SPEED (MPH)						TOTAL
	1-3	4-7	8-12	13-18	19-24	25+	
N	8	21	5	0	0	0	34
NNE	9	18	17	14	0	0	58
NE	3	15	7	0	0	0	25
ENE	5	6	1	0	0	0	12
E	4	13	3	0	0	0	20
ESE	2	11	1	0	0	0	14
SE	3	32	26	1	0	0	62
SSE	15	45	32	1	1	0	94
S	28	55	19	4	0	0	106
SSW	27	92	35	3	0	0	157
SW	21	74	32	0	0	0	127
WSW	12	57	28	1	0	0	98
W	10	70	37	4	0	0	121
WNW	9	31	44	2	0	0	86
NW	5	21	27	4	0	0	57
NNW	12	13	10	0	0	0	35
TOTAL	173	574	324	34	1	0	1106
Number of calm hours			7				
Number of variable directions			4				
Total number of observations			1117				

Table I.4-28 (CONTINUED)

HAVEN SITE WIND - STABILITY SUMMARY STABILITY CLASS - G -
METER WINDS, PERIOD 6/1/73 TO 5/31/74, NUMBER OF HOURLY
OBSERVATIONS

WINDS FROM	WIND SPEED (MPH)						TOTAL
	1-3	4-7	8-12	13-18	19-24	25+	
N	9	5	3	0	0	0	17
NNE	8	5	4	0	0	0	17
NE	9	2	2	0	0	0	13
ENE	4	4	0	0	0	0	8
E	4	3	0	0	0	0	7
ESE	3	4	0	2	0	0	9
SE	8	16	10	0	0	0	34
SSE	11	22	17	0	0	0	50
S	12	12	1	1	0	0	26
SSW	9	26	15	0	0	0	50
SW	28	38	24	0	0	0	90
WSW	32	73	9	0	0	0	114
W	22	61	15	1	0	0	99
WNW	8	13	12	0	0	0	33
NW	11	5	2	0	0	0	18
NNW	4	11	4	0	0	0	19
TOTAL	182	300	118	4	0	0	604
Number of calm hours			5				
Number of variable directions			9				
Total number of observations			618				

Table I.4-28 (CONTINUED)

HAVEN SITE WIND - STABILITY SUMMARY STABILITY CLASS - ALL -
METER WINDS, PERIOD 6/1/73 TO 5/31/74, NUMBER OF HOURLY
OBSERVATIONS

WINDS FROM	WIND SPEED (MPH)						TOTAL
	1-3	4-7	8-12	13-18	19-24	25+	
N	39	108	112	93	18	7	377
NNE	28	92	170	109	36	5	440
NE	21	93	100	95	22	8	339
ENE	31	98	62	67	20	5	283
E	44	94	87	49	16	0	290
ESE	15	99	88	41	8	0	251
SE	25	148	184	59	3	0	419
SSE	49	177	254	62	5	0	547
S	79	223	177	52	4	0	535
SSW	67	288	194	63	6	0	618
SW	78	293	251	99	14	0	735
WSW	65	225	192	105	15	0	602
W	56	223	233	156	33	2	703
WNW	33	154	368	184	50	8	797
NW	28	126	232	127	16	0	529
NNW	29	89	207	126	12	0	463
TOTAL	687	2530	2911	1487	278	35	7928
Number of calm hours							15
Number of variable directions							25
Total number of observations							7968

Table I.4-29 MILWAUKEE JOINT FREQUENCY DISTRIBUTION ANNUAL SUMMARY
6/1/73 THROUGH 5/31/74

MILWAUKEE WIND - STABILITY SUMMARY

STABILITY CLASS - A - ANNUAL 6/1/73 TO 5/31/74
NUMBER OF HOURLY OBSERVATIONS

WINDS FROM	WIND SPEED (MPH)						TOTAL
	1-3	4-7	8-12	13-18	19-24	25+	
N	0	0	0	0	0	0	0
NNE	0	0	0	0	0	0	0
NE	0	0	0	0	0	0	0
ENE	0	0	0	0	0	0	0
E	0	0	0	0	0	0	0
ESE	0	0	0	0	0	0	0
SE	0	0	0	0	0	0	0
SSE	0	0	0	0	0	0	0
S	0	0	0	0	0	0	0
SSW	0	0	0	0	0	0	0
SW	0	0	0	0	0	0	0
WSW	0	0	0	0	0	0	0
W	0	0	0	0	0	0	0
WNW	0	0	0	0	0	0	0
NW	0	0	0	0	0	0	0
NNW	0	0	0	0	0	0	0
TOTAL	0	0	0	0	0	0	0
Number of calm hours			0				
Total number of observations			0				

Table I.4-29 (CONTINUED)

MILWAUKEE WIND - STABILITY SUMMARY

STABILITY CLASS - B - ANNUAL 6/1/73 TO 5/31/74
 NUMBER OF HOURLY OBSERVATIONS

WIND SPEED (MPH)

WINDS FROM	1-3	4-7	8-12	13-18	19-24	25+	TOTAL
N	0	1	0	0	0	0	1
NNE	1	1	1	0	0	0	3
NE	0	1	3	0	0	0	4
ENE	0	0	0	0	0	0	0
E	1	0	3	0	0	0	4
ESE	0	1	1	0	0	0	2
SE	1	1	1	0	0	0	3
SSE	0	0	0	0	0	0	0
S	2	0	1	0	0	0	3
SSW	1	1	1	0	0	0	3
SW	1	0	1	0	0	0	2
WSW	0	1	2	0	0	0	3
W	1	1	1	0	0	0	3
WNW	0	0	1	0	0	0	1
NW	0	2	1	0	0	0	3
NNW	4	0	0	0	0	0	4
TOTAL	12	10	17	0	0	0	39

Number of calm hours 5
 Total number of observations 44

Table I.4-29 (CONTINUED)

MILWAUKEE WIND - STABILITY SUMMARY

STABILITY CLASS - C - ANNUAL 6/1/73 TO 5/31/74
 NUMBER OF HOURLY OBSERVATIONS

WIND SPEED (MPH)

WINDS FROM	1-3	4-7	8-12	13-18	19-24	25+	TOTAL
N	0	1	8	1	0	0	10
NNE	0	0	9	1	0	0	10
NE	0	2	3	0	0	0	5
ENE	0	1	3	0	0	0	4
E	0	3	8	0	0	0	11
ESE	0	0	8	3	0	0	11
SE	0	2	6	3	0	0	11
SSE	0	1	3	1	0	0	5
S	1	1	11	2	0	0	15
SSW	0	5	7	1	0	0	13
SW	1	3	10	0	0	0	14
WSW	3	6	10	2	0	0	21
W	1	7	19	4	0	0	31
WNW	1	2	10	0	0	0	13
NW	0	3	12	1	0	0	16
NNW	0	1	5	0	0	0	6
TOTAL	7	38	132	19	0	0	196
Number of calm hours							10
Total number of observations							206

Table I.4-29 (CONTINUED)

MILWAUKEE WIND - STABILITY SUMMARY

STABILITY CLASS - D - ANNUAL 6/1/73 TO 5/31/74
 NUMBER OF HOURLY OBSERVATIONS

WIND SPEED (MPH)

WINDS FROM	1-3	4-7	8-12	13-18	19-24	25+	TOTAL
N	2	16	41	71	21	6	157
NNE	1	15	37	37	8	3	101
NE	1	5	33	31	6	1	77
ENE	0	5	21	31	8	1	66
E	0	8	37	49	7	1	102
ESE	1	7	37	44	5	0	94
SE	2	14	51	69	6	0	142
SSE	2	10	22	34	2	1	71
S	5	20	67	60	6	0	158
SSW	0	8	35	53	8	4	108
SW	1	10	47	97	26	6	187
WSW	2	14	46	108	28	4	202
W	3	17	63	96	19	0	198
WNW	2	16	68	96	20	1	203
NW	1	10	64	68	5	0	148
NNW	3	3	33	40	5	1	85
TOTAL	26	178	702	984	180	29	2099

Number of calm hours 12
 Total number of observations 2111

Table I.4-29 (CONTINUED)

MILWAUKEE WIND - STABILITY SUMMARY

STABILITY CLASS - E - ANNUAL 6/1/73 TO 5/31/74
 NUMBER OF HOURLY OBSERVATIONS

WIND SPEED (MPH)

WINDS FROM	1-3	4-7	8-12	13-18	19-24	25+	TOTAL
N	0	5	8	0	0	0	13
NNE	0	7	3	0	0	0	10
NE	0	3	3	0	0	0	6
ENE	0	3	1	0	0	0	4
E	0	2	4	0	0	0	6
ESE	0	2	0	0	0	0	2
SE	0	10	5	0	0	0	15
SSE	0	12	7	0	0	0	19
S	0	16	34	0	0	0	50
SSW	0	13	19	0	0	0	32
SW	0	7	34	0	0	0	41
WSW	0	7	25	0	0	0	32
W	0	8	37	0	0	0	45
WNW	0	7	33	0	0	0	40
NW	0	3	14	0	0	0	17
NNW	0	0	3	0	0	0	3
TOTAL	0	105	230	0	0	0	335

Number of calm hours 0

Total number of observations 335

Table I.4-29 (CONTINUED)

MILWAUKEE WIND - STABILITY SUMMARY

STABILITY CLASS - F - ANNUAL 6/1/73 TO 5/31/74
 NUMBER OF HOURLY OBSERVATIONS

WIND SPEED (MPH)

WINDS FROM	1-3	4-7	8-12	13-18	19-24	25+	TOTAL
N	1	7	0	0	0	0	8
NNE	1	2	0	0	0	0	3
NE	0	4	0	0	0	0	4
ENE	0	2	0	0	0	0	2
E	1	4	0	0	0	0	5
ESE	2	3	0	0	0	0	5
SE	2	4	0	0	0	0	6
SSE	1	14	0	0	0	0	15
S	1	33	0	0	0	0	34
SSW	1	6	0	0	0	0	7
SW	1	10	0	0	0	0	11
WSW	0	12	0	0	0	0	12
W	1	25	0	0	0	0	26
WNW	2	12	0	0	0	0	14
NW	0	7	0	0	0	0	7
NNW	2	3	0	0	0	0	5
TOTAL	16	148	0	0	0	0	164

Number of calm hours 10
 Total number of observations 174

Table I.4-29 (CONTINUED)

MILWAUKEE WIND - STABILITY SUMMARY

STABILITY CLASS - G - ANNUAL 6/1/73 TO 5/31/74
 NUMBER OF HOURLY OBSERVATIONS

WIND SPEED (MPH)

WINDS FROM	1-3	4-7	8-12	13-18	19-24	25+	TOTAL
N	1	0	0	0	0	0	1
NNE	0	0	0	0	0	0	0
NE	1	0	0	0	0	0	1
ENE	0	0	0	0	0	0	0
E	1	0	0	0	0	0	1
ESE	1	0	0	0	0	0	1
SE	2	0	0	0	0	0	2
SSE	4	0	0	0	0	0	4
S	4	0	0	0	0	0	4
SSW	4	0	0	0	0	0	4
SW	2	0	0	0	0	0	2
WSW	5	0	0	0	0	0	5
W	4	0	0	0	0	0	4
WNW	0	0	0	0	0	0	0
NW	0	0	0	0	0	0	0
NNW	0	0	0	0	0	0	0
TOTAL	29	0	0	0	0	0	29

Number of calm hours 21

Total number of observations 50

Table I.4-29 (CONTINUED)

MILWAUKEE WIND - STABILITY SUMMARY

STABILITY CLASS - ALL - ANNUAL 6/1/73 TO 5/31/74
NUMBER OF HOURLY OBSERVATIONS

WIND SPEED (MPH)

WINDS FROM	1-3	4-7	8-12	13-18	19-24	25+	TOTAL
N	4	30	57	72	21	6	190
NNE	3	25	50	38	8	3	127
NE	2	15	42	31	6	1	97
ENE	0	11	25	31	8	1	76
E	3	17	52	49	7	1	129
ESE	4	13	46	47	5	0	115
SE	7	31	63	72	6	0	179
SSE	7	37	32	35	2	1	114
S	13	70	113	62	6	0	264
SSW	6	33	62	54	8	4	167
SW	6	30	92	97	26	6	257
WSW	10	40	83	110	28	4	275
W	10	58	120	100	19	0	307
WNW	5	37	112	96	20	1	271
NW	1	25	91	69	5	0	191
NNW	9	7	41	40	5	1	103
TOTAL	90	479	1081	1003	180	29	2862
Number of calm hours							58
Total number of observations							2920

Table I.4-30 MILWAUKEE JOINT FREQUENCY DISTRIBUTION TWO-YEAR SUMMARY
4/19/67 THROUGH 4/18/69

MILWAUKEE WIND - STABILITY SUMMARY

STABILITY CLASS - A - ANNUAL 4/19/67 TO 4/18/69
NUMBER OF HOURLY OBSERVATIONS

WINDS FROM	WIND SPEED (MPH)						TOTAL
	1-3	4-7	8-12	13-18	19-24	25+	
N	0	0	0	0	0	0	0
NNE	0	0	0	0	0	0	0
NE	0	1	0	0	0	0	1
ENE	0	2	0	0	0	0	2
E	0	1	0	0	0	0	1
ESE	0	0	0	0	0	0	0
SE	0	0	0	0	0	0	0
SSE	0	0	0	0	0	0	0
S	0	1	0	0	0	0	1
SSW	0	2	0	0	0	0	2
SW	0	0	0	0	0	0	0
WSW	0	0	0	0	0	0	0
W	0	1	0	0	0	0	1
WNW	0	0	0	0	0	0	0
NW	0	0	0	0	0	0	0
NNW	0	0	0	0	0	0	0
TOTAL	0	8	0	0	0	0	8

Number of calm hours 2
Total number of observations 10

Table I.4-30 (CONTINUED)

MILWAUKEE WIND - STABILITY SUMMARY

STABILITY CLASS - C - ANNUAL 4/19/67 TO 4/18/69
 NUMBER OF HOURLY OBSERVATIONS

WIND SPEED (MPH)

WINDS FROM	1-3	4-7	8-12	13-18	19-24	25+	TOTAL
N	1	1	2	1	0	0	5
NNE	1	6	36	11	0	0	54
NE	0	2	25	1	0	0	28
ENE	0	1	16	1	0	0	18
E	3	11	29	3	0	0	46
ESE	1	3	24	3	0	0	31
SE	2	3	31	7	0	0	43
SSE	8	1	16	1	0	0	26
S	10	3	9	2	0	0	24
SSW	5	8	27	6	0	0	46
SW	1	4	12	2	0	0	19
WSW	2	2	17	2	0	0	23
W	8	12	36	6	0	0	62
WNW	1	5	17	1	0	0	24
NW	4	5	17	4	0	0	30
NNW	5	2	15	0	0	0	22
TOTAL	52	69	329	51	0	0	501

Number of calm hours 23
 Total number of observations 524

Table I.4-30 (CONTINUED)

MILWAUKEE WIND - STABILITY SUMMARY

STABILITY CLASS - D - ANNUAL 4/19/67 TO 4/18/69
 NUMBER OF HOURLY OBSERVATIONS

WIND SPEED (MPH)

WINDS FROM	1-3	4-7	8-12	13-18	19-24	25+	TOTAL
N	5	15	28	72	17	7	144
NNE	13	42	130	153	40	7	385
NE	5	26	49	36	2	0	118
ENE	0	9	21	20	1	0	51
E	5	35	59	64	2	0	165
ESE	5	17	32	21	0	0	75
SE	5	33	76	81	5	0	200
SSE	17	68	135	140	13	1	374
S	3	39	79	86	8	4	219
SSW	7	52	136	193	18	0	406
SW	2	35	81	110	15	7	250
WSW	6	8	55	64	20	4	157
W	14	83	163	275	69	5	609
WNW	2	31	62	158	24	3	280
NW	3	24	80	151	16	0	274
NNW	6	39	88	147	19	0	299
TOTAL	98	556	1274	1771	269	38	4006

Number of calm hours 23
 Total number of observations 4029

Table I.4-30 (CONTINUED)

MILWAUKEE WIND - STABILITY SUMMARY

STABILITY CLASS - E - ANNUAL 4/19/67 TO 4/18/69
 NUMBER OF HOURLY OBSERVATIONS

WIND SPEED (MPH)

WINDS FROM	1-3	4-7	8-12	13-18	19-24	25+	TOTAL
N	0	3	6	0	0	0	9
NNE	0	6	21	0	0	0	27
NE	0	2	6	0	0	0	8
ENE	0	0	4	0	0	0	4
E	0	4	5	0	0	0	9
ESE	0	1	1	0	0	0	2
SE	0	2	4	0	0	0	6
SSE	0	17	17	0	0	0	34
S	0	12	43	0	0	0	55
SSW	0	19	59	0	0	0	78
SW	0	7	31	0	0	0	38
WSW	0	6	21	0	0	0	27
W	0	15	82	0	0	0	97
WNW	0	8	42	0	0	0	50
NW	0	8	28	0	0	0	36
NNW	0	5	30	0	0	0	35
TOTAL	0	115	400	0	0	0	515
Number of calm hours							0
Total number of observations							515

Table I.4-30 (CONTINUED)

MILWAUKEE WIND - STABILITY SUMMARY								
STABILITY CLASS - F - ANNUAL 4/19/67 TO 4/18/69								
NUMBER OF HOURLY OBSERVATIONS								
WIND SPEED (MPH)								
WINDS FROM	1-3	4-7	8-12	13-18	19-24	25+	TOTAL	
N	1	6	0	0	0	0	7	
NNE	2	18	0	0	0	0	20	
NE	2	4	0	0	0	0	6	
ENE	1	3	0	0	0	0	4	
E	1	7	0	0	0	0	8	
ESE	0	1	0	0	0	0	1	
SE	3	10	0	0	0	0	13	
SSE	7	28	0	0	0	0	35	
S	6	40	0	0	0	0	46	
SSW	4	40	0	0	0	0	44	
SW	2	15	0	0	0	0	17	
WSW	0	19	0	0	0	0	19	
W	5	72	0	0	0	0	77	
WNW	1	20	0	0	0	0	21	
NW	0	14	0	0	0	0	14	
NNW	3	12	0	0	0	0	15	
TOTAL	38	309	0	0	0	0	347	
Number of calm hours			18					
Total number of observations			365					

Sheet 6 of 8

Table I.4-30 (CONTINUED)

MILWAUKEE WIND - STABILITY SUMMARY

STABILITY CLASS - G - ANNUAL 4/19/67 TO 4/18/69
 NUMBER OF HOURLY OBSERVATIONS

WIND SPEED (MPH)

WINDS FROM	1-3	4-7	8-12	13-18	19-24	25+	TOTAL
N	3	0	0	0	0	0	3
NNE	9	0	0	0	0	0	9
NE	1	0	0	0	0	0	1
ENE	1	0	0	0	0	0	1
E	6	0	0	0	0	0	6
ESE	4	0	0	0	0	0	4
SE	3	0	0	0	0	0	3
SSE	20	0	0	0	0	0	20
S	23	0	0	0	0	0	23
SSW	24	0	0	0	0	0	24
SW	14	0	0	0	0	0	14
WSW	12	0	0	0	0	0	12
W	18	0	0	0	0	0	18
WNW	3	0	0	0	0	0	3
NW	2	0	0	0	0	0	2
NNW	3	0	0	0	0	0	3
TOTAL	146	0	0	0	0	0	146

Number of calm hours 90
 Total number of observations 236

Table I.4-30 (CONTINUED)

MILWAUKEE WIND - STABILITY SUMMARY

STABILITY CLASS - ALL - ANNUAL 4/19/67 TO 4/18/69
NUMBER OF HOURLY OBSERVATIONS

WIND SPEED (MPH)

WINDS FROM	1-3	4-7	8-12	13-18	19-24	25+	TOTAL
N	12	25	36	73	17	7	170
NNE	26	80	192	164	40	7	509
NE	13	40	90	37	2	0	182
ENE	3	17	42	21	1	0	84
E	15	75	115	67	2	0	274
ESE	13	24	65	24	0	0	126
SE	13	53	119	88	5	0	278
SSE	53	118	171	141	13	1	497
S	44	99	133	88	8	4	376
SSW	44	126	225	199	18	0	612
SW	19	62	127	112	15	7	342
WSW	20	36	94	66	20	4	240
W	49	192	287	281	69	5	883
WNW	7	65	123	159	24	3	381
NW	9	53	126	155	16	0	359
NNW	17	59	134	147	19	0	376
TOTAL	357	1124	2079	1822	269	38	5689
Number of calm hours							159
Total number of observations							5848

Table I.4-31 (CONTINUED)

MILWAUKEE WIND - STABILITY SUMMARY
 STABILITY CLASS - B - ANNUAL 1/1/56 TO 12/31/75
 NUMBER OF HOURLY OBSERVATIONS

WINDS FROM	WIND SPEED (MPH)						TOTAL
	1-3	4-7	8-12	13-18	19-24	25+	
N	22	19	13	0	0	0	54
NNE	25	61	92	0	0	0	178
NE	38	75	155	0	0	0	268
ENE	30	89	88	0	0	0	207
E	30	118	186	0	0	0	334
ESE	19	70	171	0	0	0	260
SE	25	67	74	0	0	0	166
SSE	33	38	23	0	0	0	94
S	28	36	28	0	0	0	92
SSW	29	62	64	0	0	0	155
SW	31	44	54	0	0	0	129
WSW	23	50	57	0	0	0	130
W	39	75	61	0	0	0	175
WNW	25	32	45	0	0	0	102
NW	36	28	15	0	0	0	79
NNW	13	9	12	0	0	0	34
TOTAL	446	873	1138	0	0	0	2457
Number of calm hours							71
Total number of observations							2528

Table I.4-31 (CONTINUED)

MILWAUKEE WIND - STABILITY SUMMARY
 STABILITY CLASS - C - ANNUAL 1/1/56 TO 12/31/75
 NUMBER OF HOURLY OBSERVATIONS

WINDS FROM	WIND SPEED (MPH)						TOTAL
	1-3	4-7	8-12	13-18	19-24	25+	
N	34	42	105	12	0	0	193
NNE	38	76	441	95	0	0	650
NE	41	77	482	56	0	0	656
ENE	33	66	325	29	0	0	453
E	50	114	447	32	0	0	643
ESE	45	80	635	104	0	0	864
SE	73	62	460	100	0	0	695
SSE	103	59	184	28	0	0	374
S	90	108	210	29	0	0	437
SSW	69	94	365	49	0	0	577
SW	73	91	389	49	0	0	602
WSW	66	116	451	64	0	0	697
W	84	135	476	57	0	0	752
WNW	52	114	388	40	0	0	594
NW	53	72	193	31	0	0	349
NNW	37	46	113	6	0	0	202
TOTAL	941	1352	5664	781	0	0	8738
Number of calm hours							238
Total number of observations							8976

Table I.4-31 (CONTINUED)

MILWAUKEE WIND - STABILITY SUMMARY
 STABILITY CLASS - D - ANNUAL 1/1/56 TO 12/31/75
 NUMBER OF HOURLY OBSERVATIONS

WINDS FROM	WIND SPEED (MPH)						TOTAL
	1-3	4-7	8-12	13-18	19-24	25+	
N	82	355	937	1846	734	266	4220
NNE	106	601	1622	2803	980	413	6525
NE	103	470	944	1261	338	128	3244
ENE	54	280	665	738	257	78	2072
E	85	350	733	734	139	74	2115
ESE	90	440	948	1136	211	36	2861
SE	114	507	1423	1899	311	63	4317
SSE	125	595	1497	1381	227	35	3860
S	158	687	1836	2008	416	80	5185
SSW	94	628	2029	3260	781	235	7027
SW	87	452	1557	2770	737	276	5879
WSW	92	481	1461	2625	754	289	5702
W	148	723	1760	3079	832	215	6757
WNW	85	658	1675	3632	1107	289	7446
NW	72	392	1286	2374	642	116	4882
NNW	64	302	966	1859	510	132	3833
TOTAL	1559	7921	21339	33405	8976	2725	75925
Number of calm hours							360
Total number of observations							76285

Table I.4-31 (CONTINUED)

MILWAUKEE WIND - STABILITY SUMMARY							
STABILITY CLASS - E - ANNUAL 1/1/56 TO 12/31/75							
NUMBER OF HOURLY OBSERVATIONS							
WIND SPEED (MPH)							
WINDS FROM	1-3	4-7	8-12	13-18	19-24	25+	TOTAL
N	0	129	240	0	0	0	369
NNE	0	209	326	0	0	0	535
NE	0	99	149	0	0	0	248
ENE	0	55	67	0	0	0	122
E	0	66	53	0	0	0	119
ESE	0	97	62	0	0	0	159
SE	0	186	98	0	0	0	284
SSE	0	345	340	0	0	0	685
S	0	509	809	0	0	0	1318
SSW	0	335	1116	0	0	0	1451
SW	0	238	938	0	0	0	1176
WSW	0	228	814	0	0	0	1042
W	0	286	983	0	0	0	1269
WNW	0	201	1093	0	0	0	1294
NW	0	122	548	0	0	0	670
NNW	0	82	304	0	0	0	386
TOTAL	0	3187	7940	0	0	0	11127
Number of calm hours	0						
Total number of observations	11127						

Table I.4-31 (CONTINUED)

MILWAUKEE WIND - STABILITY SUMMARY
 STABILITY CLASS - F - ANNUAL 1/1/56 TO 12/31/75
 NUMBER OF HOURLY OBSERVATIONS

WINDS FROM	WIND SPEED (MPH)						TOTAL
	1-3	4-7	8-12	13-18	19-24	25+	
N	60	216	0	0	0	0	276
NNE	63	252	0	0	0	0	315
NE	47	136	0	0	0	0	183
ENE	33	65	0	0	0	0	98
E	55	84	0	0	0	0	139
ESE	59	102	0	0	0	0	161
SE	90	167	0	0	0	0	257
SSE	141	521	0	0	0	0	662
S	155	768	0	0	0	0	923
SSW	116	786	0	0	0	0	902
SW	96	527	0	0	0	0	623
WSW	83	600	0	0	0	0	683
W	96	931	0	0	0	0	1027
WNW	67	697	0	0	0	0	764
NW	54	304	0	0	0	0	358
NNW	46	161	0	0	0	0	207
TOTAL	1261	6317	0	0	0	0	7578
Number of calm hours			331				
Total number of observations			7909				

Table I.4-31 (CONTINUED)

MILWAUKEE WIND - STABILITY SUMMARY
 STABILITY CLASS - G - ANNUAL 1/1/56 TO 12/31/75
 NUMBER OF HOURLY OBSERVATIONS

WINDS FROM	WIND SPEED (MPH)						TOTAL
	1-3	4-7	8-12	13-18	19-24	25+	
N	115	0	0	0	0	0	115
NNE	121	0	0	0	0	0	121
NE	73	0	0	0	0	0	73
ENE	52	0	0	0	0	0	52
E	85	0	0	0	0	0	85
ESE	84	0	0	0	0	0	84
SE	172	0	0	0	0	0	172
SSE	289	0	0	0	0	0	289
S	384	0	0	0	0	0	384
SSW	325	0	0	0	0	0	325
SW	285	0	0	0	0	0	285
WSW	293	0	0	0	0	0	293
W	304	0	0	0	0	0	304
WNW	155	0	0	0	0	0	155
NW	91	0	0	0	0	0	91
NNW	83	0	0	0	0	0	83
TOTAL	2911	0	0	0	0	0	2911
Number of calm hours							1144
Total number of observations							4055

Table I.4-31 (CONTINUED)

MILWAUKEE WIND - STABILITY SUMMARY
 STABILITY CLASS - ALL - ANNUAL 1/1/56 TO 12/31/75
 NUMBER OF HOURLY OBSERVATIONS

WINDS FROM	WIND SPEED (MPH)						TOTAL
	1-3	4-7	8-12	13-18	19-24	25+	
N	313	762	1295	1858	734	266	5228
NNE	353	1202	2481	2898	980	413	8327
NE	303	866	1730	1317	338	128	4682
ENE	203	560	1145	767	257	78	3010
E	307	743	1419	766	139	74	3448
ESE	299	796	1816	1240	211	36	4398
SE	475	993	2055	1999	311	63	5896
SSE	691	1559	2044	1409	227	35	5965
S	816	2109	2883	2037	416	80	8341
SSW	634	1910	3574	3309	781	235	10443
SW	572	1356	2938	2819	737	276	8698
WSW	557	1480	2783	2689	754	289	8552
W	672	2156	3280	3136	832	215	10291
WNW	385	1702	3201	3672	1107	289	10356
NW	306	919	2042	2405	642	116	6430
NNW	243	603	1395	1865	510	132	4748
TOTAL	7129	19716	36081	34186	8976	2725	108813

Number of calm hours 2151
 Total number of observations 110964

Table I.4-32 POINT BEACH JOINT FREQUENCY DISTRIBUTION TWO-YEAR SUMMARY, 4/19/67 THROUGH 4/18/69

POINT BEACH WIND - STABILITY SUMMARY

STABILITY CLASS - A - 150 FT WINDS, PERIOD 4/19/67 TO 4/18/69
NUMBER OF HOURLY OBSERVATIONS

WINDS FROM	WIND SPEED (MPH)						TOTAL
	1-3	4-7	8-12	13-18	19-24	25+	
N	3	2	1	0	0	0	6
NNE	3	0	0	0	0	0	3
NE	4	0	0	0	0	0	4
ENE	1	2	0	0	0	0	3
E	5	1	0	0	0	0	6
ESE	1	1	0	0	0	0	2
SE	6	2	0	0	0	0	8
SSE	1	1	2	0	0	0	4
S	6	0	0	0	0	0	6
SSW	2	2	3	1	0	0	8
SW	3	4	0	0	0	1	8
WSW	2	4	1	2	0	0	9
W	9	4	2	0	0	0	15
WNW	3	3	5	1	0	0	12
NW	4	4	6	0	0	1	15
NNW	2	4	0	0	0	0	6
TOTAL	55	34	20	4	0	2	115
Number of calm hours							12
Number of variable directions							0
Total number of observations							127

Table I.4-32 (CONTINUED)

POINT BEACH WIND - STABILITY SUMMARY

STABILITY CLASS - B - 150 FT WINDS, PERIOD 4/19/67 TO 4/18/69
 NUMBER OF HOURLY OBSERVATIONS

WIND SPEED (MPH)

WINDS FROM	1-3	4-7	8-12	13-18	19-24	25+	TOTAL
N	3	2	0	0	0	0	5
NNE	0	0	0	0	0	0	0
NE	4	3	0	0	0	0	7
ENE	5	2	0	0	0	0	7
E	1	4	0	0	0	0	5
ESE	3	1	0	0	0	0	4
SE	3	1	0	0	0	0	4
SSE	9	2	3	0	0	0	14
S	2	3	6	1	0	0	12
SSW	5	2	5	0	0	0	12
SW	1	3	4	2	0	0	10
WSW	2	5	1	1	0	0	9
W	3	7	4	1	0	0	15
WNW	4	13	16	6	0	0	39
NW	2	12	15	7	1	0	37
NNW	1	3	3	1	0	0	8
TOTAL	48	63	57	19	1	0	188

Number of calm hours 12
 Number of variable directions 0
 Total number of observations 200

Table I.4-32 (CONTINUED)

POINT BEACH WIND - STABILITY SUMMARY

STABILITY CLASS - C - 150 FT WINDS, PERIOD 4/19/67 TO 4/18/69
 NUMBER OF HOURLY OBSERVATIONS

WIND SPEED (MPH)

WINDS FROM	1-3	4-7	8-12	13-18	19-24	25+	TOTAL
N	5	7	5	5	1	0	23
NNE	3	4	0	1	1	1	10
NE	11	8	2	2	0	0	23
ENE	6	7	1	0	0	0	14
E	13	9	3	0	0	1	26
ESE	9	7	1	0	0	0	17
SE	6	9	3	0	0	1	19
SSE	5	9	8	4	1	1	28
S	9	17	42	12	3	4	87
SSW	1	14	29	3	2	3	52
SW	8	15	13	7	1	2	46
WSW	5	8	14	4	1	1	33
W	8	16	31	14	6	2	77
WNW	9	24	100	176	84	25	418
NW	8	45	135	158	40	15	401
NNW	6	16	32	20	5	1	80
TOTAL	112	215	419	406	145	57	1354

Number of calm hours 23
 Number of variable directions 0
 Total number of observations 1377

Table I.4-32 (CONTINUED)

POINT BEACH WIND - STABILITY SUMMARY

STABILITY CLASS - D - 150 FT WINDS, PERIOD 4/19/67 TO 4/18/69
 NUMBER OF HOURLY OBSERVATIONS

WIND SPEED (MPH)

WINDS FROM	1-3	4-7	8-12	13-18	19-24	25+	TOTAL
N	12	30	65	99	21	11	238
NNE	18	33	42	23	14	5	135
NE	19	54	35	20	6	0	134
ENE	22	26	14	10	0	0	72
E	26	36	12	3	0	2	79
ESE	30	23	10	5	2	1	71
SE	28	31	22	25	10	3	119
SSE	15	43	72	55	50	28	263
S	22	81	226	265	142	74	810
SSW	10	57	203	229	143	39	681
SW	19	39	58	79	21	9	225
WSW	14	31	71	80	45	16	257
W	17	46	79	136	85	60	423
WNW	11	63	178	265	108	37	662
NW	13	48	175	148	20	6	410
NNW	8	60	179	177	76	20	520
TOTAL	284	701	1441	1619	743	311	5099

Number of calm hours 31
 Number of variable directions 0
 Total number of observations 5130

Table I.4-32 (CONTINUED)

POINT BEACH WIND - STABILITY SUMMARY

STABILITY CLASS - E - 150 FT WINDS, PERIOD 4/19/67 TO 4/18/69
 NUMBER OF HOURLY OBSERVATIONS

WIND SPEED (MPH)

WINDS FROM	1-3	4-7	8-12	13-18	19-24	25+	TOTAL
N	23	81	201	195	87	57	644
NNE	16	64	169	165	92	95	601
NE	10	58	109	127	50	39	393
ENE	16	36	42	42	30	14	180
E	28	42	32	32	17	18	169
ESE	20	36	35	19	25	7	142
SE	18	43	47	46	33	36	223
SSE	11	43	70	49	32	7	212
S	17	53	88	33	6	0	197
SSW	19	51	254	367	106	15	812
SW	18	70	169	157	41	5	460
WSW	4	43	96	73	10	2	228
W	11	62	108	133	39	26	379
WNW	9	28	60	38	6	1	142
NW	7	21	38	24	5	0	95
NNW	11	20	80	32	6	0	149
TOTAL	238	751	1598	1532	585	322	5026

Number of calm hours 34
 Number of variable directions 0
 Total number of observations 5060

Table I.4-32 (CONTINUED)

POINT BEACH WIND - STABILITY SUMMARY

STABILITY CLASS - F - 150 FT WINDS, PERIOD 4/19/67 TO 4/18/69
 NUMBER OF HOURLY OBSERVATIONS

WIND SPEED (MPH)

WINDS FROM	1-3	4-7	8-12	13-18	19-24	25+	TOTAL
N	12	44	107	118	48	27	356
NNE	6	18	49	51	24	5	153
NE	3	14	28	33	11	3	92
ENE	7	13	15	9	8	3	55
E	13	16	8	10	2	3	52
ESE	11	15	16	1	2	0	45
SE	3	32	28	17	2	0	82
SSE	9	17	26	9	1	0	62
S	9	21	15	0	1	0	46
SSW	11	30	83	39	2	0	165
SW	9	39	151	61	4	0	264
WSW	5	15	42	17	0	0	79
W	8	12	52	31	3	0	106
WNW	5	15	43	17	2	0	82
NW	8	11	17	10	0	0	46
NNW	0	7	6	3	0	0	16
TOTAL	119	319	686	426	110	41	1701

Number of calm hours 8
 Number of variable directions 0
 Total number of observations 1709

Table I.4-32 (CONTINUED)

POINT BEACH WIND - STABILITY SUMMARY

STABILITY CLASS - G - 150 FT WINDS, PERIOD 4/19/67 TO 4/18/69
NUMBER OF HOURLY OBSERVATIONS

WIND SPEED (MPH)

WINDS FROM	1-3	4-7	8-12	13-18	19-24	25+	TOTAL
N	24	42	50	46	5	1	168
NNE	0	6	17	19	7	0	49
NE	2	13	14	6	2	0	37
ENE	2	10	2	4	2	1	21
E	5	7	9	3	0	0	24
ESE	2	14	3	0	0	0	19
SE	10	31	18	32	0	0	61
SSE	4	7	20	3	0	0	34
S	5	8	8	1	0	0	22
SSW	10	35	48	13	0	0	106
SW	6	49	113	26	0	0	194
WSW	6	16	36	14	0	0	72
W	6	20	51	36	0	0	113
WNW	6	19	20	13	0	0	58
NW	0	13	12	15	0	0	40
NNW	0	2	10	1	0	0	13
TOTAL	88	292	431	202	16	2	1031

Number of calm hours 13
Number of variable directions 0
Total number of observations 1044

Sheet 7 of 8

Table I.4-32 (CONTINUED)

POINT BEACH WIND - STABILITY SUMMARY

STABILITY CLASS - ALL - 150 FT WINDS, PERIOD 4/19/67 TO 4/18/69
 NUMBER OF HOURLY OBSERVATIONS

WIND SPEED (MPH)

WINDS FROM	1-3	4-7	8-12	13-18	19-24	25+	TOTAL
N	82	208	429	463	162	96	1440
NNE	46	125	277	259	138	106	951
NE	53	150	188	188	69	42	690
ENE	59	96	74	65	40	18	352
E	91	115	64	48	19	24	361
ESE	76	97	65	25	29	8	300
SE	74	149	118	90	45	40	516
SSE	54	122	201	120	84	36	617
S	70	183	385	312	152	78	1180
SSW	58	191	625	652	253	57	1836
SW	64	218	508	332	67	17	1207
WSW	38	122	261	191	56	19	687
W	62	167	327	351	133	88	1128
WNW	47	165	422	516	200	63	1413
NW	42	154	398	362	66	22	1044
NNW	28	112	310	234	87	21	792
TOTAL	944	2375	4652	4208	1600	735	14514

Number of calm hours 133
 Number of variable directions 0
 Total number of observations 14647

Table I.4-33 (CONTINUED)

POINT BEACH WIND - STABILITY SUMMARY

STABILITY CLASS - B - 150 FT WINDS, (JAN) PERIOD 1/1/68 TO 1/31/69
 NUMBER OF HOURLY OBSERVATIONS

WIND SPEED (MPH)

WINDS FROM	1-3	4-7	8-12	13-18	19-24	25+	TOTAL
N	0	0	0	0	0	0	0
NNE	0	0	0	0	0	0	0
NE	0	0	0	0	0	0	0
ENE	0	0	0	0	0	0	0
E	0	0	0	0	0	0	0
ESE	1	0	0	0	0	0	1
SE	0	0	0	0	0	0	0
SSE	0	0	0	0	0	0	0
S	0	0	0	0	0	0	0
SSW	0	0	0	0	0	0	0
SW	0	0	0	0	0	0	0
WSW	0	0	0	0	0	0	0
W	0	0	0	0	0	0	0
WNW	1	1	1	0	0	0	3
NW	0	0	0	0	0	0	0
NNW	0	0	0	0	0	0	0
TOTAL	2	1	1	0	0	0	4
Number of calm hours			0				
Number of variable directions			0				
Total number of observations			4				

Table I.4-33 (CONTINUED)

POINT BEACH WIND - STABILITY SUMMARY

STABILITY CLASS - C - 150 FT WINDS, (JAN) PERIOD 1/1/68 TO 1/31/69
 NUMBER OF HOURLY OBSERVATIONS

WIND SPEED (MPH)

WINDS FROM	1-3	4-7	8-12	13-18	19-24	25+	TOTAL
N	0	0	0	0	0	0	0
NNE	0	0	0	0	0	0	0
NE	0	0	0	0	0	0	0
ENE	0	0	0	0	0	0	0
E	0	0	0	0	0	0	0
ESE	0	0	0	0	0	0	0
SE	0	0	0	0	0	0	0
SSE	0	0	3	0	0	0	3
S	0	0	0	0	0	0	0
SSW	0	0	0	0	1	0	1
SW	0	1	0	0	0	0	1
WSW	1	0	0	0	0	0	1
W	1	0	1	0	0	0	2
WNW	2	2	8	13	11	1	37
NW	1	6	9	7	2	1	26
NNW	0	2	1	1	2	0	6
TOTAL	5	11	22	21	16	2	77
Number of calm hours			0				
Number of variable directions			0				
Total number of observations			77				

Table I.4-33 (CONTINUED)

POINT BEACH WIND - STABILITY SUMMARY

STABILITY CLASS - D - 150 FT WINDS, (JAN) PERIOD 1/1/68 TO 1/31/69
 NUMBER OF HOURLY OBSERVATIONS

WIND SPEED (MPH)

WINDS FROM	1-3	4-7	8-12	13-18	19-24	25+	TOTAL
N	2	6	1	11	7	0	27
NNE	2	1	0	0	1	4	8
NE	0	0	0	3	0	0	3
ENE	0	0	1	4	0	0	5
E	1	0	1	2	0	0	4
ESE	0	0	2	3	0	0	5
SE	1	0	1	12	5	1	20
SSE	0	3	7	10	18	15	53
S	0	0	26	27	10	6	69
SSW	0	1	2	11	8	7	29
SW	1	1	4	3	0	1	10
WSW	3	5	8	6	2	0	24
W	0	5	8	12	8	3	36
WNW	1	5	22	38	26	8	100
NW	1	7	31	32	7	1	79
NNW	1	12	10	18	7	1	49
TOTAL	13	46	124	192	99	47	521
Number of calm hours							0
Number of variable directions							0
Total number of observations							521

Table I.4-33 (CONTINUED)

POINT BEACH WIND - STABILITY SUMMARY

STABILITY CLASS - E - 150 FT WINDS, (JAN) PERIOD 1/1/68 TO 1/31/69
 NUMBER OF HOURLY OBSERVATIONS

WIND SPEED (MPH)

WINDS FROM	1-3	4-7	8-12	13-18	19-24	25+	TOTAL
N	2	14	15	9	9	6	55
NNE	0	2	3	2	8	15	30
NE	1	1	1	8	6	1	18
ENE	0	0	1	10	11	1	23
E	1	1	1	5	0	0	8
ESE	1	1	4	2	1	0	9
SE	0	3	4	5	8	13	33
SSE	0	2	5	4	6	4	21
S	0	3	2	3	3	0	11
SSW	0	2	7	21	8	1	39
SW	2	4	14	16	5	0	41
WSW	0	1	8	7	1	0	17
W	3	13	15	18	13	11	73
WNW	0	1	5	5	5	1	17
NW	1	1	2	4	3	0	11
NNW	3	6	5	5	0	0	19
TOTAL	14	55	92	124	87	53	425
Number of calm hours							0
Number of variable directions							0
Total number of observations							425

Table I.4-33 (CONTINUED)

POINT BEACH WIND - STABILITY SUMMARY

STABILITY CLASS - G - 150 FT WINDS, (JAN) PERIOD 1/1/68 TO 1/31/69
 NUMBER OF HOURLY OBSERVATIONS

WIND SPEED (MPH)

WINDS FROM	1-3	4-7	8-12	13-18	19-24	25+	TOTAL
N	2	4	1	1	1	0	9
NNE	0	0	0	1	0	0	1
NE	0	0	0	0	0	0	0
ENE	0	2	0	0	0	0	2
E	0	0	3	0	0	0	3
ESE	0	0	1	0	0	0	1
SE	0	0	0	0	0	0	0
SSE	0	0	0	0	0	0	0
S	0	0	0	0	0	0	0
SSW	0	0	0	1	0	0	1
SW	0	0	2	1	0	0	3
WSW	0	1	0	0	0	0	1
W	0	0	3	1	0	0	4
WNW	0	1	1	1	0	0	3
NW	0	3	0	0	0	0	3
NNW	0	0	0	0	0	0	0
TOTAL	2	11	11	6	1	0	31
Number of calm hours			0				
Number of variable directions			0				
Total number of observations			31				

Table I.4-33 (CONTINUED)

POINT BEACH WIND - STABILITY SUMMARY

STABILITY CLASS - A - 150 FT WINDS, (FEB) PERIOD 2/1/68 TO 2/28/69
 NUMBER OF HOURLY OBSERVATIONS

WIND SPEED (MPH)

WINDS FROM	1-3	4-7	8-12	13-18	19-24	25+	TOTAL
N	0	0	0	0	0	0	0
NNE	1	0	0	0	0	0	1
NE	0	0	0	0	0	0	0
ENE	0	0	0	0	0	0	0
E	0	0	0	0	0	0	0
ESE	0	0	0	0	0	0	0
SE	0	0	0	0	0	0	0
SSE	0	0	0	0	0	0	0
S	1	0	0	0	0	0	1
SSW	0	0	0	0	0	0	0
SW	0	0	0	0	0	0	0
WSW	1	0	0	0	0	0	1
W	0	0	0	0	0	0	0
WNW	0	0	0	0	0	0	0
NW	0	0	0	0	0	0	0
NNW	1	0	0	0	0	0	1
TOTAL	4	0	0	0	0	0	4
Number of calm hours			0				
Number of variable directions			0				
Total number of observations			4				

Table I.4-33 (CONTINUED)

POINT BEACH WIND - STABILITY SUMMARY

STABILITY CLASS - C - 150 FT WINDS, (FEB) PERIOD 2/1/68 TO 2/28/69
 NUMBER OF HOURLY OBSERVATIONS

WIND SPEED (MPH)

WINDS FROM	1-3	4-7	8-12	13-18	19-24	25+	TOTAL
N	1	1	0	1	1	0	4
NNE	0	1	0	0	0	0	1
NE	0	0	0	0	0	0	0
ENE	2	0	1	0	0	0	3
E	0	0	0	0	0	0	0
ESE	0	0	0	0	0	0	0
SE	0	0	0	0	0	0	0
SSE	0	0	0	0	0	0	0
S	0	0	0	0	0	0	0
SSW	0	0	0	0	0	0	0
SW	0	0	0	0	0	0	0
WSW	0	0	0	0	0	0	0
W	2	0	0	0	1	0	3
WNW	1	5	12	33	20	1	72
NW	3	5	14	18	7	2	49
NNW	0	1	3	3	1	0	8
TOTAL	9	13	30	55	30	3	140

Number of calm hours 4
 Number of variable directions 0
 Total number of observations 144

Table I.4-33 (CONTINUED)

POINT BEACH WIND - STABILITY SUMMARY

STABILITY CLASS - D - 150 FT WINDS, (FEB) PERIOD 2/1/68 TO 2/28/69
 NUMBER OF HOURLY OBSERVATIONS

WIND SPEED (MPH)

WINDS FROM	1-3	4-7	8-12	13-18	19-24	25+	TOTAL
N	2	9	11	15	1	1	39
NNE	3	1	0	2	1	0	7
NE	0	4	0	0	0	0	4
ENE	0	1	4	0	0	0	5
E	0	0	0	1	0	0	1
ESE	1	1	0	1	0	0	3
SE	0	2	1	1	0	0	4
SSE	1	1	3	0	0	0	5
S	0	2	2	4	0	0	8
SSW	0	0	0	0	0	0	0
SW	1	1	2	1	1	0	6
WSW	0	2	1	1	3	0	7
W	6	0	5	13	6	1	31
WNW	4	11	24	41	31	4	115
NW	2	8	26	19	1	3	59
NNW	2	9	38	40	22	11	122
TOTAL	22	52	117	139	66	20	416
Number of calm hours			3				
Number of variable directions			0				
Total number of observations			419				

Table I.4-33 (CONTINUED)

POINT BEACH WIND - STABILITY SUMMARY							
STABILITY CLASS - E - 150 FT WINDS, (FEB) PERIOD 2/1/68 TO 2/28/69							
NUMBER OF HOURLY OBSERVATIONS							
WIND SPEED (MPH)							
WINDS FROM	1-3	4-7	8-12	13-18	19-24	25+	TOTAL
N	7	10	14	33	11	10	85
NNE	3	4	3	19	7	1	37
NE	0	1	9	15	2	0	27
ENE	0	4	6	10	0	0	20
E	1	1	8	15	0	0	25
ESE	1	0	9	4	0	0	14
SE	2	2	3	0	0	0	7
SSE	0	1	0	0	0	0	1
S	1	1	2	0	0	0	4
SSW	2	0	0	0	1	3	6
SW	2	3	3	6	4	0	18
WSW	0	2	5	3	0	0	10
W	2	7	9	10	2	1	31
WNW	2	4	7	6	0	0	19
NW	3	3	4	4	0	0	14
NNW	0	2	12	6	4	0	24
TOTAL	26	45	94	131	31	15	342
Number of calm hours			6				
Number of variable directions			0				
Total number of observations			348				

Table I.4-33 (CONTINUED)

POINT BEACH WIND - STABILITY SUMMARY

STABILITY CLASS - G - 150 FT WINDS, (FEB) PERIOD 2/1/68 TO 2/28/69
 NUMBER OF HOURLY OBSERVATIONS

WIND SPEED (MPH)

WINDS FROM	1-3	4-7	8-12	13-18	19-24	25+	TOTAL
N	2	0	2	0	0	0	4
NNE	0	0	0	0	0	0	0
NE	0	0	1	0	0	0	1
ENE	0	0	0	0	0	0	0
E	0	0	0	0	0	0	0
ESE	0	0	0	0	0	0	0
SE	0	0	0	0	0	0	0
SSE	0	0	0	0	0	0	0
S	0	0	0	0	0	0	0
SSW	2	0	0	0	0	0	2
SW	2	4	5	0	0	0	11
WSW	1	6	2	0	0	0	9
W	3	4	1	1	0	0	9
WNW	1	1	1	2	0	0	5
NW	0	1	0	1	0	0	2
NNW	0	0	0	0	0	0	0
TOTAL	11	16	12	4	0	0	43

Number of calm hours 4
 Number of variable directions 0
 Total number of observations 47

Table I.4-33 (CONTINUED)

POINT BEACH WIND - STABILITY SUMMARY

STABILITY CLASS - ALL - 150 FT WINDS, (FEB) PERIOD 2/1/68 TO 2/28/69
 NUMBER OF HOURLY OBSERVATIONS

WIND SPEED (MPH)

WINDS FROM	1-3	4-7	8-12	13-18	19-24	25+	TOTAL
N	15	24	33	61	16	16	165
NNE	9	6	3	22	8	1	49
NE	0	6	12	17	2	0	37
ENE	4	6	13	12	0	0	35
E	2	1	10	18	0	0	31
ESE	2	1	10	5	0	0	18
SE	2	4	6	5	0	0	17
SSE	1	2	3	0	0	0	6
S	2	3	4	4	0	0	13
SSW	4	0	2	0	1	3	10
SW	7	9	14	7	5	0	42
WSW	3	12	9	4	3	0	31
W	16	13	17	28	9	2	85
WNW	9	21	46	84	51	5	216
NW	9	18	45	42	8	5	127
NNW	3	12	54	50	27	11	157
TOTAL	88	138	281	359	130	43	1039

Number of calm hours 22
 Number of variable directions 0
 Total number of observations 1061

Table I.4-33 (CONTINUED)

POINT BEACH WIND - STABILITY SUMMARY							
STABILITY CLASS - B - 150 FT WINDS, (MAR) PERIOD 3/1/68 TO 3/31/69							
NUMBER OF HOURLY OBSERVATIONS							
WIND SPEED (MPH)							
WINDS FROM	1-3	4-7	8-12	13-18	19-24	25+	TOTAL
N	0	1	0	0	0	0	1
NNE	0	0	0	0	0	0	0
NE	0	0	0	0	0	0	0
ENE	0	0	0	0	0	0	0
E	0	0	0	0	0	0	0
ESE	0	0	0	0	0	0	0
SE	0	0	0	0	0	0	0
SSE	0	0	0	0	0	0	0
S	0	0	1	0	0	0	1
SSW	1	0	0	0	0	0	1
SW	0	0	1	0	0	0	1
WSW	0	0	0	0	0	0	0
W	0	1	1	0	0	0	2
WNW	1	4	2	1	0	0	8
NW	0	2	2	0	0	0	4
NNW	0	0	0	0	0	0	0
TOTAL	2	8	7	1	0	0	18
Number of calm hours			0				
Number of variable directions			0				
Total number of observations			18				

Table I.4-33 (CONTINUED)

POINT BEACH WIND - STABILITY SUMMARY

STABILITY CLASS - C - 150 FT WINDS, (MAR) PERIOD 3/1/68 TO 3/31/69
 NUMBER OF HOURLY OBSERVATIONS

WIND SPEED (MPH)

WINDS FROM	1-3	4-7	8-12	13-18	19-24	25+	TOTAL
N	1	1	0	1	0	0	3
NNE	0	0	0	0	0	0	0
NE	0	0	0	0	0	0	0
ENE	0	1	0	0	0	0	1
E	0	1	1	0	0	1	3
ESE	0	0	0	0	0	0	0
SE	1	0	0	0	0	0	1
SSE	0	0	0	0	0	0	0
S	0	0	0	0	0	0	0
SSW	0	0	2	0	0	0	2
SW	0	1	2	0	0	0	3
WSW	1	0	2	1	0	0	4
W	0	1	2	1	0	0	4
WNW	0	0	8	22	4	0	34
NW	0	2	11	11	1	0	25
NNW	1	1	2	2	0	1	7
TOTAL	4	8	30	38	5	2	87
Number of calm hours			0				
Number of variable directions			0				
Total number of observations			87				

Table I.4-33 (CONTINUED)

POINT BEACH WIND - STABILITY SUMMARY

STABILITY CLASS - D - 150 FT WINDS, (MAR) PERIOD 3/1/68 TO 3/31/69
 NUMBER OF HOURLY OBSERVATIONS

WIND SPEED (MPH)

WINDS FROM	1-3	4-7	8-12	13-18	19-24	25+	TOTAL
N	1	5	6	5	1	1	19
NNE	1	1	4	2	0	0	8
NE	0	1	4	0	0	0	5
ENE	0	0	0	0	0	0	0
E	0	1	1	0	0	0	2
ESE	0	0	0	0	1	0	1
SE	0	1	1	0	1	0	3
SSE	0	0	1	1	0	0	2
S	0	2	3	8	17	2	32
SSW	0	0	4	10	3	1	18
SW	0	2	9	8	0	0	19
WSW	1	0	6	3	1	0	11
W	0	1	8	11	2	0	22
WNW	0	6	6	24	4	0	40
NW	1	3	12	12	1	0	29
NNW	1	5	12	22	11	1	52
TOTAL	5	28	77	106	42	5	263
Number of calm hours							0
Number of variable directions							0
Total number of observations							263

Table I.4-33 (CONTINUED)

POINT BEACH WIND - STABILITY SUMMARY

STABILITY CLASS - E - 150 FT WINDS, (MAR) PERIOD 3/1/68 TO 3/31/69
 NUMBER OF HOURLY OBSERVATIONS

WIND SPEED (MPH)

WINDS FROM	1-3	4-7	8-12	13-18	19-24	25+	TOTAL
N	3	12	29	12	12	17	85
NNE	0	6	10	16	8	14	54
NE	0	3	6	12	5	1	27
ENE	0	1	1	0	0	0	2
E	0	0	3	0	0	0	3
ESE	1	0	1	0	1	0	3
SE	0	0	0	0	0	0	0
SSE	0	1	0	0	0	0	1
S	0	2	1	0	1	0	4
SSW	0	1	7	13	7	1	29
SW	0	3	8	12	4	0	27
WSW	0	4	3	6	1	0	14
W	1	3	11	19	9	0	43
WNW	0	1	6	6	0	0	13
NW	0	2	1	5	0	0	8
NNW	0	1	7	3	1	0	12
TOTAL	5	40	94	104	49	33	325
Number of calm hours							0
Number of variable directions							0
Total number of observations							325

Table I.4-33 (CONTINUED)

POINT BEACH WIND - STABILITY SUMMARY

STABILITY CLASS - F - 150 FT WINDS, (MAR) PERIOD 3/1/68 TO 3/31/69
 NUMBER OF HOURLY OBSERVATIONS

WIND SPEED (MPH)

WINDS FROM	1-3	4-7	8-12	13-18	19-24	25+	TOTAL
N	0	3	13	4	6	16	42
NNE	1	0	5	2	0	0	8
NE	0	0	1	1	0	0	2
ENE	0	0	0	0	0	0	0
E	0	0	0	0	0	0	0
ESE	0	0	1	0	0	0	1
SE	0	1	0	1	0	0	2
SSE	0	0	0	0	0	0	0
S	0	0	0	0	0	0	0
SSW	0	0	1	1	1	0	3
SW	0	0	4	3	0	0	7
WSW	0	2	4	1	0	0	7
W	0	1	4	1	0	0	6
WNW	0	0	3	1	0	0	4
NW	0	0	0	3	0	0	3
NNW	0	0	2	0	0	0	2
TOTAL	1	7	38	18	7	16	87
Number of calm hours			0				
Number of variable directions			0				
Total number of observations			87				

Table I.4-33 (CONTINUED)

POINT BEACH WIND - STABILITY SUMMARY

STABILITY CLASS - G - 150 FT WINDS, (MAR) PERIOD 3/1/68 TO 3/31/69
 NUMBER OF HOURLY OBSERVATIONS

WIND SPEED (MPH)

WINDS FROM	1-3	4-7	8-12	13-18	19-24	25+	TOTAL
N	0	2	2	0	0	1	5
NNE	0	0	0	0	0	0	0
NE	0	0	0	0	0	0	0
ENE	0	0	0	0	0	0	0
E	0	0	0	0	0	0	0
ESE	0	0	0	0	0	0	0
SE	0	0	1	0	0	0	1
SSE	0	0	0	0	0	0	0
S	0	0	0	0	0	0	0
SSW	0	0	0	0	0	0	0
SW	0	0	1	0	0	0	1
WSW	0	1	0	1	0	0	2
W	0	1	9	7	0	0	17
WNW	0	1	1	3	0	0	5
NW	0	1	0	4	0	0	5
NNW	0	1	1	1	0	0	3
TOTAL	0	7	15	16	0	1	39
Number of calm hours			0				
Number of variable directions			0				
Total number of observations			39				

Table I.4-33 (CONTINUED)

POINT BEACH WIND - STABILITY SUMMARY

STABILITY CLASS - ALL - 150 FT WINDS, (MAR) PERIOD 3/1/68 TO 3/31/69
 NUMBER OF HOURLY OBSERVATIONS

WIND SPEED (MPH)

WINDS FROM	1-3	4-7	8-12	13-18	19-24	25+	TOTAL
N	5	24	50	22	19	35	155
NNE	2	7	19	20	8	14	70
NE	0	4	11	13	5	1	34
ENE	0	2	1	0	0	0	3
E	0	3	5	0	0	1	9
ESE	1	0	2	0	2	0	5
SE	1	2	2	1	1	0	7
SSE	0	1	1	1	0	0	3
S	0	4	5	8	18	2	37
SSW	2	1	14	24	11	2	54
SW	0	6	25	23	4	0	58
WSW	2	7	15	12	2	0	38
W	1	8	35	39	11	0	94
WNW	1	13	26	57	8	0	105
NW	2	12	26	35	2	0	77
NNW	2	11	24	28	12	2	79
TOTAL	19	105	261	283	103	57	828
Number of calm hours							0
Number of variable directions							0
Total number of observations							828

Table I.4-33 (CONTINUED)

POINT BEACH WIND - STABILITY SUMMARY

STABILITY CLASS - B - 150 FT WINDS, (APR) PERIOD 4/19/67 TO 4/18/69
 NUMBER OF HOURLY OBSERVATIONS

WIND SPEED (MPH)

WINDS FROM	1-3	4-7	8-12	13-18	19-24	25+	TOTAL
N	0	0	0	0	0	0	0
NNE	0	0	0	0	0	0	0
NE	0	0	0	0	0	0	0
ENE	1	0	0	0	0	0	1
E	1	1	0	0	0	0	2
ESE	0	0	0	0	0	0	0
SE	0	0	0	0	0	0	0
SSE	1	0	0	0	0	0	1
S	0	0	0	0	0	0	0
SSW	0	0	1	0	0	0	1
SW	0	0	0	0	0	0	0
WSW	0	1	0	0	0	0	1
W	0	1	1	0	0	0	2
WNW	0	0	0	0	0	0	0
NW	0	0	1	0	0	0	1
NNW	1	0	0	1	0	0	2
TOTAL	4	3	3	1	0	0	11

Number of calm hours 0
 Number of variable directions 0
 Total number of observations 11

Table I.4-33 (CONTINUED)

POINT BEACH WIND - STABILITY SUMMARY

STABILITY CLASS - C - 150 FT WINDS, (APR) PERIOD 4/19/67 TO 4/18/69
 NUMBER OF HOURLY OBSERVATIONS

WIND SPEED (MPH)

WINDS FROM	1-3	4-7	8-12	13-18	19-24	25+	TOTAL
N	2	0	1	0	0	0	3
NNE	0	0	0	0	0	0	0
NE	1	3	0	0	0	0	4
ENE	0	1	0	0	0	0	1
E	2	4	0	0	0	0	6
ESE	4	3	0	0	0	0	7
SE	0	2	0	0	0	1	3
SSE	0	1	1	1	0	0	3
S	1	1	3	0	0	1	6
SSW	0	1	2	0	0	1	4
SW	1	1	1	0	0	0	3
WSW	0	2	0	0	0	0	2
W	0	2	4	1	0	0	7
WNW	0	1	4	10	6	0	21
NW	1	0	6	3	2	0	12
NNW	0	0	3	2	0	0	5
TOTAL	12	22	25	17	8	3	87
Number of calm hours			0				
Number of variable directions			0				
Total number of observations			87				

Table I.4-33 (CONTINUED)

POINT BEACH WIND - STABILITY SUMMARY

STABILITY CLASS - F - 150 FT WINDS, (APR) PERIOD 4/19/67 TO 4/18/69
 NUMBER OF HOURLY OBSERVATIONS

WIND SPEED (MPH)

WINDS FROM	1-3	4-7	8-12	13-18	19-24	25+	TOTAL
N	0	2	1	6	2	0	11
NNE	0	1	2	11	2	0	16
NE	1	2	1	6	0	1	11
ENE	0	0	0	1	0	0	1
E	1	1	1	0	1	3	7
ESE	1	0	1	0	0	0	2
SE	0	2	1	0	0	0	3
SSE	0	4	2	1	0	0	7
S	0	1	5	0	0	0	6
SSW	1	5	13	7	0	0	26
SW	1	3	11	7	2	0	24
WSW	0	0	3	2	0	0	5
W	0	0	2	0	0	0	2
WNW	0	0	1	0	0	0	1
NW	1	0	1	0	0	0	2
NNW	0	0	0	0	0	0	0
TOTAL	6	21	45	41	7	4	124
Number of calm hours							0
Number of variable directions							0
Total number of observations							124

Table I.4-33 (CONTINUED)

POINT BEACH WIND - STABILITY SUMMARY

STABILITY CLASS - G - 150 FT WINDS, (APR) PERIOD 4/19/67 TO 4/18/69
 NUMBER OF HOURLY OBSERVATIONS

WIND SPEED (MPH)

WINDS FROM	1-3	4-7	8-12	13-18	19-24	25+	TOTAL
N	1	3	19	27	2	0	52
NNE	0	0	0	0	0	0	0
NE	0	1	1	1	0	0	3
ENE	0	1	0	1	0	0	2
E	0	0	0	0	0	0	0
ESE	0	1	1	0	0	0	2
SE	0	1	0	1	0	0	2
SSE	0	0	0	0	0	0	0
S	0	0	1	0	0	0	1
SSW	1	2	9	0	0	0	12
SW	1	0	7	4	0	0	12
WSW	0	0	2	0	0	0	2
W	1	2	0	0	0	0	3
WNW	0	1	1	0	0	0	2
NW	0	0	0	0	0	0	0
NNW	0	0	1	0	0	0	1
TOTAL	4	12	42	34	2	0	94

Number of calm hours 0
 Number of variable directions 0
 Total number of observations 94

Table I.4-33 (CONTINUED)

POINT BEACH WIND - STABILITY SUMMARY

STABILITY CLASS - ALL - 150 FT WINDS, (APR) PERIOD 4/19/67 TO 4/18/69
 NUMBER OF HOURLY OBSERVATIONS

WIND SPEED (MPH)

WINDS FROM	1-3	4-7	8-12	13-18	19-24	25+	TOTAL
N	3	10	32	46	8	1	100
NNE	5	8	28	46	14	29	130
NE	5	26	25	35	2	12	105
ENE	6	8	8	5	0	0	27
E	8	18	5	1	1	3	36
ESE	11	11	9	1	10	2	44
SE	9	17	10	4	3	4	47
SSE	5	18	15	9	2	2	51
S	2	25	43	28	17	18	133
SSW	2	25	72	84	55	2	240
SW	6	12	26	15	8	2	69
WSW	3	6	11	9	2	1	32
W	4	10	20	12	12	11	69
WNW	0	4	8	23	13	6	54
NW	2	1	9	8	3	0	23
NNW	2	1	10	3	0	0	16
TOTAL	73	200	331	329	150	93	1176

Number of calm hours 5
 Number of variable directions 0
 Total number of observations 1181

Table I.4-33 (CONTINUED)

POINT BEACH WIND - STABILITY SUMMARY

STABILITY CLASS - A - 150 FT WINDS, (MAY) PERIOD 5/1/67 TO 5/31/68
 NUMBER OF HOURLY OBSERVATIONS

WIND SPEED (MPH)

WINDS FROM	1-3	4-7	8-12	13-18	19-24	25+	TOTAL
N	1	0	0	0	0	0	1
NNE	0	0	0	0	0	0	0
NE	1	0	0	0	0	0	1
ENE	0	1	0	0	0	0	1
E	0	0	0	0	0	0	0
ESE	0	0	0	0	0	0	0
SE	0	0	0	0	0	0	0
SSE	0	0	2	0	0	0	2
S	1	0	0	0	0	0	1
SSW	0	0	1	0	0	0	1
SW	0	0	0	0	0	0	0
WSW	1	0	0	0	0	0	1
W	1	0	0	0	0	0	1
WNW	0	0	3	0	0	0	3
NW	0	1	1	0	0	0	2
NNW	0	0	0	0	0	0	0
TOTAL	5	2	7	0	0	0	14

Number of calm hours 0
 Number of variable directions 0
 Total number of observations 14

Table I.4-33 (CONTINUED)

POINT BEACH WIND - STABILITY SUMMARY

STABILITY CLASS - B - 150 FT WINDS, (MAY) PERIOD 5/1/67 TO 5/31/68
 NUMBER OF HOURLY OBSERVATIONS

WIND SPEED (MPH)

WINDS FROM	1-3	4-7	8-12	13-18	19-24	25+	TOTAL
N	1	0	0	0	0	0	1
NNE	0	0	0	0	0	0	0
NE	1	2	0	0	0	0	3
ENE	0	1	0	0	0	0	1
E	0	3	0	0	0	0	3
ESE	0	1	0	0	0	0	1
SE	0	0	0	0	0	0	0
SSE	0	0	2	0	0	0	2
S	0	0	0	1	0	0	1
SSW	0	0	0	0	0	0	0
SW	0	0	0	1	0	0	1
WSW	1	0	0	0	0	0	1
W	0	0	1	0	0	0	1
WNW	1	0	2	2	0	0	5
NW	0	0	3	1	0	0	4
NNW	0	0	1	0	0	0	1
TOTAL	4	7	9	5	0	0	25
Number of calm hours			0				
Number of variable directions			0				
Total number of observations			25				

Table I.4-33 (CONTINUED)

POINT BEACH WIND - STABILITY SUMMARY

STABILITY CLASS - C - 150 FT WINDS, (MAY) PERIOD 5/1/67 TO 5/31/68
 NUMBER OF HOURLY OBSERVATIONS

WIND SPEED (MPH)

WINDS FROM	1-3	4-7	8-12	13-18	19-24	25+	TOTAL
N	0	0	1	0	0	0	1
NNE	0	1	0	0	1	1	3
NE	3	2	1	1	0	0	7
ENE	1	5	0	0	0	0	6
E	3	0	1	0	0	0	4
ESE	2	1	1	0	0	0	4
SE	1	2	2	0	0	0	5
SSE	2	0	1	0	1	0	4
S	0	0	0	1	2	2	5
SSW	0	0	4	1	1	1	7
SW	0	1	0	2	1	0	4
WSW	0	0	1	2	1	0	4
W	0	0	0	5	0	1	6
WNW	0	2	7	10	7	7	33
NW	0	2	3	14	3	1	23
NNW	0	2	1	1	0	0	4
TOTAL	12	18	23	37	17	13	120
Number of calm hours			0				
Number of variable directions			0				
Total number of observations			120				

Table I.4-33 (CONTINUED)

POINT BEACH WIND - STABILITY SUMMARY

STABILITY CLASS - D - 150 FT WINDS, (MAY) PERIOD 5/1/67 TO 5/31/68
 NUMBER OF HOURLY OBSERVATIONS

WIND SPEED (MPH)

WINDS FROM	1-3	4-7	8-12	13-18	19-24	25+	TOTAL
N	2	3	0	2	0	0	7
NNE	5	8	20	8	0	0	41
NE	4	22	19	5	0	0	50
ENE	6	7	5	1	0	0	19
E	5	11	1	0	0	0	17
ESE	5	7	2	1	0	0	15
SE	2	15	6	7	1	0	31
SSE	1	3	9	5	8	3	29
S	4	5	9	19	24	15	76
SSW	1	2	5	10	12	0	30
SW	0	1	2	3	5	2	13
WSW	0	1	0	9	2	0	12
W	0	2	3	12	5	3	25
WNW	0	0	7	8	6	4	25
NW	0	0	8	4	0	0	12
NNW	1	1	6	11	4	0	23
TOTAL	36	88	102	105	67	27	425
Number of calm hours							0
Number of variable directions							0
Total number of observations							425

Table I.4-33 (CONTINUED)

POINT BEACH WIND - STABILITY SUMMARY

STABILITY CLASS - E - 150 FT WINDS, (MAY) PERIOD 5/1/67 TO 5/31/68
 NUMBER OF HOURLY OBSERVATIONS

WIND SPEED (MPH)

WINDS FROM	1-3	4-7	8-12	13-18	19-24	25+	TOTAL
N	2	9	8	8	0	0	27
NNE	2	18	60	41	18	12	151
NE	0	17	27	41	18	5	108
ENE	5	9	11	9	8	1	43
E	4	6	5	1	6	0	22
ESE	0	5	7	3	7	0	22
SE	0	4	12	9	7	1	33
SSE	0	2	13	7	5	1	28
S	1	3	5	2	0	0	11
SSW	2	2	9	26	11	1	51
SW	1	1	8	5	1	1	17
WSW	0	3	2	5	1	0	11
W	0	3	6	8	2	1	20
WNW	0	1	2	3	0	0	6
NW	0	5	0	0	0	0	5
NNW	1	0	0	2	0	0	3
TOTAL	18	88	175	170	84	23	558
Number of calm hours							0
Number of variable directions							0
Total number of observations							558

Table I.4-33 (CONTINUED)

POINT BEACH WIND - STABILITY SUMMARY

STABILITY CLASS - F - 150 FT WINDS, (MAY) PERIOD 5/1/67 TO 5/31/68
 NUMBER OF HOURLY OBSERVATIONS

WIND SPEED (MPH)

WINDS FROM	1-3	4-7	8-12	13-18	19-24	25+	TOTAL
N	1	2	5	1	0	0	9
NNE	0	2	3	9	7	1	22
NE	0	3	1	4	5	1	14
ENE	0	1	1	0	2	2	6
E	1	0	0	3	0	0	4
ESE	0	0	0	0	1	0	1
SE	0	0	5	1	0	0	6
SSE	0	0	2	0	0	0	2
S	0	2	1	0	0	0	3
SSW	0	3	7	5	1	0	16
SW	0	1	4	6	0	0	11
WSW	0	0	3	0	0	0	3
W	0	1	9	3	0	0	13
WNW	0	1	6	0	0	0	7
NW	0	2	2	0	0	0	4
NNW	0	2	0	1	0	0	3
TOTAL	2	20	49	33	16	4	124
Number of calm hours							0
Number of variable directions							0
Total number of observations							124

Table I.4-33 (CONTINUED)

POINT BEACH WIND - STABILITY SUMMARY

STABILITY CLASS - G - 150 FT WINDS, (MAY) PERIOD 5/1/67 TO 5/31/68
 NUMBER OF HOURLY OBSERVATIONS

WIND SPEED (MPH)

WINDS FROM	1-3	4-7	8-12	13-18	19-24	25+	TOTAL
N	9	12	12	11	0	0	44
NNE	0	0	0	4	0	0	4
NE	0	3	0	1	0	0	4
ENE	0	1	0	0	1	1	3
E	0	2	2	3	0	0	7
ESE	1	0	0	0	0	0	1
SE	0	0	1	0	0	0	1
SSE	0	0	2	0	0	0	2
S	0	0	1	0	0	0	1
SSW	0	1	5	2	0	0	8
SW	0	1	9	7	0	0	17
WSW	0	0	1	3	0	0	4
W	0	0	1	6	0	0	7
WNW	0	3	0	0	0	0	3
NW	0	3	1	0	0	0	4
NNW	0	0	0	0	0	0	0
TOTAL	10	26	35	37	1	1	110
Number of calm hours							0
Number of variable directions							0
Total number of observations							110

Table I.4-33 (CONTINUED)

POINT BEACH WIND - STABILITY SUMMARY

STABILITY CLASS - ALL - 150 FT WINDS, (MAY) PERIOD 5/1/67 TO 5/31/68
 NUMBER OF HOURLY OBSERVATIONS

WIND SPEED (MPH)

WINDS FROM	1-3	4-7	8-12	13-18	19-24	25+	TOTAL
N	16	26	26	22	0	0	90
NNE	7	29	83	62	26	14	221
NE	9	49	48	52	23	6	187
ENE	12	25	17	10	11	4	79
E	13	22	9	7	6	0	57
ESE	8	14	10	4	8	0	44
SE	3	21	26	17	8	1	76
SSE	3	5	31	12	14	4	69
S	6	10	16	23	26	17	98
SSW	3	8	31	44	25	2	113
SW	1	5	23	24	7	3	63
WSW	2	4	7	19	4	0	36
W	1	6	20	34	7	5	73
WNW	1	7	27	23	13	11	82
NW	0	13	18	19	3	1	54
NNW	2	5	8	15	4	0	34
TOTAL	87	249	400	387	185	68	1376

Number of calm hours 0
 Number of variable directions 0
 Total number of observations 1376

Table I.4-33 (CONTINUED)

POINT BEACH WIND - STABILITY SUMMARY

STABILITY CLASS - A - 150 FT WINDS, (JUN) PERIOD 6/1/67 TO 6/30/68
 NUMBER OF HOURLY OBSERVATIONS

WIND SPEED (MPH)

WINDS FROM	1-3	4-7	8-12	13-18	19-24	25+	TOTAL
N	0	0	0	0	0	0	0
NNE	1	0	0	0	0	0	1
NE	1	0	0	0	0	0	1
ENE	1	0	0	0	0	0	1
E	1	0	0	0	0	0	1
ESE	0	0	0	0	0	0	0
SE	3	0	0	0	0	0	3
SSE	0	0	0	0	0	0	0
S	1	0	0	0	0	0	1
SSW	0	1	0	0	0	0	1
SW	0	2	0	0	0	0	2
WSW	0	0	1	1	0	0	2
W	2	0	1	0	0	0	3
WNW	0	0	0	1	0	0	1
NW	2	1	0	0	0	1	4
NNW	0	0	0	0	0	0	0
TOTAL	12	4	2	2	0	1	21

Number of calm hours 0
 Number of variable directions 0
 Total number of observations 21

Table I.4-33 (CONTINUED)

POINT BEACH WIND - STABILITY SUMMARY							
STABILITY CLASS - B - 150 FT WINDS, (JUN) PERIOD 6/1/67 TO 6/30/68							
NUMBER OF HOURLY OBSERVATIONS							
WIND SPEED (MPH)							
WINDS FROM	1-3	4-7	8-12	13-18	19-24	25+	TOTAL
N	1	1	0	0	0	0	2
NNE	1	1	0	0	0	0	2
NE	3	0	0	0	0	0	3
ENE	2	0	0	0	0	0	2
E	2	1	1	0	0	0	4
ESE	0	1	0	0	0	0	1
SE	3	1	1	0	0	0	5
SSE	1	4	1	0	0	0	6
S	3	5	2	3	0	0	13
SSW	1	4	4	1	0	0	10
SW	0	2	1	1	0	2	6
WSW	1	1	1	0	0	0	3
W	1	1	2	2	0	0	6
WNW	1	3	7	4	2	1	18
NW	0	2	5	3	1	0	11
NNW	1	0	0	1	0	0	2
TOTAL	21	27	25	15	3	3	94
Number of calm hours			2				
Number of variable directions			0				
Total number of observations			96				

Table I.4-33 (CONTINUED)

POINT BEACH WIND - STABILITY SUMMARY							
STABILITY CLASS - E - 150 FT WINDS, (JUN) PERIOD 6/1/67 TO 6/30/68							
NUMBER OF HOURLY OBSERVATIONS							
WIND SPEED (MPH)							
WINDS FROM	1-3	4-7	8-12	13-18	19-24	25+	TOTAL
N	1	2	4	4	0	0	11
NNE	1	9	30	14	9	10	73
NE	1	5	13	5	1	7	32
ENE	2	5	2	0	1	0	10
E	4	2	1	0	0	0	7
ESE	4	2	3	1	0	0	10
SE	0	5	8	1	0	0	14
SSE	2	6	6	2	0	0	16
S	2	4	7	3	0	0	16
SSW	2	8	30	44	3	1	88
SW	2	5	18	18	1	0	44
WSW	1	4	8	4	3	0	20
W	1	3	2	3	0	0	9
WNW	2	0	4	2	0	0	8
NW	1	1	2	0	0	0	4
NNW	1	0	8	0	1	0	10
TOTAL	27	61	146	101	19	18	372
Number of calm hours				3			
Number of variable directions				0			
Total number of observations				375			

Table I.4-33 (CONTINUED)

POINT BEACH WIND - STABILITY SUMMARY							
STABILITY CLASS - F - 150 FT WINDS, (JUN) PERIOD 6/1/67 TO 6/30/68							
NUMBER OF HOURLY OBSERVATIONS							
WIND SPEED (MPH)							
WINDS FROM	1-3	4-7	8-12	13-18	19-24	25+	TOTAL
N	1	6	6	4	0	0	17
NNE	1	4	17	12	7	4	45
NE	0	1	6	12	3	0	22
ENE	0	1	2	0	0	0	3
E	0	1	0	0	0	0	1
ESE	0	1	3	0	0	0	4
SE	0	3	3	0	0	0	6
SSE	2	3	3	0	0	0	8
S	0	0	1	0	0	0	1
SSW	1	3	3	6	0	0	13
SW	1	4	17	10	0	0	32
WSW	0	1	2	0	0	0	3
W	0	1	1	1	0	0	3
WNW	0	1	0	0	0	0	1
NW	0	0	0	0	0	0	0
NNW	0	0	0	0	0	0	0
TOTAL	6	30	64	45	10	4	159
Number of calm hours	0						
Number of variable directions	0						
Total number of observations	159						

Table I.4-33 (CONTINUED)

POINT BEACH WIND - STABILITY SUMMARY

STABILITY CLASS - G - 150 FT WINDS, (JUN) PERIOD 6/1/67 TO 6/30/68
 NUMBER OF HOURLY OBSERVATIONS

WIND SPEED (MPH)

WINDS FROM	1-3	4-7	8-12	13-18	19-24	25+	TOTAL
N	0	5	2	0	0	0	7
NNE	0	0	5	6	6	0	17
NE	0	3	4	4	2	0	13
ENE	1	0	0	0	0	0	1
E	0	0	1	0	0	0	1
ESE	0	5	0	0	0	0	5
SE	2	3	2	0	0	0	7
SSE	0	1	2	0	0	0	3
S	0	0	2	0	0	0	2
SSW	1	0	2	2	0	0	5
SW	0	2	4	5	0	0	11
WSW	1	0	2	0	0	0	3
W	0	0	2	0	0	0	2
WNW	0	1	0	0	0	0	1
NW	0	0	0	0	0	0	0
NNW	0	0	0	0	0	0	0
TOTAL	5	20	28	17	8	0	78

Number of calm hours 0
 Number of variable directions 0
 Total number of observations 78

Table I.4-33 (CONTINUED)

POINT BEACH WIND - STABILITY SUMMARY

STABILITY CLASS - A - 150 FT WINDS, (JUL) PERIOD 7/1/67 TO 7/31/68
 NUMBER OF HOURLY OBSERVATIONS

WIND SPEED (MPH)

WINDS FROM	1-3	4-7	8-12	13-18	19-24	25+	TOTAL
N	0	2	1	0	0	0	3
NNE	0	0	0	0	0	0	0
NE	1	0	0	0	0	0	1
ENE	0	0	0	0	0	0	0
E	2	0	0	0	0	0	2
ESE	0	0	0	0	0	0	0
SE	1	1	0	0	0	0	2
SSE	1	0	0	0	0	0	1
S	0	0	0	0	0	0	0
SSW	0	0	0	0	0	0	0
SW	2	1	0	0	0	1	4
WSW	0	2	0	0	0	0	2
W	0	1	0	0	0	0	1
WNW	0	1	0	0	0	0	1
NW	0	0	1	0	0	0	1
NNW	0	0	0	0	0	0	0
TOTAL	7	8	2	0	0	1	18

Number of calm hours 2
 Number of variable directions 0
 Total number of observations 20

Table I.4-33 (CONTINUED)

POINT BEACH WIND - STABILITY SUMMARY							
STABILITY CLASS - B - 150 FT WINDS, (JUL) PERIOD 7/1/67 TO 7/31/68							
NUMBER OF HOURLY OBSERVATIONS							
WIND SPEED (MPH)							
WINDS FROM	1-3	4-7	8-12	13-18	19-24	25+	TOTAL
N	1	0	0	0	0	0	1
NNE	0	0	0	0	0	0	0
NE	1	0	0	0	0	0	1
ENE	0	0	0	0	0	0	0
E	0	0	0	0	0	0	0
ESE	1	0	0	0	0	0	1
SE	0	0	0	0	0	0	0
SSE	3	0	0	0	0	0	3
S	0	0	3	0	0	0	3
SSW	0	0	1	0	0	0	1
SW	0	0	1	0	0	0	1
WSW	0	0	1	0	0	0	1
W	0	1	0	0	0	0	1
WNW	0	0	1	0	0	0	1
NW	0	1	4	3	0	0	8
NNW	0	0	0	0	0	0	0
TOTAL	6	2	11	3	0	0	22
Number of calm hours	3						
Number of variable directions	0						
Total number of observations	25						

Table I.4-33 (CONTINUED)

POINT BEACH WIND - STABILITY SUMMARY

STABILITY CLASS - C - 150 FT WINDS, (JUL) PERIOD 7/1/67 TO 7/31/68
 NUMBER OF HOURLY OBSERVATIONS

WIND SPEED (MPH)

WINDS FROM	1-3	4-7	8-12	13-18	19-24	25+	TOTAL
N	0	0	1	0	0	0	1
NNE	1	1	0	0	0	0	2
NE	1	0	1	0	0	0	2
ENE	0	0	0	0	0	0	0
E	0	1	0	0	0	0	1
ESE	0	0	0	0	0	0	0
SE	0	1	0	0	0	0	1
SSE	0	2	1	1	0	0	4
S	1	5	7	1	0	0	14
SSW	0	6	6	0	0	0	12
SW	1	5	3	0	0	0	9
WSW	1	1	4	1	0	0	7
W	0	1	4	3	1	0	9
WNW	0	0	10	9	2	0	21
NW	0	1	15	13	0	0	29
NNW	1	2	7	2	0	0	12
TOTAL	6	26	59	30	3	0	124

Number of calm hours 8
 Number of variable directions 0
 Total number of observations 132

Table I.4-33 (CONTINUED)

POINT BEACH WIND - STABILITY SUMMARY							
STABILITY CLASS - D - 150 FT WINDS, (JUL) PERIOD 7/1/67 TO 7/31/68							
NUMBER OF HOURLY OBSERVATIONS							
WIND SPEED (MPH)							
WINDS FROM	1-3	4-7	8-12	13-18	19-24	25+	TOTAL
N	1	1	3	0	1	0	6
NNE	0	6	0	0	0	0	6
NE	2	8	2	0	0	0	12
ENE	3	3	0	0	0	0	6
E	3	3	1	0	0	0	7
ESE	6	1	0	0	0	0	7
SE	7	2	0	0	0	0	9
SSE	3	6	12	0	0	0	21
S	5	13	23	11	5	2	59
SSW	3	7	40	41	9	1	101
SW	5	5	9	12	1	0	32
WSW	2	3	9	4	1	2	21
W	1	3	8	12	4	2	30
WNW	0	2	14	7	0	1	24
NW	2	0	8	0	0	0	10
NNW	1	4	24	12	0	0	41
TOTAL	44	67	153	99	21	8	392
Number of calm hours			8				
Number of variable directions			0				
Total number of observations			400				

Table I.4-33 (CONTINUED)

POINT BEACH WIND - STABILITY SUMMARY							
STABILITY CLASS - E - 150 FT WINDS, (JUL) PERIOD 7/1/67 TO 7/31/68							
NUMBER OF HOURLY OBSERVATIONS							
WIND SPEED (MPH)							
WINDS FROM	1-3	4-7	8-12	13-18	19-24	25+	TOTAL
N	2	8	8	1	1	0	20
NNE	3	11	14	6	0	0	34
NE	4	11	3	2	0	0	20
ENE	1	4	0	0	0	0	5
E	3	5	2	0	0	0	10
ESE	1	5	0	0	0	0	6
SE	3	4	2	1	0	0	10
SSE	2	6	10	2	0	0	20
S	2	15	6	4	0	0	27
SSW	5	11	56	59	3	0	134
SW	3	13	19	8	0	0	43
WSW	1	4	11	8	0	0	24
W	0	5	8	7	0	0	20
WNW	2	1	6	4	0	0	13
NW	0	3	5	1	0	0	9
NNW	0	2	9	1	0	0	12
TOTAL	32	108	159	104	4	0	407
Number of calm hours			5				
Number of variable directions			0				
Total number of observations			412				

Table I.4-33 (CONTINUED)

POINT BEACH WIND - STABILITY SUMMARY							
STABILITY CLASS - F - 150 FT WINDS, (JUL) PERIOD 7/1/67 TO 7/31/68							
NUMBER OF HOURLY OBSERVATIONS							
WIND SPEED (MPH)							
WINDS FROM	1-3	4-7	8-12	13-18	19-24	25+	TOTAL
N	3	4	10	5	0	0	22
NNE	1	5	8	2	3	0	19
NE	1	4	9	1	1	0	16
ENE	4	3	6	1	0	0	14
E	1	5	0	0	0	0	6
ESE	1	3	1	0	0	0	5
SE	1	7	3	1	0	0	12
SSE	1	2	6	0	0	0	9
S	2	2	2	0	0	0	6
SSW	0	6	17	8	0	0	31
SW	0	7	27	12	0	0	46
WSW	0	2	6	4	0	0	12
W	0	0	4	3	0	0	7
WNW	1	3	2	1	0	0	7
NW	0	2	1	1	0	0	4
NNW	0	1	0	1	0	0	2
TOTAL	16	56	102	40	4	0	218
Number of calm hours			1				
Number of variable directions			0				
Total number of observations			219				

Sheet 54 of 96

Table I.4-33 (CONTINUED)

POINT BEACH WIND - STABILITY SUMMARY							
STABILITY CLASS - G - 150 FT WINDS, (JUL) PERIOD 7/1/67 TO 7/31/68							
NUMBER OF HOURLY OBSERVATIONS							
WIND SPEED (MPH)							
WINDS FROM	1-3	4-7	8-12	13-18	19-24	25+	TOTAL
N	1	5	1	0	0	0	7
NNE	0	3	9	4	1	0	17
NE	0	6	7	0	0	0	13
ENE	1	4	2	3	1	0	11
E	0	2	2	0	0	0	4
ESE	0	4	1	0	0	0	5
SE	3	10	11	1	0	0	25
SSE	1	3	7	0	0	0	11
S	3	0	0	0	0	0	3
SSW	0	9	14	5	0	0	28
SW	0	4	22	5	0	0	31
WSW	0	1	5	1	0	0	7
W	0	2	5	1	0	0	8
WNW	2	5	0	1	0	0	8
NW	0	0	3	1	0	0	4
NNW	0	1	0	0	0	0	1
TOTAL	11	59	89	22	2	0	183
Number of calm hours			2				
Number of variable directions			0				
Total number of observations			185				

Table I.4-33 (CONTINUED)

POINT BEACH WIND - STABILITY SUMMARY							
STABILITY CLASS - ALL - 150 FT WINDS, (JUL) PERIOD 7/1/67 TO 7/31/68							
NUMBER OF HOURLY OBSERVATIONS							
WIND SPEED (MPH)							
WINDS FROM	1-3	4-7	8-12	13-18	19-24	25+	TOTAL
N	8	20	24	6	2	0	60
NNE	5	26	31	12	4	0	78
NE	10	29	22	3	1	0	65
ENE	9	14	8	4	1	0	36
E	9	16	5	0	0	0	30
ESE	9	13	2	0	0	0	24
SE	15	25	16	3	0	0	59
SSE	11	19	36	3	0	0	69
S	13	35	41	16	5	2	112
SSW	8	39	134	113	12	1	307
SW	11	35	81	37	1	1	166
WSW	4	13	36	18	1	2	74
W	1	13	29	26	5	2	76
WNW	5	12	33	22	2	1	75
NW	2	7	37	19	0	0	65
NNW	2	10	40	16	0	0	68
TOTAL	122	326	575	298	34	9	1364
Number of calm hours			29				
Number of variable directions			0				
Total number of observations			1393				

Table I.4-33 (CONTINUED)

POINT BEACH WIND - STABILITY SUMMARY

STABILITY CLASS - A - 150 FT WINDS, (AUG) PERIOD 8/1/67 TO 8/31/68
 NUMBER OF HOURLY OBSERVATIONS

WIND SPEED (MPH)

WINDS FROM	1-3	4-7	8-12	13-18	19-24	25+	TOTAL
N	1	0	0	0	0	0	1
NNE	0	0	0	0	0	0	0
NE	0	0	0	0	0	0	0
ENE	0	0	0	0	0	0	0
E	0	0	0	0	0	0	0
ESE	0	0	0	0	0	0	0
SE	1	0	0	0	0	0	1
SSE	0	0	0	0	0	0	0
S	0	0	0	0	0	0	0
SSW	0	0	0	1	0	0	1
SW	0	1	0	0	0	0	1
WSW	0	1	0	1	0	0	2
W	1	1	0	0	0	0	2
WNW	1	0	0	0	0	0	1
NW	0	0	0	0	0	0	0
NNW	0	0	0	0	0	0	0
TOTAL	4	3	0	2	0	0	9

Number of calm hours 3
 Number of variable directions 0
 Total number of observations 12

Table I.4-33 (CONTINUED)

POINT BEACH WIND - STABILITY SUMMARY							
STABILITY CLASS - B - 150 FT WINDS, (AUG) PERIOD 8/1/67 TO 8/31/68							
NUMBER OF HOURLY OBSERVATIONS							
WIND SPEED (MPH)							
WINDS FROM	1-3	4-7	8-12	13-18	19-24	25+	TOTAL
N	0	0	0	0	0	0	0
NNE	0	0	0	0	0	0	0
NE	0	0	0	0	0	0	0
ENE	0	0	0	0	0	0	0
E	0	0	0	0	0	0	0
ESE	0	0	0	0	0	0	0
SE	0	1	0	0	0	0	1
SSE	2	1	0	0	0	0	3
S	0	1	1	0	0	0	2
SSW	1	0	2	0	0	0	3
SW	1	2	2	0	0	0	5
WSW	0	1	0	0	0	0	1
W	0	0	1	1	0	0	2
WNW	0	2	2	0	0	0	4
NW	0	0	3	1	0	0	4
NNW	0	2	1	0	0	0	3
TOTAL	4	10	12	2	0	0	28
Number of calm hours			2				
Number of variable directions			0				
Total number of observations			30				

Table I.4-33 (CONTINUED)

POINT BEACH WIND - STABILITY SUMMARY							
STABILITY CLASS - C - 150 FT WINDS, (AUG) PERIOD 8/1/67 TO 8/31/68							
NUMBER OF HOURLY OBSERVATIONS							
WIND SPEED (MPH)							
WINDS FROM	1-3	4-7	8-12	13-18	19-24	25+	TOTAL
N	0	0	1	0	0	0	1
NNE	0	0	0	0	0	0	0
NE	1	2	0	1	0	0	4
ENE	0	0	0	0	0	0	0
E	0	1	0	0	0	0	1
ESE	1	2	0	0	0	0	3
SE	1	1	0	0	0	0	2
SSE	0	1	0	1	0	0	2
S	1	3	14	0	1	1	20
SSW	0	1	2	0	0	0	3
SW	0	1	1	1	0	0	3
WSW	0	0	5	0	0	1	6
W	2	2	4	0	1	0	9
WNW	1	1	9	8	1	0	20
NW	0	1	7	6	0	0	14
NNW	0	0	1	3	0	0	4
TOTAL	7	16	44	20	3	2	92
Number of calm hours			2				
Number of variable directions			0				
Total number of observations			94				

Table I.4-33 (CONTINUED)

POINT BEACH WIND - STABILITY SUMMARY							
STABILITY CLASS - E - 150 FT WINDS, (AUG) PERIOD 8/1/67 TO 8/31/68							
NUMBER OF HOURLY OBSERVATIONS							
WIND SPEED (MPH)							
WINDS FROM	1-3	4-7	8-12	13-18	19-24	25+	TOTAL
N	2	5	34	22	8	0	71
NNE	2	4	8	14	19	5	52
NE	1	6	21	4	0	0	32
ENE	2	9	12	1	0	0	24
E	6	14	7	0	0	0	27
ESE	4	14	0	0	0	0	18
SE	4	6	5	0	0	0	15
SSE	1	9	11	8	0	0	29
S	7	1	8	0	0	0	16
SSW	3	10	42	34	0	0	89
SW	1	11	28	14	1	0	55
WSW	0	3	17	17	0	0	37
W	0	4	7	5	0	0	16
WNW	1	2	2	0	0	0	5
NW	0	2	2	0	1	0	5
NNW	2	2	4	1	0	0	9
TOTAL	36	102	208	120	29	5	500
Number of calm hours			2				
Number of variable directions			0				
Total number of observations			502				

Sheet 61 of 96

Table I.4-33 (CONTINUED)

POINT BEACH WIND - STABILITY SUMMARY							
STABILITY CLASS - F - 150 FT WINDS, (AUG) PERIOD 8/1/67 TO 8/31/68							
NUMBER OF HOURLY OBSERVATIONS							
WIND SPEED (MPH)							
WINDS FROM	1-3	4-7	8-12	13-18	19-24	25+	TOTAL
N	1	5	25	25	8	0	64
NNE	0	2	6	5	1	0	14
NE	0	1	8	3	1	0	13
ENE	3	3	3	1	0	0	10
E	2	6	0	0	0	0	8
ESE	5	4	2	0	0	0	11
SE	1	7	6	0	0	0	14
SSE	2	2	4	1	0	0	9
S	4	4	0	0	0	0	8
SSW	3	3	17	5	0	0	28
SW	2	12	25	6	0	0	45
WSW	0	0	8	4	0	0	12
W	0	1	2	1	0	0	4
WNW	1	2	0	0	0	0	3
NW	1	1	4	1	0	0	7
NNW	0	0	0	0	0	0	0
TOTAL	25	53	110	52	10	0	250
Number of calm hours			0				
Number of variable directions			0				
Total number of observations			250				

Sheet 62 of 96

Table I.4-33 (CONTINUED)

POINT BEACH WIND - STABILITY SUMMARY							
STABILITY CLASS - G - 150 FT WINDS, (AUG) PERIOD 8/1/67 TO 8/31/68							
NUMBER OF HOURLY OBSERVATIONS							
WIND SPEED (MPH)							
WINDS FROM	1-3	4-7	8-12	13-18	19-24	25+	TOTAL
N	0	3	7	4	1	0	15
NNE	0	3	2	2	0	0	7
NE	1	0	1	0	0	0	2
ENE	0	0	0	0	0	0	0
E	1	2	0	0	0	0	3
ESE	1	2	0	0	0	0	3
SE	3	3	1	0	0	0	7
SSE	3	1	3	2	0	0	9
S	1	1	0	1	0	0	3
SSW	3	12	11	2	0	0	28
SW	1	15	24	1	0	0	41
WSW	1	3	6	6	0	0	16
W	1	3	4	7	0	0	15
WNW	1	4	2	1	0	0	8
NW	0	0	0	1	0	0	1
NNW	0	0	4	0	0	0	4
TOTAL	17	52	65	27	1	0	162
Number of calm hours			3				
Number of variable directions			0				
Total number of observations			165				

Table I.4-33 (CONTINUED)

POINT BEACH WIND - STABILITY SUMMARY							
STABILITY CLASS - ALL - 150 FT WINDS, (AUG) PERIOD 8/1/67 TO 8/31/68							
NUMBER OF HOURLY OBSERVATIONS							
WIND SPEED (MPH)							
WINDS FROM	1-3	4-7	8-12	13-18	19-24	25+	TOTAL
N	4	14	73	57	18	0	166
NNE	2	12	18	21	20	6	79
NE	4	10	30	8	1	0	53
ENE	8	16	15	2	0	0	41
E	16	27	9	0	0	0	52
ESE	17	22	2	0	0	0	41
SE	14	20	13	0	0	0	47
SSE	8	21	28	19	0	0	76
S	15	17	56	22	2	1	113
SSW	12	30	101	76	6	0	225
SW	8	49	85	34	2	1	179
WSW	1	13	49	46	14	4	127
W	4	15	23	17	3	1	63
WNW	6	15	21	10	1	0	53
NW	3	7	23	16	1	0	50
NNW	2	7	23	8	1	0	41
TOTAL	124	295	569	336	69	13	1406
Number of calm hours			14				
Number of variable directions			0				
Total number of observations			1420				

Sheet 64 of 96

Table I.4-33 (CONTINUED)

POINT BEACH WIND - STABILITY SUMMARY

STABILITY CLASS - A - 150 FT WINDS, (SEP) PERIOD 9/1/67 TO 9/30/68
 NUMBER OF HOURLY OBSERVATIONS

WIND SPEED (MPH)

WINDS FROM	1-3	4-7	8-12	13-18	19-24	25+	TOTAL
N	0	0	0	0	0	0	0
NNE	1	0	0	0	0	0	1
NE	0	0	0	0	0	0	0
ENE	0	0	0	0	0	0	0
E	0	0	0	0	0	0	0
ESE	0	0	0	0	0	0	0
SE	0	0	0	0	0	0	0
SSE	0	0	0	0	0	0	0
S	1	0	0	0	0	0	1
SSW	0	0	1	0	0	0	1
SW	0	0	0	0	0	0	0
WSW	0	0	0	0	0	0	0
W	0	1	0	0	0	0	1
WNW	1	1	0	0	0	0	2
NW	0	0	2	0	0	0	2
NNW	0	1	0	0	0	0	1
TOTAL	3	3	3	0	0	0	9

Number of calm hours 1
 Number of variable directions 0
 Total number of observations 10

Table I.4-33 (CONTINUED)

POINT BEACH WIND - STABILITY SUMMARY							
STABILITY CLASS - B - 150 FT WINDS, (SEP) PERIOD 9/1/67 TO 9/30/68							
NUMBER OF HOURLY OBSERVATIONS							
WIND SPEED (MPH)							
WINDS FROM	1-3	4-7	8-12	13-18	19-24	25+	TOTAL
N	0	1	0	0	0	0	1
NNE	0	0	0	0	0	0	0
NE	1	0	0	0	0	0	1
ENE	1	0	0	0	0	0	1
E	0	0	0	0	0	0	0
ESE	1	0	0	0	0	0	1
SE	1	0	0	0	0	0	1
SSE	1	0	0	0	0	0	1
S	1	2	0	0	0	0	3
SSW	1	0	0	0	0	0	1
SW	0	0	0	1	0	0	1
WSW	0	0	0	1	0	0	1
W	0	3	0	0	0	0	3
WNW	0	4	0	0	0	0	4
NW	1	2	2	0	0	0	5
NNW	0	0	0	0	0	0	0
TOTAL	8	12	2	2	0	0	24
Number of calm hours			2				
Number of variable directions			0				
Total number of observations			26				

Table I.4-33 (CONTINUED)

POINT BEACH WIND - STABILITY SUMMARY							
STABILITY CLASS - C - 150 FT WINDS, (SEP) PERIOD 9/1/67 TO 9/30/68							
NUMBER OF HOURLY OBSERVATIONS							
WIND SPEED (MPH)							
WINDS FROM	1-3	4-7	8-12	13-18	19-24	25+	TOTAL
N	0	2	0	1	0	0	3
NNE	0	0	0	0	0	0	0
NE	0	1	0	0	0	0	1
ENE	1	0	0	0	0	0	1
E	4	1	0	0	0	0	5
ESE	2	0	0	0	0	0	2
SE	0	0	0	0	0	0	0
SSE	0	0	0	1	0	0	1
S	2	2	12	4	0	0	20
SSW	0	0	2	1	0	0	3
SW	3	0	3	0	0	0	6
WSW	0	0	0	0	0	0	0
W	0	4	4	0	0	0	8
WNW	0	2	8	17	4	0	31
NW	1	7	18	4	0	0	30
NNW	0	5	5	0	0	0	10
TOTAL	13	24	52	28	4	0	121
Number of calm hours			3				
Number of variable directions			0				
Total number of observations			124				

Sheet 67 of 96

Table I.4-33 (CONTINUED)

POINT BEACH WIND - STABILITY SUMMARY							
STABILITY CLASS - D - 150 FT WINDS, (SEP) PERIOD 9/1/67 TO 9/30/68							
NUMBER OF HOURLY OBSERVATIONS							
WIND SPEED (MPH)							
WINDS FROM	1-3	4-7	8-12	13-18	19-24	25+	TOTAL
N	1	0	4	14	2	0	21
NNE	3	2	3	9	10	0	27
NE	2	5	2	4	4	0	17
ENE	2	5	0	1	0	0	8
E	5	7	4	0	0	0	16
ESE	3	3	2	0	0	0	8
SE	2	3	0	1	0	0	6
SSE	2	6	9	7	6	0	30
S	3	16	56	49	11	1	136
SSW	0	4	40	14	10	1	69
SW	1	0	3	12	3	0	19
WSW	3	3	9	10	3	1	29
W	1	2	0	8	6	1	18
WNW	0	6	9	4	0	0	19
NW	0	7	15	0	0	0	22
NNW	0	6	9	10	1	0	26
TOTAL	28	75	165	143	56	4	471
Number of calm hours	6						
Number of variable directions	0						
Total number of observations	477						

Sheet 68 of 96

Table I.4-33 (CONTINUED)

POINT BEACH WIND - STABILITY SUMMARY							
STABILITY CLASS - E - 150 FT WINDS, (SEP) PERIOD 9/1/67 TO 9/30/68							
NUMBER OF HOURLY OBSERVATIONS							
WIND SPEED (MPH)							
WINDS FROM	1-3	4-7	8-12	13-18	19-24	25+	TOTAL
N	0	0	14	36	9	2	61
NNE	0	2	1	8	8	3	22
NE	1	1	0	0	3	0	5
ENE	4	2	2	1	0	0	9
E	5	7	0	1	0	0	13
ESE	5	8	2	0	0	0	15
SE	7	10	1	2	1	0	21
SSE	4	5	13	14	10	0	46
S	3	5	13	6	1	0	28
SSW	5	7	33	13	0	0	58
SW	4	9	21	5	3	0	42
WSW	0	6	15	4	0	0	25
W	0	5	6	7	0	0	18
WNW	1	4	3	0	0	0	8
NW	0	1	3	3	0	0	7
NNW	0	1	4	3	0	0	8
TOTAL	39	73	131	103	35	5	386
Number of calm hours			9				
Number of variable directions			0				
Total number of observations			395				

Sheet 69 of 96

Table I.4-33 (CONTINUED)

POINT BEACH WIND - STABILITY SUMMARY							
STABILITY CLASS - F - 150 FT WINDS, (SEP) PERIOD 9/1/67 TO 9/30/68							
NUMBER OF HOURLY OBSERVATIONS							
WIND SPEED (MPH)							
WINDS FROM	1-3	4-7	8-12	13-18	19-24	25+	TOTAL
N	2	4	4	19	1	0	30
NNE	0	0	2	0	0	0	2
NE	1	1	0	0	0	0	2
ENE	0	4	0	0	0	0	4
E	6	1	0	0	0	0	7
ESE	4	5	1	0	1	0	11
SE	1	7	4	8	2	0	22
SSE	2	5	4	3	1	0	15
S	2	5	1	0	0	0	8
SSW	5	5	5	0	0	0	15
SW	2	6	19	4	0	0	31
WSW	1	1	4	3	0	0	9
W	1	2	8	7	0	0	18
WNW	0	5	9	3	0	0	17
NW	1	1	1	3	0	0	6
NNW	0	0	1	0	0	0	1
TOTAL	28	52	63	50	5	0	198
Number of calm hours				2			
Number of variable directions				0			
Total number of observations				200			

Table I.4-33 (CONTINUED)

POINT BEACH WIND - STABILITY SUMMARY

STABILITY CLASS - ALL - 150 FT WINDS, (SEP) PERIOD 9/1/67 TO 9/30/68
 NUMBER OF HOURLY OBSERVATIONS

WINDS FROM	WIND SPEED (MPH)						TOTAL
	1-3	4-7	8-12	13-18	19-24	25+	
N	5	10	22	70	12	2	121
NNE	4	4	6	17	18	3	52
NE	6	8	2	4	7	0	27
ENE	8	13	2	2	0	0	25
E	24	17	5	1	0	0	47
ESE	15	18	5	0	1	0	39
SE	12	30	6	11	3	0	62
SSE	9	18	28	25	17	0	97
S	13	34	83	59	12	1	202
SSW	13	25	83	28	10	1	160
SW	10	26	62	25	6	0	129
WSW	4	14	38	20	3	1	80
W	2	22	35	33	6	1	99
WNW	3	22	35	27	4	0	91
NW	3	18	41	13	0	0	75
NNW	0	13	19	13	1	0	46
TOTAL	131	292	472	348	100	9	1352

Number of calm hours 25
 Number of variable directions 0
 Total number of observations 1377

Table I.4-33 (CONTINUED)

POINT BEACH WIND - STABILITY SUMMARY							
STABILITY CLASS - A - 150 FT WINDS, (OCT) PERIOD 10/1/67 TO 10/31/68							
NUMBER OF HOURLY OBSERVATIONS							
WIND SPEED (MPH)							
WINDS FROM	1-3	4-7	8-12	13-18	19-24	25+	TOTAL
N	0	0	0	0	0	0	0
NNE	0	0	0	0	0	0	0
NE	0	0	0	0	0	0	0
ENE	0	0	0	0	0	0	0
E	0	0	0	0	0	0	0
ESE	0	0	0	0	0	0	0
SE	1	0	0	0	0	0	1
SSE	0	0	0	0	0	0	0
S	0	0	0	0	0	0	0
SSW	0	1	0	0	0	0	1
SW	1	0	0	0	0	0	1
WSW	0	0	0	0	0	0	0
W	0	0	0	0	0	0	0
WNW	0	0	1	0	0	0	1
NW	1	0	2	0	0	0	3
NNW	1	0	0	0	0	0	1
TOTAL	4	1	3	0	0	0	8
Number of calm hours	0						
Number of variable directions	0						
Total number of observations	8						

Table I.4-33 (CONTINUED)

POINT BEACH WIND - STABILITY SUMMARY

STABILITY CLASS - B - 150 FT WINDS, (OCT) PERIOD 10/1/67 TO 10/31/68
 NUMBER OF HOURLY OBSERVATIONS

WIND SPEED (MPH)

WINDS FROM	1-3	4-7	8-12	13-18	19-24	25+	TOTAL
N	0	0	0	0	0	0	0
NNE	0	0	0	0	0	0	0
NE	0	0	0	0	0	0	0
ENE	0	0	0	0	0	0	0
E	0	0	0	0	0	0	0
ESE	0	0	0	0	0	0	0
SE	0	0	0	0	0	0	0
SSE	1	0	0	0	0	0	1
S	0	0	0	0	0	0	0
SSW	1	0	1	0	0	0	2
SW	0	0	0	0	0	0	0
WSW	0	0	0	0	0	0	0
W	2	0	0	0	0	0	2
WNW	0	0	3	1	0	0	4
NW	1	0	0	2	1	0	4
NNW	0	1	1	0	0	0	2
TOTAL	5	1	5	3	1	0	15

Number of calm hours 0
 Number of variable directions 0
 Total number of observations 15

Table I.4-33 (CONTINUED)

POINT BEACH WIND - STABILITY SUMMARY							
STABILITY CLASS - C - 150 FT WINDS, (OCT) PERIOD 10/1/67 TO 10/31/68							
NUMBER OF HOURLY OBSERVATIONS							
WIND SPEED (MPH)							
WINDS FROM	1-3	4-7	8-12	13-18	19-24	25+	TOTAL
N	0	0	1	0	0	0	1
NNE	0	0	0	0	0	0	0
NE	0	0	0	0	0	0	0
ENE	0	0	0	0	0	0	0
E	2	0	0	0	0	0	2
ESE	0	0	0	0	0	0	0
SE	0	0	0	0	0	0	0
SSE	1	0	0	0	0	1	2
S	1	0	3	3	0	0	7
SSW	0	2	6	0	0	0	8
SW	2	1	2	2	0	0	7
WSW	1	1	0	0	0	0	2
W	0	3	8	2	1	1	15
WNW	2	1	16	20	13	3	55
NW	0	6	16	13	2	0	37
NNW	1	1	4	3	0	0	9
TOTAL	10	15	56	43	16	5	145
Number of calm hours			2				
Number of variable directions			0				
Total number of observations			147				

Sheet 75 of 96

Table I.4-33 (CONTINUED)

POINT BEACH WIND - STABILITY SUMMARY							
STABILITY CLASS - D - 150 FT WINDS, (OCT) PERIOD 10/1/67 TO 10/31/68							
NUMBER OF HOURLY OBSERVATIONS							
WIND SPEED (MPH)							
WINDS FROM	1-3	4-7	8-12	13-18	19-24	25+	TOTAL
N	1	1	5	4	2	1	14
NNE	0	1	0	0	0	0	1
NE	1	0	0	3	1	0	5
ENE	0	0	0	3	0	0	3
E	1	0	0	0	0	0	1
ESE	1	0	0	0	0	0	1
SE	1	0	2	4	1	0	8
SSE	1	2	3	9	13	6	34
S	2	7	27	66	42	22	166
SSW	2	2	20	40	44	12	120
SW	0	4	6	7	4	0	21
WSW	2	1	4	14	7	0	28
W	1	7	13	30	20	19	90
WNW	1	8	35	22	8	3	77
NW	1	8	15	8	0	0	32
NNW	0	11	12	12	6	0	41
TOTAL	15	52	142	222	148	63	642
Number of calm hours			1				
Number of variable directions			0				
Total number of observations			643				

Sheet 76 of 96

Table I.4-33 (CONTINUED)

POINT BEACH WIND - STABILITY SUMMARY							
STABILITY CLASS - E - 150 FT WINDS, (OCT) PERIOD 10/1/67 TO 10/31/68							
NUMBER OF HOURLY OBSERVATIONS							
WIND SPEED (MPH)							
WINDS FROM	1-3	4-7	8-12	13-18	19-24	25+	TOTAL
N	0	3	17	18	7	8	53
NNE	1	1	18	6	0	0	26
NE	1	2	9	14	4	0	30
ENE	1	1	1	3	2	0	8
E	2	0	0	0	1	0	3
ESE	1	0	0	2	2	1	6
SE	0	1	0	8	5	2	16
SSE	0	3	3	7	7	0	20
S	0	8	23	8	1	0	40
SSW	0	1	27	75	26	2	131
SW	0	5	17	13	0	0	35
WSW	1	2	4	5	0	0	12
W	0	4	13	13	2	2	34
WNW	0	3	15	2	0	0	20
NW	1	0	11	0	0	0	12
NNW	1	1	12	4	0	0	18
TOTAL	9	35	170	178	57	15	464
Number of calm hours			2				
Number of variable directions			0				
Total number of observations			466				

Sheet 77 of 96

Table I.4-33 (CONTINUED)

POINT BEACH WIND - STABILITY SUMMARY							
STABILITY CLASS - F - 150 FT WINDS, (OCT) PERIOD 10/1/67 TO 10/31/68							
NUMBER OF HOURLY OBSERVATIONS							
WIND SPEED (MPH)							
WINDS FROM	1-3	4-7	8-12	13-18	19-24	25+	TOTAL
N	0	0	14	11	4	2	31
NNE	0	0	2	3	0	0	5
NE	0	2	0	1	0	0	3
ENE	0	1	1	0	0	0	2
E	0	2	0	0	0	0	2
ESE	0	1	0	0	0	0	1
SE	0	4	1	0	0	0	5
SSE	0	1	1	1	0	0	3
S	0	2	2	0	1	0	5
SSW	1	0	11	4	0	0	16
SW	0	3	12	2	0	0	17
WSW	2	2	6	2	0	0	12
W	0	0	10	2	0	0	12
WNW	0	0	7	2	0	0	9
NW	1	1	2	0	0	0	4
NNW	0	0	0	0	0	0	0
TOTAL	4	19	69	28	5	2	127
Number of calm hours	0						
Number of variable directions	0						
Total number of observations	127						

Table I.4-33 (CONTINUED)

POINT BEACH WIND - STABILITY SUMMARY							
STABILITY CLASS - G - 150 FT WINDS, (OCT) PERIOD 10/1/67 TO 10/31/68							
NUMBER OF HOURLY OBSERVATIONS							
WIND SPEED (MPH)							
WINDS FROM	1-3	4-7	8-12	13-18	19-24	25+	TOTAL
N	3	4	0	1	0	0	8
NNE	0	0	1	2	0	0	3
NE	0	0	0	0	0	0	0
ENE	0	0	0	0	0	0	0
E	0	0	0	0	0	0	0
ESE	0	0	0	0	0	0	0
SE	1	3	0	0	0	0	4
SSE	0	0	1	1	0	0	2
S	0	2	1	0	0	0	3
SSW	1	2	4	0	0	0	7
SW	1	5	15	0	0	0	21
WSW	0	0	7	1	0	0	8
W	0	2	5	0	0	0	7
WNW	1	2	5	0	0	0	8
NW	0	3	2	0	0	0	5
NNW	0	0	0	0	0	0	0
TOTAL	7	23	41	5	0	0	76
Number of calm hours			2				
Number of variable directions			0				
Total number of observations			78				

Sheet 79 of 96

Table I.4-33 (CONTINUED)

POINT BEACH WIND - STABILITY SUMMARY

STABILITY CLASS - A - 150 FT WINDS, (NOV) PERIOD 11/1/67 TO 11/30/68
 NUMBER OF HOURLY OBSERVATIONS

WIND SPEED (MPH)

WINDS FROM	1-3	4-7	8-12	13-18	19-24	25+	TOTAL
N	1	0	0	0	0	0	1
NNE	0	0	0	0	0	0	0
NE	1	0	0	0	0	0	1
ENE	0	0	0	0	0	0	0
E	0	0	0	0	0	0	0
ESE	0	0	0	0	0	0	0
SE	0	0	0	0	0	0	0
SSE	0	0	0	0	0	0	0
S	0	0	0	0	0	0	0
SSW	0	0	0	0	0	0	0
SW	0	0	0	0	0	0	0
WSW	0	1	0	0	0	0	1
W	2	1	0	0	0	0	3
WNW	0	0	0	0	0	0	0
NW	0	0	0	0	0	0	0
NNW	0	0	0	0	0	0	0
TOTAL	4	2	0	0	0	0	6

Number of calm hours 4
 Number of variable directions 0
 Total number of observations 10

Table I.4-33 (CONTINUED)

POINT BEACH WIND - STABILITY SUMMARY							
STABILITY CLASS - B - 150 FT WINDS, (NOV) PERIOD 11/1/67 TO 11/30/68							
NUMBER OF HOURLY OBSERVATIONS							
WIND SPEED (MPH)							
WINDS FROM	1-3	4-7	8-12	13-18	19-24	25+	TOTAL
N	1	0	0	0	0	0	1
NNE	0	0	0	0	0	0	0
NE	0	0	0	0	0	0	0
ENE	0	0	0	0	0	0	0
E	0	0	0	0	0	0	0
ESE	0	0	0	0	0	0	0
SE	0	0	0	0	0	0	0
SSE	0	0	0	0	0	0	0
S	0	0	0	0	0	0	0
SSW	0	0	0	0	0	0	0
SW	0	0	0	0	0	0	0
WSW	0	1	0	0	0	0	1
W	1	1	0	0	0	0	2
WNW	0	0	0	0	0	0	0
NW	0	3	0	0	0	0	3
NNW	0	0	0	0	0	0	0
TOTAL	2	5	0	0	0	0	7
Number of calm hours			2				
Number of variable directions			0				
Total number of observations			9				

Table I.4-33 (CONTINUED)

POINT BEACH WIND - STABILITY SUMMARY							
STABILITY CLASS - C - 150 FT WINDS, (NOV) PERIOD 11/1/67 TO 11/30/68							
NUMBER OF HOURLY OBSERVATIONS							
WIND SPEED (MPH)							
WINDS FROM	1-3	4-7	8-12	13-18	19-24	25+	TOTAL
N	0	2	0	1	0	0	3
NNE	1	0	0	1	0	0	2
NE	2	0	0	0	0	0	2
ENE	0	0	0	0	0	0	0
E	0	0	0	0	0	0	0
ESE	0	0	0	0	0	0	0
SE	0	0	0	0	0	0	0
SSE	0	1	1	0	0	0	2
S	0	1	0	0	0	0	1
SSW	0	0	0	0	0	0	0
SW	1	1	0	0	0	0	2
WSW	0	1	0	0	0	0	1
W	0	1	1	0	0	0	2
WNW	2	4	8	19	5	0	38
NW	2	8	26	27	13	0	76
NNW	2	0	5	1	1	0	9
TOTAL	10	19	41	49	19	0	138
Number of calm hours			2				
Number of variable directions			0				
Total number of observations			140				

Table I.4-33 (CONTINUED)

POINT BEACH WIND - STABILITY SUMMARY							
STABILITY CLASS - D - 150 FT WINDS, (NOV) PERIOD 11/1/67 TO 11/30/68							
NUMBER OF HOURLY OBSERVATIONS							
WIND SPEED (MPH)							
WINDS FROM	1-3	4-7	8-12	13-18	19-24	25+	TOTAL
N	0	2	22	31	1	1	57
NNE	0	0	1	0	0	0	1
NE	2	0	1	0	0	0	3
ENE	1	0	0	0	0	0	1
E	2	1	0	0	0	2	5
ESE	0	1	1	0	1	0	3
SE	2	0	3	0	0	0	5
SSE	2	2	6	7	0	0	17
S	1	3	10	9	1	0	24
SSW	0	2	5	4	4	1	16
SW	4	5	5	10	1	0	25
WSW	0	4	8	6	4	0	22
W	4	9	9	14	14	8	58
WNW	1	16	36	53	15	6	127
NW	2	4	38	23	5	0	72
NNW	1	1	34	27	10	1	74
TOTAL	22	50	179	184	56	19	510
Number of calm hours			7				
Number of variable directions			0				
Total number of observations			517				

Sheet 84 of 96

Table I.4-33 (CONTINUED)

POINT BEACH WIND - STABILITY SUMMARY							
STABILITY CLASS - E - 150 FT WINDS, (NOV) PERIOD 11/1/67 TO 11/30/68							
NUMBER OF HOURLY OBSERVATIONS							
WIND SPEED (MPH)							
WINDS FROM	1-3	4-7	8-12	13-18	19-24	25+	TOTAL
N	0	9	29	45	21	0	104
NNE	0	1	0	5	3	2	11
NE	1	0	1	1	9	5	17
ENE	0	0	1	5	4	3	13
E	1	0	1	2	7	9	20
ESE	1	0	2	1	2	0	6
SE	1	0	3	5	2	0	11
SSE	0	1	2	3	0	0	6
S	1	2	7	0	0	0	10
SSW	0	4	16	21	0	1	42
SW	1	5	21	31	9	0	67
WSW	0	10	10	6	0	1	27
W	3	10	13	25	5	2	58
WNW	1	5	8	5	1	0	20
NW	0	1	6	4	0	0	11
NNW	0	3	14	3	0	0	20
TOTAL	10	51	134	162	63	23	443
Number of calm hours	6						
Number of variable directions	0						
Total number of observations	449						

Sheet 85 of 96

Table I.4-33 (CONTINUED)

POINT BEACH WIND - STABILITY SUMMARY							
STABILITY CLASS - F - 150 FT WINDS, (NOV) PERIOD 11/1/67 TO 11/30/68							
NUMBER OF HOURLY OBSERVATIONS							
WIND SPEED (MPH)							
WINDS FROM	1-3	4-7	8-12	13-18	19-24	25+	TOTAL
N	0	3	14	27	23	3	70
NNE	0	0	3	1	3	0	7
NE	0	0	0	0	0	0	0
ENE	0	0	0	0	0	0	0
E	0	0	2	0	0	0	2
ESE	0	0	0	0	0	0	0
SE	0	1	0	0	0	0	1
SSE	0	0	0	1	0	0	1
S	0	2	2	0	0	0	4
SSW	0	1	4	3	0	0	8
SW	0	1	20	2	1	0	24
WSW	1	5	3	0	0	0	9
W	4	1	3	2	0	0	10
WNW	3	0	3	2	0	0	8
NW	1	1	1	0	0	0	3
NNW	0	3	1	0	0	0	4
TOTAL	9	18	56	38	27	3	151
Number of calm hours			1				
Number of variable directions			0				
Total number of observations			152				

Table I.4-33 (CONTINUED)

POINT BEACH WIND - STABILITY SUMMARY							
STABILITY CLASS - G - 150 FT WINDS, (NOV) PERIOD 11/1/67 TO 11/30/68							
NUMBER OF HOURLY OBSERVATIONS							
WIND SPEED (MPH)							
WINDS FROM	1-3	4-7	8-12	13-18	19-24	25+	TOTAL
N	2	1	2	2	1	0	8
NNE	0	0	0	0	0	0	0
NE	0	0	0	0	0	0	0
ENE	0	0	0	0	0	0	0
E	0	0	0	0	0	0	0
ESE	0	0	0	0	0	0	0
SE	0	1	0	0	0	0	1
SSE	0	0	0	0	0	0	0
S	0	0	0	0	0	0	0
SSW	0	0	0	1	0	0	1
SW	1	7	7	0	0	0	15
WSW	3	0	1	0	0	0	4
W	0	1	0	2	0	0	3
WNW	0	0	0	1	0	0	1
NW	0	0	2	0	0	0	2
NNW	0	0	0	0	0	0	0
TOTAL	6	10	12	6	1	0	35
Number of calm hours	0						
Number of variable directions	0						
Total number of observations	35						

Table I.4-33 (CONTINUED)

POINT BEACH WIND - STABILITY SUMMARY

STABILITY CLASS -ALL- 150 FT WINDS, (NOV) PERIOD 11/1/67 TO 11/30/68
 NUMBER OF HOURLY OBSERVATIONS

WINDS FROM	WIND SPEED (MPH)						TOTAL
	1-3	4-7	8-12	13-18	19-24	25+	
N	4	17	67	106	46	4	244
NNE	1	1	4	7	6	2	21
NE	6	0	2	1	9	5	23
ENE	1	0	1	5	4	3	14
E	3	1	3	2	7	11	27
ESE	1	1	3	1	3	0	9
SE	3	2	6	5	2	0	18
SSE	2	4	9	11	0	0	26
S	2	8	19	9	1	0	39
SSW	0	7	25	29	4	2	67
SW	7	19	53	43	11	0	133
WSW	4	22	22	12	4	1	65
W	14	24	26	43	19	10	136
WNW	7	25	55	80	21	6	194
NW	5	17	73	54	18	0	167
NNW	3	7	54	31	11	1	107
TOTAL	63	155	422	439	166	45	1290
Number of calm hours							22
Number of variable directions							0
Total number of observations							1312

Table I.4-33 (CONTINUED)

POINT BEACH WIND - STABILITY SUMMARY

STABILITY CLASS - A - 150 FT WINDS, (DEC) PERIOD 12/1/67 TO 12/31/68
 NUMBER OF HOURLY OBSERVATIONS

WIND SPEED (MPH)

WINDS FROM	1-3	4-7	8-12	13-18	19-24	25+	TOTAL
N	0	0	0	0	0	0	0
NNE	0	0	0	0	0	0	0
NE	0	0	0	0	0	0	0
ENE	0	0	0	0	0	0	0
E	1	0	0	0	0	0	1
ESE	1	0	0	0	0	0	1
SE	0	0	0	0	0	0	0
SSE	0	0	0	0	0	0	0
S	0	0	0	0	0	0	0
SSW	0	0	0	0	0	0	0
SW	0	0	0	0	0	0	0
WSW	0	0	0	0	0	0	0
W	0	0	0	0	0	0	0
WNW	1	0	0	0	0	0	1
NW	0	0	0	0	0	0	0
NNW	0	0	0	0	0	0	0
TOTAL	3	0	0	0	0	0	3
Number of calm hours	0						
Number of variable directions	0						
Total number of observations	3						

Table I.4-33 (CONTINUED)

POINT BEACH WIND - STABILITY SUMMARY

STABILITY CLASS - B - 150 FT WINDS, (DEC) PERIOD 12/1/67 TO 12/31/68
 NUMBER OF HOURLY OBSERVATIONS

WIND SPEED (MPH)

WINDS FROM	1-3	4-7	8-12	13-18	19-24	25+	TOTAL
N	0	0	0	0	0	0	0
NNE	0	0	0	0	0	0	0
NE	0	0	0	0	0	0	0
ENE	0	0	0	0	0	0	0
E	0	0	0	0	0	0	0
ESE	0	0	0	0	0	0	0
SE	0	0	0	0	0	0	0
SSE	0	0	0	0	0	0	0
S	0	0	0	0	0	0	0
SSW	0	1	0	0	0	0	1
SW	0	0	0	0	0	0	0
WSW	0	1	0	0	0	0	1
W	0	0	0	0	0	0	0
WNW	0	1	0	0	0	0	1
NW	0	1	0	0	0	0	1
NNW	0	0	0	0	0	0	0
TOTAL	0	4	0	0	0	0	4

Number of calm hours 0
 Number of variable directions 0
 Total number of observations 4

Table I.4-33 (CONTINUED)

POINT BEACH WIND - STABILITY SUMMARY							
STABILITY CLASS - C - 150 FT WINDS, (DEC) PERIOD 12/1/67 TO 12/31/68							
NUMBER OF HOURLY OBSERVATIONS							
WIND SPEED (MPH)							
WINDS FROM	1-3	4-7	8-12	13-18	19-24	25+	TOTAL
N	0	0	0	1	0	0	1
NNE	0	0	0	0	0	0	0
NE	0	0	0	0	0	0	0
ENE	0	0	0	0	0	0	0
E	0	0	0	0	0	0	0
ESE	0	0	0	0	0	0	0
SE	0	2	0	0	0	0	2
SSE	1	0	0	0	0	0	1
S	0	0	1	0	0	0	1
SSW	0	0	1	0	0	1	2
SW	0	1	0	1	0	0	2
WSW	0	2	1	0	0	0	3
W	2	1	1	0	2	0	6
WNW	0	3	3	11	9	12	38
NW	0	5	5	39	9	11	69
NNW	0	2	0	1	1	0	4
TOTAL	3	16	12	53	21	24	129
Number of calm hours	0						
Number of variable directions	0						
Total number of observations	129						

Table I.4-33 (CONTINUED)

POINT BEACH WIND - STABILITY SUMMARY							
STABILITY CLASS - D - 150 FT WINDS, (DEC) PERIOD 12/1/67 TO 12/31/68							
NUMBER OF HOURLY OBSERVATIONS							
WIND SPEED (MPH)							
WINDS FROM	1-3	4-7	8-12	13-18	19-24	25+	TOTAL
N	2	1	4	3	5	7	22
NNE	0	3	0	0	0	0	3
NE	0	0	1	0	0	0	1
ENE	0	0	0	0	0	0	0
E	0	0	0	0	0	0	0
ESE	0	0	0	0	0	1	1
SE	0	1	1	0	1	2	5
SSE	0	2	0	1	3	2	8
S	0	0	2	12	9	8	31
SSW	1	3	4	12	17	12	49
SW	2	3	4	3	2	2	16
WSW	0	3	8	2	3	6	22
W	0	7	12	14	6	11	50
WNW	0	2	15	47	11	5	80
NW	2	4	10	38	5	2	61
NNW	0	5	9	18	6	5	43
TOTAL	7	34	70	150	68	63	392
Number of calm hours	0						
Number of variable directions	0						
Total number of observations	392						

Sheet 92 of 96

Table I.4-33 (CONTINUED)

POINT BEACH WIND - STABILITY SUMMARY							
STABILITY CLASS - E - 150 FT WINDS, (DEC) PERIOD 12/1/67 TO 12/31/68							
NUMBER OF HOURLY OBSERVATIONS							
WIND SPEED (MPH)							
WINDS FROM	1-3	4-7	8-12	13-18	19-24	25+	TOTAL
N	4	4	19	1	5	13	46
NNE	0	3	1	0	0	4	8
NE	0	1	0	0	0	9	10
ENE	0	0	0	1	4	9	14
E	0	0	2	7	3	9	21
ESE	0	0	3	5	2	4	14
SE	0	0	4	12	8	17	41
SSE	0	1	1	2	4	2	10
S	0	1	0	2	0	0	3
SSW	0	0	5	12	15	5	37
SW	0	4	5	25	10	4	48
WSW	0	3	9	4	3	1	20
W	1	2	9	8	2	7	29
WNW	0	5	2	4	0	0	11
NW	1	2	1	2	1	0	7
NNW	3	1	3	4	0	0	11
TOTAL	9	27	64	89	57	84	330
Number of calm hours	0						
Number of variable directions	0						
Total number of observations	330						

Sheet 93 of 96

Table I.4-33 (CONTINUED)

POINT BEACH WIND - STABILITY SUMMARY							
STABILITY CLASS - F - 150 FT WINDS, (DEC) PERIOD 12/1/67 TO 12/31/68							
NUMBER OF HOURLY OBSERVATIONS							
WIND SPEED (MPH)							
WINDS FROM	1-3	4-7	8-12	13-18	19-24	25+	TOTAL
N	1	6	6	1	0	1	15
NNE	0	1	0	0	0	0	1
NE	0	0	0	0	0	0	0
ENE	0	0	0	0	2	1	3
E	0	0	0	1	1	0	2
ESE	0	0	0	0	0	0	0
SE	0	0	0	1	0	0	1
SSE	0	0	3	2	0	0	5
S	0	2	1	0	0	0	3
SSW	0	2	2	0	0	0	4
SW	1	1	2	3	0	0	7
WSW	0	0	2	1	0	0	3
W	0	2	4	1	0	0	7
WNW	0	2	5	4	0	0	11
NW	2	1	3	2	0	0	8
NNW	0	1	1	0	0	0	2
TOTAL	4	18	29	16	3	2	72
Number of calm hours	0						
Number of variable directions	0						
Total number of observations	72						

Table I.4-33 (CONTINUED)

POINT BEACH WIND - STABILITY SUMMARY							
STABILITY CLASS - G - 150 FT WINDS, (DEC) PERIOD 12/1/67 TO 12/31/68							
NUMBER OF HOURLY OBSERVATIONS							
WIND SPEED (MPH)							
WINDS FROM	1-3	4-7	8-12	13-18	19-24	25+	TOTAL
N	2	0	2	0	0	0	4
NNE	0	0	0	0	0	0	0
NE	0	0	0	0	0	0	0
ENE	0	0	0	0	0	0	0
E	0	0	0	0	0	0	0
ESE	0	0	0	0	0	0	0
SE	0	0	1	0	0	0	1
SSE	0	0	3	0	0	0	3
S	0	1	2	0	0	0	3
SSW	0	0	1	0	0	0	1
SW	0	0	1	0	0	0	1
WSW	0	0	0	0	0	0	0
W	1	0	4	0	0	0	5
WNW	0	0	3	1	0	0	4
NW	0	2	4	5	0	0	11
NNW	0	0	4	0	0	0	4
TOTAL	3	3	25	6	0	0	37
Number of calm hours	0						
Number of variable directions	0						
Total number of observations	37						

Table I.4-33 (CONTINUED)

POINT BEACH WIND - STABILITY SUMMARY							
STABILITY CLASS -ALL- 150 FT WINDS, (DEC) PERIOD 12/1/67 TO 12/31/68							
NUMBER OF HOURLY OBSERVATIONS							
WIND SPEED (MPH)							
WINDS FROM	1-3	4-7	8-12	13-18	19-24	25+	TOTAL
N	9	11	31	6	10	21	88
NNE	0	7	1	0	0	4	12
NE	0	1	1	0	0	9	11
ENE	0	0	0	1	6	10	17
E	1	0	2	8	4	9	24
ESE	1	0	3	5	2	5	16
SE	0	3	6	13	9	19	50
SSE	1	3	7	5	7	4	27
S	0	4	6	14	9	8	41
SSW	1	6	13	24	32	18	94
SW	3	9	12	32	12	6	74
WSW	0	9	20	7	6	7	49
W	4	12	30	23	10	18	97
WNW	1	13	28	67	20	17	146
NW	5	15	23	86	15	13	157
NNW	3	9	17	23	7	5	64
TOTAL	29	102	200	314	149	173	967
Number of calm hours	0						
Number of variable directions	0						
Total number of observations	967						

Sheet 96 of 96

Table I.6-1 POINT BEACH NUCLEAR PLANT NEAREST SITE BOUNDARY (METERS)

N	-	Lake:	nearest shoreline	-	300 m;	nearest land	-	4000 m.
NNE	-	Lake:	nearest shoreline	-	200 m;	nearest land	-	>50 miles
NE	-	Lake:	nearest shoreline	-	170 m;	nearest land	-	>50 miles
ENE	-	Lake:	nearest shoreline	-	170 m;	nearest land	-	>50 miles
E	-	Lake:	nearest shoreline	-	170 m;	nearest land	-	>50 miles
ESE	-	Lake:	nearest shoreline	-	210 m;	nearest land	-	>50 miles
SE	-	Lake:	nearest shoreline	-	310 m;	nearest land	-	>50 miles
SSE	-	1300 m;	nearest shoreline	-	1220 m			
S	-	1270 m		-				
SSW	-	1290 m		-				
SW	-	1520 m		-				
WSW	-	1320 m		-				
W	-	1300 m		-				
WNW	-	1630 m		-				
NW	-	2040 m		-				
NNW	-	2010 m;	nearest shoreline	-	830 m;			

Note: The nearest shoreline access points for any individual are as follows, measured from the midpoint of a line connecting the containment centers:

- a) Onsite north - at Unit 2 discharge flume, 170 m
- b) Onsite south - at Unit 1 discharge flume, 170 m
- c) Offsite north - at site boundary, 2010 m
- d) Offsite south - at site boundary, 1500 m

Table I.6-2 POINT BEACH NUCLEAR PLANT DISTANCE TO NEAREST RESIDENCE
AND NEAREST VEGETABLE GARDEN IN SEARCH SECTOR⁽¹⁾

<u>Sector</u>	<u>Distance (meters)</u>
N	4840
NNE	Lake
NE	Lake
ENE	Lake
E	Lake
ESE	Lake
SE	Lake
SSE	1930
S	2920
SSW	1460
SW	1980
WSW	2240
W	2190
WNW	1250 (onsite) ⁽²⁾ ; 2240 (offsite)
NW	2920
NNW	1980, (onsite) ⁽²⁾ ; 2660 (offsite)

Notes:

1. It is assumed that every residence (farm or non-farm) has the potential for having a vegetable garden. Distances are scaled from topographic maps and buildings were located by visual automobile survey. Accuracy is estimated to be within 100 meters.
2. There are 3 onsite residences leased to plant employees, one in the WNW sector and two in the NNW sector. Onsite residents are assumed to have vegetable gardens but do not have milk or meat producing animals. (These residences were later demolished or abandoned.)

Table I.6-3 POINT BEACH NUCLEAR PLANT DISTANCE TO NEAREST MILK COW,
MEAT ANIMAL AND MILK GOAT IN EACH SECTOR⁽¹⁾

<u>Sector</u>	<u>Distance (meters)</u>
N	none
NNE	Lake
NE	Lake
ENE	Lake
E	Lake
ESE	Lake
SE	Lake
SSE	1300 (site boundary)
S	1270 (site boundary)
SSW	2130
SW	1720
WSW	1320 (site boundary)
W	1300 (site boundary)
WNW	2340
NW	2400
NNW	2010 (site boundary)

Notes:

1. Since the PBNP area land use is predominantly agricultural, the distance to the nearest milk cow, milk goat, and meat animal is assumed to be the distance to the nearest practicing farm having a dwelling and a barn. However, it is assumed that land surrounding the site, owned by the Licensee and leased to local farmers, is unlikely to be used for pasture.

Table I.6-4 POINT BEACH NUCLEAR PLANT CONTAINMENT PURGE SUMMARY ⁽¹⁾
1/1/74 TO 2/29/76

Unit 1

<u>Date</u>	<u>Condition</u>	<u>Start Time</u>	<u>Duration</u>
3/5/74	At Power	0957	3 hrs.
4/14/74	Shutdown	0035	16 days
5/1/74	Shutdown	(Continued)	17 days
1/13/75	At Power	1615	3 hrs.
1/26/75	Shutdown	2310	5 days
2/28/75	Shutdown	1650	30 days
4/2/75	Shutdown	1830	2 days
5/21/75	At Power	1115	2 hrs.
6/6/75	At Power	0355	5 hrs.
6/11/75	At Power	0415	5 hrs.
6/12/75	At Power	0400	10 hrs.
6/28/75	Shutdown	0640	6 hrs.
8/13/75	At Power	2045	4 hrs.
9/26/75	At Power	0443	3 hrs.
9/17/75	At Power	2315	7 hrs.
9/17/75	At Power	0427	3 hrs.
11/20/75	Shutdown	1243	44 days
1/13/76	At Power	2135	3 hrs.
2/19/76	At Power	1040	22 hrs.
2/20/76	At Power	1150	7 hrs.

Table I.6-4 (CONTINUED)

POINT BEACH NUCLEAR PLANT CONTAINMENT PURGE SUMMARY ⁽¹⁾

1/1/74 TO 2/29/76

Unit 2

10/22/74	Shutdown	0935	50 days
2/21/75	Shutdown	0045	6 hrs.
4/19/75	Shutdown	0110	4 hrs.
5/10/75	Shutdown	0305	3 hrs.
7/20/75	Shutdown	0212	13 hrs.
8/13/75	Shutdown	0257	4 days
2/19/76	At Power	1545	22 hrs.
2/27/76	Shutdown	0307	23 days

Note:

1. Average purge duration at power (1/1/74 - 3/1/76) = 7 hours

Table I.6-5 POINT BEACH NUCLEAR PLANT GAS DECAY TANK RELEASES (1974-1975)

<u>Date</u>	<u>GDT#</u> ⁽³⁾	<u>Start</u>	<u>Stop</u>	<u>Time</u> (min)	<u>Ci</u>	<u>ft³</u>	<u>%Kr-85</u> ⁽¹⁾
2/6/74	D	1736	1145	1089	28.15	3544	19.9%
2/18/74	B	0900	0007 ⁽²⁾	743	10.89	3628	44.4%
10/22/74	C	1559	2220	261	4.23	3607	98.6%
1/26/75	B	0954	1410	256	24.52	3393	25.2%
2/8/75	C	1632	0450	738	11.19	3696	38.1%
3/29/75	B	1440	2215	455	6.19	3376	80.4%
4/18/75	D	0730	0815				
		1042	1820	503	3.28	2807	89.6%
5/12/75	C	1155	0355	240	3.62	3000	99.7%
5/29/75	B	1335	1505	90	14.50	200	33.9%
7/14/75	C	1150	2100	550	5.13	3393	64.1%
8/11/75	D	1605	1435	1350	2.54	3178	96.7%
9/9/75	C	1102	1115	12	0.154	173	97.0%
11/5/75	C	1628	1900	152	3.43	2357	100.0%
		1920	2055	95		857	
11/18/75	B	1845	0655	730	2.79	3625	97.8%

Notes:

1. Principally Xe-133 and Kr-85 with minor amounts of Xe-131 and Xe-133m
2. There were several start/stops during this period
3. Gas decay tank number

Table I.7 -1POINT BEACH NUCLEAR PLANT CALCULATED TOTAL ANNUAL GASEOUS RELEASES (Ci/yr)

Isotope	<u>AUXILIARY BUILDING VENT*</u>			<u>UNIT 1 CONTAINMENT PURGE VENT</u>		<u>UNIT 2 CONTAINMENT PURGE VENT</u>			<u>TURBINE BUILDING ROOF EXHAUST</u>	Total Annual Releases
	<u>Auxiliary Building Ventilation</u>	<u>Gas Decay Tank Effluent</u>	<u>Unit 1 and Unit 2 Condenser Air Ejectors</u>	<u>Unit 1 Containment Purge</u>	<u>Unit 1 Continuous Containment Ventilation</u>	<u>Unit 2 Containment Purge</u>	<u>Unit 2 Continuous Containment Ventilation</u>	<u>Gas Stripper Building Ventilation</u>	<u>Turbine Building Ventilation</u>	
Ar-41	-	-	-	2.5E+01	-	2.5E+01	-	-	-	5.0E+01
Kr-83m	7.2E-01	-	3.2E-01	5.4E-02	8.2E-03	5.4E-02	8.2E-03	2.3E-02	1.23E-04	1.2E+00
Kr-85m	3.0E+00	-	1.6E+00	4.1E-01	8.4E-02	4.1E-01	8.4E-02	1.1E-01	5.0E-04	5.7E+00
Kr-85	2.6E+00	7.2E+01	1.6E+00	1.7E+01	2.5E+00	1.7E+01	2.5E+00	2.3E+00	4.2E-04	1.2E+02
Kr-87	2.2E+00	-	8.0E-01	1.3E-01	1.7E-02	1.3E-01	1.7E-02	6.6E-02	3.4E-04	3.4E+00
Kr-88	6.4E+00	-	3.1E+00	6.3E-01	1.1E-01	6.3E-01	1.1E-01	2.2E-01	1.0E-03	1.1E+01
Kr-89	2.0E-01	-	2.5E-07	9.8E-04	6.8E-05	9.8E-04	6.8E-05	4.0E-03	3.4E-05	2.1E-01
Xe-131m	1.8E-01	-	1.1E-01	7.3E-01	1.3E-01	7.3E-01	1.3E-01	4.0E-02	3.0E-05	2.1E+00
Xe-133m	1.4E+00	-	8.3E-01	1.6E+00	3.4E-01	1.6E+00	3.4E-01	1.2E-01	2.2E-04	6.2E+00
Xe-133	5.6E+01	3.1E+01	3.4E+01	1.4E+02	2.8E+01	1.4E+02	2.8E+01	9.2E+00	8.8E-03	4.7E+02
Xe-135m	5.6E-01	-	2.2E-02	1.0E-02	8.4E-04	1.0E-02	8.4E-04	1.2E-02	8.6E-05	6.2E-01
Xe-135	7.2E+00	-	4.3E+00	1.7E+00	4.0E-01	1.7E+00	4.0E-01	3.1E-01	1.2E-03	1.6E+01
Xe-137	3.8E-01	-	4.7E-06	2.1E-03	1.5E-04	2.1E-03	1.5E-04	7.7E-03	6.0E-05	3.9E-01
Xe-138	1.8E+00	-	6.1E-02	3.3E-02	2.7E-03	3.3E-02	2.7E-03	3.9E-02	2.8E-04	2.0E+00
I-131	7.4E-02	-	4.6E-02	3.1E-03	5.7E-04	3.1E-03	5.7E-04	-	3.0E-03	1.3E-01
I-133	1.0E-01	-	6.4E-02	4.9E-04	1.7E-04	6.9E-04	1.7E-04	-	4.2E-03	1.7E-01
Co-58	1.2E-03	-	-	7.5E-04	-	7.5E-04	-	-	-	2.7E-03
Co-60	5.4E-04	-	-	3.4E-04	-	3.4E-04	-	-	-	1.2E-03

Table I.7-1 (CONTINUED)
 POINT BEACH NUCLEAR PLANT CALCULATED TOTAL ANNUAL GASEOUS RELEASES (Ci/yr)

Isotope	AUXILIARY BUILDING VENT*			UNIT 1 CONTAINMENT PURGE VENT		UNIT 2 CONTAINMENT PURGE VENT			TURBINE BUILDING ROOF EXHAUST	
	Auxiliary Building Ventilation	Gas Decay Tank Effluent	Unit 1 and Unit 2 Condenser Air Ejectors	Unit 1 Containment Purge	Unit 1 Continuous Containment Ventilation	Unit 2 Containment Purge	Unit 2 Continuous Containment Ventilation	Gas Stripper Building Ventilation	Turbine Building Ventilation	Total Annual Releases
Mn-54	3.6E-04	-	-	2.2E-04	-	2.2E-04	-	-	-	8.0E-04
Fe-59	1.2E-04	-	-	7.5E-05	-	7.5E-05	-	-	-	2.7E-04
Sr-89	2.6E-05	-	-	1.7E-05	-	1.7E-05	-	-	-	6.0E-05
Sr-90	4.0E-06	-	-	3.0E-06	-	3.0E-06	-	-	-	1.0E-05
Cs-134	3.6E-04	-	-	2.2E-04	-	2.2E-04	-	-	-	8.0E-04
Cs-137	6.0E-04	-	-	3.8E-04	-	3.8E-04	-	-	-	1.4E-03
C-14	1.6E+01	-	-	-	-	-	-	-	-	1.6E+01
H-3	<u>7.7E+01</u>	=	=	<u>2.65E+02</u>	=	<u>2.65E+02</u>	=	=	=	<u>6.1E+02</u>
Total Noble Gases	8.3E+01	1.0E+02	4.7E+01	1.9E+02	3.2E+01	1.9E+02	3.2E+01	1.2E+01	1.3E-02	6.9E+02
Total Iodines	1.7E-01	-	1.1E-01	3.8E-03	7.4E-04	3.8E-03	7.4E-04	-	7.2E-03	3.0E-01
Total Particulates	2.3E-03	-	-	2.0E-03	-	2.0E-03	-	-	-	7.2E-03

<*>.Unit 1 and 2 Auxiliary Building Ventilation Releases Include Drumming Area Vent Releases Since Exit Velocities and Locations are Essentially Identical.

Table I.7-2 POINT BEACH NUCLEAR PLANT TOTAL LIQUID RELEASES
PER PALNT - CALCULATED⁽¹⁾

<u>Isotope</u>	<u>Radioactivity ($\mu\text{Ci/gm}$)</u>	<u>Annual Release (Ci)</u>
H-3	2.7E-03	6.1E+02
Kr-85		
Kr-85m		
Kr-87		
Xe-131m		
Xe-133		
Xe-133m		
Xe-135		
Xe-138		
I-130	6.6E-12	3.8E-03
I-131	9.4E-10	5.4E-01
I-132	2.0E-10	1.2E-01
I-133	1.3E-09	7.6E-01
I-134	3.5E-11	2.0E-02
I-135	4.9E-10	2.8E-01
Na-24		
Cr-51	8.7E-12	5.0E-03
Mn-54	2.0E-12	1.1E-03
Fe-55	8.0E-12	4.6E-03
Fe-59	5.9E-12	3.4E-03
Co-57		
Co-58	8.0E-11	4.6E-02
Co-60	8.7E-12	5.0E-03
Br-83	7.7E-12	4.4E-03
Br-84	1.2E-12	7.0E-04
Br-85	2.0E-14	1.1E-05
Rb-86	4.2E-13	2.4E-04
Rb-88	5.9E-11	3.4E-02

Sheet 1 of 3

Table I.7-2 (CONTINUED)
 POINT BEACH NUCLEAR PLANT TOTAL LIQUID RELEASES
 PER PALNT - CALCULATED⁽¹⁾

<u>Isotope</u>	<u>Radioactivity ($\mu\text{Ci}/\text{gm}$)</u>	<u>Annual Release (Ci)</u>
Sr-89	2.0E-12	1.1E-03
Sr-90	3.8E-14	2.2E-05
Sr-91	5.2E-13	3.0E-04
Y-90	3.8E-14	2.2E-05
Y-91m	3.0E-13	1.7E-04
Y-91	8.7E-12	5.0E-03
Y-93	2.1E-13	1.2E-04
Zr-95	3.8E-13	2.2E-04
Nb-95	3.8E-13	2.2E-04
Mo-99	7.0E-10	4.0E-01
Tc-99m	6.3E-10	3.6E-01
Ru-103	2.0E-13	1.1E-04
Ru-106	3.8E-14	2.2E-05
Rh-103m	2.0E-13	1.1E-04
Rh-106	3.8E-14	2.2E-05
Cd-109		
Ag-110m		
Sb-124		
Sb-125		
Te-125m	5.9E-14	3.4E-05
Te-127m	9.8E-13	5.6E-04
Te-127	3.1E-12	1.8E-03
Te-129m	5.9E-12	3.4E-03
Te-129	5.9E-12	3.4E-03
Te-131m	1.0E-11	5.8E-03
Te-131	2.0E-12	1.1E-03
Te-132	1.0E-10	5.8E-02
Cs-134	1.1E-10	6.4E-02

Sheet 2 of 3

Table I.7-2 (CONTINUED)
 POINT BEACH NUCLEAR PLANT TOTAL LIQUID RELEASES
 PER PALNT - CALCULATED⁽¹⁾

<u>Isotope</u>	<u>Radioactivity ($\mu\text{Ci/gm}$)</u>	<u>Annual Release (Ci)</u>
Cs-136	6.3E-11	3.6E-02
Cs-137	9.1E-11	5.2E-02
Cs-138		
Ba-137m	8.7E-11	5.0E-02
Ba-140	9.8E-13	5.6E-04
La-140	7.0E-13	4.0E-04
Ce-141	3.8E-13	2.2E-04
Ce-143	1.0E-13	5.8E-05
Ce-144	2.0E-13	1.1E-04
Pr-143	2.0E-13	1.1E-04
Pr-144	2.0E-13	1.1E-04
Bi-207		
Th-232		
Np-239	<u>5.9E-12</u>	<u>3.4E-03</u>
Total Calculated Release	5.0E-09	2.9E+00
Anticipated Operational Occurrences	<u>5.2E-10</u>	<u>3.0E-01</u>
Total (Excluding Tritium)	5.5E-09	3.2E+00

1. Isotope Releases of less than 1.E-10 curies/year are set to 0.0.
2. Anticipated operational occurrences 3.00E-01 curies are added to calculated releases and assumed to have the same isotopic distribution for dose calculations.

Table I.7-3 POINT BEACH NUCLEAR PLANT CALCULATED ANNUAL RELEASES BY SOURCE (Ci/yr)

Isotope	Steam Generator Blowdown, Ea. Unit	Lab. Drains Per Plant	Sampling Drains Per Unit	Laundry and Shower Drains Per Plant	Containment Sump Drains Ea. Unit	Aux. Bldg. Floor Drains Per Plant	Misc. Waste Per Plant	Turb. Bldg. Floor Drains, Ea. Unit	Secondary Side Sampling Per Plant	Reactor Coolant Letdown Each Unit	Reactor Coolant Leakage Each Unit
Br-83	2.2E-03	4.5E-09	2.0E-07	0.0	2.3E-07	2.3E-07	7.8E-08	0.0	0.0	0.0	0.0
Br-84	3.5E-04	6.1E-12	2.5E-10	0.0	2.9E-10	2.9E-10	1.0E-10	0.0	0.0	0.0	0.0
Br-85	5.6E-06	0.0	0.0	0.0	0.0	0.0	0.0	0.0	0.0	0.0	0.0
I-130	1.9E-03	2.6E-08	1.2E-06	0.0	1.3E-06	1.3E-06	4.6E-07	0.0	0.0	1.0E-09	7.3E-10
I-131	2.7E-01	1.5E-05	6.2E-04	3.5E-08	7.3E-04	7.2E-04	2.5E-04	2.0E-04	3.0E-05	2.6E-04	1.8E-04
I-132	5.8E-02	1.3E-06	5.8E-05	0.0	6.6E-05	5.5E-05	2.3E-05	4.9E-08	7.5E-09	6.4E-07	4.5E-07
I-133	3.8E-01	7.7E-06	3.5E-04	0.0	4.0E-04	4.0E-04	1.4E-04	1.4E-13	2.6E-14	2.5E-06	1.8E-06
I-134	9.9E-03	1.8E-09	7.7E-08	0.0	8.8E-08	8.8E-08	3.0E-08	0.0	0.0	0.0	0.0
I-135	1.4E-01	1.1E-06	4.7E-04	0.0	5.4E-05	5.4E-05	1.9E-05	0.0	0.0	5.4E-10	3.8E-10
Rb-86	1.2E-04	5.2E-09	2.3E-07	0.0	2.6E-07	2.6E-07	9.1E-08	3.8E-08	5.9E-09	9.9E-08	1.3E-08
Rb-88	1.7E-02	2.5E-12	1.1E-10	0.0	1.3E-10	1.3E-10	4.4E-11	0.0	0.0	0.0	0.0
Cs-134	3.2E-02	1.6E-06	7.2E-05	8.7E-07	8.3E-05	8.3E-05	2.9E-05	3.0E-05	4.7E-06	6.4E-05	8.6E-06
Cs-136	1.8E-02	8.3E-07	3.5E-05	0.0	4.0E-05	4.0E-05	1.4E-05	3.5E-06	5.4E-07	1.1E-05	1.6E-06
Cs-137	2.6E-02	1.2E-06	5.3E-05	1.6E-06	6.1E-05	6.1E-05	2.1E-05	2.5E-05	3.9E-06	4.7E-05	6.5E-06
Cr-51	2.5E-03	1.1E-07	4.8E-06	0.0	5.5E-06	5.5E-06	1.9E-06	1.2E-06	1.8E-07	5.2E-07	3.7E-07
Mn-54	5.6E-04	1.9E-08	8.2E-07	6.8E-08	9.4E-07	9.4E-07	3.2E-07	5.1E-07	7.8E-08	1.5E-07	1.0E-07
Fe-55	2.3E-03	9.4E-08	4.2E-06	0.0	4.8E-06	4.8E-06	1.7E-06	2.3E-06	3.5E-07	7.6E-07	5.3E-07
Fe-59	1.7E-03	6.1E-08	2.6E-06	0.0	3.0E-06	3.0E-06	1.0E-06	1.1E-06	1.7E-07	3.3E-07	2.3E-07
Co-58	2.3E-02	9.4E-07	4.1E-05	2.6E-07	4.7E-05	4.7E-05	1.6E-05	1.7E-05	2.6E-06	5.8E-06	4.1E-06
Co-60	2.5E-03	1.3E-07	5.3E-06	6.0E-07	6.1E-06	6.1E-06	2.1E-06	2.5E-06	3.8E-07	9.9E-07	6.9E-07
Sr-89	5.7E-04	2.1E-08	9.1E-07	0.0	1.0E-06	1.0E-06	3.6E-07	3.7E-08	5.7E-09	1.2E-07	8.6E-08

Table I.7-3 (CONTINUED) POINT BEACH NUCLEAR PLANT CALCULATED ANNUAL RELEASES BY SOURCE (Ci/yr)

<u>Isotope</u>	<u>Steam Generator Blowdown, Ea. Unit</u>	<u>Lab. Drains Per Plant</u>	<u>Sampling Drains Per Unit</u>	<u>Laundry and Shower Drains Per Plant</u>	<u>Containment Sump Drains Ea. Unit</u>	<u>Aux. Bldg. Floor Drains Per Plant</u>	<u>Misc. Waste Per Plant</u>	<u>Turb. Bldg. Floor Drains, Ea. Unit</u>	<u>Secondary Side Sampling Per Plant</u>	<u>Reactor Coolant Letdown Each Unit</u>	<u>Reactor Coolant Leakage Each Unit</u>
Sr-90	1.1E-05	6.1E-10	2.6E-08	0.0	3.0E-08	3.0E-08	1.1E-08	1.1E-08	1.7E-09	4.8E-09	3.4E-09
Sr-91	1.5E-04	6.1E-09	2.6E-07	0.0	3.0E-07	3.0E-07	1.0E-07	0.0	0.0	5.0E-12	3.5E-12
Y-90	1.1E-05	8.8E-10	3.8E-08	0.0	4.4E-08	4.4E-08	1.5E-09	1.1E-08	1.7E-09	5.0E-09	3.5E-09
Y-91m	8.4E-05	4.0E-09	1.8E-07	0.0	2.0E-07	2.0E-07	7.0E-08	0.0	0.0	3.4E-12	2.4E-12
Y-91	2.5E-03	1.2E-07	5.3E-06	0.0	6.1E-06	6.1E-06	2.1E-06	1.8E-06	2.7E-07	7.6E-07	5.3E-07
Y-93	5.8E-05	1.3E-09	5.8E-08	0.0	6.6E-08	6.6E-08	2.3E-08	0.0	0.0	1.7E-12	1.2E-12
Zr-95	1.1E-04	3.6E-09	1.6E-07	9.3E-08	1.8E-07	1.8E-07	6.3E-08	7.8E-08	1.2E-08	2.3E-08	1.6E-08
Nb-95	1.1E-04	3.0E-09	1.3E-07	1.3E-07	1.5E-07	1.5E-07	5.5E-08	9.8E-08	1.5E-08	2.4E-08	1.7E-08
Mo-99	2.0E-01	1.9E-05	8.2E-04	0.0	9.4E-04	9.4E-04	3.2E-04	9.8E-08	1.5E-08	7.6E-06	5.3E-06
Tc-99m	1.8E-01	1.8E-05	7.7E-04	0.0	8.8E-04	8.8E-04	3.0E-04	9.8E-08	1.5E-08	7.6E-06	5.3E-06
Ru-103	5.7E-05	2.6E-09	1.2E-07	9.3E-09	1.3E-07	1.3E-07	4.6E-08	3.3E-08	5.1E-09	1.4E-08	9.8E-09
Ru-106	1.1E-05	6.1E-10	2.6E-08	1.6E-07	3.0E-08	3.0E-08	1.0E-08	9.8E-09	1.5E-09	4.6E-09	3.2E-09
Rh-103m	5.7E-05	2.6E-09	1.2E-07	8.7E-09	1.3E-07	1.3E-07	4.6E-08	3.2E-08	5.0E-09	1.4E-08	9.8E-09
Rh-106	1.1E-05	6.1E-10	2.6E-08	1.6E-07	3.0E-08	3.0E-08	1.0E-08	9.8E-09	1.5E-09	4.6E-09	3.2E-09
Te-125m	1.7E-05	1.7E-09	7.7E-08	0.0	8.8E-08	8.8E-08	3.0E-08	1.2E-08	1.8E-09	1.0E-08	7.3E-09
Te-127m	2.8E-04	1.7E-08	7.2E-07	0.0	8.3E-07	8.3E-07	2.9E-07	2.3E-07	3.5E-08	1.2E-07	8.2E-08
Te-127	8.7E-04	2.2E-08	9.6E-07	0.0	1.1E-06	1.1E-06	3.8E-07	2.3E-07	3.5E-08	1.1E-07	7.8E-08
Te-129m	1.7E-03	8.3E-08	3.7E-06	0.0	4.2E-06	4.2E-06	1.5E-06	8.9E-07	1.4E-07	4.3E-07	3.0E-07
Te-129	1.7E-03	5.4E-08	2.4E-06	0.0	2.7E-06	2.7E-06	9.3E-07	5.7E-07	8.7E-08	2.7E-07	1.9E-07
Te-131m	2.9E-03	7.2E-08	3.1E-06	0.0	3.5E-06	3.5E-06	1.2E-06	1.7E-13	2.6E-14	6.4E-09	4.5E-09
Te-131	5.6E-04	1.3E-08	5.8E-07	0.0	6.6E-07	6.6E-07	2.3E-07	3.0E-14	4.7E-15	1.2E-09	8.2E-10

Table I.7-3 (CONTINUED) POINT BEACH NUCLEAR PLANT CALCULATED ANNUAL RELEASES BY SOURCE (Ci/yr)

<u>Isotope</u>	<u>Steam Generator Blowdown, Ea. Unit</u>	<u>Lab. Drains Per Plant</u>	<u>Sampling Drains Per Unit</u>	<u>Laundry and Shower Drains Per Plant</u>	<u>Containment Sump Drains Ea. Unit</u>	<u>Aux. Bldg. Floor Drains Per Plant</u>	<u>Misc. Waste Per Plant</u>	<u>Turb. Bldg. Floor Drains, Ea. Unit</u>	<u>Secondary Side Sampling Per Plant</u>	<u>Reactor Coolant Letdown Each Unit</u>	<u>Reactor Coolant Leakage Each Unit</u>
Te-132	2.9E-02	1.2E-06	5.3E-05	0.0	6.1E-05	6.1E-05	2.1E-05	4.7E-08	7.2E-09	6.4E-07	4.5E-07
Ba-137m	2.5E-02	1.1E-06	4.8E-05	1.5E-06	5.5E-05	5.5E-05	1.9E-05	2.5E-05	3.8E-06	4.4E-05	6.1E-06
Ba-140	2.8E-04	1.2E-08	5.3E-07	0.0	6.1E-07	6.1E-07	2.1E-07	5.4E-08	8.3E-09	3.3E-08	5.7E-08
La-140	2.0E-04	1.1E-08	4.8E-07	0.0	5.4E-07	5.4E-07	1.9E-07	6.2E-08	9.5E-09	3.8E-08	2.7E-08
Ce-141	1.1E-04	4.1E-09	1.8E-07	0.0	2.0E-07	2.0E-07	7.0E-08	5.7E-08	8.7E-09	2.0E-08	1.4E-08
Ce-143	2.9E-05	1.2E-09	5.3E-08	0.0	6.1E-08	6.1E-08	2.1E-08	7.7E-15	1.2E-15	1.3E-10	9.4E-11
Ce-144	5.6E-05	2.0E-09	8.6E-08	3.3E-07	9.9E-08	9.9E-08	3.4E-08	5.1E-08	7.8E-09	1.5E-08	1.0E-08
Pr-143	5.7E-05	3.0E-09	1.3E-07	0.0	1.5E-07	1.5E-07	5.1E-08	1.3E-08	2.0E-09	8.7E-09	6.1E-09
Pr-144	5.6E-05	2.0E-09	8.6E-08	3.3E-07	9.9E-08	9.9E-08	3.4E-08	5.1E-08	7.8E-09	1.5E-08	1.0E-08
Np-239	1.7E-03	4.6E-08	2.0E-06	0.0	2.3E-06	2.3E-06	8.0E-07	2.5E-10	3.8E-11	1.5E-08	1.0E-08
Total	1.44E+00	6.99E-05	3.43E-03	6.15E-06	3.45E-03	3.45E-03	1.19E-03	3.13E-04	4.74E-05	4.56E-04	2.24E-04

Table I.7-4 POINT BEACH NUCLEAR PLANT AIRBORNE RELEASES (1974-1975) (Ci/yr)

<u>Isotope</u>	<u>1974</u>	<u>1975</u>	<u>Annual Average</u>
H-3	4.28E+01	1.77E+02	1.10E+02
Ar-41	3.20E+01	4.16E+02	2.24E+02
Kr-85	2.31E+01	4.48E+01	3.40E+01
Kr-85m	3.74E+02	2.48E+03	1.43E+03
Kr-87	2.51E+02	1.79E+03	1.02E+03
Kr-88	5.42E+02	3.35E+03	1.95E+03
Xe-131m	4.10E+02	8.56E-01	2.05E+02
Xe-133	6.04E+03	1.99E+04	1.30E+04
Xe-133m	1.33E+02	3.18E+02	2.26E+02
Xe-135	1.30E+03	1.05E+04	5.90E+03
Xe-135m	3.22E+02	2.68E+03	1.50E+03
Xe-138	3.21E+02	2.97E+03	1.65E+03
I-131	5.31E-02	2.35E-02	3.83E-02
I-132	4.71E-08	1.52E-01	7.60E-02
I-133	3.84E-02	1.04E-02	2.44E-02
I-134	<MDA	8.76E-04	4.38E-04
I-135	<MDA	5.58E-04	2.79E-04
F-18	6.68E-06	<MDA	3.34E-06
Na-24	3.16E-05	5.47E-06	1.85E-05
Mn-54	<MDA	4.66E-05	2.33E-05
Co-57	<MDA	5.50E-07	2.75E-07
Co-58	3.79E-03	1.13E-03	2.46E-03
Co-60	1.50E-03	2.81E-03	2.16E-03
Rb-88	9.15E-04	4.95E-03	2.93E-03
Zr-95	<MDA	1.49E-10	7.50E-11
Nb-95	3.19E-04	1.69E-04	2.44E-04
Mo-99	<MDA	3.28E-03	1.64E-03
Ru-103	<MDA	2.73E-05	1.37E-05
Cd-109	<MDA	1.95E-08	9.75E-09
Cs-134	<MDA	4.08E-05	2.04E-05

Sheet 1 of 2

Table I.7-4 (CONTINUED)
 POINT BEACH NUCLEAR PLANT AIRBORNE RELEASES (1974-1975) (Ci/yr)

<u>Isotope</u>	<u>1974</u>	<u>1975</u>	<u>Annual Average</u>
Cs-136	<MDA	7.00E-06	3.50E-06
Cs-137	2.32E-04	1.38E-03	8.06E-04
Cs-138	1.41E-04	3.55E-02	1.78E-02
Ce-141	<MDA	1.29E-05	6.45E-06
Ce-144	<MDA	1.11E-04	5.55E-05

SUMMARY OF AIRBORNE RELEASES:

	<u>Tritium</u>	<u>Noble Gases</u>	<u>Iodines</u>	<u>Particulate</u>
1974	4.28E+01	9.75E+03	9.15E-02	6.93E-03
1975	1.77E+02	4.43E+04	1.87E-01	4.95E-02
Average	1.10E+02	2.70E+04	1.39E-01	2.82E-02

Table I.7-5 POINT BEACH NUCLEAR PLANT OBSERVED MONTHLY GASEOUS RELEASES BY RELEASE POINT

PBNP AIRBORNE RELEASE SUMMARY FOR JANUARY, 1974

Unit 1 - 2 Maintenance Shutdowns; 0.3 Day Total Outage

Unit 2 - No Shutdowns

Isotope	Unit 1 Air Ej.	Unit 2 Air Ej.	Aux. Bldg. Vent	Unit 1 Contain.	Unit 2 Contain.	Turb. Bldg.	Dr. Area Vent
H-3			8.14E-01	1.03E-02	1.20E-02		3.70E-01
F-18							
Ar-41			7.00E-01	1.10E-04	1.30E-03		
Kr-85			5.80E-01	4.70E-02	7.00E-03		
Kr-85m			6.05E+01	1.25E-01	1.40E-02		
Kr-87			3.72E+01	2.40E-02	7.00E-03		
Kr-88			8.72E+01	1.13E-01	5.70E-02		
Xe-131m							
Xe-133			6.15E+02	4.61E+00	6.25E+00		6.60E+01
Xe-133m			1.28E+01	8.30E-02	1.14E-01		
Xe-135			2.52E+02	9.33E-01	6.46E-01		
Xe-135m			3.95E+01	3.00E-03	1.00E-03		
Xe-138			5.70E+01	5.00E-03	1.00E-03		
I-131			1.40E-04	7.35E-10			
I-132							
I-133			4.70E-04				
I-134							
I-135							
Na-24					6.00E-09		
Mn-54							
Co-57							
Co-58							4.12E-04
Co-60			1.90E-06	2.20E-08			4.58E-05
Rb-88							
Zr-95							
Nb-95							
Mo-99							
Ru-103							
Ru-106							
Cd-109							
Cs-134							
Cs-136							
Cs-137							
Cs-138							
Ce-141							
Ce-144							

Table I.7-5 (CONTINUED)- POINT BEACH NUCLEAR PLANT OBSERVED MONTHLY GASEOUS RELEASES BY RELEASE POINT

PBNP AIRBORNE RELEASE SUMMARY FOR FEBRUARY, 1974

Unit 1 - 0.2 Day Shutdown for Maintenance

Unit 2 - No Shutdowns

Isotope	Unit 1 Air Ej.	Unit 2 Air Ej.	Aux. Bldg. Vent	Unit 1 Contain.	Unit 2 Contain.	Turb. Bldg.	Dr. Area Vent
H-3			7.35E-01	1.48E-02	1.06E-02		3.41E-01
F-18							
Ar-41			2.00E+00		4.80E-05		
Kr-85			1.13E+01	6.10E-02			
Kr-85m			6.80E+01	1.31E-01	7.60E-04		
Kr-87			4.20E+01	2.60E-02	1.20E-04		
Kr-88			9.40E+01	1.14E-01	1.20E-03		
Xe-131m			1.37E+02	1.11E+00	7.70E-03		
Xe-133			8.21E+02	6.19E+00	6.40E-02		2.35E-01
Xe-133m			1.40E+01	1.05E-01	1.40E-03		
Xe-135			2.82E+02	9.97E-01	8.20E-03		
Xe-135m			4.80E+01	9.00E-03	1.60E-05		
Xe-138			6.30E+01	9.00E-03	1.60E-05		
I-131			2.90E-04				
I-132							
I-133			4.58E-03				
I-134							
I-135							
Na-24					6.00E-06		
Mn-54							
Co-57							
Co-58							2.34E-04
Co-60			5.61E-06				2.60E-05
Rb-88							
Zr-95							
Nb-95							
Mo-99							
Ru-103							
Ru-106							
Cd-109							
Cs-134							
Cs-136							
Cs-137							
Cs-138							
Ce-141							
Ce-144							

Table I.7-5 (CONTINUED)- POINT BEACH NUCLEAR PLANT OBSERVED MONTHLY GASEOUS RELEASES BY RELEASE POINT

PBNP AIRBORNE RELEASE SUMMARY FOR MARCH, 1974

Unit 1 - No Shutdowns

Unit 2 - No Shutdowns

Isotope	Unit 1 Air Ej.	Unit 2 Air Ej.	Aux. Bldg. Vent	Unit 1 Contain.	Unit 2 Contain.	Turb. Bldg.	Dr. Area Vent
H-3			1.65E+00	5.09E-02	1.31E-02	4.32E+00	1.21E-01
F-18							
Ar-41			1.21E+00	3.60E-03	4.80E-05		
Kr-85			5.10E-01	1.20E-01	4.63E-04		
Kr-85m			4.55E+01	2.76E-01	8.68E-04		
Kr-87			3.06E+01	5.55E-02	1.54E-04		
Kr-88			6.60E+01	2.55E-01	7.17E-04		
Xe-131m			1.00E+02	2.59E+00	8.75E-03		
Xe-133			4.61E+02	1.05E+01	7.39E-02		
Xe-133m			8.40E+00	1.81E-01	1.25E-03		
Xe-135			2.13E+02	2.33E+00	1.03E-02		
Xe-135m			4.18E+01	9.80E-03	2.10E-05		
Xe-138			4.41E+01	1.84E-01	2.10E-05		
I-131			8.03E-04		1.82E-09		
I-132							
I-133			3.56E-03				
I-134							
I-135							
Na-24					8.00E-09		
Mn-54							
Co-57							
Co-58							8.51E-05
Co-60							9.46E-06
Rb-88			7.01E-04	9.88E-06			
Zr-95							
Nb-95							
Mo-99							
Ru-103							
Ru-106							
Cd-109							
Cs-134							
Cs-136							
Cs-137							
Cs-138			1.05E-04	4.30E-06			
Ce-141							
Ce-144							

Table I.7-5 (CONTINUED)- POINT BEACH NUCLEAR PLANT OBSERVED MONTHLY GASEOUS RELEASES BY RELEASE POINT

PBNP AIRBORNE RELEASE SUMMARY FOR APRIL, 1974

Unit 1 - Commence First 24 Days of Refueling Outage

Unit 2 - No Shutdowns

Isotope	Unit 1 Air Ej.	Unit 2 Air Ej.	Aux. Bldg. Vent	Unit 1 Contain.	Unit 2 Contain.	Turb. Bldg.	Dr. Area Vent
H-3			1.65E+00	5.23E+00	1.50E-02	4.32E+00	2.11E-01
F-18							
Ar-41			6.20E-01	4.00E-04	1.00E-03		
Kr-85			3.10E-01	1.40E-02			
Kr-85m			2.09E+01	2.30E-02	4.90E-02		
Kr-87			1.60E+01	4.00E-03	6.00E-03		
Kr-88			3.14E+01	2.10E-02	4.90E-02		
Xe-131m			4.86E+01	4.48E+01	4.47E-01		
Xe-133			3.38E+02	4.27E+02	4.75E+00		3.35E-01
Xe-133m			6.20E+00	1.04E+01	7.20E-02		
Xe-135			1.13E+02	1.72E+00	6.51E-01		
Xe-135m			2.15E+01	1.00E-03	2.00E-03		
Xe-138			1.85E+01	2.00E-03	6.00E-03		
I-131			3.3E-02	1.50E-05	3.46E-09		1.59E-04
I-132							
I-133			5.56E-04				
I-134							
I-135							
Na-24					9.70E-09		
Mn-54							
Co-57							
Co-58				1.58E-06			1.80E-03
Co-60				1.78E-07			1.20E-04
Rb-88				1.98E-04			
Zr-95							
Nb-95							
Mo-99							
Ru-103							
Ru-106							
Cd-109							
Cs-134							
Cs-136							
Cs-137							
Cs-138				3.20E-05			
Ce-141							
Ce-144							

Table I.7-5 (CONTINUED)- POINT BEACH NUCLEAR PLANT OBSERVED MONTHLY GASEOUS RELEASES BY RELEASE POINT

PBNP AIRBORNE RELEASE SUMMARY FOR MAY, 1974

Unit 1 - 26 Days of Refueling Outage; 5 Days Turbine Repair Outage

Unit 2 - No Shutdowns

Isotope	Unit 1 Air Ej.	Unit 2 Air Ej.	Aux. Bldg. Vent	Unit 1 Contain.	Unit 2 Contain.	Turb. Bldg.	Dr. Area Vent
H-3			5.92E-01	3.13E+00	1.64E-02	2.34E+00	2.14E-01
F-18					1.91E-09		
Ar-41			3.30E-01		1.00E-04		
Kr-85			4.20E-01		4.40E-03		
Kr-85m			3.22E+00		8.00E-04		
Kr-87			1.90E+00		1.00E-04		
Kr-88			3.92E+00		6.00E-04		
Xe-131m			1.80E+01		1.16E-02		
Xe-133			7.62E+01	3.16E+01	7.80E-02		
Xe-133m			1.25E+00		1.20E-03		
Xe-135			1.67E+01		8.00E-03		
Xe-135m			2.67E+00		1.00E-04		
Xe-138			1.39E+00		1.00E-04		
I-131			6.17E-04	4.39E-06	1.34E-10		5.95E-04
I-132							
I-133							
I-134							
I-135							
Na-24					6.53E-09		
Mn-54							
Co-57							
Co-58				2.50E-06			1.04E-04
Co-60				2.70E-07			6.80E-05
Rb-88				1.98E-04			
Zr-95							
Nb-95							
Mo-99							
Ru-103							
Ru-106							
Cd-109							
Cs-134							
Cs-136							
Cs-137			2.32E-04				
Cs-138							
Ce-141							
Ce-144							

Table I.7-5 (CONTINUED)- POINT BEACH NUCLEAR PLANT OBSERVED MONTHLY GASEOUS RELEASES BY RELEASE POINT

PBNP AIRBORNE RELEASE SUMMARY FOR JUNE, 1974

Unit 1 - 7 Days Outage for Turbine Repair; 0.4 Day Outage for Turbine Balancing

Unit 2 - No Shutdowns

Isotope	Unit 1 Air Ej.	Unit 2 Air Ej.	Aux. Bldg. Vent	Unit 1 Contain.	Unit 2 Contain.	Turb. Bldg.	Dr. Area Vent
H-3			2.71E+00	3.00E-03	2.30E-02	1.10E-01	2.35E-01
F-18					1.39E-08		
Ar-41			4.21E+00	6.00E-03			
Kr-85			1.10E-01	1.33E-02			
Kr-85m			1.51E+01	4.52E-02	7.00E-04		
Kr-87			6.67E+00	5.30E-03	1.00E-04		
Kr-88			1.90E+01	3.73E-02	6.00E-04		
Xe-131m			4.32E+01	3.51E-01	5.11E-02		
Xe-133			1.64E+02	1.77E+00	7.78E-02		
Xe-133m			4.21E+00	4.52E-02	1.40E-03		
Xe-135			7.09E+01	3.81E-01	7.30E-03		
Xe-135m			1.90E+01	3.00E-03	1.00E-04		
Xe-138			4.91E+00	1.00E-03			
I-131			2.24E-03	1.90E-08	9.50E-11		1.41E-04
I-132							
I-133			1.96E-02				
I-134							
I-135							
Na-24					4.76E-08		
Mn-54							
Co-57							
Co-58			8.26E-04	7.10E-06			
Co-60			1.71E-03	7.70E-06			9.90E-05
Rb-88							
Zr-95							
Nb-95							
Mo-99							
Ru-103							
Ru-106							
Cd-109							
Cs-134							
Cs-136							
Cs-137							
Cs-138							
Ce-141							
Ce-144							

Table I.7-5 (CONTINUED)- POINT BEACH NUCLEAR PLANT OBSERVED MONTHLY GASEOUS RELEASES BY RELEASE POINT

PBNP AIRBORNE RELEASE SUMMARY FOR JULY, 1974

Unit 1 - No Shutdowns

Unit 2 - 3.7 Day Outage for Maintenance

Isotope	Unit 1 Air Ej.	Unit 2 Air Ej.	Aux. Bldg. Vent	Unit 1 Contain.	Unit 2 Contain.	Turb. Bldg.	Dr. Area Vent
H-3			1.99E+00	4.83E-03	1.93E-02	6.10E-02	9.40E-02
F-18					1.76E-08		
Ar-41			1.70E+00	1.09E-01	4.00E-05		
Kr-85			1.10E-01	6.80E-03	1.00E-04		
Kr-85m			9.09E+00	1.38E-01	1.10E-03		
Kr-87			7.67E+00	2.73E-02	3.00E-04		
Kr-88			1.08E+01	1.09E-01	9.00E-04		
Xe-131m			1.51E+01	9.84E-01	2.70E-03		
Xe-133			1.76E+02	1.11E+01	9.08E-02		1.89E-01
Xe-133m			3.12E+00	1.78E-01	1.50E-03		
Xe-135			4.86E+01	1.34E+00	1.19E-02		
Xe-135m			7.67E+00	6.80E-03	6.00E-05		
Xe-138			4.26E+00	4.00E-03	4.00E-05		
I-131			6.22E-04	4.16E-09	1.21E-10		6.39E-05
I-132							
I-133			1.92E-03				
I-134							
I-135							
Na-24					6.03E-08		
Mn-54							
Co-57							
Co-58			6.80E-04	6.24E-09			
Co-60			6.80E-04				
Rb-88							
Zr-95							
Nb-95			2.99E-04				
Mo-99							
Ru-103							
Ru-106							
Cd-109							
Cs-134							
Cs-136							
Cs-137							
Cs-138							
Ce-141							
Ce-144							

Table I.7-5 (CONTINUED)- POINT BEACH NUCLEAR PLANT OBSERVED MONTHLY GASEOUS RELEASES BY RELEASE POINT
PBNP AIRBORNE RELEASE SUMMARY FOR AUGUST, 1974
 Unit 1 - 0.7 Day Outage for Testing & Maintenance
 Unit 2 - No Shutdowns

<u>Isotope</u>	<u>Unit 1 Air Ej.</u>	<u>Unit 2 Air Ej.</u>	<u>Aux. Bldg. Vent</u>	<u>Unit 1 Contain.</u>	<u>Unit 2 Contain.</u>	<u>Turb. Bldg.</u>	<u>Dr. Area Vent</u>
H-3	3.44E-01		5.46E-01	6.04E-03	1.25E-02	8.67E-02	1.36E-01
F-18					5.68E-06		
Ar-41	1.66E-03		3.90E-01	5.20E-03	1.00E-04		
Kr-85							
Kr-85m	1.82E-01		4.26E+00	1.87E-01	1.20E-03		
Kr-87	1.77E-01		4.13E+00	5.37E-02	3.00E-04		
Kr-88	2.43E-01		5.68E+00	1.61E-01	8.00E-04		
Xe-131m							
Xe-133	3.62E+00		8.46E+01	1.49E+01	1.48E-01		1.73E+00
Xe-133m	6.08E-02		1.42E+00	2.30E-01	3.60E-03		
Xe-135	9.57E-01		2.23E+01	1.79E+00	1.47E-02		
Xe-135m	1.66E-01		3.88E+00	1.04E-02	1.00E-04		
Xe-138	1.11E-01		2.58E+00	6.90E-03	1.00E-04		
I-131			2.32E-04	7.73E-07	1.14E-08		2.80E-04
I-132							
I-133			8.84E-05				1.12E-04
I-134							
I-135							
Na-24					1.95E-05		
Mn-54							
Co-57							
Co-58			3.93E-05	4.45E-07			
Co-60			3.93E-05				1.56E-04
Rb-88							
Zr-95							
Nb-95			1.73E-05				
Mo-99							
Ru-103							
Ru-106							
Cd-109							
Cs-134							
Cs-136							
Cs-137							
Cs-138							
Ce-141							
Ce-144							

Table I.7-5 (CONTINUED)- POINT BEACH NUCLEAR PLANT OBSERVED MONTHLY GASEOUS RELEASES BY RELEASE POINT

PBNP AIRBORNE RELEASE SUMMARY FOR SEPTEMBER, 1974

Unit 1 - No Shutdowns

Unit 2 - No Shutdowns

Isotope	Unit 1 Air Ej.	Unit 2 Air Ej.	Aux. Bldg. Vent	Unit 1 Contain.	Unit 2 Contain.	Turb. Bldg.	Dr. Area Vent
H-3			4.04E-01	5.28E-03		8.39E-02	3.66E-01
F-18					9.58E-07		
Ar-41			5.50E-01	1.30E-03	1.00E-04		
Kr-85							
Kr-85m			5.82E+00	3.43E-02	8.00E-04		
Kr-87			3.64E+00	6.30E-03	2.00E-04		
Kr-88			7.64E+00	2.86E-02	8.00E-04		
Xe-131m							
Xe-133			1.16E+02	2.77E+00	7.64E-02		
Xe-133m			4.36E+00	9.79E-02	1.20E-03		
Xe-135			3.64E+01	3.93E-01	8.50E-03		
Xe-135m			5.09E+00	1.70E-03	3.00E-05		
Xe-138			2.91E+00	1.00E-03	3.00E-05		
I-131			6.80E-05	4.20E-08	1.29E-09	4.91E-03	
I-132							
I-133			5.45E-09		4.14E-10		
I-134							
I-135							
Na-24					5.91E-06		
Mn-54							
Co-57							
Co-58			6.99E-06	1.48E-08			
Co-60			6.99E-06			1.56E-05	
Rb-88					5.38E-06		
Zr-95							
Nb-95			3.07E-06				
Mo-99							
Ru-103							
Ru-106							
Cd-109							
Cs-134							
Cs-136							
Cs-137							
Cs-138							
Ce-141							
Ce-144							

Table I.7-5 (CONTINUED)- POINT BEACH NUCLEAR PLANT OBSERVED MONTHLY
 GASEOUS RELEASES BY RELEASE POINT
PBNP AIRBORNE RELEASE SUMMARY FOR OCTOBER, 1974
 Unit 1 - 2 Day Outage for Testing & Maintenance
 Unit 2 - Refueling & Maintenance Outage; 15 Days

Isotope	Unit 1 Air Ej.	Unit 2 Air Ej.	Aux. Bldg. Vent	Unit 1 Contain.	Unit 2 Contain.	Turb. Bldg.	Dr. Area Vent
H-3			5.06E-01	5.31E-03		1.64E-09	8.00E-02
F-18							
Ar-41	3.20E-03		1.53E+00	3.20E-03	3.70E-02		
Kr-85	4.60E-04		2.18E-01	4.20E-03			
Kr-85m	2.90E-02		1.38E+01	6.48E-02	1.85E-01		
Kr-87	1.86E-02		8.87E+00	1.21E-02	4.93E-02		
Kr-88	3.90E-02		1.86E+01	5.59E-02	1.63E-01		
Xe-131m							
Xe-133	5.00E-01		2.36E+02	4.53E+00	2.01E+01		4.79E-02
Xe-133m	7.87E-03		3.74E+00	6.48E-02	4.28E-01		
Xe-135	1.28E-01		6.10E+01	5.29E-01	1.93E+00		
Xe-135m	2.30E-02		1.09E+01	3.20E-03	9.21E-03		
Xe-138	1.80E-02		8.54E+00	2.60E-03	7.66E-03		
I-131			4.72E-03	2.16E-08	5.48E-07		1.58E-06
I-132					3.83E-09		
I-133			1.50E-03		2.72E-06		
I-134							
I-135							
Na-24							
Mn-54							
Co-57							
Co-58				3.19E-08			
Co-60							5.94E-06
Rb-88				1.98E-04			
Zr-95							
Nb-95							
Mo-99							
Ru-103							
Ru-106							
Cd-109							
Cs-134							
Cs-136							
Cs-137							
Cs-138							
Ce-141							
Ce-144							

Table I.7-5 (CONTINUED)- POINT BEACH NUCLEAR PLANT OBSERVED MONTHLY GASEOUS RELEASES BY RELEASE POINT

PBNP AIRBORNE RELEASE SUMMARY FOR NOVEMBER, 1974

Unit 1 - 2.0 Day Outage for Chemistry Adjustment in Steam Generator

Unit 2 - Refueling & Maintenance Outage; Entire Month

<u>Isotope</u>	<u>Unit 1 Air Ej.</u>	<u>Unit 2 Air Ej.</u>	<u>Aux. Bldg. Vent</u>	<u>Unit 1 Contain.</u>	<u>Unit 2 Contain.</u>	<u>Turb. Bldg.</u>	<u>Dr. Area Vent</u>
H-3	2.44E-01		4.91E+00	5.21E-03		1.64E-09	1.97E+00
F-18							
Ar-41	2.90E-02		2.40E+00	8.90E-04	7.40E-02		
Kr-85							
Kr-85m	3.74E-01		3.13E+01	2.83E-02	3.70E-01		
Kr-87	2.93E-01		2.46E+01	6.50E-03	9.90E-02		
Kr-88	4.87E-01		4.08E+01	2.37E-02	3.26E-01		
Xe-131m							
Xe-133	5.86E+00		4.91E+02	1.82E+00	4.02E+01		4.02E-01
Xe-133m	3.82E-01		3.20E+01	1.08E-01	9.64E-01		
Xe-135	1.78E+00		1.49E+02	2.48E-01	3.86E+00		
Xe-135m	2.60E-01		2.18E+01	1.00E-03	1.80E-02		
Xe-138	2.20E-01		1.84E+01	1.00E-03	1.50E-02		
I-131			2.47E-04		1.07E-07		3.05E-05
I-132					4.33E-08		
I-133			1.94E-04				
I-134							
I-135							
Na-24							
Mn-54							
Co-57							
Co-58			1.50E-04	1.95E-08	8.56E-08		1.51E-05
Co-60					1.24E-07		
Rb-88							
Zr-95							
Nb-95							
Mo-99							
Ru-103							
Ru-106							
Cd-109							
Cs-134							
Cs-136							
Cs-137							
Cs-138							
Ce-141							
Ce-144							

Table I.7-5 (CONTINUED)- POINT BEACH NUCLEAR PLANT OBSERVED MONTHLY GASEOUS RELEASES BY RELEASE POINT

PBNP AIRBORNE RELEASE SUMMARY FOR DECEMBER, 1974

Unit 1 - No Shutdowns

Unit 2 - 21 Day Outage for Refueling & Maintenance; 2 Shutdowns for Testing & Turbine Balancing (0.3 Day Additional Outage)

Isotope	Unit 1 Air Ej.	Unit 2 Air Ej.	Aux. Bldg. Vent	Unit 1 Contain.	Unit 2 Contain.	Turb. Bldg.	Dr. Area Vent
H-3	7.70E-01			5.31E-03	5.31E-04		9.77E-01
F-18							
Ar-41	3.90E-02		1.60E+01	1.50E-03	7.39E-02		
Kr-85	7.24E-03		3.00E+00	3.89E-03	6.85E-02		
Kr-85m	2.34E-01		9.41E+01	5.16E-02	1.99E-01		
Kr-87	1.6E-01		6.55E+01	1.04E-02	4.97E-01		
Kr-88	3.84E-01		1.54E+02	5.41E-02	1.83E-01		
Xe-131m							
Xe-133	4.45E+00		1.79E+03	4.07E+00	2.05E+01		6.02E-01
Xe-133m	6.08E-02		2.70E+01	5.50E-02	5.20E-01		
Xe-135	1.41E+00		5.68E+02	5.74E-01	2.07E+00		2.41E+00
Xe-135m	2.46E-01		9.90E+01	3.26E-03	1.00E-02		
Xe-138	2.36E-01		9.50E+01	3.51E-03	8.57E-03		
I-131			1.82E-03	1.92E-07	3.90E-06		1.82E-03
I-132							
I-133			5.73E-03	1.01E-08	2.29E-06		3.20E-06
I-134							
I-135							
Na-24							
Mn-54							
Co-57							
Co-58			1.27E-04	1.36E-06	3.36E-06		9.01E-05
Co-60					4.46E-06		8.32E-05
Rb-88							
Zr-95							
Nb-95							
Mo-99							
Ru-103							
Ru-106							
Cd-109							
Cs-134							
Cs-136							
Cs-137							
Cs-138							
Ce-141							
Ce-144							

Table I.7-5 (CONTINUED)- POINT BEACH NUCLEAR PLANT OBSERVED MONTHLY GASEOUS RELEASES BY RELEASE POINT

PBNP AIRBORNE RELEASE SUMMARY FOR JANUARY, 1975

Unit 1 - 18 Day Outage for Sludge Lancing & Maintenance

Unit 2 - No Shutdowns

<u>Isotope</u>	<u>Unit 1 Air Ej.</u>	<u>Unit 2 Air Ej.</u>	<u>Aux. Bldg. Vent</u>	<u>Unit 1 Contain.</u>	<u>Unit 2 Contain.</u>	<u>Turb. Bldg.</u>	<u>Dr. Area Vent</u>
H-3	1.37E-01			2.84E-03			2.14E-01
F-18							
Ar-41	9.25E-03		4.24E+01	9.16E-03	3.04E-02		
Kr-85	8.93E-04		4.09E+00	5.19E-03	3.26E-02		
Kr-85m	4.73E-02		2.17E+02	5.13E-01	2.10E-02		
Kr-87	3.82E-02		1.75E+02	1.29E-01	3.73E-03		
Kr-88	7.45E-02		3.41E+02	5.50E-01	1.97E-02		
Xe-131m							
Xe-133	5.72E-01		2.62E+03	3.83E+01	2.06E+00		
Xe-133m	9.14E-03		4.19E+01	5.92E-03	5.11E-04		
Xe-135	2.73E-01		1.25E+03	5.75E+00	2.43E-01		
Xe-135m	5.21E-02		2.39E+02	2.25E+00	5.76E-02		
Xe-138	5.40E-02		2.47E+02	4.18E-02	1.21E-03		
I-131			6.91E-03	8.81E-06	2.16E-07		1.84E-04
I-132			4.61E-05		1.80E-08		
I-133			1.56E-03	6.66E-09	1.65E-07		
I-134					3.57E-08		
I-135					6.12E-08		
Na-24							
Mn-54							1.66E-05
Co-57							
Co-58			1.70E-04	4.25E-07	1.66E-08		2.56E-06
Co-60				6.74E-07	3.12E-08		7.12E-06
Rb-88							
Zr-95							
Nb-95							3.30E-06
Mo-99							
Ru-103							5.86E-06
Ru-106							
Cd-109							
Cs-134							
Cs-136							
Cs-137							
Cs-138							
Ce-141							
Ce-144							

Table I.7-5 (CONTINUED)- POINT BEACH NUCLEAR PLANT OBSERVED MONTHLY GASEOUS RELEASES BY RELEASE POINT

PBNP AIRBORNE RELEASE SUMMARY FOR FEBRUARY, 1975

Unit 1 - 5 Day Shutdown for Steam Generator Tube Repair & CRD Maintenance

Unit 2 - 2 Shutdowns for Maintenance & Valve Lineup (Total 3.4 Day Outage)

Isotope	Unit 1 Air Ej.	Unit 2 Air Ej.	Aux. Bldg. Vent	Unit 1 Contain.	Unit 2 Contain.	Turb. Bldg.	Dr. Area Vent
H-3				8.33E-03	1.06E-01		
F-18							
Ar-41	2.04E-01		6.30E+01	3.70E-03	1.12E-01		
Kr-85							
Kr-85m	1.16E+00		3.56E+02	9.03E-02	9.86E-02		
Kr-87	7.64E-01		2.36E+02	2.18E-02	9.66E-02		
Kr-88	1.53E+00		4.56E+02	6.68E-02	8.07E-02		
Xe-131m							
Xe-133	9.74E+00		3.01E+03	2.58E+00	1.29E+01		2.67E+01
Xe-133m	1.80E-01		5.55E+01	6.60E-04	5.20E-03		
Xe-135	4.87E+00		1.50E+03	6.08E-01	8.04E-01		
Xe-135m	1.80E+00		3.33E+02	2.83E-01	3.01E-01		
Xe-138	1.53E+00		4.71E+02	7.27E-03	5.13E-03		
I-131			3.62E-03	3.58E-07	1.30E-05		1.47E-04
I-132			2.47E-05		4.10E-06		
I-133			1.41E-03	2.59E-07	1.05E-05		
I-134					1.30E-10		
I-135					1.19E-05		
Na-24					5.47E-06		
Mn-54							
Co-57							
Co-58				2.31E-08	9.02E-07		4.15E-06
Co-60					1.21E-06		1.15E-05
Rb-88							
Zr-95							
Nb-95							5.35E-06
Mo-99					1.75E-06		
Ru-103							9.50E-06
Ru-106							
Cd-109							
Cs-134					1.30E-10		
Cs-136							
Cs-137					1.16E-06		
Cs-138							
Ce-141							
Ce-144							

Table I.7-5 (CONTINUED)- POINT BEACH NUCLEAR PLANT OBSERVED MONTHLY
 GASEOUS RELEASES BY RELEASE POINT
 PBNP AIRBORNE RELEASE SUMMARY FOR MARCH, 1975
 Unit 1 - Outage for Steam Generator Tube Repair & Maintenance Continued Through
 Entire Month
 Unit 2 - No Shutdowns

Isotope	Unit 1 Air Ej.	Unit 2 Air Ej.	Aux. Bldg. Vent	Unit 1 Contain.	Unit 2 Contain.	Turb. Bldg.	Dr. Area Vent
H-3			2.34E-01	7.62E-03			
F-18							
Ar-41			4.93E+01	1.42E-02			
Kr-85							
Kr-85m			2.18E+01	2.03E-02			
Kr-87			1.16E+01	3.15E-03			
Kr-88			2.70E+01	1.62E-02			
Xe-131m							
Xe-133			7.97E+02	2.39E+00			5.46E+01
Xe-133m			7.68E+00	4.25E-04			
Xe-135			1.25E+02	1.91E-01			
Xe-135m			1.47E+02	5.10E-01			
Xe-138			1.71E+01	1.07E-03			
I-131			4.81E-03	1.51E-08			1.69E-03
I-132			1.50E-01				
I-133			2.53E-04	1.18E-09			
I-134							
I-135							
Na-24							
Mn-54							
Co-57							
Co-58			1.43E-04				1.37E-05
Co-60							
Rb-88							
Zr-95							
Nb-95				6.20E-09			7.16E-06
Mo-99							
Ru-103							
Ru-106							
Cd-109							
Cs-134							
Cs-136							
Cs-137				2.32E-09			
Cs-138							
Ce-141							
Ce-144			1.74E-05				

Table I.7-5 (CONTINUED)- POINT BEACH NUCLEAR PLANT OBSERVED MONTHLY GASEOUS RELEASES BY RELEASE POINT

PBNP AIRBORNE RELEASE SUMMARY FOR APRIL, 1975

Unit 1 - 4 Day Outage for Steam Generator Tube Repair & CRD Maintenance

Unit 2 - 1.1 Day Outage for Chemistry Adjustment

<u>Isotope</u>	<u>Unit 1 Air Ej.</u>	<u>Unit 2 Air Ej.</u>	<u>Aux. Bldg. Vent</u>	<u>Unit 1 Contain.</u>	<u>Unit 2 Contain.</u>	<u>Turb. Bldg.</u>	<u>Dr. Area Vent</u>
H-3	4.96E+01	<MDA	4.76E-01	2.53E-03	7.61E-03		6.41E-04
F-18							
Ar-41	1.38E-02		1.34E+01	4.43E-03	3.32E-03		
Kr-85							
Kr-85m	2.19E-01		2.13E+02	3.32E-01	8.04E-03		
Kr-87	1.58E-01		1.54E+02	7.00E-02	1.59E-03		
Kr-88	2.90E-01		2.82E+02	2.84E-01	6.70E-03		
Xe-131m							
Xe-133	2.18E+00		2.13E+03	1.19E+01	1.48E+00		2.80E+00
Xe-133m	5.16E-02		5.03E+01	4.47E-03	2.77E-04		
Xe-135	1.12E+00		1.09E+03	3.12E+00	8.83E-02		
Xe-135m	1.82E-01		1.77E+02	1.03E+00	2.29E-02		
Xe-138	2.36E-01		2.30E+02	2.43E-02	4.75E-04		
I-131			6.80E-04	1.43E-09	1.14E-06		6.48E-05
I-132			6.41E-04		2.34E-07		
I-133			1.96E-05		2.79E-07		
I-134							
I-135							
Na-24							
Mn-54							
Co-57							
Co-58			3.82E-05	1.85E-07			
Co-60							
Rb-88							
Zr-95							
Nb-95					3.29E-05		
Mo-99							
Ru-103							1.19E-05
Ru-106							
Cd-109							
Cs-134							
Cs-136							
Cs-137					1.23E-05		
Cs-138							
Ce-141							1.15E-05
Ce-144			9.38E-05				

Table I.7-5 (CONTINUED)- POINT BEACH NUCLEAR PLANT OBSERVED MONTHLY GASEOUS RELEASES BY RELEASE POINT

PBNP AIRBORNE RELEASE SUMMARY FOR MAY, 1975

Unit 1 - No Shutdown

Unit 2 - 2 Shutdowns for Maintenance; Total 3.4 Day Outage

<u>Isotope</u>	<u>Unit 1 Air Ej.</u>	<u>Unit 2 Air Ej.</u>	<u>Aux. Bldg. Vent</u>	<u>Unit 1 Contain.</u>	<u>Unit 2 Contain.</u>	<u>Turb. Bldg.</u>	<u>Dr. Area Vent</u>
H-3	<MDA		7.08E-01	2.38E-02	4.88E-02	1.38E-10	1.63E-01
F-18							
Ar-41	5.93E-03		8.44E+00	7.15E-03	3.35E-03		
Kr-85							
Kr-85m	2.11E-01		3.01E+02	1.21E+00	2.01E-02		
Kr-87	1.51E-01		2.15E+02	2.54E-01	2.87E-03		
Kr-88	2.83E-01		4.02E+02	1.05E+00	1.33E-02		
Xe-131m							
Xe-133	2.77E+00		3.95E+03	6.25E+01	2.13E+00		
Xe-133m	3.66E-02		5.21E+01	1.24E-02	3.74E-04		
Xe-135	1.04E+00		1.48E+03	1.10E+01	1.71E-01		
Xe-135m	2.42E-01		3.44E+02	5.16E+00	7.60E-02		
Xe-138	2.05E-01		2.92E+02	7.77E-02	1.61E-03		
I-131			3.52E-04		1.33E-08		2.96E-06
I-132							
I-133			1.81E-04				1.61E-05
I-134							
I-135							
Na-24							
Mn-54				3.62E-10			1.31E-05
Co-57							
Co-58				5.07E-10			1.41E-05
Co-60			1.80E-04				2.95E-05
Rb-88				2.48E-06			
Zr-95							
Nb-95				6.92E-10			4.98E-06
Mo-99							
Ru-103					1.82E-07		
Ru-106							
Cd-109					2.72E-09		
Cs-134							
Cs-136							
Cs-137							
Cs-138			1.87E-04				
Ce-141							
Ce-144							

Table I.7-5 (CONTINUED)- POINT BEACH NUCLEAR PLANT OBSERVED MONTHLY GASEOUS RELEASES BY RELEASE POINT

PBNP AIRBORNE RELEASE SUMMARY FOR JUNE, 1975
 Unit 1 - 1.2 Day Outage for Personnel, Licensing & Maintenance
 Unit 2 - 0.7 Day Outage for Maintenance

<u>Isotope</u>	<u>Unit 1 Air Ej.</u>	<u>Unit 2 Air Ej.</u>	<u>Aux. Bldg. Vent</u>	<u>Unit 1 Contain.</u>	<u>Unit 2 Contain.</u>	<u>Turb. Bldg.</u>	<u>Dr. Area Vent</u>
H-3	4.14E-02	<MDA	7.32E-01	1.84E-02	3.17E-03	1.63E-09	1.43E-01
F-18							
Ar-41	2.03E-02		2.00E+01	1.16E-01	2.63E-03		
Kr-85							
Kr-85m	3.10E-01		3.06E+02	6.94E+02	9.30E-03		
Kr-87	2.68E-01		2.65E+02	1.77E+00	1.77E-03		
Kr-88	4.48E-01		4.42E+02	6.44E+00	7.85E-03		
Xe-131m							
Xe-133	2.94E+00		2.90E+03	2.44E+02	1.19E+00		1.04E+03
Xe-133m	4.55E-02		4.49E+01	5.76E-02	1.90E-04		1.38E+01
Xe-135	1.39E+00		1.37E+03	5.66E+01	9.58E-02		7.44E+00
Xe-135m	3.13E-01		3.09E+02	2.66E+01	2.10E-02		
Xe-138	4.85E-01		4.78E+02	7.41E-01	5.87E-04		
I-131			3.18E-04	3.72E-06			7.96E-06
I-132							
I-133			3.54E-04	2.31E-06			
I-134							
I-135							
Na-24							8.52E-07
Mn-54							
Co-57							
Co-58				7.20E-11			1.04E-06
Co-60			1.78E-05	3.94E-07			2.24E-06
Rb-88			3.94E-05	4.75E-03			
Zr-95					1.49E-10		
Nb-95				2.25E-08			3.21E-07
Mo-99							
Ru-103							
Ru-106							
Cd-109							
Cs-134							
Cs-136							
Cs-137							
Cs-138			1.83E-04				
Ce-141							
Ce-144							

Table I.7-5 (CONTINUED)- POINT BEACH NUCLEAR PLANT OBSERVED MONTHLY GASEOUS RELEASES BY RELEASE POINT

PBNP AIRBORNE RELEASE SUMMARY FOR JULY, 1975

Unit 1 - No Shutdowns

Unit 2 - 1.8 Day Maintenance Outage

<u>Isotope</u>	<u>Combined Air Ej.</u>	<u>Aux. Bldg. Vent</u>	<u>Unit 1 Contain.</u>	<u>Unit 2 Contain.</u>	<u>Turb. Bldg.</u>	<u>Dr. Area Vent</u>	<u>Gas. Str. Bldg.</u>
H-3	2.88E-05	1.01E+00	7.79E-03	1.30E-02	1.54E-01	1.75E+01	
F-18							
Ar-41	1.49E-02	5.37E+01	4.01E-04	1.60E-03			6.26E-02
Kr-85							
Kr-85m	1.21E-01	3.33E+02	7.84E-03	7.16E-03			3.88E-01
Kr-87	6.10E-02	2.43E+02	1.71E-03	1.22E-03			2.83E-01
Kr-88	1.56E-01	4.67E+02	6.94E-03	5.81E-03			5.44E-01
Xe-131m							
Xe-133	3.06E-01	7.95E+02	4.89E-01	5.05E+00			9.27E-01
Xe-133m	5.56E-03	1.48E+01	2.13E-03	2.67E-02			1.73E-02
Xe-135	4.49E-01	1.15E+03	5.45E-02	7.26E-02		1.56E+01	1.34E+00
Xe-135m	1.17E-02	3.76E+02	4.67E-04	3.66E-04			4.38E-01
Xe-138	1.49E-02	3.48E+02	6.43E-04	5.07E-04			4.06E-01
I-131		2.15E-04	1.14E-10	2.20E-05		1.07E-05	
I-132							
I-133		1.67E-04		9.07E-05		1.20E-05	
I-134							
I-135							
Na-24							
Mn-54						1.49E-058	
Co-57							
Co-58						1.01E-05	
Co-60		2.57E-03	6.49E-07			3.28E-05	
Rb-88							
Zr-95							
Nb-95				9.84E-05		1.20E-05	
Mo-99		3.28E-03					
Ru-103							
Ru-106							
Cd-109							
Cs-134							
Cs-136							
Cs-137		1.23E-03				1.25E-05	
Cs-138							
Ce-141							
Ce-144							

Table I.7-5 (CONTINUED)- POINT BEACH NUCLEAR PLANT OBSERVED MONTHLY GASEOUS RELEASES BY RELEASE POINT

PBNP AIRBORNE RELEASE SUMMARY FOR AUGUST, 1975

Unit 1 - No Shutdowns

Unit 2 - 8.2 Days Shutdown for S. G. Tube Plugging & Minor Maint.

<u>Isotope</u>	<u>Combined Air Ej.</u>	<u>Aux. Bldg. Vent</u>	<u>Unit 1 Contain.</u>	<u>Unit 2 Contain.</u>	<u>Turb. Bldg.</u>	<u>Dr. Area Vent</u>	<u>Gas. Str. Bldg.</u>
H-3	1.05E-05	9.07E-01	3.12E-02	3.63E-03	4.18E-02	1.81E-01	
F-18							
Ar-41	7.80E-03	1.97E+01	1.35E-02	1.33E-02			1.50E-01
Kr-85							
Kr-85m	8.52E-02	1.65E+02	3.21E-01	2.53E-02			1.25E+00
Kr-87	3.86E-02	1.20E+02	6.93E-02	4.94E-03			9.08E-01
Kr-88	1.05E-01	2.27E+02	2.90E-01	2.19E-02			1.72E+00
Xe-131m							
Xe-133	2.84E-01	4.56E+02	2.12E+01	3.68E+00			3.46E+00
Xe-133m	5.24E-03	8.51E+00	1.09E-01	6.01E-02			6.47E-02
Xe-135	3.23E-01	5.67E+02	2.25E+00	1.73E-01			4.30E+00
Xe-135m	4.36E-03	1.76E+02	1.74E-02	1.80E-03			1.34E+00
Xe-138	7.89E-03	2.25E+02	2.24E-02	1.28E-03			1.71E+00
I-131		6.48E-04		1.33E-06		7.18E-05	
I-132							
I-133		6.77E-04				1.61E-06	
I-134							
I-135							
Na-24							
Mn-54						1.12E-06	
Co-57							
Co-58		5.94E-08	1.23E-08	9.50E-08		6.38E-06	
Co-60			1.75E-09	8.58E-10		1.12E-05	
Rb-88							
Zr-95							
Nb-95							
Mo-99							
Ru-103							
Ru-106							
Cd-109							
Cs-134							
Cs-136							
Cs-137							
Cs-138		1.29E-06					
Ce-141							
Ce-144							

Table I.7-5 (CONTINUED)- POINT BEACH NUCLEAR PLANT OBSERVED MONTHLY GASEOUS RELEASES BY RELEASE POINT
PBNP AIRBORNE RELEASE SUMMARY FOR SEPTEMBER, 1975
 Unit 1 - No Shutdowns
 Unit 2 - No Shutdowns

Isotope	Combined Air Ej.	Aux. Bldg. Vent	Unit 1 Contain.	Unit 2 Contain.	Turb. Bldg.	Dr. Area Vent	Gas. Str. Bldg.
H-3		9.15E-01	2.34E-02	1.98E-03		1.60E-01	
F-18							
Ar-41	2.42E-03	4.64E+01	2.95E-02	1.47E-02			2.08E-01
Kr-85							
Kr-85m	1.69E-02	2.46E+02	6.77E-01	1.28E-02			1.10E+00
Kr-87	7.99E-03	1.89E+02	1.50E-01	2.43E-03			8.46E-01
Kr-88	2.16E-02	3.52E+02	6.21E-01	1.09E-02			1.58E+00
Xe-131m							
Xe-133	6.35E-02	7.64E+02	2.41E+01	1.83E+00			3.42E+00
Xe-133m	1.46E-03	1.77E+01	1.93E-01	1.69E-02			7.92E-02
Xe-135	7.19E-02	9.44E+02	4.41E+00	1.04E-01			4.23E+00
Xe-135m	7.74E-04	2.59E+02	4.02E-02	6.16E-04			1.16E+00
Xe-138	1.33E-03	3.10E+02	5.49E-02	7.32E-04			1.39E+00
I-131		8.33E-04		5.15E-10		5.48E-05	
I-132							
I-133		8.03E-04		8.56E-10			
I-134							
I-135							
Na-24							
Mn-54							
Co-57							
Co-58			6.97E-07				
Co-60			5.29E-08				
Rb-88		1.61E-04					
Zr-95							
Nb-95							1.21E-06
Mo-99							
Ru-103							
Ru-106							
Cd-109				3.79E-09			
Cs-134							2.31E-06
Cs-136							
Cs-137							
Cs-138		2.12E-04					
Ce-141						1.10E-06	
Ce-144							

Table I.7-5 (CONTINUED)- POINT BEACH NUCLEAR PLANT OBSERVED MONTHLY GASEOUS RELEASES BY RELEASE POINT

PBNP AIRBORNE RELEASE SUMMARY FOR OCTOBER, 1975

Unit 1 - No Shutdowns

Unit 2 - 1.1 Day Maintenance Outage

Isotope	Combined Air Ej.	Aux. Bldg. Vent	Unit 1 Contain.	Unit 2 Contain.	Turb. Bldg.	Dr. Area Vent	Gas. Str. Bldg.
H-3	2.28E-05	3.91E-01	1.74E-02	2.39E-03		3.21E-01	
F-18							
Ar-41	3.29E-01	2.57E+01	2.18E-04	8.21E-03			9.26E-01
Kr-85							
Kr-85m	2.53E+00	1.04E+02	4.34E-03	7.95E-03			3.75E+00
Kr-87	1.19E+00	7.73E+01	9.39E-04	1.48E-03			2.78E+00
Kr-88	3.14E+00	1.44E+02	3.89E-03	6.77E-03			5.17E+00
Xe-131m							
Xe-133	6.43E+00	2.04E+02	2.79E-01	1.43E+00			8.64E+00
Xe-133m	1.44E-01	6.12E+00	2.21E-03	1.86E-02			2.20E-01
Xe-135	9.34E+00	3.51E+02	3.17E-01	6.71E-02			1.26E+01
Xe-135m	1.40E-01	1.09E+02	2.55E-04	3.92E-04			3.93E+00
Xe-138	2.58E-01	1.43E+02	3.48E-04	4.91E-04			5.14E+00
I-131		7.75E-04	1.83E-10	8.23E-10		6.70E-06	
I-132							
I-133		8.06E-04		1.32E-09			
I-134							
I-135							
Na-24							
Mn-54							
Co-57							
Co-58							
Co-60		4.25E-06	4.45E-10				
Rb-88							
Zr-95							
Nb-95						2.89E-06	
Mo-99							
Ru-103							
Ru-106							
Cd-109				1.20E-08			
Cs-134						5.51E-07	
Cs-136							
Cs-137							
Cs-138		8.84E-05					
Ce-141						2.62E-07	
Ce-144							

Table I.7-5 (CONTINUED)- POINT BEACH NUCLEAR PLANT OBSERVED MONTHLY GASEOUS RELEASES BY RELEASE POINT

PBNP AIRBORNE RELEASE SUMMARY FOR NOVEMBER, 1975*

Unit 1 - Refueling Shutdown; 15 Days

Unit 2 - 1.1 Day Maintenance Outage

Isotope	Combined Air Ej.	Aux. Bldg. Vent	Unit 1 Contain.	Unit 2 Contain.	Turb. Bldg.	Dr. Area Vent	Gas. Str. Bldg.
H-3	3.93E-05	6.26E-01	2.39E+00	6.20E-03	8.17E-02	1.07E+00	
F-18							
Ar-41	4.33E-03	1.65E+01	7.86E-02	9.21E-04			1.75E+01
Kr-85							
Kr-85m	2.34E-02	5.98E+01	5.70E-01	9.39E-04			6.35E+01
Kr-87	8.11E-03	4.18E+01	4.11E-01	1.65E-04			4.43E+01
Kr-88	2.71E-02	8.15E+01	7.78E-01	7.92E-04			8.64E+01
Xe-131m							
Xe-133	8.50E-02	1.65E+02	2.84E+00	1.68E-01		9.02E-01	1.75E+02
Xe-133m	8.71E-04	1.72E+00	4.99E-03	2.30E-03			1.83E+00
Xe-135	9.54E-02	2.11E+02	2.05E+00	7.54E-03			2.23E+02
Xe-135m	2.07E-04	6.31E+01	5.82E-01	4.85E-05			6.70E+01
Xe-138	5.30E-04	7.35E+01	7.51E-01	6.07E-05			7.80E+01
I-131		2.31E-06	2.21E-05	2.65E-08		9.81E-05	
I-132		2.45E-05					
I-133		1.10E-03				1.66E-05	
I-134							
I-135							
Na-24							
Mn-54							
Co-57							
Co-58						1.45E-06	
Co-60		3.18E-06	5.61E-10			7.54E-06	
Rb-88							
Zr-95							
Nb-95							
Mo-99							
Ru-103							
Ru-106							
Cd-109				1.05E-09			
Cs-134							
Cs-136							
Cs-137							
Cs-138		3.48E-02					
Ce-141							
Ce-144							

Table I.7-5 (CONTINUED)- POINT BEACH NUCLEAR PLANT OBSERVED MONTHLY GASEOUS RELEASES BY RELEASE POINT

PBNP AIRBORNE RELEASE SUMMARY FOR DECEMBER, 1975

Unit 1 - Refueling Outage; Entire Month

Unit 2 - No Shutdowns

Isotope	Combined Air Ej.	Aux. Bldg. Vent	Unit 1 Contain.	Unit 2 Contain.	Turb. Bldg.	Dr. Area Vent	Gas. Str. Bldg.
H-3	1.96E-03		7.76E+00	1.43E-02	3.12E-01	3.02E+00	
F-18							
Ar-41	1.16E-04	3.70E+01		1.24E-03			3.12E-01
Kr-85	2.71E-05	4.27E+00		9.07E-02			3.59E-02
Kr-85m	8.16E-05	1.72E+01		1.10E-03			1.45E-01
Kr-87	3.15E-05	1.37E+01		1.93E-04			1.15E-01
Kr-88	9.19E-05	2.29E+01		9.29E-04			1.93E-01
Xe-131m							
Xe-133	1.59E-03	2.53E+02		2.07E-01			2.13E+00
Xe-133m	2.63E-05	4.24E+00		2.68E-03			3.57E-02
Xe-135	4.79E-04	8.67E+01		9.05E-03			7.31E-01
Xe-135m	3.86E-07	8.55E+00		5.36E-05			7.20E-02
Xe-138	3.19E-06	4.13E+01		9.16E-05			3.48E-01
I-131		1.22E-03	1.85E-05	2.22E-09		1.34E-04	
I-132							
I-133		2.96E-05					
I-134							
I-135							
Na-24							
Mn-54						5.08E-07	
Co-57							
Co-58						1.81E-06	
Co-60		5.94E-06	2.91E-06	5.88E-10		4.06E-06	
Rb-88							
Zr-95						4.47E-07	
Nb-95			7.06E-07	4.56E-10		3.92E-06	
Mo-99							
Ru-103			6.59E-07			1.33E-06	
Ru-106							
Cd-109							
Cs-134							
Cs-136							
Cs-137				4.56E-10			
Cs-138							
Ce-141							
Ce-144							

Table I.7-6 POINT BEACH NUCLEAR PLANT LIQUID RELEASES (1974-1975) (Ci/yr)

Isotope	1974	1975	Annual Average
H3	8.33E+02	8.85E+02	8.59E+02
Kr-85	1.08E-03		5.40E-04
Kr-85m		3.72E-04	1.86E-04
Kr-87		6.00E-07	3.00E-07
Xe-131m	3.39E-04	1.69E-03	1.01E-03
Xe-133	2.01E-01	2.07E-01	2.04E-01
Xe-133m	3.36E-04	1.34E-03	8.38E-04
Xe-135	8.98E-03	1.01E-01	5.50E-02
Xe-138		3.10E-04	1.55E-04
I-131	1.82E-02	1.71E-01	9.46E-02
I-132	1.20E-03	1.29E-01	6.51E-02
I-133	2.87E-02	2.68E-01	1.48E-01
I-134		1.36E-01	6.80E-02
I-135	6.98E-03	2.71E-01	1.39E-01
Na-124		4.80E-03	2.40E-03
Cr-51		7.89E-02	3.95E-02
Mn-54	1.96E-05	1.47E-02	7.36E-03
Fe-55			
Fe-59		2.17E-03	1.09E-03
Co-57	2.32E-04	6.99E-02	3.51E-02
Co-58	1.02E-03	2.42E-01	1.22E-01
Co-60	2.12E-04	6.29E-02	3.16E-02
Br-83			
Br-84			
Br-85			
Rb-86			
Rb-88			
Sr-89	1.17E-03	7.13E-04	9.42E-04
Sr-90	1.46E-04	2.36E-03	1.25E-03
Sr-91			
Y-90			
Y-91m			
Y-91			
Y-93			
Zr-95	7.95E-05	1.31E-01	6.55E-02

Sheet 1 of 3

Table I.7-6 (CONTINUED)
 POINT BEACH NUCLEAR PLANT LIQUID RELEASES (1974-1975) (Ci/yr)

<u>Isotope</u>	<u>1974</u>	<u>1975</u>	<u>Annual Average</u>
Nb-95	1.27E-04	1.87E-01	9.36E-02
Mo-99		1.75E-05	8.75E-06
Tc-99m			
Ru-103	5.40E-04	1.20E-01	6.03E-02
Ru-106	5.79E-04	1.02E-02	5.39E-03
Rh-103m			
Rh-106			
Cd-109		2.08E-03	1.04E-03
Ag-110m		3.12E-04	1.56E-04
Sb-124		6.35E-05	3.18E-05
Sb-125		2.47E-04	1.24E-04
Te-125m			
Te-127m			
Te-127			
Te-129m			
Te-129			
Te-131m			
Te-131			
Te-132		2.43E-04	1.22E-04
Cs-134	3.84E-02	1.79E-02	2.82E-02
Cs-136		7.99E-04	4.00E-04
Cs-137	9.82E-02	6.55E-02	8.19E-02
Cs-138		1.02E-01	5.10E-02
Ba-137m			
Ba-140		9.59E-02	4.80E-02
La-140		4.11E-02	2.06E-02
Ce-141		4.88E-02	2.44E-02
Ce-143			
Ce-144	8.00E-06	1.09E-01	5.45E-02
Pr-143			
Pr-144			
Bi-207		9.34E-05	4.67E-02
Th-232		9.72E-06	4.86E-02
Np-239			

Sheet 2 of 3

Table I.7-6 (CONTINUED)
POINT BEACH NUCLEAR PLANT LIQUID RELEASES (1974-1975) (Ci/yr)

Release Summary, Average Ci/yr:

Total Tritium	8.59E+02
Total Noble Gases	2.62E-01
Total Iodines	5.65E-01
Total Others	7.56E-01
Total Non-Tritium	1.39E+00

Table I.7-7 POINT BEACH NUCLEAR PLANT PARAMETERS FOR RADIOACTIVE GASEOUS RELEASES

Unit 1 and 2 Containment Releases (applicable to each unit)

Fraction/day of primary coolant noble gas activity released to containment	0.01
Fraction/day of primary coolant iodine activity released to the containment	0.00001
Iodine exhaust filter efficiency	90%
Particulate exhaust filter efficiency	99%
Purge exhaust ventilation rate (cfm)	12,500
Purge exhaust ventilation time (hrs)	7
Number of hot purges/year/unit	12
10 purges/year during operation	
2 purges/year during hot shutdown	
Number of cold purges/year/unit	2
Continuous ventilation exhaust	10
Containment free volume (ft ³)	1.065x10 ⁶

Units 1 and 2 Auxiliary Building Releases

Auxiliary building leakage of primary coolant (lb/day/unit)	160
Iodine partition factor for primary coolant leakage in the aux. bldg.	0.0075
No charcoal filters	
Auxiliary building HEPA filter efficiency	99%

Units 1 and 2 Turbine Building Releases

Turbine building leakage (lb/hr/unit)	1700
Iodine partition coefficient for all iodines	1.0
No filters (charcoal or HEPA)	

Main Condenser Air Ejector

Fraction of the iodine inventory in the primary coolant which is volatile	0.05
Primary-to-secondary leak rate (lb/day/unit)	100
Main condenser air ejector iodine partition factor	0.15
Units 1 and 2 air ejector effluents enter a decay duct which provides a 1.0 hour delay before release to the environment	
No filters (charcoal or HEPA)	

Table I.7-7 (CONTINUED)
 POINT BEACH NUCLEAR PLANT PARAMETERS FOR RADIOACTIVE
 GASEOUS RELEASES

Blowdown Flash Tanks

PBNP has blowdown flash tanks, however, liquid which flashes is all condensed; therefore, no iodines or noble gases are released through the plant vent from the blowdown flash tanks

Gas Decay Tank Effluents

3750 ft³/month of gas decay tank effluent is released for 2 units

103 curies/yr are released from the gas decay tank in batched (70% Kr, 30% Xe-133)

Each release is intermittent and lasts for 250 minutes at a flow rate of 15 cfm

No filters (charcoal/HEPA)

Gas Stripper Building Releases

2% of the noble gases in the Appendix I analysis will be assumed to come from the gas stripper building

Gas stripper building ventilation (cfm) 400-12,000

No filters (charcoal or HEPA)

Table I.8-1 POINT BEACH NUCLEAR PLANT ANNUAL DOSES TO MAXIMUM OFFSITE INDIVIDUAL IN ADULT GROUP FROM RADIOIODINE AND PARTICULATES IN GASEOUS EFFLUENTS

<u>Pathway and Location</u>	<u>ANNUAL DOSE (mrem/yr)</u>							
	<u>Total Body</u>	<u>Skin</u>	<u>Bone</u>	<u>Liver</u>	<u>Thyroid</u>	<u>Kidney</u>	<u>Lung</u>	<u>GI Tract</u>
Inhalation - SSW (1,460 m)	3.2E-02	-	2.6E-03	3.3E-02	5.58E-02	3.2E-02	3.3E-02	3.2E-02
Deposition on Ground - SSW (1,460 m)	3.3E-02	3.8E-02	3.3E-02	3.3E-02	3.3E-02	3.3E-02	3.3E-02	3.3E-02
Fresh Vegetables - SSW (1,460 m)	1.9E-02	-	2.6E-02	2.1E-02	6.7E-01	2.1E-02	1.7E-02	1.7E-02
Stored Vegetables - SSW (1,460 m)	1.5E-01	-	2.0E-01	1.5E-01	1.7E-01	1.4E-01	1.4E-01	1.4E-01
Cow's milk - SSE (1,300 m)	4.0E-02	-	4.9E-02	4.6E-02	1.7E+00	4.2E-02	3.2E-02	3.3E-02
Goat's milk - SSE (1,300 m)	6.9E-02	-	6.2E-02	8.0E-02	1.2E+00	6.3E-02	4.6E-02	4.5E-02
Meat - SSE (1,300 m)	1.6E-02	-	3.7E-02	1.6E-02	7.4E-02	1.5E-02	1.5E-02	1.6E-02
 TOTAL OF ABOVE PATHWAYS WITH INGESTION OF COW'S MILK	 2.9E-01	 3.8E-02	 3.5E-02	 3.0E-01	 2.7E+00	 2.8E-01	 2.7E-01	 2.7E-01
 TOTAL OF ABOVE PATHWAYS WITH INGESTION OF GOAT'S MILK	 3.2E-01	 3.8E-02	 3.6E-01	 3.3E-01	 3.1E+00	 3.0E-01	 2.8E-01	 2.8E-01

Table I.8-2 POINT BEACH NUCLEAR PLANT ANNUAL DOSES TO MAXIMUM OFFSITE INDIVIDUAL IN TEEN GROUP FROM RADIOIODINE AND PARTICULATES IN GASEOUS EFFLUENTS

<u>Pathway and Location</u>	<u>ANNUAL DOSE (mrem/yr)</u>							
	<u>Total Body</u>	<u>Skin</u>	<u>Bone</u>	<u>Liver</u>	<u>Thyroid</u>	<u>Kidney</u>	<u>Lung</u>	<u>GI Tract</u>
Inhalation - SSW (1,460 m)	1.8E-02	-	5.1E-04	1.9E-02	3.9E-02	2.3E-02	1.9E-02	1.8E-02
Deposition on Ground - SSW (1,460 m)	3.3E-02	3.8E-02	3.3E-02	3.3E-02	3.3E-02	3.3E-02	3.3E-02	3.3E-02
Fresh Vegetables - SSW (1,460 m)	1.2E-03	-	6.8E-03	1.4E-02	5.0E-01	1.4E-02	1.1E-02	1.1E-02
Stored Vegetables - SSW (1,460 m)	1.6E-01	-	8.3E-02	1.8E-01	2.0E-01	1.7E-01	1.6E-01	1.6E-01
Cow's milk - SSE (1,300 m)	4.8E-02	-	3.1E-02	6.2E-02	2.5E+00	5.5E-02	3.8E-02	3.8E-02
Goat's milk - SSE (1,300 m)	7.6E-02	-	5.3E-02	1.1E-01	3.1E+00	8.2E-02	5.6E-02	5.2E-02
Meat - SSE (1,300 m)	9.6E-03	-	6.3E-03	1.0E-02	5.1E-02	9.0E-03	9.2E-03	9.7E-03
TOTAL OF ABOVE PATHWAYS WITH INGESTION OF COW'S MILK	2.8E-01	3.8E-02	1.6E-01	3.2E-01	3.3E+00	3.0E-01	2.7E-01	2.7E-01
TOTAL OF ABOVE PATHWAYS WITH INGESTION OF GOAT'S MILK	3.1E-01	3.8E-02	1.8E-01	3.7E-01	3.9E+00	3.3E-01	2.9E-01	2.8E-01

Table I.8-3 POINT BEACH NUCLEAR PLANT ANNUAL DOSES TO MAXIMUM OFFSITE INDIVIDUAL IN CHILD GROUP FROM RADIOIODINE AND PARTICULATES IN GASEOUS EFFLUENTS

<u>Pathway and Location</u>	<u>ANNUAL DOSE (mrem/yr)</u>							
	<u>Total Body</u>	<u>Skin</u>	<u>Bone</u>	<u>Liver</u>	<u>Thyroid</u>	<u>Kidney</u>	<u>Lung</u>	<u>GI Tract</u>
Inhalation - SSW (1,460 m)	1.9E-02	-	8.0E-04	1.9E-02	4.6E-02	1.2E-02	1.9E-02	1.9E-02
Deposition on Ground - SSW (1,460 m)	3.3E-02	3.8E-02	3.3E-02	3.3E-02	3.3E-02	3.3E-02	3.3E-02	3.3E-02
Fresh Vegetables - SSW (1,460 m)	1.6E-02	-	1.2E-02	1.9E-02	7.5E-01	8.4E-03	1.5E-02	1.5E-02
Stored Vegetables - SSW (1,460 m)	3.0E-01	-	1.9E-01	3.4E-01	3.9E-01	1.4E-01	3.0E-01	3.0E-01
Cow's milk - SSE (1,300 m)	7.6E-02	-	7.3E-02	1.1E-01	5.0E+00	4.5E-02	7.2E-02	7.1E-02
Goat's milk - SSE (1,300 m)	1.1E-01	-	1.3E-01	2.0E-01	6.0E+00	6.8E-02	1.0E-01	9.3E-02
Meat - SSE (1,300 m)	1.5E-02	-	1.2E-02	1.6E-02	7.7E-02	5.6E-03	1.5E-02	1.5E-02
 TOTAL OF ABOVE PATHWAYS WITH INGESTION OF COW'S MILK	 4.6E-01	 3.8E-02	 3.2E-01	 5.4E-01	 6.3E+00	 2.4E-01	 4.5E-01	 4.5E-01
 TOTAL OF ABOVE PATHWAYS WITH INGESTION OF GOAT'S MILK	 4.9E-01	 3.8E-02	 3.8E-01	 6.3E-01	 7.3E+00	 2.7E-01	 4.8E-01	 4.8E-01

Table I.8-4 POINT BEACH NUCLEAR PLANT ANNUAL DOSES TO MAXIMUM OFFSITE INDIVIDUAL IN INFANT GROUP FROM RADIOIODINE AND PARTICULATES IN GASEOUS EFFLUENTS

<u>Pathway and Location</u>	<u>ANNUAL DOSE (mrem/yr)</u>							
	<u>Total Body</u>	<u>Skin</u>	<u>Bone</u>	<u>Liver</u>	<u>Thyroid</u>	<u>Kidney</u>	<u>Lung</u>	<u>GI Tract</u>
Inhalation - SSW (1,460 m)	2.0E-02	-	1.2E-03	2.1E-02	6.6E-02	8.5E-03	2.1E-02	2.0E-02
Deposition on Ground - SSW (1,460 m)	3.3E-02	3.8E-02	3.3E-02	3.3E-02	3.3E-02	3.3E-02	3.3E-02	3.3E-02
Fresh Vegetables - SSW (1,460 m)	-	-	-	-	-	-	-	-
Stored Vegetables - SSW (1,460 m)	-	-	-	-	-	-	-	-
Cow's milk - SSE (1,300 m)	1.5E-01	-	1.6E-01	2.3E-01	1.2E+01	4.5E-02	1.3E-01	1.3E-01
Goat's milk - SSE (1,300 m)	2.0E-01	-	2.6E-01	4.0E-01	1.5E+01	6.8E-02	1.8E-01	1.6E-01
Meat - SSE (1,300 m)	-	-	-	-	-	-	-	-
 TOTAL OF ABOVE PATHWAYS WITH INGESTION OF COW'S MILK	 2.0E-01	 3.8E-02	 1.9E-01	 2.8E-01	 1.2E+01	 8.7E-02	 1.8E-01	 1.8E-01
 TOTAL OF ABOVE PATHWAYS WITH INGESTION OF GOAT'S MILK	 2.5E-01	 3.8E-02	 2.9E-01	 4.5E-01	 1.5E+01	 1.1E-01	 2.3E-01	 2.1E-01

Table I.8-5 POINT BEACH NUCLEAR PLANT ANNUAL DOSES TO MAXIMUM INDIVIDUAL FROM NOBLE GASES IN GASEOUS EFFLUENTS

<u>Individual</u>	<u>Total Body Dose</u> (mrem/yr)	<u>Skin Dose</u> (mrem/yr)
Onsite (1250 m, WNW)	1.7E-02	3.6E-02
Offsite (1460 m, SSW)	2.7E-02	5.6E-02

Table I.8-6 POINT BEACH NUCLEAR PLANT ANNUAL DOSES TO MAXIMUM OFFSITE INDIVIDUAL IN ADULT AGE GROUP FROM LIQUID EFFLUENTS UNDER EQUILIBRIUM CONDITIONS

<u>Pathway and Location</u>	<u>ANNUAL DOSE (mrem/yr)</u>							
	<u>Total Body</u>	<u>Skin</u>	<u>Bone</u>	<u>Liver</u>	<u>Thyroid</u>	<u>Kidney</u>	<u>Lung</u>	<u>GI Tract</u>
Ingestion of potable water - (Two Rivers - 12 miles S)	3.1E-04	-	1.7E-04	3.9E-04	1.3E-02	3.0E-04	1.4E-04	2.2E-04
Ingestion of fish - (edge of initial mixing zone)	1.9E-01	-	1.3E-01	2.5E-01	1.3E-01	9.0E-02	2.8E-02	2.1E-02
Ingestion of fresh vegetables - (Two Rivers - 12 miles S)	1.4E-04	-	1.0E-04	1.9E-04	3.2E-03	8.9E-05	3.0E-05	4.0E-05
Ingestion of stored vegetables - (Two Rivers - 12 miles S)	1.0E-03	-	7.4E-04	1.4E-03	2.4E-04	5.2E-04	2.3E-04	1.8E-04
Ingestion of cow's milk (Two Rivers - 12 miles S)	8.7E-04	-	5.9E-04	1.1E-03	1.1E-02	4.7E-04	1.7E-04	1.0E-04
Ingestion of meat - (Two Rivers - 12 miles S)	5.6E-05	-	3.1E-05	7.0E-05	2.1E-04	4.2E-05	2.6E-05	4.4E-05
Swimming - (edge of initial mixing zone)	1.3E-04	1.3E-04	1.3E-04	1.3E-04	1.3E-04	1.3E-04	1.3E-04	1.3E-04
Boating - (edge of initial mixing zones)	4.4E-05	4.4E-05	4.4E-05	4.4E-05	4.4E-05	4.4E-05	4.4E-05	4.4E-05
Shoreline deposits - (1500 meters - South)	<u>1.2E-06</u>	<u>1.4E-06</u>	<u>1.2E-06</u>	<u>1.2E-06</u>	<u>1.2E-06</u>	<u>1.2E-06</u>	<u>1.2E-06</u>	<u>1.2E-06</u>
TOTAL OF ABOVE PATHWAYS	1.9E-01	1.8E-04	1.3E-01	2.5E-01	1.6E-01	9.0E-02	2.9E-02	2.2E-02

Table I.8-7 POINT BEACH NUCLEAR PLANT ANNUAL DOSES TO MAXIMUM OFFSITE INDIVIDUAL IN TEEN AGE GROUP FROM LIQUID EFFLUENTS UNDER EQUILIBRIUM CONDITIONS

<u>Pathway and Location</u>	<u>ANNUAL DOSE (mrem/yr)</u>							
	<u>Total Body</u>	<u>Skin</u>	<u>Bone</u>	<u>Liver</u>	<u>Thyroid</u>	<u>Kidney</u>	<u>Lung</u>	<u>GI Tract</u>
Ingestion of potable water - (Two Rivers - 12 miles S)	1.8E-04	-	1.4E-04	3.1E-04	1.0E-02	2.1E-04	8.8E-05	1.4E-04
Ingestion of fish - (edge of initial mixing zone)	1.1E-01	-	1.3E-01	2.5E-01	1.2E-01	6.9E-02	3.1E-02	1.5E-01
Ingestion of fresh vegetables - (Two Rivers - 12 miles S)	7.4E-05	-	8.9E-05	1.7E-04	2.4E-03	5.8E-05	2.4E-02	2.4E-05
Ingestion of stored vegetables - (Two Rivers - 12 miles S)	9.6E-04	-	1.2E-03	2.2E-03	3.1E-01	6.2E-04	3.5E-04	1.9E-04
Ingestion of cow's milk (Two Rivers - 12 miles S)	8.5E-04	-	1.0E-03	1.9E-03	1.8E-02	6.2E-04	2.8E-04	1.1E-04
Ingestion of meat - (Two Rivers - 12 miles S)	2.5E-05	-	2.3E-05	4.8E-05	1.4E-04	2.4E-05	1.5E-05	2.3E-05
Swimming - (edge of initial mixing zone)	1.3E-04	1.3E-04	1.3E-04	1.3E-04	1.3E-04	1.3E-04	1.3E-04	1.3E-04
Boating - (edge of initial mixing zones)	4.4E-05	4.4E-05	4.4E-05	4.4E-05	4.4E-05	4.4E-05	4.4E-05	4.4E-05
Shoreline deposits - (1500 meters - South)	<u>6.8E-06</u>	<u>8.0E-06</u>	<u>6.8E-06</u>	<u>6.8E-06</u>	<u>6.8E-06</u>	<u>6.8E-06</u>	<u>6.8E-06</u>	<u>6.8E-06</u>
TOTAL OF ABOVE PATHWAYS	1.1E-01	1.8E-04	1.3E-01	2.6E-01	1.5E-01	7.1E-02	3.3E-02	1.5E-01

Table I.8-8 POINT BEACH NUCLEAR PLANT ANNUAL DOSES TO MAXIMUM OFFSITE INDIVIDUAL IN CHILD AGE GROUP FROM LIQUID EFFLUENTS UNDER EQUILIBRIUM CONDITIONS

<u>Pathway and Location</u>	<u>ANNUAL DOSE (mrem/yr)</u>							
	<u>Total Body</u>	<u>Skin</u>	<u>Bone</u>	<u>Liver</u>	<u>Thyroid</u>	<u>Kidney</u>	<u>Lung</u>	<u>GI Tract</u>
Ingestion of potable water - (Two Rivers - 12 miles S)	2.1E-04	-	4.0E-04	6.1E-04	2.5E-02	2.1E-04	1.7E-04	2.0E-04
Ingestion of fish - (edge of initial mixing zone)	4.3E-02	-	1.7E-01	2.1E-01	1.3E-01	3.0E-02	2.4E-02	6.6E-03
Ingestion of fresh vegetables - (Two Rivers - 12 miles S)	4.3E-05	-	1.5E-04	2.0E-04	3.6E-03	3.6E-05	2.6E-05	1.8E-05
Ingestion of stored vegetables - (Two Rivers - 12 miles S)	7.8E-04	-	2.8E-03	3.5E-03	5.7E-04	5.2E-04	5.2E-04	2.0E-04
Ingestion of cow's milk (Two Rivers - 12 miles S)	6.5E-04	-	2.3E-03	3.1E-03	3.4E-02	5.1E-04	4.1E-04	1.3E-04
Ingestion of meat - (Two Rivers - 12 miles S)	2.2E-05	-	4.4E-05	6.5E-05	2.3E-04	1.7E-06	1.8E-05	2.1E-05
Swimming - (edge of initial mixing zone)	7.3E-05	7.3E-05	7.3E-05	7.3E-05	7.3E-05	7.3E-05	7.3E-05	7.3E-05
Boating - (edge of initial mixing zones)	2.4E-05	2.4E-05	2.4E-05	2.4E-05	2.4E-05	2.4E-05	2.4E-05	2.4E-05
Shoreline deposits - (1500 meters - South)	<u>1.4E-06</u>	<u>1.7E-06</u>	<u>1.4E-06</u>	<u>1.4E-06</u>	<u>1.4E-06</u>	<u>1.4E-06</u>	<u>1.4E-06</u>	<u>1.4E-06</u>
TOTAL OF ABOVE PATHWAYS	4.5E-02	9.9E-05	1.8E-01	2.1E-01	2.0E-01	3.1E-02	2.5E-02	1.1E-02

Table I.8-9 POINT BEACH NUCLEAR PLANT ANNUAL DOSES TO MAXIMUM OFFSITE INDIVIDUAL IN INFANT AGE GROUP FROM LIQUID EFFLUENTS UNDER EQUILIBRIUM CONDITIONS

<u>Pathway and Location</u>	<u>ANNUAL DOSE (mrem/yr)</u>							
	<u>Total Body</u>	<u>Skin</u>	<u>Bone</u>	<u>Liver</u>	<u>Thyroid</u>	<u>Kidney</u>	<u>Lung</u>	<u>GI Tract</u>
Ingestion of potable water - (Two Rivers - 12 miles S)	3.7E-04	-	8.1E-04	1.3E-03	6.1E-02	2.1E-04	2.9E-04	2.5E-04
Ingestion of fish - (edge of initial mixing zone)	-	-	-	-	-	-	-	-
Ingestion of fresh vegetables - (Two Rivers - 12 miles S)	-	-	-	-	-	-	-	-
Ingestion of stored vegetables - (Two Rivers - 12 miles S)	-	-	-	-	-	-	-	-
Ingestion of cow's milk (Two Rivers - 12 miles S)	7.7E-04	-	4.8E-03	6.9E-03	8.3E-02	5.1E-04	8.8E-04	1.7E-04
Ingestion of meat - (Two Rivers - 12 miles S)	-	-	-	-	-	-	-	-
Swimming - (edge of initial mixing zone)	-	-	-	-	-	-	-	-
Boating - (edge of initial mixing zones)	-	-	-	-	-	-	-	-
Shoreline deposits - (1500 meters - South)	=	=	=	=	=	=	=	=
TOTAL OF ABOVE PATHWAYS	1.1E-03	-	5.6E-03	8.2E-03	1.4E-01	7.2E-04	1.2E-03	4.2E-04

Table I.8-10 POINT BEACH NUCLEAR PLANT ANNUAL DOSES TO MAXIMUM ONSITE INDIVIDUAL IN ADULT GROUP FROM RADIOIODINE AND PARTICULATES IN GASEOUS EFFLUENTS

<u>Pathway and Location</u>	<u>ANNUAL DOSE (mrem/yr)</u>							
	<u>Total Body</u>	<u>Skin</u>	<u>Bone</u>	<u>Liver</u>	<u>Thyroid</u>	<u>Kidney</u>	<u>Lung</u>	<u>GI Tract</u>
Inhalation - WNW - 1250 m	2.0E-02	-	6.9E-04	2.0E-02	3.2E-02	2.0E-02	2.0E-02	2.0E-02
Deposition on ground - WNW - 1250 m	2.6E-02	3.1E-02	2.6E-02	2.6E-02	2.6E-02	2.6E-02	2.6E-02	2.6E-02
Fresh vegetables - WNW - 1250 m	1.1E-02	-	8.3E-03	1.2E-02	5.1E-01	1.2E-02	8.6E-03	9.5E-03
Stored vegetables - WNW - 1250 m	<u>8.0E-02</u>	-	<u>5.7E-02</u>	<u>8.2E-02</u>	<u>9.3E-02</u>	<u>7.3E-02</u>	<u>7.0E-02</u>	<u>7.3E-02</u>
TOTAL OF ABOVE PATHWAYS	1.4E-01	3.1E-02	9.2E-02	1.4E-01	6.6E-01	1.3E-01	1.2E-01	1.3E-01

Table I.8-11 POINT BEACH NUCLEAR PLANT ANNUAL DOSES TO MAXIMUM ONSITE INDIVIDUAL IN TEEN GROUP FROM RADIOIODINE AND PARTICULATES IN GASEOUS EFFLUENTS

<u>Pathway and Location</u>	<u>ANNUAL DOSE (mrem/yr)</u>							
	<u>Total Body</u>	<u>Skin</u>	<u>Bone</u>	<u>Liver</u>	<u>Thyroid</u>	<u>Kidney</u>	<u>Lung</u>	<u>GI Tract</u>
Inhalation - WNW - 1250 m	1.1E-02	-	1.6E-04	1.1E-02	2.1E-02	1.4E-02	1.1E-02	1.1E-02
Deposition on ground - WNW - 1250 m	2.6E-02	3.1E-02	2.6E-02	2.6E-02	2.6E-02	2.6E-02	2.6E-02	2.6E-02
Fresh vegetables - WNW - 1250 m	6.4E-03	-	3.43E-03	7.6E-03	3.8E-01	7.6E-03	4.9E-03	5.5E-03
Stored vegetables - WNW - 1250 m	<u>8.2E-02</u>	-	<u>3.6E-02</u>	<u>9.3E-02</u>	<u>1.1E-01</u>	<u>8.8E-02</u>	<u>7.4E-02</u>	<u>7.6E-02</u>
TOTAL OF ABOVE PATHWAYS	1.3E-01	3.1E-02	6.6E-02	1.4E-01	5.4E-01	1.4E-02	1.2E-01	1.2E-01

Table I.8-12 POINT BEACH NUCLEAR PLANT ANNUAL DOSES TO MAXIMUM ONSITE INDIVIDUAL IN CHILD GROUP FROM RADIOIODINE AND PARTICULATES IN GASEOUS EFFLUENTS

<u>Pathway and Location</u>	<u>ANNUAL DOSE (mrem/yr)</u>							
	<u>Total Body</u>	<u>Skin</u>	<u>Bone</u>	<u>Liver</u>	<u>Thyroid</u>	<u>Kidney</u>	<u>Lung</u>	<u>GI Tract</u>
Inhalation - WNW - 1250 m	1.1E-02	-	2.4E-04	1.1E-02	2.5E-02	7.3E-03	1.1E-02	1.1E-02
Deposition on ground - WNW - 1250 m	2.6E-02	3.1E-02	2.6E-02	2.6E-02	2.6E-02	2.6E-02	2.6E-02	2.6E-02
Fresh vegetables - WNW - 1250 m	7.0E-03	-	5.7E-03	9.9E-03	5.8E-01	4.8E-03	6.4E-03	6.7E-03
Stored vegetables - WNW - 1250 m	<u>1.4E-01</u>	-	<u>7.9E-02</u>	<u>1.6E-01</u>	<u>1.9E-01</u>	<u>7.3E-02</u>	<u>1.3E-01</u>	<u>1.3E-01</u>
TOTAL OF ABOVE PATHWAYS	1.8E-01	3.1E-02	1.1E-01	2.1E-01	8.2E-01	1.1E-01	1.7E-01	1.7E-01

Table I.8-13 POINT BEACH NUCLEAR PLANT ANNUAL DOSES TO MAXIMUM ONSITE INDIVIDUAL IN INFANT GROUP FROM RADIOIODINE AND PARTICULATES IN GASEOUS EFFLUENTS

<u>Pathway and Location</u>	<u>ANNUAL DOSE (mrem/yr)</u>							
	<u>Total Body</u>	<u>Skin</u>	<u>Bone</u>	<u>Liver</u>	<u>Thyroid</u>	<u>Kidney</u>	<u>Lung</u>	<u>GI Tract</u>
Inhalation - WNW - 1250 m	1.2E-02	-	3.6E-04	1.2E-02	3.5E-02	5.2E-03	1.2E-02	1.2E-02
Deposition on ground - WNW - 1250 m	2.6E-02	3.1E-02	2.6E-02	2.6E-02	2.6E-02	2.6E-02	2.6E-02	2.6E-02
Fresh vegetables - WNW - 1250 m	-	-	-	-	-	-	-	-
Stored vegetables - WNW - 1250 m	=	=	=	=	=	=	=	=
TOTAL OF ABOVE PATHWAYS	3.8E-02	3.1E-02	2.6E-02	3.8E-02	6.1E-02	3.1E-02	3.8E-02	3.8E-02

Table I.9-1 COMPARISON OF MAXIMUM CALCULATED DOSES FROM POINT BEACH NUCLEAR PLANT WITH DESIGN OBJECTIVES IN DOCKET RM-50-2⁽¹⁾

Release	RM-50-2 Design Objective	Calculated Maximum Dose		
		Individual	Organ	Dose
<u>Liquid Effluents</u>				
1. Total body	5 millirem/year	Adult	-	0.19 millirem/year
2. Any organ	5 millirem/year	Teen	Liver	0.26 millirem/year
<u>Noble gases</u>				
1. Gamma Dose in Air ⁽²⁾	10 millirads/year	-	-	0.06 millirads/year
2. Beta Dose in Air ⁽²⁾	20 millirads/year	-	-	0.07 millirads/year
3. Total body	5 millirem/year	Any Any ⁽³⁾	- -	0.03 millirem/year 0.02 millirem/year
4. Skin	15 millirem/year	Any Any ⁽³⁾	Skin Skin	0.06 millirem/year 0.04 millirem/year
<u>Radioiodine and Particulates in Gaseous Releases⁽⁴⁾</u>				
1. Any organ from all pathways	15 millirem/year	Infant Child ⁽³⁾	Thyroid Thyroid	15.0 millirem/year 0.82 millirem/year

1. "Concluding Statement of Position of the Regulatory Staff," Docket RM-50-2, February 20, 1974, U. S. Atomic Energy Commission, Washington, D.C.
2. Calculated at site boundary
3. Onsite resident
4. Carbon-14 and tritium have been added to this category.

Figure I.2-1 LIQUID WASTE SYSTEM PROCESS FLOW DIAGRAM

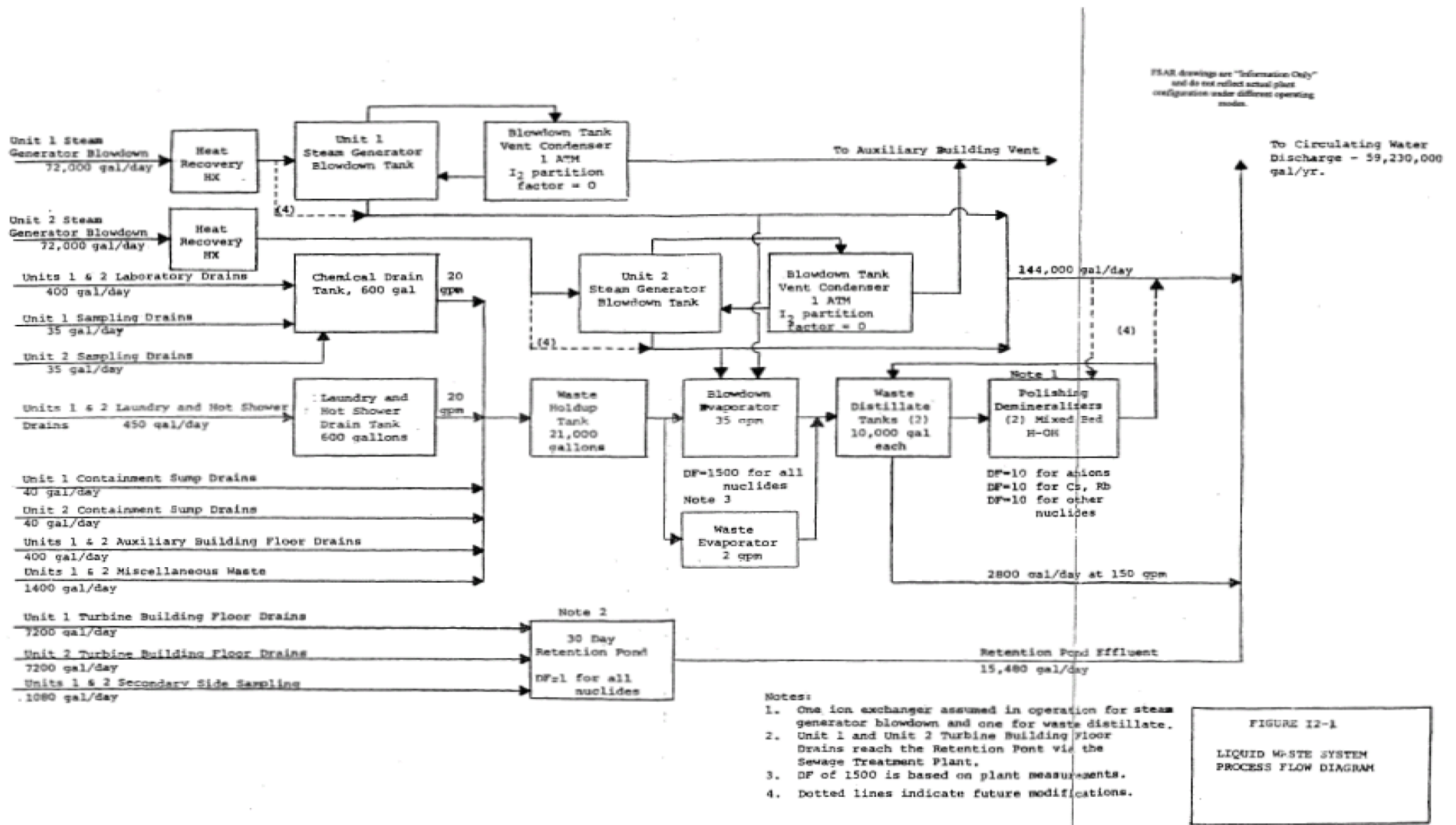

Figure I.2-2 CHEMICAL & VOLUME CONTROL SYSTEM PROCESS FLOW DIAGRAM

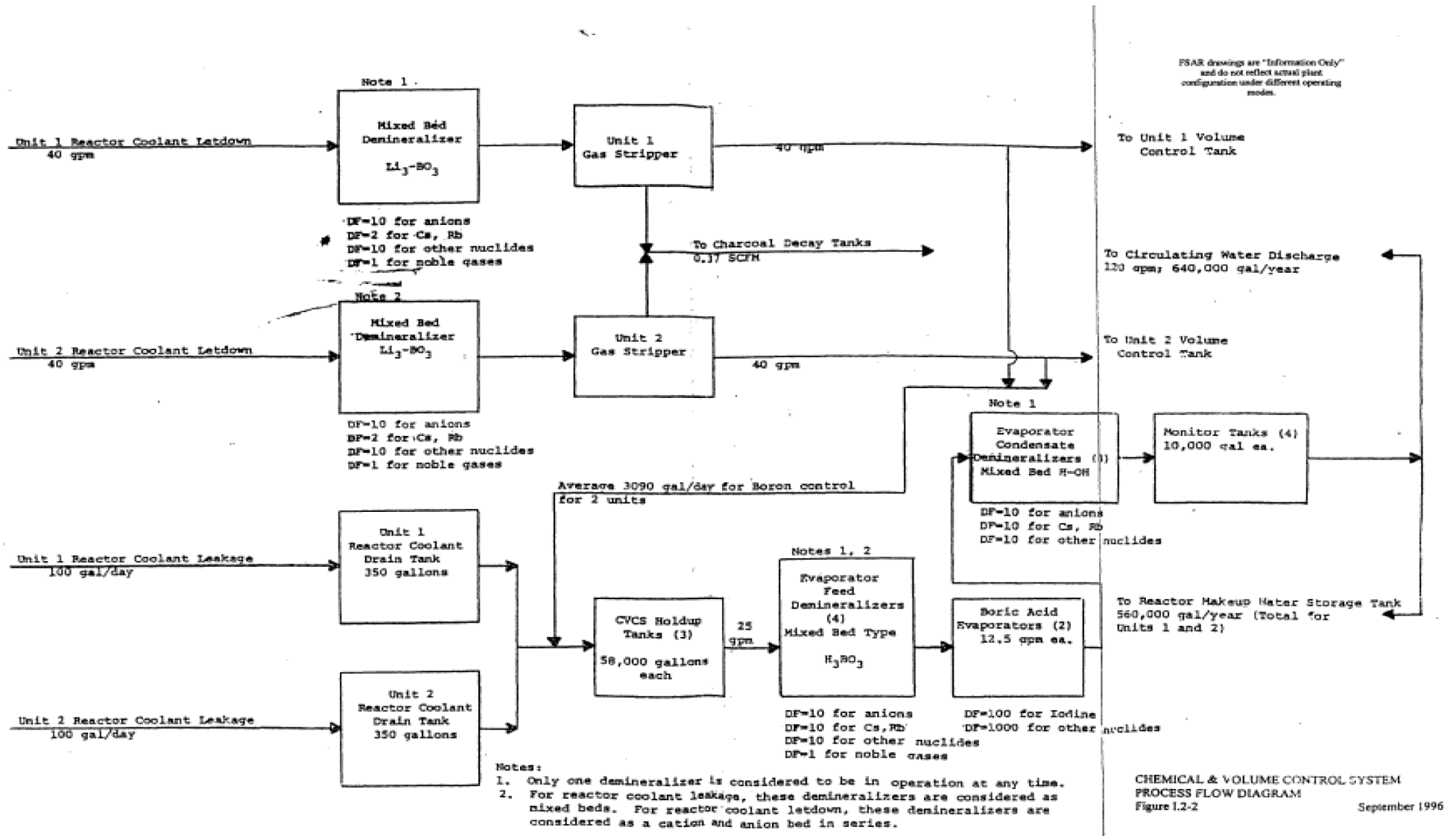

Figure I.2-3 VENTILATION AND GASEOUS WASTE PROCESS FLOW DIAGRAM

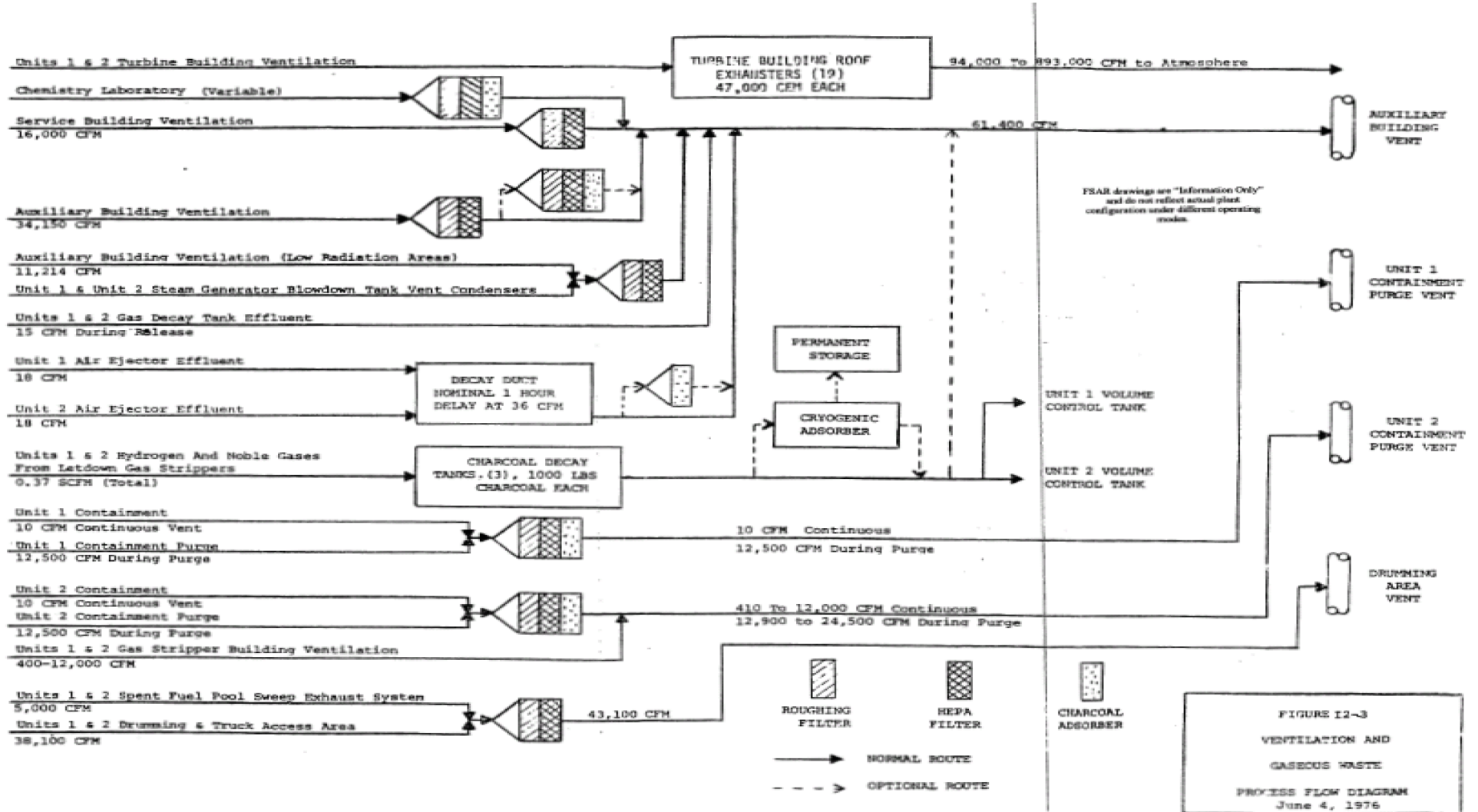

Figure I.2-4 PIPING & INSTRUMENT DIAGRAM HEATING & VENTILATION AIRFLOW

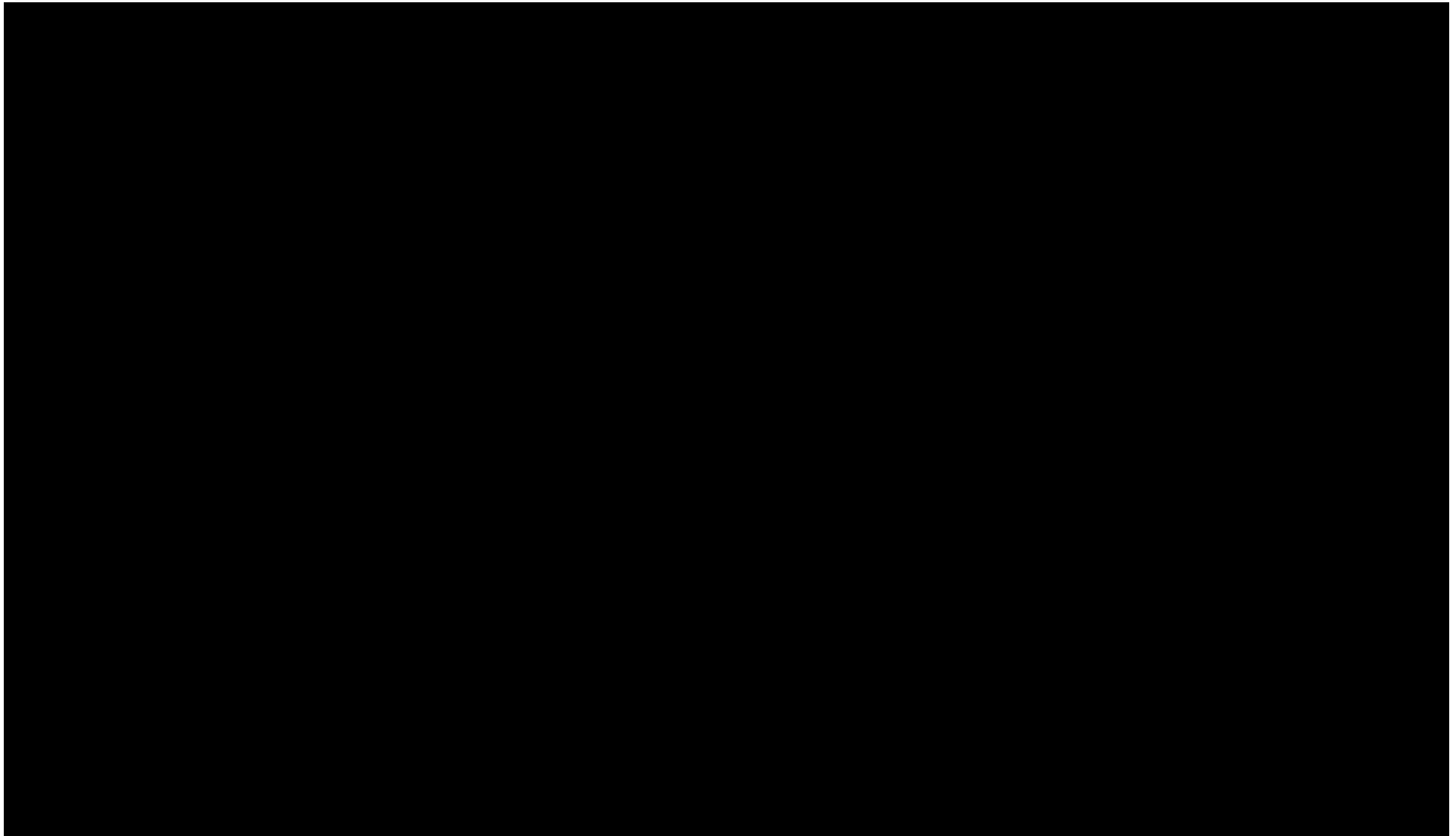

Figure I.2-5 PIPING & INSTRUMENT DIAGRAM HEATING & VENTILATION SYSTEMS

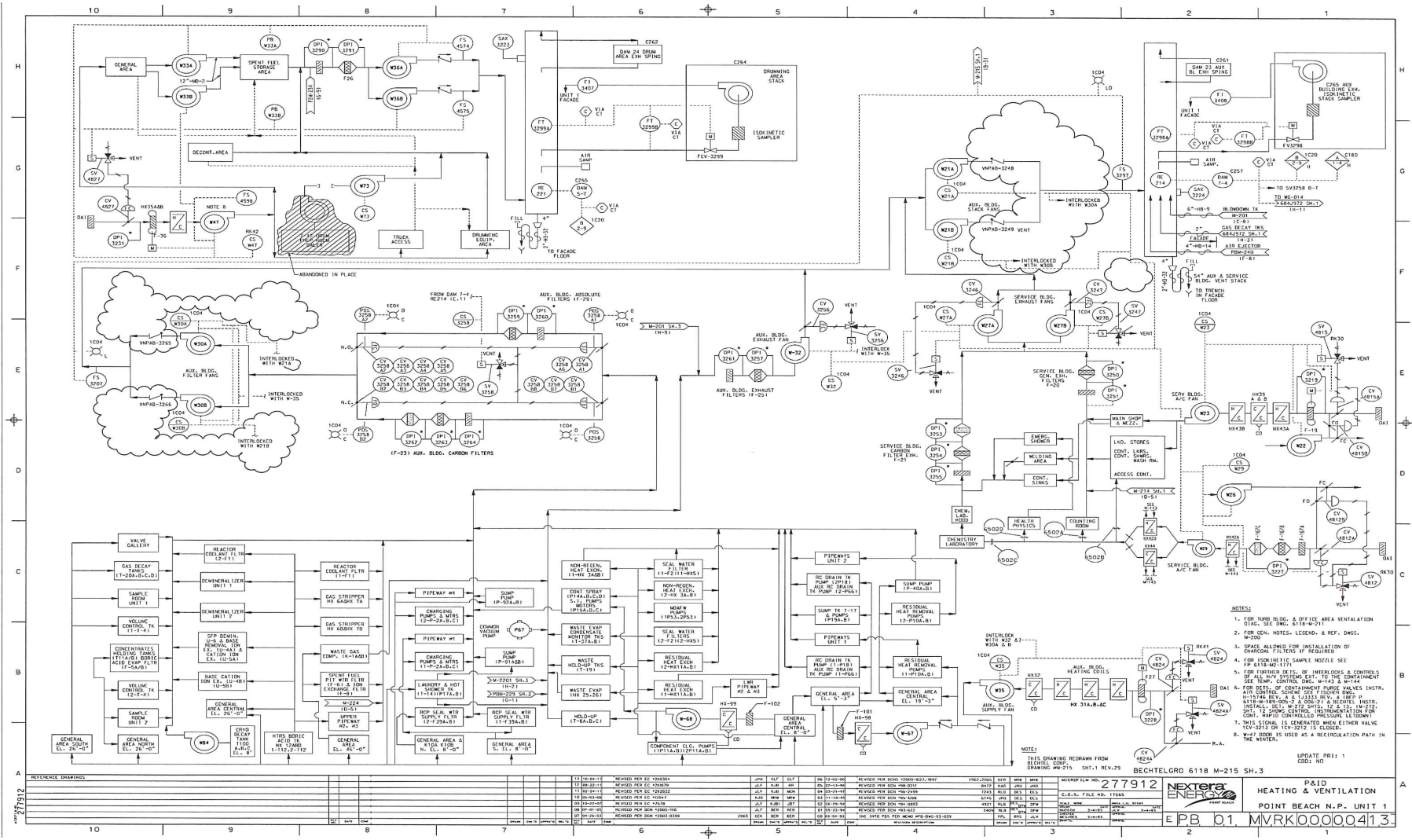

Figure I.4-1 GENERAL TOPOGRAPHY WITHIN 10-MILE RADIUS

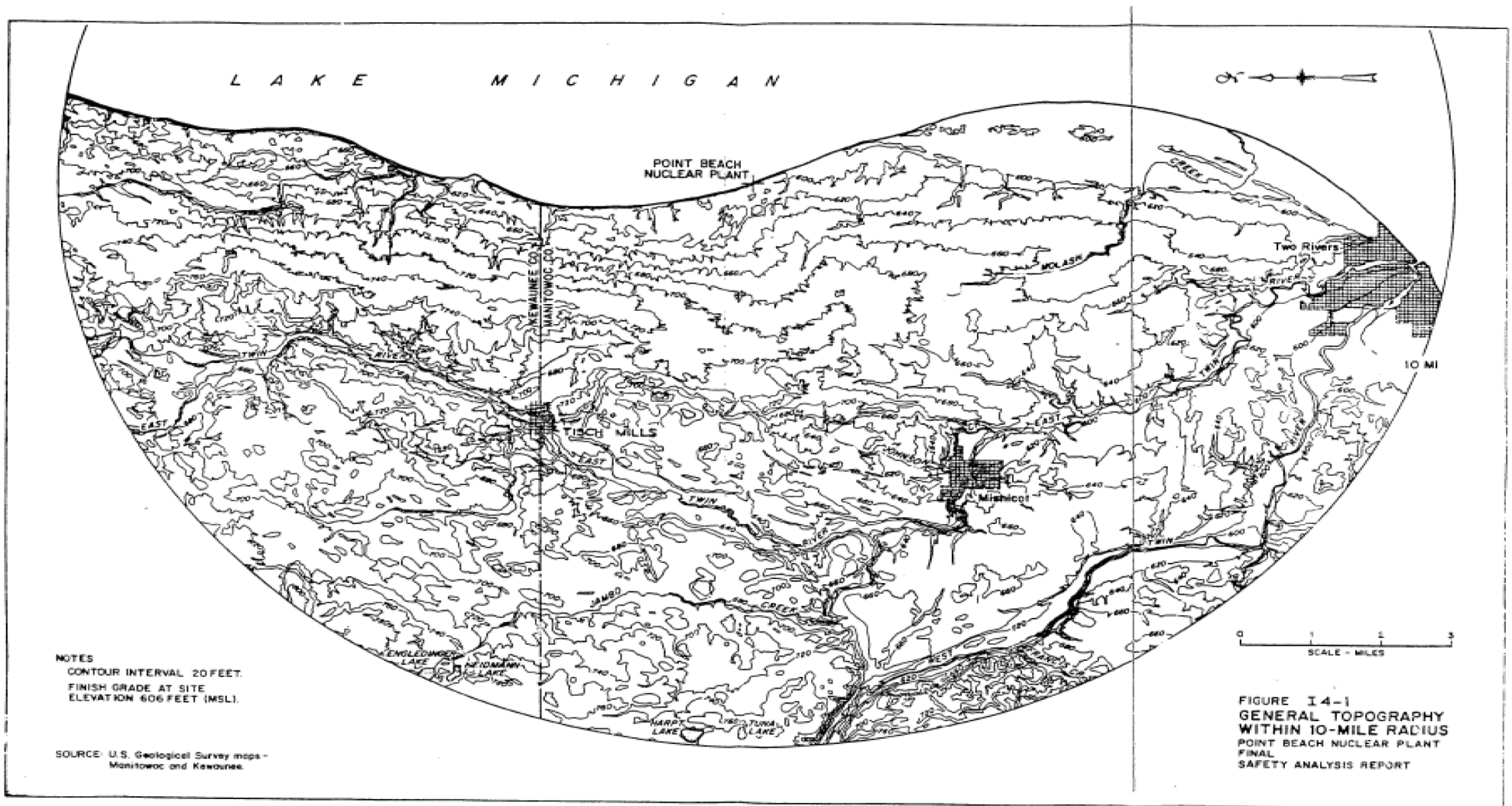
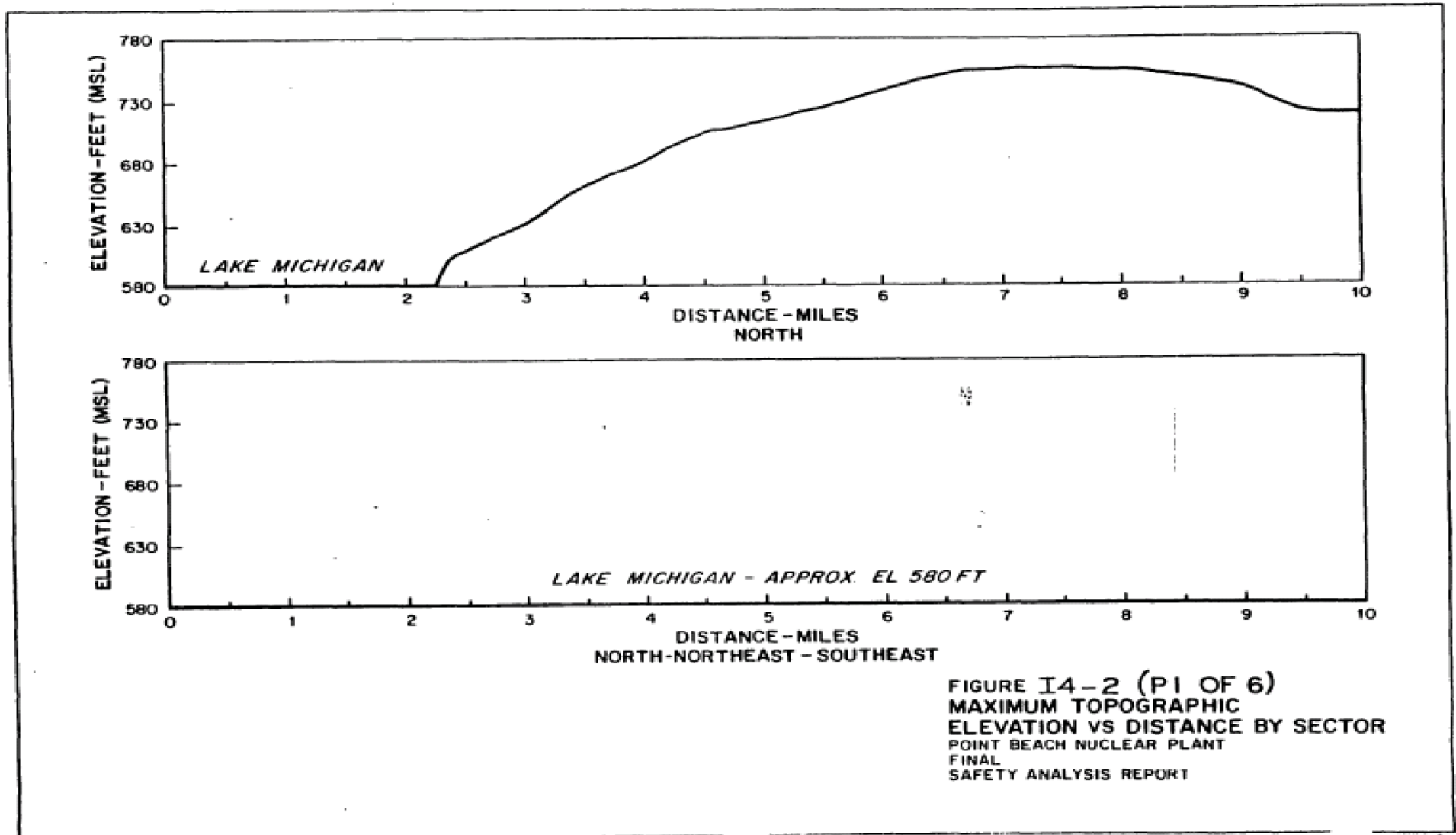
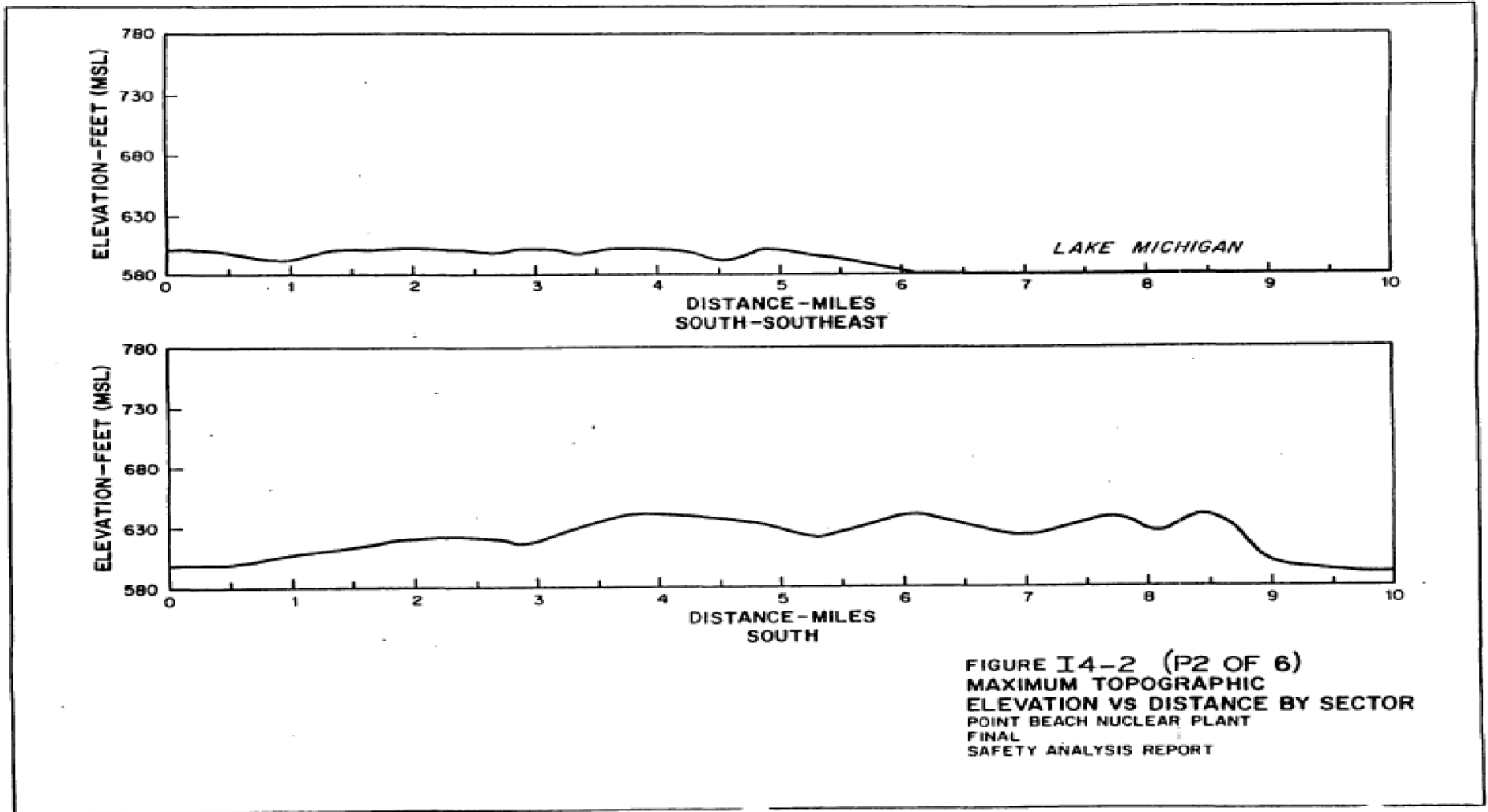
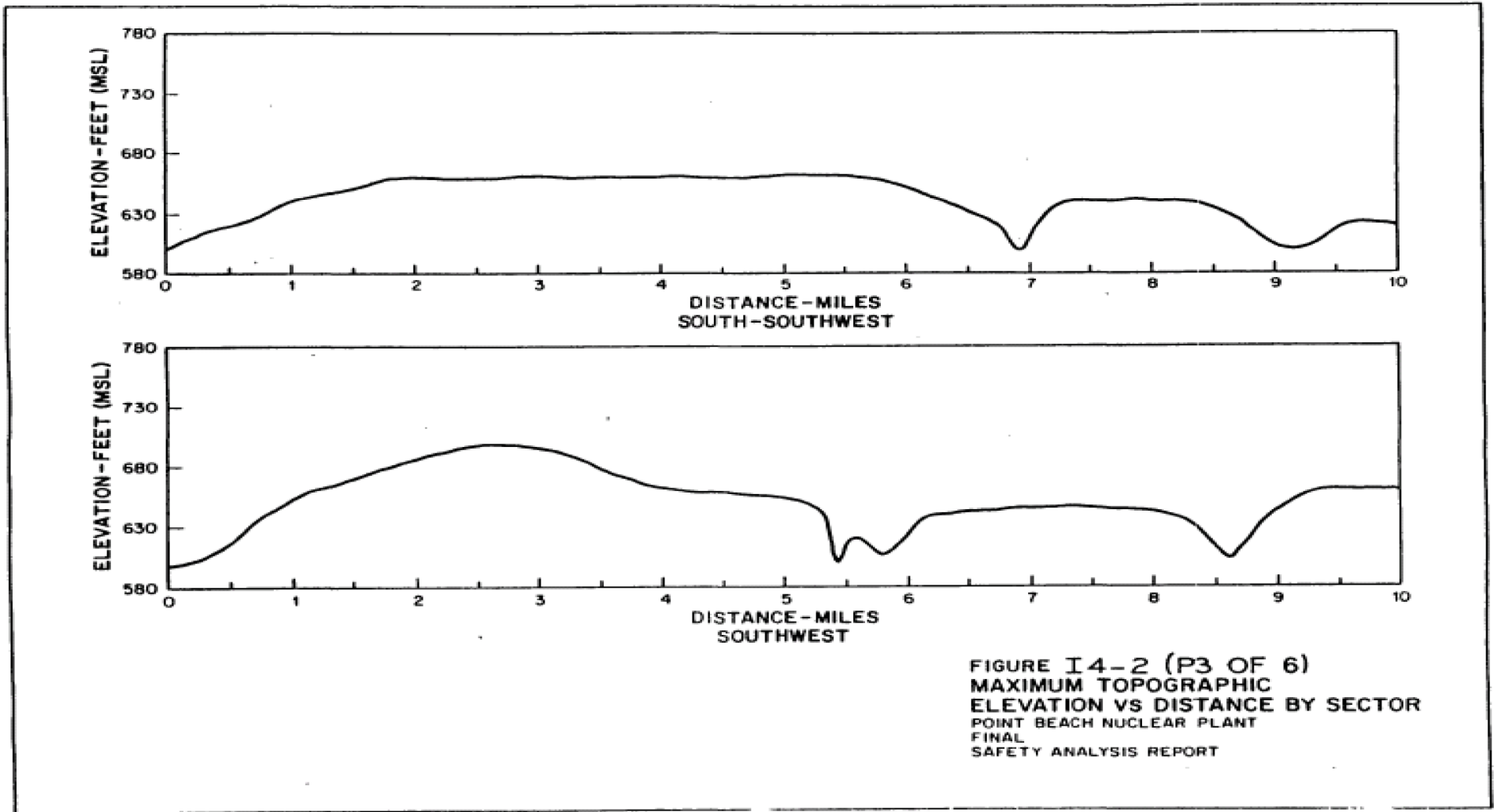
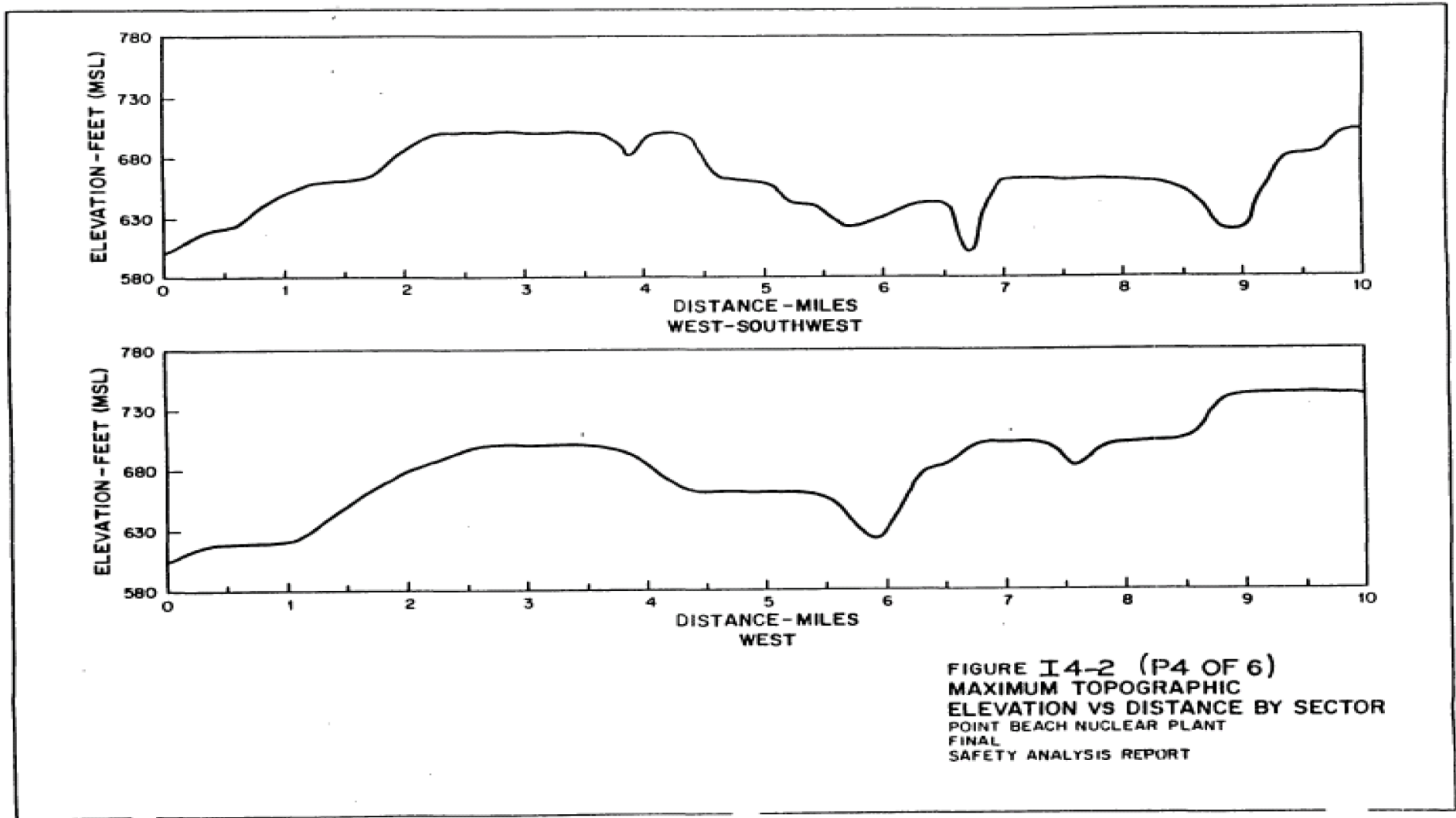

Figure I.4-2 MAXIMUM TOPOGRAPHIC ELEVATION VS DISTANCE BY SECTOR









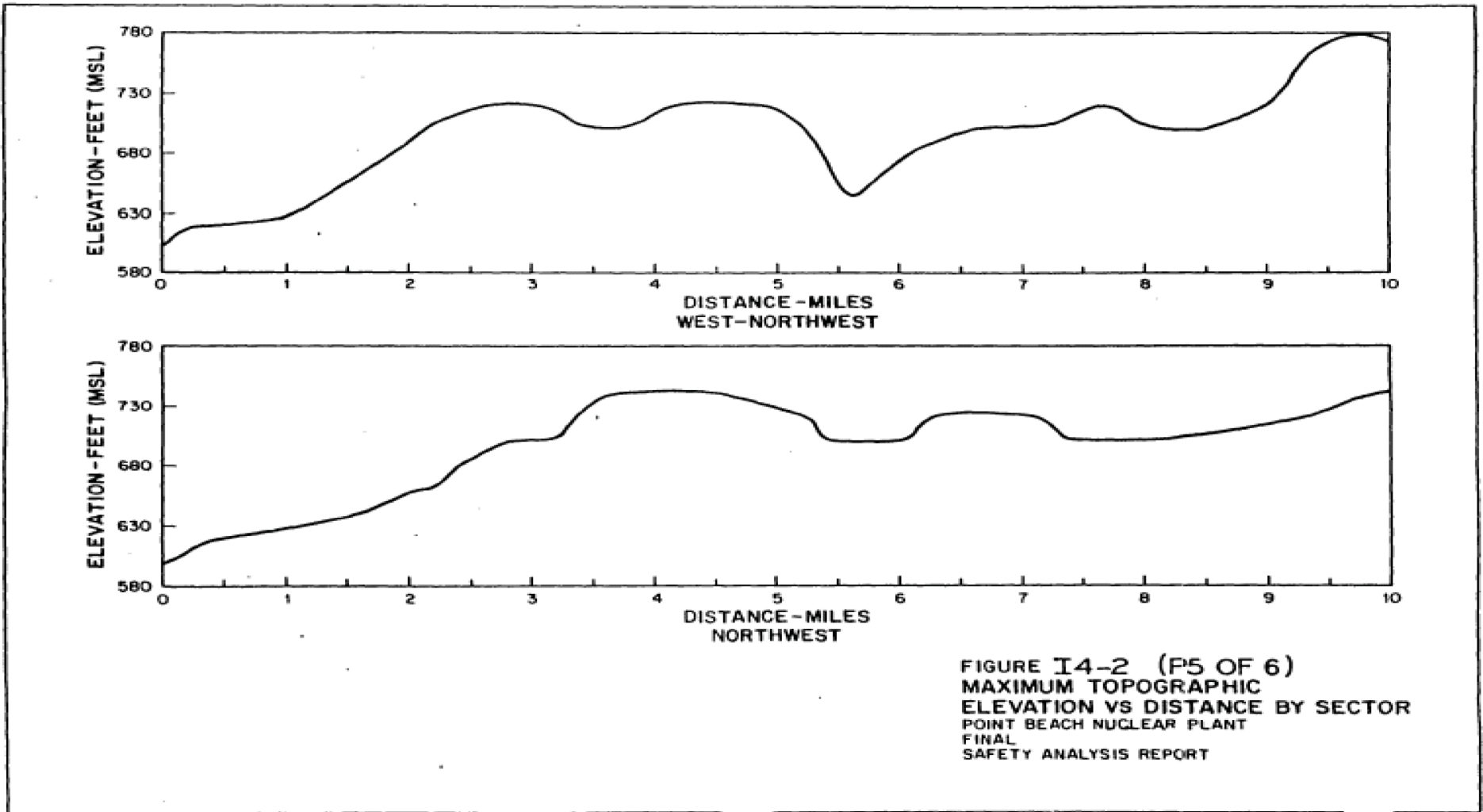

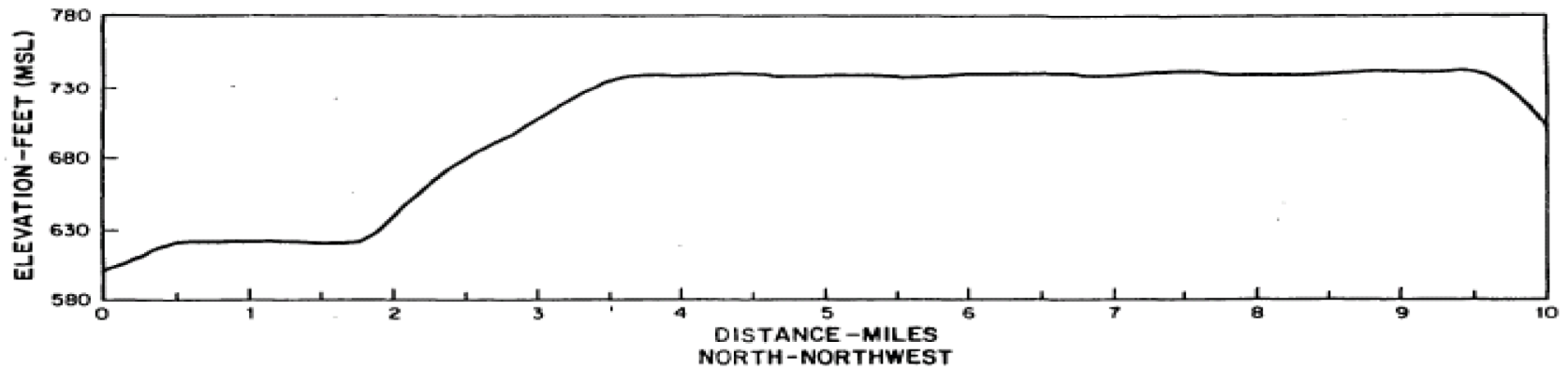

FIGURE I4-2 (P6 OF 6)
MAXIMUM TOPOGRAPHIC
ELEVATION VS DISTANCE BY SECTOR
POINT BEACH NUCLEAR PLANT
FINAL
SAFETY ANALYSIS REPORT

Figure I.6-1 FARM AND NON-FARM RESIDENCES WITHIN 3 MILES

