

**UNITED STATES NUCLEAR REGULATORY COMMISSION  
PRESSURIZED WATER REACTOR GENERIC FUNDAMENTALS EXAMINATION  
MARCH 2019 PWR – FORM A**

**Please Print**

Name: \_\_\_\_\_

Docket No.: \_\_\_\_\_

Facility: \_\_\_\_\_

Start Time: \_\_\_\_\_ Stop Time: \_\_\_\_\_

**INSTRUCTIONS TO EXAMINEE**

Answer all the test items using the answer sheet provided, ensuring a single answer is marked for each test item. Each test item has equal point value. A score of at least 80 percent is required to pass this portion of the NRC operator licensing written examination. All examination materials will be collected 3 hours after the examination begins. This examination applies to a typical U.S. pressurized water reactor (PWR) nuclear power plant.

SECTION	QUESTIONS	% OF TOTAL	SCORE
COMPONENTS	1 - 22		
REACTOR THEORY	23 - 36		
THERMODYNAMICS	37 - 50		
TOTALS	50		

All work performed on this examination is my own. I have neither given nor received aid.

\_\_\_\_\_  
Examinee's Signature

## RULES AND INSTRUCTIONS FOR THE NRC GENERIC FUNDAMENTALS EXAMINATION

During the administration of this examination the following rules apply:

NOTE: The term "control rod" refers to the length of neutron absorber material that can be positioned by the operator to change core reactivity.

NOTE: Numerical answers are rounded to the nearest whole number unless otherwise indicated.

1. Print your name in the blank provided on the cover sheet of the examination.
2. Fill in your individual docket number.
3. Fill in the name of your facility.
4. Fill in your start and stop times at the appropriate times.
5. Two aids are provided for your use during the examination:
  - (1) An Equations and Conversions Sheet contained within the examination copy, and
  - (2) Steam tables and Mollier Diagram provided by your proctor.
6. Place your answers on the answer sheet provided. Credit will only be given for answers properly marked on this sheet. Follow the instructions for filling out the answer sheet.
7. Scrap paper will be provided for calculations.
8. Cheating on the examination will result in the automatic forfeiture of this examination. Cheating could also result in severe penalties.
9. Restroom trips are limited. Only **one** examinee may leave the room at a time. In order to avoid the appearance or possibility of cheating, avoid all contact with anyone outside the examination room.
10. After you have completed the examination, sign the statement on the cover sheet indicating that the work is your own and you have neither given nor received any assistance in completing the examination. Either pencil or pen may be used.
11. Turn in your examination materials, answer sheet on top, followed by the examination copy and the examination aids, e.g., steam tables, handouts, and scrap paper.
12. After turning in your examination materials, leave the examination area as defined by the proctor. If after leaving you are found in the examination area while the examination is in progress, your examination may be forfeited.

**GENERIC FUNDAMENTALS EXAMINATION**  
**EQUATIONS AND CONVERSIONS SHEET**

**EQUATIONS**

$$\dot{Q} = \dot{m}c_p\Delta T$$

$$N = S/(1 - K_{\text{eff}})$$

$$\dot{Q} = \dot{m}\Delta h$$

$$CR_1(1 - K_{\text{eff}_1}) = CR_2(1 - K_{\text{eff}_2})$$

$$\dot{Q} = UA\Delta T$$

$$1/M = CR_1/CR_x$$

$$\dot{Q} \propto \dot{m}_{\text{Nat Circ}}^3$$

$$A = \pi r^2$$

$$\Delta T \propto \dot{m}_{\text{Nat Circ}}^2$$

$$F = PA$$

$$K_{\text{eff}} = 1/(1 - \rho)$$

$$\dot{m} = \rho A \bar{v}$$

$$\rho = (K_{\text{eff}} - 1)/K_{\text{eff}}$$

$$\dot{W}_{\text{Pump}} = \dot{m}\Delta P u$$

$$\text{SUR} = 26.06/\tau$$

$$P = I^2 R$$

$$\tau = \frac{\bar{\beta}_{\text{eff}} - \rho}{\lambda_{\text{eff}} \rho}$$

$$P = IE$$

$$\rho = \frac{\ell^*}{\tau} + \frac{\bar{\beta}_{\text{eff}}}{1 + \lambda_{\text{eff}} \tau}$$

$$P_A = \sqrt{3}IE$$

$$P_T = \sqrt{3}IEpf$$

$$\ell^* = 1.0 \times 10^{-4} \text{ sec}$$

$$P_R = \sqrt{3}IE\sin\theta$$

$$\lambda_{\text{eff}} = 0.1 \text{ sec}^{-1} \text{ (for small positive } \rho)$$

$$\text{Thermal Efficiency} = \text{Net Work Out/Energy In}$$

$$\text{DRW} \propto \varphi_{\text{tip}}^2 / \varphi_{\text{avg}}^2$$

$$\frac{g(z_2 - z_1)}{g_c} + \frac{(\bar{v}_2^2 - \bar{v}_1^2)}{2g_c} + u(P_2 - P_1) + (u_2 - u_1) + (q - w) = 0$$

$$P = P_0 e^{t/\tau}$$

$$g = 32.2 \text{ ft/sec}^2$$

$$P = P_0 10^{\text{SUR}(t)}$$

$$g_c = 32.2 \text{ lbm-ft/lbf-sec}^2$$

$$A = A_0 e^{-\lambda t}$$

**CONVERSIONS**

$$1 \text{ MW} = 3.41 \times 10^6 \text{ Btu/hr}$$

$$^\circ\text{C} = (5/9)(^\circ\text{F} - 32)$$

$$1 \text{ ft}^3_{\text{water}} = 7.48 \text{ gal}$$

$$1 \text{ hp} = 2.54 \times 10^3 \text{ Btu/hr}$$

$$^\circ\text{F} = (9/5)(^\circ\text{C}) + 32$$

$$1 \text{ gal}_{\text{water}} = 8.35 \text{ lbm}$$

$$1 \text{ Btu} = 778 \text{ ft-lbf}$$

$$1 \text{ kg} = 2.21 \text{ lbm}$$

$$1 \text{ Curie} = 3.7 \times 10^{10} \text{ dps}$$

**USNRC GENERIC FUNDAMENTALS EXAMINATION  
MARCH 2019 PWR – FORM A**

QUESTION: 1

Subcooled water is flowing through a throttled valve in an open system. The initial steady-state conditions for the throttled valve are as follows:

Inlet pressure = 60 psia  
Outlet pressure = 44 psia  
Flow rate = 800 gpm

After four hours, the current steady-state conditions for the throttled valve are as follows:

Inlet pressure = 62 psia  
Outlet pressure = 40 psia  
Flow rate = 600 gpm

Which one of the following could be responsible for the difference between the initial and current steady-state conditions for the throttled valve?

- A. The throttled valve was opened more.
- B. The throttled valve was closed more.
- C. Another valve, located upstream of the throttled valve, was partially closed.
- D. Another valve, located downstream of the throttled valve, was partially closed.

QUESTION: 2

To verify that a manual valve in a pressurized water system is closed, the operator should observe valve position indication and operate the valve handwheel in the...

- A. close direction using normal force, and verify there is no substantial handwheel movement.
- B. close direction using normal force, then turn the handwheel an additional one-half turn using additional force if necessary.
- C. open direction until flow sounds are heard, then close the valve using normal force until the handwheel stops moving.
- D. open direction until the valve stem moves, then close the valve using normal force until the handwheel stops moving.

**USNRC GENERIC FUNDAMENTALS EXAMINATION  
MARCH 2019 PWR – FORM A**

QUESTION: 3

A steam flow measuring instrument uses density compensation and square root extraction to convert the differential pressure across the flow element to flow rate in lbm/hr.

The purpose of density compensation in this flow measuring instrument is to convert \_\_\_\_\_ into \_\_\_\_\_.

- A. volumetric flow rate; mass flow rate
- B. steam pressure; mass flow rate
- C. steam velocity; volumetric flow rate
- D. differential pressure; volumetric flow rate

**USNRC GENERIC FUNDAMENTALS EXAMINATION  
MARCH 2019 PWR – FORM A**

QUESTION: 4

Refer to the drawing of a water storage tank with a differential pressure (D/P) level detection system (see figure below).

The level instrument has just been calibrated to indicate actual tank water level. Assume that tank water temperature and level remain constant. If the reference leg temperature increases by 20°F, indicated tank water level will...

- A. be unpredictable.
- B. equal the actual level.
- C. be less than the actual level.
- D. be greater than the actual level.

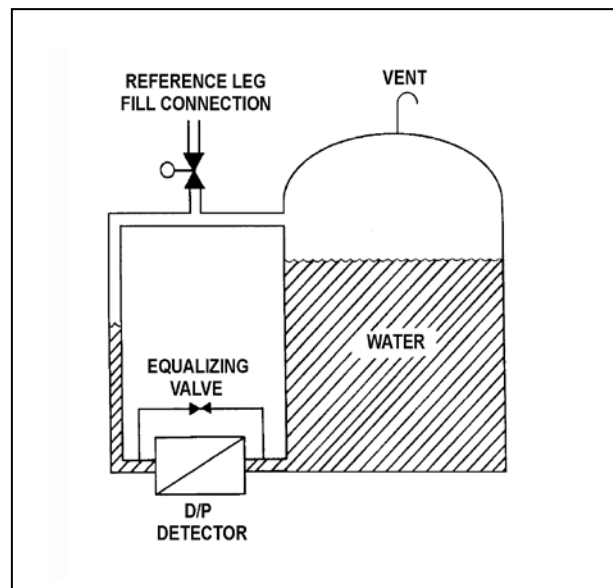

**USNRC GENERIC FUNDAMENTALS EXAMINATION  
MARCH 2019 PWR – FORM A**

QUESTION: 5

A resistance temperature detector (RTD) and a thermocouple (TC) are commonly used sensors for temperature measurement. If a temperature display fails, which of the sensors, if any, has a property that can be measured manually and converted to a temperature value with the aid of conversion tables.

- A. TC only
- B. RTD only
- C. Both TC and RTD
- D. Neither TC nor RTD

QUESTION: 6

A typical gamma ray (1 to 2 MeV) normally produces a free electron in a gas-filled radiation detector by...

- A. transferring energy to a nucleus, which recoils and leaves behind a free electron.
- B. transferring energy to a bound electron, which recoils and becomes a free electron.
- C. entering the electrostatic field of a nucleus, where it transforms into a proton and a free electron.
- D. entering the electrostatic field of a bound electron, where it transforms into a positron and a free electron.

**USNRC GENERIC FUNDAMENTALS EXAMINATION  
MARCH 2019 PWR – FORM A**

QUESTION: 7

Refer to the drawing of a 30-foot water storage tank and its level control system (see figure below).

The level control system has just been returned to service following replacement of the drain valve actuator. Unfortunately, the original direct-acting actuator was mistakenly replaced with a reverse-acting actuator.

Given:

- The drain valve will now fail open if air pressure is lost to its actuator.
- The level control system uses a direct-acting level sensor and a direct-acting proportional-integral level controller with a setpoint of 15 feet.
- The tank water level is stable at 16 feet with the drain valve 50 percent open.
- The level controller is in Manual control.

If the level controller is shifted to Automatic control, the tank water level will...

- A. increase until the tank overflows.
- B. decrease until the tank almost completely empties.
- C. initially increase, and then decrease and stabilize at 15 feet.
- D. initially decrease, and then increase and stabilize at 15 feet.

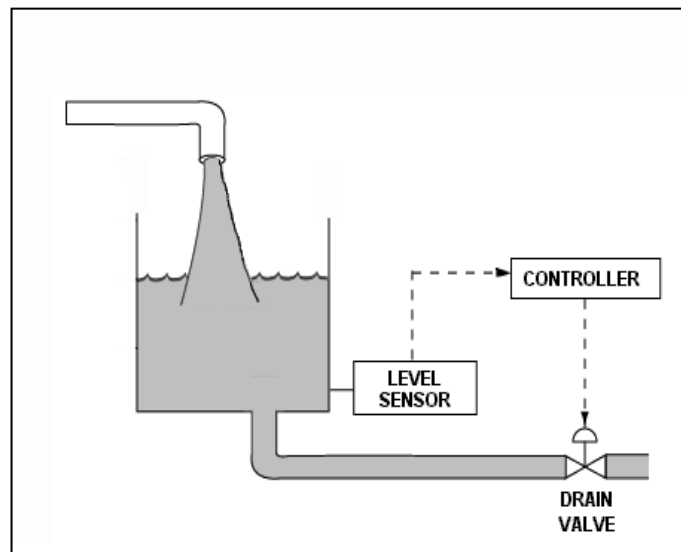



**USNRC GENERIC FUNDAMENTALS EXAMINATION  
MARCH 2019 PWR – FORM A**

QUESTION: 8

Consider a direct-acting proportional flow controller that is maintaining flow rate at a value that is offset from the controller's setpoint. If the controller's gain is decreased, the controller's offset will \_\_\_\_\_; and the controller's proportional band will \_\_\_\_\_.

- A. decrease; decrease
- B. decrease; increase
- C. increase; decrease
- D. increase; increase

QUESTION: 9

An outside water storage tank is equipped with submerged heaters. The heaters energize at minimum power when water temperature decreases to 48°F. If water temperature continues to decrease, heater power will increase directly with the temperature deviation from 48°F until maximum power is reached at 40°F. If water temperature decreases faster than 1°F/min, the heaters will reach maximum power at a higher water temperature.

Which one of the following types of control is used in the heater control circuit to produce these characteristics?

- A. Proportional only
- B. Proportional plus integral
- C. Proportional plus derivative
- D. Proportional plus integral plus derivative

**USNRC GENERIC FUNDAMENTALS EXAMINATION  
MARCH 2019 PWR – FORM A**

QUESTION: 10

After a motor-driven centrifugal pump is started, the following indications are observed:

- Oscillating flow rate
- Oscillating discharge pressure
- Oscillating motor amps

These indications are symptoms that the pump is experiencing...

- A. excessive thrust.
- B. cavitation.
- C. runout.
- D. wear ring failure.

QUESTION: 11

A centrifugal pump is taking suction from an open water storage tank. The pump is located at the base of the tank, takes a suction from the bottom of the tank, and discharges to a pressurized system.

Given:

- The tank is filled to a level of 26 feet with 60°F water.
- The pump is currently operating at 50 gpm.
- The pump requires 30 feet of net positive suction head.

Which one of the following describes the current pump status, and how the pump flow rate will be affected as the level in the storage tank decreases?

- A. The pump is currently cavitating; pump flow rate will decrease continuously as tank level decreases.
- B. The pump is currently cavitating; pump flow rate will remain about the same until the tank empties.
- C. The pump is currently not cavitating; pump flow rate will gradually decrease with tank level and then rapidly decrease when cavitation begins at a lower tank level.
- D. The pump is currently not cavitating; pump flow rate will gradually decrease with tank level and then rapidly decrease as the pump becomes air bound when the tank empties.

**USNRC GENERIC FUNDAMENTALS EXAMINATION  
MARCH 2019 PWR – FORM A**

QUESTION: 12

Refer to the drawing of a cooling water system with an operating centrifugal pump (see figure below).

If the surge tank water level increases from 8 feet to 9 feet, the pump mass flow rate will...

- A. increase, because the pump suction head will increase while the pump discharge head decreases.
- B. increase, because the pump suction head will increase while the pump discharge head remains the same.
- C. remain the same, because the pump suction and discharge heads will increase by the same amount.
- D. remain the same, because the pump suction and discharge heads will be unaffected by the change in surge tank water level.

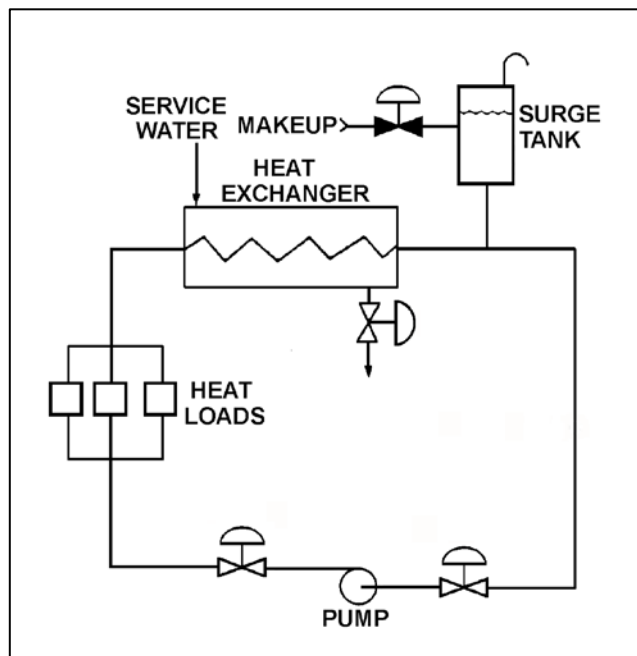

**USNRC GENERIC FUNDAMENTALS EXAMINATION  
MARCH 2019 PWR – FORM A**

QUESTION: 13

A pump is needed to supply fuel oil from a day tank to a diesel engine fuel injection system. The pump must maintain a nearly constant flow rate with a minimum of discharge pressure fluctuations as system pressure varies between 200 psig and 1,900 psig.

Which one of the following types of pumps would be most suitable for this application?

- A. Axial-flow centrifugal
- B. Radial-flow centrifugal
- C. Rotary positive displacement
- D. Reciprocating positive displacement

QUESTION: 14

A shutdown nuclear power plant is operating normally when an electrical fault causes a sustained 20 percent voltage reduction on all phases of the onsite three-phase AC electrical distribution system. Assume that all previously-operating three-phase AC induction motors continue operating, and the mechanical load on each motor remains the same.

As a result of the voltage reduction, the operating three-phase AC induction motors will draw \_\_\_\_\_ current; and will experience \_\_\_\_\_ stator temperatures.

- A. more; higher
- B. more; lower
- C. less; higher
- D. less; lower

**USNRC GENERIC FUNDAMENTALS EXAMINATION  
MARCH 2019 PWR – FORM A**

QUESTION: 15

Which one of the following is a characteristic of a typical AC induction motor that causes starting current to be greater than running current?

- A. The rotor magnetic field induces an opposing voltage in the stator that is proportional to rotor speed.
- B. After the motor starts, resistors are added to the electrical circuit to limit the running current.
- C. A large amount of starting current is required to initially establish a rotating magnetic field.
- D. The rotor does not develop maximum induced current flow until it has achieved synchronous speed.

**USNRC GENERIC FUNDAMENTALS EXAMINATION  
MARCH 2019 PWR – FORM A**

QUESTION: 16

Refer to the drawing of an operating lube oil heat exchanger (see figure below).

If scaling occurs inside the cooling water tubes, cooling water outlet temperature will \_\_\_\_\_; and lube oil outlet temperature will \_\_\_\_\_. (Assume the lube oil and cooling water flow rates do not change.)

- A. decrease; decrease
- B. decrease; increase
- C. increase; decrease
- D. increase; increase

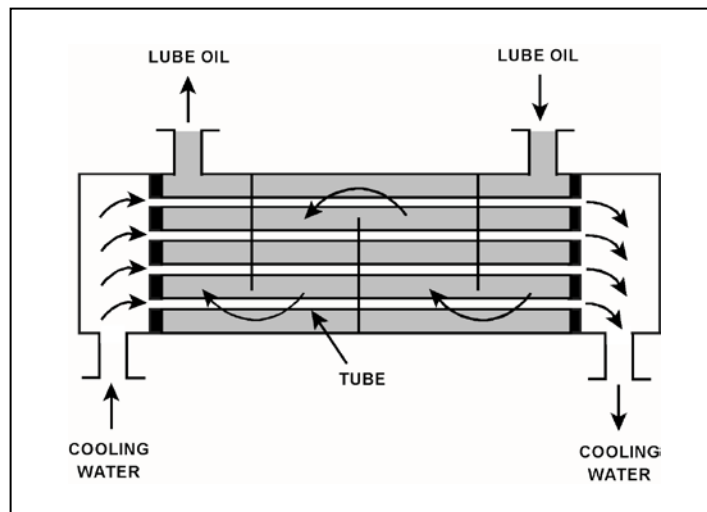

**USNRC GENERIC FUNDAMENTALS EXAMINATION  
MARCH 2019 PWR – FORM A**

QUESTION: 17

Initially, a nuclear power plant was operating at steady-state 80 percent power with the following steam generator (SG) and reactor coolant system (RCS) parameters:

RCS hot leg temperatures = 600°F  
RCS cold leg temperatures = 550°F  
RCS mass flow rate to each SG = 100 percent

Then, the reactor was shut down for a maintenance outage, during which multiple SG tube leaks were discovered and then plugged. After the outage, the RCS mass flow rate to each SG was 98 percent.

When the reactor is once again operating at 80 percent power with RCS hot leg temperatures at 600°F, the RCS cold leg temperatures will be...

- A. 548°F.
- B. 549°F.
- C. 551°F.
- D. 552°F.

QUESTION: 18

Two indications of channeling through an operating demineralizer are a \_\_\_\_\_-than-normal demineralizer differential pressure and a \_\_\_\_\_-than-normal decontamination factor for ionic impurities.

- A. higher; lower
- B. higher; higher
- C. lower; lower
- D. lower; higher

**USNRC GENERIC FUNDAMENTALS EXAMINATION  
MARCH 2019 PWR – FORM A**

QUESTION: 19

Reactor coolant system (RCS) mixed-bed ion exchanger 1A was removed from service after several months of operation with an RCS boron concentration of 550 ppm. Alternate mixed-bed ion exchanger 1B is currently in service with an RCS boron concentration of 400 ppm.

Ion exchanger 1A was drained and refilled with reactor coolant having a boron concentration of 400 ppm in preparation for being returned to service to replace ion exchanger 1B.

When ion exchanger 1A is returned to service, its effluent boron concentration initially will be \_\_\_\_\_ than its influent boron concentration because \_\_\_\_\_.

- A. lower; ion exchanger 1A will continue to remove boron atoms from the reactor coolant as it flows through the ion exchanger.
- B. higher; some of the previously-captured boron atoms will be released as the reactor coolant flows through ion exchanger 1A.
- C. the same; for each boron atom removed from the reactor coolant by ion exchanger 1A, one boron atom will be released.
- D. the same; ion exchanger 1A is boron-saturated and cannot remove additional boron atoms from the reactor coolant.

QUESTION: 20

To completely deenergize an electrical component and its associated control and indication circuits, the component breaker should be...

- A. open with the control switch in Pull-To-Lock.
- B. open with the control switch tagged in the open position.
- C. racked out and tagged in the racked-out position.
- D. racked out with control power fuses removed.



**USNRC GENERIC FUNDAMENTALS EXAMINATION  
MARCH 2019 PWR – FORM A**

QUESTION: 21

Refer to the drawing of a valve motor control circuit (see figure below) for a valve that is currently fully closed and has a 10-second stroke time.

**Note:** Limit switch (LS) contacts are shown open regardless of valve position, but relay contacts are shown open/closed according to the standard convention for control circuit drawings.

The operator takes the control switch to OPEN momentarily and the valve begins to open. Five seconds later, the operator takes the switch to CLOSE momentarily and then releases the switch. Which one of the following describes the valve response after the switch is released?

- A. The valve will stop opening and remain partially open.
- B. The valve will stop opening and then go fully closed.
- C. The valve will open fully and remain fully open.
- D. The valve will open fully and then go fully closed.

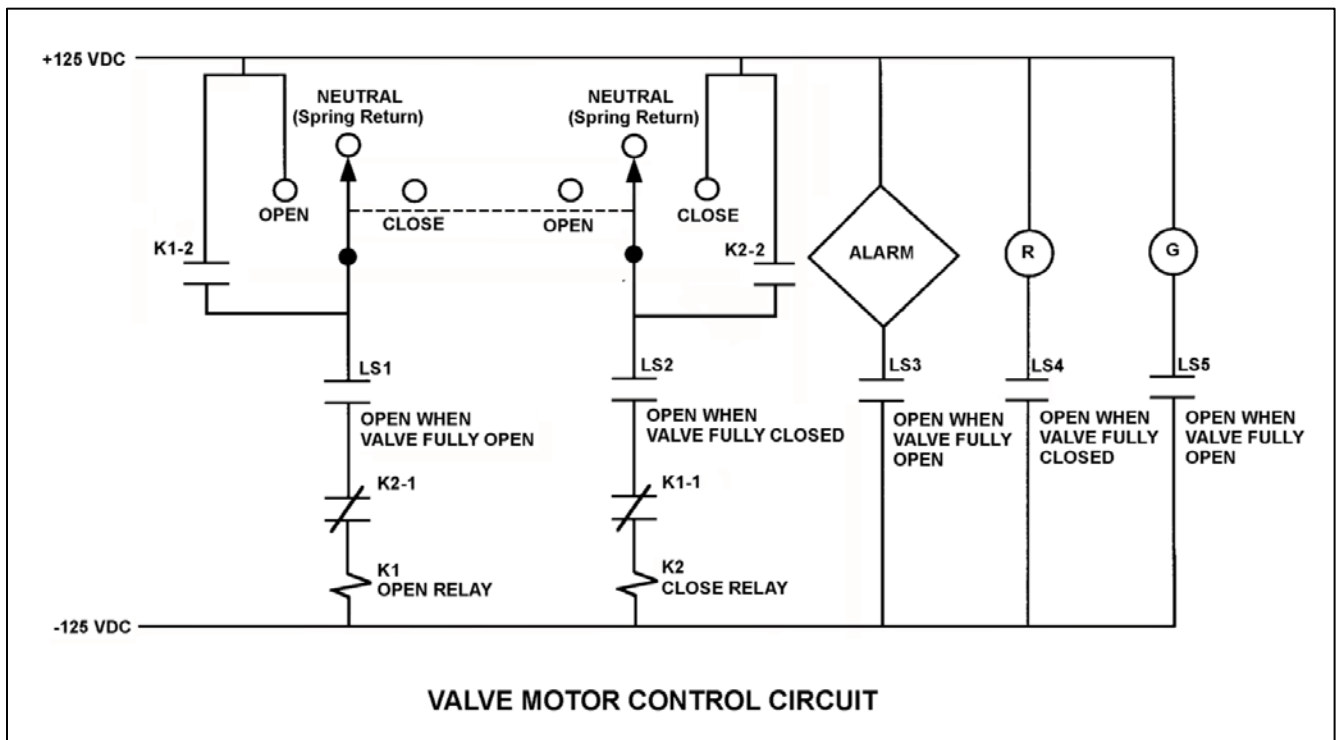

**USNRC GENERIC FUNDAMENTALS EXAMINATION  
MARCH 2019 PWR – FORM A**

QUESTION: 22

The main generator output breaker was just closed to connect the main generator to the main transformer. Just before the breaker was closed, the following parameter values existed:

<u>Main Generator</u>	<u>Main Transformer</u>
20,000 volts	20,050 volts
60.1 Hz	59.9 Hz

With no additional operator action, the main generator stabilized with the following parameter values:

25 MW  
15 MVAR (in)

Now consider this following alternate set of parameters values:

<u>Main Generator</u>	<u>Main Transformer</u>
20,020 volts	20,050 volts
60.0 Hz	59.9 Hz

If the alternate set of parameter values had existed just before the breaker was closed, the resulting main generator MW value would have been \_\_\_\_\_; and the resulting main generator MVAR (in) value would have been \_\_\_\_\_.

- A. larger; larger
- B. larger; smaller
- C. smaller; larger
- D. smaller; smaller

**USNRC GENERIC FUNDAMENTALS EXAMINATION  
MARCH 2019 PWR – FORM A**

QUESTION: 23

Delayed neutrons are neutrons that...

- A. are responsible for the majority of U-235 fissions.
- B. are expelled within  $1.0 \times 10^{-14}$  seconds of the fission event.
- C. have reached thermal equilibrium with the surrounding medium.
- D. are produced from the radioactive decay of certain fission fragments.

QUESTION: 24

Which one of the following defines K-excess?

- A.  $K_{\text{eff}} - 1$
- B.  $K_{\text{eff}} + 1$
- C.  $(K_{\text{eff}} - 1)/K_{\text{eff}}$
- D.  $(1 - K_{\text{eff}})/K_{\text{eff}}$

**USNRC GENERIC FUNDAMENTALS EXAMINATION  
MARCH 2019 PWR – FORM A**

QUESTION: 25

A reactor is critical at a constant power level of  $1.0 \times 10^{-8}$  percent. Consider the following two cases:

- Case 1: A step addition of positive 0.001  $\Delta K/K$ .
- Case 2: A step addition of negative 0.001  $\Delta K/K$ .

Which case will produce the faster rate of power change one minute after the reactivity addition, and why?

- A. Case 1, because the effective delayed neutron fraction is smaller during a power increase.
- B. Case 1, because the effective delayed neutron precursor decay constant is larger during a power increase.
- C. Case 2, because the effective delayed neutron fraction is smaller during a power decrease.
- D. Case 2, because the effective delayed neutron precursor decay constant is larger during a power decrease.

QUESTION: 26

A reactor is shut down near the middle of a fuel cycle with the shutdown cooling system in service. The initial reactor coolant temperature is 160°F. In this condition, the reactor is undermoderated.

Then, a heatup and pressurization is performed to bring the reactor coolant system to normal operating temperature and pressure. The reactor remains subcritical.

During the heatup,  $K_{\text{eff}}$  will...

- A. increase continuously.
- B. decrease continuously.
- C. initially increase, and then decrease.
- D. initially decrease, and then increase.

**USNRC GENERIC FUNDAMENTALS EXAMINATION  
MARCH 2019 PWR – FORM A**

QUESTION: 27

A reactivity coefficient measures a/an \_\_\_\_\_ change in reactivity, while a reactivity defect measures a \_\_\_\_\_ change in reactivity.

- A. integrated; total
- B. integrated; differential
- C. unit; total
- D. unit; differential

QUESTION: 28

Which one of the following is a reason for neutron flux shaping in a reactor core?

- A. To minimize local power peaking by more evenly distributing the core thermal neutron flux.
- B. To reduce thermal neutron leakage by decreasing the neutron flux at the periphery of the reactor core.
- C. To reduce the size and number of control rods needed to shut down the reactor during a reactor trip.
- D. To increase differential control rod worth by peaking the thermal neutron flux at the top of the reactor core.

**USNRC GENERIC FUNDAMENTALS EXAMINATION  
MARCH 2019 PWR – FORM A**

QUESTION: 29

The control rod insertion limits generally rise as reactor power increases because...

- A. the power defect becomes more negative as power increases.
- B. the control rod worth becomes more negative as power increases.
- C. the fuel temperature coefficient becomes more negative as power increases.
- D. the equilibrium xenon-135 reactivity becomes more negative as power increases.

QUESTION: 30

Compared to other reactor poisons, the two characteristics that make xenon-135 a major reactor poison are its relatively \_\_\_\_\_ thermal neutron absorption cross section and its relatively \_\_\_\_\_ variation in concentration for large reactor power changes.

- A. small; large
- B. small; small
- C. large; small
- D. large; large

**USNRC GENERIC FUNDAMENTALS EXAMINATION  
MARCH 2019 PWR – FORM A**

QUESTION: 31

A nuclear power plant was operating at 100 percent power for 3 months near the beginning of a fuel cycle when a reactor trip occurred. Eighteen hours after the reactor trip, the reactor was critical at the point of adding heat. Then, reactor power was increased to 100 percent over a three-hour period.

During the three-hour reactor power increase to 100 percent, most of the positive reactivity added by the operator was required to overcome the negative reactivity from...

- A. fuel burnup.
- B. xenon-135 buildup.
- C. fuel temperature increase.
- D. moderator temperature increase.

QUESTION: 32

Why are burnable poisons installed in a new reactor core instead of using a higher reactor coolant boron concentration for reactivity control?

- A. To prevent boron precipitation during normal operation.
- B. To establish a more negative moderator temperature coefficient.
- C. To minimize the distortion of the neutron flux distribution caused by soluble boron.
- D. To allow the loading of excessive reactivity in the form of higher fuel enrichment.

**USNRC GENERIC FUNDAMENTALS EXAMINATION  
MARCH 2019 PWR – FORM A**

QUESTION: 33

Given:

- C Reactors A and B are identical except that reactor A has an effective delayed neutron fraction of 0.0055 and reactor B has an effective delayed neutron fraction of 0.0052.
- C Reactor A has a stable period of 42 seconds and reactor B has a stable period of 45 seconds.
- C Both reactors pass through  $1.0 \times 10^{-8}$  percent power at the same instant.

The reactor that is supercritical by the greater amount of positive reactivity is reactor \_\_\_\_\_; and the first reactor to reach  $1.0 \times 10^{-1}$  percent power will be reactor \_\_\_\_\_.

- A. A; A
- B. A; B
- C. B; A
- D. B; B

QUESTION: 34

One week after a refueling outage, a nuclear power plant is currently operating at 80 percent power with control rods fully withdrawn. During the outage, the entire core was replaced by new fuel assemblies, and new burnable poison assemblies were installed at various locations.

Assume reactor power and control rod position do not change during the next week. If no operator action is taken, how and why will average reactor coolant temperature change during the next week?

- A. Decrease slowly, due to fuel burnup only.
- B. Decrease slowly, due to fuel burnup and fission product poison buildup.
- C. Increase slowly, due to burnable poison burnout only.
- D. Increase slowly, due to burnable poison burnout and fission product poison decay.



**USNRC GENERIC FUNDAMENTALS EXAMINATION  
MARCH 2019 PWR – FORM A**

QUESTION: 35

A reactor is operating at steady-state 80 percent power near the end of a fuel cycle with a symmetrical axial power distribution peaked at the core midplane. Control rods are in manual control.

If the reactor coolant system (RCS) boron concentration is decreased by 10 ppm, the axial power distribution will shift toward the \_\_\_\_\_ of the core. Then, if the control rods are repositioned to return RCS temperatures to normal for 80 percent power, the axial power distribution will shift toward the \_\_\_\_\_ of the core.

- A. top; top
- B. top; bottom
- C. bottom; top
- D. bottom; bottom

QUESTION: 36

Which one of the following describes how control rods are inserted during a normal reactor shutdown, and why?

- A. One bank at a time, to maintain acceptable power distribution.
- B. One bank at a time, to maintain a rapid shutdown capability from the remainder of the control rods.
- C. In a bank overlapping sequence, to maintain a relatively constant differential control rod worth.
- D. In a bank overlapping sequence, to limit the amount of positive reactivity added during a rod ejection accident.

**USNRC GENERIC FUNDAMENTALS EXAMINATION  
MARCH 2019 PWR – FORM A**

QUESTION: 37

Which one of the following is arranged from the lowest pressure to the highest pressure?

- A. 8 psia, 20 inches Hg absolute, 2 psig
- B. 8 psia, 2 psig, 20 inches Hg absolute
- C. 20 inches Hg absolute, 2 psig, 8 psia
- D. 20 inches Hg absolute, 8 psia, 2 psig

QUESTION: 38

For which of the following ideal processes, if any, is the fluid outlet enthalpy greater than the fluid inlet enthalpy? (Assume horizontal fluid flow in each process.)

- (A) Cooling water flowing through a fixed convergent nozzle.
  - (B) Cooling water flowing through an operating lube oil heat exchanger.
- A. (A) only
  - B. (B) only
  - C. Both (A) and (B)
  - D. Neither (A) nor (B)

**USNRC GENERIC FUNDAMENTALS EXAMINATION  
MARCH 2019 PWR – FORM A**

QUESTION: 39

Given a set of steam tables that lists the following parameters for saturated steam and water:

- C Pressure
- C Enthalpy
- C Specific volume
- C Entropy
- C Temperature

One can determine the \_\_\_\_\_ of a saturated steam-water mixture given only the \_\_\_\_\_.

- A. temperature; enthalpy
- B. temperature; pressure
- C. pressure; entropy
- D. pressure; specific volume

QUESTION: 40

Three days ago, a nuclear power plant experienced a sustained loss of all AC electrical power, which disabled the normal means of heat removal from the spent fuel pool. Currently, there is turbulent boiling occurring throughout the spent fuel pool. A fire truck is being used to supply pure makeup water at 70°F to maintain the spent fuel pool water level.

For simplification of calculations, assume the following:

- The spent fuel pool contains pure water.
- All steam leaving the surface of the spent fuel pool is dry saturated steam at 15.0 psia.

Approximately how much heat is each pound-mass of makeup water removing from the spent fuel pool?

- A. 143 Btu
- B. 970 Btu
- C. 1,113 Btu
- D. 1,151 Btu

**USNRC GENERIC FUNDAMENTALS EXAMINATION  
MARCH 2019 PWR – FORM A**

QUESTION: 41

Dry saturated steam at 1,000 psia is being supplied to the inlet of a partially-open steam throttle valve on a main turbine. Pressure in the steam chest downstream of the throttle valve is 150 psia. Assume a typical throttling process with no heat gain or loss to/from the steam.

When compared to the conditions at the inlet to the throttle valve, which one of the following describes the conditions in the steam chest for specific enthalpy and specific entropy?

- | Steam Chest<br><u>Specific Enthalpy</u> | Steam Chest<br><u>Specific Entropy</u> |
|---|--|
| A. Significantly lower                  | About the same                         |
| B. Significantly lower                  | Significantly higher                   |
| C. About the same                       | About the same                         |
| D. About the same                       | Significantly higher                   |

QUESTION: 42

Consider the steam cycle thermal efficiency of a nuclear power plant operating at rated power.

If the pressure at which saturated steam is produced in the steam generators is increased, thermal efficiency will \_\_\_\_\_; and if the temperature of the feedwater entering the steam generators is increased, thermal efficiency will \_\_\_\_\_.

- A. increase; increase
- B. increase; decrease
- C. decrease; increase
- D. decrease; decrease

**USNRC GENERIC FUNDAMENTALS EXAMINATION  
MARCH 2019 PWR – FORM A**

QUESTION: 43

Which one of the following will result in a higher probability and/or severity of water hammer in a flowing water system?

- A. Gradual pipe bends rather than sharp pipe bends.
- B. Shorter pipe lengths rather than longer pipe lengths.
- C. Lower initial flow rates rather than higher initial flow rates.
- D. Shorter valve stroke times rather than longer valve stroke times.

QUESTION: 44

Which one of the following changes to an operating cooling water system will decrease the head loss occurring in the system?

- A. Positioning a flow control valve more open.
- B. Shifting two heat exchangers from parallel to series operation.
- C. Replacing a 10 foot length of 10-inch diameter pipe with a 20 foot length of 10-inch diameter pipe.
- D. Replacing a 20 foot length of 12-inch diameter pipe with a 20 foot length of 10-inch diameter pipe.

**USNRC GENERIC FUNDAMENTALS EXAMINATION  
MARCH 2019 PWR – FORM A**

QUESTION: 45

A secondary heat balance calculation is being performed at 90 percent reactor power to calibrate reactor power instrumentation. Which one of the following will result in a calculated reactor power that is less than actual reactor power?

- A. Steam generator pressure indication is 20 psi greater than actual steam generator pressure.
- B. Steam generator water level indication is 3 percent less than actual steam generator water level.
- C. Feedwater flow rate indication is 3 percent greater than actual feedwater flow rate.
- D. Feedwater temperature indication is 20°F less than actual feedwater temperature.

QUESTION: 46

A reactor is shutdown with all control rods inserted. The reactor coolant system (RCS) is at normal operating temperature and pressure. Which one of the following will decrease the departure from nucleate boiling ratio for the reactor? (Assume the reactor remains shutdown.)

- A. Fully withdrawing a bank of shutdown rods.
- B. Diluting RCS boron concentration by 50 ppm.
- C. Reducing RCS flow rate by 3 percent.
- D. Increasing RCS pressure by 10 psig.

**USNRC GENERIC FUNDAMENTALS EXAMINATION  
MARCH 2019 PWR – FORM A**

QUESTION: 47

Core heat transfer rate is maximized by the presence of...

- A. laminar flow with no nucleate boiling.
- B. turbulent flow with no nucleate boiling.
- C. laminar flow with nucleate boiling.
- D. turbulent flow with nucleate boiling.

QUESTION: 48

The difference between the actual temperature and the saturation temperature of a liquid is the...

- A. critical heat flux.
- B. saturation margin.
- C. subcooling margin.
- D. departure from nucleate boiling ratio.

**USNRC GENERIC FUNDAMENTALS EXAMINATION  
MARCH 2019 PWR – FORM A**

QUESTION: 49

A reactor is operating at 3,400 MW thermal power. The core linear power density limit is 12.2 kW/ft.

Given:

- C The reactor core contains 198 fuel assemblies.
- C Each fuel assembly contains 262 fuel rods, each with an active length of 12 feet.
- C The highest total peaking factors measured in the core are as follows:

Location A: 2.5  
Location B: 2.4  
Location C: 2.3  
Location D: 2.2

Which one of the following describes the operating conditions in the core relative to the linear power density limit?

- A. All locations in the core are operating below the linear power density limit.
- B. Location A has exceeded the linear power density limit while locations B, C, and D are operating below the limit.
- C. Locations A and B have exceeded the linear power density limit while locations C and D are operating below the limit.
- D. Locations A, B, and C have exceeded the linear power density limit while location D is operating below the limit.



**USNRC GENERIC FUNDAMENTALS EXAMINATION  
MARCH 2019 PWR – FORM A**

QUESTION: 50

A reactor is shut down for refueling following 18 months of operation at an average power level of 85 percent. During the shutdown, a reactor vessel metal specimen was removed from the reactor vessel for testing. The testing determined that the nil-ductility transition (NDT) temperature of the specimen decreased from 44°F to 42°F since the previous refueling shutdown.

Which one of the following conclusions is warranted?

- A. The test results are credible and the reactor vessel is more likely to experience brittle fracture now than after the previous refueling shutdown.
- B. The test results are credible and the reactor vessel is less likely to experience brittle fracture now than after the previous refueling shutdown.
- C. The test results are questionable because the specimen NDT temperature would not decrease during the described 18-month period of operation.
- D. The test results are questionable because the specimen NDT temperature would decrease by more than 2°F during the described 18-month period of operation.

**\*\*\* FINAL ANSWER KEY \*\*\***

**MARCH 2019 NRC GENERIC FUNDAMENTALS EXAMINATION  
PRESSURIZED WATER REACTOR - ANSWER KEY**

<u>FORM A</u>	<u>FORM B</u>	<u>ANS.</u>	<u>FORM A</u>	<u>FORM B</u>	<u>ANS.</u>
1	15	B	26	40	B
2	16	A	27	41	C
3	17	A	28	42	A
4	18	B	29	43	A
5	19	C	30	44	D
6	20	B	31	45	C
7	21	A	32	46	B
8	22	D	33	47	A
9	23	C	34	48	B
10	24	B	35	49	D
11	25	D	36	50	C
12	26	C	37	1	A
13	27	C	38	2	B
14	28	A	39	3	B
15	29	A	40	4	C
16	30	B	41	5	D
17	31	B	42	6	A
18	32	C	43	7	D
19	33	B	44	8	A
20	34	D	45	9	A
21	35	C	46	10	C
22	36	D	47	11	D
23	37	D	48	12	C
24	38	A	49	13	D
25	39	B	50	14	C