



SOUTHERN CALIFORNIA EDISON

SAN ONOFRE NUCLEAR GENERATING STATION
(SONGS)

10 CFR 50.59 / 10 CFR 72.48 Review
APPLICABILITY DETERMINATION, SCREENS, and/or EVALUATIONS

For

Response to Loss of Load Monitoring System

ASSIGNMENT:

0119-53878-5

CONTENTS

Sections I through V shall be performed for each use of this form.

Sections VI through XI are performed as directed by preceding Sections or as deemed necessary.

SECTION	TITLE
I	Administrative
II	Applicability Determination
III	10 CFR 50.82(a)(6) Review
IV	References
V	Preparer / Reviewer(s)
<i>VI</i>	<i>10 CFR 50.59 Screen</i>
<i>VII</i>	<i>10 CFR 50.59 Evaluation</i>
<i>VIII</i>	<i>10 CFR 72.48 Screen</i>
<i>XI</i>	<i>10 CFR 72.48 Evaluation</i>

SECTION I – ADMINISTRATIVE:

A. Is this a revision to an existing review?

Yes: No:

Existing Review Number:

Reason for Revision:

B. Primary Document Type, Number, Revision, and Title:

Document Type: Calculation Change (DSC-002, "Holtec UMAX 72.212 Report, Revision 0)

Document Number / Revision: CCN DR 758641

Document Title: Load Monitoring System (LMS) Unavailability

C. Description of the Proposed Activity:

The proposed activity includes changes to the Licensing Basis (72.212 Report, Reference 1) and associated administrative controls (HPP-2464-400 and -600, References 2 and 3) outlining appropriate actions to take should the Load Monitoring System fail during downloading operations.

SCE (in conjunction/coordination with Holtec and J&R) has authorized the installation of a load monitoring system on the Vertical Cask Transporter (VCT) used to support canister down-loading on the SONGS ISFSI (NECP-0918-64884-1, R2, Reference 4). Administrative Controls (References 2 and 3) assure the availability and functionality of the system prior to initiating down-loading. Nevertheless, there exists a credible possibility that portions or all of the system could become non-functional during the downloading. The intent of this change is to authorize appropriate actions to place the canister in a known-safe-state should that occur.

D. Primary Reason(s) for the Proposed Activity:

The load monitoring system is considered a valuable operator aid. It was addressed in a Holtec FSAR chance (ECO-5021-39R1, Reference 5) which noted it will be required to support down-loading operations. However, no out-of-service guidance has been generically developed or issued. SCE chose to add it for clarity and completeness.

The installed equipment was selected and procured to be well-qualified for its application. Appropriate actions are and will be taken to assure its continued reliability. However, despite such appropriate actions, any such equipment can fail in-service. It is considered prudent to pre-plan the appropriate response to such failures rather than doing so in a response mode.

SECTION II - APPLICABILITY DETERMINATION (AD):

NOTE

Regulatory Guide 1.187 endorses NEI 96-07, Rev. 1, as one method to comply with 10 CFR 50.59. The term "change" is defined in NEI 96-07, Rev. 1, 3.3, as follows:

"Change means a modification or addition to, or removal from, the facility or procedures that affects: (1) a design function, (2) method of performing or controlling the function, or (3) an evaluation that demonstrates that intended functions will be accomplished."

The same definition of the term "change" is provided in 10 CFR 72.48 (a)(1), and thus is equally applicable for 72.48 reviews.

IF required, THEN see/use additional discussion provided in the associated "Discussion" in NEI 96-07, Rev. 1, 3.3, and the SONGS Resource Manual.

The basis must carefully examine whether there are any 'design functions' that are directly or indirectly impacted by the proposed activity. These will most often be detailed in the appropriate FSAR.

A. Is the proposed activity a change to the facility (including the ISFSI)? Explain fully.

Yes No

The load monitoring system is a means to support the control of a design function. The function involved is the control of a heavy load (the canister) during down-loading from the HI-TRAC transfer Overpack to the UMAX VVM Storage Overpack. The load-bearing aspects (shackles) are Important to Safety (ITS) while the load indicating hardware is characterized as an operator aid and are not ITS. Nevertheless, the load indicating aspects are relied on in the procedures to reinforce visual observation and other means of assuring appropriate load control.

The proposed activity is in response to equipment failure. In response to such failure there are only three options: the load (canister) can remain suspended where it is; it can be lifted back into the HI-TRAC Transfer Overpack; or it can be lowered into the VVM Storage Overpack. While leaving it as-is would be acceptable; either other location is more stable based on the canister resting on a fixed surface designed for that purpose. The activity (guidance) addresses when to raise or lower the canister based on potential interactions with the VVM which is the reason for the addition of the load monitoring system.

As such it is a "change" to the Storage System Controls under 10 CFR 72.48 and industry guidance. It has no impact on the Part 50 facility and need not be further evaluated under 10 CFR 50.59.

IF "Yes", THEN identify those aspects that must be appropriately addressed in Section VI or Section VIII or both, as appropriate:

B. Other regulatory processes can independently authorize or preclude changes to the facility. Indicate which other regulatory processes have been used to authorize this activity:

- Approved Specific Exemptions 10 CFR 50.12 or 72.7
- Fire Protection Program 10 CFR 50.48(f)
- Decommissioning QA Plan 10 CFR 50.54(a)
- Physical Security Plan 10 CFR 50.54(p)
- Emergency Plan 10 CFR 50.54(q)
- Approved License Amendments 10 CFR 50.90 or 72.244

C. Evaluation using one or more of the processes in Section II.B has established that the proposed change may be implemented without prior or further NRC approval.

Yes No Assignment _____ (If Yes)

IF "Yes", THEN summarize how the change is addressed. IF changes to the design basis are fully addressed by other processes, THEN no further review under 10 CFR 50.59 or 72.48 is required. For ease in cross-referencing, list the assignment(s) that tracked the completed review requirements for those items.

D. Does the proposed activity require a change to the Technical Specifications, 10 CFR 50 Operating License Condition(s) or Terms, Conditions and Specifications for a Storage System Certificate of Compliance?

Yes No Assignment _____ (If Yes)

IF "Yes", THEN the proposed activity cannot be authorized by 10 CFR 50.59. A License Amendment under 10 CFR 50.90 or 72.244 (which are the responsibility of the Certificate Holder) is required. Document the number of the assignment tracking the LAR or documenting the decision to modify or not make the proposed activity.

E. Summary of Section II

Based on the reviews documented in II.A through II.D, the following Screen(s) are required (Check either, neither, or both, as appropriate).

- 10 CFR 50.59 Screen (Perform Section VI)
- 10 CFR 72.48 Screen (Perform Section VIII)

SECTION III - 10 CFR 50.82(a)(6) REVIEW:

NOTE

10 CFR 50.82(a)(6) states in part: Licensee shall not perform any decommissioning activities as defined in Section 50.2 that - (i) Foreclose release of the site for possible unrestricted use; (ii) Result in significant environmental impacts not previously reviewed; or (iii) Result in there no longer being reasonable assurance that adequate funds will be available for decommissioning.

Question 1:

Does the proposed change foreclose release of the site for possible unrestricted use?

Yes No

Reason:

The proposed change is a relatively minor procedure change to established pre-planned activities in response to specific equipment failures. It has no physical impact on the site.

Therefore, there is no impact on the potential release of the site for possible unrestricted use.

Question 2:

Does the proposed change result in significant environmental impacts not previously reviewed?

Yes No

Reason:

The proposed change is a relatively minor procedure change to established pre-planned activities in response to specific equipment failures. It has no environmental impacts.

Therefore, there is no impact on the potential release of the site for possible unrestricted use.

Question 3:

Does the proposed change result in there no longer being reasonable assurance that adequate funds will be available for decommissioning?

Yes NO

Reason:

The proposed change is a relatively minor procedure change to established pre-planned activities in response to specific equipment failures. The incremental resource impacts are limited to staff resources which are fully allocated in the Decommissioning Cost Estimate and funded from the Decommissioning Trust Fund.

Therefore, there is no adverse impact on funding assurance.

Conclusion:

IF the subject activity is determined to be an adverse change to a major decommissioning activity due to the results of the evaluations performed for Questions III.1 through III.3, THEN the activity may NOT be performed [reference 10 CFR 50.82(a)(6)]. List the applicable assignment to track the disposition of this item.

Assignment # _____

SECTION IV – REFERENCES:

1. DCS-002, Revision 0, "HOLTEC UMAX 72.212 Report"
2. HPP-2464-400, "MPC Transfer at SONGS"
3. HPP-2464-600, "Responding to Abnormal Conditions"
4. NECP-0918-64884-1, Revision 2 VCT Load Monitoring
5. ECO-5021-39, R1

SECTION V – PREPARERS / REVIEWERS:

Technical Input (if required): Randall Granaas	Date: 1/10/19
Prepared By: Ken Wilson	Date: 1/10/19
Reviewed By: Richard Chang	Date: 1/10/19
Independent Review By: N/A	Date: 1/10/19

AFTER all reviews are complete, THEN unused Sections may be discarded.

SECTION VIII - 10 CFR 72.48 SCREEN

A. Identify and briefly summarize the aspects of the proposed activity which require a Screen.

Question 1:

Does the proposed activity change an SSC in a manner that adversely affects the applicable FSAR design function(s) or has an adverse effect on the method of performing or controlling applicable FSAR design function(s)?

Yes No

Reason:

The guidance being provided is in response to equipment failure; but, the proposed activity does not change any SSC.

Therefore, there is no SSC changes that adversely impact the performance of a design function.

Question 2:

Does the proposed activity change a procedure (i.e., applicable FSAR described process for operation or control of an SSC) in a manner that adversely affects how applicable FSAR described SSC design function(s) are performed or controlled?

Yes No

Reason:

As noted in Screening Question 1 above, the guidance minimizes the adverse impacts of equipment failure. By establishing clear direction in response to the equipment failure it reduces the impact of the equipment failure.

Therefore, the procedure changes do not cause an adverse impact to the control of the design function. However, since the condition (equipment failure) leads to other and more limited administrative controls this is conservatively characterized as "adverse."

Question 3:

Does the proposed activity involve revising or replacing an applicable FSAR described method of evaluation used in establishing the design bases or used in the safety analyses in an adverse manner?

Yes No

Reason:

No analytical method of evaluation is involved in any way.

Therefore, no method is revised or replaced.

Question 4:

Does the proposed activity involve a test or experiment not described in the applicable FSAR, where an SSC is utilized or controlled in a manner outside the reference bounds of the design for that SSC, or is inconsistent with the analysis or descriptions in the applicable FSAR?

Yes No

Reason:

No SSC is utilized or controlled in a manner outside its design.

Therefore, the proposed change does not involve a test or experiment.

B. Based on the responses to Questions VIII.1 through VIII.4 above, the proposed activity is:

- NOT adverse. (All of the responses to Questions VIII.1 through VIII.4 MUST be negative.)
GO TO Section V to obtain Reviews.
- Adverse. (One or more of the responses to Questions VIII.1 through VIII.4 are positive.)
GO TO Section IX for Evaluation.

END OF SECTION VIII

SECTION IX – 10 CFR 72.48 EVALUATION

A. Identify and briefly summarize the aspects of the proposed activity which require an evaluation.

Question 1:

Does the proposed activity result in more than a minimal increase in the frequency of occurrence of an accident previously evaluated in the applicable FSAR?

Yes No

Reason:

The addition of procedural guidance to direct actions in response to equipment failure has no impact on the frequency of accidents evaluated in the FSAR.

Question 2:

Does the proposed activity result in more than a minimal increase in the likelihood of occurrence of a malfunction of an SSC important to safety previously evaluated in the applicable FSAR?

Yes No

Reason:

The addition of procedural guidance to direct actions in response to equipment failure has no impact on the likelihood of malfunctions of any SSCs important to safety previously evaluated in the FSAR.

Question 3:

Does the proposed activity result in more than a minimal increase in the consequences of an accident previously evaluated in the applicable FSAR?

Yes No

Reason:

The addition of procedural guidance to direct actions in response to equipment failure has no impact on the consequences of accidents previously evaluated in the FSAR.

Question 4:

Does the proposed activity result in more than a minimal increase in the consequences of a malfunction of an SSC important to safety previously evaluated in the applicable FSAR?

Yes No

Reason:

The addition of procedural guidance to direct actions in response to equipment failure has no impact on the consequences of a malfunction of an SSC important to safety previously evaluated in the FSAR.

Question 5:

Does the proposed activity create a possibility for an accident of a different type than any previously evaluated in the applicable FSAR?

Yes No

Reason:

The addition of procedural guidance to direct actions in response to equipment failure does not create the possibility for an accident of different type other than any previously evaluated in the applicable FSAR.

Question 6:

Does the proposed activity create a possibility for a malfunction of an SSC important to safety with a different result than any previously evaluated in applicable FSAR?

Yes No

Reason:

The addition of procedural guidance to direct actions in response to equipment failure does not create the possibility of a malfunction of an SSC important to safety of a different result that previously evaluated in the applicable FSAR.

Question 7:

Does the proposed activity result in a design basis limit for a fission product barrier as described in the applicable FSAR being exceeded or altered?

Yes No

Reason:

The addition of procedural guidance to direct actions in response to equipment failure has no impact on any design basis limit for a fission product barrier as described in the applicable FSAR.

Question 8:

Does the proposed activity result in a departure from a method of evaluation described in the applicable FSAR used in establishing the design bases or in the safety analyses?

Yes No

Reason:

The addition of procedural guidance to direct actions in response to equipment failure does not involve a method of evaluation used in establishing the design basis or in the safety analysis. Thus, this question actually not applicable.

B. Evaluation Conclusion

- Acceptable for Implementation. (All of the above responses MUST be negative.)
GO TO Section V to obtain Reviews.
- NOT Acceptable for Implementation. (One or more of the above responses are positive.)
DO NOT PROCEED with proposed activity. A Certificate of Compliance Amendment Request by the Certificate Holder and NRC approval is required.
GO TO Section V to obtain Reviews.

C. 10 CFR 72.48 Evaluation Summary

The inclusion of additional guidance to direct actions in responses to equipment failures does not require NRC prior approval as evidenced by the response to the questions detailed above.



SOUTHERN CALIFORNIA EDISON

SAN ONOFRE NUCLEAR GENERATING STATION
(SONGS)

10 CFR 50.59 / 10 CFR 72.48 Review
APPLICABILITY DETERMINATION, SCREENS, and/or EVALUATIONS

For

Expanded Heavy Haul Path

ASSIGNMENT:

0119-54369-2

CONTENTS

Sections I through V shall be performed for each use of this form.

Sections VI through XI are performed as directed by preceding Sections or as deemed necessary.

SECTION	TITLE
I	Administrative
II	Applicability Determination
III	10 CFR 50.82(a)(6) Review
IV	References
V	Preparer / Reviewer(s)
<i>VI</i>	<i>10 CFR 50.59 Screen</i>
<i>VII</i>	<i>10 CFR 50.59 Evaluation</i>
<i>VIII</i>	<i>10 CFR 72.48 Screen</i>
<i>XI</i>	<i>10 CFR 72.48 Evaluation</i>

SECTION I – ADMINISTRATIVE:

A. Is this a revision to an existing review?

Yes: No:

Existing Review Number:

Reason for Revision:

B. Primary Document Type, Number, Revision, and Title:

Document Type: NECP and Calculations

Document Number / Revision/Title:

0119-54369-1, Rev. 0, "HI-PORT Haul Route Modification"

C. Description of the Proposed Activity:

The proposed change is a revision to the existing SCE Dry Cask Storage Route expanding it slightly to reflect changes necessary to have sufficient margin between the HI-PORT and obstacles adjacent to the haul path. The changes are provided in References 2, 3, and 4.

These were re-visited to resolve detailed procedure content and operator practices with regard to elevation and proximity to various obstacles as recommended by Holtec in References 5 and 6.

Exclusion zones around substantial obstructions along the haul path to ensure an appropriate standoff distance is maintained will be appropriately identified to assist complying with Holtec HI-PORT stability analysis (Reference 4) results. For obstructions with no safety function, it has been concluded that they would yield to the significantly greater weight of the HI-PORT/HI-TRAC during a seismic event and therefore would not materially alter the seismic response of the HI-PORT/HI-TRAC.

D. Primary Reason(s) for the Proposed Activity:

The UMAX CoC (Reference 1) requires that the transfer occur over a prescribed haul route and that the transfer systems (HI-TRAC on HI-PORT in SONGS campaign) remain stable during a design basis earthquake. Doing so requires limits on HI-PORT drop deck elevation (controlling the associated Center-of-Gravity) and no interactions to obstacles and important to safety structures near the haul route.

The technical evaluations are covered in a series of Holtec calculations and responses to technical inquiries (References 2 through 6).

In order to comply with Reference 2 it was necessary to modify the haul path.

SECTION II - APPLICABILITY DETERMINATION (AD):

NOTE

Regulatory Guide 1.187 endorses NEI 96-07, Rev. 1, as one method to comply with 10 CFR 50.59. The term "change" is defined in NEI 96-07, Rev. 1, 3.3, as follows:

"Change means a modification or addition to, or removal from, the facility or procedures that affects: (1) a design function, (2) method of performing or controlling the function, or (3) an evaluation that demonstrates that intended functions will be accomplished."

The same definition of the term "change" is provided in 10 CFR 72.48 (a)(1), and thus is equally applicable for 72.48 reviews.

IF required, THEN see/use additional discussion provided in the associated "Discussion" in NEI 96-07, Rev. 1, 3.3, and the SONGS Resource Manual.

The basis must carefully examine whether there are any 'design functions' that are directly or indirectly impacted by the proposed activity. These will most often be detailed in the appropriate FSAR.

A. Is the proposed activity a change to the facility (including the ISFSI)? Explain fully.

Yes No

Holtec provided revised analyses and recommendations based on HI-PORT stability (sliding) analysis. These analyses were performed using standard industry approach with expanded input (time histories). In addition, extensions to the haul route were added to preclude adverse interactions with existing structures. Results of these analyses demonstrate that the VCT and HI-PORT with a loaded HI-TRAC VW do not tip over or slide off the haul path or adversely interact with nearby obstacles. Exclusion zones will be clearly marked along the haul path to ensure the standoff distance reflects the analysis inputs and results.

Holtec analysis concluded that, with implementation of exclusion zones, HI-TRAC/HI-PORT will not contact safety related plant SSC during sliding. Based on the above, there are no changes to facility as defined in SONGS 2/3 UFSAR and therefore a 10 CFR 50.59 screen is not warranted.

For minor obstructions with no safety function, Holtec concluded that if interactions were to occur, the obstructions would yield to the significantly greater weight of the HI-PORT during a seismic event and therefore would not materially alter the seismic response of the HI-PORT.

Further considerations will be provided in attached 72.48 screen.

IF "Yes", THEN identify those aspects that must be appropriately addressed in Section VI or Section VIII or both, as appropriate:

B. Other regulatory processes can independently authorize or preclude changes to the facility. Indicate which other regulatory processes have been used to authorize this activity:

- Approved Specific Exemptions 10 CFR 50.12 or 72.7
- Fire Protection Program 10 CFR 50.48(f)
- Decommissioning QA Plan 10 CFR 50.54(a)
- Physical Security Plan 10 CFR 50.54(p)
- Emergency Plan 10 CFR 50.54(q)
- Approved License Amendments 10 CFR 50.90 or 72.244

C. Evaluation using one or more of the processes in Section II.B has established that the proposed change may be implemented without prior or further NRC approval.

Yes No Assignment _____ (If Yes)

IF "Yes", THEN summarize how the change is addressed. IF changes to the design basis are fully addressed by other processes, THEN no further review under 10 CFR 50.59 or 72.48 is required. For ease in cross-referencing, list the assignment(s) that tracked the completed review requirements for those items.

D. Does the proposed activity require a change to the Technical Specifications, 10 CFR 50 Operating License Condition(s) or Terms, Conditions and Specifications for a Storage System Certificate of Compliance?

Yes No Assignment _____ (If Yes)

IF "Yes", THEN the proposed activity cannot be authorized by 10 CFR 50.59. A License Amendment under 10 CFR 50.90 or 72.244 (which are the responsibility of the Certificate Holder) is required. Document the number of the assignment tracking the LAR or documenting the decision to modify or not make the proposed activity.

E. Summary of Section II

Based on the reviews documented in II.A through II.D, the following Screen(s) are required (Check either, neither, or both, as appropriate).

- 10 CFR 50.59 Screen (Perform Section VI)
- 10 CFR 72.48 Screen (Perform Section VIII)

SECTION III - 10 CFR 50.82(a)(6) REVIEW:

NOTE

10 CFR 50.82(a)(6) states in part: Licensee shall not perform any decommissioning activities as defined in Section 50.2 that - (i) Foreclose release of the site for possible unrestricted use; (ii) Result in significant environmental impacts not previously reviewed; or (iii) Result in there no longer being reasonable assurance that adequate funds will be available for decommissioning.

Question 1:

Does the proposed change foreclose release of the site for possible unrestricted use?

Yes No

Reason:

The proposed change adds minor physical changes (markings) on the haul route that will be removed during D&D.

Therefore, there is no impact to the possible release of the site for unrestricted use.

Question 2:

Does the proposed change result in significant environmental impacts not previously reviewed?

Yes No

Reason:

The minor physical change is along the haul route and has no impact on the environment.

Therefore, there is no environmental impacts that warrant additional reviews.

Question 3:

Does the proposed change result in there no longer being reasonable assurance that adequate funds will be available for decommissioning?

Yes No

Reason:

The only incremental costs are engineering resources fully detailed in the Decommissioning Cost Estimate and funded by the Decommissioning Trust Fund.

There is no adverse impact on decommissioning funding assurance.

Conclusion:

IF the subject activity is determined to be an adverse change to a major decommissioning activity due to the results of the evaluations performed for Questions III.1 through III.3, THEN the activity may NOT be performed [reference 10 CFR 50.82(a)(6)]. List the applicable assignment to track the disposition of this item.

Assignment # _____

SECTION IV – REFERENCES:

1. Holtec UMAX MSE CoC 72-1040, Appendix B, Approved Contents and Design Features Sections 3.4.14 and 3.4.15
2. HI-2146390, "San Onofre Nuclear Generating Station Haul Path and Underground Utility Evaluation."
3. HI-2156626, "VCT Stability Analysis on Route to ISFSI Pad and on ISFSI Pad for San Onofre Nuclear Generating Station."
4. HI-2167363, "Seismic Stability Analysis HI-TRAC on HI-PORT at SONGS."
5. RRTI-2464-063, "Haul Route Administrative Controls Review"
6. RRTI-2464-066, "Clarification of Haul Route Clearance Recommendations"
7. C-296-04.01 Revision 5, CCN DR 758663
8. DCS-002, Revision 0, CCN DR 758661
9. NECP 0119-54369-1, Revision 0, "HI-PORT Haul Route Modification."

SECTION V – PREPARERS / REVIEWERS:

Technical Input (if required): _____ Date: _____

(b)(7)(C)

Prepared By: Richard Chang **R. Chang** Digitally signed by R. Chang
DN: cn=R. Chang, o=... _____ Date: 1/17/19

Reviewed By: Ken Wilson **Ken Wilson** Digitally signed by Ken Wilson
DN: cn=Ken Wilson, o=ISFS Engineering,
ou_email=kenwilson@isfs.com, c=US
Date: 20190117 15:51:44 -0800 _____ Date: 1/17/19

Independent Review By: N/A _____ Date: _____



AFTER all reviews are complete, THEN unused Sections may be discarded.
SECTION VIII - 10 CFR 72.48 SCREEN

A. Identify and briefly summarize the aspects of the proposed activity which require a Screen.

Question 1:

Does the proposed activity change an SSC in a manner that adversely affects the applicable FSAR design function(s) or has an adverse effect on the method of performing or controlling applicable FSAR design function(s)?

Yes No

Reason:

The proposed change, in most cases, eliminates all possibility of a seismically induced interaction with nearby obstructions. However, it doesn't preclude all HI-TRAC/HI-PORT interaction with minor obstructions with no safety functions (e.g., K-Rail F and the Hazard Area Fence). In RRTI-2464-066 (Reference 6), Holtec proposed and SCE/MPR concurred that if interactions were to occur, the obstructions would yield to the significantly greater weight of the HI-PORT during a seismic event and therefore would not materially alter the seismic response of the HI-PORT.

Therefore, there are no adverse effects.

Question 2:

Does the proposed activity change a procedure (i.e., applicable FSAR described process for operation or control of an SSC) in a manner that adversely affects how applicable FSAR described SSC design function(s) are performed or controlled?

Yes No

Reason:

Incorporation of the changes into the appropriate procedures will provide greater assurance that no adverse interactions with existing structures will occur.

Therefore, there are no adverse effects on the performance or control of a design function.

Question 3:

Does the proposed activity involve revising or replacing an applicable FSAR described method of evaluation used in establishing the design bases or used in the safety analyses in an adverse manner?

Yes No

Reason:

There are no changes to the FSAR described method of evaluation. The HI-TRAC/HI-PORT transport analysis uses standard industry methods and continues to comply with requirements (i.e. time histories and selection of worst case results).

Therefore, this change does not involve a change in FSAR described method of evaluation.

Question 4:

Does the proposed activity involve a test or experiment not described in the applicable FSAR, where an SSC is utilized or controlled in a manner outside the reference bounds of the design for that SSC, or is inconsistent with the analysis or descriptions in the applicable FSAR?

Yes No

Reason:

No SSCs are utilized or controlled in manner outside the reference bounds of their respective designs. No test or experiments other than functional tests are associated with implementation of the change or the use of the installed equipment.

Therefore, this change does not involve a test or experiment.

B. Based on the responses to Questions VIII.1 through VIII.4 above, the proposed activity is:

- NOT adverse. (All of the responses to Questions VIII.1 through VIII.4 MUST be negative.) GO TO Section V to obtain Reviews.
- Adverse. (One or more of the responses to Questions VIII.1 through VIII.4 are positive.) GO TO Section IX for Evaluation.

END OF SECTION VIII

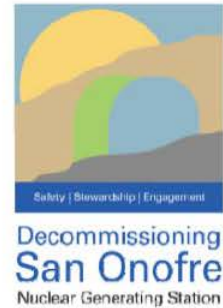

SOUTHERN CALIFORNIA EDISON

SAN ONOFRE NUCLEAR GENERATING STATION
(SONGS)

10 CFR 50.59 / 10 CFR 72.48 Review
APPLICABILITY DETERMINATION, SCREENS, and/or EVALUATIONS

For

Exceptions to HI-STORM UMAX FSAR Content Associated with Incidental Contact
during Downloading

ASSIGNMENT:

0219-87459-3

CONTENTS

Sections I through V shall be performed for each use of this form.

Sections VI through XI are performed as directed by preceding Sections or as deemed necessary.

SECTION	TITLE
I	Administrative
II	Applicability Determination
III	10 CFR 50.82(a)(6) Review
IV	References
V	Preparer / Reviewer(s)
VI	<i>10 CFR 50.59 Screen</i>
VII	<i>10 CFR 50.59 Evaluation</i>
VIII	<i>10 CFR 72.48 Screen</i>
XI	<i>10 CFR 72.48 Evaluation</i>

SECTION I – ADMINISTRATIVE:

A. Is this a revision to an existing review?

Yes: No:

Existing Review Number:

Reason for Revision:

B. Primary Document Type, Number, Revision, and Title:

Document Type: Calculation Change

Document Number / Revision: DCS-002, CCN DR758838, Rev 0

Document Title: SONGS HI-STORM UMAX 72.212 Report

C. Description of the Proposed Activity:

Clarify the SONGS position (documented within the subject HI-STORM UMAX 72.212 report, Section E.1 UMAX FSAR) with regard to assuring that operational activities (e.g., down-loading or withdrawal) do not challenge compliance with the HI-STORM UMAX design and licensing basis as summarized in Chapter 9 "Operating Procedures," Section 9.5, "Regulatory Compliance," of the UMAX FSAR (Reference 1). Conforming changes are also being made to subsection 1.2.4(b) of the 72.212 Report.

Revision 4 of the FSAR, which is the revision upon which the HI-STORM UMAX 72.212 report is based, relies on "ample lateral clearances" to conclude there is no risk of damage to the confinement boundary. An equivalent statement "vertical insertion (or withdrawal) of the MPC eliminates the risk of gouging or binding with the CEC parts" is also made in Section 1.2.4(b). However, as evidenced from recent canister loading experience and visual assessment results (Reference 2); there is a potential for incidental contact between the canister (MPC) and various VVM sub-components located within the divider shell. The proposed changes to SONGS UMAX 72.212 report acknowledges the potential for MPC contact with VVM subcomponents. Detailed visual assessment of three canisters were performed. Two were selected based on known down-loading challenges and the third was selected from the sloped portions of the ISFSI pad which had also been down-loaded earlier in the campaign. The results of the visual assessments confirm that the MPC structural design requirements will be met with substantial margin (Reference 2).

D. Primary Reason(s) for the Proposed Activity:

The proposed activity fulfills the requirement specified in 10 CFR 72.212(6) to review the applicable Storage System (HI-STORM UMAX) Safety Analysis Report to determine whether or not the site parameters are enveloped by the cask design bases considered in the report.

In this case the design parameters are unstated; but, the basis for concluding that there is no risk of damage to the confinement boundary is slightly modified. The lateral clearances have positive and negative impacts. Tight clearances increase the possibility of incidental contact but also reduce the extent of potential misalignment. Misalignment determines the available lateral load which is the motive force leading to scratching or gouging of the pressure boundary. Wider clearances would reduce the probability of such interactions; but, would increase operational dose, allow for greater misalignment during down-loading and increased seismic loading during a seismic event resulting greater impacts to the pressure boundary. Considering both probability and consequences; the risk is demonstrated to remain well within appropriate limits which remain unchanged (ASME Section III).

SECTION II - APPLICABILITY DETERMINATION (AD):

NOTE

Regulatory Guide 1.187 endorses NEI 96-07, Rev. 1, as one method to comply with 10 CFR 50.59. The term "change" is defined in NEI 96-07, Rev. 1, 3.3, as follows:

"Change means a modification or addition to, or removal from, the facility or procedures that affects: (1) a design function, (2) method of performing or controlling the function, or (3) an evaluation that demonstrates that intended functions will be accomplished."

The same definition of the term "change" is provided in 10 CFR 72.48 (a)(1), and thus is equally applicable for 72.48 reviews.

IF required, THEN see/use additional discussion provided in the associated "Discussion" in NEI 96-07, Rev. 1, 3.3, and the SONGS Resource Manual.

The basis must carefully examine whether there are any 'design functions' that are directly or indirectly impacted by the proposed activity. These will most often be detailed in the appropriate FSAR.

A. Is the proposed activity a change to the facility (including the ISFSI)? Explain fully.

Yes No

Incidental contact of the MPC with VVM sub-components is not explicitly addressed in the UMAX FSAR (Reference 1). It is not required to be addressed in the FSAR by the NRC Standard Review Plan (Reference 4).

Demonstration of compliance with the structural and confinement design basis functions are met continues to primarily rely on the material properties (i.e., hardness, thickness, etc.), fabrication practices and associated administrative controls. The design and licensing basis methods of demonstrating compliance continue to be the ASME B&PV Code including pre-service and in-service examinations, evaluations and repairs. There is no impact to other MPC design functions (heat removal or criticality control).

The proposed changes to the 72.212 Report Appendix E, do not alter the fundamental design and licensing basis. The proposed change to the 72.212 simply replaces "ample lateral clearances" with visual assessments to provide the basis for the FSAR Regulatory Compliance summary statement (HI-STORM UMAX FSAR Section 9.5) that there is "no risk of damage to the confinement boundary," as documented in Reference 2. The change to the 72.212 evaluation of Operational Characteristics (Appendix E, Section 1.2.4) is made for consistency.

IF "Yes", THEN identify those aspects that must be appropriately addressed in Section VI or Section VIII or both, as appropriate:

The use of a visual assessment to support the 72.212 statement is addressed in Section VIII.

B. Other regulatory processes can independently authorize or preclude changes to the facility. Indicate which other regulatory processes have been used to authorize this activity:

- Approved Specific Exemptions 10 CFR 50.12 or 72.7
- Fire Protection Program 10 CFR 50.48(f)
- Decommissioning QA Plan 10 CFR 50.54(a)
- Physical Security Plan 10 CFR 50.54(p)
- Emergency Plan 10 CFR 50.54(q)
- Approved License Amendments 10 CFR 50.90 or 72.244

C. Evaluation using one or more of the processes in Section II.B has established that the proposed change may be implemented without prior or further NRC approval.

Yes No Assignment _____ (If Yes)

IF "Yes", THEN summarize how the change is addressed. IF changes to the design basis are fully addressed by other processes, THEN no further review under 10 CFR 50.59 or 72.48 is required. For ease in cross-referencing, list the assignment(s) that tracked the completed review requirements for those items.

D. Does the proposed activity require a change to the Technical Specifications, 10 CFR 50 Operating License Condition(s) or Terms, Conditions and Specifications for a Storage System Certificate of Compliance?

Yes No Assignment _____ (If Yes)

SONGS is not proposing any change to the existing design and licensing basis addressed in the Certificate of Compliance including its Appendices. SONGS is proposing a direct means to support the proposed 72.212 statement.

IF "Yes", THEN the proposed activity cannot be authorized by 10 CFR 50.59. A License Amendment under 10 CFR 50.90 or 72.244 (which are the responsibility of the Certificate Holder) is required. Document the number of the assignment tracking the LAR or documenting the decision to modify or not make the proposed activity.

E. Summary of Section II

Based on the reviews documented in II.A through II.D, the following Screen(s) are required (Check either, neither, or both, as appropriate).

- 10 CFR 50.59 Screen (Perform Section VI)
- 10 CFR 72.48 Screen (Perform Section VIII)

SECTION III - 10 CFR 50.82(a)(6) REVIEW:

NOTE

10 CFR 50.82(a)(6) states in part: Licensee shall not perform any decommissioning activities as defined in Section 50.2 that - (i) Foreclose release of the site for possible unrestricted use; (ii) Result in significant environmental impacts not previously reviewed; or (iii) Result in there no longer being reasonable assurance that adequate funds will be available for decommissioning.

Question 1:

Does the proposed change foreclose release of the site for possible unrestricted use?

Yes No

Reason:

The proposed change is a change to an engineering and licensing basis document (the 72.212 report) that has no impact on the physical site.

Therefore, the change does not foreclose the release of the site for possible unrestricted use.

Question 2:

Does the proposed change result in significant environmental impacts not previously reviewed?

Yes No

Reason:

The proposed change is a change to an engineering and licensing document that has no impact on the physical site and thus, the environment.

Therefore, the change does not involve a significant environmental effect not previously reviewed.

Question 3:

Does the proposed change result in there no longer being reasonable assurance that adequate funds will be available for decommissioning?

Yes NO

Reason:

The only incremental costs associated with the change are engineering labor costs that are already funded from the Decommissioning Trust Fund based on the Decommissioning Cost Estimate.

Thus, there is no adverse impact on funding assurance.

Conclusion:

IF the subject activity is determined to be an adverse change to a major decommissioning activity due to the results of the evaluations performed for Questions III.1 through III.3, THEN the activity may NOT be performed [reference 10 CFR 50.82(a)(6)]. List the applicable assignment to track the disposition of this item.

Assignment # _____

SECTION IV – REFERENCES:

1. HI-2115090, Revision 4, "HI-STORM UMAX FSAR."
2. HI-STORM Multi-Purpose Canister Visual Assessment Report
3. 0219-92285-3 Regulatory Review of procedure for MPC inspection
4. NUREG-1536, Revision 1, "Standard Review Plan for Spent Fuel Dry Storage Systems at a General License Facility."
5. NEI 98-03, Revision 1, "Guidelines for Updating Final Safety Analysis Reports."

SECTION V – PREPARERS / REVIEWERS:

Technical Input (if required): N/A

Date:

Prepared By: Ken Wilson **Ken Wilson**

Digitally signed by Ken Wilson
DN: cn=Ken Wilson, o=ISFSI Engineering,
ou, email=kenneth.r.wilson@sce.com, c=US
Date: 2019.03.29 12:05:21 -07'00'

Date: 3/29/19

Reviewed By: Richard Chang **R. Chang**

Digitally signed by R. Chang
DN: cn=R. Chang, o=ISFSI Engineering,
ou, email=richard.chang@sce.com, c=US
Date: 2019.03.29 12:07:20 -07'00'

Date: 3/29/19

(b)(7)(C)

Independent Review By: Kim Manzione **Kimberly Manzione**

Digitally signed by Kimberly Manzione
DN: cn=Kimberly Manzione, o=ISFSI Engineering,
ou, email=kimberly.manzione@sce.com, c=US
Date: 2019.03.29 12:07:20 -07'00'

Date: 3/29/19

AFTER all reviews are complete, THEN unused Sections may be discarded.

SECTION VIII - 10 CFR 72.48 SCREEN

A. Identify and briefly summarize the aspects of the proposed activity which require a Screen.

Question 1:

Does the proposed activity change an SSC in a manner that adversely affects the applicable FSAR design function(s) or has an adverse effect on the method of performing or controlling applicable FSAR design function(s)?

Yes No

Reason:

There is no adverse impact on any SSC. The proposed change does not impact the risk from incidental contact but simply better assesses the actual consequences of such contact.

As detailed in the Holtec Multi-Purpose Visual Assessment Report (Reference 2), MPCs with and without reported difficulty during downloading showed shallow wear marks 0.026" (26 mils) in depth. The depth is insignificant compared to nominal design wall thickness of 0.500" (500 mils) or the additional 0.125" (125 mils) of margin built into SONGS MPCs based on the additional wall thickness selected by SCE. Furthermore the acceptability of the observed wear marks is also supported by the ASME Code's treatment of the character of the various observations; both those that are local stress risers and those more associated with standard thinning allowances (10% of nominal wall thickness plus additional margin from selection of 0.625" wall thickness).

Therefore, even with incidental contact with VVM sub-components, the SONGS MPCs comply with all applicable portions of the ASME code as detailed in the HI-STORM UMAX CoC and supporting FSAR (Reference 1).

The methods of performing or controlling FSAR functions remain unchanged. The design and associated acceptance criteria remain unchanged and fully met. ASME Code required examinations and inspections are unaffected.

Question 2:

Does the proposed activity change a procedure (i.e., applicable FSAR described process for operation or control of an SSC) in a manner that adversely affects how applicable FSAR described SSC design function(s) are performed or controlled?

Yes No

Reason:

The procedure for obtaining the data was authorized via 72.48 0219-92285-3 (Reference 3) and is not otherwise changed. The methods of performing or controlling FSAR functions remain unchanged.

Question 3:

Does the proposed activity involve revising or replacing an applicable FSAR described method of evaluation used in establishing the design bases or used in the safety analyses in an adverse manner?

Yes No

Reason:

There are no applicable FSAR-described methods of evaluation for estimating the potential impacts of incidental contact during down-loading. Therefore, there are no methods of evaluation described in the FSAR being revised or replaced as part of the proposed activity. Visual characterization of incidental contact (Reference 2) is used to validate the subject HI-STORM UMAX 72.212 written evaluations.

Thus, there is no impact to "an applicable FSAR described method of evaluation."

Question 4:

Does the proposed activity involve a test or experiment not described in the applicable FSAR, where an SSC is utilized or controlled in a manner outside the reference bounds of the design for that SSC, or is inconsistent with the analysis or descriptions in the applicable FSAR?

Yes No

Reason:

No tests or experiments were conducted on the SSC. The proposed activity updates the 72.212 report to reflect SONGS MPC downloading experience and reaffirms SONGS compliance with applicable ASME Code requirements by detailed visual assessment of down-loaded MPC's.

Based on the responses to Questions VIII.1 through VIII.4 above, the proposed activity is:

- NOT adverse. (All of the responses to Questions VIII.1 through VIII.4 MUST be negative.)
GO TO Section V to obtain Reviews.
- Adverse. (One or more of the responses to Questions VIII.1 through VIII.4 are positive.)
GO TO Section IX for Evaluation.

END OF SECTION VIII



SOUTHERN CALIFORNIA EDISON

SAN ONOFRE NUCLEAR GENERATING STATION
(SONGS)

10 CFR 50.59 / 10 CFR 72.48 Review
APPLICABILITY DETERMINATION, SCREENS, and/or EVALUATIONS

For

Cask Handling Crane Modifications

ASSIGNMENT:

0718-18311-2

CONTENTS

Sections I through V shall be performed for each use of this form.

Sections VI through XI are performed as directed by preceding Sections or as deemed necessary.

SECTION	TITLE
I	Administrative
II	Applicability Determination
III	10 CFR 50.82(a)(6) Review
IV	References
V	Preparer / Reviewer(s)
<i>VI</i>	<i>10 CFR 50.59 Screen</i>
<i>VII</i>	<i>10 CFR 50.59 Evaluation</i>
<i>VIII</i>	<i>10 CFR 72.48 Screen</i>
<i>XI</i>	<i>10 CFR 72.48 Evaluation</i>

SECTION I – ADMINISTRATIVE:

A. Is this a revision to an existing review?

Yes: No:

Existing Review Number:

Reason for Revision:

B. Primary Document Type, Number, Revision, and Title:

Document Type: NECP

Document Number / Revision: 0718-18311-1

Document Title: Cask Handling Crane Modifications

C. Description of the Proposed Activity:

The net effect of this NECP is to provide an option for discontinued use of the Lift Yoke Extensions (LYE) by allowing the Cask Handling Crane Hook to be lowered below pool level in the Cask Loading Area as needed.

The physical changes necessary to facilitate this process change include removing the remote hook rotation equipment, modifying limit switch settings as needed and removing the associated splash guard. The proposed physical changes will continue to allow the optional use of LYE for cask handling operation.

D. Primary Reason(s) for the Proposed Activity:

Allowing the hook to be lowered below pool level will eliminate two critical lifts from the transfer process but will also add some time for decontamination. This may expedite the process somewhat and eliminate some work from a relatively high dose location promoting ALARA dose principles.

It will also allow the hook to stay attached to the HI-TRAC at all times precluding the cask drop (or more precisely tip-over) accident currently addressed in the SONGS Units 2 and 3 Design and Licensing Basis. That site-specific hazard is also addressed in the SCE UMAX 72.212 and supporting calculations which will be modified as needed as conforming changes.

SECTION II - APPLICABILITY DETERMINATION (AD):

NOTE

Regulatory Guide 1.187 endorses NEI 96-07, Rev. 1, as one method to comply with 10 CFR 50.59. The term "change" is defined in NEI 96-07, Rev. 1, 3.3, as follows:

"Change means a modification or addition to, or removal from, the facility or procedures that affects: (1) a design function, (2) method of performing or controlling the function, or (3) an evaluation that demonstrates that intended functions will be accomplished."

The same definition of the term "change" is provided in 10 CFR 72.48 (a)(1), and thus is equally applicable for 72.48 reviews.

IF required, THEN see/use additional discussion provided in the associated "Discussion" in NEI 96-07, Rev. 1, 3.3, and the SONGS Resource Manual.

The basis must carefully examine whether there are any 'design functions' that are directly or indirectly impacted by the proposed activity. These will most often be detailed in the appropriate FSAR.

A. Is the proposed activity a change to the facility (including the ISFSI)? Explain fully.

Yes No

The function of the LYE is to preclude the hook from being lowered into the pool water. The impacts of doing so are manageable and consistent with industry experience. Potential adverse impacts can be effectively mitigated. Regardless, precluding wetting is not a design function in that it does not mitigate any design or licensing basis events.

Further, the discontinued use of the LYE and the associated hooking and unhooking of the Cask Handling Crane on the Cask Loading Pool shelf will preclude a design basis accident (characterized historically as a "cask drop") altogether. Currently, the Units 2 and 3 FSAR (Reference 4) includes the following text which is summarized in the SCE UMAX 72.212 (Reference 5):

"An analysis of the consequences of a loaded transfer cask falling from the upper shelf of the cask pool is given in Chapter 15...."

And

"Even though single-failure-proof cranes will be used at Units 2 and 3 to lift a spent fuel transfer cask out of a cask pool, a drop can be postulated when the cask is placed on the upper shelf (i.e. step) of a cask pool for lifting yoke change-out, prior to the transfer cask being welded closed. During this evolution, the transfer cask is not restrained and could fall back into the lower portion of the cask pool if an earthquake occurs."

The rotation equipment is a worker-aid and does not perform any other design function. The activity (rotating as necessary for proper alignment) can be well-accomplished manually. This partially offsets the benefits of not having to connect/disconnect the LYE; but, on balance this change does have ALARA benefits.

No design functions are impacted and the manual alignment is not a means of performing or controlling a design function no 10 CFR 50.59 or 72.48 screen is warranted.

IF "Yes", THEN identify those aspects that must be appropriately addressed in Section VI or Section VIII or both, as appropriate:

B. Other regulatory processes can independently authorize or preclude changes to the facility. Indicate which other regulatory processes have been used to authorize this activity:

- Approved Specific Exemptions 10 CFR 50.12 or 72.7
- Fire Protection Program 10 CFR 50.48(f)
- Decommissioning QA Plan 10 CFR 50.54(a)
- Physical Security Plan 10 CFR 50.54(p)
- Emergency Plan 10 CFR 50.54(q)
- Approved License Amendments 10 CFR 50.90 or 72.244

C. Evaluation using one or more of the processes in Section II.B has established that the proposed change may be implemented without prior or further NRC approval.

Yes No Assignment _____ (If Yes)

IF "Yes", THEN summarize how the change is addressed. IF changes to the design basis are fully addressed by other processes, THEN no further review under 10 CFR 50.59 or 72.48 is required. For ease in cross-referencing, list the assignment(s) that tracked the completed review requirements for those items.

D. Does the proposed activity require a change to the Technical Specifications, 10 CFR 50 Operating License Condition(s) or Terms, Conditions and Specifications for a Storage System Certificate of Compliance?

Yes No Assignment _____ (If Yes)

IF "Yes", THEN the proposed activity cannot be authorized by 10 CFR 50.59 or 72.48. A License Amendment under 10 CFR 50.90 or 72.244 (which are the responsibility of the Certificate Holder) is required. Document the number of the assignment tracking the LAR or documenting the decision to modify or not make the proposed activity.

E. Summary of Section II

Based on the reviews documented in II.A through II.D, the following Screen(s) are required (Check either, neither, or both, as appropriate).

- 10 CFR 50.59 Screen (Perform Section VI)
- 10 CFR 72.48 Screen (Perform Section VIII)

SECTION III - 10 CFR 50.82(a)(6) REVIEW:

NOTE

10 CFR 50.82(a)(6) states in part: Licensee shall not perform any decommissioning activities as defined in Section 50.2 that - (i) Foreclose release of the site for possible unrestricted use; (ii) Result in significant environmental impacts not previously reviewed; or (iii) Result in there no longer being reasonable assurance that adequate funds will be available for decommissioning.

Question 1:

Does the proposed change foreclose release of the site for possible unrestricted use?

Yes No

Reason:

The equipment (cabling and hook) were likely to require disposal as potentially contaminated low-level waste. There is no impact on material handling leading to possible unrestricted release of the site.

Therefore, this change does not foreclose the release of the site.

Question 2:

Does the proposed change result in significant environmental impacts not previously reviewed?

Yes No

Reason:

There are no external environmental impacts nor any substantive changes to radioactive waste disposition strategies.

Therefore, there are no new environmental impacts requiring regulatory review.

Question 3:

Does the proposed change result in there no longer being reasonable assurance that adequate funds will be available for decommissioning?

Yes NO

Reason:

The NECP development and implementation cost are to be funded as part of work scope (SCE level of effort) in support of a fixed price contract (Holtec) both of which are fully funded by the existing Decommissioning Trust Fund as supported by the current Decommissioning Cost Estimate.

Thus, there are no adverse impacts on funding assurance.

Conclusion:

IF the subject activity is determined to be an adverse to a major decommissioning activity due to the results of the evaluations performed for Questions III.1 through III.3, THEN the activity may NOT be performed [reference 10 CFR 50.82(a)(6)] and list the applicable assignment to track the disposition of this item.

Assignment # _____

SECTION IV – REFERENCES:

1. SONGS Unit 2/3 UFSAR 15.1.1.5.3
2. SCE UMAX 72.212 Plant Hazards Evaluation Section and Supporting 72.48
3. HOLTEC Cask Drop Report HI-2177713

SECTION V – PREPARERS / REVIEWERS:

Technical Input (if required): Robert Yale	Date: 7/26/18
Prepared By: Ken Wilson	Date: 7/26/18
Reviewed By: Richard Chang	Date: 7/26/18
Independent Review By: N/A	Date:

AFTER all reviews are complete, THEN unused Sections may be discarded.



SOUTHERN CALIFORNIA EDISON

SAN ONOFRE NUCLEAR GENERATING STATION
(SONGS)

10 CFR 50.59 / 10 CFR 72.48 Review
APPLICABILITY DETERMINATION, SCREENS, and/or EVALUATIONS

For

Assessing the Potential for Storage System Damage during Installation

ASSIGNMENT:

0818-76588-47

CONTENTS

Sections I through V shall be performed for each use of this form.

Sections VI through XI are performed as directed by preceding Sections or as deemed necessary.

SECTION	TITLE
I	Administrative
II	Applicability Determination
III	10 CFR 50.82(a)(6) Review
IV	References
V	Preparer / Reviewer(s)
<i>VI</i>	<i>10 CFR 50.59 Screen</i>
<i>VII</i>	<i>10 CFR 50.59 Evaluation</i>
<i>VIII</i>	<i>10 CFR 72.48 Screen</i>
<i>XI</i>	<i>10 CFR 72.48 Evaluation</i>

SECTION I – ADMINISTRATIVE:

A. Is this a revision to an existing review?

Yes: No:

Existing Review Number:

Reason for Revision:

B. Primary Document Type, Number, Revision, and Title:

Document Type: Nuclear Engineering Change Package

Document Number / Revision: 0818-76588-46, R0

Document Title: Assessing the Potential for Storage System Damage during Installation

C. Description of the Proposed Activity:

The proposed activity is the acceptability of potential damage to the Holtec HI-STORM UMAX Storage system during pool-to-pad operations. The potential for such damage is the proposed activity being addressed in this regulatory review package. The other background is provided for completeness and context.

There is a possibility of minor damage (scratching, etc.) to any Multi-Purpose Canister (MPC) or VVM divider shell subcomponents occurring during the down-loading phase as a result of potential interactions between the canister and divider shell. The subject NECP also issues as-built documents for any currently existing scratches and dent on the bottom of MPC-29.

Background

The generic Holtec UMAX design and licensing basis are addressed in the UMAX FSAR (Reference 1). The most recent full revision (Revision 5) does not explicitly acknowledge the potential for MPC interactions with various subcomponents (primarily the divider shell's: shield ring, support gussets or the seismic restraints) during the down-loading phase. It relied on the benefits of a vertical configuration and available clearance. The clearances were addressed in appropriate drawings; but, not otherwise acknowledged to be challenging to down-loading operations.

Further, the most extreme hypothetical down-loading event (unrestrained drop of the MPC into the storage overpack) is considered not credible. Holtec and SCE have worked through a broad review of this potential hazard. Holtec has modified the FSAR to address generic aspects. Portions of these efforts are site-specific and need to be more fully addressed in the SONGS UMAX 72.212 Report (Reference 2) and elsewhere (Reference 3-drawings) as well. The details are more fully developed in Section I.D (below).

D. Primary Reason(s) for the Proposed Activity:

Both the general licensee (SCE) and certificate holder (Holtec) have responsibilities to maintain complete and accurate design and licensing basis information. The generic Holtec efforts have addressed these issues at that level and have evaluated appropriate aspects under 10 CFR 72.48.

Background

This review was initiated as part of the response to a field condition that occurred on August 3, 2018 that was addressed in both a Holtec Root Cause Evaluation (Reference 4) and a SCE Apparent Cause Evaluation (Reference 5). These largely addressed critical administrative control aspects and improvements that have been added to the UMAX FSAR. However, there are several more technical aspects that have been addressed. These include:

1. The addition of enhanced load monitoring capabilities is noted in the FSAR change and supporting 72.48 (References 6 and 7). The site-specific aspects are detailed in a SCE design change package and 72.212 change supported by a SCE 72.48 (References 8, 9 and 10).
2. The potential for a canister to drop was evaluated (Reference 11) and shown to not challenge the integrity of the confinement boundary. Based on the enhanced robustness of the administrative controls, such events remain justifiably categorized as not "credible" (as allowed by Reference 12) and thus is not addressed in the FSAR and do not require a 72.48 review. The event was fully evaluated from a mechanical structural perspective using appropriate Finite Element Modelling (LS-DYNA) consistent with the balance of the Holtec design and licensing basis and will be referenced in the 72.212.
3. The calculated potential impact loading to the slings after a load transfer from the slings to the interference(s) and back to the slings was evaluated (also in Reference 11). Appropriate alarm and other control values to preclude adverse impacts to the slings were established (References 13 and supported by Reference 10) based on the content of a site-specific evaluation provided by Holtec (Reference 14). This site-specific evaluation was supported by a Holtec 72.48 (Reference 15).
4. The potential for adverse interactions between the MPC and the divider shell components were evaluated (Reference 16) and shown to be bounded by allowable fabrication defects/damage. These are controlled by appropriate generic guidance (Reference 17) and supported by an appropriate technical basis (Reference 18). Since this is a somewhat different circumstance this evaluation and its bases will be addressed in the 72.212 as well (Reference 10). **This is the proposed activity that this review is focused on.**

SECTION II - APPLICABILITY DETERMINATION (AD):

NOTE

Regulatory Guide 1.187 endorses NEI 96-07, Rev. 1, as one method to comply with 10 CFR 50.59. The term "change" is defined in NEI 96-07, Rev. 1, 3.3, as follows:

"Change means a modification or addition to, or removal from, the facility or procedures that affects: (1) a design function, (2) method of performing or controlling the function, or (3) an evaluation that demonstrates that intended functions will be accomplished."

The same definition of the term "change" is provided in 10 CFR 72.48 (a)(1), and thus is equally applicable for 72.48 reviews.

IF required, THEN see/use additional discussion provided in the associated "Discussion" in NEI 96-07, Rev. 1, 3.3, and the SONGS Resource Manual.

The basis must carefully examine whether there are any 'design functions' that are directly or indirectly impacted by the proposed activity. These will most often be detailed in the appropriate FSAR.

A. Is the proposed activity a change to the facility (including the ISFSI)? Explain fully.

Yes No

IF "Yes", THEN identify those aspects that must be appropriately addressed in Section VI or Section VIII or both, as appropriate:

The four change categories noted in I.D are considered separately:

1. Enhanced load monitoring capability was added to improve the man-machine interface to facilitate human performance. The original equipment is sufficient for most operational activities; but improved capabilities were added to specifically support down-loading operations with limited clearance. These enhancements improve the methods for controlling design functions and were previously evaluated in accordance with 72.48 (References 7 and 10) and will not be repeated herein.
2. The potential for a hypothetical cask drop into the storage overpack remains not credible based on the single-failure proof design of the load bearing equipment and appropriate administrative controls. Thus, the 'non-mechanistic' evaluation of a potential cask drop and any assessments of direct or indirect consequences do not represent a change to the facility nor an evaluation that demonstrates that intended functions will be accomplished. Thus, no 10 CFR 72.48 screen was/is warranted.
3. The potential impact of load transfers to/from rigging to interferences was fully addressed in References 13 and 14 and will not be repeated herein.

4. In practical and historical fact, the potential for surface damage to storage canisters is well recognized. However, this is not fully developed in the Holtec UMAX FSAR or elsewhere. Thus, documenting such a potential is a change to the storage system even though the extent of such damage is bounded by previous evaluations.

All of these activities are wholly associated with the Storage System during operations on the ISFSI and thus, appropriate ones will be addressed by a 10 CFR 72.48 Screen and no 10 CFR 50.59 Screen is warranted. Only Activity 4 is the subject of this review and warrants further Screening review as discussed above.

B. Other regulatory processes can independently authorize or preclude changes to the facility. Indicate which other regulatory processes have been used to authorize this activity:

- Approved Specific Exemptions 10 CFR 50.12 or 72.7
- Fire Protection Program 10 CFR 50.48(f)
- Decommissioning QA Plan 10 CFR 50.54(a)
- Physical Security Plan 10 CFR 50.54(p)
- Emergency Plan 10 CFR 50.54(q)
- Approved License Amendments 10 CFR 50.90 or 72.244

C. Evaluation using one or more of the processes in Section II.B has established that the proposed change may be implemented without prior or further NRC approval.

Yes No Assignment _____ (If Yes)

IF "Yes", THEN summarize how the change is addressed. IF changes to the design basis are fully addressed by other processes, THEN no further review under 10 CFR 50.59 or 72.48 is required. For ease in cross-referencing, list the assignment(s) that tracked the completed review requirements for those items.

D. Does the proposed activity require a change to the Technical Specifications, 10 CFR 50 Operating License Condition(s) or Terms, Conditions and Specifications for a Storage System Certificate of Compliance?

Yes No Assignment _____ (If Yes)

IF "Yes", THEN the proposed activity cannot be authorized by 10 CFR 50.59. A License Amendment under 10 CFR 50.90 or 72.244 (which are the responsibility of the Certificate Holder) is required. Document the number of the assignment tracking the LAR or documenting the decision to modify or not make the proposed activity.

E. Summary of Section II

Based on the reviews documented in II.A through II.D, the following Screen(s) are required (Check either, neither, or both, as appropriate).

- 10 CFR 50.59 Screen (Perform Section VI)
- 10 CFR 72.48 Screen (Perform Section VIII)

SECTION III - 10 CFR 50.82(a)(6) REVIEW:

NOTE

10 CFR 50.82(a)(6) states in part: Licensee shall not perform any decommissioning activities as defined in Section 50.2 that - (i) Foreclose release of the site for possible unrestricted use; (ii) Result in significant environmental impacts not previously reviewed; or (iii) Result in there no longer being reasonable assurance that adequate funds will be available for decommissioning.

Question 1:

Does the proposed change foreclose release of the site for possible unrestricted use?

Yes No

Reason:

The proposed change documents engineering evaluations having no physical impact on the site.

Thus, it does not foreclose the release of the site for possible unrestricted use.

Question 2:

Does the proposed change result in significant environmental impacts not previously reviewed?

Yes No

Reason:

The propose change documents engineering evaluations having no physical impact to the site generally or the environment specifically.

Thus, there is no significant environmental impact not previous evaluated.

Question 3:

Does the proposed change result in there no longer being reasonable assurance that adequate funds will be available for decommissioning?

Yes NO

Reason:

The costs for the subject activity will either be borne by Holtec or funded from existing ISFSI funds. In either case these are fully addressed in the DCE that supports the funding level for the Decommissioning Trust Fund.

Thus, there is no adverse impact on decommissioning funding assurance.

Conclusion:

IF the subject activity is determined to be an adverse change to a major decommissioning activity due to the results of the evaluations performed for Questions III.1 through III.3, THEN the activity may NOT be performed [reference 10 CFR 50.82(a)(6)]. List the applicable assignment to track the disposition of this item.

Assignment # _____

SECTION IV – REFERENCES:

1. HI-2115090, HI-STORM UMAX FSAR
2. DCS-002, SONGS HI-STORM UMAX MSE ISFSI 72.212 REPORT
3. Drawing(s) 400028, Sheet 3, Rev 2, ECN DR 758580
4. QI Number 2529 Root Cause Analysis Report, "The MPC Downloading Incident at SONGS"
5. 0818-23056, "Apparent Cause Evaluation to assess SCE Oversight effectiveness during the August 3, 2018 download of MPC #67 into VVM #022"
6. ECO-5021-039, R1
7. Holtec 72.48 # 1357
8. NECP 0918-64884-1, "VCT Live Load Monitoring System"
9. DCS-0002, CCN 758582
10. SCE 50.59/72.48 0918-64884-6, "Improved VCT Load Monitoring Capability"
11. HI-2188261, "Structural Evaluation of the MPC Handling Event at SONGS for SCE"
12. NUREG-1536, Revision 1; "Standard Review Plan for Spent Fuel Dry Storage Systems at a General License Facility-Final Report," Sections 2.5.2.2 (3) and 3.5.1.4 (3) (a)
13. NECP 0918-64884-1, "VCT Live Load Monitoring System" Revision 1/ECN 758532
14. RRTI-2464-064, "Administrative controls necessary to assure rigging, utilized in MPC downloading operations for the UMAX system at SONGS, is operated within the manufacturer load rating."
15. Holtec 72.48 # 1365
16. DS-469, "Incidence and Consequence of Canister Shell Scratching from Misaligned Insertion of a Loaded MPC at SONGS"
17. HSP-320 "Standard Remedial Work Practices in Fabrication of Safety Significant Components"
18. DS-330, "Technical Justification for the Pre-Approved Conditions in HSP-320"
19. RRTI-2464-036, 1814-AR171-C0047
20. HPP-2464-0400, Latest Revision, MPC Transfer

SECTION V – PREPARERS / REVIEWERS:

Technical Input (if required): Brian Sarno	Date: 11/27/18
Prepared By: Ken Wilson	Date: 11/27/18
Reviewed By: Richard Chang	Date: 11/27/18
Independent Review By: Ray Termini	Date: 12/07/18

AFTER all reviews are complete, THEN unused Sections may be discarded.

SECTION VIII - 10 CFR 72.48 SCREEN

A. Identify and briefly summarize the aspects of the proposed activity which require a Screen.

Question 1:

Does the proposed activity change an SSC in a manner that adversely affects the applicable FSAR design function(s) or has an adverse effect on the method of performing or controlling applicable FSAR design function(s)?

Yes No

Reason:

The potential for minor damage during down-loading was not addressed in the HOLTEC UMAX FSAR which is the generic design and licensing basis upon which the SONGS ISFSI is based. Activity 4 reflects the addition of such considerations (Reference 6) to the FSAR. Reference 16 bounds the damage potential which was determined to warrant further-site specific review.

This proposed activity documents the subsequent evaluations (References 11 and 16) and demonstrates the damage to be well within the limits fully established in DS-330 (Reference 18) for the expressed purpose of validating there was no adverse impacts from a structural, code compliance or long-term canister performance perspective. Further, as discussed in Reference 19 the potential damage extent does not exceed the compressive layer assured by rolling of the MPC shell or peening of the key weld heat affected zones.

Nevertheless, since there is a potential for adverse interactions this activity was determined to warrant a full evaluation.

Question 2:

Does the proposed activity change a procedure (i.e., applicable FSAR described process for operation or control of an SSC) in a manner that adversely affects how applicable FSAR described SSC design function(s) are performed or controlled?

Yes No

Reason:

The only process involved is the disposition of damage due to interactions between the canister and the divider shell. There are none associated with the operation or control of any applicable SSC's. Appropriate Controls to preclude, minimize or respond to potential interactions have been added to HPP-2464-0400 (Reference 20) which was evaluated separately.

Question 3:

Does the proposed activity involve revising or replacing an applicable FSAR described method of evaluation used in establishing the design bases or used in the safety analyses in an adverse manner?

Yes No

Reason:

The methods of evaluating the impacts of damage to the MPC were previously and fully established in existing Holtec design basis documentation (References 17 and 18). These have historically been applied in the manufacturing phase based on applicable code allowable limits; but, are equally applicable to other phases of the project. The methods for assessing the extent of potential damage from loading interactions are standard engineering calculational methods and are not used to establish any design basis used in the safety analysis of the canisters.

Question 4:

Does the proposed activity involve a test or experiment not described in the applicable FSAR, where an SSC is utilized or controlled in a manner outside the reference bounds of the design for that SSC, or is inconsistent with the analysis or descriptions in the applicable FSAR?

Yes No

Reason:

This activity documents analytical projections and empirical observations of material performance under appropriate interaction conditions and compares them to previously determined, acceptable results based on routine operational risks. No SSC's are utilized or controlled in a manner outside the referenced bounds of their design.

B. Based on the responses to Questions VIII.1 through VIII.4 above, the proposed activity is:

- NOT adverse. (All of the responses to Questions VIII.1 through VIII.4 MUST be negative.) GO TO Section V to obtain Reviews.
- Adverse. (One or more of the responses to Questions VIII.1 through VIII.4 are positive.) GO TO Section IX for Evaluation.

END OF SECTION VIII

SECTION IX – 10 CFR 72.48 EVALUATION

A. Identify and briefly summarize the aspects of the proposed activity which require an evaluation.

Question 1:

Does the proposed activity result in more than a minimal increase in the frequency of occurrence of an accident previously evaluated in the applicable FSAR?

Yes No

Reason:

This activity assesses routine operational interactions and no credible accidents previously evaluated in the UMAX FSAR.

Therefore, there is no increase in evaluated accident frequency.

Question 2:

Does the proposed activity result in more than a minimal increase in the likelihood of occurrence of a malfunction of an SSC important to safety previously evaluated in the applicable FSAR?

Yes No

Reason:

The potential damage assessed is limited to the extent that they would not adversely impact the confinement boundary of the MPC nor the structural capabilities addressed in the UMAX FSAR.

Therefore they do not increase the frequency of any malfunctions of ITS SSC's.

Question 3:

Does the proposed activity result in more than a minimal increase in the consequences of an accident previously evaluated in the applicable FSAR?

Yes No

Reason:

Accident consequences are generally associated with increased accident dose. The limited damage to the MPC shell does not impact the confinement boundary beyond that allowed by the governing codes and standards.

Therefore there is no increase in any accident dose.

Question 4:

Does the proposed activity result in more than a minimal increase in the consequences of a malfunction of an SSC important to safety previously evaluated in the applicable FSAR?

Yes No

Reason:

Malfunction consequences are generally associated with increased resulting dose. The limited damage to the MPC shell does not impact the confinement boundary beyond that allowed by the governing codes and standards.

Therefore there is no increase dose release potential from ITS component malfunctions.

Question 5:

Does the proposed activity create a possibility for an accident of a different type than any previously evaluated in the applicable FSAR?

Yes No

Reason:

The confinement boundary and the VVM subcomponents continue to meet all applicable codes and standards.

Therefore, there is no potential for an accident of a different type involved.

Question 6:

Does the proposed activity create a possibility for a malfunction of an SSC important to safety with a different result than any previously evaluated in applicable FSAR?

Yes No

Reason:

The confinement boundary meets all applicable codes and standards.

Therefore, there is no potential for a malfunction with different results involved.

Question 7:

Does the proposed activity result in a design basis limit for a fission product barrier as described in the applicable FSAR being exceeded or altered?

Yes No

Reason:

The only applicable fission product barrier is the confinement boundary. The assessment of potential damage and its evaluation demonstrates that it is not impacted beyond that allowed by applicable codes and standards.

Therefore, no design basis limit is exceeded or altered.

Question 8:

Does the proposed activity result in a departure from a method of evaluation described in the applicable FSAR used in establishing the design bases or in the safety analyses?

Yes No

Reason:

Not Applicable based on Screening Question 3.

B. Evaluation Conclusion

- Acceptable for Implementation. (All of the above responses MUST be negative.)
GO TO Section V to obtain Reviews.
- NOT Acceptable for Implementation. (One or more of the above responses are positive.)
DO NOT PROCEED with proposed activity. A Certificate of Compliance Amendment Request by the Certificate Holder and NRC approval is required.
GO TO Section V to obtain Reviews.

C. 10 CFR 72.48 Evaluation Summary

The potential for damage to either the MPC or the associated VVM subcomponents due to interaction during down-loading will be minimized if not absolutely precluded by appropriate administrative controls evaluated separately.

However, the extent of such damage should the controls NOT preclude or even minimize such interactions is bounded by existing mechanical/structural evaluations which demonstrate compliance with applicable codes and standards and thus conform to the fundamental design and licensing basis of the storage system.



SOUTHERN CALIFORNIA EDISON

SAN ONOFRE NUCLEAR GENERATING STATION
(SONGS)

10 CFR 50.59 / 10 CFR 72.48 Review
APPLICABILITY DETERMINATION, SCREENS, and/or EVALUATIONS

For

Training Program Evaluation Update

ASSIGNMENT:

0818-76588-49

CONTENTS

Sections I through V shall be performed for each use of this form.

Sections VI through XI are performed as directed by preceding Sections or as deemed necessary.

SECTION	TITLE
I	Administrative
II	Applicability Determination
III	10 CFR 50.82(a)(6) Review
IV	References
V	Preparer / Reviewer(s)
<i>VI</i>	<i>10 CFR 50.59 Screen</i>
<i>VII</i>	<i>10 CFR 50.59 Evaluation</i>
<i>VIII</i>	<i>10 CFR 72.48 Screen</i>
<i>XI</i>	<i>10 CFR 72.48 Evaluation</i>

SECTION I – ADMINISTRATIVE:

A. Is this a revision to an existing review?

Yes: No:

Existing Review Number:

Reason for Revision:

B. Primary Document Type, Number, Revision, and Title:

Document Type: Calculation Change

Document Number / Revision: DCS-002, Revision 0, CCN # DR758614

Document Title: SONGS UMAX 72.212 Report, Training Evaluation Update

C. Description of the Proposed Activity:

The Training Program Evaluation, Subsection 15.1.4, is being updated to reflect recent changes in the Holtec Pool-to-Pad (PTP) training program.

D. Primary Reason(s) for the Proposed Activity:

Three separate training activities are evaluated (operators, engineering support staff and Holtec Site Services PTP staff). As a result of recent events the Holtec PTP procedure content and training program were substantially revised. Holtec remains responsible for the training and certification of PTP staff but the degree of rigor was substantially enhanced to meet more standard operating industry practices.

SECTION II - APPLICABILITY DETERMINATION (AD):

NOTE

Regulatory Guide 1.187 endorses NEI 96-07, Rev. 1, as one method to comply with 10 CFR 50.59. The term "change" is defined in NEI 96-07, Rev. 1, 3.3, as follows:

"Change means a modification or addition to, or removal from, the facility or procedures that affects: (1) a design function, (2) method of performing or controlling the function, or (3) an evaluation that demonstrates that intended functions will be accomplished."

The same definition of the term "change" is provided in 10 CFR 72.48 (a)(1), and thus is equally applicable for 72.48 reviews.

IF required, THEN see/use additional discussion provided in the associated "Discussion" in NEI 96-07, Rev. 1, 3.3, and the SONGS Resource Manual.

The basis must carefully examine whether there are any 'design functions' that are directly or indirectly impacted by the proposed activity. These will most often be detailed in the appropriate FSAR.

A. Is the proposed activity a change to the facility (including the ISFSI)? Explain fully.

Yes No

The proposed change reflects the development of a new site-specific training procedure and its implementation. The proposed programmatic improvements represent a substantial increase in the rigor of the PTP staff training program. However, there is no fundamental change to the method of performing or controlling the associated function (loading, transfer, down-loading, etc.) associated with the training program changes.

Therefore, this change does not reflect a change to facility or ISFSI and no further screen is required.

IF "Yes", THEN identify those aspects that must be appropriately addressed in Section VI or Section VIII or both, as appropriate:

B. Other regulatory processes can independently authorize or preclude changes to the facility. Indicate which other regulatory processes have been used to authorize this activity:

- Approved Specific Exemptions 10 CFR 50.12 or 72.7
- Fire Protection Program 10 CFR 50.48(f)
- Decommissioning QA Plan 10 CFR 50.54(a)
- Physical Security Plan 10 CFR 50.54(p)
- Emergency Plan 10 CFR 50.54(q)
- Approved License Amendments 10 CFR 50.90 or 72.244

C. Evaluation using one or more of the processes in Section II.B has established that the proposed change may be implemented without prior or further NRC approval.

Yes No Assignment _____ (If Yes)

IF "Yes", THEN summarize how the change is addressed. IF changes to the design basis are fully addressed by other processes, THEN no further review under 10 CFR 50.59 or 72.48 is required. For ease in cross-referencing, list the assignment(s) that tracked the completed review requirements for those items.

D. Does the proposed activity require a change to the Technical Specifications, 10 CFR 50 Operating License Condition(s) or Terms, Conditions and Specifications for a Storage System Certificate of Compliance?

Yes No Assignment _____ (If Yes)

IF "Yes", THEN the proposed activity cannot be authorized by 10 CFR 50.59. A License Amendment under 10 CFR 50.90 or 72.244 (which are the responsibility of the Certificate Holder) is required. Document the number of the assignment tracking the LAR or documenting the decision to modify or not make the proposed activity.

E. Summary of Section II

Based on the reviews documented in II.A through II.D, the following Screen(s) are required (Check either, neither, or both, as appropriate).

10 CFR 50.59 Screen (Perform Section VI)

10 CFR 72.48 Screen (Perform Section VIII)

SECTION III - 10 CFR 50.82(a)(6) REVIEW:

NOTE

10 CFR 50.82(a)(6) states in part: Licensee shall not perform any decommissioning activities as defined in Section 50.2 that - (i) Foreclose release of the site for possible unrestricted use; (ii) Result in significant environmental impacts not previously reviewed; or (iii) Result in there no longer being reasonable assurance that adequate funds will be available for decommissioning.

Question 1:

Does the proposed change foreclose release of the site for possible unrestricted use?

Yes No

Reason:

This is a change to a 72.212 programmatic evaluation which has no physical impact to the facility.

Thus, it does not foreclose the possible release of the site for unrestricted use.

Question 2:

Does the proposed change result in significant environmental impacts not previously reviewed?

Yes No

Reason:

This is a change to a 72.212 programmatic evaluation which has no physical impact to the environment.

Thus, it does not result in a significant environmental impact not previously reviewed.

Question 3:

Does the proposed change result in there no longer being reasonable assurance that adequate funds will be available for decommissioning?

Yes NO

Reason:

The incremental funds associated with this administrative change are limited to level-of-effort activities of existing staff.

Therefore, there are no incremental impacts to the decommissioning trust fund balance that might adversely impact funding assurance.

Conclusion:

IF the subject activity is determined to be an adverse change to a major decommissioning activity due to the results of the evaluations performed for Questions III.1 through III.3, THEN the activity may NOT be performed [reference 10 CFR 50.82(a)(6)]. List the applicable assignment to track the disposition of this item.

Assignment # _____

SECTION IV – REFERENCES:

1. HPP-2464-1134

SECTION V – PREPARERS / REVIEWERS:

Technical Input (if required): N/A

Date:

Prepared By: Ken Wilson

Date: 12/5/18

Reviewed By: Richard Chang

Date: 12/5/18

Independent Review By: N/A

Date:

AFTER all reviews are complete, THEN unused Sections may be discarded.



SOUTHERN CALIFORNIA EDISON

SAN ONOFRE NUCLEAR GENERATING STATION
(SONGS)

10 CFR 50.59 / 10 CFR 72.48 Review
APPLICABILITY DETERMINATION, SCREENS, and/or EVALUATIONS

For

Improved VCT Load Monitoring Capability

ASSIGNMENT:

0918-64884-6

CONTENTS

Sections I through V shall be performed for each use of this form.

Sections VI through XI are performed as directed by preceding Sections or as deemed necessary.

SECTION	TITLE
I	Administrative
II	Applicability Determination
III	10 CFR 50.82(a)(6) Review
IV	References
V	Preparer / Reviewer(s)
<i>VI</i>	<i>10 CFR 50.59 Screen</i>
<i>VII</i>	<i>10 CFR 50.59 Evaluation</i>
<i>VIII</i>	<i>10 CFR 72.48 Screen</i>
<i>XI</i>	<i>10 CFR 72.48 Evaluation</i>

SECTION I – ADMINISTRATIVE:

A. Is this a revision to an existing review?

Yes: No:

Existing Review Number: 0918-64884-2

Reason for Revision: Load Monitoring Focus Shifted from Pins to Shackles

B. Primary Document Type, Number, Revision, and Title:

Document Type: Nuclear Engineering Change Package

Document Number / Revision: 0918-64884-1

Document Title: VCT Live Load Monitoring System

C. Description of the Proposed Activity:

The subject NECP authorizes the addition of a load indicating system to the VCT as an option supported by Holtec and the OEM (J&R). The load indicating system monitors the strain in the rigging via load monitoring shackles. The weight is displayed locally for each shackle and remotely via tablets, the tablet sum the individual loads and establish alarm values, or otherwise. This is the primary change being reviewed since, while the load shackles are integral to the rigging, the additional functionality (load information) supplements their rigging function.

The viability and utility of proposed change may be evaluated prior to issuance of the NECP by adding the shackles to the rigging and testing utilizing the 'simulator' as the load. The results of such testing will inform the implementing procedures, NECP content and associated training. The procedure content will be subsequently dry-run to finally confirm the efficacy of the system and the overall man-machine interface.

Other enhancements (load indicating load pins, alignment aides and tools, lights and cameras) may also be added in support of procedure changes and training. Such ancillary equipment may be added to the VCT using other work management mechanisms. These are all evaluated herein from a regulatory perspective.

D. Primary Reason(s) for the Proposed Activity:

Load monitoring both directly and indirectly are key indications of the status of the loading operations on the VCT. When it is lifted from the deck, the full load of the canister should be evident; and as it is lowered the full load should be borne by the rigging.

Currently, these loads are indirectly measured via hydraulic pressure displayed in the VCT and by visually observing sling conditions (tautness). The load indications do not have a dedicated display; but, are optional displays that may be directed to other aspects of the VCT operation.

The load is the principle indication for proper control of heavy loads and its continued visibility, by those at the controls of the operation and others observing it, facilitates the necessary monitoring of loading operations. Being able to monitor remotely promotes ALARA and facilitates a wide range of peer and oversight involvement. Finally, the system includes the ability to establish and rely upon various load limit alarms.

SECTION II - APPLICABILITY DETERMINATION (AD):

NOTE

Regulatory Guide 1.187 endorses NEI 96-07, Rev. 1, as one method to comply with 10 CFR 50.59. The term "change" is defined in NEI 96-07, Rev. 1, 3.3, as follows:

"Change means a modification or addition to, or removal from, the facility or procedures that affects: (1) a design function, (2) method of performing or controlling the function, or (3) an evaluation that demonstrates that intended functions will be accomplished."

The same definition of the term "change" is provided in 10 CFR 72.48 (a)(1), and thus is equally applicable for 72.48 reviews.

IF required, THEN see/use additional discussion provided in the associated "Discussion" in NEI 96-07, Rev. 1, 3.3, and the SONGS Resource Manual.

The basis must carefully examine whether there are any 'design functions' that are directly or indirectly impacted by the proposed activity. These will most often be detailed in the appropriate FSAR.

A. Is the proposed activity a change to the facility (including the ISFSI)? Explain fully.

Yes No

The VCT is the principal ancillary used to transport loads to and from the ISFSI storage locations from the transfer pad. Its load carrying equipment is single-failure proof and classified as Important to Safety (ITS). The design function is to control the loaded canister and preclude its uncontrolled lowering with the potential to damage the canister and its contents. The hardware is not being significantly modified but the rigging's connection to the load through shackles are being done with subcomponents capable of transmitting load information to display systems. Direct measurement of strain supplements and is functionally equivalent to the hydraulic pressure which drives the existing VCT operator display (sometimes referred to as the HMI). The substantive change is the nature of the display. The local and remotely visible digital displays have no direct safety function in that they do not perform a function (such as directly driving an interlock). They do facilitate observation and provide opportunity for monitoring by others. As such they are a valuable operator aid.

Other changes improve alignment capability but do not perform a design function. They simply make adverse interaction between the canister and VVM less likely.

The Administrative Controls reliance on load monitoring is sufficiently critical to warrant treatment as if they were a design function so a 10 CFR 72.48 screen of that aspect is appropriate.

IF "Yes", THEN identify those aspects that must be appropriately addressed in Section VI or Section VIII or both, as appropriate:

B. Other regulatory processes can independently authorize or preclude changes to the facility. Indicate which other regulatory processes have been used to authorize this activity:

- Approved Specific Exemptions 10 CFR 50.12 or 72.7
- Fire Protection Program 10 CFR 50.48(f)
- Decommissioning QA Plan 10 CFR 50.54(a)
- Physical Security Plan 10 CFR 50.54(p)
- Emergency Plan 10 CFR 50.54(q)
- Approved License Amendments 10 CFR 50.90 or 72.244

C. Evaluation using one or more of the processes in Section II.B has established that the proposed change may be implemented without prior or further NRC approval.

Yes No Assignment _____ (If Yes)

IF "Yes", THEN summarize how the change is addressed. IF changes to the design basis are fully addressed by other processes, THEN no further review under 10 CFR 50.59 or 72.48 is required. For ease in cross-referencing, list the assignment(s) that tracked the completed review requirements for those items.

D. Does the proposed activity require a change to the Technical Specifications, 10 CFR 50 Operating License Condition(s) or Terms, Conditions and Specifications for a Storage System Certificate of Compliance?

Yes No Assignment _____ (If Yes)

IF "Yes", THEN the proposed activity cannot be authorized by 10 CFR 50.59. A License Amendment under 10 CFR 50.90 or 72.244 (which are the responsibility of the Certificate Holder) is required. Document the number of the assignment tracking the LAR or documenting the decision to modify or not make the proposed activity.

E. Summary of Section II

Based on the reviews documented in II.A through II.D, the following Screen(s) are required (Check either, neither, or both, as appropriate).

- 10 CFR 50.59 Screen (Perform Section VI)
- 10 CFR 72.48 Screen (Perform Section VIII)

SECTION III - 10 CFR 50.82(a)(6) REVIEW:

NOTE

10 CFR 50.82(a)(6) states in part: Licensee shall not perform any decommissioning activities as defined in Section 50.2 that - (i) Foreclose release of the site for possible unrestricted use; (ii) Result in significant environmental impacts not previously reviewed; or (iii) Result in there no longer being reasonable assurance that adequate funds will be available for decommissioning.

Question 1:

Does the proposed change foreclose release of the site for possible unrestricted use?

Yes No

Reason:

These changes are minor physical changes to loading equipment that will not be left on-site after decommissioning of the ISFSI.

Therefore there is no impact on the possible release of the site for unrestricted use.

Question 2:

Does the proposed change result in significant environmental impacts not previously reviewed?

Yes No

Reason:

These changes are minor physical changes to loading equipment that do not impact the site environment.

Therefore there are no environmental impacts that might require additional reviews.

Question 3:

Does the proposed change result in there no longer being reasonable assurance that adequate funds will be available for decommissioning?

Yes NO

Reason:

The funds for this activity are fully funded as part of the ISFSI project.

Therefore there is no adverse impact on decommissioning funding assurance.

Conclusion:

IF the subject activity is determined to be an adverse change to a major decommissioning activity due to the results of the evaluations performed for Questions III.1 through III.3, THEN the activity may NOT be performed [reference 10 CFR 50.82(a)(6)]. List the applicable assignment to track the disposition of this item.

Assignment # _____

SECTION IV – REFERENCES:

1. 1814-AR171-M0059 - Straightpoint Handheld Plus
2. 1814-AR171-M0060 - Straightpoint Wireless Loadshackle
3. 1814-AR171-M0061 - Straightpoint SW-RWT Rugged tablets
4. 1814-AR171-M0062- Document Review Checklist for I&I Slings Supplied Product
5. HPP-2464-400, MPC Transfer at SONGS
6. HI-2115090, HI-STORM UMAX System FSAR
 - a. Section 1.2.4, Operational Characteristics of the HI-STORM UMAX
 - b. Section 9.2.3, Placement of MPC into Storage
7. HI-2114830, HI-STORM FW System FSAR
 - a. Section 1.2.1.5.5, Transporter
 - b. Section 2.2.3(a), Handling Accident

SECTION V – PREPARERS / REVIEWERS:

Technical Input (if required): Brian Sarno

Date: 10/11/18

Prepared By: Ken Wilson

Date: 10/11/18

Reviewed By: Richard Chang

Date: 10/11/18

Independent Review By:

Date: 10/11/18

AFTER all reviews are complete, THEN unused Sections may be discarded.

SECTION VIII - 10 CFR 72.48 SCREEN

A. Identify and briefly summarize the aspects of the proposed activity which require a Screen.

Question 1:

Does the proposed activity change an SSC in a manner that adversely affects the applicable FSAR design function(s) or has an adverse effect on the method of performing or controlling applicable FSAR design function(s)?

Yes No

Reason:

The proposed addition of shackles continues to comply with ANSI N14.6-1993 requirements addressed in the FW FSAR. They have been tested to demonstrate their load capacity exceeds those specified for the VCT. The proposed activities significantly improve performance of administrative controls essential to performing or controlling the design function by facilitating load monitoring by key individuals involved in the associated activities.

Therefore, there are no adverse effects.

Question 2:

Does the proposed activity change a procedure (i.e., applicable FSAR described process for operation or control of an SSC) in a manner that adversely affects how applicable FSAR described SSC design function(s) are performed or controlled?

Yes No

Reason:

Incorporation of the changes into the appropriate procedures will improve the method of controlling the design function. Man-machine interface is improved and the display features allow for more effective peer checks.

Therefore, there are no adverse effects on the performance or control of a design function.

Question 3:

Does the proposed activity involve revising or replacing an applicable FSAR described method of evaluation used in establishing the design bases or used in the safety analyses in an adverse manner?

Yes No

Reason:

This change is to ancillary support hardware and has no impact on any safety analyses.

The change actually facilitates compliance with assumptions in the drop analysis recently completed.

Question 4:

Does the proposed activity involve a test or experiment not described in the applicable FSAR, where an SSC is utilized or controlled in a manner outside the reference bounds of the design for that SSC, or is inconsistent with the analysis or descriptions in the applicable FSAR?

Yes No

Reason:

No SSCs are utilized or controlled in manner outside the reference bounds of their respective designs. No test or experiments other than functional tests are associated with implementation of the change or the use of the installed equipment.

Therefore, this change does not involve a test or experiment,

B. Based on the responses to Questions VIII.1 through VIII.4 above, the proposed activity is:

- NOT adverse. (All of the responses to Questions VIII.1 through VIII.4 MUST be negative.)
GO TO Section V to obtain Reviews.
- Adverse. (One or more of the responses to Questions VIII.1 through VIII.4 are positive.)
GO TO Section IX for Evaluation.

END OF SECTION VIII



SOUTHERN CALIFORNIA EDISON

SAN ONOFRE NUCLEAR GENERATING STATION
(SONGS)

10 CFR 50.59 / 10 CFR 72.48 Review
APPLICABILITY DETERMINATION, SCREENS, and/or EVALUATIONS

For

Improved VCT Load Monitoring Capability

ASSIGNMENT:

0918-64884-7

CONTENTS

Sections I through V shall be performed for each use of this form.

Sections VI through XI are performed as directed by preceding Sections or as deemed necessary.

SECTION	TITLE
I	Administrative
II	Applicability Determination
III	10 CFR 50.82(a)(6) Review
IV	References
V	Preparer / Reviewer(s)
VI	<i>10 CFR 50.59 Screen</i>
VII	<i>10 CFR 50.59 Evaluation</i>
VIII	<i>10 CFR 72.48 Screen</i>
XI	<i>10 CFR 72.48 Evaluation</i>

SECTION I – ADMINISTRATIVE:

A. Is this a revision to an existing review?

Yes: No:

Existing Review Number: 0918-64884-6, Revision 1

Reason for Revision: Load Monitoring Focus Shifted from Pins to Shackles

B. Primary Document Type, Number, Revision, and Title:

Document Type: Nuclear Engineering Change Package

Document Number / Revision: 0918-64884-1, Revision 2

Document Title: VCT Live Load Monitoring System

C. Description of the Proposed Activity:

The subject NECP authorizes the addition of a load indicating system to the VCT as an option supported by Holtec and the OEM (J&R). The load indicating system monitors the strain in the rigging via load monitoring shackles. The system is required for downloading operations. During MPC uploading operations the VCT load monitoring system is available for reference. However, the existing VCT protection feature (10% overload cut-off based on hydraulic system pressure) remains sufficient.

The weight is displayed locally for each shackle and transferred to supporting tablets. The tablets sum the individual loads, establish alarm values, and record loading data. This is the primary change being reviewed since, while the load shackles are integral to the rigging, the additional functionality (load information) supplements their rigging function. As part of the down-loading sling/rigging assembly the shackles are load-bearing ITS components. The monitoring hardware (strain gauges, etc.) are NOT load bearing and are NITS.

The viability and utility of these proposed changes may be evaluated prior to issuance of the NECP by adding the shackles to the rigging and testing utilizing the 'simulator' as the load. The results of such testing will inform the implementing procedures, NECP content and associated training. The procedure content will be subsequently dry-run to finally confirm the efficacy of the system and the overall man-machine interface.

Other enhancements (alignment aides and tools such as tell tales/tag lines, lights and cameras) may also be added in support of procedure changes and training. Additional rigging subcomponents may need to be added as part of implementation. Such ancillary equipment may be added to the VCT and its rigging using other appropriate work management mechanisms if not addressed in the subject NECP. These are all evaluated herein from a regulatory perspective.

D. Primary Reason(s) for the Proposed Activity:

Load monitoring both directly and indirectly are key indications of the status of the loading operations on the VCT. When it is lifted from the deck, the full load of the canister should be evident; and as it is lowered the full load should be borne by the rigging.

Currently, these loads are indirectly measured via hydraulic pressure displayed in the VCT and by visually observing sling conditions (tautness). The load indications do not have a dedicated display; but, are optional displays that may be directed to other aspects of the VCT operation.

The load is the principal indication for proper control of heavy loads and its continued visibility, by those at the controls of the operation and others observing it, facilitates the necessary monitoring of loading operations. Finally, the system includes the ability to establish and rely upon various load limit alarms.

SECTION II - APPLICABILITY DETERMINATION (AD):

NOTE

Regulatory Guide 1.187 endorses NEI 96-07, Rev. 1, as one method to comply with 10 CFR 50.59. The term "change" is defined in NEI 96-07, Rev. 1, 3.3, as follows:

"Change means a modification or addition to, or removal from, the facility or procedures that affects: (1) a design function, (2) method of performing or controlling the function, or (3) an evaluation that demonstrates that intended functions will be accomplished."

The same definition of the term "change" is provided in 10 CFR 72.48 (a)(1), and thus is equally applicable for 72.48 reviews.

IF required, THEN see/use additional discussion provided in the associated "Discussion" in NEI 96-07, Rev. 1, 3.3, and the SONGS Resource Manual.

The basis must carefully examine whether there are any 'design functions' that are directly or indirectly impacted by the proposed activity. These will most often be detailed in the appropriate FSAR.

A. Is the proposed activity a change to the facility (including the ISFSI)? Explain fully.

Yes No

The VCT is the principal ancillary used to transport loads to and from the ISFSI storage locations from the transfer pad. Its load carrying equipment (including the downloader slings and associated attachments) is single-failure proof and classified as Important to Safety (ITS). The design function is to control the loaded canister and preclude its uncontrolled lowering with the potential to damage the canister and its contents. The hardware, including rigging, is not being significantly modified but the load shackles are capable of transmitting load information to display systems. Direct measurement of strain supplements and is functionally equivalent to the hydraulic pressure which drives the existing VCT operator display (sometimes referred to as the HMI). The substantive change is the nature of the display.

The digital displays have no direct safety function in that they do not perform any active function (such as directly driving an interlock). They do facilitate observation and provide opportunity for monitoring by others. As such they are a valuable operator aid.

Other changes improve alignment capability but do not perform a design function. They simply make adverse interaction between the canister and VVM less likely.

The Administrative Controls reliance on load monitoring is sufficiently critical to warrant treatment as if they were a design function so a 10 CFR 72.48 screen of that aspect is appropriate.

IF "Yes", THEN identify those aspects that must be appropriately addressed in Section VI or Section VIII or both, as appropriate:

B. Other regulatory processes can independently authorize or preclude changes to the facility. Indicate which other regulatory processes have been used to authorize this activity:

- Approved Specific Exemptions 10 CFR 50.12 or 72.7
- Fire Protection Program 10 CFR 50.48(f)
- Decommissioning QA Plan 10 CFR 50.54(a)
- Physical Security Plan 10 CFR 50.54(p)
- Emergency Plan 10 CFR 50.54(q)
- Approved License Amendments 10 CFR 50.90 or 72.244

C. Evaluation using one or more of the processes in Section II.B has established that the proposed change may be implemented without prior or further NRC approval.

Yes No Assignment _____ (If Yes)

IF "Yes", THEN summarize how the change is addressed. IF changes to the design basis are fully addressed by other processes, THEN no further review under 10 CFR 50.59 or 72.48 is required. For ease in cross-referencing, list the assignment(s) that tracked the completed review requirements for those items.

D. Does the proposed activity require a change to the Technical Specifications, 10 CFR 50 Operating License Condition(s) or Terms, Conditions and Specifications for a Storage System Certificate of Compliance?

Yes No Assignment _____ (If Yes)

IF "Yes", THEN the proposed activity cannot be authorized by 10 CFR 50.59. A License Amendment under 10 CFR 50.90 or 72.244 (which are the responsibility of the Certificate Holder) is required. Document the number of the assignment tracking the LAR or documenting the decision to modify or not make the proposed activity.

E. Summary of Section II

Based on the reviews documented in II.A through II.D, the following Screen(s) are required (Check either, neither, or both, as appropriate).

- 10 CFR 50.59 Screen (Perform Section VI)
- 10 CFR 72.48 Screen (Perform Section VIII)

SECTION III - 10 CFR 50.82(a)(6) REVIEW:

NOTE

10 CFR 50.82(a)(6) states in part: Licensee shall not perform any decommissioning activities as defined in Section 50.2 that - (i) Foreclose release of the site for possible unrestricted use; (ii) Result in significant environmental impacts not previously reviewed; or (iii) Result in there no longer being reasonable assurance that adequate funds will be available for decommissioning.

Question 1:

Does the proposed change foreclose release of the site for possible unrestricted use?

Yes No

Reason:

These changes are minor physical changes to loading equipment that will not be left on-site after decommissioning of the ISFSI.

Therefore there is no impact on the possible release of the site for unrestricted use.

Question 2:

Does the proposed change result in significant environmental impacts not previously reviewed?

Yes No

Reason:

These changes are minor physical changes to loading equipment that do not impact the site environment.

Therefore there are no environmental impacts that might require additional reviews.

Question 3:

Does the proposed change result in there no longer being reasonable assurance that adequate funds will be available for decommissioning?

Yes NO

Reason:

The funds for this activity are fully funded as part of the ISFSI project.

Therefore there is no adverse impact on decommissioning funding assurance.

Conclusion:

IF the subject activity is determined to be an adverse change to a major decommissioning activity due to the results of the evaluations performed for Questions III.1 through III.3, THEN the activity may NOT be performed [reference 10 CFR 50.82(a)(6)]. List the applicable assignment to track the disposition of this item.

Assignment # _____

SECTION IV – REFERENCES:

1. 1814-AR171-M0059 - Straightpoint Handheld Plus
2. 1814-AR171-M0060 - Straightpoint Wireless Loadshackle
3. 1814-AR171-M0061 - Straightpoint SW-RWT Rugged tablets
4. 1814-AR171-M0062- Document Review Checklist for I&I Slings Supplied Product
5. HPP-2464-400, MPC Transfer at SONGS
6. HI-2115090, HI-STORM UMAX System FSAR
 - a. Section 1.2.4, Operational Characteristics of the HI-STORM UMAX
 - b. Section 9.2.3, Placement of MPC into Storage
7. HI-2114830, HI-STORM FW System FSAR
 - a. Section 1.2.1.5.5, Transporter
 - b. Section 2.2.3(a), Handling Accident
8. RRTI-2464-064, Latest Revision
9. ECO-5021-039, R1

SECTION V – PREPARERS / REVIEWERS:

Technical Input (if required): Brian Sarno	Date: 12/11/18
Prepared By: Ken Wilson	Date: 12/11/18
Reviewed By: Richard Chang	Date: 12/11/18
Independent Review By: N/A	Date:

AFTER all reviews are complete, THEN unused Sections may be discarded.

SECTION VIII - 10 CFR 72.48 SCREEN

A. Identify and briefly summarize the aspects of the proposed activity which require a Screen.

Question 1:

Does the proposed activity change an SSC in a manner that adversely affects the applicable FSAR design function(s) or has an adverse effect on the method of performing or controlling applicable FSAR design function(s)?

Yes No

Reason:

The proposed addition of shackles (classified as ITS-B) continues to comply with ANSI N14.6-1993 requirements addressed in the FW FSAR. They have been tested to demonstrate their load capacity exceeds those specified for the VCT. The proposed activities significantly improve performance of administrative controls essential to performing or controlling the design function by facilitating load monitoring by key individuals involved in the associated activities.

Therefore, there are no adverse effects.

Question 2:

Does the proposed activity change a procedure (i.e., applicable FSAR described process for operation or control of an SSC) in a manner that adversely affects how applicable FSAR described SSC design function(s) are performed or controlled?

Yes No

Reason:

Incorporation of the changes into the appropriate procedures will improve the method of controlling the design function. Man-machine interface is improved and the display features allow for more effective peer checks.

Therefore, there are no adverse effects on the performance or control of a design function.

Question 3:

Does the proposed activity involve revising or replacing an applicable FSAR described method of evaluation used in establishing the design bases or used in the safety analyses in an adverse manner?

Yes No

Reason:

This change is to ancillary support hardware and has no impact on any safety analyses.

The change actually facilitates compliance with assumptions in the drop analysis recently completed.

Question 4:

Does the proposed activity involve a test or experiment not described in the applicable FSAR, where an SSC is utilized or controlled in a manner outside the reference bounds of the design for that SSC, or is inconsistent with the analysis or descriptions in the applicable FSAR?

Yes No

Reason:

No SSCs are utilized or controlled in manner outside the reference bounds of their respective designs. No test or experiments other than functional tests are associated with implementation of the change or the use of the installed equipment.

Therefore, this change does not involve a test or experiment,

B. Based on the responses to Questions VIII.1 through VIII.4 above, the proposed activity is:

- NOT adverse. (All of the responses to Questions VIII.1 through VIII.4 MUST be negative.)
GO TO Section V to obtain Reviews.
- Adverse. (One or more of the responses to Questions VIII.1 through VIII.4 are positive.)
GO TO Section IX for Evaluation.

END OF SECTION VIII

From: Smith, Chris
Sent: Thursday, February 28, 2019 6:20 PM
To: MARK MORGAN; Brookhart, Lee; Simpson, Eric
Subject: RE: FW: MPC Lifting Cleat Documentation

Hi Mark,

We do have some followup questions on this.

Mostly related to the calculation HI-2188161.

It looks like the lifting cleats are made from a material called Weldox. It also appears there is no data? on the material properties on elevated temperatures. The calculation appears to derive those elevated temperatures in Appendix A, but Appendix A appears to be a certified material test report (CMTR). CMTRs are not permitted for use in design documents. Are the material properties using the proper reference?

Secondly, can you clarify if the bolts meet ANSI N14.6?

Specifically we have a question if the bolts meet requirements in section 4.2.1.1:

The load-bearing members of a special lifting device shall be capable of lifting three times the combined weight of the shipping container with which it will be used, plus the weight of intervening components of the special lifting device. without generating a combined shear stress or maximum tensile stress at any point in the device in excess of the corresponding minimum tensile yield strength of their materials of construction. They shall also be capable of lifting live times that weight without exceeding the ultimate tensile strength of the materials.

Also, can you provide the purchase spec for the bolts that are actually used? I don't understand how the calculation is deriving the length of the bolts (I believe this is why the calc was originated in the first place).

Thanks

Chris

From: MARK MORGAN <Mark.Morgan@sce.com>
Sent: Friday, February 22, 2019 10:56 AM
To: Brookhart, Lee <Lee.Brookhart@nrc.gov>; Simpson, Eric <Eric.Simpson@nrc.gov>; Smith, Chris <Chris.Smith@nrc.gov>
Cc: MARK MORGAN <Mark.Morgan@sce.com>
Subject: [External_Sender] FW: MPC Lifting Cleat Documentation

All,

Attached are several files describing SCE's process for accepting the reduced thread bolt engagement for the lift cleat bolts.

Please let me know if you have any additional questions regarding this. If need be, we can set up a discussion between you and our engineering folks.

Thanks,
Mark
(949) 368-6745

From: RANDALL GRANAAS
Sent: Thursday, February 21, 2019 2:59 PM
To: MARK MORGAN <Mark.Morgan@sce.com>
Cc: JERRY STEPHENSON <Jerry.Stephenson@sce.com>
Subject: MPC Lifting Cleat Documentation

Mark,

See attached. Summary of process:

1. IFA performed, concluding the lift cleat bolts are functional. This is based on Holtec HI-2188161, which concludes a safety factor > 1.0, with only 3.125" of thread engagement.
2. 72.48 (#1327) supporting HI-2188161 concluded prior NRC approval not required.
3. Additional margin provided by actual bolt engagement of ~3.4".
4. NCR initiated to reconcile licensing basis, with actual bolt engagement at SONGS, via a 72.212 revision and creating a SONGS-specific version of the fabrication drawing. A 72.212 update is necessary because Holtec will not be revising the FW FSAR, nor the fabrication drawing.
5. IFA and NCR currently remain open, as the 72.212 has not been updated and the SONGS drawing has not been issued.

Sincerely,

Randall Granaas, P.E.
SONGS Fuels
(949) 368-6804 (Office)
(b)(7)(C) (Mobile)

From: Smith, Chris
Sent: Wednesday, March 06, 2019 4:59 PM
To: MARK MORGAN; Brookhart, Lee; ALBERT BATES
Cc: Piotter, Jason; Simpson, Eric; Wise, John; Davis, Marlone; Katanic, Janine
Subject: RE: Response to M&TE question

Mark,

Can you elaborate on the equipment that was used please?

I assume a dial indicator was used... like this one picture here:



How was the base of the indicator flat against the curved surface of the test specimen?

It would be great if the responses included the actual equipment used or a photo of it.

The reason I ask is it looks like the resolution of "Depth gauge serial number DPG-7" is on the order of 16% of your final measurements.

Thanks
Chris

From: MARK MORGAN <Mark.Morgan@sce.com>
Sent: Wednesday, March 6, 2019 2:46 PM

To: Brookhart, Lee <Lee.Brookhart@nrc.gov>; ALBERT BATES <AL.BATES@sce.com>

Cc: Piotter, Jason <Jason.Piotter@nrc.gov>; Simpson, Eric <Eric.Simpson@nrc.gov>; Smith, Chris <Chris.Smith@nrc.gov>; Wise, John <John.Wise@nrc.gov>; Davis, Marlene <Marlene.Davis@nrc.gov>; Katanic, Janine <Janine.Katanic@nrc.gov>

Subject: [External_Sender] Response to M&TE question

Lee,

I saw from your separate e-mail that you're mulling followup to this question. In the meantime, our response to the initial question is attached.

Mark
(949) 368-6745

From: Brookhart, Lee [<mailto:Lee.Brookhart@nrc.gov>]

Sent: Tuesday, March 05, 2019 3:28 PM

To: MARK MORGAN <Mark.Morgan@sce.com>; ALBERT BATES <AL.BATES@sce.com>; Kenneth Wilson <Kenneth.R.Wilson@sce.com>

Cc: Piotter, Jason <Jason.Piotter@nrc.gov>; Simpson, Eric <Eric.Simpson@nrc.gov>; Smith, Chris <Chris.Smith@nrc.gov>; Wise, John <John.Wise@nrc.gov>; Davis, Marlene <Marlene.Davis@nrc.gov>

Subject: (External):RE: Questions status at end of Tues

Sorry I spoke too soon. We have one new question:

Test Report Question:

1.) In HI-2188450 (scratch test report), please describe the method used to determine the scratch depth.

Specifically, what measurement and test equipment was used, was it controlled M&IE and have a current calibration?

So the total now is:

2 open questions on BB calc.
2 open questions on ECO
5 open questions on Scratch/Scar Calc
1 open question on the Test Report

Thanks
Lee

From: Brookhart, Lee

Sent: Tuesday, March 05, 2019 5:18 PM

To: MARK MORGAN <Mark.Morgan@sce.com>; ALBERT BATES <AL.BATES@sce.com>; Kenneth Wilson <Kenneth.R.Wilson@sce.com>

Cc: Piotter, Jason <Jason.Piotter@nrc.gov>; Simpson, Eric <Eric.Simpson@nrc.gov>; Smith, Chris <Chris.Smith@nrc.gov>; Wise, John <John.Wise@nrc.gov>

Subject: Questions status at end of Tues

I have not received any new questions to add to the on-going list.

Status at end of Tuesday is:

2 open questions on BB calc.
2 open questions on ECO
5 open questions on Scratch/Scar Calc

Thanks
Lee

NRC Review Question Response Form

Note 1: Complete a separate form for each inspector question.

Note 2: The item tracking number will be generated when the record is entered into the inspection database.

Question Title: Scratch Test M&TE

Tracking Number: 7 AR Number: 0319-16606 Date Initiated: 03/05/2019

Holtec Support Required: Yes or No

Question description:

Test Report Question:

1.) In HI-2188450 (scratch test report), please describe the method used to determine the scratch depth.

Specifically, what measurement and test equipment was used, was it controlled M&IE and have a current calibration?

Requested Clarification (If needed):

SONGS / Holtec Response:

The following Measuring and Test Equipment (M&TE) was used to collect measurements during the Scratch Test Evaluation:

- Caliper serial number AS000652 (calibrated on 1/16/2019 and due on 7/16/19), accuracy +/- .001".
- Depth gauge serial number DPG-7 (calibrated on 11/13/18 and due on 5/13/19), accuracy +/- .001".

The equipment was calibrated in accordance with Holtec Standard Procedure 101201, Revision 2 and 101202, Revision 2. The NIST traceable standards used to perform the calibration activities are serial numbers HOH 1308924, HOH 925636 and HOH 3068.

NRC Review Question Response Form

Assigned Response Team Member: Randall Granaas

Assigned Independent / Peer Review Team Member: Richard Chang

NRC Inspector: Lee Brookhart

Response provided date / time: 3/6 @ 1440

Southern California Edison Company ENGINEERING CHANGE NOTICE (ECN)/CALCULATION CHANGE NOTICE (CCN) COVER PAGE	CALC NO. DCS-002		PAGE 1	TOTAL NO. OF PAGES 1
	NECP Order No. 0219-87459-2	CALC. REV. 0	UNIT 1	ECN/CCN NO. DR758838
SUMMARY CHANGE <input type="checkbox"/> NO <input checked="" type="checkbox"/> YES	CALCULATION SUBJECT: HOLTEC ISFSI 10 CFR 72.212 EVALUATION			
CALCULATION CROSS-INDEX <input type="checkbox"/> New/Updated Index Included <input checked="" type="checkbox"/> Existing Index is Complete	ENGINEERING SYSTEM NUMBER / PRIMARY STATION SYSTEM DESIGNATOR 1500 / ZAF		Q-CLASS ITS-A	
Site Programs/Procedure Impact? <input checked="" type="checkbox"/> NO <input type="checkbox"/> YES, NN No. _____	CONTROLLED PROGRAM OR DATABASE ACCORDING TO SO123-XXIV-5.1 <input type="checkbox"/> PROGRAM <input type="checkbox"/> DATABASE	PROGRAM / DATABASE NAME(S) <input type="checkbox"/> ALSO, LISTED BELOW _____	VERSION / RELEASE NO.(S) _____	
10CFR50.59/72.48 Assignment_0219-87459-3				

Expand or replace DCS-002, Appendix E.1, Sections 1.2.4 and 9.5, with the text below. This CCN also replaces DR758582 in its entirety.

1.2.4 Operational Characteristics of the HI-STORM UMAX

- b. The vertical insertion (or withdrawal) of the MPC eliminates the risk of gouging or binding of the MPC with the CEC parts.

SCE and Holtec acknowledge that there is a potential for incidental contact between the MPC and various sub-components located within the divider shell. Therefore, SCE is taking exception to the HI-STORM UMAX FSAR Revision 4 text.

9.5 REGULATORY COMPLIANCE:

"The operational steps required to place a loaded MPC into a HI-STORM UMAX VVM cavity have been described in this chapter. The steps to remove an MPC from a loaded VVM, which are essentially reverse of the steps in the loading sequence, have been provided in Chapter 9 of the HI-STORM FW System FSAR [9.6.1]. These loading steps are, of necessity, generic in their description and may require adaptation to a specific ISFSI. The implementation steps are nevertheless sufficiently detailed to lead to the conclusion that the guidelines of safety and ALARA set down in NUREG-1536 are fully satisfied. In particular, it can be concluded that:

- vii. Because the MPC insertion (and withdrawal) occurs in the vertical configuration with ample lateral clearances, there is no risk of scratching or gouging of the MPC's external surface (Confinement Boundary). Thus the ASME Section III Class 1 prohibition against damage to the pressure retaining boundary is maintained."

SCE and Holtec acknowledge that there is a potential for incidental contact between the MPC and various sub-components located within the divider shell. Therefore, SCE is taking exception to the HI-STORM UMAX FSAR Revision 4 text.

Based on material properties, configuration/geometry and resulting loads supporting such contact, such contact is not expected to produce "scratches or gouges" that would challenge the ASME Section III, Class 1, pressure (confinement) boundary.

To substantiate that conclusion SCE has performed a detailed, in situ visual assessment of three loaded canisters within their respective storage over-packs as discussed in Reference E.3.16. Those assessments were thoroughly and conservatively evaluated and concluded that the results of any incidental contact are well within the existing design margins defined by the ASME B&PV Code [E.3.9].



And modify the References to read as follows:

- E.3.9 HI-2188437, Latest Revision, "Incidence and Consequences of Canister Shell Wear Scars from Misaligned Insertion of a Loaded MPC at SONGS"
- E.3.16 "HI-STORM Multi-Purpose Canister Visual Assessment Report," Revision 0, 3/29/19

2. OTHER AFFECTED DOCUMENTS:

YES NO OTHER AFFECTED DOCUMENTS EXIST AND ARE IDENTIFIED ON ATTACHED FORM 26-503.

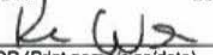
3. APPROVED BY:

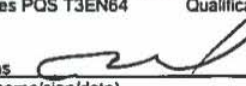
Ken Wilson  3/29/19 ORIGINATOR (Print name/sign/date) Approval requires PQS T3EN64 Qualification Verified: <u>BAS</u> Initial	Jerry Stephenson  3/29/19 FLS (Signature/date) Approval requires PQS T3EN64 Qualification Verified: <u>BAS</u> Initial
Randall Granaas  3/29/19 IRE (Print name/sign/date) Approval requires PQS T3EN64 Qualification Verified: <u>BAS</u> Initial	

Southern California Edison Company ENGINEERING CHANGE NOTICE (ECN)/CALCULATION CHANGE NOTICE (CCN) COVER PAGE SUMMARY CHANGE <input type="checkbox"/> NO <input checked="" type="checkbox"/> YES	CALC NO. DCS-002		PAGE 1	TOTAL NO. OF PAGES 2
	NECP Order No. 0718-18311-1	CALC. REV. 0	UNIT 1, 2, & 3	ECN/CCN NO. DR755192
	CALCULATION SUBJECT: HOLTEC ISFSI 10 CFR 72.212 EVALUATION			
CALCULATION CROSS-INDEX <input type="checkbox"/> New/Updated Index Included <input checked="" type="checkbox"/> Existing Index is Complete	ENGINEERING SYSTEM NUMBER / PRIMARY STATION SYSTEM DESIGNATOR <p style="text-align: center;">1500 / ZAF</p>		Q-CLASS <p style="text-align: center;">ITS-A</p>	
Site Programs/Procedure Impact? <input checked="" type="checkbox"/> NO <input type="checkbox"/> YES, NN No. _____	CONTROLLED PROGRAM OR DATABASE ACCORDING TO SO123-XXIV-5.1 <input type="checkbox"/> PROGRAM <input type="checkbox"/> DATABASE	PROGRAM / DATABASE NAME(S) <input type="checkbox"/> ALSO, LISTED BELOW _____	VERSION / RELEASE NO.(S) _____	
10CFR50.59/72.48 Assignment. 0718-18311-2				

1. BRIEF DESCRIPTION:

The following text is a complete replacement for the existing text in Section 11.1.3.5, *Earthquake*.

See Section 9.0 of this report for a thorough evaluation of general site specific seismic requirements.

During loading operations in the Fuel Handling Building the HI-TRAC VW may be placed on the upper shelf of the cask pool and not supported from above by the cask handling crane or restrained from movement. In this configuration there was and is a credible potential for the HI-TRAC VW containing a MPC to fall off the shelf as the consequence of an earthquake. The duration of this exposure is short making the risk very minimal.

The SONGS site-specific design and licensing basis [11.3.7] addresses the potential for the cask to fall into the cask pool in terms of off-site dose consequences and to both the HI-TRAC VW and MPC as well as the cask loading area floor as a result of the impact. Off-site dose was addressed by SCE separately. The two structural impacts are discussed below.

To evaluate the structural impacts of the postulated accident of the loaded HI-TRAC VW falling from the upper shelf of the cask pool, Holtec has prepared Holtec Report HI-2177713 [11.3.21] to evaluate the following design requirements:

- First, to show that the postulated accidental drop of the loaded HI-TRAC VW will not cause excessive deformation to the fuel basket cell walls potentially leading to a criticality event, and;
- Second, to show that the concrete slab and liner/backing plate at the bottom of the cask storage pool can withstand the postulated accidental drop event. A similar evaluation was previously been performed at SONGS for the loaded TN transfer cask as the same scenario existed for loading of that system as well.

(b)(4)

Table Error! No text of specified style in document..1: Peak Impact Deceleration Comparison for Cask Drop Events

Analysis [reference]	Peak Lateral Deceleration Value
HI-TRAC VW Drop at SONGS [11.3.21]	74 (g's)
HI-STAR 190 Side Drop Case [11.3.22]	85.9 (g's)

CALC NO. DCS-002	CALC. REV. 0	ECN/CCN NO. DR755192	PAGE 2	TOTAL NO. OF PAGES 2
---------------------	-----------------	-------------------------	-----------	-------------------------

(b)(4)

The following text is a complete replacement for the existing text in Section 11.1.3.13, *H-TRAC VW Transfer Cask Handling Accident*.

The analysis for this accident event has been incorporated by reference from Section 12.2.1 of the FW FSAR [11.3.6] into Section 12.2.13 of the UMAX FSAR [11.3.5].

During loading operations, the loaded HI-TRAC VW transfer cask is lifted and handled in a vertical orientation. A drop of the loaded HI-TRAC VW transfer cask is typically not a credible accident since the loaded HI-TRAC VW transfer cask is lifted and handled by devices designed with redundant drop protection features to prevent uncontrolled lowering. Therefore, postulating an uncontrolled lowering (drop) of a HI-TRAC VW transfer cask is non-credible. However, there is one optional site-specific event historically characterized as a "Cask Drop" addressed in in the SONGS Units 2/3 UFSAR. Since it is NOT a "handling event" it is addressed in 11.3.5.

2. OTHER AFFECTED DOCUMENTS:

YES NO OTHER AFFECTED DOCUMENTS EXIST AND ARE IDENTIFIED ON ATTACHED FORM 26-503.

3. APPROVED BY:

ESC: _____

Ken Wilson

Kew 7/26/18

Jerry Stephenson

[Signature] 7/26/18

ORIGINATOR (Print name/sign/date)

FLS (Signature/date)

Approval requires PQS T3EN64

Qualification Verified: BAS

Approval requires PQS T3EN64

Qualification Verified: BAS

Initial

Initial

Randall Granaas

[Signature] 7/26/18

IRE (Print name/sign/date)

Approval requires PQS T3EN64

Qualification Verified: BAS

Initial

Southern California Edison Company ENGINEERING CHANGE NOTICE (ECN)/CALCULATION CHANGE NOTICE (CCN) COVER PAGE SUMMARY CHANGE <input type="checkbox"/> NO <input checked="" type="checkbox"/> YES	CALC NO. DCS-002			PAGE 1	TOTAL NO. OF PAGES 2
	NECP Order No. 0918-64884-1	CALC. REV. 0	UNIT 1	ECN/CCN NO DR758584	
	CALCULATION SUBJECT: HOLTEC ISFSI 10 CFR 72.212 EVALUATION				
CALCULATION CROSS-INDEX <input type="checkbox"/> New/Updated Index Included <input checked="" type="checkbox"/> Existing Index is Complete	ENGINEERING SYSTEM NUMBER / PRIMARY STATION SYSTEM DESIGNATOR 1500 / ZAF			Q-CLASS ITS-A	
Site Programs/Procedure Impact? <input checked="" type="checkbox"/> NO <input type="checkbox"/> YES, NN No. _____	CONTROLLED PROGRAM OR DATABASE ACCORDING TO SO123-XXIV-5.1 <input type="checkbox"/> PROGRAM <input type="checkbox"/> DATABASE	PROGRAM / DATABASE NAME(S) <input type="checkbox"/> ALSO LISTED BELOW		VERSION / RELEASE NO.(S)	
10CFR50.59/72.48 Assignment: 0918-64884-6					

1. BRIEF DESCRIPTION:

The following text is being inserted in Appendix E.1:

HI-STORM UMAX FSAR 9.1

In the event of an extreme environmental condition, the appropriate procedural guidance to respond to the situation must be available and ready for implementation...

HI-STORM UMAX FSAR 9.1.1 Ensuring Safety in Heavy Load Handling Evolutions

ECO 5021-39 [Reference E.3.3] added the following text:

Ensuring safety in heavy load handling evolutions is critical in pool-to-pad operations. Towards this end, the following administrative and load monitoring requirements will be employed:

- *Pool-to-pad operations shall be controlled by procedures that are appropriately detailed*
- *Supervisory personnel and loading crew shall be given mandatory training, or retraining with emphasis on safety aspects of heavy load handling prior to the start of a loading campaign, as well as when necessary. Only those supervisory personnel and crew members who have demonstrated proficiency will be authorized to work in heavy load handling evolutions*
- *Required training shall emphasize the use of human performance tools during operations*

In addition to the above, a load monitoring system will be used during MPC down-loading operations. This monitoring system shall be capable of indicating experienced load. Numerical limits will be established and monitored, on a site-specific basis, so that prompt action is taken to terminate any abnormal load events and to aid in evaluating any event to confirm operation remained within evaluated safety limits.

The above preventive measures should be employed to assist in the reduction of potential for a handling mishap. The above safety-focused provisions shall also apply if a loaded MPC is being extracted from its storage cavity.

The load monitoring system and associated alarms were implemented by appropriate design package [References E.3.4]. The site specific values were established in RRTI-2464-064 [Reference E.3.5] based on a detailed mechanical structural analysis contained in HI-2188261 [Reference E.3.6]. The absolute "experienced load values" provided by the load shackles through the display equipment have substantial uncertainty, but are effective in determining load transfers (differential load) and, with the available margin, appropriate values to support procedure usage. The values, and required actions, are implemented in HPP-2464-400 [Reference E.3.7].

CALC. NO	CALC. REV.	ECN/CCN NO.	PAGE	TOTAL NO. OF PAGES
DCS-002	0	DR758584	1	2

The following text is being inserted into E.3:

- E.3.3 ECO-5021-39, Revision 1, "Ensuring Safety in Heavy Load Handling Equations"
- E.3.4 NECP 0918-64884-1, Revision 1, "Vertical Cask Transporter (VCT) Live Load Monitoring System"
- E.3.5 RRTI-2464-064, "Administrative Controls necessary to assure rigging, utilized in MPC down-loading operations for UMAX system at SONGS, is operated within manufacturer load rating"
- E.3.6 HI-2188261 [Latest Revision], "Structural Evaluation of the MPC Handling Event at SONGS"
- E.3.7 HPP-2464-400 [Latest Revision], "MPC Transport"

2. OTHER AFFECTED DOCUMENTS:

YES NO OTHER AFFECTED DOCUMENTS EXIST AND ARE IDENTIFIED ON ATTACHED FORM 26-503.

3. APPROVED BY:

ESC: _____

Ken Wilson *Ken Wilson* 11/23/18
 ORIGINATOR (Print name/sign/date)
 Approval requires PQS T3EN64 Qualification Verified: BAS
 Initial

Jerry Stephenson *Jerry Stephenson* 11/22/18
 FLS (Signature/date)
 Approval requires PQS T3EN64 Qualification Verified: BAS
 Initial

Randall Granaas *Randall Granaas* 11/23/18
 IRE (Print name/sign/date)
 Approval requires PQS T3EN64 Qualification Verified: BAS
 Initial

Southern California Edison Company ENGINEERING CHANGE NOTICE (ECN)/CALCULATION CHANGE NOTICE (CCN) COVER PAGE SUMMARY CHANGE <input type="checkbox"/> NO <input checked="" type="checkbox"/> YES	CALC NO. DCS-002		PAGE 1	TOTAL NO. OF PAGES 1
	NECP Order No. 0818-76588-48	CALC. REV. 0	UNIT 1	ECN/CCN NO. DR758614
	CALCULATION SUBJECT: HOLTEC ISFSI 10 CFR 72.212 EVALUATION			
CALCULATION CROSS-INDEX <input type="checkbox"/> New/Updated Index Included <input checked="" type="checkbox"/> Existing Index is Complete	ENGINEERING SYSTEM NUMBER / PRIMARY STATION SYSTEM DESIGNATOR 1500 / ZAF		Q-CLASS ITS-A	
Site Programs/Procedure Impact? <input checked="" type="checkbox"/> NO <input type="checkbox"/> YES, NN No. _____	CONTROLLED PROGRAM OR DATABASE ACCORDING TO SO123-XXIV-5.1 <input type="checkbox"/> PROGRAM <input type="checkbox"/> DATABASE	PROGRAM / DATABASE NAME(S) <input type="checkbox"/> ALSO, LISTED BELOW		VERSION / RELEASE NO.(S)
10CFR50.59/72.48 Assignment. 0818-76588-49				

1. BRIEF DESCRIPTION:

Revise section 15.1.4 Training Program.

The SONGS licensed operator training program has been significantly modified from operating plant requirements governed largely by INPO Accreditation Standards to a Certified Fuel Handler Program approved by the NRC on August 1, 2014. This program continues to be remains a Systematic Approach to Training (SAT) based program that includes in-pool fuel movement and monitoring of fuel stored in any of the storage systems in use on the SONGS ISFSI.

The engineering support staff responsible for authorizing fuel movement and Special Nuclear Material Accountability will continue to remain trained and qualified to provide the support they provide.

As required by UMAX FSAR Section 13.2.1 [15.3.8], training is provided by Holtec on the pool-to-pad procedures for personnel involved in cask loading and the pre-operational dry run training exercise specified in Condition 8 of CoC 72-1040 [15.3.9]. The site specific training and qualification program for Holtec Pool to Pad (PTP) loading and transfer activities at SONGS [15.3.13 and 15.3.14] identifies the PTP initial and continuing training requirements for all site-services personnel performing important to safety work under Holtec's Quality Assurance Program at SONGS. The HI-STORM-UMAX-System site specific training program is a SAT based program and training modules include the elements identified in Section 13.2.1 of the UMAX FSAR. These training activities are responsive to the training requirements of 10 CFR 72 Subpart I, Training and Certification of Personnel and 10 CFR 72.44(b)(4).

Following pool-to-pad transfer neither the operations staff nor RP staff are expected to perform monitoring activities. Training and qualification will be provided to the Security Staff to perform such functions. SCE is evaluating whether to continue to provide on-going training using SAT based concepts or to seek relief obtained by other nuclear plants. SCE will provide training using a graded approach to SAT. SAT based training will be provide to those personnel directly involved in Important to Safety activities.

Add the following reference:

15.3.13 HPP-2464-1134, "Training of Site Services Personnel at SONGS."

15.3.14 HSP-34, "Training of Field Service Personnel."

2. OTHER AFFECTED DOCUMENTS:

YES NO OTHER AFFECTED DOCUMENTS EXIST AND ARE IDENTIFIED ON ATTACHED FORM 26-503.

3. APPROVED BY:

ESC: _____ Ken Wilson <i>Ken Wilson</i> 12/15/18 ORIGINATOR (Print name/sign/date) Approval requires PQS T3EN64 Qualification Verified: <u>BAS</u> Initial	Jerry Stephenson <i>Jerry Stephenson</i> 12/6/18 FLS (Signature/date) Approval requires PQS T3EN64 Qualification Verified: <u>BAS</u> Initial
Richard Chang <i>Richard Chang</i> 12/6/18 IRE (Print name/sign/date) Approval requires PQS T3EN64 Qualification Verified: <u>BAS</u> Initial	

Southern California Edison Company ENGINEERING CHANGE NOTICE (ECN)/CALCULATION CHANGE NOTICE (CCN) COVER PAGE	CALC NO DCS-002			PAGE 1	TOTAL NO OF PAGES 2
	NECP Order No. 0918-64884-1	CALC REV 0	UNIT 1	ECN/CCN NO. DR7585630	
SUMMARY CHANGE <input type="checkbox"/> NO <input checked="" type="checkbox"/> YES	CALCULATION SUBJECT: HOLTEC ISFSI 10 CFR 72.212 EVALUATION				
CALCULATION CROSS-INDEX <input type="checkbox"/> New/Updated Index Included <input checked="" type="checkbox"/> Existing Index is Complete	ENGINEERING SYSTEM NUMBER / PRIMARY STATION SYSTEM DESIGNATOR 1500 / ZAF			Q-CLASS ITS-A	
Site Programs/Procedure Impact? <input checked="" type="checkbox"/> NO <input type="checkbox"/> YES, NM No. _____	CONTROLLED PROGRAM OR DATABASE ACCORDING TO SO123-XXIV-5.1 <input type="checkbox"/> PROGRAM <input type="checkbox"/> DATABASE	PROGRAM / DATABASE NAME(S) <input type="checkbox"/> ALSO, LISTED BELOW		VERSION / RELEASE NO(S)	
10CFR50.59/72.48 Assignment: 0918-64884-7					

1. BRIEF DESCRIPTION.

This CCN reflects CCN DR758584.

The following text is being inserted in Appendix E.1:

HI-STORM UMAX FSAR 9.1

In the event of an extreme environmental condition, the appropriate procedural guidance to respond to the situation must be available and ready for implementation...

HI-STORM UMAX FSAR 9.1.1 Ensuring Safety in Heavy Load Handling Evolutions

ECO 5021-39 [Reference E.3.3] added the following text:

Ensuring safety in heavy load handling evolutions is critical in pool-to-pad operations. Towards this end, the following administrative and load monitoring requirements will be employed:

- *Pool-to-pad operations shall be controlled by procedures that are appropriately detailed*
- *Supervisory personnel and loading crew shall be given mandatory training, or retraining with emphasis on safety aspects of heavy load handling prior to the start of a loading campaign, as well as when necessary. Only those supervisory personnel and crew members who have demonstrated proficiency will be authorized to work in heavy load handling evolutions*
- *Required training shall emphasize the use of human performance tools during operations*

In addition to the above, a load monitoring system will be used during MPC down-loading operations. This monitoring system shall be capable of indicating experienced load. Numerical limits will be established and monitored, on a site-specific basis, so that prompt action is taken to terminate any abnormal load events and to aid in evaluating any event to confirm operation remained within evaluated safety limits.

The above preventive measures should be employed to assist in the reduction of potential for a handling mishap. The above safety-focused provisions shall also apply if a loaded MPC is being extracted from its storage cavity.

The load monitoring system and associated alarms were implemented by appropriate design package [References E.3.4]. The site specific values were established in RRTI-2464-064 [Reference E.3.5] based on a detailed mechanical structural analysis contained in HI-2188261 [Reference E.3.6]. The absolute "experienced load values" provided by the load shackles through the display equipment have substantial uncertainty, but are effective in determining load transfers (differential load) and, with the available margin, appropriate values to support procedure usage. The values, and required actions, are implemented in HPP-2464-400 [Reference E.3.7].

The load monitoring system is required for down-loading operations. The existing VCT feature (10% overload cut-off) is sufficient for up-loading operations. The load monitoring system may well remain in service as a defense-in-depth operator aid. No site-specific values are warranted or implemented in the appropriate procedures. The other administrative controls bulleted in the ECO are applicable in either down-loading or up-loading (extraction).

CALC. NO	CALC. REV.	ECN/CCN NO.	PAGE	TOTAL NO OF PAGES
DCS-002	0	DR758630	1	2

The following text is being inserted into E.3:

- E.3.3 ECO-5021-39, Revision 1. "Ensuring Safety in Heavy Load Handling Equations"
- E.3.4 NECP 0918-64884-1, Revision 1. "Vertical Cask Transporter (VCT) Live Load Monitoring System"
- E.3.5 RRTI-2464-064, "Administrative Controls necessary to assure rigging, utilized in MPC down-loading operations for UMAX system at SONGS, is operated within manufacturer load rating"
- E.3.6 HI-2188261 [Latest Revision], "Structural Evaluation of the MPC Handling Event at SONGS"
- E.3.7 HPP-2464-400 [Latest Revision], "MPC Transport"

2. OTHER AFFECTED DOCUMENTS:

YES NO OTHER AFFECTED DOCUMENTS EXIST AND ARE IDENTIFIED ON ATTACHED FORM 26-503.

3. APPROVED BY

ESC:

Ken Wilson *K. Wilson* 12/13/18
 ORIGINATOR (Print name/sign/date)
 Approval requires PQS T3EN64 Qualification Verified: BAS
 Initial

Jerry Stephenson *[Signature]* 12/13/18
 FLS (Signature/date)
 Approval requires PQS T3EN64 Qualification Verified: BAS
 Initial

Richard Chang *[Signature]* 12/13/18
 IRE (Print name/sign/date)
 Approval requires PQS T3EN64 Qualification Verified: BAS
 Initial

Southern California Edison Company ENGINEERING CHANGE NOTICE (ECN)/CALCULATION CHANGE NOTICE (CCN) COVER PAGE SUMMARY CHANGE <input type="checkbox"/> NO <input checked="" type="checkbox"/> YES	CALC NO. DCS-002		PAGE 1	TOTAL NO. OF PAGES 2
	NECP Order No. 0119-53878-2	CALC. REV. 0	UNIT 1	ECN/CCN NO. DR7585641
	CALCULATION SUBJECT: HOLTEC ISFSI 10 CFR 72.212 EVALUATION			
CALCULATION CROSS-INDEX <input type="checkbox"/> New/Updated Index Included <input checked="" type="checkbox"/> Existing Index is Complete	ENGINEERING SYSTEM NUMBER / PRIMARY STATION SYSTEM DESIGNATOR 1500 / ZAF		Q-CLASS ITS-A	
Site Programs/Procedure Impact? <input checked="" type="checkbox"/> NO <input type="checkbox"/> YES, NN No. _____	CONTROLLED PROGRAM OR DATABASE ACCORDING TO SO123-XXIV-5.1 <input type="checkbox"/> PROGRAM <input type="checkbox"/> DATABASE	PROGRAM / DATABASE NAME(S) <input type="checkbox"/> ALSO, LISTED BELOW _____	VERSION / RELEASE NO(S) _____	
10CFR50.59/72.48 Assignment 0119-53878-5				

1. BRIEF DESCRIPTION:

This CCN reflects CCNs DR758584 and DR758630.

The following text is being inserted in Appendix E.1:

HI-STORM UMAX FSAR 9.1

In the event of an extreme environmental condition, the appropriate procedural guidance to respond to the situation must be available and ready for implementation...

HI-STORM UMAX FSAR 9.1.1 Ensuring Safety in Heavy Load Handling Evolutions

ECO 5021-39 [Reference E.3.3] added the following text:

Ensuring safety in heavy load handling evolutions is critical in pool-to-pad operations. Towards this end, the following administrative and load monitoring requirements will be employed:

- *Pool-to-pad operations shall be controlled by procedures that are appropriately detailed*
- *Supervisory personnel and loading crew shall be given mandatory training, or retraining with emphasis on safety aspects of heavy load handling prior to the start of a loading campaign, as well as when necessary. Only those supervisory personnel and crew members who have demonstrated proficiency will be authorized to work in heavy load handling evolutions*
- *Required training shall emphasize the use of human performance tools during operations*

In addition to the above, a load monitoring system will be used during MPC down-loading operations. This monitoring system shall be capable of indicating experienced load. Numerical limits will be established and monitored, on a site-specific basis, so that prompt action is taken to terminate any abnormal load events and to aid in evaluating any event to confirm operation remained within evaluated safety limits.

The above preventive measures should be employed to assist in the reduction of potential for a handling mishap. The above safety-focused provisions shall also apply if a loaded MPC is being extracted from its storage cavity.

The load monitoring system and associated alarms were implemented by appropriate design package [References E.3.4]. The site specific values were established in RRTI-2464-064 [Reference E.3.5] based on a detailed mechanical structural analysis contained in HI-2188261 [Reference E.3.6]. The absolute "experienced load values" provided by the load shackles through the display equipment have substantial uncertainty, but are effective in determining load transfers (differential load) and, with the available margin, appropriate values to support procedure usage. The values, and required actions, are implemented in HPP-2464-400 [Reference E.3.7].

The load monitoring system is required for down-loading operations. If the system fails during down-loading operations administrative controls have been established [Reference E.3.7 and E.3.10] to ensure the MPC is placed in a known safe condition. The most critical point in the down-loading operation is at the shield ring (identified in elevation in the referenced administrative controls). If the system were to fail prior to the bottom of the MPC clearing the shield ring elevation the MPC shall be raised back into the HI-TRAC. If below; down-loading may continue to lower the MPC to the base of the CEC. The VCT hydraulic system and other administrative controls (i.e., visual observation, tag-lines, etc.) are sufficiently robust to support continued down-loading below the most credible hang-up location (i.e., the shield ring).

CALC. NO	CALC. REV.	ECN/CCN NO.	PAGE	TOTAL NO. OF PAGES
DCS-002	0	DR758641	2	2

The existing VCT hydraulic system includes a 10% overload cut-off which is sufficient for up-loading operations. The load monitoring system may remain in service as a defense-in-depth operator aid. No site-specific values are warranted or implemented in the appropriate procedures.

The other administrative controls bulleted in the ECO are applicable in either down-loading or up-loading (extraction).

The following text is being inserted into E.3:

- E.3.3 ECO-5021-39, Revision 1, "Ensuring Safety in Heavy Load Handling Equations"
- E.3.4 NECP 0918-64884-1, Revision 1, "Vertical Cask Transporter (VCT) Live Load Monitoring System"
- E.3.5 RRTI-2464-064, "Administrative Controls necessary to assure rigging, utilized in MPC down-loading operations for UMAX system at SONGS, is operated within manufacturer load rating"
- E.3.6 HI-2188261 [Latest Revision], "Structural Evaluation of the MPC Handling Event at SONGS"
- E.3.7 HPP-2464-400 [Latest Revision], "MPC Transport"
- E.3.10 HPP-2464-600 [Latest Revision], "Responding to Abnormal Conditions"

2. OTHER AFFECTED DOCUMENTS:

YES NO OTHER AFFECTED DOCUMENTS EXIST AND ARE IDENTIFIED ON ATTACHED FORM 26-503.

3. APPROVED BY:

ESC: _____

Ken Wilson  1/10/19
 ORIGINATOR (Print name/sign/date)
 Approval requires PQS T3EN64 Qualification Verified: BAS
Initial

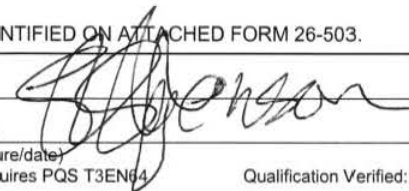
Jerry Stephenson  1/10/19
 FLS (Signature/date)
 Approval requires PQS T3EN64 Qualification Verified: BAS
Initial

Randall Granaas  1/10/19
 IRE (Print name/sign/date)
 Approval requires PQS T3EN64 Qualification Verified: BAS
Initial

Southern California Edison Company ENGINEERING CHANGE NOTICE (ECN)/CALCULATION CHANGE NOTICE (CCN) COVER PAGE SUMMARY CHANGE <input type="checkbox"/> NO <input checked="" type="checkbox"/> YES	CALC. NO. DCS-002		PAGE 1	TOTAL NO. OF PAGES 1
	NECP Order No. 0818-76588-46	CALC. REV. 0	UNIT 1	ECN/CCN NO. DR758582
	CALCULATION SUBJECT: HOLTEC ISFSI 10 CFR 72.212 EVALUATION			
CALCULATION CROSS-INDEX <input type="checkbox"/> New/Updated Index Included <input checked="" type="checkbox"/> Existing Index is Complete	ENGINEERING SYSTEM NUMBER / PRIMARY STATION SYSTEM DESIGNATOR 1500 / ZAF		Q-CLASS ITS-A	
Site Programs/Procedure Impact? <input checked="" type="checkbox"/> NO <input type="checkbox"/> YES. NN No. _____	CONTROLLED PROGRAM OR DATABASE ACCORDING TO SO123-XXIV-5.1 <input type="checkbox"/> PROGRAM <input type="checkbox"/> DATABASE	PROGRAM / DATABASE NAME(S) <input type="checkbox"/> ALSO LISTED BELOW _____	VERSION / RELEASE NO.(S) _____	
10CFR50.59/72.48 Assignment: 0818-76588-47				

1. BRIEF DESCRIPTION:

The following text is being inserted in Appendix E.1:

HI-STORM UMAX FSAR 9.5 REGULATORY COMPLIANCE

ECO-5021-39 [Reference 3.3] modified the existing text to read as follows:

vii. Even though MPC insertion (and withdrawal) occurs in the vertical configuration with adequate lateral clearances, there is a risk of damage (scratching or gouging) to the MPC's external surface (Confinement Boundary). The training, qualification, and equipment discussed in Section 9.1.1 provides reasonable assurance that the ASME Section III Class 1 prohibition against excessive wall thinning to the pressure retaining boundary is maintained. In the instance of damage exceeding that permitted in Holtec Standard Procedure HSP-320, an evaluation of the MPC shell shall be required to demonstrate code compliance.

Holtec assessed the potential for and impact of potential interactions between the canister and other storage system subcomponents during down loading in DS-469 [Reference 3.8]. The damage potential is also reflected in appropriate drawing notations [Reference 3.9].

The following text is being inserted into E.3:

E.3.8 DS-469, "Incidence and Consequences of Canister Shell Scratching from Misaligned Insertion of a Loaded MPC at SONGS"

E.3.9 40028 Sh 3, "North Industrial Area General Arrangement Equipment ID Table"

2. OTHER AFFECTED DOCUMENTS:
 YES NO OTHER AFFECTED DOCUMENTS EXIST AND ARE IDENTIFIED ON ATTACHED FORM 26-503.

3. APPROVED BY: ESC: _____

Ken Wilson <i>KWilson</i> 11/20/18 ORIGINATOR (Print name/sign/date) Approval requires PQS T3EN64 Qualification Verified: <u>BAS</u> Initial	Jerry Stephenson <i>JStephenson</i> 10/28/18 FLS (Signature/date) Approval requires PQS T3EN64 Qualification Verified: <u>BAS</u> Initial
Randall Granaas <i>RGranaas</i> 11/28/18 IRE (Print name/sign/date) Approval requires PQS T3EN64 Qualification Verified: <u>BAS</u> Initial	

From: Brookhart, Lee
Sent: Thursday, December 13, 2018 4:47 PM
To: Simpson, Eric
Subject: FW: FW: Holtec ALARA & RP Work Control Plan

From: MARK MORGAN [mailto:Mark.Morgan@sce.com]
Sent: Wednesday, December 12, 2018 10:54 PM
To: Brookhart, Lee <Lee.Brookhart@nrc.gov>
Cc: MARK MORGAN <Mark.Morgan@sce.com>
Subject: [External_Sender] FW: Holtec ALARA & RP Work Control Plan

Lee,

We had talked about providing these earlier in the week.

Mark
(949) 368-6745

From: MARK MORGAN <Mark.Morgan@sce.com>
Sent: Monday, February 25, 2019 6:19 PM
To: Brookhart, Lee
Cc: Katanic, Janine; Simpson, Eric; Smith, Chris; ALBERT BATES
Subject: [External_Sender] Load shackle test data

Lee,

In today's phone call we committed to get you the 200% load shackle test documentation today. Unfortunately, SCE engineering has some questions about the documentation that have not been resolved yet. I'll let you know tomorrow (Tuesday) morning what the new forecast is.

Mark
(949) 368-6745

From: Brookhart, Lee
Sent: Monday, March 11, 2019 10:38 AM
To: MARK MORGAN; Simpson, Eric; Smith, Chris; Katanic, Janine
Cc: ALBERT BATES; Doug Bauder; Wise, John; Davis, Marlene; Call, Michel
Subject: RE: Response to Question regarding Scratch Test Report Summary

I believe I understand the response.

SONGS was not using the test to validate Archard's wear equation. Test data confirms max depth is low during the physical tests performed.

To me, the test shows that use of the Archard's wear equation to maximize depth theoretically could be misleading. As the depth (h) can vary because the width is not constant as assumed in the conservative calculation. And as can be seen in the test data.

So I am left thinking:

Does the test data confirm max depth should be low = yes

Does the test data confirm Archard's wear equation (the way it is utilized in the calculation) to be conservative in determining max depth = not necessarily

To me, I am not sure if that is a win or a loss.

Thanks
Lee

From: MARK MORGAN [mailto:Mark.Morgan@sce.com]
Sent: Friday, March 08, 2019 4:46 PM
To: Brookhart, Lee <Lee.Brookhart@nrc.gov>; Simpson, Eric <Eric.Simpson@nrc.gov>; Smith, Chris <Chris.Smith@nrc.gov>; Katanic, Janine <Janine.Katanic@nrc.gov>
Cc: MARK MORGAN <Mark.Morgan@sce.com>; ALBERT BATES <AL.BATES@sce.com>; Doug Bauder <Doug.Bauder@sce.com>
Subject: [External_Sender] Response to Question regarding Scratch Test Report Summary

Lee,

Attached is SONGS' response to your question regarding the scratch test summary report. If you have followup questions on this or any other response, let me know if a telephone call would facilitate reaching a common understanding. We can talk more about that during our weekly call on Monday.

Thanks,
Mark
(949) 368-6745

NRC Review Question Response Form

Note 1: Complete a separate form for each inspector question.

Note 2: The item tracking number will be generated when the record is entered into the inspection database.

Question Title: Scratch Test Report Summary

Tracking Number: 9 AR Number: 0319-53688 Date Initiated: 03/06/2019

Holtec Support Required: Yes or No

Question description:

Question on the Test Report:

The summary section of the test report is vague. So vague, that I have to come up with my own conclusion and try to place the test report outcome into my own perspective.

5.0 Summary Section states:

Simulation of a high load contact force interaction between a 304 SS plate and SA 240 Type 316/316 L surface conducted at Orrvilon suggests a worse case scratch depth of 0.008" occurring on the 304 SS plate as in Trial 14.

Since there is no other guidance in the summary section. I am left to attempt to use the numbers from **Trial 14** to see if it bounds the prediction as presented in HI-2188437 using Archard's equation.

So using Trial 14 inputs:

F = 5000 lbf HBr = 86.6 N/mm² Width = 0.57 in

The maximum depth of a possible scratch per Archards wear equation = 0.00698" or 6.98 mils
(see my attached equation)

However, the test recorded a scratch depth of 0.008" (8 mils). So now I am confused, I thought the reason for the tests was to show the calculation was conservative.

Unless my math is wrong.... which it very well could be, the test summary (as presented in the Summary Section) does not seem to bound the conservative equation.

Question on Test Report:

2. Can SCE provide an enhanced summary section on how the test data can be used to bound the calculations and evaluation presented in HI-2188437?

If I had a math error please let me know and I will retract the question

NRC Review Question Response Form

Requested Clarification (If needed):

SONGS / Holtec Response:

SCE does not plan on revising the test report to provide an enhanced summary section, but does offer the following clarifying information:

The wear simulations performed at Orrvilon were intended to provide an alternate and independent means of demonstrating that significant wear or scratching was not expected to occur during the download of the MPCs into the UMAX cavity, even at side loads well in excess of what the MPC is expected to experience. The purpose of the simulations were not to validate Archard's equation. The observed results from the wear simulations do however agree with conclusions of the calculations performed (of which a 1/8" scratch width for the lower MPC guide plates and 1/16" width for the Inner seismic restraints were knowingly conservatively chosen) in that both demonstrated that any experienced wear or scratching will in fact be minor and not detrimental to the integrity of the MPC.

The above said, Archard's equation remains bounding for the Trial 14 case, provided the limited width of the 8 mils scratch is accounted for. The entire measured width of 0.57" was not significantly scratched, and a portion of the 0.57" width was not scratched at all (reference Photograph 10 of the test report). Assuming a scratch width of 0.125" for Trial 14, consistent with HI-2188437, the predicted scratch depth for 5000 lbf is 21.3 mils. This bounds the maximum measured scratch depth of 8 mils for Trial 14.

To maximize scratch depth, HI-2188437 uses a lower bound value of 130 N/mm² (Brinell) for the hardness (HBW) of the MPC shell material as input to Archard's wear equation. The NRC appears to have used Rockwell B hardness in their application of Archard's equation.

Assigned Response Team Member: Randall Granaas

Assigned Independent / Peer Review Team Member: Brian Sarno

NRC Review Question Response Form

NRC Inspector: Lee Brookhart

Response provided date / time: _____

From: MARK MORGAN <Mark.Morgan@sce.com>
Sent: Sunday, March 03, 2019 11:28 PM
To: Brookhart, Lee; Simpson, Eric; Smith, Chris; Katanic, Janine; Howell, Linda
Cc: ALBERT BATES; MARK MORGAN
Subject: [External_Sender] RE: Scratch Test Report

All,

The Scratch Evaluation, FSAR change, and associated 72.48 are now available in the Electronic Reading Room. They are named "Scratch Evaluation," "Scratch ECO/FSAR change," and "Scratch 72.48," respectively. At this time, we have provided you with all 5 of the major deliverables that we have been working on. We are still working on other issues, such as procedure changes to address issues raised during the recent inspection, as well as responses to questions on the latest documents.

We can discuss in more detail in the Monday morning phone call.

Let me know if you have any questions regarding this.

Thanks,
Mark
(949) 368-6745

From: MARK MORGAN <Mark.Morgan@sce.com>
Sent: Sunday, March 03, 2019 6:17 PM
To: Brookhart, Lee; Simpson, Eric; Smith, Chris; Katanic, Janine; Howell, Linda
Cc: ALBERT BATES; MARK MORGAN
Subject: [External_Sender] Scratch Test Report

All,

The Scratch Test Report is now available in the Electronic Reading Room. If sorted by "Name" it's under "Scratch Test Report." If sorted by "File," it's under HI-2188450R0.

Let me know if you have any questions regarding this.

Thanks,

Mark
(949) 368-6745

SAN ONOFRE NUCLEAR GENERATING STATION

UNIT 1

Q-List

M-37560

Revision 10

November 2017

Unit 1 components identified with Quality Class/PDTS designations SR/RO, NSRAQ/RO, NSRFP/NRO or NSRFP/RO remain on the list. Any components which are still installed in the plant but are not listed on the list are NSR/NRO.

All the Spent Fuel Dry Cask Storage and ISFSI components are included. The PDTS designations are not applicable to these components but are included for configuration control consistency only.

ECN DR758628
NECP 0918-64884-1
SUPERSEDING?: NO

This ECN reflects ECN D0082989.

SAN ONOFRE UNIT-1 Q-LIST

FSAR Section	Principal Component	Classification Category	Principal Design and Construction Code or Standard	Location (Bldg.)
HOLTEC HI-STORM FW MPC SYSTEM				
1.2.1.5	MPC Lifting Cleats, Lugs & Links	SR (j) ITS-A	ANSI N14.6	A/O
1.2.1.5	MPC Lifting Slings	SR (j) ITS-B	ANSI N14.6	A/O
9.1.1	Load Monitoring System (l)	NITS		O
1.2.1.5	Mating Device	ITS-B	ANSI N14.6	O
1.2.1.5	Vertical Cask Transport (VCT)	ITS-B	ASME III, NF ANSI N14.6	O
1.2.1.5	HI-PORT Auxiliary Equipment	ITS-C NITS	ASME III, NF	A/O O

- j. MPC lifting slings, lifting cleats, lugs and links are covered under 10CFR Part 50 while within the Auxiliary Building. MPC lifting slings, lifting cleat, lugs and link are covered under 10CFR Part 72 when outdoors and in the on-site area.
- k. The seismic design of the structure is based on the more governing earthquake loads of ASCE 7-10 and SONGS DBE.
- l. This refers to load sensing and display for VCT load handling operations of the MPC. The load bearing member will have the same classification category and principal design and construction or standard consistent with its use.



SOUTHERN CALIFORNIA
EDISON[®]

An *EDISON INTERNATIONAL*[®] Company

SOUTHERN CALIFORNIA EDISON
An EDISON INTERNATIONAL Company

**SAN ONOFRE NUCLEAR GENERATING STATION
HI-STORM MPC VISUAL ASSESSMENT REPORT
March 29, 2019**

Record of Revision

Revision No.	Pages/Sections/ Paragraphs Changed	Brief Description / Change Authorized
0	Entire Document	Initial Issue



An EDISON INTERNATIONAL Company

SONGS HI-STORM MPC Visual Assessment Report

Prepared by: Brian Sarno 3/24/2019
Brian Sarno
ISFSI Engineering

Reviewed by: Randall Granaas
Randall Granaas
ISFSI Engineering

Digitally signed by Randall Granaas
DN: cn=Randall Granaas, o=SCE, ou=SONGS,
email=randall.granaas@sce.com, c=US
Date: 2019.03.29 11:16:14 -0700

Approved by: Jerry Stephenson
Jerry Stephenson
Manager, ISFSI Engineering

Digitally signed by Jerry Stephenson
DN: cn=Jerry Stephenson, o=SCE, ou=SONGS,
email=jerry.stephenson@sce.com, c=US
Date: 2019.03.29 11:16:14 -0700

CC: RPA 04-0023E

INTRODUCTION

San Onofre Nuclear Generating Station (SONGS) performed a visual assessment of three multi-purpose canisters (MPCs) from March 21 - 23, 2019. This report includes the following:

- Scope of visual assessments
- Visual assessment techniques utilized
- Visual assessment results
- Conclusion

SONGS QA program requirements were applied to visual assessment activities, see Appendix C.

VISUAL ASSESSMENT SCOPE

The scope of the visual assessment is the accessible surfaces of the MPC shell and baseplate. The three MPCs included in the visual assessment were selected for the following reasons: 1) MPC serial number (S/N) 067 which was involved in the August 3, 2018 event where it was suspended by the divider shell shield ring, 2) MPC S/N 064 which was documented as having made contact with the divider shell on July 22, 2018 during downloading operations, and 3) MPC S/N 072, an MPC loaded at an earlier portion of the fuel transfer campaign, is on a different row than the previous two MPCs. A different row was selected to account for the minimal drainage slope on the HOLTEC ISFSI pad and its potential effect on MPC vertical alignment during downloading operations.

VISUAL ASSESSMENT TECHNIQUES

A robotic crawler with cameras and a borescope with interchangeable tips (general area tip and measurement tip) were deployed in two stages to perform the visual assessment. During the first stage, the robotic crawler and borescope with the general area tip was used to provide general locations of surface irregularities. These surface irregularities were compared to post-fabrication photos and areas of interest were selected for characterization in the second stage. During the second stage, the robotic crawler and borescope with the measurement tip was used to characterize the surface irregularities (width and depth measurements as applicable).

The software used in conjunction with the borescope with measurement tip is able to detect a minimum width and depth of 0.001 inches (1 mil). See Appendix C for details regarding use of the borescopes and software.

Note: This is NOT a formal "inspection" or an activity qualified to ASME Sections III, V, XI or otherwise.

VISUAL ASSESSMENT RESULTS

The information below summarizes the results of the visual assessment.

The following surface irregularities were not found:

- Cracking
- Pitting

The following surface irregularities were found:

- Wear marks
- Water staining
- Carbon steel contamination – exhibited by iron oxide staining
- Fabrication artifacts

SONGS HI-STORM MPC Visual Assessment Report

All surface irregularities were compared to post-fabrication photos taken at Holtec Manufacturing Division prior to being shipped to SONGS. This comparison was used to assist in determining whether the surface irregularity was a result of downloading operations.

Surface irregularities that were not consistent with post-fabrication photos were documented in completed visual assessment procedures (Ref. 1-3). Of those surface irregularities, areas of interest were identified to undergo characterization (width and depth measurements as applicable). Some identified areas of interest reside within the weld and heat affected zones (HAZs) of the circumferential weld and HAZ. Table 1 below provides characterization measurements for areas of interest associated with downloading operations.

The majority of wear marks identified are correlated with contact with the divider shell shield ring. The first MPC (S/N 064) had no areas of interest with a measurable depth (< 0.001 inches). A small number of the wear marks related to contact with the divider shell shield ring, in the other two MPCs, had measured depths ranging from 0.003 to 0.012 inches as noted in Table 1 below. Additional wear marks identified were correlated with contact with the MPC inner seismic restraints (SR), also referred to as upper seismic restraints. See Appendix A for figures of the cavity enclosure container and divider shell layout.

Wear profiles for divider shell shield ring and MPC inner seismic restraints are different. The divider shell shield ring wear marks are shallower in comparison. The maximum depth of a MPC inner seismic restraint is a localized narrow depth and does not apply over the entire width of the wear mark. See Appendix B for characterization images.

TABLE 1 – DOWNLOADING OPERATIONS AREA OF INTEREST CHARACTERIZATION

MPC S/N	Description	Circumferential Location ³	Length ¹ (inches)	Width ² (inches)	Depth ² (inches)
067	No areas of interest from downloading operations provided a measurable depth (< 0.001 inches)				
064	Carbon Steel Contamination	Between SR5 – SR6	30	2	0.012
064	Wear Mark	Between SR5 – SR6	6	1	0.009
064	Wear Mark	Between SR5 – SR6	6	1	0.009
064	Wear Mark	Between SR5 – SR6	8	1	0.009
064	Wear Mark ⁴	Between SR5 – SR6	1	4	0.009
064	Wear Mark	Between SR6 – SR7	15	5	0.011
064	Wear Mark	Between SR7 – SR8	30	2	0.003
072	Carbon Steel Contamination ⁴	Between SR1 – SR2	4	8	< 0.001
072	Wear Mark	Between SR1 – SR2	0.002 square inches ⁶		0.007
072	Wear Mark ⁴	Below SR1	> 120	~ SR4 wear mark	~ SR4 wear mark
072	Wear Mark ⁴	Below SR4	> 120	0.107 to 0.192	0.016 ⁵
072	Wear Mark	Below SR4	12-24	< 0.192	0.026
072	Wear Mark	Below SR5	24-36	~ SR4 wear mark	~ SR4 wear mark

- Notes: 1) Length measurements are approximate values based on the general area visual assessment.
 2) Width and depth measurements characterized during the area of interest visual assessment.
 3) See Appendix A for cavity enclosure container and divider shell reference information.
 4) Area of interest resides within the weld and/or HAZ.
 5) Maximum recorded depth of ten measurements taken over the total length.
 6) A direct surface area measurement was recorded.

The results of the visual assessment have been entered in the corrective action program and will be considered in the aging management program.

CONCLUSION

Three MPCs underwent visual assessments where various types of surface irregularities were identified. The deepest surface irregularity identified as a result of downloading operations was a wear mark due to contact with an MPC inner seismic restraint and had a maximum depth of up to 0.026 inches. Holtec Report HI-2188437 (Ref. 7) describes that the SONGS HI-STORM MPC has 0.175 inches of available margin for localized losses of shell thickness to remain in compliance with all applicable ASME Boiler & Pressure Vessel Code requirements. Based on the available margin, there is still 0.149 inches available for the worst-case observed surface irregularity. Additionally, with worst-case wear mark having a margin of almost 7 times compared to the allowable limit, the scope of the visual assessment is considered adequate. Therefore, even with incidental contact during downloading operations, the SONGS HI-STORM MPCs remain in compliance with all applicable ASME Boiler & Pressure Vessel Code requirements.

REFERENCES

- 1) SO23-X-9.1, *Robotic Inspection of Multi-Purpose Canisters*, completed 3/21/2019 (MPC S/N 067)
- 2) SO23-X-9.1, *Robotic Inspection of Multi-Purpose Canisters*, completed 3/22/2019 (MPC S/N 064)
- 3) SO23-X-9.1, *Robotic Inspection of Multi-Purpose Canisters*, completed 3/23/2019 (MPC S/N 072)
- 4) *GE Inspection Technologies Remote Visual Inspection San Onofre Nuclear Generating Station Inspection Report, Inspection: MPC 1593-9986100-67*
- 5) *GE Inspection Technologies Remote Visual Inspection San Onofre Nuclear Generating Station Inspection Report, Inspection: MPC 1593-9986100-64*
- 6) *GE Inspection Technologies Remote Visual Inspection San Onofre Nuclear Generating Station Inspection Report, Inspection: MPC 1593-9986100-72*
- 7) Holtec Report HI-2188437, *Incidence and Consequence of Canister Shell Wear Scars from Misaligned Insertion of a Loaded MPC at SONGS*

LIST OF APPENDICES

- A. Cavity Enclosure Container and Divider Shell Reference Information
- B. GE Inspection Technologies General Location Photographs and Characterization
- C. Description of GE Inspection Technologies Utilized

Appendix A

Cavity Enclosure Container and Divider Shell Reference Information

SONGS HI-STORM MPC Visual Assessment Report

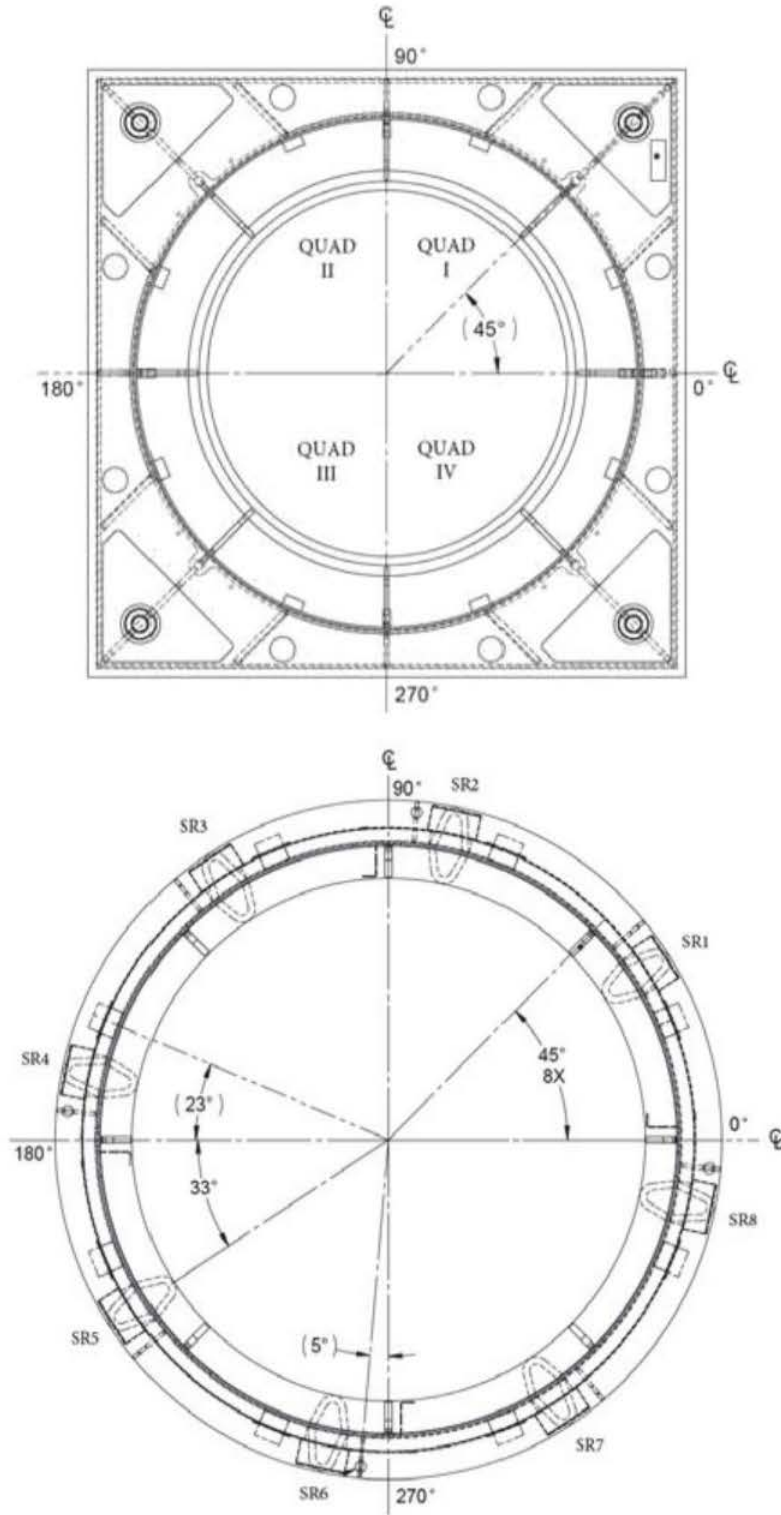

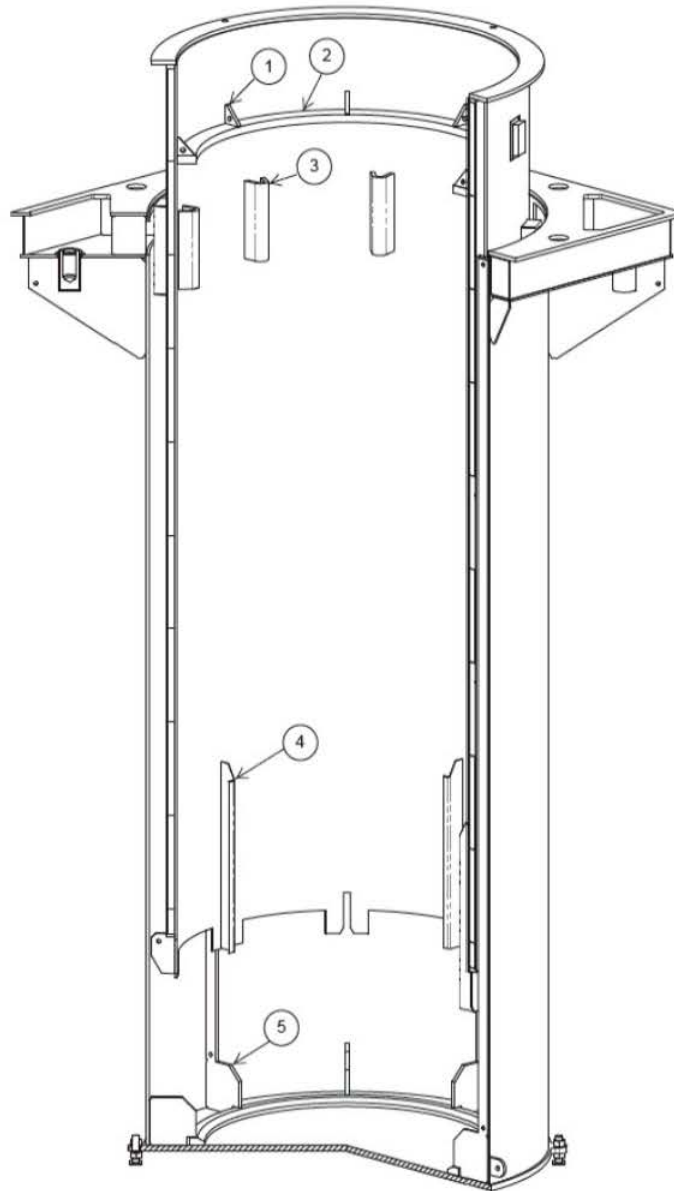

List of Potential Contact Points

- 1 Divider Shell Shield Ring Guide
- 2 Divider Shell Shield Ring
- 3 MPC Inner Seismic Restraint (also referred to as upper seismic restraint)
- 4 Divider Shell MPC Guide Cover
- 5 Lower MPC Guide / CEC Baffle (also referred to as lower seismic restraint)

Appendix B

GE Inspection Technologies General Location Photographs and Characterization

MPC S/N 064



The figures above correspond to the carbon steel conamination in the shield ring induced wear mark between MPC Inner Seismic Restraints 5 and 6 as documented in Table 1 in the body of the report.



The figures above correspond to the shield ring induced wear marks identified between MPC Inner Seismic Restraints 5 and 6 as documented in Table 1 in the body of the report.



Wear mark is located within the MPC circumferential weld.

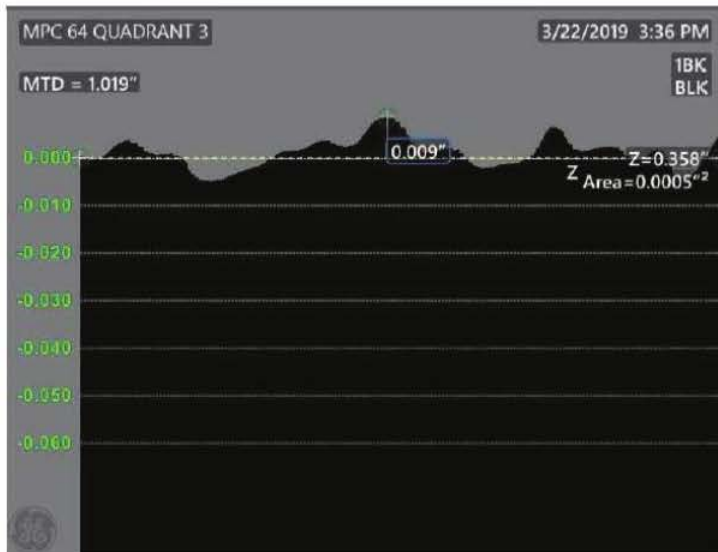

The figures above correspond to the shield ring induced wear marks identified between MPC Inner Seismic Restraints 5 and 6 as documented in Table 1 in the body of the report.

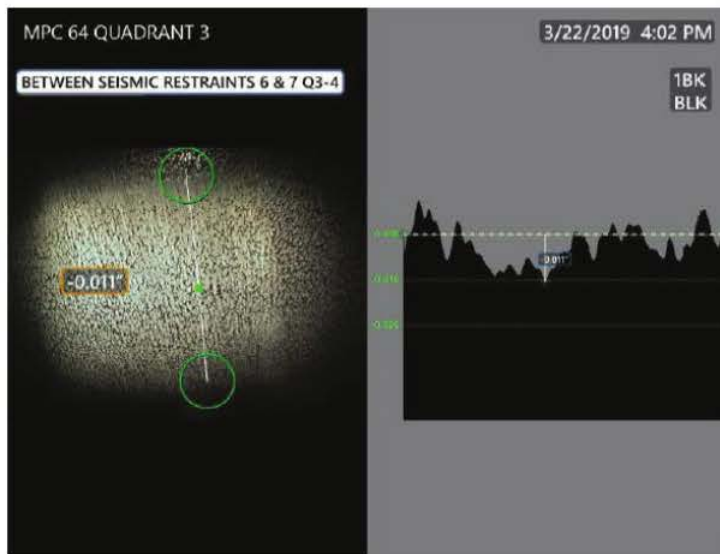

The figures above correspond to the shield ring induced wear marks identified between MPC Inner Seismic Restraints 6 and 7 as documented in Table 1 in the body of the report.



The figures above correspond to the shield ring induced wear marks identified between MPC Inner Seismic Restraints 7 and 8 as documented in Table 1 in the body of the report.

MPC S/N 072



Carbon Steel Contamination within the HAZ of the MPC circumferential weld

The figure above corresponds to the shield ring induced carbon steel contamination identified between MPC Inner Seismic Restraints 1 and 2 as documented in Table 1 in the body of the report. There was no measurable depth for this location.



The figures above correspond to the greater than 120 inch long SR induced wear mark identified below MPC Inner Seismic Restraint 4 as documented in Table 1 in the body of the report.

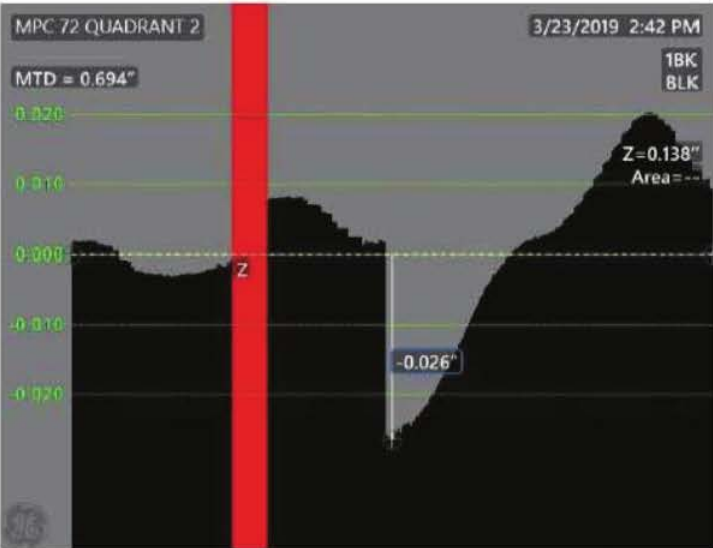
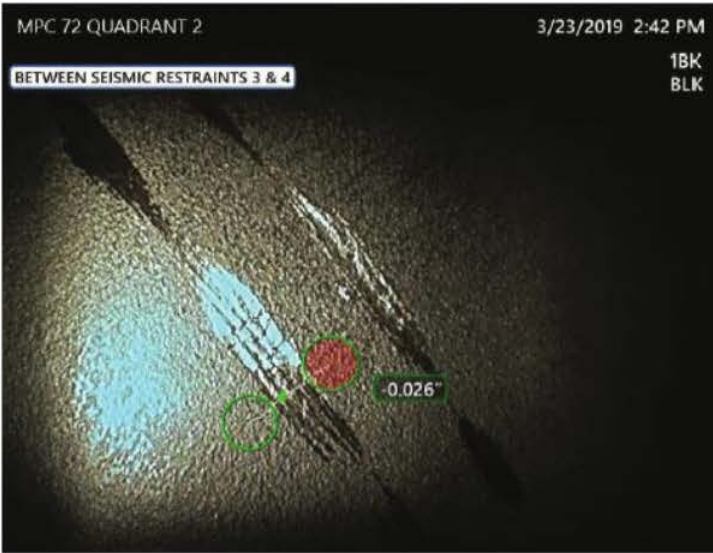

The red bar represents background noise in the characterization

The figures above correspond to the 12 to 24 inch long SR induced wear mark identified below MPC Inner Seismic Restraint 4 as documented in Table 1 in the body of the report.

Appendix C

Description of GE Inspection Technologies Utilized

SONGS HI-STORM MPC Visual Assessment Report

The GE borescope (i.e., VideoProbe™), along with the RTT robot, were adopted by EPRI's Extended Storage Collaboration Program (ESCP) NDE subcommittee, which was tasked with developing technology to support inspecting dry storage canisters. The robot and borescope have been deployed at multiple U.S. sites, most recently at Vermont Yankee and Maine Yankee. The NRC has been present during many of these inspections. The Maine Yankee inspection was performed to support renewal of NAC CoCs 72-1015 (NAC-UMS) and 72-1025 (NAC-MPC).

GE Inspection Technologies' VideoProbe, with Real3D™ point cloud surface scanning and analysis, is used widely for aviation, military, and oil & gas applications. On a daily basis, there are hundreds of technicians globally using the technology to ensure airplanes are safe to fly, and turbines are safe to operate.

GE Inspection Technologies' VideoProbe manufacturing facility is in Skaneateles, NY; this is an ISO 9001:2015 certified facility. All calibrations for all measurement-capable VideoProbes, and the related measurement accessories, are calibrated to NIST-traceable standards under GE's ISO 9001:2015 procedures.

SCE confirmed the GE inspectors' Level II visual inspection certification, and that their certification was current. A corresponding "encode" was created in SONGS training program, which was used to confirm the GE inspectors were qualified to perform the borescope inspections (procedure requirement).

SONGS QA program requirements were applied to inspection activities, including developing and issuing the inspection procedure, calibration verification, and documentation of results.

To verify a VideoProbe is in calibration for all measurement types, an NIST-traceable Verification Block ships with all measurement probes and the tips calibrated to that probe:

- A Certificate of Calibration is created for each probe(s) and the tip(s) calibrated to a given probe, as well as for all Verification Blocks.
- The Verification Block is an NIST-traceable standard with precise targets.
- The A target has two (2) distance targets with a separation of 0.1000 in. +/- .0002 in.
- The B target has a distance separation of 1.000mm +/- .005mm.
- The standard's characteristics were optimized for length measurements (x, y), and is not intended to be used as a depth (z) standard.
- With Real3D, it is the plurality of the x, y, z data that is used to generate a point cloud of data on which measurements are made.
- Thus, the Verification Blocks' targets also verify a system is in calibration for use in measuring Depths, Lengths, and Areas.

To provide additional assurance of depth measurement capabilities, SCE procured NIST-traceable gauge blocks. Two gauge blocks were placed parallel to each other, upon a NIST-traceable flat surface plate, with a small gap between the two blocks. The VideoProbe correctly measured the height of the gauge blocks (space between the two blocks).

As documented in SCE procedure SO23-X-9.1, *Robotic Inspection of Multi-Purpose Canisters*, the depth measurement function was verified prior to use on the first canister, using the GE-supplied targets and SCE-supplied gauge blocks. This verification was performed again after completing inspection of the final canister.

ENGINEERING CHANGE PACKAGE COVERSHEET

NECP Number 0918-64884-1 Page 1 of 14
Revision No. 2

Reference: SO123-XXIV-10.1

Title: Vertical Cask Transporter (VCT) Load Monitoring System

NECP Category: ISCO X As-Built Temp

Quality Class ITS-B Unit 1

NECP Type: Minor X Major

NECP Responsible Engineer: Brian Sarno

Prepared By: (RE) Brian Sarno Date *

Verified By: (IRE/Checker) Jennifer Pugh Date *

Approved By: (Manager, Engineering) Jerry Stephenson Date *

Approved By: (Implementing Organization) Jared Smith Date *

Approved By: (Manager, Decommissioning Planning) Date

Important to Safety or RO?
YES X NO

License Amendment Request required? If YES, list PCN No.
YES NO X

Are there any YES responses on Form 26-182 or 26-571?
YES NO X

Implements NCR (N-CAP) disposition item?
YES NO X If YES, indicate NCR#/Rev/Disp Item#

List the 10CFR 50.59/72.48 SCN and/or SE Operations 0918-64884-7

(Not applicable for U2/3 Tier I NECPs or Temp NECP in support of Maintenance Activities installed no more than 90 days at power)

* See associated files folder for NECP Coversheet, for electronic review, comment resolution and approval dates.

Note: This revision is considered a complete rewrite and revision bars are not used.

ENGINEERING CHANGE PACKAGE COVERSHEET

NECP Number 0918-64884-1 Page 2 of 14
Revision No. 2

Reference: SO123-XXIV-10.1

DESCRIPTION OF CHANGE

A. Reason for the change:

On August 3, 2018, during the download of Holtec Multi-Purpose Canister (MPC) Serial Number 067 into Pad Location 22 the MPC became stuck on the Cavity Enclosure Container (CEC) shield ring as the Vertical Cask Transporter (VCT) towers continued to lower. The VCT operator completely lowered the VCT towers while the MPC was suspended by the CEC shield ring. Currently, the VCT operator has one screen for the left tower and one screen for the right tower where they have to alternate between tower height and hydraulic pressure. In order to provide the VCT operator an enhanced ability to know if an MPC becomes bound during a download a load monitoring system will be installed.

B. Functional Objective of the Change:

The functional objective of this NECP is to install a load monitoring system to the VCT. The live load monitoring system is comprised of two load shackles and two digital monitors which will provide the VCT operator and other members of the loading crew the ability to monitor for potential unloading of the VCT rigging.

Another functional objective of this NECP is to allow for the use of "operator aids" such as cameras and lights to be mounted to the VCT to assist with fuel transfer operations.

C. Safety Analysis:

The load bearing portion of the VCT load monitoring system (i.e., the shackle) meets the same requirements as the MPC lifting slings.

The load sensing and display portion of the VCT load monitoring system is an "operator aid" that provides the loading crew alternate indications of a process for defense-in-depth. The indicated weight is not critical to the process and is one of many alternate indications that enhances loading crew's detection of a bound load during movement.

The displays are not a technical specification required indication. However, a change to DCS-002, *Holtec ISFSI 10CFR72.212 Evaluation*, references Holtec HI-STORM UMAX FSAR 9.1.1 *Ensuring Safety in Heavy Load Evolutions*, which describes that a load monitoring system will be used during MPC downloading operations. In addition this system will be capable of monitoring differential load (i.e., monitoring for underload).

Other "operator aids" such as lights and cameras will be mounted to the VCT in accordance with the Foreign Material Exclusion Program to prevent the impact to an open CEC or HI-TRAC.

During MPC uploading operations the VCT load monitoring system is available for reference. However, the existing VCT protection feature (10% overload cut-off based on hydraulic system pressure) remains sufficient.

ENGINEERING CHANGE PACKAGE COVERSHEET

NECP Number 0918-64884-1 Page 3 of 14
Revision No. 2

Reference: SO123-XXIV-10.1

D. Design Criteria/Inputs Discussion:

The load bearing portion of the VCT Load Monitoring System (i.e., the shackle) is classified as ITS-B which is consistent with the MPC lifting slings while the load sensing and display portion of the VCT Load Monitoring System (i.e., the strain gage and tablets) is classified as NITS. This portion is classified as NITS, for the failure of the load sensing and display portion would have no effect on the load shackles' ability to support a loaded MPC. Therefore, the failure of the load sensing portion by itself would not have an impact on the MPC integrity. The Unit 1 Q-List has been revised to reflect this change (M-37560 Rev 10 ECN DR758628).

The load shackles to be used are Straightpoint WLS85TU wireless loadshackles that are rated for 185,000 pounds.

The VCT load monitoring system is designed to provide the VCT operator and other members of the loading crew (e.g., the cask loading supervisor) a digital read out of the load in pounds and a visual alarm when an underload of 15,000 pounds is experienced. The system includes two load shackles and two digital monitors that display the left tower load, the right tower load, and combined load being seen by the load shackles. One digital monitor will be mounted on the VCT for use by the VCT operator while the other will be available for use by other members of the loading crew.

Applied load values seen by the load shackles communicate with the VCT Operator's tablet (Master Tablet) via a proprietary 2.4 GHz wireless communication channel. The data from the load shackles is received and processed by an application on the Master Tablet. This application populates the load data on a webserver running on the Master Tablet. The Master Tablet then communicates with a wireless access point. The second tablet used by other members of the loading crew (Slave Tablet) connects to the same wireless access point and is able to connect to the web server on the Master Tablet.

In order to best provide the VCT operator and loading crew the ability to monitor underloading of the rigging system the following steps should be performed. (1) The VCT Operator should lift the MPC off the HI-TRAC bottom lid to obtain full load on the rigging. (2) The mating device drawer should be opened to provide a pathway to download the VCT into the Vertical Ventilated Module. (3) Ensure centering of the MPC. (4) Zero the load readings for left tower, right tower, and combined load. By performing the steps above any increasing negative value will show unloading of the rigging system (These steps are contained in HPP-2464-400, *MPC Transfer at SONGS*). Therefore, if the MPC becomes stuck at any point during the download and the VCT towers continue to lower the combined load value will grow in magnitude. A visual alarm will be programmed into the tablets to initiate when an underload of 15,000 pounds (combined load reading) is experienced.

The VCT load monitoring system is available for reference during MPC uploading operations.

Other "operator aids" such as lights and cameras will be mounted to the VCT in accordance with the Foreign Material Exclusion Program to prevent impact to an open CEC or HI-TRAC. These items have no impact on the ability of the VCT to perform its design function.

ENGINEERING CHANGE PACKAGE COVERSHEET

NECP Number 0918-64884-1 Page 4 of 14
Revision No. 2

Reference: SO123-XXIV-10.1

E. Site Computer Software Change Requests:

N/A

F. Test Objectives/Acceptance Criteria:

Ensure that the visual alarm initiates when an underload of at least 15,000 pounds occurs. This can be achieved by lifting the Simulator and lowering it back down directly onto the HI-TRAC pool lid as well as completely downloading the Simulator to the Cavity Enclosure Container pedestal.

G. Materials:

The following major items will be implemented as part of this NECP:

- Two Straightpoint WLS85TU Wireless Loadshackles
- Two Straightpoint SW-RWT Rugged Tablets

Note: Other rigging components (e.g., slings, masterlink, and additional shackles) are controlled via SO123-I-7.24, Rigging Manual or Holtec equivalent HPP-2464-008 and are outside of the NECP process.

H. Special Construction Requirements:

Perform system installation in accordance with Holtec Work Plan ISFSI-FUEL-564-135.

The load shackles are to be rigged to the VCT in accordance with SO123-I-1.13, *NUREG-0612 Cranes, Rigging, and Lifting Controls* or Holtec equivalent HPP-2464-007 and SO123-I-7.24, *Rigging Manual* or Holtec equivalent HPP-2464-008.

Mount "operator aids" such as cameras and lights in accordance with the Foreign Material Exclusion Program.

J. Risk Assessments:

N/A

ENGINEERING CHANGE PACKAGE COVERSHEET

NECP Number 0918-64884-1 Page 5 of 14
Revision No. 2

Reference: SO123-XXIV-10.1

K. Other:

Drawing Changes Associated with this NECP:

1814-AR171-M0060 - Straightpoint Wireless Loadshackle
1814-AR171-M0061 - Straightpoint SW-RWT Rugged tablets
1814-AR171-M0062 - Document Review Checklist for I&I Slings Supplied Product
DCS-002 REV 0 CCN DR758630, Holtec ISFSI 10CFR72.212 Evaluation
M-37560 REV 10 ECN DR758628, San Onofre Nuclear Generating Station Unit 1 Q-List

Procedure Changes Associated with this NECP:

Holtec HPP-2464-400, MPC Transfer at SONGS

TESTING (FOR ISCO or Temp NECPs ONLY). Check the Applicable Block(s):

Testing required for Installation or Removal (specify required tests)

YES NO

Ensure that the visual alarm initiates when an underload of at least 15,000 pounds occurs. This can be achieved by lifting the Simulator and lowering it back down directly onto the HI-TRAC pool lid as well as completely downloading the Simulator to the Cavity Enclosure Container pedestal.

Test guidelines required (Test Guidelines Attached)

YES NO

License Amendment Request / Mode Restraints / Other Limitations: NONE

DESIGN CRITERIA REQUIREMENTS CHECKLIST

NECP No. 0918-64884-1 Rev No. 2

Page 6 of 14

THE RESPONSE TO EACH ENTRY ON THIS FORM SHALL BE BASED UPON A REVIEW OF ALL QUESTIONS PRESENTED IN THE CHECKLIST GUIDELINES (FORM 26-182-1).

Applicability

1. Cyber Security Program* NO Remarks:

* NOTE: Attach the completed 26-293 Form to this completed Form and include in the associated NECP.

2. ALARA NO Remarks:

3. Tornado Missiles NO Remarks:

4. Internal Missiles NO Remarks:

5. Other Missiles NO Remarks:

6. Flooding NO Remarks:

7. Fire Protection NO Remarks:

See associated files folder Fire Protection Program's review & approval.

8. Environmental Effects NO Remarks:

9. Seismic NO Remarks:

10. Security Systems NO Remarks:

11. Emergency Plan Impact NO Remarks:

12. Electrical System NO Remarks:

13. Digital NO Remarks:

14. Software NO Remarks:

15. Non-Safety Interaction NO Remarks:

16. Industrial Safety NO Remarks:

17. Dry Cask Storage/ISFSI NO Remarks:

18. Control Room Habitability NO Remarks:

DESIGN CRITERIA REQUIREMENTS CHECKLIST

NECP No. 0918-64884-1 Rev No. 2

Page 7 of 14

19. Lubrication Materials **NO** **Remarks:**

**20. Underground Tanks &
Piping** **NO** **Remarks:**

21. Ground Water Protection **NO** **Remarks:**

Prepared by: Brian Sarno **Date:** 12/12/2018

Fire Protection Checklist with Engineering Guidance

FIRE PROTECTION CHECKLIST

YES	NO	
<input type="checkbox"/>	<input checked="" type="checkbox"/>	1.0 COMMUNICATIONS For Units 2 & 3, does the CHANGE modify, delete or relocate communications equipment or cables in PA buildings still in service? (e.g., PAX phones, equipment or cables, UHF radio equip., antennae or coaxial cable)?
<input type="checkbox"/>	<input checked="" type="checkbox"/>	2.0 EMERGENCY LIGHTING For Units 2 & 3, does the change modify, add, block or relocate access/egress pathways? Self-contained, battery powered emergency pathway lights and emergency lighting for the Units 2 & 3 Command Center are retained, where practical, for in-service buildings.
<input type="checkbox"/>	<input checked="" type="checkbox"/>	3.0 MODIFICATIONS TO ELECTRICAL DEVICES AND CIRCUITS For Units 2 & 3, does the change modify or reroute power supplies, electrical devices or circuits which are a part of a Spent Fuel Pool Cooling, or SFP Makeup equipment cable scheme? Does the change add or relocate spent fuel pool cooling/makeup cabling into another fire area or zone? Does the change modify spent fuel pool cooling/makeup instrument/indicator ranges, remote actuation, or Command Center indication (HMI/CDAS)?
<input type="checkbox"/>	<input checked="" type="checkbox"/>	4.0 MODIFICATIONS TO THE MECHANICAL FUNCTION OF COMPONENTS For Units 2 & 3, does the change add, delete or modify a mechanical component in the Spent Fuel Pool cooling/makeup or support systems?
<input type="checkbox"/>	<input checked="" type="checkbox"/>	5.0 MISCELLANEOUS SUBJECTS For Units 2 & 3, does the change alter, add cryogenic or compressed gas vessels, or add equipment which is sensitive to radio frequencies? Add a Large Power Transformer within SONGS Units 2 & 3 Protected Area? Significantly modify firefighting requirements for SONGS Fire Brigade or the off-site responding Fire Department?
<input type="checkbox"/>	<input checked="" type="checkbox"/>	6.0 FIRE DETECTION AND SUPPRESSION SYSTEMS For Units 2 & 3, does the change add, remove, relocate, or modify equipment or components associated with the current Fire Detection and Suppression Systems (e.g., fire detectors, fire pumps, jockey pumps, fire water tanks and backup/makeup water supply, yard mains, water suppression, hydrants, standpipes, hose stations, hose houses, extinguishers, seismic Category I tank/pumper unit) and Mitigation Strategies—credited pumps?
<input type="checkbox"/>	<input checked="" type="checkbox"/>	7.0 AIR FLOW AND CONTROL For Units 2 & 3, does the change add, remove, replace, or modify air flow equipment such as HVAC fans, louvers, openings, vents, fire dampers, or ductwork required AVAILABLE for the defueled condition?

Fire Protection Checklist with Engineering Guidance

FIRE PROTECTION CHECKLIST

YES NO

- 8.0 PASSIVE FIRE PROTECTION FEATURES** For Units 2 & 3, does the change add, delete, modify, or penetrate passive fire protection features, including fire barriers which prevent the spread of fire (walls, floors, raised floors, ceilings, drop ceilings, doors, dampers, penetrations, curbs, fire area/zone boundaries, non-rated coverings of barrier openings,); barriers which protect equipment from the effects of fire (fire resistant coatings, structural steel fire proofing); or features which protect equipment from the effects of suppression activities (curbs , spray shields, or drains)?
- 9.0 PHYSICAL INTERFERENCES** For Units 2 & 3, does the change add or relocate any equipment creating access interferences, e.g., HVAC ductwork, piping, conduit, cable trays, supports, long-term scaffolding, walls or other structural elements? Change access to FP equipment or Mitigation Strategies – credited equipment?
- 10.0 AREA USE & COMBUSTIBLE HAZARDS** For Units 2 & 3, does the change increase combustible material, alter the use of a fire area/zone or add/remove a major combustible hazard from a fire area/zone (including the yard area)? This includes permanent storage of combustibles and combustible liquids, flammable gas cylinders, etc. Transient (e.g., temporary) combustibles due to construction, maintenance, or decommissioning activities are not applicable to this checklist. Does the change relocate/add/remove charcoal filters; add combustibles near the stationary fire pumps, establish battery rooms, records storage/warehouse areas, workshops, or new fuel storage tanks?
- 11.0 CHANGES TO SAFE STORAGE** For NIA, Units 2 & 3, OCA, ISFSI and their ability to maintain safe storage of radiological materials in the event of a fire, does the change *impact Pre-Fire Plans*, FP analyses, or change an existing Mitigation Strategies Action? Impact ISFSI 72.212 Evaluations?
- 12.0 PROPERTY AND LOSS INSURANCE STANDARDS** For NIA, Units 2 & 3, and OCA does the change have any potential impact on SONGS compliance with NEIL Property & Loss Insurance Standards? (See Question 12 guidance for summary of NEIL requirements)
- 13.0 OCA FIRE PROTECTION CAPABILITY AND FIRE PROTECTION PROGRAM** - For SONGS ISFSI, NIA, Owner Controlled Area (OCA), 220kV Switchyard, South Yard, and Multi-Purpose Handling Facility (MPHF), does the change have any potential impact on manual firefighting capability, 800-MHZ UHF system, Fire Protection related equipment? Does the change increase the likelihood of a significant offsite release of radioactive material due to a fire? Does the change add or delete major combustible/fire hazards?

Fire Protection Checklist with Engineering Guidance

Note 1: If all responses are "NO," the FP Checklist is complete. The Design Engineer may cite that FP concerns have been addressed. No further review is required. However, the FP Engineer should review the Design Plan for concurrence.

Note 2: For a question answered "YES," the Design Engineer should request review by the Fire Protection Engineer and cite any FP dispositions in the Design Plan.

Note 3: For a question answered "YES," continue to the following guidance in this attachment. Any further "YES" answers will likely require a Fire Protection Evaluation (FPE) to address. The FPE must be included in the Design Plan. However, any further explanatory text is optional.

CYBER SECURITY PROGRAM IMPACT DESIGN CHECKLIST
(Form 26-293)

NECP Number: 0918-64884-1
Rev. No.: 2

Page 11 of 14

STEP	ITEM	NO	YES
STEP 1	<p>Does the proposed change perform any of the following:</p> <ul style="list-style-type: none"> Add or install a new digital device, computer system or its components? Modify an existing digital device, computer system or its components? Abandon or remove an existing digital device, computer system, or its components? 		X
<p>If answer to Step 1 is YES, then proceed to Step 2. If NO, then performance of Steps 2, 3, and 4 are NOT required. Sign below and obtain a review.</p>			
STEP 2	<p>Does the proposed change affect a Critical System, i.e., a system that performs any of the following?</p> <ul style="list-style-type: none"> Safety-related and Important-to-safety functions Security functions EP functions, including offsite communications Support systems or equipment, which if compromised, would adversely impact safety, security, or EP functions. <p>OR,</p> <p>Does the proposed change add or modify components whose failure or digital compromise could adversely impact a critical function of the Critical system?</p> <p>OR,</p> <p>Does the proposed change affect interdependence of existing Critical Digital Assets or support systems, including wireless technology?</p>		X
<p>If answer to Step 2 is YES, then proceed to Step 4 and update any required changes to 90013, CDA MEL. If NO, then continue to Step 3.</p>			
STEP 3	Does the digital device contain a digital pathway to a FLOC tagged as a Critical Digital Asset?		
<p>If answer to Step 3 is YES, then proceed to Step 4 and update any required changes to 90013, CDA MEL. If NO, then performance of Step 4 is NOT required. Sign below and obtain a review.</p>			
STEP 4	<p>Create a Cyber Security Evaluation (N-CSE) operation in the associated NECP order listing known impacted Critical Digital Assets and/or Critical Systems. Operation #: <u>0918-64884-8</u></p>		
Prepared By: (print/sign) See associated files folder for review and approval		Date:	
Reviewed By Cyber Security Group: (print/sign) See associated files folder for review and approval		Date:	

**SITE PROGRAMS IMPACT ASSESSMENT
PART B**

NECP Number 0918-64884-1
Rev. No. 2 ASC No. _____

Page 12 of 14

Reference: SO123-XXIV-10.1

CONTACTS:

Organization/Impact

Contact/Assessment Information

1. OPERATIONS
 YES NO

Kurt Rauch

2. OPERATIONS/MAINTENANCE
 YES NO

Kurt Rauch

3. MAINTENANCE
 YES NO

Mike Orewyler

4. ENGINEERING PROGRAMS
 YES NO

5. PLANT ENGINEERING
 YES NO

6. CHEMISTRY
 YES NO

7. EMERGENCY PREPAREDNESS
 YES NO

8. SECURITY
 YES NO

**SITE PROGRAMS IMPACT ASSESSMENT
PART B**

NECP Number 0918-64884-1
Rev. No. 2 ASC No. _____

Page 13 of 14

Reference: SO123-XXIV-10.1

CONTACTS:

Organization/Impact

Contact/Assessment Information

9. a. RADIATION PROTECTION

YES NO

b. ALARA

YES NO

10. LICENSING DOCUMENT

YES NO

Dennis Evans

11. WAREHOUSE / FACILITIES

YES NO

12. OTHER

YES NO

13. ENVIRONMENTAL

YES NO

14. REACTOR DESIGN AND MONITORING
PROGRAM

YES NO

15. REACTIVITY MANAGEMENT PROGRAM

YES NO

**SITE PROGRAMS IMPACT ASSESSMENT
PART B**

NECP Number 0918-64884-1
Rev. No. 2 ASC No. _____

Page 14 of 14

Reference: SO123-XXIV-10.1

CONTACTS:

Organization/Impact

Contact/Assessment Information

16. GROUNDWATER PROTECTION PROGRAM

YES NO

17. TRAINING

YES NO

18. GOVERNMENT AGENCY PERMITS

YES NO

OTHER

None

DESCRIPTION OF IMPACT:

Install a live load monitoring system for the VCT and other "operator aids" as required.

REQUIRED ACTIONS:

None

LIMITATIONS (TIME OR PROCESS):

None

DESIGN SETPOINTS:

None

OTHER CONDITIONS:

None

REQUIRED IMPLEMENTATION DATE(S):

N/A

FEEDBACK REQUIREMENTS:

None

From: MARK MORGAN <Mark.Morgan@sce.com>
Sent: Friday, March 01, 2019 4:27 PM
To: Brookhart, Lee; Simpson, Eric; Smith, Chris; Piotter, Jason
Cc: MARK MORGAN
Subject: [External_Sender] RE: (External):BB Questions

Lee,

I wanted to confirm with you that we received your question and will be preparing a response over the weekend. Chris, I got your questions on the thread bolt engagement yesterday and we're working on that response, too.

Also, we've decided to tag out MPC-20 so that we can't load it until we resolve any issues surrounding it. We're hoping that will take it out of the critical path to re-starting fuel movement.

Thanks,
Mark
(949) 368-6745

From: Brookhart, Lee [mailto:Lee.Brookhart@nrc.gov]
Sent: Friday, March 01, 2019 11:51 AM
To: MARK MORGAN <Mark.Morgan@sce.com>; Simpson, Eric <Eric.Simpson@nrc.gov>; Smith, Chris <Chris.Smith@nrc.gov>; Piotter, Jason <Jason.Piotter@nrc.gov>
Cc: ALBERT BATES <AL.BATES@sce.com>; Kenneth Wilson <Kenneth.R.Wilson@sce.com>
Subject: (External):BB Questions

First Belly Band (BB) Questions:

- 1.) In the new Appendix D (to me) it appears the calculation is assuming that the VCT/HI-TRAC (w/o belly band) is at rest (not moving forward/reverse). As I don't see any conversation about 2 bodies in motion when driving. Because when transporting w/o belly band the HI-TRAC has been seen to be moving in an opposite direction (swinging front to back) as the operator stops/goes/stops/goes etc, maneuvering the VCT in between the lids as he approaches the mating device.
 - a. Am I reading correctly? Or does the driving motion and 2 bodies in either parallel/reverse motion not affect the bounding values presented?
 - b. If the calculation assumes bodies at rest, will operation procedures be changed, such that transportation (forward/reverse) must have the BB in place?
- 2.) Is there any discussions on how the pendulum effect and associated moment arm could affect the HI-TRAC SLD and the VCT (non-SLD) attachment points during this unconstrained seismic movement? Even if the w/o belly frequency is bounded by w/belly frequency for sliding and tipping evaluations. The SLDs are seeing new forces when allowing a 5.2 degree pendulum swinging effect when belly band is not installed. I would assume that previous evaluations only reviewed a static calculation since the BB was assumed to be in place and the Transfer Cask would not create a pendulum affect. I guess it would apply to both side-side and front-back pendulums.

Thanks
Lee

From: MARK MORGAN [<mailto:Mark.Morgan@sce.com>]

Sent: Thursday, February 28, 2019 3:23 PM

To: Brookhart, Lee <Lee.Brookhart@nrc.gov>; Katanic, Janine <Janine.Katanic@nrc.gov>; Simpson, Eric <Eric.Simpson@nrc.gov>; Smith, Chris <Chris.Smith@nrc.gov>

Cc: MARK MORGAN <Mark.Morgan@sce.com>; ALBERT BATES <AL.BATES@sce.com>

Subject: [External_Sender] FW: Documents Related to VCT Seismic Stability (Use of Cask Restraint, a.k.a., Belly Band)

All,

Attached are the new analyses to demonstrate acceptable operation of the VCT with the belly band loosened or disconnected.

Please let me know if you have any questions regarding this.

Thanks,
Mark
86745



SOUTHERN CALIFORNIA EDISON

SAN ONOFRE NUCLEAR GENERATING STATION
(SONGS)

10 CFR 50.59 / 10 CFR 72.48 Review
APPLICABILITY DETERMINATION, SCREENS, and/or EVALUATIONS

For

Expanded Evaluation of Seismic Stability of the
Vertical Cask Transporter (VCT)

ASSIGNMENT:

0219-88442-6

CONTENTS

Sections I through V shall be performed for each use of this form.

Sections VI through XI are performed as directed by preceding Sections or as deemed necessary.

SECTION	TITLE
I	Administrative
II	Applicability Determination
III	10 CFR 50.82(a)(6) Review
IV	References
V	Preparer / Reviewer(s)
<i>VI</i>	<i>10 CFR 50.59 Screen</i>
<i>VII</i>	<i>10 CFR 50.59 Evaluation</i>
<i>VIII</i>	<i>10 CFR 72.48 Screen</i>
<i>XI</i>	<i>10 CFR 72.48 Evaluation</i>

SECTION I – ADMINISTRATIVE:

A. Is this a revision to an existing review?

Yes: No:

Existing Review Number:

Reason for Revision:

B. Primary Document Type, Number, Revision, and Title:

Document Type: Calculation Change Notice

Document Number / Revision: DCS-002, Revision 0, CCN # DR758783

Document Title: HOLTEC HI-STORM UMAX MSE 10 CFR 72.212 Expanded Evaluation of VCT Stability

C. Description of the Proposed Activity:

Adoption of a revision to HI-2156626 (VCT Stability Analysis) into the 10 CFR 72.212 Evaluation as an updated site specific evaluation for demonstrating CoC, Section 3.4 (Site-Specific Parameters and Analysis), Item 15 (Haul Route Seismic Analysis) compliance at SONGS.

D. Primary Reason(s) for the Proposed Activity:

SCE identified aspects of incomplete treatment of seismic loads in the existing stability analyses for HI-PORT conveyance of the loaded HI-TRAC [Ref: AR 1218-46759, and AR 0918-14000]. The existing analyses were expanded in a number of areas which were addressed in a previous revision(s) to the SONGS UMAX 72.212 report.

This change to the VCT seismic stability analysis addresses additional details not evaluated in the previous revision. In particular, the existing VCT stability analyses treats the combination of a HI-TRAC/VCT as a freestanding rigid body and reflects a configuration where the VCT lateral cask restraint ("belly band") is installed and tightened. In fact, there are two transition locations where the lateral cask restraint must be removed in order to complete actions required for MPC transport and download. In particular; (1) the lateral cask restraint is not yet installed when the loaded HI-TRAC is lifted from the HI-PORT by the VCT and (2) the lateral cask restraint is removed to raise the HI-TRAC to a height to clear the mating device prior to the final approach above the mating device. The same two transition locations apply for canister uploading and transport back to the HI-PORT.

SECTION II - APPLICABILITY DETERMINATION (AD):

NOTE

Regulatory Guide 1.187 endorses NEI 96-07, Rev. 1, as one method to comply with 10 CFR 50.59. The term "change" is defined in NEI 96-07, Rev. 1, 3.3, as follows:

"Change means a modification or addition to, or removal from, the facility or procedures that affects: (1) a design function, (2) method of performing or controlling the function, or (3) an evaluation that demonstrates that intended functions will be accomplished."

The same definition of the term "change" is provided in 10 CFR 72.48 (a)(1), and thus is equally applicable for 72.48 reviews.

IF required, THEN see/use additional discussion provided in the associated "Discussion" in NEI 96-07, Rev. 1, 3.3, and the SONGS Resource Manual.

The basis must carefully examine whether there are any 'design functions' that are directly or indirectly impacted by the proposed activity. These will most often be detailed in the appropriate FSAR.

A. Is the proposed activity a change to the facility (including the ISFSI)? Explain fully.

Yes No

IF "Yes", THEN identify those aspects that must be appropriately addressed in Section VI or Section VIII or both, as appropriate:

Although the CoC, Appendix B contains the requirement for seismic stability of the cask and its conveyance, the Holtec generic FSARs do not address seismic stability for conveyance of the loaded transfer cask along the haul route. Means and methods for conveyance vary between sites and are left as site-specific evaluations.

At SONGS, movement of the loaded HI-TRAC from the Fuel Handling Building to the UMAX ISFSI Transfer Pad is performed using the HI-PORT and movement of the HI-TRAC from the Transfer Pad to the designated CEC is performed using the VCT. Holtec prepared seismic stability analyses for both the HI-PORT and VCT.

To address the configuration where the loaded HI-TRAC is lifted by the VCT and the lateral cask restraint is not installed, Holtec expanded their analysis documented in the HI-2156626 report. The expanded analysis confirms that disconnecting (or loosening) the HI-TRAC restraint strap (a.k.a., belly band) will not result in unacceptable consequences.

It should be noted that SCE and Holtec reviewed the UMAX FSAR and agreed that the only place where the single element HI-TRAC and VCT were relied upon is for the Soil Structural Interaction (SSI) analysis where the configuration is appropriate. That analysis is

fundamentally different in that the combined weight of both the VCT and HI-TRAC is modeled as a load on the monolithic pad. That load is considered in the SSI analysis, but stability of the VCT (along with the carried transfer cask) is not at issue. Therefore, there was no need to change the Holtec FSAR and it is being addressed in the site-specific 72.212. Furthermore, since there is no description of this analysis in the FSAR, the proposed activity does not involve a change in a method of evaluation described in the FSAR.

The revised analysis continues to confirm that the loaded HI-TRAC supported by the VCT is seismically stable in compliance with the CoC.

B. Other regulatory processes can independently authorize or preclude changes to the facility. Indicate which other regulatory processes have been used to authorize this activity:

- Approved Specific Exemptions 10 CFR 50.12 or 72.7
- Fire Protection Program 10 CFR 50.48(f)
- Decommissioning QA Plan 10 CFR 50.54(a)
- Physical Security Plan 10 CFR 50.54(p)
- Emergency Plan 10 CFR 50.54(q)
- Approved License Amendments 10 CFR 50.90 or 72.244

C. Evaluation using one or more of the processes in Section II.B has established that the proposed change may be implemented without prior or further NRC approval.

Yes No Assignment _____ (If Yes)

IF "Yes", THEN summarize how the change is addressed. IF changes to the design basis are fully addressed by other processes, THEN no further review under 10 CFR 50.59 or 72.48 is required. For ease in cross-referencing, list the assignment(s) that tracked the completed review requirements for those items.

D. Does the proposed activity require a change to the Technical Specifications, 10 CFR 50 Operating License Condition(s) or Terms, Conditions and Specifications for a Storage System Certificate of Compliance?

Yes No Assignment _____ (If Yes)

IF "Yes", THEN the proposed activity cannot be authorized by 10 CFR 50.59. A License Amendment under 10 CFR 50.90 or 72.244 (which are the responsibility of the Certificate Holder) is required. Document the number of the assignment tracking the LAR or documenting the decision to modify or not make the proposed activity.

E. Summary of Section II

Based on the reviews documented in II.A through II.D, the following Screen(s) are required (Check either, neither, or both, as appropriate).

- 10 CFR 50.59 Screen (Perform Section VI)
- 10 CFR 72.48 Screen (Perform Section VIII)

SECTION III - 10 CFR 50.82(a)(6) REVIEW:

NOTE

10 CFR 50.82(a)(6) states in part: Licensee shall not perform any decommissioning activities as defined in Section 50.2 that - (i) Foreclose release of the site for possible unrestricted use; (ii) Result in significant environmental impacts not previously reviewed; or (iii) Result in there no longer being reasonable assurance that adequate funds will be available for decommissioning.

Question 1:

Does the proposed change foreclose release of the site for possible unrestricted use?

Yes No

Reason:

The proposed change documents engineering evaluations having no physical impact on the site.

Thus, it does not foreclose the release of the site for possible unrestricted use.

Question 2:

Does the proposed change result in significant environmental impacts not previously reviewed?

Yes No

Reason:

The propose change documents engineering evaluations having no physical impact to the site generally or the environment specifically.

Thus, there is no significant environmental impact not previous evaluated.

Question 3:

Does the proposed change result in there no longer being reasonable assurance that adequate funds will be available for decommissioning?

Yes NO

Reason:

The costs for the subject activity will be borne by Holtec. Thus, there is no adverse impact on decommissioning funding assurance.

Conclusion:

IF the subject activity is determined to be an adverse change to a major decommissioning activity due to the results of the evaluations performed for Questions III.1 through III.3, THEN the activity may NOT be performed [reference 10 CFR 50.82(a)(6)]. List the applicable assignment to track the disposition of this item.

Assignment # _____

SECTION IV – REFERENCES:

1. HI-2115090, FSAR for the HI-STORM UMAX Canister Storage System
2. HI-2114830, FSAR for the HI-STORM FW MPC Storage System
3. SONGS Action Request (AR) 1218-46759, 10-Inch Requirement for HI-PORT Drop Deck Height
4. SONGS AR 0918-14000, Clearance Between HI-PORT and Haul Route Obstacles
5. DCS-002, Rev. 0 (CCN DR758711), Change to 10 CFR 72.212 Evaluation to address HI-PORT Seismic Stability and Clearance (Sliding)
6. HI-2156626, VCT Stability Analysis on Route to ISFSI Pad and on ISFSI Pad for SONGS

SECTION V – PREPARERS / REVIEWERS:

Technical Input (if required):

Date: _____

Prepared By: Robert Yale

robert.yale@sce
.com

Digitally signed by
robert.yale@sce.com
DN: cn=robert.yale@sce.com
Date: 2019.02.28 09:50:03 -08'00'

Date: 02/28/2019

Reviewed By: Ken Wilson

(Approved by e-mail dated 2-28-19)

Date: 02/28/2019

Independent Review By: Jon McGaw

(Approved by e-mail dated 2-28-19)

Date: 02/28/2019

AFTER all reviews are complete, THEN unused Sections may be discarded.

Southern California Edison Company		CALC NO. DCS-002		PAGE 1	TOTAL NO. OF PAGES 1
ENGINEERING CHANGE NOTICE (ECN)/CALCULATION CHANGE NOTICE (CCN) COVER PAGE		NECP Order No. 0219-88442-5	CALC. REV. 0	UNIT 1, 2, & 3	ECN/CCN NO. DR758783
SUMMARY CHANGE <input type="checkbox"/> NO <input checked="" type="checkbox"/> YES		CALCULATION SUBJECT: HOLTEC HI-STORM UMAX MSE 10 CFR 72.212 EVALUATION			
CALCULATION CROSS-INDEX <input type="checkbox"/> New/Updated Index Included <input checked="" type="checkbox"/> Existing Index is Complete		ENGINEERING SYSTEM NUMBER / PRIMARY STATION SYSTEM DESIGNATOR 1500 / ZAF		Q-CLASS ITS-A	
Site Programs/Procedure Impact? <input checked="" type="checkbox"/> NO <input type="checkbox"/> YES, NN No. _____		CONTROLLED PROGRAM OR DATABASE ACCORDING TO SO123-XXIV-5.1 <input type="checkbox"/> PROGRAM <input type="checkbox"/> DATABASE	PROGRAM / DATABASE NAME(S) <input type="checkbox"/> ALSO, LISTED BELOW		VERSION / RELEASE NO.(S)
10CFR50.59/72.48 Assignment. 0219-88442-6					

1. BRIEF DESCRIPTION:

This CCN reflects changes made under CCN DR7585711 and provides text to be added in Appendix C.

C.3.4.15 ACDF Section 3.4 - Part 15 Haul Route Seismic Analysis

15. The loaded transfer cask and its conveyance shall be evaluated to ensure, under the site specific Design Basis Earthquake, that the cask and its conveyance does not tip over or slide off the haul route.

This subsection requires an evaluation to ensure that a loaded HI-TRAC VW on the Vertical Cask Transporter (VCT) and on the HI-PORT conveying the loaded HI-TRAC VW does not tip over, slide off the haul path or adversely interact with nearby objects during the site-specific Design Basis Earthquake. Holtec Reports 2156626 [C.4.17] and HI-2167363 [C.4.18] evaluate the seismic stability of the VCT and HI-PORT, respectively, with a loaded HI-TRAC VW transfer cask during transport along the haul path at SONGS. The haul path considered for the VCT seismic analysis includes the travel along the ISFSI Ramp, Turning Pad, Approach Slab, and ISFSI Pad. The seismic event used for both of these seismic stability analyses is the SONGS Site Design Basis Earthquake. **During the campaign SCE and Holtec recognized that the analyses did not explicitly analyze some configurations. In particular the analyses used a standard configuration with the HI-TRAC suspended from the VCT and coupled together with the cask restraint strap (belly band) that resulted in the combination acting as a single element freestanding rigid body. During relatively short periods of time the cask restraint strap is not fully tightened. Expanding the explicit analysis to address the full range of configurations did not adversely impact results.**

The results of these analyses demonstrate that the VCT and HI-PORT with a loaded HI-TRAC VW do not tip over, slide off the haul path or adversely interact nearby objects.

SCE also requested Holtec review the associated Administrative Controls to confirm they supported the analytical basis and were properly implemented in controlling procedures [C.4.25 and C.4.26]. Exclusion zones with prescribed standoff distances from objects along the haul path are established in SONGS Calculation C-296-04.01 [C.4.16] to ensure that during a Design Basis Earthquake the HI-PORT will maintain its safety function. The HI-PORT wheels may not cross the exclusion zones, however, for the Hazards Area Fence and K Rail F, the HI-PORT power pack may cross into the exclusion zone.

Change the revision for the referenced VCT seismic analysis document as shown below.

C.4.17 Holtec Report HI-2156626, "VCT Stability Analysis on Route to ISFSI Pad and on ISFSI Pad for San Onofre Nuclear Generating Station", Revision 37.

2. OTHER AFFECTED DOCUMENTS:

YES NO OTHER AFFECTED DOCUMENTS EXIST AND ARE IDENTIFIED ON ATTACHED FORM 26-503.

3. APPROVED BY:

ESC:

Robert Yale
ORIGINATOR (Print name/sign/date)

Approval requires PQS T3EN64

Qualification Verified: RAY
Initial

Jerry Stephenson
IEM or EOM (Signature/date)

Approval requires PQS T3EN64

Qualification Verified: RAY
Initial

Ken Wilson (Approved by e-mail dated 02/28/2019, refer to record associated files)
IRE (Print name/sign/date)

Approval requires PQS T3EN64

Qualification Verified: RAY
Initial

From: Brookhart, Lee
Sent: Monday, March 04, 2019 11:07 AM
To: Kenneth Wilson; Davis, Marlone; Call, Michel
Cc: Smith, Chris; Simpson, Eric; MARK MORGAN; ALBERT BATES
Subject: RE: Re: (External):RE: ECO Section 2.2

Ok I think I understand your response on this. These are general statements that the AM program should consider when being developed..... right?

But if a licensee should consider this interaction...it appears to be placing a requirement on the licensee to track which canisters would be affected by this interaction to develop their AM program.

If that is true, shouldn't that be disclosed to licensees somehow?

Maybe I am still missing the mark (or scar) on this, and need more discussion on the subject.

Thanks
Lee

From: Kenneth Wilson [mailto:Kenneth.R.Wilson@sce.com]
Sent: Monday, March 04, 2019 10:49 AM
To: Brookhart, Lee <Lee.Brookhart@nrc.gov>; Davis, Marlone <Marlone.Davis@nrc.gov>; Call, Michel <Michel.Call@nrc.gov>
Cc: Smith, Chris <Chris.Smith@nrc.gov>; Simpson, Eric <Eric.Simpson@nrc.gov>; MARK MORGAN <Mark.Morgan@sce.com>; ALBERT BATES <AL.BATES@sce.com>
Subject: [External_Sender] Re: (External):RE: ECO Section 2.2

I/we appreciate the timely feedback!

Aging Management Programs already require the evaluation of any visually detected indications. That is why the first step IS visual (robotic camera's likely).

The term should was chosen because a formal program is not yet in-place. We are fairly far along in a predecessor program for the State but NRC AM is a ways down the road.

The bottom line of all of the documents, evaluations, calcs and test results is that there is not likely much, if any, impact from downloading. Interactions will occur but the depth is incredibly shallow even under worst case conditions.

From: Brookhart, Lee <Lee.Brookhart@nrc.gov>
Sent: Monday, March 4, 2019 8:38 AM
To: Kenneth Wilson; Davis, Marlone; Call, Michel
Cc: Smith, Chris; Simpson, Eric; MARK MORGAN; ALBERT BATES
Subject: (External):RE: ECO Section 2.2

Second ECO question/issue:

ECO 2.2 (8. Installation and Operability)

States: "Any potential interaction between the MPC and VVM components should be an input to aging management. The potential scratches are not adverse because they can be visually identified and non-destructively examined as needed prior to excessive degradation."

First sentence: "should be an input to aging management"

- How has SONGS adjusted procedures to meet this (I don't know what it is....is this a requirement?)?
 - For instance require a AR if scratching occurred.
- If this should be an input to aging management for a licensee shouldn't the FSAR change include this statement/requirement

Second sentence: not adverse because they can be visually identified and NDE as needed

- Really confused by this statement. Not adverse since it is inspectable. So is this stating that you need to inspect a scratch through aging management to equal not adverse for excessive degradation?

Thanks

Lee

From: Brookhart, Lee

Sent: Monday, March 04, 2019 10:01 AM

To: 'Kenneth Wilson' <Kenneth.R.Wilson@sce.com>; Davis, Marlene <Marlene.Davis@nrc.gov>; Call, Michel <Michel.Call@nrc.gov>

Cc: Smith, Chris <Chris.Smith@nrc.gov>; Simpson, Eric <Eric.Simpson@nrc.gov>; MARK MORGAN <Mark.Morgan@sce.com>; ALBERT BATES <AL.BATES@sce.com>

Subject: ECO Section 2.2

I'm pretty sure I do not agree with Section 2.2 of the ECO:

"Since any potential fabrication damage and any incidental contact would both be extremely localized, the possibility of overlap between fabrication and wear damage is extremely unlikely. Further if both impacts were co-located, the incidental damage would likely skip over a fabrication repair (which is typically seen as an indentation in the canister wall) without any further impact."

I don't believe you can make this type of an all-encompassing assumption. I believe it would have to be evaluated on a case-by-case basis, per each MPC that was damaged.

By changing the FSAR using HI-2188437 as the basis. This calc now becomes part of the FSAR design basis, any possible deviation from the design basis would require review. I would expect that any SMDR for an MPC would have to evaluate acceptance against ALL of the FSAR design basis criteria.... Which would include HSP-320 criteria and HI-2188437 criteria to ensure the new licensing basis is/was maintained.

Or maybe the wording/assumptions would require a change to HSP-320 that would enforce that MPCs could not have any "bulge" in the canister in-order of meeting FSAR design basis calc HI-2188437 and ECO assumptions.

Marlene, Chris.... Let me know if I am off on my thinking.

Thanks
Lee

From: MARK MORGAN <Mark.Morgan@sce.com>
Sent: Monday, March 11, 2019 7:11 PM
To: Brookhart, Lee; Simpson, Eric; Smith, Chris; Katanic, Janine
Cc: ALBERT BATES; MARK MORGAN
Subject: [External_Sender] Procedure Roadmap

Attachment provided in interim response #1, pages 13-14.
--

All,

We had committed to provide you a roadmap to the procedure revisions that were recently added to the electronic reading room. See attached.

Please let me know if you have questions regarding this.

Thanks,
Mark
(949) 368-6745

From: MARK MORGAN <Mark.Morgan@sce.com>
Sent: Tuesday, March 12, 2019 6:14 PM
To: Brookhart, Lee
Cc: Plotter, Jason; Simpson, Eric; Smith, Chris; Wise, John; Davis, Marlone; Katanic, Janine; Howell, Linda; Doug Bauder; DONNA FAASS; ALBERT BATES; MARK MORGAN
Subject: [External_Sender] Response to question regarding sling length

All,

See attached response to questions regarding sling length.

Please let me know if you have any questions regarding this.

Thanks,
Mark
86745

Thinking on it some more. You would need two calcs

- 1.) What happened in the past with 62.5 ft slings rated at 1116,000 lbs
- 2.) What will happen in the future using the 58 ft 6" slings with 4ft intermediates

Where did Holtec get 53ft-6inches slings at 140,000 lbs used in the calc?

Lee

From: Brookhart, Lee
Sent: Tuesday, March 05, 2019 8:27 AM
To: MARK MORGAN <Mark.Morgan@sce.com>; ALBERT BATES <AL.BATES@sce.com>; 'Kenneth Wilson' <Kenneth.R.Wilson@sce.com>
Cc: Plotter, Jason <Jason.Plotter@nrc.gov>; Davis, Marlone <Marlone.Davis@nrc.gov>; Smith, Chris <Chris.Smith@nrc.gov>; Simpson, Eric <Eric.Simpson@nrc.gov>; Wise, John <John.Wise@nrc.gov>
Subject: New Question for Scratch Calc.

Sorry, I started this question late yesterday but didn't finish it.

Scratch Calc Question:
(1 and 2 were submitted yesterday)

3.) Section A.2.2 "Stiffness of Slings" uses the wrong sling lengths to show contact at the base seam weld is not possible. It states the slings used by SONGS are 53 ft 6". But the purchase orders state SONGS uses 58ft long sling and 4ft. Intermediate slings to perform downloading operations. Where would the true "hang-up and release" contact point be for the operations at SONGS using the slings that were purchased?

Thanks
Lee

NRC Review Question Response Form

Note 1: Complete a separate form for each inspector question.

Note 2: The item tracking number will be generated when the record is entered into the inspection database.

Question Title: NRC question on HI-2188437 related to length of the slings

Tracking Number: 5 AR Number: 0319-61600 Date Initiated: 03/05/2019

Holtec Support Required: Yes or No

Question description: New Questions for Scratch Calc.

Scratch Calc Question:

(1 and 2 were submitted yesterday)

3.) Section A.2.2 "Stiffness of Slings" uses the wrong sling lengths to show contact at the base seam weld is not possible. It states the slings used by SONGS are 53 ft 6". But the purchase orders state SONGS uses 58ft long sling and 4ft. Intermediate slings to perform downloading operations. Where would the true "hang-up and release" contact point be for the operations at SONGS using the slings that were purchased?

Followed by:

Thinking on it some more. You would need two calcs

- 1.) What happened in the past with 62.5 ft slings rated at 116,000 lbs
- 2.) What will happen in the future using the 58 ft 6" slings with 4ft intermediates

Where did Holtec get 53ft-6inches slings at 140,000 lbs used in the calc?

Additional question was received by Lee Brookhart on March 6, 2019 at 6:43 A.M.

Oh I wanted to point out that Holtec during the dry run on-site had stated that the 4ft intermediate slings had been changed to 6ft intermediate slings.

So for the calc for the future operations would need to probably use those slings since it would be more limiting.

Requested Clarification (If needed):

NRC Review Question Response Form

SONGS / Holtec Response:

Answer 3

Use of the 53.5-foot sling instead of the 58.5-foot sling in the initial calculation was an error. The correct sling length will be reflected in a revision to HI-2188437R0.

Multiple sling cases were compared and evaluated (Table 1) for their effects on the “hang-up and release” contact points, using the assumed maximum elongation of 1%, which is the most conservative for this evaluation. These changes in length do not change the conclusions presented in HI-2188437R0.

It can be seen in Table 1 that the 140,000 pound rated load slings (rows 1 to 4) and the 116,000-pound rated load sling (row 5) that was used for the first 29 downloads all still meet the criteria for less than 2.0 inches discussed in HI-2188437R0 Appendix A. The 140,000-pound sling with the 6-foot intermediate sling (row 4) will be used when fuel transfer operations resume.

Table 1 – Comparison of Sling Cases using the 1% Elongation Upper Limit

1	2	3	4	5	6	7	8	9	10	11	12	13
Sling Case	Rated Load (RL)	Down-loader Sling	Inter-mediate sling	Elong. at RL	Elong. at Rated Load	Stiffness Double Slings	Load Remaining on Slings (lbs)			Unload to Release (lbs)		
							100,500	85,500	50,500	50,000	30,000	15,000
	(lbs)	(ft)	(ft)	(%)	(in)	K (lbs/in)	Stretch on Slings (in)			Distance to Regain Full Load (in)		
1	140,000	53.5	0	1.0	6.42	4.36E+04	2.30	1.96	1.16	1.15	0.69	0.34
2	140,000	58.5	0	1.0	7.02	3.99E+04	2.52	2.14	1.27	1.25	0.75	0.38
3	140,000	58.5	4	1.0	7.26	3.86E+04	2.61	2.22	1.31	1.30	0.78	0.39
4	140,000	58.5	6	1.0	7.38	3.79E+04	2.65	2.25	1.33	1.32	0.79	0.40
5	116,000	62.5	0	1.0	7.50	3.09E+04	3.25	2.76	1.63	1.62	0.97	0.48

Dynamic Displacement Consideration

To date, the evaluation in HI-2188437R0 has been to show that the distance it takes for the sling to regain full load after a release is less than the 2.0 inches. However, the MPC may be expected to travel up to two times as far as the equilibrium sling position if there is no damping, as previously described in HI-2188261R5. Table 2 increases the distances in columns 11, 12 and 13 of Table 1 by a factor of two.

Table 2 – Assessing the Effect of a 2X Dynamic Displacement

1	2	3	4	5	6	7	8	9	10	11	12	13
Sling Case	Rated Load (RL)	Down-loader Sling	Inter-mediate sling	Elong. at RL	Elong. at Rated Load	Stiffness Double Slings	Load Remaining on Slings (lbs)			Unload to Release (lbs)		
							100,500	85,500	50,500	50,000	30,000	15,000
	(lbs)	(ft)	(ft)	(%)	(in)	K (lbs/in)	Stretch on Slings (in)			2X Distance to Regain Full Load (in)		
2	140,000	58.5	0	1.0	7.02	3.99E+04	2.52	2.14	1.27	2.51	1.50	0.75
3	140,000	58.5	4	1.0	7.26	3.86E+04	2.61	2.22	1.31	2.59	1.56	0.78
4	140,000	58.5	6	1.0	7.38	3.79E+04	2.65	2.25	1.33	2.64	1.58	0.79
5	116,000	62.5	0	1.0	7.50	3.09E+04	3.25	2.76	1.63	3.23	1.94	0.97

Although unloads of 50,000 pounds are now observed to exceed 2.0 inches if released, this comparison shows that for any release after a hang-up of 30,000 pounds or less, the sling would not exceed a dynamic extension beyond the 2.0-inch criteria. This is considered a successful result, both for prior downloads with the 116,000 lbs slings, as well as for the 140,000 lbs rated load slings going forward. Experience with downloading the MPC simulator at SONGS is consistent with this understanding of stability of the MPC at high unloads. Following implementation of load monitoring equipment, no hang-ups with release were observed above 17,000 pounds, ensuring that contact is within the dimensions of the baseplate with no impact on the canister shell.

Conclusion:

These results indicate that a hang-up and release event is not expected to result in contact between the MPC shell and the shield ring even with a factor of two for dynamic loads.

NRC Review Question Response Form

In the event that a release were to cause the MPC shell to slide against the obstruction, the high vertical angle prevents the ability to maintain high normal loads against the edge of the obstruction. For this scenario, wear would still be low and a bump, if it occurs, would be momentary. As noted in HI-2188437R0, there is up to 0.175 inches of allowance for potential scratches.

Assigned Response Team Member: Brian Sarno

Assigned Independent / Peer Review Team Member: David Rackiewicz

NRC Inspector: Lee Brookhart

Response provided date / time: _____

From: MARK MORGAN <Mark.Morgan@sce.com>
Sent: Wednesday, March 13, 2019 5:48 PM
To: Brookhart, Lee
Cc: Piotter, Jason; Simpson, Eric; Smith, Chris; Wise, John; Davis, Marlone; Katanic, Janine; Howell, Linda; Doug Bauder; DONNA FAASS; ALBERT BATES; MARK MORGAN
Subject: [External_Sender] RE: Response to question regarding test data relationship to calculated scratch depth

All,

See attached response to followup question cited below.

Please let me know if you have any questions regarding this.

Thanks,
Mark
(949) 368-6745

From: Smith, Chris [<mailto:Chris.Smith@nrc.gov>]
Sent: Thursday, February 28, 2019 4:20 PM
To: MARK MORGAN <Mark.Morgan@sce.com>; Brookhart, Lee <Lee.Brookhart@nrc.gov>; Simpson, Eric <Eric.Simpson@nrc.gov>
Subject: (External):RE: FW: MPC Lifting Cleat Documentation

Hi Mark,

We do have some followup questions on this.

Mostly related to the calculation HI-2188161.

It looks like the lifting cleats are made from a material called Weldox. It also appears there is no data? on the material properties on elevated temperatures. The calculation appears to derive those elevated temperatures in Appendix A, but Appendix A appears to be a certified material test report (CMTR). CMTRs are not permitted for use in design documents. Are the material properties using the proper reference?

Secondly, can you clarify if the bolts meet ANSI N14.6?
Specifically we have a question if the bolts meet requirements in section 4.2.1.1:

The load-bearing members of a special lifting device shall be capable of lifting three times the combined weight of the shipping container with which it will be used, plus the weight of intervening components of the special lifting device. without generating a combined shear stress or maximum tensile stress at any point in the device in excess of the corresponding minimum tensile yield strength of their materials of construction.

They shall also be capable of lifting live times that weight without exceeding the ultimate tensile strength of the materials.

Also, can you provide the purchase spec for the bolts that are actually used? I don't understand how the calculation is deriving the length of the bolts (I believe this is why the calc was originated in the first place).

NRC Review Question Response Form

Question Title: MPC Lift Cleat Thread Engagement Technical Analysis

Tracking Number: 0319 – 42592 -1 Date Initiated: 3/1/2019

Question description:

Reference email from Chris Smith, dated February 28, 2019 @ 4:20 PM

1. It looks like the lifting cleats are made from a material called Weldom. It also appears there is no data? on the material properties on elevated temperatures. The calculation appears to derive those elevated temperatures in Appendix A, but Appendix A appears to be a certified material test report (CMTR). CMTRs are not permitted for use in design documents. Are the material properties using the proper reference?
2. Confirmation the bolts meet ANSI 14.6, section 4.2.1.1.
3. Would like to see the purchase specification for the lifting cleat bolts.
4. I don't understand how the calculation is deriving the length of the bolts (I believe this is why the calc was originated in the first place).

Requested Clarification (If needed):

None

SCE/HOLTEC RESPONSE:

1. Yes, the lifting cleats are made from Weldom.

Yes, the manufacturer's published data for Weldom does not include material properties at elevated temperatures.

Yes, the calculation derives the material properties at 500°F using actual test data provided by the manufacturer for a sample plate (not a CMTR), along with minimum published material strengths at room temperature.

The actual test data is only used to generate the ratio used to reduce the manufacturer's published yield and ultimate strengths at room temperature to lower values at 500°F.

Yes, the material properties were determined using proper references: manufacturer's published properties, corrected for temperature using actual test data.

2. Yes, the bolts meet ANSI 14.6, section 4.2.1.1. Per Section 5.0 of HI-2188161R2, the allowable strength for the lifting cleat bolts is calculated per ANSI N14.6, subsection 7.2.1 (i.e., minimum of 1/6th of yield strength and 1/10th of ultimate strength at applicable temperature, or twice the requirements of paragraph 4.2.1.1). The minimum bolt safety factor is 1.717 per Subsection 7.2.2 of HI-2188161R2:
 - Maximum combined tension and bending stress in lift bolt = 9.774 ksi
 - Allowable stress (minimum of $S_y/6$ and $S_u/10$) = 16.78 ksi
 - Safety factor = 1.717
3. Purchase Spec 3209 for the lifting cleat bolts is attached.
4. a. The issue was identified by SCE as result of an Extent of Condition review of Holtec ECOs, performed in response to the shim standoff issue. Specifically, ECO 102-21, dated 12/4/15, introduced ACME thread bolts, requiring 3.75" thread engagement.

b. While attempting to reconcile this ECO to the loading procedure, it was identified that the procedure did not require the appropriate thread engagement for the ACME thread bolts used at SONGS. The procedure required a minimum of 3 1/8" thread engagement, which is based on UNC threads, which is demonstrated to be acceptable by HI-2188161R2.

c. Field measurements determined thread engagement was actually 3.4" to 3.5", which is demonstrated to be acceptable by HI-2188161R2.

Assigned Response Team Member: Randall Granaas

Assigned Independent / Peer Review Team Member: Brian Sarno

AR Number: 0319 – 42592 -1/2

NRC Inspector: Chris Smith

Response provided date / time: TBD

From: MARK MORGAN <Mark.Morgan@sce.com>
Sent: Monday, March 18, 2019 7:04 PM
To: ALBERT BATES; Vaaler, Marlayna; Browder, Rachel; Brookhart, Lee; Simpson, Eric; Anderson, Stephanie; Katanic, Janine; Steely, Chris
Cc: DENNIS EVANS; Mannon, Steven; Linda M. Chou
Subject: [External_Sender] RE: Documents for Tuesday's teleconference

All,

Please see attached files.

Thanks,
Mark
(949) 368-6745

TOPIC	PURPOSE	DATE/TIME PLACE	PARTICIPANTS	COMMENTS
Canister Download Followup inspection	Review corrective actions, observe demonstrations	Jan. 28-31	Lee Brookhart Eric Simpson Chris Smith Michael Bloodgood	Janine Katanic to arrive later in the week Initial visit complete–3 items for re-start, 4 potential weaknesses Additional visit in February to view wet operations (Feb 11-14). 2 nd visit complete – 8 potential weaknesses, including 4 potential violations
2019 Inspection Plan	Decommissioning Inspections	Feb 25-28	Stephanie Anderson Rob Evans Marty Poston-Brown	Document Request Received Response provided. Inspection COMPLETE. No apparent violations.
2019 Inspection Plan	PI&R Inspection	Apr 22-25	Chris Steely Stephanie Anderson Chris Smith	Document Request received

NOTES:**2018 ISFSI Schedule**

Fuel Transfer:

- Fuel movement initiated 1/22/2018
- Dual Unit operations in progress
- 29 canisters in the ISFSI (13 from U3, 16 from U2)
- 1 canister in HI-TRAC, seismically restrained in U3 Cask Washdown area
- Further fuel movement on hold pending resolution of canister download event
- MPC-20 tagged out pending resolution of inspection questions

ALSHMA Activities

- None working at this time

From: MARK MORGAN <Mark.Morgan@sce.com>
Sent: Monday, March 25, 2019 11:01 AM
To: Brookhart, Lee; Piotter, Jason; Simpson, Eric; Smith, Chris; Wise, John; Davis, Marlene; Katanic, Janine; Howell, Linda; Doug Bauder; DONNA FAASS; ALBERT BATES
Cc: MARK MORGAN
Subject: [External_Sender] RE: Response to NRC question on ASME Code Application

My apologies, see attached document.

Mark
(949) 368-6745

From: MARK MORGAN
Sent: Monday, March 25, 2019 8:22 AM
To: Brookhart, Lee <Lee.Brookhart@nrc.gov>; Piotter, Jason <Jason.Piotter@nrc.gov>; Simpson, Eric <Eric.Simpson@nrc.gov>; Smith, Chris <Chris.Smith@nrc.gov>; Wise, John <John.Wise@nrc.gov>; Davis, Marlene <Marlene.Davis@nrc.gov>; Katanic, Janine <Janine.Katanic@nrc.gov>; linda.howell@nrc.gov; Doug Bauder <Doug.Bauder@sce.com>; DONNA FAASS <DONNA.FAASS@sce.com>; ALBERT BATES <AL.BATES@sce.com>
Cc: MARK MORGAN <Mark.Morgan@sce.com>
Subject: Response to NRC question on ASME Code Application

All,

Attached is SONGS' latest response to the questions regarding the ASME Code application.

Please let me know if you have any questions regarding this.

Thanks,
Mark
(949) 368-6745

NRC Review Question Response Form

Note 1: Complete a separate form for each inspector question.

Note 2: The item tracking number will be generated when the record is entered into the inspection database.

Question Title: Clarification of ASME Section 3 in Licensing Basis

Tracking Number: 11A AR Number: 0319-53473-3 Date Initiated: 03/21/2019

Holtec Support Required: Yes__ or No ____

Question description:

Appendix B Technical Specification 3.3 requires, that the AMSE BPVC, 2007, is the governing Code for the MPC. Additionally, Appendix B Table 3-1 tie the canister and FSAR to the requirements of ASME Section III in many areas.

The original FSAR statement for no scratches mirrored the CoC/TS design basis that no scratches would ensure the code adherence to ASME Section III.

Now under 72.48, a design change is needed to deviate to allow scratches. But instead of using ASME BPVC code criteria to inspect the canister and properly disposition the defects which would maintain conformance to the code, the calculation utilizes Archard's wear equation to bound the condition. I just don't see how that meets CoC.

Now I understand, how SCE has argued, it is not a methodology. I think it is more of CoC and Appendix B change, myself. Essentially, the change is adding an alternative to the code to not have to do inspections and repair these new defects. Alternatives to the code can only be done via license amendment. Or maybe per TS Appendix B 3.3.2.

NB-4131 "Material originally accepted on delivery in which defects exceeding limits of NB-2500 are known or discovered during the process of fabrication or installation is unacceptable. The material may be used provided the condition is corrected in accordance with the requirements of NB-2500

ASME Section III NB-2538, "Elimination of Surface Defects" requires that defects are required to be examined by either magnetic particle or liquid penetrant method to ensure that the defect has been removed or reduced to an imperfection of acceptable size."

Instead of doing that (which I understand is impossible) which would maintain code compliance, the 72.48 deviates using a calculational method to bound the defect. The only "method" that should be used to disposition these defects is some method allowed or described in the BPVC code or the licensee would need an alternative to the code to maintain compliance with the regulatory licensing basis.

NRC Review Question Response Form

Requested Clarification (If needed): None

SONGS / Holtec Response:

NOTE: For clarity, the NRC question (comment) is separated by paragraph and a response to each is provided.

NRC Comment 1

Appendix B Technical Specification 3.3 requires, that the AMSE BPVC, 2007, is the governing Code for the MPC. Additionally, Appendix B Table 3-1 tie the canister and FSAR to the requirements of ASME Section III in many areas.

Response to Comment 1

It is agreed that the ASME BPVC, 2007 is the governing code for the MPC and that Technical Specification Appendix B Table 3-1 ties the canister and FSAR to the requirements of Section III in many areas. However, other sections of the code apply as well and the relationship is described below.

Section III is the design code portion of the ASME B&PV Code. It assumes that the other parts of the Code are also involved as appropriate. ASME Code materials are selected in accordance with Section II. NDE is generally performed in accordance with Section V. Welding is performed in accordance with Section IX. Preservice examinations required by the component specifications to be done by the manufacturer are often performed in accordance with Section XI. The primary jurisdiction of the Section III design code ends when the MPC component is complete and leaves the manufacturer. The ASME Code Section XI then has jurisdiction, as selected by Holtec, after the MPC leaves the manufacturer (this is consistent with the ASME BPVC, 2007, as referenced in the FSAR).

If a scratch during installation occurs, it can, under Section XI jurisdiction, either be dispositioned as a scratch (i.e., since it not a planar flaw) by reverting back to the Construction Code, which would be Section III, or if desired be dispositioned by Section XI, Table IWB-3514-1, as if it were a planar flaw (which is more conservative than Section III). The information supplied by SCE and Holtec to date is not intended to disposition any indication; but, provide assurance that any actual indications will remain well with ASME Code Allowables.

NRC Comment 2

The original FSAR statement for no scratches mirrored the CoC/TS design basis that no scratches would ensure the code adherence to ASME Section III.

Response to Comment 2

There is no indication in the CoC, its Appendices (Technical Specifications or Approved Contents and Design Features), or NRC SER that the statement in Chapter 9 of the FSAR related to no risk of scratching was considered in the NRC's evaluation of the ASME Code compliance of the MPC.

NRC Review Question Response Form

There is no violation of ASME Section III requirements, nor any cause for repair activities, stemming from minor scratches or wear marks that result from incidental contact between the MPC and the CEC internal features during download operations at site.

HI-STORM UMAX FSAR Rev. 4: 9.5.vii states

Because the MPC insertion (and withdrawal) occurs in the vertical configuration with ample lateral clearances, there is no risk of scratching or gouging of the MPC's external surface (Confinement Boundary). Thus the ASME Section III Class 1 prohibition against damage to the pressure retaining boundary is maintained.

The Section III requirements for pressure containing plate materials is that surface defects will be removed (NB-2538). In NCA-9000, *defective material* is defined as material that does not meet specified requirements. Similarly a defect is defined in general as a rejectable flaw and a flaw is defined as an imperfection or unintentional discontinuity that is detectable by visual, surface or volumetric methods (Section XI Glossary, IWA-9000 (1992)).

A scratch, if it occurred during installation, would not be a rejectable flaw due to potential effects on peak stresses as explained in HI-2188437. This is because localized scratches or wear marks are only capable of producing peak stresses, which are only objectionable from a fatigue or brittle fracture standpoint. The HI-STORM UMAX and FW FSARs (Table 3.1.10 of both address fatigue and HI-STORM FW FSAR Section 3.4.5 for brittle fracture) explain why neither fatigue nor brittle fracture such conditions do not present any risk to a the-MPC.

A scratch would not be rejectable due to interference with material testing in NB-2000 since all of these tests would be completed prior to canister delivery.

Therefore, the only remaining cause (without further analysis) of rejection of a scratch located on the exterior of the canister wall generated during installation would be a condition where the amount of localized wall thinning was below an allowable wall thickness based on Section III. This means that the 0.625 inch nominal wall for a SONGS canister could be reduced without further analysis by 0.175 inches to 0.450 inches, which is allowable based on the licensed 0.500 inch baseline UMAX MPC as discussed in HI-2188437.

A scratch that might be formed during incidental contact of an MPC wall with the divider shell inside the cavity enclosure container during downloading would not result in a rejectable flaw condition, considering the large allowable margin for such localized thinning. This is based on engineering judgment and operational experience. Knowledge of basic wear principles with two soft materials having incidental contact under light lateral loads and many years of operating experience with acceptable canister loading of horizontal canisters inform this judgment. Scratches of a light nature, though somewhat likely, present no risk since the impact is negligible.

NRC Review Question Response Form

NRC Comment 3

Now under 72.48, a design change is needed to deviate to allow scratches. But instead of using ASME BPVC code criteria to inspect the canister and properly disposition the defects which would maintain conformance to the code, the calculation utilizes Archard's wear equation to bound the condition. I just don't see how that meets CoC.

Response to Comment 3

ECO-5021-042 is not a design change. It is a proposed change to clarify the HI-STORM UMAX FSAR. The ECO and supporting 72.48 are explicit in this regard. They further note that they are evaluated as if they were a design change to assure a more comprehensive documented review.

A change is not required to allow scratches since the FSAR statement that there is no risk of damage to the ASME Section III Class 1 pressure retaining boundary that might result from scratching remains valid.

It is not necessary to conclude that the intent of the FSAR was to state that no scratches would occur since incidental contact could occur. More likely the intent was to note that, compared to other designs with much higher contact loads and no clearance, there was negligible risk that shallow scratches in the vertical designs would be rejectable. When SCE and Holtec were asked (after the August 3, 2018 event) to justify this engineering judgment, accepted engineering practices were used for the estimation of scratches as well as laboratory tests and canister inspections. This was not a required calculation for design purposes, but the use of standard engineering explanations, all of which substantiated the initial judgment.

NRC Comment 4

Now I understand, how SCE has argued, it is not a methodology. I think it is more of CoC and Appendix B change, myself. Essentially, the change is adding an alternative to the code to not have to do inspections and repair these new defects. Alternatives to the code can only be done via license amendment. Or maybe per TS Appendix B 3.3.2.

Response to Comment 4

It is not correct to call these slight scratches "defects". By the definition of the ASME code, a defect is a flaw that is rejectable. None of these scratches approach criteria that require removal or repair. That judgment has been substantiated by accepted wear laws, first principles, laboratory tests, operating experience, and examination of installed loaded canisters that this judgment was and still is valid.

As noted in the Response to Comment 4, questions regarding the judgment arose from various stakeholders following the hang-up of the MPC on August 3, 2018. It was apparently presumed that the lateral loads during passage of the MPC into the cavity enclosure container must be higher than previously considered. After assessing the actual loads and their effect on the surfaces of the canister, the original judgment was validated.

NRC Review Question Response Form

NRC Comment 5

NB-4131 "Material originally accepted on delivery in which defects exceeding limits of NB-2500 are known or discovered during the process of fabrication or installation is unacceptable. The material may be used provided the condition is corrected in accordance with the requirements of NB-2500.

Response to Comment 5

SCE and Holtec agree with this ASME Code requirement. It is appropriately implemented by the fabricator as an attribute of the manufacturing process and its controls. Appropriate documentation is provided to Holtec and SCE certifying compliance with FSAR invoked requirements of the ASME Code.

As previously noted, no defects (i.e., rejectable flaws) were discovered or are anticipated during the process of installation. Therefore no corrections are required per NB-2500.

NRC Comment 6

ASME Section III NB-2538, "Elimination of Surface Defects" requires that defects are required to be examined by either magnetic particle or liquid penetrant method to ensure that the defect has been removed or reduced to an imperfection of acceptable size."

Response to Comment 6

No defects (rejectable flaws) have been identified that have resulted from scratches or are expected to result from scratches due to incidental contact during down-loading. The bounding scratches estimated in response to the various inquiries are theoretical projections not identified flaws.

This is consistent with the judgment in the FSAR, and validated by the means explained above. The requirement of NB-2538 might have removed a scratch during construction if it interfered with the ability to complete the surface or volumetric material examinations of the pressure boundary material.

Once this had been completed and the canister delivered, a similar surface defect occurring during installation would not need to be removed because these material examinations had already been completed.

NRC Review Question Response Form

NRC Comment 7

Instead of doing that (which I understand is impossible) which would maintain code compliance, the 72.48 deviates using a calculational method to bound the defect. The only "method" that should be used to disposition these defects is some method allowed or described in the BPVC code or the licensee would need an alternative to the code to maintain compliance with the regulatory licensing basis.

Response to Comment 7

As previously noted no "defects" due to incidental contact are anticipated. The calculational methods are tools to estimate potential scratch depth and are in no way a means to disposition any defect; real or projected.

Neither the identification nor removal of shallow scratches, wear or rub marks due to installation is required to maintain compliance with ASME Section III or the ASME B&PV Code generally.

Assigned Response Team Member: David Rackiewicz

Assigned Independent / Peer Review Team Member: Bob Yale/Ken Wilson

NRC Inspector: Lee Brookhart

Response provided date / time: 3/23/19

From: ALBERT BATES <AL.BATES@sce.com>
Sent: Tuesday, February 26, 2019 4:04 PM
To: Simpson, Eric; MARK MORGAN
Cc: Brookhart, Lee; JERRY STEPHENSON; ALBERT BATES
Subject: [External_Sender] RE: (External):RE: FW: (External):RE: Video of lab demonstration

That is correct Eric - (b)(4)

(b)(4)

Lee - (b)(4)

We should have the completed lab report in the next couple days.

Al

From: Simpson, Eric [mailto:Eric.Simpson@nrc.gov]
Sent: Tuesday, February 26, 2019 12:27 PM
To: MARK MORGAN <Mark.Morgan@sce.com>
Cc: ALBERT BATES <AL.BATES@sce.com>; Brookhart, Lee <Lee.Brookhart@nrc.gov>
Subject: (External):RE: FW: (External):RE: Video of lab demonstration

(b)(4)

Very interesting.

-Eric

From: MARK MORGAN [mailto:Mark.Morgan@sce.com]
Sent: Tuesday, February 26, 2019 11:04 AM
To: Brookhart, Lee <Lee.Brookhart@nrc.gov>
Cc: Simpson, Eric <Eric.Simpson@nrc.gov>; Smith, Chris <Chris.Smith@nrc.gov>; Katanic, Janine <Janine.Katanic@nrc.gov>; ALBERT BATES <AL.BATES@sce.com>
Subject: [External_Sender] FW: (External):RE: Video of lab demonstration

All,

Attached is one of the videos from the scratch demonstrations from last week, converted to .mp4. I'll send the other one separately, as it is 8 MB. Hopefully, they'll both make it through to you.

I tried adding these to the Electronic Reading Room, but it won't accept .mp4 files. If e-mail doesn't work, I'll burn these to disc and Fedex them to you.

Mark
(949) 368-6745

Video is being withheld in full under exemption 4, as it is an excerpt from the licensee's proprietary procedure HPP-2464-400, "MPC Transfer at SONGS". Other video (8 MP) never received.

From: Kenneth Wilson <Kenneth.R.Wilson@sce.com>
Sent: Monday, March 04, 2019 10:24 AM
To: Brookhart, Lee; Davis, Marlone; Call, Michel
Cc: Smith, Chris; Simpson, Eric; MARK MORGAN; ALBERT BATES
Subject: [External_Sender] Re: (External):ECO Section 2.2

Just to provide some initial feedback...

We understand, but, we didn't stop there. As you consider this please be reminded that...

We went on to note that impacts from both fabrication and operation would be localized peak stresses under the Code and are thus most significant WRT to fatigue or brittle fracture; neither of which are a risk to a MPC based on material properties and lack of any sort of cyclic loading.

But, if and as you reach a consensus WRT to any related question we will more formally address.

Ken

From: Brookhart, Lee <Lee.Brookhart@nrc.gov>
Sent: Monday, March 4, 2019 8:01 AM
To: Kenneth Wilson; Davis, Marlone; Call, Michel
Cc: Smith, Chris; Simpson, Eric; MARK MORGAN; ALBERT BATES
Subject: (External):ECO Section 2.2

I'm pretty sure I do not agree with Section 2.2 of the ECO:

"Since any potential fabrication damage and any incidental contact would both be extremely localized, the possibility of overlap between fabrication and wear damage is extremely unlikely. Further if both impacts were co-located, the incidental damage would likely skip over a fabrication repair (which is typically seen as an indentation in the canister wall) without any further impact."

I don't believe you can make this type of an all-encompassing assumption. I believe it would have to be evaluated on a case-by-case basis, per each MPC that was damaged.

By changing the FSAR using HI-2188437 as the basis. This calc now becomes part of the FSAR design basis, any possible deviation from the design basis would require review. I would expect that any SMDR for an MPC would have to evaluate acceptance against ALL of the FSAR design basis criteria.... Which would include HSP-320 criteria and HI-2188437 criteria to ensure the new licensing basis is/was maintained.

Or maybe the wording/assumptions would require a change to HSP-320 that would enforce that MPCs could not have any "bulge" in the canister in-order of meeting FSAR design basis calc HI-2188437 and ECO assumptions.

Marlone, Chris.... Let me know if I am off on my thinking.

Thanks
Lee

From: MARK MORGAN <Mark.Morgan@sce.com>
Sent: Monday, March 11, 2019 5:38 PM
To: Brookhart, Lee
Cc: Piotter, Jason; Simpson, Eric; Smith, Chris; Wise, John; Davis, Marlone; Katanic, Janine; Howell, Linda; Doug Bauder; DONNA FAASS; MARK MORGAN
Subject: [External_Sender] Response to question regarding 72.48

Lee,

Attached is a response to the questions below as they relate to the VCT Seismic Stability Analysis. As discussed on the phone today, we will provide a similar response for the Scratch Evaluation, likely by the end of the day tomorrow (Tuesday).

Mark
86745

From: Brookhart, Lee [mailto:Lee.Brookhart@nrc.gov]
Sent: Wednesday, March 06, 2019 8:08 AM
To: MARK MORGAN <Mark.Morgan@sce.com>; ALBERT BATES <AL.BATES@sce.com>; Kenneth Wilson <Kenneth.R.Wilson@sce.com>
Cc: Piotter, Jason <Jason.Piotter@nrc.gov>; Simpson, Eric <Eric.Simpson@nrc.gov>; Smith, Chris <Chris.Smith@nrc.gov>; Wise, John <John.Wise@nrc.gov>; Davis, Marlone <Marlone.Davis@nrc.gov>
Subject: (External):RE: Questions status at end of Tues

New questions related to BB Seismic Evaluation:

3. Is SONGS treating the adoption of a revision to the HI-2156626 (VCT Stability Analysis) into the 72.212 Evaluation as an editorial/administrative correction?
4. If the answer to question 1 is YES, then did SONGS revise the original 10 CFR 72.48 evaluation to assess the conditions that were not bounded by the UMAX FSAR?
5. How could the differences in the expanded evaluation affect the old method of evaluation (MOE)?
 - *Questions 3 – 5 are related to why SCE only performed a Applicability Determination to accept the new BB evaluation and did not perform a 72.48 screen and if necessary an evaluation.*
 - *Just an Applicability Determination does not seem to be in-line with RIS 2012-005 (attached)*
6. Is there any additional single failure scenarios SONGS need to consider with the new expanded evaluation?
7. What about effects of equipment failures such as the belly band?

Total now is:

7 open questions on BB calc.
2 open questions on ECO
5 open questions on Scratch/Scar Calc
1 open question on the Test Report

Thanks
Lee

From: Brookhart, Lee

Sent: Tuesday, March 05, 2019 5:28 PM

To: 'MARK MORGAN' <Mark.Morgan@sce.com>; 'ALBERT BATES' <AL.BATES@sce.com>; 'Kenneth Wilson' <Kenneth.R.Wilson@sce.com>

Cc: Piotter, Jason <Jason.Piotter@nrc.gov>; Simpson, Eric <Eric.Simpson@nrc.gov>; Smith, Chris <Chris.Smith@nrc.gov>; Wise, John <John.Wise@nrc.gov>; Davis, Marlone <Marlone.Davis@nrc.gov>

Subject: RE: Questions status at end of Tues

Sorry I spoke too soon. We have one new question:

Test Report Question:

1.) In HI-2188450 (scratch test report), please describe the method used to determine the scratch depth.

Specifically, what measurement and test equipment was used, was it controlled M&IE and have a current calibration?

So the total now is:

2 open questions on BB calc.

2 open questions on ECO

5 open questions on Scratch/Scar Calc

1 open question on the Test Report

Thanks

Lee

From: Brookhart, Lee

Sent: Tuesday, March 05, 2019 5:18 PM

To: MARK MORGAN <Mark.Morgan@sce.com>; ALBERT BATES <AL.BATES@sce.com>; Kenneth Wilson <Kenneth.R.Wilson@sce.com>

Cc: Piotter, Jason <Jason.Piotter@nrc.gov>; Simpson, Eric <Eric.Simpson@nrc.gov>; Smith, Chris <Chris.Smith@nrc.gov>; Wise, John <John.Wise@nrc.gov>

Subject: Questions status at end of Tues

I have not received any new questions to add to the on-going list.

Status at end of Tuesday is:

2 open questions on BB calc.

2 open questions on ECO

5 open questions on Scratch/Scar Calc

Thanks
Lee

NRC Review Question Response Form

Note 1: Complete a separate form for each inspector question.

Note 2: The item tracking number will be generated when the record is entered into the inspection database.

Question Title: 72.48/72.212 issues for the VCT stability analysis

Tracking Number: 8 AR Number: 0319-39420 Date Initiated: 03/06/2019

Holtec Support Required: Yes or No

Question description:

New questions related to BB Seismic Evaluation:

3. Is SONGS treating the adoption of a revision to the HI-2156626 (VCT Stability Analysis) into the 72.212 Evaluation as an editorial/administrative correction?
4. If the answer to question 1 is YES, then did SONGS revise the original 10 CFR 72.48 evaluation to assess the conditions that were not bounded by the UMAX FSAR?
5. How could the differences in the expanded evaluation affect the old method of evaluation (MOE)?
 - Questions 3 – 5 are related to why SONGS only performed a Applicability Determination to accept the new BB evaluation and did not perform a 72.48 screen and if necessary an evaluation.
 - Just an Applicability Determination does not seem to be in-line with RIS 2012-005 (attached)
6. Is there any additional single failure SONGS scenarios SONGS need to consider with the new expanded evaluation?
7. What about effects of equipment failures such as the belly band?

Requested Clarification (If needed):

None

SONGS / Holtec Response:

3. No, SONGS does not consider this change to be editorial or administrative.

The 72.48 review of this change to the SONGS HI-STORM UMAX 72.212 evaluation treats the subject as an expansion of the explicit analyses. The following text was added to the 72.212 Report (Appendix C, C.3.4.15):

NRC Review Question Response Form

“...SONGS and Holtec recognized that the analyses did not explicitly analyze some configurations....Expanding the explicit analysis to address the full range of configurations did not adversely impact results.”

4. While no response was required, SONGS is providing the following discussion of the actions taken. SONGS revised the SONGS HI-STORM UMAX 72.212 to acknowledge the expanded explicit analysis for certain VCT/HI-TRAC/MPC configurations.

This revision to the site-specific 72.212 evaluation was not because the HI-STORM UMAX FSAR conditions did not bound site conditions. The HI-STORM UMAX FSAR does not explicitly describe the VCT stability analysis. Because the means of “loaded cask conveyance” may vary site-to-site, Holtec deferred to the general licensees to address this in their site-specific 72.212 evaluations. Each time SONGS made refinements to this evaluation it was reviewed in accordance with the SONGS 72.48 process as required.

Therefore, SONGS performed a new, specific 72.48 review of the proposed activity. SONGS did not revise any 72.48 reviews previously performed for this Section of the HI-STORM UMAX 72.212. The subject reviewed was the incorporation of the expanded explicit VCT stability analyses. The revised analysis was performed to assure SONGS continued compliance with CoC, Appendix B, Approved Contents and Design Features, Section 3.4.15.

5. This proposed activity did not involve a change to a Method of Evaluation (MOE) described in any licensing basis documents (the HI-STORM UMAX or FW FSARs or the SONGS UMAX 72.212 Report). Therefore, it is not a change to an existing MOE.

As discussed in the response to #4, this analysis was not described in the Holtec UMAX FSAR. SONGS included an overview discussion of VCT Stability Analysis in its original 72.212 evaluation. However, that description did not include details of the analytical inputs, methods or acceptance criteria.

SONGS generated a new regulatory review using SONGS Procedure SO123-XV-44, “10 CFR 50.59, 72.48, and 50.82 Program”. This review addresses 10 CFR 50.59, 50.82 and 72.48 in three phases, Applicability Determination (AD), Screen and Full Evaluation. This is consistent with these regulations, as well as NRC and industry guidance. The SONGS AD is not a simple check-list. It includes a review to determine if there is any impact to the design or licensing basis that warrants a more detailed screen or evaluation. The AD discusses the FSAR content and that the revised analysis continues to confirm that the loaded HI-TRAC supported by the VCT is seismically stable and in compliance with the CoC. It also explicitly discusses whether a MOE described in the FSAR is involved (Section II, Item A).

The 50.59 and 72.48 reviews documented in Section II conclude that the loaded HI-TRAC supported by the VCT continues to be seismically stable and in compliance with the CoC. It also notes there was no change in a method of evaluation described in the FSAR. Hence,

NRC Review Question Response Form

the proposed activity did not adversely affect a design function or method of evaluation described in the FSAR or any aspect of the SONGS ISFSI Licensing Basis.

Applying the 10 CFR 72.48 process to the change fully complies with the intent of the RIS. The RIS draws no distinction between the separate phases of the process. The 72.48 also thoroughly addresses aspects that might have been the outcome of a Screen or Full Evaluation if one had been required by the process.

6. There is no opportunity for adversely impacting existing ITS components or creating any additional single failures.

While the scope and detail of the explicit analyses were expanded to address the CoC, Appendix B, Approved Content and Design Features 3.4.15 more fully, the Important to Safety SSCs involved, and the configurations addressed did not change. All involved components continued to meet their respective acceptance criteria and therefore no new single failures were introduced.

7. The revisions to HI-2156626 concluded that a tightened belly band was not necessary to assure compliance with the acceptance criteria during the analyzed configurations.

Although the revised evaluation demonstrates the VCT/HI-TRAC/MPC remain qualified when the belly band is not tightened, SONGS intends to maintain the belly band attached and tightened until those times that the HI-TRAC needs to be lifted, lowered, or has been moved into position above its associated CEC.

Assigned Response Team Member: Ken Wilson

Assigned Independent / Peer Review Team Member: Jon McGaw

NRC Inspector: Lee Brookhart

Response provided date/time: 3/11/19 TBD

From: MARK MORGAN <Mark.Morgan@sce.com>
Sent: Wednesday, March 13, 2019 12:39 PM
To: Brookhart, Lee
Cc: Piotter, Jason; Simpson, Eric; Smith, Chris; Wise, John; Davis, Marlone; Katanic, Janine; Howell, Linda; Doug Bauder; DONNA FAASS; ALBERT BATES; MARK MORGAN
Subject: [External_Sender] Response to question regarding test data relationship to calculated scratch depth

All,

See attached response to followup question cited below.

Please let me know if you have any questions regarding this.

Thanks,
Mark
(949) 368-6745

I believe I understand the response.

SONGS was not using the test to validate Archard's wear equation. Test data confirms max depth is low during the physical tests performed.

To me, the test shows that use of the Archard's wear equation to maximize depth theoretically could be misleading. As the depth (h) can vary because the width is not constant as assumed in the conservative calculation. And as can be seen in the test data.

So I am left thinking:

Does the test data confirm max depth should be low = yes

Does the test data confirm Archard's wear equation (the way it is utilized in the calculation) to be conservative in determining max depth = not necessarily

To me, I am not sure if that is a win or a loss.

Thanks
Lee

From: MARK MORGAN <Mark.Morgan@sce.com>
Sent: Tuesday, February 26, 2019 3:33 PM
To: Simpson, Eric
Cc: ALBERT BATES; Brookhart, Lee; Smith, Chris; JERRY STEPHENSON
Subject: [External_Sender] RE: (External):RE: FW: (External):RE: Video of lab demonstration

Eric,

(b)(4)

Lee,

You had asked about the maximum weight. We're still waiting for the report from Holtec so the results are preliminary

(b)(4)

Let me know if you have any more questions.

Mark
(949) 368-6745

From: Simpson, Eric [mailto:Eric.Simpson@nrc.gov]
Sent: Tuesday, February 26, 2019 12:27 PM
To: MARK MORGAN <Mark.Morgan@sce.com>
Cc: ALBERT BATES <AL.BATES@sce.com>; Brookhart, Lee <Lee.Brookhart@nrc.gov>
Subject: (External):RE: FW: (External):RE: Video of lab demonstration

(b)(4)

Very interesting.

-Eric

From: MARK MORGAN [mailto:Mark.Morgan@sce.com]
Sent: Tuesday, February 26, 2019 11:04 AM
To: Brookhart, Lee <Lee.Brookhart@nrc.gov>
Cc: Simpson, Eric <Eric.Simpson@nrc.gov>; Smith, Chris <Chris.Smith@nrc.gov>; Katanic, Janine <Janine.Katanic@nrc.gov>; ALBERT BATES <AL.BATES@sce.com>
Subject: [External_Sender] FW: (External):RE: Video of lab demonstration

All,

Attached is one of the videos from the scratch demonstrations from last week, converted to .mp4. I'll send the other one separately, as it is 8 MB. Hopefully, they'll both make it through to you.

I tried adding these to the Electronic Reading Room, but it won't accept .mp4 files. If e-mail doesn't work, I'll burn these to disc and Fedex them to you.

Video is being withheld in full under exemption 4, as it is an excerpt from the licensee's proprietary procedure HPP-2464-400, "MPC Transfer at SONGS". Other video (8 MB) never received.

Mark
(949) 368-6745

From: MARK MORGAN <Mark.Morgan@sce.com>
Sent: Thursday, February 28, 2019 3:28 PM
To: Brookhart, Lee; Katanic, Janine; Simpson, Eric; Smith, Chris; Howell, Linda
Cc: ALBERT BATES
Subject: [External_Sender] RE: Documents Related to VCT Seismic Stability (Use of Cask Restraint, a.k.a., Belly Band)

Al just reminded me that we had planned to put these documents and those to come in the next few days in the electronic reading room. I'll do that momentarily.

(b)(4)

Thanks,
Mark
86745

From: MARK MORGAN
Sent: Thursday, February 28, 2019 1:23 PM
To: Brookhart, Lee <Lee.Brookhart@nrc.gov>; Katanic, Janine <Janine.Katanic@nrc.gov>; Simpson, Eric <Eric.Simpson@nrc.gov>; chris.smith@nrc.gov
Cc: MARK MORGAN <Mark.Morgan@sce.com>; ALBERT BATES <AL.BATES@sce.com>
Subject: FW: Documents Related to VCT Seismic Stability (Use of Cask Restraint, a.k.a., Belly Band)

All,

Attached are the new analyses to demonstrate acceptable operation of the VCT with the belly band loosened or disconnected.

Please let me know if you have any questions regarding this.

Thanks,
Mark
86745

From: MARK MORGAN <Mark.Morgan@sce.com>
Sent: Wednesday, March 13, 2019 12:34 PM
To: Brookhart, Lee
Cc: Piotter, Jason; Simpson, Eric; Smith, Chris; Wise, John; Davis, Marlene; Katanic, Janine; Howell, Linda; Doug Bauder; DONNA FAASS; ALBERT BATES; MARK MORGAN
Subject: [External_Sender] Response to question regarding demonstration test data

All,

In Monday's phone call you inquired whether all demonstration data was included in the report. See attached response.

Please let me know if you have any questions regarding this.

Thanks,
Mark
(949) 368-6745

NRC Review Question Response Form

Note 1: Complete a separate form for each inspector question.

Note 2: The item tracking number will be generated when the record is entered into the inspection database.

Question Title: Test data taken at Orvillon and test report

Tracking Number: 14 AR Number: 0319-10578 Date Initiated: 03/11/2019

Holtec Support Required: Yes X or No

Question description:

Is all the data that was taken at Orvillon reflected in the test report?

Or were certain runs rejected due to the pre-test/validation nature of each campaign?

For example, was the initial run where chatter was experienced included in the final data set?

Requested Clarification (If needed):

SONGS / Holtec Response:

There were a total of 5 campaigns, of which 3 provided valid data. Campaign 1 and 3 demonstration results are not documented in the test report (HI-2188450). The campaigns are, however, referenced in HI-2188450, Section 4.3:

Given the nature of simulation testing and the unknown of equipment limitations of utilizing a friction stir welding machine for high contact force scratch testing an incremental approach was developed, consisting of 5 testing campaigns. As a result of the forces applied the friction stir weld machine failed to maintain correct geometry or tool orientation during simulation campaigns 1 and 3. Observations of the friction stir welding machines behavior under high loading allowed for refinement of the test simulation, ultimately allowing for successful simulation results (correct tool/plate geometry) being maintained in campaigns 2, 4, and 5. Specifics of each successful campaign are outlined in Table 2 below. A total of 19 trials were conducted utilizing 2 different tool geometries and a variety of forces, resulting in 12 valid tests in which the tool/plate geometry was maintained during simulation.

Campaign 1 had the test piece at -1 degree rather than 1 degree relative to the test plate (not physically consistent with MPC download). Thus, the campaign demonstration results were not reflected in the test report.

From: MARK MORGAN <Mark.Morgan@sce.com>
Sent: Wednesday, March 13, 2019 12:35 PM
To: Brookhart, Lee
Cc: Piotter, Jason; Simpson, Eric; Smith, Chris; Wise, John; Davis, Marlene; Katanic, Janine; Howell, Linda; Doug Bauder; DONNA FAASS; ALBERT BATES; MARK MORGAN
Subject: [External_Sender] Response to question regarding hardness of test materials

All,

In Monday's phone call you data on hardness of materials for the Orvillon demonstration. See attached response.

Please let me know if you have any questions regarding this.

Thanks,
Mark
(949) 368-6745

NRC Review Question Response Form

Note 1: Complete a separate form for each inspector question.

Note 2: The item tracking number will be generated when the record is entered into the inspection database.

Question Title: Test data taken at Orvillon and test report

Tracking Number: 15 AR Number: 0319-39699 Date Initiated: 03/11/2019

Holtec Support Required: Yes or No

Question description:

Please provide a table of minimum and maximum hardness values for the Orvillon test materials. Also, state whether the materials used conform to materials in question in the field at SONGS.

Requested Clarification (If needed):

SONGS / Holtec Response:

Item	Material	Average Hardness (HRb)	Measurement*					Min	Max
			1	2	3	4	5		
MPC Inner Seismic Restraint Tool	304 SS	79.8	80	80	79	80	80	79	80
Lower MPC Guide Plate Tool	304 SS	86.6	86	87	87	87	86	86	87
Shell Plate	SA 240 Type 316/316L	90.2	88	94	90	91	88	88	94

**Average hardness was determined from the average of 5 total measurements for one of each tool type and one 316/316L plate.*

With the exception of the use of a 3/4" thick plate for Campaign 2 (lower seismic support is 1" thick), the materials used conform to materials used for SONGS storage modules and MPCs.

NRC Review Question Response Form

Assigned Response Team Member: Randall Granaas

Assigned Independent / Peer Review Team Member: Brian Sarno

NRC Inspector: _____

Response provided date / time: _____

From: MARK MORGAN <Mark.Morgan@sce.com>
Sent: Friday, March 29, 2019 4:25 PM
To: Brookhart, Lee; Piotter, Jason; Simpson, Eric; Smith, Chris; Wise, John; Davis, Marlone; Katanic, Janine; Howell, Linda; Doug Bauder; ALBERT BATES
Cc: MARK MORGAN
Subject: [External_Sender] Latest products posted to the reading room

All,

SONGS has just posted the following products to the CERTREC Electronic Reading Room for your review:

1. The MPC Visual Assessment Report
2. A revised HI-2188437 to incorporate results of the Visual Assessment Report
3. A change to the 72.212 evaluation to evaluate incidental contact wear for ASME Code Compliance, and
4. An associated 72.48 evaluation.

If files are sorted by "name" in the reading room, they will be grouped together alphabetically under "Post Visual Assessment..."

In addition, Al asked me to pass along the latest version of our statement on Code Compliance, previously transmitted to you on Monday. The response has been updated, and is attached to this email.

Please let me know if you have any questions regarding this.

Thanks,
Mark
(949) 368-6745

NRC Review Question Response Form

Note 1: Complete a separate form for each inspector question.

Note 2: The item tracking number will be generated when the record is entered into the inspection database.

Question Title: Clarification of ASME Section 3 in Licensing Basis

Tracking Number: 11A AR Number: 0319-53473-3 Date Initiated: 03/21/2019

Holtec Support Required: Yes__ or No ____

Question description:

Appendix B Technical Specification 3.3 requires, that the AMSE BPVC, 2007, is the governing Code for the MPC. Additionally, Appendix B Table 3-1 tie the canister and FSAR to the requirements of ASME Section III in many areas.

The original FSAR statement for no scratches mirrored the CoC/TS design basis that no scratches would ensure the code adherence to ASME Section III.

Now under 72.48, a design change is needed to deviate to allow scratches. But instead of using ASME BPVC code criteria to inspect the canister and properly disposition the defects which would maintain conformance to the code, the calculation utilizes Archard's wear equation to bound the condition. I just don't see how that meets CoC.

Now I understand, how SCE has argued, it is not a methodology. I think it is more of CoC and Appendix B change, myself. Essentially, the change is adding an alternative to the code to not have to do inspections and repair these new defects. Alternatives to the code can only be done via license amendment. Or maybe per TS Appendix B 3.3.2.

NB-4131 "Material originally accepted on delivery in which defects exceeding limits of NB-2500 are known or discovered during the process of fabrication or installation is unacceptable. The material may be used provided the condition is corrected in accordance with the requirements of NB-2500

ASME Section III NB-2538, "Elimination of Surface Defects" requires that defects are required to be examined by either magnetic particle or liquid penetrant method to ensure that the defect has been removed or reduced to an imperfection of acceptable size."

Instead of doing that (which I understand is impossible) which would maintain code compliance, the 72.48 deviates using a calculational method to bound the defect. The only "method" that should be used to disposition these defects is some method allowed or described in the BPVC code or the licensee would need an alternative to the code to maintain compliance with the regulatory licensing basis.

NRC Review Question Response Form

Requested Clarification (If needed): None

SONGS / Holtec Response:

NOTE: For clarity, the NRC question (comment) is separated by paragraph and a response to each is provided.

NRC Comment 1

Appendix B Technical Specification 3.3 requires, that the AMSE BPVC, 2007, is the governing Code for the MPC. Additionally, Appendix B Table 3-1 tie the canister and FSAR to the requirements of ASME Section III in many areas.

Response to Comment 1

It is agreed that the ASME BPVC, 2007 is the governing code for the MPC and that C of C Appendix B, "Approved Contents and Design Features," Table 3-1 ties the canister and FSAR to the requirements of Section III in many areas. However, other sections of the code apply as well and the relationship is described below.

Section III is the construction code portion of the ASME B&PV Code. It assumes that the other parts of the Code are also involved as appropriate. ASME Code material specifications are in Section II. They are selected in accordance with Section III. NDE is generally performed in accordance with Section V. Welding is performed in accordance with Section IX. Preservice examinations required by the component specifications to be done by the manufacturer are often performed in accordance with Section XI. Typically, the primary jurisdiction of the Section III construction code ends when a component is stamped. Because the MPC is not actually stamped, Holtec considers jurisdiction of Section III ends when the MPC leaves the manufacturer. Although Appendix B of the C of C is silent on which Section of the ASME Code applies during inservice inspections, use of Section XI, as selected by Holtec, is typical throughout the nuclear industry and is not prohibited by the C of C. Therefore, the ASME Code Section XI has jurisdiction after the MPC leaves the manufacturer.

NRC Comment 2

The original FSAR statement for no scratches mirrored the CoC/TS design basis that no scratches would ensure the code adherence to ASME Section III.

Response to Comment 2

There is no indication in the CoC, its Appendices (Technical Specifications or Approved Contents and Design Features), or NRC SER that the statement in Chapter 9 of the FSAR related to no risk of scratching was considered in the NRC's evaluation of the ASME Code compliance of the MPC.

NRC Review Question Response Form

There is no violation of ASME Section III requirements, nor any cause for repair activities, stemming from minor scratches or wear marks that result from incidental contact between the MPC and the CEC internal features during download operations at site.

HI-STORM UMAX FSAR Rev. 4: 9.5.vii states

Because the MPC insertion (and withdrawal) occurs in the vertical configuration with ample lateral clearances, there is no risk of scratching or gouging of the MPC's external surface (Confinement Boundary). Thus the ASME Section III Class 1 prohibition against damage to the pressure retaining boundary is maintained.

The Section III requirements for pressure containing plate materials is that surface defects will be removed (NB-2538). In NCA-9000, *defective material* is defined as material that does not meet specified requirements. Similarly a defect is defined in general as a rejectable flaw and a flaw is defined as an imperfection or unintentional discontinuity that is detectable by visual, surface or volumetric methods (Section XI Glossary, IWA-9000 (1992)).

A scratch, if it occurred during installation, would not be a defect requiring repair per the Code. A scratch is a non-conformance and the engineering disposition concluded that scratches are not rejectable due to potential effects on peak stresses, as explained in HI-2188437. This is because localized scratches or wear marks are only capable of producing peak stresses, which are only objectionable from a fatigue or brittle fracture standpoint. The HI-STORM UMAX and FW FSARs (Table 3.1.10 of both address fatigue and HI-STORM FW FSAR Section 3.4.5 for brittle fracture) explain why neither fatigue nor brittle fracture present any risk to a MPC.

A scratch would not be rejectable due to interference with material testing in NB-2000 since all of these tests would be completed prior to canister delivery.

Therefore, the only remaining cause (without further analysis) of rejection of a scratch located on the exterior of the canister wall generated during installation would be a condition where the amount of localized wall thinning was below an allowable wall thickness based on Section III.

If a scratch during installation occurs, it can, under Section XI jurisdiction, either be dispositioned as a scratch (i.e., since it not a planar flaw) by reverting back (in accordance with IWA-3100 (b)) to the Construction Code, which would be Section III; or, if desired, be dispositioned by Section XI, Table IWB-3514-1, as if it were a planar flaw (which is more conservative than Section III). The information supplied by SCE and Holtec to date is not intended to disposition any indication; but, to provide assurance that any potential scratches will remain well within ASME Code allowable limits. So the SONGS canister scratch could be acceptable down to a minimum allowable wall under Section III. And the Holtec MPC with 0.500 inch wall could, if desired, allow a scratch as if a planar flaw that was up to 10% of nominal wall thickness (an allowed wall of 0.450 inches).

This means that the 0.625 inch nominal wall for a SONGS canister could, using engineering judgment, be reduced without further analysis by 0.175 inches to 0.450 inches, which is an allowable wall based on the licensed 0.500 inch baseline UMAX MPC as discussed in HI-2188437.

NRC Review Question Response Form

A scratch that might be formed during incidental contact of an MPC wall with the divider shell inside the cavity enclosure container during downloading would not result in a rejectable flaw condition, considering the large allowable margin for such localized thinning. This is based on engineering judgment and operational experience. Knowledge of basic wear principles with two soft materials having incidental contact under light lateral loads and many years of operating experience with acceptable canister loading of horizontal canisters inform this judgment. Scratches of a light nature, though somewhat likely, present no risk since the impact is negligible.

NRC Comment 3

Now under 72.48, a design change is needed to deviate to allow scratches. But instead of using ASME BPVC code criteria to inspect the canister and properly disposition the defects which would maintain conformance to the code, the calculation utilizes Archard's wear equation to bound the condition. I just don't see how that meets CoC.

Response to Comment 3

ECO-5021-042 is not a design change. It is a proposed change to clarify the HI-STORM UMAX FSAR. The ECO and supporting 72.48 are explicit in this regard. They further note that they are evaluated as if they were a design change to assure a more comprehensive documented review.

A change is not required to allow scratches since the FSAR statement that there is no risk of damage to the ASME Section III Class 1 pressure retaining boundary that might result from scratching remains valid.

It is not necessary to conclude that the intent of the FSAR was to state that no scratches would occur since incidental contact could occur. More likely the intent was to note that, compared to other designs with much higher contact loads and no clearance, there was negligible risk that shallow scratches in the vertical designs would be rejectable. When SCE and Holtec were asked (after the August 3, 2018 event) to justify this engineering judgment, accepted engineering practices were used for the estimation of scratches as well as laboratory tests and canister inspections. This was not a required calculation for design purposes, but the use of standard engineering explanations, all of which substantiated the initial judgment.

NRC Comment 4

Now I understand, how SCE has argued, it is not a methodology. I think it is more of CoC and Appendix B change, myself. Essentially, the change is adding an alternative to the code to not have to do inspections and repair these new defects. Alternatives to the code can only be done via license amendment. Or maybe per TS Appendix B 3.3.2.

Response to Comment 4

It is not correct to call these slight scratches "defects". By the definition of the ASME code, a defect is a flaw that is rejectable. None of these scratches approach criteria that require removal or repair. That judgment has been substantiated by accepted wear laws, first principles,

NRC Review Question Response Form

laboratory tests, operating experience, and examination of installed loaded canisters that this judgment was and still is valid.

As noted in the Response to Comment 4, questions regarding the judgment arose from various stakeholders following the hang-up of the MPC on August 3, 2018. It was apparently presumed that the lateral loads during passage of the MPC into the cavity enclosure container must be higher than previously considered. After assessing the actual loads and their effect on the surfaces of the canister, the original judgment was validated.

NRC Comment 5

NB-4131 "Material originally accepted on delivery in which defects exceeding limits of NB-2500 are known or discovered during the process of fabrication or installation is unacceptable. The material may be used provided the condition is corrected in accordance with the requirements of NB-2500.

Response to Comment 5

SCE and Holtec agree with this ASME Code requirement. It is appropriately implemented by the fabricator as an attribute of the manufacturing process and its controls. Appropriate documentation is provided to Holtec and SCE certifying compliance with FSAR invoked requirements of the ASME Code.

As previously noted, no defects (i.e., rejectable flaws) were discovered or are anticipated during the process of installation. Therefore no corrections are required per NB-2500.

NRC Comment 6

ASME Section III NB-2538, "Elimination of Surface Defects" requires that defects are required to be examined by either magnetic particle or liquid penetrant method to ensure that the defect has been removed or reduced to an imperfection of acceptable size."

Response to Comment 6

No defects (rejectable flaws) have been identified that have resulted from scratches or are expected to result from scratches due to incidental contact during down-loading. The bounding scratches estimated in response to the various inquiries are theoretical projections not identified flaws.

This is consistent with the judgment in the FSAR, and validated by the means explained above. The requirement of NB-2538 might have removed a scratch during construction if it interfered with the ability to complete the surface or volumetric material examinations of the pressure boundary material.

Once this had been completed and the canister delivered, a similar surface defect occurring during installation would not need to be removed because these material examinations had already been completed.

NRC Review Question Response Form

NRC Comment 7

Instead of doing that (which I understand is impossible) which would maintain code compliance, the 72.48 deviates using a calculational method to bound the defect. The only “method” that should be used to disposition these defects is some method allowed or described in the BPVC code or the licensee would need an alternative to the code to maintain compliance with the regulatory licensing basis.

Response to Comment 7

As previously noted no “defects” due to incidental contact are anticipated. The calculational methods are tools to estimate potential scratch depth and are in no way a means to disposition any defect; real or projected.

Neither the identification nor removal of shallow scratches, wear or rub marks due to installation is required to maintain compliance with ASME Section III or the ASME B&PV Code generally.

Assigned Response Team Member: David Rackiewicz

Assigned Independent / Peer Review Team Member: Bob Yale/Ken Wilson

NRC Inspector: Lee Brookhart

Response provided date / time: 3/23/19

From: Simpson, Eric
Sent: Wednesday, January 16, 2019 7:06 AM
To: RANDALL GRANAAS
Subject: RE: PREDECISIONAL ENFORCEMENT CONFERENCE WITH SOUTHERN CALIFORNIA: 1/24/2019

Randall, I you are one of the few familiar names/faces left at SONGS.

Randall, the meeting notice is here on the NRC public site:
<https://www.nrc.gov/pmns/mtg?do=details&Code=20190029>

Click the webinar link that should take you to
here: <https://register.gotowebinar.com/register/2491132005260879875>

Register to participate in the public meeting via Webinar.

A dial in number will be provided during the webinar to use in case the Webinar application fails or proves to be problematic. That is the only time the dial in number will be active.

If you have questions, please call. If you have any questions for NRC, take some time and write them out. We may be able to answer your questions after the business portion of the Conference.

Eric J. Simpson, CHP, Dry Fuel Storage Inspector

US Nuclear Regulatory Commission, RIV
1600 E. Lamar Boulevard
Arlington, TX 76011

(817) 200-1553, office
(b)(7)(C), cell

[US NRC](#)

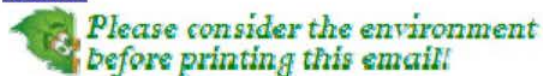

From: RANDALL GRANAAS [mailto:Randall.Granaas@sce.com]
Sent: Tuesday, January 15, 2019 4:43 PM
To: Simpson, Eric <Eric.Simpson@nrc.gov>
Subject: [External_Sender] PREDECISIONAL ENFORCEMENT CONFERENCE WITH SOUTHERN CALIFORNIA: 1/24/2019

Hello Eric,

I would like to register for the SCE PEC webinar.

Thank you,

Randall Granaas, P.E.
SONGS Fuels
(949) 368-6804 (Office)
(b)(7)(C) (Mobile)

NRC Review Question Response Form

Note 1: Complete a separate form for each inspector question.

Note 2: The item tracking number will be generated when the record is entered into the inspection database.

Question Title: Test Data Relationship to Archard Predictions

Tracking Number: 9a AR Number: 0319-53688-2 Date Initiated: 03/11/2019

Holtec Support Required: Yes or No

Question description:

Subject: Inspector follow-up question regarding Scratch Test Report Summary

Inspector statement:

I believe I understand the response.

SONGS was not using the test to validate Archard's wear equation. Test data confirms max depth is low during the physical tests performed.

To me, the test shows that use of the Archard's wear equation to maximize depth theoretically could be misleading. As the depth (h) can vary because the width is not constant as assumed in the conservative calculation. And as can be seen in the test data.

So I am left thinking:

Does the test data confirm max depth should be low = yes

Does the test data confirm Archard's wear equation (the way it is utilized in the calculation) to be conservative in determining max depth = not necessarily

To me, I am not sure if that is a win or a loss.

Requested Clarification (If needed):

SONGS / Holtec Response:

Conservative contact widths were chosen in the Scratch Evaluation (Holtec report HI-2188437), resulting in maximum (conservative) wear depth. The Orrvilon demonstration, as documented in Holtec report HI-2188450, used replicas of the actual contact geometries. The observed scratch width from the demonstration was wider than that assumed in the calculation, confirming the assumed widths are conservative.

NRC Review Question Response Form

Note 1: Complete a separate form for each inspector question.

Note 2: The item tracking number will be generated when the record is entered into the inspection database.

Question Title: Clarification of ASME Section 3 in Licensing Basis

Tracking Number: 11A AR Number: 0319-53473-3 Date Initiated: 03/21/2019

Holtec Support Required: Yes__ or No ____

Question description:

Appendix B Technical Specification 3.3 requires, that the AMSE BPVC, 2007, is the governing Code for the MPC. Additionally, Appendix B Table 3-1 tie the canister and FSAR to the requirements of ASME Section III in many areas.

The original FSAR statement for no scratches mirrored the CoC/TS design basis that no scratches would ensure the code adherence to ASME Section III.

Now under 72.48, a design change is needed to deviate to allow scratches. But instead of using ASME BPVC code criteria to inspect the canister and properly disposition the defects which would maintain conformance to the code, the calculation utilizes Archard's wear equation to bound the condition. I just don't see how that meets CoC.

Now I understand, how SCE has argued, it is not a methodology. I think it is more of CoC and Appendix B change, myself. Essentially, the change is adding an alternative to the code to not have to do inspections and repair these new defects. Alternatives to the code can only be done via license amendment. Or maybe per TS Appendix B 3.3.2.

NB-4131 "Material originally accepted on delivery in which defects exceeding limits of NB-2500 are known or discovered during the process of fabrication or installation is unacceptable. The material may be used provided the condition is corrected in accordance with the requirements of NB-2500

ASME Section III NB-2538, "Elimination of Surface Defects" requires that defects are required to be examined by either magnetic particle or liquid penetrant method to ensure that the defect has been removed or reduced to an imperfection of acceptable size."

Instead of doing that (which I understand is impossible) which would maintain code compliance, the 72.48 deviates using a calculational method to bound the defect. The only "method" that should be used to disposition these defects is some method allowed or described in the BPVC code or the licensee would need an alternative to the code to maintain compliance with the regulatory licensing basis.

NRC Review Question Response Form

Requested Clarification (If needed): None

SONGS / Holtec Response:

NOTE: For clarity, the NRC question (comment) is separated by paragraph and a response to each is provided.

NRC Comment 1

Appendix B Technical Specification 3.3 requires, that the AMSE BPVC, 2007, is the governing Code for the MPC. Additionally, Appendix B Table 3-1 tie the canister and FSAR to the requirements of ASME Section III in many areas.

Response to Comment 1

It is agreed that the ASME BPVC, 2007 is the governing code for the MPC and that Technical Specification Appendix B Table 3-1 ties the canister and FSAR to the requirements of Section III in many areas. However, other sections of the code apply as well and the relationship is described below.

Section III is the design code portion of the ASME B&PV Code. It assumes that the other parts of the Code are also involved as appropriate. ASME Code materials are selected in accordance with Section II. NDE is generally performed in accordance with Section V. Welding is performed in accordance with Section IX. Preservice examinations required by the component specifications to be done by the manufacturer are often performed in accordance with Section XI. The primary jurisdiction of the Section III design code ends when the MPC component is complete and leaves the manufacturer. The ASME Code Section XI then has jurisdiction, as selected by Holtec, after the MPC leaves the manufacturer (this is consistent with the ASME BPVC, 2007, as referenced in the FSAR).

If a scratch during installation occurs, it can, under Section XI jurisdiction, either be dispositioned as a scratch (i.e., since it not a planar flaw) by reverting back to the Construction Code, which would be Section III, or if desired be dispositioned by Section XI, Table IWB-3514-1, as if it were a planar flaw (which is more conservative than Section III). The information supplied by SCE and Holtec to date is not intended to disposition any indication; but, provide assurance that any actual indications will remain well with ASME Code Allowables.

NRC Comment 2

The original FSAR statement for no scratches mirrored the CoC/TS design basis that no scratches would ensure the code adherence to ASME Section III.

Response to Comment 2

There is no indication in the CoC, its Appendices (Technical Specifications or Approved Contents and Design Features), or NRC SER that the statement in Chapter 9 of the FSAR related to no risk of scratching was considered in the NRC's evaluation of the ASME Code compliance of the MPC.

NRC Review Question Response Form

There is no violation of ASME Section III requirements, nor any cause for repair activities, stemming from minor scratches or wear marks that result from incidental contact between the MPC and the CEC internal features during download operations at site.

HI-STORM UMAX FSAR Rev. 4: 9.5.vii states

Because the MPC insertion (and withdrawal) occurs in the vertical configuration with ample lateral clearances, there is no risk of scratching or gouging of the MPC's external surface (Confinement Boundary). Thus the ASME Section III Class 1 prohibition against damage to the pressure retaining boundary is maintained.

The Section III requirements for pressure containing plate materials is that surface defects will be removed (NB-2538). In NCA-9000, *defective material* is defined as material that does not meet specified requirements. Similarly a defect is defined in general as a rejectable flaw and a flaw is defined as an imperfection or unintentional discontinuity that is detectable by visual, surface or volumetric methods (Section XI Glossary, IWA-9000 (1992)).

A scratch, if it occurred during installation, would not be a rejectable flaw due to potential effects on peak stresses as explained in HI-2188437. This is because localized scratches or wear marks are only capable of producing peak stresses, which are only objectionable from a fatigue or brittle fracture standpoint. The HI-STORM UMAX and FW FSARs (Table 3.1.10 of both address fatigue and HI-STORM FW FSAR Section 3.4.5 for brittle fracture) explain why [neither fatigue nor brittle fracture](#) such conditions do not present any risk to [a the](#)-MPC.

A scratch would not be rejectable due to interference with material testing in NB-2000 since all of these tests would be completed prior to canister delivery.

Therefore, the only remaining cause (without further analysis) of rejection of a scratch located on the exterior of the canister wall generated during installation would be a condition where the amount of localized wall thinning was below an allowable wall thickness based on Section III. This means that the 0.625 inch nominal wall for a SONGS canister could be reduced without further analysis by 0.175 inches to 0.450 inches, which is allowable based on the licensed 0.500 inch baseline UMAX MPC as discussed in HI-2188437.

A scratch that might be formed during incidental contact of an MPC wall with the divider shell inside the cavity enclosure container during downloading would not result in a rejectable flaw condition, considering the large allowable margin for such localized thinning. This is based on engineering judgment and operational experience. Knowledge of basic wear principles with two soft materials having incidental contact under light lateral loads and many years of operating experience with acceptable canister loading of horizontal canisters inform this judgment. Scratches of a light nature, though somewhat likely, present no risk since the impact is negligible.

NRC Review Question Response Form

NRC Comment 3

Now under 72.48, a design change is needed to deviate to allow scratches. But instead of using ASME BPVC code criteria to inspect the canister and properly disposition the defects which would maintain conformance to the code, the calculation utilizes Archard's wear equation to bound the condition. I just don't see how that meets CoC.

Response to Comment 3

ECO-5021-042 is not a design change. It is a proposed change to clarify the HI-STORM UMAX FSAR. The ECO and supporting 72.48 are explicit in this regard. They further note that they are evaluated as if they were a design change to assure a more comprehensive documented review.

A change is not required to allow scratches since the FSAR statement that there is no risk of damage to the ASME Section III Class 1 pressure retaining boundary that might result from scratching remains valid.

It is not necessary to conclude that the intent of the FSAR was to state that no scratches would occur since incidental contact could occur. More likely the intent was to note that, compared to other designs with much higher contact loads and no clearance, there was negligible risk that shallow scratches in the vertical designs would be rejectable. When SCE and Holtec were asked (after the August 3, 2018 event) to justify this engineering judgment, accepted engineering practices were used for the estimation of scratches as well as laboratory tests and canister inspections. This was not a required calculation for design purposes, but the use of standard engineering explanations, all of which substantiated the initial judgment.

NRC Comment 4

Now I understand, how SCE has argued, it is not a methodology. I think it is more of CoC and Appendix B change, myself. Essentially, the change is adding an alternative to the code to not have to do inspections and repair these new defects. Alternatives to the code can only be done via license amendment. Or maybe per TS Appendix B 3.3.2.

Response to Comment 4

It is not correct to call these slight scratches "defects". By the definition of the ASME code, a defect is a flaw that is rejectable. None of these scratches approach criteria that require removal or repair. That judgment has been substantiated by accepted wear laws, first principles, laboratory tests, operating experience, and examination of installed loaded canisters that this judgment was and still is valid.

As noted in the Response to Comment 4, questions regarding the judgment arose from various stakeholders following the hang-up of the MPC on August 3, 2018. It was apparently presumed that the lateral loads during passage of the MPC into the cavity enclosure container must be higher than previously considered. After assessing the actual loads and their effect on the surfaces of the canister, the original judgment was validated.

NRC Review Question Response Form

NRC Comment 5

NB-4131 "Material originally accepted on delivery in which defects exceeding limits of NB-2500 are known or discovered during the process of fabrication or installation is unacceptable. The material may be used provided the condition is corrected in accordance with the requirements of NB-2500.

Response to Comment 5

SCE and Holtec agree with this ASME Code requirement. It is appropriately implemented by the fabricator as an attribute of the manufacturing process and its controls. Appropriate documentation is provided to Holtec and SCE certifying compliance with FSAR invoked requirements of the ASME Code.

As previously noted, no defects (i.e., rejectable flaws) were discovered or are anticipated during the process of installation. Therefore no corrections are required per NB-2500.

NRC Comment 6

ASME Section III NB-2538, "Elimination of Surface Defects" requires that defects are required to be examined by either magnetic particle or liquid penetrant method to ensure that the defect has been removed or reduced to an imperfection of acceptable size."

Response to Comment 6

No defects (rejectable flaws) have been identified that have resulted from scratches or are expected to result from scratches due to incidental contact during down-loading. The bounding scratches estimated in response to the various inquiries are theoretical projections not identified flaws.

This is consistent with the judgment in the FSAR, and validated by the means explained above. The requirement of NB-2538 might have removed a scratch during construction if it interfered with the ability to complete the surface or volumetric material examinations of the pressure boundary material.

Once this had been completed and the canister delivered, a similar surface defect occurring during installation would not need to be removed because these material examinations had already been completed.

NRC Review Question Response Form

NRC Comment 7

Instead of doing that (which I understand is impossible) which would maintain code compliance, the 72.48 deviates using a calculational method to bound the defect. The only "method" that should be used to disposition these defects is some method allowed or described in the BPVC code or the licensee would need an alternative to the code to maintain compliance with the regulatory licensing basis.

Response to Comment 7

As previously noted no "defects" due to incidental contact are anticipated. The calculational methods are tools to estimate potential scratch depth and are in no way a means to disposition any defect; real or projected.

Neither the identification nor removal of shallow scratches, wear or rub marks due to installation is required to maintain compliance with ASME Section III or the ASME B&PV Code generally.

Assigned Response Team Member: David Rackiewicz

Assigned Independent / Peer Review Team Member: Bob Yale/Ken Wilson

NRC Inspector: Lee Brookhart

Response provided date / time: 3/23/19

Subject: FW: Special Inspection followup discussion
Location: Skype Meeting

Start: Mon 01/07/2019 12:00 PM
End: Mon 01/07/2019 1:00 PM
Show Time As: Tentative

Recurrence: (none)

Meeting Status: Not yet responded

Organizer: MARK MORGAN

-----Original Appointment-----

From: MARK MORGAN [mailto:Mark.Morgan@sce.com]
Sent: Sunday, January 06, 2019 5:32 PM
To: MARK MORGAN; Katanic, Janine; Simpson, Eric; Smith, Chris; Silva, Patricia; Davis, Marlone; ALBERT BATES; Kerry Rod; Stefan Anton
Cc: Pruett, Troy; Howell, Linda
Subject: [External_Sender] Special Inspection followup discussion
When: Monday, January 07, 2019 10:00 AM-11:00 AM (UTC-08:00) Pacific Time (US & Canada).
Where: Skype Meeting

Updated to add agenda.

All,

The purpose of this weekly phone call will be for SONGS to provide updates regarding closure of issues identified during the special inspection. NRC participants please call the phone number below. SONGS participants please meet in Kerry Rod's office.

Formal agenda to follow.

Thanks,
Mark Morgan
SONGS Regulatory Affairs
(949) 368-6745

.....
[→ Join Skype Meeting](#)

Trouble Joining? [Try Skype Web App](#)

Join by phone

[626-543-6758](#) (Alhambra, CA) English (United States)
[PAX 36758 \(Internal\)](#) (Alhambra, CA) English (United States)
[Find a local number](#)

Conference ID: (b)(7)(C)
[Forgot your dial-in PIN?](#) | [Help](#) | [Legal](#)

Skype meetings MAY be recorded only if the presenter enables the recording feature AND initiates recording. If the meeting is being recorded, you will be warned and you may either consent to recording by staying on the call or hang up and contact the meeting organizer.

||OC||1093|||



Microsoft Word
Word file...



SCE/NRC Teleconference
January 2, 2019 1000-1100
626-543-6758 Conference ID (b)(6)

SAN ONOFRE NUCLEAR GENERATING STATION

Purpose of Meeting & Expected Outcome(s):

- **Keep Ongoing Communications with NRC Current**

AGENDA

Time	Topic	Who	Method	Expected Outcome
1000-1005	Introductions	Morgan	N/A	✓ Ensure alignment
1005-1010	NOV Reply	Morgan	Discuss	✓ Questions are answered
1005-1025	Followup inspection <ul style="list-style-type: none"> • Discuss dates • Procedure Revisions • Inspector Questions • Corrective Action status 	Morgan	Discuss	✓ Ensure alignment
1025-1045	Enforcement Decision <ul style="list-style-type: none"> • Notice • Agenda • Presentation Materials 	Bates	Discuss	✓ Provide updates on progress
1045-1055	Questions/Closing Remarks	All	-	✓ Identify Action Items

As employees of SONGS, we are committed to demonstrating the right behaviors required of a Nuclear Professional and embracing our Values of:

Integrity ~ Excellence ~ Respect ~ Continuous Improvement ~ Teamwork

1.2 GENERAL DESCRIPTION OF HI-STORM UMAX SYSTEM

1.2.1 System Characteristics

The HI-STORM UMAX System consists of interchangeable MPCs, which maintain the configuration of the fuel and is the confinement boundary between the stored spent nuclear fuel and the environment; and a storage overpack that provides structural protection and radiation shielding during long-term storage of the MPC. In addition, a transfer cask that provides the structural and radiation protection of an MPC during its loading, unloading, and transfer to the storage overpack is also subject to certification by the USNRC. Description of MPCs and the HI-TRAC transfer cask are provided in Section 1.2 of the HI-STORM FW FSAR. The key parameters for the UMAX MPCs are provided in Table 1.2.2 of the HI-STORM FW FSAR. The principal materials used in the manufacturing of the MPC are listed in the licensing drawings (Section 1.5) and the acceptance criteria are provided in Chapter 10 of HI-STORM FW FSAR. Alloy X description is provided in Appendix 1.A of the HI-STORM FW FSAR. The principal materials used in the manufacturing of the HI-TRAC transfer cask are listed in the licensing drawings in Section 1.5 and the acceptance criteria are provided in Chapter 10 of the HI-STORM FW FSAR. Table 1.2.6 of the HI-STORM FW FSAR provides applicable code paragraphs for manufacturing the HI-TRAC transfer cask.

All structures, systems, and components of the HI-STORM UMAX system, MPCs and HI-TRACs, which are identified as Important-to-Safety (ITS), are specified on the licensing drawings provided in Section 1.5.

The HI-STORM UMAX MPC-37 has an alternative version called, "Type 1." The MPC-37 Type 1 is identical in design and manufacturing to the MPC-37, with the exception of the basket flow holes on the periphery of the basket. In the MPC-37 Type 1, these periphery basket flow holes are not required to be open, additionally the MPC-37 Type 1 is limited to the standard height fuel defined in this FSAR. The MPC-37 Type 1 periphery basket flow holes may be closed by design options and/or a condition that causes restricted flow through the shims, for example, an MPC which has actual or postulated shim support damage. Throughout this FSAR MPC-37 is used to refer to both the MPC-37 and MPC-37 Type 1 unless otherwise differentiated.

1.2.2 Constituents of the HI-STORM UMAX Vertical Ventilated Module and ISFSI Structures

The HI-STORM UMAX VVM, shown in the licensing drawing in Section 1.5, provides for storage of the MPC in a vertical configuration inside a subterranean cylindrical cavity entirely below the top-of-grade (TOG) of the ISFSI. The key constituents of a HI-STORM UMAX VVM and ISFSI structures (see Figure 1.2.1 and Figure 1.2.2) are:

VVM Components

- a. The Cavity Enclosure Container (CEC)
- b. The Closure Lid

ISFSI Structures

- c. The ISFSI Pad

HOLTEC INTERNATIONAL COPYRIGHTED MATERIAL	
HI-2115090	Proposed Rev. 5A
1-15	

2.1.4 provide the axial distribution for the radiological source terms for PWR and BWR fuel assemblies based on the axial burnup distribution. The axial burnup distributions are representative of fuel assemblies with the design basis burnup levels considered. These distributions are used for analyses only, and do not provide a criteria for fuel assembly acceptability for storage in the HI-STORM UMAX System.

Non-fuel hardware, as defined in the Glossary, has been evaluated and is also authorized for storage in the PWR MPCs as specified in Table 2.1.1.

2.1.7 Criticality Parameters for Design Basis SNF

The criticality analyses for the MPC-37 are performed with credit taken for soluble boron in the MPC water during wet loading and unloading operations. Table 2.1.6 provides the required soluble boron concentrations for this MPC.

2.1.8 Summary of Authorized Contents

Tables 2.1.1 through 2.1.3 specify the limits for spent fuel and non-fuel hardware authorized for storage in the HI-STORM FW System. The limits in these tables are derived from the safety analyses described in the following chapters of this FSAR.

2.1.9 Permissible Heat Load for MPC-37 and MPC-89

MPC-89 (BWR) and MPC-37 (PWR) canisters are previously licensed in Docket 72-1032 for storage of spent fuel and are permitted for storage in HI-STORM UMAX with permissible heat loads as specified in Table 2.1.7. As shown in Figures 2.1.7 and 2.1.8 for MPC-37 and MPC-89 respectively, each storage location is associated with a unique cell identification number. The permissible heat loads for each cell in the canister for storage in the HI-STORM UMAX VVM are given in Figure 2.1.19 and Figures 2.1.12 through 2.1.18 for MPC-89 and MPC-37 respectively. The permissible aggregate heat load for storage in MPC-37 and MPC-89 are provided in Tables 2.1.8 and 2.1.9 respectively.

MPC-37 Type 1 permissible aggregate heat load is provided in Table 2.1.12 and the permissible per cell heat load is shown in Figure 2.1.26.

2.1.10 Permissible Heat Load for MPC-24, MPC-32 and MPC-68

The authorized heat loads in the HI-STORM 100 docket for the MPCs certified for storage in the HI-STORM 100 will be used to determine the acceptability of storing them in HI-STORM UMAX. These analyses will be performed to characterize the thermal behavior of the “UMAX” system; they are not intended to secure certification of the MPCs in docket # 72-1014 at this time.

Regionalized loading of SNF in two regions are permitted in MPC-24, MPC-32 and MPC-68 models. The definition of the two regions for each MPC model is provided in Table 2.1.10. The inner region (Region 1) and the outer region (Region 2), shown in Figures 2.1.9, 2.1.10 and 2.1.11 for different MPC types have maximum permitted specific heat loads denoted by q_1 and q_2 , respectively. The maximum permitted values of q_1 and q_2 are related through the ratio X,

where,

$$X = q_1/q_2.$$

HOLTEC INTERNATIONAL COPYRIGHTED MATERIAL	
HI-2115090	Rev. 5
2-21	

TABLE 2.1.8

HI-STORM UMAX MPC-37 PERMISSIBLE HEAT LOADS^{Note 5}

Fuel Type (see Table 2.1.7 for length data)	Description	Helium Backfill Pressure Option (Notes 2)	Heat Load per Storage Cell (Note 3)	Permissible Aggregate Heat Load (Note 1), kW
Short Fuel	Heat Load Chart 1	1	Figure 2.1.12	33.88
	Heat Load Chart 2	2	Figure 2.1.14	33.70
	Heat Load Chart 3	1	Figure 2.1.16	33.53
Standard Fuel	Heat Load Chart 1	1	Figure 2.1.12	33.88
	Heat Load Chart 2	2	Figure 2.1.14	33.70
	Heat Load Chart 3	1	Figure 2.1.17	35.30
Long Fuel	Heat Load Chart 1	1	Figure 2.1.13	35.76
	Heat Load Chart 2	2	Figure 2.1.15	35.57
	Heat Load Chart 3	1	Figure 2.1.18	37.06
Short Fuel	Sub-Design Heat Load	3	Figure 2.1.19	34.28
	Threshold Heat Load	3	Figure 2.1.21	33.46
Standard Fuel	Sub-Design Heat Load	3	Figure 2.1.19	34.28
	Threshold Heat Load	3	Figure 2.1.21	33.46
Long Fuel	Sub-Design Heat Load	3	Figure 2.1.20	36.19
	Threshold Heat Load	3	Figure 2.1.21	33.46
16x16A Fuel (see Table 2.1.2)	Intact Fuel in up to 37 DFCs (Note 4)	3	Figure 2.1-25	32.3

Note 1: The aggregate heat load is defined as a sum of all stored fuel assemblies. Thermal evaluations in Chapter 4 are performed with maximum per storage cell heat load in all locations. However, the CoC restricts the permissible aggregate heat load to the value specified in this table.

Note 2: The helium backfill range is in Table 4.4.6.

Note 3: Decay heat limits must be met for all contents in a fuel storage location (i.e., fuel and non-fuel hardware, as applicable).

Note 4: This may include undamaged fuel both in DFCs and not, and damaged fuel in DFCs. These heat load limits apply with one or more undamaged fuel assemblies stored in DFCs.

Note 5: MPC-37 Type 1 Heat Load Limits given in Table 2.1.12.

HOLTEC INTERNATIONAL COPYRIGHTED MATERIAL	
HI-2115090	Rev. 5
2-41	

TABLE 2.1.12

HI-STORM UMAX MPC-37 TYPE 1 PERMISSIBLE HEAT LOADS

Fuel Type (see Table 2.1.7 for length data)	Description Helium Backfill Pressure Option (Notes 2)	Heat Load per Storage Cell (Note 3)	Permissible Aggregate Heat Load (Note 1), kW
Standard Fuel	Option 1	Figure 2.1.26	32.3
<p>Note 1: The aggregate heat load is defined as a sum of all stored fuel assemblies. Thermal evaluations in Chapter 4 are performed with maximum per storage cell heat load in all locations.</p> <p>Note 2: The helium backfill range is in Table 4.4.6.</p> <p>Note 3: Decay heat limits must be met for all contents in a fuel storage location (i.e., fuel and non-fuel hardware, as applicable).</p>			

HOLTEC INTERNATIONAL COPYRIGHTED MATERIAL

HI-2115090

Rev. 5

2-44

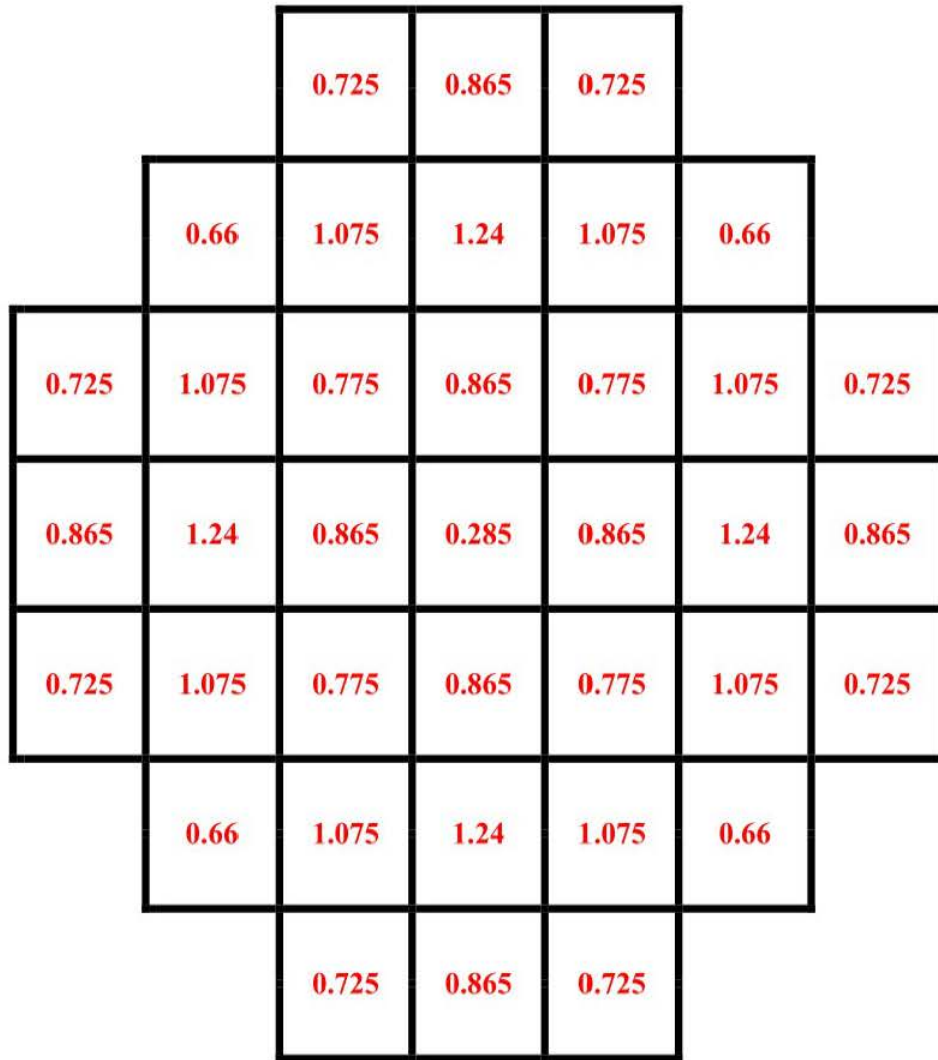

Figure 2.1.26: HI-STORM UMAX MPC-37 Type 1 Heat Permissible Heat Loads for Standard Fuel

(All storage cell heat loads are in kW)

Note that this figure shows the per cell heat load limit for storage. The permissible aggregate heat load may be less than the sum of each individual cell heat load. See Table 2.1.12 for corresponding permissible aggregate heat load and the helium backfill option.

HOLTEC INTERNATIONAL COPYRIGHTED MATERIAL	
HI-2115090	Rev. 5
2-70	

examination. These inspection and testing techniques are performed to verify the integrity of the confinement boundary.

The HI-STORM UMAX VVM does not serve a confinement function: It does not feature any safety significant seals. Therefore, leakage of one seal is not evaluated for its consequence to the storage system.

2.3.3.5 Malfunction of FHD

The FHD system is a forced helium circulation device used to effectuate moisture removal from loaded MPCs. For circulating helium, the FHD system is equipped with active components requiring external power for normal operation.

Initiating events of FHD malfunction are: (i) a loss of external power to the FHD System and (ii) an active component trip. In both cases a stoppage of forced helium circulation occurs and heat dissipation in the MPC transitions to natural convection cooling.

Although the FHD System is monitored during its operation, stoppage of FHD operations does not require actions to restore forced cooling for adequate heat dissipation. This is because the condition of natural convection cooling evaluated in Section 4.6 of HI-STORM FW FSAR shows that the fuel temperatures remain below off-normal limits. An FHD malfunction is detected by operator response to control panel visual displays and alarms.

2.3.4 Extreme Environmental Phenomena and Accident Conditions

The loadings corresponding to the extreme environmental phenomena and accident events, collectively referred to as Faulted States, are discussed as a part of load combinations.

2.3.4.1 Partial Blockage of MPC Basket Flow Holes

The MPC is designed to prevent reduction of thermosiphon action due to partial blockage of the MPC basket flow holes by fuel cladding failure, fuel debris and crud. The HI-STORM UMAX System maintains the SNF in an inert environment with fuel rod cladding temperatures below accepted values (Table 2.3.7). Therefore, there is no credible mechanism for gross fuel cladding degradation of fuel classified as undamaged during storage in the HI-STORM UMAX. Fuel classified as damaged fuel or fuel debris are placed in damaged fuel containers. The damaged fuel container is equipped with mesh screens which ensure that the damaged fuel and fuel debris will not escape to block the MPC basket flow holes. The MPC is loaded once for long-term storage and, therefore, buildup of crud in the MPC due to numerous loadings is precluded. Using crud quantities for fuel assemblies reported in an Empire State Electric Energy Research Corporation Report [2.2.3] determines a layer of crud of conservative depth that is assumed to partially block the MPC basket flow holes. The crud depth is listed in Table 2.2.8 of the HI-STORM FW FSAR. The flow holes in the bottom of the fuel basket are designed (as can be seen on the licensing drawings) to ensure that this amount of crud does not block the internal helium circulation.

MPC-37 Type 1 is designed to allow the periphery basket holes to be closed under all design basis scenarios.

HOLTEC INTERNATIONAL COPYRIGHTED MATERIAL		
HI-2115090		Rev. 5
2-79		

Table 4.1.2		
PEAK CLADDING TEMPERATURE RESULTS FOR LONG-TERM NORMAL STORAGE FOR MPC-32, MPC-37 ¹ AND MPC-89 IN HI-STORM UMAX SYSTEM**		
MPC Types		Fuel Cladding Temperature °C (°F)
MPC-37 (Heat Load Chart 1)	Short Fuel	367 (693)*
	Standard Fuel	357 (675)
	Long Fuel	351 (664)
MPC-37 (Heat Load Chart 2)	Short Fuel	363 (685)
	Standard Fuel	355 (671)
	Long Fuel	346 (655)
MPC-37 (Heat Load Chart 3)	Short Fuel	359 (678)
	Standard Fuel	364 (687)
	Long Fuel	353 (667)
MPC-37	16x16A Fuel	295 (563)***
MPC-89		357 (675)
MPC-32 (X=3)		366 (691)
<p>* Based on the results in this table, MPC-37 with short fuel under Heat Load Chart 1 is selected as the governing thermal configuration and is used to perform all the licensing basis calculations for HI-STORM UMAX System.</p> <p>** The PCT results documented in this table are for normal storage conditions under quiescent (no wind) conditions.</p> <p>*** The PCT result for 16x16A fuel assembly type documented herein corresponds to an MPC-37 with up to 37 DFCs and loaded to heat load chart specified in Table 2.1.8.</p>		

¹ Evaluation of MPC-37 Type 1 canister addressed in Table 4.4.19.

4.4.12 MPC-37 Type 1 Thermal Evaluation

The HI-STORM UMAX Chapter 1 defines an alternative MPC-37 canister called “Type 1” for storage of spent nuclear fuel. The Type 1 canister is identical to MPC-37 with the exception that the basket flow holes located on its periphery are not required in the design. This exception is limited to standard height fuel MPC-37 canisters defined in this FSAR. The permissible cell and aggregate heat load for “Type 1” canister is defined in Table 2.1.12 and Figure 2.1.26. Thermal evaluation of MPC-37 Type 1 canister is addressed in the following.

Thermal evaluation of MPC-37 Type 1 deploys the same FLUENT thermal model articulated in this section with the exception that basket flow holes are closed. To this model the permissible heat loads defined above are applied and steady state thermal solution obtained under long term normal storage. Maximum storage temperatures of limiting components are tabulated in Table 4.4.19. A review of MPC-37 Type 1 temperatures supports the following conclusions:

- Fuel cladding temperatures bounded by Design Basis MPC-37 with short fuel storage (See Table 4.4.2)
- Basket temperatures bounded by Design Basis MPC-37 with short fuel storage (See Table 4.4.2)
- MPC shell confinement boundary temperatures bounded by Design Basis MPC-37 with short fuel storage (See Table 4.4.2)
- MPC confinement boundary pressures bounded by Design Basis MPC-37 with short fuel storage (See Table 4.4.7)

The evaluation above supports safe long term storage of spent fuel in the MPC-37 Type 1 canister in HI-STORM UMAX. Evaluation of MPC-37 Type 1 under short term operations and off-normal and accident events are addressed in Sections 4.5 and 4.6.

HOLTEC INTERNATIONAL COPYRIGHTED MATERIAL	
HI-2115090	Proposed Rev. 5A
4-30	

Table 4.4.19
 MPC-37 TYPE 1 LONG-TERM NORMAL STORAGE TEMPERATURES AND PRESSURE

Component ^{Note 1}	Temperature °C (°F)
Fuel Cladding	321 (610)
MPC Basket	302 (576)
Aluminum Basket Shims	223 (433)
MPC Shell	191 (376)
Closure Lid Concrete ¹	84 (183)
MPC Cavity Pressure (psig)	
Normal Condition	
Intact Rods	87.8
1% Rods Rupture	88.9
Note 1: Limiting components tabulated.	

¹ Maximum section average temperature reported.

Cask cooldown and reflood evaluation in the HI-STORM FW FSAR Section 4.5.5 [4.1.2] is incorporated by reference.

4.5.6 Maximum Internal Pressure

After fuel loading and vacuum drying, but prior to installing the MPC closure ring, the MPC is initially filled with helium. During handling and on-site transfer operations in the HI-TRAC VW transfer cask, the gas temperature will correspond to the thermal conditions within the MPC analyzed in Section 4.5.4.3. Based on this analysis the MPC internal pressure is computed under the assumption of maximum helium backfill specified in Table 4.4.6 and confirmed to comply with the short term operations pressure limit in Table 2.3.5. The results are tabulated in Table 4.5.3.

4.5.7 Evaluation of MPC-37 Type 1 in HI-TRAC VW Transfer Cask

As evaluated in Section 4.4.12 the temperature of fuel and canister internals under MPC-37 Type 1 thermal loadings is bounded by Design Basis thermal loadings. This evaluation supports the conclusion that its temperatures in HI-TRAC VW transfer cask are reasonably bounded by Design Basis loadings evaluated in this section.

HOLTEC INTERNATIONAL COPYRIGHTED MATERIAL	
HI-2115090	Proposed Rev. 5A
4-54	

(b)(4)

4.6.2.6 Jacket Water Loss

The thermal evaluation of normal on-site transfer in HI-TRAC VW discussed in Sub-Section 4.5.4 is bounded by the normal on-site transfer evaluation of HI-TRAC VW in the HI-STORM FW FSAR Section 4.5.4 [4.1.2]. Therefore, HI-TRAC VW jacket water loss accident evaluated in the HI-STORM FW FSAR Section 4.6.2 [4.1.2] is incorporated by reference.

4.6.3 MPC-37 Type 1 Evaluation Under Off-Normal and Accident Events

Off-normal and accident events defined in herein are limited duration transient events wherein fuel, canister and internals experience bounded temperature excursions relative to baseline storage temperatures. The maximum temperatures reached under such temperature excursions are principally a function of baseline temperatures T_o , thermal inertia I of the system and cask heat load Q . As evaluated in Section 4.4, T_o is bounded by Design Basis storage temperatures, I is unaffected by "Type 1" canister design and Q is bounded by Design Basis cask heat loads. In this manner it follows that temperature excursion under MPC-37 Type 1 storage in the UMAX is reasonably bounded by Design Basis off-normal and accident event evaluations in this section.

HOLTEC INTERNATIONAL COPYRIGHTED MATERIAL	
HI-2115090	Proposed Rev. 5A
4-63	

of the ISFSI, this places the boundary at least 22 feet from the center of the module. Calculations were conservatively performed with the 6.5 ft remaining fill (soil is used in the model) around a loaded VVM instead of the 10.75 ft required by the RPS. The dose rates at the surface of the excavation are presented in table 5.4.4 for both MPC-32 and MPC-37. This dose rate is very low, specifically lower than the dose rates at 1 m from the inlet/outlet vents of the modules. The dose rates at a construction site might therefore be dominated by the dose rates from the inlet/outlet vents, and depending on the loading condition of the operating part of the ISFSI, temporary shielding might be used to reduce dose rates to the construction site. It is to be noted that 6.5 feet of soil is considered for this purpose without any concrete enclosure wall.

5.4.2 Design Basis Dose Rate Limits

As discussed in Appendix 13.A, Section B 5.3, dose rate measurements are to be performed, amongst other locations, on top of the lid of every loaded cask, and compared with calculated values. Generally, for design basis conditions, dose rate locations should be away from discontinuities such as inlet and outlet vents, where small differences in locations could result in larger dose rate differences and hence invalidate the comparison. Based on this, dose rate locations are selected to be over the annulus between the MPC and the VVM. For the standard HI-STORM UMAX and lid design, the results shown in Tables 5.4.2 and 5.4.3 together with the information in Figure 5.3.2 show that this would be location “K”, with a dose rate of about 1 mrem/hr. Dose rates in the corresponding location have also been evaluated for the Version B lid, and found to be essentially the same as that shown in Tables 5.4.2 and 5.4.3 for location “K”. Based on this, the value listed in Table 5.4.6 is specified. This value is slightly larger than the highest expected value, to assure that measurement and location uncertainties will not result in inadvertent failure of the comparison. It should be noted that this value is an overall bounding limit, which is used in addition to a site specific limit that typically will be significantly lower, and hence be the more limiting condition.

The standard lid is essentially rotational symmetric, and hence the azimuthal orientation of the 4 required dose rate locations is not critical. The Version B lid is not round, and hence the shielding configurations vary azimuthally. However, evaluations show that even for that lid, the dose rates over the annulus are also essentially azimuthally constant. Overall it is therefore recommended to have the dose rate locations at 0, 90, 180 and 270 degree of the lid. For the Version B lid, although the calculations show no relevant azimuthal variation, this would keep the locations away from the inlet and any potential disturbance of the comparison. However, based on operational or other requirements, a different orientation may be selected.

Finally, an important aspect is that the locations of the calculations to determine the limits and the locations where the measurements are taken are as close as possible to each other, so that a valid comparison is made. This needs to be recognized when selecting and identifying the locations.

For the side of the HI-TRAC VW, evaluations are performed in the HI-STORM FW, Chapter 5 [5.0.3]. The dose rate limit based on those evaluations is specified in Table 5.4.6.

HOLTEC INTERNATIONAL COPYRIGHTED MATERIAL	
HI-2115090	Proposed Rev. 5A
5-38	

Table 5.4.6	
DESIGN BASIS DOSE RATE LIMITS	
Location	Value
Side of HI-TRAC	3500 mrem/hr
VVM lid (over the annulus)	3 mremr/hr

HOLTEC INTERNATIONAL COPYRIGHTED MATERIAL	
HI-2115090	Proposed Rev. 5A
5-46	

v. Confinement

There is no effect on the confinement function of the MPC as a result of this event since the structural integrity of the confinement boundary is unaffected.

vi. Radiation Protection

Since there is minimal reduction, if any, in shielding and no effect on the confinement capabilities as discussed above, there is no effect on occupational or public exposures as a result of this accident event.

12.2.1.3 Fire Accident Corrective Actions

Upon detection of a fire adjacent to a loaded HI-STORM UMAX VVM, the ISFSI owner shall take the appropriate immediate actions necessary to extinguish the fire. Following the termination of the fire, a visual and radiological inspection of the equipment shall be performed.

If damage to the HI-STORM UMAX VVM as the result of a fire event is widespread, and/or as radiological conditions require (based on dose rate measurements), the MPC shall be removed from the HI-STORM UMAX VVM in accordance with the procedure set down in Chapter 9. However, the thermal analysis described herein demonstrates that only a limited amount of lid concrete which is behind the steel enclosure exceeds its design temperature. The HI-STORM UMAX VVM may be returned to service after appropriate restoration (reapplication of coatings, etc.) if there is no significant increase in the measured dose rates (i.e., the shielding effectiveness of the overpack is confirmed) and if the visual inspection is satisfactory.

There is no effect on the function of criticality control features of the MPC as a result of this accident event.

Based on the foregoing evaluation, it is concluded that the overpack fire accident does not affect the safe operation of the HI-STORM UMAX VVMs.

12.2.1.4 Conclusion

Based on the above evaluation, it is concluded that the Design Basis Fire accident does not affect the safe operation of the HI-STORM UMAX System.

12.2.2 Partial Blockage of MPC Basket Vent Holes

Partial blockage of MPC basket vent holes evaluated in the HI-STORM FW FSAR Section 12.2.5 [4.1.2] is incorporated by reference **for the MPC-37 and MPC-89.**

HOLTEC INTERNATIONAL COPYRIGHTED MATERIAL	
HI-2115090	Rev. 5
12-15	

For the MPC-37 Type 1, closed periphery MPC Basket Holes are part of the normal design of the system, and blockage of the remaining MPC Basket Flow Holes remains non-credible as described in the HI-STORM FW FSAR Section 12.2.5 [4.1.2].

12.2.3 Tornado (Load Case 02 in Section 2.4)

12.2.3.1 Causal Factors

Tornado and high winds are principally caused by the uneven heating of the earth’s atmosphere, coupled with gravitational forces and the rotation of the earth. The HI-STORM UMAX System will be deployed in an open area environment and thus will be subject to ambient environmental conditions throughout the storage period. Additionally, the transfer of the MPC between the HI-TRAC VW transfer cask and the storage overpack may be performed at the unsheltered ISFSI concrete pad. It is therefore possible that the HI-STORM UMAX storage system may experience the extreme environmental conditions resulting in the impact from a tornado-borne projectile.

12.2.3.2 Tornado Analysis

A tornado event is characterized by high wind velocities and tornado-generated missiles. The reference missiles considered in this FSAR (see Table 2.3.3) are of three sizes: small, medium, and large. A small projectile, upon collision with a cask, would tend to penetrate it. A large projectile, such as an automobile, on the other hand, would tend to cause deformation.

Because of its underground construction, the HI-STORM UMAX is not subject to overturning action by the tornado wind. The effect of tornado missiles propelled by high velocity winds that attempt to penetrate the exposed portions of the HI-STORM UMAX must, however, be considered.

The tornado analysis for a HI-TRAC VW transfer cask evaluated in the HI-STORM FW FSAR Section 12.2.6 [4.1.2] is incorporated by reference.

The evaluation of effects on structural, thermal, criticality, confinement, and radiation protection performance on the HI-STORM UMAX system is summarized below.

i. Structural

Analyses presented in Chapter 3 show that the impact of large and intermediate tornado missiles (see Table 2.3.3) on the HI-STORM UMAX closure lid does not result in the perforation of the lid or result in a structural collapse of the lid. The sole effect of the tornado missile impact on the HI-STORM UMAX VVM is some minor global deformation of the VVM Closure Lid under the large missile and some localized deformation of the VVM Closure Lid under the intermediate missile. All Design Basis missiles are found to be stopped by the VVM assembly before reaching the MPC stored inside. Therefore, MPC damage by impact from a Design Basis Missile is ruled out.

HOLTEC INTERNATIONAL COPYRIGHTED MATERIAL	
HI-2115090	Rev. 5
12-16	

B 3.1 SFSC Integrity

B 3.1.2 SFSC Heat Removal System

BASES

BACKGROUND The SFSC Heat Removal System is a passive, air-cooled, convective heat transfer system that ensures heat from the **fuel contained in the** MPC canister is transferred to the environs by the “chimney effect.” Air is drawn into the inlet duct **vents** and travels down **through the ducts to** the space between the Cavity Enclosure Container (CEC) and the Divider Shell, through the cut-outs at the bottom of the Divider Shell, up the space between the Divider Shell and the MPC, and out through the outlet duct **and vent**. The MPC transfers its heat from its surface to the air via natural convection. The buoyancy created by the heating of the air creates a chimney effect.

APPLICABLE SAFETY ANALYSIS The thermal analyses of the SFSC take credit for the decay heat from the spent fuel assemblies being ultimately transferred to the ambient environment. Transfer of heat away from the fuel assemblies **and the MPC** ensures that the fuel cladding and other SFSC component temperatures do not exceed applicable limits. Under normal storage conditions, the inlet and outlet duct screens are unobstructed and full air flow occurs.

Analyses have been performed for half and complete obstruction of the inlet ducts **and associated** screens. Blockage of half of the inlet ducts reduces air flow through the VVM and decreases heat transfer from the MPC. Under this off-normal condition, no SFSC components exceed the short term temperature limits.

The complete blockage of all inlet air ducts stops normal air cooling of the MPC. The MPC will continue to **transfer** heat to the relatively cooler subgrade **and limited recirculation in and out of the outlet duct will continue**. However, with the loss of normal air cooling, the SFSC component temperatures will increase toward their respective short-term temperature limits. None of the components reach their temperature limits over the duration **(32 hours)** of the analyzed event.

(continued)

BASES

LCO

The SFSC Heat Removal System must be verified to be operable to preserve the assumptions of the thermal analyses. Operability is defined as **either** 50% or more of the inlet vent duct areas are unblocked and available for flow **or when differential temperature requirements are met**. Operability of the heat removal system ensures that the decay heat generated by the stored fuel assemblies is transferred to the environs at a sufficient rate to maintain fuel cladding and other SFSC component temperatures within design limits.

The intent of this LCO is to address those occurrences of air duct screen blockage that can be reasonably anticipated to occur from time to time at the ISFSI (i.e., Design Event I and II class events per ANSI/ANS-57.9). These events are of the type where corrective actions can usually be accomplished within one operating shift to restore the heat removal system to operable status (e.g., removal of loose debris).

This LCO is not intended to address low frequency, unexpected Design Event III and IV class events (ANSI/ANS-57.9) such as design basis accidents and extreme environmental phenomena that could potentially block one or more of the air ducts for an extended period of time (i.e., longer than the total Completion Time of the LCO). This class of events is addressed **by site procedures** as required the CoC.

APPLICABILITY

The LCO is applicable during STORAGE OPERATIONS **after the lid is installed on the VVM**. Once **installed**, the heat removal system must be operable to ensure adequate dissipation of the decay heat from the fuel assemblies. **Prior to lid installation, adequate cooling is available due to the configuration without the lid, which results in larger flow areas than those in the lid and vents.**

ACTIONS

A note has been added to the ACTIONS which states that, for this LCO, separate Condition entry is allowed for each SFSC. This is acceptable since the Required Actions for each Condition provide appropriate compensatory measures for each SFSC not meeting the LCO. Subsequent SFSCs that don't meet the LCO are governed by subsequent Condition entry and application of associated Required Actions.

(continued)

BASES

ACTIONS
(continued)

A.1

Although the heat removal system remains operable, the blockage should be cleared expeditiously. **If temperature measurements are used to declare operability, no inspection of the vents is required, but if any blockage is identified it should be removed.**

B.1

If the heat removal system has been determined to be inoperable, it must be restored to operable status within eight hours. Eight hours is a reasonable period of time to take action to remove the obstructions in the air flow path.

C.1

If the heat removal system cannot be restored to operable status within eight hours, the VVM and the fuel may experience elevated temperatures. Therefore, dose rates are required to be measured to verify the effectiveness of the radiation shielding provided by the concrete. This Action must be performed immediately and repeated every twelve hours thereafter to provide timely and continued evaluation of the effectiveness of the concrete shielding. As necessary, the system user shall provide additional radiation protection measures such as temporary shielding. The Completion Time is reasonable considering the expected slow rate of deterioration, if any, of the concrete under elevated temperatures.

C.2.1

In addition to Required Action C.1, efforts must continue to restore cooling to the SFSC. Efforts must continue to restore the heat removal system to operable status by removing the air flow obstruction(s) unless optional Required Action C.2.2 is being implemented.

This Required Action must be complete in 24 hours. The Completion Time is consistent with the thermal analyses of this event, which show that all component temperatures remain below their short-term temperature limits up to 32 hours after event initiation.

The Completion Time reflects the 8 hours to complete Required Action B.1 and the appropriate balance of time consistent with the applicable analysis results. The event is assumed to begin at the time the SFSC heat removal system is declared inoperable. This is reasonable considering the low probability of all inlet ducts becoming simultaneously blocked.

(continued)

BASES

ACTIONS
(continued)

C.2.2

In lieu of implementing Required Action C.2.1, transfer of the MPC into a TRANSFER CASK will place the MPC in an analyzed condition and ensure adequate fuel cooling until actions to correct the heat removal system inoperability can be completed. Transfer of the MPC into a TRANSFER CASK removes the SFSC from the LCO Applicability since STORAGE OPERATIONS does not include times when the MPC resides in the TRANSFER CASK.

An engineering evaluation must be performed to determine if any deterioration which prevents the VVM from performing its design function. If the evaluation is successful and the air inlet duct screens have been cleared, the VVM heat removal system may be considered operable and the MPC transferred back into the VVM. Compliance with LCO 3.1.2 is then restored. If the evaluation is unsuccessful, the user must transfer the MPC into a different, fully qualified VVM to resume STORAGE OPERATIONS and restore compliance with LCO 3.1.2

In lieu of performing the engineering evaluation, the user may opt to proceed directly to transferring the MPC into a different, fully qualified VVM or place the TRANSFER CASK in the spent fuel pool or dry unloading facility and unload the MPC.

The Completion Time of 24 hours reflects the Completion Time from Required Action C.2.1 to ensure component temperatures remain below their short-term temperature limits for the respective decay heat loads.

C.2.3

In lieu of implementing Required Action C.2.2, an engineering evaluation may be performed (or a previous evaluation may be referenced) to determine if any components exceed a temperature which would prevent it from performing its design function. If the evaluation shows none of the components exceed such a temperature, and the air flow obstructions have been cleared, the SFSC heat removal system can be considered operable and the MPC remains in the VVM. Compliance with LCO 3.1.2 is then restored.

(continued)

BASES

SURVEILLANCE
REQUIREMENTS

SR 3.1.2

The long-term integrity of the stored fuel is dependent on the ability of the SFSC to reject heat from the MPC to the environment. There are two options for implementing SR 3.1.2, either of which is acceptable for demonstrating that the heat removal system is OPERABLE.

Visual observation that all air inlet duct screens are unobstructed ensures that the SFSC is operable. If greater than 50% of the air inlet duct screens are blocked the heat removal system **may be inoperable (see temperature measurement discussion below for an alternative option for evaluating system condition)**.

While 50% or less blockage of the total air inlet duct screen area does not constitute inoperability of the heat removal system, corrective actions should be taken promptly to remove the obstruction and restore full flow. Visual observation of air outlet duct screen blockage does not constitute inoperability of the heat removal system; however, corrective action should be taken to promptly remove the obstruction.

As an alternative, **monitoring of the VVM differential temperature can be performed and this is both direct and quantitative. This can be accomplished either through local manual means or remotely displayed readings of** air temperature monitoring instrumentation. Blocked air inlet duct screens will reduce air flow and increase the outlet duct air temperature. Based on the analyses, if the temperature difference between the ambient air and the outlet duct air meets the criteria in the **SR**, adequate air flow is occurring to provide assurance of long term fuel cladding integrity.

The Frequency of 24 hours is reasonable based on the time necessary for SFSC components to heat up to unacceptable temperatures assuming design basis heat loads, and allowing for corrective actions to take place upon discovery of blockage of air ducts.

REFERENCES

1. FSAR Chapter 4
 2. ANSI/ANS 57.9-1992
-

B 5.0 Administrative Controls and Programs (LCO) APPLICABILITY

B 5.3 Radiation Protection Program

BASES

- B.5.3.1 5.3.1 requires that the licensee appropriately includes provisions in their radiation protection program to account for the dry storage system from loading through unloading. These provisions should also include the requirements included in Section 5.3 of the CoC.
- B.5.3.2 5.3.2 includes the requirements of 10CFR72.212(b)(2)(i)(c) for a documented evaluation that the dose limits of 10CFR72.104(a) are met. This evaluation should utilize the site-specific ISFSI layout, the planned number of casks, and the cask contents to demonstrate compliance with 10CFR72.104
- B.5.3.3 In accordance with 5.3.3, licensees should use the analysis performed in 5.3.2 to also establish dose rate limits at the top of the VVM (above the annulus, in accordance with the measurement location specified in 5.3.8), the side of the transfer cask (mid-height, in accordance with the measurement location specified in 5.3.8), and the outlet vents on the VVM. If measured dose rates exceed these limits, it could be an indication of a loading error that may require corrective actions. These calculated limits are used in comparison with the measured values in 5.3.8.
- B.5.3.4 5.3.4 contains additional dose rate limits for a loaded VVM and transfer cask. These dose rate limits are set at a value above the maximum expected dose rates at the locations described in 5.3.8, from a system loaded with design basis fuel. If measured dose rates exceed these limits, it could be an indication of a design or loading error that may require corrective actions. Section 5.4.2 of this FSAR contains additional discussions on the selection of the location and dose rate limits.
- B.5.3.5 5.3.5 provides the requirement that the licensee measure dose rates at the locations outlined in 5.3.8 and compare them to the lower of the two limits established in Section 5.3.3 or 5.3.4. This ensures that the most conservative limit is used.
- B.5.3.6 5.3.6 establishes corrective actions that shall be taken in the event of measured dose rates that exceed the lower of the two limits in Section 5.3.3 or 5.3.4. These corrective actions include verifying that contents were loaded correctly, performing analyses to ensure 10CFR72.104 dose limits are met, and determining the cause of the higher dose rate.
- B.5.3.7 5.3.7 states that any evaluation under 5.3.6 that shows that 10CFR72.104 dose rate limits will not be met will prevent the MPC from being installed in the VVM or it will be removed from the VVM. This control ensures that the site continues to meet all regulatory requirements.

BASES

B 5.3.8

5.3.8 establishes locations for surface dose rate measurements. Compliance with 10CFR72.104 dose limits are confirmed with a comparison between these measured dose rates and the dose limits of the system set by calculation and maximum limits in 5.3.3 and 5.3.4 as described in 5.3.5. The measurement locations specified in 5.3.8 ensure the measured dose rates are compared with the analysis described in 5.3.3 at the same geometric location. Showing that the calculated dose rates at the same location provides assurance that the calculated dose (from 5.3.2) bound the actual doses at the site boundary, and therefore assures compliance with 10CFR72.104(a).

Even though comparison of dose rates can occur across any location, the locations chosen in 5.3.8 were based on positions where higher dose rates are expected. Higher dose rates provide better measurements to protect against measurement inaccuracy and the additional actions of 5.3.6 and 5.3.7 for compliance to 10CFR72.104.

B.5.3.9

5.3.9 establishes a "Radiation Protection Space" around the HI-STORM UMAX ISFSI, down to the depth of the Support Foundation Pad. This RPS only applies during construction activities, and provides assurance that there is no loss of shielding due to an event occurring during construction activities adjacent to the HI-STORM UMAX.

**ARTICLE NB-3000
DESIGN**

(b)(4)



(b)(4)

(b)(4)

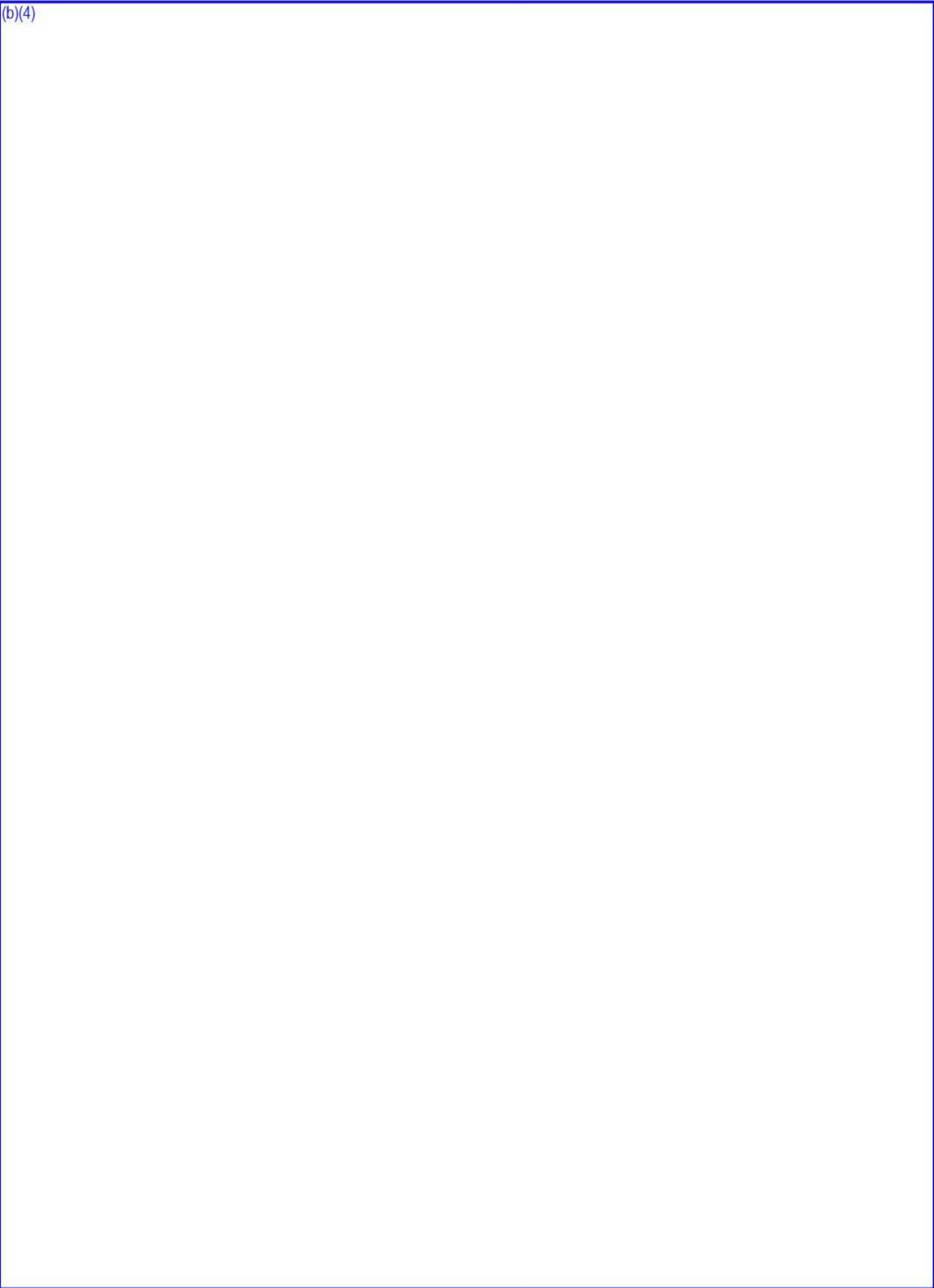

(b)(4)

From: Kenneth Wilson <Kenneth.R.Wilson@sce.com>
Sent: Wednesday, January 30, 2019 1:24 PM
To: Simpson, Eric; Brookhart, Lee
Cc: MARK MORGAN
Subject: [External_Sender] RE: NRC Request #16
Attachments: ECO-5021-39R1.pdf

ECO-5021-39R1 is being withheld in its entirety based on it consisting of the licensee's proprietary information

Here is the main ECO (FSAR change) associated with Load Monitoring. I think you already have the supporting 72.48 (since you comment on it).

Are there others associated with the RCE?

From: MARK MORGAN
Sent: Wednesday, January 30, 2019 11:04 AM
To: Simpson, Eric <Eric.Simpson@nrc.gov>; Brookhart, Lee <Lee.Brookhart@nrc.gov>
Cc: MARK MORGAN <Mark.Morgan@sce.com>; Kenneth Wilson <Kenneth.R.Wilson@sce.com>
Subject: FW: NRC Request #16

Eric,

You had requested several drawings and any FSAR updates as a result of the RCE. The drawings are attached. Ken Wilson is working on providing the FSAR update.

Mark
86745

From: Brian Sarno
Sent: Wednesday, January 30, 2019 11:01 AM
To: MARK MORGAN <Mark.Morgan@sce.com>; Kenneth Wilson <Kenneth.R.Wilson@sce.com>
Subject: NRC Request #16

Mark,

Here are the requested changes.

Regards,

Brian Sarno
Southern California Edison | San Onofre Nuclear Generating Station | ISFSI Engineering
949-368-6628 (Office) | Brian.Sarno@sce.com (Email)

 Please consider the environment before printing this email

ATTACHMENT A TO ECO-5021-39

9.1 TECHNICAL AND SAFETY BASIS FOR LOADING AND UNLOADING PROCEDURES

The procedures herein are developed for the loading, storing, and unloading of a loaded MPC in the HI-STORM UMAX System. The design of the HI-STORM UMAX System, along with the implementation procedures, the ancillary equipment, and the Technical Specifications, collectively serve to achieve ALARA, minimize risks to the operational staff, and mitigate consequences of potential adverse events.

The primary objective of the information presented in this chapter is to identify and describe the sequence of significant operations and actions that are important-to-safety for canister loading, canister handling, storage operations, and canister unloading to adequately protect crew health and to eliminate any conceivable danger to life or property, to protect the MPC's contents from dispersal, and to provide for the safe execution of tasks and operations.

In the event of an extreme environmental condition, the appropriate procedural guidance to respond to the situation must be available and ready for implementation at the nuclear plant. As a minimum, the procedures shall address establishing emergency action levels, implementation of emergency action program, establishment of personnel exclusions zones, monitoring of radiological conditions, actions to mitigate or prevent the release of radioactive materials, recovery planning and execution, and reporting to the appropriate regulatory agencies, as required.

9.1.1 Ensuring Safety in Heavy Load Handling Evolutions

(b)(4)



HOLTEC INTERNATIONAL COPYRIGHTED MATERIAL	
HI-2115090	Rev. 4
9-4	

ATTACHMENT A TO ECO-5021-39

(b)(4)

HOLTEC INTERNATIONAL COPYRIGHTED MATERIAL	
HI-2115090	Rev. 4
9-5	

ATTACHMENT A TO ECO-5021-39

9.5 REGULATORY COMPLIANCE:

The operational steps required to place a loaded MPC into a HI-STORM UMAX VVM cavity have been described in this chapter. The steps to remove an MPC from a loaded VVM, which are essentially reverse of the steps in the loading sequence, have been provided in Chapter 9 of the HI-STORM FW System FSAR [9.6.1]. These loading steps are, of necessity, generic in their description and may require adaptation to a specific ISFSI. The implementation steps are nevertheless sufficiently detailed to lead to the conclusion that the guidelines of safety and ALARA set down in NUREG-1536 are fully satisfied. In particular, it can be concluded that:

- i. There are no radiation streaming paths from the MPC during its transfer operation.
- ii. The Mating Device handling operations occur near grade level thus eliminating the need for ladders/platforms and improving the human factors aspects.
- iii. There are no freestanding structures in the MPC transfer operations and thus there is no risk of uncontrolled load movement under a (hypothetical) extreme environmental event such as tornado or high winds.
- iv. The ventilation paths to passively cool the canister using ambient air during the transfer operation is maintained at all times (except during brief operations as mentioned above) thus protecting the fuel cladding from overheating and eliminating any thermally guided time limit on the duration for implementing the transfer steps.
- v. All heavy load handling is carried out by handling devices that are equipped with redundant load drop protection features.
- vi. Each storage cavity is independently accessible. Installation or removal of any MPC does not have to contend with other stored MPCs.
- vii. Even though MPC insertion (and withdrawal) occurs in the vertical configuration with adequate lateral clearances, there is a risk of damage (scratching or gouging) to the MPC's external surface (Confinement Boundary). The training, qualification, and equipment discussed in Section 9.1.1 provides reasonable assurance that the ASME Section III Class 1 prohibition against excessive wall thinning to the pressure retaining boundary is maintained. In the instance of damage exceeding that permitted in Holtec Standard Procedure HSP-320, an evaluation of the MPC shell shall be required to demonstrate code compliance.

It is thus concluded that the HI-STORM UMAX ISFSI is engineered to meet the safety and ALARA imperatives contemplated in 10CFR 72 in full measures.

HOLTEC INTERNATIONAL COPYRIGHTED MATERIAL	
HI-2115090	Rev. 4
9-20	

ENGINEERING CHANGE ORDER NUMBER: 5021-39

Revision: 1

(b)(4)



(b)(4)



ENGINEERING CHANGE ORDER NUMBER: 5021-39

Revision: 1

(b)(4)

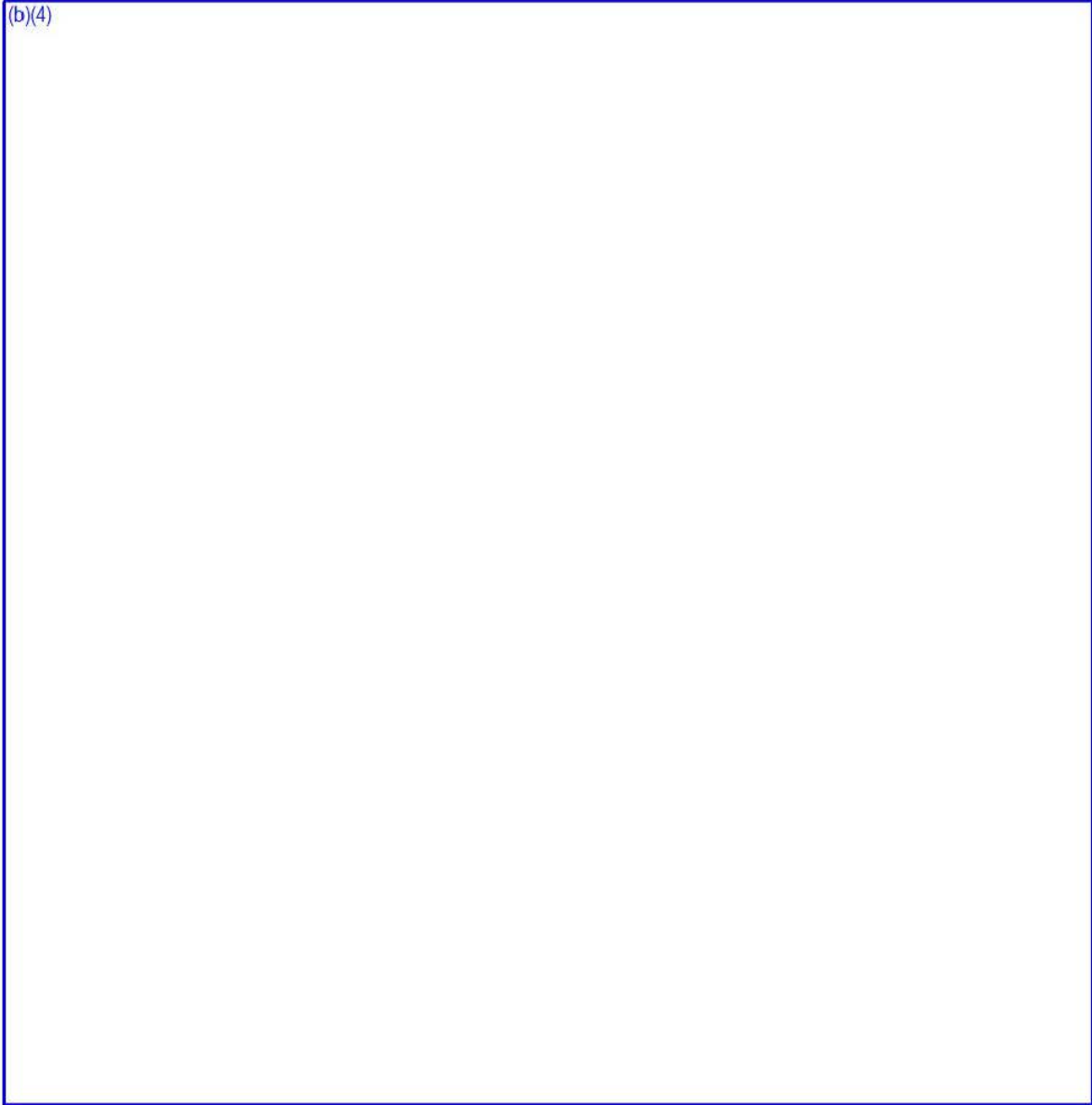

ENGINEERING CHANGE ORDER NUMBER: 5021-39

Revision: 1

(b)(4)



|
|
|
|
|
|
|
|
|

ENGINEERING CHANGE ORDER NUMBER: 5021-39

Revision: 1

(b)(4)

(b)(4)

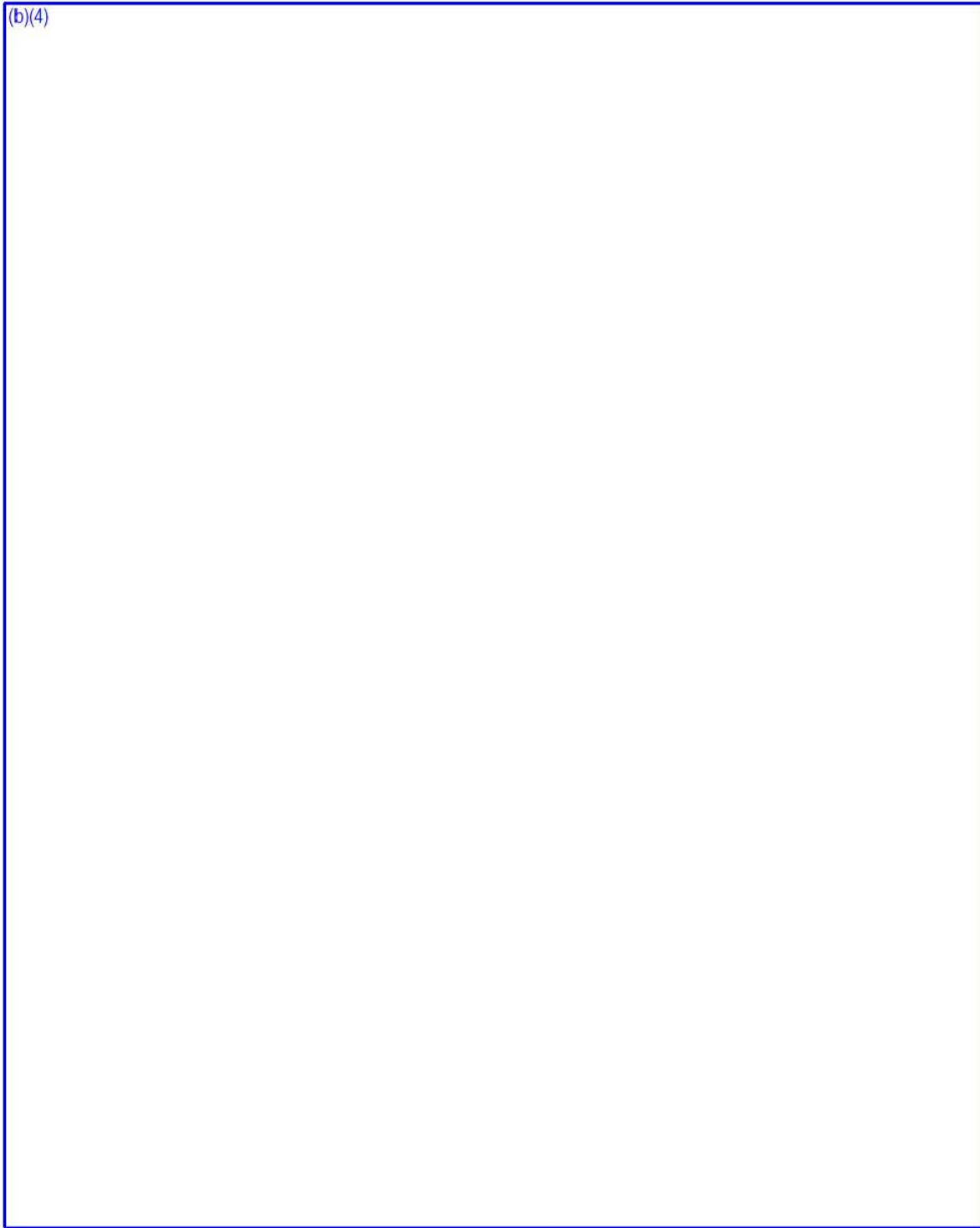

ENGINEERING CHANGE ORDER NUMBER: 5021-39

Revision: 1

(b)(4)



ENGINEERING CHANGE ORDER NUMBER: 5021-39

Revision: 1

(b)(4)

ENGINEERING CHANGE ORDER NUMBER: 5021-39

Revision: 1

(b)(4)



ENGINEERING CHANGE ORDER NUMBER: 5021-39

Revision: 1

(b)(4)



ENGINEERING CHANGE ORDER NUMBER: 5021-39

Revision: 1

(b)(4)



ENGINEERING CHANGE ORDER NUMBER: 5021-39	Revision: 1
---	--------------------

(b)(4)

2.4.1 Additional Comments:

From: [MARK MORGAN](#)
To: [Simpson, Eric](#); [Brookhart, Lee](#)
Cc: [MARK MORGAN](#); [DENNIS EVANS](#)
Subject: [External_Sender] FW: Rigging Equipment Pedigree
Date: Wednesday, January 16, 2019 11:14:57 AM
Attachments: [image001.png](#)
[Purchase Orders.pdf](#)
[PS-223R0.PDF](#)
[PS-1234R4.PDF](#)
[1 - Downloader Slings.pdf](#)
[2 - Load Cell Shackles.pdf](#)
[3 - Intermediate Slings.pdf](#)
[4 - Master Links.pdf](#)
[5 - 75 Ton Shackles.pdf](#)

Note: The 8 attachments (49 pages) are withheld in their entirety under FOIA exemption 4.

Lee, Eric,

Attached are additional documents related to the pedigree of the new VCT load monitoring equipment. Let me know if you have any additional questions related to this.

Thanks,
Mark
86745

From: Brian Sarno
Sent: Tuesday, January 15, 2019 8:59 AM
To: MARK MORGAN <Mark.Morgan@sce.com>
Cc: Chad Samples <Chad.Samples@sce.com>; Kenneth Wilson <Kenneth.R.Wilson@sce.com>; JERRY STEPHENSON <Jerry.Stephenson@sce.com>
Subject: Rigging Equipment Pedigree

Mark,

The following information provides the requested VCT rigging equipment information.

<i>Item No.</i>	<i>Component</i>	<i>Purchase Spec</i>	<i>Purchase Order</i>
1	Downloader Slings	PS-1234	112896
2	Load Shackle	PS-223	112896
3	Intermediate Slings	PS-1234	112896
4	Master Link	PS-223	112896
5	Shackle	PS-223	110740

Regards,

Brian Sarno
Southern California Edison | San Onofre Nuclear Generating Station | ISFSI Engineering
949-368-6628 (Office) | Brian.Sarno@sce.com (Email)



From: MARK MORGAN <Mark.Morgan@sce.com>
Sent: Sunday, March 03, 2019 10:48 AM
To: Brookhart, Lee; Katanic, Janine; Simpson, Eric; Smith, Chris
Cc: MARK MORGAN
Subject: [External_Sender] FW: (External):Re: Load Cell Shackles

Note: The attached revised shackle certifications (40 pages) are withheld in their entirety under FOIA exemption 4.

Lee,

Attached are the revised load shackle certifications. Please let me know if you have any questions regarding this.

Thanks,
Mark
(949) 368-6745