

CHAPTER 3

TABLE OF CONTENTS

<u>Section</u>	<u>Title</u>	<u>Page</u>
3	DESIGN OF STRUCTURES, COMPONENTS, EQUIPMENT, AND SYSTEMS	3.1-1
3.1	CONFORMANCE WITH U.S. NUCLEAR REGULATORY COMMISSION GENERAL DESIGN CRITERIA	3.1-1
3.1.1	Conformance with Single Failure Criterion	3.1-1
3.1.2	Criterion Conformance	3.1-3
3.1.3	References for Section 3.1	3.1-45
3.2	CLASSIFICATION OF STRUCTURES, COMPONENTS, AND SYSTEMS	3.2-1
3.2.1	Seismic Classification	3.2-1
3.2.2	System Quality Group Classifications	3.2-3
3.2.3	Tabulation of Codes and Classifications	3.2-7
3.3	WIND AND TORNADO LOADINGS	3.3-1
3.3.1	Wind Loadings	3.3-1
3.3.2	Tornado Loadings	3.3-2
3.3.3	References for Section 3.3	3.3-4
3.4	WATER LEVEL (FLOOD) DESIGN	3.4-1
3.4.1	Flood Protection	3.4-1
3.4.2	Analytical and Test Procedures	3.4-2
3.5	MISSILE PROTECTION	3.5-1
3.5.1	Missile Selection and Description	3.5-1
3.5.2	Structures, Systems, and Components to be Protected from Externally Generated Missiles	3.5-19
3.5.3	Barrier Design Procedures	3.5-20
3.5.4	References for Section 3.5	3.5-22
3.6	PROTECTION AGAINST DYNAMIC EFFECTS ASSOCIATED WITH THE POSTULATED RUPTURE OF PIPING	3.6-1
3.6B	PROTECTION AGAINST DYNAMIC EFFECTS ASSOCIATED WITH THE POSTULATED RUPTURE OF PIPING	3.6-1
3.6B.1	Postulated Piping Failures in Fluid Systems Outside of Containment	3.6-1
3.6B.2	Determination of Break Locations and Dynamic Effects Associated with the Postulated Rupture of Piping	3.6-16a
3.6N	PROTECTION AGAINST DYNAMIC EFFECTS ASSOCIATED WITH THE POSTULATED RUPTURE OF PIPING	3.6-49

TABLE OF CONTENTS (Cont)

<u>Section</u>	<u>Title</u>	<u>Page</u>
3.6N.1	Postulated Piping Failures in Fluid Systems Outside of Containment	3.6-49
3.6N.2	Determination of Break Locations and Dynamic Effects Associated with Postulated Rupture of Piping	3.6-50
3.6.3	Reference for Section 3.6	3.6-56
3.7	SEISMIC DESIGN	3.7-1
3.7B	SEISMIC DESIGN	3.7-1
3.7B.1	Seismic Input	3.7-1
3.7B.2	Seismic System Analysis	3.7-3
3.7B.3	Seismic Subsystem Analysis	3.7-13
3.7B.4	Seismic Instrumentation	3.7-43
3.7N	SEISMIC DESIGN	3.7-46
3.7N.1	Seismic Input	3.7-47
3.7N.2	Seismic System Analysis	3.7-48
3.7N.3	Seismic Subsystem Analysis	3.7-61
3.7N.4	Seismic Instrumentation	3.7-64
3.7.5	References for Sections 3.7B and 3.7N	3.7-64
3.8	DESIGN OF SEISMIC CATEGORY I STRUCTURES	3.8-1
3.8.1	Concrete Containment	3.8-1
3.8.2	Steel Containment	3.8-29
3.8.3	Concrete and Structural Steel Internal Structures of Steel or Concrete Containments	3.8-31
3.8.4	Other Seismic Category I Structures	3.8-38
3.8.5	Foundations	3.8-48
3.8.6	References for Section 3.8	3.8-49
3.9	MECHANICAL SYSTEMS AND COMPONENTS	3.9-1
3.9B	MECHANICAL SYSTEMS AND COMPONENTS	3.9-1
3.9B.1	Special Topics for Mechanical Components	3.9-1
3.9B.2	Dynamic Testing and Analysis	3.9-3
3.9B.3	ASME Code Class 1, 2, and 3 Components, Component Supports, and Core Support Structures	3.9-8
3.9B.6	Inservice Testing of Pumps and Valves	3.9-22
3.9N	MECHANICAL SYSTEMS AND COMPONENTS	3.9-23
3.9N.1	Special Topics for Mechanical Components	3.9-23
3.9N.2	Dynamic Testing and Analysis	3.9-35

TABLE OF CONTENTS

<u>Section</u>	<u>Title</u>	<u>Page</u>
3.9N.3	ASME Code Class 1, 2, and 3 Components, Component Supports, and Core Support Structures	3.9-45
3.9N.4	Control Rod Drive Systems	3.9-52
3.9N.5	Reactor Vessel Internals	3.9-63
3.9N.6	References for Section 3.9	3.9-70
3.10	SEISMIC QUALIFICATION OF SEISMIC CATEGORY I INSTRUMENTATION AND ELECTRICAL EQUIPMENT	3.10-1
3.10B.1	Seismic Qualification Criteria	3.10-1
3.10B.2	Methods and Procedures for Qualifying Electrical Equipment and Instrumentation	3.10-1
3.10B.3	Methods and Procedures of Analysis or Testing of Supports of Electrical Equipment and Instrumentation	3.10-1
3.10B.4	Operating License Review	3.10-2
3.10N	SEISMIC QUALIFICATION OF CATEGORY 1 INSTRUMENTATION and Electrical Equipment	3.10-2
3.10N.1	Seismic Qualification Criteria	3.10-2
3.10N.2	Methods and Procedures for Qualifying Electrical Equipment and Instrumentation	3.10-10
3.10N.3	Method and Procedure for Qualifying Supports of Electrical Equipment and Instrumentation	3.10-5
3.10N.4	Operating License Review	3.10-5
3.10N.5	References for Section 3.10N	3.10-5
3.11	ENVIRONMENTAL QUALIFICATION OF MECHANICAL AND ELECTRICAL EQUIPMENT	3.11-1
3.11.1	Equipment Identification and Environmental Conditions	3.11-1
APPENDIX 3A	COMPUTER PROGRAMS FOR DYNAMIC AND STATIC ANALYSIS OF SEISMIC CATEGORY I STRUCTURES, EQUIPMENT, AND COMPONENTS	
APPENDIX 3B	A STUDY OF THE PROBABILITY OF AN AIRCRAFT COLLISION WITH THE BEAVER VALLEY POWER STATION - UNIT 2	

LIST OF TABLES

<u>Table Number</u>	<u>Title</u>
3.2-1	Quality Assurance Category I and Seismic Category I Systems and Components
3.2-2	Classification of Structures
3.2-3	Diagrams Showing Quality Group Classification
3.3-1	Gust Factors and Coefficients
3.3-2	Design Normal Wind Loadings for Rectangular Buildings (P) Design Wind Velocity Pressure (PSF)
3.5-1	Valve Missile Characteristics
3.5-2	Summary of Control Rod Drive Mechanism Missile Analysis
3.5-3	This table has been intentionally deleted from the FSAR
3.5-4	Characteristics of Other Missiles Postulated Within Reactor Containment
3.5-5	Tornado-Generated External Missiles
3.5-6	List of Hazardous Materials with the Potential for Producing Significant Missiles
3.5-7	Summary of Exposure Distance Calculations
3.5-8	Aggregate Probability of Explosion or Violent Rupture Capable of Missile Generation
3.5-9	Tank Car Fragment Range (Feet) for 10° Launch Angle
3.5-10	Types of Tank Car Missiles
3.5-11	Deleted
3.5-12	Missile Shields on Axial Fans
3.6B-1	High-Energy Piping Systems
3.6B-2	Essential Structures, Systems, and Components Required for Safe Shutdown
3.6B-3	Energy-Absorbing Capacity of 10-inch Pipes
3.6B-4	Piping Lines Included in the LBB Program
3.7B-1	Damping Values

LIST OF TABLES (Cont)

<u>Table Number</u>	<u>Title</u>
3.7B-2	Foundation Information and Structural Dimensions for Seismic Category I Structures
3.7B-3	Methods of Seismic Analysis Used for Seismic Category I Structures
3.7B-4	Containment and Internal Structures Representative Modal Frequencies and Participation Factors Uncracked Model, Median Soil, Safe Shutdown Earthquake
3.7B-5	Containment and Internal Structures Representative Modal Frequencies and Participation Factors Cracked Model, Median Soil, Safe Shutdown Earthquake
3.7B-6	Containment and Internal Structures Representative Mode Shapes (Eigenvectors) Uncracked Model, Median Soil
3.7B-7	Containment and Internal Structures Representative Mode Shapes (Normalized Eigenvectors) Cracked Model, Median Soil, Safe Shutdown Earthquake
3.7B-8	Containment and Internal Structures SRSS Accelerations and Displacements for Safe Shutdown Earthquake Uncracked Model, Median Soil, Response Spectrum Analysis
3.7B-9	Containment and Internal Structures SRSS Accelerations and Displacements for Safe Shutdown Earthquake Cracked Model, Median Soil, Response Spectrum Analysis
3.7B-10	Containment and Internal Structures Degrees of Freedom
3.7B-11	Containment and Internal Structures Enveloped Accelerations and Displacements Horizontal Motion
3.7B-12	Containment and Internal Structures Enveloped Accelerations and Displacements Vertical Motion
3.7B-13	Fuel Building Representative Modal Frequencies and Participation Factors
3.7B-14	Fuel Building Representative Mode Shapes (Eigenvectors)
3.7B-15	Fuel Building CSM Accelerations for Safe Shutdown Earthquake from Response Spectrum Analysis
3.7B-16	Fuel Building Closely Spaced Modes Displacements for Safe Shutdown Earthquake From Response Spectrum Analysis

LIST OF TABLES (Cont)

<u>Table Number</u>	<u>Title</u>
3.7B-17	Fuel Building Square Root of the Sum of the Squares Safe Shutdown Earthquake Responses
3.7B-18	Fuel Building Degrees of Freedom
3.7B-19	Cable Vault Building Representative Modal Frequencies and Participation Factors
3.7B-20	Cable Vault Building Representative Mode Shapes (Eigenvectors)
3.7B-21	Cable Vault Building Degrees of Freedom
3.7B-22	Cable Vault Building CSM Acceleration for Safe Shutdown Earthquake From Response Spectrum Analysis
3.7B-23	Cable Vault Building CSM Displacements for Safe Shutdown Earthquake from Response Spectrum Analysis
3.7B-24	Cable Vault Building SRSS of Safe Shutdown Earthquake
3.7B-25	Comparison of Response Spectra and Time History Analysis Results Containment and Internal Structures (Uncracked Properties)
3.7B-26	Comparison of Response Spectra and Time History Analysis Results Containment and Internal Structures (Cracked Properties)
3.7B-27	Comparison of Response Spectra and Time History Analysis Results Fuel Building - Safe Shutdown Earthquake Accelerations
3.7B-28	Comparison of Response Spectra and Time History Analysis Results Cable Vault Building Safe Shutdown Earthquake Accelerations
3.7B-29	Equipment and Components 1G Flat Response
3.7B-30	Modal Density, n
3.7B-31	Amplified Response Dynamic Factor Study
3.7B-32	Piping System Seismic Design and Analysis Criteria

LIST OF TABLES (Cont)

<u>Table Number</u>	<u>Title</u>
3.7N-1	Damping Valves Used for Seismic Systems Analysis for Westinghouse Supplied Equipment Damping
3.8-1	American Concrete Institute Codes, Standards, and Specifications
3.8-2	American Society of Mechanical Engineers Specifications
3.8-3	American National Standards Institute Codes, Standards, and Specifications
3.8-4	American Society for Testing and Materials Specifications
3.8-5	USNRC Regulatory Guides
3.8-6	Principal Plant Structural Specifications for Seismic Category I Materials
3.8-7	Steel Liner, Penetrations, and Access Opening Codes, Standards, and Specifications
3.8-8	Summary of Materials Called for in Specifications for Steel Liner, Penetrations, and Access Openings
3.8-9	Load Combinations for Liner Plate and Anchors
3.8-10	ASTM A615 Reinforcing Steel Grade 50, Stone & Webster Special Chemistry Chemical and Mechanical Properties
3.8-11	Containment Internal Structure Concrete Structures Load Combinations Comparison
3.8-12	Seismic Category I Structures and Equipment for Other Than the Containment Structure
3.8-13	Criteria for Stability Factors Against Sliding and Overturning
3.9B-1	Systems and Types of Tests Conducted
3.9B-2	Deleted from the FSAR
3.9B-3	Piping Snubbers Monitored During Preoperational Testing
3.9B-4	Deleted from the FSAR
3.9B-5	Load Combinations for ASME III Class 1 Piping

LIST OF TABLES (Cont)

<u>Table Number</u>	<u>Title</u>
3.9B-6	Comparison of ASME III Class 1 Piping Requirements, Regulatory Guide 1.48 vs. Table 3.9B-5
3.9B-7	Stress Limits for ASME Section III Class 2 and 3 Components (Elastic Analysis)
3.9B-8	Load Combinations for ASME III Class 2 and 3 Piping Except Quench Spray, Recirculation Spray, and Safety Injection Systems
3.9B-9	Loading Combinations for ASME III Class 2 and 3 Piping on Quench Spray, Recirculation Spray and Safety Injection Systems
3.9B-10	Comparison of Class 2 and 3 Requirements - Regulatory Guide 1.48 vs. Tables 3.9B-7, 3.9B-8, and 3.9B-9
3.9B-11	Definitions of Loadings Applicable to Piping Systems
3.9B-12	Deleted from the FSAR
3.9B-13	Deleted
3.9B-14	Load Combinations for Pipe Supports except QSS, RSS, and SIS
3.9B-15	Load Combinations for Pipe Supports for QSS, RSS, and SIS
3.9B-16	Loads, Load Combinations, and Stress Limits for S&W Designed ASME III, Class 2 and 3 Equipment Supports
3.9B-17	Methods of Load Combinations
3.9B-18	Active Pumps (BOP)
3.9B-19	Active Valves (BOP)
3.9N-1	Summary of Reactor Coolant System Design Transients
3.9N-2	Loading Combinations for ASME Class 1 Components
3.9N-3	Allowable Stresses for ASME Section III Class 1 Components
3.9N-4	Design Loading Combinations for ASME Code Class 2 and 3 Components and Supports
3.9N-5	Stress Criteria for Safety Related ASME Class 2 and Class 3 Tanks

LIST OF TABLES (Cont)

<u>Table Number</u>	<u>Title</u>
3.9N-6	Stress Criteria for ASME Code Class 2 and Class 3 Inactive Pumps
3.9N-7	Design Criteria for Active Pumps
3.9N-8	Stress Criteria for Safety-Related ASME Code Class 2 and Class 3 Valves
3.9N-9	Active Pumps (W Scope)
3.9N-10	Active Valves (W Scope)
3.9N-11	Maximum Deflections Allowed for Reactor Internal Support
3.9N-12	Stress Limits for Reactor Vessel Internal Structures
3.9N-13	Loading Combinations for Core Support Structures
3.9N-14	Allowable Stresses for Core Support Structures
3.10B-1	Deleted
3.10N-1	Deleted
3.11-1	Deleted
3.11-2	Deleted

LIST OF FIGURES

<u>Figure Number</u>	<u>Title</u>
3.5-1	Plot Plan Orientation of Impact Areas for Turbine Missiles
3.5-2	BB281-13.9m ² Design - Comparison of External Missile Probabilities Including Overspeed with NRC Limit
3.5-3	Deleted
3.5-4	Deleted
3.6B-1	Areas of Analysis
3.6B-2	Steady State Blowdown Forces vs. Friction Parameter
3.6B-3	South Loop Strap Restraint PRR-811
3.6B-4	Dynamic Analysis Model, South Loop Strap Restraint, PRR-811
3.6B-5	Fluid Blowdown Forces Used in Mathematical Model
3.6B-6	Restraint Reaction Loads
3.6B-7	Energy Balance Sample Problem
3.6B-8	Pipe Crush Bumper
3.6B-9	Pipe Crush Bumper
3.6B-10	Two-Pin Laminated Pipe Rupture Restraint
3.6B-11	Omni Directional Pipe Rupture Restraint
3.6B-12	Pipe Break/Restraint Locations Feedwater System (FWS) Inside Reactor Containment
3.6B-13	Feedwater System (FWS) Outside Containment
3.6B-14	Main Steam System (MSS) Outside Containment

LIST OF FIGURES (Cont)

<u>Figure Number</u>	<u>Title</u>
3.6B-15	Pipe Break and Restraint Locations - Main Steam Piping Inside Containment
3.6B-16A	Reactor Coolant System (RCS) (Pressurizer/Auxiliary Spray) Inside Reactor Containment
3.6B-16B	Reactor Coolant System (Loop Drain/Excess Letdown) Inside Reactor Containment
3.6B-16C	Reactor Coolant System (Pressurizer Safety/Relief Valve) Inside Reactor Containment
3.6B-16D	Reactor Coolant System (Loop Fill Piping) Inside Reactor Containment
3.6B-16E	Two-Inch RCS Bypass-Loop 21, 22, 23 Inside Reactor Containment
3.6B-16F	Deleted
3.6B-16G	Deleted
3.6B-17A	Main Steam West Loop Break Exclusion Pipe Outside Containment
3.6B-17B	Main Steam South Loop Break Exclusion Pipe Outside Containment
3.6B-17C	Main Steam East Loop Break Exclusion Pipe Outside Containment
3.6B-18A	Chemical/Charging and Volume Control System (CHS) Pressure/Auxiliary Spray and Normal Charging Inside Reactor Containment
3.6B-18B	Chemical/Charging and Volume Control System (Normal Charging) Inside Reactor Containment
3.6B-18C	Chemical/Charging and Volume Control System (Coolant Letdown to Non-Regenerative Heat Exchanger) Inside Reactor Containment
3.6B-18D	Chemical/Charging and Volume Control System (Loop Fill Piping) Inside Reactor Containment

LIST OF FIGURES (Cont)

<u>Figure Number</u>	<u>Title</u>
3.6B-18E	Chemical/Charging and Volume Control System (CHS) (RCP Seal Water Piping) Inside Reactor Containment
3.6B-19A	Chemical/Charging and Volume Control System (CHS) HHSI Charging Pumps Outside Reactor Containment
3.6B-19B	Chemical/Charging and Volume Control System (CHS) RCP Seal Water Piping Outside Reactor Containment
3.6B-19C	Chemical/Charging and Volume Control System (CHS) (Coolant Letdown) Outside Reactor Containment
3.6B-20A	Auxiliary Steam Supply (ASS) System Outside Reactor Containment
3.6B-20B	Auxiliary Steam Supply (ASS) System Outside Reactor Containment
3.6B-21A	Safety Injection System (SIS) Low/High Head Inside Reactor Containment
3.6B-21B	Safety Injection System (SIS) Low Head Accumulator Inside Reactor Containment
3.6B-22	Safety Injection System (SIS) Outside Reactor Containment
3.6B-23	Emergency Feedwater System (FWE) Inside Reactor Containment
3.6B-24	Steam Generator Blowdown System (BDG) Inside Reactor Containment
3.6B-25A	Steam Generator Blowdown System (BDG) Outside Reactor Containment
3.6B-25B	Steam Generator Blowdown System Pipe Rupture Restraints (PRR)
3.6B-26	Nitrogen Gas Supply (GNS) System Outside Reactor Containment
3.6N-1	Deleted
3.6N-2	Loss of Reactor Coolant Accident Boundary Limits
3.7B-1	Design Response Spectra Safe Shutdown Earthquake
3.7B-2	Design Response Spectra 1/2 Safe Shutdown Earthquake

LIST OF FIGURES (Cont)

<u>Figure Number</u>	<u>Title</u>
3.7B-3	Time History Response Spectra, 1/2% Damping Value
3.7B-4	Time History Response Spectra, 1% Damping Value
3.7B-5	Time History Response Spectra, 2% Damping Value
3.7B-6	Time History Response Spectra, 5% Damping Value
3.7B-7	Time History Response Spectra, 7% Damping Value
3.7B-8	Time History Response Spectra, 10% Damping Value
3.7B-9	Dynamic Model of the Containment Structure
3.7B-10	Dynamic Model of the Fuel Building
3.7B-11	Dynamic Model of the Cable Vault Building
3.7B-12	Eigenvectors for Containment and Internal Structures Uncracked Model, Median Soil
3.7B-13	Eigenvectors for Containment and Internal Structures Uncracked Model, Median Soil
3.7B-14	Eigenvectors for Containment and Internal Structures Uncracked Model, Median Soil
3.7B-15	Eigenvectors for Containment and Internal Structures Uncracked Model, Median Soil
3.7B-16	Response Spectrum Analysis, Containment and Internal Structures, Springline Horizontal SSE
3.7B-17	Response Spectrum Analysis, Containment and Internal Structures, Mat Horizontal SSE
3.7B-18	Response Spectrum Analysis, Containment and Internal Structures, Operating Floor Horizontal SSE
3.7B-19	Response Spectrum Analysis, Containment and Internal Structures, Springline Vertical SSE
3.7B-20	Response Spectrum Analysis, Containment and Internal Structures, Mat Vertical SSE
3.7B-21	Response Spectrum Analysis, Containment and Internal Structures, Operating Floor Vertical SSE

LIST OF FIGURES (Cont)

<u>Figure Number</u>	<u>Title</u>
3.7B-22	Response Spectrum Analysis, Containment and Internal Structures, Springline Horizontal SSE
3.7B-23	Response Spectrum Analysis Containment and Internal Structures Mat Horizontal SSE
3.7B-24	Response Spectrum Analysis, Containment and Internal Structures, Operating Floor Horizontal SSE
3.7B-25	Response Spectrum Analysis, Containment and Internal Structures, Springline Vertical SSE
3.7B-26	Response Spectrum Analysis Containment and Internal Structures, Mat Vertical SSE
3.7B-27	Response Spectrum Analysis, Containment and Internal Structures, Operating Floor Vertical SSE
3.7B-28	Amplified Response Spectra, Reactor Containment, Horizontal Excitation SSE at El. 813.62', External Structure
3.7B-29	Amplified Response Spectra, Reactor Containment, Horizontal Excitation SSE at El. 691.0', Mat
3.7B-30	Amplified Response Spectra, Reactor Containment, Horizontal Excitation SSE at El. 767.83', Internal Structure
3.7B-31	Amplified Response Spectra, Reactor Containment, Vertical Excitation SSE at El. 818.00' Internal Structure
3.7B-32	Amplified Response Spectra, Reactor Containment, Vertical Excitation SSE at El. 691.0', Mat
3.7B-33	Amplified Response Spectra, Reactor Containment, Vertical Excitation SSE at El. 854.22', External Structure
3.7B-34	Time History of Acceleration at the Operating Floor, Containment, Horizontal SSE
3.7B-35	Time History of Acceleration at the Springline Containment, Horizontal SSE
3.7B-36	Site Artificial Time History, Horizontal SSE
3.7B-37	Amplified Response Spectra By Time History, Fuel Building N-S SSE at El. 729.50'

LIST OF FIGURES (Cont)

<u>Figure Number</u>	<u>Title</u>
3.7B-38	Amplified Response Spectra By Time History, Fuel Building, E-W SSE at El. 729.50'
3.7B-39	Amplified Response Spectra By Time History, Fuel Building, Vertical SSE at El. 729.50'
3.7B-40	Amplified Response Spectra By Time History, Fuel Building, N-S SSE at El. 767.33'
3.7B-41	Amplified Response Spectra By Time History, Fuel Building, E-W SSE at El. 767.33'
3.7B-42	Amplified Response Spectra By Time History, Fuel Building, Vertical SSE at El. 767.33'
3.7B-43	Amplified Response Spectra By Time History, Fuel Building Crane Rail Structure, N S SSE at El. 798.00'
3.7B-44	Amplified Response Spectra By Time History, Fuel Building Crane Rail Structure, E-W SSE at El. 798.00'
3.7B-45	Amplified Response Spectra By Time History, Fuel Building Crane Rail Structure, Vertical SSE at El. 798.00'
3.7B-46	Amplified Response Spectra By Time History, Cable Vault Building, N-S Excitation SSE at El. 718.5'
3.7B-47	Amplified Response Spectra By Time History, Cable Vault Building, N-S Excitation SSE at El. 735.5'
3.7B-48	Amplified Response Spectra By Time History, Cable Vault Building, N-S Excitation SSE at El. 805.04'
3.7B-49	Amplified Response Spectra By Time History, Cable Vault Building, E-W Excitation SSE at El. 718.5'
3.7B-50	Amplified Response Spectra By Time History, Cable Vault Building, E-W Excitation SSE at El. 735.50'
3.7B-51	Amplified Response Spectra By Time History, Cable Vault Building, E-W Excitation SSE at El. 805.04'
3.7B-52	Amplified Response Spectra By Time History, Cable Vault Building, Vertical Excitation SSE at El. 718.50'
3.7B-53	Amplified Response Spectra By Time History, Cable Vault Building, Vertical Excitation SSE at El. 805.04'

LIST OF FIGURES (Cont)

<u>Figure Number</u>	<u>Title</u>
3.7B-54	Containment-Finite Element Mode
3.7B-55	Containment-Fuel Building Structure Interaction Model
3.7B-56	A.R.S. Comparison-Finite Element vs. Lumped Mass-Spring Containment External Structure El. 854.0', Horizontal, SSE
3.7B-57	A.R.S. Comparison-Finite Element vs. Lumped Mass-Spring Containment Mat El. 681.0' to 691.0' Horizontal, SSE
3.7B-58	A.R.S. Comparison-Finite Element vs. Lumped Mass-Spring Containment Internal Structure El. 818.0', Horizontal, SSE
3.7B-59	A.R.S. Comparison-Finite Element vs. Lumped Mass-Spring Containment External Structure El. 854.0', Vertical, SSE
3.7B-60	A.R.S. Comparison-Finite Element vs. Lumped Mass-Spring Containment Mat El. 681.0' To 691.0', Vertical, SSE
3.7B-61	A.R.S. Comparison-Finite Element vs. Lumped Mass-Spring Containment, Internal Structure El. 818.0' Vertical, SSE
3.7B-62	A.R.S. Comparison-Finite Element vs. Lumped Mass-Spring Fuel Building El. 729.50' E-W, SSE
3.7B-63	A.R.S. Comparison-Finite Element vs. Lumped Mass-Spring Fuel Building, el. 729.50' Vertical, SSE
3.7B-64	A.R.S. Comparison-Finite Element vs. Lumped Mass-Spring Fuel Building, El. 767.33' E-W, SSE
3.7B-65	A.R.S. Comparison-Finite Element vs. Lumped Mass-Spring Fuel Building, El. 767.33' Vertical, SSE
3.7B-66	Ground Response Spectra vs. Response Spectra Resulting From Site Artificial Time History
3.7B-67	Typical Mathematical Model of A Piping System
3.7B-68	Representation of Family of Peak Response Curves Within Broadened Resonant Peak
3.7B-69	Hypothetical vs. Actual Response of Multiple Modes Within Broadened Response Peak
3.7B-70	Justification of Static Load Factor
3.7B-71	Typical Amplified Response Spectra

LIST OF FIGURES (Cont)

<u>Figure Number</u>	<u>Title</u>
3.7B-72	Model Beams
3.7N-1	Multi-Degree of Freedom System
3.8-1	Reactor Containment Machine Locations, Plant El. 767'-10"
3.8-2	Reactor Containment Machine Locations, Plant El. 738'-10"
3.8-3	Reactor Containment Machine Locations, Plant El. 718'-6"
3.8-4	Reactor Containment Machine Locations, Plant El. 692'-11"
3.8-5	Reactor Containment Machine Locations, Sections 1-1, 6-6, 7-7, & 10-10
3.8-6	Reactor Containment Machine Locations, Sections 2-2, 5-5, & 9-9
3.8-7	Reactor Containment Machine Locations, Sections 3-3 & 4-4
3.8-8	Plot Plan
3.8-9	Reactor Containment Waterproofing
3.8-10	Foundation Mat & Wall Base
3.8-11	Concentric Ring at Apex of Dome
3.8-12	Typical Detail of Dome-Cylinder Junction
3.8-13	Personnel Hatch Reinforcing Details
3.8-14	Equipment Hatch Reinforcing Details
3.8-15	Typical Liner Details
3.8-16	Wall and Mat Joint
3.8-17	Section-Typical Bottom Liner Bridging Plate
3.8-18	Section-Typical Bridging Bar
3.8-19	Section-Shield Wall Base
3.8-20	Typical Piping Penetrations
3.8-21	Typical Electrical Penetration

LIST OF FIGURES (Cont)

<u>Figure Number</u>	<u>Title</u>
3.8-22	DELETED
3.8-23	DELETED
3.8-24	Fuel Transfer Tube Enclosure
3.8-25	Plant Arrangement at Plan El. 735'-6"
3.8-26	Plant Arrangement at Plan El. 752'-6"
3.8-27	Plant Arrangement at Plan El. 760'-6"
3.8-28	Plant Arrangement at Plan El. 774'-6"
3.8-29	Plant Arrangement Part Plan
3.8-30	Auxiliary Building Arrangement Plan El. 710'-6" and 718'-6"
3.8-31	Auxiliary Building Arrangement Plan El. 735'-6"
3.8-32	Auxiliary Building Arrangement Plan El. 755'-6"
3.8-33	Auxiliary Building Arrangement Plan El. 773'-6"
3.8-34	Auxiliary Building Arrangement Sections 1-1 and 2-2
3.8-35	Auxiliary Building Arrangement Sections 3-3 and 4-4
3.8-36	Auxiliary Building Arrangement Sections 5-5, Plan El. 710'-6"
3.8-37	Main Steam & Cable Vault Area Plan El. 755'-6", 798'-0", 808'-6"
3.8-38	DELETED
3.8-39	DELETED
3.8-40	Control Building Plan El. 735'-6"
3.8-41	Control Building Plan El. 707'-6"
3.8-42	Control Building Sections 1-1 and 2-2
3.8-43	Diesel Generator Building Arrangement
3.8-44	Service Building Plan El. 745'-6" and 730'-6"

LIST OF FIGURES (Cont)

<u>Figure Number</u>	<u>Title</u>
3.8-45	Service Building Plan El. 760'-6" and 780'-6"
3.8-46	Service Building Sections 1-1 and 2-2
3.8-47	Electrical Cable Tunnel
3.8-48	Pipe Trench for BVPS-1 and -2 Crosstie Piping-Sheet 1
3.8-49	Pipe Trench for BVPS-1 and -2 Crosstie Piping-Sheet 2
3.8-50	Emergency Service Water Overflow Structure
3.8-51	Waste Handling Building Arrangement
3.8-52	Condensate Polishing Building Plan El. 722'-6" and 735'-6"
3.8-53	Condensate Polishing Building Plan El. 752'-6" and 774'-6"
3.8-54	Condensate Polishing Building Sections 1-1, 2-2, 3-3, 4-4, 5-5
3.8-55	Condensate Polishing Building (non-Category I) Plan El. 762'-6" and 794'-6", Section 6-6
3.8-56	Gaseous Waste Storage Tank
3.9B-1	DELETED
3.9N-1	Reactor Coolant Pump Casing With Support Feet
3.9N-2	Vibration Check-out Function Test Inspection Points
3.9N-3	Control Rod Drive Mechanism
3.9N-4	Schematic Control Rod Drive Mechanism
3.9N-5	Nominal Latch Clearance Minimum and Maximum Temperature
3.9N-6	Control Rod Drive Mechanism Latch Clearance Thermal Effect
3.9N-7	Lower Core Support Assembly (Core Barrel Assembly)
3.9N-8	Upper Core Support Structure
3.9N-9	Plan View of Upper Core Support Structure

CHAPTER 3

DESIGN OF STRUCTURES, COMPONENTS, EQUIPMENT,
AND SYSTEMS3.1 CONFORMANCE WITH U.S. NUCLEAR REGULATORY COMMISSION GENERAL
DESIGN CRITERIA

This section describes how the design of Beaver Valley Power Station - Unit 2 (BVPS-2) conforms with the U.S. Nuclear Regulatory Commission (USNRC) General Design Criteria (GDC), Appendix A of 10 CFR 50, as amended through October 27, 1978. The GDC establish minimum requirements for the design of nuclear power plants.

The GDC are intended to guide design of all water-cooled nuclear power plants. The GDC are generic in nature and subject to a variety of interpretations. For this reason, some cases will show that conformance to a particular criteria is not directly measurable. For these cases, the conformance of plant design to the interpretation of the GDC is discussed. For each of the 55 criteria promulgated, a specific assessment of the plant design is made. The final safety analysis report (FSAR) section that contains the detailed design information pertinent to that criterion is given, in addition to applicable references. For the purpose of this report, the terms "important to safety," "safety related," and "safety systems" are synonymous.

Based on the contents herein, it can be concluded that the nuclear power plant known as BVPS-2 fully satisfies and is in compliance with the GDC.

3.1.1 Conformance with Single Failure Criterion

3.1.1.1 Single Failure Criterion

Appendix A to 10 CFR 50 defines single failure criterion as follows:

"A single failure means an occurrence which results in the loss of capability of a component to perform its intended safety functions. Multiple failures resulting from a single occurrence are considered to be a single failure. Fluid and electric systems are considered to be designed against an assumed single failure if neither (1) a single failure of any active component (assuming passive components function properly) nor (2) a single failure of a passive component (assuming active components function properly) results in a loss of the capability of the system to perform its safety functions."

3.1.1.2 Definition of Terms Used in Single Failure Criterion

3.1.1.2.1 Active Component Failure

An active component failure is the failure of a powered component to act on command to perform its design function. Examples of active component failures include the failure of a powered valve to move to its correct position, the failure of an electrical breaker or relay to respond, or the failure of a pump, fan, or emergency diesel generator to start.

3.1.1.2.2 Passive Component Failure

A passive component failure is the structural failure of a static component so that it does not perform its intended function. For fluid pressure-boundary components, a passive component failure results in a breach of the pressure boundary. Typical passive components include piping, cables, valve bodies, etc.

3.1.1.2.3 Short Term

The short term is defined as that period of operation up to 24 hours following an initiating event, except for the emergency core cooling system (ECCS) following a loss-of-coolant accident (LOCA) which considers the short term as terminating after the system is transferred from the injection mode to the recirculation mode.

3.1.1.2.4 Long Term

The long term is defined as the period following the short term (that is, greater than 24 hours) during which time the system safety function is still required.

3.1.1.3 Application of Single Failure Criterion

The single failure criterion must be applied to all fluid systems, electrical power sources, control circuits, etc, which are essential to shut down the reactor and to mitigate the consequences of postulated events, as defined in American National Standards Institute (ANSI) Standard N18.2 for Conditions II, III, and IV. The following guidelines are used with regard to specific applications:

1. The most limiting single failure must be assumed in addition to the postulated event and the direct consequences of the postulated event, including loss of offsite power if the initiating event or its effects result in a reactor or turbine trip. Fluid systems required to shut down the reactor and to mitigate the event must be designed to accept either a single active failure in the short term, or a single passive failure in the long term, with no previous active failure in the short term. Passive failure need not be considered in the short term. Specific

details on how to apply single failure criteria to high energy line breaks are provided in Section 3.6B.1.3.1.

2. Although all systems required to shut down the reactor and to mitigate the consequences of the postulated event must be designed to the single failure criterion, only one single failure and its consequences need be assumed to occur in the aggregate of safety-related plant systems.
3. Passive failure in fluid systems required to shut down the reactor and to mitigate the consequences of the postulated event are limited to 50-gpm

leaks, provided the system is designed to Seismic Category I requirements. This leak rate is based on assumed maximum pump seal leakage, flange failures, or similar system pressure-boundary violations. A double-ended piping rupture or crack exceeding this leak rate is not assumed, provided the Seismic Category I design requirements are met. High-energy piping failures and the effects on safety systems are discussed further in Section 3.6.

4. The emergency onsite electrical power sources (both ac and dc) and their associated distribution systems are designed to have sufficient independence, redundancy, and testability to perform their safety functions assuming a single failure, as defined in GDC 17. The protection systems, as defined in GDC 20 with regard to failure, are designed in accordance with Regulatory Guide 1.53.
5. All safety-related electrical/control systems are designed to ensure that a single failure cannot cause mechanical motion of a passive component of a fluid system in such a way that its motion results in total loss of the system safety function.

3.1.2 Criterion Conformance

3.1.2.1 Quality Standards and Records (Criterion 1)

3.1.2.1.1 Criterion

"Structures, systems, and components important to safety shall be designed, fabricated, erected, and tested to quality standards commensurate with the importance of the safety functions to be performed. Where generally recognized codes and standards are used, they shall be identified and evaluated to determine their applicability, adequacy, and sufficiency, and shall be supplemented or modified as necessary to assure a quality product in keeping with the required safety function. A quality assurance program shall be established and implemented in order to provide adequate assurance that these structures, systems, and components will satisfactorily perform their safety functions. Appropriate records of the design, fabrication, erection, and testing of structures, systems, and components important to safety shall be maintained by or under the control of the nuclear power unit licensee throughout the life of the unit."

3.1.2.1.2 Design Conformance

Structures, systems, and components important to safety are designed, fabricated, erected, and tested to quality standards commensurate with the importance of the safety functions to be performed.

Quality standards relating to safety-related structures, systems, and components are generally contained in codes such as the American Society of Mechanical Engineers (ASME) Boiler and Pressure Vessel Code. The applicability of these codes to structures, systems, and components identified throughout this report is summarized in Section 3.2.

Chapter 17 describes the quality assurance program established to provide adequate assurance that safety-related structures, systems, and components satisfactorily perform their safety functions.

3.1.2.2 Design Bases for Protection Against Natural Phenomena (Criterion 2)

3.1.2.2.1 Criterion

"Structures, systems, and components important to safety shall be designed to withstand the effects of natural phenomena, such as earthquakes, tornadoes, hurricanes, floods, tsunamis, and seiches, without loss of capability to perform their safety functions. The design bases for these structures, systems, and components shall reflect: (1) appropriate consideration of the most severe of the natural phenomena that have been historically reported for the site and surrounding area, with sufficient margin for the limited accuracy, quantity, and period of time in which the historical data have been accumulated, (2) appropriate combinations of the effects of normal and accident conditions with the effects of the natural phenomena, and (3) the importance of the safety functions to be performed."

3.1.2.2.2 Design Conformance

The structures, systems, and components important to safety are designed to withstand, or be protected from, the effects of natural phenomena without loss of capability to perform their safety functions. Those structures, systems, and components important to safety are designed to withstand the maximum probable natural phenomena expected at the site, determined from recorded data for the site vicinity, with appropriate margin to account for uncertainties in historical data. Appropriate combinations of the effects of normal and accident conditions with the effects of natural phenomena are considered in the plant design.

The nature and magnitudes of the natural phenomena considered in the design of BVPS-2 are discussed in Sections 2.3, 2.4, and 2.5. Sections 3.3 through 3.7 discuss the design of BVPS-2 in relation to natural events. Seismic and safety classifications, as well as other pertinent standards and information, are given in the sections discussing individual structures and components.

3.1.2.3 Fire Protection (Criterion 3)

3.1.2.3.1 Criterion

"Structures, systems, and components important to safety shall be designed and located to minimize, consistent with other safety requirements, the probability and effect of fires and explosions. Noncombustible and heat-resistant materials shall be used wherever practical throughout the unit, particularly in locations such as the containment and control room. Fire detection and fighting systems of appropriate capacity and capability shall be provided and designed to minimize the adverse effects of fires on structures, systems, and components important to safety. Firefighting systems shall be designed to assure that their rupture or inadvertent operation does not significantly impair the safety capability of these structures, systems, and components."

3.1.2.3.2 Design Conformance

The BVPS-2 structures, systems, and components are designed and located to minimize the probability and effect of fires and explosions. Noncombustibles and fire-resistant materials are used wherever practicable.

The requirements of NUREG-0800, (USNRC 1981) Standard Review Plan Section 9.5.1 and its Branch Technical Position CMEB 9.5-1, the National Fire Protection Association, the American Nuclear Insurers, and other applicable codes and regulations were originally considered in the design, installation, and testing of the system and components. By issuance of License Amendment No. 190, the NRC permitted NFPA 805 to be implemented as an acceptable means for satisfying Criterion 3. The previous fire protection program is now superseded by an NFPA 805 program.

The fire protection system (FPS) is designed to detect, annunciate, and extinguish postulated fires. A suitable combination of electrical isolation, physical distance, barriers, resistance to combustion, and automatic and/or manual protection is applied to adequately maintain effective independence of redundant safety-related equipment (the availability of safety functions in spite of postulated fires).

The FPS in safety-related areas is seismically supported to assure that it does not impair the function of safety-related structures, systems, and components.

The FPS is designed in such a manner that the failure of a part, or any of its components, or inadvertent operation does not impair the safety-related structures, systems, and components. Fire detection, annunciation, and extinguishing systems are periodically tested and inspected to assure reliability and to protect against the adverse effects of fires on structures, systems, and components important to safety. The FPS is discussed in Section 9.5.1.

3.1.2.4 Environmental and Missile Design Bases (Criterion 4)

3.1.2.4.1 Criterion

"Structures, systems, and components important to safety shall be designed to accommodate the effects of and to be compatible with the environmental conditions associated with normal operation, maintenance, testing, and postulated accidents, including loss-of-coolant accidents. These structures, systems, and components shall be appropriately protected against dynamic effects, including the effects of missiles, pipe whipping, and discharging fluids, that may result from equipment failures and from events and conditions outside the nuclear power unit."

3.1.2.4.2 Design Conformance

Structures, systems, and components important to safety are designed to accommodate the effects of, and to be compatible with, the environmental conditions associated with normal operation, maintenance, testing, and postulated accidents, including LOCA. Criteria are presented in Sections 3.5 through 3.10; environmental conditions are described in Section 3.11.

These structures, systems, and components are appropriately protected against or designed to accommodate dynamic effects, including the effects of missiles, pipe whipping, and discharging fluids, that may result from equipment failures, and from events and conditions outside the nuclear power unit. Details of the design, testing, and construction of these systems, structures, and components are included in Chapters 3, 5, 6, 7, 9, 10, and 15. Evaluation of the performance of safety features is contained in Chapter 6.

3.1.2.5 Sharing of Structures, Systems, and Components (Criterion 5)

3.1.2.5.1 Criterion

"Structures, systems, and components important to safety shall not be shared between nuclear power units unless it is shown that such sharing does not significantly impair their ability to perform their safety functions, including, in the event of an accident in one unit, an orderly shutdown and cooldown of the remaining units."

3.1.2.5.2 Design Conformance

Systems, structures, and components shared by Beaver Valley Power Station - Unit 1 (BVPS-1) and BVPS-2 are presented in Section 1.2.1.

Sharing of any of these systems, structures, and components does not impair the safety of the reactor facilities in accordance with GDC 5.

3.1.2.6 Criterion 6

This criterion has not been promulgated by the USNRC.

3.1.2.7 Criterion 7

This criterion has not been promulgated by the USNRC.

3.1.2.8 Criterion 8

This criterion has not been promulgated by the USNRC.

3.1.2.9 Criterion 9

This criterion has not been promulgated by the USNRC.

3.1.2.10 Reactor Design (Criterion 10)

3.1.2.10.1 Criterion

"The reactor core and associated coolant, control, and protection systems shall be designed with appropriate margin to assure that specified acceptable fuel design limits are not exceeded during any condition of normal operation, including the effects of anticipated operational occurrences."

3.1.2.10.2 Design Conformance

The reactor core and associated coolant, control, and protection systems are designed with adequate margins to:

1. Assure that fuel damage (defined as penetration of the fission product barrier, that is the fuel rod clad) is not expected during normal core operation and operational transients (Condition I) or any transient conditions arising from occurrences of moderate frequency (Condition II). (Conditions I and II are defined by ANSI N18.2-73.) It is not possible, however, to preclude a very small number of rod failures. These are within the capability of the BVPS-2 cleanup system and are consistent with BVPS-2 design bases.
2. Ensure return of the reactor to a safe state following a Condition III (as defined by ANSI-N18.2-73) event with only a small fraction of fuel rods damaged although sufficient fuel damage might occur to preclude immediate resumption of operation.
3. Assure that the core is intact with acceptable heat transfer geometry following transients arising from occurrences of limiting faults (Condition IV as defined by ANSI-N18.2-73).

Chapter 4 discusses the design bases and design evaluation of core components. Details of the control and protection systems instrumentation design and logic are discussed in Chapter 7. This information supports the accident analyses of Chapter 15 which show that the acceptable fuel design limits are not exceeded for Conditions I and II occurrences.

3.1.2.11 Reactor Inherent Protection (Criterion 11)

3.1.2.11.1 Criterion

"The reactor core and associated coolant systems shall be designed so that in the power operating range the net effect of the prompt inherent nuclear feedback characteristics tends to compensate for a rapid increase in reactivity."

3.1.2.11.2 Design Conformance

When the reactor is critical, prompt compensatory reactivity feedback effects are assured by the negative fuel temperature effect (Doppler effect) and by the operational limit on moderator temperature coefficient of reactivity at 100 percent power, and less than +2.0 pcm/°F below 70 percent power. From 70 percent power to 100 percent power, the limit on the moderator temperature coefficient of reactivity decreases linearly from +2.0 pcm/°F to 0.0 pcm/°F. The negative Doppler coefficient of reactivity is assured by the inherent design using low-enrichment fuel. The moderator temperature coefficient limits of reactivity are assured by administratively controlling either the dissolved absorber concentration, burnable poison, and/or rod withdrawal limits.

These reactivity coefficients are discussed in Section 4.3.

3.1.2.12 Suppression of Reactor Power Oscillations (Criterion 12)

3.1.2.12.1 Criterion

"The reactor core and associated coolant, control, and protection systems shall be designed to assure that power oscillations which can result in conditions exceeding specified acceptable fuel design limits are not possible or can be reliably and readily detected and suppressed."

3.1.2.12.1.2 Design Conformance

Power oscillations of the fundamental mode are inherently eliminated by the negative Doppler and the moderator temperature coefficient limits of reactivity.

Oscillations, due to xenon spatial effects in the radial, diametral, and azimuthal overtone modes are heavily damped due to the inherent design and due to the negative Doppler and the moderator temperature coefficient limits of reactivity.

Oscillations, due to xenon spatial effects in the axial first overtone mode may occur. Assurance that fuel design limits are not

exceeded by xenon axial oscillations is provided by reactor trip functions using the measured axial power imbalance as an input.

Oscillations, due to xenon spatial effects, in axial modes higher than the first overtone, are heavily damped due to the inherent design and due to the negative Doppler coefficient of reactivity. Xenon stability control is discussed in Section 4.3.

3.1.2.13 Instrumentation and Control (Criterion 13)

3.1.2.13.1 Criterion

"Instrumentation and control shall be provided to monitor variables and systems over their anticipated ranges for normal operation, for anticipated operational occurrences, and for accident conditions as appropriate to assure adequate safety, including those variables and systems that can affect the fission process, the integrity of the reactor core, the reactor coolant pressure boundary, and the containment and its associated systems. Appropriate controls shall be provided to maintain these variables and systems within prescribed operating ranges."

3.1.2.13.2 Design Conformance

Instrumentation and controls are provided to monitor and control neutron flux, control rod position, temperature, pressures, flows, and levels as necessary to assure that adequate plant safety can be maintained. Instrumentation is provided in the reactor coolant system (RCS), steam and power conversion system, the containment, engineered safety features (ESF) systems, and other auxiliaries. Parameters that must be provided for operator use under normal operating and accident conditions are indicated in the control room in proximity to the controls for maintaining the indicated parameter in the proper range.

The quantity and types of process instrumentation provided ensure safe and orderly operation of all systems over the full design range of BVPS-2. These systems are described in Chapters 6, 7, 8, 9, 11, and 12.

3.1.2.14 Reactor Coolant Pressure Boundary (Criterion 14)

3.1.2.14.1 Criterion

"The reactor coolant pressure boundary shall be designed, fabricated, erected, and tested so as to have an extremely low probability of abnormal leakage, of rapidly propagating failure, and of gross rupture."

3.1.2.14.2 Design Conformance

The RCS boundary is designed to accommodate the system pressures and temperatures attained under all expected modes of BVPS-2 operation, including all anticipated transients, and to maintain the stresses within applicable stress limits. Refer to Section 3.9 for details. Reactor coolant pressure boundary (RCPB) materials selection and fabrication techniques ensure a low probability of gross rupture or significant leakage.

In addition to the loads imposed on the system under normal operating conditions, consideration is also given to abnormal loading conditions, such as seismic and pipe rupture as discussed in Sections 3.6 and 3.7. The system is protected from overpressure by means of pressure relieving devices as required by applicable codes. Refer to Section 5.2.2.

The RCS boundary has provisions for inspection, testing, and surveillance of critical areas to assess the structural and leaktight integrity. Details are given in Section 5.2. For the reactor vessel, a material surveillance program conforming to applicable codes is provided. Section 5.3 gives details.

3.1.2.15 Reactor Coolant System Design (Criterion 15)

3.1.2.15.1 Criterion

"The reactor coolant system and associated auxiliary, control, and protection systems shall be designed with sufficient margin to assure that the design conditions of the reactor coolant pressure boundary are not exceeded during any condition of normal operation, including anticipated operational occurrences."

3.1.2.15.2 Design Conformance

The design pressure and temperature for each component in the reactor coolant and associated auxiliary, control, and protection systems are selected to be above the maximum coolant pressure and temperature under all normal and anticipated transient load conditions.

Additionally, RCPB components achieve a large margin of safety by the use of proven ASME materials and design codes, use of proven fabrication techniques, nondestructive shop testing, and integrated hydrostatic testing of assembled components. Chapter 5 discusses the RCS design.

3.1.2.16 Containment Design (Criterion 16)

3.1.2.16.1 Criterion

"Reactor containment and associated systems shall be provided to establish an essentially leaktight barrier against the uncontrolled

release of radioactivity to the environment and to assure that the containment design conditions important to safety are not exceeded for as long as postulated accident conditions require."

3.1.2.16.2 Design Conformance

A steel-lined, reinforced concrete containment structure, maintained at subatmospheric pressure, encloses the entire RCS and provides an essentially leaktight barrier. The containment structure and the engineered safety features are designed to withstand internal and external environmental conditions that may reasonably be expected during the life of the BVPS-2 and to ensure that the short and long term conditions following a LOCA do not exceed the design bases. Following a design basis accident (DBA), the recirculation and quench spray systems (QSS) cool and depressurize the containment atmosphere to maintain the pressure and temperature below the containment design values.

Reference Sections

<u>Title</u>	<u>Section</u>
Concrete Containment	3.8.1
Containment Functional Design	6.2.1
Quench Spray System	6.2.2.2.1
Recirculation Spray System	6.2.2.2.2

3.1.2.17 Electric Power Systems (Criterion 17)

3.1.2.17.1 Criterion

"An onsite electric power system and an offsite electric power system shall be provided to permit functioning of structures, systems, and components important to safety. The safety function for each system (assuming the other system is not functioning) shall be to provide sufficient capacity and capability to assure that (1) specified acceptable fuel design limits and design conditions of the reactor coolant pressure boundary are not exceeded as a result of anticipated operational occurrences, and (2) the core is cooled and containment integrity and other vital functions are maintained in the event of postulated accidents.

"The onsite electric power sources, including the batteries, and the onsite electric distribution system, shall have sufficient independence, redundancy, and testability to perform their safety functions assuming a single failure.

"Electric power from the transmission network to the onsite electric distribution system shall be supplied by two physically independent circuits (not necessarily on separate rights of way) designed and located so as to minimize to the extent practical the likelihood of their simultaneous failure under operating and postulated accident and environmental conditions. A switchyard common to both circuits is acceptable. Each of these circuits shall be designed to be available in sufficient time following a loss of all onsite alternating current power supplies and the other offsite electric power circuit, to assure that specified acceptable fuel design limits and design conditions of the reactor coolant pressure boundary are not exceeded. One of these circuits shall be designed to be available within a few seconds following a loss-of-coolant accident to assure that core cooling, containment integrity, and other vital safety functions are maintained.

"Provisions shall be included to minimize the probability of losing electric power from any of the remaining sources as a result of, or coincident with, the loss of power generated by the nuclear power unit, the loss of power from the transmission network, or the loss of power from the onsite electric power sources."

3.1.2.17.2 Design Conformance

The electric power system (EPS) design includes two offsite power systems and two onsite power systems. Each system provides sufficient capability for operating all safety-related equipment which must be operated in the event of postulated accidents.

The onsite emergency power system consists of an ac emergency power system, a 125 V dc power system, and a 120 V ac vital bus system, as described in Section 8.3.

The ac emergency power system consists of two separate, physically independent, 4,160 V, 3-phase, 60 Hz, diesel-driven, synchronous generators, and their associated control, distribution, and auxiliary equipment, as shown on Figure 8.3-1. Each emergency diesel generator accelerates to speed and is capable of accepting load within 10 seconds.

Four 125 V dc systems, complete with batteries, charging equipment, switchgear, and distribution equipment, are provided for safety-related equipment. These systems are described in Section 8.3.2.

A safety-related 120 V ac vital bus system is provided to supply power for the engineered safeguards protection channels. This very stable and reliable system consists of four single-phase inverters and the necessary switchgear and distribution equipment. This system is described more fully in Section 8.3.1.

The onsite emergency power system has sufficient independence, redundancy, and testability, as discussed in Sections 1.8.6,

3.1.2.18, 8.3.1, and 8.3.2, to perform its safety function assuming a single failure.

Two physically separate offsite station power systems are fed by two independent circuits from separate buses in a switchyard common to both, as shown on Figures 8.1-1, 8.1-2, and 1.2-1.

Both offsite power systems are normally energized and are designed to be available immediately upon loss of all onsite ac power sources, since an automatic transfer scheme is provided for this purpose at the 4 kV bus level. This scheme is described in Section 8.3.

3.1.2.18 Inspection and Testing of Electric Power Systems (Criterion 18)

3.1.2.18.1 Criterion

"Electric power systems important to safety shall be designed to permit appropriate periodic inspection and testing of important areas and features, such as wiring, insulation, connections, and switchboards, to assess the continuity of the systems and the condition of their components. The systems shall be designed with a capability to test periodically (1) the operability and functional performance of the components of the systems, such as onsite power sources, relays, switches, and buses, and (2) the operability of the systems as a whole and, under conditions as close to design as practical, the full operation sequence that brings the systems into operation, including operation of applicable portions of the protection system, and the transfer of power among the nuclear power unit, the offsite power system, and the onsite power system."

3.1.2.18.2 Design Conformance

3.1.2.18.2.1 Preservice

Electrical equipment is specified for manufacture and testing in accordance with the requirements of the National Electrical Manufacturers Association, the Institute of Electrical and Electronics Engineers (IEEE), or the ANSI standards, where applicable, as listed in Section 8.1.

Electrical equipment is properly protected during shipment and storage.

Special attention is given to mechanical alignment and electrical ground connections. The dielectric of insulation is measured and corrected, if necessary, before equipment is energized.

Tests and inspections will be conducted to ensure that all components are correct and properly mounted, connections are correct, circuits are continuous, and components are operational.

Tests will be conducted to determine that emergency loads do not exceed the diesel generator rating and that each diesel generator is suitable for starting and for accepting and operating the required loads.

Protective relays are set and calibrated, and metering devices have calibration checked by the Applicant's trained personnel.

3.1.2.18.2.2 Inservice

The availability and proper action of safety-related EPSs can be tested periodically.

Testing of the automatic bus transfer scheme at the 4,160 V level is performed periodically.

The station batteries which supply control power for operating major motor starters and nuclear safety protection systems are kept at a constant voltage and are monitored continuously for voltage variations or undesired ground connections. Station batteries are subjected to periodic inspection.

The loading and automatic starting features of the emergency diesel generators are tested periodically.

Electrical equipment and circuits are subjected to a periodic preventive maintenance program as appropriate.

The inspection and testing of the EPS is discussed more fully in Section 8.3.

3.1.2.19 Control Room (Criterion 19)

3.1.2.19.1 Criterion

"A control room shall be provided from which actions can be taken to operate the nuclear power unit safely under normal conditions and to maintain it in a safe condition under accident conditions, including loss-of-coolant accident. Adequate radiation protection shall be provided to permit access and occupancy of the control room under accident conditions without personnel receiving radiation exposures in excess of 5 rem whole body, or its equivalent to any part of the body, for the duration of the accident.

"Equipment at appropriate locations outside the control room shall be provided with a design capability for prompt hot shutdown of the reactor, including necessary instrumentation and controls to maintain the unit in a safe condition during hot shutdown, and with a potential capability for subsequent cold shutdown of the reactor through the use of suitable procedures."

Design Conformance

A control room is provided and equipped to operate BVPS-2 safely under normal and accident conditions. Control room shielding and ventilation are designed to permit continuous occupancy of the control room for the duration of any accident, including LOCA.

An emergency shutdown panel with equipment, controls, and instrumentation is provided to accomplish, in conjunction with other controls outside the control room, a prompt hot or subsequent cold shutdown in a safe manner.

The emergency shutdown panel is located in the control building in a room physically isolated from the control room, so that any occurrence which could cause the control room to become uninhabitable has no effect on the availability of the emergency shutdown panel and other controls. Also, equipment, controls, and instrumentation are located throughout BVPS-2 and the emergency shutdown panel to provide capability for a subsequent cold shutdown of the reactor.

The design of the control building, which houses the control room and the emergency shutdown panel area, conforms with GDC 19.

Reference Sections

<u>Title</u>	<u>Section</u>
Habitability Systems	6.4
Systems Required for a Safe Shutdown	7.4
Control Building Heating, Ventilation, and Air-Conditioning Systems	9.4.1

3.1.2.20 Protection System Functions (Criterion 20)

3.1.2.20.1 Criterion

"The protection system shall be designed (1) to initiate automatically the operation of appropriate systems including the reactivity control systems, to assure that specified acceptable fuel design limits are not exceeded as a result of anticipated operational occurrences and, (2) to sense accident conditions and to initiate the operation of systems and components important to safety."

3.1.2.20.2 Design Conformance

A fully automatic protection system with appropriate redundant channels is provided to cope with transients where insufficient time is available for manual corrective action. The design basis for all

protection systems is in accordance with the intent of IEEE Standard 279-1971 and IEEE Standard 379-1972. The reactor protection system automatically initiates a reactor trip when any variable monitored by the system or combination of monitored variables exceeds the normal operating range. Set points are designed to provide an envelope of safe operating conditions with adequate margin for uncertainties to ensure that fuel design limits are not exceeded.

Reactor trip is initiated by removing power to the rod drive mechanisms of all full length rod cluster control assemblies (RCCAs). This causes the rods to insert by gravity and rapidly reduces the reactor power output. The response and adequacy of the protection system has been verified by analysis of anticipated transients.

The engineered safety features actuation system (ESFAS) automatically initiates emergency core cooling, and other safeguards functions, by sensing accident conditions using redundant analog channels measuring diverse variables. Manual actuation of safeguards may be performed where ample time is available for operator action. The ESFAS automatically trips the reactor on manual or automatic safety injection signal generation.

3.1.2.21 Protection System Reliability and Testability (Criterion 21)

3.1.2.21.1 Criterion

"The protection system shall be designed for high functional reliability and inservice testability commensurate with the safety functions to be performed. Redundancy and independence designed into the protection system shall be sufficient to assure that (1) no single failure results in loss of the protection function and (2) removal from service of any component or channel does not result in loss of the required minimum redundancy unless the acceptable reliability of operation of the protection system can be otherwise demonstrated. The protection system shall be designed to permit periodic testing of its functioning when the reactor is in operation, including a capability to test channels independently to determine failures and losses of redundancy that may have occurred."

3.1.2.21.2 Design Conformance

The protection system is designed for high functional reliability and inservice testability.

Compliance with this criterion is discussed in Sections 7.2.2.2.3 and 7.3.2.2.5.

3.1.2.22 Protection System Independence (Criterion 22)

3.1.2.22.1 Criterion

"The protection system shall be designed to assure that the effects of natural phenomena, and of normal operating, maintenance, testing, and postulated accident conditions on redundant channels do not result in loss of the protection function, or shall be demonstrated to be acceptable on some other defined basis. Design techniques, such as functional diversity or diversity in component design and principles of operation, shall be used to the extent practical to prevent loss of the protection function."

3.1.2.22.2 Design Conformance

Protection system components are designed and arranged so that the environment accompanying any emergency situation in which the components are required to function does not result in loss of the safety function. Various means are used to accomplish this. Functional diversity has been designed into the system. The extent of this functional diversity has been evaluated for a wide variety of postulated accidents. Diverse protection functions will automatically terminate an accident before intolerable consequences can occur. Each parameter is also provided with redundant channels, which are physically separated from each other. Manual initiation of reactor trip and safety injection is also provided. The reactor trip system (RTS) is discussed in Section 7.2. The ESF system is discussed in Section 7.3.

High quality components, conservative design and applicable quality control, inspection, calibration, and tests are utilized to guard against common-mode failure. Qualification testing is performed on the various safety systems to demonstrate functional operation at normal and postaccident conditions of temperature, humidity, pressure, and radiation for specified periods if required. Typical protection system equipment is subjected to type tests under simulated seismic conditions using conservatively large accelerations and applicable frequencies. The test results indicate no loss of the protection function. Further details are given in Section 3.10.

3.1.2.23 Protection System Failure Modes (Criterion 23)

3.1.2.23.1 Criterion

"The protection system shall be designed to fail into a safe state or into a state demonstrated to be acceptable on some other defined basis if conditions such as disconnection of the system, loss of energy (e.g., electric power, instrument air), or postulated adverse environments (e.g., extreme heat or cold, fire, pressure, steam, water, and radiation) are experienced."

3.1.2.23.2 Design Conformance

The protection system is designed with due consideration of the most probable failure modes of the components under various perturbations of the environment and of energy sources. Each reactor trip channel is designed on the deenergize-to-trip principle so loss of power, disconnection, open-channel faults, and the majority of internal channel short-circuit faults cause the channel to go into its tripped mode. The protection system is discussed in Sections 7.2 and 7.3

3.1.2.24 Separation of Protection and Control Systems (Criterion 24)

3.1.2.24.1 Criterion

"The protection system shall be separated from control systems to the extent that failure of any single control system component or channel, or failure or removal from service of any single protection system component or channel which is common to the control and protection systems leaves intact a system satisfying all reliability, redundancy, and independence requirements of the protection system. Interconnection of the protection and control systems shall be limited so as to assure that safety is not significantly impaired."

3.1.2.24.2 Design Conformance

The protection system is separate and distinct from the control systems. Control systems may be dependent on the protection system in that control signals are derived from protection system measurements where applicable. These signals are transferred to the control system by isolation amplifiers, which are classified as protection components. The adequacy of system isolation has been verified by testing under conditions of postulated credible faults. The failure of any single control system component or channel, or failure or removal from service of any single protection system component or channel, which is common to the control and protection system, leaves intact a system which satisfies the requirements of the protection system. Distinction between channel and train is made in this discussion. The removal of a train from service is allowed only during testing of the train.

3.1.2.25 Protection System Requirements or Reactivity Control Malfunctions (Criterion 25)

3.1.2.25.1 Criterion

"The protection system shall be designed to assure that specified acceptable fuel design limits are not exceeded for any single malfunction of the reactivity control systems, such as accidental withdrawal (not ejection or dropout) of control rods."

3.1.2.25.2 Design Conformance

The protection system is designed to limit reactivity transients so that fuel design limits are not exceeded. Reactor shutdown by full length rod insertion is completely independent of the normal control function since the trip breakers interrupt power to the rod mechanisms regardless of existing control signals. Thus, in the postulated accidental withdrawal, (assumed to be initiated by a control malfunction) flux, temperature, pressure, level, and flow signals would be independently generated. Any of these signals (trip demands) would operate the breakers to trip the reactor.

Analyses of the effects of possible malfunctions are discussed in Chapter 15. These analyses show that for postulated dilution during refueling, start-up, or manual or automatic operation at power, the operator has ample time to determine the cause of dilution, terminate the source of dilution, and initiate reboration before the shutdown margin is lost. The analyses show that acceptable fuel damage limits are not exceeded even in the event of a single malfunction of either system.

3.1.2.26 Reactivity Control System Redundancy and Capability (Criterion 26)

3.1.2.26.1 Criterion

"Two independent reactivity control systems of different design principles shall be provided. One of the systems shall use control rods, preferably including a positive means for inserting the rods, and shall be capable of reliably controlling reactivity changes to assure that under conditions of normal operation, including anticipated operational occurrences, and with appropriate margin for malfunctions such as stuck rods, specified acceptable fuel design limits are not exceeded. The second reactivity control system shall be capable of reliably controlling the rate of reactivity changes resulting from planned, normal power changes (including xenon burnout) to assure acceptable fuel design limits are not exceeded. One of the systems shall be capable of holding the reactor core subcritical under cold conditions."

3.1.2.26.2 Design Conformance

Two reactivity control systems are provided. These are rod cluster control assemblies (RCCAs) and chemical shim (boric acid). The RCCAs are inserted into the core by the force of gravity.

During operation, the shutdown rod banks are fully withdrawn. The full length control rod system automatically maintains a programmed average reactor temperature and compensates for reactivity effects associated with scheduled and transient load changes. The shutdown rod banks along with the full length control banks are designed to shut down the reactor with adequate margin under conditions of normal

operation and anticipated operational occurrences, thereby ensuring that specified fuel design limits are not exceeded. The most restrictive period in core life is assumed in all analyses and the most reactive rod cluster is assumed to be in the fully withdrawn position.

Boric acid from the chemical and volume control system (CVCS) will maintain the reactor in the cold shutdown state independent of the position of the control rods and can compensate for xenon burnout transients.

Details of the construction of the RCCAs are presented in Chapter 4 and their operations are discussed in Chapter 7. The means of controlling the boric acid concentration are described in Chapter 9. Performance analyses under accident conditions are included in Chapter 15.

3.1.2.27 Combined Reactivity Control Systems Capability (Criterion 27)

3.1.2.27.1 Criterion

"The reactivity control systems shall be designed to have a combined capability, in conjunction with poison addition by the emergency core cooling system, of reliably controlling reactivity changes to assure that under postulated accident conditions and with appropriate margin for stuck rods the capability to cool the core is maintained."

3.1.2.27.2 Design Conformance

Beaver Valley Power Station - Unit 2 is provided with means of making and holding the core subcritical under any anticipated conditions and with appropriate margin for contingencies. These means are discussed in detail in Chapters 4 and 9. Combined use of the rod cluster control system and the chemical shim control system permits the necessary shutdown margin to be maintained during long term xenon decay and BVPS-2 cooldown. The single highest worth control cluster is assumed to be stuck full out upon trip for this determination.

3.1.2.28 Reactivity Limits (Criterion 28)

3.1.2.28.1 Criterion

"The reactivity control systems shall be designed with appropriate limits on the potential amount and rate of reactivity increase to assure that the effects of postulated reactivity accidents can neither (1) result in damage to the reactor coolant pressure boundary greater than limited local yielding nor (2) sufficiently disturb the core, its support structures or other reactor pressure vessel internals to impair significantly the capability to cool the core. These postulated reactivity accidents shall include consideration of rod ejection (unless prevented by positive means), rod dropout, steam

line rupture, changes in reactor coolant temperature and pressure, and cold water addition."

3.1.2.28.2 Design Conformance

The maximum reactivity worth of control rods and the maximum rates of reactivity insertion employing control rods are limited to values that prevent rupture of the RCS boundary or disruptions of the core or vessel internals to a degree that could impair the effectiveness of emergency core cooling.

The maximum positive reactivity insertion rates for the withdrawal of RCCAs and the dilution of the boric acid in the RCS are limited by the physical design characteristics of the RCCAs and of the CVCS. Technical Specifications on shutdown margin and on RCCA insertion limits and bank overlaps as functions of power provide additional assurance that the consequences of the postulated accidents are no more severe than those presented in the analyses of Chapter 15. Reactivity insertion rates, dilution, and withdrawal limits are also discussed in Section 4.3. The capability of the CVCS to avoid an inadvertent excessive rate of boron dilution is discussed in Chapter 15.

Assurance of core cooling capability following Condition IV accidents, such as rod ejections, steam line break, etc., is given in keeping the RCPB stresses within faulted condition limits as specified by applicable ASME Codes. Structural deformations are checked also and limited to values that do not jeopardize the operation of necessary safety features.

3.1.2.29 Protection Against Anticipated Operational Occurrences (Criterion 29)

3.1.2.29.1 Criterion

"The protection and reactivity control systems shall be designed to assure an extremely high probability of accomplishing their safety functions in the event of anticipated operational occurrences."

3.1.2.29.2 Design Conformance

The protection and reactivity control systems are designed to assure extremely high probability of performing their required safety functions in any anticipated operational occurrences. Likely failure modes of system components are designed to be safe modes. Equipment used in these systems is designed, constructed, operated, and maintained with a high level of reliability. Loss of power to the protection system results in a reactor trip. Details of system design are covered in Chapter 7. Refer to GDC 20 through 25 for further discussion.

3.1.2.30 Quality of Reactor Coolant Pressure Boundary (Criterion 30)

3.1.2.30.1 Criterion

"Components which are part of the reactor coolant pressure boundary shall be designed, fabricated, erected, and tested to the highest quality standards practical. Means shall be provided for detecting and, to the extent practical, identifying the location of the source of reactor coolant leakage."

3.1.2.30.2 Design Conformance

Reactor coolant pressure boundary components are designed, fabricated, inspected and tested in conformance with ASME Nuclear Power Plant Components Code, Section III. All components are classified according to ANSI N18.2-1973 and are accorded the quality measures appropriate to the classification. The design bases and evaluations of RCPB components are discussed in Chapter 5.

Leakage is detected by an increase in the amount of makeup of water required to maintain a normal level in the pressurizer. The reactor vessel closure joint is provided with a temperature monitored leak-off between double gaskets. Leakage into the reactor containment is drained to the reactor building sump where it is monitored.

Leakage is also detected by measuring the airborne activity. Monitoring the inventory of reactor coolant in the system at the pressurizer, volume control tank, and coolant drain collection tanks provides an accurate indication of integrated leakage.

The RCPB leakage detection system is discussed in Section 5.2.5.

3.1.2.31 Fracture Prevention of Reactor Coolant Pressure Boundary (Criterion 31)

3.1.2.31.1 Criterion

"The reactor coolant pressure boundary shall be designed with sufficient margin to assure that when stressed under operating, maintenance, testing, and postulated accident conditions (1) the boundary behaves in a nonbrittle manner and (2) the probability of rapidly propagating fracture is minimized. The design shall reflect consideration of service temperatures and other conditions of the boundary material under operating, maintenance, testing and postulated accident conditions and the uncertainties in determining (1) material properties, (2) the effects of irradiation on material properties, (3) residual, steady-state and transient stresses, and (4) size of flaws."

3.1.2.31.2 Design Conformance

Close control is maintained over material selection and fabrication for the RCS to assure that the boundary behaves in a nonbrittle manner. The RCS materials, which are exposed to the coolant, are corrosion resistant stainless steel or Inconel. The reference temperature (RT_{NDT}) of the reactor vessel structural steel is established by Charpy V notch and drop weight tests in accordance with 10 CFR 50, Appendix G.

As part of the reactor vessel specification certain requirements, which are not specified by the applicable ASME Codes, are performed as follows:

1. Ultrasonic Testing - In addition to code requirements, the performance of a 100 percent volumetric ultrasonic test of reactor vessel plate for shear wave and a posthydro test ultrasonic map of all welds in the pressure vessel are required. Cladding bond ultrasonic inspection to more restrictive requirements than those specified in the code is also required to preclude interpretation problems during inservice inspection.
2. Radiation Surveillance Program - In the surveillance programs, the evaluation of the radiation damage is based on pre-irradiation and postirradiation testing of Charpy V notch and tensile specimens. These programs are directed toward evaluation of the effect of radiation on the fracture toughness of reactor vessel steels based on the reference transition temperature approach and the fracture mechanics approach, and are in accordance with the requirements of 10 CFR 50, Appendix H.
3. Reactor vessel core region material chemistry (copper and phosphorous) is controlled to reduce sensitivity to embrittlement due to irradiation over the life of BVPS-2.

The fabrication and quality control techniques used in the fabrication of the RCS are equivalent to those used for the reactor vessel. The inspections of reactor vessel, pressurizer, piping, pumps, and steam generators are governed by ASME Code requirements. Details are provided in Chapter 5.

Allowable pressure-temperature relationships for BVPS-2 heatup and cooldown rates are calculated using methods derived from the ASME Code, Section III, Appendix G, Protection Against Non-Ductile Failure. The approach specifies that allowed stress intensity factors for all vessel operating conditions shall not exceed the reference stress intensity factor for the metal temperature at any time. Operating specifications include conservative margins for

predicted changes in the material reference temperatures (RT_{NDT}) due to irradiation. These pressure-temperature relationships are in accordance with 10 CFR 50, Appendix G.

3.1.2.32 Inspection of Reactor Coolant Pressure Boundary (Criterion 32)

3.1.2.32.1 Criterion

"Components which are part of the reactor coolant pressure boundary shall be designed to permit (1) periodic inspection and testing of important areas and features to assess their structural and leaktight integrity, and (2) an appropriate material surveillance program for the reactor pressure vessel."

3.1.2.32.2 Design Conformance

The design of the RCPB provides the capability for accessibility during service life to the internal surfaces of the reactor vessel, certain external zones of the vessel (including the nozzle to reactor coolant piping welds and the top and bottom heads), and external surfaces of the reactor coolant piping except for the area of pipe within the primary shielding concrete. The inspection capability complements the leakage detection systems in assessing the integrity of pressure boundary components. The RCPB will be periodically inspected under the provisions of the ASME Boiler and Pressure Vessel Code, Section XI. Details of the inservice inspection program are presented in Section 5.2.4.

Monitoring of changes in the fracture toughness properties of the reactor vessel core region plates forging, weldment, and associated heat-affected zones are performed in accordance with 10 CFR 50, Appendix H, Reactor Vessel Material Surveillance Program Requirements. Samples of reactor vessel plate materials are retained and cataloged in case future engineering development shows the need for further testing.

The material properties surveillance program includes not only the conventional tensile and impact tests, but also fracture mechanics specimens. The observed shifts in RT_{NDT} of the core region materials with irradiation will be used to confirm the allowable limits calculated for all operational transients. Further details are given in Section 5.3.

3.1.2.33 Reactor Coolant Makeup [Criterion 33]

3.1.2.33.1 Criterion

"A system to supply reactor coolant makeup for protection against small breaks in the reactor coolant pressure boundary shall be provided. The system safety function shall be to assure that specified acceptable fuel design limits are not exceeded as a result

of reactor coolant loss due to leakage from the reactor coolant pressure boundary and rupture of small piping or other small components which are part of the boundary. The system shall be designed to assure that for onsite electric power system operation (assuming offsite power is not available) and for offsite electric power system operation (assuming onsite power is not available) the system safety function can be accomplished using the piping, pumps, and valves used to maintain coolant inventory during normal reactor operation."

3.1.2.33.2 Design Conformance

The CVCS provides a means of reactor coolant makeup and adjustment of the boric acid concentration. Makeup is added automatically if the level in the volume control tank falls below the preset level. The high-pressure centrifugal charging pumps provided are capable of supplying the required makeup and reactor coolant pump seal injection flow when power is available from either onsite or offsite EPSs. These pumps also serve as high head safety injection pumps. Functional reliability is assured by provision of standby components assuring a safe response to probable modes of failure. Details of system design are included in Sections 6.3 and 9.3 with details of the EPS included in Chapter 8.

3.1.2.34 Residual Heat Removal (Criterion 34)

3.1.2.34.1 Criterion

"A system to remove residual heat shall be provided. The system safety function shall be to transfer fission product decay heat and other residual heat from the reactor core at a rate such that specified acceptable fuel design limits and the design conditions of the reactor coolant pressure boundary are not exceeded.

"Suitable redundancy in components and features, and suitable interconnections, leak detection, and isolation capabilities shall be provided to assure that for onsite electric power system operation (assuming offsite power is not available) and for offsite electric power system operation (assuming onsite power is not available) the system safety function can be accomplished, assuming a single failure."

3.1.2.34.2 Design Conformance

The RHR system is a reliable and preferred means of residual heat removal but not the method used to meet GDC-34. BVPS-2 meets GDC-34 by providing systems to transfer fission product decay heat and other residual heat from the reactor core at a rate within acceptable design limits.

In the event the RHR system is unavailable, qualified safety grade systems are available to perform the function of removing residual

heat from the reactor core for normal, abnormal, and design basis accident conditions. These qualified safety grade systems include ECCS, AFWS, along with the main steam safety valves and the atmospheric dump and residual heat release valves.

Details of the systems' design are in Sections 5.1, 5.4.2, Appendix 5A, 6.3, and 10.4.9.

3.1.2.35 Emergency Core Cooling (Criterion 35)

3.1.2.35.1 Criterion

"A system to provide abundant emergency core cooling shall be provided. The system safety function shall be to transfer heat from the reactor core following any loss of reactor coolant at a rate such that (1) fuel and clad damage that could interfere with continued effective core cooling is prevented and (2) clad metal-water reaction is limited to negligible amounts.

"Suitable redundancy in components and features, and suitable interconnections, leak detection, isolation, and containment capabilities shall be provided to assure that for onsite electric power system operation (assuming offsite power is not available) and for offsite electric power system operation (assuming onsite power is not available) the system safety function can be accomplished, assuming a single failure."

3.1.2.35.2 Design Conformance

An ECCS is provided to cope with any LOCA in the BVPS-2 design basis. Abundant cooling water is available in an emergency to transfer heat from the core at a rate sufficient to maintain the core in a coolable geometry and to assure that clad metal-water reaction is limited to less than 1 percent. Adequate design provisions are made to assure performance of the required safety functions even with a single failure.

Details of the capability of the systems are included in Section 6.3. An evaluation of the adequacy of the system functions is included in Chapter 15. Performance evaluations have been conducted in accordance with 10 CFR 50.46 and Appendix K to 10 CFR 50.

3.1.2.36 Inspection of Emergency Core Cooling System (Criterion 36)

3.1.2.36.1 Criterion

"The emergency core cooling system shall be designed to permit appropriate periodic inspection of important components, such as spray rings in the reactor pressure vessel, water injection nozzles, and piping, to assure the integrity and capability of the system."

3.1.2.36.2 Design Conformance

Design provisions facilitate access to the critical parts of the injection nozzles, pipes, and valves for visual inspection and for nondestructive inspection where such techniques are desirable and appropriate. The design is in accordance with ASME Section XI requirements.

The components outside the containment are accessible for leaktightness inspection during operation of the reactor.

Details of the inspection program for the ECCS are discussed in Sections 6.3, 6.6, and in Chapter 16.

3.1.2.37 Testing of Emergency Core Cooling System (Criterion 37)

3.1.2.37.1 Criterion

"The emergency core cooling system shall be designed to permit appropriate periodic pressure and functional testing to assure (1) the structural and leaktight integrity of its components, (2) the operability and performance of the active components of the system, and (3) the operability of the system as a whole and, under conditions as close to design as practical, the performance of the full operational sequence that brings the system into operation, including operation of applicable portions of the protection system, the transfer between normal and emergency power sources, and the operation of the associated cooling water system."

3.1.2.37.2 Design Conformance

The BVPS-2 design conforms to the guidelines of GDC 37. During appropriate periodic tests, the components of the system located outside the containment are accessible for leaktightness inspection.

Each active component of the ECCS may be individually actuated on the normal power source (or transferred to the emergency power source) at any time during unit operation to demonstrate operability.

Individual ECCS pumps and valves may be tested for proper operation during normal BVPS-2 conditions. Tests may be performed during shutdown to demonstrate proper automatic operation of the ECCS.

These tests, including ASME OM Code requirements are described in Chapters 6, 7, and 9. The switching sequence from normal to emergency power is described in Chapter 8.

Design provisions include special instrumentation, testing, and sampling lines to perform the tests during BVPS-2 shutdown to demonstrate proper automatic operation of the ECCS.

3.1.2.38 Containment Heat Removal (Criterion 38)

3.1.2.38.1 Criterion

"A system to remove heat from the reactor containment shall be provided. The system safety function shall be to reduce rapidly, consistent with the functioning of other associated systems, the containment pressure and temperature following any loss-of-coolant accident and maintain them at acceptably low levels.

"Suitable redundancy in components and features, and suitable interconnections, leak detection, isolation, and containment capabilities shall be provided to assure that for onsite electrical power system operation (assuming offsite power is not available) and for offsite electric power system operation (assuming onsite power is not available) the system safety function can be accomplished, assuming a single failure."

3.1.2.38.2 Design Conformance

The containment depressurization system containment heat removal system conforms to GDC 38 and consists of the following:

1. Two 100-percent capacity recirculation spray subsystems (Section 6.2.2) which remove heat from the containment following a containment isolation phase B (CIB) signal via the recirculation spray heat exchangers.
2. Two 100-percent capacity quench spray subsystems (Section 6.2.2.2.1) are also provided to remove heat from the containment atmosphere.

Each recirculation system and each quench spray subsystem receives power from an independent electrical bus. Each electrical bus is connected to both offsite and onsite power.

Leak detection capabilities are discussed in Section 9.3.3 and Section 3.6B.1. Containment isolation is discussed in Section 6.2.4.

In accordance with the GDC, containment isolation valves provide containment isolation at the penetrations.

3.1.2.39 Inspection of Containment Heat Removal System (Criterion 39)

3.1.2.39.1 Criterion

"The containment heat removal system shall be designed to permit appropriate periodic inspection of important components, such as the torus, sumps, spray nozzles, and piping to assure the integrity and capability of the system."

3.1.2.39.2 Design Conformance

The containment depressurization system is designed to permit appropriate periodic inspection of its components (Section 6.2.2) in accordance with GDC 39.

3.1.2.40 Testing of Containment Heat Removal System (Criterion 40)

3.1.2.40.1 Criterion

"The containment heat removal system shall be designed to permit appropriate periodic pressure and functional testing to assure (1) the structural and leaktight integrity of its components, (2) the operability and performance of the active components of the system, and (3) the operability of the system as a whole, and, under conditions as close to the design as practical, the performance of the full operational sequence that brings the system into operation, including operation of applicable portions of the protection system, the transfer between normal and emergency power sources, and the operation of the associated cooling water system."

3.1.2.40.2 Design Conformance

The containment depressurization system (Section 6.2.2) is designed to permit periodic pressure and functional tests of the system as a whole, and of major components (pumps, valves, control systems, etc.) in accordance with GDC 40. Full flow and initiation tests after installation verify structural and leaktight integrity, operability, and performance of major components and operability of the system as a whole. The containment depressurization tests (Chapter 14) include operability tests of pumps and motor-operated valves every three months as required by the ASME OM Code. Tests of the recirculation spray system (RSS) pumps will be performed at each refueling outage. Inspections of RSS component and piping welds will be performed as required by Inspection Plan B of ASME XI, shown in Table IWB-2412-1 of the ASME XI Code. Periodic activation of the containment depressurization signals ensures operability of the initiation signals and control circuitry ESF system activation signal testing described in Section 7.3.2.2.5.

3.1.2.41 Containment Atmosphere Cleanup (Criterion 41)

3.1.2.41.1 Criterion

"Systems to control fission products, hydrogen, oxygen, and other substances which may be released into the reactor containment shall be provided as necessary to reduce, consistent with the functioning of other associated systems, the concentration and quantity of fission products released to the environment following postulated accidents, and to control the concentration of hydrogen or oxygen and other substances in the containment atmosphere following postulated accidents to assure that containment integrity is maintained."

"Each system shall have suitable redundancy in components and features, and suitable interconnections, leak detection, isolation, and containment capabilities to assure that for onsite electrical power system operation (assuming offsite power is not available) and for offsite electrical power system operation (assuming onsite power is not available) its safety function can be accomplished, assuming a single failure."

3.1.2.41.2 Design Conformance

Systems are provided in accordance with GDC 41 to control hydrogen generated, and fission products released, by a DBA which are the only significant gaseous releases post accident. Containment atmosphere purge capabilities are provided.

Leak detection capability is provided in Section 9.3.3 for liquid released and Section 11.5 for effluent monitoring. Containment isolation provisions are discussed in Section 6.2.4.

3.1.2.42 Inspection of Containment Atmosphere Cleanup Systems (Criterion 42)

3.1.2.42.1 Criterion

"The containment atmosphere cleanup systems shall be designed to permit appropriate periodic inspection of important components, such as filter frames, ducts, and piping to assure the integrity and capability of the systems."

3.1.2.42.2 Design Conformance

Both the post-DBA hydrogen control system (HCS) and the containment spray system are designed to permit appropriate periodic inspection of the important components, as described in Sections 6.2.2.2, 6.5, and 6.6.

3.1.2.43 Testing of Containment Atmosphere Cleanup Systems (Criterion 43)

3.1.2.43.1 Criterion

"The containment atmosphere cleanup systems shall be designed to permit appropriate periodic pressure and functional testing to assure (1) the structural and leaktight integrity of its components, (2) the operability and performance of the active components of the systems such as fans, filters, dampers, pumps, and valves, and (3) the operability of the systems as a whole and, under conditions as close to design as practical, the performance of the full operational sequence that brings the systems into operation, including operation of applicable portions of the protection system, the transfer between normal and emergency power sources, and the operation of associated systems."

3.1.2.43.2 Design Conformance

The containment atmosphere cleanup systems are designed to permit periodic testing of components and systems in accordance with GDC 43 to ensure their complete and reliable functioning during normal operation and in the event of a postulated accident. Specific means are provided for periodic testing of pumps and valves in accordance with the ASME OM Code. Transfer between normal and emergency power sources is accomplished during the emergency power tests as discussed in the Technical Specifications, Chapter 16. Testing of containment atmosphere cleanup systems is discussed in Sections 6.2, 6.5, and 6.6.

3.1.2.44 Cooling Water (Criterion 44)

3.1.2.44.1 Criterion

"A system to transfer heat from structures, systems, and components important to safety, to an ultimate heat sink shall be provided. The system safety function shall be to transfer the combined heat load of these structures, systems, and components under normal operating and accident conditions."

"Suitable redundancy in components and features, and suitable interconnections, leak detection, and isolation capabilities shall be provided to assure that for onsite electric power system operation (assuming offsite power is not available) and for offsite electric power system operation (assuming onsite power is not available) the system safety function can be accomplished, assuming a single failure."

3.1.2.44.2 Design Conformance

The service water system (SWS) and the primary component cooling water system (CCWS) provide heat removal from various structures, systems, and components important to safety and nonsafety systems.

The primary CCWS transfers heat from heat exchangers containing reactor coolant and from auxiliary heat exchangers associated with the primary plant to the SWS. The SWS transfers heat from the primary CCWS, other closed loop cooling systems, and certain individual components important to safety (diesel generator cooling water heat exchangers and charging pump lube oil coolers).

The detail systems designs are described in Sections 9.2.1 and 9.2.2. Suitable redundancy and isolation capabilities are provided to accomplish the system safety function, assuming a single failure.

The Seismic Category I intake structure, shared with BVPS-1, is subdivided so that each of the three service water pumps is separated and protected from floods and missiles. A discussion of BVPS-2 conformance with Regulatory Guide 1.27, "Ultimate Heat Sink for Nuclear Power Plants," is provided in FSAR Section 1.8. The intake for each of these pumps is independent with separate screen and suction arrangements. Two 30-inch, physically separated and protected service water headers in the intake structure provide redundancy. Each header runs underground until it reaches the auxiliary building basement.

In the event of a CIB signal, service water is automatically diverted from the 30-inch component cooling water headers to the two 24-inch headers which supply the recirculation spray heat exchangers. Service water is available at all times for the control room air conditioners, charging pump lube oil coolers, emergency diesel generators, safeguards area air conditioners, and rod control area air conditioners. Redundant Seismic Category I discharge lines are provided to direct the service water from this equipment to the Ohio River.

The recirculation spray heat exchangers and pumps serve to reduce the containment pressure and remove long term heat in the event of a DBA. The cooling water valving of the recirculation spray heat exchangers are automatically opened to allow operation of both 100-percent portions of the recirculation spray system during a DBA.

Two independent standby diesel generators provide emergency onsite power in the event of a loss of normal power. Each generator supplies one train of components essential to the safety-related operations of the cooling systems.

The cooling system safety function is assured with only onsite emergency power available.

Reference Sections

<u>Title</u>	<u>Section</u>
AC Power Systems	8.3.1
Service Water System	9.2.1
Primary Component Cooling Water System	9.2.2.1
Ultimate Heat Sink	9.2.5

3.1.2.45 Inspection of Cooling Water System (Criterion 45)

3.1.2.45.1 Criterion

"The cooling water system shall be designed to permit appropriate periodic inspection of important components, such as heat exchangers and piping, to assure the integrity and capability of the system." |

3.1.2.45.2 Design Conformance

The cooling water systems (CWSs) are in continuous use during the life of the unit. Normal operational inspections and monitoring of parameters are carried out in the course of operation. In addition, periodic inspections are conducted during planned outages in accordance with the requirements of ASME Section XI, Code for Inservice Inspection, and 10 CFR 50, Appendix J for containment isolation valves, Type C testing. These inspections meet with the guidelines of GDC 45. Sections 9.2.1 and 9.2.2 discuss CWS designs and testing.

3.1.2.46 Testing of Cooling Water System (Criterion 46)

3.1.2.46.1 Criterion

"The cooling water system shall be designed to permit appropriate periodic pressure and functional testing to assure (1) the structural and leaktight integrity of its components, (2) the operability and performance of the active components of the system, and (3) the operability of the system as a whole and, under conditions as close to design as practical, the performance of the full operational sequence that brings the system into operation for reactor shutdown and for loss-of-coolant accident, including operation of applicable portions of the protection system and the transfer between normal and emergency power sources. "

3.1.2.46.2 Design Conformance

The station service water system and the component cooling water system are in continuous use during the life of the unit. Thus, the

structural and leaktight integrity of the system components, and the operability of the system as a whole are continuously demonstrated. The active components that cannot be tested during normal system operation are tested during shutdown. Specific means are provided for periodic testing pumps during their normal operational mode in compliance with the ASME OM Code. Transfer between normal and emergency power sources is discussed in the Technical Specifications, Chapter 16. The systems are thus designed to allow periodic testing of the operability of the systems as required for operation during a LOCA, reactor shutdown, and/or a loss of unit power. These inspections meeting with guidelines of GDC 46. Testing of the system components is described in detail in Sections 9.2.1 and 9.2.2.

3.1.2.47 Criterion 47

This criterion has not been promulgated by the USNRC.

3.1.2.48 Criterion 48

This criterion has not been promulgated by the USNRC.

3.1.2.49 Criterion 49

This criterion has not been promulgated by the USNRC.

3.1.2.50 Containment Design Basis (Criterion 50)

3.1.2.50.1 Criterion

"The reactor containment structure, including access openings, penetrations, and the containment heat removal system, shall be designed so that the containment structure and its internal compartments can accommodate, without exceeding the design leakage rate and, with sufficient margin, the calculated pressure and temperature conditions resulting from any loss-of-coolant accident. This margin shall reflect consideration of (1) the effects of potential energy sources which have not been included in the determination of the peak conditions, such as energy in steam generators and, as required by 50.44, energy from metal-water and other chemical reactions that may result from degradation but not total failure of emergency core cooling functioning, (2) the limited experience and experimental data available for defining accident phenomena and containment responses, and (3) the conservatism of the calculational model and input parameters."

3.1.2.50.2 Design Conformance

The containment structure, including personnel and equipment hatches, piping and electrical penetrations, and recirculation and QSSs, is designed such that the containment structure's design leakage rate is not exceeded under post-LOCA conditions. In addition, the containment structure is designed to withstand, by a sufficient

margin, those pressure and temperature conditions resulting from a DBA. This margin reflects all potential energy sources not included in the conservative calculation of peak conditions.

Reference Sections

<u>Title</u>	<u>Section</u>
Concrete Containment	3.8.1
Containment Functional Design	6.2.1
Quench Spray System	6.2.2.2.1
Recirculation Spray System	6.2.2.2.2
3.1.2.51 Fracture Prevention of Containment Pressure Boundary (Criterion 51)	

3.1.2.51.1 Criterion

"The reactor containment boundary shall be designed with sufficient margin to assure that under operating, maintenance, testing, and postulated accident conditions, (1) its ferritic materials behave in a nonbrittle manner, and (2) the probability of rapidly propagating fracture is minimized. The design shall reflect consideration of service temperatures and other conditions of the containment boundary material during operation, maintenance, testing, and postulated accident conditions, and the uncertainties in determining (1) material properties, (2) residual, steady-state, and transient stresses, and (3) size of flaws."

3.1.2.51.2 Design Conformance

The design of the reactor containment pressure boundary is in conformance with General Design Criterion 51, as addressed in the DLC letter (DLC 1983).

3.1.2.52 Capability for Containment Leakage Rate Testing (Criterion 52)

3.1.2.52.1 Criterion

"The reactor containment and other equipment which may be subjected to containment test conditions shall be designed so that periodic integrated leakage rate testing can be conducted at containment design pressure."

3.1.2.52.2 Design Conformance

The containment structure and safety-related equipment which will be subjected to the containment test conditions are designed so that the periodic integrated leakage rate testing can be conducted at calculated peak containment pressure, as per Appendix J of 10 CFR 50, Reactor Containment Leakage Testing for Water Cooled Power Reactors.

Reference Section

<u>Title</u>	<u>Section</u>
Containment Functional Design	6.2.1

3.1.2.53 Provisions for Containment Testing and Inspection (Criterion-53)

3.1.2.53.1 Criterion

"The reactor containment shall be designed to permit (1) appropriate periodic inspection of all important areas, such as penetrations, (2) an appropriate surveillance program, and (3) periodic testing at containment design pressure of the leaktightness of penetrations which have resilient seals and expansion bellows."

3.1.2.53.2 Design Conformance

The design of the reactor containment provides for access to all important areas for periodic inspection. The reactor containment design allows local testing of the liner seam welds, penetration liner welds, and the electrical penetrations.

Personnel and equipment access hatches have also been designed to allow free volume and local periodic testing of access volumes and resilient seals.

Piping systems penetrating the containment (Type C as defined by Appendix J of 10 CFR 50) have been designed to allow local periodic testing of containment isolation valves.

Reference Sections

<u>Title</u>	<u>Section</u>
Containment Functional Design	6.2.1
Containment Leakage Testing	6.2.6

3.1.2.54 Piping Systems Penetrating Containment (Criterion 54)

3.1.2.54.1 Criterion

"Piping systems penetrating primary reactor containment shall be provided with leak detection, isolation, and containment capabilities having redundancy, reliability, and performance capabilities which reflect the importance to safety of isolating these piping systems. Such piping systems shall be designed with a capability to test periodically the operability of the isolation valves and associated apparatus and to determine if valve leakage is within acceptable limits."

3.1.2.54.2 Design Conformance

Piping systems penetrating the reactor containment conform with GDC 54 as described in the design bases set forth for the containment isolation system (Section 6.2.4). This ensures redundancy, reliability, and performance capabilities which reflect the importance to safety of isolating the piping systems. Special test connections, where required, ensure the capability to determine if individual isolation valve leakage is within acceptable limits.

3.1.2.55 Reactor Coolant Pressure Boundary Penetrating Containment (Criterion 55)

3.1.2.55.1 Criterion

"Each line that is part of the reactor coolant pressure boundary and that penetrates primary reactor containment shall be provided with containment isolation valves as follows, unless it can be demonstrated that the containment isolation provisions for a specific class of lines, such as instrument lines, are acceptable on some other defined basis:

1. One locked closed isolation valve inside and one locked closed isolation valve outside containment; or
2. One automatic isolation valve inside and one locked closed isolation valve outside containment; or
3. One locked closed isolation valve inside and one automatic isolation valve outside containment. A simple check valve may not be used as the automatic isolation valve outside containment; or
4. One automatic isolation valve inside and one automatic isolation valve outside containment. A simple check valve may not be used as the automatic isolation valve outside containment.

"Isolation valves outside containment shall be located as close to containment as practical and upon loss of actuating power, automatic isolation valves shall be designed to take the position that provides greater safety."

"Other appropriate requirements to minimize the probability or consequences of an accidental rupture of these lines or of lines connected to them shall be provided as necessary to assure adequate safety. Determination of the appropriateness of these requirements, such as higher quality in design, fabrication, and testing, additional provisions for inservice inspection, protection against more severe natural phenomena, and additional isolation valves and containment, shall include consideration of the population density, use characteristics, and physical characteristics of the site environs."

3.1.2.55.2 Design Conformance

The containment isolation arrangements for all lines that are part of the RCPB and that penetrate the primary reactor containment conform with the design bases listed in Section 6.2.4. These design bases require that one of the arrangements listed in items 1 through 4 of this criterion be utilized, unless other provisions for containment isolation are acceptable on some other defined basis (Section 6.2.4).

Table 6.2-60 lists the specific GDC met by piping systems penetrating containment, where locked closed, administratively-controlled, normally-closed, manually-operated valves are provided.

The requirements of GDC 55 are met, with the exception of the following penetrations in the safety injection system which are excepted from GDC 55:

1. X-61 (low-head safety injection to hot legs),
2. X-7, X-17 (high-head safety injection to hot legs),

3. X-60, X-62 (low-head safety injection to cold leg),
4. X-34 (high-head safety injection to cold leg),
5. X-113 (high-head safety injection to cold leg).

The bases and justification for these exceptions are further described in Section 6.2.4.

3.1.2.56 Primary Containment Isolation (Criterion 56)

3.1.2.56.1 Criterion

"Each line that connects directly to the containment atmosphere and penetrates primary reactor containment shall be provided with containment isolation valves as follows, unless it can be demonstrated that the containment isolation provisions for a specific class of lines, such as instrument lines, are acceptable on some other defined basis:

1. One locked closed isolation valve inside and one locked closed isolation valve outside containment; or
2. One automatic isolation valve inside and one locked closed isolation valve outside containment; or
3. One locked closed isolation valve inside and one automatic isolation valve outside containment. A simple check valve may not be used as the automatic isolation valve outside containment; or
4. One automatic isolation valve inside and one automatic isolation valve outside containment. A simple check valve may not be used as the automatic isolation valve outside containment.

"Isolation valves outside containment shall be located as close to the containment as practical and upon loss of actuating power, automatic isolation valves shall be designed to take the position that provides greater safety."

3.1.2.56.2 Design Conformance

The containment isolation arrangements for all lines that connect directly to the containment atmosphere and penetrate primary reactor containment conform with the design bases listed in Section 6.2.4. Unless an acceptable, or otherwise defined, basis is prescribed (Section 6.2.4), these design bases require that one of the arrangements listed in items 1 through 4 of this criterion be utilized.

Table 6.2-60 lists the specific GDC met by piping systems penetrating containment, where locked closed, administratively-controlled, normally-closed, manually-operated valves are provided.

The requirements of GDC 56 are met except for the following penetrations:

1. Recirculation spray system - X-66, X-67, X-68, X-69 (recirculation spray pump suction from containment sump),
2. Containment leakage monitoring system - X-55b, X-57b, X-97a, X-105c, X-105d (containment leakage monitoring open taps), and
3. Containment vacuum system - X-92, X-93 (containment vacuum pump suction penetrations are shared with the post-DBA HCS).
4. Post DBA hydrogen control system - X-87, X-88 (hydrogen recombine return lines).

The bases and justification for these exceptions are further described in Section 6.2.4.

3.1.2.57 Closed System Isolation Valves (Criterion 57)

3.1.2.57.1 Criterion

"Each line that penetrates primary reactor containment and is neither part of the reactor coolant pressure boundary nor connected directly to the containment atmosphere shall have at least one containment isolation valve which shall be either automatic, or locked closed, or capable of remote manual operation. This valve shall be outside containment and located as close to the containment as practical. A simple check valve may not be used as the automatic isolation valve."

3.1.2.57.2 Design Conformance

All lines connected to closed systems are provided with at least one isolation valve on the outside of the containment (Section 6.2.4).

The containment isolation arrangements for all lines that penetrate reactor containment and are neither part of the RCPB nor connected directly to the containment atmosphere conform with the design bases listed in Section 6.2.4. These design bases require that:

1. The outside isolation valve for such closed systems is either automatic, or normally-closed, administratively-controlled, manually-operated, or for normally open lines, capable of remote manual operation,
2. This valve is located as close to the containment as practical,
3. Piping associated with the CIS is designed, fabricated, and tested in accordance with the requirements of

ASME Section III, Class 2, as applicable (Sections 3.9B.3 and 3.9N.3), and

4. Simple check valves are not used as the automatic isolation valve.

The following penetrations meeting the requirements of GDC 57, however, receive a signal for automatic closure other than from containment isolation:

1. Main steam system - X-73, X-74, X-75,
2. Feedwater system - X-76, X-77, X-78,
3. Steam generator blowdown system - X-39, X-40, X-41, and
4. Auxiliary feedwater system - X-79, X-80, X-83.

The bases and justification for these penetrations are further described in Section 6.2.4.

3.1.2.58 Criterion 58

This criterion has not been promulgated by the USNRC.

3.1.2.59 Criterion 59

This criterion has not been promulgated by the USNRC.

3.1.2.60 Control of Releases of Radioactive Materials to the Environment (Criterion 60)

3.1.2.60.1 Criterion

"The nuclear power unit design shall include means to control suitably the release of radioactive materials in gaseous and liquid effluents and to handle radioactive solid wastes produced during normal reactor operation, including anticipated operational occurrences. Sufficient holdup capacity shall be provided for retention of gaseous and liquid effluents containing radioactive materials, particularly where unfavorable site environmental conditions can be expected to impose unusual operational limitations upon the release of such effluents to the environment."

3.1.2.60.2 Design Conformance

In all cases, the design for radioactivity control is based on the following which comply with the guidelines of GDC 60.

1. 10 CFR 20 and 10 CFR 50 requirements for normal operations and for any transient situation that might reasonably be anticipated to occur, and

2. 10 CFR 50.67 dose limit guidelines for potential accidents of exceedingly low probability of occurrence (Chapter 15).

Radioactive waste systems are described in Chapter 11. The radiation monitoring system (RMS) is described in Sections 11.5 and 12.3.4. Waste gas effluents are controlled by charcoal delay beds and, when necessary, waste gases are held in decay tanks until their activity and existing environmental conditions permit their discharge within 10 CFR 20 and 10 CFR 50 requirements. In addition, waste gas effluents are monitored prior to discharge for radioactivity and rate of flow (Section 12.3.4). Section 11.3.4 describes the results of a rupture of a gas waste storage tank and verifies that the applicable release limits are not exceeded.

Beaver Valley Power Station - Unit 2 liquid waste effluents (Section 11.2) are controlled by batch processing of station radioactive liquids, if necessary, in either BVPS-1 or BVPS-2, sampling before discharge, controlling the rate of release, and prevention of inadvertent tank discharge. Liquid effluents are monitored for radioactivity and rate of flow. Liquid waste disposal system tankage, BVPS-2 steam generator blowdown evaporator capacity, and BVPS-1 liquid waste evaporator capacity are sufficient to handle any expected transient in liquid waste volume.

Station solid wastes (Section 11.4) are prepared in batches in 55-gallon drums and other approved packages for offsite disposal by approved contractors. Solid wastes are shielded for shipment, when necessary, to meet federal regulations.

3.1.2.61 Fuel Storage and Handling and Radioactivity Control (Criterion 61)

3.1.2.61.1 Criterion

"The fuel storage and handling, radioactive waste, and other systems which may contain radioactivity shall be designed to assure adequate safety under normal and postulated accident conditions. These systems shall be designed (1) with a capability to permit appropriate periodic inspection and testing of components important to safety, (2) with suitable shielding for radiation protection, (3) with appropriate containment, confinement, and filtering systems, (4) with a residual heat removal capability having reliability and testability that reflects the importance to safety of decay heat and other residual heat removal, and (5) to prevent significant reduction in fuel storage coolant inventory under accident conditions."

3.1.2.61.2 Design Conformance

Beaver Valley Power Station - Unit 2 design conforms to the guidelines of GDC 61.

Safety-related components of the systems that contain radioactivity and fuel storage systems are designed to allow periodic inspection and testing.

Process radiation monitors and flow measuring equipment are provided for surveillance of various station waste process streams. In addition, these systems are designed to protect the health of station operating personnel, and to limit discharge of radioactive materials from the station so as not to exceed the limits of 10 CFR 20. The waste disposal systems are discussed in detail in Chapter 11.

The spent fuel storage pool is designed to meet the requirements of 10 CFR 20, by shielding operating personnel from radiation during fuel transfer and spent fuel storage. Work areas adjacent to the spent fuel pool transfer canal wall are shielded to allow personnel access during actual fuel transfers. The spent fuel pool is permanently flooded with water during all normal operations to ensure a dose rate above the pool to operating personnel of no more than 15 mRem/hr. Fuel handling shielding is discussed in Section 12.3.

The refueling cavity above the reactor vessel is flooded during refueling such that the dose rate is less than 15 mRem/hr at the water surface.

To avoid significant radioactivity releases, the spent fuel handling system is designed to preclude gross mechanical failures. Floor and trench drain systems provide backup by collecting leakage which might occur. Fuel storage pool design ensures that a significant amount of fuel storage coolant is not lost under accident conditions. Decay heat from spent fuel is dissipated in the storage pool water and subsequently removed by a cooling system (Section 9.1.3). Makeup water is provided by means of a connection from the primary grade water system (Section 9.2.8). The SWS provides a safety related source of makeup. Radioactive gases, which may leak from spent fuel, are collected by the supplementary leak collection and release system described in Section 6.5.3.2 and the vent and drain system described in Section 9.3.3. All discharges from these systems are monitored. These monitoring systems are discussed in Section 12.3.

3.1.2.62 Prevention of Criticality in Fuel Storage and Handling (Criterion 62)

3.1.2.62.1 Criterion

"Criticality in the fuel storage and handling system shall be prevented by physical systems or processes, preferably by use of geometrically safe configurations."

3.1.2.62.2 Design Conformance

The new and spent fuel storage racks are designed in accordance with GDC 62 and NUREG-0800, Sections 9.1.1 and 9.1.2. The new fuel storage rack accommodates 1/3 of a core plus 17 spare assemblies. The spent fuel storage pool accommodates the spent fuel rack and the required spent fuel shipping cask area.

The spent fuel racks are arranged so that the spacing between fuel elements cannot be less than that prescribed. Borated water is maintained in the spent fuel pool. Even if fully flooded with unborated water, the spacing and fuel storage configurations ensure $K_{eff} < 1.0$. Spent fuel rack design and criticality prevention are fully discussed in Section 9.1.2.

The new fuel assemblies are stored dry in a steel and concrete structure within the fuel building. They are arranged vertically in racks in parallel rows. The steel rack construction prevents possible criticality by requiring that the spacing between fuel elements be not less than that prescribed. The new fuel rack design and criticality prevention is discussed in detail in Section 9.1.1.

Safeguards are provided during handling so that the consequences of the hypothetical worst-case accident meet 10 CFR 50.67 guidelines. Chapter 15 provides a complete description of this worst-case accident.

3.1.2.63 Monitoring Fuel and Waste Storage (Criterion 63)

3.1.2.63.1 Criterion

"Appropriate systems shall be provided in fuel storage and radioactive waste systems and associated handling areas (1) to detect conditions that may result in loss of residual heat removal capability and excessive radiation levels, and (2) to initiate appropriate safety actions."

3.1.2.63.2 Design Conformance

The BVPS-2 design conforms to GDC 63 as follows: Gamma radiation levels in the containment and fuel storage areas are continuously monitored as described in Section 11.5. These monitors provide an audible alarm at the initiating detector indicating an unsafe condition. The fuel pool water temperature is continuously monitored. The temperature is displayed in the main control room where an audible alarm sounds if the water temperature increases above a preset level. Continuous surveillance of radiation levels in the waste storage and handling areas is maintained by ventilation-duct-mounted radiation detectors described in Section 11.5.

Radiation levels in excess of preset levels initiate audible and visible alarms locally and in the control room.

Radiological control procedures, including appropriate radiation control surveys, are initiated as necessary to decontaminate affected areas. Chapter 12 provides a more detailed description of emergency procedures.

3.1.2.64 Monitoring Radioactivity Releases (Criterion 64)

3.1.2.64.1 Criterion

"Means shall be provided for monitoring the reactor containment atmosphere, spaces containing components for recirculation of loss-of-coolant accident fluids, effluent discharge paths, and the plant environs for radioactivity that may be released from normal operations, including anticipated operational occurrences, and from postulated accident conditions."

3.1.2.64.2 Design Conformance

The containment air particulate and gas monitor monitors the containment atmosphere during normal unit operations and accident conditions as required by GDC 64. During accident conditions, samples of the containment atmosphere provide data on existing airborne radioactivity concentrations within the containment as described in Sections 11.5 and 12.3.4. The safeguards areas are monitored by the ventilation vent air particulate and gas monitors. Radioactivity levels in the normal facility radioactive effluent discharge paths and in the environs are continually monitored during normal and accident conditions by the unit radiation monitoring system (Section 11.5) and by the environmental radiological safety program for BVPS-2.

3.1.3 References for Section 3.1

Pellini, W. S. and Loss, F. J. 1969. Integration of Metallurgical and Fracture Mechanics Concepts of Transition Temperature Factors Relating to Fracture-Safe Design for Structural Steel. NRL Report 6900, April 1969.

USNRC 1981. Standard Review Plan for the Review of Safety Analysis Reports for Nuclear Power Plants (formerly issued as NUREG 75/087). NUREG-0800.

DLC 1983. Duquesne Light Company Letter 2NRC-3-087, dated November 14, 1983, from E. J. Woolever to H. R. Denton, USNRC.

3.2 CLASSIFICATION OF STRUCTURES, COMPONENTS, AND SYSTEMS

3.2.1 Seismic Classification

3.2.1.1 Nuclear Steam Supply System Components

Section 3.2.2 identifies the system, based on the guidelines of Regulatory Guide 1.29, for classifying fluid system components. Based on evaluation of seismic requirements, Westinghouse applies a rule that each component classified as Safety Class 1, 2, or 3 shall be qualified to remain functional in the event of the safe shutdown earthquake (SSE). This rule applies except when all the conditions listed as follows are met. Portions of systems required to perform the same safety function as required of a safety class component which is a part of that system shall be likewise qualified or granted exemption. The following four conditions must be met for exemption:

1. Failure would not directly cause an American Nuclear Society (ANS) Condition III or IV event (as defined in ANSI N18.2-1973).
2. There is no safety function to mitigate, nor could failure prevent mitigation of, the consequences of an ANS Condition III or IV event.
3. Failure during or following any ANS Condition II event would result in consequences no more severe than allowed for an ANS Condition III event.
4. Routine post-seismic procedures would disclose any loss of the safety function.

The following lines of reasoning apply when using the above conditions for exemption and the safety class categories to determine if a component must be seismically qualified.

1. All Safety Class 1 components must be seismically qualified because a failure of any one can directly cause an ANS Condition III or IV event, thus failing the first condition.
2. Safety Class 2 components that are a part of the reactor coolant pressure boundary must be seismically qualified because the failure of those components due to the seismic event could directly result in an ANS Condition III or IV event.
3. All other Safety Class 2 components must also be seismically qualified because they are required to mitigate, or their failure could prevent mitigation of, the consequences of an ANS Condition III or IV event, thus failing the second condition for exemption.

4. Components placed in Safety Class 3 whose failure would result in release to the environment of radioactive gasses normally required to be held for decay (ANSI N18.2, Paragraph 2.2.3(1)), or which control outside the containment airborne radioactivity released (ANSI N18.2, Paragraph 2.2.3(3)), or which remove decay heat from spent fuel (ANSI N18.2, Paragraph 2.2.3(4)), will always meet conditions 1, 2, and 4 for granting the seismic design exemption.

Thus, they need not be seismically qualified if they meet condition 3 for granting the seismic design exemption. Release of radioactive material due to ANS Condition III incidents may exceed guidelines of 10 CFR 20, Standards for Protection Against Radiation, but shall not be sufficient to interrupt or restrict public use of those areas beyond the exclusion radius.

5. Components placed in Safety Class 3 which provide or support any safety system function (ANSI N18.2, Paragraph 2.2.3(2)), must be seismically qualified for the same reason as given in item 3 (above) for ANS Condition III or IV events.
6. The NSSS components that are non-nuclear safety (NNS) class are classified Seismic Category II, as described in Sections 3.2.1.2 and 3.2.2.2.

3.2.1.2 Balance of Plant Components

Each component required to mitigate the consequences of an accident, ANS Condition IV event (as defined in ANSI N18.2), is classified Seismic Category I. As interpreted in Section 1.8, the seismic design classification of structures, systems, and components is in agreement with Regulatory Guide 1.29 and with Regulatory Guide 1.143, as applicable to radwaste handling systems. In addition, all components classified as Safety Class 1, 2, or 3 are designated Seismic Category I. Seismic Category I structures, systems, and components are designed to remain functional in the event of the SSE. All Seismic Category I components, systems, and structures are designed and constructed to Quality Assurance (QA) Category I requirements. QA categories are described in Section 3.2.3. QA Category I and Seismic Category I systems and components are shown in Table 3.2-1. QA Category I and Seismic Category I structures are shown in Table 3.2-2.

A Seismic Category II classification is identified for those portions of structures, systems, and components which are not required to perform safety functions but whose failure, including becoming a gravity missile, could adversely affect safety-related, Seismic Category I components. These structures, systems, or components shall either be seismically designed, located to preclude interactions, further restrained, structurally upgraded, or proven incapable to affecting safety. The items are designated non-nuclear safety and either QA Category II or III based on their function as defined in Section 3.2.2.3. A Seismic Category II classification is applied to the structures housing radwaste components, as defined in Regulatory Guide 1.143. A Seismic Category II designation is applied to those portions of the radwaste systems and components which are

specific radwaste equipment classifications and their seismic design are described in Sections 11.2, 11.3, and 11.4, and structure designs are described in Sections 3.7B.2.8 and 3.8.3.

Seismic Category I design requirements extend to the first seismic restraint beyond the seismic boundary and include the interface portion of the boundary itself.

For example, for piping systems, the isolation valve which forms the boundary between Seismic Category I and the nonseismic portions is designed to Seismic Category I requirements. The piping from the valve, including the first seismic restraint beyond the valve, is seismically designed in the same manner as the Seismic Category I portion; however, since the piping is not required to be ASME III, Safety Class 1, 2, or 3, this part of the system is not designated Seismic Category I. This design exceeds Seismic Category II requirements for the piping between the isolation valve and the first restraint.

By this means, the Seismic Category I boundary is defined with respect to functional capability in the event of a safe shutdown earthquake, and the interfacing portions are designed to ensure the integrity of the boundary.

3.2.2 System Quality Group Classifications

3.2.2.1 General

Fluid system components are classified in accordance with Regulatory Guide 1.26 in general, and Regulatory Guide 1.143 in particular, for radwaste handling systems. The criteria for classifying Safety Class 1 systems is also based on 10 CFR 50.55a as referenced in Regulatory Guide 1.26. Table 3.2-1 lists the safety classes of all plant components which are either Safety Class 1, 2, or 3. The classification of piping, tubing, and valves, and interfaces from one safety class to another are shown on the individual system piping and instrumentation diagrams identified on Table 3.2-3. Classification of structures is identified in Table 3.2-2.

3.2.2.2 Safety Class Definitions

Components are classified as Safety Class 1, Safety Class 2, Safety Class 3, and NNS class in accordance with their importance to nuclear safety. These safety classes correspond to the "Group" described in Regulatory Guide 1.26 as follows: Safety Class 1 is equivalent to "Group A," Safety Class 2 to "Group B," Safety Class 3 to "Group C," and NNS to "Group D." The NNS Category is also applied to those components required for reliable power generation. This order of importance, as established by the assigned safety class, is applied to the design, materials, manufacture or fabrication, assembly, erection, construction, and operation of the components. A single system may have components in more than one safety class.

The definitions of safety classes listed as follows apply to fluid pressure-boundary components. The reactor containment design and applicable codes are described in Section 3.8. Supports that have a nuclear safety function shall be the same safety class as the components that they support.

3.2.2.2.1 Safety Class 1

Safety Class 1 applies to components whose failure could cause an ANS Condition III or Condition IV loss of reactor coolant. (ANS Condition III occurrences include incidents which may occur during the lifetime of a particular plant. ANS Condition IV occurrences are faults that are not expected to occur, but are postulated because their consequences would include the potential for the release of significant amounts of radioactive material. ANS Condition IV faults are the most severe which must be designed against, and thus represent the limiting design case.)

Reactor coolant pressure boundary components are also designated Safety Class 1 if their failure during normal operation would prevent orderly reactor shutdown, assuming makeup coolant is available from normally operating systems only.

3.2.2.2.2 Safety Class 2

Safety Class 2 applies to the following:

1. The reactor coolant pressure boundary components not in Safety Class 1.
2. Safety systems that are necessary to remove heat directly from the reactor or reactor containment, or to circulate reactor coolant for any safety system purpose. (A safety system, in this context, is any system that is necessary to shut down the reactor, cool the core, cool another safety system, or, after an accident, cool the reactor containment. Furthermore, a safety system is any system that contains, controls, or reduces radioactivity released in an accident. Only those portions of a system that are designed primarily to accomplish one of the previous functions, or the failure of which could prevent accomplishing one of the previously mentioned functions, are included.)
3. Portions of the containment atmosphere purification and cleanup systems used to clean up the containment atmosphere by reducing the radioactivity present in the leakage from the containment structure. These components are located inside the containment structure or serve as an extension of the containment structure.

4. Portions of the main steam system, feedwater system and auxiliary feedwater system (AFWS) extending from and including the secondary side of the steam generator up to and including the outermost containment isolation valves. Isolation valves may include stop check valves, check valves, pressure relief valves, and safety valves.
5. Systems required to control hydrogen accumulation inside the containment.
6. Portions of the reactor coolant auxiliary systems that form a reactor coolant letdown and makeup loop.

3.2.2.2.3 Safety Class 3

Safety Class 3 applies to those components, not in Safety Class 1 or Safety Class 2, whose failure would result in release to the environment of radioactive gases normally required to be held for decay.

This safety class also applies to those components, not in Safety Classes 1 or 2, that are necessary to:

1. Provide or support any safety system function.
2. Provide reactor coolant boric acid makeup for reactivity control.
3. Control airborne radioactivity released outside the containment.
4. Remove decay heat from spent fuel.
5. The portion of the AFWS which is not Safety Class 2.

3.2.2.2.4 Non-Nuclear Safety

Non-nuclear (NNS) safety applies to those portions of the nuclear power plant not covered by Safety Classes 1, 2, or 3 that can influence safe normal operation or that may contain radioactive fluids. Non-nuclear safety components shall be designed to applicable industry codes and standards. Non-nuclear safety components may be designed to Quality Assurance (QA) Category II or III, and Seismic Category II criteria, either due to their function in a radwaste handling system or, as described in the following paragraph, to protect other safety-related components.

Where practical, plant design provides physical separation or barriers between NNS and safety-related components. In those areas where the failure of NNS components could affect safety-related components, other measures, as discussed in Section 3.2.1.2, shall be taken to preclude damage by NNS components to the safety-related components. For example, NNS piping in these areas is seismically

designed to Seismic Category II and QA Category II or III requirements.

3.2.2.3 Quality Assurance Categories

The following structures, systems, and components are classified as QA Category I:

1. Plant structures, systems, and components whose failure or malfunction could cause a release of radioactivity that would exceed design criteria.
2. Structures, systems, and components that are vital for a safe shutdown of the plant and for the removal of decay and sensible heat.
3. Equipment which is necessary to mitigate consequences to the public of a postulated accident.

All major QA Category I components are listed in Table 3.2-1.

A QA Category II classification is applied to those plant systems, portions of systems, structures and equipment that are not essential for a safe shutdown, but are essential for reliable generation of electric power. A QA Category II designation is also applied to those systems and components which contain radioactive materials but whose failure would not prejudice public safety. See also Section 1.8, BVPS-2 position on Regulatory Guide 1.143 for exceptions to the Regulatory Guide requirements for radwaste QA programs. This QA Category II classification ensures that the design, manufacture, procurement, storage, and handling, etc., are of a high quality to assure that the design requirements are met.

A QA Category III classification is applied to those plant systems or portions of systems, structures, and equipment which are not essential for a safe shutdown or the reliable generation of electric power.

3.2.2.4 Other Classification Systems

3.2.2.4.1 ASME Code Classes

ASME Code Classes 1, 2, and 3 are used in the ASME Boiler and Pressure Vessel Code, Section III (Nuclear Power Plant Components) and are referred to in this FSAR as ASME III, Classes 1, 2, and 3. Components are purchased with the objective of full compliance with the requirements of ASME III and its addenda in accordance with 10 CFR 50.55a. With regard to pumps, valves, piping, tanks, and pressure vessels, there is a direct one-for-one correlation between Code Classes 1, 2, and 3 and Safety Classes 1, 2, and 3 (Section 3.2.2).

Specific code editions and addenda used for pressure vessels, piping, pumps, and valves that are part of the reactor coolant pressure boundary are in accordance with the requirements of 10 CFR 50.55a.

Piping, tanks, heat exchangers, and miscellaneous equipment for safety-related ASME III systems are purchased in accordance with the ASME III Code Edition/Addenda indicated in the ASME Code Baseline Document. The basis for establishment of acceptable ASME III and ASME XI Code/Edition/Code Cases is 10 CFR 50.55a rules and limitations, referenced Regulatory Guides 1.84 and 1.85, and the specific Design Specifications utilized for ASME III components and piping.

Where Code Cases are utilized, which are not included in the issue/revision of Regulatory Guides 1.84 and 1.85 referenced in the FSAR, they will be specifically identified in the ASME Code Baseline Document.

3.2.2.4.2 Electrical/Control Classification Systems

Class 1E electric systems are defined as those systems that provide the electric power used to shut down the reactor and limit the release of radioactive material during and following a design basis accident, (postulated events used in the design to establish the performance requirements of the structures and systems as described in IEEE Standards 308.1974). All Class 1E systems are QA Category I and Seismic Category I. The designs of Class 1E control and electrical systems are in accordance with Regulatory Guide 1.32 as described in Chapters 7 and 8, respectively.

All other control and electrical systems are designated non-Class 1E. Their design is in accordance with applicable design codes as described in Chapters 7 and 8. These non-Class 1E electrical systems may be used to power those functions for which a highly reliable power source is required but for which a Class 1E classification is not necessary.

3.2.3 Tabulation of Codes and Classifications

Tables 3.2-1 and 3.2-2 identify major QA and Seismic Category I structures and components and their locations. These tables also provide the following information:

1. Safety classes,
2. Design codes,
3. Missile protection design criteria (including tornado protection), and
4. Flood design criteria.

BVPS-2 UFSAR

Tables for Section 3.2

TABLE 3.2-1

QUALITY ASSURANCE CATEGORY I AND SEISMIC CATEGORY I SYSTEMS AND COMPONENTS

<u>Item/Mark No.</u> ⁽¹⁶⁾	<u>Location</u> ⁽¹⁾	<u>Safety Class</u>	<u>Code or Standard</u> ⁽¹⁵⁾	<u>Missile Protection</u> ⁽²⁾	<u>Flood Protection</u> ^(3,4)	<u>Remarks</u>
Fluid Systems Components						
Reactor Coolant System (Chapter 5)						
Reactor vessel/2RCS*REV21	CS	1	ASME III	PS	PAG, PBG	
Full-length CRDM housing (Section 3.9N.4)	CS	1	ASME III	PS	PAG	
CRDM head adapter plugs	CS	1	ASME III	PS	PAG	
Steam generator/2RCS*SG21A,B,C (tube side)	CS	1	ASME III	PS	PAG	
(shell side)	CS	2	ASME III	PS	PAG ⁽⁵⁾	
Pressurizer/2RCS*PRE21	CS	1	ASME III	PS	PAG ⁽⁶⁾	
Reactor coolant hot and cold leg piping, fittings, and fabrication	CS	1	ASME III	PS	PAG	Refer to NOTES for safety class for other piping and associated valves in the reactor coolant system and other auxiliary systems ⁽⁷⁾
Eight-inch bypass piping	CS	1	ASME III	PS	PAG	
Surge pipe, fittings, and fabrication	CS	1	ASME III	PS	PAG	
Crossover leg piping, fittings, and fabrication	CS	1	ASME III	PS	PBG	
Reactor coolant thermowell	CS	1	ASME III	PS	PAG	
Reactor coolant stop valves	CS	1	ASME III	PS	PAG	

TABLE 3.2-1 (Cont)

<u>Item/Mark No.</u> ⁽¹⁶⁾	<u>Location</u> ⁽¹⁾	<u>Safety Class</u>	<u>Code or Standard</u> ⁽¹⁵⁾	<u>Missile Protection</u> ⁽²⁾	<u>Flood Protection</u> ^(3,4)	<u>Remarks</u>
Pressurizer safety valves	CS	1	ASME III	PS	PAG	
Power-operated relief valves (PORV)	CS	1	ASME III	PS	PAG	
PORV block valves	CS	1	ASME III	PS	PAG	
Reactor vessel head letdown isolation valves	CS	1	ASME III Class 1E	PS	PAG	
Reactor vessel head letdown throttling valves	CS	2	ASME III Class 1E	PS	PAG	
Valves of Safety Class 1 to Safety Class 2 interface	CS	1	ASME III Class 1E	PS	PAG, PBG	
Reactor coolant pump/2RCS*P21A,B,C	CS			PS	PBG	
Reactor coolant pump casing		1	ASME III			
Main flange		1	ASME III			
Thermal barrier		1	ASME III			
Thermal barrier heat exchanger		1	ASME III			
No. 1 seal housing		1	ASME III			
No. 2 seal housing		2	ASME III			
Pressure retaining bolting		1	ASME III			
Reactor coolant pump motor			NEMA MG1			
Motor rotor		2	(8)			
Motor shaft		1	(8)			
Shaft coupling		1	(8)			
Spool piece		2	(8)			
Flywheel		1	(8)			
Bearing (motor upper thrust)		2	(8)			

TABLE 3.2-1 (Cont)

<u>Item/Mark No.</u> ⁽¹⁶⁾	<u>Location</u> ⁽¹⁾	<u>Safety Class</u>	<u>Code or Standard</u> ⁽¹⁵⁾	<u>Missile Protection</u> ⁽²⁾	<u>Flood Protection</u> ^(3,4)	<u>Remarks</u>
Motor bolting		2	(8)			Applies only to bolting involved with coastdown function
Motor stand		2	(8)			
Motor frame		2	(8)			
Upper oil reservoir (UOR) UOR cooling coil		3 3	No Code ASME III			
Lower oil reservoir (LOR) LOR cooling coil Lube-oil piping		3 3 3	No Code ASME III		(10)	
Instrumentation and controls required to perform a safety function	CS, CB	NA ⁽¹⁷⁾ ₍₂₀₎	(9)	PS	PAG, PBG	
Safety Injection System (Section 6.3)						
LHSI pumps and motors/2SIS*P21A, B	SA	2	ASME III Class 1E	PS	PBG	Refer to NOTES (10, 11, 12, 13) if applicable
Safety injection accumulators/ 2SIS*TK21A, B, C	CS	2	ASME III	PS	PBG	
Piping and valves, including valve operators, required to perform a safety function	SA, CS, AB, Y	1, 2	ASME III Class 1E	PS	PAG, PBG	Class 1 components part of reactor coolant pressure boundary
Instrumentation and controls required to perform a safety function	SA, CS, AB, CB	N/A ⁽¹⁷⁾ ₍₂₀₎	(9)	PS	PAG, PBG	
Gaseous nitrogen system (Section 9.5.9)						
SI accumulator vent lines - piping and valves, including valve operators required to perform a safety function	CS	2	ASME III Class 1E	PS	PBG	
Instrumentation and controls required to perform a safety function	CS, CV, CB	N/A ⁽¹⁷⁾ ₍₂₀₎	(9)	PS	PBG	

TABLE 3.2-1 (Cont)

<u>Item/Mark No.</u> ⁽¹⁶⁾	<u>Location</u> ⁽¹⁾	<u>Safety Class</u>	<u>Code or Standard</u> ⁽¹⁵⁾	<u>Missile Protection</u> ⁽²⁾	<u>Flood Protection</u> ^(3,4)	<u>Remarks</u>
Residual Heat Removal System (Section 5.4.7)						
RHR pumps and motors/ 2RHS*P21A, B	CS	2	ASME III	PS	PBG	Includes seal cooler as part of pump. Refer to NOTES if ^(10, 11, 12, 13) applicable
RHR pump coolers 2RHS*E22A, B						
RHR heat exchangers/ 2RHS*E21A, B (shell side) (tube side)	CS	3 2	ASME III ASME III	PS	PBG	⁽¹²⁾
Piping and valves, including valve operators, required to perform a safety function	CS	1, 2	ASME III Class 1E	PS	PBG	Class 1 components part of reactor coolant pressure boundary
Instrumentation and controls required to perform a safety function	CS, CB	NA ⁽¹⁷⁾ ₍₂₀₎	⁽⁹⁾	PS	PBG, PAG	Includes only pump controls and instrumentation and controls for motor- operated valves to maintain reactor coolant pressure boundary
Chemical And Volume Control System (Section 9.3.4)						
Volume control tank/2CHS*TK22	AB	2	ASME III	NR ⁽¹⁸⁾	PAG	
Seal water heat exchanger/2CHS*E21 (shell side) (tube side)	AB	3 2	ASME III ASME III	NR ⁽¹⁸⁾	PAG	⁽¹⁰⁾
Seal water filter/2CHS*FLT23	AB	2	ASME III	NR ⁽¹⁸⁾	PBG	⁽¹⁰⁾
Nonregenerative heat exchanger/ 2CHS*E22 (shell side) (tube side)	AB	3 2	ASME III ASME III	NR ⁽¹⁸⁾	PAG	

TABLE 3.2-1 (Cont)

<u>Item/Mark No.</u> ⁽¹⁶⁾	<u>Location</u> ⁽¹⁾	<u>Safety Class</u>	<u>Code or Standard</u> ⁽¹⁵⁾	<u>Missile Protection</u> ⁽²⁾	<u>Flood Protection</u> ^(3,4)	<u>Remarks</u>
Reactor coolant filter/2CHS*FLT22	AB	2	ASME III	NR ⁽¹⁸⁾	PBG	
Boric acid blender/2CHS*BL21	AB	3	ASME III	PS	PAG	Located in piping to volume control tank
Deborating demineralizers/ 2CHS*DEMN23A, B	AB	3	ASME III	NR ⁽¹⁸⁾	PBG	
Cation bed demineralizer/2CHS*DEMN22	AB	3	ASME III	NR ⁽¹⁸⁾	PBG	
Mixed bed demineralizers/ 2CHS*DEMN21A, B	AB	3	ASME III	NR ⁽¹⁸⁾	PBG	
Boric acid tanks/2CHS*TK21A, B	AB	3	ASME III	PS	PAG	
Boric acid transfer pumps and motors/ 2CHS*P22A, B	AB	3	ASME III Class 1E	PS	PAG	
Boric acid filter/2CHS*FLT21	AB	3	ASME III	PS	PBG	
Excess letdown heat exchanger/2CHS*E24 (shell side) (tube side)	CS	2	ASME III	NR ⁽¹⁸⁾	PBG	
		2	ASME III			
Regenerative heat exchanger/2CHS*E23 (shell side) (tube side)	CS	2	ASME III	PS	PBG	
		2	ASME III			
Seal water injection filters/2CHS*FLT24A, B	AB	2	ASME III	NR ⁽¹⁸⁾	PBG	
Charging pumps and motor/ 2CHS*P21A, B, C	AB	2	ASME III Class 1E	PS	PAG	(10, 11, 12, 13)
Letdown orifices/2CHS*ORLD21,22,23	CS	2	ASME III	PS	PBG	
Reactor coolant pump seal bypass orifice/2CHS*ROORSB21,2,3	CS	1	ASME III	PS	PBG	

TABLE 3.2-1 (Cont)

<u>Item/Mark No.</u> ⁽¹⁶⁾	<u>Location</u> ⁽¹⁾	<u>Safety Class</u>	<u>Code or Standard</u> ⁽¹⁵⁾	<u>Missile Protection</u> ⁽²⁾	<u>Flood Protection</u> ^(3,4)	<u>Remarks</u>
Piping, valves, and valve operators required to perform a safety function	CS,AB,CV	1,2,3	ASME III Class 1E	PS	PAG, PBG	Class I components part of reactor coolant pressure boundary
Tubing supplying H ₂ and N ₂ to the VCT, 2CHS*TK22	AB	2	⁽²¹⁾	PS	PAG, PBG	
Instrumentation and controls required to perform a safety function	CS,AB,CB, CV	NA ⁽¹⁷⁾ ₍₂₀₎	⁽⁹⁾	PS	PAG, PBG	
Main Steam System (Section 10.3)						
Main steam piping and valves from steam generators up to and including main steam isolation valves and steam drains isolation valves	MV,CS	2	ASME III Class 1E	PS	PAG	
Main steam atmospheric dump valves 2SVS*PCV101A,B,C 2SVS*HCV104	MV	2	ASME III Class 1E	PS	PAG	
Main steam safety valves 2MSS*SV101A,B,C 2MSS*SV102A,B,C 2MSS*SV103A,B,C 2MSS*SV104A,B,C 2MSS*SV105A,B,C	MV	2	ASME III	PS	PAG	
Steam isolation valves to the turbine-driven auxiliary feedwater pump. Piping and valves between main steam headers and isolation valves 2MSS*SOV105A-F	MV	2	ASME III Class 1E	PS	PAG	
Piping between steam isolation valves and turbine-driven auxiliary feedwater pump, and vent piping from the turbine driver to atmosphere.	MV,CV,SA	3	ASME III Class 1E	PS	PAG, PBG	
Instrumentation and controls required to perform a safety function	CB,MV, CS,SA	NA ⁽¹⁷⁾ ₍₂₀₎	⁽⁹⁾	PS	PAG	

TABLE 3.2-1 (Cont)

<u>Item/Mark No.</u> ⁽¹⁶⁾	<u>Location</u> ⁽¹⁾	<u>Safety Class</u>	<u>Code or Standard</u> ⁽¹⁵⁾	<u>Missile Protection</u> ⁽²⁾	<u>Flood Protection</u> ^(3,4)	<u>Remarks</u>
Auxiliary Steam System (Section 10.4.10)						
Auxiliary steam header isolation valves including operators	PT	NA	ASME III Class 1E	PS	PBG	
Instrumentation and controls required to perform a safety function	PT,AB,CB	NA ⁽¹⁷⁾ ₍₂₀₎	⁽⁹⁾	PS	PAG, PBG	
Feedwater and Auxiliary Feedwater Systems (Section 10.4)						
Feedwater piping and valves from steam generator to the outside containment isolation valve	CS, MV	2	ASME III Class 1E	PS	PAG	
Auxiliary feedwater piping and valves from inside containment feedwater lines to and including outside containment isolation valve	CS, SA	2	ASME III Class 1E	PS	PAG, PBG	
Auxiliary feedwater piping and manual valves from outside containment isolation valve through auxiliary feedwater pump to 2FWE*TK210 or service water system	SA, Y	3	ASME III	PS	PBG	
Auxiliary feed pump with electric motors/2FWE*P23A, B	SA	3	ASME III Class 1E ⁽¹⁵⁾	PS	PBG	
Turbine-driven auxiliary feedwater pump 2FWE*P22	SA	3	ASME III	PS	PBG	
Turbine driver for auxiliary feedwater pump 2FWE*T22	SA	3	API No. 612	PS	PBG	

TABLE 3.2-1 (Cont)

<u>Item/Mark No.</u> ⁽¹⁶⁾	<u>Location</u> ⁽¹⁾	<u>Safety Class</u>	<u>Code or Standard</u> ⁽¹⁵⁾	<u>Missile Protection</u> ⁽²⁾	<u>Flood Protection</u> ^(3,4)	<u>Remarks</u>
Primary plant demineralized water storage tank/2FWE*TK210 (Section 10.4.9)	Y	3	ASME III	PS	PBG	
Chemical recirculation pump suction valves	Y	3	ASME III Class 1E	PS	PBG	
Feedwater control/bypass valves 2FWS*FCV 478,479,488,489,498,499	SB	3	ASME III Class 1E	⁽¹⁴⁾	PAG	
Instrumentation and controls required to perform a safety function	MV,SB, SA,Y,CB, CS	NA ⁽¹⁷⁾ ₍₂₀₎	⁽⁹⁾	PS	PAG, PBG	
Service Water System (Section 9.2.1)						
Service water system piping and valves:						
Between and including containment isolation valves	CS, CV	2	ASME III	PS	PBG	
Outside containment	IS,SA,FB, DG,AB, CB,Y,CS, and CV	3	ASME III ⁽¹⁹⁾	PS	PAG, PBG	
Inside containment	CS	3 ⁽²²⁾	ASME III ⁽²²⁾	PS	PAG, PBG	
Service water pump and motor/ 2SWS*P21A, B, C	IS	3	ASME III Class 1E	PS	PBG	
Bearing cooling water strainers/ 2SWS*STRM-47 and 48	IS	3	ASME III Class 1E	PS	PBG	
Control room cooling water pump and motor/2SWS*P25A, B	CB	3	ASME III Class 1E	PS	PAG	
Instrumentation and controls required to perform a safety function	CS,CV,IS, SB,FB,DG, AB,CB	NA ⁽¹⁷⁾ ₍₂₀₎	⁽⁹⁾	PS	PAG, PBG	

TABLE 3.2-1 (Cont)

<u>Item/Mark No.</u> ⁽¹⁶⁾	<u>Location</u> ⁽¹⁾	<u>Safety Class</u>	<u>Code or Standard</u> ⁽¹⁵⁾	<u>Missile Protection</u> ⁽²⁾	<u>Flood Protection</u> ^(3,4)	<u>Remarks</u>
Reactor Plant and Process Sampling System (Section 9.3.2.1)						
Piping, tubing and valves penetrating reactor containment and required to provide containment isolation	CS,AB,CV	2	ASME III Class 1E	PS	PAG, PBG	
All other tubing and valves required to maintain Safety Class 2 and 3 pressure boundary inside containment	CS,CV,AB	2,3	⁽²¹⁾	PS	PAG, PBG	
Piping, tubing, and valves outside containment	CV,AB	NNS	ANSI B31.1	NA	PAG, PBG	
Instrumentation and controls required to perform a safety function	CB,CS, CV,AB	NA ⁽¹⁷⁾ ₍₂₀₎	⁽⁹⁾	PS	PAG, PBG	
Emergency Diesel Generator Supporting Systems (Section 9.5)						
Air starting system						
Tanks/ 2EGA*TK21A,B 2EGA*TK22A,B Shutdown air tank	DG	3	ASME III	PS	PAG	
Piping and valves from compressor discharge check valve up to and including the air start solenoid valves, and up to the air start valves	DG	3	ASME III	PS	PAG	
Air start valves, air start distributors, and piping and valves downstream of air start valves, air start solenoid valves, and shutdown solenoid valve	DG	3	Mfr's Std	PS	PAG	

TABLE 3.2-1 (Cont)

<u>Item/Mark No.</u> ⁽¹⁶⁾	<u>Location</u> ⁽¹⁾	<u>Safety Class</u>	<u>Code or Standard</u> ⁽¹⁵⁾	<u>Missile Protection</u> ⁽²⁾	<u>Flood Protection</u> ^(3,4)	<u>Remarks</u>
Air Intake and Exhaust System						
Air intake and exhaust piping outboard of turbo charger	DG	3	ASME III	PS	PAG	
Air intake filter/ 2EDG*FLTA1A 2EDG*FLTA1B	DG	3	Mfr's Std	PS	PAG	
Air intake silencer/ 2EDG*SIL2A, B 2EDG*SIL1A, B	DG	3	Mfr's Std	PS	PAG	
Turbo charger and engine-mounted air intake and exhaust piping	DG	3	Mfr's Std	PS	PAG	
Exhaust silencer/ 2EDG*SIL3A, 3B	DG	3	Mfr's Std	PS	PAG	
Cooling Water System						
Jacket water expansion tank 2EGS*TK1A,B, intercooler water heat exchanger 2EGS*E21A,B, jacket water heat exchanger 2EGS*E22A,B, jacket water keep-warm heater 2EGS*E23A,B, jacket water keep-warm pump 2EGS*P23A,B	DG	3	ASME III	PS	PAG	

TABLE 3.2-1 (Cont)

<u>Item/Mark No.</u> ⁽¹⁶⁾	<u>Location</u> ⁽¹⁾	<u>Safety Class</u>	<u>Code or Standard</u> ⁽¹⁵⁾	<u>Missile Protection</u> ⁽²⁾	<u>Flood Protection</u> ^(3,4)	<u>Remarks</u>
Engine-driven jacket water pump 2EGS*P22A,B, engine-driven intercooler water pump 2EGS*P21A,B	DG	3	Mfr's Std	PS	PAG	
Cooling water piping and valves from jacket water expansion tank to diesel generator	DG	3	ASME III	PS	PAG	
Engine-mounted cooling water piping and valves	DG	3	ASME III/ Mfr's Std	PS	PAG	
Lubrication System						
Lube oil heat exchanger 2EGO*E21A,B, strainers 2EGO*STR22A,B	DG	3	ASME III	PS	PAG	
Engine driven lube oil pump 2EGO*P21A,B, strainers 2EGO*STR1A,B, keep warm and prelube pump 2EGO*P24A,B	DG	3	Mfr's Std	PS	PAG	
Keep warm heater 2EGO*E24A,B, strainers 2EGO*STR23A,B, filters 2EGO*FLT21A,B	DG	3	ASME III	PS	PAG	
Piping and valves external to the engine casting	DG	3	ASME III	PS	PAG	
Thermostatic control valves 2EGO*TCV200-1,2	DG	3	Mfr's Std	PS	PAG	
Strainers 2EGO*STR24A,B	DG	3	Mfr's Std	PS	PAG	
Rocker arm lubrication system	DG	3	Mfr's Std	PS	PAG	
Fuel Oil Supply System						
Fuel oil piping of diesel generator from oil storage tank to diesel	DG	3	ASME III	PS	PBG, PAG	

TABLE 3.2-1 (Cont)

<u>Item/Mark No.</u> ⁽¹⁶⁾	<u>Location</u> ⁽¹⁾	<u>Safety Class</u>	<u>Code or Standard</u> ⁽¹⁵⁾	<u>Missile Protection</u> ⁽²⁾	<u>Flood Protection</u> ^(3,4)	<u>Remarks</u>
Diesel fuel oil storage tanks 2EGF*TK21A, B	DG	3	ASME III	PS	PBG	
Diesel fuel transfer pumps with motor 2EGF*P21A,B,C,D	DG	3	ASME III Class 1E	PS	PBG, PAG	
Strainers 2EGF*STR39, 40, 41, 42	DG	3	ASME III	PS	PAG	
Diesel fuel oil day tanks 2EGF*TK22A, B	DG	3	ASME III	PS	PAG	
Motor driven fuel oil pump 2EGF*P22A, B	DG	3	ASME III	PS	PAG	
Engine driven fuel oil pump 2EGF*P23A, B	DG	3	Mfr's Std	PS	PAG	
Fuel oil filters, accumulator tank, engine mounted piping and valves	DG	3	Mfr's Std	PS	PAG	
Instrumentation and controls for fuel oil, lube oil, air, and cooling water supply systems required to perform a safety function	DG, CB	NA ⁽¹⁷⁾ ₍₂₀₎	⁽⁹⁾	PS	PBG, PAG	
Primary Plant Component Cooling Water System (Section 9.2.2)						
Piping and Valves:						
Inside containment	CS	3	ASME III Class 1E	PS	PAG, PBG	
Outside containment	AB,FB,C V	3	ASME III Class 1E	PS	PAG, PBG	
Between and including containment isolation valves	CV, CS	2	ASME III ⁽¹⁵⁾ Class 1E	PS	PBG	
Primary component cooling water surge tanks 2CCP*TK21A, B	AB	3	ASME III	PS	PAG	

TABLE 3.2-1 (Cont)

<u>Item/Mark No.</u> ⁽¹⁶⁾	<u>Location</u> ⁽¹⁾	<u>Safety Class</u>	<u>Code or Standard</u> ⁽¹⁵⁾	<u>Missile Protection</u> ⁽²⁾	<u>Flood Protection</u> ^(3,4)	<u>Remarks</u>
Primary component cooling water pumps with motors/2CCP*P21A,B,C	AB	3	ASME III Class 1E	PS	PAG	
Primary component cooling water heat exchangers	AB	3	ASME III	PS	PBG	
Instrumentation and controls required to perform a safety function	CS,AB,C B, FB	NA ⁽¹⁷⁾ ₍₂₀₎	⁽⁹⁾	PS	PAG, PBG	
Boron Recovery System (Section 9.3.4)						
Degasifier steam heater 2BRS*E21A, B	AB	3	ASME III	NR ⁽¹⁸⁾	PBG	
Degasifier recovery exchanger 2BRS*E24A1,A2,B1,B2	AB	3	ASME III	NR ⁽¹⁸⁾	PAG	
Piping and isolation valves to maintain QA Category I pressure boundary	AB	3	ASME III Class 1E	NR ⁽¹⁸⁾	PAG, PBG	
Recirculation Spray System (Section 6.2.2)						
Recirculation spray pump and motor 2RSS*P21A,B,C,D	SA	2	ASME III Class 1E	PS	PAG, PBG	
Recirculation spray cooler 2RSS*E21A,B,C,D	SA	2	ASME III Class 1E	PS	PAG, PBG	
Piping and valves required to perform a safety function	SA	2	ASME III Class 1E	PS	PAG, PBG	
Instrumentation and controls required to perform a safety function	SA, CB	NA ⁽¹⁷⁾ ₍₂₀₎	⁽⁹⁾	PS	PAG, PBG	
Quench Spray System (Section 6.2.2)						
Quench spray pumps and motors 2QSS*P21A,B	SA	2	ASME III Class 1E	PS	PBG	
Refueling water storage tank 2QSS*TK21	Y	2	ASME III	⁽¹⁴⁾	PAG	

TABLE 3.2-1 (Cont)

<u>Item/Mark No.</u> ⁽¹⁶⁾	<u>Location</u> ⁽¹⁾	<u>Safety Class</u>	<u>Code or Standard</u> ⁽¹⁵⁾	<u>Missile Protection</u> ⁽²⁾	<u>Flood Protection</u> ^(3,4)	<u>Remarks</u>
Piping and valves required to perform a safety function	SA, Y	2	ASME III Class 1E	PS	PAG, PBG	
Instrumentation and controls required to perform a safety function	SA, CB	NA ⁽¹⁷⁾ ₍₂₀₎	⁽⁹⁾	PS	PAG, PBG	
Instrumentation and controls required to perform a safety function	Y	NA ⁽¹⁷⁾ ₍₂₀₎	⁽⁹⁾	⁽¹⁴⁾	PAG	
Fuel Pool Cooling and Purification System (Section 9.1.3)						
Fuel pool cooling pumps and motors/ 2FNC*P21A,B	FB	3	ASME III Class 1E	PS	PBG	
Fuel pool heat exchangers/ 2FNC*E21A, B	FB	3	ASME III	PS	PAG	
Piping and valves required to perform safety function	FB	3	ASME III	PS	PAG, PBG	
Instrumentation and controls required to perform a safety function	FB, CB	NA ⁽¹⁷⁾ ₍₂₀₎	⁽⁹⁾	PS	PAG, PBG	
Steam Generator Blowdown System (Section 10.4.8)						
Piping and valves required to maintain containment/steam generator pressure boundary or to perform a safety function	CV, CS	2,3	ASME III Class 1E	PS	PAG	
Combustible Gas Control System (Section 6.2.5)						
Hydrogen analyzers/ 2HCS*HA100A, B	CV	NA ⁽¹⁷⁾	ASME III Class 1E	PS	PAG	

TABLE 3.2-1 (Cont)

<u>Item/Mark No.</u> ⁽¹⁶⁾	<u>Location</u> ⁽¹⁾	<u>Safety Class</u>	<u>Code or Standard</u> ⁽¹⁵⁾	<u>Missile Protection</u> ⁽²⁾	<u>Flood Protection</u> ^(3,4)	<u>Remarks</u>
Piping and valves required to perform a safety function	SA,CS	2	ASME III Class 1E	PS	PAG	
Piping and valves penetrating reactor containment and required to provide containment isolation	SA,CS	2	ASME III Class 1E	PS	PAG	
All other tubing and valves required to maintain Safety Class 2 pressure boundary	SA,CS	2	⁽²¹⁾	PS	PAG	
Hydrogen recombiner inline heaters 2HCS*H24A,B	CV	2	ASME III Class 1E	PS	PAG	
Instrumentation and controls required to perform a safety function	SA, CB	NA ⁽¹⁷⁾ ₍₂₀₎	⁽⁹⁾	PS	PAG	
Solid Waste Disposal System (Section 11.4)						
Piping and valves connecting to CHS demineralizers	AB	3	ASME III	NR ⁽¹⁸⁾	PBG	
Containment Isolation Components (All applicable fluid systems) (Section 6.2.4)						
Isolation valves	CV,SA, MV,FB	2	ASME III Class 1E	PS	PAG, PBG	
Piping between isolation valves and penetration	CV,SA, MV,FB	2	ASME III	PS	PAG, PBG	
Controls and electrical supply required to perform isolation function	CV,SA, MV,FB,CB	NA ⁽¹⁷⁾	⁽⁹⁾	PS	PAG, PBG	

TABLE 3.2-1 (Cont)

<u>Item/Mark No.</u> ⁽¹⁶⁾	<u>Location</u> ⁽¹⁾	<u>Safety Class</u>	<u>Code or Standard</u> ⁽¹⁵⁾	<u>Missile Protection</u> ⁽²⁾	<u>Flood Protection</u> ^(3,4)	<u>Remarks</u>
Containment Vacuum Leak Monitoring System (Section 6.2.6)						
Piping and valves required to perform a safety function	CS, CV	2	ASME III Class 1E	PS	PBG	
Instrumentation and controls required to perform a safety function	CV, CB	NA ⁽¹⁷⁾ ₍₂₀₎	⁽⁹⁾	PS	PAG, PBG	
Neutron Shield Tank Cooling System						
Neutron shield tank 2RCS*SUP21 (Section 5.4.14)	CS	Refer to Section 5.4.14		PS	PBG	
Neutron shield tank coolers/2NSS*E21 (Section 9.4)	CS	3	ASME III	PS	PAG	
Ventilation Systems						
Control Room Air Conditioning System (Section 9.4.1)						
Air conditioning units/ 2HVC*ACU201A,B	CB	3	AMCA/ASME III Class 1E	PS	PAG	
Emergency filtration fans motors/2HVC*FN241A,B	CB	3	AMCA/ANSI Class 1E	PS	PAG	
Supply fans motors/ 2HVC*FN266A,B	AB	3	AMCA/ANSI Class 1E	PS	PAG	
Return fans motors/ 2HVC*FN265A, B	AB	3	AMCA/ANSI Class 1E	PS	PAG	
Dampers and ductwork	CB	3	SMACNA	PS	PAG	
Electric duct heaters/ 2HVC*CH222A,B	CB	3	ASTM/ANSI Class 1E	PS	PAG	

TABLE 3.2-1 (Cont)

<u>Item/Mark No.</u> ⁽¹⁶⁾	<u>Location</u> ⁽¹⁾	<u>Safety Class</u>	<u>Code or Standard</u> ⁽¹⁵⁾	<u>Missile Protection</u> ⁽²⁾	<u>Flood Protection</u> ^(3,4)	<u>Remarks</u>
Charcoal filters/ 2HVC*FLTA 252A,B	CB	3	ASTM/ANSI ORNL-NSIC-65	PS	PAG	
HEPA filters/ 2HVC*FLTA251A,B 2HVC*FLTA253A,B	CB	3	ASTM/ANSI ORNL-NSIC-65	PS	PAG	
Moisture separators/ 2HVC*MSP21A,B	CB	3	ASTM/ANSI	PS	PAG	
Control room refrigeration Units/2HVC*REF24A,B	CB	3	ASME III Class 1E	PS	PAG	
Piping and valves for service water supply and refrigerant system	CB	3	ASME III ANSI	PS	PAG	
Instrumentation and controls required to perform a safety function	CB	NA ⁽¹⁷⁾ (20)	⁽⁹⁾	PS	PAG	
Service Building Ventilation System (Section 9.4.10)						
Emergency switchgear exhaust fans 2HVZ*FN262A,B	CV	3	AMCA/ANSI Class 1E	PS	PAG	
Emergency switchgear supply fans 2HVZ*FN261A,B	CV	3	AMCA/ANSI Class 1E	PS	PAG	
Battery room exhaust fans 2HVZ*FN216A,B	CV	3	AMCA/ANSI Class 1E	PS	PAG	
Dampers and ductwork	CV,SB	3	SMACNA	PS	PAG	
Instrumentation and controls required to perform a safety function	SB,CB,C V	NA ⁽¹⁷⁾ (20)	⁽⁹⁾	PS	PAG, PBG	

TABLE 3.2-1 (Cont)

<u>Item/Mark No.</u> ⁽¹⁶⁾	<u>Location</u> ⁽¹⁾	<u>Safety Class</u>	<u>Code or Standard</u> ⁽¹⁵⁾	<u>Missile Protection</u> ⁽²⁾	<u>Flood Protection</u> ^(3,4)	<u>Remarks</u>
Emergency Diesel Generator Building Ventilation System (Section 9.4.6)						
Ventilation supply fans 2HVD*FN270A,B 2HVD*FN271A,B	DG	3	AMCA/ANSI Class 1E	PS	PAG	
Dampers and ductwork	DG	3	SMACNA	PS	PAG	
Ventilation exhaust fans 2HVD*FN222A,B	DG	3	AMCA/ANSI Class 1E	PS	PAG	
Instrumentation and controls required to perform a safety function	DG,CB	NA ⁽¹⁷⁾ ₍₂₀₎	⁽⁹⁾	PS	PBG, PAG	
Intake Structure Ventilation System (Section 9.4.8)						
Supply fans motors 2HVW*FN257A,B,C	IS	3	AMCA/ANSI Class 1E	PS	PAG	
Dampers and ductwork	IS	3	SMACNA	PS	PAG	
Instrumentation and controls required to perform a safety function	IS	NA ⁽¹⁷⁾ ₍₂₀₎	⁽⁹⁾	PS	PAG	
Safeguards Area Ventilation System (Section 9.4.11)						
Air conditioning units 2HVR*ACU207A,B	SA	3	AMCA/ASME III Class 1E	PS	PAG	
Dampers and ductwork	MV	3	SMACNA	PS	PAG	
Instrumentation and controls required to perform a safety function	SA, CB	NA ⁽¹⁷⁾ ₍₂₀₎	⁽⁹⁾	PS	PAG	

TABLE 3.2-1 (Cont)

<u>Item/Mark No.</u> ⁽¹⁶⁾	<u>Location</u> ⁽¹⁾	<u>Safety Class</u>	<u>Code or Standard</u> ⁽¹⁵⁾	<u>Missile Protection</u> ⁽²⁾	<u>Flood Protection</u> ^(3,4)	<u>Remarks</u>
Main Steam Valve Area Ventilation System (Section 9.4.9)						
Ventilation fans 2HVR*FN206A,B	MV	3	AMCA/ANSI Class 1E	PS	PAG	
Dampers and ductwork	MV	3	SMACNA	PS	PAG	
Instrumentation and controls required to perform a safety function	MV,CB	NA ⁽¹⁷⁾ ₍₂₀₎	⁽⁹⁾	PS	PAG	
MCC Room Ventilation System (Section 9.4.3)						
Ventilation fans 2HVP*FN265A,B	AB	3	AMCA/ANSI Class 1E	PS	PAG	
Dampers and ductwork	AB	3	SMACNA	PS	PAG	
Cooling coils/2HVP*CLC265A,B	AB	3	ASME III	PS	PAG	
Instrumentation and controls required to perform a safety function	AB,CR	NA ⁽¹⁷⁾ ₍₂₀₎	⁽⁹⁾	PS	PAG	
Cable Vault and Rod Control Area Ventilation System (Section 9.4.12)						
Air conditioning units 2HVR*ACU208A,B	CV	3	AMCA/ASTM Class 1E	PS	PBG	
Dampers and ductwork	CV	3	SMACNA	PS	PBG	
Instrumentation and controls required to perform a safety function	CV, CB	NA ⁽¹⁷⁾	⁽⁹⁾	PS	PBG	

TABLE 3.2-1 (Cont)

<u>Item/Mark No.</u> ⁽¹⁶⁾	<u>Location</u> ⁽¹⁾	<u>Safety Class</u>	<u>Code or Standard</u> ⁽¹⁵⁾	<u>Missile Protection</u> ⁽²⁾	<u>Flood Protection</u> ^(3,4)	<u>Remarks</u>
Auxiliary Building and Radwaste Area Ventilation System (Section 9.4.3)						
Exhaust fans motors 2HVP*FN264A,B	AB	3	AMCA/ANSI Class 1E	PS	PAG	
Dampers and ductwork	AB	3	SMACNA	PS	PAG	
Instrumentation and controls required to perform a safety function	AB	NA ⁽¹⁷⁾	⁽⁹⁾	PS	PAG	
Supplementary Leak Collection System (Section 6.5.3.2)						
Filter exhaust fans motors 2HVS*FN204A,B	AB	3	AMCA/ANSI Class 1E	PB	PAG	
Charcoal filter assembly 2HVS*FLTA205A,B and 2HVS*FLTA208A,B	AB	3	ASTM/ANSI ORNL-NSIC-65	PB	PAG	
HEPA filters 2HVS*FLTA204A,B 2HVS*FLTA206A,B 2HVS*FLTA207A,B 2HVS*FLTA209A,B	AB	3	ASTM/ANSI ORNL-NSIC-65	PB	PAG	
Moisture separator assembly 2HVS*MSP21A,B 2HVS*CH219A,B 2HVS*FLTA250A,B	AB	3	ASTM/ANSI Class 1E ASTM/ANSI	PB	PAG	
Dampers and ductwork	AB,FB,CS, CV,SB, WH,SA,AB el 773'-6"	3	SMACNA	PS	PAG	
		3	SMACNA	PB	PAG	
Instrumentation and controls required to perform a safety function	AB, CB AB el 773'-6"	NA ⁽¹⁷⁾	⁽⁹⁾	PS PB	PBG, PAG PAG	
		NA ⁽¹⁷⁾	⁽⁹⁾			

TABLE 3.2-1 (Cont)

<u>Item/Mark No.</u> ⁽¹⁶⁾	<u>Location</u> ⁽¹⁾	<u>Safety Class</u>	<u>Code or Standard</u> ⁽¹⁵⁾	<u>Missile Protection</u> ⁽²⁾	<u>Flood Protection</u> ^(3,4)	<u>Remarks</u>
Alternate Shutdown Panel Ventilation System (Section 9.4.12)						
Air conditioning units/2HVP*ACUS301	CV	3	AMCA/ASME III Class 1E	PS	PAG	
Dampers and ductwork	CV	3	SMACNA	PS	PAG	
Instrumentation and controls required to perform a safety function	CV	NA		PS	PAG	
Containment Ventilation Systems (Section 9.4.7.1)						
Dampers and ductwork	CS	3	SMACNA	PS	PAG	
CRDM shroud cooling coils 2HVR*CLC202A-1,2,B-1,2,C-1,2	CS	3	ASME III	PS	PBG	
Instrumentation and controls required to perform a safety function	CS, CB	NA		PS	PAG,PBG	
Radiation Monitoring System (Sections 11.5 and 12.3.4)						
Area Monitors:						
In containment hi-range 2RMR*RQ206, 207	CS	NA	Class 1E	PS	PAG	
Outside personnel hatch 2RMR*RQ202	AB	NA	Class 1E	PS	PAG	
Control room 2RMC*RQ201, 202	CB	NA	Class 1E	PS	PAG	
Process Monitors:						
Containment Purge	CS	NA	Class 1E	PS	PAG	

TABLE 3.2-1 (Cont)

<u>Item/Mark No.</u> ⁽¹⁶⁾	<u>Location</u> ⁽¹⁾	<u>Safety Class</u>	<u>Code or Standard</u> ⁽¹⁵⁾	<u>Missile Protection</u> ⁽²⁾	<u>Flood Protection</u> ^(3,4)	<u>Remarks</u>
Containment purge 2HVR*RQ104A,B	CS	NA ⁽¹⁷⁾	Class 1E	PS	PAG	
Recirculation spray heat exchanger service water 2SWS*RQ1100A,B,C,D	DG	NA ⁽¹⁷⁾ ₍₂₀₎	Class 1E	PS	PAG	
Airborne Monitors:						
Containment airborne 2RMR*RQI303	CV	NA ⁽¹⁷⁾ ₍₂₀₎	Class 1E	PS	PAG	
Effluent Monitors:						
Elevated release 2HVS*RQI109B,C	AB	NA ⁽¹⁷⁾ ₍₂₀₎	Class 1E	PS	PAG	
Main steam discharge 2MSS*RQI101	Later	NA ⁽¹⁷⁾ ₍₂₀₎	Class 1E	PS	PAG	
Miscellaneous Nuclear/Mechanical Components						
Fuel handling System (Section 9.1.4)						
Spent fuel handling tool/2FNR*TL213	FB	3		PS	PAG	
RV head and upper internals lifting device/2FNR*CRN203	CS	1		PS	PAG	Only those portions that furnish support to CRDMS
Fuel transfer tube and flange/ 2FNC*TFT21	CS, FB	2	ASME III	PS	PAG	Portions of containment boundary
New and spent fuel storage racks/ 2FNR*RAK21,22	FB	3	⁽⁸⁾	PS	PAG, PBG	

TABLE 3.2-1 (Cont)

<u>Item/Mark No.</u> ⁽¹⁶⁾	<u>Location</u> ⁽¹⁾	<u>Safety Class</u>	<u>Code or Standard</u> ⁽¹⁵⁾	<u>Missile Protection</u> ⁽²⁾	<u>Flood Protection</u> ^(3,4)	<u>Remarks</u>
Reactor Vessel or Core-Related Components (Section 3.9)						
Irradiation sample holder	CS	2		PS	PAG	
Control rod drive mechanism/ 2RCS*RDMF21 (full length)	CS	1	ASME III	PS	PAG	
Control rod drive tubes/2RCS*ROGT21	CS	2		PS	PAG	Required for reactor shutdown
CRDM seismic support/2RCS*SUP21	CS	2	ASME III	PS	PAG	
CRDM seismic support/spacer plates	CS	1	ASME III	PS	PAG	
CRDM seismic support platform/ 2RCS*SUP22	CS	1	ASME III	PS	PAG	
Reactor vessel internals	CS	2		PS	PBG, PAG	The major internals direct flow, ensure core cooling, and prevent displacement of the core.
Control rod clusters (full Length)/ 2RCS*RCC22	CS	2		PS	PAG, PBG	Required for reactor shutdown
Incore Instrumentation						
Seal table assembly/ 2RCS*STP21	CS	1	ASME III	PS	PBG	
Thimble guide couplings	CS	1	ASME III	PS	PBG	
Thimble guide tubing	CS	1	ASME III	PS	PBG	
Reactor containment crane/2CRN*201	CS	NA ⁽¹⁷⁾	CMAA-70	PS	PAG	

TABLE 3.2-1 (Cont)

<u>Item/Mark No.</u> ⁽¹⁶⁾	<u>Location</u> ⁽¹⁾	<u>Safety Class</u>	<u>Code or Standard</u> ⁽¹⁵⁾	<u>Missile Protection</u> ⁽²⁾	<u>Flood Protection</u> ^(3,4)	<u>Remarks</u>
Electrical Systems (Sections 8.2 and 8.3)						
Emergency diesel generators/ 2EGS*EG2-1,2	DG	NA ⁽¹⁷⁾	Class 1E	PS	PAG	
4kV Switchgear/2AE;2DF	SB	NA ⁽¹⁷⁾	Class 1E	PS	PBG	
480 V Substation/480VUS*2-8; 480VUS*2-9	SB	NA ⁽¹⁷⁾	Class 1E	PS	PBG	
480 V Motor control centers/ MCC*2-E01,E02	IS	NA ⁽¹⁷⁾	Class 1E	PS	PBG	
MCC*2-E03,E04	AB	NA ⁽¹⁷⁾	Class 1E	PS	PAG	
MCC*2-E05,E13	CV	NA ⁽¹⁷⁾	Class 1E	PS	PAG	
MCC*2-E06,E14	MV	NA ⁽¹⁷⁾	Class 1E	PS	PAG	
MCC*2-E07,E08	DG	NA ⁽¹⁷⁾	Class 1E	PS	PAG	
MCC*2-E09,E10	CB	NA ⁽¹⁷⁾	Class 1E	PS	PBG	
MCC*2-E11,E12	SA	NA ⁽¹⁷⁾	Class 1E	PS	PAG	
MCC*2-E15	ASP	NA ⁽¹⁷⁾	Class 1E	PS	PAG	
Station batteries electrical system/ BAT*BKR2-1,2,3,4 BAT*CHG2-1,2,7 BAT*2-1,2,3,4	SB	NA ⁽¹⁷⁾	Class 1E	PS	PBG, PAG	
Vital bus inverters/ UPS*VITBS2-1,2,3,4	SB	NA ⁽¹⁷⁾	Class 1E	PS	PBG	
125 V dc switchboard/ DC*SWBD2-1,2	SB	NA ⁽¹⁷⁾	Class 1E	PS	PBG	

TABLE 3.2-1 (Cont)

<u>Item/Mark No.</u> ⁽¹⁶⁾	<u>Location</u> ⁽¹⁾	<u>Safety Class</u>	<u>Code or Standard</u> ⁽¹⁵⁾	<u>Missile Protection</u> ⁽²⁾	<u>Flood Protection</u> ^(3,4)	<u>Remarks</u>
120 V ac emergency distribution panels/ PNL*AC2-E1,E2	SB	NA ⁽¹⁷⁾	Class 1E	PS	PBG	
PNL*AC2-E3,E4,	CB	NA ⁽¹⁷⁾	Class 1E	PS	PBG	
PNL*AC2-E5,E6	IS	NA ⁽¹⁷⁾	Class 1E	PS	PBG	
PNL*AC2-E7,E8	SB	NA ⁽¹⁷⁾	Class 1E	PS	PBG	
PNL*AC2-E9	ASP	NA ⁽¹⁷⁾	Class 1E	PS	PAG	
PNL*AC2-E10, E11	CV	NA ⁽¹⁷⁾	Class 1E	PS	PAG	
125 V dc distribution panels/ PNL*DC2-02,03	CB	NA ⁽¹⁷⁾	Class 1E	PS	PBG	
PNL*DC2-06,07,	SB	NA ⁽¹⁷⁾	Class 1E	PS	PBG	
PNL*DC2-10,11	CV	NA ⁽¹⁷⁾	Class 1E	PS	PAG	
PNL*DC2-15,16	CV	NA ⁽¹⁷⁾	Class 1E	PS	PAG	
PNL*DC2-19, 20	SB	NA ⁽¹⁷⁾	Class 1E	PS	PAG	
Vital bus distribution panels/ PNL*VITBS2-1A,2A,3A,3C,4A,4C	CB	NA ⁽¹⁷⁾	Class 1E	PS	PBG	
PNL*VITBS2-1C,2C	CB	NA ⁽¹⁷⁾	Class 1E	PS	PAG	
Pressurizer heater distribution panels/ PNL*2RCP H2A,H2B,H2D,H2E	CS	NA ⁽¹⁷⁾	Class 1E	PS	PAG	
Vital bus voltage regulating transformers/ REG*VITBS2-1B,2B,3B,3C,4B,4C	CB	NA ⁽¹⁷⁾	Class 1E	PS	PBG	
TRF*IRT-ASP	ASP	NA ⁽¹⁷⁾	Class 1E	PS	PAG	

TABLE 3.2-1 (Cont)

<u>Item/Mark No.</u> ⁽¹⁶⁾	<u>Location</u> ⁽¹⁾	<u>Safety Class</u>	<u>Code or Standard</u> ⁽¹⁵⁾	<u>Missile Protection</u> ⁽²⁾	<u>Flood Protection</u> ^(3,4)	<u>Remarks</u>
Emergency ac distribution						
Transformer/TRF*PWR2-E1,E2	SB	NA ⁽¹⁷⁾	Class 1E	PS	PBG	
TRF*PWR2-E3, E4	CB	NA ⁽¹⁷⁾	Class 1E	PS	PBG	
TRF*PWR2-E5, E6	IS	NA ⁽¹⁷⁾	Class 1E	PS	PBG	
TRF*PWR2-E7, E8	SB	NA ⁽¹⁷⁾	Class 1E	PS	PAG	
TRF*PWR2-E9	ASP	NA ⁽¹⁷⁾	Class 1E	PS	PAG	
TRF*PWR2-E10, E11	CV	NA ⁽¹⁷⁾	Class 1E	PS	PAG	
Safety related distribution panels	SB,CB,IS, CV	NA ⁽¹⁷⁾	Class 1E	PS	PBG, PAG	
Class 1E cable	All	NA ⁽¹⁷⁾	Class 1E	PS	PBG, PAG	
Electrical penetrations and assemblies	CS	NA ⁽¹⁷⁾	Class 1E	PS	PBG, PAG	
Class 1E cable supports, cable tray, conduits and their supports; ductlines and manholes	All	NA ⁽¹⁷⁾	Class 1E	PS	PBG, PAG	
Main control board/2BNCHBD*A,B, and C 2VERTBD*A,B, and C 2CES*HPW101A and B	CB	NA ⁽¹⁷⁾	Class 1E	PS	PAG	
Emergency shutdown panel/PNL*2SHUTDN	CB	NA ⁽¹⁷⁾	Class 1E	PS	PBG	
Post-DBA hydrogen control panel/ PNL*2HCP	SA	NA ⁽¹⁷⁾	Class 1E	PS	PAG	

TABLE 3.2-1 (Cont)

<u>Item/Mark No.</u> ⁽¹⁶⁾	<u>Location</u> ⁽¹⁾	<u>Safety Class</u>	<u>Code or Standard</u> ⁽¹⁵⁾	<u>Missile Protection</u> ⁽²⁾	<u>Flood Protection</u> ^(3,4)	<u>Remarks</u>
Feedwater isolation test panel/PNL*2FWIV	CV	NA ⁽¹⁷⁾	Class 1E	PS	PAG	
Building service control panel/ PNL*2BLG-SER	CB	NA ⁽¹⁷⁾	Class 1E	PS	PAG	
Shutdown transfer relay panels/ PNL*REL-241 and 251	SB	NA ⁽¹⁷⁾	Class 1E	PS	PBG	
Auxiliary emergency relay panels/ PNL*REL-242, 252, 246, 256	SB	NA ⁽¹⁷⁾	Class 1E	PS	PBG	
Emergency diesel generator protection relay panels/PNL*REL-243, 253	SB	NA ⁽¹⁷⁾	Class 1E	PS	PBG	
Emergency diesel generator sequencing panels/PNL*SEQ-244, 254	SB	NA ⁽¹⁷⁾	Class 1E	PS	PBG	
Bus tie differential relay panels/ PNL*REL-245, 255	SB	NA ⁽¹⁷⁾	Class 1E	PS	PBG	
Emergency bus under-voltage test panels/ PNL*2UV-T-A,-B	SB	NA ⁽¹⁷⁾	Class 1E	PS	PBG	
Miscellaneous Electrical Relay Panels PNL*REL-247,248,249,250,257,258, 259,269,279,280,281,282,283,285,286, 290,295,296	SB	NA ⁽¹⁷⁾	Class 1E	PS	PBG	
Annunciator isolation panels/ 2IHA*OCABCB1 and 2IHA*PCABCB1	CB	NA ⁽¹⁷⁾	Class 1E	PS	PBG	
2IHA*OCABAB1 and 2IHA*PCABAB1	AB	NA ⁽¹⁷⁾	Class 1E	PS	PAG	
2IHA*OCABCV1 and 2IHA*PCABCV1 2IHA*OCABCV2 and 2IHA*PCABCV2	CV	NA ⁽¹⁷⁾	Class 1E	PS	PAG	

TABLE 3.2-1 (Cont)

<u>Item/Mark No.</u> ⁽¹⁶⁾	<u>Location</u> ⁽¹⁾	<u>Safety Class</u>	<u>Code or Standard</u> ⁽¹⁵⁾	<u>Missile Protection</u> ⁽²⁾	<u>Flood Protection</u> ^(3,4)	<u>Remarks</u>
2IHA*OCABDG1 and 2IHA*PCABDG1	DG	NA ⁽¹⁷⁾	Class 1E	PS	PAG	
2IHA*OCABSB1, 2, 3 and 2IHA*PCABSB1, 2, 3	SB	NA ⁽¹⁷⁾	Class 1E	PS	PAG	
Hydrogen recombiner panels/ PNL*2HCS-2A,B	SA	NA ⁽¹⁷⁾	Class 1E	PS	PAG	
Hydrogen analyzer panels/ 2HCS*PNL100A,B	SB	NA ⁽¹⁷⁾	Class 1E	PS	PAG	
Safety related electronic analog instrumentation racks/ RK*2SEC-PROC-A,A1,B,B1	CB	NA ⁽¹⁷⁾	Class 1E	PS	PBG	
Refrigeration condenser (control room A/C) control panel/PNL*REF24A,B	CB	NA ⁽¹⁷⁾	Class 1E	PS	PAG	
Solid state reactor protection racks/ RK*2RC-PRT-A, -B and 2RPS*AUX-A,B	CB	NA ⁽¹⁷⁾	⁽¹⁵⁾	PS	PBG	
Reactor Protection Test Racks RK*2P-TST-A,-B	CB	NA ⁽¹⁷⁾	⁽¹⁵⁾	PS	PBG	
Loop stop valve racks/RK*2VV-REL-A,-B	CB	NA ⁽¹⁷⁾	⁽¹⁵⁾	PS	PBG	
Nuclear instrumentation rack/ RK*2NUC-INS	CB	NA ⁽¹⁷⁾	⁽¹⁵⁾	PS	PBG	
Auxiliary relay cabinets/RK*2AUX-REL-A,B	CB	NA ⁽¹⁷⁾	⁽¹⁵⁾	PS	PBG	
Transformer Switches						
2RHS*TRS-MOV701B	CV	NA ⁽¹⁷⁾	Class 1E	PS	PBG	
2RHS*TRS-MOV702A	CV	NA ⁽¹⁷⁾	Class 1E	PS	PBG	
2HVW*TRS-FN257C	IS	NA ⁽¹⁷⁾	Class 1E	PS	PBG	

TABLE 3.2-1 (Cont)

<u>Item/Mark No.</u> ⁽¹⁶⁾	<u>Location</u> ⁽¹⁾	<u>Safety Class</u>	<u>Code or Standard</u> ⁽¹⁵⁾	<u>Missile Protection</u> ⁽²⁾	<u>Flood Protection</u> ^(3,4)	<u>Remarks</u>
Diesel Generator Control Panel PNL*2DIGEN-1 *2DIGEN-2	DG	NA ⁽¹⁷⁾	Class 1E	PS	PBG	
Main Steam Trip Valve Panel PNL*2MSIV-A,B,C	CV	NA ⁽¹⁷⁾	Class 1E	PS	PAG	
Auxiliary Reactor Protection Test Racks RK*2AUX-RPST-A, -B	CB	NA ⁽¹⁷⁾	Class 1E	PS	PBG	
Radiation Monitor Racks 2RMS*BAY-1 2RMS*BAY-3	CB	NA ⁽¹⁷⁾	Class 1E	PS	PBG	
Primary Process Racks RK*2PRI-PROC-1,2,3, and 4	CB	NA ⁽¹⁷⁾	Class 1E	PS	PBG	
Instrument Transmitter Racks 2CES*RAK 901, 902	IS	NA ⁽¹⁷⁾	Class 1E	PS	PBG	
Containment Penetration Back-up Protection Breaker Panels						
2PNL*RCPBP-02, 03	CB	NA ⁽¹⁷⁾	Class 1E	PS	PBG	
2PNL*RCPBP-06,07,09	CV	NA ⁽¹⁷⁾	Class 1E	PS	PAG	
2PNL*RCPBP-08	SB	NA ⁽¹⁷⁾	Class 1E	PS	PBG	
480 V Containment Back-up Protection Cabinets						
2CAB*RCPBP-04, 05,06	CV	NA ⁽¹⁷⁾	Class 1E	PS	PAG	
2CAB*RCPBP-07,08	SB	NA ⁽¹⁷⁾	Class 1E	PS	PBG	
Heat Tracing Equipment						
2HTS*TRFA1SG	SA	NA ⁽¹⁷⁾	Class 1E	PS	PAG	
2HTS*TRFB1SG	SA	NA ⁽¹⁷⁾	Class 1E	PS	PAG	
2HTS*PNLA1SG	SA	NA ⁽¹⁷⁾	Class 1E	PS	PAG	
2HTS*PNLB1SG	SA	NA ⁽¹⁷⁾	Class 1E	PS	PAG	

TABLE 3.2-1 (Cont)

NOTES:

1. Location symbols

AB	-	Auxiliary building
CB	-	Control building
CP	-	Condensate polishing building
CS	-	Reactor containment
CV	-	Cable vault area
DB	-	Decontamination building
DG	-	Diesel generator building
FB	-	Fuel building
IS	-	Intake structure
MV	-	Main steam valve area
PT	-	Pipe tunnel area
SA	-	Safeguards area
SB	-	Service building
TB	-	Turbine building
WH	-	Waste handling building
Y	-	Yard
ASP	-	Alternate shutdown panel

2. Missile protection symbols

PD	-	Designed to withstand the effects of internal or externally-generated missiles.
PS	-	Protection provided from externally-generated missiles by a structure designed for this purpose or a below grade location. Protection provided from internally-generated missiles by physical separation or barriers.
PB	-	Protection provided from internally-generated missiles by physical separation or barriers. Protection from externally-generated missiles is not required.

3. Flood protection symbols

PAG	-	External flood protection by above grade location.
PBG	-	Located below grade and external flood protected by design of enclosing structure.

4. Grade elevation is taken as el 735 feet.

5. Represents code class upgrading: As permitted by Paragraph NA-2134 of the ASME Code, Section III, this component is upgraded from the minimum required Code Class 2 to Code Class 1.

6. Service required to support a safety or other necessary function: Emergency power - manual loading, where applicable.

7. Safety classes for piping and valves are as defined by the piping and instrumentation diagrams. Code classes are those required by the safety class.

TABLE 3.2-1 (Cont)

NOTES: (Cont)

8. Parts are mechanically of safety class where applicable and must meet the structural integrity requirements of the specification and quality assurance requirements of 10 CFR 50, Appendix B.
9. Refer to Table 7.1-1 for a listing of applicable criteria.
10. Portions of equipment containing component cooling water are Safety Class 3, Code Class 3.
11. Services required to support a safety or other necessary function: Emergency power - automatic loading, where applicable.
12. Services required to support a safety or other necessary function: Component cooling water.
13. Services required to support a safety or other necessary function: Service water.
14. Components need not be missile-protected since they are used only during accident conditions for which a missile need not be postulated.
15. Seismic requirements for Class 1E components conform with or exceed those outlined in IEEE Standard-344-1975 and are in agreement with the recommendations of USNRC EICSB 10. Refer to Section 3.10 and 3.11 for further details.
16. Drawings and other detailed information are located in Section 1.7 and the appropriate equipment sections as identified.
17. NA - Not applicable
18. NR - Not required
19. Portions of the BVPS-2 Safety Class 3 service water system piping in the shared Unit 1/Unit 2 intake structure and buried lines from the intake structure to the valve pit were installed during the BVPS-1 construction effort and under BVPS-1 procedures and specifications.
20. The boundary of jurisdiction of ASME Code Section III, Class 2 and 3 process piping extends to and includes the root valve for the instrumentation tubing. The appropriate safety class extends from the root valve to the sensing instrument. Seismic Category I supports are employed for Safety Class 2 and 3 instrument tubing. The requirements for Safety Class 2 and 3 instrument tubing are listed in the ASME Code Baseline Document.
21. The tubing is classified as Quality Assurance Category I, Seismic Category I and Safety Class 2 or 3, except not ASME code stamped. However, the tubing is designed and tested in accordance with the requirements of ASME III Code Class 2 or 3. The tubing material is purchased to the requirements of ASME III. In addition, the tubing is stress analyzed and supported in accordance with ASME III.
22. The containment air recirculation system piping, valves and heat exchangers are Safety Class NNS, Non-ASME.

TABLE 3.2-2

CLASSIFICATION OF STRUCTURES

<u>Building</u>	<u>QA Category I</u>	<u>Seismic Category I</u>	<u>Tornado Protection</u>	<u>External Flood Protection</u>
Reactor containment	Yes	Yes	Yes	up to el 730 feet
Service building	up to el 780 feet ⁽⁶⁾	up to el 780 feet ⁽⁶⁾	up to el 780 feet ⁽⁶⁾	up to el 730 feet
Auxiliary building	up to el 773 feet -6 inches ⁽¹⁾	up to el 773 feet -6 inches ⁽¹⁾	up to el 773 feet -6 inches ⁽¹⁾	up to el 730 feet
Fuel and decontamination building	Yes	Yes	Yes	up to el 730 feet
Emergency diesel generator building	Yes	Yes	Yes	up to el 730 feet
Safeguards area	Yes	Yes	Yes	up to el 730 feet
Cable vault ⁽²⁾	Yes ⁽²⁾	Yes ⁽²⁾	Yes ⁽²⁾	up to el 730 feet
Main steam valve area	Yes	Yes	Yes	up to el 730 feet
Cable tunnel	Yes	Yes	Yes	up to el 730 feet
RWST/CAT pad and surrounding shield wall	Yes	Yes	No	up to el 730 feet ⁽³⁾
Control building ⁽⁴⁾	Yes	Yes	Yes	up to el 730 feet
Primary demineralized water storage tank pad and enclosure	Yes	Yes	Yes	up to el 730 feet

TABLE 3.2-2 (Cont)

<u>Building</u>	<u>QA Category I</u>	<u>Seismic Category I</u>	<u>Tornado Protection</u>	<u>External Flood Protection</u>
Pipe trenches (except north and south interconnecting trenches to BVPS-1)	Yes	Yes	Yes ⁽⁷⁾	up to el 730 feet
Service water valve pits	Yes	Yes	Yes	up to el 730 feet
Emergency outfall structure	Yes	Yes	Yes	up to el 730 feet
Equipment hatch platform	Yes	Yes	Yes	up to el 730 feet
Primary intake structure ⁽⁵⁾	Yes	Yes	Yes	up to el 737 feet

NOTES:

1. The steel frame above el 773 feet 6 inches of auxiliary building is QA Category I, Seismic Category I, but is not designed for tornado. The concrete ventilation core area, component cooling surge tank cubicle, and air conditioning room above el 773 feet 6 inches are QA Category I, Seismic Category I, and tornado-protected.
2. Structure includes pipe tunnel area at el 718 feet 6 inches from auxiliary building to reactor containment. The steel roof structure at el 797 feet and the steel structure above el 787 feet 6 inches of the cable vault are not QA Category I, Seismic Category I, or tornado-protected.
3. The surrounding shield wall is not designed to contain water level resulting from a tank rupture. The wall is designed for SSE seismic loads.
4. Extension of BVPS-1 control room.
5. Structure is a shared facility with BVPS-1 and is described in BVPS-1 FSAR.
6. Service building is Seismic Category I, QA Category I, and tornado missile-protected up to and including the floor at el 780 feet-6 inches.

TABLE 3.2-2 (Cont)

7. The QA Category I, Seismic Category I pipe trenches provide tornado protection except for approximately 103 feet of length adjacent to the fuel and decontamination building. This unprotected length of trench does not contain safety-related piping, components, or equipment.

TABLE 3.2-3

DIAGRAMS SHOWING QUALITY GROUP CLASSIFICATION

The quality group classification information shown on the station diagrams listed below are incorporated by reference into the UFSAR. Other information presented on these station diagrams is not considered part of the UFSAR. The contents of these station diagrams are controlled by station procedure.

<u>SYSTEM</u>	<u>STATION DRAWING</u>
Reactor Coolant System (Chapter 5)	RM-75A
Pressurizer Spray and Relief System	RM-75B
Safety Injection System (Section 6.3)	RM-87A RM-87B
Gaseous Nitrogen System (Section 9.5.9)	RM-71B
Miscellaneous Drains - Secondary Plant	RM-58A
Residual Heat Removal System (Section 5.4.7)	RM-76A
Chemical and Volume Control System (Section 9.3.4)	RM-79A RM-79B RM-79C RM-79D
Main Steam System (Section 10.3)	RM-41A
Feedwater and Auxiliary Feedwater Systems (Section 10.4)	RM-45A RM-45B
Service Water System (Section 9.2.1)	RM-47B RM-47C RM-47D RM-47F
Reactor Plant and Process Sampling System (Section 9.3.2.1)	RM-99F RM-99B
Post Accident Sampling System (Section 9.3.2.3)	RM-99E

TABLE 3.2-3 (Continued)

<u>SYSTEM</u>	<u>STATION DRAWING</u>
Emergency Diesel Generator Supporting Systems (Section 9.5)	RM-72A RM-72B
EDG Fuel Oil Supply System	
EDG Cooling Water System	
EDG Air Starting System	
EDG Lubrication System	RM-436-5A
EDG Air Intake and Exhaust System	
Primary Plant Component Cooling Water System (Section 9.2.2)	RM-77A RM-77B RM-77C RM-77E RM-77F
Neutron Shield Tank Cooling System	
Nuclear Equipment Vent and Drain System	RM-89A RM-89B RM-89C
Boron Recovery System (Section 9.3.4)	RM-92A
Recirculation Spray System (Section 6.2.2)	RM-85A
Quench Spray System (Section 6.2.2)	RM-85B
Fuel Pool Cooling and Purification System (Section 9.1.3)	RM-82A
Steam Generator Blowdown System (Section 10.4.8)	RM-100A
Combustible Gas Control System (Section 6.2.5)	RM-110A
Solid Waste Disposal System (Section 11.4)	RM-97A
Containment Vacuum Leak Monitoring System	RM-88A
Control Room Air Conditioning System (Section 9.4.1)	RB-84C
Service Building Ventilation System (Section 9.4.10)	RB-84A
Emergency Diesel Generator Building Ventilation System (Section 9.4.6)	RB-84H
Intake Structure Ventilation System (Section 9.4.8)	RB-84B
MCC Room Ventilation System (Section 9.4.3)	RB-84J

TABLE 3.2-3 (Continued)

<u>SYSTEM</u>	<u>STATION DRAWING</u>
Cable Vault and Rod Control Area Ventilation System (Section 9.4.12)	RB-85K
Auxiliary Building and Radwaste Area Ventilation System (Section 9.4.3)	RB-85G RB-85C
Supplementary Leak Collection System (Section 6.5.3.2)	RB-85C RB-85F RB-136B RB-85D
Alternate Shutdown Panel Ventilation System (Section 9.4.12)	RB-85K

|

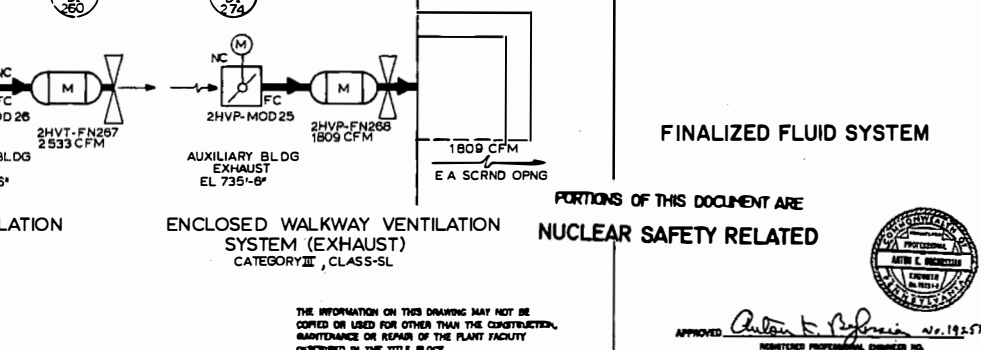
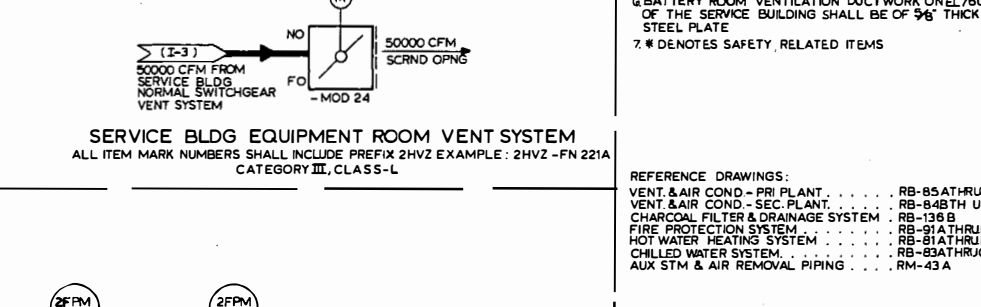
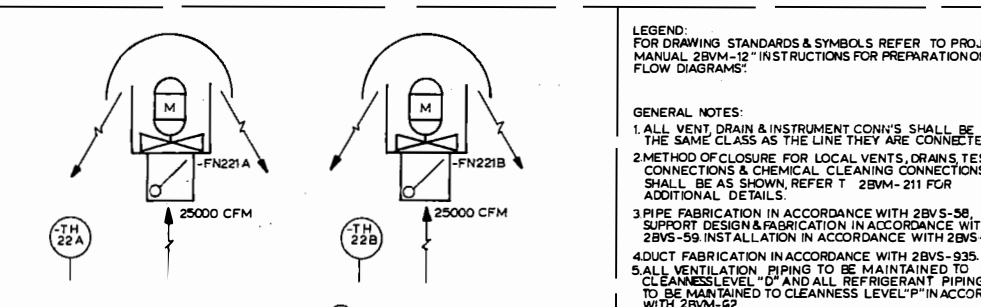
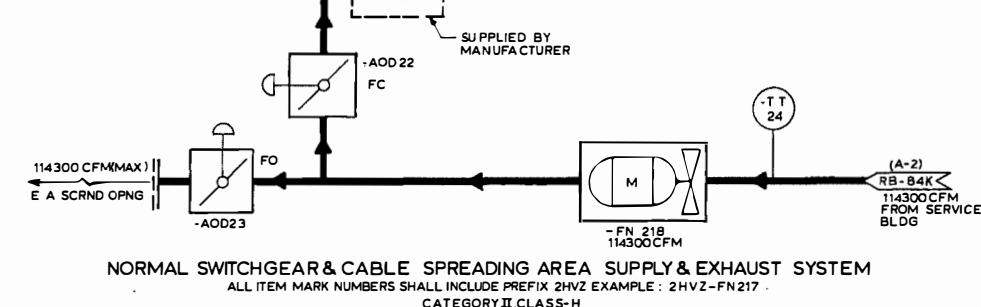
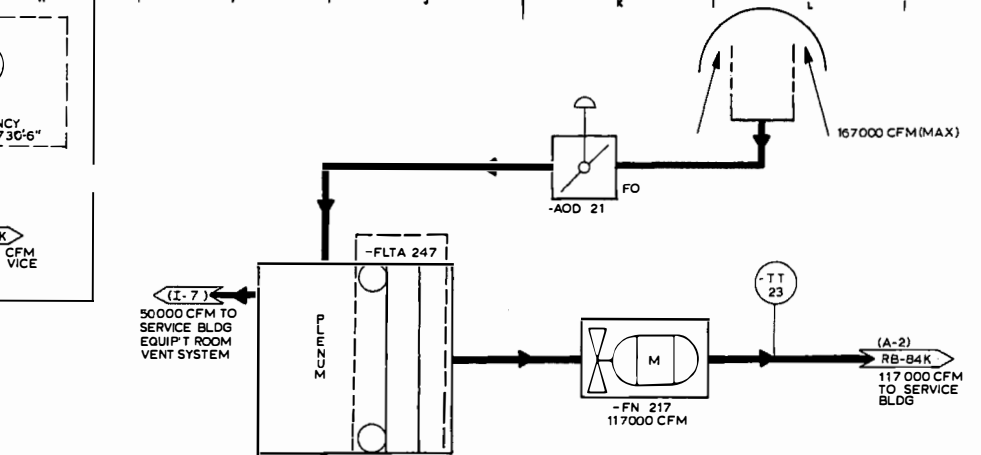
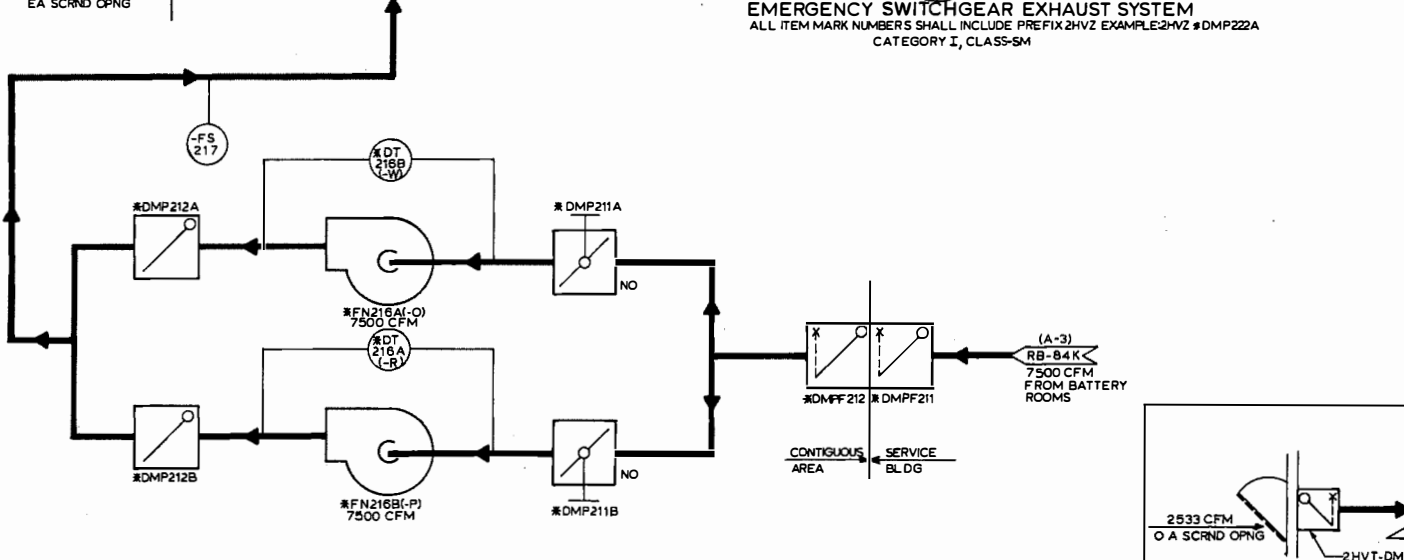
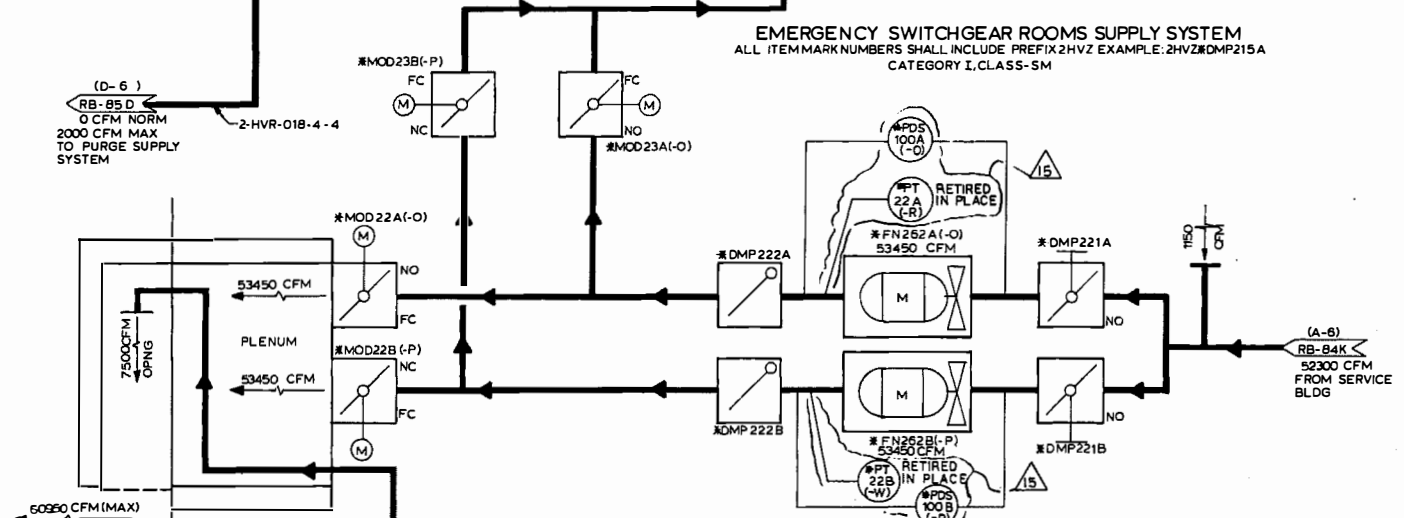
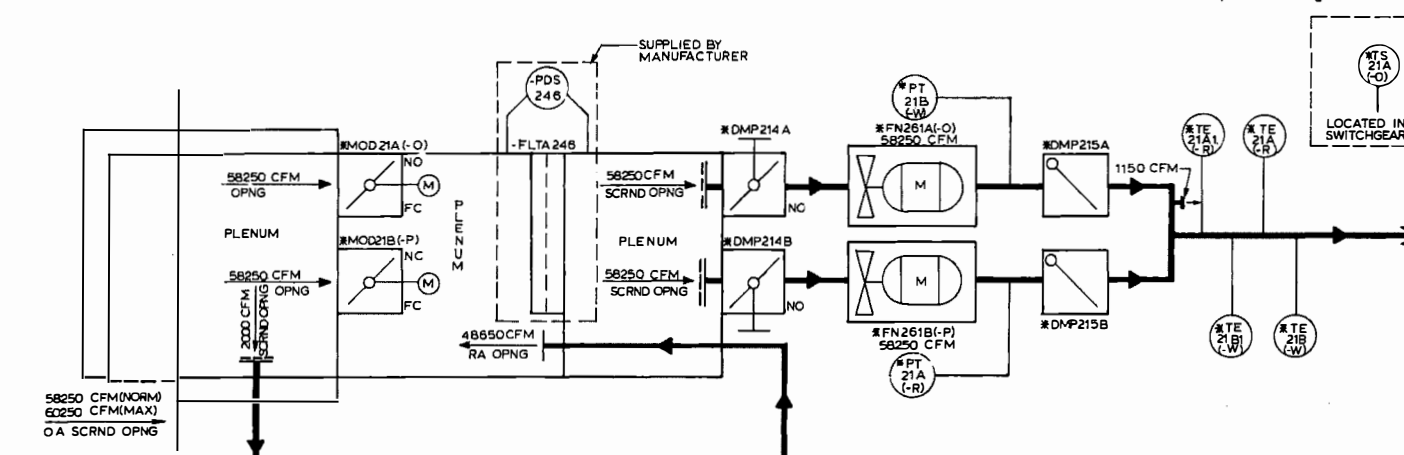

LEGEND:
FOR DRAWING STANDARDS & SYMBOLS REFER TO PROJECT MANUAL 2BVM-12 "INSTRUCTIONS FOR PREPARATION OF FLOW DIAGRAMS"

GENERAL NOTES:

1. ALL VENT DRAIN & INSTRUMENT CON'G'S SHALL BE OF THE SAME CLASS AS THE LINE THEY ARE CONNECTED TO.
2. METHOD OF CLOSURE FOR LOCAL VENTS, DRAINS, TEST CONNECTIONS & CHEMICAL CLEANING CONNECTIONS SHALL BE AS SHOWN, REFER TO 2BVM-211 FOR ADDITIONAL DETAILS.
3. PIPE FABRICATION IN ACCORDANCE WITH 2BVS-58. SUPPORT DESIGN & FABRICATION IN ACCORDANCE WITH 2BVS-59. INSTALLATION IN ACCORDANCE WITH 2BVS-920.
4. DUCT FABRICATION IN ACCORDANCE WITH 2BVS-935.
5. ALL VENTILATION, PIPING TO BE MAINTAINED TO CLEANNESS LEVEL "O" AND ALL REFRIGERANT PIPING TO BE MAINTAINED TO CLEANNESS LEVEL "P" IN ACCORDANCE WITH 2BVM-62.
6. BATTERY ROOM VENTILATION DUCTWORK ON EL. 760'-6" OF THE SERVICE BUILDING SHALL BE OF 3/8" THICK STEEL PLATE.
7. # DENOTES SAFETY RELATED ITEMS.

REFERENCE DRAWINGS:

- VENT. & AIR COND. - PRI PLANT RB-85ATHRUJ
- VENT. & AIR COND. - SEC. PLANT RB-84BTH UJ
- CHARCOAL FILTER & DRAINAGE SYSTEM RB-136B
- FIRE PROTECTION SYSTEM RB-91ATHRUJ
- HOT WATER HEATING SYSTEM RB-81ATHRUJ
- CHILLED WATER SYSTEM RB-80ATHRUJ
- AUX STM & AIR REMOVAL PIPING RM-43A

PORTIONS OF THIS DOCUMENT ARE
NUCLEAR SAFETY RELATED



APPROVED: *Arthur L. Ruffalo* No. 19257-E
REGISTERED PROFESSIONAL ENGINEER NO.
COMMONWEALTH OF PENNSYLVANIA

THE INFORMATION ON THIS DRAWING MAY NOT BE COPIED OR USED FOR OTHER THAN THE CONSTRUCTION, MAINTENANCE OR REPAIR OF THE PLANT FACILITY DESCRIBED IN THE TITLE BLOCK.

DUQUESNE LIGHT COMPANY
ENGINEERING & CONSTRUCTION PITTSBURGH, PA.

SCALE: DATE 7-6-73 ARCH. APP. DRAWN LAZARD ELECT. APP. CHECKED CTAN MECH. APP. UNCHECKED STRUCY. APP.

STONE & WEBSTER ENGINEERING CORP. BOSTON, MASS.

FLOW DIAGRAM
VENT & AIR COND.-SEC. PLANT SH I
BEAVER VALLEY POWER STATION UNIT NO. 2

G.P.E. NO. 10080
C.D. NO. 889

AA No. 10080-RB-84A

NO.	REVISIONS	DATE	BY	CHKD.	APP.	DESCRIPTION
1	ISSUED FOR CONSTRUCTION	7-6-73	LAZARD	CTAN	LAZARD	ISSUED FOR CONSTRUCTION
2	REVISION	7-6-73	LAZARD	CTAN	LAZARD	REVISION
3	REVISION	7-6-73	LAZARD	CTAN	LAZARD	REVISION
4	REVISION	7-6-73	LAZARD	CTAN	LAZARD	REVISION
5	REVISION	7-6-73	LAZARD	CTAN	LAZARD	REVISION
6	REVISION	7-6-73	LAZARD	CTAN	LAZARD	REVISION
7	REVISION	7-6-73	LAZARD	CTAN	LAZARD	REVISION
8	REVISION	7-6-73	LAZARD	CTAN	LAZARD	REVISION
9	REVISION	7-6-73	LAZARD	CTAN	LAZARD	REVISION
10	REVISION	7-6-73	LAZARD	CTAN	LAZARD	REVISION
11	REVISION	7-6-73	LAZARD	CTAN	LAZARD	REVISION
12	REVISION	7-6-73	LAZARD	CTAN	LAZARD	REVISION
13	REVISION	7-6-73	LAZARD	CTAN	LAZARD	REVISION
14	REVISION	7-6-73	LAZARD	CTAN	LAZARD	REVISION
15	REVISION	7-6-73	LAZARD	CTAN	LAZARD	REVISION

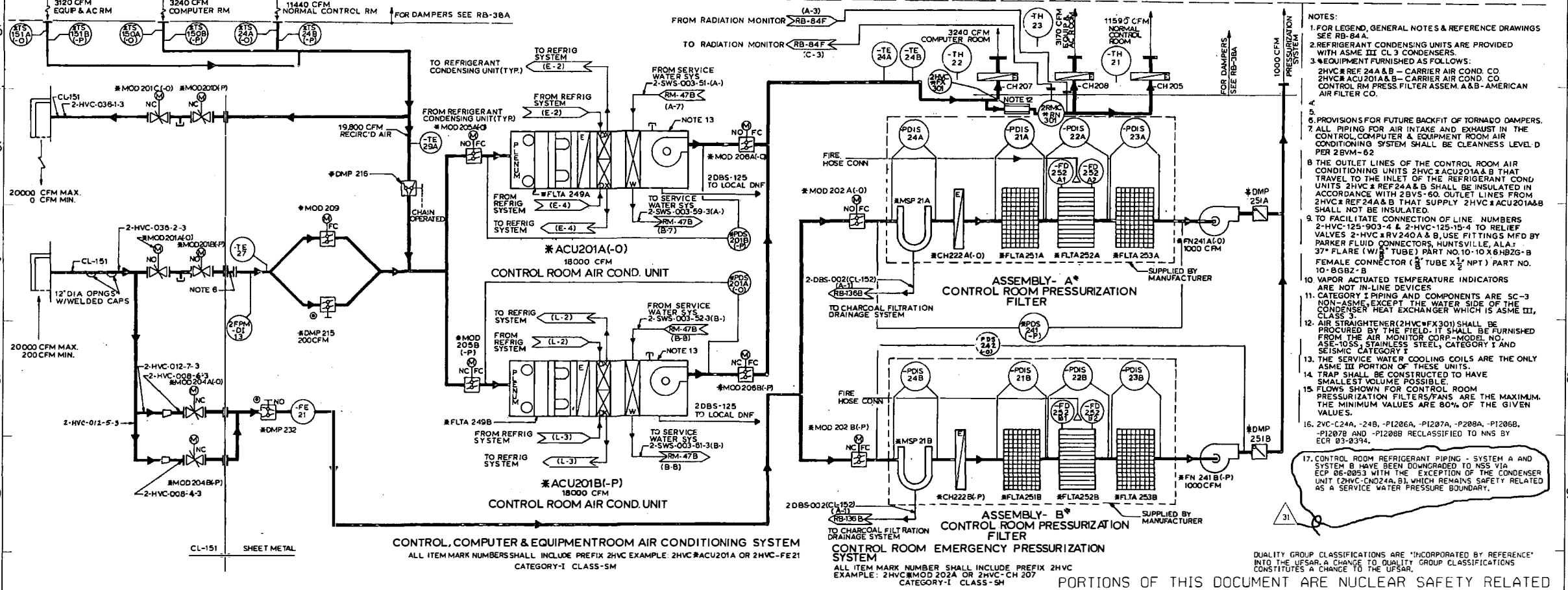
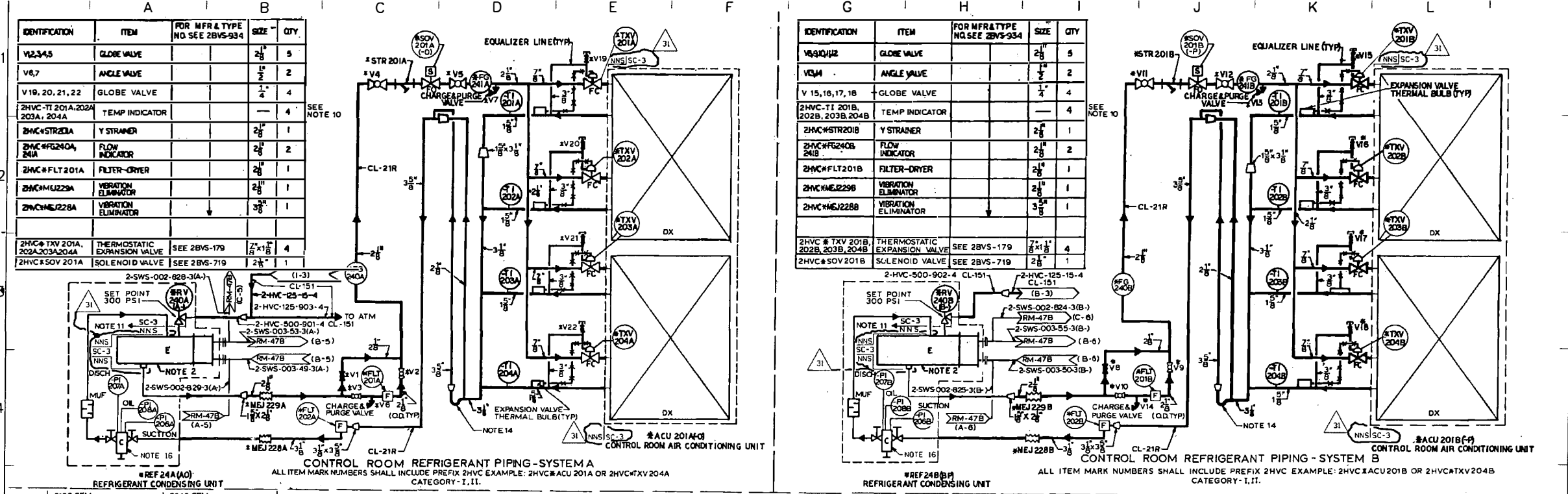

- NOTES:
- FOR LEGEND, GENERAL NOTES & REFERENCE DRAWINGS SEE RB-84A.
 - REFRIGERANT CONDENSING UNITS ARE PROVIDED WITH ASME III CL 3 CONDENSERS.
 - EQUIPMENT FURNISHED AS FOLLOWS:
 2HVC#REF 24A & B - CARRIER AIR COND. CO.
 2HVC#ACU201A & B - CARRIER AIR COND. CO.
 CONTROL RM PRESS FILTER ASSEM. A & B - AMERICAN AIR FILTER CO.
 -
 - PROVISIONS FOR FUTURE BACKFIT OF TORNADO DAMPERS.
 - ALL INLET AIR INTAKE AND EXHAUST IN THE CONTROL, COMPUTER & EQUIPMENT ROOM AIR CONDITIONING SYSTEM SHALL BE CLEANNESS LEVEL D PER 2BVM-62.
 - THE OUTLET LINES OF THE CONTROL ROOM AIR CONDITIONING UNITS 2HVC#ACU201A & B THAT TRAVEL TO THE INLET OF THE REFRIGERANT COND UNITS 2HVC#REF 24A & B SHALL BE INSULATED IN ACCORDANCE WITH 2BVS-50. OUTLET LINES FROM 2HVC#REF 24A & B THAT SUPPLY 2HVC#ACU201A & B SHALL NOT BE INSULATED.
 - TO FACILITATE CONNECTION OF LINE NUMBERS 2-15-4 TO 2-15-4 TO RELIEF VALVES 2-HVC#RV240A & B, USE FITTINGS MFD BY PARKER FLUID CONNECTORS, HUNTSVILLE, ALA.: 37" FLARE (W/ TUBE) PART NO. 10-10X6B2G-B FEMALE CONNECTOR (8" TUBE x 1/2" NPT) PART NO. 10-85B2-B
 - VAPOR ACTUATED TEMPERATURE INDICATORS ARE NOT IN-LINE DEVICES
 - CATEGORY I PIPING AND COMPONENTS ARE SC-3
 - NON-ASME EXCEPT THE WATER SIDE OF THE CONDENSER HEAT EXCHANGER WHICH IS ASME III, CLASS I
 - STRAIGHTENER (2HVC#FX301) SHALL BE PROCURED BY THE FIELD. IT SHALL BE FURNISHED FROM THE AIR MONITOR CORP. MODEL NO. ASE-1055, STAINLESS STEEL, CATEGORY I AND SEISMIC CATEGORY I
 - THE SERVICE WATER COOLING COILS ARE THE ONLY ASME III PORTION OF THESE UNITS.
 - TRAP SHALL BE CONSTRUCTED TO HAVE SMALLEST VOLUME POSSIBLE.
 - FLOWS SHOWN FOR CONTROL ROOM PRESSURIZATION FILTERS/FANS ARE THE MAXIMUM. THE MINIMUM VALUES ARE 80% OF THE GIVEN VALUES.
 - 2VC-C24A, -24B, -P1206A, -P1207A, -P288A, -P1206B, -P1207B AND -P1208B RECLASSIFIED TO NNS BY ECR 03-8394.
 - CONTROL ROOM REFRIGERANT PIPING - SYSTEM A AND SYSTEM B HAVE BEEN UPGRADED TO NNS VIA ECP 06-0053 WITH THE EXCEPTION OF THE CONDENSER UNIT (2HVC#CND24A, B) WHICH REMAINS SAFETY RELATED AS A SERVICE WATER PRESSURE BOUNDARY.

REVISION 31 INCORPORATED ECP-06-0053 ICEN-2-RB-0084C-E06-0053-01

FENOC FIRSTENERGY NUCLEAR OPERATING COMPANY

BEAVER VALLEY POWER STATION UNIT 2

FLOW DIAGRAM VENT & AIR COND - SEC PLANT SH 3

AA DWG NO. 10080-RB-84C 31

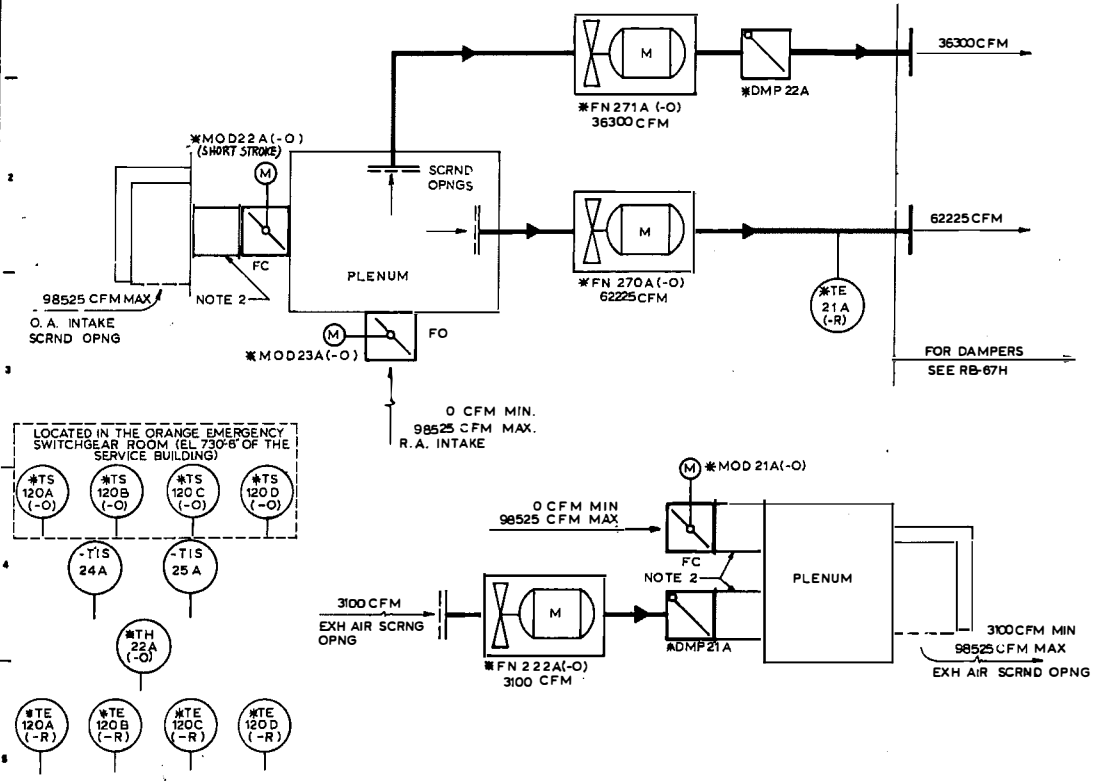

SOUTH DIESEL GENERATOR BUILDING VENTILATION SYSTEM
 ALL ITEM MARK NUMBERS SHALL INCLUDE PREFIX 2HVD
 EXAMPLE: 2HVD#DMP21A CATEGORY I, CLASS-5M

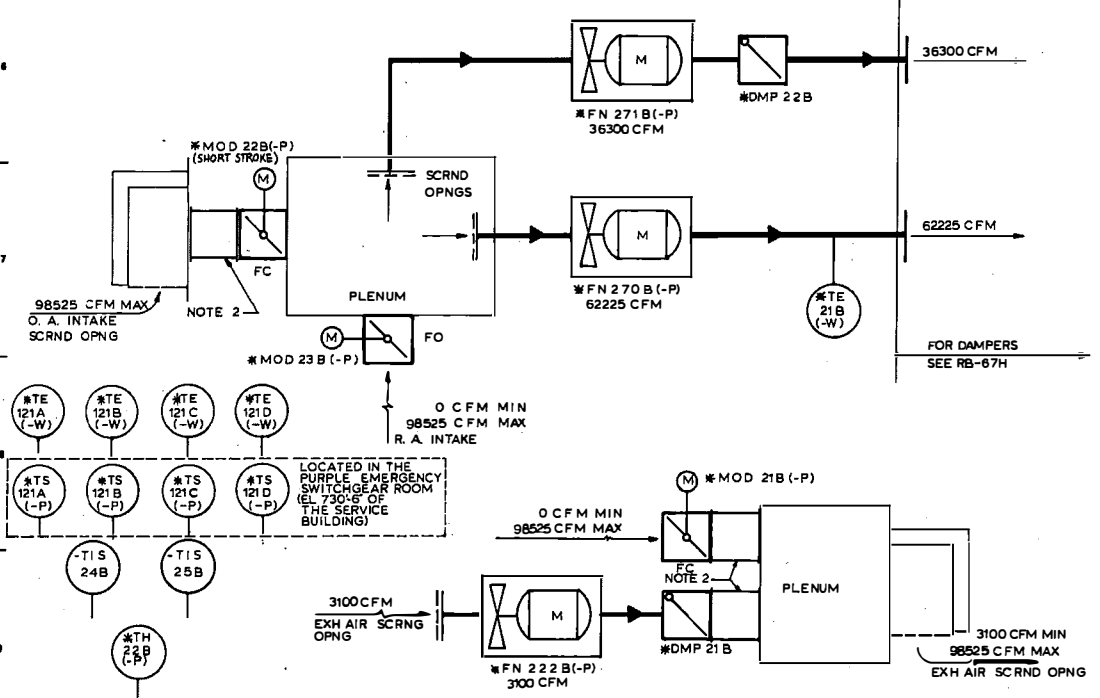

NORTH DIESEL GENERATOR BUILDING VENTILATION SYSTEM
 ALL ITEM & MARK NUMBERS SHALL INCLUDE PREFIX 2HVD
 EXAMPLE: 2HVD#MOD 22B
 CATEGORY I, CLASS-5M

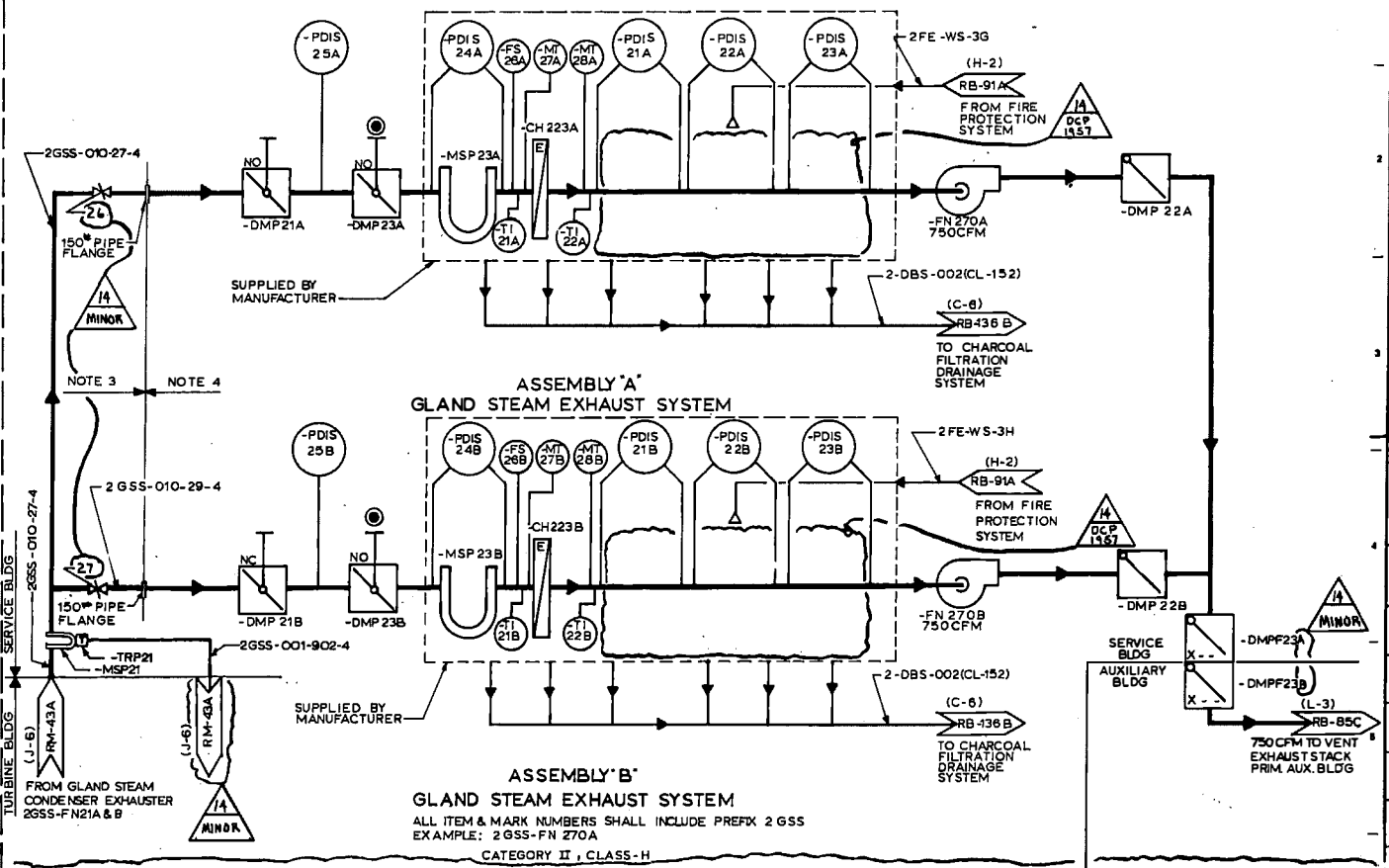

ASSEMBLY 'A' GLAND STEAM EXHAUST SYSTEM
ASSEMBLY 'B' GLAND STEAM EXHAUST SYSTEM
 ALL ITEM & MARK NUMBERS SHALL INCLUDE PREFIX 2GSS
 EXAMPLE: 2GSS-FN 270A
 CATEGORY II, CLASS-H

PORTIONS OF THIS DOCUMENT ARE
NUCLEAR SAFETY RELATED

- NOTES:
- FOR LEGEND, GENERAL NOTES & REFERENCE DRAWINGS SEE RB-84A
 - PROVISIONS FOR FUTURE BACKFIT OF TORNADO DAMPERS TO BE PROVIDED.
 - PIPE FABRICATION IN ACCORDANCE WITH 2BWS-58, SUPPORT DESIGN & FABRICATION IN ACCORDANCE 2BWS-59, INSTALLATION IN ACCORDANCE WITH 2BWS-59
 - DUCT FABRICATION AND INSTALLATION IN ACCORDANCE WITH 2BWS-935

FINALIZED FLUID SYSTEM

THE INFORMATION ON THIS DRAWING MAY NOT BE COPIED OR USED FOR OTHER THAN THE CONSTRUCTION, MAINTENANCE OR REPAIR OF THE PLANT FACILITY DESCRIBED IN THE TITLE BLOCK.

APPROVED *Walter Joseph Parker, Jr.*
 REGISTERED PROFESSIONAL ENGINEER NO. 29007-E
 COMMONWEALTH OF PENNSYLVANIA

DUQUESNE LIGHT COMPANY ENGINEERING & CONSTRUCTION PITTSBURGH, PA.		FLOW DIAGRAM VENT & AIR COND SEC PLANT SHS BEAVER VALLEY POWER STATION UNIT NO.2	
SCALE: NONE DATE: 5/23/82 DRAWN: R.W.H. CHECKED: T.C. INSPECTED:		O.F.E. NO. 10080 C.O. NO. 1288 AA No. 10080-RB-84H.	
S&W DWG. NO. 12241-RB-84H-14			

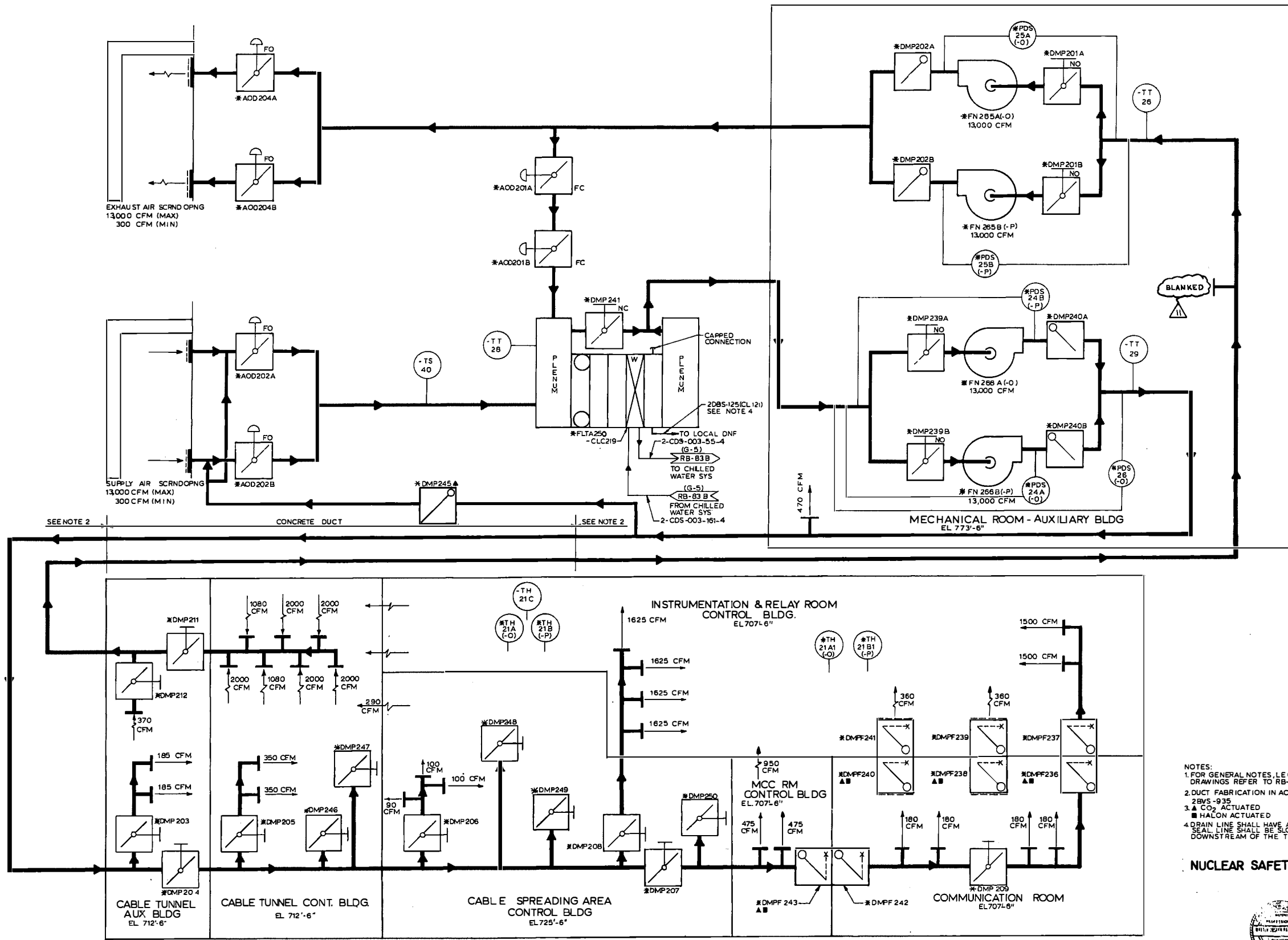

- NOTES:
 1. FOR GENERAL NOTES, LEGEND & REFERENCE DRAWINGS REFER TO RB-84A
 2. DUCT FABRICATION IN ACCORDANCE WITH 2BVS-935
 3. CO₂ ACTUATED
 ■ HALON ACTUATED
 4. DRAIN LINE SHALL HAVE A MINIMUM 2" TRAP SEAL. LINE SHALL BE SLOPED 1/4" PER FOOT DOWNSTREAM OF THE TRAP.

NUCLEAR SAFETY RELATED



APPROVED *Walter Spalding*
REGISTERED PROFESSIONAL ENGINEER NO. 29023-6
COMMONWEALTH OF PENNSYLVANIA

CONTROL BUILDING AIR CONDITIONING SYSTEM
ALL ITEM MARK NUMBERS SHALL INCLUDE PREFIX 2HVC EXAMPLE: 2HVC*ADD 20 4A
CATEGORY I, CLASS SM

FINALIZED FLUID SYSTEM

THE INFORMATION ON THIS DRAWING MAY NOT BE COPIED OR USED FOR OTHER THAN THE CONSTRUCTION, MAINTENANCE OR REPAIR OF THE PLANT FACILITY DESCRIBED IN THE TITLE BLOCK.

DUQUESNE LIGHT COMPANY ENGINEERING & CONSTRUCTION PITTSBURGH, PA.		FLOW DIAGRAM VENT & AIR COND.-SEC. PLANT SH9 BEAVER VALLEY POWER STATION UNIT NO.2 O.F.E. NO. 10080 C.O. NO. 628 AA No. 10080-RB-84J	
DATE 10/15/82 ARCH. APP. _____ NONE DRAWN/HOLMES ELEC. APP. _____ CHECKED/TOMMALS MECH. APP. _____ UNCHECKED/STRUC. APP. _____		SCALE _____ STONE & WEBSTER ENGINEERING CORP BOSTON, MASS.	

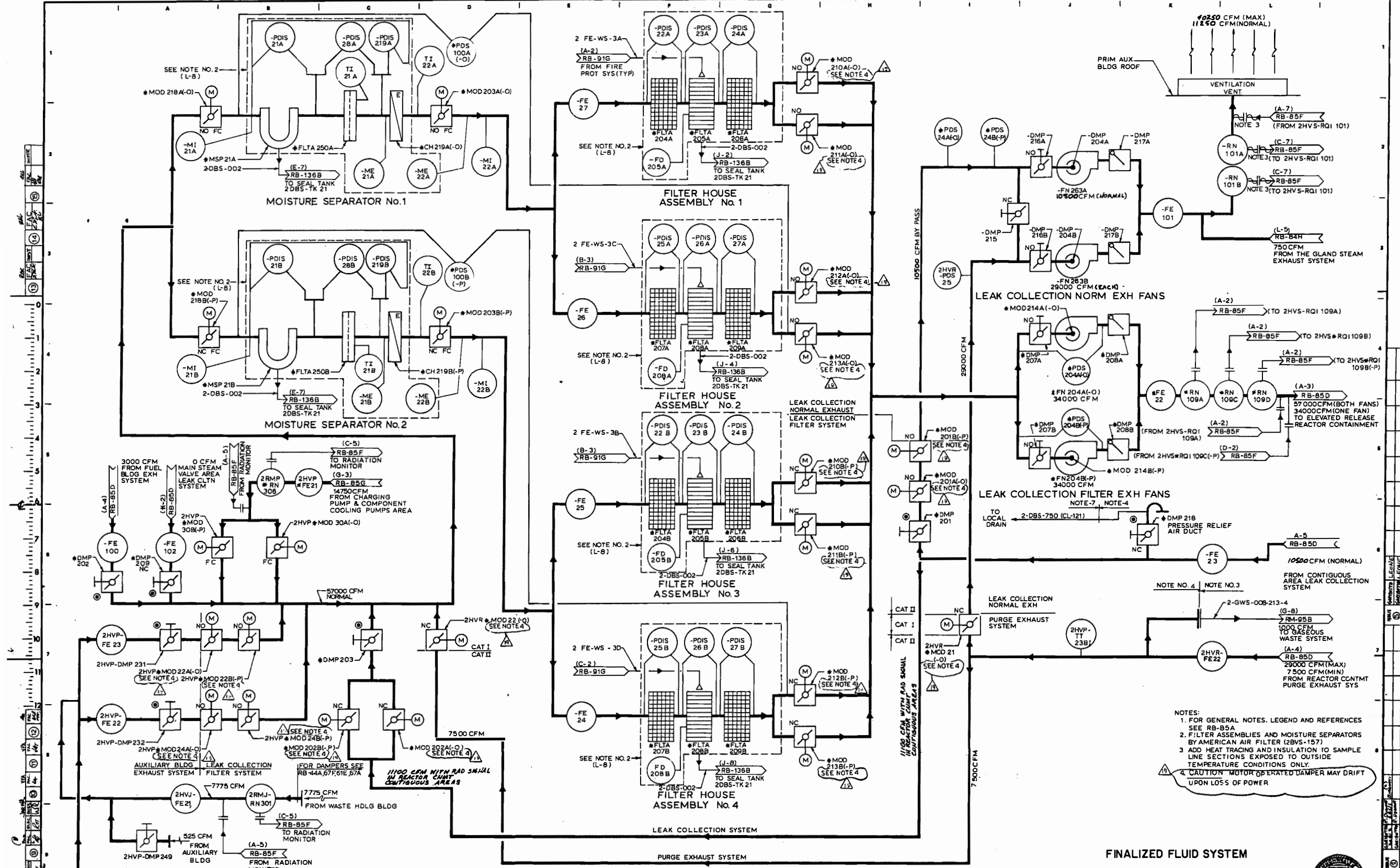

NOTES:
 1. FOR GENERAL NOTES, LEGEND AND REFERENCES SEE RB-85A
 2. FILTER ASSEMBLIES AND MOISTURE SEPARATORS BY AMERICAN AIR FILTER (28V-157)
 3. ADD HEAT TRACING AND INSULATION TO SAMPLE LINE SECTIONS EXPOSED TO OUTSIDE TEMPERATURE CONDITIONS ONLY.
 4. CAUTION MOTOR OPERATED DAMPER MAY DRIFT UPON LOSS OF POWER

AUXILIARY BUILDING SUPPLEMENTARY LEAK COLLECTION SYSTEM
 ALL ITEM MARK NUMBERS INCLUDE PREFIX 2HVS:EXAMPLE 2HVS#MOD210A(-O)
 (EXCEPT WHERE NOTED)
 CATEGORY I. CLASS SXH-LL

FINALIZED FLUID SYSTEM

PORTIONS OF THIS DOCUMENT ARE
 NUCLEAR SAFETY RELATED
 APPROVED: [Signature] 12-27-74

<p>REVISIONS</p> <p>16-2 INC. TER 698</p> <p>17 TER 140</p> <p>18 INCORPORATED NAD SHEET 2 AND EADCR D-5422-502</p>	<p>19</p> <p>20</p> <p>21</p> <p>22</p> <p>23</p> <p>24</p> <p>25</p> <p>26</p> <p>27</p> <p>28</p> <p>29</p> <p>30</p> <p>31</p> <p>32</p> <p>33</p> <p>34</p> <p>35</p> <p>36</p> <p>37</p> <p>38</p> <p>39</p> <p>40</p> <p>41</p> <p>42</p> <p>43</p> <p>44</p> <p>45</p> <p>46</p> <p>47</p> <p>48</p> <p>49</p> <p>50</p>	<p>DUQUESNE LIGHT COMPANY ENGINEERING & CONSTRUCTION PITTSBURGH, PA.</p> <p>SCALE: NONE</p> <p>DATE: 2-6-74</p> <p>DRAWN: RFB/lo</p> <p>CHECKED: C.TAN</p> <p>DESIGNED: [Signature]</p>	<p>FLOW DIAGRAM AIR COND. & VENT. PRL PLANT SH-3 BEAVER VALLEY POWER STATION UNIT NO.2</p> <p>AA No. 10080-RB-85C</p> <p>s & W DWG. NO. 12241-RB-85C-19</p>
---	---	--	---

VALVE IDENTIFICATION	MARK NUMBER	PIPE SIZE	QUANTITY
RV3, RV4	VO5060-C-2	3/4"	2

- NOTES:
- FOR LEGEND, GENERAL NOTES & REFERENCE DWGS SEE RB-85A
 -
 - FLEXIBLE CONN BY SHEET METAL CONTRACTOR. NO COMPANION FLANGE REQD ON PIPE END
 - PIPE FABRICATION IN ACCORDANCE WITH 2BVS-59 SUPPORT, DESIGN & FABRICATION IN ACCORDANCE WITH 2BVS-59. INSTALLATION IN ACCORDANCE WITH 2BVS-920
 - DUCT FABRICATION AND INSTALLATION IN ACCORDANCE WITH 2BVS-935
 - AIR STRAIGHTENER (2HVR#FX301) SHALL BE PROCURED BY THE FIELD. IT SHALL BE FURNISHED FROM THE AIR MONITOR CORP-MOD NO. ASE-1055, STAINLESS STEEL, CATEGORY I, SEISMIC CATEGORY I

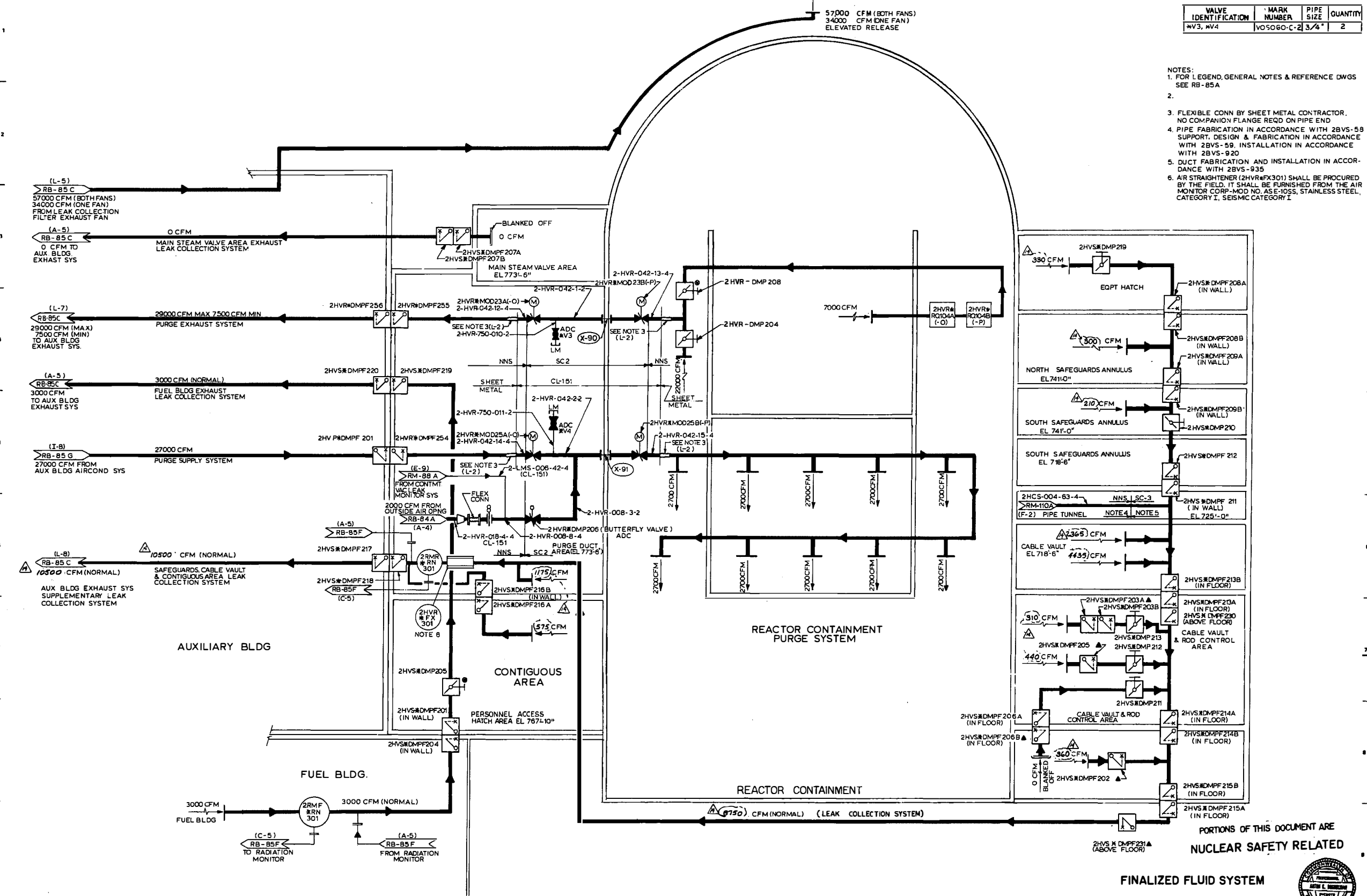

PORTIONS OF THIS DOCUMENT ARE
NUCLEAR SAFETY RELATED

FINALIZED FLUID SYSTEM

THE INFORMATION ON THIS DRAWING MAY NOT BE COPIED OR USED FOR OTHER THAN THE CONSTRUCTION, MAINTENANCE OR REPAIR OF THE PLANT FACILITY DESCRIBED IN THE TITLE BLOCK.

APPROVED: *[Signature]*
DATE: 12-2-74
SUPERVISOR OF INSTRUMENTATION

<p>INCORP 0-5300-528, 0-5422-502, A 12 AND DISCRETE FLOW RATES</p>	<p>SEE RECORD OF DRAWING CHANGES 12241-BCB-85D-11</p>	<p>INCORPORATED THIS ISSUE FOR 12241-BCB-85D-11</p>	<p>SEE RECORD OF DRAWING CHANGES 12241-BCB-85D-6</p>	<p>SEE RECORD OF DRAWING CHANGES 12241-BCB-85D-5</p>	<p>SEE RECORD OF DRAWING CHANGES 12241-BCB-85D-4</p>	<p>SCALE: NONE</p>	<p>DATE: 2-6-74</p>	<p>ARCH. APP. [Signature]</p>	<p>DUQUESNE LIGHT COMPANY ENGINEERING & CONSTRUCTION PITTSBURGH, PA.</p>	<p>FLOW DIAGRAM AIR COND & VENT PRI PLANT SH-4 BEAVER VALLEY POWER STATION UNIT NO.2</p>
<p>INCORP 0-5300-528, 0-5422-502, A 12 AND DISCRETE FLOW RATES</p>	<p>SEE RECORD OF DRAWING CHANGES 12241-BCB-85D-11</p>	<p>INCORPORATED THIS ISSUE FOR 12241-BCB-85D-11</p>	<p>SEE RECORD OF DRAWING CHANGES 12241-BCB-85D-6</p>	<p>SEE RECORD OF DRAWING CHANGES 12241-BCB-85D-5</p>	<p>SEE RECORD OF DRAWING CHANGES 12241-BCB-85D-4</p>	<p>SCALE: NONE</p>	<p>DATE: 2-6-74</p>	<p>ARCH. APP. [Signature]</p>	<p>DUQUESNE LIGHT COMPANY ENGINEERING & CONSTRUCTION PITTSBURGH, PA.</p>	<p>FLOW DIAGRAM AIR COND & VENT PRI PLANT SH-4 BEAVER VALLEY POWER STATION UNIT NO.2</p>
<p>INCORP 0-5300-528, 0-5422-502, A 12 AND DISCRETE FLOW RATES</p>	<p>SEE RECORD OF DRAWING CHANGES 12241-BCB-85D-11</p>	<p>INCORPORATED THIS ISSUE FOR 12241-BCB-85D-11</p>	<p>SEE RECORD OF DRAWING CHANGES 12241-BCB-85D-6</p>	<p>SEE RECORD OF DRAWING CHANGES 12241-BCB-85D-5</p>	<p>SEE RECORD OF DRAWING CHANGES 12241-BCB-85D-4</p>	<p>SCALE: NONE</p>	<p>DATE: 2-6-74</p>	<p>ARCH. APP. [Signature]</p>	<p>DUQUESNE LIGHT COMPANY ENGINEERING & CONSTRUCTION PITTSBURGH, PA.</p>	<p>FLOW DIAGRAM AIR COND & VENT PRI PLANT SH-4 BEAVER VALLEY POWER STATION UNIT NO.2</p>

STONE & WEBSTER ENGINEERING CORP. BOSTON, MASS.

SCALE: NONE

DATE: 2-6-74

ARCH. APP. [Signature]

DUQUESNE LIGHT COMPANY
ENGINEERING & CONSTRUCTION PITTSBURGH, PA.

FLOW DIAGRAM
AIR COND & VENT PRI PLANT SH-4
BEAVER VALLEY POWER STATION UNIT NO.2

D.P.E. No. 10080
C.O. No. 85D

AA No. 10080-RB-85D

S&W DWG. NO. 12241-RB-85D-14

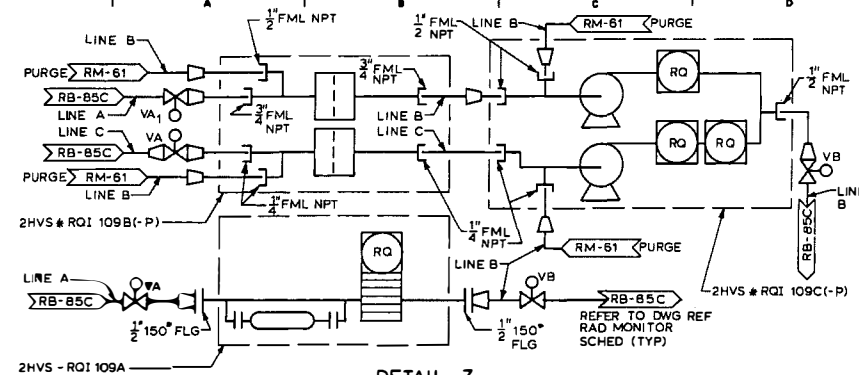

DETAIL Z
NOTE 3

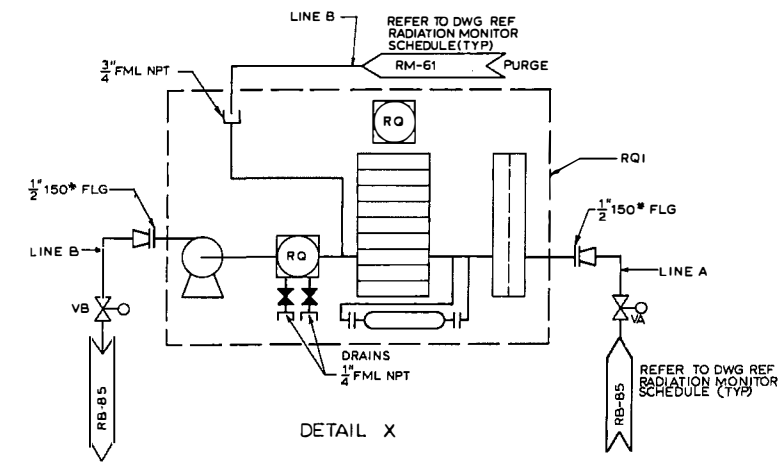

DETAIL X

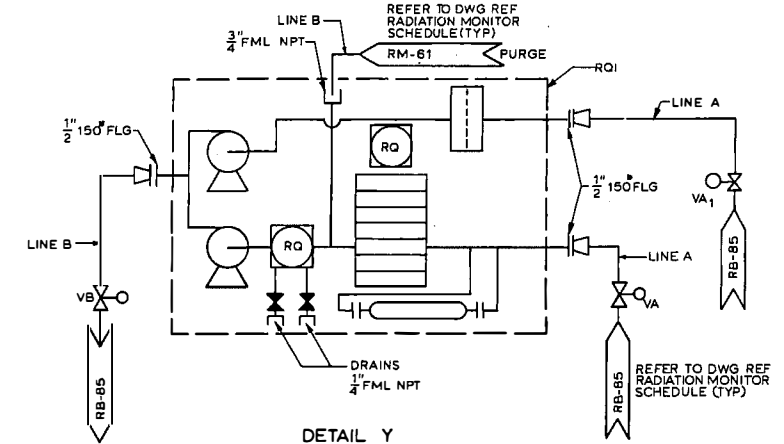

DETAIL Y

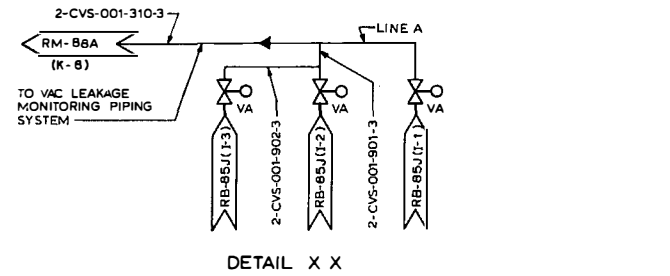

DETAIL X X

RADIATION MONITOR SCHEDULE													
RN NO.	DWG REF	DET	RQI NO.	RQ NO	RQ NO	VA	VA	VB	LINE A	LINE B	LINE C	PURGE LN NO	DWG REF
2 RMO - RN 301A, B	RB - 85HC(6)	Y	2 RMO-RQI 301	301A	301B	V30	V5	V6	1"	3/4"	—	2IAS-750-444	RM-61B, RK-15 SERIES
2 RMR * RN 303A	RB - 85J(1-1)	XX	—	303A	303B	—	V7	—	—	—	—	—	—
2 RMR * RN 303B	RB - 85J(1-2)	XX	2 RMR * RQI 303 (-P)	—	—	—	—	VB	—	—	—	—	—
2 RMR * RN 303C	RB - 85J(1-3)	XX	—	—	—	—	—	V9	—	—	—	—	—
2 RMF * RN 301	RB - 85D(B-9)	X	2 RMF - RQI 301	301A	301B	—	V10	V11	—	—	—	2IAS-750-445	—
2 RMP - RN 302	RB - 85E(C-8)	X	2 RMP - RQI 302	302A	302B	—	V12	V13	—	—	—	2IAS-750-460	—
2 RMP - RN 300	RB - 85E(A-6)	X	2 RMP - RQI 300	300A	300B	—	V14	V15	—	—	—	2IAS-750-482	—
2 RMP - RN 304	RB - 85E(C-7)	X	2 RMP - RQI 304	304A	304B	—	V16	V17	—	—	—	2IAS-750-461	—
2 RMP - RN 308	RB - 85E(B-5)	X	2 RMP - RQI 308	308A	308B	—	V18	V19	—	—	—	2IAS-750-443	—
2 RMP - RN 310	RB - 85E(B-2)	X	2 RMP - RQI 310	310A	310B	—	V20	V21	—	—	—	2IAS-750-942	—
2 RMJ - RN 301	RB - 85C(B-8)	X	2 RMJ - RQI 301	301A	301B	—	V22	V23	—	—	—	2IAS-750-463	—
2 RMP * RN 306	RB - 85C(B-5)	X	2 RMP - RQI 306	306A	306B	—	V24	V25	—	—	—	2IAS-750-943	—
2 RMP - RN 312	RB - 85C(B-5)	X	2 RMP - RQI 312	312A	312B	—	V26	V27	—	—	—	2IAS-750-441	—
2 RMR * RN 301	RB - 85D(D-6)	X	2 RMR - RQI 301	301A	301B	—	V28	V29	—	—	—	2IAS-750-464	—
—	—	—	—	—	—	—	—	—	—	—	—	—	—
2 HVS - RN 101 A, B	RB - 85CL(2)	Y	2 HVS - RQI 101	101A	101B	V38	V32	V33	1"	3/4"	—	2IAS-750-466	—
2 RMQ - RN 303 A, B	RB - 85H(F-8)	Y	2 RMQ - RQI 303	303A	303B	V42	V34	V35	—	—	—	2IAS-750-467	—
2 HVS * RN 109A	RB - 85CL(5)	Z	2 HVS - RQI 109A	109A	—	—	V37	V31	—	—	—	2IAS-750-465	—
2 HVS * RN 109C	RB - 85CL(5)	Z	2 HVS * RQI 109B(-P)	—	—	—	V39	—	—	3/4"	—	2IAS-750-147	—
2 HVS * RN 109D	RB - 85CL(5)	Z	2 HVS * RQI 109C(-P)	109B	109D	—	V40	V41	—	—	—	2IAS-750-148	—
—	—	—	—	—	—	—	—	—	—	—	—	2IAS-750-149	—

NOTE: THE VALVES LISTED BELOW WERE PURCHASED BY THE POWER DIVISION & WILL BE INSTALLED BY INSTRUMENTATION

VALVE IDENTIFICATION	MARK NUMBER	VALVE SIZE	QUANTITY	PURCHASE ORDER
V7, B9	VBS015-Y-3	1"	3	2BVS-67
V5, 10, 12, 14, 16, 18, 20, 22, 24, 26, 28, 30, 32, 34, 36, 37	VBS015-D-4	1"	16	2BVS-78
V11, 13, 15, 17, 21, 23, 25, 27, 29, 31, 33, 6, 35, 19	VBS015-D-4	3/4"	14	2BVS-78
V40, 41, 39	VBS015-Y-3	3/4"	3	2BVS-67

- NOTES:
- FOR GENERAL NOTES, LEGEND AND REFERENCE DWGS SEE RB-85A
 - THE INLET SAMPLE TUBING (LINE A) SHALL HAVE SMOOTH TRANSITIONS, MINIMUM 5D BENDS, WITH THE CONTINUOUS DOWNWARD SLOPE (FROM RN TO RQI) TO THE MAXIMUM EXTENT POSSIBLE TO MINIMIZE PARTICULATE PLATEOUT. THE RETURN TUBING (LINE B) SHALL BE CONFIGURED TO MINIMIZE PRESSURE DROP.
 - ALL LINES ASSOCIATED WITH RADIATION MONITORS 2HVS * RQI 109B(-P) AND C(-P) HAVE A MINIMUM SLOPE OF AT LEAST 15'.

PORTIONS OF THIS DOCUMENT ARE
NUCLEAR SAFETY RELATED

FINALIZED FLUID SYSTEM



THE INFORMATION ON THIS DRAWING MAY NOT BE COPIED OR USED FOR OTHER THAN THE CONSTRUCTION, MAINTENANCE OR REPAIR OF THE PLANT FACILITY DESCRIBED IN THE TITLE BLOCK.

APPROVED: PARTHO BAYSIRCAN, REGISTERED PROFESSIONAL ENGINEER NO. 12142-C, COMMONWEALTH OF PENNSYLVANIA

11	SEE RECORD OF DRAWING CHANGES 12241-RB-85F-10	12	SEE RECORD OF DRAWING CHANGES 12241-RB-85F-11	13	SEE RECORD OF DRAWING CHANGES 12241-RB-85F-12	14	SEE RECORD OF DRAWING CHANGES 12241-RB-85F-13	15	SEE RECORD OF DRAWING CHANGES 12241-RB-85F-14	16	SEE RECORD OF DRAWING CHANGES 12241-RB-85F-15	17	SEE RECORD OF DRAWING CHANGES 12241-RB-85F-16	18	SEE RECORD OF DRAWING CHANGES 12241-RB-85F-17	19	SEE RECORD OF DRAWING CHANGES 12241-RB-85F-18	20	SEE RECORD OF DRAWING CHANGES 12241-RB-85F-19	21	SEE RECORD OF DRAWING CHANGES 12241-RB-85F-20	22	SEE RECORD OF DRAWING CHANGES 12241-RB-85F-21	23	SEE RECORD OF DRAWING CHANGES 12241-RB-85F-22	24	SEE RECORD OF DRAWING CHANGES 12241-RB-85F-23	25	SEE RECORD OF DRAWING CHANGES 12241-RB-85F-24	26	SEE RECORD OF DRAWING CHANGES 12241-RB-85F-25	27	SEE RECORD OF DRAWING CHANGES 12241-RB-85F-26	28	SEE RECORD OF DRAWING CHANGES 12241-RB-85F-27	29	SEE RECORD OF DRAWING CHANGES 12241-RB-85F-28	30	SEE RECORD OF DRAWING CHANGES 12241-RB-85F-29	31	SEE RECORD OF DRAWING CHANGES 12241-RB-85F-30	32	SEE RECORD OF DRAWING CHANGES 12241-RB-85F-31	33	SEE RECORD OF DRAWING CHANGES 12241-RB-85F-32	34	SEE RECORD OF DRAWING CHANGES 12241-RB-85F-33	35	SEE RECORD OF DRAWING CHANGES 12241-RB-85F-34	36	SEE RECORD OF DRAWING CHANGES 12241-RB-85F-35	37	SEE RECORD OF DRAWING CHANGES 12241-RB-85F-36	38	SEE RECORD OF DRAWING CHANGES 12241-RB-85F-37	39	SEE RECORD OF DRAWING CHANGES 12241-RB-85F-38	40	SEE RECORD OF DRAWING CHANGES 12241-RB-85F-39	41	SEE RECORD OF DRAWING CHANGES 12241-RB-85F-40	42	SEE RECORD OF DRAWING CHANGES 12241-RB-85F-41	43	SEE RECORD OF DRAWING CHANGES 12241-RB-85F-42	44	SEE RECORD OF DRAWING CHANGES 12241-RB-85F-43	45	SEE RECORD OF DRAWING CHANGES 12241-RB-85F-44	46	SEE RECORD OF DRAWING CHANGES 12241-RB-85F-45	47	SEE RECORD OF DRAWING CHANGES 12241-RB-85F-46	48	SEE RECORD OF DRAWING CHANGES 12241-RB-85F-47	49	SEE RECORD OF DRAWING CHANGES 12241-RB-85F-48	50	SEE RECORD OF DRAWING CHANGES 12241-RB-85F-49	51	SEE RECORD OF DRAWING CHANGES 12241-RB-85F-50	52	SEE RECORD OF DRAWING CHANGES 12241-RB-85F-51	53	SEE RECORD OF DRAWING CHANGES 12241-RB-85F-52	54	SEE RECORD OF DRAWING CHANGES 12241-RB-85F-53	55	SEE RECORD OF DRAWING CHANGES 12241-RB-85F-54	56	SEE RECORD OF DRAWING CHANGES 12241-RB-85F-55	57	SEE RECORD OF DRAWING CHANGES 12241-RB-85F-56	58	SEE RECORD OF DRAWING CHANGES 12241-RB-85F-57	59	SEE RECORD OF DRAWING CHANGES 12241-RB-85F-58	60	SEE RECORD OF DRAWING CHANGES 12241-RB-85F-59	61	SEE RECORD OF DRAWING CHANGES 12241-RB-85F-60	62	SEE RECORD OF DRAWING CHANGES 12241-RB-85F-61	63	SEE RECORD OF DRAWING CHANGES 12241-RB-85F-62	64	SEE RECORD OF DRAWING CHANGES 12241-RB-85F-63	65	SEE RECORD OF DRAWING CHANGES 12241-RB-85F-64	66	SEE RECORD OF DRAWING CHANGES 12241-RB-85F-65	67	SEE RECORD OF DRAWING CHANGES 12241-RB-85F-66	68	SEE RECORD OF DRAWING CHANGES 12241-RB-85F-67	69	SEE RECORD OF DRAWING CHANGES 12241-RB-85F-68	70	SEE RECORD OF DRAWING CHANGES 12241-RB-85F-69	71	SEE RECORD OF DRAWING CHANGES 12241-RB-85F-70	72	SEE RECORD OF DRAWING CHANGES 12241-RB-85F-71	73	SEE RECORD OF DRAWING CHANGES 12241-RB-85F-72	74	SEE RECORD OF DRAWING CHANGES 12241-RB-85F-73	75	SEE RECORD OF DRAWING CHANGES 12241-RB-85F-74	76	SEE RECORD OF DRAWING CHANGES 12241-RB-85F-75	77	SEE RECORD OF DRAWING CHANGES 12241-RB-85F-76	78	SEE RECORD OF DRAWING CHANGES 12241-RB-85F-77	79	SEE RECORD OF DRAWING CHANGES 12241-RB-85F-78	80	SEE RECORD OF DRAWING CHANGES 12241-RB-85F-79	81	SEE RECORD OF DRAWING CHANGES 12241-RB-85F-80	82	SEE RECORD OF DRAWING CHANGES 12241-RB-85F-81	83	SEE RECORD OF DRAWING CHANGES 12241-RB-85F-82	84	SEE RECORD OF DRAWING CHANGES 12241-RB-85F-83	85	SEE RECORD OF DRAWING CHANGES 12241-RB-85F-84	86	SEE RECORD OF DRAWING CHANGES 12241-RB-85F-85	87	SEE RECORD OF DRAWING CHANGES 12241-RB-85F-86	88	SEE RECORD OF DRAWING CHANGES 12241-RB-85F-87	89	SEE RECORD OF DRAWING CHANGES 12241-RB-85F-88	90	SEE RECORD OF DRAWING CHANGES 12241-RB-85F-89	91	SEE RECORD OF DRAWING CHANGES 12241-RB-85F-90	92	SEE RECORD OF DRAWING CHANGES 12241-RB-85F-91	93	SEE RECORD OF DRAWING CHANGES 12241-RB-85F-92	94	SEE RECORD OF DRAWING CHANGES 12241-RB-85F-93	95	SEE RECORD OF DRAWING CHANGES 12241-RB-85F-94	96	SEE RECORD OF DRAWING CHANGES 12241-RB-85F-95	97	SEE RECORD OF DRAWING CHANGES 12241-RB-85F-96	98	SEE RECORD OF DRAWING CHANGES 12241-RB-85F-97	99	SEE RECORD OF DRAWING CHANGES 12241-RB-85F-98	100	SEE RECORD OF DRAWING CHANGES 12241-RB-85F-99	101	SEE RECORD OF DRAWING CHANGES 12241-RB-85F-100
----	---	----	---	----	---	----	---	----	---	----	---	----	---	----	---	----	---	----	---	----	---	----	---	----	---	----	---	----	---	----	---	----	---	----	---	----	---	----	---	----	---	----	---	----	---	----	---	----	---	----	---	----	---	----	---	----	---	----	---	----	---	----	---	----	---	----	---	----	---	----	---	----	---	----	---	----	---	----	---	----	---	----	---	----	---	----	---	----	---	----	---	----	---	----	---	----	---	----	---	----	---	----	---	----	---	----	---	----	---	----	---	----	---	----	---	----	---	----	---	----	---	----	---	----	---	----	---	----	---	----	---	----	---	----	---	----	---	----	---	----	---	----	---	----	---	----	---	----	---	----	---	----	---	----	---	----	---	----	---	----	---	----	---	----	---	----	---	----	---	----	---	----	---	----	---	----	---	-----	---	-----	--

DUQUESNE LIGHT COMPANY
ENGINEERING & CONSTRUCTION PITTSBURGH, PA.

STONE & WEBSTER ENGINEERING CORP.
BOSTON, MASS.

SCALE: NONE
DATE: 10/30/79
DRAWN: BERLO
CHECKED: ALLIANCE
INSPECTED: STRUCT. APP.

FLOW DIAGRAM
AIR COND & VENT PRI PLANT SH8
BEAVER VALLEY POWER STATION UNIT NO2
D.P.E. NO. 10000
C.O. NO. 000
AA No. 10080-RB-85F

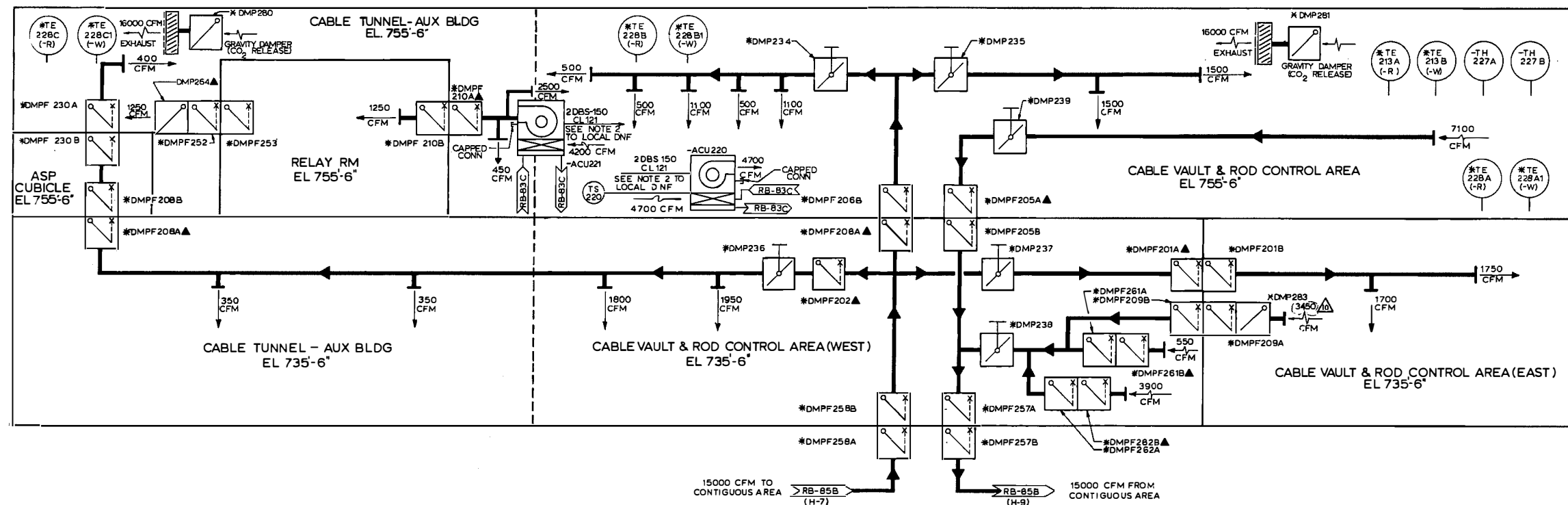

CABLE VAULT & ROD CONTROL AREA SUPPLY & RECIRCULATION SYSTEM
 ALL ITEM MARK NUMBERS SHALL INCLUDE PREFIX ZHVR; EXAMPLE: 2HVR#DMPF257 B

- NOTES:
- FOR LEGEND, GENERAL NOTES AND REFERENCE DRAWINGS SEE RB-85A.
 - A 2" MINIMUM TRAP SEAL SHALL BE INSTALLED IN DRAIN LINE PIPING DOWNSTREAM OF TRAP SHALL SLOPE DOWN 1/4" PER FOOT.

PORTIONS OF THIS DOCUMENT ARE
NUCLEAR SAFETY RELATED

FINALIZED FLUID SYSTEM

THE INFORMATION ON THIS DRAWING MAY NOT BE
 COPIED OR USED FOR OTHER THAN THE CONSTRUCTION,
 MAINTENANCE OR REPAIR OF THE PLANT FACILITY
 DESCRIBED IN THE TITLE BLOCK.

APPROVED *Walter J. ...*
 REGISTERED PROFESSIONAL ENGINEER NO. 21003-8
 COMMONWEALTH OF PENNSYLVANIA

NO.	DATE	DESCRIPTION
1	11/15/82	ISSUED FOR CONSTRUCTION
2	11/15/82	REVISIONS
3	11/15/82	INC DCP 986 & INTERIM ISSUE 7A2
4	11/15/82	INC TER NO. 590 (C-9834-90)
5	11/15/82	INC TER-450
6	11/15/82	INC TER-450
7	11/15/82	INC TER-450
8	11/15/82	INC TER-450
9	11/15/82	INC TER-450
10	11/15/82	INC TER-450
11	11/15/82	INC TER-450
12	11/15/82	INC TER-450

NO.	DATE	DESCRIPTION
13	11/15/82	INC TER-450
14	11/15/82	INC TER-450
15	11/15/82	INC TER-450
16	11/15/82	INC TER-450
17	11/15/82	INC TER-450
18	11/15/82	INC TER-450
19	11/15/82	INC TER-450
20	11/15/82	INC TER-450
21	11/15/82	INC TER-450
22	11/15/82	INC TER-450
23	11/15/82	INC TER-450
24	11/15/82	INC TER-450
25	11/15/82	INC TER-450
26	11/15/82	INC TER-450
27	11/15/82	INC TER-450
28	11/15/82	INC TER-450
29	11/15/82	INC TER-450
30	11/15/82	INC TER-450

NO.	DATE	DESCRIPTION
31	11/15/82	INC TER-450
32	11/15/82	INC TER-450
33	11/15/82	INC TER-450
34	11/15/82	INC TER-450
35	11/15/82	INC TER-450
36	11/15/82	INC TER-450
37	11/15/82	INC TER-450
38	11/15/82	INC TER-450
39	11/15/82	INC TER-450
40	11/15/82	INC TER-450
41	11/15/82	INC TER-450
42	11/15/82	INC TER-450
43	11/15/82	INC TER-450
44	11/15/82	INC TER-450
45	11/15/82	INC TER-450
46	11/15/82	INC TER-450
47	11/15/82	INC TER-450
48	11/15/82	INC TER-450
49	11/15/82	INC TER-450
50	11/15/82	INC TER-450

DUQUESNE LIGHT COMPANY		ENGINEERING & CONSTRUCTION PITTSBURGH, PA.	
SCALE	DATE 11/15/82	ARCH. APP.	
NONE		ELECT. APP.	
CHECKED	SCOTT	MECH. APP.	
INSPECTED		STRUCT. APP.	
STONE & WEBSTER ENGINEERING CORP BOSTON, MASS.			

FLOW DIAGRAM		AIR COND & VENT. PLANT SH-10	
BEAVER VALLEY POWER STATION UNIT NO. 2		D.F.E. NO. 10080	
C.O. NO. 628		AA No. 10080-RB-85K	
S&W DWG. NO. 12241-RB-85K-10			

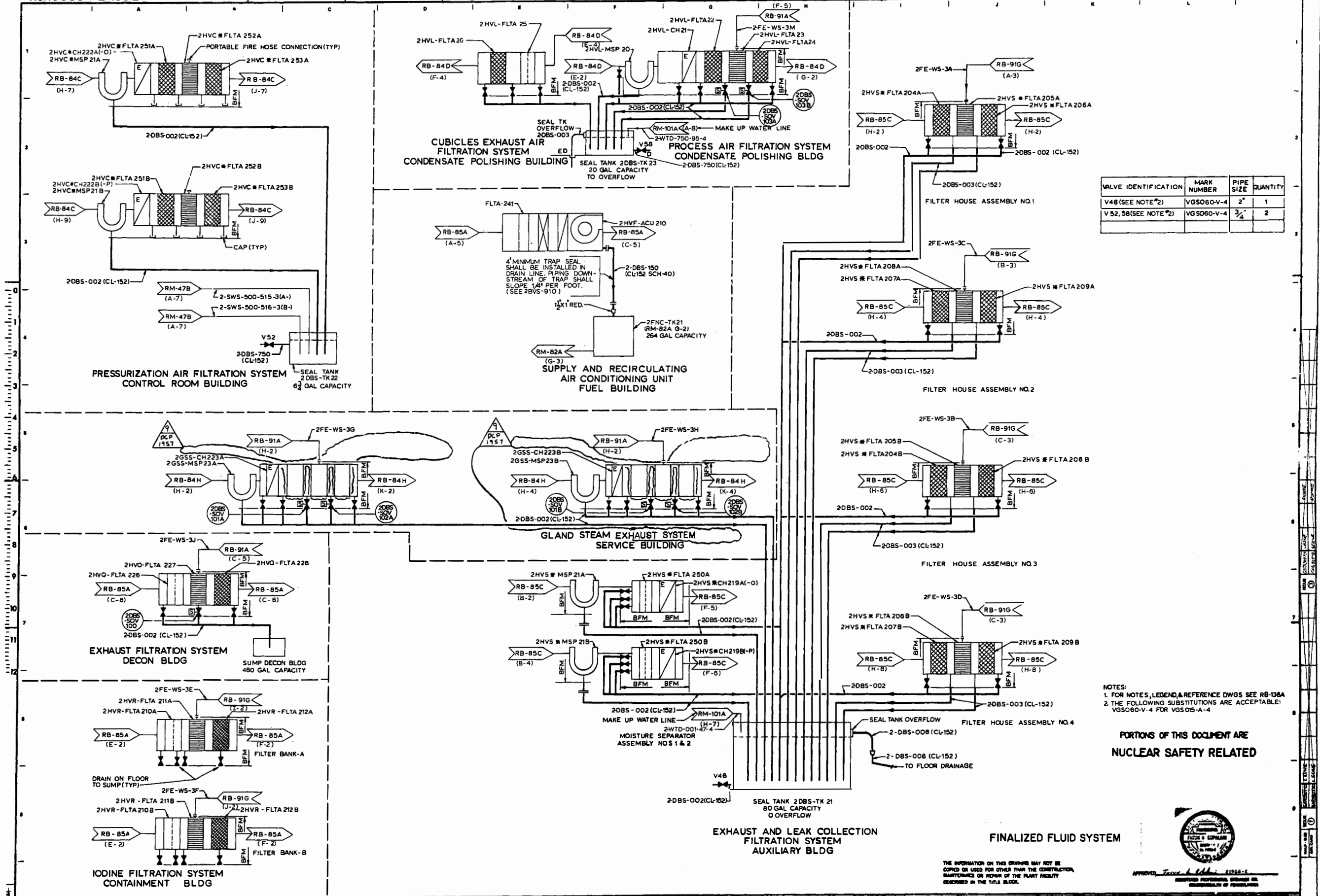

VALVE IDENTIFICATION	MARK NUMBER	PIPE SIZE	QUANTITY
V46 (SEE NOTE #2)	VGS060-V-4	2"	1
V52, 58 (SEE NOTE #2)	VGS060-V-4	3/4"	2

NOTES:
 1. FOR NOTES, LEGEND & REFERENCE DWGS SEE RB-136A
 2. THE FOLLOWING SUBSTITUTIONS ARE ACCEPTABLE:
 VGS060-V-4 FOR VGS015-A-4

PORTIONS OF THIS DOCUMENT ARE
 NUCLEAR SAFETY RELATED



APPROVED: *[Signature]*
 REGISTERED PROFESSIONAL ENGINEER IN THE STATE OF PENNSYLVANIA

THE INFORMATION ON THIS DRAWING MAY NOT BE
 COPIED OR USED FOR OTHER THAN THE CONSTRUCTION,
 MAINTENANCE OR REPAIR OF THE PLANT FACILITY
 IDENTIFIED IN THE TITLE BLOCK.

DUQUESNE LIGHT COMPANY ENGINEERING & CONSTRUCTION PITTSBURGH, PA.		FLOW DIAGRAM CHARCOAL FILTRATION DRAINAGE SYSTEM BEAVER VALLEY POWER STATION UNIT NO. 2	
SCALE: NONE DATE: 12-31-79 DESIGNED BY: BRASENAULT CHECKED BY: CH. J. HODMAN INSPECTED BY: UNDESIGNATED	ARCH. APP. ELEC. APP. MECH. APP. STRUC. APP.	AA No. 10080-RB-136B C.O. No. 005	

REV.	DATE	DESCRIPTION	BY	CHKD.
1	10-20-80	ISSUED FOR CONSTRUCTION	[Signature]	[Signature]
2	11-15-80	REVISIONS TO FILTER HOUSE ASSEMBLY NO. 1	[Signature]	[Signature]
3	11-15-80	REVISIONS TO FILTER HOUSE ASSEMBLY NO. 2	[Signature]	[Signature]
4	11-15-80	REVISIONS TO FILTER HOUSE ASSEMBLY NO. 3	[Signature]	[Signature]
5	11-15-80	REVISIONS TO FILTER HOUSE ASSEMBLY NO. 4	[Signature]	[Signature]
6	11-15-80	REVISIONS TO EXHAUST AND LEAK COLLECTION FILTRATION SYSTEM	[Signature]	[Signature]
7	11-15-80	REVISIONS TO PRESSURIZATION AIR FILTRATION SYSTEM	[Signature]	[Signature]
8	11-15-80	REVISIONS TO CUBICLES EXHAUST AIR FILTRATION SYSTEM	[Signature]	[Signature]
9	11-15-80	REVISIONS TO SUPPLY AND RECIRCULATING AIR CONDITIONING UNIT	[Signature]	[Signature]
10	11-15-80	REVISIONS TO GLAND STEAM EXHAUST SYSTEM	[Signature]	[Signature]
11	11-15-80	REVISIONS TO EXHAUST FILTRATION SYSTEM	[Signature]	[Signature]
12	11-15-80	REVISIONS TO IODINE FILTRATION SYSTEM	[Signature]	[Signature]

28 TER 10886
CHANGE DECK
VALVES IN VENT TO ATMOSPHERE
FROM 10" TO 12" AND
FROM 12" TO 14" AND
FROM 14" TO 16" AND
FROM 16" TO 18" AND
FROM 18" TO 20" AND
FROM 20" TO 24" AND
FROM 24" TO 28" AND
FROM 28" TO 32" AND
FROM 32" TO 36" AND
FROM 36" TO 40" AND
FROM 40" TO 44" AND
FROM 44" TO 48" AND
FROM 48" TO 52" AND
FROM 52" TO 56" AND
FROM 56" TO 60" AND
FROM 60" TO 64" AND
FROM 64" TO 68" AND
FROM 68" TO 72" AND
FROM 72" TO 76" AND
FROM 76" TO 80" AND
FROM 80" TO 84" AND
FROM 84" TO 88" AND
FROM 88" TO 92" AND
FROM 92" TO 96" AND
FROM 96" TO 100"

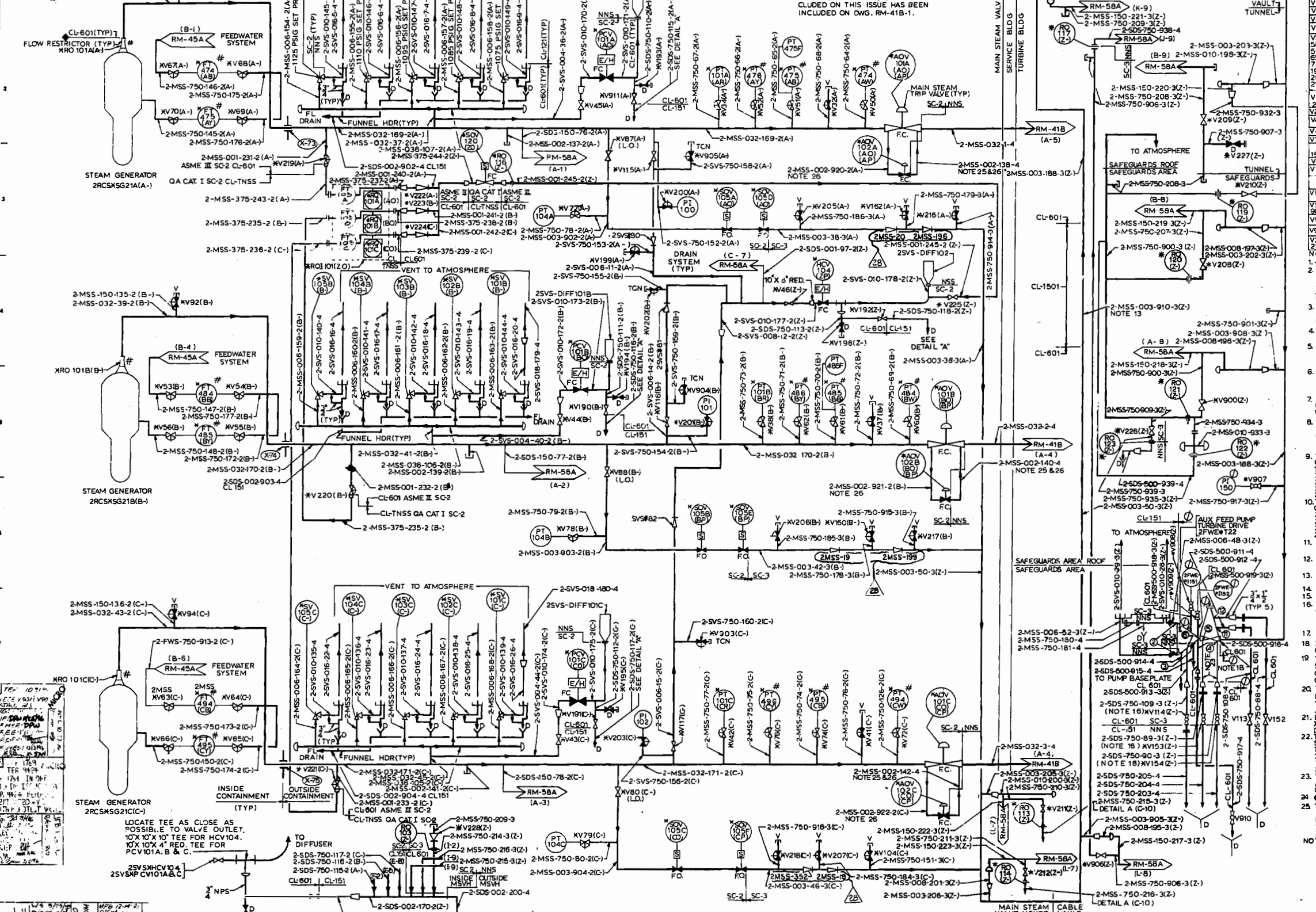

REFERENCE DRAWINGS:
MISC DRAINS SECONDARY PLANT RM-58A
TURB GLAND STEAM SEAL PIPING RM-60A
AUX STM AND AIR REMOVAL RM-43A
SAMPLE PIPING SECONDARY RM-43C
FEEDWATER PIPING RM-45A
MAIN STEAM PIPING SH. 2 RM-41B
NOTE: INFORMATION FORMERLY SHOWN ON
DRAWING RM-41A(V)-10 & NOT IN-
CLUDED ON THIS ISSUE HAS BEEN
INCLUDED ON DWS. RM-41B-1.

26. THE PIPE MATERIAL FOR THE FOLLOWING LINES SHALL
BE SA106, GR. C. 2-MSS-002-920-2, 921-2, 922-2, 923-2 AND 2-MSS-002-138-4,
MO-4, AND 142-4 AND FITTINGS TO BE SA106, 6000*.
REFERENCE DRAWINGS (G-1)

VALVE IDENTIFICATION	MARK NUMBER	PIPE SIZE	QUANTITY
V225	VG5060-B-2	1"	1
V115, 116	VG5060-A2-2	6"	2
V222, 223, 224	VC5060A2-2	1"	3
V80, 87, 88	VG5060-A2-2	3"	3
V911, 210, 226, 227	VG5060-B2-2	2"	4
V232, 347, 348, 41, 42, 53, 54, 55, 56, 57, 58, 59, 60, 61, 62, 63, 64, 65, 66, 67, 68, 69, 70, 71, 72, 73, 74, 75, 76, 77, 78, 79, 80, 81, 82, 83, 84, 85, 86, 87, 88, 89, 90, 91, 92, 93, 94, 95, 96, 97, 98, 99, 100, 101, 102, 103, 104, 105, 106, 107, 108, 109, 110, 111, 112, 113, 114, 115, 116, 117, 118, 119, 120, 121, 122, 123, 124, 125, 126, 127, 128, 129, 130, 131, 132, 133, 134, 135, 136, 137, 138, 139, 140, 141, 142, 143, 144, 145, 146, 147, 148, 149, 150, 151, 152, 153, 154, 155, 156, 157, 158, 159, 160, 161, 162, 163, 164, 165, 166, 167, 168, 169, 170, 171, 172, 173, 174, 175, 176, 177, 178, 179, 180, 181, 182, 183, 184, 185, 186, 187, 188, 189, 190, 191, 192, 193, 194, 195, 196, 197, 198, 199, 200, 201, 202, 203, 204, 205, 206, 207, 208, 209, 210, 211, 212, 213, 214, 215, 216, 217, 218, 219, 220, 221, 222, 223, 224, 225, 226, 227, 228, 229, 230, 231, 232, 233, 234, 235, 236, 237, 238, 239, 240, 241, 242, 243, 244, 245, 246, 247, 248, 249, 250, 251, 252, 253, 254, 255, 256, 257, 258, 259, 260, 261, 262, 263, 264, 265, 266, 267, 268, 269, 270, 271, 272, 273, 274, 275, 276, 277, 278, 279, 280, 281, 282, 283, 284, 285, 286, 287, 288, 289, 290, 291, 292, 293, 294, 295, 296, 297, 298, 299, 300, 301, 302, 303, 304, 305, 306, 307, 308, 309, 310, 311, 312, 313, 314, 315, 316, 317, 318, 319, 320, 321, 322, 323, 324, 325, 326, 327, 328, 329, 330, 331, 332, 333, 334, 335, 336, 337, 338, 339, 340, 341, 342, 343, 344, 345, 346, 347, 348, 349, 350, 351, 352, 353, 354, 355, 356, 357, 358, 359, 360, 361, 362, 363, 364, 365, 366, 367, 368, 369, 370, 371, 372, 373, 374, 375, 376, 377, 378, 379, 380, 381, 382, 383, 384, 385, 386, 387, 388, 389, 390, 391, 392, 393, 394, 395, 396, 397, 398, 399, 400, 401, 402, 403, 404, 405, 406, 407, 408, 409, 410, 411, 412, 413, 414, 415, 416, 417, 418, 419, 420, 421, 422, 423, 424, 425, 426, 427, 428, 429, 430, 431, 432, 433, 434, 435, 436, 437, 438, 439, 440, 441, 442, 443, 444, 445, 446, 447, 448, 449, 450, 451, 452, 453, 454, 455, 456, 457, 458, 459, 460, 461, 462, 463, 464, 465, 466, 467, 468, 469, 470, 471, 472, 473, 474, 475, 476, 477, 478, 479, 480, 481, 482, 483, 484, 485, 486, 487, 488, 489, 490, 491, 492, 493, 494, 495, 496, 497, 498, 499, 500, 501, 502, 503, 504, 505, 506, 507, 508, 509, 510, 511, 512, 513, 514, 515, 516, 517, 518, 519, 520, 521, 522, 523, 524, 525, 526, 527, 528, 529, 530, 531, 532, 533, 534, 535, 536, 537, 538, 539, 540, 541, 542, 543, 544, 545, 546, 547, 548, 549, 550, 551, 552, 553, 554, 555, 556, 557, 558, 559, 560, 561, 562, 563, 564, 565, 566, 567, 568, 569, 570, 571, 572, 573, 574, 575, 576, 577, 578, 579, 580, 581, 582, 583, 584, 585, 586, 587, 588, 589, 590, 591, 592, 593, 594, 595, 596, 597, 598, 599, 600, 601, 602, 603, 604, 605, 606, 607, 608, 609, 610, 611, 612, 613, 614, 615, 616, 617, 618, 619, 620, 621, 622, 623, 624, 625, 626, 627, 628, 629, 630, 631, 632, 633, 634, 635, 636, 637, 638, 639, 640, 641, 642, 643, 644, 645, 646, 647, 648, 649, 650, 651, 652, 653, 654, 655, 656, 657, 658, 659, 660, 661, 662, 663, 664, 665, 666, 667, 668, 669, 670, 671, 672, 673, 674, 675, 676, 677, 678, 679, 680, 681, 682, 683, 684, 685, 686, 687, 688, 689, 690, 691, 692, 693, 694, 695, 696, 697, 698, 699, 700, 701, 702, 703, 704, 705, 706, 707, 708, 709, 710, 711, 712, 713, 714, 715, 716, 717, 718, 719, 720, 721, 722, 723, 724, 725, 726, 727, 728, 729, 730, 731, 732, 733, 734, 735, 736, 737, 738, 739, 740, 741, 742, 743, 744, 745, 746, 747, 748, 749, 750, 751, 752, 753, 754, 755, 756, 757, 758, 759, 760, 761, 762, 763, 764, 765, 766, 767, 768, 769, 770, 771, 772, 773, 774, 775, 776, 777, 778, 779, 780, 781, 782, 783, 784, 785, 786, 787, 788, 789, 790, 791, 792, 793, 794, 795, 796, 797, 798, 799, 800, 801, 802, 803, 804, 805, 806, 807, 808, 809, 810, 811, 812, 813, 814, 815, 816, 817, 818, 819, 820, 821, 822, 823, 824, 825, 826, 827, 828, 829, 830, 831, 832, 833, 834, 835, 836, 837, 838, 839, 840, 841, 842, 843, 844, 845, 846, 847, 848, 849, 850, 851, 852, 853, 854, 855, 856, 857, 858, 859, 860, 861, 862, 863, 864, 865, 866, 867, 868, 869, 870, 871, 872, 873, 874, 875, 876, 877, 878, 879, 880, 881, 882, 883, 884, 885, 886, 887, 888, 889, 890, 891, 892, 893, 894, 895, 896, 897, 898, 899, 900, 901, 902, 903, 904, 905, 906, 907, 908, 909, 910, 911, 912, 913, 914, 915, 916, 917, 918, 919, 920, 921, 922, 923, 924, 925, 926, 927, 928, 929, 930, 931, 932, 933, 934, 935, 936, 937, 938, 939, 940, 941, 942, 943, 944, 945, 946, 947, 948, 949, 950, 951, 952, 953, 954, 955, 956, 957, 958, 959, 960, 961, 962, 963, 964, 965, 966, 967, 968, 969, 970, 971, 972, 973, 974, 975, 976, 977, 978, 979, 980, 981, 982, 983, 984, 985, 986, 987, 988, 989, 990, 991, 992, 993, 994, 995, 996, 997, 998, 999, 1000			

- NOTES:
1. # INDICATES FURNISHED BY WESTINGHOUSE.
2. THE CONTROL EQUIPMENT MARK NUMBERS SHALL INCLUDE A PREFIX CONSISTING OF "2" AND THE SYSTEM CODE PREFIX FOR THE ASSOCIATED EQUIPMENT OR PIPE LINE UNLESS NOTED. EXAMPLE: 2MSS-PT10B
3. ALL INSTRUMENTS AND CONTROL EQUIPMENT ON THIS SHEET IN THE "MSS" SYSTEM UNLESS OTHERWISE NOTED.
4. ALL PRESSURE CONNECTIONS ARE UNLESS DESIGNATED OTHERWISE.
5. ALL SYMBOLS SHOWN ON THIS FLOW DIAGRAM ARE IN ACCORDANCE WITH S & W STD-MM-1000-1 THRU 7
6. # DENOTES SAFETY RELATED ITEMS
7. THIS SYSTEM WILL BE MAINTAINED TO A CLEANNESS LEVEL "C" IN ACCORDANCE WITH 2BWM-62.
8. METHOD OF CLOSURE FOR LOCAL VENTS, DRAINS, TEST CONNECTIONS AND CHEMICAL CLEANING CONNECTIONS SHALL BE AS SHOWN. REFER TO 2BWM-211 FOR ADDITIONAL DETAILS.
9. THE FF LINES SHALL BE ASME 106 GR. C, 30 IN. MIN. ID, 1/8" IN. MIN. WALL THICKNESS, 30'148 IN. C. TO C. DIM. 1/4 IN. NOMINAL OD, 2-MSS-032-169-2(B), 2-MSS-032-170-2(B), 2-MSS-032-171-2(B), 2-MSS-032-172-2(B), 2-MSS-032-173-2(B), 2-MSS-032-174-2(B), 2-MSS-032-175-2(B), 2-MSS-032-176-2(B), 2-MSS-032-177-2(B), 2-MSS-032-178-2(B), 2-MSS-032-179-2(B), 2-MSS-032-180-2(B), 2-MSS-032-181-2(B), 2-MSS-032-182-2(B), 2-MSS-032-183-2(B), 2-MSS-032-184-2(B), 2-MSS-032-185-2(B), 2-MSS-032-186-2(B), 2-MSS-032-187-2(B), 2-MSS-032-188-2(B), 2-MSS-032-189-2(B), 2-MSS-032-190-2(B), 2-MSS-032-191-2(B), 2-MSS-032-192-2(B), 2-MSS-032-193-2(B), 2-MSS-032-194-2(B), 2-MSS-032-195-2(B), 2-MSS-032-196-2(B), 2-MSS-032-197-2(B), 2-MSS-032-198-2(B), 2-MSS-032-199-2(B), 2-MSS-032-200-2(B), 2-MSS-032-201-2(B), 2-MSS-032-202-2(B), 2-MSS-032-203-2(B), 2-MSS-032-204-2(B), 2-MSS-032-205-2(B), 2-MSS-032-206-2(B), 2-MSS-032-207-2(B), 2-MSS-032-208-2(B), 2-MSS-032-209-2(B), 2-MSS-032-210-2(B), 2-MSS-032-211-2(B), 2-MSS-032-212-2(B), 2-MSS-032-213-2(B), 2-MSS-032-214-2(B), 2-MSS-032-215-2(B), 2-MSS-032-216-2(B), 2-MSS-032-217-2(B), 2-MSS-032-218-2(B), 2-MSS-032-219-2(B), 2-MSS-032-220-2(B), 2-MSS-032-221-2(B), 2-MSS-032-222-2(B), 2-MSS-032-223-2(B), 2-MSS-032-224-2(B), 2-MSS-032-225-2(B), 2-MSS-032-226-2(B), 2-MSS-032-227-2(B), 2-MSS-032-228-2(B), 2-MSS-032-229-2(B), 2-MSS-032-230-2(B), 2-MSS-032-231-2(B), 2-MSS-032-232-2(B), 2-MSS-032-233-2(B), 2-MSS-032-234-2(B), 2-MSS-032-235-2(B), 2-MSS-032-236-2(B), 2-MSS-032-237-2(B), 2-MSS-032-238-2(B), 2-MSS-032-239-2(B), 2-MSS-032-240-2(B), 2-MSS-032-241-2(B), 2-MSS-032-242-2(B), 2-MSS-032-243-2(B), 2-MSS-032-244-2(B), 2-MSS-032-245-2(B), 2-MSS-032-246-2(B), 2-MSS-032-247-2(B), 2-MSS-032-248-2(B), 2-MSS-032-249-2(B), 2-MSS-032-250-2(B), 2-MSS-032-251-2(B), 2-MSS-032-252-2(B), 2-MSS-032-253-2(B), 2-MSS-032-254-2(B), 2-MSS-032-255-2(B), 2-MSS-032-256-2(B), 2-MSS-032-257-2(B), 2-MSS-032-258-2(B), 2-MSS-032-259-2(B), 2-MSS-032-260-2(B), 2-MSS-032-261-2(B), 2-MSS-032-262-2(B), 2-MSS-032-263-2(B), 2-MSS-032-264-2(B), 2-MSS-032-265-2(B), 2-MSS-032-266-2(B), 2-MSS-032-267-2(B), 2-MSS-032-268-2(B), 2-MSS-032-269-2(B), 2-MSS-032-270-2(B), 2-MSS-032-271-2(B), 2-MSS-032-272-2(B), 2-MSS-032-273-2(B), 2-MSS-032-274-2(B), 2-MSS-032-275-2(B), 2-MSS-032-276-2(B), 2-MSS-032-277-2(B), 2-MSS-032-278-2(B), 2-MSS-032-279-2(B), 2-MSS-032-280-2(B), 2-MSS-032-281-2(B), 2-MSS-032-282-2(B), 2-MSS-032-283-2(B), 2-MSS-032-284-2(B), 2-MSS-032-285-2(B), 2-MSS-032-286-2(B), 2-MSS-032-287-2(B), 2-MSS-032-288-2(B), 2-MSS-032-289-2(B), 2-MSS-032-290-2(B), 2-MSS-032-291-2(B), 2-MSS-032-292-2(B), 2-MSS-032-293-2(B), 2-MSS-032-294-2(B), 2-MSS-032-295-2(B), 2-MSS-032-296-2(B), 2-MSS-032-297-2(B), 2-MSS-032-298-2(B), 2-MSS-032-299-2(B), 2-MSS-032-300-2(B), 2-MSS-032-301-2(B), 2-MSS-032-302-2(B), 2-MSS-032-303-2(B), 2-MSS-032-304-2(B), 2-MSS-032-305-2(B), 2-MSS-032-306-2(B), 2-MSS-032-307-2(B), 2-MSS-032-308-2(B), 2-MSS-032-309-2(B), 2-MSS-032-310-2(B), 2-MSS-032-311-2(B), 2-MSS-032-312-2(B), 2-MSS-032-313-2(B), 2-MSS-032-314-2(B), 2-MSS-032-315-2(B), 2-MSS-032-316-2(B), 2-MSS-032-317-2(B), 2-MSS-032-318-2(B), 2-MSS-032-319-2(B), 2-MSS-032-320-2(B), 2-MSS-032-321-2(B), 2-MSS-032-322-2(B), 2-MSS-032-323-2(B), 2-MSS-032-324-2(B), 2-MSS-032-325-2(B), 2-MSS-032-326-2(B), 2-MSS-032-327-2(B), 2-MSS-032-328-2(B), 2-MSS-032-329-2(B), 2-MSS-032-330-2(B), 2-MSS-032-331-2(B), 2-MSS-032-332-2(B), 2-MSS-032-333-2(B), 2-MSS-032-334-2(B), 2-MSS-032-335-2(B), 2-MSS-032-336-2(B), 2-MSS-032-337-2(B), 2-MSS-032-338-2(B), 2-MSS-032-339-2(B), 2-MSS-032-340-2(B), 2-MSS-032-341-2(B), 2-MSS-032-342-2(B), 2-MSS-032-343-2(B), 2-MSS-032-344-2(B), 2-MSS-032-345-2(B), 2-MSS-032-346-2(B), 2-MSS-032-347-2(B), 2-MSS-032-348-2(B), 2-MSS-032-349-2(B), 2-MSS-032-350-2(B), 2-MSS-032-351-2(B), 2-MSS-032-352-2(B), 2-MSS-032-353-2(B), 2-MSS-032-354-2(B), 2-MSS-032-355-2(B), 2-MSS-032-356-2(B), 2-MSS-032-357-2(B), 2-MSS-032-358-2(B), 2-MSS-032-359-2(B), 2-MSS-032-360-2(B), 2-MSS-032-361-2(B), 2-MSS-032-362-2(B), 2-MSS-032-363-2(B), 2-MSS-032-364-2(B), 2-MSS-032-365-2(B), 2-MSS-032-366-2(B), 2-MSS-032-367-2(B), 2-MSS-032-368-2(B), 2-MSS-032-369-2(B), 2-MSS-032-370-2(B), 2-MSS-032-371-2(B), 2-MSS-032-372-2(B), 2-MSS-032-373-2(B), 2-MSS-032-374-2(B), 2-MSS-032-375-2(B), 2-MSS-032-376-2(B), 2-MSS-032-377-2(B), 2-MSS-032-378-2(B), 2-MSS-032-379-2(B), 2-MSS-032-380-2(B), 2-MSS-032-381-2(B), 2-MSS-032-382-2(B), 2-MSS-032-383-2(B), 2-MSS-032-384-2(B), 2-MSS-032-385-2(B), 2-MSS-032-386-2(B), 2-MSS-032-387-2(B), 2-MSS-032-388-2(B), 2-MSS-032-389-2(B), 2-MSS-032-390-2(B), 2-MSS-032-391-2(B), 2-MSS-032-392-2(B), 2-MSS-032-393-2(B), 2-MSS-032-394-2(B), 2-MSS-032-395-2(B), 2-MSS-032-396-2(B), 2-MSS-032-397-2(B), 2-MSS-032-398-2(B), 2-MSS-032-399-2(B), 2-MSS-032-400-2(B), 2-MSS-032-401-2(B), 2-MSS-032-402-2(B), 2-MSS-032-403-2(B), 2-MSS-032-404-2(B), 2-MSS-032-405-2(B), 2-MSS-032-406-2(B), 2-MSS-032-407-2(B), 2-MSS-032-408-2(B), 2-MSS-032-409-2(B), 2-MSS-032-410-2(B), 2-MSS-032-411-2(B), 2-MSS-032-412-2(B), 2-MSS-032-413-2(B), 2-MSS-032-414-2(B), 2-MSS-032-415-2(B), 2-MSS-032-416-2(B), 2-MSS-032-417-2(B), 2-MSS-032-418-2(B), 2-MSS-032-419-2(B), 2-MSS-032-420-2(B), 2-MSS-032-421-2(B), 2-MSS-032-422-2(B), 2-MSS-032-423-2(B), 2-MSS-032-424-2(B), 2-MSS-032-425-2(B), 2-MSS-032-426-2(B), 2-MSS-032-427-2(B), 2-MSS-032-428-2(B), 2-MSS-032-429-2(B), 2-MSS-032-430-2(B), 2-MSS-032-431-2(B), 2-MSS-032-432-2(B), 2-MSS-032-433-2(B), 2-MSS-032-434-2(B), 2-MSS-032-435-2(B), 2-MSS-032-436-2(B), 2-MSS-032-437-2(B), 2-MSS-032-438-2(B), 2-MSS-032-439-2(B), 2-MSS-032-440-2(B), 2-MSS-032-441-2(B), 2-MSS-032-442-2(B), 2-MSS-032-443-2(B), 2-MSS-032-444-2(B), 2-MSS-032-445-2(B), 2-MSS-032-446-2(B), 2-MSS-032-447-2(B), 2-MSS-032-448-2(B), 2-MSS-032-449-2(B), 2-MSS-032-450-2(B), 2-MSS-032-451-2(B), 2-MSS-032-452-2(B), 2-MSS-032-453-2(B), 2-MSS-032-454-2(B), 2-MSS-032-455-2(B), 2-MSS-032-456-2(B), 2-MSS-032-457-2(B), 2-MSS-032-458-2(B), 2-MSS-032-459-2(B), 2-MSS-032-460-2(B), 2-MSS-032-461-2(B), 2-MSS-032-462-2(B), 2-MSS-032-463-2(B), 2-MSS-032-464-2(B), 2-MSS-032-465-2(B), 2-MSS-032-466-2(B), 2-MSS-032-467-2(B), 2-MSS-032-468-2(B), 2-MSS-032-469-2(B), 2-MSS-032-470-2(B), 2-MSS-032-471-2(B), 2-MSS-032-472-2(B), 2-MSS-032-473-2(B), 2-MSS-032-474-2(B), 2-MSS-032-475-2(B), 2-MSS-032-476-2(B), 2-MSS-032-477-2(B), 2-MSS-032-478-2(B), 2-MSS-032-479-2(B), 2-MSS-032-480-2(B), 2-MSS-032-481-2(B), 2-MSS-032-482-2(B), 2-MSS-032-483-2(B), 2-MSS-032-484-2(B), 2-MSS-032-485-2(B), 2-MSS-032-486-2(B), 2-MSS-032-487-2(B), 2-MSS-032-488-2(B), 2-MSS-032-489-2(B), 2-MSS-032-490-2(B), 2-MSS-032-491-2(B), 2-MSS-032-492-2(B), 2-MSS-032-493-2(B), 2-MSS-032-494-2(B), 2-MSS-032-495-2(B), 2-MSS-032-496-2(B), 2-MSS-032-497-2(B), 2-MSS-032-498-2(B), 2-MSS-032-499-2(B), 2-MSS-032-500-2(B), 2-MSS-032-501-2(B), 2-MSS-032-502-2(B), 2-MSS-032-503-2(B), 2-MSS-032-504-2(B), 2-MSS-032-505-2(B), 2-MSS-032-506-2(B), 2-MSS-032-507-2(B), 2-MSS-032-508-2(B), 2-MSS-032-509-2(B), 2-MSS-032-510-2(B), 2-MSS-032-511-2(B), 2-MSS-032-512-2(B), 2-MSS-032-513-2(B), 2-MSS-032-514-2(B), 2-MSS-032-515-2(B), 2-MSS-032-516-2(B), 2-MSS-032-517-2(B), 2-MSS-032-518-2(B), 2-MSS-032-519-2(B), 2-MSS-032-520-2(B), 2-MSS-032-521-2(B), 2-MSS-032-522-2(B), 2-MSS-032-523-2(B), 2-MSS-032-524-2(B), 2-MSS-032-525-2(B), 2-MSS-032-526-2(B), 2-MSS-032-527-2(B), 2-MSS-032-528-2(B), 2-MSS-032-529-2(B), 2-MSS-032-530-2(B), 2-MSS-032-531-2(B), 2-MSS-032-532-2(B), 2-MSS-032-533-2(B), 2-MSS-032-534-2(B), 2-MSS-032-535-2(B), 2-MSS-032-536-2(B), 2-MSS-032-537-2(B), 2-MSS-032-538-2(B), 2-MSS-032-539-2(B), 2-MSS-032-540-2(B), 2-MSS-032-541-2(B), 2-MSS-032-542-2(B), 2-MSS-032-543-2(B), 2-MSS-032-544-2(B), 2-MSS-032-545-2(B), 2-MSS-032-546-2(B), 2-MSS-032-547-2(B), 2-MSS-032-548-2(B), 2-MSS-032-549-2(B), 2-MSS-032-550-2(B), 2-MSS-032-551-2(B), 2-MSS-032-552-2(B), 2-MSS-032-55

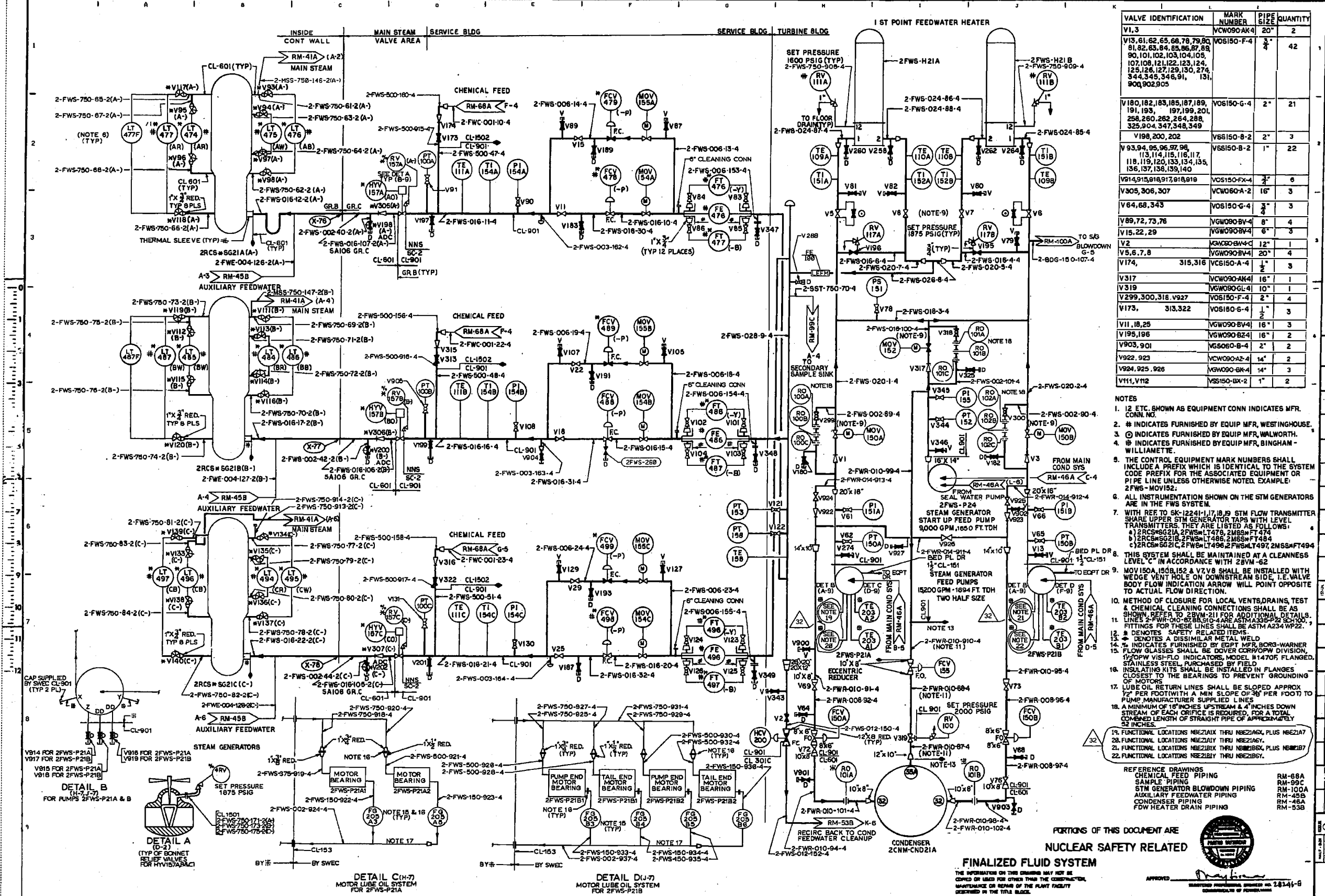

VALVE IDENTIFICATION	MARK NUMBER	PIPE SIZE	QUANTITY
V1,3	VCW090AK4	20"	2
V13, 61, 62, 65, 66, 78, 79, 80, 81, 82, 83, 84, 85, 86, 87, 88, 90, 101, 102, 103, 104, 105, 107, 108, 121, 122, 123, 124, 125, 126, 127, 129, 130, 274, 344, 345, 346, 91, 131, 90, 902, 905	VO6150-F-4	3"	42
V180, 182, 183, 185, 187, 189, 191, 193, 197, 199, 201, 258, 260, 262, 264, 288, 325, 904, 347, 348, 349	VO6150-G-4	2"	21
V198, 200, 202	VSS150-B-2	2"	3
V93, 94, 95, 96, 97, 98, 113, 114, 115, 116, 117, 118, 119, 120, 133, 134, 135, 136, 137, 138, 139, 140	VSS150-B-2	1"	22
V914, 915, 916, 917, 918, 919	VOS150-FX-4	3"	6
V305, 306, 307	VCW060A-2	16"	3
V64, 68, 343	VO6150-G-4	3"	3
V89, 72, 73, 76	VGW090BY-4	8"	4
V15, 22, 29	VGW090BY-4	6"	3
V2	KW060BY-4	12"	1
V5, 6, 7, 8	VGW090BY-4	20"	4
V174, 315, 316	VCE150-A-4	1"	3
V317	VCW090AK-4	16"	1
V319	VGW090GL-4	10"	1
V299, 300, 318, V927	VO6150-F-4	2"	4
V173, 313, 322	VO6150-G-4	1"	3
V11, 18, 25	VGW090BY-4	16"	3
V195, 196	VGW090BZ-4	16"	2
V903, 901	VGS060-B-4	2"	2
V922, 923	VCW090A-2-4	14"	2
V924, 925, 926	VGW090BK-4	14"	3
V111, V112	VSS150-BX-2	1"	2

- NOTES
1. 12 ETC. SHOWN AS EQUIPMENT CONN INDICATES MFR. CONN. NO.
 2. # INDICATES FURNISHED BY EQUIP MFR, WESTINGHOUSE.
 3. O INDICATES FURNISHED BY EQUIP MFR, WALWORTH.
 4. @ INDICATES FURNISHED BY EQUIP MFR, BINGHAM-WILLIAMETTE.
 5. THE CONTROL EQUIPMENT MARK NUMBERS SHALL INCLUDE A PREFIX WHICH IS IDENTICAL TO THE SYSTEM CODE PREFIX FOR THE ASSOCIATED EQUIPMENT OR PIPE LINE UNLESS OTHERWISE NOTED EXEMPLE: 2-FWS-150V12.
 6. ALL INSTRUMENTATION SHOWN ON THE STM GENERATORS ARE IN THE FWS SYSTEM.
 7. WITH REF TO SK-12241-1, 17, 18, 19 STM FLOW TRANSMITTER SHARE UPPER STM GENERATOR TAPS WITH LEVEL TRANSMITTERS. THEY ARE LISTED AS FOLLOWS: a) 2FWS-001-10-4, 2FWS-001-10-4, 2FWS-001-10-4 b) 2FWS-001-10-4, 2FWS-001-10-4, 2FWS-001-10-4 c) 2FWS-001-10-4, 2FWS-001-10-4, 2FWS-001-10-4
 8. THIS SYSTEM SHALL BE MAINTAINED AT A CLEANNESS LEVEL "C" IN ACCORDANCE WITH 28VM-62
 9. MOV 150A, 150B, 152 & V2V8 SHALL BE INSTALLED WITH WEDGE VENT HOLE ON DOWNSIDE, I.E. VALVE BODY FLOW INDICATION ARROW WILL POINT OPPOSITE TO ACTUAL FLOW DIRECTION.
 10. METHOD OF CLOSURE FOR LOCAL VENTS, DRAINS, TEST & CHEMICAL CLEANING CONNECTIONS SHALL BE AS SHOWN, REFER TO 28VM-211 FOR ADDITIONAL DETAILS.
 11. LINES 2-FWS-001-10-4 ARE ASTM A353-90 SCH. 40 FITTINGS FOR THESE LINES SHALL BE ASTM A234 WP22.
 12. # DENOTES SAFETY RELATED ITEMS.
 13. * DENOTES A DISSIMILAR METAL WELD
 14. @ INDICATES FURNISHED BY EQUIP MFR, BORG-WARNER
 15. FLOW GLASSES SHALL BE DOVER CORP/OPW DIVISION, 1/2" OPW VIS-FLO INDICATORS, MODEL #14705 FLANGED.
 16. INSULATING KITS SHALL BE INSTALLED IN FLANGES CLOSEST TO THE BEARINGS TO PREVENT GROUNDING OF MOTORS.
 17. LUBE OIL RETURN LINES SHALL BE SLOPED APPROX 1/2" PER FOOT WITH A MIN SLOPE OF 3/8" PER FOOT TO PUMP MANUFACTURER SUPPLIED LINES
 18. A MINIMUM OF 18" INCHES UPSTREAM & 4" INCHES DOWN STREAM OF EACH ORIFICE IS REQUIRED, FOR A TOTAL COMBINED LENGTH OF STRAIGHT PIPE OF APPROXIMATELY 32 INCHES.
 19. FUNCTIONAL LOCATIONS NBE21AX THRU NBE21AX, PLUS NBE21A7
 20. FUNCTIONAL LOCATIONS NBE21AY THRU NBE21AY, PLUS NBE21B7
 21. FUNCTIONAL LOCATIONS NBE21BZ THRU NBE21BZ, PLUS NBE21B7
 22. FUNCTIONAL LOCATIONS NBE21BY THRU NBE21BY.

REFERENCE DRAWINGS
 CHEMICAL FEED PIPING RM-68A
 SAMPLE PIPING RM-99C
 STM GENERATOR BLOWDOWN PIPING RM-100A
 AUXILIARY FEEDWATER PIPING RM-45B
 CONDENSER PIPING RM-46A
 FDW HEATER DRAIN PIPING RM-53B

PORTIONS OF THIS DOCUMENT ARE
NUCLEAR SAFETY RELATED

FINALIZED FLUID SYSTEM

THE INFORMATION ON THIS DRAWING MAY NOT BE COPIED OR USED FOR OTHER THAN THE CONSTRUCTION, MAINTENANCE OR REPAIR OF THE PLANT FACILITY DESCRIBED IN THE TITLE BLOCK.

APPROVED: [Signature]

DESIGNED BY: [Signature]

REVISIONS

31	ECP 02-09-82	INCORPORATED
32	ECR 03-03-83	ADDED NEW MONITORS PER
33	ECR 03-03-83	ADDED NEW MONITORS PER
34	ECR 03-03-83	ADDED NEW MONITORS PER

DETAIL A (D-3) MOTOR LUBE OIL SYSTEM FOR 2FWS-P21A

DETAIL B (H-2, J-7) FOR PUMPS 2FWS-P21A & B

DETAIL C (H-7) MOTOR LUBE OIL SYSTEM FOR 2FWS-P21A

DETAIL D (J-7) MOTOR LUBE OIL SYSTEM FOR 2FWS-P21B

FENOC FIRST ENERGY NUCLEAR OPERATING COMPANY

SCALE: NONE DATE: [] AREA: APP. ELECT. APP. MECH. APP. STRUCT. APP.

FLOW DIAGRAM FEEDWATER PIPING

BEAVER VALLEY POWER STATION UNIT NO 2

D.P.E. No. 10080 C.D. No. 000

AA No. 10080-RM-45A

S&W DWG. NO. 12241-RM-45A-32

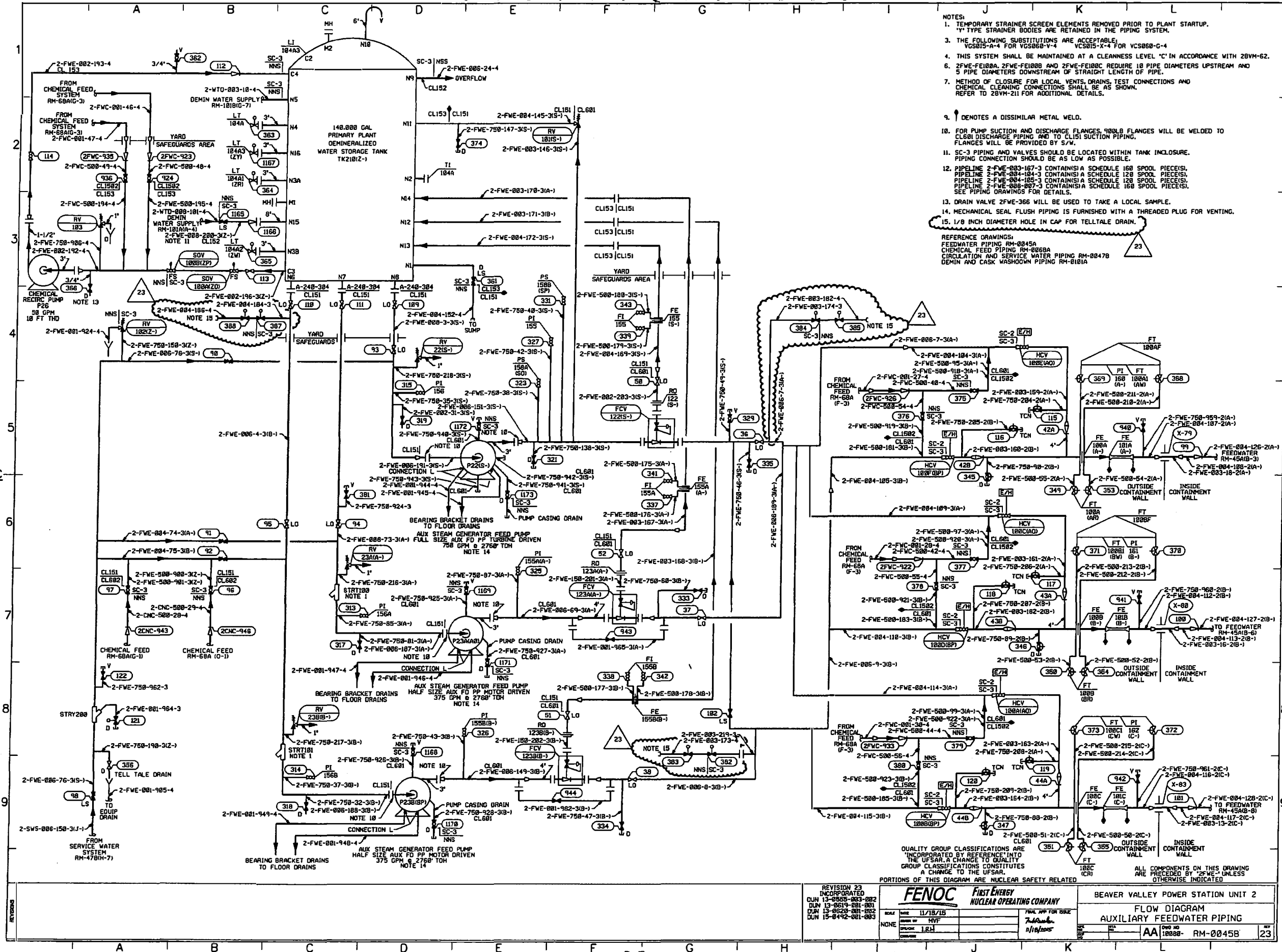

- NOTES:
1. TEMPORARY STRAINER SCREEN ELEMENTS REMOVED PRIOR TO PLANT STARTUP. "Y" TYPE STRAINER BODIES ARE RETAINED IN THE PIPING SYSTEM.
 2. THE FOLLOWING SUBSTITUTIONS ARE ACCEPTABLE: VCS815-A-4 FOR VCS868-Y-4 VCS815-X-4 FOR VCS868-C-4
 3. THIS SYSTEM SHALL BE MAINTAINED AT A CLEANNESS LEVEL "C" IN ACCORDANCE WITH 28VM-62.
 4. 2-FWE-FE108A, 2-FWE-FE108B AND 2-FWE-FE108C REQUIRE 18 PIPE DIAMETERS UPSTREAM AND 5 PIPE DIAMETERS DOWNSTREAM OF STRAIGHT LENGTH OF PIPE.
 5. METHOD OF CLOSURE FOR LOCAL VENTS, DRAINS, TEST CONNECTIONS AND CHEMICAL CLEANING CONNECTIONS SHALL BE AS SHOWN. REFER TO 28VM-211 FOR ADDITIONAL DETAILS.
 6. 9 DENOTES A DISSIMILAR METAL WELD.
 7. FOR PUMP SUCTION AND DISCHARGE FLANGES, 900LB FLANGES WILL BE WELDED TO CL681 DISCHARGE PIPING AND TO CL151 SUCTION PIPING. FLANGES WILL BE PROVIDED BY S/W.
 8. SC-3 PIPING AND VALVES SHOULD BE LOCATED WITHIN TANK ENCLOSURE. PIPING CONNECTION SHOULD BE AS LOW AS POSSIBLE.
 9. PIPELINE 2-FWE-003-167-3 CONTAINS A SCHEDULE 160 SPOOL PIECE(S). PIPELINE 2-FWE-004-184-3 CONTAINS A SCHEDULE 120 SPOOL PIECE(S). PIPELINE 2-FWE-004-185-3 CONTAINS A SCHEDULE 120 SPOOL PIECE(S). PIPELINE 2-FWE-008-007-3 CONTAINS A SCHEDULE 160 SPOOL PIECE(S). SEE PIPING DRAWINGS FOR DETAILS.
 10. DRAIN VALVE 2-FWE-365 WILL BE USED TO TAKE A LOCAL SAMPLE.
 11. MECHANICAL SEAL FLUSH PIPING IS FURNISHED WITH A THREADED PLUG FOR VENTING.
 12. 1/8 INCH DIAMETER HOLE IN CAP FOR TELLTALE DRAIN.
- REFERENCE DRAWINGS:
 FEEDWATER PIPING RM-0045A
 CHEMICAL FEED PIPING RM-0068A
 CIRCULATION AND SERVICE WATER PIPING RM-0047B
 DEMIN AND CASK WASHDOWN PIPING RM-0101A

QUALITY GROUP CLASSIFICATIONS ARE INCORPORATED BY REFERENCE INTO THE UFSAR. A CHANGE TO QUALITY GROUP CLASSIFICATIONS CONSTITUTES A CHANGE TO THE UFSAR. PORTIONS OF THIS DIAGRAM ARE NUCLEAR SAFETY RELATED. ALL COMPONENTS ON THIS DRAWING ARE PRECEDED BY "2-FWE-" UNLESS OTHERWISE INDICATED.

REVISION 23 INCORPORATED DUN 13-0805-003-002 DUN 13-0619-001-001 DUN 13-0620-001-002 DUN 13-0492-001-003	FENOC FIRST ENERGY NUCLEAR OPERATING COMPANY	BEAVER VALLEY POWER STATION UNIT 2 FLOW DIAGRAM AUXILIARY FEEDWATER PIPING Dwg No AA 10080-RM-0045B
---	---	---

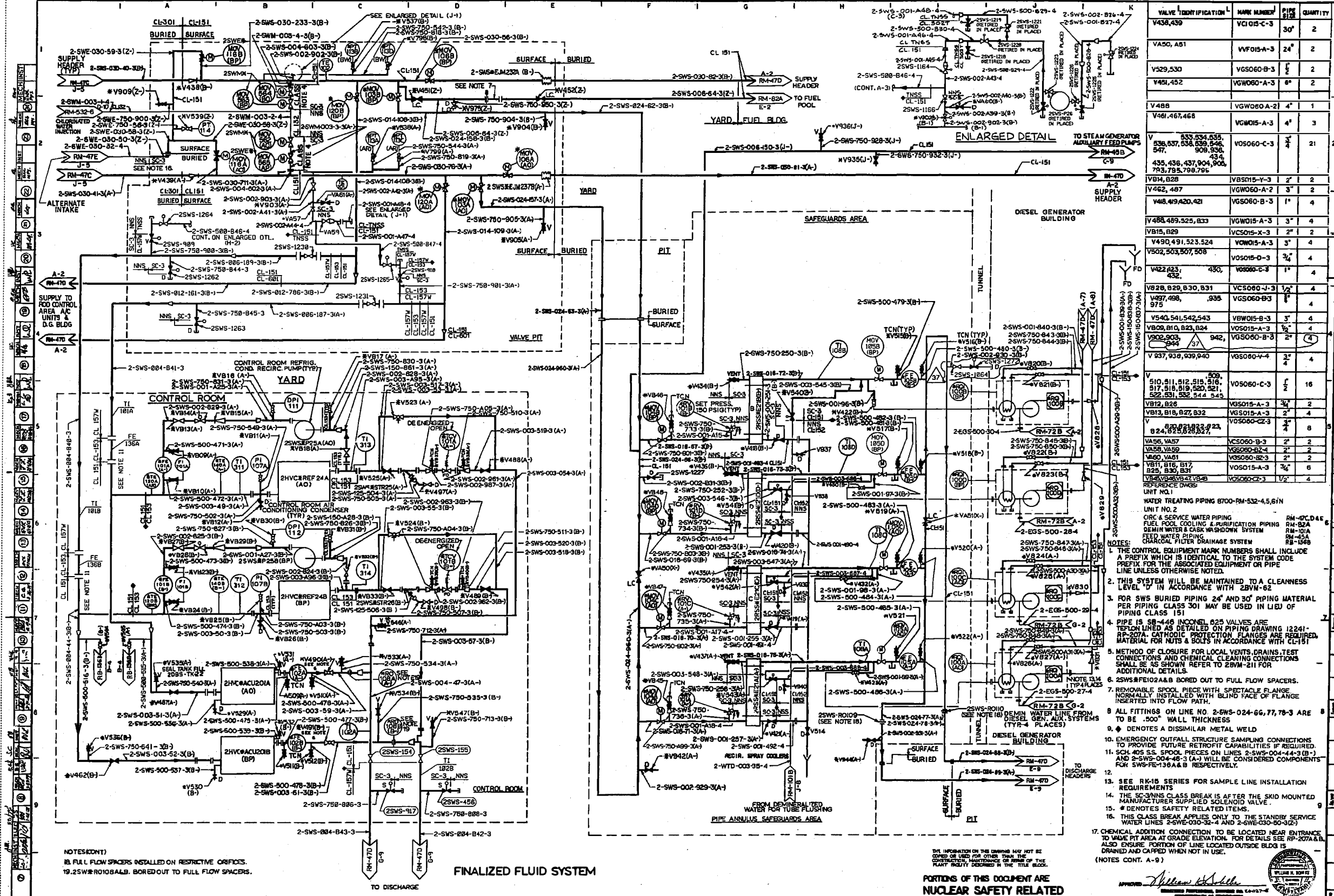

VALVE IDENTIFICATION	MARK NUMBER	PIPE SIZE	QUANTITY
V438,439	VCI 05-C-3	30"	2
V450, A51	VV015-A-3	24"	2
V529,530	VG5060-B-3	12"	2
V451,452	VG5060-A-3	8"	2
V488	VG5060-A-2	4"	1
V461,467,468	VG5015-A-3	4"	3
V336,537,538,539,540,541,542,543,544,545,546,547,435,436,437,904,905,793,795,798,799	VG5060-C-3	3/4"	21
V814,828	VV5015-Y-3	2"	2
V462,487	VG5060-A-2	3"	2
V468,499,520,421	VG5060-B-3	1"	4
V488,489,525,833	VG5015-A-3	3"	4
V815,829	VV5015-X-3	2"	2
V490,491,523,524	VV5015-A-3	3"	4
V502,503,507,508	VV5015-D-3	3/4"	4
V422,423,432,430	VG5060-C-3	1"	4
V828,829,830,831	VV5060-J-3	1/2"	4
V877,498,975	VG5060-B-3	1"	4
V540,541,542,543	VV5015-B-3	3"	4
V809,810,823,824	VV5015-A-3	1/2"	4
V902,903,944	VG5060-B-3	2"	4
V937,938,939,940	VG5060-Y-4	3/4"	4
V510,511,512,515,516,517,518,519,520,521,522,531,532,544,545	VV5060-C-3	1/2"	16
V812,826	VG5015-A-3	3/4"	2
V813,818,827,832	VV5015-A-3	2"	4
V824,825,828,829,832,834	VV5060-CZ-3	3/4"	8
V856, V857	VG5060-B-3	2"	2
V858, V859	VG5060-BZ-4	2"	2
V860, V861	VG5060-BZ-3	2"	2
V811, 816, 817, 820, 821, 822, 823, 824, 825, 826, 827, 828, 829, 830, 831, 832, 833, 834, 835, 836, 837, 838, 839, 840, 841, 842, 843, 844, 845, 846, 847, 848, 849, 850, 851, 852, 853, 854, 855, 856, 857, 858, 859, 860, 861, 862, 863, 864, 865, 866, 867, 868, 869, 870, 871, 872, 873, 874, 875, 876, 877, 878, 879, 880, 881, 882, 883, 884, 885, 886, 887, 888, 889, 890, 891, 892, 893, 894, 895, 896, 897, 898, 899, 900, 901, 902, 903, 904, 905, 906, 907, 908, 909, 910, 911, 912, 913, 914, 915, 916, 917, 918, 919, 920, 921, 922, 923, 924, 925, 926, 927, 928, 929, 930, 931, 932, 933, 934, 935, 936, 937, 938, 939, 940, 941, 942, 943, 944, 945, 946, 947, 948, 949, 950, 951, 952, 953, 954, 955, 956, 957, 958, 959, 960, 961, 962, 963, 964, 965, 966, 967, 968, 969, 970, 971, 972, 973, 974, 975, 976, 977, 978, 979, 980, 981, 982, 983, 984, 985, 986, 987, 988, 989, 990, 991, 992, 993, 994, 995, 996, 997, 998, 999, 1000	VV5015-A-3	3/4"	6
V856, V857, V858, V859, V860, V861, V862, V863, V864, V865, V866, V867, V868, V869, V870, V871, V872, V873, V874, V875, V876, V877, V878, V879, V880, V881, V882, V883, V884, V885, V886, V887, V888, V889, V890, V891, V892, V893, V894, V895, V896, V897, V898, V899, V900	VG5060-CZ-3	1/2"	4

- NOTES:
- THE CONTROL EQUIPMENT MARK NUMBERS SHALL INCLUDE A PREFIX WHICH IS IDENTICAL TO THE SYSTEM CODE PREFIX FOR THE ASSOCIATED EQUIPMENT OR PIPE LINE UNLESS OTHERWISE NOTED.
 - THIS SYSTEM WILL BE MAINTAINED TO A CLEANNESS LEVEL IN ACCORDANCE WITH 28VH-62
 - FOR SWS BURIED PIPING 24" AND 30" PIPING MATERIAL PER PIPING CLASS 301 MAY BE USED IN LIEU OF PIPING CLASS 151
 - PIPE (S 58-446 INCONEL 625 VALVES ARE TYPON LINED AS DETAILED ON PIPING DRAWING 12241-RP-1000. PROTECTION FLANGES ARE REQUIRED. MATERIAL FOR NUTS & BOLTS IN ACCORDANCE WITH 151-151
 - METHOD OF CLOSURE FOR LOCAL VENTS DRAINS TEST CONNECTIONS AND CHEMICAL CLEANING CONNECTIONS SHALL BE AS SHOWN REFER TO 28VH-211 FOR ADDITIONAL DETAILS.
 - 28VH#F102A&B BORED OUT TO FULL FLOW SPACERS.
 - REMOVABLE SPOOL PIECE WITH SPECTACLE FLANGE WATER LINE, INSTALLED WITH BLIND FACE OF FLANGE INSERTED INTO FLOW PATH.
 - ALL FITTINGS ON LINE NO 2-SWS-024-66, 77, 78-3 ARE TO BE .500" WALL THICKNESS
 - ♦ DENOTES A DISSIMILAR METAL WELD
 - EMERGENCY OUTFALL STRUCTURE SAMPLING CONNECTIONS TO PROVIDE FUTURE RETROFIT CAPABILITIES IF REQUIRED.
 - SC-1406 S.S. SPOOL PIECES ON LINES 2-SWS-004-44-3 (B-) AND 2-SWS-004-48-3 (A-) WILL BE CONSIDERED COMPONENTS FOR SWS-FE-138A&B RESPECTIVELY.
 - SEE RM-15 SERIES FOR SAMPLE LINE INSTALLATION REQUIREMENTS
 - THE SC-3/NNS CLASS BREAK IS AFTER THE SKID MOUNTED MANUFACTURER SUPPLIED SOLENOID VALVE.
 - ♦ DENOTES SAFETY RELATED ITEMS.
 - THIS CLASS BREAK APPLIES ONLY TO THE STANDBY SERVICE WATER LINES 2-SWS-024-66-3 AND 2-SWS-024-66-3(C)
 - CHEMICAL ADDITION CONNECTION TO BE LOCATED NEAR ENTRANCE TO WAVE PIT AREA AT GRADE ELEVATION. FOR DETAILS SEE RP-207A&B. ALSO ENSURE PORTION OF LINE LOCATED OUTSIDE BLDG IS DRAINED AND CAPPED WHEN NOT IN USE.
- (NOTES CONT. A-9)

PORTIONS OF THIS DOCUMENT ARE NUCLEAR SAFETY RELATED

APPROVED: *William K. Ruff*

FENOC FIRST ENERGY NUCLEAR OPERATING COMPANY

FLOW DIAGRAM CIRCULATING & SERVICE WATER PIPING SH-2

BEAVER VALLEY POWER STATION - UNIT NO.2

S&W DWG. NO. 12241-RM-47B-37

33	DCP	2/15/82	REVISED
34	TER	12/15/82	REVISED
35	DCP	12/15/82	REVISED
36	DCP	12/15/82	REVISED
37	DCP	12/15/82	REVISED

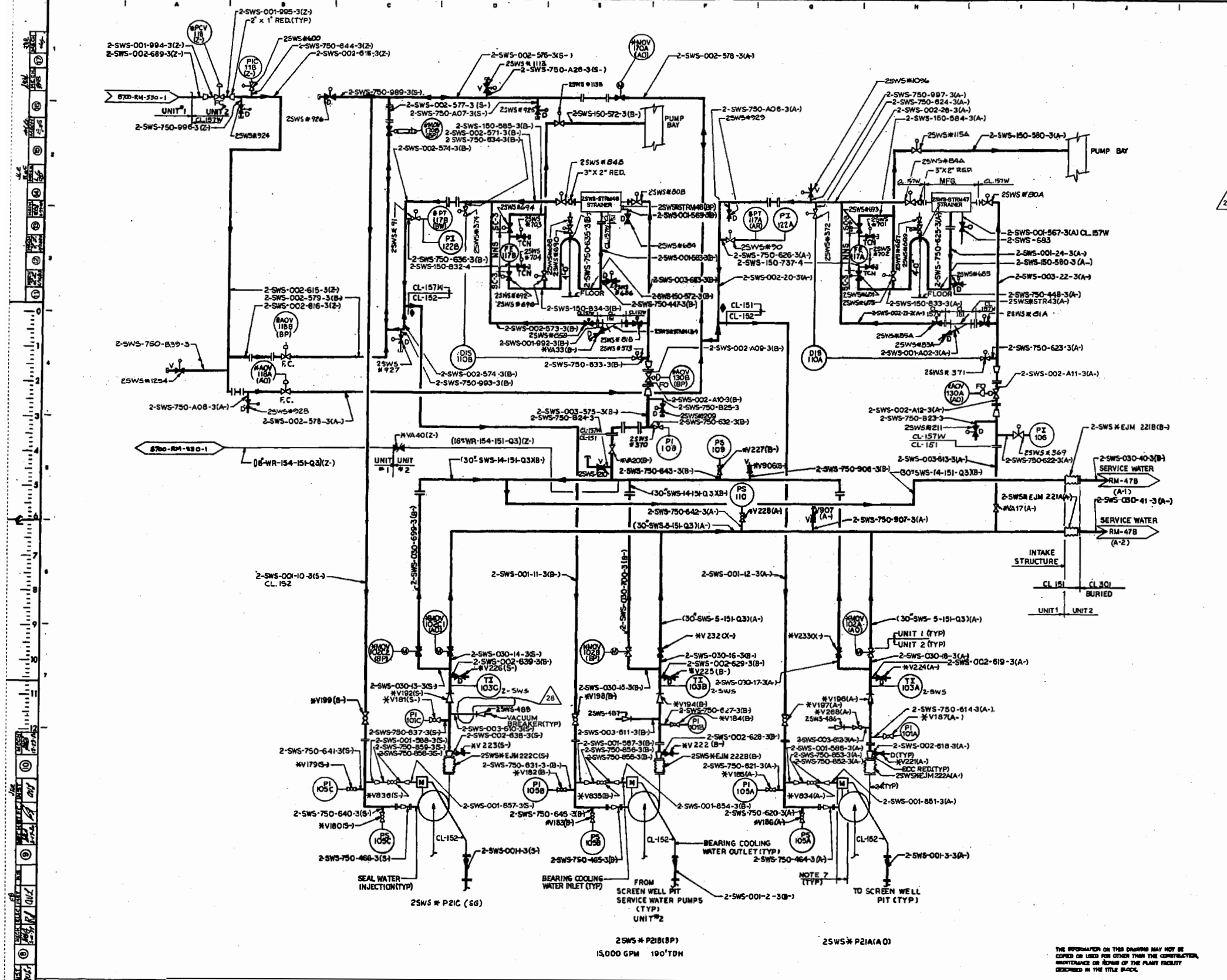

VALVE IDENTIFICATION	MARK NUMBER	PIPE SIZE	QUANTITY
V181,184, 182, 227,228, 906,907	VGS060-C-3	3"	7
A33A34, V183,180,182,185,185, V197,198,199	VGS060-B-3, VGS150-X-3, VGS150-X-3	1", 3", 1"	2, 6, 3
A20V, V26B A17, V26B A17, V22,222	VGW015-A-3, VGS060-B-3	3", 2"	3, 6
VA40, VB34, 835, 838, V232, 233	VVFD15-A-3, VGS060-W-2, VVFD15-A-3	18", 3/4", 30"	1, 3, 2
V192, 194,196	VIC105-C-3	30"	3

REFERENCE DRAWINGS:
 UNIT 1 INTAKE STRUCTURE 8700-RM-21C
 CIRCULATING SERVICE WATER PIPING RM-47B

- NOTES:
- THE CONTROL EQUIPMENT MARK NUMBER SHALL INCLUDE A PREFIX WHICH IS IDENTICAL TO THE SYSTEM CODE PREFIX FOR THE ASSOCIATED EQUIPMENT OR PIPE LINE UNLESS OTHERWISE NOTED. EXAMPLE: 2SWS-P2-106.
 - LINE DESIGNATIONS SHOWN IN PARENTHESES ARE UNIT 1 ASSIGNED NUMBERS.
 - THIS SYSTEM SHALL BE MAINTAINED TO A CLEANNESS LEVEL 'D' IN ACCORDANCE WITH 28VM-62.
 - METHOD OF CLOSURE FOR LOCAL VENTS, DRAINS, TEST CONNECTIONS & CHEMICAL CONNECTIONS SHALL BE AS SHOWN. REFER TO 28VM-211 FOR ADDITIONAL DETAILS.
 - Ø DENOTES A DISSIMILAR METAL WELD.
 - 2SWS-F1100-PORTABLE ULTRASONIC FLOW INDICATING TRANSMITTER TO BE USED FOR FLOW MEASUREMENT FOR ASME XI TESTING.
 - THE SERVICE WATER PUMP MOTORS ARE SC-3 NON ASME COMPONENTS.
 - * DENOTES SAFETY RELATED ITEMS. (SEE NOTE 9)
 - ALL ASTERISKS (*) SHOULD BE DISREGARDED. REFER TO THE ASSET EQUIPMENT LIST (AEL) AS THE OFFICIAL LISTING OF ANY ASSET'S CATEGORY.

FINALIZED FLUID SYSTEM
 NUCLEAR SAFETY RELATED

THE INFORMATION ON THIS DRAWING MAY NOT BE COPIED OR USED FOR OTHER THAN THE CONTRACTOR, MAINTENANCE OR REPAIR OF THE PLANT FACILITY DESCRIBED IN THE TITLE BLOCK.

FENOC First Energy Nuclear Operating Company

SCALE	DATE	AMDA, APP.
NONE		

FLOW DIAGRAM
 CIRCULATING & SERVICE WATER PIPING-SH3
 BEAVER VALLEY POWER STATION UNIT NO. 2
 D.P.E. NO. 1008
 C.O. NO. 220
AA No. 10080-RM-47C

REVISIONS

NO.	DATE	DESCRIPTION
1	3/3/84	ISSUED FOR CONSTRUCTION
2	3/3/84	REVISED FOR CONSTRUCTION
3	3/3/84	REVISED FOR CONSTRUCTION
4	3/3/84	REVISED FOR CONSTRUCTION
5	3/3/84	REVISED FOR CONSTRUCTION
6	3/3/84	REVISED FOR CONSTRUCTION
7	3/3/84	REVISED FOR CONSTRUCTION
8	3/3/84	REVISED FOR CONSTRUCTION
9	3/3/84	REVISED FOR CONSTRUCTION
10	3/3/84	REVISED FOR CONSTRUCTION

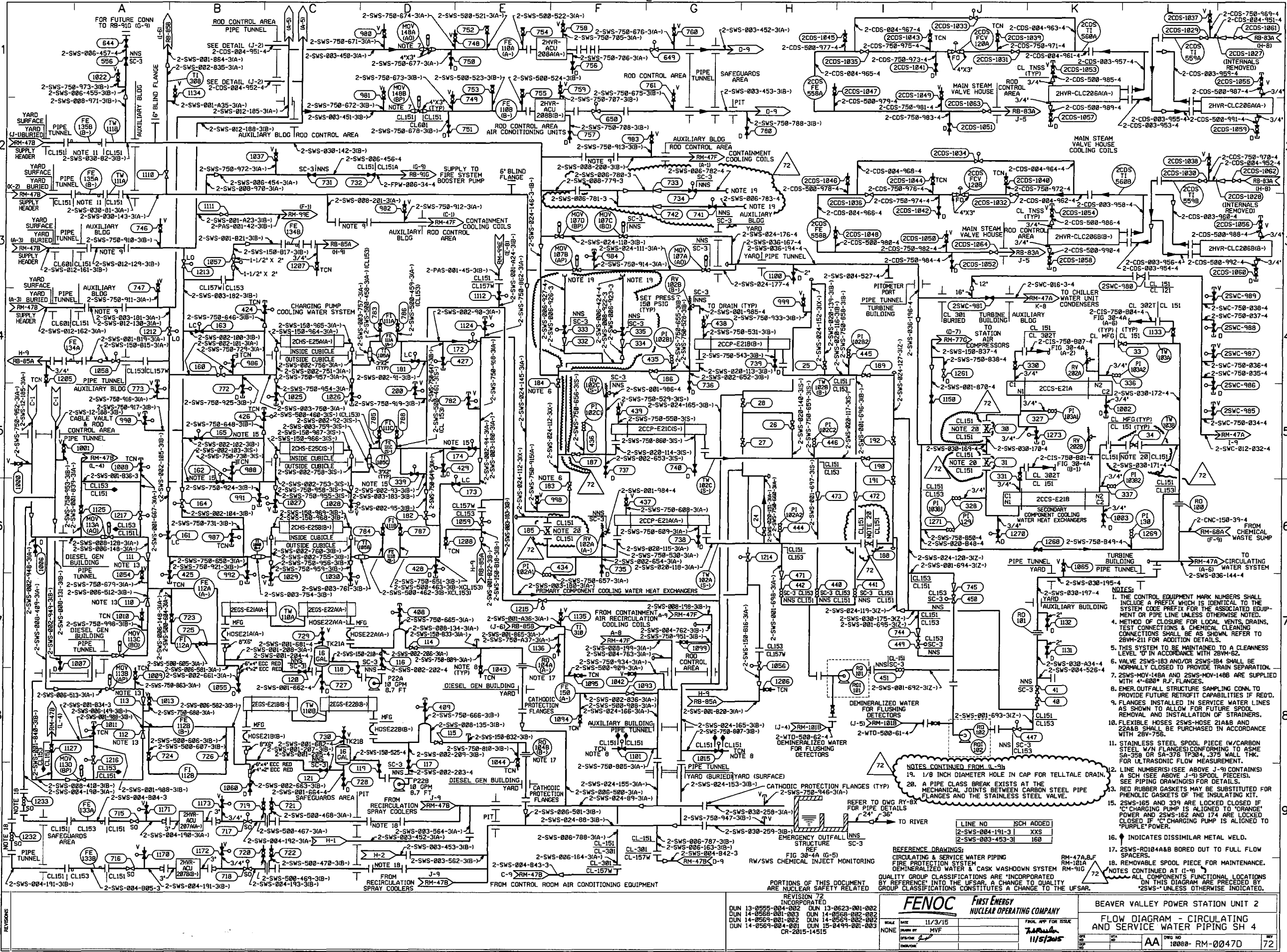

- NOTES:
1. THE CONTROL EQUIPMENT MARK NUMBERS SHALL PREFIX WHICH IS IDENTICAL TO THE SYSTEM CODE PREFIX FOR THE ASSOCIATED EQUIPMENT OR PIPE LINE UNLESS OTHERWISE NOTED.
 2. METHOD OF CLOSURE FOR LOCAL VENTS, DRAINS, TEST CONNECTIONS AND CHEMICAL CLEANING CONNECTIONS SHALL BE AS SHOWN. REFER TO 28WM-211 FOR ADDITIONAL DETAILS.
 3. THIS SYSTEM TO BE MAINTAINED TO A CLEANNESS LEVEL OF 10 IN ACCORDANCE WITH 28WM-52.
 4. VALVE 25WS-183 AND/OR 25WS-184 SHALL BE NORMALLY CLOSED TO PROVIDE STRAIN SEPARATION.
 5. 25WS-MOV-148A AND 25WS-MOV-148B ARE SUPPLIED WITH 4" 600° R.F. FLANGES.
 6. EMER. OUTFALL STRUCTURE SAMPLING CONN. TO PROVIDE FUTURE RETROFIT CAPABILITIES IF REQD.
 7. FLANGES INSTALLED IN SERVICE WATER LINES AS SHOWN TO ALLOW FOR FUTURE SPOOL REMOVAL AND INSTALLATION OF STRAINERS.
 8. FLEXIBLE HOSES 25WS-HOSE 21A&B AND 22A&B SHALL BE PURCHASED IN ACCORDANCE WITH 28W-756.
 9. STAINLESS STEEL SPOOL PIECE (W/CARBON STEEL W/N FLANGES) CONFORMING TO ASME SA-350 OR SA-276 304, 316 SHALL THK. FOR ULTRASONIC FLOW MEASUREMENT.
 10. LINE NUMBERS (SEE ABOVE J-9) CONTAINS A SCH (SEE ABOVE J-9) SPOOL PIECE(S). SEE PIPING DRAWINGS FOR DETAILS.
 11. RED RUBBER GASKETS MAY BE SUBSTITUTED FOR PNEUMATIC GASKETS IF THE INSULATING KIT.
 12. 25WS-165 AND 339 ARE LOCKED CLOSED IF 'C' CHARGING PUMP IS ALIGNED TO 'ORANGE' POWER AND 25WS-162 AND 174 ARE LOCKED CLOSED IF 'C' CHARGING PUMP IS ALIGNED TO 'PURPLE' POWER.
 13. INDICATES DISSIMILAR METAL WELD.
 14. 25WS-RD104A&B BORED OUT TO FULL FLOW SPACERS.
 15. REMOVABLE SPOOL PIECE FOR MAINTENANCE.
 16. NOTES CONTINUED AT (I-9)
 17. ALL COMPONENTS FUNCTIONAL LOCATIONS ON THIS DIAGRAM ARE PRECEDED BY "25WS-" UNLESS OTHERWISE INDICATED.

REFERENCE DRAWINGS:

LINE NO	ISCH ADDED
2-SWS-004-191-3	XXS
2-SWS-003-453-3	160

QUALITY GROUP CLASSIFICATIONS ARE INCORPORATED BY REFERENCE INTO THE USFAR. A CHANGE TO QUALITY GROUP CLASSIFICATIONS CONSTITUTES A CHANGE TO THE USFAR.

FENOC First Energy Nuclear Operating Company

DATE: 11/3/15
 DRAWN BY: MVF
 CHECKED BY: [Signature]
 APPROVED BY: [Signature]

BEAVER VALLEY POWER STATION UNIT 2
 FLOW DIAGRAM - CIRCULATING AND SERVICE WATER PIPING SH 4

AA 10080-RM-00470 72

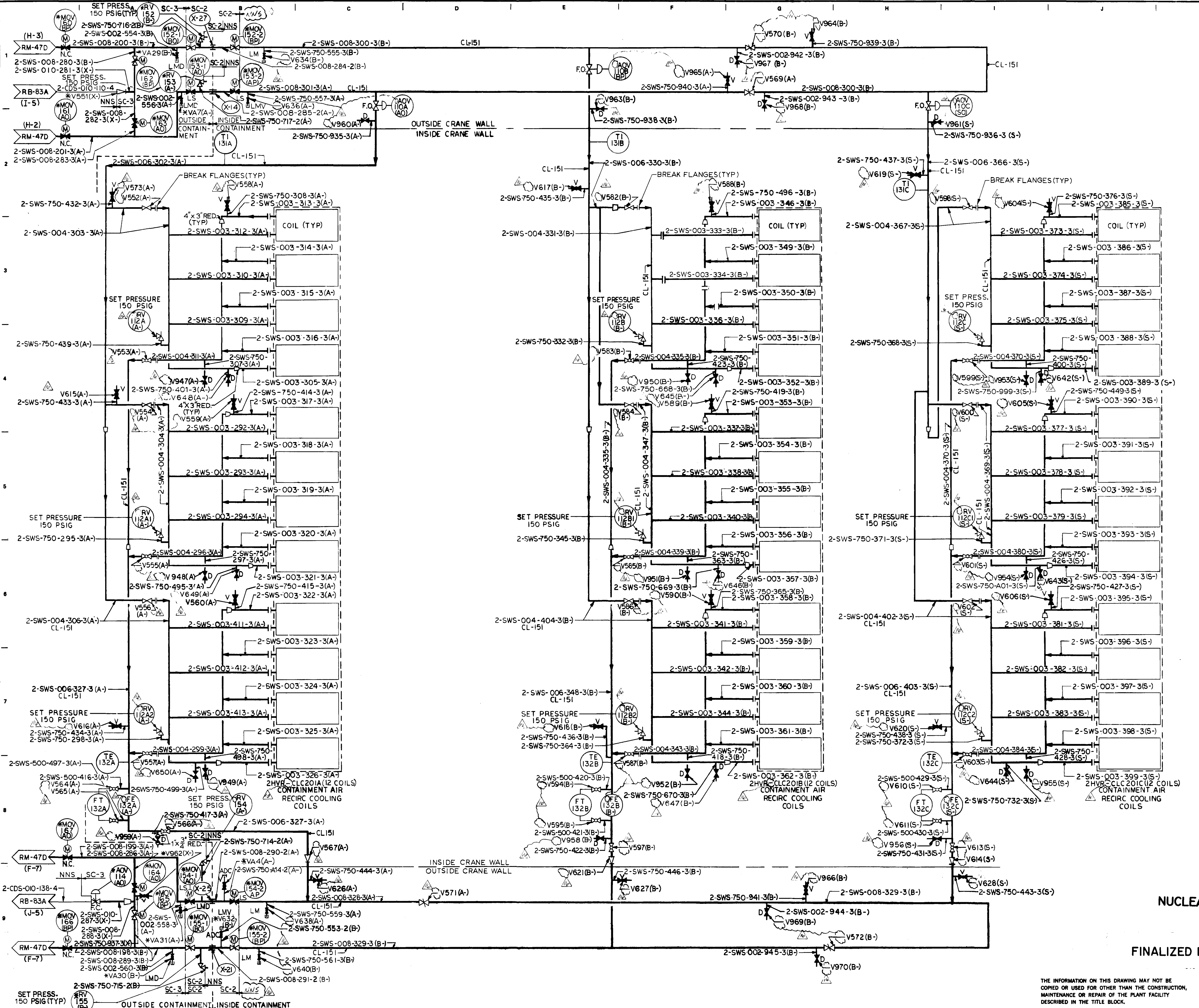

VALVE IDENTIFICATION	MARK NUMBER	PIPE SIZE	QUANTITY
V567, 614, 621	VCWO15-A-3	6"	3
951, 952, 953, 954, 955, 956, 958, 960, 961, 963, 642, 643, 644, 645, 646, 647, 648, 649, 650	VGSO60-B-3	3/4"	23
V552, 556, 562, 584, 586, 598, 600, 602	VGWO15-A-3	4"	8
V967, 968, 969, 970	VGSO60-B-3	2"	4
634, 635, 636, 637, 638, 639, 640, 641, 642, 643, 644, 645, 646, 647, 648, 649, 650	VOSO60-C-3	3/4"	28
V554	VGWO15-AZ-3	4"	1
V553, 555, 557, 583, 585, 587, 599, 601, 603	VOWO15-A-3	4"	9
V566, 597, 613	VOWO15-A-3	6"	3
V632, A4	VOSO60-C-2	3/4"	2
V569, 570, 571, 572	VVIO15-AR-3	8"	4
V551	VCIO15-A-3	10"	1
V564, 565, 594, 595, 610, 611	VOSO60-C-3	1/2"	6
VA29, A30, A31, A7	VOSO60-CZ-3	2"	4
V959	VGSO60-BZ-3	1"	1

- NOTES:
1. THE CONTROL EQUIPMENT MARK NUMBERS SHALL INCLUDE A PREFIX WHICH IS IDENTICAL TO THE SYSTEM CODE PREFIX FOR THE ASSOCIATED EQUIPMENT OR PIPELINE UNLESS OTHERWISE NOTED. EXAMPLE: 2SWS-FE 132C.
 2. ALL PIPING CLASS IS 151 UNLESS OTHERWISE NOTED.
 3. THIS SYSTEM WILL BE MAINTAINED TO A CLEANNESS LEVEL "D" IN ACCORDANCE WITH 2BVM-62.
 4. METHOD OF CLOSURE FOR LOCAL VENTS, DRAINS, TEST CONNECTIONS & CHEMICAL CLEANING CONNECTIONS SHALL BE AS SHOWN. REFER TO 2BVM-211 FOR ADDITIONAL DETAILS.
 5. * DENOTES SAFETY RELATED ITEMS.

REFERENCE DRAWINGS:
 CIRCULATING & SERVICE WATER PIPING RM-47D
 CHILLED WATER PIPING RB-83A
 NUCLEAR EQUIP VENT & DRAIN PIPING RM-89A

NUCLEAR SAFETY RELATED

FINALIZED FLUID SYSTEM

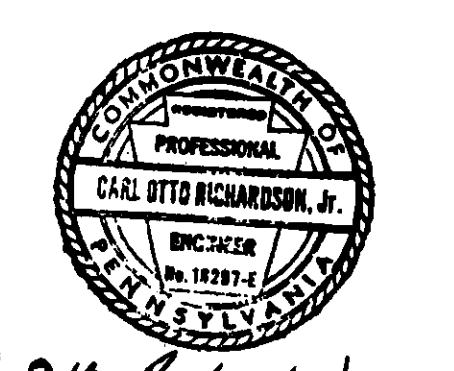

APPROVED *Carl Otto Richardson*
 REGISTERED PROFESSIONAL ENGINEER NO. 16297-E
 COMMONWEALTH OF PENNSYLVANIA

THE INFORMATION ON THIS DRAWING MAY NOT BE COPIED OR USED FOR OTHER THAN THE CONSTRUCTION, MAINTENANCE OR REPAIR OF THE PLANT FACILITY DESCRIBED IN THE TITLE BLOCK.

DUQUESNE LIGHT COMPANY ENGINEERING & CONSTRUCTION PITTSBURGH, PA.		FLOW DIAGRAM CIRCULATING & SERVICE WATER PIPING-SH.6	
DATE: 9-23-74 DRAWN: KENTON CHECKED: [Signature] INSPECTED: [Signature]	ARCH. APP. MECH. APP. STRUCT. APP.	BEAVER VALLEY POWER STATION UNIT NO.2 O.F.E. No. 10080 C.O. No. 2289	
SCALE: NONE		AA No. 10080-RM-47F	

NO.	DESCRIPTION	DATE	ISSUE
11	SEE RECORD OF DWG CHNG 12241-BCM-47F-11		
12	SEE RECORD OF DWG CHNG 12241-BCM-47F-12		
13	SEE RECORD OF DWG CHNG 12241-BCM-47F-13		
14	SEE RECORD OF DWG CHNG 12241-BCM-47F-14		
15	SEE RECORD OF DWG CHNG 12241-BCM-47F-15		
16	SEE RECORD OF DWG CHNG 12241-BCM-47F-16		
17	SEE RECORD OF DWG CHNG 12241-BCM-47F-17		
18	SEE RECORD OF DWG CHNG 12241-BCM-47F-18		
19	SEE RECORD OF DWG CHNG 12241-BCM-47F-19		
20	SEE RECORD OF DWG CHNG 12241-BCM-47F-20		
21	SEE RECORD OF DWG CHNG 12241-BCM-47F-21		
22	SEE RECORD OF DWG CHNG 12241-BCM-47F-22		
23	SEE RECORD OF DWG CHNG 12241-BCM-47F-23		
24	SEE RECORD OF DWG CHNG 12241-BCM-47F-24		
25	SEE RECORD OF DWG CHNG 12241-BCM-47F-25		
26	SEE RECORD OF DWG CHNG 12241-BCM-47F-26		
27	SEE RECORD OF DWG CHNG 12241-BCM-47F-27		
28	SEE RECORD OF DWG CHNG 12241-BCM-47F-28		
29	SEE RECORD OF DWG CHNG 12241-BCM-47F-29		
30	SEE RECORD OF DWG CHNG 12241-BCM-47F-30		

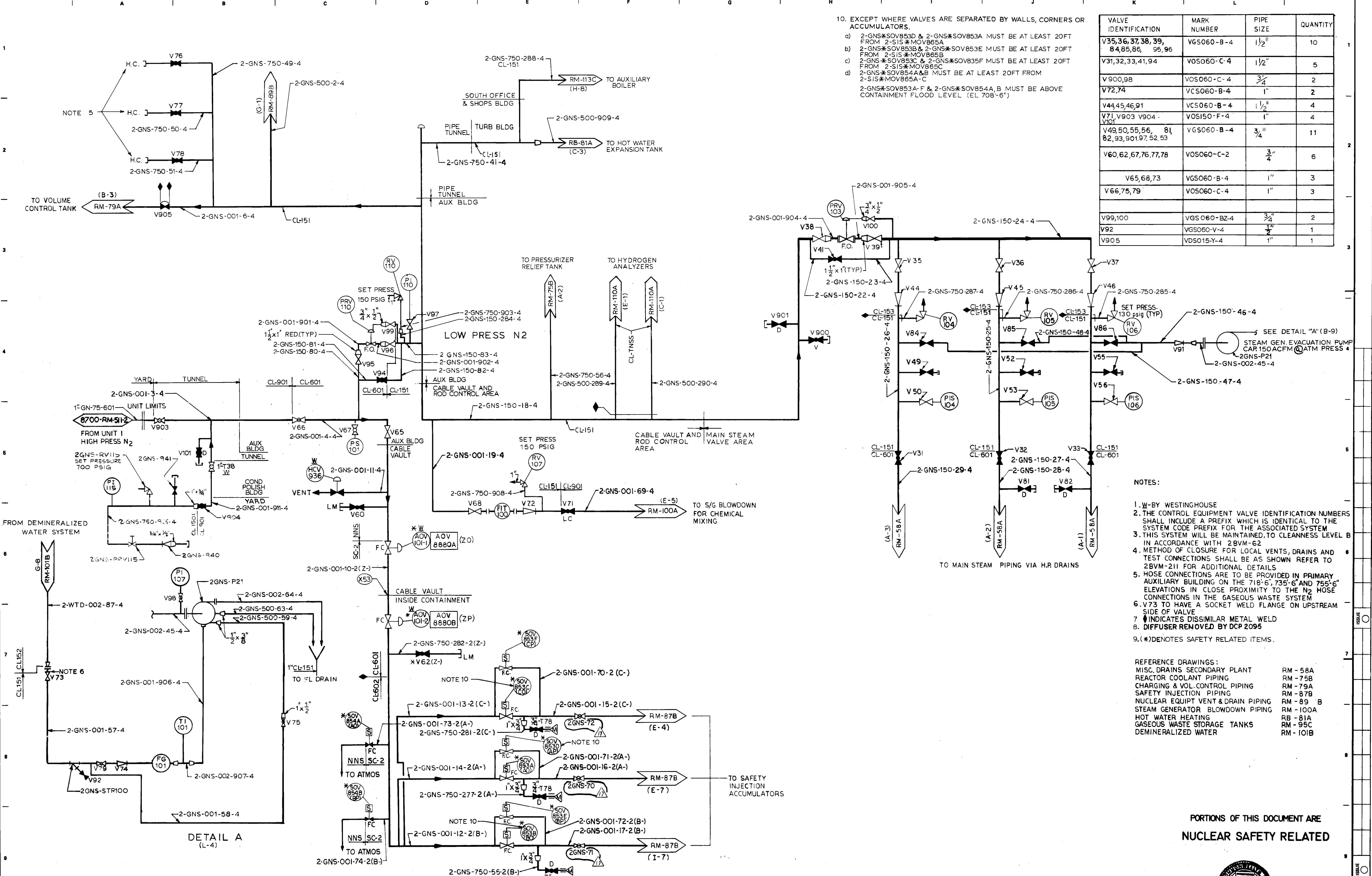

10. EXCEPT WHERE VALVES ARE SEPARATED BY WALLS, CORNERS OR ACCUMULATORS.
- a) 2-GNS*SOV853D & 2-GNS*SOV853A MUST BE AT LEAST 20FT FROM 2-S15*MOV865A
 - b) 2-GNS*SOV853B & 2-GNS*SOV853E MUST BE AT LEAST 20FT FROM 2-S15*MOV865B
 - c) 2-GNS*SOV853C & 2-GNS*SOV853F MUST BE AT LEAST 20FT FROM 2-S15*MOV865C
 - d) 2-GNS*SOV854A & B MUST BE AT LEAST 20FT FROM 2-S15*MOV865A-C
- 2-GNS*SOV853A-F & 2-GNS*SOV854A,B MUST BE ABOVE CONTAINMENT FLOOD LEVEL (EL 708'-6")

VALVE IDENTIFICATION	MARK NUMBER	PIPE SIZE	QUANTITY
V35,36,37,38,39,84,85,86,95,96	VGS060-B-4	1 1/2"	10
V31,32,33,41,94	VOS060-C-4	1 1/2"	5
V900,98	VOS060-C-4	3/4"	2
V72,74	VCS060-B-4	1"	2
V44,45,46,91	VCS060-B-4	1 1/2"	4
V71,V903,V904,V101	VOS150-F-4	1"	4
V49,50,55,56,81,82,93,901,97,52,53	VGS060-B-4	3/4"	11
V60,62,67,76,77,78	VOS060-C-2	3/4"	6
V65,68,73	VGS060-B-4	1"	3
V66,75,79	VOS060-C-4	1"	3
V99,100	VGS060-BZ-4	3/4"	2
V92	VGS060-V-4	1 1/2"	1
V905	VDS015-Y-4	1"	1

- NOTES:
1. W-BY WESTINGHOUSE
 2. THE CONTROL EQUIPMENT VALVE IDENTIFICATION NUMBERS SHALL INCLUDE A PREFIX WHICH IS IDENTICAL TO THE SYSTEM CODE PREFIX FOR THE ASSOCIATED SYSTEM
 3. THIS SYSTEM WILL BE MAINTAINED TO CLEANNESS LEVEL B IN ACCORDANCE WITH 2-BVM-62
 4. METHOD OF CLOSURE FOR LOCAL VENTS, DRAINS AND TEST CONNECTIONS SHALL BE AS SHOWN REFER TO 2-BVM-211 FOR ADDITIONAL DETAILS
 5. HOSE CONNECTIONS ARE TO BE PROVIDED IN PRIMARY AUXILIARY BUILDING ON THE 718'-6", 735'-6" AND 755'-6" ELEVATIONS IN CLOSE PROXIMITY TO THE N₂ HOSE CONNECTIONS IN THE GASEOUS WASTE SYSTEM
 6. V73 TO HAVE A SOCKET WELD FLANGE ON UPSTREAM SIDE OF VALVE
 7. ♦ INDICATES DISSIMILAR METAL WELD
 8. DIFFUSER REMOVED BY DCP 2095
 9. (*) DENOTES SAFETY RELATED ITEMS.

- REFERENCE DRAWINGS:
- | | |
|------------------------------------|-----------|
| MISC. DRAINS SECONDARY PLANT | RM - 58A |
| REACTOR COOLANT PIPING | RM - 75B |
| CHARGING & VOL. CONTROL PIPING | RM - 79A |
| SAFETY INJECTION PIPING | RM - 87B |
| NUCLEAR EQUIPT VENT & DRAIN PIPING | RM - 89 B |
| STEAM GENERATOR BLOWDOWN PIPING | RM - 100A |
| HOT WATER HEATING | RB - 81A |
| GASEOUS WASTE STORAGE TANKS | RB - 95C |
| DEMINERALIZED WATER | RM - 101B |

PORTIONS OF THIS DOCUMENT ARE
NUCLEAR SAFETY RELATED

FINALIZED FLUID SYSTEM

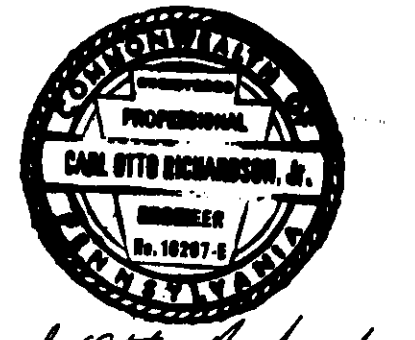

APPROVED *Carl W. Richardson*
REGISTERED PROFESSIONAL ENGINEER NO. 16297-15
COMMONWEALTH OF PENNSYLVANIA

DUQUESNE LIGHT COMPANY
ENGINEERING & CONSTRUCTION PITTSBURGH, PA.

FLOW DIAGRAM
GASEOUS NITROGEN SYSTEM
BEAVER VALLEY POWER STATION UNIT 2

SCALE: NONE
DATE: 6-1-74
DRAWN: JAROLIM
CHECKED: MECH. APP.
INSPECTED: STRUCT. APP.

O.F.E. No. 10080
C.O. No. 6280
AA No. 10080-RM-71B

STONE & WEBSTER ENGINEERING CORP.
BOSTON, MASS.

S&W DWG. NO. 12241-RM-71B-17

REV.	DATE	DESCRIPTION	BY	CHKD.	APPD.
1	5-7-99	DEH			
2		REMOVED FROM			
3		REMOVED FROM			
4		REMOVED FROM			
5		REMOVED FROM			
6		REMOVED FROM			
7		REMOVED FROM			
8		REMOVED FROM			
9		REMOVED FROM			
10		REMOVED FROM			
11		REMOVED FROM			
12		REMOVED FROM			
13		REMOVED FROM			
14		REMOVED FROM			
15		REMOVED FROM			
16		REMOVED FROM			
17		REMOVED FROM			
18		REMOVED FROM			
19		REMOVED FROM			
20		REMOVED FROM			
21		REMOVED FROM			
22		REMOVED FROM			
23		REMOVED FROM			
24		REMOVED FROM			
25		REMOVED FROM			
26		REMOVED FROM			
27		REMOVED FROM			
28		REMOVED FROM			
29		REMOVED FROM			
30		REMOVED FROM			
31		REMOVED FROM			
32		REMOVED FROM			
33		REMOVED FROM			
34		REMOVED FROM			
35		REMOVED FROM			
36		REMOVED FROM			
37		REMOVED FROM			
38		REMOVED FROM			
39		REMOVED FROM			
40		REMOVED FROM			
41		REMOVED FROM			
42		REMOVED FROM			
43		REMOVED FROM			
44		REMOVED FROM			
45		REMOVED FROM			
46		REMOVED FROM			
47		REMOVED FROM			
48		REMOVED FROM			
49		REMOVED FROM			
50		REMOVED FROM			
51		REMOVED FROM			
52		REMOVED FROM			
53		REMOVED FROM			
54		REMOVED FROM			
55		REMOVED FROM			
56		REMOVED FROM			
57		REMOVED FROM			
58		REMOVED FROM			
59		REMOVED FROM			
60		REMOVED FROM			
61		REMOVED FROM			
62		REMOVED FROM			
63		REMOVED FROM			
64		REMOVED FROM			
65		REMOVED FROM			
66		REMOVED FROM			
67		REMOVED FROM			
68		REMOVED FROM			
69		REMOVED FROM			
70		REMOVED FROM			
71		REMOVED FROM			
72		REMOVED FROM			
73		REMOVED FROM			
74		REMOVED FROM			
75		REMOVED FROM			
76		REMOVED FROM			
77		REMOVED FROM			
78		REMOVED FROM			
79		REMOVED FROM			
80		REMOVED FROM			
81		REMOVED FROM			
82		REMOVED FROM			
83		REMOVED FROM			
84		REMOVED FROM			
85		REMOVED FROM			
86		REMOVED FROM			
87		REMOVED FROM			
88		REMOVED FROM			
89		REMOVED FROM			
90		REMOVED FROM			
91		REMOVED FROM			
92		REMOVED FROM			
93		REMOVED FROM			
94		REMOVED FROM			
95		REMOVED FROM			
96		REMOVED FROM			
97		REMOVED FROM			
98		REMOVED FROM			
99		REMOVED FROM			
100		REMOVED FROM			

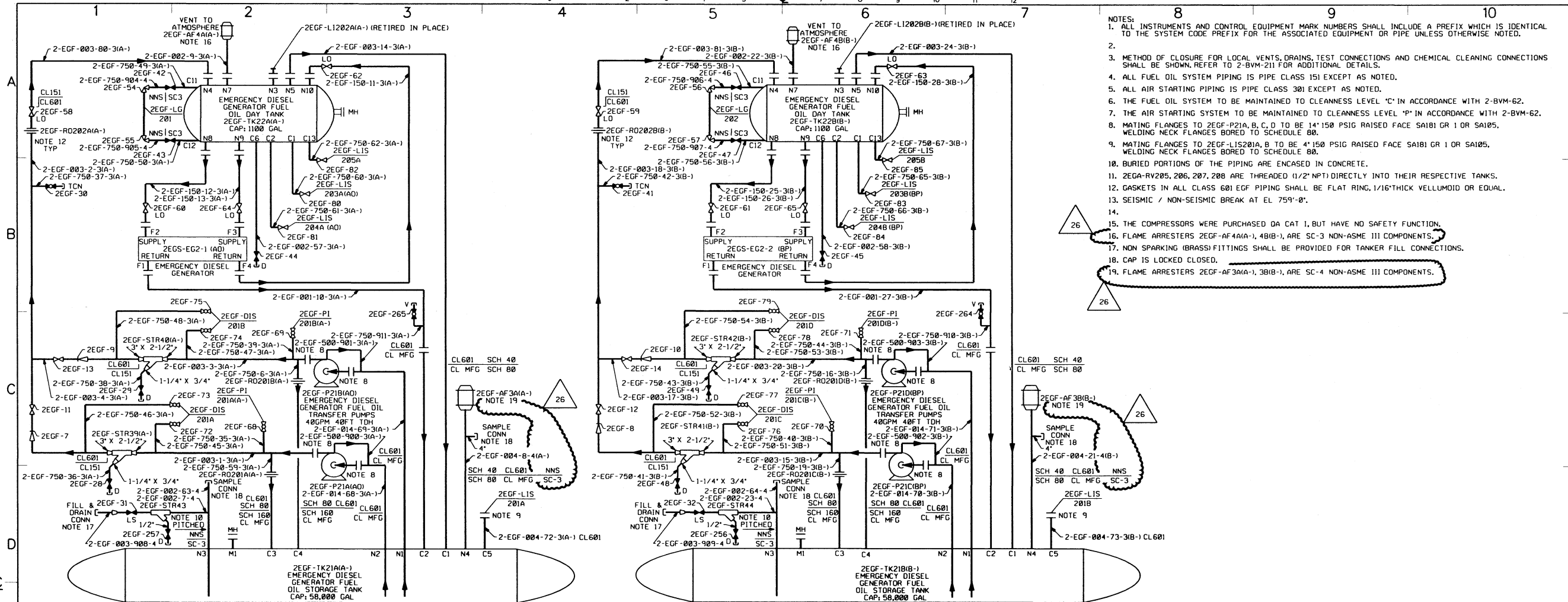

- NOTES:
1. ALL INSTRUMENTS AND CONTROL EQUIPMENT MARK NUMBERS SHALL INCLUDE A PREFIX WHICH IS IDENTICAL TO THE SYSTEM CODE PREFIX FOR THE ASSOCIATED EQUIPMENT OR PIPE UNLESS OTHERWISE NOTED.
 2. METHOD OF CLOSURE FOR LOCAL VENTS, DRAINS, TEST CONNECTIONS AND CHEMICAL CLEANING CONNECTIONS SHALL BE SHOWN, REFER TO 2-BVM-211 FOR ADDITIONAL DETAILS.
 3. ALL FUEL OIL SYSTEM PIPING IS PIPE CLASS 301 EXCEPT AS NOTED.
 4. THE AIR STARTING SYSTEM TO BE MAINTAINED TO CLEANNESS LEVEL 'C' IN ACCORDANCE WITH 2-BVM-62.
 5. THE AIR STARTING SYSTEM TO BE MAINTAINED TO CLEANNESS LEVEL 'P' IN ACCORDANCE WITH 2-BVM-62.
 6. MATING FLANGES TO 2EGF-P21A, B, C, D TO BE 14" 150 PSIG RAISED FACE SA181 GR 1 OR SA105, WELDING NECK FLANGES BORED TO SCHEDULE 80.
 7. MATING FLANGES TO 2EGF-LIS201A, B TO BE 4" 150 PSIG RAISED FACE SA181 GR 1 OR SA105, WELDING NECK FLANGES BORED TO SCHEDULE 80.
 8. BURIED PORTIONS OF THE PIPING ARE ENCASED IN CONCRETE.
 9. 2EGA-RV205, 206, 207, 208 ARE THREADED (1/2" NPT) DIRECTLY INTO THEIR RESPECTIVE TANKS.
 10. GASKETS IN ALL CLASS 601 EGF PIPING SHALL BE FLAT RING, 1/16" THICK VELLUMOID OR EQUAL.
 11. SEISMIC / NON-SEISMIC BREAK AT EL 759'-0".
 12. THE COMPRESSORS WERE PURCHASED CAT 1, BUT HAVE NO SAFETY FUNCTION.
 13. FLAME ARRESTERS 2EGF-AF41A-1, 4B1B-1, ARE SC-3 NON-ASME III COMPONENTS.
 14. NON SPARKING (BRASS) FITTINGS SHALL BE PROVIDED FOR TANKER FILL CONNECTIONS.
 15. CAP IS LOCKED CLOSED.
 16. FLAME ARRESTERS 2EGF-AF3A1A-1, 3B1B-1, ARE SC-4 NON-ASME III COMPONENTS.

FUEL OIL SUPPLY AND RETURN FOR DIESEL GENERATOR SET 2EGS-EG2-1
COMPRESSED AIR STARTING UNIT FOR DIESEL GENERATOR SET 2EGS-EG2-1

DIESEL FUEL OIL SYSTEM
DIESEL AIR STARTING SYSTEM

FUEL OIL SUPPLY AND RETURN FOR DIESEL GENERATOR SET 2EGS-EG2-2
COMPRESSED AIR STARTING UNIT FOR DIESEL GENERATOR SET 2EGS-EG2-2

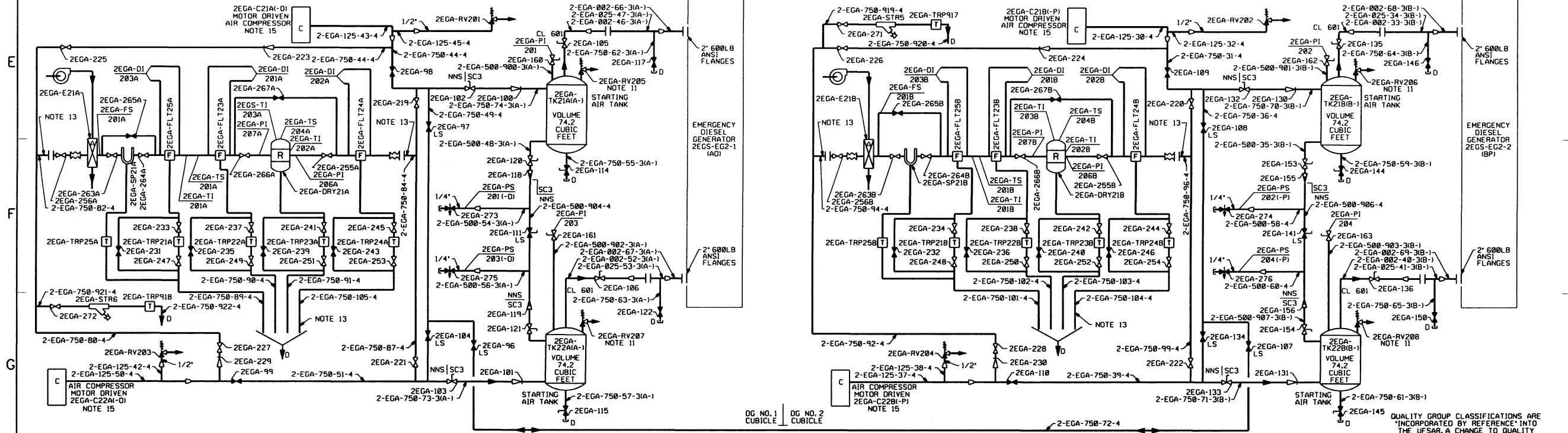

DG NO. 1
CUBIC FEET

DG NO. 2
CUBIC FEET

PORTIONS OF THIS DIAGRAM ARE NUCLEAR SAFETY RELATED

REVISION 26
INCORPORATED
DUN 14-0060-001-005
SATISFIED
ECP 89-0197

FENOC FIRST ENERGY
NUCLEAR OPERATING COMPANY

BEAVER VALLEY POWER STATION UNIT NO 2
FLOW DIAGRAM - FUEL OIL &
COMP AIR - EMER DIESEL GEN

DATE	5/7/14	DESIGNER		SCALE	
BY	MVF	CHECKED		DATE	
REVISED		REVISION		BY	
DATE		BY		DATE	

CLASS	AA	REV	26
NO.	10080-RM-0072A		

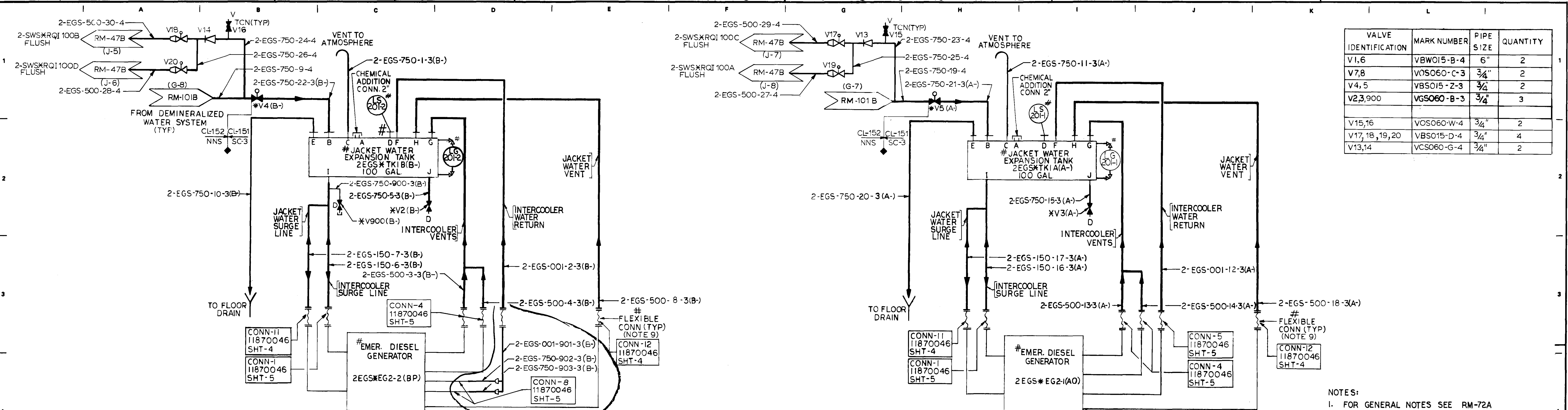

VALVE IDENTIFICATION	MARK NUMBER	PIPE SIZE	QUANTITY
V1,6	VBWO15-B-4	6"	2
V7,8	VOSO60-C-3	3/4"	2
V4,5	VBSO15-Z-3	3/4"	2
V2,3,900	VGSO60-B-3	3/4"	3
V15,16	VOSO60-W-4	3/4"	2
V17,18,19,20	VBSO15-D-4	3/4"	4
V13,14	VCSO60-G-4	3/4"	2

COOLING WATER EXPANSION AND MAKEUP FOR DIESEL GENERATOR SET 2EGS*EG2-2 DIESEL COOLING WATER SYSTEM

COOLING WATER EXPANSION AND MAKEUP FOR DIESEL GENERATOR SET 2EGS*EG2-1

- NOTES:
- FOR GENERAL NOTES SEE RM-72A
 - BOXED NUMBERS DENOTES DIESEL MFR'S CONNECTION & DRAWING NUMBER.
 - ALL COOLING WATER SYSTEM PIPING IS PIPE CLASS 151, EXCEPT AS NOTED.
 - ALL DIESEL AIR EXHAUST, AIR INTAKE & CRANKCASE VACUUM SYSTEMS PIPING IS PIPE CLASS-151, EXCEPT AS NOTED.
 - THE COOLING WATER SYSTEM TO BE MAINTAINED TO CLEANNESS LEVEL "C" IN ACCORDANCE WITH 2BVM-62
 - THE DIESEL AIR EXHAUST, AIR INTAKE & CRANKCASE VACUUM SYSTEMS TO BE MAINTAINED TO A CLEANNESS LEVEL "D" IN ACCORDANCE WITH 2BVM-62
 - ♦ DENOTES DISSIMILAR METAL WELD
 - FILL CONNECTIONS FOR LUBE OIL TO BE LOCKED CLOSED ADMINISTRATIVELY CONTROLLED.
 - THE EXHAUST AND INTAKE SILENCERS, EXPANSION JOINTS, INTAKE AIR FILTERS, AND FLEXIBLE CONNECTIONS ARE SC-3 NON-ASME III COMPONENTS.
- NOTES CONT (K-7)

- REFERENCE DRAWINGS:
- MANUFACTURER'S DWGS-11870046-SHT 4,5 & 7 S/W FILE NOS. 2002.190-230-005 2002.190-230-006 2002.190-230-008
 - DEMINEALIZED WATER SYSTEM RM-101B

- NOTES CONT
- THE DIESEL AIR INTAKE PIPING SHALL BE PAINTED ON THE INSIDE AS FOLLOWS:
 - A. PREPARE SURFACE PER CARBOLINE 193 LF PRIMER DATA SHEET
 - B. APPLY A MINIMUM OF 2 COATS OF CARBOLINE 193 LF PRIMER
 - C. NO SPECIFIC DFT MEASUREMENT IS REQUIRED. D. COATING APPLICATION SHALL BE IN ACCORDANCE WITH 193 LF DATA SHEET
 - E. SWAB APPLICATION IS ACCEPTABLE. F. VISUAL INSPECTION SHALL BE PERFORMED TO ASSURE ALL BARE SPOTS ARE COATED
 - LOCATE LOOP SEAL WITHIN 4'-0" OF FLOOR EL 732'-6"
 - LINE NUMBER(S) (SEE BELOW) CONTAIN(S) A SCH (SEE BELOW) SPOOL PIECE(S). SEE ISOMETRIC(S) FOR DETAILS.

LINE NO.	SCH. ADDED
2 EGS-750-019-4	40 S
2 EGS-750-009-4	40 S
2 EGS-750-024-4	40 S

- LINE 2-EDG-150-25-3 AND 2-EDG-150-26-3 SHALL BE INSULATED WITH CALCIUM SILICATE ALONG THE FIRST 5 FT FROM THE EXHAUST SILENCERS.

PORTIONS OF THIS DOCUMENT ARE NUCLEAR SAFETY RELATED

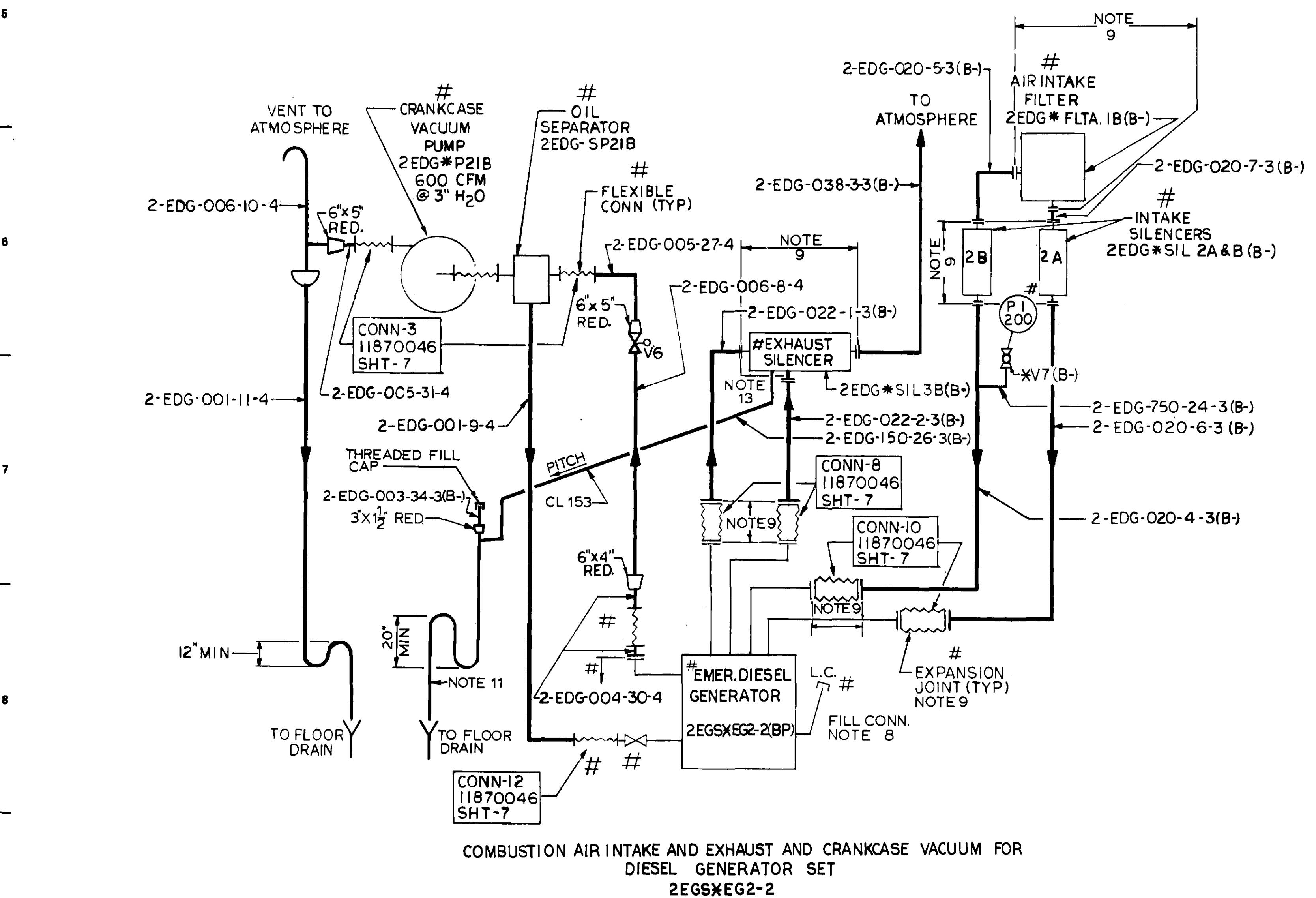

COMBUSTION AIR INTAKE AND EXHAUST AND CRANKCASE VACUUM FOR DIESEL GENERATOR SET 2EGS*EG2-2

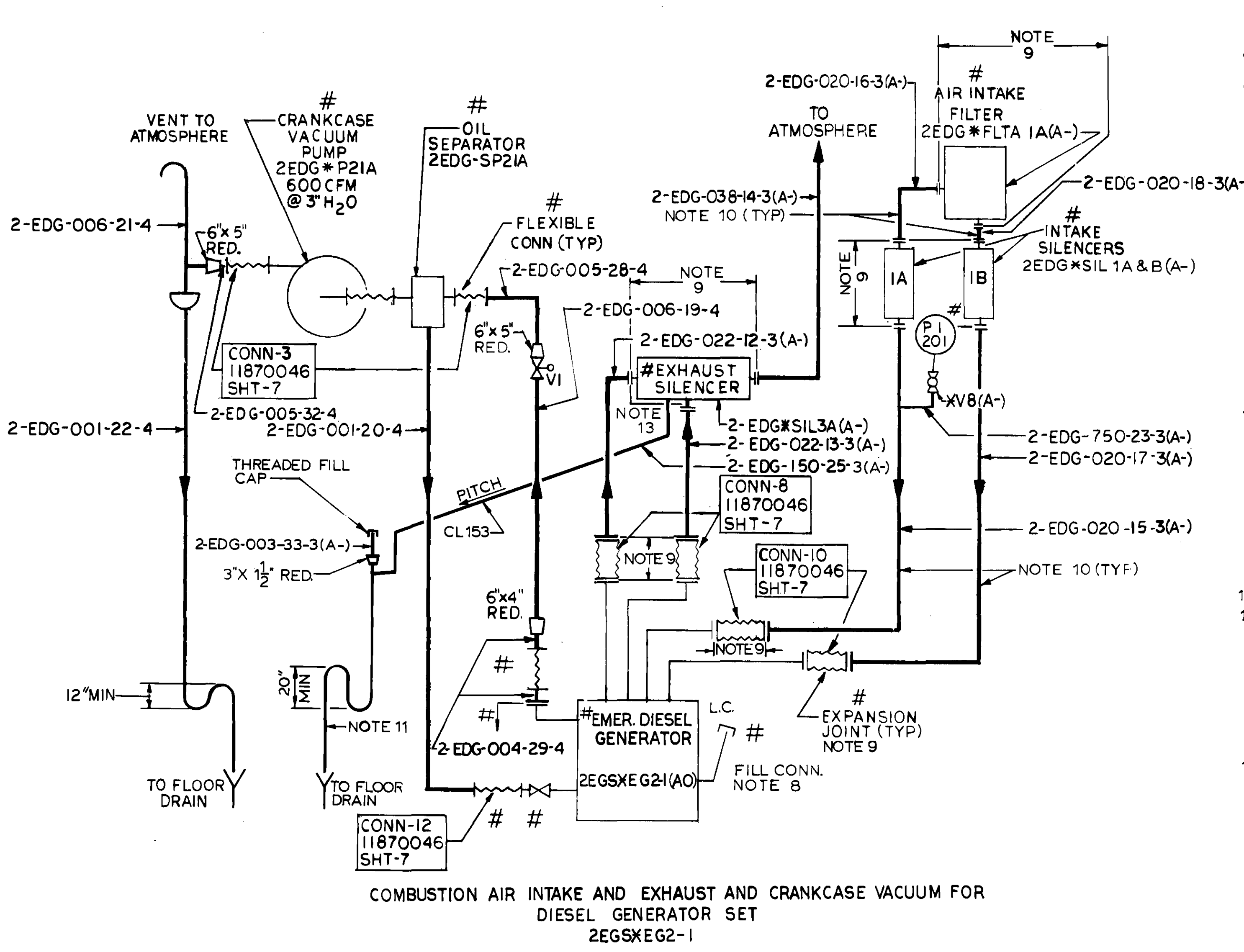

COMBUSTION AIR INTAKE AND EXHAUST AND CRANKCASE VACUUM FOR DIESEL GENERATOR SET 2EGS*EG2-1

DIESEL COMBUSTION AIR EXHAUST, COMBUSTION AIR INTAKE, & CRANKCASE VACUUM SYSTEMS

FINALIZED FLUID SYSTEM

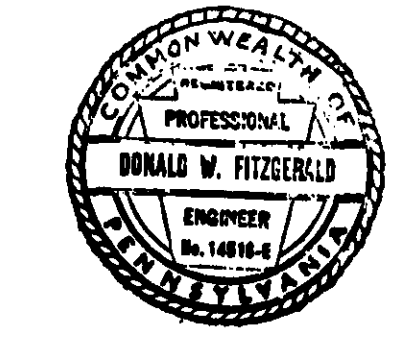

APPROVED: *Ronald W. Fitzgerald*
REGISTERED PROFESSIONAL ENGINEER NO. 14818-E
COMMONWEALTH OF PENNSYLVANIA

THE INFORMATION ON THIS DRAWING MAY NOT BE COPIED OR USED FOR OTHER THAN THE CONSTRUCTION, MAINTENANCE OR REPAIR OF THE PLANT FACILITY DESCRIBED IN THE TITLE BLOCK.

DUQUESNE LIGHT COMPANY ENGINEERING & CONSTRUCTION PITTSBURGH, PA.		FLOW DIAGRAM DIESEL GENERATOR AUXILIARY SYSTEMS	
BEAVER VALLEY POWER STATION UNIT NO. 2		O.F.E. NO. 10080 C.O. NO. 6289	
SCALE: NONE DATE: 11-2-77 DRAWN: GP/GES CHECKED: [] INSPECTED: []		ARCH. APP. [] ELEC. APP. [] MECH. APP. [] STRUCT. APP. []	
STONE & WEBSTER ENGINEERING CORP. BOSTON, MASS.			

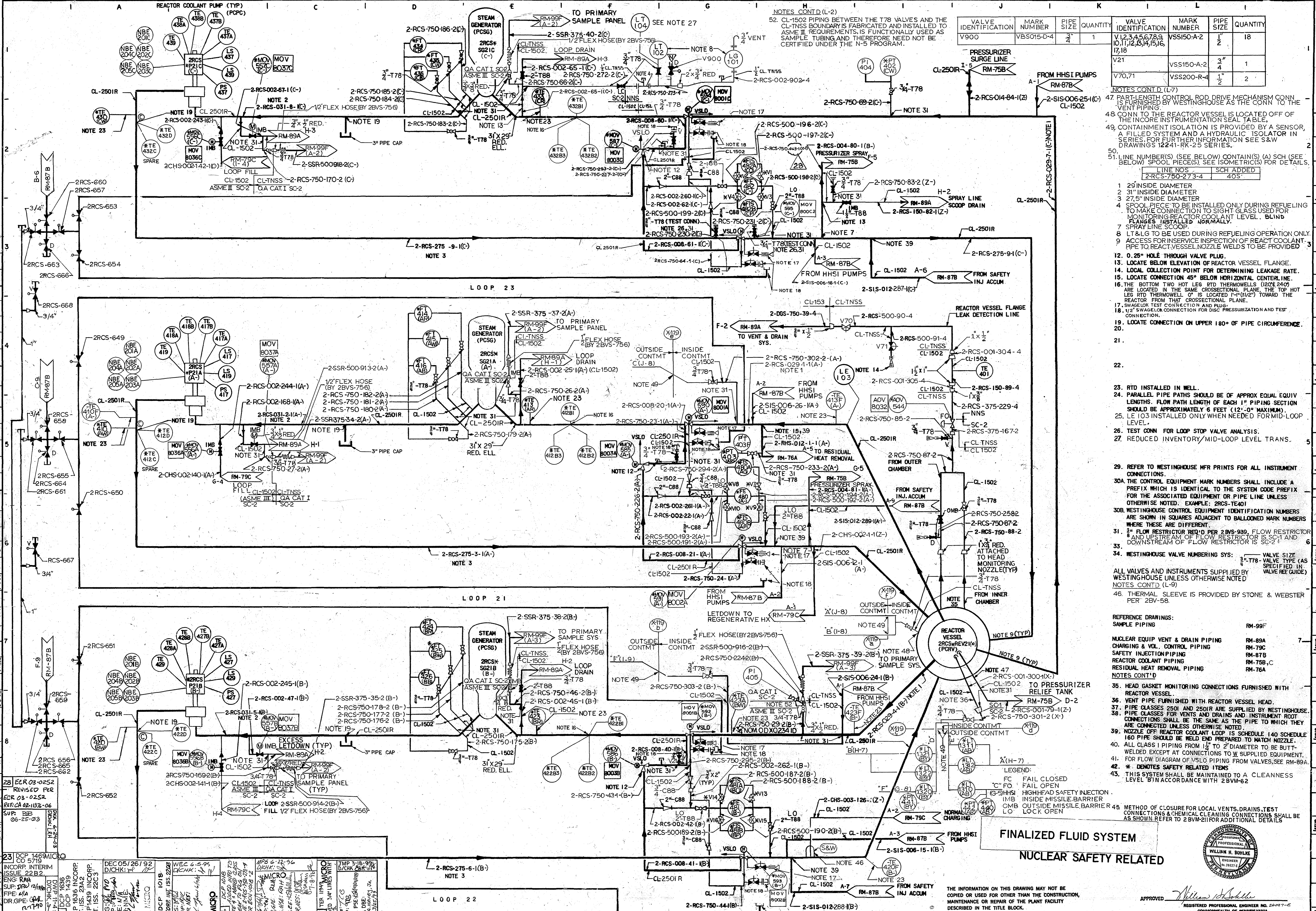

VALVE IDENTIFICATION	MARK NUMBER	PIPE SIZE	QUANTITY	VALVE IDENTIFICATION	MARK NUMBER	PIPE SIZE	QUANTITY
V900	VBS015-D-4	3"	1	V12,3,4,5,6,7,8,9,10,11,12,13,14,15,16,17,18	VSS150-A-2	1"	18
				V21	VSS150-A-2	3"	1
				V70,71	VSS200-R-4	4"	2

NOTES CONT'D (L-2)
 52. CL-1502 PIPING BETWEEN THE T78 VALVES AND THE CL-TN55 BOUNDARY IS FABRICATED AND INSTALLED TO ASME III REQUIREMENTS, IS FUNCTIONALLY USED AS SAMPLE TUBING AND THEREFORE NEED NOT BE CERTIFIED UNDER THE N-5 PROGRAM.

NOTES CONT'D (L-7)
 47. PART-LENGTH CONTROL ROD DRIVE MECHANISM CONN IS FURNISHED BY WESTINGHOUSE AS THE CONN TO THE VENT PIPING.
 48. CONN TO THE REACTOR VESSEL IS LOCATED OFF OF THE INCORE INSTRUMENTATION SEAL TABLE.
 49. CONTAINMENT ISOLATION IS PROVIDED BY A SENSOR, A FILLED SYSTEM AND A HYDRAULIC ISOLATOR IN SERIES. FOR FURTHER INFORMATION SEE S&W DRAWINGS 12241-RK-25 SERIES.

- LINE NOS
 2-RCS-750-273-4 40S
- 29" INSIDE DIAMETER
 - 31" INSIDE DIAMETER
 - 27.5" INSIDE DIAMETER
 - SPOOL PIECE TO BE INSTALLED ONLY DURING REFUELING TO MAKE CONNECTION TO SIGHT GLASS USED FOR MONITORING REACTOR COOLANT LEVEL. BLIND FLANGES INSTALLED NORMALLY.
 - SPRAY LINE COOP
 - LT & LG TO BE USED DURING REFUELING OPERATION ONLY.
 - ACCESS FOR INSERVICE INSPECTION OF REACTOR COOLANT PIPE TO REACT VESSEL NOZZLE WELDS TO BE PROVIDED

- 0.25" HOLE THROUGH VALVE PLUG.
- LOCATE BELOW ELEVATION OF REACTOR VESSEL FLANGE.
- LOCAL COLLECTION POINT FOR DETERMINING LEAKAGE RATE.
- LOCATE CONNECTION 45" BELOW HORIZONTAL CENTERLINE.
- THE BOTTOM TWO HOT LEG STD THERMOWELLS (202 & 209) ARE LOCATED IN THE SAME CROSSSECTIONAL PLANE. THE TOP HOT LEG STD THERMOWELL (1) IS LOCATED 1'-4 1/2" TOWARD THE REACTOR FROM THAT CROSSSECTIONAL PLANE.
- SWAGelok TEST CONNECTION AND PLUG.
- 1/2" SWAGelok CONNECTION FOR DISC PRESSURIZATION AND TEST CONNECTION.
- LOCATE CONNECTION ON UPPER 180° OF PIPE CIRCUMFERENCE.

- RTD INSTALLED IN WELL.
- PARALLEL PIPE PATHS SHOULD BE OF APPROX EQUAL EQUIV LENGTHS. FLOW PATH LENGTH OF EACH 1" PIPING SECTION SHOULD BE APPROXIMATELY 6 FEET (12'-0" MAXIMUM).
- LE 103 INSTALLED ONLY WHEN NEEDED FOR MID-LOOP LEVEL.
- TEST CONN FOR LOOP STOP VALVE ANALYSIS.
- REDUCED INVENTORY/MID-LOOP LEVEL TRANS.

- REFER TO WESTINGHOUSE MFR PRINTS FOR ALL INSTRUMENT CONNECTIONS.
- THE CONTROL EQUIPMENT MARK NUMBERS SHALL INCLUDE A PREFIX WHICH IS IDENTICAL TO THE SYSTEM CODE PREFIX FOR THE ASSOCIATED EQUIPMENT OR PIPE LINE UNLESS OTHERWISE NOTED. EXAMPLE: 2RCS-TE01
- WESTINGHOUSE CONTROL EQUIPMENT IDENTIFICATION NUMBERS ARE SHOWN IN SQUARES ADJACENT TO BALLOONED MARK NUMBERS WHERE THESE ARE DIFFERENT.

- 3" FLOW RESTRICTOR REQ'D PER 2BVS-939. FLOW RESTRICTOR # AND UPSTREAM AMV OF FLOW RESTRICTOR (SC-1) AND DOWNSTREAM OF FLOW RESTRICTOR IS SC-2
- WESTINGHOUSE VALVE NUMBERING SYS: VALVE SIZE 3/4" T78 VALVE TYPE (AS SPECIFIED IN VALVE REF GUIDE)
- ALL VALVES AND INSTRUMENTS SUPPLIED BY WESTINGHOUSE UNLESS OTHERWISE NOTED
- THERMAL SLEEVE IS PROVIDED BY STONE & WEBSTER PER 2BV-58.

- REFERENCE DRAWINGS:
 SAMPLE PIPING RM-99F
 NUCLEAR EQUIP VENT & DRAIN PIPING RM-89A
 CHARGING & VOL. CONTROL PIPING RM-79C
 SAFETY INJECTION PIPING RM-87B
 REACTOR COOLANT PIPING RM-75B,C
 RESIDUAL HEAT REMOVAL PIPING RM-76A

- NOTES CONT'D
 35. HEAD GASKET MONITORING CONNECTIONS FURNISHED WITH REACTOR VESSEL.
 36. VENT PIPE FURNISHED WITH REACTOR VESSEL HEAD.
 37. PIPE CLASSES 250I AND 250IR ARE SUPPLIED BY WESTINGHOUSE.
 38. PIPE CLASSES FOR VENTS AND DRAINS AND INSTRUMENT ROOT CONNECTIONS SHALL BE THE SAME AS THE PIPE TO WHICH THEY ARE CONNECTED UNLESS OTHERWISE NOTED.
 39. NOZZLE OFF REACTOR COOLANT LOOP IS SCHEDULE 140 SCHEDULE 160 PIPE SHOULD BE WELD END PREPARED TO MATCH NOZZLE.
 40. ALL CLASS 1 PIPING FROM 1 1/2" TO 2" DIAMETER TO BE BUTT-WELDED EXCEPT AT CONNECTIONS TO SUPPLIED EQUIPMENT.
 41. FOR FLOW DIAGRAM OF VSLO PIPING FROM VALVES, SEE RM-89A.
 42. * DENOTES SAFETY RELATED ITEMS
 43. THIS SYSTEM SHALL BE MAINTAINED TO A CLEANNESS LEVEL IN ACCORDANCE WITH 2BVM-62

- METHOD OF CLOSURE FOR LOCAL VENTS, DRAINS, TEST CONNECTIONS & CHEMICAL CLEANING CONNECTIONS SHALL BE AS SHOWN. REFER TO 2BVM-21 FOR ADDITIONAL DETAILS

- LEGEND:
 FC FAIL CLOSED
 FO FAIL OPEN
 HMB HIGH HEAD SAFETY INJECTION
 IMB INSIDE MISSILE BARRIER
 OMB OUTSIDE MISSILE BARRIER
 LO LOCK OPEN

FINALIZED FLUID SYSTEM
 NUCLEAR SAFETY RELATED

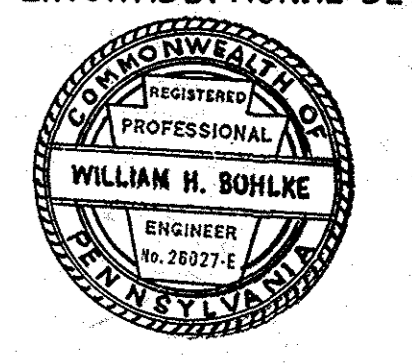

APPROVED: *William H. Bohlke*
 REGISTERED PROFESSIONAL ENGINEER NO. 20277-6
 COMMONWEALTH OF PENNSYLVANIA

THE INFORMATION ON THIS DRAWING MAY NOT BE COPIED OR USED FOR OTHER THAN THE CONSTRUCTION, MAINTENANCE OR REPAIR OF THE PLANT FACILITY DESCRIBED IN THE TITLE BLOCK.

NO.	DATE	DESCRIPTION
28	03-02-52	REVISED PER
27	03-02-52	REVISED PER
26	02-13-52	REVISED PER
25	06-25-52	REVISED PER
24	06-25-52	REVISED PER
23	06-25-52	REVISED PER
22	06-25-52	REVISED PER
21	06-25-52	REVISED PER
20	06-25-52	REVISED PER
19	06-25-52	REVISED PER
18	06-25-52	REVISED PER
17	06-25-52	REVISED PER
16	06-25-52	REVISED PER
15	06-25-52	REVISED PER
14	06-25-52	REVISED PER
13	06-25-52	REVISED PER
12	06-25-52	REVISED PER
11	06-25-52	REVISED PER
10	06-25-52	REVISED PER
9	06-25-52	REVISED PER
8	06-25-52	REVISED PER
7	06-25-52	REVISED PER
6	06-25-52	REVISED PER
5	06-25-52	REVISED PER
4	06-25-52	REVISED PER
3	06-25-52	REVISED PER
2	06-25-52	REVISED PER
1	06-25-52	REVISED PER

DUQUESNE LIGHT COMPANY
 ENGINEERING - CONSTRUCTION PITTSBURGH, PA.

SCALE: NONE
 DATE: 2-12-72
 ARCHT. APP. [Signature]
 DRAWN: JLD
 ELECT. APP. [Signature]
 CHECKED: [Signature]
 MECH. APP. [Signature]
 INSPECTED: RPB
 STRUC. APP. [Signature]

ISSUED FOR PRODUCTION
 PS&R DWG. NOS. CHANGED
 ORIGINAL RM-37A

STONE & WEBSTER ENGINEERING CORP.
 BOSTON, MASS.

FLOW DIAGRAM
 REACTOR COOLANT PIPING - SHEET 1
 BEAVER VALLEY POWER STATION UNIT NO 2
 O.F.E. NO. 10080
 C.O. NO. 6289
 AA No. 10080-RM-75A

NOTES: CONT'D FROM (L-8)
 26. VALVES ARE WIRED TO ENABLE MANUAL SWITCHING TO ALTERNATE CLASS 1E BUS. BUS SHOWN IS NORMALLY CONNECTED SUPPLY.
 27. LINE NUMBERS (SEE BELOW) CONTAIN A SCH (SEE BELOW) SPOOL PIECE. SEE PIPING DRAWING(S) FOR DETAILS.

LINE NO.	SCH ADDED
2-RHS-010-16-2	160
2-RHS-010-10-2	160
2-RHS-006-15-4	XXS
2-RHS-012-18-2	160

28. EACH MINIFLOW VALVE (2"-R78PB) IS LOCKED IN POSITION BY A CHAIN AND PADLOCK IN CONJUNCTION WITH THE VALVE LOCKOUT.
 29. TEST CONNECTION FLG. WITH 1/2" SWAGELOK CONNECTION.
 30. TEMPORARY STRAINERS 2RHS-STR116/117, INSTALLED DURING INITIAL FLUSHING OPERATIONS, HAVE BEEN REMOVED AND REPLACED BY 3/8" SPACER PLATES.

S&W SUPPLIED VALVES

VALVE IDENTIFICATION	MARK NUMBER	PIPE SIZE	QUANTITY OF VALVES
V1,15	VOW030-S-2	6"	2
V2,3	VGW060-X-2-C	6"	2
V4	VOW030-S-2	4"	1
V5	VOS060-W-4	3/4"	1
V7,8,9,10,11,2,3,14,20,21,23,24,25,26	VSSI50-A-2	1/2"	14
V16,17,18,19	VGS060-V-4	1/2"	4
V27,28,29,30,31	VSSI50-A-2	1"	5
V22	VSSI50-A-2	3/4"	1
V900	VGS060-V-2	3/4"	1

- NOTES:
- THE CONTROL EQUIPMENT MARK NUMBERS SHALL INCLUDE A PREFIX WHICH IS IDENTICAL TO THE SYSTEM CODE PREFIX FOR THE ASSOCIATED EQUIPMENT OR PIPE LINE UNLESS OTHERWISE NOTED. EXAMPLE: 2 RHS7606A.
 - LOCATE ISOLATION VALVE CLOSE TO MAIN HDR.
 - LOCATE ISOLATION VALVE CLOSE TO ACCUMULATOR LINE.
 - RCS PRESSURE INTERLOCK PREVENTS ISOL. VALVE OPENING ABOVE 425 PSIG; AUTO CLOSE ON PRESS. RISE TO 750 PSIG.
 - WESTINGHOUSE VALVE NUMBERING SYSTEM IS IN ACCORDANCE WITH VALVE REFERENCE GUIDE, EQUIPMENT SPEC. 677473.
 - SEAL COOLERS AND 1/2" PIPING INTEGRAL WITH PUMP.
 - ALL VALVES & INSTRUMENTS SUPPLIED BY WESTINGHOUSE UNLESS OTHERWISE SHOWN.
 - WESTINGHOUSE CONTROL EQUIPMENT IDENTIFICATION NUMBERS ARE SHOWN IN SQUARES ADJACENT TO BALLOONED MARK NUMBERS WHERE THEY ARE DIFFERENT.
 - * DENOTES NUCLEAR SAFETY RELATED ITEMS.
 - RHS SYSTEM WILL BE MAINTAINED TO CLEANNESS LEVEL "B" IN ACCORDANCE WITH 2 BVM-82.
 - ⊙ DENOTES CONTAINMENT PENETRATION NO CONNECTIONS ON PUMP SUCTION LINES TO BE USED FOR ADDING PRESSURE INDICATORS TO MONITOR STRAINER PERFORMANCE (SEE NOTE 30 ALSO).
 - ADJUST VALVE IN FIELD TO ESTABLISH MINIFLOW AND LOCK IN POSITION.
 - 3/8" FLOW RESTRICTOR REQ'D PER 2BVS-939
 - PIPE TO TERMINATE 1" ABOVE FUNNEL TO ALLOW OBSERVATION OF PUMP SEAL LEAK OFF.
 - METHOD OF CLOSURE FOR LOCAL VENTS, DRAINS, TEST CONNECTIONS & CHEMICAL CLEANING CONNECTIONS SHALL BE AS SHOWN. REFER TO 2 BVM-211 FOR ADDITIONAL DETAILS.
 - ORIFICE FLANGES WITH SOCKET WELDED TAPS ARE PROVIDED FOR ALL FE'S.
 - THE FOLLOWING SUBSTITUTION IS ACCEPTABLE VOS015-A-4 FOR VOS060-W-4
 - LOCATE LMV(XV22) AS CLOSE TO 2CHS4XHCV142 AS POSSIBLE.
 - FT-606A & B ARE USED FOR RHS FLOW RATES < 2000 GPM WHEN THE RCS IS IN PARTIAL DRAIN AND ARE ISOLATED DURING NORMAL PLANT OPERATION.
 - 1" FLANGED CONNECTIONS TO BE USED FOR POSSIBLE CONNECTION OF PRIMING SYSTEM.
 - CONNECTION TO BE PLACED IN THE HORIZONTAL RUN OF PIPE AS CLOSE TO "T" AS POSSIBLE.
 - CONNECTIONS TO BE USED FOR ASME XII TESTING. LOCATE VALVE AND FLANGE SO THEY ARE ACCESSIBLE TO PLANT PERSONNEL.

NUCLEAR SAFETY RELATED

FINALIZED FLUID SYSTEM

THE INFORMATION ON THIS DRAWING MAY NOT BE COPIED OR USED FOR OTHER THAN THE CONSTRUCTION, MAINTENANCE OR REPAIR OF THE PLANT FACILITY DESCRIBED IN THE TITLE BLOCK.

APPROVED: *Carlotta Kishida*
 REGISTERED PROFESSIONAL ENGINEER NO. 6897-E
 COMMONWEALTH OF PENNSYLVANIA

FENOC FIRST ENERGY NUCLEAR OPERATING COMPANY		FLOW DIAGRAM RESIDUAL HEAT REMOVAL PIPING BEAVER VALLEY POWER STATION NO. 2	
SCALE:	DATE: 2/12/02	AA No. 10080-RM-76A	
DRAWN: EBH	CHKD: DAK Jwg		
SUP: JWG FOR RDD 2-12-02	INT: 01/2		

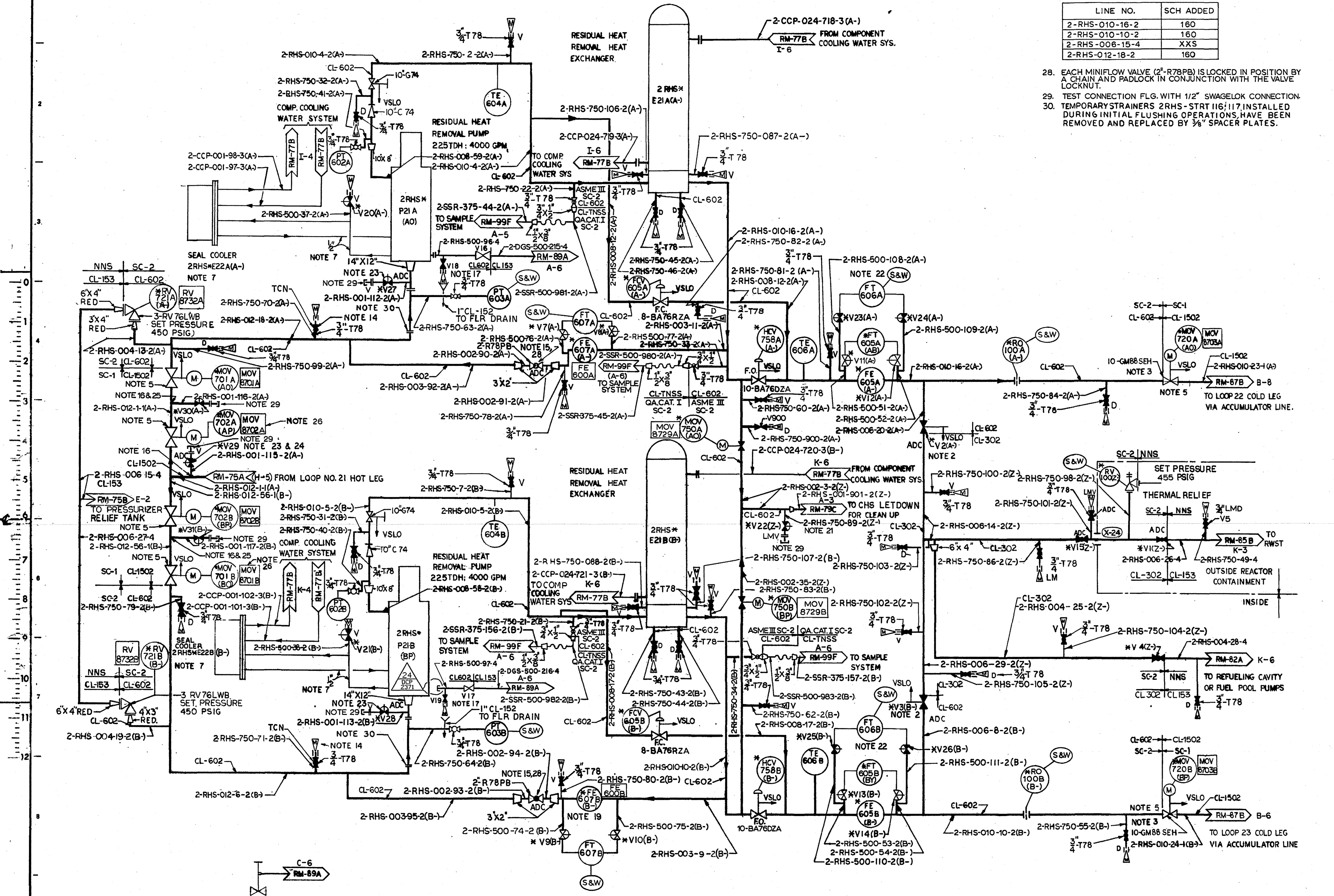

TYPICAL VALVE STEM LEAK-OFF (VSLD) ARRANGEMENT

TYPICAL VENT & DRAIN DETAIL

DCP 2371
 INCORPORATED
 24

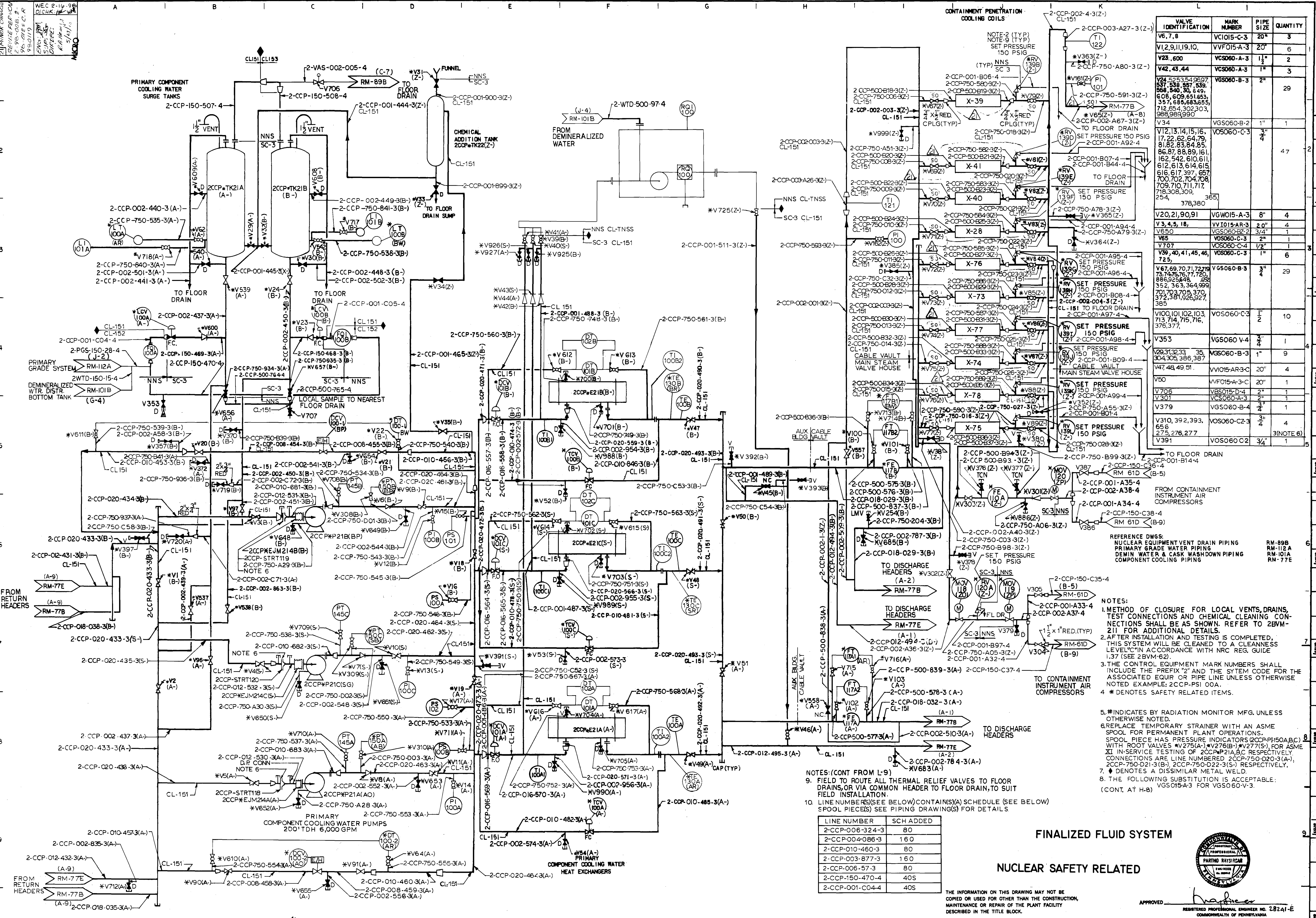

VALVE IDENTIFICATION	MARK NUMBER	PIPE SIZE	QUANTITY
V6,7,8	VCI015-C-3	20"	3
V1,2,9,11,19,10,	VVFO15-A-3	20"	6
V23,600	VCS060-A-3	1 1/2"	2
V42,43,44	VCS060-A-3	1"	3
V24,52,53,54,98,97,557,558,559,535,568,540,30,649,608,609,610,611,612,613,614,615,616,617,397,657,700,702,704,708,709,710,711,717,718,308,309,254,378,380,365,	VGS060-B-3	2"	29
V12,13,14,15,16,17,22,62,64,79,81,82,83,84,85,86,87,88,89,161,162,542,610,611,612,613,614,615,616,617,397,657,700,702,704,708,709,710,711,717,718,308,309,254,378,380,365,	VGS060-C-3	3"	47
V20,21,90,91	VGV015-A-3	8"	4
V3,4,5,18,	VV1015-A-3	2 0"	4
V650	VGS060-B-2	3 1/4"	1
V65	VGS060-C-3	2"	1
V707	VGS060-C-4	1 1/2"	1
V39,40,41,45,46,72,5,	VGS060-C-3	1"	6
V67,69,70,71,72,73,74,75,76,77,78,88,92,564,52,363,364,999,701,703,705,370,372,381,926,927,385,	VGS060-B-3	3 1/4"	29
V100,101,102,103,713,714,715,716,376,377,	VGS060-C-3	1 1/2"	10
V353	VGS060-V-4	3 1/4"	1
V29,31,32,33,35,304,305,386,387,	VGS060-B-3	1"	9
V47,48,49,51	VV1015-A-3-C	20"	4
V50	VV1015-A-3-C	20"	1
V706	VGS015-D-4	2"	1
V301	VCS060-A-3	3"	1
V379	VGS060-B-4	3 1/2"	1
V310,39,2,393,656,275,276,277,	VGS060-C-2	3 1/2"	4
V391	VGS060-C-2	3 1/4"	1

REFERENCE DWGS:
 NUCLEAR EQUIPMENT DRAIN PIPING RM-89B
 PRIMARY GRADE WATER PIPING RM-112A
 DEMIN WATER & CASK WASH DOWN PIPING RM-101A
 COMPONENT COOLING PIPING RM-77E

NOTES:
 1. METHOD OF CLOSURE FOR LOCAL VENTS, DRAINS, TEST CONNECTIONS AND CHEMICAL CLEANING CONNECTIONS SHALL BE AS SHOWN. REFER TO 2BVM-211 FOR ADDITIONAL DETAILS.
 2. AFTER INSTALLATION AND TESTING IS COMPLETED, THIS SYSTEM WILL BE CLEANED TO A CLEANNESS LEVEL IN ACCORDANCE WITH NRC REG. GUIDE 1.37 (SEE 2BVM-62).
 3. THE CONTROL EQUIPMENT MARK NUMBERS SHALL INCLUDE THE PREFIX "2" AND THE SYSTEM CODE FOR THE ASSOCIATED EQUIP OR PIPE LINE UNLESS OTHERWISE NOTED. EXAMPLE: 2CCP-P01-AA.
 4. * DENOTES SAFETY RELATED ITEMS.
 5. # INDICATES BY RADIATION MONITOR MFG. UNLESS OTHERWISE NOTED.
 6. REPLACE TEMPORARY STRAINER WITH AN ASME SPOOL FOR PERMANENT PLANT OPERATIONS. SPOOL PIECE HAS PRESSURE INDICATORS (2CCP-PH50A,B,C) WITH ROOT VALVES #V275(A), #V276(B), #V277(S), FOR ASME XI IN-SERVICE TESTING OF 2CCP-P21A,B,C RESPECTIVELY. CONNECTIONS ARE LINE NUMBERED 2CCP-750-D20-3(A), 2CCP-750-D21-3(B), 2CCP-750-D22-3(S) RESPECTIVELY.
 7. ♦ DENOTES A DISSIMILAR METAL WELD.
 8. THE FOLLOWING SUBSTITUTION IS ACCEPTABLE: (CONT. AT H-B) VGS015-A-3 FOR VGS060-V-3.

- NOTES: (CONT FROM L-9)
 9. FIELD TO ROUTE ALL THERMAL RELIEF VALVES TO FLOOR DRAINS, OR VIA COMMON HEADER TO FLOOR DRAIN, TO SUIT FIELD INSTALLATION.
 10. LINE NUMBERS (SEE BELOW) CONTAINS (A) SCHEDULE (SEE BELOW) SPOOL PIECES) SEE PIPING DRAWING(S) FOR DETAILS

LINE NUMBER	SCH ADDED
2-CCP-006-324-3	80
2-CCP-004-086-3	160
2-CCP-010-460-3	80
2-CCP-003-877-3	160
2-CCP-006-57-3	80
2-CCP-150-470-4	40S
2-CCP-001-C04-4	40S

FINALIZED FLUID SYSTEM
NUCLEAR SAFETY RELATED

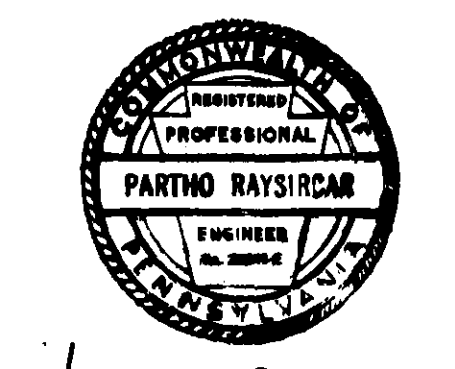

THE INFORMATION ON THIS DRAWING MAY NOT BE COPIED OR USED FOR OTHER THAN THE CONSTRUCTION, MAINTENANCE OR REPAIR OF THE PLANT FACILITY DESCRIBED IN THE TITLE BLOCK.

APPROVED: *[Signature]*
 REGISTERED PROFESSIONAL ENGINEER NO. 28241-E
 COMMONWEALTH OF PENNSYLVANIA

REVISIONS	NO.	DATE	DESCRIPTION
18	FOR RECORD OF DRAWING CHANGES SEE 12241-BCM-77A-18		
17	SEE RECORD OF DRAWING CHANGES 12241-BCM-77A-17		
16	SEE RECORD OF DRAWING CHANGES 12241-BCM-77A-16		
15	SEE RECORD OF DRAWING CHANGES 12241-BCM-77A-15		
14	SEE RECORD OF DRAWING CHANGES 12241-BCM-77A-14		
13	SEE RECORD OF DRAWING CHANGES 12241-BCM-77A-13		
12	SEE RECORD OF DRAWING CHANGES 12241-BCM-77A-12		
11	FOR RECORD OF DRAWING CHANGES SEE 12241-BCM-77A-11		
10	FOR RECORD OF DRAWING CHANGES SEE 12241-BCM-77A-10		
9	FOR RECORD OF DRAWING CHANGES SEE 12241-BCM-77A-9		
8	FOR RECORD OF DRAWING CHANGES SEE 12241-BCM-77A-8		
7	FOR RECORD OF DRAWING CHANGES SEE 12241-BCM-77A-7		
6	FOR RECORD OF DRAWING CHANGES SEE 12241-BCM-77A-6		
5	FOR RECORD OF DRAWING CHANGES SEE 12241-BCM-77A-5		
4	FOR RECORD OF DRAWING CHANGES SEE 12241-BCM-77A-4		
3	FOR RECORD OF DRAWING CHANGES SEE 12241-BCM-77A-3		
2	FOR RECORD OF DRAWING CHANGES SEE 12241-BCM-77A-2		
1	FOR RECORD OF DRAWING CHANGES SEE 12241-BCM-77A-1		

DUQUESNE LIGHT COMPANY
 ENGINEERING & CONSTRUCTION PITTSBURGH, PA.

SCALE: DATE 2-14-72 ARCH. APP. NONE
 DRAWN R.D.S. ELECT. APP. NONE
 CHECKED MECH. APP. NONE
 INSPECTED D.P.P. STRUCT. APP. NONE

FLOW DIAGRAM
BEAVER VALLEY POWER STATION No. 2
 O.F.E. No. 10080
 C.O. No. 6289

AA No. 10080-RM-77A

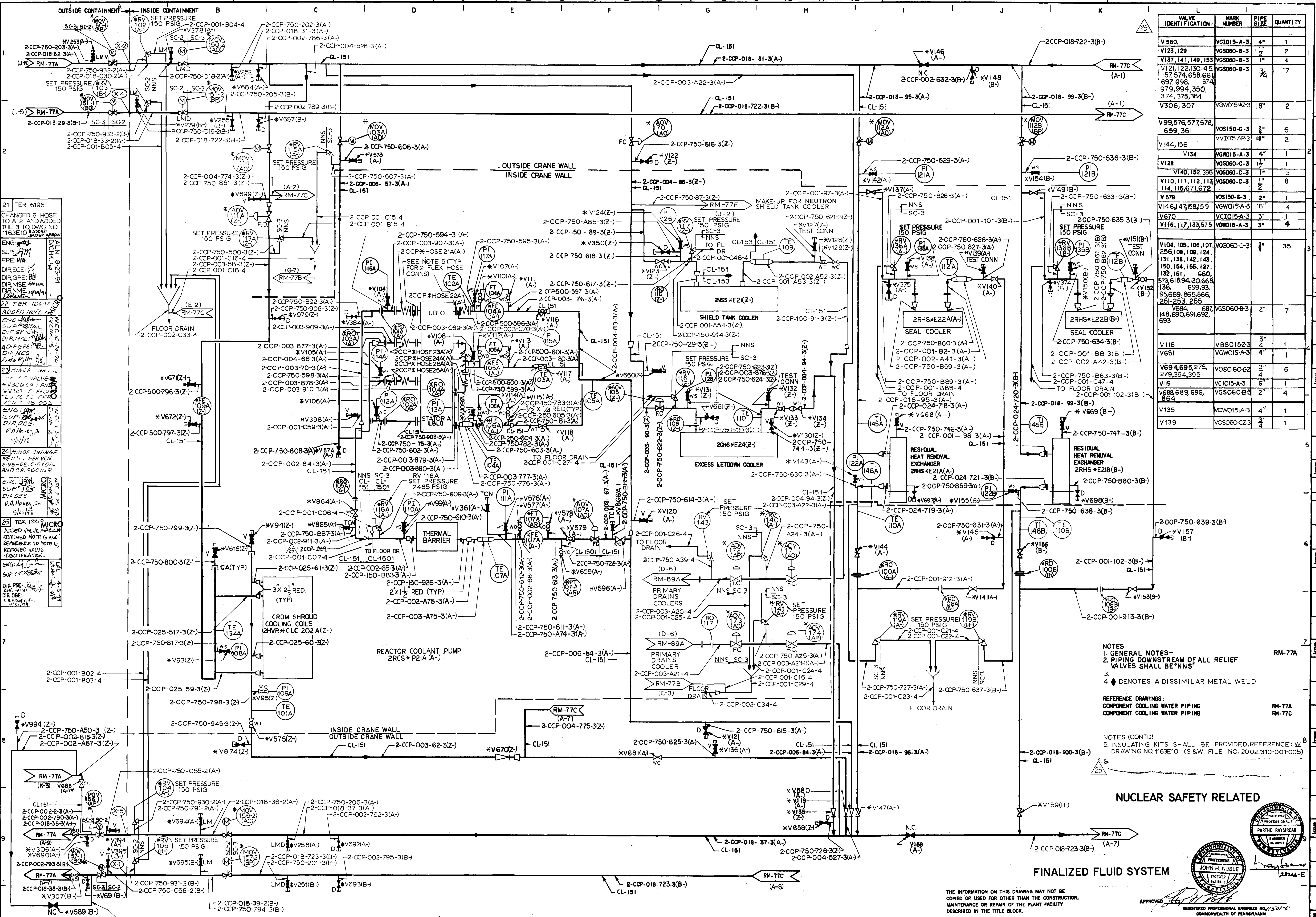

VALVE IDENTIFICATION	MARK NUMBER	PIPE SIZE	QUANTITY
V580	VC1015-A-3	4"	1
V123, 129	VGS060-B-3	1 1/2"	2
V137, 141, 149, 153	VGS060-B-3	1"	4
V121, 122, 130, 145, 157, 574, 658, 661, 697, 698, 874, 979, 994, 350, 374, 375, 384	VGS060-B-3	3/4"	17
V306, 307	VGS015-A-3	18"	2
V59, 576, 577, 578, 659, 361	VGS150-G-3	3"	6
V144, 156	VV105-AR-3	18"	2
V134	VGM015-A-3	4"	1
V128	VGS060-C-3	1 1/2"	1
V140, 152, 398	VGS060-C-3	1"	3
V110, 111, 112, 113, 114, 115, 671, 672	VGS060-C-3	1"	8
V579	VGS150-G-3	2"	1
V146, 47, 151, 59	VGS015-A-3	18"	4
V670	VC1015-A-3	3"	1
V116, 117, 133, 575	VGM015-A-3	3"	4
V104, 105, 106, 107, 256, 108, 109, 124, 131, 138, 142, 143, 150, 154, 155, 127, 132, 151, 660, 873, 618, 94, 120, 668, 136, 659, 333, 95, 669, 865, 866, 251-253, 255	VGS060-C-3	3/4"	35
V684, 687, 148, 690, 691, 692, 693	VGS060-B-3	2"	7
V118	VBS015Z-3	3/4"	1
V681	VGS015-A-3	4"	1
V69, 4, 695, 278, 279, 394, 395	VGS060-C-2	3/4"	6
V119	VC1015-A-3	6"	1
V688, 689, 696, 864	VGS060-B-3	2"	4
V135	VGS015-A-3	4"	1
V139	VGS060-C-3	2"	1

21 TER 6196
 CHANGED 6 HOSE TO A 2 AND ADDED THE 3 TO DWG NO. 1163E10. LEADER ARROW ENDS TO VALVE.

22 MINOR CHANGE TO VALVE IDENTIFICATION.

23 TER 1221
 ADDED VALVE IDENTIFICATION. REMOVED NOTE 6 AND REFERRED TO NOTE 6. REMOVED VALVE IDENTIFICATION.

24 MINOR CHANGE TO VALVE IDENTIFICATION. REMOVED NOTE 6 AND REFERRED TO NOTE 6. REMOVED VALVE IDENTIFICATION.

25 TER 1221
 ADDED VALVE IDENTIFICATION. REMOVED NOTE 6 AND REFERRED TO NOTE 6. REMOVED VALVE IDENTIFICATION.

NOTES
 1. GENERAL NOTES-
 2. PIPING DOWNSTREAM OF ALL RELIEF VALVES SHALL BE "NNS"
 3.
 4. ♦ DENOTES A DISSIMILAR METAL WELD

REFERENCE DRAWINGS:
 COMPONENT COOLING WATER PIPING RM-77A
 COMPONENT COOLING WATER PIPING RM-77C

NOTES (CONTD)
 5. INSULATING KITS SHALL BE PROVIDED. REFERENCE: W DRAWING NO. 1163E10 (S & W FILE NO. 2002.310-001-005)

NUCLEAR SAFETY RELATED

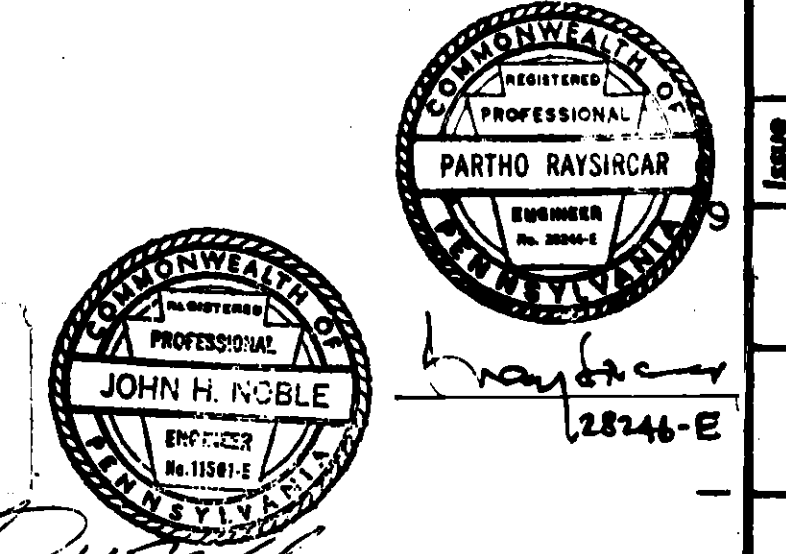

FINALIZED FLUID SYSTEM

THE INFORMATION ON THIS DRAWING MAY NOT BE COPIED OR USED FOR OTHER THAN THE CONSTRUCTION, MAINTENANCE OR REPAIR OF THE PLANT FACILITY DESCRIBED IN THE TITLE BLOCK.

REVISIONS	DESCRIPTION	DATE	ISSUE
19	SEE RECORD OF DRAWING CHANGES 12241-BCM-77B-15		
18	SEE RECORD OF DRAWING CHANGES 12241-BCM-77B-14		
17	SEE RECORD OF DRAWING CHANGES 12241-BCM-77B-13		
16	SEE RECORD OF DRAWING CHANGES 12241-BCM-77B-12		
15	SEE RECORD OF DRAWING CHANGES 12241-BCM-77B-11		
14	SEE RECORD OF DWG CHANGE 12241-BCM-77B-10		
13	SEE RECORD OF DWG CHANGE 12241-BCM-77B-9		
12	SEE RECORD OF DWG CHANGE 12241-BCM-77B-8		
11	SEE RECORD OF DWG CHANGE 12241-BCM-77B-7		
10	SEE RECORD OF DWG CHANGE 12241-BCM-77B-6		
9	SEE RECORD OF DWG CHANGE 12241-BCM-77B-5		
8	SEE RECORD OF DWG CHANGE 12241-BCM-77B-4		
7	SEE RECORD OF DWG CHANGE 12241-BCM-77B-3		
6	SEE RECORD OF DWG CHANGE 12241-BCM-77B-2		
5	SEE RECORD OF DWG CHANGE 12241-BCM-77B-1		
4	SEE RECORD OF DWG CHANGE 12241-BCM-77B-0		
3	GENERAL REVISION		
2	PASS DWG. NO'S CHANGED WAS RM-22 B-1		
1	ISSUE		

DUQUESNE LIGHT COMPANY ENGINEERING & CONSTRUCTION PITTSBURGH, PA.	SCALE: NONE	DATE: 11-26-71	ARCH. APP.:
STONE & WEBSTER ENGINEERING CORP. BOSTON, MASS.	DRAWN: R.D.S.	MECH. APP.:	STRUCT. APP.:
INSPECTED: RPB		CHECKED: MECH. APP.	

FLOW DIAGRAM COMPONENT COOLING PIPING - SH. 2	BEAVER VALLEY POWER STATION No. 2
O.F.E. No. 10080	AA No. 10080-RM-77B
C.O. No. 12219	

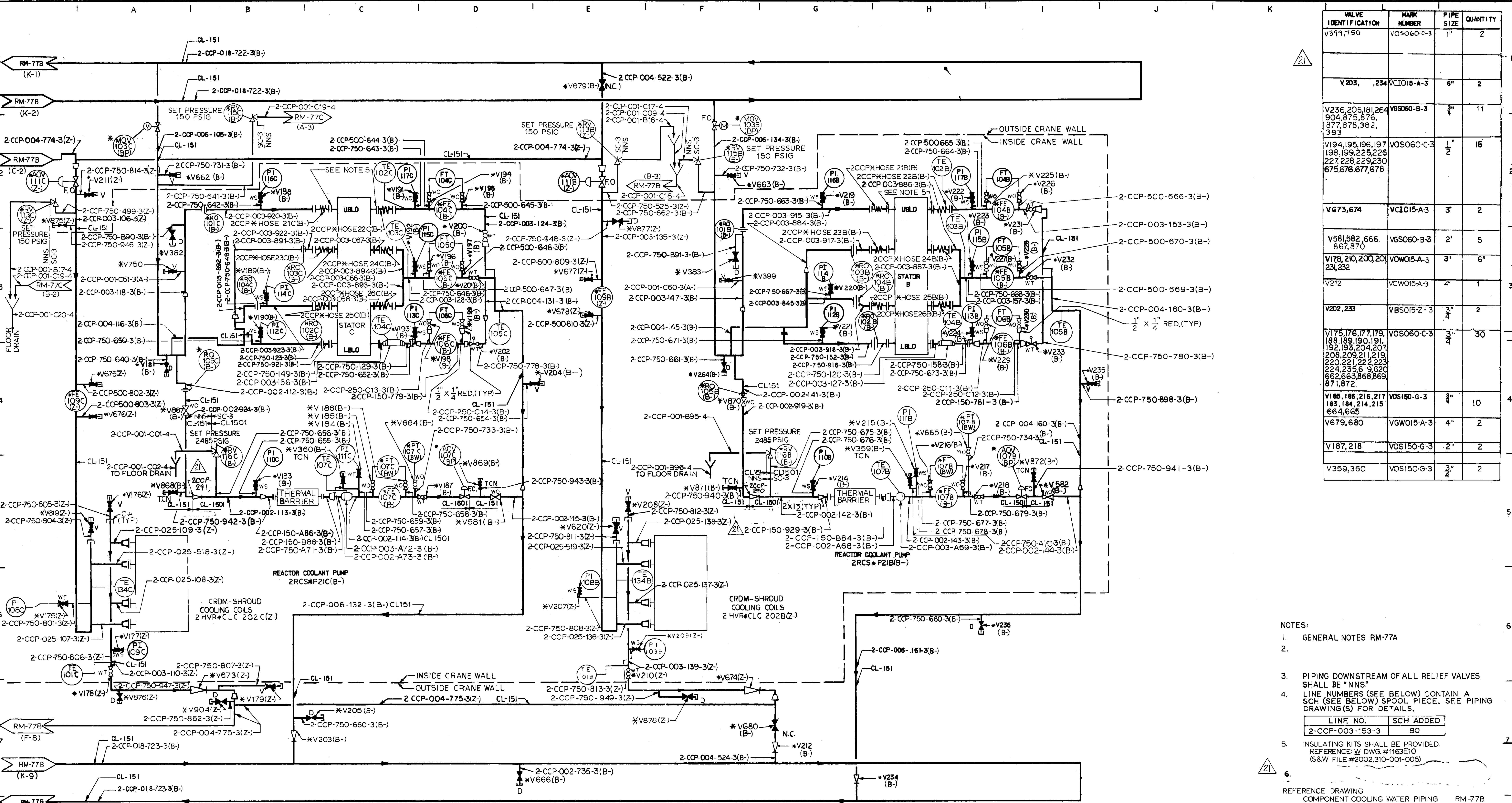

VALVE IDENTIFICATION	MARK NUMBER	PIPE SIZE	QUANTITY
V399,750	VOS060-C-3	1"	2
V203, 234	VCIO15-A-3	6"	2
V236, 205, 181, 264, 904, 875, 876, 877, 878, 382, 383	VGS060-B-3	1"	11
V194, 195, 196, 197, 198, 199, 225, 226, 227, 228, 229, 230, 675, 676, 677, 678	VOS060-C-3	1/2"	16
V673, 674	VCIO15-A-3	3"	2
V581, 582, 666, 867, 870	VGS060-B-3	2"	5
V178, 210, 200, 201, 231, 232	VOW015-A-3	3"	6
V212	VOW015-A-3	4"	1
V202, 233	VBS015-Z-3	3/4"	2
V175, 176, 177, 179, 188, 189, 190, 191, 192, 193, 204, 207, 208, 209, 211, 219, 220, 221, 222, 223, 224, 235, 619, 620, 662, 663, 668, 669, 871, 872	VOS060-C-3	3/4"	30
V185, 186, 216, 217, 183, 184, 214, 215, 664, 665	VOS150-G-3	1"	10
V679, 680	VGW015-A-3	4"	2
V187, 218	VOS150-G-3	2"	2
V359, 360	VOS150-G-3	3/4"	2

NOTES:

- GENERAL NOTES RM-77A
-
- PIPING DOWNSTREAM OF ALL RELIEF VALVES SHALL BE "NNS"
- LINE NUMBERS (SEE BELOW) CONTAIN A SCH (SEE BELOW) SPOOL PIECE. SEE PIPING DRAWING(S) FOR DETAILS.

LINE NO.	SCH ADDED
2-CCP-003-153-3	80

- INSULATING KITS SHALL BE PROVIDED. REFERENCE: W DWG. #1163E10 (S&W FILE #2002.310-001-005)
- REFERENCE DRAWING COMPONENT COOLING WATER PIPING RM-77B

NUCLEAR SAFETY RELATED
FINALIZED FLUID SYSTEM



THE INFORMATION ON THIS DRAWING MAY NOT BE COPIED OR USED FOR OTHER THAN THE CONSTRUCTION, MAINTENANCE OR REPAIR OF THE PLANT FACILITY DESCRIBED IN THE TITLE BLOCK.

APPROVED
REGISTERED PROFESSIONAL ENGINEER NO. 28246-E
COMMONWEALTH OF PENNSYLVANIA

REVISIONS	DATE	DESCRIPTION
1	10-30-92	ISSUED FOR CONSTRUCTION
2	11-15-92	REVISIONS TO PIPING
3	12-15-92	REVISIONS TO PIPING
4	01-15-93	REVISIONS TO PIPING
5	02-15-93	REVISIONS TO PIPING
6	03-15-93	REVISIONS TO PIPING
7	04-15-93	REVISIONS TO PIPING
8	05-15-93	REVISIONS TO PIPING
9	06-15-93	REVISIONS TO PIPING
10	07-15-93	REVISIONS TO PIPING
11	08-15-93	REVISIONS TO PIPING
12	09-15-93	REVISIONS TO PIPING
13	10-15-93	REVISIONS TO PIPING
14	11-15-93	REVISIONS TO PIPING
15	12-15-93	REVISIONS TO PIPING
16	01-15-94	REVISIONS TO PIPING
17	02-15-94	REVISIONS TO PIPING
18	03-15-94	REVISIONS TO PIPING
19	04-15-94	REVISIONS TO PIPING
20	05-15-94	REVISIONS TO PIPING
21	06-15-94	REVISIONS TO PIPING
22	07-15-94	REVISIONS TO PIPING
23	08-15-94	REVISIONS TO PIPING
24	09-15-94	REVISIONS TO PIPING
25	10-15-94	REVISIONS TO PIPING
26	11-15-94	REVISIONS TO PIPING
27	12-15-94	REVISIONS TO PIPING
28	01-15-95	REVISIONS TO PIPING
29	02-15-95	REVISIONS TO PIPING
30	03-15-95	REVISIONS TO PIPING
31	04-15-95	REVISIONS TO PIPING
32	05-15-95	REVISIONS TO PIPING
33	06-15-95	REVISIONS TO PIPING
34	07-15-95	REVISIONS TO PIPING
35	08-15-95	REVISIONS TO PIPING
36	09-15-95	REVISIONS TO PIPING
37	10-15-95	REVISIONS TO PIPING
38	11-15-95	REVISIONS TO PIPING
39	12-15-95	REVISIONS TO PIPING
40	01-15-96	REVISIONS TO PIPING
41	02-15-96	REVISIONS TO PIPING
42	03-15-96	REVISIONS TO PIPING
43	04-15-96	REVISIONS TO PIPING
44	05-15-96	REVISIONS TO PIPING
45	06-15-96	REVISIONS TO PIPING
46	07-15-96	REVISIONS TO PIPING
47	08-15-96	REVISIONS TO PIPING
48	09-15-96	REVISIONS TO PIPING
49	10-15-96	REVISIONS TO PIPING
50	11-15-96	REVISIONS TO PIPING
51	12-15-96	REVISIONS TO PIPING
52	01-15-97	REVISIONS TO PIPING
53	02-15-97	REVISIONS TO PIPING
54	03-15-97	REVISIONS TO PIPING
55	04-15-97	REVISIONS TO PIPING
56	05-15-97	REVISIONS TO PIPING
57	06-15-97	REVISIONS TO PIPING
58	07-15-97	REVISIONS TO PIPING
59	08-15-97	REVISIONS TO PIPING
60	09-15-97	REVISIONS TO PIPING
61	10-15-97	REVISIONS TO PIPING
62	11-15-97	REVISIONS TO PIPING
63	12-15-97	REVISIONS TO PIPING
64	01-15-98	REVISIONS TO PIPING
65	02-15-98	REVISIONS TO PIPING
66	03-15-98	REVISIONS TO PIPING
67	04-15-98	REVISIONS TO PIPING
68	05-15-98	REVISIONS TO PIPING
69	06-15-98	REVISIONS TO PIPING
70	07-15-98	REVISIONS TO PIPING
71	08-15-98	REVISIONS TO PIPING
72	09-15-98	REVISIONS TO PIPING
73	10-15-98	REVISIONS TO PIPING
74	11-15-98	REVISIONS TO PIPING
75	12-15-98	REVISIONS TO PIPING
76	01-15-99	REVISIONS TO PIPING
77	02-15-99	REVISIONS TO PIPING
78	03-15-99	REVISIONS TO PIPING
79	04-15-99	REVISIONS TO PIPING
80	05-15-99	REVISIONS TO PIPING
81	06-15-99	REVISIONS TO PIPING
82	07-15-99	REVISIONS TO PIPING
83	08-15-99	REVISIONS TO PIPING
84	09-15-99	REVISIONS TO PIPING
85	10-15-99	REVISIONS TO PIPING
86	11-15-99	REVISIONS TO PIPING
87	12-15-99	REVISIONS TO PIPING
88	01-00-00	REVISIONS TO PIPING
89	02-00-00	REVISIONS TO PIPING
90	03-00-00	REVISIONS TO PIPING
91	04-00-00	REVISIONS TO PIPING
92	05-00-00	REVISIONS TO PIPING
93	06-00-00	REVISIONS TO PIPING
94	07-00-00	REVISIONS TO PIPING
95	08-00-00	REVISIONS TO PIPING
96	09-00-00	REVISIONS TO PIPING
97	10-00-00	REVISIONS TO PIPING
98	11-00-00	REVISIONS TO PIPING
99	12-00-00	REVISIONS TO PIPING
100	01-00-00	REVISIONS TO PIPING

DUQUESNE LIGHT COMPANY
ENGINEERING & CONSTRUCTION PITTSBURGH, PA.

STONE & WEBSTER ENGINEERING CORP.
BOSTON, MASS.

SCALE: NONE
DATE: 2-12-72
DRAWN: T.H.S.T.
CHECKED: M.R.H.
INSPECTED: R.P.B.

ARCH. APP.
ELECT. APP.
MECH. APP.
STRUCT. APP.

FLOW DIAGRAM
COMPONENT COOLING PIPING - SH.3

BEAVER VALLEY POWER STATION UNIT NO. 2
O.F.E. No. 10080
C.O. No. 6289

AA No. 10080-RM-77C

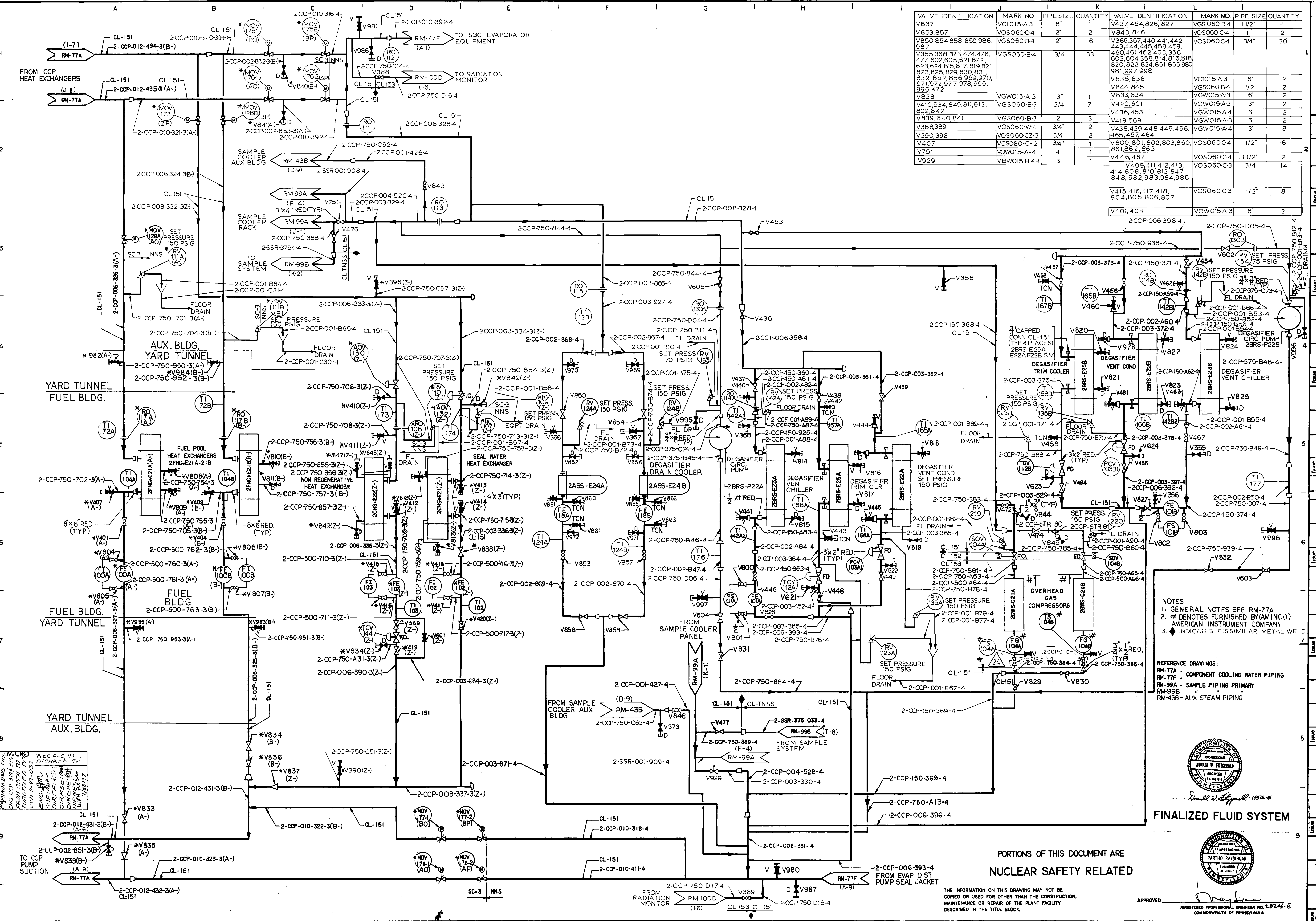

VALVE IDENTIFICATION	MARK NO.	PIPE SIZE	QUANTITY	VALVE IDENTIFICATION	MARK NO.	PIPE SIZE	QUANTITY
V837	VCI015-A-3	8"	1	V437,454,826,827	VGS060-B-4	1 1/2"	4
V853,857	VOS060-C-4	2"	2	V843,846	VOS060-C-4	1"	2
V850,854,858,859,986,987	VGS060-B-4	2"	6	V366,367,440,441,442,443,444,445,458,459,460,461,462,463,356,603,604,358,814,816,818,820,822,824,851,655,980,981,997,998	VOS060-C-4	3/4"	30
V355,368,373,474,476,477,602,605,621,622,623,624,816,817,819,821,823,825,829,830,831,832,852,856,969,970,971,972,977,978,995,996,472	VGS060-B-4	3/4"	33	V835,836	VCI015-A-3	6"	2
				V844,845	VGS060-B-4	1/2"	2
				V833,834	VGW015-A-3	6"	2
				V420,601	VOW015-A-3	3"	2
				V436,453	VGW015-A-4	6"	2
				V419,569	VGW015-A-3	6"	2
				V388,389	VOS060-W-4	3/4"	2
				V438,439,448,449,456,465,457,464	VGW015-A-4	3"	8
				V390,396	VOS060-C-3	3/4"	2
				V407	VOS060-C-2	3/4"	1
				V800,801,802,803,860,861,862,863	VOS060-C-4	1 1/2"	8
				V751	VOW015-A-4	4"	1
				V446,467	VOS060-C-3	3/4"	2
				V409,411,412,413,414,808,810,812,847,848,982,983,984,985	VOS060-C-3	1 1/2"	14
				V415,416,417,418,804,805,806,807	VOS060-C-3	1 1/2"	8
				V401,404	VOW015-A-3	6"	2

NOTES
 1. GENERAL NOTES SEE RM-77A
 2. # DENOTES FURNISHED BY (AMINCO) AMERICAN INSTRUMENT COMPANY
 3. ♦ INDICATES DISSIMILAR METAL WELD

REFERENCE DRAWINGS:
 RM-77A - COMPONENT COOLING WATER PIPING
 RM-77F - COMPONENT COOLING WATER PIPING
 RM-99A - SAMPLE PIPING PRIMARY
 RM-99B - SAMPLE PIPING SECONDARY
 RM-43B - AUX STEAM PIPING

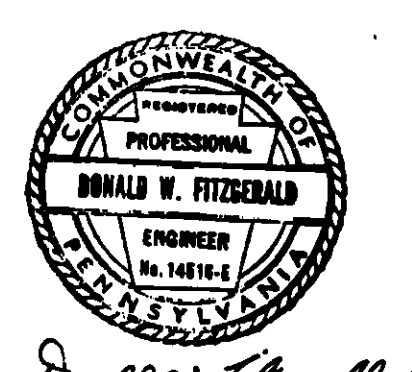

FINALIZED FLUID SYSTEM

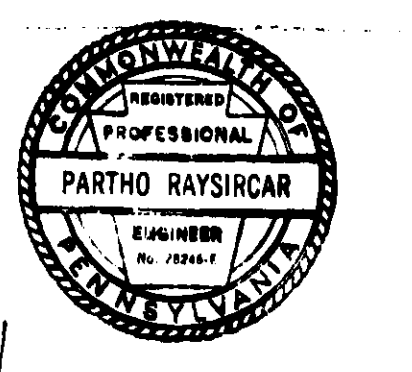

PORTIONS OF THIS DOCUMENT ARE NUCLEAR SAFETY RELATED

THE INFORMATION ON THIS DRAWING MAY NOT BE COPIED OR USED FOR OTHER THAN THE CONSTRUCTION, MAINTENANCE OR REPAIR OF THE PLANT FACILITY DESCRIBED IN THE TITLE BLOCK.

APPROVED: [Signature] REGISTERED PROFESSIONAL ENGINEER NO. 1241-E COMMONWEALTH OF PENNSYLVANIA

DUQUESNE LIGHT COMPANY
 ENGINEERING & CONSTRUCTION PITTSBURGH, PA.

DATE: 2-10-72
 DRAWN: [Name]
 CHECKED: [Name]
 INSPECTED: [Name]

FLOW DIAGRAM
 COMPONENT COOLING PIPING-SH. 5
 BEAVER VALLEY POWER STATION UNIT NO. 2

O.F.E. No. 10080
 C.O. No. 6289
AA No.10080-RM-77E

NO.	DATE	DESCRIPTION	BY	CHKD.	APPD.
1	12/21/71	ISSUE FOR CONSTRUCTION	[Name]	[Name]	[Name]
2	1/15/72	CHANGE RECORD OF DRAWING CHANGES 12241-BCM-77E-15	[Name]	[Name]	[Name]
3	1/15/72	CHANGE RECORD OF DRAWING CHANGES 12241-BCM-77E-16	[Name]	[Name]	[Name]
4	1/15/72	CHANGE RECORD OF DRAWING CHANGES 12241-BCM-77E-17	[Name]	[Name]	[Name]
5	1/15/72	CHANGE RECORD OF DRAWING CHANGES 12241-BCM-77E-18	[Name]	[Name]	[Name]
6	1/15/72	CHANGE RECORD OF DRAWING CHANGES 12241-BCM-77E-19	[Name]	[Name]	[Name]
7	1/15/72	CHANGE RECORD OF DRAWING CHANGES 12241-BCM-77E-20	[Name]	[Name]	[Name]
8	1/15/72	CHANGE RECORD OF DRAWING CHANGES 12241-BCM-77E-21	[Name]	[Name]	[Name]
9	1/15/72	CHANGE RECORD OF DRAWING CHANGES 12241-BCM-77E-22	[Name]	[Name]	[Name]
10	1/15/72	CHANGE RECORD OF DRAWING CHANGES 12241-BCM-77E-23	[Name]	[Name]	[Name]
11	1/15/72	CHANGE RECORD OF DRAWING CHANGES 12241-BCM-77E-24	[Name]	[Name]	[Name]
12	1/15/72	CHANGE RECORD OF DRAWING CHANGES 12241-BCM-77E-25	[Name]	[Name]	[Name]
13	1/15/72	CHANGE RECORD OF DRAWING CHANGES 12241-BCM-77E-26	[Name]	[Name]	[Name]
14	1/15/72	CHANGE RECORD OF DRAWING CHANGES 12241-BCM-77E-27	[Name]	[Name]	[Name]
15	1/15/72	CHANGE RECORD OF DRAWING CHANGES 12241-BCM-77E-28	[Name]	[Name]	[Name]
16	1/15/72	CHANGE RECORD OF DRAWING CHANGES 12241-BCM-77E-29	[Name]	[Name]	[Name]
17	1/15/72	CHANGE RECORD OF DRAWING CHANGES 12241-BCM-77E-30	[Name]	[Name]	[Name]
18	1/15/72	CHANGE RECORD OF DRAWING CHANGES 12241-BCM-77E-31	[Name]	[Name]	[Name]
19	1/15/72	CHANGE RECORD OF DRAWING CHANGES 12241-BCM-77E-32	[Name]	[Name]	[Name]
20	1/15/72	CHANGE RECORD OF DRAWING CHANGES 12241-BCM-77E-33	[Name]	[Name]	[Name]
21	1/15/72	CHANGE RECORD OF DRAWING CHANGES 12241-BCM-77E-34	[Name]	[Name]	[Name]
22	1/15/72	CHANGE RECORD OF DRAWING CHANGES 12241-BCM-77E-35	[Name]	[Name]	[Name]
23	1/15/72	CHANGE RECORD OF DRAWING CHANGES 12241-BCM-77E-36	[Name]	[Name]	[Name]
24	1/15/72	CHANGE RECORD OF DRAWING CHANGES 12241-BCM-77E-37	[Name]	[Name]	[Name]
25	1/15/72	CHANGE RECORD OF DRAWING CHANGES 12241-BCM-77E-38	[Name]	[Name]	[Name]
26	1/15/72	CHANGE RECORD OF DRAWING CHANGES 12241-BCM-77E-39	[Name]	[Name]	[Name]
27	1/15/72	CHANGE RECORD OF DRAWING CHANGES 12241-BCM-77E-40	[Name]	[Name]	[Name]
28	1/15/72	CHANGE RECORD OF DRAWING CHANGES 12241-BCM-77E-41	[Name]	[Name]	[Name]
29	1/15/72	CHANGE RECORD OF DRAWING CHANGES 12241-BCM-77E-42	[Name]	[Name]	[Name]
30	1/15/72	CHANGE RECORD OF DRAWING CHANGES 12241-BCM-77E-43	[Name]	[Name]	[Name]
31	1/15/72	CHANGE RECORD OF DRAWING CHANGES 12241-BCM-77E-44	[Name]	[Name]	[Name]
32	1/15/72	CHANGE RECORD OF DRAWING CHANGES 12241-BCM-77E-45	[Name]	[Name]	[Name]
33	1/15/72	CHANGE RECORD OF DRAWING CHANGES 12241-BCM-77E-46	[Name]	[Name]	[Name]
34	1/15/72	CHANGE RECORD OF DRAWING CHANGES 12241-BCM-77E-47	[Name]	[Name]	[Name]
35	1/15/72	CHANGE RECORD OF DRAWING CHANGES 12241-BCM-77E-48	[Name]	[Name]	[Name]
36	1/15/72	CHANGE RECORD OF DRAWING CHANGES 12241-BCM-77E-49	[Name]	[Name]	[Name]
37	1/15/72	CHANGE RECORD OF DRAWING CHANGES 12241-BCM-77E-50	[Name]	[Name]	[Name]
38	1/15/72	CHANGE RECORD OF DRAWING CHANGES 12241-BCM-77E-51	[Name]	[Name]	[Name]
39	1/15/72	CHANGE RECORD OF DRAWING CHANGES 12241-BCM-77E-52	[Name]	[Name]	[Name]
40	1/15/72	CHANGE RECORD OF DRAWING CHANGES 12241-BCM-77E-53	[Name]	[Name]	[Name]
41	1/15/72	CHANGE RECORD OF DRAWING CHANGES 12241-BCM-77E-54	[Name]	[Name]	[Name]
42	1/15/72	CHANGE RECORD OF DRAWING CHANGES 12241-BCM-77E-55	[Name]	[Name]	[Name]
43	1/15/72	CHANGE RECORD OF DRAWING CHANGES 12241-BCM-77E-56	[Name]	[Name]	[Name]
44	1/15/72	CHANGE RECORD OF DRAWING CHANGES 12241-BCM-77E-57	[Name]	[Name]	[Name]
45	1/15/72	CHANGE RECORD OF DRAWING CHANGES 12241-BCM-77E-58	[Name]	[Name]	[Name]
46	1/15/72	CHANGE RECORD OF DRAWING CHANGES 12241-BCM-77E-59	[Name]	[Name]	[Name]
47	1/15/72	CHANGE RECORD OF DRAWING CHANGES 12241-BCM-77E-60	[Name]	[Name]	[Name]
48	1/15/72	CHANGE RECORD OF DRAWING CHANGES 12241-BCM-77E-61	[Name]	[Name]	[Name]
49	1/15/72	CHANGE RECORD OF DRAWING CHANGES 12241-BCM-77E-62	[Name]	[Name]	[Name]
50	1/15/72	CHANGE RECORD OF DRAWING CHANGES 12241-BCM-77E-63	[Name]	[Name]	[Name]
51	1/15/72	CHANGE RECORD OF DRAWING CHANGES 12241-BCM-77E-64	[Name]	[Name]	[Name]
52	1/15/72	CHANGE RECORD OF DRAWING CHANGES 12241-BCM-77E-65	[Name]	[Name]	[Name]
53	1/15/72	CHANGE RECORD OF DRAWING CHANGES 12241-BCM-77E-66	[Name]	[Name]	[Name]
54	1/15/72	CHANGE RECORD OF DRAWING CHANGES 12241-BCM-77E-67	[Name]	[Name]	[Name]
55	1/15/72	CHANGE RECORD OF DRAWING CHANGES 12241-BCM-77E-68	[Name]	[Name]	[Name]
56	1/15/72	CHANGE RECORD OF DRAWING CHANGES 12241-BCM-77E-69	[Name]	[Name]	[Name]
57	1/15/72	CHANGE RECORD OF DRAWING CHANGES 12241-BCM-77E-70	[Name]	[Name]	[Name]
58	1/15/72	CHANGE RECORD OF DRAWING CHANGES 12241-BCM-77E-71	[Name]	[Name]	[Name]
59	1/15/72	CHANGE RECORD OF DRAWING CHANGES 12241-BCM-77E-72	[Name]	[Name]	[Name]
60	1/15/72	CHANGE RECORD OF DRAWING CHANGES 12241-BCM-77E-73	[Name]	[Name]	[Name]
61	1/15/72	CHANGE RECORD OF DRAWING CHANGES 12241-BCM-77E-74	[Name]	[Name]	[Name]
62	1/15/72	CHANGE RECORD OF DRAWING CHANGES 12241-BCM-77E-75	[Name]	[Name]	[Name]
63	1/15/72	CHANGE RECORD OF DRAWING CHANGES 12241-BCM-77E-76	[Name]	[Name]	[Name]
64	1/15/72	CHANGE RECORD OF DRAWING CHANGES 12241-BCM-77E-77	[Name]	[Name]	[Name]
65	1/15/72	CHANGE RECORD OF DRAWING CHANGES 12241-BCM-77E-78	[Name]	[Name]	[Name]
66	1/15/72	CHANGE RECORD OF DRAWING CHANGES 12241-BCM-77E-79	[Name]	[Name]	[Name]
67	1/15/72	CHANGE RECORD OF DRAWING CHANGES 12241-BCM-77E-80	[Name]	[Name]	[Name]
68	1/15/72	CHANGE RECORD OF DRAWING CHANGES 12241-BCM-77E-81	[Name]	[Name]	[Name]
69	1/15/72	CHANGE RECORD OF DRAWING CHANGES 12241-BCM-77E-82	[Name]	[Name]	[Name]
70	1/15/72	CHANGE RECORD OF DRAWING CHANGES 12241-BCM-77E-83	[Name]	[Name]	[Name]
71	1/15/72	CHANGE RECORD OF DRAWING CHANGES 12241-BCM-77E-84	[Name]	[Name]	[Name]
72	1/15/72	CHANGE RECORD OF DRAWING CHANGES 12241-BCM-77E-85	[Name]	[Name]	[Name]
73	1/15/72	CHANGE RECORD OF DRAWING CHANGES 12241-BCM-77E-86	[Name]	[Name]	[Name]
74	1/15/72	CHANGE RECORD OF DRAWING CHANGES 12241-BCM-77E-87	[Name]	[Name]	[Name]
75	1/15/72	CHANGE RECORD OF DRAWING CHANGES 12241-BCM-77E-88	[Name]	[Name]	[Name]
76	1/15/72	CHANGE RECORD OF DRAWING CHANGES 12241-BCM-77E-89	[Name]	[Name]	[Name]
77	1/15/72	CHANGE RECORD OF DRAWING CHANGES 12241-BCM-77E-90	[Name]	[Name]	[Name]
78	1/15/72	CHANGE RECORD OF DRAWING CHANGES 12241-BCM-77E-91	[Name]	[Name]	[Name]
79	1/15/72	CHANGE RECORD OF DRAWING CHANGES 12241-BCM-77E-92	[Name]	[Name]	[Name]
80	1/15/72	CHANGE RECORD OF DRAWING CHANGES 12241-BCM-77E-93	[Name]	[Name]	[Name]
81	1/15/72	CHANGE RECORD OF DRAWING CHANGES 12241-BCM-77E-94	[Name]	[Name]	[Name]
82	1/15/72	CHANGE RECORD OF DRAWING CHANGES 12241-BCM-77E-95	[Name]	[Name]	[Name]
83	1/15/72	CHANGE RECORD OF DRAWING CHANGES 12241-BCM-77E-96	[Name]	[Name]	[Name]
84	1/15/72	CHANGE RECORD OF DRAWING CHANGES 12241-BCM-77E-97	[Name]	[Name]	[Name]
85	1/15/72	CHANGE RECORD OF DRAWING CHANGES 12241-BCM-77E-98	[Name]	[Name]	[Name]
86	1/15/72	CHANGE RECORD OF DRAWING CHANGES 12241-BCM-77E-99	[Name]	[Name]	[Name]
87	1/15/72	CHANGE RECORD OF DRAWING CHANGES 12241-BCM-77E-100	[Name]	[Name]	[Name]

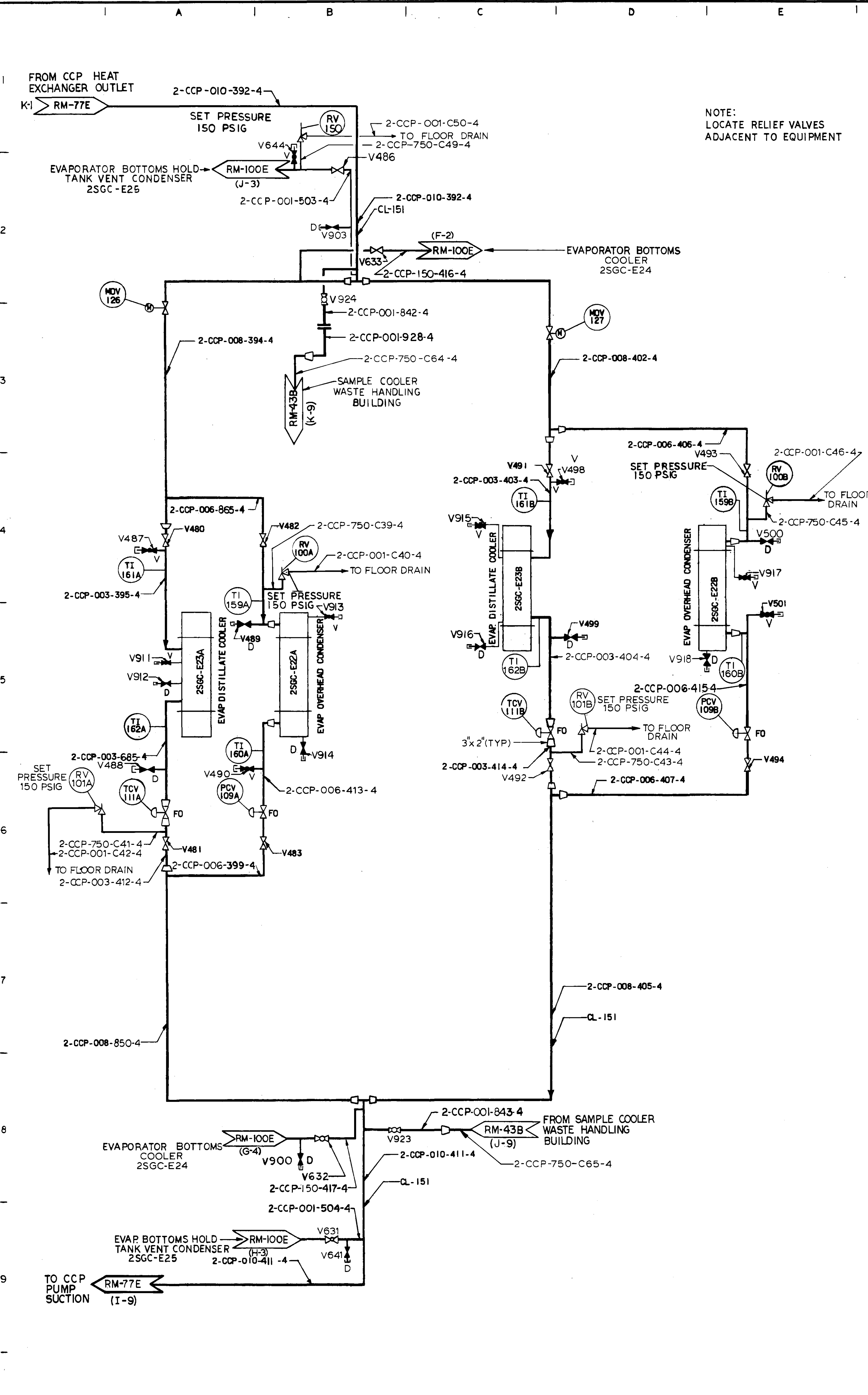

NOTE:
LOCATE RELIEF VALVES
ADJACENT TO EQUIPMENT

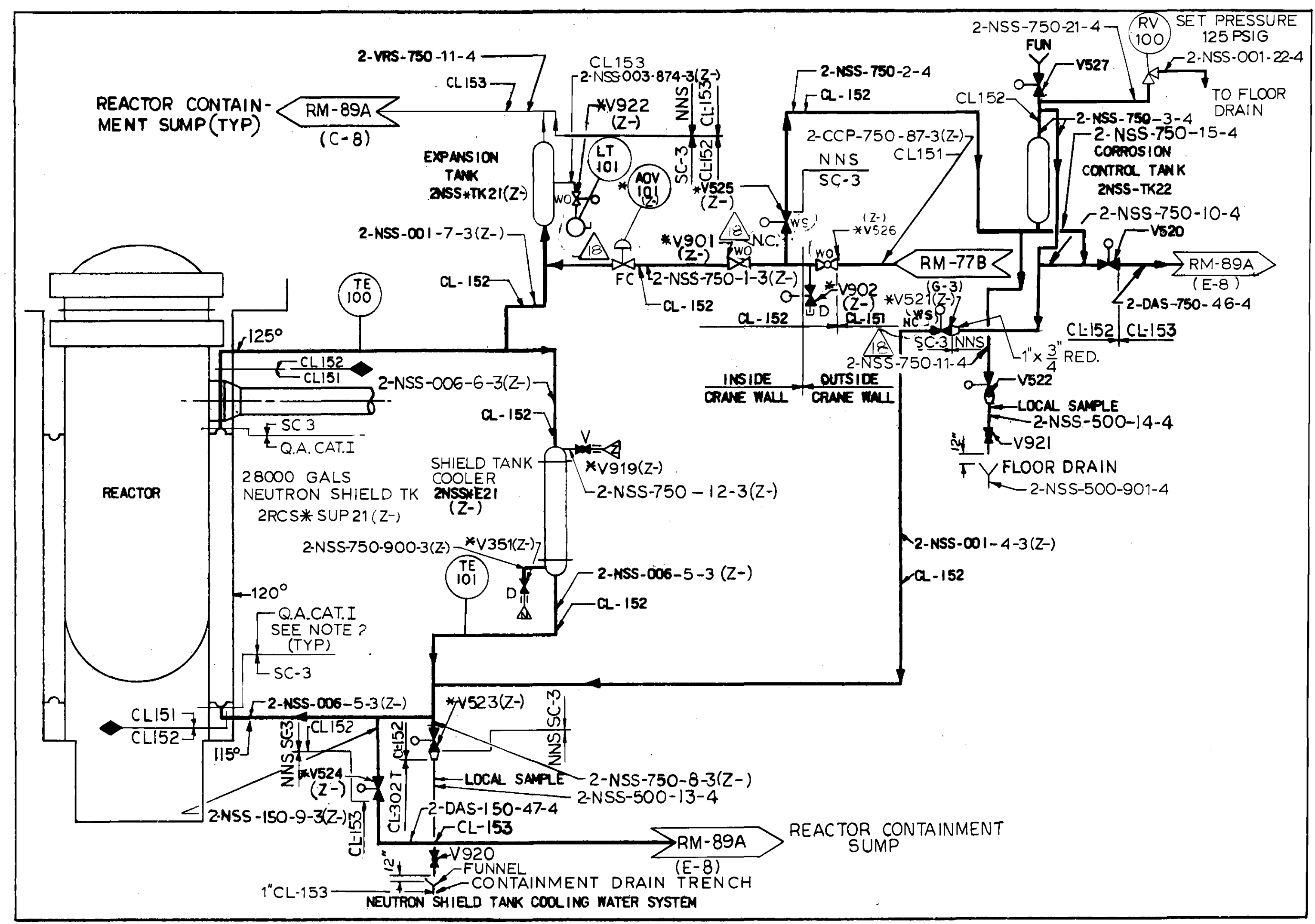

VALVE IDENTIFICATION	MARK NUMBER	PIPE SIZE	QUANTITY
V524	VBS015-Y-3	1 1/2"	1
V521	VBS015-Y-3	1"	1
V523,525,902	VBS015-Y-3	3"	3
V487,490,498,501,644,911,913,915,917	VOS060-C-4	3"	9
V482,483,493,494	VGW015-A-4	6"	4
V486	VGSO60-B-4	1"	1
V631,923,924	VOS060-C-4	1"	3
V922	VBW015-Y-3	3"	1
V480,481,491,492	VGW015-A-4	3"	4
V488,489,499,500,641	VGSO60-B-4	3"	11
900,903,912,914,916,918	VGSO60-V-3	3"	2
V901 RM-77A(NOTE-8)	VGSO60-V-3	3"	2
V351	VOS060-C-4	1 1/2"	1
V920	VOS060-S-4	1 1/2"	1
V632	VOS060-C-4	1 1/2"	1
V633	VGSO60-B-4	1 1/2"	1
V526,919	VOS150-X-3	3"	2
V921	VOS060-W-4	1"	1
V520,522,527	VBS015-D-4	3"	3

NOTES:
1. GENERAL NOTES RM-77A
2. FABRICATED TO ASME VIII, DIVISION I, GUIDELINES NO. STAMP REQUIRED. SEE SPEC 2BVS-9 FOR DESIGN DETAILS.
3. LINE NUMBER(S) (SEE BELOW) CONTAIN(S) A SCH. (SEE BELOW) SPOOL PIECE(S). SEE ISOMETRIC(S) FOR DETAILS.

LINE NO.	SCH. ADDED
2-NSS-500-901-4	40S

REFERENCE DRAWINGS:
COMPONENT COOLING WATER PIPING RM-77B
COMPONENT COOLING WATER PIPING RM-77E
NUCLEAR EQUIPMENT VENT AND DRAIN PIPING RM-89A
STEAM GENERATOR BLOWDOWN PIPING RM-100A
" " " " RM-100C
" " " " RM-100E
AUXILIARY STEAM PIPING RM-43B

PORTIONS OF THIS DOCUMENT ARE
NUCLEAR SAFETY RELATED

FINALIZED FLUID SYSTEM

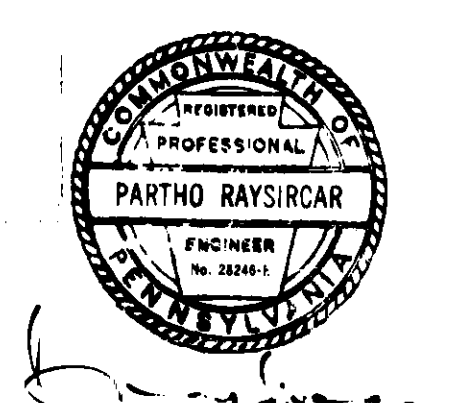

APPROVED
REGISTERED PROFESSIONAL ENGINEER NO. 28246-E
COMMONWEALTH OF PENNSYLVANIA

THE INFORMATION ON THIS DRAWING MAY NOT BE COPIED OR USED FOR OTHER THAN THE CONSTRUCTION, MAINTENANCE OR REPAIR OF THE PLANT FACILITY DESCRIBED IN THE TITLE BLOCK.

DUQUESNE LIGHT COMPANY
ENGINEERING & CONSTRUCTION PITTSBURGH, PA.

SCALE: NONE
DATE: 2-10-72
DRAWN: JLD
CHECKED: [Signature]
INSPECTED: RPB

FLOW DIAGRAM
COMPONENT COOLING PIPING-SH 6
BEAVER VALLEY POWER STATION UNIT NO. 2
D.F.E. No. 10080
C.O. No. 6289
AA No. 10080-RM-77F

GENERAL REVISION
PSAR DWG NOS. CHANGED WAS RM-22 F.

STONE & WEBSTER ENGINEERING CORP.
BOSTON, MASS.

NO.	DATE	DESCRIPTION	BY	CHKD.	APPD.	DATE
17	11/16/72	REVISION CHANGE PER 10/16 PER 12241-BCM-77F-16	[Signature]	[Signature]	[Signature]	11/16/72
16	11/16/72	REVISION CHANGE PER 10/16 PER 12241-BCM-77F-16	[Signature]	[Signature]	[Signature]	11/16/72
15	11/16/72	REVISION CHANGE PER 10/16 PER 12241-BCM-77F-16	[Signature]	[Signature]	[Signature]	11/16/72
14	11/16/72	REVISION CHANGE PER 10/16 PER 12241-BCM-77F-16	[Signature]	[Signature]	[Signature]	11/16/72
13	11/16/72	REVISION CHANGE PER 10/16 PER 12241-BCM-77F-16	[Signature]	[Signature]	[Signature]	11/16/72
12	11/16/72	REVISION CHANGE PER 10/16 PER 12241-BCM-77F-16	[Signature]	[Signature]	[Signature]	11/16/72
11	11/16/72	REVISION CHANGE PER 10/16 PER 12241-BCM-77F-16	[Signature]	[Signature]	[Signature]	11/16/72
10	11/16/72	REVISION CHANGE PER 10/16 PER 12241-BCM-77F-16	[Signature]	[Signature]	[Signature]	11/16/72
9	11/16/72	REVISION CHANGE PER 10/16 PER 12241-BCM-77F-16	[Signature]	[Signature]	[Signature]	11/16/72
8	11/16/72	REVISION CHANGE PER 10/16 PER 12241-BCM-77F-16	[Signature]	[Signature]	[Signature]	11/16/72
7	11/16/72	REVISION CHANGE PER 10/16 PER 12241-BCM-77F-16	[Signature]	[Signature]	[Signature]	11/16/72
6	11/16/72	REVISION CHANGE PER 10/16 PER 12241-BCM-77F-16	[Signature]	[Signature]	[Signature]	11/16/72
5	11/16/72	REVISION CHANGE PER 10/16 PER 12241-BCM-77F-16	[Signature]	[Signature]	[Signature]	11/16/72
4	11/16/72	REVISION CHANGE PER 10/16 PER 12241-BCM-77F-16	[Signature]	[Signature]	[Signature]	11/16/72
3	11/16/72	REVISION CHANGE PER 10/16 PER 12241-BCM-77F-16	[Signature]	[Signature]	[Signature]	11/16/72
2	11/16/72	REVISION CHANGE PER 10/16 PER 12241-BCM-77F-16	[Signature]	[Signature]	[Signature]	11/16/72
1	11/16/72	REVISION CHANGE PER 10/16 PER 12241-BCM-77F-16	[Signature]	[Signature]	[Signature]	11/16/72

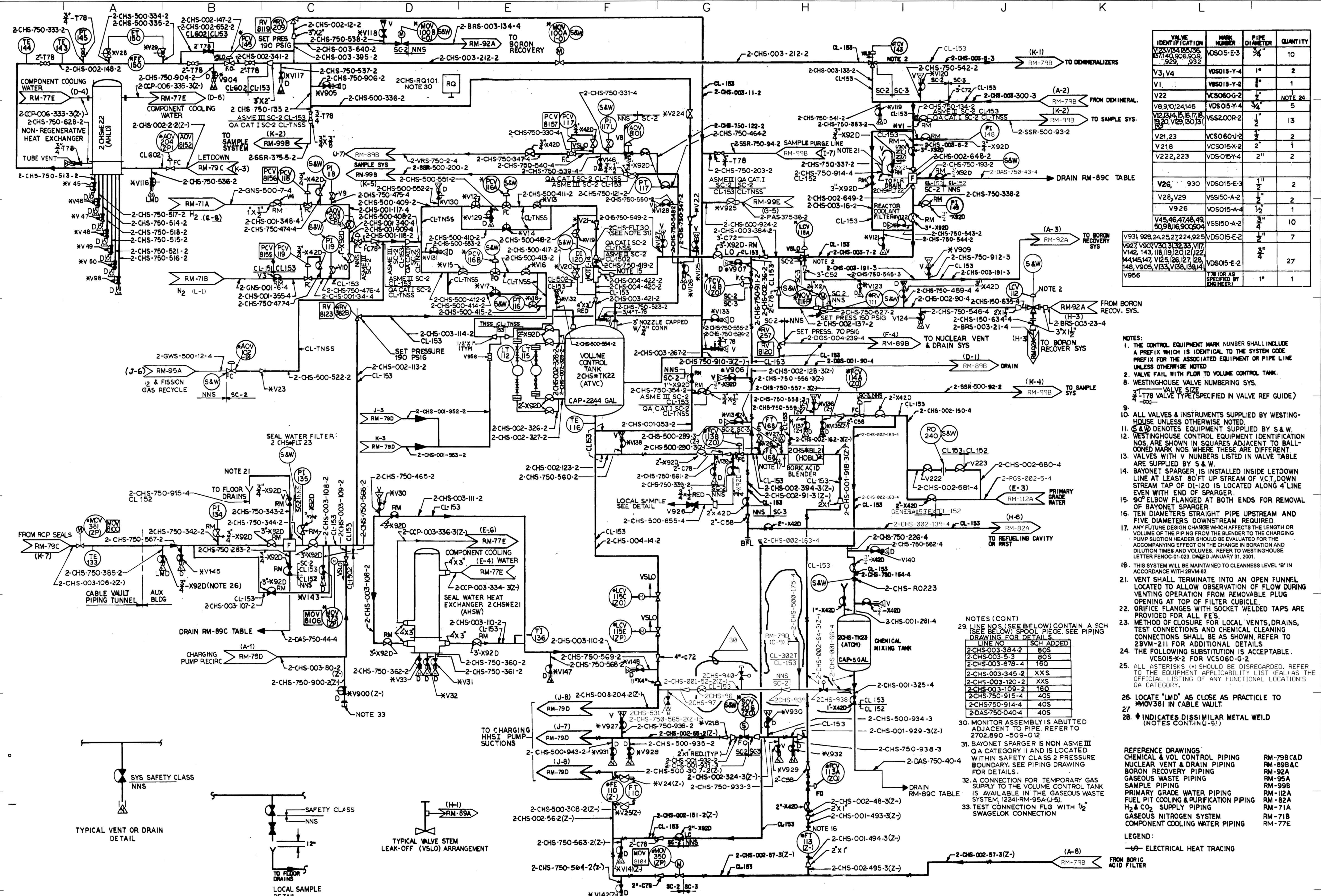

VALVE IDENTIFICATION	MARK NUMBER	PIPE DIAMETER	QUANTITY
V3, V4	VCS015-E-3	3/4"	10
V1	VCS018-Y-4	1"	2
V22	VCS060-G-2	1"	1
V8, V9, V10, V11, V12, V13, V14, V15, V16, V17, V18, V19, V20, V21, V23, V24	VDS015-Y-4	3/4"	NOTE 24
V2, V23	VCS200R-2	1"	13
V218	VCS015-X-2	2"	1
V222, V223	VDS015-Y-4	2"	2
V26	VDS015-E-3	1 1/2"	2
V28, V29	VSS015-A-2	2"	2
V9, V29	VDS015-A-4	1/2"	1
V45, V46, V47, V48, V49, V50, V51, V52, V53, V54, V55, V56, V57, V58, V59, V60, V61, V62, V63, V64, V65, V66, V67, V68, V69, V70, V71, V72, V73, V74, V75, V76, V77, V78, V79, V80, V81, V82, V83, V84, V85, V86, V87, V88, V89, V90, V91, V92, V93, V94, V95, V96, V97, V98, V99, V100	VDS015-A-2	3/4"	10
V93, V94, V95, V96, V97, V98, V99, V100	VDS015-E-2	1 1/2"	7
V101, V102, V103, V104, V105, V106, V107, V108, V109, V110, V111, V112, V113, V114, V115, V116, V117, V118, V119, V120, V121, V122, V123, V124, V125, V126, V127, V128, V129, V130, V131, V132, V133, V134, V135, V136, V137, V138, V139, V140, V141, V142, V143, V144, V145, V146, V147, V148, V149, V150, V151, V152, V153, V154, V155, V156, V157, V158, V159, V160, V161, V162, V163, V164, V165, V166, V167, V168, V169, V170, V171, V172, V173, V174, V175, V176, V177, V178, V179, V180, V181, V182, V183, V184, V185, V186, V187, V188, V189, V190, V191, V192, V193, V194, V195, V196, V197, V198, V199, V200	VDS015-E-2	3/4"	27
V101, V102, V103, V104, V105, V106, V107, V108, V109, V110, V111, V112, V113, V114, V115, V116, V117, V118, V119, V120, V121, V122, V123, V124, V125, V126, V127, V128, V129, V130, V131, V132, V133, V134, V135, V136, V137, V138, V139, V140, V141, V142, V143, V144, V145, V146, V147, V148, V149, V150, V151, V152, V153, V154, V155, V156, V157, V158, V159, V160, V161, V162, V163, V164, V165, V166, V167, V168, V169, V170, V171, V172, V173, V174, V175, V176, V177, V178, V179, V180, V181, V182, V183, V184, V185, V186, V187, V188, V189, V190, V191, V192, V193, V194, V195, V196, V197, V198, V199, V200	VDS015-E-2	1"	1

- NOTES:
- THE CONTROL EQUIPMENT MARK NUMBER SHALL INCLUDE A PREFIX WHICH IS IDENTICAL TO THE SYSTEM CODE PREFIX FOR THE ASSOCIATED EQUIPMENT OR PIPE LINE UNLESS OTHERWISE NOTED.
 - VALVE FAIL WITH FLOW TO VOLUME CONTROL TANK.
 - WESTINGHOUSE VALVE NUMBERING SYSTEM.
 - 1 1/2" VALVE SIZE.
 - 1 1/2" VALVE TYPE (SPECIFIED IN VALVE REF GUIDE).
 - ALL VALVES & INSTRUMENTS SUPPLIED BY WESTINGHOUSE UNLESS OTHERWISE NOTED.
 - S & W DENOTES EQUIPMENT SUPPLIED BY S & W.
 - WESTINGHOUSE CONTROL EQUIPMENT IDENTIFICATION NOS. ARE SHOWN IN SQUARES ADJACENT TO BALL-BOUNDED MARK NOS. WHERE THESE ARE DIFFERENT.
 - VALVES WITH V NUMBERS LISTED IN VALVE TABLE ARE SUPPLIED BY S & W.
 - BAYONET SPARGER IS INSTALLED INSIDE DOWNSTREAM LINE AT LEAST 80 FT UP STREAM OF V.C.T. DOWN STREAM TAP OF D1-120 IS LOCATED ALONG 4" LINE EVEN WITH END OF SPARGER.
 - 90° ELBOW FLANGED AT BOTH ENDS FOR REMOVAL OF BAYONET SPARGER.
 - TEN DIAMETERS STRAIGHT PIPE UPSTREAM AND FIVE DIAMETERS DOWNSTREAM REQUIRED.
 - ANY FUTURE DESIGN CHANGE WHICH AFFECTS THE LENGTH OR VOLUME OF THE PIPING FROM THE BLENDER TO THE CHARGING PUMP SUCTION HEADER SHOULD BE EVALUATED FOR THE ACCOMPANYING EFFECT ON THE CHANGE IN BORATION AND DILUTION TIMES AND VOLUMES. REFER TO WESTINGHOUSE LETTER FENOC-01-023 DATED JANUARY 31, 2001.
 - THIS SYSTEM WILL BE MAINTAINED TO CLEANNESS LEVEL "B" IN ACCORDANCE WITH 28VM-82.
 - VENT SHALL TERMINATE INTO AN OPEN FUNNEL LOCATED TO ALLOW OBSERVATION OF FLOW DURING VENTING OPERATION FROM REMOVABLE PLUG OPENING AT TOP OF FILTER CUBICLE.
 - ORIFICE FLANGES WITH SOCKET WELDED TAPS ARE PROVIDED FOR ALL FES.
 - METHOD OF CLOSURE FOR LOCAL VENTS, DRAINS, TEST CONNECTIONS AND CHEMICAL CLEANING CONNECTIONS SHALL BE AS SHOWN. REFER TO 28VM-2 FOR ADDITIONAL DETAILS.
 - THE FOLLOWING SUBSTITUTION IS ACCEPTABLE. VCS015-K-2 FOR VCS060-G-2.
 - ALL ASTERISKS (*) SHOULD BE DISREGARDED. REFER TO THE EQUIPMENT APPLICABILITY LIST (EAL) AS THE OFFICIAL LISTING OF ANY FUNCTIONAL LOCATION'S DATA CATEGORY.
 - LOCATE "LMD" AS CLOSE AS PRACTICABLE TO MOV381 IN CABLE VAULT.
 - INDICATES DISSIMILAR METAL WELD (NOTES CONTINUED).

NOTES (CONT)

29. LINE NOS. (SEE BELOW) CONTAIN A SCH LINE NO. (SEE BELOW) SPOOL PIECE. SEE PIPING DRAWING FOR DETAILS.

2-CHS-003-384-2	80S
2-CHS-003-5-3	80S
2-CHS-003-678-4	160
2-CHS-003-345-2	XXS
2-CHS-003-120-2	XXS
2-CHS-003-109-2	160
2-CHS-750-915-4	40S
2-CHS-750-914-4	40S
2-DAS-750-040-4	40S

- REFERENCE DRAWINGS
- CHEMICAL & VOL CONTROL PIPING RM-79B C&D
 - NUCLEAR VENT & DRAIN PIPING RM-89B&C
 - BORON RECOVERY PIPING RM-92A
 - GASEOUS WASTE PIPING RM-95A
 - SAMPLE PIPING RM-99B
 - PRIMARY GRADE WATER PIPING RM-112A
 - FUEL PIT COOLING & PURIFICATION PIPING RM-82A
 - H₂ & CO₂ SUPPLY PIPING RM-71A
 - GASEOUS NITROGEN SYSTEM RM-82A
 - COMPONENT COOLING WATER PIPING RM-77E
- LEGEND:
- E— ELECTRICAL HEAT TRACING

NUCLEAR SAFETY RELATED O.M. FIGURE 45D-3 & 4

REVISION 30 INCORPORATED DUN 08-0728-001-003 ECP 08-0728 SATISFIED ECP 09-0197

FENOC FirstEnergy Nuclear Operating Company

BEAVER VALLEY POWER STATION UNIT 2

FLOW DIAGRAM-CHEMICAL & VOLUME CONTROL PIPING SH 1

SCALE: DATE 10/26/10 DRAWN BY MVF ELECT APP. CHECKED BY MCH MECH APP. ENGR/CHK ENCL APP. FINAL APP FOR ISSUE

DWG NO. 10080-RM-0079A REV. 30

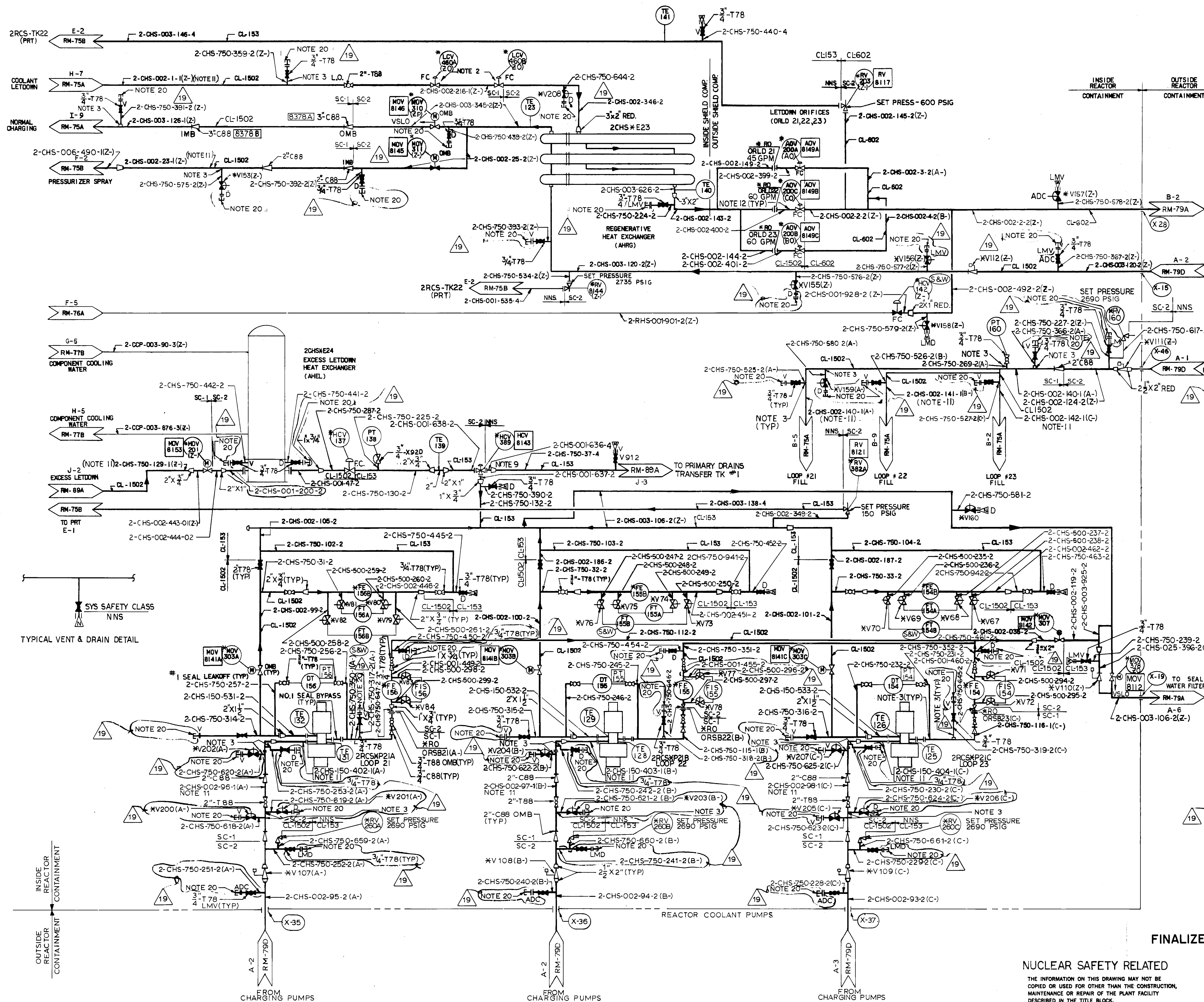

VALVE IDENTIFICATION	MARK NO	PIPE SIZE	QUANTITY
V67,68,69,70,71,72,73,74,75,76,77,78,79,80,81,82,83,84	VSS150-A-2	1/2"	18
V107,108,109, V110	VCW150-X-2	2 1/2"	4
V112	VCW150-Y-2	2 1/2"	1
V153, 155,156,157, 158,159,160,200,201, 202,203,204,205, 206,207,208	VSS150-A-2	3/4"	16
V912	VOS060-W-4	3/4"	1

NOTES (CONT'D)

20. TEST CONNECTION FLGS. WITH 1/2" SWAGelok CONNECTION.

NOTES:

1. THE CONTROL EQUIPMENT MARK NUMBERS SHALL INCLUDE A PREFIX WHICH IS IDENTICAL TO THE SYSTEM CODE PREFIX FOR THE ASSOCIATED EQUIPMENT OR PIPE LINE UNLESS OTHERWISE NOTED. EXAMPLE: 2CHS-TE14
2. PRESSURIZER LOW LEVEL SIGNAL CLOSES THESE VALVES.
3. 3/8" FLOW RESTRICTOR REQUIRED PER 2 BVS-939
4. WESTINGHOUSE VALVE NO. SYS. 2-T78 VALVE SIZE & VALVE TYPE (SPECIFIED IN VALVE REF. GUIDE)
- 5.
6. ALL VALVES & INSTRUMENTS SUPPLIED BY WESTINGHOUSE UNLESS OTHERWISE NOTED.
8. WESTINGHOUSE CONTROL EQUIPMENT IDENTIFICATION NUMBERS ARE SHOWN IN SQUARES ADJACENT TO BALLCOON MARK NUMBERS WHERE THESE ARE DIFFERENT.
9. FAILS WITH FLOW TO VCT
10. THIS SYSTEM SHALL BE MAINTAINED TO A CLEANNESS LEVEL "B" IN ACCORDANCE WITH 2BVM-62
11. ALL CL1 PIPING FROM 1/2 TO 2 DIA TO BE BUTT WELDED EXCEPT AT CONNECTIONS TO W SUPPLIED EQUIPMENT. PROVIDE A MINIMUM OF 5 FT. OF STRAIGHT RUN DOWNSTREAM OF ORIFICE.
13. VALVES WITH V NUMBERS LISTED IN THE VALVE TABLE ARE SUPPLIED BY S&W
14. ORIFICE FLANGES WITH SOCKET WELDED TAPS ARE PROVIDED FOR ALL FES.
15. METHOD OF CLOSURE FOR LOCAL VENTS, DRAINS, TEST CONNECTIONS AND CHEMICAL CLEANING CONNECTIONS SHALL BE AS SHOWN. REFER TO 2BVM-211 FOR ADDITIONAL DETAILS.
16. * DENOTES SAFETY RELATED ITEMS.
17. FABRICATE LINE NO'S 2-CHS-002-216-1 AND 2-CHS-002-1-1 FROM SA 312 OR SA 376 TYPE 316N MATERIAL.
18. (S&W) INDICATES FURNISHED BY STONE & WEBSTER ENGRG CORP. (CONT'D L-B)

LEGEND:

IMB - INSIDE MISSILE BARRIER
 OMB - OUTSIDE MISSILE BARRIER
 FC - FAIL CLOSE
 PRT - PRESSURIZER RELIEF TANK

19. LINE NUMBER 2-CHS-003-120-2 CONTAINS A SCH XXS SPOOL PIECE. SEE PIPING DWG FOR DETAILS.

REFERENCE DRAWINGS:
 REACTOR COOLANT PIPING
 RESIDUAL HEAT REMOVAL PIPING
 COMPONENT COOLING WATER PIPING
 CHEMICAL & VOL. CONTROL PIPING
 NUCLEAR VENT & DRAIN PIPING

FINALIZED FLUID SYSTEM

NUCLEAR SAFETY RELATED

THE INFORMATION ON THIS DRAWING MAY NOT BE COPIED OR USED FOR OTHER THAN THE CONSTRUCTION, MAINTENANCE OR REPAIR OF THE PLANT FACILITY DESCRIBED IN THE TITLE BLOCK.

APPROVED: *[Signature]*
 REGISTERED PROFESSIONAL ENGINEER NO. 21787-E
 COMMONWEALTH OF PENNSYLVANIA

REV.	DATE	DESCRIPTION
1	12-11-72	ISSUED FOR PRODUCTION
2	12-11-72	FOR RECORD OF DWG CHNG
3	12-11-72	FOR RECORD OF DWG CHNG
4	12-11-72	FOR RECORD OF DWG CHNG
5	12-11-72	FOR RECORD OF DWG CHNG
6	12-11-72	FOR RECORD OF DWG CHNG
7	12-11-72	FOR RECORD OF DWG CHNG
8	12-11-72	FOR RECORD OF DWG CHNG
9	12-11-72	FOR RECORD OF DWG CHNG
10	12-11-72	FOR RECORD OF DWG CHNG
11	12-11-72	FOR RECORD OF DWG CHNG
12	12-11-72	FOR RECORD OF DWG CHNG
13	12-11-72	FOR RECORD OF DWG CHNG
14	12-11-72	FOR RECORD OF DWG CHNG
15	12-11-72	FOR RECORD OF DWG CHNG
16	12-11-72	FOR RECORD OF DWG CHNG
17	12-11-72	FOR RECORD OF DWG CHNG
18	12-11-72	FOR RECORD OF DWG CHNG
19	12-11-72	FOR RECORD OF DWG CHNG

DUQUESNE LIGHT COMPANY
 ENGINEERING & CONSTRUCTION PITTSBURGH, PA.

DATE 2-9-72 ARCH. APP.
 DRAWN BAKER ELECT. APP.
 CHECKED MECH. APP.
 INSPECTED RPB STRUCT. APP.

FLOW DIAGRAM
CHEMICAL & VOLUME CONTROL PIPING SH 3
 BEAVER VALLEY POWER STATION-UNIT N02
 O.F.E. No. 10080
 C.O. No. 6289
AA No. 10080-RM-79C

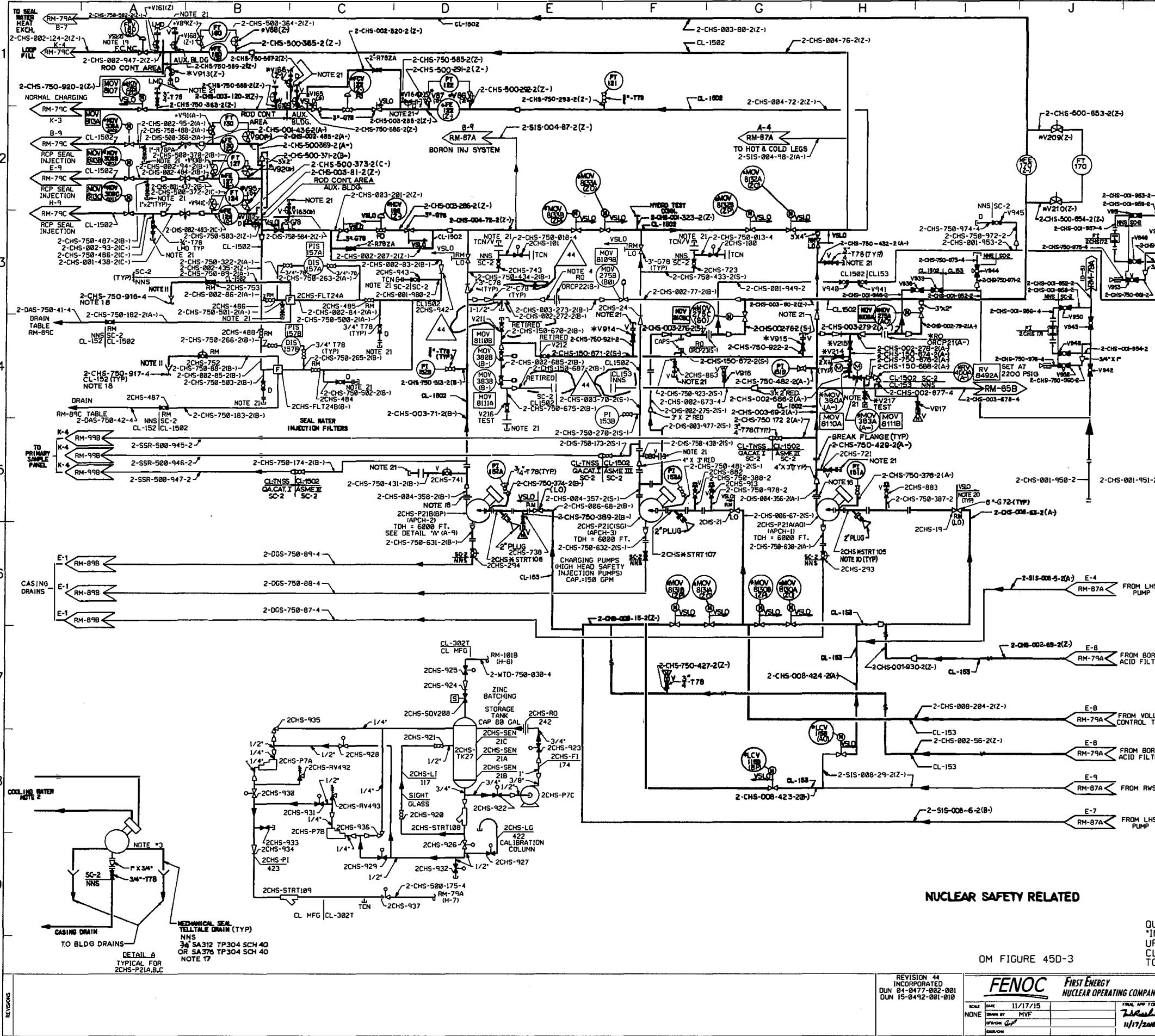

VALVE IDENTIFICATION	MARK NO	PIPE SIZE	QUANTITY
V86,87,88,89,90,91 92,93,94,95,205,210	VSS150-A-2	1/2"	12
V161,162,163,164,165 166,167,168,913	VSS150-A-2	3/4"	9
V216,217,914,915,	VOS150-X-2	3/4"	4
V211,212, 214,215	VOS150-X-2	1 1/2"	4
V916,917	VOS060-W-4	3/4"	2
V934,935,943,945,947 948,949,950,951, 952,953	T78 ICR AS SPECIFIED BY ENGINEERS	1"	14

- NOTES:
- THE CONTROL EQUIPMENT MARK NUMBER SHALL INCLUDE A PREFIX WHICH IS IDENTICAL TO THE SYSTEM CODE PREFIX FOR THE ASSOCIATED EQUIPMENT OR PIPE LINE UNLESS OTHERWISE NOTED
 - MULTIPLE COOLING WATER LINE CONNECTIONS FOR BEARING OIL COOLER ARE REQUIRED SEE PUMP DRAWINGS & RM-47D
 - MECHANICAL SEAL TELLTALE CONNECTIONS ON AUXILIARY GLAND PLATE VENT CONNECTIONS ON GLAND PLATE (NOT SHOWN) ARE PLUGGED
 - SMALL DIAMETER OF PIPE DIAMETERS STRAIGHT RUN ON THE UPSTREAM SIDE OF ORIFICE
 - WESTINGHOUSE VALVE NUMBERING SYSTEM
VALVE SIZE
VALVE TYPE (SPECIFIED IN VALVE REF GUIDE)
 - ALL VALVES & INSTRUMENTS SUPPLIED BY WESTINGHOUSE UNLESS OTHERWISE NOTED
 - (S) DENOTES EQUIPMENT SUPPLIED BY S&W
 - WESTINGHOUSE CONTROL EQUIPMENT IDENTIFICATION NOS ARE SHOWN IN SQUARES ADJACENT TO BALLOONED MARK NUMBERS WHERE THESE ARE DIFFERENT
 - VALVES WITH V NUMBERS LISTED IN THE VALVE TABLE ARE SUPPLIED BY S&W
 - STRAINER ELEMENTS HAVE BEEN REMOVED AND STRAINER BODIES HAVE BEEN ROTATED
 - VENT SHALL TERMINATE INTO AN OPEN FUNNEL LOCATED TO ALLOW OBSERVATION OF FLOW DURING VENTING OPERATION FROM REMOVABLE PLUG OFFERED AT TOP OF FILTER CUBICLE
 - ORIFICE FLANGES WITH SOCKET WELDED TAPS ARE PROVIDED FOR ALL FE'S
 - METHOD OF CLOSURE FOR LOCAL VENTILATION TEST CONNECTIONS AND CHEMICAL CLEANING CONNECTIONS SHALL BE AS SHOWN REFER TO 28VM-211 FOR ADDITIONAL DETAILS
 - THIS SYSTEM TO BE MAINTAINED TO CLEANNESS LEVEL 'B' IN ACCORDANCE WITH 28VM-62
 - (M) DENOTES SAFETY RELATED ITEMS. (SEE NOTE 22)
 - FULL ID 1/2" THICK SPACER TO BE INSERTED BETWEEN THESE FLANGES
 - WHERE UNIONS ARE NECESSARY TO FACILITATE EQUIPMENT REMOVAL USE:
A-182 F 304 3000#
WHERE THREADED FITTINGS ARE NECESSARY DUE TO SPACE RESTRICTIONS USE:
"CAJON" STAINLESS STEEL TP 316 STREET ELBOW (SE) 3/4"-12-SE ELBOW (E) 3/4"-12-E HEX COUPLING (HCG) 3/4"-12-HCG
 - LINE NUMBER(S) (SEE BELOW) CONTAIN(S) (A) SCH (SEE BELOW) SPOOL PIECE(S) SEE ISOMETRIC(S) FOR DETAILS.
- | LINE NO. | SCH ADDED |
|-----------------|-----------|
| 2-CHS-750-916-4 | 40S |
| 2-CHS-750-917-4 | 40S |
- VLSO CONNECTION 20GS-500-934 FOR 2CHS-PCV160 IS NOT REQUIRED, HOWEVER, THE LINE IS INSTALLED. 20GS-500-934 WILL REMAIN ON THE FLOW DIAGRAM AND WILL BE SHOWN FUNCTIONALLY DELETED.
 - FOR VLSO CONTINUATIONS SEE RM-898
 - TEST CONNECTION FLGS. WITH 1/2" SWAGELOK CONNECTION.
 - ALL ASTERISKS (*) SHOULD BE DISREGARDED, REFER TO THE EQUIPMENT APPLICABILITY LIST (EAL) AS THE OFFICIAL LISTING OF ANY FUNCTIONAL LOCATION'S QA CATEGORY.

REFERENCE DRAWINGS:
 CHEMICAL & VOLUME CONTROL PIPING RM-79A & C
 SAFETY INJECTION PIPING RM-87A
 NUCLEAR VENT & DRAIN PIPING RM-89B
 SAMPLE PIPING RM-99B

LEGEND:
 - - - DENOTES ELECTRICAL HEAT TRACING

NUCLEAR SAFETY RELATED

QUALITY GROUP CLASSIFICATIONS ARE INCORPORATED BY REFERENCE INTO THE UFSAR. A CHANGE TO QUALITY GROUP CLASSIFICATIONS CONSTITUTES A CHANGE TO THE UFSAR.

OM FIGURE 45D-3

REVISION 44 INCORPORATED DUN 04-0477-002-001 DUN 15-0492-001-010	FENOC FIRST ENERGY NUCLEAR OPERATING COMPANY	BEAVER VALLEY POWER STATION UNIT 2 FLOW DIAGRAM CHEMICAL & VOLUME CONTROL PIPING SH 4
SCALE NONE DATE 11/17/15 DRAWN BY MVF CHECKED BY [Signature] DATE 11/17/15	DATE 11/17/15 DRAWN BY MVF CHECKED BY [Signature] DATE 11/17/15	AA 10080-RM-0079D 44

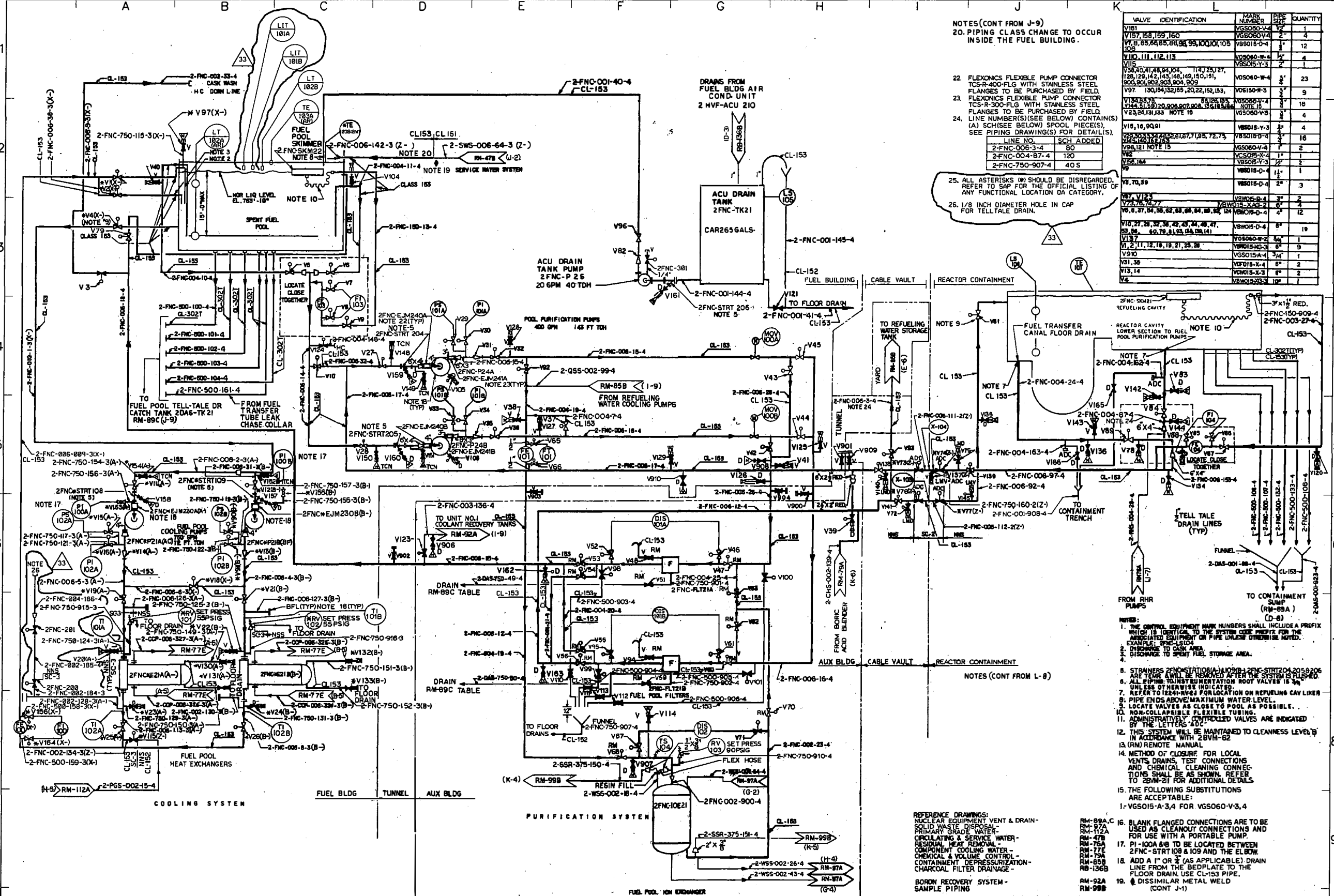

NOTES (CONT FROM J-9)
 20. PIPING CLASS CHANGE TO OCCUR INSIDE THE FUEL BUILDING.

- 22. FLEXONICS FLEXIBLE PUMP CONNECTOR TCS-R-400-FLG WITH STAINLESS STEEL FLANGES TO BE PURCHASED BY FIELD.
- 23. FLEXONICS FLEXIBLE PUMP CONNECTOR TCS-R-300-FLG WITH STAINLESS STEEL FLANGES TO BE PURCHASED BY FIELD.
- 24. LINE NUMBER(S) (SEE BELOW) CONTAIN(S) (A) SCH (SEE BELOW) SPOOL PIECE(S), SEE PIPING DRAWING(S) FOR DETAIL(S).

LINE NO.	SCH ADDED
2-FNC-006-3-4	80
2-FNC-004-87-4	120
2-FNC-750-907-4	40 S

25. ALL ASTERISKS (*) SHOULD BE DISREGARDED. REFER TO SAP FOR THE OFFICIAL LISTING OF ANY FUNCTIONAL LOCATION OR CATEGORY.

26. 1/8 INCH DIAMETER HOLE IN CAP FOR TELLTALE DRAIN.

VALVE IDENTIFICATION	MARK NUMBER	SIZE	QUANTITY
V181	VG5060-V4	2"	1
V157, 158, 159, 160	VG5060-V4	2"	4
V7, 8, 85, 86, 88, 89, 90, 91, 100, 101, 105	V8018-D-4	1"	12
V110, 111, 112, 113	V8060-W-4	1/2"	4
V116	V8015-Y-3	2"	1
V38, 40, 41, 48, 49, 104, 114, 125, 127, 138, 139, 142, 143, 148, 149, 150, 151, 900, 901, 902, 903, 904, 909	V8060-W-4	1/2"	23
V97, 130, 141, 152, 153, 202, 22, 152, 153	V8015-Y-3	3/4"	9
V134, 137, 144, 151, 152, 160, 202, 208, 135, 183, 184	V8060-W-4	1/2"	18
V23, 24, 181, 183	NOTE 18		4
V18, 16, 90, 91	V8018-Y-3	1"	4
V25, 30, 33, 4, 187, 17, 185, 72, 75, V18, 140, 142, 165	V8018-Y-3	1"	16
V96, 121	NOTE 15		2
V85	V8015-Y-3	1"	1
V155, 164	V8015-Y-3	1/2"	2
V8	V8015-D-4	1 1/2"	1
V8, 70, 89	V8015-D-4	2"	3
V81, V123	UNDES-B-A	3"	2
V23, 78, 79, 77	V8015-X-2	2"	4
V6, 8, 9, 24, 58, 62, 63, 64, 68, 69, 124	V8018-D-4	1"	12
V10, 21, 22, 32, 38, 42, 43, 44, 48, 41, 53, 58, 62, 78, 81, 93, 94, 104, 141	V8015-D-4	1"	18
V137	V8060-W-2	3/4"	1
V1, 2, 11, 12, 18, 19, 21, 23, 28	V8018-X-3	1"	9
V910	V8015-A-4	3/4"	1
V81, 58	V8018-X-4	1"	2
V13, 14	V8018-X-3	1"	2
V4	V8015-X-3	1/2"	1

NOTES (CONT FROM L-8)

- 16. BLANK FLANGED CONNECTIONS ARE TO BE USED AS CLEANOUT CONNECTIONS AND FOR USE WITH A PORTABLE PUMP.
- 17. PI-100A 818 TO BE LOCATED BETWEEN 2FNC-STRT 109 AND 109 AND THE ELBOW.
- 18. ADD A 1" OR 3/4" (AS APPLICABLE) DRAIN LINE FROM THE BEDPLATE TO THE FLOOR DRAIN. USE CL-153 PIPE.
- 19. DISSIMILAR METAL WELD (CONT J-1)

QUALITY GROUP CLASSIFICATIONS ARE INCORPORATED BY REFERENCE INTO THE UFSAR. A CHANGE TO QUALITY GROUP CLASSIFICATIONS CONSTITUTES A CHANGE TO THE UFSAR.

REVISION 33 INCORPORATED
 DUN 13-0652-001-005
 DUN 13-0652-002-005
 DUN 13-0626-001-002

DATE	9/16/15	REVISION	33
SCALE	NONE	DESIGNED BY	MVF
DATE	11/11/15	REVISION	1
SCALE	NONE	DESIGNED BY	MVF

BEAVER VALLEY POWER STATION UNIT 2
 FLOW DIAGRAM - FUEL POOL COOLING PURIFICATION PIPING

AA	10080-RM-0082A	33
----	----------------	----

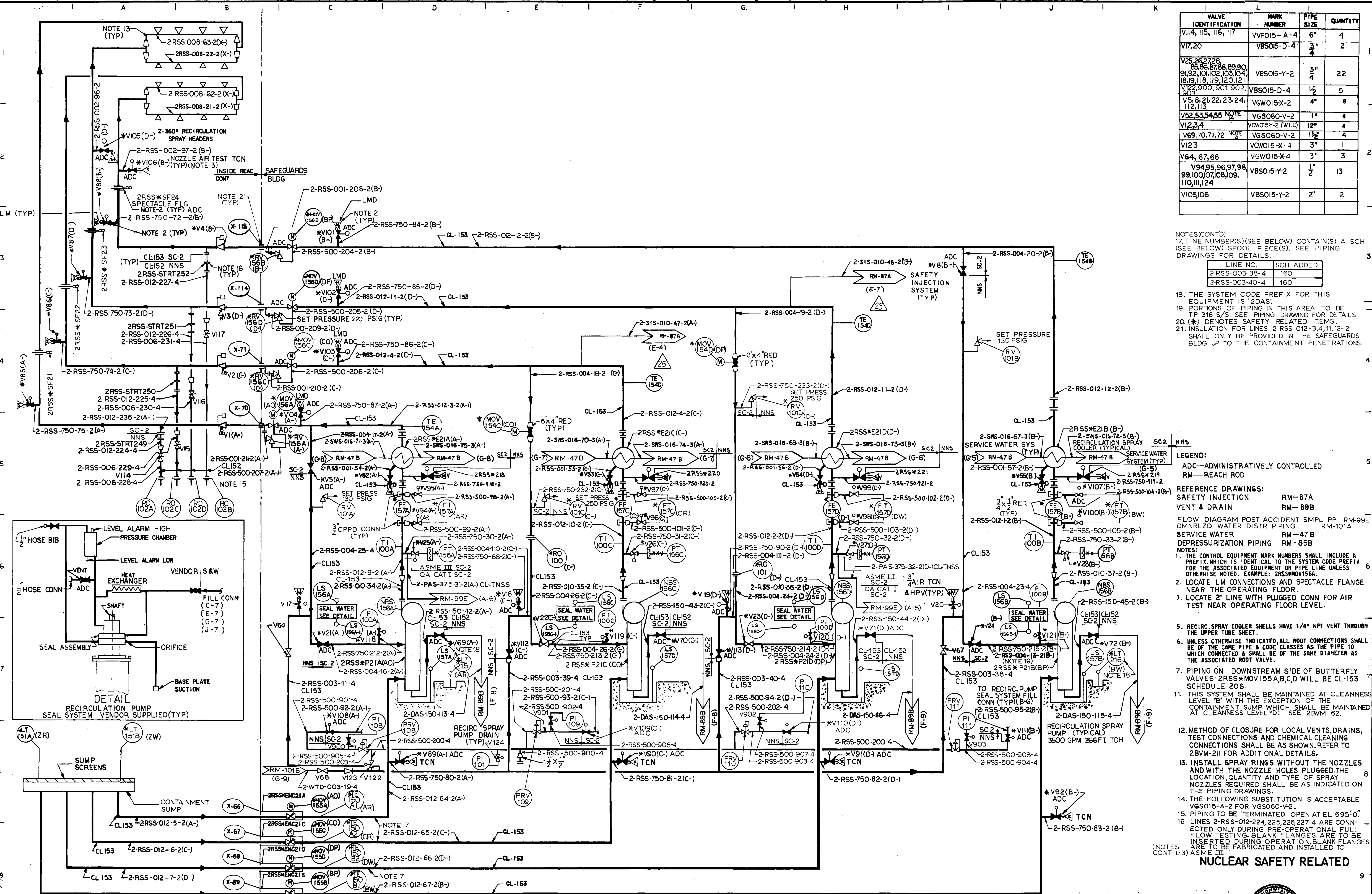

VALVE IDENTIFICATION	MARK NUMBER	PIPE SIZE	QUANTITY
VII4, 115, 116, 117	VVFO15-A-4	6"	4
V17,20	VBS015-D-4	3 1/4"	2
V25,26,27,28, 29,30,31,32,101,102,103,104, 105,106,107,108,109,110,111,112,120,121, 122,900,901,902,903	VBS015-Y-2	3 1/4"	22
V5,8,21,22,23,24, 112,113	VBS015-D-4	1 1/2"	5
V52,53,54,55	NOTE		
V12,3,4	VW015X-2 (WLC)	12"	4
V69,70,71,72	NOTE		
V123	VW015X-4	3"	1
V64,67,68	VW015X-4	3"	3
V94,95,96,97,98, 99,100,107,108,109, 110,111,124	VBS015-Y-2	1 1/2"	13
V105,106	VBS015-Y-2	2"	2

NOTES (CONT'D)
 17. LINE NUMBER(S) INDICATED BELOW CONTAIN(S) A SCH (SEE BELOW) SPOOL PIECE(S). SEE PIPING DRAWINGS FOR DETAILS.

LINE NO.	SCH ADDED
2-RSS-003-38-4	160
2-RSS-003-40-4	160

18. THE SYSTEM CODE PREFIX FOR THIS EQUIPMENT IS "2DAS".
 19. PORTIONS OF PIPING IN THIS AREA TO BE TP 316 S/S. SEE PIPING DRAWING FOR DETAILS.
 20. (*) DENOTES SAFETY RELATED ITEMS.
 21. INSULATION FOR LINES 2-RSS-012-3,4,11,12-2 SHALL ONLY BE PROVIDED IN THE SAFEGUARDS BLDG UP TO THE CONTAINMENT PENETRATIONS.

LEGEND:
 ADC-ADMINISTRATIVELY CONTROLLED
 RM-REACH ROD
 RM-87A SAFETY INJECTION
 RM-89B SAFETY & DRAIN
 RM-99E FLOW DIAGRAM POST ACCIDENT SMPL PP
 RM-101A DMNRZD WATER DISTR PIPING
 RM-47B SERVICE WATER
 RM-85B DEPRESSURIZATION PIPING

NOTES:
 1. THE CONTROL EQUIPMENT MARK NUMBERS SHALL INCLUDE A PREFIX WHICH IS IDENTICAL TO THE SYSTEM CODE PREFIX FOR THE ASSOCIATED EQUIPMENT OR PIPE LINE UNLESS OTHERWISE NOTED. EXAMPLE: 2-RSS*MOV156A.
 2. LOCATE LM CONNECTIONS AND SPECTACLE FLANGE NEAR THE OPERATING FLOOR.
 3. LOCATE 2" LINE WITH PLUGGED CONN FOR AIR TEST NEAR OPERATING FLOOR LEVEL.

4. RECIRC. SPRAY COOLER SHELLS HAVE 1/4" NPT VENT THROUGH THE UPPER TUBE SHEET.
 5. UNLESS OTHERWISE INDICATED, ALL ROOT CONNECTIONS SHALL BE OF THE SAME PIPE & CODE CLASSES AS THE PIPE TO WHICH CONNECTED & SHALL BE OF THE SAME DIAMETER AS THE ASSOCIATED ROOT VALVE.
 6. PIPING ON DOWNSTREAM SIDE OF BUTTERFLY VALVES 2-RSS*MOV155A,B,C, WILL BE CL-153 SCHEDULE 20S.
 7. THIS SYSTEM SHALL BE MAINTAINED AT CLEANNESS LEVEL 'B' WITH THE EXCEPTION OF THE CONTAINMENT SUMP WHICH SHALL BE MAINTAINED AT CLEANNESS LEVEL 'D'. SEE 2BVM 62.
 8. METHOD OF CLOSURE FOR LOCAL VENTS, DRAINS, TEST CONNECTIONS AND CHEMICAL CLEANING CONNECTIONS SHALL BE AS SHOWN, REFER TO 2BVM-211 FOR ADDITIONAL DETAILS.
 9. INSTALL SPRAY RINGS WITHOUT THE NOZZLES AND WITH THE NOZZLE HOLES PLUGGED. THE LOCATION, QUANTITY AND TYPE OF SPRAY NOZZLES REQUIRED SHALL BE AS INDICATED ON THE PIPING DRAWINGS.
 10. THE FOLLOWING SUBSTITUTION IS ACCEPTABLE VGS015-A-2 FOR VGS060-V-2.
 11. PIPING TO BE TERMINATED OPEN AT EL 695'-0".
 12. LINES 2-RSS-012-224,225,226,227-4 ARE CONNECTED ONLY DURING PRE-OPERATIONAL FULL FLOW TESTING. BLANK FLANGES ARE TO BE INSERTED DURING OPERATION. BLANK FLANGES SHALL BE FABRICATED AND INSTALLED TO ASME III.

(NOTES CONT L-3) ASME III
NUCLEAR SAFETY RELATED

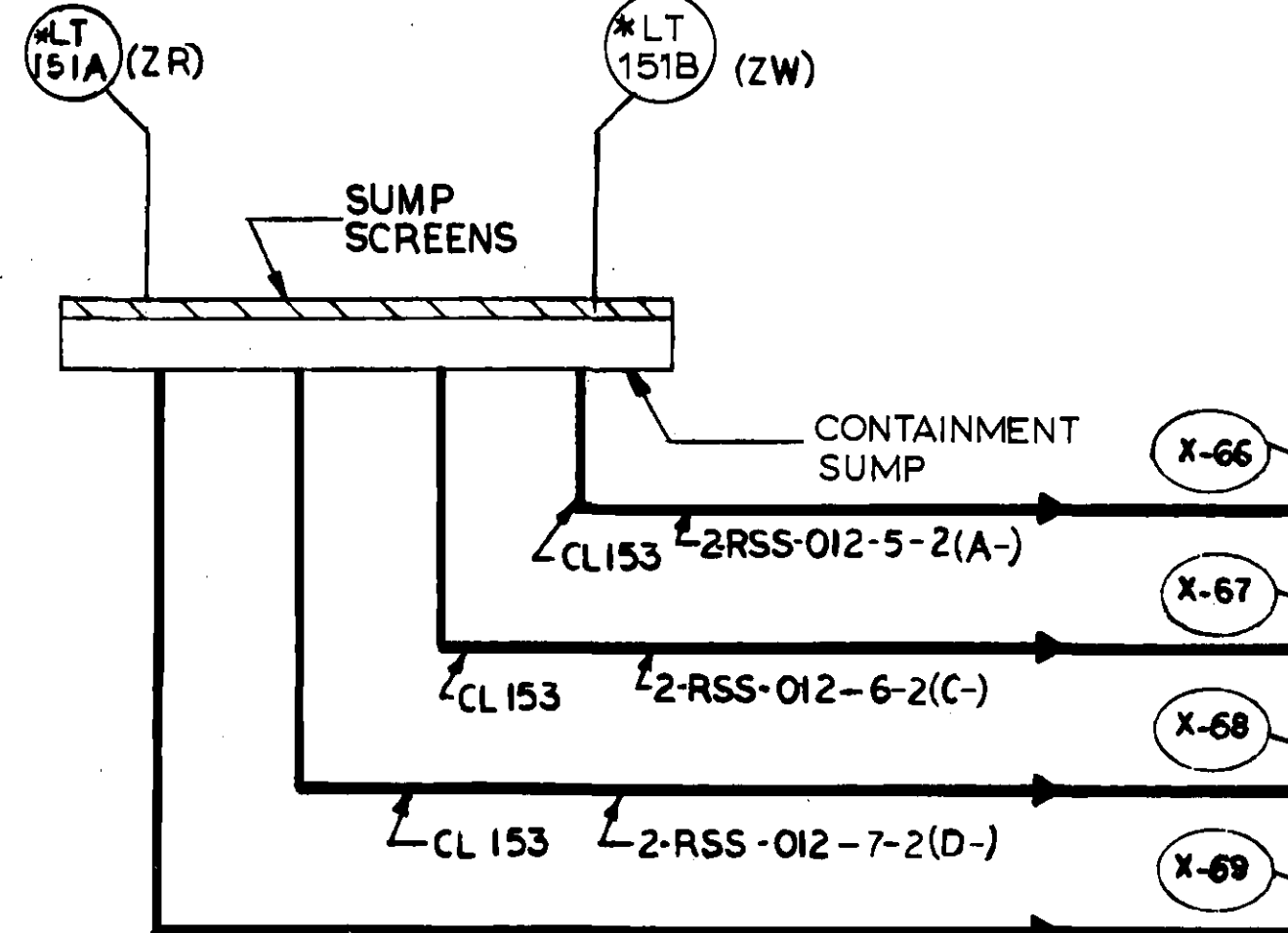
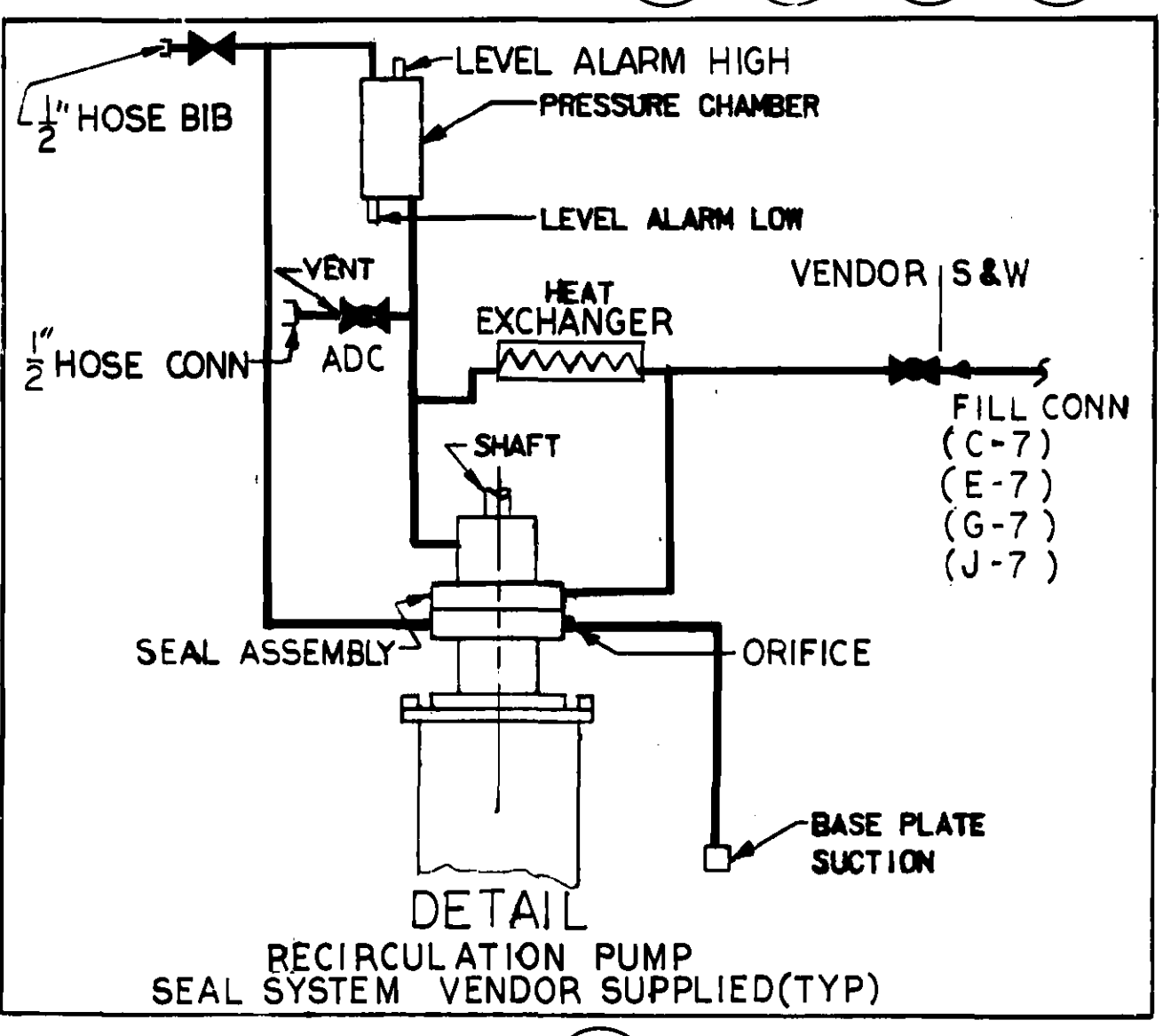

FINALIZED FLUID SYSTEM

THE INFORMATION ON THIS DRAWING MAY NOT BE CORRECT OR USED FOR OTHER THAN THE CONSTRUCTION, MAINTENANCE OR REPAIR OF THE PLANT FACILITY DESCRIBED IN THE TITLE BLOCK.

APPROVED: *[Signature]*
 REGISTERED PROFESSIONAL ENGINEER NO. 62972
 COMMONWEALTH OF PENNSYLVANIA

O.M. FIGURE 45D-15

NO.	REVISIONS	DESCRIPTION	DATE	BY	CHKD	APP'D
1	ISSUE	ISSUE				
2	REVISION	REVISION				
3	REVISION	REVISION				
4	REVISION	REVISION				
5	REVISION	REVISION				
6	REVISION	REVISION				
7	REVISION	REVISION				
8	REVISION	REVISION				
9	REVISION	REVISION				
10	REVISION	REVISION				
11	REVISION	REVISION				
12	REVISION	REVISION				
13	REVISION	REVISION				
14	REVISION	REVISION				
15	REVISION	REVISION				
16	REVISION	REVISION				
17	REVISION	REVISION				
18	REVISION	REVISION				
19	REVISION	REVISION				
20	REVISION	REVISION				
21	REVISION	REVISION				
22	REVISION	REVISION				
23	REVISION	REVISION				
24	REVISION	REVISION				
25	REVISION	REVISION				
26	REVISION	REVISION				
27	REVISION	REVISION				
28	REVISION	REVISION				
29	REVISION	REVISION				
30	REVISION	REVISION				

DUQUESNE LIGHT COMPANY
 ENGINEERING & CONSTRUCTION PITTSBURGH, PA.

FLOW DIAGRAM - CONTAINMENT DEPRESSURIZATION PIPING - SH. I

SCALE: NONE
 DATE: 6-1-72
 DRAWN: RJB
 CHECKED: MECH. APP.
 INSPECTED: RPB
 STRUCT. APP.

BEAVER VALLEY POWER STATION UNIT NO. 2
 O.F.E. No. 10080
 C.O. No. 6289

AA No. 10080-RM-85A

STONE & WEBSTER ENGINEERING CORP.
 BOSTON, MASS.

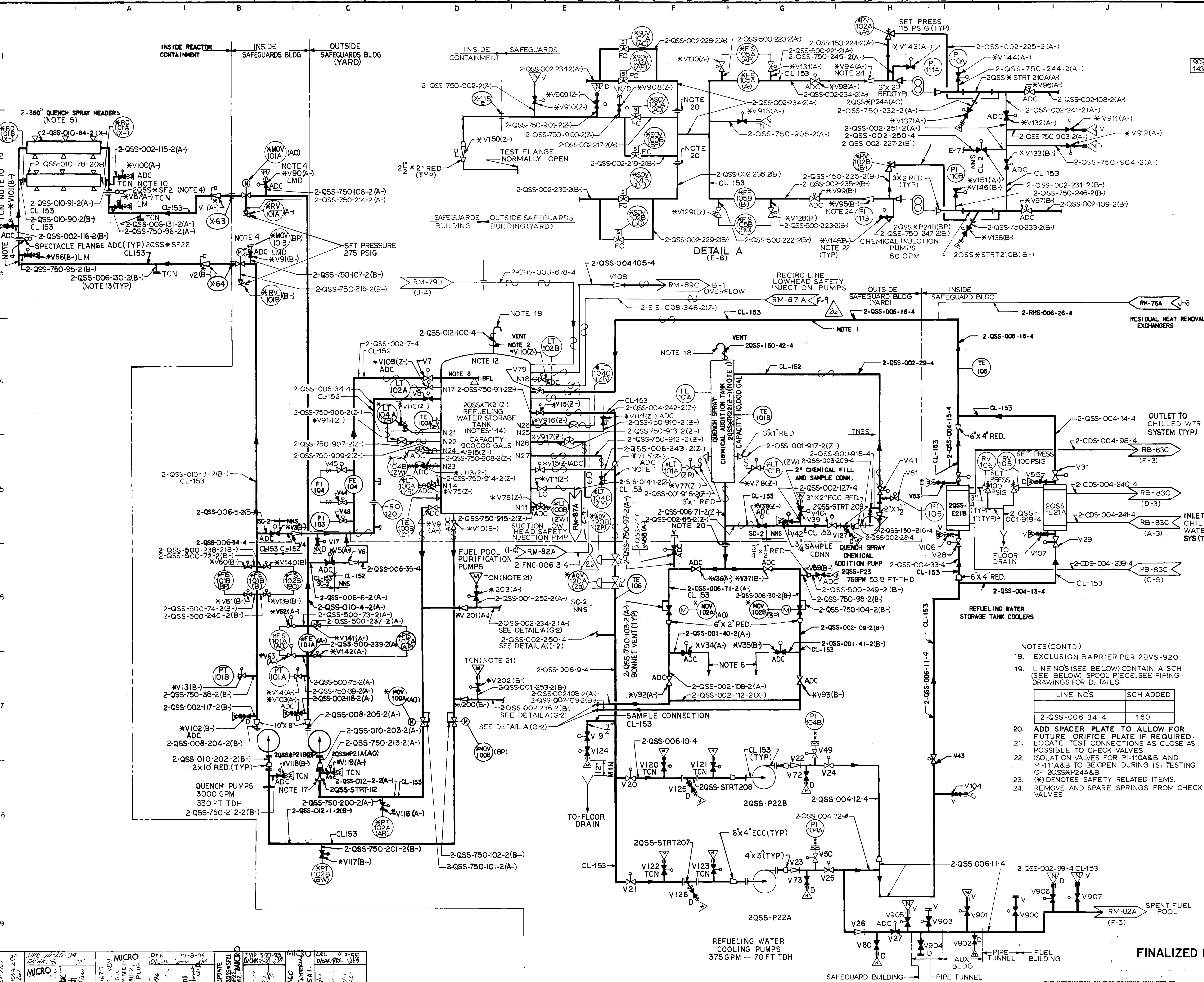

VALVE IDENTIFICATION	MARK NUMBER	PIPE SIZE	QUANTITY
V44,45	VBS015-D-4	1"	2
V60,61,62,63,128,129,130,131,139,140,141,142	VBS015-Y-2	1"	12
909,910,911,912,913,134,90,91,86,87,88,143,144,145,146,908,116,117,118,119,137,138	VBS015-Y-2	1"	23
V904,93,95,96,97,98,125,126,127,128,129,130,131,132,133,134,135,136,137,138,139,140,141,142,143,144,145,146,147,148,149,150,151,152,153,154,155,156,157,158,159,160,161,162,163,164,165,166,167,168,169,170,171,172,173,174,175,176,177,178,179,180,181,182,183,184,185,186,187,188,189,190,191,192,193,194,195,196,197,198,199,200,201,202,203,204,205,206,207,208,209,210,211,212,213,214,215,216,217,218,219,220,221,222,223,224,225,226,227,228,229,230,231,232,233,234,235,236,237,238,239,240,241,242,243,244,245,246,247,248,249,250,251,252,253,254,255,256,257,258,259,260,261,262,263,264,265,266,267,268,269,270,271,272,273,274,275,276,277,278,279,280,281,282,283,284,285,286,287,288,289,290,291,292,293,294,295,296,297,298,299,300,301,302,303,304,305,306,307,308,309,310,311,312,313,314,315,316,317,318,319,320,321,322,323,324,325,326,327,328,329,330,331,332,333,334,335,336,337,338,339,340,341,342,343,344,345,346,347,348,349,350,351,352,353,354,355,356,357,358,359,360,361,362,363,364,365,366,367,368,369,370,371,372,373,374,375,376,377,378,379,380,381,382,383,384,385,386,387,388,389,390,391,392,393,394,395,396,397,398,399,400,401,402,403,404,405,406,407,408,409,410,411,412,413,414,415,416,417,418,419,420,421,422,423,424,425,426,427,428,429,430,431,432,433,434,435,436,437,438,439,440,441,442,443,444,445,446,447,448,449,450,451,452,453,454,455,456,457,458,459,460,461,462,463,464,465,466,467,468,469,470,471,472,473,474,475,476,477,478,479,480,481,482,483,484,485,486,487,488,489,490,491,492,493,494,495,496,497,498,499,500,501,502,503,504,505,506,507,508,509,510,511,512,513,514,515,516,517,518,519,520,521,522,523,524,525,526,527,528,529,530,531,532,533,534,535,536,537,538,539,540,541,542,543,544,545,546,547,548,549,550,551,552,553,554,555,556,557,558,559,560,561,562,563,564,565,566,567,568,569,570,571,572,573,574,575,576,577,578,579,580,581,582,583,584,585,586,587,588,589,590,591,592,593,594,595,596,597,598,599,600,601,602,603,604,605,606,607,608,609,610,611,612,613,614,615,616,617,618,619,620,621,622,623,624,625,626,627,628,629,630,631,632,633,634,635,636,637,638,639,640,641,642,643,644,645,646,647,648,649,650,651,652,653,654,655,656,657,658,659,660,661,662,663,664,665,666,667,668,669,670,671,672,673,674,675,676,677,678,679,680,681,682,683,684,685,686,687,688,689,690,691,692,693,694,695,696,697,698,699,700,701,702,703,704,705,706,707,708,709,710,711,712,713,714,715,716,717,718,719,720,721,722,723,724,725,726,727,728,729,730,731,732,733,734,735,736,737,738,739,740,741,742,743,744,745,746,747,748,749,750,751,752,753,754,755,756,757,758,759,760,761,762,763,764,765,766,767,768,769,770,771,772,773,774,775,776,777,778,779,780,781,782,783,784,785,786,787,788,789,790,791,792,793,794,795,796,797,798,799,800,801,802,803,804,805,806,807,808,809,810,811,812,813,814,815,816,817,818,819,820,821,822,823,824,825,826,827,828,829,830,831,832,833,834,835,836,837,838,839,840,841,842,843,844,845,846,847,848,849,850,851,852,853,854,855,856,857,858,859,860,861,862,863,864,865,866,867,868,869,870,871,872,873,874,875,876,877,878,879,880,881,882,883,884,885,886,887,888,889,890,891,892,893,894,895,896,897,898,899,900,901,902,903,904,905,906,907	VBS015-D-4	1"	10
V18,48,49,50,17,42,81,120,121,22,23,24,900,901,903,905,906,907	VBS015-D-4	1"	18
V34,35,77,78,202,203	VBS015-Y-2	1"	6
V109,110	VBF015-Y-2	3"	2
V39,40,41,27,7	VBS015-G-4	2"	5
V26	NOTE 16	2"	1
V38,96,97,98,99,100,101,132,133,151	VBS015-Y-2	2"	10
V24,25,28,29,30,31	VBS015-Y-4	4"	6
V5,5,16	VBN015-X-G	6"	3
V4,6	VCO15-X-4	6"	2
V22,23,108	VCO15-X-4	4"	3
V75,76,112,113,114,115,914,915,916,917	VSS150-A-2	3/4"	10
V15	VBS015-Y-2	4"	1
V8,20,21,43,79	VBS015-Y-4	6"	5
V94,95,200,201	VCS060-G-2	2"	4
V36,37	VGS015-X-2	6"	2
V1,2	NOTE 7	10"	2
V89	VGS015-A-2	1/2"	1
V9,10	VGS015-X-2	12"	2
V92,93,102,103	VGS060-V-2	2"	4
V104,106,107	VOS060-W-4	3/4"	3
VIII	VV1015-AR-2	14"	1
V150	VCO15-Y-2	2 1/2"	1

- NOTES:
- INSTRUMENTS AND OUTDOOR PORTIONS OF LINES CONNECTED TO 2QSS*TK21(Z) AND 2QSS*TK22(Z) TO BE PROVIDED WITH ELECTRIC HEAT TRACING.
 - THE 12" VENT ON THE REFUELING WATER STORAGE TANK WILL BE PROVIDED BY THE TANK MANUFACTURER.
 - THE CONTROL EQUIPMENT MARK NUMBERS SHALL INCLUDE A PREFIX WHICH IS IDENTICAL TO THE SYSTEM CODE PREFIX FOR THE ASSOCIATED EQUIPMENT OR PIPE LINE, UNLESS OTHERWISE NOTED. EXAMPLE: 2QSS-TE101A
 - LOCATE SPECTACLE FLANGES AND LM CONNECTIONS NEAR THE OPERATING FLOOR LEVEL.
 - INSTALL PLUGS IN SPRAY NOZZLES DURING CONSTRUCTION. ACTUAL NOZZLES WILL BE INSTALLED AFTER TESTING IS COMPLETED.
 - LOCATE VALVES V34 & V35 4 FT. ABOVE OPERATING FLOOR AT 718'-6" ELEVATION.
 - VALVES 1 & 2 ARE WEIGHT LOADED CHECK VALVES: VCM 015-Y-2(WLC)
 - QUENCH SPRAY NOZZLES (3) ARE INSTALLED ON THE EXTENSION OF LINE 2-QSS-002-7-4
 - UNLESS OTHERWISE INDICATED, ALL ROOT CONNECTIONS SHALL BE 6 OF THE SAME PIPE & CODE GLASSES AS THE PIPE TO WHICH CONNECTED & SHALL BE OF THE SAME DIAMETER AS THE ASSOCIATED ROOT VALVE
 - VALVES V100 & V101 ARE AIR TEST CONNECTIONS, AND WILL BE LOCATED NEAR AN OPERATING FLOOR LEVEL.
 - ALL PIPING INSIDE & OUTSIDE REACTOR CONT. SHALL BE MAINTAINED TO CLEANNESS LEVEL B IN ACCORDANCE WITH 2BVM-62
 - ALL CLASS 4 LINES ON THE REFUELING WATER STORAGE TANK AND QUENCH SPRAY CHEMICAL ADDITION TANK WILL BE ABOVE THE NORMAL LOW FLUID LEVEL
 - DURING PLANT OPERATION LINES 2-QSS-006-130-2 AND 2-QSS-006-131-2 ARE BOLTED BLANK.
 - ALL CONNECTIONS TO THE REFUELING WATER STORAGE TANK ARE MADE DIRECTLY TO TANK NOZZLES.
 - METHOD OF CLOSURE FOR LOCAL VENTS, DRAINS, TEST CONNECTIONS SHALL BE AS SHOWN, REFER TO 2BVM-211 FOR ADDITIONAL DETAILS.
 - THE FOLLOWING SUBSTITUTIONS ARE ACCEPTABLE: VCS015-X-2A FOR VCS060-G-2A RESPECTIVELY VGS015-A-2A FOR VGS060-V-2A RESPECTIVELY VOS015-A-2A FOR VOS060-W-2A RESPECTIVELY CONICAL STRAINER TO BE REMOVED AFTER INITIAL SYSTEM FLUSH. SPOOL PIECES FOR CONICAL STRAINER & 3/8" SPACER RINGS ARE TO BE PROVIDED BY THE PIPING FABRICATOR (CONTD J-6)

- NOTES (CONTD)
- EXCLUSION BARRIER PER 2BVS-920
 - LINE NOS (SEE BELOW) CONTAIN A SCH (SEE BELOW) SPOOL PIECE. SEE PIPING DRAWINGS FOR DETAILS.
- | LINE NOS | SCH ADDED |
|----------------|-----------|
| 2-QSS-006-34-4 | 160 |
- ADD SPACER PLATE TO ALLOW FOR FUTURE ORIFICE PLATE IF REQUIRED.
 - LOCATE TEST CONNECTIONS AS CLOSE AS POSSIBLE TO CHECK VALVES
 - ISOLATION VALVES FOR PI-110A&B AND PI-111A&B TO BE OPEN DURING ISI TESTING OF 2QSS*P24A&B
 - (*) DENOTES SAFETY RELATED ITEMS.
 - REMOVE AND SPARE SPRINGS FROM CHECK VALVES.

REFERENCE DRAWINGS:

- SAFETY INJECTION PIPING RM-87A
- NUCLEAR EQUIP VENT & DRAIN PIPING RM-89C
- RESIDUAL HEAT REMOVAL PIPING RM-76A
- CHILLED WATER SYSTEM RB-83C
- FUEL POOL COOLING PURIFICATION PIPING RM-82A

NUCLEAR SAFETY RELATED

FINALIZED FLUID SYSTEM

THE INFORMATION ON THIS DRAWING MAY NOT BE COPIED OR USED FOR OTHER THAN THE CONSTRUCTION, MAINTENANCE OR REPAIR OF THE PLANT FACILITY DESCRIBED IN THE TITLE BLOCK.

APPROVED: *[Signature]*
REGISTERED PROFESSIONAL ENGINEER NO. 16277-E
COMMONWEALTH OF PENNSYLVANIA

O.M. FIGURE 45D-7&8

DUQUESNE LIGHT COMPANY
ENGINEERING & CONSTRUCTION PITTSBURGH, PA.

SCALE: NONE
DATE: 6-17-72
DRAWN: R.C.G.
CHECKED: MECH. APP.
INSPECTED: R.B.B.
STRUCT. APP.

STONE & WEBSTER ENGINEERING CORP.
BOSTON, MASS.

FLOW DIAGRAM
CONTAINMENT DEPRESSURIZATION PIPING-SH2
BEAVER VALLEY POWER STATION UNIT NO2
G.P.E. No. 10080
C.O. No. 6289
AA No. 10080-RM-85B
S&W DWG. NO. 12241-RM-85B-26

REV	NO	DATE	DESCRIPTION
1	1	10-20-72	ISSUE FOR CONSTRUCTION
2	2	11-15-72	REVISIONS
3	3	12-10-72	REVISIONS
4	4	1-10-73	REVISIONS
5	5	2-10-73	REVISIONS
6	6	3-10-73	REVISIONS
7	7	4-10-73	REVISIONS
8	8	5-10-73	REVISIONS
9	9	6-10-73	REVISIONS
10	10	7-10-73	REVISIONS
11	11	8-10-73	REVISIONS
12	12	9-10-73	REVISIONS
13	13	10-10-73	REVISIONS
14	14	11-10-73	REVISIONS
15	15	12-10-73	REVISIONS
16	16	1-10-74	REVISIONS
17	17	2-10-74	REVISIONS
18	18	3-10-74	REVISIONS
19	19	4-10-74	REVISIONS
20	20	5-10-74	REVISIONS
21	21	6-10-74	REVISIONS
22	22	7-10-74	REVISIONS
23	23	8-10-74	REVISIONS
24	24	9-10-74	REVISIONS
25	25	10-10-74	REVISIONS
26	26	11-10-74	REVISIONS
27	27	12-10-74	REVISIONS
28	28	1-10-75	REVISIONS
29	29	2-10-75	REVISIONS
30	30	3-10-75	REVISIONS
31	31	4-10-75	REVISIONS
32	32	5-10-75	REVISIONS
33	33	6-10-75	REVISIONS
34	34	7-10-75	REVISIONS
35	35	8-10-75	REVISIONS
36	36	9-10-75	REVISIONS
37	37	10-10-75	REVISIONS
38	38	11-10-75	REVISIONS
39	39	12-10-75	REVISIONS
40	40	1-10-76	REVISIONS
41	41	2-10-76	REVISIONS
42	42	3-10-76	REVISIONS
43	43	4-10-76	REVISIONS
44	44	5-10-76	REVISIONS
45	45	6-10-76	REVISIONS
46	46	7-10-76	REVISIONS
47	47	8-10-76	REVISIONS
48	48	9-10-76	REVISIONS
49	49	10-10-76	REVISIONS
50	50	11-10-76	REVISIONS
51	51	12-10-76	REVISIONS
52	52	1-10-77	REVISIONS
53	53	2-10-77	REVISIONS
54	54	3-10-77	REVISIONS
55	55	4-10-77	REVISIONS
56	56	5-10-77	REVISIONS
57	57	6-10-77	REVISIONS
58	58	7-10-77	REVISIONS
59	59	8-10-77	REVISIONS
60	60	9-10-77	REVISIONS
61	61	10-10-77	REVISIONS
62	62	11-10-77	REVISIONS
63	63	12-10-77	REVISIONS
64	64	1-10-78	REVISIONS
65	65	2-10-78	REVISIONS
66	66	3-10-78	REVISIONS
67	67	4-10-78	REVISIONS
68	68	5-10-78	REVISIONS
69	69	6-10-78	REVISIONS
70	70	7-10-78	REVISIONS
71	71	8-10-78	REVISIONS
72	72	9-10-78	REVISIONS
73	73	10-10-78	REVISIONS
74	74	11-10-78	REVISIONS
75	75	12-10-78	REVISIONS
76	76	1-10-79	REVISIONS
77	77	2-10-79	REVISIONS
78	78	3-10-79	REVISIONS
79	79	4-10-79	REVISIONS
80	80	5-10-79	REVISIONS
81	81	6-10-79	REVISIONS
82	82	7-10-79	REVISIONS
83	83	8-10-79	REVISIONS
84	84	9-10-79	REVISIONS
85	85	10-10-79	REVISIONS
86	86	11-10-79	REVISIONS
87	87	12-10-79	REVISIONS
88	88	1-10-80	REVISIONS
89	89	2-10-80	REVISIONS
90	90	3-10-80	REVISIONS
91	91	4-10-80	REVISIONS
92	92	5-10-80	REVISIONS
93	93	6-10-80	REVISIONS
94	94	7-10-80	REVISIONS
95	95	8-10-80	REVISIONS
96	96	9-10-80	REVISIONS
97	97	10-10-80	REVISIONS
98	98	11-10-80	REVISIONS
99	99	12-10-80	REVISIONS
100	100	1-10-81	REVISIONS

ARCH.	CONC.	STEL.	MECH.	VESEL.	INS.	ELEC.
1	1	1	1	1	1	1
2	2	2	2	2	2	2
3	3	3	3	3	3	3
4	4	4	4	4	4	4
5	5	5	5	5	5	5
6	6	6	6	6	6	6
7	7	7	7	7	7	7
8	8	8	8	8	8	8
9	9	9	9	9	9	9
10	10	10	10	10	10	10
11	11	11	11	11	11	11
12	12	12	12	12	12	12
13	13	13	13	13	13	13
14	14	14	14	14	14	14
15	15	15	15	15	15	15
16						

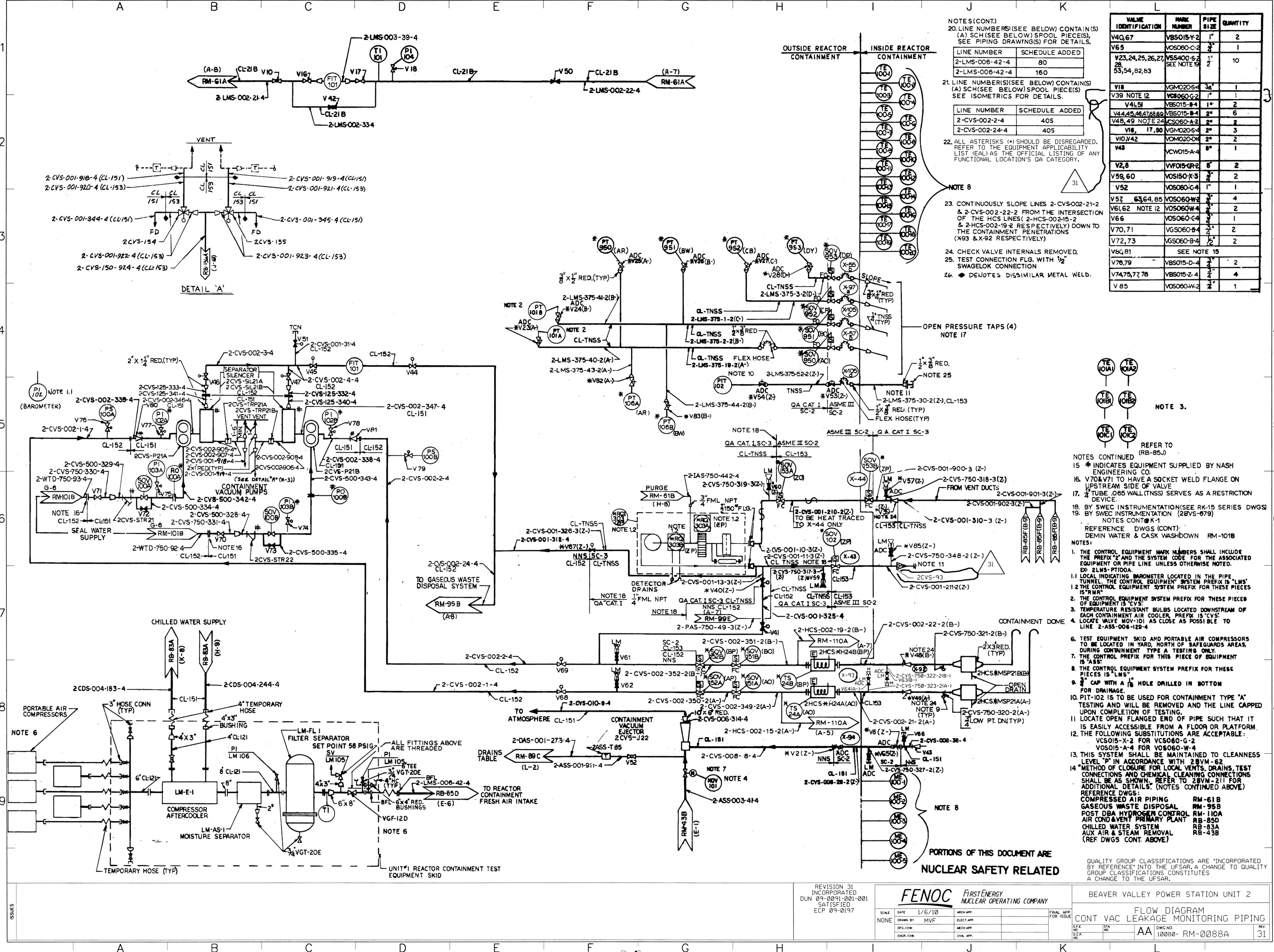

- NOTES (CONT.)
20. LINE NUMBER(S) (SEE BELOW) CONTAIN(S) (A) SCH (SEE BELOW) SPOOL PIECE(S). SEE PIPING DRAWING(S) FOR DETAILS.
- | LINE NUMBER | SCHEDULE ADDED |
|----------------|----------------|
| 2-LMS-006-42-4 | 80 |
| 2-LMS-006-42-4 | 160 |
21. LINE NUMBER(S) (SEE BELOW) CONTAIN(S) (A) SCH (SEE BELOW) SPOOL PIECE(S). SEE ISOMETRICS FOR DETAILS.
- | LINE NUMBER | SCHEDULE ADDED |
|---------------|----------------|
| 2-CVS-002-2-4 | 40S |
| 2-CVS-002-2-4 | 40S |
22. ALL ASTERISKS (*) SHOULD BE DISREGARDED. REFER TO THE EQUIPMENT APPLICABILITY LIST (EAL) AS THE OFFICIAL LISTING OF ANY FUNCTIONAL LOCATION'S QA CATEGORY.
- NOTE 8
23. CONTINUOUSLY SLOPE LINES 2-CVS-002-21-2 & 2-CVS-002-22-2 FROM THE INTERSECTION OF THE HCS LINES (2-HCS-002-15-2 & 2-HCS-002-19-2 RESPECTIVELY) DOWN TO THE CONTAINMENT PENETRATIONS (X93 & X92 RESPECTIVELY).
24. CHECK VALVE INTERNALS REMOVED.
25. TEST CONNECTION FLG. WITH 1/2" SWAGelok CONNECTION
26. ♦ DENOTES DISSIMILAR METAL WELD.

VALVE IDENTIFICATION	MARK NUMBER	PIPE SIZE	QUANTITY
V40,67	VSO15-Y-2	1"	2
V65	VSO60-C-2	2"	1
V23,24,25,26,27,28,53,54,82,83	VSS400-4-2	1"	10
V18	VGM0205-4	3/4"	1
V39 NOTE 12	VCS060-G-2	1"	1
V41,51	VSO15-B-4	1"	2
V44,45,46,47,68,69	VSO15-B-4	2"	6
V48,49 NOTE 24	VSO60-A-2	2"	2
V16, 17,50	VGM0205-4	2"	3
V10,V42	VGM0205-4	2"	2
V43	VW015-A-4	8"	1
V2,8	VV015-GR-2	8"	2
V59,60	VOS150-X-3	2"	2
V52	VOS060-C-4	1"	1
V57, 63,64,85	VSO60-W-2	2"	4
V61,62 NOTE 12	VSO60-W-4	2"	2
V66	VSO60-C-4	2"	1
V70,71	VGS060-B-4	2"	2
V72,73	VGS060-B-4	2"	2
V84,81	SEE NOTE 15		
V76,79	VBS015-D-4	2"	2
V74,75,77,78	VBS015-Z-4	2"	4
V85	VSO60-W-2	2"	1

- NOTE 10
- NOTE 11
- NOTE 12
- NOTE 13
- NOTE 14
- NOTE 15
- NOTE 16
- NOTE 17
- NOTE 18
- NOTE 19
- NOTE 20
- NOTE 21
- NOTE 22
- NOTE 23
- NOTE 24
- NOTE 25
- NOTE 26
- NOTE 27
- NOTE 28
- NOTE 29
- NOTE 30
- NOTE 31
- NOTE 32
- NOTE 33
- NOTE 34
- NOTE 35
- NOTE 36
- NOTE 37
- NOTE 38
- NOTE 39
- NOTE 40
- NOTE 41
- NOTE 42
- NOTE 43
- NOTE 44
- NOTE 45
- NOTE 46
- NOTE 47
- NOTE 48
- NOTE 49
- NOTE 50
- NOTE 51
- NOTE 52
- NOTE 53
- NOTE 54
- NOTE 55
- NOTE 56
- NOTE 57
- NOTE 58
- NOTE 59
- NOTE 60
- NOTE 61
- NOTE 62
- NOTE 63
- NOTE 64
- NOTE 65
- NOTE 66
- NOTE 67
- NOTE 68
- NOTE 69
- NOTE 70
- NOTE 71
- NOTE 72
- NOTE 73
- NOTE 74
- NOTE 75
- NOTE 76
- NOTE 77
- NOTE 78
- NOTE 79
- NOTE 80
- NOTE 81
- NOTE 82
- NOTE 83
- NOTE 84
- NOTE 85
- NOTE 86
- NOTE 87
- NOTE 88
- NOTE 89
- NOTE 90
- NOTE 91
- NOTE 92
- NOTE 93
- NOTE 94
- NOTE 95
- NOTE 96
- NOTE 97
- NOTE 98
- NOTE 99
- NOTE 100
- NOTE 101
- NOTE 102
- NOTE 103
- NOTE 104
- NOTE 105
- NOTE 106
- NOTE 107
- NOTE 108
- NOTE 109
- NOTE 110
- NOTE 111
- NOTE 112
- NOTE 113
- NOTE 114
- NOTE 115
- NOTE 116
- NOTE 117
- NOTE 118
- NOTE 119
- NOTE 120
- NOTE 121
- NOTE 122
- NOTE 123
- NOTE 124
- NOTE 125
- NOTE 126
- NOTE 127
- NOTE 128
- NOTE 129
- NOTE 130
- NOTE 131
- NOTE 132
- NOTE 133
- NOTE 134
- NOTE 135
- NOTE 136
- NOTE 137
- NOTE 138
- NOTE 139
- NOTE 140
- NOTE 141
- NOTE 142
- NOTE 143
- NOTE 144
- NOTE 145
- NOTE 146
- NOTE 147
- NOTE 148
- NOTE 149
- NOTE 150
- NOTE 151
- NOTE 152
- NOTE 153
- NOTE 154
- NOTE 155
- NOTE 156
- NOTE 157
- NOTE 158
- NOTE 159
- NOTE 160
- NOTE 161
- NOTE 162
- NOTE 163
- NOTE 164
- NOTE 165
- NOTE 166
- NOTE 167
- NOTE 168
- NOTE 169
- NOTE 170
- NOTE 171
- NOTE 172
- NOTE 173
- NOTE 174
- NOTE 175
- NOTE 176
- NOTE 177
- NOTE 178
- NOTE 179
- NOTE 180
- NOTE 181
- NOTE 182
- NOTE 183
- NOTE 184
- NOTE 185
- NOTE 186
- NOTE 187
- NOTE 188
- NOTE 189
- NOTE 190
- NOTE 191
- NOTE 192
- NOTE 193
- NOTE 194
- NOTE 195
- NOTE 196
- NOTE 197
- NOTE 198
- NOTE 199
- NOTE 200
- NOTE 201
- NOTE 202
- NOTE 203
- NOTE 204
- NOTE 205
- NOTE 206
- NOTE 207
- NOTE 208
- NOTE 209
- NOTE 210
- NOTE 211
- NOTE 212
- NOTE 213
- NOTE 214
- NOTE 215
- NOTE 216
- NOTE 217
- NOTE 218
- NOTE 219
- NOTE 220
- NOTE 221
- NOTE 222
- NOTE 223
- NOTE 224
- NOTE 225
- NOTE 226
- NOTE 227
- NOTE 228
- NOTE 229
- NOTE 230
- NOTE 231
- NOTE 232
- NOTE 233
- NOTE 234
- NOTE 235
- NOTE 236
- NOTE 237
- NOTE 238
- NOTE 239
- NOTE 240
- NOTE 241
- NOTE 242
- NOTE 243
- NOTE 244
- NOTE 245
- NOTE 246
- NOTE 247
- NOTE 248
- NOTE 249
- NOTE 250
- NOTE 251
- NOTE 252
- NOTE 253
- NOTE 254
- NOTE 255
- NOTE 256
- NOTE 257
- NOTE 258
- NOTE 259
- NOTE 260
- NOTE 261
- NOTE 262
- NOTE 263
- NOTE 264
- NOTE 265
- NOTE 266
- NOTE 267
- NOTE 268
- NOTE 269
- NOTE 270
- NOTE 271
- NOTE 272
- NOTE 273
- NOTE 274
- NOTE 275
- NOTE 276
- NOTE 277
- NOTE 278
- NOTE 279
- NOTE 280
- NOTE 281
- NOTE 282
- NOTE 283
- NOTE 284
- NOTE 285
- NOTE 286
- NOTE 287
- NOTE 288
- NOTE 289
- NOTE 290
- NOTE 291
- NOTE 292
- NOTE 293
- NOTE 294
- NOTE 295
- NOTE 296
- NOTE 297
- NOTE 298
- NOTE 299
- NOTE 300
- NOTE 301
- NOTE 302
- NOTE 303
- NOTE 304
- NOTE 305
- NOTE 306
- NOTE 307
- NOTE 308
- NOTE 309
- NOTE 310
- NOTE 311
- NOTE 312
- NOTE 313
- NOTE 314
- NOTE 315
- NOTE 316
- NOTE 317
- NOTE 318
- NOTE 319
- NOTE 320
- NOTE 321
- NOTE 322
- NOTE 323
- NOTE 324
- NOTE 325
- NOTE 326
- NOTE 327
- NOTE 328
- NOTE 329
- NOTE 330
- NOTE 331
- NOTE 332
- NOTE 333
- NOTE 334
- NOTE 335
- NOTE 336
- NOTE 337
- NOTE 338
- NOTE 339
- NOTE 340
- NOTE 341
- NOTE 342
- NOTE 343
- NOTE 344
- NOTE 345
- NOTE 346
- NOTE 347
- NOTE 348
- NOTE 349
- NOTE 350
- NOTE 351
- NOTE 352
- NOTE 353
- NOTE 354
- NOTE 355
- NOTE 356
- NOTE 357
- NOTE 358
- NOTE 359
- NOTE 360
- NOTE 361
- NOTE 362
- NOTE 363
- NOTE 364
- NOTE 365
- NOTE 366
- NOTE 367
- NOTE 368
- NOTE 369
- NOTE 370
- NOTE 371
- NOTE 372
- NOTE 373
- NOTE 374
- NOTE 375
- NOTE 376
- NOTE 377
- NOTE 378
- NOTE 379
- NOTE 380
- NOTE 381
- NOTE 382
- NOTE 383
- NOTE 384
- NOTE 385
- NOTE 386
- NOTE 387
- NOTE 388
- NOTE 389
- NOTE 390
- NOTE 391
- NOTE 392
- NOTE 393
- NOTE 394
- NOTE 395
- NOTE 396
- NOTE 397
- NOTE 398
- NOTE 399
- NOTE 400
- NOTE 401
- NOTE 402
- NOTE 403
- NOTE 404
- NOTE 405
- NOTE 406
- NOTE 407
- NOTE 408
- NOTE 409
- NOTE 410
- NOTE 411
- NOTE 412
- NOTE 413
- NOTE 414
- NOTE 415
- NOTE 416
- NOTE 417
- NOTE 418
- NOTE 419
- NOTE 420
- NOTE 421
- NOTE 422
- NOTE 423
- NOTE 424
- NOTE 425
- NOTE 426
- NOTE 427
- NOTE 428
- NOTE 429
- NOTE 430
- NOTE 431
- NOTE 432
- NOTE 433
- NOTE 434
- NOTE 435
- NOTE 436
- NOTE 437
- NOTE 438
- NOTE 439
- NOTE 440
- NOTE 441
- NOTE 442
- NOTE 443
- NOTE 444
- NOTE 445
- NOTE 446
- NOTE 447
- NOTE 448
- NOTE 449
- NOTE 450
- NOTE 451
- NOTE 452
- NOTE 453
- NOTE 454
- NOTE 455
- NOTE 456
- NOTE 457
- NOTE 458
- NOTE 459
- NOTE 460
- NOTE 461
- NOTE 462
- NOTE 463
- NOTE 464
- NOTE 465
- NOTE 466
- NOTE 467
- NOTE 468
- NOTE 469
- NOTE 470
- NOTE 471
- NOTE 472
- NOTE 473
- NOTE 474
- NOTE 475
- NOTE 476
- NOTE 477
- NOTE 478
- NOTE 479
- NOTE 480
- NOTE 481
- NOTE 482
- NOTE 483
- NOTE 484
- NOTE 485
- NOTE 486
- NOTE 487
- NOTE 488
- NOTE 489
- NOTE 490
- NOTE 491
- NOTE 492
- NOTE 493
- NOTE 494
- NOTE 495
- NOTE 496
- NOTE 497
- NOTE 498
- NOTE 499
- NOTE 500

PORTIONS OF THIS DOCUMENT ARE NUCLEAR SAFETY RELATED

REVISION 31 INCORPORATED DUN 09-0091-001-001 SATISFIED ECP 09-0197

FENOC FIRST ENERGY NUCLEAR OPERATING COMPANY

SCALE: DATE: 1/6/10 ARCH APP: MVF ELECT APP: MECH APP: CIVL APP: NONE

BEAVER VALLEY POWER STATION UNIT 2

FLOW DIAGRAM CONT VAC LEAKAGE MONITORING PIPING

AA 10080-RM-0088A 31

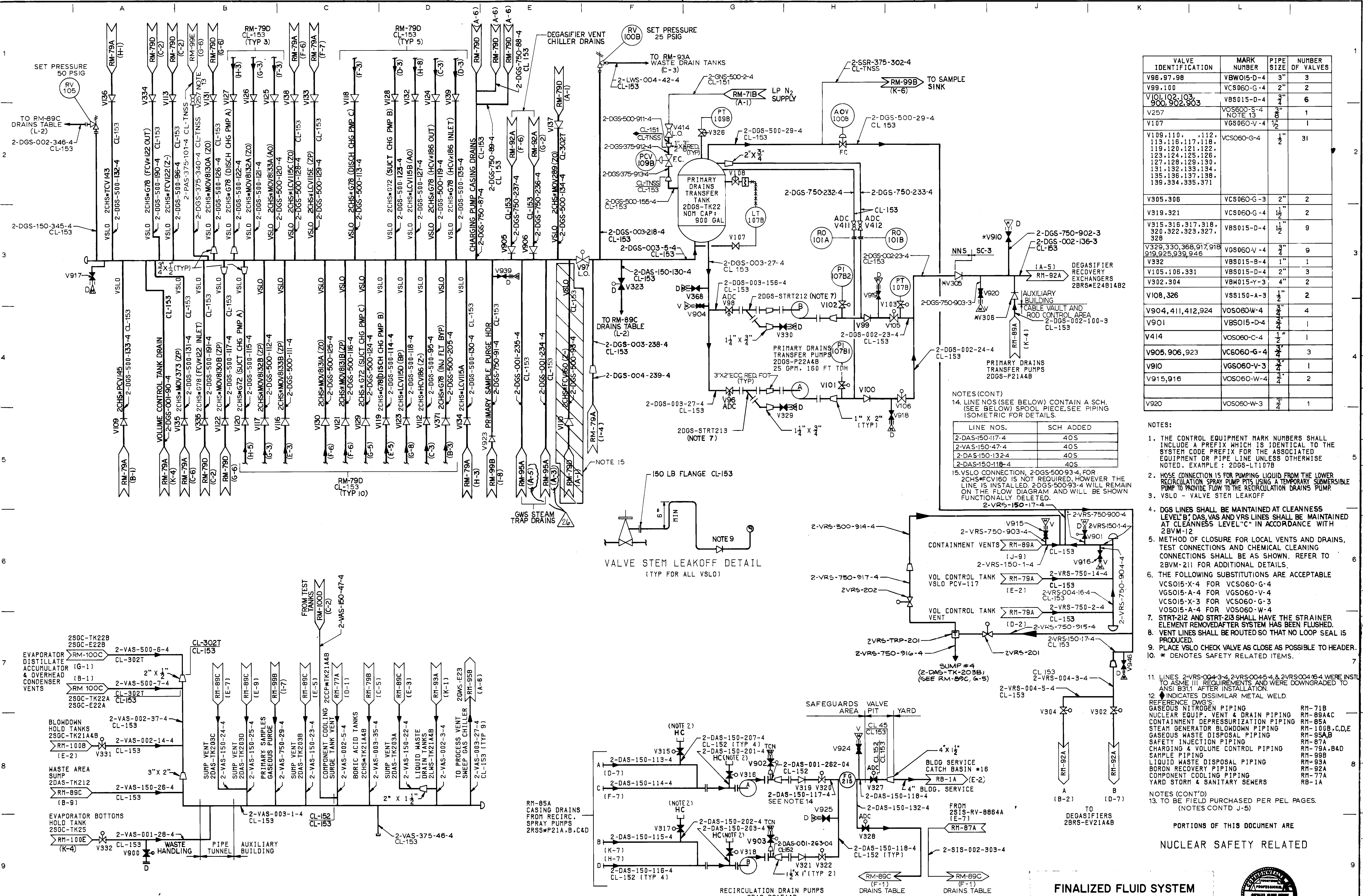

FINALIZED FLUID SYSTEM

THE INFORMATION ON THIS DRAWING MAY NOT BE COPIED OR USED FOR OTHER THAN THE CONSTRUCTION, MAINTENANCE OR REPAIR OF THE PLANT FACILITY DESCRIBED IN THE TITLE BLOCK.

APPROVED: [Signature] REGISTERED PROFESSIONAL ENGINEER NO. COMMONWEALTH OF PENNSYLVANIA

DUQUESNE LIGHT COMPANY
ENGINEERING & CONSTRUCTION PITTSBURGH, PA.

STONE & WEBSTER ENGINEERING CORP.
BOSTON, MASS.

FLOW DIAGRAM
NUCLEAR EQUIP. VENT & DRAIN PIPING-SH.2
BEAVER VALLEY POWER STATION NO.2
AA No. 10080-RM-89B

SCALE: NONE
DATE: JUNE 1979
DRAWN BY: J. EVERY
CHECKED BY: MFCB
INSPECTED BY: [Signature]

REVISIONS:

NO.	DESCRIPTION	DATE
1	ISSUE FOR CONSTRUCTION	6/19/79
2	ISSUE FOR CONSTRUCTION	6/19/79
3	ISSUE FOR CONSTRUCTION	6/19/79
4	ISSUE FOR CONSTRUCTION	6/19/79
5	ISSUE FOR CONSTRUCTION	6/19/79
6	ISSUE FOR CONSTRUCTION	6/19/79
7	ISSUE FOR CONSTRUCTION	6/19/79
8	ISSUE FOR CONSTRUCTION	6/19/79
9	ISSUE FOR CONSTRUCTION	6/19/79
10	ISSUE FOR CONSTRUCTION	6/19/79
11	ISSUE FOR CONSTRUCTION	6/19/79
12	ISSUE FOR CONSTRUCTION	6/19/79
13	ISSUE FOR CONSTRUCTION	6/19/79
14	ISSUE FOR CONSTRUCTION	6/19/79
15	ISSUE FOR CONSTRUCTION	6/19/79
16	ISSUE FOR CONSTRUCTION	6/19/79
17	ISSUE FOR CONSTRUCTION	6/19/79
18	ISSUE FOR CONSTRUCTION	6/19/79
19	ISSUE FOR CONSTRUCTION	6/19/79
20	ISSUE FOR CONSTRUCTION	6/19/79
21	ISSUE FOR CONSTRUCTION	6/19/79
22	ISSUE FOR CONSTRUCTION	6/19/79
23	ISSUE FOR CONSTRUCTION	6/19/79

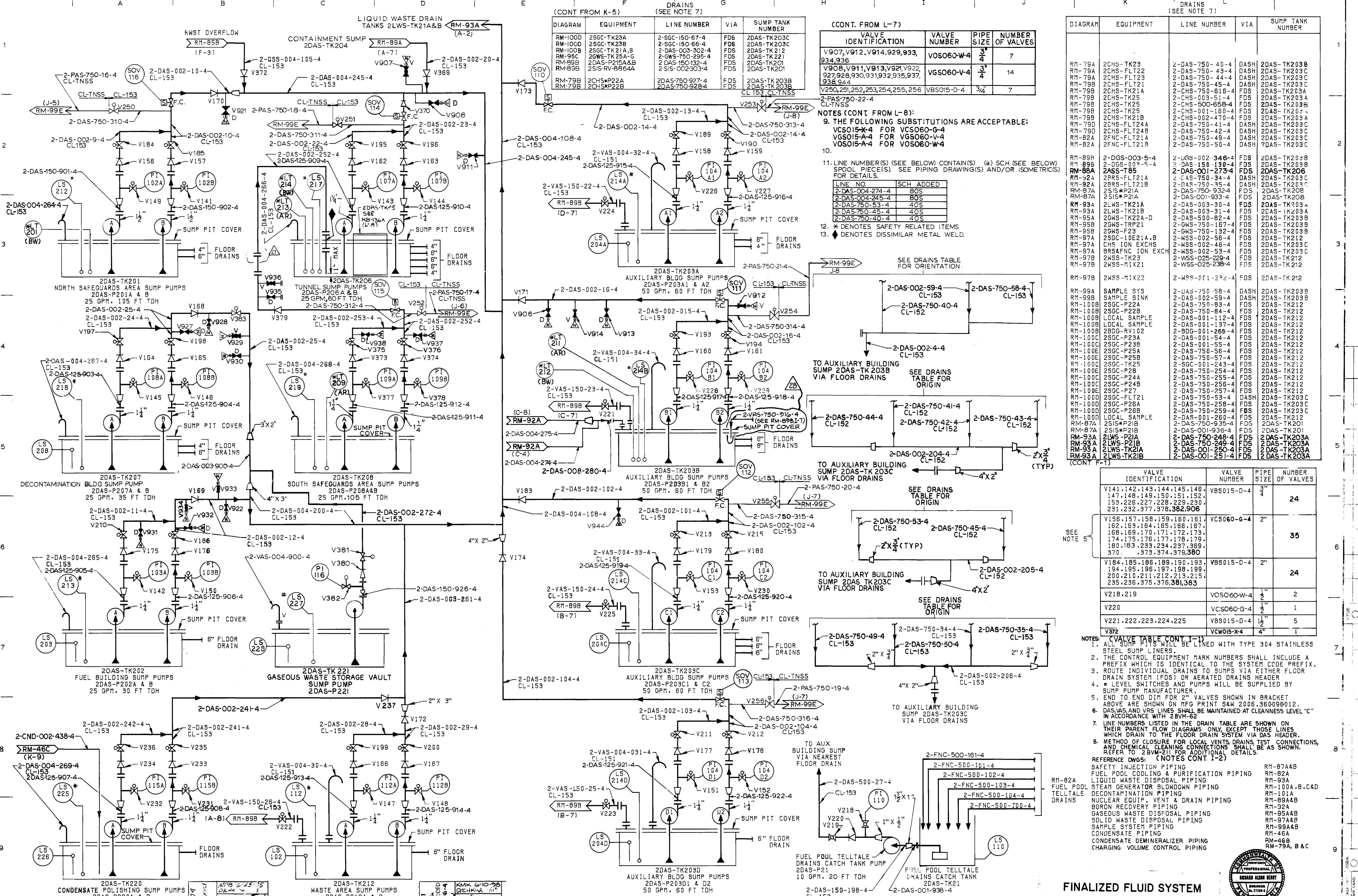

(CONT FROM K-5)

DIAGRAM	EQUIPMENT	LINE NUMBER	VIA	SUMP TANK NUMBER
RM-100D	2SGC-TK23A	2-SGC-150-67-4	FDS	2DAS-TK203C
RM-100D	2SGC-TK23B	2-SGC-150-66-4	FDS	2DAS-TK203C
RM-100B	2SGC-TK21A,B	2-DAS-003-302-4	FDS	2DAS-TK212
RM-95C	2GWS-TK25A-G	2-GWS-750-295-4	FDS	2DAS-TK221
RM-89B	2DAS-P215A&B	2-DAS-150-132-4	FDS	2DAS-TK201
RM-89B	2SIS-RV-8864A	2-SIS-002-303-4	FDS	2DAS-TK201
RM-79B	2CHS-P22A	2DAS-750-927-4	FDS	2DAS-TK203B
RM-79B	2CHS-P22B	2DAS-750-928-4	FDS	2DAS-TK203B

(CONT FROM L-7)

VALVE IDENTIFICATION	VALVE NUMBER	PIPE SIZE	NUMBER OF VALVES
V907, V912, V914, 929, 933, 934, 936	VOSO60-W-4	3/4"	7
V908, V911, V913, V921, V922, 927, 928, 930, 931, 932, 935, 937, 938, 944	VGS060-W-4	3/4"	14
V250, 251, 252, 253, 254, 255, 256	VBS015-D-4	3/4"	7

(CONT FROM L-7)

DIAGRAM	EQUIPMENT	LINE NUMBER	VIA	SUMP TANK NUMBER
RM-79A	2CHS-TK23	2-DAS-750-40-4	DASH	2DAS-TK203B
RM-79A	2CHS-FLT23	2-DAS-750-43-4	DASH	2DAS-TK203C
RM-79A	2CHS-FLT23	2-DAS-750-44-4	DASH	2DAS-TK203C
RM-79B	2CHS-FLT21	2-DAS-750-45-4	DASH	2DAS-TK203C
RM-79B	2CHS-FLT21A	2-DAS-750-618-4	FDS	2DAS-TK203A
RM-79B	2CHS-TK25	2-CHS-003-51-4	FDS	2DAS-TK203A
RM-79B	2CHS-TK25	2-CHS-500-658-4	FDS	2DAS-TK203A
RM-79B	2CHS-TK25	2-CHS-001-160-4	FDS	2DAS-TK203A
RM-79B	2CHS-TK21B	2-CHS-002-470-4	FDS	2DAS-TK203A
RM-79D	2CHS-FLT24A	2-DAS-750-41-4	DASH	2DAS-TK203C
RM-79D	2CHS-FLT24B	2-DAS-750-157-4	DASH	2DAS-TK203C
RM-82A	2FNC-FLT21A	2-DAS-750-49-4	DASH	2DAS-TK203C
RM-82A	2FNC-FLT21B	2-DAS-750-50-4	DASH	2DAS-TK203C

NOTES (CONT FROM L-8):
 9. THE FOLLOWING SUBSTITUTIONS ARE ACCEPTABLE:
 VCS015-X-4 FOR VCS060-G-4
 VGS015-A-4 FOR VGS060-W-4
 VSO15-A-4 FOR VSO60-W-4

11. LINE NUMBER(S) (SEE BELOW) CONTAIN(S) (a) SCH (SEE BELOW) SPOOL PIECE(S). (SEE PIPING DRAWING(S) AND/OR ISOMETRIC(S)) FOR DETAILS.

LINE NO.	SCH ADDED
2-DAS-004-274-4	80S
2-DAS-004-274-4	80S
2-DAS-750-53-4	40S
2-DAS-750-45-4	40S
2-DAS-750-40-4	40S

12. * DENOTES SAFETY RELATED ITEMS
 13. ♦ DENOTES DISSIMILAR METAL WELD.

(CONT FROM L-7)

DIAGRAM	EQUIPMENT	LINE NUMBER	VIA	SUMP TANK NUMBER
RM-89B	2-DGS-003-5-4	2-LGS-002-346-4	FDS	2DAS-TK203B
RM-89B	2-DGS-003-5-4	2-DGS-003-5-4	FDS	2DAS-TK203B
RM-89A	2ASS-T05	2-DAS-001-273-4	FDS	2DAS-TK206
RM-92A	2BRS-FLT21B	2-DAS-750-34-4	DASH	2DAS-TK203C
RM-87A	2SIS-P21A	2-DAS-750-35-4	DASH	2DAS-TK203C
RM-87A	2SIS-P21A	2-DAS-001-933-4	FDS	2DAS-TK208
RM-93A	2LWS-TK21A	2-DAS-003-30-4	FDS	2DAS-TK203A
RM-93A	2LWS-TK21B	2-DAS-003-31-4	FDS	2DAS-TK203A
RM-93A	2GWS-TK22A-D	2-DAS-500-82-4	FDS	2DAS-TK203B
RM-93B	2GWS-TK22B	2-GWS-750-157-4	FDS	2DAS-TK203B
RM-95B	2GWS-F23	2-GWS-750-132-4	FDS	2DAS-TK203B
RM-97A	2SGC-10E21A,B	2-SGS-002-56-4	FDS	2DAS-TK212
RM-97A	CHS ION EXCHS	2-NSS-002-46-4	FDS	2DAS-TK203C
RM-97A	BR54FNC ION EXCH	2-NSS-002-53-4	FDS	2DAS-TK203C
RM-97B	2WSS-TK23	2-WSS-025-229-4	FDS	2DAS-TK212
RM-97B	2WSS-M121	2-WSS-025-238-4	FDS	2DAS-TK212

(CONT FROM L-7)

DIAGRAM	EQUIPMENT	LINE NUMBER	VIA	SUMP TANK NUMBER
RM-99A	SAMPLE SYS	2-DAS-750-58-4	DASH	2DAS-TK203B
RM-99B	SAMPLE SINK	2-DAS-002-59-4	DASH	2DAS-TK203B
RM-100B	2SGC-P22A	2-DAS-750-83-4	FDS	2DAS-TK212
RM-100B	2SGC-P22B	2-DAS-750-84-4	FDS	2DAS-TK212
RM-100B	LOCAL SAMP	2-DAS-001-112-4	FDS	2DAS-TK212
RM-100B	LOCAL SAMP	2-DAS-001-137-4	FDS	2DAS-TK212
RM-100B	2BDG-RV102	2-BDG-001-266-4	FDS	2DAS-TK212
RM-100C	2SGC-P23A	2-DAS-001-54-4	FDS	2DAS-TK212
RM-100C	2SGC-P23B	2-DAS-001-55-4	FDS	2DAS-TK212
RM-100E	2SGC-P25A	2-DAS-750-56-4	FDS	2DAS-TK212
RM-100E	2SGC-P25B	2-DAS-750-57-4	FDS	2DAS-TK212
RM-100C	2SGC-TK25	2-SGC-001-243-4	FDS	2DAS-TK212
RM-100E	2SGC-P28	2-DAS-750-254-4	FDS	2DAS-TK212
RM-100C	2SGC-P24A	2-DAS-750-255-4	FDS	2DAS-TK212
RM-100C	2SGC-P24B	2-DAS-750-256-4	FDS	2DAS-TK212
RM-100E	2SGC-P27	2-DAS-750-257-4	FDS	2DAS-TK212
RM-100D	2SGC-FLT21	2-DAS-750-53-4	DASH	2DAS-TK203C
RM-100D	2SGC-P26A	2-DAS-750-258-4	FDS	2DAS-TK203C
RM-100D	2SGC-P26B	2-DAS-750-259-4	FDS	2DAS-TK203C
RM-100D	LOCAL SAMP	2-DAS-001-260-4	FDS	2DAS-TK212
RM-87A	2SIS-P21B	2-DAS-750-935-4	FDS	2DAS-TK201
RM-87A	2SIS-P21B	2-DAS-001-936-4	FDS	2DAS-TK201
RM-93A	2LWS-P21A	2-DAS-750-248-4	FDS	2DAS-TK203A
RM-93A	2LWS-P21B	2-DAS-750-249-4	FDS	2DAS-TK203A
RM-93A	2LWS-TK21A	2-DAS-001-250-4	FDS	2DAS-TK203A
RM-93A	2LWS-TK21B	2-DAS-001-251-4	FDS	2DAS-TK203A

(CONT FROM L-7)

VALVE IDENTIFICATION	VALVE NUMBER	PIPE SIZE	NUMBER OF VALVES
V141,142,143,144,145,146,147,148,149,150,151,152,153,226,227,228,229,230,231,232,377,378,382,906	VBS015-D-4	3/4"	24
V156,157,158,159,160,161,162,163,164,165,166,167,168,169,170,171,172,173,174,175,176,177,178,179,180,183,233,234,237,369,370,373,374,379,380	VCS060-G-4	2"	35
V184,185,186,189,190,193,194,195,198,199,198,199,200,210,211,212,213,215,235,236,375,376,381,383	VBS015-D-4	2"	24
V218,219	VOSO60-W-4	1 1/2"	2
V220	VCS060-G-4	2"	1
V221,222,223,224,225	VBS015-D-4	1 1/2"	5
V372	VCS015-X-4	4"	1

NOTES: (C) VALVE TABLE CONT 1-1
 1. ALL SUMP PITS WILL BE LINED WITH TYPE 304 STAINLESS STEEL SUMP LINERS.
 2. THE CONTROL EQUIPMENT MARK NUMBERS SHALL INCLUDE A PREFIX WHICH IS IDENTICAL TO THE SYSTEM CODE PREFIX.
 3. ROUTE INDIVIDUAL DRAINS TO SUMP VIA EITHER FLOOR DRAIN SYSTEM (FDS) OR AERATED DRAINS HEADER.
 4. LEVEL SWITCHES AND PUMPS WILL BE SUPPLIED BY SUMP PUMP MANUFACTURER.
 5. END TO END DIM FOR 2" VALVES SHOWN IN BRACKET ABOVE ARE SHOWN ON NFG PRINT S&W 2006.360098012.
 6. DASH AND VRS LINES SHALL BE MAINTAINED AT CLEANNESS LEVEL "C" IN ACCORDANCE WITH 2BVM-62.
 7. LINE NUMBERS LISTED IN THE DRAIN TABLE ARE SHOWN ON THEIR PARENT FLOW DIAGRAMS ONLY, EXCEPT THOSE LINES WHICH DRAIN TO THE FLOOR DRAIN SYSTEM VIA DAS HEADER.
 8. METHOD OF CLOSURE FOR LOCAL VENTS DRAINS TO SUMP CONNECTIONS, AND CHEMICAL CLEANING CONNECTIONS SHALL BE AS SHOWN. REFER TO 2BVM-211 FOR ADDITIONAL DETAILS.

REFERENCE DWGS: (NOTES CONT 1-2)
 SAFETY INJECTION PIPING RM-87A&B
 FUEL POOL COOLING & PURIFICATION PIPING RM-82A
 LIQUID WASTE DISPOSAL PIPING RM-93A
 STEAM GENERATOR BLOWDOWN PIPING RM-100A,B,C&D
 TELLTALE DECONTAMINATION PIPING RM-101A
 NUCLEAR EQUIP. VENT & DRAIN PIPING RM-89A&B
 BORON RECOVERY PIPING RM-92A
 GASEOUS WASTE DISPOSAL PIPING RM-95A&B
 SOLID WASTE DISPOSAL PIPING RM-97B
 SAMPLE SYSTEM PIPING RM-99A&B
 CONDENSATE PIPING RM-46A
 CONDENSATE DEMINERALIZER PIPING RM-46B
 CHARGING VOLUME CONTROL PIPING RM-79A, B & C

PORTIONS OF THIS DOCUMENT ARE
 NUCLEAR SAFETY RELATED

THE INFORMATION ON THIS DRAWING MAY NOT BE COPIED OR USED FOR OTHER THAN THE CONSTRUCTION, MAINTENANCE OR REPAIR OF THE PLANT FACILITY DESCRIBED IN THE TITLE BLOCK.
 APPROVED: [Signature]
 REGISTERED PROFESSIONAL ENGINEER NO. [Number]
 COMMONWEALTH OF PENNSYLVANIA

DUQUESNE LIGHT COMPANY
 ENGINEERING & CONSTRUCTION PITTSBURGH, PA.

SCALE: [Blank] DATE: [Blank] ARCH. APP. [Blank]
 CHECKED: [Blank] MECH. APP. [Blank]
 INSPECTED: [Blank] STRUCT. APP. [Blank]

STONE & WEBSTER ENGINEERING CORP.
 PITTSBURGH, PA.

BEAVER VALLEY POWER STATION NO. 2
 O.F.E. NO. 1006
 C.O. NO. 4286
 No. 10080-RM-89C

S&W DWG. NO. 12241-RM-89C-28

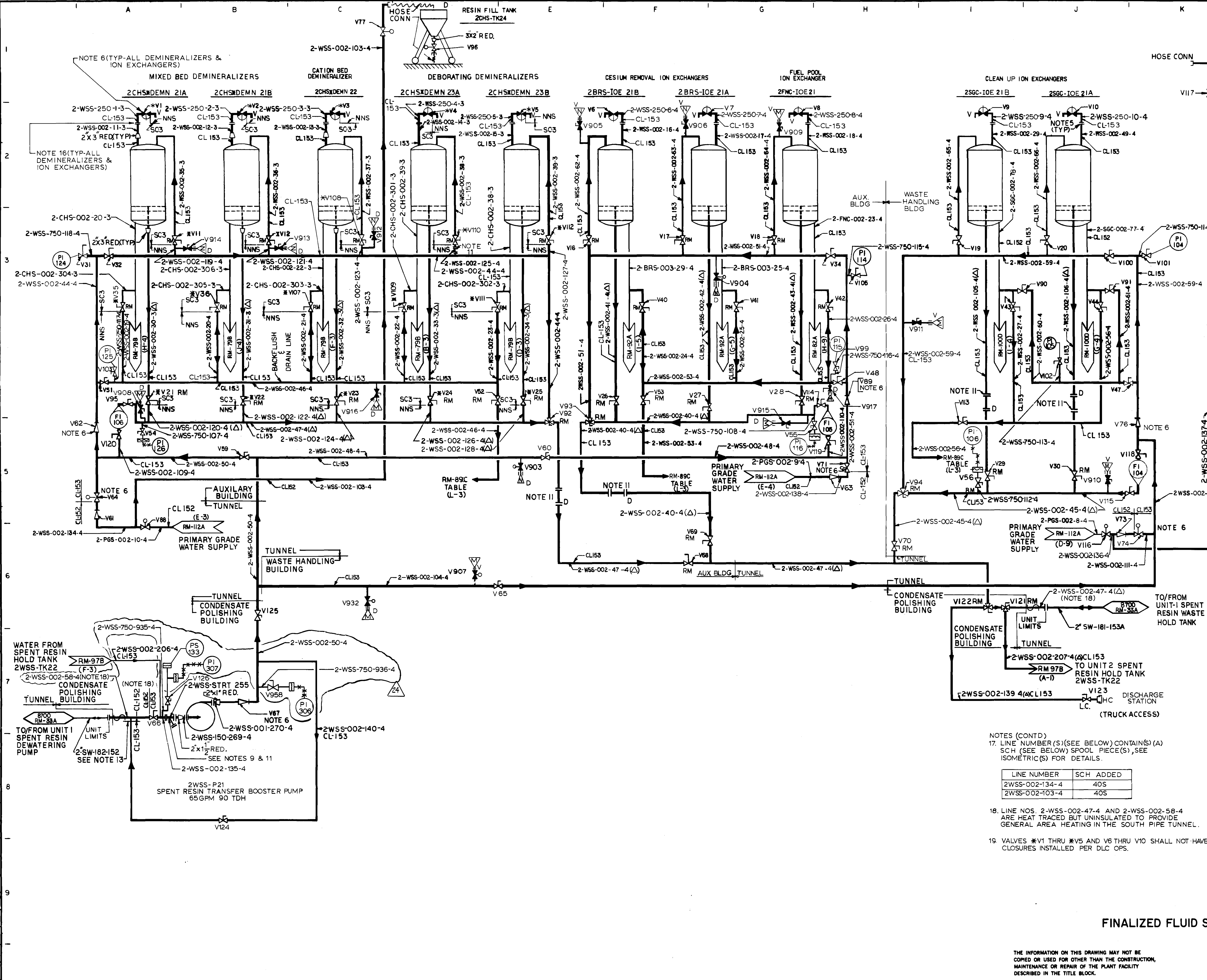

- NOTES:
1. THE CONTROL EQUIPMENT VALVE IDENTIFICATION NO.'S SHALL INCLUDE A PREFIX WHICH IS IDENTICAL TO THE SYSTEM CODE PREFIX FOR THE ASSOCIATED EQUIPMENT OR PIPE LINE UNLESS OTHERWISE NOTED EX 2WSS-FI 104.
 2. BUTT WELD CL-153 PIPE
 3. DESIGNATED LINES(A) WILL UTILIZE LATERALS & BENDS INSTEAD OF TEES & ELBOWS
 4. THIS SYSTEM WILL BE MAINTAINED TO CLEANNESS LEVEL C IN ACCORDANCE WITH 2BVM-62
 5. GRAYLOC BUTT WELDING HUB NO.2 WITH SEAL RING.
 6. VALVE IS SOCKET WELDED-PROVIDE PIPE END CONNECTIONS TO MATCH.
 7. VALVES WILL BE PURCHASED BY FIELD.

8. THE FOLLOWING SUBSTITUTIONS ARE ACCEPTABLE: VCS015-X-4 FOR VCS060-G-4
9. STRAINER BODY TO BE REPLACED BY CL 153 SPOOL PIECE ON COMPLETION OF SYSTEM FLUSH
10. METHOD OF CLOSURE FOR LOCAL VENTS, DRAINS, TEST CONNECTIONS AND CHEMICAL CLEANING CONNECTIONS SHALL BE AS SHOWN REFER TO 2BVM-211 FOR ADDITIONAL DETAIL.
11. REMOVABLE SPOOL PIECES SHALL BE SUBSTITUTED FOR DRAINS IN SOLID WASTE SLURRY LINES.
12. SYSTEM VALVES ONLY OPEN WHEN PROCESS LINES ARE ISOLATED.
13. PIPE CLASS BREAK OCCURS AT INTERSECTION OF TWO LINES.
14. CORROSION INSULATED JOINT PER 2BVS-920.
15. VSS150-X-3 IS AN ACCEPTABLE SUBSTITUTE (CONTD L-8)

- NOTES (CONTD)
17. LINE NUMBER(S) (SEE BELOW) CONTAIN(S) (A) SCH (SEE BELOW) SPOOL PIECE(S), SEE ISOMETRIC(S) FOR DETAILS.
 18. LINE NOS. 2-WSS-002-47-4 AND 2-WSS-002-58-4 ARE HEAT TRACED BUT UNINSULATED TO PROVIDE GENERAL AREA HEATING IN THE SOUTH PIPE TUNNEL.
 19. VALVES #V1 THRU #V5 AND V6 THRU V10 SHALL NOT HAVE CLOSURES INSTALLED PER DLC OPS.

LINE NUMBER	SCH	ADDED
2WSS-002-134-4	40S	
2WSS-002-103-4	40S	

FINALIZED FLUID SYSTEM



THE INFORMATION ON THIS DRAWING MAY NOT BE COPIED OR USED FOR OTHER THAN THE CONSTRUCTION, MAINTENANCE OR REPAIR OF THE PLANT FACILITY DESCRIBED IN THE TITLE BLOCK.

APPROVED: *Richard Alan Long*
REGISTERED PROFESSIONAL ENGINEER NO. 27287-6
COMMONWEALTH OF PENNSYLVANIA

DUQUESNE LIGHT COMPANY
ENGINEERING & CONSTRUCTION PITTSBURGH, PA.

FLOW DIAGRAM
SOLID WASTE DISPOSAL PIPING

SCALE: NONE
DATE: 2-24-72
DRAWN: JLD
CHECKED: RDB
INSPECTED: RDB

BEAVER VALLEY POWER STATION UNIT NO-2
O.P.E. No. 10080
C.D. No. 6289
AA No. 10080-RM-97A

REV.	DATE	DESCRIPTION	BY	CHKD	APPD	DATE
1	10-7-92	ISSUED FOR PRODUCTION				
2	10-7-92	FOR RECORD OF DWG CHGS				
3	10-7-92	FOR RECORD OF DWG CHGS				
4	10-7-92	FOR RECORD OF DWG CHGS				
5	10-7-92	FOR RECORD OF DWG CHGS				
6	10-7-92	FOR RECORD OF DWG CHGS				
7	10-7-92	FOR RECORD OF DWG CHGS				
8	10-7-92	FOR RECORD OF DWG CHGS				
9	10-7-92	FOR RECORD OF DWG CHGS				
10	10-7-92	FOR RECORD OF DWG CHGS				
11	10-7-92	FOR RECORD OF DWG CHGS				
12	10-7-92	FOR RECORD OF DWG CHGS				
13	10-7-92	FOR RECORD OF DWG CHGS				
14	10-7-92	FOR RECORD OF DWG CHGS				
15	10-7-92	FOR RECORD OF DWG CHGS				
16	10-7-92	FOR RECORD OF DWG CHGS				
17	10-7-92	FOR RECORD OF DWG CHGS				
18	10-7-92	FOR RECORD OF DWG CHGS				
19	10-7-92	FOR RECORD OF DWG CHGS				
20	10-7-92	FOR RECORD OF DWG CHGS				

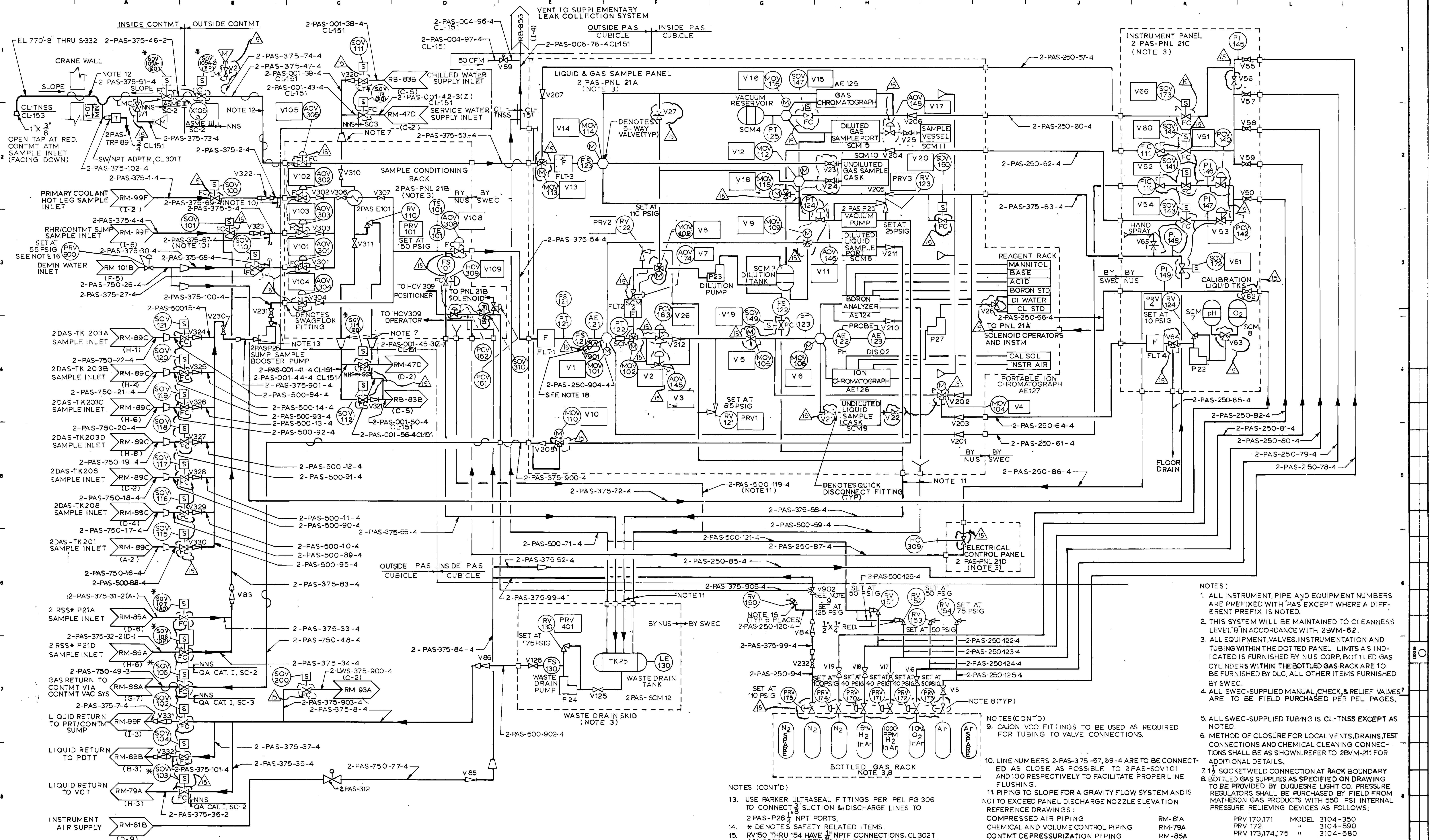

- NOTES:
1. ALL INSTRUMENT, PIPE AND EQUIPMENT NUMBERS ARE PREFIXED WITH 'PAS' EXCEPT WHERE A DIFFERENT PREFIX IS NOTED.
 2. THIS SYSTEM WILL BE MAINTAINED TO CLEANNESS LEVEL 'B' IN ACCORDANCE WITH 2BVM-62.
 3. ALL EQUIPMENT, VALVES, INSTRUMENTATION AND TUBING WITHIN THE DOTTED PANEL LIMITS AS INDICATED IS FURNISHED BY NUS CORP. BOTTLED GAS CYLINDERS WITHIN THE BOTTLED GAS RACK ARE TO BE FURNISHED BY DLC. ALL OTHER ITEMS FURNISHED BY SWEC.
 4. ALL SWEC-SUPPLIED MANUAL CHECK & RELIEF VALVES ARE TO BE FIELD PURCHASED PER PEL PAGES.
 5. ALL SWEC-SUPPLIED TUBING IS CL-TNSS EXCEPT AS NOTED.
 6. METHOD OF CLOSURE FOR LOCAL VENTS, DRAINS, TEST CONNECTIONS AND CHEMICAL CLEANING CONNECTIONS SHALL BE AS SHOWN. REFER TO 2BVM-211 FOR ADDITIONAL DETAILS.
 7. SOCKETWELD CONNECTION AT RACK BOUNDARY AND 100 RESPECTIVELY TO FACILITATE PROPER LINE FLUSHING.
 8. BOTTLED GAS SUPPLIES AS SPECIFIED ON DRAWING TO BE PROVIDED BY DUQUESNE LIGHT CO. PRESSURE REGULATORS SHALL BE PURCHASED BY FIELD FROM MATHESON GAS PRODUCTS WITH 550 PSI INTERNAL PRESSURE RELIEFING DEVICES AS FOLLOWS:

- NOTES (CONT'D)
9. CAJON VCO FITTINGS TO BE USED AS REQUIRED FOR TUBING TO VALVE CONNECTIONS.
 10. LINE NUMBERS 2-PAS-375-67, 69-4 ARE TO BE CONNECTED AS CLOSE AS POSSIBLE TO 2-PAS-SOV101 AND 100 RESPECTIVELY TO FACILITATE PROPER LINE FLUSHING.
 11. PIPING TO SLOPE FOR A GRAVITY FLOW SYSTEM AND IS NOT TO EXCEED PANEL DISCHARGE NOZZLE ELEVATION REFERENCE DRAWINGS:

- NOTES (CONT'D)
12. FITTINGS IN ATMOSPHERE SAMPLING LINES ARE TO BE AVOIDED WHERE POSSIBLE. WHERE REQUIRED, BEND RADIUS SHALL BE KEPT AS LARGE AS POSSIBLE BUT NOT LESS THAN 20 DIAMETERS.
 13. USE PARKER ULTRASEAL FITTINGS PER PEL PG 306 TO CONNECT 3/8\"/>

COMPONENT	MARK NUMBER	PIPE SIZE	QUANTITY	COMPONENT	MARK NUMBER	PIPE SIZE	QUANTITY
COMPRESSED AIR PIPING	RM-61A			PRV 170,171	MODEL 3104-350		
CHEMICAL AND VOLUME CONTROL PIPING	RM-79A			PRV 172	" 3104-590		
CONTMT DEPRESSURIZATION PIPING	RM-85A			PRV 173,174,175	" 3104-580		
CONTMT VACUUM LEAKAGE MONITORING PIPING	RM-88A						
NUCLEAR EQUIPMENT VENT/ DRAIN PIPING	RM-89B & C						
SAMPLE PIPING	RM-99A						
DEMINERALIZED WATER AND CASK WASHDOWN	RM-101B						
SYSTEM PIPING							
EMERGENCY EXHAUST VENT SYSTEM FOR	RB-85G						
CHARGING PUMPS & COMPONENT COOLING PUMPS							

PORTIONS OF THIS DOCUMENT ARE
NUCLEAR SAFETY RELATED

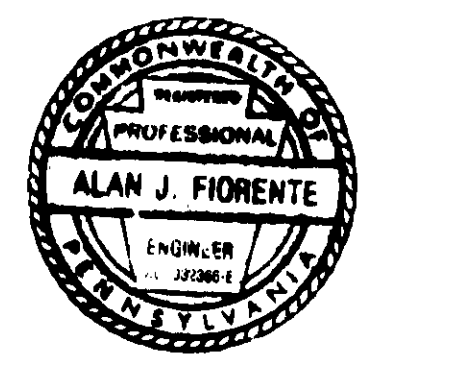

APPROVED: *Alan J. Fiorenza*
REGISTERED PROFESSIONAL ENGINEER NO. 032366-0
COMMONWEALTH OF PENNSYLVANIA

VALVE IDENTIFICATION	MARK NUMBER	PIPE SIZE	QUANTITY	VALVE IDENTIFICATION	VALVE NUMBER	PIPE SIZE	QUANTITY	VALVE IDENTIFICATION	VALVE NUMBER	PIPE SIZE	QUANTITY
V1,2	VSS400-S-4 NOTE 4	3"	2	V21,V22,V23,V24, V50,V55,V56,V57, V58,V59	HOKE 7115G4Y (NOTE 3)	1"	10	V205, V206	WHITEY SS-2C-1 (NOTE 3)	1"	2
V83,84,86, 322,323,331,332	VCS500-Z-4 NOTE 4	1"	7	V63,V64	HOKE 7673G4Y (NOTE 3)	1"	2	V306, V307	NUPRO SS-6NBS-6 (NOTE 3)	3/8"	2
V15,16,17,18,19,232	VOS600-S-4 NOTE 4	1"	6	V65	HOKE 03712G4S (NOTE 3)	1"	1	V125, V126	NUPRO SS-8UW (NOTE 3)	1/2"	2
V85	VCS500-Z-4 NOTE 4	3/4"	1	V31Q, V311	ITT GRINNEL 2472-25-M (NOTE 3)	1"	2	V27	WHITEY SS-21R4 (NOTE 3)	1"	1
V89	VBW015-Z-4 NOTE 4	4"	1	V201, V202, V203, V204, V207, V208, V210, V211, V212	NUPRO SS-4C-1 (NOTE 3)	1"	9	V28	WHITEY SS-41X52 (NOTE 3)	1"	1
V320, 321 V230, 231	VCS060-BZ-4 NOTE 4	1"	2	V301, V302, V303, V304	NUPRO SS-6C-1 (NOTE 3)	3/8"	4	V25	WHITEY SS-43F4 (NOTE 3)	1"	1
V324, 325, 326, 327, 328, 329, 330	VCS500-Z-4 NOTE 4	1"	7								

FINALIZED FLUID SYSTEM

DUQUESNE LIGHT COMPANY
ENGINEERING & CONSTRUCTION PITTSBURGH, PA.

FLOW DIAGRAM
POST ACCIDENT SMPL PP SH5
BEAVER VALLEY POWER STATION UNIT NO.2

SCALE	DATE	MECH. APP.	ELECT. APP.
NONE			
CHECKED			
INSPECTED			

O.M. FIGURE 45D-14
O.F.E. NO. 10080
C.O. NO. 6289
AA No. 10080-RM-99E
SWEC DWG. NO. 12241-RM-99E-15

REVISIONS	DESCRIPTION	DATE	BY	CHKD	APPD
1	ISSUE				
2	FOR RECORD OF DWG CHGS 12241-BCM-99E-11				
3	FOR RECORD OF DWG CHGS 12241-BCM-99E-11				
4	FOR RECORD OF DWG CHGS 12241-BCM-99E-11				
5	FOR RECORD OF DWG CHGS 12241-BCM-99E-11				
6	FOR RECORD OF DWG CHGS 12241-BCM-99E-11				
7	FOR RECORD OF DWG CHGS 12241-BCM-99E-11				
8	FOR RECORD OF DWG CHGS 12241-BCM-99E-11				
9	FOR RECORD OF DWG CHGS 12241-BCM-99E-11				
10	FOR RECORD OF DWG CHGS 12241-BCM-99E-11				
11	FOR RECORD OF DWG CHGS 12241-BCM-99E-11				
12	FOR RECORD OF DWG CHGS 12241-BCM-99E-11				
13	FOR RECORD OF DWG CHGS 12241-BCM-99E-11				
14	FOR RECORD OF DWG CHGS 12241-BCM-99E-11				
15	FOR RECORD OF DWG CHGS 12241-BCM-99E-11				
16	FOR RECORD OF DWG CHGS 12241-BCM-99E-11				
17	FOR RECORD OF DWG CHGS 12241-BCM-99E-11				
18	FOR RECORD OF DWG CHGS 12241-BCM-99E-11				
19	FOR RECORD OF DWG CHGS 12241-BCM-99E-11				
20	FOR RECORD OF DWG CHGS 12241-BCM-99E-11				

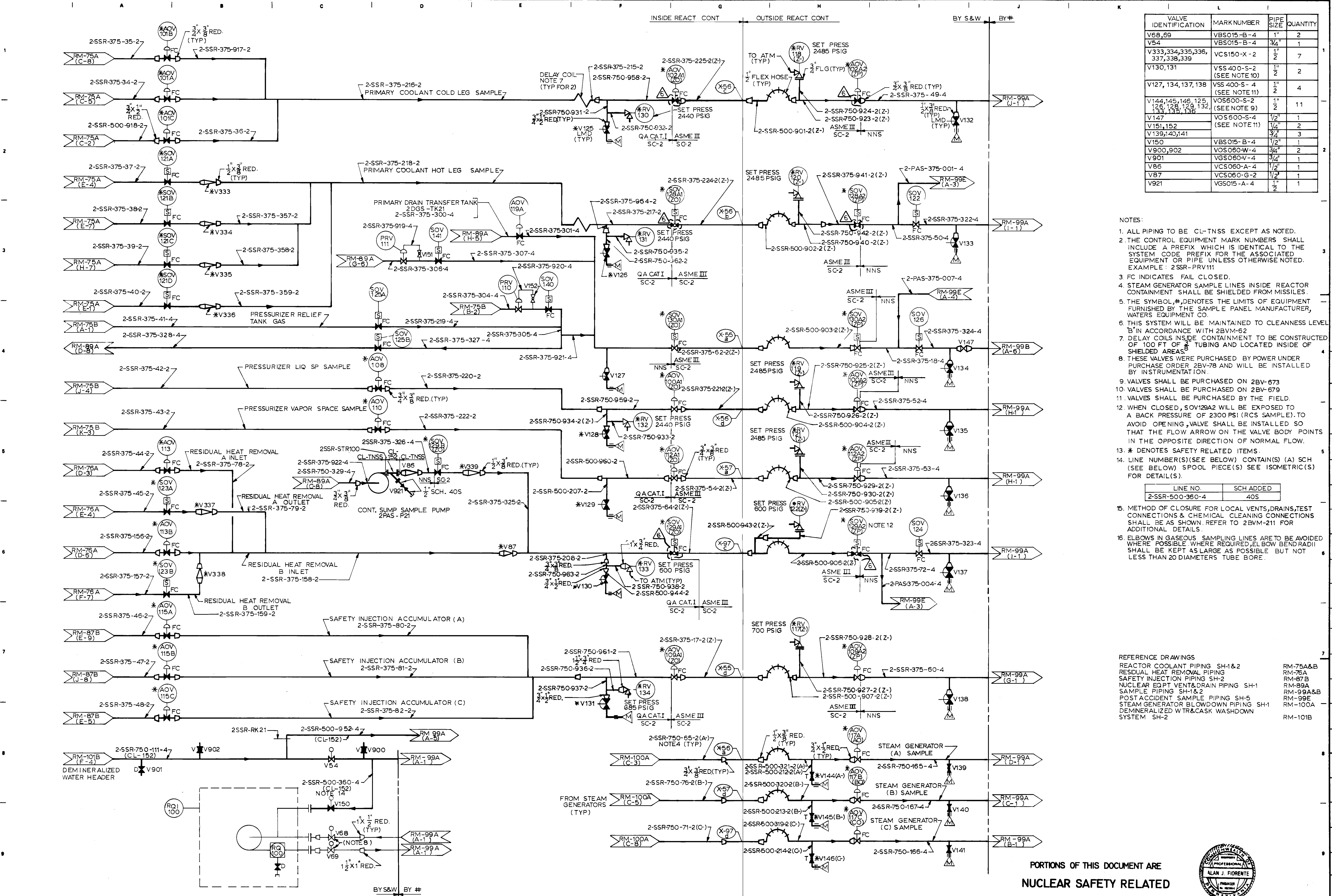

VALVE IDENTIFICATION	MARK NUMBER	PIPE SIZE	QUANTITY
V68,69	VBS015-B-4	1"	2
V54	VBS015-B-4	3/4"	1
V333,334,335,336,337,338,339	VCS150-X-2	1/2"	7
V130,131	VSS 400-S-2 (SEE NOTE 10)	1"	2
V127, 134, 137, 138	VSS 400-S-4 (SEE NOTE 11)	1"	4
V144,145,146, 125, 126, 128, 129, 132, 133, 135, 136	VOS600-S-2 (SEE NOTE 9)	1"	11
V147	VOS 600-S-4	1/2"	1
V151,152	(SEE NOTE 11)	1/4"	2
V139,140,141		3/4"	3
V150	VBS015-B-4	1/2"	1
V900,902	VOS060-W-4	3/4"	2
V901	VGS060-V-4	3/4"	1
V86	VCS060-A-4	1/2"	1
V87	VCS060-G-2	1/2"	1
V921	VGS015-A-4	1"	1

- NOTES:
1. ALL PIPING TO BE CL-TN55 EXCEPT AS NOTED.
 2. THE CONTROL EQUIPMENT MARK NUMBERS SHALL INCLUDE A PREFIX WHICH IS IDENTICAL TO THE SYSTEM CODE PREFIX FOR THE ASSOCIATED EQUIPMENT OR PIPE, UNLESS OTHERWISE NOTED. EXAMPLE: 2-SSR-PRV111
 3. FC INDICATES FAIL CLOSED.
 4. STEAM GENERATOR SAMPLE LINES INSIDE REACTOR CONTAINMENT SHALL BE SHIELDED FROM MISSILES.
 5. THE SYMBOL # DENOTES THE LIMITS OF EQUIPMENT FURNISHED BY THE SAMPLE PANEL MANUFACTURER, WATERS EQUIPMENT CO.
 6. THIS SYSTEM WILL BE MAINTAINED TO CLEANNESS LEVEL "B" IN ACCORDANCE WITH 2BVM-62
 7. DELAY COILS INSIDE CONTAINMENT TO BE CONSTRUCTED OF 100 FT OF 3/4" TUBING AND LOCATED INSIDE OF SHIELDED AREAS.
 8. THESE VALVES WERE PURCHASED BY POWER UNDER PURCHASE ORDER 2BV-78 AND WILL BE INSTALLED BY INSTRUMENTATION.
 9. VALVES SHALL BE PURCHASED ON 2BV-673
 10. VALVES SHALL BE PURCHASED ON 2BV-679
 11. VALVES SHALL BE PURCHASED BY THE FIELD.
 12. WHEN CLOSED, SOV129A2 WILL BE EXPOSED TO A BACK PRESSURE OF 2300 PSI (RCS SAMPLE). TO AVOID OPENING VALVE SHALL BE INSTALLED SO THAT THE FLOW ARROW ON THE VALVE BODY POINTS IN THE OPPOSITE DIRECTION OF NORMAL FLOW.
 13. * DENOTES SAFETY RELATED ITEMS.
 14. LINE NUMBER(S) (SEE BELOW) CONTAIN(S) (A) SCH (SEE BELOW) SPOOL PIECE(S) SEE ISOMETRIC(S) FOR DETAILS(S).

LINE NO.	SCH ADDED
2-SSR-500-360-4	405

15. METHOD OF CLOSURE FOR LOCAL VENTS, DRAINS, TEST CONNECTIONS & CHEMICAL CLEANING CONNECTIONS SHALL BE AS SHOWN REFER TO 2BVM-211 FOR ADDITIONAL DETAILS.
16. ELBOWS IN GASEOUS SAMPLING LINES ARE TO BE AVOIDED WHERE POSSIBLE WHERE REQUIRED, ELBOW BEND RADIUS SHALL BE KEPT AS LARGE AS POSSIBLE BUT NOT LESS THAN 20 DIAMETERS TUBE BORE.

REFERENCE DRAWINGS
 REACTOR COOLANT PIPING SH-1&2 RM-75A&B
 RESIDUAL HEAT REMOVAL PIPING RM-76A
 SAFETY INJECTION PIPING SH-2 RM-87B
 NUCLEAR EQPT VENT&DRAIN PIPING SH-1 RM-89A
 SAMPLE PIPING SH-1&2 RM-99A&B
 POST ACCIDENT SAMPLE PIPING SH-5 RM-100A
 STEAM GENERATOR BLOWDOWN PIPING SH-1 RM-100A
 DEMINERALIZED WTR&CASK WASHDOWN SYSTEM SH-2 RM-101B

PORTIONS OF THIS DOCUMENT ARE
NUCLEAR SAFETY RELATED

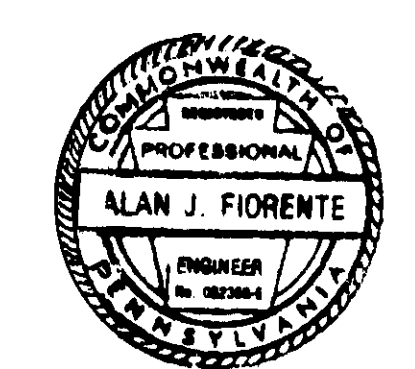

APPROVED: *Alan J. Fiorente*
 REGISTERED PROFESSIONAL ENGINEER NO. 037266-E
 COMMONWEALTH OF PENNSYLVANIA

REVISIONS

NO.	DATE	DESCRIPTION
1	12/21/80	ISSUED FOR CONSTRUCTION
2	01/15/81	REVISED TO REFLECT CHANGES IN RM-99A
3	02/10/81	REVISED TO REFLECT CHANGES IN RM-99A
4	03/05/81	REVISED TO REFLECT CHANGES IN RM-99A
5	04/01/81	REVISED TO REFLECT CHANGES IN RM-99A
6	05/01/81	REVISED TO REFLECT CHANGES IN RM-99A
7	06/01/81	REVISED TO REFLECT CHANGES IN RM-99A
8	07/01/81	REVISED TO REFLECT CHANGES IN RM-99A
9	08/01/81	REVISED TO REFLECT CHANGES IN RM-99A
10	09/01/81	REVISED TO REFLECT CHANGES IN RM-99A
11	10/01/81	REVISED TO REFLECT CHANGES IN RM-99A
12	11/01/81	REVISED TO REFLECT CHANGES IN RM-99A

NO.	DATE	DESCRIPTION	BY	CHKD	APPD
1	12/21/80	ISSUED FOR CONSTRUCTION
2	01/15/81	REVISED TO REFLECT CHANGES IN RM-99A
3	02/10/81	REVISED TO REFLECT CHANGES IN RM-99A
4	03/05/81	REVISED TO REFLECT CHANGES IN RM-99A
5	04/01/81	REVISED TO REFLECT CHANGES IN RM-99A
6	05/01/81	REVISED TO REFLECT CHANGES IN RM-99A
7	06/01/81	REVISED TO REFLECT CHANGES IN RM-99A
8	07/01/81	REVISED TO REFLECT CHANGES IN RM-99A
9	08/01/81	REVISED TO REFLECT CHANGES IN RM-99A
10	09/01/81	REVISED TO REFLECT CHANGES IN RM-99A
11	10/01/81	REVISED TO REFLECT CHANGES IN RM-99A
12	11/01/81	REVISED TO REFLECT CHANGES IN RM-99A

DUQUESNE LIGHT COMPANY
 ENGINEERING & CONSTRUCTION PITTSBURGH, PA.

FLOW DIAGRAM
 SAMPLE PIPING SH-6
 BEAVER VALLEY POWER STATION UNIT NO.2
 O.F.E. NO. 10080
 C.O. NO. 0289
AA No. 10080-RM-99F

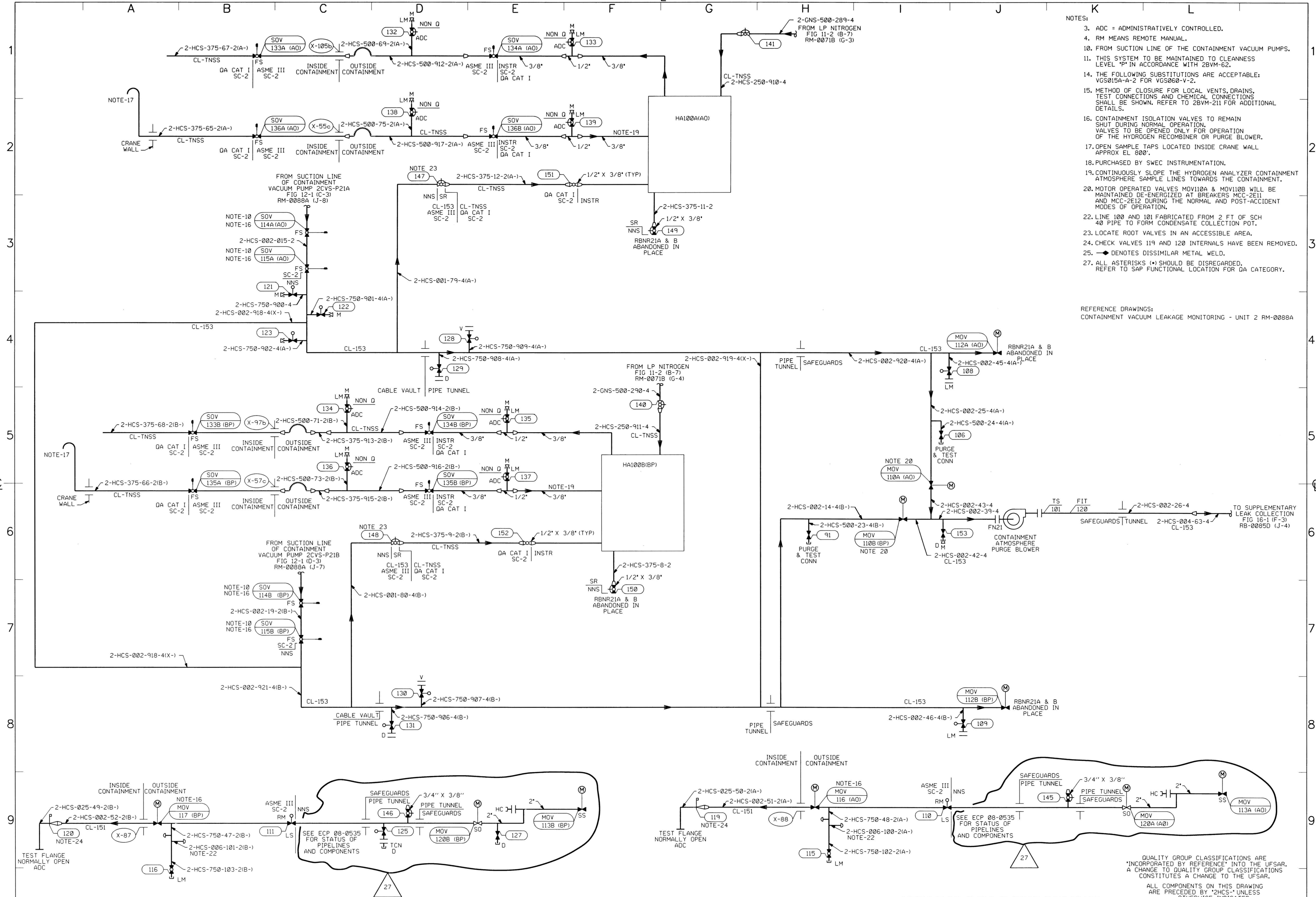

- NOTES:
3. ADC = ADMINISTRATIVELY CONTROLLED.
 4. RM MEANS REMOTE MANUAL.
 10. FROM SUCTION LINE OF THE CONTAINMENT VACUUM PUMPS.
 11. THIS SYSTEM TO BE MAINTAINED TO CLEANNESS LEVEL "P" IN ACCORDANCE WITH 2BVM-62.
 14. THE FOLLOWING SUBSTITUTIONS ARE ACCEPTABLE: VGS015A-A-2 FOR VGS060-V-2.
 15. METHOD OF CLOSURE FOR LOCAL VENTS, DRAINS, TEST CONNECTIONS AND CHEMICAL CONNECTIONS SHALL BE SHOWN. REFER TO 2BVM-211 FOR ADDITIONAL DETAILS.
 16. CONTAINMENT ISOLATION VALVES TO REMAIN SHUT DURING NORMAL OPERATION. VALVES TO BE OPENED ONLY FOR OPERATION OF THE HYDROGEN RECOMBINER OR PURGE BLOWER.
 17. OPEN SAMPLE TAPS LOCATED INSIDE CRANE WALL APPROX EL 800'.
 18. PURCHASED BY SWEC INSTRUMENTATION.
 19. CONTINUOUSLY SLOPE THE HYDROGEN ANALYZER CONTAINMENT ATMOSPHERE SAMPLE LINES TOWARDS THE CONTAINMENT.
 20. MOTOR OPERATED VALVES MOV110A & MOV110B WILL BE MAINTAINED DE-ENERGIZED AT BREAKERS MCC-2E11 AND MCC-2E12 DURING THE NORMAL AND POST-ACCIDENT MODES OF OPERATION.
 22. LINE 100 AND 101 FABRICATED FROM 2 FT. OF SCH 40 PIPE TO FORM CONDENSATE COLLECTION POT.
 23. LOCATE ROOT VALVES IN AN ACCESSIBLE AREA.
 24. CHECK VALVES 119 AND 120 INTERNALS HAVE BEEN REMOVED.
 25. * DENOTES DISSIMILAR METAL WELD.
 27. ALL ASTERISKS (*) SHOULD BE DISREGARDED. REFER TO SAP FUNCTIONAL LOCATION FOR DA CATEGORY.

REFERENCE DRAWINGS:
CONTAINMENT VACUUM LEAKAGE MONITORING - UNIT 2 RM-0088A

QUALITY GROUP CLASSIFICATIONS ARE INCORPORATED BY REFERENCE INTO THE UFSAR. A CHANGE TO QUALITY GROUP CLASSIFICATIONS CONSTITUTES A CHANGE TO THE UFSAR. ALL COMPONENTS ON THIS DRAWING ARE PRECEDED BY '2HCS-' UNLESS OTHERWISE INDICATED.

PORTIONS OF THIS DIAGRAM ARE NUCLEAR SAFETY RELATED

REVISION 27 INCORPORATED DUN 08-0535-001-004 DUN 08-0597-001-010		FENOC FIRSTENERGY NUCLEAR OPERATING COMPANY DATE 11/10/08 DRAWN BY MVF DFC/CHK ENGR/CHK		BEAVER VALLEY POWER STATION UNIT 2 FLOW DIAGRAM POST DBA HYDROGEN CONTROL SYSTEM AA DWG NO 10080-RM-0110A REV 27	
--	--	--	--	--	--

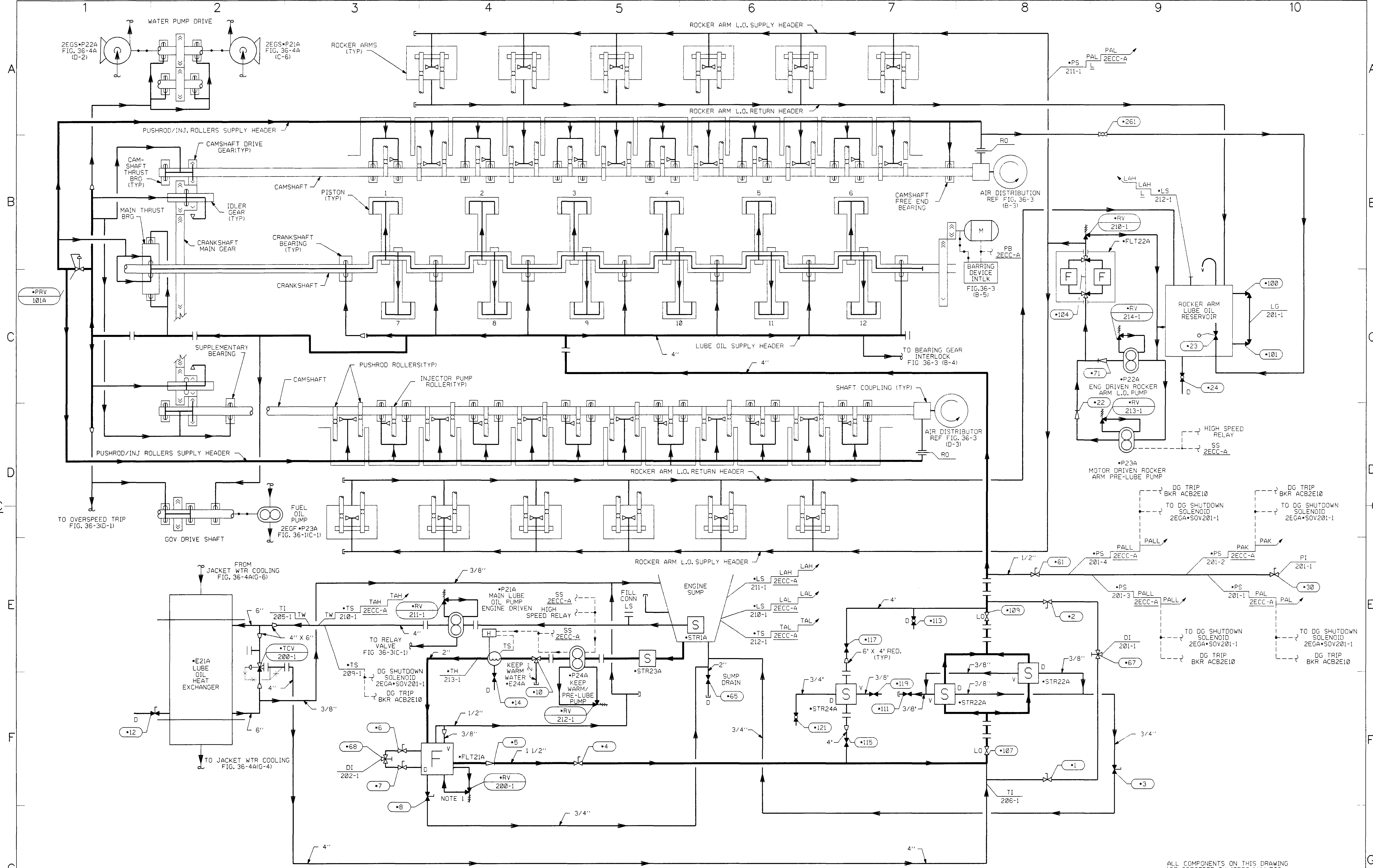

ALL COMPONENTS ON THIS DRAWING ARE PRECEDED BY "2EG0-" UNLESS OTHERWISE INDICATED.

OP MANUAL FIG. NO. 36-5A

ISSUES	ORIGINAL	UNO.S.	3-2-87	INCORP'D	UNO.S.	4-10-90	INCORP'D	UNO.S.	10-8-90	INCORP'D	UNO.S.	3-30-92	INCORP'D	UNO.S.	4-14-93
1		UNO.S.	3-2-87	2	UNO.S.	4-10-90	3	UNO.S.	10-8-90	4	UNO.S.	3-30-92	5	UNO.S.	4-14-93
		FDS	3-2-87		FDS	4-10-90		FDS	10-8-90		FDS	3-30-92		FDS	4-14-93
		WDR	2-87-29		WDR	2-90-11		WDR	2-90-11		WDR	2-92-39		WDR	2-93-39
		WDR	2-87-62		WDR	2-89-92		WDR	2-89-92		WDR	2-91-68		WDR	2-91-68
		WDR	2-89-92		WDR	2-89-92		WDR	2-89-92		WDR	2-89-92		WDR	2-89-92
		JFC FOR FDS	4-10-90		JFC FOR FDS	4-10-90		JFC FOR FDS	4-10-90		JFC FOR FDS	4-10-90		JFC FOR FDS	4-10-90
		D/CHK: MVF/KRV			D/CHK: MVF/KRV			D/CHK: MVF/KRV			D/CHK: MVF/KRV			D/CHK: MVF/KRV	
		D/CHK: MVF/FMC			D/CHK: MVF/FMC			D/CHK: MVF/FMC			D/CHK: MVF/FMC			D/CHK: MVF/FMC	
		CR 971841			CR 971841			CR 971841			CR 971841			CR 971841	
		SUP. CM: <i>[Signature]</i>			SUP. CM: <i>[Signature]</i>			SUP. CM: <i>[Signature]</i>			SUP. CM: <i>[Signature]</i>			SUP. CM: <i>[Signature]</i>	
		DMNO: <i>[Signature]</i>			DMNO: <i>[Signature]</i>			DMNO: <i>[Signature]</i>			DMNO: <i>[Signature]</i>			DMNO: <i>[Signature]</i>	

Duquesne Light Company
NUCLEAR GROUP
PITTSBURGH, PA

BEAVER VALLEY POWER STATION UNIT NO. 2

VALVE OPER. NO. DIAGRAM
DIESEL GEN. LUBE OIL

SCALE: DATE: 12-19-86
DRAWN BY: M. MURPHY
ENGR/CHK: M. MURPHY

APP. BY: M. MURPHY
ELECT APP: M. MURPHY
MECH APP: M. MURPHY
CIVIL APP: M. MURPHY

REV: AA
DWG NO: 10080-RM-436-5A
REV: 5

3.3 WIND AND TORNADO LOADINGS

3.3.1 Wind Loadings

3.3.1.1 Design Wind Velocity

An 80-mph fastest mile wind speed, at an assumed elevation of 30 feet, is used as the design wind velocity to determine wind loadings on Seismic Category I structures, in accordance with Section 2.3.

This basic wind speed has a 100-year mean recurrence interval.

3.3.1.1.1 Basis for Wind Velocity Selection

The basic wind speed of 80 mph corresponds to the expected fastest mile of sustained wind for a 100-year mean recurrence interval in the general area of the Beaver Valley Power Station (BVPS), (Section 2.3). As noted in Section 2.3, the wind velocity design values are conservative due to the sheltered location of the site. Additional meteorological data are presented in Section 2.3.

3.3.1.1.2 Vertical Velocity Distribution and Gust Factor

The vertical velocity distribution and effect of gust factors are in accordance with ASCE Paper No. 3269. The gust factors are included in the determination of gust velocity pressures.

3.3.1.2 Determination of Applied Forces

The resultant design wind pressures (W) applied to Seismic Category I structures are determined in the following manner:

V_{30} = Fastest mile wind at 30 feet above ground (mph)

V_z = Fastest mile wind at Z feet above ground (mph) (from ASCE Paper No. 3269, Table 1 for inland areas)

f = Gust factor dependent upon building width (Table 3.3-1)

V_g = Gust velocity (mph) (used for design), $V_g = fV_z$

q_z = Dynamic pressure at Z feet above ground (psf),
 $q_z = 0.00256 V_z^2$

K = Gust coefficient dependent upon building width,
 $K = f^2$ (Table 3.3-1)

q_g = Gust dynamic pressure, (psf)
 $q_g = 0.00256 (fV_z)^2 = Kq_z$

C_d = Structure shape factor, $C_d = 1.3$ for rectangular buildings

P_o = Normal wind loading on rectangular buildings, (psf), $P_o = C_d q_z$

P_w = Design normal wind loading on rectangular buildings (psf),
 $P_w = C_d q_g = C_d K q_z = K P_o$

Based on the preceding, the design normal wind loading (P_w) for rectangular buildings is as presented in Table 3.3-2.

Where wind pressures on other than typical building walls are considered, the design normal wind loading is adjusted for the appropriate shape or drag factor (ASCE Paper No. 3269).

Design wind pressures are combined with dead and live loads and other loadings related to the structure, as presented in Section 3.8.4. Wind and earthquake loadings are not considered to apply at the same time. Structures designed for tornadoes are not checked for maximum normal wind pressures, as the tornado design causes maximum stress conditions.

3.3.2 Tornado Loadings

3.3.2.1 Applicable Design Parameters

The probability of tornado occurrence and the associated recurrence interval at the site is determined in Section 2.3.1.2. Tornado loading is not considered to be coincident with earthquake or design basis accident loadings. The following are the maximum tornado design parameters:

1. Maximum wind speed	360 mph
2. Rotational wind speed	290 mph
3. Translational speed	70 mph
4. Damage path diameter	1,000 feet
5. Pressure drop	3 psi
6. Average rate of pressure drop	3 psi in 3 seconds

The maximum wind speed is the sum of the rotational speed component (290 mph at 30 feet above grade) and the tornado translation (70 mph). The pressure drop of 3 psi takes place over a 3 second interval. The rate of pressure drop is not constant. The maximum rate of pressure drop is 2 psi per second. The damage path diameter

of 1,000 feet corresponds to a radius of maximum rotational speed of 150 feet. With these parameters, the site tornado model is consistent with the Region I model specified in Regulatory Guide 1.76, Design Basis Tornado for Nuclear Power Plants (USNRC 1974).

3.3.2.2 Determination of Loadings on Structures

Total tornado loads (W_t) generated by the design tornado specified for the site include loads due to tornado wind pressure (W_w), tornado-created differential pressure (W_p), and tornado-generated missiles (W_m).

Pressures and loads are determined in the manner described in the following subsections.

3.3.2.2.1 Wind Loads

The tornado wind pressure for the tornado model is determined by the formula:

$$P = 0.00256 V^2$$

where:

P = Tornado wind pressure (in psf)

V = maximum tornado velocity (in mph)

The tornado wind pressure is assumed constant with height. This pressure is multiplied by applicable shape factors and drag coefficients (ASCE Data; Singell 1958) to provide the tornado design pressure (P_w) which is applied to the exposed surfaces of the structure.

The tornado wind pressure load (W_w) is the area integral of the tornado design pressure (P_w) acting over the exposed surface of the structure or component.

3.3.2.2.2 Differential Pressure Loads

A tornado-generated differential pressure drop of 3 psi is used in the design of tornado-resistant structures.

The differential pressure load (W_p) is the area integral of the tornado-generated pressure load acting on the structure or component.

3.3.2.2.3 Tornado-Generated Missile Loads

The structural response to tornado-generated missile loads (W_m) is determined as described in Section 3.5.

3.3.2.2.4 Total Tornado Design Loads

Seismic Category I structures are designed to withstand tornado load combinations as follows:

1. $W_t = W_w$
2. $W_t = W_p$
3. $W_t = W_m$
4. $W_t = W_w + 0.5 W_p$
5. $W_t = W_w + W_m$
6. $W_t = W_w + 0.5W_p + W_m$

where:

W_t = Total tornado load

W_w = Tornado wind load

W_p = Tornado differential pressure load

W_m = Tornado missile load

For each particular structure, or portion thereof, the most adverse of the above combinations are used, as appropriate.

3.3.2.3 Effect of Failure of Structures of Components Not Designed for Tornado Loads

Seismic Category I structures are listed in Section 3.2 and are designed to withstand tornado-induced loads, where required, to ensure the integrity of safety-related systems. The design of all other structures allows a partial or complete structural failure under tornado conditions when safety-related structures, systems, or components are not endangered.

3.3.3 References for Section 3.3

American Society of Civil Engineers (ASCE). Wind Forces on Structures. Transactions, Paper No. 3269.

Singell, T.W. Forces on Enclosed Structures. ASCE Journal of the Structural Division, July 1958.

U.S. Nuclear Regulatory Commission (USNRC), Design Basis Tornado for Nuclear Power Plants. Regulatory Guide 1.76, Washington, D.C., 1974.

BVPS-2 UFSAR

Tables for Section 3.3

TABLE 3.3-1

GUST FACTORS AND COEFFICIENTS^(*)

<u>Width of Structure (ft)</u>	<u>Gust Factor (f)</u>	<u>Gust Coefficient (K)</u>
0-50	1.3	1.7
51-100	1.2	1.4
101-150	1.1	1.2
Greater than 150	1.0	1.0

NOTE:

*Based on: American Society of Civil Engineers. Wind Forces on Structures. Transactions, Paper No. 3269.

TABLE 3.3-2

DESIGN NORMAL WIND LOADINGS FOR RECTANGULAR BUILDINGS^(*) (P_W)

DESIGN WIND VELOCITY PRESSURE (PSF)

Elevation Above Grade (ft)	Width of Structure(ft)			
	<u>0-50</u>	<u>51-100</u>	<u>101-150</u>	<u>>150</u>
0-50	36.2	29.8	25.6	21.3
51-150	51.1	42.0	36.0	30.0
151-400	68.5	56.4	48.3	40.3

NOTE:

*Based on procedure outlined in: American Society of Civil Engineers.
Wind Forces on Structures. Transactions, Paper No. 3269.

3.4 WATER LEVEL (FLOOD) DESIGN

The plant finished grade (el 730 feet 4 inches to 735 feet mean sea level (msl)) is equal to or above the maximum external flood level calculated for the site. Refer to Section 2.4.2.2 for discussion of Flood Design Considerations. The determination of the probable maximum flood (PMF) originating external to plant structures (Section 2.4.3) is in compliance with Regulatory Guide 1.59, Revision 2, issued August 1977. Groundwater levels are described in Section 2.4.13. Buoyancy and static water force design for Seismic Category I structures is based on the PMF level of 730 feet msl. Flood protection for the site is in compliance with Regulatory Guide 1.102, Revision 1, issued September 1976.

The site and plant drainage system is designed to mitigate the effects of local intense precipitation (Section 2.4.2.3).

Internal flooding due to postulated piping system failures has been considered in the internal design and arrangement of structures containing safety-related components. Section 3.6B.1 describes the postulated piping failures and Section 3.6B.1.3.4 describes the environmental effects, including flooding, of these failures.

3.4.1 Flood Protection

Safety-related systems and components are protected from external floods by locating them in Seismic Category I buildings described in Sections 3.8.1.1 and 3.8.4.1.

Access to these structures is located above grade. In general, construction joints in the exterior walls and mats below el 730 feet, are provided with water stops. In addition, the containment structure has a continuous waterproof membrane below grade. Penetrations entering these buildings below grade are adequately sealed to prevent in-leakage. For example, piping penetrations in exterior walls of valve pits include flexible, water-tight boots to maintain the integrity of the building. As an added precaution, potential in-leakage to the containment structure is collected in sumps at the lower building elevation and pumped out.

The intake structure is the only safety-related structure which could be subjected to the effects of coincident waves and associated runup from external flooding. The intake structure, which is flood-protected to el 737 feet msl by extending the ventilation air intakes to this elevation, allows for a 6.7 feet runup above the standing water level of 730 feet associated with a 5 feet maximum wave (Section 2.4.3.6). The cubicles containing the service water pump motors can be completely sealed so that the entire intake structure could be under water without affecting pump operability, the cubicles are vented to the atmosphere by vent ducts that extend above maximum wave height.

A plant flood alert will be issued for an Ohio River water level of 690 feet msl or above. Actions to protect safety-related equipment are initiated when the river water level reaches 695 feet msl and water is rising upstream. Further discussion of implementation times and procedures to bring the plant to a cold shutdown is included in Section 2.4.14.

As the lowest floor levels of all Category I structures are located above ground water level, a permanent dewatering system is not required.

3.4.2 Analytical and Test Procedures

The following analyses have determined the extent of flooding external and internal to plant structures, so that adequate protection features could be designed and implemented.

Since the plant finished grade is higher than the maximum flood level, no dynamic water force is applied to Seismic Category I structures, with the exception of the intake structure.

For the intake structure design, hydrostatic forces associated with the maximum flood level are included in the fluid pressure loads to be imposed on the structure as identified in Sections 3.8.1 and 3.8.4. Forces acting on this structure are calculated on the basis of full external hydrostatic pressure and coincident wave forces, corresponding to this flood level. As discussed in Section 2.4.10, all Seismic Category I structures are designed for forces resulting from the load combinations which include the design flood.

3.5 MISSILE PROTECTION

3.5.1 Missile Selection and Description

3.5.1.1 Internally-Generated Missiles (Outside Containment)

Components outside containment but internal to plant structures have been evaluated for potential missile sources.

Valves in high pressure fluid system ($P > 275$ psig) have been evaluated as potential missile sources. The parts which could become possible missiles are valve stems and bonnets.

Valve stems are not considered potential missiles because there is more than one feature capable of preventing stem ejection, such as face-hardened backseats and air and motor operators.

Bolted bonnets of ASME Code, Section III, valves are not considered potential missiles because they are designed against bonnet-to-body connection failure and subsequent bonnet ejection by means of the following:

1. Compliance with the ASME Code, Section III, and
2. Control of load during tightening of bonnet-to-body joints.

The proper stud torquing procedures limit the stress of the studs to the allowable limits established in the ASME Code. This stress level is far below the material yield. Pressure-retaining parts of the valves are constructed and hydrotested in accordance with the ASME Code, Section III. The bodies and bonnets are volumetrically and surface tested to verify soundness. Critical valves are in-service inspected in accordance with the ASME Code Section XI.

The failure of all other valves in high pressure systems has been evaluated and found not to affect the items required for safe shutdown.

Pumps and fans located outside containment in areas containing safety-related components have been evaluated for missiles associated with overspeed failures. The maximum no-load speed of these pumps and fans is equivalent to the maximum operating speed of their motors. Consequently, no pipe break or single failure affecting the suction line would increase pump or fan speed above that of the no-load condition. Furthermore, there are no pipe breaks plus single failure combinations which could result in a significant increase in pump suction or discharge head. Therefore, no overspeed is expected.

For axial fans, the typical failure mode is the loss of a vane. For centrifugal fans, the failure mode is the failure of the impeller rotor or an attached blade. The fan to motor coupling is also a potential missile source. In the case of four axial fans

(Table 3.5-12), missile shields have been installed to retain fan blades which could otherwise be ejected through the inlet air flex connection. For all other cases, it has been demonstrated that either the fan housing is adequate to retain the fragments or a stress analysis has determined that the safety factors against the failure of these components is acceptable.

Pump missiles may be generated by failure of either the impeller or a shaft coupling. It has been demonstrated that either the pump casing is adequate to retain the fragments or a stress analysis has determined that safety factors against the failure of these components is acceptable. This includes the turbine-driven auxiliary feedwater pump where an analysis has been completed which documents that the generated missile does not escape the pump or turbine casing.

Shaft couplings have been evaluated and it was found that no single failure mode existed that could result in a generated missile.

The rod control motor-generator sets were evaluated for potential missile generation. The fabrication specifications of the motor-generator set flywheels control the material to meet ASTM-A533-70, Grade B, Class 12, or equivalent, with inspections per MIL-I-45208A, and flame cutting and machining operations governed to prevent flaws in the material. Nondestructive testing (NDT) for nil ductility (ASTM-E-208), Charpy V-notch (ASTM-A593), ultrasonic (ASTM-A577 and A578), and magnetic particle (ASTM Section III, NB2545), is performed on each flywheel material lot. In addition to these requirements, stress calculations are performed consistent with guidelines of the ASME Code, Section III, Appendix A, to show that the combined primary stresses due to centrifugal forces and the shaft interference fit shall not exceed $1/3$ of yield strength at normal operating speeds (1,800 rpm), and shall not exceed $2/3$ of the yield strength at 25 percent overspeed. However, no overspeed is expected because the flywheel weighs approximately 1,300 pounds, and is 35.26 inches in diameter by 4.76 inches wide. The flywheel mounted on the generator shaft, which is directly coupled to the motor shaft, is driven by a 200 hp 1,800 rpm induction motor. The torque developed by the motor is insufficient for overspeed. Therefore, there are no credible missiles from the motor-generator sets.

Table 3.6B-2 shows the safety-related structures, systems, and components outside containment required for safe shutdown of the reactor.

There are no known missiles generated due to gravitational effects. All safety components, and those nonsafety-related components which could affect safety-related components, are seismically supported in accordance with Sections 3.2 and 3.7.

Those tanks that are in areas that contain safe shutdown systems are designed to the requirements of the ASME Code, and are therefore not considered credible sources of missiles.

Missiles produced from non-ASME Code pressurized tanks and compressed air/gas cylinders have been evaluated and will not affect the items required for safe shutdown.

Refrigeration compressors and condensing units have been evaluated and will not affect the items required for safe shutdown.

An additional credible source of jet-propelled missiles outside of the containment are temperature and pressure sensor assemblies. These have been investigated and shown not to be credible missile sources.

3.5.1.2 Internally-Generated Missiles (Inside Containment)

3.5.1.2.1 Bases for Missile Selection

Catastrophic failure of the reactor vessel, steam generators, pressurizer, and reactor coolant pump (RCP) casings leading to the generation of missiles is not considered credible. Massive and rapid failure of these components is not credible because of the material characteristics, inspections, quality control during fabrication, erection, conservative design, and prudent operation as applied to the particular component. The RCP flywheel is not considered a source of missiles for the reasons discussed in Section 5.4.1. Nuts and bolts are of negligible concern because of the small amount of stored elastic energy.

The following nuclear steam supply system components do have a potential for missile generation inside the reactor containment:

1. Control rod drive mechanism (CRDM) housing plug, drive shaft, and the drive shaft and drive mechanism latched together,
2. Valves (Table 3.5-1),
3. Temperature and pressure sensor assemblies, and
4. Pressurizer heaters.

Gross failure of a CRDM housing, sufficient to allow a control rod to be rapidly ejected from the core, is not considered credible for the following reasons:

1. Control rod drive mechanisms are shop hydrotested at 4,100 \pm 75 psi,
2. Control rod drive mechanism housings are individually hydrotested to 3,107 psi after they are installed on the reactor vessel to the head adapters, and checked again during the hydrotest of the completed reactor coolant system (RCS), and
3. Control rod drive mechanism housings are made of Type 304 stainless steel, which exhibits excellent notch toughness at all temperatures that will be encountered.

However, it is postulated that the top plug on the CRDM will become loose and will be forced upward by the water jet. The following sequence of events is assumed: 1) the drive shaft and control rod

cluster are forced out of the core by the differential pressure of 2,500 psi across the drive shaft (the drive shaft and control rod cluster, latched together, are assumed fully inserted when the accident starts); 2) after traveling approximately 12 feet, the rod cluster control spider hits the underside of the upper support plate; 3) upon impact, the flexure arms in the coupling joining the drive shaft and the control cluster fracture, completely freeing the drive shaft from the control rod cluster; and 4) the control cluster is completely stopped by the upper support plate; however, the drive shaft continues to accelerate upward, hitting the missile shield provided.

Valves within the reactor coolant pressure boundary (RCPB) have been examined to identify potential missiles. This review identified no credible failures that could result in missile formation. Therefore, valves within RCPB are not considered credible sources of missiles. Motor-operated valves and air-operated valves contain design features which will effectively preclude the ejection of valve stems.

Valves in high-pressure systems inside containment have been reviewed. All valves are designed against bonnet-to-body connection failure and subsequent bonnet ejection by means of the following:

1. Compliance with the ASME Code, Section III, and
2. Control of load during tightening of bonnet-to-body joints.

The proper stud torquing procedures limit the stress of the studs to the allowable limits established in the ASME Code. This stress level is far below the material yield. Pressure-retaining parts of the valves are constructed and hydrotested in accordance with the ASME Code, Section III. The bodies and bonnets are volumetrically and surface tested to verify soundness. Critical valves are in-service inspected in accordance with ASME Section XI.

Valve missiles are postulated in the region where the pressurizer extends above the operating floor. Valves in this region are the pressurizer safety valves, the motor-operated isolation valves in the relief line, and the air-operated relief valves. Although failure of these valves is not considered credible, failure of the valve bonnet body bolts is postulated. The integrity of the containment liner and safety-related equipment from the resultant bonnet missile is assured by the pressurizer cubicle walls and roof, which act as a missile barrier.

The only credible source of jet-propelled missiles from the reactor coolant piping and piping systems connected to the RCS is represented by the temperature and pressure sensor assemblies. The resistance temperature sensor assemblies can be of two types: those located in a well, and those without a well. Two rupture locations have been postulated:

1. Around the welding between the boss and the pipe wall, and
2. At the welding (or thread) between the temperature element assembly and the boss without the well element, and the welding (or thread) between the well and the boss with the well element.

A temperature sensor is installed on the RCP close to the radial bearing assembly. A hole is drilled in the gasket and sealed on the internal end of a steel plate. In evaluating missile potential, it is assumed that this plate breaks, and the pipe plug on the external end of the hole can become a missile.

In addition, a failure of the weld between the instrumentation well and the pressurizer wall is assumed, causing the well and sensor assembly to become a potential missile.

Analyses have been done to ensure that conservative factors of safety exist against the weld failure, thus concluding that missiles from temperature and pressure assemblies are not credible.

Pumps and fans located inside containment in areas containing safety-related components have been evaluated for potential missiles. In the case of one axial fan (Table 3.5-12), a missile shield was installed to retain fan blades which could otherwise be ejected through the inlet air flex connection. Three other axial fans (Table 3.5-12) missile shields were installed to retain fan blades which could otherwise be ejected through the fan housing. In all other cases, it has been demonstrated that either the fan housing or pump casing is adequate to retain the fragments, or a stress analysis has determined that the safety factors against the failure of these components is acceptable.

Finally, it is postulated that the pressurizer heaters could loosen and become jet-propelled missiles. These missiles have been analyzed and shown not to have any adverse effects on essential equipment.

3.5.1.2.2 Missile Description

The missile characteristics of the valves in the region where the pressurizer extends above the operating deck are given in Table 3.5-1.

The CRDM missiles are summarized in Table 3.5-2. The missile velocities have been calculated by balancing the forces due to the water jet. No spreading of the water jet has been assumed.

The missile characteristics of the instrumentation well of the pressurizer and the pressurizer heaters are given in Table 3.5-4.

3.5.1.2.3 Missile Protection Provided

The following comprise the principal design bases:

1. Missiles generated inside the reactor containment shall neither cause loss of function of any redundant engineered safety features nor damage the containment boundary. In addition, a missile not generated by a loss-of-coolant-accident (LOCA) shall not initiate a LOCA.
2. Missiles generated outside of containment but internal to BVPS-2 structures shall not cause loss of function of any design feature provided for either continued safe operation or shutdown during operating conditions, operational transients, and postulated accident conditions associated with the effects of missile formation.

The most positive method employed to prevent damage from internally-generated missiles is to assure design adequacy against generation of missiles, rather than allow missile formation and try to mitigate the effects. Where potential missiles are identified, safety-related structures, systems, and components whose safety function might be impaired are protected by either locating the systems or components in individual missile-proof structures, physically separating redundant systems or components of the system, or providing special localized protective shields or barriers.

The following protection is provided for the missiles described in Section 3.5.1.2.2. Since CRDM missiles travel directly upward, a concrete shield is supported above the CRDMs to limit their travel. Valve missiles in the pressurizer cubicle above the operating floor travel directly upward where they are contained by the roof of the pressurizer cubicle. Pressurizer instrument sensor missiles are contained by the pressurizer cubicle roof and walls. Since the pressurizer heater missiles have no adverse effects on essential equipment, no protection is provided.

The ability of structures or barriers to withstand the effects of potential internally-generated missiles and to minimize the production of secondary missiles is discussed in Section 3.5.3.

Table 3.6B-2 identifies essential systems, structures, and components required for safe shutdown.

There are no known missiles generated due to gravitational effects. All safety components and those nonsafety components which could affect safety components are seismically supported in accordance with Sections 3.2 and 3.7.

Missiles produced from non-ASME Code pressurized tanks and compressed air/gas cylinders have been evaluated and will not affect items required for safe shutdown.

3.5.1.3 Turbine Missiles

Postulated turbine missiles have been evaluated by considering the probabilities of missile generation and of impact to safety-related items.

The probability (P4) of damage to plant structures, systems, and components important to safety is:

$$P4 = P1 \times P2 \times P3$$

where:

P1 = the probability of generation and ejection of a high energy missile,

P2 = the probability that a missile strikes a critical plant region, given its generation and ejection, and

P3 = the probability that the missile strike damages its target in a manner leading to unacceptable consequences. Unacceptable consequences are defined here as the loss of the capacity to maintain the integrity of the RCPB, to shut down the plant, maintain it in a safe shutdown condition, and/or limit offsite radiation exposures.

3.5.1.3.1 Probability of Generation and Ejection (P1)

A turbine missile can be caused by brittle fracture of a rotating turbine part at or near turbine operating speed, or by ductile fracture upon runaway after extensive, highly improbable, control system failures.

The probabilities of such failures is, however, significantly reduced by the effects of inservice testing and inspection frequencies. Reduced probability of missile generation and ejection is the approach used by BVPS-2 for ensuring that the probability of unacceptable damage to essential structures, systems, and components is sufficiently low.

Therefore, the turbine manufacturer, Siemens, has performed an analysis of turbine reliability which considers known and likely failure mechanisms and expresses such failure probability in terms of the intervals between inservice inspection and test. Consequently, the design-speed missile generation probability is related to disk design parameters, material properties, and the inservice volumetric (ultrasonic) disk inspection interval. Further, the overspeed missile generation probability is related to the turbine governor and overspeed protection system's sensing and tripping characteristics, the design and arrangement of main steam control and stop valves and the reheat steam intercept and stop valves, and the inservice testing and inspection intervals for system components and valves. Inspection and test schedules which meet the necessary safety objectives are provided in Section 10.2.

3.5.1.3.2 Probability of Missile Strike (P2)

In the event of missile ejection, the probability of a strike on a plant region (P2) is a function of the energy and direction of an ejected missile and of the orientation of the turbine with respect to the plant region. Figure 3.5-1 shows the turbine placement and orientation for BVPS-1 and BVPS-2, as well as the ± 25 degree missile ejection zones for the low pressure turbine wheels. (Both BVPS-1 and BVPS-2 turbines are considered as possible missile sources).

The BVPS-2 target areas are identified by shaded areas in Figure 3.5-1. The target areas include all the Category I buildings that contain essential systems, as well as those essential systems outside of Category I buildings.

As shown on Figure 3.5-1, due to the plant arrangement, all cross-unit damage associated with low trajectory turbine missiles is precluded and the potential for cross-unit damage from high trajectory turbine missiles is minimized. The ability of BVPS-1 to satisfy its own plant safety objective in regard to turbine missiles provides adequate assurance that the damage probability to BVPS-2 due to the BVPS-1 turbine is also acceptably low.

3.5.1.3.3 Probability of Damage (P3)

The probability of damage (P3) is a function of the energy of the missile, its angle of impact upon the affected structure, and the ability of that structure to prevent unacceptable damage to the essential systems it protects.

3.5.1.3.4 Probability Evaluation

The probability of unacceptable damage to safety-related structures, systems and components by turbine disk fragments is less than the plant safety objective of 10^{-7} per year. This is accomplished by a sufficiently frequent turbine testing and inspection schedule which provides that the probability of turbine missile generation (P1) is maintained at 10^{-5} per year or less.

The combined probability of strike and damage (P2 P3) is considered to be 10^{-2} per year or less. This conservatively considers the unfavorable orientation of the turbine generator.

Figure 3.5-2 shows the P1 missile generation probability vs. hours of operation since the last disk inspection, with a comparison to the NRC requirements.

The P1 values are for the entire unit considering all rotors and both design and overspeed conditions. The turbine testing and inspection program is provided in Section 10.2.

A calculation was performed to determine the turbine missile ejection probability resulting from an extension of reheat stop and intercept valve test intervals. A reheat stop and intercept valve inspection interval of 60 months was assumed in the calculation. Based on the calculation, it was determined that the total turbine missile generation probability meets applicable acceptance criteria with an 18 month reheat stop and intercept valve test interval.

3.5.1.3.5 Turbine Overspeed Protection

The turbine speed control system has adequate redundancy to ensure that the turbine does not attain destructive overspeed. The standard Westinghouse analog electro-hydraulic control (EHC) system and electromechanical trip system includes three separate speed sensors mounted on the turbine stub shaft located in the turbine front pedestal. These sensors are:

1. Mechanical overspeed trip weight (spring-loaded bolt),
2. Electromagnetic pickup for main speed governing channel, and
3. Electromagnetic pickup for the overspeed protection control channel. This pickup uses the same toothed wheel as item 2.

An overspeed protection controller is provided and is activated in the event turbine speed exceeds 103 percent of rated speed (1,800 rpm), or

during a full load drop. In either event, both the governor and the interceptor valves close. The governor valves remain closed until the speed is decreased to rated speed (1,800 rpm). The interceptor valves are modulated and reopen when speed decreases to below 103 percent of rated speed to remove entrapped steam in the reheat system. If speed again increases above 103 percent, they reclose and continue to modulate until speed remains below 103 percent of 1,800 rpm.

The overspeed protection controller is the first line of overspeed protection and is designed to prevent the turbine from reaching the overspeed trip point.

Should the turbine exceed approximately 110 percent of rated speed, the throttle (stop), governor, reheat stop, and intercept valves will all be tripped closed by both the mechanical overspeed bolt and the backup electrical trip. Thus, the turbine is tripped by redundant trip systems from independent speed sensors to assure utmost safety.

The electromechanical trip system also trips the turbine generator on excessive thrust bearing wear, low bearing oil pressure, and low condenser vacuum.

The turbine is tripped by the dumping of control system hydraulic fluid from all valve pistons, causing the heavy springs to close the throttle (stop), governor, reheat stop, and intercept valves in 0.15 second. Two valves in series in each steam entrance to the turbine are closed simultaneously upon a unit trip to provide redundant steam isolation to the turbine. The turbine operation, trip, and overspeed protection are discussed in more detail in Sections 10.2.2.1.1, 10.2.2.1.2, and 10.2.2.1.3.

The redundancy, component reliability, and test procedures of the turbine control system are detailed in Section 10.2.2.1.

3.5.1.3.6 Turbine Valve Testing

Throttle, governor, interceptor, and reheat stop valves of the turbine generator are tested periodically in the single valve mode while the EHC system is in operator automatic and load first stage pressure feedback is in service.

Throttle and governor valves are tested individually. Upon completion of each test, the valve is returned to its original position before the next valve is tested. Interceptor and reheat stop valves are interlocked so that a pair of these valves in one crossover pipe is tested together. Each pair of valves is returned to the open position before the next pair is tested.

Reducing load when testing valves is not necessary since valves may be tested at any load. The maximum load reduction during any valve test occurs when the unit is at full load. Under these circumstances, a test of a governor valve results in a short-time load reduction of about 4 percent of full load. The test of a throttle valve or an interceptor-reheat stop valve pair at full load results in a load decrease of 1 to 3 percent of full load. When valve tests are made below full load, the control system acts to maintain load.

When governor valves are tested at full load, the pressure drops are those normally experienced at the 75 percent admission operating

point (that is, 3 out of 4 governor valves open). When governor valves are tested at less than full load, the pressure drops are no different than those experienced in normal operation at reduced load.

3.5.1.4 Missiles Generated by Natural Phenomena

The only missiles considered credible which are generated by natural phenomena are those generated by either tornado or flood.

Tornado-generated missiles are selected and used as a design basis for all Seismic Category I structures. These missiles have the aerodynamic characteristics necessary for flight in a tornado. Table 3.5-5 describes the characteristics of the missiles selected by the National Bureau of Standards (NBS) as being representative of construction site debris (NBS 1976).

All Seismic Category I systems and components are located in Seismic Category I structures. Those Category I structures designed to withstand the effects of tornado missiles and the systems and components thus protected are identified in Tables 3.2-1 and 3.2-2.

In general, a minimum of 2 feet thickness of reinforced concrete having a minimum strength of 3,000 psi (28 day compressive strength) was used for walls, roofs and floors designated as missile protection. A lesser concrete thickness was used in several areas where it was shown by analysis to be adequate for the postulated missiles. The minimum reinforcing steel each way in each face of any square foot of wall or slab providing missile protection is 1.85 square inches.

Ventilation or penetration openings in the various buildings housing essential shutdown equipment are protected from tornado missiles by reinforced concrete walls or labyrinths or steel missile barriers.

As discussed in Section 2.4, flood levels do not approach the site grade and, therefore, waterborne missiles are not considered, except in the case of the primary intake structure.

The alternate intake structure is designed to provide a redundant system for the primary intake structure. This was provided expressly for the purpose of providing a backup system in the event the primary intake structure is damaged due to a gasoline barge explosion.

3.5.1.5 Missiles Generated by Events Near the Site

The acceptance criteria of NUREG-0800 (USNRC 1981) state that the aggregate probability of exceeding BVPS-2 design criteria associated with all identified external man-made hazards be less than 1.0. In particular, the total probability per year of penetrating site proximity missile strikes on safety-related structures should be

shown to be less than 10^{-7} per year, or the design bases modified to accommodate them.

This report provides an analysis of nearby transportation modes of hazardous materials judged capable of generating significant missiles.

The relative importance of potential sources of missiles derives from two primary factors, the nature of the shipment lading itself, and the shipment frequency past the site. Several studies (U.S. Department of Transportation (USDOT) 1981a, 1981b; Association of American Railroads and Railway Progress Institute (AAR-RPI) 1972a and 1972b; National Transportation and Safety Board (NTSB) 1971, 1972, 1974, 1979, 1980) have borne out the historical record, which shows that shipments of flammable compressed gas are the most likely to

produce tank fragments with a range and kinetic energy of any significance to site safety-related structures. These shipments are almost exclusively limited to rail tank cars on the section of ConRail track in the Midland node to the west of the site.

A search of U.S. Army Corps of Engineers data for mile point 35 of Ohio River barge traffic showed that there are no significant shipments of liquified petroleum gas past the site. The only flammable liquid carried in bulk tank barges with a significant explosion potential is gasoline. An alternate intake structure has been provided to address this concern (Section 9.2.1.2).

Telephone and letter surveys of nearby industrial firms have shown that there are no known shipments of flammable compressed gas which use the Highway 168 bridge at Shippingport. There are occasional bulk shipments of chemicals such as solvents, and regular use of the bridge by gasoline tank trucks, but these use low pressure tank trailers of all welded ductile construction that are unlikely to produce missiles of any consequence to the site.

At intervals of about once every 18 months, for a period of one or two weeks, tank truck shipments of nonflammable compressed gas (LOX, LN₂, Argon) are received at the Crucible Plant in Midland. These are estimated at a maximum two loads per day during this period. From the historical experience with these products, the missile generating potential of the shipments is deemed negligible (USDOT 1981a, 1981b).

Hence, the following analysis concentrates primarily upon rail shipments of flammable compressed gas. The shipments of flammable compressed gas are listed in Table 3.5-6.

Rail Shipment Analysis

The following algorithm is used to estimate the aggregate probability of a violent rupture or explosion from a rail shipment of hazardous materials capable of producing large missiles able to reach safety-related structures at the site:

$$P_e = \sum_{i=1}^R E S_{i,T_i} L_i \quad (3.5-7)$$

where:

P_e = aggregate probability of missile generating ruptures or explosions from rail accidents of significance to safety-related structures (events/year).

R = number of hazardous materials likely to produce violent ruptures or explosions with significant missile generating capability (dimensionless).

E = frequency of events which result in explosions or violent ruptures capable of producing significant missiles (events/shipment).

S_i = shipment frequent of i-th hazardous material past site (shipment/year).

L_i = track exposure length for the i-th material (miles).

T_i = average shipment trip length for i-th material (miles).

Number of Hazardous Materials, R:

The hazardous materials deemed likely to produce significant missiles in terms of size and potential range were selected from the list of STCC code 4902, 4905, and 4906 hazardous materials in the ConRail (1980) Midland node report. These materials were also found to be prevalent in accident/incident data contained in special USDOT (1980, 1981) computer printouts of March 26 and April 15, 1981, and rupture data from The Railroad Tank Car Safety Research and Test Project Report RA-01-2-7 (AAR-RPI 1972a) as well as several pertinent railroad accident reports by the NTSB.

The materials selected (Table 3.5-6) were generally flammable compressed gases, and they produce a characteristic rupture event ranging from a simple overpressure and subsequent fire, to a boiling liquid expanding vapor explosion (BLEVE). Two flammable liquids, ethylene and propylene oxide, and a compressed gas that is slightly flammable, anhydrous ammonia, were added to the list because of their particular material properties and their incident rate.

Frequency of Events Resulting in Explosions or Ruptures, E:

The event incidence for significant missile-producing ruptures is infrequent enough that material specific data were not judged to be a reliable indication. In addition, ConRail-specific data for the period March 30, 1976 through December 31, 1979, contained no incidents involving explosions. Instead, a comparison was made between the risk assessment made for propane transport by Battelle Memorial Institute in PNL-3308 (Geffen 1980) and the USDOT data in accident/incident bulletins for the years 1975-1979. In terms of the incidence of tank car violent rupture or explosions per tank car mile, the predicted values were as follows:

PNL-3308 3.1×10^{-9} events/tank car-mile

USDOT ('75-'79) 1.5×10^{-9} events/tank car-mile

The Battelle report considers nonaccident related tank failures, as well as transportation accidents, and about 20 percent of ruptures occur in nonaccident situations, the Battelle event frequency was used in this analysis even though it is recognized to be demonstrably conservative. This also accounts for the contribution to the average rate from the slightly higher incidence for propane and liquid petroleum gas (LPG) shipments. The latter are not controlling for the site because approximately 3/4 of the hazardous material tank car shipments in question contain vinyl chloride monomer (Table 3.5-6).

Shipment Frequency, S_i :

Shipment frequencies are derived from applicable data in the ConRail (1980) Midland node report for the period January 1978 through June 1979. Tank cars per year and per train for the commodities in question appear in Table 3.5-6.

Track Exposure Length, L_i :

Although it is obvious from the accident data examined that the total lading from each car is not involved in producing ruptures and rupture effects, the rail line exposure distance for the i -th material was estimated using the equivalent alpha-trinitrotoluene (TNT) method to calculate radii, as suggested by Regulatory Guide 1.91. The method of Eichler and Napadensky (1977) in final report J6405 was used to estimate TNT equivalents (W) using the net or gaseous product heats of combustion for each material. The radii $R = 45W^{1/3}$ were calculated, and the corresponding exposure distances estimated from arcs intercepting the rail line from safety-related structures other than the intake structure. The closest point of approach to the site safety-related structures is then taken to be about 2,030 feet. From this analysis, summarized in Table 3.5-7, the shipments of dimethyl ether are seen to be incapable of producing a significant missile.

Average Shipment Trip Length, T_i :

The average shipment lengths for each hazardous material were derived from the One Percent Waybill Sample of U.S. Tank Car Shipments or Appendix E to the Final Phase 02 Report RA-02-2-18 (AAR-RPI 1972b).

Aggregate Probability of Missile Generating Ruptures or Explosions, P_e :

Results from the previous effort are summarized in Table 3.5-8. The aggregate probability of tank car violent ruptures or explosions which can produce significant missiles is conservatively calculated to be 4.9×10^{-6} per year. This is slightly above the NUREG-0800 (USNRC 1981) Section 3.5.1.5 suggested limit for conservatively estimated explosion probability so an assessment of potential missile ranges was made, using a simplified explosion model, and a comparison

made with accident experience contained in AAR-RPI RA-01-2-7 (1972a). These distances are contained in Table 3.5-9.

Discussion of Results

According to Mr. William F. Black, Chief of the Office of Safety, Federal Railroad Administrations (FRA), USDOT, the types "J", "S", and "T" pressure tank car retrofits, which establish such things as thermal insulation protection, head puncture shields, shelf couplers, and upgraded safety relief valve capacities, have all been installed on existing tank cars as of December 31, 1980. All new compressed gas tank cars must also meet these provisions, which were proposed under Docket No. HM 144 and modified in subsequent notices under Title 49, Parts 173 and 179. Consequently, a substantial reduction is expected in the severity and incidence of violent ruptures and explosions. Recent experience at the July 26, 1980, derailment in Muldraugh, Kentucky, which involved the shell rupture of two out of six tank cars of vinyl chloride monomer, showed that the J type modification "greatly enhanced the crashworthiness of the chemically laden tank cars during and after the derailment ... catastrophic releases of hazardous materials did not occur." "Top and bottom shelf couplers, tank head shields, and tank shell insulation were performed within design limits as intended, and prevented head punctures in all of the derailed tank cars" (NTSB 1980). The FRA believes that compressed flammable gas tank car head punctures and fire-induced violent ruptures will be greatly reduced or eliminated in nine out of ten accident cases as a result of the improvements. In fact, accident experience has already started to reflect this improvement but sufficient data are not yet available to quantify the results. It should be noted that these changes are not being uniformly applied to flammable liquid tank cars such as those used for ethylene oxide. This experience is expected to improve because the lading loss savings and cost of damage make retrofits of thermal insulation and shelf couplers attractive to shippers. However, where this analysis reflects data from past experience, the benefits from the USDOT required retrofits are not taken credit for. It also reflects, by virtue of the referenced propane risk assessment, the contribution of nonaccident ruptures (Geffen 1980). The risk to BVPS-2 is nevertheless subject to further reducing factors, according to the model used on NUREG-0800 (USNRC 1981) in Section 3.5.1.5.

$$P_T = P_m \times P_{mr} \times P_{sc} \times P_p \times N$$

(3.5-8)

where:

P_T = Total probability per year of a damaging missile strike.

P_m = Probability of an explosion (capable of missile generation).

P_m = Probability of an explosion (capable of missile generation).

P_{mr} = Probability of a missile reaching the plant (distance to safety-related structures).

P_{sc} = Probability of a missile striking a critical area (safety-related structure).

P_p = Probability of a missile energy exceeding the energy required to penetrate (the safety-related structures).

N = Number of missiles per explosion.

Some perspective is in order at this point. Not all major ruptures produce missiles. In fact, the Final Phase 01 Report (AAR-RPI 1972a) shows that in about one third of major ruptures, no significant missiles are created. Therefore, a conditional probability of an explosion capable of missile generation, $P_m = 0.67$, should be added to the equation. Also, a dependency exists between the probability of a missile reaching BVPS-2 and its energy exceeding that of the design basis tornado missile, generally assumed to be the "flying telephone pole." A study of 84 tank car fragmentations by Siewert (1972) showed that for distances exceeding 2,000 feet (610 meters), there is only a probability of 0.05 that the missile will reach the BVPS-2 structures at all. In the specific case discussed here, the minimum approach distance is 2,030 feet. Hence P_{mr} could be taken as 0.05. In addition, the energy remaining in missiles exceeding this distance is believed minimal because of likely size (small) and air resistance efforts (cumulative) for a tumbling object. The punching shear characteristic of the 200 mph telephone pole is much different than the damage typically inflicted by tank car fragments, such as an elliptical head. These heads have been known to demolish brick walls, but to bounce over fieldstone walls with little damage (Black 1981). Therefore, the probability, P_p , of a tank car missile exceeding the tornado missile design basis for reinforced concrete structures is judged to be proportional to their (mass)^{1/2}, (velocity)¹ and (mass to aspect ratio)^{-1/2}, or:

$$P_p = \left(\frac{3500}{1500}\right)^{1/2} \left(\frac{180}{200}\right)^1 \left(\frac{1.0}{10.5}\right)^{-1/2} = 0.42$$

(3.5-9)

The number of missiles generated per explosion is usually two parts of one tank car which head in opposing directions. From Table 3.5-6, and the number of cars of any one commodity per train, we see this as a reasonable assumption. Therefore, only one missile per explosion would be postulated to be directed at the site, hence, $N = 1$.

Table 3.5-6 of the U.S. Atomic Energy Commission (USAEC) Topical Meeting Report (Iotti et al 1973) gives an estimate of the hit

probability of missiles from explosion striking a critical area, which places P_{SC} in the range of .01 or less for a distance of over 2,000 feet and a multi-unit site. Hence, the calculated total probability per year of a rail accident missile causing significant damage to a safety-related structure is:

$$\begin{aligned} P_T(\text{rail}) &= 4.93 \times 10^{-6} \times 0.67 \times 0.05 \times 0.01 \times 0.42 \times 1.0 \\ &= 7.0 \times 10^{-10} \end{aligned}$$

(3.5-10)

An upper bound estimate assuming $P_m = 1.0$, $P_{mr} = 0.10$,

$P_{SC} = 0.10$, $P_p = 0.6$, and $N = 2.0$ is:

$$\begin{aligned} P_T(\text{rail}) &= 4.93 \times 10^{-6} \times 1.0 \times 0.10 \times 0.10 \times 0.6 \times 2.0 \\ &= 5.9 \times 10^{-8} \end{aligned}$$

(3.5-11)

From the previously mentioned analysis, we conclude that a realistic assessment of the risk of significant missile generation events from railroad traffic near the site is that they do not constitute a design basis, and pose no unacceptable hazard to the BVPS-2 safety-related structures.

Estimation of Fragment Ranges from Rail Tank Car Explosion

In an accident involving easily liquified compressed gases, for example LPG and anhydrous ammonia, large fragments (greater than one-fourth of the container size) may travel by "thrusting." These fragments travel by a process which results from changing all or part of the liquid into gas by flash vaporization. The flash vaporization occurs because the internal pressure in the container is abruptly released during fracturing of the vessel. The mechanisms of this thrusting process is fully explained in the National Aeronautics and Space Administration (NASA 1978) Contractor Report 3023 and is considered applicable for the accidents involving hazardous materials of interest in this report. According to the NASA Report, the thrusting fragments have a low launch angle (5-10 degrees).

The NASA Report 3023 computer program entitled "THRUST" was utilized in calculating the acceleration, velocity, and displacement distances of fragments propelled by a vaporizing liquid. The NASA analysis assumes that a large portion of the vessel containing a liquid/gas mixture in equilibrium at greater than atmospheric pressure will separate from the rest of the storage vessel. As the liquid under pressure converts to gas when released to atmospheric pressure, a

thrust is produced causing the fragment to move away from the scene of the accident.

The types of tank car fragments are illustrated in Table 3.5-10. In Type A, the tank is shown to rupture in two equal halves. In Type B, the tank car is assumed to split in 2:1 ratio and the smaller fragment is assumed to move away from the accident scene. Types C and D ruptures are not considered in this analysis because in Type C, the manway has no significant amount of liquid to provide it with thrust, and in Type D, the leak is relatively too slow to create a violent change in vapor/liquid equilibrium within the tank. In Table 3.5-7 the ranges of thrusting fragments generated by LPG and anhydrous ammonia are shown. We note that for the identical rupture of the tank car, the fragment ranges for ammonia are approximately twice those for LPG. The ranges are however, still well below the nearest distance (2,030 feet) to the safety-related structure from the railroad track.

Estimate of Maximum Missile Range from Gasoline Truck Explosions

Using the model presented by Rhoads (1978), an estimate was made of the maximum equivalent weight of TNT (Brasie & Simpsons method) of an explosive mixture entirely filling a gasoline tank truck trailer tank of 8,400 gallon capacity. The minimum distance from the nearest highway to the nearest safety-related structure is 760 feet, and this is outside the maximum calculated range of gasoline truck missiles (380 feet).

3.5.1.6 Aircraft Hazards

A study of the probability of aircraft which use nearby airports and airways colliding with the safety-related structures of BVPS-2 is presented in Appendix 3B. Due to the conservatism of the analysis, the values derived by the analytical model are believed to be substantially higher than the true probability. The study concludes that the aircraft accident probability would be less than 1.0×10^{-7} per year through the year 2024.

3.5.2 Structures, Systems, and Components to be Protected from Externally Generated Missiles

Missile protection is provided for all components required to achieve and maintain a safe shutdown condition and prevent the missile accident from propagating into a more serious accident. Table 3.2-1 lists all QA Category I components by systems and identifies the missile protection for those safety-related components considered. Also listed in the table are the safety class, location, design code, and flood protection provided for each component. Table 3.2-2 lists all QA Category I structures and identifies the structures for which tornado and flood protection are required. Table 3.6B-2 describes which Category I components are required for safe shutdown. Details of the component and system designs, including redundancy and extent

of safety-related requirements, are included in the sections describing each component.

As discussed in Section 3.5.1.2.3, safety components are physically separated by barriers and located in individual cubicles so that a postulated missile does not affect the minimum number of components required for safe shutdown. The general arrangement drawings in Section 3.8 show the physical separation and barriers provided.

3.5.3 Barrier Design Procedures

Missile barriers are designed to withstand the effects of missiles described in Section 3.5.1 without compromising plant safety.

Missile barrier design requirements include:

1. To prevent perforation of the missile into safety-related areas with one or more barriers,
2. Secondary missiles are not generated or are limited to energy levels which permit safe shutdown of the plant, and
3. Structural response to missile impact to permit the barrier and its supports to safely carry other design loads during and after impact. In addition, the deflection of the barrier does not impair the safety or safety function of a Seismic Category I system.

The procedure used to evaluate the local response of concrete barriers to missile impact is based on Appendix B of SWECO 7703 (SWEC 1977). The thickness of concrete barriers conforms to the minimum acceptable barrier thickness requirements specified in Table 1 of SRP 3.5.3, NUREG-0800 (USNRC 1981).

Local response of steel barriers is evaluated by using the Stanford Research Formula (Gwaltney 1968) and the Ballistics Research Laboratory Formula (Gwaltney 1968).

The overall structural response of the concrete barriers to missile impact is evaluated using methods presented in Appendix C of SWECO 7703 (SWEC 1977). Using these methods, the structural design of the barrier is controlled by the ductility factor as described herein.

If the barrier is required to carry loads during and after missile impact, the maximum allowable ductility is limited to a factor of 10. In particular:

1. For beam-column members where the compressive load is equal to or less than one-third of that which would produce balanced conditions (P_b or $0.1f_cA_g$, whichever is smaller), the allowable ductility is 10.

Where:

P_b = axial load capacity at simultaneous assumed ultimate strain of concrete and yielding of tension steel

f'_c = specified compressive strength of concrete (psi)

A_g = gross area of section (in²).

2. For beam-column members where the design is controlled by compression, the allowable ductility is 1.3.
3. For members which are between the cases of items 1 and 2, the ductility ratio should be taken as decreasing linearly from 10 to 1.3.

The overall structural response of the steel barriers to missile impact is evaluated in accordance with the following:

1. When flexural compression or shear governs, the allowable ductility is ≤ 10 .
2. For columns with slenderness ratio (l/r):
 - a. equal to or less than 20, the allowable ductility is ≤ 1.3 .
 - b. greater than 20, the allowable ductility is ≤ 1.0 .

where:

l = effective length of the member.

r = least radius of gyration.

3. When the members are subjected to tension, the ductility ratio (u) is given by:

$$u = 0.5 \frac{\epsilon_u}{\epsilon_y} \quad (3.5-12)$$

where:

ϵ_u = ultimate strain

ϵ_y = yield strain

If a concrete barrier is not required to carry other loads during and after impact, the maximum allowable ductility ratio is limited to correspond to a rebar elongation of 5 percent. Similarly, for steel

barriers not required to carry other loads, the maximum allowable ductility ratio is also limited to correspond to an elongation of 5 percent (Sihweil 1976).

3.5.4 References for Section 3.5

Association of American Railroads and Railway Progress Institute 1972a. Final Phase 01 Report on Summary of Ruptured Tank Cars Involved in Past Accidents. AAR-RPI Report No. RA-01-2-7, Chicago, Ill.

Association of American Railroads and Railway Progress Institute 1972b. Final Phase 02 Report on Accident Review. AAR-RPI Report No. RA-02-2-18, Chicago, Ill.

Black, W.F. (Federal Railroad Administration (FRA) Office of Safety) personal communication (dated April 6, 1981).

Regulatory Guide 1.115, Protection Against Low Trajectory Turbine Missiles, Revision 1, July 1977.

ConRail 1980. Hazardous Materials Node Report. Node Activity for Midland, Pa. by Type, from January 1978 through June 1979. Prepared for Stone & Webster Engineering Corporation (SWEC), Boston, Mass.

Eichler, T.V. and Napadensky, H.S. 1977. Accidental Vapor Phase Explosions on Transportation Routes Near Nuclear Power Plants. Final Report J6405.

Geffen, C.A. Project Coordinator, 1980. An Assessment of the Risk of Transporting Propane by Truck or Train. Report prepared for the U.S. Department of Energy (USDOE) by Pacific Northwest Laboratory, Battelle Memorial Institute, Richland, Wash.

Gwaltney, R. C. 1968. Missile Generation and Protection in Light Water-Cooled Reactor Power Plants. ORNL-NSIC-22.

Iotti, R.C.; Krotiuk, W.S.; and Deboisblanc, D.R. 1973. Hazards to Nuclear Plants from (or near) Site Gaseous Explosions. In: Report of Topical Meeting on Water Reactor Safety. U.S. Atomic Energy Commission (USAEC), Washington, D.C.

National Aeronautics and Space Administration (NASA) 1978. Workbook for Estimating the Effects of Accidental Explosions in Propellant Ground Handling and Transport Systems. Report 3023.

National Bureau of Standards (NBS) 1976. Tornado-Borne Missile Speeds. NBSIR 76-1050.

National Transportation Safety Board (NTSB) 1971. Railroad Accident Report for Houston, Tex. No. NTSB-RAR-72-6.

Siemens Technical Report CT-27472, Missile Report, Revision 2, August 5, 2011.

National Transportation Safety Board 1972. Railroad Accident Report for East St. Louis, Ill. No. NTSB-RAR-73-1.

National Transportation Safety Board 1974, Railroad Accident Report for Houston, Tex. No. NTSB-RAR-75-7.

National Transportation Safety Board 1979. Railroad Accident Report for Muldraugh, Ky. No. NTSB-RAR-81-1.

National Transportation Safety Board 1980. Railroad Accident Report for Crestview, Fla. No. NTSB-RAR-79-11.

Rhoads, R.E. 1978. An Assessment of the Risk of Transporting Gasoline by Truck. PNL-2133, Pacific Northwest Laboratory, Battelle Memorial Institute, Richland, Wash.

Siewert, R.D. 1972. Evacuation Areas for Transportation Accidents Involving Propellant Tank Pressure Bursts. NASA Technical Memorandum Y68277.

Sihweil, I. 1976. SEB Interim Position on Ductility Ratios of Reinforced Concrete Structural Elements. Memorandum, USNRC, (SEB:808).

Stone & Webster Engineering Corporation (SWEC) 1977. Missile Barrier Interaction, Topical Report SWECO-7703.

U.S. Nuclear Regulatory Commission (USNRC) 1981. Standard Review Plan for the Review of Safety Analysis Report for Nuclear Power Plants. Barrier Design Procedures. Revision 1, NUREG-0800.

U.S. Department of Transportation (USDOT) 1981a (Research and Special Programs Administration). Incidents Involving Deaths, Injuries, Damages Greater than \$50,000 or Evacuations. Computer printout, periods covering 12/22/70 to 9/5/80, Washington, D.C.

U.S. Department of Transportation (USDOT) 1981b (Research and Special Programs Administration). Incidents Involving Fire and Explosions by Rail. Computer printout, periods covering 6/6/73 to 11/1/80, Washington, D.C.

Westinghouse Electric Corporation November 1986. Power Generation Operating Division. Turbine Missile Report, CT-25266, Revision 0, Results of Probability Analysis of Disc Rupture and Missile Generation for the Beaver Valley Partially Integral Rotors.

Westinghouse Electric Corporation April 1992. Calculation of Turbine Missile Ejection Probability Resulting From Extending The Test Intervals Of Interceptor And Reheat Stop Valves At Beaver Valley Units 1 and 2.

Sieber, J. D., May 28, 1992. Turbine Valve Surveillance Testing. Letter, Duquesne Light Company to the Nuclear Regulatory Commission (ND2NSM:5568).

BVPS-2 UFSAR

Tables for Section 3.5

TABLE 3.5-1

VALVE MISSILE CHARACTERISTICS*

<u>Missile Description</u>	<u>Missile Weight (lb)</u>	<u>Flow Discharge Area (in²)</u>	<u>Thrust Area (in²)</u>	<u>Impact Area (in²)</u>	<u>Missile Weight to Impact Area Ratio (psi)</u>	<u>Velocity (fps)</u>
Safety valve bonnet	350	2.86	80	24	14.6	110
A 3-inch motor-operated isolation valve bonnet (plus motor and stem)	400	5.5	113	28	14.1	135
A 3-inch air-operated valve bonnet (plus stem)	125	2.08	17.8	123	1.0	165

NOTE:

*For valves in the region where the pressurizer extends above the operating floor.

TABLE 3.5-2

SUMMARY OF CONTROL ROD DRIVE MECHANISM MISSILE ANALYSIS

<u>Postulated Missile</u>	<u>Missile Weight (lb)</u>	<u>Thrust Area (in²)</u>	<u>Impact Area (in²)</u>	<u>Distance to Target (ft)</u>	<u>Impact Velocity (fps)</u>	<u>Kinetic Energy (ft-lb)</u>
Mechanism housing plug	11	4.91	7.07	5	90	1,380
Drive shaft	133	2.40	2.41	5	150	46,757
Drive shaft latched to mechanism	1,295	12.57	11.04	5	12.1	1,490

TABLE 3.5-4

CHARACTERISTICS OF OTHER MISSILES
POSTULATED WITHIN REACTOR CONTAINMENT

<u>Missile Description</u>	<u>Weight (lb)</u>	<u>Discharge Area (in²)</u>	<u>Thrust Area (in²)</u>	<u>Impact Area (in²)</u>	<u>Missile Weight to Impact Area Ratio (psi)</u>	<u>Velocity (fps)</u>
Instrument well of pressurizer	5.5	0.442	1.35	1.35	4.1	100
Pressurizer heaters	15	0.61	2.4	2.4	6.25	55

TABLE 3.5-5

TORNADO-GENERATED EXTERNAL MISSILES*

<u>Type of Missile</u>		<u>Weight (lb)</u>	<u>Horizontal Velocity (fps)</u>
1. Wood plank	4 in x 12 in x 12 ft	114.6	272
2. Steel rod	1 in dia x 3 ft long	8.8	167
3. Steel pipe	6 in dia, Schedule 40, 15 ft long	286.6	171
4. Steel pipe	12 in dia, Schedule 40, 15 ft long	749.6	154
5. Utility pole	13.5 in dia, 35 ft long	1124.4	180
6. Automobile	Frontal area - 28 ft ²	3990.4	194

NOTE:

* These missiles are considered to be capable of striking in all directions with vertical velocities equal to 70 percent of the acceptable horizontal velocities except for Missile 2, which is assumed to have the same speed in all directions. Missiles 5 and 6 need not be considered more than 30 feet above all grade levels within 1/2 mile of the facility structures.

TABLE 3.5-6

LIST OF HAZARDOUS MATERIALS WITH THE POTENTIAL
FOR PRODUCING SIGNIFICANT MISSILES

<u>Material</u>	<u>Avg No. cars/train*</u>	<u>Approx No. cars/yr</u>
1. Ethylene oxide	0.097	254
2. Propylene oxide	0.040	105
3. Vinyl chloride monomer	1.150	3,035
4. Dimethyl ether	0.059	156
5. Butadiene 1, 3	0.019	48
6. Isobutane	0.004	11
7. Isobutylene	0.028	73
8. Liquified petroleum gas (LPG)	0.105	277
9. Ethylene	0.016	41
10. Anhydrous ammonia	<u>0.023</u>	<u>61</u>
	1.541	4,061

NOTE:

*Conrail Node Report: 18,075 Hazmat cars/1.5 year average.

AAR Yearbook of RR Facts: 66 cars/train average.

USDOT 1977-1979 Accident/Incident: 4.58 Hazmat cars/train average.

TABLE 3.5-7

SUMMARY OF EXPOSURE DISTANCE CALCULATIONS

<u>Hazardous Material</u>	<u>W Equiv lb</u>	<u>TNT</u>	<u>$R=45W^{1/3}$ ft</u>	<u>S Exposure Dist;miles</u>
1. Ethylene oxide	206,000		2,657	0.621
2. Propylene oxide	214,700		2,693	0.629
3. Vinyl chloride monomer	173,400		2,508	0.508
4. Dimethyl ether	90,450		2,019	0
5. Butadiene 1, 3	369,600		3,229	0.850
6. Isobutane	143,360		2,354	0.470
7. Isobutylene	305,800		3,030	0.831
8. LPG	328,320		3,103	0.831
9. Ethylene	303,920		3,025	0.831
10. Anhydrous ammonia	101,900		2,101	0.260

TABLE 3.5-8

AGGREGATE PROBABILITY OF EXPLOSION OR
VIOLENT RUPTURE CAPABLE OF MISSILE GENERATION

<u>Hazardous Material</u>	<u>$P_e \cdot 10^{-6}$ Ruptures/Yr</u>
1. Ethylene oxide	0.4236
2. Propylene oxide	0.1794
3. Vinyl chloride monomer	3.1130
4. Butadiene 1,3	0.1056
5. Isobutane	0.0155
6. Isobutylene	0.1788
7. LPG	0.7166
8. Ethylene	0.1022
9. Anhydrous ammonia	<u>0.0988</u>
	Total 4.933×10^{-6}

TABLE 3.5-9

TANK CAR FRAGMENT RANGE (FEET) FOR 10° LAUNCH ANGLE

<u>Chemical</u>	Postulated Missile Type			
	<u>Type A</u>	<u>Type B</u>	<u>Type C</u>	<u>Type D</u>
1. LPG	142	370	-	-
2. Anhydrous ammonia	264	803	-	-

TABLE 3.5-10
 TYPES OF TANK CAR MISSILES



<u>Type</u>		Description
A		Tank splits at mid-seam
B		Tank splits in 2:1 ratio with the smaller section "thrusting"
C		Manway separates
D		Tank punctured at head

TABLE 3.5-12

MISSILE SHIELDS ON AXIAL FANS

<u>Axial Fan No.</u>	<u>Location</u>	<u>Elevation</u>	<u>Notes</u>
2HVP*FN264A	Auxiliary Building	766' - 6"	1
2HVP*FN264B	Auxiliary Building	766' - 6"	1
2HVZ*FN261A	Cable Vault Building	786' - 5 1/2"	1
2HVZ*FN261B	Cable Vault Building	777' - 6"	1
2HVR-FN203B	Containment Structure	707' - 8"	1
2HVR-FN201A	Containment Structure	692' - 11"	1, 2
2HVR-FN201B	Containment Structure	692' - 11"	1, 2
2HVR-FN201C	Containment Structure	692' - 11"	1, 2
2HVT-FN245	Turbine Building	774' - 6"	1
2HVT-FN246	Turbine Building	774' - 6"	1

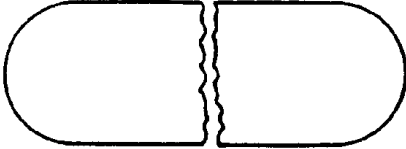
Notes:

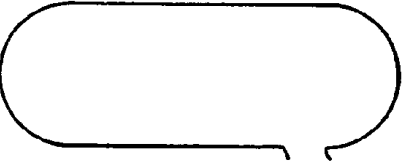
1. Missile Shields added to listed fans to provide missile protection for postulated missiles ejected through their inlet air flex connections.
2. Missile Shields added to listed fans to provide missile protection for missiles ejected through the fan housing.

BB281-13.9m² DESIGN

COMPARISON OF EXTERNAL MISSILE PROBABILITIES INCLUDING OVERSPEED WITH NRC LIMIT

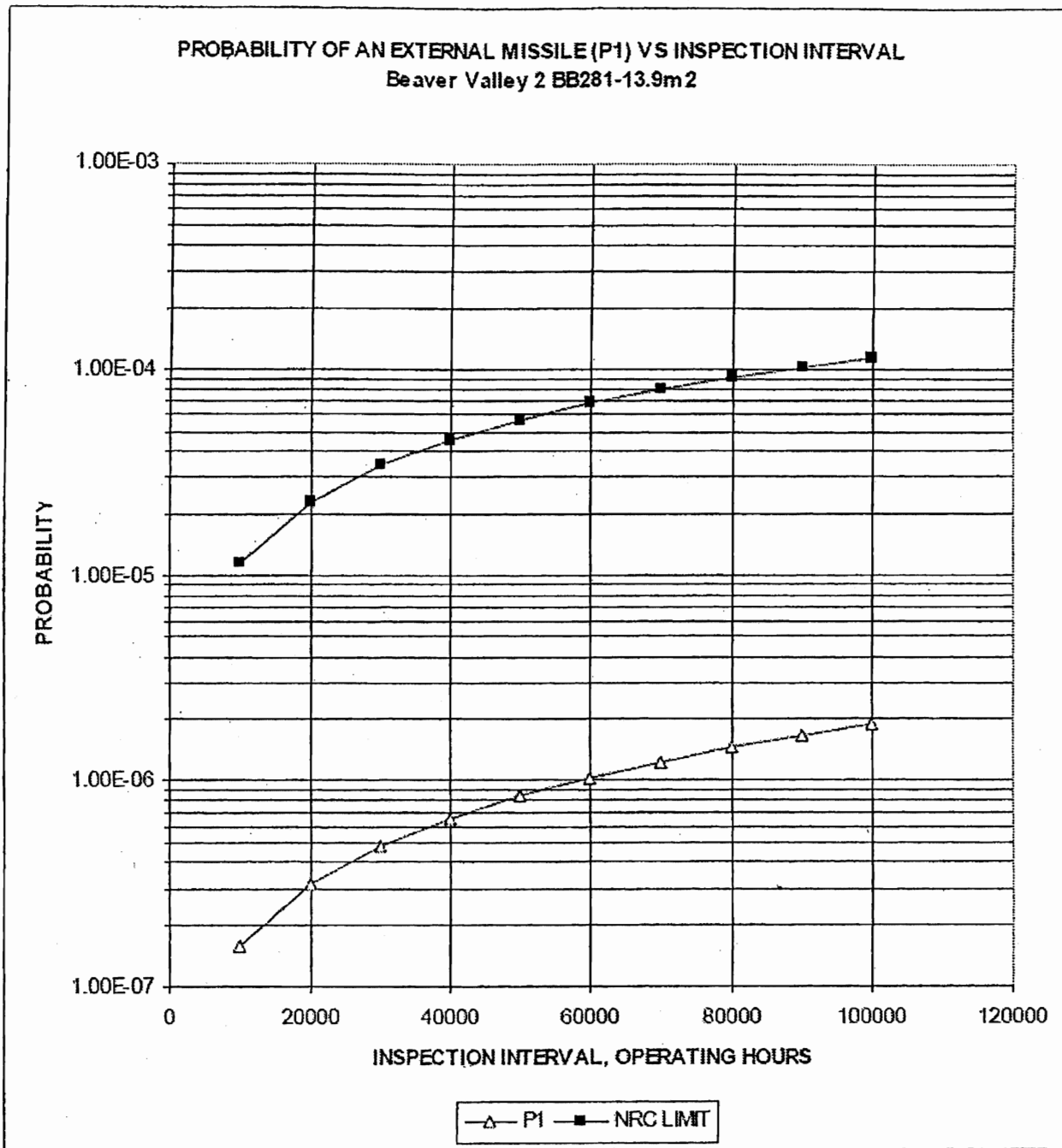

FIGURE 3.5-2

PROBABILITY OF AN EXTERNAL MISSILE (P1)
VS INSPECTION INTERVAL

BEAVER VALLEY POWER STATION-UNIT 2
UPDATED FINAL SAFETY ANALYSIS REPORT

3.6 PROTECTION AGAINST DYNAMIC EFFECTS ASSOCIATED WITH THE POSTULATED RUPTURE OF PIPING

Sections whose identification number includes the letter B contain material within balance-of-plant (BOP) scope, while sections whose identification number includes the letter N contain material within the nuclear steam supply system (NSSS) scope.

3.6B PROTECTION AGAINST DYNAMIC EFFECTS ASSOCIATED WITH THE POSTULATED RUPTURE OF PIPING

The effects of piping failures inside and outside containment are evaluated to ensure:

1. That the minimum requirements of essential safety-related systems and structures are not compromised,
2. That the plant can be shut down safely, and
3. That offsite doses in excess of applicable guidelines do not occur.

3.6B.1 Postulated Piping Failures in Fluid Systems Outside of Containment

Piping failures in systems outside containment, postulated in accordance with the criteria of Section 3.6B.2, are evaluated to determine the effects of these failures on essential safety-related components. The containment boundary equipment and all systems essential for a safe shutdown are protected against the effects of a postulated piping failure. The criteria for protection against pipe failure outside the containment conform with the guidelines contained in U.S. Nuclear Regulatory Commission Branch Technical Position ASB 3-1. In addition, the environmental effects of a piping failure are determined and are used as input to the Environmental Qualification Program described in Section 3.11.

3.6B.1.1 Design Bases of Postulated Piping Failures

3.6B.1.1.1 Applicable Systems

Piping breaks are postulated to occur in high internal fluid energy level piping systems (or portions of systems) in accordance with the criteria stated in Section 3.6B.2.1. High energy piping systems are defined as fluid systems that are either in operation or maintained pressurized under conditions where either or both of the following are met; a maximum operating temperature exceeding 200°F or pressure exceeding 275 psig. Maximum operating temperature and pressure are the maximum temperature and pressure in the piping systems during normal plant conditions which are expected frequently or regularly in the course of reactor start-up, operation at power, hot standby, or reactor cooldown to a cold shutdown condition excluding refueling.

High and moderate energy systems inside and outside containment are listed in Tables 3.6B-1 and 3.6B-1a, respectively.

Through-wall leakage cracks are postulated in accordance with the criteria stated in Section 3.6B.2 for piping systems outside the containment that are either in operation or maintained pressurized under conditions where both the maximum operating temperature and pressure are equal to or below 200°F and 275 psig. These piping systems are defined as moderate energy systems and generally include all systems which are not high energy.

3.6B.1.1.2 Break Exclusion

The main steam and feedwater lines in the main steam valve house and all high energy branch lines within the main steam valve house are considered break exclusion zones.

3.6B.1.2 Description of Essential Components

Table 3.6B-2 lists essential systems and components required to mitigate the consequences of accidents, defined by American National Standards Institute (ANSI) Standard N18.2, to achieve safe shutdown and maintain offsite doses within acceptable limits. Protection for all systems, structures, etc required for control room habitability is also ensured. All essential components are safety-related Class 1E, and designed to ASME Section III, QA Category I, Seismic Category I requirements. Each postulated piping failure is evaluated to determine its effect on those essential structures, systems, and components required to perform a safety function following the postulated failure. Only those components required to function following a specific break are protected from the effects of that break. A detailed analysis of all postulated failures considers these effects in conjunction with single failure criteria, loss of offsite power (LOOP), seismic events, and all other design considerations chosen to maximize the deleterious effects on safety equipment. The minimum required number of safety equipment must remain operable under all postulated conditions.

3.6B.1.2.1 Design Approach

The following design features are provided to minimize the effects of piping failures.

3.6B.1.2.1.1 Separation

A primary objective in the piping layout and plant arrangement is to separate high energy fluid system from essential structures, systems, and components so that the effects of postulated piping breaks at any location are isolated or physically remote from these components. If complete separation is not possible, then redundant safety equipment is located in separate areas so a single pipe failure cannot affect both safety components simultaneously. Inside each redundant

cubicle, high-energy piping is minimized or located remotely from the safety component, to the extent practicable, so that the effects of pipe whip or jet impingement are negligible.

Safety-related electrical and control system equipment is located, whenever possible, in areas which do not have piping (the emergency switchgear area). Cable tray runs and instrumentation process lines, which cannot be separated from piping runs, are located as far as possible from postulated piping failure locations. Every attempt is made to separate redundant cable runs and instrumentation lines physically. For all safety components where physical separation is impossible, one or more of the design features described succeedingly are provided to ensure that the minimum required number of safety components remain operable.

3.6B.1.2.1.2 Enclosures

Where physical separation by distance is not practical, protective structures are used. These structures are concrete walls, cubicles, etc, which are part of the building design and as such are described in Section 3.8. For example, each charging pump is located in a separate cubicle with concrete walls between redundant pumps. Redundant electrical and control systems in the area of piping runs are provided with barriers to minimize the effects of piping failures. The arrangement drawings in Section 3.8 show the concrete walls, barriers, and cubicles around the safety-related components listed in Table 3.6B-2.

3.6B.1.2.1.3 Restraints

Where neither of the preceding design approaches is possible, protection is provided by pipe restraints to limit pipe movement following a rupture and restrict the area affected by the postulated failure. Placement of restraints is based on postulated pipe break locations. The design of the restraints for these locations limits pipe whip and jet impingement to acceptable levels, thereby preventing damage to essential equipment. The design of pipe rupture restraints is described in Section 3.6B.2.

3.6B.1.3 Safety Evaluation

3.6B.1.3.1 Operability of Systems

The operability of a component following a postulated piping failure may be dependent on one or more of the following assumptions in addition to consideration of the effects of the failure.

1. Single failure application

In addition to the postulated piping failure and its effects, the most limiting single active failure (Section 3.1.1) must be assumed in essential structures, electrical and controls components, or fluid systems when

- (a) A plant shutdown is required as a result of the postulated piping failure and its effects, or
- (b) The essential structures, electrical and controls components, or fluid systems are necessary to mitigate the consequences of the postulated piping failure and its effects.

If neither (a) nor (b) are applicable, then a single active failure need not be postulated. However, the effects of the postulated piping failure must then be limited to prevent a complete loss of safe shutdown function, that is, loss of redundancy is permitted.

For all piping failures postulated to occur in one redundant train of a high or moderate energy essential fluid system, i.e., "dual purpose" nuclear safety-related system (Table 3.6B-2), a single active failure in the redundant train is not assumed provided the system is designed, constructed, operated, and inspected to Seismic Category I, Safety Class 1, 2, or 3, and QA Category I requirements.

2. Loss of offsite power (Loop)

A LOOP is considered to occur if the direct consequence of the postulated piping failure, or its effects, results in a trip of the turbine generator system or reactor protection system. A LOOP, when assumed, is considered to occur coincident with the postulated piping failure and is not part of the single failure criterion. Also, only essential components which do not depend on offsite power sources alone can be considered available, provided the failure and associated effects including single failure do not affect its operability.

3. Seismic event

Credit for mitigating the consequences of a postulated event may be taken only for those systems and components designed to Seismic Category I requirements.

To mitigate the effects of potential flooding of the cable vault air conditioning unit enclosure at elevation 718 ft-6 in, the installed building floor drain system is employed. Although not designed to Seismic Category I requirements, the drainage line is embedded in the concrete mat of the Seismic Category I cable vault structure and terminates in an open sump containing safety-related, redundant, Class 1E level instrumentation. Periodic surveillance will be employed to ensure that an available flow path exists through this portion of the drainage system.

All available systems, including those actuated by operator actions, are employed to mitigate the consequences of a postulated event. In judging the availability of systems, the postulated failure and its direct consequences, unit trip, LOOP, and the assumed single active component failure and its direct consequences are taken into account. With regard to

determining the components to be protected, only those components required to function for the three design criteria listed under Section 3.6B following a specific break are evaluated for potential effects and protection/operability ensured. The feasibility of the operator taking action is judged on the basis of availability of ample time and adequate access to equipment for performing the proposed actions. Regulatory Guide 1.62 and ANSI N660 were used in evaluation of the feasibility of operator action.

3.6B.1.3.2 Failure Modes and Effects

When analyzing breaks in high-energy piping systems, cracks in moderate-energy piping systems, and the consequent failure modes and effects (for example, pipe whip, jet impingement, and environmental), their sources and targets must be considered. The source consists of the pipe which is postulated to fail and the resulting dynamic effects of the failure. The target consists of structures, systems, and components considered essential for shutting down the plant safely, maintaining the safe shutdown, maintaining acceptable offsite doses, and mitigating the effects of the postulated pipe failure.

Interactions between sources and targets are analyzed individually to determine how each affects essential equipment in the area of the source. Interactions include pipe whip, jet impingement, and environmental effects.

3.6B.1.3.2.1 Pipe Whip

Break locations in piping systems are determined as described in Section 3.6B.2.1. Pipe whip analysis to define forcing functions and pipe responses is described in Section 3.6B.2.2. The effects of a particular piping failure are evaluated for each target which is essential to mitigate the effects of the specified failure. This evaluation is based on the location of the break and the forces generated by the whipping pipe. The targets impacted by the pipe are either designed to withstand these forces or are protected by rupture restraints as described in Sections 3.6B.2.3.1 and 3.6N.2.3.4. (See special cases addressed in Section 3.6B.1.3.2.3.)

3.6B.1.3.2.2 Jet Impingement

The blowdown forces are calculated (Section 3.6B.2.2), and the location and direction of the resulting jet of fluid determined for each piping failure which could affect an essential target. Essential targets impacted by the fluid must either be designed for these jet forces or shielded as discussed in Section 3.6B.2.3. (See special cases addressed in Section 3.6B.1.3.2.3.)

3.6B.1.3.2.3 Interaction With Pipe Targets

An unrestrained whipping pipe is considered capable of causing circumferential and longitudinal breaks, individually, in impacted pipes of smaller nominal pipe size and developing through-wall cracks in equal or larger nominal pipe sizes with thinner wall thickness. The impact into pipes of equal or larger nominal pipe sizes and wall thicknesses is considered inconsequential and is not evaluated.

In all cases, the effects of jet impingement are less severe than the corresponding pipe whip impact. (In the limiting case of no clearance between the broken pipe and target pipe, the impact force equals the total thrust force and is localized whereas the jet force is less, being moderated by a shape factor, and is distributed. As the gap increases the whip impact is enhanced, but the jet forces diminishes and becomes more diffuse.) Therefore, jet impingement on pipes of equal or larger nominal pipe size and wall thickness is considered inconsequential and is not evaluated. In all other cases the jet interaction is either avoided or the target pipe and its supports are evaluated for the jet load using faulted allowables.

3.6B.1.3.2.4 Environmental Effects

The environmental effects of postulated pipe breaks and cracks are established as design basis environmental conditions for safety-related components in these areas and are included as environmental qualification criteria for these structures and equipment. Section 3.11 describes the environmental qualification of safety components. The determination of pipe break environments are not dependent on postulated break locations determined by the criteria in Section

3.6B.2. Environmental conditions are determined by postulating a high energy pipe break or moderate energy pipe crack at any location which results in the worst environment affecting safety-related components. The following environmental effects are considered.

Fluid Spray

Essential equipment and components located proximate to high- and moderate- energy fluid systems are designed to withstand the most severe environmental conditions resulting from fluid spray without loss of safety function. The most severe environmental conditions resulting from fluid spray are:

1. Humidity of 100 percent,
2. Maximum expected temperature due to the ruptured fluid system, and
3. Water of specified worst-case chemistry spraying equipment or components.

Internal Flooding

Compartments and areas containing essential equipment and components are examined for flooding potential. Flooding height is based on the particular arrangement of a cubicle with regard to hydraulic boundary, available volume to be flooded, the leak rate from the piping failure, and the time required to detect and isolate the leak. No operator action is considered until 30 minutes has elapsed from the initiation of the pipe failure with the exception of the main feedline piping failure in the service building. Service building flood heights are based on a 10 minute operator response time to trip the main feed pumps for event termination. Compartment wall structural integrity is maintained when subjected to the hydrostatic head resulting from the calculated flood level.

Pressure/Temperature Rise in Compartments

The pressure and temperature rise in compartments outside containment is calculated based on the maximum operating fluid conditions in the pipe which fails, the available vent area in the cubicle, and the size and arrangement within the cubicle. Pipe failure locations are assumed at those points which result in the most adverse environment for safety components inside the cubicle. The results of the pressure calculations indicate the differential pressure design and whether sufficient vent area is provided for building compartments. Maximum calculated temperatures and pressures are used to determine essential equipment qualification requirements (Section 3.11).

3.6B.1.3.2.5 Specific Protection Criteria - Pipe Targets

In evaluating interactions between secondary system sources and targets, propagation of damage is permitted to occur under certain conditions. The following criteria shall be adhered to in addition to any criteria specified in Section 3.6N.2.3.2.

1. Steam and Feedwater System Breaks:
 - a. A steam or feedwater line break shall not propagate to a loss of coolant break.
 - b. Damage to any high head safety injection lines (LOCA or non-LOCA) must be prevented.
 - c. Damage to any portion of the auxiliary feedwater lines supplying the intact steam generators must be prevented.
 - d. Damage to auxiliary feedwater piping of the affected steam generator is allowed downstream of the cavitating venturi (2FWE*FE101A, B, C) on the associated FWE line but is not allowed for the venturi and all upstream FWE piping, since FWE flow to the intact steam generators depends on the restriction effect of the venturi on the flow to the affected steam generator.
 - e. A steam or feedwater line break is not allowed to propagate to any line connected to the intact steam generators which has a larger cross-sectional area than 2.5 sq. in.
 - f. A steam or feedwater line break is allowed to propagate to any line connected to the affected steam generator except as limited in paragraph (d) above.
2. Steam Generator Blowdown (BDG) Breaks

BDG line breaks must follow the same criteria as specified for steam and feedwater system breaks with the following additional requirements.

- a. A steam generator blowdown break occurring in a line outside containment is allowed to propagate to the blowdown lines connected to the intact steam generators. This is allowed provided the break or its consequences does not prevent the closing of the below listed valves:

2BDG*AOV101A1, AOV101A2
2BDG*AOV101B1, AOV101B2
2BDG*AOV101C1, AOV101C2

2BDG*AOV103A and B are used to assure isolation of high energy sources in the turbine building from reaching the pipe tunnel and cable vault areas.

- b. A BDG break inside containment either upstream or downstream of the valves listed above cannot be allowed to propagate to the BDG lines of the intact steam generators unless the 2.5 sq. in. criterion in 1.e. above applies.
- c. A BDG break inside containment cannot be allowed to propagate to the BDG containment penetration, isolation valves and interconnecting piping (i.e. piping inside and outside containment) for the intact steam generators. This is required in order to ensure adequate auxiliary feedwater supply to the intact steam generators unless the 2.5 sq. in. criterion in 1.e. above applies.

3.6B.1.3.3 Results of Analysis

3.6B.1.3.3.1 Pipe Whip/Jet Impingement Results

For all high energy-lines outside containment, each postulated break type and orientation is investigated to determine if the unrestrained whipping of severed pipe could impact and damage any safety components. Jet impingement from the severed pipe was also considered.

Main Steam Valve House

Piping in the main steam valve house (MSVH) includes the main steam and feedwater headers, the various branch lines from these headers such as the steam vent/relief lines, and other small diameter lines, such as steam drains and primary plant gas supply lines, not connected to the main headers.

The main steam and feedwater headers from the containment wall up to the main steam isolation valves and feedwater isolation valves and all branch lines, from these headers up to the first isolation valve on each branch are designed according to the "break exclusion" criteria described in Section 3.6B.2.1.2.1. Therefore, no pipe whip/jet impingement need be considered from these lines. The other small diameter lines, not connected to the main steam or feedwater lines, were elevated for pipe whip/jet impingement effects on safety-related equipment based on postulated break locations. These lines are separated from any essential safety components; therefore, breaks in these lines do not affect the safe shutdown capability of the plant.

Cable Vault and Rod Control Area (pipe tunnel at el 718-feet 6 inches)

Breaks in the auxiliary steam line and the steam generator blowdown (BDG) lines result in jet impingement or pipe whip effects on the containment wall, a service water supply valve for the containment air recirculation coolers, and the outside containment isolation valves on the BDG lines of all three steam generators.

The loads on the containment wall are accommodated within those allowable (Section 3.8.1) for the containment.

The service water supply valve experiences jet impingement which could affect containment cooling. No pipe whip effects are experienced by this service water supply valve. However, the calculated loads on the valve from the jet impingement of a ruptured auxiliary spray line are negligible. The outside containment isolation valves on the BDG lines may be damaged due to both pipe whip and jet impingement; however, two valves are provided on each line inside containment to provide isolation of the steam generator pressure boundary. These valves are automatically closed as described in Section 3.6B.1.3.4.3.

Service Building

The steam drain piping and main steam and feedwater headers are physically separated from any safety-related targets and no adverse pipe whip/jet impingement effects occur in this building.

Safeguards Building

There are no normally pressurized high energy pipes in this building.

Auxiliary Building

High-energy pipe breaks are postulated in the chemical and volume control system (CHS), auxiliary steam system (ASS), boron recovery system (BRS), and gaseous waste system (GWS).

All safety-related components are physically separated from the breaks postulated in the ASS, BRS, and GWS. Breaks in the CHS outside containment occur in either charging pump discharge lines or letdown piping upstream of the letdown heat exchanger. Neither of these types of breaks possess enough energy following the break to produce significant pipe whip or jet impingement effects. Charging pump runout and the pressure drop effects of the letdown orifices immediately reduce the blowdown driving force after the break. Therefore, no adverse effects on safety components occur following CHS breaks.

3.6B.1.3.4 Environmental Effects

3.6B.1.3.4.1 Fluid Spray

Fluid spray is assumed to wet the entire cubicle from a postulated piping failure near safety-related equipment. With humidity of 100 percent assumed inside the cubicle, the maximum temperature following the failure is calculated as described in Pressure/Temperature Rise as follows. Section 3.11 tabulates the environmental conditions in each area following a postulated piping failure.

3.6B.1.3.4.2 Internal Flooding

Each area which contains safety-related components has been evaluated for potential flooding due to piping failures, ruptures of large tanks, post-accident passive failures in a fluid system pressure boundary or inadvertent actuation of fire water spray/sprinkler system. The following design features protect safety components:

1. Redundant components are located in hydraulically separate areas. For example, the safeguard building is separated into two areas, each housing the low head safety injection (LHSI), auxiliary feedwater, and quench spray pumps of one safety-related flow path.
2. Wherever possible, safety components are located above the maximum internal flood level. For those components which could be affected by internal floods, sufficient system redundancy is provided to ensure availability of the required safety function, or the components are qualified for submergence.
3. Safety-related monitoring instrumentation in building sumps and fluid systems is provided to alert the operator of failures resulting in flooding conditions (for example, tank level, pump flow and pressure, sump levels).
4. Isolation valves are provided on all piping connected to large tanks which, although located outside safety-related structures, could flood the buildings due to failures in piping. Tanks located within safety structures are assumed to fail and flood the affected areas.

The flooding analysis for those areas where fluid system piping is located close to safety components is discussed subsequently, including the specific cause for the highest flood level in these areas. The resulting flood levels are provided in the Equipment Qualification Report under the accident conditions for the applicable area. All other areas containing safety components do not have fluid system piping in the same area and, therefore, are not discussed further. The flooding analysis for the auxiliary building and cable vault areas considers a double ended rupture of the main feedwater line on elevation 780'-6" of the service building as the governing flooding condition. However, when applying the criteria of Section 3.6.2, it is only necessary to consider a crack in this piping. The Environmental Qualification Report contains the flood heights for a double ended rupture event as this yields conservative results.

Below el 735 feet-6 inches, the auxiliary building arrangement provides two separate areas which could be flooded independently of one another. A wall separates the portion of the building below el 735 feet-6 inches into a north and a south cubicle. Since most floods above this elevation will drain through floor grating, stairways, pipe chases, etc, to the lower cubicles, pipe/tank failures in the upper elevations were included in the flood analysis of the north and south cubicle below el 735 feet-6 inches. The source of the highest flood level in the north cubicle is a moderate energy pipe crack in a 36-inch diameter service water line. In the south cubicle, the source of the highest level is a double-ended rupture of a main feedline occurring on el 780'-6" of the service building which drains to the lower elevation of the auxiliary building.

Elevations 735 feet-6 inches and above are comprised of general areas and equipment cubicles which were analyzed separately. Water from any system failure in the general area or component cooling water pump area on el 735 feet-6 inches will drain to lower elevations. The charging pump cubicle is subject to flooding to the curb height from a high energy pipe break in a 3-inch diameter chemical and volume control system line. Excess water would overflow the curb and drain to lower elevations.

On el 755 feet-6 inches, a double-ended rupture of a main feedline occurring on el 780'-6" of the service building produces the limiting flood level in both the general area and the HVAC cubicle. Boric acid tank ruptures account for the highest flood level in each of the boric acid tank cubicles. The volume control tank cubicle is subjected to flooding from a moderate energy pipe crack in a 4 in diameter charging system line. The highest flood levels in the boric acid transfer pump cubicles are caused by passive failures, postulated to occur post-accident and consisting of a 50 gpm leak for 30 minutes (Section 3.1.1 discusses passive failures).

In the general area of el 773 feet-6 inches, a double-ended rupture of a main feedline occurring on el 780' -6" of the service building produces the limiting flood height. Rupture of the component cooling water surge tank produces the highest flood height in the surge tank cubicle.

Suction lines running from the refueling water storage tank, located in the yard, to components inside the auxiliary building have isolation valves to prevent the entire tank contents from flooding the building. Failures (moderate energy cracks) of these suction lines were considered assuming 30 minutes for break termination. These failures were not the most limiting case in either area.

Safety-related, Class 1E, redundant level instrumentation is provided in the sump in the south area of the building to detect a high water level and alert the operator. High level alarms are provided in the control room. Since the north area could flood to above the dividing wall without affecting safety components, and once above the wall would spill into the south area and be detected, no instrumentation need be provided in the north area.

Safeguards Building

The safeguard building at el 718 feet-6 inches is separated into two separate areas, north and south, each containing the LHSI quench spray, and auxiliary feedwater pumps of one redundant flow path. These north and south areas include a sump which has a safety-related, Class 1E, level instrument providing a high level alarm in the control room.

There are relatively few pipes in the safeguards building which are normally pressurized. The source of the highest flood level in the north and south pump cubicles is a moderate energy pipe crack in the safety injection pump suction line from the RWST. The LHSI, quench spray, and auxiliary feedwater pumps in each area are located above the highest flood level.

The portion of the safeguards building closest to the containment houses the four recirculation spray pumps. Each pump is in a separate area from el 690 feet-11 inches down. From el 690 feet-11 inches up to el 697 feet-6 inches, the four pumps are in one open area. This area also contains the pump suction valves (2RSS*MOV155A,B,C,D). Above el 697 feet-6 inches, the four pumps are in separate areas.

Flooding in the recirculation spray pump areas was considered in two parts, above el 718 feet-6 inches where the pump motor is located, and below el 697 feet-6 inches where the pump suction valves are located. These two areas are hydraulically separate (that is, a flood in the upper area cannot reach the lower area). The source of the highest flood level in the upper area is a passive failure. Only one recirculation spray pump cubicle is affected by this failure. This failure mode and flood height is typical for the four upper cubicles. The pump motors are located well above the highest flood level.

The lower area of the pump cubicle is common to all four pumps. All piping in this area is not normally pressurized. Since all these lines are designed as Safety Class 2, Seismic Category I, and QA Category I, and are pressurized only during accident conditions, only a passive failure is considered. This failure floods the area around the pump column up to el 689 feet-4 inches. There is no adverse effect on pump operability from immersing the pump column in water. The motors of the pump suction valves (2RSS*MOV155A,B,C,D) are located well above el 689 feet-4 inches.

Redundant safety-related Class 1E level instruments are provided at el 690 feet-11 inches by locating one instrument powered from one Class 1E bus in each of the two sumps at this elevation.

The turbine-driven (TD) auxiliary feedwater pump cubicle is subject to flooding from a moderate energy pipe crack in the safety injection pump suction line from the RWST. The TD auxiliary feedwater pump is located above the flood level.

The safeguards building above el 738 feet-6 inches houses the hydrogen analyzers and safety-related air conditioning units in separate cubicles. Safety-related motor control centers (MCCs) are also located in these areas. There is no fluid system piping in the hydrogen recombiner or analyzer cubicles which is normally pressurized. The source of flooding in the air conditioning and MCC

cubicles is a moderate energy crack in the service water piping to the air-conditioning units. The air-conditioning units and MCC are located above the highest flood level.

Cable Vault and Rod Control Area

The cable vault and rod control area houses safety-related valves and piping which penetrate the containment and run between other safety-related areas. The source of the highest flood level at el 718 feet-6 inches is a moderate energy crack in an 18-inch primary plant component cooling water line. All safety-related valves and electrical/control equipment are located above the highest flood level. Safety-related, redundant, Class 1E level instruments are located in the sump at el 718 feet-6 inches to alarm in the control room at high level. The shielded cubicle at el 718 ft-6 in is subjected to flooding from a letdown line high energy pipe break. The cooling water lines in the ACU enclosure at this elevation have been crack excluded by demonstration that stress levels in the piping are below the limits established in BTP MEB 3-1, to preclude the flooding potential in this cubicle. Leakage from mechanical joints is handled by the installed building floor drains.

The highest flood level at el 735 feet-6 inches is due to a moderate energy pipe crack in a 4-inch diameter fire water line. At el 755 feet-6 inches, water from a main feedwater high energy line break in the service building drains via a stairwell to lower elevations. The fire protection-water lines in the alternate shutdown panel room at el 755 feet-6 inches have been crack excluded so no flooding potential exists in this area. The highest flood level at el 773 feet-6 inches is from a main feedwater high energy line break in the service building.

Intake Structure

The intake structure is shared between Beaver Valley Power Station - Unit 1 (BVPS-1) and Beaver Valley Power Station - Unit 2 (BVPS-2). It has four separate cubicles, three of which contain one of the BVPS-2 service water pumps. The pump motors and all piping are located above the operating deck in each cubicle, which is capable of being sealed to protect against external floods.

The postulated piping failure, which causes the highest flood level above the operating deck, is a moderate energy crack in a 30-inch service water line. The service water pump motor in the affected cubicle would then be inoperable. However, three service water pumps are provided (Section 9.2). One service water pump is sufficient for emergency shutdown and loss of one pump during normal operation does not require immediate plant shutdown. The Technical Specifications (Chapter 16) govern the length of time BVPS-2 can operate with one of the redundant service water flow paths out of service. The length of time allowed is sufficient for the operator to align the third (spare) service water pump electrically and hydraulically to the flow path of the inoperable pump. As discussed in Section 3.6B.1.3.1, Single Failure Application, single failure of the operating service water pump during this scenario need not be assumed because the service water system (SWS) (moderate energy) is designed to QA Category I and

Seismic Category I standards and the pumps are powered from the Class 1E buses. Therefore, loss of one pump due to flooding has no adverse safety considerations.

Since the intake structure pump cubicles are shared between BVPS-1 and BVPS-2, internal flooding concerns have been evaluated. The external flood protection doors leading into each intake structure pump cubicle are normally open with their associated security/fire doors normally closed. The interconnecting flood protection doors that are located between the pump cubicles are normally closed with their seals depressurized, along with their associated security/fire doors normally closed. These door seals will be pressurized in the event of an external flood or for seal testing purposes. This arrangement is designed to protect the interconnecting cubicles from the consequences of a major pipe rubber expansion joint failure. For piping failures in systems other than service water, a single failure of the Service Water System is then considered. The Standby Service Water System is designed for automatic operation in the short term following the break.

Main Steam Valve House

The MSVH contains safety-related components required for steam and feedwater isolation, which are located in one area at el 773 feet-6 inches. The source of the highest flood level in this area is a moderate energy pipe crack in a 4-inch service water line. As discussed in Section 3.6B.1.3.4.3, a nonmechanistic break is postulated with regard to determining environmental conditions, which will result in a steam release to the cubicle following a piping failure. Other small diameter lines in the area are also high energy for which breaks are postulated resulting in steam release. No significant flood levels are experienced from any of these breaks since the steam release to the cubicle results in a pressure increase and a major portion of the released mass is vented through openings in the cubicle to reduce pressure.

Service Building

The service building houses safety-related electrical/control components associated with many different safety functions. These components are located between el 730 feet-6 inches and el 780 feet-6 inches. No piping is run in these areas except for a vertical pipe chase in the southeast corner of the building and domestic water lines to the safety showers on el 730 feet-6 inches and el 760 feet-6 inches. A pipe failure of any pipe in the chase will flood only the vertical chase and the horizontal pipe tunnel which runs below the building. A crack in a high energy main feedwater line on the top floor of the service building drains down to lower elevations and produces the limiting flood height in each area. No safety-related electrical switchgear equipment located on el 730 feet-6 inches is potentially affected by the resultant flood height. Flood heights are based on 10 minute operator action time to trip the main feedwater pumps following a reactor trip due to low-low steam generator level.

Diesel Generator Building

The diesel generator building is separated into two areas, each housing one emergency diesel generator and its associated auxiliary system and electrical/control equipment. The cubicles are hydraulically separate and a flood from a moderate energy pipe crack in an 8-inch diameter chilled water line in one area affects only one emergency diesel generator. Plant shutdown would not be immediately required as a result of the failure and Technical Specifications govern the length of time during which the plant could continue operation. One diesel generator is sufficient to shutdown the plant when required by Technical Specifications.

Control Building

The only safety-related components in the control building which are located near fluid system piping subject to moderate or high energy failures are the air-conditioning and ventilation components. These components are located in a common area separate from the remainder of the control building. Service water piping is the only fluid system in the area and is used for cooling these safety-related components. The service water system piping has been crack excluded by demonstrating that the stress levels are below the limits established in BTP MEB 3-1, in this area to preclude flooding of the HVAC equipment used to assure control room habitability. Leakage from mechanical joints can be accommodated by the control building's seismic floor drain system.

Valve Pits

Safety-related valves on SWS piping running outside of the major buildings are located in valve pits which are concrete enclosures sealed to exterior flooding. Redundant valves of the SWS are located in separate pits which are sealed from one another such that a flood in one pit cannot affect the valves of a redundant pit. As discussed in Section 3.6B.1.3.1 Single Failure Application, single failure of the redundant valves need not be assumed since the SWS (moderate

energy) is Safety Class 3, Seismic Category I and powered from the Class 1E bus.

Fuel Building

The fuel pool cooling pump cubicles (el 729 feet-6 inches) are subject to flooding. The limiting flood source is a moderate energy pipe crack in a 6-inch diameter primary component cooling water line. In the event that the fuel pool cooling pumps are rendered inoperable, a Seismic Category I source of fuel pool makeup water is provided from the service water system. (Refer to Section 9.1.3).

3.6B.1.3.4.3 Pressure/Temperature Rise

A detailed thermal hydraulic analysis determines the maximum pressures resulting from high energy line breaks. These pressures and temperatures are used for safety-related equipment environmental qualification discussed in the Equipment Qualification Documentation Report. The analysis was done as follows:

1. The location of all safety-related equipment requiring environmental qualification and the routing of all high energy lines are identified.
2. These locations are evaluated to determine which high energy line breaks could affect the ambient environment at the equipment location. All possible venting paths of steam from an area containing a high energy line to an area containing safety-related equipment are identified.
3. Ambient pressure/temperature transients are calculated for all safety-related equipment locations based on the various break sizes and break locations which could affect a specific area.
4. The calculated transients initially assume that the break release lasts for between 10 and 30 minutes unless the available water inventory is exhausted prior to 30 minutes, or unless it is determined that the operator can identify and isolate the ruptured line in less than 30 minutes. Some main steam line breaks are assumed to be isolated as soon as 10 minutes. These initial transients are reviewed against equipment qualification requirements and structural differential pressure design. If unacceptable, automatic isolation of the breaks was implemented into the plant design to result in acceptable environments. All equipment to achieve isolation is considered Class 1E, safety-related and is designed in accordance with ASME Class III, QA Category I, and Seismic Category I.
5. Assumptions used in the analysis are:
 - a. Initial building temperature is the maximum expected during normal plant operation (Tables I and II, Appendix A, Equipment Qualification Documentation Report).

- b. The effect of building heat sinks, primarily concrete, is included.
 - c. The pipe breaks are assumed to occur anywhere along the piping run. The worst location with regard to effects on safety-related equipment was chosen.
6. Safety-related building ventilation exhaust is incorporated in the model. It has a positive effect in reducing environmental transients in the auxiliary building (el 710 feet-6 inches through el 755 feet-6 inches) and cable vault (el 718 feet-6 inches).
 7. The calculated pressure transients are compared to the design capacities for Seismic Category I structures, determined in accordance with Sections 3.8.3 and 3.8.4 to ensure that building integrity is not compromised.

All buildings containing Class 1E, safety-related equipment were evaluated; however, there are no high energy lines in the following buildings or portions of buildings.

1. Control building
2. Safeguards building
3. Service building (All elevations except el 780 feet-6 inches)
4. Cable Vault/rod control (All elevations except el 718 feet-6 inches)
5. Intake structure
6. Diesel generator building
7. Fuel and decontamination building
8. Valve pits

The remaining buildings or portions of buildings are discussed subsequently. The specific temperature-pressure transients are given in the Equipment Qualification Documentation Report.

Main Steam Valve House

Although the main steam and feedwater piping in the MSVH is designed to "break exclusion" criteria of Section 3.6B.2.1.2.1, the environmental conditions resulting from up to a maximum of a one square foot area break in a main steam line are calculated. This break size conservatively envelopes all branch lines in the MSVH. The MSVH is considered a homogeneous area such that the pressure-temperature rise is relatively constant over the entire area. Blowdown from the break assumes that the affected steam generator is emptied out by the break and that blowdown continues after that time from the addition of auxiliary feedwater to the affected steam generator. Isolation of auxiliary feedwater occurs about 10 minutes after the steam generator reaches the MSIV isolation setpoint pressure. Vent panels are in the walls of a structure located near the MSVH roof. The vent panels, when in the closed position, will automatically open upon pressure increase inside to reduce pressure following the most limiting break to a value which is less than the design

capacity of the structure, determined in accordance with Sections 3.8.3 and 3.8.4. The calculated pressure temperature transient is shown on Figures IIA and B, Appendix A of the BVPS-2 Equipment Qualification Documentation Report.

Cable Vault and Rod Control Area (pipe tunnel at el 718 feet-6 inches)

The building arrangement at this elevation includes walls and doorways such that this elevation is separated into three areas (Figure IX, Appendix A, of the BVPS-2 Equipment Qualification Documentation Report) each with different environmental transients. However, the Air Conditioning Units cubicle contains no high energy lines, is sealed from the general area, and, therefore, is not included in this analysis. Vent paths between the other two areas are included in the calculation.

The high energy lines located in these areas are part of the BDG, CHS, and safety injection system. The analyses result in the most limiting environment as an envelope of short- and long-term environments. In the short-term, the limiting environment is due to a break of any one of three BDG lines directly connected to the steam generators. In the long-term, the source of the limiting environment is a letdown (CHS) line break. Due to the high energy of the blowdown fluid in the BDG lines, automatic isolation is required. Redundant, Class 1E, QA Category I temperature sensors and switches will automatically close redundant isolation valves located inside containment on each BDG line from the steam generators. The design of the sensors, switches, control circuits and isolation valves ensure that isolation occurs 20 seconds after the area temperature reaches 120°F. Also, AOVs are used to isolate the feedwater supply in the turbine building from the cable vault and pipe tunnel areas within 10 seconds. A letdown line break is detected by the operator and manually isolated within 15 minutes of the break as discussed in UFSAR Section 15.6.2. A vent panel is also provided in the wall of the pipe tunnel which automatically opens as pressure rises to reduce pressure following the most limiting break to a value which is conservatively less than the design capacity of the structure, determined in accordance with Sections 3.8.3 and 3.8.4. The calculated temperature-pressure transient is shown on Figure X, Appendix A of the Equipment Qualification Documentation Report.

Auxiliary Building

The auxiliary building is separated into 30 specific areas based on the arrangement of walls, doorways and safety equipment. Vent paths between these areas are also considered. Figures III through VII, Appendix A of the Equipment Qualification Documentation Report show the areas.

The high energy lines in this building are part of the ASS, BRS, GWS, and CHS. Breaks in all systems, except GWS, contribute to the limiting pressure/temperature transients. A break in the main ASS header is required to be automatically isolated, because of the high environmental temperature that would result from the continued release of effluent from this system. The location of redundant isolation valves is outside the auxiliary building and isolation occurs 25 seconds after the temperature in any one area reaches 120°F. (NOTE: 20 seconds for valve stroke time plus 5 seconds for sensor response time.) A break in a BRS line connected to either of the degasifiers causes the entire contents to be released. A break of a 2 inch letdown line is manually isolated within 15 minutes of the break as discussed in Section 15.6.2. The resulting differential pressures given in Appendix A of the Equipment Qualification Documentation Report are less than the design capacity of the structure, determined in accordance with Sections 3.8.3 and 3.8.4.

Service Building

A multi-node thermal hydraulic model of the service building is developed for the analysis. The main steam system (MSS) lines run through elevation 780 feet-6 inches and the most limiting environment occurs from a postulated break in one of the MSS headers. A MSS double-ended rupture and a longitudinal break are postulated to develop the most limiting environment for elevations 780 feet-6 inches, 760 feet-6 inches, and 745 feet-6 inches of the service building. The pressure-temperature transient is shown on Figures XIA B, C, and D, Appendix A of the Equipment Qualification Documentation Report. The resulting differential pressures are less than the design capacity of the Seismic Category I structure, determined in accordance with Sections 3.8.3 and 3.8.4. Analysis indicates that if non-seismic Category I portions of the structure fail, no adverse effects on adjacent Seismic Category I structures or components will occur. The resulting pressure transient for the longitudinal break is less severe than the double-ended rupture. A blowout panel to the atmosphere is installed to relieve the pressure so the harsh environment does not spread into adjacent areas containing safety-related equipment required for this event.

3.6B.1.3.5 Quality Assurance and Inspection

The quality assurance program described in Chapter 17, and the inservice inspection measures, described in Section 6.6.1, minimize the potential for a pipe break.

3.6B.2 Determination of Break Locations and Dynamic Effects Associated with the Postulated Rupture of Piping

3.6B.2.1 Criteria Used to Define Break and Crack Locations and Configurations

A combination of conventional methodology (Standard Review plan Section 3.6.2) along with an alternative leak-before-break (NUREG-1061, Volume 3) approach is used for the provision of protection from the mechanistic effects of postulated pipe rupture. The alternative approach, also known as leak-before-break (LBB), demonstrates that the fluid leakage from a postulated defect at the highest stress location concurrent with minimum material properties (in terms of normal plus Safe Shutdown Earthquake loads) in a high energy piping line can be detected well before the rupture of the pipe. Since LBB uses elastic-plastic fracture mechanics to assess the potential for pipe rupture, this approach is consistent with the procedural recommendations and analytical criteria found in NUREG-1061, Volume 3.

Portions of the reactor coolant system (RCS), residual heat removal system (RHR), and safety injection system (SIS) have been exempted from consideration of pipe whip and jet impingement effects by the application of the Leak-Before-Break Program. The original BVPS-2 LBB analyses consisted of the WHIPJET Program and a separate LBB analysis of the main reactor coolant loop piping. The pressurizer surge line was subsequently removed from the WHIPJET scope and qualified for LBB as part of surge line reanalysis for IEB 88-11. Specific lines covered by the alternative approach of SRP 3.6.3 (LBB) are listed by line number in Table 3.6B-4.

The following subsections describe the criteria used to define break and crack locations and configurations. To ensure that the pipe rupture criteria have been, properly implemented, documentation is provided which includes the following:

Figures showing the locations of the postulated pipe ruptures, including identification of longitudinal and circumferential breaks, structural barriers, restraint locations, and the constrained directions for each restraint.

The requirement for a minimum of two intermediate breaks regardless of stress, in Branch Technical Position MEB 3-1 Revision 1, July 1981 Paragraphs B.1.c(1)(d) and B.1.c(2)(b)(ii), for ASME III Code Class 1 and Code Classes 2 and 3 piping has been waived per NRC letter dated May 21, 1985 for Docket 50-412 for the following exempt high energy systems:

1. Reactor coolant system (not including the primary loop) (RCS)
2. Hydrogenated drain system (DGS)
3. Residual heat removal system (RHS)
4. Safety injection system (SIS)
5. Main steam system (MSS)
6. Main feedwater system (FWS)
7. Auxiliary feedwater system (FWE)
8. Steam generator blowdown system (BDG)

9. Chemical and volume control system (CHS)
10. Gaseous nitrogen system (GNS)
11. Auxiliary steam system (ASS)

Note: The requirement for a minimum of two intermediate breaks was removed from Branch Technical Position MEB 3-1 when that document was revised (Revision 2, June 1987). The revised BTP is endorsed in the Standard Review Plan. Postulation of intermediate breaks, that do not exceed the applicable acceptance criteria, is no longer required.

3.6B.2.1.1 Criteria for Inside the Containment

All breaks postulated are systematically analyzed to determine what potential damage may occur, due to pipe whip, jet impingement, cubicle pressurization, and environmental conditions, to systems and structures required for safe shutdown. Offsite release not exceeding the limits specified in 10 CFR 50.67 is also verified. If the potential damage or effects are unacceptable, protection is provided by either separation or enclosure, or by the installation of pipe whip restraints and jet impingement shields. Essential instrumentation and controls, electrical cabling, and valve operators are either qualified to operate or protected, as required, from the environmental effects of pipe rupture. The protection criteria are provided in Sections 3.6B.1 and 3.6N.2.2.3. The environmental qualification procedures are provided in Sections 3.10 and 3.11.

Design basis break locations and types are postulated as described in Sections 3.6B.2.1.1.1, 3.6B.2.1.1.2, and 3.6B.2.1.3.

3.6B.2.1.1.1 Break Locations - ASME Section III Class 1 Piping

The reactor coolant loop piping and large branch line piping have been excluded from consideration of dynamic effects associated with postulated pipe rupture.

The exemption of the reactor coolant loop piping is in accordance with NRC Letter Docket No. 50-412 dated October 11, 1985. Subsequent reanalysis of the reactor coolant loop piping was accepted by NRC Letter dated April 8, 1991. In 2011, the reactor coolant loop LBB analysis was revised to incorporate the latest piping loads and current operating conditions.

Branch line piping has been excluded by application of various analyses as discussed in Section 3.6B.2.1. This exception to NUREG-0800, SRP 3.6.2 is documented for the original analysis in Table 1.9-2. Subsequent reanalysis for the surge line was accepted by NRC Letter dated January 18, 1990. In 2011, the surge line LBB analysis was revised to address structural weld overlay of the surge to Pressurizer nozzle and the concerns raised by Regulatory Issue Summary (RIS) 2010-07, "Regulatory Requirements for Application of Weld Overlays and Other Mitigation Techniques in Piping Systems Approved for Leak-Before-Break."

Breaks in all other high-energy ASME Section III, Code Class 1 piping are postulated to occur at the following locations in each piping run or branch run:

1. At terminal ends of the pressurized portions of the runs.
Terminal ends are extremities of piping runs that connect to structures, components (for example, vessels, pumps), or pipe anchors. A branch connection to a main piping run is a terminal end of the branch run. However, if the branch is included in the structural model with the main run and if the branch has a significant influence on the behavior of the main run (that is, similar piping sizes), the branch is considered part of the main run.
2. At intermediate locations between terminal ends selected by any of the following criteria:
 - a. At any intermediate location between terminal ends where the maximum stress intensity range (S), for normal and upset plant conditions and for an operating basis earthquake (OBE) event transient, exceeds the allowable as identified below, when calculated by equation 10 and by either equation 12 or equation 13 in paragraph NB-3653 of the ASME Code, Section III.

The allowable is $3.0S_m$ when the piping analysis is based on the BVPS Unit 2 original Code of Record, ASME Section III, 1971 Edition through the Winter of 1972 Addenda, or the ASME codes and addenda prior to Summer of 1979 Addenda to the 1977 Edition.

The allowable is $2.4S_m$ when the piping analysis is based on ASME Section III Code Editions beginning with the Summer of 1979 Addenda to the 1977 Edition and including all later editions or addenda.

(S_m is the design stress intensity as specified in Section III of the ASME Boiler and Pressure Vessel Code.)
 - b. At any intermediate locations between terminal ends where the cumulative usage factor (U), derived from the piping fatigue analysis under the loadings associated with OBE and operational plant conditions, exceeds 0.1.

(U is the cumulative usage factor as specified in Section III of the ASME Boiler and Pressure Vessel Code.)
 - c. If there are no intermediate locations where S exceeds the allowable as described above or locations where U exceeds 0.1, intermediate breaks are not required.

3.6B.2.1.1.2 Break Locations - ASME Section III Class 2 and 3 Piping

Breaks in high-energy ASME Section III, Code Class 2 and 3 piping are postulated to occur at the following locations in each piping run or branch run:

1. At terminal ends of the pressurized portions of the runs.
2. At intermediate locations selected by either of the following criteria:
 - a. At each pipe fitting (for example, elbow, tee, cross, flange, and nonstandard fitting), welded attachment, and valve; or

- b. At each location where the maximum stress range (S), associated with normal and upset conditions and an OBE event and as calculated from the sum of Equations 9 and 10 of the ASME Code, Section III, Subsection NC, exceed the allowable as identified below:

The allowable is $0.8(1.2S_h + S_A)$ when the original code of record for BVPS Unit 2, the ASME Code, Section III, 1971 Edition up to and including the Winter 1972 Addenda is used for piping analysis.

The allowable of $0.8(1.8S_h + S_A)$ may be used if the piping analysis is performed using the ASME Code, Section III, Winter of 1981 Addenda to 1980 Edition, or later editions and addenda.

(S_h is the stress calculated by the rules of Section III to the ASME Code, subsection NC-3600 and ND-3600 for Class 2 and 3 components, respectively. S_A is the allowable stress range for expansion stress calculated by the rules of ASME Section III, subsection NC-3600 or the USA Standard Code for Pressure Piping, ANSI B31.1)

- c. If there are no intermediate locations where S exceeds the allowable mentioned above, intermediate breaks are not postulated.

3.6B.2.1.1.3 This section intentionally deleted from the UFSAR.

3.6B.2.1.1.4 Separating Structure for High Energy Fluid Systems

If a structure separates a high energy line from an essential component, that separating structure is designed to withstand the consequences of the pipe break in the high energy line which produces the greatest effect at the structure irrespective of the fact that the criteria in Section 3.6B.2.1 might not require such a break location to be postulated.

3.6B.2.1.2 Criteria for Outside of the Containmentment

3.6B.2.1.2.1 High-Energy Fluid Systems

The following criteria are used to define break and crack locations in high-energy fluid systems outside of the containmentment.

1. Fluid systems separated from essential structures, systems, and components

By plant arrangement, certain high energy lines are isolated by barriers or are remote from essential structures, systems, and components. Isolation is demonstrated by the existence of barriers capable of containing the effects of a rupture and a line is determined to be remote by consideration of the distances to targets versus rupture effects. All of the preceding is done on a case by case basis. Restraint systems are not designed for lines determined to be isolated or remote.

2. Fluid system piping in containment penetration areas

Breaks are not postulated in the following portions of high energy piping, designated as break exclusion zones:

- a. MSS and FWS main run lines within the Main Steam Valve House (MSVH) from the containment penetration to the MSVH/Service Building (SB) wall (Refer to Figures 3.6B-13 and 3.6B-14).
- b. All MSS high-energy branch lines within the MSVH. This includes portions of the SDS, SVS, and GNS systems (Refer to Figures 3.6B-17a, 3.6B-17b and 3.6B-17c for limits of piping in break exclusion zone).

The piping within the break exclusion zones is designed to meet the following design requirements:

- i. The following design stress limits are not exceeded for Class 2 piping:
 - (a) The maximum stress ranges, as calculated by the sum of equations 9 and 10 of the ASME Code, Section III, Subsection NC, considering normal and upset BVPS-2 conditions including an OBE event do not exceed the following limits:

The allowable is $0.8(1.2S_h + S_A)$ when the original code of record for BVPS Unit 2, the ASME Code, Section III, 1971 Edition up to and including the Winter 1972 Addenda is used for piping analysis.

The allowable of $0.8(1.8S_h + S_A)$ may be used if the piping analysis is performed using the ASME Code, Section III, Winter of 1981 Addenda to 1980 Edition, or later editions and addenda.
 - (b) The maximum stresses as calculated by Equation 9 of the ASME Code, Section III, Subsection NC under the loadings resulting from a postulated piping failure of fluid system piping beyond these portions of the piping do not exceed the following limits:

The allowable is $1.8 S_h$ when the original code of record for BVPS Unit 2, the ASME Code, Section III, 1971 Edition up to and including the Winter 1972 Addenda are utilized for piping analysis.

The allowable based on the lesser of $2.25 S_h$ and $1.8 S_Y$ may be used if the piping analysis is performed using the ASME Code, Section III, Winter of 1981 Addenda to 1980 Edition, or later editions and addenda.
- ii. Welded attachments, for pipe supports or other purposes, to these portions of piping are avoided, except where detailed stress analysis demonstrates compliance with the limits discussed in Section 3.6B.2.1.2.1, item 2.i.

- iii. The number of circumferential and longitudinal piping welds and branch connections are minimized.
- iv. The length of these portions of piping is reduced to the minimum length practical.
- v. The design of pipe anchors or restraints (for example, connections to containment penetrations and pipe whip restraints), does not require welding directly to the outer surface of the piping (for example, fluid integrally forged pipe fittings are used), except where such welds are capable of 100-percent volumetric in-service inspection (ISI). This criterion is also applicable to the portion of piping between the containment and the inside containment isolation valves.
- vi. Details of containment penetration, identification of pipe welds, access for (ISI), and points of fixity and discontinuity are provided in Section 3.8.1.

The Safety Class 2 portion of break excluded piping from the containment penetration up to and including the isolation valve is designed in accordance with ASME III Subarticle NE-1120. The piping between the isolation valve and MSVH/SB wall is classified as non-nuclear safety, and is designed in accordance with ANSI B31.1.

- 3. Break Locations - ASME Section III Class 2 and 3 Piping and Seismic Non-Nuclear Piping
 - a. Breaks in ASME Code, Section III, Class 2 and 3 piping and in non-nuclear class piping designed for seismic loading are postulated at the following locations in each piping and branch run (except those portions of fluid system piping identified in Section 3.6B.2.1.2.1, items 1 and 2):
 - (1) At terminal ends of the pressurized portions of the runs.
 - (2) At intermediate locations selected by either of the following criteria:
 - (a) At each pipe fitting (for example, elbow, tee, cross, and nonstandard fitting) welded attachment and valve.
 - (b) At each location where the stresses associated with normal and upset plant conditions including an OBE event as calculated from the sum of Equations 9 and 10 of the ASME Code, Section III, Subsection NC, exceed the allowable as identified below:

The allowable is $0.8(1.2S_h + S_A)$ when the original code of record for BVPS Unit 2, the ASME Code, Section III, 1971 Edition up to and including the Winter 1972 Addenda is used for piping analysis.

The allowable of $0.8(1.8S_h + S_A)$ may be used if the piping analysis is performed using the ASME Code, Section III, Winter of 1981 Addenda to 1980 Edition, or later editions and addenda.

- (c) If there are no intermediate locations where S exceeds the above mentioned limits, intermediate breaks are not postulated.
- b. Piping or support modifications, however minor, may result in a shift of the calculated highest stress points in the piping. To eliminate the unnecessary relocation of postulated intermediate breaks during the late stages of design, some practical conditions for relocation have been established. Once a high energy piping system has been analyzed and break locations selected, the postulated intermediate break locations do not vary with subsequent stress reanalysis, provided no major change has occurred in the pipe parameters such as the routing of the piping being analyzed. Less significant design modifications, such as support changes to minimize the use of snubbers, are not cause for new break postulation. However, if the reanalysis, regardless of the reason, results in stresses that exceed the threshold level defined previously, then new breaks are postulated at those points where the criteria are exceeded. Evaluation and mitigation criteria for these new breaks will be identical to that imposed on the original design.
4. Break Locations - Nonseismic, Non-Nuclear Piping

Breaks in non-nuclear safety class piping not designed for seismic loading are postulated at the following locations in each piping or branch run:

- a. At terminal ends of the pressurized portions of the runs.
- b. At each pipe fitting, welded attachment, and valve.

3.6B.2.1.2.2 Moderate-Energy Fluid Systems

The following criteria are used to define crack locations in moderate energy fluid systems outside of the containment.

- 1. For the purpose of satisfying the separation provisions of BVPS-2 arrangement, a review of the piping layout and BVPS-2 arrangement drawings is conducted. The effects of through-

wall leakage cracks are isolated or made physically remote from safe shutdown systems, to the extent that it is practical.

2. Leakage cracks are not postulated in those portions of piping between the isolation valve and the containment, provided they meet the requirements of the ASME Code, Section III, Subarticle NE-1120, and are designed such that the maximum stress range associated with normal and upset plant conditions and an OBE event does not exceed the allowable as identified below:

The allowable is $0.4(1.2S_h + S_A)$ when the original code of record for BVPS Unit 2, the ASME Code, Section III, 1971 Edition up to and including the Winter 1972 Addenda are used for piping analysis.

The allowable of $0.4(1.8S_h + S_A)$ may be used if the piping analysis is performed using the ASME Code, Section III, Winter of 1981 Addenda to 1980 Edition, or later editions and addenda.

3. Through-wall leakage cracks are postulated in fluid system piping, except where exempted by section 3.6B.2.1.2.2, items 2 and 4 or where the maximum stress range, associated with normal and upset plant conditions and an OBE event, in these portions of ASME Class 2 or 3 piping and non-nuclear piping is less than the allowable identified below:

The allowable is $0.4(1.2S_h + S_A)$ when the original code of record for BVPS Unit 2, the ASME Code, Section III, 1971 Edition up to and including the Winter 1972 Addenda are utilized for piping analysis.

The allowable of $0.4(1.8S_h + S_A)$ may be used if the piping analysis is performed using the ASME Code, Section III, Winter of 1981 Addenda to 1980 Edition, or later editions and addenda.

The cracks are postulated to occur individually at locations that result in the maximum effects from fluid spray and flooding. Only environmental effects that develop from these cracks are considered.

4. Cracks are not postulated in moderate-energy fluid system piping located in an area in which a break in high-energy piping occurs and is more limiting. Where a postulated leakage crack in the moderate energy fluid system piping results in more limiting environmental conditions than the break in proximate high-energy fluid system piping, the provisions identified in Section 3.6B.2.1.2.2, item 3, are applied.
5. Through-wall leakage cracks, instead of breaks, are postulated in the piping of those fluid systems that qualify as high-energy fluid systems for only short operational periods, but qualify as moderate energy fluid systems for the major operational period. An operational period is considered short if the fraction of time that the system operates within the pressure-temperature conditions specified for high-energy fluid systems is less than 2 percent of the time that the system operates as a moderate-energy fluid system (for example, systems such as the reactor residual heat removal systems qualify as moderate-energy fluid systems).

3.6B.2.1.2.3 Separating Structures for High Energy Fluid System

If a structure separates a high energy line from an essential component, that separating structure is designed to withstand the consequences of the pipe break in the high energy line which produces the greatest effect at the structure irrespective of the fact that the criteria specified in Section 3.6B.2.1.2.1 might not require such a break location to be postulated.

3.6B.2.1.3 Design Basis Break/Crack Types and Orientation

3.6B.2.1.3.1 Circumferential Pipe Breaks

The following circumferential breaks are postulated in high-energy fluid system piping at the locations specified in Sections 3.6B.2.1.1 and 3.6B.2.1.2:

1. Circumferential breaks are postulated in fluid system piping runs and branches exceeding a nominal pipe size of 1 inch. However, when the maximum stress range or usage factor exceeds the limits specified for break postulation, and if it is determined by detailed stress analysis that the maximum stress range in the circumferential direction is at least 1.5 times that in the axial direction, then only longitudinal breaks will be postulated.

2. Where break locations are selected at pipe fittings without the benefit of stress calculations, breaks are postulated at the piping weld to each fitting, valve, or welded attachment. If detailed stress analyses or tests are performed, the maximum stressed location in the fitting may be selected instead of the pipe-to-fitting weld.
3. Circumferential breaks are assumed to result in pipe severance and separation amounting to a one-diameter lateral displacement of the ruptured piping sections unless physically limited by piping restraints, structural members, or piping stiffness as may be demonstrated by analysis.
4. The dynamic force of the jet discharge at the break location is based on the effective cross-sectional flow area of the pipe and on a calculated fluid pressure as modified by an analytically- or experimentally-determined thrust coefficient. Limited pipe displacement at the break location, line restrictions, flow limiters, positive pump-controlled flow, and the absence of energy reservoirs are taken into account, as applicable, in the reduction of jet discharge.
5. Pipe whipping is assumed to occur in the plane defined by the piping geometry and is assumed to cause pipe movement in the direction of the jet reaction.

3.6B.2.1.3.2 Longitudinal Pipe Breaks

The following longitudinal breaks are postulated in high-energy fluid system piping at the locations of each break specified in Sections 3.6B.2.1.1, and 3.6B.2.1.2 except as noted:

1. Longitudinal breaks in fluid system piping and branch runs are postulated in nominal pipe sizes 4 inches and larger. However, when the maximum stress range or usage factor exceeds the limits specified for break postulation, and it is determined by detailed stress analysis that the maximum stress range in the axial direction is at least 1.5 times that in the circumferential direction, then only a circumferential break will be postulated.
2. Longitudinal breaks are not postulated at:
 - a. Terminal ends.
3. Longitudinal breaks are assumed to result in an axial split without pipe severance. Splits are located (but not concurrently) at two diametrically-opposed points on the piping circumference such that a jet reaction causing out-of-plane bending of the piping configuration results.

Alternately, a single split may be assumed at the section of highest stress as determined by detailed stress analysis.

4. The dynamic force of the fluid jet discharge is based on a circular break area equal to the effective cross-sectional flow area of the pipe at the break location, and on a calculated fluid pressure modified by an analytically- or experimentally-determined thrust coefficient as determined for a circumferential break at the same location. Line restrictions, flow limiters, positive pump-controlled flow, and the absence of energy reservoirs are taken into account, as applicable, in the reduction of jet discharge.
5. Pipe movement is assumed to occur in the directions defined by the stiffness of the piping configuration and jet reaction forces, unless limited by structural members or piping restraints.

3.6B.2.1.3.3 Through-Wall Leakage Cracks (Outside of the Containment Only)

The following through-wall leakage cracks are postulated in moderate-energy fluid system piping at the locations specified in Section 3.6B.2.1.2.2:

1. Cracks are postulated in moderate-energy fluid system piping and branch runs exceeding a nominal pipe size of 1 inch.
2. Fluid flow from a crack is based on a circular opening of area equal to that of a rectangle one-half the nominal pipe diameter in length and one-half pipe wall thickness in width.
3. The flow from the crack is assumed to result in an environment that wets all unprotected components within the compartment, with consequent flooding in the compartment and communicating compartments. Flooding effects are determined on the basis of a conservatively estimated time period required to effect corrective actions.

3.6B.2.1.4 Conformance with Regulatory Guide 1.46

Section 1.8 discusses conformance with Regulatory Guide 1.46.

3.6B.2.2 Analytical Methods to Define Forcing Functions and Response Models

3.6B.2.2.1 Introduction

Pipe rupture analyses consist of calculations to determine the fluid forces generated by the blowdown of pressurized lines, complemented by dynamic or energy-balance analyses to determine pipe motion,

impact effects (Figure 3.6B-1), and jet impingement effects (Paragraph 3.6B.2.3). Restraints for lines 6 inches and less in diameter are usually qualified on a generic basis using an energy balance analysis. However, restraints for larger lines are engineered individually for each system, usually using standard design concepts and worst case dynamic analysis to qualify several similar restraints in different locations. The response of unrestrained lines is analyzed by either inelastic dynamic analysis or energy balance analysis.

Criteria for the response analyses are as follows:

1. An analysis of the pipe run or branch is performed for each postulated longitudinal and circumferential rupture or, alternatively, for a worst case. Worst cases are selected on the basis of gap, fluid force, and piping system stiffness.
2. The loading condition of a pipe run or branch, prior to a postulated rupture, in terms of internal pressure, temperature, and stress state, for piping pressurized during operation at power is assumed to be either hot standby or 102 percent power, depending on which condition has the greater contained energy.
3. For a circumferential rupture, pipe whip dynamic analyses are only performed for that end (or ends) of the pipe or branch connected to a pressure source (that is, fluid reservoir or pumped flow) sufficient to cause pipe whip. For the pipe run or branch where there is no physical potential for pipe whipping because of the level of energy in the piping, such as a dead end pipe, the jet impingement effect due to blowdown flow coming from the other end shall be taken into consideration.
4. Dynamic analytical methods, used for calculating the piping or piping/restraint system response to the jet thrust developed after a postulated rupture, adequately account for the effects of the following:
 - a. Mass inertia and stiffness properties of the system.
 - b. Impact and rebound (if any) as permitted by gaps between piping and restraint.
 - c. Elastic and inelastic deformation of piping and/or restraint.
 - d. Support boundary conditions.
5. An allowable design strain limit of 0.5 ultimate uniform strain of the restraints is used for tensile energy-absorbing components. For compressive energy-absorbing

components, a design limit of 80 percent of energy absorbing capacity is used.

6. A 10-percent increase of minimum specified yield strength (S_y) may be used to account for strain rate effects in inelastic nonlinear analyses. Alternatively, experimental data may be used to determine the strain rate parameters for use in nonlinear codes which monitor strain rate.

3.6B.2.2.2 Time Dependent Blowdown Force

The blowdown force calculations, which are similar to those of Moody (1973), are based on the transient pressures, velocities, and other thermodynamic properties of the fluid. To provide the time history of pressure, velocity, etc., the method of characteristics is used to solve the continuity and momentum equations simultaneously. A general description of the method can be found in most gas dynamics textbooks (De Haller 1945; Rudinger 1969; and Owzarek 1968). For these one-dimensional fluid mechanics analyses, the pipe is regarded as straight, despite numerous bends. The calculated momentum and pressure forces are applied at changes in direction or cross-section of the piping to provide time-dependent loads for pipe dynamic analysis.

The transient forces result from wave propagation and fluid momentum. It is assumed that pipe bends and elbows neither attenuate the traveling pressure waves nor cause reflections. Immediately following the rupture of a pipe, a decompression wave travels from the break at the speed of sound relative to the fluid. The fluids ahead of and behind the wave are at different states. This initial blowdown condition will last until a return signal from a pressure reservoir reaches the break. Repeated wave reflections between the reservoir and break prevail until a steady-state flow condition is established. Boundary conditions that govern the flow at the break end and at the inlet from the vessel to the pipe are applied.

The blowdown force is a function of the pressure, mass flow rate, and other thermodynamic properties of the fluid which vary with time. The force the fluid exerts on the pipe at any point in time is calculated using the following equation:

$$F = \left[P - P_a + \frac{RU^2}{144g} \right] A \quad (3.6B-1)$$

where:

F = Blowdown force (lb)

P = Local static pressure, (psia)

P_a = Ambient pressure (psia)

U = Velocity of fluid (fps)

R = Density of fluid (lb /ft³)

A = Pipe break area (in²)

g = Gravitational constant (lb_m -ft/lb_f-sec²)

The effects of line friction are included in the evaluation of steady state blowdown. For the calculation of the transient fluid response, however, friction may or may not be considered.

3.6B.2.2.2.1 Subcooled Nonflashing Waterline Blowdown

Immediately following the postulated rupture, a flow disturbance propagates from the break at a speed of sound relative to the fluid, leaving the fluid behind the wave at a thermodynamic state of U₀ and P = P_a. The governing equation across the wave is:

$$P = \pm \frac{RC}{g} \Delta U \quad (3.6B-2)$$

where:

P = Differential pressure across wave

ΔU = Differential velocity wave

C = Speed of sound in fluid.

When the disturbance reaches a pressure reservoir, it is reflected and travels toward the break end. The boundary conditions that govern the flow at the break location and at the inlet to the pipe (from the reservoir) are:

$$P_e = P_a$$

$$P_i = P_o - \frac{RU_i^2}{2g} \quad (3.6B-3)$$

where:

P_i = Pressure at pipe inlet

U_i = Velocity of fluid at pipe inlet

P_e, P_a = Pressure at the break location

P_o = Reservoir pressure.

The initial blowdown flow remains constant until the disturbance, which is reflected from the vessel, reaches the break end. Then it is reflected again, and that brings a change of blowdown flow. These repeated wave transmissions and reflections continue until the steady-state flow is established. The total initial force exerted by the fluid on the pipe is $1.0 P_o A$ and is comprised of forces due to the wave and the discharge of fluid at the break point.

Steady State With Friction

For steady state flow with friction, the blowdown forcing function calculations become:

$$F = \left[\frac{2(P_o - P_a)}{P_o} \frac{1}{1 + \frac{fL_e}{D}} \right] P_o A \quad (3.6B-4)$$

which is derived by applying Bernoulli's equation across the pipe and by using the expression for the forcing function calculation, where:

L_e = Total equivalent length of pipe friction

f = Friction factor (Reynolds number and pipe surface roughness dependent)

D = Pipe inside diameter.

Transient Flow With Friction

With friction losses taken into consideration, the transient pressures and velocities of the subcooled nonflashing water line blowdown can be obtained by simultaneously solving the continuity and momentum equations. The finite difference approximation using the method of characteristics is used as a principle for numerical solution of these two governing equations (Streeter 1967).

The computations proceed in the following manner. A grid is chosen in such a way that $\Delta x = C \Delta t$, where Δx is a space increment, Δt a time increment, and C the propagation speed of the disturbance. Starting from the initial conditions along the pipe, the pressure and velocity at $t_{n+1} = t_n + \Delta t$, and at any interior points of the pipe, can be calculated by using two characteristic equations. Whenever a boundary point is reached, the corresponding characteristic equation and boundary condition are used. Then the process proceeds until the steady state is reached.

The friction losses are expressed in terms of pressure drop of the system. To accurately model the system with friction losses, a smaller Δx must be used. This method can be applied for flow with or without friction losses.

The transient pressures, velocities, etc, are then used to calculate the blowdown forces using the equation described previously.

3.6B.2.2.2.2 Steamline Blowdown

Transient Flow Without Friction

Steam is treated as an ideal, single-phase gas with a constant specific heat ratio, k , of 1.3. Except for the case of steady-state blowdown flow, the flow is assumed to be isentropic with negligible pipe friction. The characteristic method (Jonssen et al 1973 and Hartree 1952) which is a finite difference approximation using the principle of characteristics, is used as a basis for the numerical solution of the continuity and momentum equations. The transient pressure, mass flow rate, and other thermodynamic properties are then used to calculate the transient-state forcing function.

Immediately following the break, a decompression wave travels into the pipe toward the pressure reservoir. The fluid in front of the wave is at a state

$$U_1 = 0$$

$$C_1 = C_0$$

where:

U_1 = Velocity of fluid

C_0 = Speed of sound in fluid.

The fluid state at the exit is at the sonic condition, because the initial pressure was sufficiently high (Shapiro 1953):

$$\frac{U_e}{C_0} = \frac{C_e}{C_0} = \frac{2}{k+1} = 0.8695 \text{ for } k=1.3 \quad (3.6B-5)$$

The blowdown force can be calculated as:

$$F = \left[\frac{P_e - P_a}{P_o} + \frac{R_e C_e^2}{g P_o} \right] P_o A$$

$$= \left[\frac{P_e - P_a}{P_o} + \frac{R_e}{R_o} \left(\frac{C_e}{C_o} \right)^2 \frac{R_o C_o^2}{g P_o} \right] P_o A \quad (3.6B-6)$$

where: $C_o^2 = k g P_o / R_o$

The pressure ratio across the wave is:

$$\frac{P_e}{P_o} = \left(\frac{T_e}{T_o} \right) \frac{k}{k-1} = \left(\frac{C_e}{C_o} \right) \frac{2k}{k-1} \quad (3.6B-7)$$

$$= \left(\frac{2}{k+1} \right) \frac{2k}{k-1} = 0.298$$

where:

T = Temperature

and the density ratio is:

$$\frac{R_e}{R_o} = \left(\frac{P_e}{P_o}\right)^{\frac{1}{k}} = \left(\frac{C_e}{C_o}\right)^{\frac{2k}{k-1}} \left(\frac{1}{k}\right)$$

(3.6B-8)

$$= \left(\frac{2}{k+1}\right)^{\frac{2}{k-1}}$$

Therefore, the blowdown force can be reformulated as

$$F = (1+k) \left(\frac{2}{k+1}\right)^{\frac{2k}{k-1}} P_o A - P_a A$$

(3.6B-9)

$$= 0.685 P_o A - P_a A$$

The total initial force exerted by the fluid on the pipe is 1.0 P_oA and is comprised of forces due to the wave and the preceding force due to the discharge of fluid at the break point.

The blowdown force is constant until a return signal from the pressure source reaches the break.

When the wave reaches the reservoir, it is reflected as a compression wave. The boundary condition at the pressure source lies on the steady-state ellipse,

(3.6B-10)

$$\left(\frac{C_i}{C_o}\right)^2 + \frac{k-1}{2} \left(\frac{U_i}{C_o}\right) = 1$$

which is the energy equation applied across the vessel-pipe inlet. The boundary condition for this case is:

(3.6B-11)

$$T_o = T_i + \frac{U_i^2}{2C_p}$$

where:

C_p = the constant pressure specific heat of a fluid

i = the state at the inlet to the pipe.

If the steady state is reached, the flow in the pipe is uniform and, if the pressure in the pressure vessel remains high, then the boundary condition at the break always lies on the sonic line; that is,

$$\frac{U^*}{C_o} = \frac{C^*}{C_o}$$

Then from the critical flow condition,

(3.6B-12)

$$\frac{U^*}{C_o} = \frac{C^*}{C_o} = \sqrt{\frac{2}{k+1}} = 0.9325$$

where * = the critical flow condition.

Then, the steady-state blowdown force is:

(3.6B-13)

$$F = \left[\frac{P^*}{P_o} + \frac{R^*(U^*)^2}{P_o g} \right] P_o A$$

$$= (1+k) \left(\frac{2}{k+1} \right)^{\frac{k}{k+1}} P_o A = 1.2555 P_o A$$

Steady State With Friction

For steady state flow with friction losses, the analysis is based on the theory of compressible flow with friction (Shapiro 1953). The pipe friction is the chief factor bringing about the change of fluid properties in the flow. A curve which describes the variation of steady state steam blowdown force versus friction parameter fL_e/D is shown on Figure 3.6B-2 (Moody 1973).

Transient Flow With Friction

Using a method similar to the transient flow analysis for a nonflashing waterline, a hybrid method of characteristics has been adopted from Jonssen et al (1973) to solve simultaneous one-dimensional governing equations of mass, momentum, and energy for pipe having a constant cross-sectional area with friction effects taken into consideration. The governing equations are first transformed into a system of characteristic equations, and, then, the finite difference approximation is used to integrate the fluid variables which represent the pressure, velocity, and entropy along the characteristic lines and the path line. These transient pressures, velocities, etc., are used to calculate the blowdown forcing functions using the equation described previously.

3.6B.2.2.2.3 Flashing Water Blowdown

For saturated water blowdown through a long pipe ($L/D > 12$), a two phase annular critical flow model developed by Fauske (1962) is utilized. The Fauske model uses the assumptions of thermal equilibrium and phase slip summarized as follows:

1. Annular flow with slip occurs and the slip ratio for critical flow is:

$$S = (V_g/V_f)^{1/2} \quad (3.6B-14)$$

where:

S = Slip ratio
 V_g = Specific volume of the vapor phase
 V_f = Specific volume of the liquid phase

2. Thermodynamic equilibrium and isenthalpic expansion are assumed.
3. The specific volume of the mixture (V_m) is given by:

$$V_m = \left[\frac{(1-x)^2}{(1-\alpha)} + \frac{x^2}{\alpha} \left(\frac{V_g}{V_f} \right) \right]^{1/2} V_f \quad (3.6B-15)$$

where:

$$\alpha = \text{The void fraction} = \left\{ 1 / \left[\left(\frac{1-x}{x} \right) \left(\frac{V_f}{V_g} \right) \right]^{1/2} + 1 \right\} \quad (3.6B-15A)$$

X = Mixture quality by weight

The critical mass flow rate exists when the pressure gradient along the pipe has an absolute, finite maximum value for a given flow rate and quality. This leads to the following equation for maximum mass velocity, G_c :

$$G_c = \left\{ \frac{-gS}{\left[F_1 \frac{dV_g}{dp} + F_2 \frac{dX}{dP} + F_3 \frac{dV_g}{dP} \right]} \right\}^{1/2} \quad (3.6B-16)$$

where:

$$F_1 = X[1 + (S - 1)X]$$

$$F_2 = V_g[1 + 2X(S - 1)] + V_f S[2(x - 1) + S(1 - 2X)]$$

$$F_3 = S[1 + X(S - 2) - X^2(S - 1)] \quad (3.6B-16A)$$

$$\frac{dV_g}{dP}, \frac{dX}{dP}, \text{ and } \frac{dV_f}{dP} \text{ can be approximated as} \quad (3.6B-16B)$$

$$\frac{dV_g}{dP} \approx \frac{\Delta V_g}{\Delta P}$$

$$\frac{dX}{dP} \approx \frac{\Delta X}{\Delta P} = \frac{1}{h_{fg}} \left[\frac{\Delta h_f}{\Delta P} + X \frac{\Delta h_{fg}}{\Delta P} \right]$$

$$\frac{dV_f}{dP} \approx \frac{\Delta V_f}{\Delta P}$$

The exit quality and enthalpy relation are related by the energy equation which is written for two phase flow as:

$$h_o = (1-X) \left[h_f + \frac{V_f^2}{2g_c J} \right] + X \left[h_g + \frac{V_g^2}{2g_c J} \right] \quad (3.6B-17)$$

This equation can be rewritten in terms of the mass velocity, G_c , and the slip ratio, S , as:

$$h_o = h_f + X(h_g - h_f) + \frac{G_c^2}{2g_c J} \left[(1-X) S V_f + X V_g \right]^2 \left[X + \frac{(1-X)}{S^2} \right] \quad (3.6B-18)$$

where V_f , V_g , h_f , and h_g are evaluated at the critical pressure. With the previous, the properties of the mixture at the exit can be evaluated and the critical mass velocity, G_c , can be determined.

In computing the blowdown flow rate of a saturated water blowdown through a long pipe, the pressure drops due to friction as a result of flashing, and the change of momentum become significant and should not be neglected.

The pressure drop for boiling water flowing in a long pipe in a horizontal plane can be estimated as:

$$\Delta P = \Delta P_{ACC.} + \Delta P_{FRICT.} \quad (3.6B-19)$$

where:

$\Delta P_{ACC.}$ is the acceleration pressure drop, which is due to the change of momentum between the phases as a result of flashing. $\Delta P_{FRICT.}$ is the pressure drop due to pipe friction of a two phase flow.

The acceleration pressure drop is customarily expressed in the following form:

$$\Delta P_{\text{ACC.}} = r_2 \frac{V_f G^2}{g_c} \quad (3.6B-20)$$

where:

r_2 = The acceleration pressure drop multiplier

$$r_2 \approx \left\{ 1 + X \left[\left(\frac{V_g}{V_f} \right)^{1/2} - 1 \right] \right\}^2 - 1 \quad (3.6B-21)$$

This pressure drop due to friction for two phase flow can be expressed as:

$$\Delta P_{\text{FRICT.}} = r_3 \frac{FL}{D} \frac{V_f G^2}{2g_c} \quad (3.6B-22)$$

where:

r_3 = The two phase frictional pressure drop multiplier

An estimate of r_3 developed by Thorn (1964) is utilized. The following expression fits the referenced data over the range of pressures considered.

$$r_3 = 1 + X \left(\frac{V_g}{V_f} - 1 \right) \quad (3.6B-23)$$

To calculate the blowdown flow rate for two phase flow using Fauske's critical flow envelope, an iteration procedure is necessary, since the critical pressure and the percent of flashing at the discharge end are not known a priori. By using the critical flow envelope, together with the following equation, one can find the:

$$P_o = P_c \left[1 + 2r_2 + r_3 \left(\frac{FL}{D} \right) \right] \left[\frac{V_f G_c^2}{2g_c} \right] \quad (3.6B-24)$$

Exit quality and critical pressure, P_c . It is assumed that the specific volume of the liquid phase does not change drastically across the pipe.

The iteration procedure is outlined as follows:

1. Assuming a critical pressure, P_c , one can determine the critical mass velocity and the exit quality.
2. Using the exit quality and the critical pressure, one can obtain the two phase pressure drop multiplier, r_3 , and the acceleration pressure drop multiplier, r_2 .
3. The total pressure drop across the pipe is calculated. If the total pressure drop plus the critical pressure equals the total pressure in the pressure source, then the iteration stops. Otherwise the procedure is repeated by assuming a new critical pressure.

After obtaining the critical mass velocity, pressure, and exit quality, the blowdown thrust can be calculated as:

$$F = \left[P_c - P_a + \frac{V_m G_c^2}{g_c} \right] A \quad (3.6B-25)$$

where:

$$V_m = (1 + r_2) V_f \quad (3.6 B-26)$$

For short flow passages ($L/D < 12$), the flow is characterized by non-equilibrium conditions and a metastable state results. This flow is unstable since, for initially subcooled or saturated water, the flow accelerates so rapidly as it leaves the pressure source at the pipe inlet that there is insufficient time to form any appreciable amount of vapor. Therefore, the flow has a negligible exit quality and the pressure drop due to the change of momentum between the phases is negligible. For these flow regimes, the thermodynamic fluid

properties as functions of time are predicted by the Henry-Fauske (1971) theory.

3.6B.2.2.3 Simplified Blowdown Analysis

A conservative steady state forcing function may be used for calculations based on the energy balance method. The function has a magnitude of:

$$T = KPA$$

where:

- P = System pressure prior to pipe break
- A = Pipe break area
- K = Thrust coefficient (theoretical maximum)

K values are as follows:

1. 1.26 for saturated steam, water, and steam/water mixture
2. 2.00 for nonflashing sub-cooled water.

If pressure drop due to friction is taken into consideration, the values of K can be reduced.

An amplification factor of 1.0 or 1.1 is applied to the previous force to account for rebound. A rebound factor of 1.0 is used if the analysis is verified by a subsequent dynamic analysis; otherwise a value of 1.1 is used. After the break, there is a short period of time during which the magnitude of the fluid force (that is, until the wave passes the first elbow) is $1.0 P_0A$. This is ignored since the initial pipe velocity is low and the resulting work input is inconsequential, and the magnitude of the fluid force is assumed to rise immediately to its maximum value, during the energy input phase, as determined by the detailed methods of Section 3.6B.2.2.2.

3.6B.2.2.4 Lumped-Parameter Dynamic Analysis

The piping system is modeled mathematically as a series of beam elements connected at nodes. The geometry of the model matches that of the pipe. The distributed mass of the pipe and contained fluid is modeled as lumped masses located at the nodes. The beam elements have the stiffness properties of the pipe in the elastic range and approximate the plastic behavior after yield.

Before a rupture, the pipe is stressed by internal pressure, and is in static equilibrium. This is simulated in the mathematical model by applying forces at points in the system where changes in the flow direction or changes in the flow area occur. The initial stresses contribute to the total stresses of the system and are considered in

situations where they are significant, such as ensuring that the total stresses in break exclusion zones or that the total loads on attached components are within appropriate allowables subsequent to a break or where close gapped restraints are used.

As a postulated circumferential break propagates, the load-carrying metal area of the pipe decreases so that a force unbalance results. The force initially transmitted across the break is assumed to drop linearly to zero in 1 millisecond. After the break, the forces exerted on the pipe by the fluid are determined by the time-dependent blowdown force derived in Section 3.6B.2.2.2. Similarly, for a longitudinal split, the crack propagation speed limits the rate at which the split opens, so a 1-millisecond force rise time is assumed. Other break opening times may be used if justified.

Subsequent to a postulated rupture, the inelastic system response is analyzed by the use of an elastic-plastic lumped-mass beam element computer code such as DINASAW or LIMITA (Appendix Sections 3A.2.1, 3A.2.2, and 3A.2.3). The analysis considers the free motion of the pipe through a gap, if one exists, using the appropriate initial conditions and the fluid blowdown forces as calculated in Section 3.6B.2.2.2. The mathematical model includes the restraint or barrier, and sometimes a member simulating the local crush resistance of the pipe. Rebound effects are considered by automatically connecting and disconnecting that member for impact and rebound, respectively.

3.6B.2.2.4.1 Sample Dynamic Analysis

Pipe rupture restraint 2MSS-PRR811 limits the motion of the main steam line following a postulated circumferential rupture at the top of the steam generator. The restraint is a "U" configuration with 10 layers of 11 gauge stainless steel having an 8-inch strainable width (Figure 3.6B-3). The initial clearance between the hot pipe and restraint is 0.94 inch in the outward and side directions, resulting in a total acceleration gap, after slack take-up, of 2.34 inches.

The analysis of the pipe-restraint interaction used the LIMITA3 computer code and the three-dimensional finite element model shown on Figure 3.6B-4. The restraint model is equivalent to a single member 49.06 inches long with a 20-in² cross section. The elastic-plastic properties of this restraint were for stainless steel, with corrections for strain variations in the arch due to friction against the pipe and in the tapered transition region at each end of the strap. A sufficient length of pipe was included in the model to minimize the effect of the boundary condition at the far end.

The fluid forces depicted on Figure 3.6B-5 were applied to nodes where the pipe is curved. First, the pipe was brought into static equilibrium with the fluid forces at time zero, considering the pipe fixed to the steam generator. Then, the mechanical forces from the steam generator were ramped down to zero in 1 millisecond to simulate

the rupture. The subsequent fluid force history represents the decompression wave traveling away from the break. No reflection wave from the other end of the pipe occurs in the time period analyzed.

The restraint reaction load is shown on Figure 3.6B-6. The stainless steel strap is stretched during the impact event, thereby absorbing energy in plastic deformation. The maximum restraint strain recorded during the impact analysis was 6 percent. The restraint force then oscillates about the value of the fluid blowdown force.

3.6B.2.2.5 Energy Balance Analysis

The energy balance technique for analyzing pipe impact equates the work done by the escaping fluid to the energy absorbed in deforming the ruptured pipe and the impacted target. A steady-state blowdown force is used for the energy balance analysis. The magnitude of the force is described in Section 3.6B.2.2.3.

The input energy of the system is determined by multiplying the pipe displacement at the break end by the component of the fluid blowdown force in the direction of the displacement.

The input energy is:

$$E = F (g + d)$$

where:

F = component of blowdown force in direction of pipe displacement (lb)

g = pipe-target gap (in)

d = displacement of break end of pipe after impact (in)

The strain energy absorbed during pipe whip and impact consists of the energy absorbed by pipe bending, E_{pb} the energy absorbed by pipe crush during impact, E_{pc} and the energy absorbed by deformation of the target, E_t .

To determine post-impact target deformation and the peak reaction force, the input energy is equated to the strain energy absorbed by the pipe and target. The energy absorption characteristics of the pipe crush and target deformation are calculated on the basis of the displacement integral of the appropriate force-deformation curves.

Sample Energy Balance Analysis

Analyze the impact of a 10-inch, schedule 160 pipe into a pipe crush bumper following a circumferential break at an elbow (Figure 3.6B-7). One source of energy input is recognized: the fluid blowdown force

traveling through the distance moved by the ruptured end of the pipe. The input energy is:

$$E_{in} = F_b(g+d) \left(\frac{L_h}{L_h-L} \right) \quad (3.6B-27)$$

where:

F_b = Fluid blowdown force (lb)

g = Acceleration gap (in)

d = Restraint deflection (in)

L_h = Length from break to plastic hinge (in)

L = Length from break to restraint (in)

The ratio $L_h/(L_h-L)$ represents the increased pipe displacement at the break, compared to displacement at the restraint, due to the assumed pipe rotation about a plastic hinge.

The fluid force is calculated:

$$F_b = K_r K_f P_o A = 100.5 \text{ kips} \quad (3.6B-28)$$

where:

K_r = Rebound factor (1.1)

K_f = Thrust coefficient (0.7)

P_o = Initial pressure (2,300 psi)

A = Pipe flow area (56.75 in²)

The maximum thrust coefficient in the period when the energy balance occurs is 1.0. However, this drops to 0.7 as soon as the decompression wave passes the elbow ($t \leq 0.001$ second) and occurs when the pipe is just starting to accelerate. Since the displacement

and resulting energy input are negligible during this interval, 0.7 rather than 1.0 was used as the thrust coefficient. The duration of the entire energy balance event is evaluated after the restraint is sized. This permits a quick review of the fluid force history to assure that a higher thrust coefficient did not occur later in the dynamic event.

Energy may be absorbed in plastic bending of the pipe and in crush of the restraint. The energy absorbed by bending at the plastic hinge is

$$E_b = M_p \theta = M_p (g+d)/(L_h-L) \quad (3.6B-29)$$

where:

M_p = Plastic moment

θ = Hinge rotation.

The value of M_p may be obtained from rigid, perfect-plastic limit theory, but, for this application, a strain hardening moment (Gerber 1974) is more correct. This requires an estimate of the hinge rotation (that is, g , d , L_h and L must be determined). The gap may be set to 3 inches ($g=3$ inches). The values of d and L are dependent on the bumper. Let the bumper pipe have the same diameter as the process pipe. Then let $d = 0.7 \times \text{I.D.} = 6.5$ inches to achieve approximately 50 percent of the energy-absorbing capacity (Peach et al 1977). Set $L = 27.9$ inches to allow for the elbow (15 inches), the restraint half-width (5.375 inches) and access to the elbow weld for inservice inspection (6.5 inches). Using the common expression for plastic hinge length ($L = 3 M_p/F_b$) and the method described by Gerber (1974) an iterative solution shows that

$$M_p = 3,363 \text{ inches kips}$$

$$L_h = 100.4 \text{ in.}$$

Thus the energy to be absorbed by the bumper pipe is:

$$\begin{aligned} E &= (F_b L_h - M_p) (g+d)/(L_h-L) \\ &= 882 \text{ in. kips} \end{aligned}$$

Size the bumper pipe thickness subject to the following constraint:

$$t_b \leq 0.75 t_p \left(\frac{r_b}{r_p} \right)^{0.131} = 0.84 \text{ inch} \quad (3.6B-30)$$

where:

t_b = Bumper pipe wall thickness (in)

t_p = Process pipe wall thickness (in)

r_b = Bumper pipe radius (in)

r_p = Process pipe radius (in)

This restriction assures that the bumper pipe will crush without causing crush of the process pipe. Thus, any bumper pipe of schedule 120 or thinner is acceptable. Table 3.6B-3 presents the energy absorbing capacity of 10-inch pipes at a crush displacement of 0.7 x I.D., using a multiplier of 1.1 for strain rate effects.

Use the schedule 80 pipe for the bumper, since this comes closest to meeting the energy absorption requirements. Iterate to find the exact point of energy balance

d = 6.1 inches

E = 845 in kips
= 45 percent of capacity

F = 195 kips

The restraint reaction load is thus 1.94 times the fluid blowdown force.

Finally, determine the approximate time of peak restraint load to assure that the fluid force did not exceed $0.7 P_0 A$ during the energy balance event:

$$t = \sqrt{\frac{2mL_h^3 (g+d)^2}{3(L_h - L) g} \left(\frac{1}{F_b L_h - M_p} \right)} \quad (3.6B-31)$$

where:

m = the mass per unit length of the pipe.

thus:

t = 30.1 milliseconds

3.6B.2.2.6 Local Pipe Indentation

The local shell indentation stiffness of the pipe is usually considered where other energy-absorbing mechanisms are not available at the point of impact. Examples include impacts into rigid displacement-limiting bumpers, concrete walls, and the omnidirectional restraint weldment (the latter interposes a significant mass between the impacting pipe and the energy absorbers).

Two methods have been used to determine the shell indentation stiffness. The earlier was analytical and tended to overpredict conservatively the indentation stiffness. The other was a series of pseudo-static pipe crush tests covering several crush geometries and a sufficient range of pipe thicknesses and diameters to develop parametric scaling laws (Peach 1977). This was augmented by analyses to determine the sensitivity to material strength, dynamics, and variations in loading geometry.

3.6B.2.2.7 Concrete Barrier Impact

In a pipe whip impact, the force on the barrier is a complex function of time depending primarily on the sudden deceleration of the pipe wall at the impact point (slug impact), the shell indentation of the pipe as it locally crushes against the wall, and the force transmitted to the impact point by the more gradual deceleration of the adjacent run of pipe. After impact, the pipe also transmits a more enduring force resulting from the continuing fluid blowdown. The concrete is affected by this, much like any other missile impact, the only significant difference being the long term fluid force. To evaluate this postulated event, the pipe is transformed into an equivalent missile and the concrete is analyzed for scabbing and structural response using the procedure described in Section 3.5.3. The analysis for structural response includes the impulse of the initial impact as well as the subsequent fluid blowdown force and other concurrent loads.

Four basic parameters must be determined to define the equivalent missile: the kinetic energy (or impulse), the impact velocity, the pipe crush stiffness, and the bearing area. The kinetic energy and velocity can be found by either of two methods:

1. Simplified Method - Use the total input energy (fluid blowdown force x distance of pipe travel) less the energy absorbed in pipe bending prior to impact. Compute the velocity using approximate formulae (Roemer and East 1980).
2. Lumped Parameter Dynamic Analysis (Section 3.6B.2.2.4) - This method is especially suited for evaluating the impact of piping systems with complex geometries and can even

consider multiple impact points. As an alternative to the kinetic energy, the impact force history (impulse) can be computed.

Regardless of which analysis method is used, the crush resistance of the equivalent missile and the bearing area are derived from the experimental data described in Section 3.6B.2.2.6. This data is modified to account for the effect of dynamics and internal pressure.

3.6B.2.3 Dynamic Analysis Methods to Verify Integrity and Operability

Pipe rupture loads to determine the integrity of mechanical components are determined using the analytical methods described in Section 3.6B.2.2. The applicable load combinations for the components and for break exclusion regions are presented in Sections 3.9 and 3.6B.2.1, respectively. Criteria for rupture restraints are presented in Section 3.6B.2.3.1.

Jet impingement loadings are determined as follows:

1. Jet forces are represented by time-dependent forcing functions, which are determined according to the methods presented in Section 3.6B.2.2.1. The effects of the piping geometry, capacity of the upstream energy reservoir, source pressure, and fluid enthalpy are considered in these forcing functions.
2. The steady-state jet force has a magnitude of:

$$F = K_j P A$$

where:

$$P = \text{System pressure prior to pipe break (psi)}$$

$$A = \text{Pipe break area (in}^2\text{)}$$

$$K_j = \text{Jet coefficient.}$$

The following K_j values are used whenever the reservoir pressure is constant, pipe friction is negligible, and there are no upstream flow restrictions:

- a. A value of 1.26 for saturated steam, saturated water, and steam/water mixture.
- b. A value of 2.00 for nonflashing subcooled water.

If pressure drop due to friction is taken into consideration, values of k_j can be reduced.

3. The jet impingement pressure on

any target is calculated assuming the jet force is constant in any plane normal to the jet stream and assuming that the jet stream diverges conically at a solid angle of 20 degrees for steam or water-steam mixtures. For those cases where the 20 degree divergence assumption is shown to be unnecessarily conservative, Moody's asymptotic jet expansion model is utilized (Moody 1969). Jet expansion is not used for cases involving saturated water or subcooled water blowdown that have an initial fluid temperature below the saturation temperature at the ambient pressure beyond the break.

4. The effective range of jet impingement force from piping containing steam or subcooled, flashing water at pressures between 870 and 2,465 psia and with no greater than 70°C subcooling may be limited to ten times the nominal pipe diameter (NUREG/CR-2913, 1983). The jet intensity within the limited jet impingement zone is determined as in Section 3.6B.2.3(3.) above.
5. The proportion of the total jet force acting on the target is determined from the fraction of the jet intercepted and by the shape factor of the target. For a target with its flat surface area normal to the center of the jet stream, the impingement load is the product of the pressure and the intercepted jet area. For those cases where the target area is such that the intercepted jet stream is deflected rather than totally stopped, a shape factor which is less than unity and which is a function of the target geometry is used in calculating the total jet impingement load.

Since the jet impingement force is a dynamically applied load, the target will be analyzed either by static methods using an appropriate dynamic load factor, or dynamically using elastic or inelastic structural response codes (Appendix 3A). The load combinations and design allowable are given in Sections 3.8.3 and 3.9.

3.6B.2.3.1 Pipe Rupture Restraints

Two basic restraint types are used: elastic and energy-absorbing. The elastic restraints are generally used where displacements subsequent to a postulated pipe rupture must be minimized to either restrict the break opening area or limit loads in the broken piping run. Energy-absorbing restraints are used where the primary objective to dissipate the energy is of a ruptured pipe.

3.6B.2.3.1.1 Elastic Restraints

Since elastic restraints are used to minimize displacements of the broken pipe, they are close gapped. For some applications, this requires that they contact the pipe during conditions other than a postulated rupture, in which case they are designed as a pipe support in accordance with the applicable code (Section 3.9.3). If an elastic restraint will only contact the pipe following a rupture, it is designed according to the criteria for structural steel (Section 3.8.3).

3.6B.2.3.1.2 Energy-Absorbing Restraints

Several approaches are used for energy absorption in pipe rupture restraints. In tension, stainless steel studs or straps are used, with a design limit of 50 percent of uniform ultimate strain. In compression, honeycomb panels or pipe sections are used. Compressive components are designed to 80 percent or less of their energy absorption capacity. Other energy-absorbing devices may be used and will be designed to these same limits.

One or more of the above energy-absorbing mechanisms are utilized in each of the typical restraints described below. When a single energy-absorbing mechanism is utilized, the design limits will be met for the design range of loading directions. Designs with more than one form of energy absorption may not fully utilize compressive absorbers for some loading directions. These are allowed to bottom out if other active energy absorbers remain within their design limit.

Elastic components of energy-absorbing restraints are designed to the criteria for structural steel (Section 3.8.3).

Pipe Crush Bumper

The pipe crush bumper absorbs impact energy in a direction toward the supporting structure. The energy absorber is a length of pipe placed normal to the axis of the process pipe. Subsequent to a rupture, the bumper pipe is crushed between its support structure and the moving process pipe. This absorbs energy and forms a retaining recess in the bumper pipe. The bumper pipe is attached to its support by welding, bolting, etc (Figures 3.6B-8 and 3.6B-9).

Laminated Strap Restraint

The laminated strap restraint is capable of absorbing impact loads in the outward direction from the supporting structure (Figure 3.6B-10). The energy-absorbing component is a U-shaped strap which consists of one or more strips (depending on energy to be absorbed) of highly ductile material (Type 304 stainless steel).

This laminated design provides great flexibility. If the process pipe contacts the sides of the restraint during an event other than pipe rupture, negligible loads result. The design also minimizes bending strains, permitting the strap to act mainly as a membrane during the postulated rupture event.

Omni-Directional Restraint

The omni-directional restraint is capable of absorbing impact loads applied in any direction in the plane of the restraint (Figure 3.6B-11). This restraint consists of a base weldment, an arch, ductile holddown studs on each side of the base weldment, and a honeycomb panel. The primary function of the studs is to absorb energy from impact loads acting outward from the support structure. The honeycomb panel absorbs energy from impact

loads acting in an inward direction. Side load impacts will be absorbed by the combined action of the studs and honeycomb.

Combinations of pipe crush bumpers and laminated straps may also be used to achieve energy absorption over a range of impact directions up to a full 360 degrees.

3.6B.2.4 Guard Pipe Assembly Design Criteria

The Beaver Valley Power Station - Unit 2 does not utilize guard pipes.

3.6B.2.5 Material to be Submitted for the Operating License Review

Pipe break and crack locations are obtained in accordance with the criteria of Section 3.6B.2.1. High-energy piping with break locations identified are provided in isometric drawings and/or system descriptive drawings (Figures 3.6B-12, 3.6B-13, 3.6B-14, 3.6B-15, 3.6B-16A, 3.6B-16B, 3.6B-16C, 3.6B-16D, 3.6B-16E, 3.6B-16F, 3.6B-17A, 3.6B-17B, 3.6B-17C, 3.6B-18A, 3.6B-18B, 3.6B-18C, 3.6B-18D, 3.6B-18E, 3.6B-19A, 3.6B-19B, 3.6B-19C, 3.6B-20A, 3.6B-20B, 3.6B-21A, 3.6B-21B, 3.6B-22, 3.6B-23, 3.6B-24, 3.6B-25A, 3.6B-25B and 3.6B-26). These figures show the locations of all break locations and corresponding pipe whip restraints where required. The following details are provided for each high-energy system:

1. Line designation numbers showing system, size, line number, and safety class of pipe.
2. Break identification numbers showing break type (i.e., longitudinal or circumferential), reason for postulation (i.e., stress or usage factor exceeds allowable (EA) or terminal end location (TE)), and plant location.
3. Pipe whip restraints showing identification number, type, and restrained direction of ruptured pipe.
4. The valves and major components in the high energy systems considered are provided for the convenience in locating break points only.

Pipe whip restraints are designed as discussed in Section 3.6B.2.3.1. Jet thrust and impingement forces are determined in accordance with Section 3.6B.2.3. Based on this approach and the case-by-case review of all postulated jet impingement events, no jet shields are required. The evaluation of all pipe break dynamic effects and the resolution of all associated safety concerns has been documented in the BVPS-2 Hazard Analysis Evaluation Report (1987).

The effects of breaks and cracks are discussed in detail in Section 3.6B.1 and they are based on the protection evaluation criteria of that section. Any protective measures to assure a safe shutdown (barriers, separation, and restraints) are also discussed.

3.6N PROTECTION AGAINST DYNAMIC EFFECTS ASSOCIATED WITH THE POSTULATED RUPTURE OF PIPING

This section describes the design bases and protective measures which are used to ensure that the containment and all vital equipment within the containment are adequately protected from the dynamic effects caused by postulated rupture of the reactor coolant system (RCS) piping. Components of the RCS system are given in Section 5.4.

3.6N.1 Postulated Piping Failures in Fluid Systems Outside of Containment

Refer to Section 3.6B.1

3.6N.2 Determination of Break Locations and Dynamic Effects Associated with Postulated Rupture of Piping

Refer to Section 3.6B.2

3.6N.2.1 Criteria Used to Determine Break and Crack Location and Configuration

Refer to Section 3.6B.2.1.

3.6N.2.2 Analytical Methods to Define Forcing Functions and Response Models

3.6N.2.2.1 Dynamic Analyses

Refer to Section 3.6B.2.2.1

3.6N.2.2.2 Time Functions of Jet Thrust Force on Ruptured and Intact Loop Piping

This section has been deleted based on the exemption to consideration of dynamic effects associated with reactor coolant loop breaks. Refer to Section 3.6B.2.1.1.1.

This page is intentionally blank.

3.6N.2.2.3 Dynamic Analysis of the Reactor Coolant Loop Piping Equipment Supports and Pipe Whip Restraints

Refer to Section 5.4.14.

3.6N.2.3 Dynamic Analysis Methods to Verify Integrity and Operability

3.6N.2.3.1 Protective Measures

The fluid discharged from the ruptured piping will produce thrust and reaction forces in the piping systems. The effects of these loadings are considered in assuring the continued integrity of the vital components and the engineered safety features (ESF).

To account for these effects in the design, a combination of component restraints, barriers, and layout is utilized to ensure that for a loss of coolant, steam line break, or feedwater line break, propagation of damage from the original event is limited, and the components as needed, are protected and available.

3.6N.2.3.2 Criteria for Protection Against Postulated Pipe Breaks in Reactor Coolant System Piping

A loss of reactor coolant accident is assumed to occur for a branch line break down to the restraint of the second normally open automatic isolation valve (Case II on Figure 3.6N-2) on outgoing lines (it is assumed that motion of the unsupported line containing the isolation valves could cause failure of the operators of both valves to function) and down to and including the second check valve (Case III on Figure 3.6N-2) on oncoming lines normally with flow. A pipe break beyond the restraint or second check valve will not result in an uncontrolled loss of reactor coolant if either of the two valves in the line close. Accordingly, both of the automatic isolation valves are suitably protected and restrained as close to the valves as possible so that a pipe break beyond the restraint will not jeopardize the integrity and operability of the valves. Further, periodic testing to ensure that the valves are capable of performing their intended function is essential. These criteria apply to all

branch lines with automatic isolation valves as the first isolation valve whether the lines are normally with or without flow (Case II on Figure 3.6N-2).

This criterion takes credit for only one of the two valves performing its intended function. For normally closed manual isolation valves or incoming check valves (Cases I and IV on Figure 3.6N-2) as the first isolation valve, a loss of reactor coolant accident is assumed to occur for pipe breaks on the reactor side of the valve.

Branch lines connected to the RCS are defined as "large" for the purpose of these criteria as having an inside diameter greater than 4 inches up to the largest connecting line, generally the pressurizer surge line. Rupture of these lines results in a rapid blowdown from the RCS and protection is basically provided by the accumulators and the low head safety injection pumps.

Branch lines connected to the RCS are defined as "small" if they have an inside diameter equal to or less than 4 inches. This size is such that emergency core cooling system (ECCS) analyses using realistic assumptions show that no clad damage is expected for a break area of up to 12.5 in² corresponding to 4 inch inside diameter piping.

Engineered safety features are provided for core cooling and boration, pressure reduction, and activity confinement in the event of a loss of a reactor coolant or steam line break or feedwater line break accident to ensure that the public is protected in accordance with 10 CFR 50.67 requirements. These safety systems have been designed to provide protection for a RCS pipe rupture of a size up to and including a double ended severance of the RCS main loop. In order to assure the continued integrity of the vital components and the ESF, consideration is given to the consequential effects of the break itself to the extent that:

1. The minimum performance capabilities of the ESF are not reduced below those required to protect against the postulated break;
2. The containment leak tightness is not decreased below the design value, if the break leads to a loss of reactor coolant (the containment is here defined as the containment structure liner and penetrations, the steam generator shell, the steam generator steam side instrumentation connections, and the steam, feedwater, blowdown and steam generator drain pipes within the containment structure); and
3. Propagation of damage is limited in type and/or degree to the extent that:
 - a. A pipe break which is not a loss of reactor coolant will not cause a loss of reactor coolant or steam or feedwater line break. Certain limited exemptions to this rule have been granted for breaks occurring in Safety Class 2 portions of piping systems outside the reactor coolant pressure boundary which, if ruptured may result in a small LOCA or rupture of a steam generator

blowdown line. These ruptures, however, are less limiting than the bounding events considered in the Beaver Valley Unit-2 Small Break LOCA ECCS Analysis and do not seriously impact the availability of the steam generator heat sink.

- b. A RCS pipe break will not cause a steam or feedwater system pipe break and vice versa.

3.6N.2.3.2.1 Large Reactor Coolant System Piping

Propagation of damage resulting from rupture of the main reactor coolant loop is permitted to occur but does not exceed the design basis for calculating containment and subcompartment pressures, loop hydraulic forces, reactor internals reactor loads, primary equipment support loads, or ECCS performance.

Large branch line piping, as defined in Section 3.6N.2.3.2, is restrained to meet the following criteria in addition to items 1 through 3 of Section 3.6N.2.3.2 for a pipe break resulting in a loss of reactor coolant with the exception of those lines considered under LBB (refer to Section 3.6B.2.1).

A break in a pressurizer safety and relief line is allowed to propagate to the other two safety or relief lines since these lines are connected to the pressurizer above the pressurizer water level and the release of saturated steam is less severe than the loss of liquid coolant through a break of equal size.

3.6N.2.3.2.2 Small Branch Lines

In the unlikely event that one of the small pressurized lines, as defined in Section 3.6N.2.3.2, should fail and result in a LOCA the piping is restrained or arranged to meet the following criteria in addition to items 1 through 3 of Section 3.6N.2.3.2.

1. Break propagation is limited to the affected leg, that is, propagation to the other leg of the affected loop and the other loops is prevented.
2. In addition to the initial failure of a small pressurized line, propagation of the break in the affected leg is permitted but is limited to a total break area of 12.5 in² (4 inch inside diameter). The exception to this case is when the initiating small break is a cold leg high head safety injection line. Further propagation is not permitted for this case.

3. Damage to the high head safety injection lines connected to the other leg of the affected loop or to the other loops is prevented.
4. Propagation of the break to a high head safety injection line connected to the affected leg is prevented if the line break results in a loss of core cooling capability due to a spilling injection line.

3.6N.2.3.3 Protective Provisions for Vital Equipment

In addition to pipe restraints, barriers and the arrangement of the vital equipment are used to provide protection from pipe whip, blowdown jet, and reactive forces.

The following are some of the barriers utilized for protection against pipe whip. The polar crane wall serves as a barrier between the reactor coolant loops and the containment liner. In addition, the refueling cavity walls, the operating floor, and the crane wall, enclose each reactor coolant loop into a separate compartment, thereby preventing an accident, which may occur in any loop, from affecting another loop or the containment liner. The portion of the steam and feedwater lines within the containment have been routed behind barriers which separate these lines from all reactor coolant piping. The barriers described previously will withstand loadings caused by jet forces and pipe whip impact forces.

Other than for the ECCS lines, which must circulate cooling water to the vessel, the ESFs are located outside of the crane wall. The safety injection accumulators are located at el 692 feet and are separated from the reactor coolant loops by physical barriers. The ECCS lines which penetrate the crane wall are routed around and outside the crane wall to penetrate the crane wall in the vicinity of the loop to which they are attached.

It has been demonstrated that lines hitting equal or larger size lines of the same schedule will not cause failure of the line being hit, for example, a 1 inch line, should it fail, will not cause subsequent failure of a 1 inch or larger size line. The reverse, however, is assumed to be probable, (a 4 inch line, should it fail and whip as a result of the fluid discharged through the line, could break smaller size lines such as neighboring 3 inch or 2 inch lines). In this case, the total break area is less than 12.5 in² (refer to Section 3.6B.1.3.2.3).

If the layout is planned such that whipping of the two free sections cannot reach equipment or other pipes for which protection is required, plastic hinge formation is permitted. As an alternative, barriers are erected to prevent the whipping pipe from impacting on equipment or piping requiring protection. Finally, tests and/or analyses are performed to demonstrate that the whipping pipe will not cause damage in excess of acceptable limits.

Whipping in bending of a broken stainless steel pipe section such as used in the RCS does not cause this section to become a missile. This design basis has been demonstrated by Westinghouse Nuclear Energy Systems bending tests on large and small diameter, heavy and thin walled stainless steel pipes.

3.6N.2.3.4 Pipe Restraints and Locations

Refer to Section 3.6B.2.5.

3.6N.2.3.5 Design Loading Combinations

Refer to Section 3.6B.2.3.

3.6N.2.4 Guard Pipe Assembly Design Criteria

Refer to Section 3.6B.2.4.

3.6N.2.5 Material to be Submitted at the Operating License Review

Refer to Section 3.6B.2.5.

3.6.3 References for Section 3.6

Bordelon, F.M. 1971. A Comprehensive Space-Time Dependent Analysis of Loss of Coolant (SATAN-IV Digital Code). WCAP-7263, (Proprietary) and WCAP-7750, (Non-Proprietary).

De Haller, P. 1945. The Application of Graphical Method to Some Dynamic Problems in Gases. Sulzer Technical Review No. 1, p 6-24.

Fauske, H.K. 1962. Contribution to the Theory of Two Phase, One-Component Critical Flow, ANL-6633, Argonne National Laboratory.

Gerber, T.L. 1974. Plastic Deformation of Piping Due to Pipe Whip Loading. ASME Paper 74-NE-1.

Hartree, D.R. 1952. Some Practical Methods of Using Characteristics in the Calculation of Non-Steady Compressible Flow. Los Alamos Report LA-HU-1.

Henry, R.E. and Fauske, H.K. 1971. Two Phase Critical Flow of One-Component Mixtures in Nozzles, Orifices, and Short Tubes. Journal of Heat Transfer, ASME.

Hazard Analysis Evaluation Report 1987. Documents the Evaluation and Resolution of All Safety Issues Associated with BVPS-2 Pipe Rupture Postulated Events.

Jonssen, V.K.; Matthews, L.; and Spalding, D.B. 1973. Numerical Solution Procedure for Calculating the Unsteady, One-Dimensional Flow of Compressible Fluid with Allowance for the Effect of Heat Transfer and Friction. ASME Paper 73-FE-30.

Moody, J.F. 1969. Prediction of Blowdown Thrust and Jet Forces. ASME Paper 69-HT-31.

Owzarek, J.A. 1968. Fundamentals of Gas Dynamics. International Textbook Company, Second Printing, Scranton, Pa.

Peach, J.M.; Roemer, R.E.; Pirotin, S.D.; East, G.H., and Goldstein, N.A. 1977. Local Crush Rigidity of Pipes and Elbows. Paper F3/8, Transactions of the Fourth International Conference on Structural Mechanics in Reactor Technology, San Francisco, Calif.

Roemer, R.E. and East, G.H. 1980. Prediction of Large Deformation Pipe Whip and Barrier Impact: A Simplified Approach. ASME Paper 80 C2/PVP 48.

Rudinger, G. 1969. Nonsteady Duct Flow-Wave Diagram Analysis. Dover Publications, Inc.

Shapiro, A.H. 1953. The Dynamics and Thermodynamics of Compressible Fluid Flow, Vol. I and II. Ronald Press, New York, N.Y.

Streeter, V.L. and Wylie, E.G. 1967. Hydraulic Transients. McGraw-Hill Book Co., New York, N.Y., p 32-37.

TER 8484 Revision 1, "QA Category Downgrade of Raw Water System Piping and Appurtenances in the Intake Structure."

Thom, J.R.S. 1964. Prediction of Pressure Drops During Forced Circulation Boiling of Water, International Journal of Heat and Mass Transfer, Vol. 7, p 709-724.

Weigand, G.G.; Thompson, S.L.; and Tomasko, D. 1983. Two-Phase Jet Loads. NUREG/CR-2913.

WHIPJET Program Final Report, January 30, 1987, as amended by Letter dated February 13, 1987. Documentation of an Alternative Method for Addressing Pipe Break Concerns by a Leak-Before-Break Approach.

Sieber, J.D. (BVPS), Letter to Harold R. Denton (NRC), Beaver Valley Power Station - Unit No. 2, Docket No. 50-412, WHIPJET Program Report, February 13, 1987.

WCAP-11923, Technical Justification for Eliminating Large Primary Loop Pipe Rupture as the Structural Design Basis for Beaver Valley Unit 2 After Reduction of Snubbers, September 1988, including Supplements 1, 2 and 3.

De Agazio, Albert W. (NRC), Letter to J.D. Sieber (BVPS), Elimination of Dynamic Effects of Postulated Pressurizer Surge Line Rupture and Elimination of Reactor Coolant System Component Support Snubbers, April 8, 1991.

WCAP-12093, Evaluation of Thermal Stratification for the Beaver Valley Unit 2 Pressurizer Surge Line, December 1988.

Tam, Peter S. (NRC), Letter to J.D. Sieber (BVPS), Beaver Valley Unit 2 - Completion of Review on Pressurizer Surge Line Thermal Stratification, January 18, 1990.

Sieber, J.D. (BVPS), Letter to NRC, Beaver Valley Power Station, Unit No. 2, Docket No. 50-412, License No. NPF-73, Primary Component Support Snubber Elimination, August 10, 1990.

NUREG-1057, Supplement No. 4, Safety Evaluation Report Related to the Operation of Beaver Valley Power Station Unit 2, Docket No. 50-412 Duquesne Light Company, March 1987.

WCAP-17488-P, Leak-Before-Break Analysis Update for the Beaver Valley Unit 2 Primary Loop Piping, February 2012.

WCAP-17394-P, Leak-Before-Break Analysis Update for the Beaver Valley Unit 2 Pressurizer Surge Line, December 2011.

BVPS-2 UFSAR

Tables for Section 3.6

TABLE 3.6B-1

HIGH-ENERGY PIPING SYSTEMS

<u>System</u>	<u>UFSAR Section</u>	<u>Location</u>	
		<u>Inside Containment</u>	<u>Outside Containment</u>
Auxiliary steam	10.4.10		X
Blowdown - steam generator	10.4.8	X	X
Boron recovery	9.3.4.6		X
Charging and volume control	9.3.4	X	X
Condensate -aux condensate	10.4.10		X
Condensate -chemical treatment	10.3.5		X
Condensate - demineralizer	10.4.6		X
Condensate -main condensate	10.4.7		X
Condensate -makeup, drawoff, transfer, storage	10.4.7		X
Electrohydraulic control system - turbine generator	10.2		X
Extraction steam	10.3		X
Feedwater - chemical treatment	10.3.5		X
Feedwater - auxiliary feedwater	10.4.9	X	
Feedwater - main	10.4.7	X	X
Primary plant gas supply	9.5.9	X	X
Gland steam	10.4.3		X
Heater drains- high-pressure	10.4.7		X
Heater drains- low-pressure	10.4.7		X
Main steam	10.3	X	X
Reactor coolant	5.2	X	
Residual heat removal	5.4.7	X	

TABLE 3.6B-1 (Cont)

<u>System</u>	<u>UFSAR Section</u>	<u>Location</u>	
		<u>Inside Containment</u>	<u>Outside Containment</u>
Service air system	9.3.1.1		X
Steam drains	10.3		X
Steam generator water cleanup	10.4.8		X
Safety injection	6.3	X	X
Steam vents	10.3		X
Hydrogenated drains	9.3.3	X	X
Sampling system (radioactive)	9.3.2	X	X
Hot water heating	10.4.10		
Emergency diesel - air start	9.5.6		X
Turbine plant sampling	9.3.2		X

TABLE 3.6B-1a

MODERATE ENERGY PIPING SYSTEMS

<u>System</u>	UFSAR <u>Section</u>	<u>Location</u>	
		<u>Inside Containment</u>	<u>Outside Containment</u>
Air removal condenser	10.4.2		X
Auxiliary steam	10.4.10		X
Blowdown - steam generator	10.4.8		X
Boron recovery	9.3.4.6		X
Chilled water	9.2.2.2		X
Charging & volume control	9.3.4	X	X
Circulating water	10.4.5		X
Circulating water - condenser tube cleaning	10.4.5		X
Component cooling -primary	9.2.2.1	X	X
Component cooling -secondary	9.2.7		X
Condensate - auxiliary condensate	10.4.10		X
Condensate - chemical treatment	10.3.5		X
Condensate - demineralizer	10.4.6		X
Condensate - main condensate	10.4.7		X
Condensate - makeup, drawoff, transfer, storage	10.4.7		X
Containment vacuum	9.5.10	X	X
Decontamination	9.2.3		X
Domestic water	9.2.4.2		X
Drains - aerated	9.3.3	X	X
Drains - hydrogenated	9.3.3	X	X

TABLE 3.6B-1a (Cont)

<u>System</u>	<u>UFSAR Section</u>	<u>Location</u>	
		<u>Inside Containment</u>	<u>Outside Containment</u>
Emergency diesel fuel	9.5.4		X
Emergency diesel generator system	9.5.5		X
Feedwater - chemical treatment	10.3.5		X
Feedwater - auxiliary feedwater	10.4.9	X	X
Fire protection - water	9.5.1	X	X
Fuel pool cooling and cleanup	9.1.3	X	X
Gaseous waste	11.3		X
Gland steam	10.4.3		X
Heater drains - low press.	10.4.7		X
Hot water heating system	10.4.10		X
HVAC - control building	9.4.1		X
HVAC - decontamination building	9.4.13		X
HVAC - primary auxiliary building	9.4.3		X
HVAC - reactor building	9.4.7	X	X
Hydrogen control - post-DBA	6.2.5	X	X
Instrument air - containment	9.3.1.3	X	X
Instrument air system	9.3.1.1		X
Leakage monitoring system	9.5.10	X	X
Liquid waste system	11.2		X
Main generator - hydrogen	10.2.2.5		X
Main generator - seal oil	10.2.2.4		X

TABLE 3.6B-1a (Cont)

<u>System</u>	<u>UFSAR Section</u>	<u>Location</u>	
		<u>Inside Containment</u>	<u>Outside Containment</u>
Main turbine - lube oil	10.2.2		X
Neutron shield tank cooling	9.2.2.3	X	
Primary grade water	9.2.8		X
Primary plant gas supply	9.5.9		X
Quench spray system	6.3	X	X
Reactor coolant system	5.2	X	
Recirculation spray	6.3	X	X
Residual heat removal	5.4.7	X	
Safety injection	6.3	X	X
Sampling - primary plant	9.3.2.1		X
Sampling - turbine plant	9.3.2.2		X
Service air system	9.3.1.1	X	X
Service water- chilled	9.2.1.1		X
Service water- emergency	9.2.1.2		X
Service water- marine growth control	9.2.1.1		X
Service water system	9.2.1.1	X	X
Solid waste system	11.4		X
Steam generator water cleanup	10.4.8		X
Steam vents - feedwater	10.4.11		X
Vacuum priming system	10.4.5		X
Vents - aerated	9.3.3		X
Vents - gaseous	9.3.3	X	X

TABLE 3.6B-1a (Cont)

<u>System</u>	<u>UFSAR Section</u>	<u>Location</u>	
		<u>Inside Containment</u>	<u>Outside Containment</u>
Water - filtered	----		X
Water treating - demineralizer	9.2.3		X

TABLE 3.6B-2

ESSENTIAL STRUCTURES, SYSTEMS, AND COMPONENTS REQUIRED FOR SAFE SHUTDOWN

<u>Item/Mark No.</u>	<u>Building Location*</u>	<u>Associated Support System**</u>	<u>Required Safety Function***</u>
REACTOR COOLANT SYSTEM			
Reactor vessel/2RCS*REV21	CS	---	PB
Pressurizer/2RCS*PRE21	CS		PB
Steam generator/2RCS*SG21A,B,C	CS	---	PB
Reactor coolant pumps/2RCS*P21A,B,C	CS	---	PB
Control rod drive mechanisms	CS	---	PB
Safety relief valves/2RCS*RV551A,B,C	CS	---	Op.
PRESSURIZER PORVS AND BLOCK VALVES			
2RCS*PCV455C 2RCS*PCV455D 2RCS*PCV456 2RCS*MOV535 2RCS*MOV536 2RCS*MOV537	CS	E,C	Op
REACTOR VESSEL HEAD LETDOWN VALVES			
2RCS*SOV200A 2RCS*SOV200B 2RCS*SOV201A 2RCS*SOV201B 2RCS*HCV250A 2RCS*HCV250B	CS	E,C	Provide safety grade letdown capability Op.
Piping and valves required for reactor coolant pressure boundary protection.			

TABLE 3.6B-2 (Cont)

<u>Item/Mark No.</u>	<u>Building Location*</u>	<u>Associated Support System**</u>	<u>Required Safety Function***</u>
RESIDUAL HEAT REMOVAL SYSTEM			Maintain integrity of reactor coolant pressure boundary and remove RCS decay heat (See Appendix 5A)
RHS PUMPS	CS	E,C,CW	Op.
2RHS*P21A 2RHS*P21B			
RHS ISOLATION VALVES	CS	E,C	Op.
2RHS*MOV701A 2RHS*MOV701B 2RHS*MOV702A 2RHS*MOV702B 2RHS*MOV720A 2RHS*MOV720B			
RHS FLOW CONTROL VALVES	CS	---	FO
2RHS*HCV758A 2RHS*HCV758B 2RHS*FCV605A 2RHS*FCV605B			FC
RHS HEAT EXCHANGERS	CS	CW	PB
2RHS*E21A 2RHS*E21B			
RHS PUMP COOLERS	CS	CW	PB
2RHS*E22A 2RHS*E22B			
RHS CROSSCONNECT VALVES	CS	---	PB
2RHS*MOV750A 2RHS*MOV750B			
Piping and valves (SC-1) required for reactor coolant pressure boundary protection.	CS	---	PB

TABLE 3.6B-2 (Cont)

<u>Item/Mark No.</u>	<u>Building Location*</u>	<u>Associated Support System**</u>	<u>Required Safety Function***</u>
CHEMICAL AND VOLUME CONTROL SYSTEM	CS	---	High pressure safety injection/RCS makeup and boron addition
Charging pumps/2CHS*P21A,B,C	AB	C,E,CW	Op.
Boric acid transfer pumps/2CHS*P22A,B	AB	C,E	Op.
Boric acid tanks/2CHS*TK21A,B	AB	---	PB
Regenerative heat exchanger/2CHS*E23	CS	---	PB
Boric acid filter/2CHS*FLT21	AB	---	PB
Boric acid blender 2CHS*BL21	AB	---	PB
Valves required to operate:			
2CHS*SOV206	AB	E,C	Op.
2CHS*MOV350			
2CHS*LCV115B			
2CHS*LCV115C			
2CHS*LCV115D			
2CHS*LCV115E			
2CHS*MOV310			
2CHS*MOV100A,B			

TABLE 3.6B-2 (Cont)

<u>Item/Mark No.</u>	<u>Building Location*</u>	<u>Associated Support System**</u>	<u>Required Safety Function***</u>
CHARGING PUMP SUCTION AND DISCHARGE VALVES			
2CHS*MOV8130A	AB	E,C	Op.
2CHS*MOV8130B			
2CHS*MOV8131A			
2CHS*MOV8131B			
2CHS*MOV8132A			
2CHS*MOV8132B			
2CHS*MOV8133A			
2CHS*MOV8133B	CS	E,C	Op./FC
2CHS*LCV460A			
2CHS*LCV460B			
Piping and valves required for essential pressure boundary (heat tracing for piping included)			
SAFETY INJECTION SYSTEM			ECCS cooling water supply to maintain reactor water level and remove heat
LHSI pumps/ 2SIS*P21A,B	SA	E,C	Op.
SI accumulators/ 2SIS*TK21A,B,C	CS	---	PB
Valves required to operate:			
Low Head Safety Injection			
2SIS*MOV8809A,B	SA	E,C	Op.
2SIS*MOV8890A,B			
2SIS*MOV8811A,B			
2SIS*MOV863A,B			
2SIS*MOV864A,B			
2SIS*MOV8888A,B			

TABLE 3.6B-2 (Cont)

<u>Item/Mark No.</u>	<u>Building Location*</u>	<u>Associated Support System**</u>	<u>Required Safety Function***</u>
2SIS*MOV8889			
High Head Safety Injection			
2SIS*MOV867A,B	AB	E,C	Op.
2SIS*MOV867C,D	CV	E,C	Op.
2SIS*MOV869A,B	CV	E,C	Op.
2SIS*MOV836	CV	E,C	Op.
2SIS*HCV868A,B	CV,AB	E,C	Op.
2SIS*MOV840	AB	E,C	Op.
2SIS*MOV841	CV	E,C	Op.
Piping and valves required for essential pressure boundary (heat tracing for piping included).			
MAIN STEAM SYSTEM			Maintain pressure boundary of steam generators and control steam release for heat removal
Valves required to operate:			
2MSS*AOV101A,B,C	Main steam isolation valves	MV	E,C Op.
2SVS*PCV101A,B,C 2SVS*HCV104	Atmospheric steam dump valves	MV	E,C Op.
2SDS*AOV111A1,B1,C1 2SDS*AOV111A2,B2,C2 2SDS*AOV129A,B	Steam drain lines isolation	MV	E,C FC
2MSS*SV101A,B,C 2MSS*SV102A,B,C 2MSS*SV103A,B,C 2MSS*SV104A,B,C 2MSS*SV105A,B,C	Steam release safety valves	MV	--- Op.

TABLE 3.6B-2 (Cont)

<u>Item/Mark No.</u>	<u>Building Location*</u>	<u>Associated Support System**</u>	<u>Required Safety Function***</u>
2MSS*SOV105A-F Steam valves to turbine driven auxiliary feedwater pump	SA	E,C	Op.
Piping and valves required for essential pressure boundary.			
AUXILIARY STEAM SYSTEM			
2ASS*AOV130A 2ASS*AOV130B Header isolation	PT	E,C	Isolate HELB lines in auxiliary building
FEEDWATER AND AUXILIARY FEEDWATER SYSTEMS			
Decay heat removal by supply of cooling water to steam generators			
Auxiliary feedwater pumps/ 2FWE*P23A,B 2FWE*P22 Motor-driven Turbine-driven	SA SA	E,C SS	Op.
Primary plant demineralized water storage tank/ 2FWE*TK210	Y	---	PB
Valves required to operate: 2FWS*HYV157A,B,C Feedwater isolation	MV	E,C	Op.
2FWS*FCV478,479 2FWS*FCV488,489 2FWS*FCV498,499 Feedwater control/bypass valves	SB	E,C	Op.
2FWE*HCV100A - F Auxiliary feedwater supply	SA	E,C	Op.
2FWE*SOV100A,B Chem. recirc. pump suction valves	Y	E,C	FC
2FWE*FCV122 2FWE*FCV123A,B Aux. feedwater pump recirc. valves	SA	---	Op.
Piping valves required for essential pressure boundary.			

TABLE 3.6B-2 (Cont)

<u>Item/Mark No.</u>	<u>Building Location*</u>	<u>Associated Support System**</u>	<u>Required Safety Function***</u>
SERVICE WATER SYSTEM			Transfer of heat from reactor cooling systems to ultimate heat sink
Service water pumps and discharge valves 2SWS*P21A,B,C 2SWS*MOV102A,B 2SWS*MOV102C1,C2	IS	CW,E,C	Op.
Bearing cooling water strainers/ 2SWS*STR-M-47 2SWS*STR-M-48	IS	E,C	Op.
Control room cooling water pumps 2SWS*P25A,B	CB	E,C	Op.
Valves required to operate:			
2SWS*AOV118A,B,C Bearing CW valves	IS	E,C	FC
2SWS*MOV170A,B CW valves			
2SWS*MOV104A,B,C,D RSS heat exchanger isolation 2SWS*MOV105A,B,C,D	SA	E,C	Op.
2SWS*MOV106A,B SW header isolation 2SWS*MOV103A,B	Valve pit outside (yard)	E,C	Op.
2SWS*MOV148A,B Air conditioning units and diesel generator cooling 2SWS*MOV113A,B,C,D	CV DG	E,C E,C	Op. Op.
2SWM*MOV562 2SWM*MOV563 2SWM*MOV564 2SWM*MOV565 Chemical injection isolation	Valve pit	E,C	Op.

TABLE 3.6B-2 (Cont)

<u>Item/Mark No.</u>	<u>Building Location*</u>	<u>Associated Support System**</u>	<u>Required Safety Function***</u>	
2SWS*MOV107A,B,C,D	Isolate NNS portion	AB	E,C	Op.
2SWS*MOV162 2SWS*MOV163 2SWS*MOV164 2SWS*MOV165	Cont. air recirc cooler operation	CV,CS	E,C	Although they do not have a safety function, they should be protected to allow for containment cooling whenever possible
2SWS*MOV160 2SWS*MOV161 2SWS*MOV166 2SWS*MOV167		CV	E,C	
2SWS*AOV114 2SWS*AOV110A,B,C		CV CS	--- ---	
Piping and valves required for essential pressure boundary.				
2SWS*FCV120A,B	MSVH cooling coil supply valves	MV	E	Only required for cold shutdown.
GASEOUS NITROGEN SYSTEM				Maintain SI accumulator integrity and pressure
2GNS*SOV853A-F 2GNS*SOV854A,B	SI accumulator vent lines	CS	E,C	Op.
Piping and valves required for essential pressure boundary.				

TABLE 3.6B-2 (Cont)

<u>Item/Mark No.</u>	<u>Building Location*</u>	<u>Associated Support System**</u>	<u>Required Safety Function***</u>
RECIRCULATION AND QUENCH SPRAY SYSTEMS			
Containment spray and recirculation of ECCS water following an accident			
Recirculation spray pumps/2RSS*P21A,B,C,D	SA	E,C	Op.
Recirculation spray coolers/2RSS*E21A,B,C,D	SA	CW	PB
Quench spray pumps/2QSS*P21A,B	SA	E,C	Op.
Refueling water storage tank/2QSS*TK21	Y	---	PB
Valves required to operate:			
2QSS*MOV100A,B 2QSS*MOV101A,B	SA	E,C	Op.
2QSS*SOV101B 2QSS*SOV102B 2QSS*AOV120A,B	SA	E,C	FC
2RSS*MOV155A,B,C,D 2RSS*MOV156A,B,C,D 2RSS*MOV154C,D	SA	E,C	Op.
Piping and valves required for essential pressure boundary.			

TABLE 3.6B-2 (Cont)

<u>Item/Mark No.</u>	<u>Building Location*</u>	<u>Associated Support System**</u>	<u>Required Safety Function***</u>
PRIMARY SAMPLING SYSTEM			
2SSR*AOV117A,B,C	CV	E,C	FC
STEAM GENERATOR BLOWDOWN SYSTEM			
2BDG*AOV100A1,B1,C1	CV	E,C	FC
2BDG*AOV101A1,B1,C1	CS	E,C	Isolate HELB lines in cable vault
2BDG*AOV101A2,B2,C2	CS	E,C	
2BDG*AOV102A1,B1,C1	CS	E,C	FC
2BDG*AOV102A2,B2,C2			
Piping and valves required for essential pressure boundary.			
POST-DBA HYDROGEN CONTROL SYSTEM			
			Remove hydrogen from containment following an accident

There is no safety function associated with the Hydrogen Control System.

TABLE 3.6B-2 (Cont)

<u>Item/Mark No.</u>	<u>Building Location*</u>	<u>Associated Support System**</u>	<u>Required Safety Function***</u>
Hydrogen Analyzers/2HCS*HA100A,B	CV	E,C	Op.
Valves required to operate:			
2HCS*SOV114A,B 2HCS*SOV115A,B 2HCS*SOV116 2HCS*SOV117	SA	E,C	Op.
2HCS*SOV133A 2HCS*SOV133B 2HCS*SOV134A 2HCS*SOV134B 2HCS*SOV135A 2HCS*SOV135B 2HCS*SOV136A 2HCS*SOV136B	CS CS SA SA CS SA CS SA	E,C	Op.
Piping and valves required for essential pressure boundary.			
VENTILATION SYSTEMS			Maintain environment for essential components and provide filtration of airborne radiation
CONTAINMENT AIR RECIRCULATION SYSTEM			
2HVR-CLC201A,B,C 2HVR-FN201A,B,C	CS	E,C,CW	Although they do not have a safety function, they should be protected to allow for containment cooling whenever possible
A/C CONDENSERS AND COOLING COILS - CONTROL ROOM BLDG			
2HVC*CLC219 2HVC*REF24A,B 2HVR*ACU201A,B	AB CB	CW E,C	PB Op.

TABLE 3.6B-2 (Cont)

<u>Item/Mark No.</u>	<u>Building Location*</u>	<u>Associated Support System**</u>	<u>Required Safety Function***</u>
SAFEGUARDS AREA			
2HVR*ACU207A,B	SA	E,C,CW	Op.
ROD CONTROL AREA			
2HVR*ACU208A,B MCC Room - EI 755'-6"	CV	E,C,CW	Op.
2HVP*CLC265A,B 2HVP*FN265A,B	AB	CW E,C	Op.
SUPPLEMENTARY LEAK COLLECTION SYSTEM			
2HVS*FN204A,B	AB	E,C	Op.
2HVS*MSP21A,B 2HVS*CH219A,B 2HVS*FLTS250A,B 2HVS*FLTA204A,B 2HVS*FLTA205A,B 2HVS*FLTA206A,B 2HVS*FLTA207A,B 2HVS*FLTA208A,B 2HVS*FLTA209A,B			
CONTROL ROOM EMERGENCY VENTILATION SYSTEM			
2HVC*FN241A,B 2HVC*CH222A,B 2HVC*FLTA251A,B 2HVC*FLTA252A,B 2HVC*FLTA253A,B 2HVC*MSP21A,B	CB	E,C	Op.

TABLE 3.6B-2 (Cont)

<u>Item/Mark No.</u>	<u>Building Location*</u>	<u>Associated Support System**</u>	<u>Required Safety Function***</u>
MAIN STEAM VALVE HOUSE			
2HVR*CLC206A,B 2HVR*FN206A,B	MV	CW E,C	Only required for cold shutdown
SUPPLY AND EXHAUST FANS			
2HVP*FN264A,B (Exh)	AB	E,C	Op.
2HVD*FN270A,B (Sup)	DG		
2HVD*FN271A,B (Sup)			
2HVD*FN222A,B (Exh)			
2HVZ*FN261A,B (Sup)	CV		
2HVZ*FN262A,B (Exh)			
2HVZ*FN262A,B (Exh)			
2HVZ*FN216A,B (Exh)			
2HVW*FN257A,B,C (Sup)	IS		
2HVC*FN266A,B (Sup)	AB		
2HVC*FN265A,B (Exh)			
Temperature and pressure sensing devices in each area for operating the above equipment	AB, CB, DG IS, SB, CV SA	E,C	Op.
Ductwork and dampers for essential flow paths			
EMERGENCY DIESEL GENERATOR FUEL OIL SYSTEM			Operation of diesel generators to supply Class 1E bus
Fuel oil storage tanks/2EGF*TK21A,B	Y, DG	---	PB
Fuel oil day tanks/2EGF*TK22A,B	DG	---	PB
14.9			
Fuel oil transfer pumps/2EGF*P21A,B,C,D	DG	E,C	Op.
Piping and valves required for essential pressure boundary.			

TABLE 3.6B-2 (Cont)

<u>Item/Mark No.</u>	<u>Building Location*</u>	<u>Associated Support System**</u>	<u>Required Safety Function***</u>
EMERGENCY DIESEL GENERATOR AIR START SYSTEM			
Air start tanks			
2EGA*TK21A,B	DG	---	PB
2EGA*TK22A,B	DG	---	PB
Piping, valves, and appurtenances required for essential pressure boundary.	DG	E,C	PB, Op.
EMERGENCY DIESEL GENERATOR AIR INTAKE AND EXHAUST SYSTEM			
Air intake filters			
2EDG*FLTA1A,1B	DG	---	PB
Air intake silencer			
2EDG*SIL2A&2B	DG	---	PB
2EDG*SIL1A&1B	DG	---	PB
Air exhaust silencer			
2EDG*SIL3A&3B	DG	---	PB
Piping required for essential pressure boundary.	DG	---	PB
EMERGENCY DIESEL GENERATOR COOLING WATER SYSTEMS			
Expansion tank 2EGS*TK1A,B	DG	---	PB
Piping, valves, and appurtenances required for essential pressure boundary.	DG	E,C	PB, Op.
CONTAINMENT ISOLATION SYSTEM			Maintain containment integrity after an accident
Piping and isolation valves for containment integrity (Table 6.2-60)	CS and connecting structures	E,C	Op.

TABLE 3.6B-2 (Cont)

<u>Item/Mark No.</u>	<u>Building Location*</u>	<u>Associated Support System**</u>	<u>Required Safety Function***</u>
COMPONENT COOLING WATER SYSTEM			
CCP pumps 2CCP*P21A,B,C	AB	E,C	Op.
CCP heat exchangers 2CCP*E21A,B,C	AB	---	PB
CCP surge tank 2CCP*TK21A,B	AB	---	PB
CCP flow control valves 2CCP*DCV100-1 2CCP*DCV100-2	AB	E,C	Op.
CCP supply valves	CV,CS	E,C	Op.
2CCP*MOV150-1			
2CCP*MOV150-2			
2CCP*MOV151-1			
2CCP*MOV151-2			
2CCP*MOV156-1			
2CCP*MOV156-2			
2CCP*MOV157-1			
2CCP*MOV157-2			
2CCP*MOV112A,B			
2CCP*MOV177-1	AB		
2CCP*MOV177-2			
2CCP*MOV178-1			
2CCP*MOV178-2			
2CCP*MOV175-1	AB	E,C	Op.
2CCP*MOV175-2			
2CCP*MOV176-1			
2CCP*MOV176-2			
2CCP*MOV128A,B			
2CCP*MOV118	CV		
2CCP*MOV119			
2CCP*MOV120			
2CCP*AOV171	CS		FC
2CCP*AOV172			
2CCP*AOV173			
2CCP*AOV174			

TABLE 3.6B-2 (Cont)

<u>Item/Mark No.</u>	<u>Building Location*</u>	<u>Associated Support System**</u>	<u>Required Safety Function***</u>
2CCP*AOV107A,B,C	CS	E,C	Only required to operate after a thermal barrier rupture
CCP piping valves and components required for ESF and SS pressure boundary.			
FUEL POOL COOLING AND PURIFICATION SYSTEM			
FP Cooling Pumps 2FNC*P21A,B	FB	E,C	Op.
FP Coolers 2FNC*E21A,B	FB	---	PB
FNC piping and valves required for ESF and SS pressure boundary.			
INSTRUMENTATION			
RCS hot leg temperature	CS	E	Post-accident monitoring
RCS cold leg temperature	CS	E	Post-accident monitoring
Pressurizer level	CS	E,C	Reactor trip/Post-accident monitoring
Pressurizer pressure	CS	E,C	Initiation of safety injection/Reactor trip
RCS hot leg pressure	CS	E	Cold overpressure protection
RCS wide range pressure	CV	E	Post-accident monitoring
Steam line pressure	MV	E,C	Steam line isolation/Initiation of safety injection/Post-accident monitoring
Steam line pressure for atmospheric steam dump	MV	E,C	Control of steam dump for decay heat removal
Core exit temperature	CS	E	Post-accident monitoring
HELB temperature elements, ASS and BDG lines	AB, CV	E,C	Indicate a HELB in the aux. bldg. or cable vault, send signal to valves to isolate break

TABLE 3.6B-2 (Cont)

<u>Item/Mark No.</u>	<u>Building Location*</u>	<u>Associated Support System</u>	<u>Required Safety Function***</u>
Aux. feedwater flow transmitters	SA	E,C	Post-accident monitoring
Neutron flux detectors	CS	E	Post-accident monitoring
HVAC temperature/pressure sensors	AB, CB, CV, SB, IS, DG, SA, MV	E	Temp. monitoring to keep environments below Class 1E equipment qualification parameters or startup of redundant Cat. I HVAC equipment to account for single failure
Steam generator narrow - range level	CS	E,C	Feedwater isolation/Auxiliary feedwater pump start/Reactor trip
Steam generator wide - range level	CS	E	Post-accident monitoring
Primary plant demin. water storage tank level	Y	E	Post-accident monitoring/auxiliary feedwater supply
Containment pressure	CV	E,C	Initiation of safety injection and containment isolation signals on high and high-high containment pressure, post-accident monitoring
RWST level	Y	E	Post-accident monitoring and transfer to recirculation mode
Containment sump level	CS	E	Post-accident monitoring and reactor coolant pressure boundary leak detection
Containment sump temperature	CS	E	Post-accident monitoring
HHSI flow/RCS boration	CV, AB	E	Post-accident monitoring
RHS flow	CS	E	Post-accident monitoring
RCS flow	CS	E	Low RCS flow reactor trip
CCP flow	AB	E	Post-accident monitoring

|

TABLE 3.6B-2 (Cont)

<u>Item/Mark No.</u>	<u>Building Location*</u>	<u>Associated Support System**</u>	<u>Required Safety Function***</u>
Recirculation spray pump minimum flow actuation	SA	E,C	Provide pump protection during accident conditions
Fuel pool level and temperature	FB	E	Post-accident monitoring
LHSI pump recirculation control	SA	E,C	Provide pump protection during accident conditions
Recirculation spray/SWS HX radiation monitors	DG	E	Post-accident monitoring
Containment purge radiation monitor	CS	E	Post-accident monitoring controls release of radioactivity from containment
Main steam discharge radiation monitors	MV	E	Post-accident effluent release monitoring
In containment hi-range radiation monitors	CS	E	Post-accident monitoring inside containment
SW pump bearing CW supply	IS	E,C	Provide bearing cooling for SW pump operation to supply cooling water
Boric acid tank level	AB	E	Post-Accident Monitoring
D/G day oil tank level control	DG	E,C	Control fuel oil supply for D/G power to Class 1E buses
Turbine Driven Aux. Feedwater Pump discharge pressure switch	SA	E,C	Identifies failure of turbine driven pump and activates motor driven pumps
Service Water Supply Header pressure	Y	E,C	Activates standby service water pumps on low service water supply header pressure
Component cooling water flow and pressure transmitters	CS	E,C	Detect rupture in reactor coolant pump thermal barriers
CONTROL SYSTEMS			
Same as Table 3.2-1	E		Initiation and operation of essential functions and components

TABLE 3.6B-2 (Cont)

<u>Item/Mark No.</u>	<u>Building Location*</u>	<u>Associated Support System**</u>	<u>Required Safety Function***</u>
ELECTRICAL SYSTEMS			
Same as Table 3.2-1	C		Class 1E power supply for essential components
STRUCTURES			
Same as Table 3.2-2			Protection and separation of essential components

NOTES:

* Building Location Symbols

- AB - Auxiliary Building
- CB - Control Building
- CS - Containment Structure
- CV - Cable Vault and Rod Control Area
- DG - Diesel Generator Building
- FB - Fuel Building
- IS - Intake Structure
- MV - Main Steam Valve Area
- PT - Pipe Tunnel Area
- SA - Safeguards Area
- SB - Service Building
- Y - Yard

** Associated Support System Symbols

- A - Air Supply
- C - Controls
- CW - Cooling Water
- E - Electrical Power
- Ht - Heat Tracing
- SS - Steam Supply

*** Required Safety Function Symbols

- NR - Not Required
- Op. - Component Operability
- PB - Pressure Boundary Only
- FO - Fail Open
- FC - Fail Closed

TABLE 3.6B-3
ENERGY-ABSORBING CAPACITY OF 10-INCH PIPES

<u>Schedule</u>	<u>Crush Displacement d (0.7 x I.D.) (inches)</u>	<u>Energy (in-kips)</u>
120	6.245	1,860
100	6.520	1,405
80	6.695	969
60	6.825	694

TABLE 3.6B-4

PIPING LINES INCLUDED IN THE LBB PROGRAM

Line Number ⁽²⁾	OD	Wall	Material	Location ⁽¹⁾	Note
2-SIS-006-012-1	6.625	0.718	SA376 TYPE 316	CUBICLE A	3
2-SIS-006-269-1	6.625	0.718	SA376 TYPE 316	CUBICLE A	3
2-SIS-006-015-1	6.625	0.718	SA376 TYPE 316	CUBICLE B	3
2-SIS-006-270-1	6.625	0.718	SA376 TYPE 316	CUBICLE B	3
2-SIS-006-016-1	6.625	0.718	SA376 TYPE 316	CUBICLE C	3
2-SIS-006-271-1	6.625	0.718	SA376 TYPE 316	CUBICLE C	3
2-SIS-006-026-1	6.625	0.718	SA376 TYPE 316	CUBICLE A	3
2-SIS-006-268-1	6.625	0.718	SA376 TYPE 316	CUBICLE A	3
2-SIS-006-024-1	6.625	0.718	SA376 TYPE 316	CUBICLE B	3
2-SIS-006-266-1	6.625	0.718	SA376 TYPE 316	CUBICLE B	3
2-SIS-006-025-1	6.625	0.718	SA376 TYPE 316	CUBICLE C	3
2-SIS-006-267-1	6.625	0.718	SA376 TYPE 316	CUBICLE C	3
2-RCS-008-020-1	8.625	0.906	SA376 TYPE 304	CUBICLE A	3
2-RCS-008-021-1	8.625	0.906	SA376 TYPE 304	CUBICLE A	3
2-RCS-008-040-1	8.625	0.906	SA376 TYPE 304	CUBICLE B	3
2-RCS-008-041-1	8.625	0.906	SA376 TYPE 304	CUBICLE B	3
2-RCS-008-060-1	8.625	0.906	SA376 TYPE 304	CUBICLE C	3
2-RCS-008-061-1	8.625	0.906	SA376 TYPE 304	CUBICLE C	3
2-RHS-010-023-1	10.750	1.125	SA376 TYPE 316	CUBICLE B	3
2-RHS-010-024-1	10.750	1.125	SA376 TYPE 316	CUBICLE C	3
2-RHS-012-001-1	12.750	1.312	SA376 TYPE 316	CUBICLE A	3
2-RHS-012-056-1	12.750	1.312	SA376 TYPE 316	CUBICLE A	3
2-SIS-012-289-1	12.750	1.312	SA376 TYPE 316	CUBICLE A	3
2-SIS-012-067-1	12.750	1.312	SA376 TYPE 316	CUBICLE A	3
2-SIS-012-066-2	12.750	1.312	SA376 TYPE 316	CUBICLE A	3
2-SIS-012-250-2	12.750	0.375	SA376 TYPE 304	CUBICLE A	3
2-SIS-012-288-1	12.750	1.312	SA376 TYPE 316	CUBICLE B	3
2-SIS-012-071-1	12.750	1.312	SA376 TYPE 316	CUBICLE B	3
2-SIS-012-070-2	12.750	1.312	SA376 TYPE 316	CUBICLE B	3
2-SIS-012-252-2	12.750	0.375	SA376 TYPE 304	CUBICLE B	3
2-SIS-012-287-1	12.750	1.312	SA376 TYPE 316	CUBICLE C	3
2-SIS-012-069-1	12.750	1.312	SA376 TYPE 316	CUBICLE C	3
2-SIS-012-068-2	12.750	1.312	SA376 TYPE 316	CUBICLE C	3
2-SIS-012-251-2	12.750	0.375	SA376 TYPE 304	CUBICLE C	3

TABLE 3.6B-4 (Cont)

Line Number ⁽²⁾	OD	Wall	Material	Location ⁽¹⁾	Note
2-RCS-014-084-1	14.00	1.406	SA376 TYPE 304	PRESSURIZER CUBICLE	4
2-RCS-029-1-1	29.00	2.45	SA376 TYPE 304	CUBICLE A	5
2-RCS-031-2-1	31.00	2.60	SA376 TYPE 304	CUBICLE A	5
2-RCS-275-3-1	27.50	2.32	SA376 TYPE 304	CUBICLE A	5
2-RCS-029-4-1	29.00	2.45	SA376 TYPE 304	CUBICLE B	5
2-RCS-031-5-1	31.00	2.60	SA376 TYPE 304	CUBICLE B	5
2-RCS-275-6-1	27.50	2.32	SA376 TYPE 304	CUBICLE B	5
2-RCS-029-7-1	29.00	2.45	SA376 TYPE 304	CUBICLE C	5
2-RCS-031-8-1	31.00	2.60	SA376 TYPE 304	CUBICLE C	5
2-RCS-275-9-1	27.50	2.32	SA376 TYPE 304	CUBICLE C	5

NOTES:

- All lines located inside containment structure. See Figure 3.8-3 for location plan of cubicles.
- These lines are exempted from consideration of pipe whip and jet impingement effects as pipe break concerns are addressed using a leak-before-break approach.
- These pipelines are qualified for LBB by the WHIPJET Program as described in Section 3.6B-4.
- Pipeline 2-RCS-014-084-1 (Pressurizer Surge Line) was originally part of the WHIPJET Program. As part of the reanalysis to address surge line stratification (NRC Bulletin 88-11), WCAP-12093 was developed. This reanalysis incorporated LBB for the surge line, which effectively removed it from WHIPJET.

RIS 2010-07 describes a concern that the application of structural weld overlay may affect the results of LBB. The pressurizer surge line was reanalyzed for LBB in WCAP-17394-P to address weld overlay and RIS 2010-07.
- The reactor coolant loop piping was originally qualified for LBB in WCAP-11923. Updated loop piping analysis for LBB can be found in WCAP-17488-P.

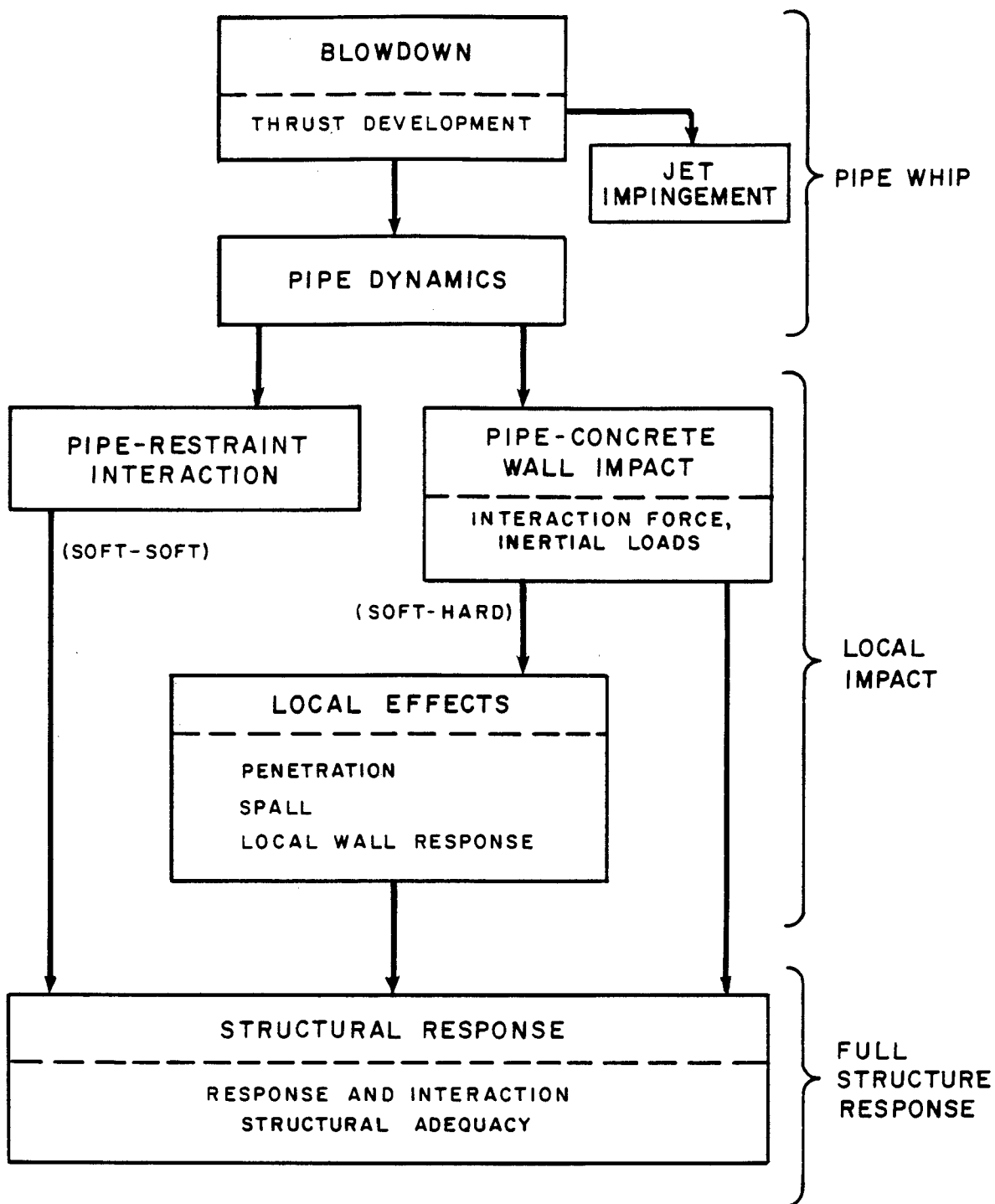
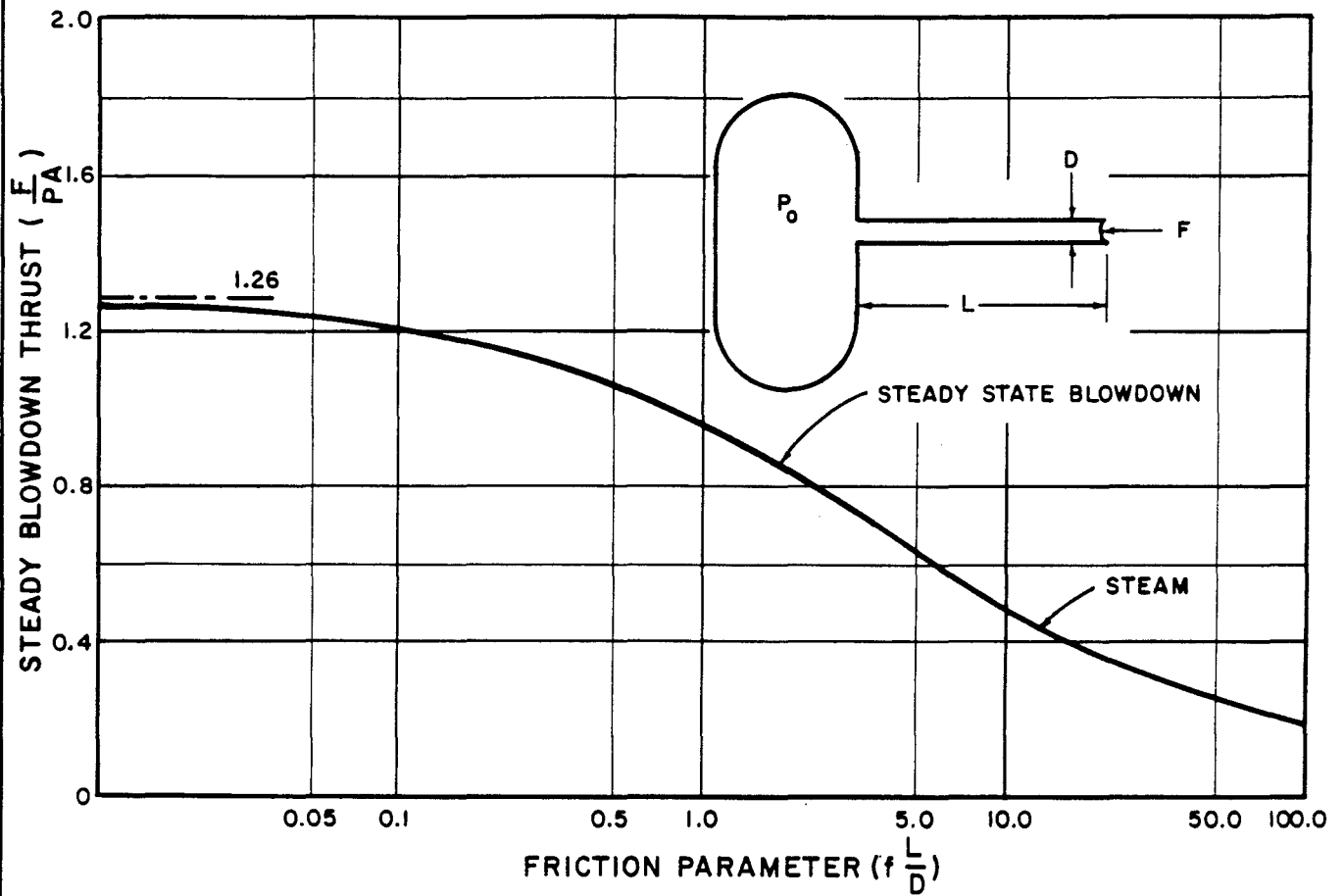

FIGURE 3.6 B-1
 AREAS OF ANALYSIS
 BEAVER VALLEY POWER STATION-UNIT 2
 FINAL SAFETY ANALYSIS REPORT



Source:

Moody, J.F.
 Time-Dependent Pipe Forces Caused
 by Blowdown and Flow Stoppage.
 ASME Paper F3-FE-23, 1973.

FIGURE 3.6B-2
 STEADY STATE BLOWDOWN FORCES
 VS FRICTION PARAMETER
 BEAVER VALLEY POWER STATION-UNIT 2
 FINAL SAFETY ANALYSIS REPORT

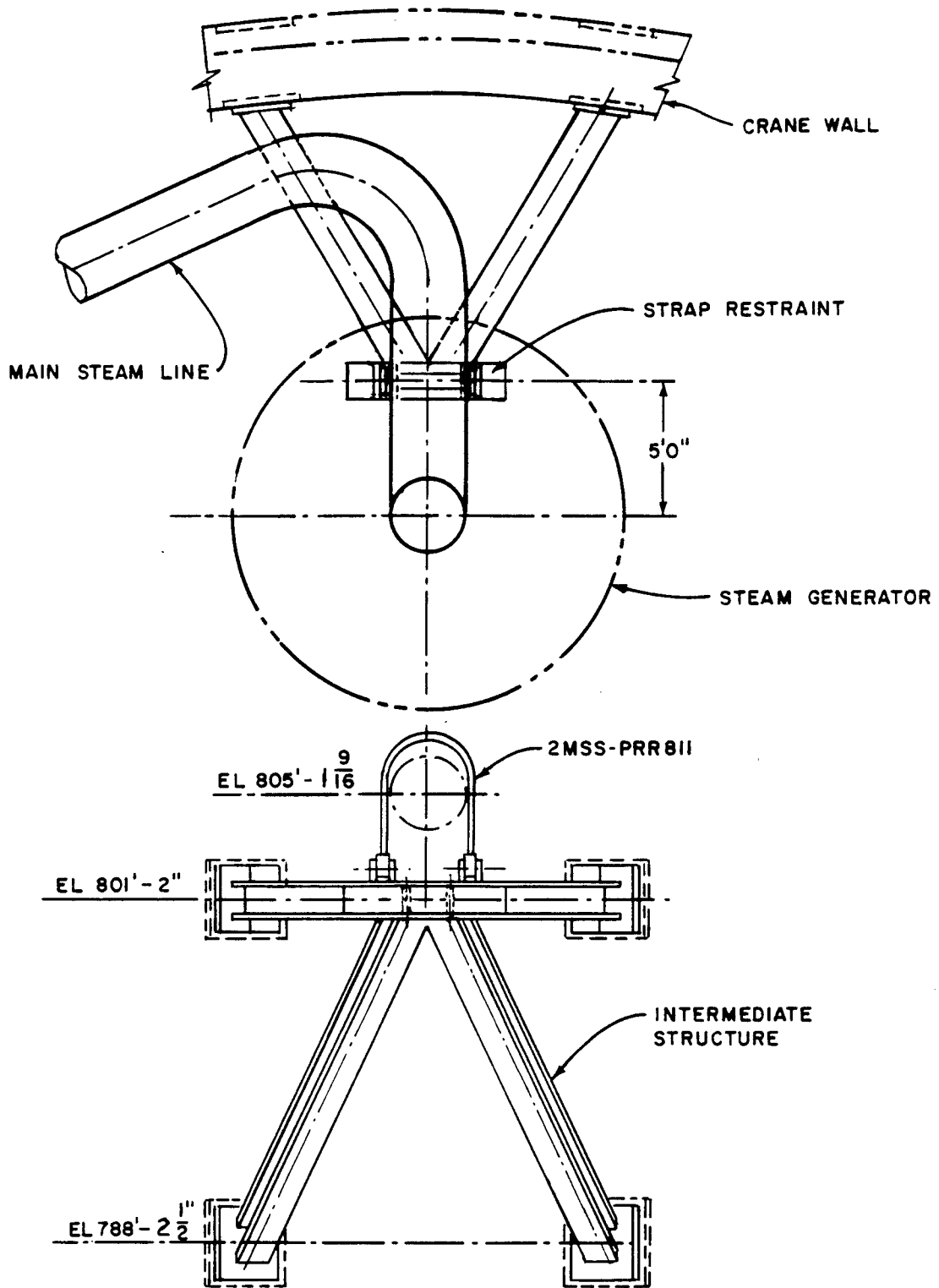

FIGURE 3.6B-3
 SOUTH LOOP STRAP
 RESTRAINT, PRR-811
 BEAVER VALLEY POWER STATION-UNIT 2
 FINAL SAFETY ANALYSIS REPORT

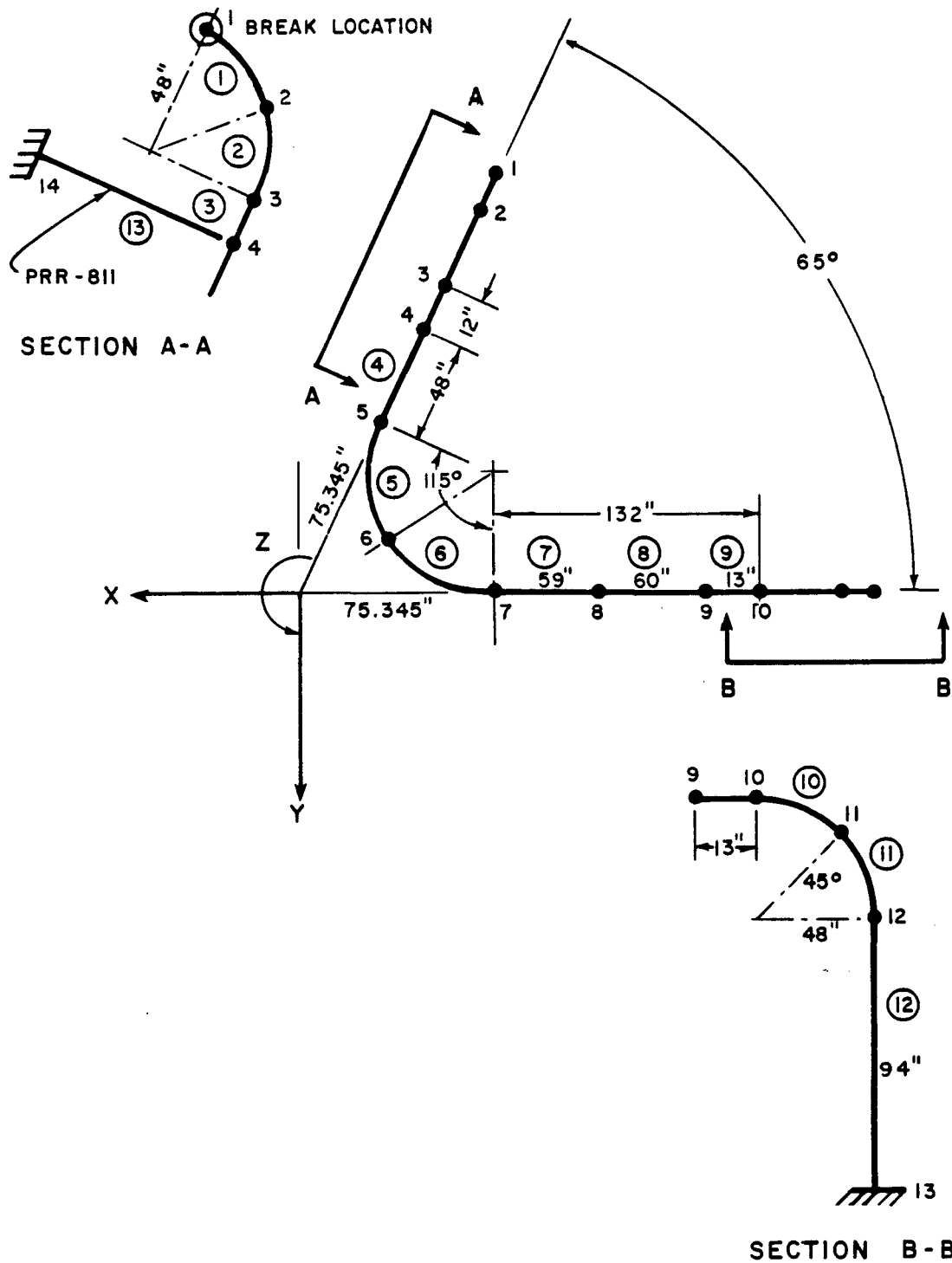
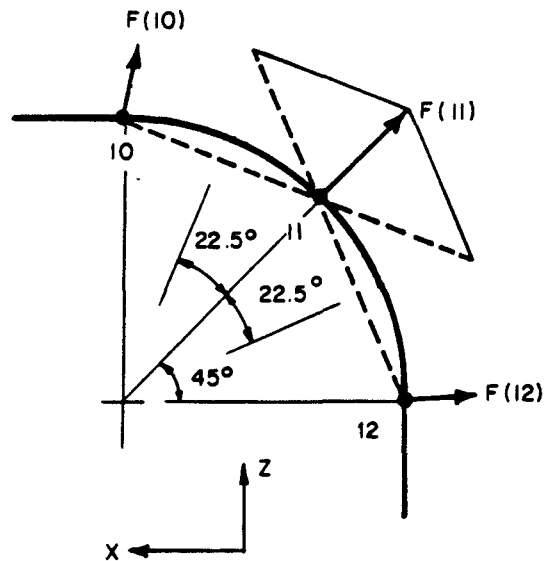
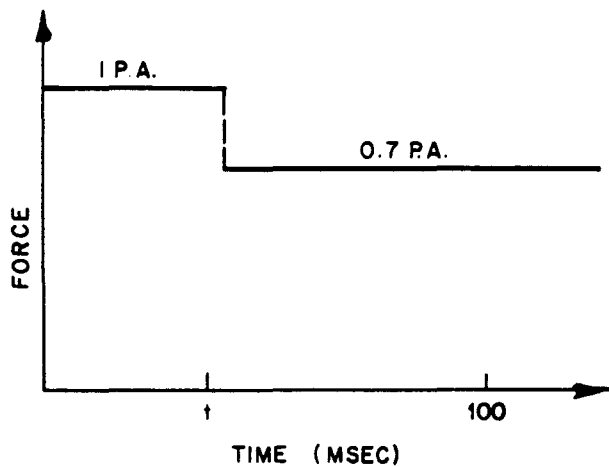

FIGURE 3.6B-4
 DYNAMIC ANALYSIS MODEL, SOUTH
 LOOP STRAP RESTRAINT, PRR-811
 BEAVER VALLEY POWER STATION-UNIT 2
 FINAL SAFETY ANALYSIS REPORT

$P \rightarrow$ OPERATING PRESSURE } 1.0 PA = 725 kips
 $A \rightarrow$ PIPE FLOW AREA }



JOINT NO.	TIME, t (msec)
1	0.0
2	3.0
3	5.0
5	8.0
6	10.5
7	13.0
10	20.0
11	22.0
12	24.0

$$F_x(10) = F \cdot (\cos(22.5) - 1)$$

$$F_z(10) = F \cdot \sin(22.5)$$

$$F_x(11) = F \cdot (\cos(67.5) - \cos(22.5))$$

$$F_z(11) = F \cdot (\sin(67.5) - \sin(22.5))$$

$$F_x(12) = F \cdot \cos(67.5)$$

$$F_z(12) = F \cdot (1 - \sin(67.5))$$

FIGURE 3.6B-5
 FLUID BLOWDOWN FORCES
 USED IN MATHEMATICAL MODEL
 BEAVER VALLEY POWER STATION-UNIT 2
 FINAL SAFETY ANALYSIS REPORT

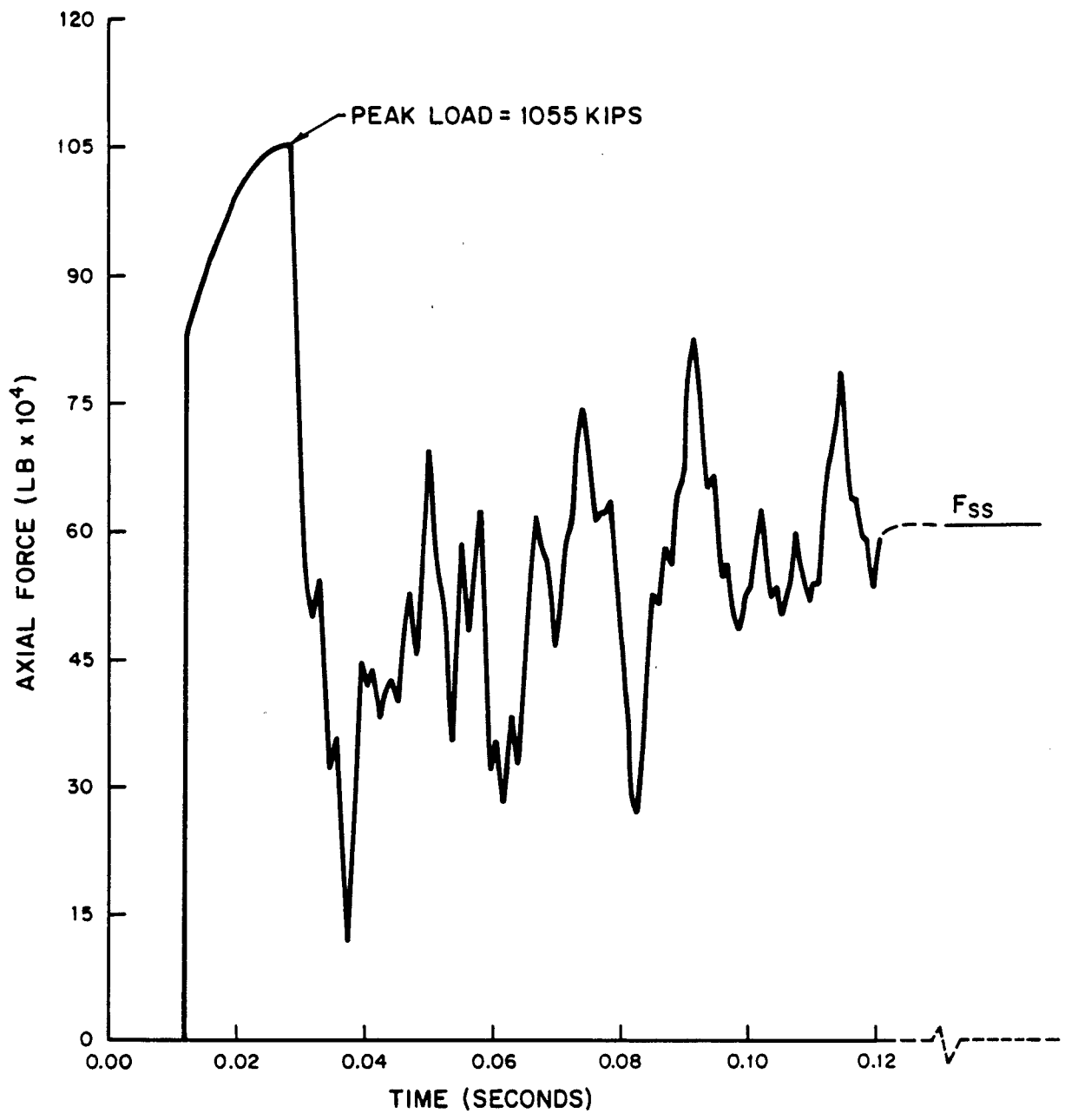

RESTRAINT } 2MSS* PRR - 811
 LOAD-PXB } MEMBER 19, NODE 20

PIPE }
 BREAK } 2MSS-005-C-C

FIGURE 3.6B-6
 RESTRAINT REACTION LOADS
 BEAVER VALLEY POWER STATION-UNIT 2
 FINAL SAFETY ANALYSIS REPORT

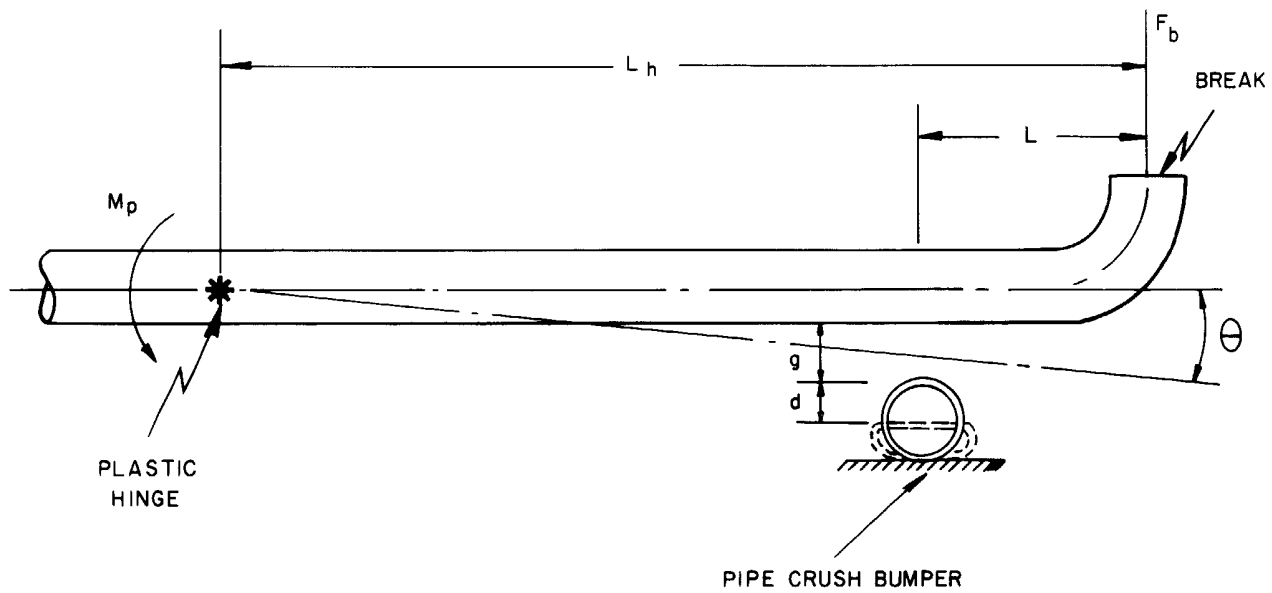

FIGURE 3.6B-7
 ENERGY BALANCE SAMPLE PROBLEM
 BEAVER VALLEY POWER STATION - UNIT 2
 FINAL SAFETY ANALYSIS REPORT

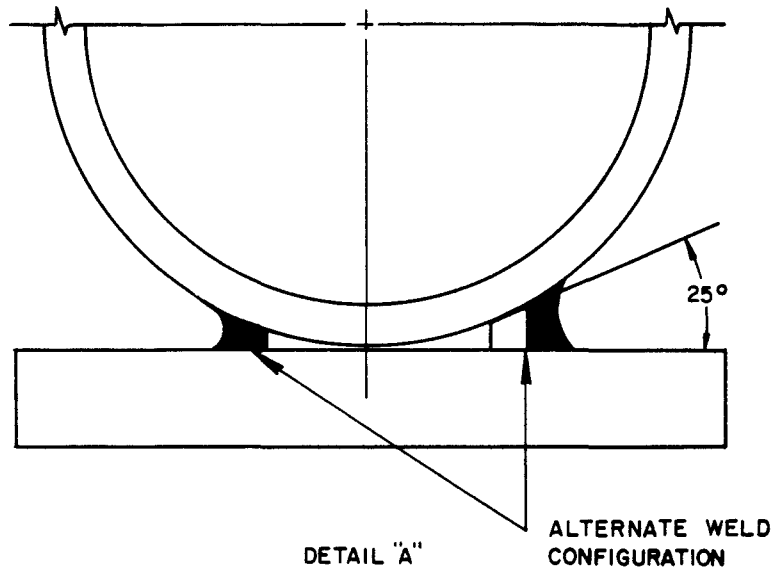
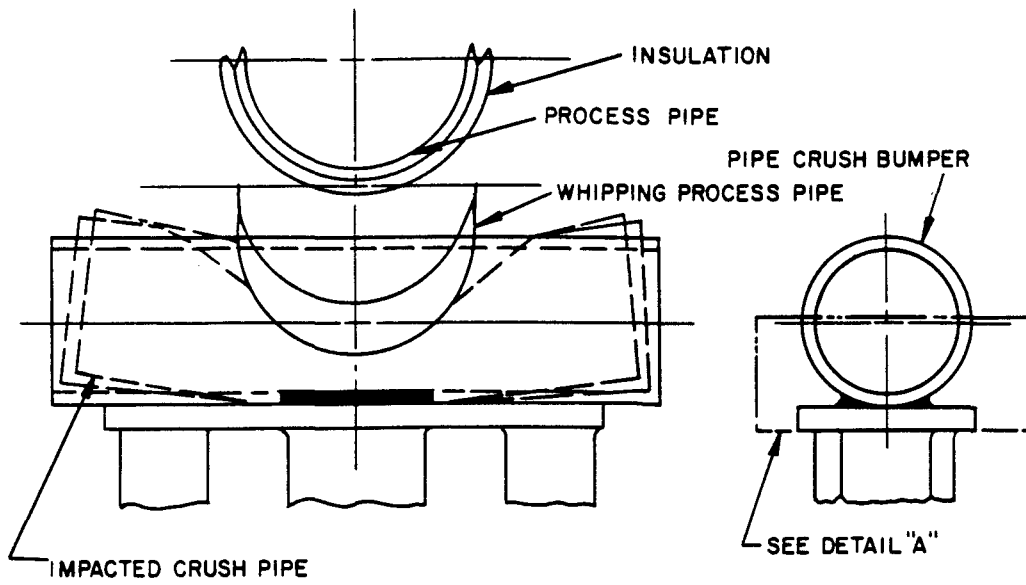
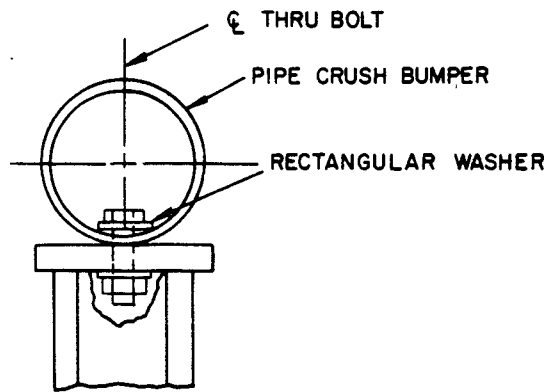
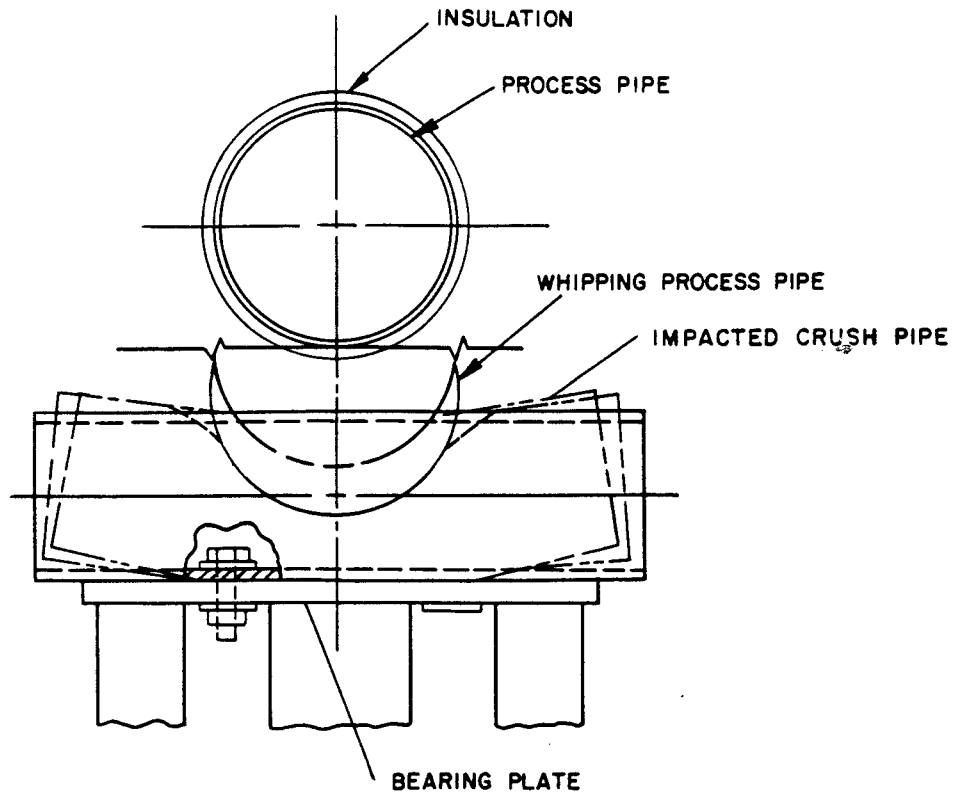

FIGURE 3.6B-8
 PIPE CRUSH BUMPER
 BEAVER VALLEY POWER STATION-UNIT 2
 FINAL SAFETY ANALYSIS REPORT



END VIEW OF PIPE

FIGURE 3.6B-9
PIPE CRUSH BUMPER
 BEAVER VALLEY POWER STATION-UNIT 2
 FINAL SAFETY ANALYSIS REPORT

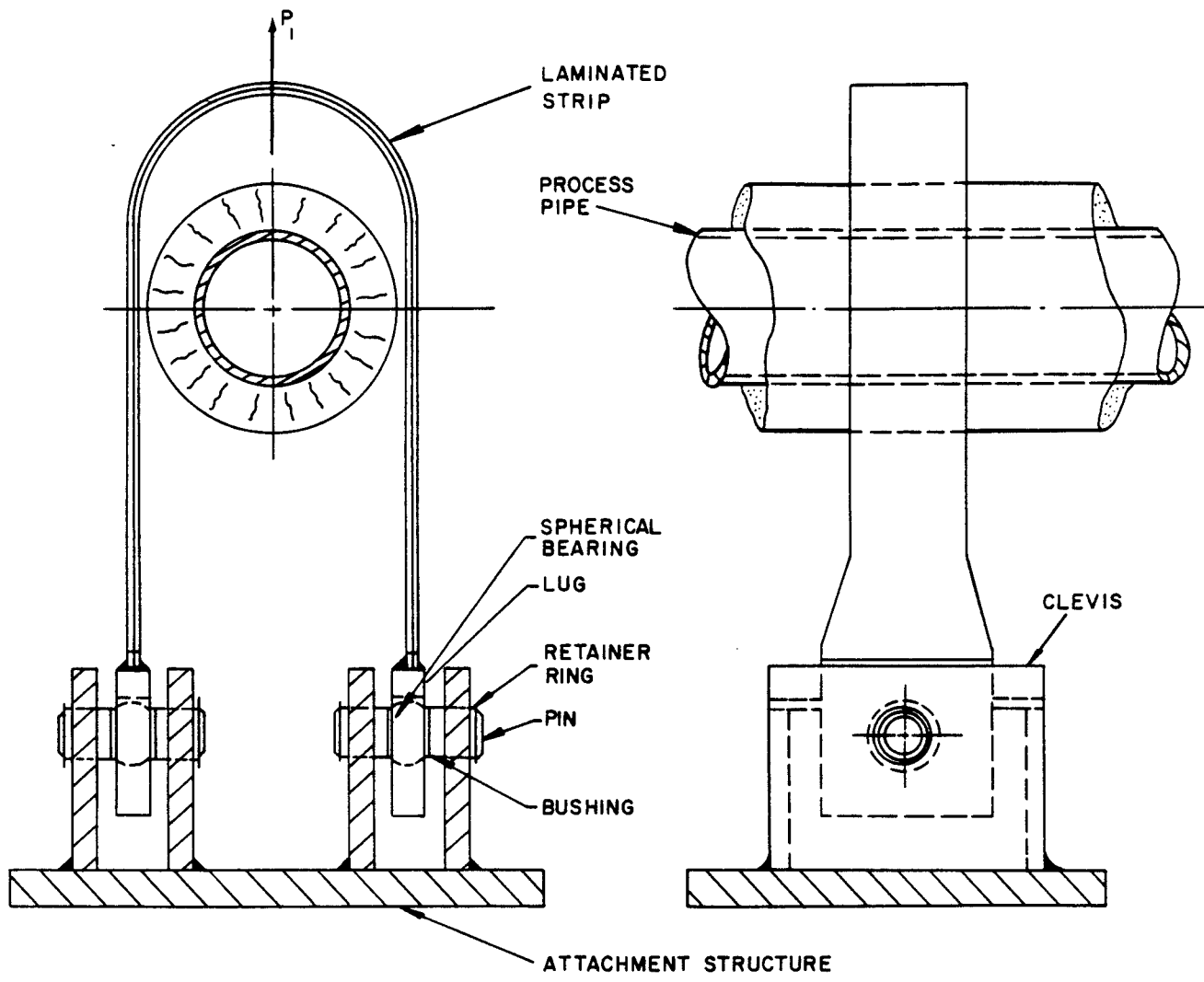

FIGURE 3.6B-10
 TWO-PIN LAMINATED PIPE
 RUPTURE RESTRAINT
 BEAVER VALLEY POWER STATION-UNIT 2
 FINAL SAFETY ANALYSIS REPORT

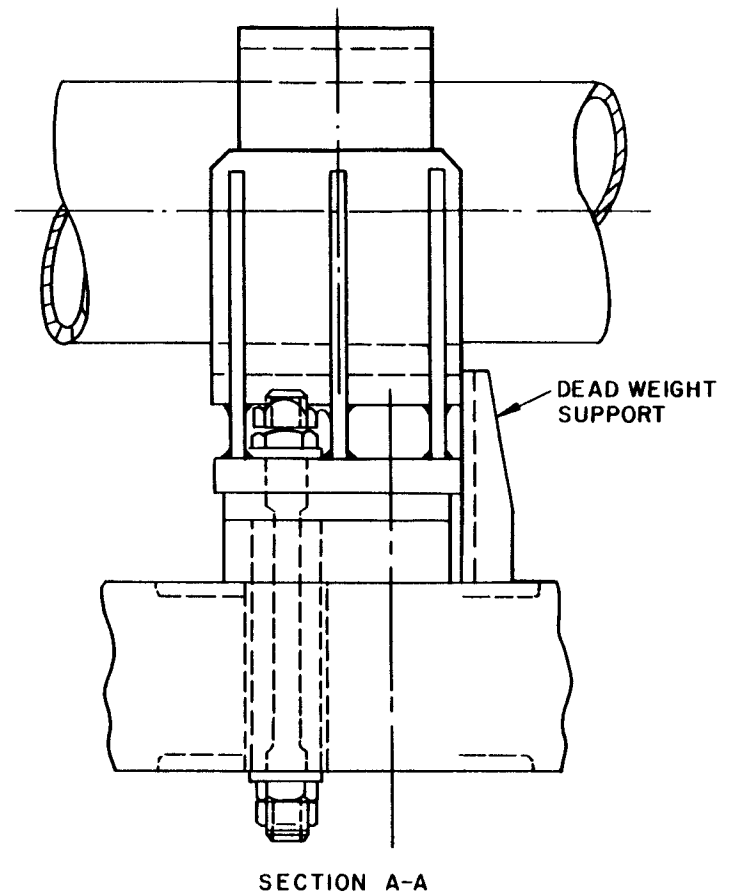
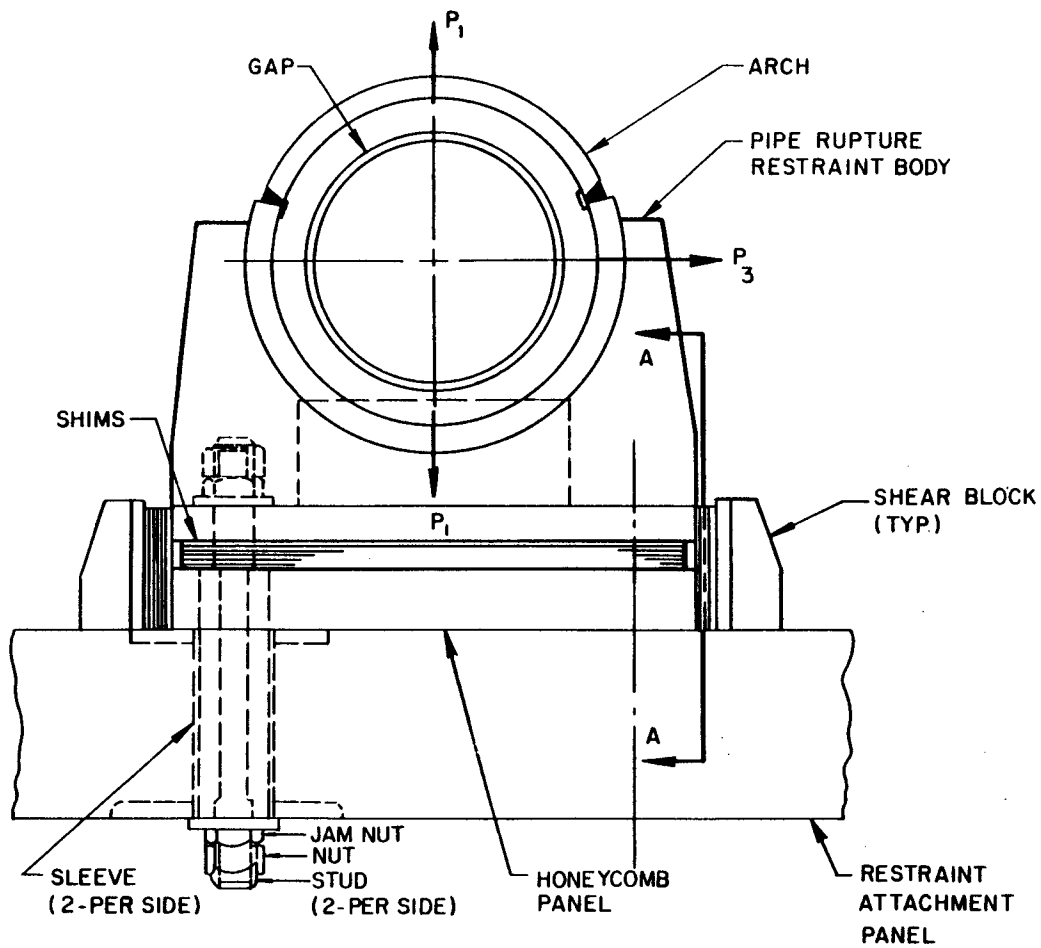
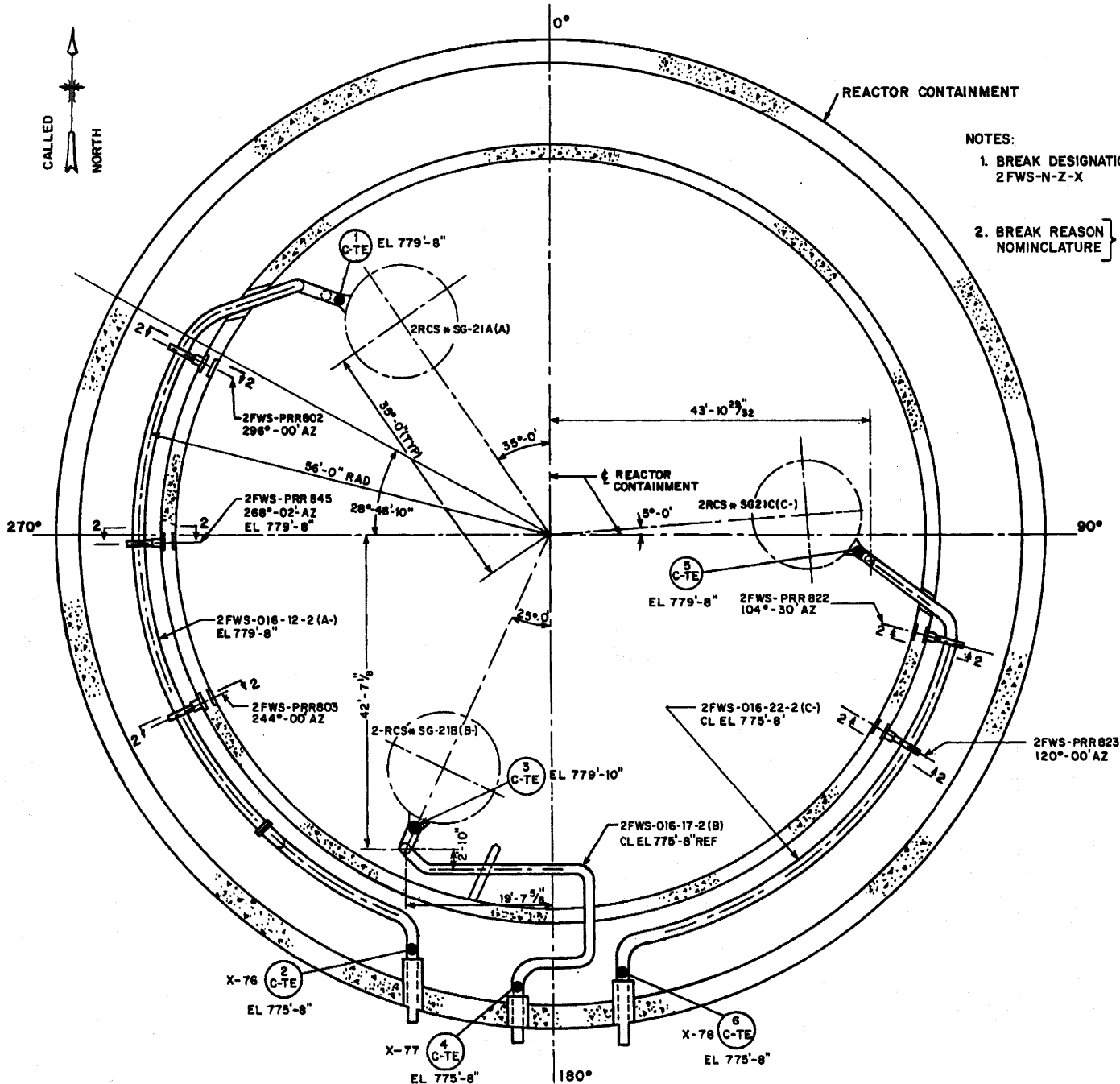

FIGURE 3.6B-11
 OMNI-DIRECTIONAL PIPE
 RUPTURE RESTRAINT
 BEAVER VALLEY POWER STATION-UNIT 2
 FINAL SAFETY ANALYSIS REPORT



NOTES:

1. BREAK DESIGNATION
2FWS-N-Z-X

WHERE, \textcircled{N} X-Y

N → BREAK NUMBER
X → TYPE C OR L (CIRCUMFERENTIAL OR LONGITUDINAL)
Y → REASON (EA or TE)
Z → LOCATION (C or A)

2. BREAK REASON
NOMINCLATURE

EA = LOCATION EXCEEDS ALLOWABLE STRESS.
TE = TERMINAL END @ ANCHOR/EQUIPMENT.

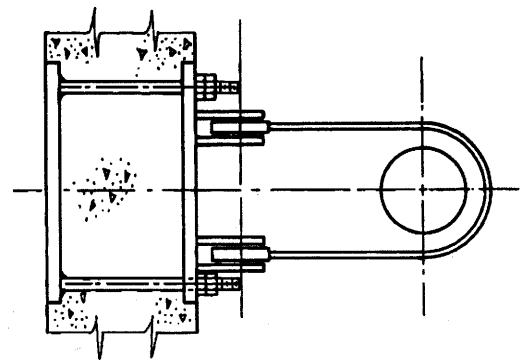

VIEW 2-2

FIGURE 3.6B-12

PIPE BREAK/RESTRAINT LOCATIONS
FEEDWATER SYSTEM (FWS)
INSIDE REACTOR CONTAINMENT

BEAVER VALLEY POWER STATION - UNIT 2
UPDATED FINAL SAFETY ANALYSIS REPORT

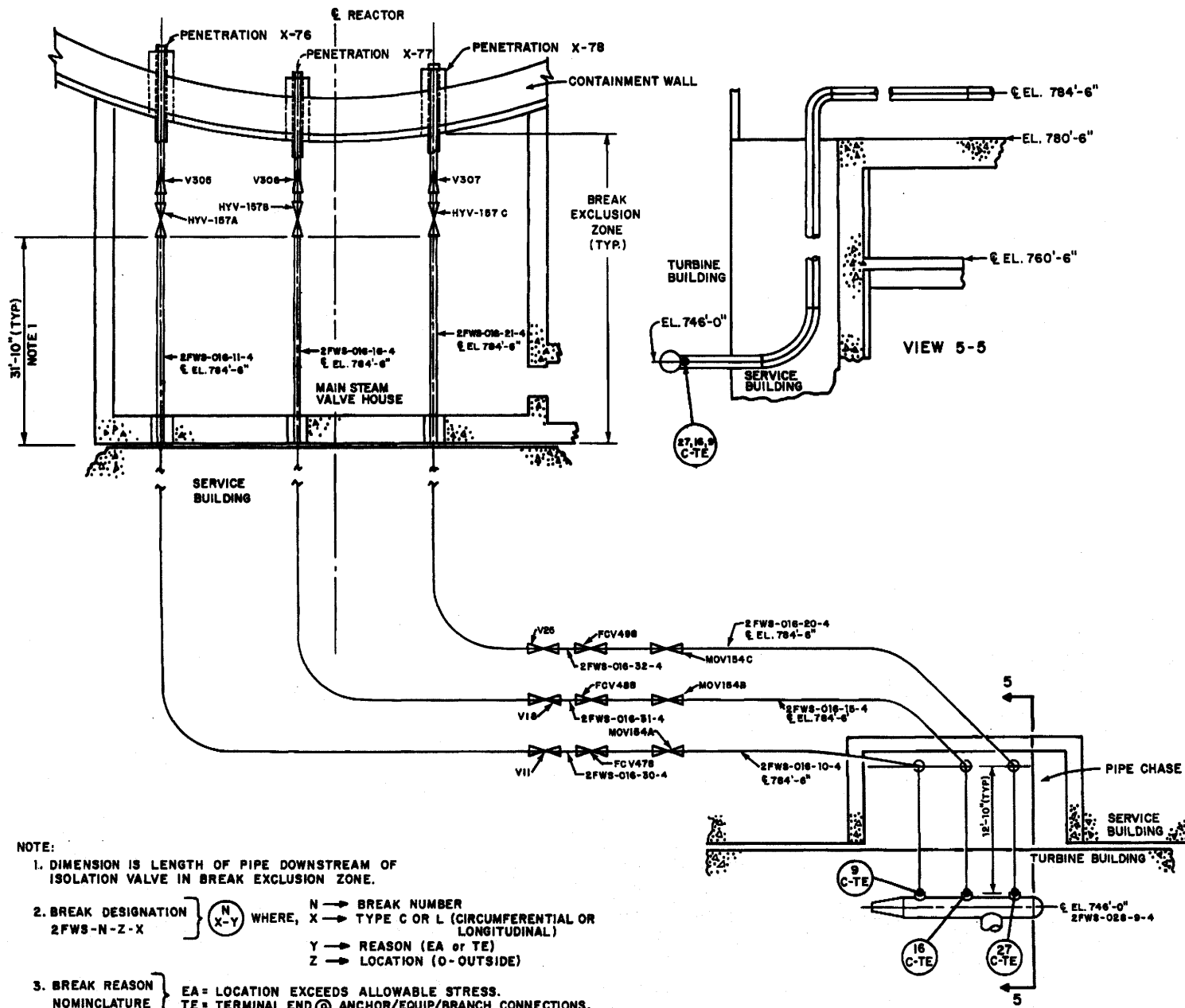

- NOTE:
1. DIMENSION IS LENGTH OF PIPE DOWNSTREAM OF ISOLATION VALVE IN BREAK EXCLUSION ZONE.
 2. BREAK DESIGNATION } $\begin{matrix} N \\ X-Y \end{matrix}$ WHERE, N → BREAK NUMBER
 2FWS-N-Z-X } X → TYPE C OR L (CIRCUMFERENTIAL OR LONGITUDINAL)
 Y → REASON (EA or TE)
 Z → LOCATION (O- OUTSIDE)
 3. BREAK REASON } EA = LOCATION EXCEEDS ALLOWABLE STRESS.
 NOMINCLATURE } TE = TERMINAL END (@ ANCHOR/EQUIP/BRANCH CONNECTIONS.

FIGURE 3.6B-13
 FEEDWATER SYSTEM (FWS)
 OUTSIDE CONTAINMENT
 BEAVER VALLEY POWER STATION - UNIT 2
 UPDATED FINAL SAFETY ANALYSIS REPORT

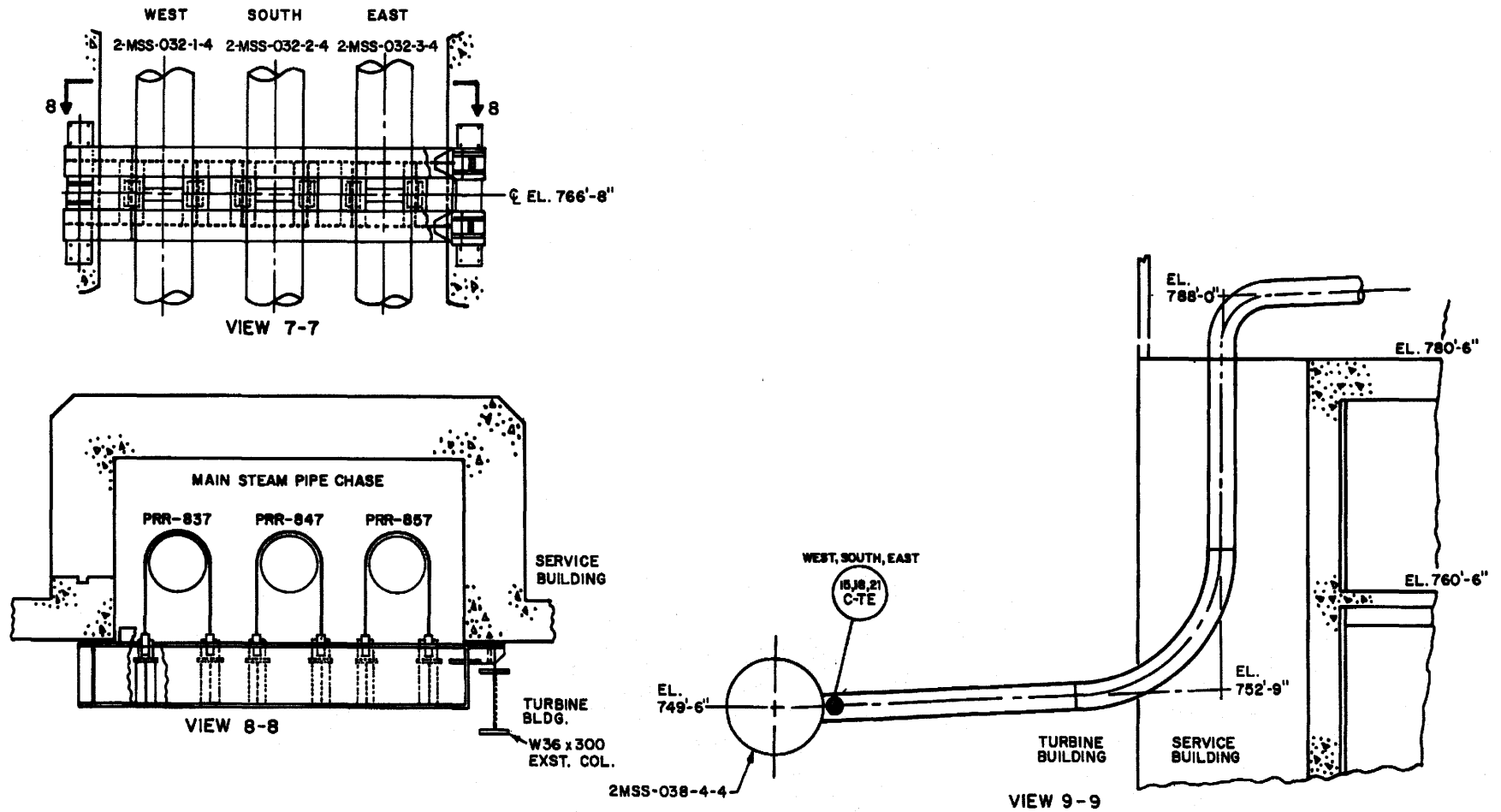

FIGURE 3.6B-14 (2 OF 2)

MAIN STEAM SYSTEM (MSS)
OUTSIDE CONTAINMENT

BEAVER VALLEY POWER STATION - UNIT 2
UPDATED FINAL SAFETY ANALYSIS REPORT

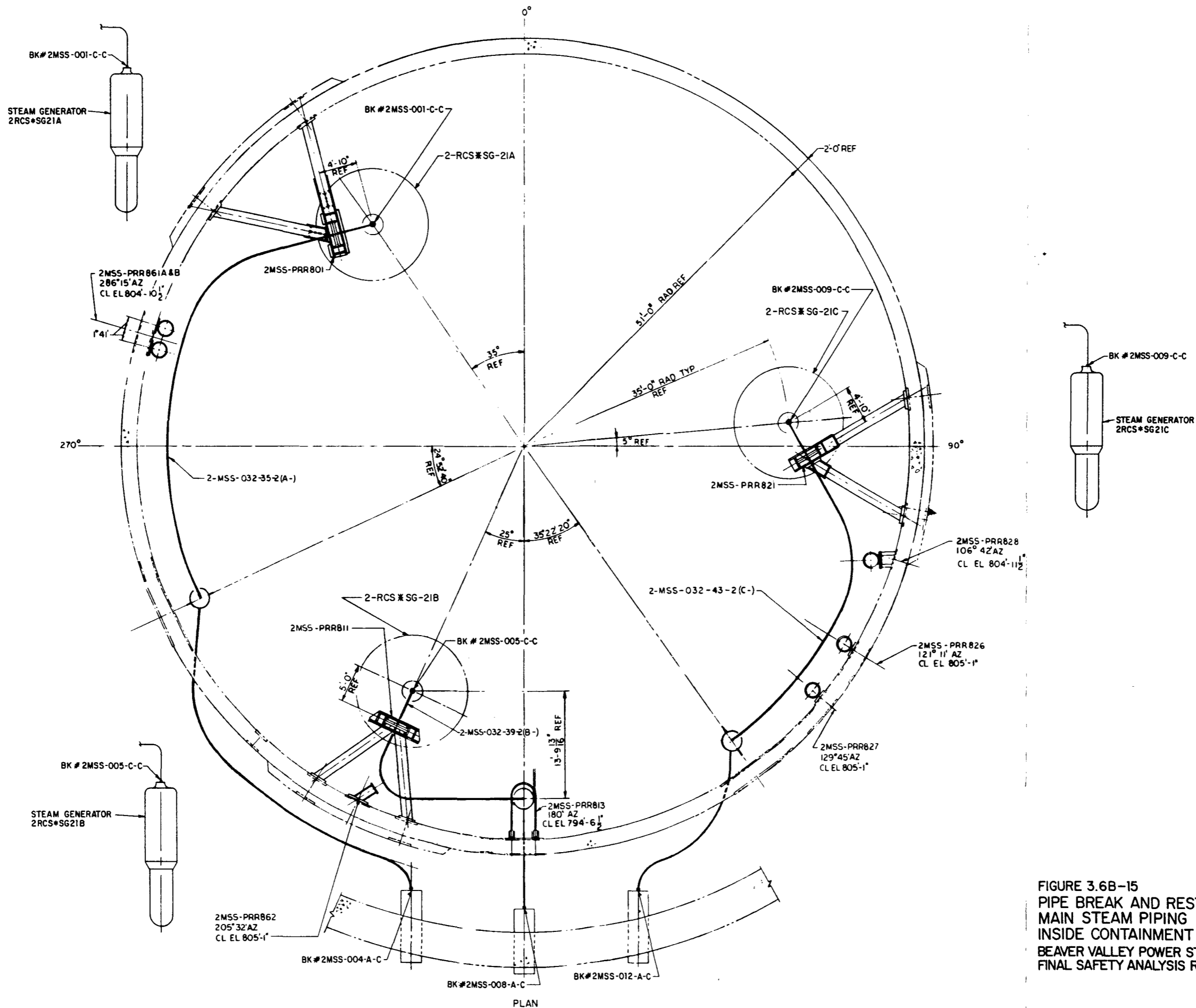
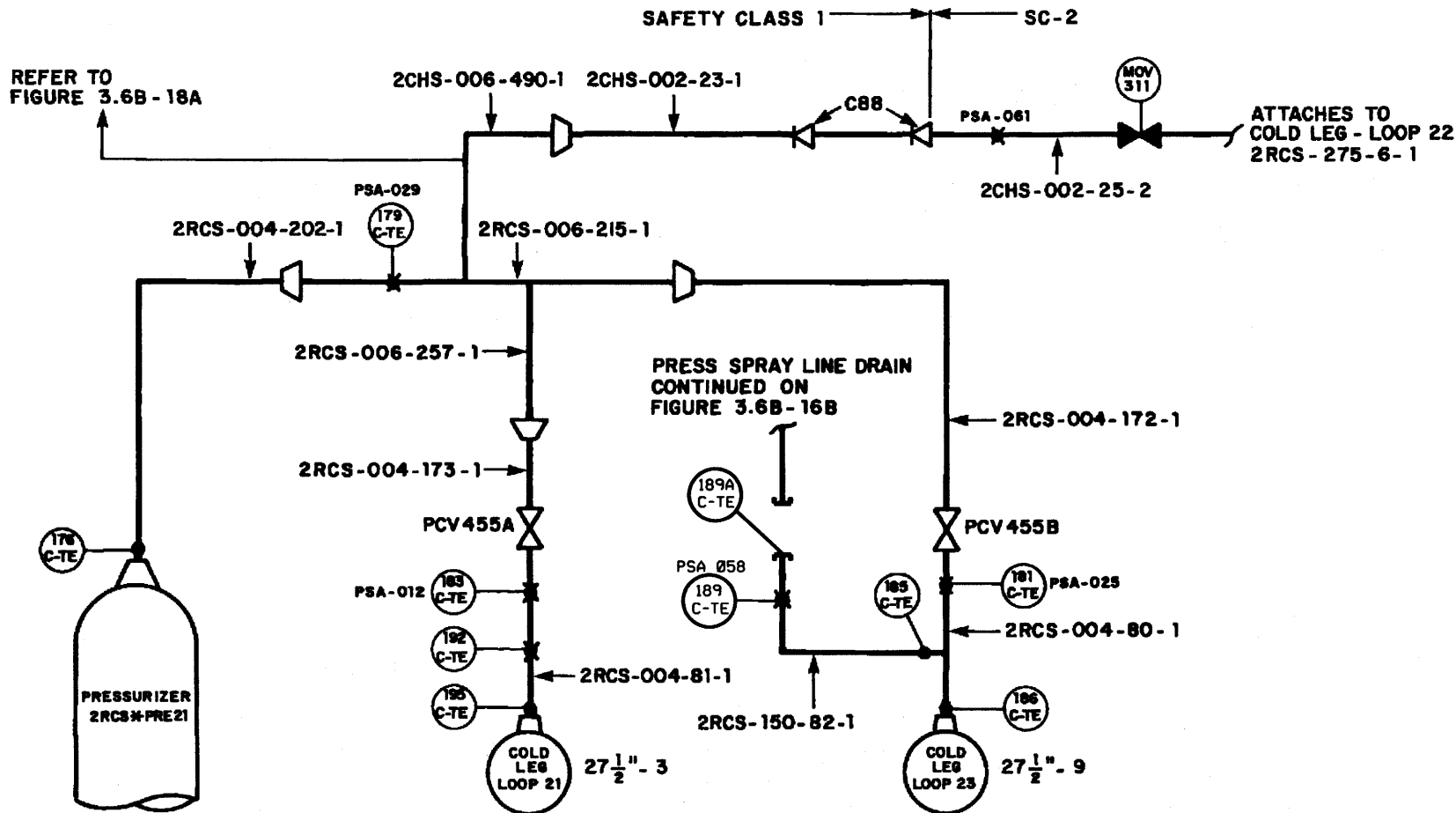

FIGURE 3.6B-15
 PIPE BREAK AND RESTRAINT LOCATIONS-
 MAIN STEAM PIPING
 INSIDE CONTAINMENT
 BEAVER VALLEY POWER STATION-UNIT 2
 FINAL SAFETY ANALYSIS REPORT



NOTES:

1. PIPING NOT TO SCALE; DIAGRAMMATIC FOR CLARITY.
2. BREAK DESIGNATION } $\begin{matrix} N \\ \text{X-Y} \end{matrix}$ WHERE, N → BREAK NUMBER
 2RCS-N-Z-X } X → TYPE (C or L)
 } Y → REASON (TE or EA)
 } Z → LOCATION (C or A)
3. BREAK REASON } EA= EXCEEDS ALLOWABLE STRESS.
 NOMINCLATURE } TE= TERMINAL ENDS AT ANCHOR/EQUIPMENT AND BRANCH
 CONNECTIONS/PRESSURE BOUNDARIES.
4. BREAKS ON THE CHS PIPING ARE SHOWN ON FIGURE 3.6B-18.

FIGURE 3.6B-16A

REACTOR COOLANT SYSTEM (RCS)
 (PRESSURIZER/AUXILIARY SPRAY)
 INSIDE REACTOR CONTAINMENT

BEAVER VALLEY POWER STATION UNIT NO. 2
 UPDATED FINAL SAFETY ANALYSIS REPORT

ATTACHES TO
PRESSURIZER
RELIEF TANK
2RCS-TK22

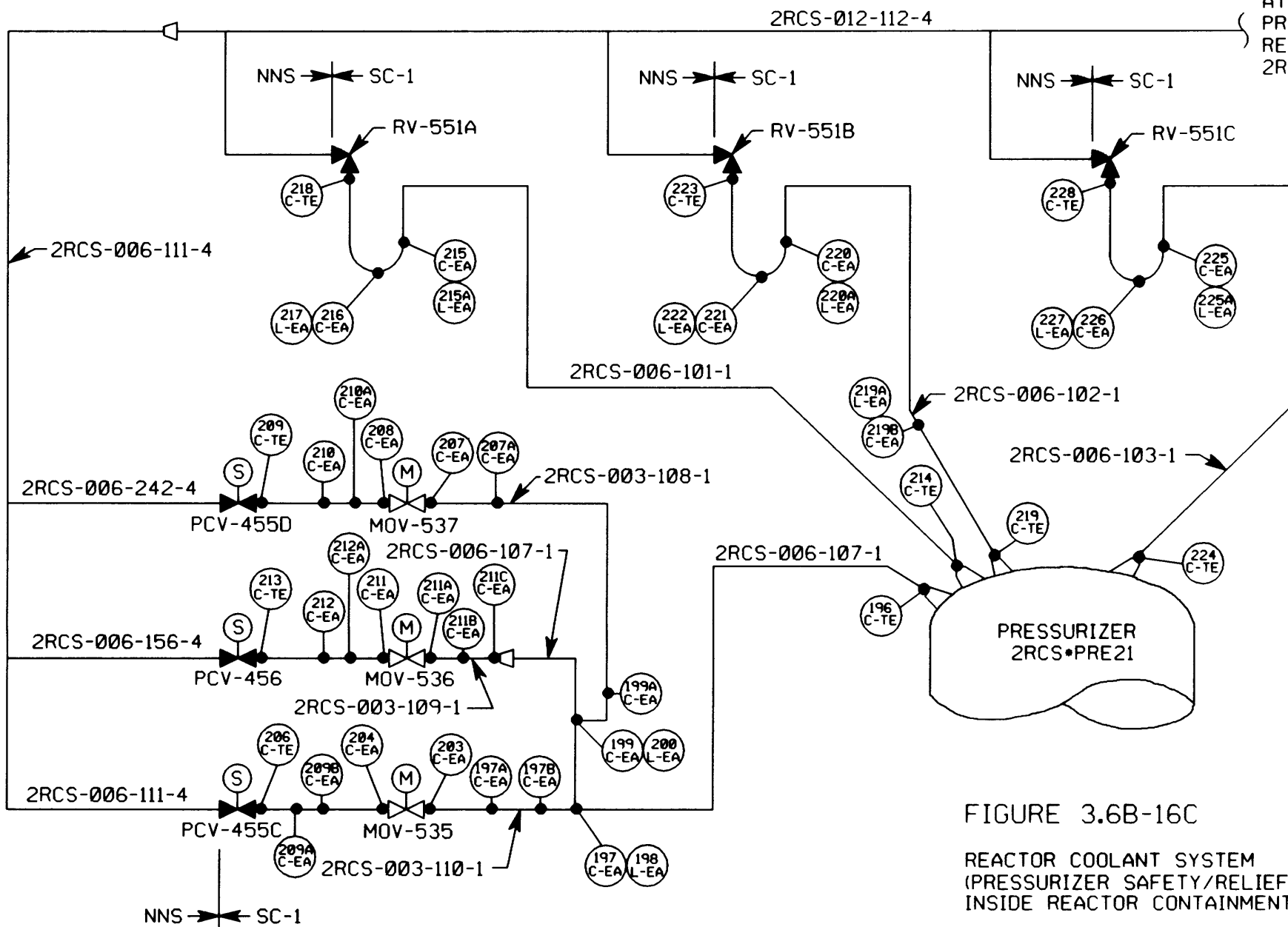

FIGURE 3.6B-16C

REACTOR COOLANT SYSTEM
(PRESSURIZER SAFETY/RELIEF VALVE)
INSIDE REACTOR CONTAINMENT

BEAVER VALLEY POWER STATION UNIT NO. 2
UPDATED FINAL SAFETY ANALYSIS REPORT

TAG:175870 306b016c 07/30/2007 08:07:03 AM

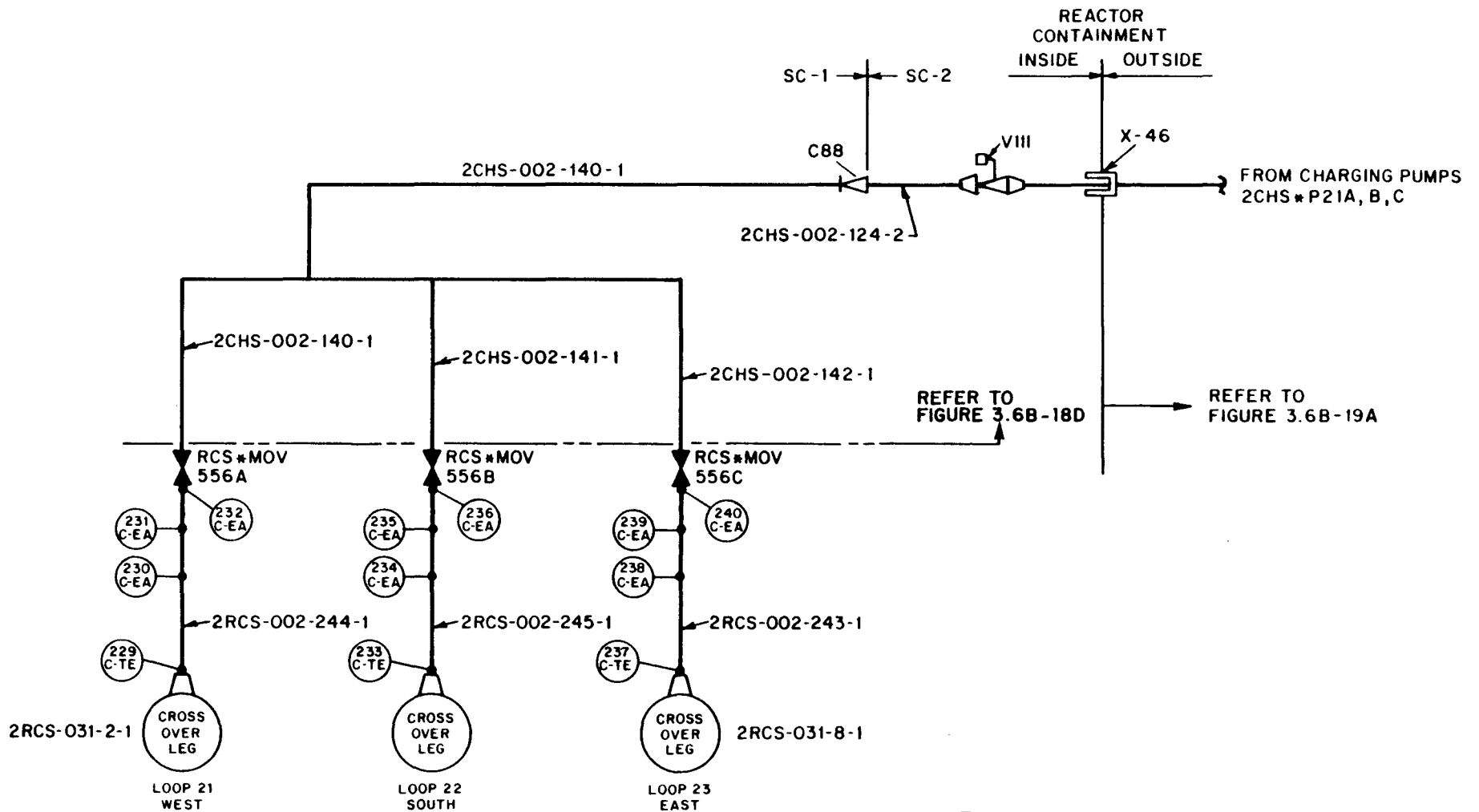
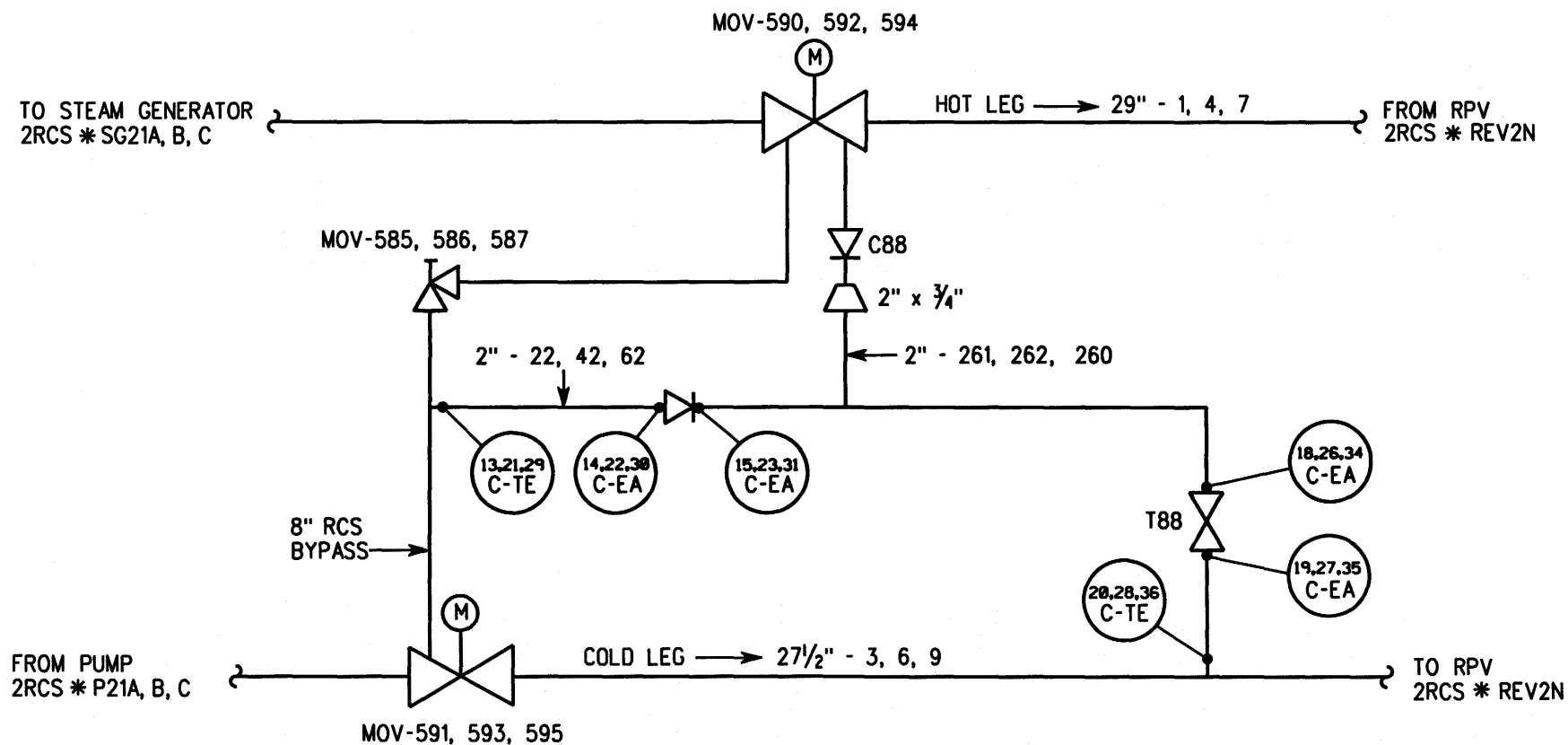

FIGURE 3.6B-16D
 REACTOR COOLANT SYSTEM
 (LOOP FILL PIPING)
 INSIDE REACTOR CONTAINMENT
 BEAVER VALLEY POWER STATION-UNIT 2
 FINAL SAFETY ANALYSIS REPORT



NOTES:

1. REFER TO FIGURE 3.6B-16A FOR GENERAL NOTES.
2. ALL VALVE/PIPE MARK NUMBERS ARE PRECEDED BY THE PLANT UNIT NUMBER AND SYSTEM DESIGNATION (2RCS-).
3. PIPING IS SAFETY CLASS 1 (SC-1).

FIGURE 3.6B-16E

2" RCS BYPASS - LOOP 21, 22, 23
INSIDE REACTOR CONTAINMENT

BEAVER VALLEY POWER STATION UNIT NO. 2
UPDATED FINAL SAFETY ANALYSIS REPORT

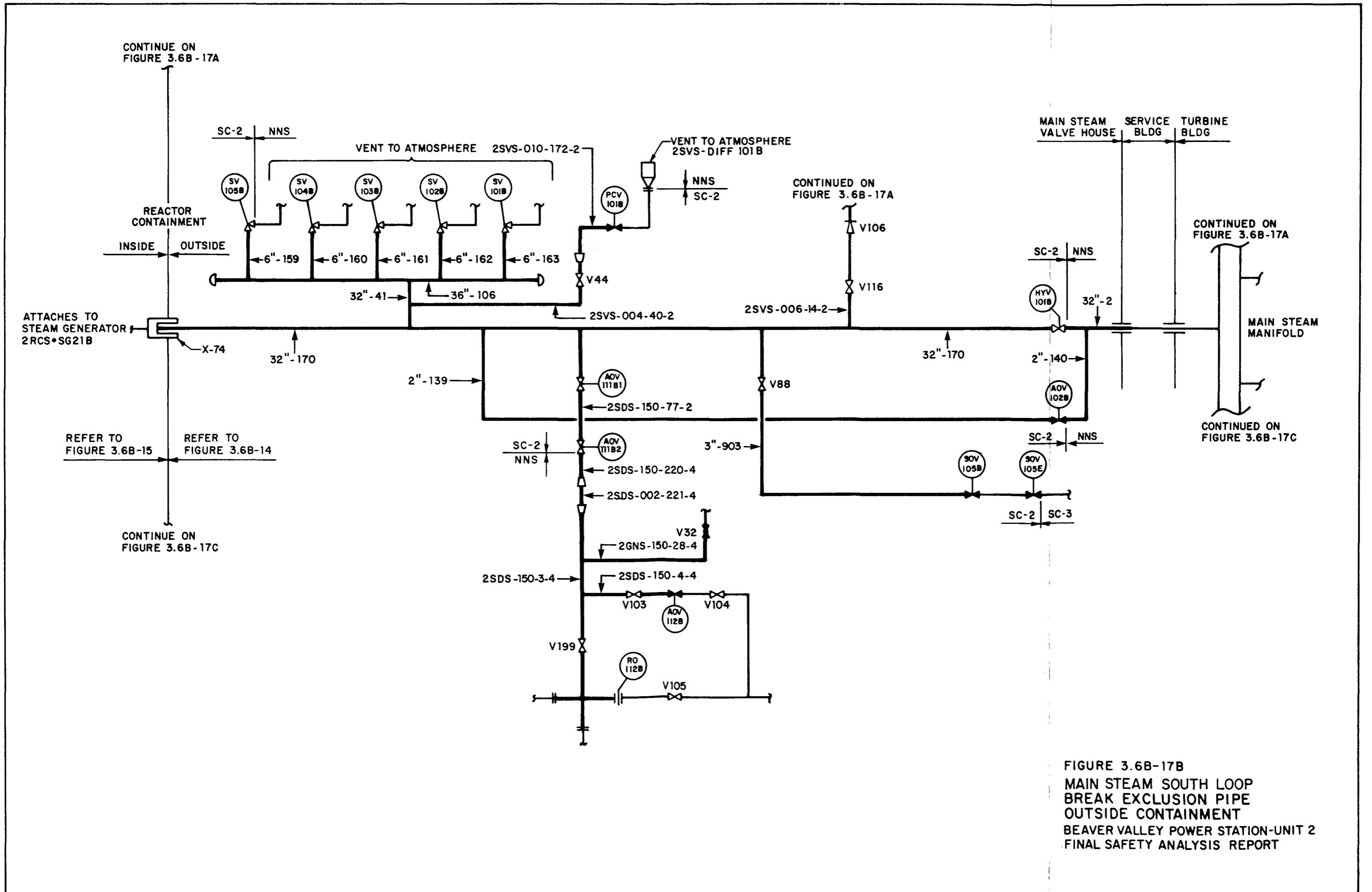

FIGURE 3.6B-17B
 MAIN STEAM SOUTH LOOP
 BREAK EXCLUSION PIPE
 OUTSIDE CONTAINMENT
 BEAVER VALLEY POWER STATION-UNIT 2
 FINAL SAFETY ANALYSIS REPORT

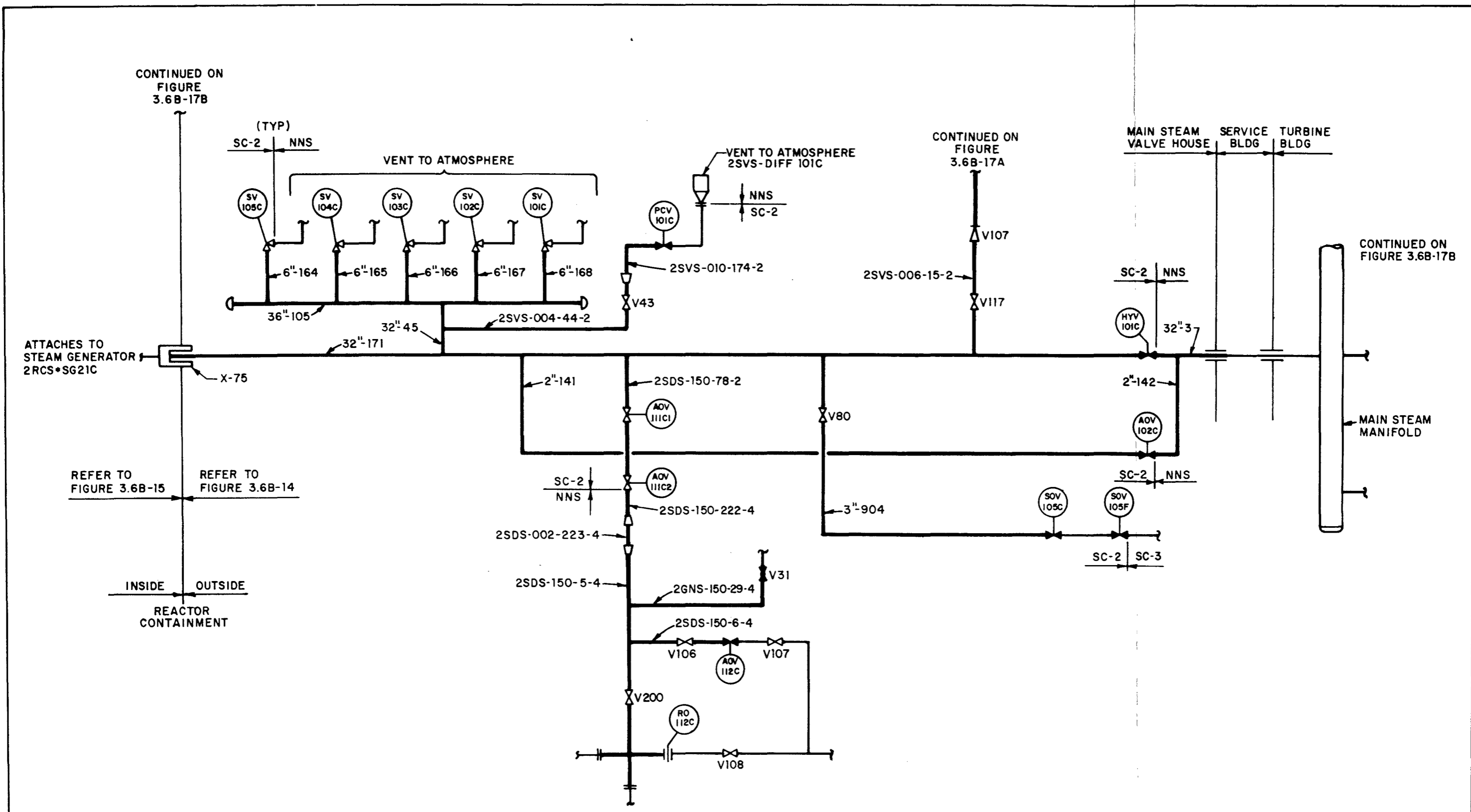
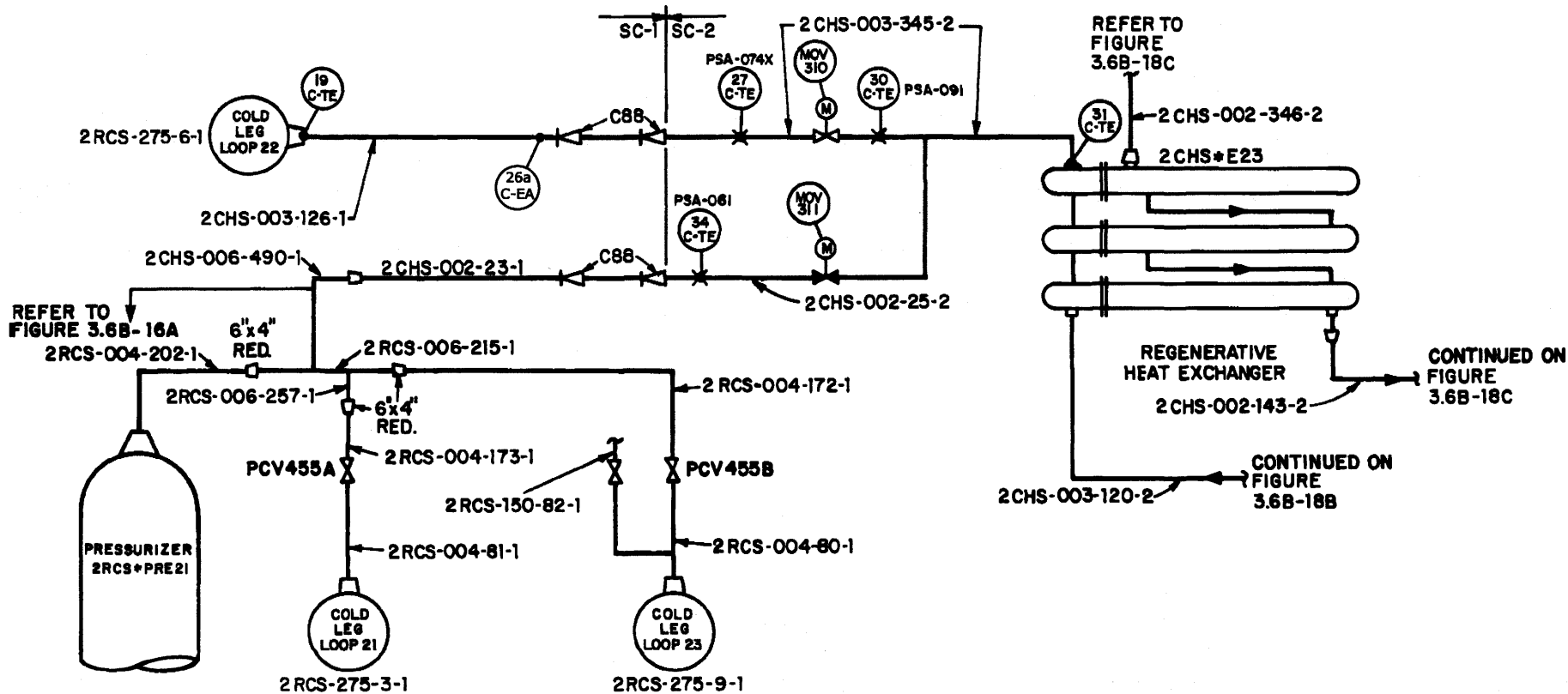

FIGURE 3.6B-17C
 MAIN STEAM EAST LOOP
 BREAK EXCLUSION PIPE
 OUTSIDE CONTAINMENT
 BEAVER VALLEY POWER STATION-UNIT 2
 FINAL SAFETY ANALYSIS REPORT



NOTES:

1. PIPING NOT TO SCALE, SHOWN DIAGRAMMATIC FOR CLARITY
2. BREAK DESIGNATION } \textcircled{N} WHERE, N → BREAK NUMBER
 2CHS-N-Z-X } X → TYPE (C OR L)
 Y → REASON (TE OR EA)
 Z → LOCATION (C OR A)
3. BREAK REASON } EA= EXCEEDS ALLOWABLE STRESS.
 NOMINCLATURE } TE= TERMINAL ENDS AT ANCHOR/EQUIPMENT/BRANCH CONN.
4. BREAKS ON THE RCS PIPING ARE SHOWN ON FIGURE 3.6B-16.

FIGURE 3.6B-18A

CHEM./CHARGING & VOL. CONTROL SYS. (CHS)
 (PRESS./AUX.SPRAY & NORMAL CHARGING)
 INSIDE REACTOR CONTAINMNET

BEAVER VALLEY POWER STATION - UNIT 2
 UPDATED FINAL SAFETY ANALYSIS REPORT

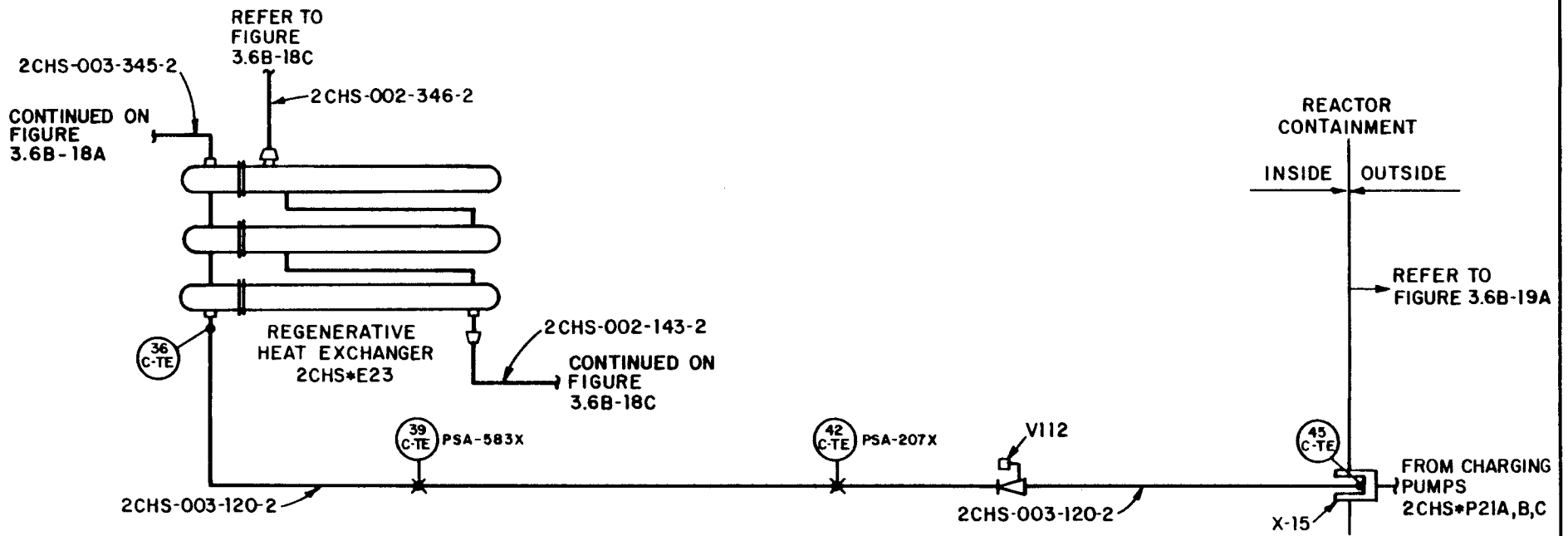

FIGURE 3.6B-18B
 CHEM./CHARGING & VOL. CONTROL SYS.
 (NORMAL CHARGING)
 INSIDE REACTOR CONTAINMENT
 BEAVER VALLEY POWER STATION-UNIT 2
 FINAL SAFETY ANALYSIS REPORT

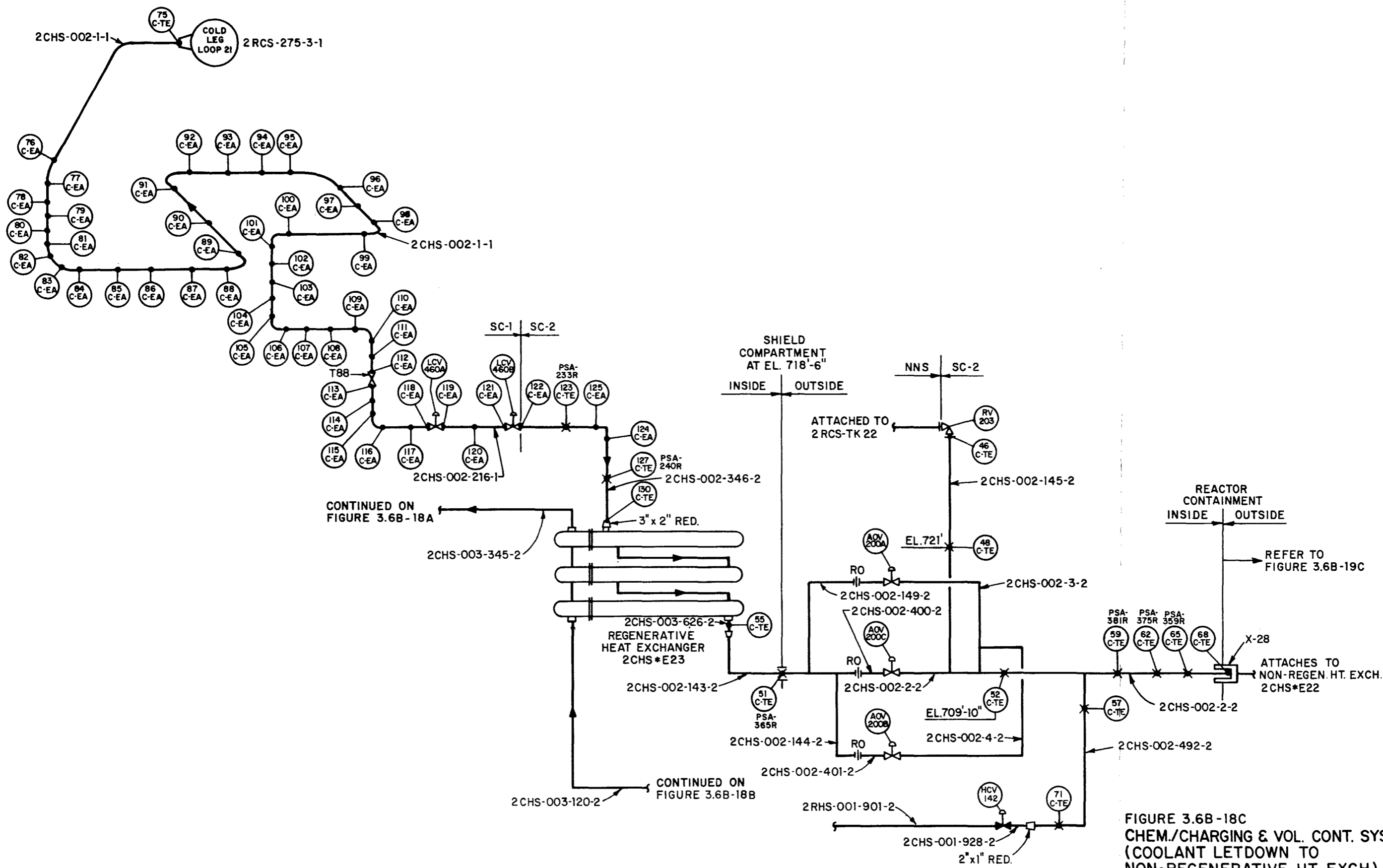

FIGURE 3.6B-18C
 CHEM./CHARGING & VOL. CONT. SYS.
 (COOLANT LETDOWN TO
 NON-REGENERATIVE HT EXCH)
 INSIDE REACTOR CONTAINMENT
 BEAVER VALLEY POWER STATION-UNIT 2
 FINAL SAFETY ANALYSIS REPORT

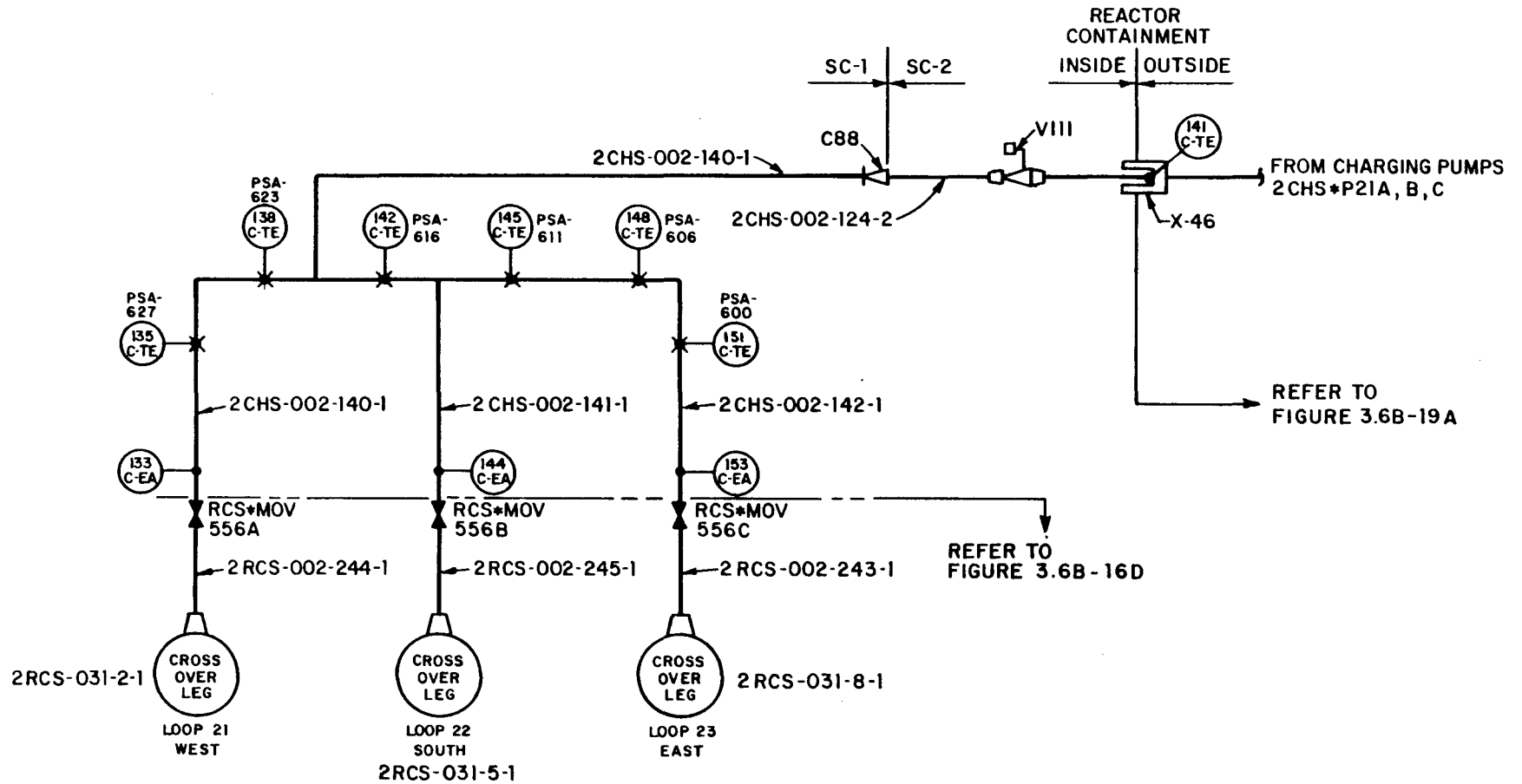

FIGURE 3.6B-18D
 CHEM./CHARGING & VOL. CONTROL SYS.
 (LOOP FILL PIPING)
 INSIDE REACTOR CONTAINMENT
 BEAVER VALLEY POWER STATION-UNIT 2
 FINAL SAFETY ANALYSIS REPORT

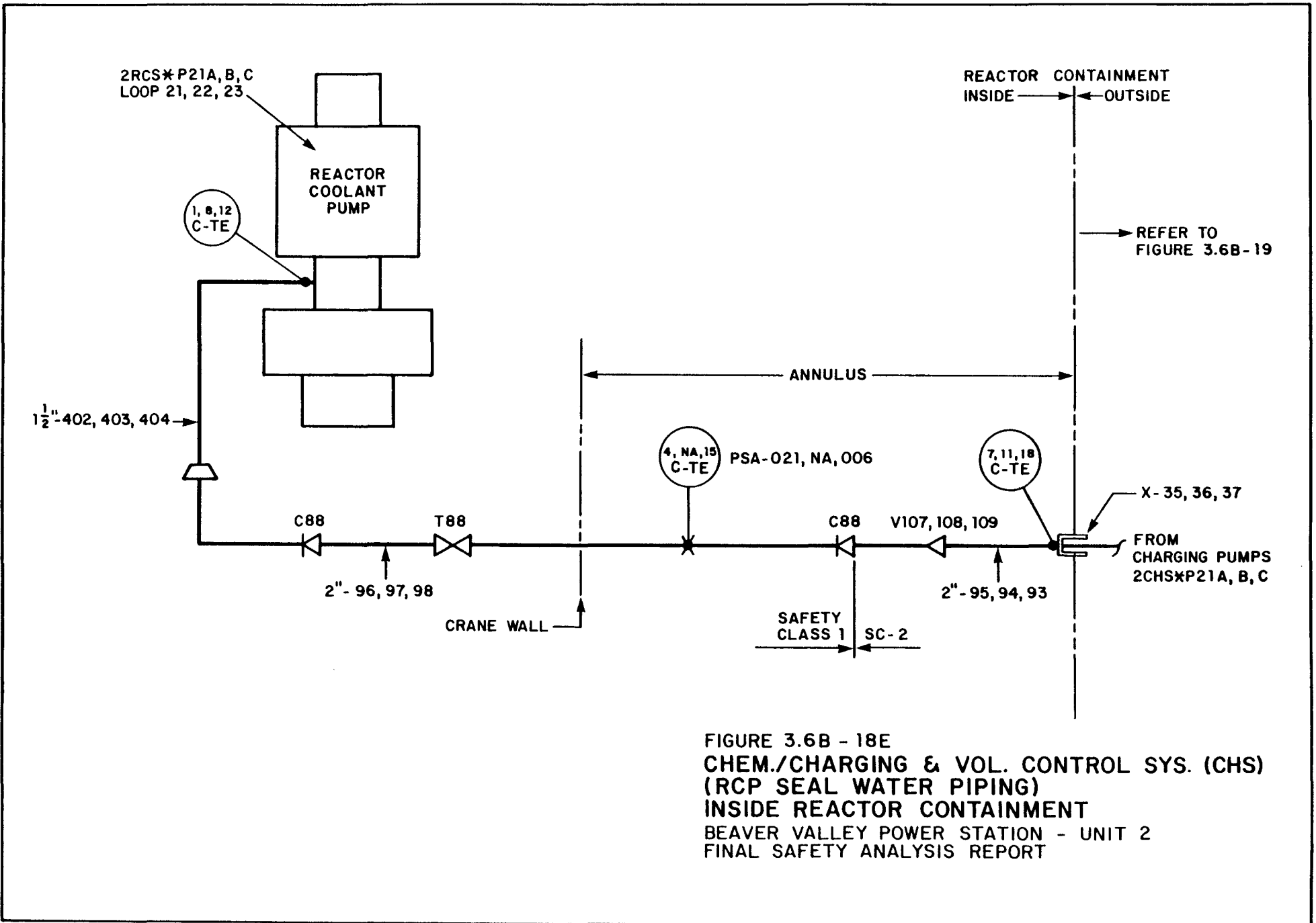
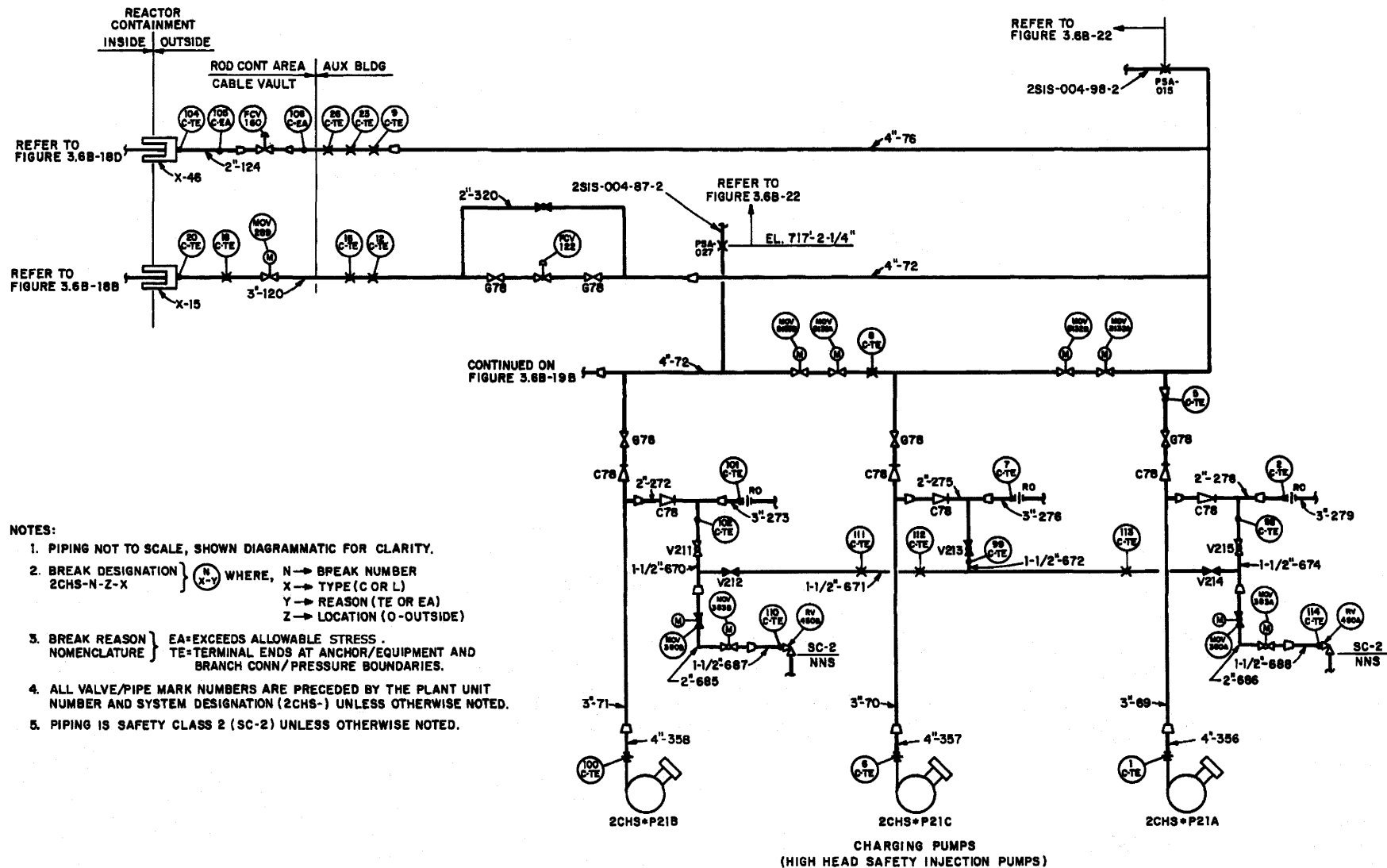

FIGURE 3.6B - 18E
 CHEM./CHARGING & VOL. CONTROL SYS. (CHS)
 (RCP SEAL WATER PIPING)
 INSIDE REACTOR CONTAINMENT
 BEAVER VALLEY POWER STATION - UNIT 2
 FINAL SAFETY ANALYSIS REPORT



- NOTES:**
1. PIPING NOT TO SCALE, SHOWN DIAGRAMMATIC FOR CLARITY.
 2. BREAK DESIGNATION } $\begin{matrix} N \\ X-Y \end{matrix}$ WHERE, N → BREAK NUMBER
 } $\begin{matrix} X \\ Y-Z \end{matrix}$ WHERE, X → TYPE (C OR L)
 } Y → REASON (TE OR EA)
 } Z → LOCATION (O-OUTSIDE)
 3. BREAK REASON } EA=EXCEEDS ALLOWABLE STRESS.
 } TE=TERMINAL ENDS AT ANCHOR/EQUIPMENT AND
 } BRANCH CONN/PRESSURE BOUNDARIES.
 4. ALL VALVE/PIPE MARK NUMBERS ARE PRECEDED BY THE PLANT UNIT NUMBER AND SYSTEM DESIGNATION (2CHS-) UNLESS OTHERWISE NOTED.
 5. PIPING IS SAFETY CLASS 2 (SC-2) UNLESS OTHERWISE NOTED.

FIGURE 3.6B-19A
 CHEM./CHARGING & VOL. CONT. SYS.(CHS)
 HSI CHARGING PUMPS
 OUTSIDE REACTOR CONTAINMENT
 BEAVER VALLEY POWER STATION - UNIT 2
 UPDATED FINAL SAFETY ANALYSIS REPORT

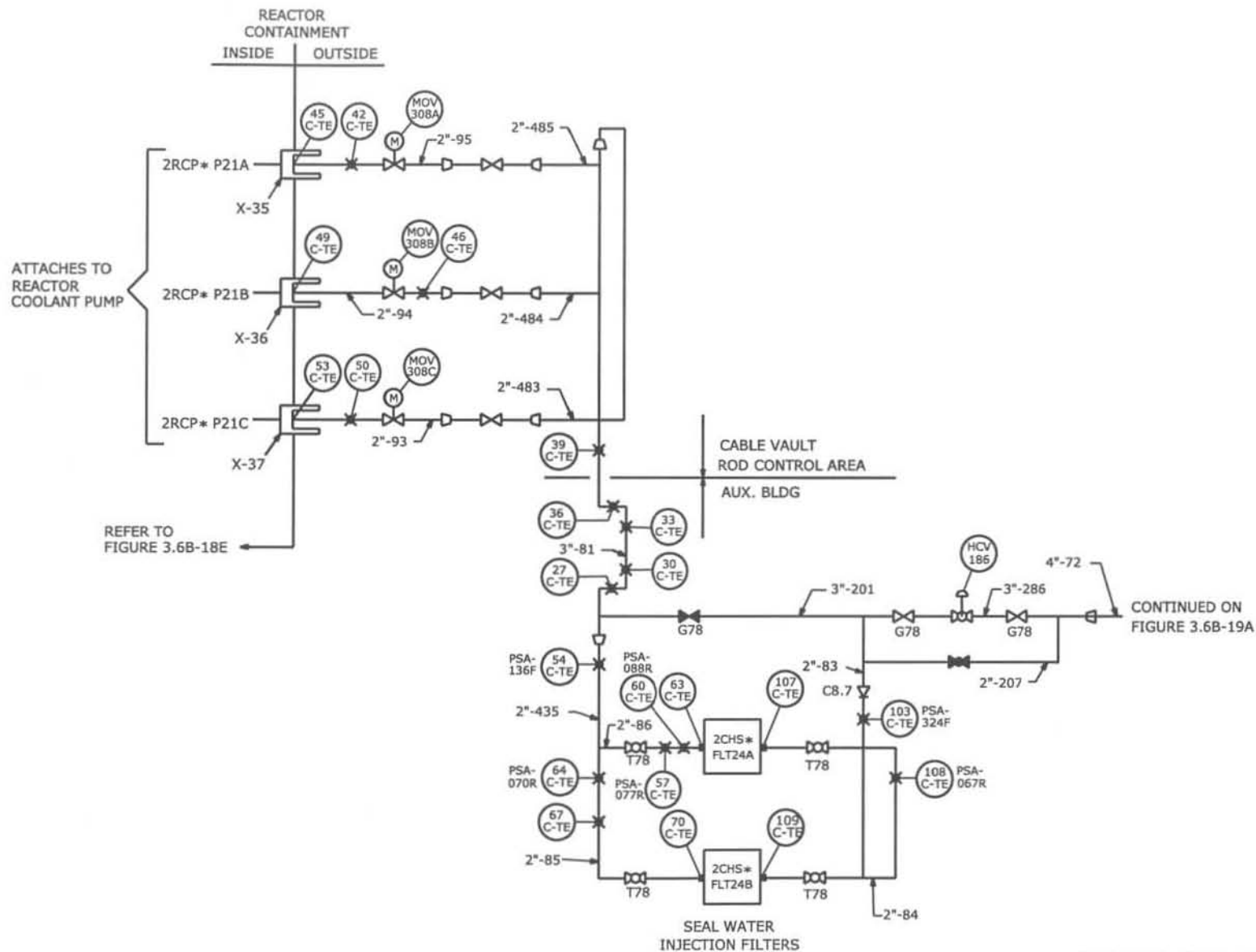

FIGURE 3.6B-19B

CHEM./CHARGING & VOL. CONT. SYS.(CHS)
 RCP SEAL WATER PIPING
 OUTSIDE REACTOR CONTAINMENT
 BEAVER VALLEY POWER STATION - UNIT 2
 UPDATED FINAL SAFETY ANALYSIS REPORT

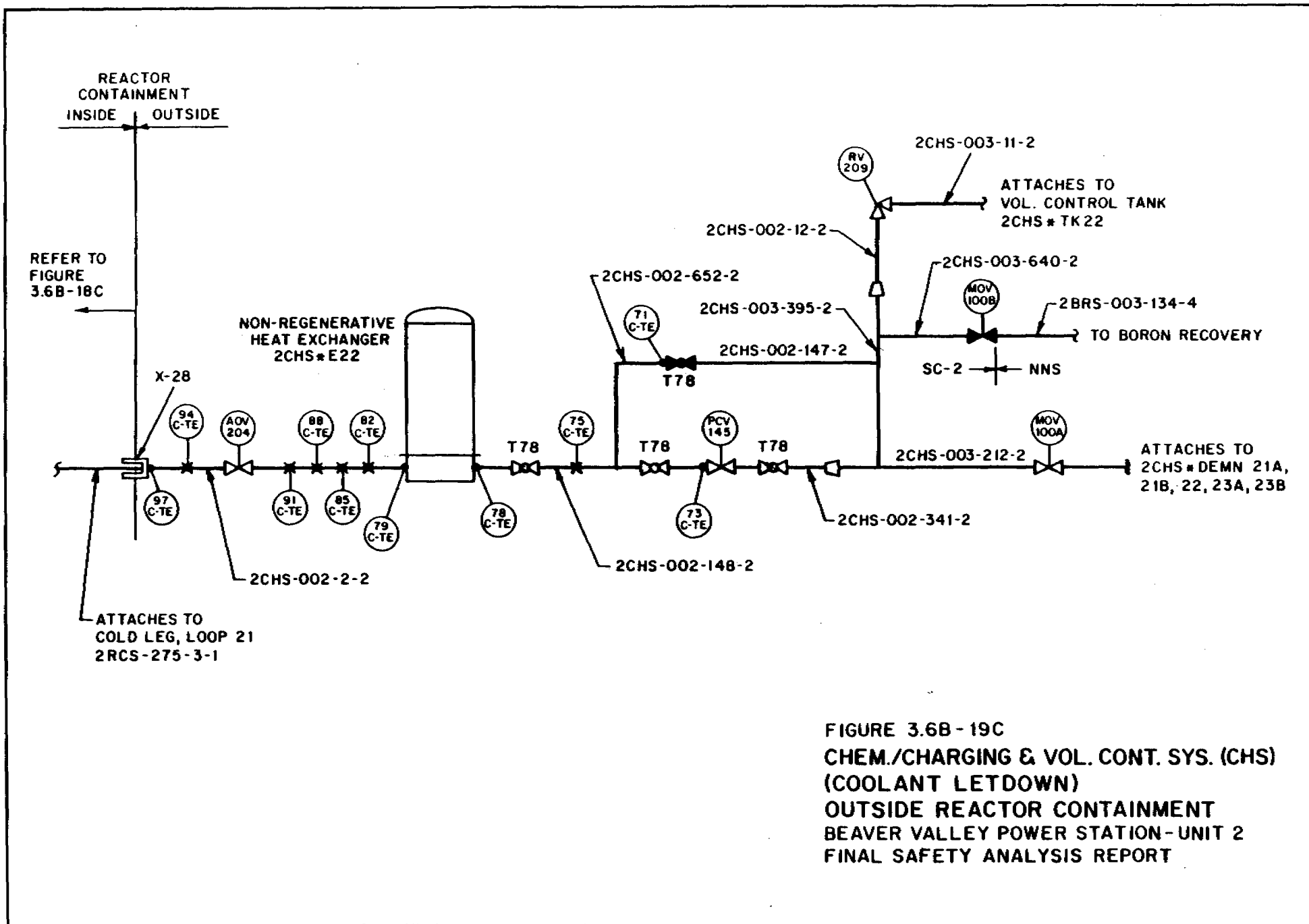
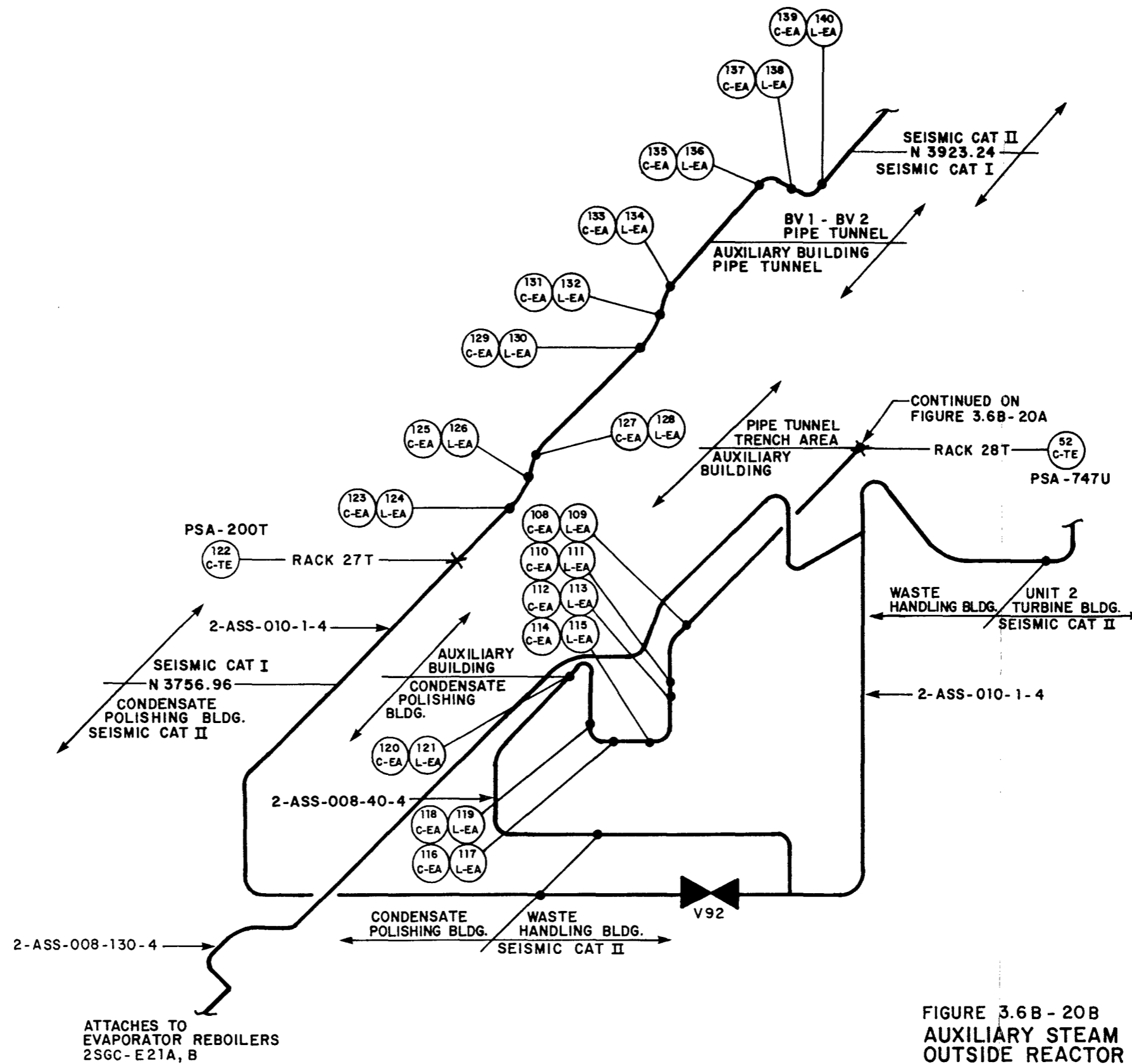
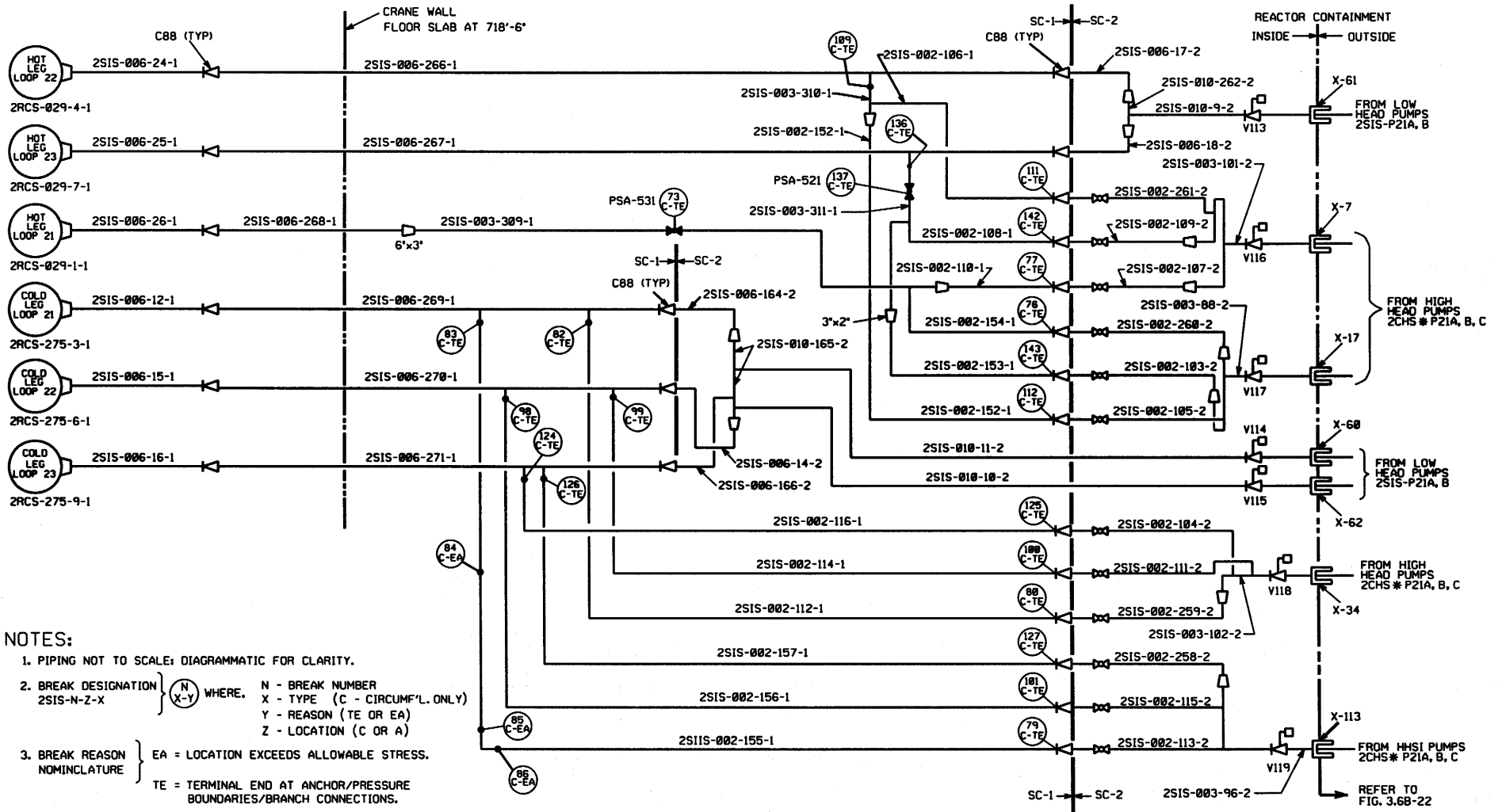

FIGURE 3.6B-19C
CHEM./CHARGING & VOL. CONT. SYS. (CHS)
(COOLANT LETDOWN)
OUTSIDE REACTOR CONTAINMENT
BEAVER VALLEY POWER STATION-UNIT 2
FINAL SAFETY ANALYSIS REPORT



ATTACHES TO
EVAPORATOR REBOILERS
2SGC-E21A, B

FIGURE 3.6B - 20B
AUXILIARY STEAM SUPPLY (ASS) SYSTEM
OUTSIDE REACTOR CONTAINMENT
BEAVER VALLEY POWER STATION - UNIT 2
FINAL SAFETY ANALYSIS REPORT



- NOTES:**
1. PIPING NOT TO SCALE; DIAGRAMMATIC FOR CLARITY.
 2. BREAK DESIGNATION } $\left(\begin{matrix} N \\ X-Y \end{matrix} \right)$ WHERE: N - BREAK NUMBER
X - TYPE (C - CIRCUMF'L. ONLY)
Y - REASON (TE OR EA)
Z - LOCATION (C OR A)
 3. BREAK REASON NOMINCLATURE } EA = LOCATION EXCEEDS ALLOWABLE STRESS.
TE = TERMINAL END AT ANCHOR/PRESSURE BOUNDARIES/BRANCH CONNECTIONS.

FIGURE 3.6B-21A
SAFETY INJECTION SYSTEM (SIS)
LOW/HIGH HEAD
INSIDE REACTOR CONTAINMENT
 BEAVER VALLEY POWER STATION - UNIT 2
 UPDATED FINAL SAFETY ANALYSIS REPORT

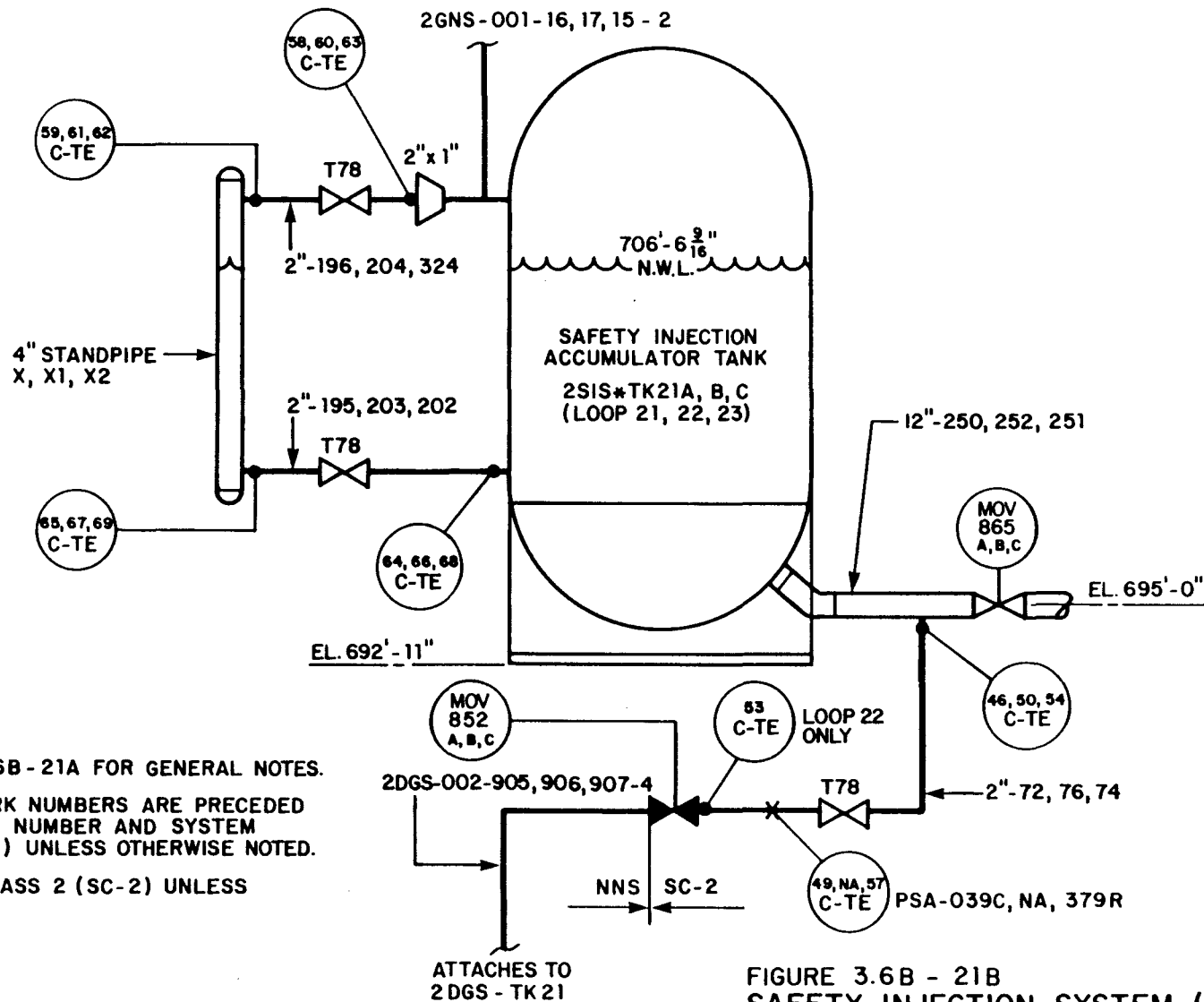

NOTES:

1. REFER TO FIGURE 3.6B - 21A FOR GENERAL NOTES.
2. ALL VALVE/PIPE MARK NUMBERS ARE PRECEDED BY THE PLANT UNIT NUMBER AND SYSTEM DESIGNATION (2 SIS-) UNLESS OTHERWISE NOTED.
3. PIPING IS SAFETY CLASS 2 (SC-2) UNLESS OTHERWISE NOTED.

**FIGURE 3.6B - 21B
SAFETY INJECTION SYSTEM (SIS)
LOW HEAD ACCUMULATOR
INSIDE REACTOR CONTAINMENT
BEAVER VALLEY POWER STATION - UNIT 2
FINAL SAFETY ANALYSIS REPORT**

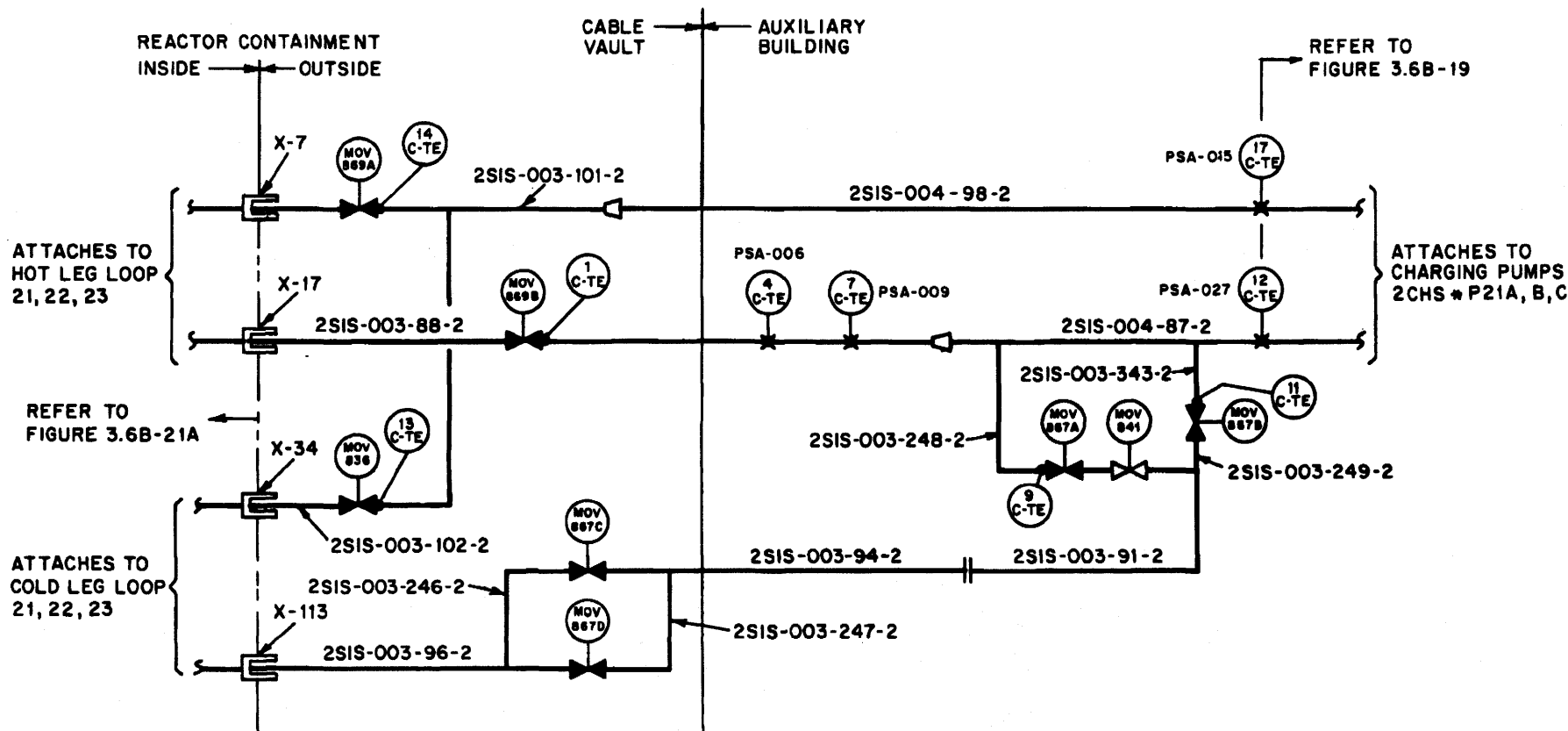

NOTES:

1. PIPING NOT TO SCALE; DIAGRAMMATIC FOR CLARITY.
2. BREAK DESIGNATION } N
 2SIS-N-Z-X } X-Y WHERE, N — BREAK NUMBER
 X — TYPE (C OR L)
 Y — REASON (TE OR EA)
 Z — LOCATION (O-OUTSIDE)
3. BREAK REASON } EA = EXCEEDS ALLOWABLE STRESS.
 NOMINCLATURE } TE = TERMINAL ENDS AT EITHER ANCHORS OR
 PRESSURE BOUNDARIES.

FIGURE 3.6B-22
 SAFETY INJECTION SYSTEM (SIS)
 OUTSIDE REACTOR CONTAINMENT
 BEAVER VALLEY POWER STATION - UNIT 2
 UPDATED FINAL SAFETY ANALYSIS REPORT

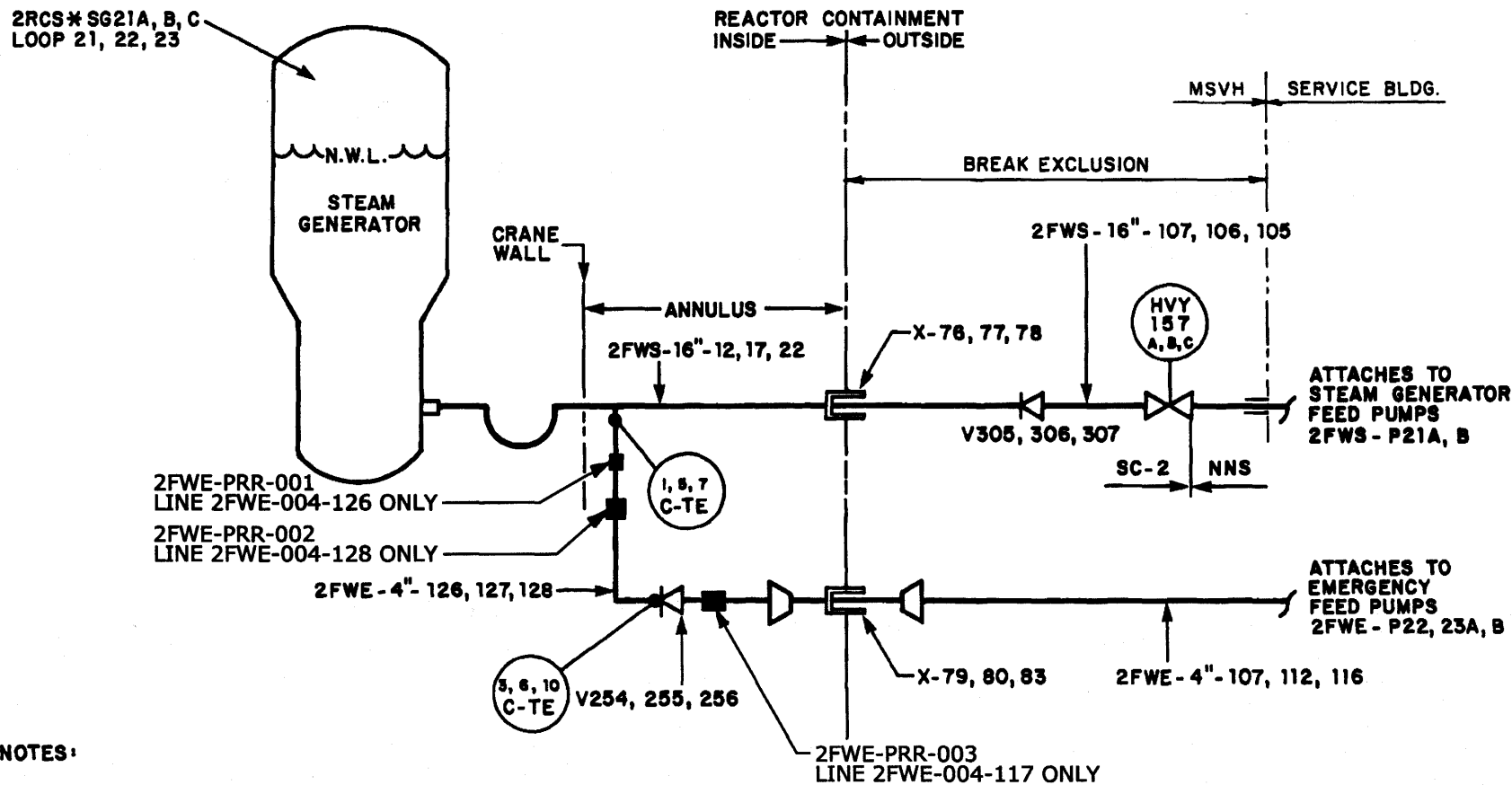

NOTES:

1. PIPING NOT TO SCALE; SHOWN DIAGRAMMATIC FOR CLARITY.
2. BREAK DESIGNATION } $\begin{matrix} N \\ X-Y \end{matrix}$ WHERE, $\begin{matrix} N \rightarrow \text{BREAK NUMBER} \\ X \rightarrow \text{TYPE (C or L)} \\ Y \rightarrow \text{REASON (EA or TE)} \\ Z \rightarrow \text{LOCATION (C or A)} \end{matrix}$
3. BREAK REASON } $\begin{matrix} EA = \text{LOCATION EXCEEDS ALLOWABLE STRESS} \\ NOMINCLATURE} \\ TE = \text{TERMINAL END @ BRANCH CONN./PRESSURE BOUNDARIES} \end{matrix}$
4. PIPING SHOWN IS SAFETY CLASS 2.
5. BREAKS ON THE FWS PIPING ARE SHOWN ON FIGURE 3.6B-12.

FIGURE 3.6B-23

EMERGENCY FEEDWATER SYSTEM (FWE)
INSIDE REACTOR CONTAINMENT
BEAVER VALLEY POWER STATION - UNIT 2
UPDATED FINAL SAFETY ANALYSIS REPORT

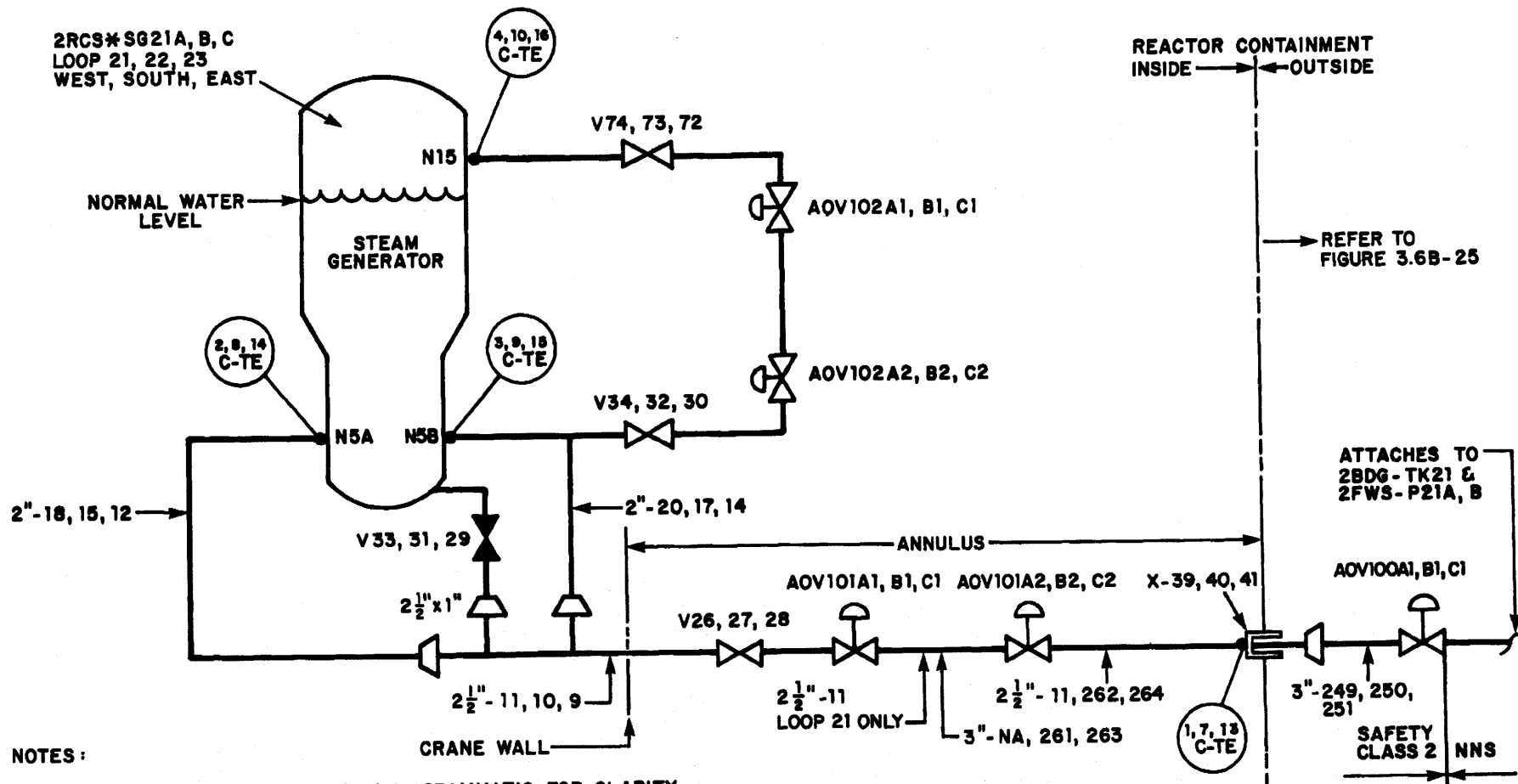

NOTES:

1. PIPING NOT TO SCALE; SHOWN DIAGRAMMATIC FOR CLARITY.
2. BREAK DESIGNATION } $\begin{matrix} N \\ X-Y \end{matrix}$ WHERE, N → BREAK NUMBER
 2BDG - N - Z - X } X → CIRCUMFERENTIAL ONLY
 } Y → REASON (EA or TE)
 } Z → LOCATION (C or A)
3. BREAK REASON } EA = LOCATION EXCEEDS ALLOWABLE STRESS.
 NOMINCLATURE } TE = TERMINAL END @ ANCHOR/EQUIP/BRANCH CONNECTIONS.
4. ALL VALVE/PIPE MARK NUMBERS ARE PRECEDED BY THE PLANT UNIT NUMBER AND SYSTEM DESIGNATION (2BDG-) UNLESS OTHERWISE NOTED.

FIGURE 3.6B-24
 STEAM GENERATOR BLOWDOWN SYSTEM (BLG)
 INSIDE REACTOR CONTAINMENT

BEAVER VALLEY POWER STATION - UNIT 2
 UPDATED FINAL SAFETY ANALYSIS REPORT

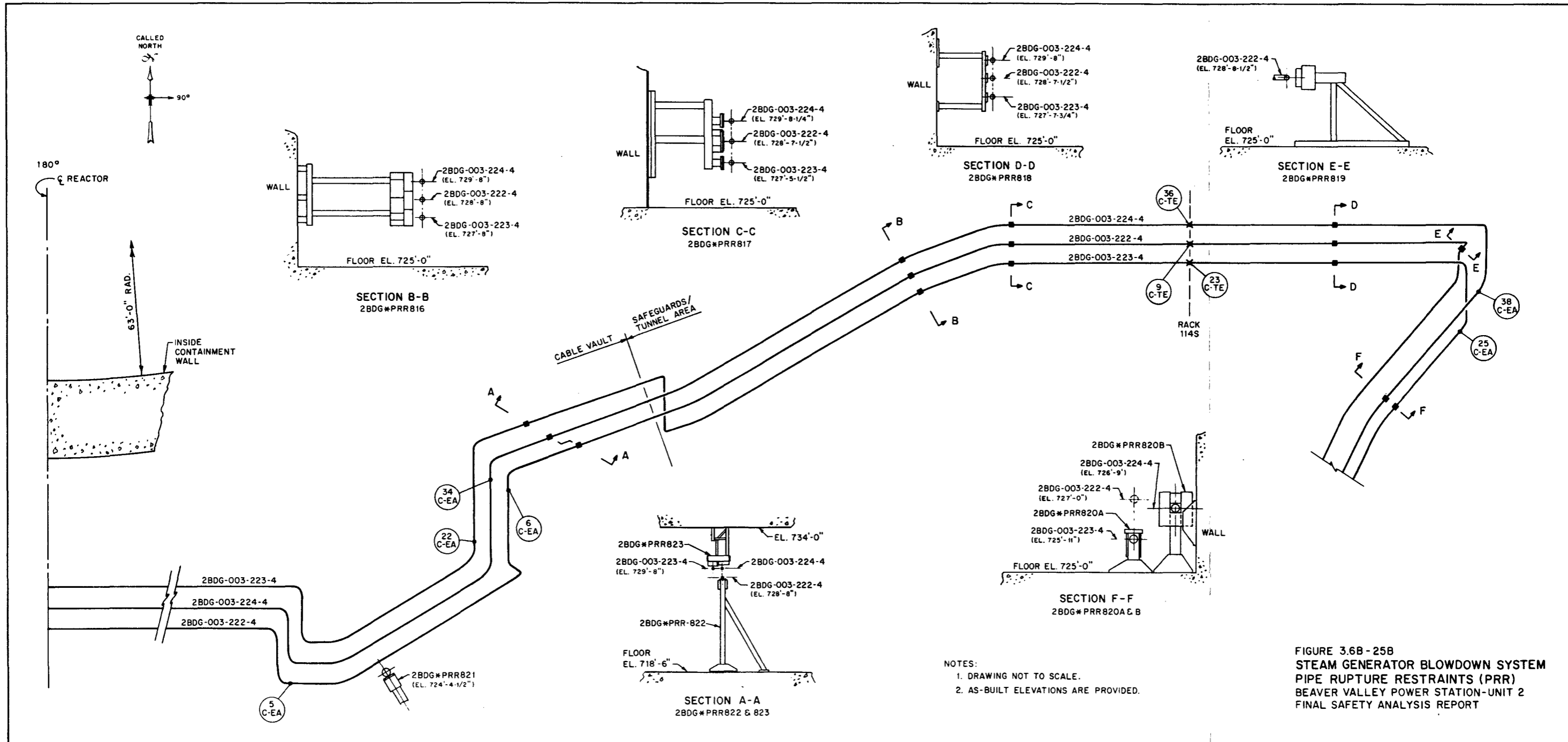

NOTES:
 1. DRAWING NOT TO SCALE.
 2. AS-BUILT ELEVATIONS ARE PROVIDED.

FIGURE 3.6B-25B
 STEAM GENERATOR BLOWDOWN SYSTEM
 PIPE RUPTURE RESTRAINTS (PRR)
 BEAVER VALLEY POWER STATION-UNIT 2
 FINAL SAFETY ANALYSIS REPORT

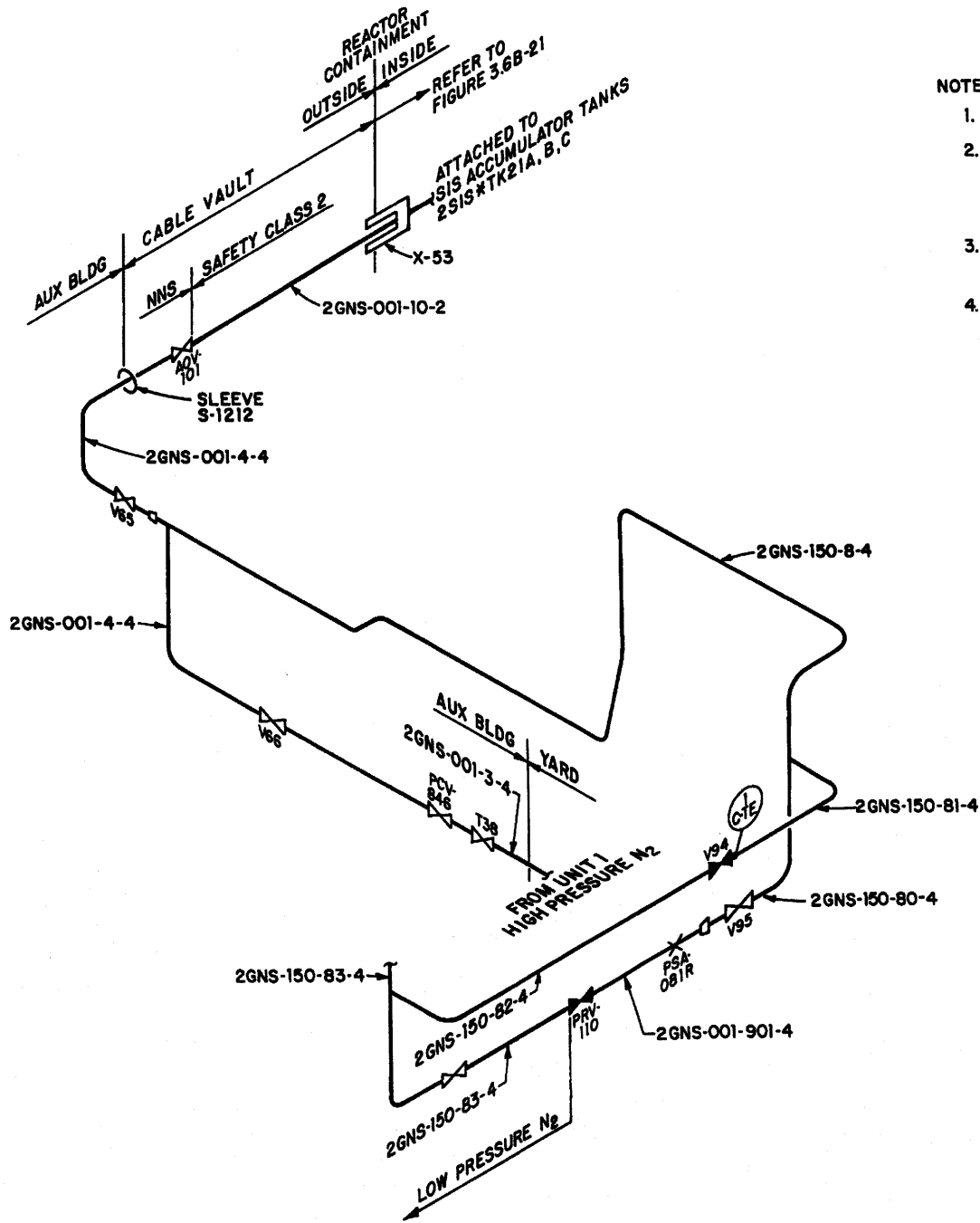

NOTES:

1. PIPING NOT TO SCALE
2. BREAK DESIGNATION } (NXY) WHERE, N → BREAK NUMBER
 2GNS-N-Z-X } X → TYPE (C-CIRCUMFERENTIAL ONLY)
 Y → REASON (TE OR EA)
 Z → LOCATION (O-OUTSIDE)
3. BREAK REASON } EA = LOCATION EXCEEDS ALLOWABLE STRESS.
 NOMINCLATURE } TE = TERMINAL END AT PRESSURE BOUNDARY.
4. THE SEGMENTS OF THE GNS SYSTEM IN THE AUX BLDG/CABLE VAULT AREA ARE SEISMICALLY SUPPORTED NON-NUCLEAR SAFETY CLASS (SC4) PIPING.

FIGURE 3.6B-26
 NITROGEN GAS SUPPLY (GNS) SYSTEM
 OUTSIDE REACTOR CONTAINMENT
 BEAVER VALLEY POWER STATION - UNIT 2
 UPDATED FINAL SAFETY ANALYSIS REPORT

CASE I OUTGOING LINES WITH NORMALLY CLOSED VALVE

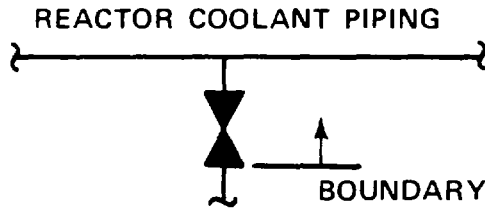

NOTE: PRESSURIZER SAFETY VALVES ARE INCLUDED UNDER THIS CASE.

CASE II OUTGOING LINES WITH NORMALLY OPEN VALVES

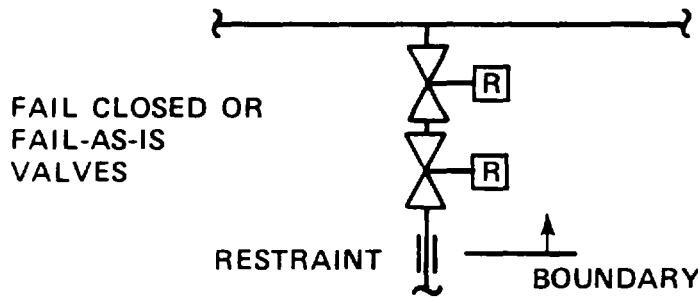

NOTE: THE REACTOR COOLANT PUMP NO. 1 SEAL IS ASSUMED TO BE EQUIVALENT TO THE FIRST VALVE.

CASE III INCOMING LINES NORMALLY WITH FLOW

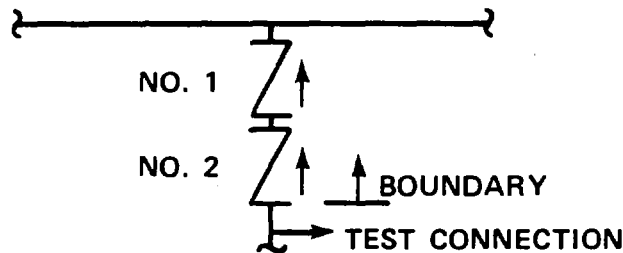

CASE IV INCOMING LINES NORMALLY WITHOUT FLOW

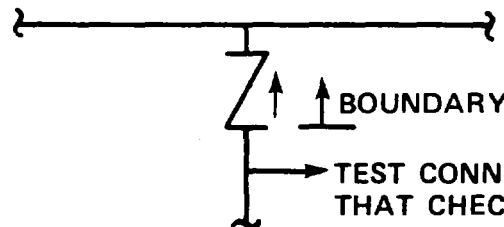

CASE V ALL INSTRUMENTATION TUBING AND INSTRUMENTS CONNECTED DIRECTLY TO THE REACTOR COOLANT SYSTEM IS CONSIDERED AS A BOUNDARY. HOWEVER, A BREAK WITHIN THIS BOUNDARY RESULTS IN A RELATIVELY SMALL FLOW WHICH CAN NORMALLY BE MADE UP WITH THE CHARGING SYSTEM.

FIGURE 3.6N-2
LOSS OF REACTOR COOLANT
ACCIDENT BOUNDARY LIMITS
BEAVER VALLEY POWER STATION-UNIT 2
FINAL SAFETY ANALYSIS REPORT

3.7 SEISMIC DESIGN

Sections whose identification numbers include the letter B contain material within balance-of-plant (BOP) scope, while sections whose identification numbers include the letter N contain material within the nuclear steam supply system scope (including material pertaining to the reactor coolant loop piping out to the first weld of any connecting piping).

3.7B.1 Seismic Input

3.7B.1.1 Design Response Spectra

The horizontal design response spectra used for seismic analysis are shown on Figures 3.7B-1 and 3.7B-2. The spectra for the safe shutdown earthquake (SSE) correspond to a maximum ground surface acceleration of 0.125g, and the spectra for the 1/2 safe shutdown earthquake (1/2 SSE) correspond to a maximum ground acceleration of 0.06g. (The operating basis earthquake, which is referenced in Section 3.2, and Regulatory Guide 1.143, is equivalent to 1/2 of the SSE.) These spectra differ from the spectra in Regulatory Guide 1.60. The Beaver Valley Power Station - Unit 2 (BVPS-2) spectra are based in Appendices 2C and 2D of the BVPS-2 PSAR, and as revised in the response to USAEC Regulatory Position 3 of May 25, 1973 (Question 3.15, BVPS-2 PSAR, Amendment 7, July 9, 1973). The vertical design response spectra are taken to be two-thirds of the horizontal design response spectra.

3.7B.1.2 Design Time History

The horizontal SSE design time histories yield response spectra which envelop the horizontal design response spectra as shown on Figures 3.7B-3, 3.7B-4, 3.7B-5, 3.7B-6, 3.7B-7 and 3.7B-8. The magnitudes of the vertical design time histories are taken to be two-thirds of that for the horizontal design time histories for both the SSE and the 1/2 SSE. A plot of the horizontal SSE time history is shown on Figure 3.7B-36.

Where finite element soil structure interaction analysis is performed, the time history is applied at grade in the free field. Where analysis is performed using frequency-independent springs representing soil stiffness, the time history is applied at the foundation level.

The horizontal design time history is checked by comparing its spectral values with those of the site design response spectra at 250 oscillator periods between 0.04 second and 5.0 seconds. The oscillator periods are distributed logarithmically according to the following expression:

$$T_i = \lambda T_{i-1}$$

$$\lambda = (T_{250}/T_1)^{1/249} = (5/.04)^{1/249}$$

$$\lambda = 1.019 \quad (3.7B-1)$$

where:

T_i and T_{i-1} are any two consecutive oscillator periods.

T_i / T_{i-1} is the period ratio (ratio between the i th period, T_i , and the $(i-1)$ th period, T_{i-1}).

3.7B.1.3 Critical Damping Values

The values of the percentage of critical damping used in the analysis of Seismic Category I structures, systems, and components depend on the seismic input motion used in the analysis and the type of construction or fabrication.

The values of damping used for the BVPS-2 input motion are listed in Table 3.7B-1.

3.7B.1.4 Support Media for Seismic Category I Structures

Category I structures are founded on compacted select granular fill overlying dense in situ granular soil which extends to bedrock, or directly on the in situ granular soil, with one exception. The in situ soil beneath the safeguards area and the refueling water storage tank (RWST) was excavated as shown on Figures 2.5.4-8 and 2.5.4-9, respectively, and replaced with select granular fill to the founding grades of the respective structures. Beneath the northern portions of these two structures is a layer of stiff, silty clay with a top surface at approximately el 688 feet. The layer is about 20 feet thick at the northern edge of the safeguards area and about 10 feet thick at the northern edge of the RWST. The layer thins to the south and is no longer present at about the east-west centerline of the safeguards area.

Foundation information for Category I structures is given in Table 3.7B-2. The dynamic properties of the soil and select granular fill underlying the Category I structures are discussed in Section 2.5.4.7. The use of these properties in the analysis of soil-structure interaction is discussed in Section 3.7B.2.4.

3.7B.2 Seismic System Analysis

Seismic system analyses discussed in this section are defined to be Seismic Category I structures that are considered in conjunction with the foundation media in forming a soil-structure interaction model. Other systems and components are considered seismic subsystems and are discussed in Sections 3.7B.3 and 5.4.14.

3.7B.2.1 Seismic Analysis Methods

Analysis of seismic systems was performed using either the modal analysis response spectra method or the modal analysis time history method. Response spectrum analysis uses the natural frequencies, mode shapes, and weighted modal dampings to determine the maximum seismic response of multi-degree-of-freedom systems with lumped masses and elastic connecting members. Time history modal analysis uses the same free vibration characteristics and damping factors as the spectrum analysis, primarily to determine acceleration response spectra at selected locations within the structure. The methods used for seismic analysis of particular Seismic Category I structures are summarized in Table 3.7B-3.

Mathematical models of three buildings representative of Seismic Category I structures are discussed in detail. Models selected are the containment structure (Figure 3.7B-9), the fuel building (Figure 3.7B-10), and the cable vault building (Figure 3.7B-11).

Descriptions of these buildings are provided in Sections 3.8.1 and 3.8.3.

Foundation effects, namely torsion, rocking, and translation, were included in the dynamic analysis by use of soil-structure interaction techniques discussed in Section 3.7B.2.4. The containment structure is, for the purposes of seismic analysis, axisymmetric. A planar model was thus employed for its analysis. All other Seismic Category I structures were analyzed considering six degrees-of-freedom: three translation, two rocking, and one torsional.

The containment structure was analyzed using both a discrete soil spring-dashpot model (computer programs STRUDL-II and TIME HISTORY) and a finite element soil structure interaction model computer program (PLAXLY) was used. The design of buried piping is explained in Section 3.7B.3.12. The finite element model better represents the actual conditions as described by the U.S. Nuclear Regulatory Commission (USNRC 1975) since the containment structure is deeply embedded.

A comparison of results from the two analyses show the high degree of conservatism in the discrete soil spring method (Figures 3.7B-56, 3.7B-57, 3.7B-58, 3.7B-59, 3.7B-60 and 3.7B-61).

The finite element results are applicable for the containment structure. Other structures were analyzed using the discrete springs and dashpots suggested by Whitman and Richart (1967), Richart (et al 1970), Wass (1972) and Kausel and Roesset (1975). Springs associated with the degrees-of-freedom in a global orthogonal coordinate system were used.

In developing the lumped-mass models for Seismic Category I structures, an adequate number of degrees-of-freedom was ensured by providing a lumped mass at the mat, floor, and roof elevations. Additional masses were used when changes in geometry or stiffness warranted them. In the cases of the containment shell, seven lumped masses were selected at critical points of interest. Studies have been conducted which show the difference in base shear and overturning moments between a 3-mass and a 15-mass model to be less than 3 percent. Comparisons between 3-, 5-, 10-, and 15- mass models have shown a difference in natural frequency for the first two modes of less than 1 percent.

The number of degrees of freedom considered in the seismic models is equal to approximately twice the number of modes with frequencies less than 33 Hz.

Each Seismic Category I building has a foundation mat which serves as a single structural support. Four-inch shake spaces, larger than any predicted structure-to-structure displacements, are provided between all Seismic Category I structures. Relative displacements were considered for all Category I systems and components which run between structures. Special seismic effects such as hydrodynamic loads and nonlinear responses were considered where appropriate.

3.7B.2.2 Natural Frequencies and Response Loads

Response spectrum analyses for the containment structure, the fuel building, and the cable vault building are summarized below. They are representative samples of Category I structures.

3.7B.2.2.1 Containment Summary

The response spectrum analysis of the containment and internal structures included the enveloping of six discrete analyses. The dynamic model of the containment (Figure 3.7B-9) was analyzed with cracked and uncracked concrete properties. The soil springs were analyzed for three different values of soil shear moduli. The three soils analyzed had shear moduli of 12, 18, and 24 ksi, with 18 ksi being the best estimate of the founding material (BVPS-2 PSAR Section 2.5.3).

The significant natural frequencies and modal participation factors, resulting from analyses for the cracked and uncracked containment structure with median soil stiffness, are presented in Tables 3.7B-4 and 3.7B-5. Significant mode shapes resulting from these analyses are presented in Tables 3.7B-6 and 3.7B-7 and Figures 3.7B-12, 3.7B-13, 3.7B-14 and 3.7B-15; the response loads obtained by the square root of the sum of the squares method (SRSS) are summarized in Tables 3.7B-8 and 3.7B-9. Table 3.7B-10 presents the degrees-of-freedom corresponding to x- and y-direction translation and rotation about the z axis for the containment and internal structures response loads obtained by the SRSS method. Tables 3.7B-11 and 3.7B-12 contain the maximum responses at each mass point resulting from enveloping all six analyses.

The amplified response spectra (ARS) produced using the modal analysis time history method for the median soil, cracked and uncracked containment cases are provided at the springline, mat, and operating floor for horizontal and vertical SSE excitations (Figures 3.7B-16, 3.7B-17, 3.7B-18, 3.7B-19, 3.7B-20, 3.7B-21, 3.7B-22, 3.7B-23, 3.7B-24, 3.7B-25, 3.7B-26 and 3.7B-27). Typical ARS resulting from the enveloping of all six analyses are shown on Figures 3.7B-28, 3.7B-29, 3.7B-30, 3.7B-31, 3.7B-32 and 3.7B-33.

Examples of the resulting acceleration time histories at the springline and operating floor, as well as the original input time history, are shown on Figures 3.7B-34, 3.7B-35, 3.7B-36.

3.7B.2.2.2 Fuel Building Summary

The dynamic model of the fuel building (Figure 3.7B-10) was excited separately by one vertical and two orthogonal horizontal excitations. The resulting significant natural frequencies, participation factors, and mode shapes are listed in Tables 3.7B-13 and 3.7B-14. The maximum responses due to each excitation are obtained by combining the modal responses according to the closely spaced modes modal combination method discussed in Section 3.7B.2.7. Summaries of the maximum responses due to each SSE excitation are presented in Tables 3.7B-15 and 3.7B-16. The total responses, considering all three base excitations simultaneously, are obtained by combining the maximum responses from each excitation by the SRSS method. Refer to Table 3.7B-17 for a summary of the total SSE responses.

Table 3.7B-18 presents, for the fuel building analysis, the relationship between the degrees-of-freedom and the motion of the lumped masses given in Tables 3.7B-15, 3.7B-16, and 3.7B-17.

Examples of the ARS resulting from each direction of excitation produced using the modal analysis time history method are provided at the mat (Figures 3.7B-37, 3.7B-38, 3.7B-39), the top of the fuel pool (Figures 3.7B-40, 3.7B-41, 3.7B-42), and at the top of the crane rail support structure (Figures 3.7B-43, 3.7B-44, 3.7B-45).

3.7B.2.2.3 Cable Vault Building Summary

The seismic analysis of the cable vault building was conducted in a manner identical to that of the fuel building. The dynamic model shown on Figure 3.7B-11 was excited separately by three orthogonal excitations. The significant natural frequencies, participation factors, and mode shapes resulting from these excitations are listed in Tables 3.7B-19 and 3.7B-20. The maximum responses due to each excitation are obtained by combining the modal responses according to the closely spaced modes combination method discussed in Section 3.7B.2.7. Summaries of the maximum responses due to each SSE excitation are presented in Tables 3.7B-15 and 3.7B-16. The total responses, considering all three base excitations simultaneously, are obtained by combining the maximum responses from each excitation by the SRSS method. Refer to Table 3.7B-17 for a summary of the total SSE responses.

Table 3.7B-21 presents, for the cable vault building analysis, the relationship between the degrees-of-freedom and the motion of the lumped masses given in Tables 3.7B-22, 3.7B-23, and 3.7B-24.

Typical ARS at el 718 feet-6 inches, 735 feet-6 inches, and 805 feet-5 inches, produced using the modal analysis time history method, are shown on Figures 3.7B-46, 3.7B-47, 3.7B-48, 3.7B-49, 3.7B-50, 3.7B-51, 3.7B-52 and 3.7B-53.

3.7B.2.3 Procedures Used for Analytical Modeling

The dynamic model of a Seismic Category I structure is constructed to obtain a satisfactory representation of the dynamic behavior of the structure. Major Seismic Category I structures that are considered in conjunction with foundation media in forming a soil-structure interaction model are defined as seismic systems. Other Seismic Category I systems and components that are not designated as seismic systems are considered as seismic subsystems. In most cases, equipment and components come under the definition of seismic subsystems and are analyzed as a decoupled system from the primary structure. To define criteria for decoupling subsystems, R_m , the mass ratio, and R_f , the frequency ratio, are significant. R_m and R_f are defined as:

$$R_m = \frac{\text{Total mass of the supported subsystem}}{\text{Mass that supports the subsystem}}$$

$$R_f = \frac{\text{Fundamental frequency of the supported subsystem}}{\text{Frequency of the dominant support motion}}$$

The following criteria are used.

1. If $R_m < 0.01$, decoupling is acceptable for any R_f ,
2. If $0.01 \leq R_m \leq 0.1$, decoupling is acceptable if $0.8 \geq R_f \geq 1.25$,

3. If $R_m > 0.1$, an approximate model of the subsystem is included in the primary system model.

If the subsystem is comparatively rigid and also rigidly connected to the primary system, only the mass of the subsystem is included at the support point in the primary system model. In the case of a subsystem supported by very flexible connections (for example, a pipe supported by hangers), the subsystem is not included in the primary model.

In most cases, the equipment and components which come under the definition of subsystems were analyzed separately from the primary structure, and the seismic input for the subsystem is obtained from the analysis of the structure. One important exception to this procedure is the analysis of the reactor coolant system (RCS), which was considered to be a subsystem but was analyzed using a coupled model of the RCS and primary structure with ground motion as the seismic input (Section 5.4.14).

The dynamic model of a seismic system consists of a set of lumped masses, generally having 6 degrees-of-freedom per mass connected by weightless elastic members. Masses are usually lumped at floor levels and include the masses of the floors, walls, columns, equipment, and piping. The floors are treated as rigid diaphragms that transfer the earthquake inertia forces to frames and shearwalls, which in turn transfer the loads to the foundation mat and the subgrade. Beam theory, combining the effects of shear, flexure, torsion, and axial deformation, is used to establish the stiffness characteristics of the frame-wall systems. Eccentricities between the centers of mass and centers of rigidity are considered.

As an example, the lumped mass model of the containment is shown on Figure 3.7B-9. The model was constructed so that it properly represents the free vibration of a cantilevered structure in shear and flexure. The model consists of a system of lumped masses, each with 3 degrees-of-freedom, connected by weightless members. The base of the model is supported on a deformable subgrade represented by equivalent springs whose stiffness was determined as indicated in Section 3.7B.2.4. Masses M_1 through M_7 represent the dome and the cylindrical portion of the containment shell. M_8 consists of the mat and portions of the walls and columns which are attached to the mat. The internal structure, consisting of equipment, primary shield wall, cubicle walls, crane wall, etc, were modeled by masses M_9 through M_{13} .

3.7B.2.4 Soil-Structure Interaction

The site, as discussed in Section 2.5.1, is a relatively uniform gravel terrace approximately 110 feet deep resting on a Pennsylvanian-age shale bedrock. The embedment and founding elevations data presented in Table 3.7B-2 indicate that some Seismic

Category I structures are deeply embedded and some have shallow embedments as described by the USNRC (1975).

Finite element soil-structure interaction analysis is appropriate for either shallowly or deeply-embedded structures, and is required for deeply-embedded structures (USNRC 1975). The containment structure and the fuel building were analyzed using the finite element soil structure interaction method. They were also analyzed using discrete, nonfrequency-dependent soil springs, as were all other Seismic Category I structures.

For the finite element analysis, the containment lumped mass model discussed in Section 3.7B.2.3 was attached to a finite element representation of the soil subgrade, as shown on Figure 3.7B-54. For discussion of soil properties used, refer to the BVPS-2 Report on Soil Densification program (DLC 1976). This model was then subjected to horizontal and vertical excitations by means of the program PLAXLY. The bottom boundary was taken at bedrock and the side boundaries used PLAXLY'S energy transmitting boundary corresponding to layers of soil extending laterally to infinity. The material properties of the soil were assumed to be linearly viscoelastic, and the dynamic equations were solved in the frequency domain using Fourier transformation techniques. Nonlinear behavior in the subgrade was simulated by an iterative algorithm, in which the soil parameters were adjusted according to the resulting levels of strain (for a more detailed discussion of PLAXLY, refer to Appendix Section 3A.1.7).

For comparison purposes the containment and fuel buildings were also analyzed using a common finite element soil grid, as shown on Figure 3.7B-55, by means of the program FLUSH (Lysmer et al 1975). The analyses with discrete nonfrequency-dependent soil springs used spring constants calculated by equations suggested by Whitman (et al 1967), Richart (et al 1970), Wass (1972), and Kausel and Roesset (1975). A value of 10 percent maximum soil damping assured the conservatism of the discrete spring method.

Comparisons of the containment ARS generated by both analyses, (Figures 3.7B-56, 3.7B-57, 3.7B-58, 3.7B-59, 3.7B-60 and 3.7B-61) demonstrate that the discrete spring method is considerably more conservative than the finite element analysis. Similar comparisons for the fuel building are shown on Figures 3.7B-62, 3.7B-63, 3.7B-64 and 3.7B-65.

Thus, the discrete spring method, as formulated for the soil conditions described in Section 2.5.1, provides conservative results for Seismic Category I buildings, and is used in place of more extensive finite element analysis for buildings other than the containment structure. Since the containment structure is deeply embedded, the finite element method is used for its seismic analysis as described by the USNRC (1975).

3.7B.2.5 Development of Floor Response Spectra

Floor response spectra were developed separately for one vertical and two mutually perpendicular horizontal earthquake motions using the modal analysis time history method discussed in Section 3A.1.6 for all buildings except the containment structure. Floor response spectra for the containment were developed using the modal analysis method in PLAXLY, Section 3A.1.7.

Combination of the three components of floor response spectra for use in subsystem seismic analysis is discussed in Section 3.7B.3.

3.7B.2.6 Three Components of Earthquake Motion

Procedures to combine three components of earthquake motion to determine the response of seismic systems meet the recommendations of Regulatory Guide 1.92 to the extent described in Section 1.8.

3.7B.2.7 Combination of Modal Responses

In general, for those Seismic Category I systems analyzed by the modal analysis response spectrum method, the influence of closely spaced modes was considered by use of the "double sum method," described in Regulatory Guide 1.92 and in Singh (et al 1973) to the extent described in Table 1.8-1. If there are no closely spaced modes, the responses are combined by using the SRSS method.

3.7B.2.8 Interaction of Non-Category I Structures with Seismic Category I Structures

All Seismic Category I structures are separated from adjacent structures by a 4-inch shake space. The 4-inch clearance is larger than the predicted relative displacements of any adjacent buildings. Section 2.5.4 provides a discussion for determining relative displacements.

Non-Category I structures are sufficiently remote from Seismic Category I structures to preclude interaction or are designed as discussed in Section 3.8.3 to avoid collapse during an SSE, thus preventing significant damage to adjacent Category I structures.

3.7B.2.9 Effects of Parameter Variations on Floor Response Spectra

In order to consider the effects of variations of structural properties, dampings, and soil properties, peak resonant period values of the floor response spectra were spread plus 25 and minus 20 percent with vertical sides except as indicated in Section 3.7B.3.1.2. For the containment structure which experiences substantial cracking during the structural acceptance test, floor response spectra for the cracked and uncracked cases were enveloped.

The use of floor time histories in subsystem analysis is discussed in Section 5.4.14.

3.7B.2.10 Use of Constant Vertical Static Factors

Dynamic vertical responses were calculated in all seismic system analyses, precluding the need to use constant vertical static factors.

3.7B.2.11 Method Used to Account for Torsional Effects

The containment structure is axisymmetric and was analyzed using 3 degrees-of-freedom per mass. All other Seismic Category I structures were analyzed dynamically using 6 degrees-of-freedom per mass. Effects of eccentricity between centers of mass and centers of stiffness or soil contact were included in determining appropriate member stiffnesses in the dynamic models.

3.7B.2.12 Comparison of Responses

As discussed in Section 3.7B.2.1, the results of the response spectrum analysis were used for the design of all Seismic Category I structures except the containment structure, and the results of the modal time history analyses provided the floor time histories used to create floor response spectra.

The maximum responses attained from the time history analysis are compared with those resulting from the response spectrum technique in Tables 3.7B-25, 3.7B-26, 3.7B-27 and 3.7B-28 for representative structures.

The generally higher time history results are attributable to the fact that the artificial ground time history yield response spectra conservatively envelop the BVPS-2 ground response spectra. The extent of this conservatism is illustrated on Figures 3.7B-3, 3.7B-4, 3.7B-5, 3.7B-6, 3.7B-7, and 3.7B-8 which compares the BVPS-2 ground response spectra with response spectra generated by using the site artificial time history as the forcing function. The increased acceleration response, particularly in the 1.0-5.0 Hz range, resulting from the artificial time history, is comparable to the increases witnessed in Tables 3.7B-25, 3.7B-26, 3.7B-27 and 3.7B-28. The finite element studies discussed in Section 3.7B.2.4 support the conservatism of both the response spectrum and the time history analyses.

3.7B.2.13 Methods for Seismic Analysis of Category I Dams

There are no Category I dams at this site.

3.7B.2.14 Determination of Category I Structure Overturning Moments

Overturning moments for Seismic Category I structures are determined by taking the accelerations derived from combinations of the three components of earthquake motion and conservatively combining the vertical and lateral forces in order to maximize the overturning moment.

The structural overturning moment was calculated by multiplying each lumped mass and its horizontal acceleration by its distance above the founding elevation. To this moment was added the moment resulting from multiplying the lumped mass by its vertical acceleration and the horizontal eccentricity between its center of mass and the mat-soil center of contact. In order to consider the action of vertical and lateral forces conservatively, eight separate cases were generally investigated. Horizontal accelerations were studied acting in four perpendicular directions (North, South, East, and West) and each of these horizontals was combined with the vertical acceleration acting up and acting down. The resulting overturning moment was then compared with the minimum resisting moment to determine the factor of safety against overturning which was required to be greater than the value given in Table 3.8-13. The peak soil bearing pressure was then checked against the allowable value specified. Bearing capacities and required factors of safety against overturning and sliding are discussed in Section 2.5.4.

3.7B.2.15 Analysis Procedure for Damping

An equivalent viscous modal damping, reflecting the different damping rates in various portions of the structure, is computed for use in structural dynamic analysis. The modal damping ratio is a weighted average of member and support spring damping, based on the contribution of each to the total strain energy of the mode shape. The method is based on work by Roesset (et al 1973). The following discussion is meant to serve as a general description. The more theoretical derivations (Roesset et al 1973; Whitman 1970) are found in the literature.

3.7B.2.15.1 Damping and Strain Energy Methods

An important factor in determining structural response is the damping phenomenon. Two types of damping are generally recognized: viscous (in which the energy dissipated per cycle is proportional to frequency) and hysteretic (in which no frequency dependence is seen). Most structural elements display hysteretic behavior, while supporting soils appear to combine both hysteretic and viscous damping mechanisms.

For certain applications (for example, pipe breaks) in which foundation motion can be neglected, only hysteretic damping need be considered. Whitman's (1970) analysis of Biggs' formula gives a useful approximation for the damping of each mode when material damping varies from element to element. The expression for the equivalent viscous modal damping is obtained by a strain-energy weighting of element damping:

$$B_{eqv}^j = \frac{\sum_{i=1}^N D_i E_i^j}{\sum_{i=1}^N E_i^j} \quad (3.7B-2)$$

where:

- B_{eqv}^j = Equivalent viscous damping ratio (fraction of critical) for structure vibrating in mode j,
- N = Number of elements,
- D_i = Hysteretic damping ratio for element i,
- E_i^j = Strain energy in element i when deflected into mode shape j

In particular, when damping is uniform (that is, $D_i = D$) then $B_{eqv}^j = D$ for all modes. When damping is not uniform, modal damping is weighted toward those elements which make the largest contribution to the energy of each mode. In other applications (for example, earthquakes) in which foundation motion is significant, viscous damping also must be considered. Current practice treats the soil damping as viscous for translational motion, and hysteretic for rotational motion. Roesset (et al 1973) extended Biggs' formula to include the viscous damping contributions of the soil:

$$B_{eqv}^j = \frac{\sum_{i=1}^{N_H} D_i E_i^j + \sum_{k=1}^{N_V} \left(\frac{W_k^j}{W_k} \right) B_k E_k^j}{\sum_{i=1}^{N_H} E_i^j + \sum_{k=1}^{N_V} E_k^j} \quad (3.7B-3)$$

where:

N_H	=	Number of hysteretically damped elements,
N_V	=	Number of viscously damped elements,
W_j	=	Frequency of structure mode j (radians per second),
W_k	=	Frequency of element k (radians per second),
B_k	=	Critical damping ratio of element k at frequency W_k

The square of the natural frequency W^2 of the soil element, is equal to the ratio of the soil spring stiffness to total mass of the structure plus foundation.

This formula reflects the fact that the energy dissipation per cycle by the viscous mechanism is proportional to frequency of motion. Any element which displays both hysteretic and viscous damping appears in both summations of the numerator, but is not repeated in the denominator.

Each element strain energy appearing in Equation 3.7B-2 is evaluated from the element stiffness matrix and the displacement of the element's boundary joints. After comparing the Biggs and Roesset modal damping ratios calculated from Equations 3.7B-2 and 3.7B-3, the lower value for each mode is selected for use in the dynamic analysis, thus assuring that the composite modal damping value never exceeds the hysteretic damping value. In no case do modal damping values exceed 10 percent.

3.7B.3 Seismic Subsystem Analysis

3.7B.3.1 Seismic Analysis Methods

3.7B.3.1.1 Equipment and Components

Seismic Category I equipment is documented for seismic adequacy. Depending upon equipment location, the basic source of seismic design data is either the ground response spectra, the ARS, or floor time history, derived through a dynamic analysis of the relevant structure as described in Sections 3.7B.2.5 and 3.7B.2.9.

Three principal methods of documenting adequacy for Seismic Category I equipment are:

1. Static analysis,
2. Dynamic analysis, and
3. Testing.

The effects of supports are reflected in the input to seismically qualified equipment and components. General stress limits are given in Section 3.9B.3.1. Specific component stress allowables are given in Tables 3.9B-7 and 3.9B-10. Such limits either conform to, or are more conservative than, those of ASME Section III, Subsection NF.

Laboratory tests are performed on Seismic Category I mechanical and electrical equipment, and complex instrumentation that do not lend themselves to being modeled to accurately predict response. Conversely, analytical methods are employed when mathematical modeling techniques are appropriate (as described here), or when equipment characteristics (size rating) preclude laboratory testing. Combinations of analysis and testing are also employed to ensure adequacy of Seismic Category I equipment.

The SSE is the load basis which ensures the safety function of Seismic Category I equipment. The 1/2 SSE loadings are used to ensure continued normal operation of the Seismic Category I equipment. Earthquake loadings are combined with operating loadings to ensure necessary functions during 1/2 SSE and SSE conditions.

Equipment vendors and suppliers are required to formulate programs for Seismic Category I equipment qualification in accordance with specification requirements. Documentation of the seller's qualification program is reviewed and approved by the Applicant or Agent of Applicant.

3.7B.3.1.1.1 Static Analysis

Static analysis is utilized for equipment and components that can be characterized as relatively simple structures. This type of analysis involves the multiplication of the equipment or component total weight by the specified seismic acceleration (direction dependent loading), to produce forces that are applied at the center of gravity in the horizontal and vertical directions. A stress analysis of equipment components, such as supports, holddown bolts, and other structural members, is performed to determine their adequacy.

In the specification of equipment for static analysis, two or more sets of acceleration data are provided. The choice of which set to use is dependent upon the equipment's fundamental natural frequency. The relevant response curves are reviewed to determine a cutoff frequency, which separates the rigid range from the resonance range of the response curves. Equipment and components having fundamental natural frequencies above the cutoff frequency of the relevant response curve are analyzed to rigid range response accelerations.

For components or equipment having a fundamental natural frequency below the cutoff frequency, analysis is based on response accelerations that are not less than those indicated by the amplified response curves over the full frequency range of the component. If

the fundamental mode of the component falls within any of the resonant response peaks, and if the component cannot be characterized as a single degree of freedom system, the resonant response acceleration is multiplied by a factor of 1.3 as a justified factor for conservatism, in order to account for all significant dynamic modes under a resonant situation (Section 3.7B.3.5).

Each of the three defined directions of earthquake input (two horizontal and one vertical taken orthogonally) is evaluated separately. Horizontal and vertical seismic loads are added considering a single horizontal direction earthquake acting concurrently with the vertical direction earthquake on a most severe basis. The stresses resulting from the orthogonal earthquake inputs are combined by the absolute addition of the worst horizontal plus vertical stress. Equipment is designed to withstand the combined effects of normal operating loads acting simultaneously with the earthquake loadings without loss of safety function or structural integrity.

3.7B.3.1.1.2 Dynamic Analysis

A detailed dynamic analysis is performed when equipment complexity or dynamic interaction precludes static analysis, or when static analysis is too conservative. Dynamic analysis methods include:

1. Response spectrum modal analysis,
2. Time-history by modal superposition, and
3. Time-history by numerical integration.

The response spectrum modal analysis technique is most commonly used.

Modeling

To describe fully the behavior of complex equipment subjected to dynamic loads, infinite numbers of coordinates would be required. Because calculating every point of the complex equipment model is impractical, the analysis is simplified by taking a judicious selection of a limited number of mass points. The lumped mass, or consistent mass, approach is employed in the dynamic analysis. In the lumped and the consistent mass idealizations, the main structure is divided into substructures and the masses of these substructures are concentrated at a number of discrete points. The nature of these substructures, and the stiffness properties of the corresponding modeling elements, determine the minimum spacing of the mass points and the degrees of freedom to associate to each point. In accordance with the minimum spacing requirements, the analyst can then choose, for the model, particular mass points which reflect predominant masses of subcomponents which are believed to contribute significantly to the total response.

Modeling of equipment structures for dynamic analysis starts with the calculation of lumped masses at discrete stations, and the evaluation of the elastic properties (or stiffness) of connecting members. The number of discrete mass points is selected to adequately describe the dynamic characteristics and natural frequency of the equipment. General modeling guidelines indicate that good natural frequency characteristics are obtained when the number of discrete mass or node points selected is twice the number of the highest mode of interest. Papers prepared by Lin and Hadjian (1976), Johnson and Kennedy (1977), and Lin (1974), and Sections 3.7B.2.1 and 3.7B.2.3 provide supplemental modeling guidance.

Response Spectrum Modal Analysis

The normal mode approach is employed for seismic analysis of equipment and components. Natural frequencies, eigenvectors, participation factors, and modal member-end forces and moments of the undamped structure are calculated. The system of equations which describes the free vibrations of an n-degree of freedom, undamped structure is presented in Section 3.7B.3.8.

Eigenvector-eigenvalue extraction routines, such as Householder-QR, Jacobi Reduction, and Inverse Iteration, are used, depending upon the total number of dynamic degrees of freedom and the number of modes desired.

The basis for the combination of maximum modal response is discussed in Section 3.7B.3.7.

Time-History Methods

There are two separate approaches to the solution of the equations of dynamic equilibrium for time-history motions. The modal superposition method involves the modal solution of the free vibration response of the system, and the transformation to normal coordinates utilizing the mode shapes of the system. This procedure uncouples the equations of motion so that the response of the system in each individual mode may be evaluated independently. Total system response can be determined by combining responses of individual modes oscillating simultaneously. The second method of time-history analysis is the direct integration solution that includes numerical integration of the simultaneous differential equations of dynamic equilibrium without transformation to normal coordinates. System response at each time point is evaluated by this technique.

Time-history solutions, due to their analytical complexity, are only used when results of other methods are too conservative, and when acceptable numerical solutions are available in a computer program. Computer program capability for time-history solutions is outlined in Appendix Section 3A.2.

3.7B.3.1.1.3 Testing

Equipment and components that are tested are seismically qualified in accordance with the following general instructions for earthquake testing. For tested equipment, these requirements conform with other applicable industry standards such as IEEE Standard 344-1971 (Section 3.10), or provide guidance for testing where no such standards are available. Equipment packages or components are shown to be seismically adequate by being tested individually, either as part of a simulated structural section, or part of an assembled module or unit. In any case, the minimum acceptance criteria includes:

1. No loss of safety function, or ability to function, before, during (for those components that may be required to function during a seismic event), or after the test,
2. No structural/electrical failure (connections and anchorages) that would compromise safety-related component integrity, and
3. No adverse or maloperation before, during, or after the test that could result in an improper safety action.

Equipment vendors and suppliers are required to formulate programs for qualifying the equipment in accordance with the conditions specified in the seismic design requirements contained in the equipment specifications. The vendor must submit a summary of the proposed effort for review and approval.

The characteristics of the testing input at the equipment mounting locations are defined by ARS curves, zero period response curve levels, time-history motions, or combinations of these as applicable. Equipment mounted in piping systems derive their input from piping systems analysis as described in Section 3.7B.3.3.2.

Single and multifrequency input testing are accepted as a method of seismic qualification, based upon the particular plant site, structure, and floor response characteristics. Structures, particularly at lower elevations, exhibit a broad frequency range response similar to the ground motion during an earthquake. This broad range frequency motion is filtered at higher structural elevations and response becomes more periodic in nature. Knowledge of the floor response characteristics of the structure and response characteristics of the equipment generally dictate the requirements for testing. Single frequency testing is applicable where periodic floor motion is indicated and, conversely, random input testing is most applicable for broad frequency range input to components. Single frequency testing can be used to envelop multiple peak floor responses, as well as single peak, providing sufficiently high testing input is used. For equipment exhibiting multiple response modes, single frequency input may be used, providing the input has

sufficient intensity to envelop the floor response spectra of the individual modes of the equipment.

The testing machine (fixture) setup is arranged so that the equipment tested is mounted to simulate, to the extent possible, the actual service mounting, in order to properly simulate the actual dynamic input to the tested component. Equipment is tested in the operating condition wherever possible, and functions are monitored and verified both during and after testing. However, a true operating environment is sometimes not obtainable for equipment such as pumps.

The in situ application of vibratory devices, to superimpose the seismic vibratory loadings on the complex active device for operability testing, is acceptable when application is justifiable.

A qualification test program may be based upon selectively testing a representative number of mechanical components according to type, load level, size, etc, on a prototype basis.

In addition to the single and multifrequency testing programs outlined, laboratory shock results, in-shipment shock data, or adequate historical dynamic adequacy data (previous relevant test or environmental data) are also given consideration. The test method selected must demonstrate the adequacy of principal structural and functional capability of the equipment.

General testing guidance criteria specified for equipment include the following:

1. Single Frequency Testing

Testing is performed for as much of the range between 1 and 33 Hz as practicable or justified. Input for qualification should, as a minimum, equal the zero period response curve level.

2. Sinusoidal Input

- a. A frequency scan (two octaves per minute, maximum), at a constant acceleration level, is performed over the frequency range of interest. The objective of this test is to determine the natural frequencies and amplification factors of the tested equipment, and its critical components or appurtenances, and to ensure general seismic adequacy over the full frequency range of interest. The acceleration inputs used are the maximum rigid range accelerations indicated by the relevant response spectrum curves (damping independent).

- b. A dwell test of the equipment at its fundamental natural frequency is included at the acceleration

values specified in item a. Additionally, other frequencies are selected if amplification factors of 2.0 or more are indicated. A minimum 20-second duration is considered acceptable for each dwell.

- c. Other methods of sinusoidal testing may be employed as justified. Included are exploratory tests per Item a which employ a low acceleration level input to identify equipment response characteristics, and to aid in selecting requirements for further testing. A geometrically spaced constant frequency input may be employed for further testing. Intervals of one-half octave or less are employed for this spacing.

3. Sine Beat Input

A sine beat test may be performed in conjunction with a sine scan, as an alternative to the dwell portion of the program outlined in item 2b previously listed. The sine beat test is performed at natural frequencies, and regions of large amplification identified during the sine scan. The duration and peak amplitude of the beat for each particular test frequency are chosen to produce a magnitude of equipment response most nearly equivalent to that produced by the particular floor response spectrum at justifiable damping levels.

Current practice indicates that a minimum of 10 cycles per beat should be used, unless a lower number of cycles is shown sufficient to duplicate or exceed the response spectra for the equipment at the appropriate location. Five sine beats, with a time delay between beats, are commonly used.

An alternative qualification program consists of applying a series of sine beats at geometrically-spaced frequency intervals of one-half octave or less over the frequency range of interest. The peak amplitude of the beat employed is, as a minimum, the maximum rigid range acceleration indicated by the relevant response spectrum curve.

4. Multifrequency Testing

Multifrequency testing is applicable as a general qualification method. Input excitation in this category includes time history, random, power spectral density, complex wave shapes, and others as justified. For the type of input applied, the testing machine input must equal, as a minimum, the zero period acceleration of the applicable response curve. A frequency range of 1 to 33 Hz is normally considered.

5. Time-History Input

A time-history of the equipment support location, or one based on a synthesized response curve, may be used as testing machine input. A 15- to 30-second time-history input is normally employed. The test table input must develop a response curve, which envelops the relevant response spectrum curve when a synthesized record is used.

6. Random Motion Input

Random input testing is performed so that the applicable response spectrum curve is enveloped by that produced by the table motion. The input is controlled by one-third octave (or less) bandwidth filters over the frequency range of interest with a minimum of 15 seconds or greater test duration. Normally, random tests are performed to produce a response curve based on test machine input, which envelops the relevant response spectrum curve. A special case random test may be performed when a power spectral density equivalent of the applicable response curve is specified.

Tests combining random input in conjunction with other wave forms may be employed as justified.

7. Complex Wave Test

A complex wave test may be performed by subjecting the equipment to an input motion, generated by summing a group of decaying sinusoids spaced at one-third octave, or narrower frequency intervals, over the frequency range of interest. Individual decay rate controls from 0.5 to 10 percent are used. Response curves based on test table input must be shown to envelop the relevant response curve.

3.7B.3.1.2 Piping Systems

Analyses of BOP supplied Seismic Category I and Seismic Category II piping systems are generally performed by the modal analysis response spectra method. The equivalent static load method of analysis is used primarily for small bore fire protection piping (Seismic Category II) and instrument tubing (Seismic Categories I and II). However, its applicability for applications to other piping shall remain optional. Piping which is not Seismic Category I is seismically analyzed when its failure could affect a Seismic Category I system.

The criteria and procedures used for modeling are described in Section 3.7B.3.3.2. A typical mathematical model of a piping system is shown on Figure 3.7B-67. Boundaries, such as anchors, are defined

so as to analytically isolate the piping system, treating the model as a bounded system.

The following describes input used for the design basis of nuclear safety-related piping systems that are dynamically analyzed by the modal analysis response spectra method:

1. Amplified Response Spectra

Obtained for discrete locations in the structure proximate to the point where the piping systems are supported. Enveloping and peak broadening procedures are applied to these ARS before utilization, as described as follows. Damping values used for piping are 0.5 percent for 1/2 SSE and 1 percent for SSE, except as indicated below, as defined in Table 3.7B-1.

2. Seismic Piping Anchor Movements

Obtained from calculated seismic displacements of structures proximate to piping anchor and support locations. These movements are used as static input to calculate the resulting internal forces and moments throughout the piping system (Section 3.7B.3.8).

Where a piping system is subjected to more than one response spectrum, as when support points are located in different parts of the structure or in separate structures, an enveloping procedure as well as a peak broadening with vertical sides (plus 25 percent and minus 20 percent of peak resonant period values, except as indicated below) is applied to generate a composite or worst-case spectrum for analysis. The response spectra modal analysis provides response quantities for each mode which are then combined over all significant modes (Section 3.7B.3.7). Significant dynamic modes under seismic excitation are defined as those modes with frequencies less than 50 cps or the first 50 modes, whichever is reached first. The combined seismic responses, together with internal forces and moments due to seismic anchor movements, are then combined with other loadings according to ASME Section III Code, Articles NB-3600 (Class 1 piping), NC-3600 (Class 2 piping), or ND-3600 (Class 3 piping).

The higher, frequency dependent damping values provided in ASME III Code Case N-411 may be used for pipe stress reconciliation and for support optimization. This code case also employs peak broadening consistent with the intent of Regulatory Guide 1.122 (plus and minus 15 percent of peak resonant period values with parallel sides).

Time history analysis is generally employed for fluid-induced transient dynamic problems (water hammer and steam hammer) in piping systems but time history analysis is not normally used for piping seismic analysis.

Detailed descriptions of analytical procedures and design criteria for Seismic Category I piping can be found in Section 3.7B.3.8.

No tests or empirical methods are utilized in lieu of analytical methods for any Seismic Category I piping.

3.7B.3.2 Determination of Number of Earthquake Cycles

3.7B.3.2.1 Equipment and Components

ASME III (NB-3112.3b) requires that the number of earthquake cycles to be used in the analysis of ASME III Code Class 1 components be specified as part of the design mechanical loads. The following criteria are used for all components within the jurisdiction of the ASME III code:

1. A total of five 1/2 SSE and one SSE is assumed.
2. A minimum of 10 maximum stress cycles per earthquake is assumed.

3.7B.3.2.2 Piping Systems

All ASME Class 1 piping systems have been designed for a minimum of 10 maximum stress cycles per seismic event in the analysis. A total of five 1/2 SSE and one SSE is assumed.

3.7B.3.3 Procedures Used for Modeling

3.7B.3.3.1 Equipment and Components

The procedures used for modeling of equipment and components are contained in Section 3.7B.3.1.

3.7B.3.3.2 Piping Systems

The basic method of analysis used is the finite element stiffness method. In accordance with this method, the piping is mathematically idealized as an assembly of elastic structural beam members connecting discrete nodal points. Nodal points are placed in such a manner as to identify particular types of piping elements, such as straight runs of pipe, elbows, valves, etc, for which force-deformation-stress characteristics can be computed. Nodal points are also placed at all discontinuities, such as piping supports, concentrated weights, branch lines, and changes in cross section. Inertial characteristics of the piping system are simulated by discrete masses of pipe and pipe components (including all concentrated and eccentric masses such as valves and valve operators) lumped at selected node points. The spacing between lumped masses for straight run of pipe is chosen to be smaller than the span of a simply supported beam with fundamental frequency of 33 cps. Generally, at least three mass points are located between pipe

supports acting in the same direction. System loads other than weights, such as thermal forces and earthquake inertial forces, are calculated and applied at the nodal points. The stiffness matrix of the piping system is calculated based upon the elastic properties of the pipe and pipe components, and includes the effects of bending,

torsional, axial, and shear deformations. The stiffness of piping elbows, and certain branch connections, is modified to account for local deformation effects by the flexibility factors published in the ASME Section III Code, Articles NB-3600 (Class 1 piping), NC-3600 (Class 2 piping), and ND-3600 (Class 3 piping).

Where the equivalent static load method of analysis is used, the modeling criterion is described in Section 3.7B.3.5.2.

3.7B.3.4 Basis for Selection of Frequencies

3.7B.3.4.1 Equipment and Components

The ARS (floor) developed for horizontal (two directions) and vertical direction earthquakes are the basic sources of seismic design accelerations. As noted in Section 3.7B.3.1.1, seismic accelerations are selected from the ARS based on natural frequency calculations for the equipment.

3.7B.3.4.2 Piping Systems

In the seismic design and multi-mass modal analysis of Seismic Category I piping systems (Section 3.7B.3.8), the practice of selecting piping fundamental natural frequencies to preclude resonance is not used. This practice is also not used in the equivalent static load method of analysis (Section 3.7B.3.5.2).

3.7B.3.5 Use of Equivalent Static Load Method of Analysis

3.7B.3.5.1 Equipment and Components

Those components which are considered relatively simple or rigid are designed, by virtue of natural frequency calculations, to withstand the effects of amplified seismic acceleration values dependent upon frequency and amplitude ranges associated with the installation, location, and corresponding relevant ARS. Analysis of components to the peak value of resonant response is considered conservative, since fundamental natural frequencies do not generally coincide with the frequency at resonance of the relevant response curve. Components having fundamental natural frequencies within the broadened response peak are designed to peak acceleration values, increased by a factor of 1.3, or as justified, to account for the contribution of all significant dynamic modes under a resonant condition. Generally, the vibratory characteristics of the components, qualified by resonant static analysis, are such that no possibility exists for adjacent or multiple modes to exist within the relatively narrow peak of a typical response spectrum.

The discussion which follows justifies the use of a factor of 1.3 as a conservative multiplier to be applied to single or multiple degree-of-freedom systems having fundamental frequencies within the broadened resonant response peak. Multiply-supported, or continuous

type, span components are not part of this proof. When multiply-supported equipment and components are analyzed by simplified methods, a factor of 1.5 times the peak resonant response is used.

3.7B.3.5.1.1 Single Degree-of-Freedom Systems

Peak broadening is intended to reflect a range of uncertainty in the precise location of the resonant peak of the response curve, and not indicate that the multiple peak resonant response is possible within this broadened range. What is concluded is that there is a fairly equal chance that the peak of the curve (singular) would fall in the specified range and, thus, what exists, in fact, is a family of resonant response curves, each having only one point of peak resonant response (Figure 3.7B-68). If more than one system or component mode of vibration falls within the broadened peak, one and only one mode (a presumed worst case) can be presumed at an actual response peak value (Figure 3.7B-69). All other possible modes would realistically respond to lower values. Using the simple vibration theory and some simplifying assumptions, it is shown that a factor of 1.3 is conservative.

A simple damped oscillator responds with a transmissibility:

$$TR = \frac{\sqrt{1 + (2\beta\omega/\omega_n)^2}}{\sqrt{[1 - (\omega/\omega_n)^2]^2 + [2\beta/\omega_n]^2}} \quad (3.7B-4)$$

where :

- ω_n = the undamped natural circular frequency,
- ω = the frequency of the exciting force,
- β = ratio of damping to critical damping.

The value of TR is dependent on the damping value β , and the ratio of exciting frequency to oscillator natural frequency. When the exciting frequency equals the oscillator natural frequency, the steady state input is amplified by the value of TR and the response amplitude is maximum. In a seismic environment, maximum response is equal to the peak of the ARS curve.

If additional modes are assumed around the peak of the response curve, as illustrated on Figure 3.7B-69, values of TR can be determined for each mode and the SRSS of these values computed. It is shown that TR increases as the number of modes increase, and that

the most conservative placement of assumed modes is with one mode at the peak and other modes centered around this peak.

Data shown on Figure 3.7B-70 justify the use of a factor of 1.3 as conservative for all potential equipment applications. The curves are developed for two planes representing five modes and nine modes assumed acting within the broadened resonant peak. These numbers are intended to show an upper bound for general equipment application.

As further conservatism, all modes are considered participating equally. This is never the case in dynamic analysis. The higher frequencies of the component are given equal weight to the fundamental resonant frequency and the modes are centered on the nominal response curve. If the fundamental frequency was placed on the peak of the nominal curve, the results would show even lower transmissibilities.

The factor 1.3 is applicable only for those components whose fundamental natural frequency falls within the broadened response peak.

It has been shown that, for the range of values associated with component and system static analysis, use of the 1.3 factor is conservative. In fact, for a predominant number of likely cases, a value far less than this could be justified on the basis of the data.

For example, a value of 1.1 could easily be justified for most components which present only a few significant modes of vibration within the broadened response peak. It is further emphasized that, in reaching these conclusions, the most conservative assumptions regarding location of the nominal response curve and the placement of response modes for the arbitrary component have been made.

3.7B.3.5.1.2 Multi-Degree of Freedom Systems

As a conclusive supplement to the previous discussion, a study was performed utilizing rigorous dynamic analysis of models closely representative of typical components.

This investigation consists of computing the ratio of maximum dynamic stress to maximum static stress (the factor denoted by K) for several model beams subject to a flat response and typical ARS. Since bending stress is dominant for frame/equipment constructions, the actual ratio employed equals:

$$K = \frac{\text{maximum dynamic moment}}{\text{maximum static moment}} \quad (3.7B-5)$$

Both SRSS and absolute moments are computed for comparison purposes, but conclusions are based solely on SRSS moments because they most closely represent actual dynamic stress.

Maximum static moment corresponds, in the case of the lg flat response, to lg static load. In the case of a typical amplified response, the maximum static load is based upon the following frequency relationships (Figure 3.7B-7):

$$\begin{aligned} f_o \leq f_p, \quad g &= g_{\max} \text{ (peak acceleration)} \\ f_o > f_p, \quad g &= \text{acceleration at } f_o \end{aligned} \quad (3.7B-6)$$

where:

$$\begin{aligned} f_o &= \text{the fundamental frequency of the model beam, Hz} \\ f_p &= \text{the frequency at which the peak acceleration occurs, Hz} \end{aligned}$$

The effect of peak spreading is investigated by using a flat response, thus giving all modes the same acceleration. This is equivalent to infinite peak spreading. The importance of the uncertainty in the location of the peak acceleration with respect to the fundamental mode of the model beams is examined by adjusting the fundamental frequency from well below to well above the peak resonant frequency of a typical response spectrum.

The model beams selected for this study are shown on Figure 3.7B-72. These beams are typical of the frames and equipment combinations used in nuclear power plants. All dynamic analyses were conducted using the STRUDL computer program described in Appendix 3A. Static analyses were carried out by hand, except for the simple/fixed beam with overhang. Consistent with design practice, all mountings in this study are assumed rigid.

3.7B.3.5.1.3 Results for Flat Response

Table 3.7B-29 summarizes the results for a lg flat response applied to the model beams of Figure 3.7B-72. Three K factors were computed for comparison purposes:

$$K_{s/c} = \frac{\text{Maximum SRSS dynamic moment}}{\text{Maximum static moment from concentrated load}} \quad (3.7B-7)$$

$$K_{s/u} = \frac{\text{Maximum SRSS dynamic moment}}{\text{Maximum static moment from uniform load}} \quad (3.7B-8)$$

$$K_{a/u} = \frac{\text{Maximum ABS dynamic moment}}{\text{Maximum static moment from uniform load}} \quad (3.7B-9)$$

All conclusions in this study are based on $K_{s/u}$ because it most closely represents the actual ratio of dynamic moment to static moment. $K_{a/u}$ was not chosen because, as can be seen in Table 3.7B-30, modes are so widely spaced that no more than one modal frequency lies within a ± 10 percent frequency band. $K_{s/c}$ is shown since this is the K factor which represents a typical simplification used in component analysis (concentrated static loads at component center of gravity).

The lg flat response was selected to give infinite peak spreading. As can be seen, $K_{s/u}$ was never greater than unity.

3.7B.3.5.1.4 Results for Amplified Response

Table 3.7B-31 presents the results for the simply supported/fixed model beam with 33 percent overhang subjected to the response spectra of Figure 3.7B-71. The 1st Mode column (Table 3.7B-31) gives the fundamental frequency, f_o , and response acceleration, g_o , at f_o . Note that f_o was adjusted (by density variation) from well below to well above the peak frequency, f_o , of the response spectra to determine the effect on K of the uncertainty in the location of the peak frequency with respect to the fundamental frequency of the model beam. Since all values of $K_{s/u}$ were less than unity, it is concluded that this uncertainty has no important effects on the K factor. Additional results are provided by Gwinn and Goldstein (1974).

3.7B.3.5.1.5 Conclusions

1. Peak acceleration times 1.3 applied as a static load to equipment whose fundamental natural frequency is within the broadened peak of the ARS curve is conservative.
2. No amount of peak spreading can itself result in a $K_{s/u}$ factor significantly greater than unity.

3. Uncertainty in the frequency at which the peak response acceleration occurs itself has no important effects on the K factor.
4. Multiply supported continuous spans are not included in the scope of this study. Components or equipment which make up a system of continuous multiple span supports utilize a factor no less than 1.5 times peak acceleration as in Item 1, if applicable.

3.7B.3.5.2 Piping Systems

Where the equivalent static load method of analysis is used, stress calculations are performed in a sectionalized (between supports) (Section 3.7B.3.1.2) manner using acceleration values from the ARS. A system with closely-spaced pipe supports represents many one-dimensional straight beam problems, wherein the coupling effects of three-dimensional piping systems can be reduced by locating restraints near elbows, tees, and concentrated masses (such as valves). These manual calculations provide a sufficient basis to satisfy requirements of Articles NC-3600 and ND-3600 of Section III of the ASME Code.

If the fundamental frequency of piping section between restraints (f_p) is less than or equal to 33 cps, simplified seismic analysis computes the seismic stress components by multiplying the deadload stresses by an equivalent load factor of 1.5 times the peak of the ARS. The SRSS of these seismic stress components in two horizontal and one vertical direction is formed to obtain the resultant seismic stress. If f_p is greater than 33 cps, an equivalent load factor of 1.0, instead of 1.5, is used. Deadload and thermal responses are also calculated using a simple beam formulation based on the length of the predetermined span.

3.7B.3.6 Three Components of Earthquake Motion

In the seismic analysis of equipment and components, each of the three defined directions of earthquake input (two horizontal and one vertical taken orthogonally) is evaluated independently. The stresses resulting from the orthogonal earthquake inputs are combined by the absolute addition of the worst horizontal plus vertical stress. Operating stresses are added to the maximum seismic stress.

In the seismic analysis of piping systems, the effects of simultaneous action of three spatial components of earthquake motion are considered. When the response spectrum modal analysis method is utilized for seismic analysis, the maximum piping modal responses (moments and displacements) due to the three spatial components of earthquake motion may be obtained by either SRSS method or by a modified SRSS method. In the modified SRSS method, when considering a particular vibration mode, responses in a particular direction due to the two horizontal direction excitations are combined by SRSS and then combined with response (in this same direction) due to the vertical direction excitation, using absolute summation. It has been

demonstrated by Chang (1973) that this modified SRSS method is always conservative compared with the SRSS method described in position C.2.1 of Regulatory Guide 1.92.

Mathematically the modified SRSS method of response can be expressed as:

$$\begin{aligned}
 (R_{ix})_j &= \sqrt{(R_{ix})_{jx}^2 + (R_{ix})_{jz}^2} + |(R_{ix})_{jy}| \\
 (R_{iy})_j &= \sqrt{(R_{iy})_{jx}^2 + (R_{iy})_{jz}^2} + |(R_{iy})_{jy}| \\
 (R_{iz})_j &= \sqrt{(R_{iz})_{jx}^2 + (R_{iz})_{jz}^2} + |(R_{iz})_{jy}|
 \end{aligned}
 \tag{3.7B-10}$$

where:

$(R_{ix})_j$ combined response in the x, y
 $(R_{iy})_j$ = or z direction, respectively,
 $(R_{iz})_j$ at node point i for mode j

 $(R_{ix})_{jz}$ = response at node i in the x direction
 in mode j due to the z earthquake

$(R_{ix})_j$, $(R_{iy})_j$, and $(R_{iz})_j$ are then combined for modes 1 to N by methods described in Section 3.7B.3.7, where N is the number of significant modes considered in the modal response combination.

3.7B.3.7 Combination of Modal Responses

For equipment and components, the following methods of combination of modal responses are employed for each direction of earthquake motion:

1. When performing response spectrum modal analysis, the representative maximum value of a particular response earthquake is obtained by taking the SRSS of corresponding maximum values of the response of the element attributed to individual significant modes of the structure, system, or component. Mathematically, this can be expressed as:

$$R = \left[\sum_{k=1}^N R_k^2 \right]^{1/2} \tag{3.7B-11}$$

where:

R = the representative maximum value of a particular response of a given node to a given component of an earthquake,

R_k = the peak value of the response of the node due to the kth mode,

N = the number of significant modes considered in the modal response combination.

- When performing response spectrum modal analysis, if closely spaced modes exist, the grouping method as described in Regulatory Guide 1.92 is employed to combine modal responses. Mathematically, this can be expressed as follows:

$$R = \left[\sum_{k=1}^N R_k^2 - \sum_{q=1}^P \sum_{\ell=i}^j \sum_{m=i}^j |R_{\ell q} R_{mq}| \right]^{1/2} \quad (3.7B-12)$$

$\ell \neq m$

where:

$R_{\ell q}$ and R_{mq} are modal responses R_{ℓ} and R_m within the qth group, respectively,

i is the number of the mode where a group starts,

j is the number of the mode where a group ends,

R , R_k , and N are as defined previously in Position 1.1 of Regulatory Guide 1.92, and

P is the number of groups of closely spaced modes, excluding individual separated modes.

- The method used for combination of three components of earthquake motion is described in Section 3.7B.3.6.

The following methods are applicable to BOP piping systems employing the modal analysis response spectra method.

- If the modes are not closely spaced (two consecutive modes are defined as closely spaced if their frequencies differ from each other by 10 percent or less of the lower frequency), the maximum responses of piping are obtained by taking the SRSS of corresponding maximum modal responses of the piping attributed to individual significant modes. This is in agreement with Position C.1.1 of Regulatory Guide 1.92, dated February 1976.
- If closely spaced modes exist, then the grouping method is employed to combine various modal responses from a dynamic

modal analysis. This is in conformance with Position C.1.2.1 of Regulatory Guide 1.92.

3.7B.3.8 Analytical Procedures for Piping

The general analytical procedure of the modal analysis response spectra method for BOP piping systems is described in Section 3.7B.3.1.2. Basic steps and equations used in the analytical procedure are described as follows:

For dynamic analysis, the piping is represented by a lumped mass, multi-degree-of-freedom mathematical model. The distributed piping mass is lumped at the system nodal points. The equation of motion for the system is:

$$[M] \{\ddot{X}\} + [C] \{\dot{X}\} + [K] \{X\} = \{F\} \quad (3.7B-13)$$

where:

$[M]$ = Mass matrix for assembled system,

$[C]$ = Damping matrix for assembled system,

$[K]$ = Stiffness matrix for assembled system,

$\{X\}$ = Nodal displacement vector
 $= [X(t)]$,

$\{\dot{X}\}$ = Nodal velocity vector
 $= \{\dot{X}(t)\}$,

$\{\ddot{X}\}$ = Nodal acceleration vector
 $= \{\ddot{X}(t)\}$,

$\{F\}$ = Applied dynamic force vector = $\{F(t)\}$,
 $= -[M] \{\ddot{U}_g\}$ for seismic analysis,

$\{\ddot{U}_g\}$ = Seismic absolute acceleration vector for points of pipe support.

This equation is solved to determine the system dynamic response as follows: First, the frequency equation, obtained by removing the forcing and damping terms from the previous equation, is solved for the system natural frequencies and mode shapes. Next, the natural mode shapes are used to transform this equation into a series of independent equations of motion uncoupled in the system modes. Then, the uncoupled equations are solved by the response spectrum method to obtain system response in each mode, and finally the individual modal results are combined to determine the total system dynamic response.

The mathematical formulation of these steps is as described in the following sections.

3.7B.3.8.1 Natural Frequencies and Mode Shapes

First, the eigenvalues (natural angular frequencies) and the eigenvectors (mode shapes) for each of the natural modes are calculated by solving the frequency equation:

$$\left(\begin{bmatrix} [K] & -\omega_n^2 [M] \end{bmatrix} \right) \{\phi\}_n = \{0\} \quad (3.7B-14)$$

$$n = 1, 2, 3, \dots, N$$

where:

$$\omega_n = \text{natural frequency of the } n\text{th mode,}$$

$$\{\phi\}_n = \text{mode shape vector of the } n\text{th mode,}$$

$$\{0\} = \text{null vector,}$$

$$N = \text{number of significant modes considered}$$

The eigenvalues and eigenvectors are obtained using the Householder-QR algorithm.

3.7B.3.8.2 Dynamic Response

Next, let $\{\eta(t)\}$ be the generalized coordinate vector, substitute $\{X\} = [\phi] \{\eta\}$ into the equation of motion and pre-multiply by $[\phi]^T$; an orthogonal transformation results, from which the uncoupled equations of motion shown as follows are obtained.

$$\ddot{\eta}_n + 2\beta_n \omega_n \dot{\eta}_n + \omega_n^2 \eta_n = P_n \quad (3.7B-15)$$

$$n = 1, 2, 3, \dots, N$$

where:

$$[\phi] = \text{The square matrix of mode shape vectors,}$$

$$\eta_n = \text{Generalized coordinate for the } n\text{th mode}$$

$$= \eta_n(t),$$

β_n = Damping ratio of the nth mode expressed as percent of critical damping,

P_n = Generalized force of the nth mode,

$$= \{\phi\}_n^T \{F\} / M_n \text{ for applied dynamic force } \{F\},$$

$$= \{\phi\}_n^T [M] \left\{ \ddot{U}_g \right\} / M_n \text{ for seismic analysis,}$$

$$M_n = \text{Generalized mass of the nth mode} = \{\phi\}_n^T [M] \{\phi\}_n$$

Solutions to these differential equations are obtained by the method of ARS superposition, as described by the following:

3.7B.3.8.3 Response Spectrum Superposition

The response of a piping system to seismic excitations is obtained using the method of response spectrum superposition. Seismic input is represented by a set of ARS, applied in each appropriate global coordinate direction. These ARS are generated from the application of simultaneous time-history acceleration responses obtained from the structure or equipment time-history analysis. These ARS are peak broadened (Section 3.7B.2.9) to reflect variations in structure properties. Where a piping system is subject to more than one set of ARS, such as support points located in different structures or different parts of the same structure, the enveloping and peak broadening are applied to all participating sets of ARS (Section 3.7B.3.1.2). This results in a final set of ARS, one in each global coordinate direction, to be used for final design. The maximum acceleration for the nth mode of the piping system in the jth global coordinate direction due to the simultaneous action of three spatial components of an earthquake, is then given by:

$$\{\ddot{X}\}_{nj} = \{\phi\}_n \ddot{\eta}_{nj \max} \quad (3.7B-16)$$

where:

$$\ddot{\eta}_{nj \max} = \frac{\Gamma_{nj} (S_a)_{nj}}{M_N}$$

$$n = 1, 2, 3, \dots, N$$

$j = 1, 2, 3$ corresponds to response in X, Y, or Z global coordinate direction, respectively.

and:

$\{\ddot{X}\}_{nj} =$ Maximum acceleration vector of mode n , in the j direction,

$\ddot{\eta}_{nj \max} =$ Maximum generalized coordinate acceleration of mode n , in the j direction,

$\Gamma_{nj} =$ Modal participation factor for the n th mode in j th global coordinate direction,

$$= \{\phi\}_n^T [M] \{e\}_j,$$

$\{e\}_j =$ A vector with components of unity in all directions parallel to j th global coordinate direction and zero, otherwise,

$(S_a)_{nj} =$ Spectral acceleration for the n th mode, in j th global coordinate direction (from enveloped and peak broadened ARS),

and the maximum inertia force vector for the n th mode is given by

$$\{F\}_{nj \max} = M_n \{\phi\}_n \ddot{\eta}_{nj \max} \quad (3.7B-17)$$

These inertia forces are calculated for each of the system natural modes and applied as static forces in the same manner as the weight or thermal forces, to find internal moments and forces in each mode. The total maximum member forces and moments due to seismic excitation are then obtained by combining the modal responses described in Section 3.7B.3.7. The seismic anchor displacement effect is considered separately from the seismic inertial effect as described in Section 3.7B.3.9.

Piping systems are also evaluated to assess the potential for significant flow induced dynamic loadings that could result from various modes of system operation as defined in the design specification. These dynamic force loadings are included as occasional mechanical loadings in piping analysis.

The plant design criteria, applicable to BOP Seismic Category I piping systems are tabulated in Tables 3.7B-32, 3.9B-8, 3.9B-9, 3.9B-10 and 3.9B-11.

3.7B.3.9 Multiply-Supported Equipment and Components with Distinct Inputs

To calculate the maximum inertial response of multiply-supported subsystems, an upper bound envelope of all the individual response spectra for the support locations is used. In addition, the relative displacements at the support points are considered by imposing seismic anchor displacements statically on the subsystem as described below.

For support locations attached to the same Seismic Category I structure, seismic anchor displacements are considered to be in phase. Horizontal displacements between different Seismic Category I structures on the same mat foundation are considered to be out-of-phase, and the maximum relative displacements between the structures are thus determined from absolute sums of the support displacements.

When Seismic Category I structures are not attached to the same mat foundation, additional displacements caused by the movement of the ground surface resulting from the passage of seismic waves are combined with the structural inertial displacements as shown in equation 3.7B-18.

$$\bar{X} = \sqrt{(|X_1| + |X_2|)^2 + [X(\text{REL}_{1-2})]^2} \quad (3.7B-18)$$

where: \bar{X} = Total relative dynamic displacement (X, Y, or Z direction)

$|X_1|$ = Inertial effect of first structure, including translational and rotational displacements (X, Y, or Z direction)

$|X_2|$ = Inertial effect of second structure including translational and rotational displacements (X, Y, or Z direction)

$X(\text{REL}_{1-2})$ = Max relative ground surface displacement between structures in absence of structures (X, Y, or Z direction)

The procedures used to compute structural inertial displacements and the relative ground surface displacements are described in FSAR Sections 3.7B.2 and 2.5.4.7.4, respectively.

Each maximum relative directional component of seismic anchor displacement is treated individually as input and a static analysis is performed. The resulting member forces and moments from all three directions of seismic anchor displacement input are combined by the SRSS method. Total seismic response is developed by absolute summation of the inertia and anchor displacement effects for OBE. For SSE, anchor displacement effects are considered only for the piping systems identified in Table 3.9B-9, and for containment penetrations.

These seismic member moments and forces are then combined with loads from deadweight, pressure, other mechanical or thermal loads, to complete the stress analysis of all Seismic Category I and some non-ASME piping. For ASME Code Class 1 piping, the formulation specified in Subarticle NB-3600, ASME Section III, is employed. For ASME Code Class 2 and 3 piping, the formulations in Subarticle NC-3600 and ND-3600, respectively, are used.

3.7B.3.10 Use of Constant Vertical Static Factors

3.7B.3.10.1 Equipment and Components

Constant load factors are not utilized for vertical floor response in the design of Seismic Category I equipment and components.

3.7B.3.10.2 Piping Systems

The method of applying constant static factors as vertical response loads, based on the assumption of vertically rigid structures, for the seismic design of Seismic Category I piping is not used. However, a simplified analysis (equivalent static load method), using constant load factors for both the vertical and horizontal directions based on the peaks of applicable ARS, is used for some small bore piping systems, as described in Section 3.7B.3.5.2.

3.7B.3.11 Torsional Effects of Eccentric Masses

The effect of eccentric masses, such as valves and valve operators, is considered in the seismic piping analysis described in Section 3.7B.3.1.2. These eccentric masses are included in the mathematical model for the system analysis and the torsional effects caused by them are evaluated and included in the total system response. The total response must meet the limits of the criteria applicable to the Safety Class of the piping for ASME III piping, and the criteria described in Section 3.7B.3.13 for non-ASME III piping which is seismically analyzed.

3.7B.3.12 Buried Seismic Category I Piping Systems

In performing stress analysis of buried Seismic Category I piping systems, the following loadings are considered:

1. Internal pressure,
2. Soil pressure (includes dead load and live loads due to traffic when applicable),
3. Thermal expansion,

4. Differential movements between structures and adjacent soil or along buried piping away from structures due to settlement and seismic motion, and
5. Seismic wave effects.

Effects of loadings 1 and 2 are assessed by well-known methods (Sections 21-29 to 21-33 of the Piping Handbook) according to King and Crocker (1967). Effects of loadings 3 and 4 are accounted for by a static analysis considering piping modeled together with soil springs. This is basically a beam on elastic foundation approach. Both loadings 4 and 5 are discussed in detail in the sections immediately following.

The basic assumptions concerning buried piping stress analysis are:

1. Piping satisfies the elementary theory of beams,
2. Soil is linear elastic, homogeneous, and isotropic, and time independent
3. Piping moves with the surrounding soil during an earthquake.
4. It is assumed that the BVPS-2 site is not subjected to near field effects of earthquake shaking. That is, it is far enough away from the source so that body waves (compression and shear) have largely been attenuated and the surface waves control the amplitudes of motion. Therefore, for this procedure only, Rayleigh waves are assumed to induce stresses in the buried piping system since this type of seismic wave induces the highest axial strains.

3.7B.3.12.1 Seismic Wave Effect in the Free Field

Various seismic waves develop during an earthquake. There are compression waves (P-waves), shear waves (S-waves), and different kinds of surface waves such as Rayleigh waves (R-waves). When seismic waves propagate through the soil, responses of buried Seismic Category I piping are calculated by making use of the analytical approach proposed by Goodling (1978, 1979, 1980).

Straight portions of buried piping far from the effect of external supports, bends and tees are assumed to move with the soil when seismic waves propagate through it. Since Rayleigh waves induce the highest axial strains in buried piping, only these waves are considered in the analysis. The strains of the soil have been conservatively established as follows:

$$\text{Axial strain } \varepsilon_m = \frac{V_m}{C_R} \quad (3.7B-19)$$

$$\text{Bending curvature } \chi = \frac{a_m}{C_R^2} \quad (3.7B-20)$$

where:

- V_m = peak ground velocity, in/sec.
- a_m = peak ground acceleration, in/sec².
- C_R = Rayleigh wave velocity, in/sec.

Therefore, the stresses on the straight portions of buried piping mentioned above are given by:

$$\text{Axial stress } \sigma_a = \frac{EV_m}{C_R} \frac{F_{\max}}{A} = \varepsilon_m E \quad (3.7B-21)$$

$$\text{Bending stress } \sigma_b = \frac{E D_o a_m}{2 C_R^2} = \frac{E D_o \chi}{2} \quad (3.7B-22)$$

where:

- E = Young's modulus of pipe, psi.
- D_o = outside diameter of pipe, in.
- F_{\max} = maximum axial force, lb.
- A_m = cross-sectional area of pipe, in².

Seismic wave effect on bends and tees in the free field are considered separately. For a bend, the maximum stresses are determined by assuming that its longitudinal leg is in the direction of maximum soil strain and its transverse leg is in the perpendicular direction.

The longitudinal leg may terminate into another bend, an anchor, or a free end. The bend is classified accordingly and the actual slippage length (L') along which slippage between pipe and soil occurs is determined as outlined by Goodling (1978).

The net relative displacement Δ , between soil and pipe at the bend is given by:

$$\Delta_1 = \varepsilon_m L' - \frac{fL'^2}{2A_m E} - \frac{S_1 L'}{A_m E} \quad (3.7B-23)$$

where:

- $\varepsilon_m L'$ = theoretical unrestrained relative movement at the elbow over length L' ;

- $S_1 L' / A_m E$ = the amount of pipe elongation due to the bearing force of soil against the transient T' leg producing the shear force S_1 at the elbow and which is transformed into an axial force in the longitudinal 'P' leg.
- $f L'^2 / 2 A_m E$ = the pipe elongation due to friction along the soil/pipe interface.
- S_1 = the axial force in the longitudinal leg, lb.
- f = frictional force per unit length of pipe, lb/in.

The bend legs are considered as beams on elastic foundation for which its parameter λ is given by:

$$\lambda = 4 \sqrt{\frac{k}{4EI}} \tag{3.7B-24}$$

where:

- k = soil spring constant, per unit length, lb/in².
- I = moment of inertia of pipe cross section, in⁴.

In case of long-transverse leg (its length is greater than $3\pi/4\lambda$ the following equations are derived by incorporating the interdependence of forces, moments, soil deformation, and rotation of the pipe in the immediate vicinity of the bend (Goodling 1980).

$$M = \frac{\lambda \Delta_1}{R\phi / K'EI} \tag{3.7B-25}$$

$$S_1 = \frac{k \Delta_1}{2\lambda} + \lambda M \tag{3.7B-26}$$

where:

- M = bending moment, in-lb/in.
- ϕ = elbow angle, radians
- R = radius of elbow in.
- K' = $1 - \frac{9}{10 + 12 \left(\frac{tR}{a^2}\right)^2}$
- t = actual pipe wall thickness, in.
- a = outside radius of pipe, in.

In case of short transverse leg, the following conservative equations derived by Goodling (1978) are used:

$$\Delta_1 = \frac{\varepsilon_m L' - \frac{fL'^2}{2A_m E}}{kL' \frac{C_3}{1 + \frac{2C_1 C_3 - C_2^2}{A_m E \lambda}}} \quad (3.7B-27)$$

$$S_1 = \frac{k\Delta_1}{\lambda} \frac{C_3}{2C_1 C_3 - C_2^2} \quad (3.7B-28)$$

$$M = \frac{k\Delta_1}{2\lambda^2} \frac{C_2}{2C_1 C_3 - C_2^2} S_{in} \phi \quad (3.7B-29)$$

where:

C_1 , C_2 and C_3 are coefficients given by Goodling (1978)

The maximum axial force in the longitudinal leg, F_{max} , induced by the seismic motion is given by:

$$F_{max} = S_1 + fL' \quad (3.7B-30)$$

Having determined the values of S_1 , M and F_{max} , the stresses due to local deformation at the bend can be evaluated. These stresses are superimposed on stresses caused by the curvature of the pipe during seismic wave propagation. The combined stresses at the bend are multiplied by an intensification factor (0.75 i) to account for the higher intensity of stresses at the elbow.

The following expressions for stress result:

$$(1) \quad \frac{\text{Stress at an Elbow}}{S_{o1}(\text{elbow})} = 0.75i \left[ED_o \chi / 2 + M / Z \right] + S_1 / A_m \quad (3.7B-31)$$

$$(2) \quad \frac{\text{Stress in the Longitudinal Run}}{S_{o1}(\text{long})} = F_{max} / A_m + ED_o \chi / 2 \quad (3.7B-32)$$

where:

Z = section modulus of pipe, in^3 .

Occasionally, when the conservative equations used in case of short transverse leg result in unacceptable stresses, the technique

incorporating the passive resistance of soil, as presented by Goodling (1978), may be used.

A similar approach is used for analyzing tees (Goodling 1978).

3.7B.3.12.2 Effects of Differential Movement Between Structure and Adjacent Soil Due to Seismic Motion

During an earthquake, it is assumed differential seismic motions occur between structures and adjacent soils. The effect on the buried piping systems due to these differential motions can be evaluated by considering separately the effects of different components, (differential motion components transverse to the direction of the piping axis, and differential motion components parallel to the direction of the piping axis).

1. Differential motion components transverse to the direction of the piping axis:

The subgrade reaction approach is used here to simulate the effect of soil on the deformation and stress of the buried pipe due to differential motion components transverse to the direction of piping axis.

The approach is based on the assumption that soil subjected to pressure behaves like a system of uniformly spaced elastic springs with predetermined stiffness. The soil is thus represented by a series of orthogonal pairs of elastic springs in directions transverse to the piping axis and attached to the piping in the mathematical model. The elastic springs in the vertical direction are calculated according to the Vesic equation.

$$k_{ov} = \frac{0.65}{D_o} \sqrt{\frac{E_s D_o^4}{E_p I_p}} \left(\frac{E_s}{1-\nu^2} \right) \quad (3.7B-33)$$

where:

- k_{ov} = coefficient of subgrade reaction (FL^{-3})
- D_o = outside diameter of pipe (L)
- E_s = Young's modulus soil (FL^{-2})
- E_p = Young's modulus pipe (FL^{-2})
- I_p = moment of inertia of pipe (L^4)
- ν = Poisson's ratio soil

The elastic springs in the horizontal direction are calculated based on the method described by Audibert and Nyman (1977). The maximum expected transverse seismic structural displacements at the structural penetration are used as input in the calculation. The

stress computation is done by the computer program NUPIPE S-W, which is listed in Appendix 3A. In principle, this approach is basically a beam analysis on an elastic foundation (Hetenyi 1946).

2. Differential motion components parallel to the direction of piping axis.

The effect on buried long straight piping due to differential seismic motions along the direction of piping axis at a penetration is assessed by considering the frictional force between pipe and soil, and the maximum axial stress due to this effect is (Yeh 1974):

$$S \text{ (displ.)} = \sqrt{(2 E f \Delta_a / A_m)} \quad (3.7B-34)$$

where:

Δ_a = axial displacement of pipe at penetration point through structure,
in.

When bends or tees exist close to the penetration, the effect of differential motion parallel to the direction of the piping axis is analyzed by using the NUPIPE-SW Computer Program.

3.7B.3.12.3 Effects of Differential Settlement

Three areas of concern for effects of settlement on buried piping are as follows:

1. Settlement of structures,
2. Settlement of soil adjacent to structures to which buried piping is attached, and
3. Settlement of soil in which piping is buried away from structures.

The magnitude of settlement for each of these areas is determined as described in Section 2.5.4.

Settlement of a structure can occur either due to its own weight over a period of time or due to an earthquake. The settlement of a structure where piping is connected, as well as the soil adjacent to the structure where piping is buried, are imposed on the buried piping, and the approach outlined in "differential motion components transverse to the direction of piping axis" given previously is used to evaluate stresses in the buried piping.

Generally, the piping is considered to be sufficiently flexible to withstand the gradual differential settlements that may occur along buried piping away from structures without exceeding allowable pipe stress levels. For this reason, stress analysis due to settlement of buried piping away from structures is usually unnecessary. However, analysis is performed for piping in those areas where it is anticipated that differential settlements may be of such a magnitude that the resulting pipe stress levels are potentially of concern. The method of analysis is the same as for buried piping connected to a structure.

3.7B.3.12.4 Accommodations for Buried Piping Structural Penetration

The resultant loadings imposed by thermal, structural, and seismic distortions may cause severe local stresses in buried piping at structure penetration points. The piping, if anchored at the structural wall, may be too stiff to accommodate these distortions for such locations. In such cases, the buried piping design includes

a structural penetration, consisting of a concrete box or a conduit, which is not attached to the structure, and is free to move with the soil rather than with the structure. Within the box or conduit, the piping may be provided with expansion joints or piping loops to accommodate relative displacements in both axial and transverse directions, if necessary.

3.7B.3.13 Interaction of Other Piping with Seismic Category I Piping

Non-ASME piping systems are designed to be isolated from any Seismic Category I piping system by either an anchor or barrier, or are removed from the location of the Seismic Category I piping system. If it is not feasible or practical to isolate the Seismic Category I piping system from the non-ASME, the adjacent non-ASME piping is then seismically analyzed. For the non-ASME piping systems attached to Seismic Category I piping systems, the dynamic effects of the non-ASME piping are simulated in the analysis modeling of the Seismic Category I piping and analyzed to the same criteria as the Seismic Category I piping system up to and including the first anchor beyond the ASME/non-ASME class break, except that if the non-ASME piping is connected to ASME III Class 1 piping a fatigue analysis is not required for the piping beyond the connection to the Class 1 piping.

For non-ASME piping systems which are not attached to Seismic Category I piping systems but whose failure could compromise the design and/or function of Seismic Category I components/piping due to its close proximity, the non-ASME piping is seismically analyzed and the seismic stresses are evaluated in accordance with equation 9 of Subarticle NC-3600, ASME Code, Section III but equated to faulted allowable ($2.4 S_h$) only to ensure that its structural integrity is maintained.

3.7B.3.14 Seismic Analyses for Reactor Internals

This information is provided in Section 3.7N.3.14.

3.7B.3.15 Analysis Procedure for Damping

The analysis procedure, which include consideration of damping, are contained in Sections 3.7B.3.1 and 3.7B.3.8. Damping values utilized in the design and analysis of equipment, components, and piping systems are provided in Section 3.7B.1.3.

3.7B.4 Seismic Instrumentation

3.7B.4.1 Comparison with Regulatory Guide 1.12

Beaver Valley Power Station - Unit 2 seismic instrumentation is provided, in accordance with the recommendations of ANSI/ANS-2.2-1978, as modified by the Regulatory Guide 1.12, Revision 1, for a SSE with the maximum acceleration less than 0.3g, with the exceptions listed in Table 1.8-1.

3.7B.4.2 Location and Description of Instrumentation

Seismic instrumentation packages are located in areas where they can be serviced during BVPS-2 shutdown.

All instruments are oriented to the same azimuths, except one remote accelerograph sensor which is mounted to the containment crane wall. It is oriented such that it will respond to horizontal motion in the radial and tangential directions of the containment. Instrument characteristics conform to the requirements of Section 5 of ANSI/ANS-2.2-1978, as modified by Regulatory Guide 1.12, Revision 1.

The seismic instrumentation system comprises the following instruments:

Time-History Accelerograph System

A triaxial time-history accelerograph system is provided to sense, record and analyze data associated with seismic events. Except for the sensors, the system is located in the BVPS-2 control room.

A seismic trigger from either the containment mat or freefield sensor initiates recording when seismic activity exceeds an established threshold. When activated by the seismic trigger, signals from the sensors on the containment mat and in the freefield are processed by a response spectrum analyzer that compares actual conditions with pre-determined building response spectra. Capability for printing event-specific response spectra from the analyzer is also provided.

Two acceleration sensors are located inside the reactor containment structure. One is mounted on the mat, between the cranewall and the exterior wall at elevation 692 feet-11 inches. The second is located directly above the first, on the operating floor at elevation 767 feet-10 inches. A free-field sensor is located on a concrete pad in the switchyard.

Triaxial Accelerograph Units

Three independent triaxial accelerograph units consisting of an accelerometer, seismic trigger, recorder, clock and auxiliary power supply are also provided. The event is recorded as acceleration versus time and can be manually transferred to a response spectrum analyzer to obtain the corresponding response spectra.

Locations of the accelerometers for the three units are as follows:

1. Reactor Containment Structure on the outside face of the crane wall above elevation 738 feet-10 inches.
2. Center of auxiliary building mat, elevation 710 feet-6 inches
3. At base of 480 V motor control center, MCC*2-E03, elevation 755 feet-6 inches

Triaxial Peak Accelerograph

Three triaxial peak accelerographs capable of measuring and permanently recording peak acceleration are provided. These units are passive and require no power input.

Two triaxial peak accelerographs are located within the reactor containment structure. One unit is mounted on the residual heat removal heat exchanger, (2RHS-E21A) at elevation 715 feet-6 inches. The other unit is attached to the 6-inch safety injection piping, (2SIS-006-269-1(A) CL 1502), at elevation 741 feet-5 inches.

The third triaxial peak accelerograph is attached to the 480 V motor control center, (MCC*2-E03), at elevation 755 feet-6 inches in the auxiliary building.

3.7B.4.3 Control Room Notification

The recorders and control unit for the triaxial time-history accelerograph system is located in the BVPS-2 control room. The seismic trigger visual signals are displayed on the control unit panel. Following an event, the recorded data can be displayed or printed to review absolute acceleration versus time at each sensor.

The response spectrum analyzer monitors input data from the sensor on the containment mat and in the switchyard. Response spectra are calculated for the event. If the specified 1/2 SSE limit is exceeded at one or more of the specified frequencies, a visual indicator is activated. Thus the operator has notification when the 1/2 SSE design response spectra have been exceeded.

3.7B.4.4 Comparison of Measured and Predicted Responses

In the event of an earthquake, the control room operator, having been informed as discussed in Section 3.7B.4.3, shall determine if the response spectra experienced at the foundation of the containment structure or in the switchyard have exceeded 1/2 SSE values.

Recorded time-history responses from the triaxial time-history accelerographs will be processed by the response spectrum analyzer thus allowing comparison of actual building response to design response spectra.

Amplified response spectra (ARS) for the floor elevations of the sensors in the containment, generated by a response spectrum analyzer using the recorded floor motion data, shall be compared with the existing containment design ARS for those locations. The comparison will establish whether design basis motion levels were exceeded in support of post-earthquake plant evaluation.

3.7B.4.5 In-Service Surveillance of Seismic Instrumentation

The in-service surveillance of the seismic monitoring instrumentation will be performed as described in the BVPS-2 [Licensing Requirements Manual](#).

3.7N SEISMIC DESIGN

In addition to the steady state loads imposed on the system under normal operating conditions, the design of equipment and equipment supports requires that consideration also be given to abnormal loading conditions such as earthquakes. Seismic loadings are considered for earthquakes of two magnitudes: safe shutdown earthquake (SSE) and operating basis earthquake (OBE). The SSE is defined as the maximum vibratory ground motion at the plant site that can reasonably be predicted from geologic and seismic evidence. The OBE is that earthquake which, considering the local geology and seismology, can be reasonably expected to occur during the plant life.

For the OBE loading condition, the nuclear steam supply system (NSSS) is designed to be capable of continued safe operation. The design for the SSE is intended to assure:

1. That the integrity of the reactor coolant pressure boundary is not compromised,
2. That the capability to shut down the reactor and maintain it in a safe condition is not compromised, and

3. That the capability to prevent or mitigate the consequences of accidents which could result in potential offsite exposures comparable to the guideline exposures of 10 CFR 100 is not compromised.

The seismic requirements for safety-related instrumentation and electrical equipment are contained in Section 3.10. The safety class definitions, classification lists, operating condition categories, and the methods used for seismic qualification of mechanical equipment are given in Section 3.2.

3.7N.1 Seismic Input

3.7N.1.1 Design Response Spectra

Refer to Section 3.7B.1.1.

3.7N.1.2 Design Time History

Refer to Section 3.7B.1.2.

3.7N.1.3 Critical Damping Values

The damping values used in the analysis of Westinghouse equipment are given in Table 3.7N-1. These damping values are consistent with Regulatory Guide 1.61 and WCAP-7921 AR (Westinghouse 1974a) which has been approved by the U.S. Nuclear Regulatory Commission.

The damping values listed in Regulatory Guide 1.61 are acceptable to Westinghouse for plants using 3D seismic analysis. Westinghouse uses one exception to the values. A conservative value of 4 percent of critical for that of large piping systems faulted conditions is used instead of 3 percent of critical set forth in Regulatory Guide 1.61. The Westinghouse value of 4 percent has been justified by testing for the Westinghouse reactor coolant loop configuration in WCAP-8288 Report (Westinghouse 1974b) and has been approved by the staff.

Tests on fuel assembly bundles justified conservative component damping values. Documentation of the fuel assembly tests is found in WCAP-7921-AR (Westinghouse 1974a).

The damping values used in component analysis of control rod drive mechanisms (CRDMs) and their seismic supports were developed by testing programs performed by Westinghouse. The test conducted was on a full size CRDM complete with rod position indicator coils, attachment to a simulated vessel head, and variable gap between the top of the pressure housing support plate and a rigid bumper representing the support.

The program consisted of transient vibration tests in which the CRDM was deflected a specified initial amount and suddenly released. A logarithmic decrement analysis of the decaying transient provides the

effective damping of the assembly. The effect on damping of variations in the drive shaft axial position, upper seismic support clearance, and initial deflection amplitude was investigated.

The upper support clearance had the largest effect on the CRDM damping with the damping increasing with increasing clearance. With an upper clearance of 0.06 inches, the measured damping was approximately 8 percent. The clearances in a typical upper seismic CRDM support is a minimum of 0.10 inches. The increasing damping with increasing clearances trend from the test results indicated that the damping would be greater than 8 percent for both the OBE and the SSE based on a comparison between typical deflections of the mechanisms in the test. Component damping values of 5 percent are, therefore, conservative for both the OBE and the SSE.

3.7N.1.4 Supporting Media for Seismic Category I Structures

Refer to Section 3.7B.1.4.

3.7N.2 Seismic System Analysis

This section describes the methods of seismic analysis performed for safety-related components and systems within Westinghouse's scope.

3.7N.2.1 Seismic Analysis Methods

Those components and systems that must remain functional in the event of the SSE (Seismic Category I) are identified by applying the criteria of Section 3.2.1. In general, the dynamic analyses are performed using a modal analysis with either the response spectrum analysis or integration of the uncoupled modal equations as described in Sections 3.7N.2.1.3 and 3.7N.2.1.4, respectively; or by direct integration of the coupled differential equations of motion described in Section 3.7N.2.1.5.

3.7N.2.1.1 Dynamic Analysis - Mathematical Model

The first step in any dynamic analysis is to model the structure or component (convert the real structure or component into a system of masses, springs, and dashpots suitable for mathematical analysis). The essence of this step is to select a model so that the displacements obtained will be a good representation of the motion of the structure or component. Stated differently, the true inertia forces should not be altered so as to appreciably affect the internal stresses in the structure or component. Some typical modeling techniques are presented in Lin (1974).

Equation of Motion

Consider the multi-degree of freedom system shown on Figure 3.7N-1. Making a force balance on each mass point r , the equations of motion can be written in the form:

$$m_r \ddot{y}_r + \sum^i c_{ri} \ddot{u}_i + \sum^i k_{ri} u_i = 0 \quad (3.7N-1)$$

where:

- m_r = the value of the mass or mass moment of rotational inertia at mass point r
- \ddot{y}_r = absolute translational or angular acceleration of mass point r
- c_{ri} = damping coefficient - external force or moment required at mass point r to produce unit translational or angular velocity at mass point i, maintaining zero translational or angular velocity at all other mass points. Force or moment is positive in the direction of positive translational or angular velocity
- \dot{u}_r = translational or angular velocity of mass point i relative to the base
- k_{ri} = stiffness coefficient - the external force (moment) required at mass point r to produce a unit deflection (rotation) at mass point i, maintaining zero displacement (rotation) at all other mass points. Force (moment) is positive in the direction of positive displacement (rotation)
- u_i = displacement (rotation) of mass point i relative to the base

As an example, note that Figure 3.7N-1 does not attempt to show all of the springs (not any of the dashpots) which are represented in Equation 3.7N-1.

Because:

$$\ddot{y}_r = \ddot{u}_r + \ddot{y}_s \quad (3.7N-2)$$

where:

- \ddot{y}_s = absolute translational (angular) acceleration of the base
- \ddot{u}_r = translational (angular) acceleration of mass point r relative to the base

Equation 3.7N-1 can be written as:

$$m_r \ddot{u}_r + \sum^i c_{ri} \ddot{u}_i + \sum^i k_{ri} u_i = -m_r \ddot{y}_s \quad (3.7N-3)$$

For a single degree of freedom system with displacement u , mass m , damping c , and stiffness k , the corresponding equation of motion is:

$$m\ddot{u} + c\dot{u} + ku = m\ddot{y}_s \quad (3.7N-4)$$

3.7N.2.1.2 Modal Analysis

Natural Frequencies and Mode Shapes

The first step in the modal analysis method is to establish the normal modes, which were determined by eigen solution of Equation 3.7N-3. The right hand side and the damping term are set equal to zero for this purpose as illustrated in Biggs (1964). Thus, Equation 3.7N-3 becomes:

$$m_r \ddot{u}_r + \sum^i k_{ri} u_i = \{0\} \quad (3.7N-5)$$

The equation given for each mass point r in Equation 3.7N-5 can be written as a system of equations in matrix form as:

$$[M] \{\ddot{\Delta}\} + K \{\Delta\} = \{0\} \quad (3.7N-6)$$

where:

$[M]$ = mass and rotational inertia matrix

$\{\Delta\}$ = column matrix of the general displacement and rotation at each mass point relative to the base

$[K]$ = square stiffness matrix

$\{\ddot{\Delta}\}$ = column matrix of general translational and angular accelerations at each mass point relative to the base, $d^2 [\Delta]/dt^2$

Harmonic motion is assumed and the $[\Delta]$ is expressed as:

$$\{\Delta\} = \{\delta\} \sin \omega t \quad (3.7N-7)$$

where:

$\{\delta\}$ = column matrix of the spatial displacement and rotation at each mass point relative to the base

ω = natural frequency of harmonic motion in radians per second

The displacement function and its second derivative are substituted into Equation 3.7N-6 and yield:

$$[K] \{\delta\} = \omega^2 [M] \{\delta\} \quad (3.7N-8)$$

The determinant $|[K] - \omega^2 [M]|$ is set equal to zero and is then solved for the natural frequencies. The associated mode shapes are then obtained from Equation 3.7N-8. This yields n natural frequencies and mode shapes where n equals the number of dynamic degrees of freedom of the system. The mode shapes are all orthogonal to each other and sometimes referred to as normal mode vibrations. For a single degree of freedom system, the stiffness matrix and mass matrix are single terms and the determinant $|[K] - \omega^2 [M]|$ when set equal to zero yields simply:

$$k - \omega^2 m = 0$$

or

$$\omega = \sqrt{\frac{k}{m}} \quad (3.7N-9)$$

where ω is the natural angular frequency in radians per second.

The natural frequency in cycles per second is therefore:

$$f = \frac{1}{2\pi} \sqrt{\frac{k}{m}} \quad (3.7N-10)$$

To find the mode shapes, the natural frequency corresponding to a particular mode, ω_n can be substituted in Equation 3.7N-8.

Modal Equations

The response of a structure or component is always some combination of its normal modes. Good accuracy can usually be obtained by using only the first few modes of vibration. In the normal mode method, the mode shapes are used as principal coordinates to reduce the equations of motion to a set of uncoupled differential equations that describe the motion of each mode n . These equations may be written as described by Biggs (1964):

$$\ddot{A}_n + 2\omega_n p_n \dot{A}_n + n^2 \omega_n^2 A_n = -\Gamma_n y_s \quad (3.7N-11)$$

Where the modal displacement or rotation, A_n , is related to the displacement or rotation of mass point r in mode n , u_{rn} , by the equation:

$$u_m = A_n \phi_m \quad (3.7N-12)$$

where :

ω_n = natural frequency of mode n in radians per second

p_n = critical damping ratio of mode n

Γ_n = modal participation factor of mode n given by:

$$\Gamma_n = \frac{\sum_r^n m_r \phi_r n'}{\sum_r^n m_r \phi_r n^2} \quad (3.7N-13)$$

where :

ϕ_m' = value of ϕ_m in the direction of the earthquake

ϕ_m = mode shape for mode n with degree of freedom r

The essence of the modal analysis lies in the fact that Equation 3.7N-11 is analogous to the equation of motion for a single degree of freedom system that will be developed from Equation 3.7N-4. Dividing Equation 3.7N-4 by m gives:

$$\ddot{u} + \frac{c}{m} \dot{u} + \frac{k}{m} u = y_s \quad (3.7N-14)$$

The critical damping ratio of the single degree of freedom system, p , is defined by the equation:

$$p = \frac{c}{c_c} \quad (3.7N-15)$$

where the critical damping coefficient is given by the expression:

$$c_c = 2 m \omega \quad (3.7N-16)$$

Substituting Equation 3.7N-16 into Equation 3.7N-15 and solving for c/m gives:

$$\frac{c}{m} = 2\omega p \quad (3.7N-17)$$

Substituting this expression and the expression for k/m given by Equation 3.7N-9 into Equation 3.7N-14 gives:

$$\ddot{u} + 2\omega p \dot{u} + \omega^2 u = -y_s \quad (3.7N-18)$$

Note the similarity of Equations 3.7N-11 and 3.7N-18. Thus, each mode may be analyzed as though it were a single degree of freedom system and all modes are independent of each other. By this method a fraction of critical damping (that is, c/c_c) may be assigned to each mode, and it is not necessary to identify or evaluate individual damping coefficients, (that is, c). However, assigning only a single damping ratio to each mode has a drawback. There are three ways used to overcome this limitation when considering a slightly damped structure (such as steel) supported by a massive moderately damped structure (such as concrete).

There are several methods which can be used to incorporate damping in a structural system. The first method is to develop and analyze separate mathematical models for both structures using their respective damping values. The massive moderately damped support structure is analyzed first. The calculated response at the support points for the slightly damped structures is used as a forcing function for the subsequent detailed analysis. The second method is to inspect the mode shapes to determine which modes correspond to the slightly damped structure and then use the damping associated with the slightly damped structure having predominant motion. The third method is to use the Rayleigh damping method based on computed modal energy distribution.

3.7N.2.1.3 Response Spectrum Analysis

The response spectrum is a plot showing the variation in the maximum response (Thomas et al 1963) (displacement, velocity, and acceleration) of a single degree of freedom system versus its natural frequency of vibration when subjected to a time history motion at its base.

The response spectrum concept can be best explained by outlining the steps involved in developing a spectrum curve. Determination of a single point on the curve requires that response (displacement, velocity, and acceleration) of a single degree of freedom system with a given damping and natural frequency be calculated for a given base motion.

The variations in response are established and the maximum absolute value of each is plotted as an ordinate with natural frequency used as the abscissa. The process is repeated for other assumed values of frequency in sufficient detail to establish the complete curve. Other curves corresponding to different fractions of critical damping are obtained in a similar fashion. Thus, the determination of each point of the curve requires a complete dynamic response analysis, and the determination of a complete spectrum may be used to analyze each structure and component with the base motion. The spectral acceleration, velocity, and displacement are related by the equation:

$$s_{a_n} = \omega_n S_{v_n} = \omega_n^2 S_{d_n} \quad (3.7N-19)$$

There are two types of response spectra that must be considered. If a given building is shown to be rigid and to have a hard foundation, the ground response spectrum or ground time history is used. It is referred to as a ground response spectrum. If the building is flexible and/or has a soft foundation, the ground response spectrum is modified to include these effects. The response spectrum at various support points must be developed. These are called floor response spectra.

3.7N.2.1.4 Integration of Modal Equations

This method can be separated into the following two basic parts:

1. Integration procedure for the uncoupled modal Equation 3.7N-11 to obtain the modal displacements and accelerations as a function of time.
2. Using these modal displacements and accelerations to obtain the total displacements, accelerations, forces, and stresses.

Integration Procedure

Integration of these uncoupled modal equations is done by step-by-step numerical integration. The step-by-step numerical integration procedure consists of selecting a suitable time interval, Δt , and calculating modal acceleration, \ddot{A}_n , modal velocity, \dot{A}_n , and modal displacement, A_n , at discrete time stations Δt apart, starting at $t = 0$ and continuing through the range of interest for a given time history of base acceleration.

Total Displacements, Accelerations, Forces, and Stresses

From the modal displacements and accelerations, the total displacements, accelerations, forces, and stresses can be determined as follows:

1. Displacement of mass point r in mode n as a function of time is given by Equation 3.7N-12 as:

$$u_m = A_n \phi_m \quad (3.7N-20)$$

with the corresponding acceleration of mass point r in mode n as:

$$\ddot{u}_m = \ddot{A}_n \phi_m \quad (3.7N-21)$$

2. The displacement and acceleration values obtained for the various modes are superimposed algebraically to give the total displacement and acceleration at each time interval.
3. The total acceleration at each time interval is multiplied by the mass to give an equivalent static force. Stresses are calculated by applying these forces to the model or from applying the deflections at each time interval.

3.7N.2.1.5 Integration of Coupled Equations of Motion

The dynamic transient analysis is a time history solution of the response of a given structure to known forces and/or displacement forcing functions. The structure may include linear or nonlinear elements, gaps, interfaces, plastic elements, and viscous and Coulomb dampers. Nodal displacements, nodal forces, pressure, and/or temperatures may be considered as forcing functions. Nodal displacements and elemental stresses for the complete structure are calculated as functions of time.

The basic equations for the dynamic analysis are as follows:

$$M \{\ddot{x}\} + C \{\dot{x}\} + K \{x\} = \{F(t)\} \quad (3.7N-22)$$

where the terms are as defined earlier and $\{F(t)\}$ may include the effects of applied displacements, forces, pressures, temperature, on nonlinear effects such as plasticity and dynamic elements with gaps. Options of translational accelerations input to a structural system and the inclusion of static deformation and/or preload may be considered in nonlinear dynamic transient analysis. The option of translational input such as uniform base motion to a structural system is considered by introducing an inertia force term of $-M\{\ddot{z}\}$ to the right hand side of the basic Equation 3.7N-22, that is,

$$M \{\ddot{x}\} + C \{\dot{x}\} + K \{x\} = \{F\} - M \{\ddot{z}\} \quad (3.7N-23)$$

The vector $\{\ddot{z}\}$ is defined by its components \ddot{z}_i where i refers to each degree of freedom of the system. If the i -th degree of freedom is aligned with the direction of the system translational acceleration

\ddot{a}_1 , \ddot{a}_2 , or \ddot{a}_3 , respectively, \ddot{z} is equal to \ddot{a}_1 , \ddot{a}_2 , or $0 \ddot{a}_3$. If the i -th degree of freedom is not aligned with any direction of the system translational acceleration, $\ddot{z}_i = 0$. Typical application of this option is a structural system subjected to a seismic excitation of a given ground acceleration record. The displacement $\{x\}$ obtained from the solution of Equation 3.7N-23 is the displacement relative to the ground.

The option of the inclusion of initial static deformation or preload in a nonlinear transient dynamic structural analysis is considered by solving the static problem prior to the dynamic analysis. At each state of integration in transient analysis, the portion of internal forces due to static deformation is always balanced by the portion of the forces which are statically applied. Hence, only the portion of the forces which deviate from the static loads will produce dynamic effects. The output of this analysis is the total result due to static and dynamic applied loads.

One available method for the numerical integration of Equations 3.7N-22 and 3.7N-23 is the Newmark Beta integration scheme proposed by Chan (et al 1962). In this integration scheme, Equations 3.7N-22 and 3.7N-23 are replaced by:

$$\begin{aligned} \frac{1}{(\Delta t)^2} [M] \{x_{n+2} - 2x_{n+1} + x_n\} + \frac{1}{2(\Delta t)} \{x_{n+2} - x_n\} [C] \\ + [K] \{\beta x_{n+2} + (1-2\beta)x_{n+1} + \beta x_n\} \quad (3.7N-24) \\ = \{\beta F_{n+2} + (1-2\beta) F_{n+1} + \beta F_n\} \end{aligned}$$

where:

- $n, n+1, n+2$ = past, present, and future (updated) values of the variables
- β = parameter to be selected on the basis of numerical stability and accuracy
- F = the total right hand side of the equation of motion (Equation 3.7N-22 or 3.7N-23)

$$\Delta t = t_{n+2} - t_{n+1} = t_{n+1} - t_n$$

The value of β is chosen equal to $1/3$ in order to provide a margin of numerical stability for nonlinear problems. Since the numerical stability of Equation 3.7N-24 is mostly determined by the left hand side terms of that equation, the right hand side terms were replaced by F_{n+2} . Furthermore, since the time increment may vary between two successive time substeps. Equation 3.7N-24 may be modified as follows:

$$\begin{aligned} & \frac{2}{(\Delta t + \Delta t_1)} [M] \left[\frac{x_{n+2} - x_{n+1}}{\Delta t} \right] \\ & + \frac{1}{(\Delta t + \Delta t_1)} C [x_{n+2} - x_n] + \end{aligned} \quad (3.7N-25)$$

$$\frac{1}{3} [K] [x_{n+2} + x_{n+1} + x_n] = [F_{n+2}]$$

By factoring x_{n+2} , x_{n+1} , and x_n , and rearranging terms, Equation 3.7N-25 is obtained as follows:

$$\begin{aligned} & [C_5 [M] + C_3 C + (1/3) [K]] [x_{n+2}] = [F_{n+2}] \\ & + [C_7 [M] - (1/3) [K]] [x_{n+1}] \\ & + [-C_2 [M] + C_3 [C] - (1/3) [K]] [x_n] \end{aligned} \quad (3.7N-26)$$

where:

$$C_2 = \frac{2}{\Delta t_1 (\Delta t + \Delta t_1)}$$

$$C_3 = \frac{1}{\Delta t + \Delta t_1}$$

$$C_5 = \frac{2}{\Delta t (\Delta t + \Delta t_1)}$$

$$C_7 = C_2 + C_5$$

The preceding set of simultaneous linear equations is solved to obtain the present values of nodal displacements $\{x_t\}$ in terms of the previous (known) values of the nodal displacements. Since M , C , and K are included in the equation, they can also be time or displacement dependent.

3.7N.2.2 Natural Frequencies and Response Loads

Refer to Section 3.7B.2.2.

3.7N.2.3 Procedures Used for Modeling

Procedures used for modeling are discussed in Section 3.7N.2.1.1.

3.7N.2.4 Soil/Structure Interaction

Refer to Section 3.7B.2.4.

3.7N.2.5 Development of Floor Response Spectra

Refer to Section 3.7B.2.5.

3.7N.2.6 Three Components of Earthquake Motion

The seismic design of the NSSS equipment includes the effect of the seismic response of the supports, equipment, structures and components. Floor response spectra are generated for two perpendicular horizontal directions (N-S, E-W) and the vertical direction. The equipment response is determined using horizontal and vertical umbrella spectra, which envelop the appropriate floor response spectra. The damping values used in the analysis are those given in Table 3.7N-1.

The modal responses are determined by taking the absolute sum of the horizontal response and the vertical response utilizing the modal participation factors and mode shapes. The total seismic response is then obtained by combining the individual modal responses using the square root of the sum of the squares (SRSS) method endorsed by Regulatory Guide 1.92.

3.7N.2.7 Combination of Modal Response

The total unidirectional seismic response is obtained by combining the individual modal responses, utilizing the SRSS method. For systems having modes with closely-spaced frequencies, this method is modified to include the possible effect of these modes. The groups of closely spaced modes are chosen so that the difference between the frequencies of the first mode and the last mode in the group does not exceed 10 percent of the lower frequency. Groups are formed, starting from the lowest frequency and working toward successively higher frequencies. No one frequency is in more than one group. Combined total response for systems which have such closely-spaced

modal frequencies is obtained by adding to the SRSS of all modes the product of the responses of the modes in each of closely-spaced modes and a coupling factor ϵ . This can be represented mathematically as:

$$R_T^2 = \sum_{i=1}^N R_i^2 + 2 \sum_{j=1}^S \sum_{K=M_j}^{N_j-1} \sum_{\ell=K+1}^{N_j} R_K R_\ell \epsilon_{K\ell} \quad (3.7N-27)$$

where:

- R_T = total unidirectional response,
 R_i = absolute value of response of mode i ,
 N = total number of modes considered,
 S = number of groups of closely-spaced modes,
 M_j = lowest modal number associated with group j of closely-spaced modes, and
 N_j = highest modal number associated with group j of closely-spaced modes.
 $\epsilon_{K\ell}$ = coupling factors with:

$$\epsilon_{K\ell} = \left\{ 1 + \left[\frac{\omega_K' - \omega_\ell'}{(\beta_K' \omega_K + \beta_\ell' \omega_\ell)} \right]^2 \right\}^{-1}$$

$$\omega_K' = \omega_K \left[1 - (\beta_K')^2 \right]^{1/2}$$

$$\beta_K' = \beta_K + \frac{2}{\omega_K t_d}$$

where:

ω_K = frequency of closely-spaced mode K

β_K = fraction of critical damping in closely-spaced mode K

t_d = duration of the earthquake

An example of this equation applied to a system can be supplied with the following considerations. Assume that the predominant contributing modes have frequencies as follows:

Mode	1	2	3	4	5	6	7	8
Frequency	5.0	8.0	8.3	8.6	11.0	15.5	16.0	20

There are two groups of closely-spaced modes, namely with modes {2, 3, 4} and {6, 7}. Therefore:

- S = 2 number of groups of closely spaced modes,
- M_1 = 2 lowest modal number associated with group 1,
- N_1 = 4 highest modal number associated with group 1,
- M_2 = 6 lowest modal number associated with group 2,
- N_2 = 7 highest modal number associated with group 2, and
- N = 8 total number of modes considered.

The total response for this system is, as derived from the expansion of Equation 3.7N-29:

$$\begin{aligned}
 R_T^2 = & R_1^2 + R_2^2 + R_3^2 + \dots + R_8^2 \\
 & + 2 R_2 R_3 \epsilon_{23} + 2 R_2 R_4 \epsilon_{24} \\
 & + 2 R_3 R_4 \epsilon_{34} + 2 R_6 R_7 \epsilon_{67}
 \end{aligned}
 \tag{3.7N-28}$$

3.7N.2.8 Interaction of Non-Category I Structures with Seismic Category I Structures

Refer to Section 3.7B.2.8.

3.7N.2.9 Effects of Parameter Variations on Floor Response Spectra

Refer to Section 3.7B.2.9.

3.7N.2.10 Use of Constant Vertical Static Factors

Constant vertical static factors are not used because the vertical floor response load for the seismic design of safety class systems

and components within Westinghouse's scope of responsibility is used. All such systems and components are rigorously analyzed in vertical direction.

3.7N.2.11 Methods Used to Account for Torsional Effects

Refer to Section 3.7B.2.11.

3.7N.2.12 Comparison of Responses

Refer to Section 3.7B.2.12.

3.7N.2.13 Methods for Seismic Analysis of Dams

Refer to Section 3.7B.2.13.

3.7N.2.14 Determination of Seismic Category I Structure Overturning Moments

Refer to Section 3.7B.2.14.

3.7N.2.15 Analysis Procedure for Damping

The damping values and procedures used for Westinghouse's scope of supply and analysis are discussed in Sections 3.7N.1.3 and 3.7N.2.1.

3.7N.3 Seismic Subsystem Analysis

3.7N.3.1 Seismic Analysis Methods

Seismic analysis methods for subsystems within Westinghouse's scope of responsibility are given Section 3.7N.2.1.

3.7N.3.2 Determination of Number of Earthquake Cycles

Where fatigue analyses of mechanical systems and components are required, Westinghouse specifies in the equipment specification the number of cycles of the OBE to be considered. The number of cycles for NSSS components is given in Table 3.9N-1. The fatigue analyses are performed and presented as part of the stress report.

3.7N.3.3 Procedure Used for Modeling

Section 3.7N.2.1 discusses modeling procedures for subsystems in Westinghouse's scope of responsibility.

3.7N.3.4 Basis for Selection of Frequencies

The analysis of equipment subjected to seismic loading involves several basic steps, the first of which is the establishment of the intensity of the seismic loading. Considering that the seismic input originates at the point of support, the response of the equipment,

and its associated supports based upon the mass and stiffness characteristics of the system will determine the seismic accelerations which the equipment must withstand.

Three ranges of equipment/support behavior which affect the magnitude of the seismic acceleration are possible:

1. If the equipment is rigid relative to the structure, the maximum acceleration of the equipment mass approaches that of the structure at the point of equipment support. Equipment and their support systems are considered rigid if their natural frequencies are greater than 33 Hz. The equipment acceleration value in this case corresponds to the high frequency region of the floor response spectra.
2. If the equipment is very flexible relative to the structure, the equipment will show very little response.
3. If the frequencies of the equipment and supporting structure are nearly equal, resonance may occur and must be taken into account.

In all cases, equipment under earthquake loadings is designed to be within ASME III Code.

3.7N.3.5 Use of Equivalent Static Load Method of Analysis

The static load equivalent or static analysis method involves the multiplication of the total weight of the equipment or component member by the specified seismic acceleration coefficient. The magnitude of the seismic acceleration coefficient is established on the basis of the expected dynamic response characteristics of the component. Components which can be adequately characterized as single degree of freedom systems are considered to have a modal participation factor of one. Seismic acceleration coefficients for multi-degree of freedom systems which may be in the resonance region of the amplified response spectra curves are increased by 50 percent to account conservatively for the increased modal participation.

3.7N.3.6 Three Components of Earthquake Motion

Methods used to account for the horizontal and vertical components of earthquake motion for subsystems in Westinghouse's scope of responsibility are given in Section 3.7N.2.6.

3.7N.3.7 Combination of Modal Responses

Methods used to combine modal responses for subsystems in Westinghouse's scope of responsibility are given in Section 3.7N.2.7.

3.7N.3.8 Analytical Procedures for Piping

Refer to Section 3.7B.3.8.

3.7N.3.9 Multiply Supported Equipment Components with Distinct Inputs

When response spectrum methods are used to evaluate reactor coolant system (RCS) primary components interconnected between floors, the following procedures are used. There are no components in the Westinghouse's scope of analysis which are connected between buildings. The primary components of the RCS are supported at no more than two floor elevations.

A dynamic response spectrum analysis is first made assuming no relative displacement between support points. The response spectra used in this analysis are the umbrella of the floor response spectra.

Secondly, the effect of differential seismic movement of components interconnected between floors is considered statically in the detailed component analysis. The results of the building analysis are reviewed on a mode-by-mode basis to determine the differential motion in each mode. The differential motion will be evaluated as a free end displacement, since, in accordance with Section III of the ASME Code, paragraph NB-3213.19, examples of a free end displacement are motions "that would occur because of relative thermal expansion of piping, equipment, and equipment supports, or because of rotations imposed upon the equipment by sources other than the piping." The effect of the differential motion is to impose a rotation on the component from the building. This motion, then, being a free end displacement and being similar to thermal expansion loads, will cause stresses which will be evaluated with ASME Code methods including the rules of NB-3227.5 used for stresses or originating from restrained free end displacements.

The results of these two steps, the dynamic inertia analysis and the static differential motion analysis, are combined absolutely with due consideration for the ASME classification of the stresses.

3.7N.3.10 Use of Constant Vertical Static Factors

Constant vertical load factors are not used as the vertical floor response load for the seismic design of safety-related components and equipment within Westinghouse's scope of responsibility.

3.7N.3.11 Torsional Effects of Eccentric Masses

Refer to Section 3.7B.3.11.

3.7N.3.12 Buried Seismic Category I Piping Systems

Refer to Section 3.7B.3.12.

3.7N.3.13 Interaction of Other Piping with Seismic Category I Piping

Refer to Section 3.7B.3.13.

3.7N.3.14 Seismic Analyses of Reactor Internals

Fuel assembly component stresses induced by horizontal seismic disturbances are analyzed through the use of finite element computer modeling.

The time history floor response based on a standard seismic time history normalized to SSE levels is used as the seismic input. The reactor internals and the fuel assemblies are modeled as spring and lumped mass systems or beam elements. The component seismic response of the fuel assemblies is analyzed to determine design adequacy. A detailed discussion of the analyses performed for fuel assemblies is contained in WCAP 8236 (Westinghouse 1974b and Lin 1974).

Fuel assembly lateral structural damping obtained experimentally is presented on Figure B-4 of WCAP 8288 (Westinghouse 1974b). The distribution of fuel assembly amplitudes decreases as one approaches the center of the core. Fuel assembly displacement time history for the SSE seismic input is contained in WCAP 8236 (Westinghouse 1974b). The data indicate that no damping values less than 10 percent were obtained for fuel assembly displacements greater than 0.11 inch.

The CRDMS are seismically analyzed to confirm that system stresses under the combined loading conditions as described in Section 3.9N.1 do not exceed allowable levels as defined by the ASME Code, Section III for upset and faulted conditions. The CRDM is mathematically modeled as a system of lumped and distributed masses. The model is analyzed under appropriate seismic excitation and the resultant seismic bending moments along the length of the CRDM are calculated. The corresponding stresses are then combined, with the stresses from the other loadings required and the combination is shown to meet ASME Code, Section III requirements.

3.7N.3.15 Analysis Procedure for Damping

Analysis procedures for damping for subsystems in Westinghouse's scope of responsibility are given in Sections 3.7N.1.3 and 3.7N.2.1.

3.7N.4 Seismic Instrumentation

Refer to Section 3.7B.4.

3.7.5 References for Section 3.7B

American Society of Mechanical Engineers 1984. ASME Boiler and Pressure Vessel Code, September 17, 1984. Case N-411, Alternative Damping Values for Seismic Analysis of Classes 1, 2, and 3 Piping Sections, Section III, Division 1.

Audibert, J. M. E. and Nyman, K. J. 1977. Soil Restraint Against Horizontal Motion of Pipes. Journal of the Geotechnical Engineering Division, p 1119-1142.

Biggs, J. M. 1964. Introduction to Structural Dynamics; p 83-111, 116-125; McGraw-Hill, New York, N.Y.

Chan, S. P.; Cox, H. L.; and Benfield, W. A. 1962. Transient Analysis of Forced Vibration of Complex Structural-Mechanical Systems. J. Royal Aeronautical Society.

Chang, T. Y. 1973. Comparison of Seismic Response Combination Procedures for Piping Systems. Stone & Webster Engineering Corporation (SWEC).

Duquesne Light Company 1976. Report on Soil Densification Program, Beaver Valley Power Station - Unit 2.

Goodling, E. C. 1978. Flexibility Analysis of Buried Pipe. ASME Publication 78-PVP-82 Joint ASME/CSME Pressure Vessels and Piping Conference, Montreal, Canada.

Goodling, E. C. 1979. Seismic Stresses in Buried Elbows. Preprint 3595, ASCE National Convention, Boston, Mass.

Goodling, E. C. 1980. More on Flexibility Analysis of Buried Pipe. ASME Pressure Vessels and Piping Conference, San Francisco, Calif.

Gwinn, J. H. and Goldstein, N. A. 1974. Equivalent Static Load from Amplified Response Curves. ASME Paper 74-NE-6, Presented at the Pressure Vessels and Piping Conference, Miami, Fl.

Hetenyi, M. 1946. Beams on Elastic Foundation. The University of Michigan Press, Ann Arbor, Mi.

Johnson J. J. and Kennedy, R. P. 1977. Earthquake Response of Nuclear Power Facilities. Presented at the ASCE Fall Convention and Exhibit San Francisco, Ca.

Kausel, E. and Roesset, J. 1975. Dynamic Stiffness of Circular Foundations. ASCE, Eng. Mechanics Division.

King, R. C. and Crocker, C. 1967. Piping Handbook. McGraw-Hill Book Co. New York, NY

Lin, C. W. 1974. How to Lump the Masses - A Guide to the Piping Seismic Analysis. SAME Paper 74-NE-7 presented at the Pressure Vessels and Piping Conference, Miami, Fl.

Lin, Y. Y. and Hadjian, A. H. 1976. Discrete Modeling of Containment Structures. Presented at the International Symposium on Earthquake Structural Engineering, St. Louis, Mo.

Lysmer, J.; Udaka T.; Tsai, C. F.; and Seed, H. B. 1975. Flush User's Manual Based Upon Earthquake Engineering Report 75-30, Control Data Corporations Version 2.200, Scope 3.4.

- Newmark, N. M. and Rosenblueth, E. 1971. Fundamentals of Earthquake Engineering, Prentice-Hall, Inc., Englewood, N.J.
- Newmark, N. M. 1972. Earthquake Response Analysis of Reactor Structures. Nuclear Engineering and Design, Vol 20, p 303-322.
- Richart, F. E., Jr.; Hall, J. R., Jr.; and Woods, R. D. 1970. Vibrations of Soils and Foundations. Prentice-Hall, Inc., Englewood Cliffs, N.J.
- Roesset, J. M.; Whitman, R. V.; and Doby, R. 1973, Modal Analysis for Structures with Foundation Interaction. Journal of the Structural Division, Proceeding ASCE, p 399-416.
- Shah, H. H. and Chu, S. L. 1974. Seismic Analysis of Underground Structural Elements. Journal of the Power Division, Proceedings of ASCE, Vol 100, No. P01, p 53-62.
- Singh, A. K.; Chu, S. L.; and Singh, S. L. 1973. Influence of Closely Spaced Modes in Response Spectrum Method of Analysis. Presented at the Specialty Conference on Structural Design of Nuclear Plant Facilities, Chicago, Ill.
- Thomas, T. H. et al 1963. Nuclear Reactors and Earthquakes. TID-7024, U. S. Atomic Energy Commission, P 24-51, Washington, D.C.
- U.S. Nuclear Regulatory Commission (USNRC) 1975. Seismic System Analysis. Standard Review Plan, Section 3.7.2, NUREG-75/087.
- Wass, G. 1972. Linear Two-Dimensional analysis of Soil Dynamics in Semi-Infinite Layered Media. PhD Thesis, presented to J. Lysmer, University of Calif., Berkeley, Calif.
- Westinghouse 1974a. Damping Values of Nuclear Power Plant Components. (Class 3 WCAP-7921-AR).
- Westinghouse 1974b. Safety Analysis of the 8-Grid 17 x 17 Fuel Assembly for Combined Seismic and Loss-of-Coolant Accident. WCAP-8236, Addendum 1 (Proprietary) and WCAP-8288, Addendum 1 (Non-Proprietary).
- Whitman, R. V. and Richart, F. E., Jr. 1967. Design Procedures for Dynamically Loaded Foundations. Journal of the Soil Mechanics and Foundation Division, Proceedings of the ASCE.
- Whitman, R. V. 1970. Soil Structure Interaction. In: Seismic Design for Nuclear Power Plants, MIT Press, Cambridge, Mass. p 241-269.
- Yeh, G. C. K. 1974. Seismic Analysis of Slender Buried Beams. Bulletin of the Seismological Society of America, Vol 64, No. 5, p 1,551-1,562.

BVPS-2 UFSAR

Tables for Section 3.7

TABLE 3.7B-1

DAMPING VALUES

(Percent of Critical Damping)

<u>Structure or Component</u>	<u>1/2 Safe Shutdown Earthquake</u>	<u>Safe Shutdown Earthquake</u>
Piping and piping components (except as listed below)	0.5	1.0
For stress reconciliation or support optimization of piping only	*	*
Reinforced concrete structures	2.0	7.0
Bolted steel structures	4.0	7.0
Welded steel structures	2.0	4.0
Cable tray and conduit systems	4.0	8.0
Soil	10.0	10.0

NOTE:

*ASME III Code Case N-411 for both 1/2 SSE and SSE.

TABLE 3.7B-2

FOUNDATION INFORMATION AND STRUCTURAL DIMENSIONS
FOR SEISMIC CATEGORY 1 STRUCTURES

Category I Structure	Foundation Embedment Depth (ft)*	Structure Founding Elevation (ft)**	Approximate Depth of Soil over Bedrock (ft)***	Approximate Dimensions of Foundation Area (ft)	Total Structural Height (ft)****	Founding Conditions
Auxiliary building	32	703	83	120 x 146	95.25	In situ soil
Cable tunnels	4-25.5	varies 709.5 to 731	89.5-111	Width varies 7 to 21	-	Select granular fill
Control room extension	32	703	83	81 x 65	48.9	Select granular fill
Demineralized water tank	5	730	110	40 x 38	59	Select granular fill
Diesel generator building	22	713	93	81 x 83	76	Select granular fill
Emergency outfall structure	21	714	35*****	25 x 30	26	In situ soil
Fuel building	11.5-17.7	717.3 & 723.5	97.3-103.5	110 x 44	75.9-94.7	Select granular fill
Main intake structure	38	637	17	88 x 84	125	In situ soil
Main steam and cable Vault	0-9.5	712.5	92.5	135 x 90	84.75	Select granular fill
Reactor containment	54.1	680.9	60.9	142 dia	195.6	In situ soil
Refueling water storage tank	5	730.5	110	57 x 58	74.0	Select granular fill
Safeguards area	20.5	714.5	94.5	96 x 60	43.5	Select granular fill
Service building	6.5-22.5	725.5	105.5	55 x 186	64.25	Select granular fill
Valve pit	18.8	716.2	96.2	35 x 23	18.8	In situ soil

NOTES:

- * If the structure is surrounded by adjacent structures only, the range of embedment depth is given; otherwise the embedment from the plant grade near the structure is given.
- ** Mean sea level (msl).
- *** Elevation of bedrock is approximately 620 in main plant area.
- **** Total height from the foundation to the roof.
- ***** Elevation of bedrock is approximately 679.

TABLE 3.7B-3

METHODS OF SEISMIC ANALYSIS USED FOR
SEISMIC CATEGORY I STRUCTURES

<u>Structure</u>	<u>Response Spectrum Analysis</u>	<u>Modal Time History Analysis</u>
Reactor Containment and Internals	X	X
Cable Vault and Main Steam Valve Area	X	X
Cable Tunnel	X	X
Pipe Tunnel	X	
Safeguards Area	X	X
Auxiliary Building	X	X
Fuel and Decontamination Building	X	X
Control Room Extension	X	X
Service Building	X	X
Diesel Generator Building	X	X
Service Water Valve Pit	X	X
Refueling Water Storage and Chemical Addition Tanks	X	X
Primary Plant Demineralizer Water Storage Tank and Enclosure	X	X
Primary Intake Structure (Analyzed for BVPS-1)	X	

TABLE 3.7B-4

CONTAINMENT AND INTERNAL STRUCTURES
 REPRESENTATIVE MODAL FREQUENCIES AND PARTICIPATION FACTORS
 UNCRACKED MODEL, MEDIAN SOIL, SAFE SHUTDOWN EARTHQUAKE

<u>Mode</u>	<u>Frequency (Hz)</u>	<u>Participation Factors</u>	
		<u>Horizontal Earthquake</u>	<u>Vertical Earthquake</u>
1*	1.496	461.23	-1.14
2*	2.656	1.78	368.09
3*	3.679	-289.71	-0.26
4*	5.004	87.49	-2.40
5	11.096	4.61	-0.28
6	12.702	3.43	-2.19
7	13.692	12.08	1.31
8	17.189	-11.07	0.36

NOTE:

* For plots of mode shapes 1 through 4, refer to Figures 3.7B-12, 3.7B-13, 3.7B-14 and 3.7B-15.

TABLE 3.7B-5

CONTAINMENT AND INTERNAL STRUCTURES
 REPRESENTATIVE MODAL FREQUENCIES AND PARTICIPATION FACTORS
 CRACKED MODEL, MEDIAN SOIL, SAFE SHUTDOWN EARTHQUAKE

<u>Mode</u>	<u>Frequency (Hz)</u>	<u>Participation Factors</u>	
		<u>Horizontal Earthquake</u>	<u>Vertical Earthquake</u>
1	1.354	422.27	1.19
2	2.515	-1.33	-544.70
3	2.905	-305.77	5.01
4	4.553	178.07	0.23
5	5.753	3.78	87.97
6	6.401	27.50	-1.78
7	10.017	-8.18	-0.23
8	10.545	-7.17	-6.39

TABLE 3.7B-6

CONTAINMENT AND INTERNAL STRUCTURES
 REPRESENTATIVE MODE SHAPES (EIGENVECTORS)
 UNCRACKED MODEL, MEDIAN SOIL

<u>Mode</u>	<u>Mass No.</u>	<u>Displacement</u>	
		<u>X</u>	<u>Y</u>
1	1	1.0	0
	2	0.796	0
	3	0.676	0
	4	0.559	0
	5	0.437	0
	6	0.337	0
	7	0.103	0
	8	0.102	0
	9	0.334	0
	10	0.435	0
	11	0.577	0
	12	0.698	0
	13	0.816	0
2	1	0	-1.0
	2	0	-0.979
	3	0	-0.979
	4	0	-0.973
	5	0	-0.963
	6	0	-0.957
	7	0	-0.947
	8	0	-0.936
	9	0	-0.968
	10	0	-0.973
	11	0	-0.973
	12	0	-0.979
	13	0	-0.979
3	1	1.0	0
	2	0.486	0
	3	0.223	0
	4	-0.040	0
	5	-0.295	0
	6	-0.498	0
	7	-0.658	0
	8	-0.809	0
	9	-0.727	0
	10	-0.615	0
	11	-0.451	0
	12	-0.312	0
	13	-0.167	0

TABLE 3.7B-6 (Cont.)

<u>Mode</u>	<u>Mass No.</u>	<u>Displacement</u>	
		<u>X</u>	<u>Y</u>
4	1	0.356	0
	2	0.318	0
	3	0.316	0
	4	0.308	0
	5	0.291	0
	6	0.275	0
	7	0.261	0
	8	0.235	0
	9	-0.177	0
	10	-0.372	0
	11	-0.542	0
	12	-0.787	0
	13	-1.0	0
5	1	-1.0	0.057
	2	-0.357	0.037
	3	-0.571	0.034
	4	-0.651	0.030
	5	-0.581	0.024
	6	-0.408	0.019
	7	-0.216	0.014
	8	0.078	0.006
	9	0.558	-0.048
	10	0.340	-0.032
	11	0.021	-0.039
	12	-0.350	-0.048
	13	-0.698	-0.011
6	1	0.209	-1.0
	2	-0.068	-0.544
	3	-0.081	-0.473
	4	-0.070	-0.380
	5	-0.036	-0.269
	6	0.004	-0.164
	7	0.038	-0.073
	8	0.072	0.059
	9	-0.092	0.399
	10	-0.072	0.453
	11	0.002	0.501
	12	0.094	0.541
	13	0.162	0.547

TABLE 3.7B-6 (Cont.)

<u>Mode</u>	<u>Mass No.</u>	<u>Displacement</u>	
		<u>X</u>	<u>Y</u>
7	1	0.571	0.251
	2	-0.259	0.117
	3	-0.265	0.109
	4	-0.172	0.073
	5	-0.028	0.044
	6	0.107	0.017
	7	0.203	-0.006
	8	0.267	-0.037
	9	-0.453	-0.056
	10	-0.341	-0.090
	11	0.026	-0.089
	12	0.575	-0.081
	13	1.0	-0.126
8	1	0.956	0.123
	2	0.547	0.020
	3	0.650	0.008
	4	0.452	-0.005
	5	0.026	-0.018
	6	-0.375	-0.027
	7	-0.646	-0.034
	8	-1.0	-0.041
	9	0.505	-0.009
	10	0.349	0.004
	11	0.361	0.028
	12	0.276	0.040
	13	0.078	0.071

TABLE 3.7B-7

CONTAINMENT AND INTERNAL STRUCTURES
 REPRESENTATIVE MODE SHAPES (NORMALIZED EIGENVECTORS)
 CRACKED MODEL, MEDIAN SOIL, SAFE SHUTDOWN EARTHQUAKE

<u>Mode</u>	<u>Mass No.</u>	<u>Displacement</u>	
		<u>X</u>	<u>Y</u>
1	1	1.0	0
	2	0.717	0
	3	0.582	0
	4	0.451	0
	5	0.328	0
	6	0.234	0
	7	0.166	0
	8	0.101	0
	9	0.215	0
	10	0.284	0
	11	0.379	0
	12	0.459	0
	13	0.538	0
2	1	0	1.0
	2	0	0.926
	3	0	0.896
	4	0	0.852
	5	0	0.794
	6	0	0.733
	7	0	0.677
	8	0	0.634
	9	0	0.653
	10	0	0.655
	11	0	0.658
	12	0	0.660
	13	0	0.660
3	1	1.0	0
	2	0.304	0
	3	0.069	0
	4	-0.136	0
	5	-0.299	0
	6	-0.392	0
	7	-0.434	0
	8	-0.444	0
	9	-0.585	0
	10	-0.648	0
	11	-0.730	0
	12	-0.801	0
	13	-0.864	0
4	1	-0.200	-0.024

TABLE 3.7B-7 (Cont.)

<u>Mode</u>	<u>Mass No.</u>	<u>Displacement</u>	
		<u>X</u>	<u>Y</u>
	2	-0.147	-0.018
	3	-0.188	-0.016
	4	-0.230	-0.013
	5	-0.278	-0.009
	6	-0.326	-0.005
	7	-0.377	-0.002
	8	-0.435	-0.000
	9	-0.106	0.027
	10	0.123	0.009
	11	0.444	0.012
	12	0.730	0.014
	13	1.0	-0.018
5	1	-0.0215	1.0
	2	0.0043	0.616
	3	0.0039	0.483
	4	0.0018	0.309
	5	-0.0019	0.108
	6	-0.0064	-0.069
	7	-0.0108	-0.214
	8	-0.0157	-0.310
	9	0.0000	-0.365
	10	0.0059	-0.375
	11	0.0123	-0.382
	12	0.0188	-0.387
	13	0.0261	-0.390
6	1	1.0	0.021
	2	-0.754	0.011
	3	-0.778	0.007
	4	-0.662	0.003
	5	-0.435	-0.000
	6	-0.199	-0.004
	7	-0.013	-0.007
	8	0.170	-0.009
	9	0.258	-0.006
	10	0.253	-0.004
	11	0.233	-0.002
	12	0.214	-0.001
	13	0.185	0.002

TABLE 3.7B-7 (Cont.)

<u>Mode</u>	<u>Mass No.</u>	<u>Displacement</u>	
		<u>X</u>	<u>Y</u>
7	1	1.0	0.011
	2	-0.647	-0.005
	3	-0.036	-0.012
	4	0.433	-0.016
	5	0.997	-0.016
	6	0.464	-0.012
	7	0.220	-0.007
	8	-0.142	-0.003
	9	-0.453	0.018
	10	-0.342	0.003
	11	-0.103	0.004
	12	0.163	0.007
	13	0.419	-0.022
8	1	-0.011	1.0
	2	0.012	-0.290
	3	0.004	-0.512
	4	-0.001	-0.588
	5	-0.003	-0.496
	6	-0.001	-0.297
	7	0.002	-0.090
	8	0.006	0.064
	9	-0.008	0.145
	10	-0.006	0.158
	11	-0.000	0.169
	12	0.005	0.177
	13	0.008	0.180

TABLE 3.7B-8

CONTAINMENT AND INTERNAL STRUCTURES SRSS ACCELERATIONS
AND DISPLACEMENTS FOR SAFE SHUTDOWN EARTHQUAKE
UNCRACKED MODEL, MEDIAN SOIL, RESPONSE SPECTRUM ANALYSIS

<u>Degree of Freedom*</u>	<u>Acceleration**</u>		<u>Displacements***</u>	
	<u>Horizontal Earthquake</u>	<u>Vertical Earthquake</u>	<u>Horizontal Earthquake</u>	<u>Vertical Earthquake</u>
1	0.415	0.279x10 ⁻²	0.137	0.427x10 ⁻³
2	0.372x10 ⁻²	0.180	0.137x10 ⁻³	0.0208
3	0.256x10 ⁻²	0.166x10 ⁻⁴	0.655x10 ⁻³	0.19x10 ⁻⁵
4	0.313	0.225x10 ⁻²	0.109	0.343x10 ⁻³
5	0.228x10 ⁻²	0.177	0.133x10 ⁻³	0.0204
6	0.237x10 ⁻²	0.104x10 ⁻⁴	0.630x10 ⁻³	0.17x10 ⁻⁵
7	0.260	0.205x10 ⁻²	0.093	0.296x10 ⁻³
8	0.209x10 ⁻²	0.176	0.133x10 ⁻³	0.0203
9	0.235x10 ⁻²	0.106x10 ⁻⁴	0.627x10 ⁻³	0.17x10 ⁻⁵
10	0.213	0.182x10 ⁻²	0.076	0.249x10 ⁻³
11	0.187x10 ⁻²	0.175	0.132x10 ⁻³	0.0202
12	0.230x10 ⁻²	0.107x10 ⁻⁴	0.621x10 ⁻³	0.17x10 ⁻⁵
13	0.176	0.158x10 ⁻²	0.060	0.202x10 ⁻³
14	0.164x10 ⁻²	0.174	0.131x10 ⁻³	0.0201
15	0.224x10 ⁻²	0.108x10 ⁻⁴	0.611x10 ⁻³	0.17x10 ⁻⁵
16	0.156	0.139x10 ⁻²	0.046	0.162x10 ⁻³
17	0.148x10 ⁻²	0.172	0.130x10 ⁻³	0.0199
18	0.218x10 ⁻²	0.110x10 ⁻⁴	0.600x10 ⁻³	0.16x10 ⁻⁵
19	0.150	0.125x10 ⁻²	0.035	0.130x10 ⁻³
20	0.140x10 ⁻²	0.171	0.129x10 ⁻³	0.0197
21	0.212x10 ⁻²	0.113x10 ⁻⁴	0.589x10 ⁻³	0.16x10 ⁻⁵
22	0.154	0.108x10 ⁻²	0.024	0.954x10 ⁻⁴
23	0.138x10 ⁻²	0.168	0.127x10 ⁻³	0.0195
24	0.202x10 ⁻²	0.118x10 ⁻⁴	0.571x10 ⁻³	0.15x10 ⁻⁵
25	0.176	0.779x10 ⁻³	0.046	0.122x10 ⁻³
26	0.473x10 ⁻²	0.174	0.133x10 ⁻²	0.0201
27	0.217x10 ⁻²	0.396x10 ⁻⁴	0.627x10 ⁻³	0.39x10 ⁻⁵
28	0.198	0.110x10 ⁻²	0.060	0.153x10 ⁻³
29	0.186x10 ⁻²	0.175	0.246x10 ⁻³	0.0202

TABLE 3.7B-8 (Cont)

Degree of Freedom*	Acceleration**		Displacements***	
	Horizontal Earthquake	Vertical Earthquake	Horizontal Earthquake	Vertical Earthquake
30	0.221×10^{-2}	0.372×10^{-4}	0.632×10^{-3}	0.34×10^{-5}
31	0.240	0.230×10^{-2}	0.079	0.250×10^{-3}
32	0.220×10^{-2}	0.176	0.289×10^{-3}	0.0203
33	0.224×10^{-2}	0.402×10^{-4}	0.637×10^{-3}	0.35×10^{-5}
34	0.285	0.349×10^{-2}	0.096	0.347×10^{-3}
35	0.244×10^{-2}	0.176	0.314×10^{-3}	0.0204
36	0.226×10^{-2}	0.426×10^{-4}	0.639×10^{-3}	0.35×10^{-5}
37	0.332	0.458×10^{-2}	0.112	0.434×10^{-3}
38	0.684×10^{-2}	0.180	0.179×10^{-2}	0.0204
39	0.226×10^{-2}	0.107×10^{-3}	0.64×10^{-3}	0.35×10^{-5}

NOTES:

* Degrees of freedom corresponding to x- and y- direction translation and rotation about the z axis are identified in Table 3.7B-10.

** Tabulated accelerations are in units of g for translational degrees of freedom, and g/feet for rotational degrees of freedom.

*** Tabulated displacements are in units of feet for translational degrees of freedom, and rads for rotational degrees of freedom.

TABLE 3.7B-9

CONTAINMENT AND INTERNAL STRUCTURES SRSS ACCELERATIONS
AND DISPLACEMENTS FOR SAFE SHUTDOWN EARTHQUAKE
CRACKED MODEL, MEDIAN SOIL, RESPONSE SPECTRUM ANALYSIS

Degree of Freedom(*)	Acceleration(**)		Displacements(***)	
	Horizontal Earthquake	Vertical Earthquake	Horizontal Earthquake	Vertical Earthquake
1	0.447	0.537×10^{-2}	0.167	0.679×10^{-3}
2	0.717×10^{-2}	0.266	0.378×10^{-3}	0.033
3	0.381×10^{-2}	0.629×10^{-4}	0.102×10^{-2}	0.630×10^{-5}
4	0.279	0.245×10^{-2}	0.119	0.354×10^{-3}
5	0.542×10^{-2}	0.243	0.322×10^{-3}	0.031
6	0.304×10^{-2}	0.399×10^{-4}	0.909×10^{-3}	0.480×10^{-5}
7	0.221	0.167×10^{-2}	0.096	0.247×10^{-3}
8	0.473×10^{-2}	0.234	0.302×10^{-3}	0.030
9	0.283×10^{-2}	0.363×10^{-4}	0.875×10^{-3}	0.44×10^{-5}
10	0.178	0.113×10^{-2}	0.075	0.165×10^{-3}
11	0.387×10^{-2}	0.221	0.275×10^{-3}	0.028
12	0.251×10^{-2}	0.315×10^{-4}	0.818×10^{-3}	0.37×10^{-5}
13	0.153	0.104×10^{-2}	0.055	0.129×10^{-3}
14	0.317×10^{-2}	0.205	0.243×10^{-3}	0.026
15	0.212×10^{-2}	0.274×10^{-4}	0.734×10^{-3}	0.28×10^{-5}
16	0.144	0.123×10^{-2}	0.040	0.130×10^{-3}
17	0.258×10^{-2}	0.189	0.214×10^{-3}	0.024
18	0.178×10^{-2}	0.249×10^{-4}	0.639×10^{-3}	0.19×10^{-5}
19	0.143	0.145×10^{-2}	0.029	0.136×10^{-3}
20	0.221×10^{-2}	0.175	0.191×10^{-3}	0.023
21	0.158×10^{-2}	0.242×10^{-4}	0.546×10^{-3}	0.12×10^{-5}
22	0.143	0.168×10^{-2}	0.020	0.136×10^{-3}
23	0.215×10^{-2}	0.165	0.176×10^{-3}	0.021
24	0.154×10^{-2}	0.244×10^{-4}	0.472×10^{-3}	0.11×10^{-5}
25	0.165	0.204×10^{-2}	0.038	0.224×10^{-3}
26	0.618×10^{-2}	0.170	0.105×10^{-2}	0.022
27	0.219×10^{-2}	0.399×10^{-4}	0.515×10^{-3}	0.48×10^{-5}
28	0.192	0.270×10^{-2}	0.049	0.317×10^{-3}
29	0.264×10^{-2}	0.171	0.188×10^{-3}	0.022

TABLE 3.7B-9 (Cont)

Degree of Freedom(*)	Acceleration(**)		Displacements(***)	
	Horizontal Earthquake	Vertical Earthquake	Horizontal Earthquake	Vertical Earthquake
30	0.227×10^{-2}	0.375×10^{-4}	0.519×10^{-3}	0.43×10^{-5}
31	0.244	0.387×10^{-2}	0.065	0.47×10^{-3}
32	0.308×10^{-2}	0.172	0.215×10^{-3}	0.022
33	0.234×10^{-2}	0.398×10^{-4}	0.522×10^{-3}	0.45×10^{-5}
34	0.296	0.498×10^{-2}	0.078	0.60×10^{-3}
35	0.344×10^{-2}	0.172	0.236×10^{-3}	0.022
36	0.238×10^{-2}	0.415×10^{-4}	0.524×10^{-3}	0.45×10^{-5}
37	0.350	0.604×10^{-2}	0.091	0.713×10^{-3}
38	0.554×10^{-2}	0.172	0.150×10^{-2}	0.022
39	0.239×10^{-2}	0.421×10^{-4}	0.525×10^{-3}	0.65×10^{-5}

NOTES:

- * Degrees of freedom corresponding to x- and y- direction translation and rotation about the z axis are identified in Table 3.7B.2-8.
- ** Tabulated accelerations are in units of g for translational degrees of freedom, and g/feet for rotational degrees of freedom.
- *** Tabulated displacements are in units of feet for translational degrees of freedom, and rads for rotational degrees of freedom.
- **** SRSS - square root of the sum of the squares.

TABLE 3.7B-10
CONTAINMENT AND INTERNAL STRUCTURES
DEGREES OF FREEDOM

<u>Mass Point</u>	<u>Degree of Freedom</u>	<u>Direction of Motion (Global Coordinates)*</u>	
1	1	Translation	X
1	2	Translation	Y
1	3	Rotation	θ_z
2	4	Translation	X
2	5	Translation	Y
2	6	Rotation	θ_z
3	7	Translation	X
3	8	Translation	Y
3	9	Rotation	θ_z
4	10	Translation	X
4	11	Translation	Y
4	12	Rotation	θ_z
5	13	Translation	X
5	14	Translation	Y
5	15	Rotation	θ_z
6	16	Translation	X
6	17	Translation	Y
6	18	Rotation	θ_z
7	19	Translation	X
7	20	Translation	Y
7	21	Rotation	θ_z
8	22	Translation	X

TABLE 3.7B-10 (Cont)

<u>Mass Point</u>	<u>Degree of Freedom</u>	<u>Direction of Motion (Global Coordinates)*</u>	
8	23	Translation	Y
8	24	Rotation	θ_z
9	25	Translation	X
9	26	Translation	Y
9	27	Rotation	θ_z
10	28	Translation	X
10	29	Translation	Y
10	30	Rotation	θ_z
11	31	Translation	X
11	32	Translation	Y
11	33	Rotation	θ_z
12	34	Translation	X
12	35	Translation	Y
12	36	Rotation	θ_z
13	37	Translation	X
13	38	Translation	Y
13	39	Rotation	θ_z

NOTE:

*Refer to Figure 3.7B-9.

TABLE 3.7B-11

CONTAINMENT AND INTERNAL STRUCTURES
ENVELOPED ACCELERATIONS AND DISPLACEMENTS
HORIZONTAL MOTION*

External Structure

Mass No	Elevation (ft)	Acceleration**		Displacement***	
		SSE	OBE	SSE	OBE
1	854.22	0.473	0.239	0.189	0.099
2	813.62	0.359	0.180	0.139	0.073
3	788.62	0.300	0.151	0.114	0.060
4	763.62	0.245	0.123	0.091	0.047
5	738.62	0.198	0.100	0.068	0.036
6	717.32	0.167	0.085	0.051	0.027
7	699.72	0.151	0.078	0.039	0.020
8	680.92	0.154	0.0775	0.027	0.014

Internal Structure

9	716.0	0.188	0.096	0.049	0.026
10	738.0	0.224	0.114	0.064	0.033
11	767.83	0.284	0.145	0.083	0.044
12	793.	0.343	0.175	0.100	0.052
13	818.0	0.402	0.206	0.117	0.061

NOTES:

*Maximum of cracked, uncracked, G = 18 ksi \pm 33 percent.

**Tabulated accelerations are in units of g.

***Displacements are listed in feet.

TABLE 3.7B-12

CONTAINMENT AND INTERNAL STRUCTURES
ENVELOPED ACCELERATIONS AND DISPLACEMENTS
VERTICAL MOTION*

External Structure

<u>Mass No.</u>	<u>Elevation (ft)</u>	<u>Acceleration**</u>		<u>Displacement***</u>	
		<u>SSE</u>	<u>OBE</u>	<u>SSE</u>	<u>OBE</u>
1	854.22	0.266	0.135	0.044	0.022
2	813.62	0.242	0.122	0.041	0.021
3	788.62	0.234	0.117	0.040	0.020
4	763.62	0.221	0.111	0.039	0.0196
5	738.62	0.205	0.102	0.037	0.019
6	717.32	0.193	0.096	0.035	0.018
7	699.72	0.188	0.095	0.034	0.017
8	680.92	0.1845	0.093	0.032	0.016

Internal Structure

9	716.0	0.193	0.0965	0.033	0.016
10	738.0	0.194	0.097	0.033	0.0165
11	767.83	0.195	0.097	0.033	0.0165
12	793.0	0.196	0.098	0.033	0.017
13	818.0	0.196	0.098	0.033	0.017

NOTES:

*Maximum of cracked, uncracked, G = 18 ksi \pm 33 percent.

**Tabulated accelerations are in units of g.

***Displacements are listed in feet.

TABLE 3.7B-13

FUEL BUILDING
 REPRESENTATIVE MODAL FREQUENCIES AND
 PARTICIPATION FACTORS

<u>Mode</u>	<u>Frequency (Hz)</u>	<u>Participation Factors</u>		
		<u>X-Earthquake</u>	<u>Y-Earthquake</u>	<u>Z-Earthquake</u>
1	2.704	1.328	-8.467	201.785
2	2.881	31.494	0.506	-3.921
3	3.342	253.884	7.430	1.504
4	3.884	6.966	-349.883	-7.826
5	4.753	31.608	0.070	52.593
6	5.135	55.373	5.015	-194.360
7	5.309	128.304	1.603	67.510
8	6.722	3.226	19.865	-9.463
9	9.195	0.218	2.202	-0.856
10	13.262	0.159	-41.917	-0.401

TABLE 3.7B-14

FUEL BUILDING
 REPRESENTATIVE MODE SHAPES
 (EIGENVECTORS)

<u>Mode</u>	<u>Mass No.</u>	<u>Displacement</u>		
		<u>X</u>	<u>Y</u>	<u>Z</u>
1	2	0.000	-0.005	0.137
	3	-0.002	-0.063	0.471
	4	0.001	-0.047	0.828
	5	0.025	0.170	1.0
	6	0.001	0.003	0.000
	7	0.151	0.023	0.881
	2	2	0.002	0.000
3		0.003	0.000	-0.001
4		0.005	0.001	-0.002
5		0.007	-0.001	-0.000
6		0.006	-0.000	-0.000
7		1.0	-0.001	-0.012
3		2	0.383	0.008
	3	0.694	0.029	-0.002
	4	0.867	0.149	0.005
	5	1.0	-0.164	0.029
	6	-0.004	-0.000	-0.000
	7	-0.705	-0.002	0.050
	4	2	0.028	-0.973
3		0.028	-0.984	-0.032
4		0.029	-0.993	-0.045
5		0.028	-1.0	-0.052
6		0.000	0.000	0.000
7		0.000	0.000	-0.051
5		2	0.159	0.000
	3	0.220	0.003	0.275
	4	0.060	-0.035	0.429
	5	-0.800	0.029	-0.943
	6	0.003	-0.004	0.000
	7	0.438	-0.003	-1.0
	6	2	0.330	0.023
3		0.092	-0.115	-0.426
4		-0.145	-0.177	0.292
5		-0.364	0.563	0.395
6		0.000	-0.011	0.000
7		0.058	0.065	0.140

TABLE 3.7B-14 (Cont)

<u>Mode</u>	<u>Mass No.</u>	<u>Displacement</u>		
		<u>X</u>	<u>Y</u>	<u>Z</u>
7	2	1.0	0.010	0.454
	3	0.103	-0.019	0.150
	4	-0.619	-0.343	-0.338
	5	-0.780	0.449	-0.071
	6	0.000	-0.004	0.000
	7	-0.010	-0.026	0.063
	8	2	0.012	0.013
3		-0.003	0.008	-0.009
4		-0.016	0.001	0.055
5		-0.018	0.030	0.073
6		0.002	0.179	0.000
7		0.033	1.0	0.070
9		2	0.002	0.006
	3	0.034	-0.050	0.403
	4	0.038	-0.001	-0.519
	5	-0.192	0.133	-0.843
	6	0.000	0.032	0.000
	7	0.016	0.146	-1.0
	10	2	0.000	0.001
3		0.000	0.000	0.002
4		-0.001	0.000	0.002
5		-0.003	0.000	-0.001
6		0.001	-0.494	0.000
7		0.001	-1.0	0.000

TABLE 3.7B-15

FUEL BUILDING
CSM ACCELERATIONS FOR
SAFE SHUTDOWN EARTHQUAKE
FROM RESPONSE SPECTRUM ANALYSIS

<u>Degree of Freedom*</u>	<u>X-Earthquake**</u>	<u>Y-Earthquake**</u>	<u>Z-Earthquake**</u>
1	0.210	0.012	0.110
2	0.009	0.265	0.009
3	0.095	0.012	0.211
4	0.001	0.000	0.005
5	0.002	0.000	0.002
6	0.004	0.000	0.002
7	0.273	0.013	0.031
8	0.021	0.269	0.037
9	0.041	0.015	0.224
10	0.002	0.000	0.005
11	0.002	0.000	0.002
12	0.004	0.000	0.002
13	0.379	0.016	0.057
14	0.074	0.272	0.055
15	0.056	0.020	0.369
16	0.002	0.000	0.005
17	0.002	0.000	0.002
18	0.004	0.000	0.002
19	0.451	0.018	0.134
20	0.109	0.275	0.143
21	0.056	0.023	0.450
22	0.002	0.000	0.005
23	0.002	0.000	0.002
24	0.004	0.000	0.002
25	0.184	0.000	0.001
26	0.002	0.165	0.015
27	0.000	0.000	0.181
28	0.000	0.000	0.000
29	0.000	0.000	0.000
30	0.001	0.000	0.000
31	0.859	0.016	0.149
32	0.012	0.361	0.061
33	0.054	0.022	0.393
34	0.243	0.021	0.020
35	0.002	0.000	0.003
36	0.012	0.000	0.002

NOTES:

*The relationship between the degrees of freedom and the motion of the lumped masses is given in Table 3.7B-18.

**Tabulated accelerations are in units of g for translational degrees of freedom, and g/feet for rotational degrees.

TABLE 3.7B-16

FUEL BUILDING CLOSELY SPACED MODES DISPLACEMENTS
FOR SAFE SHUTDOWN EARTHQUAKE
FROM RESPONSE SPECTRUM ANALYSIS

<u>Degree of Freedom*</u>	<u>X-Earthquake**</u>	<u>Y-Earthquake**</u>	<u>Z-Earthquake**</u>
1	0.013	0.667×10^{-3}	0.337×10^{-2}
2	0.504×10^{-3}	0.014	0.516×10^{-3}
3	0.291×10^{-2}	0.550×10^{-3}	0.909×10^{-2}
4	0.456×10^{-4}	0.120×10^{-4}	0.395×10^{-3}
5	0.484×10^{-4}	0.120×10^{-5}	0.674×10^{-4}
6	0.209×10^{-3}	0.540×10^{-5}	0.689×10^{-4}
7	0.020	0.836×10^{-3}	0.103×10^{-2}
8	0.128×10^{-2}	0.015	0.320×10^{-2}
9	0.133×10^{-2}	0.934×10^{-3}	0.023
10	0.469×10^{-4}	0.127×10^{-4}	0.413×10^{-3}
11	0.593×10^{-4}	0.13×10^{-5}	0.805×10^{-4}
12	0.218×10^{-3}	0.62×10^{-5}	0.715×10^{-4}
13	0.027	0.101×10^{-2}	0.175×10^{-2}
14	0.427×10^{-2}	0.015	0.285×10^{-2}
15	0.183×10^{-2}	0.152×10^{-2}	0.040
16	0.485×10^{-4}	0.132×10^{-4}	0.422×10^{-3}
17	0.632×10^{-4}	0.33×10^{-5}	0.983×10^{-4}
18	0.224×10^{-3}	0.61×10^{-5}	0.735×10^{-4}
19	0.031	0.112×10^{-2}	0.450×10^{-2}
20	0.600×10^{-2}	0.015	0.909×10^{-2}
21	0.219×10^{-2}	0.181×10^{-2}	0.048
22	0.499×10^{-4}	0.134×10^{-4}	0.427×10^{-3}
23	0.692×10^{-4}	0.30×10^{-5}	0.972×10^{-4}
24	0.232×10^{-3}	0.63×10^{-5}	0.722×10^{-4}
25	0.815×10^{-3}	0.84×10^{-5}	0.853×10^{-4}
26	0.477×10^{-4}	0.757×10^{-3}	0.205×10^{-3}
27	0.400×10^{-6}	0.10×10^{-5}	0.605×10^{-3}
28	0.200×10^{-6}	0.4×10^{-6}	0.016×10^{-4}
29	0.000	0.000	0.000
30	0.109×10^{-3}	0.19×10^{-5}	0.209×10^{-4}
31	0.079	0.137×10^{-2}	0.015
32	0.287×10^{-3}	0.181×10^{-2}	0.129×10^{-2}
33	0.291×10^{-2}	0.166×10^{-2}	0.043
34	0.303×10^{-3}	0.699×10^{-3}	0.986×10^{-3}
35	0.848×10^{-4}	0.41×10^{-5}	0.107×10^{-3}
36	0.100×10^{-2}	0.184×10^{-4}	0.193×10^{-3}

NOTES:

*The relationship between the degrees of freedom and the motion of the lumped masses is given in Table 3.7B-18.

**Tabulated displacements are in units of feet for translational degrees of freedom, and rads for rotational degrees.

TABLE 3.7B-17

FUEL BUILDING SQUARE ROOT OF THE SUM OF THE SQUARES
SAFE SHUTDOWN EARTHQUAKE RESPONSES

<u>Degree of Freedom*</u>	<u>Acceleration**</u>	<u>Displacement***</u>
1	0.237	0.013
2	0.266	0.014
3	0.231	0.010
4	0.005	0.398×10^{-3}
5	0.003	0.829×10^{-4}
6	0.004	0.220×10^{-3}
7	0.276	0.020
8	0.272	0.015
9	0.228	0.023
10	0.005	0.416×10^{-3}
11	0.002	0.999×10^{-4}
12	0.004	0.230×10^{-3}
13	0.383	0.027
14	0.287	0.016
15	0.374	0.040
16	0.005	0.425×10^{-3}
17	0.003	0.117×10^{-3}
18	0.004	0.236×10^{-3}
19	0.471	0.032
20	0.329	0.019
21	0.454	0.049
22	0.005	0.430×10^{-3}
23	0.003	0.119×10^{-3}
24	0.004	0.243×10^{-3}
25	0.184	0.001
26	0.166	0.001
27	0.181	0.001
28	0.000	0.160×10^{-5}
29	0.000	0.000
30	0.001	0.111×10^{-3}
31	0.872	0.080
32	0.366	0.002
33	0.397	0.043
34	0.245	0.123×10^{-2}
35	0.004	0.137×10^{-3}
36	0.012	0.101×10^{-2}

NOTES:

- * Refer to Table 3.7B-18 for definition of degrees of freedom.
- ** Tabulated accelerations are in units of g for translational degrees of freedom and g/feet for rotational degrees of freedom.
- *** Tabulated displacements are in units of feet for translational degrees of freedom and rads for rotational degrees.

TABLE 3.7B-18

FUEL BUILDING
DEGREES OF FREEDOM

<u>Mass Point*</u>	<u>Degree of Freedom</u>	<u>Direction of Motion</u>
2	1	Translation X
2	2	Translation Y
2	3	Translation Z
2	4	Rotation θ_x
2	5	Rotation θ_y
2	6	Rotation θ_z
3	7	Translation X
3	8	Translation Y
3	9	Translation Z
3	10	Rotation θ_x
3	11	Rotation θ_y
3	12	Rotation θ_z
4	13	Translation X
4	14	Translation Y
4	15	Translation Z
4	16	Rotation θ_x
4	17	Rotation θ_y
4	18	Rotation θ_z
5	19	Translation X
5	20	Translation Y
5	21	Translation Z
5	22	Rotation θ_x
5	23	Rotation θ_y
5	24	Rotation θ_z
6	25	Translation X
6	26	Translation Y
6	27	Translation Z
6	28	Rotation θ_x
6	29	Rotation θ_y
6	30	Rotation θ_z
7	31	Translation X
7	32	Translation Y
7	33	Translation Z
7	34	Rotation θ_x
7	35	Rotation θ_y
7	36	Rotation θ_z

NOTE:

*For locations of lumped masses, refer to Figure 3.7B-37.

TABLE 3.7B-19

CABLE VAULT BUILDING
 REPRESENTATIVE MODAL FREQUENCIES AND PARTICIPATION FACTORS

<u>Mode</u>	Frequency (Hz)	<u>Participation</u> <u>Factors</u>		
		<u>X-Earthquake</u>	<u>Y-Earthquake</u>	<u>Z-Earthquake</u>
1	1.963	-0.810	-6.295	207.529
2	2.997	-234.177	7.874	1.724
3	3.212	-24.874	0.106	5.900
4	5.094	-31.969	-181.426	-21.641
5	5.879	-125.582	31.608	-82.137
6	6.007	-63.890	0.108	160.797
7	12.488	-12.696	-1.885	6.856
8	14.466	-2.322	-0.627	9.237
9	15.273	-6.330	2.169	-18.060

TABLE 3.7B-20

CABLE VAULT BUILDING
 REPRESENTATIVE MODE SHAPES
 (EIGENVECTORS)

<u>Mode</u>	<u>Mass No.</u>	<u>Displacements</u>		
		<u>X</u>	<u>Y</u>	<u>Z</u>
1	1	-0.000	-0.002	0.088
	2	-0.001	-0.038	0.303
	3	-0.002	-0.043	0.495
	4	-0.002	-0.023	0.688
	5	0.003	0.092	0.862
	6	-0.010	-0.150	1.000
2	1	0.300	-0.009	-0.001
	2	0.470	-0.040	-0.005
	3	0.619	-0.043	-0.007
	4	0.764	-0.049	-0.007
	5	0.884	0.169	0.042
	6	1.000	-0.264	-0.056
3	1	-0.064	0.000	0.013
	2	-0.023	-0.000	-0.049
	3	-0.055	-0.001	-0.011
	4	-0.165	0.004	0.004
	5	-0.544	-0.019	1.000
	6	0.157	0.024	-0.893
4	1	0.156	0.818	0.094
	2	0.125	0.863	0.069
	3	0.098	0.890	0.058
	4	0.066	0.917	0.052
	5	0.027	0.852	0.047
	6	0.010	1.000	0.049
5	1	1.000	-0.232	0.582
	2	0.718	-0.128	0.454
	3	0.449	-0.124	0.327
	4	0.141	-0.150	0.149
	5	-0.191	-0.850	-0.067
	6	-0.390	0.550	-0.186

TABLE 3.7B-20 (Cont)

<u>Mode</u>	<u>Mass No.</u>	<u>Displacements</u>		
		<u>X</u>	<u>Y</u>	<u>Z</u>
6	1	-0.445	0.000	1.000
	2	-0.316	0.026	0.775
	3	-0.192	0.029	0.539
	4	-0.048	-0.027	0.209
	5	0.102	0.008	-0.140
	6	0.212	-0.039	-0.420
7	1	-0.303	-0.041	0.145
	2	-0.200	-0.008	-0.042
	3	-0.054	0.000	-0.199
	4	0.222	0.028	-0.124
	5	0.295	-0.144	-0.497
	6	0.474	0.217	1.000
8	1	0.054	0.013	-0.193
	2	-0.036	0.025	-0.059
	3	-0.109	0.022	0.149
	4	-0.175	-0.024	0.157
	5	-0.340	-0.118	0.212
	6	1.000	0.085	-0.207
9	1	-0.364	0.115	-0.926
	2	-0.174	0.158	-0.363
	3	0.060	0.123	0.697
	4	0.412	-0.148	1.000
	5	0.771	-0.732	0.143
	6	-0.544	0.440	-0.247

TABLE 3.7B-21

CABLE VAULT BUILDING
DEGREES OF FREEDOM

<u>Mass Point</u>	<u>Degree of Freedom</u>	<u>Direction of Motion</u>	
1	1	Translation	X
1	2	Translation	Y
1	3	Translation	Z
1	4	Rotation	θ_x
1	5	Rotation	θ_y
1	6	Rotation	θ_z
2	7	Translation	X
2	8	Translation	Y
2	9	Translation	Z
2	10	Rotation	θ_x
2	11	Rotation	θ_y
2	12	Rotation	θ_z
3	13	Translation	X
3	14	Translation	Y
3	15	Translation	Z
3	16	Rotation	θ_x
3	17	Rotation	θ_y
3	18	Rotation	θ_z
4	19	Translation	X
4	20	Translation	Y
4	21	Translation	Z
4	22	Rotation	θ_x
4	23	Rotation	θ_y
4	24	Rotation	θ_z
5	25	Translation	X
5	26	Translation	Y
5	27	Translation	Z
5	28	Rotation	θ_x
5	29	Rotation	θ_y
5	30	Rotation	θ_z
6	31	Translation	X
6	32	Translation	Y
6	33	Translation	Z
6	34	Rotation	θ_x
6	35	Rotation	θ_y
6	36	Rotation	θ_z

TABLE 3.7B-22

CABLE VAULT BUILDING
CSM ACCELERATION FOR SAFE SHUTDOWN EARTHQUAKE
FROM RESPONSE SPECTRUM ANALYSIS

<u>Degree of Freedom*</u>	<u>X-Earthquake**</u>	<u>Y-Earthquake**</u>	<u>Z-Earthquake**</u>
1	0.154	0.046	0.128
2	0.043	0.142	0.028
3	0.114	0.027	0.184
4	0.002	0.000	0.004
5	0.001	0.000	0.000
6	0.002	0.001	0.002
7	0.168	0.036	0.092
8	0.039	0.148	0.029
9	0.088	0.021	0.167
10	0.002	0.000	0.004
11	0.001	0.000	0.000
12	0.002	0.001	0.002
13	0.196	0.026	0.057
14	0.040	0.153	0.030
15	0.063	0.017	0.178
16	0.002	0.000	0.004
17	0.001	0.000	0.000
18	0.003	0.001	0.002
19	0.234	0.017	0.027
20	0.044	0.158	0.030
21	0.028	0.013	0.209

TABLE 3.7B-22 (Cont)

<u>Degree of Freedom*</u>	<u>X-Earthquake**</u>	<u>Y-Earthquake**</u>	<u>Z-Earthquake**</u>
22	0.002	0.000	0.004
23	0.001	0.000	0.000
24	0.003	0.001	0.002
25	0.277	0.014	0.030
26	0.114	0.159	0.072
27	0.035	0.013	0.259
28	0.002	0.000	0.004
29	0.001	0.000	0.000
30	0.003	0.001	0.002
31	0.308	0.016	0.057
32	0.114	0.179	0.071
33	0.057	0.016	0.307
34	0.002	0.000	0.004
35	0.001	0.000	0.001
36	0.003	0.001	0.002

NOTES:

*The relationship between the degrees of freedom and the motion of the lumped masses is given in Table 3.7B-21.

**Tabulated accelerations are in units of g for translational degrees of freedom, and g/feet for rotational degrees.

TABLE 3.7B-23

CABLE VAULT BUILDING
CSM DISPLACEMENTS FOR SAFE SHUTDOWN EARTHQUAKE
FROM RESPONSE SPECTRUM ANALYSIS

Degree of Freedom*	X-Earthquake**	Y-Earthquake**	Z-Earthquake**
1	0.833×10^{-2}	0.132×10^{-2}	0.297×10^{-2}
2	0.122×10^{-2}	0.444×10^{-2}	0.810×10^{-3}
3	0.265×10^{-2}	0.781×10^{-3}	0.694×10^{-2}
4	0.396×10^{-4}	0.207×10^{-4}	0.522×10^{-3}
5	0.783×10^{-4}	0.23×10^{-5}	0.330×10^{-4}
6	0.159×10^{-3}	0.172×10^{-4}	0.421×10^{-4}
7	0.013	0.111×10^{-2}	0.213×10^{-2}
8	0.160×10^{-2}	0.465×10^{-2}	0.255×10^{-2}
9	0.207×10^{-2}	0.818×10^{-3}	0.019
10	0.399×10^{-4}	0.199×10^{-4}	0.538×10^{-3}
11	0.764×10^{-4}	0.210×10^{-5}	0.323×10^{-4}
12	0.166×10^{-3}	0.178×10^{-4}	0.439×10^{-4}
13	0.017	0.957×10^{-3}	0.134×10^{-2}
14	0.169×10^{-2}	0.479×10^{-2}	0.286×10^{-2}
15	0.149×10^{-2}	0.105×10^{-2}	0.031
16	0.412×10^{-4}	0.195×10^{-4}	0.533×10^{-3}
17	0.753×10^{-4}	0.200×10^{-5}	0.305×10^{-4}
18	0.171×10^{-3}	0.181×10^{-4}	0.462×10^{-4}
19	0.021	0.854×10^{-3}	0.489×10^{-3}
20	0.185×10^{-2}	0.494×10^{-2}	0.170×10^{-2}
21	0.706×10^{-3}	0.136×10^{-2}	0.043
22	0.455×10^{-4}	0.185×10^{-4}	0.569×10^{-3}
23	0.702×10^{-4}	0.180×10^{-5}	0.327×10^{-4}
24	0.174×10^{-3}	0.183×10^{-4}	0.476×10^{-4}
25	0.025	0.869×10^{-3}	0.777×10^{-3}
26	0.538×10^{-2}	0.490×10^{-2}	0.606×10^{-2}
27	0.255×10^{-2}	0.168×10^{-2}	0.054
28	0.458×10^{-4}	0.185×10^{-5}	0.571×10^{-4}
29	0.692×10^{-3}	0.180×10^{-4}	0.351×10^{-4}
30	0.176×10^{-3}	0.190×10^{-4}	0.483×10^{-4}
31	0.028	0.969×10^{-3}	0.149×10^{-2}
32	0.767×10^{-2}	0.558×10^{-2}	0.963×10^{-2}
33	0.297×10^{-4}	0.195×10^{-4}	0.063
34	0.479×10^{-4}	0.187×10^{-4}	0.584×10^{-3}
35	0.553×10^{-4}	0.190×10^{-5}	0.399×10^{-4}
36	0.178×10^{-3}	0.184×10^{-4}	0.493×10^{-4}

NOTES:

*The relationship between the degrees of freedom and the motion of the lumped masses is given in Table 3.7B-3.

**Tabulated displacements are in units of feet for translational degrees of freedom and in rads for rotational degrees.

TABLE 3.7B-24

CABLE VAULT BUILDING
SRSS OF SAFE SHUTDOWN EARTHQUAKE

<u>Degree of Freedom*</u>	<u>Acceleration**</u>	<u>Displacement***</u>
1	0.206	0.009
2	0.152	0.005
3	0.218	0.008
4	0.004	0.554×10^{-3}
5	0.001	0.850×10^{-4}
6	0.003	0.165×10^{-3}
7	0.195	0.013
8	0.156	0.006
9	0.191	0.020
10	0.004	0.539×10^{-3}
11	0.001	0.829×10^{-4}
12	0.003	0.173×10^{-3}
13	0.206	0.017
14	0.161	0.006
15	0.189	0.031
16	0.004	0.555×10^{-3}
17	0.001	0.812×10^{-4}
18	0.004	0.178×10^{-4}
19	0.236	0.021
20	0.167	0.005
21	0.211	0.043
22	0.005	0.571×10^{-3}
23	0.001	0.774×10^{-4}
24	0.004	0.181×10^{-3}
25	0.279	0.025
26	0.208	0.010
27	0.261	0.055
28	0.005	0.573×10^{-3}
29	0.001	0.776×10^{-4}
30	0.004	0.183×10^{-3}
31	0.314	0.028
32	0.224	0.014
33	0.313	0.063
34	0.004	0.586×10^{-3}
35	0.001	0.648×10^{-4}
36	0.004	0.186×10^{-3}

NOTES:

- * Table 3.7B-21 defines degrees of freedom.
- ** Tabulated accelerations are in units of g for translational degrees of freedom, and g/feet for rotational degrees of freedom.
- *** Tabulated displacements are in units of feet for translational degrees of freedom and rads for rotational degrees.

TABLE 3.7B-25

COMPARISON OF RESPONSE SPECTRA AND TIME HISTORY
ANALYSIS RESULTS
CONTAINMENT AND INTERNAL STRUCTURES
(UNCRACKED PROPERTIES)

SSE Accelerations*

<u>Mass No**</u>	<u>Response Spectrum</u>		<u>Time History</u>	
	<u>Horizontal</u>	<u>Vertical</u>	<u>Horizontal</u>	<u>Vertical</u>
1	0.415	0.180	0.509	0.196
2	0.313	0.177	0.371	0.192
3	0.260	0.176	0.295	0.192
4	0.213	0.175	0.230	0.191
5	0.176	0.174	0.195	0.190
6	0.156	0.172	0.181	0.188
7	0.150	0.171	0.190	0.187
8	0.154	0.168	0.198	0.185
9	0.176	0.174	0.198	0.190
10	0.198	0.175	0.210	0.191
11	0.240	0.176	0.253	0.191
12	0.285	0.176	0.307	0.192
13	0.332	0.180	0.360	0.192

NOTES:

*Safe shutdown earthquake accelerations are in units of g.

**Figure 3.7B-3 illustrates the location of the lumped masses.

TABLE 3.7B-26

COMPARISON OF RESPONSE SPECTRA AND TIME HISTORY
ANALYSIS RESULTS
CONTAINMENT AND INTERNAL STRUCTURES
(CRACKED PROPERTIES)

SSE Accelerations*

<u>Mass No**</u>	<u>Response Spectrum</u>		<u>Time History</u>	
	<u>Horizontal</u>	<u>Vertical</u>	<u>Horizontal</u>	<u>Vertical</u>
1	0.447	0.266	0.580	0.296
2	0.279	0.243	0.346	0.272
3	0.221	0.234	0.257	0.263
4	0.178	0.221	0.221	0.249
5	0.153	0.205	0.199	0.230
6	0.144	0.189	0.178	0.215
7	0.143	0.175	0.160	0.202
8	0.143	0.165	0.159	0.192
9	0.165	0.170	0.185	0.196
10	0.192	0.171	0.210	0.196
11	0.244	0.172	0.255	0.197
12	0.296	0.172	0.303	0.197
13	0.350	0.172	0.363	0.197

NOTES:

- *Safe shutdown earthquake accelerations are in units of g.
- **Figure 3.7B-3 illustrates locations of lumped masses.

TABLE 3.7B-27

COMPARISON OF RESPONSE SPECTRA AND TIME HISTORY
ANALYSIS RESULTS
FUEL BUILDING - SAFE SHUTDOWN EARTHQUAKE ACCELERATIONS*

<u>Mass No**</u>	<u>Response Spectra</u>			<u>Time History</u>		
	<u>N-S</u>	<u>E-W</u>	<u>Vertical</u>	<u>N-S</u>	<u>E-W</u>	<u>Vertical</u>
2	0.231	0.237	0.266	0.258	0.283	0.332
3	0.228	0.276	0.272	0.368	0.277	0.338
4	0.374	0.383	0.287	0.520	0.340	0.341
5	0.454	0.471	0.329	0.637	0.440	0.340
6	0.181	0.184	0.166	0.168	0.171	0.158
7	0.397	0.872	0.366	0.526	0.404	0.271

NOTES:

*Safe shutdown earthquake accelerations are in units of g.

**Figure 3.7B-37 illustrates the location of the lumped masses.

TABLE 3.7B-28

COMPARISON OF RESPONSE SPECTRA
AND TIME HISTORY ANALYSIS RESULTS
CABLE VAULT BUILDING
SAFE SHUTDOWN EARTHQUAKE ACCELERATIONS*

<u>Mass No**</u>	<u>Response Spectra</u>			<u>Time History</u>		
	<u>N-S</u>	<u>E-W</u>	<u>Vertical</u>	<u>N-S</u>	<u>E-W</u>	<u>Vertical</u>
1	0.218	0.206	0.152	0.205	0.188	0.151
2	0.191	0.195	0.156	0.184	0.199	0.155
3	0.189	0.206	0.161	0.225	0.237	0.157
4	0.211	0.236	0.167	0.273	0.287	0.160
5	0.261	0.279	0.208	0.315	0.340	0.158
6	0.313	0.314	0.224	0.349	0.372	0.164

NOTES:

*Safe shutdown earthquake accelerations are in units of g.

**Figure 3.7B-31 illustrates the location of the lumped masses.

TABLE 3.7B-29

EQUIPMENT AND COMPONENTS
1G FLAT RESPONSE

<u>Model Beam</u>	<u>Fundamental Frequency</u>	<u>Max Dynamic</u>		<u>Max Dynamic</u>		<u>Location</u>	<u>S/C</u>	<u>K S/U</u>	<u>A/U</u>
		<u>Sum</u>	<u>Moment (in-lb)</u>	<u>Load Type</u>	<u>Moment (in-lb)</u>				
Cantilever	1	SRS	620,000	Conc	700,000	Fixed end	0.89	0.89	0.99
		S	649,000	Unif	700,000				
		ABS							
Simple-simple	1	SRS	179,000	Conc	348,000	Midspan	0.51	1.03	1.07
		S	186,000	Unif	174,000				
		ABS							
Fixed-fixed	1	SRS	103,000	Conc	174,000	Fixed end	0.59	0.89	0.97
		S	112,000	Unif	116,000				
		ABS							
Simple-fixed - no overhang	1	SRS	152,000	Conc	261,000	Fixed end	0.58	0.87	0.97
		S	169,000	Unif	174,000				
		ABS							
Simple-fixed - 16% overhang	1.34	SRS	83,200	Conc	162,000	Fixed end	0.51	0.75	1.03
		S	114,000	Unif	111,000				
		ABS							
Simple-fixed - 33% overhang	1.04	SRS	57,000	Conc	77,400	Fixed end	0.74	0.74	1.15
		S	89,000	Unif	77,200				
		ABS							
Simple-fixed - 50% overhang	0.62	SRS	152,000	Conc	174,000	Simple support	0.87	0.87	1.01
		S	176,000	Unif	174,000				
		ABS							

TABLE 3.7B-30

MODAL DENSITY, n*

Mode No	Cantileve r Freq(Hz)	Fixed- Fixed Freq(Hz)	Simple- Fixed Freq(Hz)	Simple- Simple Freq(Hz)	Simple- Fixed 33% Overhang Freq(Hz)
1	1.0	1.0	1.0	1.0	1.0
2	5.8	2.7	3.2	3.8	2.9
3	15.3	4.9	6.3	8.2	6.5
4	28.0	7.5	10.2	13.6	8.4
5	43.2	10.2	14.0	19.5	13.3
6	59.6				

NOTE:*Modal density based on a ± 10 percent criterion.

TABLE 3.7B-31

AMPLIFIED RESPONSE
DYNAMIC FACTOR STUDY

<u>Model Beam</u>	<u>1st Mode</u>	<u>Dynamic Load</u>		<u>Max Dynamic Moment</u>			<u>Max Static Moment* Uniform Load (U) (in-lb)</u>	<u>K S/U A/U</u>
		<u>High</u>	<u>Low</u>	<u>Sum (S)</u>	<u>Moment (in-lb)</u>	<u>Location</u>		
Simple-fixed-33% overhang	g f(Hz)	g f(Hz)	g f(Hz)					
Model 6A	0.10 0.70	2.87 3-4	0.33 20	SRSS ABS	20,000 30,000	Fixed Fixed	222,000 s	0.09 0.13
Model 6B	0.10 1.0	2.87 3-4	0.33 20	SRSS ABS	148,000 157,000	Fixed Fixed	222,000 s	0.67 0.71
Model 6C	2.87 3.3	2.87 3-4	0.33 20	SRSS ABS	102,000 118,000	Simple support Simple support	222,000 s	0.45 0.53
Model 6D	0.40 10.0	2.87 3-4	0.33 20	SRSS ABS	22,000 32,000	Fixed Fixed	31,000 s	0.71 1.03
Model 6E	0.33 20.0	2.87 3-4	0.33 20	SRSS ABS	20,000 27,000	Fixed Fixed	25,700 s	0.78 1.05
Model 6F	0.30 33.0	2.87 3-4	0.33 20	SRSS ABS	18,000 25,000	Fixed Fixed	23,400 s	0.77 1.07

NOTE:

* g_{max} , if $f_o \leq f_p$; g at f_o if $f_o > f_p$.

TABLE 3.7B-32

PIPING SYSTEM SEISMIC DESIGN AND ANALYSIS CRITERIA

<u>ASME Section III Code Class</u>	<u>Type of Earthquake</u>	<u>Type of Seismic Analyses</u>	<u>Combined Stress Calculations and Stress Criteria</u>
Class 1 (All sizes)	SSE	Dynamic response spectra	ASME Code, Section III, Subarticle NB-3600*
	OBE	Dynamic response spectra	ASME Code, Section III, Subarticles NB-3600*
Classes 2 and 3 (All sizes)	SSE	Dynamic response spectra	ASME Code, Section III, Subarticles NC-3600 and ND-3600
	OBE	Dynamic response spectra	ASME Code, Section III, Subarticles NC-3600 and ND-3600

NOTES:

*For Class 1 piping 1 inch and below, Subarticle NC-3600 is used.

TABLE 3.7N-1

DAMPING VALVES USED FOR SEISMIC SYSTEMS
ANALYSIS FOR WESTINGHOUSE SUPPLIED EQUIPMENT DAMPING

<u>Item</u>	(Percent of Critical)	
	<u>Upset Conditions (OBE)</u>	<u>Faulted Condition (SSE, DBA)</u>
Primary coolant loop system components	2	4
Welded steel structures	2	4
Bolted and/or riveted steel structures	4	7
Fuel assemblies	7	10
CRDMs/CRDM supports	4	7

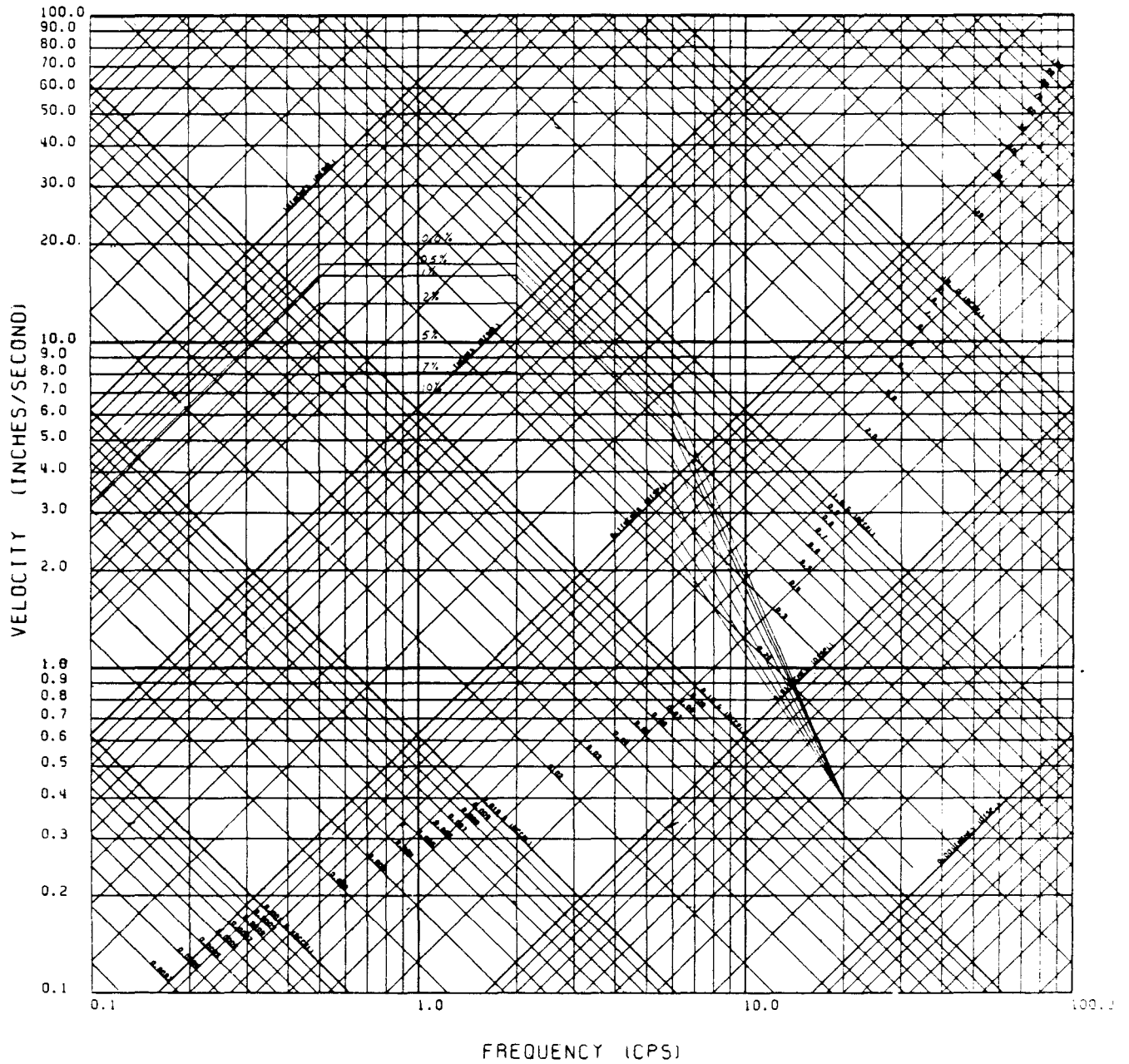
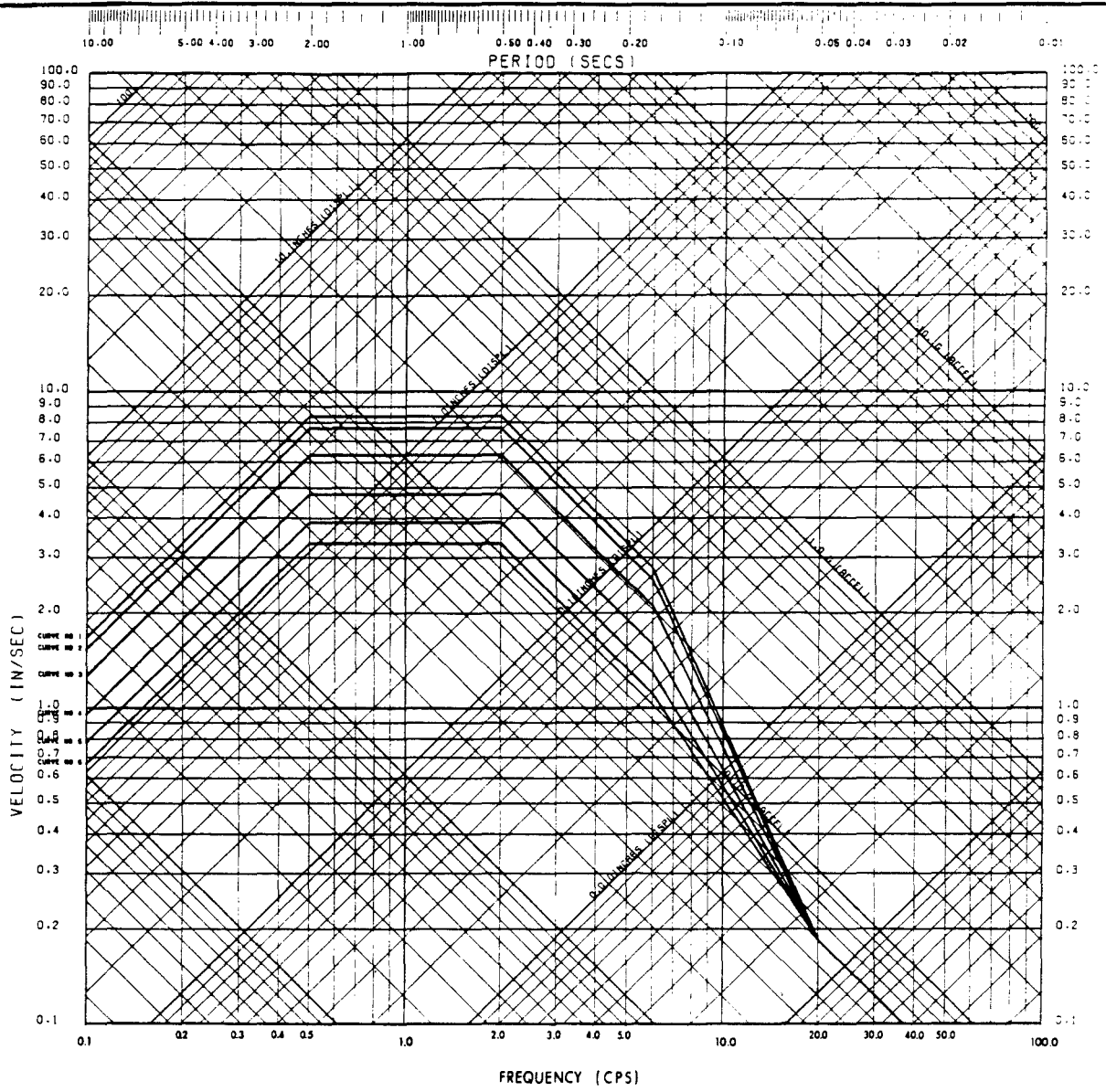

FIGURE 3.7B-1
 DESIGN RESPONSE SPECTRA
 SAFE SHUTDOWN EARTHQUAKE
 BEAVER VALLEY POWER STATION-UNIT 2
 FINAL SAFETY ANALYSIS REPORT



CURVE NO 1	DAMPING 0.05	PERIOD 10.00
CURVE NO 2	DAMPING 0.05	PERIOD 10.00
CURVE NO 3	DAMPING 0.05	PERIOD 10.00
CURVE NO 4	DAMPING 0.05	PERIOD 10.00
CURVE NO 5	DAMPING 0.05	PERIOD 10.00
CURVE NO 6	DAMPING 0.05	PERIOD 10.00

FIGURE 3.7B-2
 DESIGN RESPONSE SPECTRA
 1/2 SAFE SHUTDOWN EARTHQUAKE
 BEAVER VALLEY POWER STATION-UNIT 2
 FINAL SAFETY ANALYSIS REPORT

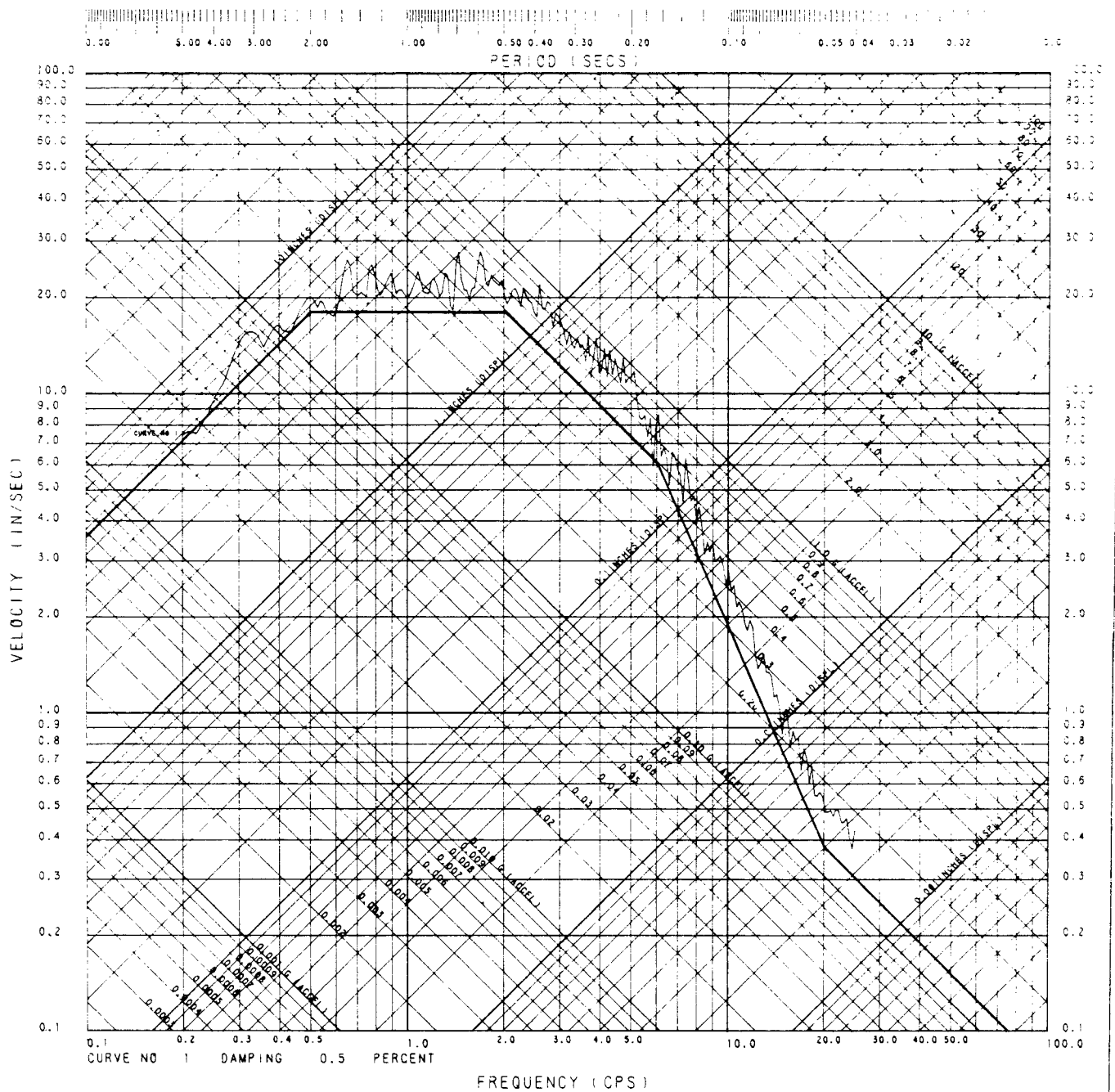

FIGURE 3.7B-3
 SSE TIME HISTORY RESPONSE
 SPECTRA, 1/2% DAMPING VALUE
 BEAVER VALLEY POWER STATION-UNIT 2
 FINAL SAFETY ANALYSIS REPORT

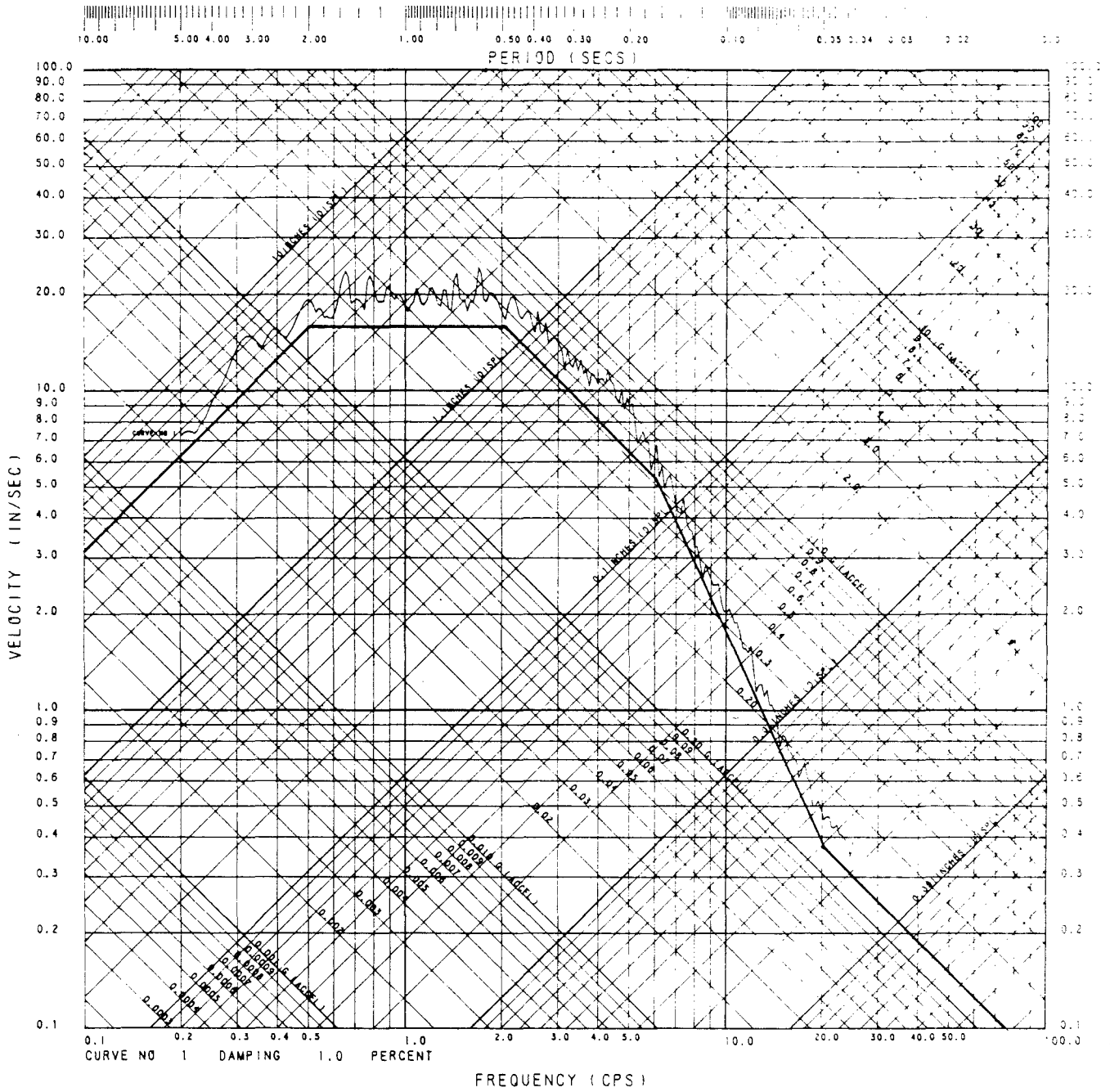

FIGURE 3.7B-4
 SSE TIME HISTORY RESPONSE
 SPECTRA, 1% DAMPING VALUE
 BEAVER VALLEY POWER STATION-UNIT 2
 FINAL SAFETY ANALYSIS REPORT

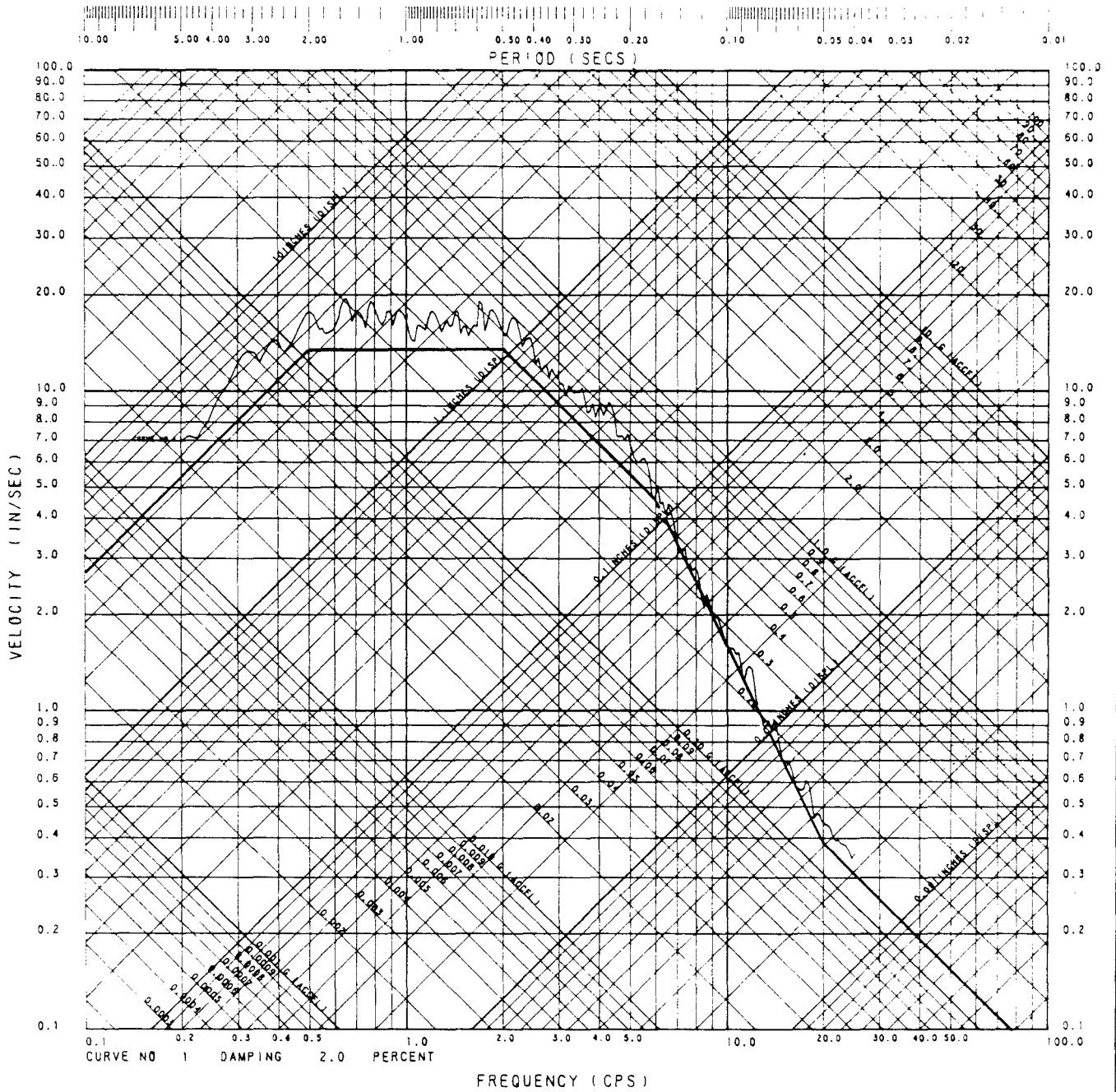

FIGURE 3.7B-5
 SSE TIME HISTORY RESPONSE
 SPECTRA, 2% DAMPING VALUE
 BEAVER VALLEY POWER STATION-UNIT 2
 FINAL SAFETY ANALYSIS REPORT

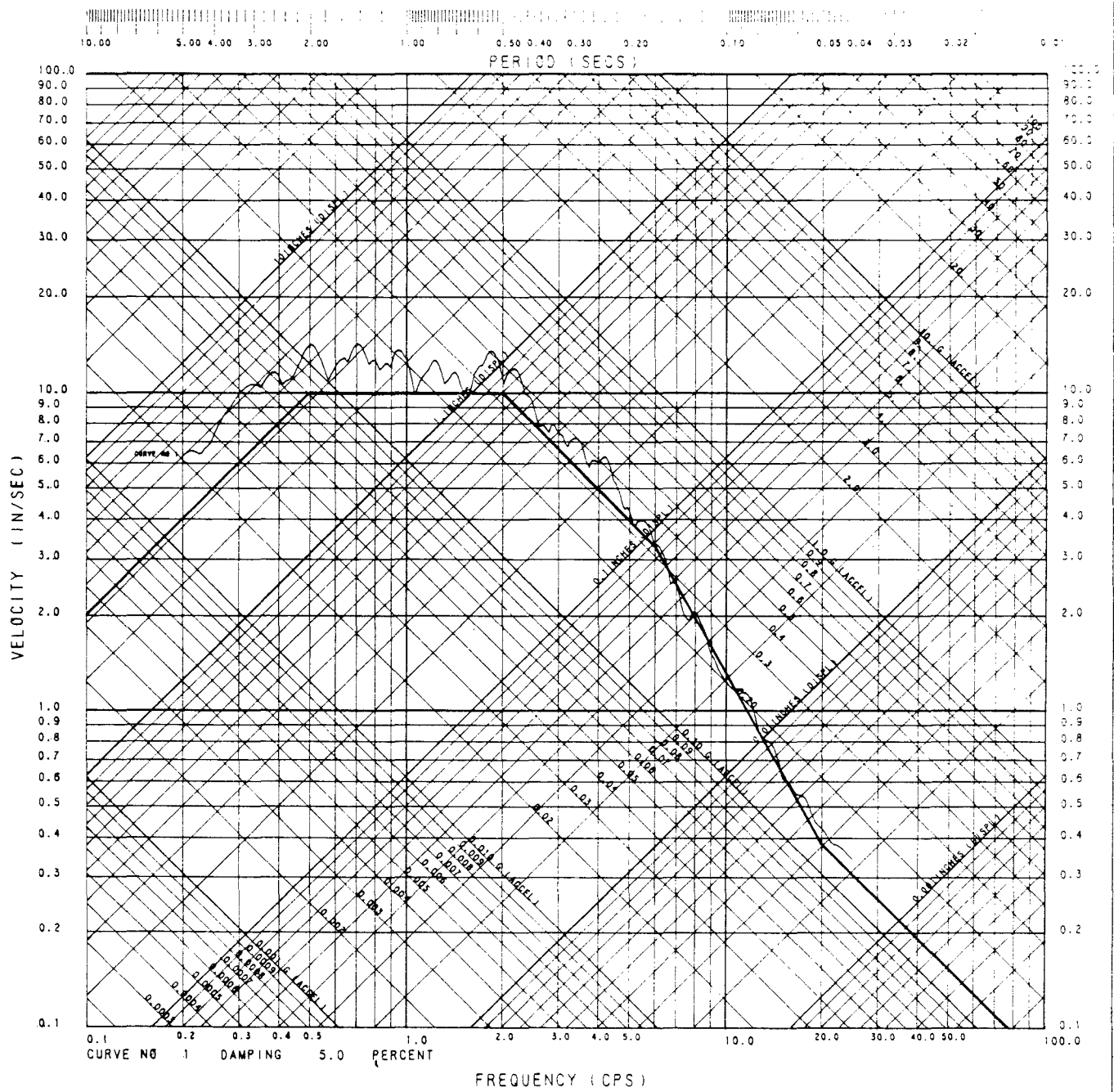

FIGURE 3.7B-6
 SSE TIME HISTORY RESPONSE
 SPECTRA, 5% DAMPING VALUE
 BEAVER VALLEY POWER STATION-UNIT 2
 FINAL SAFETY ANALYSIS REPORT

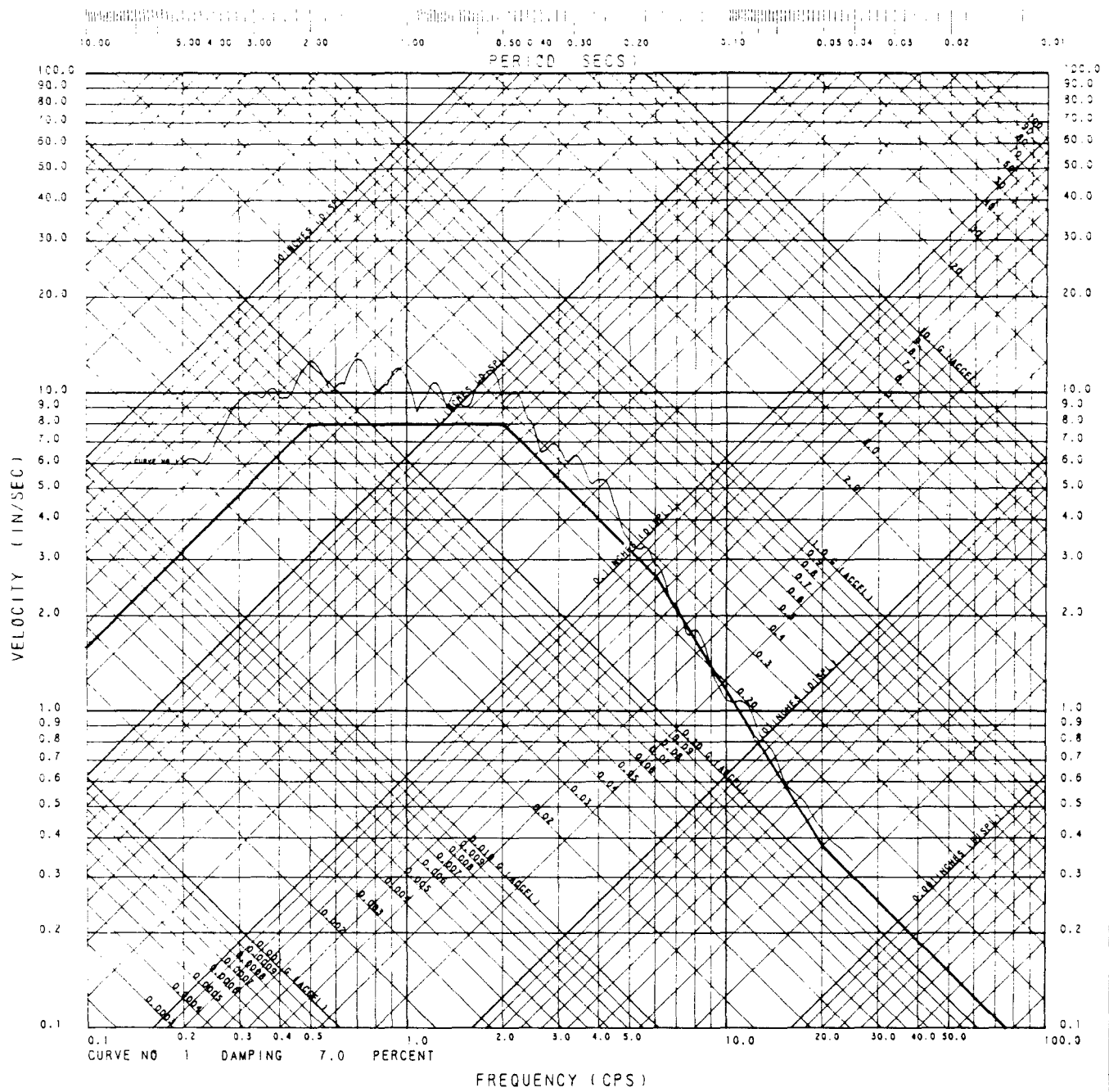

FIGURE 3.7B-7
 SSE TIME HISTORY RESPONSE
 SPECTRA, 7% DAMPING VALUE
 BEAVER VALLEY POWER STATION-UNIT 2
 FINAL SAFETY ANALYSIS REPORT

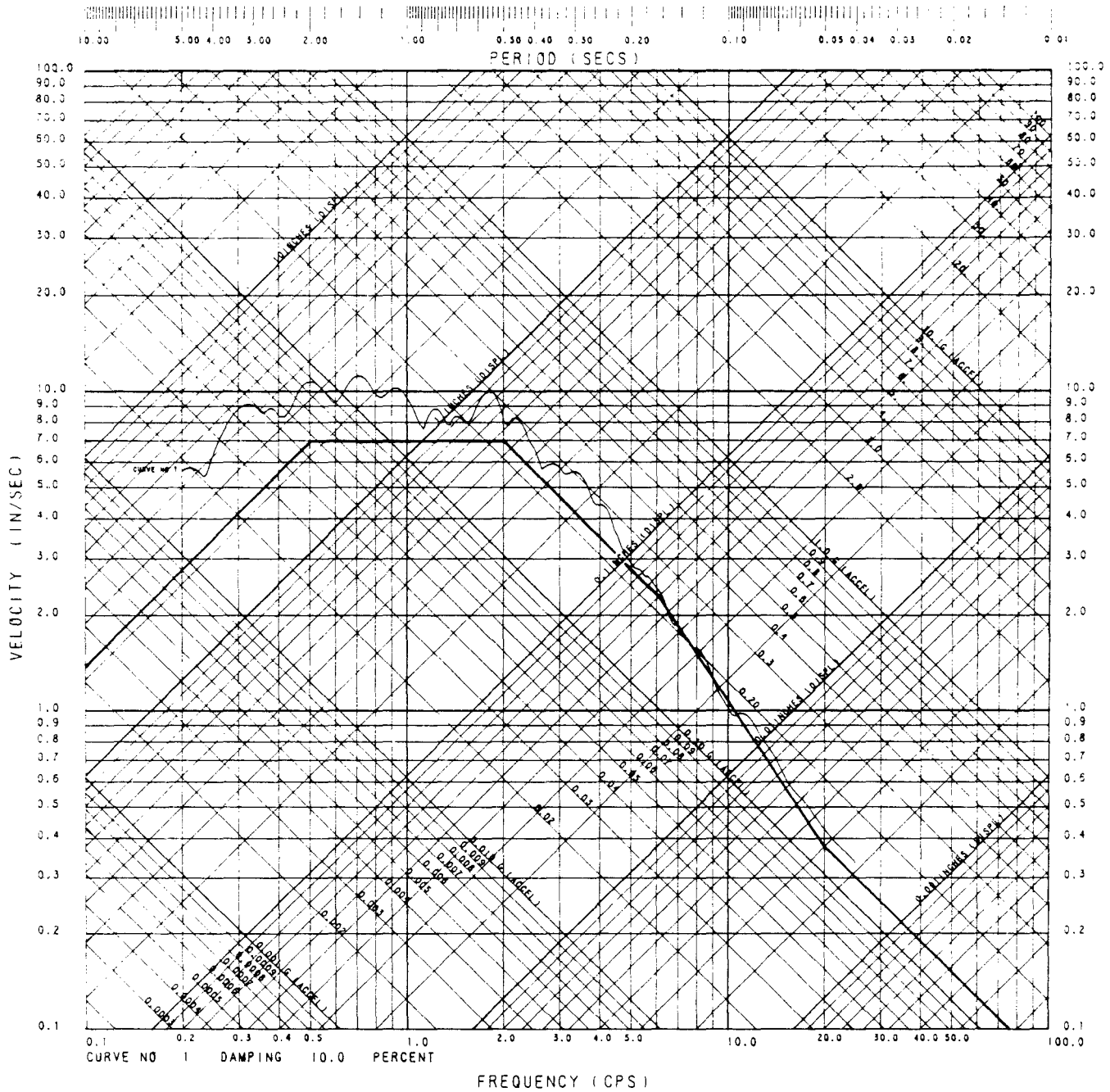
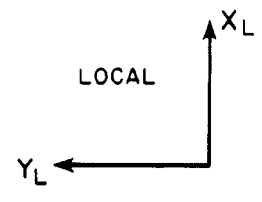
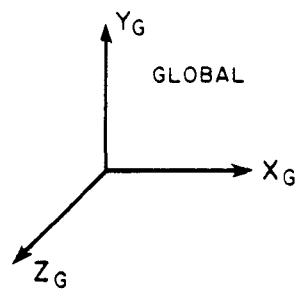
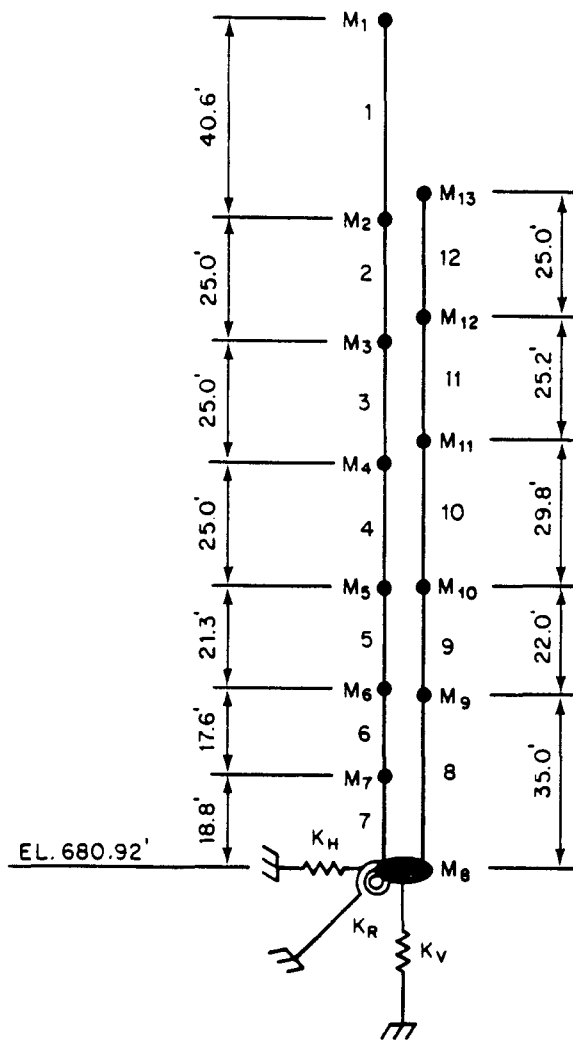
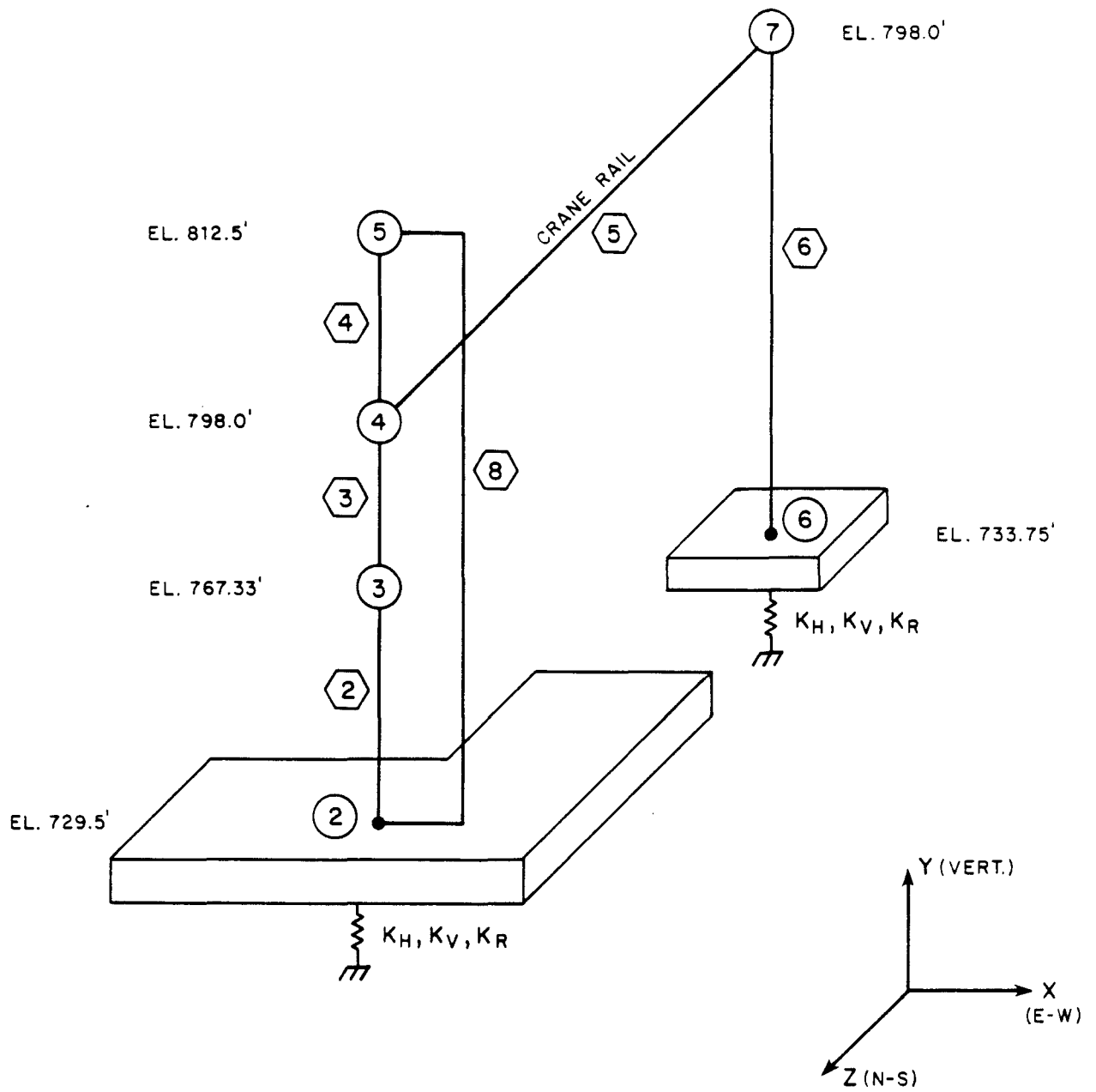

FIGURE 3.7B-8
 SSE TIME HISTORY RESPONSE
 SPECTRA, 10% DAMPING VALUE
 BEAVER VALLEY POWER STATION- UNIT 2
 FINAL SAFETY ANALYSIS REPORT



NOTE
MEMBER PROPERTIES ARE IN
LOCAL COORDINATES

FIGURE 3.7B-9
DYNAMIC MODEL OF THE
CONTAINMENT STRUCTURE
BEAVER VALLEY POWER STATION-UNIT 2
FINAL SAFETY ANALYSIS REPORT



LEGEND



-  MEMBER NUMBER
-  MASS NUMBER

FIGURE 3.7B-10
DYNAMIC MODEL OF THE
FUEL BUILDING
BEAVER VALLEY POWER STATION - UNIT 2
FINAL SAFETY ANALYSIS REPORT



LEGEND

○ MEMBER NUMBER

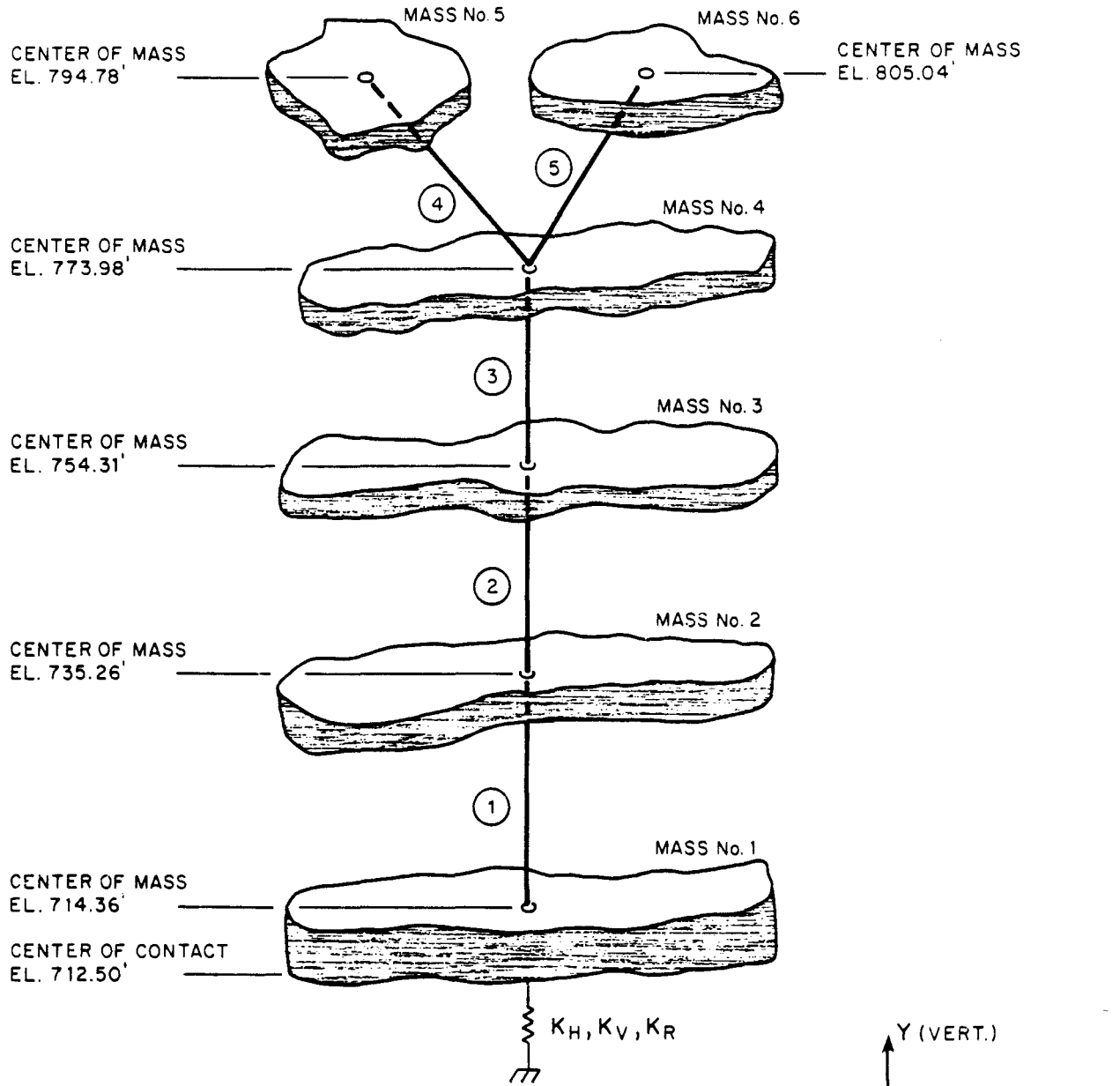
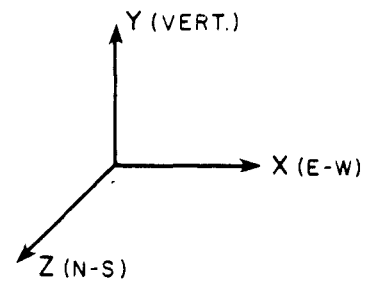
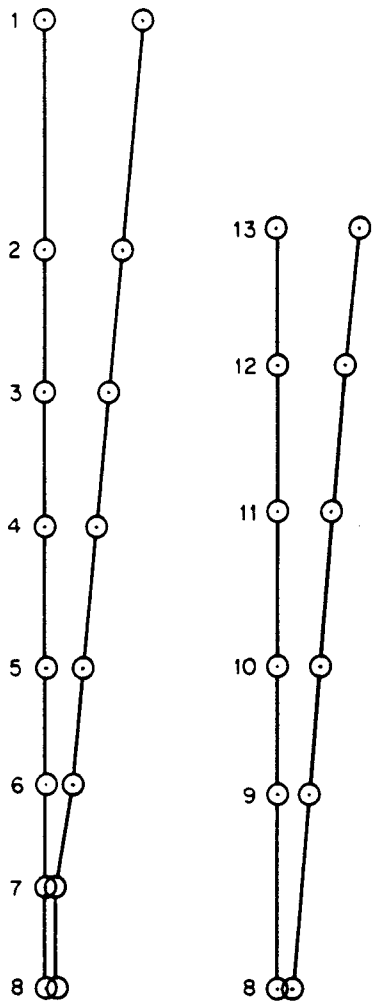
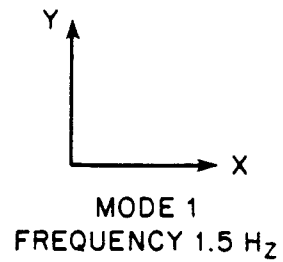

FIGURE 3.7B-11
 DYNAMIC MODEL OF THE
 CABLE VAULT BUILDING
 BEAVER VALLEY POWER STATION-UNIT 2
 FINAL SAFETY ANALYSIS REPORT



CONTAINMENT INTERNALS

MASS	APPROX ELEVATION (FEET)	X	Y
1	854	1.0	0
2	813	0.796	0
3	788	0.676	0
4	763	0.559	0
5	738	0.437	0
6	717	0.337	0
7	699	0.103	0
8	691	0.102	0
9	716	0.334	0
10	738	0.435	0
11	767	0.577	0
12	793	0.698	0
13	818	0.816	0



NOTE
REFERENCE TABLE 3.7B-4 AND TABLE 3.7B-6

FIGURE 3.7B-12
EIGENVECTORS FOR CONTAINMENT
AND INTERNAL STRUCTURES
UNCRACKED MODEL, MEDIAN SOIL
BEAVER VALLEY POWER STATION-UNIT 2
FINAL SAFETY ANALYSIS REPORT

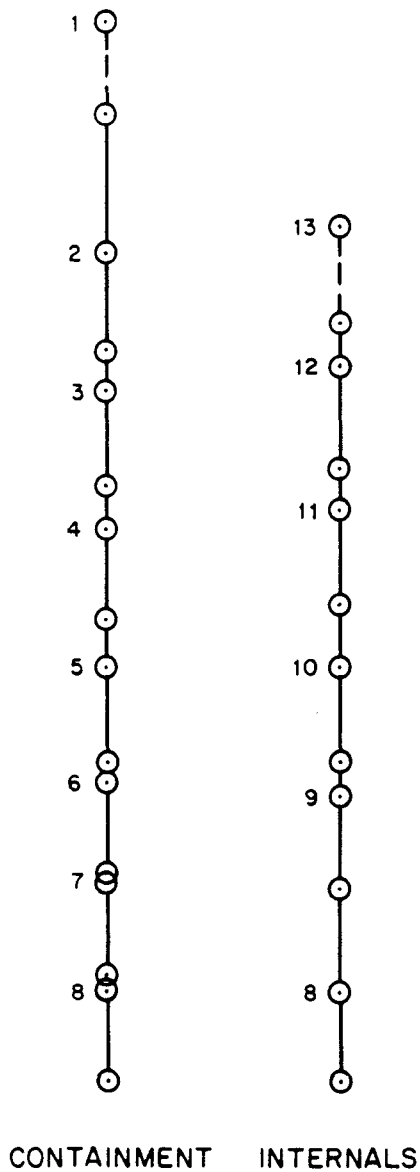

MASS	APPROX. ELEVATION (FEET)	X	Y
1	854	0	-1.000
2	813	0	-0.979
3	788	0	-0.979
4	763	0	-0.973
5	738	0	-0.963
6	717	0	-0.957
7	699	0	-0.947
8	691	0	-0.936
9	716	0	-0.968
10	738	0	-0.973
11	767	0	-0.973
12	793	0	-0.979
13	818	0	-0.979

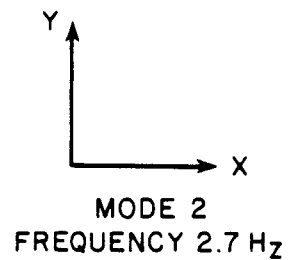

NOTE
REFERENCE TABLE 3.7B-4 AND TABLE 3.7B-6

FIGURE 3.7B-13
EIGENVECTORS FOR CONTAINMENT
AND INTERNAL STRUCTURES
UNCRACKED MODEL, MEDIAN SOIL
BEAVER VALLEY POWER STATION-UNIT 2
FINAL SAFETY ANALYSIS REPORT

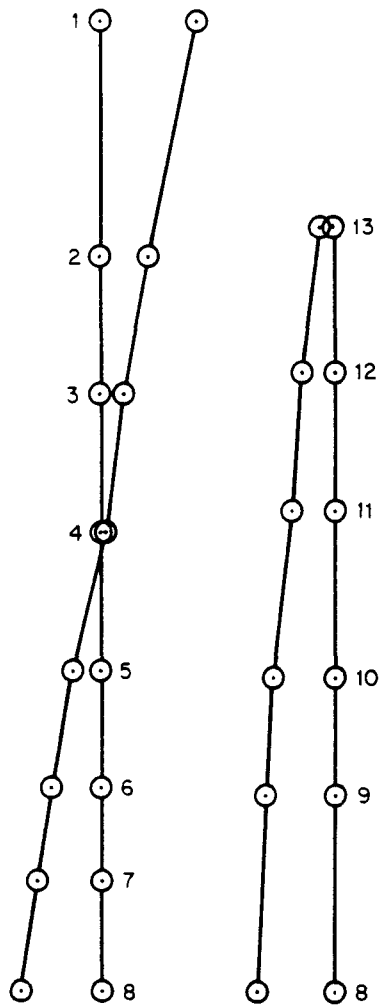

CONTAINMENT INTERNALS

MASS	APPROX. ELEVATION (FEET)	X	Y
1	854	1.0	0
2	813	0.486	0
3	788	0.223	0
4	763	-0.040	0
5	738	-0.295	0
6	717	-0.498	0
7	699	-0.658	0
8	691	-0.809	0
9	716	-0.724	0
10	738	-0.615	0
11	767	-0.451	0
12	793	-0.312	0
13	818	-0.167	0

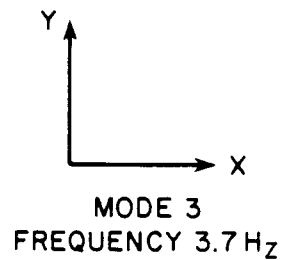

NOTE
REFERENCE TABLE 3.7B-4 AND 3.7B-6

FIGURE 3.7B-14
EIGENVECTORS FOR CONTAINMENT
AND INTERNAL STRUCTURES
UNCRAKED MODEL, MEDIAN SOIL
BEAVER VALLEY POWER STATION-UNIT 2
FINAL SAFETY ANALYSIS REPORT

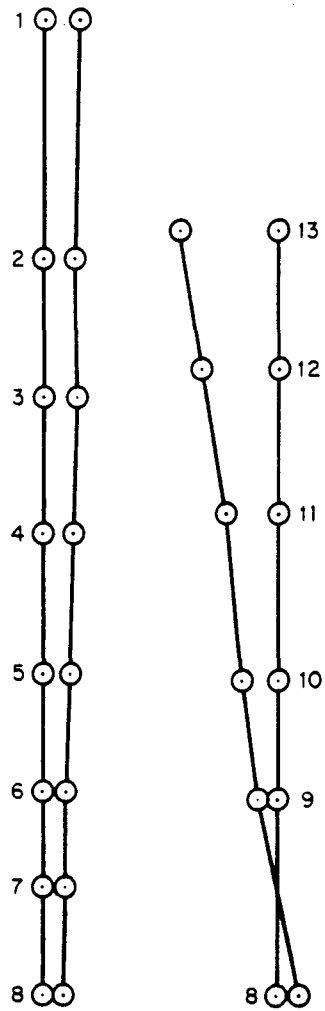

CONTAINMENT INTERNALS

MASS	APPROX. ELEVATION (FEET)	X	Y
1	854	0.356	0
2	813	0.318	0
3	788	0.316	0
4	763	0.308	0
5	738	0.291	0
6	717	0.275	0
7	699	0.261	0
8	691	0.235	0
9	716	-0.177	0
10	738	-0.372	0
11	767	-0.542	0
12	793	-0.787	0
13	818	-1.0	0

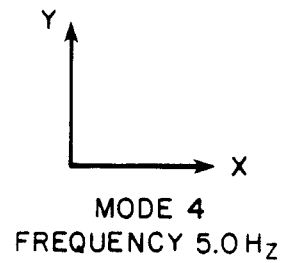

NOTE
REFERENCE TABLE 3.7B-4 AND TABLE 3.7B-6

FIGURE 3.7B-15
EIGENVECTORS FOR CONTAINMENT
AND INTERNAL STRUCTURES
UNCRACKED MODEL, MEDIAN SOIL
BEAVER VALLEY POWER STATION-UNIT 2
FINAL SAFETY ANALYSIS REPORT

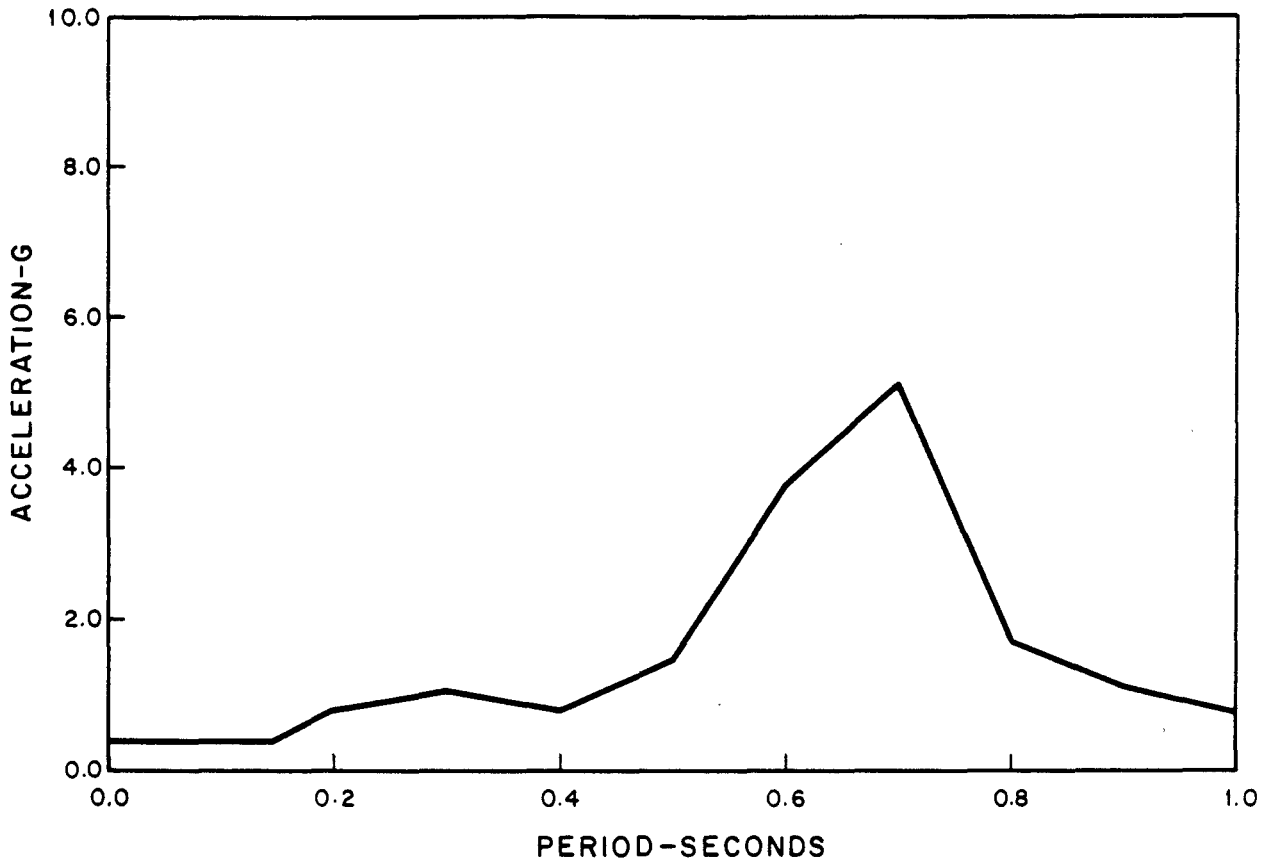

NOTE:
0.5 PERCENT DAMPING,
UNCRACKED PROPERTIES

FIGURE 3.7B-16
RESPONSE SPECTRUM ANALYSIS,
CONTAINMENT AND INTERNAL
STRUCTURES, SPRINGLINE
HORIZONTAL SSE
BEAVER VALLEY POWER STATION-UNIT 2
FINAL SAFETY ANALYSIS REPORT

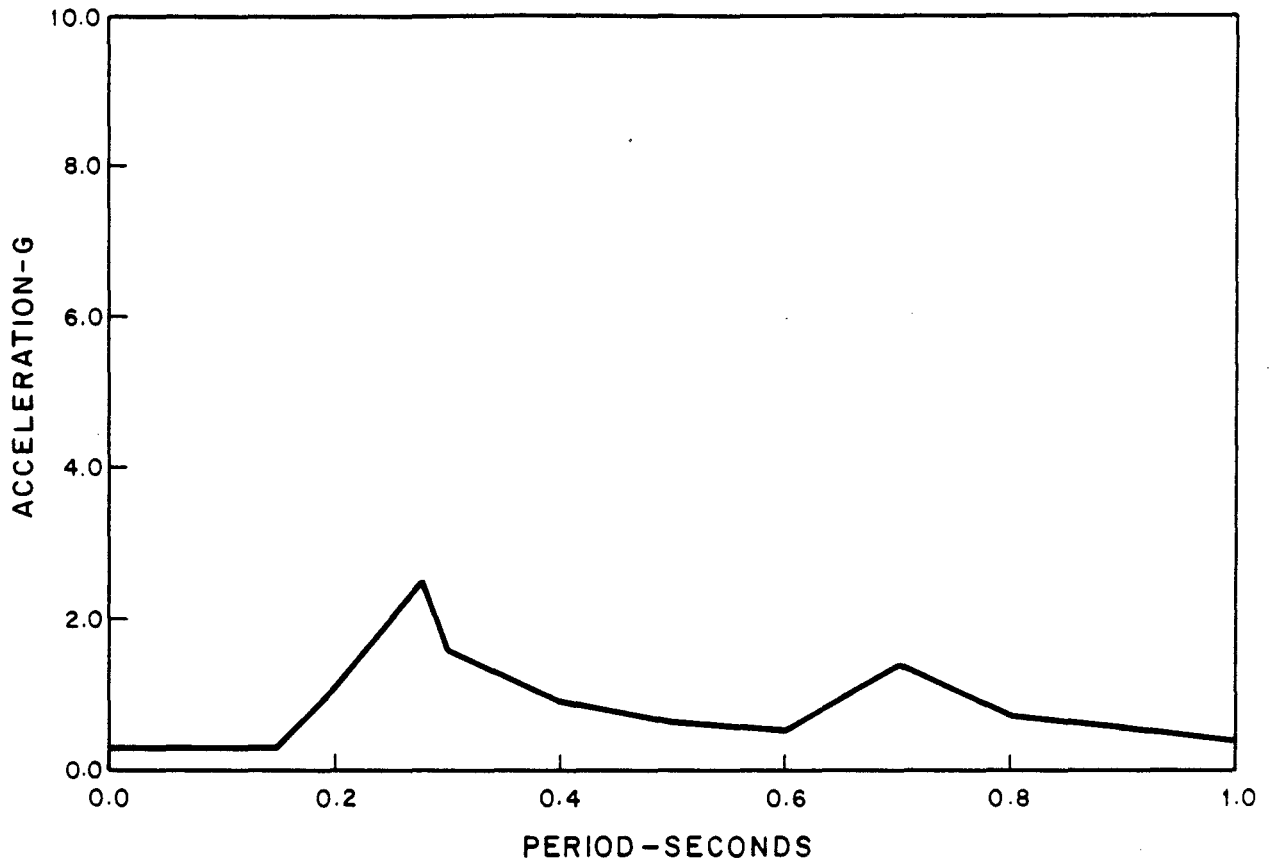

NOTE:
0.5 PERCENT DAMPING,
UNCRACKED PROPERTIES

FIGURE 3.7B-17
RESPONSE SPECTRUM ANALYSIS,
CONTAINMENT AND INTERNAL
STRUCTURES, MAT
HORIZONTAL SSE
BEAVER VALLEY POWER STATION-UNIT 2
FINAL SAFETY ANALYSIS REPORT

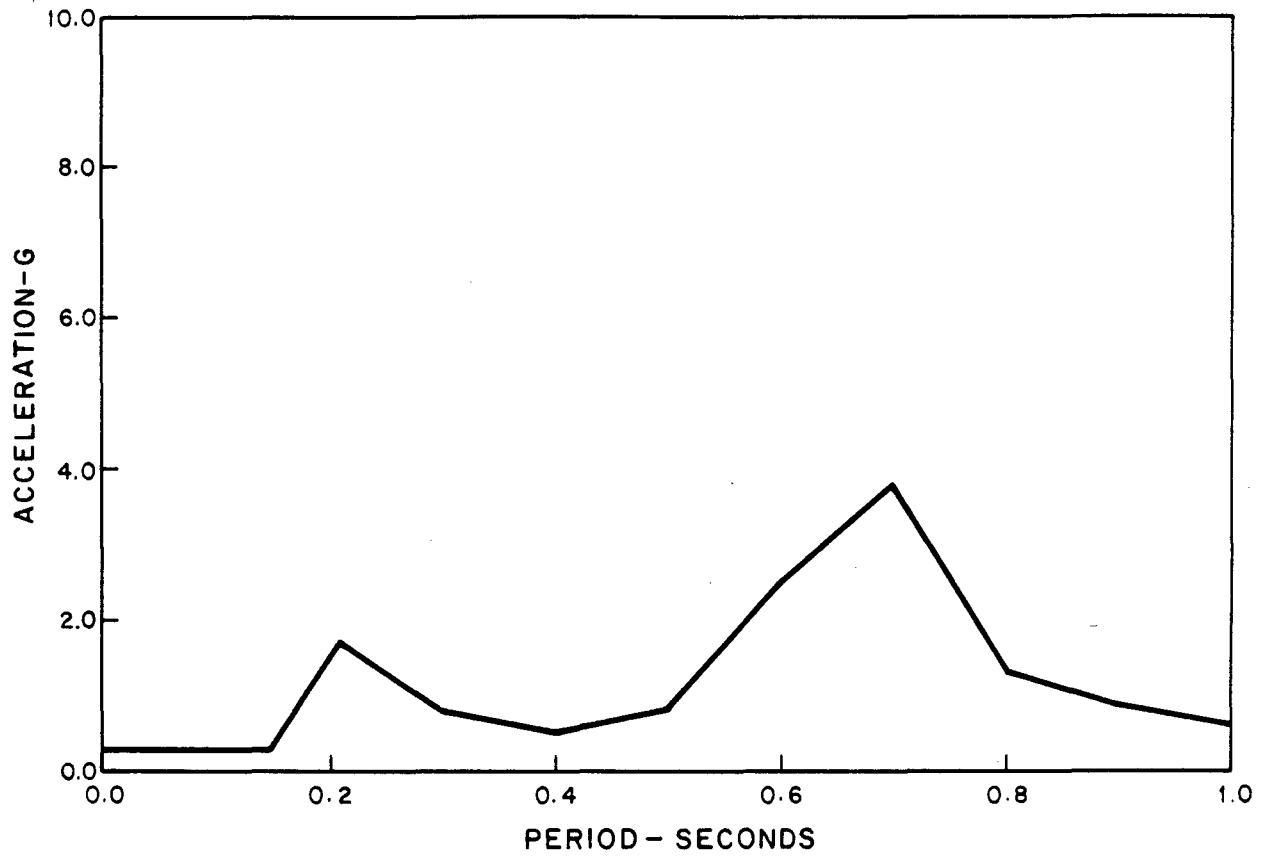

NOTE:
0.5 PERCENT DAMPING,
UNCRACKED PROPERTIES

FIGURE 3.7B-18
RESPONSE SPECTRUM ANALYSIS,
CONTAINMENT AND INTERNAL
STRUCTURES, OPERATING FLOOR
HORIZONTAL SSE
BEAVER VALLEY POWER STATION-UNIT 2
FINAL SAFETY ANALYSIS REPORT

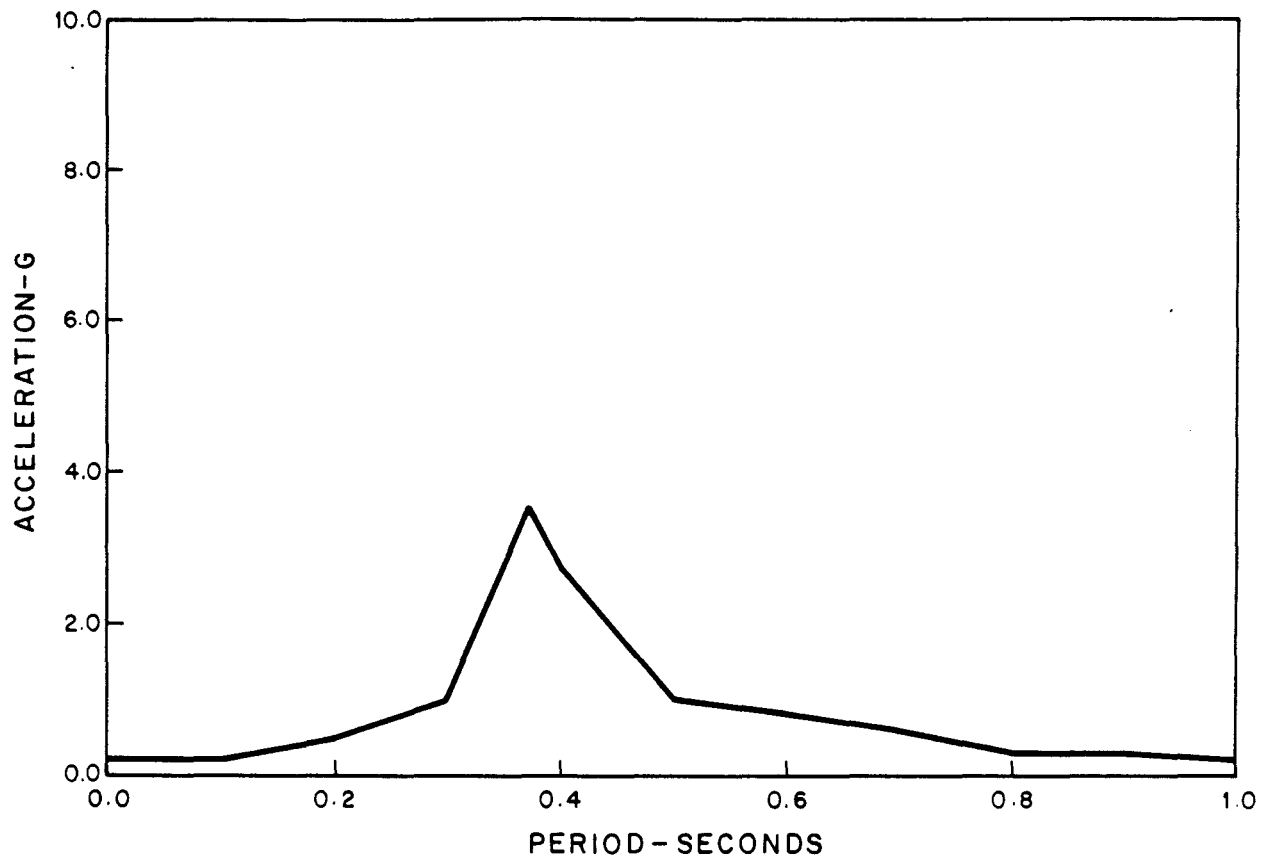

NOTE:
0.5 PERCENT DAMPING,
UNCRACKED PROPERTIES

FIGURE 3.7B-19
RESPONSE SPECTRUM ANALYSIS,
CONTAINMENT AND INTERNAL
STRUCTURES, SPRINGLINE
VERTICAL SSE
BEAVER VALLEY POWER STATION-UNIT 2
FINAL SAFETY ANALYSIS REPORT

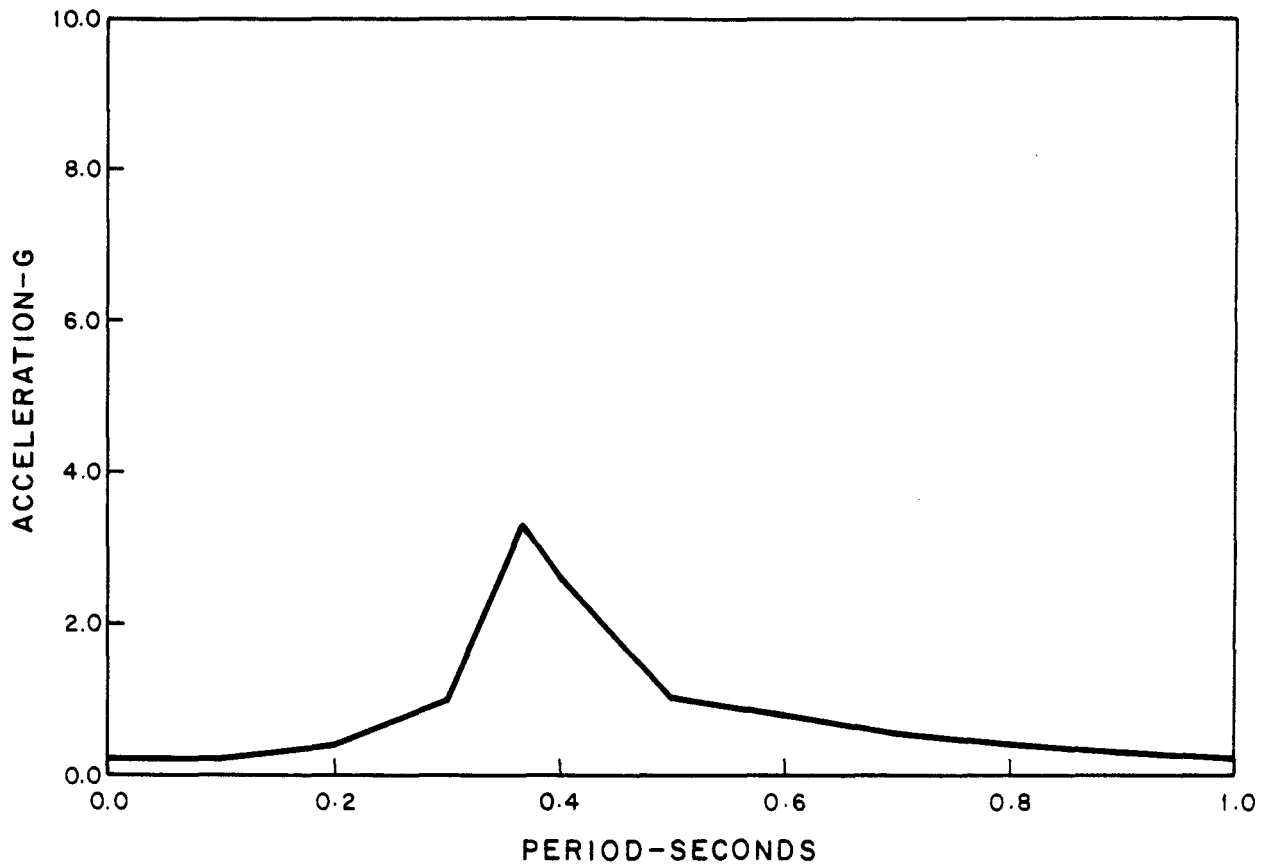

NOTE:
0.5 PERCENT DAMPING,
UNCRACKED PROPERTIES

FIGURE 3.7B-20
RESPONSE SPECTRUM ANALYSIS,
CONTAINMENT AND INTERNAL
STRUCTURES, MAT
VERTICAL SSE
BEAVER VALLEY POWER STATION-UNIT 2
FINAL SAFETY ANALYSIS REPORT

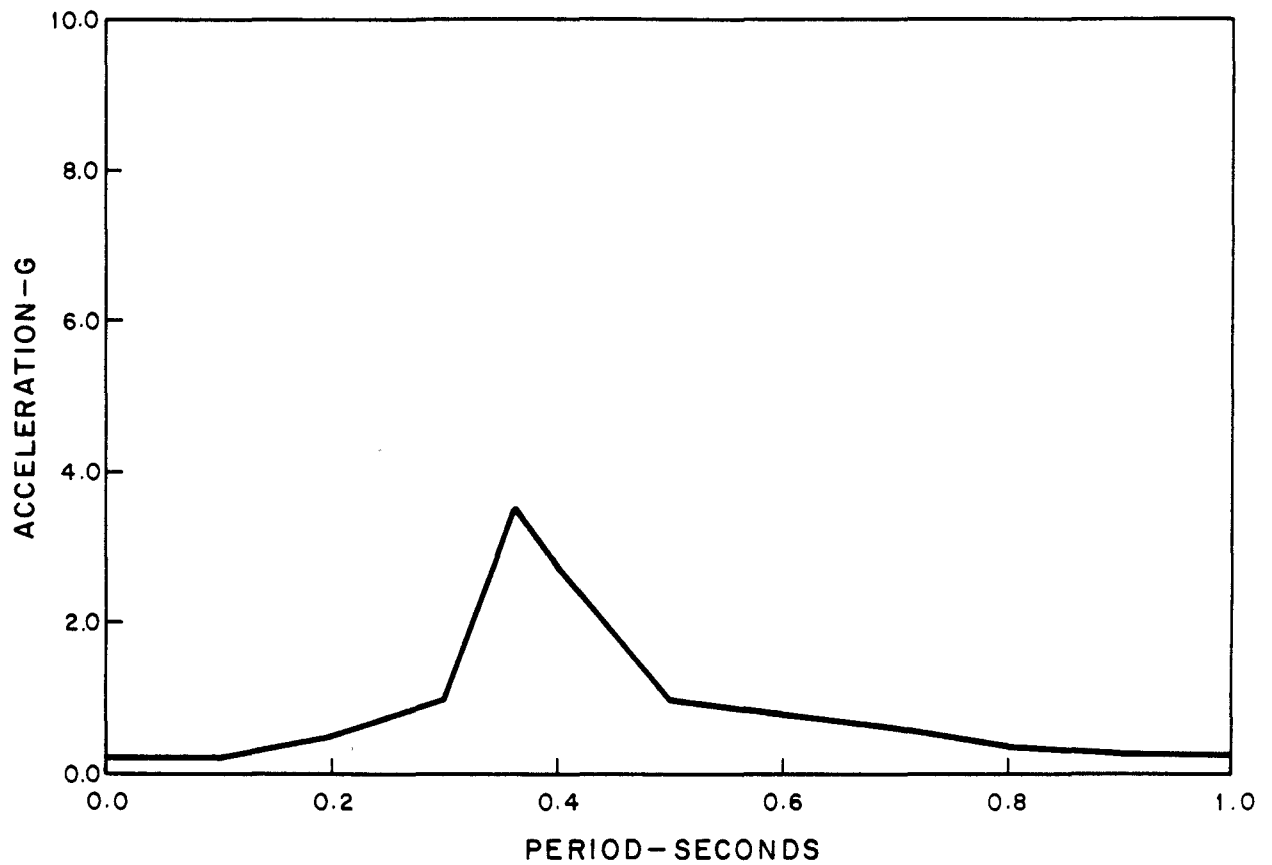

NOTE:
0.5 PERCENT DAMPING,
UNCRACKED PROPERTIES

FIGURE 3.7B-21
RESPONSE SPECTRUM ANALYSIS,
CONTAINMENT AND INTERNAL
STRUCTURES, OPERATING FLOOR
VERTICAL SSE
BEAVER VALLEY POWER STATION-UNIT 2
FINAL SAFETY ANALYSIS REPORT

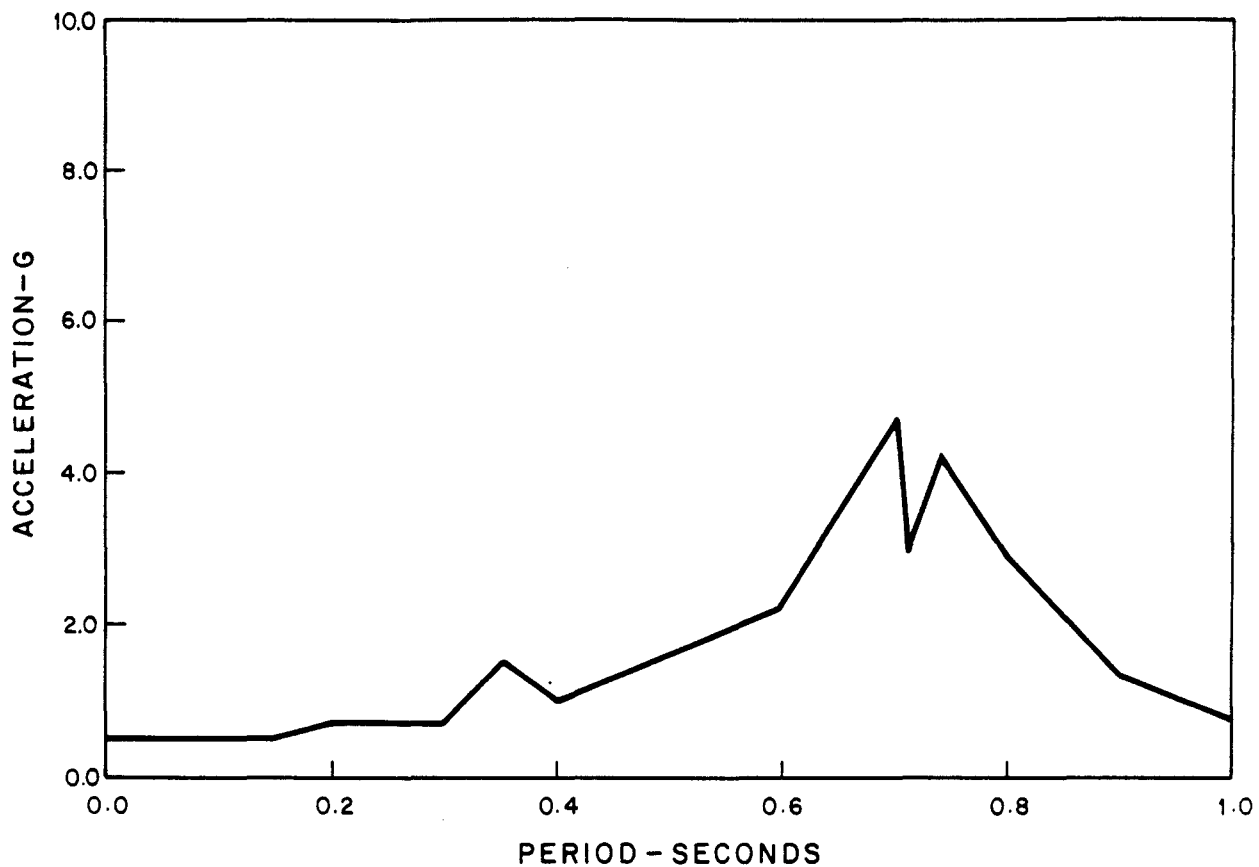

NOTE:
0.5 PERCENT DAMPING,
CRACKED PROPERTIES

FIGURE 3.7B-22
RESPONSE SPECTRUM ANALYSIS,
CONTAINMENT AND INTERNAL
STRUCTURES, SPRINGLINE
HORIZONTAL SSE
BEAVER VALLEY POWER STATION-UNIT 2
FINAL SAFETY ANALYSIS REPORT

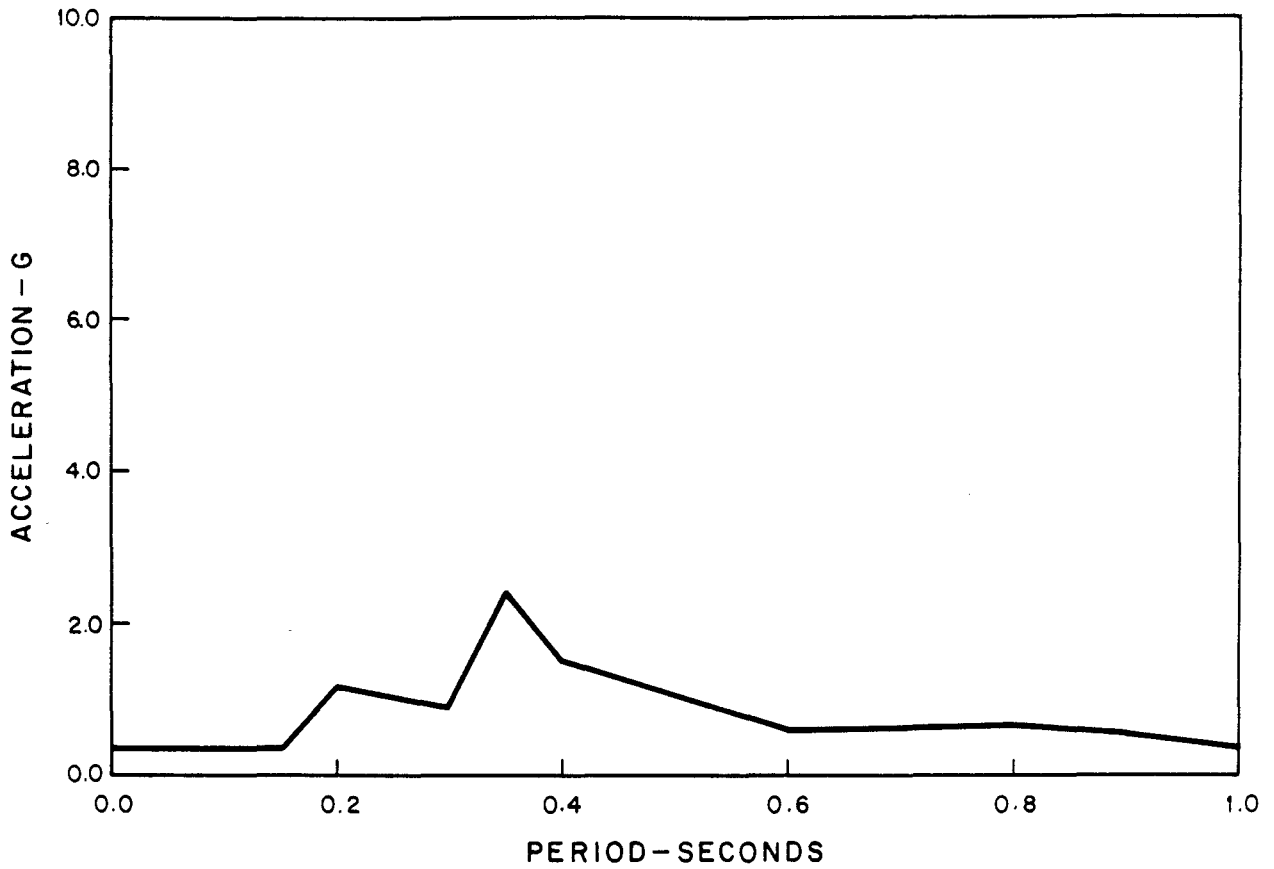

NOTE:
0.5 PERCENT DAMPING,
CRACKED PROPERTIES

FIGURE 3.7B-23
RESPONSE SPECTRUM ANALYSIS,
CONTAINMENT AND INTERNAL
STRUCTURES, MAT
HORIZONTAL SSE
BEAVER VALLEY POWER STATION-UNIT 2
FINAL SAFETY ANALYSIS REPORT

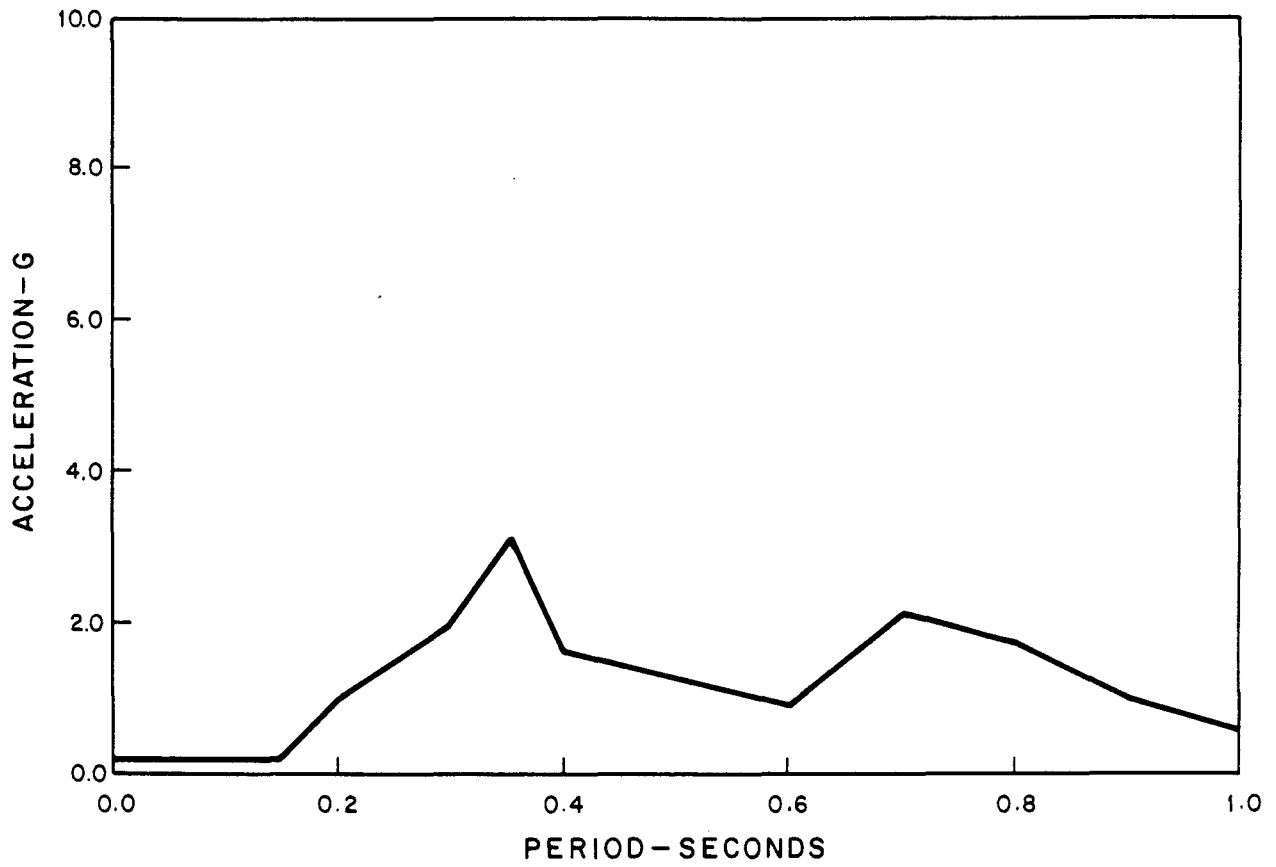

NOTE:
0.5 PERCENT DAMPING,
CRACKED PROPERTIES

FIGURE 3.7B-24
RESPONSE SPECTRUM ANALYSIS,
CONTAINMENT AND INTERNAL
STRUCTURES, OPERATING FLOOR
HORIZONTAL SSE
BEAVER VALLEY POWER STATION-UNIT 2
FINAL SAFETY ANALYSIS REPORT

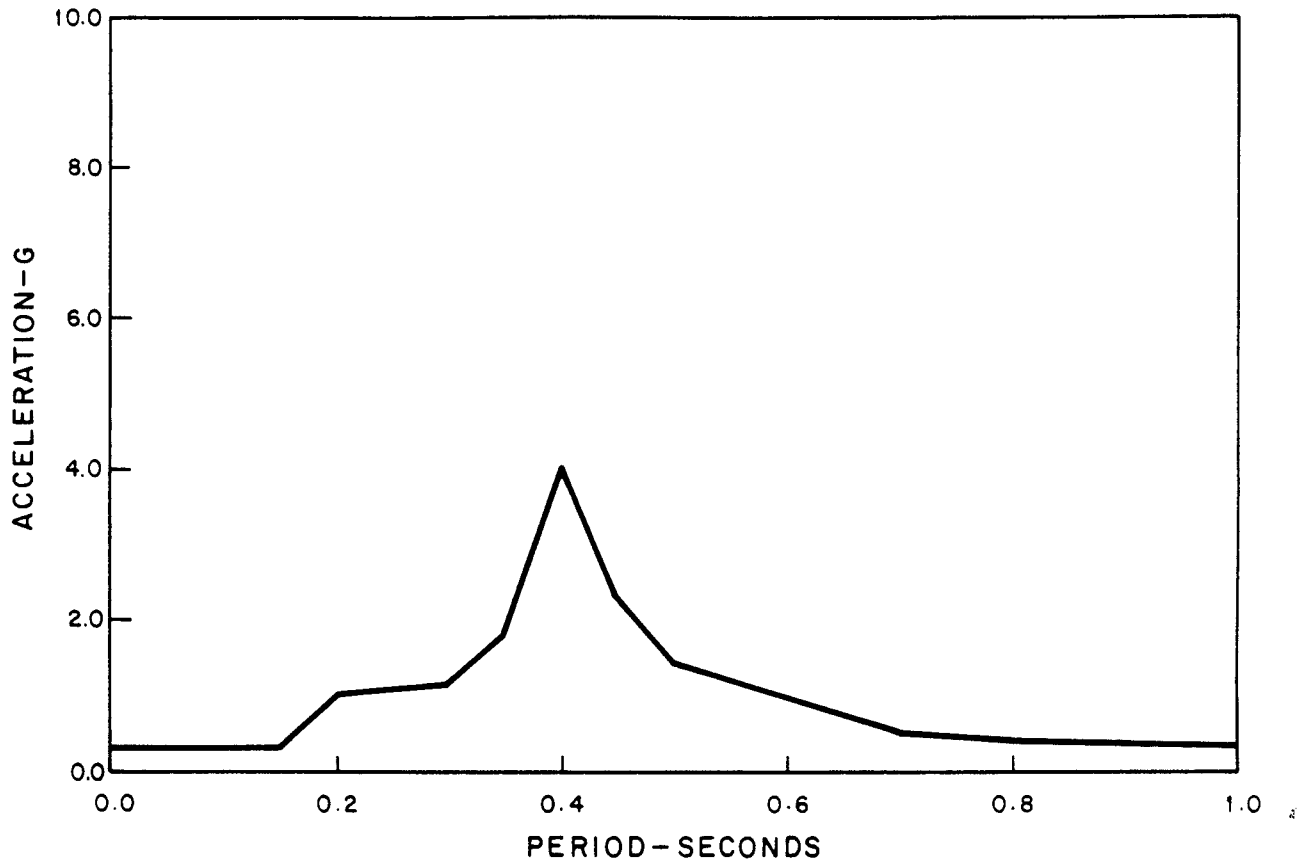

NOTE:
0.5 PERCENT DAMPING,
CRACKED PROPERTIES

FIGURE 3.7B-25
RESPONSE SPECTRUM ANALYSIS,
CONTAINMENT AND INTERNAL
STRUCTURES, SPRINGLINE
VERTICAL SSE
BEAVER VALLEY POWER STATION-UNIT 2
FINAL SAFETY ANALYSIS REPORT

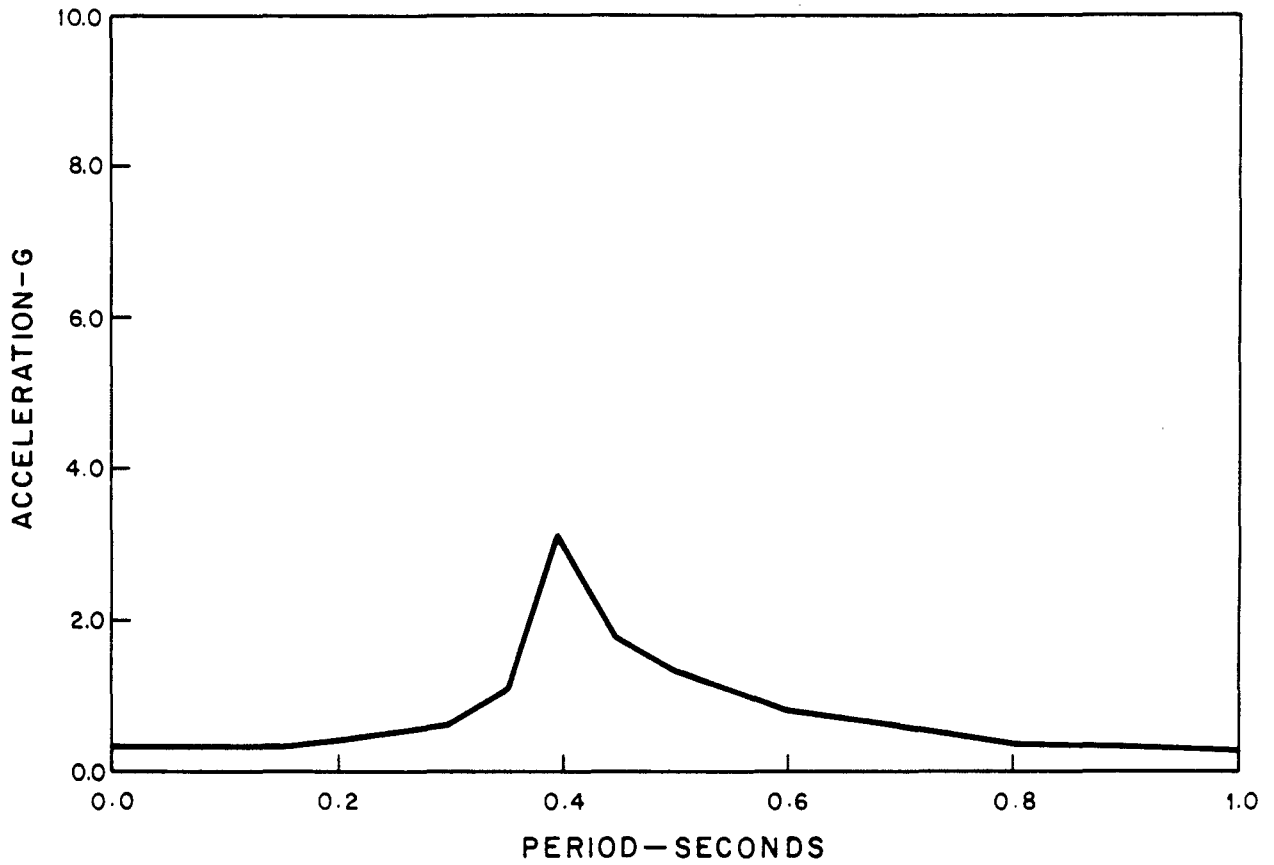

NOTE
0.5 PERCENT DAMPING,
CRACKED PROPERTIES

FIGURE 3.7B-26
RESPONSE SPECTRUM ANALYSIS,
CONTAINMENT AND INTERNAL
STRUCTURES, MAT
VERTICAL SSE
BEAVER VALLEY POWER STATION-UNIT 2
FINAL SAFETY ANALYSIS REPORT

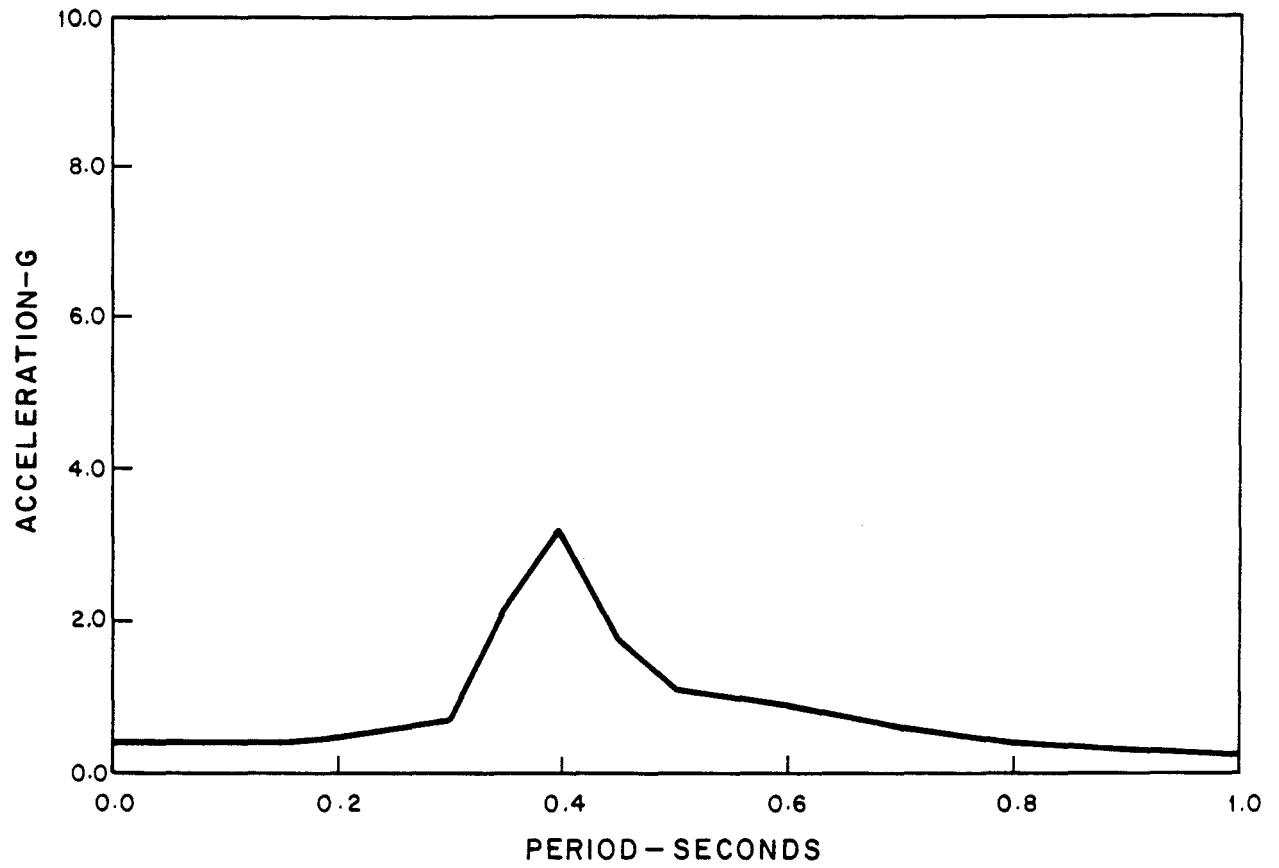

NOTE:
0.5 PERCENT DAMPING,
CRACKED PROPERTIES

FIGURE 3.7B-27
RESPONSE SPECTRUM ANALYSIS,
CONTAINMENT AND INTERNAL
STRUCTURES, OPERATING FLOOR
VERTICAL SSE
BEAVER VALLEY POWER STATION-UNIT 2
FINAL SAFETY ANALYSIS REPORT

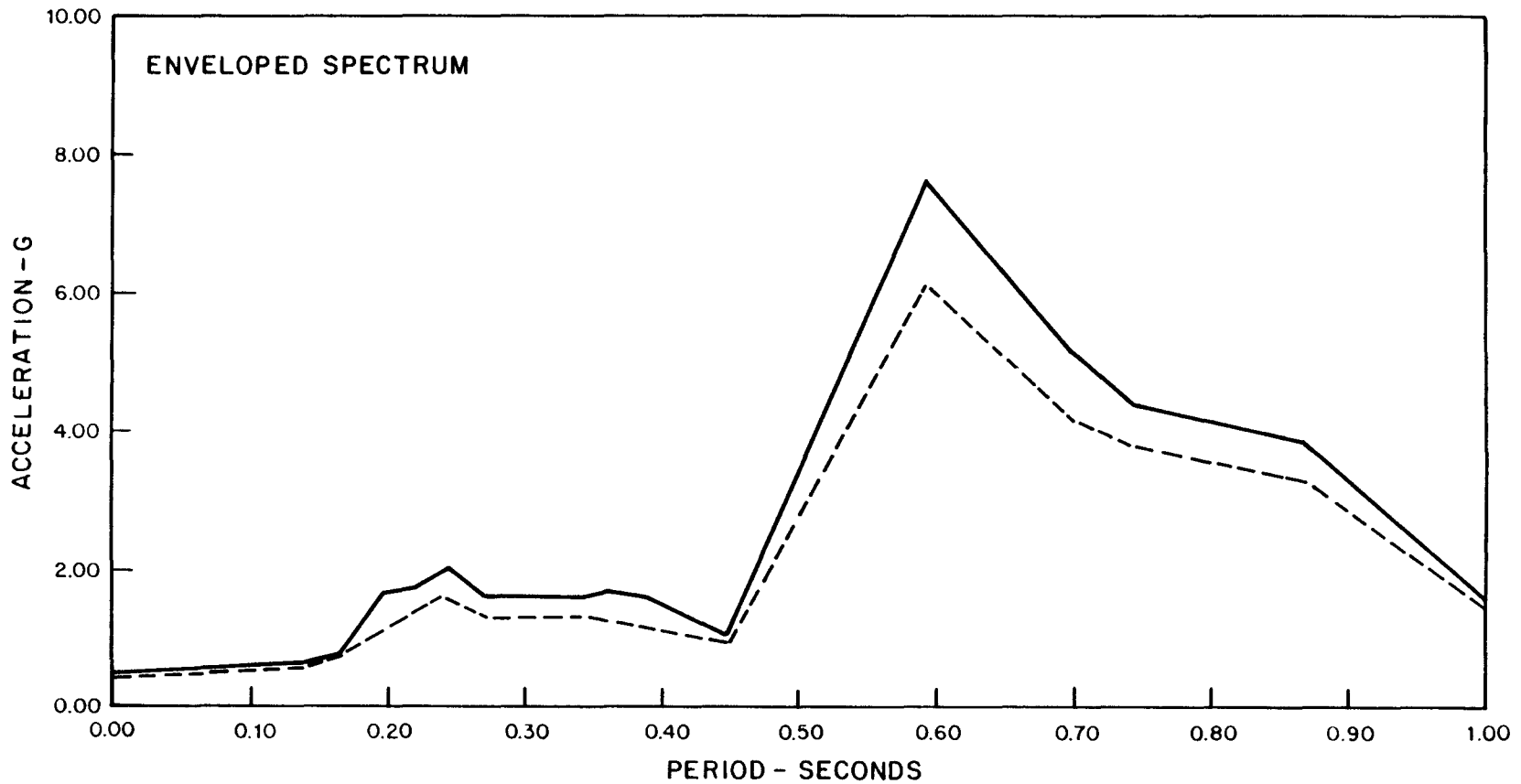

LEGEND

- MODAL DAMPING AND 0.5 PERCENT EQUIPMENT DAMPING
- - - MODAL DAMPING AND 1.0 PERCENT EQUIPMENT DAMPING

FIGURE 3.7B-28
AMPLIFIED RESPONSE SPECTRA,
REACTOR CONTAINMENT, HORIZONTAL
EXCITATION SSE AT EL. 813.62',
EXTERNAL STRUCTURE
BEAVER VALLEY POWER STATION-UNIT 2
FINAL SAFETY ANALYSIS REPORT

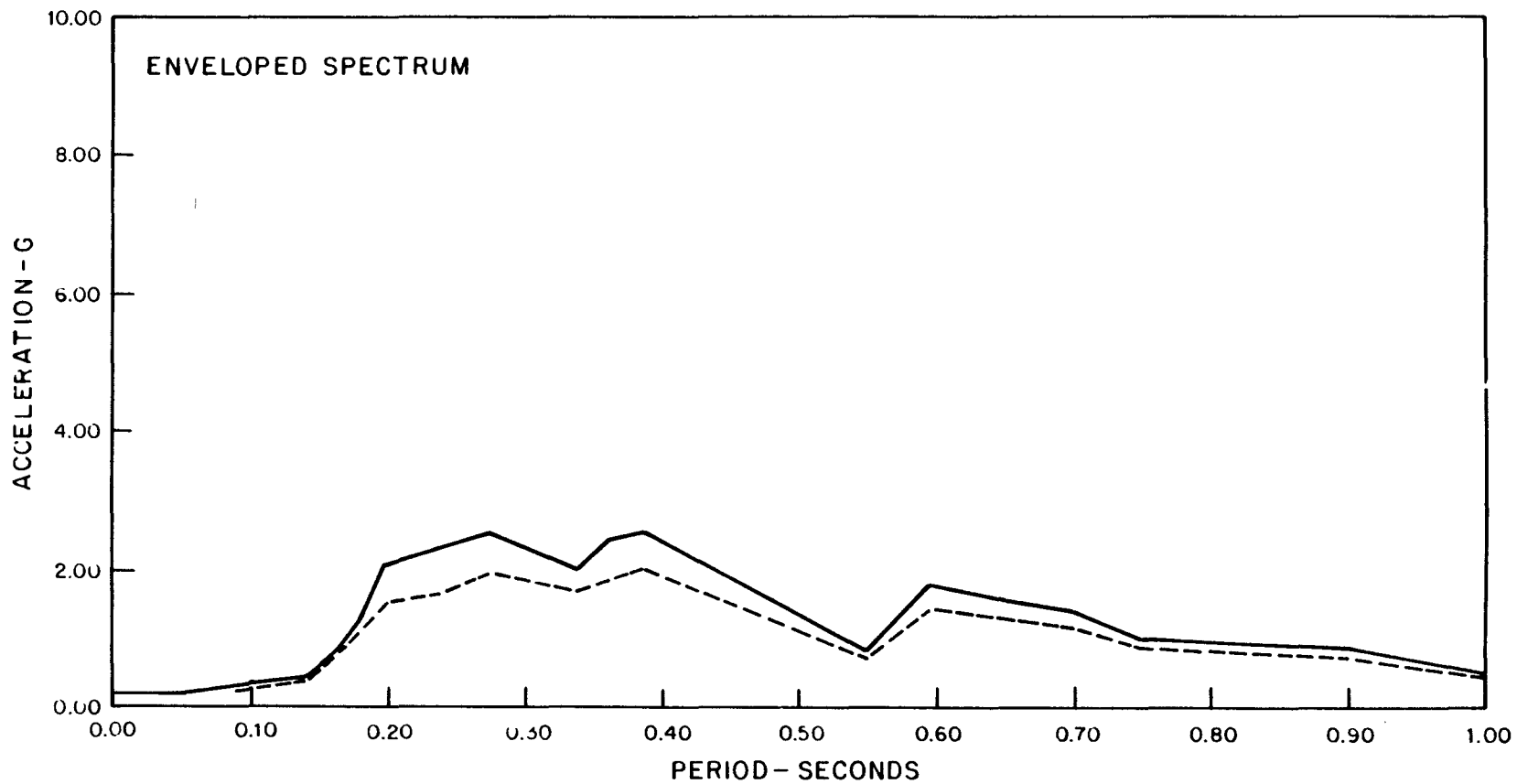

LEGEND

- MODAL DAMPING AND 0.5 PERCENT EQUIPMENT DAMPING
- - - MODAL DAMPING AND 1.0 PERCENT EQUIPMENT DAMPING

FIGURE 3.7B-29
 AMPLIFIED RESPONSE SPECTRA,
 REACTOR CONTAINMENT, HORIZONTAL
 EXCITATION SSE AT EL. 691.0', MAT
 BEAVER VALLEY POWER STATION-UNIT 2
 FINAL SAFETY ANALYSIS REPORT

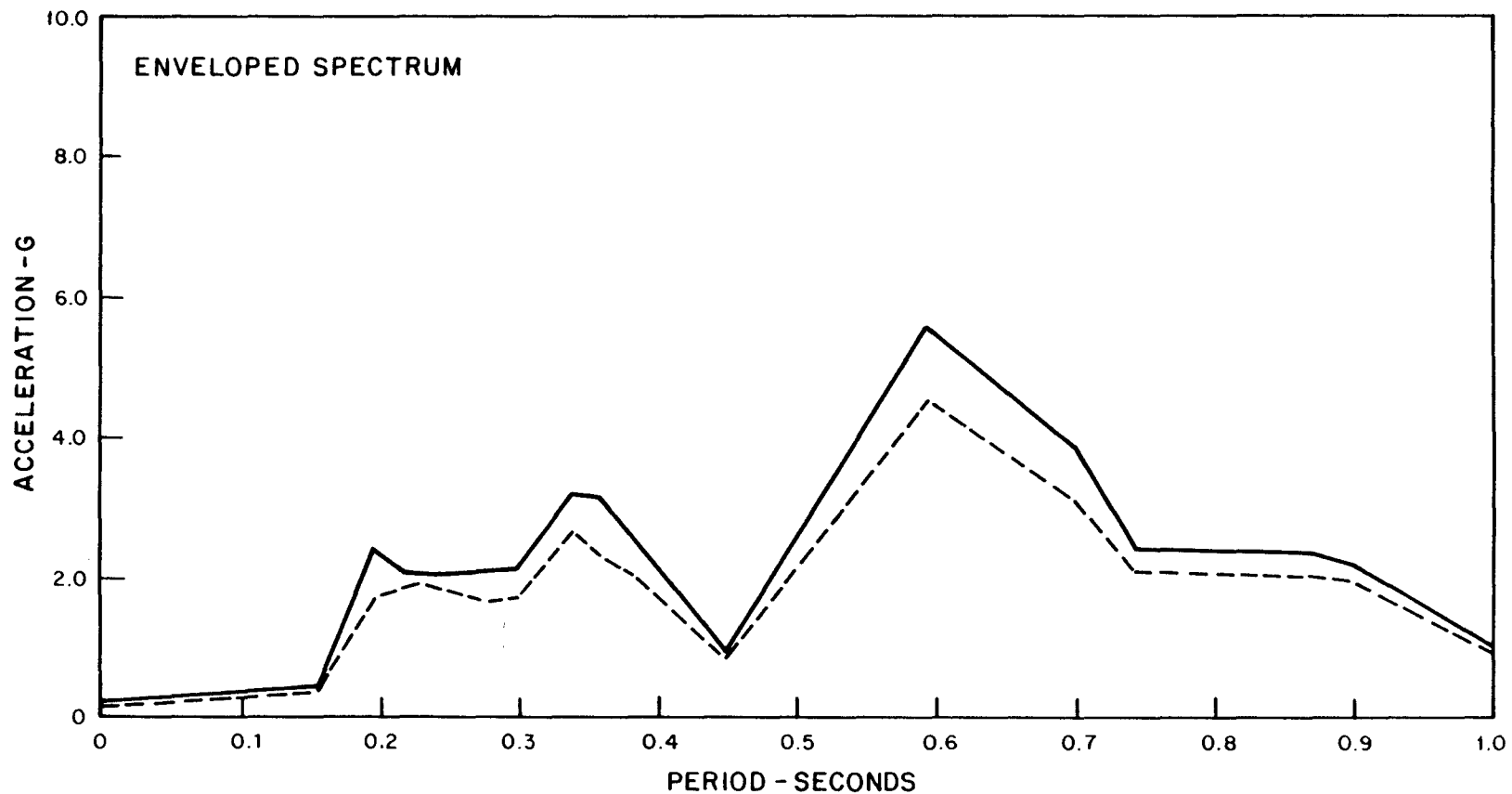

LEGEND

- MODAL DAMPING AND 0.5 PERCENT EQUIPMENT DAMPING
- - - MODAL DAMPING AND 1.0 PERCENT EQUIPMENT DAMPING

FIGURE 3.7B-30
 AMPLIFIED RESPONSE SPECTRA,
 REACTOR CONTAINMENT, HORIZONTAL
 EXCITATION SSE AT EL. 767.83',
 INTERNAL STRUCTURE
 BEAVER VALLEY POWER STATION-UNIT 2
 FINAL SAFETY ANALYSIS REPORT

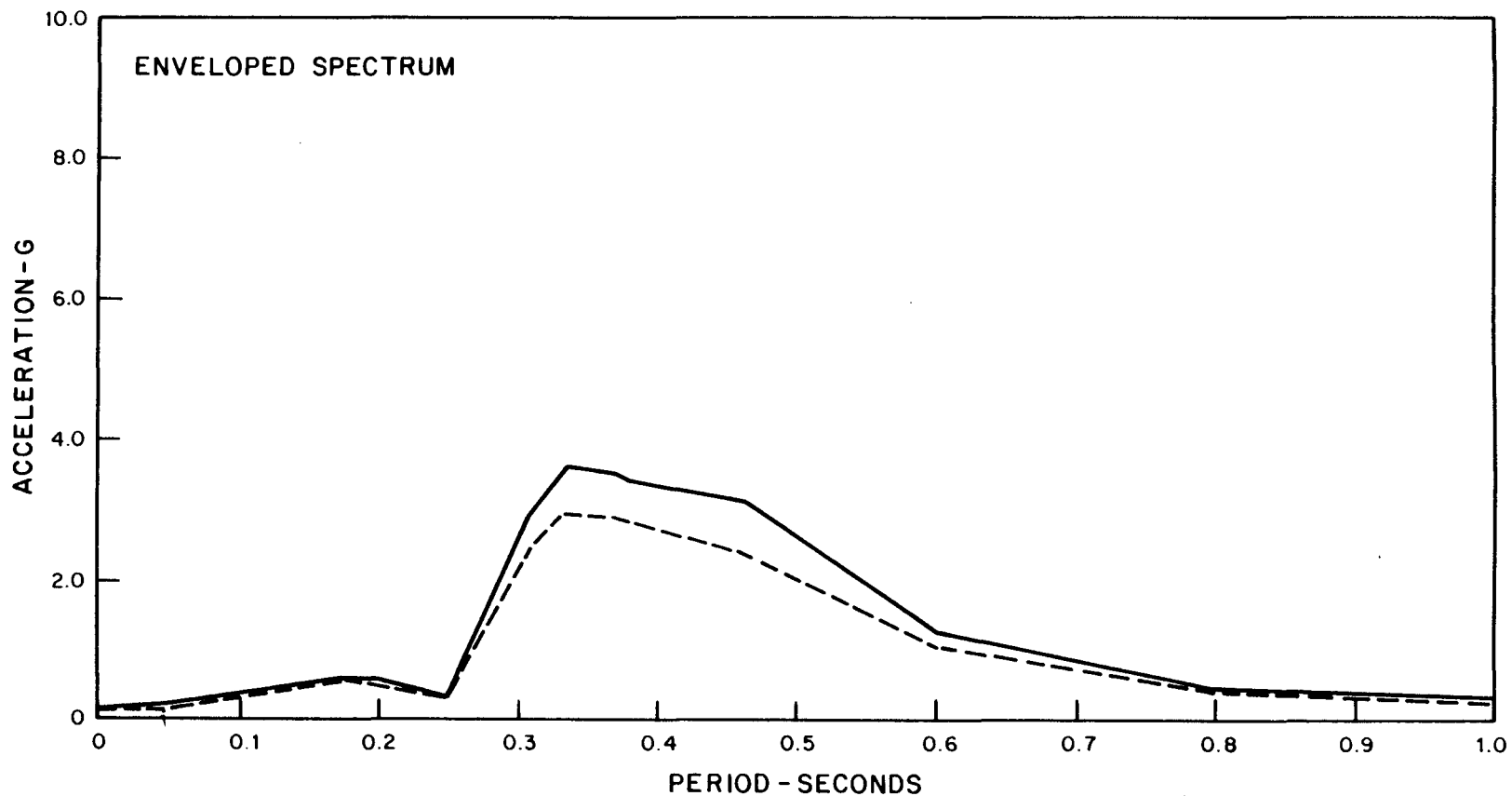

LEGEND

- MODAL DAMPING AND 0.5 PERCENT EQUIPMENT DAMPING
- - - MODAL DAMPING AND 1.0 PERCENT EQUIPMENT DAMPING

FIGURE 3.7B-31
 AMPLIFIED RESPONSE SPECTRA,
 REACTOR CONTAINMENT, VERTICAL
 EXCITATION SSE AT EL. 818.00'
 INTERNAL STRUCTURE
 BEAVER VALLEY POWER STATION-UNIT 2
 FINAL SAFETY ANALYSIS REPORT

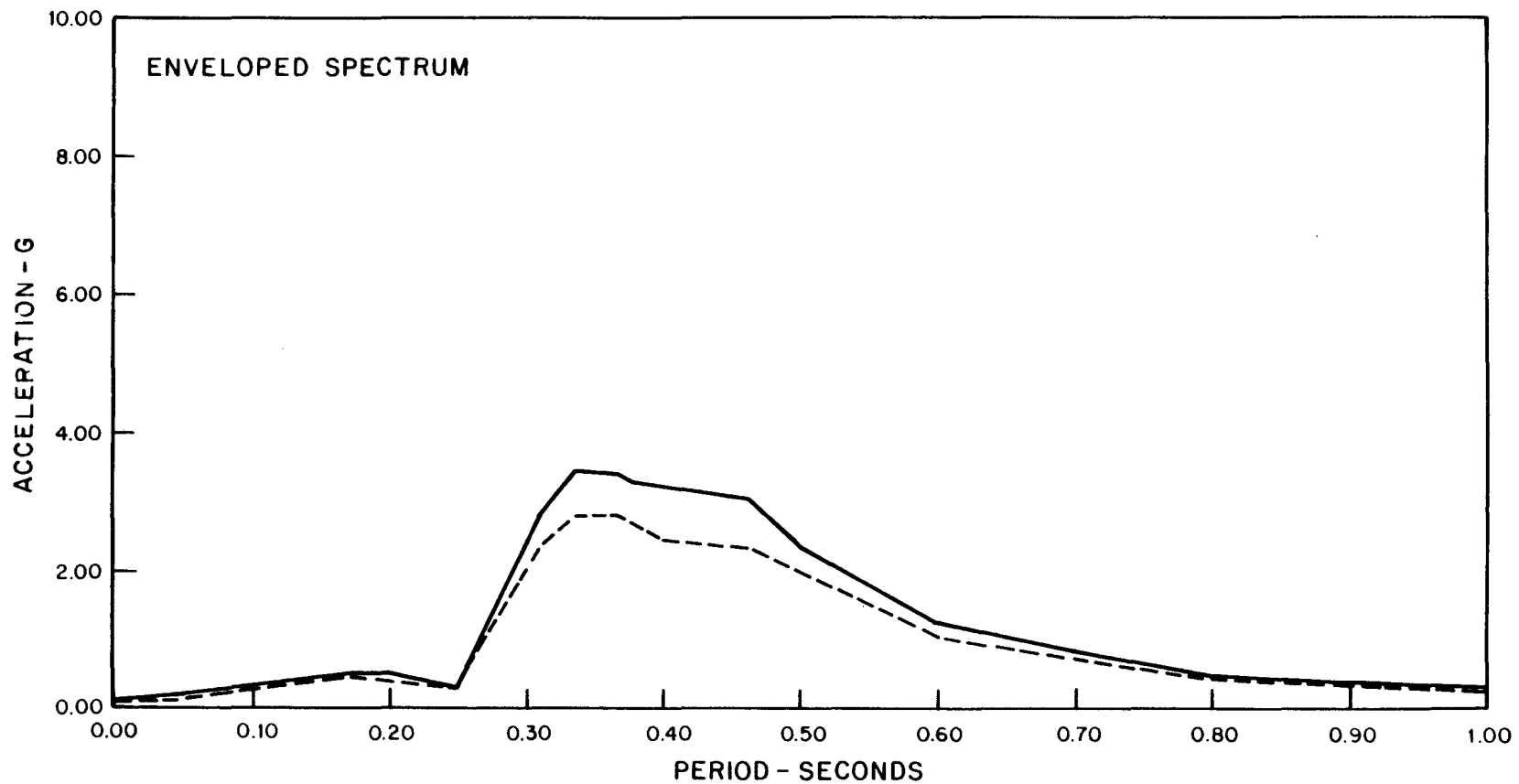

LEGEND

- MODAL DAMPING AND 0.5 PERCENT EQUIPMENT DAMPING
- - - MODAL DAMPING AND 1.0 PERCENT EQUIPMENT DAMPING

FIGURE 3.7B-32
 AMPLIFIED RESPONSE SPECTRA,
 REACTOR CONTAINMENT, VERTICAL
 EXCITATION SSE AT EL. 691.0', MAT
 BEAVER VALLEY POWER STATION-UNIT 2
 FINAL SAFETY ANALYSIS REPORT

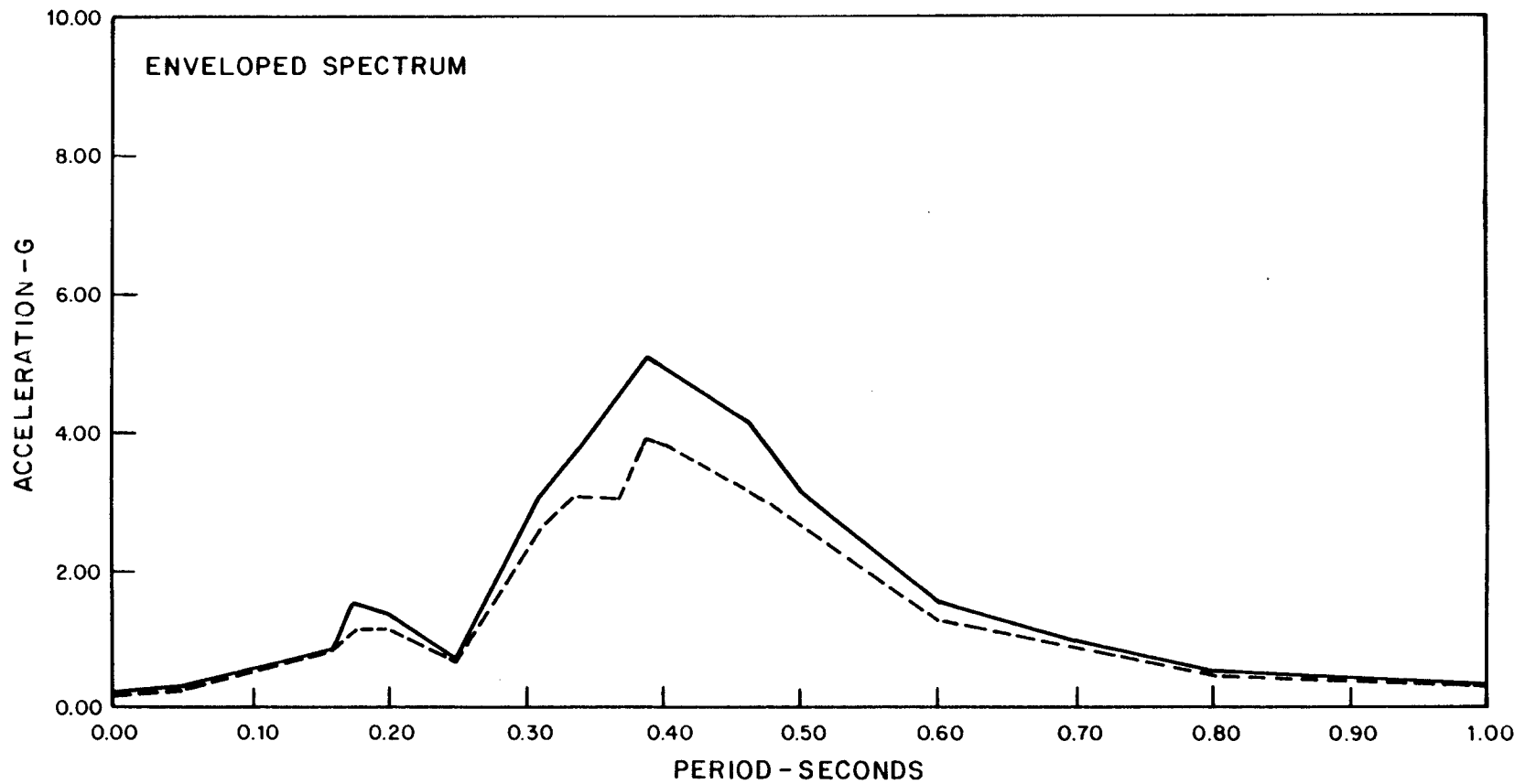

LEGEND

- MODAL DAMPING AND 0.5 PERCENT EQUIPMENT DAMPING
- - - MODAL DAMPING AND 1.0 PERCENT EQUIPMENT DAMPING

FIGURE 3.7B-33
AMPLIFIED RESPONSE SPECTRA,
REACTOR CONTAINMENT, VERTICAL
EXCITATION SSE AT EL. 854.22',
EXTERNAL STRUCTURE
BEAVER VALLEY POWER STATION-UNIT 2
FINAL SAFETY ANALYSIS REPORT

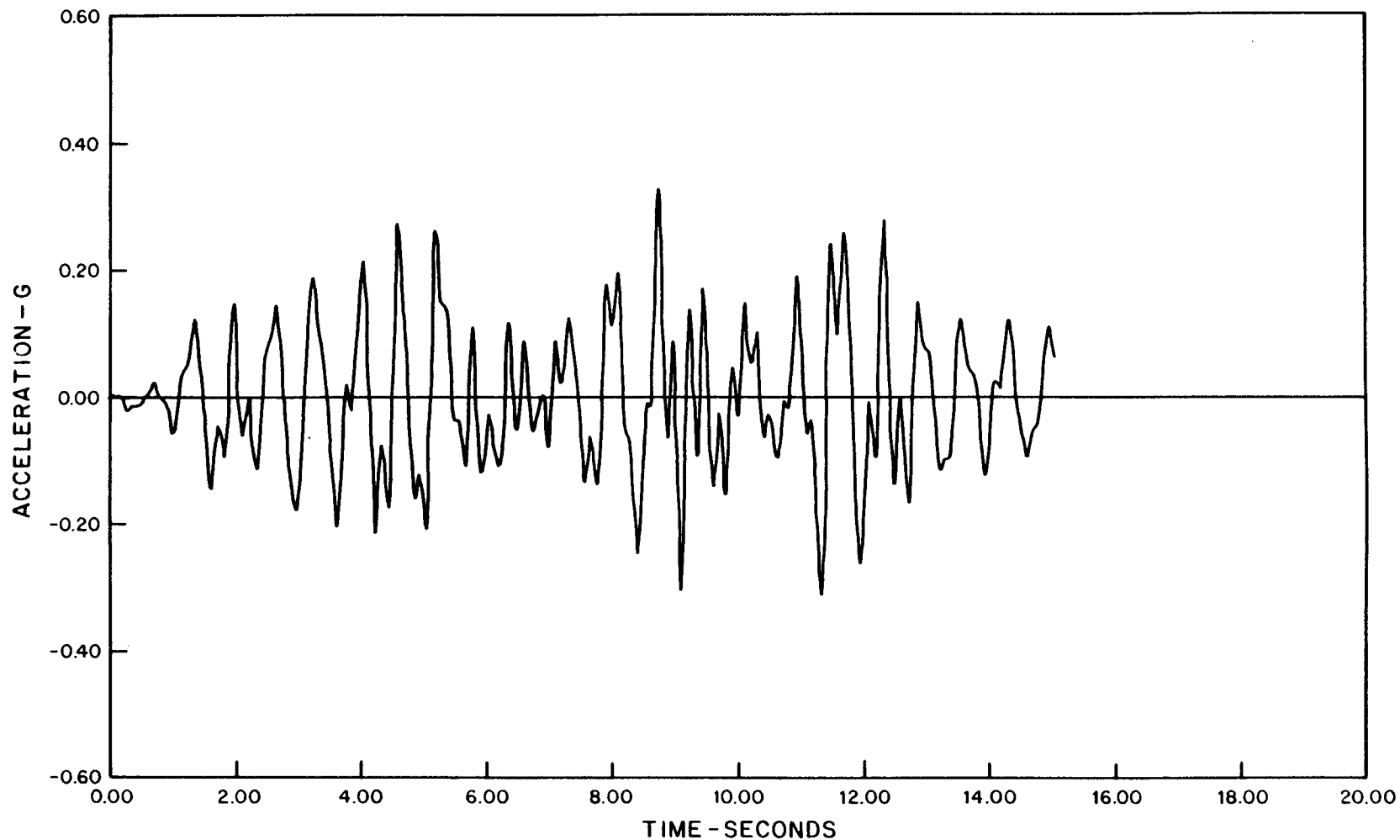

NOTES

1. MAXIMUM ACCELERATION = 0.32261 AT TIME 8.760
2. SOIL SHEAR MODULUS = 18KSI
3. UNCRACKED CONTAINMENT

FIGURE 3.7B-34
TIME HISTORY OF ACCELERATION
AT THE OPERATING FLOOR,
CONTAINMENT, HORIZONTAL SSE
BEAVER VALLEY POWER STATION-UNIT 2
FINAL SAFETY ANALYSIS REPORT

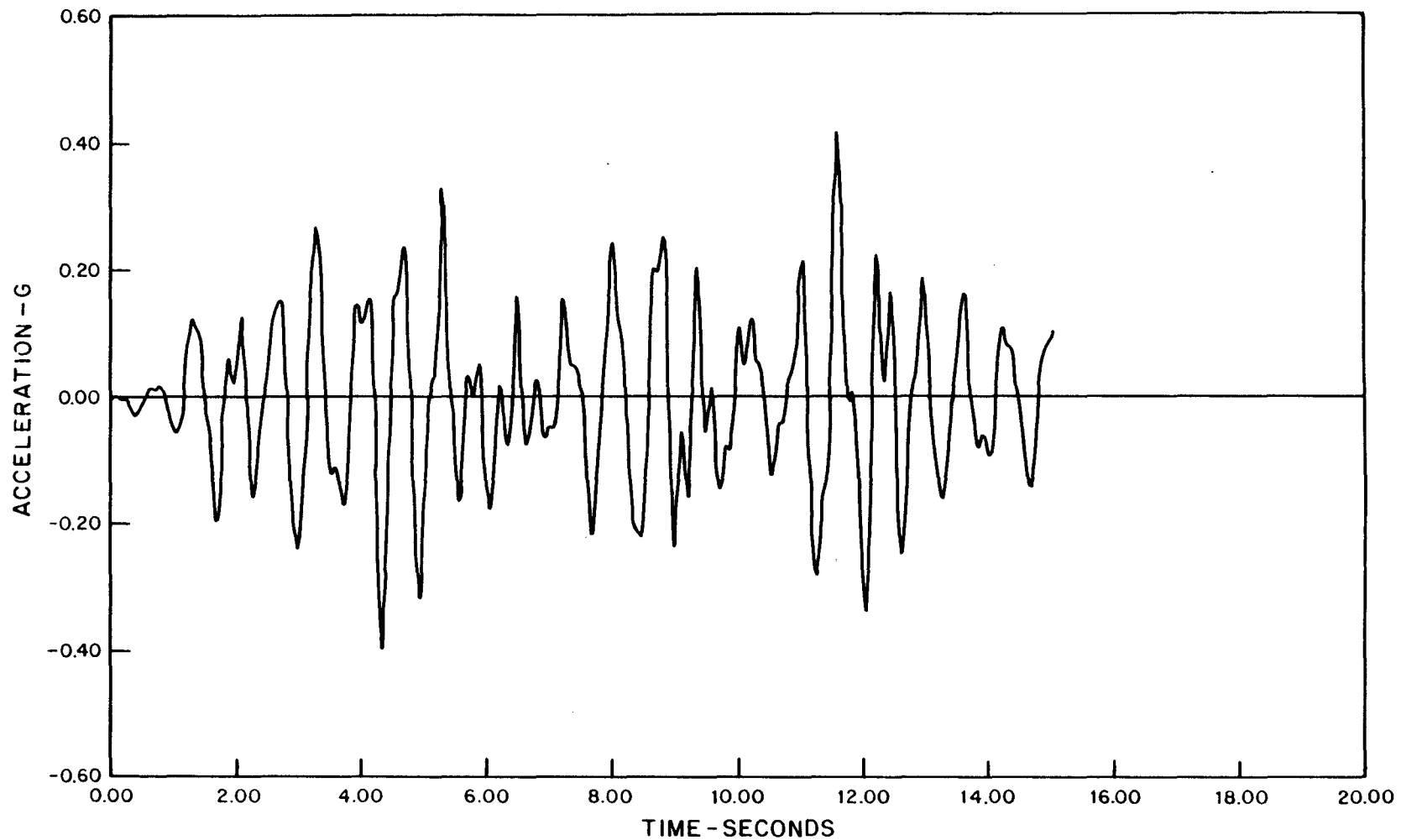

NOTES

1. MAXIMUM ACCELERATION = 0.42040 AT TIME 11.610
2. SOIL SHEAR MODULUS = 18KSI
3. UNCRACKED CONTAINMENT

FIGURE 3.7B-35
TIME HISTORY OF ACCELERATION
AT THE SPRINGLINE,
CONTAINMENT, HORIZONTAL SSE
BEAVER VALLEY POWER STATION-UNIT 2
FINAL SAFETY ANALYSIS REPORT

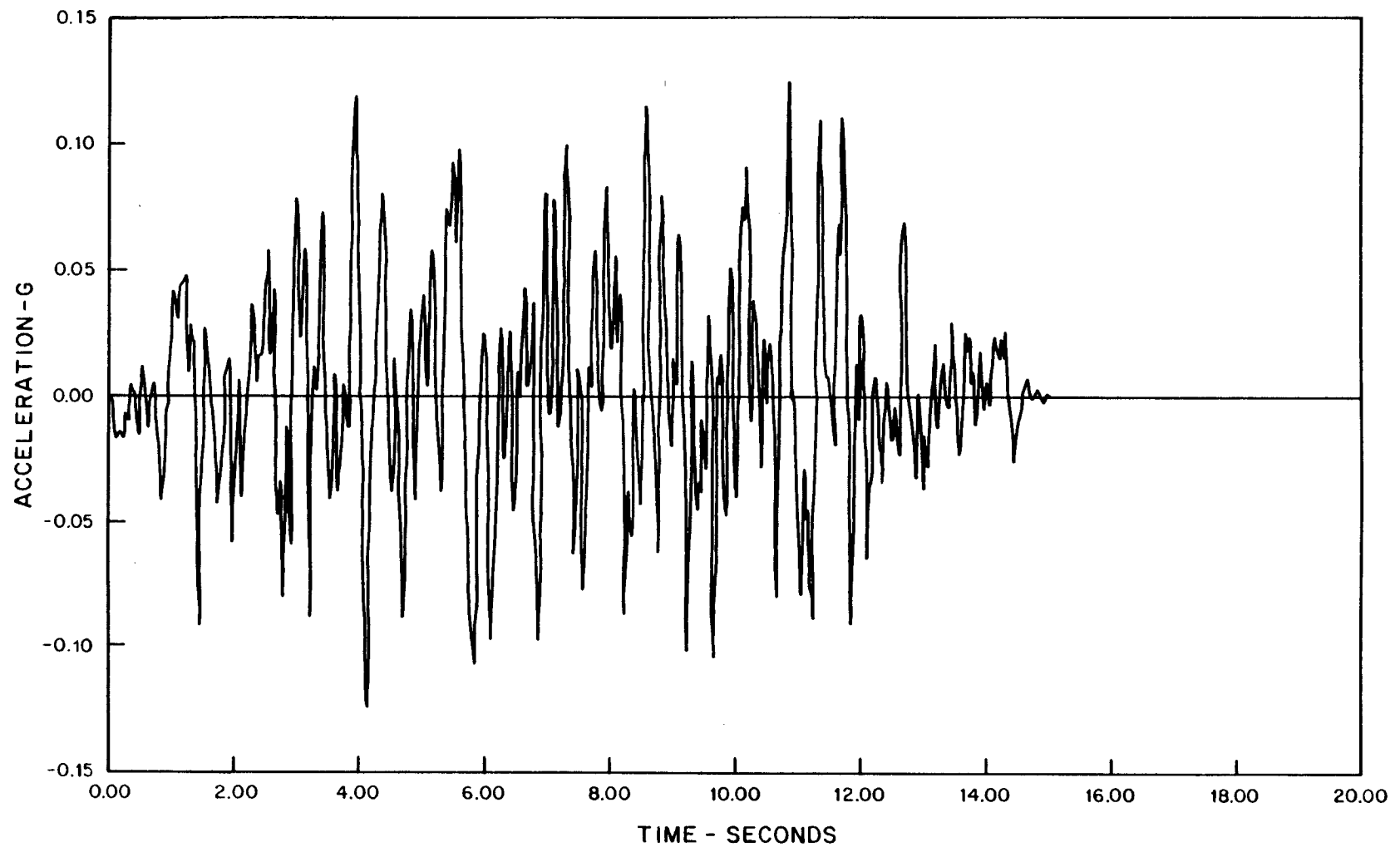

NOTES

1. MAXIMUM ACCELERATION = 0.12500 AT TIME 10.870
2. $\Delta T = 0.01$ SECONDS

FIGURE 3.7B-36
SITE ARTIFICIAL TIME HISTORY,
HORIZONTAL SSE
BEAVER VALLEY POWER STATION-UNIT 2
FINAL SAFETY ANALYSIS REPORT

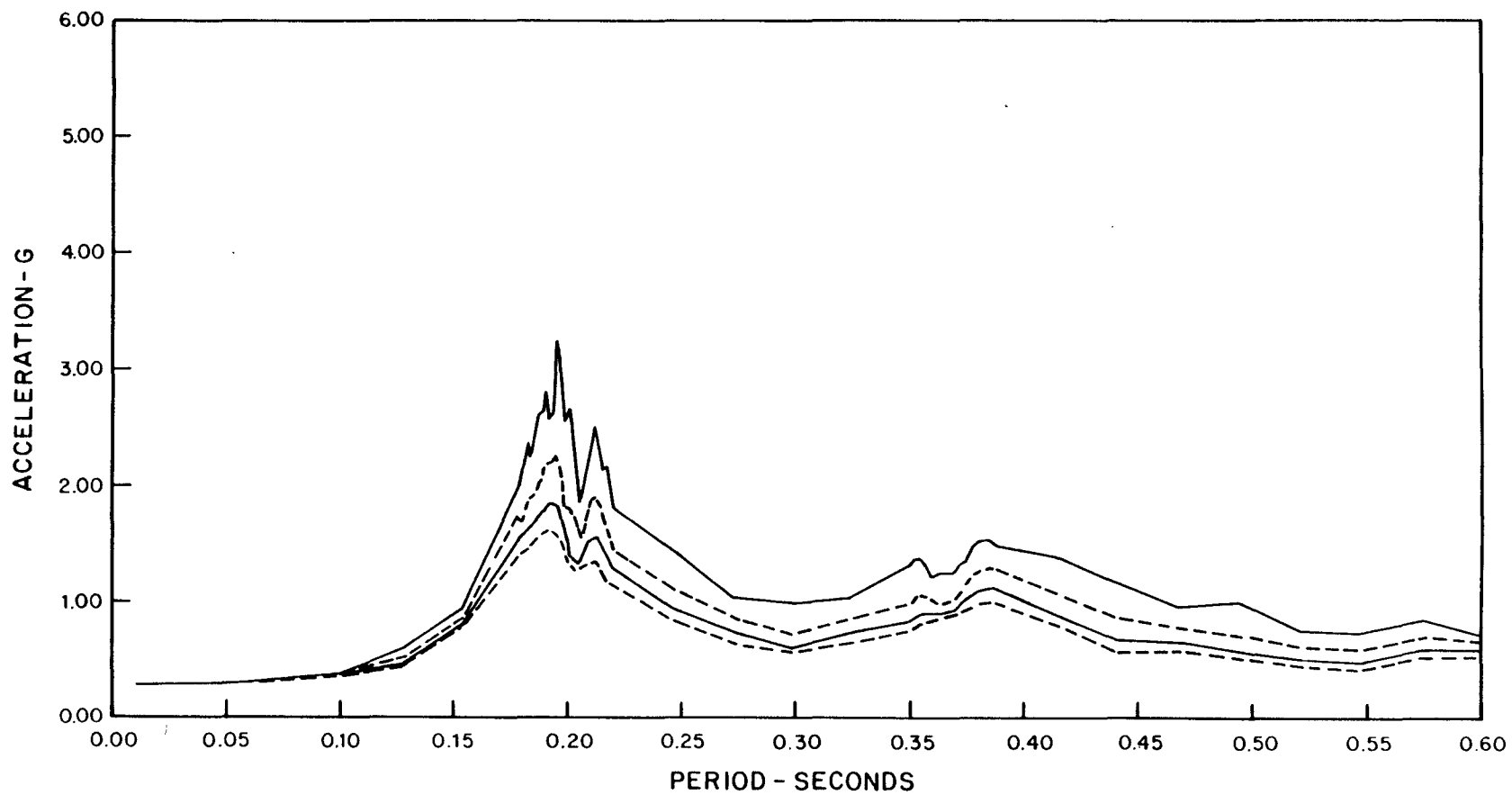

LEGEND

- 0.010 OSCILLATOR DAMPING
- 0.020 OSCILLATOR DAMPING
- 0.030 OSCILLATOR DAMPING
- .-.-.- 0.040 OSCILLATOR DAMPING

NOTE
 FOR EQUIPMENT WITH A NATURAL PERIOD WITHIN +25 OR
 -20 PERCENT OF RESONANCE PERIOD, USE PEAK VALUES.

FIGURE 3.7B-37
AMPLIFIED RESPONSE SPECTRA
BY TIME HISTORY, FUEL BUILDING,
N-S SSE AT EL. 729.50'
BEAVER VALLEY POWER STATION-UNIT 2
FINAL SAFETY ANALYSIS REPORT

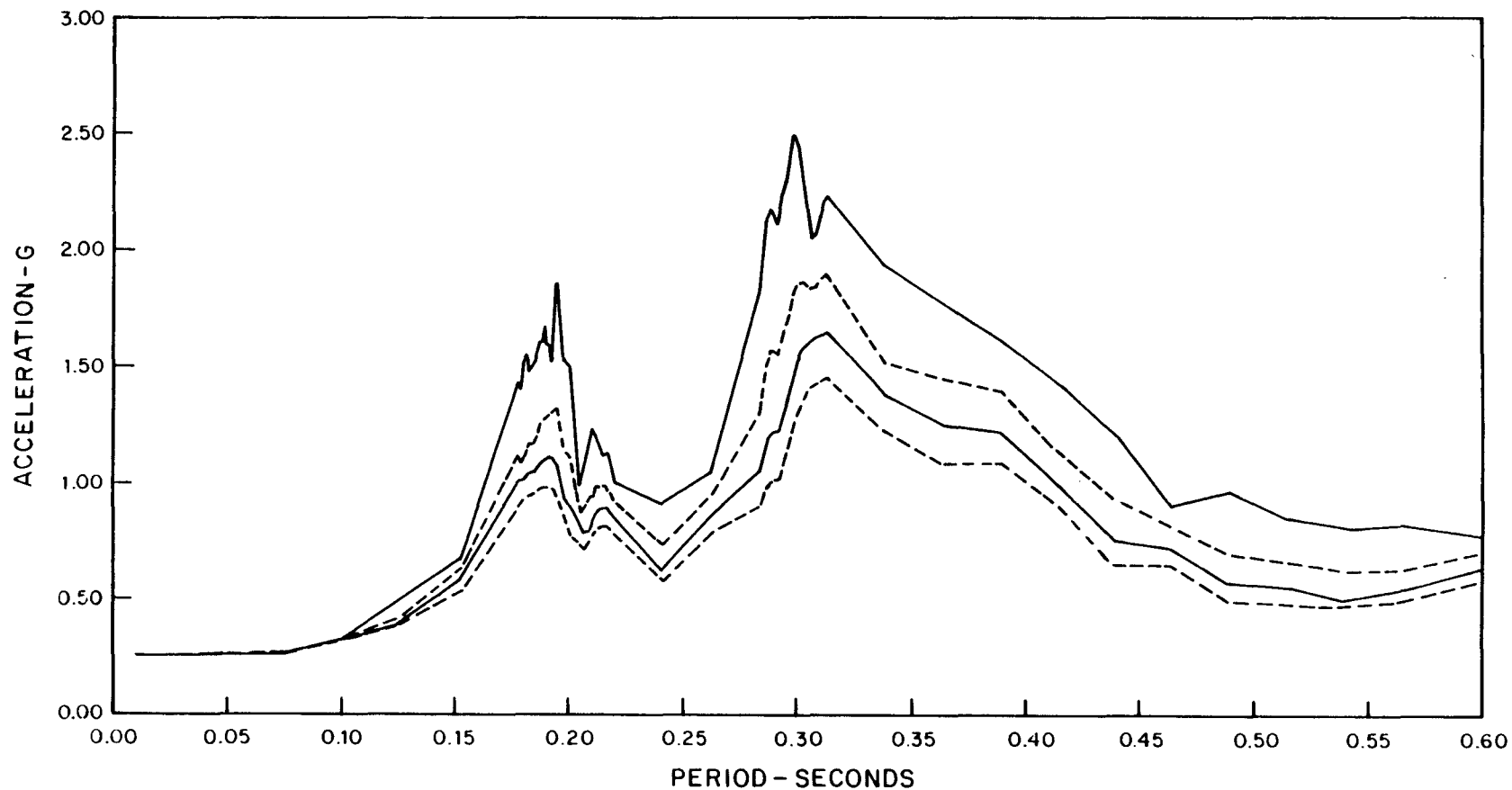

LEGEND

- 0.010 OSCILLATOR DAMPING
- 0.020 OSCILLATOR DAMPING
- 0.030 OSCILLATOR DAMPING
- 0.040 OSCILLATOR DAMPING

NOTE

FOR EQUIPMENT WITH A NATURAL PERIOD WITHIN +25 OR
-20 PERCENT OF RESONANCE PERIOD, USE PEAK VALUES.

FIGURE 3.7B-38
AMPLIFIED RESPONSE SPECTRA
BY TIME HISTORY, FUEL BUILDING,
E-W SSE AT EL. 729.50'
BEAVER VALLEY POWER STATION-UNIT 2
FINAL SAFETY ANALYSIS REPORT

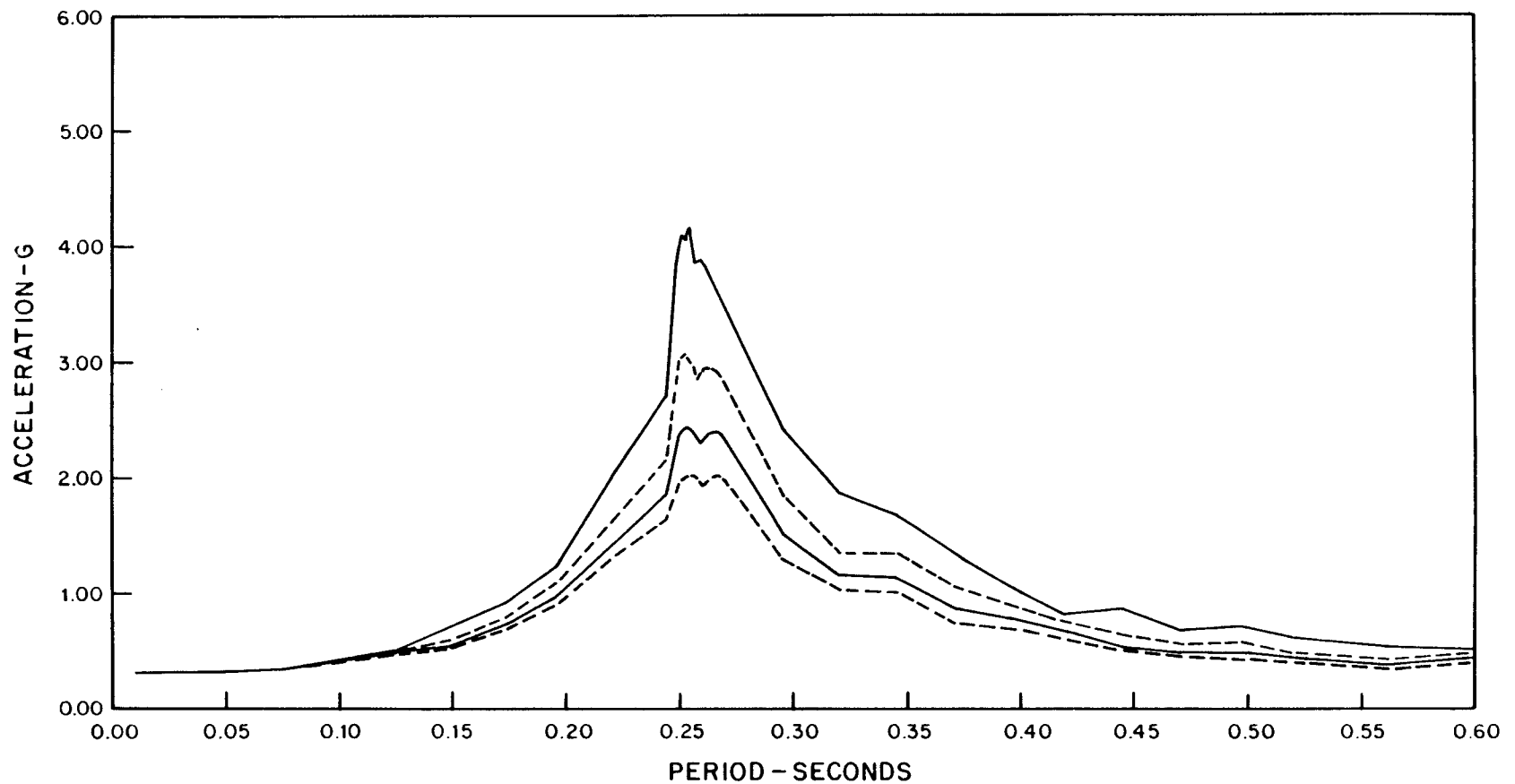

LEGEND

- 0.010 OSCILLATOR DAMPING
- 0.020 OSCILLATOR DAMPING
- 0.030 OSCILLATOR DAMPING
- 0.040 OSCILLATOR DAMPING

NOTE
 FOR EQUIPMENT WITH A NATURAL PERIOD WITHIN +25 OR
 -20 PERCENT OF RESONANCE PERIOD, USE PEAK VALUES.

FIGURE 3.7B- 39
 AMPLIFIED RESPONSE SPECTRA
 BY TIME HISTORY, FUEL BUILDING,
 VERTICAL SSE AT EL. 729.50'
 BEAVER VALLEY POWER STATION-UNIT 2
 FINAL SAFETY ANALYSIS REPORT

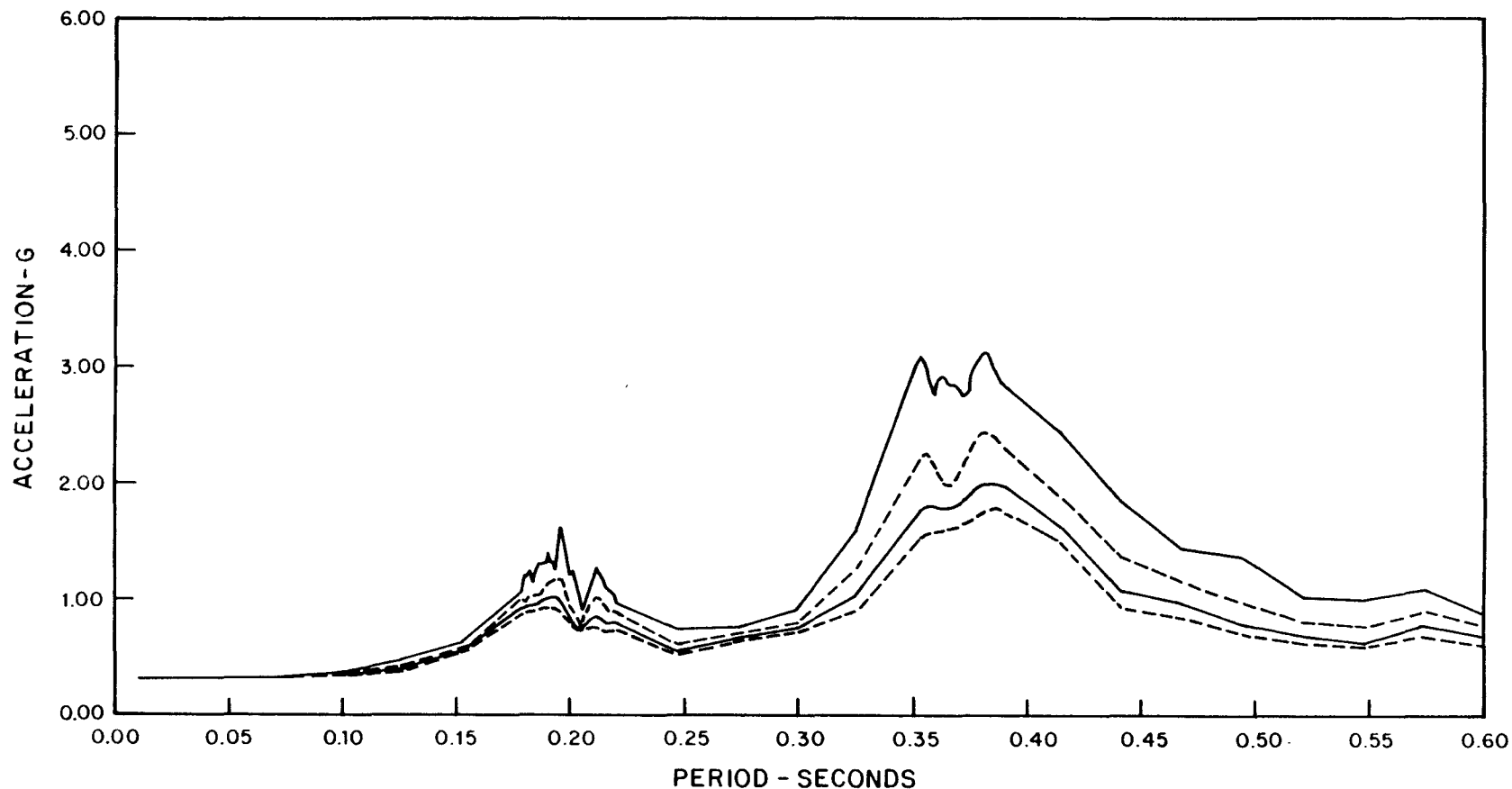

LEGEND

- 0.010 OSCILLATOR DAMPING
- 0.020 OSCILLATOR DAMPING
- 0.030 OSCILLATOR DAMPING
- 0.040 OSCILLATOR DAMPING

NOTE
 FOR EQUIPMENT WITH A NATURAL PERIOD WITHIN +25 OR
 -20 PERCENT OF RESONANCE PERIOD, USE PEAK VALUES.

FIGURE 3.7B-40
AMPLIFIED RESPONSE SPECTRA
BY TIME HISTORY, FUEL BUILDING,
N-S SSE AT EL. 767.33'
BEAVER VALLEY POWER STATION-UNIT 2
FINAL SAFETY ANALYSIS REPORT

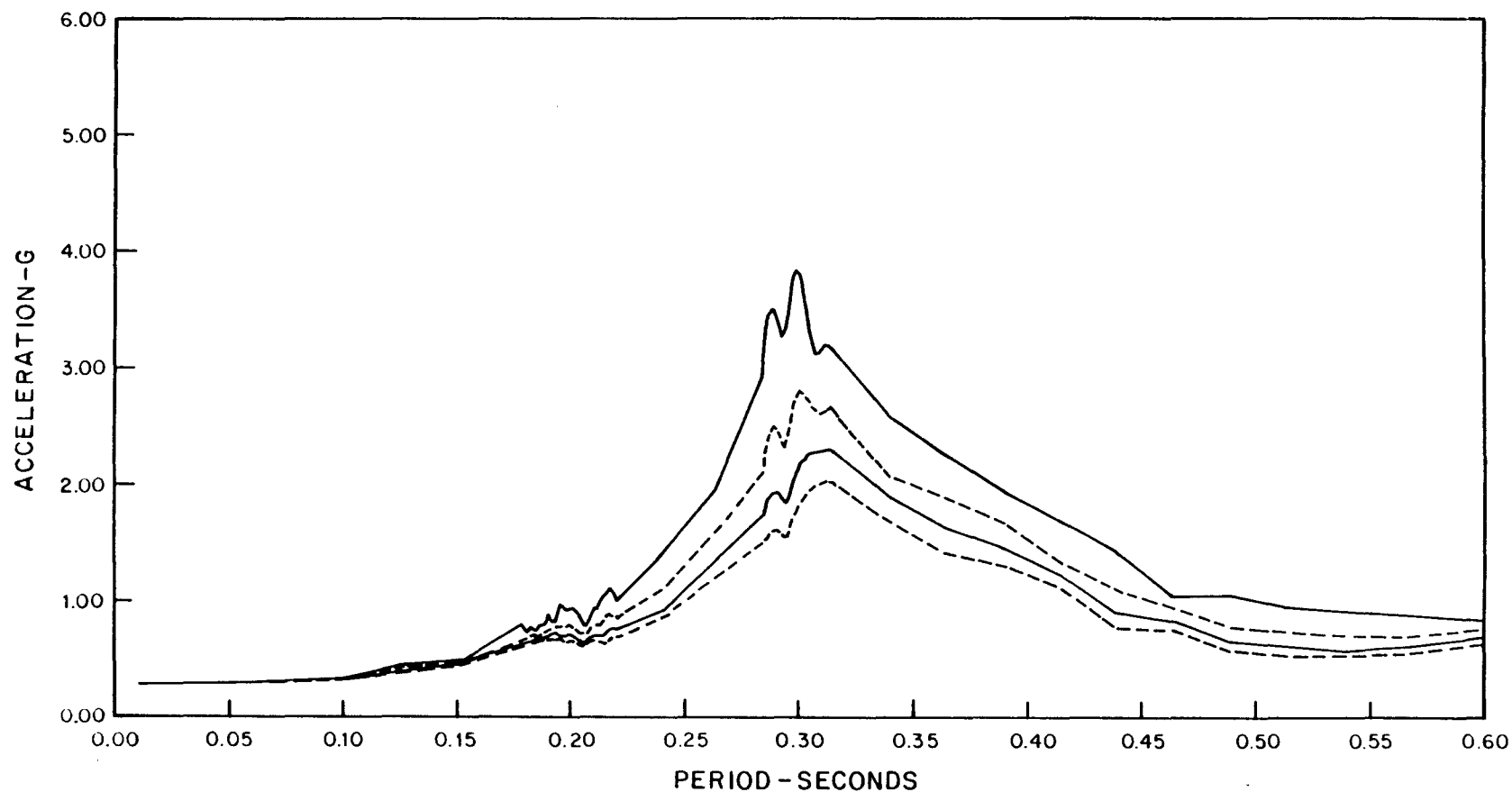

LEGEND

- 0.010 OSCILLATOR DAMPING
- 0.020 OSCILLATOR DAMPING
- 0.030 OSCILLATOR DAMPING
- 0.040 OSCILLATOR DAMPING

NOTE
 FOR EQUIPMENT WITH A NATURAL PERIOD WITHIN +25 OR
 -20 PERCENT OF RESONANCE PERIOD, USE PEAK VALUES.

FIGURE 3.7B-41
 AMPLIFIED RESPONSE SPECTRA
 BY TIME HISTORY, FUEL BUILDING,
 E-W SSE AT EL. 767.33'
 BEAVER VALLEY POWER STATION-UNIT 2
 FINAL SAFETY ANALYSIS REPORT

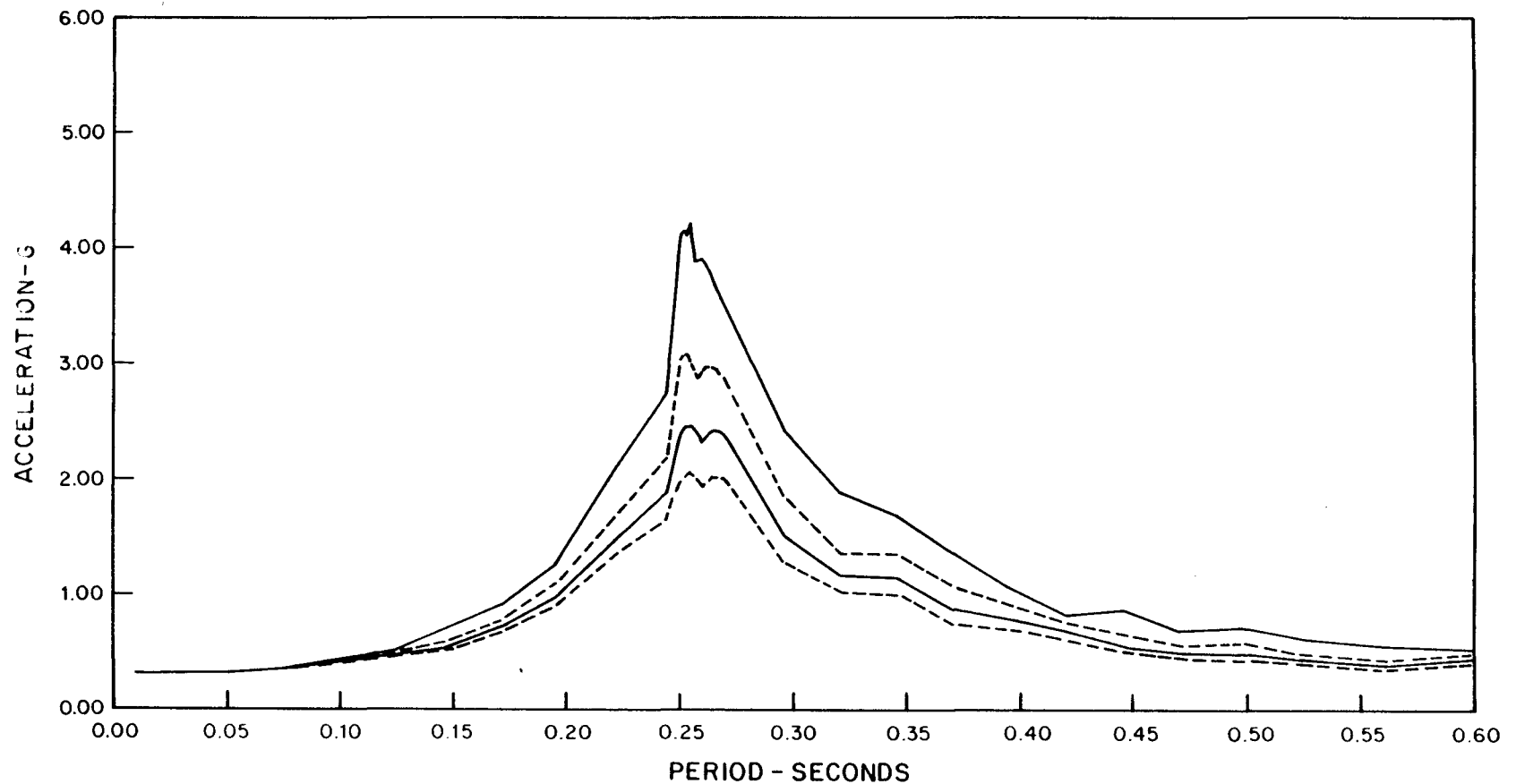

LEGEND

- 0.010 OSCILLATOR DAMPING
- 0.020 OSCILLATOR DAMPING
- 0.030 OSCILLATOR DAMPING
- 0.040 OSCILLATOR DAMPING

NOTE

FOR EQUIPMENT WITH A NATURAL PERIOD WITHIN +25 OR
-20 PERCENT OF RESONANCE PERIOD, USE PEAK VALUES.

FIGURE 3.7B-42
AMPLIFIED RESPONSE SPECTRA
BY TIME HISTORY, FUEL BUILDING,
VERTICAL SSE AT EL. 767.33'
BEAVER VALLEY POWER STATION-UNIT 2
FINAL SAFETY ANALYSIS REPORT

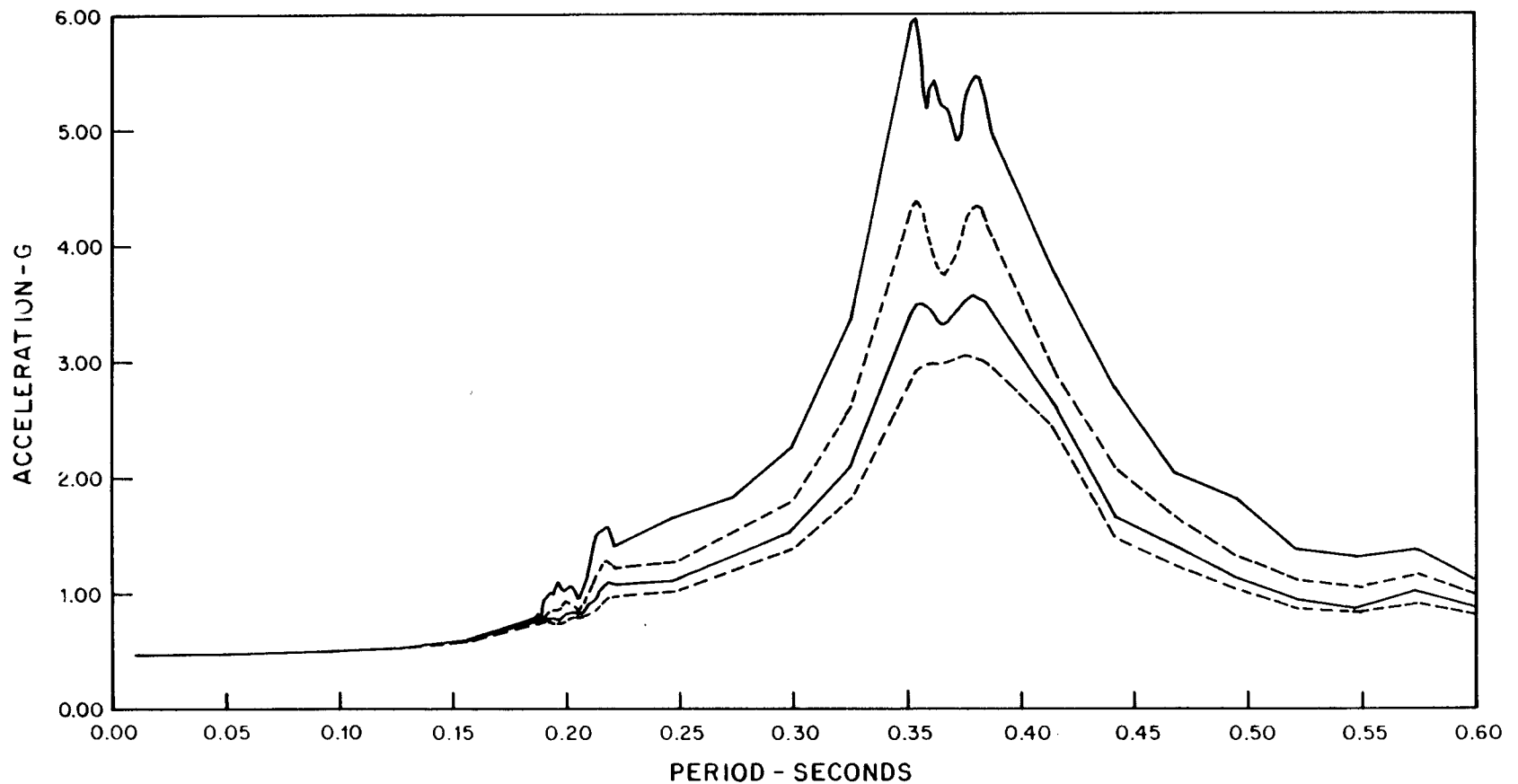

LEGEND

- 0.010 OSCILLATOR DAMPING
- 0.020 OSCILLATOR DAMPING
- 0.030 OSCILLATOR DAMPING
- 0.040 OSCILLATOR DAMPING

NOTE

FOR EQUIPMENT WITH A NATURAL PERIOD WITHIN +25 OR
-20 PERCENT OF RESONANCE PERIOD, USE PEAK VALUES.

FIGURE 3.7B-43
AMPLIFIED RESPONSE SPECTRA
BY TIME HISTORY, FUEL BUILDING
CRANE RAIL STRUCTURE,
N-S SSE AT EL. 798.00'
BEAVER VALLEY POWER STATION-UNIT 2
FINAL SAFETY ANALYSIS REPORT

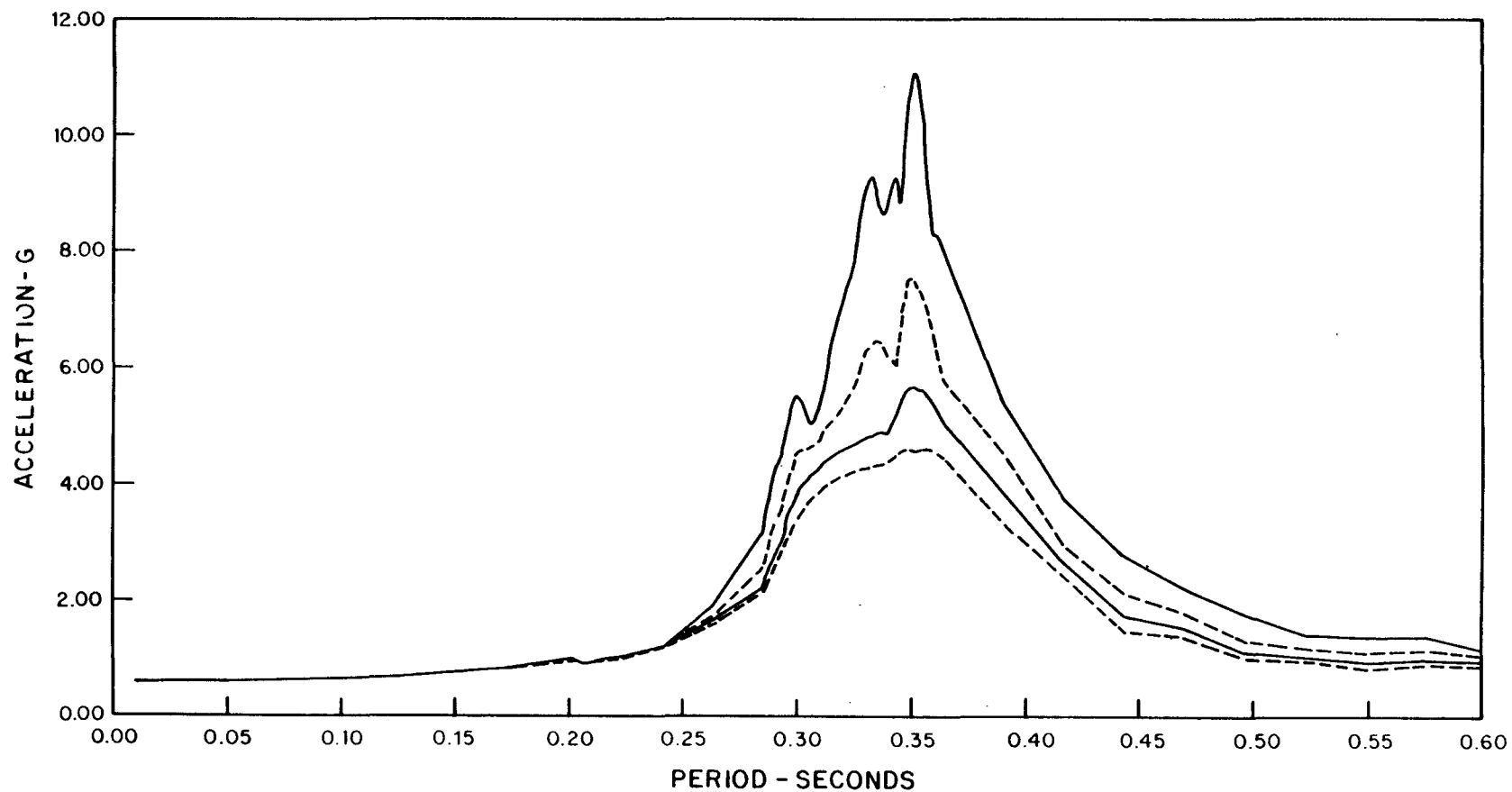

LEGEND

- 0.010 OSCILLATOR DAMPING
- 0.020 OSCILLATOR DAMPING
- 0.030 OSCILLATOR DAMPING
- 0.040 OSCILLATOR DAMPING

NOTE

FOR EQUIPMENT WITH A NATURAL PERIOD WITHIN +25 OR
-20 PERCENT OF RESONANCE PERIOD, USE PEAK VALUES.

FIGURE 3.7B-44

**AMPLIFIED RESPONSE SPECTRA
BY TIME HISTORY, FUEL BUILDING
CRANE RAIL STRUCTURE,
E-W SSE AT EL. 798.00'
BEAVER VALLEY POWER STATION-UNIT 2
FINAL SAFETY ANALYSIS REPORT**

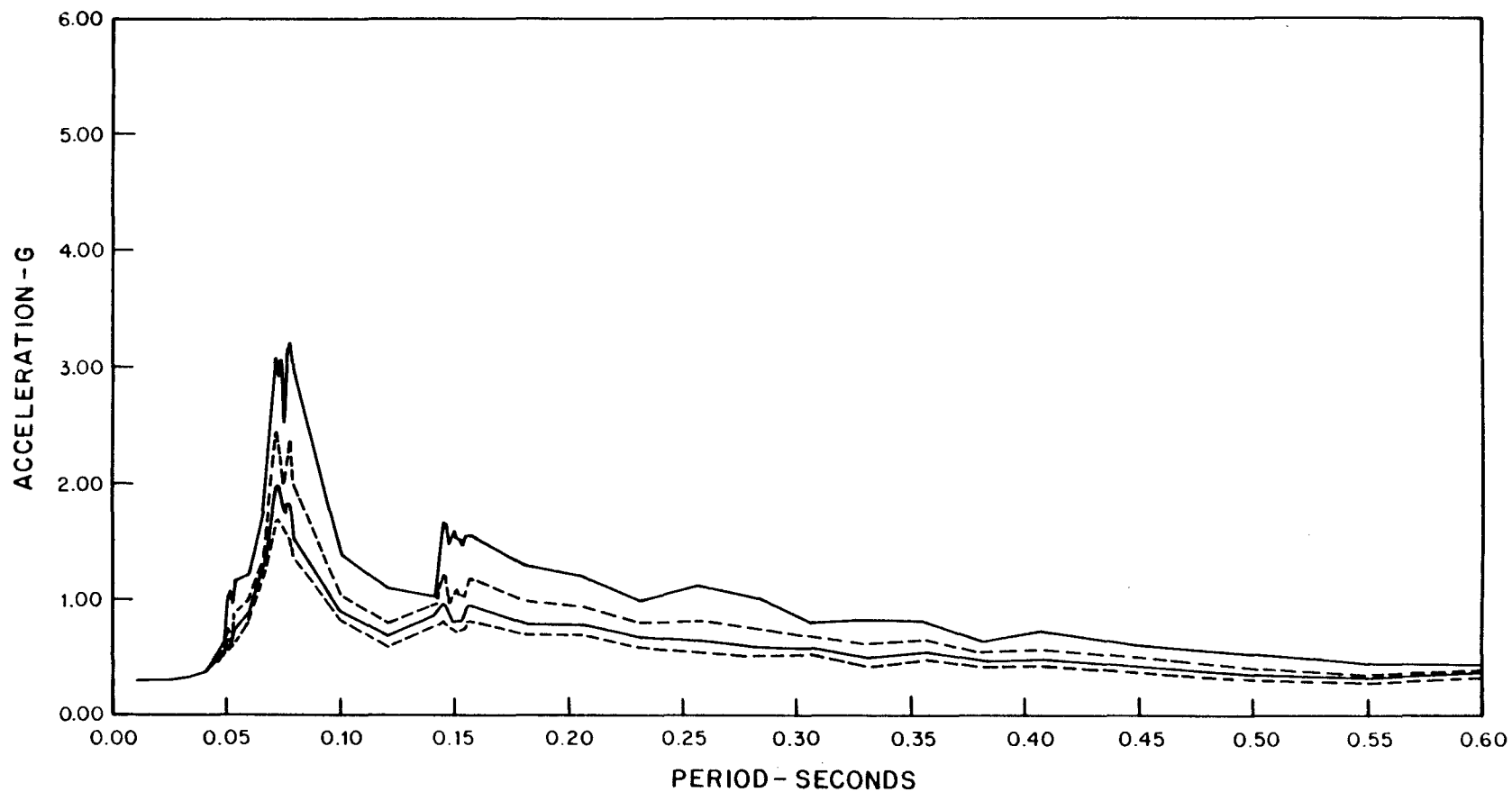

LEGEND

- 0.010 OSCILLATOR DAMPING
- 0.020 OSCILLATOR DAMPING
- 0.030 OSCILLATOR DAMPING
- 0.040 OSCILLATOR DAMPING

NOTE

FOR EQUIPMENT WITH A NATURAL PERIOD WITHIN +25 OR
-20 PERCENT OF RESONANCE PERIOD, USE PEAK VALUES.

FIGURE 3.7B-45
AMPLIFIED RESPONSE SPECTRA
BY TIME HISTORY, FUEL BUILDING
CRANE RAIL STRUCTURE,
VERTICAL SSE AT EL. 798.00'
BEAVER VALLEY POWER STATION-UNIT 2
FINAL SAFETY ANALYSIS REPORT

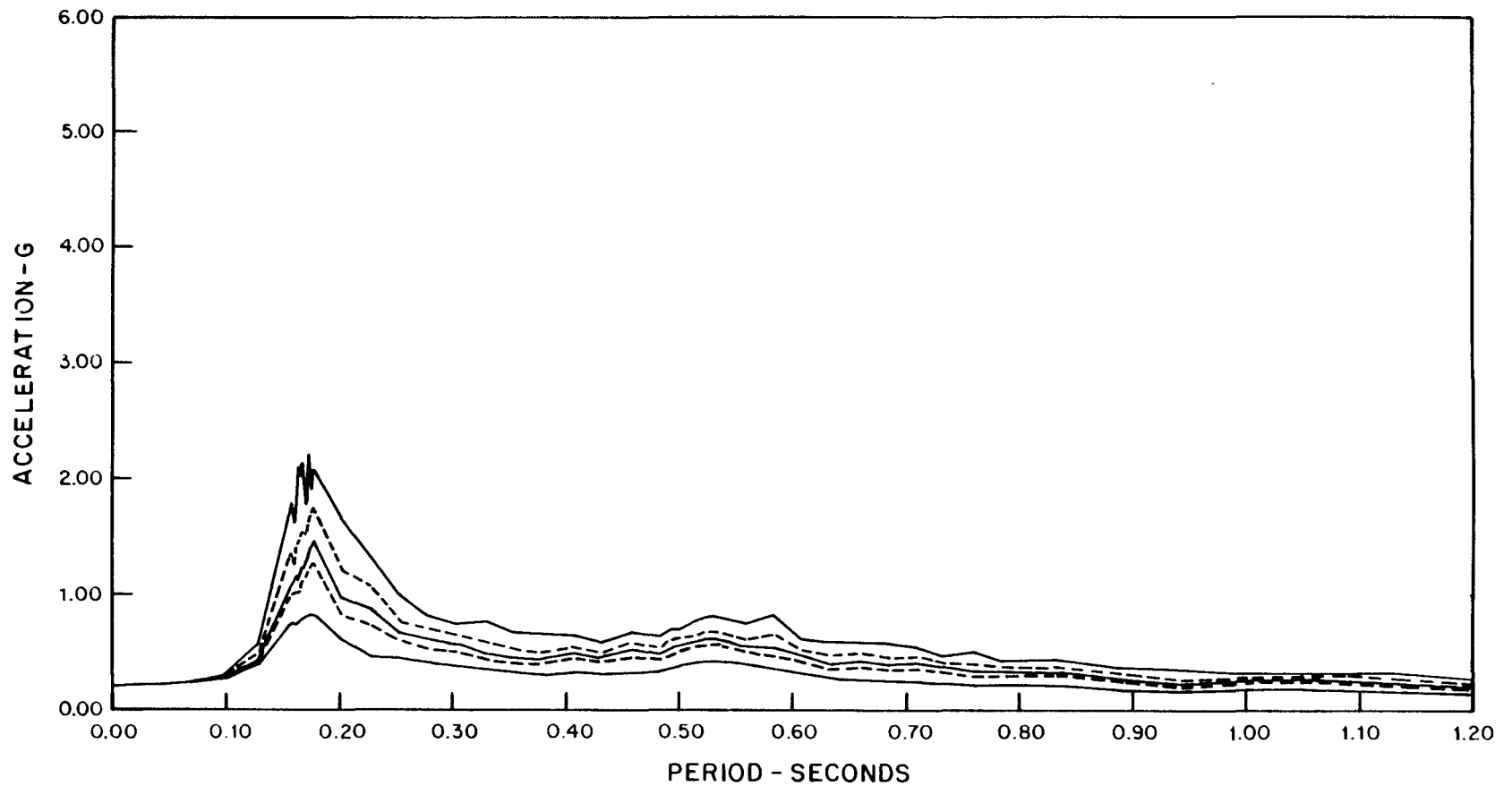

LEGEND

- 0.010 OSCILLATOR DAMPING
- 0.020 OSCILLATOR DAMPING
- 0.030 OSCILLATOR DAMPING
- 0.040 OSCILLATOR DAMPING
- 0.080 OSCILLATOR DAMPING

NOTE
 FOR EQUIPMENT WITH A NATURAL PERIOD WITHIN
 ± 25 PERCENT OF RESONANCE, USE PEAK VALUES.

FIGURE 3.7B-46
AMPLIFIED RESPONSE SPECTRA
BY TIME HISTORY, CABLE VAULT
BUILDING, N-S EXCITATION SSE
AT EL. 718.5'
BEAVER VALLEY POWER STATION-UNIT 2
FINAL SAFETY ANALYSIS REPORT

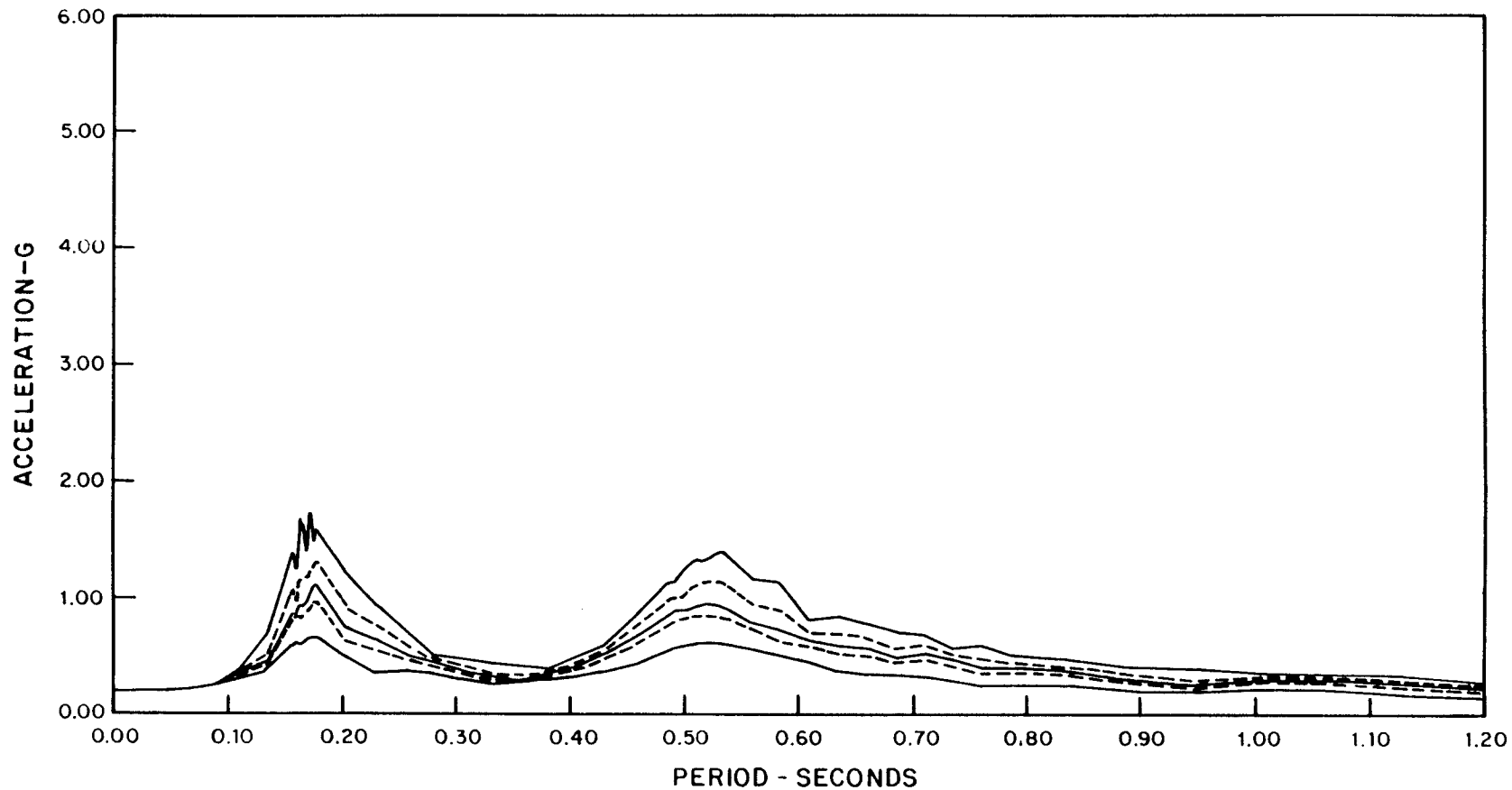

LEGEND

- 0.010 OSCILLATOR DAMPING
- 0.020 OSCILLATOR DAMPING
- 0.030 OSCILLATOR DAMPING
- 0.040 OSCILLATOR DAMPING
- 0.080 OSCILLATOR DAMPING

NOTE

FOR EQUIPMENT WITH A NATURAL PERIOD WITHIN
 ± 25 PERCENT OF RESONANCE, USE PEAK VALUES.

FIGURE 3.7B-47

**AMPLIFIED RESPONSE SPECTRA
 BY TIME HISTORY, CABLE VAULT
 BUILDING, N-S EXCITATION SSE
 AT EL. 735.5'**

**BEAVER VALLEY POWER STATION-UNIT 2
 FINAL SAFETY ANALYSIS REPORT**

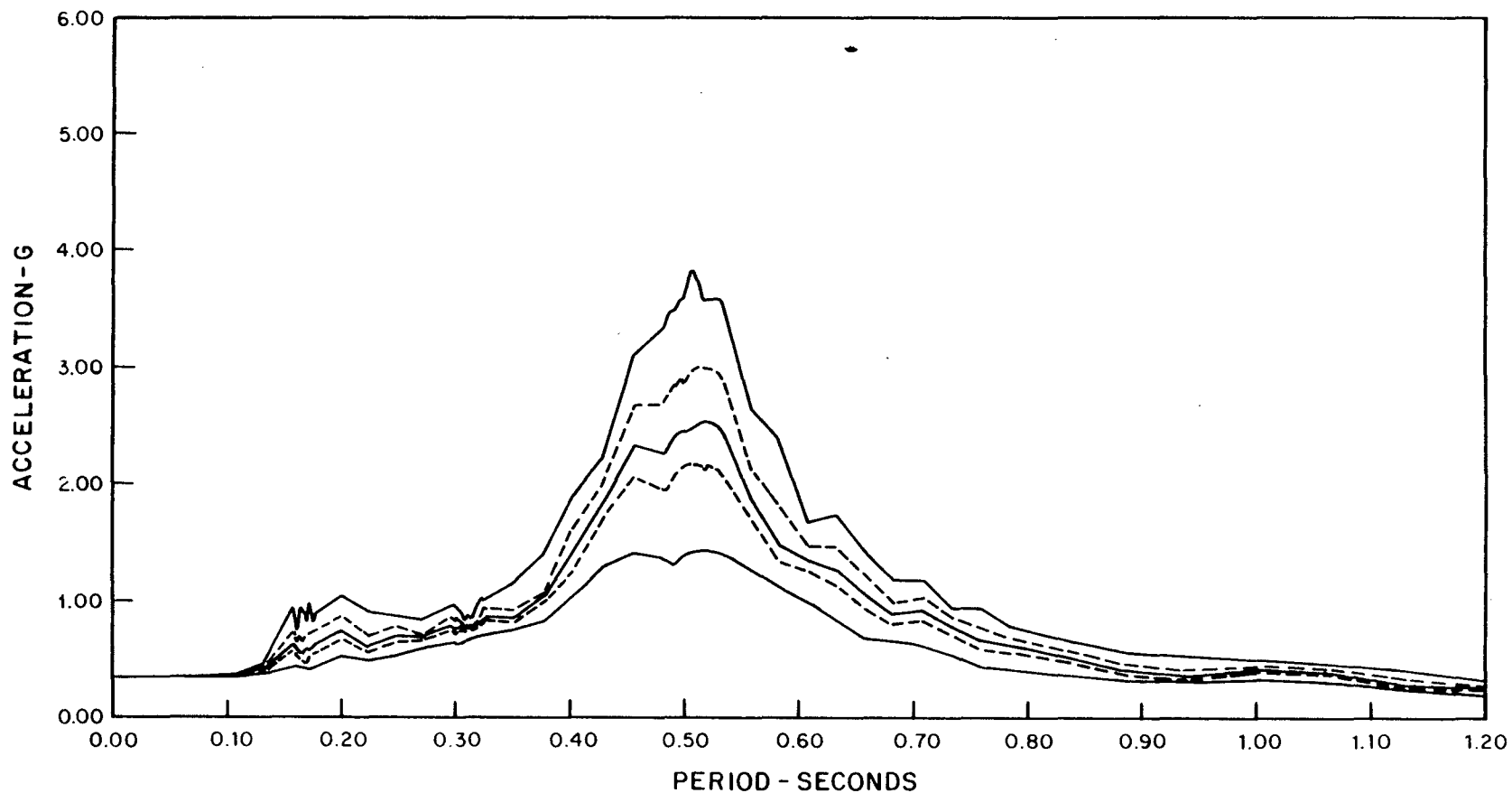

LEGEND

- 0.010 OSCILLATOR DAMPING
- 0.020 OSCILLATOR DAMPING
- 0.030 OSCILLATOR DAMPING
- 0.040 OSCILLATOR DAMPING
- 0.080 OSCILLATOR DAMPING

NOTE

FOR EQUIPMENT WITH A NATURAL PERIOD WITHIN
 ± 25 PERCENT OF RESONANCE, USE PEAK VALUES.

FIGURE 3.7B-48
AMPLIFIED RESPONSE SPECTRA
BY TIME HISTORY, CABLE VAULT
BUILDING, N-S EXCITATION SSE
AT EL. 805.04'
BEAVER VALLEY POWER STATION-UNIT 2
FINAL SAFETY ANALYSIS REPORT

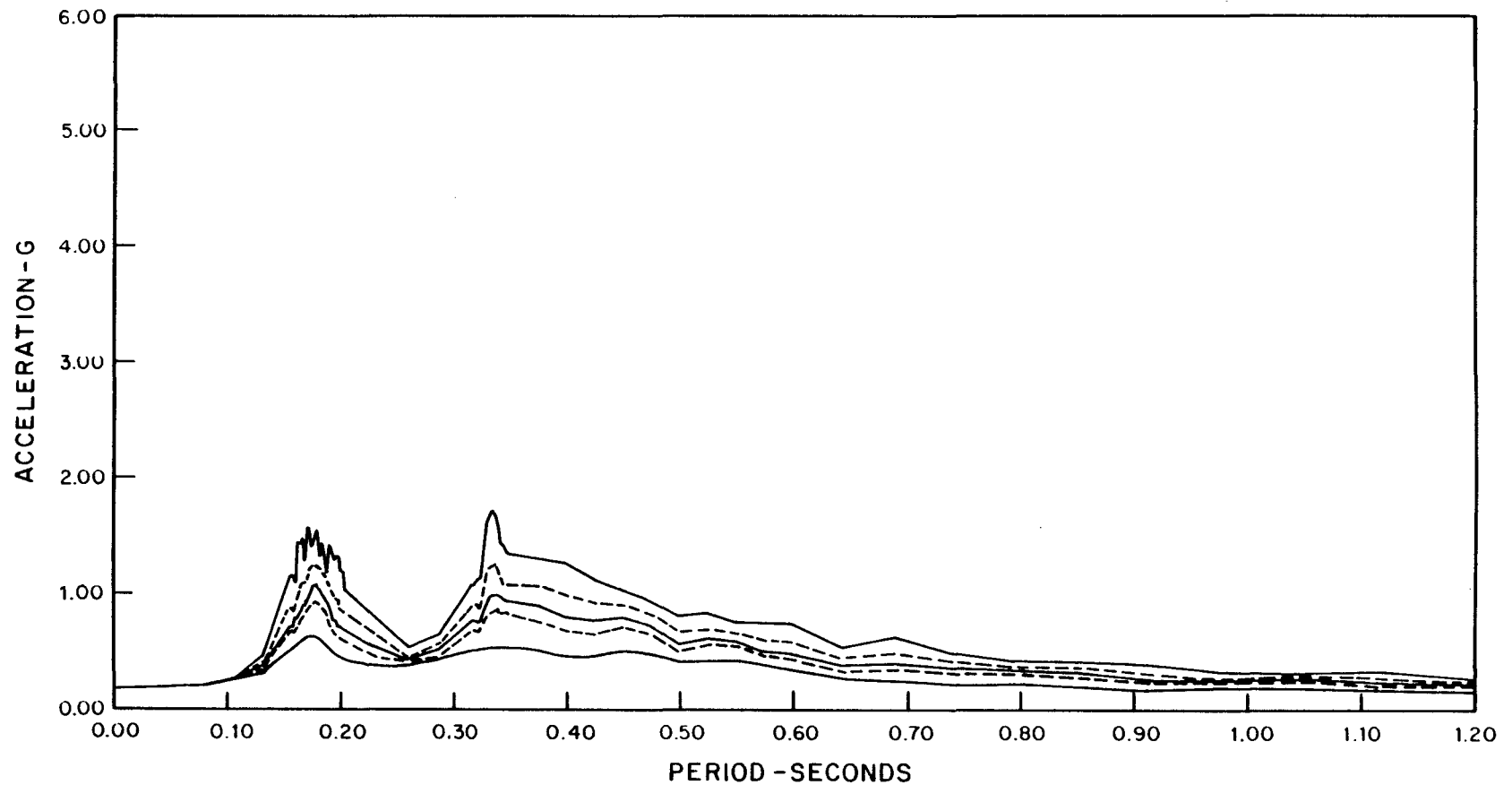

LEGEND

- 0.010 OSCILLATOR DAMPING
- 0.020 OSCILLATOR DAMPING
- 0.030 OSCILLATOR DAMPING
- 0.040 OSCILLATOR DAMPING
- 0.080 OSCILLATOR DAMPING

NOTE
 FOR EQUIPMENT WITH A NATURAL PERIOD WITHIN
 ± 25 PERCENT OF RESONANCE, USE PEAK VALUES.

FIGURE 3.7B-49
 AMPLIFIED RESPONSE SPECTRA
 BY TIME HISTORY, CABLE VAULT
 BUILDING, E-W EXCITATION SSE
 AT EL. 718.5'
 BEAVER VALLEY POWER STATION-UNIT 2
 FINAL SAFETY ANALYSIS REPORT

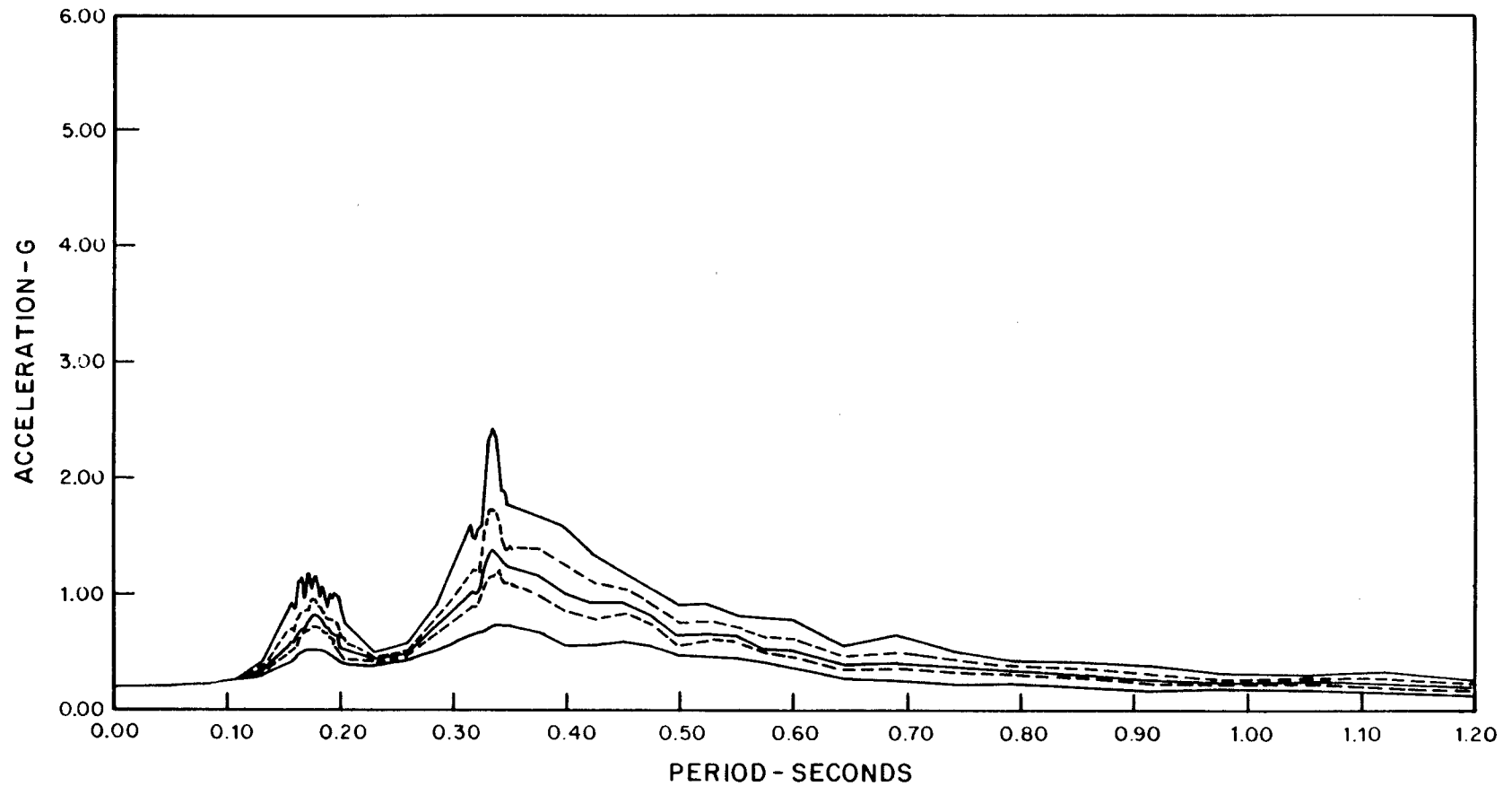

LEGEND

- 0.010 OSCILLATOR DAMPING
- 0.020 OSCILLATOR DAMPING
- 0.030 OSCILLATOR DAMPING
- 0.040 OSCILLATOR DAMPING
- 0.080 OSCILLATOR DAMPING

NOTE

FOR EQUIPMENT WITH A NATURAL PERIOD WITHIN
 ± 25 PERCENT OF RESONANCE, USE PEAK VALUES.

FIGURE 3.7B-50

**AMPLIFIED RESPONSE SPECTRA
 BY TIME HISTORY, CABLE VAULT
 BUILDING, E-W EXCITATION SSE
 AT EL. 735.50'**

**BEAVER VALLEY POWER STATION-UNIT 2
 FINAL SAFETY ANALYSIS REPORT**

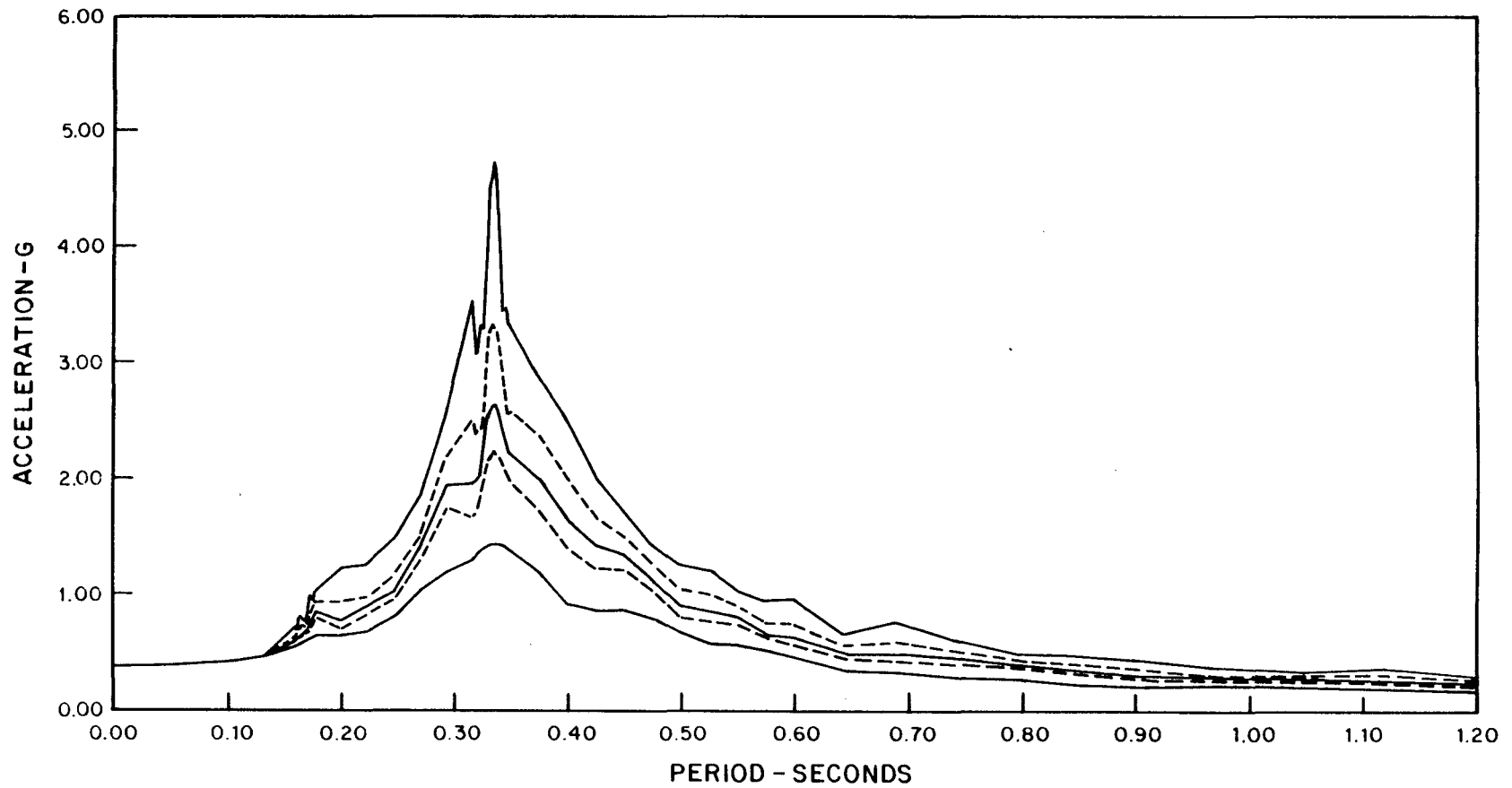

LEGEND

- 0.010 OSCILLATOR DAMPING
- 0.020 OSCILLATOR DAMPING
- 0.030 OSCILLATOR DAMPING
- 0.040 OSCILLATOR DAMPING
- 0.080 OSCILLATOR DAMPING

NOTE
 FOR EQUIPMENT WITH A NATURAL PERIOD WITHIN
 ± 25 PERCENT OF RESONANCE, USE PEAK VALUES.

FIGURE 3.7B-51
AMPLIFIED RESPONSE SPECTRA
BY TIME HISTORY, CABLE VAULT
BUILDING, E-W EXCITATION SSE
AT EL. 805.04'
BEAVER VALLEY POWER STATION-UNIT 2
FINAL SAFETY ANALYSIS REPORT

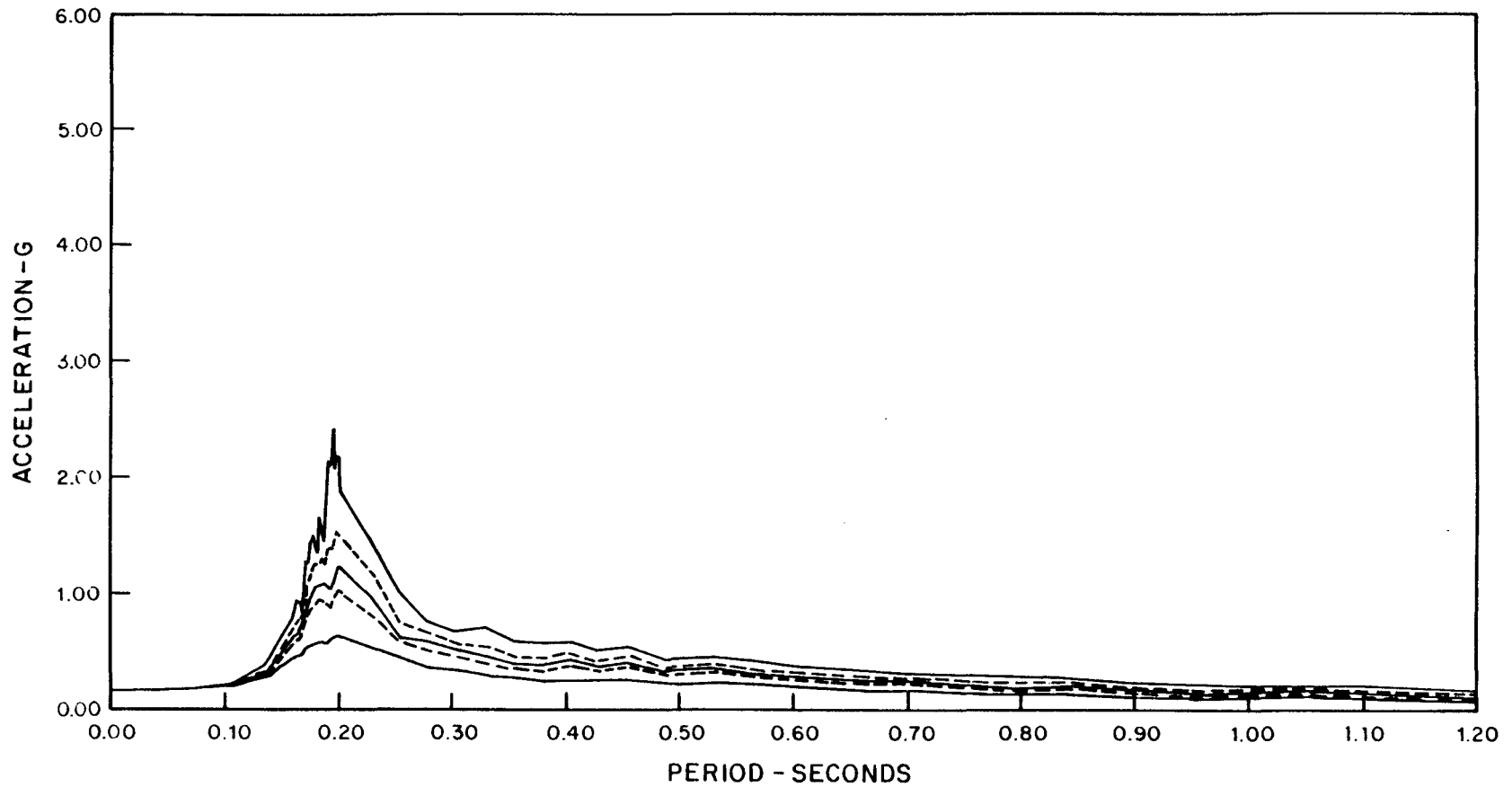

LEGEND

- 0.010 OSCILLATOR DAMPING
- 0.020 OSCILLATOR DAMPING
- 0.030 OSCILLATOR DAMPING
- 0.040 OSCILLATOR DAMPING
- 0.080 OSCILLATOR DAMPING

NOTE
 FOR EQUIPMENT WITH A NATURAL PERIOD WITHIN
 ± 25 PERCENT OF RESONANCE, USE PEAK VALUES.

FIGURE 3.7B-52
 AMPLIFIED RESPONSE SPECTRA
 BY TIME HISTORY, CABLE VAULT
 BUILDING, VERTICAL EXCITATION
 SSE AT EL. 718.50'
 BEAVER VALLEY POWER STATION-UNIT 2
 FINAL SAFETY ANALYSIS REPORT

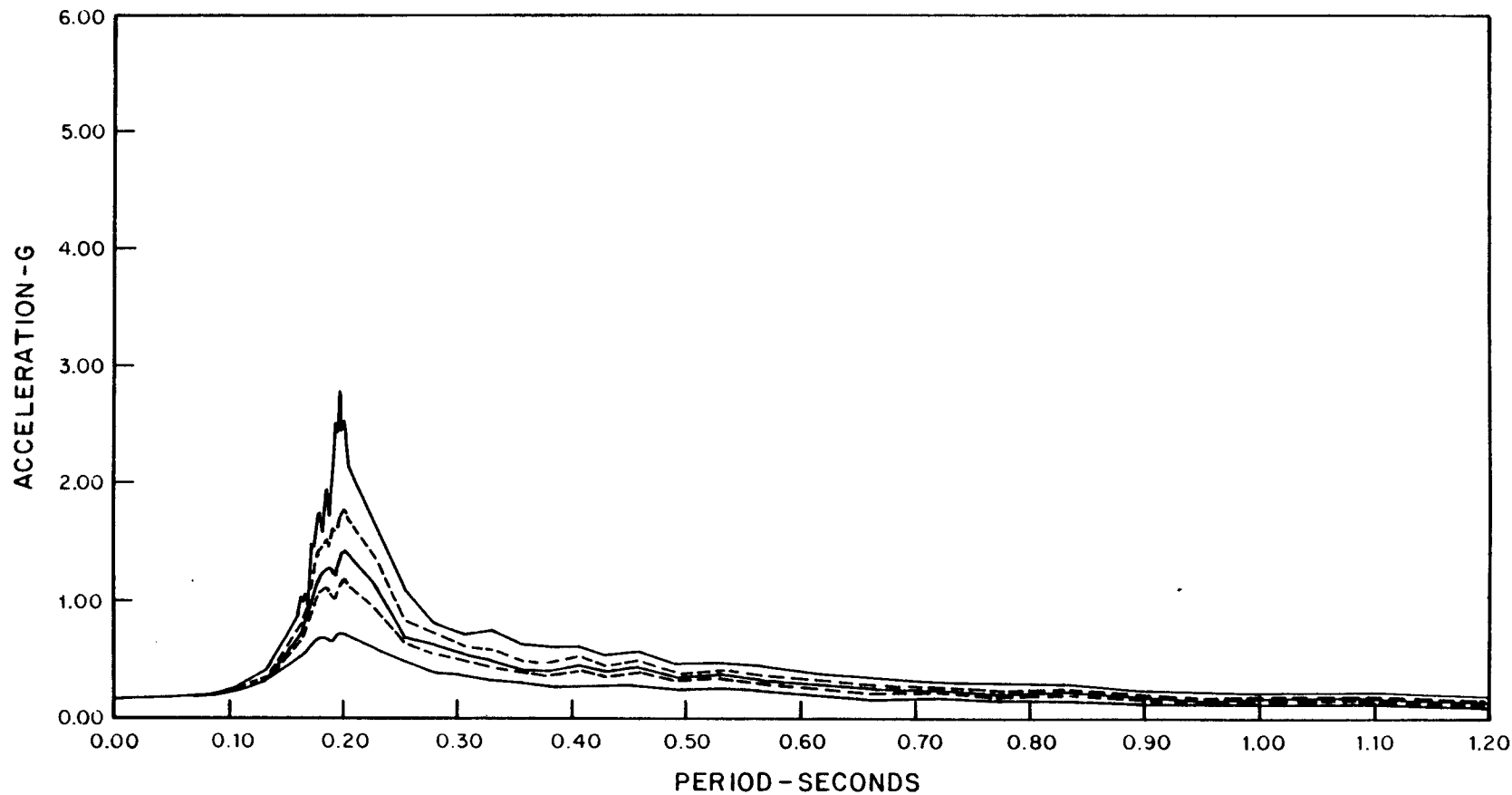

LEGEND

- 0.010 OSCILLATOR DAMPING
- 0.020 OSCILLATOR DAMPING
- 0.030 OSCILLATOR DAMPING
- 0.040 OSCILLATOR DAMPING
- 0.080 OSCILLATOR DAMPING

NOTE
 FOR EQUIPMENT WITH A NATURAL PERIOD WITHIN
 ± 25 PERCENT OF RESONANCE, USE PEAK VALUES.

FIGURE 3.7B-53
AMPLIFIED RESPONSE SPECTRA
BY TIME HISTORY, CABLE VAULT
BUILDING, VERTICAL EXCITATION
SSE AT EL. 805.04'
BEAVER VALLEY POWER STATION-UNIT 2
FINAL SAFETY ANALYSIS REPORT

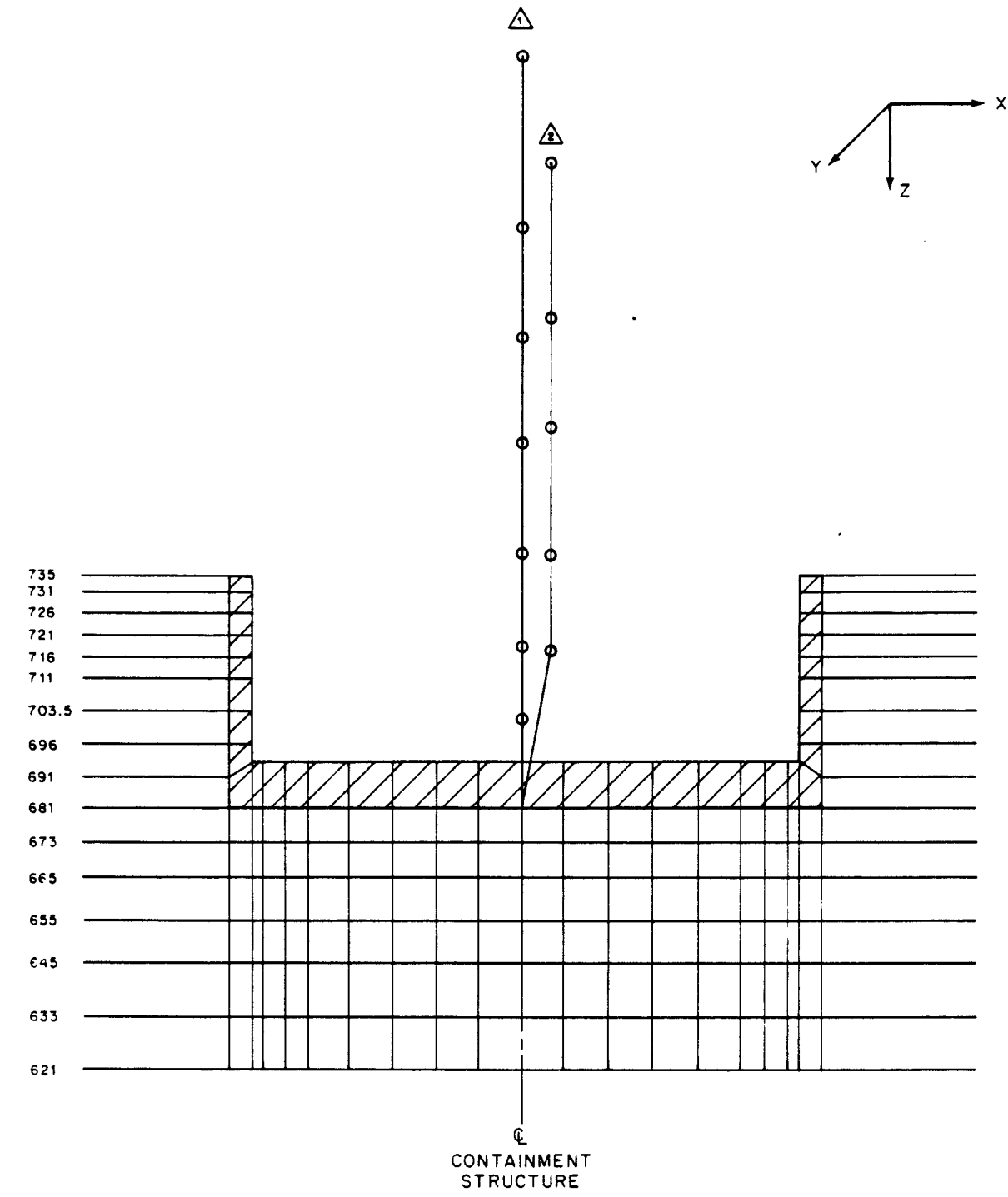

LEGEND

 CONTAINMENT STRUCTURE

FIGURE 3.7B-54
CONTAINMENT-FINITE ELEMENT MODE
BEAVER VALLEY POWER STATION-UNIT 2
FINAL SAFETY ANALYSIS REPORT

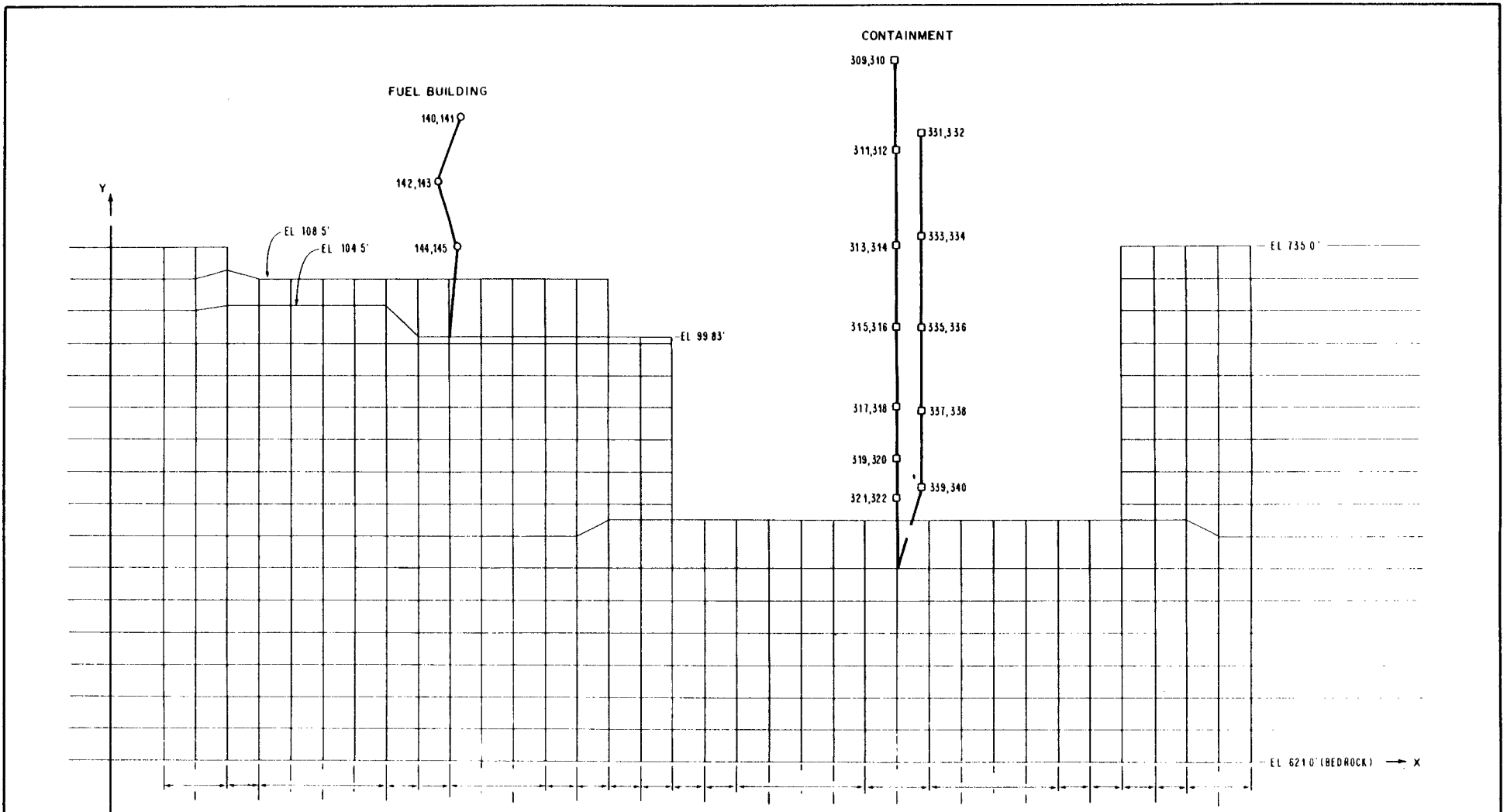
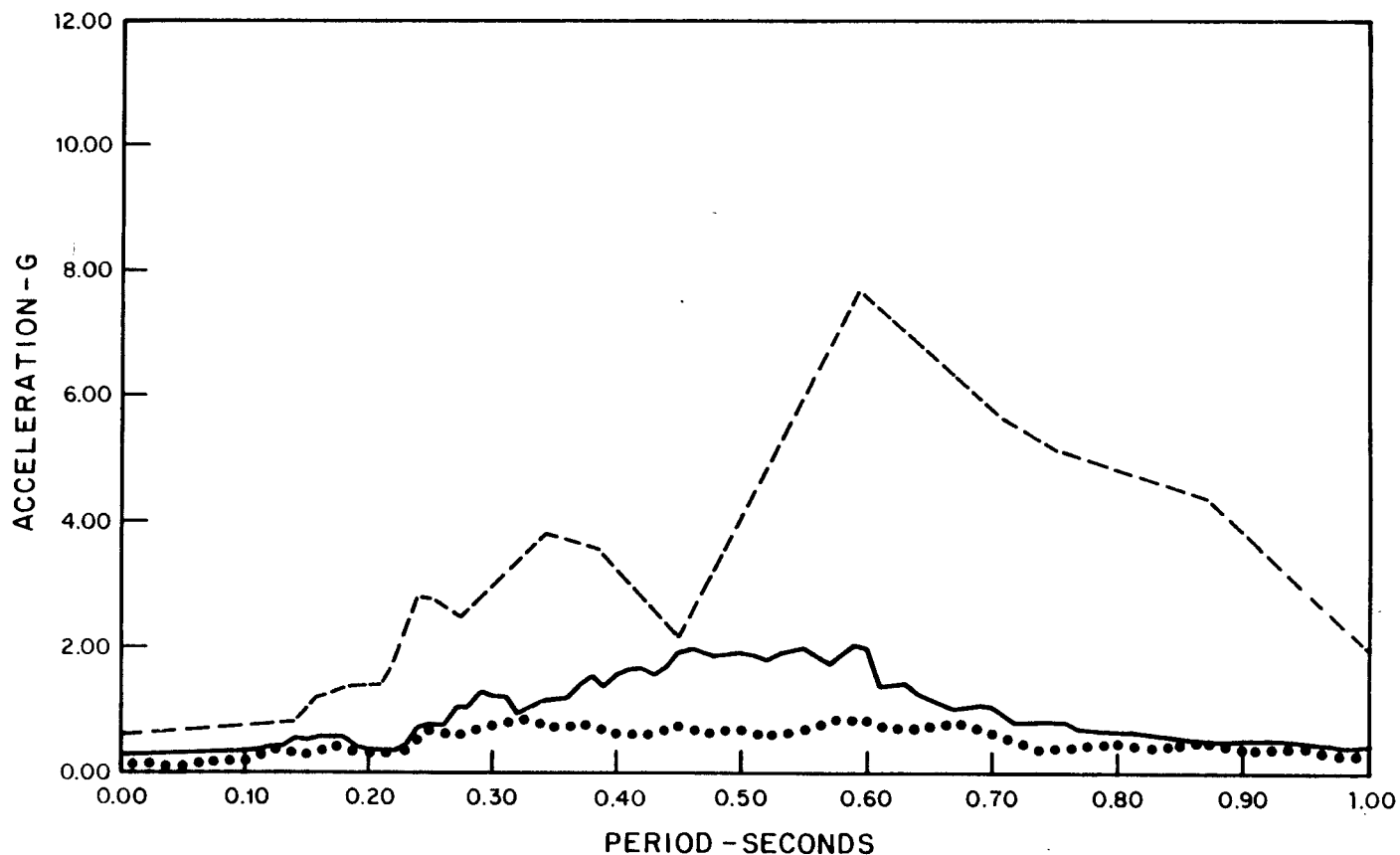

FIGURE 3.7B-55
 CONTAINMENT-FUEL BUILDING
 STRUCTURE, INTERACTION MODEL
 BEAVER VALLEY POWER STATION-UNIT 2
 FINAL SAFETY ANALYSIS REPORT



NOTE
 BASED ON THE ENVELOPE OF CRACKED
 AND UNCRACKED PROPERTIES OF CONCRETE.

LEGEND

- 0.010 OSCILLATOR DAMPING PLAXLY (FINITE ELEMENT)
- 0.010 OSCILLATOR DAMPING STRUDL/TIME HISTORY (LUMPED MASS-SPRING)
- 0.010 OSCILLATOR DAMPING FLUSH (FINITE ELEMENT)

FIGURE 3.7B-56
 A.R.S. COMPARISON-FINITE ELEMENT
 VS. LUMPED MASS-SPRING
 CONTAINMENT EXTERNAL STRUCTURE
 EL. 854.0', HORIZONTAL, SSE
 BEAVER VALLEY POWER STATION-UNIT 2
 FINAL SAFETY ANALYSIS REPORT

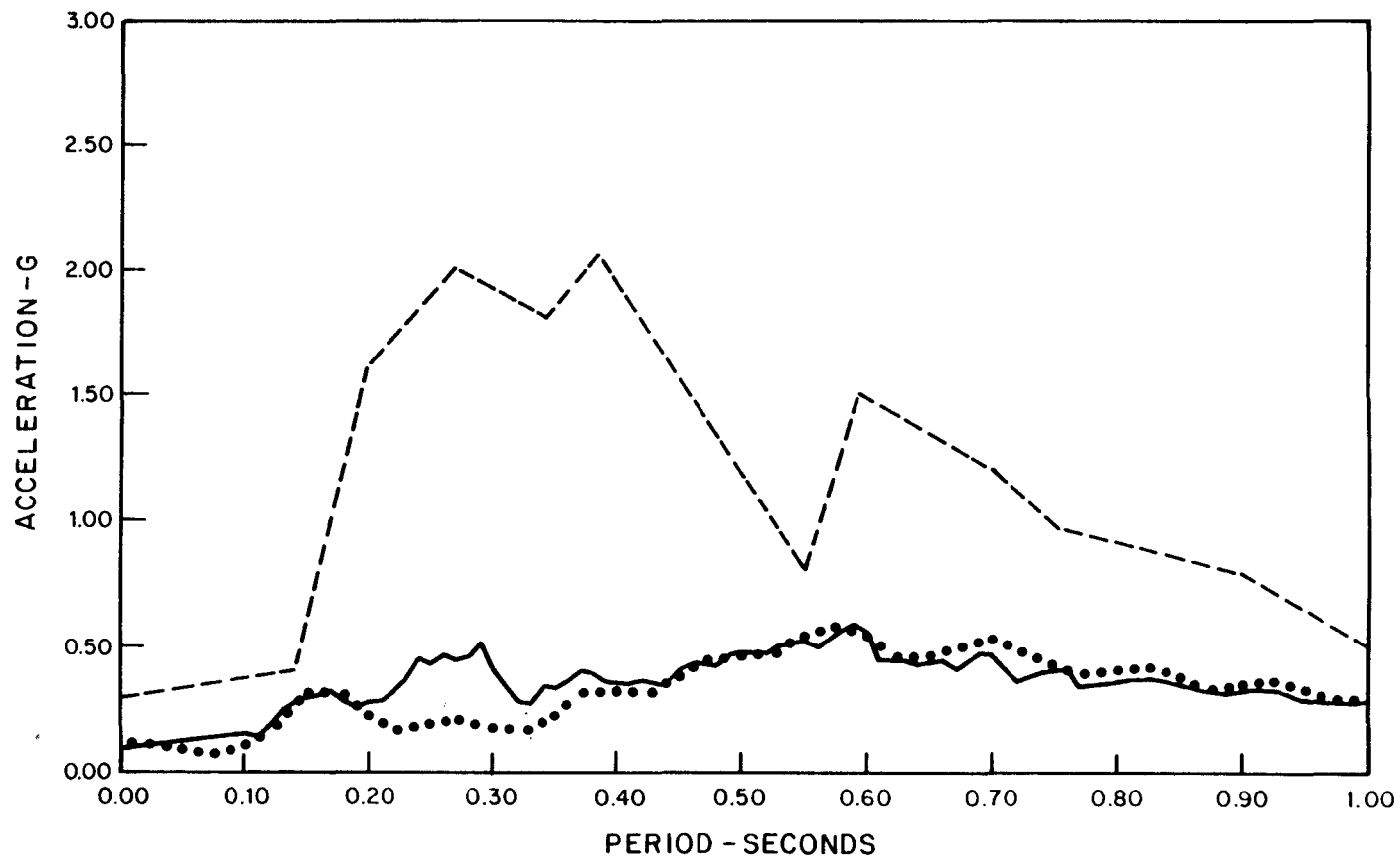

NOTE
 BASED ON THE ENVELOPE OF CRACKED
 AND UNCRACKED PROPERTIES OF CONCRETE.

LEGEND

- 0.010 OSCILLATOR DAMPING PLAXLY (FINITE ELEMENT)
- - - - - 0.010 OSCILLATOR DAMPING STRUDL/TIME HISTORY (LUMPED MASS-SPRING)
- 0.010 OSCILLATOR DAMPING FLUSH (FINITE ELEMENT)

FIGURE 3.7B-57
 A.R.S. COMPARISON-FINITE ELEMENT
 VS. LUMPED MASS-SPRING
 CONTAINMENT MAT EL. 681.0'
 TO 691.0', HORIZONTAL, SSE
 BEAVER VALLEY POWER STATION-UNIT 2
 FINAL SAFETY ANALYSIS REPORT

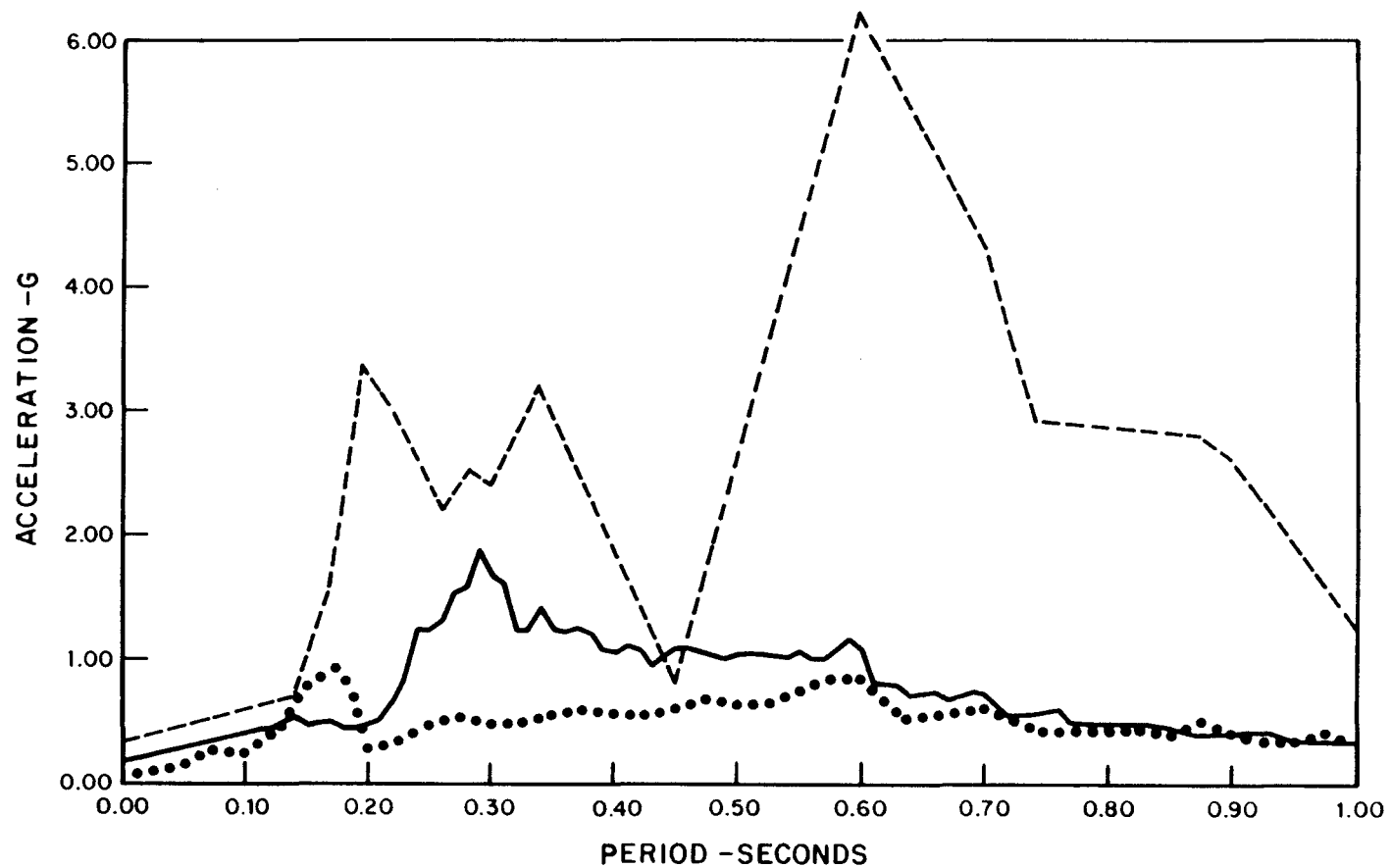

NOTE
 BASED ON THE ENVELOPE OF CRACKED
 AND UNCRACKED PROPERTIES OF CONCRETE.

LEGEND

- 0.010 OSCILLATOR DAMPING PLAXLY (FINITE ELEMENT)
- 0.010 OSCILLATOR DAMPING STRUDL/TIME HISTORY (LUMPED MASS-SPRING)
- 0.010 OSCILLATOR DAMPING FLUSH (FINITE ELEMENT)

FIGURE 3.7B-58
 A.R.S. COMPARISON-FINITE ELEMENT
 VS. LUMPED MASS-SPRING
 CONTAINMENT INTERNAL STRUCTURE
 EL. 818.0', HORIZONTAL, SSE
 BEAVER VALLEY POWER STATION-UNIT 2
 FINAL SAFETY ANALYSIS REPORT

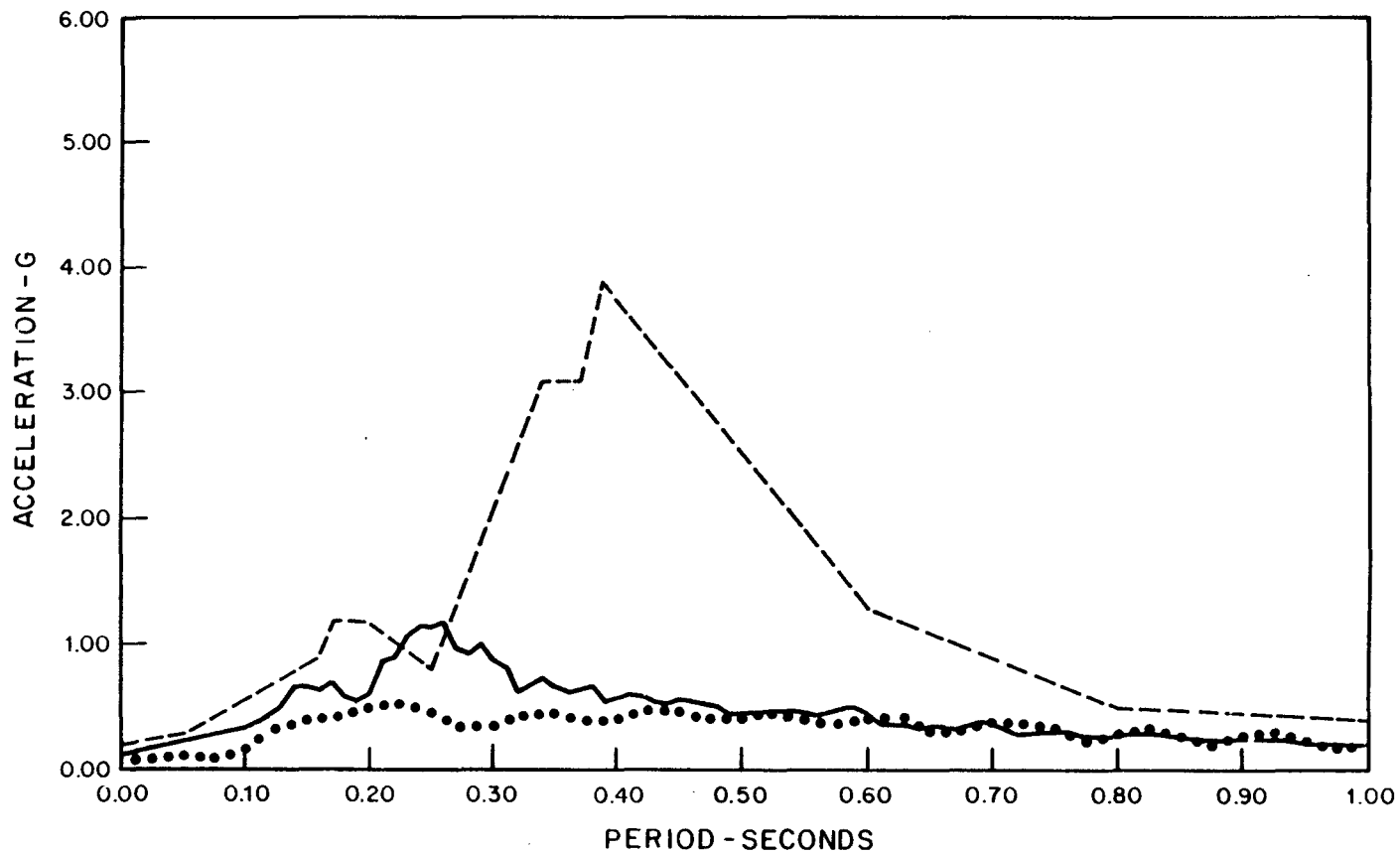

NOTE
 BASED ON THE ENVELOPE OF CRACKED
 AND UNCRACKED PROPERTIES OF CONCRETE.

LEGEND

- 0.010 OSCILLATOR DAMPING PLAXLY (FINITE ELEMENT)
- 0.010 OSCILLATOR DAMPING STRUDL/TIME HISTORY (LUMPED MASS-SPRING)
- 0.010 OSCILLATOR DAMPING FLUSH (FINITE ELEMENT)

FIGURE 3.7B-59
 A.R.S. COMPARISON-FINITE ELEMENT
 VS. LUMPED MASS-SPRING
 CONTAINMENT EXTERNAL STRUCTURE
 EL. 854.0', VERTICAL, SSE
 BEAVER VALLEY POWER STATION-UNIT 2
 FINAL SAFETY ANALYSIS REPORT

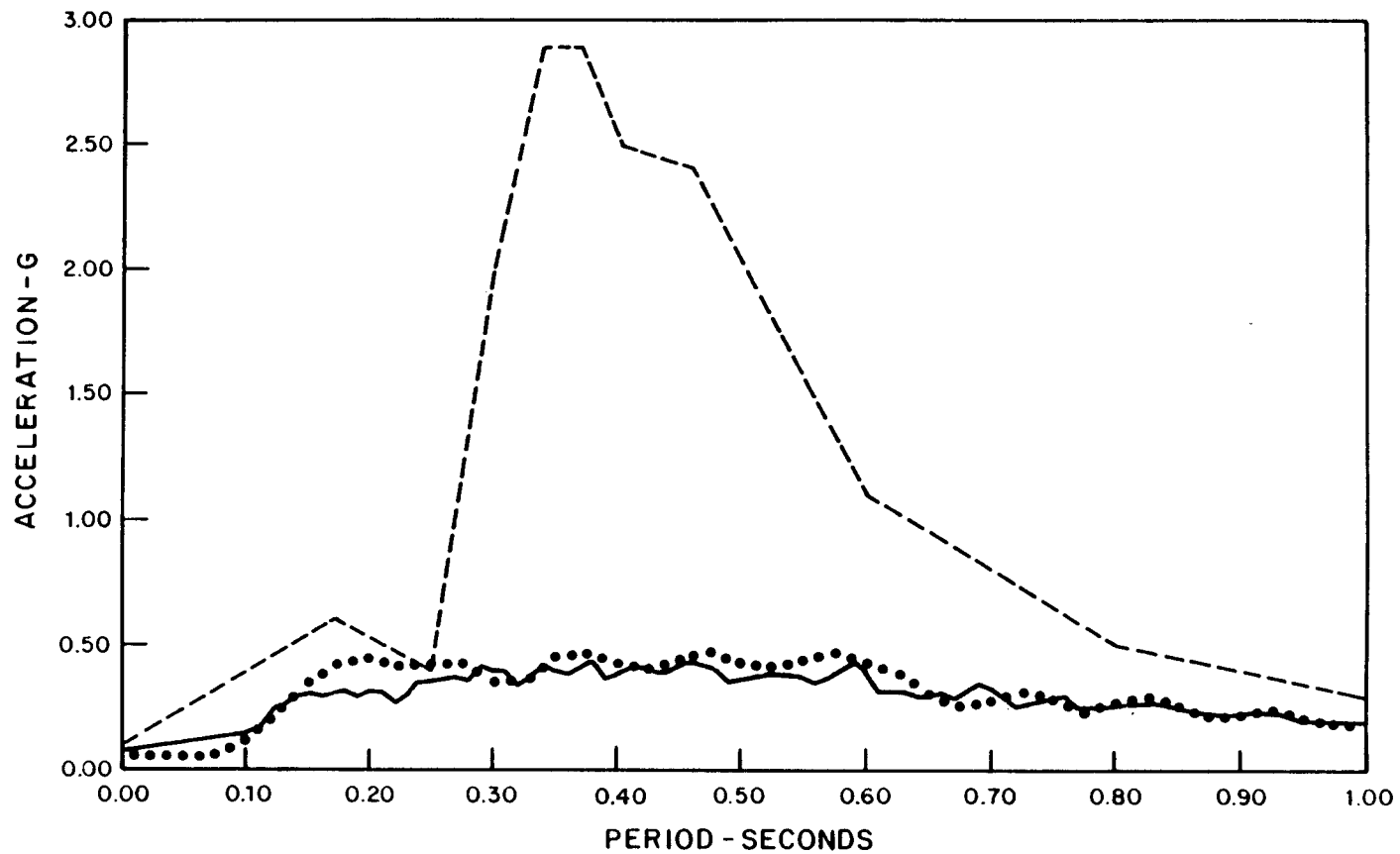

NOTE
 BASED ON THE ENVELOPE OF CRACKED
 AND UNCRACKED PROPERTIES OF CONCRETE.

LEGEND

- 0.010 OSCILLATOR DAMPING PLAXLY (FINITE ELEMENT)
- 0.010 OSCILLATOR DAMPING STRUDL/TIME HISTORY (LUMPED MASS-SPRING)
- 0.010 OSCILLATOR DAMPING FLUSH (FINITE ELEMENT)

FIGURE 3.7B-60
 A.R.S. COMPARISON-FINITE ELEMENT
 VS. LUMPED MASS-SPRING
 CONTAINMENT MAT EL. 681.0'
 TO 691.0', VERTICAL, SSE
 BEAVER VALLEY POWER STATION-UNIT 2
 FINAL SAFETY ANALYSIS REPORT

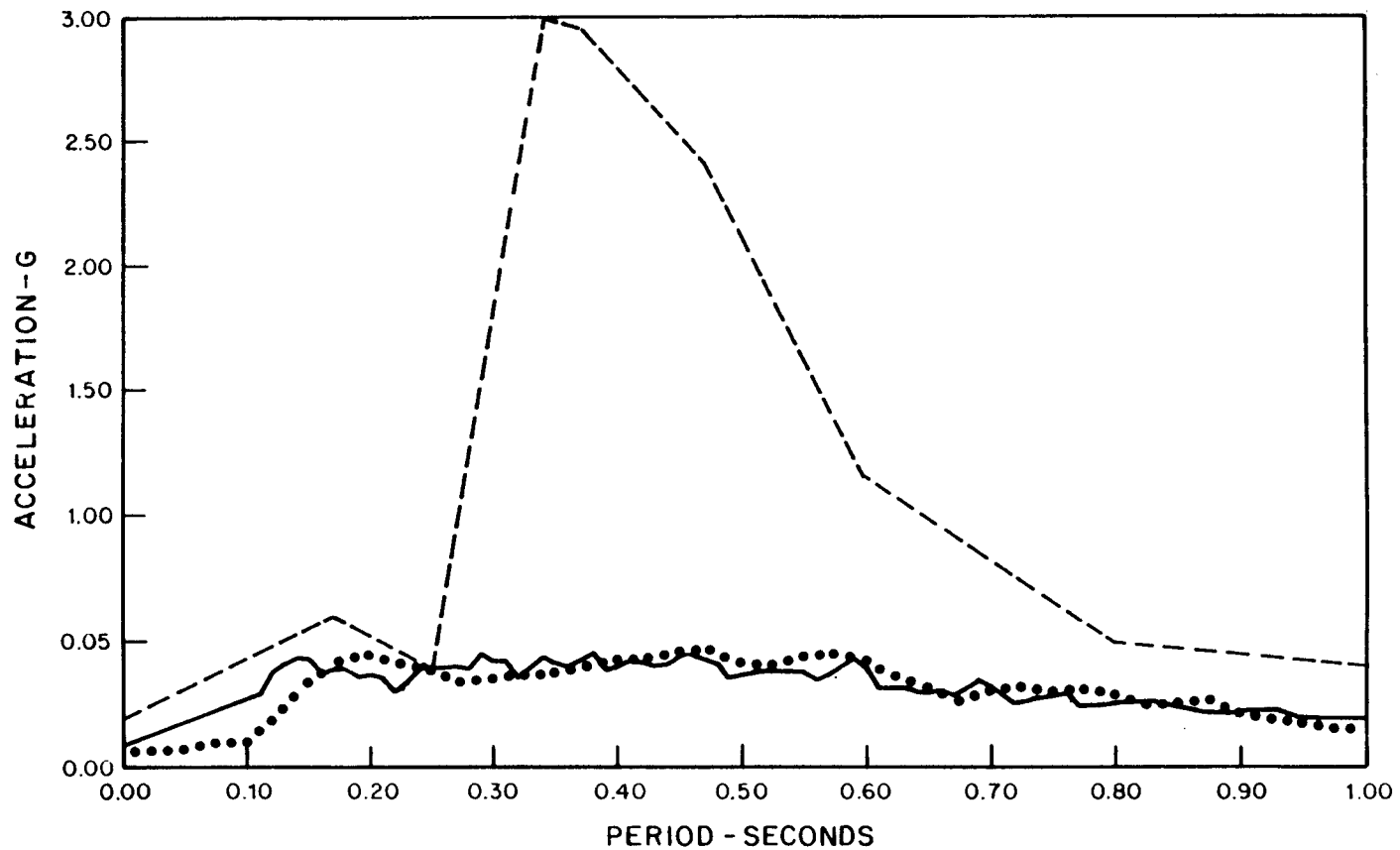

NOTE
 BASED ON THE ENVELOPE OF CRACKED
 AND UNCRACKED PROPERTIES OF CONCRETE.

LEGEND

- 0.010 OSCILLATOR DAMPING PLAXLY (FINITE ELEMENT)
- 0.010 OSCILLATOR DAMPING STRUDL/TIME HISTORY (LUMPED MASS-SPRING)
- 0.010 OSCILLATOR DAMPING FLUSH (FINITE ELEMENT)

FIGURE 3.7B-61
 A.R.S. COMPARISON-FINITE ELEMENT
 VS. LUMPED MASS-SPRING
 CONTAINMENT INTERNAL STRUCTURE
 EL. 818.0', VERTICAL, SSE
 BEAVER VALLEY POWER STATION-UNIT 2
 FINAL SAFETY ANALYSIS REPORT

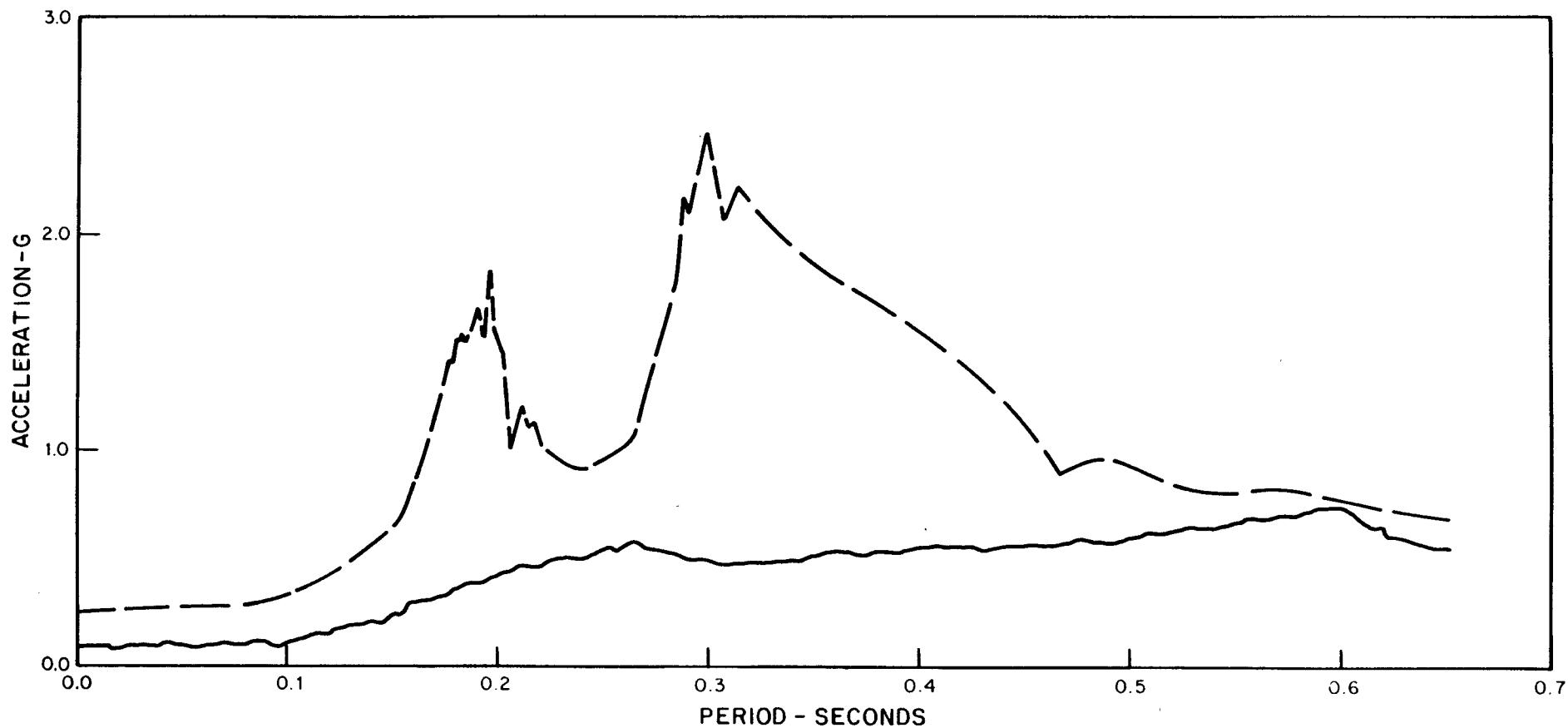

LEGEND

- 0.010 OSCILLATOR DAMPING FLUSH (FINITE ELEMENT)
- - - 0.010 OSCILLATOR DAMPING STRUCL / TIME HISTORY (LUMPED MASS-SPRING)

FIGURE 3.7B-62
A.R.S. COMPARISON-FINITE ELEMENT
VS. LUMPED MASS-SPRING
FUEL BUILDING, EL. 729.50'
EAST-WEST, SSE
BEAVER VALLEY POWER STATION - UNIT 2
FINAL SAFETY ANALYSIS REPORT

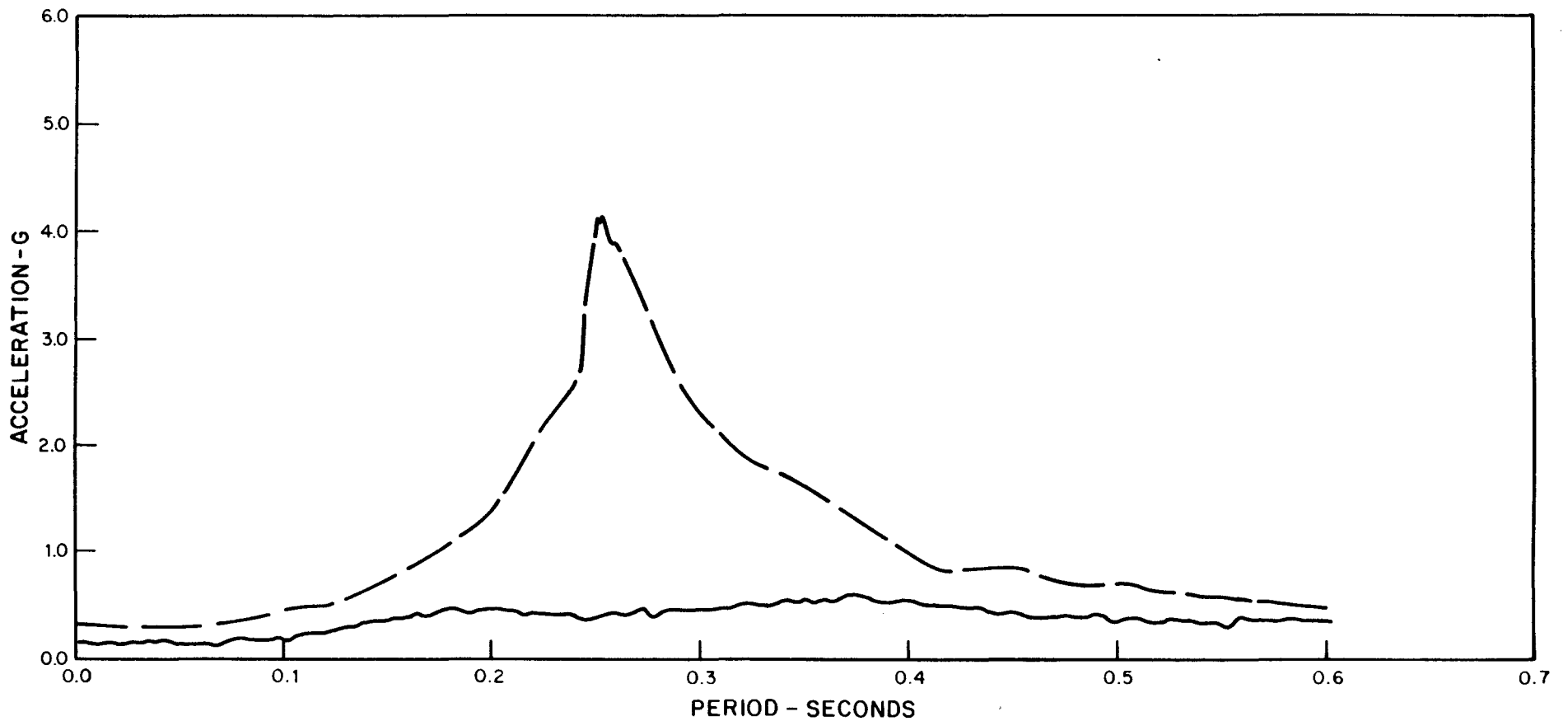

LEGEND

- 0.010 OSCILLATOR DAMPING FLUSH (FINITE ELEMENT)
- - - 0.010 OSCILLATOR DAMPING STRUDL / TIME HISTORY (LUMPED MASS-SPRING)

FIGURE 3.7B-63
 A.R.S. COMPARISON-FINITE ELEMENT
 VS. LUMPED MASS-SPRING
 FUEL BUILDING, EL. 729.50'
 VERTICAL, SSE
 BEAVER VALLEY POWER STATION-UNIT 2
 FINAL SAFETY ANALYSIS REPORT

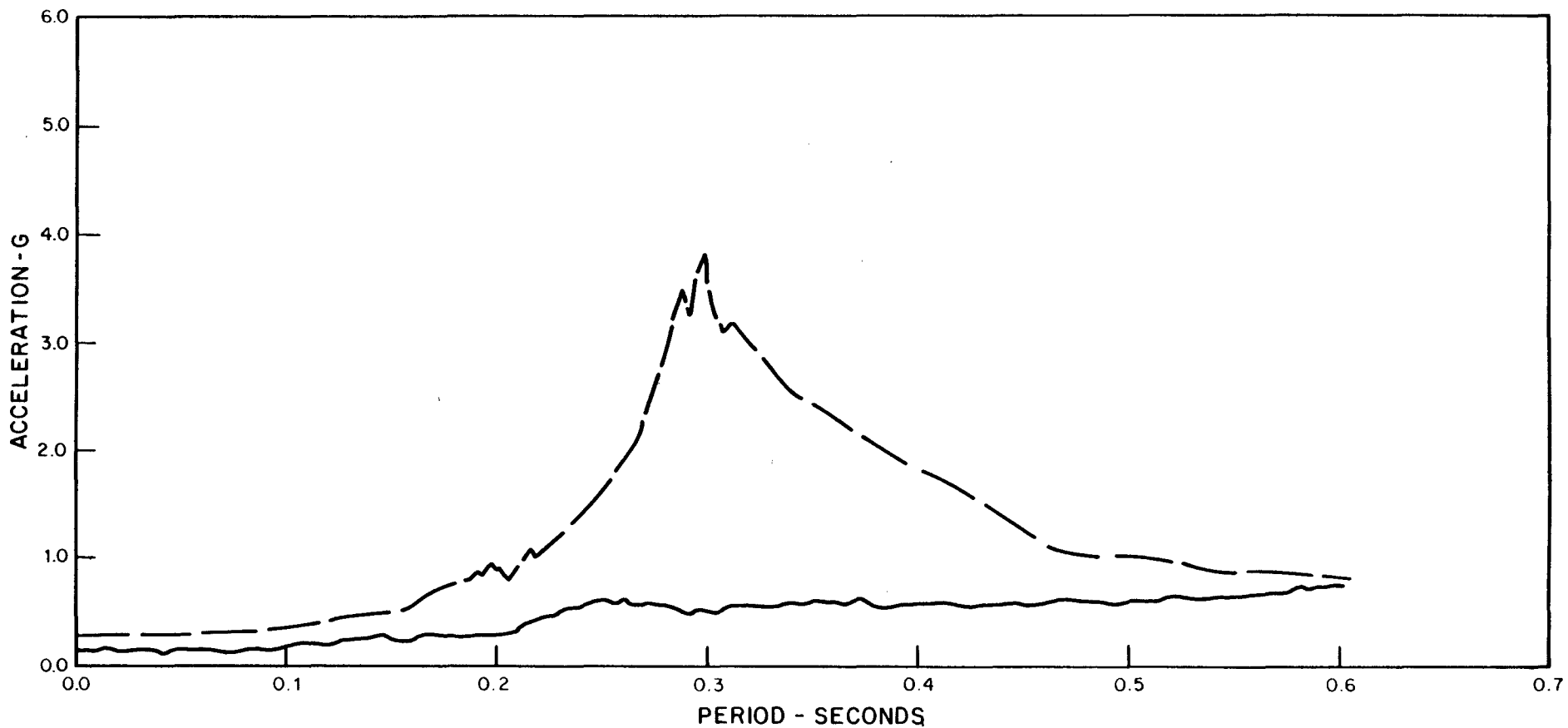

LEGEND

- 0.010 OSCILLATOR DAMPING FLUSH (FINITE ELEMENT)
- - - 0.010 OSCILLATOR DAMPING STRUDL/TIME HISTORY (LUMPED MASS-SPRING)

FIGURE 3.7B-64
 A.R.S. COMPARISON-FINITE ELEMENT
 VS. LUMPED MASS-SPRING
 FUEL BUILDING, EL. 767.33'
 EAST-WEST, SSE
 BEAVER VALLEY POWER STATION - UNIT 2
 FINAL SAFETY ANALYSIS REPORT

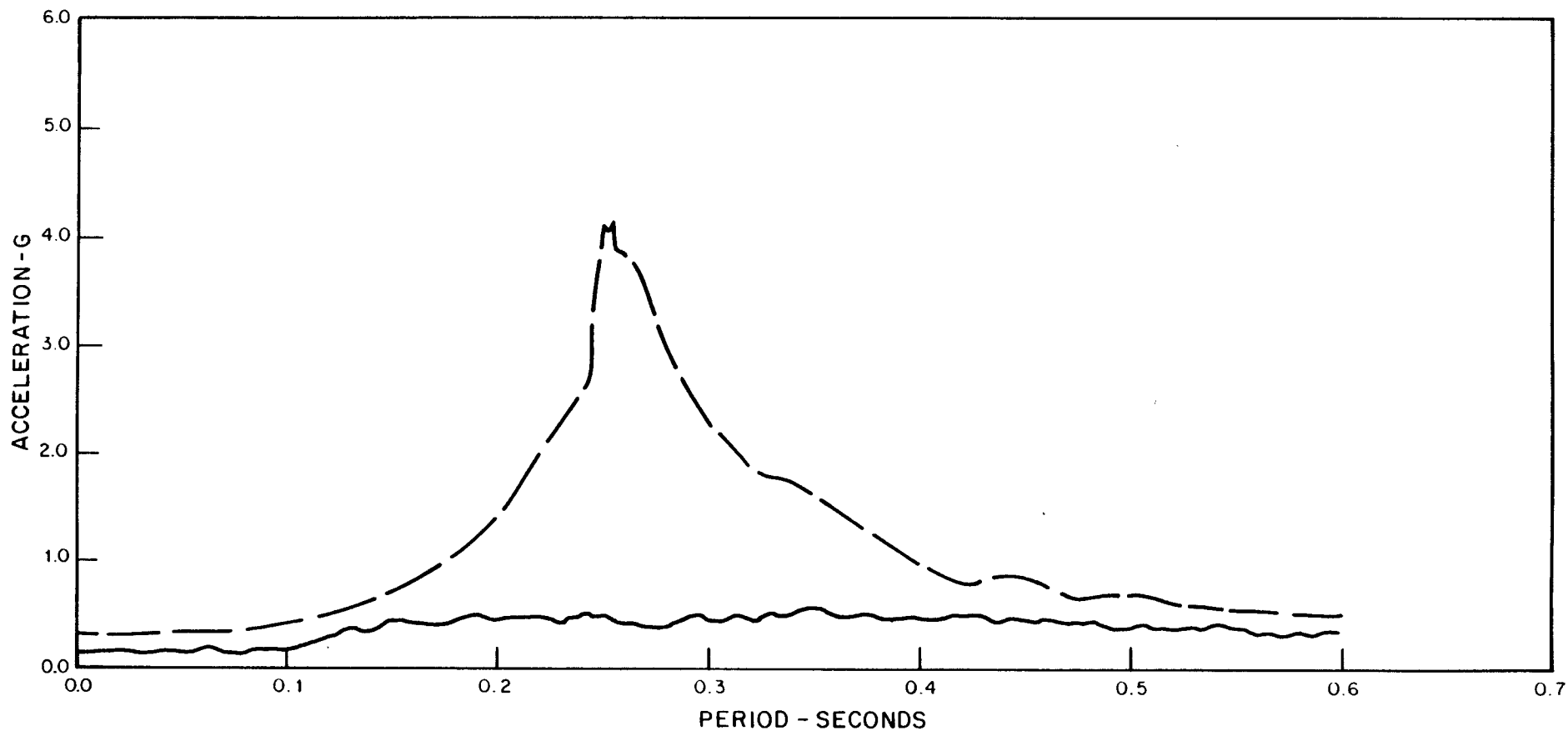

LEGEND

- 0.010 OSCILLATOR DAMPING FLUSH (FINITE ELEMENT)
- - - 0.010 OSCILLATOR DAMPING STRUDL / TIME HISTORY (LUMPED MASS-SPRING)

FIGURE 3.7B-65
A.R.S. COMPARISON-FINITE ELEMENT
VS. LUMPED MASS-SPRING
FUEL BUILDING, EL. 767.33'
VERTICAL, SSE
BEAVER VALLEY POWER STATION-UNIT 2
FINAL SAFETY ANALYSIS REPORT

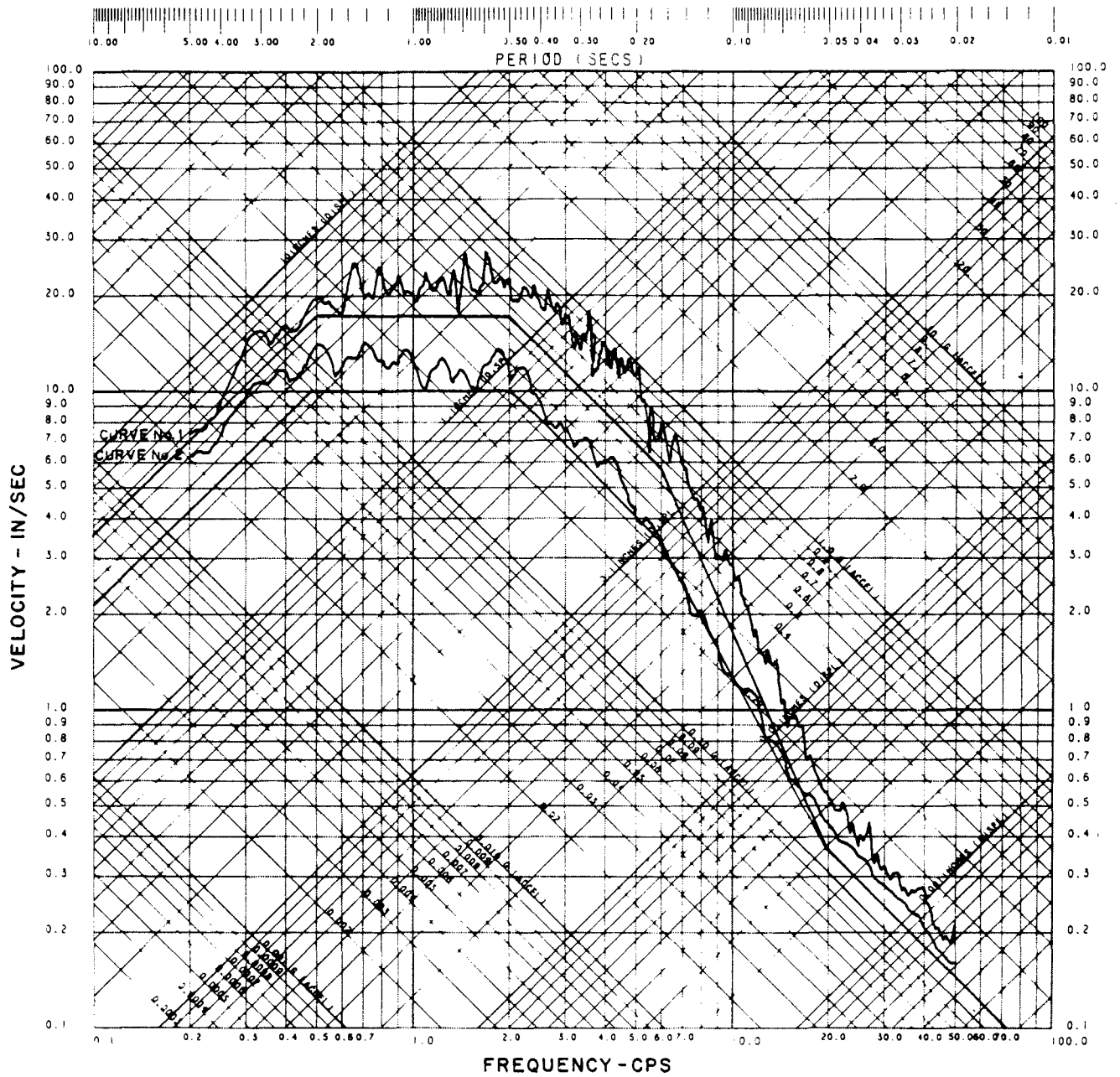

LEGEND

- GROUND RESPONSE SPECTRA
- ~~~~~ SPECTRA RESULTING FROM TIME HISTORY

NOTES

CURVE No. 1 DAMPING 0.5 PERCENT
 CURVE No. 2 DAMPING 5.0 PERCENT
 DBE GRS BASED ON 0.125G MAX. GA

FIGURE 3.7B-66
GROUND RESPONSE SPECTRA VS.
RESPONSE SPECTRA RESULTING FROM
SITE ARTIFICIAL TIME HISTORY
BEAVER VALLEY POWER STATION-UNIT 2
FINAL SAFETY ANALYSIS REPORT

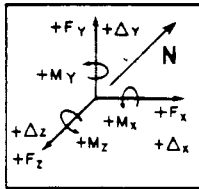

CONSTRAINT TABLE							
CONSTRAINT	DIRECTION & SPRING CONSTANTS						
NODE	TYPE	X	Y	Z	θ_x	θ_y	θ_z
17,31,38	VC			1×10^6			
42	NS			1×10^6			
50	VC&NS			1×10^6			
59	NSS			4×10^5			
65	VSS			4×10^5			
1	PENET	1×10^8	1×10^8	1×10^8	1×10^{10}	1×10^{10}	1×10^{10}
575	ANCHOR	1×10^8	1×10^8	1×10^8	1×10^{10}	1×10^{10}	1×10^{10}

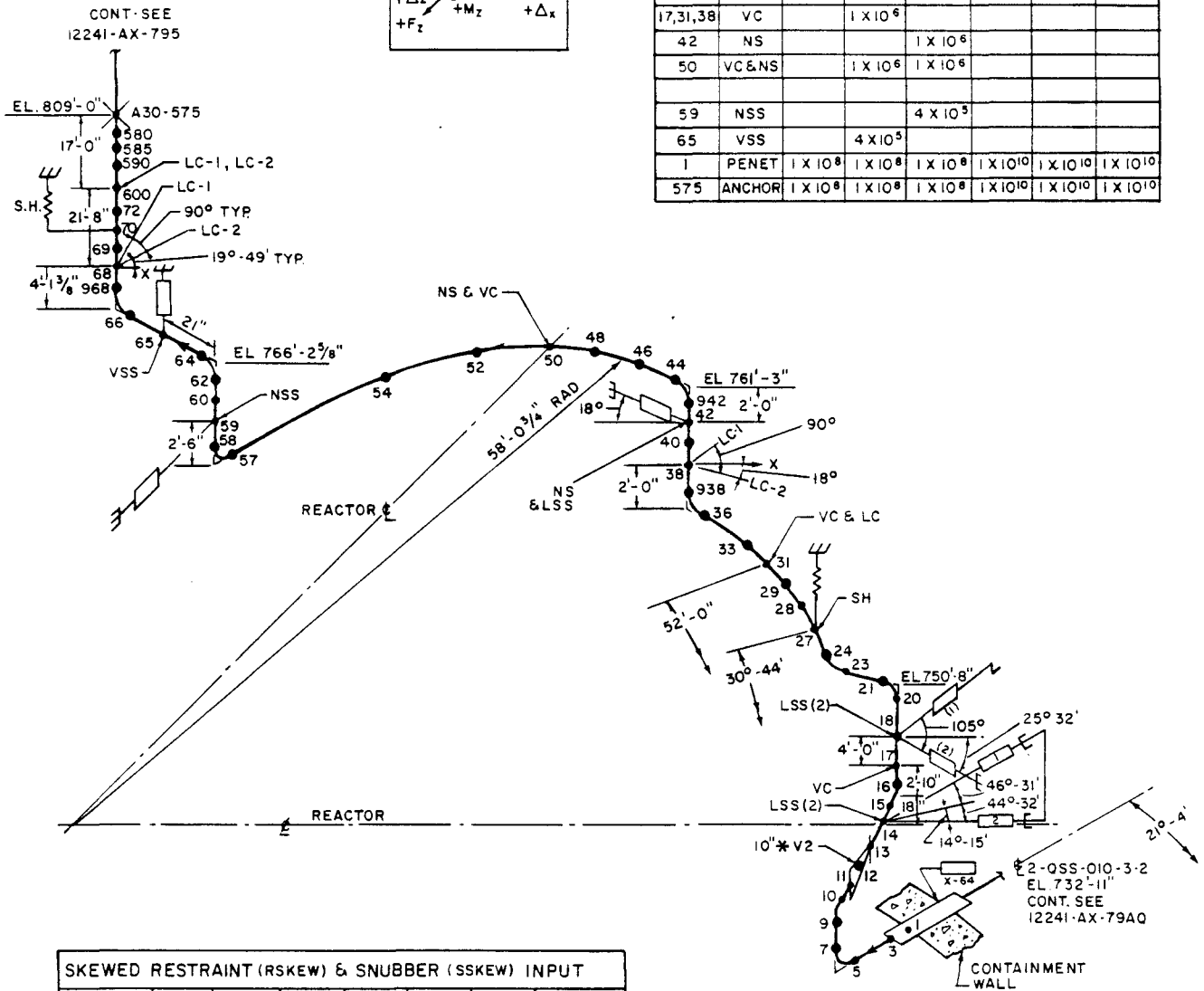

SKEWED RESTRAINT (RSKEW) & SNUBBER (SSKEW) INPUT							
RESTRAINT	NODE	S TYPE 1.0 TRANS 2.0 ROT	PD 1.0 OFFSETS 2.0 DIR COS	P_x α_x	P_y α_y	P_z α_z	K (IN-LBS) OR K ϕ (IN-LBS/RAD)
SKS-1	14	1.0	2.0	.6669	.7257	-.1693	4×10^5
LSS-1	18	1.0	2.0	.1828		-.9832	4×10^5
LSS-2	18	1.0	2.0	.9024		.431	4×10^5
LC	31	1.0	2.0	.6157		-.788	1×10^6
LSS	42	1.0	2.0	.951		.309	4×10^5
SKS-2	14	1.0	2.0	.6909	-.7014	-.1754	4×10^5
LC-1	68,600	1.0	2.0	-.339		-.9408	1×10^6
LC-2	68,600	1.0	2.0	.9408		-.339	1×10^6
LC-1	38	1.0	2.0	.309		-.951	1×10^6
LC-2	38	1.0	2.0	.951		.309	1×10^6

FIGURE 3.7B-67
 TYPICAL MATHEMATICAL MODEL
 OF A PIPING SYSTEM
 BEAVER VALLEY POWER STATION- UNIT 2
 FINAL SAFETY ANALYSIS REPORT

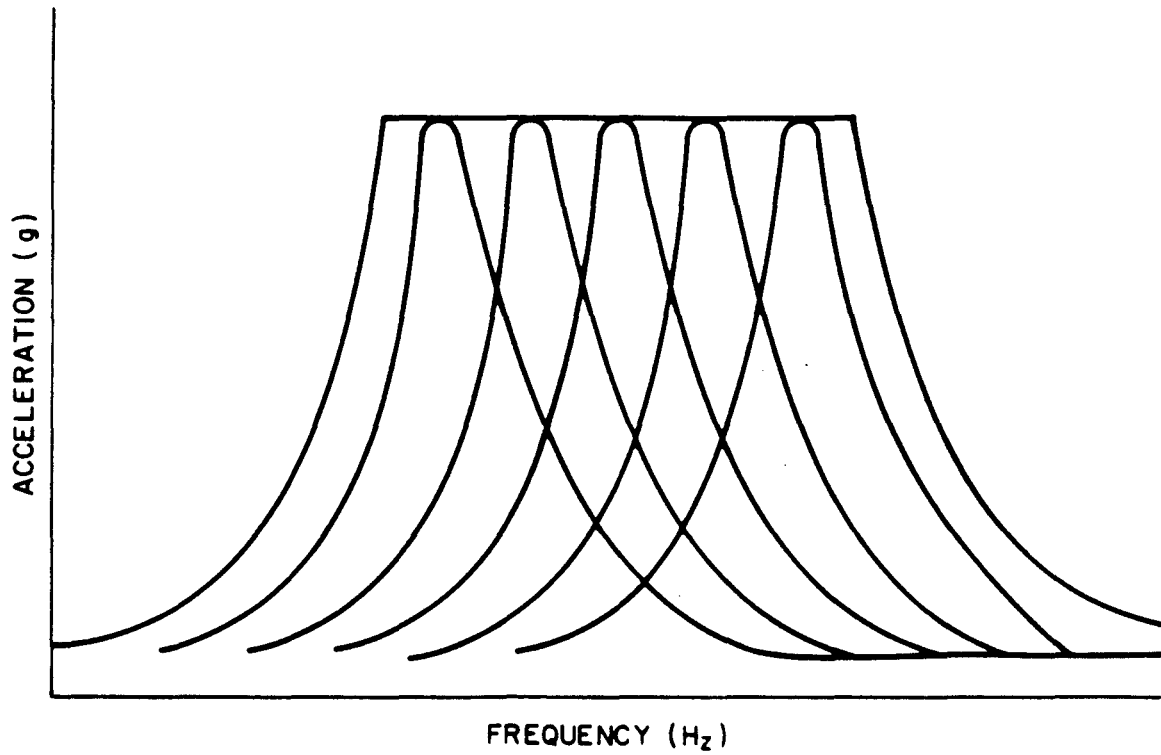

FIGURE 3.7B-68
REPRESENTATION OF FAMILY
OF PEAK RESPONSE CURVES
WITHIN BROADENED RESONANT PEAK
BEAVER VALLEY POWER STATION-UNIT 2
FINAL SAFETY ANALYSIS REPORT

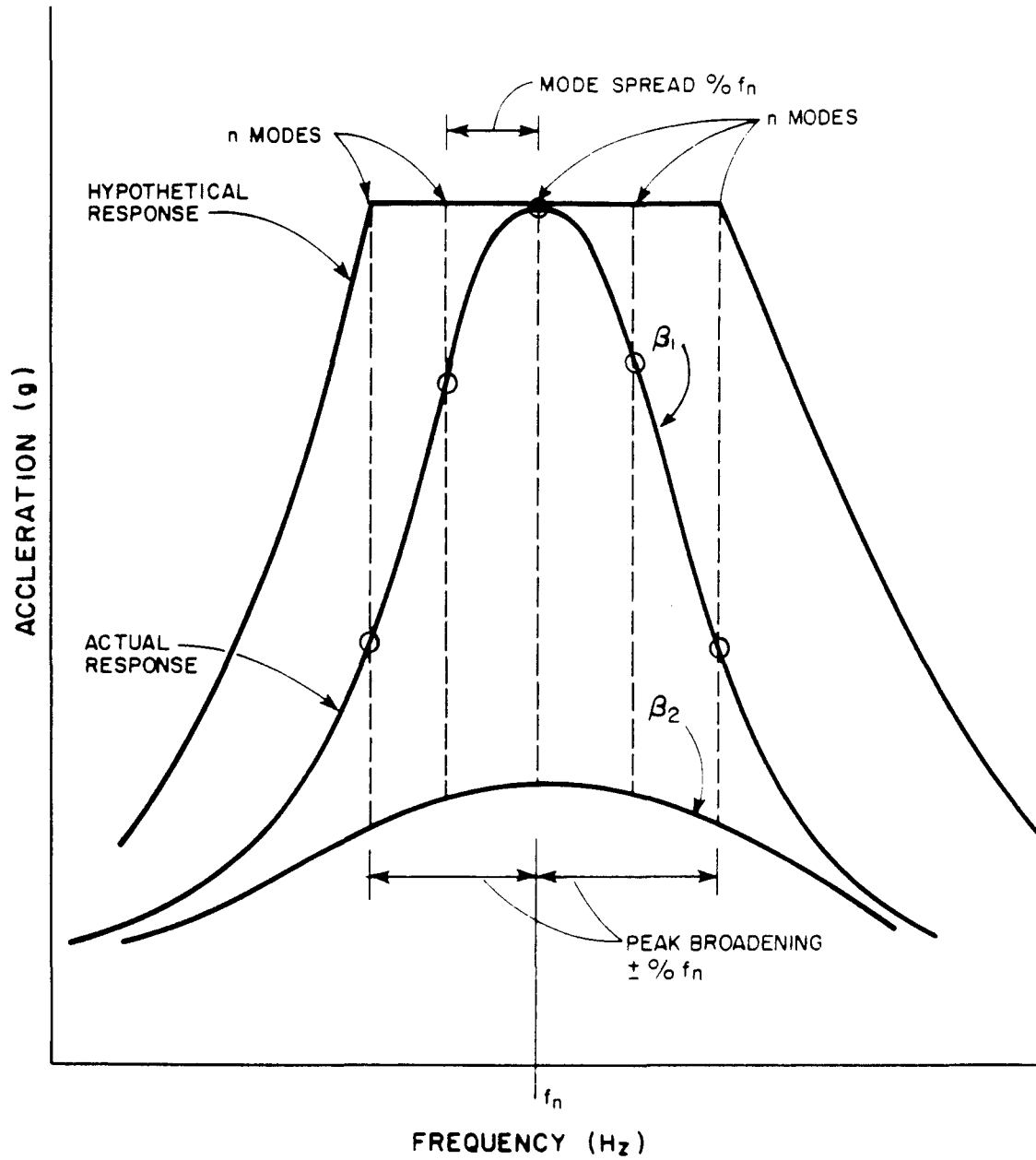

FIGURE 3.7B-69
 HYPOTHETICAL VS ACTUAL
 RESPONSE OF MULTIPLE
 MODES WITHIN BROADENED
 RESPONSE PEAK
 BEAVER VALLEY POWER STATION-UNIT 2
 FINAL SAFETY ANALYSIS REPORT

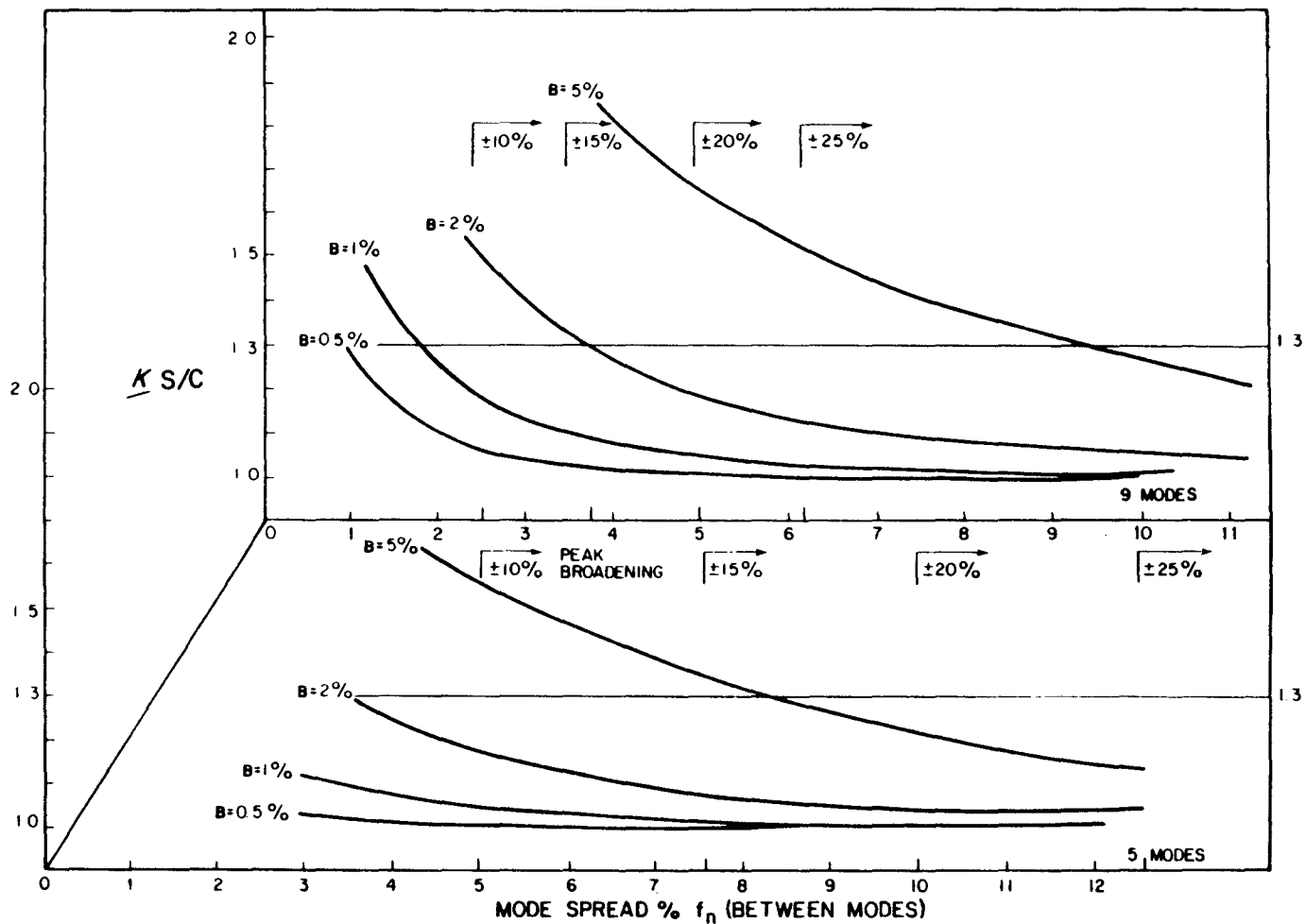

FIGURE 3.7B-70
 JUSTIFICATION OF
 STATIC LOAD FACTOR
 BEAVER VALLEY POWER STATION-UNIT 2
 FINAL SAFETY ANALYSIS REPORT

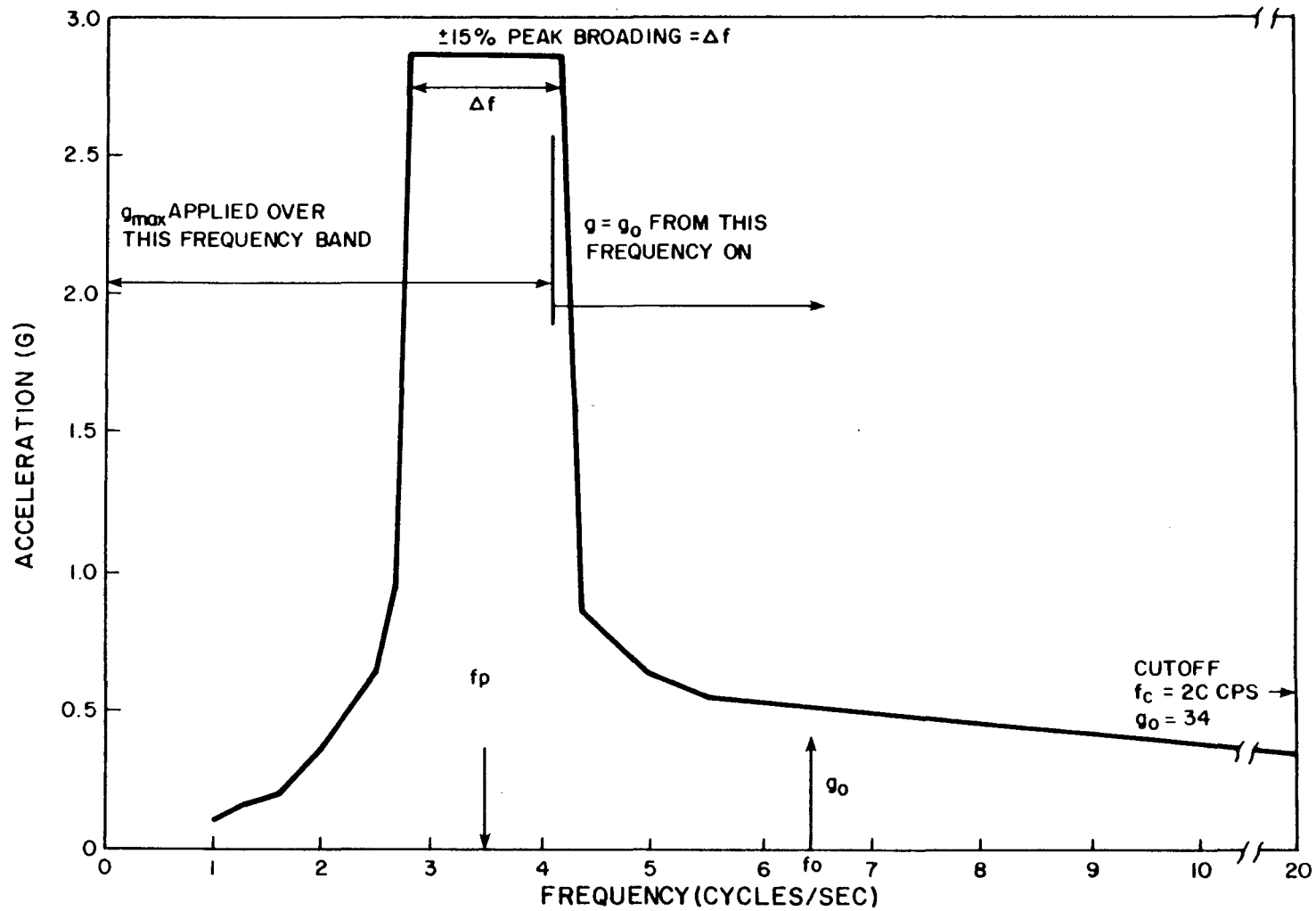

FIGURE 3.7B-71
 TYPICAL AMPLIFIED
 RESPONSE SPECTRA
 BEAVER VALLEY POWER STATION-UNIT 2
 FINAL SAFETY ANALYSIS REPORT

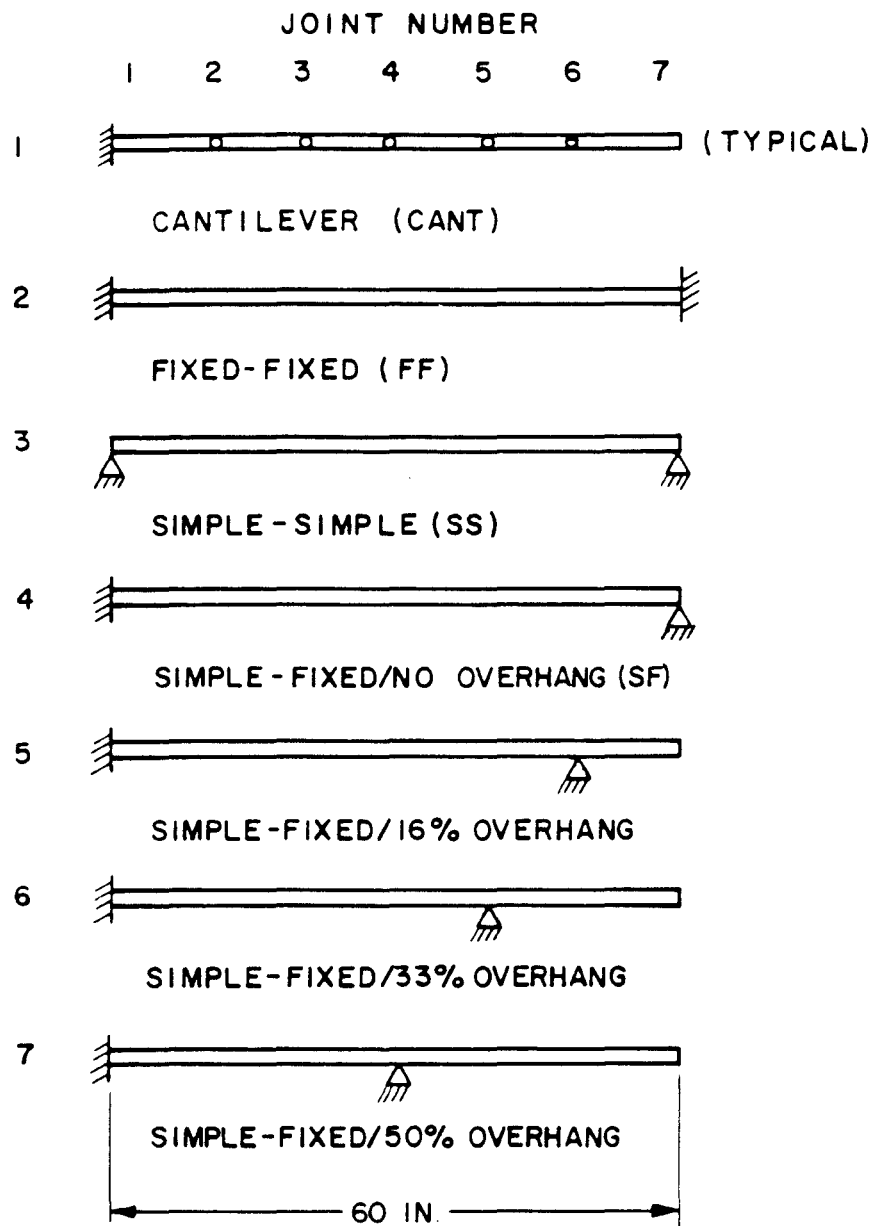

FIGURE 3.7B-72
 MODEL BEAMS
 BEAVER VALLEY POWER STATION-UNIT 2
 FINAL SAFETY ANALYSIS REPORT

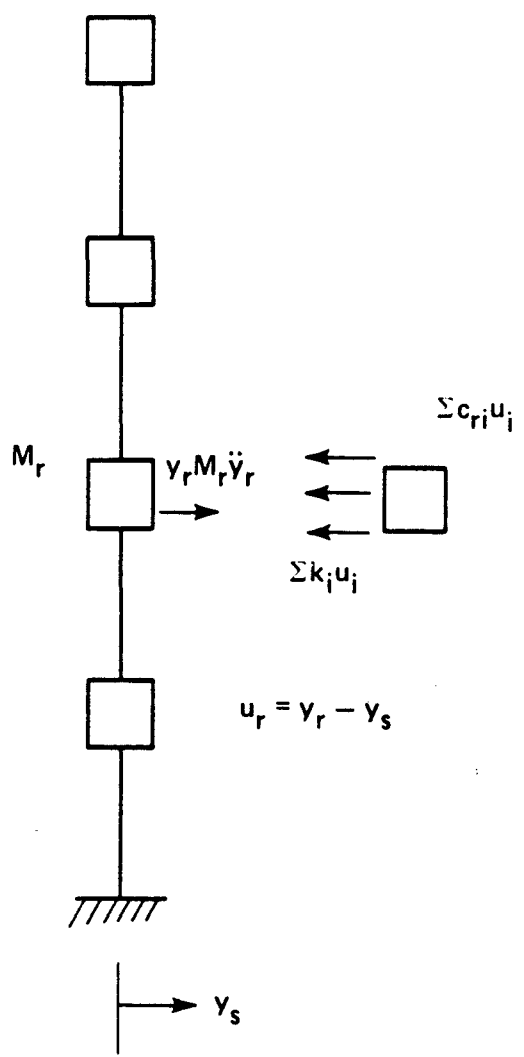

FIGURE 3.7N-1
 MULTI-DEGREE OF FREEDOM SYSTEM
 BEAVER VALLEY POWER STATION-UNIT 2
 FINAL SAFETY ANALYSIS REPORT