

CHAPTER 2

TABLE OF CONTENTS

<u>Section</u>	<u>Title</u>	<u>Page</u>
2	THE SITE .....	2.1-1
2.1	GEOGRAPHY AND DEMOGRAPHY.....	2.1-1
2.1.1	Site Location and Description.....	2.1-1
2.1.2	Exclusion Area Authority and Control.....	2.1-2
2.1.3	Population Distribution.....	2.1-3
2.1.4	References for Section 2.1.....	2.1-9
2.2	NEARBY INDUSTRIAL, TRANSPORTATION, AND MILITARY FACILITIES.....	2.2-1
2.2.1	Location and Routes.....	2.2-1
2.2.2	Description of Facilities, Products, and Materials.....	2.2-2
2.2.3	Evaluation of Potential Accidents.....	2.2-4
2.2.4	References for Section 2.2.....	2.2-19
2.3	METEOROLOGY.....	2.3-1
2.3.1	Regional Climatology.....	2.3-1
2.3.2	Local Meteorology.....	2.3-7
2.3.3	Onsite Meteorological Measurement Program.....	2.3-17
2.3.4	Short-Term (Accident) Diffusion Estimates.....	2.3-19
2.3.5	Long-Term (Routine) Diffusion Estimates.....	2.3-24b
2.3.6	References for Section 2.3.....	2.3-29

APPENDICES

2.3A	SALT AND WATER DRIFT	
2.3B	VISIBLE PLUME MODEL	
2.3C	BEAVER VALLEY POWER STATION JOINT FREQUENCY DISTRIBUTION AT THE 35-FOOT LEVEL (JANUARY 1, 1976 TO DECEMBER 31, 1980)	
2.3D	BEAVER VALLEY POWER STATION JOINT FREQUENCY DISTRIBUTION AT THE 500-FOOT LEVEL (JANUARY 1, 1976 TO DECEMBER 31, 1980)	
2.3E	BEAVER VALLEY POWER STATION JOINT FREQUENCY DISTRIBUTION AT THE 150-FOOT LEVEL (JANUARY 1, 1976 TO DECEMBER 31, 1980)	
2.4	HYDROLOGIC ENGINEERING.....	2.4-1
2.4.1	Hydrologic Description.....	2.4-1
2.4.2	Floods.....	2.4-3
2.4.3	Probable Maximum Flood on Streams and Rivers.....	2.4-5

TABLE OF CONTENTS

<u>Section</u>	<u>Title</u>	<u>Page</u>
2.4.4	Potential Dam Failures, Seismically Induced.....	2.4-8
2.4.5	Probable Maximum Surge and Seiche Flooding.....	2.4-9
2.4.6	Probable Maximum Tsunami Flooding.....	2.4-9
2.4.7	Ice Effects.....	2.4-9
2.4.8	Cooling Water Canals and Reservoirs.....	2.4-14
2.4.9	Channel Diversions.....	2.4-14
2.4.10	Flooding Protection Requirements.....	2.4-14
2.4.11	Low Water Considerations.....	2.4-15
2.4.12	Dispersion, Dilution, and Travel Times of Accidental Releases of Liquid Effluents in Surface Waters....	2.4-17
2.4.13	Ground Water.....	2.4-19
2.4.14	Technical Specification and Emergency Operation Requirements.....	2.4-27
2.4.15	References for Section 2.4.....	2.4-28

APPENDIX

2.4A	TECHNICAL REPORT - ANALYSIS OF FLOOD HEIGHTS, OHIO RIVER AT SHIPPINGPORT, PA HYDROLOGIC ENGINEERING INVESTIGATION	
2.5	GEOLOGY, SEISMOLOGY, AND GEOTECHNICAL ENGINEERING.....	2.5.1-1
2.5.1	BASIC GEOLOGIC AND SEISMIC INFORMATION.....	2.5.1-1
2.5.2	VIBRATORY GROUND MOTION.....	2.5.2-1
2.5.3	SURFACE FAULTING.....	2.5.3-1
2.5.4	STABILITY OF SUBSURFACE MATERIALS AND FOUNDATIONS.	2.5.4-1
2.5.5	SLOPE STABILITY.....	2.5.5-1
2.5.6	EMBANKMENTS AND DAMS.....	2.5.6-1

APPENDICES

2.5A	OHIO RIVER ELEVATIONS AND PIEZOMETER DATA
2.5B	BORING LOGS
2.5C	RELATIVE DENSITY PLOTS FOR VERIFICATION BORINGS
2.5D	LABORATORY TEST DATA IN SITU SOILS
2.5E	STABILITY OF SLOPES AT THE EMERGENCY OUTFALL STRUCTURE

## LIST OF TABLES

<u>Table Number</u>	<u>Title</u>
2.1-1	1970-1980 Population Growth for Townships, Boroughs, and Districts within 10 Miles of the Site BVPS-2
2.1-2	1980 Population and Population Density for Townships, Boroughs, and Districts within 10 Miles of BVPS-2
2.1-3	Population Distribution for 1980, 0-10 Miles
2.1-4	Population Distribution for 1985, 0-10 Miles
2.1-5	Population Distribution for 1990, 0-10 Miles
2.1-6	Population Distribution for 2000, 0-10 Miles
2.1-7	Population Distribution for 2010, 0-10 Miles
2.1-8	Population Distribution for 2020, 0-10 Miles
2.1-9	Population Distribution for 2030, 0-10 Miles
2.1-10	Population Distribution for 1980, 10-50 Miles
2.1-11	Population Distribution for 1985, 10-50 Miles
2.1-12	Population Distribution for 1990, 10-50 Miles
2.1-13	Population Distribution for 2000, 10-50 Miles
2.1-14	Population Distribution for 2010, 10-50 Miles
2.1-15	Population Distribution for 2020, 10-50 Miles
2.1-16	Population Distribution for 2030, 10-50 Miles
2.1-17	Population Distribution for 1980, 50-350 Miles
2.1-18	Population Distribution for 1985, 50-350 Miles
2.1-19	Population Distribution for 1990, 50-350 Miles
2.1-20	Population Distribution for 2000, 50-350 Miles
2.1-21	Population Distribution for 2010, 50-350 Miles
2.1-22	Population Distribution for 2020, 50-350 Miles
2.1-23	Population Distribution for 2030, 50-350 Miles

## LIST OF TABLES (Cont)

<u>Table Number</u>	<u>Title</u>
2.1-24	Population Centers with Over 25,000 People in 1980 within 50 Miles of BVPS-2
2.1-25	Cities and Towns Projected to Become Population Centers by 2030
2.1-26	Total 1970-1980 Population Growth for SMSA within 50 Miles of BVPS-2
2.1-27	Approximate Daily Transient Population by Sector within 10 Miles of BVPS-2
2.1-28	Educational Facilities within 10 Miles of BVPS-2
2.1-29	Parks and Recreation Facilities within 10 Miles of BVPS-2
2.1-30	LPZ 1980 Population Distribution
2.1-31	Transient Population in LPZ
2.1-32	Approximate Daily Transient Population by Sector Within the LPZ for BVPS-2
2.1-33	Population Density for 1980, 0-10 Miles (People/Mile <sup>2</sup> )
2.1-34	Population Density for 1985, 0-10 Miles (People/Mile <sup>2</sup> )
2.1-35	Population Density for 2030, 0-10 Miles
2.1-36	Population Density for 1980, 10-50 Miles (People/Mile <sup>2</sup> )
2.1-37	Population Density for 1985, 10-50 Miles (People/Mile <sup>2</sup> )
2.1-38	Population Density for 2030, 10-50 Miles (People/Mile <sup>2</sup> )
2.2-1	Employment by Job Classification Beaver County, PA.
2.2-2	Major Industrial Employers within 10 Miles of BVPS
2.2-3	Pipelines in the Vicinity of BVPS-2
2.2-4	Southwestern Pennsylvania Provisional Employment Forecast
2.2-5	Deleted
2.2-6	Probabilities of Catastrophic Rupture Events



## LIST OF TABLES (Cont)

<u>Table Number</u>	<u>Title</u>
2.2-7	Estimated Ignition Probabilities
2.2-8	Probability of an Unconfined Vapor Cloud Explosion
2.2-9	Toxic Chemicals Stored Onsite
2.2-10	Stationary Offsite Toxic Chemicals Stored within 5 Miles of the BVPS-2 Control Room Air Intake
2.2-11	Predicted Toxic Vapor Concentrations in the Control Room
2.2-12	ConRail Track Lengths and Wind Direction Frequencies
2.2-13	Aggregate Probability of Toxic Chemical Spill Transported by ConRail
2.2-14	Aggregate Probability of Toxic Chemical Spill Transported by Barge
2.2-15	Onsite Liquid Storage
2.2-16	Liquids Transported on Ohio River
2.3-1	Normals Means and/or Extremes of Climatological Data from the National Weather Service Station at Greater Pittsburgh Airport
2.3-2	Expected Rainfall in the BVPS Area for Selected Rainfall Duration Periods and Recurrence Intervals (Inches)
2.3-3	Maximum Rainfall for Select Rainfall Duration Periods at Pittsburgh, 1895-1961 (Inches)
2.3-4	This table has been deleted from the UFSAR
2.3-5	Tornadoes within 1° Square for the BVPS Site
2.3-6	Tornado Damage Class Numbers
2.3-7	Range of Each Fujita-Pearson Scale
2.3-8	Seasonal and Annual Frequencies of Cloud-to-Ground Lightning Flashes in the Vicinity of the Beaver Valley Site
2.3-9	Comparison of Wind Direction Frequencies (Percent of Year) at the BVPS Site (35-Ft Level) and Greater Pittsburgh Airport for Concurrent and Long-Term Periods

## LIST OF TABLES (Cont)

<u>Table Number</u>	<u>Title</u>
2.3-10	Monthly and Annual Average Wind Speed (mph) for BVPS and the National Weather Service at Pittsburgh from January 1, 1976 to December 31, 1980
2.3-11	Summary of BVPS 35-Foot Wind Persistence Episodes Period 1/1/76 - 12/31/80
2.3-12	Summary of BVPS 500-Foot Wind Persistence Episodes Period 1/1/76 - 12/31/80
2.3-13	Summary of Greater Pittsburgh Airport Wind Persistence Episodes Period 1/1/76 - 12/31/80
2.3-14	Comparison of Average Annual and Monthly Dry-Bulb Temperatures (°F) at the BVPS Site and Greater Pittsburgh Airport for Concurrent and Long-Term Time Periods
2.3-15	Comparison of Annual and Monthly Extreme Dry-Bulb Temperatures (°F) at the BVPS Site and Greater Pittsburgh Airport for Concurrent and Long-Term Time Periods
2.3-16	Comparison of Average Annual and Monthly Diurnal Dry-Bulb Temperature Variations (°F) at the BVPS Site and Greater Pittsburgh Airport for Concurrent and Long-Term Time Periods
2.3-17	Comparison of Average Annual and Monthly Dew Point Temperatures (°F) at the BVPS Site and Greater Pittsburgh Airport for Concurrent and Long-Term Time Periods
2.3-18	Comparison of Average Annual and Monthly Relative Humidity Values (Percent) at the BVPS Site and Greater Pittsburgh Airport for Concurrent Time Period (1/1/76 - 12/31/80)
2.3-19	Comparison of Annual and Monthly Extreme Dew Point Temperatures (°F) at the BVPS Site and Greater Pittsburgh Airport for Concurrent and Long-Term Time Periods
2.3-20	Comparison of Average Annual and Monthly Diurnal Dew Point Temperature Variations (°F) at the BVPS Site and Greater Pittsburgh Airport for Concurrent and Long-Term Time Periods

## LIST OF TABLES (Cont)

<u>Table Number</u>	<u>Title</u>
2.3-21	Comparison of Average Annual and Monthly Diurnal Relative Humidity Value Variations (Percent) at the BVPS Site and Greater Pittsburgh Airport for Concurrent Time Period (1/1/76 - 12/31/80)
2.3-22	Monthly and Annual BVPS Site Absolute Humidity ( $\text{g/m}^3$ ) Summary (Average, Extremes, and Diurnal Variation) for the Period 1/1/76 through 12/31/80
2.3-23	Comparison of Monthly and Annual Precipitation Data (Inches) at the BVPS Site and Greater Pittsburgh Airport
2.3-24	Monthly and Annual Average and Extremes of Hours with Precipitation at the BVPS Site for the Period 1/1/76 through 12/31/80
2.3-25	Monthly and Annual Maximum 1-Hour and 24-Hour Precipitation Values (Inches) at the BVPS Site for the Period 1/1/76 to 12/31/80
2.3-26	BVPS Monthly $\Delta R_{150}$ ft-15 ft and $\Delta T_{500}$ ft-35 ft Stability Distributions from January 1, 1976 to December 31, 1980 (Percent)
2.3-27	Monthly Occurrence Summaries of Inversion Durations at the BVPS Site for the Period 1/1/76 through 12/31/80 (Number of Occurrences)
2.3-28	Monthly Means of Daily Morning and Daily Afternoon Mixing Levels for Pittsburgh from 1960 through 1964 (Meters)
2.3-29	Maximum Relative Humidity Increases (RH) Due to Natural Draft Cooling Tower Operation for BVPS-1 and BVPS-2
2.3-30	Seasonal and Annual Frequencies of Centerline Interactions between BVPS Cooling Towers and BMP Stacks 31 and 32 for WSW Winds Blowing from the Cooling Towers Toward the Stacks
2.3-31	Seasonal and Annual Frequencies of Centerline Interactions between BVPS Cooling Towers and BMP Stacks 31 and 32 for ENE Winds Blowing from the Stacks Toward the Cooling Towers
2.3-32	Seasonal and Annual Frequencies of Centerline Interactions between BVPS Cooling Towers and BMP Stack 36 for WSW Winds Blowing from the Cooling Towers Toward the Stack

## LIST OF TABLES (Cont)

<u>Table Number</u>	<u>Title</u>
2.3-33	Seasonal and Annual Frequencies of Centerline Interactions between BVPS Cooling Towers and BMP Stack 36 for ENE Winds Blowing from the Stack Toward the Cooling Towers
2.3-34	Meteorological System Equipment Specifications for BVPS
2.3-35	US Nuclear Regulatory Commission $\Delta T$ Stability Categories
2.3-36	BVPS Monthly and Annual Data Recovery for the Period from January 1, 1976 to December 31, 1980 (Percent)
2.3-37	BVPS Monthly and Annual Joint $\Delta T$ and Wind Data Recovery for the Period from January 1, 1976 to December 31, 1980 (Percent)
2.3-37a	BVPS Monthly and Annual Joint $\Delta T$ and Wind Data Recovery for Each Year of the Period from January 1, 1976 to December 31, 1980
2.3-38	0.5 Percent Sector-dependent 0- to 2-Hour X/Q Values at the Exclusion Area Boundary
2.3-38a	Fifty Percent Sector-dependent 0- to 2-Hour X/Q Values at the Exclusion Area Boundary
2.3-38b	0.5 Percent Sector-dependent 0- to 2-Hour X/Q Values at the Exclusion Area Boundary
2.3-39	0.5 Percent Sector-dependent X/Q Values for Various Time Periods at the Low Population Zone Outer Boundary
2.3-39a	Fifty Percent Sector-dependent X/Q Values for Various Time Periods at the Low Population Zone Outer Boundary
2.3-39b	0.5 Percent Sector-dependent X/Q Values for Various Time Periods at the Low Population Zone Outer Boundary
2.3-40	Terrain Recirculation Factors for Ground Level Releases
2.3-41	Distances of Limiting Maximum Individual Receptors to Release Points (Meters) for Annual X/Q Values
2.3-42	Release Point Design Parameters
2.3-43	Annual Average X/Q Values ( $\times 10^7 \text{ sec/m}^3$ ) for BVPS-1 Ventilation Vent Release
2.3-44	Grazing Season Average X/Q Values ( $\times 10^7 \text{ sec/m}^3$ ) for BVPS-1 Ventilation Vent Release
2.3-45	Annual Average D/Q Values ( $\times 10^9 \text{ m}^{-2}$ ) for BVPS-1 Ventilation Vent Release

## LIST OF TABLES (Cont)

<u>Table Number</u>	<u>Title</u>
2.3-46	Grazing Season Average D/Q Values ( $\times 10^9 \text{ m}^{-2}$ ) for BVPS-1 Ventilation Vent Release
2.3-47	Annual Average X/Q Values ( $\times 10^7 \text{ sec/m}^3$ ) for BVPS-2 Elevated Release
2.3-48	Grazing Season Average X/Q Values ( $\times 10^7 \text{ sec/m}^3$ ) for BVPS-2 Elevated Release
2.3-49	Annual Average D/Q Values ( $\times 10^9 \text{ m}^{-2}$ ) for BVPS-2 Elevated Release
2.3-50	Grazing Season Average D/Q Values ( $\times 10^9 \text{ m}^{-2}$ ) for BVPS-2 Elevated Release
2.3-51	Annual Average X/Q Values ( $\times 10^7 \text{ sec/m}^3$ ) for Process Vent Release
2.3-52	Grazing Season Average X/Q Values ( $\times 10^7 \text{ sec/m}^3$ ) for Process Vent Release
2.3-53	Annual Average D/Q Values ( $\times 10^9 \text{ m}^{-2}$ ) for Process Vent Release
2.3-54	Grazing Season Average D/Q Values ( $\times 10^9 \text{ m}^{-2}$ ) for Process Vent Release
2.3-55	Annual Average X/Q Values ( $\times 10^7 \text{ sec/m}^3$ ) for BVPS-2 Ventilation and BVPS-1 Containment Vent Purge Release
2.3-56	Grazing Season Average X/Q Values ( $\times 10^7 \text{ sec/m}^3$ ) for BVPS-2 Ventilation and BVPS-1 Containment Vent Purge Release
2.3-57	Annual Average D/Q Values ( $\times 10^9 \text{ m}^{-2}$ ) for BVPS-2 Ventilation and BVPS-1 Containment Vent Purge Release
2.3-58	Annual Average D/Q Values ( $\times 10^9 \text{ m}^{-2}$ ) for BVPS-2 Ventilation and BVPS-1 Containment Vent Purge Release
2.3-59	Terrain Recirculation Factors for Elevated Releases
2.4-1	Locks and Dams on the Ohio River within 50 Miles of the Site
2.4-2	Downstream Potable Water Intakes
2.4-3	Tributaries within 50 Miles of the Site Having a Mean Discharge Greater Than 100 CFS
2.4-4	Reservoirs Upstream of the Site
2.4-5	All-Season Envelope Probable Maximum Precipitation at the Site

## LIST OF TABLES (Cont)

<u>Table Number</u>	<u>Title</u>
2.4-6	Runoff Analysis, Water Depths Adjacent to Safety-Related Building Openings
2.4-7	Time Distribution of Isohyets
2.4-8	Drainage Areas
2.4-9	Flood Forecast for Dashields Beginning on October 15, 1954
2.4-10	Summary of Occurrences of Ice on Ohio River at Cincinnati, Ohio 1874-1964
2.4-11	Summary of Occurrences of Ice on New Cumberland Pool, 1963 - 1979
2.4-12	Summary of Survey of Icing Problems at Upper Ohio River Intakes
2.4-13	Minimum Dilution Factors at East Liverpool, Ohio, for Accidental Releases from Various Tanks
2.4-14	Wells in Vicinity of Beaver Valley Power Station
2.4-15	Parameters Used to Determine Horizontal Dispersion and Travel Time
2.5.2-1	Modified Mercali Intensity Scale of 1931
2.5.2-2	Earthquake Catalogue, Beaver Valley Power Station - Unit 2, 200-Mile Radius
2.5.4-1	Boring Log Index
2.5.4-2	Materials Testing Requirements and Frequency
2.5.4-3	Summary of Predicted Dynamic Settlements
2.5.4-4	Bearing Capacity - Category I Structures
2.5.4-5	Summary of Lateral Earth Pressure Coefficients
2.5.4-6	Structural Fill Supplier and Quantities Provided

## LIST OF TABLES (Cont)

<u>Table Number</u>	<u>Title</u>
2.5.4-7	Liquefaction Analysis at Intake Structure Earthquake Records
2.5.4-8	Main Intake Structure Liquefaction Analysis
2.5.4-9	Site Matched Ground Surface Earthquake Records
2.5.4-10	Relative Displacement of Selected Structures Using the Earthquake Time-History Method

## LIST OF FIGURES

<u>Figure Number</u>	<u>Title</u>
2.1-1	Site Location
2.1-2	Local Site Topography
2.1-3	Towns and Boroughs Within 10-Mile Area of BVPS-2
2.1-4	Population Distribution: Annular Sectors Within 0-10 Mile Area of BVPS-2
2.1-5	Counties and Towns Within 50 Mile Region of BVPS-2
2.1-6	Population Distribution: Annular Sectors Within 10-50 Mile Region of BVPS-2
2.1-7	350 Mile Region Surrounding BVPS-2
2.1-8	Population Distribution: Annular Sectors Within 50-350 Mile Region of BVPS-2
2.1-9	SMSA's Within 50 Mile Region of BVPS-2
2.2-1	Transportation Routes
2.2-2	Major Industries Within 10 Miles of the Site
2.2-3	Pipelines in the vicinity of the Site
2.3-1	Total "Agnes" Rainfall June 20 Through 25, 1972 (inches)
2.3-2	Estimated Frequency of Occurrence of Visible Plume From BVPS-1 Natural Draft Cooling Tower
2.3-3	Estimated Frequency of Occurrence of Visible Plume From BVPS-1 Natural Draft Cooling Tower
2.3-4	Estimated Frequency of Occurrence of Visible Plume From BVPS-1 Natural Draft Cooling Tower
2.3-5	Estimated Frequency of Occurrence of Visible Plume From BVPS-1 Natural Draft Cooling Tower
2.3-6	Estimated Frequency of Occurrence of Visible Plume From BVPS-1 Natural Draft Cooling Tower
2.3-7	Estimated Frequency of Occurrence of Visible Plume From BVPS-2 Natural Draft Cooling Tower
2.3-8	Estimated Frequency of Occurrence of Visible Plume From BVPS-2 Natural Draft Cooling Tower



## LIST OF FIGURES (Cont)

<u>Figure Number</u>	<u>Title</u>
2.3-9	Estimated Frequency of Occurrence of Visible Plume From BVPS-2 Natural Draft Cooling Tower
2.3-10	Estimated Frequency of Occurrence of Visible Plume From BVPS-2 Natural Draft Cooling Tower
2.3-11	Estimated Frequency of Occurrence of Visible Plume From BVPS-2 Natural Draft Cooling Tower
2.3-12	Icing Due to Drift From BVPS-1 and BVPS-2 (inches/year) Natural Draft Cooling Towers
2.3-13	Topographic Cross Sections to 50 Miles for the North Sector
2.3-14	Topographic Cross Sections to 50 Miles for the North Northeast Sector
2.3-15	Topographic Cross Sections to 50 Miles for the Northeast Sector
2.3-16	Topographic Cross Sections to 50 Miles for the East Northeast Sector
2.3-17	Topographic Cross Sections to 50 Miles for the East Sector
2.3-18	Topographic Cross Sections to 50 Miles for the East Southeast Sector
2.3-19	Topographic Cross Sections to 50 Miles for the Southeast Sector
2.3-20	Topographic Cross Sections to 50 Miles for the South Southeast Sector
2.3-21	Topographic Cross Sections to 50 Miles for the South Sector
2.3-22	Topographic Cross Sections to 50 Miles for the South Southwest Sector
2.3-23	Topographic Cross Sections to 50 Miles for the Southwest Sector

## LIST OF FIGURES (Cont)

<u>Figure Number</u>	<u>Title</u>
2.3-24	Topographic Cross Sections to 50 Miles for the West Southwest Sector
2.3-25	Topographic Cross Sections to 50 Miles for the West Sector
2.3-26	Topographic Cross Sections to 50 Miles for the West Northwest Sector
2.3-27	Topographic Cross Sections to 50 Miles for the Northwest Sector
2.3-28	Topographic Cross Sections to 50 Miles for the North Northwest Sector
2.3-29	Meander as a Function of Wind Speed and Stability
2.4-1	Regional Hydrology
2.4-2	Isohyetal Storm Pattern
2.4-3	Rainfall Duration vs Infiltration
2.4-4	Unit Areas and Routing Reaches
2.4-5	Ohio River Profiles
2.4-6	Ohio River Dashields, Locks, and Dam Comparison of Actual and Reproduced October 1954 Floods
2.4-7	Hydrograph of Probable Maximum Flood at the Site
2.4-8	Ohio River Topography Mile 30.9 to Mile 53.7
2.4-9	Ohio River Topography Mile 30.9 to Mile 53.7
2.4-10	Ohio River Topography Mile 30.9 to Mile 53.7
2.4-11	Ohio River Topography Mile 30.9 to Mile 53.7
2.4-12	Ohio River Topography Mile 30.9 to Mile 53.7
2.4-13	Ohio River Topography Mile 30.9 to Mile 53.7
2.4-14	Ohio River Topography Mile 30.9 to Mile 53.7

## LIST OF FIGURES (Cont)

<u>Figure Number</u>	<u>Title</u>
2.4-15	Flow-Stage Relation at Site Ohio River - 34.8
2.4-16	Drought Frequency Curve - Ohio River at Shippingport
2.4-17	Regional Groundwater Map
2.4-18	Generalized Bedrock and Surficial Geology
2.5.1-1	Regional Physiographic Provinces
2.5.1-2	Site Area Geologic Map
2.5.1-3	Regional Bedrock Geology
2.5.1-4	Generalized Geologic Cross-Section Across Pennsylvania and Eastern Ohio
2.5.1-5	Epicenters and Tectonic Provinces Within 200 Miles of the Site
2.5.1-6	Regional Stratigraphic Correlation Chart
2.5.1-7	Geologic Structures and Tectonic Provinces Within 200 Miles of the Site
2.5.1-8	Stewart Hill Fault
2.5.1-9	Coal Bearing Areas of the Site Region
2.5.1-10	Oil and Gas Fields of the Site Region
2.5.2-1	Epicenters and Felt Reports Within 200 Miles of the Site
2.5.2-2	Epicenters and Geologic Structures Within 200 Miles of the Site
2.5.2-3	Isoseismal Map - New Madrid Earthquake, 1811
2.5.2-4	Isoseismal Map - Charleston Earthquake, 1886
2.5.2-5	Isoseismal Map - St. Lawrence Earthquake, 1925
2.5.2-6	Areas Affected by Attica Earthquake, August 12, 1929
2.5.2-7	Isoseismal Map - Timiskaming Earthquake, 1935

## LIST OF FIGURES (Cont)

<u>Figure Number</u>	<u>Title</u>
2.5.2-8	Isoseismal Map - Anna Ohio Earthquake, March 9, 1937
2.5.2-9	Isoseismal Map - Cornwall-Massena Earthquake, September 5, 1944
2.5.2-10	Earthquake Frequency Map
2.5.2-11	Earthquake Frequency Map
2.5.2-12	Cumulative Strain Release
2.5.4-1	Typical Terrace Section
2.5.4-2	Subsurface Profile A-A'
2.5.4-3	Subsurface Profile B-B'
2.5.4-4	Subsurface Profile C-C'
2.5.4-5	Subsurface Profile D-D'
2.5.4-6	Subsurface Profile E-E'
2.5.4-7	Subsurface Profile F-F'
2.5.4-8	Subsurface Profile G-G'
2.5.4-9	Subsurface Profile H-H'
2.5.4-10	Boring Location Plan - Plant Area
2.5.4-11	Borings Outside Densified Zone - Main Plant Area Relative Density Plot
2.5.4-12	Shear Modulus vs Depth
2.5.4-13	Boring Location Plan
2.5.4-14	Benchmark and Piezometer Location Plan
2.5.4-15	In Situ Densification Program - Boring and Cross Section Location Plan
2.5.4-16	Limits of Densification - Terra Probe and Vibroflotation
2.5.4-17	Generalized "P" and "S" Wave Velocity Values, 1968 and 1977 Surveys

## LIST OF FIGURES (Cont)

<u>Figure Number</u>	<u>Title</u>
2.5.4-18	Comparison of In Situ Shear Wave Velocities Before and After Densification
2.5.4-19	General Excavation - Plant Area
2.5.4-20	Predicted Total Static Settlement
2.5.4-21	Gradation Limits - Structural Fill
2.5.4-22	Observation Well Location Plan
2.5.4-23	Observation Well Data - OW-1
2.5.4-24	Observation Well Data - OW-2
2.5.4-25	Observation Well Data - OW-3
2.5.4-26	Observation Well Data - OW-4
2.5.4-27	Piezometer Installation Detail
2.5.4-28	Dynamic Triaxial Test Data
2.5.4-29	Correlation Between $\tau/\sigma_{v0}$ Causing Liquefaction and $N_1$
2.5.4-29A	Correlation Between $\tau/\sigma_{v0}$ Causing Liquefaction and $N_1$
2.5.4-30	Relative Displacements for SSE
2.5.4-31	Relationship Between Rayleigh Wave Velocity and Soil Parameters
2.5.4-32	Terra Probe Densification - Main Intake Structure
2.5.4-33	Liquefaction Analysis at Main Intake Structure - Onshore Densified Areas
2.5.4-34	Liquefaction Analysis at Main Intake Structure - Intake Channel
2.5.4-35	Liquefaction Analysis at Main Intake Structure - Offshore Densified Areas
2.5.4-36	Deleted from UFSAR
2.5.4-37	Main Intake Channel - Slope Stability Section 1-1

## LIST OF FIGURES (Cont)

<u>Figure Number</u>	<u>Title</u>
2.5.4-38	Number of Cycles Necessary for Liquefaction, $N_l$ , vs Cyclic Stress Ratio
2.5.4-39	Shear Stress in Soil for Design Earthquake
2.5.4-39a	Shear Stress in Soil for Design Earthquake
2.5.4-40	Volumetric Strain vs Cycle Ratio
2.5.4-41	Plant Foundation Elevation and Load Data
2.5.4-42	Lateral Earth Pressures on Rigid Walls
2.5.4-43	Summary Plots - Terra Probe Densification at Main Intake Structure
2.5.4-44	Settlement Marker Location Plan
2.5.4-45	Settlement Marker Location Plan - Cooling Tower
2.5.4-46	Summary of Observed Settlements
2.5.4-47	Benchmark Installation Detail
2.5.4-48	Settlement Marker Installation Detail
2.5.4-49	Typical Settlement Monitoring Data Report
2.5.4-50	Top of Rock Contours
2.5.4-51	Subsurface Profile I-II"
2.5.4-52	Subsurface Profile J-J"
2.5.4-53	Subsurface Profile K-K"
2.5.4-54	Subsurface Profile L-L"
2.5.4-55	Subsurface Profile M-M"
2.5.4-56	Summary Plot Vibroflotation - River Water Intake Pipeline Trench
2.5.4-57	Slope Stability Section A-A Riverward Slope Analysis
2.5.4-58	Typical Section - Vibroflotation Densification for Service Water System Pipelines
2.5.4-59	Borings Outside Densified Zone - Main Plant Area

## LIST OF FIGURES (Cont)

<u>Figure Number</u>	<u>Title</u>
2.5.4-60	Subsurface Profile N-N"
2.5.4-61	Main Intake Channel
2.5.4-62	Vertical Coefficient of Subgrade Reaction for Buried Pipe
2.5.4-63	Horizontal Bearing Capacity Factor and Ultimate Displacement for Buried Pipe
2.5.4-64	Rayleigh Wave Velocity
2.5.4-65	Main Intake Structure Dynamic Sliding Stability
2.5.4-66	Main Intake Structure Typical Section
2.5.4-67	Main Intake Structure Soil Profile Before Terra-Probe Densification
2.5.4-68	Liquefaction Analysis Main Intake Structure
2.5.4-69	Soil Model - Free Field
2.5.4-70	Soil Model - Intake Structure
2.5.4-71	Strain Dependent Soil Parameters

## CHAPTER 2

## THE SITE

This chapter primarily describes the site characteristics for the Beaver Valley Power Station as they existed when the facility was licensed. As such, current site characteristics may not agree with these descriptions. The site characteristics described here include description; geography and demography; nearby industrial, transportation and military facilities; meteorology, hydrology, geology, seismology, and geotechnical engineering. This information was gathered to support or develop the original plant design bases. Chapter 2 also contains evaluations of these site characteristics demonstrating how applicable siting criteria were met at the time of original licensing of the facility. This information was accurate at the time the plant was originally licensed, but is considered historical and is not intended or expected to be updated for the life of the plant. Additionally, the operating term of the plant has been extended from 40 to 60 years by issuance of a renewed operating license. References to a 40-year plant life in this section are historical and have not been revised. Descriptions of requirements specific to the period of extended operation are contained in Chapter 19 of the UFSAR.

In the past, minor changes to site characteristics have been incorporated into Chapter 2. While updates were not required, these changes have not been removed. Therefore, some parts of this chapter reflect more recent information.

## 2.1 GEOGRAPHY AND DEMOGRAPHY

## 2.1.1 Site Location and Description

## 2.1.1.1 Specification of Location

The Beaver Valley Power Station (BVPS) is located in Shippingport Borough, Beaver County, Pennsylvania, on the south bank of the Ohio River. The site is approximately 1 mile southeast of Midland, Pennsylvania, 5 miles east of East Liverpool, Ohio, and approximately 25 miles northwest of Pittsburgh, Pennsylvania. The coordinates of the Beaver Valley Power Station - Unit 2 (BVPS-2) reactor containment are 40 degrees 37 minutes 23 seconds north and 80 degrees 25 minutes 57 seconds west; the Universal Transverse Mercator coordinates are 548,010 meters east and 4,496,890 meters north. Figure 2.1-1 shows the general site location.

## 2.1.1.2 Site Area Map

The BVPS site contains approximately 453 acres including 26 acres of right-of-way. Immediately to the west of the BVPS-2 reactor location, and also onsite, are Beaver Valley Power Station - Unit 1 (BVPS-1) and the former site of the Shippingport Atomic Power Station (SAPS). The SAPS was managed by DLC for the Division of Naval Reactors, U.S. Department of Energy (USDOE). The SAPS terminated operations October 1, 1982



and was dismantled by the USDOE. The Pennsylvania Department of Transportation has a right-of-way across the eastern end of the site on which a portion of Pennsylvania Route 168, including the southerly approach to the Shippingport Bridge, is located.

Local site topography, site boundary, and exclusion area are shown on Figure 2.1-2, and the general site plan is shown on Figure 1.2-1.

#### 2.1.1.3 Boundaries for Establishing Effluent Release Limits

The BVPS-2 exclusion area is defined by a 2,000-foot radius around the BVPS-1 containment building and extending in part to the north shore of the Ohio River (Figure 2.1-2). The exclusion area provides the basis for the Offsite Dose Calculation Manual limits on gaseous effluents and meets the requirements of 10 CFR 50.67. The BVPS-2 gaseous releases will occur at the containment building, at the BVPS-1 cooling tower, and at the auxiliary building and turbine building ventilation vents. The shortest distance to the site boundary from the BVPS-2 containment building is approximately 1,500 feet. The nearest occupied residence is located approximately 2,323 feet from the centerpoint of the BVPS-1 and BVPS-2 reactor containment locations. Within the site boundary there is a residence located on a 1 acre parcel not owned by the licensee (Figure 2.1-2). The residence is located approximately 4,000 feet SSW of the BVPS-2 containment.

Boundaries for establishing effluent release limits are defined and controlled as required by 10 CFR 20 to ensure that individuals are protected from exposure to radiation and radioactive materials. The description of the restricted area boundary required by this section should be understood to be that presently approved for use in the Radiological Control Manual established for BVPS. The Radiological Control Manual describes how access to any areas required under this section is controlled for radiation protection purposes, including monitoring of access to these areas.

## 2.1.2 Exclusion Area Authority and Control

### 2.1.2.1 Authority

A 2,000-foot radius around the BVPS-1 containment building and an extension to the north shore of the Ohio River constitutes the BVPS-2 exclusion area (Figure 2.1-2) as defined by 10 CFR 100.3(a). The United States of America (USA), owner of Phillis Island which is located approximately 400 feet off the shoreline from BVPS, through the purchase agreement with Dravo Corporation, has agreed not to use or permit the use of the land for any structure, place, or area where the public at large can assemble. The agreement, binding on the USA or on any future purchaser or lessee has an expiration date of 2010 and delineates and restricts the uses which can be made of the island.

The Freeport Development Corporation purchased approximately 46 acres from DLC in 1995. This Land, located along the southern site boundary, includes 7.4 acres which are within the 2000-foot exclusion area boundary. An agreement binding on Freeport Development Corporation or on any future purchaser or lessee delineates and restricts the uses which can be made of the land.

The Applicant owns all other land within the exclusion area, including the mineral rights to it.

A Consolidated Rail Corporation (ConRail) right-of-way on the site is approximately 400 feet from the BVPS-2 containment at its closest point. The line is controlled by the licensee and its use is limited to servicing BVPS-1 and BVPS-2. The Pennsylvania Department of Transportation has a right-of-way across the eastern end of the property on which a portion of Pennsylvania Route 168, the southerly approach to the Shippingport Bridge, is located. Route 168 from the south follows along the northeast and east corner of the site and, crossing the Shippingport Bridge, joins State Highway 68.

### 2.1.2.2 Control of Activities Unrelated to Plant Operation

As required by 10 CFR 100.3(a) and as discussed in the BVPS Emergency Preparedness Plan referenced in Section 13.3, the Applicant has control of removal of personnel and property from the exclusion area.

The BVPS area is served by pipelines carrying natural gas and petroleum products. Six pipelines cross the BVPS-2 site: one natural gas pipeline and five petroleum product pipelines.

The Applicant has demonstrated control of the pipelines within the exclusion area, as evidenced by a DLC letter to the U.S. Nuclear Regulatory Commission (USNRC) (DLC 1978) and by relocation of the Mobil pipeline so that, in the unlikely event of a pipe rupture, pipeline contents would be diverted away from BVPS-2.

A coal ash slurry line from the Bruce Mansfield Plant (BMP) traverses the site. This line, owned in part by the Applicant, was originally routed to ensure that a failure of this line would not affect BVPS-2.

#### 2.1.2.3 Arrangements for Traffic Control

The only highway within the exclusion area, with the exception of the site access road, is State Highway 168 including the Shippingport Bridge. Beaver County Civil Defense and the Pennsylvania State Police have arranged to reroute the traffic on Route 168 in the event of an emergency, thus permitting crossing of the Ohio River without using the Shippingport Bridge, as well as using roadblocks at other locations. Also, arrangements have been made with the Army Corps of Engineers and the Coast Guard for navigation control on the Ohio River within the exclusion area in the event of an accident (BVPS-2 Emergency Preparedness Plan referenced in Section 13.3).

#### 2.1.2.4 Abandonment or Relocation of Roads

Public roads traversing the exclusion area will not have to be abandoned or relocated to ensure the Applicant's control of the exclusion area.

#### 2.1.3 Population Distribution

Beaver Valley Power Station - Unit 2 (BVPS-2) is located on the Ohio River in the Borough of Shippingport in Beaver County, Pennsylvania. The county population in 1970 equalled 208,418, which was dispersed at a density of 478 people per square mile. According to the U.S. Department of Commerce (USDOC 1982a), between 1970 and 1980 the Beaver County population declined approximately 1.9 percent to 204,441 at an average density of 469 people per square mile. Table 2.1-1 presents 1970 and 1980 populations and growth factors for townships, boroughs, and districts within 10 miles of the site. Figure 2.1-3 identifies the location of BVPS-2 as well as cities and townships within a radius of 10 miles surrounding the station.

Population information contained in BVPS-2 PSAR Section 2.1.2 has been revised herein to reflect 1980 demographic data and trends. Beaver Valley Power Station-Unit 2 PSAR Section 2.1.2 identifies the city of East Liverpool, Ohio as the nearest population center to the station. Due to declining population growth rates for the city of East Liverpool, its current and projected population does not approach 25,000 in the years 1980-2030, and therefore does not meet the criteria of 10 CFR 100 for the nearest population center. The nearest population center, based on 10 CFR 100 criteria, is the township of McCandless, Pennsylvania, which supported a 1980 population of 26,250 and is located approximately 17 miles east of the station.

#### 2.1.3.1 Population within 10 Miles

The 1980 population within 10 miles of BVPS-2 was approximately 141,286, a 1.7 percent decrease from the 1970 total of 143,736. This population is projected to increase to approximately 155,232 by the year 2030. The 10-mile area contains portions of Beaver County, Pennsylvania; Columbiana County, Ohio; and Hancock County, West Virginia. Of the 16 boroughs, 17 townships, 2 districts, and 1 city located totally or in part within the 10-mile radius surrounding the station, the Borough of Aliquippa, Pennsylvania supported the largest population, 17,094 in 1980.

Population distribution within 10 miles of the station is based on a house count from U.S. Geological Survey (USGS) maps on which houses have been identified. Houses were used to estimate the area population by applying 1980 town-specific, people-per-household factors derived from U.S. Bureau of the Census data to sector house counts. House counts were supplemented and verified through field reconnaissance conducted during March and June, 1983. In urbanized areas, where no houses appear on the USGS maps, population was determined by land area allocation. It was assumed that in urbanized areas, population was evenly distributed over the land area. Future population estimates within 10 miles of the station were adjusted by multiplying the 1980 base year population by the county-specific growth factors, supplied by the Pennsylvania Southwest Regional Planning Commission (1983), the Pennsylvania Department of Environmental Resources (1981), the West Virginia Department of Health (1981), and the Ohio Department of Development (1982). Finally, population densities were calculated by dividing the population in each annular sector by the sector's land area. Population and population densities in 1980 for townships, boroughs, and districts located within 10 miles of the station are presented in Table 2.1-2. Population distribution for the 10-mile area for the years 1980 through 2030 is listed in Tables 2.1-3, 2.1-4, 2.1-5, 2.1-6, 2.1-7, 2.1-8 and 2.1-9. Figure 2.1-4 presents the location of annular sectors within the 0-10 mile area surrounding BVPS-2.

Population projections for the year 1985 are being used to approximate the population for the year of initial commercial operation of BVPS-2. The populations of 1985 and 1986, the year of actual commercial start-up, should not differ to any significant extent. Therefore, since projections are calculated at 5-year intervals based on the decennial census, 1985 provides

the best estimate of population distribution at the start of commercial operation.

#### 2.1.3.2 Population between 10 and 50 Miles

The area within 50 miles of BVPS-2, containing a total population of approximately 3,555,283 in 1980, is expected to grow to approximately 3,726,327 in the year 2000 and to reach a total of approximately 4,631,398 by the year 2030 (USDOC 1982a, 1982b, 1982c). Figure 2.1-5 presents the counties and major towns within the 50-mile radius of the station. Polar-grid sector populations between 10 and 50 miles are based on 1980 U.S. Census data for Pennsylvania and Ohio; 1980 US Census data, updated to reflect the 1982 redistricting of Hancock County, for West Virginia (Brooke-Hancock-Jefferson, W. Va. Metropolitan Planning Commission 1983a, 1983b); and population projections of the states of Pennsylvania, Ohio, and West Virginia. Sector populations were determined by assuming that the population of a minor civil division is evenly distributed over its geographic area. The proportion of each civil division area in each annular sector was calculated and applied to each civil division's total population, yielding the population in each annular sector. Population growth factors, based on 1981 projections, supplied by the Pennsylvania Department of Environmental Resources (1981); 1983 updated projections for Beaver County, supplied by Pennsylvania Southwest Regional Planning Commission; 1981 projections, supplied by the West Virginia State Department of Health; and 1981 projections updated in 1983, supplied by the Ohio Department of Economic and Community Development, were applied to each civil division assuming that each portion would maintain its relative share of any population change (Pennsylvania Department of Environmental Resources 1981; Pennsylvania Southwest Regional Planning Commission 1983; Ohio Department of Economic and Community Development 1981 and 1983; and West Virginia Department of Health 1981). Population density was calculated by dividing the population in each sector by its land area. Figure 2.1-6 presents the annular sectors for population distribution within 10-50 miles of BVPS-2. Population distribution the 50-mile area for the years 1980-2030 is listed in Tables 2.1-10, 2.1-11, 2.1-12, 2.1-13, 2.1-14, 2.1-15 and 2.1-16.

The 50-mile region is heavily populated. In 1980, 22 boroughs, townships, and cities exceeded a population of 25,000 people. However, only three cities of over 100,000 people are located in the region: Pittsburgh, Pennsylvania; Canton City, Ohio; and Youngstown City, Ohio (USDOC 1982a, 1982b, and 1982c). Table 2.1-24 lists civil divisions with more than 25,000 people. Table 2.1-25 lists an additional six civil divisions projected to contain 25,000 or more people in the period 1980-2030.

Supporting a combined 1980 population of approximately 4.2 million, seven standard metropolitan statistical areas (SMSAs) are located totally or partially within the 50-mile radius of the station. Table 2.1-26 lists the seven SMSAs and their 1970 and 1980 populations and growth factors. Figure 2.1-9 represents the SMSAs within the 50-mile region.

### 2.1.3.3 Population between 50 and 350 Miles

Figure 2.1-7 shows the 350-mile region surrounding BVPS-2. Population distribution within 350 miles of the station for the years 1980-2030 was calculated in the same manner as that for 10-50 miles and is listed in Tables 2.1-17, 2.1-18, 2.1-19, 2.1-20, 2.1-21, 2.1-22 and 2.1-23. Figure 2.1-8 locates the annular sectors for population distribution within 50-350 miles of the station.

Population sector distributions and projections for the 50-350 mile area surrounding BVPS-2 are based on 1980 US Census data, population projections for the District of Columbia and the 13 states located in the 350-mile area, 1981 Canadian census data, and population projections for the Canadian Province of Ontario. (Delaware Development Office 1982, Illinois Office of State Planning 1981, Indiana University 1981, Maryland Center for Health Statistics 1980 and 1981, Maryland Department of State Planning 1981, Metropolitan Washington Council of Governments 1979, Michigan Department of Management and Budget 1978, New Jersey Department of Labor 1982, New York State Economic Development Board 1978, North Carolina Office of State Budget and Management 1981, Ohio Department of Development 1982, Ohio Department of Economic and Community Development 1983, Ontario Ministry of Treasury and Economics 1979, Pennsylvania Department of Environmental Resources 1981, Pennsylvania Southwest Regional Planning Commission 1983, Statistics Canada 1981, Tennessee Valley Authority 1980, University of Louisville 1981, Virginia Department of Planning and Budget 1980, West Virginia Department of Health 1981).

### 2.1.3.4 Transient Population

Within 10 miles of BVPS-2 several land uses attract seasonal and daily transient populations. Table 2.1-27 presents approximate daily transient population by annular sector within 10 miles of the station. Land uses and facilities that account for transient population include industries, recreational sites, and educational institutions. Transient population variations associated with industrial employment and school enrollment represent redistribution of existing population within the 10-mile area.

#### 2.1.3.4.1 Industry

Industries and employment are discussed in Section 2.2.2.

#### 2.1.3.4.2 Educational Institutions

Schools within the 10-mile radius area generate daily variations in population distribution. Table 2.1-28 identifies educational institutions within 10 miles of the station and their enrollments.

Total school enrollment for the 10-mile area equals approximately 29,000 (Pennsylvania Department of Education 1982; Western Beaver School District 1982; Beaver Area School District 1982; Blackhawk Area School District 1982; Hopewell Area School District 1982; Southside Area School District 1982; Center Area School District 1982; Midland Public Schools 1982; West Virginia Department of Education 1982). However, approximately 77 percent of the total, or 22,639 students served by the elementary and secondary schools reside within the 10-mile area (Pennsylvania Department of Education 1982; Western Beaver School District 1982; Beaver Area School District 1982; Blackhawk Area School District 1982; Hopewell Area School District 1982; Southside Area School District 1982; Center Area School District 1982; Midland Public Schools 1982; West Virginia Department of Education 1982).

Three colleges are located within the 10-mile area: the Beaver Campus of Pennsylvania State University, Beaver Community College, and the East Liverpool Campus of Kent State University. Pennsylvania State University-Beaver Campus is located in Monaca, approximately 8.5 miles east-northeast of the station. The university serves 200 on-campus residents, 1,004 full-time day students, and an additional 700 part-time evening students, generally residents of Beaver County (Pennsylvania State University 1982).

Beaver Community College is also located east-northeast of BVPS-2 at a distance of 7.5 miles. There are no on-campus residents at the college. Its fall and spring enrollment in 1981 equaled 964 and 1,109 full-time day students and 1,110 and 1,174 part-time evening students, respectively. The college operates a summer school which served 1,356 full and part-time students in 1981 (Beaver Community College 1982). Finally, the East Liverpool Campus of Kent State University is located approximately 7.5 miles west of BVPS-2. The East Liverpool Campus serves a 1982-83 enrollment of 660 full time students. No on-campus residents are associated with this campus (East Liverpool Campus of Kent State University 1983).

#### 2.1.3.4.3 Parks and Recreation

Local recreational sites generate a moderate level of transient population. Total estimated daily transient population associated with recreation equals 3,904 people; total 1981 visitor-day attendance figures of the recreational areas within 10 miles of the station equals 1,424,962. Table 2.1-29 presents transient population counts for recreational areas by annular sector. The Pennsylvania section of the 10-mile area contains the Raccoon State Park, the Brady Run County Park, and State Game Lands Numbers 173 and 189. No visitor attendance figures exist for the state game lands (Pennsylvania Department of Natural Resources 1982a). However, combined state and county park attendance within the Pennsylvania section totaled 501,152 in 1981. Both of these parks are located between 6 and 9 miles from the station. Camping facilities are available at both parks. Camping attendance in 1981 at the Raccoon

State Park equalled 14,423 visitor days (Pennsylvania Department of Natural Resources 1982a). No camping counts are recorded for the County park, which operates annually from May to September and attracts predominantly county residents (Pennsylvania Department of Natural Resources 1982b, and Beaver County Parks Department 1982).

Two additional state parks are located within 10 miles of the station: Tomlinson State Park in West Virginia and Beaver Creek State Forest in Ohio. The 1981 attendance counts for West Virginia and Ohio state recreational areas totaled 923,810 persons. Beaver Creek State Forest accounted for approximately 79 percent of this total, or 729,930 visitors. Of its 1981 total, the state forest includes 34,110 campers (Ohio Department of Natural Resources 1982). Tomlinson State Park, located approximately 10 miles southwest and west-southwest of the station, attracted 193,880 visitors in 1981. In 1981, 50 campsites were opened at the park; however, no camping counts are available.

#### 2.1.3.5 Low Population Zone

The low population zone (LPZ) surrounding BVPS-2 encompasses an area within approximately a 3.6-mile radius of the BVPS-2 reactor containment centerline. The distance for the LPZ is determined based on the requirements of 10 CFR 100. No population centers with populations equal to or greater than 25,000 exist within the LPZ, or within an area of radius  $1 \frac{1}{3}$  times the LPZ radius, approximately 4.8 miles.

The 3.6-mile boundary also meets the requirement that the LPZ should be an area in which sufficient protective measures can be taken to assure that the resident population does not receive a dose in excess of a specified level resulting from a postulated accident condition.

The LPZ contained a 1980 resident population of approximately 10,828 at an average density of 284 people per square mile. Table 2.1-30 presents the 1980 LPZ population distribution. By the years 1985 and 2030 the LPZ population is expected to have increased to 11,114 and 11,656 at average densities of 292 and 306 people per square mile, respectively. Table 2.1-30 identifies permanent population distribution in the LPZ. Transient population within the LPZ is identified by institution and by sector in Table 2.1-31 and 2.1-32, respectively.

#### 2.1.3.6 Population Centers

The nearest population center to BVPS-2, as defined by 10 CFR 100, is the township of McCandless, Pennsylvania which supported approximately 26,250 people in 1980 with a density of 1,608 people per square mile. The township's closest corporate boundary to the station is approximately 17 miles east. Table 2.1-24 lists existing population centers with over 25,000 people. Cities and towns



projected to become population centers in the period 1980 to 2030 are listed in Table 2.1-25.

#### 2.1.3.7 Population Density

The area within 30 miles of the station is expected to contain approximately 1,570,449 people at an average density of 565 people per square mile in 1985. This density is only slightly greater than the USNRC comparison figure of 500 people per square mile given in Regulatory Guide 1.70, Revision 3. Population within the area is expected to increase to a total of approximately 2,150,291 by the year 2030. Population density in 2030 will reach an average of approximately 773 people per square mile, which is below the USNRC density comparison for the end year of plant life of 1,000 people per square mile. Tables 2.1-33, 2.1-34 and 2.1-35 present population density by sector for distances 0-10 miles for the years 1980, 1985, and 2030. Sector population density for distances 10-50 miles for the same years are presented in Tables 2.1-36, 2.1-37 and 2.1-38.

#### 2.1.4 References for Section 2.1

Beaver Area School District 1982. Personal Communication between J. Haddad, Beaver Area School District, and K.A. Baraniak, SWEC, telephone conversation June 23, 1982.

Beaver Community College 1982. Personal Communication between S. Ensworth, Beaver Community College, and K.A. Baraniak, SWEC, telephone conversation June 22, 1982.

Beaver Valley Parks Department 1982. Personal Communication between F. Cona, Beaver Valley Parks Department, and K.A. Baraniak, SWEC, telephone conversation June 18, 1982.

Blackhawk Area School District 1982. Personal Communication between P. McCullough, Blackhawk Area School District, and K.A. Baraniak, SWEC, telephone conversation June 23, 1982.

Brooke-Hancock-Jefferson, W. Va. Metropolitan Planning Commission 1983a. Transmittal from Dorman R. Jefferis to K. Baraniak (SWEC), dated June 8, 1983.

Brooke-Hancock-Jefferson, W. Va. Metropolitan Planning Commission 1983b. Transmittal from Dorman R. Jefferis to K. Sutton (Hancock County Emergency Help Assistance), dated May 12, 1983.

Center Area District 1982. Personal Communication between H. Fink, Center Area School District, and K.A. Baraniak, SWEC, telephone conversation June 23, 1982.

Delaware Development Office 1982. Delaware Population Consortium, Population Projection Series Version: May 1982.

Duquesne Light Company (DLC) 1978. Personal communication between C.N. Dunn, DLC, Vice President of Operations, and A. Schwencer, USNRC, Chief, Division of Operating Reactors, letter dated July 17, 1978.

East Liverpool campus at Kent State University 1983. Personal communication between Mr. Daly, Kent State University, and K.A. Baraniak, SWEC, telephone conversation May 23, 1983.

Hopewell Area School District 1982. Personal communication between Hopewell Area School District Administrator, and K.A. Baraniak, SWEC, telephone conversation June 21, 1982.

Illinois Office of State Planning 1981. Population Projections by County: Open Population, 1970-2025, 1981.

Indiana University 1981. Division of Research of School of Business. 1978 Indiana County Population Projections Adjusted for 1980 Census Results, 1981.

Maryland Center for Health Statistics, Department of Health and Mental Hygiene. Maryland Population Estimates: July 1, 1978 and Projections to 1984, 1980.

Maryland Center for Health Statistics, Department of Health and Mental Hygiene Advance Report. Maryland Population Estimates: July 1, 1979 and July 1, 1980 and Projections to 1986 with Maryland Population at the 1970 and 1980 Censuses, 1981.

Maryland Department of State Planning 1981. Interim Population Projections for Maryland Political Subdivisions 1980-2000, 1981.

Metropolitan Washington Council of Governments 1979. Cooperative Forecasting, Round II Summary Report - 1979.

Michigan Department of Management and Budget 1978. Population Projections for Michigan to the Year 2000, Summary Report, State, Regions, Counties, 1978.

Midland Public Schools (Superintendent's Office) 1982. Personal communication between B. Coffin, Midland Public Schools, and K.A. Baraniak, SWEC, telephone conversation June 21, 1982.

New Jersey Department of Labor 1982. Division of Planning and Research, Office of Demographic and Economic Analysis. New Jersey Population Projections July 1, 1980-2000, 1982.

New York State Economic Development Board 1978. 1978 Official Population Projections by Age and Sex for New York State Counties, 1978.

North Carolina Office of State Budget and Management 1981.  
Research and Planning Services Update, North Carolina Population  
Projections, 1981.

Ohio Department of Development (Ohio Data Users Center) 1982.  
Population Projections for Ohio and Counties by Age and Sex, 1980  
to 2005, 1982.

Ohio Department of Economic and Community Development 1981. 1981 Ohio Industrial Directory, published by Harris Publishing Company, 1981.

Ohio Department of Economic and Community Development 1983. Personal communication between Jerry Cheider, Ohio Department of Economic and Community Development, and K.A. Baraniak, SWEC, telephone conversation April 25, 1983.

Ohio Department of Education 1982. Personal communication between J. Daubenmier, Ohio Department of Education, and K.A. Baraniak, SWEC, telephone conversation June 22, 1982.

Ohio Department of Natural Resources (Division of Parks and Recreation) 1982. Personal communication between M. Shuter, Ohio Department of Natural Resources, and K.A. Baraniak, SWEC, telephone conversation June 22, 1982.

Ontario Ministry of Treasury and Economics 1979, Social and Economic Data Central Statistical Services. Ontario: Population Projections by Regions and Counties for Years 1981, 1986, 1991, 1996, 2001, 1979.

Pennsylvania Department of Education 1982. Personal communication between R. Burrows, Pennsylvania Department of Education, and K.A. Baraniak, SWEC, telephone conversation June 23, 1982.

Pennsylvania Department of Environmental Resources 1981. DER Preliminary Population Projections, 1981.

Pennsylvania Department of Natural Resources (Game Commission) 1982a. Personal communication between J. Sitlinger, Pennsylvania Department of Natural Resources, and K.A. Baraniak, SWEC telephone conversations July 18, 1982.

Pennsylvania Department of Natural Resources (Bureau of State Parks) 1982b. Personal communication between R. Eberly, Pennsylvania Department of Natural Resources, and K.A. Baraniak, SWEC, telephone conversation June 18, 1982.

Pennsylvania Southwest Regional Planning Commission 1983. Personal communication between Mr. Howenstein, Pennsylvania Southwest Regional Planning Commission, and K.A. Baraniak, SWEC, telephone conversation April 22, 1983.

Pennsylvania State University Beaver Campus 1982. Personal communication between S. Hutchinson, Pennsylvania State University, and K.A. Baraniak, SWEC, telephone conversation June 21, 1982.

Southside Area School District 1982. Personal communication between Mrs. Collins, Southside Area School District, and K.A. Baraniak, SWEC, telephone conversation June 23, 1982.

Statistics Canada 1981. Interim Population Counts for Census Divisions and Census Subdivisions, 1981.

Tennessee Valley Authority. Bureau of Economic Analysis 1980. Total Personal Income, Population, Per Capita Income, and Earnings by Industry, Selected Years, 1969-2040, 1980.

University of Louisville. Urban Studies Center, Population Research Unit 1981. How Many Kentuckians: Population Forecasts, 1980-2020, the 1981 Preliminary Update, 1981.

U.S. Department of Commerce (Bureau of the Census) 1982a. Number of Inhabitants, Pennsylvania PC80-1-A40.

U.S. Department of Commerce (Bureau of the Census) 1982b. Number of Inhabitants, Ohio PC80-1-A37.

U.S. Department of Commerce (Bureau of the Census) 1982c. Number of Inhabitants, West Virginia PC80-1-A50.

U.S. Department of Commerce (Bureau of the Census) 1982d. Number of Inhabitants, Indiana PC80-1-A16.

U.S. Department of Commerce (Bureau of the Census) 1982e. Number of Inhabitants, Virginia PC80-1-A48.

U.S. Department of Commerce (Bureau of the Census) 1982f. Number of Inhabitants, Maryland PC80-1-A22.

U.S. Department of Commerce (Bureau of the Census) 1982g. Number of Inhabitants, Tennessee PC80-1-A44.

U.S. Department of Commerce (Bureau of the Census) 1982h. Number of Inhabitants, Illinois PC80-1-A15.

U.S. Department of Commerce (Bureau of the Census) 1982i. Number of Inhabitants, Delaware PC80-1-A09.

U.S. Department of Commerce (Bureau of the Census) 1982j. Number of Inhabitants, New Jersey PC80-1-A32.

U.S. Department of Commerce (Bureau of the Census) 1982k. Number of Inhabitants, New York PC80-1-A34.

U.S. Department of Commerce (Bureau of the Census) 1982l. Number of Inhabitants, Kentucky PC80-1-A19.

U.S. Department of Commerce (Bureau of the Census) 1982m. Number of Inhabitants, North Carolina PC80-1-A35.

U.S. Department of Commerce (Bureau of the Census) 1982n. Number of Inhabitants, Michigan PC80-1-A24.

U.S. Department of Commerce (Bureau of the Census) 1982o. Number of Inhabitants, Washington, D.C. PC80-1-A10.

Virginia Department of Planning and Budget 1980. Research Section. Population Projections, Virginia Counties and Cities, 1980-2000, 1980.

Western Beaver School District 1982. Personal communication between Mrs. Krakoss, Western Beaver School District, and K.A. Baraniak, SWEC, telephone conversation June 23, 1982.

West Virginia Department of Education 1982. Personal communication between G. Harper, West Virginia Department of Education, and K.A. Baraniak, SWEC, telephone conversation June 22, 1982.

West Virginia Department of Health 1981. Health Planning Guideline: Midyear County Population Projections 1981-1998.

West Virginia Department Natural Resources (Division of Parks and Recreation) 1982. Personal communication between D. Andrews, West Virginia Department of Natural Resources, and K.A. Baraniak, SWEC, telephone conversation June 18, 1982.

BVPS-2 UFSAR

Tables for Section 2.1

TABLE 2.1-1

1970-1980 POPULATION GROWTH FOR TOWNSHIPS, BOROUGHES,  
AND DISTRICTS LOCATED PARTIALLY OR ENTIRELY WITHIN  
10 MILES OF BVPS-2\*

	<u>1970</u>	<u>1980</u>	<u>1970-1980 Percent Change</u>
Pennsylvania - Beaver County	208,418	204,441	-1.9
<u>Boroughs</u>			
Aliquippa	22,277	17,094	-23.3
Beaver	6,100	5,441	-10.8
Bridgewater	966	879	-9.0
East Rochester	920	789	-14.2
Fallston	571	312	-45.4
Frankfort Springs	144	187	+29.9
Georgetown	234	231	-1.3
Glasgow	112	106	-5.4
Hookstown	246	228	-7.3
Industry	2,442	2,417	-1.0
Midland	5,271	4,310	-18.2
Monaca	7,486	7,661	+2.3
New Brighton	7,637	7,364	-3.6
Ohioville	3,918	4,217	+7.6
Rochester	4,819	4,759	-1.2
Shippingport	328	225	-31.4
<u>Townships</u>			
Brighton	7,532	7,858	+4.3
Center	10,598	10,733	+1.3
Chippewa	6,654	7,245	+8.9



TABLE 2.1-1 (Cont)

<u>Townships</u>	<u>1970</u>	<u>1980</u>	<u>1970-1980 Percent Change</u>
Greene	1,489	2,422	+62.7
Hanover	2,154	3,443	+59.8
Hopewell	14,133	14,662	+3.7
Independence	1,761	2,534	+43.9
Patterson	3,442	3,288	-4.5
Potter	484	605	+25.0
Pulaski	2,126	1,998	-6.0
Raccoon	2,615	3,133	+19.8
Rochester	4,089	3,427	-16.2
South Beaver	2,339	2,932	+25.4
Vanport	2,122	2,013	-5.1
Ohio - Columbiana County	108,310	113,572	+4.9
<u>Cities</u>			
East Liverpool	20,020	16,687	-16.6
<u>Townships</u>			
Liverpool	3,678	4,921	+33.8
Middleton	2,677	3,426	+28.0
St. Clair	7,428	8,080	+8.8
West Virginia - Hancock County	39,749	40,418	+1.7
<u>Districts</u>			
Clay	NA**	13,932	NA**
Grant	NA**	13,595	NA**

TABLE 2.1-1 (Cont)

NOTES:

\*Includes entire township, borough, and district populations.

\*\*NA - Not available due to 1980 changes in boundary definitions.

TABLE 2.1-2

1980 POPULATION AND POPULATION DENSITY FOR TOWNSHIPS, BOROUGHES,  
AND DISTRICTS LOCATED PARTIALLY OR ENTIRELY  
WITHIN 10 MILES OF BVPS-2\*

	Area <u>(mile<sup>2</sup>)</u>	1980 <u>Population</u>	Population Density <u>(people/mile<sup>2</sup>)</u>
Pennsylvania - Beaver County			
<u>Boroughs</u>			
Aliquippa	4.74	17,094	3606.3
Beaver	1.01	5,441	5387.1
Bridgewater	0.41	879	2143.9
East Rochester	0.49	789	1610.2
Fallston	0.88	312	354.5
Frankfort Springs	0.23	187	813.0
Georgetown	0.15	231	1540.0
Glasgow	0.17	106	623.5
Hookstown	0.14	228	1628.6
Industry	10.67	2,417	226.5
Midland	1.83	4,310	2355.2
Monaca	2.16	7,661	3546.8
New Brighton	0.95	7,364	7751.6
Ohioville	23.66	4,217	178.2
Rochester	0.63	4,759	7554.0
Shippingport	3.90	255	65.4
<u>Townships</u>			
Brighton	18.82	7,858	417.5
Center	14.77	10,733	726.7
Chippewa	16.48	7,245	439.6

TABLE 2.1-2 (Cont)

<u>Townships</u>	<u>Area</u> <u>(mile<sup>2</sup>)</u>	<u>1980</u> <u>Population</u>	<u>Population</u> <u>Density</u> <u>(people/mile<sup>2</sup>)</u>
Greene	26.72	2,422	90.6
Hanover	44.76	3,443	76.9
Hopewell	15.78	14,662	929.2
Independence	23.66	2,534	107.1
Patterson	1.41	3,288	2331.9
Potter	6.48	605	93.4
Pulaski	0.69	1,998	2895.7
Raccoon	19.27	3,133	162.6
Rochester	0.60	3,427	5711.7
South Beaver	28.88	2,932	101.5
Vanport	0.95	2,013	2118.9
Ohio - Columbiana County			
<u>Cities</u>			
East Liverpool	4.5	16,687	3708.2
<u>Townships</u>			
Liverpool	8.0	4,921	615.1
Middleton	35.5	3,128	88.1
St. Clair	30.0	8,080	269.3
West Virginia - Hancock County			
<u>Districts</u>			
Clay	26.0	13,932	535.8
Grant	48.4	13,595	280.9

\* Based on entire population and land area of each township, borough, or district.

TABLE 2.1-3  
POPULATION DISTRIBUTION FOR 1980, 0-10 MILES

Distance from BVPS-2 (miles)

<u>Direction</u>	<u>0.0- 0.5</u>	<u>0.5- 1.0</u>	<u>1.0- 1.5</u>	<u>1.5- 2.0</u>	<u>2.0- 2.5</u>	<u>2.5- 3.0</u>	<u>3.0- 3.5</u>	<u>3.5- 4.0</u>	<u>4.0- 4.5</u>	<u>4.5- 5.0</u>	<u>5.0- 6.0</u>	<u>6.0- 7.0</u>	<u>7.0- 8.5</u>	<u>8.5- 10.0</u>	<u>Total</u>
N	0	0	0	37	37	47	217	137	156	227	467	281	529	959	3,094
NNE	0	0	7	311	27	40	81	61	100	131	2,591	592	698	3,808	8,447
NE	23	34	0	0	154	351	554	93	82	230	507	1,546	4,893	12,682	21,149
ENE	2	55	54	0	61	99	91	69	33	43	302	3,523	2,057	10,183	16,572
E	28	0	16	40	266	102	272	136	99	43	235	1,276	10,353	14,293	27,159
ESE	6	28	3	136	53	77	121	173	142	167	361	393	1,207	7,579	10,446
SE	11	2	19	133	65	130	83	25	0	0	349	87	610	653	2,167
SSE	0	2	11	7	49	19	60	29	68	343	178	70	261	392	1,489
S	0	0	11	14	124	68	21	82	138	180	474	45	519	429	2,105
SSW	0	11	11	21	50	28	67	78	46	77	249	24	401	398	1,461
SW	0	0	4	71	89	274	202	135	156	89	283	243	354	638	2,538
WSW	0	0	4	7	53	107	60	64	25	72	543	651	694	499	2,779
W	0	0	4	11	21	36	53	14	25	91	2,257	4,719	12,256	6,354	25,841
WNW	0	5	0	11	0	6	23	276	161	416	537	371	3,243	2,227	7,276
NW	0	284	1,049	938	553	1,661	227	434	321	136	386	84	298	238	6,609
NNW	0	74	95	63	26	49	66	0	16	343	690	102	368	262	2,154
Total	70	495	1,288	1,800	1,628	3,094	2,198	1,806	1,568	2,588	10,409	14,007	38,741	61,594	141,286

TABLE 2.1-4  
POPULATION DISTRIBUTION FOR 1985, 0-10 MILES

<u>Direction</u>	<u>Distance from BVPS-2 (miles)</u>														<u>Total</u>
	<u>0.0-0.5</u>	<u>0.5-1.0</u>	<u>1.0-1.5</u>	<u>1.5-2.0</u>	<u>2.0-2.5</u>	<u>2.5-3.0</u>	<u>3.0-3.5</u>	<u>3.5-4.0</u>	<u>4.0-4.5</u>	<u>4.5-5.0</u>	<u>5.0-6.0</u>	<u>6.0-7.0</u>	<u>7.0-8.5</u>	<u>8.5-10.0</u>	
N	0	0	0	37	37	47	220	138	158	230	472	284	535	969	3,127
NNE	0	0	7	314	27	41	82	62	101	132	2,620	599	705	3,851	8,541
NE	24	34	0	0	155	355	561	94	83	232	513	1,563	4,947	12,822	21,383
ENE	2	56	55	0	62	100	92	69	33	44	306	3,562	2,080	10,296	16,757
E	28	0	16	41	269	103	275	137	100	43	238	1,290	10,467	14,451	27,458
ESE	6	29	3	137	53	78	122	175	144	169	365	398	1,221	7,662	10,562
SE	11	2	19	134	66	131	84	25	0	0	353	88	617	660	2,190
SSE	0	2	11	7	49	20	61	29	69	346	180	71	264	396	1,505
S	0	0	11	14	126	69	22	83	139	182	479	45	525	434	2,129
SSW	0	11	11	22	50	28	68	79	47	77	252	24	405	402	1,476
SW	0	0	4	72	90	278	205	136	158	90	286	245	357	644	2,565
WSW	0	0	4	7	54	108	61	65	25	73	548	658	701	504	2,808
W	0	0	4	11	22	36	54	14	25	93	2,300	4,801	12,520	6,472	26,352
WNW	0	5	0	11	0	6	23	280	162	426	549	380	3,319	2,280	7,441
NW	0	287	1,061	948	559	1,680	230	439	325	138	390	85	305	243	6,690
NNW	0	75	96	64	26	50	67	0	16	347	698	103	372	265	2,179
Total	71	501	1,302	1,819	1,645	3,130	2,227	1,825	1,585	2,622	10,549	14,196	39,340	62,351	143,163

TABLE 2.1-5  
POPULATION DISTRIBUTION FOR 1990, 0-10 MILES

Distance from BVPS-2 (miles)

<u>Direction</u>	<u>0.0-0.5</u>	<u>0.5-1.0</u>	<u>1.0-1.5</u>	<u>1.5-2.0</u>	<u>2.0-2.5</u>	<u>2.5-3.0</u>	<u>3.0-3.5</u>	<u>3.5-4.0</u>	<u>4.0-4.5</u>	<u>4.5-5.0</u>	<u>5.0-6.0</u>	<u>6.0-7.0</u>	<u>7.0-8.5</u>	<u>8.5-10.0</u>	<u>Total</u>
N	0	0	0	38	38	48	222	140	159	232	478	288	541	981	3,165
NNE	0	0	7	318	27	41	83	62	102	134	2,652	606	715	3,898	8,645
NE	24	35	0	0	157	359	568	96	84	235	519	1,582	5,009	12,981	21,649
ENE	2	57	55	0	63	101	94	70	34	45	309	3,606	2,105	10,424	16,965
E	28	0	16	41	272	104	278	139	101	44	240	1,306	10,597	14,630	27,796
ESE	7	29	3	139	54	79	123	177	145	171	369	402	1,235	7,758	10,691
SE	11	2	19	136	66	133	85	25	0	0	357	89	624	669	2,216
SSE	0	2	11	7	50	20	62	29	69	351	183	72	267	401	1,524
S	0	0	11	15	127	70	22	84	141	184	485	46	531	439	2,155
SSW	0	11	11	22	51	28	69	80	47	79	255	25	410	407	1,495
SW	0	0	4	73	91	280	207	138	160	91	289	247	361	649	2,590
WSW	0	0	4	7	55	109	62	65	25	73	552	663	706	508	2,829
W	0	0	4	11	22	36	55	15	25	94	2,343	4,877	12,775	6,582	26,839
WNW	0	5	0	11	0	6	23	283	164	435	561	388	3,396	2,332	7,604
NW	0	291	1,074	960	566	1,700	232	444	329	139	395	88	311	250	6,779
NNW	0	76	97	65	27	50	67	0	16	351	706	104	377	268	2,204
Total	72	508	1,316	1,843	1,666	3,164	2,252	1,847	1,601	2,658	10,693	14,389	39,960	63,177	145,146

TABLE 2.1-6  
POPULATION DISTRIBUTION FOR 2000, 0-10 MILES

<u>Direction</u>	<u>Distance from BVPS-2 (miles)</u>														<u>Total</u>
	<u>0.0-0.5</u>	<u>0.5-1.0</u>	<u>1.0-1.5</u>	<u>1.5-2.0</u>	<u>2.0-2.5</u>	<u>2.5-3.0</u>	<u>3.0-3.5</u>	<u>3.5-4.0</u>	<u>4.0-4.5</u>	<u>4.5-5.0</u>	<u>5.0-6.0</u>	<u>6.0-7.0</u>	<u>7.0-8.5</u>	<u>8.5-10.0</u>	
N	0	0	0	37	37	47	221	139	158	231	474	286	538	974	3,142
NNE	0	0	7	316	27	41	82	62	102	133	2,632	601	710	3,868	8,581
NE	24	35	0	0	156	356	563	94	83	234	515	1,571	4,971	12,882	21,484
ENE	2	56	55	0	62	101	93	70	34	44	307	3,579	2,090	10,346	16,839
E	28	0	16	41	270	104	276	138	100	44	239	1,296	10,518	14,519	27,589
ESE	6	29	3	138	53	78	122	176	144	170	367	399	1,226	7,700	10,611
SE	11	2	19	135	66	132	85	25	0	0	354	88	620	664	2,201
SSE	0	2	11	7	49	20	61	29	69	348	182	71	265	398	1,512
S	0	0	11	14	126	69	22	83	140	183	482	46	527	436	2,139
SSW	0	11	11	22	50	28	69	79	47	79	253	24	407	406	1,486
SW	0	0	4	72	90	279	206	137	159	90	287	250	356	659	2,598
WSW	0	0	4	7	54	108	61	65	25	73	560	672	717	515	2,861
W	0	0	4	11	22	36	54	14	25	96	2,422	5,022	13,269	6,794	27,769
WNW	0	5	0	11	0	6	23	281	163	451	583	405	3,541	2,432	7,901
NW	0	288	1,066	953	561	1,687	231	441	326	138	392	90	324	260	6,757
NNW	0	75	96	64	26	50	67	0	16	348	701	103	374	266	2,186
Total	71	503	1,307	1,828	1,649	3,142	2,236	1,833	1,591	2,662	10,750	14,503	40,462	63,119	145,656



TABLE 2.1-7

POPULATION DISTRIBUTION FOR 2010, 0-10 MILES

Distance from BVPS-2 (miles)

<u>Direction</u>	<u>0.0- 0.5</u>	<u>0.5- 1.0</u>	<u>1.0- 1.5</u>	<u>1.5- 2.0</u>	<u>2.0- 2.5</u>	<u>2.5- 3.0</u>	<u>3.0- 3.5</u>	<u>3.5- 4.0</u>	<u>4.0- 4.5</u>	<u>4.5- 5.0</u>	<u>5.0- 6.0</u>	<u>6.0- 7.0</u>	<u>7.0- 8.5</u>	<u>8.5- 10.0</u>	<u>Total</u>
N	0	0	0	38	38	48	224	141	161	234	483	289	546	991	3,193
NNE	0	0	7	321	28	41	83	63	103	135	2,675	611	721	3,931	8,719
NE	24	35	0	0	159	362	573	96	84	237	523	1,597	5,053	13,094	21,837
ENE	2	57	56	0	64	102	94	71	34	45	312	3,638	2,124	10,515	17,114
E	29	0	16	41	274	105	281	140	102	44	243	1,318	10,691	14,760	28,044
ESE	7	29	3	140	54	80	124	179	147	172	372	406	1,246	7,826	10,785
SE	11	2	19	137	67	134	86	26	0	0	360	90	630	674	2,236
SSE	0	2	11	7	50	20	63	29	71	354	184	73	270	405	1,539
S	0	0	11	15	128	70	22	84	142	186	489	46	536	443	2,172
SSW	0	11	11	22	51	29	70	81	48	79	257	25	414	411	1,509
SW	0	0	4	73	92	283	209	139	161	92	292	251	367	661	2,624
WSW	0	0	4	7	55	110	62	66	26	74	562	675	719	517	2,877
W	0	0	4	11	22	37	55	15	26	98	2,495	5,144	13,740	6,979	28,626
WNW	0	5	0	11	0	6	24	286	166	468	607	421	3,687	2,532	8,213
NW	0	293	1,083	969	571	1,715	234	448	332	140	399	93	337	271	6,885
NNW	0	76	98	66	27	51	68	0	17	354	713	106	380	271	2,227
Total	73	510	1,327	1,858	1,680	3,193	2,272	1,864	1,620	2,712	10,966	14,783	41,461	64,281	148,600

TABLE 2.1-8

POPULATION DISTRIBUTION FOR 2010, 0-10 MILES

Distance from BVPS-2 (miles)

<u>Direction</u>	<u>0.0- 0.5</u>	<u>0.5- 1.0</u>	<u>1.0- 1.5</u>	<u>1.5- 2.0</u>	<u>2.0- 2.5</u>	<u>2.5- 3.0</u>	<u>3.0- 3.5</u>	<u>3.5- 4.0</u>	<u>4.0- 4.5</u>	<u>4.5- 5.0</u>	<u>5.0- 6.0</u>	<u>6.0- 7.0</u>	<u>7.0- 8.5</u>	<u>8.5- 10.0</u>	<u>Total</u>
N	0	0	0	39	39	49	228	144	165	238	491	297	556	1,008	3,254
NNE	0	0	7	327	28	42	85	65	105	138	2,725	622	734	4,004	8,882
NE	25	36	0	0	162	369	583	98	87	241	534	1,626	5,145	13,335	22,241
ENE	2	58	57	0	65	104	96	72	35	45	318	3,705	2,163	10,709	17,429
E	29	0	16	42	279	107	286	143	104	45	247	1,341	10,886	15,030	28,555
ESE	7	29	3	143	55	81	127	182	149	175	379	413	1,269	7,969	10,981
SE	11	2	19	140	68	136	88	26	0	0	367	91	642	687	2,277
SSE	0	2	11	7	51	20	64	30	71	360	188	73	274	412	1,563
S	0	0	11	15	131	71	22	86	145	189	498	47	546	451	2,212
SSW	0	11	11	22	52	29	71	82	49	81	262	25	422	417	1,534
SW	0	0	4	75	93	289	213	142	164	93	297	251	365	658	2,644
WSW	0	0	4	7	56	112	63	67	26	75	561	672	716	515	2,874
W	0	0	4	11	22	37	56	15	26	99	2,559	5,244	14,187	7,141	29,401
WNW	0	5	0	11	0	6	24	291	168	486	628	438	3,830	2,631	8,518
NW	0	299	1,103	986	582	1,747	239	456	338	143	406	96	350	281	7,026
NNW	0	78	100	67	27	52	70	0	17	361	726	107	387	276	2,268
Total	74	520	1,350	1,892	1,710	3,251	2,315	1,899	1,649	2,769	11,186	15,048	42,472	65,524	151,659

TABLE 2.1-9

POPULATION DISTRIBUTION FOR 2030, 0-10 MILES

Distance from BVPS-2 (miles)

<u>Direction</u>	<u>0.0- 0.5</u>	<u>0.5- 1.0</u>	<u>1.0- 1.5</u>	<u>1.5- 2.0</u>	<u>2.0- 2.5</u>	<u>2.5- 3.0</u>	<u>3.0- 3.5</u>	<u>3.5- 4.0</u>	<u>4.0- 4.5</u>	<u>4.5- 5.0</u>	<u>5.0- 6.0</u>	<u>6.0- 7.0</u>	<u>7.0- 8.5</u>	<u>8.5- 10.0</u>	<u>Total</u>
N	0	0	0	40	40	50	234	147	168	245	502	302	569	1,033	3,330
NNE	0	0	7	334	29	43	87	66	108	141	2,789	637	752	4,098	9,091
NE	25	37	0	0	165	377	597	100	88	247	546	1,664	5,267	13,650	22,763
ENE	2	60	58	0	66	107	98	74	36	47	325	3,792	2,214	10,961	17,840
E	30	0	17	43	286	110	293	146	106	47	253	1,373	11,143	15,383	29,230
ESE	7	31	3	146	57	83	130	186	153	180	388	423	1,299	8,158	11,244
SE	11	2	20	143	70	140	90	27	0	0	376	94	656	702	2,331
SSE	0	2	11	7	52	21	65	31	74	369	192	76	281	422	1,603
S	0	0	13	15	134	73	23	88	148	194	510	48	559	461	2,266
SSW	0	11	11	23	53	30	73	84	50	83	268	26	432	424	1,568
SW	0	0	4	76	96	295	218	145	168	96	304	250	362	650	2,664
WSW	0	0	4	8	57	115	65	69	27	77	554	663	707	508	2,854
W	0	0	4	11	23	38	57	15	27	100	2,617	5,325	14,610	7,281	30,108
WNW	0	5	0	11	0	6	25	298	173	502	652	454	3,971	2,727	8,824
NW	0	306	1,129	1,010	595	1,787	244	467	346	146	415	100	362	291	7,198
NNW	0	80	102	68	28	53	71	0	17	369	743	109	396	282	2,318
Total	75	534	1,383	1,935	1,751	3,328	2,370	1,943	1,689	2,843	11,434	15,336	43,580	67,031	155,232

TABLE 2.1-10

POPULATION DISTRIBUTION FOR 1980, 10-50 MILES

Distance from BVPS-2 (miles)

<u>Distance</u>	<u>0.0- 10.0</u>	<u>10.0- 12.5</u>	<u>12.5- 15.0</u>	<u>15.0- 17.5</u>	<u>17.5- 20.0</u>	<u>20.0- 25.0</u>	<u>25.0- 30.0</u>	<u>30.0- 35.0</u>	<u>35.0- 40.0</u>	<u>40.0- 45.0</u>	<u>45.0- 50.0</u>	<u>0.0- 50.0</u>
N	3,094	5,547	2,415	1,801	1,525	11,510	43,796	14,041	16,527	59,506	13,845	173,607
NNE	8,447	19,094	3,158	5,595	13,631	8,814	9,163	4,596	8,616	19,262	5,493	105,869
NE	21,149	12,048	3,478	2,428	7,564	4,563	6,084	8,833	7,684	4,086	6,182	84,099
ENE	16,572	8,794	3,394	5,553	5,838	10,446	12,355	37,733	12,087	10,664	15,960	139,396
E	27,159	15,787	5,138	4,011	8,032	28,544	23,950	27,292	69,721	20,492	25,759	255,885
ESE	10,446	14,813	12,002	13,463	13,443	175,492	266,348	260,478	141,869	60,329	52,204	1,020,887
SE	2,167	3,437	4,476	7,254	8,693	70,018	206,491	102,055	66,465	61,489	36,983	569,528
SSE	1,489	1,107	1,474	2,523	4,054	11,696	29,411	43,100	9,669	11,323	14,889	130,735
S	2,105	646	1,036	3,377	2,251	3,307	4,805	6,570	7,009	3,911	3,892	38,909
SSW	1,461	1,105	1,998	15,064	15,256	34,232	12,811	9,151	26,360	57,646	30,738	205,822
SW	2,538	1,729	6,695	7,512	3,134	21,347	5,575	5,475	7,499	4,910	8,125	74,539
WSW	2,779	1,347	1,173	1,492	818	1,349	4,041	2,179	4,169	3,068	3,165	25,580
W	25,841	5,293	3,074	1,676	677	3,035	1,593	3,525	8,756	7,705	12,242	73,417
WNW	7,276	2,516	1,257	1,308	1,028	6,290	4,446	5,806	14,360	38,556	39,385	122,228
NW	6,609	1,427	1,153	1,489	1,818	10,076	20,938	14,192	11,067	10,230	16,531	95,570
NNW	2,154	1,068	1,279	6,563	2,905	8,420	30,681	118,625	121,374	62,094	84,049	439,212
Total	141,286	95,758	53,200	81,109	90,667	409,139	682,488	663,651	533,232	435,311	369,442	3,555,283

TABLE 2.1-11

POPULATION DISTRIBUTION FOR 1985, 10-50 MILES

Distance from BVPS-2 (miles)

<u>Distance</u>	<u>0.0- 10.0</u>	<u>10.0- 12.5</u>	<u>12.5- 15.0</u>	<u>15.0- 17.5</u>	<u>17.5- 20.0</u>	<u>20.0- 25.0</u>	<u>25.0- 30.0</u>	<u>30.0- 35.0</u>	<u>35.0- 40.0</u>	<u>40.0- 45.0</u>	<u>45.0- 50.0</u>	<u>Total 0.0- 50.0</u>
N	3,127	5,608	2,443	1,829	1,553	11,726	44,553	14,232	16,839	60,975	14,172	177,057
NNE	8,541	19,304	3,193	5,664	13,881	8,982	9,352	4,705	8,976	19,824	5,649	108,071
NE	21,383	12,182	3,516	2,454	7,884	4,767	6,421	9,320	8,106	4,313	6,506	86,852
ENE	16,757	8,891	3,435	5,818	6,160	11,025	13,037	39,819	12,756	11,167	16,407	145,272
E	27,458	15,961	5,193	4,053	8,129	28,862	24,273	27,676	71,208	21,047	26,441	260,301
ESE	10,562	14,963	12,112	13,589	13,564	177,112	268,805	262,882	143,330	61,876	53,569	1,032,364
SE	2,190	3,468	4,517	7,321	8,774	70,662	208,488	103,242	67,408	63,022	38,128	577,220
SSE	1,505	1,122	1,502	2,574	4,154	11,998	30,319	44,436	9,967	11,677	15,444	134,698
S	2,129	666	1,067	3,482	2,322	3,409	4,950	6,748	7,156	4,003	4,100	40,032
SSW	1,476	1,121	2,026	15,224	15,401	33,761	12,764	9,048	26,098	57,225	31,389	205,533
SW	2,565	1,746	6,615	7,382	3,051	20,781	5,431	5,433	7,593	5,017	8,225	73,839
WSW	2,808	1,360	1,151	1,454	795	1,312	3,989	2,311	4,360	3,230	3,296	26,066
W	26,352	5,413	3,146	1,710	687	3,109	1,704	3,800	9,436	8,112	12,500	75,969
WNW	7,441	2,577	1,286	1,338	1,051	6,438	4,562	5,955	14,498	38,759	39,638	123,543
NW	6,690	1,461	1,181	1,524	1,862	10,296	21,290	14,238	10,775	10,235	16,913	96,465
NNW	2,179	1,085	1,302	6,714	2,972	8,254	29,871	115,488	119,103	62,889	85,178	435,035
Total	143,163	96,928	53,685	82,130	92,240	412,494	689,809	669,333	537,609	443,371	377,555	3,598,317

TABLE 2.1-12

POPULATION DISTRIBUTION FOR 1990, 10-50 MILES

Distance from BVPS-2 (miles)

<u>Distance</u>	<u>0.0-10.0</u>	<u>10.0-12.5</u>	<u>12.5-15.0</u>	<u>15.0-17.5</u>	<u>17.5-20.0</u>	<u>20.0-25.0</u>	<u>25.0-30.0</u>	<u>30.0-35.0</u>	<u>35.0-40.0</u>	<u>40.0-45.0</u>	<u>45.0-50.0</u>	<u>Total 0.0-50.0</u>
N	3,165	5,677	2,472	1,860	1,584	11,959	45,379	14,448	17,156	62,531	14,516	180,747
NNE	8,645	19,544	3,232	5,739	14,152	9,158	9,547	4,815	9,292	20,400	5,813	110,337
NE	21,649	12,333	3,559	2,486	8,144	4,934	6,688	9,709	8,447	4,493	6,772	89,214
ENE	16,965	9,004	3,479	6,036	6,418	11,484	13,583	41,481	13,287	11,584	16,833	150,154
E	27,796	16,159	5,274	4,157	8,344	29,616	24,929	28,395	72,974	21,543	27,072	266,259
ESE	10,691	15,240	12,422	13,935	13,908	181,615	275,640	269,566	146,945	63,241	54,749	1,057,952
SE	2,216	3,556	4,632	7,508	8,996	72,462	213,804	105,916	69,184	64,656	39,206	592,136
SSE	1,524	1,152	1,543	2,645	4,273	12,342	31,215	45,748	10,262	12,020	15,970	138,694
S	2,155	684	1,099	3,585	2,391	3,510	5,092	6,925	7,299	4,092	4,298	41,130
SSW	1,495	1,137	2,051	15,352	15,536	33,365	12,732	8,958	25,855	56,817	32,006	205,304
SW	2,590	1,760	6,543	7,269	2,979	20,292	5,307	5,403	7,694	5,120	8,319	73,276
WSW	2,829	1,371	1,132	1,420	778	1,281	3,946	2,432	4,541	3,383	3,421	26,534
W	26,839	5,530	3,219	1,746	699	3,187	1,807	4,056	10,068	8,489	12,735	78,375
WNW	7,604	2,635	1,317	1,369	1,075	6,586	4,674	6,103	14,637	38,950	39,875	124,825
NW	6,779	1,494	1,209	1,559	1,905	10,514	21,648	14,306	10,525	10,221	17,281	97,441
NNW	2,204	1,101	1,325	6,865	3,038	8,118	29,178	112,812	117,165	63,554	86,124	431,484
Total	145,146	98,377	54,508	83,531	94,220	420,423	705,169	681,073	545,331	451,094	384,990	3,663,862

TABLE 2.1-13

POPULATION DISTRIBUTION FOR 2000, 10-50 MILES

Distance from BVPS-2 (miles)

<u>Distance</u>	<u>0.0-10.0</u>	<u>10.0-12.5</u>	<u>12.5-15.0</u>	<u>15.0-17.5</u>	<u>17.5-20.0</u>	<u>20.0-25.0</u>	<u>25.0-30.0</u>	<u>30.0-35.0</u>	<u>35.0-40.0</u>	<u>40.0-45.0</u>	<u>45.0-50.0</u>	<u>Total 0.0-50.0</u>
N	3,142	5,634	2,453	1,866	1,599	12,071	45,764	14,536	17,496	63,942	14,840	183,343
NNE	8,581	19,397	3,209	5,709	14,269	9,243	9,651	4,884	9,595	20,908	5,960	111,406
NE	21,484	12,241	3,533	2,468	8,368	5,087	6,964	10,110	8,792	4,679	7,046	90,772
ENE	16,839	8,935	3,458	6,241	6,682	11,957	14,143	43,190	13,837	11,992	17,181	154,455
E	27,589	16,039	5,273	4,257	8,551	30,339	25,560	29,044	74,265	21,851	27,473	270,241
ESE	10,611	15,341	12,716	14,263	14,238	185,913	282,161	275,946	150,293	63,890	55,286	1,080,658
SE	2,201	3,639	4,742	7,686	9,209	74,175	218,863	108,426	70,826	65,852	39,937	605,556
SSE	1,512	1,178	1,580	2,708	4,374	12,636	31,957	46,837	10,505	12,309	16,479	142,075
S	2,139	700	1,125	3,670	2,446	3,593	5,213	7,072	7,399	4,186	4,581	42,124
SSW	1,486	1,155	2,086	15,580	15,771	33,076	12,763	8,872	25,504	56,092	32,923	205,308
SW	2,598	1,785	6,495	7,176	2,911	19,826	5,189	5,417	7,902	5,279	8,439	73,017
WSW	2,861	1,391	1,119	1,388	760	1,252	3,930	2,630	4,830	3,625	3,612	27,398
W	27,769	5,758	3,357	1,814	721	3,328	1,971	4,453	11,056	9,098	13,152	82,477
WNW	7,901	2,748	1,373	1,428	1,122	6,868	4,885	6,379	14,977	39,515	40,510	127,706
NW	6,757	1,558	1,261	1,625	1,987	10,944	22,403	14,566	10,295	10,315	17,935	99,646
NNW	2,186	1,109	1,352	7,141	3,162	8,012	28,537	110,328	115,609	64,818	87,891	430,145
Total	145,656	98,608	55,132	85,020	96,170	428,320	719,954	692,690	553,181	458,351	393,245	3,726,327

TABLE 2.1-14

POPULATION DISTRIBUTION FOR 2010, 10-50 MILES

Distance from BVPS-2 (miles)

<u>Distance</u>	<u>0.0-10.0</u>	<u>10.0-12.5</u>	<u>12.5-15.0</u>	<u>15.0-17.5</u>	<u>17.5-20.0</u>	<u>20.0-25.0</u>	<u>25.0-30.0</u>	<u>30.0-35.0</u>	<u>35.0-40.0</u>	<u>40.0-45.0</u>	<u>45.0-50.0</u>	<u>Total 0.0-50.0</u>
N	3,193	5,727	2,493	1,915	1,650	12,452	47,155	14,929	18,003	66,685	15,433	189,635
NNE	8,719	19,717	3,261	5,814	14,711	9,536	9,943	5,017	9,795	21,800	6,250	114,563
NE	21,837	12,443	3,590	2,508	8,434	5,137	6,995	10,152	8,831	4,698	7,117	91,742
ENE	17,114	9,082	3,514	6,281	6,712	12,008	14,205	43,378	13,895	12,121	17,655	155,965
E	28,044	16,306	5,496	4,760	9,520	33,856	28,358	31,938	78,193	22,200	27,992	286,663
ESE	10,785	16,344	14,256	15,991	15,964	208,422	316,323	309,359	167,408	64,590	55,702	1,195,135
SE	2,236	4,074	5,316	8,615	10,324	83,153	244,993	120,524	78,026	68,643	41,037	666,941
SSE	1,539	1,293	1,711	2,920	4,637	13,346	33,161	48,596	10,901	12,774	17,126	148,004
S	2,172	725	1,167	3,808	2,539	3,727	5,402	7,310	7,584	4,311	4,852	43,597
SSW	1,509	1,171	2,107	15,655	15,954	32,969	12,833	8,817	25,193	55,391	33,815	205,414
SW	2,624	1,792	6,447	7,102	2,866	19,523	5,115	5,458	8,129	5,436	8,548	73,040
WSW	2,877	1,396	1,112	1,367	749	1,233	3,933	2,807	5,110	3,851	3,783	28,218
W	28,626	5,982	3,494	1,885	747	3,467	2,117	4,802	11,917	9,626	13,499	86,162
WNW	8,213	2,861	1,429	1,486	1,169	7,150	5,097	6,652	15,299	39,931	41,002	130,289
NW	6,885	1,622	1,312	1,693	2,067	11,377	23,185	14,876	10,167	10,482	18,546	102,212
NNW	2,227	1,137	1,393	7,428	3,291	7,978	28,178	108,946	114,702	65,408	88,715	429,403
Total	148,600	101,672	58,098	89,228	101,334	465,334	786,993	743,552	583,153	467,947	401,072	3,946,983



TABLE 2.1-15

POPULATION DISTRIBUTION FOR 2020, 10-50 MILES

Distance from BVPS-2 (miles)

<u>Distance</u>	<u>0.0-10.0</u>	<u>10.0-12.5</u>	<u>12.5-15.0</u>	<u>15.0-17.5</u>	<u>17.5-20.0</u>	<u>20.0-25.0</u>	<u>25.0-30.0</u>	<u>30.0-35.0</u>	<u>35.0-40.0</u>	<u>40.0-45.0</u>	<u>45.0-50.0</u>	<u>Total 0.0-50.0</u>
N	3,254	5,832	2,540	1,967	1,704	12,863	48,669	15,381	18,495	69,577	16,049	196,331
NNE	8,882	20,076	3,322	5,932	15,183	9,850	10,237	5,128	9,784	22,673	6,552	117,619
NE	22,241	12,670	3,656	2,552	8,260	5,038	6,746	9,793	8,520	4,534	6,934	90,944
ENE	17,429	9,248	3,576	6,111	6,474	11,583	13,700	41,840	13,405	11,884	17,999	153,249
E	28,555	16,609	5,799	5,487	10,905	38,909	32,317	36,005	82,914	22,278	28,212	307,990
ESE	10,981	17,754	16,492	18,499	18,469	241,127	365,958	357,892	192,094	64,414	55,236	1,358,916
SE	2,277	4,707	6,150	9,968	11,944	96,203	282,860	137,835	88,130	71,605	41,756	753,435
SSE	1,563	1,454	1,886	3,198	4,951	14,168	34,216	50,136	11,245	13,176	17,634	153,627
S	2,212	748	1,204	3,929	2,619	3,847	5,572	7,516	7,750	4,417	5,065	44,879
SSW	1,534	1,179	2,115	15,616	16,086	33,205	12,971	8,822	24,973	54,742	34,551	205,794
SW	2,644	1,784	6,442	7,103	2,871	19,555	5,128	5,550	8,379	5,570	8,623	73,649
WSW	2,874	1,389	1,119	1,369	750	1,234	3,979	2,949	5,346	4,036	3,925	28,970
W	29,401	6,200	3,632	1,955	772	3,602	2,229	5,067	12,576	10,033	13,768	89,235
WNW	8,518	2,972	1,485	1,544	1,213	7,428	5,299	6,917	15,641	40,328	41,467	132,812
NW	7,026	1,686	1,363	1,759	2,147	11,808	23,997	15,279	10,224	10,745	19,095	105,129
NNW	2,268	1,164	1,435	7,711	3,416	8,064	28,336	109,558	115,243	65,513	88,853	431,561
Total	151,659	105,472	62,216	94,700	107,764	518,484	882,214	815,668	624,719	475,525	405,719	4,244,140

TABLE 2.1-16

POPULATION DISTRIBUTION FOR 2030, 10-50 MILES

Distance from BVPS-2 (miles)

<u>Distance</u>	<u>0.0-10.0</u>	<u>10.0-12.5</u>	<u>12.5-15.0</u>	<u>15.0-17.5</u>	<u>17.5-20.0</u>	<u>20.0-25.0</u>	<u>25.0-30.0</u>	<u>30.0-35.0</u>	<u>35.0-40.0</u>	<u>40.0-45.0</u>	<u>45.0-50.0</u>	<u>Total 0.0-50.0</u>
N	3,330	5,969	2,599	2,031	1,767	13,340	50,456	15,929	19,006	72,815	16,732	203,974
NNE	9,091	20,552	3,399	6,083	15,736	10,217	10,558	5,233	9,579	23,598	6,896	120,942
NE	22,763	12,969	3,742	2,612	7,863	4,796	6,225	9,037	7,862	4,183	6,510	88,562
ENE	17,840	9,466	3,654	5,737	5,974	10,689	12,643	38,610	12,369	11,291	18,253	146,526
E	29,230	17,006	6,204	6,471	12,763	45,708	37,605	41,421	88,737	22,135	28,210	335,490
ESE	11,244	19,659	19,517	21,893	21,857	285,361	433,096	423,547	225,382	63,518	54,020	1,579,094
SE	2,331	5,562	7,279	11,797	14,135	113,852	334,022	161,093	101,584	74,966	42,221	868,842
SSE	1,603	1,671	2,114	3,553	5,334	15,149	35,225	51,604	11,575	13,561	18,043	159,432
S	2,266	770	1,239	4,043	2,696	3,958	5,731	7,714	7,910	4,516	5,228	46,071
SSW	1,568	1,181	2,108	15,452	16,168	33,479	13,177	8,888	24,831	54,144	35,153	206,419
SW	2,664	1,761	6,471	7,165	2,920	19,892	5,218	5,689	8,641	5,687	8,665	74,773
WSW	2,854	1,372	1,142	1,393	761	1,256	4,065	4,029	5,546	4,188	4,029	29,666
W	30,108	6,411	3,765	2,025	799	3,730	2,310	5,255	13,040	10,325	13,963	91,731
WNW	8,824	3,082	1,540	1,602	1,258	7,702	5,494	7,170	15,994	40,682	41,882	135,230
NW	7,198	1,748	1,414	1,824	2,228	12,237	24,844	15,766	10,451	11,103	19,585	108,398
NNW	2,318	1,197	1,479	7,992	3,542	8,267	28,971	112,010	117,102	65,106	88,264	436,248
Total	155,232	110,376	67,666	101,673	115,801	589,903	1,009,640	912,026	679,609	481,818	407,654	4,631,398

TABLE 2.1-17

## POPULATION DISTRIBUTION FOR 1980, 50-350 MILES

Distance from BVPS-2 (miles)

<u>Direction</u>	<u>50-55</u>	<u>55-60</u>	<u>60-65</u>	<u>65-70</u>	<u>70-85</u>	<u>85-100</u>	<u>100-150</u>	<u>150-200</u>	<u>200-350</u>	<u>Total 0-350</u>
N	17,552	9,525	7,012	9,816	28,839	67,949	243,080	1,545,026	952,862	3,055,268
NNE	6,850	5,889	19,065	10,273	50,087	34,475	231,252	1,666,372	1,047,870	3,178,002
NE	5,286	6,072	7,028	31,462	12,227	4,860	159,331	190,212	2,127,937	2,628,514
ENE	6,650	9,635	6,297	6,435	33,777	43,532	88,503	198,738	1,649,052	2,182,015
E	10,197	6,346	10,517	40,372	34,853	72,243	317,737	619,188	19,918,213	21,285,551
ESE	58,460	46,627	19,913	10,289	117,089	63,685	112,053	717,191	5,790,710	7,956,904
SE	15,037	39,899	59,325	13,868	16,879	21,147	144,628	300,224	3,880,156	5,060,691
SSE	23,740	14,007	17,488	20,689	91,355	33,372	69,884	191,829	1,377,384	1,970,483
S	2,123	6,055	1,776	6,364	52,715	80,472	83,067	116,547	2,263,548	2,651,576
SSW	21,452	6,683	5,017	11,454	25,493	35,324	156,788	443,626	1,544,041	2,455,700
SW	4,523	8,407	2,902	5,580	30,002	28,478	164,404	461,827	1,162,183	1,942,845
WSW	19,558	4,122	3,642	8,152	47,461	72,500	1,131,348	477,870	4,408,141	6,198,374
W	44,518	29,262	18,447	15,936	58,985	31,580	366,854	367,524	2,559,231	3,565,754
WNW	151,183	109,498	176,887	216,993	139,096	126,530	435,468	842,146	2,585,508	4,905,537
NW	21,833	47,167	59,788	46,482	581,295	1,061,165	80,414	4,003,582	2,604,766	8,602,062
NNW	23,586	8,204	8,909	13,691	53,161	145,905	78,754	500,461	206,774	1,478,657
Total	432,548	357,398	424,013	467,856	1,373,314	1,923,217	3,863,565	12,642,363	54,078,376	79,117,933

TABLE 2.1-18

POPULATION DISTRIBUTION FOR 1985, 50-350 MILES

Distance from BVPS-2 (miles)

<u>Direction</u>	<u>50-55</u>	<u>55-60</u>	<u>60-65</u>	<u>65-70</u>	<u>70-85</u>	<u>85-100</u>	<u>100-150</u>	<u>150-200</u>	<u>200-350</u>	<u>Total 0-350</u>
N	17,993	9,741	7,264	10,154	29,860	70,413	254,701	1,636,097	1,025,652	3,238,932
NNE	7,035	6,082	19,745	10,654	52,016	35,796	238,211	1,725,033	1,115,453	3,318,096
NE	5,496	6,331	7,331	32,720	12,708	4,951	164,272	199,148	2,218,619	2,738,428
ENE	6,864	9,962	6,528	6,717	35,418	45,586	91,141	204,654	1,726,844	2,278,986
E	10,529	6,617	10,995	42,383	36,304	73,849	326,499	644,957	20,067,878	21,480,312
ESE	59,990	47,847	20,537	10,558	120,081	65,568	117,942	768,492	6,075,949	8,319,328
SE	15,589	41,211	61,667	14,416	17,558	22,270	148,523	336,049	4,113,174	5,347,677
SSE	24,963	14,687	18,301	21,913	98,138	36,261	75,268	203,236	1,461,990	2,089,455
S	2,241	6,390	1,863	6,716	54,614	83,605	88,724	123,294	2,390,054	2,797,533
SSW	22,422	6,867	5,299	12,035	26,855	37,559	166,033	464,672	1,653,882	2,601,157
SW	4,573	8,574	3,038	5,927	31,861	30,203	174,766	484,611	1,228,706	2,046,098
WSW	20,405	4,315	3,816	8,550	49,632	75,236	1,167,123	484,933	4,520,272	6,360,348
W	45,764	29,939	18,757	17,301	63,444	33,070	376,193	379,949	2,643,862	3,684,248
WNW	152,248	109,219	172,154	210,996	151,268	131,290	448,594	866,280	2,680,930	5,046,522
NW	22,813	49,283	60,940	46,681	546,251	991,978	84,150	4,083,985	2,755,999	8,738,545
NNW	23,903	8,316	9,196	14,499	55,694	150,309	82,439	529,013	226,854	1,535,258
Total	442,828	365,381	427,431	472,220	1,381,702	1,887,944	4,004,579	13,134,403	55,906,118	81,620,923

TABLE 2.1-19

POPULATION DISTRIBUTION FOR 1990, 50-350 MILES

Distance from BVPS-2 (miles)

<u>Direction</u>	<u>50-55</u>	<u>55-60</u>	<u>60-65</u>	<u>65-70</u>	<u>70-85</u>	<u>85-100</u>	<u>100-150</u>	<u>150-200</u>	<u>200-350</u>	<u>Total 0-350</u>
N	18,461	9,964	7,478	10,447	30,734	72,773	266,247	1,715,116	1,087,247	3,399,214
NNE	7,232	6,282	20,433	11,011	53,644	37,032	246,528	1,798,885	1,176,040	3,467,424
NE	5,687	6,561	7,597	33,897	13,128	5,037	169,590	208,709	2,330,553	2,869,973
ENE	7,058	10,256	6,731	6,952	36,846	47,337	93,405	210,312	1,809,585	2,378,636
E	10,817	6,830	11,362	43,870	37,458	75,642	333,424	667,207	20,418,878	21,871,747
ESE	61,309	48,899	21,047	10,790	123,144	67,399	123,072	811,494	6,368,197	8,693,303
SE	16,132	42,452	64,011	14,963	18,184	23,237	152,485	371,208	4,331,528	5,626,336
SSE	26,094	15,325	19,075	23,119	104,753	39,047	80,419	213,708	1,545,523	2,205,757
S	2,350	6,701	1,946	7,059	56,444	86,623	94,216	129,776	2,512,677	2,938,922
SSW	23,365	7,042	5,577	12,606	28,177	39,709	175,022	485,292	1,763,504	2,745,598
SW	4,619	8,736	3,177	6,282	33,772	31,881	185,075	505,860	1,307,336	2,160,014
WSW	21,188	4,497	3,980	8,930	51,814	77,967	1,199,524	491,723	4,632,163	6,518,320
W	46,915	30,566	19,044	18,694	67,954	34,548	385,121	392,598	2,735,615	3,809,430
WNW	153,269	109,054	168,083	205,856	162,736	136,034	462,016	893,733	2,771,655	5,187,261
NW	23,797	51,410	62,185	46,960	516,039	931,994	88,012	4,183,316	2,901,641	8,902,795
NNW	24,168	8,411	9,459	15,263	58,068	154,288	86,117	555,187	246,990	1,589,435
Total	452,461	372,986	431,185	476,699	1,392,895	1,860,548	4,140,273	13,634,124	57,939,132	84,364,165

TABLE 2.1-20

POPULATION DISTRIBUTION FOR 2000, 50-350 MILES

Distance from BVPS-2 (miles)

<u>Direction</u>	<u>50-55</u>	<u>55-60</u>	<u>60-65</u>	<u>65-70</u>	<u>70-85</u>	<u>85-100</u>	<u>100-150</u>	<u>150-200</u>	<u>200-350</u>	<u>Total 0-350</u>
N	18,880	10,185	7,727	10,821	31,783	75,850	277,214	1,895,169	1,206,015	3,716,987
NNE	7,406	6,484	21,155	11,373	55,204	38,276	260,784	1,835,804	1,276,497	3,624,389
NE	5,896	6,830	7,911	35,227	13,592	5,071	174,413	221,872	2,521,334	3,082,918
ENE	7,242	10,547	6,944	7,218	38,554	49,331	95,265	215,813	1,899,671	2,485,040
E	11,052	7,024	11,701	45,288	38,432	76,500	337,997	689,287	21,134,165	22,621,687
ESE	61,913	49,381	21,361	10,897	124,909	68,721	129,638	866,586	6,672,101	9,086,165
SE	16,524	43,261	65,796	15,381	18,786	24,752	160,537	436,396	4,748,536	6,135,525
SSE	27,340	15,982	19,829	24,726	115,759	43,693	89,004	230,592	1,711,630	2,420,630
S	2,501	7,142	2,076	7,628	59,436	91,545	103,296	141,898	2,769,282	3,226,928
SSW	24,912	7,310	6,013	13,502	30,311	43,076	189,868	519,890	1,955,402	2,995,592
SW	4,673	8,975	3,405	6,886	37,076	34,515	200,070	541,101	1,447,332	2,357,040
WSW	22,356	4,772	4,233	9,526	55,622	82,779	1,250,880	507,318	4,874,159	6,839,043
W	48,752	31,607	19,564	21,452	76,641	37,262	402,938	418,431	2,908,668	4,047,792
WNW	155,875	109,847	164,519	201,373	180,529	144,960	489,670	948,363	2,940,988	5,463,830
NW	25,441	54,962	64,659	48,016	485,047	868,093	92,219	4,148,793	3,128,201	9,015,077
NNW	24,664	8,588	9,926	16,613	62,210	160,847	89,447	584,031	271,873	1,658,344
Total	465,427	382,897	436,819	485,927	1,423,891	1,845,271	4,343,240	14,201,344	61,465,844	88,776,987

TABLE 2.1-21

POPULATION DISTRIBUTION FOR 2010, 50-350 MILES

Distance from BVPS-2 (miles)

<u>Direction</u>	<u>50-55</u>	<u>55-60</u>	<u>60-65</u>	<u>65-70</u>	<u>70-85</u>	<u>85-100</u>	<u>100-150</u>	<u>150-200</u>	<u>200-350</u>	<u>Total 0-350</u>
N	19,712	10,562	7,861	11,050	32,370	79,178	293,832	1,997,908	1,265,393	3,907,501
NNE	7,761	6,822	22,248	11,772	55,961	39,654	283,699	2,011,665	1,348,848	3,902,993
NE	6,087	7,035	8,137	36,621	13,905	5,151	184,223	241,470	2,845,534	3,439,905
ENE	7,424	10,797	7,096	7,324	39,669	50,416	96,406	222,795	2,054,618	2,652,510
E	11,216	7,010	11,618	44,600	38,443	79,725	337,080	703,233	22,874,615	24,394,203
ESE	62,376	49,750	21,411	10,978	129,250	70,934	133,876	891,489	7,161,685	9,726,884
SE	17,203	44,520	69,044	16,140	19,411	25,617	168,892	500,466	5,094,711	6,622,945
SSE	28,591	16,727	20,766	26,635	126,943	48,224	97,166	244,359	1,872,311	2,629,726
S	2,638	7,548	2,205	8,203	62,391	96,392	112,430	152,976	2,998,857	3,487,237
SSW	26,477	7,581	6,482	14,468	32,484	46,437	204,870	555,468	2,132,143	3,231,824
SW	4,721	9,228	3,668	7,583	40,917	37,249	217,561	573,327	1,582,879	2,550,173
WSW	23,376	5,026	4,470	10,112	59,774	87,881	1,290,414	520,412	5,114,296	7,143,979
W	50,303	32,476	19,987	24,378	85,768	40,038	418,528	445,237	3,126,085	4,328,962
WNW	157,957	110,707	162,306	198,695	197,014	154,087	518,524	1,021,373	3,090,517	5,741,469
NW	27,274	58,922	67,648	49,258	465,899	826,784	98,877	4,334,950	3,356,346	9,388,170
NNW	24,896	8,674	10,291	17,817	65,776	165,767	94,744	611,553	304,787	1,733,708
Total	478,012	393,385	445,238	495,634	1,465,975	1,853,534	4,551,122	15,028,68	66,223,625	94,882,189

TABLE 2.1-22

POPULATION DISTRIBUTION FOR 2020, 50-350 MILES

Distance from BVPS-2 (miles)

<u>Direction</u>	<u>50-55</u>	<u>55-60</u>	<u>60-65</u>	<u>65-70</u>	<u>70-85</u>	<u>85-100</u>	<u>100-150</u>	<u>150-200</u>	<u>200-350</u>	<u>Total 0-350</u>
N	20,598	10,945	7,837	11,089	32,341	81,955	308,961	2,058,246	1,282,895	4,011,198
NNE	8,141	7,168	23,306	12,044	55,438	40,589	311,403	2,232,656	1,393,244	4,201,608
NE	6,190	7,116	8,208	37,611	13,955	5,203	194,850	262,795	3,245,050	3,871,922
ENE	7,514	10,892	7,122	7,234	39,886	50,234	95,895	228,237	2,220,304	2,820,567
E	11,183	6,756	11,077	41,816	37,223	83,357	328,424	701,923	25,278,197	26,807,946
ESE	61,856	49,336	20,973	10,887	133,417	72,727	134,930	882,595	7,660,140	10,385,777
SE	17,774	45,349	72,010	16,833	19,770	25,863	177,508	561,541	5,384,648	7,074,731
SSE	29,401	17,260	21,478	28,399	137,275	52,275	104,291	254,255	2,028,911	2,827,172
S	2,735	7,853	2,316	8,734	65,029	100,701	120,765	162,982	3,215,198	3,731,192
SSW	27,905	7,816	6,921	15,373	34,461	49,387	218,610	588,806	2,291,858	3,446,931
SW	4,748	9,453	3,933	8,299	44,895	39,734	234,276	600,516	1,710,366	2,729,869
WSW	24,121	5,229	4,666	10,616	63,914	92,896	1,316,128	532,699	5,366,180	7,445,419
W	51,457	33,137	20,322	27,404	95,045	42,752	432,602	472,928	3,368,790	4,633,672
WNW	159,933	112,101	162,998	199,763	210,373	163,103	548,539	1,106,626	3,221,445	6,017,693
NW	29,093	62,850	70,977	50,842	467,563	825,138	105,653	4,567,815	3,557,307	9,842,367
NNW	24,934	8,693	10,560	18,843	68,692	168,973	99,607	627,924	336,383	1,796,170
Total	487,583	401,954	454,704	505,787	1,519,277	1,894,887	4,732,442	15,842,544	71,560,916	101,644,234



TABLE 2.1-23

POPULATION DISTRIBUTION FOR 2030, 50-350 MILES

Distance from BVPS-2 (miles)

<u>Direction</u>	<u>50-55</u>	<u>55-60</u>	<u>60-65</u>	<u>65-70</u>	<u>70-85</u>	<u>85-100</u>	<u>100-150</u>	<u>150-200</u>	<u>200-350</u>	<u>Total 0-350</u>
N	21,595	11,358	7,666	10,946	31,722	84,316	323,789	2,070,362	1,255,594	4,021,322
NNE	8,573	7,541	24,397	12,214	53,714	41,177	344,543	2,514,411	1,409,670	4,537,182
NE	6,218	7,081	8,134	38,275	13,758	5,237	206,990	286,634	3,729,570	4,390,459
ENE	7,528	10,848	7,034	6,955	39,254	48,844	93,895	232,641	2,405,751	2,999,276
E	10,976	6,266	10,086	36,934	34,817	87,720	312,402	686,546	28,394,665	29,915,902
ESE	60,494	48,249	20,086	10,647	137,871	74,316	132,949	840,505	8,193,487	11,097,698
SE	18,302	45,897	74,985	17,529	19,910	25,485	186,390	619,940	5,615,885	7,493,165
SSE	29,844	17,632	22,034	30,089	146,930	55,906	110,484	260,408	2,181,216	3,013,975
S	2,799	8,064	2,412	9,226	67,396	104,550	128,447	171,927	3,416,013	3,956,905
SSW	29,223	8,024	7,339	16,240	36,278	51,993	231,325	620,437	2,416,814	3,624,092
SW	4,757	9,660	4,205	9,044	49,075	42,028	250,766	623,311	1,809,720	2,877,339
WSW	24,613	5,385	4,823	11,053	68,102	97,886	1,328,352	543,899	5,706,816	7,820,595
W	52,233	33,594	20,566	30,541	104,520	45,426	445,042	501,518	3,639,963	4,965,134
WNW	161,732	113,953	166,336	204,252	220,910	172,063	579,725	1,205,149	3,333,568	6,292,918
NW	30,930	66,821	74,674	52,741	488,544	860,310	112,931	4,876,379	3,734,778	10,407,616
NNW	24,769	8,642	10,733	19,699	70,969	170,479	104,439	634,786	368,224	1,848,988
Total	494,586	409,015	465,510	516,385	1,583,770	1,967,736	4,892,469	16,688,853	77,612,844	109,262,566

TABLE 2.1-24

POPULATION CENTERS WITH OVER 25,000 PEOPLE IN 1980  
WITHIN 50 MILES OF BVPS-2

<u>City/Township/Borough</u>	<u>County</u>	<u>Distance* and Direction from Site</u>	<u>1980 Population</u>
Pennsylvania**			
New Castle City	Lawrence	23.5 miles/N	33,621
Bethel Park Borough	Allegheny	28 miles/SE	34,755
McCandless Township	Allegheny	17 miles/E	26,250
McKeesport City	Allegheny	35 miles/ESE	31,012
Monroeville Borough	Allegheny	36 miles/ESE	30,977
Mt. Lebanon Borough	Allegheny	26 miles/SE	34,414
Penn Hills Township	Allegheny	31 miles/ESE	57,632
Pittsburgh City	Allegheny	22 miles/ESE & SE	423,938
Plum Borough	Allegheny	32 miles/ESE	25,390
Ross Township	Allegheny	21 miles/ESE	35,102
Shaler Township	Allegheny	24 miles/ESE	33,694
West Mifflin Borough	Allegheny	32 miles/SE	26,279
Hempfield Township	Westmoreland	45 miles/ESE	43,396
North Huntingdon Township	Westmoreland	39 miles/ESE	31,517
Ohio***			
Warren City	Trumbull	45 miles/NNW	56,629
Canton City	Stark	50 miles/WNW	110,053
Plain Township	Stark	48.5 miles/WNW	32,431
Steubenville City	Jefferson	23 miles/SSW	26,400
Austintown Township	Mahoning	34 miles/NNW	37,664
Boardman Township	Mahoning	33 miles/NNW	41,833
Youngstown City	Mahoning	32 miles/NNW	115,427
West Virginia****			
Wheeling City	Ohio	36.5 miles/SSW	42,874

NOTES:

- \*Distance to closest boundary
- \*\*U.S. Department of Commerce, Bureau of the Census, 1982a.
- \*\*\*U.S. Department of Commerce, Bureau of the Census, 1982b.
- \*\*\*\*U.S. Department of Commerce, Bureau of the Census, 1982c.

TABLE 2.1-25

CITIES AND TOWNS PROJECTED TO BECOME POPULATION CENTERS BY 2030

<u>City/Township/Borough</u>	<u>County</u>	<u>Distance* and Direction from Site</u>	<u>Population</u>		
			<u>1980</u>	<u>2000</u>	<u>2030</u>
Pennsylvania					
Baldwin Borough	Allegheny	29 miles/SE	24,598	25,717	36,948
Scott Township	Allegheny	24 miles/SE	20,413	21,341	30,662
Upper St. Clair Township	Allegheny	26 miles/SE	19,023	19,888	28,574
New Kensington City	Westmoreland	38 miles/SE	20,312	23,317	29,276
Ohio					
Niles City	Trumbull	42 miles/NNW	23,088	24,000	26,203
Alliance City	Stark	40 miles/WNW	24,315	25,669	29,302

NOTE:

\*Distance to closest boundary.

TABLE 2.1-26

TOTAL 1970-1980 POPULATION GROWTH FOR SMSA\*  
WITHIN 50 MILES OF BVPS-2

<u>SMSA</u>		<u>Total 1970 Population</u>	<u>Total 1980 Population</u>	<u>Percent Change 1970-1980</u>
Steubenville-Weirton, Ohio-WVa**,***				
1970 Ohio	1970-WVa			
128,397	37,230	165,627	163,099	-1.53
1980 Ohio	1980 WVa			
91,564	71,535			
Wheeling, WVa-Ohio**,***				
1970 Ohio	1970 WVa			
182,712	60,705	243,417	185,566	-23.77
1980 Ohio	1980 Wva			
82,569	102,997			
Sharon, Pa**		N/A****	128,299	NA****
Pittsburgh, Pa**		1,846,042	2,263,894	+22.64
Youngstown-Warren, Ohio*****		536,003	531,350	-0.87
Canton, Ohio*****		372,210	404,421	+8.65
Akron, Ohio*****		679,239	660,328	-2.78

NOTES:

- \*SMSA - Standard Metropolitan Statistical Area
- \*\*U.S. Department of Commerce, Bureau of the Census, 1982a.
- \*\*\*U.S. Department of Commerce, Bureau of the Census, 1982c.
- \*\*\*\*Not applicable due to 1980 changes in the definitions of urbanized areas.
- \*\*\*\*\*U.S. Department of Commerce, Bureau of the Census, 1982b.

TABLE 2.1-27

APPROXIMATE DAILY TRANSIENT POPULATION BY SECTOR WITHIN 10 MILES OF BVPS-2

<u>Direction</u>	<u>Distance (miles)</u>										<u>Total 0-10</u>
	<u>0-1</u>	<u>1-2</u>	<u>2-3</u>	<u>3-4</u>	<u>4-5</u>	<u>5-6</u>	<u>6-7</u>	<u>7-8</u>	<u>8-9</u>	<u>9-10</u>	
N	0	0	0	0	650	0	0	0	0	0	650
NNE	0	200	0	0	0	550	0	0	0	256	1,006
NE	0	0	0	441	600	489	0	1,631	2,723	1,699	7,583
ENE	1,027	0	0	0	0	0	551	6,213	2,041	123	9,955
E	0	0	0	0	0	0	0	0	8,062	2,089	10,151
ESE	0	0	0	275	0	0	0	0	0	1,945	2,220
SE	0	0	0	0	0	0	291	0	0	0	291
SSE	0	0	0	0	0	0	0	0	0	0	0
S	0	0	0	0	0	0	0	1,285	0	0	1,285
SSW	0	0	0	0	0	0	0	0	0	0	0
SW	0	0	1,649	0	0	0	0	0	0	266	1,915
WSW	0	0	0	0	0	0	0	0	0	266	266
W	0	0	0	0	0	1,482	1,622	1,238	3,372	588	8,302
WNW	0	0	0	0	0	0	0	0	512	2,000	2,512
NW	540	565	0	0	0	0	0	0	0	0	1,105
NNW	0	0	0	0	0	0	0	89	88	0	177
Total	1,567	765	1,649	716	1,250	2,521	2,464	10,367	16,798	9,232	35,946

TABLE 2.1-28

EDUCATIONAL FACILITIES WITHIN 10 MILES OF BVPS-2

<u>School</u>	<u>Location</u>	<u>District Jurisdiction</u> <sup>1, 2, 3</sup>	<u>1981-82 School Year Enrollment 1-12</u>	<u>Sector Distance from Station</u>	<u>Direction from Station</u>
Neels Elementary	Midland, Pa	Midland	317 <sup>4</sup>	1-2 miles	NW
Lincoln High School	Midland, Pa	Midland	248 <sup>4</sup>	1-2 miles	NW
Southside Elementary	Hookstown, Pa	Southside	767 <sup>5</sup>	2-3 miles	SW
Southside Middle and Senior High School	Hookstown, Pa	Southside	882 <sup>5</sup>	2-3 miles	SW
Brighton Township Elementary	Brighton, Pa	Beaver	550 <sup>6</sup>	5-6 miles	NNE
College Square Elementary	Beaver, Pa	Beaver	588 <sup>6</sup>	8-9 miles	NE
Beaver Junior & Senior High School	Beaver, Pa	Beaver	1,191 <sup>6</sup>	8-9 miles	NE
Patterson Elementary	Patterson, Pa	Blackhawk	256 <sup>7</sup>	9-10 miles	NNE
Margaret Ross Elementary	Hopewell, Pa	Hopewell	234 <sup>8</sup>	8-9 miles	E
Hopewell Elementary	Hopewell, Pa	Hopewell	328 <sup>8</sup>	8-9 miles	E
Independence Elementary	Independence, Pa	Hopewell	291 <sup>8</sup>	6-7 miles	SE
Raccoon Elementary	Raccoon, Pa	Hopewell	275 <sup>8</sup>	3-4 miles	ESE
Hopewell Junior High School	Hopewell, Pa	Hopewell	1,060 <sup>8</sup>	9-10 miles	ESE
Hopewell Senior High School	Hopewell, Pa	Hopewell	885 <sup>8</sup>	9-10 miles	ESE
Center High School	Center, Pa	Center	670 <sup>9</sup>	7-8 miles	ENE
Center Junior High School	Center, Pa	Center	412 <sup>9</sup>	7-8 miles	ENE
Todd Lane Elementary	Center, Pa	Center	774 <sup>9</sup>	7-8 miles	ENE

TABLE 2.1-28 (Cont)

<u>School</u>	<u>Location</u>	<u>District Jurisdiction<sup>1, 2, 3</sup></u>	<u>1981-82 School Year Enrollment 1-12</u>	<u>Sector Distance from Station</u>	<u>Direction from Station</u>
Center Grange Elementary	Center, Pa	Center	551 <sup>9</sup>	6-7 miles	ENE
Western Beaver High School	Industry, Pa	Western Beaver	650 <sup>10</sup>	4-5 miles	N
Ray W. Synder	Industry, Pa	Western Beaver	200 <sup>10</sup>	1-2 miles	NNE
Fairview Elementary	Industry, Pa	Western Beaver	441 <sup>10</sup>	3-4 miles	NE
Aliquippa Elementary	Aliquippa, Pa	Aliquippa	799 <sup>1</sup>	8-9 miles	E
Aliquippa Middle School	Aliquippa, Pa	Aliquippa	641 <sup>1</sup>	9-10 miles	E
Aliquippa High School	Aliquippa, Pa	Aliquippa	678 <sup>1</sup>	9-10 miles	E
Fourth Ward Elementary	Monaca, Pa	Monaca	137 <sup>1</sup>	8-9 miles	ENE
Fifth Ward Elementary	Monaca, Pa	Monaca	123 <sup>1</sup>	9-10 miles	ENE
C.Z. Mangin Elementary	Monaca, Pa	Monaca	168 <sup>1</sup>	9-10 miles	E
Monaca Junior & Senior High School	Monaca, Pa	Monaca	602 <sup>1</sup>	9-10 miles	E
Rochester Education Complex <sup>11</sup>	Rochester Township, Pa	Rochester	1,472	9-10 miles	NE
Jefferson Elementary	Newell, WVa	Grant	387 <sup>2</sup>	8-9 miles	W
Wells Junior High School	Newell, WVa	Grant	171 <sup>2</sup>	9-10 miles	W
Chester Elementary	Chester, WVa	Grant	721 <sup>2</sup>	6-7 miles	W
Chester Junior High School	Chester, WVa	Grant	313 <sup>2</sup>	6-7 miles	W
Grandview Elementary	Grant District, Wva	Grant	66 <sup>2</sup>	5-6 miles	W
East Liverpool High School	East Liverpool, Ohio	East Liverpool	1,055 <sup>3</sup>	8-9 miles	W
East Liverpool High School East Campus	East Liverpool, Ohio	East Liverpool	305 <sup>3</sup>	6-7 miles	W

TABLE 2.1-28 (Cont)

<u>School</u>	<u>Location</u>	<u>District Jurisdiction</u> <sup>1, 2, 3</sup>	<u>1981-82 School Year Enrollment 1-12</u>	<u>Sector Distance from Station</u>	<u>Direction from Station</u>
East Elementary	East Liverpool, Ohio	East Liverpool	508 <sup>3</sup>	5-6 miles	W
East Middle	East Liverpool, Ohio	East Liverpool	908 <sup>3</sup>	5-6 miles	W
LaCroft Elementary	East Liverpool, Ohio	East Liverpool	460 <sup>3</sup>	8-9 miles	W
North Elementary	East Liverpool, Ohio	East Liverpool	578 <sup>3</sup>	7-8 miles	W
Westgate School	East Liverpool, Ohio	East Liverpool	465 <sup>3</sup>	8-9 miles	W
Calcutta Elementary	St. Clair, Ohio	East Liverpool	512 <sup>3</sup>	8-9 miles	WNW
Beaver Community College	Monaca, Pa	privately operated	2,073-Full-time students <sup>12</sup> 2,284-Part-time students	7-8 miles	ENE
Pennsylvania State University-Beaver Campus	Monaca, Pa	State of Pennsylvania	200-on-campus residents <sup>13</sup> 1,004-Full-time students 700-Part-time students	8-9 miles	ENE
Kent State University East Liverpool Campus	East Liverpool, Ohio	State of Ohio	660-Full-time students <sup>14</sup>	7-8 miles	W

NOTES:

1. Pennsylvania Department of Education 1982
2. West Virginia Department of Education 1982
3. Ohio Department of Education 1982
4. Midland Public Schools, Superintendent's Office 1982
5. Southside Area School District 1982
6. Beaver Area School District 1982
7. Blackhawk Area District 1982
8. Hopewell Area School District Administrator 1982
9. Center Area School District 1982
10. Western Beaver School District 1982
11. Complex includes grades Kindergarten through 12th grade
12. Beaver Community College 1982
13. Pennsylvania State University - Beaver Campus 1982
14. East Liverpool Campus of Kent State University 1983



TABLE 2.1-29

PARKS AND RECREATION FACILITIES WITHIN 10 MILES OF BVPS-2

<u>Park/Recreation Area</u>	<u>Sponsorship</u>	<u>1981 Attendance (Visitor-days)</u>	<u>Approximate Distance from Station (Miles)</u>	<u>Direction from Station</u>
Game Lands Number 189	Pennsylvania Game Commission	Not tabulated <sup>(1)</sup>	7	SSE
Game Lands Number 173	Pennsylvania Game Commission	Not tabulated <sup>(1)</sup>	3.5	NNW
Raccoon State Park	State of Pennsylvania	468,852 <sup>(2)</sup>	6-9 <sup>(3)</sup>	S-SSW <sup>(3)</sup>
Brady Run County Park	Beaver County, Pennsylvania	32,300 <sup>(4)</sup>	8-9 <sup>(5)</sup>	NNW
Tomlinson State Park	State of West Virginia	193,880 <sup>(6)</sup>	10	SW-WSW <sup>(7)</sup>
Beaver Creek State Forest	State of Ohio	729,930 <sup>(8)</sup>	10	WNW

NOTES:

1. Pennsylvania Department of Natural Resources, Game Commission 1982a.
2. Pennsylvania Department of Natural Resources, Bureau of State Parks 1982b.
3. Allocates visitors to south sector, 8 miles from station at park entrance and camping areas.
4. Beaver Valley Parks Department 1982.
5. West Virginia Department of Natural Resources 1982.
6. Operates May 21-September 30, allocates visitors 8 miles from station at park entrance.
7. Allocates visitors equally between SW and WSW sectors.
8. Ohio Department of Natural Resources, Division of Parks and Recreation 1982.

TABLE 2.1-30

LPZ 1980 Population Distribution

Distance from BVPS-2 (miles)

<u>Distance</u>	<u>0-1</u>	<u>1-2</u>	<u>2-3</u>	<u>3-3.6</u>	<u>Total</u>
N	0	37	84	224	345
NNE	0	318	67	84	469
NE	57	0	505	581	1,143
ENE	57	54	160	139	410
E	28	56	368	297	749
ESE	34	139	130	161	464
SE	13	152	195	95	455
SSE	2	18	68	67	155
S	0	25	192	21	238
SSW	11	32	78	71	192
SW	0	75	363	220	658
WSW	0	11	160	60	231
W	0	15	57	57	129
WNW	5	11	6	41	63
NW	284	1,987	2,214	269	4,754
NNW	74	158	75	66	373
Total	565	3,088	4,722	2,453	10,828

TABLE 2.1-31

TRANSIENT POPULATION IN LPZ

<u>Facility</u>	<u>Population</u>	<u>Location</u> <u>(Distance-Direction)</u>
<u>Educational Institutions*</u>		
Neils Elementary	317	1-2 NW
Lincoln High School	248	1-2 NW
Ray W. Snyder	200	1-2 NNE
Southside Elementary	767	2-3 SW
Southside Middle and Senior High School	882	2-3 SW
Fairview Elementary	441	3-36 NE
<u>Parks and Recreation Areas</u>		
Pennsylvania State Game Lands. Number 173	not available	3-3.6 NNW
<u>Industries and Major Employers**</u>		
F.W. Bliss Company- MacIntosh- Hemphill Division	290	0-1 NW
Jones Laughlin Steel Corp.- Midland Works	250	0-1 NW
Pennsylvania Power Company- Bruce Mansfield Power Plant	1,027	0-1 ENE
Total Transient Population	4,422	

NOTES:

- \*1981-82 school year enrollments
- \*\*1983 employment

TABLE 2.1-32

Approximate Daily Transient Population by Sector  
within the LPZ for BVPS-2

Distance from BVPS-2 (miles)

<u>Direction</u>	<u>0-1</u>	<u>1-2</u>	<u>2-3</u>	<u>3-3.6</u>
N	0	0	0	0
NNE	0	200	0	0
NE	0	0	0	441
ENE	1,027	0	0	0
E	0	0	0	0
ESE	0	0	0	0
SE	0	0	0	0
SSE	0	0	0	0
S	0	0	0	0
SSW	0	0	0	0
SW	0	0	1,649	0
WSW	0	0	0	0
W	0	0	0	0
WNW	0	0	0	0
NW	540	565	0	0
NNW	0	0	0	0
Total	1,567	765	1,649	441

TABLE 2.1-33

POPULATION DENSITY FOR 1980, 0-10 MILES (PEOPLE/MILE<sup>2</sup>)

Distance from BVPS-2 (miles)

<u>Direction</u>	<u>0.0- 0.5</u>	<u>0.5- 1.0</u>	<u>1.0- 1.5</u>	<u>1.5- 2.0</u>	<u>2.0- 2.5</u>	<u>2.5- 3.0</u>	<u>3.0- 3.5</u>	<u>3.5- 4.0</u>	<u>4.0- 4.5</u>	<u>4.5- 5.0</u>	<u>5.0- 6.0</u>	<u>6.0- 7.0</u>	<u>7.0- 8.5</u>	<u>8.5- 10.0</u>
N	0	0	0	108	84	87	340	186	187	243	216	110	116	176
NNE	0	0	29	905	61	74	127	83	120	140	1,200	232	159	713
NE	772	431	0	0	455	1,006	1,055	178	98	271	241	650	1,094	2,358
ENE	72	373	220	0	138	183	151	130	46	81	137	1,380	459	1,911
E	1,107	0	65	116	602	189	426	185	119	46	109	500	2,268	2,623
ESE	252	190	12	396	120	143	190	235	170	197	168	154	264	1,391
SE	472	14	77	387	147	241	130	34	0	0	171	34	134	120
SSE	0	14	45	20	111	35	94	39	81	368	82	27	73	84
S	0	0	45	41	281	126	33	111	165	193	219	18	135	92
SSW	0	75	45	61	113	52	105	106	55	83	115	9	92	73
SW	0	0	16	207	201	507	317	183	187	95	131	95	78	117
WSW	0	0	16	20	120	198	94	87	30	77	251	255	152	97
W	0	0	24	33	48	67	83	19	30	106	1,179	2,121	2,743	1,180
WNW	0	39	0	48	0	14	47	667	250	518	248	146	710	409
NW	0	1,929	4,274	2,786	1,252	3,076	379	810	497	146	178	35	65	44
NNW	0	503	387	183	59	91	124	0	93	368	319	40	81	48

TABLE 2.1-34

POPULATION DENSITY FOR 1985, 0-10 MILES (PEOPLE/MILE<sup>2</sup>)

Distance from BVPS-2 (miles)

<u>Direction</u>	<u>0.0- 0.5</u>	<u>0.5- 1.0</u>	<u>1.0- 1.5</u>	<u>1.5- 2.0</u>	<u>2.0- 2.5</u>	<u>2.5- 3.0</u>	<u>3.0- 3.5</u>	<u>3.5- 4.0</u>	<u>4.0- 4.5</u>	<u>4.5- 5.0</u>	<u>5.0- 6.0</u>	<u>6.0- 7.0</u>	<u>7.0- 8.5</u>	<u>8.5- 10.0</u>
N	0	0	0	108	84	87	345	187	189	247	219	111	117	178
NNE	0	0	29	914	61	76	128	84	121	142	1,213	235	160	721
NE	805	431	0	0	458	1,018	1,068	180	100	273	243	657	1,106	2,384
ENE	72	380	224	0	140	185	153	130	46	83	139	1,395	465	1,932
E	1,107	0	65	119	609	191	431	186	120	46	110	505	2,293	2,652
ESE	252	197	12	399	120	144	191	238	173	199	170	156	267	1,406
SE	472	14	77	390	149	243	132	34	0	0	173	34	135	121
SSE	0	14	45	20	111	37	96	39	83	371	83	28	74	85
S	0	0	45	41	285	128	34	113	167	195	222	18	137	93
SSW	0	75	45	64	113	52	107	107	56	83	117	9	92	74
SW	0	0	16	210	204	515	321	185	189	96	132	96	78	118
WSW	0	0	16	20	122	200	96	88	30	78	254	258	154	98
W	0	0	24	33	50	67	85	19	30	108	1,201	2,157	2,802	1,202
WNW	0	39	0	48	0	14	47	676	251	530	254	149	727	418
NW	0	1,949	4,323	2,816	1,265	3,111	384	819	503	148	180	36	67	45
NNW	0	509	391	186	59	93	126	0	93	372	323	40	81	49

TABLE 2.1-35

POPULATION DENSITY FOR 2030, 0-10 MILES (PEOPLE/MILE<sup>2</sup>)

Distance from BVPS-2 (miles)

<u>Direction</u>	<u>0.0- 0.5</u>	<u>0.5- 1.0</u>	<u>1.0- 1.5</u>	<u>1.5- 2.0</u>	<u>2.0- 2.5</u>	<u>2.5- 3.0</u>	<u>3.0- 3.5</u>	<u>3.5- 4.0</u>	<u>4.0- 4.5</u>	<u>4.5- 5.0</u>	<u>5.0- 6.0</u>	<u>6.0- 7.0</u>	<u>7.0- 8.5</u>	<u>8.5- 10.0</u>
N	0	0	0	116	91	93	367	200	201	263	232	118	125	190
NNE	0	0	29	972	66	80	136	90	129	151	1,291	250	171	767
NE	839	469	0	0	487	1,081	1,137	192	106	291	259	700	1,178	2,538
ENE	72	407	236	0	149	198	163	139	51	89	148	1,486	495	2,057
E	1,186	0	69	125	647	204	459	198	127	50	117	538	2,441	2,823
ESE	294	211	12	425	129	154	204	253	183	212	180	166	285	1,497
SE	472	14	81	416	158	259	141	37	0	0	184	37	144	129
SSE	0	14	45	20	118	39	102	42	89	396	89	30	79	91
S	0	0	53	44	303	135	36	120	177	208	236	19	146	99
SSW	0	75	45	67	120	56	114	114	60	89	124	10	99	78
SW	0	0	16	221	217	546	342	197	201	103	141	98	79	119
WSW	0	0	16	23	129	213	102	94	32	83	257	260	155	99
W	0	0	24	33	52	70	89	20	32	116	1,367	2,393	3,270	1,352
WNW	0	39	0	48	0	14	52	720	268	625	302	179	870	500
NW	0	2,078	4,600	3,000	1,347	3,309	407	871	536	157	192	42	79	53
NNW	0	543	416	198	63	98	133	0	99	396	344	43	87	52

TABLE 2.1-36

POPULATION DENSITY FOR 1980, 10-50 MILES (PEOPLE/MILE<sup>2</sup>)

Distance from BVPS-2 (miles)

<u>Direction</u>	<u>10.0-12.5</u>	<u>12.5-15.0</u>	<u>15.0-17.5</u>	<u>17.5-20.0</u>	<u>20.0-25.0</u>	<u>25.0-30.0</u>	<u>30.0-35.0</u>	<u>35.0-40.0</u>	<u>40.0-45.0</u>	<u>45.0-50.0</u>	<u>Average 0-50.0</u>
N	502	179	113	83	261	811	220	224	713	148	354
NNE	1,851	243	357	741	200	171	72	117	231	59	217
NE	1,093	258	152	411	103	123	150	105	49	66	175
ENE	796	251	348	318	236	229	591	164	128	174	286
E	1,432	381	251	439	646	444	430	984	256	290	534
ESE	1,460	944	896	761	4,212	5,415	4,370	1,945	723	560	2,149
SE	319	407	478	472	1,585	3,824	1,607	942	755	405	1,192
SSE	100	109	158	220	265	545	675	131	136	162	268
S	60	77	212	122	75	89	101	95	47	42	79
SSW	100	148	910	895	805	245	148	368	709	335	430
SW	157	553	507	171	483	103	86	102	59	88	153
WSW	131	95	94	44	31	75	34	57	38	36	53
W	527	229	105	37	69	30	55	119	92	131	150
WNW	228	93	82	56	142	82	91	195	464	429	251
NW	129	85	93	99	228	388	222	152	131	177	197
NNW	97	95	411	158	187	567	1,859	1,688	760	901	902



TABLE 2.1-37

POPULATION DENSITY FOR 1985, 10-50 MILES (PEOPLE/MILE<sup>2</sup>)

Distance from BVPS-2 (miles)

<u>Direction</u>	<u>10.0-12.5</u>	<u>12.5-15.0</u>	<u>15.0-17.5</u>	<u>17.5-20.0</u>	<u>20.0-25.0</u>	<u>25.0-30.0</u>	<u>30.0-35.0</u>	<u>35.0-40.0</u>	<u>40.0-45.0</u>	<u>45.0-50.0</u>	<u>Average 0-50.0</u>
N	508	181	115	84	265	825	223	229	731	152	361
NNE	1,871	245	361	754	203	174	74	122	238	61	222
NE	1,105	260	154	428	108	130	158	111	52	70	181
ENE	805	254	365	335	250	241	624	173	134	179	298
E	1,448	385	254	444	653	450	436	1,005	263	297	543
ESE	1,475	953	905	768	4,251	5,465	4,410	1,965	741	574	2,173
SE	322	410	483	477	1,599	3,861	1,626	955	774	418	1,208
SSE	102	111	161	226	272	562	696	135	140	168	276
S	62	79	218	126	77	92	104	97	48	44	82
SSW	101	150	919	904	794	244	147	365	704	343	430
SW	159	547	498	166	470	101	85	103	60	89	151
WSW	132	93	91	43	30	74	36	59	40	37	54
W	539	235	107	37	70	32	60	128	97	134	155
WNW	233	95	84	57	146	84	93	197	466	432	254
NW	132	87	96	101	233	394	223	148	130	181	199
NNW	98	96	421	161	183	552	1,810	1,657	770	913	894

TABLE 2.1-38

POPULATION DENSITY FOR 2030, 10-50 MILES (PEOPLE/MILE<sup>2</sup>)

Distance from BVPS-2 (miles)

<u>Direction</u>	<u>10.0-12.5</u>	<u>12.5-15.0</u>	<u>15.0-17.5</u>	<u>17.5-20.0</u>	<u>20.0-25.0</u>	<u>25.0-30.0</u>	<u>30.0-35.0</u>	<u>35.0-40.0</u>	<u>40.0-45.0</u>	<u>45.0-50.0</u>	<u>Average 0-50.0</u>
N	540	193	127	96	302	934	250	258	873	179	416
NNE	1,992	261	388	855	231	197	82	130	283	75	248
NE	1,176	277	164	427	109	126	153	108	50	70	185
ENE	857	271	360	325	242	234	605	168	135	199	300
E	1,543	460	406	698	1,035	696	653	1,253	277	317	700
ESE	1,938	1,535	1,458	1,238	6,850	8,805	7,106	3,091	761	579	3,323
SE	517	661	778	768	2,577	6,186	2,537	1,440	921	463	1,818
SSE	151	157	223	290	343	652	809	157	163	196	327
S	71	92	253	146	90	106	118	107	54	56	94
SSW	107	156	933	949	794	252	144	347	666	384	431
SW	160	535	484	159	450	97	89	117	68	93	153
WSW	133	93	87	41	28	75	48	75	52	43	60
W	638	281	127	43	84	43	82	177	124	150	188
WNW	279	114	100	68	174	102	112	217	489	457	278
NW	158	105	114	121	277	460	247	144	140	210	224
NNW	108	110	501	192	184	536	1,755	1,629	797	946	896



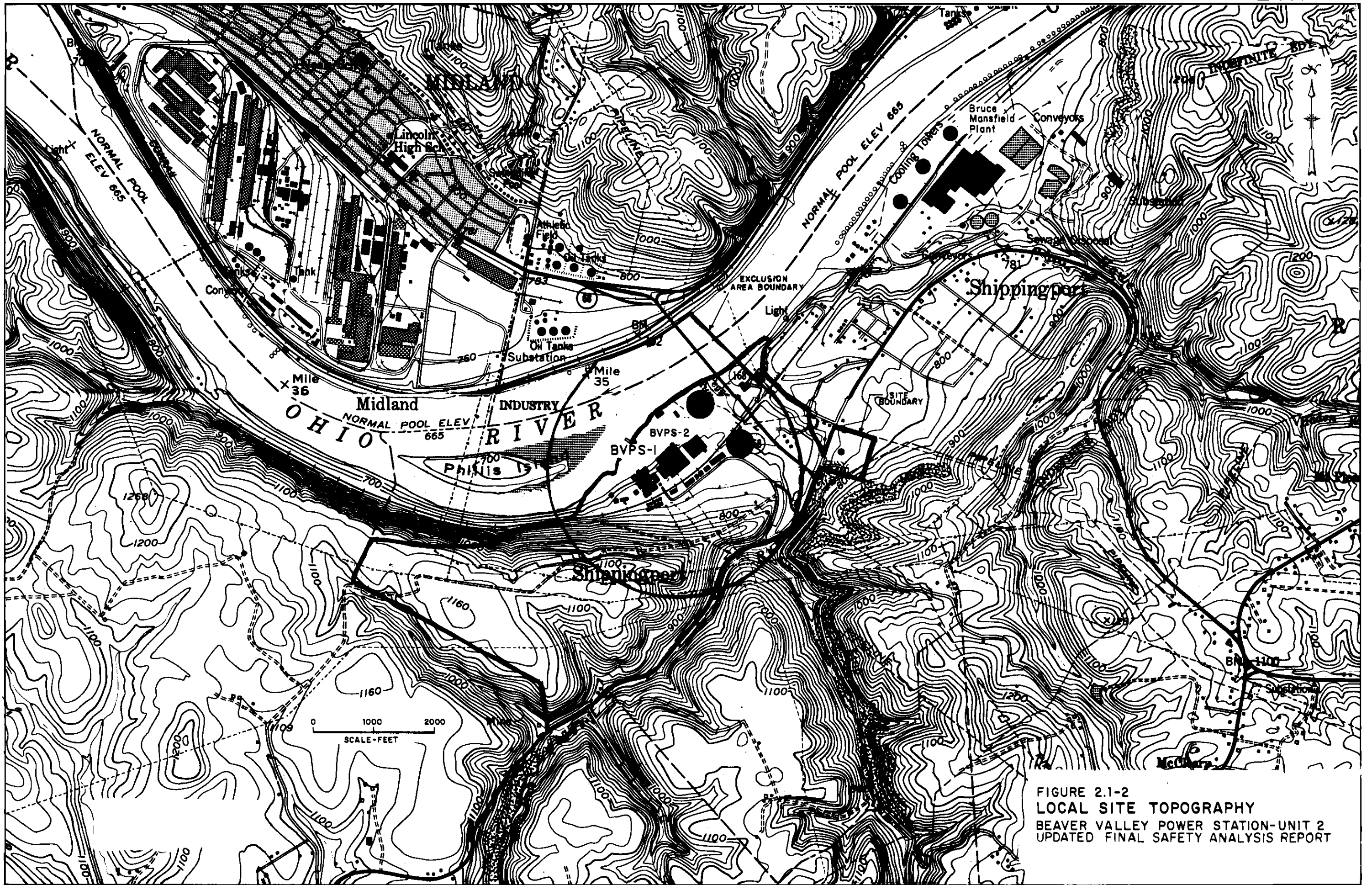

FIGURE 2.1-2  
LOCAL SITE TOPOGRAPHY  
BEAVER VALLEY POWER STATION-UNIT 2  
UPDATED FINAL SAFETY ANALYSIS REPORT

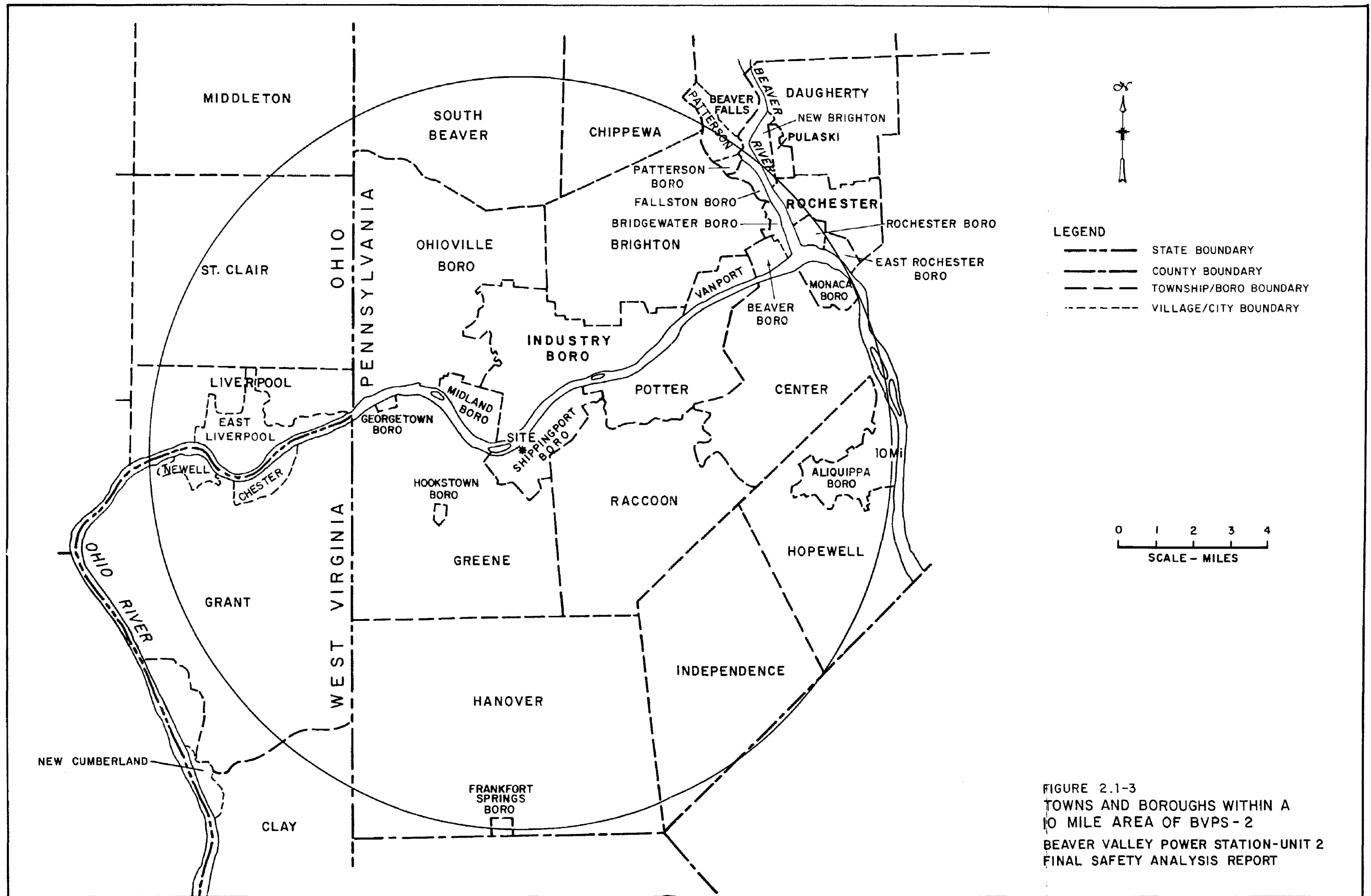

FIGURE 2.1-3  
TOWNS AND BOROUGHS WITHIN A  
10 MILE AREA OF BVPS - 2  
BEAVER VALLEY POWER STATION-UNIT 2  
FINAL SAFETY ANALYSIS REPORT

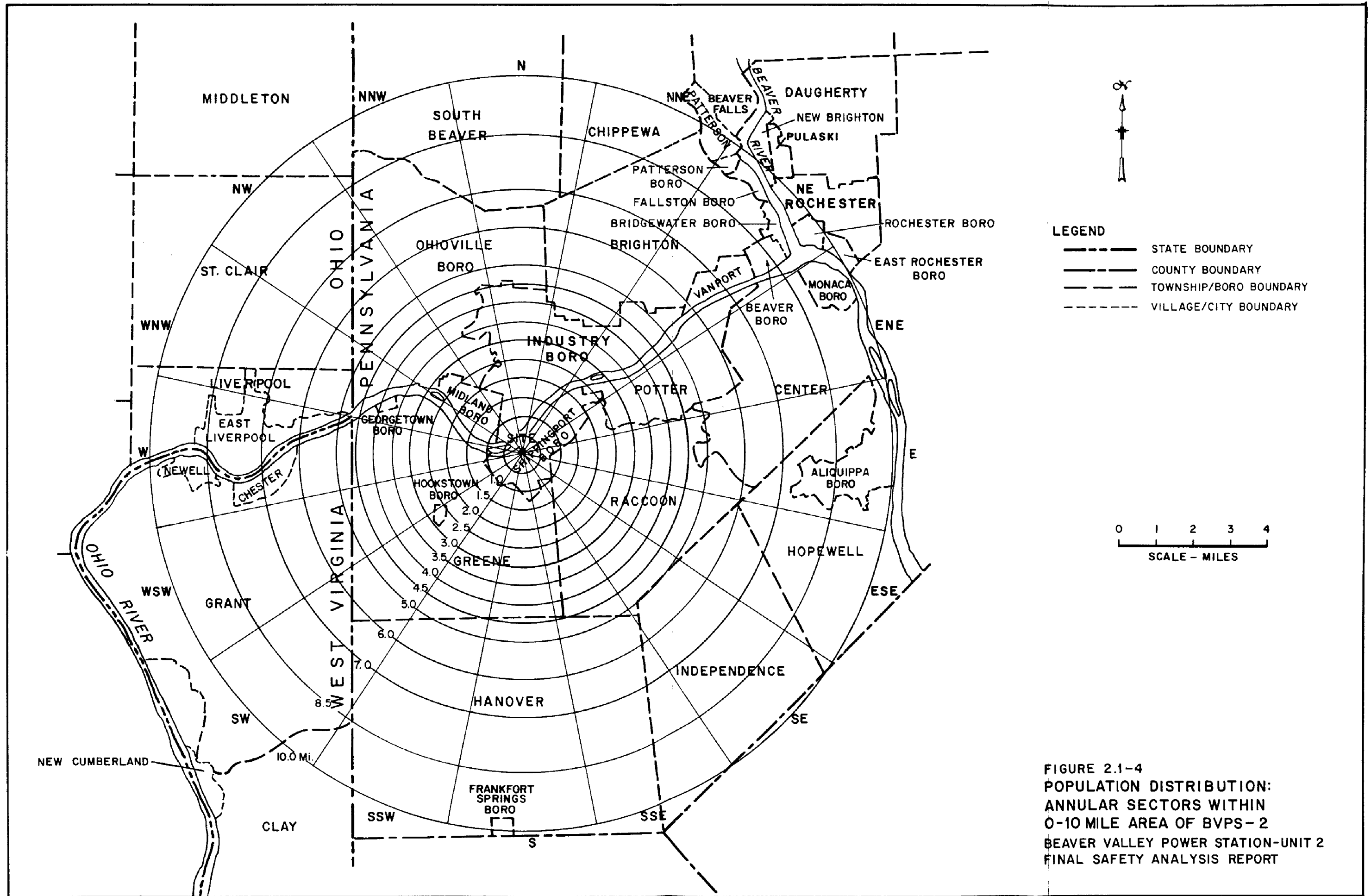
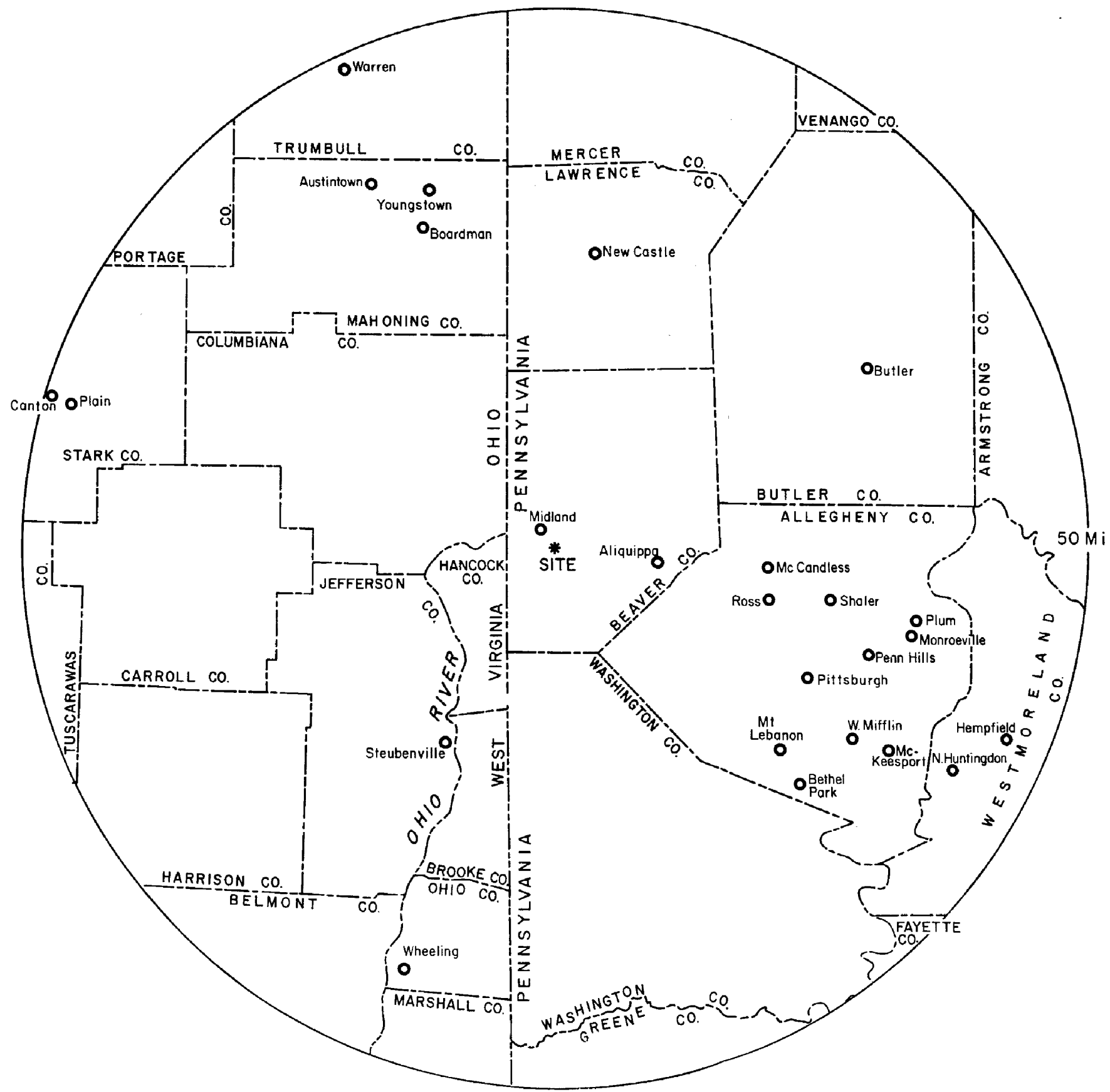

FIGURE 2.1-4  
 POPULATION DISTRIBUTION:  
 ANNULAR SECTORS WITHIN  
 0-10 MILE AREA OF BVPS-2  
 BEAVER VALLEY POWER STATION-UNIT 2  
 FINAL SAFETY ANALYSIS REPORT



**LEGEND**

- STATE BOUNDARIES
- COUNTY BOUNDARIES

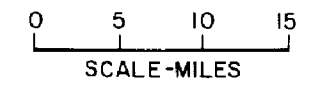
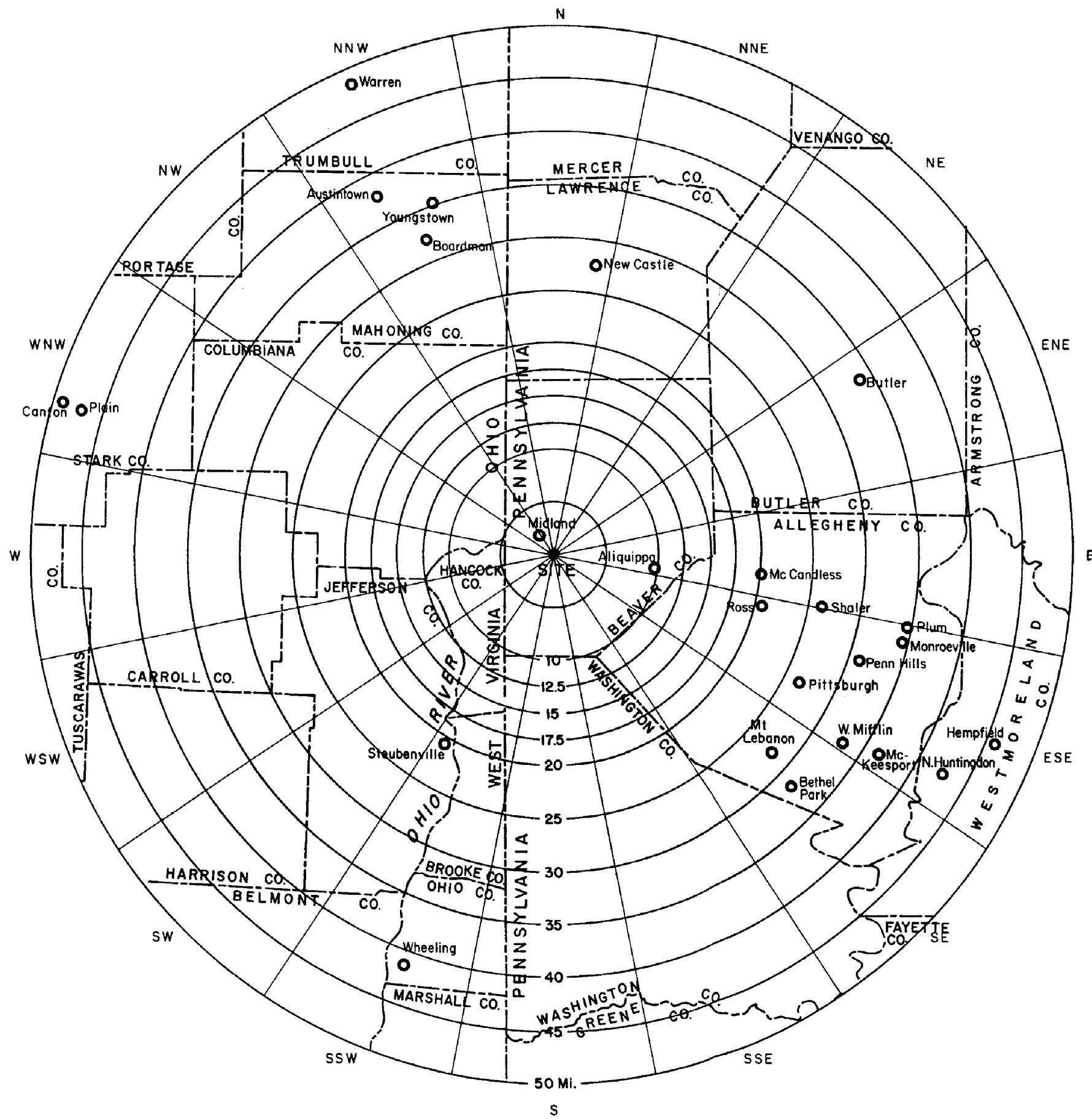
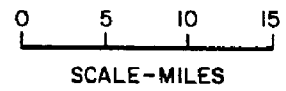

FIGURE 2.1-5  
 COUNTIES AND TOWNS WITHIN  
 50 MILE REGION OF BVPS-2  
 BEAVER VALLEY POWER STATION - UNIT 2  
 FINAL SAFETY ANALYSIS REPORT



**LEGEND**  
 ——— STATE BOUNDARIES  
 - - - COUNTY BOUNDARIES



**FIGURE 2.1-6**  
**POPULATION DISTRIBUTION**  
**ANNULAR SECTORS WITHIN**  
**10-50 MILE REGION OF BVPS-2**  
**BEAVER VALLEY POWER STATION - UNIT 2**  
**FINAL SAFETY ANALYSIS REPORT**



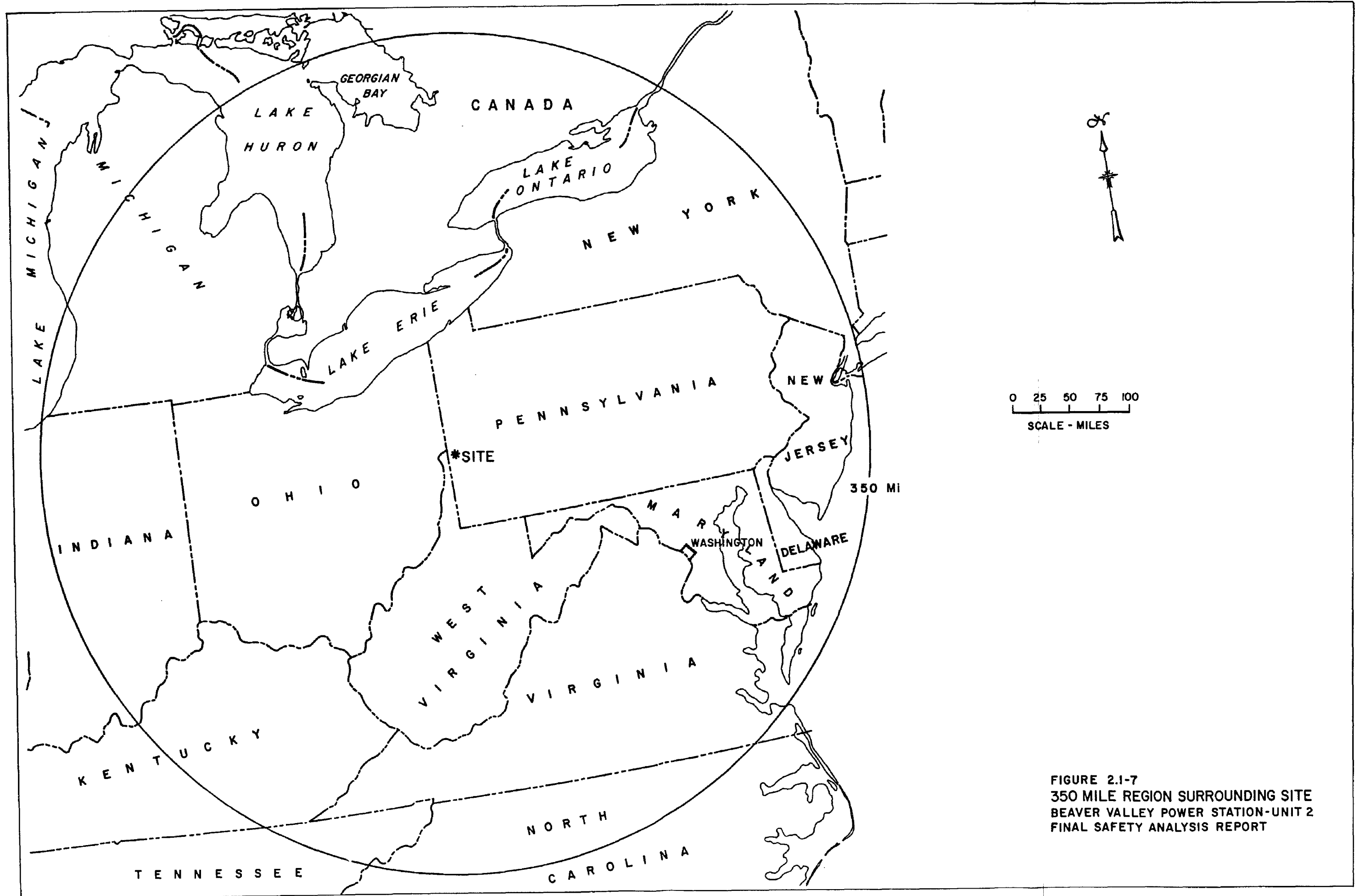

FIGURE 2.1-7  
 350 MILE REGION SURROUNDING SITE  
 BEAVER VALLEY POWER STATION-UNIT 2  
 FINAL SAFETY ANALYSIS REPORT

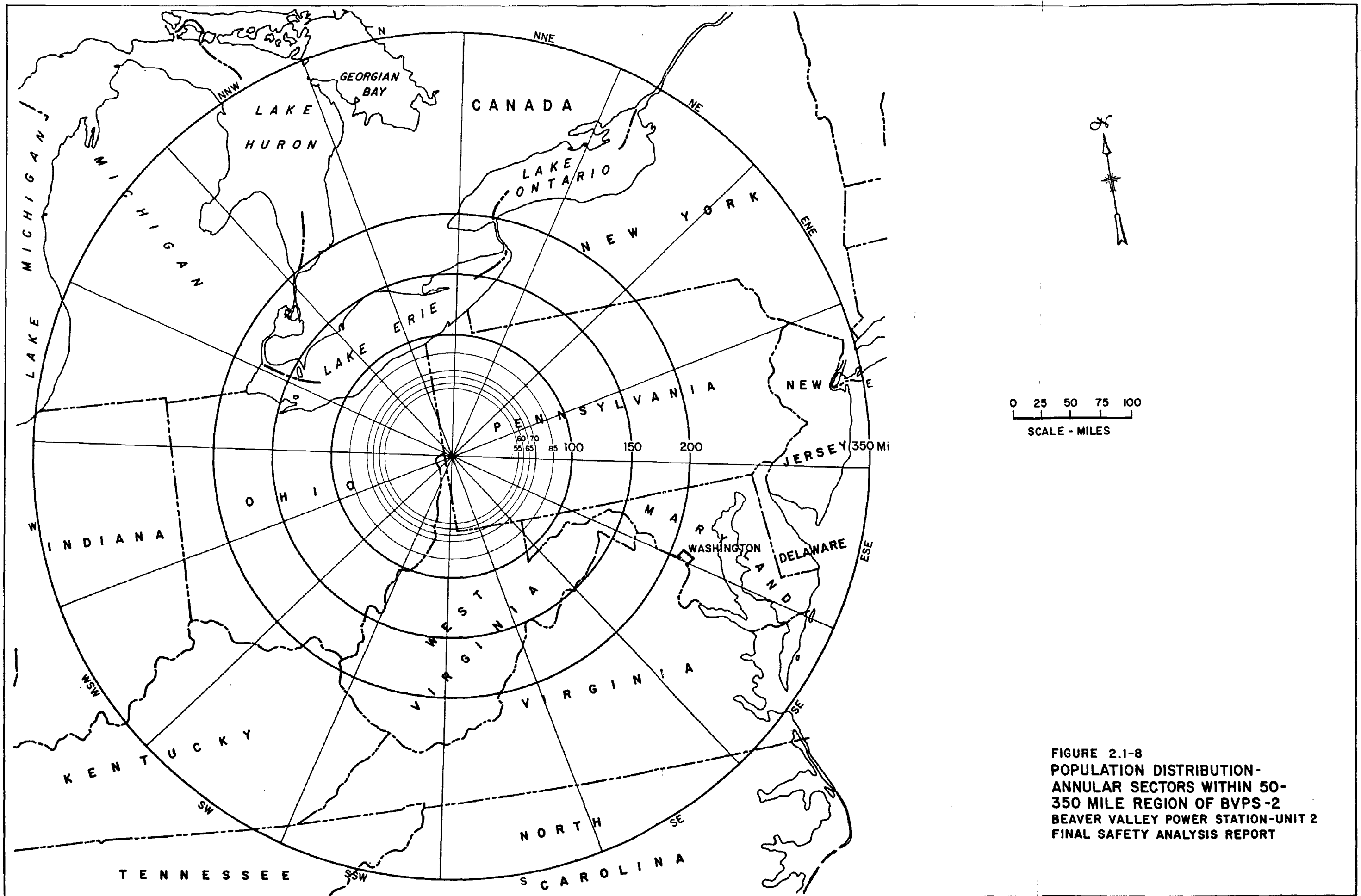

FIGURE 2.1-8  
 POPULATION DISTRIBUTION-  
 ANNULAR SECTORS WITHIN 50-  
 350 MILE REGION OF BVPS-2  
 BEAVER VALLEY POWER STATION-UNIT 2  
 FINAL SAFETY ANALYSIS REPORT

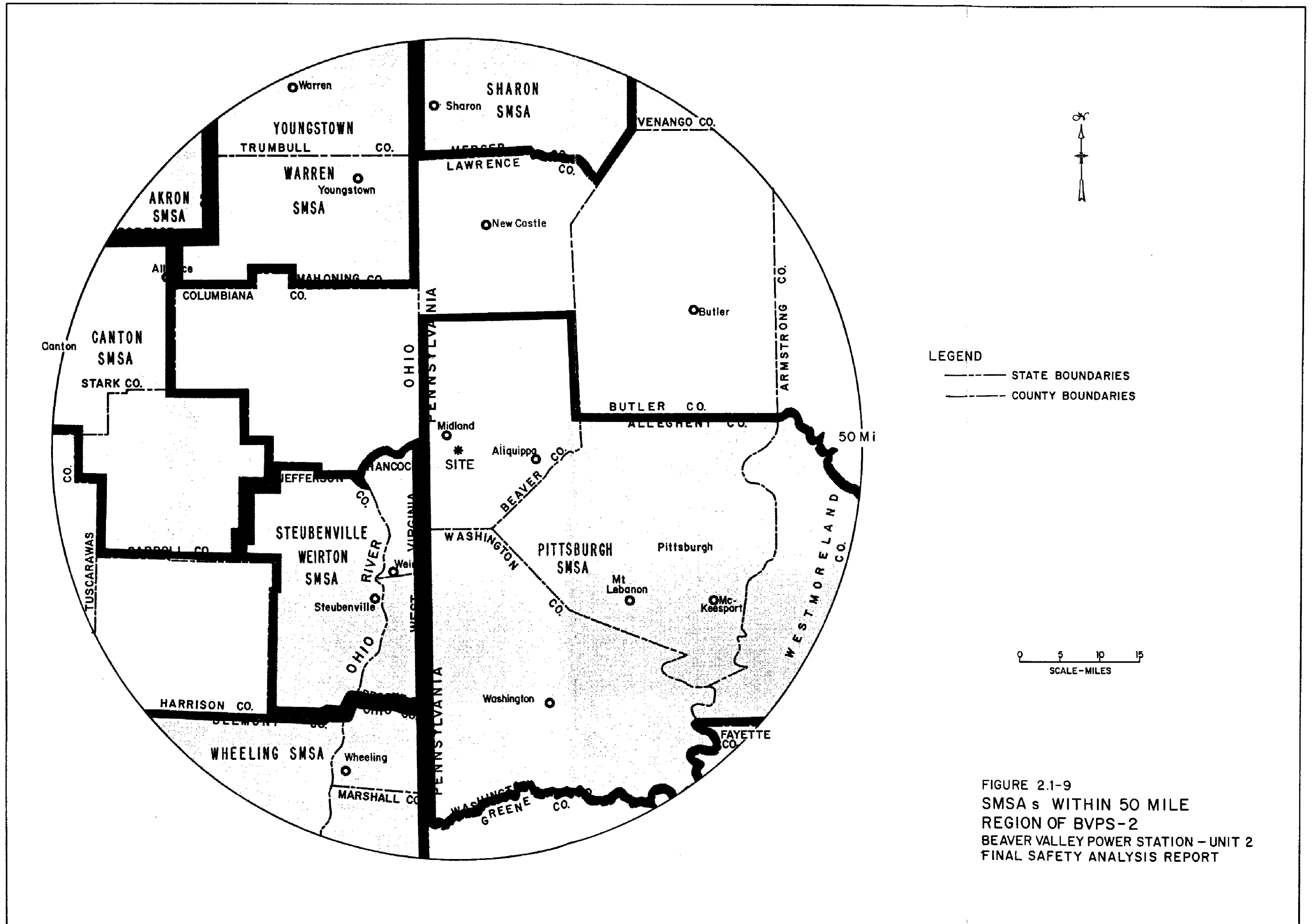

FIGURE 2.1-9  
 SMSAs WITHIN 50 MILE  
 REGION OF BVPS-2  
 BEAVER VALLEY POWER STATION - UNIT 2  
 FINAL SAFETY ANALYSIS REPORT

## 2.2 NEARBY INDUSTRIAL, TRANSPORTATION, AND MILITARY FACILITIES

### 2.2.1 Location and Routes

The area in which the Beaver Valley Power Station (BVPS) is located is part of the large industrial complex centered around the city of Pittsburgh. Due to the combination of available raw materials, product markets, and transportation facilities, the region has developed into a major industrial center, with iron and steel manufacturing constituting the most important factor in the region's economy. The steep slopes and general topography of the Ohio River valley have contributed to the development of river mill towns where the majority of industries and residences are located on flat shelves of land adjacent to the river.

The region is served by five transportation systems: waterways, railroads, highways, airways, and pipelines.

The rivers provided the first major regional transportation system. The Ohio River, under the control of the U.S. Army Corps of Engineers, still serves as a major route for the transport of industrial materials. The normal river tow, generally 1,200 feet in length (including towboat), follows the channel which is located about 0.3 mile from BVPS. Section 2.2.3 describes the Beaver Valley Power Station - Unit 2 (BVPS-2) intake structure location and the potential for river transport accidents affecting the intake or general BVPS-2 structures.

The railroads transport the bulk of industrial materials. The placement of the rail lines was governed by the topography. Because the railroads needed level and continuous corridors, they followed essentially the same courses as the rivers and streams. One of the first rail lines in the region ran from Pittsburgh up the eastern bank of the Beaver River to the Great Lakes region. That line is now one of the main lines of the Consolidated Rail Corporation (ConRail). Another heavily traveled ConRail line follows the north bank of the Ohio across the river from the station site. A 30-foot-wide easement, maintained by ConRail, traverses the BVPS site. This line is of minor importance since the line is controlled by the licensee and its use is limited to the servicing of BVPS-1 and BVPS-2.

Pennsylvania State Highway 68 provides the main access from the residential areas east of the site to the industrial complexes along the north bank of the Ohio River. State Highway 168 from the south follows roughly along the northeast and east corner of the site and joins Highway 68 immediately across the river from the site. State Highway 18 provides additional access to the east of the site while U.S. Route 30 passes by 3 miles southwest of the site. Transportation routes within 5 miles of the station are shown on Figure 2.2-1.

The interstate highway nearest the site is the Pennsylvania Turnpike (I-76), which runs through the northeastern section of Beaver County about 15 miles northeast of the site. Interstate 79, which runs north and south, is located about 18 miles east of the site.

The outmoded highway system has hampered recent development of the local area and of the region as a whole. The topography of the area and the location of the communities dictated that early roads would be located in the river valleys. The Beaver Valley Expressway (Route 60) provides the first four-lane, limited-access highway between the industrial centers of Beaver County and Pittsburgh. The expressway traverses north to south about 6 miles east of the site. This expressway will have a significant influence on the future growth and development of the region. There are no plans at present for other major highways within 10 miles of the site.

#### 2.2.2 Description of Facilities, Products, and Materials

About 40 percent of the Beaver County labor force is employed by manufacturing companies. Approximately 67 percent of the total manufacturing labor force is employed in the primary metals group - blast furnaces, steelworks, and rolling mills. Heavy manufacturing employs approximately 29 percent of the manufacturing labor force, concentrated in fabricated structural steel. The remainder of the manufacturing labor force is employed in the electrical equipment industry, the stone, clay, glass, and concrete industries, and the chemical group. Employment in Beaver County is identified by industry category in Table 2.2-1 (Southwestern Pennsylvania Regional Planning Commission 1983).

Pennsylvania Power Company's Bruce Mansfield Plant (BMP), located approximately 1 mile northeast of the site, employs about 1,000 persons. The nearest industrial activity to the site is the steel mill complex in Midland, between 1 and 2 miles northwest of the site, where approximately 250 persons are employed.

The urban complex of East Liverpool, Ohio, including Chester and Newell, West Virginia, begins about 5 miles west of the site and stretches for several miles down the Ohio River. The East Liverpool area's industrial base depends on pottery for most of its employment, even though the pottery industry has declined due to foreign competition and the use of plastic materials for tableware.

Table 2.2-2 lists major employers in the 10-mile area surrounding the site. Figure 2.2-2 shows their general locations.

Mineral resources including coal, clay, gas, oil, sand, and gravel are found in the region surrounding the site. Bituminous coal is the most important mineral being extracted and coal reserves are considered extensive. Relatively few workers are presently engaged in mining operations; however, the Southwestern Pennsylvania Regional Planning Commission (SPRPC) forecasts an increase in mining

employment (SPRPC 1978). In Beaver County, deep mining is the predominant method used to extract coal, although extensive areas of strip mining are found within the region, especially in northern Beaver County and in northern Washington County. One industrial operation, the Pegg's Run Coal Company, is located in Shippingport Borough approximately 1 mile southwest of the site. Employing about 60 people, the company operates coal washing facilities and a deep mine.

The majority of storage tank facilities for gasoline and oil in the site vicinity are located along the river. The closest oil tanks are in Midland, Pennsylvania, directly across the river from the site (SWEC 1980a). Storage tank facilities in the site vicinity, identified on Figure 2.2-3, are equipped to handle shipments by barge. Across the river from the site, at river mile 34.8, a Pennzoil barge facility handles an average of two outbound shipments per week and one inbound shipment per month of gasoline and fuel products. At river mile 35.2, Mobil Oil Corporation maintains barge facilities to serve the Midland Terminal used by Mobil Pipe Line Company. Mobil's barge facility is presently inactive.

At river mile 33.3, Shell Chemical Corporation ships approximately ninety percent of its chemicals by barge to the Great Lakes Terminal and Transport Facility at Industry, PA. These inbound shipments occur approximately once a month. No outbound shipments are made by barge. Connecting pipelines link the barge facilities to the tank storage areas. Storage tank facilities and contents are described in Section 2.2.3.

The area is served by pipelines carrying natural gas and petroleum products (SWEC 1980b). Pipelines and their products are described in Table 2.2-3 and shown on Figure 2.2-3.

There are eight airports within a 15-mile radius of BVPS. Four airports are located in Pennsylvania: Greater Pittsburgh International, Beaver County, Fino, and Kindelberger; Columbiana, Dyer, and Johnston airports are in Ohio; and Herron Airport is in West Virginia. According to criteria set forth in USNRC Regulatory Guide 1.70, Revision 3, the operations of Greater Pittsburgh, Beaver County, Fino, and Herron airports must be examined in detail due to their proximity to the power plant and/or due to their respective levels of operation. Appendix 3.B describes these four airports, and accidents which have occurred in their vicinity, as well as the analyses performed to define the probability of an aircraft striking BVPS-2.

The total number of persons employed in southwestern Pennsylvania is expected to increase approximately 15 percent between 1974 and the year 2000 (SPRPC 1978). However, not all industry groups will experience this growth. Historically, the southwestern Pennsylvania region has been a center for heavy industry dominated by iron and steel manufacturing. The employment forecast for the region (Table 2.2-4) indicates that in the manufacturing category,

employment gains in machinery and chemical manufacturing will be offset by declines in primary and fabricated metals production and in the stone industries. The net result will be a slight decrease in the number of persons employed in manufacturing production jobs. Employment statistics for the southwestern Pennsylvania region show that this has been the trend for the past several years (Pennsylvania Office of State Planning and Development 1976). Increased automation, foreign competition, dispersion of markets, and the development of steel-making capacity in other areas of the country have all contributed to this trend.

Nonmanufacturing job employment is projected to grow about 12 percent between 1974 and the year 2000 (SPRPC 1978). The largest growth will occur in mining and trade (Table 2.2-4).

### 2.2.3 Evaluation of Potential Accidents

#### 2.2.3.1 Determination of Design Basis Events

A commodity traffic analysis of the transportation routes near the BVPS-2 site was carried out to identify materials potentially capable of causing explosions and subsequently forming vapor clouds in the event of an accidental spill. This analysis included a comprehensive review of the Ohio River barge traffic data compiled by the U.S. Army Corps of Engineers, telephone and letter surveys of the nearby industrial facilities, and the ConRail-Midland Node Activity Report (ConRail 1980).

The Ohio River barge traffic data indicate that the bulk of the activity involves gasoline transport. The shipment of flammable compressed gases is insignificant. The potential risk to BVPS-2 due to barge traffic on the Ohio River has been addressed and subsequently resolved in the BVPS-2 PSAR Amendment 12 dated December 21, 1973 and Amendment 13 dated February 28, 1974. As documented in the BVPS-2 PSAR, the risk was eliminated by the construction of an alternate cooling water intake structure. The alternate intake structure is capable of providing heat sink functions in the event of the loss of the primary intake structure as a result of a gasoline barge impact and explosion (Section 9.2.1.2).

Telephone and letter surveys of the nearby industrial facilities show that there are no known shipments of flammable compressed gases which use the Shippingport Bridge on Route 168 (SWEC 1980a). There are regular bulk shipments of solvents and gasoline by tank trucks which use the bridge. However, these shipments are not considered to cause an explosion or vapor cloud hazard in the event of an accidental spill.

Pipelines carrying natural gas and other petroleum products in the vicinity of BVPS-2 are identified in Table 2.2-3. None of the pipelines carry liquified hydrocarbon gases, such as LNG or LPG, which can form combustible vapor clouds. The only source of potentially combustible vapor cloud is a rupture of the pipeline owned and operated by Mobil Pipeline Company. This pipeline is used for transporting gasoline, kerosene, and heating oil. A 2,150-foot section of this pipeline skirts the BVPS-2 site, with the closest distance to a safety-related structure (the BVPS-2 diesel generator building) being approximately 950 feet. Because of the close proximity of

the pipeline to BVPS-2, the probability of an explosion/fire due to a pipeline rupture is discussed in Section 2.2.3.1.1.

The transportation of flammable liquified gases by ConRail is a concern due to the potential for explosions and the formation of vapor clouds in the event of an accident. The probability of a vapor cloud explosion resulting from a railroad transportation accident is discussed in Section 2.2.3.1.2.

#### 2.2.3.1.1 Mobil Pipeline Rupture

**Removed in Accordance with RIS 2015-17**



**Removed in Accordance with RIS 2015-17**

**Removed in Accordance with RIS 2015-17**

**Removed in Accordance with RIS 2015-17**

**Removed in Accordance with RIS 2015-17**

**Removed in Accordance with RIS 2015-17**

**Removed in Accordance with RIS 2015-17**

**Removed in Accordance with RIS 2015-17**

**Removed in Accordance with RIS 2015-17**



**Removed in Accordance with RIS 2015-17**

**Removed in Accordance with RIS 2015-17**

**Removed in Accordance with RIS 2015-17**

**Removed in Accordance with RIS 2015-17**

**Removed in Accordance with RIS 2015-17**

## Removed in Accordance with RIS 2015-17

### 2.2.3.1.3 Fires

The production of high heat fluxes and smoke from fires at industrial or storage facilities, oil and gas pipelines, or transportation routes in the site vicinity does not present a hazard to the safe operation of BVPS-2. This is due primarily to the separation distances of these potential fires from the site. The nearest storage facility of large quantities of flammable materials is in Midland, Pennsylvania, which is about 0.5 mile from the site. The nearest truck route on which flammable materials may be transported (Route 168) is approximately 760 feet from the site. Large quantities of flammable materials are frequently transported past the site by rail (ConRail) and by barge. However, the separation distances of 2,100 feet for the ConRail line and 790 feet for barge traffic at the closest points of passage from the site are sufficient to prevent any hazardous heat fluxes or smoke plumes from reaching the station in the event of an accidental fire.

In addition to the mitigating effect of the separation distances of potential fires from the site, the control room is equipped with smoke detectors and manually operated intake dampers to identify and isolate outside smoke, respectively. These systems are described in detail in Section 9.4.1.2.1.

Seven natural gas pipelines and seven petroleum product pipelines are located near the site, generally eastward of BVPS-2. These buried lines are described in more detail in Section 2.2.2.

The site is sufficiently cleared in areas adjacent to BVPS-2 such that forest or brush fires pose no safety hazards. Likewise, onsite fuel storage fires do not jeopardize BVPS-2 safety since these facilities are designed in accordance with applicable fire codes. A detailed description of the BVPS-2 fire protection system is presented in Section 9.5.1.

#### 2.2.3.1.4 Collisions with Intake Structure

As stated previously, the potential impact on BVPS-2 due to damage to the primary intake structure has been eliminated with the construction of an alternate intake structure which is capable of providing heat sink functions in the event of the loss of the primary intake structure. The postulated events which could damage the primary intake structure (gasoline barge impact and subsequent explosion) are discussed in Section 9.2.1.2.

#### 2.2.3.1.5 Liquid Spills

Liquid spills from onsite and offsite sources are evaluated to determine the potential of such spills to be drawn into the intake structure or otherwise affect the safe operation of the plant.

There is a potential for liquid spills in the Ohio River to enter the plant's circulating water system via the intake structure and the service water system (SWS). A liquid spill from sources onsite is possible, but it is unlikely that a spill of this nature would affect safety-related equipment, be drawn into the intake structure, or otherwise affect the safe operation of BVPS-2.

Table 2.2-15 lists the liquids stored at the site, storage capacities, locations, and methods to contain or process overflow or spillage. Adequate protection is provided to minimize the effects of a spill on surrounding systems and equipment.

Table 2.2-16 gives the average quantities and types of liquids transported on the Ohio River per year. These values, as well as commodities and amounts transported by the railroads, are tabulated in the Control Room Habitability Study for BVPS-1 and BVPS-2 (SWEC 1981a). Liquids transported by pipelines consist solely of petroleum products as indicated in Table 2.2-3. Relative locations of railroads and pipelines are shown on Figure 2.2-3.

Liquids transported by railroads and pipelines do not pose a serious threat of being drawn into the intake structure or to the safe operation of BVPS-2.

Railroad service is provided by ConRail in the vicinity of the BVPS-2 site; however, this line is of minor importance since it is controlled by the licensee and is limited to the servicing of the BVPS.

The upstream release of oil or cryogenic liquids in the river due to either a pipeline rupture or a barge accident would not present a hazard to BVPS-2 operation, as these liquids would float on the river surface. The intake invert of the intake structure is located more than 18 feet below the normal low water level of the river (Section 2.4.11.5).

Other liquids spilled into the river from a barge accident would be diluted by the river and would not pose a significant threat to BVPS-2 operations. In the unlikely event a coagulant liquid enters the SWS, it would affect the discharge pressure of the SWS pumps and automatically start the standby service water pumps in the alternate intake structure in the event of low header pressure.

Depending on the location of the accident and subsequent spill, the alternate intake structure may be used to provide safety-related cooling water from the standby service water system (Section 9.2.1.2). Located approximately one-quarter mile upstream of the intake structure, the alternate intake structure is designed to accommodate BVPS-2 shutdown and cooldown after a postulated loss of the main intake structure.

#### 2.2.3.2 Effects of Design Basis Events

Potential design basis events are identified in Section 2.2.3.1. The effects of potential accidents from present and projected industrial, transportation, and military installations and operations have been evaluated as follows. Safety-related components and structures have been evaluated from the effects of these accidents and safe shutdown of BVPS-2 will not be impaired.

Missile protection is provided for all components required to achieve and maintain a safe shutdown condition. Safety components are physically separated by barriers, located in individual cubicles, or located below grade so that a postulated missile does not affect the components required for safe shutdown.

The redundant emergency diesel generators are completely independent satisfying the single failure criterion for safety-related equipment. This ensures that there are no effects from fires on the emergency diesel generators.

An alternate intake structure is provided to ensure that safety-related cooling water is available in a postulated event where the primary intake structure is affected. These postulated events include damage from a gasoline barge impact/explosion (Section 9.2.1.2). The redundant intake structures ensure against loss of safety-related service water cooling in the event of a liquid spill in the river.



## 2.2.4 References for Section 2.2

- American Conference of Governmental Industrial Hygienists 1980. Documentation of the Threshold Limit Values. Fourth edition. Cincinnati, Ohio.
- Battelle Pacific Northwest Laboratories 1980. An Assessment of the Risk of Transporting Propane by Truck and Train. PNL-3308.
- Consolidated Rail Corporation (ConRail) 1980. Node Activity for Midland, Pa; by Type, from January 1978 through June 1979. Hazardous Materials Node Activity Report prepared by Stone & Webster Engineering Corporation, Boston, Mass.
- Eichler, T.V. and Napadensky, H.S. 1977. Accidental Vapor Phase Explosions on Transportation Routes near Nuclear Power Plants. Final Report J6405, p. 57.
- International Technical Information Institute 1979. Toxic and Hazardous Industrial Chemicals Safety Manual for Handling and Disposal with Toxicity and Hazard Data. Tokyo, Japan.
- Kaiser, G. D. and Griffiths, R.F. 1982. The Accidental Release of Anhydrous Ammonia: A System Study of Factors Influencing Cloud Density and Dispersion. Journal of the Air Pollution Control Association, Vol. 32, No. 1.
- Mobil Oil Corporation 1983. Personal communication between G. Lehner, Mobil Oil Corporation, Trenton, New Jersey, and C. S. Ellis, Stone & Webster Engineering Corporation, October 5, 1983.
- Mobil Pipe Line Company 1983. Letter from A. D. Bell, Mobil Pipe Line Company, to R. J. Washabaugh, Duquesne Light Company (DLC) dated February 8, 1983.
- Mobil Pipe Line Company 1984. Letter from A. D. Bell, Mobil Pipe Line Company, to R. J. Washabaugh, DLC, dated April 4, 1984.
- National Institute for Occupational Safety and Health (NIOSH) 1978. Registry of Toxic Effects of Chemical Substances.
- Ohio Department of Economic and Community Development 1981. 1981 Ohio Industrial Directory, Harris Publishing company.
- Patty, F. A. (ed). 1978. Industrial Hygiene & Toxicology Vols I & II. Interscience Publishers, New York, N.Y.
- Pennsylvania Office of State Planning and Development 1976. Historical Annual Industrial Employment for the Six-County Region, 1960-1974.
- Pennzoil 1983. Personal communication between S. Craig, Pennzoil, Midland, Pa., and C. S. Ellis, Stone & Webster Engineering Corporation, October 6, 1983.

Sax, N.E. 1968. Dangerous Properties of Industrial Materials, 3rd Edition, Van Nostrand Reinhold, New York, N.Y.

Shell Chemical Corporation 1983. Personal communication between T. Gimbus, Great Lakes Terminal and Transport, Industry, Pa., and C. S. Ellis, Stone & Webster Engineering Corporation, October 6, 1983.

Southwestern Pennsylvania Regional Planning Commission (SPRPC) 1983. Personal communication with Bob Schwartz (SPRPC) and K. Baraniak (SWEC), June 1983.

SRPC 1980. Dimensions for the year 2000.

Stone & Webster Engineering Corporation (SWEC) 1980a. Survey of Industries. Prepared for Duquesne Light Company.

Stone & Webster Engineering Corporation (SWEC) 1980b. Survey of Pipelines. Prepared for Duquesne Light Company.

Stone & Webster Engineering Corporation (SWEC) 1981a, Control Room Habitability Study, BVPS-1 and BVPS-2. Prepared for Duquesne Light Company.

Stone & Webster Engineering Corporation (SWEC) 1981b. Consultation with Dr. Thomas Smith, Consultant, Occupational Health Services. Cambridge, Mass.

Stone & Webster Engineering Corporation (SWEC) 1983. Survey of Industries - Employment Updates. Prepared for Duquesne Light Company.

U.S. Department of the Army 1969. Structures to Resist the Effects of Accidental Explosions. Technical Manual TM5-1300/NAVFACP-397/AFM88-22.

U.S. Department of Transportation (USDOT) 1981. Incidents Involving LPG and Ammonia. Computer Runs Prepared for SWEC.

U.S. Environmental Protection Agency (USEPA) 1980. Criteria Review for Vapor Phase Hydrocarbons. 600/8-80-045.

U.S. Nuclear Regulatory Commission (USNRC) 1975. Reactor Safety Study: An Assessment of Risks in U.S. Commercial Nuclear Power Plants, NUREG-75/104 (WASH 1400), Appendix III, Table 2-1 (Data Assessment Tabulation), December 1975.

USNRC 1979. Toxic Vapor Concentrations in the Control Room Following a Postulated Accidental Release. NUREG-0570.

USNRC 1981a. Standard Review Plan for the Review of Safety Analysis Reports for Nuclear Power Plants. NUREG-0800.

USNRC 1981b. Personal Communication between K. Murphy, USNRC, and Stone & Webster Engineering Corporation, February 4, 1981.

USNRC 1982. Personal Communication between D. A. Chaney, USNRC  
Project Manager, Operating Reactors Branch No. 1, Division of

Licensing, and J. J. Carey, Duquesne Light Company, Vice President. Letter dated February 19, 1982.

West Virginia Office of Economic and Community Development 1980.  
1980 West Virginia Manufacturing Directory.

BVPS-2 UFSAR

Tables for Section 2.2

TABLE 2.2-1  
 EMPLOYMENT BY JOB CLASSIFICATION  
 BEAVER COUNTY, PA\*

Employment Classification	1980		1990 (projected)		2000 (projected)	
	Employees	% of Total	Employees	% of Total	Employees	% of Total
Nonmanufacturing	45,358	57.8	47,560	60.8	50,002	64.9
Government	4,931	6.3	4,844	6.2	4,951	6.4
Education	5,321	6.8	5,550	7.1	5,935	7.7
T.U.C.**	5,279	6.7	5,359	6.9	5,533	7.2
Medical	4,292	5.5	4,990	6.4	5,548	7.2
Retail	12,508	15.9	13,066	16.7	13,727	17.8
Services	6,092	7.8	6,572	8.4	7,183	9.3
Wholesale	1,559	2.0	1,828	2.3	2,117	2.7
F.I.R.E.***	1,869	2.4	2,099	2.7	2,334	3.0
Construction	2,745	3.5	2,571	3.3	2,090	2.7
Agriculture	509	<1	389	<1	295	<1
Mining	242	<1	281	<1	278	<1
Nonproduction mfg.	11	<1	11	<1	11	<1
Manufacturing production	33,189	42.3	30,651	39.2	27,072	35.1
Heavy	9,573	12.2	9,736	12.4	9,613	12.5
Light	1,330	1.7	1,476	1.9	1,632	2.1
Primary metals	22,286	28.4	19,439	24.9	15,827	20.5
Total employment	78,547	100	78,211	100	77,074	100

NOTES:

\*Southwestern Pennsylvania Regional Planning Commission 1980.

\*\*Transportation, Utilities, and Communication.

\*\*\*Finance, Insurance, and Real Estate.

TABLE 2.2-2  
MAJOR INDUSTRIAL EMPLOYERS WITHIN  
10 MILES OF BVPS

<u>No.*</u>	<u>Product Type</u>	<u>Name of Facility</u>	<u>Location</u>	<u>Approximate Distance &amp; Direction from Site (miles)</u>	<u>Estimated Number of Employees** (1983)</u>
1	Steel	Jones & Laughlin Steel Corporation - Midland Works	Midland, Pa.	1 NW	250
2	Steel	E. W. Bliss Co. - MacIntosh-Hemphill Division	Midland, Pa.	1 NW	290
3	Zinc	St. Joe Minerals Co., - Smelting Division	Potter Township, Pa.	6 NE	489
4	Electrical	Westinghouse Electric Corp.	Beaver, Pa.	8 NE	1,631
5	Chinaware	The Hall China Co.	East Liverpool, Ohio	7 W	283
6	Petroleum refining	Quaker State Oil Refining Corp.	Newell, W.Va.	10 W	188
7	Dinnerware	Homer Laughlin China Co.	Newell, W.Va.	9 W	855
8	Plastics	Arco-Polymers	Potter Township, Pa.	4.5 NE	600
9	Steel	PBI Industries	Rochester, Pa.	9.5 NE	125
10	Glassware	Anchor Hocking Corp. - Phoenix Glass	Monaca, Pa.	9 NE	600

TABLE 2.2-2 (Cont)

<u>No.*</u>	<u>Product Type</u>	<u>Name of Facility</u>	<u>Location</u>	<u>Approximate Distance &amp; Direction from Site (miles)</u>	<u>Estimated Number of Employees** (1983)</u>
11	Steel tubing	Pittsburgh Tube Co.	Monaca, Pa.	9 NE	239
12	Steel	Teledyne Vasco-Colonial	Monaca, Pa.	9 NE	105
13	Electricity	Pennsylvania Power Company, Bruce Mansfield Plant	Shippingport, Pa.	1 ENE	1,027
14	Steel	Jones & Laughlin Steel Corp. Aliquippa Works	Aliquippa, Pa.	9 E	7,500
15	Ladle Brick	Globe Refractories, Inc.	Newell, W.Va.	9.5 W	229
16	Elec. insulators	Ohio Brass Co.	Newell, W.Va.	9 W	150

NOTES:

\*Refer to Figure 2.2-1 for industry locations.

\*\*Stone & Webster Engineering Corporation 1983.



TABLE 2.2-3  
 PIPELINES IN THE VICINITY OF BVPS-2\*

<u>Pipeline Identification**</u>	<u>Pipe Size (inches)</u>	<u>Pipe Age*** (years)</u>	<u>Operating Pressure</u>	<u>Location of Source</u>	<u>Depth of Burial</u>	<u>Type of Liquid or Gas Presently Carried</u>	<u>Percent of Usage</u>	<u>Planned Changes to Pipeline or Material Carried</u>
Ashland Pipe Line Co. Line No. 1	8	70	400 psig	Columbiana Co., Ohio	30-36"	Petroleum products & crude oil	95	None
Line No. 2	8	3	300 psig	Columbiana Co., Ohio	30-36"	Petroleum products	75	None
Line No. 3	6	22	400 psig	Columbiana Co., Ohio	30-36"	Petroleum products & crude oil	75	None
Laurel Pipe Line Co. Line No. 4	14	20	330 psi Normal (1,200 psi allowable)	Aliquippa Station, Independence Township, Beaver County, Pa.	Variable 30-48" Nominal	Refined products	100	None
National Transit Co. Line No. 5****	8	71	600 psi*****	Ohio	36"	Crude oil	0	Indefinite
The Peoples Natural Gas Co. Line No. 6	4	11	9 lbs	No. 8	30"	Natural gas	100	None
Line No. 7	2	4	9 lbs	No. 6	30"	Natural gas	100	None
Line No. 8	12	23	290 lbs	Gibson Pump Station & Black Hawk Regulator Station	48"	Natural gas	100	None
Line No. 9	12	1	290 lbs	Gibson Pump Station & Black Hawk Regulator Station	48"	Natural gas	100	None

TABLE 2.2-3 (Cont)

<u>Pipeline Identification**</u>	<u>Pipe Size (inches)</u>	<u>Pipe Age*** (years)</u>	<u>Operating Pressure</u>	<u>Location of Source</u>	<u>Depth of Burial</u>	<u>Type of Liquid or Gas Presently Carried</u>	<u>Percent of Usage</u>	<u>Planned Changes to Pipeline or Material Carried</u>
Line No. 10	12	7	290 lbs	Gibson Pump Station & Black Hawk Regulator Station	48"	Natural gas	100	None
Line No. 11	2	11	9 lbs	No. 6	30"	Natural gas	100	None
Line No. 12	4	1	9	No. 8	30"	Natural gas	100	None
Mobil Pipe Line Co. Line No. 13	8	Between 4 and 40	1,440 psig	Midland Pump Station, Midland, Pa. or Altoona Pump Station, Altoona, Pa. and/or Harrisburg Pump Station, Harrisburg, Pa.	24" to 48"	Refined petroleum products	up to 100	Pipeline relocated
Buckeye Pipe Line Co. Line No. 14	11	28	625 psi	Columbiana, Ohio	48" minimum	Refined petroleum products	65	None

NOTES:

- \* Stone & Webster Engineering Corporation 1980b.
- \*\* Refer to Figure 2.2-3 for the locations of these pipelines. Company names are from time of BVPS-2 license. Pipeline owners may change.
- \*\*\* Approximate age as of 1978-79.
- \*\*\*\* Pipeline presently out of service.
- \*\*\*\*\* Operating pressure when last used.

TABLE 2.2-4

SOUTHWESTERN PENNSYLVANIA  
PROVISIONAL EMPLOYMENT FORECAST \*,\*\*

<u>Employment Group</u>	<u>Thousands of Persons</u>			<u>Percent Change (1974 to 2000)</u>
	<u>(1974)</u>	<u>(1980)</u>	<u>(2000)</u>	
Manufacturing	287.8	287.4	273.0	-5
Selected manufacturing groups				
Primary metals	113.1	106.8	82.9	-27
Fabricated metals	25.3	25.3	22.7	-10
Stone	21.7	20.6	17.3	-20
Chemicals	10.9	11.3	15.9	+46
Nonelectrical machinery	23.1	23.7	30.0	+30
Electrical machinery	30.3	31.3	33.1	+9
Food	14.7	14.1	10.0	-32
Nonmanufacturing	772.4	805.6	945.3	+22
Selected nonmanufacturing groups				
Services	130.1	129.8	145.2	+12
Wholesale and retail trade	233.4	245.7	283.5	+22
Government	66.6	61.0	64.0	-4
Contract construction	52.3	53.2	48.6	-7
Mining	14.1	19.7	30.4	+116
Agriculture	8.8	7.7	4.7	-47
Total employment	1,060.2	1,093.0	1,218.3	+15

NOTES:

- \* Pennsylvania Office of State Planning and Development 1976.
- \*\* Southwestern Pennsylvania Regional Planning Commission 1978.

TABLE 2.2-6

## PROBABILITIES OF CATASTROPHIC RUPTURE EVENTS

<u>Hazardous Material</u>	<u>P<sub>ri</sub> (Ruptures/yr)</u>
Ethylene oxide	0.4236 x 10 <sup>-6</sup>
Propylene oxide	0.1794 x 10 <sup>-6</sup>
Vinyl chloride monomer	3.1130 x 10 <sup>-6</sup>
Butadiene	0.1056 x 10 <sup>-6</sup>
Isobutane	0.0155 x 10 <sup>-6</sup>
Isobutylene	0.1788 x 10 <sup>-6</sup>
LPG	0.7166 x 10 <sup>-6</sup>
Ethylene	0.1022 x 10 <sup>-6</sup>
Anhydrous ammonia	<u>0.0988 x 10<sup>-6</sup></u>
Total	4.933 x 10 <sup>-6</sup>

TABLE 2.2-7

## ESTIMATED IGNITION PROBABILITIES

<u>Hazardous Material</u>	<u>P<sub>ii</sub>, Ignition Probabilities</u>
Ethylene oxide	0.0287
Propylene oxide	0.0287
Vinyl chloride monomer	0.0615
Butadiene	0.0287
Isobutane	0.0479
Isobutylene	0.0287
LPG	0.0479
Ethylene	0.0969
Anhydrous ammonia	0.0287

TABLE 2.2-8

## PROBABILITY OF AN UNCONFINED VAPOR CLOUD EXPLOSION

<u>Hazardous Material</u>	<u>Probability of Unconfined Vapor Cloud Explosion per Year</u>
Ethylene oxide	$1.216 \times 10^{-9}$
Propylene oxide	$5.149 \times 10^{10}$
Vinyl chloride monomer	$1.914 \times 10^{-8}$
Butadiene	$3.031 \times 10^{-10}$
Isobutane	$7.425 \times 10^{-11}$
Isobutylene	$5.132 \times 10^{-10}$
LPG	$3.433 \times 10^{-9}$
Ethylene	$9.903 \times 10^{-10}$
Anhydrous ammonia	<u><math>2.836 \times 10^{-10}</math></u>
Total	$2.65 \times 10^{-8}$

TABLE 2.2-9

TOXIC CHEMICALS STORED ONSITE

**Removed in Accordance with RIS 2015-17**

TABLE 2.2-10

STATIONARY OFFSITE TOXIC CHEMICALS STORED WITHIN 5 MILES  
OF THE BVPS-2 CONTROL ROOM AIR INTAKE

**Removed in Accordance with RIS 2015-17**



TABLE 2.2-11

PREDICTED TOXIC VAPOR CONCENTRATIONS  
IN THE CONTROL ROOM

**Removed in Accordance with RIS 2015-17**

TABLE 2.2-11 (Cont)

**Removed in Accordance with RIS 2015-17**

TABLE 2.2-11 (Cont)

**Removed in Accordance with RIS 2015-17**

TABLE 2.2-11 (Cont)

**Removed in Accordance with RIS 2015-17**

TABLE 2.2-12

CONRAIL TRACK LENGTHS AND  
WIND DIRECTION FREQUENCIES

<u>Upwind Sector</u>	<u>Track/River Length*</u> (miles)	<u>Wind Direction Frequency</u> (percent of total time)
NE	3.25	4.1
NNE	1.41	3.3
N	0.32	5.2
NNW	0.18	3.5
NW	0.19	4.4
WNW	0.34	4.1
W	0.75	7.7
WNW**	4.24	4.1

NOTES:

- \* The track and river lengths are assumed equal since the track runs along the north shore of the Ohio River.
- \*\* Track passes through WNW sector twice.

TABLE 2.2-13

AGGREGATE PROBABILITY OF TOXIC  
CHEMICAL SPILL TRANSPORTED BY CONRAIL

**Removed in Accordance with RIS 2015-17**

TABLE 2.2-13 (Cont)

**Removed in Accordance with RIS 2015-17**

TABLE 2.2-13 (Cont)

**Removed in Accordance with RIS 2015-17**



TABLE 2.2-13 (Cont)

**Removed in Accordance with RIS 2015-17**

TABLE 2.2-13 (Cont)

**Removed in Accordance with RIS 2015-17**

TABLE 2.2-13 (Cont)

**Removed in Accordance with RIS 2015-17**

TABLE 2.2-14

AGGREGATE PROBABILITY OF TOXIC  
CHEMICAL SPILL TRANSPORTED BY BARGE

**Removed in Accordance with RIS 2015-17**

TABLE 2.2-15

ONSITE LIQUID STORAGE

**Removed in Accordance with RIS 2015-17**

TABLE 2.2-16

## LIQUIDS TRANSPORTED ON OHIO RIVER

<u>Commodity</u>	<u>Amount</u> <u>(short tons)*</u>	
	<u>1977</u>	<u>1978</u>
Sulfuric acid	110,345	149,500
Oil (food products)	2,748	3,899
Alcohols	138,452	136,567
Benzene/toluene	259,752	208,847
Crude petroleum	46,621	23,028
Gasoline	1,008,125	1,007,456
Jet fuel	302,187	244,778
Kerosene	26,934	51,737
Distillate fuel oil	899,399	663,558
Residual fuel oil	979,145	1,388,415
Lubricating oil	362,156	357,545
Naphtha, mineral spirits solvents	95,326	79,199

NOTE:

\*Typical barge sizes are 1,450 and 4,500 tons.

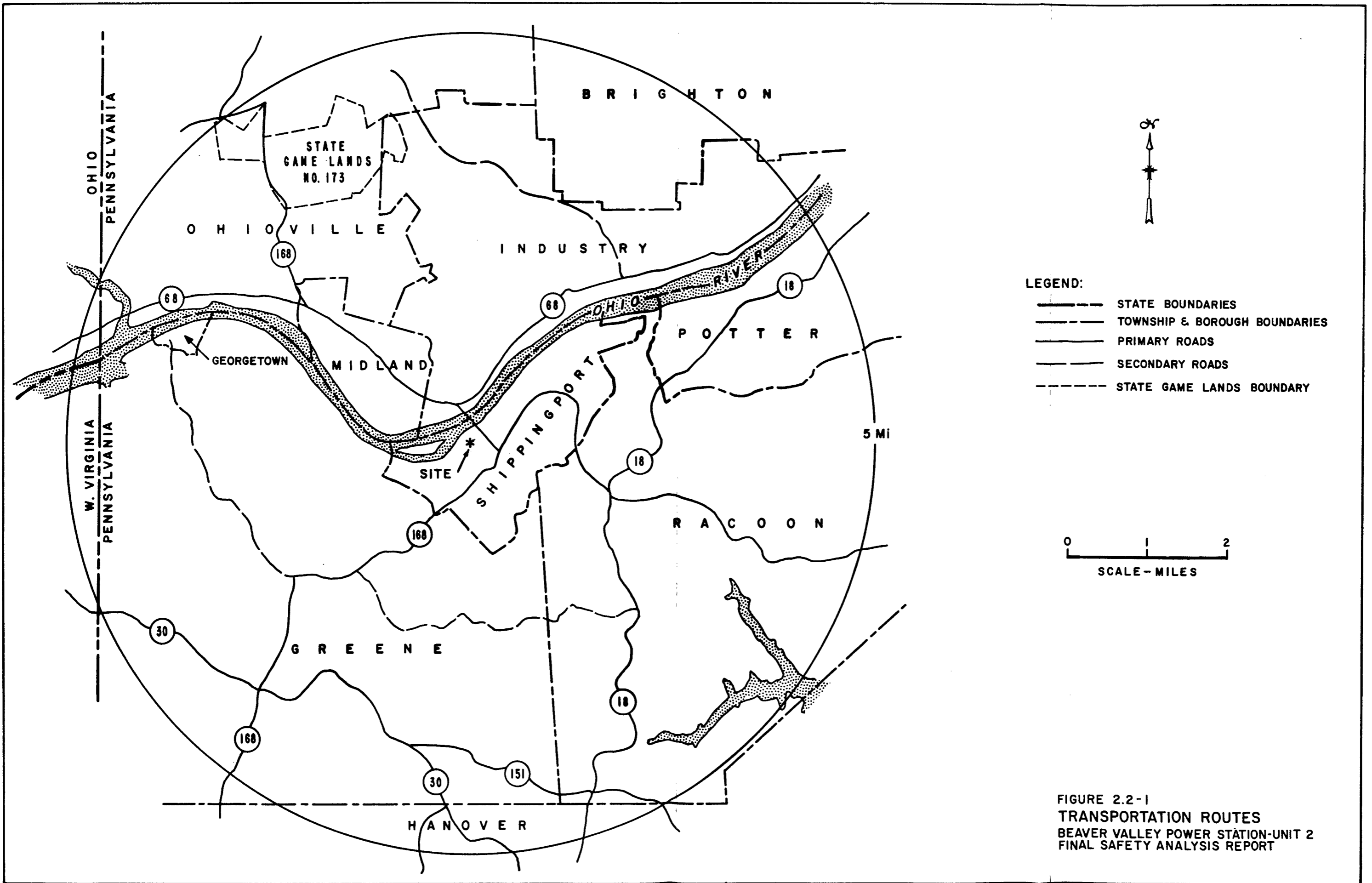

**LEGEND:**

- STATE BOUNDARIES
- TOWNSHIP & BOROUGH BOUNDARIES
- PRIMARY ROADS
- SECONDARY ROADS
- STATE GAME LANDS BOUNDARY

0 1 2  
SCALE - MILES

FIGURE 2.2-1  
TRANSPORTATION ROUTES  
BEAVER VALLEY POWER STATION-UNIT 2  
FINAL SAFETY ANALYSIS REPORT

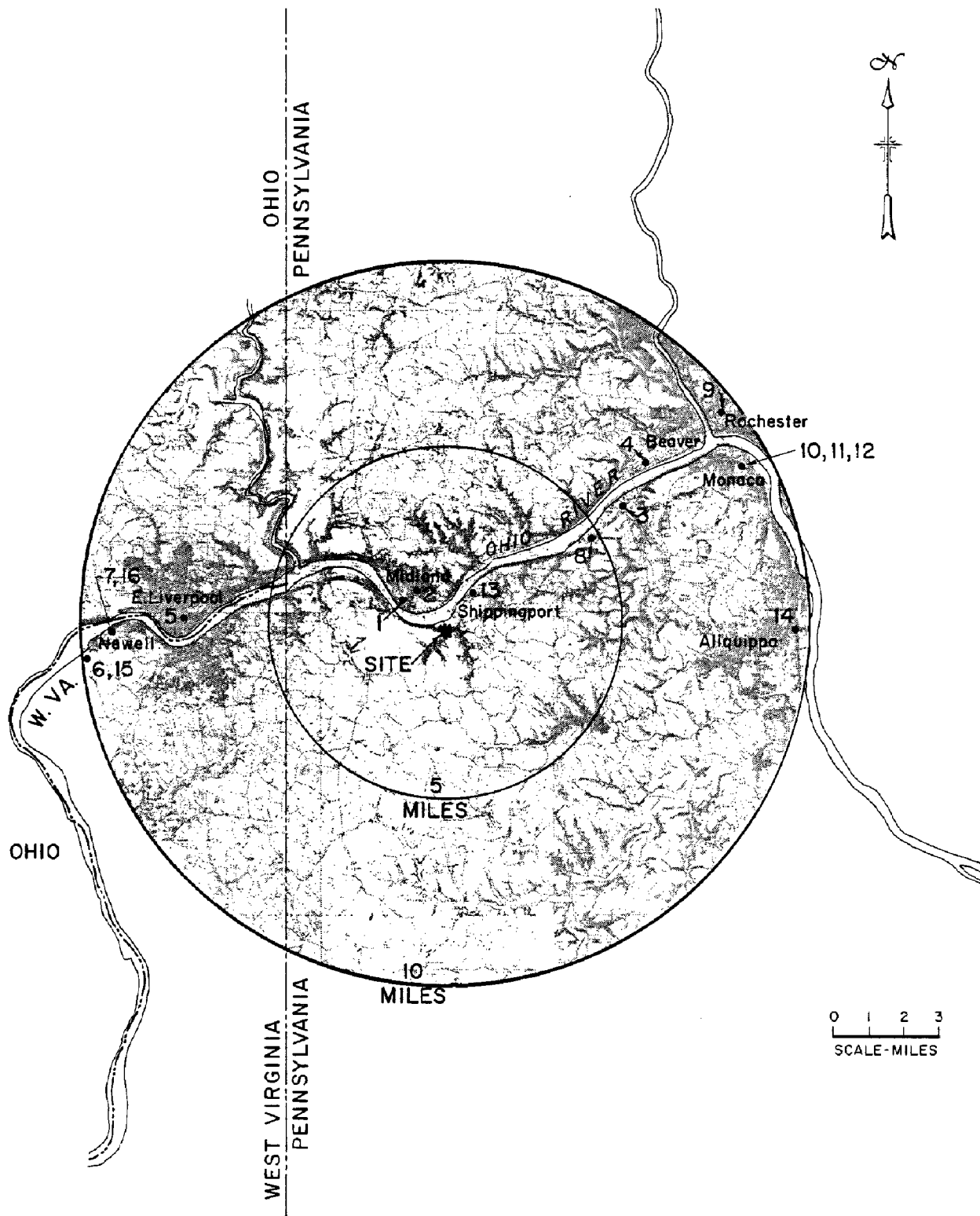

NOTE:  
 NUMBERS CORRESPOND TO TABLE 2.2-2

FIGURE 2.2-2  
 MAJOR INDUSTRIES WITHIN  
 10 MILES OF THE SITE  
 BEAVER VALLEY POWER STATION - UNIT 2  
 FINAL SAFETY ANALYSIS REPORT



Removed in Accordance with RIS 2015-17

FIGURE 2.2-3  
PIPELINES IN THE VICINITY  
OF THE SITE  
BEAVER VALLEY POWER STATION-UNIT 2  
FINAL SAFETY ANALYSIS REPORT

## 2.3 METEOROLOGY

### 2.3.1 Regional Climatology

#### 2.3.1.1 General Climate

##### 2.3.1.1.1 Types of Air Masses

The Beaver Valley Power Station - Unit 2 (BVPS-2) is located in a humid continental type of climate. The predominant types of air masses which influence this region are polar continental and maritime tropical. The polar continental air masses originating in Canada usually influence the region's climate during the winter, resulting in cold temperatures. Occasional outbreaks of arctic air masses during the winter bring extremely cold temperatures to the area. Maritime tropical air masses originating over the Gulf of Mexico usually influence the region's climate during the summer bringing warm humid weather to the Beaver Valley Power Station (BVPS) area.

In general, the BVPS site experiences cool winters and moderately warm summers with ample annual precipitation evenly distributed throughout the year.

Table 2.3-1 presents the normals, means, and/or extremes of climatological data from the National Weather Service (NWS) Office at Greater Pittsburgh Airport, located approximately 16 miles southeast of the BVPS site.

##### 2.3.1.1.2 Regional Synoptic Features

In winter and early spring, the normal circulation over the region varies as eastward-moving migratory high- and low-pressure systems, identified with the mid-latitude westerly upper air circulation, alternately carry cold and warm air into the region. In the summer and early fall, the migratory systems are less frequent and less intense. Specifically, the summer and early fall climate of the BVPS region is influenced by the Azores-Bermuda anticyclone circulation, which is associated with extended periods of fair weather and periods of air stagnation. Frontal activity, associated with the interaction of continental polar and maritime tropical air masses and migrating low pressure systems, predominates especially in the late fall, winter, and spring.

##### 2.3.1.1.3 General Airflow Patterns

The orientation of the mountains in the area strongly influences prevailing winds in the region. The prevailing wind direction is from the southwest quadrant (National Climatic Center 1980). The wind speeds are moderate, averaging 9.3 mph, based on a 28-year period of record (Table 2.3-1).

##### 2.3.1.1.4 Temperature and Humidity

Temperature patterns conform to the seasonal trends of the humid continental climate. The normal daily maximum and minimum temperatures for the region range from approximately 35°F to 21°F in January and from 83°F to 61°F in July, respectively. The mean annual number of days when the

minimum temperature is 0°F and below is 5, while 124 days are 32°F and below. The mean annual number of days when the maximum temperature is 90°F and above is 7. The mean daily temperature range in January is approximately 15°F and in July 21°F. Table 2.3-1 presents the monthly normals and extremes of Pittsburgh temperature.

The highest relative humidity in the region generally occurs during the early morning hours of the summer and fall, frequently ranging between 80 and 90 percent (National Climatic Center 1980; Baldwin 1977). The lowest relative humidity in the region generally occurs during the early afternoon hours of the spring and summer, frequently ranging between 50 and 60 percent (National Climatic Center 1980; Baldwin 1977). Annually, the mean regional daily relative humidity is approximately 70 percent.

#### 2.3.1.1.5 Precipitation

Precipitation is normally well distributed throughout the year, but monthly amounts are generally greatest in the spring and summer and least in the late summer, fall, and winter (National Climatic Center 1980). The maximum usually occurs in July in the form of thunderstorm activity. The minimum monthly precipitation usually occurs in February. The normal annual total precipitation expected for the region, which is site dependent due to local topographic influence, is approximately 36 inches. During the winter months, about one-fourth of the precipitation occurs as snow. Mean annual snowfall in the region is approximately 45 inches, based on a 25-year NWS period of record for Pittsburgh (Wallis 1978). Approximately 4 to 8 days per year, ice pellets and/or glaze (freezing rain) may be expected. Table 2.3-1 presents the monthly normal and extremes of precipitation for Pittsburgh.

Table 2.3-2 presents the expected rainfall in the BVPS area for various rainfall duration time periods and recurrence intervals (Frederick 1977; National Oceanic and Atmospheric Administration (NOAA) 1963). The expected rainfall amounts are generally less than amounts typical of the eastern two-thirds of the United States, especially those states located to the southeast, west, and southwest of the site.

Table 2.3-3 gives the maximum recorded rainfall for various rainfall duration periods at Pittsburgh (Jennings 1963).

### 2.3.1.1.6 Relationships Between Synoptic and Local Meteorological Conditions

The topography of the region strongly influences the climate at specific locations. The general orientation of mountain ranges in a northeast-southwest axis alters the synoptic wind flow. The higher mountain ranges which frequently prevent coastal storms from affecting the area also tend to cause greater precipitation east of the site region. The valley location of the BVPS site also favors the occurrence of nocturnal inversions due to cold air drainage (NOAA 1974).

### 2.3.1.2 Regional Meteorological Conditions for Design and Operating Bases

#### 2.3.1.2.1 Hurricanes

Hurricanes, or low pressure systems with a tropical origin, seldom affect western Pennsylvania, since this area is far inland and such storms lose force rapidly when deprived of their source of moisture (NOAA 1972). Consequently, if they penetrate the western Pennsylvania region, the hurricanes have degenerated with reduced wind speeds and diminished precipitation. In 1972, "Tropical Storm" Agnes, a downgraded hurricane, was the last major storm of tropical origin to influence the state of Pennsylvania. Figure 2.3-1 shows the total precipitation induced by Agnes for the 6-day period in the state of Pennsylvania. The torrential rains were confined to the eastern and central parts of the state, while the BVPS area received 4 inches or less. The worst impact of Agnes on the BVPS region was from stream flooding. However, at Pittsburgh, the Ohio River reached its highest crest since 1942 (NOAA 1972).

#### 2.3.1.2.2 Tornadoes

Regulatory Guide 1.76 has designated three tornado intensity regions in the continental United States and has promulgated a design-basis tornado (DBT) for each region (Markee 1974). BVPS-2 is located in Region I. As discussed in Section 3.3.2, the BVPS-2 design meets all structural requirements of the Region I DBT.

To determine the probability of a tornado striking a particular point in a given area, the following relationship may be used (Markee 1974).

$$p = \bar{n} (a/A) \quad (2.3-1)$$

where:

p = probability of a tornado strike  
in a given area

$\bar{n}$  = average number of tornadoes per year

a = mean individual tornado path area

A = total area in which the tornado frequency has been determined.

Based on data obtained from the National Severe Storms Forecast Center in Kansas City, Missouri, tornadoes occurring within the 1-degree square for BVPS-2 were determined for the period 1950 through 1981. For the 32-year period, 39 tornadoes (1.22 per year) touched down within the 1-degree square for the BVPS site (National Severe Storms Forecast Center 1982). The mean path area of the tornadoes was 0.4 mile<sup>2</sup>. From Equation 2.3-1, the calculated probability of a tornado hitting the BVPS site is  $1.4 \times 10^{-4}$  per year, and the recurrence interval is  $7.1 \times 10^3$  years.

Table 2.3-5 lists each of the 39 tornadoes, including location of occurrence, path length, path width, injuries and deaths, and damage class. Damage class numbers range from 1 to 9 and provide an estimate of the damage according to Tables 2.3-6 and 2.3-7. The columns labeled F, P<sub>L</sub>, and P<sub>W</sub> provide the Fujita-Pearson scale estimates of force, path length, and path width, respectively. All three scales are logarithmic with values ranging from -1 for the smallest category to +5 for the largest. Table 2.3-7 shows the range for each scale. The path length and path width values represent estimates of the actual amount of ground contact for each tornado.

#### 2.3.1.2.3 Extreme Winds

The fastest-mile wind speed, which is a valid indicator of extreme wind, is defined as the highest speed of a 1-mile passage of wind, and is inclusive of all meteorological phenomena (extratropical cyclones, thunderstorms, and hurricanes) except tornadoes.

The maximum fastest-mile wind speed recorded at Greater Pittsburgh Airport from January 1945 through December 1980, as shown in Table 2.3-1, was 58 mph from the west, occurring in February 1967 (National Climatic Center 1980). Historical records dating back to 1870 do not indicate any fastest-mile wind speeds that exceed the February 1967 value. The fastest-mile wind speed in Pittsburgh in the winter of 1978 occurred on January 26 (52 mph) from the southwest. On this same day, the highest recorded hourly wind speed at the BVPS site was 43 mph from the southwest at the 500-foot level.

The extreme wind at the BVPS site for a 100-year recurrence interval is 80 mph (American Society of Civil Engineers 1961). Discussion of this wind speed as a design basis is contained in Section 3.3.1.

#### 2.3.1.2.4 Thunderstorms

Thunderstorms normally occur during all but the mid-winter months and have a maximum frequency in mid-summer (National Severe Storms Forecast Center 1982). The mean annual number of days with thunderstorms is 36, based on a 28-year period (Table 2.3-1).

#### 2.3.1.2.5 Lightning

Seasonal and annual frequencies of lightning strikes to the reactor containment building have been estimated based on the frequency of thunderstorms in the BVPS site area and the structure's "attractive area". Since the attractive area of a structure is proportional to the magnitude of the lightning bolt's current, an estimate of the frequency of lightning strikes was determined for lightning bolts having currents of 20, 40, 60, 90 and 135 KA. Table 2.3-8 provides a seasonal and annual summary of thunderstorm frequency and frequency of lightning strikes, as well as the various attractive areas.

The reactor containment building is the largest safety-related structure, system, or component on the BVPS-2 site. Strike frequency estimates are provided in Table 2.3-8 to reflect lightning strikes to the containment building. All other safety-related structures would be subjected to lightning strikes on a less frequent basis than that reported for the containment building.

The lightning strike frequency calculation is based on the technique described by Marshall (1973). The average number of cloud-to-ground lightning strikes is calculated using the following formula:

$$NE = (0.1 + 0.35 \sin\lambda) (0.40 \pm 0.20) \quad (2.3-2)$$

where:

NE = number of flashes to earth per square kilometer per thunderstorm day

$\lambda$  = geographical latitude (for Pittsburgh  $\lambda = 40^{\circ}30'$ )

To assure conservatism in the calculation, the term  $(0.40 \pm 0.20)$ , is assumed to be  $(0.40 + 0.20)$ , or 0.6. Therefore, for Pittsburgh,  $NE = 0.196$  flashes/km<sup>2</sup> per thunderstorm day. Multiplying this value by the seasonal and annual number of thunderstorm days at Pittsburgh, as taken from NUREG/CR-2252 (USNRC 1981), the number of seasonal and annual cloud-to-ground lightning flashes is determined as shown in Table 2.3-8.

The attractive area of the containment building is determined following the technique of Marshall (1973):

$$K = \pi R_T^2 = \pi (R_A = R_B)^2 \quad (2.3-2a)$$

where:

- K = Total attractive area (m<sup>2</sup>)
- R<sub>T</sub> = Total radial distance (m)
- R<sub>A</sub> = Radius of containment building (m)
- R<sub>B</sub> = Radial distance to the edge of the attractive zone (m)

The parameter R is an increasing multiple of the building height (H) with increasing bolt current. According to Marshall (1973), R<sub>B</sub> = 2H, 4H, 6H, 8H, and 10H for bolt currents of 20, 40, 60, 90, and 135 KA, respectively. Given a building height of 43.6 meters and a radius of 20.6 meters, the attractive area of the containment building is calculated for each of the five bolt currents and presented in Table 2.3-8.

The number of lightning strikes to the containment building is then calculated by multiplying the number of cloud-to-ground lightning flashes/km<sup>2</sup>/year by the attractive area of the containment building for each bolt current and then multiplying that product by the frequency of occurrence of each bolt current:

$$NS = NE \times K \times F \quad (2.3-2b)$$

where:

NS = Number of lightning strikes to the containment building (strikes/yr)

F = Frequency of each bolt current (dimensionless)

Marshall (1973) assigns frequencies of 50, 22, 10, 2, and 0.5 percent to bolt currents of 20, 40, 60, 90, and 135 KA, respectively. The results of these calculations are given in Table 2.3-8.

#### 2.3.1.2.6 Hail, Freezing Rain, and Ice Pellets

Annually, the mean number of days with hail in the region ranges between 2 and 4 (Baldwin 1977). In Pennsylvania, the months with high frequencies of occurrence of hail are May through July, with the maximum frequency in July (Environmental Science Services Administration (ESSA) 1969). There were eight occurrences of hail 3/4-inch and greater in diameter reported in the 1-degree square in which the site is located during the period 1955 to 1967 (ESSA 1969). The frequency of hail in the site area is significantly lower than that in the central United States. The severity of the hailstorms is also significantly less than in the midwest. A review of "Storm Data" for the period 1966 through 1980 indicates that of the cases reported, the largest hailstones were "golfball in size" for two cases occurring in Beaver County and Mercer County in August 1969 and July 1971, respectively (National Weather Records Center 1966 through 1975). The mean annual number of days with freezing rain (glaze) in the region is about 8 (Baldwin 1977).

#### 2.3.1.2.7 High Air Pollution Potential

The frequency of inversions is an important consideration in determining the dispersion capability of the atmosphere. Hosler (1961) has analyzed weather records of many U.S. meteorological stations in an effort to characterize regional atmospheric dispersion potential. The frequency of low-level inversions or isothermal layers based at or below a 152-meter elevation in the site region is approximately 25 percent of the total hours on an annual basis. The seasonal frequencies of these inversions are approximately 18 percent in winter, 28 percent in spring, 25 percent in summer, and 32 percent in fall. The frequencies are relatively low compared to most areas of the United States and indicate a relatively high atmospheric dispersion potential in these areas.

Korshover (1976) investigated the occurrences of stagnating anti-cyclones in the eastern United States for a 40-year period. The seasonal distribution of atmospheric stagnation (4 days or more) in the BVPS region indicates that this region may experience 1 stagnation case during the winter (December, January, February), 2 stagnation cases during the spring (March, April, May), 18 stagnation cases during the summer (June, July, August), and 20 stagnation cases during the fall (September, October, November). The frequencies are relatively low compared to most of the states in the southeastern United States.

#### 2.3.1.2.8 Droughts

A drought is a period of abnormally dry weather which causes a serious hydrologic imbalance (American Meteorological Society 1959). The severity of a drought is difficult to assess because of the variations in precipitation patterns, degree of moisture deficiency, duration, and the size of the affected area. Dry spells which are not as severe as a drought are defined as periods of abnormally dry weather which may develop and persist for several months in the region. Occurrences of drought have not been reported for the period from 1938 to 1977; however, dry spells have been reported and can occur during any season in this region (NOAA 1974).

#### 2.3.1.2.9 Snowfall

The weight of the 100-year return period snowpack for the BVPS site vicinity is 19.5 lbs/ft<sup>2</sup> (American National Standards Institute 1972). The weight of the 48-hour probable maximum winter precipitation (PMP) for the site region is 71.2 lbs/ft<sup>2</sup> based on a 48-hour PMP for a 10-mile<sup>2</sup> area of 13.7 inches occurring in the month of March (Riedel et al 1956).



## 2.3.2 Local Meteorology

### 2.3.2.1 Normal and Extreme Values of Meteorological Parameters

#### 2.3.2.1.1 Wind Direction and Wind Speed

Monthly and annual wind direction frequencies for the 35-foot, 500-foot, and 150-foot levels for the period January 1, 1976 through December 31, 1980 are presented in Appendices 2.3C, 2.3D, and 2.3E, respectively. The 35-foot onsite wind data indicate that the winds are primarily from the southwest. Secondary peak frequency from the southeast is associated with low wind speed as a result of the drainage wind. The 500-foot onsite wind data indicate that the winds are primarily from the southwest and are not influenced by the valley circulation.

Table 2.3-9 presents annual wind direction frequency information based on NWS data collected at Greater Pittsburgh Airport for the period January 1, 1976 through December 31, 1980 and for the period January 1, 1953 through December 31, 1980. Onsite wind data for the 150-foot and 500-foot level agree well with NWS data with some month-to-month differences. Differences in the 35-foot level wind data can be attributed to the wind sensor at Pittsburgh being located on a plateau above the river valley, effectively removed from the influence of the valley circulation.

Monthly and annual mean wind speeds for onsite data from January 1, 1976 to December 31, 1980 are compared with concurrent NWS data at Pittsburgh in Table 2.3-10. Table 2.3-10 also gives the average monthly and annual wind speed data for NWS data at Pittsburgh from 1952 to 1980. Onsite wind speed data at the 500-foot level, which is effectively removed from the valley circulation, and NS data agree well during the concurrent period and to the long-term period (1952-1980). Variations are primarily due to the differences in exposures of the wind instruments.

Calms occurred 0.8 percent of the time at the 35-foot level and 0.2 percent at the 500-foot level from January 1, 1976 to December 31, 1980.

Wind direction persistence information for the BVPS 35-foot and 500-foot levels for the period January 1, 1976 through December 31, 1980 is presented in Tables 2.3-11 and 2.3-12, respectively. This same information for Pittsburgh is presented in Table 2.3-13. At the 35-foot level, winds persist primarily from the north, northwest, southwest, west-southwest, west, and east-northeast, with a maximum number of 20 hours from the southwest and the west-southwest. At the 500-foot level, preferred directions of hourly winds are more variable with the maximum persistence of 34 hours from the east followed by 28 hours from the west-southwest during the same data collection periods. The Pittsburgh wind direction persistence data for the same period show preferred wind persistence from the north, west-northwest, west, southeast, east, and west-southwest, with a maximum of 29 hours from the north.

#### 2.3.2.1.2 Ambient Temperature

Monthly and annual means of ambient temperature at BVPS, based on onsite and Pittsburgh data recorded from January 1, 1976 to December 31, 1980 are

presented in Table 2.3-14. The monthly mean temperatures, based on onsite data, agree well with the average monthly mean temperatures, based on concurrent data for Pittsburgh and with the climatological normals. The annual average temperature for the period January 1, 1976 to December 31, 1980 at the 35-foot level was 49°F. Monthly and annual extremes of ambient temperature for both onsite and Pittsburgh data are presented in Table 2.3-15. The highest temperature recorded onsite was 94°F and the lowest was -15°F for the period January 1, 1976 to December 31, 1980. Neither exceeded the highest and lowest temperature recorded at Pittsburgh from 1952 to 1980. Monthly and annual average diurnal temperature variations for BVPS and Pittsburgh for the concurrent 5-year data period and for the long-term time period (1952-1980) at Pittsburgh are presented in Table 2.3-16.

#### 2.3.2.1.3 Atmospheric Water Vapor

Monthly and annual averages of dew point values and relative humidity calculated from recorded onsite measurements at the 35-foot level and from Pittsburgh are presented in Tables 2.3-17 and 2.3-18 respectively for the period January 1, 1976 to December 31, 1980. The data agree well and show slightly higher relative humidities and dew points for the BVPS site than measurements at Pittsburgh. Table 2.3-19 presents the monthly and annual maximum and minimum dew point temperatures collected onsite from January 1, 1976 to December 31, 1980 and for the concurrent 5-year period and long-term period (1953-1980) from Pittsburgh. Monthly and annual diurnal dew point and relative humidity variations for BVPS and Pittsburgh are presented in Tables 2.3-20 and 2.3-21, respectively, for the 5-year data period. Monthly and annual averages, extremes, and diurnal variations of absolute humidity from onsite humidity measurements for the 5-year period are presented in Table 2.3-22.

#### 2.3.2.1.4 Precipitation

Monthly and annual averages and extremes of precipitation for the BVPS site are presented in Table 2.3-23 for January 1, 1976 through December 31, 1980, along with long-term data from Pittsburgh. The average annual precipitation recorded onsite from January 1, 1976 to December 31, 1980 was 22.5 inches. This is less than the normal 36.2 inches for Pittsburgh. Monthly and annual averages and extremes of hours with precipitation and maximum 1- and 24-hour precipitation amounts are presented in Tables 2.3-24 and 2.3-25, respectively. The maximum amount of precipitation recorded onsite for a 1-hour period was 1.47 inches, and the maximum amount of precipitation recorded

onsite for a 24-hour period was 2.39 inches. Snowfall is not measured onsite.

#### 2.3.2.1.5 Fog

The BVPS site is located in a region where heavy fog occurs with relatively moderate frequency. Heavy fog can be expected to occur approximately 18 days per year (National Climatic Center 1980). Fog occurs most frequently during late summer and fall and least frequently during the winter and spring.

#### 2.3.2.1.6 Atmospheric Stability

Monthly frequency distributions of onsite  $\Delta T_{150}$  feet-35 feet and  $\Delta T_{500}$  feet-35 feet stability classes for BVPS are presented in Table 2.3-26 for the period January 1, 1976 through December 31, 1980. The predominant stability class for  $\Delta T_{150}$  feet-35 feet is neutral and slightly stable with extremely unstable as a secondary peak. Neutral conditions are predominant for  $\Delta T_{150}$  feet-35 feet. Table 2.3-27 presents monthly summaries of inversion durations for the BVPS site for the period January 1, 1976 to December 31, 1980 based on  $\Delta T_{150}$  feet-35 feet. The longest persistence period of a  $\Delta T_{150}$  feet-35 feet inversion occurred for 48 hours in the month of January.

#### 2.3.2.1.7 Monthly Mixing Height Data

Mixing level is defined as the height above the surface below which relatively vigorous vertical mixing occurs. Therefore, the mixing level indicates the practical vertical limit of dispersion and is significant for dispersion over large distances and for cases involving significant plume rise. Monthly means of daily morning and afternoon mixing levels for Pittsburgh are presented in Table 2.3-28.

The nearest NWS station to the BVPS site for which the frequency of restrictive dispersion information is available is Pittsburgh. A total of 39 episode-days associated with 16 episodes was reported during a 5-year period (Holzworth 1972). These episodes occurred primarily during the autumn season. The frequency of occurrences of restrictive dispersion episodes at the BVPS site is not considered to differ significantly from those values reported for Pittsburgh.

#### 2.3.2.2 Potential Influence of the Plant and Its Facilities on Local Meteorology

Plant construction activity such as tree removal and ground leveling, as well as the newly constructed plant buildings, switchyard gear, roads, and parking facilities is not expected to have a significant influence on the local meteorology.

The natural draft cooling towers at the site are expected to provide the only plant effluents capable of slightly influencing local meteorology. The cooling tower effluents of concern are commonly described as drift and visible plumes (fog). These effluents and their impact on local weather are described in the following subsections.

### 2.3.2.2.1 Salt and Water Drift

A mathematical model was developed to determine the downwind distribution of salt and water deposition rate and airborne salt concentration resulting from cooling tower operation. A detailed description of the model and modeling results are contained in Appendix 2.3A. The model takes into account the following: configuration and performance of the towers, drift rate, exit velocity, total dissolved solids level, droplet size distribution, evaporation rate, plume buoyancy, wind speed, wind direction, wet-bulb temperature, and relative humidity. One year of onsite meteorological data (January 1, 1976 to December 31, 1976) was used in the drift model.

A maximum salt deposition rate of 9.9 pounds per acre per year ( $0.11 \text{ mg/cm}^2/\text{year}$ ) occurs approximately 4,750 feet east of the cooling towers. The maximum water deposition rate of 20,300 pounds per acre per year ( $227.3 \text{ mg/cm}^2/\text{year}$ ) occurs approximately 4,000 feet east of the towers. The maximum annual average airborne salt concentration is predicted to be 0.07 microgram per cubic meter ( $\mu\text{g/m}^3$ ) ( $7 \times 10^{-8} \text{ mg/l}$ ) approximately 7,000 feet east of the towers, while the maximum hourly airborne concentration of  $21.9 \mu\text{g/m}^3$  ( $2.19 \times 10^{-5} \text{ mg/l}$ ) occurs 3,250 feet west-southwest of the towers. These maxima are the largest values occurring over the entire spatial grid of the model. Spatial averages of these concentrations are not given, due to their insignificance in light of the small impacts caused by the maximum values.

### 2.3.2.2.2 Visible Plume Occurrence

Ambient air becomes heated and moisture-laden when induced through natural draft cooling towers. This air is discharged from the towers as a plume, which may occasionally be visible. The extent and frequency of visible plume occurrence depend on the meteorological conditions existing at the time, and the design and physical parameters of the tower.

A mathematical model, using as input simultaneous observations of wind speed, wind direction, ambient wet-bulb temperature, ambient dry-bulb temperature, and relative humidity, was used to determine the configuration and extent of visible plumes from the Beaver Valley Power Station - Unit 1 (BVPS-1) and BVPS-2 natural draft cooling towers. Onsite meteorological data for the period January 1, 1976 through December 31, 1976, were used for the cooling tower visible plume predictions.

The mathematical model used in this analysis is described in detail in Appendix 2.3B.

The results of these model calculations are shown on Figures 2.3-2, 2.3-3, 2.3-4, 2.3-5, 2.3-6, 2.3-7, 2.3-8, 2.3-9, 2.3-10 and 2.3-11. The BVPS-2 cooling tower is situated close to the BVPS-1 tower and there will undoubtedly be some interaction of the two plumes. The state-of-the-art of plume modeling does not permit a realistic assessment of plume dynamics in such a complex situation with two towers of different emission characteristics. Therefore, the plumes from the BVPS-2 tower have been shown separately from the BVPS-1 plumes.

As can be seen from these figures, the plume rarely descends below heights of 250 feet. The plume remains aloft because it is initially injected into the atmosphere at a height of about 500 feet with an exit velocity of approximately 10 to 20 feet per second, and is buoyant because its temperature exceeds that of the ambient air. Occurrences of visible plumes below the height of the tower are due to strong winds and the associated tower-induced turbulence in the wind field. Air traffic will be unimpeded by the cooling tower plumes.

#### 2.3.2.2.3 Ground-Level Fogging and Icing Potential

The visible plume rarely descends below heights of 250 feet above the ground. Thus, it does not impinge the ground surface, nor will it contribute to ground fogging or icing. Therefore, impacts to highway or river traffic are not expected.

To estimate the amount of ground icing due to the deposition of cooling tower water drift, the mathematical model described in Section 2.3.2.2.1 was utilized, using as input those hours from the onsite meteorological data (January 1, 1976 through December 31, 1976) when ambient temperatures were less than or equal to 32°F. Drift droplet distribution characteristics and predicted deposition rates are presented in Section 2.3.2.2.1. Conditions under which icing could take place occurred a total of 1,375 hours based on 1 year of onsite meteorological data. Figure 2.3-12 presents the predicted spatial distribution of icing.

The maximum annual surface icing accumulation, which may occur due to cooling tower drift, is 0.024 inch. This is insignificant when compared with a "light" ice storm, defined as one that deposits less than 0.1 inch of ice per hour (U.S. Government Printing Office (USGPO) undated). Furthermore, the maximum surface icing accumulation was conservatively estimated assuming that all occurrences of freezing temperatures ( $\leq 32^\circ\text{F}$ ) occurred consecutively.

#### 2.3.2.2.4 Ambient Relative Humidity Increases

The large amounts of moisture emitted from cooling towers not only contribute to visible plume formation, but also may increase ambient ground level relative humidities, even if the plume remains aloft. In order to evaluate the potential augmentation of ambient relative humidities due to cooling tower operation, a mathematical diffusion model, which incorporates tower-specific information and onsite meteorological data, was developed.

The model is based on the Gaussian diffusion equation for calculating ground level concentrations from an elevated buoyant source, which is expressed as:

$$X_v = \Delta\rho_w = \frac{C_x Q_v}{\pi\sigma_y\sigma_z u} \text{EXP}\left[-1/2\left(\frac{h_{ct} + \Delta h - h_t}{\sigma_z}\right)^2\right] \left[\frac{x}{x+2.5D}\right]$$

(2.3-3)

where:

where:

- $X$  = ground level concentration of water vapor ( $\text{g}/\text{m}^3$ )  
 $\Delta\rho_w$  = increase in water vapor density ( $\text{g}/\text{m}^3$ )  
 $C_x$  = time-averaging correction factor = 0.7  
 $Q_v$  = emission rate of water vapor ( $\text{g}/\text{sec}$ )  
 $\sigma_y$  = horizontal diffusion coefficient (m)  
 $\sigma_z$  = vertical diffusion coefficient (m)  
 $\bar{u}$  = mean wind speed (m/sec)  
 $h_{ct}$  = cooling tower height (m)  
 $\Delta h$  = plume rise from cooling tower (m)  
 $h_t$  = topographic height (m)  
 $x$  = downwind distance (m)  
 $D$  = cooling tower exit diameter (m)

The term  $\left[ \frac{x}{x+2.5D} \right]$  geometrically accounts for initial dispersion from the area source of a cooling tower (virtual point correction to a volume source). The resultant increase in relative humidity can now be calculated from:

$$\Delta RH = \frac{\Delta\rho_w}{\rho_{ws}(T, T_w)} \quad (2.3-3a)$$

where:

- $\Delta RH$  = relative humidity increase (percent)  
 $\Delta\rho_w$  = increase in water vapor density ( $\text{g}/\text{m}^3$ )  
 $\rho_{ws}$  = saturation vapor density as a function of ambient temperature (T) and wet-bulb temperature ( $T_w$ ).

Equation 2.3-3 is applicable to short-term concentrations only. For greater time periods, the water vapor concentration is sector-averaged according to the expression:

$$(\Delta\rho_w)_i = \frac{2.032}{N} \sum_{j=i}^{N_i} \frac{Q_v}{\sigma_z \bar{U}_x} \text{EXP} \left[ -\frac{1}{2} \left( \frac{h_{ct} + \Delta h + h_t}{\sigma_z} \right)^2 \right]$$

(2.3-3b)

The plume rise from the tower is calculated using Briggs' plume rise equations (Appendix 2.3A), and the dispersion coefficients  $\sigma_y$  and  $\sigma_z$  are obtained from Turner's (1969) curves. The hourly emission rate of water vapor ( $Q_v$ ) is based on evaporation performance curves obtained from the cooling tower manufacturer.

The input data to the model consist of tower-specific information obtained from the manufacturers and 1 year of onsite meteorological data. For each hour of meteorological data, the ground-level water vapor concentration due to cooling tower operation is calculated at specific downwind intervals from the tower. The resultant increase in relative humidity is then calculated according to Equation 2.3-3a based on the ambient meteorological conditions for that hour. Annual, monthly, daily, and hourly relative humidity increases are calculated for each of the sixteen 22.5 degree compass sectors.

The diffusion model was utilized to determine relative humidity increases due to the operation of the BVPS-1 and BVPS-2 natural draft cooling towers at the BVPS site. One year (1976) of onsite data was used in the analyses. Also, the topography of the BVPS region, obtained from U.S. Geological Survey maps, was used conservatively as input to the model by specifying the maximum height at 1/2-mile intervals for each of the 16 downwind sectors.

The results of the analyses performed for the two cooling towers can be found in Table 2.3-29. This table presents the maximum relative humidity increase for each of the 16 downwind sectors for the annual, monthly, daily, and hourly time periods. It is clear from this table that the cooling towers will have very little effect on the ambient relative humidity levels. The worst hourly increase of 2.31 percent is small compared to ambient fluctuations of relative humidity. The reason for such a small increase can be related to the large discharge height of the cooling towers (500 feet), which allows the moisture to effectively disperse before reaching the ground.

#### 2.3.2.2.5 Induced Precipitation

One of the potential environmental impacts resulting from the discharge of cooling tower moisture is the regional augmentation of natural precipitation. Estimates of the total contribution to surface precipitation from cooling towers, based on a 2,200 MW station, would be only 0.4 inch annually (Huff 1972). This amount is inconsequential compared to the total annual rainfall (36.1 inches) experienced in this region (Section 2.3.1).

Induced snowfall due to operating cooling towers has been observed in West Virginia (Kramer et al 1976). However, the accumulation was found to be less than 1 inch of very light, fluffy snow. Other documented induced snowfall occurrences generally preceded actual snowfall occurrences. An investigation into the climatic conditions conducive to induced snowfall indicated that a very cold, stable atmosphere with light winds optimized this situation. It was assessed that this type of meteorological condition at BVPS is similar to that of the mountainous West Virginia region. Thus, an occasional induced snowfall of light fluffy snow may occur. When compared to the large winter snowfalls experienced in this region (46.0 in/yr), this potential contribution is very small. Therefore, there is no reason to expect that the proposed cooling towers would significantly alter local meteorology.

#### 2.3.2.2.6 Cooling Tower Noise

The hyperbolic natural draft cooling tower will be one of the dominant station operational external noise sources. Cooling tower and other operational noise sources are discussed in Environmental Report Section 5.6.

#### 2.3.2.2.7 Synergistic Effects

Interaction between the saturated cooling tower plumes and local industrial emissions has the potential to form hazardous substances such as acids. High concentrations of sulfur dioxide emitted by fossil-fueled sources, in combination with the saturated cooling tower plumes, may result in significant catalytic oxidation of  $\text{SO}_2$  to sulfuric acid. Droplet growth within the mixing plumes could also



occur, resulting in an increase of ambient ground-level concentrations of sulfuric acid.

In order to assess the potential of the BVPS-1 and BVPS-2 cooling tower plumes interacting with stack plumes from nearby industrial sources, a detailed emissions inventory for the region was obtained from the Pennsylvania Department of Environmental Resources and used in a plume rise analysis to estimate the frequency of occurrence of plume intersection. This analysis involved calculating plume rises from each of the nearly 300 sources in the inventory, using a computer program which employs Briggs' plume rise equations (Appendix 2.3A) and onsite meteorological data. The plume trajectories were computed with those computed for the cooling towers, using 1 year (1976) of onsite meteorological data, and plume interaction occurrences were compiled. Based on the frequency of plume interaction and the emission rates of pollutants from the various sources in the area, only one stack plume warranted consideration for possible acid formation. This plume is emitted from the 950-foot stack at the fossil-fueled Bruce Mansfield Plant (BMP), located approximately 1 mile east-northeast of BVPS-2. The buoyancy, exit velocity, and emission height of the cooling tower plumes precluded interaction with most other sources.

The potential for oxidation of  $\text{SO}_2$  to sulfuric acid in the BMP plume, as a result of mixing with the cooling tower plumes, was examined in detail by determining the actual locations of plume centerline intersections in relation to the cooling tower visible plume extents shown on figures 2.3-2, 2.3-3, 2.3-4, 2.3-5, 2.3-6, 2.3-7, 2.3-8, 2.3-9, 2.3-10 and 2.3-11. This was accomplished by calculating centerline trajectories for the BMP stack plume and the cooling tower plumes for each of 35 classes of wind speed and stability, and then determining the point of intersection for each class.

The frequency of occurrence of each wind speed-stability class was then computed based on 1 year (1976) of onsite meteorological data. For each of the seven Pasquill stability classes (A-g), the following five wind speed classes were chosen: 1 to 3, 4 to 7, 8 to 12, 13 to 18, and 19 to 24 miles per hour. Only the two wind directions which transport the plumes directly from the cooling towers toward the stack and vice versa were considered in the analysis.

Plume centerline interaction coordinates and frequency of occurrence for each wind speed-stability class are given in Tables 2.3-30 through 2.3-33. The interaction coordinates presented in these tables are applicable to both the BVPS-1 and BVPS-2 cooling towers since they are approximately the same distance from the BMP. The data presented in Tables 2.3-30 and 2.3-31 apply to the operation of either of two flues, labeled by the Pennsylvania Power Company as Source No. 31 and 32, and Tables 2.3-32 and 2.3-33 contain results for the remaining flue (No. 36). The calculations were performed in this manner due to differences in the flue gas flow rates from the BMP stack, depending on which flues are in use, which affect the plume rise determination.

According to the data presented in the tables, the cooling tower plumes intersect the BMP plumes most frequently at heights of approximately 400 to 3,000 meters above ground and at downwind distances of 50 to 1,500 meters from the stacks or cooling towers. A comparison of these intersection points with the cooling tower visible plume frequency contours presented for the east-northeast and west-southwest wind directions on Figures 2.3-2, 2.3-3, 2.3-7, and 2.3-9 indicates that the stack plumes intersect the visible portion of the cooling tower plumes for a maximum of 0.1 percent of the time in each wind direction, or approximately 18 hr/yr total. This low frequency of interaction can be attributed to the separation distance of 1 mile between the cooling towers and the BMP stacks and also to low frequency of occurrence of the meteorological conditions which allow interaction to occur.

The increase in ground-level sulfate concentrations resulting from the interaction of the BVPS cooling tower visible plume and the BMP stack plume cannot be predicted accurately due to the large number of unknown variables. However, it is expected that any ground level impacts would be minimal due to the small amount of time over which these chemical reactions could take place. Ambient levels of sulfates at ground level due to stack plume interactions with natural fog would far outweigh any contribution due to interaction with the cooling tower plumes.

#### 2.3.2.2.8 Topographical Description

The BVPS site is located on the south bank of the Ohio River, approximately 25 miles northwest of Pittsburgh, Pa. The normal pool elevation of the Ohio River at the site is 664 feet 6 inches above msl. The Ohio River Valley is sharply defined by the hills and bluffs which extend to an average height of 400 to 500 feet above the river level within short distances of the river banks. The average width of the valley in the vicinity of the site is approximately 1,600 meters. The general topography of the site is shown on Figure 2.1-2. Topographic cross sections for each of 16 22.5-degree sectors radiating from BVPS-2 can be found on Figures 2.3-13, 2.3-14, 2.3-15, 2.3-16, 2.3-17, 2.3-18, 2.3-19, 2.3-20, 2.3-21, 2.3-22, 2.3-23, 2.3-24, 2.3-25, 2.3-26, 2.3-27 and 2.3-28.

#### 2.3.2.3 Local Meteorological Conditions for Design and Operating Bases

Meteorological conditions considered for design and operating bases are regional in nature and are discussed in Section 2.3.1.2. There are no other local sources of data that could be used for design and operating bases. This is substantiated in the following discussion.

The design basis tornado parameters from Regulatory Guide 1.76 used in the design of BVPS-2 are extremely conservative. These parameters correspond to a scale 5 tornado on the Fujita-Pearson scale which has not been observed within the 1-degree latitude/longitude box for BVPS-2 over a 32-year period. The most severe tornado observed in this area was a scale 3 tornado on May 13, 1956 which had an estimated wind speed of 158-206 mph. In

addition, the calculation of the probability of a tornado strike at the BVPS-2 site was performed using the most recent data for the site area itself. Therefore, there are no other local sources of data on tornadoes which could be used for design and operating purposes.

The design wind speed of 80 mph discussed in Section 2.3.1.2.3 is also a conservative value in that the observed fastest mile of wind at Pittsburgh over a 36-year period was 58 mph in February 1967. Wind speed data obtained at the site by the pre-operational meteorological program over a period of 5 years (1976-1980) do not indicate that an 80-mph wind speed is likely to occur since the highest hourly wind speed recorded at the 500-foot level was 43 mph. Although this is an hourly value, there is no reason to believe that a fastest-mile speed of 80 mph could have occurred during data collection at the site. In fact, the sheltering effects of the valley produce lower wind speeds at the site than those observed at the Greater Pittsburgh Airport, as shown in Table 2.3-10. Only the 500-foot wind speed measurements at the site indicate faster winds than at the airport. Wind speeds at the level of the containment dome (150 feet) are generally slower than those observed at the airport. Therefore, locally obtained data do not indicate the need for a faster design wind speed than that addressed in Section 2.3.1.2.

There are no local data available on snowfall other than those obtained at the Greater Pittsburgh Airport. Since these data have already been factored into the isopaths of 100-year return period snowloads given in ANSI A58.1-1972, there are no other means of determining snowloads on a more local level. However, there are no special conditions at the site such as large water bodies or mountainous terrain to indicate that this estimate of snowload is inappropriate.

Since the PMP used in the calculation of the design flood is based on the theoretically highest possible precipitation amount in the area, local precipitation data are not needed in assessing the design flood level.

No long-term data in the site area are available for the determination of a design wet-bulb temperature for the BVPS-2 cooling tower other than those collected at the Greater Pittsburgh Airport. However, comparisons of average dew-point temperatures between those collected at the site for 5 years and those obtained at the airport indicate very little difference in atmospheric moisture between the site and the airport, as shown in Table 2.3-20.

### 2.3.3 Onsite Meteorological Measurement Program

#### 2.3.3.1 System Description

The onsite meteorological program began on January 1, 1976. The 500-foot guyed meteorological tower is located approximately 3,600 feet northeast of BVPS-1. The base of the tower is at approximately 730 feet msl (223 meters). The meteorological monitoring system consists of two redundant trains of instrumentation located at three levels on the tower. Wind speed and direction measurements are made at elevations of 35, 150, and 500 feet. Ambient temperature measurements are made at the 35-foot level. Temperature differential measurements are made between 35 feet and 150 feet ( $\Delta T_{150 \text{ foot}-35 \text{ foot}}$ ) and 35 feet and 500 feet ( $\Delta T_{500 \text{ foot}-35 \text{ foot}}$ ). Precipitation data are obtained a few feet above the surface from a rain gauge near the base of the tower.

The tower is situated on a relatively flat plot of land in the Ohio River Valley and is enclosed by a fence. The ground surface in the immediate area is composed of slag and dirt.

Meteorological instrumentation includes:

1. Wind Instrumentation

Wind direction and speed sensors at the 35-, 150-, and 500-foot levels.

2. Temperature Instrumentation

RTD temperature sensors in aspirated solar radiation shields at the 35-, 150-, and 500-foot levels.

3. Precipitation Instrumentation

Tipping bucket rain gauge at the surface near the tower.

4. Data recorders

5. Data collection computer.

6. Back-up diesel generator power supply.

The specifications for this equipment which follow the guidance of Regulatory Guide 1.23 and Appendix 2 of NUREG-0654 (USNRC 80) are summarized in Table 2.3-34.

Monthly and annual joint frequency distribution tables for the 5-year data period (January 1, 1976 to December 31, 1980) for  $\Delta T_{150 \text{ foot}-35 \text{ foot}}$  and 35-foot wind,  $\Delta T_{500 \text{ foot}-35 \text{ foot}}$  and 500-foot wind, and  $\Delta T_{150 \text{ foot}-35 \text{ foot}}$  and 150-foot wind are presented in Appendices 2.4C, 2.3D, and 2.3E, respectively.

The redundant meteorological instrumentation is located in an environmentally controlled shelter structure located near the base of the tower.

The meteorological data from the primary and redundant meteorological instrumentation is obtained from redundant digital recorders, located in the meteorological shelter, via redundant dedicated telecommunications lines.

The system polls meteorological sensors approximately every five seconds and stores the received data. The 15-minute average data for each primary and redundant sensor are calculated and stored (and are retrievable) individually. For wind speed sensors the standard deviation is also stored. Statistics are applied to determine the best values, and then stored.

This system supplies data to the Emergency Response Data System (ERDS).

In addition to the 15-minute average processing, hourly average values are stored for select data. The data are periodically reviewed onsite and by an offsite meteorologist to identify any anomalous condition or instrumentation problems.

### 2.3.3.2 Meteorological Data Reduction

The meteorological monitoring system uses two redundant sets of digital recorders for data acquisition. Data includes wind, temperature, and rainfall.

The data is stored and available for real-time display as current, 1-minute average, and 15-minute average values in the control rooms and technical support center. Hourly average values are also displayed and stored for select data.

Data required for joint frequency distributions is stored and available for retrieval. Atmospheric stability, based on the temperature differential, is classified according to USNRC Regulatory Guide 1.23. Table 2.3-35 presents the USNRC  $\Delta T$  stability categories.

### 2.3.3.3 Meteorological Data Recovery

Monthly and annual meteorological data recovery rates of combined analog and digital data for 35-, 150-, and 500-foot wind,  $\Delta T_{150}$  foot-35foot;  $\Delta T_{500}$  foot-35foot, 35-foot dew point, ambient temperature, and precipitation are provided in Table 2.3-36 for the period January 1, 1976 to December 31, 1980. Table 2.3-37 provides the monthly and annual data recovery rate for joint 35-foot wind and  $\Delta T_{150}$  foot-35foot and joint 500-foot wind and  $\Delta T_{500}$  foot-35foot from January 1, 1976 to December 31, 1980.

### 2.3.4 Short-Term (Accident) Diffusion Estimates

#### 2.3.4.1 Objective

All accidents hypothesized for BVPS-2 are considered to result in ground level effluent releases from the containment structure. For various time periods after an accident, atmospheric dilution factors ( $x/Q$ ) were calculated at the minimum distance to the BVPS-2 exclusion area and the low population zone (LPZ) (5,794 meters) for each of the 16 downwind sectors.

For the 0- to 2-hour time period (represented by 1 hour of meteorological data) at the exclusion boundary, the 0.5-percent and 50-percent sector-dependent x/Q values for each of the 16 downwind sectors are presented in Tables 2.3-38 and 2.3-38a.

For the time periods of 0 to 2 hours, 0 to 8 hours, 8 to 24 hours, 1 to 4 days, and 4 to 30 days, 0.5-percent and 50-percent sector dependent x/Q values at the LPZ are presented in Tables 2.3-39 and 2.3-39a.

#### 2.3.4.2 Calculations

The x/Q dilution factors presented in Tables 2.3-38 and 2.3-39 were calculated using the hi-variate normal or Gaussian diffusion model, modified for source configuration and lateral meander under neutral and stable conditions. Input parameters were determined from onsite meteorological data acquired during the January 1, 1976 through December 31, 1980 period. These included the hourly-average values of wind speed and wind direction at the 10-meter level, and atmospheric stability determined from the hourly-average values of temperature difference measured between the 10- and 46-meter levels. Atmospheric stability was classified according to the temperature gradient values listed for the various Pasquill stability categories in Regulatory Guide 1.23.

Hourly-average x/Q values for the 1-hour accident period (representative of the 0- to 2-hour period) were calculated from the following equations from Regulatory Guide 1.145.

For Class D-G stability conditions, when the wind speed is less than 6 meters per second (mps),

$$\frac{x}{Q} = \left( \bar{u}_{10} \pi \sum_y \sigma_z \right)^{-1} \quad (2.3-4)$$

where:

$$\sum_y = M [\bar{u}_{10}, S] \sigma_y$$

for distances up to 800 meters, and

$$\sum_y = (M-1) [\bar{u}_{10}, S] \sigma_{y800m} + \sigma_y$$

for distances beyond 800 meters. (2.3-5)

Figure 2.3-29 depicts the functional relationship of M (meander factor) with respect to wind speed ( $u_{10}$ ) and atmospheric stability (S). If the  $x/Q$  value calculated in Equation 2.3-4 is less than the greater  $x/Q$  value of either of the following equations,

$$\frac{\chi}{Q} = \left[ \bar{u}_{10} \left( \pi \sigma_y \sigma_z + \frac{A}{2} \right) \right]^{-1} \quad (2.3-6)$$



$$\frac{\chi}{Q} = \left[ \bar{u}_{10} (3\pi \sigma_Y \sigma_Z) \right]^{-1} \quad (2.3-7)$$

it is retained; otherwise the applicable x/Q value is the greater of those calculated by Equations 2.3-6 and 2.3-7.

For all Class A-C stability conditions, and for Class D-G stability conditions when the wind speed is greater than or equal to 6 mps, the greater x/Q value calculated from Equations 2.3-6 and 2.3-7 is chosen.

In the preceding equations, the parameter A corresponds to the minimum cross sectional area (1,600 m<sup>2</sup>) of the containment structure, while  $\sigma_Y$  and  $\sigma_Z$  represent the standard deviations of plume concentration distribution in the horizontal and vertical planes, respectively, with  $u_{10}$  representing the mean wind speed at the lowest (10<sub>10</sub> meter) tower level.

For the time periods of 8 hours (representative of the 0- to 8-hour period), 16 hours (representative of the 8- to 24- hour period), 3 days (representative of the 1- to 4-day period), and 26 days (representative of the 4- to 30- day period), a graphical technique, described later in this section, was used to estimate the x/Q values.

Each valid hour of the January 1, 1976 through December 31, 1980 onsite meteorological data was utilized for the calculation. An hour of data was considered valid if recovery of the 10-meter wind speed, 10-meter wind direction, and 10- to 46-meter temperature difference was simultaneously accomplished. For the January 1, 1976 through December 31, 1980 period of BVPS-2, approximately 90 percent of the data fulfilled this criterion.

For each valid hour of meteorological data, a x/Q value was calculated with Equations 2.3-5 through 2.3-7 (whichever was applicable), where the wind direction determined the downwind sector. In the calculation, the actual exclusion area or low population zone distances, as defined in Section 2.3.4.1, were used (along with the Regulatory Guide 1.23 stability class typing scheme) to determine magnitudes of  $\sigma_Y$  and  $\sigma_Z$  according to the method outlined in Regulatory Guide 1.145, Revision 1.

For the hourly-average calm winds, a wind speed of 0.34 mps (instrument threshold) was assigned. Wind directions during calm conditions were assigned in proportion to the directional distribution of noncalm conditions bounded by a wind speed ranging from just above threshold to 1.5 mps. For the hours with variable wind directions, the last valid wind direction and the actual recorded wind speed were coupled.

For each of the 16 downwind sectors, all nonzero x/Q values were stored and arranged in descending order, and the 0.5-percent values

were chosen. All 0.5-percent values were compared, and the sector with the largest x/Q value determined the ultimate design basis 0.5-percent sector-dependent x/Q value, for use in the Chapter 15 dose calculations.

The equation has been intentionally deleted from the UFSAR. (2.3-8)

At the LPZ, the 0.5-percent sector-dependent x/Q value for the 0- to 2-hour period was plotted at 2 hours on logarithmic x/Q versus time coordinates, while the ground-level release, annual average x/Q value for the same sector was plotted at 8,760 hours. Logarithmic interpolation was applied to establish x/Q values for time periods corresponding to 0 to 8 hours, 8 to 24 hours, 1 to 4 days, and 4 to 30 days following an accident.

The equation that was applied for the calculation of the annual average x/Q value for each sector was:

$$\left(\frac{X}{Q}\right)_{k,\ell} = \sum_{j=1}^{N_\ell} \frac{2.032(\Omega g)_k}{\bar{u}_{10} \times \left(\sigma_{z_k}^2 + \frac{0.5h_b^2}{\pi}\right)^{1/2} N} \quad (2.3-9)$$

where:

- j = the index for the number of hours
- k = the index for a particular receptor distance

- $\ell$  = the index for a particular 22.5-degree sector
- $N_{\ell}$  = the number of hours of wind in sector  $\ell$
- $\Omega_g$  = the ground level release terrain  
recirculation factor
- $x$  = the minimum distance to the LPZ
- $h_b$  = the height of the containment building

Additional dispersion due to the building wake effect was limited to  $\sqrt{3}\sigma_z$ , as outlined in Regulatory Guide 1.145. Table 2.3-40 presents the site specific terrain recirculation factors for a ground-level release.

In 1996, short-term diffusion estimates were re-calculated using the USNRC computer code PAVAN. Input data were hourly meteorological observations collected by the onsite meteorological monitoring program between 0000 1/1/86 and 2300 12/31/95. The 0.5% sector dependent and the 5% sector independent values defined in Regulatory Guide 1.145 were determined and are tabulated in Tables 2.3-38b and 2.3-39b. Data recoverability during this ten year period was 99.6%. The minimum recoverability for any year in this period was 99%. This re-analysis indicated a maximum 0-2 hour exclusion area boundary 0.5% value of  $1.25E-3 \text{ sec/m}^3$  (NW sector).

#### 2.3.4.3 Main Control Room Short-Term Diffusion Estimates

The original licensing basis control room atmospheric dispersion factor (X/Q) values were calculated for both Units 1 and 2 using the methodology described by Murphy and Campe. Releases were postulated from each of the identified release points. The X/Q values were calculated to encompass 95 percent of the meteorological conditions (i.e., that are exceeded for only 5 percent of the meteorological conditions). Stability class G was assumed for conservatism. Adjustments for occupancy were included.

In 1991, the X/Q values for the control room were re-analyzed using a newer methodology outlined in NUREG/CR-5055. The updated X/Qs did not include adjustments for occupancy. In NUREG/CR-5055, Ramsdell considered the methodology of Murphy-Campe and proposed new methodologies to improve the predictive capabilities of calculations of atmospheric dispersion in the presence of building wakes. NUREG/CR-5055 reported on the results of seven field experiments that showed that the Murphy-Campe methodology accounted for little of the variability in concentrations affected by wakes. An empirical model was proposed that showed a significant improvement in predicting centerline concentrations. The model, using multiple-variable linear regression, relates downwind distance, building cross-sectional area, wind velocity, and stability class to X/Q.

Because circulation in building wakes distributes effluents entering the wake more widely than normal atmospheric diffusion, it was recommended that relatively wide wind-direction sectors (perhaps as wide as 90 degrees) be used in applying the methodology to evaluating concentrations affected by these wakes.

In reports published subsequent to NUREG/CR-5055, Ramsdell generalized the statistical model into one that had comparable accuracy but had its basis in the physical mechanisms of importance. The concentrations near the source were seen to be directly related to wind speed, rather than the inverse relationship of previous models.

For Beaver Valley, Halliburton NUS Environmental Corporation adapted the work of Ramsdell to the site terrain, plant configuration, and site meteorology. As the releases at Beaver Valley are low velocity releases, all were treated as ground level releases that were fully entrained in the building wake. For short-term averaging periods of eight hours or less, the methodology assumed that if the wind direction is within 30 degrees to either side of a line (effective centerline width of 60 degrees) between release point and control room intake, the plume centerline passed over the control room intake. For longer term averaging periods (e.g., 8-24, 24-96, 96-720 hours) a Gaussian distribution normal to the centerline was assumed.

On-site meteorological data for the 5-year period of 1986-1990 were applied along with the physical parameters appropriate for each release point. Only 1% of the individual hourly data contained any missing data. A sensitivity analysis of the input parameters was performed indicating acceptable model performance [x].

As part of the plant modifications associated with containment conversion and core power uprate, the control room X/Q values were re-calculated using the latest version of the "Atmospheric Relative Concentrations in Building Wakes" (ARCON96) methodology. The control room X/Q values applicable to release points associated with an accident at BVPS-1 or BVPS-2, are presented in Table 15.0-14 and 15.0-15, respectively. The Emergency Response Facility (ERF) X/Q values for the environmental release paths associated with the Loss-Of-Coolant Accident are also provided. The X/Q values for all of the release-receptor combinations utilized to develop the post-accident control room operator occupancy doses are summarized in Table 15.0-15. The X/Q values for all of the release-receptor combinations associated with BVPS-1 accidents addressed in Table 15.0-14 are taken into consideration when the dose consequences of the event are established based on an analysis that is bounding for both units. Occupancy factors are not included.

Input data consist of hourly on-site meteorological data, release characteristics (e.g., release height and stack flow rate), the cross-sectional building area affecting the release, and receptor information (e.g., distance and direction from the release to the control room air intake and intake height). All input data for the ARCON96 runs were developed in accordance with draft NRC guidance on control room habitability assessments; Draft Regulatory Guide DG-1111, "Atmospheric Relative Concentrations for Control Room Habitability Assessments at Nuclear Power Plants," December 2001.

The ARCON96 methodology has the ability to evaluate ground-level, vent, and elevated stack releases and treats building wake effects and stable plume meander effects when applicable. This methodology is also able to evaluate diffuse and area source releases using the virtual point source technique, wherein initial values of the dispersion coefficients are assigned based on the size of the diffuse or area source. The various averaging period X/Q values are calculated directly from running averages of the hourly X/Q values.

A continuous temporally representative 5-year period of hourly average data from the BVPS meteorological tower (i.e., January 1, 1990 through December 31, 1994) is used in this calculation. Each hour of data, at a minimum, must have a validated wind speed and direction at the 10-meter level and a temperature difference between the 45- and 10-meter levels. The BVPS meteorological measurement program meets the requirements of RG 1.23 and Regulatory Position C.1.1 of RG 1.145 and is described in detail in Chapter 2.2.3.

All releases are conservatively treated as ground-level as there are no releases at this site that are high enough to escape the aerodynamic effects of the plant buildings (i.e., 2.5 times Containment Building height). The applicable structure relative to building wake effects on the releases is based on release/receptor orientation. The distances from the Unit 2 containment building edge to the receptors are determined from the closest edge of the containment building. The release elevations are set equal to the receptor elevations in cases where the releases are not from a clearly defined point, such as the containment edge releases. Where both the release and receptor are not clearly defined points, both elevations are set equal to grade elevation.

Only the containment edge release is considered to be a diffuse source as the release is from the entire containment surface. Diffuse source treatment allows the calculation of initial values of the dispersion coefficients. These values are determined by the height and width of the containment building divided by a factor of six based on the draft NRC guidance on control room habitability assessments (NRC, 2001). All other releases are conservatively treated as point sources.

The ARCON96 default wind direction range of 90°, centered on the direction that transports the gaseous effluents from the release points to the receptors, is used in the calculation along with values for surface roughness length (i.e., 0.20 meter) and sector averaging constant (4.3) based on draft NRC guidance (NRC, 2001).

The control room air intake X/Q values are representative of the worst case X/Q values for control room unfiltered in-leakage purposes since the distances and directions from the release points to these receptors are very similar.

Control room tracer gas tests have indicated that a potential source of unfiltered inleakage into the control room during the post accident pressurization mode are the normal operation dampers associated with the control room ventilation system to which it is reasonable to assign the same X/Q as that of the Control Room air intake. The other source of inleakage is potentially that associated with ingress/egress and leakage via door seals. This inleakage is assigned to the door leading into the control room that is considered the point of primary access. This door is located in-between the BVPS-1 and BVPS-2 control room air intakes and is located close enough to the referenced air intakes to allow the assumption that the X/Q associated with this source of inleakage would be reasonably similar to that associated with the air intakes.

The X/Q values at the ERF edge closest to Containment is conservatively assumed to be representative of the post-accident X/Q values to the Emergency Response Facility which includes the Technical Support Center (TSC) and the Emergency Operations Facility (EOF).

### 2.3.5 Long-Term (Routine) Diffusion Estimates

#### 2.3.5.1 Objective

Annual average and grazing season average x/Q and D/Q diffusion factor estimates are calculated for each of the sixteen 22.5-degree sectors using methodology consistent with Regulatory Guide 1.111, Revision 1. Table 2.3-41 provides the distances of the controlling maximum individual receptors. In accordance with the Annex to Appendix I, 10 CFR 50, the BVPS site must consider radioactive release sources from all reactors. Therefore, diffusion estimates are provided herein for both BVPS-1 and BVPS-2. The five release points at BVPS and their radioactive release frequencies are:

BVPS-1	Ventilation vent	Continuous
BVPS-1	Elevated release	Intermittent
BVPS-2	Ventilation vent	Intermittent
BVPS-2	Elevated release	Continuous
Combined BVPS-1 and BVPS-2	process vent	Continuous

Release point design parameters are listed in Table 2.3-42, and release point locations are shown on ER Figure 3.1-1.

The resultant x/Q and D/Q values for the three continuous release vents are calculated as discussed in Sections 2.3.5.2.2 and 2.3.5.2.3, respectively, and are listed in Tables 2.3-43, 2.3-44, 2.3-45, 2.3-46, 2.3-47, 2.3-48, 2.3-49, 2.3-50, 2.3-51, 2.3-52, 2.3-53 and 2.3-54.

The two intermittent release vents have identical x/Q and D/Q values. Methodology for estimating these diffusion factors is discussed in Section 2.3.5.2.4 and the results shown in Tables 2.3-55, 2.3-56, 2.3-57 and 2.3-58.

## 2.3.5.2 Calculations

## 2.3.5.2.1 Nomenclature

$\pi$	=	3.14159... (dimensionless)
$\exp$	=	2.71828... (dimensionless)
$E_T$	=	entrainment coefficient (dimensionless)
$\Omega$	=	terrain recirculation factor (dimensionless)
$\Omega_g$	=	ground release
$\Omega_e$	=	elevated release
$C$	=	building shape coefficient (dimensionless)
$x$	=	downwind receptor distance (m)
$\sigma_z$	=	vertical dispersion coefficient (m)
$\bar{u}_{10}$	=	10-meter average wind speed (m/sec)
$\bar{u}_{150}$	=	150-meter average wind speed (m/sec)
$x/Q$	=	annual average or grazing season average concentration normalized by source strength ( $\text{sec}/\text{m}^3$ )
$(x/Q_D)$	=	depleted $X/Q$ ( $\text{sec}/\text{m}^3$ )
$F_m$	=	momentum flux ( $\text{m}^4/\text{sec}^2$ )
$h_D$	=	building height (m)
$h_r$	=	release height (m)
$h_e$	=	effective release height (m)
$h_{pr}$	=	nonbuoyant plume rise (m)
$h_t$	=	topographic height of receptor above plant grade (m)
$D$	=	stack or vent diameter (m)



- $u_e$  = efflux velocity (m/sec)  
 $N$  = total number of valid hours of wind in all sectors for applicable averaging period (dimensionless)  
 $\delta/Q$  = relative deposition rate normalized by source strength ( $m^{-1}$ )  
 $D/Q$  = relative deposition rate per unit area normalized by source strength ( $m^{-2}$ )  
 $i$  = index for elevated release stability group  
     1 = unstable (Classes A-C)  
     2 = neutral (Class D)  
     3 = stable (Classes E-G)  
 $j$  = index for number of hours  
 $k$  = index for a particular receptor distance  
 $i$  = index for a particular 22.5-degree sector  
 $n$  = number of hours of wind in a particular 22.5-degree sector (dimensionless)  
 $S$  = stability parameter ( $sec^{-2}$ )

#### 2.3.5.2.2 x/Q Modeling Technique

Annual average and grazing season average values of relative concentration are calculated for continuous gaseous releases of activity from the BVPS-1 ventilation vent, BVPS-2 elevated release, and the process vent located on top of the BVPS-1 natural draft cooling tower, according to the straight-line airflow (Gaussian) model described in Regulatory Guide 1.111, Revision 1. The basic equation for this model is as follows:

$$\left(\frac{X}{Q}\right)_{k,\ell} = \frac{2.032}{N} \sum_{j=1}^{N_\ell} \left(\frac{\Omega}{X}\right)_k \left[ \frac{E_T}{\bar{u}_{10} \left( \sigma_{z_k}^2 + \frac{0.5h_b^2}{\pi} \right)^{1/2}} + \frac{(1-E_T) \exp^{-1/2} \left( \frac{h_e}{\sigma_{z_k}} \right)^2}{\bar{u}_{150} \sigma_{z_k}} \right] \quad (2.3-10)$$

Airflow reversals are accounted for by applying the terrain recirculation factor,  $\Omega$ , presented in Tables 2.3-40 and 2.3-59 for both ground and elevated releases at the site.

For vent releases occurring below the level of a nearby structure, 100 percent downwash (total entrainment) is conservatively assumed ( $E_T = 1$ ). For vent releases occurring at a height that is twice the height of a nearby structure, downwash is precluded and the entrainment coefficient ( $E_T$ ) is set equal to zero.

The process vent, attached to the BVPS-1 natural draft cooling tower, is more than twice the height of the nearest adjacent solid structure, and is considered to be a totally elevated release. The BVPS-1 ventilation vent and the BVPS-2 elevated release are conservatively considered as ground-level release points although the releases are slightly higher than nearby adjacent solid structures.

Equation 2.3-10 was evaluated at the nearest site boundary, nearest resident, nearest vegetable garden greater than 500 feet<sup>2</sup>, nearest milk cow, nearest milk goat, and nearest meat animal; all within 5 miles in each downwind sector. This evaluation was performed for each continuously emitting release point.

The annual average period is the January 1, 1976 through December 31, 1980 onsite data period, while the 6-month grazing season period is represented by the May 1 through October 31 period for each year of the 5-year meteorological data base. The grazing season corresponds reasonably well with the growing season.

The effective release height was computed from the following equation:

$$h_e = h_r - (h_{t_k}) + h_{pr} \quad (2.3-11)$$

Values of topographic heights are conservatively assessed as the maximum height within a particular annulus-sector (annsect). An annsect is an area bounded by a 22.5-degree sector and any two radial distances from the release point. Plume rise for nonbuoyant sources was calculated by the following algorithm from Regulatory Guide 1.111:

$$h_{pr} = 1.44 \left( \frac{u_e}{\bar{u}_{150}} \right)^{2/3} \left( \frac{X}{D} \right)^{1/3} D \quad (2.3-12)$$

for A-D stabilities, and:

$$u_e / \bar{u}_{150} < 1.5$$

$$h_{pr} = 1.44 \left( \frac{u_e}{\bar{u}_{150}} \right)^{2/3} \left( \frac{X}{D} \right)^{1/3} D - 3 \left[ 1.5 - \left( \frac{u_e}{\bar{u}_{150}} \right) \right] D \quad (2.3-13)$$

for A-D stabilities, and

where:

$$u_e / \bar{u}_{150} < 1.5$$

$$h_{pr} \leq 3 \left( \frac{u_e}{\bar{u}_{150}} \right) D \quad (2.3-14)$$

For E-G stability conditions, Equations 2.3-12 and 2.3-14 are compared with:

$$h_{pr} = 4 (F_m / S)^{1/4} \quad (2.3-15)$$

and:

$$h_{pr} = 1.5 (F_m / \bar{u}_{150})^{1/3} S^{-1/6} \quad (2.3-16)$$

where:

$$F_m = \frac{(u_e)^2 D^2}{4} \quad (2.3-17)$$

and the smallest value is chosen.

In the ground level portion of Equation 2.3-10, the vertical dispersion term was constrained to be less than or equal to  $1.7324\sigma_z$ .

#### 2.3.5.2.3 x/Q and D/Q Modeling Techniques

Annual average and grazing season average depleted relative concentration values are conservatively assumed to be equal to annual average and grazing season average relative concentration values  $[x/Q = (x/Q)D]$ , respectively. Therefore, no credit is taken for attendant plume depletion of radioiodines and particulates.

Annual average and grazing season average relative deposition values are calculated using Regulatory Guide 1.111 (Figure 6), with the following equation:

$$\left(\frac{D}{Q}\right)_{k\ell} = \left(\frac{\Omega}{X}\right)_k \left(\frac{2\pi N}{16}\right)^{-1} \left\{ \sum_{j=1}^{N_j} \left[ n_{\ell} \left\{ \left(\frac{\delta}{Q}\right)_{Gk} E_T + \frac{1}{n_{\ell}} \sum_{n=1}^3 \left[ 1 - (E_T)_i n_{i\ell} \left(\frac{\delta}{Q}\right)_{ik} \right] \right\} \right] \right\} \quad (2.3-18)$$

#### 2.3.5.2.4 Methodology Employed for Intermittent Releases

The methodology employed in the calculation of intermittent release x/Q and D/Q values is as follows (USNRC 1976):

1. One-hour sector-averaged x/Q values are calculated without terrain recirculation factors.
2. The 15-percent, 1-hour value is plotted at 1 hour on log-log coordinates, while the annual average value is plotted at 8,760 hours. A straight line, connecting the two points, is drawn.

3. Log-log interpolation based on total ground intermittent release hours versus annual hours yields  $x/Q$  multiplier.
4. The multiplier is applied to annual average and grazing season average  $x/Q$  and  $D/Q$  values to obtain intermittent annual average and grazing season average  $x/Q$  and  $D/Q$  values.

For BVPS, intermittent purges totaling 32 hours per year from the BVPS-1 elevated release and the BVPS-2 ventilation vent were evaluated.

#### 2.3.6 References for Section 2.3

American Meteorological Society 1959. Glossary of Meteorology. Boston, Massachusetts.

American National Standards Institute 1972. American National Standard Building Code Requirements for Minimum Design Loads in Buildings and Other Structures. ANSI A58.1.

American Society of Civil Engineers (ASCE) 1961. Wind Forces on Structures. Transactions of the ASCE, Part II, Volume 126, Paper No. 3269. Figure (1), p 124.

Baldwin, J.L. 1977. Climates of the United States. National Oceanic and Atmospheric Administration, Washington, D.C.

Briggs, G.A. 1972. Discussion on Chimney Plumes in Neutral and Stable Surrounding Atmosphere Environment 6, p 507-510.

Environmental Science Services Administration (ESSA) 1969. Severe Local Storm Occurrences, 1955-1967. Editor, Pautz, M.E., ESSA Technical Memorandum, WBTM FCST 12, Washington, D.C.

Frederick, R.H.; Myers, VA.; and Auciello, E.P. 1977. Five-to-Sixty-Minute Precipitation Frequency for the Eastern and Central United States. Technical Memorandum NWS HYDRO-35-NOAA, National Oceanic and Atmospheric Administration, Silver Spring, M.D.

Halliburton NUS Environmental Corporation 1991, Control Room  $x/Q$  Values for the Beaver Valley Power Station.

Holzworth, G.C. 1972. Mixing Heights Wind Speeds, and Potential for Urban Air Pollution Throughout the Contiguous United States. U.S. Environmental Protection Agency (USEPA), Washington, D.C.

Hosler, C.R. 1961. Low-Level Inversion Frequency in the Contiguous United States. In: Monthly Weather Review (September).

Huff, F.A. 1972. Potential Augmentation of Precipitation from Cooling Towers. Bulletin of the American Meteorological Society, 53, p 639-644.

Jennings, A.H. 1963. Maximum Recorded United States Point Rainfall for 5 Minutes to 24 Hours at 296 First-Order Stations. Technical Paper No. 2, U.S. Department of Commerce, Weather Bureau, Washington, D.C.

Korshover, J. 1976. Climatology of Stagnating Anticyclones East of the Rocky Mountains 1936-1975. NOAA Technical Memorandum ERL ARL-55.

Kramer, M.L.; Seymour, D.E.; Smith, M.E.; Reeves, R.W.; and Frankenberg T.T. 1976. Snowfall Observations from Natural Draft Cooling Tower Plumes. Science (1931), pp 1,239b-1,241.

Markee, E.H., Jr. 1974. Technical Basis for Interim Regional Tornado Criteria. WASH - 1300 (UC-11) U.S. Atomic Energy Commission (USAEC), Washington, D.C.

Marshall, J.L. 1973. Lightning Protection. John Wiley & Sons, New York, N.Y.

National Climatic Center 1980. Local Climatological Data for Pittsburgh, Pennsylvania Greater Pittsburgh Airport.

National Oceanic and Atmospheric Administration (NOAA) 1963. Rainfall Frequency Atlas for the United States for Durations from 30 Minutes to 24 Hours and Return Periods from 1 to 100 Years. Technical Paper No. 40, NOAA, Washington, D.C.

National Oceanic and Atmospheric Administration 1972. Climatological Data - Pennsylvania.

National Oceanic and Atmospheric Administration 1974. Climates of the States. Vol I - Eastern States. U.S. Department of Commerce.

National Severe Storms Forecast Center 1982. Tornado Data, Printout of Occurrences within 50 N.M. of the Beaver Valley Power Plant. Kansas City, Missouri.

National Weather Records Center 1966 through 1975. Storm Data. National Oceanic and Atmospheric Administration, Environmental Data Service, Asheville, N.C.

Ramsdell, J.V., 1988, Atmospheric Diffusion for Control Room Habitability Assessments, NUREG/CR-5055.

Riedel, J.T.; Appleby, J.F.; and Schloremer, R.W. 1956. Seasonal Variation of the Probable Maximum Precipitation East of the 105th Meridian for Areas from 10 to 1,000 Square Miles and Durations of 6, 12, 24 and 48 Hours. Hydrometeorological Report No. 33.

Turner, D.B. 1969. Workbook of Atmospheric Dispersion Estimates. Air Resources Field Research Office, Environmental Sciences Services Administration.

United States Government Printing Office (USGPO) (Undated). Condensed Table of Critical Values. Federal Meteorology Handbook No. 1.

U.S. Nuclear Regulatory Commission (USNRC) 1976. Calculation of Intermittent (Purge) Releases When Using Joint Frequency Data. Distributed during a public meeting in Bethesda, Maryland, May 13, 1976.

USNRC 1981. National Thunderstorm Frequency for the Contiguous United States. NUREG/CR-2252.

Wallis, A.L., Jr. 1978, Comparative Climatic Data Through 1977. U.S. Department of Commerce, NOAA, NCC, Asheville, N.C.

Ramsdell, J. V. Jr. and C. A. Simonen, "Atmospheric Relative Concentrations in Building Wakes." Prepared by Pacific Northwest Laboratory for the U.S. Nuclear Regulatory Commission, PNL-10521, NUREG/CR-6331, Rev. 1, May 1997.

U.S. Nuclear Regulatory Commission, Office of Nuclear Regulatory Research, Draft Regulatory Guide DG-1111, "Atmospheric Relative Concentrations for Control Room Habitability Assessments at Nuclear Power Plants," December 2001.

BVPS-2 UFSAR

Tables for Section 2.3



TABLE 2.3-1  
 NORMALS <sup>(1)</sup> MEANS AND/OR EXTREMES <sup>(2,3)</sup> OF CLIMATOLOGICAL DATA  
 FROM THE NATIONAL WEATHER SERVICE STATION AT GREATER PITTSBURGH AIRPORT

Month	Temperatures (°F)						Normal Degree Days Base 65°F		
	Normal			Extremes			Heating	Cooling	
	Daily Maximum	Daily Minimum	Monthly	Record Highest	Year	Lowest			Record Year
(4)				28		28			
Jan	35.3	20.8	28.1	68	1972	-18	1963	1,144	0
Feb	37.3	21.3	29.3	69	1954	-12	1979	1,000	0
Mar	47.2	29.0	38.1	80	1977	-1	1960	834	0
Apr	60.9	39.4	50.2	87	1970	15	1977	444	0
May	70.8	48.7	59.8	91	1962	26	1970	208	46
June	79.5	57.7	68.6	96	1971	34	1972	26	134
July	82.5	61.3	71.9	99	1954	42	1963	7	221
Aug	80.9	59.4	70.2	97	1953	40	1665	16	177
Sept	74.9	52.7	63.8	97	1954	31	1959	98	62
Oct	63.9	42.4	53.2	87	1959	16	1965	372	7
Nov	49.3	33.3	41.3	82	1961	-1	1958	711	0
Dec	37.3	23.6	30.5	72	1971	-7	1976	1,070	0
Year	60.0	40.8	50.4	99	1954	July -18	1963	Jan 5,930	647

TABLE 2.3-1 (Cont)

Month	Precipitation (inches)										Relative Humidity (percent)				
	Water Equivalent						Snow, Ice Pellets				Relative Humidity (percent)				
	Normal	Maximum Monthly	Year	Minimum Monthly	Year	Maximum in 24 hrs	Year	Maximum Monthly	Year	Maximum in 24 hrs	Year	01 Hour	07 Hour (Local Time)	13 Hour	19 Hour
(4)	28		28		28		28		28		20	21	20	20	
Jan	2.79	6.25	1978	1.06	1967	1.43	1978	40.2	1978	14.0	1966	73	75	66	67
Feb	2.35	5.98	1956	0.51	1969	2.30	1975	24.2	1972	12.3	1960	70	73	62	63
Mar	3.60	6.10	1967	1.14	1969	2.00	1964	21.3	1960	14.7	1962	69	74	58	60
Apr	3.40	7.61	1964	0.48	1971	2.15	1964	5.9	1961	3.9	1953	66	72	50	53
May	3.63	6.36	1968	1.21	1965	2.44	1971	3.1	1966	3.1	1966	72	76	52	54
June	3.48	5.08	1974	0.90	1967	1.93	1955	0.0		0.0		77	79	52	57
July	3.84	7.43	1958	1.82	1965	2.97	1971	0.0		0.0		80	83	53	59
Aug	3.15	7.56	1975	0.78	1957	3.06	1956	0.0		0.0		82	86	56	63
Sept	2.52	5.42	1972	0.74	1964	2.25	1975	0.0		0.0		82	86	57	66
Oct	2.52	8.20	1954	0.16	1963	3.56	1954	1.8	1972	1.8	1972	76	81	54	62
Nov	2.47	4.70	1972	0.90	1976	1.38	1961	11.0	1958	10.5	1958	75	79	63	68
Dec	2.48	5.24	1978	0.40	1955	1.76	1978	21.2	1974	12.5	1974	74	76	67	70
Year	36.23	8.20	Oct 1954	0.16	Oct 1963	3.56	Oct 1954	40.2	Jan 1978	14.7	Mar 1962	75	78	57	62

TABLE 2.3-1 (Cont)

Month	Wind					Percent of Possible Sunshine	Mean Sky Cover Tenth, Sunrise to Sunset	Mean Number of Days		
	Mean Speed (mph)	Prevailing Direction <sup>(5)</sup>	Fastest Mile					Clear	Partly Cloudy	Cloudy
			Speed <sup>(6)</sup> (mph)	Direction <sup>(7)</sup>	Year					
<sup>(4)</sup>	28	11	28	28		28	28	28	28	
Jan	10.7	WSW	52	23	1978	34	8.1	3	6	22
Feb	10.8	WSW	58	26	1967	39	7.8	3	6	19
Mar	11.0	WSW	48	25	1954	44	7.6	4	7	20
Apr	10.6	WSW	46	27	1974	48	7.2	4	8	18
May	9.1	WSW	42	25	1957	51	6.9	5	9	17
June	8.2	WSW	40	27	1957	57	6.4	5	12	13
July	7.5	WSW	51	25	1956	57	6.4	5	13	13
Aug	7.1	WSW	46	29	1963	56	6.3	6	12	13
Sept	7.5	WSW	32	02	1960	58	6.1	8	10	12
Oct	8.5	WSW	35	27	1959	53	6.1	8	9	14
Nov	9.9	WSW	45	29	1969	39	7.7	4	6	20
Dec	10.5	WSW	48	25	1968	30	8.2	3	5	23
Year	9.3	WSW	58	26	1967	Feb 48	7.1	58	103	204

TABLE 2.3-1 (Cont)

Month	Mean Number of Days				Temperatures (°F)				Average Station Pressure (mb)  EI 1225 (feet msl)
	Precipitation .01 inch or more	Ice pellets Snow, 1.0 inch or more	Thunderstorms	Heavy fog, visibility 1/4 mile or less	Maximum		Minimum		
					90° and above <sup>(8)</sup>	32° and below	32° and below	0° and below	
<sup>(4)</sup>		28	22	28	21	21	21	21	8
Jan	17	4	<sup>(9)</sup>	1	0	15	27	3	973.1
Feb	14	3	<sup>(9)</sup>	1	0	12	25	2	973.2
Mar	16	2	2	1	0	4	19	<sup>(9)</sup>	971.9
Apr	13	<sup>(9)</sup>	4	1	0	<sup>(9)</sup>	8	0	971.9
May	12	<sup>(9)</sup>	5	1	<sup>(9)</sup>	0	1	0	971.1
June	11	0	7	1	2	0	0	0	972.9
July	11	0	7	2	3	0	0	0	973.5
Aug	10	0	6	2	1	0	0	0	975.1
Sept	9	0	3	2	1	0	0	0	974.8
Oct	10	<sup>(9)</sup>	1	2	0	0	4	0	974.6
Nov	13	1	1	2	0	2	15	<sup>(9)</sup>	974.4
Dec	16	3	<sup>(9)</sup>	2	0	11	25	1	973.5
Year	153	14	36	18	7	43	124	5	973.3

NOTES:

1. Normals - Based on record for the 1941-1970 period.
2. Means and extremes are from existing and comparable exposures. Annual extremes have been exceeded at other sites in the locality as follows:
  - a. Airport - highest temperature = 102°F in July 1936; maximum monthly precipitation = 10.25 inches in June 1951; maximum monthly snowfall = 32.3 inches in November 1950; and maximum snowfall in 24 hours = 17.5 inches in November 1950.
  - b. City Office - highest temperature = 103°F in July 1936; lowest temperature = 20°F in February 1899; minimum monthly precipitation = 0.06 inch in October 1874; maximum precipitation in 24 hours = 4.08 inches in September 1876; and maximum monthly snowfall = 36.3 inches in December 1890.
3. Date of an extreme - The most recent in cases of multiple occurrence.
4. Length of record (years) through the current year, unless otherwise noted, based on January data.
5. Prevailing wind direction - Record through 1963.
6. Fastest mile wind - Speed is fastest observed 1-minute value when the direction is in tens of degrees.
7. Wind direction - Numerals indicate tens of degrees clockwise from true north, 00 indicates calm.
8. 70°F and above at Alaskan Stations.
9. Less than 1/2.

TABLE 2.3-2

EXPECTED RAINFALL IN THE  
BVPS AREA FOR SELECTED RAINFALL  
DURATION PERIODS AND RECURRENCE INTERVALS  
(INCHES)

Recurrence Interval	<u>Rainfall Duration</u>					
	<u>5 Minutes</u>	<u>15 Minutes</u>	<u>1 Hour</u>	<u>6 Hours</u>	<u>12 Hours</u>	<u>24 Hours</u>
2-Year	0.4*	0.8*	1.2*	1.8	2.3	2.5
10-Year	NA**	NA	1.8	2.7	3.3	4.0
25-Year	NA	NA	2.1	3.5	3.8	4.5
50-Year	NA	NA	2.4	3.5	4.0	5.0
100-Year	0.7	1.5*	2.5*	4.0	4.5	5.0

NOTES:

\*Fredrick et al 1977.

\*\*NA - These data are not available.

TABLE 2.3-3

MAXIMUM RAINFALL FOR SELECT RAINFALL  
DURATION PERIODS AT PITTSBURGH, 1895-1961\*, \*\*  
(INCHES)

	<u>Rainfall Duration</u>									
	<u>5 minutes</u>	<u>10 minutes</u>	<u>15 minutes</u>	<u>30 minutes</u>	<u>1 hour</u>	<u>2 hours</u>	<u>3 hours</u>	<u>6 hours</u>	<u>12 hours</u>	<u>24 hours</u>
Amount (inches)	0.72	1.09	1.23	1.46	2.09	2.34	2.35	2.45	2.93	4.08
Month/Day	6/26	6/26	6/26	7.04	7/27	6/24	8/15	9/29	9/29	9/17
Year	1931	1931	1931	1903	1943	1951	1941	1936	1936	1876

NOTES:

\*Rainfall amount records have not been exceeded since 1961; the major precipitation event in 1972, Hurricane Agnes, did not set any new precipitation records in Pittsburgh.

\*\*Durations less than one hour were not recorded in 1895.

TABLE 2.3-5

TORNADOES WITHIN 1° SQUARE FOR THE BVPS SITE

Year	Month /Day	Time Zulu	State	Se-quence*	Seg-ment*	Beginning		Ending		Length (miles)	Width (feet)	Deaths	In-juries	Damage Class	F	P	P	AZRAN**
						Lati-tude	Longi-tude	Lati-tude	Longi-tude									
1954	4/27	2355	OH	2	1	4013	8053			001.0		0	1	5	2	0	1	221/32
1954	6/10	0200	PA	12	1	4045	8015	4051	08011	008.0		0	1	4	1	2	1	46/11
1954	6/10	0215	PA	12	2	4051	8011	4053	08010	002.0		0	2	4	1			39/18
1954	6/10	0315	PA	13	1	4017	8007					0	0	2	1	0	0	145/25
1955	3/11	1025	OH	3	1	4053	8050			001.0	0300	0	0	5	2	1	2	311/24
1955	3/22	1400	OH	5	1	4057	8041	4101	08037	006.0	1200	0	3	0	1	0	3	330/23
1956	5/13	0545	PA	1	1	4036	8018					0	0	5	3			101/6
1962	4/19	2200	OH	9	1	4102	8052	4102	08034	015.0		0	0	5	2	2	1	321/32
1965	4/12	0601	OH	16	1	4016	8100					0	1	3	1	0	1	231/34
1966	4/23	2030	PA	1	1	4045	8020			001.0	0050	0	0	4	1	1	0	29/9
1967	6/13	1930	OH	2	1	4048	8042				0090	0	0	3	1	0	1	311/16
1967	7/25	0030	OH	6	1	4049	8041	4049	08033	006.0	0880	0	2	5	2	1	3	316/16
1968	8/19	1930	PA	4	1	4056	7959					0	0	3	2	0	1	47/28
1970	7/31	2200	PA	7	1	4038	8005			000.5	0600	0	0	3	1	0	3	87/16
1970	9/3	0027	PA	12	1	4041	8021	4041	08017	003.0	0600	0	5	6	1	1	3	44/5
1972	6/4	0030	OH	15	1	4056	8055			000.5		0	0	2	1	0	1	310/29
1972	7/26	2100	OH	37	1	4052	8102			000.1	0020	0	0	2	1	-1	0	298/31
1973	5/10	0230	PA	2	1	4006	8024			002.0		0	3	4	1	1	0	177/31
1975	3/24	2100	PA	1	1	4041	8014					0	0	4	1	-1	1	67/10
1975	6/4	2345	PA	4	1	4035	8013	4011	07932	040.0	0090	0	0	2	2	1	1	103/10
1976	2/17	0435	OH	2	1	4104	8050			001.5	1800	0	0	5	2	1	3	326/32
1976	3/27	1900	PA	8	1	3956	8023			000.1		0	0	4		-1		177/41
1976	4/25	1855	PA	9	1	4026	7959			000.1		0	0	3	0	-1	0	119/23
1976	6/24	2020	PA	11	1	4007	8002	4008	07959	003.0	0100	0	0	4	1	-1	1	149/35
1976	7/11	1830	PA	14	1	4045	8020			000.1		0	0	3		-1	0	29/9
1976	7/15	2200	PA	18	1	4005	7955			000.5		0	1	5	0	-1	-1	144/40
1977	9/24	0045	PA	10	1	4100	8021					0	0	6				9/23
1977	7/25	0200	WV	2	1	4011	8035			000.5		0	4	0		0	1	195/27
1978	6/16	2120	PA	6	1	4048	8088					0	1	5				
1978	10/12	2325	OH															
1979	10/3	0645	PA	7	1	4024	8006	4025	8003	003.0		0	0	4	1	1	1	
1980	5/31	1730	PA	5	1	4009	8017			001.0		0	0	4	1	1	0	
1980	7/6	2342	OH															
1981	6/8	2100	OH															
1981	6/21	1921	OH															
1981	6/22	2350	OH															
1981	6/21	1430	PA	5	1	4030	7955	4038	7955	005.0		0	0	4	1	2	-1	
1981	6/21	1350	PA	4	1	4045	8010					0	0	4	1	-1	-1	
1981	7/20	1200	PA	8	1	4051	8000					0	0	5	2	-1	-1	

TABLE 2.3-5 (Cont)

NOTES:

\*These columns indicate the sequence number and segment number of each tornado. Sequence numbers are assigned chronologically within each state. The first tornado in 1953 in Ohio is given sequence number 1 for the State of Ohio that year. Many tornadoes have more than one touchdown point; that is, they may touch down, lift from the ground, and then touch down again. These tornadoes are broken down into segments which are indicated by segment numbers. For a tornado with three segments, the sequence number stays the same but the segment number is different for each separate touchdown. The statistics in the tables are based only on the initial touchdown points.

\*\*This column indicates the azimuth and range from the center point.



TABLE 2.3-6  
TORNADO DAMAGE CLASS NUMBERS

<u>Class</u>	<u>Amount of Damage</u>
1	less than \$50
2	\$50 to \$500
3	\$500 to \$5,000
4	\$5,000 to \$50,000
5	\$50,000 to \$500,000
6	\$500,000 to \$5 million
7	\$5 million to \$50 million
8	\$50 million to \$500 million
9	\$500 million to \$5 billion

TABLE 2.3-7  
RANGE OF EACH FUJITA-PEARSON SCALE

<u>Scale</u>	<u>F (mph)</u>	<u>Damage</u>	<u>P<sub>L</sub> (length in miles)</u>	<u>P<sub>W</sub> (width in yards)</u>
-1	less than 40	(little or no damage)	less than 0.3	less than 6
0	40-72	Light	0.3-1.0	6-17
1	73-112	Moderate	1.0-3.1	18-55
2	113-157	Considerable	3.2-9.9	56-175
3	158-206	Severe	10-31	176-556
4	207-260	Devastating	32-99	0.3-0.9 miles
5	261-318	Incredible	100-315	1.0-3.1 miles

TABLE 2.3-8

SEASONAL AND ANNUAL FREQUENCY OF LIGHTNING STRIKES  
TO THE REACTOR CONTAINMENT BUILDING FOR BOLTS OF  
VARIOUS CURRENT MAGNITUDE

Season	Average No. of Thunderstorm Days (Pittsburgh)*	Average No. of Cloud-to-Ground Flashes/km <sup>2</sup>	Magnitude of Bolt's Current									
			20 kA		40 kA		60 kA		90 kA		135 kA	
			Area (km <sup>2</sup> )	Strikes (yr <sup>-1</sup> )	Area (km <sup>2</sup> )	Strikes (yr <sup>-1</sup> )	Area (km <sup>2</sup> )	Strikes (yr <sup>-1</sup> )	Area (km <sup>2</sup> )	Strikes (yr <sup>-1</sup> )	Area (km <sup>2</sup> )	Strikes (yr <sup>-1</sup> )
Winter (Dec., Jan., Feb.)	1	0.2	0.036	0.0036	0.119	0.0052	0.25	0.005	0.428	0.0017	0.655	0.00065
Spring (Mar., Apr. May)	16	3	0.036	0.054	0.119	0.078	0.25	0.075	0.428	0.0255	0.655	0.0097
Summer (June, Jul., Aug.)	29	6	0.036	0.108	0.119	0.156	0.25	0.15	0.428	0.051	0.655	0.0195
Fall (Sept., Oct., Nov.)	7	1	0.036	0.018	0.119	0.026	0.25	0.025	0.428	0.0085	0.655	0.0032
Annual	53	10	0.036	0.18	0.119	0.26	0.25	0.25	0.428	0.085	0.655	0.032

NOTE:

\*From NUREG/CR-2252.

TABLE 2.3-9

COMPARISON OF WIND DIRECTION FREQUENCIES (PERCENT OF YEAR)  
 AT THE BVPS SITE (35-FT LEVEL)  
 AND GREATER PITTSBURGH AIRPORT FOR CONCURRENT AND  
 LONG-TERM PERIODS

<u>Wind Direction</u>	<u>BVPS Site</u>		<u>Greater Pittsburgh Airport</u>	
	<u>(1/1/76 to 12/31/80)</u>	<u>(1/1/76 to 12/31/80)</u>	<u>(1/1/53 to 12/31/80)</u>	<u>(1/1/53 to 12/31/80)</u>
Calm	0.8	6.7	6.8	
N	4.8	6.7	5.4	
NNE	3.4	2.4	3.1	
NE	4.7	3.0	3.1	
ENE	5.2	2.9	3.7	
E	5.5	4.3	4.6	
ESE	6.8	3.0	4.2	
SE	9.2	4.8	4.7	
SSE	5.5	4.5	3.8	
S	5.9	8.2	5.8	
SSW	6.6	4.5	5.3	
SW	10.5	8.3	8.7	
WSW	10.3	9.4	12.3	
W	7.5	13.0	10.6	
WNW	4.6	7.4	7.5	
NW	4.7	6.0	6.1	
NNW	3.8	4.8	4.4	

TABLE 2.3-10

MONTHLY AND ANNUAL AVERAGE WIND SPEED (MPH)  
 FOR BVPS AND THE NATIONAL WEATHER SERVICE AT PITTSBURGH  
 FROM JANUARY 1, 1976 TO DECEMBER 31, 1980

<u>Month</u>	<u>BVPS Site</u> <u>(1/1/76 - 12/31/80)</u>			<u>Pittsburgh</u> <u>(1/1/76-</u>	<u>Pittsburgh</u> <u>(9/16/52-</u>
	<u>35-ft</u>	<u>150-ft</u>	<u>500-ft</u>	<u>12/31/80</u>	<u>12/31/80</u>
January	5.5	8.4	11.6	9.3	9.4
February	4.8	7.6	11.0	8.7	9.5
March	5.0	8.2	11.8	9.2	9.8
April	4.5	7.2	10.5	8.4	9.4
May	3.6	5.8	9.1	7.2	8.0
June	3.6	5.6	8.8	7.0	7.2
July	3.3	5.2	7.8	6.4	6.6
August	3.1	4.8	7.7	5.6	6.3
September	3.1	5.1	8.2	5.6	6.7
October	4.0	6.5	10.4	7.5	7.5
November	4.5	7.1	10.9	8.0	8.8
December	5.2	7.7	11.8	9.0	9.3
Annual 1976-1980	4.2	6.6	10.0	7.6	8.2

TABLE 2.3-11  
 SUMMARY OF BVPS 35-FOOT  
 WIND PERSISTENCE EPISODES  
 PERIOD 1/1/76 - 12/31/80

Wind From	Hours of Persistence																									Total
	2	3	4	5	6	7	8	9	10	11	12	13	14	15	16	17	18	19	20	21	22	23	24	25*		
N	238	79	40	20	6	2	4	3	0	0	0	0	2	0	0	1	0	0	0	0	0	0	0	0	0	395
NNE	192	43	15	4	1	0	0	0	0	0	0	0	0	0	0	0	0	0	0	0	0	0	0	0	0	255
NE	202	61	35	15	11	7	2	2	0	1	2	0	0	0	0	0	0	0	0	0	0	0	0	0	0	338
ENE	227	73	43	17	13	11	5	2	1	2	1	0	1	0	0	0	0	0	0	0	0	0	0	0	1	397
E	282	84	37	18	6	5	0	0	1	0	0	0	0	0	0	0	0	0	0	0	0	0	0	0	0	433
ESE	339	108	55	22	16	8	2	7	1	0	1	0	0	0	0	0	0	0	0	0	0	0	0	0	0	559
SE	455	183	80	34	29	15	7	4	3	1	2	0	0	0	0	0	0	0	0	0	0	0	0	0	0	813
SSE	292	81	24	10	5	2	0	2	0	0	0	0	0	0	0	0	0	0	0	0	0	0	0	0	0	416
S	296	82	41	26	13	4	2	0	2	0	0	0	0	0	0	0	0	0	0	0	0	0	0	0	0	466
SSW	316	125	60	29	10	3	5	1	1	0	1	0	0	0	0	0	0	0	0	0	0	0	0	0	0	551
SW	432	187	117	68	32	18	21	7	5	4	2	2	1	2	0	0	0	0	1	0	0	0	0	0	0	899
WSW	431	97	97	54	31	26	18	10	5	4	5	0	0	1	0	3	0	0	1	0	0	0	0	0	1	884
W	336	156	53	46	26	13	2	4	5	2	1	3	1	0	0	0	0	0	0	0	0	0	0	0	0	648
WNW	230	71	35	17	5	3	1	0	1	1	0	0	0	0	0	0	0	0	0	0	0	0	0	0	0	364
NW	210	85	31	21	15	6	2	2	0	0	0	1	0	0	2	0	0	0	0	0	0	0	0	0	0	375
NNW	217	52	15	5	0	2	2	0	0	0	0	0	0	0	0	0	0	0	0	0	0	0	0	0	0	293
Total	4,695	1,667	778	406	219	125	73	44	25	15	15	6	5	3	2	4	0	0	2	0	0	0	0	0	2	8,086

NOTE:

\*Two occurrences of 30 hours of persistence.

TABLE 2.3-12  
 SUMMARY OF BVPS 500-FOOT  
 WIND PERSISTENCE EPISODES  
 PERIOD 1/1/76 - 12/31/80

Wind From	Hours of Persistence																									Total
	2	3	4	5	6	7	8	9	10	11	12	13	14	15	16	17	18	19	20	21	22	23	24	25		
N	178	89	48	43	20	9	7	7	6	1	1	1	0	0	1	0	0	0	0	0	0	0	0	0	411	
NNE	129	53	20	7	6	0	0	1	0	0	0	0	0	0	1	0	0	0	0	0	0	0	0	0	217	
NE	161	44	26	24	11	8	6	3	1	3	1	0	0	0	0	0	0	0	0	0	0	0	0	0	288	
ENE	163	75	33	21	17	16	6	5	6	4	2	0	1	1	0	0	0	0	0	1	0	0	0	0	351	
E	166	71	42	22	17	12	10	4	8	3	1	3	1	0	0	0	0	0	0	0	0	0	0	1*	361	
ESE	150	90	38	21	17	6	5	2	2	0	1	1	0	0	0	0	0	0	0	0	0	0	0	0	333	
SE	158	92	29	16	12	7	4	3	5	2	0	1	1	1	0	0	1	0	0	0	0	0	0	0	332	
SSE	155	54	34	19	14	9	4	0	0	0	0	0	0	0	0	1	0	0	0	0	0	0	0	0	290	
S	254	125	46	28	10	8	5	3	0	4	1	0	0	0	1	0	0	0	0	0	0	0	0	0	485	
SSW	354	158	66	54	24	22	12	2	4	5	1	1	0	1	0	0	0	0	1	0	0	0	0	0	705	
SW	450	226	136	81	45	32	31	27	9	12	8	7	6	2	5	3	3	2	1	1	0	1	1	0	1,089	
WSW	440	231	115	75	55	24	24	10	7	6	4	2	2	1	2	0	1	1	0	0	0	0	0	2**	1,002	
W	398	223	128	89	52	35	35	23	20	10	9	6	10	0	2	1	1	2	0	1	1	0	0	0	1,046	
WNW	311	149	74	49	25	14	10	10	5	2	1	0	1	1	0	1	0	0	0	0	0	0	0	0	653	
NW	280	114	63	33	12	10	4	4	4	4	2	1	1	0	0	0	0	0	0	0	0	0	0	0	532	
NNW	218	74	53	22	9	4	2	2	1	1	0	1	1	0	0	0	0	0	0	0	0	0	0	0	388	
Total	3,965	1,868	951	604	346	216	165	106	78	57	32	24	24	7	12	6	6	5	2	3	1	1	1	3	8,483	

NOTE:

\*Occurrence of 34 hours of persistence.

\*\*Two occurrences of 25 to 28 hours of persistence, respectively.

TABLE 2.3-13

SUMMARY OF GREATER PITTSBURGH AIRPORT  
WIND PERSISTENCE EPISODES  
PERIOD 1/1/76 - 12/31/80

Wind From	Hours of Persistence																									Total
	2	3	4	5	6	7	8	9	10	11	12	13	14	15	16	17	18	19	20	21	22	23	24	25*		
N	292	133	78	53	30	17	13	3	4	2	1	3	3	1	0	0	0	0	0	0	0	0	0	0	1	634
NNE	122	37	8	8	3	2	1	0	0	0	0	0	0	0	0	0	0	0	0	0	0	0	0	0	0	181
NE	153	52	27	11	8	1	0	0	0	0	0	0	0	0	0	0	0	0	0	0	0	0	0	0	0	252
ENE	156	45	25	13	8	2	1	2	1	0	1	0	0	0	0	0	0	0	0	0	0	0	0	0	0	254
E	195	78	43	24	7	11	8	4	2	1	1	0	0	0	0	1	0	0	0	0	0	0	0	0	0	243
ESE	146	62	20	4	6	0	2	0	2	1	0	0	0	0	0	0	0	0	0	0	0	0	0	0	0	375
SE	249	79	37	22	17	4	1	5	1	4	0	0	0	1	1	0	0	0	0	0	0	0	0	0	0	420
SSE	246	91	31	14	5	2	0	3	0	0	0	0	0	0	0	0	0	0	0	0	0	0	0	0	0	392
S	383	174	96	44	33	12	4	4	5	3	0	1	1	0	0	0	0	0	0	0	0	0	0	0	0	760
SSW	270	63	36	6	2	3	1	0	0	0	0	0	0	0	0	0	0	0	0	0	0	0	0	0	0	381
SW	395	172	82	44	28	12	7	7	1	1	0	0	1	0	0	0	0	0	0	0	0	0	0	0	0	750
WSW	465	173	84	50	30	13	9	6	4	6	3	0	1	3	0	0	0	0	1	0	0	0	0	0	0	949
W	469	254	120	97	45	32	20	18	18	13	13	7	2	3	1	4	1	0	1	1	0	0	1	0	0	1,120
WNW	380	150	73	40	17	10	6	2	2	0	0	0	0	2	0	0	0	0	0	0	0	0	0	0	0	692
NW	301	127	50	22	14	3	5	1	2	0	1	0	0	0	0	0	0	0	0	0	0	0	0	0	0	526
NNW	247	100	46	15	11	8	2	3	3	0	1	0	0	0	0	0	0	0	0	0	0	0	0	0	0	436
Total	4,883	1,998	978	573	334	188	122	84	63	47	45	23	8	12	1	5	1	2	2	1	0	0	1	1	0	9,377

NOTE:

\*Occurrence of 9 hours of persistence.



TABLE 2.3-14

COMPARISON OF AVERAGE ANNUAL AND MONTHLY DRY-BULB  
 TEMPERATURES (°F) AT THE BVPS SITE  
 AND GREATER PITTSBURGH AIRPORT FOR CONCURRENT  
 AND LONG-TERM TIME PERIODS

<u>Month</u>	BVPS Site	Greater Pittsburgh Airport	
	<u>(1/1/76-12/31/80)</u>	<u>(1/1/76-12/31/80)</u>	<u>(9/16/52-12/31/80)</u>
January	21.8	21.6	26.5
February	26.3	25.8	29.0
March	40.5	40.8	38.3
April	49.0	50.3	50.0
May	59.0	60.1	60.0
June	66.3	67.3	67.8
July	70.9	71.3	71.6
August	69.8	69.5	70.4
September	63.4	64.2	64.0
October	49.1	48.9	52.5
November	41.1	40.8	41.9
December	30.6	30.4	31.6
Annual	49.1	49.4	50.4

TABLE 2.3-15

COMPARISON OF ANNUAL AND MONTHLY EXTREME DRY-BULB  
TEMPERATURES (°F) AT THE BVPS SITE  
AND GREATER PITTSBURGH AIRPORT FOR CONCURRENT  
AND LONG-TERM TIME PERIODS

<u>Month</u>	<u>BVPS Site</u> <u>(1/1/76-12/31/80)</u>		<u>Greater Pittsburgh Airport</u> <u>(1/1/76-12/31/80) (9/16/52-12/31/80)</u>			
	<u>Maximum</u>	<u>Minimum</u>	<u>Maximum</u>	<u>Minimum</u>	<u>Maximum</u>	<u>Minimum</u>
January	56	-15	58	-17	68	-18
February	69	-9	68	-12	68	-12
March	79	0	80	-1	80	-1
April	88	18	86	15	87	15
May	89	26	88	30	90	10
June	91	36	92	39	96	34
July	94	45	98	44	99	43
August	90	43	91	42	96	40
September	89	35	90	35	97	33
October	81	22	79	22	85	17
November	75	6	74	0	82	0
December	64	-1	64	-6	83	-6
Annual	94	-15	98	-17	99	-18

TABLE 2.3-16

COMPARISON OF AVERAGE ANNUAL AND MONTHLY DIURNAL  
 DRY BULB TEMPERATURE VARIATIONS (°F) AT THE  
 BVPS SITE AND GREATER PITTSBURGH AIRPORT  
 FOR CONCURRENT AND LONG-TERM PERIODS

<u>Month</u>	BVPS Site	Greater Pittsburgh Airport	
	<u>(1/1/76-12/31/80)</u>	<u>(1/1/76-12/31/80)</u>	<u>(9/16/52-12/31/80)</u>
January	14.1	13.3	14.1
February	16.4	15.6	15.2
March	19.9	18.8	17.4
April	22.7	20.8	20.0
May	23.3	20.9	20.7
June	23.0	20.6	20.4
July	20.4	19.0	19.5
August	18.9	17.5	19.1
September	20.7	19.0	19.7
October	18.7	17.2	19.1
November	16.8	15.3	15.2
December	15.5	15.2	13.2
Annual	19.2	17.8	17.8

TABLE 2.3-17

COMPARISON OF AVERAGE ANNUAL AND MONTHLY  
DEW POINT TEMPERATURES (°F) AT THE  
BVPS SITE AND GREATER PITTSBURGH AIRPORT  
FOR CONCURRENT AND LONG-TERM PERIODS

<u>Month</u>	BVPS Site	Greater Pittsburgh Airport	
	<u>(1/1/76-12/31/80)</u>	<u>(1/1/76-12/31/80)</u>	<u>(9/16/52-12/31/80)</u>
January	14.4	12.8	18.0
February	16.5	15.1	19.4
March	27.9	26.5	26.6
April	36.1	34.4	35.4
May	48.0	45.4	46.1
June	56.8	53.3	55.4
July	63.3	60.2	59.9
August	63.8	61.0	60.0
September	56.5	54.6	53.5
October	41.1	39.1	41.2
November	32.4	30.4	31.9
December	22.2	20.0	23.0
Annual	40.4	37.9	39.3

TABLE 2.3-18

COMPARISON OF AVERAGE ANNUAL AND MONTHLY  
RELATIVE HUMIDITY VALUES (PERCENT) AT  
THE BVPS SITE AND GREATER PITTSBURGH AIRPORT  
FOR CONCURRENT TIME PERIOD (1/1/76 - 12/31/80)

<u>Month</u>	<u>BVPS Site</u>	<u>Greater Pittsburgh Airport</u>
January	72.7	69.2
February	67.2	61.9
March	64.1	59.7
April	65.7	58.3
May	71.6	61.9
June	75.0	63.2
July	79.4	70.1
August	83.0	75.7
September	80.2	73.4
October	76.4	71.1
November	73.5	68.6
December	71.6	66.6
Annual	73.5	66.7

TABLE 2.3-19

COMPARISON OF ANNUAL AND MONTHLY EXTREME DEW POINT  
TEMPERATURES (°F) AT THE BVPS SITE  
AND GREATER PITTSBURGH AIRPORT FOR CONCURRENT  
AND LONG-TERM TIME PERIODS

<u>Month</u>	<u>BVPS Site</u> <u>(1/1/76-12/31/80)</u>		<u>Greater Pittsburgh Airport</u> <u>(1/1/76-12/31/80) (9/16/52-12/31/80)</u>			
	<u>Maximum</u>	<u>Minimum</u>	<u>Maximum</u>	<u>Minimum</u>	<u>Maximum</u>	<u>Minimum</u>
January	55	-22	56	-22	57	-22
February	54	-13	50	-18	57	-20
March	59	-8	58	-9	59	-10
April	65	6	62	6	68	6
May	69	12	70	14	71	14
June	77	32	78	30	78	28
July	79	43	76	39	78	34
August	77	41	76	39	76	37
September	74	32	73	30	75	20
October	64	16	65	15	69	11
November	62	-2	60	-8	63	-10
December	58	-9	60	-17	60	-17
Annual	79	-22	78	-22	78	-22

TABLE 2.3-20

COMPARISON OF AVERAGE ANNUAL AND MONTHLY DIURNAL DEW POINT  
TEMPERATURE VARIATIONS (°F) AT THE BVPS SITE  
AND GREATER PITTSBURGH AIRPORT FOR CONCURRENT  
AND LONG-TERM PERIODS

<u>Month</u>	BVPS Site		Greater Pittsburgh Airport	
	<u>(1/1/76-12/31/80)</u>	<u>(1/1/76-12/31/80)</u>	<u>(9/16/52-12/31/80)</u>	<u>(9/16/52-12/31/80)</u>
January	14.4	14.2	13.7	
February	12.1	12.8	13.6	
March	14.0	14.1	13.4	
April	13.8	13.1	12.9	
May	10.8	10.7	11.7	
June	10.6	9.89	9.42	
July	9.00	8.47	8.48	
August	8.24	7.70	8.20	
September	10.1	9.71	9.38	
October	10.5	10.6	10.6	
November	11.8	11.8	11.5	
December	13.4	14.3	12.4	
Annual	11.6	11.4	11.3	

TABLE 2.3-21

COMPARISON OF AVERAGE ANNUAL AND MONTHLY DIURNAL  
 RELATIVE HUMIDITY VALUE VARIATIONS (PERCENT) AT  
 THE BVPS SITE AND GREATER PITTSBURGH AIRPORT  
 FOR CONCURRENT TIME PERIOD (1/1/76 - 12/31/80)

<u>Month</u>	<u>BVPS Site</u>	<u>Greater Pittsburgh Airport</u>
January	30.1	23.6
February	37.2	25.6
March	45.4	34.9
April	52.3	38.4
May	53.0	39.4
June	51.3	38.6
July	46.8	38.7
August	42.5	35.7
September	46.9	39.3
October	45.3	36.1
November	41.2	31.0
December	34.5	27.4
Annual	44.0	34.1



TABLE 2.3-22

MONTHLY AND ANNUAL BVPS SITE ABSOLUTE  
 HUMIDITY ( $\text{g}/\text{m}^3$ ) SUMMARY (AVERAGE, EXTREMES, AND  
 DIURNAL VARIATION) FOR THE PERIOD 1/1/76 THROUGH  
 12/31/80

<u>Month</u>	<u>Average</u>	<u>Maximum</u>	<u>Minimum</u>	<u>Diurnal Variation</u>
January	2.6	10.5	0.5	1.6
February	3.0	10.8	0.7	1.6
March	4.6	12.8	0.9	2.6
April	6.0	15.7	1.6	3.1
May	9.2	17.8	2.2	3.4
June	12.2	21.7	4.6	4.3
July	15.0	24.3	7.0	4.5
August	15.2	23.1	6.5	4.2
September	12.0	20.8	4.6	4.1
October	7.2	15.1	2.4	2.9
November	5.2	14.2	1.1	2.4
December	3.6	12.0	0.8	2.0
Annual	8.1	24.3	0.5	3.1

TABLE 2.3-23

COMPARISON OF MONTHLY AND ANNUAL PRECIPITATION DATA  
(INCHES) AT THE BVPS SITE  
AND GREATER PITTSBURGH AIRPORT

<u>Month</u>	<u>BVPS Site (1/1/76 - 12/31/80)</u>			<u>Greater Pittsburgh Airport</u>		
	<u>Average</u>	<u>Maximum Monthly</u>	<u>Minimum Monthly</u>	<u>Normal*</u>	<u>Maximum Monthly**</u>	<u>Minimum Monthly**</u>
January	1.19	2.28	0.80	2.79	4.52	1.06
February	0.92	1.92	0.12	2.35	5.98	0.51
March	1.40	2.90	0.84	3.60	6.10	1.14
April	1.19	1.35	1.07	3.40	7.61	0.48
May	1.84	3.53	1.14	3.63	6.36	1.21
June	2.55	3.87	0.87	3.48	5.08	0.90
July	2.81	5.11	0.31	3.84	7.43	1.82
August	3.99	8.02	1.25	3.15	7.56	0.78
September	2.15	3.60	0.66	2.52	5.42	0.74
October	1.79	2.58	0.95	2.52	8.20	0.16
November	1.13	2.87	0.46	2.47	4.70	0.90
December	1.52	3.68	0.41	2.48	4.26	0.40
Annual	22.49	8.02	0.12	36.23	8.20	0.16

NOTES:

\*Data from 1941 to 1970

\*\*Data from 1953 to 1977

TABLE 2.3-24

MONTHLY AND ANNUAL AVERAGE AND EXTREMES  
 OF HOURS WITH PRECIPITATION AT THE  
 BVPS SITE FOR THE PERIOD 1/1/76  
 THROUGH 12/31/80

	<u>Average</u>	<u>Maximum</u>	<u>Minimum</u>
January	38	75	19
February	19	38	2
March	32	65	10
April	36	45	27
May	34	43	16
June	35	49	13
July	34	47	6
August	42	89	26
September	36	59	12
October	45	62	26
November	31	54	15
December	39	70	21
Annual	422	89	2

TABLE 2.3-25

MONTHLY AND ANNUAL MAXIMUM 1-HOUR AND 24-HOUR  
PRECIPITATION VALUES (INCHES) AT THE BVPS SITE  
FOR THE PERIOD 1/1/76 TO 12/31/80

<u>Month</u>	<u>Maximum 1-Hour</u>	<u>24-Hour</u>
January	0.24	0.60
February	0.97	1.00
March	0.30	0.71
April	0.15	0.43
May	0.69	1.13
June	1.47	1.49
July	0.78	1.10
August	1.10	2.39
September	0.58	1.14
October	0.50	1.19
November	0.42	1.32
December	0.20	1.20
Annual	1.47	2.39

TABLE 2.3-26

BVPS MONTHLY  $\Delta T_{150}$  FT-35 FT AND  $\Delta T_{500}$  FT-35 FT  
 STABILITY DISTRIBUTIONS  
 FROM JANUARY 1, 1976 TO DECEMBER 31, 1980  
 (PERCENT)

<u>Month</u>	<u>T</u>						
	<u>A</u>	<u>B</u>	<u>C</u>	<u>D</u>	<u>E</u>	<u>F</u>	<u>G</u>
January							
$\Delta T$ (150 ft)	3.04	1.60	2.72	58.04	21.28	7.06	6.26
$\Delta T$ (500 ft)	0.0	0.0	0.03	79.13	15.69	4.56	0.59
February							
$\Delta T$ (150 ft)	6.40	2.72	3.65	46.11	19.06	8.47	13.59
$\Delta T$ (500 ft)	0.13	0.03	0.63	68.17	20.08	9.99	0.97
March							
$\Delta T$ (150 ft)	14.63	2.37	3.73	36.88	21.15	8.56	12.68
$\Delta T$ (500 ft)	0.09	0.84	2.46	64.02	19.14	0.49	2.97
April							
$\Delta T$ (150 ft)	20.83	2.93	3.33	27.95	17.01	10.11	17.84
$\Delta T$ (500 ft)	0.00	1.18	4.62	54.99	20.55	15.56	3.10
May							
$\Delta T$ (150 ft)	23.60	2.99	4.00	23.82	17.51	11.44	16.65
$\Delta T$ (500 ft)	0.81	2.49	5.48	7.41	2.52	17.31	3.98
June							
$\Delta T$ (150 ft)	29.21	3.18	3.85	19.56	16.29	14.41	13.50
$\Delta T$ (500 ft)	1.60	3.71	7.51	40.78	6.11	19.18	1.12
July							
$\Delta T$ (150 ft)	27.28	2.45	2.60	19.07	19.66	17.85	11.08
$\Delta T$ (500 ft)	1.17	3.45	5.82	43.42	0.02	15.75	0.37
August							
$\Delta T$ (150 ft)	23.88	2.79	2.45	17.87	25.09	19.22	8.72
$\Delta T$ (500 ft)	0.99	2.47	3.83	4.59	34.58	3.52	0.03
September							
$\Delta T$ (150 ft)	21.56	2.32	2.77	18.05	21.80	18.15	14.95
$\Delta T$ (500 ft)	0.84	2.03	4.09	3.13	31.69	7.95	0.27
October							
$\Delta T$ (150 ft)	9.55	2.87	3.75	32.39	22.05	12.48	16.92
$\Delta T$ (500 ft)	0.12	0.53	1.33	54.39	6.80	15.19	1.65

TABLE 2.3-26 (Cont)

<u>Month</u>	<u>T</u>						
	<u>A</u>	<u>B</u>	<u>C</u>	<u>D</u>	<u>E</u>	<u>F</u>	<u>G</u>
November							
$\Delta T$ (150 ft)	5.03	2.03	3.25	44.26	22.10	10.22	13.11
$\Delta T$ (500 ft)	0.0	0.0	0.29	65.56	0.19	11.24	1.72
December							
$\Delta T$ (150 ft)	3.23	1.81	2.48	50.66	22.84	9.03	9.94
$\Delta T$ (500 ft)	0.0	0.0	0.26	68.43	1.82	8.47	1.01
Annual							
$\Delta T$ (150 ft)	15.86	2.51	3.21	32.65	20.51	12.34	12.92
$\Delta T$ (500 ft)	0.49	1.42	3.08	55.82	24.29	13.40	1.49

TABLE 2.3-27

MONTHLY OCCURRENCE SUMMARIES OF INVERSION DURATIONS AT THE BVPS SITE FOR THE PERIOD 1/1/76 THROUGH 12/31/80 (NUMBER OF OCCURRENCES)

<u>Month</u>	<u>Inversion Durations (hr)</u>																			<u>Maximum Inversion Length</u>
	<u>1</u>	<u>2</u>	<u>3</u>	<u>4</u>	<u>5</u>	<u>6</u>	<u>7</u>	<u>8</u>	<u>9</u>	<u>10</u>	<u>11</u>	<u>12</u>	<u>13</u>	<u>14</u>	<u>15</u>	<u>16</u>	<u>17</u>	<u>18</u>	<u>&gt;18</u>	
January	19	6	10	8	9	1	2	1	4	3	3	1	0	0	2	3	1	0	4	24
February	14	12	14	12	4	4	6	5	2	4	5	2	5	3	3	3	4	2	1	21
March	27	11	6	10	6	9	7	3	3	1	3	4	5	9	7	6	1	1	0	18
April	30	18	13	6	7	6	5	4	5	6	8	11	10	13	7	2	1	1	0	18
May	24	13	9	12	5	4	10	3	3	9	13	16	23	7	4	3	0	0	1	22
June	23	16	6	8	6	5	4	3	6	10	22	19	21	3	2	0	0	0	0	15
July	33	14	8	10	5	6	4	8	6	12	22	18	19	6	3	0	0	0	0	15
August	23	13	11	6	8	7	5	2	5	12	8	15	23	16	4	4	0	0	0	16
September	31	17	8	12	10	7	5	4	4	4	7	10	15	14	14	6	0	3	0	18
October	25	15	11	7	10	2	4	6	3	5	6	8	4	6	13	8	6	5	0	18
November	23	21	9	10	8	9	3	4	2	1	5	1	4	2	9	3	2	5	6	20
December	20	10	9	7	2	6	3	3	5	4	4	4	2	1	1	5	2	3	5	22
Total	292	166	114	108	80	66	58	46	48	71	106	109	131	80	69	43	17	20	17	24

TABLE 2.3-28

MONTHLY MEANS OF DAILY MORNING AND DAILY AFTERNOON  
MIXING LEVELS FOR PITTSBURGH FROM 1960 THROUGH 1964  
(METERS)

<u>Month</u>	<u>Morning Mixing Level</u>		<u>Afternoon Mixing Level</u>	
	<u>No Precipitation</u>	<u>Precipitation*</u>	<u>No Precipitation</u>	<u>Precipitation*</u>
January	496	889	787	580
February	343	945	902	641
March	406	1,017	1,366	882
April	390	1,109	1,925	1,196
May	413	801	1,884	1,033
June	340	682	1,801	1,248
July	315	737	1,883	1,260
August	344	800	1,705	1,035
September	333	787	1,532	847
October	380	1,222	1,477	859
November	533	1,083	1,028	635
December	407	981	748	589
Annual	390	**	1,430	**

NOTES:

\*Defined as days on which precipitation occurred for 2 hours or more with light intensity or for 1 hour with moderate or heavy intensity during the hours of 1000 to 2100 LST for the afternoon or during the hours 2200 (previous day) to 0900 LST for the morning.

\*\*Not available.



TABLE 2.3-29

MAXIMUM RELATIVE HUMIDITY INCREASES (RH) DUE TO NATURAL  
DRAFT COOLING TOWER OPERATION FOR BVPS-1 AND BVPS-2

Downwind Sector	Maximum RH Annual Average %	Distance (ft)	Maximum RH Monthly Average %	Distance (ft)	Maximum RH Daily Average (%)	Distance (ft)	Maximum RH Hourly (%)	Distance (ft)
N	0.00008	25,000	0.0003	25,000	0.009	25,000	0.195	25,000
NNE	0.0008	3,000	0.009	2,750	0.074	2,750	1.16	2,750
NE	0.0002	25,000	0.002	17,500	0.036	12,500	0.271	12,250
ENE	0.0003	25,000	0.002	3,250	0.054	3,250	0.950	3,250
E	0.0007	25,000	0.004	25,000	0.083	3,250	1.65	3,250
ESE	0.002	2,750	0.019	2,750	0.200	3,000	2.31	2,750
SE	0.001	3,000	0.017	2,750	0.237	2,750	1.38	2,750
SSE	0.0005	3,500	0.003	3,250	0.073	3,500	1.31	3,500
S	0.002	3,500	0.014	3,500	0.236	3,500	1.26	3,750
SSW	0.0001	24,000	0.0005	22,750	0.016	22,750	0.250	19,750
SW	0.00008	25,000	0.001	7,750	0.022	7,750	0.426	7,750
WSW	0.0001	23,000	0.001	22,750	0.022	17,750	0.225	18,000
W	0.0003	3,000	0.003	3,000	0.111	3,000	1.30	3,250
WNW	0.001	3,250	0.006	3,000	0.178	3,000	1.18	2,750
NW	0.0002	3,250	0.0023	3,250	0.064	3,250	1.12	3,250
NNW	0.0004	3,000	0.0028	2,750	0.080	2,750	1.38	3,000
Worst Sector	0.002 (S) (ESE)	3,500 2,750	0.019 (ESE)	2,750	0.237 (SE)	2,750	2.31 (ESE)	2,750

TABLE 2.3-30

SEASONAL AND ANNUAL FREQUENCIES OF CENTERLINE INTERACTIONS BETWEEN  
BVPS COOLING TOWERS AND BMP STACKS 31 AND 32\* FOR WSW WINDS  
BLOWING FROM THE COOLING TOWERS TOWARD THE STACKS

Stability Class	Average Wind Speed in Class (m/sec)	Frequency of WSW Winds (Number of Hourly Observations)					Centerline Interaction Coordinates**	
		Fall	Winter	Spring	Summer	Annual	Downwind distance (m)	Height Above Ground (m)
A	0.89	0	0	0	0	0	NI***	
	2.46	0	0	0	0	0		
	4.47	0	0	0	1	1		
	6.93	0	0	0	0	0		
	9.61	0	0	0	0	0		
B	0.89	0	0	0	0	0	NI	
	2.46	0	0	0	1	1		
	4.47	0	0	2	1	3		
	6.93	0	0	0	0	0		
	9.61	0	0	0	0	0		
C	0.89	0	0	0	0	0	NI	
	2.46	0	0	1	4	5		
	4.47	1	0	5	11	17		
	6.93	0	0	8	5	13		
	9.61	0	0	1	1	2		
D	0.89	1	3	2	6	12	NI	
	2.46	11	6	17	33	67		
	4.47	43	34	21	48	146		
	6.93	66	55	59	33	213		
	9.61	21	23	16	1	61		
E	0.89	3	2	1	9	15	NI	NI
	2.46	12	6	6	29	53	167	495
	4.47	35	4	12	24	76	239	433
	6.93	19	5	19	6	48	290	395
	9.61	1	7	1	0	9	316	370
F	0.89	11	0	6	11	28	NI	NI
	2.46	20	2	21	25	68	83	418
	4.47	4	5	21	8	38	100	370
	6.93	3	2	0	0	5	96	340
	9.61	0	0	0	0	0	74	320

TABLE 2.3-30 (Cont)

Stability Class	Average Wind Speed in Class (m/sec)	Frequency of WSW Winds (Number of Hourly Observations)					Centerline Interaction Coordinates**	
		Fall	Winter	Spring	Summer	Annual	Downwind distance (m)	Height Above Ground (m)
G	0.89	0	0	0	0	0	56	564
	2.46	1	0	0	0	1	48	379
	4.47	0	0	0	0	0	47	338
	6.93	0	0	0	0	0	30	313
	9.61	0	0	0	0	0	7	296
	Total		252	154	219	257	882	

NOTES:

\*Pennsylvania Power Company Stacks No. 31 and 32 are located at the Bruce Mansfield Plant (BMP).

\*\*Centerline interaction coordinates are presented for all meteorological conditions, regardless of their occurrence or nonoccurrence.

\*\*\*NI - No Interaction.

TABLE 2.3-31

SEASONAL AND ANNUAL FREQUENCIES OF CENTERLINE INTERACTIONS BETWEEN  
 BVPS COOLING TOWERS AND BMP STACKS 31 AND 32\* FOR ENE WINDS  
 BLOWING FROM THE STACKS TOWARD THE COOLING TOWERS

Stability Class	Average Wind Speed in Class (m/sec)	Frequency of ENE Winds (Number of Hourly Observations)					Centerline Interaction Coordinates**	
		Fall	Winter	Spring	Summer	Annual	Downwind Distance (m)	Height Above Ground (m)
A	0.89	0	0	0	0	0	1,072	3,242
	2.46	0	0	0	0	0	1,202	1,358
	4.47	0	0	0	0	0	1,374	877
	6.93	0	0	0	0	0	1,599	669
	9.61	0	0	0	0	0	1,853	563
B	0.89	0	0	0	0	0	1,072	3,242
	2.46	1	0	0	0	1	1,202	1,358
	4.47	1	0	0	3	4	1,374	877
	6.93	0	0	0	0	0	1,599	669
	9.61	0	0	0	0	0	1,853	563
C	0.89	0	0	0	0	0	1,072	3,242
	2.46	0	0	0	2	2	1,202	1,358
	4.47	0	1	0	2	3	1,374	877
	6.93	0	0	0	0	0	1,599	669
	9.61	0	0	0	0	0	1,853	563
D	0.89	3	2	0	7	12	1,072	3,242
	2.46	10	6	9	13	38	1,202	1,358
	4.47	5	2	16	12	35	1,374	877
	6.93	2	1	1	0	4	1,599	669
	9.61	0	0	0	0	0	1,853	563
E	0.89	3	0	0	3	6	93	756
	2.46	10	3	1	4	18	NI***	***
	4.47	11	1	3	6	21	NI	***
	6.93	0	0	0	0	0	NI	***
	9.61	0	0	0	0	0	NI	***
F	0.89	7	3	3	1	14	64	640
	2.46	8	5	6	6	25	NI	NI
	4.47	5	2	8	3	18	NI	NI
	6.93	1	0	0	0	1	NI	NI
	9.61	0	0	0	0	0	NI	NI

TABLE 2.3-31 (Cont)

Stability Class	Average Wind Speed in Class (m/sec)	Frequency of WSW Winds (Number of Hourly Observations)					Centerline Interaction Coordinates**	
		Fall	Winter	Spring	Summer	Annual	Downwind distance (m)	Height Above Ground (m)
G	0.89	0	0	0	0	0	NI	
	2.46	0	0	0	0	0		
	4.47	0	0	0	0	0		
	6.93	0	0	0	0	0		
	9.61	0	0	0	0	0		
	Total	67	26	47	62	202		

NOTES:

\*Pennsylvania Power Company Stacks No. 31 and 32 are located at the Bruce Mansfield Plant (BMP).

\*\*Centerline interaction coordinates are presented for all meteorological conditions, regardless of their occurrence or nonoccurrence.

\*\*\*NI - No Interaction.

TABLE 2.3-32

SEASONAL AND ANNUAL FREQUENCIES OF CENTERLINE INTERACTIONS BETWEEN  
 BVPS COOLING TOWERS AND BMP STACK 36\* FOR WSW WINDS  
 BLOWING FROM THE COOLING TOWERS TOWARD THE STACK

Stability Class	Average Wind Speed in Class (m/sec)	Frequency of WSW Winds (Number of Hourly Observations)					Centerline Interaction Coordinates**	
		Fall	Winter	Spring	Summer	Annual	Downwind Distance (m)	Height Above Ground (m)
A	0.89	0	0	0	0	0	NI***	
	2.46	0	0	0	0	0		
	4.47	0	0	0	1	1		
	6.93	0	0	0	0	0		
	9.61	0	0	0	0	0		
B	0.89	0	0	0	0	0	NI***	
	2.46	0	0	0	1	1		
	4.47	0	0	2	1	3		
	6.93	0	0	0	0	0		
	9.61	0	0	0	0	0		
C	0.89	0	0	0	0	0	NI***	
	2.46	0	0	1	4	5		
	4.47	1	0	5	11	17		
	6.93	0	0	8	5	13		
	9.61	0	0	1	1	2		
D	0.89	1	3	2	6	12	NI***	
	2.46	11	6	17	33	67		
	4.47	43	34	21	48	146		
	6.93	66	55	59	33	213		
	9.61	21	23	16	1	61		
E	0.89	3	2	1	9	15	NI***	NI***
	2.46	12	6	6	29	53	NI***	NI***
	4.47	35	4	12	24	76	273	433
	6.93	19	5	19	6	48	332	395
	9.61	1	7	1	0	9	361	370
F	0.89	11	0	6	11	28	***	***
	2.46	20	2	21	25	68	94	418
	4.47	4	5	21	8	38	114	370
	6.93	3	2	0	0	5	110	340
	9.61	0	0	0	0	0	84	320

TABLE 2.3-32 (Cont)

Stability Class	Average Wind Speed in Class (m/sec)	Frequency of WSW Winds (Number of Hourly Observations)					Centerline Interaction Coordinates**	
		Fall	Winter	Spring	Summer	Annual	Downwind distance (m)	Height Above Ground (m)
G	0.89	0	0	0	0	0	64	564
	2.46	1	0	0	0	1	55	379
	4.47	0	0	0	0	0	53	338
	6.93	0	0	0	0	0	35	313
	9.61	0	0	0	0	0	8	296
	Total		252	154	219	257	882	

NOTES:

\*Pennsylvania Power Company Stack No. 36 is located at the Bruce Mansfield Plant (BMP).

\*\*Centerline interaction coordinates are presented for all meteorological conditions, regardless of their occurrence or nonoccurrence.

\*\*\*NI - No Interaction.

TABLE 2.3-33

SEASONAL AND ANNUAL FREQUENCIES OF CENTERLINE INTERACTIONS BETWEEN  
BVPS COOLING TOWERS AND BMP STACK 36\* FOR ENE WINDS  
BLOWING FROM THE STACK TOWARD THE COOLING TOWERS

Stability Class	Average Wind Speed in Class (m/sec)	Frequency of ENE Winds (Number of Hourly Observations)					Centerline Interaction Coordinates**	
		Fall	Winter	Spring	Summer	Annual	Downwind Distance (m)	Height Above Ground (m)
A	0.89	0	0	0	0	0	854	2,807
	2.46	0	0	0	0	0	974	1,200
	4.47	0	0	0	0	0	1,137	791
	6.93	0	0	0	0	0	1,347	613
	9.61	0	0	0	0	0	1,590	523
B	0.89	0	0	0	0	0	854	2,807
	2.46	1	0	0	0	1	974	1,200
	4.47	1	0	0	3	4	1,137	791
	6.93	0	0	0	0	0	1,347	613
	9.61	0	0	0	0	0	1,590	523
C	0.89	0	0	0	0	0	854	2,807
	2.46	0	0	0	2	2	974	1,200
	4.47	0	1	0	2	3	1,137	791
	6.93	0	0	0	0	0	1,347	613
	9.61	0	0	0	0	0	1,590	523
D	0.89	3	2	0	7	12	854	2,807
	2.46	10	6	9	13	38	974	1,200
	4.47	5	2	16	12	35	1,137	791
	6.93	2	1	1	0	4	1,347	613
	9.61	0	0	0	0	0	1,590	523
E	0.89	3	0	0	3	6	86	726
	2.46	10	3	1	4	18	179	490
	4.47	11	1	3	6	21	NI****	***
	6.93	0	0	0	0	0	***	***
	9.61	0	0	0	0	0	***	***



TABLE 2.3-33 (Cont)

Stability Class	Average Wind Speed in Class (m/sec)	Frequency of ENE Winds (Number of Hourly Observations)					Centerline Interaction Coordinates**	
		Fall	Winter	Spring	Summer	Annual	Downwind Distance (m)	Height Above Ground (m)
F	0.89	7	3	3	1	14	63	618
	2.46	8	5	6	6	25	***	***
	4.47	5	2	8	3	18	***	***
	6.93	1	0	0	0	1	***	***
	9.61	0	0	0	0	0	***	***
G	0.89	0	0	0	0	0	NI***	
	2.46	0	0	0	0	0		
	4.47	0	0	0	0	0		
	6.93	0	0	0	0	0		
	9.61	0	0	0	0	0		
	Total	67	26	47	62	202		

NOTES:

\*Pennsylvania Power Company Stack No. 36 is located at the Bruce Mansfield Plant (BMP).

\*\*Centerline interaction coordinates are presented for all meteorological conditions, regardless of their occurrence or nonoccurrence.

\*\*\*NI - No Interaction.

TABLE 2.3-34

METEOROLOGICAL SYSTEM EQUIPMENT SPECIFICATIONS FOR BVPS

<u>Instrument</u>	<u>Level</u>	<u>Performance Specifications</u>
Wind speeds	35 ft	Threshold < 1 mph
Sensor & processor	150 ft	Accuracy $\pm 0.5$ mph
	500 ft	
Wind directions	35 ft	Threshold 0.7 mph
Sensor & processor	150 ft	Accuracy $\pm 5^\circ$
	500 ft	
Temperatures	35 ft	Accuracy $\pm 0.9^\circ\text{F}$ ( $\pm 0.5^\circ\text{C}$ )
RTD & processor		Range $-20^\circ\text{F}$ to $100^\circ\text{F}$
$\Delta$ Temperatures	150-35 ft	Accuracy $\pm 0.18^\circ\text{F}$ ( $\pm 0.1^\circ\text{C}$ )
RTD & processor	500-35 ft	Range (150-35 ft) = $-8.0$ to $+20.0^\circ\text{F}$
		Range (500-35 ft) = $-8.0$ to $+20.0^\circ\text{F}$
Precipitation	Ground	Accuracy $\pm 2$ percent for 1 in/hr
Data loggers		Indicated Accuracy $\pm 1.0$ percent of full scale
		wd = 0 to $540^\circ$
		ws = 0 to 100 mph
		T = $-20$ to $100^\circ\text{F}$
		$\Delta T$ = $-8.0$ to $+20.0^\circ\text{F}$

TABLE 2.3-35

U.S. NUCLEAR REGULATORY COMMISSION  
ΔT STABILITY CATEGORIES

<u>Stability Category</u>	<u>Range of Vertical Temperature Gradient (°C/100m)</u>
A	$\Delta T < -1.9$
B	$-1.9 \leq \Delta T < -1.7$
C	$-1.7 \leq \Delta T < -1.5$
D	$-1.5 \leq \Delta T < -0.5$
E	$-0.5 \leq \Delta T < 1.5$
F	$1.5 \leq \Delta T < 4.0$
G	$4.0 \leq \Delta T$

TABLE 2.3-36

BVPS MONTHLY AND ANNUAL DATA RECOVERY  
 FOR THE PERIOD FROM  
 JANUARY 1, 1976 TO DECEMBER 31, 1980  
 (PERCENT)

<u>Month</u>	<u>Wind Speed and Wind Direction</u>			<u>Ambient Temperature (35-ft)</u>	<u>Dew Point (35-ft)</u>	<u>T 150 ft</u>	<u>T 500 ft</u>	<u>Precipitation</u>
	<u>35-ft</u>	<u>150-ft</u>	<u>500-ft</u>					
January	93	93	88	90	92	89	89	94
February	99	93	95	90	80	93	93	90
March	97	93	96	91	88	92	93	85
April	95	95	92	95	95	97	95	96
May	93	93	95	92	93	94	93	92
June	95	88	92	93	96	95	92	96
July	94	89	90	89	91	95	95	92
August	96	91	94	89	95	96	97	93
September	97	91	95	89	93	96	96	94
October	94	93	97	89	94	90	93	89
November	94	90	89	93	94	94	95	94
December	96	91	95	90	90	92	85	95
Annual	95	92	94	91	92	94	93	92

TABLE 2.3-37

BVPS MONTHLY AND ANNUAL JOINT  $\Delta T$  AND  
WIND DATA RECOVERY FOR THE PERIOD FROM  
JANUARY 1, 1976 TO DECEMBER 31, 1980  
(PERCENT)

<u>Month</u>	<u><math>\Delta T</math> (150-ft) and 35-ft wind</u>	<u><math>\Delta T</math> (500-ft) and 500-ft wind</u>
January	84	78
February	92	88
March	91	90
April	91	90
May	88	90
June	92	87
July	91	87
August	93	93
September	94	93
October	85	91
November	91	87
December	89	82
Annual	90	88

TABLE 2.3-37A

BVPS MONTHLY AND ANNUAL JOINT  $\Delta T$  AND  
WIND DATA RECOVERY FOR EACH YEAR OF THE PERIOD  
FROM JANUARY 1, 1976 TO DECEMBER 31, 1980

<u>Month</u>	<u><math>\Delta T</math> (150-ft) and 35-ft wind</u>					<u><math>\Delta T</math> (500-ft) and 500-ft wind</u>				
	<u>1976</u>	<u>1977</u>	<u>1978</u>	<u>1979</u>	<u>1980</u>	<u>1976</u>	<u>1977</u>	<u>1978</u>	<u>1979</u>	<u>1980</u>
January	62.8	98.3	77.2	91.0	91.4	40.5	99.3	68.4	90.3	90.5
February	83.9	90.3	97.3	90.9	96.4	73.0	92.0	95.2	86.9	93.8
March	91.5	77.3	92.5	97.6	94.9	87.4	75.7	92.7	98.4	94.5
April	93.9	94.9	90.8	93.5	81.7	87.2	97.8	95.6	73.6	93.9
May	88.2	83.3	86.2	91.5	91.5	90.2	84.0	87.0	96.5	91.1
June	92.6	93.6	86.1	92.5	93.1	74.2	91.0	85.1	91.7	92.6
July	84.1	90.2	94.1	92.5	93.8	69.1	88.6	94.8	92.3	91.4
August	88.0	94.9	91.9	95.7	96.6	90.2	89.8	93.8	92.9	96.6
September	96.5	96.5	91.5	94.2	93.3	95.4	92.2	90.8	93.2	93.3
October	67.1	95.7	91.4	90.7	81.7	88.7	96.1	91.7	92.5	87.5
November	85.8	86.2	94.4	92.8	93.2	67.5	89.4	94.0	91.4	92.5
December	86.2	81.6	92.7	93.8	90.6	83.9	46.9	93.5	92.7	93.8
Annual	85.0	90.2	90.5	93.1	91.5	78.9	86.8	90.2	91.0	92.6

TABLE 2.3-38

0.5 PERCENT SECTOR-DEPENDENT 0- TO 2-HOUR X/Q VALUES  
AT THE EXCLUSION AREA BOUNDARY\*\*

Downwind Sector	Downwind Distance* (meters)	0- to 2-Hour X/Q (x 10 <sup>-3</sup> sec/m <sup>3</sup> )
N	457	0.88
NNE	457	0.50
NE	457	0.33
ENE	457	0.26
E	457	0.24
ESE	490	0.20
SE	550	0.18
SSE	615	0.17
S	695	0.18
SSW	755	0.21
SW	780	0.30
WSW	710	0.49
W	610	0.95
WNW	558	1.40
NW	547	1.44
NNW	547	1.06
Worst (NW)	547	1.44
5% overall site X/Q value		1.10

NOTES:

\*Regulatory Guide 1.145 extended distances.

\*\*0.5 percent sector-dependent 0- to 2-hour X/Q values at the exclusion area boundary recalculated in 1996. See Table 2.3-38b. The values shown above were used in design basis accident radiological consequence analysis performed prior to 10/96, and are shown here for historical purposes.

TABLE 2.3-38A

FIFTY PERCENT SECTOR-DEPENDENT 0- to 2-HOUR X/Q VALUES  
AT THE EXCLUSION AREA BOUNDARY

Downwind Sector	Downwind Distance* (meters)	0- to 2-Hour X/Q (x 10 <sup>-4</sup> sec/m <sup>3</sup> )
N	457	2.88
NNE	457	1.67
NE	457	1.40
ENE	457	1.12
E	457	1.04
ESE	490	0.60
SE	550	0.76
SSE	615	0.07
S	695	0.41
SSW	755	0.04
SW	780	0.86
WSW	710	1.18
W	610	3.21
WNW	558	8.11
NW	547	9.91
NNW	547	5.03
Worst (NW)	547	9.91
50% overall site X/Q value		1.31

**NOTE:**

\*Regulatory Guide 1.145 extended distances.



TABLE 2.3-38B

0.5 PERCENT SECTOR-DEPENDENT 0- to 2-HOUR X/Q VALUES  
AT THE EXCLUSION AREA BOUNDARY

Downwind Sector	Downwind Distance* (meters)	0- to 2-Hour X/Q (x 10 <sup>-3</sup> sec/m <sup>3</sup> )
N	437	0.95
NNE	437	0.58
NE	437	0.37
ENE	437	0.34
E	447	0.30
ESE	478	0.30
SE	545	0.23
SSE	616	0.19
S	690	0.17
SSW	752	0.17
SW	756	0.22
WSW	696	0.32
W	622	0.55
WNW	597	0.83
NW	547	1.25
NNW	547	0.88
Worst (NW)	547	1.25
5% overall site		0.41

\*Regulatory Guide 1.145 Distances

Ref: ERS-SFL-96-021

NOTE:

These data were generated in 1996 using meteorological observations collected between 1/1/86 and 12/31/95. This table is applicable to design basis accident radiological consequence analyses performed subsequent to 10/96.

TABLE 2.3-39

0.5 PERCENT SECTOR-DEPENDENT X/Q VALUES FOR VARIOUS TIME PERIODS  
AT THE LOW POPULATION ZONE OUTER BOUNDARY\*

Downwind Sector	Distance (m)	X/Q (x 10 <sup>-4</sup> sec/m <sup>3</sup> )				
		0-2 Hours	0-8 Hours	8-24 Hours	1-4 Days	4-30 Days
N	5,794	0.56	0.24	0.16	0.06	0.02
NNE	5,794	0.25	0.12	0.08	0.03	0.01
NE	5,794	0.15	0.07	0.05	0.02	0.008
ENE	5,794	0.09	1.15	0.03	0.02	0.006
E	5,794	0.09	0.04	0.03	0.01	0.004
ESE	5,794	0.08	0.04	0.03	0.01	0.003
SE	5,794	0.09	0.04	0.03	0.01	0.004
SSE	5,794	0.10	0.04	0.03	0.01	0.004
S	5,794	0.16	1.15	0.05	0.02	0.006
SSW	5,794	0.22	1.07	0.06	0.03	0.007
SW	5,794	0.38	0.17	0.11	0.05	0.01
WSW	5,794	0.61	0.27	0.18	0.08	0.02
W	5,794	0.98	0.44	0.30	0.12	0.04
WNW	5,794	1.33	0.67	0.48	0.23	0.08
NW	5,794	1.33	0.71	0.52	0.26	0.10
NNW	5,794	0.98	0.45	0.30	0.13	0.04
Worst (NW)	5,794	1.33	0.71	0.52	0.26	0.10
5% overall site X/Q values		0.98	0.32	0.19	0.07	0.02

NOTE:

\* 0.5 percent sector-dependent X/Q values for various time periods at the low population zone outer boundary recalculated in 1996. See Table 2.3-39b. The values shown above were used in design basis accident radiological consequence analyses performed prior to 10/96, and are shown here for historical purposes.

TABLE 2.3-39a

FIFTY PERCENT SECTOR-DEPENDENT X/Q VALUES FOR VARIOUS TIME PERIODS  
AT THE LOW POPULATION ZONE OUTER BOUNDARY

Downwind Sector	Distance (m)	X/Q ( $\times 10^{-5}$ sec/m <sup>3</sup> )				
		0-2 Hours	0-8 Hours	8-24 Hours	1-4 Days	4-30 Days
N	5,794	1.22	0.68	0.51	0.27	0.11
NNE	5,794	0.56	0.33	0.25	0.14	0.06
NE	5,794	0.44	0.26	0.20	0.12	0.05
ENE	5,794	0.29	0.19	0.15	0.09	0.05
E	5,794	0.25	0.15	0.11	0.06	0.03
ESE	5,794	0.09	0.06	0.05	0.03	0.02
SE	5,794	0.24	0.14	0.11	0.06	0.03
SSE	5,794	0.008	0.008	0.008	0.008	0.008
S	5,794	0.10	0.07	0.06	0.04	0.02
SSW	5,794	0.02	0.02	0.02	0.02	0.02
SW	5,794	0.75	0.44	0.33	0.18	0.08
WSW	5,794	0.91	0.56	0.44	0.26	0.12
W	5,794	2.36	1.34	1.01	0.55	0.23
WNW	5,794	6.62	3.75	2.82	1.52	0.63
NW	5,794	8.63	4.92	3.71	2.02	0.84
NNW	5,794	3.76	2.01	1.47	0.74	0.28
Worst (NW)	5,794	8.63	4.92	3.71	2.02	0.84
50% overall site X/Q values		0.61	0.37	0.29	0.18	0.10

TABLE 2.3-39b

0.5 PERCENT SECTOR-DEPENDENT X/Q VALUES FOR VARIOUS TIME PERIODS  
AT THE LOW POPULATION ZONE OUTER BOUNDARY

Downwind Sector	Distance (m)	X/Q (sec/m <sup>3</sup> )				
		0-2 Hours	0-8 Hours	8-24 Hours	1-4 Days	4-30 Days
N	5,794	5.22E-05	2.42E-05	1.64E-05	7.12E-06	2.14E-06
NNE	5,794	2.79E-05	1.33E-05	9.16E-06	4.09E-06	1.29E-06
NE	5,794	1.66E-05	8.16E-06	5.72E-06	2.65E-06	8.76E-07
ENE	5,794	1.40E-05	7.50E-06	5.49E-06	2.80E-06	1.06E-06
E	5,794	1.32E-05	6.52E-06	4.59E-06	2.14E-06	7.17E-07
ESE	5,794	1.28E-05	6.16E-06	4.27E-06	1.93E-06	6.19E-07
SE	5,794	1.45E-05	6.95E-06	4.81E-06	2.17E-06	6.92E-07
SSE	5,794	1.47E-05	6.80E-06	4.62E-06	2.00E-06	5.99E-07
S	5,794	1.64E-05	7.51E-06	5.09E-06	2.18E-06	6.48E-07
SSW	5,794	1.88E-05	8.68E-06	5.90E-06	2.55E-06	7.65E-07
SW	5,794	2.80E-05	1.30E-05	8.83E-06	3.83E-06	1.15E-06
WSW	5,794	4.22E-05	1.99E-05	1.37E-05	6.08E-06	1.89E-06
W	5,794	6.41E-05	3.00E-05	2.06E-05	9.03E-06	2.77E-06
WNW	5,794	9.06E-05	4.58E-05	3.26E-05	1.56E-05	5.38E-06
NW	5,794	1.18E-04	6.04E-05	4.33E-05	2.10E-05	7.44E-06
NNW	5,794	8.32E-05	3.94E-05	2.71E-05	1.21E-05	3.78E-06
Worst (NW)	5,794	1.18E-04	6.04E-05	4.33E-05	2.10E-05	7.44E-06
5% Site Value		6.68E-05	3.77E-05	2.83E-05	1.52E-05	6.23E-06

\*Regulatory Guide 1.145 Distances  
Ref: ERS-SFL-96-021

NOTE:

These data were generated in 1996 using meteorological observations collected between 1/1/86 and 12/31/95. This table is applicable to design basis accident radiological consequence analyses performed subsequent to October 1996.

TABLE 2.3-40

## TERRAIN RECIRCULATION FACTORS FOR GROUND LEVEL RELEASES

Downwind Sector	Distance (miles)								
	<u>0-1</u>	<u>1-2</u>	<u>2-3</u>	<u>3-4</u>	<u>4-5</u>	<u>5-6</u>	<u>6-7</u>	<u>7-8</u>	<u>&gt;8</u>
N	1.3	1.3	1.2	1.1	1.0	1.0	1.0	1.0	1.0
NNE	1.4	1.2	1.2	1.2	1.2	1.1	1.0	1.0	1.0
NE	1.2	1.4	1.4	1.2	1.1	1.0	1.0	1.0	1.0
ENE	1.3	1.5	1.6	1.6	1.3	1.1	1.0	1.0	1.0
E	1.4	1.2	1.2	1.1	1.1	1.0	1.0	1.0	1.0
ESE	1.2	1.3	1.2	1.1	1.0	1.0	1.0	1.0	1.0
SE	1.2	1.3	1.3	1.1	1.1	1.0	1.0	1.0	1.0
SSE	1.3	1.3	1.1	1.0	1.0	1.0	1.0	1.0	1.0
S	1.3	1.1	1.1	1.0	1.0	1.0	1.0	1.0	1.0
SSW	1.3	1.1	1.1	1.1	1.0	1.0	1.0	1.0	1.0
SW	1.1	1.3	1.1	1.1	1.0	1.0	1.0	1.0	1.0
WSW	1.5	1.5	1.5	1.4	1.3	1.0	1.0	1.0	1.0
W	2.0	2.0	1.4	1.4	1.4	1.4	1.2	1.0	1.0
WNW	2.3	2.2	2.1	2.1	1.7	1.5	1.4	1.2	1.0
NW	2.2	2.2	2.1	2.1	1.7	1.6	1.4	1.2	1.0
NNW	1.6	1.6	1.5	1.4	1.3	1.2	1.1	1.0	1.0

TABLE 2.3-41

## DISTANCES OF LIMITING MAXIMUM INDIVIDUAL RECEPTORS TO RELEASE POINTS (METERS) FOR ANNUAL X/Q VALUES

Downwind Sector	Site Boundary <sup>1</sup>		Vegetable Garden <sup>2</sup>		Milk Cow <sup>2</sup>		Milk Goat <sup>2</sup>		Meat Animal <sup>2</sup>		Resident <sup>2</sup>	
	Ground	Elevated	Ground	Elevated	Ground	Elevated	Ground	Elevated	Ground	Elevated	Ground	Elevated
N	579	413	2,623	2,423	-	-	4,651	4,418	4,152	3,919	2,527	2,295
NNE	792	632	2,704	2,461	-	-	6,276	6,033	2,848	2,605	2,639	2,461
NE	442	327	724 <sup>3</sup>	901	7,741	7,526	20,760	20,545	7,741	7,526	708	790
ENE	448	394	1,674	1,658	-	-	6,824	6,671	-	-	708	1,562
E	546	551	1,979	1,922	7,065	6,998	4,265	4,200	4,265	4,200	756	1,922
ESE	607	672	1,577	1,619	-	-	2,865	2,899	1,577	1,619	1,577	1,650
SE	701	815	1,835 <sup>3</sup>	1,961	5,729	5,848	5,729	5,848	3,299	3,420	1,835	1,961
SSE	762	912	1,738	1,933	5,053	5,244	9,977 <sup>4</sup>	10,166	1,770	1,964	1,432	1,628
S	887	1,054	3,138	3,372	3,347	3,539	- <sup>4</sup>	-	2,253	2,487	2,189	2,423
SSW	1,064	1,226	2,317	2,560	3,347	3,590	5,616	5,859	2,317	2,560	1,223	1,466
SW	1,439	1,574	2,221 <sup>3</sup>	2,439	-	-	2,993	3,210	2,414	2,632	2,221	2,439
WSW	561	660	2,301	2,463	5,182	5,341	-	-	2,446	2,608	2,301	2,463
W	640	681	3,556	3,635	5,118	5,195	-	-	4,088	4,166	3,556	3,635
WNW	701	676	3,605	3,590	4,538	4,521	22,529 <sup>4</sup>	22,507	3,605	3,590	3,605	3,590
NW	567	482	1,464	1,415	-	-	10,944	10,832	4,570	4,461	1,432	1,383
NNW	558	420	1,464 <sup>3</sup>	1,285	-	-	15,450	15,262	3,959	3,774	1,143	1,253

NOTES:

<sup>1</sup>Distances from ground releases are measured from the outer edge of the BVPS-2 containment building.

Distances from elevated releases are measured from the BVPS-1 cooling tower.

<sup>2</sup>Distances from ground releases are measured from the centerpoint between the BVPS-1 and BVPS-2 containment buildings.

Distances from elevated releases are measured from the BVPS-1 cooling tower.

<sup>3</sup>These values differ from those presented in ER Table 2.1-3. These vegetable gardens are smaller than the 500-ft<sup>2</sup> criteria used in developing ER Table 2.1-3.

<sup>4</sup>These values differ from those presented in ER Table 2.1-3. Milk goats listed here are those being milked.

The distances listed in the corresponding sectors of ER Table 2.1-3 represent locations of milk goats which are not currently being milked.

TABLE 2.3-42

## RELEASE POINT DESIGN PARAMETERS

<u>Release Point</u>	<u>Type</u>	<u>Efflux Velocity (m/sec)</u>	<u>Diameter (m)</u>	<u>Height Above Grade (m)*</u>
BVPS-1 ventilation vent	Ground	NA**	NA	19.1
BVPS-2 elevated release	Ground	NA	NA	43.7
Process vent	Elevated	9.53	0.25	155.4
BVPS-2 ventilation vent	Ground	NA	NA	19.1
BVPS-1 elevated release	Ground	NA	NA	43.7

NOTE:

\*Building height used to determine wake effect; not actual release height.  
 \*\*NA-Not applicable, since nonbouyant plume rise is not calculated.

TABLE 2.3-43

ANNUAL AVERAGE  $\chi/Q$  VALUES ( $\times 10^7$  SEC/M<sup>3</sup>) FOR BVPS-1 VENTILATION VENT RELEASE

Downwind Sector	Individual Receptors						Population Distances (meters)									
	Site Boundar	Veg. Garden	Milk Cow	Milk Goat	Meat Animal	Residence	805	2,412	4,023	5,633	7,242	12,070	24,140	40,230	56,330	72,420
N	152	15.0	-	5.98	7.06	15.9	92.0	17.1	7.40	4.15	2.63	1.29	.517	.274	.180	.132
NNE	62.3	7.66	-	2.15	7.08	7.95	60.7	9.12	4.20	2.53	1.74	.689	.268	.138	.089	.064
NE	132	57.9	1.24	.269	1.24	60.2	48.5	9.49	4.30	2.19	1.37	.582	.220	.110	.070	.050
ENE	110	13.6	-	1.27	-	50.4	40.4	7.55	3.60	2.11	1.16	.409	.149	.073	.045	.032
E	67.8	6.66	.828	1.99	1.99	38.8	34.8	4.86	2.18	1.18	.797	.334	.123	.060	.038	.027
ESE	38.0	7.64	-	3.20	7.64	7.64	23.5	4.19	1.74	.939	.578	.267	.098	.049	.031	.022
SE	33.3	7.27	1.03	1.03	2.88	7.27	26.3	4.71	2.11	1.05	.712	.297	.109	.054	.034	.024
SSE	29.1	7.41	1.08	.382	7.19	10.1	26.5	4.41	1.68	.909	.618	.287	.108	.054	.034	.024
S	32.8	3.65	3.30	-	6.10	6.38	38.6	5.48	2.48	1.34	.917	.428	.162	.081	.052	.037
SSW	28.7	7.08	4.04	1.85	7.08	22.9	45.0	6.66	3.06	1.84	1.15	.545	.211	.108	.070	.050
SW	26.2	15.7	-	9.98	13.8	15.7	66.3	13.9	5.40	3.26	2.04	.968	.377	.194	.126	.091
WSW	201	22.4	6.23	-	20.4	22.4	115	20.8	9.70	5.51	3.55	1.32	.521	.272	.178	.129
W	345	18.0	10.6	-	14.7	18.0	244	45.7	15.1	9.27	6.48	2.28	.922	.489	.322	.236
WNW	598	48.6	35.0	1.92	48.6	48.6	489	91.3	41.5	25.7	14.6	5.16	1.77	.953	.636	.470
NW	1,030	262	-	9.52	47.8	271	632	125	57.2	35.5	20.2	7.17	2.46	1.34	.897	.665
NNW	345	83.4	-	1.84	18.1	121	204	39.6	17.7	10.2	6.66	2.55	1.05	.565	.377	.278



TABLE 2.3-44

GRAZING SEASON AVERAGE  $\chi/Q$  VALUES ( $\times 10^7$  SEC/M<sup>3</sup>) FOR BVPS-1 VENTILATION VENT RELEASE

Downwind Sector	Individual Receptors						Population Distances (meters)									
	Site Boundar	Veg. Garden	Milk Cow	Milk Goat	Meat Animal	Residence	805	2,412	4,023	5,633	7,242	12,070	24,140	40,230	56,330	72,420
N	186	18.2	-	7.21	8.52	19.2	112	20.6	8.92	5.00	3.17	1.54	.619	.326	.214	.156
NNE	67.7	8.24	-	2.32	7.26	8.55	65.9	9.82	4.52	2.72	1.87	.741	.288	.148	.096	.069
NE	122	52.6	1.09	.234	1.09	54.6	43.9	8.38	3.78	1.93	1.20	.507	.191	.096	.061	.043
ENE	86.6	10.1	-	.937	-	38.6	30.8	5.58	2.65	1.56	.854	.301	.110	.054	.034	.024
E	57.8	5.66	.722	1.71	1.71	33.1	29.7	4.14	1.87	1.02	.695	.295	.111	.056	.035	.025
ESE	29.8	5.84	-	2.44	5.84	5.84	18.3	3.19	1.32	.717	.442	.204	.076	.037	.024	.017
SE	25.9	5.59	.795	.795	2.22	5.59	20.4	3.62	1.63	.816	.554	.232	.087	.043	.027	.019
SSE	31.3	7.82	1.13	.398	7.59	10.7	28.4	4.64	1.77	.952	.647	.299	.112	.056	.035	.025
S	38.7	4.31	3.91	-	7.19	7.53	45.5	6.47	2.95	1.60	1.10	.517	.197	.100	.064	.046
SSW	27.9	6.81	3.88	1.77	6.81	22.2	44.0	6.40	2.93	1.76	1.10	.521	.201	.102	.066	.047
SW	23.6	14.1	-	8.96	12.4	14.1	60.2	12.5	4.85	2.92	1.83	.864	.336	.172	.111	.080
WSW	183	20.4	5.70	-	18.6	20.4	105	19.0	8.86	5.04	3.25	1.21	.482	.252	.165	.120
W	405	20.9	12.3	-	17.1	20.9	286	53.0	17.5	10.7	7.51	2.64	1.07	.563	.370	.270
WNW	840	67.8	48.7	2.67	67.8	67.8	687	127	57.9	35.9	20.4	7.18	2.45	1.32	.879	.649
NW	1,340	338	-	12.2	61.3	349	819	161	73.5	45.6	26.0	9.18	3.15	1.71	1.14	.843
NNW	395	93.5	-	2.03	20.1	136	231	44.2	19.6	11.3	7.37	2.81	1.15	.614	.407	.300

TABLE 2.3-45

ANNUAL AVERAGE D/Q VALUES (X 10<sup>9</sup> M<sup>-2</sup>) FOR BVPS-1 VENTILATION VENT RELEASE

Downwind Sector	Individual Receptors						Population Distances (meters)									
	Site Boundar	Veg. Garden	Milk Cow	Milk Goat	Meat Animal	Residence	805	2,412	4,023	5,633	7,242	12,070	24,140	40,230	56,330	72,420
N	25.4	2.05	-	.693	.847	2.19	15.0	2.37	.895	.452	.262	.106	.034	.014	.007	.005
NNE	18.8	2.02	-	.459	1.85	2.11	18.3	2.47	1.01	.556	.355	.120	.038	.015	.008	.005
NE	63.4	29.3	.455	.078	.455	30.4	24.7	4.54	1.86	.878	.513	.189	.060	.024	.013	.008
ENE	65.9	8.92	-	.661	-	32.2	26.2	4.76	2.08	1.15	.594	.185	.059	.024	.013	.008
E	38.0	3.90	.382	1.02	1.02	22.7	20.5	2.77	1.13	.573	.365	.135	.043	.017	.009	.006
ESE	17.1	3.56	-	1.38	3.56	3.56	10.9	1.86	.703	.355	.206	.084	.027	.011	.006	.004
SE	13.8	3.03	.350	.350	1.10	3.03	11.1	1.89	.774	.361	.230	.085	.027	.011	.006	.004
SSE	10.5	2.65	.317	.094	2.57	3.68	9.57	1.51	.522	.261	.167	.068	.021	.009	.005	.003
S	10.6	1.05	.934	-	1.86	1.95	12.4	1.65	.677	.339	.216	.088	.028	.011	.006	.004
SSW	5.59	1.26	.663	.266	1.26	4.42	8.80	1.17	.480	.265	.153	.062	.020	.008	.004	.003
SW	3.94	2.21	-	1.32	1.92	2.21	10.3	1.92	.665	.366	.213	.086	.027	.011	.006	.004
WSW	27.5	2.65	.596	-	2.38	2.65	15.5	2.44	.999	.514	.304	.095	.030	.012	.007	.004
W	31.6	1.23	.645	-	.960	1.23	21.9	3.45	.988	.544	.347	.101	.032	.013	.007	.004
WNW	39.1	2.23	1.49	.045	2.23	2.23	31.3	4.71	1.84	1.01	.524	.150	.040	.016	.009	.005
NW	70.6	15.0	-	.276	1.99	15.6	40.4	6.37	2.49	1.37	.708	.203	.054	.022	.012	.007
NNW	31.5	6.52	-	.068	1.09	9.91	17.6	2.77	1.06	.547	.324	.101	.032	.013	.007	.004

TABLE 2.3-46

GRAZING SEASON AVERAGE D/Q VALUES (X 10<sup>9</sup> M<sup>-2</sup>) FOR BVPS-1 VENTILATION VENT RELEASE

Downwind Sector	Individual Receptors						Population Distances (meters)									
	Site Boundar	Veg. Garden	Milk Cow	Milk Goat	Meat Animal	Residence	805	2,412	4,023	5,633	7,242	12,070	24,140	40,230	56,330	72,420
N	30.3	2.44	-	.825	1.01	2.60	17.9	2.82	1.07	.538	.312	.126	.040	.016	.009	.005
NNE	19.8	2.14	-	.485	1.96	2.23	19.3	2.61	1.07	.589	.376	.127	.040	.016	.009	.005
NE	60.5	28.0	.435	.074	.435	29.0	23.6	4.33	1.77	.838	.490	.181	.057	.023	.013	.008
ENE	52.5	7.11	-	.527	-	25.7	20.9	3.80	1.66	.914	.474	.148	.047	.019	.010	.006
E	27.7	2.84	.279	.747	.747	16.6	15.0	2.02	.828	.418	.267	.098	.031	.013	.007	.004
ESE	12.8	2.66	-	1.03	2.66	2.66	8.14	1.39	.525	.265	.154	.062	.020	.008	.004	.003
SE	10.2	2.24	.259	.259	.811	2.24	8.19	1.40	.572	.267	.170	.063	.020	.008	.004	.003
SSE	11.9	3.02	.363	.107	2.93	4.21	10.9	1.72	.597	.299	.191	.077	.025	.010	.005	.003
S	12.7	1.26	1.12	-	2.24	2.35	14.9	1.99	.815	.408	.260	.105	.034	.014	.007	.005
SSW	5.45	1.23	.647	.259	1.23	4.31	8.58	1.14	.468	.258	.150	.061	.019	.008	.004	.003
SW	3.26	1.83	-	1.09	1.59	1.83	8.53	1.59	.550	.303	.176	.071	.023	.009	.005	.003
WSW	21.0	2.02	.454	-	1.82	2.02	11.8	1.86	.762	.392	.232	.072	.023	.009	.005	.003
W	33.6	1.31	.687	-	1.02	1.31	23.3	3.67	1.05	.579	.370	.107	.034	.014	.007	.005
WNW	52.5	3.00	2.00	.060	3.00	3.00	42.0	6.33	2.47	1.36	.704	.201	.053	.022	.012	.007
NW	89.4	19.0	-	.350	2.52	19.7	51.2	8.06	3.15	1.74	.897	.257	.068	.028	.015	.009
NNW	36.5	7.55	-	.079	1.27	11.5	20.4	3.21	1.23	.633	.375	.117	.037	.015	.008	.005

TABLE 2.3-47

ANNUAL AVERAGE  $\chi/Q$  VALUES (X  $10^7$  SEC/M<sup>3</sup>) FOR BVPS-2 ELEVATED RELEASE

Downwind Sector	Individual Receptors						Population Distances (meters)									
	Site Boundar	Veg. Garden	Milk Cow	Milk Goat	Meat Animal	Residence	805	2,412	4,023	5,633	7,242	12,070	24,140	40,230	56,330	72,420
N	125	12.8	-	5.36	6.27	13.5	72.4	14.4	6.55	3.77	2.42	1.21	.495	.263	.174	.128
NNE	50.2	6.92	-	2.04	6.42	7.16	48.9	8.16	3.89	2.38	1.66	.664	.261	.135	.087	.063
NE	102	47.4	1.20	.265	1.20	49.1	40.1	8.75	4.08	2.11	1.33	.568	.216	.109	.069	.050
ENE	85.8	12.5	-	1.24	-	42.2	34.4	7.12	3.47	2.05	1.13	.403	.147	.072	.045	.032
E	54.5	6.16	.807	1.91	1.91	32.6	29.5	4.56	2.09	1.14	.777	.328	.121	.060	.038	.027
ESE	31.1	6.92	-	3.01	6.92	6.92	20.0	3.91	1.66	.907	.562	.261	.097	.048	.030	.021
SE	27.8	6.70	.994	.994	2.74	6.70	22.4	4.41	2.03	1.02	.694	.292	.108	.053	.033	.024
SSE	24.1	6.68	1.03	.372	6.50	9.01	22.1	4.08	1.60	.874	.598	.281	.106	.053	.034	.024
S	27.5	3.40	3.09	-	5.57	5.81	32.1	5.03	2.35	1.29	.883	.417	.158	.080	.051	.037
SSW	23.8	6.31	3.70	1.74	6.31	19.3	36.5	5.95	2.83	1.73	1.09	.525	.205	.106	.068	.049
SW	22.3	13.9	-	9.05	12.3	13.9	53.5	12.4	4.99	3.06	1.93	.931	.366	.189	.123	.089
WSW	163	19.3	5.72	-	17.7	19.3	91.2	18.0	8.77	5.08	3.31	1.25	.503	.264	.173	.126
W	278	15.7	9.54	-	13.0	15.7	189.0	38.0	13.3	8.37	5.94	2.14	.880	.470	.311	.228
WNW	487	40.7	30.1	1.81	40.7	40.7	384.0	72.4	35.2	22.6	13.1	4.75	1.66	.905	.606	.450
NW	924	194	-	8.66	40.5	200	501.0	97.4	47.8	30.8	17.9	6.55	2.31	1.27	.852	.634
NNW	302	63.0	-	1.72	15.4	92.3	161.0	31.5	15.0	8.98	5.97	2.35	.987	.537	.359	.266

TABLE 2.3-48

GRAZING SEASON AVERAGE  $\chi/Q$  VALUES ( $\times 10^7 \text{ SEC/M}^3$ ) FOR BVPS-2 ELEVATED RELEASE

Downwind Sector	Individual Receptors						Population Distances (meters)									
	Site Boundar	Veg. Garden	Milk Cow	Milk Goat	Meat Animal	Residence	805	2,412	4,023	5,633	7,242	12,070	24,140	40,230	56,330	72,420
N	151	15.6	-	6.51	7.63	16.4	87.9	17.5	7.97	4.57	2.94	1.46	.594	.315	.207	.152
NNE	54.3	7.46	-	2.20	6.92	7.73	52.9	8.80	4.19	2.57	1.79	.715	.281	.145	.094	.068
NE	94.2	43.3	1.06	.231	1.06	44.9	36.5	7.78	3.61	1.86	1.17	.497	.188	.095	.060	.043
ENE	68.3	9.30	-	.915	-	32.7	26.5	5.26	2.56	1.51	.835	.296	.109	.054	.034	.024
E	46.7	5.14	.697	1.62	1.62	27.5	24.8	3.82	1.77	.978	.671	.287	.109	.055	.035	.025
ESE	24.3	5.30	-	2.30	5.30	5.30	15.5	2.99	1.27	.693	.430	.200	.075	.037	.023	.017
SE	21.4	5.12	.769	.769	2.11	5.12	17.2	3.38	1.56	.789	.539	.228	.085	.043	.027	.019
SSE	26.0	7.12	1.09	.390	6.93	9.61	23.8	4.33	1.69	.921	.630	.294	.110	.055	.035	.025
S	32.2	3.97	3.61	-	6.48	6.76	37.7	5.85	2.75	1.52	1.05	.499	.192	.098	.063	.045
SSW	23.2	6.15	3.59	1.68	6.15	18.8	35.4	5.80	2.74	1.67	1.05	.505	.196	.100	.065	.046
SW	20.2	12.6	-	8.19	11.2	12.6	48.3	11.2	4.51	2.76	1.74	.836	.328	.169	.109	.079
WSW	147	17.5	5.23	-	16.1	17.5	82.2	16.4	8.00	4.65	3.04	1.15	.464	.244	.160	.117
W	320	18.3	11.1	-	15.2	18.3	218.0	44.6	15.5	9.77	6.93	2.49	1.02	.543	.358	.262
WNW	678	57.1	42.1	2.52	57.1	57.1	535.0	102.0	49.4	31.6	18.3	6.63	2.32	1.26	.841	.622
NW	1,190	251	-	11.1	52.3	260	643.0	126.0	61.8	39.7	23.1	8.42	2.96	1.62	1.09	.806
NNW	336	71.8	-	1.90	17.3	104	180.0	35.9	17.0	10.1	6.68	2.61	1.09	.587	.391	.288

TABLE 2.3-49

ANNUAL AVERAGE D/Q VALUES (X 10<sup>9</sup> M<sup>-2</sup>) FOR BVPS-2 ELEVATED RELEASE

Downwind Sector	Individual Receptors						Population Distances (meters)									
	Site Boundar	Veg. Garden	Milk Cow	Milk Goat	Meat Animal	Residence	805	2,412	4,023	5,633	7,242	12,070	24,140	40,230	56,330	72,420
N	25.4	2.05	-	.693	.847	2.19	15.0	2.37	.895	.452	.262	.106	.034	.014	.007	.005
NNE	18.8	2.02	-	.459	1.85	2.11	18.3	2.47	1.01	.556	.355	.120	.038	.015	.008	.005
NE	63.4	29.3	.455	.078	.455	30.4	24.7	4.54	1.86	.878	.513	.189	.060	.024	.013	.008
ENE	65.9	8.92	-	.661	-	32.2	26.2	4.76	2.08	1.15	.594	.185	.059	.024	.013	.008
E	38.0	3.90	.382	1.02	1.02	22.7	20.5	2.77	1.13	.573	.365	.135	.043	.017	.009	.006
ESE	17.1	3.56	-	1.38	3.56	3.56	10.9	1.86	.703	.355	.206	.084	.027	.011	.006	.004
SE	13.8	3.03	.350	.350	1.10	3.03	11.1	1.89	.774	.361	.230	.085	.027	.011	.006	.004
SSE	10.5	2.65	.317	.094	2.57	3.68	9.57	1.51	.522	.261	.167	.068	.021	.009	.005	.003
S	10.6	1.05	.934	-	1.86	1.95	12.4	1.65	.677	.339	.216	.088	.028	.011	.006	.004
SSW	5.59	1.26	.663	.266	1.26	4.42	8.80	1.17	.480	.265	.153	.062	.020	.008	.004	.003
SW	3.94	2.21	-	1.32	1.92	2.21	10.3	1.92	.665	.366	.213	.086	.027	.011	.006	.004
WSW	27.5	2.65	.596	-	2.38	2.65	15.5	2.44	.999	.514	.304	.095	.030	.012	.007	.004
W	31.6	1.23	.645	-	.960	1.23	21.9	3.45	.988	.544	.347	.101	.032	.013	.007	.004
WNW	39.1	2.23	1.49	.045	2.23	2.23	31.3	4.71	1.84	1.01	.524	.150	.040	.016	.009	.005
NW	70.6	15.0	-	.276	1.99	15.6	40.4	6.37	2.49	1.37	.708	.203	.054	.022	.012	.007
NNW	31.5	6.52	-	.068	1.09	9.91	17.6	2.77	1.06	.547	.324	.101	.032	.013	.007	.004

TABLE 2.3-50

GRAZING SEASON AVERAGE D/Q VALUES (X 10<sup>9</sup> M<sup>-2</sup>) FOR BVPS-2 ELEVATED RELEASE

Downwind Sector	Individual Receptors						Population Distances (meters)									
	Site Boundar	Veg. Garden	Milk Cow	Milk Goat	Meat Animal	Residence	805	2,412	4,023	5,633	7,242	12,070	24,140	40,230	56,330	72,420
N	30.3	2.44	-	.825	1.01	2.60	17.9	2.82	1.07	.538	.312	.126	.040	.016	.009	.005
NNE	19.8	2.14	-	.485	1.96	2.23	19.3	2.61	1.07	.589	.376	.127	.040	.016	.009	.005
NE	60.5	28.0	.435	.074	.435	29.0	23.6	4.33	1.77	.838	.490	.181	.057	.023	.013	.008
ENE	52.2	7.11	-	.527	-	25.7	20.9	3.80	1.66	.914	.474	.148	.047	.019	.010	.006
E	27.7	2.84	.279	.747	.747	16.6	15.0	2.02	.828	.418	.267	.098	.031	.013	.007	.004
ESE	12.8	2.66	-	1.03	2.66	2.66	8.14	1.39	.525	.265	.154	.062	.020	.008	.004	.003
SE	10.2	2.24	.259	.259	.811	2.24	8.19	1.40	.572	.267	.170	.063	.020	.008	.004	.003
SSE	11.9	3.02	.363	.107	2.93	4.21	10.9	1.72	.597	.299	.191	.077	.025	.010	.005	.003
S	12.7	1.26	1.12	-	2.24	2.35	14.9	1.99	.815	.408	.260	.105	.034	.014	.007	.005
SSW	5.45	1.23	.647	.259	1.23	4.31	8.58	1.14	.468	.258	.150	.061	.019	.008	.004	.003
SW	3.26	1.83	-	1.09	1.59	1.83	8.53	1.59	.550	.303	.176	.071	.023	.009	.005	.003
WSW	21.0	2.02	.454	-	1.82	2.02	11.8	1.86	.762	.392	.232	.072	.023	.009	.005	.003
W	33.6	1.31	.687	-	1.02	1.31	23.3	3.67	1.05	.579	.370	.107	.034	.014	.007	.005
WNW	52.5	3.00	2.00	.060	3.00	3.00	42.0	6.33	2.47	1.36	.704	.201	.053	.022	.012	.007
NW	89.4	19.0	-	.350	2.52	19.7	51.2	8.06	3.15	1.74	.897	.257	.068	.028	.015	.009
NNW	36.5	7.55	-	.079	1.27	11.5	20.4	3.21	1.23	.633	.375	.117	.037	.015	.008	.005

TABLE 2.3-51

ANNUAL AVERAGE  $\chi/Q$  VALUES ( $\times 10^7$  SEC/M<sup>3</sup>) FOR PROCESS VENT RELEASE

Downwind Sector	Individual Receptors						Population Distances (meters)									
	Site Boundar	Veg. Garden	Milk Cow	Milk Goat	Meat Animal	Residence	805	2,412	4,023	5,633	7,242	12,070	24,140	40,230	56,330	72,420
N	.031	6.72	-	1.91	2.27	6.79	.053	6.31	2.18	1.33	.915	.437	.170	.087	.055	.041
NNE	.029	6.69	-	1.43	6.14	6.69	.034	5.54	2.82	1.58	1.19	.518	.201	.093	.060	.043
NE	.002	.074	1.61	.350	1.61	.055	.057	.299	4.58	2.58	1.72	.743	.282	.096	.084	.060
ENE	.010	9.09	-	1.77	-	.525	.073	5.83	4.03	2.35	1.57	.597	.227	.114	.073	.052
E	.021	8.30	1.24	2.87	2.87	8.30	.055	6.29	3.13	1.96	1.18	.629	.239	.120	.076	.054
ESE	.069	11.6	-	4.57	11.6	11.2	.090	6.10	2.55	1.22	.764	.375	.142	.071	.045	.032
SE	6.77	7.89	1.23	1.23	3.05	7.89	2.07	5.67	2.37	1.31	.744	.245	.133	.066	.042	.030
SSE	9.88	7.39	1.16	.357	7.20	9.77	1.14	5.19	2.19	1.04	.592	.278	.098	.052	.033	.021
S	5.01	3.76	3.49	-	6.06	6.31	.472	6.36	2.86	1.23	.710	.261	.114	.057	.036	.026
SSW	7.09	3.61	2.14	.872	3.61	5.82	14.7	3.16	1.80	.925	.741	.203	.097	.049	.032	.023
SW	8.45	3.90	-	2.56	3.47	3.90	21.0	3.75	1.53	1.09	1.06	.291	.123	.069	.045	.033
WSW	.980	4.35	1.42	-	3.98	4.35	1.39	3.80	2.03	1.31	.845	.403	.156	.080	.051	.037
W	.029	2.49	.746	-	2.02	2.49	.032	4.68	2.13	.685	.787	.266	.163	.083	.054	.034
WNW	.034	2.53	1.78	.163	2.53	2.53	.034	.102	2.13	1.00	.731	.254	.149	.063	.040	.029
NW	.013	.074	-	.305	1.67	.073	.032	.141	1.96	1.08	.739	.266	.126	.064	.041	.027
NNW	.015	6.46	-	.224	1.81	6.59	.036	3.77	1.65	.941	.649	.273	.121	.062	.039	.029



TABLE 2.3-52

GRAZING SEASON AVERAGE  $\chi/Q$  VALUES ( $\times 10^7$  SEC/M<sup>3</sup>) FOR PROCESS VENT RELEASE

Downwind Sector	Individual Receptors						Population Distances (meters)									
	Site Boundar	Veg. Garden	Milk Cow	Milk Goat	Meat Animal	Residence	805	2,412	4,023	5,633	7,242	12,070	24,140	40,230	56,330	72,420
N	.060	7.98	-	2.27	2.69	8.03	.103	7.45	2.59	1.58	1.09	.518	.202	.104	.065	.048
NNE	.056	8.03	-	1.72	7.38	8.03	.066	6.72	3.39	1.90	1.43	.622	.241	.112	.072	.052
NE	.004	.139	1.92	.421	1.92	.104	.107	.344	5.47	3.09	2.06	.891	.340	.117	.101	.073
ENE	.020	10.3	-	2.10	-	.586	.134	6.73	4.75	2.77	1.86	.709	.272	.137	.088	.063
E	.036	9.18	1.45	3.35	3.35	9.18	.082	7.06	3.66	2.31	1.38	.751	.289	.146	.094	.067
ESE	.112	13.6	-	5.39	13.6	13.2	.141	7.19	3.02	1.44	.908	.452	.173	.088	.056	.040
SE	6.36	9.36	1.48	1.48	3.63	9.36	1.97	6.73	2.83	1.57	.897	.278	.164	.083	.053	.038
SSE	10.7	8.92	1.41	.439	8.70	11.8	1.30	6.27	2.65	1.27	.724	.343	.121	.066	.042	.026
S	5.60	4.74	4.40	-	7.62	7.94	.640	7.99	3.61	1.56	.901	.328	.147	.074	.047	.034
SSW	9.02	4.71	2.80	1.14	4.71	7.46	18.6	4.11	2.35	1.21	.974	.268	.128	.065	.042	.030
SW	9.65	4.51	-	2.96	4.01	4.51	23.5	4.34	1.77	1.27	1.23	.339	.145	.081	.054	.039
WSW	.990	4.84	1.58	-	4.43	4.84	1.28	4.20	2.25	1.46	.948	.454	.177	.091	.058	.042
W	.050	2.88	.792	-	2.34	2.88	.054	5.40	2.47	.733	.908	.296	.195	.100	.064	.041
WNW	.056	2.71	1.91	.176	2.71	2.71	.051	.092	2.28	1.07	.781	.269	.161	.068	.044	.032
NW	.022	.102	-	.329	1.86	.101	.049	.152	2.18	1.20	.824	.288	.141	.073	.047	.030
NNW	.030	7.10	-	.260	2.09	7.23	.069	4.35	1.90	1.09	.751	.315	.141	.072	.046	.034

TABLE 2.3-53  
ANNUAL AVERAGE D/Q VALUES (X 10<sup>9</sup> M<sup>-2</sup>) FOR PROCESS VENT RELEASE

Downwind Sector	Individual Receptors						Population Distances (meters)									
	Site Boundar	Veg. Garden	Milk Cow	Milk Goat	Meat Animal	Residence	805	2,412	4,023	5,633	7,242	12,070	24,140	40,230	56,330	72,420
N	.600	*2.34	-	.572	.707	2.51	.550	2.30	.675	.372	.237	.096	.031	.012	.007	.004
NNE	.673	3.22	-	.524	2.92	3.22	.690	1.46	1.11	.592	.412	.153	.049	.018	.010	.006
NE	.766	1.28	.660	.111	.660	1.20	1.21	1.18	2.18	1.08	.708	.263	.085	.016	.017	.010
ENE	1.01	5.08	-	.702	-	1.76	1.25	2.71	1.92	1.06	.611	.197	.067	.027	.015	.009
E	1.37	4.42	.401	1.29	1.29	4.42	1.45	3.01	1.59	.886	.381	.229	.073	.030	.016	.010
ESE	.984	6.39	-	2.34	6.39	6.18	.998	3.22	1.22	.497	.295	.134	.043	.017	.009	.006
SE	11.0	3.68	.466	.466	1.30	3.68	3.24	2.57	.979	.498	.265	.072	.034	.014	.007	.005
SSE	7.06	3.22	.423	.105	3.14	4.32	2.45	2.20	.845	.372	.198	.080	.026	.010	.006	.003
S	5.78	1.54	1.41	-	2.61	2.73	.952	2.75	1.13	.448	.242	.076	.028	.012	.006	.004
SSW	2.04	1.04	.578	.208	1.04	1.46	5.48	.577	.473	.224	.166	.042	.015	.006	.003	.002
SW	1.61	1.12	-	.693	.979	1.12	7.22	1.14	.218	.140	.230	.058	.026	.011	.005	.003
WSW	1.71	1.31	.370	-	1.19	1.31	1.67	1.00	.453	.336	.196	.079	.025	.010	.005	.003
W	.377	.659	.138	-	.518	.659	.382	1.35	.551	.121	.106	.033	.025	.010	.005	.004
WNW	.424	.746	.497	.029	.746	.746	4.12	.267	.611	.172	.106	.033	.026	.009	.005	.003
NW	.447	.425	-	.070	.488	.422	.409	.247	.585	.295	.188	.064	.022	.009	.005	.004
NNW	.340	1.84	-	.043	.545	1.92	.318	1.19	.487	.245	.156	.056	.020	.008	.004	.003

NOTE:

\*Distance of 2391 differs from  $\chi/Q$  distance.

TABLE 2.3-54

GRAZING SEASON AVERAGE D/Q VALUES (X 10<sup>9</sup> M<sup>-2</sup>) FOR PROCESS VENT RELEASE

Downwind Sector	Individual Receptors						Population Distances (meters)									
	Site Boundar	Veg. Garden	Milk Cow	Milk Goat	Meat Animal	Residence	805	2,412	4,023	5,633	7,242	12,070	24,140	40,230	56,330	72,420
N	1.14	2.62*	-	.643	.794	2.82	.944	2.58	.758	.418	.266	.108	.034	.014	.008	.005
NNE	1.15	3.68	-	.599	3.34	3.68	1.09	1.59	1.24	.677	.471	.175	.056	.021	.011	.007
NE	1.40	1.77**	.708	.120	.708	1.77	1.77	1.21	2.34	1.12	.760	.282	.091	.016	.018	.011
ENE	1.74	4.16	-	.617	-	1.90****	1.73	2.22	1.80	.990	.540	.186	.063	.025	.014	.008
E	1.69	2.90	.291	.955	.955	2.90	1.56	1.98	1.31	.743	.280	.192	.061	.025	.013	.008
ESE	1.27	5.63	-	2.07	5.63	5.45	1.20	2.84	1.08	.394	.239	.118	.038	.015	.008	.005
SE	9.23	3.51	.445	.445	1.24	3.51	3.06	2.46	.935	.475	.253	.060	.033	.013	.007	.004
SSE	7.44	3.62	.475	.118	3.52	4.86	2.77	2.47	.950	.418	.222	.090	.031	.012	.006	.003
S	6.03	1.78	1.63	-	3.02	3.16	1.33	3.18	1.30	.519	.280	.088	.033	.013	.007	.004
SSW	2.20	1.26	.699	.252	1.26	1.58	6.35	.622	.572	2.70	.201	.051	.019	.007	.004	.003
SW	1.39	1.19	-	.739	1.04	1.19	7.08	1.21	.189	.127	.245	.062	.030	.013	.005	.003
WSW	1.73	1.26	.355	-	1.14	1.26	1.58	.838	.381	.323	.188	.076	.024	.010	.005	.003
W	.498	.604	.103	-	.475	.604	.472	1.23	.506	.091	.088	.025	.023	.009	.005	.004
WNW	.517	.656	.437	.025	.656	.656	.482	.226	.537	.134	.088	.026	.022	.008	.004	.003
NW	.648	.478***	-	.068	.485	.479*****	.551	.252	.582	.294	.188	.063	.022	.009	.005	.004
NNW	.635	1.83	-	.045	.559	1.91	.524	1.23	.500	.251	.160	.058	.021	.008	.005	.003

NOTES:

- \* Distance of 2,391m differs from annual  $\chi/Q$  distance.
- \*\* Distance of 790m differs from annual  $\chi/Q$  distance.
- \*\*\* Distance of 1,367m differs from annual  $\chi/Q$  distance.
- \*\*\*\* Distance of 506m differs from annual  $\chi/Q$  distance.
- \*\*\*\*\* Distance of 1,335m differs from annual  $\chi/Q$  distance.

TABLE 2.3-55

ANNUAL AVERAGE  $\chi/Q$  VALUES ( $\times 10^7 \text{ SEC/M}^3$ ) FOR BVPS-2 VENTILATION AND BVPS-1 CONTAINMENT VENT PURGE RELEASE

Downwind Sector	Individual Receptors						Population Distances (meters)									
	Site Boundar	Veg. Garden	Milk Cow	Milk Goat	Meat Animal	Residence	805	2,412	4,023	5,633	7,242	12,070	24,140	40,230	56,330	72,420
N	975	100	-	42.1	49.5	106										
NNE	378	51.1	-	14.3	47.2	53.0										
NE	613	270	6.20	1.40	6.20	281										
ENE	483	55.8	-	5.71	.278	224										
E	366	39.9	5.25	11.9	11.9	210										
ESE	299	61.3	-	24.3	61.3	61.3										
SE	255	52.9	8.24	8.24	21.3	52.9										
SSE	265	67.2	11.2	3.95	65.3	92.2										
S	252	31.4	28.3	-	52.9	55.3										
SSW	260	73.4	41.5	19.2	73.4	209										
SW	213	118	-	74.1	104	118										
WSW	1,340	151	44.6	-	138	151										
W	1,770	125	74.0	-	102	125										
WNW	2,329	207	149.0	13.0	207	207										
NW	3,323	857	-	42.4	164	885										
NNW	1,897	469	-	14.5	109	675										

NA\*

NOTE:

\*NA - Not applicable

TABLE 2.3-56

GRAZING SEASON AVERAGE  $\chi/Q$  VALUES ( $\times 10^7$  SEC/M<sup>3</sup>) FOR BVPS-2 VENTILATION AND BVPS-1 CONTAINMENT VENT PURGE RELEASE

Downwind Sector	Individual Receptors						Population Distances (meters)									
	Site Boundar	Veg. Garden	Milk Cow	Milk Goat	Meat Animal	Residence	805	2,412	4,023	5,633	7,242	12,070	24,140	40,230	56,330	72,420
N	1,079	108	-	45.9	54.0	114										
NNE	390	52.9	-	15.0	48.9	54.8										
NE	634	276	6.13	1.38	6.13	287										
ENE	467	53.6	-	5.33	.249	214										
E	410	44.6	5.85	13.5	13.5	235										
ESE	298	60.0	-	24.0	60.0	60.0										
SE	262	54.8	8.73	8.73	22.1	54.8										
SSE	275	70.7	11.9	4.15	68.6	97.1										
S	268	33.5	30.2	-	56.4	58.9										
SSW	265	72.6	41.4	18.9	72.6	212										
SW	221	119	-	75.6	105	119										
WSW	1,408	158	46.8	-	144	158										
W	1,964	136	81.2	-	112	136										
WNW	2,652	242	175.0	15.5	242	242										
NW	3,674	944	-	46.6	181	975										
NNW	2,000	490	-	14.6	113	704										

NA\*

NOTE:

\*NA - Not applicable

TABLE 2.3-57

ANNUAL AVERAGE D/Q VALUES (X 10<sup>9</sup> SEC/M<sup>2</sup>) FOR BVPS-2 VENTILATION  
AND BVPS-1 CONTAINMENT VENT PURGE RELEASE

Downwind Sector	Individual Receptors						Population Distances (meters)									
	Site Boundar	Veg. Garden	Milk Cow	Milk Goat	Meat Animal	Residence	805	2,412	4,023	5,633	7,242	12,070	24,140	40,230	56,330	72,420
N	163	13.6	-	4.87	5.94	14.5										
NNE	114	13.5	-	3.05	12.3	14.1										
NE	294	137	2.27	.402	2.27	142										
ENE	288	36.6	-	2.97	-	143										
E	205	23.4	2.42	6.12	6.12	123										
ESE	135	28.6	-	10.5	28.6	28.6										
SE	106	22.0	2.82	2.82	8.08	22.0										
SSE	95.3	24.0	3.31	.966	23.3	33.5										
S	81.3	8.99	8.02	-	16.1	16.9										
SSW	50.7	13.0	6.81	2.76	13.0	40.4										
SW	32.0	16.6	-	9.81	14.4	16.6										
WSW	183	17.9	4.27	-	16.1	17.9										
W	162	8.49	4.49	-	6.65	8.49										
WNW	152	9.49	6.33	.302	9.49	9.49										
NW	227	49.0	-	1.23	6.83	50.8										
NNW	174	36.7	-	.535	6.57	55.2										

NA\*

NOTE:

\*NA - Not applicable

TABLE 2.3-58

ANNUAL AVERAGE D/Q VALUES (X 10<sup>9</sup> SEC/M<sup>2</sup>) FOR BVPS-2 VENTILATION  
AND BVPS-1 CONTAINMENT VENT PURGE RELEASE

Downwind Sector	Individual Receptors						Population Distances (meters)									
	Site Boundar	Veg. Garden	Milk Cow	Milk Goat	Meat Animal	Residence	805	2,412	4,023	5,633	7,242	12,070	24,140	40,230	56,330	72,420
N	175	14.4	-	5.25	6.39	15.4										
NNE	114	13.7	-	3.15	12.6	14.3										
NE	314	147	2.45	.436	2.45	152										
ENE	283	37.7	-	3.00	-	143										
E	196	22.4	2.26	5.89	5.89	118										
ESE	128	27.3	-	10.2	27.3	27.3										
SE	103	21.9	2.85	2.85	8.07	21.9										
SSE	105	27.4	3.82	1.11	26.5	38.1										
S	88.4	9.77	8.70	-	17.5	18.4										
SSW	51.9	13.1	6.90	2.76	13.1	41.1										
SW	304	15.4	-	9.22	13.4	15.4										
WSW	161	15.7	3.73	-	14.1	15.7										
W	163	8.51	4.52	-	6.69	8.51										
WNW	166	10.7	7.17	.348	10.7	10.7										
NW	245	53.0	-	1.33	7.41	55.0										
NNW	185	39.5	-	.563	7.13	59.2										

NA\*

NOTE:

\*NA - Not applicable

TABLE 2.3-59

## TERRAIN RECIRCULATION FACTORS FOR ELEVATED RELEASES

<u>Receptor Direction</u>	<u>Distance (miles)</u>							
	<u>0-1</u>	<u>1-2</u>	<u>2-3</u>	<u>3-4</u>	<u>4-5</u>	<u>5-10</u>	<u>10-20</u>	<u>20</u>
N	1.6	1.4	1.0	1.0	1.0	1.0	1.0	1.0
NNE	1.6	1.4	1.3	1.1	1.2	1.1	1.1	1.0
NE	1.6	1.3	1.3	1.3	1.2	1.1	1.1	1.0
ENE	1.5	1.2	1.3	1.3	1.3	1.0	1.0	1.0
E	1.5	1.2	1.0	1.0	1.0	1.0	1.0	1.0
ESE	1.5	1.4	1.3	1.1	1.0	1.0	1.0	1.0
SE	1.5	1.4	1.3	1.2	1.0	1.0	1.0	1.0
SSE	1.5	1.6	1.5	1.2	1.0	1.0	1.0	1.0
S	1.5	1.8	1.8	1.3	1.1	1.0	1.0	1.0
SSW	1.5	1.4	1.4	1.2	1.4	1.0	1.0	1.0
SW	1.5	1.0	1.0	1.1	1.4	1.0	1.0	1.0
WSW	1.5	1.0	1.1	1.1	1.0	1.0	1.0	1.0
W	1.5	1.0	1.0	1.0	1.0	1.0	1.0	1.0
WNW	1.5	1.3	1.3	1.1	1.2	1.2	1.2	1.0
NW	1.6	1.3	1.2	1.1	1.1	1.1	1.0	1.0
NNW	1.6	1.1	1.1	1.0	1.0	1.0	1.0	1.0



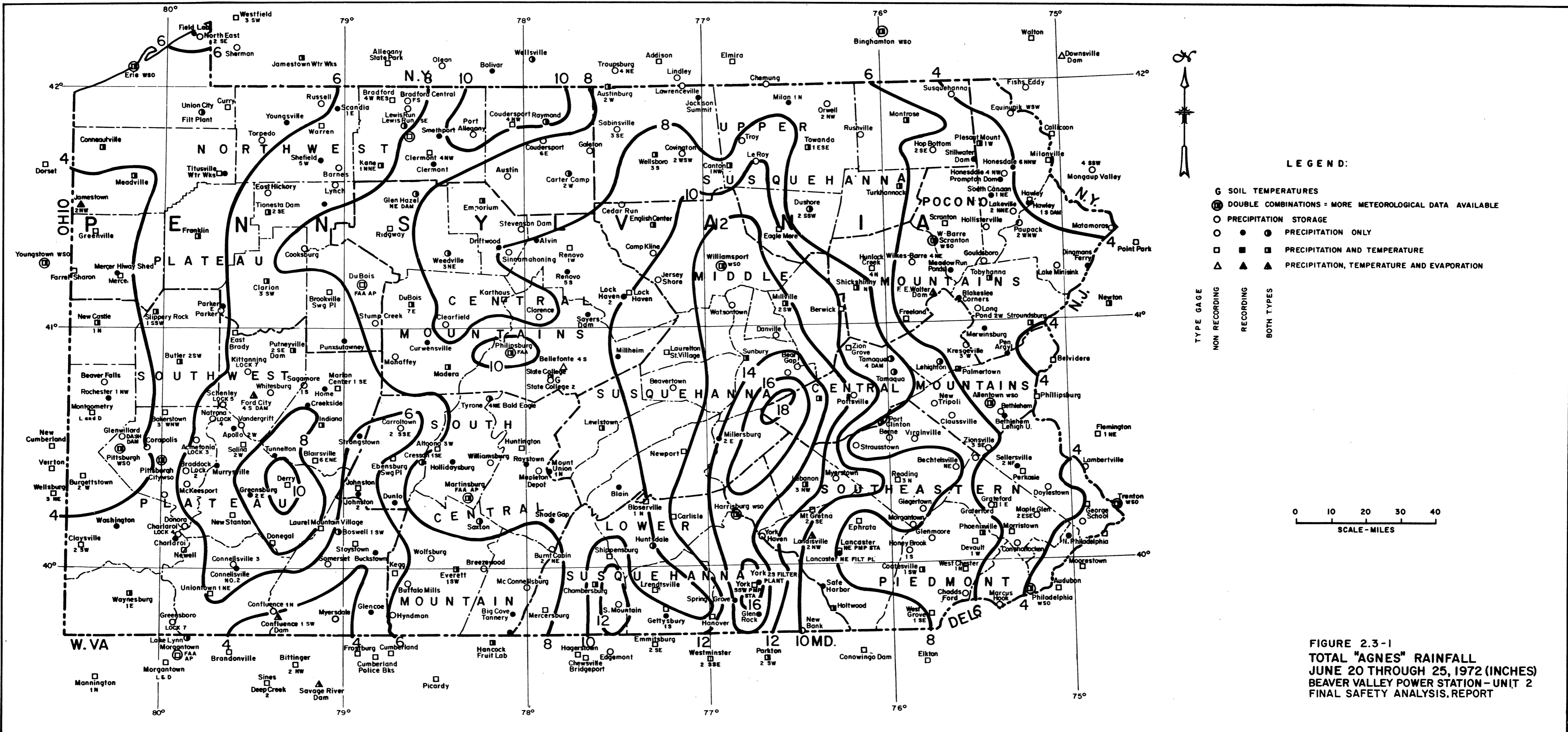

LEGEND:

- G SOIL TEMPERATURES
  - ⊕ DOUBLE COMBINATIONS = MORE METEOROLOGICAL DATA AVAILABLE
  - PRECIPITATION STORAGE
  - ● ● PRECIPITATION ONLY
  - ■ □ PRECIPITATION AND TEMPERATURE
  - △ ▲ ▲ PRECIPITATION, TEMPERATURE AND EVAPORATION
- TYPE GAGE  
 NON RECORDING  
 RECORDING  
 BOTH TYPES

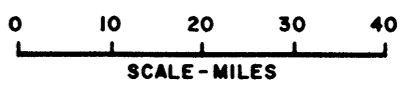
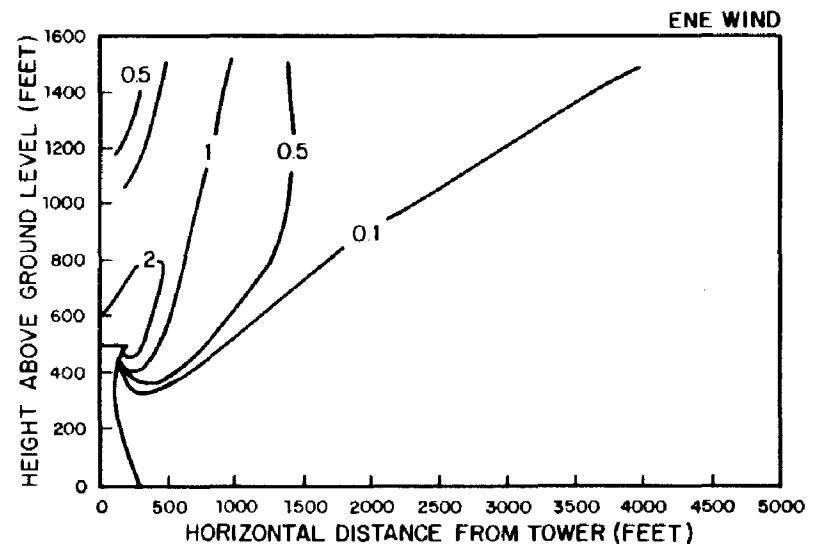
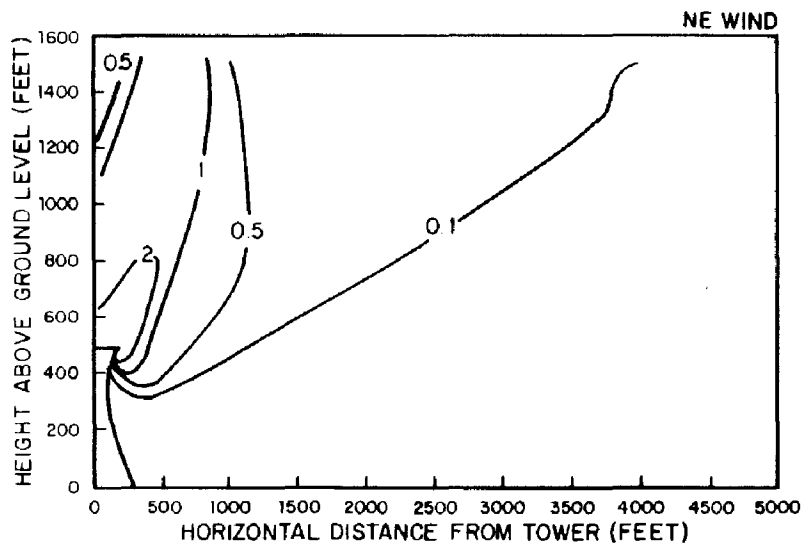
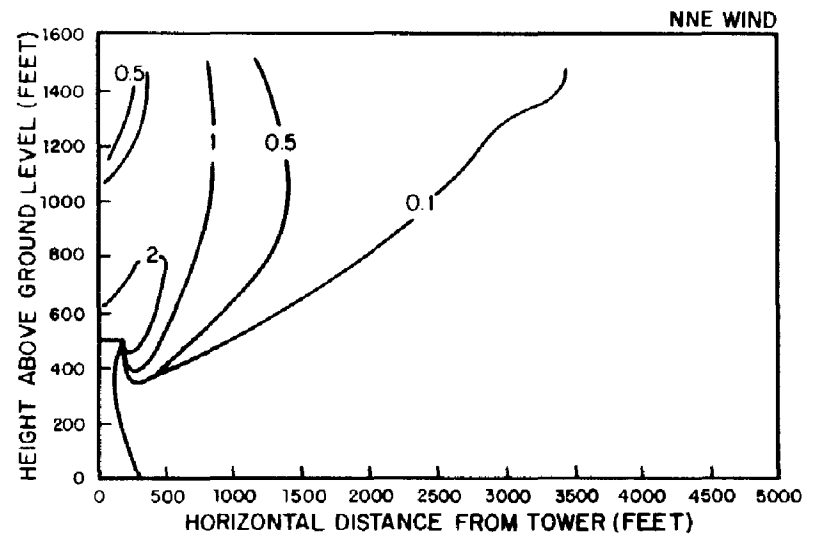
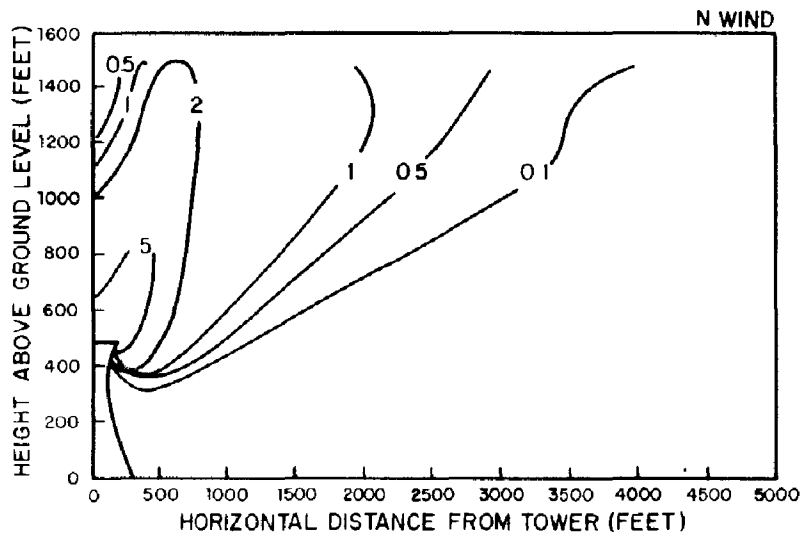
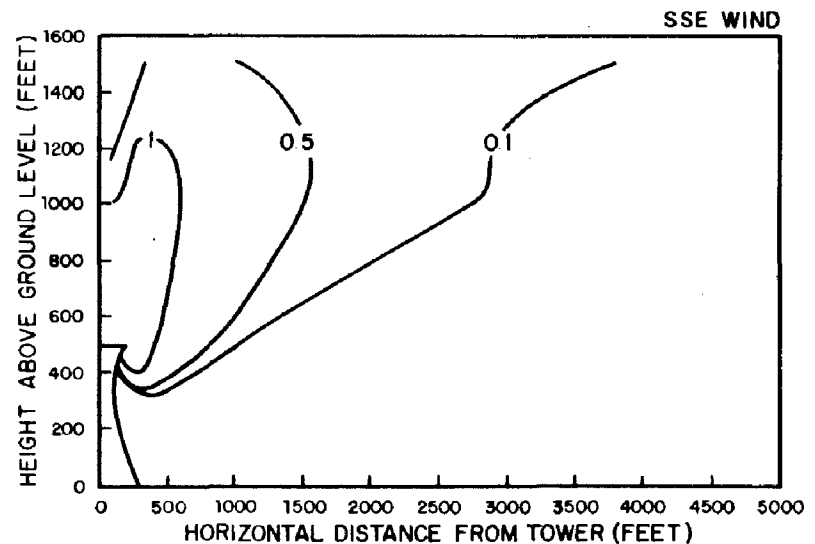
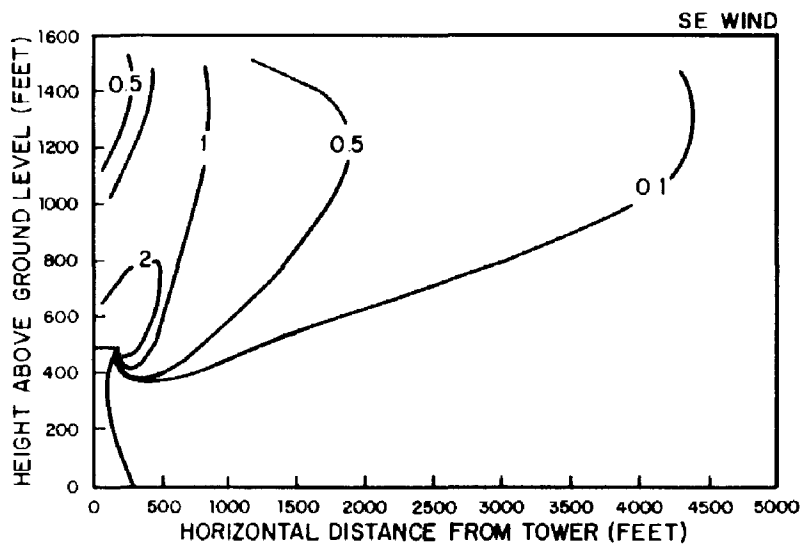
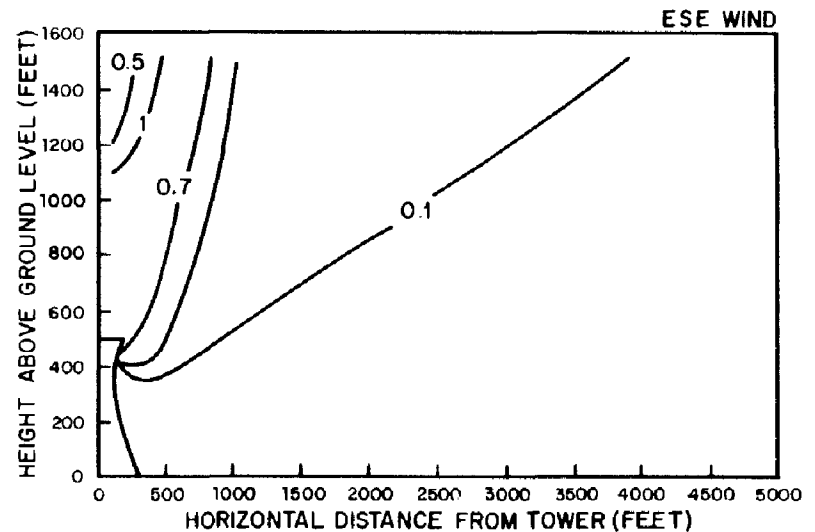
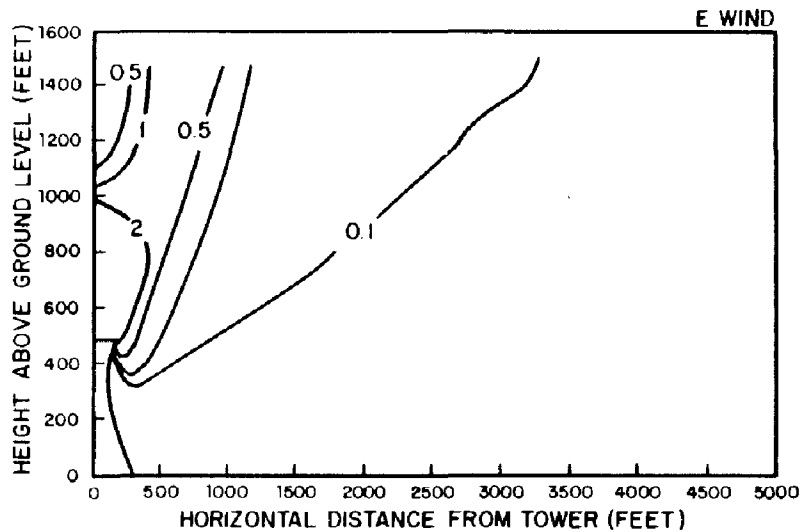

FIGURE 2.3-1  
 TOTAL "AGNES" RAINFALL  
 JUNE 20 THROUGH 25, 1972 (INCHES)  
 BEAVER VALLEY POWER STATION - UNIT 2  
 FINAL SAFETY ANALYSIS REPORT



NOTE: THE FIGURES DENOTE PERCENT OF TIME THAT THE VISIBLE PLUME FROM A NATURAL DRAFT COOLING TOWER EXTENDS TO THE GIVEN CONTOUR.

**FIGURE 2.3-2  
ESTIMATED FREQUENCY OF OCCURRENCE  
OF VISIBLE PLUME FROM BVPS-1  
NATURAL DRAFT COOLING TOWER  
BEAVER VALLEY POWER STATION - UNIT 2  
FINAL SAFETY ANALYSIS REPORT**



NOTE: THE FIGURES DENOTE PERCENT OF TIME THAT THE VISIBLE PLUME FROM A NATURAL DRAFT COOLING TOWER EXTENDS TO THE GIVEN CONTOUR.

**FIGURE 2.3-3**  
**ESTIMATED FREQUENCY OF OCCURRENCE**  
**OF VISIBLE PLUME FROM BVPS-1**  
**NATURAL DRAFT COOLING TOWER**  
**BEAVER VALLEY POWER STATION-UNIT 2**  
**FINAL SAFETY ANALYSIS REPORT**

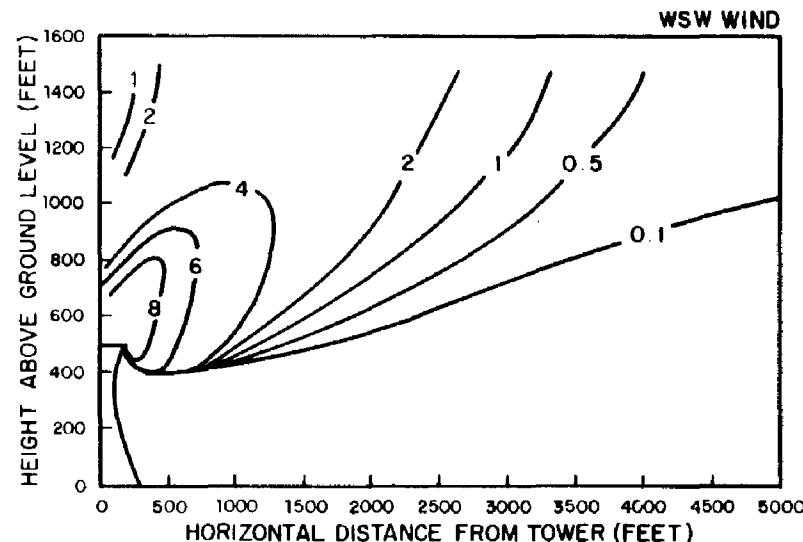
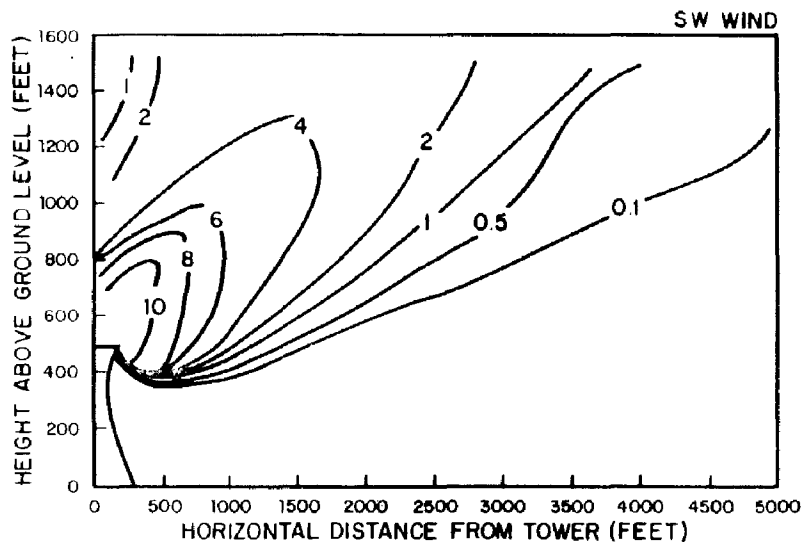
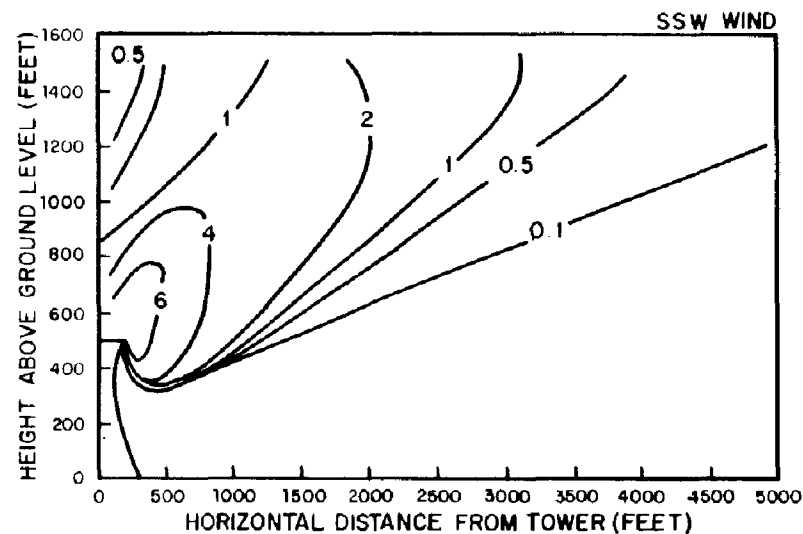
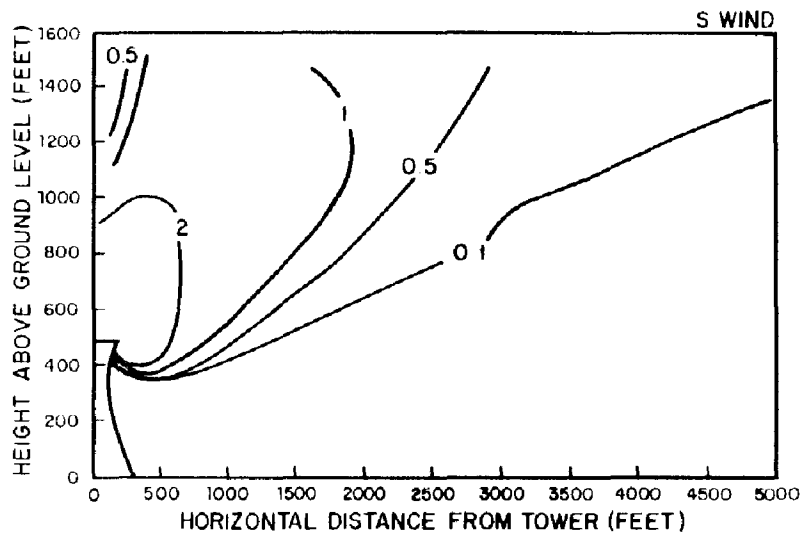

NOTE: THE FIGURES DENOTE PERCENT OF TIME THAT THE VISIBLE PLUME FROM A NATURAL DRAFT COOLING TOWER EXTENDS TO THE GIVEN CONTOUR.

FIGURE 2.3-4  
 ESTIMATED FREQUENCY OF OCCURRENCE  
 OF VISIBLE PLUME FROM BVPS-1  
 NATURAL DRAFT COOLING TOWER  
 BEAVER VALLEY POWER STATION-UNIT 2  
 FINAL SAFETY ANALYSIS REPORT

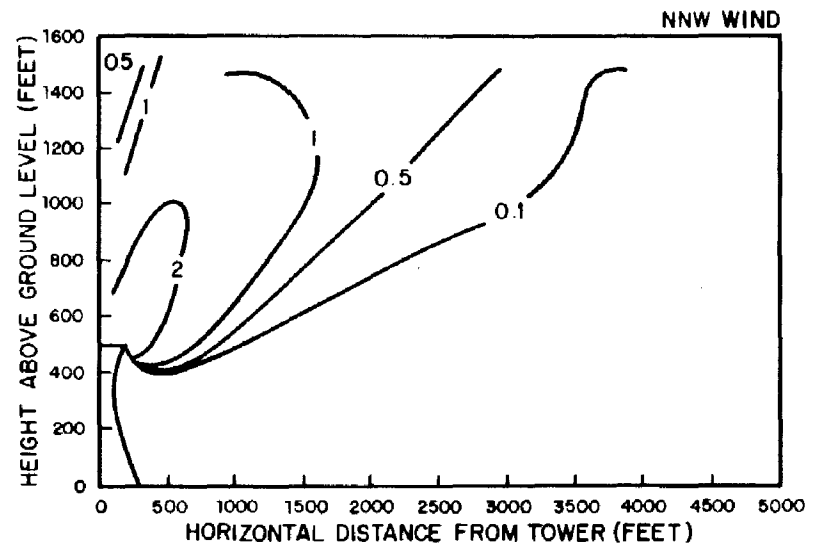
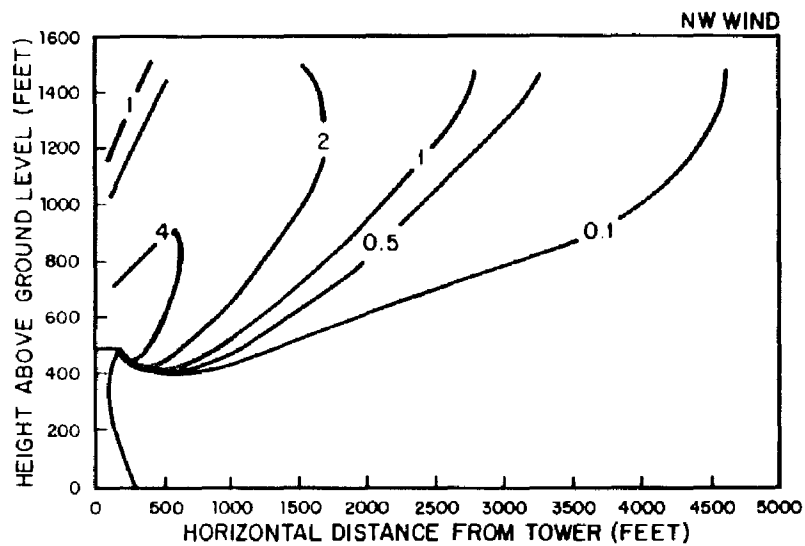
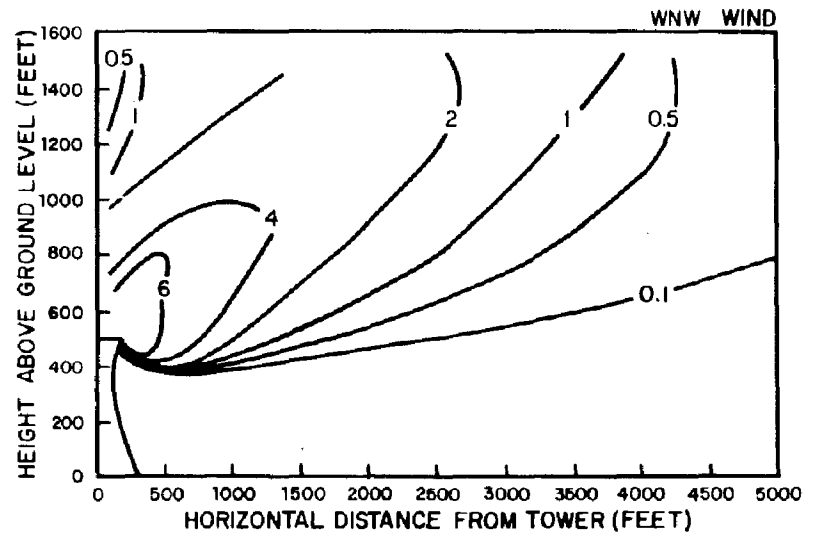
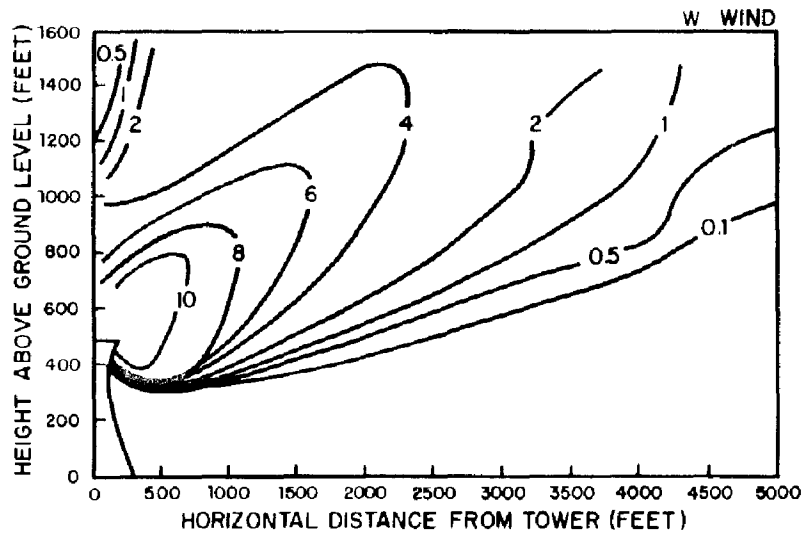

NOTE: THE FIGURES DENOTE PERCENT OF TIME THAT THE VISIBLE PLUME FROM A NATURAL DRAFT COOLING TOWER EXTENDS TO THE GIVEN CONTOUR.

FIGURE 2.3-5  
 ESTIMATED FREQUENCY OF OCCURRENCE  
 OF VISIBLE PLUME FROM BVPS-1  
 NATURAL DRAFT COOLING TOWER  
 BEAVER VALLEY POWER STATION - UNIT 2  
 FINAL SAFETY ANALYSIS REPORT

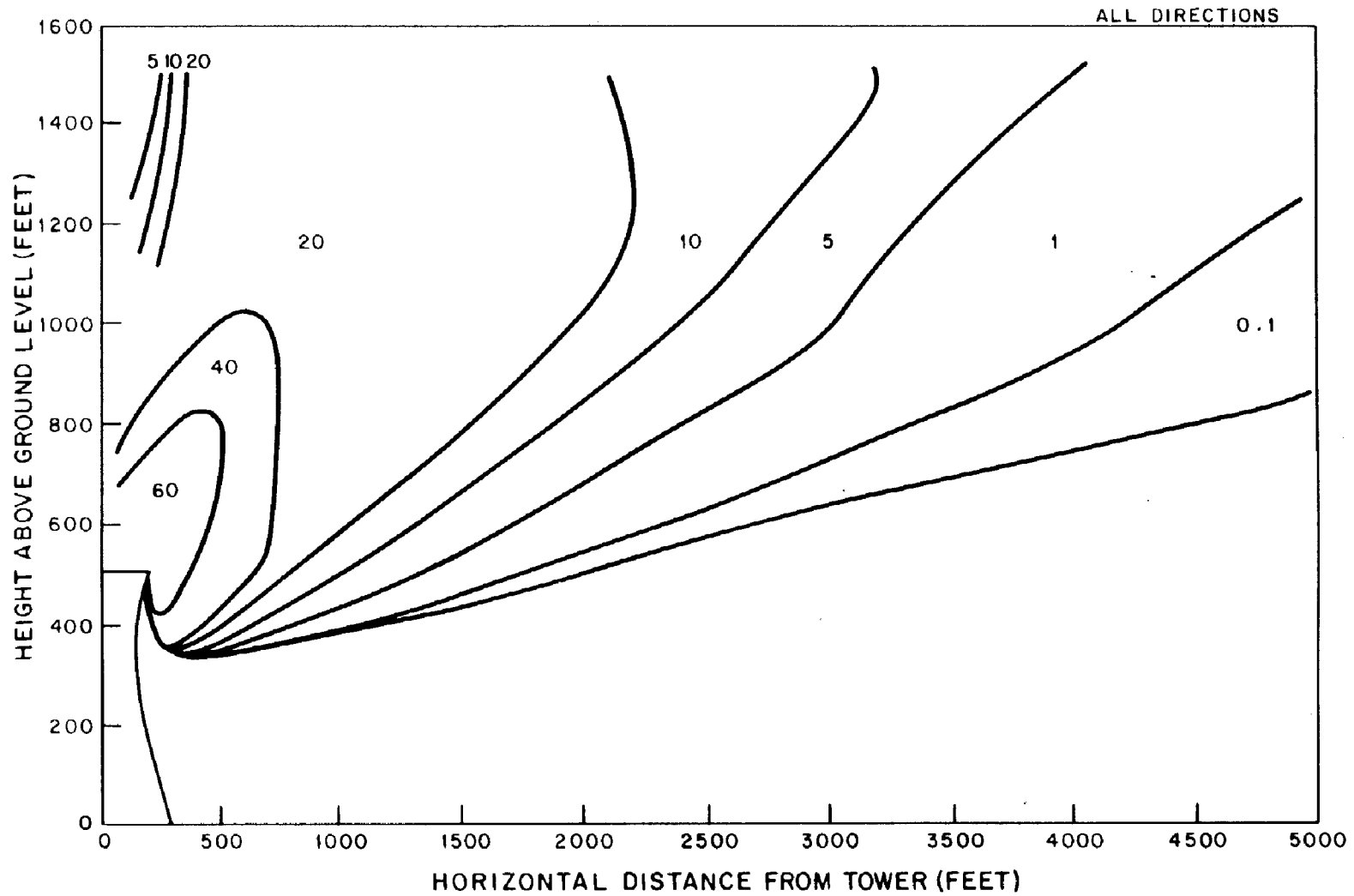

**NOTE:**

THE FIGURES DENOTE PERCENT OF TIME THAT THE VISIBLE PLUME FROM A NATURAL DRAFT COOLING TOWER EXTENDS TO THE GIVEN CONTOUR.

**FIGURE 2.3-6  
ESTIMATED FREQUENCY OF OCCURRENCE  
OF VISIBLE PLUME FROM BVPS-I  
NATURAL DRAFT COOLING TOWER  
BEAVER VALLEY POWER STATION-UNIT 2  
FINAL SAFETY ANALYSIS REPORT**

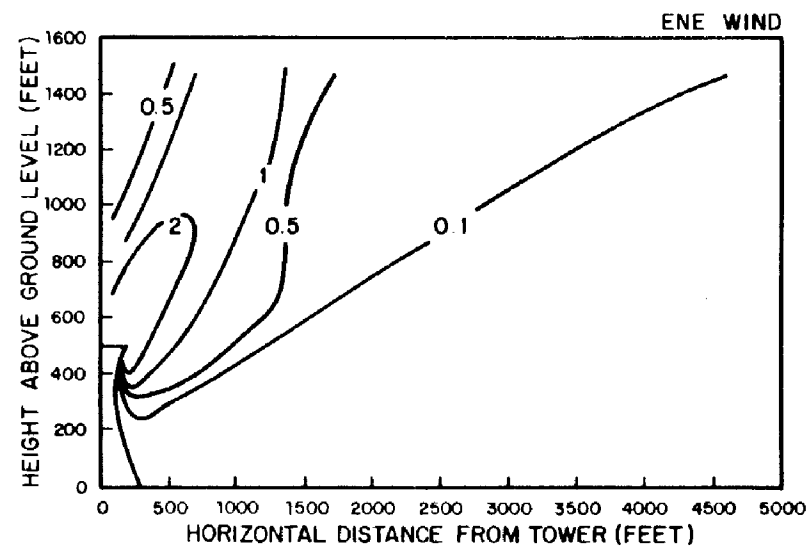
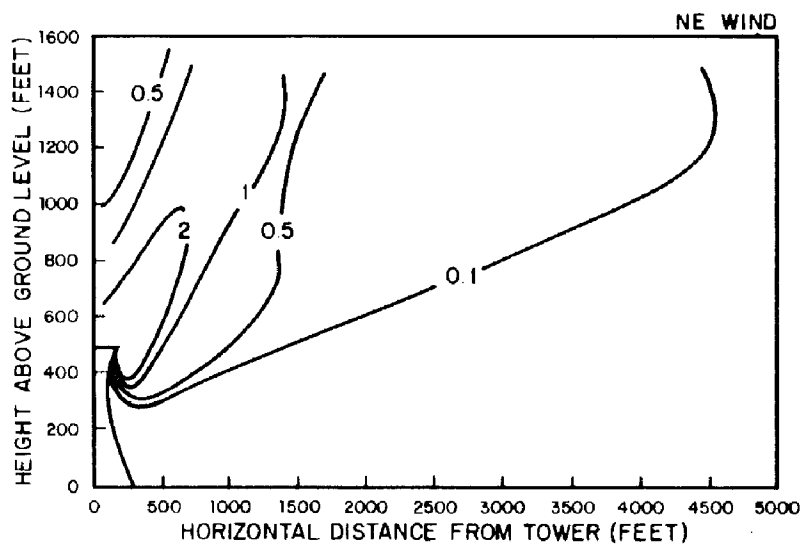
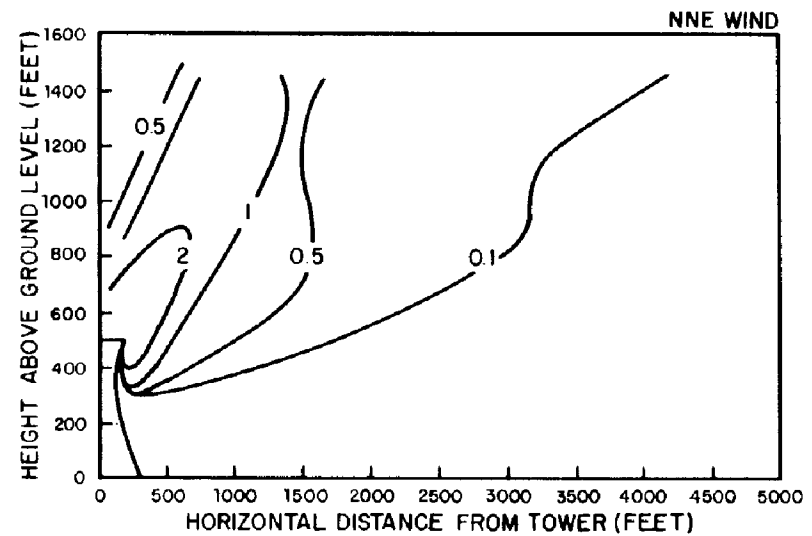
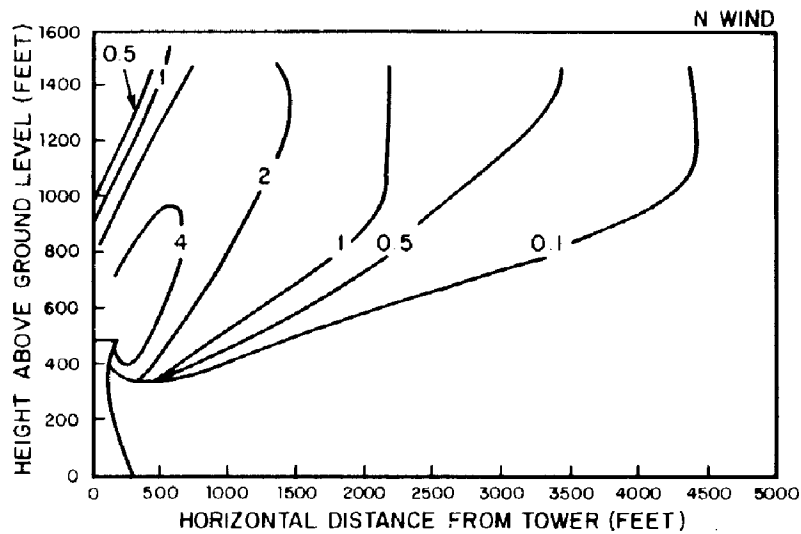

NOTE: THE FIGURES DENOTE PERCENT OF TIME THAT THE VISIBLE PLUME FROM A NATURAL DRAFT COOLING TOWER EXTENDS TO THE GIVEN CONTOUR.

FIGURE 2.3-7  
 ESTIMATED FREQUENCY OF OCCURRENCE  
 OF VISIBLE PLUME FROM BVPS-2  
 NATURAL DRAFT COOLING TOWER  
 BEAVER VALLEY POWER STATION-UNIT 2  
 FINAL SAFETY ANALYSIS REPORT

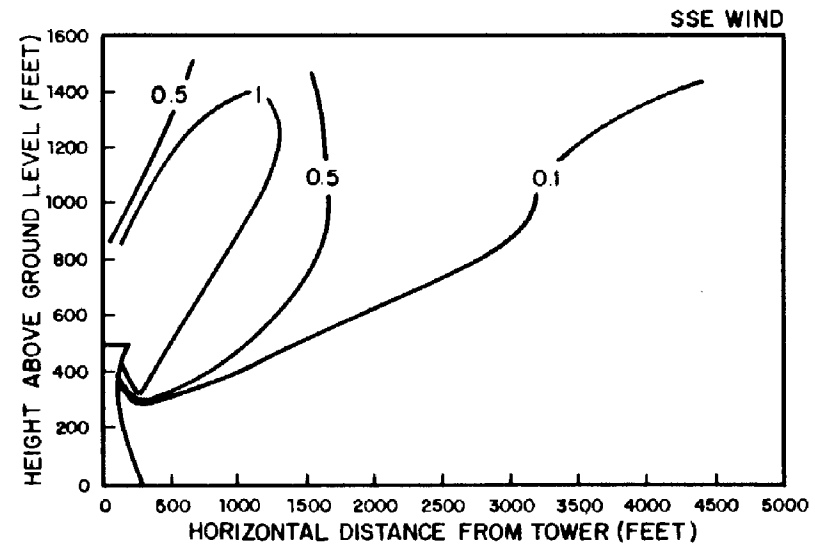
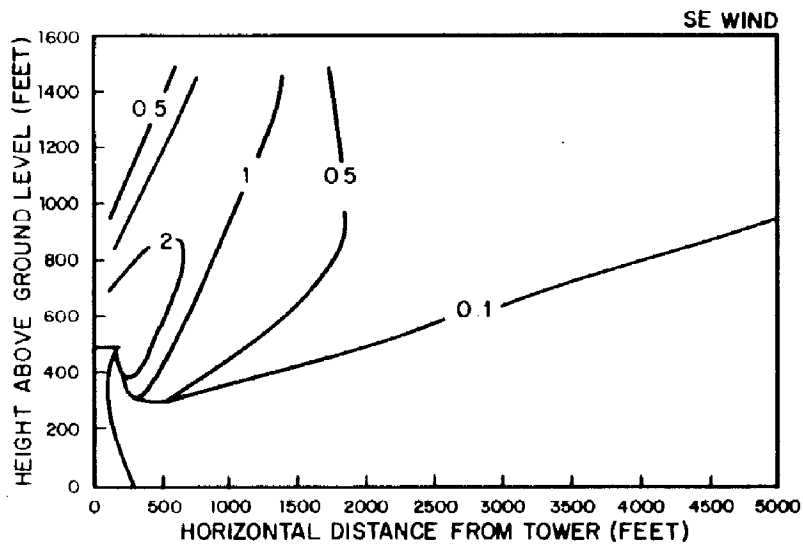
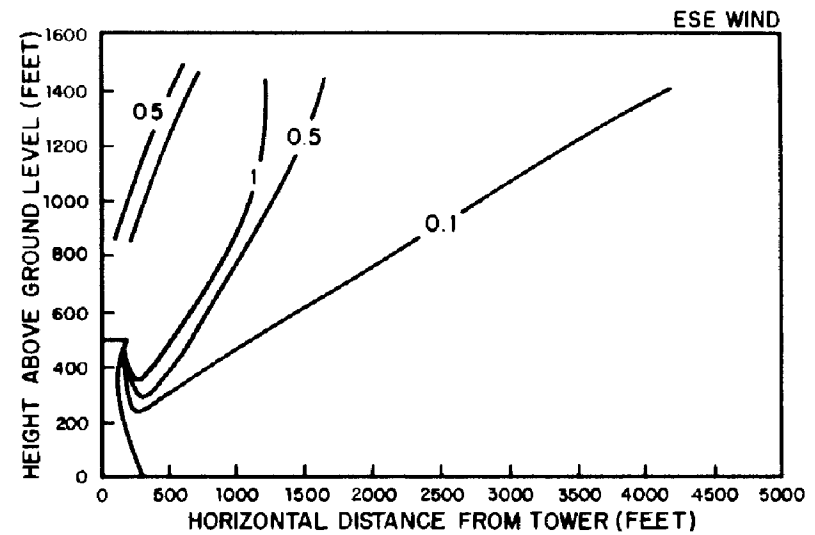
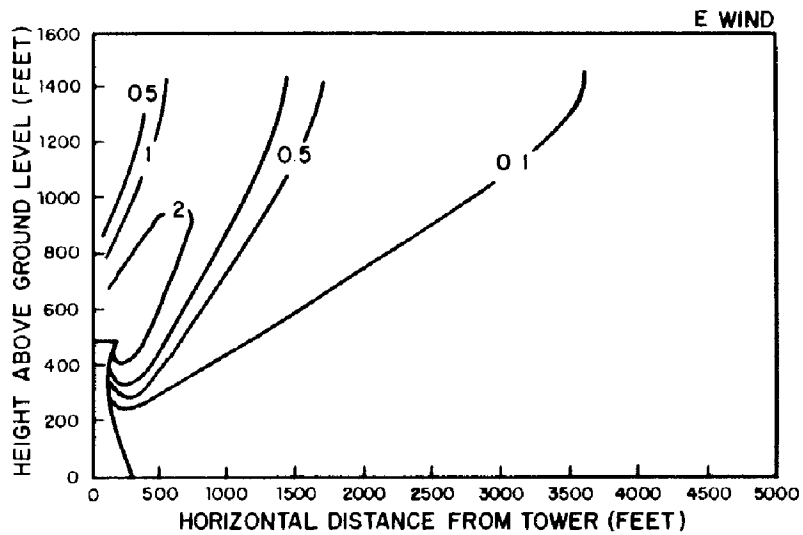

NOTE: THE FIGURES DENOTE PERCENT OF TIME THAT THE VISIBLE PLUME FROM A NATURAL DRAFT COOLING TOWER EXTENDS TO THE GIVEN CONTOUR.

**FIGURE 2.3-8  
ESTIMATED FREQUENCY OF OCCURRENCE  
OF VISIBLE PLUME FROM BVPS-2  
NATURAL DRAFT COOLING TOWER  
BEAVER VALLEY POWER STATION - UNIT 2  
FINAL SAFETY ANALYSIS REPORT**



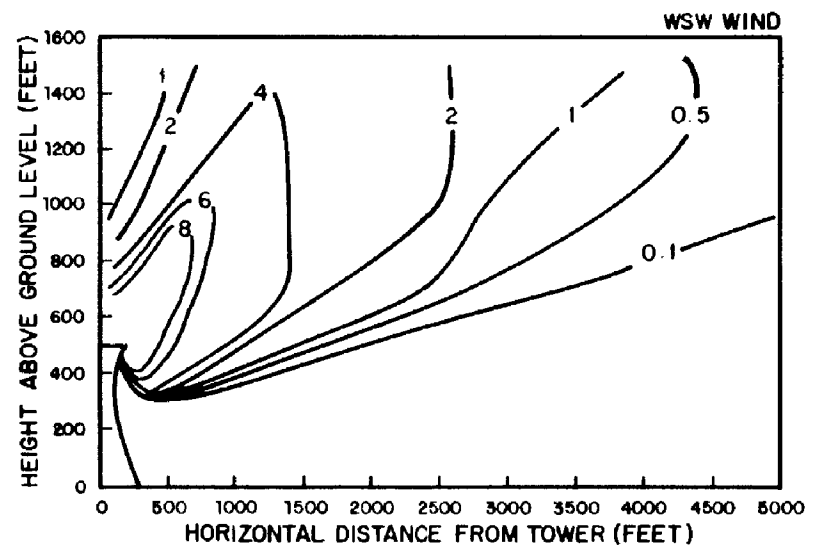
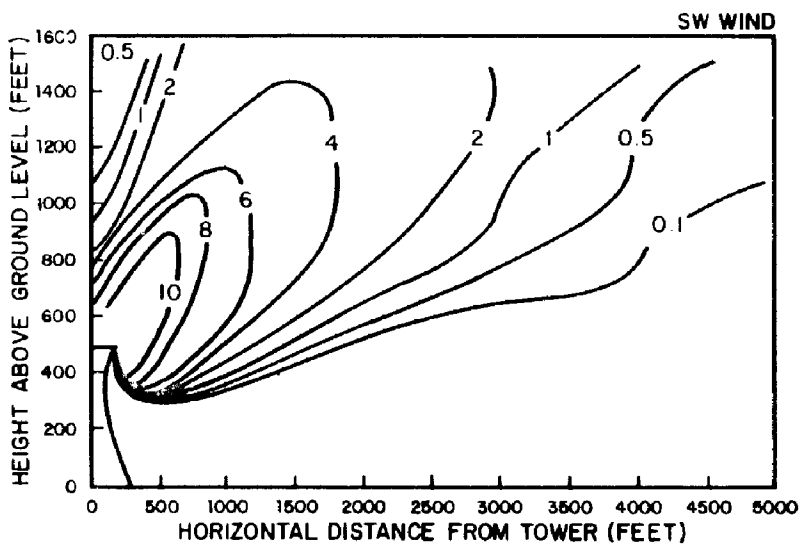
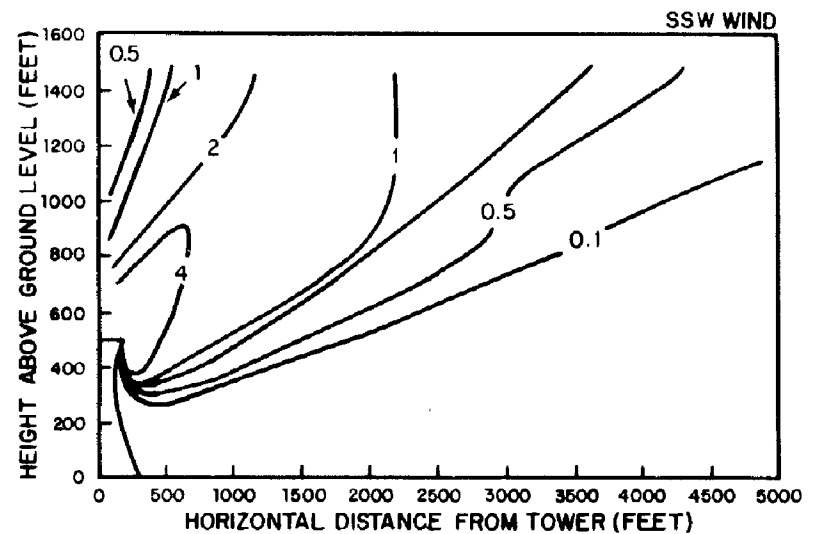
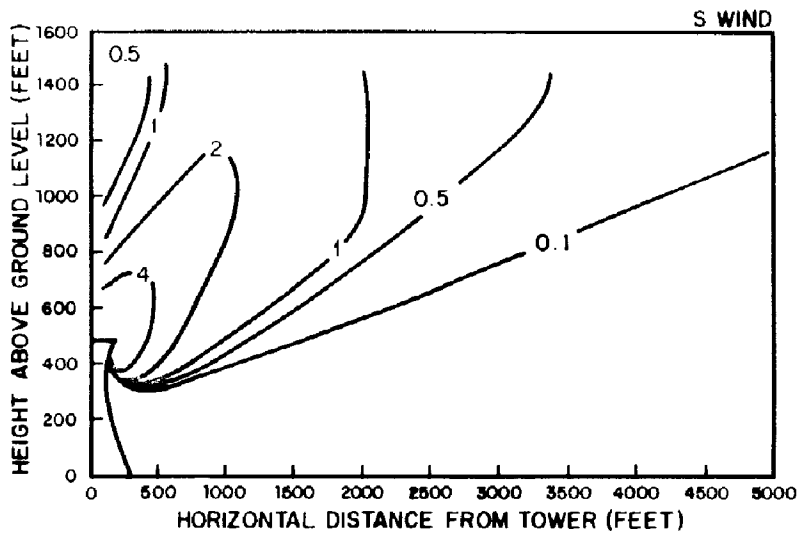

NOTE: THE FIGURES DENOTE PERCENT OF TIME THAT THE VISIBLE PLUME FROM A NATURAL DRAFT COOLING TOWER EXTENDS TO THE GIVEN CONTOUR.

FIGURE 2.3-9  
 ESTIMATED FREQUENCY OF OCCURRENCE  
 OF VISIBLE PLUME FROM BVPS-2  
 NATURAL DRAFT COOLING TOWER  
 BEAVER VALLEY POWER STATION - UNIT 2  
 FINAL SAFETY ANALYSIS REPORT

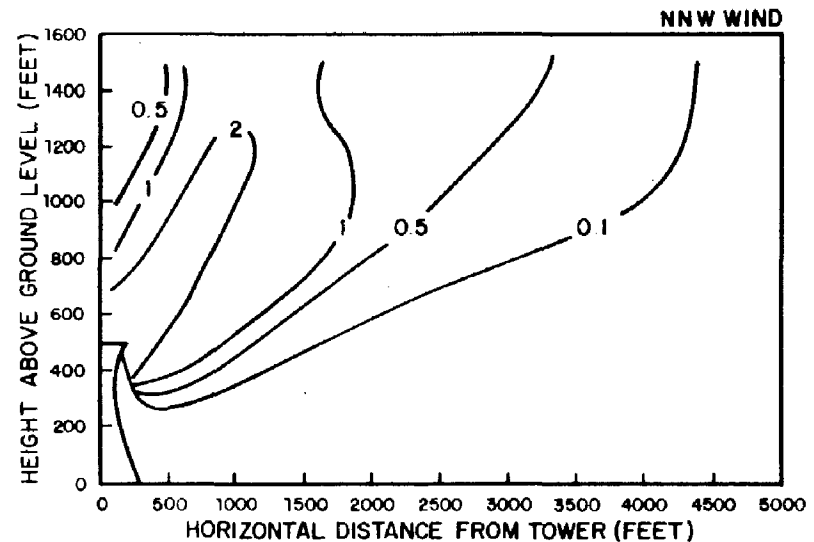
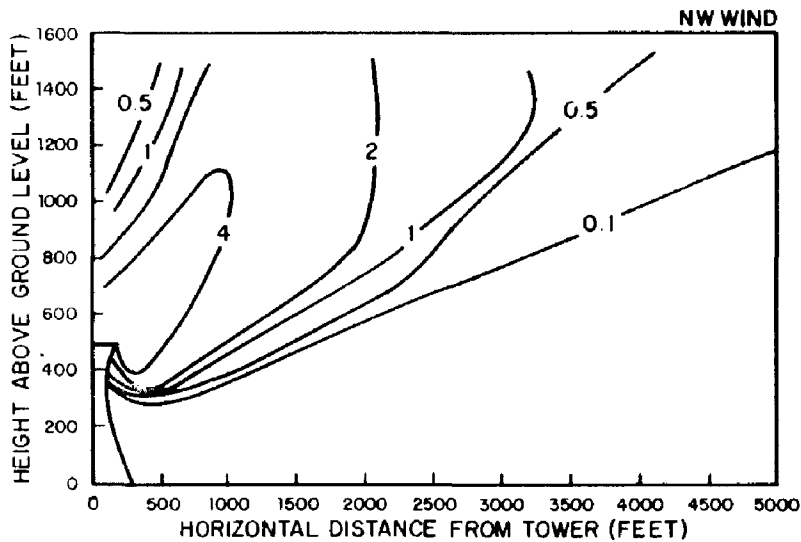
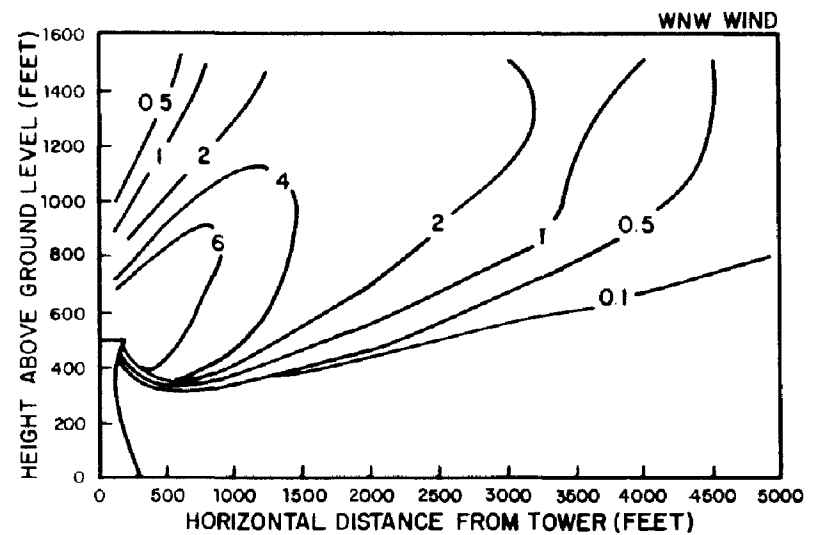
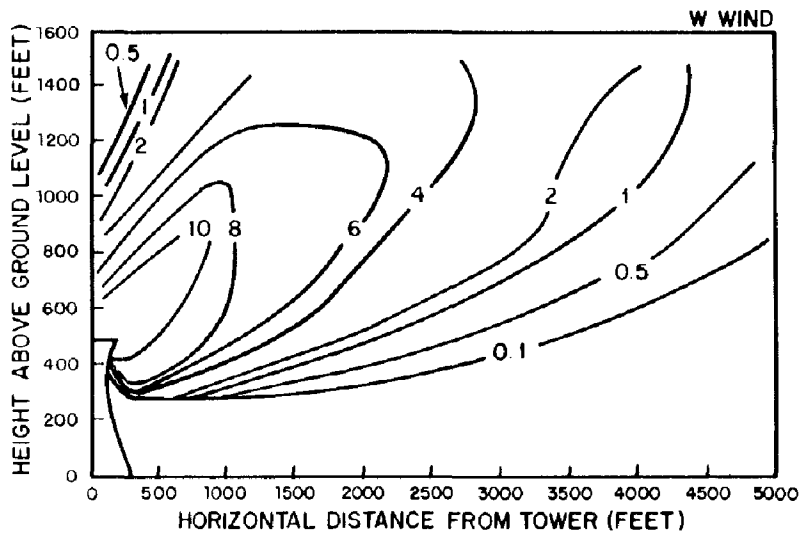

NOTE: THE FIGURES DENOTE PERCENT OF TIME THAT THE VISIBLE PLUME FROM A NATURAL DRAFT COOLING TOWER EXTENDS TO THE GIVEN CONTOUR.

FIGURE 2.3-10  
**ESTIMATED FREQUENCY OF OCCURRENCE  
 OF VISIBLE PLUME FROM BVPS-2  
 NATURAL DRAFT COOLING TOWER**  
 BEAVER VALLEY POWER STATION - UNIT 2  
 FINAL SAFETY ANALYSIS REPORT

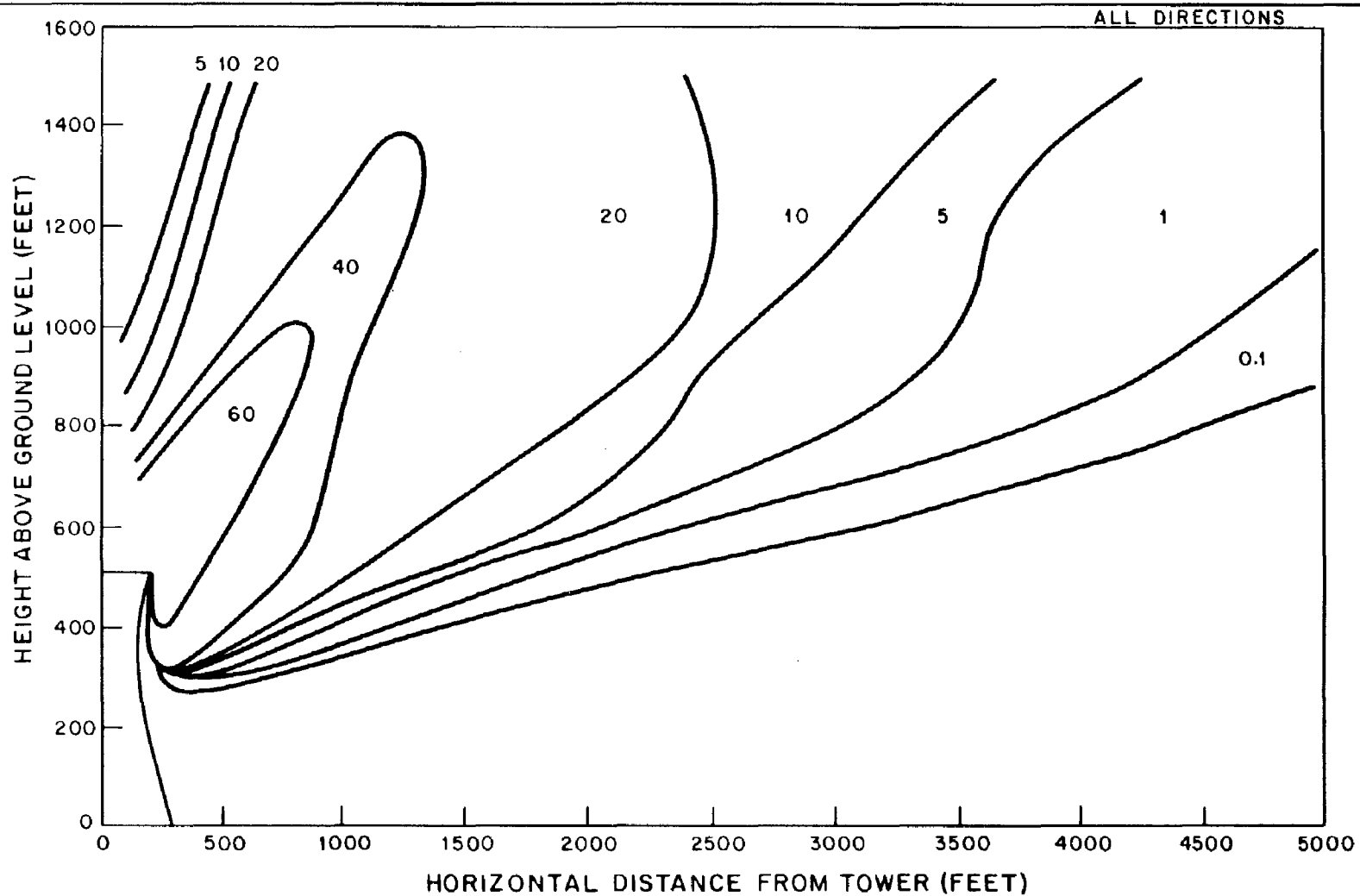

NOTE:  
 THE FIGURES DENOTE PERCENT OF TIME  
 THAT THE VISIBLE PLUME FROM A NATURAL  
 DRAFT COOLING TOWER EXTENDS TO THE  
 GIVEN CONTOUR.

FIGURE 2.3-11  
 ESTIMATED FREQUENCY OF OCCURRENCE  
 OF VISIBLE PLUME FROM BVPS -2  
 NATURAL DRAFT COOLING TOWER  
 BEAVER VALLEY POWER STATION - UNIT 2  
 FINAL SAFETY ANALYSIS REPORT



0 0.5 1  
SCALE - MILES

FIGURE 2.3-12  
 ICING DUE TO DRIFT FROM  
 BVPS-1 AND BVPS-2 (INCHES/YEAR)  
 NATURAL DRAFT COOLING TOWERS  
 BEAVER VALLEY POWER STATION-UNIT 2  
 FINAL SAFETY ANALYSIS REPORT

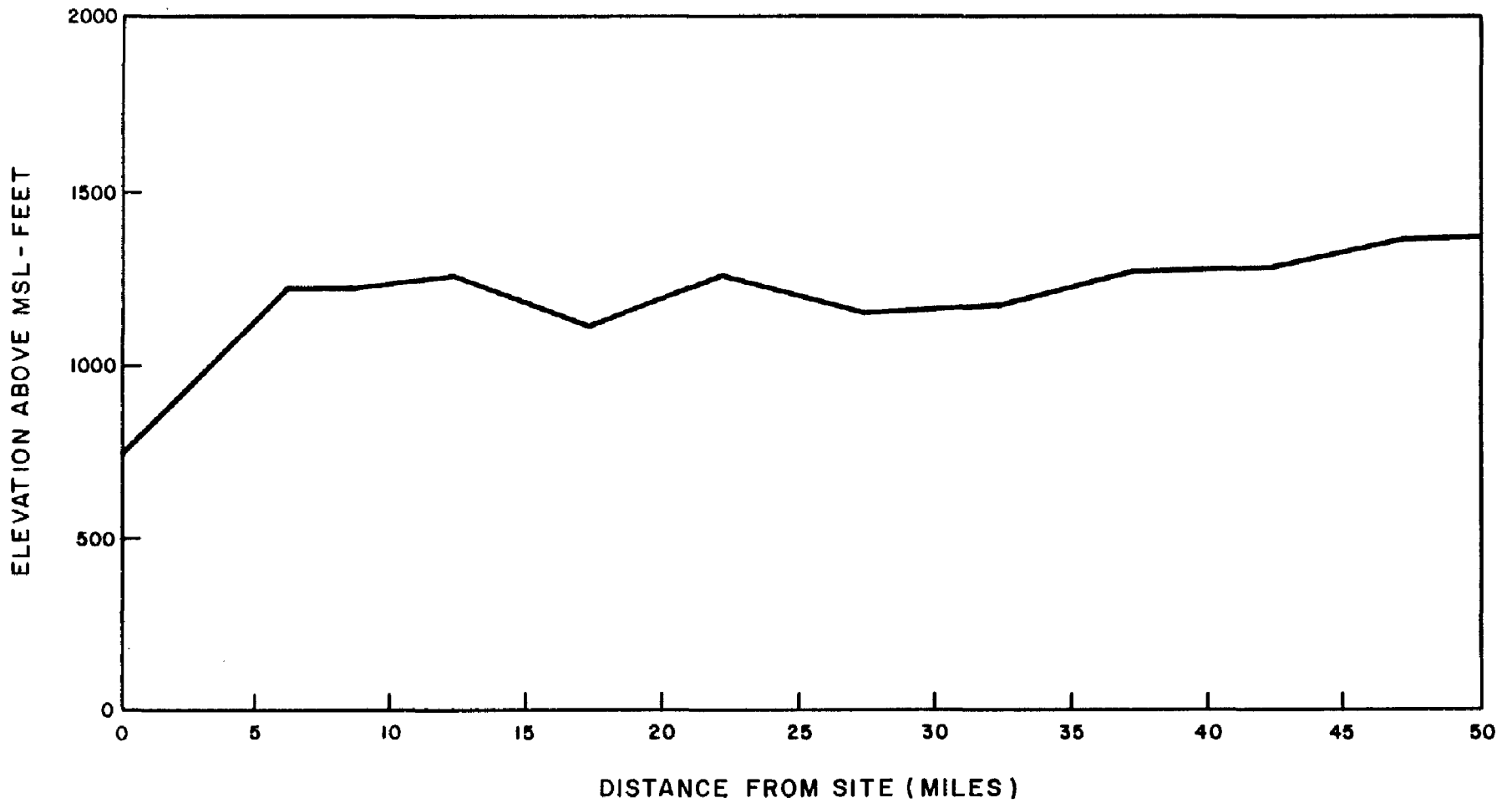

FIGURE 2.3-13  
TOPOGRAPHIC CROSS SECTIONS  
TO 50 MILES FOR THE  
NORTH SECTOR  
BEAVER VALLEY POWER STATION-UNIT 2  
FINAL SAFETY ANALYSIS REPORT

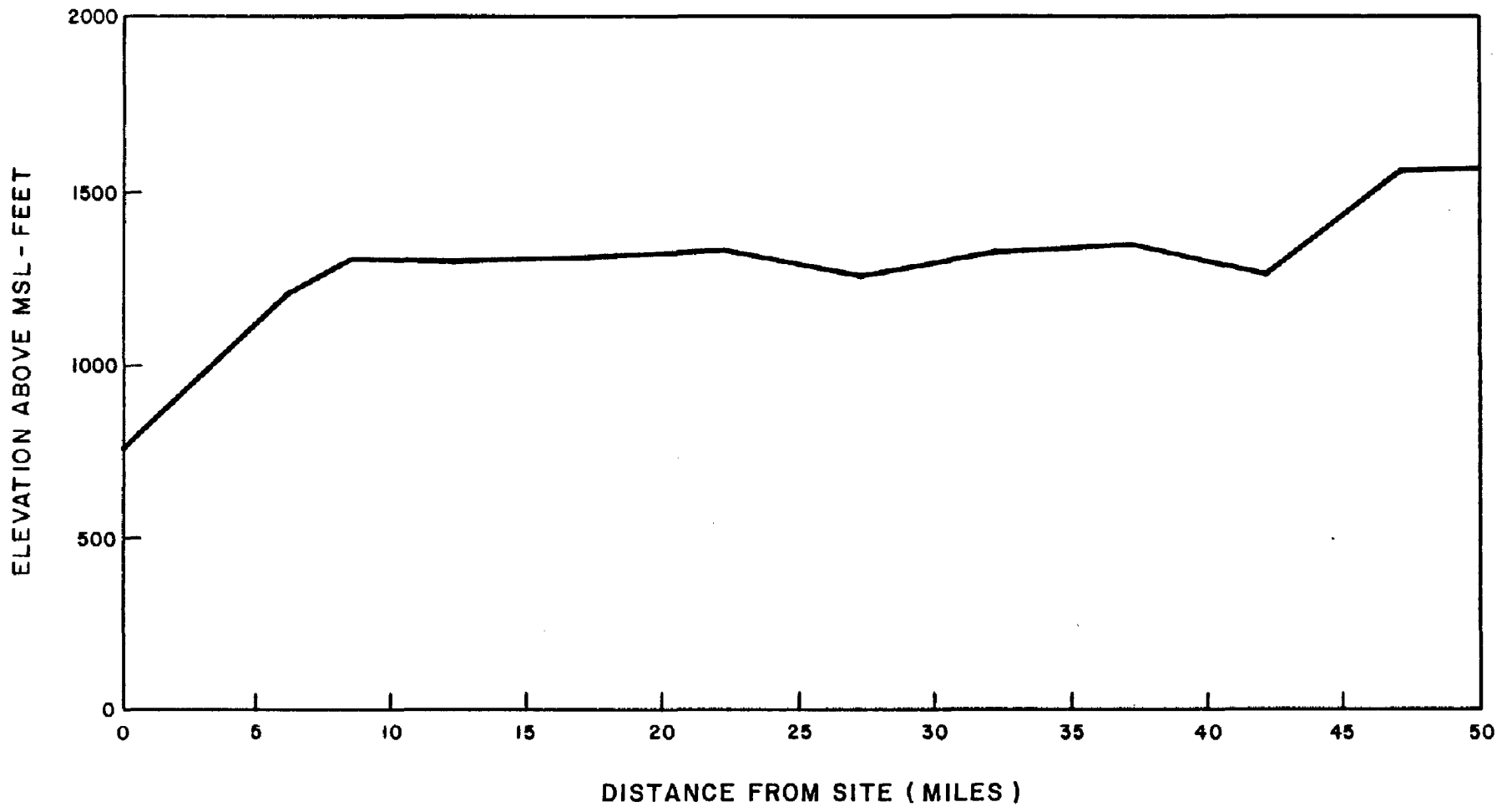

FIGURE 2.3 - 14  
TOPOGRAPHIC CROSS SECTIONS  
TO 50 MILES FOR THE  
NORTH NORTHEAST SECTOR  
BEAVER VALLEY POWER STATION - UNIT 2  
FINAL SAFETY ANALYSIS REPORT

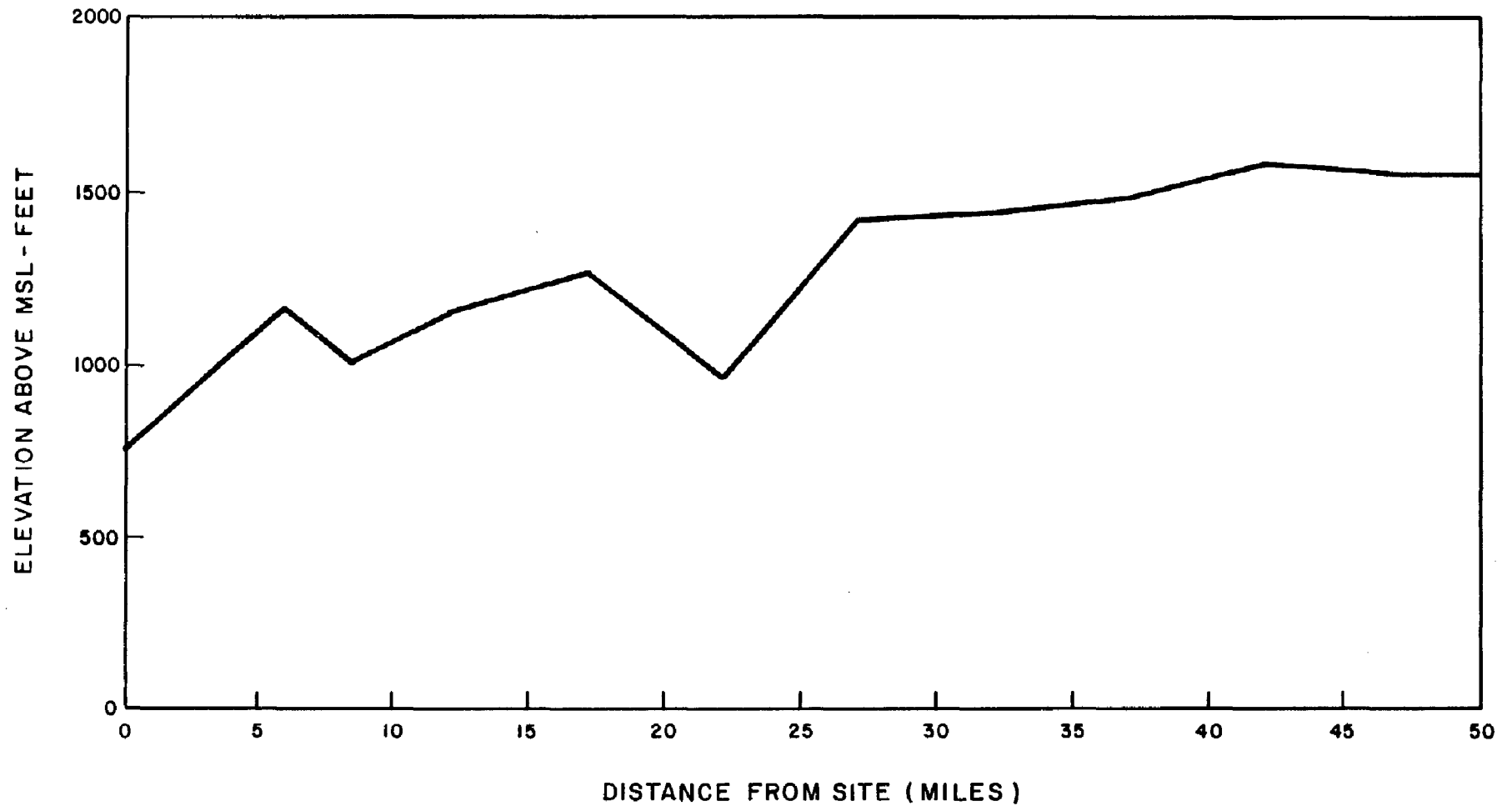

FIGURE 2.3 - 15  
TOPOGRAPHIC CROSS SECTIONS  
TO 50 MILES FOR THE  
NORTHEAST SECTOR  
BEAVER VALLEY POWER STATION - UNIT 2  
FINAL SAFETY ANALYSIS REPORT

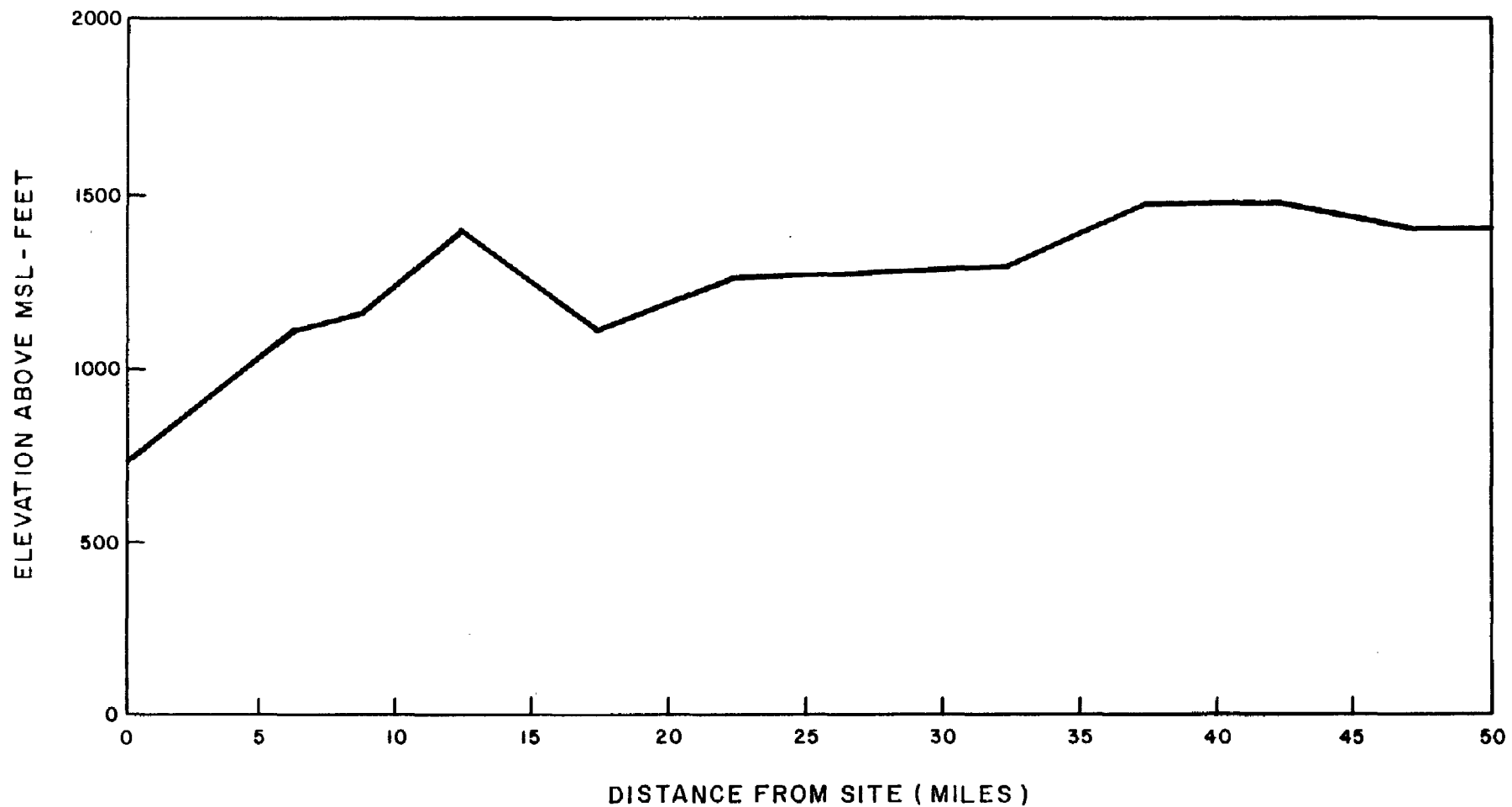

FIGURE 2.3 - 16  
TOPOGRAPHIC CROSS SECTIONS  
TO 50 MILES FOR THE  
EAST NORTHEAST SECTOR  
BEAVER VALLEY POWER STATION - UNIT 2  
FINAL SAFETY ANALYSIS REPORT



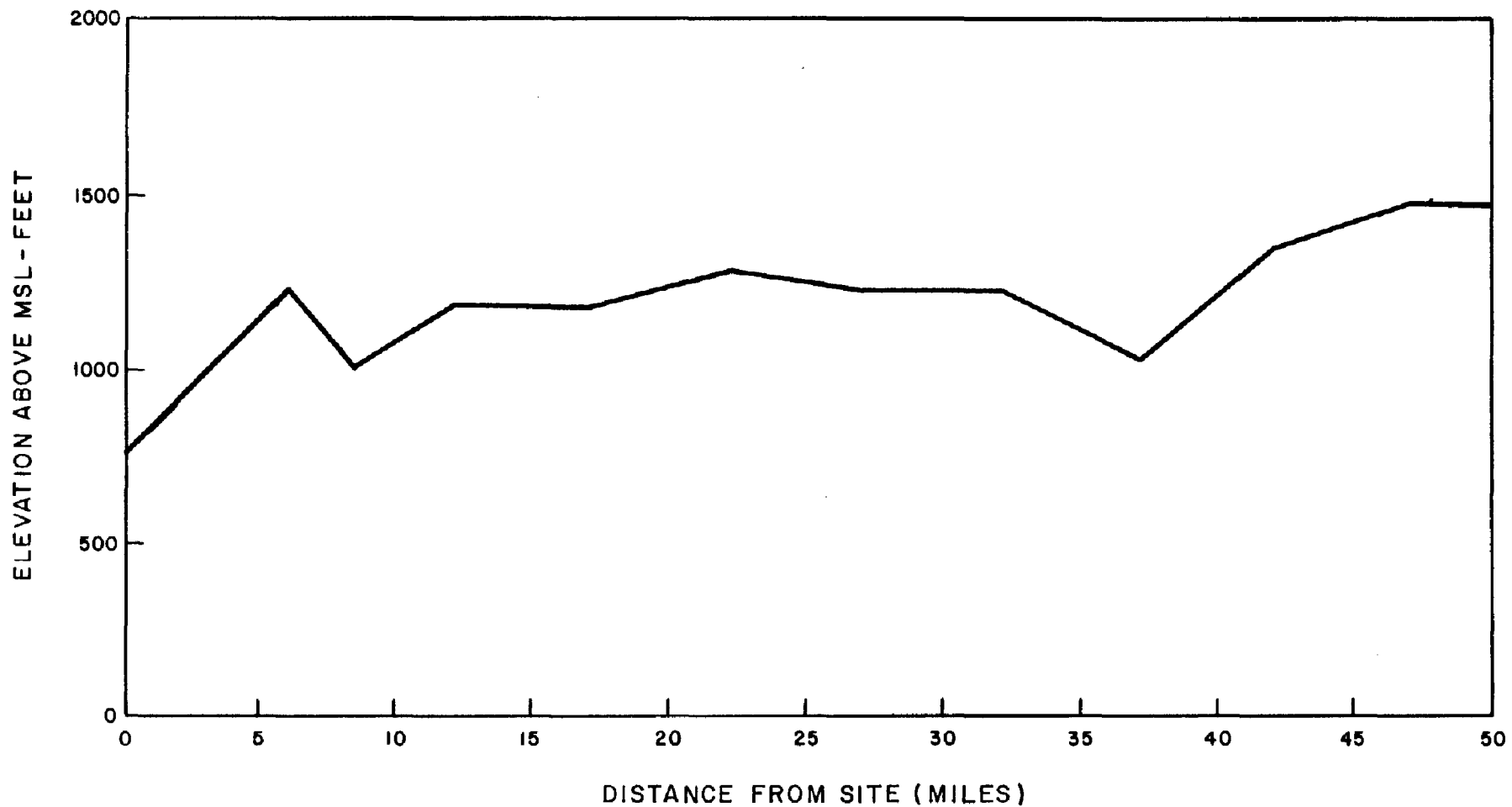

FIGURE 2.3 - 17  
TOPOGRAPHIC CROSS SECTIONS  
TO 50 MILES FOR THE  
EAST SECTOR  
BEAVER VALLEY POWER STATION - UNIT 2  
FINAL SAFETY ANALYSIS REPORT

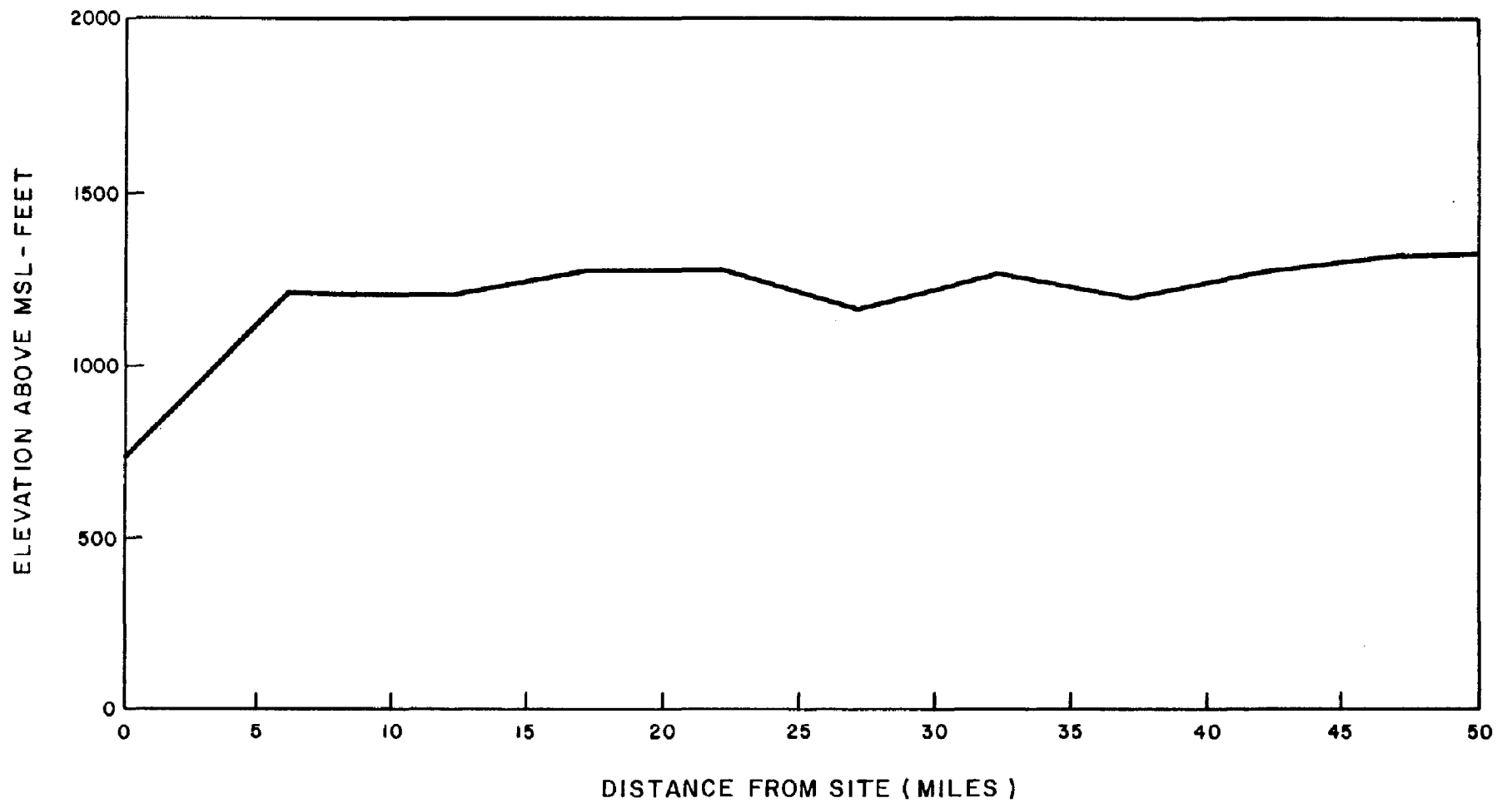

FIGURE 2.3 - 18  
TOPOGRAPHIC CROSS SECTIONS  
TO 50 MILES FOR THE  
EAST SOUTHEAST SECTOR  
BEAVER VALLEY POWER STATION - UNIT 2  
FINAL SAFETY ANALYSIS REPORT

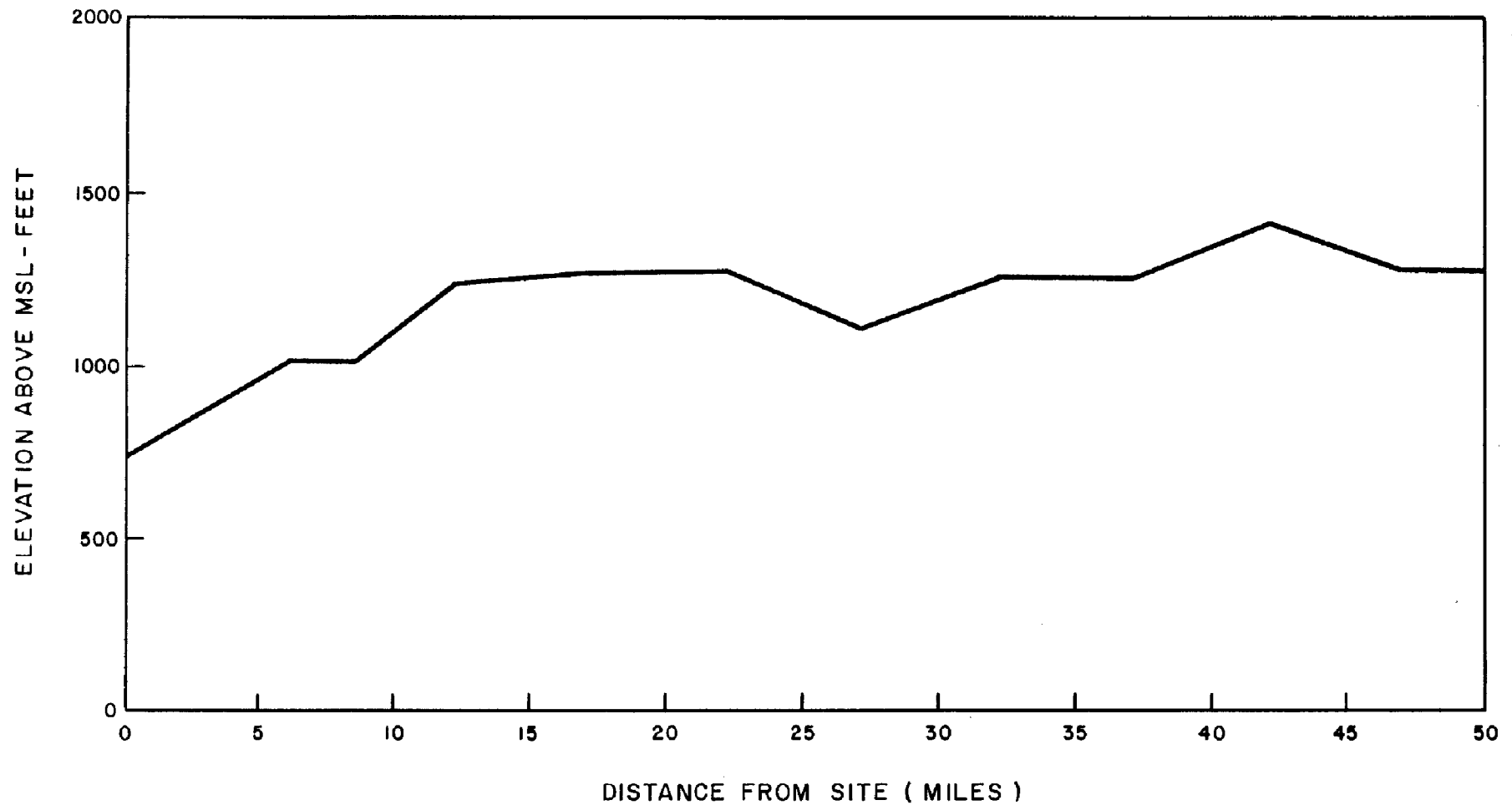

FIGURE 2.3 - 19  
TOPOGRAPHIC CROSS SECTIONS  
TO 50 MILES FOR THE  
SOUTHEAST SECTOR  
BEAVER VALLEY POWER STATION - UNIT 2  
FINAL SAFETY ANALYSIS REPORT

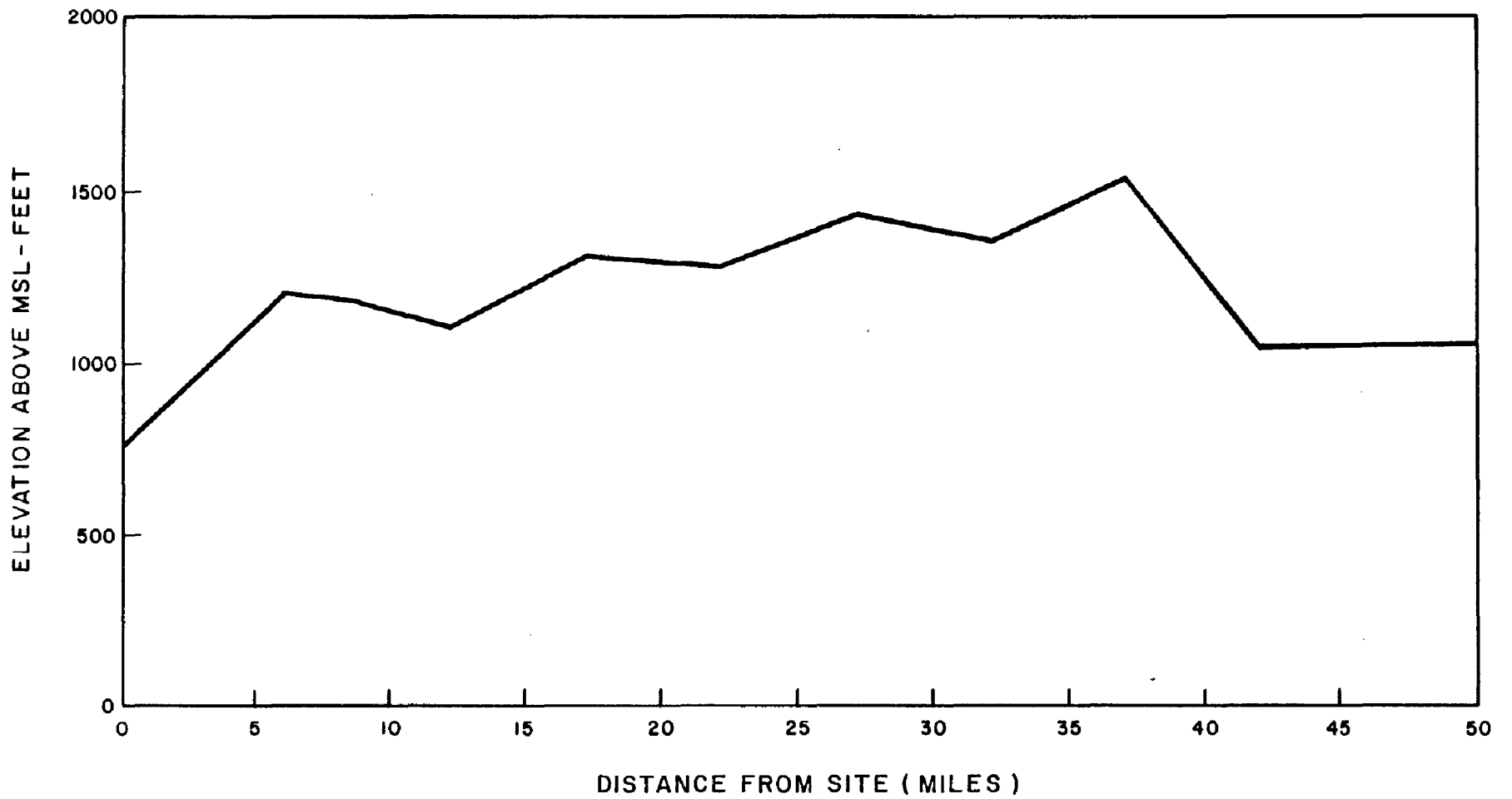

FIGURE 2.3 - 20  
TOPOGRAPHIC CROSS SECTIONS  
TO 50 MILES FOR THE  
SOUTH SOUTHEAST SECTOR  
BEAVER VALLEY POWER STATION - UNIT 2  
FINAL SAFETY ANALYSIS REPORT

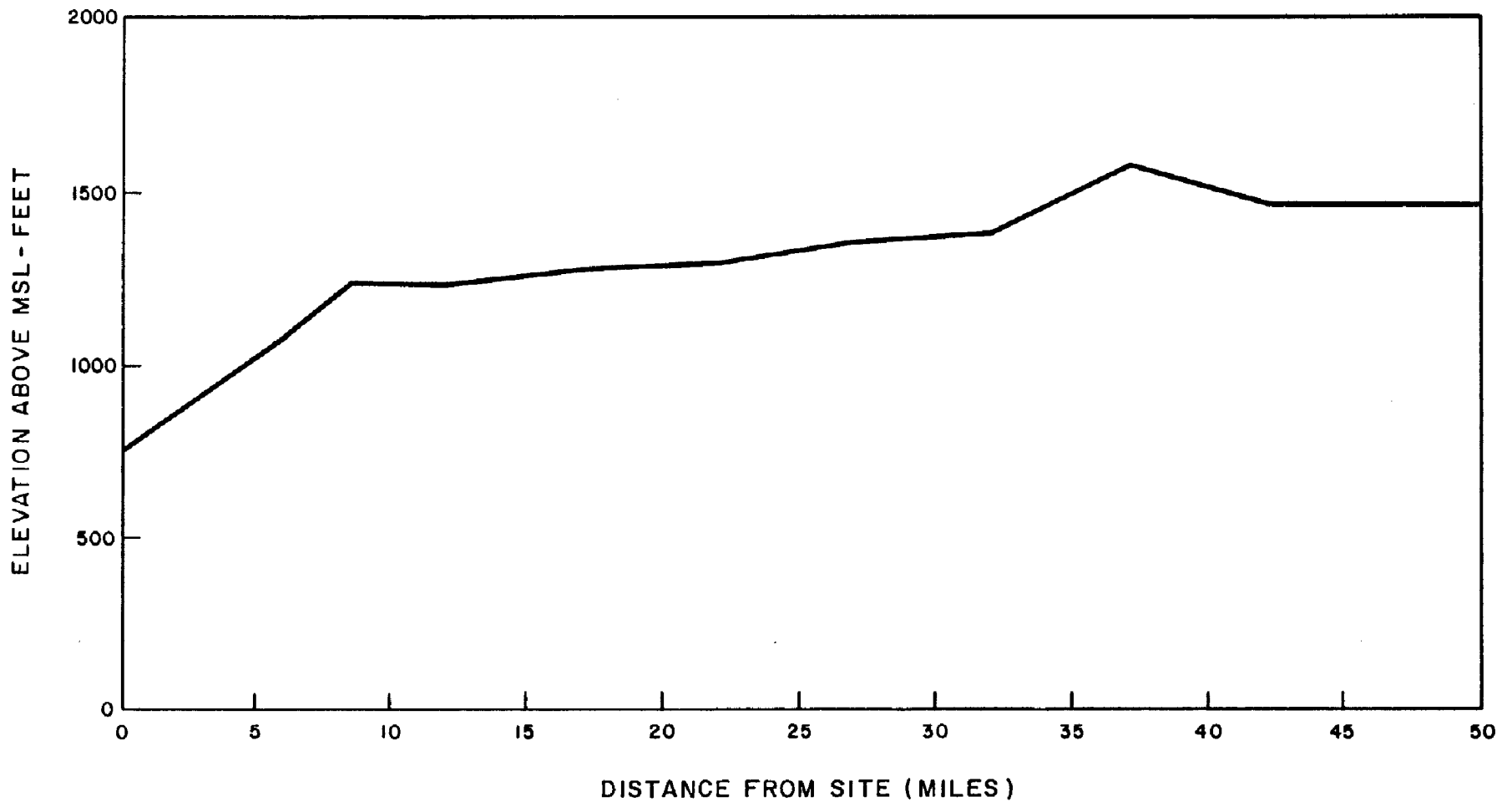

FIGURE 2.3 - 21  
TOPOGRAPHIC CROSS SECTIONS  
TO 50 MILES FOR THE  
SOUTH SECTOR  
BEAVER VALLEY POWER STATION - UNIT 2  
FINAL SAFETY ANALYSIS REPORT

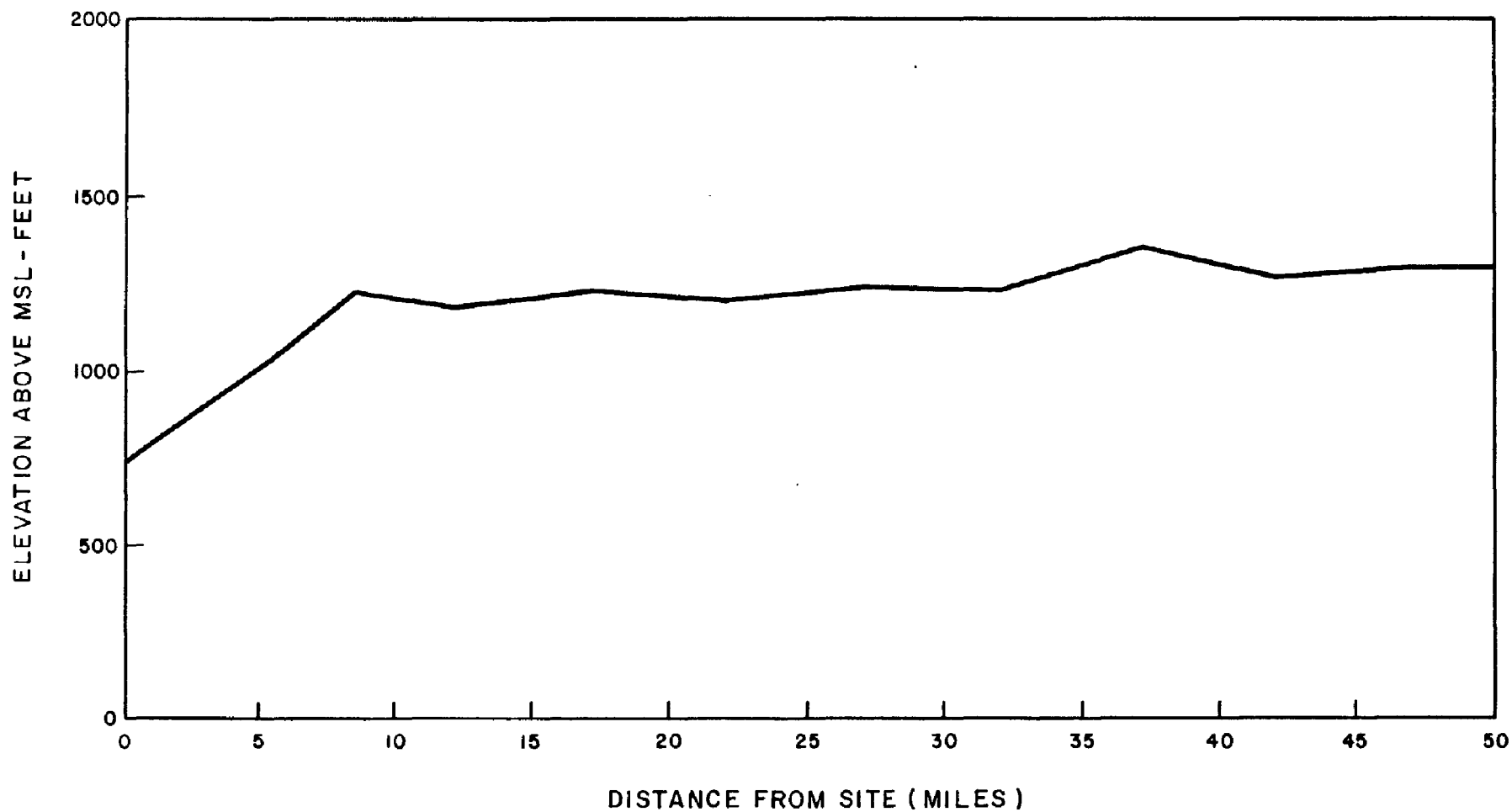

FIGURE 2.3 - 22  
TOPOGRAPHIC CROSS SECTIONS  
TO 50 MILES FOR THE  
SOUTH SOUTHWEST SECTOR  
BEAVER VALLEY POWER STATION - UNIT 2  
FINAL SAFETY ANALYSIS REPORT

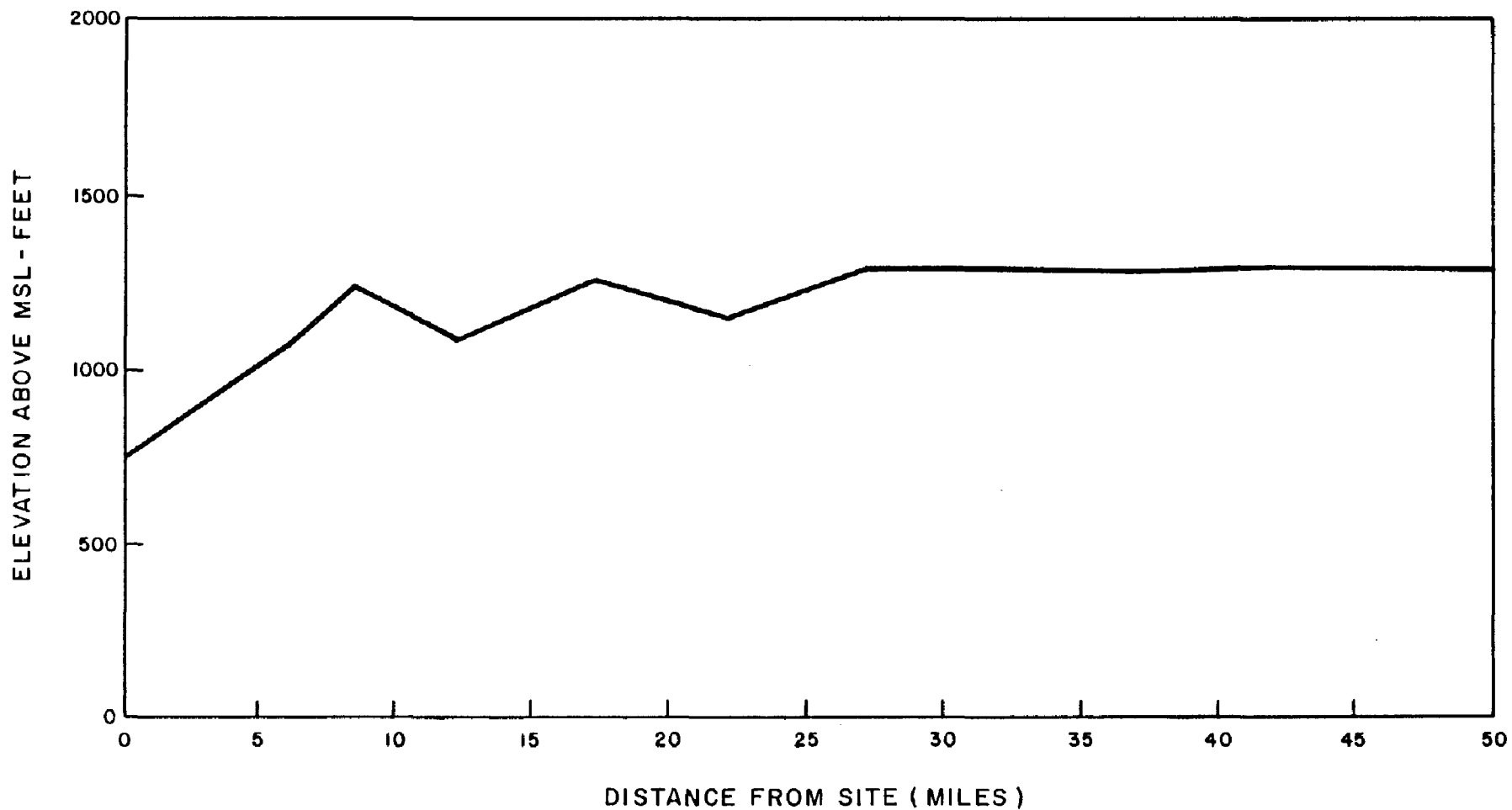

FIGURE 2.3 - 23  
TOPOGRAPHIC CROSS SECTIONS  
TO 50 MILES FOR THE  
SOUTHWEST SECTOR  
BEAVER VALLEY POWER STATION - UNIT 2  
FINAL SAFETY ANALYSIS REPORT

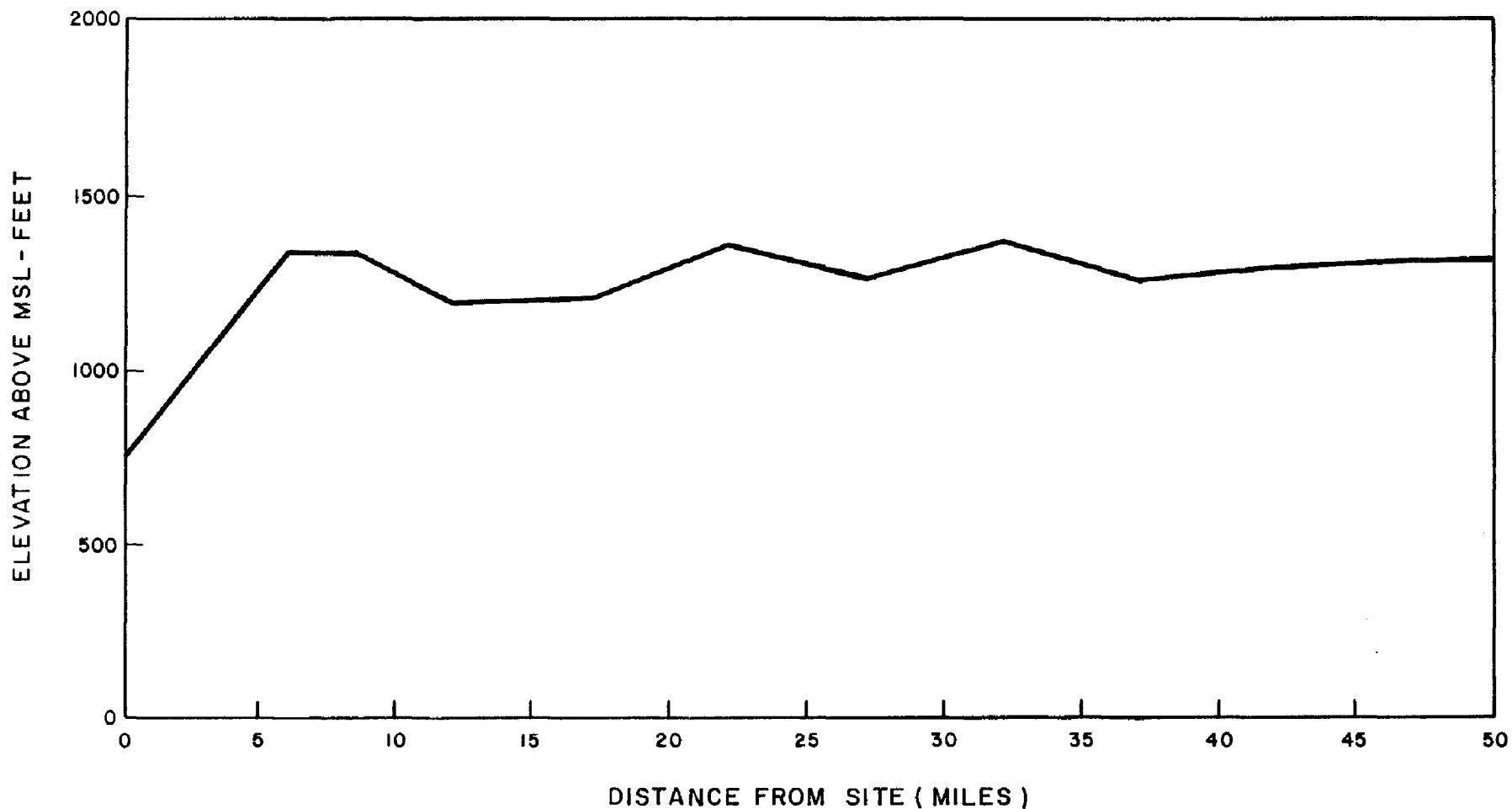

FIGURE 2.3 - 24  
TOPOGRAPHIC CROSS SECTIONS  
TO 50 MILES FOR THE  
WEST SOUTHWEST SECTOR  
BEAVER VALLEY POWER STATION - UNIT 2  
FINAL SAFETY ANALYSIS REPORT



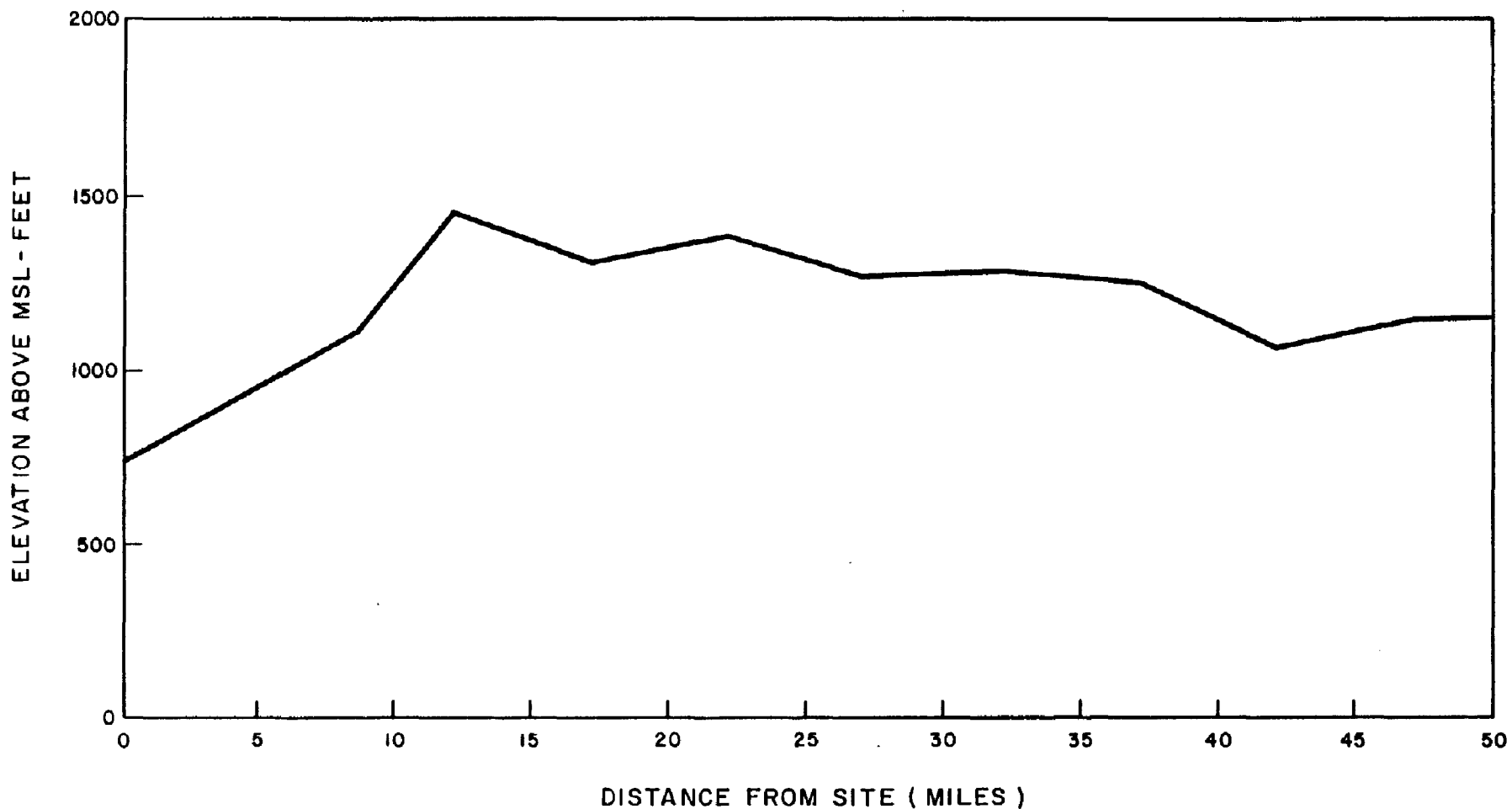

FIGURE 2.3 - 25  
TOPOGRAPHIC CROSS SECTIONS  
TO 50 MILES FOR THE  
WEST SECTOR  
BEAVER VALLEY POWER STATION - UNIT 2  
FINAL SAFETY ANALYSIS REPORT

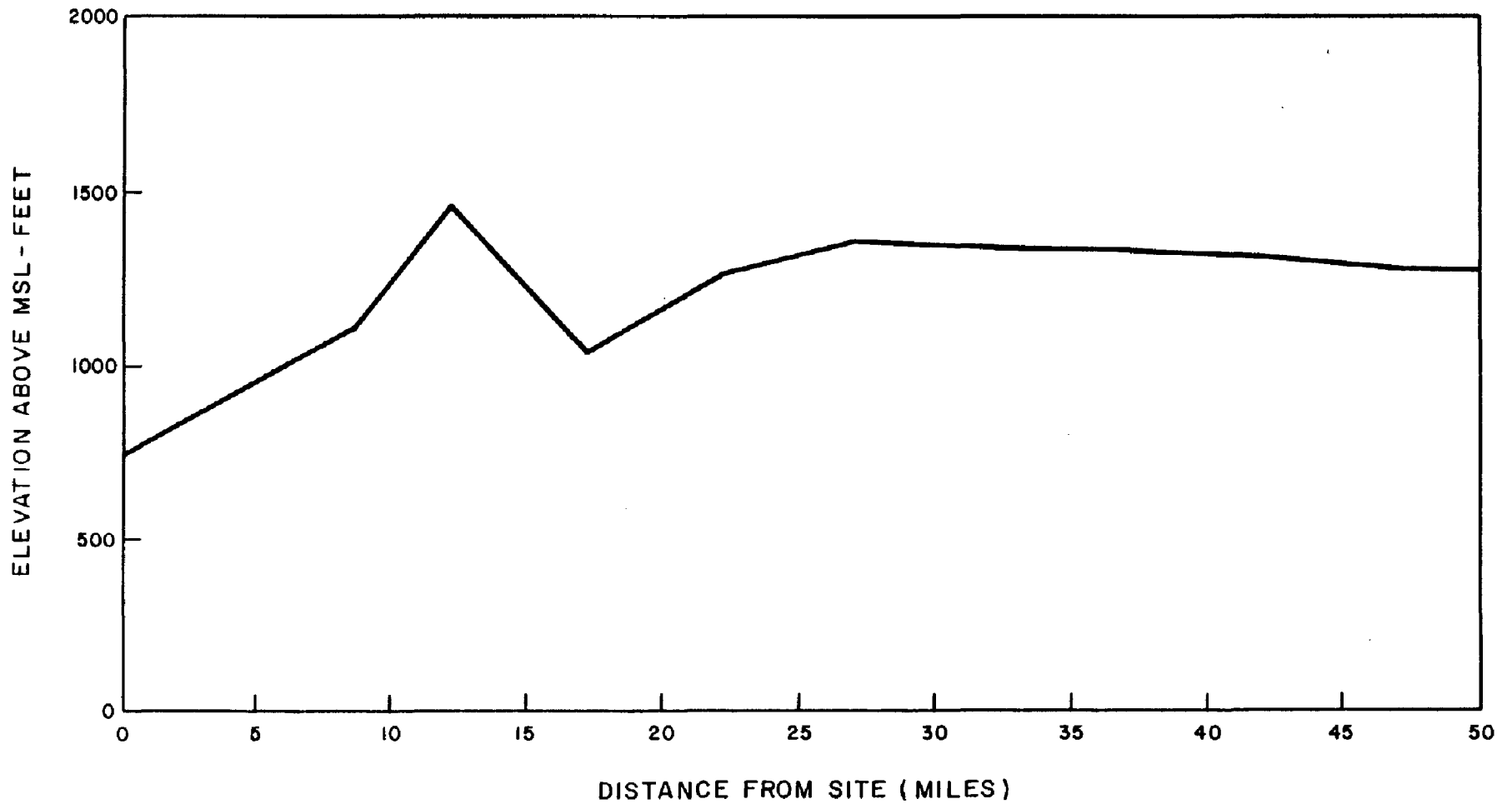

FIGURE 2.3 - 26  
TOPOGRAPHIC CROSS SECTIONS  
TO 50 MILES FOR THE  
WEST NORTHWEST SECTOR  
BEAVER VALLEY POWER STATION - UNIT 2  
FINAL SAFETY ANALYSIS REPORT

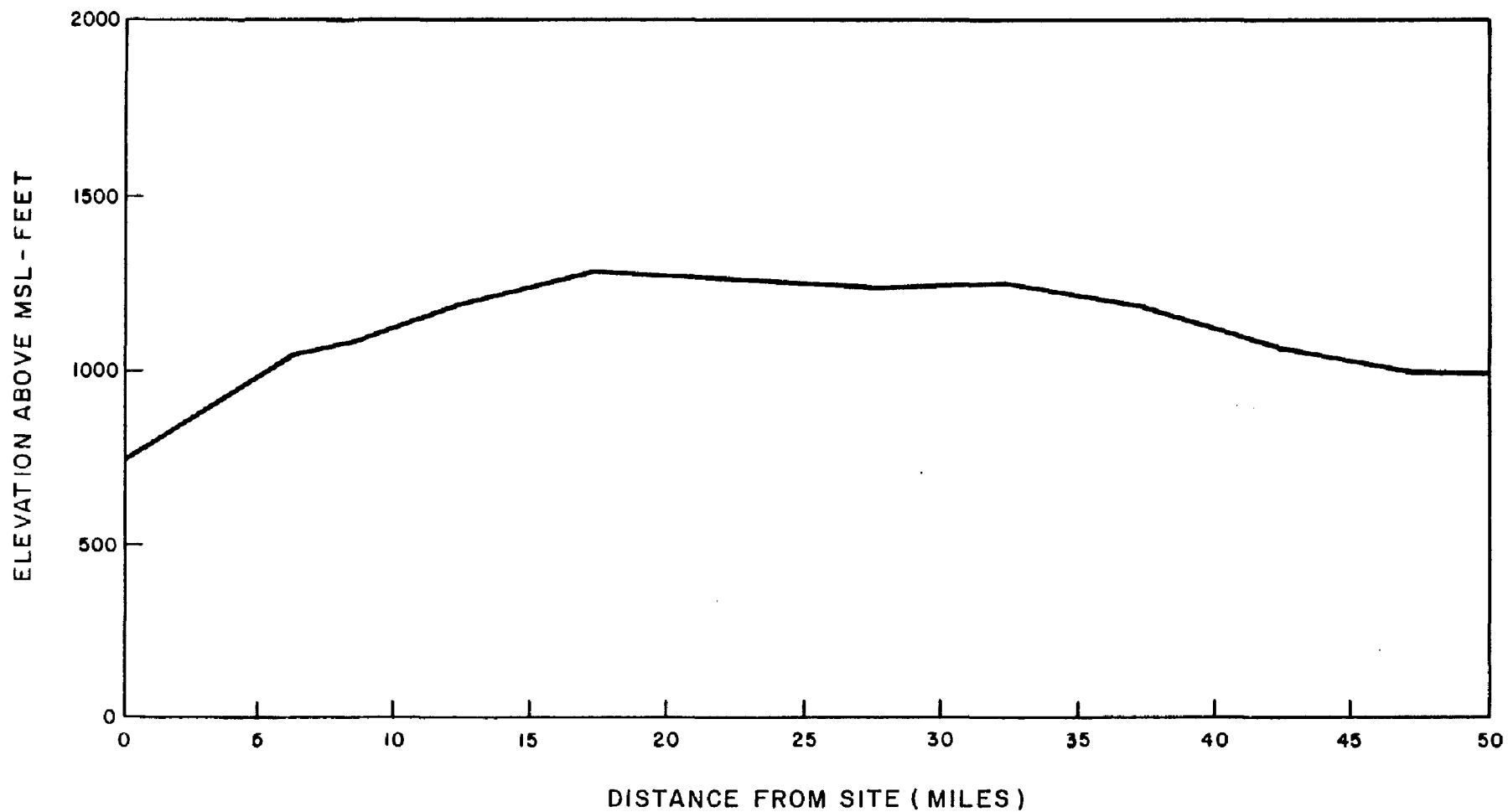

FIGURE 2.3 - 27  
TOPOGRAPHIC CROSS SECTIONS  
TO 50 MILES FOR THE  
NORTHWEST SECTOR  
BEAVER VALLEY POWER STATION - UNIT 2  
FINAL SAFETY ANALYSIS REPORT

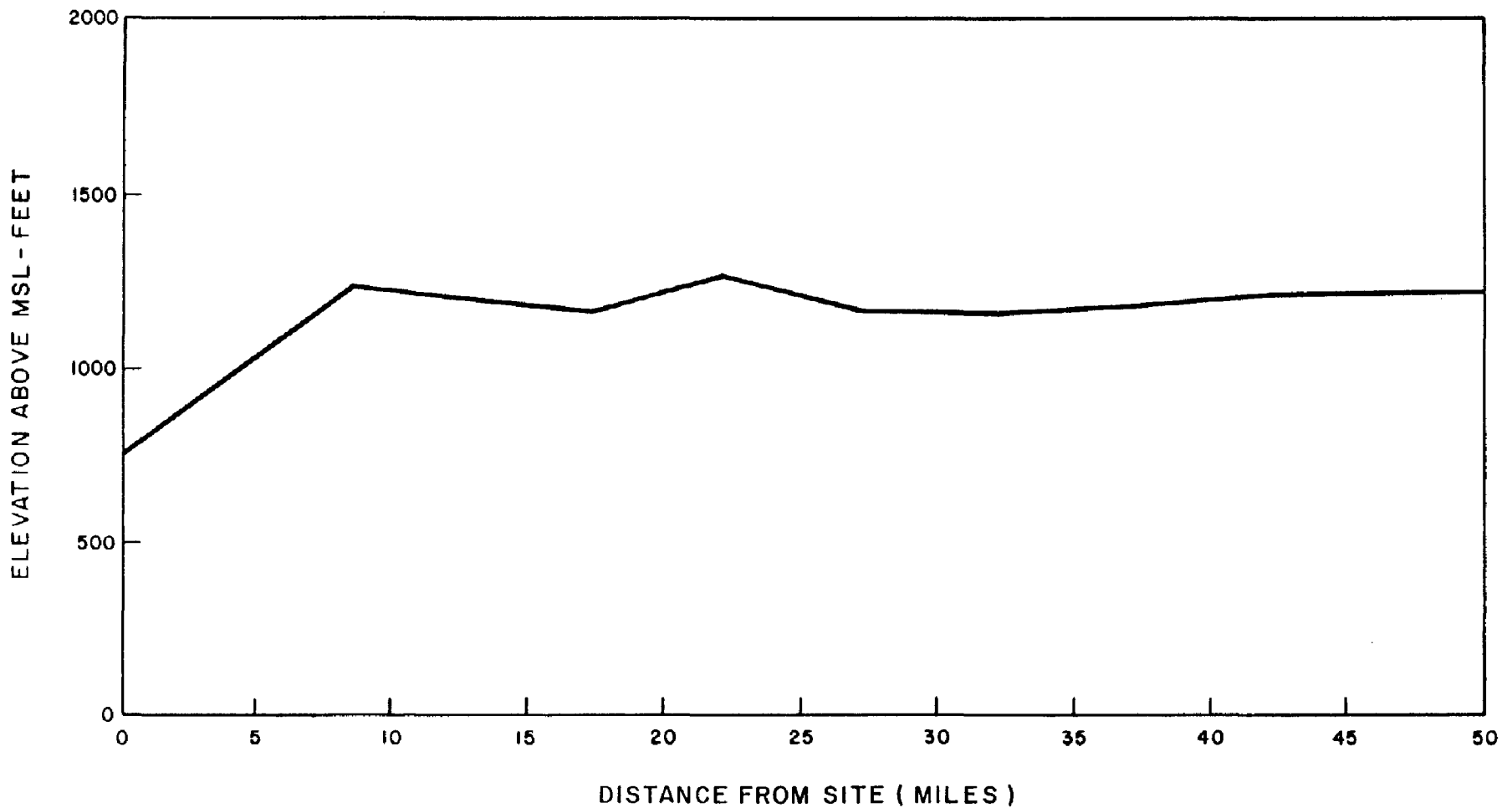
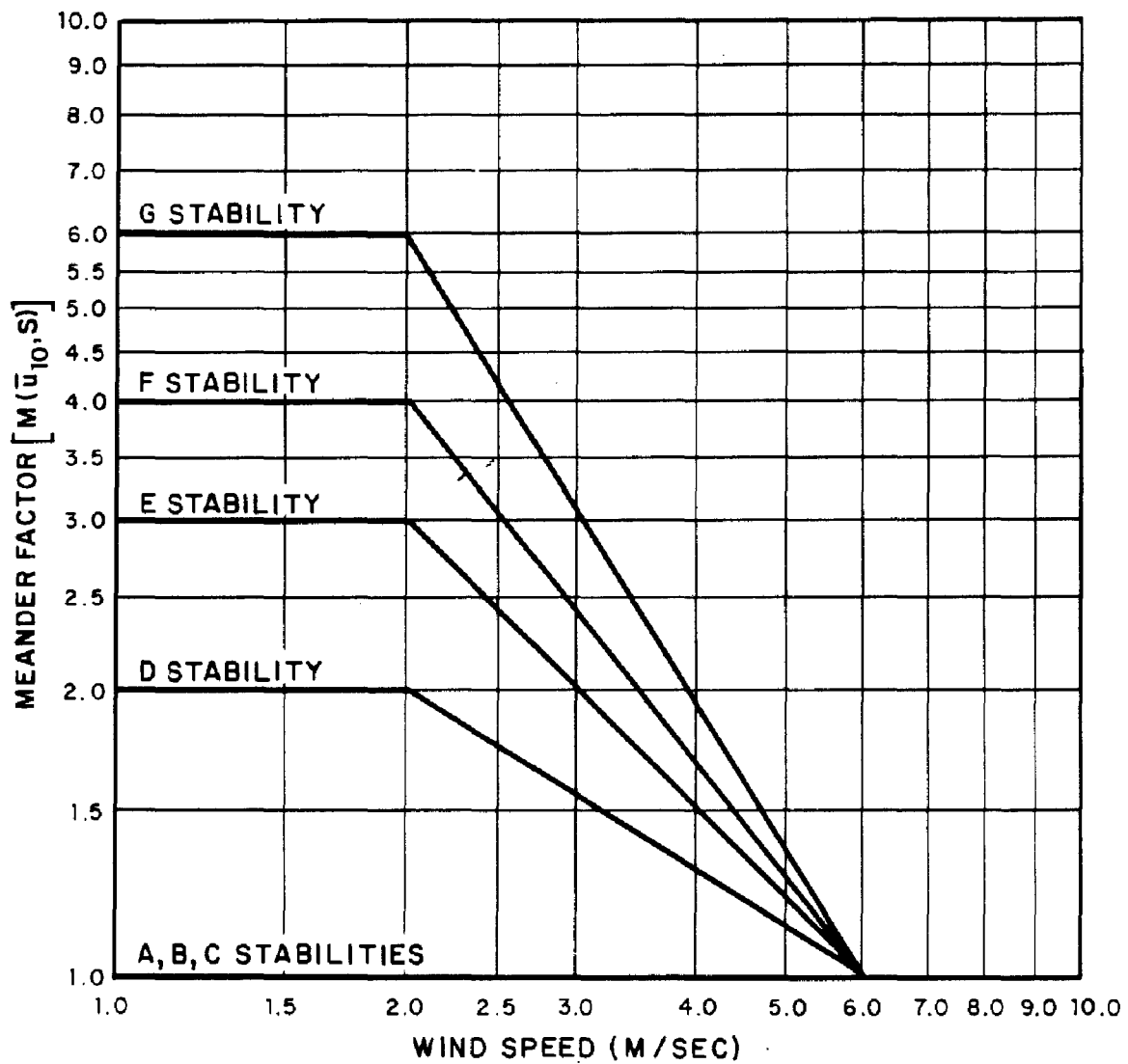

FIGURE 2.3 - 28  
TOPOGRAPHIC CROSS SECTIONS  
TO 50 MILES FOR THE  
NORTH NORTHWEST SECTOR  
BEAVER VALLEY POWER STATION - UNIT 2  
FINAL SAFETY ANALYSIS REPORT



NOTE:  
FROM REGULATORY GUIDE 1.145 AUGUST 1979.

FIGURE 2.3-29  
MEANDER AS A FUNCTION OF  
WIND SPEED AND STABILITY  
BEAVER VALLEY POWER STATION - UNIT 2  
FINAL SAFETY ANALYSIS REPORT

APPENDIX 2.3A

SALT AND WATER DRIFT

## APPENDIX 2.3A

## SALT AND WATER DRIFT

As the normal service and circulating water flows through the fill section of a cooling tower, the impact of the falling water on the splash bars creates small water droplets, some of which are carried away by the air stream moving through the tower. When these entrained droplets, called drift, leave the cooling tower, the exit velocity and buoyancy of the warm exit air provide the energy necessary to push the drift particles aloft. The downward force on the particles is the force of gravity, and its effect depends on the mass of the particles. Some of the drift droplets exiting the tower are sufficiently small that gravitational forces on them are negligible and atmospheric turbulence dominates their movement. Other droplets are initially affected by gravity but partially evaporate so that they become affected primarily by atmospheric turbulence. Ambient temperature and moisture content determine the reduction of particle size due to evaporation, and the particle terminal velocity is governed by the particle size and the air viscosity. As the plume disperses and cools, the buoyancy in the plume is dissipated, evaporation of the droplets begins, and a separation takes place between drift particles which will eventually deposit dissolved salts (salt drift) and water (water drift) on the ground, and particles which will remain suspended.

A mathematical model was developed to determine salt and water drift deposition rates and to predict downwind suspended particulate concentration contributions from the cooling tower drift. A discussion of the mathematical theory employed, the assumptions made, and the output of the model is presented as follows.

#### 2.3A.1 Tower Performance

The performance of the natural draft tower is determined by the ambient air conditions. The air draft through the tower is induced by the density difference between the air inside and outside of the tower. Cooling tower performance data, defining the exit air volume for a given ambient wet bulb temperature and relative humidity, were obtained from cooling tower manufacturers. The volume of exit air is proportional to the ambient relative humidity and inversely proportional to the ambient wet bulb temperature.

#### 2.3A.2 Drift Rate and Concentration

The air flow through the tower entrains droplets formed by mechanical breakdown of the cooling water splashing through the tower fill. Those droplets that pass through the drift eliminators exit the tower as drift and contain the same concentration of total dissolved solids as the circulating water. The total dissolved solids of the system represent the ambient dissolved solids in the makeup water concentrated by the evaporative cooling plus small chemical additions for biofouling control and pH adjustment. The drift rate is expressed as a percentage of the total cooling water flow.

### 2.3A.3 Droplet Size Distribution

The drift droplets are not buoyant particles. They must be entrained by an air draft velocity at least as great as their fall velocity. The typical shape of the curve of the droplet size distributions above the drift eliminators has been obtained from two reports by the Jersey Central Power and Light Company Forked River (1972) and U.S. Environmental Protection Agency (USEPA) (1971) reports. It is approximated by the six classes of droplet sizes shown on Figure 2.3A-1. Each droplet class is expressed as a percentage of the total drift mass.

Once the distribution is calculated, it is assumed constant for that specific operating condition. Air velocities increase beyond the drift eliminators and should be able to support the same droplet sizes. There is also evidence that there is no appreciable droplet growth by condensation (Jersey Central Power and Light Company 1972) or decay by mechanical breakdown (USEPA 1971) to change the size distribution.

### 2.3A.4 Plume and Droplet Rise

The method for computing the plume rise from the natural draft tower is based on a set of equations developed by Briggs (1972). The symbols used are defined as follows:

$h_t$  = cooling tower height (m)

$\Delta h$  = plume rise (m)

$F$  = buoyancy flux ( $m^4/sec^3$ )

$\bar{u}$  = average wind speed (m/s)

$x$  = downwind distance (m)

$S$  = stability parameter ( $sec^{-2}$ )

$$= \frac{\partial}{\partial T} \cdot \frac{\partial \theta}{\partial z}$$

$g$  = gravitational acceleration ( $m/sec^2$ )

$T$  = average absolute ambient air temperature ( $^{\circ}K$ )

$\frac{\partial \theta}{\partial x}$  = atmospheric vertical potential temperature gradient ( $^{\circ}K/m$ )

$$\frac{\partial \theta}{\partial x} = \frac{\Delta T}{\Delta z} + \Gamma$$

$\frac{\Delta T}{\Delta z}$  = vertical temperature gradient between the 500-foot and 35-foot levels of the onsite meteorological tower ( $^{\circ}K/m$ )



$\Gamma$  = dry adiabatic lapse rate ( $^{\circ}\text{K}/\text{m}$ )  
 $x^*$  = distance at which atmospheric turbulence begins to dominate entrainment (m) =  $34 F^{2/5}$

For unstable or neutral atmospheric conditions:

$$\Delta h = 1.6 F^{1/3} x^{2/3} u^{-1} \text{ for } x < 3.5x^* \quad (2.3A-1)$$

$$\Delta h = 1.6 F^{1/3} (3.5x^*)^{2/3} U^{-1} \text{ for } x \geq 3.5x^*$$

For stable atmospheric conditions:

$$\Delta h = 1.6 F^{1/3} \bar{u}^{-1} x^{2/3} \text{ for } x < 3.14 \bar{u} S^{-1/2} \quad (2.3A-2)$$

$$\Delta h = 2.4 F^{1/3} \bar{u}^{-1/3} S^{-1/3} \text{ for } x \geq 3.14 \bar{u} S^{-1/2}$$

For any calm condition near the ground,  $\bar{u}$  is set equal to 1.0 m/s a value considered representative at the height at which the plume will occur, and the preceding hourly wind direction is used.

The height of the plume above the ground at any given downwind distance is  $\Delta h + h_t$ .

Since some droplets within the plume are sufficiently large so that they do not follow the centerline of the plume, the departure of these droplets from the plume's centerline as a function of downwind distance was estimated.

The following equations were used (Briggs 1972):

$$r = 0.5z + r_0$$

$$s = V_d x / \bar{u}$$

where

$r$  = radius of plume (m)  
 $s$  = droplet departure from plume centerline (m)  
 $x$  = downwind distance (m)  
 $\bar{u}$  = average wind speed (m/s)  
 $r_0$  = tower top radius (m)

$V_d$  = fall velocity of droplet (m/s)

$z$  = rise for the plume centerline (m)

The droplet trajectories within the plume are computed. Should  $s$  become equal to  $r$  for specific large droplets, they would leave the plume and evaporation would begin at that height and distance downwind. Droplets remaining within the plume to the downwind distance of final plume rise are assumed to begin to evaporate at a height of  $h_t + \Delta h - S$ .

### 2.3A.5 Droplet Trajectory

When the droplets leave the plume, the droplet trajectory is determined by the horizontal wind velocity and the vertical droplet fall velocity. In general, smaller droplets are transported farther from the tower by the wind because they are carried higher by the cooling tower plume, and because their fall velocity is smaller. Larger droplets, however, do not rise as high above the tower and fall closer to the tower. Evaporation decreases the droplet size and, therefore, the fall velocity. As a result, the slope of the droplet trajectory decreases until the equilibrium diameter is attained, or until the droplet can be treated as a suspended particulate (diameter  $\leq 50\mu$ ).

### 2.3A.6 Droplet Fall Velocity

The drift droplet falls at a terminal fall velocity where the vertical drag force balances the gravitational force; this velocity is largely dependent upon the droplet size. The fall velocity for a droplet smaller than  $80 \mu$  in diameter is computed from Stokes Law (List 1966):

$$v = \frac{2r^2g}{9} \cdot \frac{S_1 - S_2}{n} \quad (2.3A-6)$$

where:

$V$  = fall velocity (cm/sec)

$r$  = droplet radius (cm)

$g$  = acceleration of gravity (cm/sec<sup>2</sup>)

$S_1$  = droplet density (g/cm<sup>3</sup>)

$S_2$  = air density (g/cm<sup>3</sup>)

$n$  = dynamic viscosity of air (poise)

Since the air density is much smaller than the water density, the  $S_1 - S_2$  term may be assumed equal to  $S_1$ .

The dynamic viscosity is independent of pressure except at very low pressures. the Sutherland equation describes viscosity as a function of absolute temperature (List 1966).

$$\frac{n}{n_o} = \frac{T_o + C}{T + C} \left( \frac{T}{T_o} \right)^{3/2}$$

$n$  = dynamic viscosity of air (poise)

$n_o$  =  $1.8325 \times 10^{-4}$  (poise)

$T_o$  = 296.16°K

$T$  = air temperature (°K)

$C$  = 120°C (Sutherland's constant)

The terminal velocity for a droplet larger than 80  $\mu$  in diameter is based on the empirical results for distilled water droplets in stagnant air (List 1966).

### 2.3A.7 Droplet Evaporation

The mass evaporation rate of freely falling water droplets is expressed as the product of two terms: (List 1966) and (Figure 2.3A-2).

$$\frac{dM}{dt} = \left[ 4\pi r \left( 1 + \frac{Fr}{S} \right) \right] \cdot \left[ K(\rho_a - \rho_b) \right] \quad (2.3A-7)$$

where:

$M$  = mass (g)

$t$  = time (sec)

$r$  = radius of droplet (cm)

$F$  = dimensionless factor

$S$  = equivalent thickness of transition shell outside the droplet (cm)

$K$  = coefficient of diffusion ( $\text{cm}^2/\text{sec}$ )

$\rho_a$  = saturated vapor density at the surface of the droplet ( $\text{g}/\text{cm}^3$ )

$\rho_b$  = ambient vapor density ( $\text{g}/\text{cm}^3$ )

Droplet evaporation is shown on Figure 2.3A-2

The first term in Equation 2.3A-7 is a function of droplet diameter and ambient air temperature. Since the effect due to ambient air temperature is slight, the factor is expressed in terms of droplet diameter at a mean temperature of 15°C. The second term is a function of ambient air temperature and relative humidity. The evaporation is considered to be zero if the air temperature is below freezing or the relative humidity is above 98.6 percent (Jersey Central Power and Light Company 1972).

The evaporation of saline droplets is limited by the hygroscopic properties of the solution (Israel and Overcamp 1974). As water evaporates from a droplet, the concentration of the droplet solution increases. For high ambient relative humidities, evaporation ceases when the droplet vapor pressure reaches equilibrium with the atmosphere. Intermediate humidities allow the droplet to evaporate to a saturated or supersaturated solution. Under conditions of low humidity, evaporation occurs until supersaturation, and the solution changes phase and crystallizes into a dry particle. Figure 2.3A-3 depicts the equilibrium diameter as a function of the concentration of dissolved solids and the ambient relative humidity. The transition from droplet to dry particle occurs for relative humidities of less than 40 percent.

#### 2.3A.8 Dispersion of Drift

Droplets larger than 50  $\mu$  in diameter were dispersed as described previously. In addition, the droplets were assumed to be uniformly dispersed laterally across the downwind sector of 22.5 degrees. The drift mass is divided into six droplet size classes (Figure 2.3A-1) and the area of deposition for each size class is defined by the distances of deposit of the largest and smallest droplets contained in each class. The droplets of each class are assumed to be uniformly dispersed over the area of deposition for the class.

Droplets equal to or smaller than 50 $\mu$  in diameter, whether emitted initially from the tower or formed through evaporation of larger droplets downwind, were considered suspended particulates and were dispersed according to Gaussian principles (Israel and Overcamp 1974).

The total ground level suspended particulate concentration at any downwind distance is the summation of the contributions of all droplet size classes which reach the 50  $\mu$  diameter cutoff. This cutoff was used to distinguish the suspended particulate portion of the drift from the salt drift deposition portion because a hi-vol sampler, the standard suspended particulate instrument, measures particles of this size magnitude. Furthermore, Roffman and Van Vleck, (1974) in a salt drift deposition review paper, refer to drift droplets that fall to the ground as having a diameter greater than 50 microns in diameter.

Airborne salt concentrations can be obtained by dividing the salt drift deposition rate from each of the six droplet size classes by the deposition velocity of the droplets (just prior to their impact upon the ground) in the appropriate size class. The resultant sum of these "resuspended" settleable particulate concentrations and suspended particulate

concentrations at each grid point constitutes the airborne salt concentration.

In the evaluation of the foliar salinization effects of airborne salt, the maximum hourly concentration at any point downwind is representative of the short-term period value, while the maximum annual average concentration at any point downwind is representative of the long-term period value.

The amount of drift leaving the proposed cooling towers is assumed to be 0.05 and 0.013 percent of the circulating water flow through the tower for BVPS 1 and BVPS 2, respectively. These numbers are guaranteed by the cooling tower manufacturers and, in fact, even lower drift rate percentages may be achieved. The annual average TDS concentration in the blowdown and 1 year of onsite, hourly average meteorological data (January 1, 1976-December 31, 1976) were used as input to the salt drift model, which has been discussed within this section. Meteorological parameters used in the model were low-level (35 feet above ground) wet-bulb temperature and relative humidity to determine tower performance and upper level (500 feet above ground) dry-bulb temperature, wind speed, and wind direction to calculate droplet transport. The atmospheric stability parameter  $T_{500\text{feet}-35\text{feet}}$  was also used to determine plume rise and droplet dispersion.

The results of the drift model are produced at 250-foot intervals out to a distance of about 5 miles from the towers in each of the 16 downwind directions. Monthly and annual drift deposition rates are calculated at each grid point.

Surface areas affected by cooling tower salt drift and water drift for both units are shown on Figures 2.3A-4 and 2.3A-5, respectively. The maximum salt deposition rate of 9.9 lb/acre/yr occurs approximately 4,750 feet east of the cooling towers. The maximum water deposition rate of 20,300 lb/acre/yr (0.09 in/yr) occurs at a distance approximately 4,000 feet east of the towers. The maximum annual average airborne salt concentration is predicted to be  $0.07 \text{ g/m}^3$  approximately 7,000 feet east of the towers,<sup>3</sup> while the maximum hourly airborne concentration of  $21.9 \text{ } \mu\text{g/m}^3$  occurs 3,250 feet west-southwest of the towers.

#### 2.3A.9 References for Appendix 2.3A

Briggs, G.A. 1972. Discussion on Chimney Plumes in Neutral and Stable Surrounding. Atmosphere Environment 6, p 507-510.

Israel, G.W. and Overcamp, T.J. 1974. Drift Deposition Model for Natural Draft Cooling Towers. University of Maryland, College Park, MD.

Jersey Central Power and Light Company 1972. Salt Water Cooling Tower Report. Forked River Nuclear Generating Station Unit 1, Environmental Report, Docket No. 50-363, Appendix B, Attachment 5.

List, R.J. 1966. Smithsonian Meteorological Tables. No. 4014, Smithsonian Institution.

Roffman, A. and Van Vleck, D.L. 1974. The State of the Art of Measuring Cooling Tower Drift and Its Deposition. APCA Journal, Vol 24, No. 9.

U.S. Environmental Protection Agency (USEPA) 1971. Development and Demonstration of Low-Level Drift Instrumentation. Office of Research and Monitoring, Corvallis, Ore.

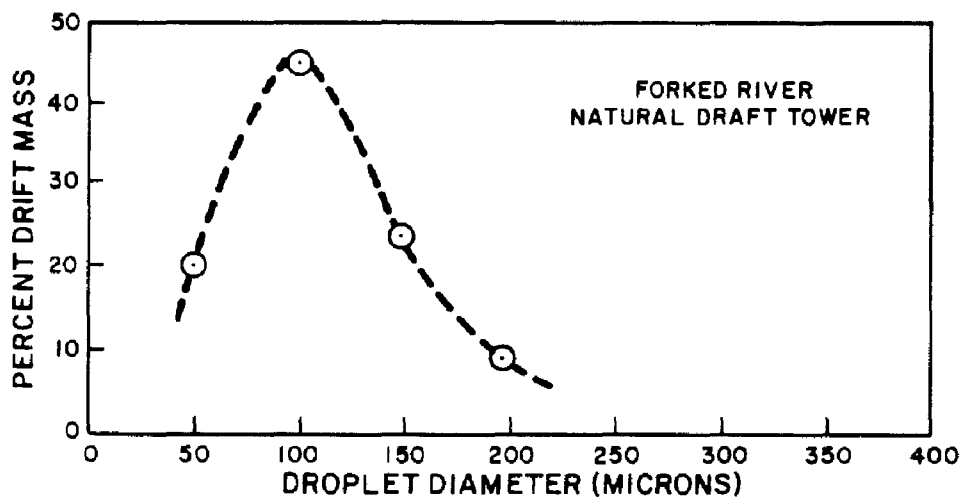
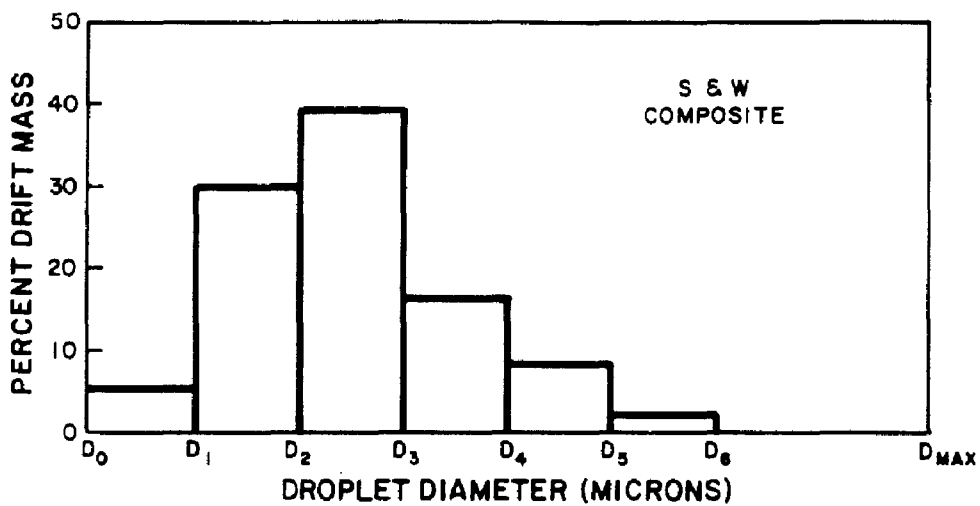
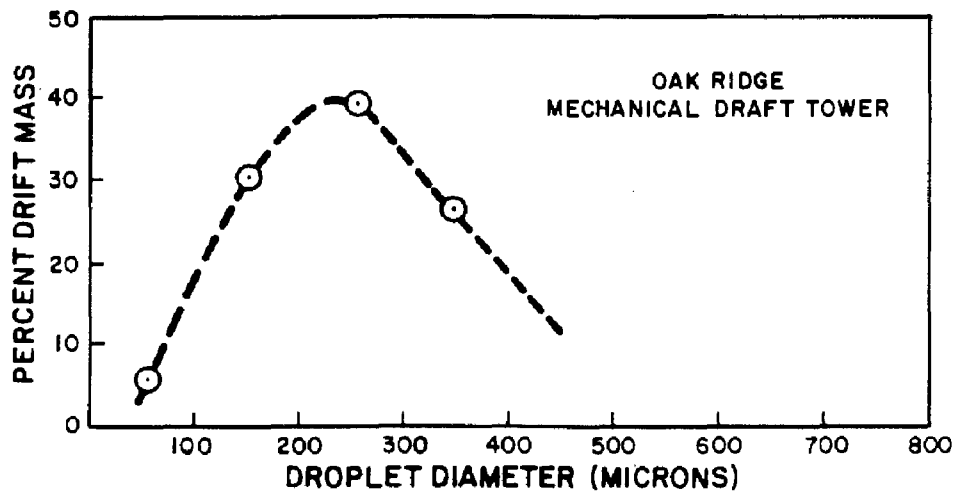
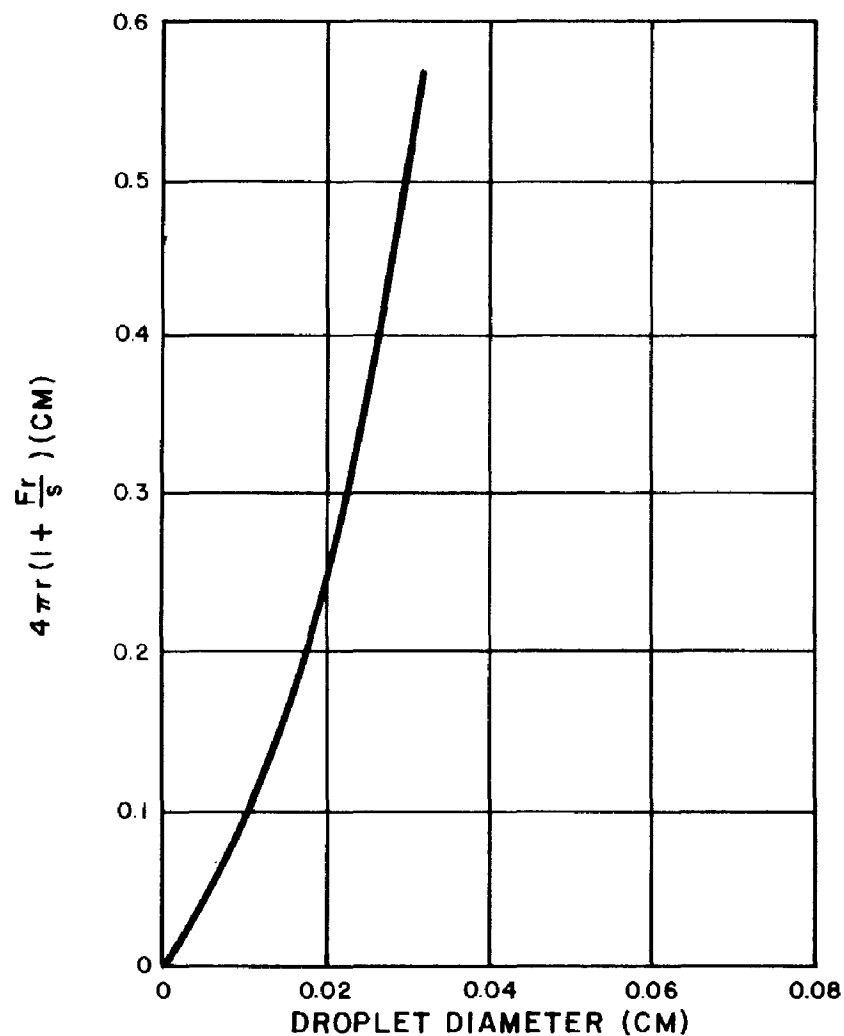

FIGURE 2.3.A-1  
 DRIFT MASS DISTRIBUTION  
 BY DROPLET SIZES  
 BEAVER VALLEY POWER STATION-UNIT 2  
 FINAL SAFETY ANALYSIS REPORT



NOTE:

$$\frac{dM}{dt} = \left[ 4\pi r \left( 1 + \frac{Fr}{s} \right) \right] \left[ K(\rho_a - \rho_b) \right]$$

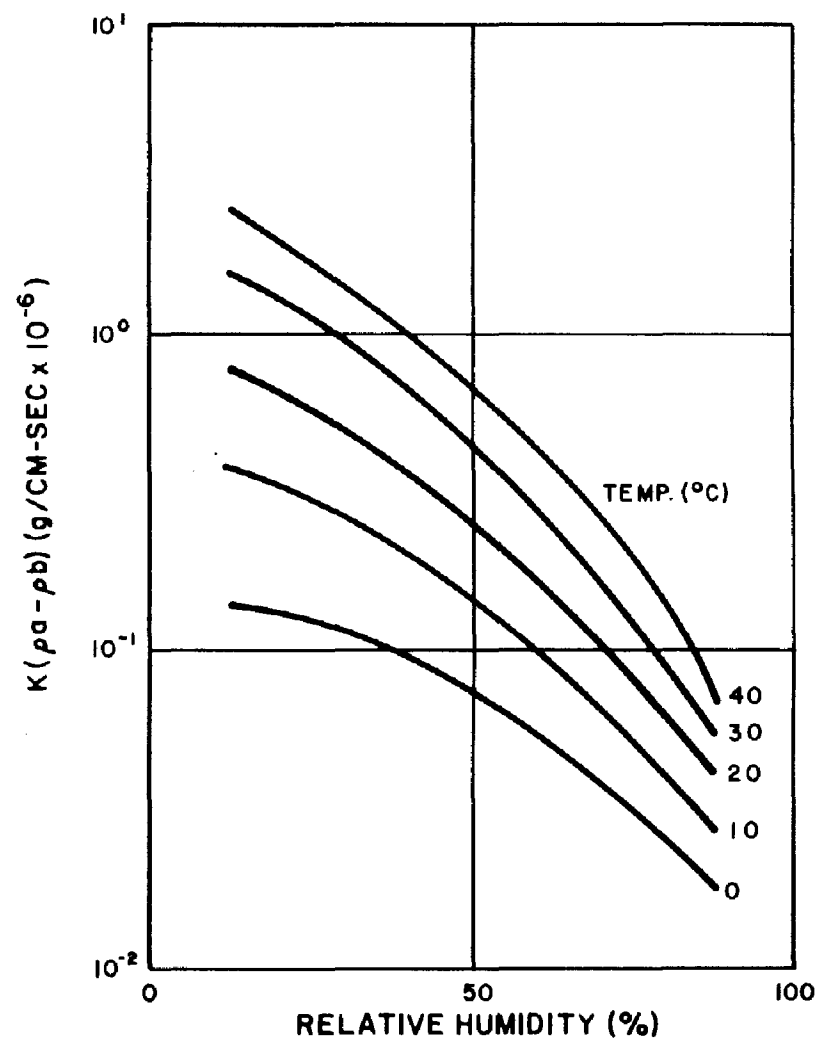
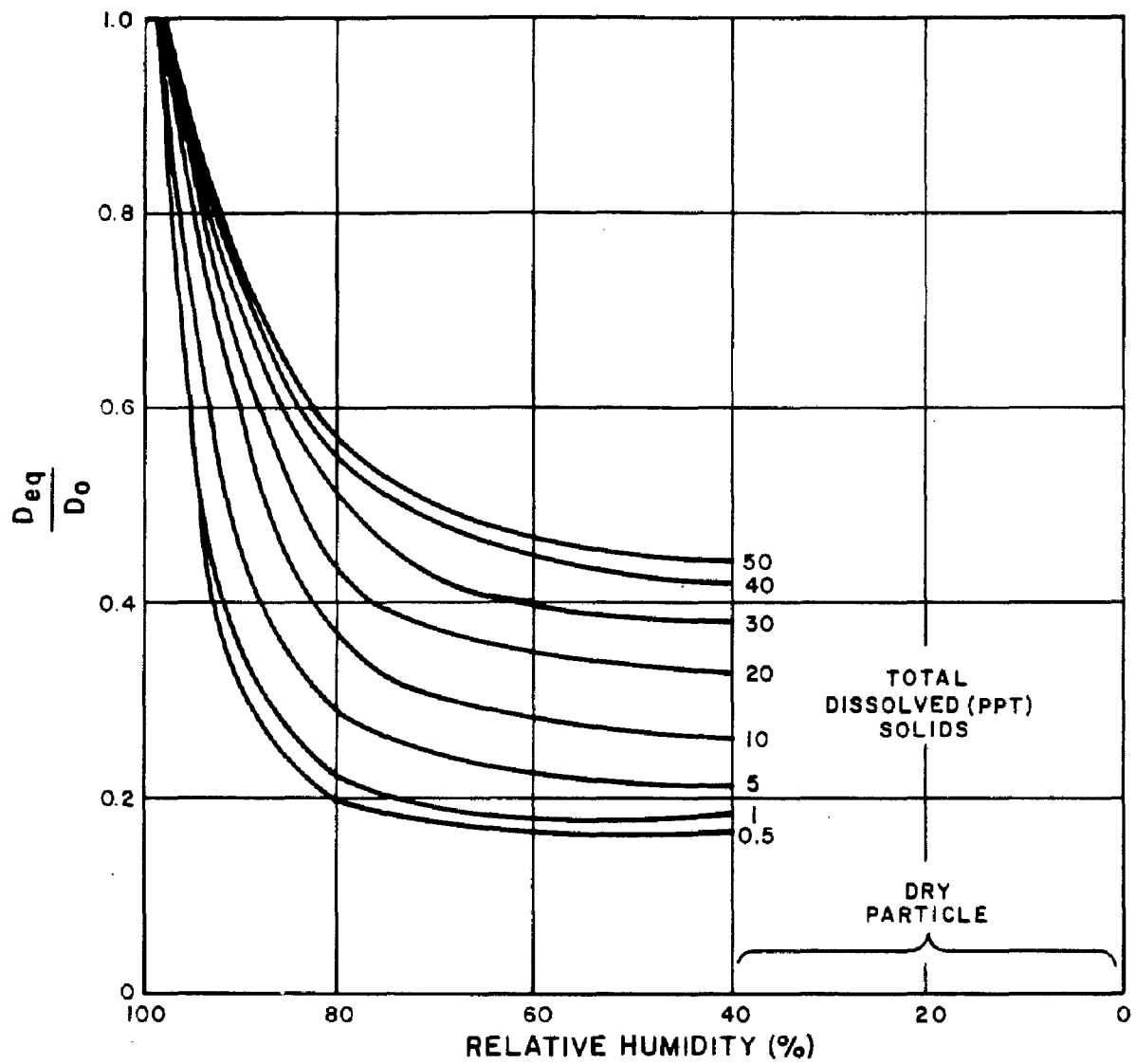

FIGURE 2.3.A-2  
 DROPLET EVAPORATION  
 BEAVER VALLEY POWER STATION-UNIT 2  
 FINAL SAFETY ANALYSIS REPORT





NOTES:  
 $D_0$  = INITIAL DROPLET DIAMETER  
 $D_{eq}$  = EQUILIBRIUM DROPLET DIAMETER

FIGURE 2.3.A-3  
 EQUILIBRIUM DROPLET DIAMETER  
 BEAVER VALLEY POWER STATION-UNIT 2  
 FINAL SAFETY ANALYSIS REPORT



NOTE:

⊗ MAXIMUM VALUE OF 9.9 LB/ACRE/YR...  
4,750 FT. EAST

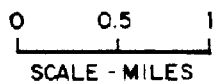

FIGURE 2.3A-4  
ANNUAL SALT DEPOSITION  
(LB/ACRE/YR)  
BEAVER VALLEY POWER STATION-UNIT 2  
FINAL SAFETY ANALYSIS REPORT



NOTE:

⊗ MAXIMUM VALUE OF 20,300 LB/ACRE/YR  
4,000 FT EAST

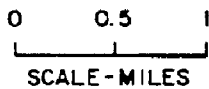

FIGURE 2.3A-5  
ANNUAL WATER DEPOSITION  
(LB/ACRE/YR)  
BEAVER VALLEY POWER STATION-UNIT 2  
FINAL SAFETY ANALYSIS REPORT

APPENDIX 2.3B

VISIBLE PLUME MODEL

## APPENDIX 2.3B

## VISIBLE PLUME MODEL

The mathematical model used to predict the configuration and characteristics of the visible plumes resulting from the operation of natural draft cooling towers is based on the work of Fan (1967) and Abraham (1970). The basic assumptions and mathematical formulations of turbulent, round, buoyant jets are adopted and applied to determine the configuration of a visible cooling tower plume. The method takes into account the entrainment of the cooler ambient air, momentum of the balanced system, and buoyant force and heat content of the plume.

The governing equations, basic assumptions, and a definitive sketch for the turbulent jet method are presented on Figure 2.3B-1.

The variables used in the equations of Figure 2.3B-2 are defined as follows:

$d$	=	increment of distance along plume path (m)
$b$	=	radius of plume jet (m)
$U$	=	horizontal wind velocity (m/sec)
$V$	=	vertical velocity of plume (m/sec)
$\theta$	=	angle of plume trajectory with respect to the horizontal direction (degrees)
$\alpha_m$	=	entrainment coefficient for a momentum jet-constant (dimensionless)
$\alpha_t$	=	entrainment coefficient for a thermal-constant (dimensionless)
$C$	=	drag coefficient (dimensionless)
$g$	=	acceleration of gravity ( $m/sec^2$ )
$\rho_a$	=	density of ambient air ( $g/cm^3$ )
$\rho$	=	density of plume ( $g/cm^3$ )
$x$	=	horizontal coordinate of the plume centerline from the center of the tower (m)
$z$	=	vertical coordinate of the plume centerline from the top of the tower (m).

A further discussion of plume predictions, with comparisons to observations based on photographs of emitted plumes from five natural

draft cooling tower sites under varying meteorological conditions, has been published recently (Policastro et al 1977). In comparison with seven other models tested in this independent verification study, the model described above ranked second in its height predictions and third in its length predictions, with the best absolute log mean ratio. Based on these verifications, it is concluded that the overall configuration and size of cooling tower plumes are well simulated by the mathematical model used.

The turbulent jet method is based on the following assumptions:

1. Substitution of a mixing and entrainment mechanism for a dispersion mechanism,
2. Gaussian distribution for heat, mass density, and velocity profiles, and
3. Conservation of mass and momentum within plume boundaries.

As shown on Figure 2.3B-1, a round buoyant plume rises at a velocity,  $V$ , into ambient air with a velocity of  $U$ . The temperature and density of the plume at any given distance downwind, and the temperature and density of the ambient air, are represented by  $T$ ,  $\rho$ ,  $T_d$ , and  $\rho_a$ , respectively.

The trajectory of the plume is curved in the downwind direction due to the effects of a tower-induced low pressure region. The angle between the axis of the plume and the horizontal is  $\theta$ . The entrainment, or lateral mixing of the surrounding ambient air, is balanced by deceleration of the entire central portion of the plume. Since these portions cannot be sharply defined, a local characteristic length,  $b$ , (linearly related to the standard deviation) is represented. The plume size is then calculated as  $2\sqrt{2}b$ . The entrainment coefficients used for continuity of mass and conservation of momentum are those recommended by Abraham (1970). The effect of the presence of the pressure field can be lumped into a gross drag term proportional to the square of the velocity component of the air flow normal to the plume axis. The drag coefficient,  $C$ , is assumed to be a constant. Buoyant forces can arise due to density differences, whether they are due to plume temperature or moisture content. The buoyancy of the cooling tower plume plays an important role in the analysis, since a large quantity of heat and moisture is rejected from the tower. The effects of aerodynamic downwash are not included in the model due to the large emission height of a natural draft cooling tower which precludes downwashing of the plume.

Numerical analysis is used to solve the seven ordinary differential equations listed on Figure 2.3B-1. The parameters defining the visible plume behavior which is also depicted on Figure 2.3B-1, are obtained from the solution of these equations.

Figure 2.3B-2 shows the predicted natural draft cooling tower performance curves (which are essentially the same for both units),

assuming 100-percent heat load, which were used to develop Figures 2.3B-1 and 2.3B-2.

For given cooling tower operating conditions and specified meteorological conditions, the mathematical model calculates the size and configuration of the visible plume. The plume is visible as fog when the air in the plume is at or below its saturation temperature. Ambient air at 100 percent relative humidity is not included as a given meteorological input to the model because it is assumed that fog occurs naturally during this condition. Based on 1 year (January 1, 1976 to December 31, 1976) of onsite meteorological data, 100-percent relative humidity occurred 5 percent of the time.

The mathematical model is constructed to accept input meteorological parameters grouped into the classes presented in Table 2.3B-1 (ambient dry bulb temperature and relative humidity at 10 meters above ground level were used, as well as wind speed and wind direction at 150 meters above ground level).

Given the information in Table 2.3B-1, the model calculates the visible plume spatial extent in terms of plume length, trajectory, and radius for each combination of variables. These data are summarized for all meteorological combinations on a grid, whose dimensions are 1,500 feet (vertical) by 5,000 feet (horizontal), showing the frequency of occurrences of visible plumes by hours and by percent of total time.

The frequency of visible plume occurrence was calculated using all combinations of meteorological conditions (except 100-percent relative humidity) for each of 16 wind directions, utilizing the performance curves shown on Figure 2.3B-2 and based on a design wet-bulb temperature of 74°F. This is equaled or exceeded in 0.3 percent of the 1945 to 1977 Pittsburgh, Pa., observations.

#### References for Appendix 2.3B

Abraham, G. 1970. The Flow of Round Buoyant Jets Issuing Vertically into Ambient Fluid Flowing in a Horizontal Direction. Presented at the Fifth International Water Pollution Research Conference, San Francisco, Calif and Honolulu, Hawaii, July 26,- August 5, 1970.

Fan, L.N. 1967. Turbulent Buoyant Jets into Stratified or Flowing Ambient Fluid. California Institute of Technology, Pasadena, Calif. Report No. KH-R-15.

Policastro, A.J.; Carhart, R.A.; and DeVantier, B. 1977. Validation of Selected Mathematical Models for Plume Dispersion from Natural Draft Cooling Towers. Presented at Waste Heat Management and Utilization Conference, Miami, Fla., May 9-11, 1977.

Tables for Section 2.3B



TABLE 2.3B-1

CLASSES OF METEOROLOGICAL PARAMETERS  
USED AS INPUT TO THE MATHEMATICAL MODEL

<u>Air Temperature</u> (°F)	<u>Relative Humidity</u> (Percent)	<u>Wind Speed</u> (Knots)
-20 to -10	0 to 25	0 to 2
-9 to 0	26 to 40	3 to 7
1 to 10	41 to 50	8 to 12
11 to 20	51 to 60	13 to 17
21 to 30	61 to 70	18 to 22
31 to 40	71 to 75	23 to 27
41 to 50	76 to 80	28 to 32
51 to 60	81 to 85	>32
61 to 70	86 to 90	
71 to 80	91 to 93	
81 to 90	94 to 96	
91 to 100	97 to 99	
>100		

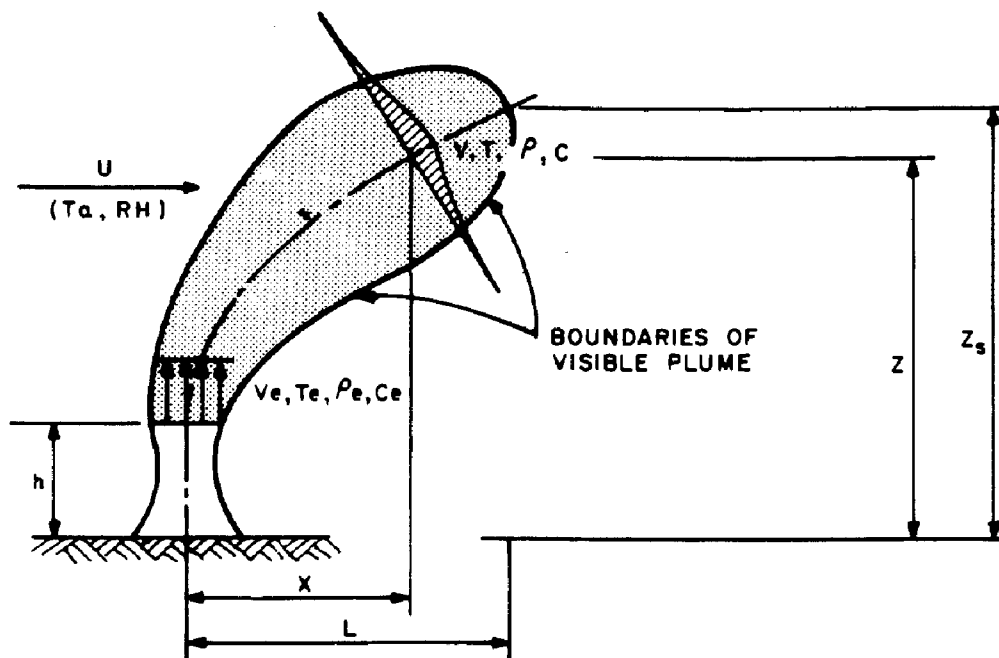

### BASIC EQUATIONS

CONTINUITY:

$$\frac{d}{ds} [b^2 (2U \cos \theta + V)] = 2b (\alpha_m V + \alpha_t U \sin \theta \cos \theta)$$

x-MOMENTUM:

$$\frac{d}{ds} \left[ \frac{b^2}{2} (2U \cos \theta + V)^2 \cos \theta \right] = 2bU (\alpha_m V + \alpha_t U \sin \theta \cos \theta) + \frac{\sqrt{2}}{\pi} Cd U^2 b \sin^3 \theta$$

z-MOMENTUM:

$$\frac{d}{ds} \left[ \frac{b^2}{2} (2U \cos \theta + V)^2 \sin \theta \right] = b^2 g \frac{\rho_a - \rho}{\rho_a} - \frac{\sqrt{2}}{\pi} Cd U^2 b \sin \theta \cos \theta$$

DENSITY:

$$\frac{d}{ds} [b^2 (2U \cos \theta + V) (\rho_a - \rho)] = 0$$

CONSERVATION:

$$\frac{d}{ds} [b^2 (2U \cos \theta + V) \phi] = 0$$

GEOMETRIC:

$$\frac{dx}{ds} = \cos \theta, \quad \frac{dz}{ds} = \sin \theta$$

### BASIC ASSUMPTIONS

- PLUME INDUCED TURBULENCE PREVAILS
- ROUND BUOYANT TURBULENT JET THEORY APPLIED
- MIXING AND ENTRAINMENT MECHANISM TAKES PLACE OF DISPERSION MECHANISM
- GAUSSIAN DISTRIBUTION FOR HEAT, MOISTURE, DENSITY AND VELOCITY PROFILES
- HEAT, MOISTURE, BUOYANCY AND MOMENTUM CONSERVED.

FIGURE 2.3.B-1  
 COOLING TOWER PLUME  
 MATHEMATICAL MODEL  
 BEAVER VALLEY POWER STATION-UNIT 2  
 FINAL SAFETY ANALYSIS REPORT

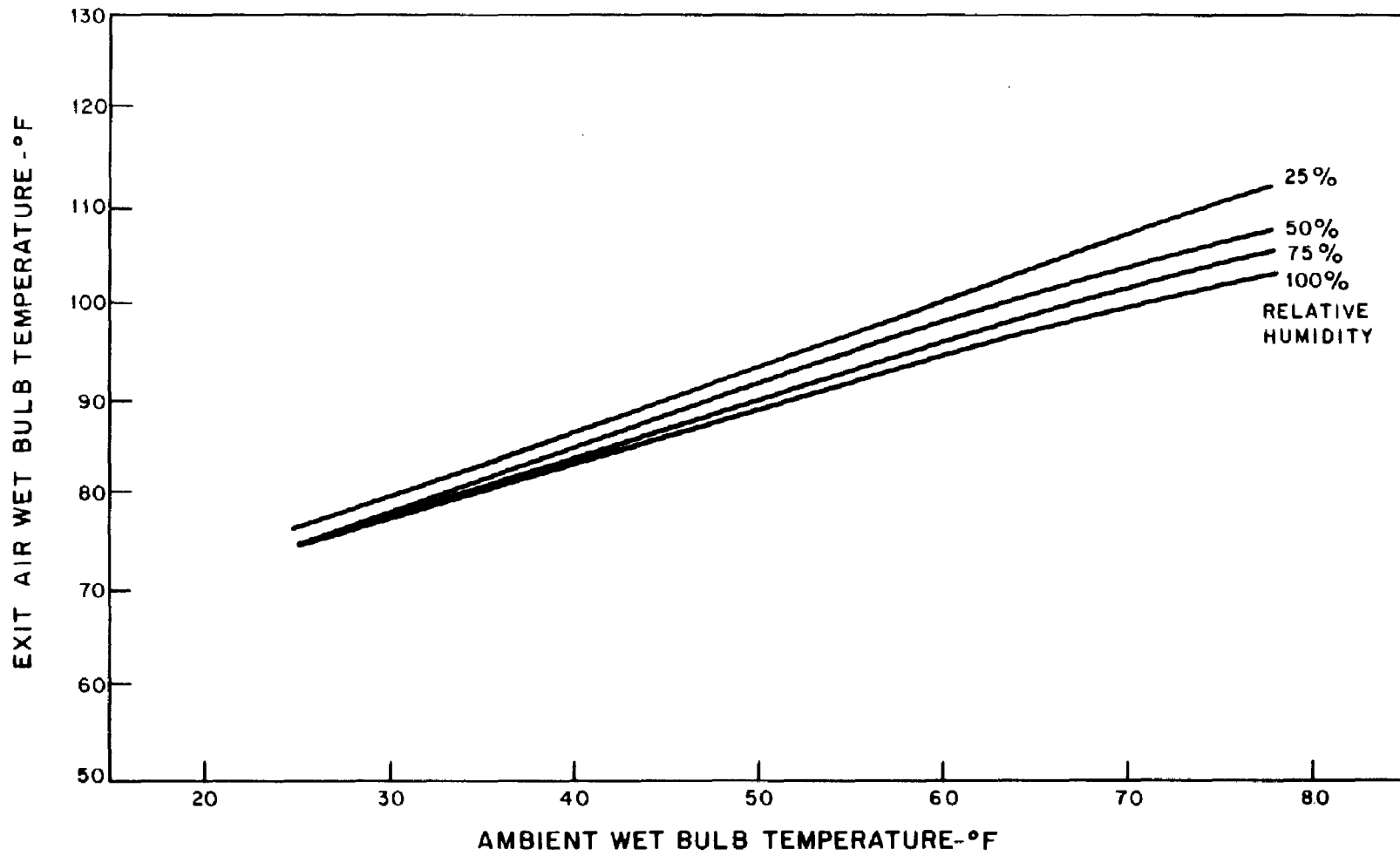

**NOTES:**

RANGE - 25.5°F  
 APPROACH - 16°F  
 DESIGN POINT - 74°F

**FIGURE 2.3.B-2  
 PREDICTED PERFORMANCE CURVE  
 OF NATURAL DRAFT COOLING TOWERS  
 BEAVER VALLEY POWER STATION-UNIT 2  
 FINAL SAFETY ANALYSIS REPORT**

APPENDIX 2.3C

BEAVER VALLEY POWER STATION  
JOINT FREQUENCY DISTRIBUTION  
AT THE 35-FOOT LEVEL  
(JANUARY 1, 1976 TO DECEMBER 31, 1980)

## LIST OF TABLES

<u>Table Number</u>	<u>Title</u>
2.3C-1	BVPS Wind - Stability Summary Stability Class - A, 35 Ft Winds January: 1976-1980
2.3C-2	BVPS Wind - Stability Summary Stability Class - B, 35 Ft Winds January: 1976-1980
2.3C-3	BVPS Wind - Stability Summary Stability Class - C, 35 Ft Winds January: 1976-1980
2.3C-4	BVPS Wind - Stability Summary Stability Class - D, 35 Ft Winds January: 1976-1980
2.3C-5	BVPS Wind - Stability Summary Stability Class - E, 35 Ft Winds January: 1976-1980
2.3C-6	BVPS Wind - Stability Summary Stability Class - F, 35 Ft Winds January: 1976-1980
2.3C-7	BVPS Wind - Stability Summary Stability Class - G, 35 Ft Winds January: 1976-1980
2.3C-8	BVPS Wind - Stability Summary Stability Class - ALL, 35 Ft Winds January: 1976-1980
2.3C-9	BVPS Wind - Stability Summary Stability Class - A, 35 Ft Winds February: 1976-1980
2.3C-10	BVPS Wind - Stability Summary Stability Class - B, 35 Ft Winds February: 1976-1980
2.3C-11	BVPS Wind - Stability Summary Stability Class - C, 35 Ft Winds February: 1976-1980
2.3C-12	BVPS Wind - Stability Summary Stability Class - D, 35 Ft Winds February: 1976-1980
2.3C-13	BVPS Wind - Stability Summary Stability Class - E, 35 Ft Winds February: 1976-1980
2.3C-14	BVPS Wind - Stability Summary Stability Class - F, 35 Ft Winds February: 1976-1980
2.3C-15	BVPS Wind - Stability Summary Stability Class - G, 35 Ft Winds February: 1976-1980
2.3C-16	BVPS Wind - Stability Summary Stability Class - ALL, 35 Ft Winds February: 1976-1980

## LIST OF TABLES (Cont)

<u>Table Number</u>	<u>Title</u>
2.3C-17	BVPS Wind - Stability Summary Stability Class - A, 35 Ft Winds March: 1976-1980
2.3C-18	BVPS Wind - Stability Summary Stability Class - B, 35 Ft Winds March: 1976-1980
2.3C-19	BVPS Wind - Stability Summary Stability Class - C, 35 Ft Winds March: 1976-1980
2.3C-20	BVPS Wind - Stability Summary Stability Class - D, 35 Ft Winds March: 1976-1980
2.3C-21	BVPS Wind - Stability Summary Stability Class - E, 35 Ft Winds March: 1976-1980
2.3C-22	BVPS Wind - Stability Summary Stability Class - F, 35 Ft Winds March: 1976-1980
2.3C-23	BVPS Wind - Stability Summary Stability Class - G, 35 Ft Winds March: 1976-1980
2.3C-24	BVPS Wind - Stability Summary Stability Class - ALL, 35 Ft Winds March: 1976-1980
2.3C-25	BVPS Wind - Stability Summary Stability Class - A, 35 Ft Winds April: 1976-1980
2.3C-26	BVPS Wind - Stability Summary Stability Class - B, 35 Ft Winds April: 1976-1980
2.3C-27	BVPS Wind - Stability Summary Stability Class - C, 35 Ft Winds April: 1976-1980
2.3C-28	BVPS Wind - Stability Summary Stability Class - D, 35 Ft Winds April: 1976-1980
2.3C-29	BVPS Wind - Stability Summary Stability Class - E, 35 Ft Winds April: 1976-1980
2.3C-30	BVPS Wind - Stability Summary Stability Class - F, 35 Ft Winds April: 1976-1980
2.3C-31	BVPS Wind - Stability Summary Stability Class - G, 35 Ft Winds April: 1976-1980
2.3C-32	BVPS Wind - Stability Summary Stability Class - ALL, 35 Ft Winds April: 1976-1980

## LIST OF TABLES (Cont)

<u>Table Number</u>	<u>Title</u>
2.3C-33	BVPS Wind - Stability Summary Stability Class - A, 35 Ft Winds May: 1976-1980
2.3C-34	BVPS Wind - Stability Summary Stability Class - B, 35 Ft Winds May: 1976-1980
2.3C-35	BVPS Wind - Stability Summary Stability Class - C, 35 Ft Winds May: 1976-1980
2.3C-36	BVPS Wind - Stability Summary Stability Class - D, 35 Ft Winds May: 1976-1980
2.3C-37	BVPS Wind - Stability Summary Stability Class - E, 35 Ft Winds May: 1976-1980
2.3C-38	BVPS Wind - Stability Summary Stability Class - F, 35 Ft Winds May: 1976-1980
2.3C-39	BVPS Wind - Stability Summary Stability Class - G, 35 Ft Winds May: 1976-1980
2.3C-40	BVPS Wind - Stability Summary Stability Class - ALL, 35 Ft Winds May: 1976-1980
2.3C-41	BVPS Wind - Stability Summary Stability Class - A, 35 Ft Winds June: 1976-1980
2.3C-42	BVPS Wind - Stability Summary Stability Class - B, 35 Ft Winds June: 1976-1980
2.3C-43	BVPS Wind - Stability Summary Stability Class - C, 35 Ft Winds June: 1976-1980
2.3C-44	BVPS Wind - Stability Summary Stability Class - D, 35 Ft Winds June: 1976-1980
2.3C-45	BVPS Wind - Stability Summary Stability Class - E, 35 Ft Winds June: 1976-1980
2.3C-46	BVPS Wind - Stability Summary Stability Class - F, 35 Ft Winds June: 1976-1980
2.3C-47	BVPS Wind - Stability Summary Stability Class - G, 35 Ft Winds June: 1976-1980
2.3C-48	BVPS Wind - Stability Summary Stability Class - ALL, 35 Ft Winds June: 1976-1980

## LIST OF TABLES (Cont)

<u>Table Number</u>	<u>Title</u>
2.3C-49	BVPS Wind - Stability Summary Stability Class - A, 35 Ft Winds July: 1976-1980
2.3C-50	BVPS Wind - Stability Summary Stability Class - B, 35 Ft Winds July: 1976-1980
2.3C-51	BVPS Wind - Stability Summary Stability Class - C, 35 Ft Winds July: 1976-1980
2.3C-52	BVPS Wind - Stability Summary Stability Class - D, 35 Ft Winds July: 1976-1980
2.3C-53	BVPS Wind - Stability Summary Stability Class - E, 35 Ft Winds July: 1976-1980
2.3C-54	BVPS Wind - Stability Summary Stability Class - F, 35 Ft Winds July: 1976-1980
2.3C-55	BVPS Wind - Stability Summary Stability Class - G, 35 Ft Winds July: 1976-1980
2.3C-56	BVPS Wind - Stability Summary Stability Class - ALL, 35 Ft Winds July: 1976-1980
2.3C-57	BVPS Wind - Stability Summary Stability Class - A, 35 Ft Winds August: 1976-1980
2.3C-58	BVPS Wind - Stability Summary Stability Class - B, 35 Ft Winds August: 1976-1980
2.3C-59	BVPS Wind - Stability Summary Stability Class - C, 35 Ft Winds August: 1976-1980
2.3C-60	BVPS Wind - Stability Summary Stability Class - D, 35 Ft Winds August: 1976-1980
2.3C-61	BVPS Wind - Stability Summary Stability Class - E, 35 Ft Winds August: 1976-1980
2.3C-62	BVPS Wind - Stability Summary Stability Class - F, 35 Ft Winds August: 1976-1980
2.3C-63	BVPS Wind - Stability Summary Stability Class - G, 35 Ft Winds August: 1976-1980
2.3C-64	BVPS Wind - Stability Summary Stability Class - ALL, 35 Ft Winds August: 1976-1980



## LIST OF TABLES (Cont)

<u>Table Number</u>	<u>Title</u>
2.3C-65	BVPS Wind - Stability Summary Stability Class - A, 35 Ft Winds September: 1976-1980
2.3C-66	BVPS Wind - Stability Summary Stability Class - B, 35 Ft Winds September: 1976-1980
2.3C-67	BVPS Wind - Stability Summary Stability Class - C, 35 Ft Winds September: 1976-1980
2.3C-68	BVPS Wind - Stability Summary Stability Class - D, 35 Ft Winds September: 1976-1980
2.3C-69	BVPS Wind - Stability Summary Stability Class - E, 35 Ft Winds September: 1976-1980
2.3C-70	BVPS Wind - Stability Summary Stability Class - F, 35 Ft Winds September: 1976-1980
2.3C-71	BVPS Wind - Stability Summary Stability Class - G, 35 Ft Winds September: 1976-1980
2.3C-72	BVPS Wind - Stability Summary Stability Class - ALL, 35 Ft Winds September: 1976-1980
2.3C-73	BVPS Wind - Stability Summary Stability Class - A, 35 Ft Winds October: 1976-1980
2.3C-74	BVPS Wind - Stability Summary Stability Class - B, 35 Ft Winds October: 1976-1980
2.3C-75	BVPS Wind - Stability Summary Stability Class - C, 35 Ft Winds October: 1976-1980
2.3C-76	BVPS Wind - Stability Summary Stability Class - D, 35 Ft Winds October: 1976-1980
2.3C-77	BVPS Wind - Stability Summary Stability Class - E, 35 Ft Winds October: 1976-1980
2.3C-78	BVPS Wind - Stability Summary Stability Class - F, 35 Ft Winds October: 1976-1980
2.3C-79	BVPS Wind - Stability Summary Stability Class - G, 35 Ft Winds October: 1976-1980
2.3C-80	BVPS Wind - Stability Summary Stability Class - ALL, 35 Ft Winds October: 1976-1980

## LIST OF TABLES (Cont)

<u>Table Number</u>	<u>Title</u>
2.3C-81	BVPS Wind - Stability Summary Stability Class - A, 35 Ft Winds November: 1976-1980
2.3C-82	BVPS Wind - Stability Summary Stability Class - B, 35 Ft Winds November: 1976-1980
2.3C-83	BVPS Wind - Stability Summary Stability Class - C, 35 Ft Winds November: 1976-1980
2.3C-84	BVPS Wind - Stability Summary Stability Class - D, 35 Ft Winds November: 1976-1980
2.3C-85	BVPS Wind - Stability Summary Stability Class - E, 35 Ft Winds November: 1976-1980
2.3C-86	BVPS Wind - Stability Summary Stability Class - F, 35 Ft Winds November: 1976-1980
2.3C-87	BVPS Wind - Stability Summary Stability Class - G, 35 Ft Winds November: 1976-1980
2.3C-88	BVPS Wind - Stability Summary Stability Class ALL, 35 Ft Winds November: 1976-1980
2.3C-89	BVPS Wind - Stability Summary Stability Class - A, 35 Ft Winds December: 1976-1980
2.3C-90	BVPS Wind - Stability Summary Stability Class - B, 35 Ft Winds December: 1976-1980
2.3C-91	BVPS Wind - Stability Summary Stability Class - C, 35 Ft Winds December: 1976-1980
2.3C-92	BVPS Wind - Stability Summary Stability Class - D, 35 Ft Winds December: 1976-1980
2.3C-93	BVPS Wind - Stability Summary Stability Class - E, 35 Ft Winds December: 1976-1980
2.3C-94	BVPS Wind - Stability Summary Stability Class - F, 35 Ft Winds December: 1976-1980
2.3C-95	BVPS Wind - Stability Summary Stability Class - G, 35 Ft Winds December: 1976-1980
2.3C-96	BVPS Wind - Stability Summary Stability Class ALL, 35 Ft Winds December: 1976-1980

## LIST OF TABLES (Cont)

<u>Table Number</u>	<u>Title</u>
2.3C-97	BVPS Wind - Stability Summary Stability Class - A, 35 Ft Winds Annual: 1976-1980
2.3C-98	BVPS Wind - Stability Summary Stability Class - B, 35 Ft Winds Annual: 1976-1980
2.3C-99	BVPS Wind - Stability Summary Stability Class - C, 35 Ft Winds Annual: 1976-1980
2.3C-100	BVPS Wind - Stability Summary Stability Class - D, 35 Ft Winds Annual: 1976-1980
2.3C-101	BVPS Wind - Stability Summary Stability Class - E, 35 Ft Winds Annual: 1976-1980
2.3C-102	BVPS Wind - Stability Summary Stability Class - F, 35 Ft Winds Annual: 1976-1980
2.3C-103	BVPS Wind - Stability Summary Stability Class - G, 35 Ft Winds Annual: 1976-1980
2.3C-104	BVPS Wind - Stability Summary Stability Class ALL, 35 Ft Winds Annual: 1976-1980

TABLES 2.3C-1 thru 2.3C-104 - BVPS WIND-STABILITY SUMMARIES

TABLE 2.3C-1

BVPS WIND - STABILITY SUMMARY  
 STABILITY CLASS - A, 35 Ft Winds  
 JANUARY: 1976-1980

Number of Hourly Observations

Winds From	Wind Speed (mph)						Total
	<u>1-3</u>	<u>4-7</u>	<u>8-12</u>	<u>13-18</u>	<u>19-24</u>	<u>25+</u>	
N	0	0	0	0	0	0	0
NNE	0	3	0	0	0	0	3
NE	1	3	0	0	0	0	4
ENE	1	6	0	0	0	0	7
E	1	1	0	0	0	0	2
ESE	0	1	0	0	0	0	1
SE	1	3	0	0	0	0	4
SSE	0	2	0	0	0	0	2
S	1	0	0	0	0	0	1
SSW	0	3	0	0	0	0	3
SW	0	4	2	1	0	0	7
WSW	0	8	7	3	0	0	18
W	1	7	15	2	2	0	25
WNW	0	5	4	0	0	0	9
NW	0	1	3	0	0	0	4
NNW	0	0	0	0	0	0	0
Total	<u>6</u>	<u>47</u>	<u>31</u>	<u>6</u>	<u>0</u>	<u>0</u>	<u>90</u>

Number of Calm Hours - 5  
 Number of Variable Directions - 0  
 Total Number of Observations - 95

TABLE 2.3C-2

BVPS WIND - STABILITY SUMMARY  
 STABILITY CLASS - B, 35 Ft Winds  
 JANUARY: 1976-1980

Number of Hourly Observations

Winds From	Wind Speed (mph)						Total
	1-3	4-7	8-12	13-18	19-24	25+	
N	0	0	0	0	0	0	0
NNE	0	1	1	0	0	0	2
NE	0	0	0	0	0	0	0
ENE	0	0	0	0	0	0	0
E	0	0	0	0	0	0	0
ESE	0	1	0	0	0	0	1
SE	0	0	0	0	0	0	0
SSE	0	0	0	0	0	0	0
S	1	1	0	0	0	0	2
SSW	0	2	1	0	0	0	3
SW	0	2	9	0	0	0	11
WSW	0	4	8	1	0	0	13
W	1	2	4	5	0	0	12
WNW	0	1	1	0	0	0	2
NW	0	2	1	0	0	0	3
NNW	0	1	0	0	0	0	1
Total	2	17	25	6	0	0	50

Number of Calm Hours - 0  
 Number of Variable Directions - 0  
 Total Number of Observations - 50

TABLE 2.3C-3

BVPS WIND - STABILITY SUMMARY  
 STABILITY CLASS - C, 35 Ft Winds  
 JANUARY: 1976-1980

Number of Hourly Observations

Winds From	Wind Speed (mph)						Total
	1-3	4-7	8-12	13-18	19-24	25+	
N	0	0	0	0	0	0	0
NNE	1	0	0	0	0	0	1
NE	2	1	0	0	0	0	3
ENE	1	4	0	0	0	0	5
E	1	3	0	0	0	0	4
ESE	0	0	0	0	0	0	0
SE	0	1	0	0	0	0	1
SSE	1	0	0	0	0	0	1
S	0	1	0	0	0	0	1
SSW	0	2	0	0	0	0	2
SW	0	2	8	1	0	0	11
WSW	2	6	11	3	0	0	22
W	0	8	11	1	0	0	20
WNW	0	3	4	0	0	0	7
NW	0	5	1	0	0	0	6
NNW	0	1	0	0	0	0	1
Total	8	37	35	5	0	0	85

Number of Calm Hours - 0  
 Number of Variable Directions - 0  
 Total Number of Observations - 85

TABLE 2.3C-4

BVPS WIND - STABILITY SUMMARY  
 STABILITY CLASS - D, 35 Ft Winds  
 JANUARY: 1976-1980

Number of Hourly Observations

Winds From	Wind Speed (mph)						Total
	1-3	4-7	8-12	13-18	19-24	25+	
N	33	22	0	0	0	0	55
NNE	41	16	0	0	0	0	57
NE	75	34	3	0	0	0	112
ENE	59	22	2	0	0	0	83
E	46	2	1	0	0	0	49
ESE	19	2	0	0	0	0	21
SE	8	0	0	0	0	0	8
SSE	13	3	0	0	0	0	16
S	18	22	2	0	0	0	42
SSW	17	47	15	0	0	0	79
SW	13	124	106	7	5	0	255
WSW	13	193	267	37	3	0	513
W	14	113	113	4	0	0	244
WNW	20	61	31	1	0	0	113
NW	20	80	13	0	0	0	113
NNW	17	36	1	0	0	0	54
Total	426	777	554	49	8	0	1814

Number of Calm Hours - 2  
 Number of Variable Directions - 0  
 Total Number of Observations - 1816

TABLE 2.3C-5

BVPS WIND - STABILITY SUMMARY  
 STABILITY CLASS - E, 35 Ft Winds  
 JANUARY: 1976-1980

Number of Hourly Observations

Winds From	Wind Speed (mph)						Total
	1-3	4-7	8-12	13-18	19-24	25+	
N	22	2	0	0	0	0	24
NNE	30	13	0	0	0	0	43
NE	54	23	5	0	0	0	82
ENE	38	22	3	0	0	0	63
E	41	1	0	0	0	0	42
ESE	23	0	0	0	0	0	23
SE	27	1	0	0	0	0	28
SSE	22	3	0	0	0	0	25
S	20	29	0	0	0	0	49
SSW	20	47	5	0	1	0	73
SW	9	48	29	4	0	0	90
WSW	9	14	30	6	0	0	59
W	3	7	5	1	0	0	16
WNW	11	4	2	0	0	0	17
NW	7	3	0	0	0	0	10
NNW	8	4	0	0	0	0	12
Total	344	221	79	11	1	0	656

Number of Calm Hours - 10  
 Number of Variable Directions - 0  
 Total Number of Observations - 666



TABLE 2.3C-6

BVPS WIND - STABILITY SUMMARY  
 STABILITY CLASS - F, 35 Ft Winds  
 JANUARY: 1976-1980

Number of Hourly Observations

Winds From	Wind Speed (mph)						Total
	1-3	4-7	8-12	13-18	19-24	25+	
N	3	3	0	0	0	0	6
NNE	9	2	0	0	0	0	11
NE	17	1	0	0	0	0	18
ENE	20	0	0	0	0	0	20
E	38	0	0	0	0	0	38
ESE	17	0	0	0	0	0	17
SE	30	0	0	0	0	0	30
SSE	22	3	0	0	0	0	25
S	9	11	0	0	0	0	20
SSW	5	8	0	0	0	0	13
SW	2	3	1	0	0	0	6
WSW	0	3	1	1	0	0	5
W	3	0	0	0	0	0	3
WNW	0	0	0	0	0	0	0
NW	0	0	0	0	0	0	0
NNW	4	0	0	0	0	0	4
Total	179	34	2	1	0	0	216

Number of Calm Hours - 5  
 Number of Variable Directions - 0  
 Total Number of Observations - 221

TABLE 2.3C-7

BVPS WIND - STABILITY SUMMARY  
 STABILITY CLASS - G, 35 Ft Winds  
 JANUARY: 1976-1980

Number of Hourly Observations

Winds From	Wind Speed (mph)						Total
	1-3	4-7	8-12	13-18	19-24	25+	
N	1	0	0	0	0	0	1
NNE	2	1	0	0	0	0	3
NE	4	2	0	0	0	0	6
ENE	9	1	0	0	0	0	10
E	20	0	0	0	0	0	20
ESE	19	0	0	0	0	0	19
SE	57	0	0	0	0	0	57
SSE	46	5	0	0	0	0	51
S	9	12	0	0	0	0	21
SSW	2	0	0	0	0	0	2
SW	0	0	0	0	0	0	0
WSW	0	0	0	0	0	0	0
W	0	0	0	0	0	0	0
WNW	0	0	0	0	0	0	0
NW	0	0	0	0	0	0	0
NNW	0	0	0	0	0	0	0
Total	169	21	0	0	0	0	190

Number of Calm Hours - 6  
 Number of Variable Directions - 0  
 Total Number of Observations - 196

TABLE 2.3C-8

BVPS WIND - STABILITY SUMMARY  
 STABILITY CLASS - ALL, 35 Ft Winds  
 JANUARY: 1976-1980

Number of Hourly Observations

Winds From	Wind Speed (mph)						Total
	1-3	4-7	8-12	13-18	19-24	25+	
N	59	27	0	0	0	0	86
NNE	83	36	1	0	0	0	120
NE	153	64	8	0	0	0	225
ENE	128	55	5	0	0	0	188
E	147	7	1	0	0	0	155
ESE	78	4	0	0	0	0	82
SE	123	5	0	0	0	0	128
SSE	104	16	0	0	0	0	120
S	58	76	2	0	0	0	136
SSW	44	109	21	0	1	0	175
SW	24	183	155	13	5	0	380
WSW	24	228	324	51	3	0	630
W	22	137	148	13	0	0	320
WNW	31	74	42	1	0	0	148
NW	27	91	18	0	0	0	136
NNW	29	42	1	0	0	0	72
Total	1134	1154	726	78	9	0	3101

Number of Calm Hours - 28  
 Number of Variable Directions - 0  
 Total Number of Observations - 3129

TABLE 2.3C-9

BVPS WIND - STABILITY SUMMARY  
 STABILITY CLASS - A, 35 Ft Winds  
 FEBRUARY: 1976-1980

Number of Hourly Observations

Winds From	Wind Speed (mph)						Total
	1-3	4-7	8-12	13-18	19-24	25+	
N	1	8	0	0	0	0	9
NNE	1	3	0	0	0	0	4
NE	6	5	0	0	0	0	11
ENE	2	12	0	0	0	0	14
E	0	4	0	0	0	0	4
ESE	1	0	0	0	0	0	1
SE	2	2	0	0	0	0	4
SSE	0	0	0	0	0	0	0
S	0	5	0	0	0	0	5
SSW	1	5	0	0	0	0	6
SW	1	9	1	1	0	0	12
WSW	0	22	5	1	0	0	28
W	3	26	24	2	0	0	55
WNW	1	15	8	1	0	0	25
NW	0	13	4	0	0	0	17
NNW	0	4	1	0	0	0	5
Total	19	133	43	5	0	0	200

Number of Calm Hours - 0  
 Number of Variable Directions - 0  
 Total Number of Observations - 200

TABLE 2.3C-10

BVPS WIND - STABILITY SUMMARY  
 STABILITY CLASS - B, 35 Ft Winds  
 FEBRUARY: 1976-1980

Number of Hourly Observations

Winds From	Wind Speed (mph)						Total
	1-3	4-7	8-12	13-18	19-24	25+	
N	0	3	0	0	0	0	3
NNE	2	0	0	0	0	0	2
NE	3	4	0	0	0	0	7
ENE	0	3	0	0	0	0	3
E	0	1	0	0	0	0	1
ESE	1	0	0	0	0	0	1
SE	0	1	0	0	0	0	1
SSE	0	0	0	0	0	0	0
S	0	0	0	0	0	0	0
SSW	0	1	2	0	0	0	3
SW	2	2	2	0	0	0	6
WSW	1	14	4	0	0	0	19
W	0	5	11	1	0	0	17
WNW	0	9	5	0	0	0	14
NW	0	5	1	0	0	0	6
NNW	0	2	0	0	0	0	2
Total	9	50	25	1	0	0	85

Number of Calm Hours - 0  
 Number of Variable Directions - 0  
 Total Number of Observations - 85

TABLE 2.3C-11

BVPS WIND - STABILITY SUMMARY  
 STABILITY CLASS - C, 35 Ft Winds  
 FEBRUARY: 1976-1980

Number of Hourly Observations

Winds From	Wind Speed (mph)						Total
	1-3	4-7	8-12	13-18	19-24	25+	
N	0	6	0	0	0	0	6
NNE	2	3	0	0	0	0	5
NE	1	2	0	0	0	0	3
ENE	3	7	0	0	0	0	10
E	0	0	0	0	0	0	0
ESE	0	0	0	0	0	0	0
SE	2	0	0	0	0	0	2
SSE	1	0	0	0	0	0	1
S	0	1	0	0	0	0	1
SSW	0	2	1	0	0	0	3
SW	2	2	10	0	0	0	14
WSW	1	12	3	0	0	0	16
W	1	16	9	0	0	0	26
WNW	0	9	2	0	0	0	11
NW	0	9	1	0	0	0	10
NNW	2	3	1	0	0	0	6
Total	15	72	27	0	0	0	114

Number of Calm Hours - 0  
 Number of Variable Directions - 0  
 Total Number of Observations - 114

TABLE 2.3C-12

BVPS WIND - STABILITY SUMMARY  
 STABILITY CLASS - D, 35 Ft Winds  
 FEBRUARY: 1976-1980

Number of Hourly Observations

Winds From	Wind Speed (mph)						Total
	1-3	4-7	8-12	13-18	19-24	25+	
N	24	57	4	0	0	0	85
NNE	24	26	1	0	0	0	51
NE	43	22	2	0	0	0	67
ENE	54	34	0	0	0	0	88
E	17	3	0	0	0	0	20
ESE	5	0	0	0	0	0	5
SE	7	1	1	0	0	0	9
SSE	5	3	0	0	0	0	8
S	5	6	1	0	0	0	12
SSW	4	41	20	0	0	0	65
SW	11	80	86	4	0	0	181
WSW	20	112	100	8	0	0	240
W	25	117	57	2	0	0	201
WNW	30	108	26	0	0	0	164
NW	22	126	15	0	0	0	163
NNW	25	52	6	0	0	0	83
Total	321	788	319	14	0	0	1442

Number of Calm Hours	-	0
Number of Variable Directions	-	0
Total Number of Observations	-	1442

TABLE 2.3C-13

BVPS WIND - STABILITY SUMMARY  
 STABILITY CLASS - E, 35 Ft Winds  
 FEBRUARY: 1976-1980

Number of Hourly Observations

Winds From	Wind Speed (mph)						Total
	1-3	4-7	8-12	13-18	19-24	25+	
N	12	6	0	0	0	0	18
NNE	23	7	0	0	0	0	30
NE	29	18	1	0	0	0	48
ENE	37	11	1	0	0	0	49
E	24	3	0	0	0	0	27
ESE	21	0	0	0	0	0	21
SE	16	0	0	0	0	0	16
SSE	9	1	0	0	0	0	10
S	13	11	0	0	0	0	24
SSW	9	37	11	0	0	0	57
SW	15	62	51	0	0	0	128
WSW	11	37	20	0	0	0	68
W	8	11	6	0	0	0	25
WNW	6	12	3	0	0	0	21
NW	13	15	0	0	0	0	28
NNW	13	12	0	0	0	0	25
Total	259	243	93	0	0	0	595

Number of Calm Hours - 1  
 Number of Variable Directions - 0  
 Total Number of Observations - 596



TABLE 2.3C-14

BVPS WIND - STABILITY SUMMARY  
 STABILITY CLASS - F, 35 Ft Winds  
 FEBRUARY: 1976-1980

Number of Hourly Observations

Winds From	Wind Speed (mph)						Total
	1-3	4-7	8-12	13-18	19-24	25+	
N	6	0	0	0	0	0	6
NNE	5	1	0	0	0	0	6
NE	15	2	0	0	0	0	17
ENE	23	5	0	0	0	0	28
E	23	0	0	0	0	0	23
ESE	18	0	0	0	0	0	18
SE	35	0	1	0	0	0	36
SSE	29	2	0	0	0	0	31
S	16	27	0	0	0	0	43
SSW	7	10	1	0	0	0	18
SW	7	15	4	0	0	0	26
WSW	1	4	0	0	0	0	5
W	3	2	0	0	0	0	5
WNW	0	0	0	0	0	0	0
NW	0	2	0	0	0	0	2
NNW	1	0	0	0	0	0	1
Total	189	70	6	0	0	0	265

Number of Calm Hours - 0  
 Number of Variable Directions - 0  
 Total Number of Observations - 265

TABLE 2.3C-15

BVPS WIND - STABILITY SUMMARY  
 STABILITY CLASS - G, 35 Ft Winds  
 FEBRUARY: 1976-1980

Number of Hourly Observations

Winds From	Wind Speed (mph)						Total
	1-3	4-7	8-12	13-18	19-24	25+	
N	3	0	0	0	0	0	3
NNE	7	3	0	0	0	0	10
NE	15	1	0	0	0	0	16
ENE	14	2	0	0	0	0	16
E	39	3	0	0	0	0	42
ESE	39	0	0	0	0	0	39
SE	114	1	0	0	0	0	115
SSE	85	9	0	0	0	0	94
S	21	27	0	0	0	0	48
SSW	9	13	0	0	0	0	22
SW	5	3	1	0	0	0	9
WSW	2	3	0	0	0	0	5
W	0	0	0	0	0	0	0
WNW	1	0	0	0	0	0	1
NW	2	0	0	0	0	0	2
NNW	2	0	0	0	0	0	2
Total	358	65	1	0	0	0	424

Number of Calm Hours	-	1
Number of Variable Directions	-	0
Total Number of Observations	-	425

TABLE 2.3C-16

BVPS WIND - STABILITY SUMMARY  
 STABILITY CLASS - ALL, 35 Ft Winds  
 FEBRUARY: 1976-1980

Number of Hourly Observations

Winds From	Wind Speed (mph)						Total
	1-3	4-7	8-12	13-18	19-24	25+	
N	46	80	4	0	0	0	130
NNE	64	43	1	0	0	0	108
NE	112	54	3	0	0	0	169
ENE	133	74	1	0	0	0	208
E	103	14	0	0	0	0	117
ESE	85	0	0	0	0	0	85
SE	176	5	2	0	0	0	183
SSE	129	15	0	0	0	0	144
S	55	77	1	0	0	0	133
SSW	30	109	35	0	0	0	174
SW	43	173	155	5	0	0	376
WSW	36	204	132	9	0	0	381
W	40	177	107	5	0	0	329
WNW	38	153	44	1	0	0	236
NW	37	170	21	0	0	0	228
NNW	43	73	8	0	0	0	124
Total	1170	1421	514	20	0	0	3125

Number of Calm Hours - 2  
 Number of Variable Directions - 0  
 Total Number of Observations - 3127

TABLE 2.3C-17

BVPS WIND - STABILITY SUMMARY  
 STABILITY CLASS - A, 35 Ft Winds  
 MARCH: 1976-1980

Number of Hourly Observations

Winds From	Wind Speed (mph)						Total
	1-3	4-7	8-12	13-18	19-24	25+	
N	1	32	0	0	0	0	33
NNE	3	21	0	0	0	0	24
NE	1	15	0	0	0	0	16
ENE	1	11	0	0	0	0	12
E	0	11	0	0	0	0	11
ESE	4	19	0	0	0	0	23
SE	2	21	1	0	0	0	24
SSE	1	16	3	0	0	0	20
S	1	9	6	0	0	0	16
SSW	0	11	16	3	0	0	30
SW	2	15	31	4	0	0	52
WSW	1	29	37	1	0	0	68
W	0	38	43	2	0	0	83
WNW	0	21	24	1	0	0	46
NW	2	9	12	0	0	0	23
NNW	2	10	1	0	0	0	13
Total	21	288	174	11	0	0	494

Number of Calm Hours - 0  
 Number of Variable Directions - 0  
 Total Number of Observations - 494

TABLE 2.3C-18

BVPS WIND - STABILITY SUMMARY  
 STABILITY CLASS - B, 35 Ft Winds  
 MARCH: 1976-1980

## Number of Hourly Observations

Winds From	Wind Speed (mph)						Total
	1-3	4-7	8-12	13-18	19-24	25+	
N	0	3	0	0	0	0	3
NNE	0	3	0	0	0	0	3
NE	2	2	0	0	0	0	4
ENE	2	1	0	0	0	0	3
E	0	0	0	0	0	0	0
ESE	0	0	0	0	0	0	0
SE	0	2	1	0	0	0	3
SSE	1	2	0	0	0	0	3
S	0	3	1	0	0	0	4
SSW	0	1	2	0	0	0	3
SW	1	7	5	2	0	0	15
WSW	2	7	4	1	0	0	14
W	0	5	5	0	0	0	10
WNW	1	3	3	0	0	0	7
NW	0	4	2	0	0	0	6
NNW	1	1	0	0	0	0	2
Total	10	44	23	3	0	0	80

Number of Calm Hours - 0  
 Number of Variable Directions - 0  
 Total Number of Observations - 80

TABLE 2.3C-19

BVPS WIND - STABILITY SUMMARY  
 STABILITY CLASS - C, 35 Ft Winds  
 MARCH: 1976-1980

Number of Hourly Observations

Winds From	Wind Speed (mph)						Total
	1-3	4-7	8-12	13-18	19-24	25+	
N	2	3	0	0	0	0	5
NNE	3	5	0	0	0	0	8
NE	3	3	0	0	0	0	6
ENE	0	3	0	0	0	0	3
E	0	2	0	0	0	0	2
ESE	1	2	0	0	0	0	3
SE	1	2	0	0	0	0	3
SSE	0	2	1	0	0	0	3
S	1	2	1	0	0	0	4
SSW	0	2	7	0	0	0	9
SW	1	8	8	4	0	0	21
WSW	1	8	10	0	0	0	19
W	1	2	14	0	0	0	17
WNW	2	3	7	0	0	0	12
NW	2	5	0	0	0	0	7
NNW	0	2	1	0	0	0	3
Total	18	54	49	4	0	0	125

Number of Calm Hours - 1  
 Number of Variable Directions - 0  
 Total Number of Observations - 126

TABLE 2.3C-20

BVPS WIND - STABILITY SUMMARY  
 STABILITY CLASS - D, 35 Ft Winds  
 MARCH: 1976-1980

## Number of Hourly Observations

Winds From	Wind Speed (mph)						Total
	1-3	4-7	8-12	13-18	19-24	25+	
N	21	55	1	0	0	0	77
NNE	24	13	1	0	0	0	38
NE	37	23	0	0	0	0	60
ENE	36	44	0	0	0	0	80
E	13	21	0	0	0	0	34
ESE	9	6	0	0	0	0	15
SE	9	7	1	0	0	0	17
SSE	2	7	0	0	0	0	9
S	5	12	9	0	0	0	26
SSW	5	40	25	2	0	0	72
SW	8	68	85	6	0	0	167
WSW	8	61	69	16	0	0	154
W	9	85	75	3	0	0	172
WNW	13	64	34	4	0	0	115
NW	14	89	36	0	0	0	139
NNW	20	45	5	0	0	0	70
Total	233	640	341	31	0	0	1245

Number of Calm Hours - 0  
 Number of Variable Directions - 0  
 Total Number of Observations - 1245

TABLE 2.3C-21

BVPS WIND - STABILITY SUMMARY  
 STABILITY CLASS - E, 35 Ft Winds  
 MARCH: 1976-1980

Number of Hourly Observations

Winds From	Wind Speed (mph)						Total
	1-3	4-7	8-12	13-18	19-24	25+	
N	18	5	0	0	0	0	23
NNE	25	6	0	0	0	0	31
NE	58	24	0	0	0	0	82
ENE	69	43	0	0	0	0	112
E	41	22	0	0	0	0	63
ESE	18	2	1	0	0	0	21
SE	17	5	0	0	0	0	22
SSE	13	5	1	0	0	0	19
S	22	28	3	0	0	0	53
SSW	7	44	7	0	0	0	58
SW	9	41	21	4	0	0	75
WSW	8	31	8	0	0	0	47
W	16	13	7	1	0	0	37
WNW	10	11	0	0	0	0	21
NW	14	15	0	0	0	0	29
NNW	9	8	0	0	0	0	17
Total	354	303	48	5	0	0	710

Number of Calm Hours - 4  
 Number of Variable Directions - 0  
 Total Number of Observations - 714



TABLE 2.3C-22

BVPS WIND - STABILITY SUMMARY  
 STABILITY CLASS - F, 35 Ft Winds  
 MARCH: 1976-1980

Number of Hourly Observations

Winds From	Wind Speed (mph)						Total
	1-3	4-7	8-12	13-18	19-24	25+	
N	3	0	0	0	0	0	3
NNE	9	2	0	0	0	0	11
NE	10	1	0	0	0	0	11
ENE	29	2	0	0	0	0	31
E	34	0	0	0	0	0	34
ESE	44	0	0	0	0	0	44
SE	54	1	0	0	0	0	55
SSE	26	1	0	0	0	0	27
S	18	14	0	0	0	0	32
SSW	7	8	0	0	0	0	15
SW	8	7	0	0	0	0	15
WSW	2	1	0	0	0	0	3
W	0	1	0	0	0	0	1
WNW	0	0	0	0	0	0	0
NW	1	1	0	0	0	0	2
NNW	2	0	0	0	0	0	2
Total	247	39	0	0	0	0	286

Number of Calm Hours - 3  
 Number of Variable Directions - 0  
 Total Number of Observations - 289

TABLE 2.3C-23

BVPS WIND - STABILITY SUMMARY  
 STABILITY CLASS - G, 35 Ft Winds  
 MARCH: 1976-1980

Number of Hourly Observations

Winds From	Wind Speed (mph)						Total
	1-3	4-7	8-12	13-18	19-24	25+	
N	4	0	0	0	0	0	4
NNE	7	0	0	0	0	0	7
NE	19	0	0	0	0	0	19
ENE	34	4	0	0	0	0	38
E	50	0	0	0	0	0	50
ESE	88	0	0	0	0	0	88
SE	113	0	0	0	0	0	113
SSE	55	3	0	0	0	0	58
S	16	9	0	0	0	0	25
SSW	4	2	0	0	0	0	6
SW	7	0	0	0	0	0	7
WSW	0	0	0	0	0	0	0
W	4	0	0	0	0	0	4
WNW	0	0	0	0	0	0	0
NW	3	0	0	0	0	0	3
NNW	2	0	0	0	0	0	2
Total	406	18	0	0	0	0	424

Number of Calm Hours - 4  
 Number of Variable Directions - 0  
 Total Number of Observations - 428

TABLE 2.3C-24

BVPS WIND - STABILITY SUMMARY  
 STABILITY CLASS - ALL, 35 Ft Winds  
 MARCH: 1976-1980

Number of Hourly Observations

Winds From	Wind Speed (mph)						Total
	1-3	4-7	8-12	13-18	19-24	25+	
N	49	98	1	0	0	0	148
NNE	71	50	1	0	0	0	122
NE	130	68	0	0	0	0	198
ENE	171	108	0	0	0	0	279
E	138	56	0	0	0	0	194
ESE	164	29	1	0	0	0	194
SE	196	38	3	0	0	0	237
SSE	98	36	5	0	0	0	139
S	63	77	20	0	0	0	160
SSW	23	108	57	5	0	0	193
SW	36	146	150	20	0	0	352
WSW	22	137	128	18	0	0	305
W	30	144	144	6	0	0	324
WNW	26	102	68	5	0	0	201
NW	36	123	50	0	0	0	209
NNW	36	66	7	0	0	0	109
Total	1289	1386	635	54	0	0	3364

Number of Calm Hours	-	12
Number of Variable Directions	-	0
Total Number of Observations	-	3376

TABLE 2.3C-25

BVPS WIND - STABILITY SUMMARY  
 STABILITY CLASS - A, 35 Ft Winds  
 APRIL: 1976-1980

## Number of Hourly Observations

Winds From	Wind Speed (mph)						Total
	1-3	4-7	8-12	13-18	19-24	25+	
N	5	50	15	0	0	0	70
NNE	3	35	2	0	0	0	40
NE	1	16	1	0	0	0	18
ENE	1	13	0	0	0	0	14
E	0	13	0	0	0	0	13
ESE	0	2	0	0	0	0	2
SE	0	7	0	0	0	0	7
SSE	0	4	0	0	0	0	4
S	2	6	0	0	0	0	8
SSW	1	12	4	0	0	0	17
SW	4	37	45	4	0	0	90
WSW	5	56	31	6	0	0	98
W	5	64	33	6	1	0	109
WNW	4	44	21	2	0	0	71
NW	4	34	14	0	0	0	52
NNW	3	48	18	0	0	0	69
Total	38	441	184	18	1	0	682

Number of Calm Hours - 0  
 Number of Variable Directions - 0  
 Total Number of Observations - 682

TABLE 2.3C-26

BVPS WIND - STABILITY SUMMARY  
 STABILITY CLASS - B, 35 Ft Winds  
 APRIL: 1976-1980

## Number of Hourly Observations

Winds From	Wind Speed (mph)						Total
	1-3	4-7	8-12	13-18	19-24	25+	
N	3	4	0	0	0	0	7
NNE	0	3	0	0	0	0	3
NE	3	3	0	0	0	0	6
ENE	2	2	0	0	0	0	4
E	1	0	0	0	0	0	1
ESE	1	1	0	0	0	0	2
SE	1	1	0	0	0	0	2
SSE	0	0	0	0	0	0	0
S	1	0	0	0	0	0	1
SSW	1	3	4	0	0	0	8
SW	2	2	9	2	0	0	15
WSW	0	7	5	0	0	0	12
W	0	4	4	0	0	0	8
WNW	1	6	1	1	0	0	9
NW	0	7	2	0	0	0	9
NNW	1	7	1	0	0	0	9
Total	17	50	26	3	0	0	96

Number of Calm Hours	-	0
Number of Variable Directions	-	0
Total Number of Observations	-	96

TABLE 2.3C-27

BVPS WIND - STABILITY SUMMARY  
 STABILITY CLASS - C, 35 Ft Winds  
 APRIL: 1976-1980

Number of Hourly Observations

Winds From	Wind Speed (mph)						Total
	1-3	4-7	8-12	13-18	19-24	25+	
N	2	11	1	0	0	0	14
NNE	1	1	0	0	0	0	2
NE	3	1	0	0	0	0	4
ENE	1	3	0	0	0	0	4
E	0	2	0	0	0	0	2
ESE	0	1	0	0	0	0	1
SE	0	0	0	0	0	0	0
SSE	0	1	0	0	0	0	1
S	0	2	0	0	0	0	2
SSW	1	2	2	0	0	0	5
SW	2	3	1	1	0	0	7
WSW	3	4	3	0	0	0	10
W	1	10	3	1	0	0	15
WNW	0	9	2	0	0	0	11
NW	4	15	1	0	0	0	20
NNW	0	8	3	0	0	0	11
Total	18	73	16	2	0	0	109

Number of Calm Hours	-	0
Number of Variable Directions	-	0
Total Number of Observations	-	109

TABLE 2.3C-28

BVPS WIND - STABILITY SUMMARY  
 STABILITY CLASS - D, 35 Ft Winds  
 APRIL: 1976-1980

Number of Hourly Observations

Winds From	Wind Speed (mph)						Total
	1-3	4-7	8-12	13-18	19-24	25+	
N	15	51	2	0	0	0	68
NNE	16	15	0	0	0	0	31
NE	22	11	0	0	0	0	33
ENE	16	30	1	0	0	0	47
E	14	30	2	0	0	0	46
ESE	3	7	0	0	0	0	10
SE	9	8	0	0	0	0	17
SSE	2	4	0	0	0	0	6
S	9	5	0	0	0	0	14
SSW	14	24	6	0	0	0	44
SW	10	56	62	3	1	0	132
WSW	16	47	50	16	0	0	129
W	15	23	27	3	1	0	69
WNW	10	55	24	0	0	0	89
NW	23	90	11	0	0	0	124
NNW	8	47	1	0	0	0	56
Total	202	503	186	22	2	0	915

Number of Calm Hours - 0  
 Number of Variable Directions - 0  
 Total Number of Observations - 915

TABLE 2.3C-29

BVPS WIND - STABILITY SUMMARY  
 STABILITY CLASS - E, 35 Ft Winds  
 APRIL: 1976-1980

Number of Hourly Observations

Winds From	Wind Speed (mph)						Total
	1-3	4-7	8-12	13-18	19-24	25+	
N	14	16	0	0	0	0	30
NNE	20	11	0	0	0	0	31
NE	47	10	0	0	0	0	57
ENE	31	16	0	0	0	0	47
E	39	7	0	0	0	0	46
ESE	23	8	0	0	0	0	31
SE	17	4	0	0	0	0	21
SSE	21	2	0	0	0	0	23
S	17	18	2	0	0	0	37
SSW	14	23	7	1	0	0	45
SW	11	23	15	2	0	0	51
WSW	9	10	14	0	0	0	33
W	11	6	6	2	0	0	25
WNW	18	11	3	1	0	0	33
NW	9	11	2	0	0	0	22
NNW	15	8	0	0	0	0	23
Total	316	184	49	6	0	0	555

Number of Calm Hours	-	2
Number of Variable Directions	-	0
Total Number of Observations	-	557



TABLE 2.3C-30

BVPS WIND - STABILITY SUMMARY  
 STABILITY CLASS - F, 35 Ft Winds  
 APRIL: 1976-1980

Number of Hourly Observations

Winds From	Wind Speed (mph)						Total
	1-3	4-7	8-12	13-18	19-24	25+	
N	7	0	0	0	0	0	7
NNE	2	1	0	0	0	0	3
NE	13	1	0	0	0	0	14
ENE	36	1	0	0	0	0	37
E	40	0	0	0	0	0	40
ESE	44	0	0	0	0	0	44
SE	49	0	0	0	0	0	49
SSE	45	1	0	0	0	0	46
S	28	7	1	0	0	0	36
SSW	20	7	1	0	0	0	28
SW	6	3	0	0	0	0	9
WSW	4	2	0	0	0	0	6
W	1	0	0	0	0	0	1
WNW	2	0	0	0	0	0	2
NW	2	0	0	0	0	0	2
NNW	4	0	0	0	0	0	4
Total	303	23	2	0	0	0	328

Number of Calm Hours - 3  
 Number of Variable Directions - 0  
 Total Number of Observations - 331

TABLE 2.3C-31

BVPS WIND - STABILITY SUMMARY  
 STABILITY CLASS - G, 35 Ft Winds  
 APRIL: 1976-1980

Number of Hourly Observations

Winds From	Wind Speed (mph)						Total
	1-3	4-7	8-12	13-18	19-24	25+	
N	2	0	0	0	0	0	2
NNE	5	0	0	0	0	0	5
NE	7	0	0	0	0	0	7
ENE	18	0	0	0	0	0	18
E	43	0	0	0	0	0	43
ESE	85	0	0	0	0	0	85
SE	208	1	0	0	0	0	209
SSE	140	2	0	0	0	0	142
S	24	7	0	0	0	0	31
SSW	6	2	0	0	0	0	8
SW	1	0	0	0	0	0	1
WSW	1	0	0	0	0	0	1
W	1	0	0	0	0	0	1
WNW	0	0	0	0	0	0	0
NW	0	0	0	0	0	0	0
NNW	1	0	0	0	0	0	1
Total	542	12	0	0	0	0	554

Number of Calm Hours - 30  
 Number of Variable Directions - 0  
 Total Number of Observations - 584

TABLE 2.3C-32

BVPS WIND - STABILITY SUMMARY  
 STABILITY CLASS - ALL, 35 Ft Winds  
 APRIL: 1976-1980

Number of Hourly Observations

Winds From	Wind Speed (mph)						Total
	1-3	4-7	8-12	13-18	19-24	25+	
N	48	132	18	0	0	0	198
NNE	47	66	2	0	0	0	115
NE	96	42	1	0	0	0	139
ENE	105	65	1	0	0	0	171
E	137	52	2	0	0	0	191
ESE	156	19	0	0	0	0	175
SE	284	21	0	0	0	0	305
SSE	208	14	0	0	0	0	222
S	81	45	3	0	0	0	129
SSW	57	73	24	1	0	0	155
SW	36	124	132	12	1	0	305
WSW	38	126	103	22	0	0	289
W	34	107	73	12	2	0	228
WNW	35	125	51	4	0	0	215
NW	42	157	30	0	0	0	229
NNW	32	118	23	0	0	0	173
Total	1436	1286	463	51	3	0	3239

Number of Calm Hours	-	35
Number of Variable Directions	-	0
Total Number of Observations	-	3274

TABLE 2.3C-33

BVPS WIND - STABILITY SUMMARY  
 STABILITY CLASS - A, 35 Ft Winds  
 MAY: 1976-1980

Number of Hourly Observations

Winds From	Wind Speed (mph)						Total
	1-3	4-7	8-12	13-18	19-24	25+	
N	6	87	7	0	0	0	100
NNE	5	29	1	0	0	0	35
NE	4	24	0	0	0	0	28
ENE	5	15	0	0	0	0	20
E	5	12	2	0	0	0	19
ESE	4	6	0	0	0	0	10
SE	7	5	0	0	0	0	12
SSE	4	10	0	0	0	0	14
S	10	25	3	0	0	0	38
SSW	1	39	5	0	0	0	45
SW	6	65	27	3	0	0	101
WSW	1	48	20	2	0	0	71
W	6	75	20	0	0	0	101
WNW	6	47	7	0	0	0	60
NW	5	39	15	0	0	0	59
NNW	4	51	6	0	0	0	61
Total	79	577	113	5	0	0	774

Number of Calm Hours	-	0
Number of Variable Directions	-	0
Total Number of Observations	-	774

TABLE 2.3C-34

BVPS WIND - STABILITY SUMMARY  
 STABILITY CLASS - B, 35 Ft Winds  
 MAY: 1976-1980

## Number of Hourly Observations

Winds From	Wind Speed (mph)						Total
	1-3	4-7	8-12	13-18	19-24	25+	
N	2	5	0	0	0	0	7
NNE	3	2	0	0	0	0	5
NE	2	1	0	0	0	0	3
ENE	0	1	0	0	0	0	1
E	1	1	0	0	0	0	2
ESE	1	0	0	0	0	0	1
SE	1	0	0	0	0	0	1
SSE	1	0	0	0	0	0	1
S	2	0	0	0	0	0	2
SSW	0	3	0	0	0	0	3
SW	4	19	4	0	0	0	27
WSW	1	5	2	1	0	0	9
W	1	6	1	0	0	0	8
WNW	2	8	1	0	0	0	11
NW	3	3	0	0	0	0	6
NNW	1	7	3	0	0	0	11
Total	25	61	11	1	0	0	98

Number of Calm Hours - 0  
 Number of Variable Directions - 0  
 Total Number of Observations - 98

TABLE 2.3C-35

BVPS WIND - STABILITY SUMMARY  
 STABILITY CLASS - C, 35 Ft Winds  
 MAY: 1976-1980

## Number of Hourly Observations

Winds From	Wind Speed (mph)						Total
	1-3	4-7	8-12	13-18	19-24	25+	
N	2	10	1	0	0	0	13
NNE	5	0	0	0	0	0	5
NE	4	0	0	0	0	0	4
ENE	5	1	0	0	0	0	6
E	3	4	0	0	0	0	7
ESE	1	0	0	0	0	0	1
SE	2	0	0	0	0	0	2
SSE	0	0	0	0	0	0	0
S	1	2	0	0	0	0	3
SSW	0	6	1	0	0	0	7
SW	0	11	3	0	0	0	14
WSW	2	13	2	0	0	0	17
W	3	9	8	0	0	0	20
WNW	4	7	1	0	0	0	12
NW	4	5	0	0	0	0	9
NNW	2	8	1	0	0	0	11
Total	38	76	17	0	0	0	131

Number of Calm Hours - 0  
 Number of Variable Directions - 0  
 Total Number of Observations - 131

TABLE 2.3C-36

BVPS WIND - STABILITY SUMMARY  
 STABILITY CLASS - D, 35 Ft Winds  
 MAY: 1976-1980

## Number of Hourly Observations

Winds From	Wind Speed (mph)						Total
	1-3	4-7	8-12	13-18	19-24	25+	
N	30	28	1	0	0	0	59
NNE	23	12	0	0	0	0	35
NE	49	2	0	0	0	0	51
ENE	33	22	0	0	0	0	55
E	18	10	0	0	0	0	28
ESE	15	4	0	0	0	0	19
SE	10	4	0	0	0	0	14
SSE	11	2	0	0	0	0	13
S	14	14	0	0	0	0	28
SSW	20	39	2	0	0	0	61
SW	22	73	20	1	0	0	116
WSW	20	54	16	1	0	0	91
W	27	20	7	0	0	0	54
WNW	15	31	0	0	0	0	46
NW	19	35	0	0	0	0	54
NNW	14	42	1	0	0	0	57
Total	340	392	47	2	0	0	781

Number of Calm Hours - 0  
 Number of Variable Directions - 0  
 Total Number of Observations - 781

TABLE 2.3C-37

BVPS WIND - STABILITY SUMMARY  
 STABILITY CLASS - E, 35 Ft Winds  
 MAY: 1976-1980

## Number of Hourly Observations

Winds From	Wind Speed (mph)						Total
	1-3	4-7	8-12	13-18	19-24	25+	
N	19	9	0	0	0	0	28
NNE	28	4	0	0	0	0	32
NE	58	2	0	0	0	0	60
ENE	45	9	0	0	0	0	54
E	59	2	0	0	0	0	61
ESE	36	1	0	0	0	0	37
SE	28	2	0	0	0	0	30
SSE	29	1	0	0	0	0	30
S	41	11	2	0	0	0	54
SSW	31	28	1	0	0	0	60
SW	18	28	0	0	0	0	46
WSW	7	10	2	0	0	0	19
W	13	6	0	0	0	0	19
WNW	8	1	0	0	0	0	9
NW	15	2	0	0	0	0	17
NNW	13	4	0	0	0	0	17
Total	448	120	5	0	0	0	573

Number of Calm Hours	-	1
Number of Variable Directions	-	0
Total Number of Observations	-	574



TABLE 2.3C-38

BVPS WIND - STABILITY SUMMARY  
 STABILITY CLASS - F, 35 Ft Winds  
 MAY: 1976-1980

Number of Hourly Observations

Winds From	Wind Speed (mph)						Total
	1-3	4-7	8-12	13-18	19-24	25+	
N	3	1	0	0	0	0	4
NNE	7	0	0	0	0	0	7
NE	11	0	0	0	0	0	11
ENE	24	0	0	0	0	0	24
E	58	0	0	0	0	0	58
ESE	74	2	0	0	0	0	76
SE	77	0	0	0	0	0	77
SSE	42	2	0	0	0	0	44
S	30	5	0	0	0	0	35
SSW	9	8	0	0	0	0	17
SW	4	4	0	0	0	0	8
WSW	2	1	0	0	0	0	3
W	2	0	0	0	0	0	2
WNW	0	0	0	0	0	0	0
NW	4	0	0	0	0	0	4
NNW	2	0	0	0	0	0	2
Total	349	23	0	0	0	0	372

Number of Calm Hours - 3  
 Number of Variable Directions - 0  
 Total Number of Observations - 375

TABLE 2.3C-39

BVPS WIND - STABILITY SUMMARY  
 STABILITY CLASS - G, 35 Ft Winds  
 MAY: 1976-1980

Number of Hourly Observations

Winds From	Wind Speed (mph)						Total
	1-3	4-7	8-12	13-18	19-24	25+	
N	4	0	0	0	0	0	4
NNE	5	1	0	0	0	0	6
NE	7	0	0	0	0	0	7
ENE	14	0	0	0	0	0	14
E	38	0	0	0	0	0	38
ESE	134	0	0	0	0	0	134
SE	211	1	0	0	0	0	212
SSE	89	2	0	0	0	0	91
S	21	5	0	0	0	0	26
SSW	3	1	0	0	0	0	4
SW	5	0	0	0	0	0	5
WSW	0	0	0	0	0	0	0
W	0	0	0	0	0	0	0
WNW	1	0	0	0	0	0	1
NW	1	0	0	0	0	0	1
NNW	1	0	0	0	0	0	1
Total	534	10	0	0	0	0	544

Number of Calm Hours - 2  
 Number of Variable Directions - 0  
 Total Number of Observations - 546

TABLE 2.3C-40

BVPS WIND - STABILITY SUMMARY  
 STABILITY CLASS - ALL, 35 Ft Winds  
 MAY: 1976-1980

Number of Hourly Observations

Winds From	Wind Speed (mph)						Total
	1-3	4-7	8-12	13-18	19-24	25+	
N	66	140	9	0	0	0	215
NNE	76	48	1	0	0	0	125
NE	135	29	0	0	0	0	164
ENE	126	48	0	0	0	0	174
E	182	29	2	0	0	0	213
ESE	265	13	0	0	0	0	278
SE	336	12	0	0	0	0	348
SSE	176	17	0	0	0	0	193
S	119	62	5	0	0	0	186
SSW	64	124	9	0	0	0	197
SW	59	200	54	4	0	0	317
WSW	33	131	42	4	0	0	210
W	52	116	36	0	0	0	204
WNW	36	94	9	0	0	0	139
NW	51	84	15	0	0	0	150
NNW	37	112	11	0	0	0	160
Total	1813	1259	193	8	0	0	3273

Number of Calm Hours - 6  
 Number of Variable Directions - 0  
 Total Number of Observations - 3279

TABLE 2.3C-41

BVPS WIND - STABILITY SUMMARY  
 STABILITY CLASS - A, 35 Ft Winds  
 JUNE: 1976-1980

## Number of Hourly Observations

Winds From	Wind Speed (mph)						Total
	1-3	4-7	8-12	13-18	19-24	25+	
N	7	50	3	0	0	0	60
NNE	14	15	3	0	0	0	32
NE	12	20	1	0	0	0	33
ENE	5	14	0	0	0	0	19
E	7	9	0	0	0	0	16
ESE	6	2	0	0	0	0	8
SE	13	5	0	0	0	0	18
SSE	10	14	0	0	0	0	24
S	15	53	1	0	0	0	69
SSW	12	54	14	0	0	0	80
SW	14	87	59	0	0	0	160
WSW	5	72	29	4	0	0	110
W	14	58	26	1	0	0	99
WNW	8	48	14	0	0	0	70
NW	11	52	7	1	0	0	71
NNW	10	77	7	0	0	0	94
Total	163	630	164	6	0	0	963

Number of Calm Hours - 0  
 Number of Variable Directions - 0  
 Total Number of Observations - 963

TABLE 2.3C-42

BVPS WIND - STABILITY SUMMARY  
 STABILITY CLASS - B, 35 Ft Winds  
 JUNE: 1976-1980

Number of Hourly Observations

Winds From	Wind Speed (mph)						Total
	1-3	4-7	8-12	13-18	19-24	25+	
N	0	5	0	0	0	0	5
NNE	2	0	0	0	0	0	2
NE	2	0	0	0	0	0	2
ENE	2	0	0	0	0	0	2
E	2	0	0	0	0	0	2
ESE	0	0	0	0	0	0	0
SE	0	0	0	0	0	0	0
SSE	1	0	0	0	0	0	1
S	3	1	0	0	0	0	4
SSW	1	4	1	0	0	0	6
SW	3	14	7	0	0	0	24
WSW	6	15	4	0	0	0	25
W	5	3	2	0	0	0	10
WNW	1	5	0	0	0	0	6
NW	1	8	0	0	0	0	9
NNW	3	3	0	0	0	0	6
Total	32	58	14	0	0	0	104

Number of Calm Hours - 1  
 Number of Variable Directions - 0  
 Total Number of Observations - 105

TABLE 2.3C-43

BVPS WIND - STABILITY SUMMARY  
 STABILITY CLASS - C, 35 Ft Winds  
 JUNE: 1976-1980

## Number of Hourly Observations

Winds From	Wind Speed (mph)						Total
	1-3	4-7	8-12	13-18	19-24	25+	
N	5	12	0	0	0	0	17
NNE	1	1	0	0	0	0	2
NE	5	0	0	0	0	0	5
ENE	2	1	0	0	0	0	3
E	1	0	0	0	0	0	1
ESE	0	0	0	0	0	0	0
SE	2	0	0	0	0	0	2
SSE	0	1	0	0	0	0	1
S	3	3	0	0	0	0	6
SSW	1	9	0	0	0	0	10
SW	3	23	8	0	0	0	34
WSW	3	8	8	0	0	0	19
W	0	2	0	0	0	0	2
WNW	3	1	0	0	0	0	4
NW	1	8	1	0	0	0	10
NNW	4	6	1	0	0	0	11
Total	34	75	18	0	0	0	127

Number of Calm Hours - 0  
 Number of Variable Directions - 0  
 Total Number of Observations - 127

TABLE 2.3C-44

BVPS WIND - STABILITY SUMMARY  
 STABILITY CLASS - D, 35 Ft Winds  
 JUNE: 1976-1980

Number of Hourly Observations

Winds From	Wind Speed (mph)						Total
	1-3	4-7	8-12	13-18	19-24	25+	
N	41	24	0	0	0	0	65
NNE	27	3	0	0	0	0	30
NE	21	2	0	0	0	0	23
ENE	16	3	0	0	0	0	19
E	11	0	0	0	0	0	11
ESE	11	0	0	0	0	0	11
SE	12	1	0	0	0	0	13
SSE	8	8	0	0	0	0	16
S	24	19	2	0	0	0	45
SSW	22	48	3	0	0	0	73
SW	12	58	18	0	0	0	88
WSW	19	31	17	1	0	0	68
W	7	22	5	0	0	0	34
WNW	13	22	3	0	0	0	38
NW	20	32	0	0	0	0	52
NNW	24	30	0	0	0	0	54
Total	288	303	48	1	0	0	640

Number of Calm Hours - 5  
 Number of Variable Directions - 0  
 Total Number of Observations - 645

TABLE 2.3C-45

BVPS WIND - STABILITY SUMMARY  
 STABILITY CLASS - E, 35 Ft Winds  
 JUNE: 1976-1980

## Number of Hourly Observations

Winds From	Wind Speed (mph)						Total
	1-3	4-7	8-12	13-18	19-24	25+	
N	19	4	1	0	0	0	24
NNE	21	0	0	0	0	0	21
NE	27	1	0	0	0	0	28
ENE	35	1	0	0	0	0	36
E	51	0	0	0	0	0	51
ESE	40	0	0	0	0	0	40
SE	31	0	0	0	0	0	31
SSE	28	0	0	0	0	0	28
S	47	17	0	0	0	0	64
SSW	33	48	0	0	0	0	81
SW	15	30	0	0	0	0	45
WSW	5	9	1	0	0	0	15
W	8	6	0	0	0	0	14
WNW	4	10	0	0	0	0	14
NW	15	1	0	0	0	0	16
NNW	17	4	2	0	0	0	23
Total	396	131	4	0	0	0	531

Number of Calm Hours - 6  
 Number of Variable Directions - 0  
 Total Number of Observations - 537



TABLE 2.3C-46

BVPS WIND - STABILITY SUMMARY  
 STABILITY CLASS - F, 35 Ft Winds  
 JUNE: 1976-1980

Number of Hourly Observations

Winds From	Wind Speed (mph)						Total
	1-3	4-7	8-12	13-18	19-24	25+	
N	1	0	0	0	0	0	1
NNE	10	0	0	0	0	0	10
NE	13	0	0	0	0	0	13
ENE	25	0	0	0	0	0	25
E	52	0	0	0	0	0	52
ESE	97	0	0	0	0	0	97
SE	112	1	0	0	0	0	113
SSE	74	0	0	0	0	0	74
S	39	9	0	0	0	0	48
SSW	7	9	0	0	0	0	16
SW	2	0	0	0	0	0	2
WSW	2	0	0	0	0	0	2
W	0	1	0	0	0	0	1
WNW	1	0	0	0	0	0	1
NW	1	0	0	0	0	0	1
NNW	4	0	0	0	0	0	4
Total	440	20	0	0	0	0	460

Number of Calm Hours - 15  
 Number of Variable Directions - 0  
 Total Number of Observations - 475

TABLE 2.3C-47

BVPS WIND - STABILITY SUMMARY  
 STABILITY CLASS - G, 35 Ft Winds  
 JUNE: 1976-1980

Number of Hourly Observations

Winds From	Wind Speed (mph)						Total
	1-3	4-7	8-12	13-18	19-24	25+	
N	3	0	0	0	0	0	3
NNE	2	0	0	0	0	0	2
NE	8	0	0	0	0	0	8
ENE	9	0	0	0	0	0	9
E	19	0	0	0	0	0	19
ESE	100	0	0	0	0	0	100
SE	200	0	0	0	0	0	200
SSE	62	1	0	0	0	0	63
S	23	0	0	0	0	0	23
SSW	5	0	0	0	0	0	5
SW	0	0	0	0	0	0	0
WSW	2	0	0	0	0	0	2
W	1	0	0	0	0	0	1
WNW	1	0	0	0	0	0	1
NW	0	0	0	0	0	0	0
NNW	1	0	0	0	0	0	1
Total	436	1	0	0	0	0	437

Number of Calm Hours - 8  
 Number of Variable Directions - 0  
 Total Number of Observations - 445

TABLE 2.3C-48

BVPS WIND - STABILITY SUMMARY  
 STABILITY CLASS - ALL, 35 Ft Winds  
 JUNE: 1976-1980

Number of Hourly Observations

Winds From	Wind Speed (mph)						Total
	1-3	4-7	8-12	13-18	19-24	25+	
N	76	95	4	0	0	0	175
NNE	77	19	3	0	0	0	99
NE	88	23	1	0	0	0	112
ENE	94	19	0	0	0	0	113
E	143	9	0	0	0	0	152
ESE	254	2	0	0	0	0	256
SE	370	7	0	0	0	0	377
SSE	183	24	0	0	0	0	207
S	154	102	3	0	0	0	259
SSW	81	172	18	0	0	0	271
SW	49	212	92	0	0	0	353
WSW	42	135	59	5	0	0	241
W	35	92	33	1	0	0	161
WNW	31	86	17	0	0	0	134
NW	49	101	8	1	0	0	159
NNW	63	120	10	0	0	0	193
Total	1789	1218	248	7	0	0	3262

Number of Calm Hours	-	35
Number of Variable Directions	-	0
Total Number of Observations	-	3297

TABLE 2.3C-49

BVPS WIND - STABILITY SUMMARY  
 STABILITY CLASS - A, 35 Ft Winds  
 JULY: 1976-1980

Number of Hourly Observations

Winds From	Wind Speed (mph)						Total
	1-3	4-7	8-12	13-18	19-24	25+	
N	20	89	1	0	0	0	110
NNE	12	18	0	0	0	0	30
NE	15	7	0	0	0	0	22
ENE	11	3	0	0	0	0	14
E	11	9	0	0	0	0	20
ESE	9	1	0	0	0	0	10
SE	11	4	0	0	0	0	15
SSE	12	7	0	0	0	0	19
S	16	35	1	0	0	0	52
SSW	6	73	13	0	0	0	92
SW	16	102	45	0	0	0	163
WSW	5	90	25	2	0	0	122
W	10	73	13	0	0	0	96
WNW	14	36	2	0	0	0	52
NW	10	33	1	0	0	0	44
NNW	8	53	1	0	0	0	62
Total	186	633	102	2	0	0	923

Number of Calm Hours - 0  
 Number of Variable Directions - 0  
 Total Number of Observations - 923

TABLE 2.3C-50

BVPS WIND - STABILITY SUMMARY  
 STABILITY CLASS - B, 35 Ft Winds  
 JULY: 1976-1980

Number of Hourly Observations

Winds From	Wind Speed (mph)						Total
	1-3	4-7	8-12	13-18	19-24	25+	
N	5	6	0	0	0	0	11
NNE	2	0	0	0	0	0	2
NE	2	0	0	0	0	0	2
ENE	2	0	0	0	0	0	2
E	2	0	0	0	0	0	2
ESE	0	0	0	0	0	0	0
SE	1	0	0	0	0	0	1
SSE	0	1	0	0	0	0	1
S	1	1	0	0	0	0	2
SSW	1	13	0	0	0	0	14
SW	2	7	1	0	0	0	10
WSW	3	9	0	0	0	0	12
W	2	4	0	0	0	0	6
WNW	1	2	0	0	0	0	3
NW	0	5	0	0	0	0	5
NNW	3	7	0	0	0	0	10
Total	27	55	1	0	0	0	83

Number of Calm Hours - 0  
 Number of Variable Directions - 0  
 Total Number of Observations - 83

TABLE 2.3C-51

BVPS WIND - STABILITY SUMMARY  
 STABILITY CLASS - C, 35 Ft Winds  
 JULY: 1976-1980

Number of Hourly Observations

Winds From	Wind Speed (mph)						Total
	1-3	4-7	8-12	13-18	19-24	25+	
N	6	9	0	0	0	0	15
NNE	2	1	0	0	0	0	3
NE	4	0	0	0	0	0	4
ENE	3	0	0	0	0	0	3
E	3	0	0	0	0	0	3
ESE	0	0	0	0	0	0	0
SE	0	0	0	0	0	0	0
SSE	0	0	0	0	0	0	0
S	0	4	0	0	0	0	4
SSW	1	2	0	0	0	0	3
SW	1	6	3	0	0	0	10
WSW	4	9	4	0	0	0	17
W	1	7	0	0	0	0	8
WNW	0	1	0	0	0	0	1
NW	2	4	0	0	0	0	6
NNW	0	11	0	0	0	0	11
Total	27	54	7	0	0	0	88

Number of Calm Hours - 0  
 Number of Variable Directions - 0  
 Total Number of Observations - 88

TABLE 2.3C-52

BVPS WIND - STABILITY SUMMARY  
 STABILITY CLASS - D, 35 Ft Winds  
 JULY: 1976-1980

Number of Hourly Observations

Winds From	Wind Speed (mph)						Total
	1-3	4-7	8-12	13-18	19-24	25+	
N	32	21	0	0	0	0	53
NNE	32	3	0	0	0	0	35
NE	29	1	0	0	0	0	30
ENE	31	0	0	0	0	0	31
E	17	0	0	0	0	0	17
ESE	4	3	0	0	0	0	7
SE	12	0	0	0	0	0	12
SSE	11	4	0	0	0	0	15
S	19	7	0	0	0	0	26
SSW	20	52	3	0	0	0	75
SW	15	67	31	0	0	0	113
WSW	14	57	18	0	0	0	89
W	14	19	2	0	0	0	35
WNW	16	11	0	0	0	0	27
NW	18	17	0	0	0	0	35
NNW	27	15	0	0	0	0	42
Total	311	277	54	0	0	0	642

Number of Calm Hours - 3  
 Number of Variable Directions - 0  
 Total Number of Observations - 645

TABLE 2.3C-53

BVPS WIND - STABILITY SUMMARY  
 STABILITY CLASS - E, 35 Ft Winds  
 JULY: 1976-1980

Number of Hourly Observations

Winds From	Wind Speed (mph)						Total
	1-3	4-7	8-12	13-18	19-24	25+	
N	24	3	0	0	0	0	27
NNE	17	1	0	0	0	0	18
NE	31	1	0	0	0	0	32
ENE	51	1	0	0	0	0	52
E	52	0	1	0	0	0	53
ESE	48	1	0	0	0	0	49
SE	52	1	0	0	0	0	53
SSE	69	4	0	0	0	0	73
S	79	25	0	0	0	0	104
SSW	32	26	1	0	0	0	59
SW	24	32	0	0	0	0	56
WSW	15	5	0	0	0	0	20
W	17	8	0	0	0	0	25
WNW	7	2	0	0	0	0	9
NW	5	1	0	0	0	0	6
NNW	20	2	0	0	0	0	22
Total	543	113	2	0	0	0	658

Number of Calm Hours - 7  
 Number of Variable Directions - 0  
 Total Number of Observations - 665



TABLE 2.3C-54

BVPS WIND - STABILITY SUMMARY  
 STABILITY CLASS - F, 35 Ft Winds  
 JULY: 1976-1980

Number of Hourly Observations

Winds From	Wind Speed (mph)						Total
	1-3	4-7	8-12	13-18	19-24	25+	
N	3	0	0	0	0	0	3
NNE	9	0	0	0	0	0	9
NE	9	0	0	0	0	0	9
ENE	22	0	0	0	0	0	22
E	63	0	0	0	0	0	63
ESE	127	0	0	0	0	0	127
SE	190	1	1	0	0	0	192
SSE	91	1	0	0	0	0	92
S	40	8	0	0	0	0	48
SSW	18	5	0	0	0	0	23
SW	2	2	0	0	0	0	4
WSW	2	0	0	0	0	0	2
W	1	0	0	0	0	0	1
WNW	0	0	0	0	0	0	0
NW	0	0	0	0	0	0	0
NNW	2	0	0	0	0	0	2
Total	579	17	1	0	0	0	597

Number of Calm Hours - 7  
 Number of Variable Directions - 0  
 Total Number of Observations - 604

TABLE 2.3C-55

BVPS WIND - STABILITY SUMMARY  
 STABILITY CLASS - G, 35 Ft Winds  
 JULY: 1976-1980

Number of Hourly Observations

Winds From	Wind Speed (mph)						Total
	1-3	4-7	8-12	13-18	19-24	25+	
N	1	0	0	0	0	0	1
NNE	1	0	0	0	0	0	1
NE	1	0	0	0	0	0	1
ENE	4	0	0	0	0	0	4
E	21	0	0	0	0	0	21
ESE	79	0	0	0	0	0	79
SE	175	0	0	0	0	0	175
SSE	56	1	0	0	0	0	57
S	27	1	0	0	0	0	28
SSW	3	0	0	0	0	0	3
SW	0	0	0	0	0	0	0
WSW	0	0	0	0	0	0	0
W	0	0	0	0	0	0	0
WNW	0	0	0	0	0	0	0
NW	1	0	0	0	0	0	1
NNW	1	0	0	0	0	0	1
Total	370	2	0	0	0	0	372

Number of Calm Hours - 3  
 Number of Variable Directions - 0  
 Total Number of Observations - 375

TABLE 2.3C-56

BVPS WIND - STABILITY SUMMARY  
 STABILITY CLASS - ALL, 35 Ft Winds  
 JULY: 1976-1980

## Number of Hourly Observations

Winds From	Wind Speed (mph)						Total
	1-3	4-7	8-12	13-18	19-24	25+	
N	91	128	1	0	0	0	220
NNE	75	23	0	0	0	0	98
NE	91	9	0	0	0	0	100
ENE	124	4	0	0	0	0	128
E	169	9	1	0	0	0	179
ESE	267	5	0	0	0	0	272
SE	441	6	1	0	0	0	448
SSE	239	18	0	0	0	0	257
S	182	81	1	0	0	0	264
SSW	81	171	17	0	0	0	269
SW	60	216	80	0	0	0	356
WSW	43	170	47	2	0	0	262
W	45	111	15	0	0	0	171
WNW	38	52	2	0	0	0	92
NW	36	60	1	0	0	0	97
NNW	61	88	1	0	0	0	150
Total	2043	1151	167	2	0	0	3363

Number of Calm Hours - 20  
 Number of Variable Directions - 0  
 Total Number of Observations - 3383

TABLE 2.3C-57

BVPS WIND - STABILITY SUMMARY  
 STABILITY CLASS - A, 35 Ft Winds  
 AUGUST: 1976-1980

Number of Hourly Observations

Winds From	Wind Speed (mph)						Total
	1-3	4-7	8-12	13-18	19-24	25+	
N	22	57	0	0	0	0	79
NNE	11	26	0	0	0	0	37
NE	15	9	0	0	0	0	24
ENE	11	12	0	0	0	0	23
E	12	8	0	0	0	0	20
ESE	10	3	0	0	0	0	13
SE	5	1	0	0	0	0	6
SSE	10	2	0	0	0	0	12
S	11	15	0	0	0	0	26
SSW	6	46	9	0	0	0	61
SW	8	125	42	0	0	0	175
WSW	15	115	35	0	0	0	165
W	15	60	6	0	0	0	81
WNW	9	15	1	0	0	0	25
NW	15	20	1	0	0	0	36
NNW	16	31	0	0	0	0	47
Total	191	545	94	0	0	0	830

Number of Calm Hours - 0  
 Number of Variable Directions - 0  
 Total Number of Observations - 830

TABLE 2.3C-58

BVPS WIND - STABILITY SUMMARY  
 STABILITY CLASS - B, 35 Ft Winds  
 AUGUST: 1976-1980

Number of Hourly Observations

Winds From	Wind Speed (mph)						Total
	1-3	4-7	8-12	13-18	19-24	25+	
N	7	3	0	0	0	0	10
NNE	2	2	0	0	0	0	4
NE	3	0	0	0	0	0	3
ENE	1	0	0	0	0	0	1
E	1	0	0	0	0	0	1
ESE	3	0	0	0	0	0	3
SE	3	0	0	0	0	0	3
SSE	0	0	0	0	0	0	0
S	1	0	0	0	0	0	1
SSW	2	9	0	0	0	0	11
SW	2	14	7	0	0	0	23
WSW	2	14	2	0	0	0	18
W	0	6	0	0	0	0	6
WNW	2	0	0	0	0	0	2
NW	0	3	0	0	0	0	3
NNW	3	5	0	0	0	0	8
Total	32	56	9	0	0	0	97

Number of Calm Hours - 0  
 Number of Variable Directions - 0  
 Total Number of Observations - 97

TABLE 2.3C-59

BVPS WIND - STABILITY SUMMARY  
 STABILITY CLASS - C, 35 Ft Winds  
 AUGUST: 1976-1980

Number of Hourly Observations

Winds From	Wind Speed (mph)						Total
	1-3	4-7	8-12	13-18	19-24	25+	
N	3	2	0	0	0	0	5
NNE	3	1	0	0	0	0	4
NE	2	0	0	0	0	0	2
ENE	2	0	0	0	0	0	2
E	4	0	0	0	0	0	4
ESE	0	0	0	0	0	0	0
SE	0	0	0	0	0	0	0
SSE	4	0	0	0	0	0	4
S	2	3	0	0	0	0	5
SSW	1	5	0	0	0	0	6
SW	3	11	4	0	0	0	18
WSW	2	7	3	0	0	0	12
W	4	6	0	0	0	0	10
WNW	1	3	0	0	0	0	4
NW	3	1	0	0	0	0	4
NNW	2	3	0	0	0	0	5
Total	36	42	7	0	0	0	85

Number of Calm Hours - 0  
 Number of Variable Directions - 0  
 Total Number of Observations - 85

TABLE 2.3C-60

BVPS WIND - STABILITY SUMMARY  
 STABILITY CLASS - D, 35 Ft Winds  
 AUGUST: 1976-1980

Number of Hourly Observations

Winds From	Wind Speed (mph)						Total
	1-3	4-7	8-12	13-18	19-24	25+	
N	32	19	0	0	0	0	51
NNE	32	0	0	0	0	0	32
NE	46	0	0	0	0	0	46
ENE	24	1	0	0	0	0	25
E	20	0	0	0	0	0	20
ESE	11	0	0	0	0	0	11
SE	12	0	0	0	0	0	12
SSE	10	2	0	0	0	0	12
S	18	11	0	0	0	0	29
SSW	14	39	2	0	0	0	55
SW	23	72	20	0	0	0	115
WSW	16	59	4	0	0	0	79
W	23	25	0	0	0	0	48
WNW	17	13	0	0	0	0	30
NW	9	7	0	0	1	0	17
NNW	22	13	0	0	0	0	35
Total	329	261	26	0	1	0	617

Number of Calm Hours - 4  
 Number of Variable Directions - 0  
 Total Number of Observations - 621

TABLE 2.3C-61

BVPS WIND - STABILITY SUMMARY  
 STABILITY CLASS - E, 35 Ft Winds  
 AUGUST: 1976-1980

Number of Hourly Observations

Winds From	Wind Speed (mph)						Total
	1-3	4-7	8-12	13-18	19-24	25+	
N	20	7	0	0	0	0	27
NNE	43	3	0	0	0	0	46
NE	57	1	0	0	0	0	58
ENE	35	0	0	0	0	0	35
E	76	0	0	0	0	0	76
ESE	78	0	0	0	0	0	78
SE	68	2	0	0	0	0	70
SSE	78	1	0	0	0	0	79
S	84	22	0	0	0	0	106
SSW	47	65	0	0	0	0	112
SW	23	32	4	0	0	0	59
WSW	6	11	1	0	0	0	18
W	17	4	0	0	0	0	21
WNW	8	1	1	0	0	0	10
NW	16	4	0	0	0	0	20
NNW	18	7	0	0	0	0	25
Total	674	160	6	0	0	0	840

Number of Calm Hours - 32  
 Number of Variable Directions - 0  
 Total Number of Observations - 872



TABLE 2.3C-62

BVPS WIND - STABILITY SUMMARY  
 STABILITY CLASS - F, 35 Ft Winds  
 AUGUST: 1976-1980

Number of Hourly Observations

Winds From	Wind Speed (mph)						Total
	1-3	4-7	8-12	13-18	19-24	25+	
N	4	0	0	0	0	0	4
NNE	3	0	0	0	0	0	3
NE	5	0	0	0	0	0	5
ENE	27	0	0	0	0	0	27
E	73	0	0	0	0	0	73
ESE	169	0	0	0	0	0	169
SE	208	0	0	0	0	0	208
SSE	64	3	0	0	0	0	67
S	41	13	0	0	0	0	54
SSW	11	4	0	0	0	0	15
SW	3	0	0	0	0	0	3
WSW	0	0	0	0	0	0	0
W	0	0	0	0	0	0	0
WNW	0	1	0	0	0	0	1
NW	1	0	0	0	0	0	1
NNW	4	0	0	0	0	0	4
Total	613	21	0	0	0	0	634

Number of Calm Hours - 34  
 Number of Variable Directions - 0  
 Total Number of Observations - 668

TABLE 2.3C-63

BVPS WIND - STABILITY SUMMARY  
 STABILITY CLASS - G, 35 Ft Winds  
 AUGUST: 1976-1980

Number of Hourly Observations

Winds From	Wind Speed (mph)						Total
	1-3	4-7	8-12	13-18	19-24	25+	
N	0	0	0	0	0	0	0
NNE	1	0	0	0	0	0	1
NE	2	0	0	0	0	0	2
ENE	2	0	0	0	0	0	2
E	15	0	0	0	0	0	15
ESE	84	0	0	0	0	0	84
SE	124	0	0	0	0	0	124
SSE	46	1	0	0	0	0	47
S	17	1	0	0	0	0	18
SSW	3	0	0	0	0	0	3
SW	1	0	0	0	0	0	1
WSW	0	0	0	0	0	0	0
W	0	0	0	0	0	0	0
WNW	0	0	0	0	0	0	0
NW	1	0	0	0	0	0	1
NNW	0	0	0	0	0	0	0
Total	296	2	0	0	0	0	298

Number of Calm Hours - 5  
 Number of Variable Directions - 0  
 Total Number of Observations - 303

TABLE 2.3C-64

BVPS WIND - STABILITY SUMMARY  
 STABILITY CLASS - ALL, 35 Ft Winds  
 AUGUST: 1976-1980

Number of Hourly Observations

Winds From	Wind Speed (mph)						Total
	1-3	4-7	8-12	13-18	19-24	25+	
N	88	88	0	0	0	0	176
NNE	95	32	0	0	0	0	127
NE	130	10	0	0	0	0	140
ENE	102	13	0	0	0	0	115
E	201	8	0	0	0	0	209
ESE	355	3	0	0	0	0	358
SE	420	3	0	0	0	0	423
SSE	212	9	0	0	0	0	221
S	174	65	0	0	0	0	239
SSW	84	168	11	0	0	0	263
SW	63	254	77	0	0	0	394
WSW	41	206	45	0	0	0	292
W	59	101	6	0	0	0	166
WNW	37	33	2	0	0	0	72
NW	45	35	1	0	1	0	82
NNW	65	59	0	0	0	0	124
Total	2171	1087	142	0	1	0	3401

Number of Calm Hours - 75  
 Number of Variable Directions - 0  
 Total Number of Observations - 3476

TABLE 2.3C-65

BVPS WIND - STABILITY SUMMARY  
 STABILITY CLASS - A, 35 Ft Winds  
 SEPTEMBER: 1976-1980

Number of Hourly Observations

Winds From	Wind Speed (mph)						Total
	1-3	4-7	8-12	13-18	19-24	25+	
N	19	75	2	0	0	0	96
NNE	7	20	0	0	0	0	27
NE	10	6	0	0	0	0	16
ENE	4	6	0	0	0	0	10
E	9	8	0	0	0	0	17
ESE	9	8	0	0	0	0	17
SE	5	6	0	0	0	0	11
SSE	6	8	0	0	0	0	14
S	9	30	1	0	0	0	40
SSW	9	36	3	0	0	0	48
SW	9	70	24	0	0	0	103
WSW	7	102	29	0	0	0	138
W	9	42	14	0	0	0	65
WNW	8	29	7	0	0	0	44
NW	5	18	1	0	0	0	24
NNW	12	43	1	0	0	0	56
Total	137	507	82	0	0	0	726

Number of Calm Hours	-	0
Number of Variable Directions	-	0
Total Number of Observations	-	726

TABLE 2.3C-66

BVPS WIND - STABILITY SUMMARY  
 STABILITY CLASS - B, 35 Ft Winds  
 SEPTEMBER: 1976-1980

Number of Hourly Observations

Winds From	Wind Speed (mph)						Total
	1-3	4-7	8-12	13-18	19-24	25+	
N	2	6	0	0	0	0	8
NNE	5	0	0	0	0	0	5
NE	2	0	0	0	0	0	2
ENE	2	0	0	0	0	0	2
E	1	0	0	0	0	0	1
ESE	0	1	0	0	0	0	1
SE	0	0	0	0	0	0	0
SSE	0	1	0	0	0	0	1
S	1	1	0	0	0	0	2
SSW	3	7	0	0	0	0	10
SW	2	5	8	0	0	0	15
WSW	0	9	5	0	0	0	14
W	1	6	0	0	0	0	7
WNW	3	2	0	0	0	0	5
NW	1	2	0	0	0	0	3
NNW	1	2	0	0	0	0	3
Total	24	42	13	0	0	0	79

Number of Calm Hours	-	0
Number of Variable Directions	-	0
Total Number of Observations	-	79

TABLE 2.3C-67

BVPS WIND - STABILITY SUMMARY  
 STABILITY CLASS - C, 35 Ft Winds  
 SEPTEMBER: 1976-1980

Number of Hourly Observations

Winds From	Wind Speed (mph)						Total
	1-3	4-7	8-12	13-18	19-24	25+	
N	6	6	0	0	0	0	12
NNE	4	3	0	0	0	0	7
NE	3	1	0	0	0	0	4
ENE	1	0	0	0	0	0	1
E	1	1	0	0	0	0	2
ESE	1	0	0	0	0	0	1
SE	0	0	0	0	0	0	0
SSE	0	0	0	0	0	0	0
S	3	0	0	0	0	0	3
SSW	0	2	2	0	0	0	4
SW	3	10	2	0	0	0	15
WSW	1	11	5	0	0	0	17
W	2	7	1	0	0	0	10
WNW	2	4	0	0	0	0	6
NW	4	2	0	0	0	0	6
NNW	1	5	0	0	0	0	6
Total	32	52	10	0	0	0	94

Number of Calm Hours - 0  
 Number of Variable Directions - 0  
 Total Number of Observations - 94

TABLE 2.3C-68

BVPS WIND - STABILITY SUMMARY  
 STABILITY CLASS - D, 35 Ft Winds  
 SEPTEMBER: 1976-1980

Number of Hourly Observations

Winds From	Wind Speed (mph)						Total
	1-3	4-7	8-12	13-18	19-24	25+	
N	41	30	0	0	0	0	71
NNE	33	10	0	0	0	0	43
NE	38	2	0	0	0	0	40
ENE	23	1	0	0	0	0	24
E	9	1	0	0	0	0	10
ESE	10	0	0	0	0	0	10
SE	12	1	0	0	0	0	13
SSE	10	2	0	0	0	0	12
S	21	9	0	0	0	0	30
SSW	15	19	2	0	0	0	36
SW	16	72	11	0	0	0	99
WSW	13	50	14	0	0	0	77
W	13	29	4	0	0	0	46
WNW	26	11	0	0	0	0	37
NW	15	20	3	0	0	0	38
NNW	19	26	0	0	0	0	45
Total	314	283	34	0	0	0	631

Number of Calm Hours	-	3
Number of Variable Directions	-	0
Total Number of Observations	-	634

TABLE 2.3C-69

BVPS WIND - STABILITY SUMMARY  
 STABILITY CLASS - E, 35 Ft Winds  
 SEPTEMBER: 1976-1980

Number of Hourly Observations

Winds From	Wind Speed (mph)						Total
	1-3	4-7	8-12	13-18	19-24	25+	
N	29	7	0	0	0	0	36
NNE	25	3	0	0	0	0	28
NE	64	3	0	0	0	0	67
ENE	64	0	0	0	0	0	64
E	49	0	0	0	0	0	49
ESE	64	1	0	0	0	0	65
SE	47	0	0	0	0	0	47
SSE	55	1	0	0	0	0	56
S	48	17	0	0	0	0	65
SSW	36	40	0	0	0	0	76
SW	36	28	2	0	0	0	66
WSW	12	18	1	0	0	0	31
W	18	6	1	0	0	0	25
WNW	9	3	0	0	0	0	12
NW	15	7	0	0	0	0	22
NNW	15	3	0	0	0	0	18
Total	586	137	4	0	0	0	727

Number of Calm Hours - 14  
 Number of Variable Directions - 0  
 Total Number of Observations - 741



TABLE 2.3C-70

BVPS WIND - STABILITY SUMMARY  
 STABILITY CLASS - F, 35 Ft Winds  
 SEPTEMBER: 1976-1980

Number of Hourly Observations

Winds From	Wind Speed (mph)						Total
	1-3	4-7	8-12	13-18	19-24	25+	
N	6	0	0	0	0	0	6
NNE	10	0	0	0	0	0	10
NE	15	0	0	0	0	0	15
ENE	25	0	0	0	0	0	25
E	84	0	0	0	0	0	84
ESE	136	0	0	0	0	0	136
SE	150	0	0	0	0	0	150
SSE	86	1	0	0	0	0	87
S	42	12	0	0	0	0	54
SSW	13	9	0	0	0	0	22
SW	5	5	0	0	0	0	10
WSW	1	0	0	0	0	0	1
W	0	0	0	0	0	0	0
WNW	0	0	0	0	0	0	0
NW	0	0	0	0	0	0	0
NNW	2	0	0	0	0	0	2
Total	575	27	0	0	0	0	602

Number of Calm Hours - 15  
 Number of Variable Directions - 0  
 Total Number of Observations - 617

TABLE 2.3C-71

BVPS WIND - STABILITY SUMMARY  
 STABILITY CLASS - G, 35 Ft Winds  
 SEPTEMBER: 1976-1980

Number of Hourly Observations

Winds From	Wind Speed (mph)						Total
	1-3	4-7	8-12	13-18	19-24	25+	
N	1	0	0	0	0	0	1
NNE	1	0	0	0	0	0	1
NE	4	0	0	0	0	0	4
ENE	12	0	0	0	0	0	12
E	33	0	0	0	0	0	33
ESE	146	0	0	0	0	0	146
SE	194	1	0	0	0	0	195
SSE	64	1	0	0	0	0	65
S	27	4	0	0	0	0	31
SSW	3	2	0	0	0	0	5
SW	0	1	0	0	0	0	1
WSW	0	0	0	0	0	0	0
W	1	0	0	0	0	0	1
WNW	0	0	0	0	0	0	0
NW	0	0	0	0	0	0	0
NNW	0	0	0	0	0	0	0
Total	486	9	0	0	0	0	495

Number of Calm Hours - 13  
 Number of Variable Directions - 0  
 Total Number of Observations - 508

TABLE 2.3C-72

BVPS WIND - STABILITY SUMMARY  
 STABILITY CLASS - ALL, 35 Ft Winds  
 SEPTEMBER: 1976-1980

Number of Hourly Observations

Winds From	Wind Speed (mph)						Total
	<u>1-3</u>	<u>4-7</u>	<u>8-12</u>	<u>13-18</u>	<u>19-24</u>	<u>25+</u>	
N	104	124	2	0	0	0	230
NNE	85	36	0	0	0	0	121
NE	136	12	0	0	0	0	148
ENE	131	7	0	0	0	0	138
E	186	10	0	0	0	0	196
ESE	366	10	0	0	0	0	376
SE	408	8	0	0	0	0	416
SSE	221	14	0	0	0	0	235
S	151	73	1	0	0	0	225
SSW	79	115	7	0	0	0	201
SW	71	191	47	0	0	0	309
WSW	34	190	54	0	0	0	278
W	44	90	20	0	0	0	154
WNW	48	49	7	0	0	0	104
NW	40	49	4	0	0	0	93
NNW	50	79	1	0	0	0	130
Total	<u>2154</u>	<u>1057</u>	<u>143</u>	<u>0</u>	<u>0</u>	<u>0</u>	<u>3354</u>

Number of Calm Hours	-	45
Number of Variable Directions	-	0
Total Number of Observations	-	3399

TABLE 2.3C-73

BVPS WIND - STABILITY SUMMARY  
 STABILITY CLASS - A, 35 Ft Winds  
 OCTOBER: 1976-1980

Number of Hourly Observations

Winds From	Wind Speed (mph)						Total
	1-3	4-7	8-12	13-18	19-24	25+	
N	3	20	1	0	0	0	24
NNE	3	8	0	0	0	0	11
NE	5	7	0	0	0	0	12
ENE	5	7	0	0	0	0	12
E	7	10	0	0	0	0	17
ESE	2	9	0	0	0	0	11
SE	1	9	0	0	0	0	10
SSE	3	3	0	0	0	0	6
S	1	11	0	0	0	0	12
SSW	0	16	2	0	0	0	18
SW	3	14	11	0	0	0	28
WSW	2	26	28	3	0	0	59
W	2	13	20	1	0	0	36
WNW	3	15	6	0	0	0	24
NW	1	8	0	0	0	0	9
NNW	3	11	0	0	0	0	14
Total	44	187	68	4	0	0	303

Number of Calm Hours - 0  
 Number of Variable Directions - 0  
 Total Number of Observations - 303

TABLE 2.3C-74

BVPS WIND - STABILITY SUMMARY  
 STABILITY CLASS - B, 35 Ft Winds  
 OCTOBER: 1976-1980

## Number of Hourly Observations

Winds From	Wind Speed (mph)						Total
	1-3	4-7	8-12	13-18	19-24	25+	
N	1	2	0	0	0	0	3
NNE	0	1	0	0	0	0	1
NE	0	1	0	0	0	0	1
ENE	1	1	0	0	0	0	2
E	1	0	0	0	0	0	1
ESE	1	0	0	0	0	0	1
SE	1	0	0	0	0	0	1
SSE	1	0	0	0	0	0	1
S	1	3	0	0	0	0	4
SSW	0	3	4	0	0	0	7
SW	0	4	7	0	0	0	11
WSW	0	17	12	0	0	0	29
W	0	6	5	0	0	0	11
WNW	1	10	2	0	0	0	13
NW	2	2	0	0	0	0	4
NNW	0	1	0	0	0	0	1
Total	10	51	30	0	0	0	91

Number of Calm Hours - 0  
 Number of Variable Directions - 0  
 Total Number of Observations - 91

TABLE 2.3C-75

BVPS WIND - STABILITY SUMMARY  
 STABILITY CLASS - C, 35 Ft Winds  
 OCTOBER: 1976-1980

Number of Hourly Observations

Winds From	Wind Speed (mph)						Total
	1-3	4-7	8-12	13-18	19-24	25+	
N	3	5	0	0	0	0	8
NNE	3	0	0	0	0	0	3
NE	1	2	0	0	0	0	3
ENE	3	0	0	0	0	0	3
E	1	1	0	0	0	0	2
ESE	0	1	0	0	0	0	1
SE	0	1	0	0	0	0	1
SSE	0	0	0	0	0	0	0
S	1	1	0	0	0	0	2
SSW	3	9	3	0	0	0	15
SW	1	4	12	1	0	0	18
WSW	2	17	10	0	0	0	29
W	0	8	7	0	0	0	15
WNW	1	5	1	0	0	0	7
NW	0	5	1	0	0	0	6
NNW	4	1	1	0	0	0	6
Total	23	60	35	1	0	0	119

Number of Calm Hours	-	0
Number of Variable Directions	-	0
Total Number of Observations	-	119

TABLE 2.3C-76

BVPS WIND - STABILITY SUMMARY  
 STABILITY CLASS - D, 35 Ft Winds  
 OCTOBER: 1976-1980

Number of Hourly Observations

Winds From	Wind Speed (mph)						Total
	1-3	4-7	8-12	13-18	19-24	25+	
N	26	52	2	0	0	0	80
NNE	32	10	0	0	0	0	42
NE	26	2	0	0	0	0	28
ENE	22	3	0	0	0	0	25
E	19	5	0	0	0	0	24
ESE	11	3	0	0	0	0	14
SE	10	2	0	0	0	0	12
SSE	5	4	0	0	0	0	9
S	13	19	1	0	0	0	33
SSW	17	31	9	0	0	0	57
SW	13	66	52	4	0	0	135
WSW	8	90	100	7	0	0	205
W	16	78	44	3	0	0	141
WNW	13	58	6	0	0	0	77
NW	16	57	5	0	0	0	78
NNW	13	42	1	0	0	0	56
Total	260	522	220	14	0	0	1016

Number of Calm Hours - 12  
 Number of Variable Directions - 0  
 Total Number of Observations - 1028

TABLE 2.3C-77

BVPS WIND - STABILITY SUMMARY  
 STABILITY CLASS - E, 35 Ft Winds  
 OCTOBER: 1976-1980

Number of Hourly Observations

Winds From	Wind Speed (mph)						Total
	1-3	4-7	8-12	13-18	19-24	25+	
N	21	3	0	0	0	0	24
NNE	21	7	0	0	0	0	28
NE	49	7	0	0	0	0	56
ENE	32	2	0	0	0	0	34
E	55	10	0	0	0	0	65
ESE	42	2	0	0	0	0	44
SE	42	1	0	0	0	0	43
SSE	28	3	0	0	0	0	31
S	59	27	0	0	0	0	86
SSW	32	50	5	0	0	0	87
SW	17	41	15	0	0	0	73
WSW	7	17	6	0	0	0	30
W	10	14	4	0	0	0	28
WNW	13	14	0	0	0	0	27
NW	10	6	1	0	0	0	17
NNW	11	7	0	0	0	0	18
Total	449	211	31	0	0	0	691

Number of Calm Hours - 9  
 Number of Variable Directions - 0  
 Total Number of Observations - 700



TABLE 2.3C-78

BVPS WIND - STABILITY SUMMARY  
 STABILITY CLASS - F, 35 Ft Winds  
 OCTOBER: 1976-1980

## Number of Hourly Observations

Winds From	Wind Speed (mph)						Total
	1-3	4-7	8-12	13-18	19-24	25+	
N	9	1	0	0	0	0	10
NNE	7	1	0	0	0	0	8
NE	9	0	0	0	0	0	9
ENE	20	1	0	0	0	0	21
E	62	0	0	0	0	0	62
ESE	69	0	0	0	0	0	69
SE	73	0	0	0	0	0	73
SSE	49	4	0	0	0	0	53
S	31	17	0	0	0	0	48
SSW	11	5	0	0	0	0	16
SW	6	2	0	0	0	0	8
WSW	2	1	0	0	0	0	3
W	1	0	0	0	0	0	1
WNW	0	0	0	0	0	0	0
NW	0	0	0	0	0	0	0
NNW	3	0	0	0	0	0	3
Total	352	32	0	0	0	0	384

Number of Calm Hours - 12  
 Number of Variable Directions - 0  
 Total Number of Observations - 396

TABLE 2.3C-79

BVPS WIND - STABILITY SUMMARY  
 STABILITY CLASS - G, 35 Ft Winds  
 OCTOBER: 1976-1980

Number of Hourly Observations

Winds From	Wind Speed (mph)						Total
	1-3	4-7	8-12	13-18	19-24	25+	
N	0	0	0	0	0	0	0
NNE	3	0	0	0	0	0	3
NE	7	0	0	0	0	0	7
ENE	27	0	0	0	0	0	27
E	50	0	0	0	0	0	50
ESE	153	1	0	0	0	0	154
SE	183	1	0	0	0	0	184
SSE	64	2	0	0	0	0	66
S	22	11	0	0	0	0	33
SSW	2	1	0	0	0	0	3
SW	2	0	0	0	0	0	2
WSW	2	0	0	0	0	0	2
W	1	0	0	0	0	0	1
WNW	1	0	0	0	0	0	1
NW	0	0	0	0	0	0	0
NNW	1	0	0	0	0	0	1
Total	518	16	0	0	0	0	534

Number of Calm Hours - 3  
 Number of Variable Directions - 0  
 Total Number of Observations - 537

TABLE 2.3C-80

BVPS WIND - STABILITY SUMMARY  
 STABILITY CLASS - ALL, 35 Ft Winds  
 OCTOBER: 1976-1980

Number of Hourly Observations

Winds From	Wind Speed (mph)						Total
	1-3	4-7	8-12	13-18	19-24	25+	
N	63	83	3	0	0	0	149
NNE	69	27	0	0	0	0	96
NE	97	19	0	0	0	0	116
ENE	110	14	0	0	0	0	124
E	195	26	0	0	0	0	221
ESE	278	16	0	0	0	0	294
SE	310	14	0	0	0	0	324
SSE	150	16	0	0	0	0	166
S	128	89	1	0	0	0	218
SSW	65	115	23	0	0	0	203
SW	42	131	97	5	0	0	275
WSW	23	168	156	10	0	0	357
W	30	119	80	4	0	0	233
WNW	32	102	15	0	0	0	149
NW	29	78	7	0	0	0	114
NNW	35	62	2	0	0	0	99
Total	1656	1079	384	19	0	0	3138

Number of Calm Hours	-	36
Number of Variable Directions	-	0
Total Number of Observations	-	3174

TABLE 2.3C-81

BVPS WIND - STABILITY SUMMARY  
 STABILITY CLASS - A, 35 Ft Winds  
 NOVEMBER: 1976-1980

Number of Hourly Observations

Winds From	Wind Speed (mph)						Total
	1-3	4-7	8-12	13-18	19-24	25+	
N	0	7	0	0	0	0	7
NNE	1	3	0	0	0	0	4
NE	1	6	0	0	0	0	7
ENE	0	11	0	0	0	0	11
E	1	6	0	0	0	0	7
ESE	0	2	0	0	0	0	2
SE	0	5	0	0	0	0	5
SSE	0	8	0	0	0	0	8
S	2	4	3	0	0	0	9
SSW	1	7	0	0	0	0	8
SW	2	4	3	0	0	0	9
WSW	1	15	9	0	0	0	25
W	0	16	8	0	0	0	24
WNW	2	9	9	0	0	0	20
NW	1	13	1	0	0	0	15
NNW	0	2	1	0	0	0	3
Total	12	118	34	0	0	0	164

Number of Calm Hours - 0  
 Number of Variable Directions - 0  
 Total Number of Observations - 164

TABLE 2.3C-82

BVPS WIND - STABILITY SUMMARY  
 STABILITY CLASS - B, 35 Ft Winds  
 NOVEMBER: 1976-1980

Number of Hourly Observations

Winds From	Wind Speed (mph)						Total
	1-3	4-7	8-12	13-18	19-24	25+	
N	0	0	0	0	0	0	0
NNE	0	2	0	0	0	0	2
NE	0	0	0	0	0	0	0
ENE	1	1	0	0	0	0	2
E	1	2	0	0	0	0	3
ESE	0	1	0	0	0	0	1
SE	0	0	0	0	0	0	0
SSE	0	1	0	0	0	0	1
S	0	1	0	0	0	0	1
SSW	0	3	1	0	0	0	4
SW	1	4	5	0	0	0	10
WSW	0	10	9	0	0	0	19
W	0	2	7	0	0	0	9
WNW	0	3	4	0	0	0	7
NW	0	6	1	0	0	0	7
NNW	0	0	0	0	0	0	0
Total	3	36	27	0	0	0	66

Number of Calm Hours - 0  
 Number of Variable Directions - 0  
 Total Number of Observations - 66

TABLE 2.3C-83

BVPS WIND - STABILITY SUMMARY  
 STABILITY CLASS - C, 35 Ft Winds  
 NOVEMBER: 1976-1980

Number of Hourly Observations

Winds From	Wind Speed (mph)						Total
	1-3	4-7	8-12	13-18	19-24	25+	
N	1	3	0	0	0	0	4
NNE	1	0	0	0	0	0	1
NE	0	1	0	0	0	0	1
ENE	2	0	0	0	0	0	2
E	1	4	0	0	0	0	5
ESE	0	1	0	0	0	0	1
SE	0	1	0	0	0	0	1
SSE	0	0	0	0	0	0	0
S	0	3	0	0	0	0	3
SSW	0	3	2	0	0	0	5
SW	1	10	12	0	0	0	23
WSW	2	10	8	0	0	0	20
W	3	11	8	0	0	0	22
WNW	0	6	3	0	0	0	9
NW	0	4	4	0	0	0	8
NNW	0	1	0	0	0	0	1
Total	11	58	37	0	0	0	106

Number of Calm Hours - 0  
 Number of Variable Directions - 0  
 Total Number of Observations - 106

TABLE 2.3C-84

BVPS WIND - STABILITY SUMMARY  
 STABILITY CLASS - D, 35 Ft Winds  
 NOVEMBER: 1976-1980

## Number of Hourly Observations

Winds From	Wind Speed (mph)						Total
	1-3	4-7	8-12	13-18	19-24	25+	
N	25	22	0	0	0	0	47
NNE	49	15	0	0	0	0	64
NE	62	13	0	0	0	0	75
ENE	64	26	0	0	0	0	90
E	31	17	0	0	0	0	48
ESE	15	2	0	0	0	0	17
SE	12	3	0	0	0	0	15
SSE	10	5	0	0	0	0	15
S	12	12	6	0	0	0	30
SSW	9	57	25	1	0	0	92
SW	12	63	83	2	0	0	160
WSW	13	94	145	6	0	0	258
W	12	99	97	3	0	0	211
WNW	20	81	17	1	0	0	119
NW	18	114	15	0	0	0	147
NNW	25	27	0	0	0	0	52
Total	389	650	388	13	0	0	1440

Number of Calm Hours - 2  
 Number of Variable Directions - 0  
 Total Number of Observations - 1442

TABLE 2.3C-85

BVPS WIND - STABILITY SUMMARY  
 STABILITY CLASS - E, 35 Ft Winds  
 NOVEMBER: 1976-1980

## Number of Hourly Observations

Winds From	Wind Speed (mph)						Total
	1-3	4-7	8-12	13-18	19-24	25+	
N	8	2	0	0	0	0	10
NNE	28	4	0	0	0	0	32
NE	45	10	0	0	0	0	55
ENE	61	35	0	0	0	0	96
E	45	4	0	0	0	0	49
ESE	29	6	0	0	0	0	35
SE	29	10	0	0	0	0	39
SSE	26	3	0	0	0	0	29
S	26	25	1	0	0	0	52
SSW	25	56	14	0	0	0	95
SW	11	65	26	0	0	0	102
WSW	7	29	20	1	0	0	57
W	9	9	7	0	0	0	25
WNW	8	5	0	0	0	0	13
NW	8	6	2	0	0	0	16
NNW	6	4	0	0	0	0	10
Total	371	273	70	1	0	0	715

Number of Calm Hours - 5  
 Number of Variable Directions - 0  
 Total Number of Observations - 720



TABLE 2.3C-86

BVPS WIND - STABILITY SUMMARY  
 STABILITY CLASS - F, 35 Ft Winds  
 NOVEMBER: 1976-1980

Number of Hourly Observations

Winds From	Wind Speed (mph)						Total
	1-3	4-7	8-12	13-18	19-24	25+	
N	2	1	0	0	0	0	3
NNE	1	1	0	0	0	0	2
NE	16	1	0	0	0	0	17
ENE	20	0	0	0	0	0	20
E	29	0	0	0	0	0	29
ESE	55	0	0	0	0	0	55
SE	71	1	0	0	0	0	72
SSE	40	0	0	0	0	0	40
S	21	30	1	0	0	0	52
SSW	9	11	0	0	0	0	20
SW	5	8	0	0	0	0	13
WSW	2	1	0	0	0	0	3
W	1	2	0	0	0	0	3
WNW	1	0	0	0	0	0	1
NW	0	0	0	0	0	0	0
NNW	1	0	0	0	0	0	1
Total	274	56	1	0	0	0	331

Number of Calm Hours - 2  
 Number of Variable Directions - 0  
 Total Number of Observations - 333

TABLE 2.3C-87

BVPS WIND - STABILITY SUMMARY  
 STABILITY CLASS - G, 35 Ft Winds  
 NOVEMBER: 1976-1980

Number of Hourly Observations

Winds From	Wind Speed (mph)						Total
	1-3	4-7	8-12	13-18	19-24	25+	
N	0	1	0	0	0	0	1
NNE	4	2	0	0	0	0	6
NE	5	0	0	0	0	0	5
ENE	17	1	0	0	0	0	18
E	32	0	0	0	0	0	32
ESE	70	2	0	0	0	0	72
SE	165	0	0	0	0	0	165
SSE	76	0	0	0	0	0	76
S	17	16	0	0	0	0	33
SSW	6	5	0	0	0	0	11
SW	0	1	0	0	0	0	1
WSW	0	0	0	0	0	0	0
W	0	1	0	0	0	0	1
WNW	3	1	0	0	0	0	4
NW	0	0	0	0	0	0	0
NNW	0	0	0	0	0	0	0
Total	395	30	0	0	0	0	425

Number of Calm Hours - 2  
 Number of Variable Directions - 0  
 Total Number of Observations - 427

TABLE 2.3C-88

BVPS WIND - STABILITY SUMMARY  
 STABILITY CLASS - ALL, 35 Ft Winds  
 NOVEMBER: 1976-1980

Number of Hourly Observations

Winds From	Wind Speed (mph)						Total
	1-3	4-7	8-12	13-18	19-24	25+	
N	36	36	0	0	0	0	72
NNE	84	27	0	0	0	0	111
NE	129	31	0	0	0	0	160
ENE	165	74	0	0	0	0	239
E	140	33	0	0	0	0	173
ESE	169	14	0	0	0	0	183
SE	277	20	0	0	0	0	297
SSE	152	17	0	0	0	0	169
S	78	91	11	0	0	0	180
SSW	50	142	42	1	0	0	235
SW	32	155	129	2	0	0	318
WSW	25	159	191	7	0	0	382
W	25	140	127	3	0	0	295
WNW	34	105	33	1	0	0	173
NW	27	143	23	0	0	0	193
NNW	32	34	1	0	0	0	67
Total	1455	1221	557	14	0	0	3247

Number of Calm Hours - 11  
 Number of Variable Directions - 0  
 Total Number of Observations - 3258

TABLE 2.3C-89

BVPS WIND - STABILITY SUMMARY  
 STABILITY CLASS - A, 35 Ft Winds  
 DECEMBER: 1976-1980

Number of Hourly Observations

Winds From	Wind Speed (mph)						Total
	1-3	4-7	8-12	13-18	19-24	25+	
N	0	5	0	0	0	0	5
NNE	0	4	0	0	0	0	4
NE	1	0	0	0	0	0	1
ENE	1	4	0	0	0	0	5
E	3	3	0	0	0	0	6
ESE	0	1	0	0	0	0	1
SE	2	0	0	0	0	0	2
SSE	0	0	0	0	0	0	0
S	1	2	0	0	0	0	3
SSW	0	4	0	0	0	0	4
SW	0	3	3	0	0	0	6
WSW	0	4	10	0	0	0	14
W	0	15	12	1	0	0	28
WNW	0	4	9	1	0	0	14
NW	0	6	3	0	0	0	9
NNW	0	5	0	0	0	0	5
Total	8	60	37	2	0	0	107

Number of Calm Hours - 0  
 Number of Variable Directions - 0  
 Total Number of Observations - 107

TABLE 2.3C-90

BVPS WIND - STABILITY SUMMARY  
 STABILITY CLASS - B, 35 Ft Winds  
 DECEMBER: 1976-1980

Number of Hourly Observations

Winds From	Wind Speed (mph)						Total
	1-3	4-7	8-12	13-18	19-24	25+	
N	2	1	0	0	0	0	3
NNE	0	1	0	0	0	0	1
NE	2	0	0	0	0	0	2
ENE	1	2	0	0	0	0	3
E	4	1	0	0	0	0	5
ESE	0	0	0	0	0	0	0
SE	0	1	0	0	0	0	1
SSE	0	1	0	0	0	0	1
S	0	2	0	0	0	0	2
SSW	0	2	4	0	0	0	6
SW	1	0	1	0	0	0	2
WSW	0	4	2	0	0	0	6
W	0	8	2	1	0	0	11
WNW	1	1	4	0	0	0	6
NW	2	3	2	0	0	0	7
NNW	1	2	1	0	0	0	4
Total	14	29	16	1	0	0	60

Number of Calm Hours	-	0
Number of Variable Directions	-	0
Total Number of Observations	-	60

TABLE 2.3C-91

BVPS WIND - STABILITY SUMMARY  
 STABILITY CLASS - C, 35 Ft Winds  
 DECEMBER: 1976-1980

Number of Hourly Observations

Winds From	Wind Speed (mph)						Total
	1-3	4-7	8-12	13-18	19-24	25+	
N	2	2	0	0	0	0	4
NNE	1	4	0	0	0	0	5
NE	3	2	0	0	0	0	5
ENE	1	0	0	0	0	0	1
E	1	0	0	0	0	0	1
ESE	0	1	0	0	0	0	1
SE	0	0	0	0	0	0	0
SSE	0	2	0	0	0	0	2
S	0	2	0	0	0	0	2
SSW	2	3	0	0	0	0	5
SW	0	1	5	0	0	0	6
WSW	0	2	4	0	0	0	6
W	1	3	12	1	0	0	17
WNW	0	2	5	0	0	0	7
NW	1	4	4	0	0	0	9
NNW	4	5	2	0	0	0	11
Total	16	33	32	1	0	0	82

Number of Calm Hours - 0  
 Number of Variable Directions - 0  
 Total Number of Observations - 82

TABLE 2.3C-92

BVPS WIND - STABILITY SUMMARY  
 STABILITY CLASS - D, 35 Ft Winds  
 DECEMBER: 1976-1980

Number of Hourly Observations

Winds From	Wind Speed (mph)						Total
	1-3	4-7	8-12	13-18	19-24	25+	
N	24	47	0	0	0	0	71
NNE	30	20	0	0	0	0	50
NE	66	11	0	0	0	0	77
ENE	51	6	0	0	0	0	57
E	13	11	0	0	0	0	24
ESE	6	2	0	0	0	0	8
SE	7	6	0	0	0	0	13
SSE	8	7	0	0	0	0	15
S	18	24	5	0	0	0	47
SSW	15	75	43	1	0	0	134
SW	9	118	129	3	0	0	259
WSW	11	133	181	27	0	0	352
W	9	76	166	29	0	0	280
WNW	9	55	54	5	0	0	123
NW	11	66	38	1	0	0	116
NNW	11	32	5	0	0	0	48
Total	298	689	621	66	0	0	1674

Number of Calm Hours - 3  
 Number of Variable Directions - 0  
 Total Number of Observations - 1677

TABLE 2.3C-93

BVPS WIND - STABILITY SUMMARY  
 STABILITY CLASS - E, 35 Ft Winds  
 DECEMBER: 1976-1980

Number of Hourly Observations

Winds From	Wind Speed (mph)						Total
	1-3	4-7	8-12	13-18	19-24	25+	
N	15	6	0	0	0	0	21
NNE	23	11	0	0	0	0	34
NE	72	5	0	0	0	0	77
ENE	54	10	0	0	0	0	64
E	40	9	0	0	0	0	49
ESE	20	5	0	0	0	0	25
SE	13	2	0	0	0	0	15
SSE	23	5	0	0	0	0	28
S	27	37	3	0	0	0	67
SSW	22	85	6	0	0	0	113
SW	14	78	38	0	0	0	130
WSW	7	24	19	3	0	0	53
W	4	16	5	3	0	0	28
WNW	4	10	0	0	0	0	14
NW	12	11	1	0	0	0	24
NNW	3	6	0	0	0	0	9
Total	353	320	72	6	0	0	751

Number of Calm Hours	-	5
Number of Variable Directions	-	0
Total Number of Observations	-	756



TABLE 2.3C-94

BVPS WIND - STABILITY SUMMARY  
 STABILITY CLASS - F, 35 Ft Winds  
 DECEMBER: 1976-1980

Number of Hourly Observations

Winds From	Wind Speed (mph)						Total
	1-3	4-7	8-12	13-18	19-24	25+	
N	3	2	0	0	0	0	5
NNE	9	1	0	0	0	0	10
NE	16	1	0	0	0	0	17
ENE	26	0	0	0	0	0	26
E	41	1	0	0	0	0	42
ESE	42	0	0	0	0	0	42
SE	54	0	0	0	0	0	54
SSE	29	1	0	0	0	0	30
S	18	19	0	0	0	0	37
SSW	6	9	0	0	0	0	15
SW	3	3	0	0	0	0	6
WSW	2	2	2	0	0	0	6
W	1	0	0	0	0	0	1
WNW	0	0	0	0	0	0	0
NW	1	0	0	0	0	0	1
NNW	1	0	0	0	0	0	1
Total	252	39	2	0	0	0	293

Number of Calm Hours - 6  
 Number of Variable Directions - 0  
 Total Number of Observations - 299

TABLE 2.3C-95

BVPS WIND - STABILITY SUMMARY  
 STABILITY CLASS - G, 35 Ft Winds  
 DECEMBER: 1976-1980

Number of Hourly Observations

Winds From	Wind Speed (mph)						Total
	1-3	4-7	8-12	13-18	19-24	25+	
N	3	0	0	0	0	0	3
NNE	5	0	0	0	0	0	5
NE	17	0	0	0	0	0	17
ENE	21	4	0	0	0	0	25
E	47	2	0	0	0	0	49
ESE	69	1	0	0	0	0	70
SE	78	0	0	0	0	0	78
SSE	37	1	0	0	0	0	38
S	17	8	0	0	0	0	25
SSW	3	6	0	0	0	0	9
SW	3	1	0	0	0	0	4
WSW	0	0	0	0	0	0	0
W	0	0	0	0	0	0	0
WNW	0	0	0	0	0	0	0
NW	0	1	0	0	0	0	1
NNW	2	0	0	0	0	0	2
Total	302	24	0	0	0	0	326

Number of Calm Hours - 3  
 Number of Variable Directions - 0  
 Total Number of Observations - 329

TABLE 2.3C-96

BVPS WIND - STABILITY SUMMARY  
 STABILITY CLASS - ALL, 35 Ft Winds  
 DECEMBER: 1976-1980

Number of Hourly Observations

Winds From	Wind Speed (mph)						Total
	1-3	4-7	8-12	13-18	19-24	25+	
N	49	63	0	0	0	0	112
NNE	68	41	0	0	0	0	109
NE	177	19	0	0	0	0	196
ENE	155	26	0	0	0	0	181
E	149	27	0	0	0	0	176
ESE	137	10	0	0	0	0	147
SE	154	9	0	0	0	0	163
SSE	97	17	0	0	0	0	114
S	81	94	8	0	0	0	183
SSW	48	184	53	1	0	0	286
SW	30	204	176	3	0	0	413
WSW	20	169	218	30	0	0	437
W	15	118	197	35	0	0	365
WNW	14	72	72	6	0	0	164
NW	27	91	48	1	0	0	167
NNW	22	50	8	0	0	0	80
Total	1243	1194	780	76	0	0	3293

Number of Calm Hours - 17  
 Number of Variable Directions - 0  
 Total Number of Observations - 3310

TABLE 2.3C-97

BVPS WIND - STABILITY SUMMARY  
 STABILITY CLASS - A, 35 Ft Winds  
 ANNUAL: 1976-1980

Number of Hourly Observations

Winds From	Wind Speed (mph)						Total
	1-3	4-7	8-12	13-18	19-24	25+	
N	84	480	29	0	0	0	593
NNE	60	185	6	0	0	0	251
NE	72	118	2	0	0	0	192
ENE	47	114	0	0	0	0	161
E	56	94	2	0	0	0	152
ESE	45	54	0	0	0	0	99
SE	49	68	1	0	0	0	118
SSE	46	74	3	0	0	0	123
S	69	195	15	0	0	0	279
SSW	37	306	66	3	0	0	412
SW	65	535	293	13	0	0	906
WSW	42	587	265	22	0	0	916
W	65	487	234	15	1	0	802
WNW	55	288	112	5	0	0	460
NW	54	246	62	1	0	0	363
NNW	58	335	36	0	0	0	429
Total	904	4166	1126	59	1	0	6256

Number of Calm Hours - 5  
 Number of Variable Directions - 0  
 Total Number of Observations - 6261

TABLE 2.3C-98

BVPS WIND - STABILITY SUMMARY  
 STABILITY CLASS - B, 35 Ft Winds  
 ANNUAL: 1976-1980

Number of Hourly Observations

Winds From	Wind Speed (mph)						Total
	1-3	4-7	8-12	13-18	19-24	25+	
N	22	38	0	0	0	0	60
NNE	16	15	1	0	0	0	32
NE	21	11	0	0	0	0	32
ENE	14	11	0	0	0	0	25
E	14	5	0	0	0	0	19
ESE	7	4	0	0	0	0	11
SE	7	5	1	0	0	0	13
SSE	4	6	0	0	0	0	10
S	11	13	1	0	0	0	25
SSW	8	51	19	0	0	0	78
SW	20	80	65	4	0	0	169
WSW	15	115	57	3	0	0	190
W	10	57	41	7	0	0	115
WNW	13	50	21	1	0	0	85
NW	9	50	9	0	0	0	68
NNW	14	38	5	0	0	0	57
Total	205	549	220	15	0	0	989

Number of Calm Hours - 1  
 Number of Variable Directions - 0  
 Total Number of Observations - 990

TABLE 2.3C-99

BVPS WIND - STABILITY SUMMARY  
 STABILITY CLASS - C, 35 Ft Winds  
 ANNUAL: 1976-1980

Number of Hourly Observations

Winds From	Wind Speed (mph)						Total
	1-3	4-7	8-12	13-18	19-24	25+	
N	32	69	2	0	0	0	103
NNE	27	19	0	0	0	0	46
NE	31	13	0	0	0	0	44
ENE	24	19	0	0	0	0	43
E	16	17	0	0	0	0	33
ESE	3	6	0	0	0	0	9
SE	7	5	0	0	0	0	12
SSE	6	6	1	0	0	0	13
S	11	24	1	0	0	0	36
SSW	9	47	18	0	0	0	74
SW	17	91	76	7	0	0	191
WSW	23	107	71	3	0	0	204
W	17	89	73	3	0	0	182
WNW	13	53	25	0	0	0	91
NW	21	67	13	0	0	0	101
NNW	19	54	10	0	0	0	83
Total	276	686	290	13	0	0	1265

Number of Calm Hours - 1  
 Number of Variable Directions - 0  
 Total Number of Observations - 1266

TABLE 2.3C-100

BVPS WIND - STABILITY SUMMARY  
 STABILITY CLASS - D, 35 Ft Winds  
 ANNUAL: 1976-1980

Number of Hourly Observations

Winds From	Wind Speed (mph)						Total
	1-3	4-7	8-12	13-18	19-24	25+	
N	344	428	10	0	0	0	782
NNE	363	143	2	0	0	0	508
NE	514	123	5	0	0	0	642
ENE	429	192	3	0	0	0	624
E	228	100	3	0	0	0	331
ESE	119	29	0	0	0	0	148
SE	120	33	2	0	0	0	155
SSE	95	51	0	0	0	0	146
S	176	160	26	0	0	0	362
SSW	172	512	155	4	0	0	843
SW	164	917	703	30	6	0	1820
WSW	171	981	981	119	3	0	2255
W	184	706	597	47	1	0	1535
WNW	202	570	195	11	0	0	978
NW	205	733	136	1	1	0	1076
NNW	225	407	20	0	0	0	652
Total	3711	6085	2838	212	11	0	12857

Number of Calm Hours - 34  
 Number of Variable Directions - 0  
 Total Number of Observations - 12891

TABLE 2.3C-101

BVPS WIND - STABILITY SUMMARY  
 STABILITY CLASS - E, 35 Ft Winds  
 ANNUAL: 1976-1980

Number of Hourly Observations

Winds From	Wind Speed (mph)						Total
	1-3	4-7	8-12	13-18	19-24	25+	
N	221	70	1	0	0	0	292
NNE	304	70	0	0	0	0	374
NE	591	105	6	0	0	0	702
ENE	552	150	4	0	0	0	706
E	572	58	1	0	0	0	631
ESE	442	26	1	0	0	0	469
SE	387	28	0	0	0	0	415
SSE	401	29	1	0	0	0	431
S	483	267	11	0	0	0	761
SSW	308	549	57	1	1	0	916
SW	202	508	201	10	0	0	921
WSW	103	215	122	10	0	0	450
W	134	106	41	7	0	0	288
WNW	106	84	9	1	0	0	200
NW	139	82	6	0	0	0	227
NNW	148	69	2	0	0	0	219
Total	5093	2416	463	29	1	0	8002

Number of Calm Hours - 96  
 Number of Variable Directions - 0  
 Total Number of Observations - 8098



TABLE 2.3C-102

BVPS WIND - STABILITY SUMMARY  
 STABILITY CLASS - F, 35 Ft Winds  
 ANNUAL: 1976-1980

Number of Hourly Observations

Winds From	Wind Speed (mph)						Total
	1-3	4-7	8-12	13-18	19-24	25+	
N	50	8	0	0	0	0	58
NNE	81	9	0	0	0	0	90
NE	149	7	0	0	0	0	156
ENE	297	9	0	0	0	0	306
E	597	1	0	0	0	0	598
ESE	892	2	0	0	0	0	894
SE	1103	4	2	0	0	0	1109
SSE	597	19	0	0	0	0	616
S	333	172	2	0	0	0	507
SSW	123	93	2	0	0	0	218
SW	53	52	5	0	0	0	110
WSW	20	15	3	1	0	0	39
W	13	6	0	0	0	0	19
WNW	4	1	0	0	0	0	5
NW	10	3	0	0	0	0	13
NNW	30	0	0	0	0	0	30
Total	4352	401	14	1	0	0	4768

Number of Calm Hours - 105  
 Number of Variable Directions - 0  
 Total Number of Observations - 4873

TABLE 2.3C-103

BVPS WIND - STABILITY SUMMARY  
 STABILITY CLASS - G, 35 Ft Winds  
 ANNUAL: 1976-1980

Number of Hourly Observations

Winds From	Wind Speed (mph)						Total
	1-3	4-7	8-12	13-18	19-24	25+	
N	22	1	0	0	0	0	23
NNE	43	7	0	0	0	0	50
NE	96	3	0	0	0	0	99
ENE	181	12	0	0	0	0	193
E	407	5	0	0	0	0	412
ESE	1066	4	0	0	0	0	1070
SE	1822	5	0	0	0	0	1827
SSE	820	28	0	0	0	0	848
S	241	101	0	0	0	0	342
SSW	49	32	0	0	0	0	81
SW	24	6	1	0	0	0	31
WSW	7	3	0	0	0	0	10
W	8	1	0	0	0	0	9
WNW	7	1	0	0	0	0	8
NW	8	1	0	0	0	0	9
NNW	11	0	0	0	0	0	11
Total	4812	210	1	0	0	0	5023

Number of Calm Hours - 80  
 Number of Variable Directions - 0  
 Total Number of Observations - 5103

TABLE 2.3C-104

BVPS WIND - STABILITY SUMMARY  
 STABILITY CLASS - ALL, 35 Ft Winds  
 ANNUAL: 1976-1980

Number of Hourly Observations

Winds From	Wind Speed (mph)						Total
	1-3	4-7	8-12	13-18	19-24	25+	
N	775	1094	42	0	0	0	1911
NNE	894	448	9	0	0	0	1351
NE	1474	380	13	0	0	0	1867
ENE	1544	507	7	0	0	0	2058
E	1890	280	6	0	0	0	2176
ESE	2574	125	1	0	0	0	2700
SE	3495	148	6	0	0	0	3649
SSE	1969	213	5	0	0	0	2187
S	1324	932	56	0	0	0	2312
SSW	706	1590	317	8	1	0	2622
SW	545	2189	1344	64	6	0	4148
WSW	381	2023	1499	158	3	0	4064
W	431	1452	986	79	2	0	2950
WNW	400	1047	362	18	0	0	1827
NW	446	1182	226	2	1	0	1857
NNW	505	903	73	0	0	0	1481
Total	19353	14513	4952	329	13	0	39160

Number of Calm Hours - 322  
 Number of Variable Directions - 0  
 Total Number of Observations - 39482

APPENDIX 2.3D

BEAVER VALLEY POWER STATION  
JOINT FREQUENCY DISTRIBUTION  
AT THE 500-FOOT LEVEL  
(JANUARY 1, 1976 TO DECEMBER 31, 1980)

## LIST OF TABLES

<u>Table Number</u>	<u>Title</u>
2.3D-1	BVPS Wind - Stability Summary Stability Class - A, 500 Ft Winds January: 1976-1980
2.3D-2	BVPS Wind - Stability Summary Stability Class - B, 500 Ft Winds January: 1976-1980
2.3D-3	BVPS Wind - Stability Summary Stability Class - C, 500 Ft Winds January: 1976-1980
2.3D-4	BVPS Wind - Stability Summary Stability Class - D, 500 Ft Winds January: 1976-1980
2.3D-5	BVPS Wind - Stability Summary Stability Class - E, 500 Ft Winds January: 1976-1980
2.3D-6	BVPS Wind - Stability Summary Stability Class - F, 500 Ft Winds January: 1976-1980
2.3D-7	BVPS Wind - Stability Summary Stability Class - G, 500 Ft Winds January: 1976-1980
2.3D-8	BVPS Wind - Stability Summary Stability Class - ALL, 500 Ft Winds January: 1976-1980
2.3D-9	BVPS Wind - Stability Summary Stability Class - A, 500 Ft Winds February: 1976-1980
2.3D-10	BVPS Wind - Stability Summary Stability Class - B, 500 Ft Winds February: 1976-1980
2.3D-11	BVPS Wind - Stability Summary Stability Class - C, 500 Ft Winds February: 1976-1980
2.3D-12	BVPS Wind - Stability Summary Stability Class - D, 500 Ft Winds February: 1976-1980
2.3D-13	BVPS Wind - Stability Summary Stability Class - E, 500 Ft Winds February: 1976-1980
2.3D-14	BVPS Wind - Stability Summary Stability Class - F, 500 Ft Winds February: 1976-1980
2.3D-15	BVPS Wind - Stability Summary Stability Class - G, 500 Ft Winds February: 1976-1980

## LIST OF TABLES (Cont)

<u>Table Number</u>	<u>Title</u>
2.3D-16	BVPS Wind - Stability Summary Stability Class - ALL, 500 Ft Winds February: 1976-1980
2.3D-17	BVPS Wind - Stability Summary Stability Class - A, 500 Ft Winds March: 1976-1980
2.3D-18	BVPS Wind - Stability Summary Stability Class - B, 500 Ft Winds March: 1976-1980
2.3D-19	BVPS Wind - Stability Summary Stability Class - C, 500 Ft Winds March: 1976-1980
2.3D-20	BVPS Wind - Stability Summary Stability Class - D, 500 Ft Winds March: 1976-1980
2.3D-21	BVPS Wind - Stability Summary Stability Class - E, 500 Ft Winds March: 1976-1980
2.3D-22	BVPS Wind - Stability Summary Stability Class - F, 500 Ft Winds March: 1976-1980
2.3D-23	BVPS Wind - Stability Summary Stability Class - G, 500 Ft Winds March: 1976-1980
2.3D-24	BVPS Wind - Stability Summary Stability Class - ALL, 500 Ft Winds March: 1976-1980
2.3D-25	BVPS Wind - Stability Summary Stability Class - A, 500 Ft Winds April: 1976-1980
2.3D-26	BVPS Wind - Stability Summary Stability Class - B, 500 Ft Winds April: 1976-1980
2.3D-27	BVPS Wind - Stability Summary Stability Class - C, 500 Ft Winds April: 1976-1980
2.3D-28	BVPS Wind - Stability Summary Stability Class - D, 500 Ft Winds April: 1976-1980
2.3D-29	BVPS Wind - Stability Summary Stability Class - E, 500 Ft Winds April: 1976-1980
2.3D-30	BVPS Wind - Stability Summary Stability Class - F, 500 Ft Winds April: 1976-1980

## LIST OF TABLES (Cont)

<u>Table Number</u>	<u>Title</u>
2.3D-31	BVPS Wind - Stability Summary Stability Class - G, 500 Ft Winds April: 1976-1980
2.3D-32	BVPS Wind - Stability Summary Stability Class - ALL, 500 Ft Winds April: 1976-1980
2.3D-33	BVPS Wind - Stability Summary Stability Class - A, 500 Ft Winds May: 1976-1980
2.3D-34	BVPS Wind - Stability Summary Stability Class - B, 500 Ft Winds May: 1976-1980
2.3D-35	BVPS Wind - Stability Summary Stability Class - C, 500 Ft Winds May: 1976-1980
2.3D-36	BVPS Wind - Stability Summary Stability Class - D, 500 Ft Winds May: 1976-1980
2.3D-37	BVPS Wind - Stability Summary Stability Class - E, 500 Ft Winds May: 1976-1980
2.3D-38	BVPS Wind - Stability Summary Stability Class - F, 500 Ft Winds May: 1976-1980
2.3D-39	BVPS Wind - Stability Summary Stability Class - G, 500 Ft Winds May: 1976-1980
2.3D-40	BVPS Wind - Stability Summary Stability Class - ALL, 500 Ft Winds May: 1976-1980
2.3D-41	BVPS Wind - Stability Summary Stability Class - A, 500 Ft Winds June: 1976-1980
2.3D-42	BVPS Wind - Stability Summary Stability Class - B, 500 Ft Winds June: 1976-1980
2.3D-43	BVPS Wind - Stability Summary Stability Class - C, 500 Ft Winds June: 1976-1980
2.3D-44	BVPS Wind - Stability Summary Stability Class - D, 500 Ft Winds June: 1976-1980
2.3D-45	BVPS Wind - Stability Summary Stability Class - E, 500 Ft Winds June: 1976-1980

## LIST OF TABLES (Cont)

<u>Table Number</u>	<u>Title</u>
2.3D-46	BVPS Wind - Stability Summary Stability Class - F, 500 Ft Winds June: 1976-1980
2.3D-47	BVPS Wind - Stability Summary Stability Class - G, 500 Ft Winds June: 1976-1980
2.3D-48	BVPS Wind - Stability Summary Stability Class - ALL, 500 Ft Winds June: 1976-1980
2.3D-49	BVPS Wind - Stability Summary Stability Class - A, 500 Ft Winds July: 1976-1980
2.3D-50	BVPS Wind - Stability Summary Stability Class - B, 500 Ft Winds July: 1976-1980
2.3D-51	BVPS Wind - Stability Summary Stability Class - C, 500 Ft Winds July: 1976-1980
2.3D-52	BVPS Wind - Stability Summary Stability Class - D, 500 Ft Winds July: 1976-1980
2.3D-53	BVPS Wind - Stability Summary Stability Class - E, 500 Ft Winds July: 1976-1980
2.3D-54	BVPS Wind - Stability Summary Stability Class - F, 500 Ft Winds July: 1976-1980
2.3D-55	BVPS Wind - Stability Summary Stability Class - G, 500 Ft Winds July: 1976-1980
2.3D-56	BVPS Wind - Stability Summary Stability Class - ALL, 500 Ft Winds July: 1976-1980
2.3D-57	BVPS Wind - Stability Summary Stability Class - A, 500 Ft Winds August: 1976-1980
2.3D-58	BVPS Wind - Stability Summary Stability Class - B, 500 Ft Winds August: 1976-1980
2.3D-59	BVPS Wind - Stability Summary Stability Class - C, 500 Ft Winds August: 1976-1980
2.3D-60	BVPS Wind - Stability Summary Stability Class - D, 500 Ft Winds August: 1976-1980



## LIST OF TABLES (Cont)

<u>Table Number</u>	<u>Title</u>
2.3D-61	BVPS Wind - Stability Summary Stability Class - E, 500 Ft Winds August: 1976-1980
2.3D-62	BVPS Wind - Stability Summary Stability Class - F, 500 Ft Winds August: 1976-1980
2.3D-63	BVPS Wind - Stability Summary Stability Class - G, 500 Ft Winds August: 1976-1980
2.3D-64	BVPS Wind - Stability Summary Stability Class - ALL, 500 Ft Winds August: 1976-1980
2.3D-65	BVPS Wind - Stability Summary Stability Class - A, 500 Ft Winds September: 1976-1980
2.3D-66	BVPS Wind - Stability Summary Stability Class - B, 500 Ft Winds September: 1976-1980
2.3D-67	BVPS Wind - Stability Summary Stability Class - C, 500 Ft Winds September: 1976-1980
2.3D-68	BVPS Wind - Stability Summary Stability Class - D, 500 Ft Winds September: 1976-1980
2.3D-69	BVPS Wind - Stability Summary Stability Class - E, 500 Ft Winds September: 1976-1980
2.3D-70	BVPS Wind - Stability Summary Stability Class - F, 500 Ft Winds September: 1976-1980
2.3D-71	BVPS Wind - Stability Summary Stability Class - G, 500 Ft Winds September: 1976-1980
2.3D-72	BVPS Wind - Stability Summary Stability Class - ALL, 500 Ft Winds September: 1976-1980
2.3D-73	BVPS Wind - Stability Summary Stability Class - A, 500 Ft Winds October: 1976-1980
2.3D-74	BVPS Wind - Stability Summary Stability Class - B, 500 Ft Winds October: 1976-1980
2.3D-75	BVPS Wind - Stability Summary Stability Class - C, 500 Ft Winds October: 1976-1980

## LIST OF TABLES (Cont)

<u>Table Number</u>	<u>Title</u>
2.3D-76	BVPS Wind - Stability Summary Stability Class - D, 500 Ft Winds October: 1976-1980
2.3D-77	BVPS Wind - Stability Summary Stability Class - E, 500 Ft Winds October: 1976-1980
2.3D-78	BVPS Wind - Stability Summary Stability Class - F, 500 Ft Winds October: 1976-1980
2.3D-79	BVPS Wind - Stability Summary Stability Class - G, 500 Ft Winds October: 1976-1980
2.3D-80	BVPS Wind - Stability Summary Stability Class - ALL, 500 Ft Winds October: 1976-1980
2.3D-81	BVPS Wind - Stability Summary Stability Class - A, 500 Ft Winds November: 1976-1980
2.3D-82	BVPS Wind - Stability Summary Stability Class - B, 500 Ft Winds November: 1976-1980
2.3D-83	BVPS Wind - Stability Summary Stability Class - C, 500 Ft Winds November: 1976-1980
2.3D-84	BVPS Wind - Stability Summary Stability Class - D, 500 Ft Winds November: 1976-1980
2.3D-85	BVPS Wind - Stability Summary Stability Class - E, 500 Ft Winds November: 1976-1980
2.3D-86	BVPS Wind - Stability Summary Stability Class - F, 500 Ft Winds November: 1976-1980
2.3D-87	BVPS Wind - Stability Summary Stability Class - G, 500 Ft Winds November: 1976-1980
2.3D-88	BVPS Wind - Stability Summary Stability Class - ALL, 500 Ft Winds November: 1976-1980
2.3D-89	BVPS Wind - Stability Summary Stability Class - A, 500 Ft Winds December: 1976-1980
2.3D-90	BVPS Wind - Stability Summary Stability Class - B, 500 Ft Winds December: 1976-1980

## LIST OF TABLES (Cont)

<u>Table Number</u>	<u>Title</u>
2.3D-91	BVPS Wind - Stability Summary Stability Class - C, 500 Ft Winds December: 1976-1980
2.3D-92	BVPS Wind - Stability Summary Stability Class - D, 500 Ft Winds December: 1976-1980
2.3D-93	BVPS Wind - Stability Summary Stability Class - E, 500 Ft Winds December: 1976-1980
2.3D-94	BVPS Wind - Stability Summary Stability Class - F, 500 Ft Winds December: 1976-1980
2.3D-95	BVPS Wind - Stability Summary Stability Class - G, 500 Ft Winds December: 1976-1980
2.3D-96	BVPS Wind - Stability Summary Stability Class - ALL, 500 Ft Winds December: 1976-1980
2.3D-97	BVPS Wind - Stability Summary Stability Class - A, 500 Ft Winds Annual: 1976-1980
2.3D-98	BVPS Wind - Stability Summary Stability Class - B, 500 Ft Winds Annual: 1976-1980
2.3D-99	BVPS Wind - Stability Summary Stability Class - C, 500 Ft Winds Annual: 1976-1980
2.3D-100	BVPS Wind - Stability Summary Stability Class - D, 500 Ft Winds Annual: 1976-1980
2.3D-101	BVPS Wind - Stability Summary Stability Class - E, 500 Ft Winds Annual: 1976-1980
2.3D-102	BVPS Wind - Stability Summary Stability Class - F, 500 Ft Winds Annual: 1976-1980
2.3D-103	BVPS Wind - Stability Summary Stability Class - G, 500 Ft Winds Annual: 1976-1980
2.3D-104	BVPS Wind - Stability Summary Stability Class - ALL, 500 Ft Winds Annual: 1976-1980

TABLES 2.3D-1 thru 2.3D-104 - BVPS WIND-STABILITY SUMMARIES

TABLE 2.3D-1

BVPS WIND - STABILITY SUMMARY  
 STABILITY CLASS - A, 500 Ft Winds  
 JANUARY: 1976-1980

Number of Hourly Observations

Winds From	Wind Speed (mph)						Total
	<u>1-3</u>	<u>4-7</u>	<u>8-12</u>	<u>13-18</u>	<u>19-24</u>	<u>25+</u>	
N	0	0	0	0	0	0	0
NNE	0	0	0	0	0	0	0
NE	0	0	0	0	0	0	0
ENE	0	0	0	0	0	0	0
E	0	0	0	0	0	0	0
ESE	0	0	0	0	0	0	0
SE	0	0	0	0	0	0	0
SSE	0	0	0	0	0	0	0
S	0	0	0	0	0	0	0
SSW	0	0	0	0	0	0	0
SW	0	0	0	0	0	0	0
WSW	0	0	0	0	0	0	0
W	0	0	0	0	0	0	0
WNW	0	0	0	0	0	0	0
NW	0	0	0	0	0	0	0
NNW	0	0	0	0	0	0	0
Total	<u>0</u>	<u>0</u>	<u>0</u>	<u>0</u>	<u>0</u>	<u>0</u>	<u>0</u>

Number of Calm Hours - 0  
 Number of Variable Directions - 0  
 Total Number of Observations - 0

TABLE 2.3D-2

BVPS WIND - STABILITY SUMMARY  
 STABILITY CLASS - B, 500 Ft Winds  
 JANUARY: 1976-1980

Number of Hourly Observations

Winds From	Wind Speed (mph)						Total
	1-3	4-7	8-12	13-18	19-24	25+	
N	0	0	0	0	0	0	0
NNE	0	0	0	0	0	0	0
NE	0	0	0	0	0	0	0
ENE	0	0	0	0	0	0	0
E	0	0	0	0	0	0	0
ESE	0	0	0	0	0	0	0
SE	0	0	0	0	0	0	0
SSE	0	0	0	0	0	0	0
S	0	0	0	0	0	0	0
SSW	0	0	0	0	0	0	0
SW	0	0	0	0	0	0	0
WSW	0	0	0	0	0	0	0
W	0	0	0	0	0	0	0
WNW	0	0	0	0	0	0	0
NW	0	0	0	0	0	0	0
NNW	0	0	0	0	0	0	0
Total	0	0	0	0	0	0	0

Number of Calm Hours - 0  
 Number of Variable Directions - 0  
 Total Number of Observations - 0

TABLE 2.3D-3

BVPS WIND - STABILITY SUMMARY  
 STABILITY CLASS - C, 500 Ft Winds  
 JANUARY: 1976-1980

Number of Hourly Observations

Winds From	Wind Speed (mph)						Total
	1-3	4-7	8-12	13-18	19-24	25+	
N	0	0	0	0	0	0	0
NNE	0	0	0	0	0	0	0
NE	0	0	0	0	0	0	0
ENE	0	0	0	0	0	0	0
E	0	1	0	0	0	0	1
ESE	0	0	0	0	0	0	0
SE	0	0	0	0	0	0	0
SSE	0	0	0	0	0	0	0
S	0	0	0	0	0	0	0
SSW	0	0	0	0	0	0	0
SW	0	0	0	0	0	0	0
WSW	0	0	0	0	0	0	0
W	0	0	0	0	0	0	0
WNW	0	0	0	0	0	0	0
NW	0	0	0	0	0	0	0
NNW	0	0	0	0	0	0	0
Total	0	1	0	0	0	0	1

Number of Calm Hours - 0  
 Number of Variable Directions - 0  
 Total Number of Observations - 1

TABLE 2.3D-4

BVPS WIND - STABILITY SUMMARY  
 STABILITY CLASS - D, 500 Ft Winds  
 JANUARY: 1976-1980

Number of Hourly Observations

Winds From	Wind Speed (mph)						Total
	1-3	4-7	8-12	13-18	19-24	25+	
N	11	12	36	3	0	0	62
NNE	5	12	18	0	0	0	35
NE	7	15	44	24	2	0	92
ENE	7	48	46	11	4	0	116
E	6	35	15	12	0	0	68
ESE	7	41	26	3	1	0	78
SE	7	26	9	3	0	0	45
SSE	8	17	19	1	0	0	45
S	4	28	14	22	1	0	69
SSW	4	12	21	12	7	2	58
SW	3	41	76	122	38	24	304
WSW	3	25	159	194	89	44	514
W	2	19	100	204	94	25	444
WNW	2	12	64	59	27	5	169
NW	5	24	61	34	1	0	125
NNW	3	22	34	5	0	0	64
Total	84	389	742	709	264	100	2288

Number of Calm Hours - 2  
 Number of Variable Directions - 0  
 Total Number of Observations - 2290

TABLE 2.3D-5

BVPS WIND - STABILITY SUMMARY  
 STABILITY CLASS - E, 500 Ft Winds  
 JANUARY: 1976-1980

Number of Hourly Observations

Winds From	Wind Speed (mph)						Total
	1-3	4-7	8-12	13-18	19-24	25+	
N	5	11	0	0	0	0	16
NNE	2	0	0	0	0	0	2
NE	3	6	3	0	0	0	12
ENE	4	12	17	1	0	0	34
E	3	16	12	3	4	0	38
ESE	2	12	7	5	0	0	26
SE	3	19	28	1	0	1	52
SSE	6	6	15	6	3	0	36
S	5	24	10	8	1	0	48
SSW	3	12	7	6	2	0	30
SW	3	19	22	12	1	0	57
WSW	1	12	21	5	2	0	41
W	3	8	13	5	2	0	31
WNW	4	7	5	0	0	0	16
NW	3	1	1	1	0	0	6
NNW	4	3	2	0	0	0	9
Total	54	168	163	53	15	1	454

Number of Calm Hours - 0  
 Number of Variable Directions - 0  
 Total Number of Observations - 454



TABLE 2.3D-6

BVPS WIND - STABILITY SUMMARY  
 STABILITY CLASS - F, 500 Ft Winds  
 JANUARY: 1976-1980

Number of Hourly Observations

Winds From	Wind Speed (mph)						Total
	1-3	4-7	8-12	13-18	19-24	25+	
N	0	2	1	0	0	0	3
NNE	1	1	0	0	0	0	2
NE	1	3	0	0	0	0	4
ENE	4	5	4	0	0	0	13
E	1	2	0	0	0	0	3
ESE	2	2	0	0	0	0	4
SE	3	4	3	1	0	0	11
SSE	0	9	5	1	0	0	15
S	3	6	6	0	0	0	15
SSW	2	4	3	2	0	0	11
SW	4	9	0	0	0	0	13
WSW	1	9	4	1	0	0	15
W	3	5	9	1	0	0	18
WNW	0	1	1	0	0	0	2
NW	1	0	1	0	0	0	2
NNW	1	0	0	0	0	0	1
Total	27	62	37	6	0	0	132

Number of Calm Hours - 0  
 Number of Variable Directions - 0  
 Total Number of Observations - 132

TABLE 2.3D-7

BVPS WIND - STABILITY SUMMARY  
 STABILITY CLASS - G, 500 Ft Winds  
 JANUARY: 1976-1980

Number of Hourly Observations

Winds From	Wind Speed (mph)						Total
	1-3	4-7	8-12	13-18	19-24	25+	
N	0	0	0	0	0	0	0
NNE	0	0	0	0	0	0	0
NE	0	0	0	0	0	0	0
ENE	0	0	0	0	0	0	0
E	2	0	0	0	0	0	2
ESE	0	0	0	0	0	0	0
SE	1	1	0	0	0	0	2
SSE	1	2	0	0	0	0	3
S	0	6	0	0	0	0	6
SSW	1	2	0	0	0	0	3
SW	0	0	0	0	0	0	0
WSW	1	0	0	0	0	0	1
W	0	0	0	0	0	0	0
WNW	0	0	0	0	0	0	0
NW	0	0	0	0	0	0	0
NNW	0	0	0	0	0	0	0
Total	6	11	0	0	0	0	17

Number of Calm Hours - 0  
 Number of Variable Directions - 0  
 Total Number of Observations - 17

TABLE 2.3D-8

BVPS WIND - STABILITY SUMMARY  
 STABILITY CLASS - ALL, 500 Ft Winds  
 JANUARY: 1976-1980

Number of Hourly Observations

Winds From	Wind Speed (mph)						Total
	1-3	4-7	8-12	13-18	19-24	25+	
N	16	25	37	3	0	0	81
NNE	8	13	18	0	0	0	39
NE	11	24	47	24	2	0	108
ENE	15	65	67	12	4	0	163
E	12	54	27	15	4	0	112
ESE	11	55	33	8	1	0	108
SE	14	50	40	5	0	1	110
SSE	15	34	39	8	3	0	99
S	12	64	30	30	2	0	138
SSW	10	30	31	20	9	2	102
SW	10	69	98	134	39	24	374
WSW	6	46	184	200	91	44	571
W	8	32	122	210	96	25	493
WNW	6	20	70	59	27	5	187
NW	9	25	63	35	1	0	133
NNW	8	25	36	5	0	0	74
Total	171	631	942	768	279	101	2892

Number of Calm Hours - 2  
 Number of Variable Directions - 0  
 Total Number of Observations - 2894

TABLE 2.3D-9

BVPS WIND - STABILITY SUMMARY  
 STABILITY CLASS - A, 500 Ft Winds  
 FEBRUARY: 1976-1980

Number of Hourly Observations

Winds From	Wind Speed (mph)						Total
	1-3	4-7	8-12	13-18	19-24	25+	
N	0	0	0	0	0	0	0
NNE	0	0	0	0	0	0	0
NE	0	0	4	0	0	0	4
ENE	0	0	0	0	0	0	0
E	0	0	0	0	0	0	0
ESE	0	0	0	0	0	0	0
SE	0	0	0	0	0	0	0
SSE	0	0	0	0	0	0	0
S	0	0	0	0	0	0	0
SSW	0	0	0	0	0	0	0
SW	0	0	0	0	0	0	0
WSW	0	0	0	0	0	0	0
W	0	0	0	0	0	0	0
WNW	0	0	0	0	0	0	0
NW	0	0	0	0	0	0	0
NNW	0	0	0	0	0	0	0
Total	0	0	4	0	0	0	4

Number of Calm Hours - 0  
 Number of Variable Directions - 0  
 Total Number of Observations - 4

TABLE 2.3D-10

BVPS WIND - STABILITY SUMMARY  
 STABILITY CLASS - B, 500 Ft Winds  
 FEBRUARY: 1976-1980

Number of Hourly Observations

Winds From	Wind Speed (mph)						Total
	1-3	4-7	8-12	13-18	19-24	25+	
N	0	0	0	0	0	0	0
NNE	0	0	0	0	0	0	0
NE	0	0	1	0	0	0	1
ENE	0	0	0	0	0	0	0
E	0	0	0	0	0	0	0
ESE	0	0	0	0	0	0	0
SE	0	0	0	0	0	0	0
SSE	0	0	0	0	0	0	0
S	0	0	0	0	0	0	0
SSW	0	0	0	0	0	0	0
SW	0	0	0	0	0	0	0
WSW	0	0	0	0	0	0	0
W	0	0	0	0	0	0	0
WNW	0	0	0	0	0	0	0
NW	0	0	0	0	0	0	0
NNW	0	0	0	0	0	0	0
Total	0	0	1	0	0	0	1

Number of Calm Hours - 0  
 Number of Variable Directions - 0  
 Total Number of Observations - 1

TABLE 2.3D-11

BVPS WIND - STABILITY SUMMARY  
 STABILITY CLASS - C, 500 Ft Winds  
 FEBRUARY: 1976-1980

Number of Hourly Observations

Winds From	Wind Speed (mph)						Total
	1-3	4-7	8-12	13-18	19-24	25+	
N	0	0	0	0	0	0	0
NNE	0	0	0	0	0	0	0
NE	0	1	0	0	0	0	1
ENE	0	1	1	0	0	0	2
E	0	1	3	0	0	0	4
ESE	1	1	0	0	0	0	2
SE	0	0	0	0	0	0	0
SSE	0	0	0	0	0	0	0
S	0	0	0	0	0	0	0
SSW	0	0	0	0	0	0	0
SW	0	0	0	0	0	0	0
WSW	0	0	0	0	0	0	0
W	0	0	3	3	0	0	6
WNW	0	0	2	1	0	0	3
NW	0	0	0	1	0	0	1
NNW	0	0	0	0	0	0	0
Total	1	4	9	5	0	0	19

Number of Calm Hours - 0  
 Number of Variable Directions - 0  
 Total Number of Observations - 19

TABLE 2.3D-12

BVPS WIND - STABILITY SUMMARY  
 STABILITY CLASS - D, 500 Ft Winds  
 FEBRUARY: 1976-1980

Number of Hourly Observations

Winds From	Wind Speed (mph)						Total
	1-3	4-7	8-12	13-18	19-24	25+	
N	6	27	61	12	2	0	108
NNE	6	9	13	3	0	0	31
NE	4	34	21	16	7	5	87
ENE	4	38	25	11	1	1	80
E	7	33	19	2	0	0	61
ESE	6	11	14	0	0	1	32
SE	2	7	1	1	1	1	13
SSE	3	12	3	2	0	0	20
S	4	8	14	2	0	0	28
SSW	2	8	21	27	11	1	70
SW	2	41	76	111	50	2	282
WSW	3	33	87	81	44	8	256
W	6	21	122	162	56	23	390
WNW	3	11	118	101	28	6	267
NW	2	36	122	36	1	0	197
NNW	10	38	62	15	0	0	125
Total	70	367	779	582	201	48	2047

Number of Calm Hours - 0  
 Number of Variable Directions - 0  
 Total Number of Observations - 2047

TABLE 2.3D-13

BVPS WIND - STABILITY SUMMARY  
 STABILITY CLASS - E, 500 Ft Winds  
 FEBRUARY: 1976-1980

Number of Hourly Observations

Winds From	Wind Speed (mph)						Total
	1-3	4-7	8-12	13-18	19-24	25+	
N	3	13	13	0	0	0	29
NNE	5	12	1	0	0	0	18
NE	7	13	2	1	0	0	23
ENE	0	13	5	1	0	0	19
E	4	15	18	1	0	0	38
ESE	3	11	13	1	1	0	29
SE	2	10	9	5	2	1	29
SSE	1	3	12	0	0	0	16
S	2	3	18	6	0	0	29
SSW	4	7	16	19	2	0	48
SW	2	6	13	31	20	0	72
WSW	6	12	29	25	8	1	81
W	4	17	41	17	7	2	88
WNW	3	12	12	6	0	0	33
NW	2	3	14	4	0	0	23
NNW	5	16	6	0	0	0	27
Total	53	166	222	117	40	4	602

Number of Calm Hours - 1  
 Number of Variable Directions - 0  
 Total Number of Observations - 603



TABLE 2.3D-14

BVPS WIND - STABILITY SUMMARY  
 STABILITY CLASS - F, 500 Ft Winds  
 FEBRUARY: 1976-1980

Number of Hourly Observations

Winds From	Wind Speed (mph)						Total
	1-3	4-7	8-12	13-18	19-24	25+	
N	4	7	0	0	0	0	11
NNE	3	2	0	0	0	0	5
NE	4	5	1	0	0	0	10
ENE	4	6	1	0	0	0	11
E	6	11	1	0	0	0	18
ESE	3	10	9	3	0	0	25
SE	1	6	8	1	2	0	18
SSE	5	9	3	0	0	0	17
S	3	10	14	1	0	0	28
SSW	3	4	23	17	1	0	48
SW	9	6	15	17	2	0	49
WSW	8	6	6	5	0	0	25
W	4	6	4	1	0	0	15
WNW	3	3	1	0	0	0	7
NW	1	3	1	1	0	0	6
NNW	2	4	0	0	0	0	6
Total	63	98	87	46	5	0	299

Number of Calm Hours	-	1
Number of Variable Directions	-	0
Total Number of Observations	-	300

TABLE 2.3D-15

BVPS WIND - STABILITY SUMMARY  
 STABILITY CLASS - G, 500 Ft Winds  
 FEBRUARY: 1976-1980

Number of Hourly Observations

Winds From	Wind Speed (mph)						Total
	1-3	4-7	8-12	13-18	19-24	25+	
N	0	0	0	0	0	0	0
NNE	0	0	0	0	0	0	0
NE	0	0	0	0	0	0	0
ENE	0	0	0	0	0	0	0
E	0	0	0	0	0	0	0
ESE	0	0	0	0	0	0	0
SE	0	0	5	0	0	0	5
SSE	0	0	0	0	2	0	2
S	0	0	7	0	0	0	7
SSW	0	4	7	2	0	0	13
SW	0	0	1	1	0	0	2
WSW	0	0	0	0	0	0	0
W	0	0	0	0	0	0	0
WNW	0	0	0	0	0	0	0
NW	0	0	0	0	0	0	0
NNW	0	0	0	0	0	0	0
Total	0	4	20	3	2	0	29

Number of Calm Hours - 0  
 Number of Variable Directions - 0  
 Total Number of Observations - 29

TABLE 2.3D-16

BVPS WIND - STABILITY SUMMARY  
 STABILITY CLASS - ALL, 500 Ft Winds  
 FEBRUARY: 1976-1980

Number of Hourly Observations

Winds From	Wind Speed (mph)						Total
	1-3	4-7	8-12	13-18	19-24	25+	
N	13	47	74	12	2	0	148
NNE	14	23	14	3	0	0	54
NE	15	53	29	17	7	5	126
ENE	8	58	32	12	1	1	112
E	17	60	41	3	0	0	121
ESE	13	33	36	4	1	1	88
SE	5	23	23	7	5	2	65
SSE	9	24	18	2	2	0	55
S	9	21	53	9	0	0	92
SSW	9	23	67	65	14	1	179
SW	13	53	105	160	72	2	405
WSW	17	51	122	111	52	9	362
W	14	44	170	183	63	25	499
WNW	9	26	133	108	28	6	310
NW	5	42	137	42	1	0	227
NNW	17	58	68	15	0	0	158
Total	187	639	1122	753	248	52	3001

Number of Calm Hours - 2  
 Number of Variable Directions - 0  
 Total Number of Observations - 3003

TABLE 2.3D-17

BVPS WIND - STABILITY SUMMARY  
 STABILITY CLASS - A, 500 Ft Winds  
 MARCH: 1976-1980

Number of Hourly Observations

Winds From	Wind Speed (mph)						Total
	1-3	4-7	8-12	13-18	19-24	25+	
N	0	0	0	0	0	0	0
NNE	0	0	0	0	0	0	0
NE	0	0	0	0	0	0	0
ENE	0	0	0	0	0	0	0
E	0	0	1	0	0	0	1
ESE	0	0	1	0	0	0	1
SE	0	0	0	1	0	0	1
SSE	0	0	0	0	0	0	0
S	0	0	0	0	0	0	0
SSW	0	0	0	0	0	0	0
SW	0	0	0	0	0	0	0
WSW	0	0	0	0	0	0	0
W	0	0	0	0	0	0	0
WNW	0	0	0	0	0	0	0
NW	0	0	0	0	0	0	0
NNW	0	0	0	0	0	0	0
Total	0	0	2	1	0	0	3

Number of Calm Hours - 0  
 Number of Variable Directions - 0  
 Total Number of Observations - 3

TABLE 2.3D-18

BVPS WIND - STABILITY SUMMARY  
 STABILITY CLASS - B, 500 Ft Winds  
 MARCH: 1976-1980

## Number of Hourly Observations

Winds From	Wind Speed (mph)						Total
	1-3	4-7	8-12	13-18	19-24	25+	
N	0	2	1	0	0	0	3
NNE	0	1	0	0	0	0	1
NE	0	1	1	1	0	0	3
ENE	0	0	0	1	0	0	1
E	0	0	2	0	0	0	2
ESE	0	3	4	1	0	0	8
SE	0	1	2	3	0	0	6
SSE	0	0	0	0	0	0	0
S	0	0	0	0	0	0	0
SSW	0	0	0	0	0	0	0
SW	0	0	0	0	0	0	0
WSW	0	0	0	0	0	0	0
W	0	0	0	1	2	0	3
WNW	0	0	0	0	0	0	0
NW	0	0	0	0	0	0	0
NNW	0	0	1	0	0	0	1
Total	0	8	11	7	2	0	28

Number of Calm Hours - 0  
 Number of Variable Directions - 0  
 Total Number of Observations - 28

TABLE 2.3D-19

BVPS WIND - STABILITY SUMMARY  
 STABILITY CLASS - C, 500 Ft Winds  
 MARCH: 1976-1980

## Number of Hourly Observations

Winds From	Wind Speed (mph)						Total
	1-3	4-7	8-12	13-18	19-24	25+	
N	0	5	5	0	0	0	10
NNE	0	1	1	0	0	0	2
NE	0	0	1	2	0	0	3
ENE	0	0	0	1	0	0	1
E	0	1	0	0	0	0	1
ESE	0	9	2	0	0	0	11
SE	0	3	2	3	0	0	8
SSE	0	0	0	1	0	0	1
S	0	0	0	0	0	0	0
SSW	0	0	1	0	0	0	1
SW	0	0	0	0	0	0	0
WSW	0	0	0	2	1	0	3
W	0	1	5	5	6	2	19
WNW	0	0	3	4	2	1	10
NW	0	0	2	2	2	0	6
NNW	0	1	5	0	0	0	6
Total	0	21	27	20	11	3	82

Number of Calm Hours - 0  
 Number of Variable Directions - 0  
 Total Number of Observations - 82

TABLE 2.3D-20

BVPS WIND - STABILITY SUMMARY  
 STABILITY CLASS - D, 500 Ft Winds  
 MARCH: 1976-1980

Number of Hourly Observations

Winds From	Wind Speed (mph)						Total
	1-3	4-7	8-12	13-18	19-24	25+	
N	3	34	55	2	0	0	94
NNE	2	18	15	7	0	0	42
NE	7	23	14	8	0	0	52
ENE	6	21	45	17	0	0	89
E	7	32	58	14	1	0	112
ESE	2	23	16	32	5	0	78
SE	1	24	30	35	13	1	104
SSE	1	10	21	12	6	0	50
S	6	10	22	20	13	2	73
SSW	3	5	35	49	15	7	114
SW	5	13	62	85	29	7	201
WSW	3	19	48	127	43	14	254
W	4	19	65	150	97	44	379
WNW	8	11	69	100	33	29	250
NW	4	22	70	53	11	4	164
NNW	3	28	37	11	1	0	80
Total	65	312	662	722	267	108	2136

Number of Calm Hours - 1  
 Number of Variable Directions - 0  
 Total Number of Observations - 2137

TABLE 2.3D-21

BVPS WIND - STABILITY SUMMARY  
 STABILITY CLASS - E, 500 Ft Winds  
 MARCH: 1976-1980

## Number of Hourly Observations

Winds From	Wind Speed (mph)						Total
	1-3	4-7	8-12	13-18	19-24	25+	
N	1	1	1	0	0	0	3
NNE	1	15	0	0	0	0	16
NE	5	14	6	2	0	0	27
ENE	4	8	16	1	0	0	29
E	6	13	17	1	0	0	37
ESE	5	21	17	14	3	0	60
SE	3	14	18	20	11	0	66
SSE	3	11	19	15	2	0	50
S	3	14	22	22	5	0	66
SSW	6	5	17	25	5	2	60
SW	5	11	11	23	12	0	62
WSW	5	8	22	15	2	0	52
W	7	13	19	8	1	0	48
WNW	3	7	15	4	0	0	29
NW	3	14	5	1	0	1	24
NNW	0	6	4	0	0	0	10
Total	60	175	209	151	41	3	639

Number of Calm Hours - 0  
 Number of Variable Directions - 0  
 Total Number of Observations - 639



TABLE 2.3D-22

BVPS WIND - STABILITY SUMMARY  
 STABILITY CLASS - F, 500 Ft Winds  
 MARCH: 1976-1980

Number of Hourly Observations

Winds From	Wind Speed (mph)						Total
	1-3	4-7	8-12	13-18	19-24	25+	
N	2	5	2	0	0	0	9
NNE	2	6	2	0	0	0	10
NE	3	11	8	0	0	0	22
ENE	3	12	17	0	0	0	32
E	2	7	7	0	0	0	16
ESE	3	25	15	4	1	1	49
SE	5	16	4	3	5	0	33
SSE	3	8	4	5	0	0	20
S	3	10	14	10	0	0	37
SSW	4	4	14	21	0	0	43
SW	4	17	10	2	0	0	33
WSW	0	9	0	0	0	0	9
W	2	4	4	0	0	0	10
WNW	0	2	6	0	0	0	8
NW	3	5	3	0	0	0	11
NNW	3	2	2	0	0	0	7
Total	42	143	112	45	6	1	349

Number of Calm Hours - 1  
 Number of Variable Directions - 0  
 Total Number of Observations - 350

TABLE 2.3D-23

BVPS WIND - STABILITY SUMMARY  
 STABILITY CLASS - G, 500 Ft Winds  
 MARCH: 1976-1980

Number of Hourly Observations

Winds From	Wind Speed (mph)						Total
	1-3	4-7	8-12	13-18	19-24	25+	
N	0	1	0	1	0	0	2
NNE	2	2	0	0	0	0	4
NE	3	5	0	0	0	0	8
ENE	5	6	1	0	0	0	12
E	1	6	3	2	0	0	12
ESE	2	1	1	3	0	0	7
SE	0	0	0	0	1	0	1
SSE	1	0	1	1	0	0	3
S	0	3	10	2	0	0	15
SSW	1	1	7	12	1	0	22
SW	1	1	3	0	1	0	6
WSW	0	0	2	0	0	0	2
W	0	0	0	0	0	0	0
WNW	2	0	0	0	0	0	2
NW	1	0	0	0	0	0	1
NNW	0	1	1	0	0	0	2
Total	19	27	29	21	3	0	99

Number of Calm Hours - 0  
 Number of Variable Directions - 0  
 Total Number of Observations - 99

TABLE 2.3D-24

BVPS WIND - STABILITY SUMMARY  
 STABILITY CLASS - ALL, 500 Ft Winds  
 MARCH: 1976-1980

Number of Hourly Observations

Winds From	Wind Speed (mph)						Total
	1-3	4-7	8-12	13-18	19-24	25+	
N	6	48	64	3	0	0	121
NNE	7	43	18	7	0	0	75
NE	18	54	30	13	0	0	115
ENE	18	47	79	20	0	0	164
E	16	59	88	17	1	0	181
ESE	12	82	56	54	9	1	214
SE	9	58	56	65	30	1	219
SSE	8	29	45	34	8	0	124
S	12	37	68	54	18	2	191
SSW	14	15	74	107	21	9	240
SW	15	42	86	110	42	7	302
WSW	8	36	72	144	46	14	320
W	13	37	93	164	106	46	459
WNW	13	20	93	108	35	30	299
NW	11	41	80	56	13	5	206
NNW	6	38	50	11	1	0	106
Total	186	686	1052	967	330	115	3336

Number of Calm Hours - 2  
 Number of Variable Directions - 0  
 Total Number of Observations - 3338

TABLE 2.3D-25

BVPS WIND - STABILITY SUMMARY  
 STABILITY CLASS - A, 500 Ft Winds  
 APRIL: 1976-1980

Number of Hourly Observations

Winds From	Wind Speed (mph)						Total
	1-3	4-7	8-12	13-18	19-24	25+	
N	0	0	0	0	0	0	0
NNE	0	0	0	0	0	0	0
NE	0	0	0	0	0	0	0
ENE	0	0	0	0	0	0	0
E	0	0	0	0	0	0	0
ESE	0	0	0	0	0	0	0
SE	0	0	0	0	0	0	0
SSE	0	0	0	0	0	0	0
S	0	0	0	0	0	0	0
SSW	0	0	0	0	0	0	0
SW	0	0	0	0	0	0	0
WSW	0	0	0	0	0	0	0
W	0	0	0	0	0	0	0
WNW	0	0	0	0	0	0	0
NW	0	0	0	0	0	0	0
NNW	0	0	0	0	0	0	0
Total	0	0	0	0	0	0	0

Number of Calm Hours - 0  
 Number of Variable Directions - 0  
 Total Number of Observations - 0

TABLE 2.3D-26

BVPS WIND - STABILITY SUMMARY  
 STABILITY CLASS - B, 500 Ft Winds  
 APRIL: 1976-1980

Number of Hourly Observations

Winds From	Wind Speed (mph)						Total
	1-3	4-7	8-12	13-18	19-24	25+	
N	0	0	5	1	0	0	6
NNE	0	0	1	1	0	0	2
NE	1	0	2	0	0	0	3
ENE	0	0	0	0	0	0	0
E	0	0	1	0	0	0	1
ESE	0	0	0	0	0	0	0
SE	0	0	0	0	0	0	0
SSE	0	0	0	0	0	0	0
S	0	0	0	0	0	0	0
SSW	0	0	0	0	0	0	0
SW	0	0	2	0	0	0	2
WSW	0	0	2	0	0	0	2
W	0	1	5	5	0	0	11
WNW	0	0	3	2	0	0	5
NW	0	0	1	0	0	0	1
NNW	0	1	2	1	1	0	5
Total	1	2	24	10	1	0	38

Number of Calm Hours - 0  
 Number of Variable Directions - 0  
 Total Number of Observations - 38

TABLE 2.3D-27

BVPS WIND - STABILITY SUMMARY  
 STABILITY CLASS - C, 500 Ft Winds  
 APRIL: 1976-1980

Number of Hourly Observations

Winds From	Wind Speed (mph)						Total
	1-3	4-7	8-12	13-18	19-24	25+	
N	0	6	14	8	0	0	28
NNE	0	1	2	0	0	0	3
NE	0	2	2	0	0	0	4
ENE	0	0	1	5	0	0	6
E	0	1	1	0	0	0	2
ESE	0	0	1	2	0	0	3
SE	0	0	0	0	0	0	0
SSE	0	0	0	0	0	0	0
S	0	0	0	0	0	0	0
SSW	0	1	1	1	0	0	3
SW	0	1	0	1	0	0	2
WSW	0	1	6	3	0	0	10
W	1	5	13	5	1	0	25
WNW	1	2	4	8	8	1	24
NW	0	4	10	6	2	0	22
NNW	0	1	9	7	0	0	17
Total	2	25	64	46	11	1	149

Number of Calm Hours - 0  
 Number of Variable Directions - 0  
 Total Number of Observations - 149

TABLE 2.3D-28

BVPS WIND - STABILITY SUMMARY  
 STABILITY CLASS - D, 500 Ft Winds  
 APRIL: 1976-1980

## Number of Hourly Observations

Winds From	Wind Speed (mph)						Total
	1-3	4-7	8-12	13-18	19-24	25+	
N	4	26	76	32	0	0	138
NNE	4	20	31	6	0	1	62
NE	4	41	6	0	0	0	51
ENE	3	9	14	11	2	0	39
E	3	8	25	17	2	0	55
ESE	2	7	20	22	15	1	67
SE	1	14	9	23	12	1	60
SSE	3	6	10	7	5	1	32
S	5	12	10	6	4	1	38
SSW	4	17	27	33	6	1	88
SW	3	24	52	62	28	2	171
WSW	6	30	37	72	36	9	190
W	6	21	41	72	53	25	218
WNW	1	17	61	100	28	9	216
NW	6	31	95	69	4	2	207
NNW	8	16	76	36	5	0	141
Total	63	299	590	568	200	53	1773

Number of Calm Hours	-	1
Number of Variable Directions	-	0
Total Number of Observations	-	1774

TABLE 2.3D-29

BVPS WIND - STABILITY SUMMARY  
 STABILITY CLASS - E, 500 Ft Winds  
 APRIL: 1976-1980

Number of Hourly Observations

Winds From	Wind Speed (mph)						Total
	1-3	4-7	8-12	13-18	19-24	25+	
N	4	20	13	5	0	0	42
NNE	0	17	10	2	0	0	29
NE	9	12	5	0	1	0	27
ENE	4	15	14	4	1	0	38
E	9	21	18	4	0	0	52
ESE	5	19	8	4	0	0	36
SE	8	15	12	14	0	0	49
SSE	1	11	12	6	0	0	30
S	1	17	15	13	0	0	46
SSW	4	8	12	9	2	0	35
SW	7	13	19	7	5	1	52
WSW	3	15	14	21	4	0	57
W	4	17	26	11	3	1	62
WNW	2	13	18	5	1	0	39
NW	5	9	11	5	0	0	30
NNW	5	9	18	4	0	0	36
Total	71	231	225	114	17	2	660

Number of Calm Hours - 3  
 Number of Variable Directions - 0  
 Total Number of Observations - 663



TABLE 2.3D-30

BVPS WIND - STABILITY SUMMARY  
 STABILITY CLASS - F, 500 Ft Winds  
 APRIL: 1976-1980

Number of Hourly Observations

Winds From	Wind Speed (mph)						Total
	1-3	4-7	8-12	13-18	19-24	25+	
N	6	9	4	1	0	0	20
NNE	4	12	4	0	0	0	20
NE	7	22	5	2	0	0	36
ENE	6	18	9	0	0	0	33
E	8	18	7	0	0	0	33
ESE	2	12	6	0	0	0	20
SE	5	6	6	2	1	0	20
SSE	2	12	4	3	0	0	21
S	9	13	3	3	0	0	28
SSW	8	10	6	5	0	0	29
SW	8	11	15	6	2	0	42
WSW	5	22	30	5	0	0	62
W	10	28	20	3	0	0	61
WNW	5	13	12	1	0	0	31
NW	6	14	3	1	0	0	24
NNW	6	7	5	2	0	0	20
Total	97	227	139	34	3	0	500

Number of Calm Hours - 2  
 Number of Variable Directions - 0  
 Total Number of Observations - 502

TABLE 2.3D-31

BVPS WIND - STABILITY SUMMARY  
 STABILITY CLASS - G, 500 Ft Winds  
 APRIL: 1976-1980

Number of Hourly Observations

Winds From	Wind Speed (mph)						Total
	1-3	4-7	8-12	13-18	19-24	25+	
N	1	0	0	0	0	0	1
NNE	5	1	0	0	0	0	6
NE	2	6	0	0	0	0	8
ENE	0	7	0	0	0	0	7
E	1	0	0	0	0	0	1
ESE	2	0	0	0	0	0	2
SE	0	1	2	3	0	0	6
SSE	0	0	3	2	0	0	5
S	0	3	0	0	0	0	3
SSW	0	2	3	0	0	0	5
SW	3	10	5	1	2	0	21
WSW	0	11	11	0	0	0	22
W	0	1	7	0	0	0	8
WNW	0	3	0	0	0	0	3
NW	0	0	0	0	0	0	0
NNW	2	0	0	0	0	0	2
Total	16	45	31	6	2	0	100

Number of Calm Hours - 0  
 Number of Variable Directions - 0  
 Total Number of Observations - 100

TABLE 2.3D-32

BVPS WIND - STABILITY SUMMARY  
 STABILITY CLASS - ALL, 500 Ft Winds  
 APRIL: 1976-1980

Number of Hourly Observations

Winds From	Wind Speed (mph)						Total
	1-3	4-7	8-12	13-18	19-24	25+	
N	15	61	112	47	0	0	235
NNE	13	51	48	9	0	1	122
NE	23	83	20	2	1	0	129
ENE	13	49	38	20	3	0	123
E	21	48	52	21	2	0	144
ESE	11	38	35	28	15	1	128
SE	14	36	29	42	13	1	135
SSE	6	29	29	18	5	1	88
S	15	45	28	22	4	1	115
SSW	16	38	49	48	8	1	160
SW	21	59	93	77	37	3	290
WSW	14	79	100	101	40	9	343
W	21	73	112	96	57	26	385
WNW	9	48	98	116	37	10	318
NW	17	58	120	81	6	2	284
NNW	21	34	110	50	6	0	221
Total	250	829	1073	778	234	56	3220

Number of Calm Hours - 6  
 Number of Variable Directions - 0  
 Total Number of Observations - 3226

TABLE 2.3D-33

BVPS WIND - STABILITY SUMMARY  
 STABILITY CLASS - A, 500 Ft Winds  
 MAY: 1976-1980

Number of Hourly Observations

Winds From	Wind Speed (mph)						Total
	1-3	4-7	8-12	13-18	19-24	25+	
N	0	0	2	2	0	0	4
NNE	0	0	0	1	0	0	1
NE	0	0	2	0	0	0	2
ENE	0	0	3	0	0	0	3
E	0	0	2	3	0	0	5
ESE	0	0	0	0	0	0	0
SE	0	0	1	0	0	0	1
SSE	0	0	1	0	0	0	1
S	0	0	0	2	0	0	2
SSW	0	0	0	0	0	0	0
SW	0	0	0	0	0	0	0
WSW	0	0	0	0	0	0	0
W	0	0	1	0	0	0	1
WNW	0	0	2	3	0	0	5
NW	0	0	0	0	0	0	0
NNW	0	0	2	0	0	0	2
Total	0	0	16	11	0	0	27

Number of Calm Hours - 0  
 Number of Variable Directions - 0  
 Total Number of Observations - 27

TABLE 2.3D-34

BVPS WIND - STABILITY SUMMARY  
 STABILITY CLASS - B, 500 Ft Winds  
 MAY: 1976-1980

Number of Hourly Observations

Winds From	Wind Speed (mph)						Total
	1-3	4-7	8-12	13-18	19-24	25+	
N	0	2	7	6	0	0	15
NNE	0	0	3	1	0	0	4
NE	0	1	5	1	0	0	7
ENE	0	1	2	1	0	0	4
E	0	2	0	1	0	0	3
ESE	0	1	1	1	0	0	3
SE	0	2	2	1	0	0	5
SSE	0	2	3	0	0	0	5
S	0	1	0	1	0	0	2
SSW	0	0	3	0	0	0	3
SW	0	1	0	0	0	0	1
WSW	0	0	5	0	0	0	5
W	0	0	6	1	0	0	7
WNW	0	0	2	1	1	2	6
NW	1	0	3	5	0	0	9
NNW	0	0	3	1	0	0	4
Total	1	13	45	21	1	2	83

Number of Calm Hours	-	0
Number of Variable Directions	-	0
Total Number of Observations	-	83

TABLE 2.3D-35

BVPS WIND - STABILITY SUMMARY  
 STABILITY CLASS - C, 500 Ft Winds  
 MAY: 1976-1980

## Number of Hourly Observations

Winds From	Wind Speed (mph)						Total
	1-3	4-7	8-12	13-18	19-24	25+	
N	1	7	12	2	0	0	22
NNE	0	3	2	0	0	0	5
NE	0	6	3	1	0	0	10
ENE	0	2	4	0	0	0	6
E	0	5	2	0	0	0	7
ESE	0	4	3	0	0	0	7
SE	0	3	4	2	0	0	9
SSE	0	0	4	0	0	0	4
S	0	1	2	0	0	0	3
SSW	0	2	3	1	0	0	6
SW	0	4	6	4	1	0	15
WSW	0	2	4	6	0	1	13
W	1	6	11	6	2	0	26
WNW	0	4	8	5	3	1	21
NW	0	0	7	6	0	0	13
NNW	1	2	3	10	0	0	16
Total	3	51	78	43	6	2	183

Number of Calm Hours - 0  
 Number of Variable Directions - 0  
 Total Number of Observations - 183

TABLE 2.3D-36

BVPS WIND - STABILITY SUMMARY  
 STABILITY CLASS - D, 500 Ft Winds  
 MAY: 1976-1980

Number of Hourly Observations

Winds From	Wind Speed (mph)						Total
	1-3	4-7	8-12	13-18	19-24	25+	
N	5	22	53	19	3	0	102
NNE	9	18	16	5	0	0	48
NE	8	22	20	8	0	0	58
ENE	6	34	22	7	0	0	69
E	7	17	23	11	4	0	62
ESE	3	23	21	16	1	0	64
SE	3	11	28	20	1	0	63
SSE	2	14	14	8	1	0	39
S	3	16	23	8	1	1	52
SSW	2	21	42	21	4	0	90
SW	6	42	68	72	16	3	207
WSW	6	42	55	59	3	2	167
W	8	32	40	63	18	6	167
WNW	7	22	57	38	12	2	138
NW	3	39	63	43	2	0	150
NNW	3	24	50	28	2	0	107
Total	81	399	595	426	68	14	1583

Number of Calm Hours - 0  
 Number of Variable Directions - 0  
 Total Number of Observations - 1583

TABLE 2.3D-37

BVPS WIND - STABILITY SUMMARY  
 STABILITY CLASS - E, 500 Ft Winds  
 MAY: 1976-1980

## Number of Hourly Observations

Winds From	Wind Speed (mph)						Total
	1-3	4-7	8-12	13-18	19-24	25+	
N	13	16	12	8	0	0	49
NNE	4	22	6	7	0	0	39
NE	1	22	15	2	0	0	40
ENE	5	19	22	0	0	0	46
E	8	22	9	0	0	0	39
ESE	8	18	12	2	0	0	40
SE	3	13	13	16	6	0	51
SSE	5	11	12	8	0	0	36
S	6	19	13	9	6	0	53
SSW	3	13	17	18	0	0	51
SW	2	19	23	32	4	0	80
WSW	7	30	15	11	2	1	66
W	8	20	25	13	0	0	66
WNW	7	19	13	0	0	0	39
NW	4	10	17	1	0	0	32
NNW	3	6	12	4	0	0	25
Total	87	279	236	131	18	1	752

Number of Calm Hours - 0  
 Number of Variable Directions - 0  
 Total Number of Observations - 752



TABLE 2.3D-38

BVPS WIND - STABILITY SUMMARY  
 STABILITY CLASS - F, 500 Ft Winds  
 MAY: 1976-1980

Number of Hourly Observations

Winds From	Wind Speed (mph)						Total
	1-3	4-7	8-12	13-18	19-24	25+	
N	5	15	1	1	0	0	22
NNE	5	13	3	0	0	0	21
NE	9	18	5	1	0	0	33
ENE	7	24	14	2	0	0	47
E	7	27	6	1	0	0	41
ESE	5	13	10	1	0	0	29
SE	8	9	11	9	1	0	38
SSE	4	11	10	2	1	0	28
S	7	15	6	2	0	0	30
SSW	1	11	20	9	0	0	41
SW	4	25	16	7	0	0	52
WSW	6	24	7	1	0	0	38
W	7	35	9	1	0	0	52
WNW	7	27	9	1	0	0	44
NW	11	20	8	2	0	0	41
NNW	7	9	2	1	0	0	19
Total	100	296	137	41	2	0	576

Number of Calm Hours	-	2
Number of Variable Directions	-	0
Total Number of Observations	-	578

TABLE 2.3D-39

BVPS WIND - STABILITY SUMMARY  
 STABILITY CLASS - G, 500 Ft Winds  
 MAY: 1976-1980

Number of Hourly Observations

Winds From	Wind Speed (mph)						Total
	1-3	4-7	8-12	13-18	19-24	25+	
N	2	2	0	0	0	0	4
NNE	0	3	2	0	0	0	5
NE	5	3	1	0	0	0	9
ENE	10	2	0	0	0	0	12
E	2	4	1	0	0	0	7
ESE	0	8	1	0	0	0	9
SE	3	7	0	0	0	0	10
SSE	1	3	4	1	0	0	9
S	3	4	1	0	0	0	8
SSW	2	2	7	0	0	0	11
SW	2	4	3	2	1	0	12
WSW	1	5	6	0	0	0	12
W	3	3	4	0	0	0	10
WNW	1	3	0	0	0	0	4
NW	3	1	1	0	0	0	5
NNW	2	2	1	0	0	0	5
Total	40	56	32	3	1	0	132

Number of Calm Hours - 1  
 Number of Variable Directions - 0  
 Total Number of Observations - 133

TABLE 2.3D-40

BVPS WIND - STABILITY SUMMARY  
 STABILITY CLASS - ALL, 500 Ft Winds  
 MAY: 1976-1980

Number of Hourly Observations

Winds From	Wind Speed (mph)						Total
	1-3	4-7	8-12	13-18	19-24	25+	
N	26	64	87	38	3	0	218
NNE	18	59	32	14	0	0	123
NE	23	72	51	13	0	0	159
ENE	28	82	67	10	0	0	187
E	24	77	43	16	4	0	164
ESE	16	67	48	20	1	0	152
SE	17	45	59	48	8	0	177
SSE	12	41	48	19	2	0	122
S	19	56	45	22	7	1	150
SSW	8	49	92	49	4	0	202
SW	14	95	116	117	22	3	367
WSW	20	103	92	77	5	4	301
W	27	96	96	84	20	6	329
WNW	22	75	91	48	16	5	257
NW	22	70	99	57	2	0	250
NNW	16	43	73	44	2	0	178
Total	312	1094	1139	676	96	19	3336

Number of Calm Hours	-	3
Number of Variable Directions	-	0
Total Number of Observations	-	3339

TABLE 2.3D-41

BVPS WIND - STABILITY SUMMARY  
 STABILITY CLASS - A, 500 Ft Winds  
 JUNE: 1976-1980

Number of Hourly Observations

Winds From	Wind Speed (mph)						Total
	1-3	4-7	8-12	13-18	19-24	25+	
N	0	3	5	0	0	0	8
NNE	0	0	1	0	0	0	1
NE	0	1	0	0	0	0	1
ENE	0	0	1	0	0	0	1
E	0	0	1	0	0	0	1
ESE	0	0	3	1	0	0	4
SE	0	0	1	1	0	0	2
SSE	0	0	2	2	0	0	4
S	0	1	3	1	0	0	5
SSW	0	1	3	1	0	0	5
SW	0	0	0	0	0	0	0
WSW	0	0	2	0	0	0	2
W	0	0	2	1	0	0	3
WNW	0	0	1	2	0	0	3
NW	0	1	4	2	0	0	7
NNW	0	0	3	0	0	0	3
Total	0	7	32	11	0	0	50

Number of Calm Hours - 0  
 Number of Variable Directions - 0  
 Total Number of Observations - 50

TABLE 2.3D-42

BVPS WIND - STABILITY SUMMARY  
 STABILITY CLASS - B, 500 Ft Winds  
 JUNE: 1976-1980

Number of Hourly Observations

Winds From	Wind Speed (mph)						Total
	1-3	4-7	8-12	13-18	19-24	25+	
N	0	4	3	0	0	0	7
NNE	0	1	0	0	0	0	1
NE	1	3	1	0	0	0	5
ENE	0	2	9	0	0	0	11
E	0	3	7	0	0	0	10
ESE	0	1	3	0	0	0	4
SE	0	1	3	0	0	0	4
SSE	0	3	3	3	0	0	9
S	0	2	4	2	0	0	8
SSW	0	0	5	3	0	0	8
SW	0	1	3	2	0	0	6
WSW	0	2	5	0	2	0	9
W	0	2	3	1	1	0	7
WNW	0	0	8	3	3	0	14
NW	0	0	7	0	0	0	7
NNW	0	2	3	1	0	0	6
Total	1	27	67	15	6	0	116

Number of Calm Hours	-	0
Number of Variable Directions	-	0
Total Number of Observations	-	116

TABLE 2.3D-43

BVPS WIND - STABILITY SUMMARY  
 STABILITY CLASS - C, 500 Ft Winds  
 JUNE: 1976-1980

## Number of Hourly Observations

Winds From	Wind Speed (mph)						Total
	1-3	4-7	8-12	13-18	19-24	25+	
N	0	1	7	3	0	0	11
NNE	0	0	2	1	0	1	4
NE	0	3	1	0	0	0	4
ENE	0	1	5	0	0	0	6
E	0	1	4	0	0	0	5
ESE	0	1	0	0	0	0	1
SE	0	5	1	0	0	0	6
SSE	0	3	6	0	0	0	9
S	0	9	9	2	0	0	20
SSW	0	1	6	5	1	0	13
SW	0	3	8	7	3	5	26
WSW	0	3	11	4	7	2	27
W	1	8	13	7	7	0	36
WNW	0	7	9	1	5	0	22
NW	0	5	11	8	1	1	26
NNW	0	2	14	3	0	0	19
Total	1	53	107	41	24	9	235

Number of Calm Hours - 0  
 Number of Variable Directions - 0  
 Total Number of Observations - 235

TABLE 2.3D-44

BVPS WIND - STABILITY SUMMARY  
 STABILITY CLASS - D, 500 Ft Winds  
 JUNE: 1976-1980

Number of Hourly Observations

Winds From	Wind Speed (mph)						Total
	1-3	4-7	8-12	13-18	19-24	25+	
N	3	11	43	15	1	1	74
NNE	0	14	10	1	0	0	25
NE	3	16	5	1	0	0	25
ENE	4	10	9	0	0	0	23
E	4	7	12	1	0	0	24
ESE	1	8	3	1	0	0	13
SE	4	12	5	3	0	0	24
SSE	1	16	17	7	0	0	41
S	3	19	42	23	4	0	91
SSW	3	28	56	45	10	2	144
SW	6	25	69	81	15	2	198
WSW	6	32	49	48	7	3	145
W	8	32	25	35	12	2	114
WNW	6	15	31	24	10	1	87
NW	3	25	55	42	6	0	131
NNW	2	29	59	23	4	0	117
Total	57	299	490	350	69	11	1276

Number of Calm Hours - 0  
 Number of Variable Directions - 0  
 Total Number of Observations - 1276

TABLE 2.3D-45

BVPS WIND - STABILITY SUMMARY  
 STABILITY CLASS - E, 500 Ft Winds  
 JUNE: 1976-1980

Number of Hourly Observations

Winds From	Wind Speed (mph)						Total
	1-3	4-7	8-12	13-18	19-24	25+	
N	6	10	17	5	0	0	38
NNE	6	12	5	4	0	0	27
NE	9	15	4	0	0	0	28
ENE	3	13	5	0	0	0	21
E	9	14	6	0	0	0	29
ESE	17	22	6	1	0	0	46
SE	12	16	9	2	1	0	40
SSE	8	18	6	6	0	0	38
S	4	24	19	25	1	0	73
SSW	6	24	44	32	3	0	109
SW	12	20	40	24	4	0	100
WSW	4	19	30	17	0	0	70
W	14	38	22	7	1	0	82
WNW	5	21	12	1	0	0	39
NW	5	11	8	16	0	0	40
NNW	3	15	10	4	1	0	33
Total	123	292	243	144	11	0	813

Number of Calm Hours - 4  
 Number of Variable Directions - 0  
 Total Number of Observations - 817



TABLE 2.3D-46

BVPS WIND - STABILITY SUMMARY  
 STABILITY CLASS - F, 500 Ft Winds  
 JUNE: 1976-1980

Number of Hourly Observations

Winds From	Wind Speed (mph)						Total
	1-3	4-7	8-12	13-18	19-24	25+	
N	7	12	3	0	0	0	22
NNE	6	10	3	0	0	0	19
NE	6	11	1	0	0	0	18
ENE	9	17	1	0	0	0	27
E	26	23	1	1	0	0	51
ESE	7	12	3	1	0	0	23
SE	4	6	6	2	0	0	18
SSE	8	14	3	3	0	0	28
S	10	17	8	4	0	0	39
SSW	9	22	20	9	0	0	60
SW	11	29	16	6	0	0	62
WSW	17	36	15	0	0	0	68
W	22	48	11	1	1	0	83
WNW	8	20	1	0	0	0	29
NW	9	15	2	0	0	0	26
NNW	7	6	3	1	0	0	17
Total	166	298	97	28	1	0	590

Number of Calm Hours	-	10
Number of Variable Directions	-	0
Total Number of Observations	-	600

TABLE 2.3D-47

BVPS WIND - STABILITY SUMMARY  
 STABILITY CLASS - G, 500 Ft Winds  
 JUNE: 1976-1980

Number of Hourly Observations

Winds From	Wind Speed (mph)						Total
	1-3	4-7	8-12	13-18	19-24	25+	
N	0	0	0	0	0	0	0
NNE	0	0	0	0	0	0	0
NE	1	0	0	0	0	0	1
ENE	0	1	0	0	0	0	1
E	2	1	1	0	0	0	4
ESE	1	1	1	0	0	0	3
SE	3	2	1	2	0	0	8
SSE	0	6	1	1	0	0	8
S	1	3	1	0	0	0	5
SSW	0	0	1	0	0	0	1
SW	0	2	1	0	0	0	3
WSW	0	0	0	0	0	0	0
W	0	0	0	0	0	0	0
WNW	0	0	0	0	0	0	0
NW	0	0	0	0	0	0	0
NNW	0	0	0	0	0	0	0
Total	8	16	7	3	0	0	34

Number of Calm Hours - 1  
 Number of Variable Directions - 0  
 Total Number of Observations - 35

TABLE 2.3D-48

BVPS WIND - STABILITY SUMMARY  
 STABILITY CLASS - ALL, 500 Ft Winds  
 JUNE: 1976-1980

Number of Hourly Observations

Winds From	Wind Speed (mph)						Total
	<u>1-3</u>	<u>4-7</u>	<u>8-12</u>	<u>13-18</u>	<u>19-24</u>	<u>25+</u>	
N	16	41	78	23	1	1	160
NNE	12	37	21	6	0	1	77
NE	20	49	12	1	0	0	82
ENE	16	44	30	0	0	0	90
E	41	49	32	2	0	0	124
ESE	26	45	19	4	0	0	94
SE	23	42	26	10	1	0	102
SSE	17	60	38	22	0	0	137
S	18	75	86	57	5	0	241
SSW	18	76	135	95	14	2	340
SW	29	80	137	120	22	7	395
WSW	27	92	112	69	16	5	321
W	45	128	76	52	22	2	325
WNW	19	63	62	31	18	1	194
NW	17	57	87	68	7	1	237
NNW	12	54	92	32	5	0	195
Total	<u>356</u>	<u>992</u>	<u>1043</u>	<u>592</u>	<u>111</u>	<u>20</u>	<u>3114</u>

Number of Calm Hours	-	15
Number of Variable Directions	-	0
Total Number of Observations	-	3129

TABLE 2.3D-49

BVPS WIND - STABILITY SUMMARY  
 STABILITY CLASS - A, 500 Ft Winds  
 JULY: 1976-1980

Number of Hourly Observations

Winds From	Wind Speed (mph)						Total
	1-3	4-7	8-12	13-18	19-24	25+	
N	0	1	2	0	0	0	3
NNE	0	1	2	0	0	0	3
NE	1	3	1	0	0	0	5
ENE	0	1	3	0	0	0	4
E	0	1	0	0	0	0	1
ESE	0	0	1	0	0	0	1
SE	0	1	0	0	0	0	1
SSE	0	0	1	0	0	0	1
S	0	2	3	1	0	0	6
SSW	0	1	2	2	0	0	5
SW	0	0	3	1	0	0	4
WSW	0	1	1	0	0	0	2
W	0	1	0	0	0	0	1
WNW	0	0	0	0	0	0	0
NW	0	1	0	0	0	0	1
NNW	0	0	0	0	0	0	0
Total	1	14	19	4	0	0	38

Number of Calm Hours - 0  
 Number of Variable Directions - 0  
 Total Number of Observations - 38

TABLE 2.3D-50

BVPS WIND - STABILITY SUMMARY  
 STABILITY CLASS - B, 500 Ft Winds  
 JULY: 1976-1980

Number of Hourly Observations

Winds From	Wind Speed (mph)						Total
	1-3	4-7	8-12	13-18	19-24	25+	
N	1	3	8	5	0	0	17
NNE	0	0	2	0	0	0	2
NE	0	3	1	0	0	0	4
ENE	0	1	1	0	0	0	2
E	0	3	0	0	0	0	3
ESE	0	0	2	0	0	0	2
SE	0	1	0	0	0	0	1
SSE	0	3	1	1	0	0	5
S	0	1	9	0	0	0	10
SSW	0	2	3	3	1	0	9
SW	0	2	9	3	1	0	15
WSW	0	1	7	2	1	0	11
W	0	4	4	0	0	0	8
WNW	0	0	0	8	0	0	8
NW	0	1	4	2	2	0	9
NNW	0	3	3	0	0	0	6
Total	1	28	54	24	5	0	112

Number of Calm Hours	-	0
Number of Variable Directions	-	0
Total Number of Observations	-	112

TABLE 2.3D-51

BVPS WIND - STABILITY SUMMARY  
 STABILITY CLASS - C, 500 Ft Winds  
 JULY: 1976-1980

Number of Hourly Observations

Winds From	Wind Speed (mph)						Total
	1-3	4-7	8-12	13-18	19-24	25+	
N	0	10	7	2	0	0	19
NNE	0	5	0	1	0	0	6
NE	0	1	1	0	0	0	2
ENE	0	3	1	0	0	0	4
E	1	2	0	0	0	0	3
ESE	0	2	0	0	0	0	2
SE	0	5	0	0	0	0	5
SSE	0	2	2	0	0	0	4
S	1	7	8	1	0	0	17
SSW	0	3	12	4	0	0	19
SW	0	9	13	5	0	0	27
WSW	0	9	13	8	1	0	31
W	0	6	8	3	0	0	17
WNW	0	3	6	3	2	0	14
NW	0	3	6	2	0	0	11
NNW	0	5	2	1	0	0	8
Total	2	75	79	30	3	0	189

Number of Calm Hours - 0  
 Number of Variable Directions - 0  
 Total Number of Observations - 189

TABLE 2.3D-52

BVPS WIND - STABILITY SUMMARY  
 STABILITY CLASS - D, 500 Ft Winds  
 JULY: 1976-1980

Number of Hourly Observations

Winds From	Wind Speed (mph)						Total
	1-3	4-7	8-12	13-18	19-24	25+	
N	11	34	60	7	0	0	112
NNE	5	16	5	1	2	0	29
NE	9	17	14	1	0	0	41
ENE	12	12	16	2	0	0	42
E	6	12	33	0	0	0	51
ESE	7	8	6	0	0	0	21
SE	6	9	6	3	1	0	25
SSE	3	12	8	1	0	0	24
S	2	21	34	9	3	0	69
SSW	6	18	84	33	1	0	142
SW	9	39	78	72	7	0	205
WSW	11	62	68	55	8	0	204
W	11	30	62	45	4	1	153
WNW	7	32	28	22	4	0	93
NW	9	24	42	9	1	0	85
NNW	4	33	55	18	1	0	111
Total	118	379	599	278	32	1	1407

Number of Calm Hours - 2  
 Number of Variable Directions - 0  
 Total Number of Observations - 1409

TABLE 2.3D-53

BVPS WIND - STABILITY SUMMARY  
 STABILITY CLASS - E, 500 Ft Winds  
 JULY: 1976-1980

Number of Hourly Observations

Winds From	Wind Speed (mph)						Total
	1-3	4-7	8-12	13-18	19-24	25+	
N	8	19	20	6	0	0	53
NNE	9	13	4	0	0	0	26
NE	12	24	5	0	0	0	41
ENE	14	17	5	1	0	0	37
E	6	11	1	1	0	0	19
ESE	9	12	0	0	1	0	22
SE	4	19	6	0	0	0	29
SSE	10	12	4	1	0	0	27
S	23	23	24	7	1	0	78
SSW	6	27	49	40	2	0	124
SW	16	36	51	24	3	1	131
WSW	11	56	31	7	0	0	105
W	27	62	33	9	1	0	132
WNW	14	33	16	4	0	0	67
NW	11	18	10	5	0	0	44
NNW	8	9	15	6	0	0	38
Total	188	391	274	111	8	1	973

Number of Calm Hours	-	1
Number of Variable Directions	-	0
Total Number of Observations	-	974



TABLE 2.3D-54

BVPS WIND - STABILITY SUMMARY  
 STABILITY CLASS - F, 500 Ft Winds  
 JULY: 1976-1980

Number of Hourly Observations

Winds From	Wind Speed (mph)						Total
	1-3	4-7	8-12	13-18	19-24	25+	
N	11	15	6	2	0	0	34
NNE	7	13	1	0	0	0	21
NE	10	7	0	0	0	0	17
ENE	10	8	1	0	0	0	19
E	17	10	0	0	0	0	27
ESE	9	3	2	0	0	0	14
SE	8	7	3	1	0	0	19
SSE	9	10	1	0	0	0	20
S	12	14	5	4	0	0	35
SSW	12	21	10	2	0	0	45
SW	17	21	7	4	0	0	49
WSW	22	26	4	0	0	0	52
W	21	24	14	0	0	0	59
WNW	7	21	8	1	0	0	37
NW	11	7	7	3	0	0	28
NNW	11	11	6	1	0	0	29
Total	194	218	75	18	0	0	505

Number of Calm Hours - 6  
 Number of Variable Directions - 0  
 Total Number of Observations - 511

TABLE 2.3D-55

BVPS WIND - STABILITY SUMMARY  
 STABILITY CLASS - G, 500 Ft Winds  
 JULY: 1976-1980

Number of Hourly Observations

Winds From	Wind Speed (mph)						Total
	1-3	4-7	8-12	13-18	19-24	25+	
N	0	0	0	0	0	0	0
NNE	0	0	0	0	0	0	0
NE	0	0	0	0	0	0	0
ENE	0	0	0	0	0	0	0
E	2	0	0	0	0	0	2
ESE	1	0	0	0	0	0	1
SE	1	1	0	0	0	0	2
SSE	0	1	0	0	0	0	1
S	0	2	1	0	0	0	3
SSW	2	0	0	0	0	0	2
SW	0	0	0	0	0	0	0
WSW	0	0	0	0	0	0	0
W	0	0	0	0	0	0	0
WNW	0	1	0	0	0	0	1
NW	0	0	0	0	0	0	0
NNW	0	0	0	0	0	0	0
Total	6	5	1	0	0	0	12

Number of Calm Hours - 0  
 Number of Variable Directions - 0  
 Total Number of Observations - 12

TABLE 2.3D-56

BVPS WIND - STABILITY SUMMARY  
 STABILITY CLASS - ALL, 500 Ft Winds  
 JULY: 1976-1980

Number of Hourly Observations

Winds From	Wind Speed (mph)						Total
	1-3	4-7	8-12	13-18	19-24	25+	
N	31	82	103	22	0	0	238
NNE	21	48	14	2	2	0	87
NE	32	55	22	1	0	0	110
ENE	36	42	27	3	0	0	108
E	32	39	34	1	0	0	106
ESE	26	25	11	0	1	0	63
SE	19	43	15	4	1	0	82
SSE	22	40	17	3	0	0	82
S	38	70	84	22	4	0	218
SSW	26	72	160	84	4	0	346
SW	42	107	161	109	11	1	431
WSW	44	155	124	72	10	0	405
W	59	127	121	57	5	1	370
WNW	28	90	58	38	6	0	220
NW	31	54	69	21	3	0	178
NNW	23	61	81	26	1	0	192
Total	510	1110	1101	465	48	2	3236

Number of Calm Hours	-	9
Number of Variable Directions	-	0
Total Number of Observations	-	3245

TABLE 2.3D-57

BVPS WIND - STABILITY SUMMARY  
 STABILITY CLASS - A, 500 Ft Winds  
 AUGUST: 1976-1980

Number of Hourly Observations

Winds From	Wind Speed (mph)						Total
	1-3	4-7	8-12	13-18	19-24	25+	
N	0	1	0	0	0	0	1
NNE	0	2	0	0	0	0	2
NE	0	0	1	0	0	0	1
ENE	0	1	4	0	0	0	5
E	0	1	4	0	0	0	5
ESE	0	1	3	0	0	0	4
SE	0	0	0	0	0	0	0
SSE	0	0	0	0	0	0	0
S	0	1	4	0	0	0	5
SSW	0	1	5	0	0	0	6
SW	0	1	1	0	0	0	2
WSW	0	0	0	1	0	0	1
W	0	0	0	2	0	0	2
WNW	0	0	0	0	0	0	0
NW	0	0	0	0	0	0	0
NNW	0	0	0	0	0	0	0
Total	0	9	22	3	0	0	34

Number of Calm Hours - 0  
 Number of Variable Directions - 0  
 Total Number of Observations - 34

TABLE 2.3D-58

BVPS WIND - STABILITY SUMMARY  
 STABILITY CLASS - B, 500 Ft Winds  
 AUGUST: 1976-1980

Number of Hourly Observations

Winds From	Wind Speed (mph)						Total
	1-3	4-7	8-12	13-18	19-24	25+	
N	0	1	2	0	0	0	3
NNE	0	2	3	0	0	0	5
NE	0	3	3	0	0	0	6
ENE	0	3	5	0	0	0	8
E	0	2	0	0	0	0	2
ESE	0	0	2	0	0	0	2
SE	0	2	0	0	0	0	2
SSE	0	0	0	0	0	0	0
S	0	1	1	0	0	0	2
SSW	0	0	9	2	0	0	11
SW	0	1	9	2	0	0	12
WSW	0	6	6	4	0	0	16
W	0	1	3	3	0	0	7
WNW	0	0	4	2	0	0	6
NW	0	1	0	1	0	0	2
NNW	0	1	0	0	0	0	1
Total	0	24	47	14	0	0	85

Number of Calm Hours - 0  
 Number of Variable Directions - 0  
 Total Number of Observations - 85

TABLE 2.3D-59

BVPS WIND - STABILITY SUMMARY  
 STABILITY CLASS - C, 500 Ft Winds  
 AUGUST: 1976-1980

Number of Hourly Observations

Winds From	Wind Speed (mph)						Total
	1-3	4-7	8-12	13-18	19-24	25+	
N	1	1	2	0	0	0	4
NNE	0	2	1	0	0	0	3
NE	0	1	1	1	0	0	3
ENE	1	4	1	1	0	0	7
E	0	2	3	0	0	0	5
ESE	1	4	1	0	0	0	6
SE	0	1	2	0	0	0	3
SSE	0	1	0	0	0	0	1
S	0	3	5	0	0	0	8
SSW	0	2	9	3	0	0	14
SW	0	3	11	11	0	0	25
WSW	0	7	12	5	0	0	24
W	0	9	0	2	0	0	11
WNW	0	1	1	4	0	0	6
NW	0	3	4	1	0	0	8
NNW	0	2	2	0	0	0	4
Total	3	46	55	28	0	0	132

Number of Calm Hours - 0  
 Number of Variable Directions - 0  
 Total Number of Observations - 132

TABLE 2.3D-60

BVPS WIND - STABILITY SUMMARY  
 STABILITY CLASS - D, 500 Ft Winds  
 AUGUST: 1976-1980

Number of Hourly Observations

Winds From	Wind Speed (mph)						Total
	1-3	4-7	8-12	13-18	19-24	25+	
N	7	29	53	6	0	0	95
NNE	9	18	27	5	0	0	59
NE	7	13	21	4	0	0	45
ENE	13	27	9	0	0	0	49
E	16	24	9	0	0	0	49
ESE	9	19	8	1	0	0	37
SE	11	11	9	3	0	0	34
SSE	10	14	5	2	0	0	31
S	13	24	21	3	1	0	62
SSW	9	28	65	41	4	0	147
SW	8	51	133	142	5	1	340
WSW	6	60	105	48	3	0	222
W	4	24	65	32	1	0	126
WNW	9	19	36	12	0	0	76
NW	9	21	45	9	1	0	85
NNW	9	29	32	8	0	0	78
Total	149	411	643	316	15	1	1535

Number of Calm Hours - 2  
 Number of Variable Directions - 0  
 Total Number of Observations - 1537

TABLE 2.3D-61

BVPS WIND - STABILITY SUMMARY  
 STABILITY CLASS - E, 500 Ft Winds  
 AUGUST: 1976-1980

## Number of Hourly Observations

Winds From	Wind Speed (mph)						Total
	1-3	4-7	8-12	13-18	19-24	25+	
N	20	15	15	7	0	0	57
NNE	12	12	5	0	0	0	29
NE	18	40	6	0	0	0	64
ENE	18	35	6	0	0	0	59
E	20	18	13	0	0	0	51
ESE	13	22	5	2	0	0	42
SE	6	23	5	0	0	0	34
SSE	18	20	5	0	0	0	43
S	20	29	32	16	1	0	98
SSW	12	37	70	38	2	0	159
SW	20	57	41	53	4	0	175
WSW	30	50	30	3	0	0	113
W	28	56	31	6	0	0	121
WNW	18	33	6	1	0	0	58
NW	17	10	11	5	1	1	45
NNW	13	9	9	10	0	0	41
Total	283	466	290	141	8	1	1189

Number of Calm Hours - 3  
 Number of Variable Directions - 0  
 Total Number of Observations - 1192



TABLE 2.3D-62

BVPS WIND - STABILITY SUMMARY  
 STABILITY CLASS - F, 500 Ft Winds  
 AUGUST: 1976-1980

Number of Hourly Observations

Winds From	Wind Speed (mph)						Total
	1-3	4-7	8-12	13-18	19-24	25+	
N	7	12	5	1	0	0	25
NNE	10	11	3	0	0	0	24
NE	9	10	0	0	0	0	19
ENE	12	10	2	0	0	0	24
E	13	21	3	0	0	0	37
ESE	5	9	5	0	0	0	19
SE	2	11	2	0	0	0	15
SSE	6	4	0	0	0	0	10
S	8	3	12	5	0	0	28
SSW	12	18	15	7	0	0	52
SW	13	30	17	8	0	0	68
WSW	17	22	0	0	0	0	39
W	22	14	2	0	0	0	38
WNW	9	17	2	0	0	0	28
NW	10	8	3	0	0	0	21
NNW	9	4	3	0	0	0	16
Total	164	204	74	21	0	0	463

Number of Calm Hours	-	3
Number of Variable Directions	-	0
Total Number of Observations	-	466

TABLE 2.3D-63

BVPS WIND - STABILITY SUMMARY  
 STABILITY CLASS - G, 500 Ft Winds  
 AUGUST: 1976-1980

Number of Hourly Observations

Winds From	Wind Speed (mph)						Total
	1-3	4-7	8-12	13-18	19-24	25+	
N	0	0	0	0	0	0	0
NNE	0	0	0	0	0	0	0
NE	0	0	0	0	0	0	0
ENE	0	0	0	0	0	0	0
E	0	0	0	0	0	0	0
ESE	0	0	0	0	0	0	0
SE	1	0	0	0	0	0	1
SSE	0	0	0	0	0	0	0
S	0	0	0	0	0	0	0
SSW	0	0	0	0	0	0	0
SW	0	0	0	0	0	0	0
WSW	0	0	0	0	0	0	0
W	0	0	0	0	0	0	0
WNW	0	0	0	0	0	0	0
NW	0	0	0	0	0	0	0
NNW	0	0	0	0	0	0	0
Total	1	0	0	0	0	0	1

Number of Calm Hours - 0  
 Number of Variable Directions - 0  
 Total Number of Observations - 1

TABLE 2.3D-64

BVPS WIND - STABILITY SUMMARY  
 STABILITY CLASS - ALL, 500 Ft Winds  
 AUGUST: 1976-1980

Number of Hourly Observations

Winds From	Wind Speed (mph)						Total
	1-3	4-7	8-12	13-18	19-24	25+	
N	35	59	77	14	0	0	185
NNE	31	47	39	5	0	0	122
NE	34	67	32	5	0	0	138
ENE	44	80	27	1	0	0	152
E	49	68	32	0	0	0	149
ESE	28	55	24	3	0	0	110
SE	20	48	18	3	0	0	89
SSE	34	39	10	2	0	0	85
S	41	61	75	24	2	0	203
SSW	33	86	173	91	6	0	389
SW	41	143	212	216	9	1	622
WSW	53	145	153	61	3	0	415
W	54	104	101	45	1	0	305
WNW	36	70	49	19	0	0	174
NW	36	43	63	16	2	1	161
NNW	31	45	46	18	0	0	140
Total	600	1160	1131	523	23	2	3439

Number of Calm Hours	-	8
Number of Variable Directions	-	0
Total Number of Observations	-	3447

TABLE 2.3D-65

BVPS WIND - STABILITY SUMMARY  
 STABILITY CLASS - A, 500 Ft Winds  
 SEPTEMBER: 1976-1980

Number of Hourly Observations

Winds From	Wind Speed (mph)						Total
	1-3	4-7	8-12	13-18	19-24	25+	
N	0	1	5	0	0	0	6
NNE	0	0	0	0	0	0	0
NE	0	0	0	0	0	0	0
ENE	0	0	0	0	0	0	0
E	0	2	2	0	0	0	4
ESE	1	3	2	1	0	0	7
SE	0	1	0	1	0	0	2
SSE	0	0	2	1	0	0	3
S	0	0	0	0	0	0	0
SSW	0	0	0	0	0	0	0
SW	0	0	0	0	0	0	0
WSW	0	0	2	0	0	0	2
W	0	0	2	1	0	0	3
WNW	0	0	0	0	0	0	0
NW	0	0	0	0	0	0	0
NNW	0	0	1	0	0	0	1
Total	1	7	16	4	0	0	28

Number of Calm Hours	-	0
Number of Variable Directions	-	0
Total Number of Observations	-	28

TABLE 2.3D-66

BVPS WIND - STABILITY SUMMARY  
 STABILITY CLASS - B, 500 Ft Winds  
 SEPTEMBER: 1976-1980

Number of Hourly Observations

Winds From	Wind Speed (mph)						Total
	1-3	4-7	8-12	13-18	19-24	25+	
N	0	3	11	0	0	0	14
NNE	0	2	1	0	0	0	3
NE	0	1	1	0	0	0	2
ENE	0	1	1	0	0	0	2
E	0	3	0	0	0	0	3
ESE	0	1	1	0	0	0	2
SE	0	1	0	0	0	0	1
SSE	0	1	1	1	0	0	3
S	0	3	0	1	0	0	4
SSW	0	0	0	0	0	0	0
SW	0	1	4	1	0	0	6
WSW	0	2	3	6	0	0	11
W	0	0	2	6	1	0	9
WNW	0	1	1	0	0	0	2
NW	0	2	0	0	0	0	2
NNW	1	1	2	0	0	0	4
Total	1	23	28	15	1	0	68

Number of Calm Hours - 0  
 Number of Variable Directions - 0  
 Total Number of Observations - 68

TABLE 2.3D-67

BVPS WIND - STABILITY SUMMARY  
 STABILITY CLASS - C, 500 Ft Winds  
 SEPTEMBER: 1976-1980

Number of Hourly Observations

Winds From	Wind Speed (mph)						Total
	1-3	4-7	8-12	13-18	19-24	25+	
N	1	5	2	1	0	0	9
NNE	0	1	0	0	0	0	1
NE	0	4	5	0	0	0	9
ENE	0	1	2	0	0	0	3
E	0	1	1	0	0	0	2
ESE	0	1	1	0	0	0	2
SE	1	2	2	0	0	0	5
SSE	0	3	1	0	0	0	4
S	0	4	2	2	0	0	8
SSW	0	2	3	0	0	0	5
SW	0	6	8	3	0	0	17
WSW	0	10	12	3	0	0	25
W	1	3	8	3	1	0	16
WNW	1	5	3	5	0	0	14
NW	0	2	2	1	0	0	5
NNW	1	3	7	1	0	0	12
Total	5	53	59	19	1	0	137

Number of Calm Hours	-	0
Number of Variable Directions	-	0
Total Number of Observations	-	137

TABLE 2.3D-68

BVPS WIND - STABILITY SUMMARY  
 STABILITY CLASS - D, 500 Ft Winds  
 SEPTEMBER: 1976-1980

Number of Hourly Observations

Winds From	Wind Speed (mph)						Total
	1-3	4-7	8-12	13-18	19-24	25+	
N	12	24	57	10	0	0	103
NNE	8	17	22	10	0	0	57
NE	8	20	10	9	1	0	48
ENE	6	7	19	3	0	0	35
E	8	13	29	6	0	0	56
ESE	5	24	16	2	0	0	47
SE	4	19	17	7	1	0	48
SSE	0	5	15	8	0	0	28
S	2	19	29	17	4	0	71
SSW	2	21	50	31	1	0	105
SW	9	41	76	66	9	0	201
WSW	7	41	77	33	7	0	165
W	12	27	64	55	12	4	174
WNW	5	17	34	29	4	1	90
NW	4	19	61	20	2	0	106
NNW	7	29	61	10	3	0	110
Total	99	343	637	316	44	5	1444

Number of Calm Hours - 0  
 Number of Variable Directions - 0  
 Total Number of Observations - 1444

TABLE 2.3D-69

BVPS WIND - STABILITY SUMMARY  
 STABILITY CLASS - E, 500 Ft Winds  
 SEPTEMBER: 1976-1980

Number of Hourly Observations

Winds From	Wind Speed (mph)						Total
	1-3	4-7	8-12	13-18	19-24	25+	
N	10	14	10	7	0	1	42
NNE	9	22	6	3	0	0	40
NE	11	33	15	0	0	0	59
ENE	10	38	10	0	0	0	58
E	14	29	7	0	0	0	50
ESE	14	21	5	4	0	0	44
SE	10	17	19	15	4	0	65
SSE	11	14	18	16	0	0	59
S	9	17	17	10	0	0	53
SSW	13	16	38	33	2	0	102
SW	13	41	67	50	1	0	172
WSW	11	37	44	25	2	0	119
W	23	46	28	5	0	0	102
WNW	10	19	8	5	0	0	42
NW	3	10	8	1	0	0	22
NNW	3	7	15	2	0	0	27
Total	174	381	315	176	9	1	1056

Number of Calm Hours	-	5
Number of Variable Directions	-	0
Total Number of Observations	-	1061



TABLE 2.3D-70

BVPS WIND - STABILITY SUMMARY  
 STABILITY CLASS - F, 500 Ft Winds  
 SEPTEMBER: 1976-1980

Number of Hourly Observations

Winds From	Wind Speed (mph)						Total
	1-3	4-7	8-12	13-18	19-24	25+	
N	9	6	3	1	0	0	19
NNE	10	5	2	0	0	0	17
NE	10	24	4	0	0	0	38
ENE	12	39	5	1	0	0	57
E	10	11	5	0	0	0	26
ESE	5	19	1	1	0	0	26
SE	8	17	4	6	1	0	36
SSE	5	9	4	2	1	0	21
S	9	13	18	1	0	0	41
SSW	7	15	17	10	0	0	49
SW	11	55	13	4	1	0	84
WSW	16	47	3	1	0	0	67
W	15	19	12	2	0	0	48
WNW	12	7	1	3	0	0	23
NW	15	10	2	0	0	0	27
NNW	5	5	5	0	0	0	15
Total	159	301	99	32	3	0	594

Number of Calm Hours	-	7
Number of Variable Directions	-	0
Total Number of Observations	-	601

TABLE 2.3D-71

BVPS WIND - STABILITY SUMMARY  
 STABILITY CLASS - G, 500 Ft Winds  
 SEPTEMBER: 1976-1980

Number of Hourly Observations

Winds From	Wind Speed (mph)						Total
	1-3	4-7	8-12	13-18	19-24	25+	
N	0	0	0	0	0	0	0
NNE	0	0	0	0	0	0	0
NE	0	0	0	0	0	0	0
ENE	0	0	0	0	0	0	0
E	0	0	0	0	0	0	0
ESE	0	0	0	0	0	0	0
SE	0	0	0	0	0	0	0
SSE	0	3	0	0	0	0	3
S	0	0	0	0	0	0	0
SSW	0	0	0	0	0	0	0
SW	0	0	0	0	0	0	0
WSW	0	1	0	0	0	0	1
W	0	0	0	0	0	0	0
WNW	1	0	0	0	0	0	1
NW	2	0	0	0	0	0	2
NNW	2	0	0	0	0	0	2
Total	5	4	0	0	0	0	9

Number of Calm Hours - 0  
 Number of Variable Directions - 0  
 Total Number of Observations - 9

TABLE 2.3D-72

BVPS WIND - STABILITY SUMMARY  
 STABILITY CLASS - ALL, 500 Ft Winds  
 SEPTEMBER: 1976-1980

Number of Hourly Observations

Winds From	Wind Speed (mph)						Total
	1-3	4-7	8-12	13-18	19-24	25+	
N	32	53	88	19	0	1	193
NNE	27	47	31	13	0	0	118
NE	29	82	35	9	1	0	156
ENE	28	86	37	4	0	0	155
E	32	59	44	6	0	0	141
ESE	25	69	26	8	0	0	128
SE	23	57	42	29	6	0	157
SSE	16	35	41	28	1	0	121
S	20	56	66	31	4	0	177
SSW	22	54	108	74	3	0	261
SW	33	144	168	124	11	0	480
WSW	34	138	141	68	9	0	390
W	51	95	116	72	14	4	352
WNW	29	49	47	42	4	1	172
NW	24	43	73	22	2	0	164
NNW	19	45	91	13	3	0	171
Total	444	1112	1154	562	58	6	3336

Number of Calm Hours	-	12
Number of Variable Directions	-	0
Total Number of Observations	-	3348

TABLE 2.3D-73

BVPS WIND - STABILITY SUMMARY  
 STABILITY CLASS - A, 500 Ft Winds  
 OCTOBER: 1976-1980

Number of Hourly Observations

Winds From	Wind Speed (mph)						Total
	1-3	4-7	8-12	13-18	19-24	25+	
N	0	0	1	0	0	0	1
NNE	0	0	0	0	0	0	0
NE	0	0	0	1	0	0	1
ENE	0	0	1	0	0	0	1
E	0	0	0	0	0	0	0
ESE	0	0	0	1	0	0	1
SE	0	0	0	0	0	0	0
SSE	0	0	0	0	0	0	0
S	0	0	0	0	0	0	0
SSW	0	0	0	0	0	0	0
SW	0	0	0	0	0	0	0
WSW	0	0	0	0	0	0	0
W	0	0	0	0	0	0	0
WNW	0	0	0	0	0	0	0
NW	0	0	0	0	0	0	0
NNW	0	0	0	0	0	0	0
Total	0	0	2	2	0	0	4

Number of Calm Hours - 0  
 Number of Variable Directions - 0  
 Total Number of Observations - 4

TABLE 2.3D-74

BVPS WIND - STABILITY SUMMARY  
 STABILITY CLASS - B, 500 Ft Winds  
 OCTOBER: 1976-1980

Number of Hourly Observations

Winds From	Wind Speed (mph)						Total
	1-3	4-7	8-12	13-18	19-24	25+	
N	0	2	2	0	0	0	4
NNE	0	0	1	0	0	0	1
NE	0	0	1	0	0	0	1
ENE	0	0	3	0	0	0	3
E	0	0	0	0	0	0	0
ESE	0	0	1	0	1	0	2
SE	0	0	1	1	0	0	2
SSE	0	0	0	0	0	0	0
S	0	0	0	0	0	0	0
SSW	0	0	3	0	0	0	3
SW	0	0	0	1	0	0	1
WSW	0	0	0	0	0	0	0
W	0	1	0	0	0	0	1
WNW	0	0	0	0	0	0	0
NW	0	0	0	0	0	0	0
NNW	0	0	0	0	0	0	0
Total	0	3	12	2	1	0	18

Number of Calm Hours - 0  
 Number of Variable Directions - 0  
 Total Number of Observations - 18

TABLE 2.3D-75

BVPS WIND - STABILITY SUMMARY  
 STABILITY CLASS - C, 500 Ft Winds  
 OCTOBER: 1976-1980

## Number of Hourly Observations

Winds From	Wind Speed (mph)						Total
	1-3	4-7	8-12	13-18	19-24	25+	
N	0	1	2	0	0	0	3
NNE	0	0	0	0	0	0	0
NE	0	1	0	0	0	0	1
ENE	0	0	2	0	0	0	2
E	0	1	2	1	0	0	4
ESE	0	0	2	3	0	0	5
SE	0	2	3	3	0	0	8
SSE	0	0	1	0	0	0	1
S	0	0	0	0	0	0	0
SSW	0	0	1	1	0	0	2
SW	0	0	3	3	0	0	6
WSW	0	0	3	0	0	0	3
W	0	0	3	1	1	0	5
WNW	0	1	1	0	1	0	3
NW	0	0	1	0	0	0	1
NNW	0	1	0	0	0	0	1
Total	0	7	24	12	2	0	45

Number of Calm Hours - 0  
 Number of Variable Directions - 0  
 Total Number of Observations - 45

TABLE 2.3D-76

BVPS WIND - STABILITY SUMMARY  
 STABILITY CLASS - D, 500 Ft Winds  
 OCTOBER: 1976-1980

## Number of Hourly Observations

Winds From	Wind Speed (mph)						Total
	<u>1-3</u>	<u>4-7</u>	<u>8-12</u>	<u>13-18</u>	<u>19-24</u>	<u>25+</u>	
N	3	29	56	24	0	0	112
NNE	5	19	20	13	2	0	59
NE	5	26	9	4	0	0	44
ENE	3	19	21	4	0	0	47
E	2	19	18	0	0	0	39
ESE	4	5	10	6	4	0	29
SE	1	13	14	14	7	0	49
SSE	3	14	18	20	2	1	58
S	1	18	33	23	1	0	76
SSW	2	17	36	45	5	1	106
SW	4	23	103	118	20	1	269
WSW	2	21	64	134	32	7	260
W	1	20	75	156	58	11	321
WNW	2	13	64	99	23	1	202
NW	1	15	38	35	3	0	92
NNW	6	16	48	13	1	0	84
Total	<u>45</u>	<u>287</u>	<u>627</u>	<u>708</u>	<u>158</u>	<u>22</u>	<u>1847</u>

Number of Calm Hours - 0  
 Number of Variable Directions - 0  
 Total Number of Observations - 1847

TABLE 2.3D-77

BVPS WIND - STABILITY SUMMARY  
 STABILITY CLASS - E, 500 Ft Winds  
 OCTOBER: 1976-1980

Number of Hourly Observations

Winds From	Wind Speed (mph)						Total
	1-3	4-7	8-12	13-18	19-24	25+	
N	2	13	14	6	0	0	35
NNE	7	16	9	1	1	0	34
NE	4	22	4	1	0	0	31
ENE	7	13	23	1	0	0	44
E	5	22	27	6	0	0	60
ESE	5	7	10	8	0	0	30
SE	4	13	14	13	6	0	50
SSE	7	24	14	8	2	0	55
S	10	23	21	8	1	0	63
SSW	2	7	21	32	1	1	64
SW	6	41	46	58	7	0	158
WSW	9	29	29	19	0	0	86
W	12	41	36	9	3	0	101
WNW	12	15	16	12	1	0	56
NW	3	7	9	2	0	0	21
NNW	3	10	8	1	0	0	22
Total	98	303	301	185	22	1	910

Number of Calm Hours - 0  
 Number of Variable Directions - 0  
 Total Number of Observations - 910



TABLE 2.3D-78

BVPS WIND - STABILITY SUMMARY  
 STABILITY CLASS - F, 500 Ft Winds  
 OCTOBER: 1976-1980

## Number of Hourly Observations

Winds From	Wind Speed (mph)						Total
	<u>1-3</u>	<u>4-7</u>	<u>8-12</u>	<u>13-18</u>	<u>19-24</u>	<u>25+</u>	
N	1	13	2	0	0	0	16
NNE	1	6	3	0	0	0	10
NE	2	19	17	0	0	0	38
ENE	2	22	15	0	0	0	39
E	2	11	8	2	0	0	23
ESE	2	8	9	3	0	0	22
SE	4	9	9	3	2	0	27
SSE	12	16	11	3	1	0	43
S	1	22	17	11	0	0	51
SSW	5	27	20	17	0	0	69
SW	10	47	24	22	0	0	103
WSW	5	10	3	0	0	0	18
W	8	10	11	0	0	0	29
WNW	2	6	0	0	0	0	8
NW	2	5	4	0	0	0	11
NNW	0	6	1	0	0	0	7
Total	<u>59</u>	<u>237</u>	<u>154</u>	<u>61</u>	<u>3</u>	<u>0</u>	<u>514</u>

Number of Calm Hours - 2  
 Number of Variable Directions - 0  
 Total Number of Observations - 516

TABLE 2.3D-79

BVPS WIND - STABILITY SUMMARY  
 STABILITY CLASS - G, 500 Ft Winds  
 OCTOBER: 1976-1980

Number of Hourly Observations

Winds From	Wind Speed (mph)						Total
	1-3	4-7	8-12	13-18	19-24	25+	
N	0	0	0	0	0	0	0
NNE	0	0	0	0	0	0	0
NE	0	0	0	0	0	0	0
ENE	0	1	0	0	0	0	1
E	0	0	0	0	0	0	0
ESE	0	1	0	0	0	0	1
SE	0	4	1	2	0	0	7
SSE	0	4	4	0	0	0	8
S	3	6	5	0	0	0	14
SSW	1	6	4	0	0	0	11
SW	2	4	4	3	0	0	13
WSW	0	0	0	0	0	0	0
W	0	0	0	0	0	0	0
WNW	0	1	0	0	0	0	1
NW	0	0	0	0	0	0	0
NNW	0	0	0	0	0	0	0
Total	6	27	18	5	0	0	56

Number of Calm Hours - 0  
 Number of Variable Directions - 0  
 Total Number of Observations - 56

TABLE 2.3D-80

BVPS WIND - STABILITY SUMMARY  
 STABILITY CLASS - ALL, 500 Ft Winds  
 OCTOBER: 1976-1980

Number of Hourly Observations

Winds From	Wind Speed (mph)						Total
	1-3	4-7	8-12	13-18	19-24	25+	
N	6	58	77	30	0	0	171
NNE	13	41	33	14	3	0	104
NE	11	68	31	6	0	0	116
ENE	12	55	65	5	0	0	137
E	9	53	55	9	0	0	126
ESE	11	21	32	21	5	0	90
SE	9	41	42	36	15	0	143
SSE	22	58	48	31	5	1	165
S	15	69	76	42	2	0	204
SSW	10	57	85	95	6	2	255
SW	22	115	180	205	27	1	550
WSW	16	60	99	153	32	7	367
W	21	72	125	166	62	11	457
WNW	16	36	81	111	25	1	270
NW	6	27	52	37	3	0	125
NNW	9	33	57	14	1	0	114
Total	208	864	1138	975	186	23	3394

Number of Calm Hours - 2  
 Number of Variable Directions - 0  
 Total Number of Observations - 3396

TABLE 2.3D-81

BVPS WIND - STABILITY SUMMARY  
 STABILITY CLASS - A, 500 Ft Winds  
 NOVEMBER: 1976-1980

Number of Hourly Observations

Winds From	Wind Speed (mph)						Total
	1-3	4-7	8-12	13-18	19-24	25+	
N	0	0	0	0	0	0	0
NNE	0	0	0	0	0	0	0
NE	0	0	0	0	0	0	0
ENE	0	0	0	0	0	0	0
E	0	0	0	0	0	0	0
ESE	0	0	0	0	0	0	0
SE	0	0	0	0	0	0	0
SSE	0	0	0	0	0	0	0
S	0	0	0	0	0	0	0
SSW	0	0	0	0	0	0	0
SW	0	0	0	0	0	0	0
WSW	0	0	0	0	0	0	0
W	0	0	0	0	0	0	0
WNW	0	0	0	0	0	0	0
NW	0	0	0	0	0	0	0
NNW	0	0	0	0	0	0	0
Total	0	0	0	0	0	0	0

Number of Calm Hours - 0  
 Number of Variable Directions - 0  
 Total Number of Observations - 0

TABLE 2.3D-82

BVPS WIND - STABILITY SUMMARY  
 STABILITY CLASS - B, 500 Ft Winds  
 NOVEMBER: 1976-1980

Number of Hourly Observations

Winds From	Wind Speed (mph)						Total
	1-3	4-7	8-12	13-18	19-24	25+	
N	0	0	0	0	0	0	0
NNE	0	0	0	0	0	0	0
NE	0	0	0	0	0	0	0
ENE	0	0	0	0	0	0	0
E	0	0	0	0	0	0	0
ESE	0	0	0	0	0	0	0
SE	0	0	0	0	0	0	0
SSE	0	0	0	0	0	0	0
S	0	0	0	0	0	0	0
SSW	0	0	0	0	0	0	0
SW	0	0	0	0	0	0	0
WSW	0	0	0	0	0	0	0
W	0	0	0	0	0	0	0
WNW	0	0	0	0	0	0	0
NW	0	0	0	0	0	0	0
NNW	0	0	0	0	0	0	0
Total	0	0	0	0	0	0	0

Number of Calm Hours - 0  
 Number of Variable Directions - 0  
 Total Number of Observations - 0

TABLE 2.3D-83

BVPS WIND - STABILITY SUMMARY  
 STABILITY CLASS - C, 500 Ft Winds  
 NOVEMBER: 1976-1980

Number of Hourly Observations

Winds From	Wind Speed (mph)						Total
	1-3	4-7	8-12	13-18	19-24	25+	
N	0	0	0	0	0	0	0
NNE	0	0	0	0	0	0	0
NE	0	0	1	0	0	0	1
ENE	0	0	1	0	0	0	1
E	0	0	1	0	0	0	1
ESE	0	0	0	0	0	0	0
SE	0	0	1	2	0	0	3
SSE	0	0	0	0	0	0	0
S	0	0	1	0	0	0	1
SSW	0	0	0	0	0	0	0
SW	0	0	0	0	0	0	0
WSW	0	0	0	0	0	0	0
W	0	0	1	0	0	0	1
WNW	0	0	0	0	0	0	0
NW	0	0	0	0	0	0	0
NNW	0	0	1	0	0	0	1
Total	0	0	7	2	0	0	9

Number of Calm Hours - 0  
 Number of Variable Directions - 0  
 Total Number of Observations - 9

TABLE 2.3D-84

BVPS WIND - STABILITY SUMMARY  
 STABILITY CLASS - D, 500 Ft Winds  
 NOVEMBER: 1976-1980

Number of Hourly Observations

Winds From	Wind Speed (mph)						Total
	1-3	4-7	8-12	13-18	19-24	25+	
N	9	22	40	2	0	0	73
NNE	6	27	21	2	0	0	56
NE	11	36	17	4	0	0	68
ENE	10	49	38	8	0	0	105
E	8	15	64	29	0	0	116
ESE	4	23	24	18	2	0	71
SE	1	13	21	11	5	0	51
SSE	4	11	22	15	6	0	58
S	2	11	20	14	3	0	50
SSW	3	10	55	62	12	0	142
SW	1	16	55	148	26	3	249
WSW	3	26	45	110	57	7	248
W	4	27	73	177	78	9	368
WNW	1	18	81	90	26	4	220
NW	1	22	79	50	1	0	153
NNW	6	13	32	5	0	0	56
Total	74	339	687	745	216	23	2084

Number of Calm Hours - 0  
 Number of Variable Directions - 0  
 Total Number of Observations - 2084

TABLE 2.3D-85

BVPS WIND - STABILITY SUMMARY  
 STABILITY CLASS - E, 500 Ft Winds  
 NOVEMBER: 1976-1980

Number of Hourly Observations

Winds From	Wind Speed (mph)						Total
	1-3	4-7	8-12	13-18	19-24	25+	
N	5	3	4	0	0	0	12
NNE	2	7	1	0	0	0	10
NE	4	7	5	0	0	0	16
ENE	6	12	22	1	0	0	41
E	3	15	13	2	0	0	33
ESE	2	15	13	19	4	0	53
SE	4	8	10	7	6	1	36
SSE	6	14	10	7	0	0	37
S	1	15	18	11	0	0	45
SSW	2	7	25	11	4	0	49
SW	8	11	31	49	7	0	106
WSW	3	19	23	13	2	0	60
W	11	24	27	13	1	1	77
WNW	3	10	11	2	0	0	26
NW	9	6	2	0	0	0	17
NNW	2	6	4	0	0	0	12
Total	71	179	219	135	24	2	630

Number of Calm Hours - 2  
 Number of Variable Directions - 0  
 Total Number of Observations - 632



TABLE 2.3D-86

BVPS WIND - STABILITY SUMMARY  
 STABILITY CLASS - F, 500 Ft Winds  
 NOVEMBER: 1976-1980

Number of Hourly Observations

Winds From	Wind Speed (mph)						Total
	<u>1-3</u>	<u>4-7</u>	<u>8-12</u>	<u>13-18</u>	<u>19-24</u>	<u>25+</u>	
N	1	2	0	0	0	0	3
NNE	0	2	0	0	0	0	2
NE	3	8	1	0	0	0	12
ENE	3	7	4	0	0	0	14
E	1	9	5	0	0	0	15
ESE	5	7	1	0	0	0	13
SE	6	12	9	1	1	0	29
SSE	7	12	16	4	0	0	39
S	4	16	8	2	1	0	31
SSW	1	16	11	6	0	0	34
SW	4	24	20	7	2	0	57
WSW	7	15	10	3	0	0	35
W	8	20	8	3	0	0	39
WNW	4	7	7	1	0	0	19
NW	7	0	2	0	0	0	9
NNW	0	0	0	0	0	0	0
Total	<u>61</u>	<u>157</u>	<u>102</u>	<u>27</u>	<u>4</u>	<u>0</u>	<u>351</u>

Number of Calm Hours	-	1
Number of Variable Directions	-	0
Total Number of Observations	-	352

TABLE 2.3D-87

BVPS WIND - STABILITY SUMMARY  
 STABILITY CLASS - G, 500 Ft Winds  
 NOVEMBER: 1976-1980

Number of Hourly Observations

Winds From	Wind Speed (mph)						Total
	1-3	4-7	8-12	13-18	19-24	25+	
N	1	0	0	0	0	0	1
NNE	1	0	0	0	0	0	1
NE	0	0	0	0	0	0	0
ENE	0	0	0	0	0	0	0
E	1	0	0	0	0	0	1
ESE	0	0	0	0	0	0	0
SE	1	0	0	0	0	0	1
SSE	1	2	2	0	0	0	5
S	0	4	0	1	0	0	5
SSW	1	5	2	5	0	0	13
SW	2	8	2	2	0	0	14
WSW	3	5	0	0	0	0	8
W	1	1	0	0	0	0	2
WNW	0	2	0	0	0	0	2
NW	1	0	0	0	0	0	1
NNW	0	0	0	0	0	0	0
Total	13	27	6	8	0	0	54

Number of Calm Hours - 0  
 Number of Variable Directions - 0  
 Total Number of Observations - 54

TABLE 2.3D-88

BVPS WIND - STABILITY SUMMARY  
 STABILITY CLASS - ALL, 500 Ft Winds  
 NOVEMBER: 1976-1980

## Number of Hourly Observations

Winds From	Wind Speed (mph)						Total
	1-3	4-7	8-12	13-18	19-24	25+	
N	16	27	44	2	0	0	89
NNE	9	36	22	2	0	0	69
NE	18	51	24	4	0	0	97
ENE	19	68	65	9	0	0	161
E	13	39	83	31	0	0	166
ESE	11	45	38	37	6	0	137
SE	12	33	41	21	12	1	120
SSE	18	39	50	26	6	0	139
S	7	46	47	28	4	0	132
SSW	7	38	93	84	16	0	238
SW	15	59	108	206	35	3	426
WSW	16	65	78	126	59	7	351
W	24	72	109	193	79	10	487
WNW	8	37	99	93	26	4	267
NW	18	28	83	50	1	0	180
NNW	8	19	37	5	0	0	69
Total	219	702	1021	917	244	25	3128

Number of Calm Hours - 3  
 Number of Variable Directions - 0  
 Total Number of Observations - 3131

TABLE 2.3D-89

BVPS WIND - STABILITY SUMMARY  
 STABILITY CLASS - A, 500 Ft Winds  
 DECEMBER: 1976-1980

Number of Hourly Observations

Winds From	Wind Speed (mph)						Total
	1-3	4-7	8-12	13-18	19-24	25+	
N	0	0	0	0	0	0	0
NNE	0	0	0	0	0	0	0
NE	0	0	0	0	0	0	0
ENE	0	0	0	0	0	0	0
E	0	0	0	0	0	0	0
ESE	0	0	0	0	0	0	0
SE	0	0	0	0	0	0	0
SSE	0	0	0	0	0	0	0
S	0	0	0	0	0	0	0
SSW	0	0	0	0	0	0	0
SW	0	0	0	0	0	0	0
WSW	0	0	0	0	0	0	0
W	0	0	0	0	0	0	0
WNW	0	0	0	0	0	0	0
NW	0	0	0	0	0	0	0
NNW	0	0	0	0	0	0	0
Total	0	0	0	0	0	0	0

Number of Calm Hours - 0  
 Number of Variable Directions - 0  
 Total Number of Observations - 0

TABLE 2.3D-90

BVPS WIND - STABILITY SUMMARY  
 STABILITY CLASS - B, 500 Ft Winds  
 DECEMBER: 1976-1980

Number of Hourly Observations

Winds From	Wind Speed (mph)						Total
	1-3	4-7	8-12	13-18	19-24	25+	
N	0	0	0	0	0	0	0
NNE	0	0	0	0	0	0	0
NE	0	0	0	0	0	0	0
ENE	0	0	0	0	0	0	0
E	0	0	0	0	0	0	0
ESE	0	0	0	0	0	0	0
SE	0	0	0	0	0	0	0
SSE	0	0	0	0	0	0	0
S	0	0	0	0	0	0	0
SSW	0	0	0	0	0	0	0
SW	0	0	0	0	0	0	0
WSW	0	0	0	0	0	0	0
W	0	0	0	0	0	0	0
WNW	0	0	0	0	0	0	0
NW	0	0	0	0	0	0	0
NNW	0	0	0	0	0	0	0
Total	0	0	0	0	0	0	0

Number of Calm Hours - 0  
 Number of Variable Directions - 0  
 Total Number of Observations - 0

TABLE 2.3D-91

BVPS WIND - STABILITY SUMMARY  
 STABILITY CLASS - C, 500 Ft Winds  
 DECEMBER: 1976-1980

Number of Hourly Observations

Winds From	Wind Speed (mph)						Total
	1-3	4-7	8-12	13-18	19-24	25+	
N	0	0	0	0	0	0	0
NNE	0	0	0	0	0	0	0
NE	0	0	0	0	0	0	0
ENE	0	0	2	0	0	0	2
E	0	3	0	0	0	0	3
ESE	0	0	0	0	0	0	0
SE	0	0	0	0	0	0	0
SSE	0	0	0	0	0	0	0
S	0	0	0	0	0	0	0
SSW	0	0	0	0	0	0	0
SW	0	1	0	0	0	0	1
WSW	0	0	0	0	0	0	0
W	0	0	1	1	0	0	2
WNW	0	0	0	0	0	0	0
NW	0	0	0	0	0	0	0
NNW	0	0	0	0	0	0	0
Total	0	4	3	1	0	0	8

Number of Calm Hours - 0  
 Number of Variable Directions - 0  
 Total Number of Observations - 8

TABLE 2.3D-92

BVPS WIND - STABILITY SUMMARY  
 STABILITY CLASS - D, 500 Ft Winds  
 DECEMBER: 1976-1980

## Number of Hourly Observations

Winds From	Wind Speed (mph)						Total
	1-3	4-7	8-12	13-18	19-24	25+	
N	3	18	46	13	0	0	80
NNE	4	9	8	2	1	0	24
NE	9	16	7	0	0	0	32
ENE	3	36	22	3	0	0	64
E	3	38	31	3	0	0	75
ESE	7	20	20	6	0	0	53
SE	3	18	11	2	0	0	34
SSE	5	8	20	7	1	0	41
S	2	10	51	18	6	0	87
SSW	3	12	43	84	14	0	156
SW	3	38	81	164	38	5	329
WSW	2	21	96	111	45	19	294
W	1	21	88	173	103	60	446
WNW	2	5	48	59	44	19	177
NW	1	12	57	40	6	0	116
NNW	0	24	47	12	1	0	84
Total	51	306	676	697	259	103	2092

Number of Calm Hours - 0  
 Number of Variable Directions - 0  
 Total Number of Observations - 2092

TABLE 2.3D-93

BVPS WIND - STABILITY SUMMARY  
 STABILITY CLASS - E, 500 Ft Winds  
 DECEMBER: 1976-1980

Number of Hourly Observations

Winds From	Wind Speed (mph)						Total
	1-3	4-7	8-12	13-18	19-24	25+	
N	2	1	2	0	0	0	5
NNE	2	5	0	0	0	0	7
NE	4	5	3	0	0	0	12
ENE	0	4	15	0	0	0	19
E	3	29	21	0	0	0	53
ESE	6	19	32	0	0	0	57
SE	4	18	20	3	1	0	46
SSE	6	24	31	1	0	0	62
S	5	21	36	12	0	0	74
SSW	3	10	40	47	2	1	103
SW	1	15	41	49	6	0	112
WSW	2	8	31	11	1	0	53
W	4	4	22	8	0	0	38
WNW	4	1	2	0	0	0	7
NW	2	3	3	0	1	0	9
NNW	3	2	1	0	0	0	6
Total	51	169	300	131	11	1	663

Number of Calm Hours - 4  
 Number of Variable Directions - 0  
 Total Number of Observations - 667



TABLE 2.3D-94

BVPS WIND - STABILITY SUMMARY  
 STABILITY CLASS - F, 500 Ft Winds  
 DECEMBER: 1976-1980

Number of Hourly Observations

Winds From	Wind Speed (mph)						Total
	1-3	4-7	8-12	13-18	19-24	25+	
N	2	0	0	0	0	0	2
NNE	1	0	0	0	0	0	1
NE	2	7	0	0	0	0	9
ENE	1	20	5	0	0	0	26
E	5	16	5	0	0	0	26
ESE	0	3	4	3	0	0	10
SE	2	6	6	2	0	0	16
SSE	2	12	11	0	0	0	25
S	2	11	30	6	0	0	49
SSW	0	10	18	10	1	0	39
SW	6	7	19	9	0	0	41
WSW	1	3	3	0	0	0	7
W	0	0	0	0	0	0	0
WNW	1	4	0	0	0	0	5
NW	0	1	0	0	0	0	1
NNW	1	0	0	0	0	0	1
Total	26	100	101	30	1	0	258

Number of Calm Hours - 1  
 Number of Variable Directions - 0  
 Total Number of Observations - 259

TABLE 2.3D-95

BVPS WIND - STABILITY SUMMARY  
 STABILITY CLASS - G, 500 Ft Winds  
 DECEMBER: 1976-1980

Number of Hourly Observations

Winds From	Wind Speed (mph)						Total
	1-3	4-7	8-12	13-18	19-24	25+	
N	0	0	0	0	0	0	0
NNE	0	0	0	0	0	0	0
NE	0	0	0	0	0	0	0
ENE	0	1	1	0	0	0	2
E	0	1	1	0	0	0	2
ESE	0	0	0	0	0	0	0
SE	0	0	0	0	0	0	0
SSE	0	0	0	0	0	0	0
S	1	5	1	1	0	0	8
SSW	2	0	5	6	0	0	13
SW	0	1	4	1	0	0	6
WSW	0	0	0	0	0	0	0
W	0	0	0	0	0	0	0
WNW	0	0	0	0	0	0	0
NW	0	0	0	0	0	0	0
NNW	0	0	0	0	0	0	0
Total	3	8	12	8	0	0	31

Number of Calm Hours - 0  
 Number of Variable Directions - 0  
 Total Number of Observations - 31

TABLE 2.3D-96

BVPS WIND - STABILITY SUMMARY  
 STABILITY CLASS - ALL, 500 Ft Winds  
 DECEMBER: 1976-1980

Number of Hourly Observations

Winds From	Wind Speed (mph)						Total
	<u>1-3</u>	<u>4-7</u>	<u>8-12</u>	<u>13-18</u>	<u>19-24</u>	<u>25+</u>	
N	7	19	48	13	0	0	87
NNE	7	14	8	2	1	0	32
NE	15	28	10	0	0	0	53
ENE	4	61	45	3	0	0	113
E	11	87	58	3	0	0	159
ESE	13	42	56	9	0	0	120
SE	9	42	37	7	1	0	96
SSE	13	44	62	8	1	0	128
S	10	47	118	37	6	0	218
SSW	8	32	106	147	17	1	311
SW	10	62	145	223	44	5	489
WSW	5	32	130	122	46	19	354
W	5	25	111	182	103	60	486
WNW	7	10	50	59	44	19	189
NW	3	16	60	40	7	0	126
NNW	4	26	48	12	1	0	91
Total	<u>131</u>	<u>587</u>	<u>1092</u>	<u>867</u>	<u>271</u>	<u>104</u>	<u>3052</u>

Number of Calm Hours	-	5
Number of Variable Directions	-	0
Total Number of Observations	-	3057

TABLE 2.3D-97

BVPS WIND - STABILITY SUMMARY  
 STABILITY CLASS - A, 500 Ft Winds  
 ANNUAL: 1976-1980

Number of Hourly Observations

Winds From	Wind Speed (mph)						Total
	1-3	4-7	8-12	13-18	19-24	25+	
N	0	6	15	2	0	0	23
NNE	0	3	3	1	0	0	7
NE	1	4	8	1	0	0	14
ENE	0	2	12	0	0	0	14
E	0	4	10	3	0	0	17
ESE	1	4	10	3	0	0	18
SE	0	2	2	3	0	0	7
SSE	0	0	6	3	0	0	9
S	0	4	10	4	0	0	18
SSW	0	3	10	3	0	0	16
SW	0	1	4	1	0	0	6
WSW	0	1	5	1	0	0	7
W	0	1	5	4	0	0	10
WNW	0	0	3	5	0	0	8
NW	0	2	4	2	0	0	8
NNW	0	0	6	0	0	0	6
Total	2	37	113	36	0	0	188

Number of Calm Hours	-	0
Number of Variable Directions	-	0
Total Number of Observations	-	188

TABLE 2.3D-98

BVPS WIND - STABILITY SUMMARY  
 STABILITY CLASS - B, 500 Ft Winds  
 ANNUAL: 1976-1980

Number of Hourly Observations

Winds From	Wind Speed (mph)						Total
	1-3	4-7	8-12	13-18	19-24	25+	
N	1	17	39	12	0	0	69
NNE	0	6	11	2	0	0	19
NE	2	12	16	2	0	0	32
ENE	0	8	21	2	0	0	31
E	0	13	10	1	0	0	24
ESE	0	6	14	2	1	0	23
SE	0	8	8	5	0	0	21
SSE	0	9	8	5	0	0	22
S	0	8	14	4	0	0	26
SSW	0	2	23	8	1	0	34
SW	0	6	27	9	1	0	43
WSW	0	11	28	12	3	0	54
W	0	9	23	17	4	0	53
WNW	0	1	18	16	4	2	41
NW	1	4	15	8	2	0	30
NNW	1	8	14	3	1	0	27
Total	5	128	289	108	17	2	549

Number of Calm Hours - 0  
 Number of Variable Directions - 0  
 Total Number of Observations - 549

TABLE 2.3D-99

BVPS WIND - STABILITY SUMMARY  
 STABILITY CLASS - C, 500 Ft Winds  
 ANNUAL: 1976-1980

Number of Hourly Observations

Winds From	Wind Speed (mph)						Total
	1-3	4-7	8-12	13-18	19-24	25+	
N	3	36	51	16	0	0	106
NNE	0	13	8	2	0	1	24
NE	0	19	15	4	0	0	38
ENE	1	12	20	7	0	0	40
E	1	19	17	1	0	0	38
ESE	2	22	10	5	0	0	39
SE	1	21	15	10	0	0	47
SSE	0	9	14	1	0	0	24
S	1	24	27	5	0	0	57
SSW	0	11	36	15	1	0	63
SW	0	27	49	34	4	5	119
WSW	0	32	61	31	9	3	136
W	4	38	66	36	18	2	164
WNW	2	23	37	31	21	3	117
NW	0	17	43	27	5	1	93
NNW	2	17	43	22	0	0	84
Total	17	340	512	247	58	15	1189

Number of Calm Hours - 0  
 Number of Variable Directions - 0  
 Total Number of Observations - 1189

TABLE 2.3D-100

BVPS WIND - STABILITY SUMMARY  
 STABILITY CLASS - D, 500 Ft Winds  
 ANNUAL: 1976-1980

Number of Hourly Observations

Winds From	Wind Speed (mph)						Total
	1-3	4-7	8-12	13-18	19-24	25+	
N	77	288	636	145	6	1	1153
NNE	63	197	206	55	5	1	527
NE	82	279	188	79	10	5	643
ENE	77	310	286	77	7	1	758
E	77	253	336	95	7	0	768
ESE	57	212	184	107	28	2	590
SE	44	177	160	125	41	3	550
SSE	43	139	172	90	21	2	467
S	47	196	313	165	41	4	766
SSW	43	197	535	483	90	14	1362
SW	59	394	929	1243	281	50	2956
WSW	58	412	890	1072	374	113	2919
W	67	293	820	1324	586	210	3300
WNW	53	192	691	733	239	77	1985
NW	48	290	788	440	39	6	1611
NNW	61	301	593	184	18	0	1157
Total	956	4130	7727	6417	1793	489	21512

Number of Calm Hours - 8  
 Number of Variable Directions - 0  
 Total Number of Observations - 21520

TABLE 2.3D-101

BVPS WIND - STABILITY SUMMARY  
 STABILITY CLASS - E, 500 Ft Winds  
 ANNUAL: 1976-1980

Number of Hourly Observations

Winds From	Wind Speed (mph)						Total
	1-3	4-7	8-12	13-18	19-24	25+	
N	79	136	121	44	0	1	381
NNE	59	153	47	17	1	0	277
NE	87	213	73	6	1	0	380
ENE	75	199	160	10	1	0	445
E	90	225	162	18	4	0	499
ESE	89	199	128	60	9	0	485
SE	63	185	163	96	37	3	547
SSE	82	168	158	74	7	0	489
S	89	229	245	147	16	0	726
SSW	64	173	356	310	27	4	934
SW	95	289	405	412	74	2	1277
WSW	92	295	319	172	23	2	903
W	145	346	323	111	19	4	948
WNW	85	190	134	40	2	0	451
NW	67	102	99	41	2	2	313
NNW	52	98	104	31	1	0	286
Total	1313	3200	2997	1589	224	18	9341

Number of Calm Hours - 23  
 Number of Variable Directions - 0  
 Total Number of Observations - 9364



TABLE 2.3D-102

BVPS WIND - STABILITY SUMMARY  
 STABILITY CLASS - F, 500 Ft Winds  
 ANNUAL: 1976-1980

Number of Hourly Observations

Winds From	Wind Speed (mph)						Total
	1-3	4-7	8-12	13-18	19-24	25+	
N	55	98	27	6	0	0	186
NNE	50	81	21	0	0	0	152
NE	66	145	42	3	0	0	256
ENE	73	188	78	3	0	0	342
E	98	166	48	4	0	0	316
ESE	48	123	65	16	1	1	254
SE	56	109	71	31	13	0	280
SSE	63	126	72	23	3	0	287
S	71	150	141	49	1	0	412
SSW	64	162	177	115	2	0	520
SW	101	281	172	92	7	0	653
WSW	105	229	85	16	0	0	435
W	122	213	104	12	1	0	452
WNW	58	128	48	7	0	0	241
NW	76	88	36	7	0	0	207
NNW	52	54	27	5	0	0	138
Total	1158	2341	1214	389	28	1	5131

Number of Calm Hours - 36  
 Number of Variable Directions - 0  
 Total Number of Observations - 5167

TABLE 2.3D-103

BVPS WIND - STABILITY SUMMARY  
 STABILITY CLASS - G, 500 Ft Winds  
 ANNUAL: 1976-1980

Number of Hourly Observations

Winds From	Wind Speed (mph)						Total
	1-3	4-7	8-12	13-18	19-24	25+	
N	4	3	0	1	0	0	8
NNE	8	6	2	0	0	0	16
NE	11	14	1	0	0	0	26
ENE	15	18	2	0	0	0	35
E	11	12	6	2	0	0	31
ESE	6	11	3	3	0	0	23
SE	10	16	9	7	1	0	43
SSE	4	21	15	5	2	0	47
S	8	36	26	4	0	0	74
SSW	10	22	36	25	1	0	94
SW	10	30	23	10	4	0	77
WSW	5	22	19	0	0	0	46
W	4	5	11	0	0	0	20
WNW	4	10	0	0	0	0	14
NW	7	1	1	0	0	0	9
NNW	6	3	2	0	0	0	11
Total	123	230	156	57	8	0	574

Number of Calm Hours - 3  
 Number of Variable Directions - 0  
 Total Number of Observations - 576

TABLE 2.3D-104

BVPS WIND - STABILITY SUMMARY  
 STABILITY CLASS - ALL, 500 Ft Winds  
 ANNUAL: 1976-1980

Number of Hourly Observations

Winds From	Wind Speed (mph)						Total
	1-3	4-7	8-12	13-18	19-24	25+	
N	219	584	889	226	6	2	1926
NNE	180	459	298	77	6	2	1022
NE	249	686	343	95	11	5	1389
ENE	241	737	579	99	8	1	1665
E	277	692	589	124	11	0	1693
ESE	203	577	414	196	39	3	1432
SE	174	518	428	277	92	6	1495
SSE	192	472	445	201	33	2	1345
S	216	647	776	378	58	4	2079
SSW	181	570	1173	959	122	18	3023
SW	265	1028	1609	1801	371	57	5131
WSW	260	1002	1407	1304	409	118	4500
W	342	905	1352	1504	628	216	4947
WNW	202	544	931	832	266	82	2857
NW	199	504	986	525	48	9	2271
NNW	174	481	789	245	20	0	1709
Total	3574	10406	13008	8843	2128	525	38484

Number of Calm Hours - 69  
 Number of Variable Directions - 0  
 Total Number of Observations - 38553

APPENDIX 2.3E

BEAVER VALLEY POWER STATION  
JOINT FREQUENCY DISTRIBUTION  
AT THE 150-FOOT LEVEL  
(JANUARY 1, 1976 TO DECEMBER 31, 1980)

## APPENDIX 2.3E

## LIST OF TABLES

<u>Table Number</u>	<u>Title</u>
2.3E-1	BVPS Wind - Stability Summary Stability Class - A, 150 Ft Winds Period: 1/01/76 to 1/31/80
2.3E-2	BVPS Wind - Stability Summary Stability Class - B, 150 Ft Winds Period: 1/01/76 to 1/31/80
2.3E-3	BVPS Wind - Stability Summary Stability Class - C, 150 Ft Winds Period: 1/01/76 to 1/31/80
2.3E-4	BVPS Wind - Stability Summary Stability Class - D, 150 Ft Winds Period: 1/01/76 to 1/31/80
2.3E-5	BVPS Wind - Stability Summary Stability Class - E, 150 Ft Winds Period: 1/01/76 to 1/31/80
2.3E-6	BVPS Wind - Stability Summary Stability Class - F, 150 Ft Winds Period: 1/01/76 to 1/31/80
2.3E-7	BVPS Wind - Stability Summary Stability Class - G, 150 Ft Winds Period: 1/01/76 to 1/31/80
2.3E-8	BVPS Wind - Stability Summary Stability Class - All, 150 Ft Winds Period: 1/01/76 to 1/31/80
2.3E-9	BVPS Wind - Stability Summary Stability Class - A, 150 Ft Winds Period: 2/01/76 to 2/29/80
2.3E-10	BVPS Wind - Stability Summary Stability Class - B, 150 Ft Winds Period: 2/01/76 to 2/29/80
2.3E-11	BVPS Wind - Stability Summary Stability Class - C, 150 Ft Winds Period: 2/01/76 to 2/29/80
2.3E-12	BVPS Wind - Stability Summary Stability Class - D, 150 Ft Winds Period: 2/01/76 to 2/29/80
2.3E-13	BVPS Wind - Stability Summary Stability Class - E, 150 Ft Winds Period: 2/01/76 to 2/29/80
2.3E-14	BVPS Wind - Stability Summary Stability Class - F, 150 Ft Winds Period: 2/01/76 to 2/29/80
2.3E-15	BVPS Wind - Stability Summary Stability Class - G, 150 Ft Winds Period: 2/01/76 to 2/29/80

## LIST OF TABLES (Cont)

<u>Table Number</u>	<u>Title</u>
2.3E-16	BVPS Wind - Stability Summary Stability Class - All, 150 Ft Winds Period: 2/01/76 to 2/29/80
2.3E-17	BVPS Wind - Stability Summary Stability Class - A, 150 Ft Winds Period: 3/01/76 to 3/31/80
2.3E-18	BVPS Wind - Stability Summary Stability Class - B, 150 Ft Winds Period: 3/01/76 to 3/31/80
2.3E-19	BVPS Wind - Stability Summary Stability Class - C, 150 Ft Winds Period: 3/01/76 to 3/31/80
2.3E-20	BVPS Wind - Stability Summary Stability Class - D, 150 Ft Winds Period: 3/01/76 to 3/31/80
2.3E-21	BVPS Wind - Stability Summary Stability Class - E, 150 Ft Winds Period: 3/01/76 to 3/31/80
2.3E-22	BVPS Wind - Stability Summary Stability Class - F, 150 Ft Winds Period: 3/01/76 to 3/31/80
2.3E-23	BVPS Wind - Stability Summary Stability Class - G, 150 Ft Winds Period: 3/01/76 to 3/31/80
2.3E-24	BVPS Wind - Stability Summary Stability Class - All, 150 Ft Winds Period: 3/01/76 to 3/31/80
2.3E-25	BVPS Wind - Stability Summary Stability Class - A, 150 Ft Winds Period: 4/01/76 to 4/30/80
2.3E-26	BVPS Wind - Stability Summary Stability Class - B, 150 Ft Winds Period: 4/01/76 to 4/30/80
2.3E-27	BVPS Wind - Stability Summary Stability Class - C, 150 Ft Winds Period: 4/01/76 to 4/30/80
2.3E-28	BVPS Wind - Stability Summary Stability Class - D, 150 Ft Winds Period: 4/01/76 to 4/30/80
2.3E-29	BVPS Wind - Stability Summary Stability Class - E, 150 Ft Winds Period: 4/01/76 to 4/30/80
2.3E-30	BVPS Wind - Stability Summary Stability Class - F, 150 Ft Winds Period: 4/01/76 to 4/30/80
2.3E-31	BVPS Wind - Stability Summary Stability Class - G, 150 Ft Winds Period: 4/01/76 to 4/30/80

## LIST OF TABLES (Cont)

<u>Table Number</u>	<u>Title</u>
2.3E-32	BVPS Wind - Stability Summary Stability Class - All, 150 Ft Winds Period: 4/01/76 to 4/30/80
2.3E-33	BVPS Wind - Stability Summary Stability Class - A, 150 Ft Winds Period: 5/01/76 to 5/31/80
2.3E-34	BVPS Wind - Stability Summary Stability Class - B, 150 Ft Winds Period: 5/01/76 to 5/31/80
2.3E-35	BVPS Wind - Stability Summary Stability Class - C, 150 Ft Winds Period: 5/01/76 to 5/31/80
2.3E-36	BVPS Wind - Stability Summary Stability Class - D, 150 Ft Winds Period: 5/01/76 to 5/31/80
2.3E-37	BVPS Wind - Stability Summary Stability Class - E, 150 Ft Winds Period: 5/01/76 to 5/31/80
2.3E-38	BVPS Wind - Stability Summary Stability Class - F, 150 Ft Winds Period: 5/01/76 to 5/31/80
2.3E-39	BVPS Wind - Stability Summary Stability Class - G, 150 Ft Winds Period: 5/01/76 to 5/31/80
2.3E-40	BVPS Wind - Stability Summary Stability Class - All, 150 Ft Winds Period: 5/01/76 to 5/31/80
2.3E-41	BVPS Wind - Stability Summary Stability Class - A, 150 Ft Winds Period: 6/01/76 to 6/30/80
2.3E-42	BVPS Wind - Stability Summary Stability Class - B, 150 Ft Winds Period: 6/01/76 to 6/30/80
2.3E-43	BVPS Wind - Stability Summary Stability Class - C, 150 Ft Winds Period: 6/01/76 to 6/30/80
2.3E-44	BVPS Wind - Stability Summary Stability Class - D, 150 Ft Winds Period: 6/01/76 to 6/30/80
2.3E-45	BVPS Wind - Stability Summary Stability Class - E, 150 Ft Winds Period: 6/01/76 to 6/30/80
2.3E-46	BVPS Wind - Stability Summary Stability Class - F, 150 Ft Winds Period: 6/01/76 to 6/30/80
2.3E-47	BVPS Wind - Stability Summary Stability Class - G, 150 Ft Winds Period: 6/01/76 to 6/30/80

## LIST OF TABLES (Cont)

<u>Table Number</u>	<u>Title</u>
2.3E-48	BVPS Wind - Stability Summary Stability Class - All, 150 Ft Winds Period: 6/01/76 to 6/30/80
2.3E-49	BVPS Wind - Stability Summary Stability Class - A, 150 Ft Winds Period: 7/01/76 to 7/31/80
2.3E-50	BVPS Wind - Stability Summary Stability Class - B, 150 Ft Winds Period: 7/01/76 to 7/31/80
2.3E-51	BVPS Wind - Stability Summary Stability Class - C, 150 Ft Winds Period: 7/01/76 to 7/31/80
2.3E-52	BVPS Wind - Stability Summary Stability Class - D, 150 Ft Winds Period: 7/01/76 to 7/31/80
2.3E-53	BVPS Wind - Stability Summary Stability Class - E, 150 Ft Winds Period: 7/01/76 to 7/31/80
2.3E-54	BVPS Wind - Stability Summary Stability Class - F, 150 Ft Winds Period: 7/01/76 to 7/31/80
2.3E-55	BVPS Wind - Stability Summary Stability Class - G, 150 Ft Winds Period: 7/01/76 to 7/31/80
2.3E-56	BVPS Wind - Stability Summary Stability Class - All, 150 Ft Winds Period: 7/01/76 to 7/31/80
2.3E-57	BVPS Wind - Stability Summary Stability Class - A, 150 Ft Winds Period: 8/01/76 to 8/31/80
2.3E-58	BVPS Wind - Stability Summary Stability Class - B, 150 Ft Winds Period: 8/01/76 to 8/31/80
2.3E-59	BVPS Wind - Stability Summary Stability Class - C, 150 Ft Winds Period: 8/01/76 to 8/31/80
2.3E-60	BVPS Wind - Stability Summary Stability Class - D, 150 Ft Winds Period: 8/01/76 to 8/31/80
2.3E-61	BVPS Wind - Stability Summary Stability Class - E, 150 Ft Winds Period: 8/01/76 to 8/31/80
2.3E-62	BVPS Wind - Stability Summary Stability Class - F, 150 Ft Winds Period: 8/01/76 to 8/31/80
2.3E-63	BVPS Wind - Stability Summary Stability Class - G, 150 Ft Winds Period: 8/01/76 to 8/31/80



## LIST OF TABLES (Cont)

<u>Table Number</u>	<u>Title</u>
2.3E-64	BVPS Wind - Stability Summary Stability Class - All, 150 Ft Winds Period: 8/01/76 to 8/31/80
2.3E-65	BVPS Wind - Stability Summary Stability Class - A, 150 Ft Winds Period: 9/01/76 to 9/30/80
2.3E-66	BVPS Wind - Stability Summary Stability Class - B, 150 Ft Winds Period: 9/01/76 to 9/30/80
2.3E-67	BVPS Wind - Stability Summary Stability Class - C, 150 Ft Winds Period: 9/01/76 to 9/30/80
2.3E-68	BVPS Wind - Stability Summary Stability Class - D, 150 Ft Winds Period: 9/01/76 to 9/30/80
2.3E-69	BVPS Wind - Stability Summary Stability Class - E, 150 Ft Winds Period: 9/01/76 to 9/30/80
2.3E-70	BVPS Wind - Stability Summary Stability Class - F, 150 Ft Winds Period: 9/01/76 to 9/30/80
2.3E-71	BVPS Wind - Stability Summary Stability Class - G, 150 Ft Winds Period: 9/01/76 to 9/30/80
2.3E-72	BVPS Wind - Stability Summary Stability Class - All, 150 Ft Winds Period: 9/01/76 to 9/30/80
2.3E-73	BVPS Wind - Stability Summary Stability Class - A, 150 Ft Winds Period: 10/01/76 to 10/31/80
2.3E-74	BVPS Wind - Stability Summary Stability Class - B, 150 Ft Winds Period: 10/01/76 to 10/31/80
2.3E-75	BVPS Wind - Stability Summary Stability Class - C, 150 Ft Winds Period: 10/01/76 to 10/31/80
2.3E-76	BVPS Wind - Stability Summary Stability Class - D, 150 Ft Winds Period: 10/01/76 to 10/31/80
2.3E-77	BVPS Wind - Stability Summary Stability Class - E, 150 Ft Winds Period: 10/01/76 to 10/31/80
2.3E-78	BVPS Wind - Stability Summary Stability Class - F, 150 Ft Winds Period: 10/01/76 to 10/31/80
2.3E-79	BVPS Wind - Stability Summary Stability Class - G, 150 Ft Winds Period: 10/01/76 to 10/31/80

## LIST OF TABLES (Cont)

<u>Table Number</u>	<u>Title</u>
2.3E-80	BVPS Wind - Stability Summary Stability Class - All, 150 Ft Winds Period: 10/10/76 to 10/31/80
2.3E-81	BVPS Wind - Stability Summary Stability Class - A, 150 Ft Winds Period: 11/01/76 to 11/30/80
2.3E-82	BVPS Wind - Stability Summary Stability Class - B, 150 Ft Winds Period: 11/01/76 to 11/30/80
2.3E-83	BVPS Wind - Stability Summary Stability Class - C, 150 Ft Winds Period: 11/01/76 to 11/30/80
2.3E-84	BVPS Wind - Stability Summary Stability Class - D, 150 Ft Winds Period: 11/01/76 to 11/30/80
2.3E-85	BVPS Wind - Stability Summary Stability Class - E, 150 Ft Winds Period: 11/01/76 to 11/30/80
2.3E-86	BVPS Wind - Stability Summary Stability Class - F, 150 Ft Winds Period: 11/01/76 to 11/30/80
2.3E-87	BVPS Wind - Stability Summary Stability Class - G, 150 Ft Winds Period: 11/01/76 to 11/30/80
2.3E-88	BVPS Wind - Stability Summary Stability Class - All, 150 Ft Winds Period: 11/01/76 to 11/30/80
2.3E-89	BVPS Wind - Stability Summary Stability Class - A, 150 Ft Winds Period: 12/01/76 to 12/31/80
2.3E-90	BVPS Wind - Stability Summary Stability Class - B, 150 Ft Winds Period: 12/01/76 to 12/31/80
2.3E-91	BVPS Wind - Stability Summary Stability Class - C, 150 Ft Winds Period: 12/01/76 to 12/31/80
2.3E-92	BVPS Wind - Stability Summary Stability Class - D, 150 Ft Winds Period: 12/01/76 to 12/31/80
2.3E-93	BVPS Wind - Stability Summary Stability Class - E, 150 Ft Winds Period: 12/01/76 to 12/31/80
2.3E-94	BVPS Wind - Stability Summary Stability Class - F, 150 Ft Winds Period: 12/01/76 to 12/31/80
2.3E-95	BVPS Wind - Stability Summary Stability Class - G, 150 Ft Winds Period: 12/01/76 to 12/31/80

## LIST OF TABLES (Cont)

<u>Table Number</u>	<u>Title</u>
2.3E-96	BVPS Wind - Stability Summary Stability Class - All, 150 Ft Winds Period: 12/01/76 to 12/31/80
2.3E-97	BVPS Wind - Stability Summary Stability Class - A, 150 Ft Winds Period: 1/01/76 to 12/31/80
2.3E-98	BVPS Wind - Stability Summary Stability Class - B, 150 Ft Winds Period: 1/01/76 to 12/31/80
2.3E-99	BVPS Wind - Stability Summary Stability Class - C, 150 Ft Winds Period: 1/01/76 to 12/31/80
2.3E-100	BVPS Wind - Stability Summary Stability Class - D, 150 Ft Winds Period: 1/01/76 to 12/31/80
2.3E-101	BVPS Wind - Stability Summary Stability Class - E, 150 Ft Winds Period: 1/01/76 to 12/31/80
2.3E-102	BVPS Wind - Stability Summary Stability Class - F, 150 Ft Winds Period: 1/01/76 to 12/31/80
2.3E-103	BVPS Wind - Stability Summary Stability Class - G, 150 Ft Winds Period: 1/01/76 to 12/31/80
2.3E-104	BVPS Wind - Stability Summary Stability Class - All, 150 Ft Winds Period: 1/01/76 to 12/31/80

TABLES 2.3E-1 thru 2.3E-104 - BVPS WIND-STABILITY SUMMARIES

TABLE 2.3E-1

BVPS WIND - STABILITY SUMMARY  
 STABILITY CLASS - A, 150 Ft Winds  
 PERIOD: 1/01/76 TO 1/31/80

Number of Hourly Observations

Winds From	Wind Speed (mph)						Total
	<u>1-3</u>	<u>4-7</u>	<u>8-12</u>	<u>13-18</u>	<u>19-24</u>	<u>25+</u>	
N	0	1	1	0	0	0	2
NNE	0	1	0	0	0	0	1
NE	1	4	1	0	0	0	6
ENE	0	3	2	1	0	0	6
E	0	3	3	0	0	0	6
ESE	0	1	0	0	0	0	1
SE	0	2	2	0	0	0	4
SSE	0	2	0	0	0	0	2
S	0	0	0	0	0	0	0
SSW	0	2	0	0	0	0	2
SW	0	3	2	0	0	0	5
WSW	0	4	2	6	0	0	12
W	0	3	8	17	3	2	33
WNW	0	3	4	6	1	0	14
NW	0	0	2	0	0	0	2
NNW	0	0	0	0	0	0	0
Total	<u>1</u>	<u>32</u>	<u>27</u>	<u>30</u>	<u>4</u>	<u>2</u>	<u>96</u>

Number of Calm Hours - 3  
 Number of Variable Directions - 0  
 Total Number of Observations - 99

TABLE 2.3E-2

BVPS WIND - STABILITY SUMMARY  
 STABILITY CLASS - B, 150 Ft Winds  
 PERIOD: 1/01/76 TO 1/31/80

Number of Hourly Observations

Winds From	Wind Speed (mph)						Total
	1-3	4-7	8-12	13-18	19-24	25+	
N	0	0	0	0	0	0	0
NNE	0	0	0	0	0	0	0
NE	0	1	0	0	0	0	1
ENE	0	0	0	0	0	0	0
E	0	0	0	0	0	0	0
ESE	0	1	0	0	0	0	1
SE	0	0	0	0	0	0	0
SSE	0	0	0	0	0	0	0
S	0	1	1	0	0	0	2
SSW	0	1	1	0	0	0	2
SW	0	0	3	0	1	0	4
WSW	0	3	6	7	1	0	17
W	0	2	3	4	4	0	13
WNW	0	0	2	1	0	0	3
NW	0	0	0	1	2	0	3
NNW	0	0	2	0	0	0	2
Total	0	9	18	13	8	0	48

Number of Calm Hours - 0  
 Number of Variable Directions - 0  
 Total Number of Observations - 48

TABLE 2.3E-3

BVPS WIND - STABILITY SUMMARY  
 STABILITY CLASS - C, 150 Ft Winds  
 PERIOD: 1/01/76 TO 1/31/80

Number of Hourly Observations

Winds From	Wind Speed (mph)						Total
	1-3	4-7	8-12	13-18	19-24	25+	
N	0	0	0	0	0	0	0
NNE	0	0	0	0	0	0	0
NE	0	2	0	0	0	0	2
ENE	1	1	4	0	0	0	6
E	0	4	0	0	0	0	4
ESE	0	1	0	0	0	0	1
SE	0	0	0	0	0	0	0
SSE	0	2	0	0	0	0	2
S	1	0	1	0	0	0	2
SSW	0	0	0	1	0	0	1
SW	0	1	2	1	1	0	5
WSW	1	2	4	9	0	0	16
W	0	3	12	7	3	1	26
WNW	0	2	2	4	1	0	9
NW	0	1	0	1	0	0	2
NNW	0	0	0	0	0	0	0
Total	3	19	25	23	5	1	76

Number of Calm Hours - 0  
 Number of Variable Directions - 0  
 Total Number of Observations - 76

TABLE 2.3E-4

BVPS WIND - STABILITY SUMMARY  
 STABILITY CLASS - D, 150 Ft Winds  
 PERIOD: 1/01/76 TO 1/31/80

Number of Hourly Observations

Winds From	Wind Speed (mph)						Total
	1-3	4-7	8-12	13-18	19-24	25+	
N	2	39	8	0	0	0	49
NNE	6	30	6	0	0	0	42
NE	28	47	42	7	0	0	124
ENE	24	69	8	1	0	0	102
E	15	15	5	2	0	0	37
ESE	10	13	1	0	0	0	24
SE	4	10	0	0	0	0	14
SSE	5	10	1	0	0	0	16
S	9	22	5	0	0	0	36
SSW	10	21	18	3	0	0	52
SW	5	55	88	9	9	4	170
WSW	5	46	211	108	20	4	394
W	3	33	193	197	35	1	462
WNW	4	54	65	40	6	0	169
NW	6	53	46	5	0	0	110
NNW	2	32	7	0	0	0	41
Total	138	549	704	372	70	9	1842

Number of Calm Hours - 0  
 Number of Variable Directions - 0  
 Total Number of Observations - 1842

TABLE 2.3E-5

BVPS WIND - STABILITY SUMMARY  
 STABILITY CLASS - E, 150 Ft Winds  
 PERIOD: 1/01/76 TO 1/31/80

Number of Hourly Observations

Winds From	Wind Speed (mph)						Total
	1-3	4-7	8-12	13-18	19-24	25+	
N	5	5	1	0	0	0	11
NNE	13	7	0	0	0	0	20
NE	56	40	11	7	0	0	114
ENE	20	48	12	1	0	0	81
E	13	10	9	3	0	0	35
ESE	9	4	1	0	0	0	14
SE	8	7	0	0	0	0	15
SSE	5	9	4	0	0	0	18
S	9	14	5	1	0	0	29
SSW	7	20	12	3	0	1	43
SW	4	47	29	3	1	0	84
WSW	3	18	31	16	7	1	76
W	3	10	14	19	7	3	56
WNW	1	9	4	1	0	0	15
NW	6	9	0	0	0	0	15
NNW	5	10	1	0	0	0	16
Total	167	267	134	54	15	5	642

Number of Calm Hours - 1  
 Number of Variable Directions - 0  
 Total Number of Observations - 643



TABLE 2.3E-6

BVPS WIND - STABILITY SUMMARY  
 STABILITY CLASS - F, 150 Ft Winds  
 PERIOD: 1/01/76 TO 1/31/80

Number of Hourly Observations

Winds From	Wind Speed (mph)						Total
	1-3	4-7	8-12	13-18	19-24	25+	
N	7	3	0	0	0	0	10
NNE	18	8	0	0	0	0	26
NE	19	35	1	0	0	0	55
ENE	9	10	0	0	0	0	19
E	7	1	0	0	0	0	8
ESE	4	0	0	0	0	0	4
SE	3	2	0	0	0	0	5
SSE	1	0	0	0	0	0	1
S	7	6	1	0	0	0	14
SSW	4	7	1	0	0	0	12
SW	5	18	8	1	0	0	32
WSW	2	6	3	1	0	0	12
W	5	3	0	0	1	0	9
WNW	2	1	0	0	0	0	3
NW	2	2	0	0	0	0	4
NNW	2	0	0	0	0	0	2
Total	97	102	14	2	1	0	216

Number of Calm Hours - 1  
 Number of Variable Directions - 0  
 Total Number of Observations - 217

TABLE 2.3E-7

BVPS WIND - STABILITY SUMMARY  
 STABILITY CLASS - G, 150 Ft Winds  
 PERIOD: 1/01/76 TO 1/31/80

## Number of Hourly Observations

Winds From	Wind Speed (mph)						Total
	1-3	4-7	8-12	13-18	19-24	25+	
N	7	0	0	0	0	0	7
NNE	21	13	0	0	0	0	34
NE	25	21	0	0	0	0	46
ENE	5	6	0	0	0	0	11
E	2	3	0	0	0	0	5
ESE	1	0	0	0	0	0	1
SE	1	3	0	0	0	0	4
SSE	1	0	0	0	0	0	1
S	6	3	0	0	0	0	9
SSW	7	8	2	0	0	0	17
SW	8	23	3	0	0	0	34
WSW	5	2	2	0	0	0	9
W	7	6	0	0	0	0	13
WNW	0	2	0	0	0	0	2
NW	1	0	0	0	0	0	1
NNW	1	0	0	0	0	0	1
Total	98	90	7	0	0	0	195

Number of Calm Hours - 1  
 Number of Variable Directions - 0  
 Total Number of Observations - 196

TABLE 2.3E-8

BVPS WIND - STABILITY SUMMARY  
 STABILITY CLASS - ALL, 150 Ft Winds  
 PERIOD: 1/01/76 TO 1/31/80

Number of Hourly Observations

Winds From	Wind Speed (mph)						Total
	1-3	4-7	8-12	13-18	19-24	25+	
N	21	48	10	0	0	0	79
NNE	58	59	6	0	0	0	123
NE	129	150	55	14	0	0	348
ENE	59	137	26	3	0	0	225
E	37	36	17	5	0	0	95
ESE	24	20	2	0	0	0	46
SE	16	24	2	0	0	0	42
SSE	12	23	5	0	0	0	40
S	32	46	13	1	0	0	92
SSW	28	59	34	7	0	1	129
SW	22	147	135	14	12	4	334
WSW	16	81	259	147	28	5	536
W	18	60	230	244	53	7	612
WNW	7	71	77	52	8	0	215
NW	15	65	48	7	2	0	137
NNW	10	42	10	0	0	0	62
Total	504	1068	929	494	103	17	3115

Number of Calm Hours - 6  
 Number of Variable Directions - 0  
 Total Number of Observations - 3121

TABLE 2.3E-9

BVPS WIND - STABILITY SUMMARY  
 STABILITY CLASS - A, 150 Ft Winds  
 PERIOD: 2/01/76 TO 2/29/80

Number of Hourly Observations

Winds From	Wind Speed (mph)						Total
	1-3	4-7	8-12	13-18	19-24	25+	
N	0	2	6	0	0	0	8
NNE	0	2	1	0	0	0	3
NE	2	7	4	0	0	0	13
ENE	0	4	8	0	0	0	12
E	2	2	4	0	0	0	8
ESE	0	2	1	0	0	0	3
SE	1	2	0	0	0	0	3
SSE	1	1	0	0	0	0	2
S	0	3	1	0	0	0	4
SSW	0	2	0	0	0	0	2
SW	0	4	1	0	0	0	5
WSW	0	2	10	3	1	0	16
W	0	9	33	11	5	0	58
WNW	0	2	23	9	2	0	36
NW	0	1	8	3	0	0	12
NNW	0	0	2	0	0	0	2
Total	6	45	102	26	8	0	187

Number of Calm Hours - 0  
 Number of Variable Directions - 0  
 Total Number of Observations - 187

TABLE 2.3E-10

BVPS WIND - STABILITY SUMMARY  
 STABILITY CLASS - B, 150 Ft Winds  
 PERIOD: 2/01/76 TO 2/29/80

Number of Hourly Observations

Winds From	Wind Speed (mph)						Total
	1-3	4-7	8-12	13-18	19-24	25+	
N	0	3	1	0	0	0	4
NNE	0	0	0	0	0	0	0
NE	0	6	2	0	0	0	8
ENE	0	2	2	0	0	0	4
E	0	1	0	0	0	0	1
ESE	0	0	0	0	0	0	0
SE	0	1	0	0	0	0	1
SSE	0	0	0	0	0	0	0
S	0	1	0	0	0	0	1
SSW	0	0	0	0	0	0	0
SW	1	0	2	1	0	0	4
WSW	0	4	9	3	0	0	16
W	0	4	7	6	1	0	18
WNW	0	0	6	5	0	0	11
NW	0	3	7	1	0	0	11
NNW	0	1	1	0	0	0	2
Total	1	26	37	16	1	0	81

Number of Calm Hours - 0  
 Number of Variable Directions - 0  
 Total Number of Observations - 81

TABLE 2.3E-11

BVPS WIND - STABILITY SUMMARY  
 STABILITY CLASS - C, 150 Ft Winds  
 PERIOD: 2/01/76 TO 2/29/80

Number of Hourly Observations

Winds From	Wind Speed (mph)						Total
	1-3	4-7	8-12	13-18	19-24	25+	
N	0	3	2	0	0	0	5
NNE	0	4	1	0	0	0	5
NE	0	4	3	0	0	0	7
ENE	1	4	3	0	0	0	8
E	0	1	0	0	0	0	1
ESE	0	1	0	0	0	0	1
SE	0	0	0	0	0	0	0
SSE	0	2	0	0	0	0	2
S	0	0	1	0	0	0	1
SSW	0	1	2	0	0	0	3
SW	0	0	4	5	0	0	9
WSW	0	6	2	3	0	0	11
W	0	4	10	4	3	0	21
WNW	0	3	11	2	1	0	17
NW	1	4	3	0	0	0	8
NNW	1	2	1	0	0	0	4
Total	3	39	43	14	4	0	103

Number of Calm Hours - 0  
 Number of Variable Directions - 0  
 Total Number of Observations - 103

TABLE 2.3E-12

BVPS WIND - STABILITY SUMMARY  
 STABILITY CLASS - D, 150 Ft Winds  
 PERIOD: 2/01/76 TO 2/29/80

Number of Hourly Observations

Winds From	Wind Speed (mph)						Total
	1-3	4-7	8-12	13-18	19-24	25+	
N	9	37	28	2	0	0	76
NNE	5	23	18	0	0	0	46
NE	12	31	16	6	3	0	68
ENE	9	41	33	0	0	0	83
E	10	11	4	0	0	0	25
ESE	4	2	0	0	0	0	6
SE	3	4	1	2	0	0	10
SSE	2	2	0	0	0	0	4
S	2	8	1	0	0	0	11
SSW	0	9	16	4	0	0	29
SW	4	33	60	30	1	0	128
WSW	8	58	70	46	7	0	189
W	8	31	115	82	21	2	259
WNW	11	66	112	37	4	1	231
NW	14	58	55	2	0	0	129
NNW	16	33	16	1	0	0	66
Total	117	447	545	212	36	3	1360

Number of Calm Hours - 0  
 Number of Variable Directions - 0  
 Total Number of Observations - 1360

TABLE 2.3E-13

BVPS WIND - STABILITY SUMMARY  
 STABILITY CLASS - E, 150 Ft Winds  
 PERIOD: 2/01/76 TO 2/29/80

Number of Hourly Observations

Winds From	Wind Speed (mph)						Total
	1-3	4-7	8-12	13-18	19-24	25+	
N	7	10	0	0	0	0	17
NNE	7	14	3	0	0	0	24
NE	20	36	7	9	1	0	73
ENE	13	28	5	0	1	0	47
E	8	4	1	1	0	0	14
ESE	1	2	0	1	0	0	4
SE	2	4	0	0	0	0	6
SSE	7	2	0	0	0	0	9
S	4	4	1	0	0	0	9
SSW	8	14	12	3	0	0	37
SW	6	19	51	12	0	0	88
WSW	6	20	45	23	1	0	95
W	8	13	26	19	1	0	67
WNW	6	16	18	5	1	0	46
NW	0	14	9	0	0	0	23
NNW	5	15	2	0	0	0	22
Total	108	215	180	73	5	0	581

Number of Calm Hours - 4  
 Number of Variable Directions - 0  
 Total Number of Observations - 585



TABLE 2.3E-14

BVPS WIND - STABILITY SUMMARY  
 STABILITY CLASS - F, 150 Ft Winds  
 PERIOD: 2/01/76 TO 2/29/80

Number of Hourly Observations

Winds From	Wind Speed (mph)						Total
	1-3	4-7	8-12	13-18	19-24	25+	
N	11	1	0	0	0	0	12
NNE	14	6	0	0	0	0	20
NE	25	26	1	0	0	0	52
ENE	5	5	2	0	0	0	12
E	4	4	0	0	0	0	8
ESE	3	1	0	0	0	0	4
SE	3	0	0	0	0	0	3
SSE	2	1	1	0	0	0	4
S	1	2	0	0	0	0	3
SSW	5	10	0	0	0	0	15
SW	5	29	16	2	0	0	52
WSW	1	16	13	0	0	0	30
W	1	3	2	1	0	0	7
WNW	2	3	0	0	0	0	5
NW	4	1	2	0	0	0	7
NNW	1	0	0	0	0	0	1
Total	87	108	37	3	0	0	235

Number of Calm Hours - 4  
 Number of Variable Directions - 0  
 Total Number of Observations - 239

TABLE 2.3E-15

BVPS WIND - STABILITY SUMMARY  
 STABILITY CLASS - G, 150 Ft Winds  
 PERIOD: 2/01/76 TO 2/29/80

Number of Hourly Observations

Winds From	Wind Speed (mph)						Total
	1-3	4-7	8-12	13-18	19-24	25+	
N	10	0	0	0	0	0	10
NNE	26	16	1	0	0	0	43
NE	44	41	4	0	0	0	89
ENE	12	7	0	0	0	0	19
E	3	4	0	0	0	0	7
ESE	3	0	1	0	0	0	4
SE	3	2	0	0	0	0	5
SSE	4	0	0	0	0	0	4
S	6	9	0	0	0	0	15
SSW	14	24	0	0	0	0	38
SW	26	44	6	0	0	0	76
WSW	12	25	12	1	0	0	50
W	10	4	0	1	0	0	15
WNW	4	5	0	0	0	0	9
NW	1	0	0	0	0	0	1
NNW	3	0	0	0	0	0	3
Total	181	181	24	2	0	0	388

Number of Calm Hours - 0  
 Number of Variable Directions - 0  
 Total Number of Observations - 388

TABLE 2.3E-16

BVPS WIND - STABILITY SUMMARY  
 STABILITY CLASS - ALL, 150 Ft Winds  
 PERIOD: 2/01/76 TO 2/29/80

Number of Hourly Observations

Winds From	Wind Speed (mph)						Total
	1-3	4-7	8-12	13-18	19-24	25+	
N	37	56	37	2	0	0	132
NNE	52	65	24	0	0	0	141
NE	103	151	37	15	4	0	310
ENE	40	91	53	0	1	0	185
E	27	27	9	1	0	0	64
ESE	11	8	2	1	0	0	22
SE	12	13	1	2	0	0	28
SSE	16	8	1	0	0	0	25
S	13	27	4	0	0	0	44
SSW	27	60	30	7	0	0	124
SW	42	129	140	50	1	0	362
WSW	27	131	161	79	9	0	407
W	27	68	193	124	31	2	445
WNW	23	95	170	58	8	1	355
NW	20	81	84	6	0	0	191
NNW	26	51	22	1	0	0	100
Total	503	1061	968	346	54	3	2935

Number of Calm Hours - 8  
 Number of Variable Directions - 0  
 Total Number of Observations - 2943

TABLE 2.3E-17

BVPS WIND - STABILITY SUMMARY  
 STABILITY CLASS - A, 150 Ft Winds  
 PERIOD: 3/01/76 TO 3/31/80

Number of Hourly Observations

Winds From	Wind Speed (mph)						Total
	1-3	4-7	8-12	13-18	19-24	25+	
N	1	10	8	0	0	0	19
NNE	0	11	11	0	0	0	22
NE	0	3	8	0	0	0	11
ENE	0	4	6	2	0	0	12
E	0	5	4	0	0	0	9
ESE	0	12	7	0	0	0	19
SE	0	14	15	0	0	0	29
SSE	0	8	14	4	0	0	26
S	1	1	5	0	0	0	7
SSW	0	2	6	11	1	0	20
SW	1	4	26	8	3	0	42
WSW	1	9	26	19	0	0	55
W	0	17	41	37	14	0	109
WNW	1	3	19	22	10	0	55
NW	2	4	5	8	1	0	20
NNW	1	6	8	2	0	0	17
Total	8	113	209	113	29	0	472

Number of Calm Hours - 0  
 Number of Variable Directions - 0  
 Total Number of Observations - 472

TABLE 2.3E-18

BVPS WIND - STABILITY SUMMARY  
 STABILITY CLASS - B, 150 Ft Winds  
 PERIOD: 3/01/76 TO 3/31/80

Number of Hourly Observations

Winds From	Wind Speed (mph)						Total
	1-3	4-7	8-12	13-18	19-24	25+	
N	1	1	1	0	0	0	3
NNE	0	4	1	0	0	0	5
NE	0	1	0	0	0	0	1
ENE	0	3	0	0	0	0	3
E	1	2	0	0	0	0	3
ESE	0	0	0	0	0	0	0
SE	0	0	0	1	0	0	1
SSE	0	3	0	0	0	0	3
S	0	0	3	0	0	0	3
SSW	0	0	0	2	0	0	2
SW	1	1	7	2	1	0	12
WSW	1	2	5	2	0	0	10
W	1	1	2	7	1	1	13
WNW	0	2	3	4	0	0	9
NW	0	0	3	0	0	0	3
NNW	0	1	1	0	0	0	2
Total	5	21	26	18	2	1	73

Number of Calm Hours - 0  
 Number of Variable Directions - 0  
 Total Number of Observations - 73

TABLE 2.3E-19

BVPS WIND - STABILITY SUMMARY  
 STABILITY CLASS - C, 150 Ft Winds  
 PERIOD: 3/01/76 TO 3/31/80

Number of Hourly Observations

Winds From	Wind Speed (mph)						Total
	1-3	4-7	8-12	13-18	19-24	25+	
N	0	1	2	0	0	0	3
NNE	1	3	1	0	0	0	5
NE	0	4	3	0	0	0	7
ENE	1	3	0	1	0	0	5
E	0	0	1	0	0	0	1
ESE	0	2	1	0	0	0	3
SE	0	1	1	1	0	0	3
SSE	0	3	1	1	0	0	5
S	0	3	0	0	0	0	3
SSW	0	0	7	3	0	0	10
SW	0	3	9	7	0	0	19
WSW	0	2	8	4	0	0	14
W	1	1	6	11	5	0	24
WNW	1	2	4	8	0	0	15
NW	0	2	2	0	0	0	4
NNW	0	0	2	0	0	0	2
Total	4	30	48	36	5	0	123

Number of Calm Hours - 0  
 Number of Variable Directions - 0  
 Total Number of Observations - 123

TABLE 2.3E-20

BVPS WIND - STABILITY SUMMARY  
 STABILITY CLASS - D, 150 Ft Winds  
 PERIOD: 3/01/76 TO 3/31/80

Number of Hourly Observations

Winds From	Wind Speed (mph)						Total
	1-3	4-7	8-12	13-18	19-24	25+	
N	3	42	16	1	0	0	62
NNE	7	17	15	2	0	0	41
NE	17	20	5	0	0	0	42
ENE	4	38	31	4	0	0	77
E	5	20	21	2	0	0	48
ESE	3	11	9	0	0	0	23
SE	1	6	6	1	0	0	14
SSE	0	3	2	1	0	0	6
S	4	8	11	5	1	0	29
SSW	2	9	23	9	2	1	46
SW	2	14	54	20	3	0	93
WSW	5	21	81	44	15	3	169
W	3	7	92	101	26	2	231
WNW	2	25	66	62	23	0	178
NW	8	30	48	11	1	0	98
NNW	4	29	12	4	0	0	49
Total	70	300	492	267	71	6	1206

Number of Calm Hours - 1  
 Number of Variable Directions - 0  
 Total Number of Observations - 1207

TABLE 2.3E-21

BVPS WIND - STABILITY SUMMARY  
 STABILITY CLASS - E, 150 Ft Winds  
 PERIOD: 3/01/76 TO 3/31/80

Number of Hourly Observations

Winds From	Wind Speed (mph)						Total
	1-3	4-7	8-12	13-18	19-24	25+	
N	10	9	0	0	0	0	19
NNE	5	9	4	0	0	0	18
NE	28	34	8	0	0	0	70
ENE	14	31	34	2	0	0	81
E	10	36	14	0	0	0	60
ESE	8	17	8	0	0	0	33
SE	5	17	6	1	0	0	29
SSE	2	11	4	0	0	0	17
S	6	10	9	4	0	0	29
SSW	8	14	18	3	0	0	43
SW	10	31	48	12	0	0	101
WSW	4	13	26	3	0	0	46
W	2	17	21	15	1	0	56
WNW	2	20	14	2	0	0	38
NW	5	12	5	1	0	0	23
NNW	3	11	1	0	0	0	15
Total	122	292	220	43	1	0	678

Number of Calm Hours - 0  
 Number of Variable Directions - 0  
 Total Number of Observations - 678



TABLE 2.3E-22

BVPS WIND - STABILITY SUMMARY  
 STABILITY CLASS - F, 150 Ft Winds  
 PERIOD: 3/01/76 TO 3/31/80

## Number of Hourly Observations

Winds From	Wind Speed (mph)						Total
	1-3	4-7	8-12	13-18	19-24	25+	
N	7	1	0	0	0	0	8
NNE	16	12	0	0	0	0	28
NE	47	26	1	0	0	0	74
ENE	12	2	1	0	0	1	16
E	3	6	5	0	0	0	14
ESE	3	1	0	0	0	0	4
SE	5	0	0	0	0	0	5
SSE	2	5	2	0	0	0	9
S	6	6	2	0	0	0	14
SSW	14	13	5	0	0	0	32
SW	9	15	9	0	0	0	33
WSW	5	5	7	0	0	0	17
W	5	3	1	1	0	0	10
WNW	2	2	1	0	0	0	5
NW	3	1	1	0	0	0	5
NNW	3	0	0	0	0	0	3
Total	142	98	35	1	0	1	277

Number of Calm Hours - 4  
 Number of Variable Directions - 0  
 Total Number of Observations - 281

TABLE 2.3E-23

BVPS WIND - STABILITY SUMMARY  
 STABILITY CLASS - G, 150 Ft Winds  
 PERIOD: 3/01/76 TO 3/31/80

Number of Hourly Observations

Winds From	Wind Speed (mph)						Total
	1-3	4-7	8-12	13-18	19-24	25+	
N	8	0	0	0	0	0	8
NNE	40	28	0	0	0	0	68
NE	57	57	0	0	0	0	114
ENE	21	13	1	0	0	0	35
E	8	4	0	0	0	0	12
ESE	5	3	0	0	0	0	8
SE	2	3	0	0	0	0	5
SSE	5	3	0	0	0	0	8
S	5	13	0	0	0	0	18
SSW	8	27	0	0	0	0	35
SW	17	23	5	0	0	0	45
WSW	10	7	0	0	0	0	17
W	8	1	0	0	0	0	9
WNW	4	1	0	0	0	0	5
NW	9	1	0	0	0	0	10
NNW	7	1	0	0	0	0	8
Total	214	185	6	0	0	0	405

Number of Calm Hours - 4  
 Number of Variable Directions - 0  
 Total Number of Observations - 405

TABLE 2.3E-24

BVPS WIND - STABILITY SUMMARY  
 STABILITY CLASS - ALL, 150 Ft Winds  
 PERIOD: 3/01/76 TO 3/31/80

Number of Hourly Observations

Winds From	Wind Speed (mph)						Total
	1-3	4-7	8-12	13-18	19-24	25+	
N	30	64	27	1	0	0	122
NNE	69	84	32	2	0	0	187
NE	149	145	25	0	0	0	319
ENE	52	94	73	9	0	1	229
E	27	73	45	2	0	0	147
ESE	19	46	25	0	0	0	90
SE	13	41	28	4	0	0	86
SSE	9	36	23	6	0	0	74
S	22	41	30	9	1	0	103
SSW	32	65	59	28	3	1	188
SW	40	91	158	49	7	0	345
WSW	26	59	153	72	15	3	328
W	20	47	163	172	47	3	452
WNW	12	55	107	98	33	0	305
NW	27	50	64	20	2	0	163
NNW	18	48	24	6	0	0	96
Total	565	1039	1036	478	108	8	3234

Number of Calm Hours - 5  
 Number of Variable Directions - 0  
 Total Number of Observations - 3239

TABLE 2.3E-25

BVPS WIND - STABILITY SUMMARY  
 STABILITY CLASS - A, 150 Ft Winds  
 PERIOD: 4/01/76 TO 4/30/80

Number of Hourly Observations

Winds From	Wind Speed (mph)						Total
	1-3	4-7	8-12	13-18	19-24	25+	
N	2	36	33	9	0	0	80
NNE	0	15	16	2	0	0	33
NE	0	8	9	0	0	0	17
ENE	0	10	7	7	0	0	24
E	1	6	5	5	0	0	17
ESE	0	3	3	0	0	0	6
SE	0	2	1	1	0	0	4
SSE	0	2	0	1	0	0	3
S	0	4	5	0	0	0	9
SSW	1	6	4	3	0	0	14
SW	2	12	16	15	0	0	45
WSW	3	25	39	19	8	1	95
W	2	27	50	31	11	3	124
WNW	1	16	35	39	9	0	100
NW	5	18	27	14	0	0	64
NNW	3	6	25	7	0	0	41
Total	20	196	275	153	28	4	676

Number of Calm Hours - 0  
 Number of Variable Directions - 0  
 Total Number of Observations - 676

TABLE 2.3E-26

BVPS WIND - STABILITY SUMMARY  
 STABILITY CLASS - B, 150 Ft Winds  
 PERIOD: 4/01/76 TO 4/30/80

Number of Hourly Observations

Winds From	Wind Speed (mph)						Total
	1-3	4-7	8-12	13-18	19-24	25+	
N	1	5	3	0	0	0	9
NNE	1	3	1	0	0	0	5
NE	0	4	0	0	0	0	4
ENE	0	5	1	0	0	0	6
E	0	2	1	2	0	0	5
ESE	0	0	1	0	0	0	1
SE	2	1	0	0	0	0	3
SSE	0	0	0	0	0	0	0
S	0	0	0	1	0	0	1
SSW	0	1	1	2	0	0	4
SW	0	2	3	3	0	0	8
WSW	1	2	4	5	0	0	12
W	0	3	4	6	3	0	16
WNW	0	1	10	0	2	0	13
NW	2	4	3	1	0	0	10
NNW	1	2	5	0	0	0	8
Total	8	35	37	20	5	0	105

Number of Calm Hours - 0  
 Number of Variable Directions - 0  
 Total Number of Observations - 105

TABLE 2.3E-27

BVPS WIND - STABILITY SUMMARY  
 STABILITY CLASS - C, 150 Ft Winds  
 PERIOD: 4/01/76 TO 4/30/80

Number of Hourly Observations

Winds From	Wind Speed (mph)						Total
	1-3	4-7	8-12	13-18	19-24	25+	
N	1	2	5	1	0	0	9
NNE	1	3	2	0	0	0	6
NE	0	4	0	0	0	0	4
ENE	0	1	1	1	0	0	3
E	0	0	3	0	0	0	3
ESE	0	0	1	0	0	0	1
SE	0	0	0	0	0	0	0
SSE	0	0	1	0	0	0	1
S	0	0	1	0	0	0	1
SSW	0	2	1	0	0	0	3
SW	3	1	2	2	0	0	8
WSW	0	0	4	3	1	0	8
W	1	5	6	5	1	0	18
WNW	0	2	11	3	0	0	16
NW	0	5	9	0	0	0	14
NNW	2	3	9	0	0	0	14
Total	8	28	56	15	2	0	109

Number of Calm Hours - 0  
 Number of Variable Directions - 0  
 Total Number of Observations - 109

TABLE 2.3E-28

BVPS WIND - STABILITY SUMMARY  
 STABILITY CLASS - D, 150 Ft Winds  
 PERIOD: 4/01/76 TO 4/30/80

Number of Hourly Observations

Winds From	Wind Speed (mph)						Total
	1-3	4-7	8-12	13-18	19-24	25+	
N	6	26	30	0	0	0	62
NNE	3	23	9	0	0	0	35
NE	8	17	3	0	0	0	28
ENE	5	22	18	1	0	0	46
E	2	14	20	3	0	0	39
ESE	1	4	9	3	0	0	17
SE	1	7	5	1	0	0	14
SSE	0	2	3	0	0	0	5
S	3	6	3	0	0	0	12
SSW	9	9	16	0	0	0	34
SW	8	21	36	23	1	0	89
WSW	5	15	51	39	8	5	123
W	11	15	36	36	6	3	107
WNW	2	33	65	33	5	0	138
NW	4	50	48	6	0	0	108
NNW	3	20	15	0	0	0	38
Total	71	284	367	145	20	8	895

Number of Calm Hours - 0  
 Number of Variable Directions - 0  
 Total Number of Observations - 895

TABLE 2.3E-29

BVPS WIND - STABILITY SUMMARY  
 STABILITY CLASS - E, 150 Ft Winds  
 PERIOD: 4/01/76 TO 4/30/80

Number of Hourly Observations

Winds From	Wind Speed (mph)						Total
	1-3	4-7	8-12	13-18	19-24	25+	
N	4	20	6	0	0	0	30
NNE	7	15	3	0	0	0	25
NE	22	34	2	3	0	0	61
ENE	18	36	19	4	0	0	77
E	8	16	8	1	0	0	33
ESE	2	13	5	0	0	0	20
SE	2	4	3	0	0	0	9
SSE	4	4	1	2	0	0	11
S	1	10	2	1	0	0	14
SSW	6	17	10	1	0	0	34
SW	13	21	18	8	0	0	60
WSW	2	11	13	5	3	1	35
W	5	15	12	13	2	0	47
WNW	4	16	21	2	2	0	45
NW	6	14	3	1	0	0	24
NNW	7	14	1	0	0	0	22
Total	111	260	127	41	7	1	547

Number of Calm Hours - 0  
 Number of Variable Directions - 0  
 Total Number of Observations - 547



TABLE 2.3E-30

BVPS WIND - STABILITY SUMMARY  
 STABILITY CLASS - F, 150 Ft Winds  
 PERIOD: 4/01/76 TO 4/30/80

Number of Hourly Observations

Winds From	Wind Speed (mph)						Total
	1-3	4-7	8-12	13-18	19-24	25+	
N	8	3	1	0	0	0	12
NNE	15	12	0	0	0	0	27
NE	37	39	2	0	0	0	78
ENE	18	11	1	0	0	0	30
E	9	5	0	0	0	0	14
ESE	2	3	0	0	0	0	5
SE	2	1	0	0	0	0	3
SSE	5	3	0	0	0	0	8
S	9	9	1	0	0	0	19
SSW	7	18	1	0	0	0	26
SW	17	18	9	0	0	0	44
WSW	11	15	3	0	0	0	29
W	4	7	2	0	0	0	13
WNW	5	8	1	0	0	0	14
NW	7	1	0	0	0	0	8
NNW	4	2	0	0	0	0	6
Total	160	155	21	0	0	0	336

Number of Calm Hours - 2  
 Number of Variable Directions - 0  
 Total Number of Observations - 338

TABLE 2.3E-31

BVPS WIND - STABILITY SUMMARY  
 STABILITY CLASS - G, 150 Ft Winds  
 PERIOD: 4/01/76 TO 4/30/80

## Number of Hourly Observations

Winds From	Wind Speed (mph)						Total
	1-3	4-7	8-12	13-18	19-24	25+	
N	15	2	0	0	0	0	17
NNE	47	21	0	0	0	0	68
NE	75	44	1	0	0	0	120
ENE	19	18	0	0	0	0	37
E	10	0	0	0	0	0	10
ESE	4	1	0	0	0	0	5
SE	5	2	0	0	0	0	7
SSE	5	5	0	0	0	0	10
S	10	10	0	0	0	0	20
SSW	30	47	2	0	0	0	79
SW	47	54	8	0	0	0	109
WSW	22	19	0	0	0	0	41
W	20	6	0	0	0	0	26
WNW	5	0	0	0	0	0	5
NW	12	2	0	0	0	0	14
NNW	13	2	0	0	0	0	15
Total	339	233	11	0	0	0	583

Number of Calm Hours - 2  
 Number of Variable Directions - 0  
 Total Number of Observations - 585

TABLE 2.3E-32

BVPS WIND - STABILITY SUMMARY  
 STABILITY CLASS - ALL, 150 Ft Winds  
 PERIOD: 4/01/76 TO 4/30/80

Number of Hourly Observations

Winds From	Wind Speed (mph)						Total
	1-3	4-7	8-12	13-18	19-24	25+	
N	37	94	78	10	0	0	219
NNE	74	92	31	2	0	0	199
NE	142	150	17	3	0	0	312
ENE	60	103	47	13	0	0	223
E	30	43	37	11	0	0	121
ESE	9	24	19	3	0	0	55
SE	12	17	9	2	0	0	40
SSE	14	16	5	3	0	0	38
S	23	39	12	2	0	0	76
SSW	53	100	35	6	0	0	194
SW	90	129	92	51	1	0	363
WSW	44	87	114	71	20	7	343
W	43	78	110	91	23	6	351
WNW	17	76	143	77	18	0	331
NW	36	94	90	22	0	0	242
NNW	33	49	55	7	0	0	144
Total	717	1191	894	374	62	13	3251

Number of Calm Hours - 4  
 Number of Variable Directions - 0  
 Total Number of Observations - 3255

TABLE 2.3E-33

BVPS WIND - STABILITY SUMMARY  
 STABILITY CLASS - A, 150 Ft Winds  
 PERIOD: 5/01/76 TO 5/31/80

Number of Hourly Observations

Winds From	Wind Speed (mph)						Total
	1-3	4-7	8-12	13-18	19-24	25+	
N	0	33	33	7	0	0	73
NNE	3	21	19	6	0	0	49
NE	0	24	12	1	0	0	37
ENE	0	12	11	0	0	0	23
E	1	11	8	3	0	0	23
ESE	2	12	3	0	0	0	17
SE	1	14	10	0	0	0	25
SSE	0	11	11	0	0	0	22
S	2	12	19	2	0	0	35
SSW	1	12	19	4	0	0	36
SW	0	25	36	12	2	0	75
WSW	2	25	39	9	3	0	78
W	2	32	41	25	0	1	101
WNW	5	17	43	18	3	0	86
NW	1	14	23	11	0	0	49
NNW	1	16	22	9	0	0	48
Total	21	291	349	107	8	1	777

Number of Calm Hours - 1  
 Number of Variable Directions - 0  
 Total Number of Observations - 778

TABLE 2.3E-34

BVPS WIND - STABILITY SUMMARY  
 STABILITY CLASS - B, 150 Ft Winds  
 PERIOD: 5/01/76 TO 5/31/80

Number of Hourly Observations

Winds From	Wind Speed (mph)						Total
	1-3	4-7	8-12	13-18	19-24	25+	
N	0	1	1	0	0	0	2
NNE	0	2	1	0	0	0	3
NE	0	5	0	0	0	0	5
ENE	0	2	1	0	0	0	3
E	0	2	0	1	0	0	3
ESE	0	1	0	0	0	0	1
SE	0	1	0	0	0	0	1
SSE	1	0	0	0	0	0	1
S	0	2	0	0	0	0	2
SSW	0	1	4	0	0	0	5
SW	1	6	0	1	0	0	8
WSW	1	5	10	2	0	0	18
W	2	4	3	5	0	0	14
WNW	0	6	5	3	0	0	14
NW	0	1	3	0	0	0	4
NNW	1	7	4	0	0	0	12
Total	6	46	32	12	0	0	96

Number of Calm Hours - 0  
 Number of Variable Directions - 0  
 Total Number of Observations - 96

TABLE 2.3E-35

BVPS WIND - STABILITY SUMMARY  
 STABILITY CLASS - C, 150 Ft Winds  
 PERIOD: 5/01/76 TO 5/31/80

## Number of Hourly Observations

Winds From	Wind Speed (mph)						Total
	1-3	4-7	8-12	13-18	19-24	25+	
N	1	3	2	1	0	0	7
NNE	1	4	1	0	0	0	6
NE	3	3	0	0	0	0	6
ENE	1	2	0	0	0	0	3
E	0	7	2	1	0	0	10
ESE	0	0	0	0	0	0	0
SE	0	1	0	0	0	0	1
SSE	0	1	0	0	0	0	1
S	0	2	0	0	0	0	2
SSW	0	6	1	1	0	0	8
SW	0	8	5	0	0	0	13
WSW	3	10	5	2	0	0	20
W	0	6	1	7	1	0	15
WNW	1	8	7	1	0	0	17
NW	0	5	4	0	0	0	9
NNW	1	6	2	0	0	0	9
Total	11	72	30	13	1	0	127

Number of Calm Hours - 1  
 Number of Variable Directions - 0  
 Total Number of Observations - 128

TABLE 2.3E-36

BVPS WIND - STABILITY SUMMARY  
 STABILITY CLASS - D, 150 Ft Winds  
 PERIOD: 5/01/76 TO 5/31/80

Number of Hourly Observations

Winds From	Wind Speed (mph)						Total
	1-3	4-7	8-12	13-18	19-24	25+	
N	8	21	15	0	0	0	44
NNE	17	17	9	0	0	0	43
NE	20	24	3	0	0	0	47
ENE	13	20	12	1	0	0	46
E	6	22	4	1	0	0	33
ESE	7	18	6	0	0	0	31
SE	3	7	0	0	0	0	10
SSE	2	7	5	0	0	0	14
S	5	13	6	0	0	0	24
SSW	3	29	8	3	0	0	43
SW	10	43	52	4	0	0	109
WSW	11	27	40	4	2	0	84
W	17	21	29	11	3	0	81
WNW	4	34	25	3	0	0	66
NW	5	29	18	1	0	0	53
NNW	3	12	15	0	0	0	30
Total	134	344	247	28	5	0	758

Number of Calm Hours - 1  
 Number of Variable Directions - 0  
 Total Number of Observations - 759

TABLE 2.3E-37

BVPS WIND - STABILITY SUMMARY  
 STABILITY CLASS - E, 150 Ft Winds  
 PERIOD: 5/01/76 TO 5/31/80

Number of Hourly Observations

Winds From	Wind Speed (mph)						Total
	1-3	4-7	8-12	13-18	19-24	25+	
N	6	13	4	0	0	0	23
NNE	17	9	4	0	0	0	30
NE	42	28	5	0	0	0	75
ENE	29	29	7	0	0	0	65
E	17	19	3	0	0	0	39
ESE	8	12	2	0	0	0	22
SE	6	7	3	0	0	0	16
SSE	9	9	2	0	0	0	20
S	11	12	3	0	0	0	26
SSW	16	34	14	0	0	0	64
SW	22	27	16	1	0	0	66
WSW	14	11	16	1	0	0	42
W	9	12	4	2	0	0	27
WNW	5	17	4	0	0	0	26
NW	6	5	1	0	0	0	12
NNW	6	11	0	0	0	0	17
Total	223	255	88	4	0	0	570

Number of Calm Hours - 2  
 Number of Variable Directions - 0  
 Total Number of Observations - 572



TABLE 2.3E-38

BVPS WIND - STABILITY SUMMARY  
 STABILITY CLASS - F, 150 Ft Winds  
 PERIOD: 5/01/76 TO 5/31/80

Number of Hourly Observations

Winds From	Wind Speed (mph)						Total
	1-3	4-7	8-12	13-18	19-24	25+	
N	6	3	0	0	0	0	9
NNE	29	6	1	0	0	0	36
NE	62	24	1	0	0	0	87
ENE	28	12	1	0	0	0	41
E	7	10	0	0	0	0	17
ESE	4	3	0	0	0	0	7
SE	9	4	0	1	0	0	14
SSE	6	2	0	0	0	0	8
S	9	5	1	0	0	0	15
SSW	14	29	0	0	0	0	43
SW	14	15	5	1	0	0	35
WSW	4	9	5	0	0	0	18
W	6	8	2	0	0	0	16
WNW	3	3	0	0	0	0	6
NW	4	3	0	0	0	0	7
NNW	9	2	0	0	0	0	11
Total	214	138	16	2	0	0	370

Number of Calm Hours - 1  
 Number of Variable Directions - 0  
 Total Number of Observations - 371

TABLE 2.3E-39

BVPS WIND - STABILITY SUMMARY  
 STABILITY CLASS - G, 150 Ft Winds  
 PERIOD: 5/01/76 TO 5/31/80

Number of Hourly Observations

Winds From	Wind Speed (mph)						Total
	1-3	4-7	8-12	13-18	19-24	25+	
N	21	1	0	0	0	0	22
NNE	66	16	0	0	0	0	82
NE	108	43	0	0	0	0	151
ENE	24	9	0	0	0	0	33
E	9	3	0	0	0	0	12
ESE	5	4	0	0	0	0	9
SE	6	2	0	0	0	0	8
SSE	3	2	0	0	0	0	5
S	9	7	1	0	0	0	17
SSW	23	40	4	0	0	0	67
SW	31	51	1	0	0	0	83
WSW	10	10	0	0	0	0	20
W	5	6	0	0	0	0	11
WNW	5	5	0	0	0	0	10
NW	7	1	0	0	0	0	8
NNW	8	1	0	0	0	0	9
Total	340	201	6	0	0	0	547

Number of Calm Hours - 2  
 Number of Variable Directions - 0  
 Total Number of Observations - 549

TABLE 2.3E-40

BVPS WIND - STABILITY SUMMARY  
 STABILITY CLASS - ALL, 150 Ft Winds  
 PERIOD: 5/01/76 TO 5/31/80

Number of Hourly Observations

Winds From	Wind Speed (mph)						Total
	1-3	4-7	8-12	13-18	19-24	25+	
N	42	75	55	8	0	0	180
NNE	133	75	35	6	0	0	249
NE	235	151	21	1	0	0	408
ENE	95	86	32	1	0	0	214
E	40	74	17	6	0	0	137
ESE	26	50	11	0	0	0	87
SE	25	36	13	1	0	0	75
SSE	21	32	18	0	0	0	71
S	36	53	30	2	0	0	121
SSW	57	151	50	8	0	0	266
SW	78	175	115	19	2	0	389
WSW	45	97	115	18	5	0	280
W	41	89	80	50	4	1	265
WNW	23	90	84	25	3	0	225
NW	23	58	49	12	0	0	142
NNW	29	55	43	9	0	0	136
Total	949	1347	768	166	14	1	3245

Number of Calm Hours - 8  
 Number of Variable Directions - 0  
 Total Number of Observations - 3253

TABLE 2.3E-41

BVPS WIND - STABILITY SUMMARY  
 STABILITY CLASS - A, 150 Ft Winds  
 PERIOD: 6/01/76 TO 6/30/80

Number of Hourly Observations

Winds From	Wind Speed (mph)						Total
	1-3	4-7	8-12	13-18	19-24	25+	
N	3	24	15	0	0	0	42
NNE	4	18	12	5	1	0	40
NE	4	10	11	0	0	0	25
ENE	3	16	17	0	0	0	36
E	2	16	5	0	0	0	23
ESE	2	7	4	0	0	0	13
SE	1	15	3	0	0	0	19
SSE	3	29	13	0	0	0	45
S	2	37	27	0	0	0	66
SSW	4	28	33	5	0	0	70
SW	4	25	53	6	1	0	89
WSW	3	35	47	7	2	0	94
W	4	37	27	27	6	0	101
WNW	4	20	47	18	1	0	90
NW	7	27	28	8	1	0	71
NNW	3	26	32	3	0	0	64
Total	53	370	374	79	12	0	888

Number of Calm Hours - 0  
 Number of Variable Directions - 0  
 Total Number of Observations - 888

TABLE 2.3E-42

BVPS WIND - STABILITY SUMMARY  
 STABILITY CLASS - B, 150 Ft Winds  
 PERIOD: 6/01/76 TO 6/30/80

Number of Hourly Observations

Winds From	Wind Speed (mph)						Total
	1-3	4-7	8-12	13-18	19-24	25+	
N	2	5	1	0	0	0	8
NNE	1	1	0	1	0	0	3
NE	0	1	1	0	0	0	2
ENE	0	0	0	0	0	0	0
E	0	2	0	0	0	0	2
ESE	0	0	0	0	0	0	0
SE	1	1	0	0	0	0	2
SSE	0	1	0	0	0	0	1
S	1	3	1	1	0	0	6
SSW	0	4	4	0	0	0	8
SW	1	5	4	1	0	0	11
WSW	0	3	12	3	0	0	18
W	5	7	1	3	0	0	16
WNW	0	1	4	1	0	0	6
NW	1	1	5	0	0	0	7
NNW	2	1	3	0	0	0	6
Total	14	36	36	10	0	0	96

Number of Calm Hours - 1  
 Number of Variable Directions - 0  
 Total Number of Observations - 97

TABLE 2.3E-43

BVPS WIND - STABILITY SUMMARY  
 STABILITY CLASS - C, 150 Ft Winds  
 PERIOD: 6/01/76 TO 6/30/80

Number of Hourly Observations

Winds From	Wind Speed (mph)						Total
	1-3	4-7	8-12	13-18	19-24	25+	
N	1	6	5	0	0	0	12
NNE	1	4	3	0	0	0	8
NE	1	2	0	0	0	0	3
ENE	0	3	0	0	0	0	3
E	0	1	0	0	0	0	1
ESE	0	0	0	0	0	0	0
SE	0	1	0	0	0	0	1
SSE	0	2	0	0	0	0	2
S	2	3	5	0	0	0	10
SSW	2	3	9	0	0	0	14
SW	0	5	16	1	0	0	22
WSW	1	5	7	4	0	0	17
W	1	2	4	0	0	0	7
WNW	0	2	2	1	0	0	5
NW	1	3	4	2	0	0	10
NNW	0	3	4	0	0	0	7
Total	10	45	59	8	0	0	122

Number of Calm Hours - 0  
 Number of Variable Directions - 0  
 Total Number of Observations - 122

TABLE 2.3E-44

BVPS WIND - STABILITY SUMMARY  
 STABILITY CLASS - D, 150 Ft Winds  
 PERIOD: 6/01/76 TO 6/30/80

Number of Hourly Observations

Winds From	Wind Speed (mph)						Total
	1-3	4-7	8-12	13-18	19-24	25+	
N	12	22	11	0	0	0	45
NNE	21	15	3	0	0	0	39
NE	28	13	1	0	0	0	42
ENE	11	4	3	0	0	0	18
E	6	4	0	0	0	0	10
ESE	2	4	0	0	0	0	6
SE	1	4	0	0	0	0	5
SSE	4	9	2	0	0	0	15
S	7	14	16	0	0	0	37
SSW	8	34	21	1	0	0	64
SW	9	32	35	7	0	0	83
WSW	7	20	24	5	1	0	57
W	7	19	15	5	0	0	46
WNW	6	18	15	6	2	0	47
NW	7	25	19	0	0	0	51
NNW	4	30	4	0	0	0	38
Total	140	267	169	24	3	0	603

Number of Calm Hours - 1  
 Number of Variable Directions - 0  
 Total Number of Observations - 604

TABLE 2.3E-45

BVPS WIND - STABILITY SUMMARY  
 STABILITY CLASS - E, 150 Ft Winds  
 PERIOD: 6/01/76 TO 6/30/80

Number of Hourly Observations

Winds From	Wind Speed (mph)						Total
	1-3	4-7	8-12	13-18	19-24	25+	
N	4	9	3	2	0	0	18
NNE	23	6	0	0	0	0	29
NE	43	16	1	0	0	0	60
ENE	15	12	2	0	0	0	29
E	15	11	1	0	0	0	27
ESE	11	2	2	0	0	0	15
SE	5	7	0	0	0	0	12
SSE	6	8	2	0	0	0	16
S	18	29	5	0	0	0	52
SSW	12	44	10	0	0	0	66
SW	12	38	26	0	0	0	76
WSW	8	18	9	0	0	0	35
W	9	5	4	0	0	0	18
WNW	4	7	12	1	0	0	24
NW	7	12	4	0	0	0	23
NNW	7	9	0	0	0	0	16
Total	199	233	81	3	0	0	516

Number of Calm Hours - 3  
 Number of Variable Directions - 0  
 Total Number of Observations - 519



TABLE 2.3E-46

BVPS WIND - STABILITY SUMMARY  
 STABILITY CLASS - F, 150 Ft Winds  
 PERIOD: 6/01/76 TO 6/30/80

Number of Hourly Observations

Winds From	Wind Speed (mph)						Total
	1-3	4-7	8-12	13-18	19-24	25+	
N	18	5	0	0	0	0	23
NNE	67	5	0	0	0	0	72
NE	59	20	0	0	0	0	79
ENE	28	5	0	0	0	0	33
E	13	3	0	0	0	0	16
ESE	7	2	0	0	0	0	9
SE	6	1	0	0	0	0	7
SSE	7	3	0	0	0	0	10
S	17	12	0	0	0	0	29
SSW	19	32	3	0	0	0	54
SW	24	25	4	0	0	0	53
WSW	8	13	0	0	0	0	21
W	5	1	0	0	0	0	6
WNW	2	2	0	0	0	0	4
NW	5	1	0	0	0	0	6
NNW	4	3	0	0	0	0	7
Total	289	133	7	0	0	0	429

Number of Calm Hours - 4  
 Number of Variable Directions - 0  
 Total Number of Observations - 433

TABLE 2.3E-47

BVPS WIND - STABILITY SUMMARY  
 STABILITY CLASS - G, 150 Ft Winds  
 PERIOD: 6/01/76 TO 6/30/80

Number of Hourly Observations

Winds From	Wind Speed (mph)						Total
	1-3	4-7	8-12	13-18	19-24	25+	
N	25	0	0	0	0	0	25
NNE	59	2	0	0	0	0	61
NE	99	12	0	0	0	0	111
ENE	16	5	0	0	0	0	21
E	8	2	0	0	0	0	10
ESE	5	1	0	0	0	0	6
SE	8	0	0	0	0	0	8
SSE	9	1	0	0	0	0	10
S	19	12	0	0	0	0	31
SSW	13	34	1	0	0	0	48
SW	14	23	0	0	0	0	37
WSW	9	3	0	0	0	0	12
W	3	0	0	0	0	0	3
WNW	5	0	0	0	0	0	5
NW	5	1	0	0	0	0	6
NNW	12	2	0	0	0	0	14
Total	309	98	1	0	0	0	408

Number of Calm Hours - 5  
 Number of Variable Directions - 0  
 Total Number of Observations - 413

TABLE 2.3E-48

BVPS WIND - STABILITY SUMMARY  
 STABILITY CLASS - ALL, 150 Ft Winds  
 PERIOD: 6/01/76 TO 6/30/80

Number of Hourly Observations

Winds From	Wind Speed (mph)						Total
	1-3	4-7	8-12	13-18	19-24	25+	
N	65	71	35	2	0	0	173
NNE	176	51	18	6	1	0	252
NE	234	74	14	0	0	0	322
ENE	73	45	22	0	0	0	140
E	44	39	6	0	0	0	89
ESE	27	16	6	0	0	0	49
SE	22	29	3	0	0	0	54
SSE	29	53	17	0	0	0	99
S	66	110	54	1	0	0	231
SSW	58	179	81	6	0	0	324
SW	64	153	138	15	1	0	371
WSW	36	97	99	19	3	0	254
W	34	71	51	35	6	0	197
WNW	21	50	80	27	3	0	181
NW	33	70	60	10	1	0	174
NNW	32	74	43	3	0	0	152
Total	1014	1182	727	124	15	0	3062

Number of Calm Hours - 14  
 Number of Variable Directions - 0  
 Total Number of Observations - 3076

TABLE 2.3E-49

BVPS WIND - STABILITY SUMMARY  
 STABILITY CLASS - A, 150 Ft Winds  
 PERIOD: 7/01/76 TO 7/31/80

Number of Hourly Observations

Winds From	Wind Speed (mph)						Total
	1-3	4-7	8-12	13-18	19-24	25+	
N	4	43	29	2	0	0	78
NNE	2	25	12	1	0	0	40
NE	13	20	6	0	0	0	39
ENE	3	11	5	0	0	0	19
E	3	7	0	0	0	0	10
ESE	3	6	1	0	0	0	10
SE	6	10	1	0	0	0	17
SSE	5	15	7	0	0	0	27
S	4	27	22	1	0	0	54
SSW	2	31	37	7	0	0	77
SW	5	31	42	11	0	0	89
WSW	1	54	54	13	0	0	122
W	4	42	48	20	3	1	118
WNW	3	21	31	3	0	0	58
NW	4	14	21	2	0	0	41
NNW	4	25	18	0	0	0	47
Total	66	382	334	60	3	1	846

Number of Calm Hours - 2  
 Number of Variable Directions - 0  
 Total Number of Observations - 848

TABLE 2.3E-50

BVPS WIND - STABILITY SUMMARY  
 STABILITY CLASS - B, 150 Ft Winds  
 PERIOD: 7/01/76 TO 7/31/80

Number of Hourly Observations

Winds From	Wind Speed (mph)						Total
	1-3	4-7	8-12	13-18	19-24	25+	
N	1	7	1	0	0	0	9
NNE	0	2	0	0	0	0	2
NE	2	2	0	1	0	0	5
ENE	0	1	0	0	0	0	1
E	0	0	0	0	0	0	0
ESE	1	1	0	0	0	0	2
SE	0	1	0	0	0	0	1
SSE	1	0	0	0	0	0	1
S	1	4	1	0	0	0	6
SSW	1	6	6	0	0	0	13
SW	1	5	1	0	0	0	7
WSW	0	5	6	0	0	0	11
W	0	5	3	0	0	0	8
WNW	3	1	5	0	0	0	9
NW	0	4	1	0	0	0	5
NNW	2	3	1	1	0	0	7
Total	13	47	25	2	0	0	87

Number of Calm Hours - 0  
 Number of Variable Directions - 0  
 Total Number of Observations - 87

TABLE 2.3E-51

BVPS WIND - STABILITY SUMMARY  
 STABILITY CLASS - C, 150 Ft Winds  
 PERIOD: 7/01/76 TO 7/31/80

Number of Hourly Observations

Winds From	Wind Speed (mph)						Total
	1-3	4-7	8-12	13-18	19-24	25+	
N	1	5	0	0	0	0	6
NNE	1	6	1	0	0	0	8
NE	0	2	0	1	0	0	3
ENE	3	0	0	0	0	0	3
E	0	2	0	0	0	0	2
ESE	1	2	0	0	0	0	3
SE	1	0	0	0	0	0	1
SSE	1	1	1	0	0	0	3
S	0	1	2	0	0	0	3
SSW	2	1	1	0	0	0	4
SW	1	2	2	0	0	0	5
WSW	2	8	5	1	0	0	16
W	1	5	4	1	0	0	11
WNW	1	1	1	0	0	0	3
NW	1	1	5	0	0	0	7
NNW	0	5	4	0	0	0	9
Total	16	42	26	3	0	0	87

Number of Calm Hours - 0  
 Number of Variable Directions - 0  
 Total Number of Observations - 87

TABLE 2.3E-52

BVPS WIND - STABILITY SUMMARY  
 STABILITY CLASS - D, 150 Ft Winds  
 PERIOD: 7/01/76 TO 7/31/80

Number of Hourly Observations

Winds From	Wind Speed (mph)						Total
	1-3	4-7	8-12	13-18	19-24	25+	
N	17	21	5	0	0	0	43
NNE	12	12	3	0	0	0	27
NE	12	9	2	0	0	0	23
ENE	11	20	7	0	0	0	38
E	8	3	0	0	0	0	11
ESE	7	1	2	0	0	0	10
SE	3	4	2	0	0	0	9
SSE	4	2	1	0	0	0	7
S	1	15	4	1	0	0	21
SSW	11	32	19	1	0	0	63
SW	7	36	41	1	0	0	85
WSW	10	52	59	6	0	0	127
W	11	27	21	3	0	0	62
WNW	10	21	7	0	0	0	38
NW	4	19	5	0	0	0	28
NNW	19	26	3	0	0	0	48
Total	147	300	181	12	0	0	640

Number of Calm Hours - 1  
 Number of Variable Directions - 0  
 Total Number of Observations - 641

TABLE 2.3E-53

BVPS WIND - STABILITY SUMMARY  
 STABILITY CLASS - E, 150 Ft Winds  
 PERIOD: 7/01/76 TO 7/31/80

Number of Hourly Observations

Winds From	Wind Speed (mph)						Total
	1-3	4-7	8-12	13-18	19-24	25+	
N	15	11	0	0	0	0	26
NNE	18	4	0	0	0	0	22
NE	31	16	4	1	0	0	52
ENE	38	23	6	0	0	0	67
E	18	5	1	0	0	0	24
ESE	6	1	1	0	0	0	8
SE	18	5	0	0	0	0	23
SSE	11	8	0	0	0	0	19
S	30	30	7	1	0	0	68
SSW	35	57	14	0	0	0	106
SW	21	41	11	0	0	0	73
WSW	15	20	10	0	0	0	45
W	10	25	7	1	0	0	43
WNW	8	13	2	0	0	0	23
NW	8	8	2	0	0	0	18
NNW	5	9	0	0	0	0	14
Total	287	276	65	3	0	0	631

Number of Calm Hours - 2  
 Number of Variable Directions - 0  
 Total Number of Observations - 633



TABLE 2.3E-54

BVPS WIND - STABILITY SUMMARY  
 STABILITY CLASS - F, 150 Ft Winds  
 PERIOD: 7/01/76 TO 7/31/80

Number of Hourly Observations

Winds From	Wind Speed (mph)						Total
	1-3	4-7	8-12	13-18	19-24	25+	
N	25	5	0	0	0	0	30
NNE	69	3	0	0	0	0	72
NE	81	7	0	0	0	0	88
ENE	33	3	1	0	0	0	37
E	16	0	0	0	0	0	16
ESE	15	0	0	0	0	0	15
SE	10	0	0	0	0	0	10
SSE	12	3	0	0	0	0	15
S	28	28	3	0	0	0	59
SSW	33	52	3	0	0	0	88
SW	18	27	3	0	0	0	48
WSW	10	7	1	0	0	0	18
W	10	4	0	0	0	0	14
WNW	6	4	0	0	0	0	10
NW	6	2	0	0	0	0	8
NNW	10	6	0	0	0	0	16
Total	382	151	11	0	0	0	544

Number of Calm Hours - 16  
 Number of Variable Directions - 0  
 Total Number of Observations - 560

TABLE 2.3E-55

BVPS WIND - STABILITY SUMMARY  
 STABILITY CLASS - G, 150 Ft Winds  
 PERIOD: 7/01/76 TO 7/31/80

## Number of Hourly Observations

Winds From	Wind Speed (mph)						Total
	1-3	4-7	8-12	13-18	19-24	25+	
N	21	0	0	0	0	0	21
NNE	30	0	0	0	0	0	30
NE	42	8	0	0	0	0	50
ENE	15	0	0	0	0	0	15
E	4	0	0	0	0	0	4
ESE	10	1	0	0	0	0	11
SE	9	2	0	0	0	0	11
SSE	6	5	0	0	0	0	11
S	20	18	1	0	0	0	39
SSW	24	43	1	0	0	0	68
SW	15	19	0	0	0	0	34
WSW	10	7	0	0	0	0	17
W	7	4	0	0	0	0	11
WNW	2	3	0	0	0	0	5
NW	6	3	1	0	0	0	10
NNW	3	3	0	0	0	0	6
Total	224	116	3	0	0	0	343

Number of Calm Hours - 9  
 Number of Variable Directions - 0  
 Total Number of Observations - 352

TABLE 2.3E-56

BVPS WIND - STABILITY SUMMARY  
 STABILITY CLASS - ALL, 150 Ft Winds  
 PERIOD: 7/01/76 TO 7/31/80

Number of Hourly Observations

Winds From	Wind Speed (mph)						Total
	1-3	4-7	8-12	13-18	19-24	25+	
N	84	92	35	2	0	0	213
NNE	132	52	16	1	0	0	201
NE	181	64	12	3	0	0	260
ENE	103	58	19	0	0	0	180
E	49	17	1	0	0	0	67
ESE	43	12	4	0	0	0	59
SE	47	22	3	0	0	0	72
SSE	40	34	9	0	0	0	83
S	84	123	40	3	0	0	250
SSW	108	222	81	8	0	0	419
SW	68	161	100	12	0	0	341
WSW	48	153	135	20	0	0	356
W	43	112	83	25	3	1	267
WNW	33	64	46	3	0	0	146
NW	29	51	35	2	0	0	117
NNW	43	77	26	1	0	0	147
Total	1135	1314	645	80	3	1	3178

Number of Calm Hours - 30  
 Number of Variable Directions - 0  
 Total Number of Observations - 3208

TABLE 2.3E-57

BVPS WIND - STABILITY SUMMARY  
 STABILITY CLASS - A, 150 Ft Winds  
 PERIOD: 8/01/76 TO 8/31/80

Number of Hourly Observations

Winds From	Wind Speed (mph)						Total
	1-3	4-7	8-12	13-18	19-24	25+	
N	15	31	14	0	0	0	60
NNE	4	21	8	0	0	0	33
NE	5	13	8	0	0	0	26
ENE	5	14	6	0	0	0	25
E	1	19	3	0	0	0	23
ESE	3	9	2	0	0	0	14
SE	5	12	2	0	0	0	19
SSE	2	7	0	0	0	0	9
S	1	20	16	0	0	0	37
SSW	2	19	37	3	0	0	61
SW	3	34	101	6	1	0	145
WSW	4	60	62	10	0	0	136
W	6	42	37	12	0	0	97
WNW	5	11	12	3	0	0	31
NW	7	11	17	0	0	0	35
NNW	5	22	9	0	0	0	36
Total	73	345	334	34	1	0	787

Number of Calm Hours - 0  
 Number of Variable Directions - 0  
 Total Number of Observations - 787

TABLE 2.3E-58

BVPS WIND - STABILITY SUMMARY  
 STABILITY CLASS - B, 150 Ft Winds  
 PERIOD: 8/01/76 TO 8/31/80

Number of Hourly Observations

Winds From	Wind Speed (mph)						Total
	1-3	4-7	8-12	13-18	19-24	25+	
N	5	3	1	0	0	0	9
NNE	0	0	1	0	0	0	1
NE	1	1	0	0	0	0	2
ENE	0	3	0	0	0	0	3
E	1	0	0	0	0	0	1
ESE	3	2	1	0	0	0	6
SE	0	0	0	0	0	0	0
SSE	0	1	0	0	0	0	1
S	0	1	5	0	0	0	6
SSW	1	4	2	0	0	0	7
SW	0	5	11	1	0	0	17
WSW	1	7	7	1	0	0	16
W	0	3	3	0	0	0	6
WNW	1	2	0	0	0	0	3
NW	0	1	2	0	0	0	3
NNW	1	2	0	0	0	0	3
Total	14	35	33	2	0	0	84

Number of Calm Hours - 0  
 Number of Variable Directions - 0  
 Total Number of Observations - 84

TABLE 2.3E-59

BVPS WIND - STABILITY SUMMARY  
 STABILITY CLASS - C, 150 Ft Winds  
 PERIOD: 8/01/76 TO 8/31/80

Number of Hourly Observations

Winds From	Wind Speed (mph)						Total
	1-3	4-7	8-12	13-18	19-24	25+	
N	3	2	0	0	0	0	5
NNE	2	2	0	0	0	0	4
NE	2	1	0	0	0	0	3
ENE	2	0	0	0	0	0	2
E	1	0	0	0	0	0	1
ESE	2	0	0	0	0	0	2
SE	0	1	0	0	0	0	1
SSE	1	1	0	0	0	0	2
S	0	6	2	0	0	0	8
SSW	0	2	4	0	0	0	6
SW	1	9	5	0	0	0	15
WSW	2	4	5	1	0	0	12
W	3	7	5	0	0	0	15
WNW	0	2	1	0	0	0	3
NW	1	1	1	0	0	0	3
NNW	0	2	1	0	0	0	3
Total	20	40	24	1	0	0	85

Number of Calm Hours - 0  
 Number of Variable Directions - 0  
 Total Number of Observations - 85

TABLE 2.3E-60

BVPS WIND - STABILITY SUMMARY  
 STABILITY CLASS - D, 150 Ft Winds  
 PERIOD: 8/01/76 TO 8/31/80

Number of Hourly Observations

Winds From	Wind Speed (mph)						Total
	1-3	4-7	8-12	13-18	19-24	25+	
N	15	14	7	0	0	0	36
NNE	14	15	0	0	0	0	29
NE	16	22	4	0	0	0	42
ENE	10	19	1	0	0	0	30
E	12	7	0	0	0	0	19
ESE	7	2	0	0	0	0	9
SE	8	7	0	0	0	0	15
SSE	2	4	0	0	0	0	6
S	7	11	3	0	0	0	21
SSW	7	25	19	0	0	0	51
SW	8	42	54	1	0	0	105
WSW	6	47	25	1	0	0	79
W	8	22	19	0	0	0	49
WNW	10	25	10	0	0	0	45
NW	8	12	4	1	0	0	25
NNW	6	17	1	0	0	0	24
Total	144	291	147	3	0	0	585

Number of Calm Hours - 3  
 Number of Variable Directions - 0  
 Total Number of Observations - 588

TABLE 2.3E-61

BVPS WIND - STABILITY SUMMARY  
 STABILITY CLASS - E, 150 Ft Winds  
 PERIOD: 8/01/76 TO 8/31/80

Number of Hourly Observations

Winds From	Wind Speed (mph)						Total
	1-3	4-7	8-12	13-18	19-24	25+	
N	15	17	3	0	0	0	35
NNE	38	21	0	0	0	0	59
NE	71	30	2	0	0	0	103
ENE	47	25	1	0	0	0	73
E	28	4	0	0	0	0	32
ESE	15	10	0	0	0	0	25
SE	9	3	0	0	0	0	12
SSE	12	5	0	0	0	0	17
S	41	42	2	1	0	0	86
SSW	36	68	20	0	0	0	124
SW	22	70	31	0	0	0	123
WSW	14	30	5	0	0	0	49
W	12	11	3	0	0	0	26
WNW	11	14	2	0	0	0	27
NW	5	10	1	1	0	0	17
NNW	6	15	1	0	0	0	22
Total	382	375	71	2	0	0	830

Number of Calm Hours - 10  
 Number of Variable Directions - 0  
 Total Number of Observations - 840



TABLE 2.3E-62

BVPS WIND - STABILITY SUMMARY  
 STABILITY CLASS - F, 150 Ft Winds  
 PERIOD: 8/01/76 TO 8/31/80

Number of Hourly Observations

Winds From	Wind Speed (mph)						Total
	1-3	4-7	8-12	13-18	19-24	25+	
N	40	2	0	0	0	0	42
NNE	88	4	0	0	0	0	92
NE	106	13	0	0	0	0	119
ENE	33	10	0	0	0	0	43
E	21	3	0	0	0	0	24
ESE	15	0	0	0	0	0	15
SE	11	2	0	0	0	0	13
SSE	11	2	0	0	0	0	13
S	37	34	0	0	0	0	71
SSW	40	44	4	0	0	0	88
SW	15	16	2	0	0	0	33
WSW	8	7	0	0	0	0	15
W	11	1	0	0	0	0	12
WNW	7	1	0	0	0	0	8
NW	10	3	0	0	0	0	13
NNW	11	5	0	0	0	0	16
Total	464	147	6	0	0	0	617

Number of Calm Hours - 17  
 Number of Variable Directions - 0  
 Total Number of Observations - 634

TABLE 2.3E-63

BVPS WIND - STABILITY SUMMARY  
 STABILITY CLASS - G, 150 Ft Winds  
 PERIOD: 8/01/76 TO 8/31/80

Number of Hourly Observations

Winds From	Wind Speed (mph)						Total
	1-3	4-7	8-12	13-18	19-24	25+	
N	9	0	0	0	0	0	9
NNE	30	1	0	0	0	0	31
NE	65	8	0	0	0	0	73
ENE	12	3	0	0	0	0	15
E	7	1	0	0	0	0	8
ESE	6	1	0	0	0	0	7
SE	3	0	0	0	0	0	3
SSE	2	1	0	0	0	0	3
S	11	21	1	0	0	0	33
SSW	9	41	1	0	0	0	51
SW	11	7	1	0	0	0	19
WSW	2	2	0	0	0	0	4
W	2	0	0	0	0	0	2
WNW	2	0	0	0	0	0	2
NW	3	0	0	0	0	0	3
NNW	3	1	0	0	0	0	4
Total	177	87	3	0	0	0	267

Number of Calm Hours - 4  
 Number of Variable Directions - 0  
 Total Number of Observations - 271

TABLE 2.3E-64

BVPS WIND - STABILITY SUMMARY  
 STABILITY CLASS - ALL, 150 Ft Winds  
 PERIOD: 8/01/76 TO 8/31/80

Number of Hourly Observations

Winds From	Wind Speed (mph)						Total
	1-3	4-7	8-12	13-18	19-24	25+	
N	102	69	25	0	0	0	196
NNE	176	64	9	0	0	0	249
NE	266	88	14	0	0	0	368
ENE	109	74	8	0	0	0	191
E	71	34	3	0	0	0	108
ESE	51	24	3	0	0	0	78
SE	36	25	2	0	0	0	63
SSE	30	21	0	0	0	0	51
S	97	135	29	1	0	0	262
SSW	95	203	87	3	0	0	388
SW	60	183	205	8	1	0	457
WSW	37	157	104	13	0	0	311
W	42	86	67	12	0	0	207
WNW	36	55	25	3	0	0	119
NW	34	38	25	2	0	0	99
NNW	32	64	12	0	0	0	108
Total	1274	1320	618	42	1	0	3255

Number of Calm Hours - 34  
 Number of Variable Directions - 0  
 Total Number of Observations - 3289

TABLE 2.3E-65

BVPS WIND - STABILITY SUMMARY  
 STABILITY CLASS - A, 150 Ft Winds  
 PERIOD: 9/01/76 TO 9/30/80

Number of Hourly Observations

Winds From	Wind Speed (mph)						Total
	1-3	4-7	8-12	13-18	19-24	25+	
N	5	42	32	1	0	0	80
NNE	3	11	10	0	0	0	24
NE	4	12	8	0	0	0	24
ENE	1	4	7	0	0	0	12
E	1	10	6	0	0	0	17
ESE	1	21	3	0	0	0	25
SE	0	10	5	0	0	0	15
SSE	1	10	11	1	0	0	23
S	1	20	18	1	0	0	40
SSW	2	25	22	2	0	0	51
SW	5	20	36	4	0	0	65
WSW	3	34	36	9	0	0	82
W	6	33	28	22	0	0	89
WNW	1	22	10	13	2	0	48
NW	4	10	9	2	0	0	25
NNW	4	26	19	1	0	0	50
Total	42	310	260	56	2	0	670

Number of Calm Hours - 0  
 Number of Variable Directions - 0  
 Total Number of Observations - 670

TABLE 2.3E-66

BVPS WIND - STABILITY SUMMARY  
 STABILITY CLASS - B, 150 Ft Winds  
 PERIOD: 9/01/76 TO 9/30/80

Number of Hourly Observations

Winds From	Wind Speed (mph)						Total
	1-3	4-7	8-12	13-18	19-24	25+	
N	0	3	2	0	0	0	5
NNE	0	2	1	0	0	0	3
NE	3	1	0	0	0	0	4
ENE	1	2	1	0	0	0	4
E	0	0	0	0	0	0	0
ESE	0	1	1	0	0	0	2
SE	0	0	0	0	0	0	0
SSE	0	3	0	0	0	0	3
S	1	2	0	0	0	0	3
SSW	1	3	2	1	0	0	7
SW	3	3	2	0	0	0	8
WSW	0	7	5	3	1	0	16
W	1	3	3	2	0	0	9
WNW	2	2	3	1	0	0	8
NW	1	2	1	0	0	0	4
NNW	1	0	0	0	0	0	1
Total	14	34	21	7	1	0	77

Number of Calm Hours - 0  
 Number of Variable Directions - 0  
 Total Number of Observations - 77

TABLE 2.3E-67

BVPS WIND - STABILITY SUMMARY  
 STABILITY CLASS - C, 150 Ft Winds  
 PERIOD: 9/01/76 TO 9/30/80

Number of Hourly Observations

Winds From	Wind Speed (mph)						Total
	1-3	4-7	8-12	13-18	19-24	25+	
N	1	4	2	0	0	0	7
NNE	0	3	4	0	0	0	7
NE	1	4	0	0	0	0	5
ENE	0	3	0	0	0	0	3
E	1	0	1	0	0	0	2
ESE	1	1	0	0	0	0	2
SE	0	1	0	0	0	0	1
SSE	1	0	0	0	0	0	1
S	0	2	0	0	0	0	2
SSW	0	4	1	0	0	0	5
SW	1	2	8	2	0	0	13
WSW	2	10	3	0	0	0	15
W	2	2	5	3	1	0	13
WNW	1	2	2	0	1	0	6
NW	1	2	0	0	0	0	3
NNW	2	3	4	0	0	0	9
Total	14	43	30	5	2	0	94

Number of Calm Hours - 0  
 Number of Variable Directions - 0  
 Total Number of Observations - 94

TABLE 2.3E-68

BVPS WIND - STABILITY SUMMARY  
 STABILITY CLASS - D, 150 Ft Winds  
 PERIOD: 9/01/76 TO 9/30/80

## Number of Hourly Observations

Winds From	Wind Speed (mph)						Total
	1-3	4-7	8-12	13-18	19-24	25+	
N	11	26	8	0	0	0	45
NNE	15	25	13	0	0	0	53
NE	12	22	4	0	0	0	38
ENE	8	21	8	0	0	0	37
E	7	5	0	0	0	0	12
ESE	2	5	0	0	0	0	7
SE	2	4	2	0	0	0	8
SSE	2	5	0	0	0	0	7
S	8	17	4	0	0	0	29
SSW	8	13	10	1	0	0	32
SW	8	30	32	2	0	0	72
WSW	4	33	23	3	0	0	63
W	5	24	30	11	0	0	70
WNW	7	21	13	2	0	0	43
NW	11	32	8	0	0	0	51
NNW	11	38	5	0	0	0	54
Total	121	321	160	19	0	0	621

Number of Calm Hours - 1  
 Number of Variable Directions - 0  
 Total Number of Observations - 622

TABLE 2.3E-69

BVPS WIND - STABILITY SUMMARY  
 STABILITY CLASS - E, 150 Ft Winds  
 PERIOD: 9/01/76 TO 9/30/80

Number of Hourly Observations

Winds From	Wind Speed (mph)						Total
	1-3	4-7	8-12	13-18	19-24	25+	
N	10	8	1	0	0	0	19
NNE	22	3	4	0	0	0	29
NE	47	35	3	0	0	0	85
ENE	33	45	5	1	0	0	84
E	16	14	1	0	0	0	31
ESE	17	13	1	0	0	0	31
SE	14	12	1	0	0	0	27
SSE	5	7	0	0	0	0	12
S	19	15	5	0	0	0	39
SSW	14	45	14	0	0	0	73
SW	16	50	26	1	0	0	93
WSW	9	25	7	1	0	0	42
W	8	21	8	1	0	0	38
WNW	4	19	7	0	0	0	30
NW	9	16	7	0	0	0	32
NNW	7	14	1	0	0	0	22
Total	250	342	91	4	0	0	687

Number of Calm Hours - 3  
 Number of Variable Directions - 0  
 Total Number of Observations - 690



TABLE 2.3E-70

BVPS WIND - STABILITY SUMMARY  
 STABILITY CLASS - F, 150 Ft Winds  
 PERIOD: 9/01/76 TO 9/30/80

Number of Hourly Observations

Winds From	Wind Speed (mph)						Total
	1-3	4-7	8-12	13-18	19-24	25+	
N	16	4	0	0	0	0	20
NNE	55	12	0	0	0	0	67
NE	93	29	0	0	0	0	122
ENE	32	13	0	0	0	0	45
E	27	4	0	0	0	0	31
ESE	4	2	0	0	0	0	6
SE	9	2	0	0	0	0	11
SSE	15	1	0	0	0	0	16
S	12	13	1	0	0	0	26
SSW	33	43	4	0	0	0	80
SW	24	40	5	0	0	0	69
WSW	12	12	6	0	0	0	30
W	7	4	1	0	0	0	12
WNW	5	3	0	0	0	0	8
NW	9	4	0	0	0	0	13
NNW	5	4	0	0	0	0	9
Total	358	190	17	0	0	0	565

Number of Calm Hours - 15  
 Number of Variable Directions - 0  
 Total Number of Observations - 580

TABLE 2.3E-71

BVPS WIND - STABILITY SUMMARY  
 STABILITY CLASS - G, 150 Ft Winds  
 PERIOD: 9/01/76 TO 9/30/80

Number of Hourly Observations

Winds From	Wind Speed (mph)						Total
	1-3	4-7	8-12	13-18	19-24	25+	
N	18	0	0	0	0	0	18
NNE	51	7	0	0	0	0	58
NE	91	23	0	0	0	0	114
ENE	36	8	0	0	0	0	44
E	12	2	0	0	0	0	14
ESE	10	5	0	0	0	0	15
SE	8	3	0	0	0	0	11
SSE	6	2	0	0	0	0	8
S	22	14	0	0	0	0	36
SSW	24	38	1	0	0	0	63
SW	24	29	4	0	0	0	57
WSW	10	2	0	0	0	0	12
W	2	1	0	0	0	0	3
WNW	2	2	0	0	0	0	4
NW	2	3	0	0	0	0	5
NNW	5	2	0	0	0	0	7
Total	323	141	5	0	0	0	469

Number of Calm Hours - 9  
 Number of Variable Directions - 0  
 Total Number of Observations - 478

TABLE 2.3E-72

BVPS WIND - STABILITY SUMMARY  
 STABILITY CLASS - ALL, 150 Ft Winds  
 PERIOD: 9/01/76 TO 9/30/80

Number of Hourly Observations

Winds From	Wind Speed (mph)						Total
	1-3	4-7	8-12	13-18	19-24	25+	
N	61	87	45	1	0	0	194
NNE	146	63	32	0	0	0	241
NE	251	126	15	0	0	0	392
ENE	111	96	21	1	0	0	229
E	64	35	8	0	0	0	107
ESE	35	48	5	0	0	0	88
SE	33	32	8	0	0	0	73
SSE	30	28	11	1	0	0	70
S	63	83	28	1	0	0	175
SSW	82	171	54	4	0	0	311
SW	81	174	113	9	0	0	377
WSW	40	123	80	16	1	0	260
W	31	88	75	39	1	0	234
WNW	22	71	35	16	3	0	147
NW	37	69	25	2	0	0	133
NNW	35	87	29	1	0	0	152
Total	1122	1381	584	91	5	0	3183

Number of Calm Hours - 28  
 Number of Variable Directions - 0  
 Total Number of Observations - 3211

TABLE 2.3E-73

BVPS WIND - STABILITY SUMMARY  
 STABILITY CLASS - A, 150 Ft Winds  
 PERIOD: 10/01/76 TO 10/31/80

Number of Hourly Observations

Winds From	Wind Speed (mph)						Total
	1-3	4-7	8-12	13-18	19-24	25+	
N	2	13	6	0	0	0	21
NNE	1	7	7	1	0	0	16
NE	0	4	4	2	0	0	10
ENE	0	11	7	0	0	0	18
E	0	6	4	1	0	0	11
ESE	0	9	7	0	0	0	16
SE	0	6	11	2	0	0	19
SSE	0	4	4	0	0	0	8
S	0	4	7	0	0	0	11
SSW	0	1	9	0	0	0	10
SW	1	8	23	2	0	0	34
WSW	1	13	13	15	2	0	44
W	0	9	23	17	4	0	53
WNW	1	5	13	7	0	0	26
NW	0	4	5	0	0	0	9
NNW	1	5	3	1	0	0	10
Total	7	109	146	48	6	0	316

Number of Calm Hours - 0  
 Number of Variable Directions - 0  
 Total Number of Observations - 316

TABLE 2.3E-74

BVPS WIND - STABILITY SUMMARY  
 STABILITY CLASS - B, 150 Ft Winds  
 PERIOD: 10/01/76 TO 10/31/80

Number of Hourly Observations

Winds From	Wind Speed (mph)						Total
	1-3	4-7	8-12	13-18	19-24	25+	
N	0	1	0	0	0	0	1
NNE	0	2	0	0	0	0	2
NE	0	1	1	0	0	0	2
ENE	0	2	1	0	0	0	3
E	0	1	0	0	0	0	1
ESE	0	0	0	0	0	0	0
SE	0	2	0	0	0	0	2
SSE	0	2	1	0	0	0	3
S	0	1	2	0	0	0	3
SSW	0	1	2	0	0	0	3
SW	0	5	11	3	0	0	19
WSW	0	6	11	5	0	0	22
W	0	3	6	7	0	0	16
WNW	0	0	9	3	0	0	12
NW	0	1	1	3	0	0	5
NNW	0	0	0	0	0	0	0
Total	0	28	45	21	0	0	94

Number of Calm Hours - 0  
 Number of Variable Directions - 0  
 Total Number of Observations - 94

TABLE 2.3E-75

BVPS WIND - STABILITY SUMMARY  
 STABILITY CLASS - C, 150 Ft Winds  
 PERIOD: 10/01/76 TO 10/31/80

Number of Hourly Observations

Winds From	Wind Speed (mph)						Total
	1-3	4-7	8-12	13-18	19-24	25+	
N	1	3	1	0	0	0	5
NNE	1	3	1	0	0	0	5
NE	1	1	0	0	0	0	2
ENE	1	2	2	0	0	0	5
E	0	0	0	0	0	0	0
ESE	0	0	2	0	0	0	2
SE	0	0	1	0	0	0	1
SSE	0	3	1	0	0	0	4
S	0	1	2	0	0	0	3
SSW	0	3	5	0	0	0	8
SW	0	4	14	5	1	0	24
WSW	0	2	9	2	1	0	14
W	1	1	8	10	0	0	20
WNW	0	2	10	2	0	0	14
NW	1	1	0	1	0	0	3
NNW	0	3	1	0	0	0	4
Total	6	29	57	20	2	0	114

Number of Calm Hours - 0  
 Number of Variable Directions - 0  
 Total Number of Observations - 114

TABLE 2.3E-76

BVPS WIND - STABILITY SUMMARY  
 STABILITY CLASS - D, 150 Ft Winds  
 PERIOD: 10/01/76 TO 10/31/80

Number of Hourly Observations

Winds From	Wind Speed (mph)						Total
	1-3	4-7	8-12	13-18	19-24	25+	
N	3	39	15	0	0	0	57
NNE	7	26	11	8	0	0	52
NE	15	23	3	0	0	0	41
ENE	11	19	6	0	0	0	36
E	7	11	0	0	0	0	18
ESE	3	3	4	0	0	0	10
SE	3	3	3	0	0	0	9
SSE	4	10	5	0	0	0	19
S	5	18	11	1	0	0	35
SSW	4	21	15	1	0	0	41
SW	2	25	62	9	0	0	98
WSW	9	26	101	37	7	0	180
W	2	17	85	53	11	0	168
WNW	1	36	61	16	0	0	114
NW	1	29	31	3	0	0	64
NNW	5	32	10	1	0	0	48
Total	82	338	423	129	18	0	990

Number of Calm Hours - 0  
 Number of Variable Directions - 0  
 Total Number of Observations - 990

TABLE 2.3E-77

BVPS WIND - STABILITY SUMMARY  
 STABILITY CLASS - E, 150 Ft Winds  
 PERIOD: 10/01/76 TO 10/31/80

Number of Hourly Observations

Winds From	Wind Speed (mph)						Total
	1-3	4-7	8-12	13-18	19-24	25+	
N	4	21	1	0	0	0	26
NNE	12	8	5	0	0	0	25
NE	40	27	4	0	0	0	71
ENE	21	31	6	0	0	0	58
E	19	26	2	0	0	0	47
ESE	3	16	8	0	0	0	27
SE	10	14	6	0	0	0	30
SSE	7	9	2	0	0	0	18
S	11	25	3	0	0	0	39
SSW	12	52	23	2	0	0	89
SW	8	39	41	5	0	0	93
WSW	9	17	16	2	0	0	44
W	3	12	14	5	0	0	34
WNW	7	20	14	4	0	0	45
NW	2	13	7	2	0	0	24
NNW	5	15	0	0	0	0	20
Total	173	345	152	20	0	0	690

Number of Calm Hours - 2  
 Number of Variable Directions - 0  
 Total Number of Observations - 692



TABLE 2.3E-78

BVPS WIND - STABILITY SUMMARY  
 STABILITY CLASS - F, 150 Ft Winds  
 PERIOD: 10/01/76 TO 10/31/80

Number of Hourly Observations

Winds From	Wind Speed (mph)						Total
	1-3	4-7	8-12	13-18	19-24	25+	
N	9	4	0	0	0	0	13
NNE	17	10	0	0	0	0	27
NE	40	42	0	0	0	0	82
ENE	18	25	5	0	0	0	48
E	5	3	1	0	0	0	9
ESE	10	5	0	0	0	0	15
SE	5	1	0	0	0	0	6
SSE	2	1	0	0	0	0	3
S	12	8	1	0	0	0	21
SSW	8	39	5	0	0	0	52
SW	2	48	6	0	0	0	56
WSW	9	10	1	0	0	0	20
W	5	5	2	0	0	0	12
WNW	6	3	0	0	0	0	9
NW	8	4	0	0	0	0	12
NNW	6	5	1	0	0	0	12
Total	162	213	22	0	0	0	397

Number of Calm Hours - 3  
 Number of Variable Directions - 0  
 Total Number of Observations - 400

TABLE 2.3E-79

BVPS WIND - STABILITY SUMMARY  
 STABILITY CLASS - G, 150 Ft Winds  
 PERIOD: 10/01/76 TO 10/31/80

Number of Hourly Observations

Winds From	Wind Speed (mph)						Total
	1-3	4-7	8-12	13-18	19-24	25+	
N	11	1	0	0	0	0	12
NNE	56	12	0	0	0	0	68
NE	102	58	0	0	0	0	160
ENE	25	25	1	0	0	0	51
E	9	6	0	0	0	0	15
ESE	5	5	0	0	0	0	10
SE	7	2	1	0	0	0	10
SSE	5	4	1	0	0	0	10
S	12	11	1	0	0	0	24
SSW	18	50	1	0	0	0	69
SW	21	49	4	0	0	0	74
WSW	7	13	5	0	0	0	25
W	10	5	0	0	0	0	15
WNW	7	3	0	0	0	0	10
NW	4	2	0	0	0	0	6
NNW	9	1	0	0	0	0	10
Total	308	247	14	0	0	0	569

Number of Calm Hours - 0  
 Number of Variable Directions - 0  
 Total Number of Observations - 569

TABLE 2.3E-80

BVPS WIND - STABILITY SUMMARY  
 STABILITY CLASS - ALL, 150 Ft Winds  
 PERIOD: 10/01/76 TO 10/31/80

Number of Hourly Observations

Winds From	Wind Speed (mph)						Total
	1-3	4-7	8-12	13-18	19-24	25+	
N	30	82	23	0	0	0	135
NNE	94	68	24	9	0	0	195
NE	198	156	12	2	0	0	368
ENE	76	115	28	0	0	0	219
E	40	53	7	1	0	0	101
ESE	21	38	21	0	0	0	80
SE	25	28	22	2	0	0	77
SSE	18	33	14	0	0	0	65
S	40	68	27	1	0	0	136
SSW	42	167	60	3	0	0	272
SW	34	178	161	24	1	0	398
WSW	35	87	156	61	10	0	349
W	21	52	138	92	15	0	318
WNW	22	69	107	32	0	0	230
NW	16	54	44	9	0	0	123
NNW	26	61	15	2	0	0	104
Total	738	1309	859	238	26	0	3170

Number of Calm Hours - 5  
 Number of Variable Directions - 0  
 Total Number of Observations - 3175

TABLE 2.3E-81

BVPS WIND - STABILITY SUMMARY  
 STABILITY CLASS - A, 150 Ft Winds  
 PERIOD: 11/01/76 TO 11/30/80

Number of Hourly Observations

Winds From	Wind Speed (mph)						Total
	1-3	4-7	8-12	13-18	19-24	25+	
N	0	3	4	0	0	0	7
NNE	0	0	3	0	0	0	3
NE	0	1	3	0	0	0	4
ENE	0	7	11	0	0	0	18
E	0	1	5	0	0	0	6
ESE	0	0	1	0	0	0	1
SE	0	3	5	1	0	0	9
SSE	0	3	5	2	0	0	10
S	0	4	2	1	0	0	7
SSW	0	1	5	0	0	0	6
SW	0	4	2	2	0	0	8
WSW	0	5	3	3	0	0	11
W	0	5	19	10	0	0	34
WNW	0	6	10	11	0	0	27
NW	1	3	4	2	0	0	10
NNW	0	1	0	0	0	0	1
Total	1	47	82	32	0	0	162

Number of Calm Hours - 0  
 Number of Variable Directions - 0  
 Total Number of Observations - 162

TABLE 2.3E-82

BVPS WIND - STABILITY SUMMARY  
 STABILITY CLASS - B, 150 Ft Winds  
 PERIOD: 11/01/76 TO 11/30/80

Number of Hourly Observations

Winds From	Wind Speed (mph)						Total
	1-3	4-7	8-12	13-18	19-24	25+	
N	0	0	0	0	0	0	0
NNE	0	1	0	0	0	0	1
NE	0	1	0	0	0	0	1
ENE	0	2	0	0	0	0	2
E	0	1	2	0	0	0	3
ESE	0	0	0	0	0	0	0
SE	0	0	1	0	0	0	1
SSE	0	1	0	0	0	0	1
S	0	1	1	0	0	0	2
SSW	0	2	1	0	0	0	3
SW	0	1	4	0	0	0	5
WSW	0	3	9	5	0	0	17
W	0	5	3	7	0	0	15
WNW	0	1	4	4	0	0	9
NW	0	2	1	0	0	0	3
NNW	0	1	0	0	0	0	1
Total	0	22	26	16	0	0	64

Number of Calm Hours - 0  
 Number of Variable Directions - 0  
 Total Number of Observations - 64

TABLE 2.3E-83

BVPS WIND - STABILITY SUMMARY  
 STABILITY CLASS - C, 150 Ft Winds  
 PERIOD: 11/01/76 TO 11/30/80

## Number of Hourly Observations

Winds From	Wind Speed (mph)						Total
	1-3	4-7	8-12	13-18	19-24	25+	
N	0	1	0	0	0	0	1
NNE	0	1	0	0	0	0	1
NE	1	1	1	0	0	0	3
ENE	0	1	0	0	0	0	1
E	0	1	3	0	0	0	4
ESE	0	0	1	0	0	0	1
SE	0	0	1	0	0	0	1
SSE	0	2	1	0	0	0	3
S	0	0	0	0	0	0	0
SSW	0	2	4	0	0	0	6
SW	1	5	7	2	0	0	15
WSW	1	5	5	8	0	0	19
W	2	4	7	8	1	0	22
WNW	0	1	7	6	0	0	14
NW	0	1	5	2	0	0	8
NNW	1	2	0	0	0	0	3
Total	6	27	42	26	1	0	102

Number of Calm Hours - 0  
 Number of Variable Directions - 0  
 Total Number of Observations - 102

TABLE 2.3E-84

BVPS WIND - STABILITY SUMMARY  
 STABILITY CLASS - D, 150 Ft Winds  
 PERIOD: 11/01/76 TO 11/30/80

Number of Hourly Observations

Winds From	Wind Speed (mph)						Total
	1-3	4-7	8-12	13-18	19-24	25+	
N	15	39	9	0	0	0	63
NNE	9	32	3	0	0	0	44
NE	15	26	7	1	0	0	49
ENE	19	52	35	0	0	0	106
E	17	21	10	0	0	0	48
ESE	4	4	5	0	0	0	13
SE	7	8	2	0	0	0	17
SSE	4	11	1	0	0	0	16
S	3	14	6	4	0	0	27
SSW	8	22	35	8	0	0	73
SW	6	15	81	22	0	0	124
WSW	3	34	76	72	4	0	189
W	4	28	113	119	15	0	279
WNW	6	37	94	17	4	0	158
NW	1	49	46	4	0	0	100
NNW	12	24	5	0	0	0	41
Total	133	416	528	247	23	0	1347

Number of Calm Hours - 2  
 Number of Variable Directions - 0  
 Total Number of Observations - 1349

TABLE 2.3E-85

BVPS WIND - STABILITY SUMMARY  
 STABILITY CLASS - E, 150 Ft Winds  
 PERIOD: 11/01/76 TO 11/30/80

Number of Hourly Observations

Winds From	Wind Speed (mph)						Total
	1-3	4-7	8-12	13-18	19-24	25+	
N	7	4	0	0	0	0	11
NNE	14	10	2	0	0	0	26
NE	33	35	8	0	0	0	76
ENE	21	55	33	0	0	0	109
E	13	27	3	0	0	0	43
ESE	7	9	4	0	0	0	20
SE	7	7	6	0	0	0	20
SSE	10	5	6	0	0	0	21
S	10	13	7	1	0	0	31
SSW	6	21	22	3	0	0	52
SW	9	36	71	8	0	0	124
WSW	4	20	46	14	0	0	84
W	4	8	9	10	0	0	31
WNW	6	11	8	1	0	0	26
NW	2	3	4	0	0	0	9
NNW	5	5	1	0	0	0	11
Total	158	269	230	37	0	0	694

Number of Calm Hours - 4  
 Number of Variable Directions - 0  
 Total Number of Observations - 698



TABLE 2.3E-86

BVPS WIND - STABILITY SUMMARY  
 STABILITY CLASS - F, 150 Ft Winds  
 PERIOD: 11/01/76 TO 11/30/80

Number of Hourly Observations

Winds From	Wind Speed (mph)						Total
	1-3	4-7	8-12	13-18	19-24	25+	
N	13	0	0	0	0	0	13
NNE	34	8	0	0	0	0	42
NE	47	25	0	0	0	0	72
ENE	8	13	0	0	0	0	21
E	3	2	1	0	0	0	6
ESE	3	0	1	0	0	0	4
SE	4	1	0	0	0	0	5
SSE	2	3	0	0	0	0	5
S	5	3	0	0	0	0	8
SSW	10	26	5	0	0	0	41
SW	12	21	9	0	0	0	42
WSW	7	16	4	0	0	0	27
W	5	10	3	0	0	0	18
WNW	4	1	0	0	0	0	5
NW	3	1	0	0	0	0	4
NNW	2	0	1	0	0	0	3
Total	162	130	24	0	0	0	316

Number of Calm Hours - 2  
 Number of Variable Directions - 0  
 Total Number of Observations - 318

TABLE 2.3E-87

BVPS WIND - STABILITY SUMMARY  
 STABILITY CLASS - G, 150 Ft Winds  
 PERIOD: 11/01/76 TO 11/30/80

Number of Hourly Observations

Winds From	Wind Speed (mph)						Total
	1-3	4-7	8-12	13-18	19-24	25+	
N	17	4	0	0	0	0	21
NNE	41	13	0	0	0	0	54
NE	36	26	0	0	0	0	62
ENE	16	9	0	0	0	0	25
E	6	0	0	0	0	0	6
ESE	14	4	0	0	0	0	18
SE	5	4	0	0	0	0	9
SSE	4	2	0	0	0	0	6
S	6	10	1	0	0	0	17
SSW	17	23	5	0	0	0	45
SW	41	42	8	0	0	0	91
WSW	11	17	7	0	0	0	35
W	5	5	0	0	0	0	10
WNW	9	3	0	0	0	0	12
NW	3	0	0	0	0	0	3
NNW	5	0	0	0	0	0	5
Total	236	162	21	0	0	0	419

Number of Calm Hours - 4  
 Number of Variable Directions - 0  
 Total Number of Observations - 423

TABLE 2.3E-88

BVPS WIND - STABILITY SUMMARY  
 STABILITY CLASS - ALL, 150 Ft Winds  
 PERIOD: 11/01/76 TO 11/30/80

Number of Hourly Observations

Winds From	Wind Speed (mph)						Total
	1-3	4-7	8-12	13-18	19-24	25+	
N	52	51	13	0	0	0	116
NNE	98	65	8	0	0	0	171
NE	132	115	19	1	0	0	267
ENE	64	139	79	0	0	0	282
E	39	53	24	0	0	0	116
ESE	28	17	12	0	0	0	57
SE	23	23	15	1	0	0	62
SSE	20	27	13	2	0	0	62
S	24	45	17	6	0	0	92
SSW	41	97	77	11	0	0	226
SW	69	124	182	34	0	0	409
WSW	26	100	150	102	4	0	382
W	20	65	154	154	16	0	409
WNW	25	60	123	39	4	0	251
NW	10	59	60	8	0	0	137
NNW	25	33	7	0	0	0	65
Total	696	1073	953	358	24	0	3104

Number of Calm Hours - 12  
 Number of Variable Directions - 0  
 Total Number of Observations - 3116

TABLE 2.3E-89

BVPS WIND - STABILITY SUMMARY  
 STABILITY CLASS - A, 150 Ft Winds  
 PERIOD: 12/01/76 TO 12/31/80

Number of Hourly Observations

Winds From	Wind Speed (mph)						Total
	1-3	4-7	8-12	13-18	19-24	25+	
N	0	3	3	0	0	0	6
NNE	0	0	0	0	0	0	0
NE	0	2	0	0	0	0	2
ENE	0	6	2	0	0	0	8
E	0	5	0	0	0	0	5
ESE	0	0	0	0	0	0	0
SE	0	0	0	0	0	0	0
SSE	0	1	0	0	0	0	1
S	0	1	1	0	0	0	2
SSW	0	0	1	0	0	0	1
SW	0	2	4	1	0	0	7
WSW	0	2	3	2	0	0	7
W	0	5	19	6	6	0	36
WNW	0	2	6	9	0	0	17
NW	0	1	2	2	0	0	5
NNW	0	5	1	0	0	0	6
Total	0	35	42	20	6	0	103

Number of Calm Hours - 0  
 Number of Variable Directions - 0  
 Total Number of Observations - 103

TABLE 2.3E-90

BVPS WIND - STABILITY SUMMARY  
 STABILITY CLASS - B, 150 Ft Winds  
 PERIOD: 12/01/76 TO 12/31/80

Number of Hourly Observations

Winds From	Wind Speed (mph)						Total
	1-3	4-7	8-12	13-18	19-24	25+	
N	0	4	0	0	0	0	4
NNE	0	0	0	0	0	0	0
NE	0	0	0	0	0	0	0
ENE	0	3	0	0	0	0	3
E	1	5	0	0	0	0	6
ESE	0	0	0	0	0	0	0
SE	0	0	1	0	0	0	1
SSE	0	0	0	1	0	0	1
S	0	0	1	0	0	0	1
SSW	0	0	3	1	0	0	4
SW	0	2	0	0	0	0	2
WSW	0	2	4	0	0	0	6
W	0	1	3	2	1	0	7
WNW	1	2	4	2	1	0	10
NW	0	2	3	0	0	0	5
NNW	0	3	1	0	0	0	4
Total	2	24	20	6	2	0	54

Number of Calm Hours - 0  
 Number of Variable Directions - 0  
 Total Number of Observations - 54

TABLE 2.3E-91

BVPS WIND - STABILITY SUMMARY  
 STABILITY CLASS - C, 150 Ft Winds  
 PERIOD: 12/01/76 TO 12/31/80

Number of Hourly Observations

Winds From	Wind Speed (mph)						Total
	1-3	4-7	8-12	13-18	19-24	25+	
N	0	8	2	0	0	0	10
NNE	0	1	1	0	0	0	2
NE	1	3	2	0	0	0	6
ENE	0	0	1	0	0	0	1
E	0	1	0	0	0	0	1
ESE	0	0	1	0	0	0	1
SE	0	0	0	0	0	0	0
SSE	0	2	0	0	0	0	2
S	0	1	1	0	0	0	2
SSW	1	1	0	0	0	0	2
SW	1	1	2	0	0	0	4
WSW	0	1	1	2	0	0	4
W	0	2	6	7	0	0	15
WNW	0	0	3	5	1	1	10
NW	0	3	2	2	0	0	7
NNW	0	4	2	0	0	0	6
Total	3	28	24	16	1	1	73

Number of Calm Hours - 0  
 Number of Variable Directions - 0  
 Total Number of Observations - 73

TABLE 2.3E-92

BVPS WIND - STABILITY SUMMARY  
 STABILITY CLASS - D, 150 Ft Winds  
 PERIOD: 12/01/76 TO 12/31/80

Number of Hourly Observations

Winds From	Wind Speed (mph)						Total
	1-3	4-7	8-12	13-18	19-24	25+	
N	10	28	20	0	0	0	58
NNE	7	26	12	1	0	0	46
NE	10	34	1	0	0	0	45
ENE	15	68	5	0	0	0	88
E	8	16	3	0	0	0	27
ESE	3	4	3	0	0	0	10
SE	1	8	7	0	0	0	16
SSE	4	11	6	0	0	0	21
S	9	26	20	1	0	0	56
SSW	5	26	54	11	1	0	97
SW	3	53	129	30	1	0	216
WSW	3	40	171	67	9	3	293
W	4	22	122	138	47	7	340
WNW	2	30	73	54	15	0	174
NW	3	25	40	17	0	0	85
NNW	4	24	12	0	0	0	40
Total	91	441	678	319	73	10	1612

Number of Calm Hours - 0  
 Number of Variable Directions - 0  
 Total Number of Observations - 1612

TABLE 2.3E-93

BVPS WIND - STABILITY SUMMARY  
 STABILITY CLASS - E, 150 Ft Winds  
 PERIOD: 12/01/76 TO 12/31/80

Number of Hourly Observations

Winds From	Wind Speed (mph)						Total
	1-3	4-7	8-12	13-18	19-24	25+	
N	4	5	0	0	0	0	9
NNE	9	8	0	0	0	0	17
NE	29	50	0	0	0	0	79
ENE	21	49	10	0	0	0	80
E	14	15	6	0	0	0	35
ESE	9	8	3	0	0	0	20
SE	3	11	1	0	0	0	15
SSE	13	9	2	0	0	0	24
S	9	21	6	1	0	0	37
SSW	9	54	46	1	0	0	110
SW	5	56	70	6	0	0	137
WSW	7	20	22	10	2	2	63
W	5	11	17	3	4	0	40
WNW	1	14	6	4	0	0	25
NW	4	5	4	0	0	0	13
NNW	5	5	2	0	0	0	12
Total	147	341	195	25	6	2	716

Number of Calm Hours - 1  
 Number of Variable Directions - 0  
 Total Number of Observations - 717



TABLE 2.3E-94

BVPS WIND - STABILITY SUMMARY  
 STABILITY CLASS - F, 150 Ft Winds  
 PERIOD: 12/01/76 TO 12/31/80

Number of Hourly Observations

Winds From	Wind Speed (mph)						Total
	1-3	4-7	8-12	13-18	19-24	25+	
N	2	0	0	0	0	0	2
NNE	30	6	0	0	0	0	36
NE	47	40	0	0	0	0	87
ENE	14	15	3	0	0	0	32
E	5	4	0	0	0	0	9
ESE	1	0	0	0	0	0	1
SE	5	0	0	0	0	0	5
SSE	1	1	0	0	0	0	2
S	6	4	0	0	0	0	10
SSW	5	21	7	0	0	0	33
SW	6	23	2	0	0	0	31
WSW	3	10	3	0	0	0	16
W	8	0	0	0	0	0	8
WNW	4	2	0	0	0	0	6
NW	0	0	0	0	0	0	0
NNW	1	0	0	0	0	0	1
Total	138	126	15	0	0	0	279

Number of Calm Hours - 3  
 Number of Variable Directions - 0  
 Total Number of Observations - 282

TABLE 2.3E-95

BVPS WIND - STABILITY SUMMARY  
 STABILITY CLASS - G, 150 Ft Winds  
 PERIOD: 12/01/76 TO 12/31/80

Number of Hourly Observations

Winds From	Wind Speed (mph)						Total
	1-3	4-7	8-12	13-18	19-24	25+	
N	11	3	0	0	0	0	14
NNE	30	16	0	0	0	0	46
NE	42	51	0	0	0	0	93
ENE	15	9	0	0	0	0	24
E	6	0	0	0	0	0	6
ESE	5	1	0	0	0	0	6
SE	3	1	0	0	0	0	4
SSE	2	1	0	0	0	0	3
S	4	6	1	0	0	0	11
SSW	6	14	6	0	0	0	26
SW	11	18	6	0	0	0	35
WSW	13	7	1	0	0	0	21
W	6	1	0	0	0	0	7
WNW	5	0	0	0	0	0	5
NW	4	1	0	0	0	0	5
NNW	3	0	0	0	0	0	3
Total	166	129	14	0	0	0	309

Number of Calm Hours - 0  
 Number of Variable Directions - 0  
 Total Number of Observations - 309

TABLE 2.3E-96

BVPS WIND - STABILITY SUMMARY  
 STABILITY CLASS - ALL, 150 Ft Winds  
 PERIOD: 12/01/76 TO 12/31/80

Number of Hourly Observations

Winds From	Wind Speed (mph)						Total
	1-3	4-7	8-12	13-18	19-24	25+	
N	27	51	25	0	0	0	103
NNE	76	57	13	1	0	0	147
NE	129	180	3	0	0	0	312
ENE	65	150	21	0	0	0	236
E	34	46	9	0	0	0	89
ESE	18	13	7	0	0	0	38
SE	12	20	9	0	0	0	41
SSE	20	25	8	1	0	0	54
S	28	59	30	2	0	0	119
SSW	26	116	117	13	1	0	273
SW	26	155	213	37	1	0	432
WSW	26	82	205	81	11	5	410
W	23	42	167	156	58	7	453
WNW	13	50	92	74	17	1	247
NW	11	37	51	21	0	0	120
NNW	13	41	18	0	0	0	72
Total	547	1124	988	386	88	13	3146

Number of Calm Hours - 4  
 Number of Variable Directions - 0  
 Total Number of Observations - 3150

TABLE 2.3E-97

BVPS WIND - STABILITY SUMMARY  
 STABILITY CLASS - A, 150 Ft Winds  
 PERIOD: 1/01/76 TO 12/31/80

Number of Hourly Observations

Winds From	Wind Speed (mph)						Total
	1-3	4-7	8-12	13-18	19-24	25+	
N	32	241	184	19	0	0	476
NNE	17	132	99	15	1	0	264
NE	29	108	74	3	0	0	214
ENE	12	102	89	10	0	0	213
E	11	91	47	9	0	0	158
ESE	11	82	32	0	0	0	125
SE	14	90	55	4	0	0	163
SSE	12	93	65	8	0	0	178
S	11	133	123	5	0	0	272
SSW	12	129	173	35	1	0	350
SW	21	172	342	67	7	0	609
WSW	18	268	334	115	16	1	752
W	24	261	374	235	52	7	953
WNW	21	128	253	158	28	0	588
NW	31	107	151	52	2	0	343
NNW	22	138	139	23	0	0	322
Total	298	2275	2534	758	107	8	5980

Number of Calm Hours - 6  
 Number of Variable Directions - 0  
 Total Number of Observations - 5986

TABLE 2.3E-98

BVPS WIND - STABILITY SUMMARY  
 STABILITY CLASS - B, 150 Ft Winds  
 PERIOD: 1/01/76 TO 12/31/80

Number of Hourly Observations

Winds From	Wind Speed (mph)						Total
	1-3	4-7	8-12	13-18	19-24	25+	
N	10	33	11	0	0	0	54
NNE	2	17	5	1	0	0	25
NE	6	24	4	1	0	0	35
ENE	1	25	6	0	0	0	32
E	3	16	3	3	0	0	25
ESE	4	6	3	0	0	0	13
SE	3	7	2	1	0	0	13
SSE	2	11	1	1	0	0	15
S	3	16	15	2	0	0	36
SSW	3	23	26	6	0	0	58
SW	8	35	48	12	2	0	105
WSW	4	49	88	36	2	0	179
W	9	41	41	49	10	1	151
WNW	7	18	55	24	3	0	107
NW	4	21	30	6	2	0	63
NNW	8	21	18	1	0	0	48
Total	77	363	356	143	19	1	959

Number of Calm Hours - 1  
 Number of Variable Directions - 0  
 Total Number of Observations - 960

TABLE 2.3E-99

BVPS WIND - STABILITY SUMMARY  
 STABILITY CLASS - C, 150 Ft Winds  
 PERIOD: 1/01/76 TO 12/31/80

Number of Hourly Observations

Winds From	Wind Speed (mph)						Total
	1-3	4-7	8-12	13-18	19-24	25+	
N	9	38	21	2	0	0	70
NNE	8	34	15	0	0	0	57
NE	10	31	9	1	0	0	51
ENE	10	20	11	2	0	0	43
E	2	17	10	1	0	0	30
ESE	4	7	6	0	0	0	17
SE	1	5	3	1	0	0	10
SSE	3	19	5	1	0	0	28
S	3	19	15	0	0	0	37
SSW	5	25	35	5	0	0	70
SW	8	41	76	25	2	0	152
WSW	12	55	58	39	2	0	166
W	12	42	74	63	15	1	207
WNW	4	27	61	32	4	1	129
NW	6	29	35	8	0	0	78
NNW	7	33	30	0	0	0	70
Total	104	442	464	180	23	2	1215

Number of Calm Hours - 1  
 Number of Variable Directions - 0  
 Total Number of Observations - 1216

TABLE 2.3E-100

BVPS WIND - STABILITY SUMMARY  
 STABILITY CLASS - D, 150 Ft Winds  
 PERIOD: 1/01/76 TO 12/31/80

Number of Hourly Observations

Winds From	Wind Speed (mph)						Total
	1-3	4-7	8-12	13-18	19-24	25+	
N	111	354	172	3	0	0	640
NNE	123	261	102	11	0	0	497
NE	193	288	91	14	3	0	589
ENE	140	393	167	7	0	0	707
E	103	149	67	8	0	0	327
ESE	53	71	39	3	0	0	166
SE	37	72	28	4	0	0	141
SSE	33	76	26	1	0	0	136
S	63	172	90	12	1	0	338
SSW	75	250	254	42	3	1	625
SW	72	399	724	158	15	4	1372
WSW	76	419	932	432	73	15	1947
W	83	266	870	756	164	15	2154
WNW	65	400	606	270	59	1	1401
NW	72	411	368	50	1	0	902
NNW	89	317	105	6	0	0	517
Total	1388	4298	4641	1777	319	36	12459

Number of Calm Hours - 10  
 Number of Variable Directions - 0  
 Total Number of Observations - 12469

TABLE 2.3E-101

BVPS WIND - STABILITY SUMMARY  
 STABILITY CLASS - E, 150 Ft Winds  
 PERIOD: 1/01/76 TO 12/31/80

Number of Hourly Observations

Winds From	Wind Speed (mph)						Total
	1-3	4-7	8-12	13-18	19-24	25+	
N	91	132	19	2	0	0	244
NNE	185	114	25	0	0	0	324
NE	462	381	55	20	1	0	919
ENE	290	412	140	8	1	0	851
E	179	187	49	5	0	0	420
ESE	96	107	35	1	0	0	239
SE	89	98	26	1	0	0	214
SSE	91	86	23	2	0	0	202
S	169	225	55	10	0	0	459
SSW	169	440	215	16	0	1	841
SW	148	475	438	56	1	0	1118
WSW	95	223	246	75	13	4	656
W	78	160	139	88	15	3	483
WNW	59	176	112	20	3	0	370
NW	60	121	47	5	0	0	233
NNW	66	133	10	0	0	0	209
Total	2327	3470	1634	309	34	8	7782

Number of Calm Hours - 32  
 Number of Variable Directions - 0  
 Total Number of Observations - 7814



TABLE 2.3E-102

BVPS WIND - STABILITY SUMMARY  
 STABILITY CLASS - F, 150 Ft Winds  
 PERIOD: 1/01/76 TO 12/31/80

Number of Hourly Observations

Winds From	Wind Speed (mph)						Total
	1-3	4-7	8-12	13-18	19-24	25+	
N	162	31	1	0	0	0	194
NNE	452	92	1	0	0	0	545
NE	663	326	6	0	0	0	995
ENE	238	124	14	0	0	1	377
E	120	45	7	0	0	0	172
ESE	71	17	1	0	0	0	89
SE	72	14	0	1	0	0	87
SSE	66	25	3	0	0	0	94
S	149	130	10	0	0	0	289
SSW	192	334	38	0	0	0	564
SW	151	295	78	4	0	0	528
WSW	80	126	46	1	0	0	253
W	72	49	13	2	1	0	137
WNW	48	33	2	0	0	0	83
NW	61	23	3	0	0	0	87
NNW	58	27	2	0	0	0	87
Total	2655	1691	225	8	1	1	4581

Number of Calm Hours - 72  
 Number of Variable Directions - 0  
 Total Number of Observations - 4653

TABLE 2.3E-103

BVPS WIND - STABILITY SUMMARY  
 STABILITY CLASS - G, 150 Ft Winds  
 PERIOD: 1/01/76 TO 12/31/80

Number of Hourly Observations

Winds From	Wind Speed (mph)						Total
	1-3	4-7	8-12	13-18	19-24	25+	
N	173	11	0	0	0	0	184
NNE	497	145	1	0	0	0	643
NE	786	392	5	0	0	0	1183
ENE	216	112	2	0	0	0	330
E	84	25	0	0	0	0	109
ESE	73	26	1	0	0	0	100
SE	60	24	1	0	0	0	85
SSE	52	26	1	0	0	0	79
S	130	134	6	0	0	0	270
SSW	193	389	24	0	0	0	606
SW	266	382	46	0	0	0	694
WSW	121	114	27	1	0	0	263
W	85	39	0	1	0	0	125
WNW	50	24	0	0	0	0	74
NW	57	14	1	0	0	0	72
NNW	72	13	0	0	0	0	85
Total	2915	1870	115	2	0	0	4902

Number of Calm Hours - 36  
 Number of Variable Directions - 0  
 Total Number of Observations - 4938

TABLE 2.3E-104

BVPS WIND - STABILITY SUMMARY  
 STABILITY CLASS - ALL, 150 Ft Winds  
 PERIOD: 1/01/76 TO 12/31/80

## Number of Hourly Observations

Winds From	Wind Speed (mph)						Total
	<u>1-3</u>	<u>4-7</u>	<u>8-12</u>	<u>13-18</u>	<u>19-24</u>	<u>25+</u>	
N	588	840	408	26	0	0	1862
NNE	1284	795	248	27	1	0	2355
NE	2149	1550	244	39	4	0	3986
ENE	907	1188	429	27	1	1	2553
E	502	530	183	26	0	0	1241
ESE	312	316	117	4	0	0	749
SE	276	310	115	12	0	0	713
SSE	259	336	124	13	0	0	732
S	528	829	314	29	1	0	1701
SSW	649	1590	765	104	4	2	3114
SW	674	1799	1752	322	27	4	4578
WSW	406	1254	1731	699	106	20	4216
W	363	858	1511	1194	257	27	4210
WNW	254	806	1089	504	97	2	2752
NW	291	726	635	121	5	0	1778
NNW	322	682	304	30	0	0	1338
Total	<u>9764</u>	<u>14409</u>	<u>9969</u>	<u>3177</u>	<u>503</u>	<u>56</u>	<u>37878</u>

Number of Calm Hours - 158  
 Number of Variable Directions - 0  
 Total Number of Observations - 38036

## 2.4 HYDROLOGIC ENGINEERING

### 2.4.1 Hydrologic Description

#### 2.4.1.1 Site and Facilities

The Beaver Valley Power Station (BVPS) is located on the south side of the Ohio River at river mile 34.7. The general site area is characterized by sloping topography, with the exception of the northeast corner of the site on which the station is located. Ground elevations vary from 664.5 feet mean sea level (msl) (normal river pool elevation) to a maximum elevation of 1,160 feet msl. Station grades are approximately 730 to 735 feet msl. Peggs Run, a small stream flowing through the eastern portion of the site, is channeled through a culvert near the station and enters the Ohio River just west of Route 168. Figure 1.2-1 shows the developed site. A complete description of the site is provided in Section 2.1. Figure 2.1-2 shows the hydrological features in the vicinity of the site.

All Seismic Category I structures are protected from the probable maximum flood (PMF) level of 730.0 feet as described in Section 3.4.1. All safety-related equipment and connecting piping and wiring is either located above el 730.0 feet or adequately protected so that its function is unaffected by a flood to el 730.0 feet. Section 3.4.1 discusses flood protection for safety-related structures and facilities.

#### 2.4.1.2 Hydrosphere

The BVPS site is located on the south side of the Ohio River at river mile 34.7 at a location on the New Cumberland Pool that is 3.1 river miles downstream of the Montgomery Lock and Dam and 19.6 miles upstream of the New Cumberland Locks and Dam. The total drainage area upstream of the site is approximately 23,000 square miles. The normal pool elevation at the site is maintained at el 664.5 feet msl by the New Cumberland Dam for river flows up to about 20,000 cubic feet per second (cfs). Figure 2.4-1 shows the major hydrological features in the region of the site. The local site drainage is discussed in Section 2.4.2.3.

##### 2.4.1.2.1 Surface Water

The Ohio River is formed in Pittsburgh, Pennsylvania, by the confluence of the Monongahela and Allegheny Rivers. The Ohio River flows southwesterly for 981 miles to Cairo, Illinois, where it joins the Mississippi River. The river is highly regulated by many reservoirs on its tributaries and by numerous navigation locks and dams. The navigation locks and dams on the Ohio River within 50 miles of the site are listed in Table 2.4-1, with their respective storage capacities. Table 2.4-2 lists the intakes (including their owners, locations, and rates of withdrawal from the Ohio River) that

could be adversely affected by accidental release of contaminants. Tributaries within 50 miles of the site that have a mean flow greater than 100 cfs are listed in Table 2.4-3. The major tributaries are the Beaver, Allegheny, and Monongahela Rivers.

#### 2.4.1.2.1.1 Beaver River

The Beaver River joins the Ohio River at river mile 25.2 on the Montgomery Pool, about 9.5 miles upstream of the site. The Beaver River at the Beaver Falls Gauge has a drainage area of 3,106 square miles with an average discharge of 3,530 cfs. The river basin contains eight major reservoirs, most of which are multi-purpose. The eight reservoirs are listed in Table 2.4-4, along with information on owner, storage capacity, and use.

#### 2.4.1.2.1.2 Allegheny River

The Allegheny River flows southerly from its headwaters in Potter County, Pennsylvania, approximately 270 miles to its confluence with the Monongahela River to form the Ohio River. The Allegheny River at the Natrona Gauge has a drainage area of 11,410 square miles with an average discharge of 19,270 cfs. The river has eight navigation locks and dams on the lowermost 72 miles. The Allegheny River Basin contains nine major reservoirs, many of which are multi-purpose. The East Branch Dam and the Kinzua Dam are equipped for low-flow augmentation. These reservoirs are listed in Table 2.4-4 along with owner, storage capacity, and use.

#### 2.4.1.2.1.3 Monongahela River

The Monongahela River is formed at the confluence of the West Fork and Tygart Rivers. The river, which is divided into individual pools by nine navigational locks and dams, flows northward 128 miles to its confluence with the Allegheny River. The Monongahela River at the Braddock Gauge has a drainage area of 7,337 square miles with an average discharge of 12,260 cfs. The river basin contains three multi-purpose reservoirs located on the Tygart and Youghiogheny Rivers. The owner, storage capacity, and use of the reservoirs are listed in Table 2.4-4. An additional reservoir, proposed for the Cheat River at Rowlesburg, would add an additional 1,000 cfs during extremely low flow conditions.

#### 2.4.1.2.2 Ground Water

Ground-water conditions in the BVPS-2 site area are discussed in Section 2.4.13.

## 2.4.2 Floods

### 2.4.2.1 Flood History

The greatest recorded flow on the Ohio River in the vicinity of the site occurred on March 15, 1936 (U.S. Geological Survey (USGS) 1978). The USGS gauging station at Sewickley, Pennsylvania, recorded a peak discharge of 574,000 cfs and a stage of 725.2 feet msl. As a result of flooding, an extensive flood control program for the Ohio River Basin was initiated to reduce peak stages and resultant economic losses. The Army Corps of Engineers now maintains 15 flood control projects above the site, all of which were built after the 1936 flood.

As indicated in response to Question 2.1 of the Beaver Valley Power Station - Unit 2 (BVPS-2) PSAR, the largest flood in recent history occurred in June 1972 due to Hurricane Agnes which produced a peak discharge of 370,000 cfs and a stage of 714.8 feet msl at the Sewickley Gauge. The reservoir system is credited for greatly reducing the impact of this flood.

### 2.4.2.2 Flood Design Considerations

The effects of flooding at the site were evaluated quantitatively for the following conditions: local intense precipitation, PMF on the Ohio River, potential dam failures, and ice effects. The design flood elevation, derived from the PMF, is 730 feet msl.

In addition to the structural design of safety-related buildings to withstand a PMF level of 730 feet msl, the design of the intake structure also provides for protection against coincident windwave activity and associated wave runup as discussed in Sections 2.4.3.6, 2.4.10, and [Licensing Requirements Manual](#) LR 3.7.2 (Section 2.4.14). Section 2.4.2.3 demonstrates the design integrity of safety-related structures against flooding resulting from a local probable maximum precipitation (PMP) event.

### 2.4.2.3 Effects of Local Intense Precipitation

The effect of local intense precipitation on the adjacent drainage area and the site drainage system were evaluated.

The all-season envelope PMP at the site, based on information from the U.S. Weather Bureau (1956), is listed in Table [2.4-5](#).

The precipitation intensity was computed on the basis of a 10-square-mile area, since no variation is assumed between point and 10-square-mile precipitation. For durations shorter than 6 hours, the time distribution of 6-hour PMP was obtained from U.S. Army data (U.S. Department of the Army 1965).

#### 2.4.2.3.1 Peggs Run

The local watershed in which the site is located is shown on Figure 2.1-2. The watershed, with an area of approximately 4 square miles, is a hilly forested area, rising southward from the southern bank of the Ohio River. The hills forming the small drainage course slope at approximately 2 horizontally to 1 vertically. The watershed boundary defines the area contributing runoff to Peggs Run which flows generally from south to north into the Ohio River and is approximately 3 miles long. The flow in Peggs Run is normally very low with a mean annual flow estimated to be under 5 cfs.

A portion of Peggs Run (1,400 feet) is enclosed in a 15-foot-diameter culvert which connects to the culvert under the New Cumberland-Pittsburgh Railroad. Downstream of the railroad culvert, Peggs Run follows the existing stream bed for about 350 feet before entering a channel which connects to the Ohio River. The design flow of the 15-foot culvert is 2,000 cfs with a maximum capacity of 2,960 cfs. The small drainage area of Peggs Run makes it susceptible to a flash flood, which could occur during a period of low river stage. In order to determine the response of the watershed to a worst case of rainfall, a flood analysis was performed.

The analysis evaluates the effects of flooding due to local PMP and due to the flood of one-half of the local PMF in conjunction with a safe shutdown earthquake (SSE). The 6-hour PMP having a maximum intensity of 9.3 in/hr for a 1 hour duration is used to simulate the local PMF. In both cases, the 15-foot-diameter culvert in Peggs Run is assumed to pass negligible flow, due to blockage by debris or seismic failure. The general approach taken is to route flow from contributing areas to the Ohio River and to compute the resulting maximum water depth at the safety-related structures. The U.S. Army Corps of Engineers HEC-2 water surface profile program (1980) is utilized to generate a series of water surface elevations. In both cases, the resulting water levels in the vicinity of the safety-related structures are below the design basis flood of el 730 feet msl.

#### 2.4.2.3.2 Site Drainage System

The 10-minute PMP having an intensity of 3.5 inches is chosen for evaluation. The distribution of a 1-hour PMP down to a 10-minute duration is carried out following the same principle for distributing the 6-hour PMP down to the 1-hour duration (U.S. Department of the Army 1965).

The storm drains are designed to pass, without flooding, a rainfall intensity of 4 in/hr. Site ground elevation surrounding all buildings is at or above el 730 feet msl with all safety-related building entrances set 6 inches above ground level, except for one door to the service building where the sill is at grade. A runoff analysis was performed for the 10-minute period of highest

precipitation intensity (21.0 in./hr). The yard drains are assumed to be ineffective due to a concurrent high water elevation.

Roof drains are assumed to be blocked by debris. Critical flow paths and contributing drainage areas were determined using roof plans and site drawings containing topographic information. Peak water surface elevations along the flow paths were computed using the HEC-2 program (U.S. Army 1980). The water depths adjacent to the openings of safety-related buildings are presented in Table 2.4-6.

As shown in Table 2.4-6 the maximum water surface is above the sill of only one door to a safety-related structure. Since the sill to the affected door for the service building is at grade, runoff water from local site flooding will seep under the door during the PMP until the site drainage system becomes operational or the water level dissipates.

An analysis was performed to calculate the quantity of water entering the service building under the affected door. HEC-2 runs were made using flows from time periods of the PMP less than the peak 10-minute intensity. From the water levels computed using HEC-2, an estimate was made of the quantity of water seeping between the bottom of the door and the sill. In the analysis, a maximum gap of 1/16 in. between the bottom of the door and the door sill was assumed. A door width of 8 ft and 1.5 in. thick was used. The flow rate was calculated by assuming laminar steady flow between fixed-parallel plates. In the most intense 1 hour rainfall, the water depths over the door sill varies from 0.2 to 0.5 ft. The total volume of water seeping through the door was calculated to be 475 ft<sup>3</sup>. Taking into consideration the size of the room, equipment location, and with no credit taken for floor drains and sumps, the accumulation of water in the service building has been calculated to be 1.3 in. deep. Since there are no QA Category I equipment or electrical connections located closer than 2 in. to the floor, there is no impact on the operation of safety-related equipment due to a PMP.

Since the intensity of winter PMP is only about half of the annual PMP and the snow accumulation on the road will be plowed regularly, flooding at the site is not anticipated. Furthermore, the topography around BVPS-2 beyond the contour of el 730 feet slopes down sharply toward the north and the east; therefore, even with ice accumulation on unplowed areas, the drainage in these directions would not be hindered. The access road on the southern side of the buildings will be plowed regularly and will provide drainage for storm flow from the west and the south of the buildings toward Peggs Run.

#### 2.4.3 Probable Maximum Flood on Streams and Rivers

The PMF on the Ohio River has been evaluated by the U.S. Army Corps of Engineers, Pittsburgh District (1970). The Corps of Engineers concludes that the PMF has a peak flow of 1,500,000 cfs with an elevation of 730.0 feet msl at Ohio River Mile 35.0.



The information presented in Sections 2.4.3.1 through 2.4.3.5 was obtained from the U.S. Army Corps of Engineers (1970) (Appendix 2.4A).

#### 2.4.3.1 Probable Maximum Precipitation

The tributary area upstream of BVPS is adjacent to the Susquehanna River basin where a probable maximum storm has been previously developed. This PMP study (U.S. Weather Bureau 1965) presented a storm pattern in the form of isohyetal lines developed for 24,100 square miles of drainage area in the Susquehanna basin above Harrisburg, Pennsylvania. This is about the same size as the area above BVPS. Consultation with the Office of Chief of Engineers, Army Corps of Engineers, and the Weather Bureau Hydrometeorological Section confirmed that data for the Susquehanna basin could be reasonably applied to the Pittsburgh area (U.S. Army Corps of Engineers, Pittsburgh District 1970).

Orientation of the storm pattern over the Pittsburgh District was performed by transposing it 2.5 degrees longitude west and 0.8 degree latitude south. This was believed to be not only a logical transposition, but also one conducive to the peak runoff maximization. The isohyetal storm pattern is shown on Figure 2.4-2; the values of intensity and time distribution of the isohyets are presented in Table 2.4-7.

#### 2.4.3.2 Precipitation Losses

Being a summer-type storm, the PMF probably would occur when rainfall is normal or below normal. Antecedent stream flow would also be low and infiltration loss to runoff high. The infiltration rates computed for the high intensity storm of August 3, 1964, which occurred over the French Creek basin, were used in the PMP computations. This storm possessed typical antecedent characteristics from which the PMP storm is generated. These infiltration rates were applied to several high intensity summer storms that occurred in or near the Stonewall Jackson Lake area, and the losses were found to be in close agreement with the actual losses. The infiltration rates used for the PMF are shown on Figure 2.4-3.

#### 2.4.3.3 Runoff and Stream Course Model

The sub-basin area is shown on Figure 2.4-4. The map has been subdivided into drainage areas. Each numbered area represents an uncontrolled area for which unit hydrographs have been established. Each shaded area is controlled by a dam and named accordingly. Except for Meander and Chautauqua, which are private, all of these dams are operated by the Corps of Engineers. The different routing reaches used in the PMF analysis are indicated by letters. A separate tabulation of drainage areas is included in Table 2.4-8.

Individual hydrographs for each of the 61 subareas in the basin and for the areas above the 13 reservoirs were developed from the unit graphs and the 6-hour rainfall values, applicable to the particular areas, modified by infiltration losses. These losses have been found applicable to storms of similar characteristics and seasonal occurrences in this area.

The reservoir inflow hydrographs were developed in a similar manner with unit graphs and the oriented rainfall values. In no case were these flood flows as great as the spillway design floods which were used to assure the safety of the dam against overtopping and failure. Reservoir storage during the early storm periods was sustained long enough to permit downstream passage of the flood peak before spillway discharge could appreciably add to its magnitude. Ultimate reservoir storage heights were below structural design levels.

The hourly unit hydrographic values and Muskingum routing coefficients cross-referenced to the area and reaches are presented as Table Response 2.10.2-1 in the BVPS-2 PSAR.

After the flow hydrograph for the PMF was computed, a stage-discharge relationship was developed which would accommodate this flow while maintaining all of the hydrologic characteristics. These characteristics require that the valley storage reflect the inflow and outflow into any reach and that the stage-discharge relationship adequately represent the computed flows.

During analysis of a particular reach, the average volume within that reach (the average of the upstream and downstream stages) was the valley storage. Stage capacity relationships developed for these

reaches determined a height equalling the maximum volume stored within that reach, which represents the difference between the inflow and outflow. A water surface profile was established from these computations (Figure 2.4-5). The slope of this profile was then inserted into Manning's equation along with the other known values to compute a discharge. This value was then checked against the PMF peak to satisfy all of the requirements. The Manning's roughness coefficient used and the basis for it is given in the response to U.S. Atomic Energy Commission (USAEC) Question 2.11.3 and is included in Amendment 4 to the BVPS-2 PSAR.

Figure 2.4-6 compares actual and reproduced Ohio River flow rates at the Dashields Lock and Dam during the October 1954 flood. Table 2.4-9 presents one page of the flood forecast.

#### 2.4.3.4 Probable Maximum Flood Flow

The uncontrolled area hydrographs routed to Shippingport resulted in a combined flood hydrograph of 1,430,000 cfs.

Reservoir outflows were subsequently routed downstream through the basin and were combined with the uncontrolled flow hydrographs to form the PMF as modified by the 13 existing reservoirs.

This flood has a maximum flow magnitude of 1,500,000 cfs. It is almost 4 times as great as the maximum reduced flood of 200 years of record. The hydrograph of this flood is shown as Figure 2.4-7.

The analysis shows that outflow from the flood control reservoirs would only contribute 70,000 cfs to the flood peak. Reservoirs would operate according to their predetermined schedules and would be in no danger of failure since their own design criteria provide for flows of even greater magnitude.

None of the flood control dams are realistically expected to fail during peak flood flow, or at any other time.

#### 2.4.3.5 Water Level Determination

Using contour and profile data developed from Figures 2.4-8, 2.4-9, 2.4-10, 2.4-11, 2.4-12, 2.4-13 and 2.4-14, the U.S. Army Corps of Engineers (Pittsburgh District, 1970) determined that the PMF would attain an elevation of 730.0 feet msl at Ohio River Mile 35.0.

#### 2.4.3.6 Coincident Wind Wave Activity

An analysis of the coincident wind and wave activity during the PMF event was requested by the U.S. Nuclear Regulatory Commission (USNRC) during the BVPS-2 PSAR review. This additional analysis was performed in response to (USAEC) Question 2.13 and is included in Amendment 2 to the BVPS-2 PSAR.

The following is a summary of that analysis:

1. The maximum wave height,  $H_{\max}$ , is 5.0 feet with a wave period,  $T$ , of 4.0 seconds.
2. The maximum overpressure on a vertical wall due to wave action is 360 psf at the still water level.
3. The associated wave runup is 6.7 feet above the standing water level of 730 feet msl.
4. As discussed in Section 3.4, protection has been provided against wave action and there will be no loss of ability to maintain a safe shutdown condition.

#### 2.4.4 Potential Dam Failures, Seismically Induced

##### 2.4.4.1 Dam Failure Permutations

An analysis of the seismically-induced flood potential was requested by the USNRC during the BVPS-2 PSAR review. This analysis is presented in response to USAEC Question 2.12.1 and is included in Amendment 2 to the BVPS-2 PSAR. Detailed information including dam heights, long-term storage volumes and levels, flood control volumes and levels, and channel distances upstream of BVPS-2 for the major flood control reservoirs is presented in the response to USAEC Question 2.10.4 and is included in Amendment 2 to the BVPS-2 PSAR.

##### 2.4.4.2 Unsteady Flow Analysis of Potential Dam Failures

As discussed in the response to USAEC Question 2.12, contained in Amendment 2 to the BVPS-2 PSAR, and to Question 2.12.2 of Amendment 4, failure of the Conemaugh Dam (the most critically located dam with respect to flooding resulting from a dam failure) is not expected to occur due to shear failure or liquefaction for either the 25-year flood plus the SSE, or the standard project flood (SPF) plus the historic earthquake. Even though the Conemaugh Dam has been analyzed to be safe against these loading conditions, it was assumed to fail coincident with the SPF. An analysis performed by the U.S. Army Corps of Engineers (Pittsburgh District, 1970) (Appendix 2.4A) shows that the resultant peak stage at the site would be el 725.2 feet. This is less critical than the stage resulting from the PMF (el 730.0 feet), as discussed in Section 2.4.3.

Consideration was also given to the possibility of more than one dam failing. This situation could arise due to either seismically-induced simultaneous failures or due to the failure of dams downstream from the flood wave caused by a single, seismically-induced upstream dam failure. All dams which could potentially affect water levels at the plant site are located on separate tributaries of the Ohio River. There are no dams in series on a single stream; thus, potential for cascade effects does not exist.

All dams are designed to withstand an earthquake loading of 0.1g horizontal, and safety factors indicate that these structures are safe against the postulated loading systems. Simultaneous failure of two or more dams under these conditions is not considered credible.

#### 2.4.4.3 Water Level at the Plant Site

As discussed in Section 2.4.4.2, the failure of the most critically-located dam (Conemaugh) would result in a maximum water elevation of 725.2 feet at the site. In addition, multiple dam failures is not a credible postulated event. The most critical flood condition at the site of el 730.0 feet results from the PMF, as discussed in Section 2.4.3. All safety-related equipment and connecting piping and wiring are either located above that elevation or adequately protected so that their function is unaffected by a flood up to el 730.0 feet.

#### 2.4.5 Probable Maximum Surge and Seiche Flooding

This section is not applicable to the BVPS-2 site since the site is not located near a large body of water where surge and seiche flooding would be a significant consideration.

#### 2.4.6 Probable Maximum Tsunami Flooding

A tsunami is a gravity wave system formed in the sea following any large scale, short duration disturbance of the free surface. Tsunamis usually occur following undersea earthquakes of a certain magnitude, although landslides, bottom slumping, and volcanic eruptions have generated tsunamis in certain cases. This section is not applicable to the situation at the BVPS-2 site.

#### 2.4.7 Ice Effects

##### 2.4.7.1 Potential Ice Jamming

The statistical summary of ice in the Ohio River at Cincinnati, Ohio for 1874 - 1964, prepared by the National Weather Service, is the most complete long-term record of icing on the Ohio River. This summary is regarded as a good average between the colder upstream reaches and the warmer downstream reaches by the Ohio River Division Ice Committee of the U.S. Army Corps of Engineers (1978). During the 90 years of record, 62 winters have experienced icing, including 13 winters when the river was frozen over and 28 winters which were ice-free. Table 2.4-10 provides a summary of the amount of time various degrees of icing were experienced.

Except for a 12-day period in February 1948, the longest periods of continuous river ice at Cincinnati occurred prior to 1919. As development of the Ohio River has increased, the influence of reservoirs and of impurities on ice formation has increased, which may have contributed to shorter periods of continuous ice in more recent times. Frozen-over reservoirs will release warmer flows

downstream than would have been released without the reservoir. Population and industry growth have increased the amount of impurities in the water, thus lowering the freezing point of the river. Tributary storage reservoirs, however, trap some impurities, and recently there have been major efforts to reduce pollution, including waste heat. The net effect of these factors is unknown at this time.

Icing records at the New Cumberland locks and dam are maintained by the U.S. Army Corps of Engineers (1963-1979). The Corps has not, however, performed any special icing studies in the New Cumberland Pool, nor is it known whether ice conditions have caused lower or higher than normal water levels (U.S. Army Corps of Engineers, Pittsburgh District 1979). Available data for 1963 - 1979 are summarized in Table 2.4-11. Differences in definitions for various ice conditions prevent detailed comparison of the 17-year record at New Cumberland with the 90-year record at Cincinnati. It can be seen, however, that the majority of ice occurrences are, as expected, in January and February and that the average number of ice occurrences per year are similar, about 12 per year at New Cumberland and 15 per year at Cincinnati. The icing season is shorter at New Cumberland, perhaps reflecting the influences discussed in the preceding paragraph.

Of particular interest is the fact that the New Cumberland data show no occurrences of jamming or gorging or any reports of rising water levels due to ice buildup. Although the data indicate that navigation was occasionally delayed because of difficulty moving through thick ice or because of locking ice prior to locking traffic, there were no relatively long suspensions of navigation or damage to either the vessels or the locks and dam, such as were experienced at the Markland locks and dam in 1978. It appears that New Cumberland was able to move ice through the locks and maintain sufficient traffic to prevent severe problems. The Ohio River Division Ice Committee Summary Report made the following comments which may explain the less severe difficulties experienced at New Cumberland compared to downriver reaches (U.S. Army Corps of Engineers 1978):

On the extreme upper portion of the Ohio and on the two streams that combine to form the Ohio; that is, the Allegheny and the Monongahela, significant ice is an every-year fact of life. There are problems, but people expect them and have learned to cope with them with some degree of success. While temperatures in that area during the 1977 and 1978 ice periods were not as much below normal as in other portions of the Ohio basin, they were below normal. Even so, ice problems in 1977 and 1978 were essentially no different from any other year, largely due to experience in coping with them. This was not the case elsewhere.

There is no reason to believe that operating procedures at the New Cumberland locks and dam will not continue to be successful in preventing significant ice problems.

The only significant occurrence of ice jamming in the plant vicinity was in 1936. At that time, all nonadjustable wicket-type gates on an old navigations dam were dropped to avoid damage by a large ice floe coming down from the Allegheny River. The resulting low pool caused an ice jam with about a 5-foot rise in water level behind it. All of the old dams in this reach of the river have been removed. The New Cumberland Dam is now equipped with tainter gates, some of which are lowered to pass ice and then raised to maintain the normal navigation pool. Ice may also be passed through the locks. Thus, the circumstances of the 1936 ice jam cannot be repeated.

Although it occurred about 500 miles downstream of BVPS-2, the Markland ice jam of 1978 will be discussed since it was one of the most severe ice jams experienced on the Ohio River and because it occurred at a dam equipped with tainter gates. This ice jam caused considerable disruption of navigation as well as damage to vessels due to barges breaking free of moorings and piling against the dam and some gates becoming inoperable. An unusual combination of extreme meteorological events combined with less than optimum operating decisions contributed to the difficult situation. The following description of the events at Markland is taken from a U.S. Army Corps of Engineers' Memo to Record (Whitlock 1978).

During mid- to late January, the lower Ohio River contained heavy ice, including considerable slush ice from tributaries. The river flow at that time was extremely low and the tainter gates at Markland locks and dam, all of which are non-submergible, could not be raised to pass ice. In addition, due to a coal strike and extreme cold, the hydroelectric station at the dam was operating at full power and this further decreased the amount of water available to move ice. The only recourse was to lock ice and barges through sequentially. The very heavy ice and some lack of coordination among industry, however, slowed traffic and made keeping the channel open very difficult. Simultaneously, an ice jam formed several miles upstream of the Markland Dam in a shallow bar area at a narrow point in the river. Heavy precipitation, meanwhile, had begun causing a rapid rise in the river and associated flooding. The ice jam began moving and some barges moored upstream broke free. By the time Markland Dam had raised several gates to pass ice, a number of barges had already piled up on the dam and some gates were inoperable. Significant effort was required to free barges and unjam gates to resume normal operations after the flood flows subsided.

The possibility of a Markland type ice jam forming on the New Cumberland pool is very low for the following reasons. First, the meteorological conditions which led to the Markland ice jam, extreme cold and low flow followed by severe flooding, are extremely unlikely combined events. Second, some of the tainter gates at the New Cumberland Dam are submergible, permitting ice to be passed even during low flow periods. Third, an Ohio River Industry Ice Committee was formed following the Markland ice jam in order to ensure better

communication, operating procedures, and other measures to prevent a recurrence of the problems experienced at Markland.

The characteristics of the river in the vicinity of the plant also contribute to a very low possibility of an ice jam forming. Normally, ice jams form at obstructions and irregularities which do not exist at the vicinity of the intake structure, and there is no reason to believe that the intake would ever be blocked by an ice jam. The Shippingport Bridge is located about 1,000 feet upstream of the intake, but its three pointed support piers do not form a significant channel obstruction. Thus, there is no reason to conclude that an ice jam would form there.

From the preceding discussion of historical events and the conditions in the BVPS-2 vicinity, it can be concluded that the formation of an ice jam that would cause a significant rise in the water elevation in the New Cumberland pool or that would physically block the intake structure is extremely unlikely to occur. Thus, the present design of the station intake is adequate to assure BVPS-2 its required water supply.

#### 2.4.7.2 Potential Blockage of the Intake by Ice

Blockage of the intake and thus the inability to supply BVPS-2 with sufficient water could occur by means of ice floes plugging the front of the structure or by formation of frazil or anchor ice on the bar racks or traveling water screens. Because of the relatively straight shoreline in the immediate vicinity of the intake and the fact that the intake withdraws water from el 646.0 to 659.5 feet msl, it is extremely unlikely that ice floes could pile up in such a way as to block a significant portion of the intake opening below the curtain wall (659.5 feet msl). In addition, the cleaning mechanism for the bar racks should remove ice just as it removes leaves, branches, and other debris should the broken ice floes pass through the intake opening and block the bar racks. The potential for frazil and anchor ice formation is a more complicated issue and is discussed in detail as follows.

Frazil ice formation takes place in the presence of supercooling, where the turbulence is too great to allow a surface sheet to form. It first appears as finely divided colloidal particles which grow and cluster together, resembling cinders from which the French Canadian term "Frazil" has come into general use (Book 1948). Supercooling can result from rapid agitation through the action of the wind or through exposure in going through rapids (Book 1948). With respect to supercooling, precise temperature measurements made at the Holtwood and Safe Harbor hydrostations in Pennsylvania showed that:

On the Susquehanna River, it has been found that frazil ice always forms when the river water becomes supercooled and that



supercooling occurs only when the rate of cooling is greater than  $0.018^{\circ}\text{F/hr}$  ( $0.01^{\circ}\text{C/hr}$ ) within the temperature range  $32.18^{\circ}$  to  $32.0^{\circ}\text{F}$  ( $0.1^{\circ}$  -  $0.0^{\circ}\text{C}$ ).

Cooling that occurs outside this temperature range is unimportant, and at cooling rates less than  $0.018^{\circ}\text{F}$  per hour ( $0.01^{\circ}\text{C/hr}$ ), a natural ice cover will form. Furthermore, experience shows frazil ice will not form once the ice cover has formed... It has also been noted that frazil ice formation does not occur during daylight hours because of the influence of solar radiation ( $80 \text{ Btu/hr/ft}^2$  or  $25 \text{ watts/m}^2$ ) (U.S. Bureau of Reclamation 1974).

Frazil ice crystals have a tendency to adhere to surfaces, such as metal trash racks, with a temperature equal to or less than the freezing point of water. The crystals can also clot together loosely in soft masses commonly referred to as slush ice. The term slush ice is also applied to a mixture of water and snow, either freshly fallen or resulting from river ice break up.

Anchor ice, in contrast to frazil ice, does not form throughout the water body, but only on the bottom or on submerged objects near the bottom during periods of excessive radiational heat loss. Anchor ice could form directly on trash racks, or could accumulate on the racks after breaking loose from the stream bottom. Like frazil ice, anchor ice can build up and completely block an intake structure.

The potential for frazil or anchor ice formation in the vicinity of the station intake was examined. Since there are no rapids immediately upstream of the intake, only wind and/or a sufficiently rapid drop in air temperature could permit supercooling to take place. There are no precise temperature data available for the Ohio River in the station vicinity that is measured to  $0.018^{\circ}\text{F}$  or  $0.01^{\circ}\text{C/hr}$ . Therefore, it was determined that experience would provide the best indication of the potential for frazil ice formation.

A discussion with a member of the staff of the Cold Region Research Laboratory (1979) has indicated that no historic data exist on frazil ice formation for the Ohio River. Therefore, a telephone survey was conducted of facilities on the upper Ohio River which were reported by the Ohio River Valley Water Sanitation Commission (ORSANCO 1978) to have intakes on the river. This survey of icing problems is summarized in Table 2.4-12. A number of the facilities contacted have been using riverbank intakes equipped with trash racks and traveling water screens similar to the configuration of the BVPS intake. Some of these intakes had curtain walls, while others did not. In all cases, however, no problems with icing that prevented withdrawal of their required flow, due either to frazil ice formation or blockage by ice floes, were experienced (Duquesne Light Company 1980; American Bridge Company 1980; Jones and Laughlin Steel Corporation 1980; St. Joe Zinc Company 1980; Pennsylvania Power and Light Company 1980; Crucible Steel Company 1980; City of Wellsville

1979; Crescent Brick Company 1980; Toronto Waterworks Company 1980; Toronto Titanium Metal Company 1980; Steubenville Water Plant 1980; Wheeling Pittsburgh Steel Corporation 1980; Mingo Junction Water Department 1983; Bellaire City Water System 1978; American Electric Power Fuel Supply 1983; Martins Ferry Sanitation Department 1979; and Ohio Edison Company 1980).

In particular, neither Beaver Valley Power Station - Unit 1 (BVPS-1), which has been operating since 1976, nor the neighboring Bruce Mansfield Plant (BMP), which has been operating since 1975 with a similar intake design, have experienced any difficulties related to icing. It should be noted that their operating experience includes the severe winters of 1977 and 1978.

Based on the review of experience at similar installations and consideration of conditions in the BVPS-2 vicinity, it is concluded that the proposed intake design provides sufficient protection against icing problems.

#### 2.4.8 Cooling Water Canals and Reservoirs

Beaver Valley Power Station - Unit 2 does not utilize any safety-related cooling water canals or reservoirs. Therefore, this section does not apply to BVPS-2.

#### 2.4.9 Channel Diversions

There is no potential for upstream diversion since the Ohio River Valley is deeply entrenched in bedrock of sandstones and shales.

#### 2.4.10 Flooding Protection Requirements

The PMF will not cause any safety-related structure, system, or component to lose its design function. The flood design basis is determined in accordance with Regulatory Guide 1.59. Sections 2.4.3 and 2.4.4 describe the flood and the resulting flood elevation. Flood protection of the site is discussed in Section 3.4.1.

Protection of the intake structure against coincident wind wave activity and associated wave runup is described in the response to USAEC Question 2.13 which is included in Amendment 4 to the BVPS-2 PSAR. The [Licensing Requirements Manual](#) ensures adequate flood protection for all safety-related systems, components, and structures when the water level of the Ohio River exceeds 695.0 feet msl at the intake structure. This requirement is discussed more fully in Section 2.4.14.

#### 2.4.11 Low Water Considerations

##### 2.4.11.1 Low Flow in Streams

The New Cumberland Lock and Dam maintains the New Cumberland Pool at el 664.5 feet. Records indicate that this elevation can be maintained at flows up to 20,000 cfs as shown on Figure 2.4-15.

A low-flow frequency curve for the Ohio River at Shippingport is shown on Figure 2.4-16. This curve represents the lowest continuous 7-day mean flows that would occur. It is based on a statistical analysis of historical flows for the past 44 years (1929-1973) modified by the present reservoir system (U.S. Army Corps of Engineers, Pittsburgh District 1970). An instantaneous flow could be lower, but with the large impoundments behind the storage dams, the 7-day flow could be provided continuously by temporarily drawing on the river storage when needed.

Computerized models developed by the U.S. Army Corps of Engineers were used to simulate regulated stream flows in the Ohio River. Results of the analysis show that a minimum flow of 4,000 cfs would have occurred at the site during the record drought of 1930 with the contemporary reservoir system. A design basis failure of the nearest downstream dam (the New Cumberland Dam) as described in 9.2.1.1.3 during minimum flow would result in a minimum water surface elevation at the site of 648.6 feet msl (U.S. Army Corps of Engineers, Pittsburgh District 1969, 1973). This minimum water surface elevation of 648.6 ft msl is considered to be the design level for BVPS-2. This is discussed in more detail in Section 2.3.4 of the BVPS-2 PSAR. Corps correspondence related to river flow and elevation is provided in Appendix 2.4B.

The USNRC, in its review of the BVPS-2 PSAR, indicated that, by extrapolating an unregulated low-flow frequency for drought conditions which may be characterized as the most severe reasonably possible at the plant site, an instantaneous low flow of 800 cfs could occur.

Information received from the Corps of Engineers (1973) indicates that during any low flow period, including postulated flows as low as 800 cfs, navigation pools would not be intentionally lowered. Their analysis considered an extreme drought of 800 cfs coincident with the loss of a lock gate, the only damage they felt could reasonably be expected to occur with this flow. The Corps stated that following loss of a lock gate, the bulkheads could be installed in 4 hours, during which time the pool would drop 1.8 feet to elevation 662.7 ft msl. Therefore, the postulated flow of 800 cfs coincident with lock gate failure is less critical than a flow of 4,000 cfs coincident with complete dam failure.

A Technical Specification, described in Section 2.4.14 and earlier established in BVPS-1, requires that plant shutdown be initiated when the river level falls to 654 ft msl. The basis for the 654 ft msl shutdown elevation is described in Applicant Response to NRC Regulatory Staff Position 1 (07/19/73), BVPS-1 FSAR Question 2.14. The design minimum net positive suction head for the BVPS-1 raw water pumps, necessary for normal station operation, is reached at 654 msl.

BVPS-2 does not have any equivalent to the BVPS-1 raw water pumps. Even though the service water pumps in the primary intake structure are designed to provide adequate water for normal reactor shutdown down to 648.6 ft msl, shutdown is initiated at 654 ft msl.

#### 2.4.11.2 Low Water Resulting from Surges, Seiches, or Tsunami

Because the site is not located on the coast or on a lakeshore, this section is not applicable to BVPS-2.

#### 2.4.11.3 Historical Low Water

The lowest flow of record occurred during the extreme drought of 1930. A minimum of 1,250 cfs flowed past Shippingport in August of that year. Since that time, eight reservoirs with low flow augmentation capabilities have been constructed. The lowest flow that would have occurred in 1930 with the contemporary reservoir system is 4,000 cfs.

#### 2.4.11.4 Future Controls

Several reservoirs in the authorized or planning stages would have a substantial influence on low flows. Included in this group are Stonewall Jackson, Rowlesburg, and St. Petersburg Reservoirs. Collectively, they would increase the minimum flow to approximately 6,000 cfs at Shippingport.

#### 2.4.11.5 Plant Requirements

The service water system (SWS) (Section 9.2.1) provides the safety-related source of cooling water to the various plant components requiring heat removal for ensuring plant shutdown and for the mitigation of accident conditions. The minimum required flow rates for safety-related components served by the SWS are given in Table 9.2-2. The SWS is also designed to provide the maximum normal operation flows as required to maintain plant operation. (Section 9.2.1).

The ultimate heat sink (UHS) (Section 9.2.5) is the Ohio River which provides the source of cooling water for the SWS. Section 2.4.14 describes the operation of the intake structure of the SWS during the worst case maximum and minimum river water levels.

#### 2.4.11.6 Heat Sink Dependability Requirements

Cooling water for normal and emergency plant operation is provided by the Ohio River via the SWS. The Ohio River and the SWS combine to function as the safety-related means of heat removal to maintain the plant in a safe condition following all postulated events as described in Sections 9.2.1 and 9.2.5.

The SWS, as described in Section 9.2.1, is a safety-related Category I system designed and located in structures capable of withstanding the effects of natural phenomena, missiles, and pipe breaks. The system consists of three identical service water pumps each of which is capable of minimum flow required for safe shutdown following all unit operating conditions.

The service water pumps are located in and take suction from three separate cubicles of the intake structure. The intake structure elevation is chosen to provide satisfactory service water pump operations at all river water levels, as described in Section 9.2.1.

It is anticipated that silt will collect in the main intake structure. Therefore, as a minimum, the depth of silt in the intake structure bays will be measured semi-annually (twice in the period). Silt exceeding the 15-inch allowable level will be removed. The silt limit is 22 inches, as described in Section 9.2.1.1.3, so that a more than adequate water supply is ensured.

The Ohio River provides a continuous, inexhaustible source of cooling, water, dependent only on operation of the SWS. Drift and evaporation

losses are insignificant and the maximum and minimum river water levels are evaluated as described in Sections 2.4.3 and 2.4.11.1 to ensure that the SWS pumps suctions are maintained full.

A standby service water system (SSWS) as described in Section 9.2.1, is provided to meet heat sink requirements when the Seismic Category I intake structure is not available. The SSWS is designed to duplicate the cooldown capacity of the SWS to accommodate unit shutdown from 100-percent reactor power to cold shutdown conditions.

The SWS takes suction from the intake structure and discharges to the Ohio River. A study has shown that recirculation will not occur even during a design basis accident with a low river flow of 4,000 cfs and maximum heat rejection to the river.

The design basis hydrometeorology is as specified in Section 2.3.

#### 2.4.12 Dispersion, Dilution, and Travel Times of Accidental Releases of Liquid Effluents in Surface Waters

##### 2.4.12.1 Surface Water

The refueling water storage tank (Section 6.2.2) was considered for potential spills to the surface water environment. For the analysis, the tank was assumed to be initially 80 percent full.

The analytical technique used to determine dilution factors and travel times is the instantaneous release stream tube model described in USNRC Regulatory Guide 1.113. This technique uses the following equation in order to obtain downstream concentrations:

$$C = \frac{M}{(4\pi K_x t)^{1/2} A} \exp\left\{-\frac{(x-ut)^2}{4K_x t} - \lambda t\right\}$$

$$\left[1 + 2 \sum_{n=1}^{\infty} \exp\left(-\frac{n^2 \pi^2 K_y t}{B^2}\right) \cos n\pi \frac{y_s}{B} \cos n\pi \frac{y}{B}\right]$$

(2.4-1)

where:

- c = concentration
- M = amount of activity released
- $K_x, K_y$  = dispersion coefficients in x,y directions
- x,y = longitudinal, lateral coordinates

t	=	time of calculation
A	=	cross-section area
u	=	stream velocity
$\lambda$	=	decay coefficient
B	=	width of river
$y_s$	=	lateral location of source

Dilution factors (DF) are then determined by:

$$DF = M/CV \quad (2.4-2)$$

where:

$$V = \text{instantaneous volume released}$$

The river flow rate used in this analysis is 4,000 cfs. The longitudinal and lateral dispersion coefficients used are 4,740 ft<sup>2</sup>/hr and 6542 ft<sup>2</sup>/hr, respectively.

The longitudinal dispersion coefficient was determined from Regulatory Guide 1.113 to be:

$$\frac{K_x}{u \cdot d} = 5.93 \quad (2.4-3)$$

where:

$$u^* = u \left[ \frac{\sqrt{g} \cdot n}{1.49 R^{1/6}} \right] = \text{shear velocity}$$

$$n = \text{Manning's roughness coefficient}$$

$$R = A/P = \text{hydraulic radius}$$

$$P = \text{wetted perimeter of the cross section}$$

$$d = \text{depth}$$

The lateral dispersion coefficient was determined from Yotsukura and Sayre (1976) whose results have been adequately confirmed in field tests.

$$\frac{K_y}{u \cdot d} = 0.4 \left[ \frac{B}{r_c} \cdot \frac{u}{u^*} \right]^2 \quad (2.4-4)$$

where:

$r_c$  = radius of curvature of river bends

Yotsukura and Sayre report that the local values of  $K$  in meandering channels vary periodically in the longitudinal direction, usually reaching a maximum value of about twice the average in the downstream portion of the bend and a minimum of about half the average in the upstream portion. The reduction in the upstream portion is caused by the process of reversal in the secondary circulation as the bend curvature is reversed. If bends are followed by short lengths of straight channel, the established secondary circulation is sustained throughout the straight portion of the channel. Thus, the longitudinal average of value of  $K_y$  is actually larger than that determined by Equation 2.4-4.

The analysis was performed for three downstream locations: Midland, Pennsylvania (1.3 miles downstream and 1,250 feet from the south river bank), East Liverpool, Ohio (5.2 miles downstream and 1,100 feet from the south river bank), and Chester, West Virginia (7.1 miles downstream and 30 feet from the south river bank). The analysis indicates that the maximum concentrations (minimum dilution factors) are experienced at Chester, West Virginia. The minimum dilution factor and the corresponding travel time for the tank considered are given in Table 2.4-13. The effects of this analysis are discussed in Section 15.7.3.

#### 2.4.12.2 Sediment Uptake Models

Sediment uptake reduces radionuclide concentrations in the water column as predicted by the transient source model utilized to predict far-field dilution factors. Because only limited information is available on sediment uptake, the effect of this process is conservatively neglected in the analysis.

#### 2.4.12.3 Water Use Models

There are no planned changes in water use or flow regulations in the Ohio River or adjoining tributaries that could have an appreciable effect on the far-field dilution estimate during the operating life of the station.



## 2.4.13 Ground Water

### 2.4.13.1 Description and Onsite Use

#### 2.4.13.1.1 Regional Aquifers

The general geology of the area is described in Section 2.5. Additional information on ground water may be found in BVPS-2 PSAR Section 2.4, and the responses to USAEC Questions 2.21-2.28 (Amendment 4) and Question 2.29 (Amendment 6).

The BVPS-2 site is located within the bedrock valley of the Ohio River on an alluvial terrace along the south side of the channel. Bedrock under the site consists of horizontally bedded shales with occasional sandstone and a few small coal seams, all of Pennsylvanian age. One thin limestone member, the Vanport limestone, outcrops in the valley wall south of the plant. The power station is located approximately 600 feet north of the south bedrock wall of the valley. At the plant location, bedrock is at approximately el 620 feet and drops only slightly toward the north where it underlies the river. It is overlain by a terrace of granular material which extends approximately to el 735 feet at the plant. The northerly portion of this terrace was eroded subsequent to its placement and replaced by recent deposits of the river in two low level terraces. These younger terraces of silts and clays overlies the sands and gravels, which in turn rest directly on the bedrock.

The Ohio River at this location is controlled by a system of locks and dams for navigation purposes. The navigation pool at the site is normally held at el 664.5 feet.

The upland surface in the vicinity of BVPS-2 is above el 1,100 feet. The ground water in the bedrock underlying the upland surface occurs in joints and occasional permeable sandstone beds. Migration takes place along bedding and nearly vertical joint planes and along weathered zones. Water well records indicate that normal ground-water flow potential in these rocks ranges from less than 1 to about 10 gallons per minute (gpm) for each well, with 2 to 4 gpm as average. Sixteen seeps were observed to originate from bedrock along the rock wall of the valley above the terrace during a survey undertaken June 13 to June 16, 1972; all but one seep were less than 1 to 2 gpm. The remaining seep at el 900 feet, 4,000 feet southeast of the station, flowed at 4 to 5 gpm along shale joints overlying a confined sandstone bed.

The regional ground-water map (Figure 2.4-17) indicates that the ground water occurs under hydrostatic conditions with the phreatic surface having a contour in subdued relief approximating the land surface. The topographic divides along the ridge crests also mark the local ground-water basin divides. Ground-water level under the upland surface lies at depths of 10 to 50 feet below the surface, averaging 30 feet. The phreatic surface has a gradient of 50 percent

on steep hillsides, 25 to 30 percent on gentler hillsides, and 15 percent or less along tributary streams. In all areas, the ground water flows downslope and eventually enters the terrace. Ground-water migration in the bedrock appears to be constant and slow. Due to the low permeability of the bedrock, recharge from rock to the terrace gravels is negligible. There are no known aquifers in the bedrock under the site.

#### 2.4.13.1.2 Local Aquifer

Figure 2.4-18 shows the extent of the alluvial valley-fill deposits which form the terrace system along this portion of the Ohio River as described in Section 2.5.4.

The terrace on which the station is located is about 4,000 feet long and 1,800 feet wide at its widest point. The sands and gravels of this terrace form the only significant aquifer in the immediate site area. Both downstream and upstream of the station, the terrace pinches out against the steep bedrock valley wall (Figure 2.4-18).

To the northeast of the station, ground-water flow is impeded by a buried structure, probably a bedrock bench which is suggested by the ground-water contours shown on Figure 2.4-17. This structure extends northwesterly almost to the river's edge at a point about 2,500 feet upstream of the station.

The terrace soils are predominantly sands and gravels except for the overlying recent deposits of the clay and silt near the river. Section 2.5.4.6 discusses the observation that measured ground-water levels from piezometers in the plant area reflect changes in the Ohio River elevation with little or no time lag, suggesting good ground-water communication between the terrace soils and the river. Permeability of the sands and gravels was determined from field tests as described in Section 2.5.4.6.

Recharge to the terrace aquifer in the site area is primarily from precipitation in the immediate area. Infiltration of about 35 percent (which would be expected for these soils, topography, and climatic conditions) would amount to an average infiltration of about 12 inches of water per year (about 900 gallons per day (gpd) per acre). Under normal river conditions, the ground-water levels under the terrace at the station location slope very gently towards the northwest as shown by the ground-water contours on Figure 2.4-17.

#### 2.4.13.1.3 Onsite Use of Ground Water

Two temporary wells onsite provided water for sanitary and construction purposes during construction of BVPS-2. One of these wells had originally been drilled for use during construction of BVPS-1. Although the actual capacity of these wells is unknown, yields up to 300 gpm have been observed at each well. Domestic water for BVPS-2, the emergency response facility, and for other structures

located to the east of Route 168 will be supplied by two wells (55 and 56) located adjacent to the emergency response facility. Water for BVPS-1 will be supplied by the intake on the Ohio River.

Two wells in the terrace gravels were drilled to supply cooling water (and augment the river water supply) at a rate of 300 gpm each to the Shippingport Atomic Power Station (SAPS, now decommissioned). This water supply is located close to the river (Figure 2.4-17).

#### 2.4.13.2 Sources

##### 2.4.13.2.1 Present Regional Ground-water Use

Wells in the station vicinity are listed in Table 2.4-14. The location of these and approximately 43 additional domestic and farm wells is shown on Figure 2.4-17. These are mostly drilled wells, with a few old dug wells. Wells 16, 17, 18, 47, 48, and 49 are believed to be in alluvial deposits; all others are in shale and sandstone bedrock. These wells were drilled prior to state law requiring filing of well logs (1966) and almost no data are available. In some cases, even though a well was not definitely identified, it was assumed that each house or trailer required a well.

As indicated in Section 2.4.13.1.3, the present ground-water use at the site is limited to two wells for SAPS (10 and 11) and two construction wells (8 and 8A) for BVPS-1 and BVPS-2. Three wells (55, 56, and 57) have been drilled to supply domestic water to BVPS-2, the emergency response facility, and other structures to the east of Route 68. Well 57 has been capped due to low flow and at present there are no plans to make use of it. The BMP is serviced by Wells 5, 6, and 9. The remaining wells in the area are used for residential water supply. Most of the wells are located on or upstream of the buried bedrock spur and are thus isolated from the site aquifer. Bedrock wells in the upland areas are of low yield and all terminate at elevations well above yard elevation at the plant site.

A similar alluvial terrace is found on the north side of the river and slightly downstream from the plant site on which the town of Midland is situated (Figure 2.4-18). Ground-water data are not shown for this terrace since it is isolated from the plant site aquifer by the Ohio River which forms a ground-water boundary.

##### 2.4.13.2.2 Future Regional Ground-water Use

As described in Section 2.4.13.1.2, the only significant aquifer in the site area is a sand and gravel terrace overlying the site bedrock through which ground water interconnects with the river. The terrace is about 4,000 feet long and up to 1,800 feet wide. It is limited by the steep valley wall downstream and a buried bedrock bench extending almost to the river's edge about 2,500 feet upstream. This bedrock

and the surrounding upland region (above el 1,100) effectively isolate the terrace and directs ground-water flow toward the river.

Future ground-water use in the site region is expected to follow the existing pattern (Section 2.4.13.2.1). Shippingport Borough, in which the site is located, has no municipal water supply (ER Section 2.1.3) so future residential development will rely on wells for water supply. As discussed in Section 2.1.3, extensive residential development is not expected and, in addition, areas which are likely to be developed are located outside the site area aquifer. Thus, future domestic use of ground water should not be significantly different from present use. There are no known plans for industrial development in the site area. Future industrial use of ground water is expected to remain limited to the existing wells at SAPS, to those at BMP located about 6,000 feet upstream, and to wells 55 and 56 for BVPS-2 use.

Intrusion of river water into the aquifer, caused by excessive pumping on the site, would not affect any domestic or industrial supplies because they all lie upstream and upgradient of the station site. Use of ground water at the site is not expected to deplete regional or local supplies because the alluvium is hydrostatically connected with the Ohio River which recharges the aquifer and prevents excessive drawdown due to well pumping.

The location of the station and the characteristics of the local aquifers ensure that any future development of ground-water resources in the site region would be either isolated from the ground water under the site or located upgradient of the station in the site aquifer.

#### 2.4.13.3 Accidental Effects

##### 2.4.13.3.1 Tank Failure and Dilution/Dispersion Modes

As discussed in Section 2.4.13.1.2, all ground-water movement under BVPS is directed northwest toward the Ohio River. Ground-water migration is effectively blocked to the southwest where the alluvium pinches out against a bedrock cut scarp covered by relatively impervious colluvium just above river grade.

In order to evaluate the dilution and dispersion of an accidental spill of high level radioactive liquid waste to the ground-water system, a release from the BVPS-2 steam generator blowdown (SGB) hold tank was postulated. This tank, which is housed in the waste handling building, could potentially hold 50,000 gallons of high-level liquid waste. Eighty percent of the tank's capacity was assumed to enter the ground-water system instantaneously upon tank failure. As shown on Figure 2.4-17, there are no down-gradient residential or municipal wells that could be affected by the postulated accidental release. Future ground-water use in the site region is anticipated to follow the existing pattern (Section

2.4.13.2.1). Therefore, the ground-water pathway to the nearest water user includes ground-water travel to the Ohio River and subsequent travel by the river to the nearest surface water user.

The minimum dilution factor and associated travel time for ground-water travel to the Ohio River due to the SGB tank failure are 842 and 24 years, respectively. The surface water travel time is negligible compared with ground-water travel time. The total dilution factor for the ground-water path to the most critical water user ( $3.07 \times 10^9$ ) is equal to the dilution factor for the ground-water path to the river (842) multiplied by the dilution factor at Chester, West Virginia, due to the dispersion in the river ( $3.65 \times 10^6$ ).

The Ohio River and associated ground-water levels for this analysis were selected on the basis of annual average conditions. The river elevation was assumed to be 664.5 feet msl with an associated ground-water elevation of 665.5 feet msl. All parameters utilized in the computation of dilution and travel time are presented in Table 2.4-15.

The permeability of the in situ sand and gravel was estimated from field tests discussed in Section 2.5.4.6.

#### 2.4.13.3.2 Vertical Travel and Horizontal Dispersion Source Configuration

The spill volume is conservatively assumed to enter the ground-water system instantaneously upon the occurrence of a tank failure with an associated vertical travel time of zero. The source configuration for the computation of horizontal dispersion is modeled as an instantaneous point source located in an aquifer of finite thickness. The source configuration for the computation of dispersion in the river was simulated as a continuous vertical line source at the river bank.

#### 2.4.13.3.3 Horizontal Dispersion and Travel Time

The dispersion of the contaminant in the ground-water system was modeled by the application of the solution obtained by Yeh and Tsai (1976) for transient, three-dimensional dispersion:

$$\frac{\partial C}{\partial t} + U \frac{\partial C}{\partial x} = \frac{\partial}{\partial x} \left( K_x \frac{\partial C}{\partial x} + \frac{\partial}{\partial y} \right) \left( K_y \frac{\partial C}{\partial y} \right) + \frac{\partial}{\partial z} \left( K_z \frac{\partial C}{\partial z} \right)$$

(2.4-5)

Initial and boundary conditions are:

$$C = 0 \text{ at } t < 0 \text{ and } x, y, z, = 0, 0, 0$$

$$C = C_0 \text{ at } t = 0 \text{ and } x, y, z, = 0, 0, 0$$

$$C = 0 \text{ at } x = \pm \infty$$

$$K_z \frac{\partial C}{\partial z} = 0 \text{ at } z = 0$$

$$K_z \frac{\partial C}{\partial z} = 0 \text{ at } z = H$$

(2.4-6)

$$C = 0 \text{ @ } y = \pm \infty$$

where:

C = concentration (percent),

C<sub>0</sub> = initial concentration (percent),

U = seepage velocity (ft/sec),

K<sub>x</sub>, K<sub>y</sub>, K<sub>z</sub> = dispersion coefficients in the horizontal directions (x and y) and in the vertical direction (z), respectively (ft<sup>2</sup>/sec).

T = the time of travel to the receptor (sec),

x, y, z = downgradient, transverse horizontal, and vertical distances to the receptor, respectively (ft),

H = the aquifer thickness (ft).

For an instantaneous point source release at the origin in a finite aquifer, the dilution factor DF is:

(2.4-7)

$$\frac{1}{DF} = \frac{C}{C_0} = \frac{V}{n_e} \cdot \frac{1}{4\pi H t (K_x K_y)^{1/2}} \cdot \exp \left\{ \frac{-(x - u \cdot t)^2}{4K_x t} \right\}$$

$$\cdot \exp \left[ \frac{-y^2}{4K_y t} \right] \left\{ 1 + 2 \sum_{n=1}^{\infty} \cos \left( \frac{n\pi z}{H} \right) \exp \left[ - \left( \frac{n\pi}{H} \right)^2 K_z \cdot t \right] \right\}$$

where :

V = tank volume postulated for spill analysis (ft<sup>3</sup>),

n<sub>e</sub> = the effective porosity,

The seepage velocity is determined from Darcy's law as follows:

$$U = \frac{Ki}{n_e}$$

(2.4-8)

where:

K = the horizontal permeability coefficient (ft/sec),

i = the hydraulic gradient (ft/ft).

The dispersion coefficients, K<sub>x</sub>, K<sub>y</sub>, K<sub>z</sub>, are determined from dispersivity values as follows: The dispersion coefficient is a linear function of the dispersivity (α) and ground-water velocity (U), that is, (K=αU). Longitudinal dispersivity (α<sub>x</sub>) and transverse dispersivity (α<sub>y</sub>) are related by the approximation α<sub>y</sub> = 0.3α (Brederhoeft and Pinder 1973). For the granular soils at the site, α<sub>z</sub> = α<sub>y</sub>.

Robertson (1970) has referenced field data collected at the National Reactor Testing Station in Idaho near the Snake River. Based on the best fit between field data and analytical solution along the centerline of dispersion, the transverse dispersivity (α<sub>ys</sub>) of the Snake River aquifer was determined to be 59 feet. Robertson's field experimental results show that dispersivity varies with aquifer composition and that more permeable aquifers have higher dispersivity. If one assumes that the properties of the aquifer

(other than porosity) are similar, then the value of the dispersivity at the site may be estimated by:

$$\alpha_y = \frac{n_{es}}{n_e} \cdot \alpha_{ys}$$

(2.4-9)

where:

- $n_{es}$  = the Snake River aquifer porosity  
 = 10 percent,
- $n_e$  = the porosity of the aquifer under consideration.
- $\alpha_{ys}$  = the Snake River aquifer transverse dispersivity  
 = 59 feet

The coefficient of permeability measured for the granular soils at the site ranged from  $5.7 \times 10^{-5}$  feet per second (fps) to  $2.00 \times 10^{-4}$  fps. A value of  $2.0 \times 10^{-4}$  fps was utilized in this analysis as representative of the permeability along the pathway considered. The parameters used to determine horizontal dispersion and travel time through the ground-water system are presented in Table 2.4-15.

#### 2.4.13.3.4 Sorption and Decay

The effect of these two processes was conservatively neglected in the computation of the dilution factor and associated travel time.

#### 2.4.13.4 Monitoring

In the event of radioactive materials spillage to ground water, no contamination of wells would occur, since there are no wells downgradient of the station, with the possible exception of SAPS wells 10 and 11. Since SAPS will be decommissioned by the time BVPS-2 is operational, no hazard is expected. Thus, monitoring of ground water to protect users is considered unnecessary and is not provided.

#### 2.4.13.5 Design Basis for Substructure Hydrostatic Loading

As concluded in Sections 2.4.13.1 and 2.5.4.6, the ground-water elevation at the plant site is assumed to coincide approximately with the Ohio River elevation. The following river elevations are possible at BVPS:



<u>Flood Stage</u>	<u>Elevation (feet)</u>
Normal Water Level	664.5
Ordinary High Water	675.0
25-Year Flood	690.0
Standard Project Flood	705.0
Probable Maximum Flood	730.0

Since monitoring river elevation began in June 1977, the maximum level recorded was el 681.3 feet in February 1979. Ground-water data is presented in Appendix 2.5A.

All major buildings and structures are located or constructed so as to be unaffected by the SPF or lower flood stages. Any structure founded below SPF elevation is designed to withstand buoyancy and water pressure of the SPF and to be watertight and operative for that condition. The main intake structure is also designed for the water pressure and buoyancy of the PMF, assuming that one of the intake bays is dewatered during its occurrence.

Category I structures are designed to be watertight against, and to withstand the buoyancy and water pressure of, the PMF. Hydrostatic pressure occurs only during flood stages since the ground water at the site is normally well below the founding elevation of all structures, except those located directly adjacent to the river.

Hydrostatic pressure combined with the lateral earth pressure produces maximum stress conditions in the containment walls. Buoyancy of the containment is not a design problem, since the structure has enough dead load to balance the buoyancy due to a PMF. Flood stages and the wave resulting from a dam break upstream are discussed in Section 2.4.4.

Liquefaction and dynamic settlement analyses are performed for Category I structures using as a minimum design the 25-year flood coincident with the SSE. These analyses are discussed in Section 2.5.4.

#### 2.4.14 Technical Specification, [Licensing Requirements Manual](#), and Emergency Operation Requirements

As discussed in Sections 2.4.2.2 and 2.4.11, the following Technical Specifications, [Licensing Requirements Manual](#) requirements, and associated plans of action are part of operational procedures. These specifications ensure a safe shutdown while an adequate water supply is available, and ensure the integrity of the UHS.

The PMF, with an associated water level of 730 feet msl (Sections 2.4.2 and 3.4.1), is the design basis for all safety-related structures. A requirement (derived from the response to USAEC Regulatory Staff Position 2), now located in the [Licensing Requirements Manual](#), requires flood protection for all safety-related systems, components, and structures when the water level of the Ohio River at the intake structure exceeds 695 feet msl.

The dependability requirements of the UHS, as discussed in Section 2.4.11.6, are ensured as described by the following Technical Specification. This specification limits the operation of BVPS-2 to the conditions of the water level and water temperatures of the Ohio River as follows:

1. A minimum water level at or above el 654 feet msl, at the intake structure, and
2. An average water temperature less than or equal to 89°F.

When the requirements of the above specification are not satisfied, the station is required to achieve hot standby within 6 hours and cold shutdown within the following 30 hours.

Operability of the UHS will be determined at least once every 24 hours by verifying that the average water temperature and water level are within their limits.

Implementation procedures for these Technical Specifications and [Licensing Requirements Manual](#) requirements are discussed in Section 13.3.

#### 2.4.15 References for Section 2.4

American Bridge Company 1980. Personal communication between W. Martin, American Bridge Company, and N. A. Blum, Stone & Webster Engineering Corporation (SWEC).

American Society of Civil Engineers, Journal of the Hydraulics Division 1974. River Ice Problems: A State-of-the-Art Survey and Assessment of Research Needs. Report of the Task Committee on Hydromechanics of Ice of the Committee on Hydromechanics of the Hydraulics Division.

Bellaire City Water System 1978. Personal communication with R. Bomer, Superintendent, Bellaire City Water System.

Book, C. F. 1948. Factors Contributing to Temperature Change and Ice Formation in Rivers and Lakes, as Affecting the Operation of Hydroelectric Plants. Hydroelectric Power Commission of Ontario.

Brederhoeft, J. D. and Pinder, C. F. 1973. Nass Transport in Flowing Ground Water. Water Resources Research, Vol 9, No. 1, p 194-210.

Chow, V. T. 1959. Open-Channel Hydraulics. McGraw-Hill Book Company, Inc., New York, N.Y.

City of Wellsville 1979. Personal communication between the City of Wellsville and D. A. Leonard, SWEC.

Cold Region Research Laboratory 1979. Personal communication between G. Vance, Cold Region Research Laboratory, and T. A. Adams, SWEC.

Crescent Brick Company 1980. Personal communication between Crescent Brick Company and N. A. Blum, SWEC.

Crucible Steel Company 1980. Personal communication between M. Carnahan, Crucible Steel Company, and N. A. Blum, SWEC.

Duquesne Light Company (DLC) 1980, Personal communication between C. Fietknecht, DLC, and T.A. Adams, SWEC.

Jones & Laughlin Steel Corporation 1980. Personal communication between R. Spoor, Jones and Laughlin Steel Corporation and N. A. Blum, SWEC.

Martins Ferry Sanitation Department 1979. Personal communication between Martins Ferry Sanitation Department, and D. A. Leonard, SWEC.

Mingo Junction Water Department 1978. Personal communication with J. Shimentsky, Mingo Junction Water Department.

Ohio Edison Company 1980. Personal communication between Mr. Swaidan, Ohio Edison Company, R.E. Burger Plant, and N. A. Blum, SWEC.

Ohio Power Company, 1980. Personal communication between Ohio Power Company and N. A. Blum, SWEC.

Ohio River Valley Water Sanitation Commission (ORSANCO) 1978a. Tabulation of Drinking Water Intakes.

Ohio River Valley Water Sanitation Commission (ORSANCO) 1978b. Water Intakes on the Ohio River Main Stem.

Pennsylvania Power & Light Company (PP&L) 1980. Personal communication between R. Bolli, PP&L, Bruce Mansfield Plant, and N. A. Blum, SWEC.

Roberston, J. B. 1970. A Method to Describe the Flow of Radioactive Ions in Ground Water. Scandia Labs, Report SCCR-70-6139.

Steubenville Water Plant 1980. Personal communication between J. McMenamin, Steubenville Water Plant, and N. A. Blum, SWEC.

St. Joe Zinc Company 1980. Personal communication between J. Singleton, St. Joe Zinc Company, and N. A. Blum, SWEC.

Toronto Titanium Metal Company 1980. Personal communication between Toronto Titanium Metal Company, and N. A. Blum, SWEC.

Toronto Waterworks Company 1980. Personal communication between G. Wise, Toronto Waterworks Company, and N. A. Blum, SWEC 1980.

U.S. Army Corps of Engineers 1963-1979. Lockmaster. Ice Conditions at New Cumberland Locks and Dam.

U.S. Army Corps of Engineers 1973. HEC-2 Flood Hydrograph Package, Computer Program 723-X6-L2010. Hydrologic Engineering Center, Davis, Ca.

U.S. Army Corps of Engineers 1978. Summary Report, Ohio River Division Ice Committee.

U.S. Army Corps of Engineers, Pittsburgh District 1969. Personal communication between W. G. Nichols, Corps of Engineers, and R. P. Kitchell, SWEC, letter dated August 26, 1969.

U.S. Army Corps of Engineers, Pittsburgh District 1970. Analysis of Flood Heights, Ohio River at Shippingport, Pa. Technical Report, Pittsburgh, Pa.

U.S. Army Corps of Engineers, Pittsburgh District 1973. Personal communication between D. A. Conner, Corps of Engineers, and R. J. McAllister, Duquesne Light Company (DLC), Letter dated March 29, 1973.

U.S. Army Corps of Engineers, Pittsburgh District 1979. Personal communication between L. J. Lucas, Corps of Engineers, and E. G. Nelson, SWEC, letter dated November 7, 1979.

U.S. Bureau of Reclamation 1974. Prevention of Frazil Ice Clogging of Water Intakes by Application of Heat. Engineering and Research Center, REC-ERC-74-15.

U.S. Department of the Army 1965 (Revised). Standard Project Flood Determination. Civil Engineer Bulletin No. 52-8.

U.S. Geological Survey 1976. Water Resources Data for Ohio, Water Year 1975, Vol. 1, Ohio River Basin.

U.S. Geological Survey 1978. Water Resources Data For Pennsylvania, Water Year 1977, Vol. 3. USGS Water-Data Report.

U.S. Weather Bureau 1956. Seasonal Variation of the Probable Maximum Precipitation East of the 105th Meridian for Areas from 10 to 10,000 Square Miles and Durations of 6, 12, and 48 Hours. Hydrometeorological Report No. 33.

U.S. Weather Bureau 1965. Probable Maximum Precipitation, Susquehanna River Drainage Above Harrisburg, Pennsylvania. Hydrometeorological Report No. 40.

Uzuner, M.S. and Kennedy, J.F. 1974. Hydraulics and Mechanics of River Ice Jams, Iowa Institute of Hydraulic Research, Report No. 161.

Wheeling Pittsburgh Steel Corporation 1980. Personal communication between J. Mannarino, Wheeling Pittsburgh Steel Corporation, and N. A. Blum, SWEC.

Whitlock, W.N. 1978. Memo to Record, the Markland Ice of January 1978. U.S. Army Corps of Engineers, Louisville District, Operations Division.

Yeh, G. T. and Tsai, Y. J. 1976. Analytical Three Dimensional Transient Modeling of Effluent Discharges. Water Resources Research, Vol. 12, No. 3, p 533-540.

BVPS-2 UFSAR

Tables for Section 2.4

TABLE 2.4-1

LOCKS AND DAMS\* ON THE OHIO RIVER  
WITHIN 50 MILES OF THE SITE

<u>Project Name</u>	<u>Ohio River Mile</u>	<u>Usable Storage (acre-ft)</u>
Emsworth	6.2	42,700
Dashiels	13.3	17,000
Montgomery	31.7	57,500
New Cumberland	54.4	74,000
Pike Island	84.3	89,300

NOTE:

\*All owned and operated by the U.S. Army Engineer District,  
Pittsburgh, PA

TABLE 2.4-2

## DOWNSTREAM POTABLE WATER INTAKES

<u>Downstream Distance (miles)*,**</u>	<u>Town</u>	<u>Owner*,**</u>	<u>Withdrawal Rate (mgd)</u>
1.3	Midland, Pa.	Midland Borough Water Department - Midland Borough	5
5.2	East Liverpool, Ohio	East Liverpool Water Company -	3.2
7.1	Chester, W. Va	City of East Liverpool Chester Municipal Water Works - City of Chester	
24.1	Toronto, Ohio	Toronto Water Works Company	0.5
27.0	Weirton, W. Va.	City of Weirton, W. Va.***	
30.2	Steubenville, Ohio	City of Steubenville - Steubenville Water Works	6
36	Mingo Junction, Ohio	Mingo Junction Water Company	2.0-2.2
51.8	Wheeling, W. Va.	Wheeling Water Department - City of Wheeling	10.5-11
53.6	Martins Ferry, Ohio	Martins Ferry Water and Department - City of Martins Ferry***	
59	Bellaire, Ohio	Bellaire Water Works Company***	1.5

NOTES:

- \* Ohio River Valley Water Sanitation Commission 1978a.
- \*\* Ohio River Valley water Sanitation Commission 1978b.
- \*\*\* Employs Ranney Collector under Ohio River bed which may contact station effluents.



TABLE 2.4-3

TRIBUTARIES WITHIN 50 MILES OF THE SITE HAVING A MEAN  
DISCHARGE GREATER THAN 200 CFS

<u>River</u>	<u>USGS Gauging Station No.</u>	<u>Mean Flow (cfs)</u>
Allegheny River	03049500	19,270*
Beaver River	03107500	3,530*
Chartiers Creek	03085500	285*
Little Beaver Creek	03109500	514**
Monongahela River	03085000	12,260*
Raccoon Creek	03108000	188*
Short Creek	03111500	123**
Yellow Creek	03110000	157**

NOTE:

\* USGS 1978

\*\* USGS 1976

TABLE 2.4-4  
RESERVOIRS UPSTREAM OF THE SITE

<u>Reservoir</u>	<u>Usable Storage (acre-feet)</u>	<u>Owner</u>	<u>Use*</u>
Beaver River Basin			
Berlin Lake	91,150	Corps of Engineers	F,L,W
Milton Reservoir	29,150	City of Youngstown, Ohio	L, W
Michael J. Kirwan Reservoir	78,660	Corps of Engineers	F, L
Mosquito Creek Lake	102,200	Corps of Engineers	F,L,W
Meander Creek Reservoir	32,410	Corps of Engineers	W
Pymatuning Reservoir	188,040	State of Pennsylvania	F,R
Shenango River Lake	191,360	Corps of Engineers	F,L,R
Lake Arthur	37,000	State of Pennsylvania	R
Allegheny River Basin			
Allegheny Reservoir	1,180,000	Corps Engineers	of F,L,R,P
Conemaugh River Lake	273,600	Corps Engineers	of F,R
Crooked Creek Lake	93,900	Corps Engineers	of F,R
East Branch Clarion River Lake	83,300	Corps Engineers	of F,L,R
Loyalhanna Lake	95,300	Corps Engineers	of F,R
Mahoning Creek Lake	74,100	Corps Engineers	of F,R
Tionesta Lake	133,400	Corps Engineers	of F,R
Union City Reservoir	48,650	Corps Engineers	of F
Woodcock Lake	20,000	Corps Engineers	of F,R

TABLE 2.4-4 (Cont)

<u>Reservoir</u>	<u>Usable Storage (acre-feet)</u>	<u>Owner</u>	<u>Use*</u>
Monongahela River Basin			
Deep Creek Reservoir	92,975	Pennsylvania Electric Company	P
Tygart Lake	285,000	Corps Engineers	of F,L,R
Youghiogheny River Lake	210,250	Corps Engineers	of F,L,R

NOTE:

\*Use

- P = Power
- R = Recreation
- F = Flood control
- L = Low flow agmentation
- W = Water supply

TABLE 2.4-5  
ALL-SEASON ENVELOPE  
PROBABLE MAXIMUM PRECIPITATION  
AT THE SITE\*

<u>Duration (hr)</u>	<u>Rainfall (in)</u>
0.17	3.5
0.25	4.3
1	9.3
2	13.0
3	16.5
6	24.6
24	31.3

NOTE:

\*U.S. Weather Bureau 1956

TABLE 2.4-6  
 RUNOFF ANALYSIS,  
 WATER DEPTHS ADJACENT TO SAFETY-RELATED BUILDING OPENINGS

Category I Structures	Lowest Access to Bldg. (ft-msl)	Max. Water Surface Elev. at Access Doors (ft)	Max. Water Depth Over Sill (ft)
Main Steam valve building area	735.5	732.5	-
Safeguards building	737.5	732.5	-
Reactor containment (equipment hatch)	767.83	735.1	-
Emergency diesel generator building			
1 door	732.5	732.5	-
3 doors	732.5	732.4	-
Auxiliary building			
3 doors	735.5	735.4	-
Fuel and decontamination building			
1 door	735.5	735.3	-
3 doors	735.5	735.3	-
Control building			
3 doors (south)	735.5	735.4	-
1 door (north)	735.5	735.4	-
Service building			
1 door (SB30-8)	732.0	732.5	0.5
1 door	732.5	732.5	-

TABLE 2.4-7

TIME DISTRIBUTION OF ISOHYETS\*, \*\*

Duration	Centers		<u>A<sub>1</sub></u>	<u>A<sub>2</sub></u>	<u>A<sub>3</sub></u>	<u>B<sub>1</sub></u>	<u>B<sub>2</sub></u>	<u>B<sub>3</sub></u>	<u>B<sub>4</sub></u>	<u>C<sub>2</sub></u>	<u>C<sub>3</sub></u>	<u>C<sub>4</sub></u>	<u>D</u>	<u>E</u>
	<u>M</u>	<u>N</u>												
72 hours	23.0	19.9	19.6	19.9	19.6	16.5	16.9	16.1	16.8	13.0	12.3	14.6	10.1	7.6
1st 6 hours	9.1	7.8	6.7	6.8	6.7	4.9	5.1	4.9	5.1	3.4	3.2	3.8	2.3	1.4
2nd 6 hours	3.0	2.6	2.5	2.5	2.5	2.2	2.2	2.1	2.2	1.9	1.8	2.1	1.5	1.2
3rd 6 hours	2.0	1.8	1.9	1.9	1.9	1.7	1.7	1.7	1.7	1.4	1.4	1.6	1.2	0.9
4th 6 hours	1.8	1.6	1.7	1.8	1.7	1.5	1.6	1.5	1.6	1.3	1.2	1.4	1.0	0.8
2nd day***	4.9	4.2	4.6	4.7	4.6	4.2	4.2	4.0	4.2	3.4	3.3	3.9	2.8	2.3
3rd day****	2.2	1.9	2.1	2.1	2.1	1.8	1.9	1.8	1.9	1.5	1.4	1.7	1.2	1.0
Total area of Isohyet	10	10	114	87	124	654	471	859	196	3,389	4,645	1,092	22,990	41,760

NOTES:

- \* U.S. Weather Bureau 1965.
- \*\* M, N, A<sub>1</sub>, A<sub>2</sub> ....., etc are the symbols shown on Figure 2.4-2
- \*\*\* For successive 6-hour values, use 34, 28, 21, and 17 percent of 2nd day values.
- \*\*\*\* For successive 6-hour values, use 29, 26, 23, and 22 percent of 3rd day values.

TABLE 2.4-8  
DRAINAGE AREAS

<u>Unit Drainage Area*</u>	<u>Area (mi<sup>2</sup>)</u>	<u>Unit Drainage Area*</u>	<u>Area (mi<sup>2</sup>)</u>	<u>Dam*</u>	<u>Area (mi<sup>2</sup>)</u>
1	290	31	200	Berlin	249
2	332	32	241	Chautaugua	194
3	136	33	227	Conemaugh	1,351
4	321	34	354	Crooked Creek	277
5	205	35	119	East Branch	72.4
6	222	36	180	Kinzua	2,180
7	576	37	74	Kirwan	80.5
8	230	38	458	Loyalhanna	290
9	166	39	382	Mahoning	340
10	303	40	121	Meander	84
11	350	41	94	Milton	27
12	234	42	295	Mosquito	97.4
13	501	43	389	Shenango	589
14	144	44	145	Tionesta	478
15	738	45	267	Tygart	1,184
16	329	46	257	Youghiogheny	434
17	199	47	504		
18	443	48	242		
19	137	49	120		
20	184	50	203		
21	498	51	239		
22	384	52	304		
23	121	53	398		
24	125	54	356		
25	129	55	118		
26	116	56	178		
27	330	57	505		
28	214	58	149		
29	504	59	409		
30	254	60	124		
		61	667		

NOTE:

\*Figure 2.4-4 illustrates these locations

TABLE 2.4-9  
 FLOOD FORECAST FOR DASHIELDS BEGINNING ON  
 OCTOBER 15, 1954

<u>1954</u>	<u>Time (hr)</u>	<u>Increase In Predicted Flow (cfs)</u>
Oct. 15	6	47.0
	12	1,463.0
	18	22,381.0
	24	111,396.0
Oct. 16	6	212,113.0
	12	275,696.0
	18	317,480.0
	24	321,660.0
Oct. 17	6	294,720.0
	12	248,305.0
	18	198,122.0
	24	154,732.0
Oct. 18	6	122,149.0
	12	98,827.0
	18	81,785.0
	24	68,974.0



TABLE 2.4-10

SUMMARY OF OCCURRENCES OF ICE ON OHIO RIVER  
AT CINCINNATI, OHIO 1874 - 1964\*

Type of Ice Condition	Frequency of Icing								Total	Date of Occurrence		Length Of Icing Season (Days)
	December		January		February		March			Earliest	Latest	
	No. Days	% of Occur.**	No. Days	% of Occur.**	No. Days	% of Occur.**	No. Days	% of Occur.**				
Light***	76	15	237	48	174	35	10	2	497	December 6	March 9	94
Heavy***	84	17	220	45	186	38	2	0	492	December 9	March 2	84
Frozen over	11	10	57	49	48	41	0	0	116	December 10	February 23	76
Gorged****	<u>58</u>	<u>29</u>	<u>100</u>	<u>51</u>	<u>38</u>	<u>19</u>	<u>1</u>	<u>1</u>	<u>197</u>	December 10	March 1	82
Total of any type	229	18%	614	47%	446	34%	13	1%	1,302			

NOTES:

- \* U. S. Army Corps of Engineers 1978.
- \*\* Percent of total occurrences of a particular type of ice condition which occurred in a particular month.
- \*\*\* Definition of icing condition not provided by the U.S. Army Corps of Engineers (1978).
- \*\*\*\* Indicates both a) "Jamming" where ice is stopped in current, bridged all the way across the river on the surface but not obstructing water flow in a way that causes damming and b) "Gorging" where ice is stopped in current, bridged all the way across the river, and is obstructing water flow in a damming effect causing head differential.

TABLE 2.4-11

SUMMARY OF OCCURRENCES OF ICE ON  
NEW CUMBERLAND POOL, 1863 - 1979\*,\*\*

Type of Ice Condition	Frequency of Icing								Total	Date of Occurrence		Length Of Icing Season (Days)
	December		January		February		March			Earliest	Latest	
	No. Days	% of Occur.***	No. Days	% of Occur.***	No. Days	% of Occur.***	No. Days	% of Occur.**				
Skim or shore	3	20	9	60	3	20	0	0	15	December 20	February 22	22
Moving	0	0	10	40	13	52	2	8	25	January 8	March 6	58
Frozen over (<1 in)	2	25	6	75	0	0	0	0	8	December 21	February 28	70
Frozen over (1 in - 6 in)	5	5	44	45	48	50	0	0	97	December 21	February 21	65
Frozen Over (>6 in)	<u>0</u>	<u>0</u>	<u>31</u>	<u>51</u>	<u>30</u>	<u>49</u>	<u>0</u>	<u>0</u>	<u>61</u>			
Total of any type	10	5%	100	48%	94	46%	2	1%	206			

NOTES:

\* U. S. Army Corps of Engineers, Lockmaster 1963 - 1979

\*\* Since definitions for icing conditions were not provided for the data in Table 2.4-10, it was not possible to present the above data in the same format. For example, some of the small thickness of frozen over category above may be equivalent to heavy ice in Table 2.4-10, while some greater thickness in the frozen over category may be equivalent to the "Jamming" condition included in the gorged category of Table 2.4-10.

\*\*\* Percent of total occurrences of a particular type of ice condition which occurred in a particular month.

TABLE 2.4-12

SUMMARY OF SURVEY OF ICING PROBLEMS AT UPPER OHIO RIVER INTAKES\*

<u>Facility</u>	<u>Location</u>	<u>River Mile</u>	<u>Description of Intake**</u>	<u>Flow (gpm)</u>	<u>Icing Problems</u>	<u>Source</u>
Duquesne Light Company	Pittsburgh, Pa	2.1, 2.3	Riverbank intake with CW, TR, and TWS		None	DLC 1980
Phillips Station Duquesne Light Company	Weirton, PA	15.1	Riverbank intake with CW, TR, and TWS		None	DLC 1980
American Bridge Company	Ambridge, Pa.	15.8	Wells	***	***	American Bridge Co. 1980
Jones & Laughlin Steel Corporation	Aliquippa, Pa.	18.6	Riverbank wells	***	***	Jones & Laughlin Steel Corp. 1980
St. Joe Zinc Company	Monaca, Pa.	28.4, 29.1	Riverbank intake with CW, TR, and TWS	70,000	Occasional (less than once per winter) icing of TWS when not in Operation. Start-up has not been a problem.	St. Joe Zinc Co. 1980
Bruce Mansfield Power Station Pennsylvania Power & Light Company	Shippingport, Pa.	33.6	Riverbank intake with TR and TWS	25,500	None	Pennsylvania Power & Light Company 1980
Beaver Valley - Duquesne Light Company	Shippingport, Pa.	34.8	Riverbank intake with CW, TR, and TWS		None	DLC 1980

TABLE 2.4-12 (Cont)

<u>Facility</u>	<u>Location</u>	<u>River Mile</u>	<u>Description of Intake**</u>	<u>Flow (gpm)</u>	<u>Icing Problems</u>	<u>Source</u>
Shipping Atomic Power Station Duquesne Light Company	Shippingport, Pa	35.0	Riverbank intake with TR, CW, and TWS		None	DLC 1980
Crucible Steel Company	Midland, Pa.	36.0	Riverbank intake with TR and TWS	50,000 60,000	None	Crucible Steel Co. 1980
City of Wellsville	Wellsville, Ohio	47.2	Reservoir	***	***	City of Wellsville 1979
Crescent Brick Company	New Cumberland, W. Va.	54.6	City Water	***	***	Crescent Brick Co. 1980
Toronto Waterworks	Toronto, Ohio	59.2	24-in cast iron swivel lock pipe, 500 ft from shore, at 18-19 ft depth with stationary screens		None	Toronto Waterworks Co. 1980
Toronto Titanium Metal Company	Toronto, Ohio	60.6	Wells	***	***	Toronto Titanium Metal Company 1980
Steubenville Water Works	Steubenville, Ohio	65.2	2 crib intakes on river bottom about 750 ft from shore	7,000	None	Steubenville Water Plant 1980
Wheeling Pittsburgh Steel Corporation	Mingo Junction, Ohio	70.8	Riverbank intake with TR and TWS	112,000	None	Wheeling Pittsburgh Steel Corp. 1980
Mingo Junction Water Department	Mingo Junction, Ohio	71.0	Ranney wells	***	***	Mingo Junction Water Department 1983

TABLE 2.4-12 (Cont)

<u>Facility</u>	<u>Location</u>	<u>River Mile</u>	<u>Description of Intake**</u>	<u>Flow (gpm)</u>	<u>Icing Problems</u>	<u>Source</u>
Coal Mine American Electric Power Fuel Supply	Beech Bottom, W Va.	79.8	Wells	***	***	American Electric Power Fuel Supply
City of Martins Ferry	Martins Ferry Ohio	88.6	Riverbank wells	***	***	Martins Ferry Sanitation Dept. 1979
Bellaire Water Works Company	Bellaire, Ohio	94.0	Ranney wells	***	***	Bellaire City Water System 1978
Burger Plant Ohio Edison Company	Shadyside, Ohio	102.2	3 riverbank intakes each with TR and TWS	210,000	None	Ohio Edison Company 1980

NOTES:

- \* Potential information sources based on ORSANCO (1978b)
- \*\* CW = Curtain Wall, TR = Trash Racks, TWS = Traveling Water Screens
- \*\*\* Information not applicable

TABLE 2.4-13

MINIMUM DILUTION FACTORS AT  
CHESTER, WEST VIRGINIA FOR ACCIDENTAL RELEASES  
IN SURFACE WATER FROM THE RWST TANK

<u>Tank</u>	Minimum Dilution <u>Factor</u>	Corresponding <u>Travel Time (Hours)</u>
Refueling water storage tank	476	65

TABLE 2.4-14

## WELLS IN VICINITY OF BEAVER POWER STATION

<u>No.*</u>	<u>Depth Wells (ft)</u>	<u>Diameter (in)</u>	<u>Producing From</u>	<u>Capacity (gpm)</u>
<u>Wells Drilled After 1966</u>				
1	100	10	Shale and sandstone bedrock	4
2	115	6	Shale and sandstone bedrock	<5**
3	111	6	Shale and sandstone bedrock	<5**
4	120	10	Shale and sandstone bedrock	4
5	109	16	Alluvial gravels	600
6	109	16	Alluvial gravels	600
7	200	6	Shale and sandstone bedrock	6
9	109	8	Alluvial gravels	200
55	90	12	Alluvial gravels	210
56	93	12	Alluvial gravels	115
57	200	12**	Shale and sandstone bedrock	3
<u>Wells Drilled Before 1966</u>				
8	95	8	Terrace gravels	50
10	65	10	Alluvial gravels	500
11	65	10	Alluvial gravels	500

NOTES:

\* Well numbers correspond to Figure 2.4-17. Only those wells for which data are available are shown in this table.

\*\* Estimated - data not available.

TABLE 2.4-15

PARAMETERS USED TO DETERMINE HORIZONTAL  
DISPERSION AND TRAVEL TIME  
FOR ACCIDENTAL RELEASES FROM JGBH TANK

<u>Parameter</u>	<u>Value</u>
Ohio River elevation (ft msl)	664.5
Ground-water elevation (ft msl)	665.5
Distance from waste handling building to Ohio River (ft)	900
Distance from River Bank to Chester, West Virginia (Miles)	7.1
Hydraulic gradient, $i$	$1.11 \times 10^{-3}$
Permeability, $k$ (ft/sec)	$2.0 \times 10^{-4}$
Effective porosity, $n_e$ (percent)	23.1
Seepage velocity, $U$ (ft/sec)	$9.62 \times 10^{-7}$
Longitudinal dispersivity, $\alpha_x$ (ft)	85.3
Transverse dispersivity, $\alpha_y$ (ft)	25.5
Dispersion coefficients (ft <sup>2</sup> /sec)	
$K_x$	$8.2 \times 10^{-5}$
$K_y$	$2.45 \times 10^{-5}$
$K_z = K_y$	$2.45 \times 10^{-5}$
Average aquifer thickness, $H$ (ft)	40.6



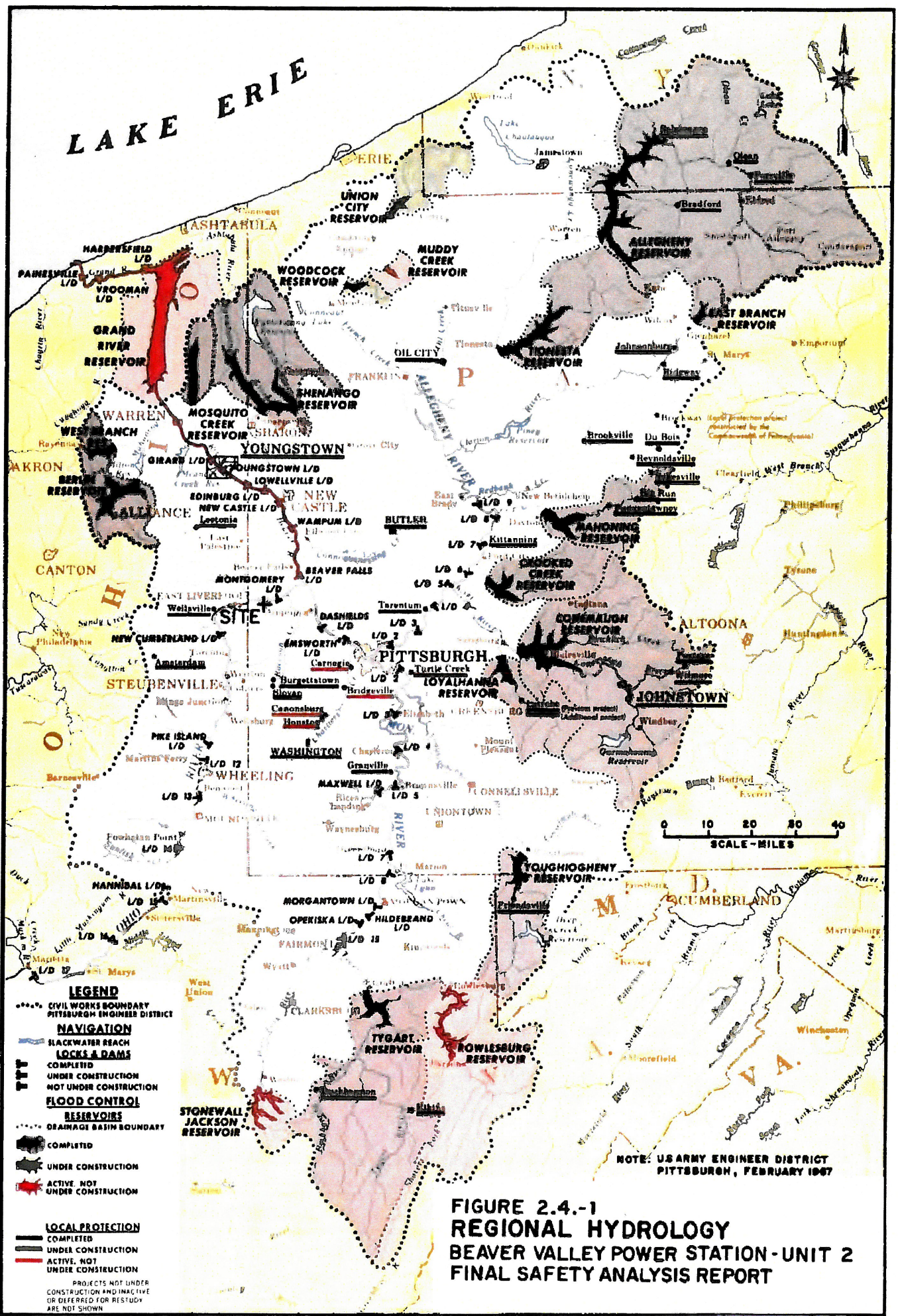



NOTE:  
U.S. ARMY CORPS OF ENGINEERS, PITTSBURGH DISTRICT 1970

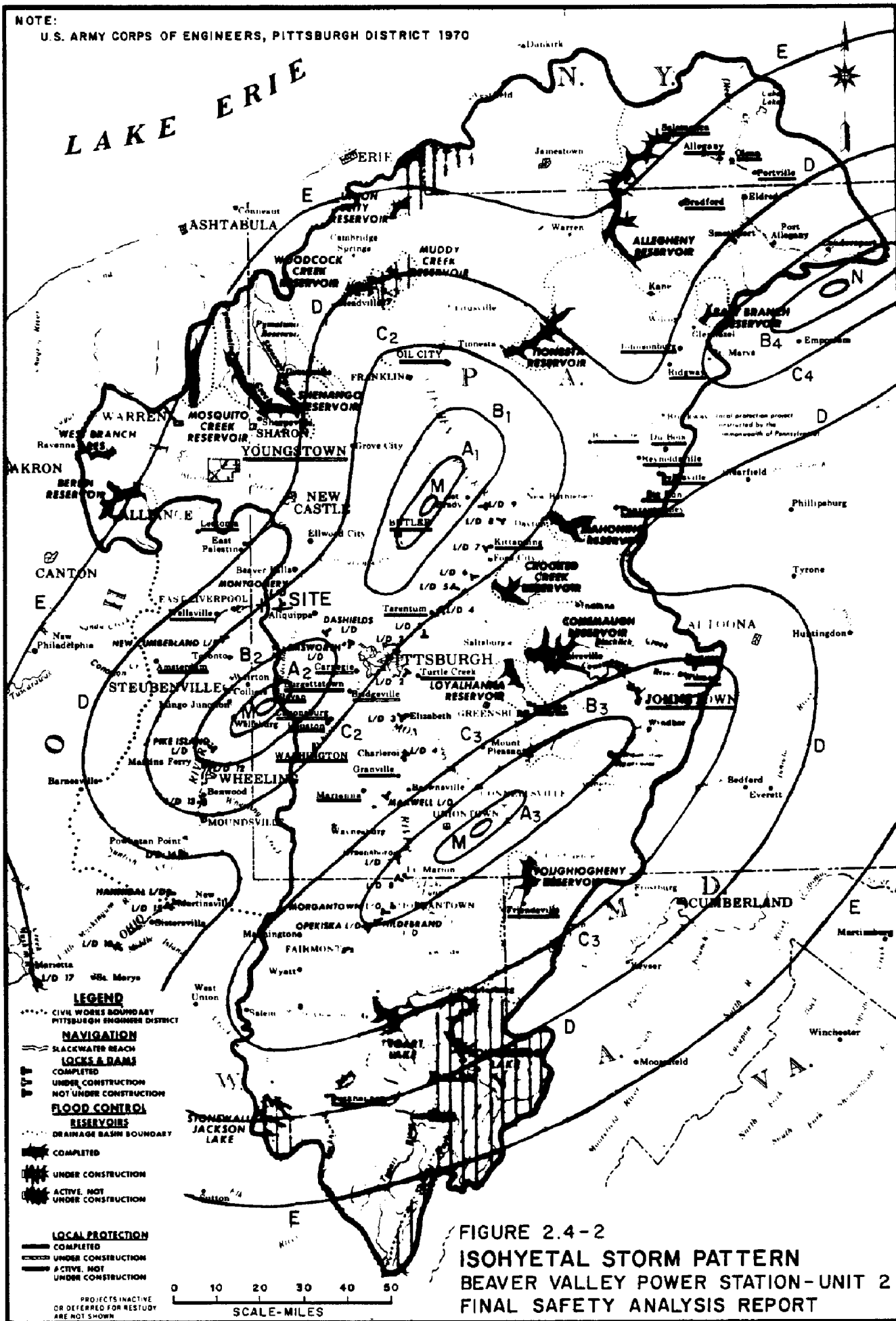
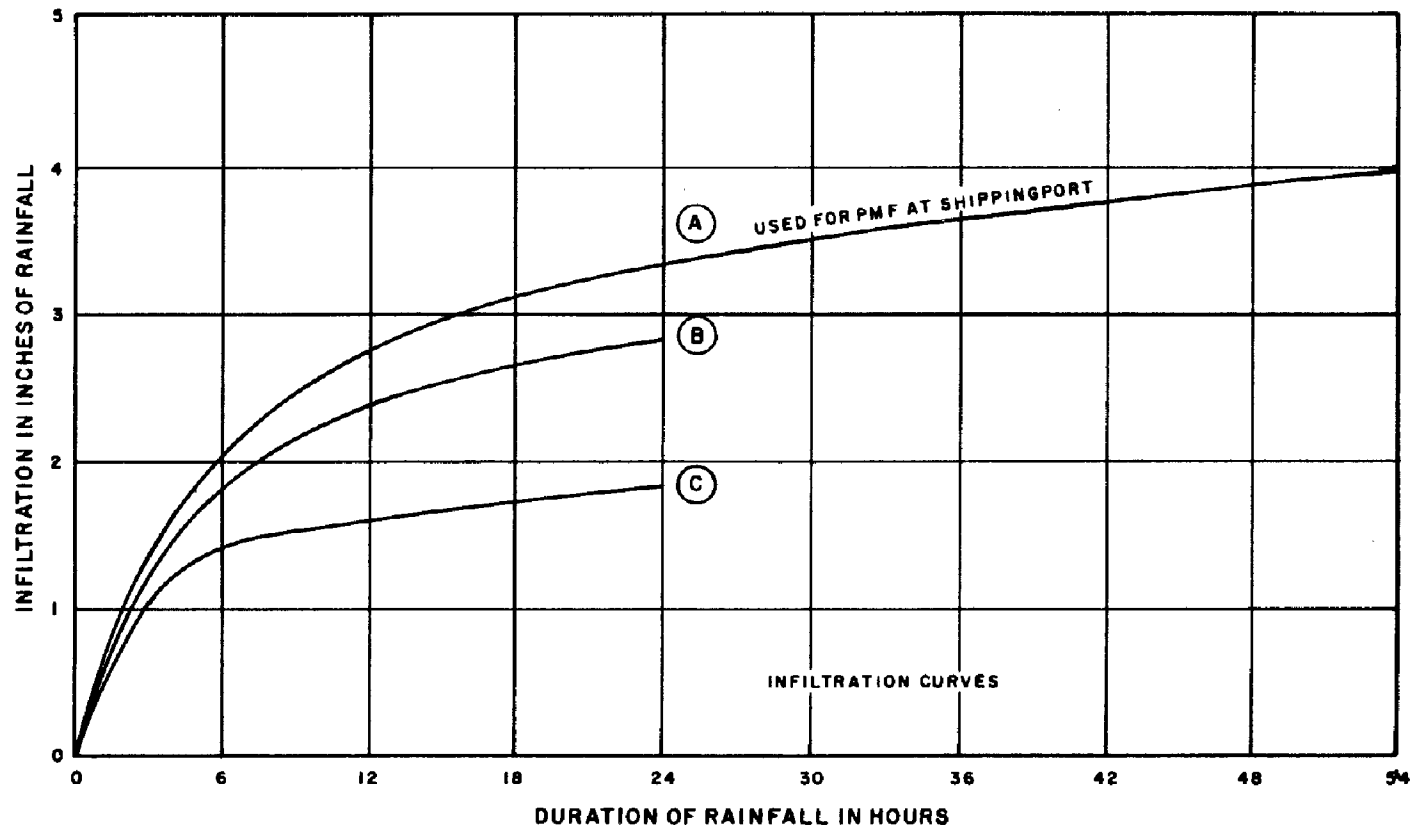

FIGURE 2.4-2  
ISOHYETAL STORM PATTERN  
BEAVER VALLEY POWER STATION-UNIT 2  
FINAL SAFETY ANALYSIS REPORT



- (A) LOSSES  
 54-60 HOURS - 0.06"  
 60-66 HOURS - 0.05"  
 66-72 HOURS - 0.04"
- (A) SUMMER STORM - BELOW NORMAL RAINFALL  
 ANTECEDENT CONDITIONS
- (B) FALL STORM - HURRICANE HAZEL  
 (OCTOBER 1954)
- (C) SUMMER STORM - ABOVE NORMAL RAINFALL  
 ANTECEDENT CONDITIONS

NOTE:  
 INFILTRATION CURVES BASED ON COMPUTATIONS USING  
 RAINFALL AND RUNOFF FOR THE WOODCOCK CREEK BASIN.

FIGURE 2.4-3  
 RAINFALL DURATION  
 VS. INFILTRATION  
 BEAVER VALLEY POWER STATION-UNIT 2  
 FINAL SAFETY ANALYSIS REPORT

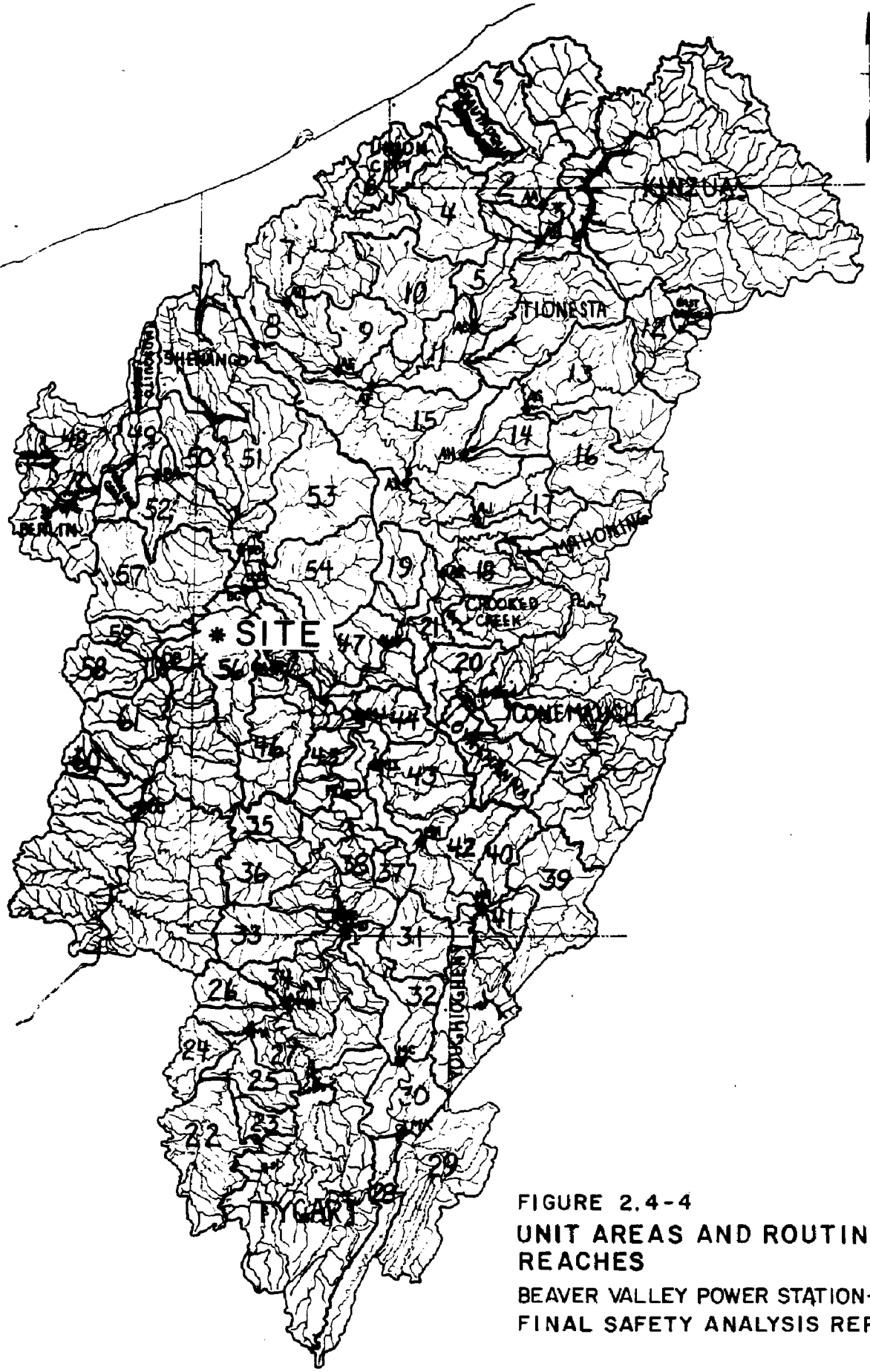

FIGURE 2.4-4  
 UNIT AREAS AND ROUTING  
 REACHES  
 BEAVER VALLEY POWER STATION-UNIT 2  
 FINAL SAFETY ANALYSIS REPORT

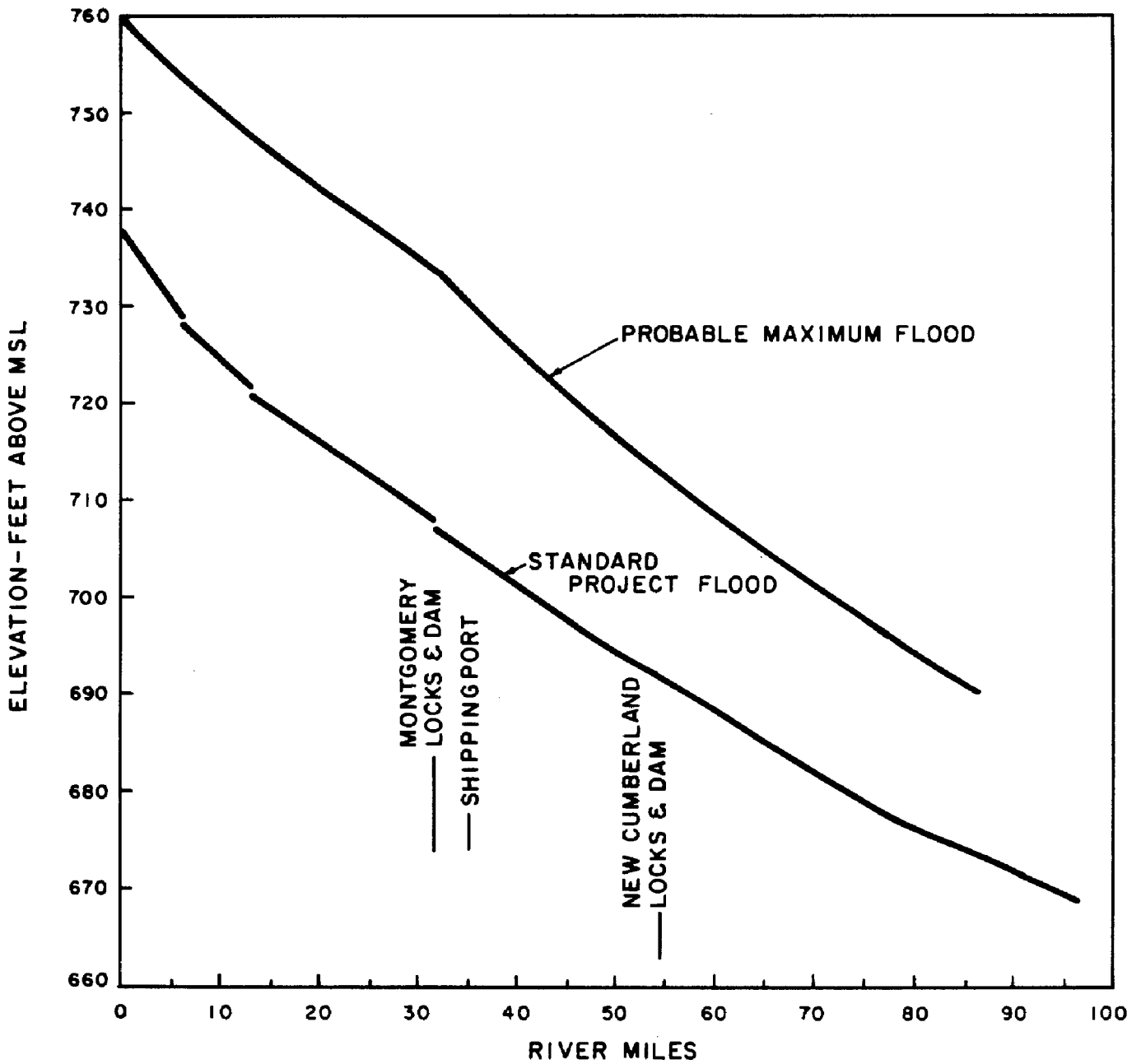
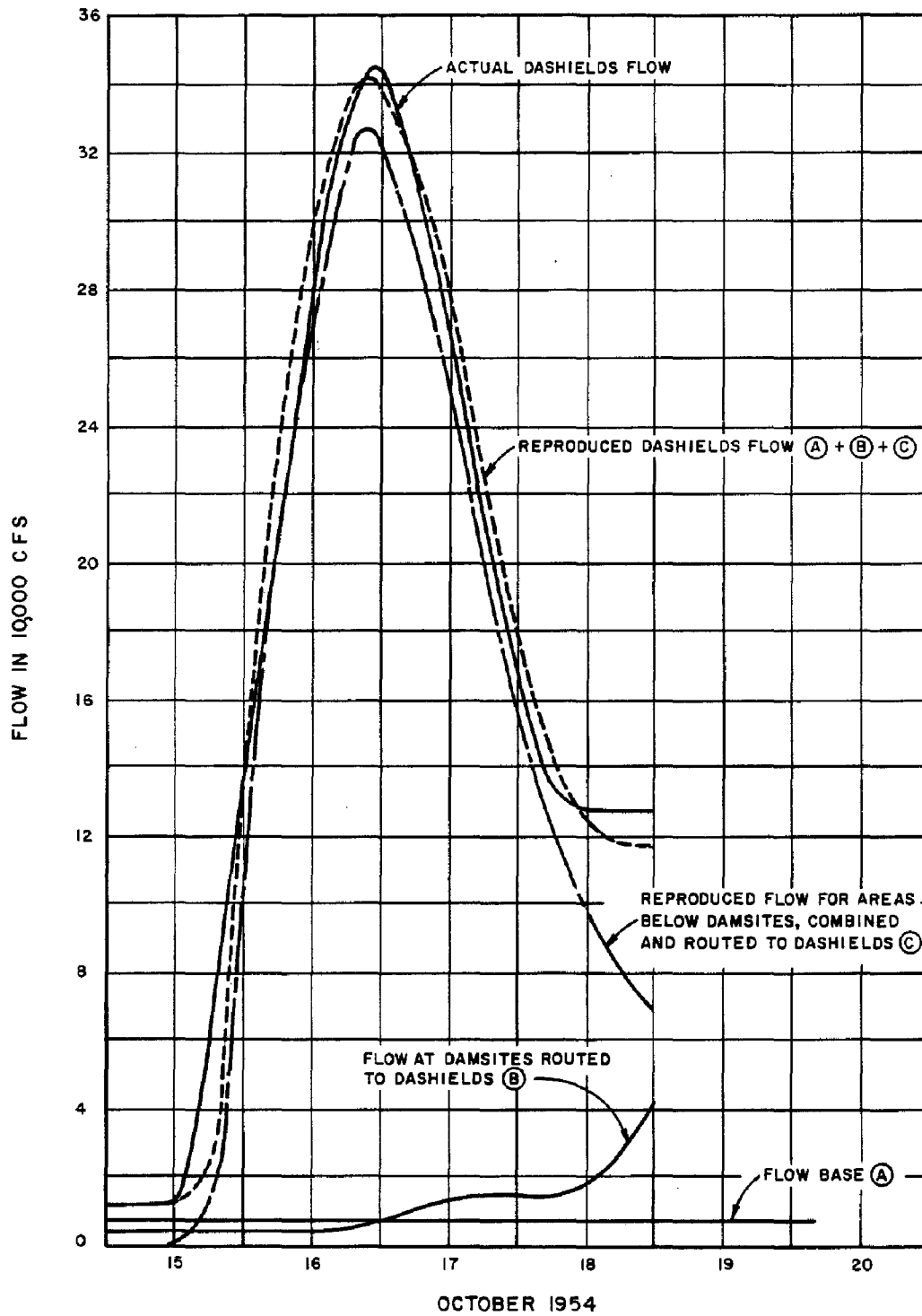

FIGURE 2.4-5  
 OHIO RIVER PROFILES  
 BEAVER VALLEY POWER STATION-UNIT 2  
 FINAL SAFETY ANALYSIS REPORT



NOTE:  
 USING ACTUAL RAINFALL AND LOSSES,  
 AND APPLYING THESE VALUES TO THE  
 DEVELOPED UNIT HYDROGRAPHS U. S.  
 ARMY ENGINEER DISTRICT,  
 PITTSBURGH, PA.

FIGURE 2.4-6  
 OHIO RIVER AT DASHIELDS LOCKS & DAM  
 COMPARISON OF ACTUAL & REPRODUCED  
 OCTOBER 1954 FLOODS  
 BEAVER VALLEY POWER STATION - UNIT 2  
 FINAL SAFETY ANALYSIS REPORT

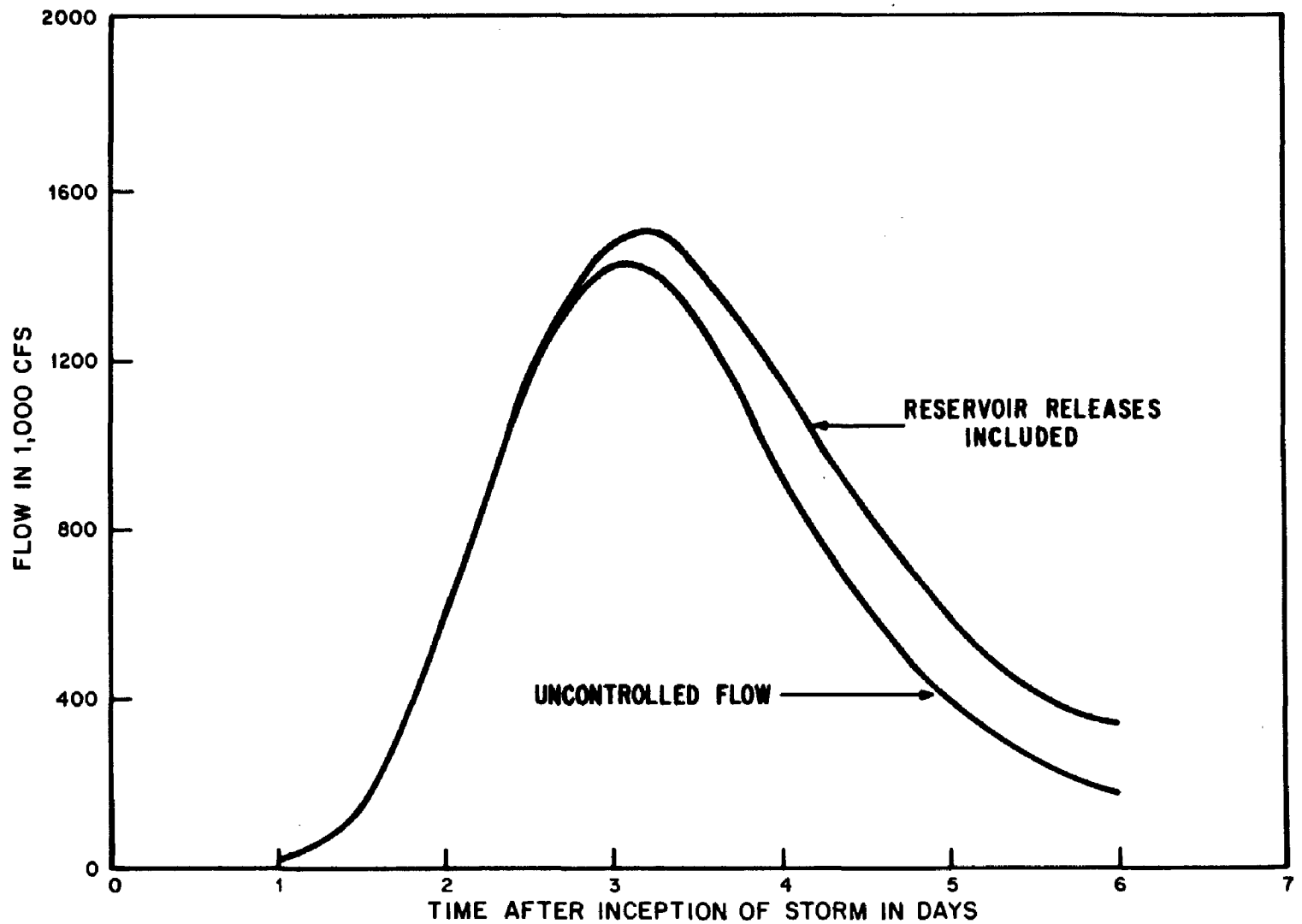
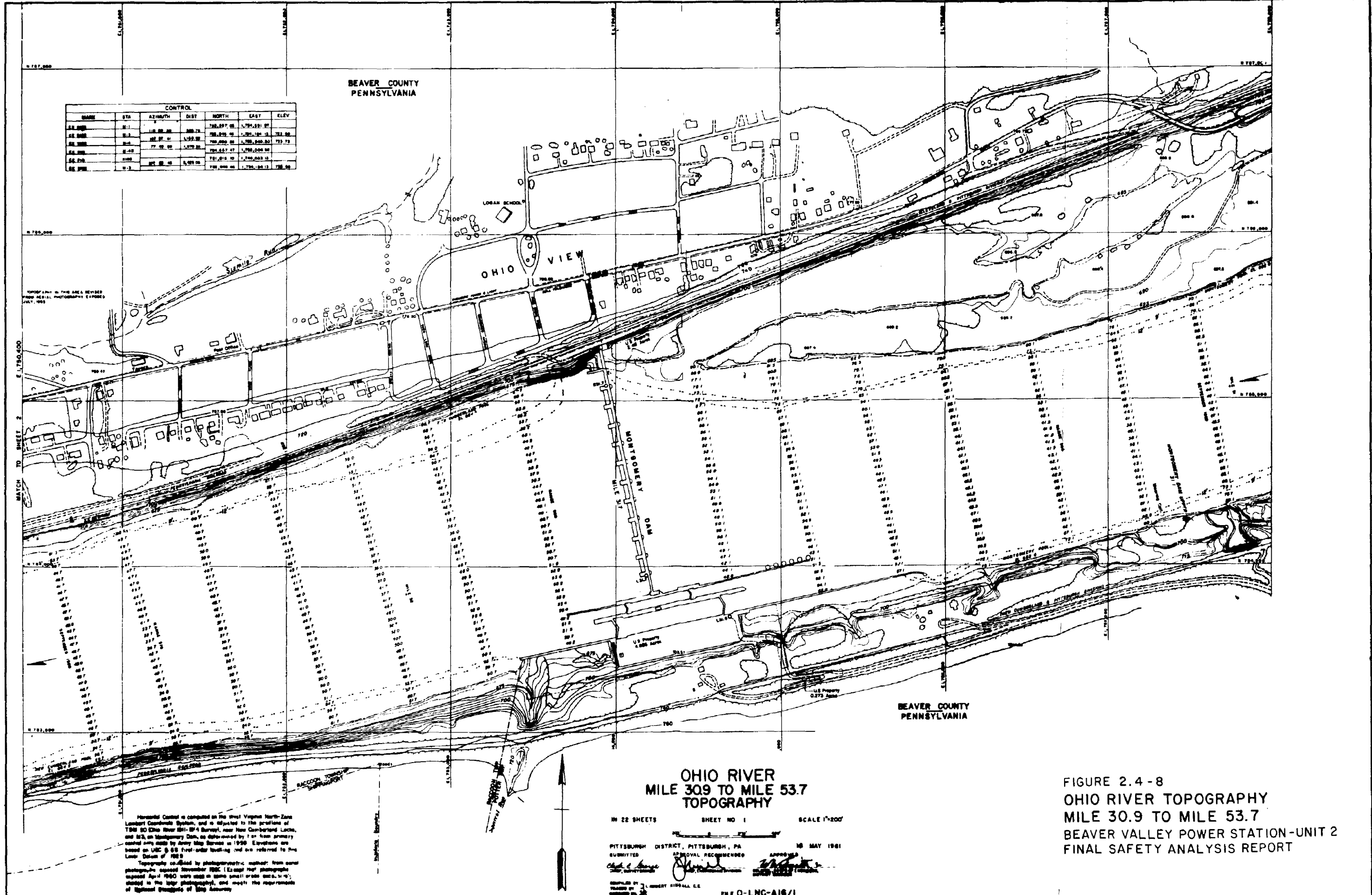

FIGURE 2.4-7  
 HYDROGRAPH OF PROBABLE  
 MAXIMUM FLOOD AT THE SITE  
 BEAVER VALLEY POWER STATION-UNIT 2  
 FINAL SAFETY ANALYSIS REPORT

NOTE  
 U.S. ARMY CORPS OF ENGINEERS,  
 PITTSBURGH DISTRICT, 1970.



CONTROL						
MARK	STA	AZIMUTH	DIST	NORTH	EAST	ELEV
21	11.1	118 00 00	300.75	780,897.00	1,781,831.97	751.50
22	11.2	102 00 00	1,192.50	780,897.00	1,780,101.13	753.73
23	11.3	77 00 00	1,079.00	781,637.47	1,780,000.00	751.50
24	11.4	00 00 00	5,000.00	781,637.47	1,780,000.00	751.50

TOPOGRAPHY IN THIS AREA DERIVED FROM AERIAL PHOTOGRAPHY EXPLORED JULY, 1955

Horizontal Control is computed on the West Virginia North-Zone Lambert Coordinate System, and is adjusted to the projection of T.M. 80 Ohio River (M-1-B) Survey, near New Cumberland Lock, and M-3, an Montgomery Dam, as determined by 1 or 4 km primary control only data by Army Map Service in 1959. Elevations are based on U.S.C. & G.S. first-order leveling and are referred to the Mean Ocean of 1929.

Topography collected by photogrammetric method from aerial photographs exposed November 1955. (Except for photographs exposed April 1960 were used in some small areas 1:25,000), checked in the larger photographs, and meet the requirements of highest standards of map accuracy.

FIGURE 2.4-8  
OHIO RIVER TOPOGRAPHY  
MILE 30.9 TO MILE 53.7  
BEAVER VALLEY POWER STATION-UNIT 2  
FINAL SAFETY ANALYSIS REPORT



Horizontal Control is computed on the West Virginia North Zone Lambert Conformal System, and is adjusted to the positions of TBM 90 (Ohio River 191-194 Survey), near New Cumberland Locks, and 93, on Montgomery Dam, as determined by first from primary control data made by Army Map Service in 1958. Elevations are based on USCG 8 65 first-order leveling and are referred to Sea Level Datum of 1929.

Topography compiled by photogrammetric methods from aerial photographs exposed November 1960 (Except that photographs resampled April 1960 were used in some areas where necessary checked in the later photographs), and meets the requirements of National Standards of Map Accuracy.

NAME	STA	CONTROL		ELEV
		DIST	NORTH	
93	21	120.00	787,507.46	699.16
VSC RLS 015C	12	120.00	787,776.98	699.22
93	22	121.00	787,466.94	746,800.00
93	23	121.00	787,428.32	746,800.00
93	24	121.00	787,400.00	746,800.00
93	25	121.00	787,380.00	746,800.00
93	26	121.00	787,360.00	746,800.00
93	27	121.00	787,340.00	746,800.00
93	28	121.00	787,320.00	746,800.00
93	29	121.00	787,300.00	746,800.00
93	30	121.00	787,280.00	746,800.00
93	31	121.00	787,260.00	746,800.00
93	32	121.00	787,240.00	746,800.00
93	33	121.00	787,220.00	746,800.00
93	34	121.00	787,200.00	746,800.00
93	35	121.00	787,180.00	746,800.00
93	36	121.00	787,160.00	746,800.00
93	37	121.00	787,140.00	746,800.00
93	38	121.00	787,120.00	746,800.00
93	39	121.00	787,100.00	746,800.00
93	40	121.00	787,080.00	746,800.00
93	41	121.00	787,060.00	746,800.00
93	42	121.00	787,040.00	746,800.00
93	43	121.00	787,020.00	746,800.00
93	44	121.00	787,000.00	746,800.00
93	45	121.00	786,980.00	746,800.00
93	46	121.00	786,960.00	746,800.00
93	47	121.00	786,940.00	746,800.00
93	48	121.00	786,920.00	746,800.00
93	49	121.00	786,900.00	746,800.00
93	50	121.00	786,880.00	746,800.00
93	51	121.00	786,860.00	746,800.00
93	52	121.00	786,840.00	746,800.00
93	53	121.00	786,820.00	746,800.00
93	54	121.00	786,800.00	746,800.00
93	55	121.00	786,780.00	746,800.00
93	56	121.00	786,760.00	746,800.00
93	57	121.00	786,740.00	746,800.00
93	58	121.00	786,720.00	746,800.00
93	59	121.00	786,700.00	746,800.00
93	60	121.00	786,680.00	746,800.00
93	61	121.00	786,660.00	746,800.00
93	62	121.00	786,640.00	746,800.00
93	63	121.00	786,620.00	746,800.00
93	64	121.00	786,600.00	746,800.00
93	65	121.00	786,580.00	746,800.00
93	66	121.00	786,560.00	746,800.00
93	67	121.00	786,540.00	746,800.00
93	68	121.00	786,520.00	746,800.00
93	69	121.00	786,500.00	746,800.00
93	70	121.00	786,480.00	746,800.00
93	71	121.00	786,460.00	746,800.00
93	72	121.00	786,440.00	746,800.00
93	73	121.00	786,420.00	746,800.00
93	74	121.00	786,400.00	746,800.00
93	75	121.00	786,380.00	746,800.00
93	76	121.00	786,360.00	746,800.00
93	77	121.00	786,340.00	746,800.00
93	78	121.00	786,320.00	746,800.00
93	79	121.00	786,300.00	746,800.00
93	80	121.00	786,280.00	746,800.00
93	81	121.00	786,260.00	746,800.00
93	82	121.00	786,240.00	746,800.00
93	83	121.00	786,220.00	746,800.00
93	84	121.00	786,200.00	746,800.00
93	85	121.00	786,180.00	746,800.00
93	86	121.00	786,160.00	746,800.00
93	87	121.00	786,140.00	746,800.00
93	88	121.00	786,120.00	746,800.00
93	89	121.00	786,100.00	746,800.00
93	90	121.00	786,080.00	746,800.00
93	91	121.00	786,060.00	746,800.00
93	92	121.00	786,040.00	746,800.00
93	93	121.00	786,020.00	746,800.00
93	94	121.00	786,000.00	746,800.00
93	95	121.00	785,980.00	746,800.00
93	96	121.00	785,960.00	746,800.00
93	97	121.00	785,940.00	746,800.00
93	98	121.00	785,920.00	746,800.00
93	99	121.00	785,900.00	746,800.00
93	100	121.00	785,880.00	746,800.00

**OHIO RIVER  
MILE 30.9 TO MILE 53.7  
TOPOGRAPHY**

IN 22 SHEETS SHEET NO. 2 SCALE 1"=200'

PITTSBURGH DISTRICT, PITTSBURGH, PA  
SUBMITTED: *[Signature]* APPROVED: *[Signature]* 18 MAY 1961  
CHECKED BY: *[Signature]*  
FILE O-LNC-A16/2

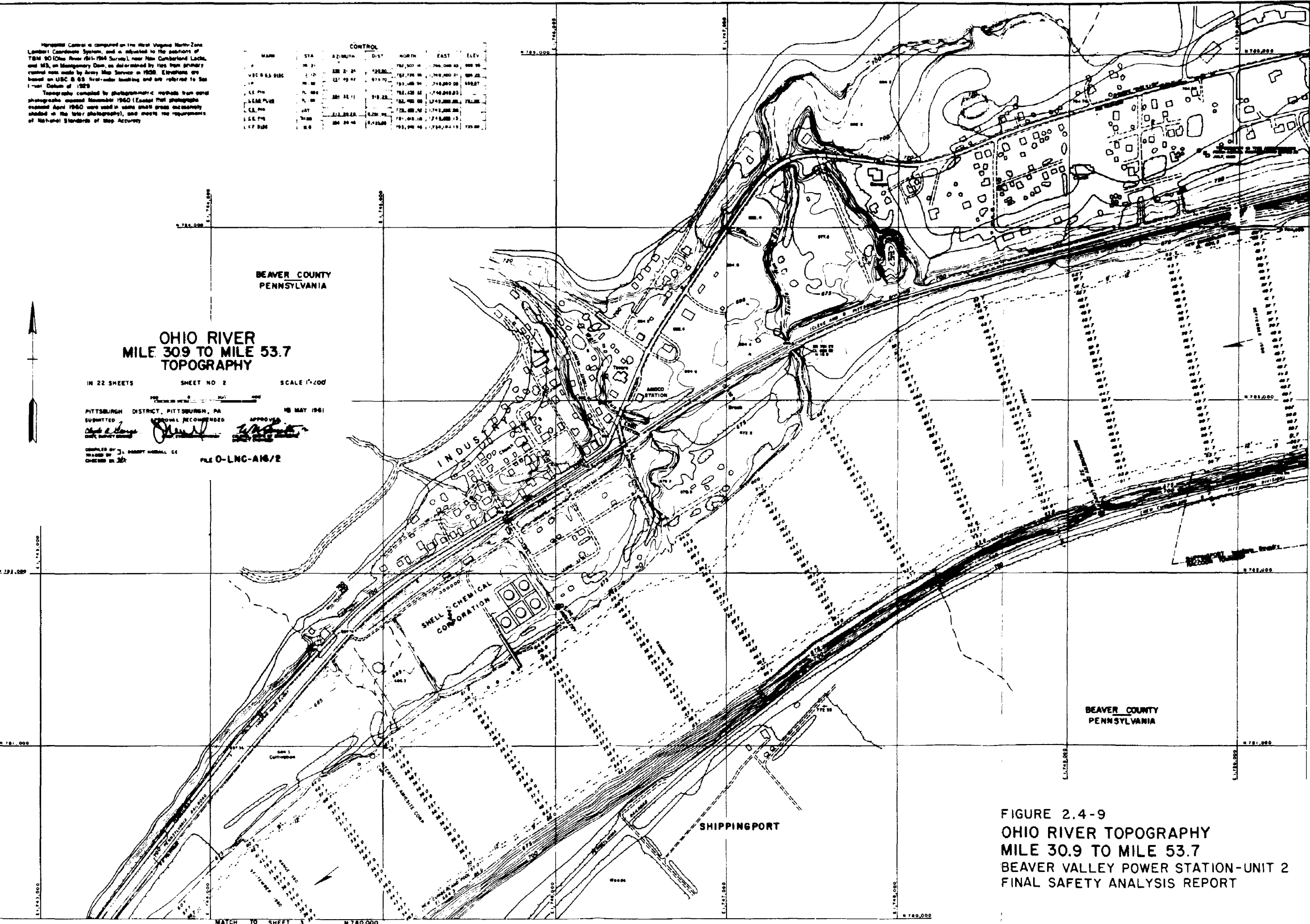
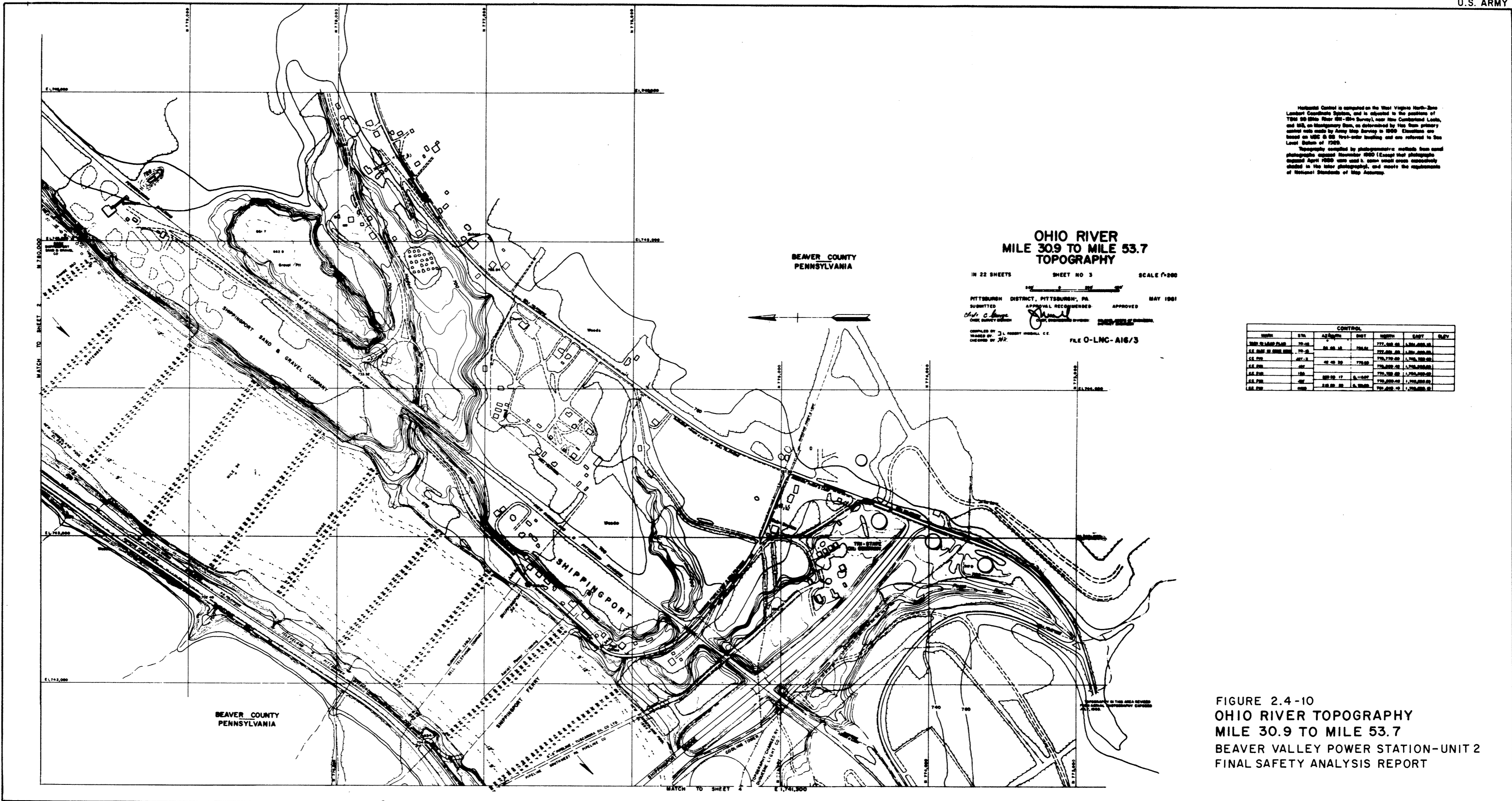

FIGURE 2.4-9  
OHIO RIVER TOPOGRAPHY  
MILE 30.9 TO MILE 53.7  
BEAVER VALLEY POWER STATION-UNIT 2  
FINAL SAFETY ANALYSIS REPORT



**OHIO RIVER  
MILE 30.9 TO MILE 53.7  
TOPOGRAPHY**

IN 22 SHEETS SHEET NO 3 SCALE 1"=200'

PITTSBURGH DISTRICT, PITTSBURGH, PA. MAY 1961  
 SUBMITTED APPROVED  
 CHECKED BY  
 FILE O-LNC-A16/3

Horizontal Control is computed on the West Virginia North-South  
 Lambert Coordinate System, and is related to the positions of  
 The 50 0000 River H.C. (H.C. Survey), near New Cumberland Lock,  
 and 551, on Maryland Dam, as determined by the then primary  
 control data made by Army Map Service in 1950. Elevations are  
 based on M.S.C. 5 500 North-south leveling and are referred to Sea  
 Level Datum of 1929.  
 Topography compiled by photogrammetric methods from aerial  
 photographs dated November 1950 (Except that photographs  
 dated April 1950 were used in some small areas immediately  
 adjacent to the later photographs), and meets the requirements  
 of National Standards of Map Accuracy.

CONTROL						
POINT	DATE	EASTING	NORTHING	EAST	NORTH	REMARKS
5000	1950	777,000.00	1,700,000.00			
5001	1950	777,000.00	1,700,000.00			
5002	1950	777,000.00	1,700,000.00			
5003	1950	777,000.00	1,700,000.00			
5004	1950	777,000.00	1,700,000.00			
5005	1950	777,000.00	1,700,000.00			
5006	1950	777,000.00	1,700,000.00			
5007	1950	777,000.00	1,700,000.00			
5008	1950	777,000.00	1,700,000.00			
5009	1950	777,000.00	1,700,000.00			
5010	1950	777,000.00	1,700,000.00			

FIGURE 2.4-10  
 OHIO RIVER TOPOGRAPHY  
 MILE 30.9 TO MILE 53.7  
 BEAVER VALLEY POWER STATION-UNIT 2  
 FINAL SAFETY ANALYSIS REPORT



Horizontal Control is computed on the New Virginia North-South Lambert Quadrangle System, and is adjusted to the positions of TBM 50 White River 1914-1916 Survey, near New Cumberland Lock, and 475, an Interim Point, as determined by 1955 from primary control marks by Army Map Service in 1955. Elevations are based on USC & GS First-order leveling and are referred to the Level Datum of 1929.

Topography compiled by photogrammetric methods from aerial photographs covered November 1959 (except that photographs exposed April 1960 were used in some small areas immediately adjacent to the later photographs), and meets the requirements of National Standards of Map Accuracy.

CONTROL						
NAME	STA	AZIMUTH	DIST	NORTH	EAST	ELEV
MARK IN LAMP PILE	75-10			777,419.44	1,701,630.15	
C.E. MARK IN CONCRETE	75-10	04 46 12	789.21	777,691.50	1,701,630.00	
I.P.	75-9			778,479.78	1,729,320.25	597.51
I.P.	75-7	07 48 07	569.51	778,488.59	1,726,717.57	599.58
C.E. PIV	ABEL			778,488.59	1,726,320.50	
C.E. PIV	DEY	02 30 30	1,129.26	778,699.21	1,737,888.91	

**OHIO RIVER  
MILE 30.9 TO MILE 53.7  
TOPOGRAPHY**

IN 22 SHEETS SHEET NO. 4 SCALE 1"=200'

PITTSBURGH DISTRICT, PITTSBURGH, PA. 10 MAY 1961  
SUBMITTED APPROVAL RECOMMENDED  
C. E. HARRIS  
C. E. HARRIS  
C. E. HARRIS

COMPILED BY: L. HENRY WINDALL, C.E.  
TRACED BY: [Signature]  
CHECKED BY: [Signature]

FILE O-LNC-A16/4

FIGURE 2.4-11  
OHIO RIVER TOPOGRAPHY.  
MILE 30.9 TO MILE 53.7  
BEAVER VALLEY POWER STATION-UNIT 2  
FINAL SAFETY ANALYSIS REPORT

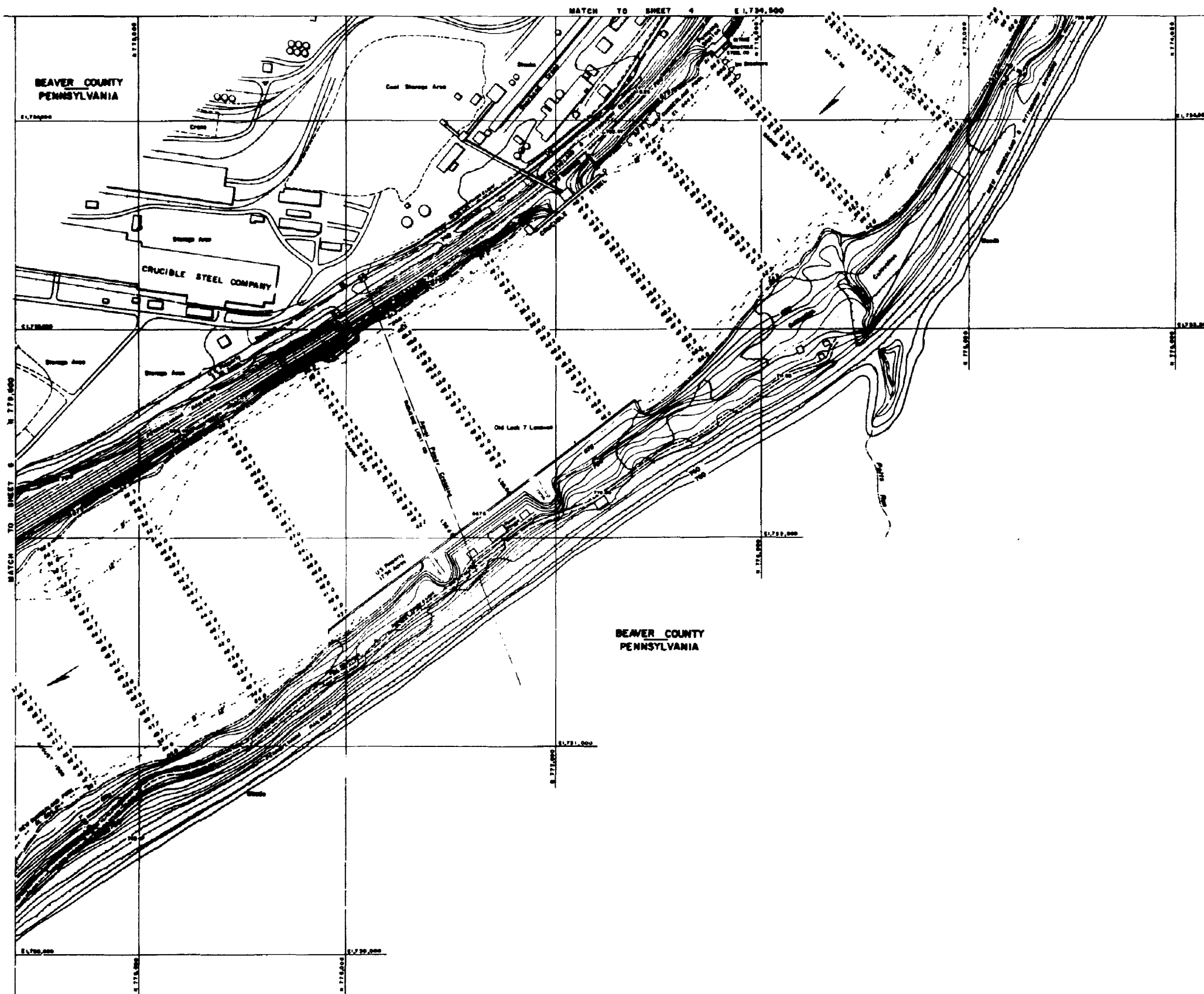

Horizontal Control is computed on the West Virginia North-South Lambert Cassinoid System, and is referred to the platform of TBM 90 (Ohio River 1911-1914 Survey), near New Cumberland Lock, and M.S. on Montgomery Dam, as determined by two first order control runs made by Army Map Service in 1939. Elevations are based on USC S 85 first-order leveling and are referred to Sea Level Datum of 1929.

Topography compiled by photogrammetric methods from aerial photographs exposed November 1960 (Except that photographs exposed April 1960 were used in some areas where necessary shaded in the later photography), and meets the requirements of National Standards of Map Accuracy.

NAME	STN	CONTROL				
		AZIMUTH	DIST	NORTH	EAST	ELV
...	...	...	...	...	...	...
...	...	...	...	...	...	...
...	...	...	...	...	...	...
...	...	...	...	...	...	...
...	...	...	...	...	...	...
...	...	...	...	...	...	...
...	...	...	...	...	...	...
...	...	...	...	...	...	...
...	...	...	...	...	...	...
...	...	...	...	...	...	...

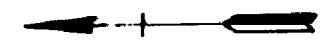

**OHIO RIVER  
MILE 30.9 TO MILE 53.7  
TOPOGRAPHY**

IN 22 SHEETS SHEET NO 8 SCALE 1:25,000

PITTSBURGH DISTRICT, PITTSBURGH, PA 16 MAY 1961

SUBMITTED APPROVED APPROVED

COMPILED BY: J. L. HENRY, SENIOR C.E.  
CHECKED BY: J.H.

FILE O-LNC-A16/5

FIGURE 2.4-12  
OHIO RIVER TOPOGRAPHY  
MILE 30.9 TO MILE 53.7  
BEAVER VALLEY POWER STATION-UNIT 2  
FINAL SAFETY ANALYSIS REPORT

CONTROL						
MARK	SPK	AZIMUTH	DIST	NORTH	EAST	ELEV
S.P. 2000	2000	370 40 30	664.71	781,100.84	1,736,117.27	888.54
S.P. 2001	2001	370 40 30	664.71	781,100.84	1,731,000.00	879.70
C.P. 200	2000	300 30 30	6,372.72	775,337.2	1,712,888.00	
C.P. 201	2001	300 30 30	6,372.72	775,337.2	1,717,000.00	
C.P. 202	2002	300 30 30	6,372.72	775,337.2	1,721,112.00	
C.P. 203	2003	300 30 30	6,372.72	775,337.2	1,725,224.00	
C.P. 204	2004	300 30 30	6,372.72	775,337.2	1,729,336.00	
C.P. 205	2005	300 30 30	6,372.72	775,337.2	1,733,448.00	
C.P. 206	2006	300 30 30	6,372.72	775,337.2	1,737,560.00	
C.P. 207	2007	300 30 30	6,372.72	775,337.2	1,741,672.00	
C.P. 208	2008	300 30 30	6,372.72	775,337.2	1,745,784.00	
C.P. 209	2009	300 30 30	6,372.72	775,337.2	1,749,896.00	
C.P. 210	2010	300 30 30	6,372.72	775,337.2	1,754,008.00	
C.P. 211	2011	300 30 30	6,372.72	775,337.2	1,758,120.00	
C.P. 212	2012	300 30 30	6,372.72	775,337.2	1,762,232.00	
C.P. 213	2013	300 30 30	6,372.72	775,337.2	1,766,344.00	
C.P. 214	2014	300 30 30	6,372.72	775,337.2	1,770,456.00	
C.P. 215	2015	300 30 30	6,372.72	775,337.2	1,774,568.00	
C.P. 216	2016	300 30 30	6,372.72	775,337.2	1,778,680.00	
C.P. 217	2017	300 30 30	6,372.72	775,337.2	1,782,792.00	
C.P. 218	2018	300 30 30	6,372.72	775,337.2	1,786,904.00	
C.P. 219	2019	300 30 30	6,372.72	775,337.2	1,791,016.00	
C.P. 220	2020	300 30 30	6,372.72	775,337.2	1,795,128.00	

Horizontal Control is computed on the West Virginia North-Zone Lambert Coordinate System, and is adjusted to the post town of TSM 90 (Ohio River 1911-1914 Survey), near New Cumberland Lock, and M3, an Montgomery Dam, as determined by ties from primary control now made by Army Map Service in 1959. Elevations are based on USC & GS first-order leveling and are referred to Sea Level Datum of 1929.

Topography compiled by photogrammetric methods from aerial photographs issued November 1960 (Except that photographs issued April 1960 were used in some small areas unaccountably shaded in the later photography), and meets the requirements of National Standards of Map Accuracy.

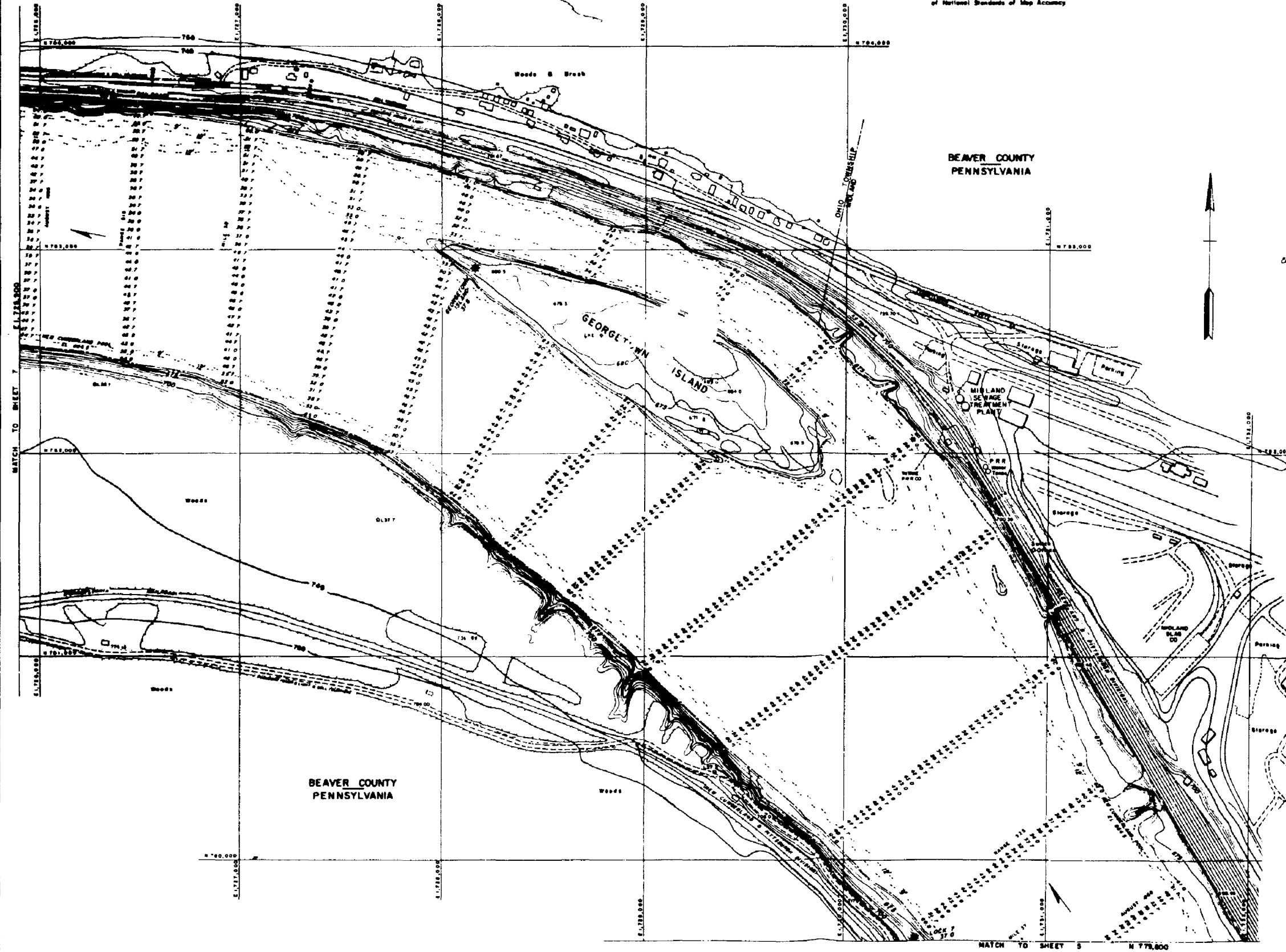

**OHIO RIVER  
MILE 30.9 TO MILE 53.7  
TOPOGRAPHY**

IN 22 SHEETS SHEET NO. 6 SCALE 1"=200'

PITTSBURGH DISTRICT, PITTSBURGH, PA 18 MAY 1961

SUBMITTED APPROVAL RECOMMENDED APPROVED

COMPILED BY J. ROBERT HINDALL, C.E. FILE O-LNC-A16/6

FIGURE 2.4-13  
OHIO RIVER TOPOGRAPHY  
MILE 30.9 TO MILE 53.7  
BEAVER VALLEY POWER STATION-UNIT 2  
FINAL SAFETY ANALYSIS REPORT



CONTROL						
NAME	STA.	AZIMUTH	DIST.	NORTH	EAST	ELEV.
IMPERIAL	107+1.4	87° 27' 31"	1,241.88	795,746.92	1,770,970.82	1,297.99
LE 210				795,814.05	1,770,892.82	
1745-CUT				795,446.87	1,762,566.81	887.27

Horizontal Control is computed on the West Virginia North-Zone Lambert Coordinate System, and is adjusted to the position of TBM 90 (Ohio River BM-246 Survey), near New Cumberland Lock, and BM on Montgomery Dam, as determined by first class primary control data made by Army Map Service in 1938. Elevation are based on USC & GS first-order leveling and are referred to the Level Datum of 1929.

Topography compiled by photogrammetric methods from aerial photographs exposed November 1960 (E sheet) and photographs exposed April 1960 were used to show small areas inadequately shown in the 1957 photography, and made the requirements of National Standard of Map Accuracy.



**OHIO RIVER  
MILE 30.9 TO MILE 53.7  
TOPOGRAPHY**

IN 22 SHEETS SHEET NO. 7 SCALE 1"=200'

1:25,000

PITTSBURGH DISTRICT, PITTSBURGH, PA. 18 MAY 1961

SUBMITTED BY: *[Signature]* APPROVED: *[Signature]*

COMPILED BY: J. ROBERT KIRKALL, C.E. CHECKED BY: *[Signature]*

FILE O-LNC-A16/7

FIGURE 2.4-14  
OHIO RIVER TOPOGRAPHY  
MILE 30.9 TO MILE 53.7  
BEAVER VALLEY POWER STATION-UNIT 2  
FINAL SAFETY ANALYSIS REPORT

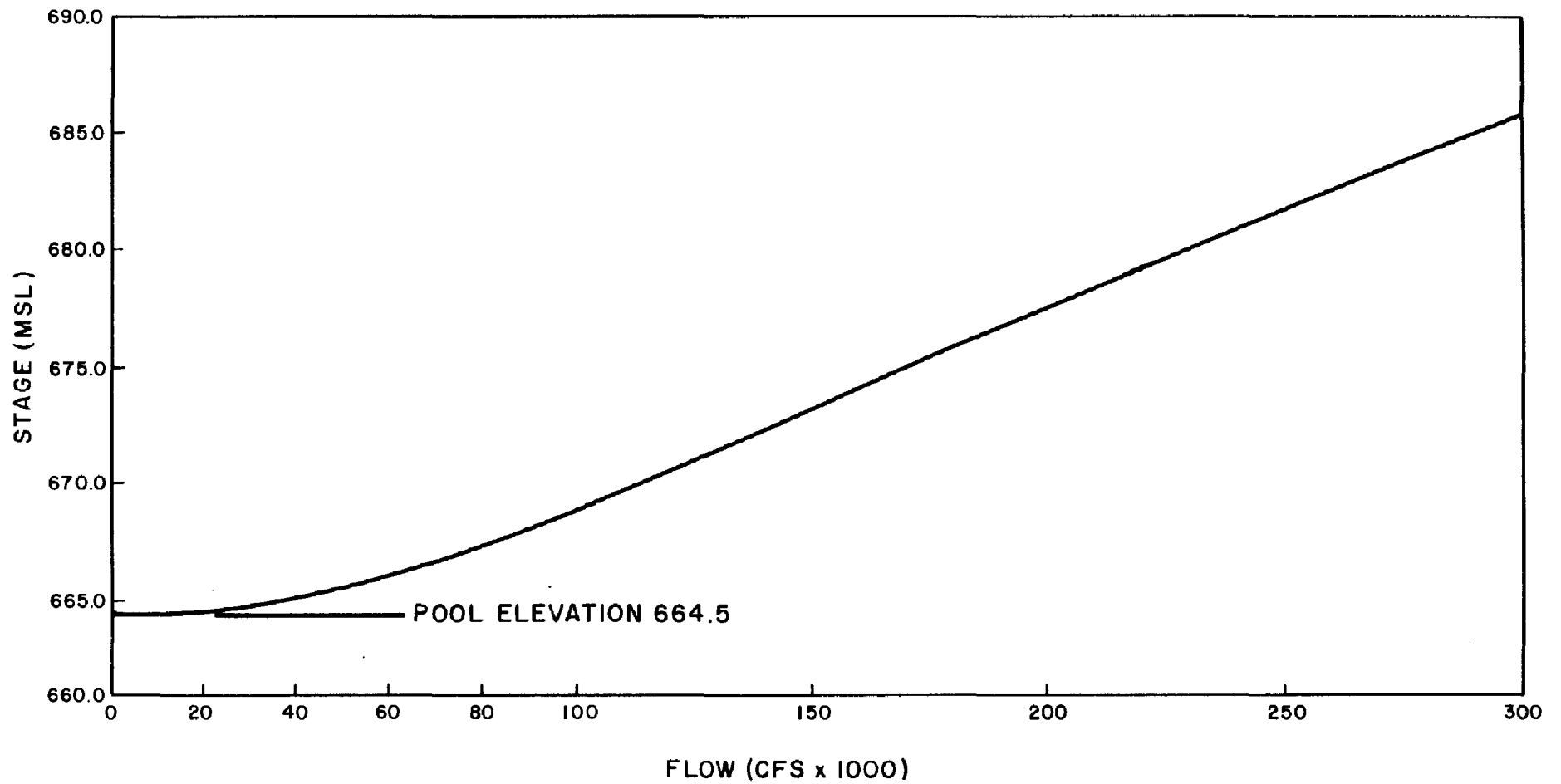
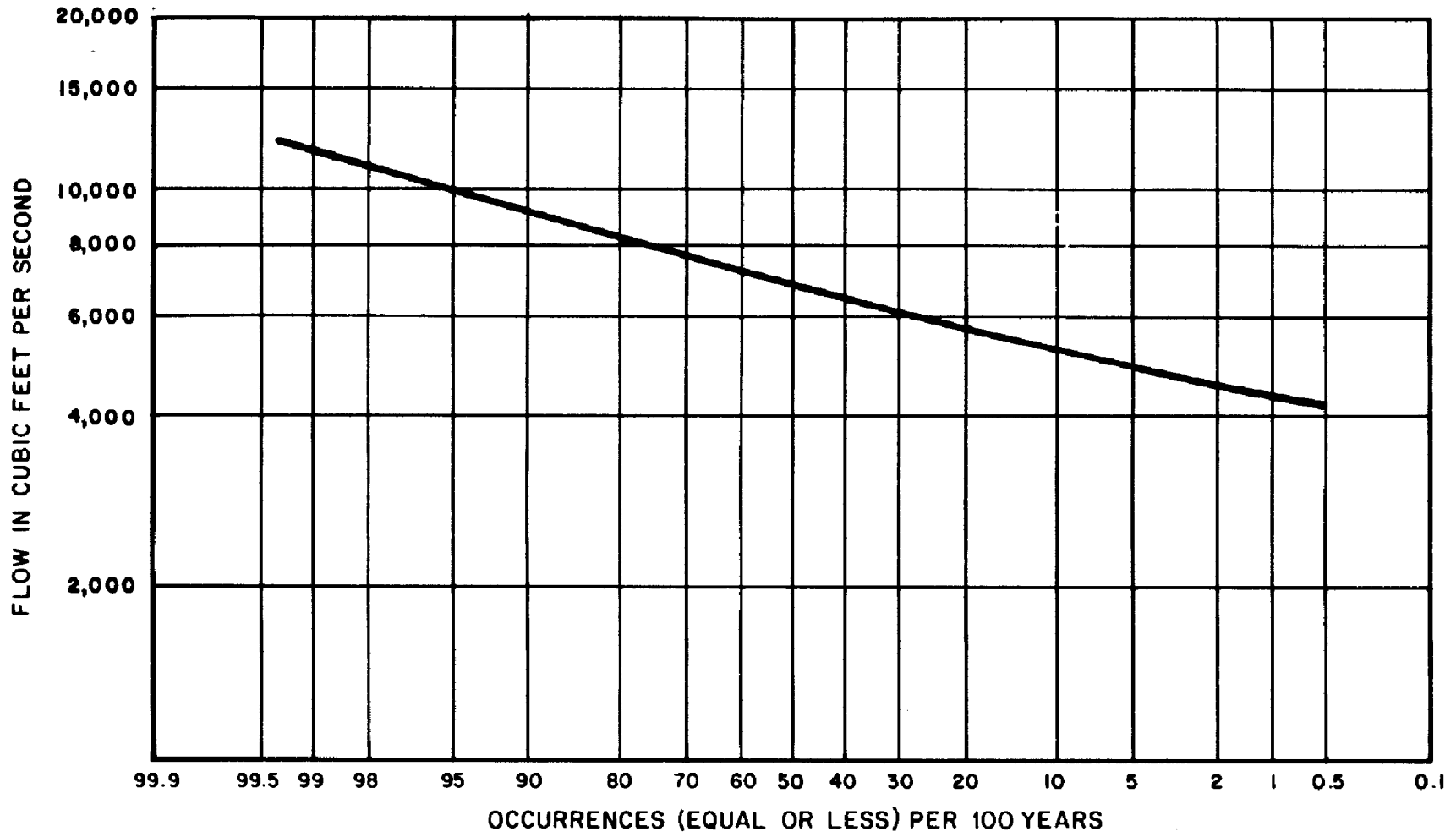

FIGURE 2.4 - 15  
FLOW - STAGE RELATION AT SITE  
OHIO RIVER - 34.8  
BEAVER VALLEY POWER STATION - UNIT 2  
FINAL SAFETY ANALYSIS REPORT



NOTE  
 LOWEST CONTINUOUS 7-DAY AVERAGE FLOWS.

FIGURE 2.4-16  
 DROUGHT FREQUENCY CURVE -  
 OHIO RIVER AT SHIPPINGPORT  
 BEAVER VALLEY POWER STATION-UNIT 2  
 FINAL SAFETY ANALYSIS REPORT





- al VALLEY-FILL DEPOSITS
- Co CONEMAUGH FORMATION
- Ca ALLEGHENY FORMATION

- R □ SEEP OR SPRING WITH ELEV. AND DIRECTION OF FLOW
- WELL WITH GROUND WATER ELEV.
- ⊙ WELL DRILLED 1966-1972
- GROUNDWATER CONTOUR
- GROUNDWATER PROFILE LINE
- ⋯ GROUNDWATER DIVIDE

0 2000 4000  
SCALE IN FEET

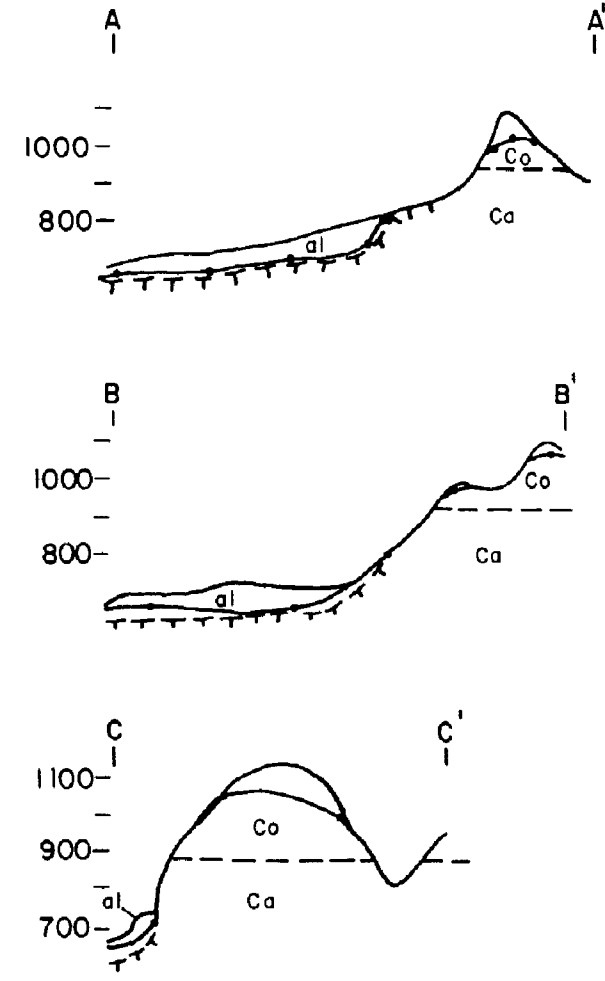
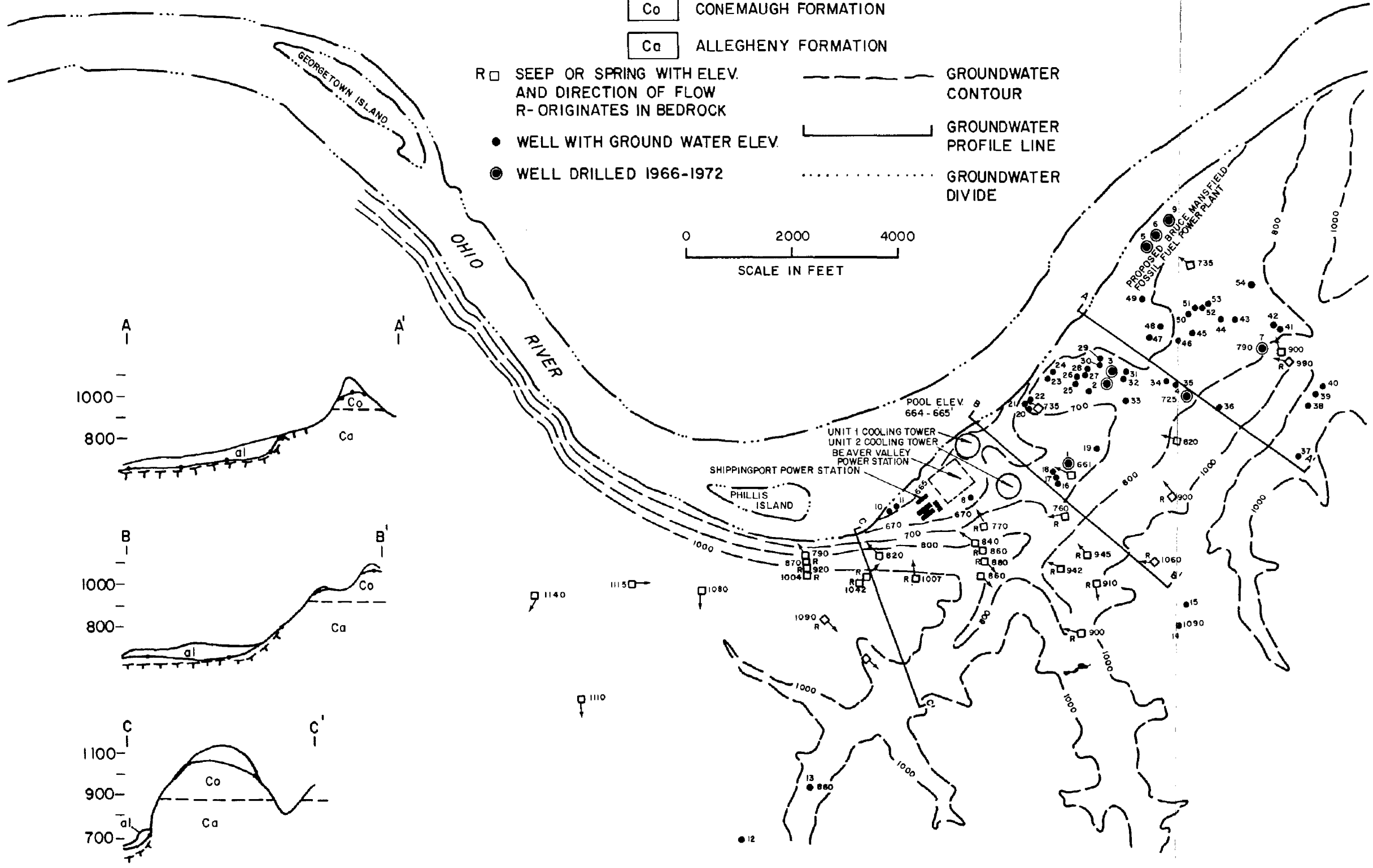

SCALE: VERT. 1" = 500'  
HOR. 1" = 2000'

FIGURE 2.4-17  
REGIONAL GROUNDWATER MAP  
BEAVER VALLEY POWER STATION - UNIT 2  
FINAL SAFETY ANALYSIS REPORT





- VALLEY-FILL DEPOSITS
- CONEMAUGH FORMATION
- ALLEGHENY FORMATION

0 1000 2000 3000 4000 5000  
SCALE - FEET

FIGURE 2.4 - 18  
GENERALIZED BEDROCK AND  
SURFICIAL GEOLOGY  
BEAVER VALLEY POWER STATION-UNIT 2  
FINAL SAFETY ANALYSIS REPORT



APPENDIX 2.4A

TECHNICAL REPORT

ANALYSIS OF FLOOD HEIGHTS,  
OHIO RIVER AT SHIPPINGPORT, PA  
HYDROLOGIC ENGINEERING INVESTIGATION

Prepared by

U.S. Army Engineer District, Pittsburgh,  
Corps of Engineers,  
Pittsburgh, Pa., January 1970

## APPENDIX 2.4A

ANALYSIS OF FLOOD HEIGHTS  
OHIO RIVER AT SHIPPINGPORT, PA.Scope

The proposed Shippingport Atomic Energy Plant site of the Duquesne Light Company is located on the left bank of the Ohio River, 35 miles below the head of the Ohio River at Pittsburgh, Pennsylvania.

The total drainage area of the river at this site is 22,989 square miles. Thirteen Federal reservoirs control flood runoff from 7,648 square miles of this area. The remaining area is 15,341 square miles.

Five additional Federal reservoirs which will control 1,367 square miles or about 9 percent of the now uncontrolled area should be in operation within about 5 years.

Runoff from the 15,341 square miles below the existing dams will be virtually unaffected by any other structures during floods of maximum proportions.

The drainage area limits above the site are shown on Plate 1 as are the area's tributary to the 13 completed reservoirs and the 5 future reservoirs presently under construction or in an active status for near future construction.

Actual Floods of Record

Actual flood records in the immediate vicinity of mile 35.0 are only available since 1911. Comparable longer term records, however, have been obtained at Pittsburgh, Pennsylvania, 35 miles upstream and at Wheeling, West Virginia, about 52 miles downstream. The record at Pittsburgh dates back to 1762. Continuous records, however, did not begin until 1854, thus providing 116 years of records available for mathematical frequency analysis but a record of 208 years for historical analysis. Continuous records at Wheeling extend from 1838 to 1850 and from 1861 to date with 110 years of uninterrupted data and an historical period of 132 years.

Between 1937 and 1967, the flood control reservoirs were consecutively built and flood heights have been progressively reduced. An adjustment for reservoir reduction was required to place all floods of record in a natural or modified-by-reservoir status. Consequently, computations were made for reservoir storage impoundment and release for all floods since 1935, not only to determine the effect by completed reservoirs, but also to develop a relationship between natural and modified peak flood flow magnitude. The natural and modified peaks were used to compute the frequency of

natural flooding and by relationship, the frequency of modified flooding.

These computations also showed how effective the reservoir system would have been on the March 1936 flood which was the highest of record. It attained an el 703 feet 1 inch at mile 35 with a peak flow of 510,000 cfs.

This flood resulted from average runoff equal to 3.0 inches of precipitation from the whole basin. Maximum precipitation intensity occurred over the Conemaugh River basin in the contiguous areas now predominately controlled by reservoirs. The Conemaugh River is especially well situated near the center of the tributary area above Shippingport so that it was formerly a prime contributor to a great many of the district floods. Because the controlled areas were a source of much of the March 1936 flood runoff, the reduction they could have exerted was above average. The maximum computed reduced flood therefore was not the 1936 flood but that of December 1942. This maximum reduced flood flow at mile 35.0 would be 390,000 cfs having a corresponding el 692 feet 9 inches.

#### Hydraulic Characteristics

Analysis of the 1936 and subsequent floods throughout the basin, stream flow measurements, backwater studies, and detailed topographic maps of the navigable portions of the Allegheny, Monongahela, and Ohio Rivers have provided unit graph and flood routing data for use in determination of actual flood factors and development of theoretical flood hydrographs. Unit hydrographs for 61 drainage areas comprising a separation into significant portions of the total uncontrolled basin, and 13 unit graphs for the reservoir inflows have been developed for flood forecasting and reservoir operation. Flood wave routing coefficients for the Muskingum method have been developed for transposition of the unit graph flows downstream through the basin. Valley storage curves 30 to 40 feet above the maximum flood of record profile were determined to check routing values and flood storage volumes. The stage discharge relation curve for the Ohio River at mile 35 and other critical locations used in the flood routing procedures have been developed by projection of the curves beyond the flood of record by use of established channel roughness, measured cross sections, and slope values based on various elevations and the related valley storage between rating station reaches. The stage discharge relation for the Ohio River at mile 35.0 is shown as Plate 2.

#### Standard Project Flood

Although the March 1936 flood is indicated to be the maximum for a period as long as 200 years, undoubtedly higher floods can occur. The Ohio River Standard Project Flood was developed to establish a plausible event in excess of the record. It was to be used for design of riverside structures where an extremely high degree of

flood safety was advisable. Its storm rainfall values were those of an actual storm, over a further west location in the Ohio River Basin where rainfall intensities are greater due to closer proximity to the Gulf source of moisture. It was assumed that they could possibly have been more closely centered over this area. Total storm intensities used were as great as 10 inches over portions of the basin. All of the existing reservoirs were assumed to be in flood control operation during the storm. As in the 1936 storm, high intensities occurred over the Conemaugh Reservoir basin and this reservoir was filled by the time the flood had crested downstream. Spillway discharge from this reservoir and several others occurred on the flood recession. This flood has a computed peak flow of 630,000 cfs at Shippingport with a maximum stage at el 705 feet 0 inches. This flow is about 60 percent greater than the maximum reduced flood and would appear to have only a one or two thousand to one chance of occurring in any year.

#### Dam Stability

The chance of augmentation of flood flows by dam failure superimposes an extreme improbability on remote probability.

All of the Pittsburgh District Corps of Engineers dams were designed for localized probable maximum storm runoff. They will not fail from overtopping especially from less intense rainfall of more generalized widespread storms such as the Standard Project Flood.

Military personnel also consider it highly improbable to critically breach these dams by sabotage, using conventional means or weapons, because of their mass. The most likely cause of their failure would be from a catastrophic event such as an atomic explosion or an earthquake in the immediate area coincidental with full or near full impoundment. The widespread destruction resulting from an atomic blast, or more significantly from an atomic attack of which it could be a part, could minimize the more local effects that might be caused by dam failure. The Pittsburgh District reservoirs whose failure would most likely have the greatest flooding effect at Shippingport function solely as flood control projects and consequently are usually at minimum storage. The decreased chance of destruction of these reservoirs when full compounds the improbability of flooding from this source.

At the World Conference of Earthquake Engineering in Chile, various charts and discussions indicated the improbability of dam failure from earthquakes in this area. Civil Engineering, October 1969, page 73, shows the seismic risk map presented at the conference. It indicates that this basin lies within a zone-one designation where earthquake damage can be only minor. Also presented at this conference was a paper that described an earthquake which produced horizontal cracks through a new 300-foot high concrete gravity dam at Koyna, India, in 1967. The shock was of high magnitude registering

6.5 on the Richter scale. Breaching did not occur (Civil Engineering, March 1969, page 83).

A more local example of the relation between stability of our gravity dams and earth shock was observed on November 19, 1969 at Bluestone Dam located in southeastern West Virginia. A tremor registered at 4.75 on the Richter scale occurred about 40 miles from the dam at 8 p.m. of this day. A thorough investigation at the dam showed no effect. Personnel on duty at the dam were not conscious of the tremor although people in nearby homes were alarmed at the vibration in these less substantial structures.

Even though breaching is believed to be improbable, especially coincidental with the peak of the Standard Project Flood, it was given consideration and a computation was made to show the effect of failure of the critically located Conemaugh Dam. The attendant wave from this failure would have raised the peak flow at Shippingport to 1,280,000 cfs with a peak stage at el 725 feet 2 inches.

#### Probable Maximum Flood

Despite the extreme magnitude of such theoretical flood conditions, still more critical conditions are conceivable from the Probable Maximum Rainfall. Such a rainfall represents the culmination of combined critical meteorological factors. Meteorologists do not reasonably concur that more critical rainfall can be experienced. The flood runoff resulting from such rainfall, when compared to frequency projections developed by the accepted conventional computation methods, show this maximum event to be in excess of even extreme probability projections, indicating a frequency of once in a geologic age.

Although a probable maximum storm had not been previously developed for the tributary area upstream of Shippingport, a study of this type had been made for the Susquehanna River basin which is adjacent to this area and located to the east. This probable maximum precipitation was presented in Weather Bureau Hydrometeorological Report 40. Consultation with the Office of Chief of Engineers and the Weather Bureau Hydrometeorological Section confirmed the assumption that data in this report could be reasonably applied to the Pittsburgh area. This report presented a storm pattern in the form of isohyetal lines (contours of equal precipitation) developed for 24,100 square miles of drainage area in the Susquehanna basin above Harrisburg, Pennsylvania. This area is of about the same size as that above Shippingport.

Orientation of the storm pattern over the Pittsburgh District was performed by transposing it 2.5 degrees longitude west and 0.8 degrees latitude south. This was believed to be not only a logical transposition but also one conducive to the peak runoff maximization. The isohyetal storm pattern is shown on Plate 1 with the values of intensity and time distribution of the isohyets

tabulated on Plate 3. Both the pattern and table were obtained from Report No. 40.

Individual hydrographs for each of the 61 subareas in the basin and for the areas above the 13 reservoirs were developed from the unit graphs and the 6-hour rainfall values, applicable to the particular areas, modified by infiltration losses. These losses have been found applicable to storms of similar characteristics and seasonal occurrence in this area.

The uncontrolled area hydrographs routed to Shippingport resulted in a combined flood hydrograph of 1,430,000 cfs.

The reservoir inflow hydrographs were developed in a similar manner with unit graphs and the oriented rainfall values. In no case were these flood flows as great as the spillway design floods which were used to assure the safety of the dam against overtopping and failure. Reservoir storage during the early storm periods was sustained long enough to permit downstream passage of the flood peak before spillway discharge could appreciably add to its magnitude. Ultimate reservoir storage heights were below structural design levels.

Reservoir outflows were subsequently routed downstream through the basin and were combined with the uncontrolled flow hydrographs to form the probable maximum flood as modified by the 13 existing reservoirs.

This flood so developed has a maximum flow magnitude of 1,500,000 cfs and would attain an el 730 feet 0 inches at Ohio river mile 35. It is almost 4 times as great as the maximum reduced flood in our 200 years of record. The hydrograph of this flood is shown as Plate 4.

The mean velocity of the peak flood flow is estimated to be 10 feet per second or about 7 miles per hour. Bank velocities at the proposed structure should not exceed 3 mph.

#### Duration of Inundation

These floods would not only cause the river to rise to the high peak stages which have been discussed but would subject the banks and contiguous structures to protracted durations of inundation. Plate 5 presents stage-duration curves which show the length of time that various elevations would be equalled or exceeded during the Maximum Probable, Standard Project, and maximum actual reduced floods. The short duration of additional flooding caused by breaching of Conemaugh Dam during the Standard Project Flood can be readily observed.

#### Results and Conclusions

1. The most critical conditions which we believe possible would result from the probable maximum flood (PMF).



2. The probable maximum flood would have a peak flow of 1,500,000 cfs and attain an el 730 feet 0 inches at mile 35 feet 0 inches.
3. Outflow from the flood control reservoirs would only contribute 70,000 cfs to the flood peak. Reservoirs would operate according to their predetermined schedules and would be in no danger of failure as this flood is not as critical to them as results from their own design criteria.
4. Maximum scouring velocities at the structure would not exceed three miles per hour.
5. Failure of any of the flood control dams at any time and particularly coincidental with peak flood flow is not believed of practical consideration.
6. The probable maximum flow is 400 percent of the comparable maximum reduced flood in the 200-year period of record. Frequency computations which give consideration to the overall pattern of events, place this flood as only a 100-year event. The same computations indicate the probable maximum value to be so far beyond reasonable projection limits it might be termed as a geologic era event.
7. The Ohio River Standard Project Flood at mile 35.0 is 630,000 cfs with a maximum el of 705 feet 0 inches. This flood has a computed frequency of about once in 1,000 to 2,000 years.
8. The Standard Project Flood augmented by breaching of the Conemaugh Dam (an event believed unlikely) is 1,280,000 cfs with an elevation of 725 feet 2 inches.

The studies have been of sufficient depth and detail to assure a degree of accuracy commensurate with the reliability of projections made.

APPENDIX 2.4B

SELECTED U.S. ARMY CORPS OF ENGINEERS  
CORRESPONDENCE RELATED TO  
OHIO RIVER FLOW AND ELEVATION

## ATTACHMENT 2.4B



DEPARTMENT OF THE ARMY  
 PITTSBURGH DISTRICT, CORPS OF ENGINEERS  
 FEDERAL BUILDING, 1000 LIBERTY AVENUE  
 PITTSBURGH, PENNSYLVANIA 15222

ORPED-DH

26 August 1969

Mr. Robert P. Kitchell  
 Engineer - Hydraulic Division  
 Stone & Webster Engineering Corporation  
 225 Franklin Street  
 Boston, Massachusetts 02107

Beaver Valley Power Station - Unit No. 1  
 J.O. NO. 11700 - O.F.E. NO. 5700 - C.O.  
 NO. 3468; Duquesne Light Company

Dear Mr. Kitchell:

The information you requested in your letter of 25 July 1969 is furnished below.

The possibility of a complete failure of the New Cumberland Locks and Dam, in addition to the failure of all the gates that you mentioned in your letter, is conceivable only as a result of deliberate hostile action. The major part of the project, including the dam and lock sills, the dam piers and the lock walls, are of concrete gravity construction founded on sound rock. The entire structure is considered safe against earthquake as discussed in our letter of 16 December 1968 addressed to Mr. Robert J. McAllister of Duquesne Light Company.

In the event that a catastrophic failure would take place during a period when the record minimum river flow of 4,700 c.f.s. occurs, we estimate that the river would revert to an open channel flow condition. A minimum water surface elevation of 649.0 feet m.s.l. would result at the proposed Beaver Valley Power Station site.

The minimum water surface elevation of 649.0 would also apply during failure of all gates of the New Cumberland Dam. This supersedes the minimum water surface elevation of 647.0, furnished in our above mentioned letter, which inadequately represented the effect of channel control.

Inclosed are four drawings. One is a map showing the physical features of the New Cumberland Locks and Dam, one is a topographic map showing the contours of the surrounding ground and the elevations of the river bed recorded on the given dates, and two are plans of soundings of the upper and lower pools taken in September 1968.

Sincerely yours,

WAYNE G. NICHOLS  
 Colonel, Corps of Engineers  
 District Engineer

4 Incl  
 As stated



## ATTACHMENT 2.4B

**DEPARTMENT OF THE ARMY**  
**PITTSBURGH DISTRICT, CORPS OF ENGINEERS**  
**FEDERAL BUILDING, 1000 LIBERTY AVENUE**  
**PITTSBURGH, PENNSYLVANIA 15222**

ORPED-C

29 March 1973

Mr. Robert J. McAllister  
Structural Engineer  
Duquesne Light Company  
435 Sixth Avenue  
Pittsburgh, Pennsylvania 15219

Dear Mr. McAllister:

Minimum River Flows at the  
Beaver Valley Power Station

We have made a reanalysis of low flows in the Ohio River. Computerized simulation models were developed to reproduce the hydrologic system of the Pittsburgh District. Included in this system were all of the reservoirs that normally augment low flows. The model was then used to simulate regulated stream flows for the period of record (1929-1966) according to the operating schedules adopted for each reservoir.

Results of these computer analyses show that, with the contemporary system of reservoirs, a minimum flow of 4000 c.f.s. would have occurred at Shippingport during the record drought of 1930. This value supersedes the minimum value of 4700 c.f.s. furnished several years ago. The corresponding minimum water surface elevation at the Beaver Valley Power Station site would be 648.6 instead of 649.0.

Sincerely,

DAN A. CONNER  
Major, Corps of Engineers  
Acting District Engineer

Copy furnished:

Mr. Richard C. Miller  
Hydraulic-Environmental Engineer  
Stone & Webster Engineering Corp.  
225 Franklin Street  
Boston, Mass. 02107

## ATTACHMENT 2.4B



**DEPARTMENT OF THE ARMY**  
**PITTSBURGH DISTRICT, CORPS OF ENGINEERS**  
**FEDERAL BUILDING, 1000 LIBERTY AVENUE**  
**PITTSBURGH, PENNSYLVANIA 15222**

ORPED-0

1 November 1973

Mr. Richard C. Miller  
Senior Hydraulic-Environmental Engineer  
Stone & Webster Engineering Corporation  
P. O. Box 2325  
Boston, Massachusetts 02107

Dear Mr. Miller: Beaver Valley Power Station -  
Loss of Pool

In response to your letter of 2 October 1973, we are submitting the following information relative to the possibility of a drop in the New Cumberland normal pool level during extreme low flow conditions.

Should such an event occur or be anticipated, the Pittsburgh District Emergency Center will be alerted. The Center will then be responsible for directly notifying the Beaver Valley Power Station, landings, intakes and other interested parties affected by a drawdown in the pool. It will also notify the public through press releases to the various news media.

During any low flow period, navigation pools such as New Cumberland would not be intentionally lowered. Locking activities could be continued at normal rates without any drawdown of the pool, even if the flow was at the minimum rate of 800 c.f.s. stated in your letter.

The only lock or tainter gate damage reasonable to assume during a drought period would be the loss of a lock gate due to a navigation accident. Sabotage is not considered in this evaluation. Inclosed is a copy of a letter sent to Mr. Robert J. McAllister of Duquesne Light Company explaining the situations which could cause loss of pool and the resulting measures that could be taken to correct the problem. In that letter, a flow of 4,700 c.f.s. was used for the analysis. Loss of more than one gate was also discussed. It was assumed that any such incident would occur during a flood and that repairs would be made within two weeks. At that time the flow would be no less than 20,000 c.f.s. with a corresponding elevation of 654 feet above mean sea level (m.s.l.) at the plant.

ORPED-0

1 November 1973

Mr. Richard C. Miller

Our present analysis considers an extreme drought with a flow of 800 c.f.s. Since the only damage that could reasonably be expected to occur with this flow is the loss of a lock gate, the bulkheads could be installed within four hours and there would be no further loss of pool. During these four hours of open lock flow, the pool would drop 1.8 feet to elevation 662.7 feet m.s.l.

Computations were made to evaluate the loss of a tainter gate or lock gate without placing the bulkheads, although we do not consider this a reasonable possibility. Since you are interested in the rate of fall to your critical elevation of 948.0 m.s.l., we have included Plate 1 showing the pool recession for these conditions.

Sincerely,



N. G. DELBRIDGE  
Colonel, Corps of Engineers  
District Engineer

2 Incl  
As stated

2.4B-5

PLATE 1

FLOW = 800 CFS  
LOCK SILL ELEV. = 647.5 FT. M.S.L.  
TAINTER GATE SILL ELEV. = 645.0 FT. M.S.L.

BVPS Information  
654' M.S.L. - Cold Shutdown in 36 hours required by Technical Specifications  
648.6' M.S.L. - Minimum Design Basis Level

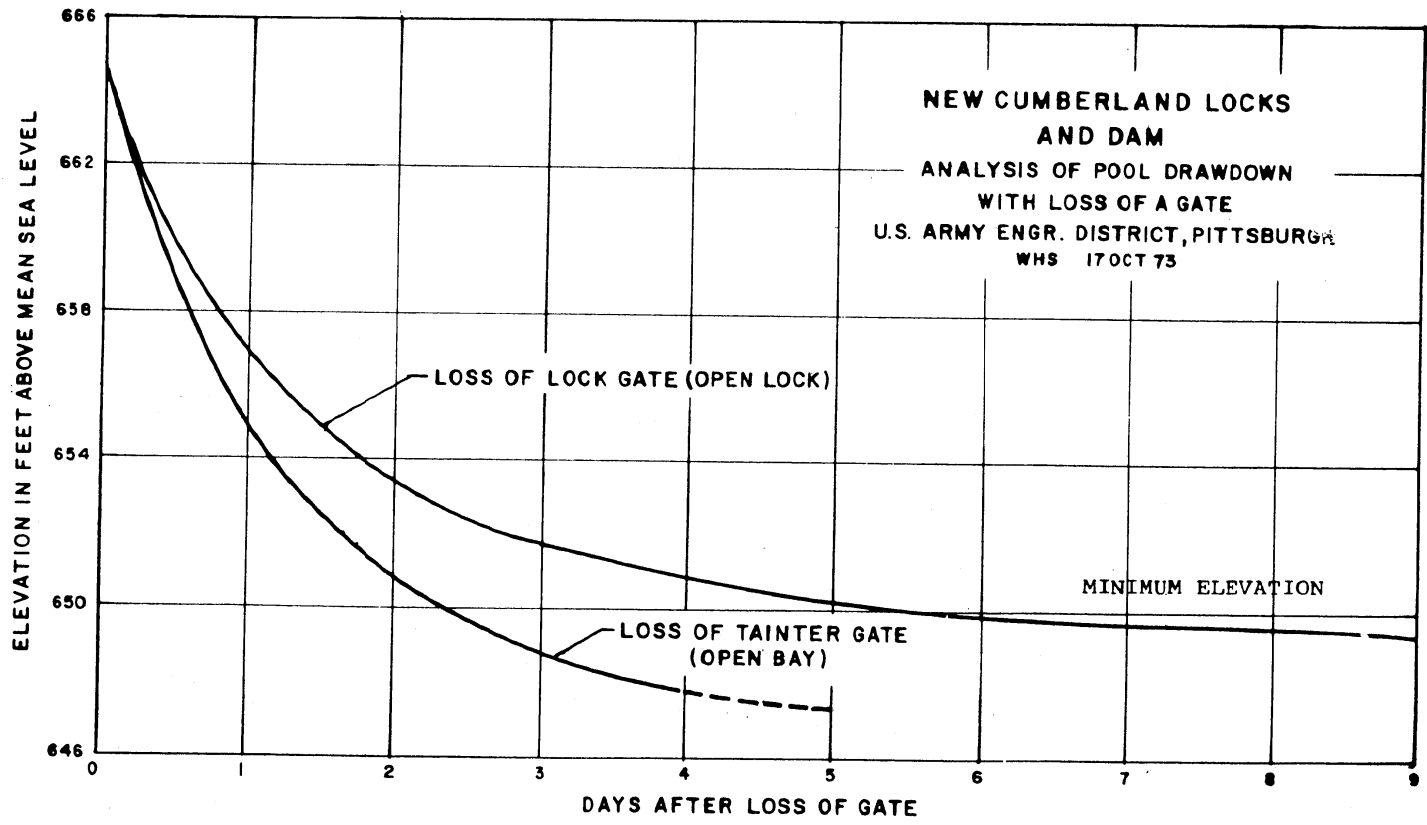

BVPS-2 UFSAR

REV. 15