

Vogle PEmails

From: Habib, Donald
Sent: Thursday, May 30, 2019 1:48 PM
To: Vogle PEmails
Subject: FW: Clarification: LAR 19-004 Drawing Inconsistencies
Attachments: LAR 19-004 Differences in Drawing Symbols_ (002).docx

From: Habib, Donald
Sent: Thursday, May 30, 2019 11:10 AM
To: Quarles, Adam Graham <AGQUARLE@southernco.com>
Cc: Hearn, Peter <Peter.Hearn@nrc.gov>; Budzynski, John <John.Budzynski@nrc.gov>; Stubbs, Angelo <Angelo.Stubbs@nrc.gov>
Subject: Clarification: LAR 19-004 Drawing Inconsistencies

Adam –

For LAR 19-004, the staff identified differences in the Tier 1 and Tier 2 drawings. Please contact the Project Manager for this LAR, Peter Hearn, about whether SNC would like to discuss this clarification question in a future public meeting.

Thanks

Don Habib
U.S. Nuclear Regulatory Commission
Office of New Reactors
Project Manager
NRO/DLSE, Licensing Branch 2
O-8D13
301-415-1035

Hearing Identifier: Vogtle_COL_Docs_Public
Email Number: 450

Mail Envelope Properties (SN4PR0901MB21759BFA037FB93444829A2597180)

Subject: FW: Clarification: LAR 19-004 Drawing Inconsistencies
Sent Date: 5/30/2019 1:47:32 PM
Received Date: 5/30/2019 1:47:37 PM
From: Habib, Donald

Created By: Donald.Habib@nrc.gov

Recipients:
"Vogtle PEmails" <Vogtle.PEmails@nrc.gov>
Tracking Status: None

Post Office: SN4PR0901MB2175.namprd09.prod.outlook.com

Files	Size	Date & Time
MESSAGE	772	5/30/2019 1:47:37 PM
LAR 19-004 Differences in Drawing Symbols_ (002).docx		168929

Options
Priority: Standard
Return Notification: No
Reply Requested: No
Sensitivity: Normal
Expiration Date:
Recipients Received:

Below are 2 examples where the valves do not match up symbolically between Tier 2 Figure 10 and Tier 1 Figure 2. For the symbol differences of the same component, please provide an explanation.

1. The valves in figure 10 below do not match the valve in figure 2 and valve shown in the Tier 2 Chapter 1 legend drawings.

Tier 2, Figure 10.3.2-2 Main Steam System Diagram

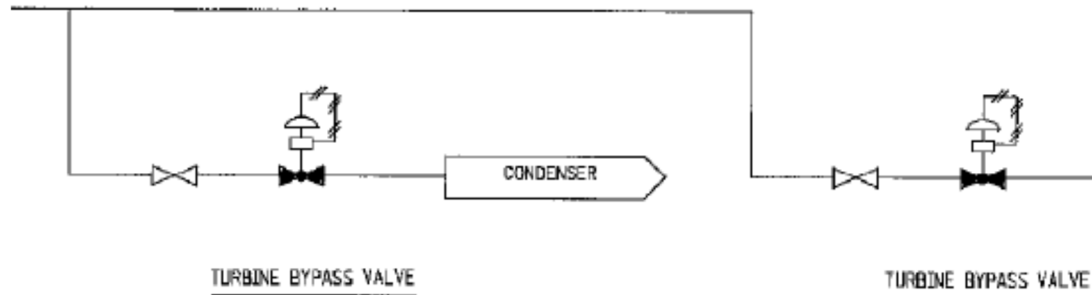

Tier 1, Figure 2.2.4-1 (Sheet 3) Proposed revision:

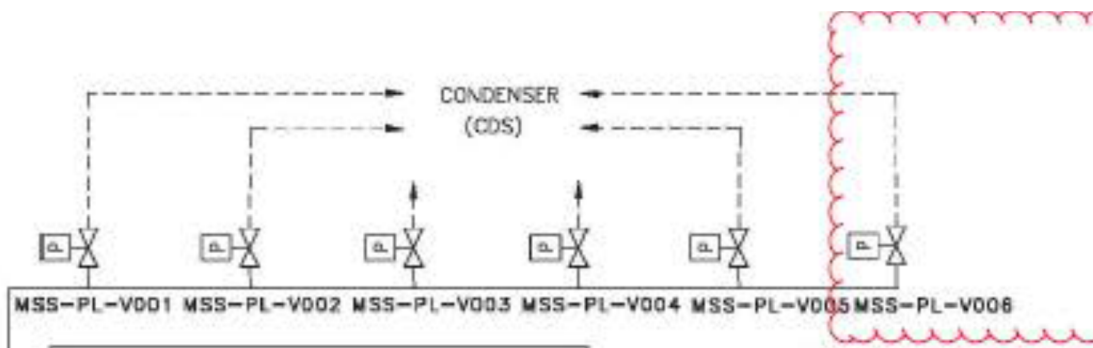

2. The relief valves below do not match the

Tier 2, Figure 10.3.2-1 (Sheet 2 of 2)

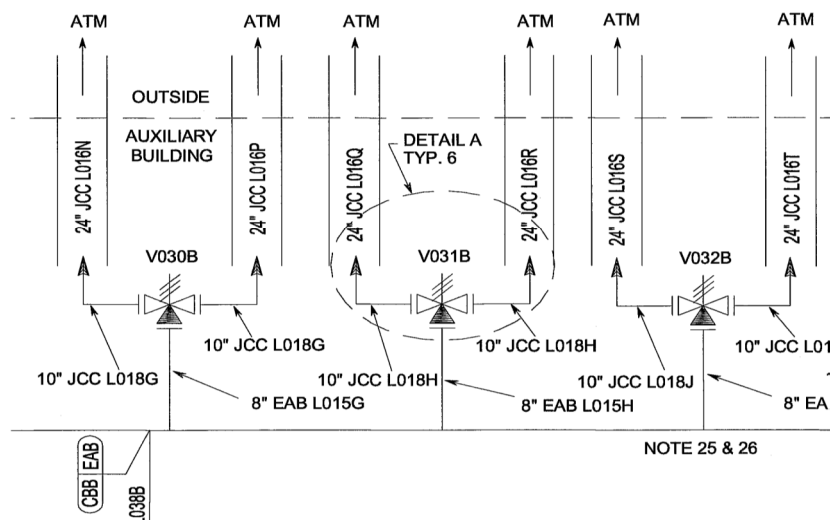

Figure 2.2.4-1 (Sheet 2 of 3) Steam Generator System

