

NON-PROPRIETARY VERSION

SAFETY ANALYSIS REPORT

on

THE HI-STAR 190 PACKAGE

(Proposed Revision 2A)

by

Holtec International
Krishna P. Singh Technology Campus
1 Holtec Boulevard
Camden, NJ 08104
(holtecinternational.com)

USNRC Docket No. : 71-9373
Holtec Report No. : HI-2146214
Quality Designation : Safety Significant*

Copyright Notice

This document is a copyrighted intellectual property of Holtec International. All rights reserved. Excerpting any part of this document, except for public domain citations included herein, by any person or entity except for the USNRC, a Holtec User Group (HUG) member company, or a foreign regulatory authority with jurisdiction over a HUG member's nuclear facility without written consent of Holtec International is unlawful.

* The safety designation is pursuant to Holtec International's Quality Assurance Program.

HOLTEC INTERNATIONAL

DOCUMENT NUMBER: HI-2146214

PROJECT NUMBER: 5024

DOCUMENT ISSUANCE AND REVISION STATUS (See Notes)										
DOCUMENT NAME: Safety Analysis Report on the HI-STAR 190 Package					DOCUMENT CATEGORY: <input checked="" type="checkbox"/> GENERIC <input type="checkbox"/> PROJECT SPECIFIC					
No.	Document Portion	REVISION No. <u>2A</u>			REVISION No. _____			REVISION No. _____		
		Author's Initials	Date Approved	VIR #	Author's Initials	Date Approved	VIR #	Author's Initials	Date Approved	VIR #
1	Chapter 1 (1.A)	RRN	7/31/28	444825	-	-	-	-	-	-
2	Chapt. 1, 7, 8 Structural	-	-	-	-	-	-	-	-	-
3	Chapt. 1, 7, 8 Thermal	-	-	-	-	-	-	-	-	-
4	Chapt. 1, 7, 8 Containment	-	-	-	-	-	-	-	-	-
5	Chapt. 1, 7, 8 Shielding	-	-	-	-	-	-	-	-	-
6	Chapt. 1, 7, 8 Criticality	-	-	-	-	-	-	-	-	-
7	Chapter 2	AB	7/27/18	519412	-	-	-	-	-	-
8	Chapter 3	-	-	-	-	-	-	-	-	-
9	Chapter 4	-	-	-	-	-	-	-	-	-
10	Chapter 5	-	-	-	-	-	-	-	-	-
11	Chapter 6	-	-	-	-	-	-	-	-	-
12	Chapter 7	-	-	-	-	-	-	-	-	-
13	Appendix 7.C	BK	7/19/18	865719	-	-	-	-	-	-
	Appendix 7.D	RRN	7/31/18	275511	-	-	-	-	-	-
14	Chapter 8	-	-	-	-	-	-	-	-	-

HOLTEC INTERNATIONALDOCUMENT NUMBER: HI-2146214PROJECT NUMBER: 5024**DOCUMENT ISSUANCE AND REVISION STATUS (See Notes)**

DOCUMENT NAME: Safety Analysis Report on the HI-STAR 190 Package

DOCUMENT CATEGORY: GENERIC PROJECT SPECIFIC

No.	Document Portion	REVISION No. <u>0</u>			REVISION No. <u>1</u>			REVISION No. <u>2</u>		
		Author's Initials	Date Approved	VIR #	Author's Initials	Date Approved	VIR #	Author's Initials	Date Approved	VIR #
1	Chapter 1	KSM	8/6/15	940700	LEH	6/8/17	39853	N/A	N/A	N/A
2	Chapt. 1, 7, 8 Structural	CB	8/6/15	589209	JZ	6/8/17	173476	AB	1/23/18	800454
3	Chapt. 1, 7, 8 Thermal	AHM	8/7/15	726048	AHM	6/8/17	291381	IR	1/23/18	42609
4	Chapt. 1, 7, 8 Containment	RT	8/6/15	823247	RT	6/8/17	195806	N/A	N/A	N/A
5	Chapt. 1, 7, 8 Shielding	SF	8/6/15	43196	SF	6/8/17	874452	BK	1/23/18	691778
6	Chapt. 1, 7, 8 Criticality	TH	8/6/15	261782	TH	6/8/17	552783	TH	1/23/18	403920
7	Chapter 2	JZ	8/7/15	427540	JZ	6/8/17	341150	AB	1/23/18	841765
8	Chapter 3	AHM	8/7/15	431050	AHM	6/8/17	787054	IR	1/23/18	843007
9	Chapter 4	RT	8/6/15	649941	RT	6/8/17	111783	N/A	N/A	N/A
10	Chapter 5	SF	8/6/15	761749	SF	6/8/17	93037	SF	1/23/18	793528
11	Chapter 6	VM	8/6/15	967185	VM	6/8/17	474212	VM	1/23/18	21983
12	Chapter 7	SA	8/7/15	341543	LEH	6/8/17	756259	N/A	N/A	N/A
13	Appendix 7.C	PS	8/7/15	894355	SF	6/8/17	176125	PS	1/23/18	587678
14	Chapter 8	LEH	8/6/15	177683	LEH	6/8/17	629815	MB	1/23/18	476800

HOLTEC INTERNATIONAL

DOCUMENT NUMBER: HI-2146214

PROJECT NUMBER: 5024

DOCUMENT CATEGORIZATION

In accordance with the Holtec Quality Assurance Manual and associated Holtec Quality Procedures (HQPs), this document is categorized as a:

- Calculation Package³ (Per HQP 3.2) Technical Report (Per HQP 3.2)(Such as a Licensing Report)
- Design Criterion Document (Per HQP 3.4) Design Specification (Per HQP 3.4)
- Other (Specify):

DOCUMENT FORMATTING

The formatting of the contents of this document is in accordance with the instructions of HQP 3.2 or 3.4 except as noted below:

DECLARATION OF PROPRIETARY STATUS

- Nonproprietary Holtec Proprietary Privileged Intellectual Property (PIP)

Documents labeled Privileged Intellectual Property contain extremely valuable intellectual/commercial property of Holtec International. They cannot be released to external organizations or entities without explicit approval of a company corporate officer. The recipient of Holtec’s proprietary or Top Secret document bears full and undivided responsibility to safeguard it against loss or duplication. Proprietary information in this document is either noted as proprietary or highlighted in gray.

Notes:

1. This document has been subjected to review, verification and approval process set forth in the Holtec Quality Assurance Procedures Manual. Password controlled signatures of Holtec personnel who participated in the preparation, review, and QA validation of this document are saved in the N-drive of the company’s network. The Validation Identifier Record (VIR) number is a random number that is generated by the computer after the specific revision of this document has undergone the required review and approval process, and the appropriate Holtec personnel have recorded their password-controlled electronic concurrence to the document.
2. A revision to this document will be ordered by the Project Manager and carried out if any of its contents is materially affected during evolution of this project. The determination as to the need for revision will be made by the Project Manager with input from others, as deemed necessary by him.
3. Revisions to this document may be made by adding supplements to the document and replacing the “Table of Contents”, this page and the “Revision Status”.
4. The revision of this SAR is the same as the latest revision of any Chapter in this SAR. Document portions that have not been revised have author, date and VIR # indicated with not applicable “N/A”.

TABLE OF CONTENTS

TOC..... T1

SAR REVISION SUMMARY S1

GLOSSARY AND NOTATIONSG1

CHAPTER 1: GENERAL INFORMATION

1.0 OVERVIEW 1.0-1

1.1 INTRODUCTION TO THE HI-STAR 190 PACKAGE 1.1-1

1.2 DESCRIPTION OF PACKAGING COMPONENTS AND THEIR DESIGN & OPERATIONAL FEATURES 1.2-1

1.2.1 Packaging..... 1.2-1

1.2.2 Contents of Package..... 1.2-11

1.2.3 Special Requirements for Plutonium 1.2-11

1.2.4 Operational Features 1.2-11

1.3 ENGINEERING DRAWINGS 1.3-1

- Holtec Licensing DWG 9841, “HI-STAR 190 Cask”
- Holtec Licensing DWG 6505, “MPC-37 Enclosure Vessel”
- Holtec Licensing DWG 6506 “MPC-37 Fuel Basket”
- Holtec Licensing DWG 6507, “MPC-89 Fuel Basket”
- Holtec Licensing DWG 6512, “MPC-89 Enclosure Vessel”
- Holtec Licensing DWG 9848, “HI-STAR 190 Impact Limiters” (a.k.a. AL-STAR 190)
- Holtec Licensing DWG 10234, “Damaged Fuel Container (DFC)”
- Holtec Licensing DWG 9849, “HI-STAR 190 MPC Spacer Ring”

1.4 SUMMARY OF COMPLIANCE WITH 10CFR71 REQUIREMENTS 1.4-1

1.5 LOCATION OF PROPERTIES OF SPECIAL PURPOSE MATERIALS 1.5-1

1.6 QUALITY ASSURANCE AND DESIGN CONTROL 1.6-1

1.7 REFERENCES 1.7-1

Appendix 1.A: Justification for Package Approval Based on Moderator Exclusion Under Hypothetical Accident Conditions

CHAPTER 2: STRUCTURAL EVALUATION

2.0 INTRODUCTION..... 2.0-1

2.1 STRUCTURAL DESIGN. 2.1-1

 2.1.1 Discussion..... 2.1-1

 2.1.2 Design Criteria..... 2.1-3

 2.1.3 Weights and Centers of Gravity..... 2.1-18

 2.1.4 Identification of Codes and Standards for Package Design..... 2.1-18

2.2 MATERIALS..... 2.2-1

 2.2.1 Mechanical Properties and Specifications 2.2-1

 2.2.2 Chemical, Galvanic or Other Reactions..... 2.2-6

 2.2.3 Effects of Radiation on Materials 2.2-7

2.3 FABRICATION AND EXAMINATIONS..... 2.3-1

 2.3.1 Fabrication 2.3-1

 2.3.2 Examinations 2.3-2

2.4 GENERAL REQUIREMENTS 2.4-1

 2.4.1 Minimum Package Size 2.4-1

 2.4.2 Tamper-Indicating Feature..... 2.4-1

 2.4.3 Positive Closure 2.4-1

2.5 LIFTING AND TIE-DOWN STANDARDS..... 2.5-1

 2.5.1 Lifting Devices..... 2.5-1

 2.5.2 Tie-Down Devices 2.5-4

 2.5.3 Safety Evaluation of Lifting and Tie-Down Devices..... 2.5-4

 2.5.4 MPC Lifting..... 2.5-4

 2.5.5 Structural Integrity of Damaged Fuel Containers (DFCs) 2.5-5

2.6 NORMAL CONDITIONS OF TRANSPORT..... 2.6-1

 2.6.1 Heat..... 2.6-3

 2.6.2 Cold..... 2.6-19

 2.6.3 Reduced External Pressure 2.6-20

 2.6.4 Increased External Pressure 2.6-20

2.6.5	Vibration	2.6-20
2.6.6	Water Spray.....	2.6-22
2.6.7	Free Drop	2.6-22
2.6.8	Corner Drop	2.6-22
2.6.9	Compression	2.6-22
2.6.10	Penetration	2.6-22
2.7	HYPOTHETICAL ACCIDENT CONDITIONS.....	2.7-1
2.7.1	9-Meter Free Drop	2.7-2
2.7.2	Crush.....	2.7-12
2.7.3	Puncture	2.7-12
2.7.4	Thermal	2.7-13
2.7.5	Immersion - Fissile Material	2.7-14
2.7.6	Immersion - All Packages	2.7-15
2.7.7	Deep Water Immersion Test	2.7-15
2.7.8	Summary of Damage.....	2.7-15
2.8	ACCIDENT CONDITIONS FOR AIR TRANSPORT OF PLUTONIUM.....	2.8-1
2.9	ACCIDENT CONDITIONS FOR FISSILE MATERIALS FOR AIR TRANSPORT.	2.9-1
2.10	SPECIAL FORM	2.10-1
2.11	FUEL RODS.....	2.11-1
2.12	REFERENCES	2.12-1
Appendix 2.A: Description of Computer Codes for Structural Evaluation		2.A-1

CHAPTER 3: THERMAL EVALUATION

3.0	INTRODUCTION.....	3.0-1
3.1	DESCRIPTION OF THERMAL DESIGN.....	3.1-1
3.1.1	Design Features.....	3.1-1
3.1.2	Contents Decay Heat.....	3.1-3
3.1.3	Summary Table of Temperatures.....	3.1-3
3.1.4	Summary Table of Maximum Pressures.....	3.1-4
3.1.5	Cask Surface Temperature Evaluation.....	3.1-4
3.2	MATERIAL PROPERTIES AND COMPONENT SPECIFICATIONS	3.2-1

3.2.1	Material Properties.....	3.2-1
3.2.2	Component Specifications	3.2-1
3.3	THERMAL EVALUATION UNDER NORMAL CONDITIONS OF TRANSPORT	3.3-1
3.3.1	Overview of the Thermal Model.....	3.3-1
3.3.2	Heat and Cold	3.3-8
3.3.3	Maximum Normal Operating Pressure (MNOP)	3.3-9
3.3.4	Loading Operations.....	3.3-11
3.3.5	Thermal Evaluation of Sub-design Basis Heat Load	3.3-13
3.3.6	Thermal Evaluation of an MPC-37 with Damaged Fuel Container (DFC)	3.3-13
3.3.7	Fuel Reconfiguration under Normal Condition	3.3-14
3.4	THERMAL EVALUATION UNDER HYPOTHETICAL ACCIDENT	3.4-1
3.4.1	Initial Conditions	3.4-2
3.4.2	Fire Conditions.....	3.4-2
3.4.3	Maximum Temperatures and Pressures	3.4-3
3.4.4	Maximum Thermal Stresses	3.4-5
3.4.5	Fuel Reconfiguration.....	3.4-5
3.5	REFERENCES	3.5-1

CHAPTER 4: CONTAINMENT

4.0	INTRODUCTION	4.0-1
4.0.1	Double Containment credited for High Burnup Fuel (HBF).....	4.0-1
4.1	DESCRIPTION OF THE OUTER CONTAINMENT SYSTEM	4.1-1
4.1.1	Containment Vessel.....	4.1-1
4.1.2	Containment Penetrations.....	4.1-1
4.1.3	Seals and Welds.....	4.1-1
4.1.4	Closure Lid	4.1-2
4.2	OUTER CONTAINMENT UNDER NORMAL CONDITIONS OF TRANSPORT	4.2-1
4.2.1	Containment Criteria	4.2-1

4.3	OUTER CONTAINMENT UNDER HYPOTHETICAL ACCIDENT CONDITIONS OF TRANSPORT.....	4.3-1
4.3.1	Containment Criteria.....	4.3-1
4.4	LEAKAGE RATE TESTS FOR THE HI-STAR 190 OVERPACK.....	4.4-1
4.4.1	Fabrication Leakage Rate Test	4.4-1
4.4.2	Pre-Shipment Leakage Rate Test	4.4-1
4.4.3	Periodic Leakage Rate Test	4.4-1
4.4.4	Maintenance Leakage Rate Test.....	4.4-1
4.5	DESCRIPTION OF THE INNER CONTAINMENT SYSTEM.....	4.5-1
4.6	INNER CONTAINMENT UNDER NORMAL CONDITIONS OF TRANSPORT	4.6-1
4.6.1	Applicable Loadings and System Performance.....	4.6-1
4.6.2	Containment Criteria	4.6-1
4.7	INNER CONTAINMENT UNDER HYPOTHETICAL ACCIDENT CONDITIONS OF TRANSPORT.....	4.7-1
4.7.1	Applicable Loadings and System Performance.....	4.7-1
4.7.2	Containment Criteria	4.7-1
4.8	SAFETY CASE FOR THE INTEGRITY OF INNER AND OUTER CONTAINMENTS.....	4.8-1
4.9	REGULATORY COMPLIANCE	4.9-1
4.10	REFERENCES	4.10-1

CHAPTER 5: SHIELDING EVALUATION

5.0	INTRODUCTION.....	5.0-1
5.1	DESCRIPTION OF SHIELDING DESIGN	5.1-1
5.1.1	Design Features.....	5.1-1
5.1.2	Summary of Maximum Radiation Levels.....	5.1-1
5.1.3	Normal Conditions.....	5.1-2
5.1.4	Hypothetical Accident Conditions	5.1-3

5.2	SOURCE SPECIFICATION	5.2-1
5.2.1	Gamma Source.....	5.2-2
5.2.2	Neutron Source	5.2-3
5.2.3	Non-Fuel Hardware.....	5.2-4
5.2.4	Fuel Assembly Neutron Sources.....	5.2-6
5.2.5	Source Term Input Uncertainties	5.2-7
5.3	SHIELDING MODEL	5.3-1
5.3.1	Configuration of Shielding and Source.....	5.3-1
5.3.2	Material Properties.....	5.3-4
5.3.3	Tally Specifications.....	5.3-4
5.4	SHIELDING EVALUATION.....	5.4-1
5.4.1	Methods	5.4-1
5.4.2	Input and Output Data.....	5.4-4
5.4.3	Flux-to-Dose-Rate Conversion	5.4-4
5.4.4	External Radiation Levels.....	5.4-4
5.4.5	Fuel Reconfiguration.....	5.4-5
5.4.6	Effect of Uncertainties and Sensitivity Studies.....	5.4-8
5.4.7	Fuel Assembly Types.....	5.4-10
5.4.8	Non-Fuel Hardware.....	5.4-10
5.4.9	Damaged Fuel Post-Accident Shielding Evaluation	5.4-11
5.4.10	Axial Burnup Profile.....	5.4-11
5.4.11	Fuel Assemblies with Longer Active Fuel Length.....	5.4.11
5.4.12	Sensitivity Study of the Accident Condition Model – Lead Slump Analysis	5.4-12
5.4.13	Acceptable Variations in Loading Patterns.....	5.4-13
5.4.14	Fuel Assemblies with Stainless Steel Rods Replacing Fuel Rods	5.4-13
5.4.15	CE16x16 Assemblies with High Activity APSRs and/or NSA	5.4.13
5.5	REFERENCES	5.5-1

Appendix 5.A: Sample Input File for MCNP MPC-37, Normal Conditions, Neutron Source in Region 1

Appendix 5.B: Sample Input File for MCNP MPC-89 Basket, Normal Conditions, Neutron Source in Region 1

Appendix 5.C: Axial Profiles in Shielding and Thermal Analyses

CHAPTER 6: CRITICALITY EVALUATION

6.0 INTRODUCTION..... 6.0-1

6.1 DESCRIPTION OF CRITICALITY DESIGN 6.1-1

 6.1.1 Design Features..... 6.1-1

 6.1.2 Summary Table of Criticality Evaluation 6.1-3

 6.1.3 Criticality Safety Index 6.1-6

6.2 FISSILE MATERIAL CONTENT 6.2-1

 6.2.1 General..... 6.2-1

 6.2.2 Definition of Assembly Classes..... 6.2-1

 6.2.3 PWR Fuel Assemblies 6.2-3

 6.2.4 BWR Fuel Assemblies..... 6.2-4

 6.2.5 Damaged Fuel Assemblies and Fuel Debris 6.2-6

 6.2.6 High Burnup Fuel..... 6.2-8

6.3 GENERAL CONSIDERATIONS 6.3-1

 6.3.1 Description of Calculation Model..... 6.3-1

 6.3.2 Material Properties..... 6.3-3

 6.3.3 Computer Codes and Cross Section Libraries 6.3-4

 6.3.4 Demonstration of Maximum Reactivity 6.3-4

 6.3.5 Potential Fuel Reconfiguration 6.3-10

 6.3.6 Partial Loading..... 6.3-12

 6.3.7 Fuel Assemblies with Missing Rods..... 6.3-12

 6.3.8 Sealed Rods Replacing BWR Water Rods 6.3-12

 6.3.9 Non-fuel Hardware in PWR Fuel Assemblies 6.3-13

 6.3.10 Neutron Sources in Fuel Assemblies 6.3-13

 6.3.11 Low Enriched, Channeled BWR Fuel..... 6.3-13

 6.3.12 BWR Fuel and MPC-89 Basket Misalignment..... 6.3-14

6.4 SINGLE PACKAGE EVALUATION..... 6.4-1

 6.4.1 Configuration 6.4-1

 6.4.2 Results 6.4-3

6.5 EVALUATION OF PACKAGE ARRAYS UNDER NORMAL
CONDITIONS OF TRANSPORT 6.5-1

 6.5.1 Configuration 6.5-1

 6.5.2 Results 6.5-1

6.6 PACKAGE ARRAYS UNDER HYPOTHETICAL ACCIDENT CONDITIONS 6.6-1

 6.6.1 Configuration 6.6-1

 6.6.2 Results 6.6-1

6.7 FISSILE MATERIAL PACKAGES FOR AIR TRANSPORT 6.7-1

6.8 BENCHMARK EVALUATIONS 6.8-1

6.9 REFERENCES 6.9-1

Appendix 6.A: Applicability of Criticality Benchmark Calculations

Appendix 6.B: Burnup Credit for MPC-37

Appendix 6.C: Partial Burnup Credit for MPC-89

Appendix 6.D: Miscellaneous Information

Appendix 6.E: Verification of Assembly Burnup in the HI-STAR 190 Cask

CHAPTER 7: PACKAGE OPERATIONS

7.0 INTRODUCTION..... 7.0-1

7.1 PACKAGE LOADING 7.1-1

 7.1.1 Preparation of the Overpack for Loading..... 7.1-1

 7.1.2 Acceptance of the MPC 7.1-1

 7.1.3 Transfer of MPC to the HI-STAR 190 Overpack 7.1-2

 7.1.4 Cask Closure 7.1-3

 7.1.5 Preparation for Transport..... 7.1-3

 7.1.6 Loading the MPC with Spent Fuel (“Load and go” Scenario)..... 7.1-6

7.2 PACKAGE UNLOADING..... 7.2-1

 7.2.1 Receipt of Package from Carrier..... 7.2-1

 7.2.2 Removal of MPC 7.2-1

 7.2.3 Removal of Contents from MPC 7.2-2

7.3 PREPARATION OF EMPTY PACKAGE FOR TRANSPORT 7.3-1

 7.3.1 Overview of Empty Package Transport 7.3-1

 7.3.2 Preparation for Empty Package Shipment 7.3-1

7.4 OTHER OPERATIONS 7.4-1

7.5 REFERENCES 7.5-1

Appendix 7.A: Bounding Weights and Illustrations of Typical Loading Operations

Appendix 7.B: Additional Requirements for the Transport of HBF

Appendix 7.C: Permissible Content Conditions of the HI-STAR 190 Package

Appendix 7.D: Burnup Verification Conditions of the HI-STAR 190 Package

CHAPTER 8: ACCEPTANCE TESTS AND MAINTENANCE PROGRAM

8.0 INTRODUCTION..... 8.0-1

8.1 ACCEPTANCE TESTS 8.1-1

8.1.1 Visual Inspections and Measurements 8.1-1

8.1.2 Weld Examination 8.1-1

8.1.3 Structural and Pressure Tests 8.1-3

8.1.4 Leakage Tests..... 8.1-4

8.1.5 Component and Material Tests 8.1-5

8.1.6 Shielding Tests..... 8.1-9

8.1.7 Thermal Tests..... 8.1-9

8.1.8 MPC Enclosure Vessel Shell Surface Defect Inspection 8.1-11

8.1.9 Miscellaneous Acceptance Tests 8.1-12

8.2 MAINTENANCE PROGRAM..... 8.2-1

8.2.1 Structural and Pressure Tests 8.2-1

8.2.2 Leakage Tests..... 8.2-1

8.2.3 Component and Material Tests 8.2-2

8.2.4 Periodic Thermal Tests 8.2-4

8.2.5 Miscellaneous Tests 8.2-5

8.3 REFERENCES 8.3-1

Appendix 8.A: MPC Transportability Checklist

GLOSSARY AND NOTATION (HI-STAR 190)

GLOSSARY

AFR is an acronym for Away From Reactor.

ALARA is an acronym for As Low As Reasonably Achievable.

AL-STAR is the trademark name of the impact limiter design used in the family of HI-STAR dual-purpose casks.

Basket Shims are aluminum alloy parts (typically extrusions) that serve to maintain the fuel basket coaxial with the cask's storage cavity.

BWR is an acronym for Boiling Water Reactor.

Cask is a generic term used to describe a device that is engineered to hold high level waste, including spent nuclear fuel, in a safe configuration.

Cask Bottom Region (CBR) refers to the bottom thick nickel steel forging with a Holtite insert

Cask Top Region (CTR) refers to the top nickel steel forging with a Holtite insert

CG is an acronym for Center of Gravity.

Closure Lid is a generic term to indicate a gasketed flat cover that bolts to the top flange of the cask.

Closure Lid System (CLS) refers to the specially shaped lid with concentric grooves. The bolted lid joint is engineered to meet the leak-tight criterion of ANSI N14.5.

CoC is an acronym for Certificate of Compliance

Commercial Spent Fuel (CSF) refers to nuclear fuel used to produce energy in a commercial nuclear power plant.

Containment Boundary means the enclosure formed by the cask inner shell welded to a bottom plate and top flange plus dual closure lids with seal(s) and associated penetration port closure(s) and seal(s).

Containment System means the assembly of containment components of the packaging intended to contain the radioactive material during transport.

Cooling Time (or post-irradiation decay time, PCDT) for a spent fuel assembly is the time between reactor shutdown and the time the spent fuel assembly is loaded into the cask. Cooling Time is also referred to as the “age” of the CSF.

Critical Characteristic means a feature of a component or assembly that is necessary for the component or assembly to render its intended function. Critical characteristics of a material are those attributes that have been identified, in the associated material specification, as necessary to render the material’s intended function.

Criticality Safety Index (CSI) means the dimensionless number (rounded to up to the next tenth) assigned to and placed on the label of a fissile material package, to designate the degree of control of accumulation of packages containing fissile material during transportation.

Damaged Fuel Assembly is a fuel assembly with known or suspected cladding defects, as determined by a review of records, greater than pinhole leaks or hairline cracks, empty fuel rod locations that are not filled with dummy fuel rods, whose structural integrity has been impaired such that geometric rearrangement of fuel or gross failure of the cladding is expected based on engineering evaluations, or that cannot be handled by normal means. Also see fuel debris.

Damaged Fuel Container (or Canister) (DFC) means a specially designed vessel for damaged fuel or fuel debris, which may permit gaseous and liquid media to escape while minimizing dispersal of gross particulates or which may be hermetically sealed. The DFC features a lifting location, which is suitable for remote handling of a loaded or unloaded DFC.

DBE means Design Basis Earthquake.

DCSS is an acronym for Dry Cask Storage System.

Design Heat Load or Design Basis Heat Load is the computed heat rejection capacity of the cask system with the ambient at the normal temperature and the peak cladding temperature (PCT) at 400°C. The Design Heat Load is less than the thermal capacity of the system by a suitable margin that reflects the conservatism in the system thermal analysis.

Design Life is the minimum duration for which the component is engineered to perform its intended function if operated and maintained in accordance with the instructions provided by the system supplier.

Design Report is a document prepared, reviewed and QA validated in accordance with the provisions of Holtec’s Quality Program. The Design Report shall demonstrate compliance with the requirements set forth in the Design Specification. A Design Report is mandatory for systems, structures, and components designated as *Important-to-Safety*. The SAR serves as the Design Report for the HI-STAR 190 package.

Design Specification is a document prepared in accordance with the quality assurance requirements of 10CFR71 Subpart H to provide a complete set of design criteria and functional

requirements for a system, structure, or component, designated as *Important-to-Safety*. The SAR serves as the Design Specification for the HI-STAR 190 package.

Dose Blocker Parts means the shielding components installed outside the Containment Boundary to enable the cask to meet the dose requirements of 10CFR71 during transport.

Enclosure Vessel (or MPC Enclosure Vessel) means the pressure vessel defined by the cylindrical shell, baseplate, port cover plates, lid, closure ring, and associated welds that provides confinement for the helium gas contained within the MPC. The EV and the fuel basket together constitute the multi-purpose canister.

EV is an acronym for the Enclosure Vessel defined above.

Exclusive use means the sole use by a single consignor of a conveyance for which all initial, intermediate, and final loading and unloading are carried out in accordance with the direction of the consignor or consignee. The consignor and the carrier must ensure that loading or unloading personnel have radiological training and resources appropriate for safe handling of the consignment. The consignor must issue specific instructions, in writing, for maintenance of exclusive use shipment controls, and include them with the shipping paper information provided to the carrier by the consignor.

Expanded Containment Boundary means a second barrier against leakage of radiological contents of the package engineered into the system for added safety or to meet a specific jurisdictional regulation.

Fastener Strain Limiter is a device to protect the impact limiter fastener bolts from experiencing excessive axial strain.

Fracture Toughness is a material property, which is a measure of the ability of the material to limit crack propagation under a suddenly applied load.

FSAR is an acronym for Final Safety Analysis Report.

Fuel Basket means a honeycombed cavity structure with square openings that can accept a fuel assembly of the type for which it is designed.

Fuel Debris is ruptured fuel rods, severed rods and loose fuel pellets from damaged fuel assemblies, and fuel assemblies with known or suspected defects which cannot be handled by normal means due to fuel cladding damage, including containers and structures supporting these parts.

Fuel Package is the generic term to represent the physical embodiment consisting of the batch of CSF contained in a Fuel Basket (bare Fuel Package) or the MPC (containerized Fuel Package).

Gamma Capture Space (GCS) means the annular space defined by the Containment shell and the Intermediate Composite Shell occupied by lead.

GTCC is an acronym for Greater Than Class C waste.

HAC is an acronym for Hypothetical Accident Condition under 10 CFR 71.73

High Burnup Fuel (HBF) is a commercial spent fuel assembly with an average burnup greater than 45,000 MWD/MTU.

HI-STAR is a generic term used to denote the family of metal casks consisting of HI-STAR 60, HI-STAR 100, HI-STAR 180, HI-STAR 190 and HI-STAR HB.

HI-STAR 190 Cask or cask means the cask that receives and contains the spent nuclear fuel. It provides the containment system boundary for radioactive materials and fulfills all requirements of 10CFR71 to merit certification as a B(U) package.

HI-STAR 190 Package consists of the HI-STAR 190 cask and MPC with two impact limiters installed at the extremities, a personnel barrier if required, and the licensed radioactive contents loaded for transport.

HI-STAR 190 Packaging consists of the HI-STAR 190 Package without the licensed radioactive contents loaded.

Holtite™ is the trade name for the neutron shielding materials used in the HI-STAR/HI-STORM family of casks.

Impact Limiters means a set of fully enclosed energy absorbers that are attached to the top and bottom of the cask during transport. The impact limiters are used to absorb kinetic energy resulting from normal and hypothetical accident drop conditions. The HI-STAR impact limiters are called AL-STAR.

Important-to-Safety (ITS) means a function or condition required to transport spent nuclear fuel safely; to prevent damage to spent nuclear fuel; and to provide reasonable assurance that spent nuclear fuel can be received, handled, packaged, transported, and retrieved without undue risk to the health and safety of the public.

Incore Grid Spacers are fuel assembly grid spacers located within the active fuel region (i.e., not including top and bottom spacers).

Intermediate Shell is the cylinder between the Gamma Capture Space and the Neutron Capture Space

LLNL is an acronym for Lawrence Livermore National Laboratory.

Leaktight (is defined in this SAR to be same as defined in ANSI N14.5) means a degree of package containment that in a practical sense precludes any significant release of radioactive materials. This degree of containment is achieved by demonstration of a leakage rate less than or equal to 1×10^{-7} ref-cm³/s of air at an upstream pressure of 1 atmosphere absolute and a downstream pressure of 0.01 atmosphere absolute or less. Reference cubic centimeter per second (ref-cm³/s) means a volume of one cubic centimeter of dry air per second at 1 atmosphere absolute pressure (760 mm Hg) and 25°C. Finally, 1×10^{-7} ref-cm³/s air is equal to 4.09×10^{-12} gram-moles/s of dry air or helium and is approximately equivalent to 2×10^{-7} ref-cm³/s helium.

Licensing Drawings or Licensing Drawing Package is an integral part of this SAR wherein the essential geometric and material information on HI-STAR 190 is compiled to enable the safety evaluations pursuant to 10 CFR 71 to be carried out.

License Life means the duration for which the system is authorized by virtue of its certification by the U.S. NRC.

Light Water Reactor (LWR): are nuclear reactors moderated by light water. Commercial LWRs typically utilize enriched uranium and/or the so-called MOX fuel for power generation.

Load-and-Go is a term used in this SAR that means the practice of loading authorized contents into the HI-STAR System packaging and placing the packaging into transportation service under 10 CFR 71, without first deploying the system at an Independent Spent Fuel Storage Installation (ISFSI) under 10 CFR 72. A transfer cask may be loaded under 10CFR72 and used to transfer the sealed canister into the HI-STAR cask without first deploying at an ISFSI.

Lowest Service Temperature (LST) is the minimum metal temperature of a part for the specified service condition.

Maximum Normal Operating Pressure (MNOP) means the maximum pressure that would develop in the containment system in a period of 1 year under the heat condition specified in 10CFR71.71(c)(1), in the absence of venting, external cooling by an ancillary system, or operational controls during transport.

Maximum Reactivity means the highest possible k-effective including bias, uncertainties, and calculational statistics evaluated for the worst-case combination of fuel basket manufacturing tolerances.

Metamic™ is a trade name for an aluminum/boron carbide composite neutron absorber material qualified for use in the HI-STAR/HI-STORM fuel baskets.

Metamic-HT is the trade name for the metal matrix composite made by imbedding nanoparticles of aluminum oxide and fine boron carbide powder on the grain boundaries of aluminum resulting in improved structural strength properties at elevated temperatures. (“HT” stands for high temperature)

MGDS is an acronym for Mined Geological Depository System.

Minimum Enrichment is the minimum assembly average enrichment. Natural uranium blankets are not considered in determining minimum enrichment.

Moderate Burnup Fuel (MBF) is a commercial spent fuel assembly with an average burnup less than or equal to 45,000 MWD/MTU.

Moderator Exclusion means no moderator intrusion into the cask storage cavity under hypothetical accident conditions of transport.

Multi-Purpose Canister (MPC) means the strength welded canister consisting of a honeycombed fuel basket for spent nuclear fuel storage, contained in a cylindrical canister shell (the MPC Enclosure Vessel).

NCT is an acronym for “Normal Condition of Transport”

NDT is an acronym for Nil Ductility Transition, which is defined as the temperature at which the fracture stress in a material with a small flaw is equal to the yield stress in the same material if it had no flaws.

Neutron Absorber Material is a generic term used in this SAR to indicate any neutron absorber material qualified for use in the HI-STAR/HI-STORM fuel basket.

Neutron Capture Space (NCS) means the annular space defined by the Intermediate Shell and the outer shell filled with Holtite.

Neutron Shielding means a material used to thermalize and capture neutrons emanating from the radioactive spent nuclear fuel.

Neutron Sources means specially designed inserts for fuel assemblies that produce neutrons for startup of the reactor.

Non-Fuel Hardware (NFH) means high-level waste not used to produce thermal energy in the reactor. Examples of NFH are Burnable Poison Rod Assemblies (BPRAs), Thimble Plug Devices (TPDs), Control Rod Assemblies (CRAs), Axial Power Shaping Rods (APSRs), Wet Annular Burnable Absorbers (WABAs), Rod Cluster Control Assemblies (RCCAs), Control Element Assemblies (CEAs), water displacement guide tube plugs, orifice rod assemblies, Instrument Tube Tie Rods (ITTRs), Guide Tube Anchors (GTAs), and vibration suppressor inserts.

Not-Important-to-Safety (NITS) is the term used where a function or condition is not deemed as *Important-to-Safety*. See the definition for *Important-to-Safety*.

O&M Manual is an abbreviation for operation and maintenance manual.

ORNL is an acronym for Oak Ridge National Laboratory

Overpack is an alternative term used in this SAR to denote a cask containing a Fuel Package.

Planar-Average Initial Enrichment is the average of the distributed fuel rod initial enrichments within a given axial plane of the assembly lattice.

Post-Core Decay Time (PCDT) is synonymous with cooling time.

PWR is an acronym for Pressurized Water Reactor.

Reactivity is used synonymously with effective neutron multiplication factor or k-effective.

Regionalized Fuel Loading is a term used to describe an optional fuel loading strategy used in lieu of uniform fuel loading. Regionalized fuel loading allows higher heat emitting fuel assemblies to be stored in certain fuel storage locations provided lower heat emitting fuel assemblies are stored in other fuel storage locations.

SAR is an acronym for Safety Analysis Report.

SCG is an acronym for the intermediate spent fuel storage container building located at the Doel Site.

Service Life means the duration for which the component is reasonably expected to perform its intended function, if operated and maintained in accordance with the provisions of this SAR. Service Life may be much longer than the Design Life because of the conservatism inherent in the codes, standards, and procedures used to design, fabricate, operate, and maintain the component.

Short-term Operations means those normal operational evolutions necessary to support fuel loading or fuel unloading operations.

Single Failure Proof means that the handling system is designed so that a single failure will not result in the loss of the capability of the system to safely retain the load. Single Failure Proof means that the handling system is designed so that all directly loaded tension and compression members are engineered to satisfy the enhanced safety criteria of Paragraphs 5.1.6(1)(a) and (b) of NUREG-0612.

SNF is an acronym for Spent Nuclear Fuel (also referred to as CSF in this SAR).

Specific Heat Load means the heat emission rate from one fuel assembly. Sum of the Specific Heat loads of all fuel assemblies in a Fuel Package is referred to as the Aggregate heat Load.

STP is Standard Temperature (298K) and Pressure (1 atm) conditions.

SSC is an acronym for Structures, Systems and Components.

Surface Contaminated Object (SCO) means a solid object that is not itself classed as radioactive material, but which has radioactive material distributed on any of its surfaces. See 10CFR71.4 for surface activity limits and additional requirements.

Transport Index (TI) means the dimensionless number (rounded up to the next tenth) placed on the label of a package, to designate the degree of control to be exercised by the carrier during transportation. The transport index is determined as the number determined by multiplying the maximum radiation level in millisievert per hour at one meter (3.3 ft) from the external surface of the package by 100 (equivalent to the maximum radiation level in millirem per hour at one meter (3.3 ft)).

Transport Package consists of a HI-STAR Package with a set of support saddles, a personnel barrier and licensed radioactive contents loaded for transport. It excludes all lifting devices, tie-downs, longitudinal stops, rigging, transporters, welding machines, and auxiliary equipment (such as the drying and helium backfill system) used during fuel loading operations and preparation for off-site transportation.

Transport Packaging consists of a Transport Package without licensed radioactive contents loaded.

Uniform Fuel Loading is a fuel loading strategy where any authorized fuel assembly may be stored in any fuel storage location, subject to other restrictions in the CoC, such as those applicable to non-fuel hardware, and damaged fuel containers.

Undamaged Fuel Assembly is defined as a fuel assembly without known or suspected cladding defects greater than pinhole leaks and hairline cracks, and which can be handled by normal means. Fuel assemblies without fuel rods in fuel rod locations shall not be classified as Undamaged Fuel Assemblies unless dummy fuel rods are used to displace an amount of water greater than or equal to that displaced by the original fuel rod(s).

Water Tight is defined as a degree of leak-tightness that in a practical sense precludes any significant intrusion of water through all water exclusion barriers. This degree of leak-tightness ranges from 1×10^{-2} std cm^3/s air to 1×10^{-4} std cm^3/s air in accordance with ASTM E1003-05 "Standard Test Method for Hydrostatic Leak Testing."

ZPA is an acronym for Zero Period Acceleration.

Zr means any zirconium-based fuel cladding material authorized for use in a commercial nuclear power plant reactor. Any reference to Zircaloy fuel cladding in this SAR applies to any zirconium-based fuel cladding material. This SAR permits Zircaloy 2, Zircaloy 4, ZIRLO and M5 fuel cladding material as allowable contents.

NOTATION

- α Mean Coefficient of thermal expansion, cm/cm-°C x 10⁻⁶ (in/in-°F x 10⁻⁶)
- d_{\max} : Maximum predicted crush of the impact limiters in a package free drop event
- e: Elongation in percent (i.e., maximum tensile strain expressed in percentage at which the ASME Code test specimen will fail)
- E Young's Modulus, MPa x 10⁴ (psi x 10⁶)
- f: Factor-of-Safety (dimensionless)
- m: Metric for bolted joint leakage
- P_b Primary bending stress intensity
- P_e Expansion stress
- $P_L + P_b$ Either primary or local membrane plus primary bending
- P_L Local membrane stress intensity
- P_m Primary membrane stress intensity
- Q Secondary stress
- S_u Ultimate Stress, MPa (ksi)
- S_y Yield Stress, MPa (ksi)
- S_m Stress intensity values per ASME Code
- T_c : Allowable fuel cladding temperature
- T_p : Peak computed fuel cladding temperature
- α_{\max} : Maximum value measured or computed deceleration from a package drop event.
 α_{\max} can be parallel or lateral to the centerline of the cask.
- β : Weight percent of boron carbide in the neutron shield
- β_{\max} : The value of maximum deceleration selected to bound all values of α_{\max} for a package drop event. Values for β_{\max} in axial and lateral directions are selected

from the population of drop scenarios for a particular regulatory drop event (such as §71.73, free drop).

- Γ : Total gasket spring back in the unloading cycle
- Δ : Initial inter-part gap immediately before impact
- δ : Lateral (global) deflection of the basket panel
- δ_g : Maximum permissible gasket relaxation to maintain leak tightness
- δ_{max} : Maximum value of δ
- ϵ : Charpy lateral expansion at -28.9 °C (-20 °F)
- ξ : Weight percent of hydrogen in the neutron shield material
- ρ : Density
- φ : Coefficient of thermal expansion (average between ambient and the temperature of interest)
- ψ : Thermal conductivity
- θ : Orientation of free drop

GLOSSARY AND NOTATION (HI-STAR 190)

GLOSSARY

AFR is an acronym for Away From Reactor.

ALARA is an acronym for As Low As Reasonably Achievable.

AL-STAR is the trademark name of the impact limiter design used in the family of HI-STAR dual-purpose casks.

Basket Shims are aluminum alloy parts (typically extrusions) that serve to maintain the fuel basket coaxial with the cask's storage cavity.

BWR is an acronym for Boiling Water Reactor.

Cask is a generic term used to describe a device that is engineered to hold high level waste, including spent nuclear fuel, in a safe configuration.

Cask Bottom Region (CBR) refers to the bottom thick nickel steel forging with a Holtite insert

Cask Top Region (CTR) refers to the top nickel steel forging with a Holtite insert

CG is an acronym for Center of Gravity.

Closure Lid is a generic term to indicate a gasketed flat cover that bolts to the top flange of the cask.

Closure Lid System (CLS) refers to the specially shaped lid with concentric grooves. The bolted lid joint is engineered to meet the leak-tight criterion of ANSI N14.5.

CoC is an acronym for Certificate of Compliance

Commercial Spent Fuel (CSF) refers to nuclear fuel used to produce energy in a commercial nuclear power plant.

Containment Boundary means the enclosure formed by the cask inner shell welded to a bottom plate and top flange plus dual closure lids with seal(s) and associated penetration port closure(s) and seal(s).

Containment System means the assembly of containment components of the packaging intended to contain the radioactive material during transport.

Cooling Time (or post-irradiation decay time, PCDT) for a spent fuel assembly is the time between reactor shutdown and the time the spent fuel assembly is loaded into the cask. Cooling Time is also referred to as the “age” of the CSF.

Critical Characteristic means a feature of a component or assembly that is necessary for the component or assembly to render its intended function. Critical characteristics of a material are those attributes that have been identified, in the associated material specification, as necessary to render the material’s intended function.

Criticality Safety Index (CSI) means the dimensionless number (rounded to up to the next tenth) assigned to and placed on the label of a fissile material package, to designate the degree of control of accumulation of packages containing fissile material during transportation.

Damaged Fuel Assembly is a fuel assembly with known or suspected cladding defects, as determined by a review of records, greater than pinhole leaks or hairline cracks, empty fuel rod locations that are not filled with dummy fuel rods, whose structural integrity has been impaired such that geometric rearrangement of fuel or gross failure of the cladding is expected based on engineering evaluations, or that cannot be handled by normal means. Also see fuel debris.

Damaged Fuel Container (or Canister) (DFC) means a specially designed vessel for damaged fuel or fuel debris, which may permit gaseous and liquid media to escape while minimizing dispersal of gross particulates or which may be hermetically sealed. The DFC features a lifting location, which is suitable for remote handling of a loaded or unloaded DFC.

DBE means Design Basis Earthquake.

DCSS is an acronym for Dry Cask Storage System.

Design Heat Load or Design Basis Heat Load is the computed heat rejection capacity of the cask system with the ambient at the normal temperature and the peak cladding temperature (PCT) at 400°C. The Design Heat Load is less than the thermal capacity of the system by a suitable margin that reflects the conservatism in the system thermal analysis.

Design Life is the minimum duration for which the component is engineered to perform its intended function if operated and maintained in accordance with the instructions provided by the system supplier.

Design Report is a document prepared, reviewed and QA validated in accordance with the provisions of Holtec’s Quality Program. The Design Report shall demonstrate compliance with the requirements set forth in the Design Specification. A Design Report is mandatory for systems, structures, and components designated as *Important-to-Safety*. The SAR serves as the Design Report for the HI-STAR 190 package.

Design Specification is a document prepared in accordance with the quality assurance requirements of 10CFR71 Subpart H to provide a complete set of design criteria and functional

requirements for a system, structure, or component, designated as *Important-to-Safety*. The SAR serves as the Design Specification for the HI-STAR 190 package.

Dose Blocker Parts means the shielding components installed outside the Containment Boundary to enable the cask to meet the dose requirements of 10CFR71 during transport.

Enclosure Vessel (or MPC Enclosure Vessel) means the pressure vessel defined by the cylindrical shell, baseplate, port cover plates, lid, closure ring, and associated welds that provides confinement for the helium gas contained within the MPC. The EV and the fuel basket together constitute the multi-purpose canister.

EV is an acronym for the Enclosure Vessel defined above.

Exclusive use means the sole use by a single consignor of a conveyance for which all initial, intermediate, and final loading and unloading are carried out in accordance with the direction of the consignor or consignee. The consignor and the carrier must ensure that loading or unloading personnel have radiological training and resources appropriate for safe handling of the consignment. The consignor must issue specific instructions, in writing, for maintenance of exclusive use shipment controls, and include them with the shipping paper information provided to the carrier by the consignor.

Expanded Containment Boundary means a second barrier against leakage of radiological contents of the package engineered into the system for added safety or to meet a specific jurisdictional regulation.

Fastener Strain Limiter is a device to protect the impact limiter fastener bolts from experiencing excessive axial strain.

Fracture Toughness is a material property, which is a measure of the ability of the material to limit crack propagation under a suddenly applied load.

FSAR is an acronym for Final Safety Analysis Report.

Fuel Basket means a honeycombed cavity structure with square openings that can accept a fuel assembly of the type for which it is designed.

Fuel Debris is ruptured fuel rods, severed rods and loose fuel pellets from damaged fuel assemblies, and fuel assemblies with known or suspected defects which cannot be handled by normal means due to fuel cladding damage, including containers and structures supporting these parts.

Fuel Package is the generic term to represent the physical embodiment consisting of the batch of CSF contained in a Fuel Basket (bare Fuel Package) or the MPC (containerized Fuel Package).

Gamma Capture Space (GCS) means the annular space defined by the Containment shell and the Intermediate Composite Shell occupied by lead.

GTCC is an acronym for Greater Than Class C waste.

HAC is an acronym for Hypothetical Accident Condition under 10 CFR 71.73

High Burnup Fuel (HBF) is a commercial spent fuel assembly with an average burnup greater than 45,000 MWD/MTU.

HI-STAR is a generic term used to denote the family of metal casks consisting of HI-STAR 60, HI-STAR 100, HI-STAR 180, HI-STAR 190 and HI-STAR HB.

HI-STAR 190 Cask or cask means the cask that receives and contains the spent nuclear fuel. It provides the containment system boundary for radioactive materials and fulfills all requirements of 10CFR71 to merit certification as a B(U) package.

HI-STAR 190 Package consists of the HI-STAR 190 cask and MPC with two impact limiters installed at the extremities, a personnel barrier if required, and the licensed radioactive contents loaded for transport.

HI-STAR 190 Packaging consists of the HI-STAR 190 Package without the licensed radioactive contents loaded.

Holtite™ is the trade name for the neutron shielding materials used in the HI-STAR/HI-STORM family of casks.

Impact Limiters means a set of fully enclosed energy absorbers that are attached to the top and bottom of the cask during transport. The impact limiters are used to absorb kinetic energy resulting from normal and hypothetical accident drop conditions. The HI-STAR impact limiters are called AL-STAR.

Important-to-Safety (ITS) means a function or condition required to transport spent nuclear fuel safely; to prevent damage to spent nuclear fuel; and to provide reasonable assurance that spent nuclear fuel can be received, handled, packaged, transported, and retrieved without undue risk to the health and safety of the public.

Incore Grid Spacers are fuel assembly grid spacers located within the active fuel region (i.e., not including top and bottom spacers).

Intermediate Shell is the cylinder between the Gamma Capture Space and the Neutron Capture Space

LLNL is an acronym for Lawrence Livermore National Laboratory.

Leaktight (is defined in this SAR to be same as defined in ANSI N14.5) means a degree of package containment that in a practical sense precludes any significant release of radioactive materials. This degree of containment is achieved by demonstration of a leakage rate less than or equal to 1×10^{-7} ref-cm³/s of air at an upstream pressure of 1 atmosphere absolute and a downstream pressure of 0.01 atmosphere absolute or less. Reference cubic centimeter per second (ref-cm³/s) means a volume of one cubic centimeter of dry air per second at 1 atmosphere absolute pressure (760 mm Hg) and 25°C. Finally, 1×10^{-7} ref-cm³/s air is equal to 4.09×10^{-12} gram-moles/s of dry air or helium and is approximately equivalent to 2×10^{-7} ref-cm³/s helium.

Licensing Drawings or Licensing Drawing Package is an integral part of this SAR wherein the essential geometric and material information on HI-STAR 190 is compiled to enable the safety evaluations pursuant to 10 CFR 71 to be carried out.

License Life means the duration for which the system is authorized by virtue of its certification by the U.S. NRC.

Light Water Reactor (LWR): are nuclear reactors moderated by light water. Commercial LWRs typically utilize enriched uranium and/or the so-called MOX fuel for power generation.

Load-and-Go is a term used in this SAR that means the practice of loading authorized contents into the HI-STAR System packaging and placing the packaging into transportation service under 10 CFR 71, without first deploying the system at an Independent Spent Fuel Storage Installation (ISFSI) under 10 CFR 72. A transfer cask may be loaded under 10CFR72 and used to transfer the sealed canister into the HI-STAR cask without first deploying at an ISFSI.

Lowest Service Temperature (LST) is the minimum metal temperature of a part for the specified service condition.

Maximum Normal Operating Pressure (MNOP) means the maximum pressure that would develop in the containment system in a period of 1 year under the heat condition specified in 10CFR71.71(c)(1), in the absence of venting, external cooling by an ancillary system, or operational controls during transport.

Maximum Reactivity means the highest possible k-effective including bias, uncertainties, and calculational statistics evaluated for the worst-case combination of fuel basket manufacturing tolerances.

Metamic™ is a trade name for an aluminum/boron carbide composite neutron absorber material qualified for use in the HI-STAR/HI-STORM fuel baskets.

Metamic-HT is the trade name for the metal matrix composite made by imbedding nanoparticles of aluminum oxide and fine boron carbide powder on the grain boundaries of aluminum resulting in improved structural strength properties at elevated temperatures. (“HT” stands for high temperature)

MGDS is an acronym for Mined Geological Depository System.

Minimum Enrichment is the minimum assembly average enrichment. Natural uranium blankets are not considered in determining minimum enrichment.

Moderate Burnup Fuel (MBF) is a commercial spent fuel assembly with an average burnup less than or equal to 45,000 MWD/MTU.

Moderator Exclusion means no moderator intrusion into the cask storage cavity under hypothetical accident conditions of transport.

Multi-Purpose Canister (MPC) means the strength welded canister consisting of a honeycombed fuel basket for spent nuclear fuel storage, contained in a cylindrical canister shell (the MPC Enclosure Vessel).

NCT is an acronym for “Normal Condition of Transport”

NDT is an acronym for Nil Ductility Transition, which is defined as the temperature at which the fracture stress in a material with a small flaw is equal to the yield stress in the same material if it had no flaws.

Neutron Absorber Material is a generic term used in this SAR to indicate any neutron absorber material qualified for use in the HI-STAR/HI-STORM fuel basket.

Neutron Capture Space (NCS) means the annular space defined by the Intermediate Shell and the outer shell filled with Holtite.

Neutron Shielding means a material used to thermalize and capture neutrons emanating from the radioactive spent nuclear fuel.

Neutron Sources means specially designed inserts for fuel assemblies that produce neutrons for startup of the reactor.

Non-Fuel Hardware (NFH) means high-level waste not used to produce thermal energy in the reactor. Examples of NFH are Burnable Poison Rod Assemblies (BPRAs), Thimble Plug Devices (TPDs), Control Rod Assemblies (CRAs), Axial Power Shaping Rods (APSRs), Wet Annular Burnable Absorbers (WABAs), Rod Cluster Control Assemblies (RCCAs), Control Element Assemblies (CEAs), water displacement guide tube plugs, orifice rod assemblies, Instrument Tube Tie Rods (ITTRs), Guide Tube Anchors (GTAs), and vibration suppressor inserts.

Not-Important-to-Safety (NITS) is the term used where a function or condition is not deemed as *Important-to-Safety*. See the definition for *Important-to-Safety*.

O&M Manual is an abbreviation for operation and maintenance manual.

ORNL is an acronym for Oak Ridge National Laboratory

Overpack is an alternative term used in this SAR to denote a cask containing a Fuel Package.

Planar-Average Initial Enrichment is the average of the distributed fuel rod initial enrichments within a given axial plane of the assembly lattice.

Post-Core Decay Time (PCDT) is synonymous with cooling time.

PWR is an acronym for Pressurized Water Reactor.

Reactivity is used synonymously with effective neutron multiplication factor or k-effective.

Regionalized Fuel Loading is a term used to describe an optional fuel loading strategy used in lieu of uniform fuel loading. Regionalized fuel loading allows higher heat emitting fuel assemblies to be stored in certain fuel storage locations provided lower heat emitting fuel assemblies are stored in other fuel storage locations.

SAR is an acronym for Safety Analysis Report.

SCG is an acronym for the intermediate spent fuel storage container building located at the Doel Site.

Service Life means the duration for which the component is reasonably expected to perform its intended function, if operated and maintained in accordance with the provisions of this SAR. Service Life may be much longer than the Design Life because of the conservatism inherent in the codes, standards, and procedures used to design, fabricate, operate, and maintain the component.

Short-term Operations means those normal operational evolutions necessary to support fuel loading or fuel unloading operations.

Single Failure Proof means that the handling system is designed so that a single failure will not result in the loss of the capability of the system to safely retain the load. Single Failure Proof means that the handling system is designed so that all directly loaded tension and compression members are engineered to satisfy the enhanced safety criteria of Paragraphs 5.1.6(1)(a) and (b) of NUREG-0612.

SNF is an acronym for Spent Nuclear Fuel (also referred to as CSF in this SAR).

Specific Heat Load means the heat emission rate from one fuel assembly. Sum of the Specific Heat loads of all fuel assemblies in a Fuel Package is referred to as the Aggregate heat Load.

STP is Standard Temperature (298K) and Pressure (1 atm) conditions.

SSC is an acronym for Structures, Systems and Components.

Surface Contaminated Object (SCO) means a solid object that is not itself classed as radioactive material, but which has radioactive material distributed on any of its surfaces. See 10CFR71.4 for surface activity limits and additional requirements.

Transport Index (TI) means the dimensionless number (rounded up to the next tenth) placed on the label of a package, to designate the degree of control to be exercised by the carrier during transportation. The transport index is determined as the number determined by multiplying the maximum radiation level in millisievert per hour at one meter (3.3 ft) from the external surface of the package by 100 (equivalent to the maximum radiation level in millirem per hour at one meter (3.3 ft)).

Transport Package consists of a HI-STAR Package with a set of support saddles, a personnel barrier and licensed radioactive contents loaded for transport. It excludes all lifting devices, tie-downs, longitudinal stops, rigging, transporters, welding machines, and auxiliary equipment (such as the drying and helium backfill system) used during fuel loading operations and preparation for off-site transportation.

Transport Packaging consists of a Transport Package without licensed radioactive contents loaded.

Uniform Fuel Loading is a fuel loading strategy where any authorized fuel assembly may be stored in any fuel storage location, subject to other restrictions in the CoC, such as those applicable to non-fuel hardware, and damaged fuel containers.

Undamaged Fuel Assembly is defined as a fuel assembly without known or suspected cladding defects greater than pinhole leaks and hairline cracks, and which can be handled by normal means. Fuel assemblies without fuel rods in fuel rod locations shall not be classified as Undamaged Fuel Assemblies unless dummy fuel rods are used to displace an amount of water greater than or equal to that displaced by the original fuel rod(s).

Water Tight is defined as a degree of leak-tightness that in a practical sense precludes any significant intrusion of water through all water exclusion barriers. This degree of leak-tightness ranges from 1×10^{-2} std cm^3/s air to 1×10^{-4} std cm^3/s air in accordance with ASTM E1003-05 "Standard Test Method for Hydrostatic Leak Testing."

ZPA is an acronym for Zero Period Acceleration.

Zr means any zirconium-based fuel cladding material authorized for use in a commercial nuclear power plant reactor. Any reference to Zircaloy fuel cladding in this SAR applies to any zirconium-based fuel cladding material. This SAR permits Zircaloy 2, Zircaloy 4, ZIRLO and M5 fuel cladding material as allowable contents.

NOTATION

- α Mean Coefficient of thermal expansion, cm/cm-°C x 10⁻⁶ (in/in-°F x 10⁻⁶)
- d_{\max} : Maximum predicted crush of the impact limiters in a package free drop event
- e: Elongation in percent (i.e., maximum tensile strain expressed in percentage at which the ASME Code test specimen will fail)
- E Young's Modulus, MPa x 10⁴ (psi x 10⁶)
- f: Factor-of-Safety (dimensionless)
- m: Metric for bolted joint leakage
- P_b Primary bending stress intensity
- P_e Expansion stress
- $P_L + P_b$ Either primary or local membrane plus primary bending
- P_L Local membrane stress intensity
- P_m Primary membrane stress intensity
- Q Secondary stress
- S_u Ultimate Stress, MPa (ksi)
- S_y Yield Stress, MPa (ksi)
- S_m Stress intensity values per ASME Code
- T_c : Allowable fuel cladding temperature
- T_p : Peak computed fuel cladding temperature
- α_{\max} : Maximum value measured or computed deceleration from a package drop event.
 α_{\max} can be parallel or lateral to the centerline of the cask.
- β : Weight percent of boron carbide in the neutron shield
- β_{\max} : The value of maximum deceleration selected to bound all values of α_{\max} for a package drop event. Values for β_{\max} in axial and lateral directions are selected

from the population of drop scenarios for a particular regulatory drop event (such as §71.73, free drop).

- Γ : Total gasket spring back in the unloading cycle
- Δ : Initial inter-part gap immediately before impact
- δ : Lateral (global) deflection of the basket panel
- δ_g : Maximum permissible gasket relaxation to maintain leak tightness
- δ_{max} : Maximum value of δ
- ϵ : Charpy lateral expansion at -28.9 °C (-20 °F)
- ξ : Weight percent of hydrogen in the neutron shield material
- ρ : Density
- φ : Coefficient of thermal expansion (average between ambient and the temperature of interest)
- ψ : Thermal conductivity
- θ : Orientation of free drop

CHAPTER 1: GENERAL INFORMATION

1.0 OVERVIEW

HI-STAR 190 is the model name of a transport package engineered to serve as a type B(U)F-96 package for transporting radioactive material including commercial spent fuel (CSF), reactor-related non-fuel waste, and high level waste. This Safety Analysis Report (SAR)¹ considers only CSF as the package contents. The principal design and performance objectives for HI-STAR 190 are:

- (a) The transportation of MPCs initially loaded and stored under CoC 72-1032 and 72-1040. To achieve this objective, the following approach is implemented:
- MPC fuel loading operations are only addressed in this SAR for the “load and go”² scenario.
 - The approved content of the 10CFR71 CoC is a subset of the approved content of the 10CFR72 CoC under which the MPC was initially loaded. However this SAR may specify additional allowable content restrictions as necessary for transport qualification.
 - Potential changes in the physical characteristics of the MPC and its content due to aging effects during the time period of initial (20 year) storage under 10CFR72 are only considered as necessary to address transportation safety as explicitly described in this SAR.
 - “Load-and-go”² transportation of MPC-37 and MPC-89 which are certified for loading and storage in the HI-STORM FW under CoC 72-1032 and the HI-STORM UMAX under CoC 72-1040 (see Table 1.1.2) and with MPC contents meeting the approved content under CoC 71-9373, is performed by loading under the Part 72 storage certificate, prior to transporting under this SAR.
 - The following observations apply to the design of HI-STAR 190:
 - Features a larger inside diameter (ID) than all other certified HI-STAR models (see Table 1.1.1).
 - Provides a storage cavity that is intended to be larger in diameter than any spent fuel canister thus far licensed by the USNRC and deployed at a US plant. Hence could be qualified to serve as a "universal" cask that can be used to transport the majority of canisters presently stored at US plants.
- (b) The transportation of both high burnup fuel (HBF) and moderately burned fuel (MBF). To achieve this objective, the following strategy is implemented:
- Principal qualification for HBF is moderator exclusion.
 - Consistent with the intent of ISG-19, and with the approach used for the HI-STAR 180 [1.0.4], the qualification is based on a double barrier (double containment) approach.
 - Outer Barrier/Containment is the cask’s containment boundary.
 - Inner Barrier/Containment is the MPC’s confinement boundary

¹ See Glossary for definition and abbreviation of terms used throughout this SAR.

² The term “Load-and-go” is defined in the Glossary. This SAR only qualifies the dry loading of HI-STAR 190 via MPC transfer using a transfer cask where the MPC is initially loaded and sealed under the provisions of 10CFR72.

- Additional safety evaluations are presented as a defense-in-depth including:
 - Structural evaluations of fuel rods under accident conditions
 - Criticality evaluations of reconfigured fuel under accident conditions, assuming flooding of the cask
- Additional defense-in-depth provided by the aging management of MPC pressure boundary and containment boundary on MPCs stored beyond the duration of the initial 20 year license period under the provisions of 10CFR 72.
- Additional defense-in-depth by direct surface inspection of MPC shell exterior surfaces of MPCs stored under the provisions of 10CFR 72 prior to transport.
- No double barrier needed for MBF.
 - Only the cask's containment boundary is credited for the containment function.
 - No specific aging related requirements and tests needed for the MPC's confinement boundary since it is not credited as a containment boundary in the transport safety analyses for MBF.
 - Additional defense-in-depth provided by the aging management of MPC pressure boundary on MPC stored beyond the duration of the initial 20 year license period under the provisions of 10CFR 72.

1.1 INTRODUCTION TO THE HI-STAR 190 PACKAGE

This SAR for the HI-STAR 190 Package is a compilation of information and analyses in the format suggested in Reg. Guide 7.9 [1.0.1] to support a United States Nuclear Regulatory Commission (USNRC) licensing review for certification as a spent nuclear fuel transportation package pursuant to the provisions of 10CFR71 Subpart D [1.0.2] and 49 CFR 173 [1.0.3].

The HI-STAR 190 is designed as the transportation cask for the MPCs certified for storage in HI-STORM FW and HI-STORM UMAX (Table 1.1.2), in the same way that the HI-STAR 100 [1.0.5] is designed and licensed for MPCs certified for storage in the HI-STORM 100 storage system [1.0.6]. It is the latest addition to the HI-STAR family of casks (see Table 1.1.1). HI-STAR 190 is available in two discrete lengths to accommodate all BWR and all PWR canisters. The two versions are identified as Version SL (standard length) and Version XL (extended length).

All design and design concepts of the HI-STAR 190 Package are directly adapted from Holtec's various licensed transport, storage, and transfer cask systems (see Table 1.1.1). There are no principal design concepts that have not been previously licensed. Design features and basic approach include:

- **Cask construction:** The principal cask construction is identical to the HI-STAR family of casks.
- **Containment system:** The containment system is engineered to parallel the anatomical design and construction of the containment system of the HI-STAR 100. More specifically, the containment system materials of construction, welding joint details, NDE requirements, seal joint type, and code of construction are identical to those of the HI-STAR 100.
- **Double Containment for High Burnup Fuel:** Qualification to transport high burnup fuel (HBF) follows the double barrier approach in the certified HI-STAR 180. However, whereas HI-STAR 180 has two bolted lids, HI-STAR 190 utilizes a single bolted lid and the second barrier is formed by the MPC inside the HI-STAR. In this respect, HI-STAR 190 presents a true double containment system for HBF.
- **Burnup Credit:** The MPC-37 utilizes burnup credit as a criticality control method based on the burnup credit approach approved for the MPC-32 in the HI-STAR 100. The approach is updated in this SAR based on the latest NRC guidance. With the presence of the Metamic-HT basket, the required fuel burnup is significantly reduced compared to the MPC-32.
- **Metamic-HT Baskets:** Metamic-HT™ is the principal constituent material for the latest generation of fuel baskets in the MPCs. Metamic-HT has been qualified for transport in the certified HI-STAR 180 and HI-STAR 180D, and for storage in the certified HI-STORM 100 and HI-STORM FW.
- **Gamma Shielding:** Gamma shielding performance is optimized by using lead as radial gamma shielding material. The gamma shielding material and design is commonly used in Type B(U) transportation casks and implemented in various licensed HI-TRAC transfer casks (Docket 72-1014 and 72-1032).
- **Neutron shielding:** Neutron shielding performance is optimized by featuring Holtite as radial neutron shielding material placed within the annular sectors formed by the outer-most

shell and the intermediate shell joined by an array of circumferentially equally spaced radial connectors. The neutron shielding material and similar design is implemented in HI-STAR 180 and HI-STAR 100.

- **Impact Limiters:** The design embodiment and cask interface features of the HI-STAR 190 AL-STAR impact limiters are similar to those for the HI-STAR 180 and the HI-STAR 180D AL-STAR impact limiters. Moreover, the outer surfaces of the top and bottom forgings provide the cylindrical interface to the impact limiter "skirt" with a tight annular clearance to essentially restrain the impact limiter from rotating out of axial alignment with the cask's centerline. Bereft of the trunnions, the top and bottom forgings present conformal bearing surfaces for the Impact Limiters' skirts.
- **MPC Spacers:** In order to accommodate MPCs of various lengths (as allowed in the HI-STORM FW MPC certification) MPC spacers are used external to the MPC to restrict axial movement and control the center of gravity of the package. MPC spacers are already qualified in the certified HI-STAR 100. Both Version SL and XL are qualified to use MPC spacers.

Figures 1.1.1 and 1.1.2 provide pictorials of the exterior of the HI-STAR 190 Cask and HI-STAR 190 Packaging, respectively. The drawing package in Section 1.3 details the important-to-safety features considered in the packaging evaluation and also includes certain details on *not-important-to-safety* features. For the reader's convenience and clarity, additional pictorials of the cask and packaging components are provided throughout this SAR.

This SAR supports a transport packaging License Life of 5 years, after which a renewal by the USNRC is required. However, all safety evaluations are based on a design or service life that is substantially longer than 5 years, to provide a suitable basis for future license renewals. This is generally accomplished by using materials of construction that have been exhaustively tested and determined capable of withstanding HI-STAR 190's operating environments with little or no degradation and with negligible reduction, if any, in their capability to render their intended function (materials of construction and testing are discussed in Section 1.2, Section 2.2 and Chapter 8 of this SAR).

Chapter 8 of this SAR specifies a maintenance program that is implemented to ensure the cask will meet a Design Life of at least 50 years. The technical considerations that assure the packaging performs its design functions throughout its Design Life include all areas germane to the long-term integrity of the system, such as:

- Consideration of Exposure to Environmental Effects
- Consideration of Material Corrosion, Degradation and Aging Effects
- Provision of Preventive Maintenance and Inspections
- Consideration of Structural Fatigue, Brittle Fracture and Creep Effects
- Assurance of Long-Term Effectiveness of the Neutron Absorber

MPCs that are transported in the HI-STAR 190 Package must already be certified under their respective 10 CFR 72 storage certificate, which defines its licensing and design life for the purpose of storage operations. Additionally, each MPC will only be in the HI-STAR 190 cask for a limited amount of time during transport. Defining a license and design life for MPCs for

transport operations is therefore not meaningful. Instead, the MPC license and design life considerations for storage have been reviewed for their applicability to transportation. The review considers the MPC design and its operation during the storage period. Any additional considerations and acceptance criteria necessary for transport are specified in Chapter 7 and 8 of this SAR.

Table 1.1.1

HI-STAR FAMILY OF TRANSPORT PACKAGES

Model Name	USNRC Docket and SAR Reference	Year certified	Content (Fuel Type)	Cask Cavity Length (inch)	Cask ID (inch)	Cask OD (inch)
HI-STAR 100	71-9261 [1.0.5]	1998	BWR & PWR	191 1/8	68 ¾	86 ¼
HI-STAR 60	71-9336 [1.0.7]	2009	PWR	139.60	42.50	82.00
HI-STAR 180	71-9325 [1.0.4]	2009	PWR	140.66	72.83	106.30
HI-STAR 180D	71-9367 [1.0.9]	2014	PWR	115.87	72.83	106.77
HI-STAR 190	71-9373 [this SAR]	-	BWR & PWR	190 3/16 (SL) 213 5/16 (XL)	76	106.5
<p>Note: All dimensions are nominal and taken from respective licensing drawing packages approved at the time of this writing.</p>						

Table 1.1.2

PERMISSIBLE “FUEL PACKAGES” FOR HI-STAR 190

Canister ID	Fuel Type	Fuel Package Type	USNRC Docket and SAR Reference	MPC OD (inch) (Note 1)	Basket Material
MPC-37	PWR	Hermetic Canister	72-1032 (HI-STORM FW) [1.08] (Note 2)	75 ¾	Metamic-HT
MPC-89	BWR	Hermetic Canister	72-1032 (HI-STORM FW) [1.08] (Note 2)	75 ¾	Metamic-HT
<p>Notes: (1) All dimensions are nominal and taken from respective licensing drawing packages approved at the time of this writing.</p> <p>(2) These canisters are also approved for storage in the HI-STORM UMAX system (Docket number 72-1040)</p>					

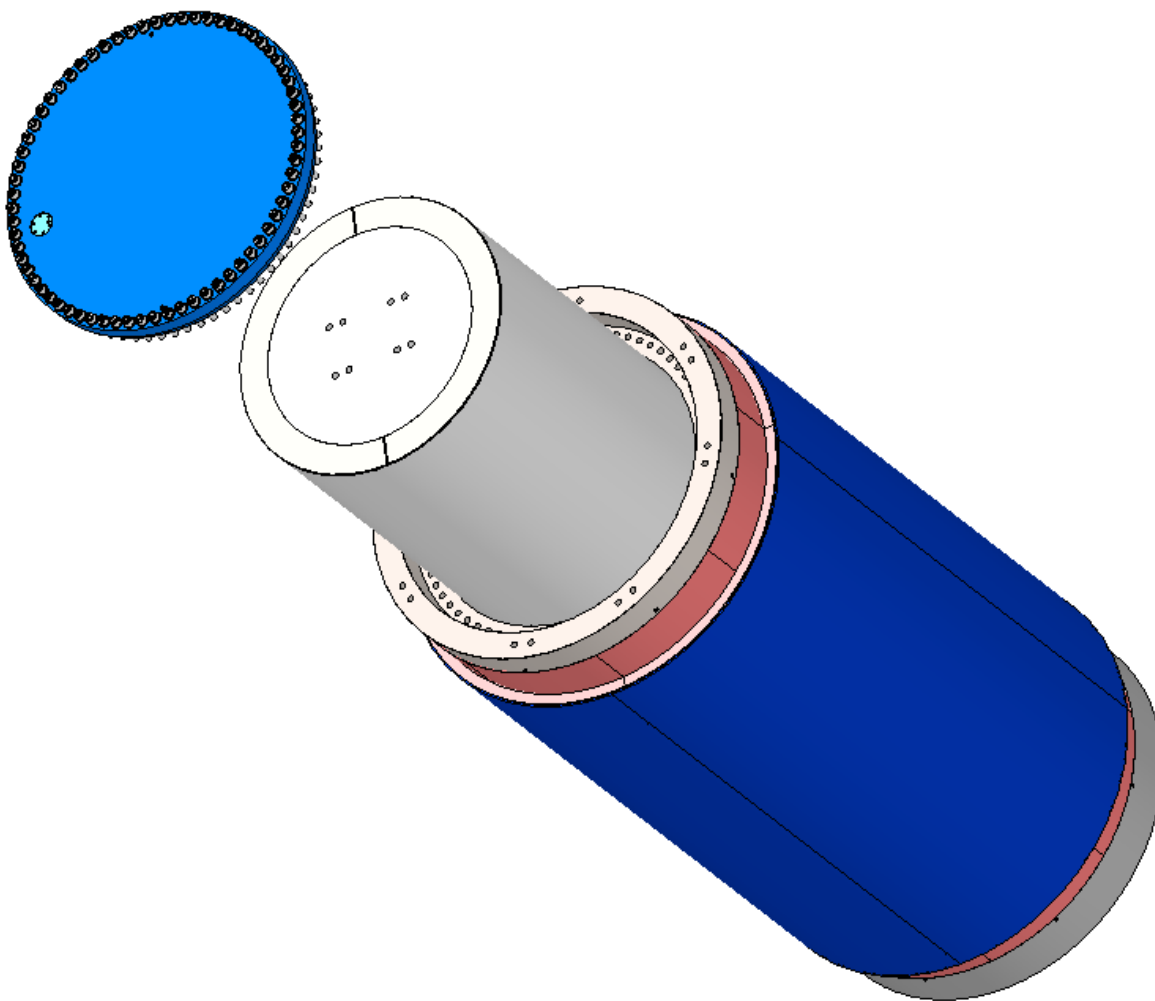

FIGURE 1.1.1: PICTORIAL OF HI-STAR 190 WITH AN MPC IN EXPLODED VIEW

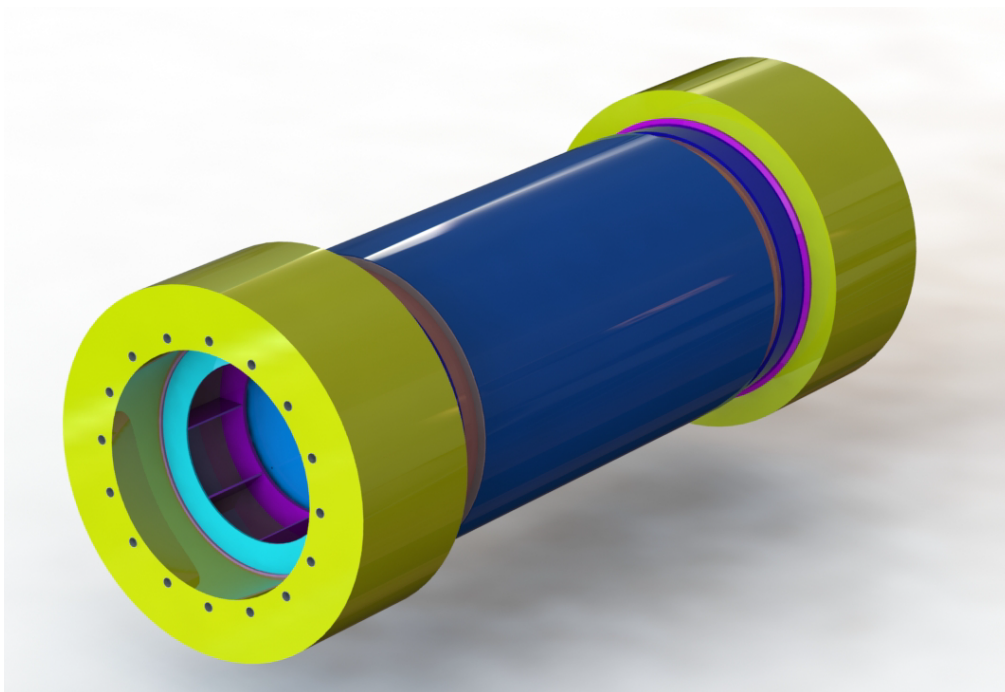

FIGURE 1.1.2: PICTORIAL OF HI-STAR 190 PACKAGING

1.2 DESCRIPTION OF PACKAGING COMPONENTS AND THEIR DESIGN AND OPERATIONAL FEATURES

1.2.1 Packaging

1.2.1.1 Major Packaging Components and Packaging Supports and Restraints

The HI-STAR 190 Packaging consists of the five major components (Cask, MPC, MPC Spacer, Impact Limiters and Personnel Barrier) discussed in (a) through (e) below. Additionally, auxiliary equipment in the form of packaging supports and restraints typically necessary for package transport, is described in subparagraph (f) below.

(a) Cask

The main function of the cask is containment and shielding. When transporting HBF, the cask containment system is considered the outer containment boundary and credited as a barrier for moderator exclusion. The containment of the radiological contents is provided by a nickel steel (also referred to as “cryogenic steel”) shell welded to a nickel steel baseplate at the bottom and a suitably machined nickel steel forging at the top, which is equipped with machined surfaces to fasten a high integrity closure lid system equipped with concentric elastomeric seals. The fully low temperature-capable steel weldment and the cryogenic steel closure lid define the “Containment Boundary” for the cask. The Containment Boundary, including the closure lid system, is designed and manufactured to ASME Section III Division 1, Subsection NB [1.2.1] as further clarified in this SAR.

For purposes of description, the HI-STAR 190 cask is divided into six constituent parts, each with distinct roles and features, as follows:

- 1) The Containment Shell: The innermost cylindrical member of the cask containment system.
- 2) Cask Bottom Region (CBR): The CBR consists of a thick nickel steel forging, the Containment Bottom Forging, with a Holtite insert for additional dose reduction.
- 3) Cask Top Region (CTR): The CTR consists of a massive nickel steel forging, the Containment Top Forging, with a Holtite insert for additional dose reduction. The CTR includes the collapsible trunnions which are the cask’s interfacing lift points.
- 4) Closure Lid System (CLS): The CLS consists of a specially shaped lid, the Closure Lid, with two machined concentric grooves to provide containment protection. The bolted lid joint is engineered to meet the leak-tight criterion of ANSI N14.5 [8.1.6] under the normal and hypothetical accident conditions of transport.
- 5) Gamma Capture Space (GCS): The GCS refers to the annular space around the Containment shell containing lead, which is enclosed by the “intermediate shell” (IS) and strengthened by radial gussets. The space is non-structural in its function and has the principal role to block gamma radiation.
- 6) Neutron Capture Space (NCS): The NCS is the outermost annular space, which is enclosed by an alloy shell buttressed by radial gussets and filled with Holtite-B whose

principal function is to block the neutrons accreted by the contained CSF. This space is also non-structural.

The above description of the constituent parts is summarized in Table 1.2.1 for ease of reference. Figure 1.2.1 provides a cut-away view of the HI-STAR 190 cask to illustrate the above constituent parts.

(b) The Multi-Purpose Canister (MPC)

The MPCs consists of the stainless steel enclosure vessel (EV), and the honeycomb basket made from panels of Metamic-HT. Figure 1.1.1 shows an MPC in an exploded view with the HI-STAR 190 cask. Figures 1.2.2 and 1.2.3 show the cut-away views of typical MPCs.

The Enclosure Vessel is seal-welded and leak-tight and provides additional protection against release of radionuclides, in addition to that provided by the cask containment. When transporting HBF, the EV is considered the inner containment boundary and credited as an additional barrier for moderator exclusion.

In the fuel basket, the honeycomb design arrays the cell walls in two orthogonal sets of plates; consequently, the walls of the cells are either completely coplanar (no offset) or orthogonal with each other. The coplanar honeycomb design of the basket renders it extremely rugged under lateral drop scenarios. The final form of the fuel basket plates is extruded and has the dimensional precision that rivals machining. As a result, the fuel basket is assured to be a cellular structure with excellent dimensional precision, specifically regarding verticality and cross-sectional dimensions. Furthermore, the cell-to-cell connectivity inherent in the honeycomb basket structure provides an uninterrupted heat transmission path, making the MPC an effective heat rejection device.

Precision extruded and/or machined blocks of aluminum alloy with axial holes (basket shims) are installed in the peripheral space between the fuel basket and the enclosure vessel to provide conformal contact surfaces between the basket shims and the fuel basket and between the basket shims and the enclosure vessel shell. The axial holes in the basket shims serve as the passageway for the flow of the helium gas under natural convection.

Table 1.1.2 provides a list of MPCs analyzed in this SAR. Their design details relevant for the safety analyses are illustrated in the drawings in Section 1.3.

(c) MPC Spacer

The MPCs qualified for transport in HI-STAR 190 may be of different lengths. To transport an MPC that is shorter than the cask cavity, one or more internal spacers are utilized to limit the axial movement of the MPC during transport conditions and to limit the inertia loads and impulse of impact exerted on fuel assemblies during impact events including the “free drop” scenarios of 10 CFR 71. The spacers may be positioned at both ends of the MPC so that the axial

location of the CG continues to accord with this SAR. The spacers are made of a cylindrical steel shell with flat ends.

(d) Impact Limiters

Two impact limiters (also referred to as AL-STAR 190) are installed at the two extremities of the HI-STAR 190 Cask and provide energy absorption capability for the normal and hypothetical accident conditions of transport. The impact limiters feature extremely rigid cylindrical barrels (backbone structures) that engage the top and bottom of the cask with a snug fit. Each impact limiter backbone is enveloped by crushable material, which in turn is enclosed by a stainless steel skin. The selection of the crushable material ensures that the performance of the impact limiters will be essentially insensitive to the ambient environment (temperature and humidity). The AL-STAR 190 impact limiters are of the same design genre as the AL-STAR 180 used in the HI-STAR 180 Package (Docket No. 71-9325). The following key design features typify the AL-STAR 190 impact limiters:

- Each impact limiter is configured in such a manner that under all potential free-fall scenarios, the collision of the package with the regulatory target surface will always occur in the crush material space (i.e. will be cushioned by the impact limiter crush material).
- The impact limiter will protect the cask under all angular drop orientations onto the regulatory strike surface.
- External surface of the impact limiter surrounding the crushable material is made of stainless steel, a ductile, corrosion-resistant material.
- Axial (longitudinal) tension rods of high-strength material fasten the impact limiter to the two extremities of the cask body.
- Both impact limiters feature a skirt (shell) that fits the outside of the cask forging with a small radial clearance.
- The fasteners are engineered to be readily installable and removable for ALARA purposes.
- Each impact limiter is designed to render its intended function in the entire range of applicable ambient temperature conditions of the package.

Impact limiter details are shown in the drawing package in Section 1.3. The *critical characteristics* and the attainment of the required critical characteristics through a comprehensive qualification process and production testing are discussed in Chapters 2 and 8, respectively. Figure 1.1.2 shows the HI-STAR 190 cask equipped with the impact limiters at its two extremities.

(e) Personnel Barrier:

During transport the cask lies in a horizontal orientation with the two impact limiters on its two extremities. The personnel barrier is placed over the cask to provide a physical barrier to prevent manual access to hot, 85°C (185°F) or higher, areas of the cask when configured for transportation as required by 10 CFR 71.43(g) and 10 CFR 71.51(2). The personnel barrier for HI-STAR 190 only envelopes the cask body, not the impact limiters as shown in Figure 1.2.4.

The personnel barrier is not a structural part of the HI-STAR 190 Packaging but is designated as a packaging component when in use. Since the personnel barrier is not a structural part of the HI-STAR 190 Packaging, it is not required to remain in place under normal condition tests in 10 CFR 71.71.

[

PROPRIETARY INFORMATION WITHHELD PER 10 CFR 2.390

]

(f) Packaging Supports and Restraints:

The HI-STAR 190 Package lends itself to horizontal transport as shown in Figure 1.2.4 and is engineered for shipment by seagoing vessel, railroads and roadways using appropriate supports and restraints. An illustrative example of packaging supports and restraints is provided in Figure 1.2.4. The arrangement of packaging supports and restraints may vary as long as the package is properly secured and qualified for the specific mode of transport. Tapered wedge shims that close the gap between the impact limiters and the axial restraints (longitudinal stops) of the transport vehicle are examples of auxiliary equipment that may be used to restrain the package against axial movement. Packaging supports and restraints such as support saddles, transport cradle, longitudinal stops, slings or straps and wedge shims are not structural parts of the HI-STAR 190 Package and as such are designated as auxiliary equipment.

Packaging supports, and restraints shall be designed as appropriate for either rail, road (i.e. public highway) or seagoing vessel transport applications in compliance with the applicable requirements of 10 CFR 71 and 49 CFR as indicated by 10 CFR 71.5, with additional consideration to the applicable industry (railroad, road and sea transportation) standards. More specifically, 10 CFR 71.45(a) and (b) requirements must be complied with.

In the transport package configuration, the HI-STAR 190 cask trunnions are not qualified to be used to lift the HI-STAR 190 Package (i.e., loaded cask with impact limiters). In the transport package configuration, the HI-STAR 190 cask trunnions remain attached to the package and are

not removable during transport. Therefore for compliance with 10CFR71.45 the cask trunnions must be rendered inoperable when HI-STAR 190 is configured as a transport package (i.e. loaded cask with impact limiters) as indicated in Figure 1.2.4.

1.2.1.2 Overall Packaging Dimensions and Weight

The overall dimensions of the HI-STAR 190 Package are summarized in Table 1.2.2.

The nominal weights for the HI-STAR 190 Package and its main components, including the nominal weight of the MPCs at maximum capacity with design basis SNF, are provided in Section 2.1 (and Table 2.1.11). The weight of the package contents is discussed in Subsection 1.2.2 below. The maximum gross transport weight of the HI-STAR 190 Package, (without the personnel barrier), marked on the packaging nameplate, is provided in the drawing package in Section 1.3.

The actual as-built (empty) packaging weight will vary slightly due to dimensional tolerances and small variations in material density. A verification of the as-manufactured empty packaging weight is not required because the safety analysis contained in this SAR considers such variations to ensure that the analyses are conservative.

1.2.1.3 High Burnup Fuel Transportation and Moderator Exclusion Features

The HI-STAR 190 packaging is designed to transport both moderate burn-up (MBF) and high burn-up fuel (HBF). In recognition of the uncertainty surrounding the cladding material properties of HBF, a multi-layered safety-focused strategy to transport HBF has been adopted for HI-STAR 190. The principal approach is consistent with that used in HI-STAR 180 (Table 1.1.1), and consists of assurance of moderator exclusion under accident conditions, following the intent of and performance objectives of ISG-19. The approach is supplemented by defense-in-depth evaluations including structural evaluations of fuel performance under accident conditions, and criticality evaluations of reconfigured fuel. However, there are some important extensions and modifications to the approach used for the HI-STAR 180 to address the specific situation of the HI-STAR 190:

- For HI-STAR 180, there is a single walled barrier body with double barrier closure. This double barrier system with two bolted lids is used to assure moderator exclusion and meet the intent of ISG-19. For HI-STAR 190, the double barrier system consists of a cask containment body with a single bolted lid in conjunction with the seal welded MPC. This configuration not only provides a double barrier against water intrusion, it also forms a true double containment system since both barriers are completely independent from each other. Further discussion on this double containment system are presented in Paragraph 1.2.1.4.

The second (inner) containment boundary formed by the MPC enclosure vessel is only credited for moderator exclusion when HBF is present in the MPC. For MBF, the MPC,

while present, just serves as a defense-in-depth additional barrier against water inleakage and radiological release and as a pressure boundary.

- MPCs are loaded into the HI-STAR 190 for transport as “load-and-go” transport or after a period of interim storage. While cladding damage to HBF is not expected during the interim storage period, it is not feasible to physically examine the fuel at that time to verify its condition. However, for compliance with 10 CFR 71.55(b) flooding of the containment needs to be assumed and moderator exclusion cannot be applied. Under this condition, the criticality evaluations for the HI-STAR 190 are performed considering already a certain level of fuel reconfiguration. Consequently, the definition of undamaged fuel for the HI-STAR 190 for the purpose of criticality evaluation already includes consideration of a certain level of fuel reconfiguration.

Nevertheless, in addition to considering fuel defects of HBF, additional acceptance criteria and supplemental requirements need to be satisfied before an MPC with HBF or MBF can be accepted for transport, these criteria and supplemental requirements are described in Chapter 8, including Table 8.2.1 and Appendix 8.A.

- The criticality analyses assuming re-configuration of HBF have been performed, like HI-STAR 180, with assumptions of either fresh fuel or with burnup assumed, as described in Table 1.2.3. These analyses could lead to the false impression that reconfigured HBF has the same or even less criticality margin than MBF. To disprove this, some criticality calculations for the HI-STAR 190 apply a minimum burnup for the HBF, and hence show that the reactivity effect of potential fuel reconfiguration is more than compensated by the higher burnup.

Summarizing the above, Table 1.2.3 shows the approach used for the criticality evaluations for the various cases required to show compliance with 10 CFR 71.55 and 10 CFR 71.59. Similarly, thermal analysis and shielding analysis in Chapter 3 and 5 of this SAR, respectively, evaluate the package under the assumption of reconfigured fuel.

As the structural defense-in-depth evaluations for NCT and HAC, a best-estimate rod integrity safety case is made by a series of realistic, but conservative assumptions. The finite element fuel rod analysis summarized in Chapter 2, Section 2.11, of this SAR demonstrates that the fuel rods are not expected to undergo failure under the normal conditions of transport described in 10 CFR 71.71 nor during the hypothetical accident conditions in 10 CFR 71.73. A positive safety margin against a primary failure of the fuel rods is determined to exist even under the worst case accident scenario.

The overall licensing approach (including the defense-in-depth approach) from both safety and regulatory compliance perspectives is summarized in Table 1.2.4.

Other aspects of the design and analyses that support the conclusion that HBF can safely be transported in the HI-STAR 190 are summarized below.

1. The adoption of ANSI N14.5 reference leakage rate of “leaktight” conservatively precludes any containment concerns with HBF under NCT and HAC.
2. The Metamic-HT baskets minimize the criticality safety implications of potential HBF reconfiguration under all conditions of transport.
3. Containment boundary integrity is maintained under hypothetical 100% rod rupture with coincident hypothetical fire accident consistent with RG 7.6 [2.1.2] (HAC).
4. Cask handling drops are rendered non-credible through ANSI N14.6 qualification of cask interfacing lift points (loading/unloading) and robust handling procedures.
5. Compliance with ISG-11 Rev. 3 [1.2.6] for all conditions of transport has been demonstrated (see Chapter 3).

In conclusion, the combination of conservative assumptions and analyses with a robust design provide a reasonable assurance that the HI-STAR 190 Package containing HBF will protect public health and safety under all operational scenarios postulated by 10 CFR Part 71.

Further details of the design measures and technical confirmation to meet the intent and performance objectives of ISG-19 are described in Appendix 1.A.

1.2.1.4 Containment Features

The HI-STAR 190 Cask Containment System serves as the outer containment boundary of the package and forms an internal cylindrical cavity for housing the MPC. The MPC’s enclosure vessel serves as the inner Containment Boundary of the package when loaded with HBF.

The cask’s Containment Boundary is formed by a cryogenic steel inner shell (containment shell) welded at the bottom to a thick cryogenic forging (containment bottom forging) and welded at the top to a heavy cryogenic forging (containment top forging). Circumferential welds are 100% radiographed in compliance with the quality requirements of Section III Class 1 of the ASME Code. The containment top forging contains gasket seating surfaces configured to recess the closure lid inside the lip of the containment top forging, which protects the closure lid bolts and seals in the event of a drop accident. The closure lid features dual concentric seals. The inter-seal test port is closed by a threaded port plug and seal. The closure lid has an access port that is closed by a threaded port plug (a redundant closure feature) and by a bolted port cover plate (a containment closure feature).

The cask closure lid has been engineered to perform the containment function with final qualification by leak testing according to ANSI N14.5 [8.1.6] as specified in Chapter 8, Table 8.1.2 and to the leakage acceptance criterion specified in Chapter 8, Table 8.1.1. The closure lid joint features equally proficient seals, one seal serving as a back-up to the other seal.

In addition to the cask containment boundary, the MPC’s Enclosure Vessel renders the function of the second of the two Containment Boundaries in the HI-STAR 190 Package, if it contains HBF. To be deemed suitable to serve as an autonomous Containment Boundary inside the cask, it is necessary that the MPC meet the criteria listed in Section 8.1.

Chapter 4, devoted to containment integrity evaluation provides the regulatory basis for qualifying the inner and outer containment boundaries as two discrete, autonomous and competent leak-tight enclosures under the provisions of 10 CFR 71.

1.2.1.5 Neutron and Gamma Shielding Features

The HI-STAR 190 Cask Containment is circumscribed by the Gamma Capture Space (GCS) and the Neutron Capture Space (NCS), described in the foregoing, that respectively attenuate gamma radiation and neutron fluence emitted from the contained fuel to minimal practical levels consistent with ALARA principles. The HI-STAR 190 Packaging (with or without the personnel barrier) ensures the external radiation standards of 10 CFR 71.47 under exclusive shipment are met when loaded with design basis fuel. The drawing package in Section 1.3 and the summary description in Section 1.1 provide information on the configuration of neutron and gamma shielding features.

While most of the shielding in the transport package is contained in the body of the cask and specifically in the Gamma Capture Space (GCS) and the Neutron Capture Space (NCS) described in Section 1.1, a certain amount of shielding is also provided by the Fuel Basket, the Basket Shims, and the Enclosure Vessel. The arrangement of the shielding materials shown in the licensing drawings reflects the shielding optimization carried out for the HI-STAR 190 cask.

During transport, the impact limiters provide additional gamma shielding (steel) at the ends of the cask and help prevent loss of shielding as a result of normal and accident conditions of transport by encapsulation of the containment top forging and the bottom forging regions. Note that for normal conditions of transport, the impact limiters are not credited for shielding, except for the stand-off distance they provide from the cask body.

Critical Characteristics of the Holtite Neutron Shielding Material used in the safety analyses are provided in Table 1.5.3.

1.2.1.6 Criticality Control Features

Criticality control in the HI-STAR 190 Packaging is provided by the coplanar grid work of the Fuel Basket honeycomb, made entirely of the Metamic™-HT extruded borated metal matrix composite plates. Thus the entire body of the Fuel Basket, made exclusively from Metamic-HT, serves as the neutron absorber in the HI-STAR 190 Packaging. Therefore, unlike baskets made of steel, the neutron absorber is not attached to the cell walls by mechanical means that may be vulnerable to detachment. Hence, the locational fixity of the neutron absorber is guaranteed.

[

PROPRIETARY INFORMATION WITHHELD PER 10 CFR 2.390

]

Metamic-HT was first certified by the USNRC in 2009 for use in the HI-STAR 180 transport application under Docket No. 71-9325 as the sole constituent material for the fuel basket types F-37 and F-32 for transporting high burn up and MOX fuel. Subsequently, MPC-68M, a Metamic-HT equipped fuel basket for BWR fuel was certified in the HI-STORM 100, Docket No. 72-1014. All fuel baskets presently used in HI-STORM FW (Docket No. 72-1032), HI-STORM UMAX (Docket No. 72-1040) and HI-STAR 180D (Docket No. 71-9367) utilize Metamic-HT for neutron absorbing and structural functions.

Additionally, for transporting PWR fuel, burnup credit is applied as an additional criticality control feature, following the guidance in ISG-8 Rev. 3 [1.2.12]. Since the Metamic basket material contains the B-10 neutron absorber at a significant higher level than steel based baskets, the burnup requirements for PWR fuel are comparatively low.

Finally, there are no moderators in the HI-STAR 190 Packaging.

1.2.1.7 Lifting and Tie-Down Devices

Lifting trunnions are attached via the trunnion support structure to the neutron shield ribs for lifting and also for rotating the cask body between vertical and horizontal positions. Two lifting trunnions are located 180° apart in the sides of the top flange. Two additional trunnions are attached near the bottom extremity of the cask and located 180° apart.

The pair of top lifting trunnions is conservatively qualified to independently lift the cask in compliance with ANSI N14.6 increased stress margins as specified in Section 8.1. The cask trunnions are not qualified to be used to lift the package (loaded cask with impact limiters) and must therefore be rendered inoperable according to 10CFR71.45(a) during routine conditions of transport. The cask trunnions are also designed to collapse in the event of a drop accident to a completely flush position. Upending and down-ending are typically performed with the cask pivoting on an ancillary tilting device specifically designed for this purpose.

Figure 1.2.4 provides a conceptual illustration of a typical transport configuration. The support saddles provide attachment points for belly slings/straps around the cask body to prevent excessive vertical or lateral movement of the cask during normal transportation. The impact limiters affixed to both ends of the cask are designed to transmit the design basis axial transport loads into the longitudinal stops.

1.2.1.8 Heat Transfer Features

The HI-STAR 190 Package can safely transport SNF by maintaining the fuel cladding temperature below the limits for normal and accident conditions consistent with the guidance in the NRC Interim Staff Guidance, ISG-11 Rev. 3 [1.2.6]. The temperature of the fuel cladding is dependent on the decay heat and the heat dissipation capabilities of the cask. The SNF decay heat is passively dissipated without any mechanical or forced cooling. The primary heat transfer mechanisms in the HI-STAR 190 Package are conduction and thermal radiation.

The free volume in the MPC enclosure vessel (Inner Containment) is filled with high purity helium (see Chapter 7 of this SAR) during fuel loading operations. The free volume between the MPC and the cask is also filled with high purity helium before the transport shipment. Besides providing an inert dry atmosphere for the fuel cladding, the helium gas also provides conductive heat transfer between each assembly and the surrounding basket walls and across any gaps between any metal surfaces inside the containment systems. Metal conduction transfers the heat throughout the fuel basket, through the containment system boundaries, and finally through the Gamma Capture Space and the Neutron Capture Space to the external surface of the package. The data on helium backfilling requirements is provided in Table 7.1.2.

Distinguishing features of the HI-STAR 190 package that enables it to dissipate heat efficiently are:

- A high conductivity basket material (Metamic-HT) and coplanar honeycomb basket design which facilitates an efficient transmission of heat along the fuel basket's walls.
- Use of aluminum alloy shims inside the MPC to provide a near conformal contact between the periphery walls of the basket and the inner surface of the canister.

1.2.1.9 Internal Support Features

Internal supports within the cask cavity are required to mitigate the inertia loads (decelerations) produced under the postulated "free drop" scenarios.

In the axial direction, the space between the Fuel Package (MPC) and the Cask Closure Lid is minimized consistent with the need to provide for differential thermal expansion between the contents and the cask cavity. The smallest nominal axial gap in the cask cavity is sized such that there is no risk of constraint of thermal expansion of the MPC under all credible conditions of transport. However, an excessive axial gap is undesirable as it would increase the deceleration experienced by the fuel and MPC under certain vertical drop (10 CFR 71.73) scenarios. Therefore, one or more MPC Spacers may be used to limit the deceleration sustained by the MPC under the most adverse "Free Drop" scenarios, and to ensure the Center of Gravity of the package is within the bounding value shown in Section 2.1.

1.2.1.10 Packaging Markings

Each HI-STAR 190 Packaging shall have a unique identification plate with appropriate markings per 10 CFR 71.85(c). The identification plate shall not be installed until each HI-STAR 190 Packaging component has completed the fabrication acceptance test program and been accepted by authorized Holtec International personnel.

1.2.1.11 Package Post-Accident Performance

In this SAR, the HI-STAR 190 design is demonstrated to have predicted responses to accident conditions that are clearly acceptable with respect to certification requirements for post-accident

containment system integrity, maintenance of subcriticality margin, dose rates, and adequate heat rejection capability. At the first level, the integrity of the MPC enclosure vessel prevents release of radioactive material or helium from the MPC and ingress of moderator. The integrity of the MPC enclosure vessel as the inner containment and pressure boundary is demonstrated in Chapter 4, although the MPC is only credited as a containment boundary for the transport of high burnup fuel. Therefore, these results constitute an acceptable basis for certification of the HI-STAR 190 for the safe transport of spent nuclear fuel. Additionally, the outer containment boundary of the cask is shown to meet the requirements for a post-accident performance. Even with a postulated failure of the MPC, the performance of the HI-STAR 190 System is acceptable for the transport of undamaged and damaged fuel assemblies, showing the defense-in-depth methodology incorporated into HI-STAR 190.

1.2.2 Contents of Package

The HI-STAR 190 Package is classified as a Category I Type B package since the maximum activity of the contents to be transported in the HI-STAR 190 Package is above limits shown in Table 1 of Regulatory Guide 7.11 [1.2.2]. The radioactive and fissile material is in the form of solid fuel pellets meeting the description in Appendix 7.C. There are no moderating material or neutron absorbers in the contents, nor any other material that would create a chemical, galvanic or other reaction leading to the release of combustible gases.

As already stated and discussed in Section 1.0, the HI-STAR 190 is qualified to transport MPCs that were loaded under the CoC for the HI-STORM FW or HI-STORM UMAX and certified to comply with all Tech Spec requirements for that storage system. The approved content (fuel assemblies) of the HI-STAR 190 is therefore a subset of that described in the CoC and TS of the HI-STORM FW and HI-STORM UMAX in terms of the dimensions and physical description. However, some of the performance parameters of those fuel assemblies, which include the limits on heat load, burnup and cooling times, are different and more restrictive than those from the HI-STORM FW or HI-STORM UMAX dockets.

Chapter 7 contains the allowable contents for the HI-STAR 190, including heat load, burnup and cooling time restrictions of the fuel assemblies. The information is placed in Chapter 7, rather than Chapter 1, to facilitate an easier reference of this information by the CoC without duplication of that information.

1.2.3 Special Requirements for Plutonium

The contents of package provided in Section 1.2.2 and to be transported in the HI-STAR 190 Package contain plutonium in solid form and in varying quantities.

1.2.4 Operational Features

The HI-STAR 190 Packaging has been developed to facilitate loading and unloading of fuel with ALARA protection against handling accidents and a minimum number of handling evolutions (i.e., simplicity of handling). There are no complex operational steps that may encumber the crew with excessive dose. Similar to the HI-STAR 180 cask, the HI-STAR 190 cask closure lid

is equipped with a penetration (port) for drying and inertizing the cask's content. The port configuration on the closure lid is configured to minimize radiation streaming as indicated in the drawing package in Section 1.3. The closure lid port shown in the drawing package in Section 1.3 is typical of ports equipped with port plugs. Port caps, in lieu of plugs, are equally effective and may be used. A loaded and sealed HI-STAR 190 Packaging in accordance with the guidance in Chapter 7 is a completely passive system. The abbreviated narrative below on typical loading operations helps illustrate the overall simplicity of the loading process. Chapter 7 provides the essential elements of cask operations.

Typical Loading Operations

Transporting a loaded and sealed MPC is a straightforward operation because the canister is already in inertized and ready-to-ship state. However, it is necessary to ensure that the MPC is transport-worthy prior to its loading. For this purpose, it is necessary to demonstrate that the entire set of acceptance criteria and supplemental requirements set down in Chapter 8 have been met.

The process to load the MPC in HI-STAR 190 consists of the following major steps:

- a. Verify the MPC meets the acceptance criteria and supplemental requirements in Chapter 8
- b. Transfer the MPC to the HI-TRAC transfer cask with the aid of the Mating Device (following the procedure in the HI-STORM FW FSAR).
- c. Stack the transfer cask atop HI-STAR 190 with the 190 Mating Device interposed between them and lower the MPC into HI-STAR 190
- d. Remove the transfer cask and the Mating Device. Install the Cask Closure Lid.
- e. If HBF is transported, perform the MPC pre-shipment leakage rate test to confirm the integrity of the MPC containment boundary.
- f. Evacuate the cask cavity and fill the cask cavity space with helium.
- g. Close the closure lid port plug and install closure lid cover plate.
- h. Perform the necessary leakage tests on the cask containment seals

The cask is next secured on the transport vehicle with impact limiters attached, a security seal (tamper device) is attached, and the personnel barrier is installed (if required). The HI-STAR 190 Package is then ready for transport.

Figure 1.2.5 provides a visual essay of the above sequence of operations.

The inspections and tests (acceptance criteria and maintenance requirements) required to prepare the package for shipment are specified in Chapter 8 in this SAR.

Typical Unloading Operations

The sequence of unloading the HI-STAR 190 is essentially the reverse of the loading operation, including only those operations that are necessary to remove the MPC from the HI-STAR 190. Any further operations, such as unloading fuel assemblies from the MPC if that is required, and

consideration of HBF condition during unloading need to be performed under the jurisdiction of the location where the cask is unloaded, and is not part of this SAR.

Table 1.2.1

CONSTITUENT PARTS OF THE HI-STAR 190 CASK

Item No.	Part name	Principal Function	Comments
1	Containment shell	Containment of radionuclides, pressure retention	Items 1, 2, 3 and 4 comprise the cask's containment system; all parts must meet ASME Section III Subsection NB in all respects.
2	Cask Bottom Region (CBR)	Containment of radionuclides, pressure retention and radiation blockage; Mounting surface for the bottom impact limiter	No thru-thickness penetrations; Only structural containment welded joint is with the Containment shell which is butt welded and volumetrically examined to meet the ASME code.
3	Cask Top Region (CTR)	Containment of radionuclides, seating surface for the Closure Lid system and mounting surface for the top Impact Limiter	No thru-thickness penetrations; Only structural containment welded joint is with the Containment shell which is butt welded and volumetrically examined to meet the ASME code.
4	Closure Lid System (CLS)	Defines the top region of the Containment Boundary. Serves to provide access to the Fuel Package.	Must meet Section III Subsection NB of the ASME Code and must be sufficiently robust to withstand loadings under accident conditions of transport.
5	Gamma Capture Space (GCS)	Blockage of gamma radiation, rendered by the mass of lead installed to preclude macro-voids and large spatial discontinuities.	Defined by the external surface of the Containment Shell on the inside and the Intermediate Shell (IS) on the outside. The annular space is reinforced by radial steel ribs and filled with lead.
6	Neutron Capture Space (NCS)	Attenuation of neutrons, rendered by Holtite-B	Defined by the annular space bounded by the Intermediate Shell (IS) on the inside and the enclosure shell on the outside. Radial connectors serve to buttress the IS and the enclosure shell. Annular space filled with Holtite-B. Over-pressure protection provided to prevent pressure build up during a fire accident.

Table 1.2.2 PROPRIETARY INFORMATION WITHHELD PER 10 CFR 2.390

HI-STAR 190 SAR Report HI-2146214	1.2-15	Revision 1
--------------------------------------	--------	------------

Table 1.2.3: PROPRIETARY INFORMATION WITHHELD PER 10 CFR 2.390

HI-STAR 190 SAR Report HI-2146214	1.2-16	Revision 1
--------------------------------------	--------	------------

Table 1.2.4 PROPRIETARY INFORMATION WITHHELD PER 10 CFR 2.390

HI-STAR 190 SAR
Report HI-2146214

1.2-17

Revision 1

Table 1.2.5: Typical Axial Burnup Profile		
NORMALIZED DISTRIBUTION BASED ON BURNUP PROFILE		
PWR DISTRIBUTION¹		
Interval	Axial Distance From Bottom of Active Fuel (% of Active Fuel Length)	Normalized Distribution
1	0% to 4-1/6%	0.5485
2	4-1/6% to 8-1/3%	0.8477
3	8-1/3% to 16-2/3%	1.0770
4	16-2/3% to 33-1/3%	1.1050
5	33-1/3% to 50%	1.0980
6	50% to 66-2/3%	1.0790
7	66-2/3% to 83-1/3%	1.0501
8	83-1/3% to 91-2/3%	0.9604
9	91-2/3% to 95-5/6%	0.7338
10	95-5/6% to 100%	0.4670
BWR DISTRIBUTION²		
Interval	Axial Distance From Bottom of Active Fuel (% of Active Fuel Length)	Normalized Distribution
1	0% to 4-1/6%	0.2200
2	4-1/6% to 8-1/3%	0.7600
3	8-1/3% to 16-2/3%	1.0350
4	16-2/3% to 33-1/3%	1.1675
5	33-1/3% to 50%	1.1950
6	50% to 66-2/3%	1.1625
7	66-2/3% to 83-1/3%	1.0725
8	83-1/3% to 91-2/3%	0.8650
9	91-2/3% to 95-5/6%	0.6200
10	95-5/6% to 100%	0.2200

¹ Reference 2.1.7

² Reference 2.1.8

Figure 1.2.1: PROPRIETARY INFORMATION WITHHELD PER 10 CFR 2.390

Figure 1.2.2: PROPRIETARY INFORMATION WITHHELD PER 10 CFR 2.390

Figure 1.2.3: PROPRIETARY INFORMATION WITHHELD PER 10 CFR 2.390

Figure 1.2.4: PROPRIETARY INFORMATION WITHHELD PER 10 CFR 2.390

Figure 1.2.5: (5 Sheets) PROPRIETARY INFORMATION WITHHELD PER 10 CFR 2.390

1.3 ENGINEERING DRAWINGS

This section contains a HI-STAR 190 Drawing Package prepared under Holtec's QA Program. This drawing package contains the details of the safety features considered in the analysis documented in this SAR. In particular, this drawing package includes:

- A list of materials and parts, including their safety significance status.
- All dimensions that define the package's *Critical Characteristics*.
- All interface dimensions to ensure fit-up between mating parts.
- Requisite information on *safety significant* parts such as the containment boundary parts as well as processes such as welding, non-destructive examinations, including appropriate weld symbols and NDE acceptance criteria.
- Details on configuration of gasket joints germane to their sealing function.
- Identification of the Containment System Boundary.
- Design details on the impact limiters.

The manufacturing of the HI-STAR 190 components is required to be in strict compliance with the Drawing Package in this section.

Figure 1.2.4 provides an illustration of the assembled HI-STAR 190 Package for transport. The last image in Figure 1.2.5 provides an illustration of the HI-STAR 190 Package on a railcar with personnel barrier, support saddles and other typical components.

PROPRIETARY DRAWINGS WITHHELD PER 10 CFR 2.390

1.4 SUMMARY OF COMPLIANCE WITH 10CFR71 REQUIREMENTS

The safety analyses which demonstrate that the HI-STAR 190 Package complies with the requirements of Subparts E and F of 10CFR71 are provided in this SAR. HI-STAR 190 complies with all of the requirements of 10CFR71 for a Type B(U) F-96 package. In particular, the prescribed maximum normal operating pressure (MNOP) of 700 kPa (100 lb/in²) for a type B(U) package is observed. The HI-STAR 190 containment boundary (10CFR71.43(e) and 10CFR71.43(h)) contains no pressure relief device, rupture disc, or any other means of unplanned (involuntary) communication with the external environment. Therefore, accidental venting of the containment space during transport is not possible. Indeed, there is no design feature that may permit release of radioactive material from HI-STAR 190 under the tests specified in 10CFR71.73. Analyses that demonstrate the compliance of the HI-STAR 190 Package with the requirements of Subparts E and F of 10CFR71 are provided in this SAR¹.

The criticality safety index (CSI) for the HI-STAR 190 Package is 0.0, as an unlimited number of packages will remain subcritical under the provisions of 10CFR71.59(a). The transport index (TI) is in excess of 10 for the HI-STAR 190 Packaging with design basis fuel contents (Section 5.0 provides the determination of the TI). Therefore, the HI-STAR 190 Package must be transported by exclusive use shipment (10CFR71.47). An empty but previously loaded HI-STAR 190 Package may be shipped as an excepted package provided the descriptions and limits for surface contaminated objects (SCO) material set forth in 10CFR71.4 are satisfied.

The HI-STAR 190 Package complies with the general standards for all packages – 10CFR71.43 – as demonstrated in Chapter 2. Under the tests specified in 10CFR71.71 (normal conditions of transport) the HI-STAR 190 Package is demonstrated to sustain no impairment of its safety function capability, enabling the HI-STAR 190 Package to meet the requirements of 10CFR71, Paragraphs 71.45, 71.51, and 71.55 (see discussion on high burnup fuel in sub-section 1.2.1.3). Under the tests specified in 10CFR71.73 (hypothetical accident conditions) and 10CFR71.61 (special requirement for irradiated nuclear fuel shipments), the damage sustained by the HI-STAR 190 Package is shown to be within the permissible limits set forth in 10CFR71, Paragraphs 71.51, and 71.55 (see discussion on high burnup fuel in Paragraph 1.2.1.3).

The HI-STAR 190 Package meets the structural, thermal, containment, shielding and criticality requirements of 10CFR71, as described in Chapters 2 through 6. The package operations and acceptance tests and maintenance program provided in Chapters 7 and 8 ensure compliance of the package with the requirements of 10CFR71.

The following is a summary of the information provided in Chapter 1, which in conjunction with the information provided in Chapters 2, 7, and 8 is directly applicable to verifying HI-STAR 190's compliance with 10CFR71:

- The HI-STAR 190 Packaging description including the drawing package provided in Section 1.3 provides an adequate basis for evaluation of the HI-STAR 190 Packaging against the 10CFR71 requirements for each technical criterion. Each drawing is

identified, consistent with the text of the SAR, and contains appropriate annotations to explain and clarify information on the drawing.

- The NRC-approved Holtec International quality assurance program for the HI-STAR 190 packaging has been identified. (see also Section 1.6)
- The applicable codes and standards for the HI-STAR 190 Packaging design, fabrication, assembly, and testing have been identified in the drawing package in Section 1.3 and in Chapter 2.
- Allowable contents in the HI-STAR 190 Packaging are specified in Section 1.2 (referencing Chapter 7).

1.5 LOCATION OF PROPERTIES OF SPECIAL PURPOSE MATERIALS

Requirements for special purpose materials and parts (essentially non-code materials) utilized in the HI-STAR 190 Package such as Holtite, containment seals, impact limiter crush materials, etc., are provided in their proper context in this SAR and are thus scattered across this document. To ensure that the applicable properties of such materials used in the safety analyses are correctly extracted in the Purchasing Specification for each special purpose material, Table 1.5.1 provides the location where the required information can be found in this SAR.

Table 1.5.1: Location of Properties of Special Purpose Materials in This SAR

Item No.	Material	Location
1	Holtite-B [1.2.10]	Table 1.5.3 Table 8.1.9
2	Metamic –HT [1.2.3]	Table 1.5.2 Table 8.1.3 Table 8.1.4A Table 8.1.10A
3	Containment Seals	Table 2.2.10 Table 2.2.11
4	AL-STAR Impact Limiter Crush Material	Table 2.2.8 Table 3.2.1 Table 3.2.2 Table 3.2.7
5	Alternate Coatings for Cask Liner	Table 8.1.12
6	Extruded Basket Shims and Solid Shims	Table 8.1.10B

Table 1.5.2: PROPRIETARY INFORMATION WITHHELD PER 10 CFR 2.390

HI-STAR 190 SAR Report HI-2146214	1.5-3	Revision 1
--------------------------------------	-------	------------

Table 1.5.3: Critical Characteristics of Holtite-B

Property (Note 1)	Property Value
Bulk Density, g/cm ³	See Table 8.1.9
Hydrogen Density, g/cm ³	See Table 8.1.9
Boron Carbide Content, wt%	See Table 8.1.9
Design Temperature, °C (°F)	204 (400)

Note 1: Properties with characteristics needed for shielding are defined in Table 8.1.9

1.6 QUALITY ASSURANCE AND DESIGN CONTROL

1.6.1 Quality Assurance Program:

The HI-STAR 190 Package design, material acquisition, fabrication, assembly, and testing shall be performed in accordance with Holtec International's QA program. Holtec International's QA program was originally developed to meet NRC requirements delineated in 10CFR50, Appendix B, and was expanded in the early 90s to include provisions of 10CFR71, Subpart H, and 10CFR72, Subpart G, for structures, systems, and components (SSCs) designated as *important-to-safety*. NRC approval of Holtec International's QA program is documented by the Quality Assurance Program Approval for Radioactive Material Packages (NRC Form 311), Approval Number 0784, Docket No. 71-0784.

1.6.2 Package Design Control:

The design information presented in this SAR is subject to validation, safety compliance, and configuration control in accordance with Holtec's NRC-approved quality assurance (QA) program which comports with the provisions of 10CFR71.107. Chapters 7 and 8 and the licensing drawing package collectively contain conditions to the CoC, and as such, they can be modified only through an NRC licensing action. The other chapters contain substantiating information to support the safety case and can be amended subject to the stipulations of 71.107(c).

1.7 REFERENCES

The following generic industry and Holtec produced references may have been consulted in the preparation of this document. Where specifically cited, the identifier is listed in the SAR text or table. Active Holtec Calculation Packages which are the repository of all relevant licensing and design basis calculations are annotated as “latest revision”. Submittal of the latest revision of such Calculation Packages to the USNRC and other regulatory authorities during the course of regulatory reviews is managed under the company’s Configuration Control system.

- [1.0.1] Regulatory Guide 7.9, "Standard Format and Content of Part 71 Applications for Approval of Packaging for Radioactive Material", Revision 2, USNRC, March 2005.
- [1.0.2] 10CFR Part 71, "Packaging and Transportation of Radioactive Materials", Title 10 of the Code of Federal Regulations, Office of the Federal Register, Washington, D.C.
- [1.0.3] 49CFR Part 173, "Shippers - General Requirements For Shipments and Packagings", Title 49 of the Code of Federal Regulations, Office of the Federal Register, Washington, D.C.
- [1.0.4] “Safety Analysis Report for the HI-STAR 180 Package”, Holtec Report HI-2073681, latest revision, Docket No. 71-9325 (USNRC).
- [1.0.5] “Safety Analysis Report for the HI-STAR 100 Package”, Holtec Report HI-951251, latest revision, Docket No. 71-9261 (USNRC).
- [1.0.6] “HI-STORM 100 Final Safety Analysis Report”, Holtec Report HI-2002444, latest revision, Docket No. 72-1014.
- [1.0.7] “Safety Analysis Report for the HI-STAR 60 Package”, Holtec Report HI-951251, latest revision, Docket No. 71-9336 (USNRC).
- [1.0.8] “Final Safety Analysis Report on the HI-STORM FW System”, Holtec Report HI-2114830. Latest revision, Docket No. 72-1032 (USNRC).
- [1.0.9] “Safety Analysis Report on HI-STAR 180D transport package, Holtec Report HI-2125175. Latest revision, Docket # 71-9367 (USNRC)
- [1.2.1] American Society of Mechanical Engineers, "Boiler and Pressure Vessel Code", Section III, Div. 1, Subsection NB 2007 Edition, 2008 Addenda.

- [1.2.2] Regulatory Guide 7.11, "Fracture Toughness Criteria of Base Material for Ferritic Steel Shipping Cask Containment Vessels with a Maximum Wall Thickness of 4 Inches (0.1m)", U.S. Nuclear Regulatory Commission, Washington, D.C., June 1991.
- [1.2.3] "Metamic-HT Qualification Sourcebook," Holtec Report N. HI-2084122, Latest Revision, (Holtec Proprietary).
- [1.2.4] NUREG-0612, "Control of Heavy Loads at Nuclear Power Plants", U.S. Nuclear Regulatory Commission, Washington, D.C., July 1980.
- [1.2.5] ANSI N14.6-1993, "Special Lifting Devices for Shipping Containers Weighing 10,000 Pounds (4500 Kg) or More", June 1993.
- [1.2.6] Interim Staff Guidance ISG-11, Rev. 3, USNRC, November, 2003.
- [1.2.7] American National Standards Institute, Institute for Nuclear Materials Management, "American National Standard for Radioactive Materials Leakage Tests on Packages for Shipment", ANSI N14.5, 1997.
- [1.2.8] Interim Staff Guidance ISG-19, Rev. 0, USNRC, May, 2003.
- [1.2.9] ASME Boiler & Pressure Vessel Code, Section II, Part A, SA-352-LCC American Society of Mechanical Engineers, 2007 Edition, 2008 Addenda.
- [1.2.10] "Holtite-B Sourcebook", Holtec Report HI-2167314, Latest Revision. (Holtec Proprietary)
- [1.2.11] NUREG-1617, Standard Review Plan for Transportation Packages for Spent Nuclear Fuel, 2000.
- [1.2.12] Interim Staff Guidance (ISG)-8, Revision 3, USNRC, September 2012.
- [1.2.13] NRC Draft Regulatory Issue Summary (RIS) 2015-XX, "Consideration in Licensing High Burnup Spent Fuel in Dry Storage and Transportation", ADAMS Accession No. ML14175A203.
- [1.A.1] "On-Site Storage, Transport, Consolidated Interim Storage, and Disposal of Used Nuclear Fuel", K.P. Singh, Continuing and Changing Priorities of ASME B&PV Codes, Chapter 13, Ed. K.R. Rao, 2014.
- [1.A.2] "NRC Draft Regulatory Issue Summary 2015-XX Consideration in Licensing High Burnup Spent Fuel in Dry Storage and Transportation," US NRC, Docket ID NRC-2015-0047.

APPENDIX 1.A: PROPRIETARY APPENDIX WITHHELD PER 10 CFR 2.390

CHAPTER 2: STRUCTURAL EVALUATION

2.0 INTRODUCTION

This chapter presents a synopsis of the Design Criteria relevant to the mechanical and structural characteristics of the HI-STAR 190 Package that ensure compliance with the performance requirements of 10CFR71. It also summarizes all structural evaluations and analyses of the package pursuant to the provisions of 10CFR§71.61, 10CFR§71.71, and 10CFR§71.73.

In particular, the objectives of this chapter are twofold:

- a. To demonstrate that the structural performance of the HI-STAR 190 Package has been adequately evaluated for the normal conditions of transport and for the hypothetical accident conditions set forth in 10CFR§71.61, 10CFR§71.71, and 10CFR§71.73.
- b. To demonstrate that the HI-STAR 190 Package design has adequate structural integrity to meet the regulatory requirements of 10CFR§71.61, 10CFR§71.71, and 10CFR§71.73.

Among the topical areas addressed in this chapter are:

- i. Structural characterization of the cask and its enclosed MPC.
- ii. Identification of the materials used in the package and their *critical characteristics*.
- iii. Identification of the loads applied on the package during handling, normal conditions of transport and accident conditions. Definition of miscellaneous bounding conditions for design such as a fire and immersion in water.
- iv. Derivation of acceptance criteria for the package's performance under the aforementioned various conditions of service from the ASME B&PV Codes and other reference standards.
- v. Analyses of the package using appropriate methodologies to establish the margins of safety under each condition of service. In addition to the typical evaluations for normal and accident conditions, these analyses include:
 - Evaluation of the physical integrity of the spent fuel under the postulated impactive loading events.
 - A demonstration of the adequacy of the minimum acceptable Charpy impact values specified for the parts subject to potential impact loadings. This is based on a methodology that determines the fracture strength of a material using the Charpy impact strength data.

Appendix 2.A provides introductory information on the principal codes used in the structural analysis (ANSYS and LS-DYNA). Appendix 2.B of HI-STAR 180 SAR [1.0.4] provides a comprehensive summary of the three-stage benchmarking effort by Holtec International to establish the veracity of the LS-DYNA solution for predicting the peak deceleration of the package and crush performance of the AL-STAR impact limiters using aluminum honeycomb as the impact energy absorber. A discussion of the finite element discretization level to ensure that

the solutions are fully converged is also provided. Note that aluminum honeycomb is also used as the impact energy absorbing material for the HI-STAR 190 impact limiter.

Throughout this chapter, to facilitate regulatory review, the assumptions and conservatism inherent in the analyses are identified along with a complete description of the analytical methods, models, and acceptance criteria. A summary of other considerations germane to satisfactory structural performance, such as protection against fatigue, corrosion, creep and brittle fracture, is also provided.

Consistency with the recently approved methods of safety analysis is a key cornerstone of the work performed for HI-STAR 190. Accordingly, the analysis methods, models and acceptance criteria utilized in the safety evaluation documented in this chapter are consistent with those used in the recent transport SARs such as HI-STAR 180 certified in Docket #71-9325.

Technical descriptions and structural safety analyses pertaining to the components common to the HI-STAR 190 and the HI-STORM FW systems are referenced to the HI-STORM FW FSAR [2.1.13]. To facilitate convenient access to the referenced material, the latest edition of the HI-STORM FW FSAR [2.1.13] has been placed in this docket and a list of HI-STORM FW FSAR sections germane to this chapter is provided in a tabular form below.

TABLE 2.0.1 HI-STORM FW FSAR MATERIAL ADOPTED IN THIS SAR BY REFERENCE			
Location in HI-STAR 190 SAR	Subject of the Reference	Location in Reference Document (HI-STORM FW FSAR, Revision 4, Ref 2.1.13)	Technical Justification of Applicability to HI-STAR 190
Subsection 2.1.2.1, Table 2.1.1 and Table 3.2.10	MPC Design Pressure and Temperature values	Table 2.2.1 Table 2.2.3	MPC 37 and MPC 89 enclosure vessels are common components of the HI-STAR 190 transport cask and the HI-STORM FW storage cask and have a design internal pressure of 100 psig. The MPC design temperatures listed in Table 2.2.3 of the HI-STORM FW FSAR are also identical to those in Table 3.2.10 of the HI-STAR 190 SAR.
Subsection 2.6.1.3.5	Re-flood event	Subsection 3.4.4.1.11	See Subsection 2.6.1.3.5 of the HI-STAR 190 SAR
Subsection 2.6.1.4.2	MPC structural qualification under the design internal pressure (Load Combination N1)	Subsection 3.4.4.1.5	See Subsection 2.6.1.4.2 of the HI-STAR 190 SAR
Subsection 2.7.4.3	MPC structural qualification under the maximum internal pressure (with a minimum safety factor)	Subsection 3.4.4.1.6	See Subsection 2.7.4.3 of the HI-STAR 190 SAR
Subsection 2.5.4	MPC Lifting	Subsection 3.4.3.2	See Subsection 2.5.4 of the HI-STAR 190 SAR

2.1 STRUCTURAL DESIGN

2.1.1 Discussion

This subsection presents the essential characteristics of the principal structural members and systems that are important to the safe operation of the HI-STAR 190 Package. These members are the containment system components (together with those parts that render the radiation shielding function in the cask), the structural components that constitute the *Fuel Package* (the Multi-purpose canister) and the surrounding support, and the impact limiters needed to protect the cask in the event of a hypothetical accident event (§71.73).

2.1.1.1 Cask

The structural functions of the cask in the transport mode are:

- To house an MPC containing a high integrity fuel basket.
- To serve as a penetration and puncture barrier to protect the contained fuel.
- To provide a high-integrity containment system.
- To provide a structurally robust enclosure shielding of the radiation emitted by the fuel.

The HI-STAR 190 cask consists of three discrete regions; namely:

1. the containment space
2. the gamma blockage space
3. the neutron blockage space

The containment space (or space within the containment boundary as identified in the drawing package in Section 1.3 and described in Sections 1.2 and 4.1) is the heart of the package. It must ensure a leak-tight enclosure for its contents under all normal and accident conditions of transport. Accordingly, it is designed to meet the most rigorous industry requirements, to the extent germane to its function, of Section III, Subsection NB of the ASME Boiler & Pressure Vessel Code [2.1.1]. Section 1.5.2.6 of NUREG-1617 [2.1.11] states the following:

“ASME has published Section III, Division 3, ASME Boiler and Pressure Vessel (B&PV Division 3) Code for the design and construction of the containment system of SNF transport packagings. NRC staff expects full compliance with the B&PV Division 3 Code for the containment system, including the services of an Authorized Inspection Agency. However, the SAR may justify alternatives as appropriate.”

In this SAR, ASME Section III, Division 1, Subsection NB is used for the design and construction of the HI-STAR 190 containment system, in lieu of the Division 3 Code, since Subsection NB has an established history of use and NRC approval for similar cask designs (e.g., HI-STAR 100, HI-STAR 60, HI-STAR 180, HI-STAR 180D etc.).

The gap between the MPC lid and the Cask lid is minimized to the extent practicable with due recognition of the increase in the length of fuel assembly due to irradiation and thermal expansion such that there is no risk of restraint of free end expansion of the fuel under any transport condition.

The gamma and neutron capture spaces consist primarily of lead, steel and Holtite. To perform their function, these dose blocker parts must not undergo body extensive damage resulting in an appreciable loss of their shielding capacity under normal and accident conditions of transport.

2.1.1.2 Multi-purpose Canister (MPC)

As stated in Chapters 1 and 4, the MPC’s Enclosure Vessel is designated as the inner Containment Boundary which requires that it be qualified to demonstrate compliance with the same “NB” stress limits as the outer Containment Boundary provided by the overpack under all postulated service and accident conditions.

The structural function of the fuel basket and fuel basket support (basket shims) contained in the MPC (see drawing package in Section 1.3) in the transport mode is to maintain the position of the fuel in a sub-critical configuration. In its role as the guarantor of subcriticality, the fuel basket must exhibit global physical integrity (i.e., no potential for large plastic deformation or structural failure in the active fuel region) under the most structurally demanding conditions of transport (see 2.1.2.2 (ii) for acceptance criterion).

2.1.1.3 Impact Limiters

The impact limiters used in the HI-STAR family of transport casks utilize suitably shaped blocks of a crushable material arrayed around a stiff cylindrical core in such a manner that the cask is protected from excessive inertia forces under a (hypothetical) uncontrolled drop event *regardless* of the orientation of drop. [

PROPRIETARY INFORMATION WITHHELD PER 10CFR2.390

]

The impact limiter configured on the above design platform is referred to as “AL-STAR” and is used in all models of HI-STAR transport packages, including the first package (HI-STAR 100), and subsequent packages labeled HI-STAR HB, HI-STAR 60, HI-STAR 180, HI-STAR 180D and the current package (HI-STAR 190).

The structural function of the AL-STAR impact limiters (shown in the drawing package in Section 1.3) in the transport mode is to cushion the HI-STAR 190 cask and the contained fuel during normal transport package handling, and during a hypothetical drop accident. The AL-STAR impact limiters and other appurtenances such as the support saddle and the personnel

barrier necessary for the transport package must also meet all applicable regulatory requirements.

In what follows, explicit design criteria for the components of the transport package and essential appurtenances are presented.

2.1.2 Design Criteria

Regulatory Guide 7.6 [2.1.2] provides guidance for design criteria for the structural analysis of shipping cask containment vessels. Loading conditions and load combinations for transport are defined in 10CFR71 [2.1.3] and in Regulatory Guide 7.8 [2.1.4]. Consistent with the provisions of these documents, the central objective of the structural requirements presented in this section is to ensure that the HI-STAR 190 Package possesses sufficient structural capability to meet the demands of both normal (§71.71) and hypothetical accident conditions (§71.73) of transport articulated in the regulatory guidance documents, specifically Reg. Guide 7.6. The following table provides a synoptic matrix to demonstrate the explicit compliance with the seven regulatory positions with respect to the Containment Boundary stated in Regulatory Guide 7.6.

USNRC's Regulatory Position regarding the Containment Boundary for the Transport Package
1. Material properties, design stress intensities, and fatigue curves are obtained from the ASME Code.
2. Under normal conditions of transport, the limits on stress intensity are those limits defined by the ASME Code for primary membrane and for primary membrane plus bending for Level A conditions.
3. Perform fatigue analysis for normal conditions of transport using ASME Code Section III methodology (NB) and appropriate fatigue curves.
4. The stress intensity S_n associated with the range of primary plus secondary stresses under normal conditions should be less than $3S_m$ where S_m is the primary membrane stress intensity from the ASME Code.
5. Buckling of the containment vessel should not occur under normal or accident conditions.
6. Under accident conditions, the values of primary membrane stress intensity should not exceed the lesser of $2.4S_m$ and $0.7S_u$ (ultimate strength), and primary membrane plus bending stress intensity should not exceed the lesser of $3.6S_m$ and S_u .
7. The extreme total stress intensity range should be less than $2S_a$ at 10 cycles as given by the appropriate fatigue curves.

The following design requirements are applicable to the remainder of the transport package:

- The lead and Holtite dose blocker parts are required to remain in place and functional after all Normal and Hypothetical mechanical Accident Conditions of Transport.
- The fuel basket is required to maintain its shape so as to ensure reactivity control after all Normal and Hypothetical Accident Conditions of Transport.
- The fuel basket supports are required to maintain global positioning of the fuel basket after all Normal and Hypothetical Accident Conditions of Transport.
- The impact limiters are required to have an appropriate shape and energy absorption capacity to ensure that impacts, resulting from hypothetical accident events, do not cause any of the

containment and shielding components to fail to meet their specified requirements.

2.1.2.1 Loading and Load Combinations

10CFR71 and Regulatory Guide 7.6 define two conditions that must be considered for qualification of a transport package. These are defined as “Normal Conditions of Transport” and “Hypothetical Accident Conditions”.

The loadings applicable to the HI-STAR 190 package can be broadly divided into five categories, namely:

1. permanent loads
2. design condition loads
3. handling loads
4. normal condition of transport loads (§71.71)
5. hypothetical accident condition loads (§71.73)

1. Permanent Loads

Permanent loads in HI-STAR 190 arise from bolt preload to seat the gasketed joints. The preload applied to the cask lid bolts seats the lid seals and creates a contact pressure on the inside metal-to-metal annulus, referred to as the “land”, to protect the joint from leakage under postulated impact loading events. Bolt preload produces a state of stress in the closure lid, the cask closure flange, and the cask shell region adjacent to the flange.

The stress field in the cask body and the lid from the bolt preload combines with the stresses produced under a specific event such as during the hypothetical accident condition (item #5 above). Thus, the bolt preload induced stress participates in every load combination analyzed for the cask.

The initial preload should be set to maintain a seal under the maximum internal pressure. It is acceptable for the seal to experience instantaneous relaxation under the action of the maximum normal operating internal pressure (MNOP specified in Table 2.1.1) plus the effective pressure calculated as the cask content weight times the maximum rigid body deceleration from the free 9-meter top end drop.

Stresses from weld shrinkage endemic to every welded component also lie in the category of permanent stresses. However, weld shrinkage induced stresses are not computed or included in the load combinations because they are of the secondary genre’ (i.e., they arise to satisfy compatibility, not equilibrium).

2. Design Condition Loads

The ASME Code [2.1.1] requires that a pressure vessel be qualified to a design internal and external (if applicable) pressure. The Design Pressure should be selected to bound all normal operating condition pressures. The applicable Design Temperature, likewise, should be one that bounds the metal temperature of the affected pressure parts under all normal service conditions. For the HI-STAR 190 Package, the Design Internal Pressure and Design Temperatures, set down in Table 2.1.1, accordingly bound all service condition values. Because the HI-STAR 190 Package has two Containment Boundaries, Table 2.1.1 has pressure and temperature data on both the MPC Enclosure Vessel and the overpack pressure boundary.

Stress analysis of the containment system under the Design Pressure is required to demonstrate compliance with “NB” stress limits, as identified in [2.1.1], for the containment system material and to demonstrate the leak tightness of the bolted joints. The Design Temperature is utilized to establish the applicable allowable stress intensity, S_m , for the “pressure part” (a term used in the ASME B&PV Code). The following pressure loading scenarios are identified:

- **Maximum Normal Operating Pressure (MNOP):** The MNOPs for the cask and MPC containment boundaries are given in Table 2.1.1 as the internal pressures under normal conditions of transport and bound the calculated internal pressure values reported in Table 3.1.2. The coincident external pressure of the cask is atmospheric. The MNOP value for MPC in Table 2.1.1 is identical to the value specified in the HI-STORM FW FSAR [2.1.13].
- **Design Internal Pressure:** A design internal pressure is defined in Table 2.1.1 for the containment system of the cask as a pressure vessel. The coincident external pressure of the cask is atmospheric. The design internal pressure for the MPC remains identical to that specified in the HI-STORM FW FSAR [2.1.13].
- **External Pressure under Normal Condition of Transport:** The external pressures for the cask overpack and the MPC are both 0.0 psig in Table 2.1.1. The external pressure of the cask under this condition is atmospheric, and the increased cask external pressure (20 psia) specified in 10CFR§71.71 is bounded by the minimum cask overpack backfill pressure. Moreover, the required MPC and cask overpack backfill pressures ensure that the MPC internal pressure is always greater than the pressure in the overpack cavity.
- **Accident Condition Internal Pressure:** An accident condition internal pressure is defined in Table 2.1.1 for the containment cavity of the cask pressure vessel. The coincident external pressure is atmospheric. The accident condition internal pressure of the MPC in HI-STAR 190 is slightly increased from the value defined in the HI-STORM FW FSAR [2.1.13].
- **Accident Condition External Pressure:** An accident condition external pressure with cavity depressurized is defined in Table 2.1.1 for the cask overpack. This loading, in conjunction with the buckling analysis of the cask containment shell, is intended to

demonstrate that the containment system is in compliance with the requirements of 10CFR§71.61. This loading bounds the external pressure specified by 10CFR§71.73(c) (5) and (6); therefore, it is considered in Section 2.7. The accident condition external pressure of the MPC is conservatively set to be identical to that defined in the HI-STORM FW FSAR [2.1.13].

Table 2.1.1 provides the above values of design basis internal and external pressures. The Design Internal Pressure of the Cask Cavity Space is conservatively set higher than the Cask Cavity Space MNOP.

The most adverse possible internal pressure state occurs under the simultaneous effect of fire and 100% rod rupture. This pressure is bounded by the accident condition internal pressure specified in Table 2.1.1.

The case of deep submergence (§71.61) is enveloped by the accident condition external pressure specified in Table 2.1.1.

3. Handling Loads

The lifting devices for the HI-STAR 190 cask are subject to the specific stress limits set forth by NUREG-0612 [2.1.5], which require that the primary stresses in a lifting device must be less than the smaller of 1/10 of the material ultimate strength and 1/6 of the material yield strength while subject to the lifted load that includes an appropriate dynamic load amplifier. These limits are conservatively applied to the lifting trunnions in the cask body and to the threaded holes in the lid, although they are actually interfacing lifting points per NUREG-0612 [2.1.5] and are only required to maintain a minimum safety factor of 10 based on the material ultimate strength. An associated requirement is an evaluation of the stress intensity state in the cask baseplate when the package is being lifted. Baseplate loads considered are the self-weight of the baseplate plus attached shielding, and the loaded MPC. Under lifting (and handling) condition a 15% load amplifier is applied as discussed in Section 2.5. The component acceptance limits are based on the Level A stress intensity allowables from ASME Code, Section III, Subsection NB.

Section 2.5 documents the lifting analyses applicable to the HI-STAR 190 package.

4. Normal Conditions of Transport Loads (§71.71)

The normal conditions of transport loads that warrant structural evaluation are:

- a. Reduced external pressure 25 kPa (3.5 psia).
- b. Increased external pressure (140 kPa or 20 psi absolute).
- c. Free drop from 0.3-meter (1-foot) height in the most vulnerable orientation onto an essentially unyielding horizontal surface (henceforth called the “1- foot drop event”).
- d. Normal vibratory loads incidental to transport.
- e. Normal operating conditions (pressure and temperature).

External pressure loads ((a) and (b) above) are clearly enveloped by the design external pressure set by a deep submersion of the package (10CFR§71.61). This condition is evaluated in Section 2.7. The normal operating conditions (e) are evaluated to demonstrate that the containment meets the requirements of the ASME Code (as clarified in Subsection 2.1.4) to be designated as a “pressure vessel”. The “1-foot drop event” (c) evaluation is the “Side Drop”. The HI-STAR 190 Package is assumed to drop with its axis parallel with respect to the horizontal surface, such that the collision of the two impact limiters with the target is coincident in time. Vibratory loads transmitted to the HI-STAR 190 Package (d) by the transport vehicle will produce negligibly small stresses in comparison with stresses that will be produced by the loadings described previously. Therefore, vibratory loading is neglected in the analyses performed herein. Fatigue considerations due to mechanical vibrations are further discussed in Section 2.6.

Based on the above considerations, the governing Load Combinations to be considered in Section 2.6, for both Heat and Cold conditions, are:

- Load Combination N1:
Bolt preload plus Design Internal pressure and Normal operating temperature.
- Load Combination N2:
Free drop from 1 foot plus Bolt preload and Maximum Normal Operating Pressure (MNOP).

5. Hypothetical Accident Condition Loads (§71.73)

These loads pertain to hypothetical accident conditions. Specifically, they are:

- a. Free Drop of 9 m (30 ft) (§71.73 (c) (1))
- b. Puncture (§71.73 (c)(3))
- c. Engulfing fire @ 800°C (1475°F) (§71.73 (c)(4))
- d. Immersion in 15 m (50 ft) head of water (§71.73 (c) (6)).

a. Free Drop

The free drop event can be broken down into seven candidate scenarios with potential to cause maximum damage:

- Bottom End Drop: The packaging is assumed to drop vertically with its cask containment baseplate sustaining the impulsive load transmitted by the contents. The weight of the package is included in all drop load cases.
- Top End Drop: This drop condition is the opposite of the preceding case. The cask’s closure lid withstands the impact load transmitted through the impact limiter which is transmitted to the MPC and the Containment Boundary .
- Side Drop: The cask along with its contents drops with its longitudinal axis horizontal.

The contents of the cask bear down on the cask as it decelerates under the resistance offered by the two impact limiters pressing against an essentially unyielding surface.

- Bottom Center-of-Gravity Over-the-Corner Drop: In this drop scenario, the HI-STAR 190 Package is assumed to impact an essentially unyielding surface with its center-of-gravity directly above its initial point of contact in the drop event.
- Top Center-of-Gravity Over-the-Corner Drop: This loading case is identical to the preceding case, except that the package is assumed to be dropping with its top end down and its center-of-gravity is aligned over the initial point of contact.
- Slapdown – Initial Impact at Top End: In this case, the package drops with its axis at a small angle with the horizontal with the top end impacting first. Subsequent to the primary impact, the package begins to rotate with the bottom end impacting the target at a later time (secondary impact). Higher decelerations are experienced during the secondary impact. The governing slapdown angle, θ , is determined by a parametric analysis.
- Slapdown – Initial Impact at Bottom End: This case is the same as above, except for the location of primary and secondary impacts.

b. Puncture

The puncture event is broken down into two limiting scenarios, namely:

- Side Puncture Force Event: This event consists of a 1-m (40-in) free drop (impact limiters are ignored) onto a stationary and vertical mild steel bar of 15 cm (6 in) diameter with its leading edge (top edge) rounded to 6 mm (1/4-in) radius. The bar is assumed to be of such a length as to cause maximum damage to the cask. The package is assumed to be dropping horizontally with the penetrant force being applied at the mid-length of the cask.
- Top End Puncture Force: This event is similar to the preceding case except the penetrant force is assumed to act at the center of the closure lid. Because of the proximity of the bolted joints, this case is considered limiting for an end puncture.

The above loading events may occur under the so-called “hot” (maximum ambient temperature) or “cold” condition at -29°C (-20°F). In the latter thermal state, the effects of brittle fracture must also be evaluated.

Because the HI-STAR 190 Package operates at a relatively low internal pressure, the impact and puncture loadings under service conditions are orders of magnitude greater than pressure loadings. However, for completeness the force/stress results from pressure loads are directly added with the results from the drop and puncture analyses as applicable to maximize the force or stress results on the cask system.

c. Fire

Fire is not a mechanical loading event; its chief consequence is to challenge the integrity of the neutron shielding material. The results are presented in Chapter 3. The results show that the gas pressure inside the containment system remains below the accident pressure limit for the package (see Table 2.1.1). Based on the temperature changes established in Chapter 3, an evaluation is performed to demonstrate that the land compression load at the lid/flange joint does not degrade to an unacceptable value.

d. Immersion

Finally, from the structural standpoint, the 15-m (50-ft) immersion case is clearly bounded by the accident external pressure loading of 2 MPa (290 psi) deemed to satisfy the requirements of 10CFR§71.61. The ability of the package to maintain moderator exclusion pursuant to §71.61 is discussed in Appendix 1.B and in Section 2.7.

Based on the above considerations, the Load Combinations that are considered in Section 2.7, for both Heat and Cold conditions, are:

Hypothetical Accident Load Cases*
9-m free drops
End and Side Puncture
Deep Submergence 2 MPa (290 psi)
Gasket Relaxation from Fire

* Permanent Loads are in-place at the start of every load case.

2.1.2.2 Acceptance Criteria

[

PROPRIETARY INFORMATION WITHHELD PER 10CFR2.390

]

[

PROPRIETARY INFORMATION WITHHELD PER 10CFR2.390

]

[

PROPRIETARY INFORMATION WITHHELD PER 10CFR2.390

]

[

PROPRIETARY INFORMATION WITHHELD PER 10CFR2.390

]

[

PROPRIETARY INFORMATION WITHHELD PER 10CFR2.390

]

[

PROPRIETARY INFORMATION WITHHELD PER 10CFR2.390

]

[

PROPRIETARY INFORMATION WITHHELD PER 10CFR2.390

]

[

PROPRIETARY INFORMATION WITHHELD PER 10CFR2.390

]

2.1.3 Weights and Centers of Gravity

Table 2.1.11 provides the weights of the individual HI-STAR 190 components as well as the total Transport Package weights, and the weight of the heaviest loaded HI-STAR 190 Cask.

Table 2.1.12 provides the location of the center of gravity (CG) for the package relative to the bottom surface of the bottom impact limiter. The CG is assumed to be located on the cask centerline since the non-axisymmetric effects of the cask plus contents are negligible.

2.1.4 Identification of Codes and Standards for Package Design

The design of the HI-STAR 190 Package does not invoke ASME Code Section III in its entirety. Specific Code paragraphs in NB-3000 of Section III, Subsection NB of the ASME Boiler and Pressure Vessel Code (ASME Code) [2.1.1], and Appendix F [2.1.10] that are cited herein are invoked for design of the containment system of the HI-STAR 190 Package.

Table 2.1.13 lists each major structure, system, and component (SSC) of the HI-STAR 190 Packaging, along with its function, and applicable code or standard. The drawing package in Section 1.3 identifies whether items are “Important to Safety” (ITS) or “Not Important to Safety” (NITS); the identification is carried out using the guidance of NUREG/CR-6407, “Classification of Transportation Packaging and Dry Spent Fuel Storage System Components”. Table 8.1.6 lists some alternatives to the ASME Code where appropriate. Table 8.1.5 provides applicable sections of the ASME Code and other documents for Material Procurement, Design, Fabrication, and Inspection, and Testing pursuant to the guidance in NUREG 1617 [2.1.11].

All materials and sub-components that do not constitute the containment system in the HI-STAR 190 cask are procured to ASTM or ASME Specifications, except for the fuel basket (made of Metamic-HT) and the neutron shield identified by the trade name Holtite B described in Chapter 1.

The *critical characteristics* of all materials set down in this SAR establish the minimum requirements that must be met by the material. The applicable *critical characteristics* for each part in the HI-STAR 190 cask are listed in Table 2.1.14 with the required limiting values, as applicable.

Table 2.1.1: [PROPRIETARY INFORMATION WITHHELD PER 10CFR2.390]

Table 2.1.2: Stress Intensity Limits for Different Service Conditions for Section III Class 1 Pressure Vessels (Elastic Analysis per NB-3220)

Stress Category	Level A	Level D
Primary Membrane, P_m	S_m	Lesser of $2.4S_m$ and $0.7S_u$
Local Membrane, P_L	$1.5S_m$	150% of P_m Limit
Membrane plus Primary Bending	$1.5S_m$	150% of P_m Limit
Primary Membrane plus Primary Bending	$1.5S_m$	150% of P_m Limit
Membrane plus Primary Bending plus Secondary	$3S_m$	N/A
Average [†] Primary Shear (Section in pure shear)	$0.6S_m$	$0.42S_u$

Notes:

1. Fatigue analysis (as applicable) also includes peak stress (denoted by “F” in the nomenclature of the ASME Code [2.1.1]).

[†] Governed by NB-3227.2 or F-1331.1(d) of the ASME Code, Section III (NB or Appendix F)

Table 2.1.3: Stress Limits for Lid Closure Bolts (Elastic Analysis per NB-3230)

Stress Category	Level A	Level D
Average Service Stress	$2S_m$	Cannot exceed Yield Strength
Maximum Service Stress (tension + bending but no stress concentrations)	$3S_m$	Joint Remains Leak Tight (see Note 2). Cannot exceed Ultimate Strength

Notes:

1. Stress limits for Level A loading ensure that bolt remains elastic.
2. Limit set on primary tension plus primary bending for Level D loading is based on an elastic stress evaluation; however, the overriding acceptability of the joint design is performance based on an assured absence of leakage.
3. Since the cask closure lid bolt joint is a friction type connection as explained below, the bolts are exempt from shear stress evaluation per ASME Section III, F-1135.2 and NF-3324.6. The closure lid bolt joint is sufficiently preloaded (3.035×10^6 lbf per Table 2.2.10), and the friction force (based on a conservatively assumed static friction coefficient of 0.5) at the lid-to-flange interface can prevent the 13,000 lb lid from sliding as long as the lid's deceleration is less than 117 g's. Per Table 2.7.2 of the SAR, the maximum lid deceleration in all analyzed 30 ft drop events is 89.2 g's. Therefore, the bolt joint is qualified as a friction type connection per ASME Section III, NF-3324.1.

Table 2.1.4: Design, Levels A and B: Stress Intensity – SA-203 E

Code: ASME NB
 Material: SA-203 E
 Item: Stress Intensity

Temperature °C (°F)	Classification and Value, MPa (ksi)					
	S_m	P_m (Note 1)	P_L (Note 1)	$P_L + P_b$ (Note 1)	$P_L + P_b + Q$	P_e (Note 2)
-29 to 38 (-20 to 100)	160.6 (23.3)	160.6 (23.3)	241.3 (35.0)	241.3 (35.0)	481.9 (69.9)	481.9 (69.9)
93,3 (200)	160.6 (23.3)	160.6 (23.3)	241.3 (35.0)	241.3 (35.0)	481.9 (69.9)	481.9 (69.9)
149 (300)	160.6 (23.3)	160.6 (23.3)	241.3 (35.0)	241.3 (35.0)	481.9 (69.9)	481.9 (69.9)
204 (400)	157.9 (22.9)	157.9 (22.9)	237.2 (34.4)	237.2 (34.4)	473.7 (68.7)	473.7 (68.7)
260 (500)	148.9 (21.6)	148.9 (21.6)	223.4 (32.4)	223.4 (32.4)	446.8 (64.8)	446.8 (64.8)

Definitions:

- S_m = Stress intensity values per ASME Code
- P_m = Primary membrane stress intensity
- P_L = Local membrane stress intensity
- P_b = Primary bending stress intensity
- P_e = Expansion stress
- Q = Secondary stress
- $P_L + P_b$ = Either primary or local membrane plus primary bending

Notes:

1. Evaluation required for Design condition only per NB-3220.
2. P_e not applicable to vessels per Fig. NB-3221-1.
3. Values are in accordance with stress intensity limits provided in Table 2.1.2.

Table 2.1.5: Level D Stress Intensity – SA-203 E

Code: ASME NB
 Material: SA-203 E
 Item: Stress Intensity

Temperature °C (°F)	Classification and Value, MPa (ksi)		
	P _m	P _L	P _L + P _b
-29 to 38 (-20 to 100)	337.8 (49.0)	506.8 (73.5)	506.8 (73.5)
93.3 (200)	337.8 (49.0)	506.8 (73.5)	506.8 (73.5)
149 (300)	337.8 (49.0)	506.8 (73.5)	506.8 (73.5)
204 (400)	337.8 (49.0)	506.8 (73.5)	506.8 (73.5)
260 (500)	337.8 (49.0)	506.8 (73.5)	506.8 (73.5)

Notes:

1. Level D allowables per NB-3225 and Appendix F, Paragraph F-1331.
2. Average primary shear stress across a section loaded in pure shear may not exceed 0.42 S_u.
3. Values are in accordance with stress intensity limits provided in Table 2.1.2.
4. See Table 2.1.4 for stress classification definitions.

Table 2.1.6: Design, Levels A and B: Stress Intensity – SA-350 LF3

Code: ASME NB
 Material: SA-350 LF3
 Item: Stress Intensity

Temperature °C (°F)	Classification and Value, MPa (ksi)					
	S_m	P_m (Note 3)	P_L (Note 3)	$P_L + P_b$ (Note 3)	$P_L + P_b + Q$	P_e (Note 4)
-29 to 38 (-20 to 100)	160.6 (23.3)	160.6 (23.3)	240.9 (35.0)	240.9 (35.0)	481.9 (69.9)	481.9 (69.9)
93.3 (200)	157.9 (22.9)	157.9 (22.9)	236.9 (34.4)	236.9 (34.4)	473.7 (68.7)	473.7 (68.7)
149 (300)	152.4 (22.1)	152.4 (22.1)	228.6 (33.2)	228.6 (33.2)	457.2 (66.3)	457.2 (66.3)
204 (400)	147.5 (21.4)	147.5 (21.4)	221.3 (32.1)	221.3 (32.1)	442.5 (64.2)	442.5 (64.2)
260 (500)	140.0 (20.3)	140.0 (20.3)	210.0 (30.5)	210.0 (30.5)	420.0 (60.9)	420.0 (60.9)
316 (600)	129.6 (18.8)	129.6 (18.8)	194.4 (28.2)	194.4 (28.2)	388.8 (56.4)	388.8 (56.4)
371 (700)	116.5 (16.9)	116.5 (16.9)	174.8 (25.4)	174.8 (25.4)	349.5 (50.7)	349.5 (50.7)

Notes:

1. Source for S_m is Table 2A of ASME Section II, Part D.
2. Values are in accordance with stress intensity limits provided in Table 2.1.2.
3. Evaluation required for Design condition only per NB-3220.
4. P_e not applicable to vessels per Fig. NB-3221-1.
5. See Table 2.1.4 for stress classification definitions.

Table 2.1.7: Level D, Stress Intensity – SA-350 LF3

Code: ASME NB
 Material: SA-350 LF3
 Item: Stress Intensity

Temperature °C (°F)	Classification and Value, MPa (ksi)		
	P _m	P _L	P _L + P _b
-29 to 38 (-20 to 100)	337.8 (49.0)	506.8 (73.5)	506.8 (73.5)
93.3 (200)	337.8 (49.0)	506.8 (73.5)	506.8 (73.5)
149 (300)	337.8 (49.0)	506.8 (73.5)	506.8 (73.5)
204 (400)	337.8 (49.0)	506.8 (73.5)	506.8 (73.5)
260 (500)	335.8 (48.7)	506.8 (73.5)	506.8 (73.5)
316 (600)	311.0 (45.1)	462.6 (67.7)	462.6 (67.7)
371 (700)	279.9 (40.6)	419.9 (60.9)	419.9 (60.9)

Notes:

1. Level D allowables per NB-3225 and Appendix F, Paragraph F-1331.
2. Average primary shear stress across a section loaded in pure shear may not exceed 0.42 S_u.
3. Values are in accordance with stress intensity limits provided in Table 2.1.2.
4. See Table 2.1.4 for stress classification definitions.

Table 2.1.8: Design Stress Intensity – Bolting Material

Code: ASME NB
 Material: SA-193 B7 (Bolt < 2.5 inch diameter),
 SA-564/705 630 (H1025)
 & SB-637 N07718 (Bolt ≤ 6 inch diameter),
 Item: Stress Intensity

Temperature °C (°F)	Design Stress Intensity SA-193 B7 MPa (ksi)	Design Stress Intensity SA-564/705 630 MPa (ksi)	Design Stress Intensity SB-637 MPa (ksi)
-29 to 38 (-20 to 100)	241.3 (35)	333.0 (48.3)	344.7 (50)
93.3 (200)	224.8 (32.6)	333.0 (48.3)	330.9 (48)
149 (300)	216.5 (31.4)	333.0 (48.3)	323.4 (46.9)
204 (400)	210.3 (30.5)	324.1 (47.0)	317.8 (46.1)
260 (500)	203.4 (29.5)	317.8 (46.1)	314.4 (45.6)
316 (600)	195.8 (28.4)	313.0 (45.4)	310.95 (45.1)
343 (650)	-	309.6 (44.9)	-
371 (700)	185.5 (26.9)	-	308.9 (44.8)

Notes:

1. Level A and D limits per Table 2.1.3.
2. Tables 2.2.2a and 2.2.2b contain other mechanical and thermal properties of the bolting material.
3. Sources for design stress intensity values for SA-193 B7 and SB-637 N07718 is Table 4 and that for SA-564/705 630 material, is Table 2A of ASME Section II, Part D.
4. Values for SA-564/705 630 are conservatively based on age hardening at 1075°F (H1075).

Table 2.1.9

DESIGN, LEVELS A AND B: STRESS INTENSITY

Code: ASME NB
 Component: MPC Enclosure Vessel
 Material: Alloy X
 Service Conditions: Design, Levels A and B (Normal and Off-Normal)
 Item: Stress Intensity

Temp. (Deg. F)	Classification and Numerical Value					
	S_m	P_m^\dagger	P_L^\dagger	$P_L + P_b^\dagger$	$P_L + P_b + Q^{\dagger\dagger}$	$P_e^{\dagger\dagger}$
-20 to 100	20.0	20.0	30.0	30.0	60.0	60.0
200	20.0	20.0	30.0	30.0	60.0	60.0
300	20.0	20.0	30.0	30.0	60.0	60.0
400	18.6	18.6	27.9	27.9	55.8	55.8
500	17.5	17.5	26.3	26.3	52.5	52.5
600	16.5	16.5	24.75	24.75	49.5	49.5
650	16.0	16.0	24.0	24.0	48.0	48.0
700	15.6	15.6	23.4	23.4	46.8	46.8
750	15.2	15.2	22.8	22.8	45.6	45.6
800	14.8	14.8	22.2	22.2	44.4	44.4

Notes:

1. S_m = Stress intensity values per Table 2A of ASME II, Part D.
2. Alloy X S_m values are the lowest values for each of the candidate materials at corresponding temperature.
3. Stress classification per NB-3220.
4. Limits on values are presented in Table 2.1.2.
5. P_m , P_L , P_b , Q , and P_e are defined in Subsection 2.1.2 and in Subsection NB of the ASME Code, Section III.
6. This Table is reproduced from Table 3.1.7 of the HI-STORM FW FSAR [2.1.13].

[†] Evaluation required for Design condition only.

^{††} Evaluation required for Levels A, B conditions only. P_e not applicable to vessels.

Table 2.1.10

LEVEL D: STRESS INTENSITY

Code: ASME NB
 Component: MPC Enclosure Vessel
 Material: Alloy X
 Service Conditions: Level D (Accident)
 Item: Stress Intensity

Temp. (Deg. F)	Classification and Value (ksi)		
	P_m	P_L	$P_L + P_b$
-20 to 100	48.0	72.0	72.0
200	48.0	72.0	72.0
300	46.3	69.45	69.45
400	44.6	66.9	66.9
500	42.0	63.0	63.0
600	39.6	59.4	59.4
650	38.4	57.6	57.6
700	37.4	56.1	56.1
750	36.5	54.8	54.8
800	35.5	53.25	53.25

Notes:

1. Level D stress intensities per ASME NB-3225 and Appendix F, Paragraph F-1331.
2. The average primary shear strength across a section loaded in pure shear may not exceed $0.42 S_u$.
3. This Table is reproduced from Table 3.1.8 of HI-STORM FW FSAR [2.1.13].

Table 2.1.11: [PROPRIETARY INFORMATION WITHHELD PER 10CFR2.390]

Table 2.1.12: [PROPRIETARY INFORMATION WITHHELD PER 10CFR2.390]

Table 2.1.13: Applicable Codes and Standards for the Materials Used in The HI-STAR 190 Packaging

Item		Principal Function	Applicable Codes and Reference Standard
1.	Containment Baseplate	Containment Boundary	ASME Code Section III Subsection NB
2.	Containment Shell	Containment Boundary	ASME Code Section III Subsection NB
3.	Containment Closure Flange	Containment Boundary	ASME Code Section III Subsection NB
4.	Closure Lid	Containment Boundary	ASME Code Section III Subsection NB
5.	Closure Lid Bolts	Containment Boundary	ASME Code Section III Subsection NB
6.	MPC Enclosure Vessel	Containment Boundary	ASME Code Section III Subsection NB
7.	Vent and Drain Port Plugs	Containment Boundary	ASME Code Section II
8.	Seals and Gaskets	Containment Boundary	Non-Code (Manufacturer's Catalog and Test Data)
9.	Fuel Basket (Metamic-HT)	Positioning of Fuel Assemblies/ Criticality Control	Non-Code (Manufacturer's Test Data [1.2.3])
10.	Lead in the Gamma Capture Space (GCS)	Gamma Shielding	Non-code
11.	Holtite-B	Neutron Shielding	Non-Code (Manufacturer's Test Data [1.2.10])
12.	Lifting Trunnions	Lifting and Handling	ASME Code Section II and ANSI N14.6
13.	Steel in Neutron Capture Space (NCS) and Gamma Capture Space (GCS)	(non-structural)	Non-code

Table 2.1.13: Applicable Codes and Standards for the Materials Used in The HI-STAR 190 Packaging (Continued)

Item		Principal Function	Applicable Codes and Reference Standard
14.	Basket Shims	Positioning of Basket in the Containment Cavity	ASTM B221
15.	Impact Limiter Backbone Plate Material	Structural Support of Impact Limiter	ASME Code Section II
16.	Impact Limiter Attachment Rods and Nuts	Structural Support of Impact Limiter	ASME Code Section II
17.	Impact Limiter Crush Material	Impact Energy Absorption	Non-Code (Manufacturer's Catalog and Test Data)
18.	[PROPRIETARY INFORMATION WITHHELD PER 10CFR2.390]	[PROPRIETARY INFORMATION WITHHELD PER 10CFR2.390]	[PROPRIETARY INFORMATION WITHHELD PER 10CFR2.390]

Notes:

1. Materials for ITS components not listed above shall meet ASME, ASTM, or other standard industrial codes, as approved by Holtec International. Materials for NITS components shall meet standard industrial codes or the manufacturer's product sheets as approved by Holtec International.

Table 2.1.14: [PROPRIETARY INFORMATION WITHHELD PER 10CFR2.390]

2.2 MATERIALS

2.2.1 Mechanical Properties and Specifications

This subsection provides the mechanical properties used in the structural evaluations. The properties include, as appropriate, yield stress, ultimate stress, modulus of elasticity, strength, weight density, and coefficient of thermal expansion. The property values are presented for a range of temperatures for which structural calculations are performed.

2.2.1.1 Structural Materials

2.2.1.1.1 Nickel Alloy, Low-Alloy Steel

The nickel alloy and low-alloy steels used in the HI-STAR 190 overpack are SA-203E and SA-350 LF3, respectively. The material properties (used in structural evaluations) of SA-203 E and SA-350 LF3 are given in Table 2.2.1.

Properties of steel, which are not included in any of the tables at the end of the section, are weight density and Poisson's ratio. These properties are assumed constant for all structural analyses. The values used are shown in the table below.

Property	Value
Weight Density, kg/m ³ (lb/in ³)	7,833 (0.283) 8,027 (0.290) (for Stainless Steel)
Poisson's Ratio	0.30

2.2.1.1.2 Bolting Materials

Material properties (for structural evaluations) of the closure lid bolting materials used in the HI-STAR 190 Package are given in Tables 2.2.2 and 2.2.3.

2.2.1.1.3 Fuel Basket

The Fuel Basket is made of Metamic-HT.

Metamic-HT, a high strength, nanotechnology-based counterpart of the classic Metamic neutron absorber material, is extensively characterized in the supplier's report [1.2.3]. Minimum guaranteed values (MGVs) of Metamic-HT are provided in Table 8.1.3.

2.2.1.1.4 Weld Material

All weld filler materials utilized in the welding of the Code components, which excludes the Metamic-HT fuel basket, will comply with the provisions of the appropriate ASME Code

Subsection (e.g., cited paragraphs of Subsection NB and with applicable paragraphs of Section IX). Inter-panel Metamic-HT welds will be made using the Friction Stir welding (FSW) process in conformance with Section IX of the Code. Subsection 1.2.1, Subsection 8.1.2, and the drawing package in Section 1.3 provide additional information and requirements on joining of Metamic-HT panels.

The minimum tensile strength of the weld wire and filler material (where applicable) will be equal to or greater than the tensile strength of the base metal listed in the ASME Code.

All non-destructive examinations specifications will comply with Section V of the ASME Code.

2.2.1.1.5 AL-STAR Impact Limiter

The AL-STAR impact limiter for the HI-STAR 190 Package is shown in the drawing package in Section 1.3. The impact limiter consists of a rigid cylindrical core, a cylindrical skirt that girdles the cask forging, the energy absorbing material, an outer skin, and attachment bolts. The energy absorbing material is positioned in the impact limiter to realize adequate crush modulus in all potential impact modes. The external surface of the impact limiter consists of a stainless steel skin to provide long-term protection against weather and inclement environmental conditions.

Rail transport considerations limit the maximum diameter of the impact limiter. The axial dimension of the impact limiter is limited by the considerations of maximum permissible packaging weight for rail transport. Within the limitations of space and weight, the impact limiter should possess sufficient energy absorption capacity so as to meet the structural demands on the package under all postulated drop orientations. The sizing of the impact limiter internal structure is principally guided by the above considerations. For example, in order to ensure that a sufficient portion of the energy absorbing material participates in lateral impacts, a thick high strength steel shell, buttressed with gussets, provides a hard backing surface for the impact energy absorbing material to crush against.

The material properties for the stainless and carbon steels, for structural evaluations, are provided in Tables 2.2.4 and 2.2.5, respectively. Material properties for the impact limiter attachment bolts are provided in Table 2.2.6.

Two properties of the impact energy absorbing material germane to its function are the crush strength and the nominal density. The crush strength is the more important of the two properties; the density is significant in establishing the total weight of the package. A characteristic load-crush relation for the crush material is shown in Figure 2.2.1 for a constant crush area. The relation shows an essentially constant force over a large crush depth, followed by a “hockey stick” rise in the force when the material becomes compacted. Table 2.2.8 documents the *critical characteristics* of the impact limiter material in tabular form.

Table 2.2.8 also contains the required *critical characteristics* of the Fastener Strain Limiters (FSL), which protect the impact limiter attachment bolts against excessive tensile strains during a drop accident.

[

PROPRIETARY INFORMATION WITHHELD PER 10CFR2.390

]

2.2.1.1.6 Closure Lid Seals

The containment integrity of the HI-STAR 190 Package relies on a closure lid system with elastomeric seals, as shown in the licensing drawings in Section 1.3.

To ensure that the effectiveness of the leak barriers is optimal, the grooves are machined in the precise configuration and surface finish called for the type of self-energizing gasket selected for this application. The gasket chosen for the HI-STAR 190 cask must fulfill the principal requirements set down in the following:

[

PROPRIETARY INFORMATION WITHHELD PER 10CFR2.390

]

The load required to “seat” the gaskets is a small percentage of the total applied bolt preload force; hence the required “seating load” (an ASME Boiler & Pressure Vessel code term) is not an important parameter. The size of the gasket in relation to the size of the groove, on the other hand, is a critical dimension that is based on the gasket supplier’s test data and which must be controlled through the gasket Procurement Specification. The critical sealing dimensions consistent with seal manufacturers’ data are provided in the HI-STAR 190 cask drawing in Section 1.3. The gaskets will be procured as an *Important-to-Safety* part.

The closure seals for the HI-STAR 190 overpack have been conservatively specified to provide a high degree of assurance of leak tightness under normal and accident conditions of transport so that package service conditions at normal or accident pressures under high and low temperatures will not challenge the capabilities of cask closure seals. Creep of the cask closure seals, even under long term use in a loaded cask (50 years), is not credible due to its materials of construction and the nickel alloy seal spring. The specifications for the closure lid seals are provided below:

[

PROPRIETARY INFORMATION WITHHELD PER 10CFR2.390

]

[
PROPRIETARY INFORMATION WITHHELD PER 10CFR2.390
]

2.2.1.2 Nonstructural Materials

2.2.1.2.1 Gamma Shielding Material

Lead is not considered as a structural member of the HI-STAR 190 Package. However, it is included in the dynamic simulation models for Normal and Accident Conditions of Transport. Applicable mechanical properties of lead are provided in Table 2.2.9.

2.2.1.2.2 Neutron Shielding Material

The non-structural properties of the neutron shielding material Holtite B are provided in Section 1.2. Holtite B does not serve a structural function in the HI-STAR 190 package.

2.2.1.2.3 Fuel Basket Supports

Representative mechanical properties for the basket supports are tabulated in Table 2.2.7. Table 2.2.4 provides the mechanical properties for the stainless steel basket support.

PROPRIETARY INFORMATION WITHHELD PER 10CFR2.390

2.2.1.2.4 Cask Exterior Surface Coating

The HI-STAR 190 cask's exterior surfaces are coated with a conventional surface preservative such as Carboguard[®] 890 (see www.carboline.com for product data sheet) and/or equivalent

surface preservative. CarboGuard[®] 890 and equivalent surface preservatives have provided years of proven performance on HI-STAR 100 casks. Chemically equivalent products with different trade names that can be shown to have had proven performance in similar applications and environments are permitted. The proposed exterior surface coating is not important to safety, since its failure would not reduce the package shielding effectiveness and would not adversely affect public health and safety.

2.2.1.2.5 Cask Liner

A cask liner may be used to protect containment boundary steel components against increased corrosion from submersions into the spent fuel pools. The HI-STAR 190 cask cavity and inter-lid space alloy steel surfaces (except for threaded features) may be lined with conventional surface preservative according to the drawing package in Section 1.3. The cask liner is not important to safety, since its failure would not reduce the package shielding effectiveness and would not adversely affect public health and safety.

The HI-STAR 190 cask interior steel surfaces may be coated with conventional surface preservatives such as Thermaline[®] 450 (see www.carboline.com for product data sheet) or equivalent surface preservative. Thermaline[®] 450 and equivalent surface preservatives have provided years of proven performance on HI-STAR 100 casks. Conventional surface preservatives refer to sprayed/rolled on and cured “paints”. Although interior cask surfaces are not accessible for routine liner repair during loaded cask operation, the dry helium environment protects cask contents and internals, including cask liners from long-term degradation. Conventional surface preservatives shall be applied in accordance with the manufacturer’s recommendation and to the recommended dry film thickness. Conventional surface preservatives shall not result in significant chemical reaction with borated water. Thermaline[®] 450 is the product name at the time of this SAR writing. Chemically identical products with different names are permitted. Performance criteria are specified conservatively for conventional surface preservatives in SAR Table 8.1.12.

2.2.2 Chemical, Galvanic or Other Reactions

Similar to the HI-STAR 100 and HI-STAR 180 packaging, the HI-STAR 190 packaging combines low-alloy and nickel alloy steels, carbon steels, neutron and gamma shielding, and bolting materials. All of these materials have a long history of non-galvanic behavior within close proximity of each other. The external surfaces of the cask are coated to preclude surface oxidation. The internal surfaces of the cask are lined to preclude any significant surface oxidation. The coatings and liners do not chemically react significantly with borated water. The cask is dried and helium backfilled as discussed in Chapter 7 to eliminate any credible corrosion from moisture and oxidizing gases. [PROPRIETARY INFORMATION WITHHELD PER 10CFR2.390] Therefore, chemical, galvanic or other reactions involving the cask materials are unlikely and are not expected.

[

PROPRIETARY INFORMATION WITHHELD PER 10CFR2.390

]

In accordance with NRC Bulletin 96-04 [2.2.4], a review of the potential for chemical, galvanic, or other reactions among the materials of the HI-STAR 190 Package, its contents and the operating environment, which may produce adverse reactions, has been performed. As a result of this review, no operations were identified which could produce adverse reactions. No closure welding is performed and thus hydrogen generation while the cask is in the pool is of minor consequence to cask operations based on previous experience with the same cask materials. Because no welding activities are involved in the cask closure operations, the potential of a hydrogen ignition event does not exist.

2.2.3 Effects of Radiation on Materials

The general physical effects of radiation of metals by fast neutrons and other high-energy particles are summarized in the following table excerpted from a DOE Handbook on Material Science [2.2.3].

General Effect of Fast Neutron Irradiation on Metals	
Property Increases	Property Decreases
<ul style="list-style-type: none"> • Yield Strength • Tensile Strength • NDT Temperature • Young’s Modulus (Slight) • Hardness • High Temperature Creep Rate (During Irradiation) 	<ul style="list-style-type: none"> • Ductility • Stress-Rupture Strength • Density • Impact Strength • Thermal Conductivity

The HI-STAR 190 Package is composed of materials that either have a proven history of use in the nuclear industry or have been extensively tested. The radiation levels from spent nuclear fuel do not affect the packaging materials. Gamma radiation damage to metals (e.g., aluminum, stainless steel, and carbon steel) does not occur until the fluence level reaches 10^{18} rads or more. The 50-year gamma fluence (assuming design basis fuel for 50 years without radioactive decay) from the spent nuclear fuel transported in the HI-STAR 190 Package is on the order of 1.25×10^9 rads and reduces significantly as it penetrates through cask components. Moreover, significant radiation damage due to neutron exposure does not occur for neutron fluences below approximately 10^{19} n/cm² [2.2.3, 2.2.4, 2.2.5], which is far greater than the 50-year neutron fluence from spent nuclear fuel transported in the HI-STAR 190 Package, which is on the order of 1.25×10^{16} n/cm² assuming design basis fuel for 50 years without radioactive decay. Also, as indicated in reference [2.2.3], “The effects listed in the table above are generally less significant

at elevated temperatures for a given fluence and some defects can be removed by heating (annealing).”

As discussed in Section 1.2 and its references, the Metamic-HT neutron absorber and Holtite have been tested extensively to prove that it will not degrade over the service life of the package. Elastomeric seal compounds selected demonstrate a proven and predictable response to absorbed radiation. Analysis indicates that seal life is not limited by absorbed dose in the HI-STAR 190 package [5.0.7]. No adhesives are used in the cask packaging and packaging coatings (especially cask liners) are selected for the high radiation environment.

Table 2.2.1: Mechanical Properties of SA-350 LF3/SA-203 E

Temperature °C (°F)	SA-350 LF3/SA-203 E for Cask Containment Boundary					
	S _y	S _u	E	α	S _y	S _u
-73.30 (-100)	258.6 (37.5)	482.6 (70.0)	19.72 (28.6)	-	275.8 (40.0)	482.6 (70.0)
37.78 (100)	258.6 (37.5)	482.6 (70.0)	19.03 (27.6)	11.7 (6.5)	275.8 (40.0)	482.6 (70.0)
93.33 (200)	235.8 (34.3)	482.6 (70.0)	18.68 (27.1)	12.06 (6.7)	252.3 (36.6)	482.6 (70.0)
148.89 (300)	228.9 (33.2)	482.6 (70.0)	18.41 (26.7)	12.42 (6.9)	244.1 (35.4)	482.6 (70.0)
204.4 (400)	220.6 (32.0)	482.6 (70.0)	18.07 (26.2)	12.78 (7.1)	235.8 (34.2)	482.6 (70.0)
260 (500)	209.6 (30.4)	482.6 (70.0)	17.72 (25.7)	13.14 (7.3)	224.1 (32.5)	482.6 (70.0)
316 (600)	194.4 (28.2)	482.6 (70.0)	17.31 (25.1)	13.32 (7.4)	207.5 (30.0)	482.6 (70.0)

Definitions:

- S_y = Yield Stress MPa (ksi)
- S_u = Ultimate Stress MPa (ksi)
- α = Coefficient of Thermal Expansion, cm/cm-°C x 10⁻⁶ (in./in. per degree F x 10⁻⁶)
- E = Young's Modulus MPa x 10⁴ (ksi x 10³)

- Notes:
1. Source for S_y values is Table Y-1 of [2.1.6].
 2. Source for S_u values is ratioing S_m values.
 3. Source for α values is material group 1 in Table TE-1 of [2.1.6].
 4. Source for E values is material group B in Table TM-1 of [2.1.6].

Table 2.2.2a: Mechanical Properties of SA-193 Grade B7

SA-193 Grade B7 [less than 64 mm (2.5 in) diameter] for Containment Boundary Port Cover Bolts					
Temperature, °C (°F)	S _y	S _u	E	α	S _m
38 (100)	724.0 (105.0)	861.8 (125.00)	20.3 (29.5)	11.7 (6.5)	241.3 (35.0)
93.3 (200)	675.9 (98.0)	861.8 (125.00)	19.99 (29.0)	12.06 (6.7)	224.8 (32.6)
149 (300)	648.8 (94.1)	861.8 (125.00)	19.65 (28.5)	12.42 (6.9)	216.5 (31.4)
204 (400)	630.9 (91.5)	861.8 (125.00)	19.31 (28.0)	12.78 (7.1)	210.3 (30.5)
260 (500)	610.2(88.5)	861.8 (125.00)	18.89 (27.4)	13.14 (7.3)	203.4 (29.5)
316 (600)	588.1 (85.3)	861.8 (125.00)	18.55 (26.9)	13.32 (7.4)	195.8 (28.4)
371 (700)	555.72 (80.6)	824.6 (119.6)	18.06 (26.2)	13.68 (7.6)	185.5 (26.9)

Definitions:

- S_y = Yield Stress, MPa (ksi)
α = Mean Coefficient of thermal expansion, cm/cm-°C x 10⁻⁶ (in/in-°F x 10⁻⁶)
S_u = Ultimate Stress, MPa (ksi)
E = Young's Modulus, MPa x 10⁴ (psi x 10⁶)

Notes:

1. Source for S_y values is Table Y-1 of [2.1.6] for ferrous materials.
2. Source for S_u values is Table U of [2.1.6] for ferrous materials, or from Section II, Part A. Where ultimate strength is unavailable, values above 300 deg. F are based on 100 deg.F value multiplied by ratio of yield strength at room temperature to yield strength at desired temperature.
3. Source for α values is Tables TE-1 and TE-4 of [2.1.6] for ferrous materials.
4. SA-705 630/SA-564 630 (H1025) per Table 2.2.3 is optional material for Port Cover Lid Bolts.

Table 2.2.2b: Closure Lid Bolt Material – Mechanical Properties

SA-705 630, SA-564 630 (H1025 Condition)				
Temperature, °C (°F)	S _y	S _u	E	α
38 (100)	999.5 (145.0)	1068.7 (155)	19.7 (28.5)	11.16 (6.2)
93.3 (200)	924.4 (134.1)	1068.7 (155)	19.1 (27.8)	11.34 (6.3)
149 (300)	885.1 (128.4)	1068.7 (155)	18.8 (27.2)	11.52 (6.4)
204 (400)	854.1 (123.9)	1039 (150.7)	18.4 (26.7)	11.70 (6.5)
260 (500)	827.9 (120.1)	1018 (147.7)	18. (26.1)	11.70 (6.5)
288 (550)	816.2 (118.4)	1011 (146.6)	17.8 (25.8)	11.88 (6.6)
SB-637 N07718 (less than or equal to 6 inches diameter)				
38 (100)	1034 (150.0)	1276 (185.0)	19.83 (28.76)	12.9 (7.1)
93.3 (200)	992.8 (144.0)	1225 (177.6)	19.51 (28.3)	13.0 (7.2)
149 (300)	970.1 (140.7)	1196 (173.5)	19.24 (27.9)	13.2 (7.3)
204 (400)	953.5 (138.3)	1176 (170.6)	18.96 (27.5)	13.4 (7.5)
260 (500)	943.2 (136.8)	1163 (168.7)	18.75 (27.2)	13.6 (7.6)
316 (600)	932.9 (135.3)	1151 (166.9)	18.48 (26.8)	13.9 (7.7)

Definitions:

S_m = Design stress intensity MPa (ksi)S_y = Yield Stress MPa (ksi)α = Mean Coefficient of thermal expansion (in./in. per degree F x 10⁻⁶)S_u = Ultimate Stress MPa (ksi)E = Young's Modulus MPa 10⁴ (psi x 10⁶)

Notes:

1. Source for S_m values is Table 4 of [3.3.1].
2. Source for S_y values is ratioing design stress intensity values and Table Y-1 of [3.3.1], as applicable.
3. Source for S_u values is ratioing design stress intensity values and Table U of [3.3.1], as applicable.
4. Source for α values is Tables TE-1 and TE-4 of [3.3.1], as applicable.
5. Source for E values is Tables TM-1 and TM-4 of [3.3.1], as applicable.
6. Source for α values is Table TE-1 of [2.1.6] for ferrous materials. Values for α are for H1075 condition in lieu of H1025 condition.
7. SA-705 630 and SA-564 630 (both UNS No. S17400) have the same chemistry requirements and are considered equivalent for the intended application.

Table 2.2.3: Mechanical Properties of SA-705 630, SA-564 630

SA-705 630, SA-564 630 for Trunnions (H1100 Condition)				
Temperature, °C (°F)	S _y	S _u	E	α
38 (100)	792.9 (115)	965.3 (140)	19.8 (28.68)	11.16 (6.2)
93.3 (200)	732.9 (106.3)	965.3 (140)	19.1 (27.8)	11.34 (6.3)
149 (300)	701.9 (101.8)	965.3 (140)	18.8 (27.2)	11.52 (6.4)
204 (400)	677.8 (98.3)	938.4 (136.1)	18.4 (26.7)	11.70 (6.5)
260 (500)	656.4 (95.2)	919.8 (133.4)	18. (26.1)	11.70 (6.5)
288 (550)	647.8 (93.95)	912.9 (132.4)	17.8 (25.8)	11.88 (6.6)

Definitions:

- S_y = Yield Stress, MPa (ksi)
α = Mean Coefficient of thermal expansion, cm/cm-°C x 10⁻⁶ (in/in-°F x 10⁻⁶)
S_u = Ultimate Stress, MPa (ksi)
E = Young's Modulus, MPa x 10⁴ (psi x 10⁶)

Notes:

1. Source for S_y values is Table Y-1 of [2.1.6] for ferrous materials.
2. Source for S_u values is Table U of [2.1.6] for ferrous materials, or from Section II, Part A. Where ultimate strength is unavailable, values above 300 deg. F are based on 100 deg.F value multiplied by ratio of yield strength at room temperature to yield strength at desired temperature.
3. Source for α values is Table TE-1 of [2.1.6] for ferrous materials. Values for α are for H1075 condition in lieu of H1100 condition.
4. SA-705 630 and SA-564 630 (both UNS No. S17400) have the same chemistry requirements and are considered equivalent for the intended application.

**Table 2.2.4: Alloy X – Mechanical Properties
(Minimum Values of SA-240 304, 304LN, 316, 316LN)**

Temperature °C (°F)	S _y	S _u	α	E
-40 (-40)	206.8 (30.0)	517.1 (75.0)	14.58 (8.1)*	19.91 (28.88)
38 (100)	206.8 (30.0)	517.1 (75.0)	15.48 (8.6)	19.44 (28.2)
65.6 (150)	186.8 (26.7)	-	15.84 (8.8)	-
93.3 (200)	172.4 (25.0)	489.5 (71.0)	16.02 (8.9)	18.96 (27.5)
121 (250)	162.8 (23.6)	-	16.38 (9.1)	-
149 (300)	155.1 (22.5)	456.4 (66.2)	16.56 (9.2)	18.62 (27.0)
204 (400)	142.7 (20.7)	441.3 (64.0)	17.1 (9.5)	18.2 (26.4)

Definitions:

- S_y = Yield Stress, MPa (ksi)
 α = Mean Coefficient of thermal expansion, cm/cm-°C x 10⁻⁶ (in/in-°F x 10⁻⁶)
 S_u = Ultimate Stress, MPa (ksi)
 E = Young's Modulus, MPa x 10⁴ (psi x 10⁶)

Notes:

1. Source for S_y values is Table Y-1 of [2.1.6].
2. Source for S_u values is Table U of [2.1.6].
3. Source for α values is Table TE-1, Group 3 of [2.1.6]. * Value at -40 deg. F is extrapolated.
4. Source for E values is material group G in Table TM-1 of [2.1.6].
5. The listed yield and ultimate stress is the minimum value of SA-240 304, 304LN, 316, and 316LN.

Table 2.2.5: Miscellaneous Steel – Mechanical Properties

Temperature °C (°F)	SA-36			
	S _y	S _u	α	E
37,8 (100)	248.2 (36.0)	399.9 (58.0)	11.7 (6.5)	20.17 (29.26)
93,3 (200)	227.5 (33.0)	399.9 (58.0)	12.06 (6.7)	19.86 (28.8)
149 (300)	219.3 (31.8)	399.9 (58.0)	12.42 (6.9)	19.51 (28.3)
204 (400)	212.4 (30.8)	399.9 (58.0)	12.78 (7.1)	19.24 (27.9)
260 (500)	202.0 (29.3)	399.9 (58.0)	13.14 (7.3)	18.82 (27.3)
316 (600)	190.3 (27.6)	399.9 (58.0)	13.32 (7.4)	18.27 (26.5)
371 (700)	177.9 (25.8)	399.9 (58.0)	14.04 (7.8)	17.58 (25.5)

Table 2.2.5 (Continued): Miscellaneous Steel – Mechanical Properties

Temperature °C (°F)	SA-516 Grade 70 or A516 Gr 70			
	S _y	S _u	α	E
38 (100)	262.0 (38.0)	482.6 (70.0)	11.7 (6.5)	20.17 (29.26)
93.3 (200)	239.9 (34.8)	482.6 (70.0)	12.06 (6.7)	19.86 (28.8)
149 (300)	231.7 (33.6)	482.6 (70.0)	12.42 (6.9)	19.51 (28.3)
204 (400)	224.1 (32.5)	482.6 (70.0)	12.78 (7.1)	19.24 (27.9)
260 (500)	213.7 (31.0)	482.6 (70.0)	13.14 (7.3)	18.82 (27.3)
316 (600)	200.6 (29.1)	482.6 (70.0)	13.32 (7.4)	18.27 (26.5)
371 (700)	187.5 (27.2)	482.6 (70.0)	14.04 (7.8)	17.58 (25.5)

Definitions:

- S_y = Yield Stress, MPa (ksi)
α = Mean Coefficient of thermal expansion, cm/cm-°C x 10⁻⁶ (in/in-°F x 10⁻⁶)
S_u = Ultimate Stress, MPa (ksi)
E = Young's Modulus, MPa x 10⁴ (psi x 10⁶)

Notes:

1. Source for S_y values is Table Y-1 of [2.1.6].
2. Source for S_u values is Table U of [2.1.6].
3. Source for α values is material group 1 in Table TE-1 of [2.1.6].
4. Source for E values is "Carbon steels with C less than or equal to 0.30%" in Table TM-1 of [2.1.6].

Table 2.2.6: Yield and Ultimate Strength of Impact Limiter Attachment Bolts

SA-193 B7 (≤ 2.5 inches)		
Temp. °C (°F)	S_y	S_u
Room Temperature	724.0 (105.0)	861.8 (125.0)
165.6 (250)	662.2 (96.05)	861.8 (125.0)

Definitions:

S_y = Yield Stress, MPa (ksi)

S_u = Ultimate Stress, MPa (ksi)

Notes:

1. Source for S_y and S_u values is Part D of the ASME B&PV code [2.1.6].

Table 2.2.7: Basket Shims – Nominal Mechanical Properties

Aluminum Alloy (B221 2219-T8511)					
Temp. °C (°F)	S _y	S _u	E	α	% Elongation
25 (75)	290 (42)	400 (58)	7.2 (10.5)	–	5
150 (300)	243 (35)	307 (44)	6.8 (9.5)	23.9 (13.3)	6.4
204 (400)	188 (27)	231 (34)	6.3 (9.1)	24.5 (13.6)	8.2
230 (450)	171 (25)	209 (30)	6.1 (8.8)	24.8 (13.8)	8.6
260 (500)	154 (22)	182 (26)	5.9 (8.5)	25.0 (13.9)	8.6
290 (550)	98 (14)	116 (17)	5.5 (8.0)	25.4 (14.1)	10.5

Definitions:

S_y = Yield Stress, MPa (ksi)α = Mean Coefficient of thermal expansion, cm/cm-°C x 10⁻⁶ (in/in-°F x 10⁻⁶)S_u = Ultimate Stress, MPa (ksi)E = Young's Modulus, MPa x 10⁴ (psi x 10⁶)

Notes:

1. Source for E values is "Properties of Aluminum Alloys", page 82 [2.2.7].
2. Source for the S_y, S_u, and % Elongation values at room temperature is ASTM Specification B221M [2.2.9]. Strength values at elevated temperatures are factored lower-bound values corresponding to 10,000 hours at temperature from [2.2.7]. The strength reduction factor is taken as the ratio of the strength value at room temperature from [2.2.9] to the typical strength value at room temperature from [2.2.7]. Elongation values at elevated temperatures are obtained in the same manner.
3. Source for α is Table TE-2 of [2.1.6] (values listed in TE-2 are also considered representative of Aluminum Alloy (2219-T8511) (UNS No. A92219)).

Table 2.2.8: Critical Characteristics of the AL-STAR Impact Limiter Crush Material, and Fastener Strain Limiters

Item & Property Category	Value	Comment
Crush strength (nominal), σ_c , of crush material, psi (Primary property) <ul style="list-style-type: none"> • Type 1 • Type 2 • Type 3 	(Target volumetric average value) See impact limiter drawing in Section 1.3	[PROPRIETARY INFORMATION WITHHELD PER 10CFR2.390]
Density (reference) of crush material, lb/ft ³ (kg/m ³) (Secondary property) <ul style="list-style-type: none"> • Type 1 • Type 2 • Type 3 	See impact limiter drawing in Section 1.3	[PROPRIETARY INFORMATION WITHHELD PER 10CFR2.390]
[PROPRIETARY INFORMATION WITHHELD PER 10CFR2.390]	[PROPRIETARY INFORMATION WITHHELD PER 10CFR2.390]	[PROPRIETARY INFORMATION WITHHELD PER 10CFR2.390]
[PROPRIETARY INFORMATION WITHHELD PER 10CFR2.390]	[PROPRIETARY INFORMATION WITHHELD PER 10CFR2.390]	[PROPRIETARY INFORMATION WITHHELD PER 10CFR2.390]

Table 2.2.9: Mechanical Properties of Lead

LEAD:	-40°C (-40°F)	-29°C (-20°F)	21°C (70°F)	93°C (200°F)	149°C (300°F)	316°C (600°F)
Yield Strength, MPa (psi)	4.83 (700)	4.69 (680)	4.41 (640)	3.38 (490)	2.62 (380)	0.138 (20)
Modulus of Elasticity, MPa (ksi)	1.65E+4 (2.4E+3)	1.65E+4 (2.4E+3)	1.59E+4 (2.3E+3)	1.38E+4 (2.0E+3)	1.31E+4 (1.9E+3)	1.03E+4 (1.5E+3)
Coefficient of Thermal Expansion, cm/cm/°C (in/in/°F)	28.1E-6 (15.6E-6)	28.3E-6 (15.7E-6)	29.0E-6 (16.1E-6)	29.9E-6 (16.6E-6)	31.0E-6 (17.2E-6)	36.4E-6 (20.2E-6)
Poisson's Ratio	0.40					
Density, kg/m ³ (lb/cubic ft.)	11,340 (708)					

Note: References [2.2.6] and [2.2.9] provide the yield strength data for lead. The modulus of elasticity of lead can be found from Reference [2.2.10], and the Poisson's ratio and density data for lead are documented in Reference [2.2.11].

Table 2.2.10: [PROPRIETARY INFORMATION WITHHELD PER 10CFR2.390]

HI-STAR 190 SAR Report HI-2146214	2.2-22	Revision 1
--------------------------------------	--------	------------

Table 2.2.11: [PROPRIETARY INFORMATION WITHHELD PER 10CFR2.390]

HI-STAR 190 SAR Report HI-2146214	2.2-23	Revision 1
--------------------------------------	--------	------------

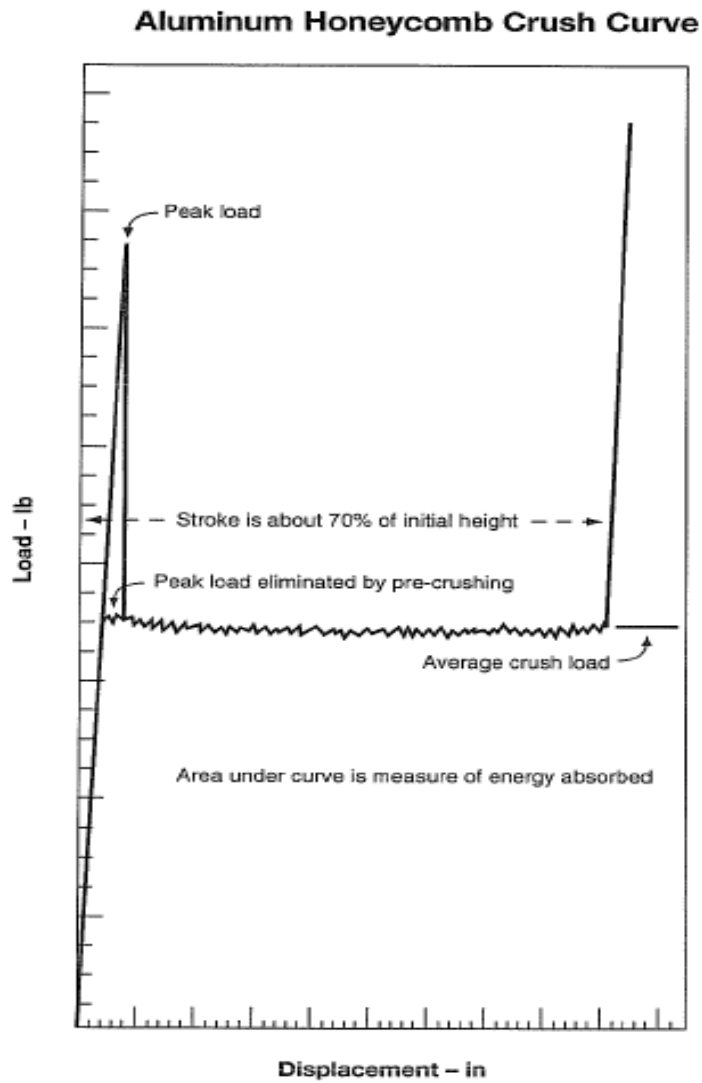

**Figure 2.2.1: Aluminum Honeycomb Load vs. Crush Curve
(Typical, reproduced from Ref. [2.2.1])**

2.3 FABRICATION AND EXAMINATIONS

2.3.1 Fabrication

Consideration of the manufacturing process of a cask must be an integral part of its design evolution to ensure that the as-engineered cask can be manufactured to meet the intents of the design. For HI-STAR 190, as in all other cask models, Holtec International utilizes the following key criteria during the design stage to ensure that design objectives will be realized during manufacturing:

- i. The tolerances specified for the sub-components are achievable with state-of-the-art equipment and machinery.
- ii. The design is not overly reliant on tight tolerances to ensure functional compliance.
- iii. Suitable (compatible) material combinations are specified whenever two dissimilar materials are to be welded.
- iv. Post-weld heat treatment and other means to alleviate weld shrinkage stresses are specified, as appropriate, to enhance the quality of the hardware and to comply with the applicable ASME Code.
- v. The manufacturing sequence must permit all required non-destructive examinations to be performed and remedial repairs to be made to ensure compliance with the applicable codes and standards. This requirement is particularly relevant to the Containment Boundary in which the butt-welded joints must undergo 100% volumetric examination.
- vi. The manufacturing sequence must permit machining of critical surfaces, such as the gasket seating surfaces in the top flange, to be carried out after all welding and forming related operations (that inevitably produce distortion) have been completed.
- vii. The manufacturing steps do not involve operations that entail unnecessary risk to worker safety.

The above objectives are fully realized in the manufacturing process envisioned for HI-STAR 190. Of course, there are several candidate manufacturing sequences that will meet the above criteria. A different manufacturing sequence may be used provided they meet the above criteria for quality fabrication.

[

PROPRIETARY INFORMATION WITHHELD PER 10CFR2.390

]

[
 PROPRIETARY INFORMATION WITHHELD PER 10CFR2.390

]

2.3.2 Examinations

The design, material procurement, fabrication, and inspection of the HI-STAR 190 are performed in accordance with applicable codes and standards. The following fabrication controls and required inspections shall be performed on the HI-STAR 190 in order to assure compliance with the SAR and the Certificate of Compliance.

1. Materials of construction specified for the HI-STAR 190 are identified in the drawings. Important-to-safety (ITS) materials shall be procured with certification and supporting documentation as required by ASME Code, Section II (when applicable); the applicable subsection of ASME Code Section III (when applicable); and Holtec procurement specifications. Materials and components shall be receipt inspected for visual and dimensional acceptability, material conformance to specification requirements, and traceability markings, as applicable. Material traceability is maintained throughout fabrication for ITS items through a computerized process that has been implemented by Holtec International in the manufacture of all safety-significant components.
2. Welding of Code materials, shall be performed using welders and weld procedures that have been qualified in accordance with ASME Code Section IX and the applicable ASME Section III Subsections. Welding of welds identified as NITS welds may be performed as described above for code welds or using welders and weld procedures that have been qualified in accordance with AWS D1.1 or AWS D1.2 as applicable.
3. Welds shall be examined in accordance with ASME Code Section V with acceptance criteria per ASME Code Section III. Acceptance criteria for NDE shall be in accordance with the applicable Code for which the item was fabricated. Weld inspections shall be detailed in a weld inspection plan that identifies the weld and the examination requirements, the sequence of examination, and the acceptance criteria. The inspection plan is subject to mandatory review and approval by Holtec International in accordance with its QA program prior to its use. NDE inspections shall be performed in accordance with written and approved procedures by personnel qualified in accordance with SNT-TC-1A as specified in Holtec's QA program. The requirements stated in this paragraph are not applicable to non-Code welds or Metamic-HT welds.
4. The HI-STAR 190 containment boundary shall be examined and tested by a combination of methods (including helium leak test, pressure test, UT, MT and/or PT, as applicable) to verify that it is free of cracks, pinholes, uncontrolled voids or other defects that could significantly reduce the effectiveness of the packaging. All Category A and B welds are subject to 100% volumetric examination per Subsection NB of the ASME Code.

5. Grinding and machining operations of the HI-STAR 190 containment boundary shall be controlled through written and approved procedures and quality assurance oversight to ensure that material removal operations do not reduce base metal wall thicknesses of the boundaries beyond that allowed by the design. The thicknesses of base metals shall be ultrasonically tested, as necessary, in accordance with written and approved procedures to verify base metal thickness meets design requirements.
6. Dimensional inspections of the HI-STAR 190 shall be performed in accordance with written and approved procedures in order to verify compliance to design drawings and fit-up of individual components. All inspections of critical dimensions and functional fit-up tests shall be documented.
7. The containment boundary shall be hydrostatically or pneumatically pressure tested, if necessary, in accordance with the requirements of the ASME Code and 10CFR71. The test shall be performed in accordance with written and approved procedures. The written and approved test procedure shall clearly define the test equipment arrangement and acceptance criteria.

After completion of the pressure testing, the internal surfaces shall be visually examined for cracking or deformation. Any evidence of cracking or deformation shall be cause for rejection or repair and retest, as applicable. Test results shall be documented and shall become part of the final quality documentation package.

8. The majority of materials used in the HI-STAR 190 cask body are ferritic steels. ASME Code Section III and Regulatory Guides 7.11 and 7.12 require that certain materials be tested in order to assure that these materials are not subject to brittle fracture failures.

Drop weight testing and Charpy impact testing of each plate and forging for the HI-STAR 190 containment boundary are carried out in accordance with Table 8.1.6. Weld material used in welding the containment boundary is also tested as specified in Table 8.1.7.

Non-containment portions of the HI-STAR 190, as required, shall be impact tested in accordance with Table 8.1.8. Test results shall be documented and shall become part of the final quality documentation record package.

9. A containment boundary leakage test of the welded structure shall be performed at any time after the containment boundary fabrication is complete. Preferably, this test should be performed at the completion of fabrication. The leakage test instrumentation shall have a minimum test sensitivity of one half of the leak test rate. Containment boundary welds shall have indicated leakage rates not exceeding leak test acceptance criteria. At the completion of fabrication, the helium leakage through all containment boundary penetrations shall be demonstrated to not exceed the leakage rate acceptance criteria. The leakage rate acceptance criterion is provided in Chapter 8.

10. All required inspections, examinations, and tests shall be documented. The inspection, examination, and test documentation shall become part of the final quality documentation package.
11. The HI-STAR 190 shall be inspected for cleanliness and proper preparation for shipping in accordance with written and approved procedures.
12. A completed quality documentation record package shall be prepared and maintained during fabrication of each HI-STAR 190 to include detailed records and evidence that the required inspections and tests have been performed for important to safety items. The quality document record package shall be reviewed to verify that the HI-STAR 190 has been fabricated and inspected in accordance with the governing Certificate-of-Compliance.

Figure 2.3.1: [PROPRIETARY INFORMATION WITHHELD PER 10CFR2.390]

Figure 2.3.2: [PROPRIETARY INFORMATION WITHHELD PER 10CFR2.390]

Figure 2.3.3: [PROPRIETARY INFORMATION WITHHELD PER 10CFR2.390]

Figure 2.3.4: [PROPRIETARY INFORMATION WITHHELD PER 10CFR2.390]

Figure 2.3.5: [PROPRIETARY INFORMATION WITHHELD PER 10CFR2.390]

Figure 2.3.6: [PROPRIETARY INFORMATION WITHHELD PER 10CFR2.390]

Figure 2.3.7: [PROPRIETARY INFORMATION WITHHELD PER 10CFR2.390]

Figure 2.3.8: [PROPRIETARY INFORMATION WITHHELD PER 10CFR2.390]

Figure 2.3.9: [PROPRIETARY INFORMATION WITHHELD PER 10CFR2.390]

Figure 2.3.10: [PROPRIETARY INFORMATION WITHHELD PER 10CFR2.390]

2.4 GENERAL REQUIREMENTS

The compliance of the HI-STAR 190 Packaging to the general standards for all packaging, specified in 10CFR§71.43, is demonstrated in the following subsections.

2.4.1 Minimum Package Size

As can be seen from the external dimensions of the packaging, in Section 1.3, the HI-STAR 190 Packaging meets the requirements of 10CFR§71.43(a).

2.4.2 Tamper-Indicating Feature

During transport operations, a cover is installed over the access tube above one of the impact limiter attachment bolts as shown in the drawing package for the impact limiters in Section 1.3. A wire tamper-indicating seal with a stamped identifier is attached to hold the cover in place to indicate possible tampering with the upper impact limiter. The upper impact limiter must be removed to gain access to the closure lid bolting and the radioactive contents; thus, the absence of tampering is an indication that the radioactive contents of the package have not been accessed. This tamper seal satisfies the requirements of 10CFR§71.43(b).

As shown in the drawing package for the cask in Section 1.3, the cask closure lid bolts may include holes for installation of wire tamper-indicating seals (security seals). The use of the security seals on the cask closure lid bolts is specified by the user or may be mandated by the authority designated to enforce and inspect such security features.

2.4.3 Positive Closure

There are no quick-connect/disconnect valves in the containment boundary of the HI-STAR 190 Packaging. [

PROPRIETARY INFORMATION WITHHELD PER 10CFR2.390

]

2.5 LIFTING AND TIE-DOWN STANDARDS

All proposed fuel loading configurations (with and without DFC's), heat load patterns and cooling times in Chapter 7 are enveloped by the structural evaluations performed in this section as the calculations use:

- i) bounding fuel assembly weights (including DFC's, GTA's, ITTR's, fuel debris and non-fuel hardware) per Appendix 7.C;
- ii) bounding MPC and overpack loaded weights per Table 2.1.11;
- iii) bounding MPC and overpack internal pressures per Table 2.1.1;
- iv) component temperatures bounding those in Tables 3.1.1 and 3.2.10, as applicable.

2.5.1 Interfacing Lifting Points

Per Reg. Guide 7.9, this subsection presents analyses for all lifting operations applicable to the transport of a HI-STAR 190 package to demonstrate compliance with requirements of paragraph 71.45(a) of 10CFR71.

The HI-STAR 190 Cask has the following types of interfacing lifting points: two lifting trunnions located on the upper cask body for lifting the loaded and unloaded cask and threaded holes on the cask closure lid that serve as attachment locations to lift the lid. In addition, two trunnions are located in the lower cask body for rotation of the loaded and unloaded cask. As noted previously in Subsection 2.1.2.1, these interfacing lifting points are conservatively treated as lifting devices, which are subjected to a more stringent stress requirement per NUREG-0612 [2.1.5].

The evaluation of the adequacy of the interfacing lifting points entails careful consideration of the applied loading and associated stress limits. The load combination D+H, where H is the "handling load", is the generic case for all lifting adequacy assessments. The term D denotes the dead load. Quite obviously, D must be taken as the bounding value of the dead load of the component being lifted. Table 2.1.11 provides package component weights. In all lifting analyses considered in this document, the handling load H is assumed to be equal to 0.15D. In other words, the inertia amplifier during the lifting operation is assumed to be equal to 0.15g. This value is consistent with the guidelines of the Crane Manufacturer's Association of America (CMAA), Specification No. 70, 1988 [2.5.5], Section 3.3, which stipulates a dynamic factor equal to 0.15 for slowly executed lifts. Thus, the "apparent dead load" of the component for stress analysis purposes is $D^* = 1.15D$. Unless otherwise stated, all lifting analyses in this chapter use the "apparent dead load", D^* , in the lifting analysis.

For use as part of a transportation package, the lifting trunnions that are a part of the HI-STAR 190 package are designed to meet the requirements of 10CFR§71.45(a) and NUREG 1617 [2.1.11]. Accordingly, the lifting trunnions are required to maintain a safety factor of 3 based on the material yield strength. The lifting attachments that are part of the HI-STAR 190 package and conservatively considered as lifting devices are required to meet the design provisions of

NUREG-1536 [2.5.6] and NUREG-0612 [2.1.5], which specify higher safety factors of 6 on yield strength and 10 on ultimate strength to ensure safe handling of heavy loads in critical regions within nuclear power plants. Satisfying the more conservative design requirements of NUREG-0612 ensures that the design requirements of 10CFR§71.45(a) are met. Hence the lifting trunnions are conservatively analyzed to meet a minimum safety factor of 6 based on material yield strength and a safety factor of 10 based on material ultimate strength.

Unless explicitly stated otherwise, all stress results for lifting devices are presented in dimensionless form, as safety factors, defined as SF, where:

$$SF = (\text{Allowable Stress Intensity in the Region Considered}) / (\text{Computed Maximum Stress Intensity in the Region})$$

It should be emphasized that in the results for the stress levels in the lifting trunnions, the safety factor, SF represents the additional margin that is over and beyond the margin built into NUREG 0612 (e.g., a minimum safety factor of 10 on ultimate strength or 6 on yield strength).

2.5.1.1 Stress Analysis of Lifting Operations:

The lifting trunnion for the HI-STAR 190 cask is presented in the drawing package provided in Section 1.3. The two top lifting trunnions for HI-STAR 190 are circumferentially spaced at 180 degrees and are engaged to perform the lifting operations. The trunnions are designed for a two-point lift and are sized to satisfy the aforementioned NUREG-0612 criteria. The trunnion material is identified in the drawing package shown in Section 1.3. There are also two trunnions near the base of the cask body. These trunnions may be used as rotation supports when changing cask orientation from vertical to horizontal (or vice-versa), or may be used to support 50% of the loaded cask when it is lifted in a horizontal orientation. In the former case, the lower trunnions may support 100% of the load but they are not acting as lifting trunnions so the requirements of a safety factor of 3 on yield strength need not be satisfied. In the latter case, the lower trunnions are acting as lifting trunnions and must show a minimum safety factor of 3 on yield strength, but the maximum lifted load is 50% of the total load.

The embedded trunnion is analyzed as a cantilever beam subjected to a line load applied at the outer edge of the trunnion (see Figure 2.5.1). This assumption is clearly very conservative because the moment arm of the load has been maximized. In reality the loading is distributed over the exposed surface of the trunnion with the resultant force acting closer to the root of the cantilever than the mid-span location. A Strength of Materials methodology (classical beam theory) is used to represent the trunnion as a cantilever beam with a solid circular cross section. The bending moment and shear force at the root of the trunnion cantilever are compared against allowable values based on either yield or ultimate strength. Calculations demonstrate (Holtec Proprietary Report [2.1.12]) that the stresses in the upper and lower trunnions, computed in the manner of the foregoing, comply with requirements of paragraph 71.45(a) of 10CFR71 and also satisfy NUREG-0612 strength limits.

Key stress results are presented in Table 2.5.1 along with the corresponding safety factors demonstrating that the HI-STAR 190 trunnions are an ANSI N14.6-compliant handling appurtenance.

2.5.1.2 Cask Closure Lid and Baseplate During Lifting

2.5.1.2.1 Closure Lid Lifting Holes

The closure lid contains tapped lifting holes used to move the lid over and onto the closure flange of the cask. Since the cask contains fuel during this movement, the tapped lifting holes in the closure lid are sized so that adequate thread strength and engagement length exist using allowable stresses in accordance with 10CFR§71.45(a) requirements. The method of analysis is based on an industry standard approach to determine the capacity of a threaded connection.

Minimum safety factors are computed in the Holtec Proprietary Report [2.1.12], and are summarized in Table 2.5.2.

2.5.1.2.2 Baseplate

During lifting of a loaded HI-STAR 190 the containment baseplate is subject to amplified dead load, D^* from the loaded MPC, from the self-weight of the baseplate and any attached shielding, and from the overpack internal pressure. Note that the internal pressure loading bounds the weight of the water inside the cask, which acts on the baseplate during cask lifting from the loading pool. To analyze this condition, the baseplate and a portion of the containment shell is modeled using the ANSYS finite element code [2.5.2] and a static analysis performed. The lid is included in the model, and the bolted connection is simulated by merged nodes (common nodes) at the lid to shell interface. In addition to the load applied to the baseplate from the loaded MPC, the maximum normal operating pressure (MNOP) load is applied normal to the surface of the containment boundary (viz. the baseplate, the containment shell and the lid). In this load case, the 15% amplifier is applied to the lifted load. Figure 2.5.2a shows the model and applied loads; the distribution of temperature on the containment boundary is also shown in the figure. Stress intensity results obtained from the finite element analysis are presented in Figure 2.5.2b.

Details of the evaluation and locations of maximum stress intensity are provided in the calculation package [2.1.12]. The results from the analysis of the top-end lift, subject to Level A service load conditions, are summarized in Table 2.5.3, where the minimum safety factors for components in the load path are computed using the ASME allowable stress intensities from Table 2.1.2.

2.5.1.3 Failure of Lifting Devices

10CFR§71.45 also requires that the lifting attachments permanently attached to the cask be designed in a manner such that a structural failure during lifting will not impair the ability of the

transportation package to meet other requirements of 10CFR71. The ultimate load carrying capacity of the lifting trunnion is governed by the cross section of the trunnion outboard of the cask rather than by any section within the cask. Loss of the external shank of the trunnion, therefore, will not cause loss of any other structural or shielding function of the HI-STAR 190 cask; therefore, the requirement imposed by 10CFR§71.45(a) is satisfied.

2.5.2 Tie-Down Devices

There are no tie-down devices that are a structural part of the package. It should be noted that the cask trunnions are made inaccessible during transport per Subsection 7.1.5. Therefore, 10CFR§71.45(b) is not applicable to the HI-STAR 190 Package.

The saddle supports under the cask, the straps, and the front and rear end structures that resist longitudinal load are not part of the HI-STAR 190 package. The loads used to design these components may be determined using the load amplifiers given by the American Association of Railroads (AAR) Field Manual, Rule 88 [2.5.4] or other appropriate standard.

2.5.3 Safety Evaluation of Lifting and Tie-Down Devices

Lifting devices have been considered in Subsection 2.5.1 and tie-down devices have been considered in Subsection 2.5.2. It is shown that requirements of 10CFR§71.45(a) (lifting devices) and 10CFR§71.45(b) (tie-down devices) are satisfied. All safety factors exceed 1.0.

No tie-down device is a permanent part of the cask. All tie-down devices (saddle, tie-down straps, etc.) are part of the transport conveyance and accordingly are not evaluated in this SAR.

2.5.4 MPC Lifting

The MPCs allowed to be transported by the HI-STAR190 transport cask are also licensed to be stored in the HI-STORM FW storage cask. The threaded holes on the MPC lid used for MPC lifting operations have been demonstrated in Subsection 3.4.3.1 of the HI-STORM FW FSAR [2.1.13] to maintain a minimum safety factor of 3 based on material yield strength and a minimum safety factor of 10 based on material ultimate strength. Therefore, the applicable stress requirements of NUREG 1617 [2.1.11], 10CFR§71.45(a) and NUREG-0612 [2.1.5] for lifting attachments or interfacing lift points are all satisfied, and there is no need to repeat the structural evaluation for the MPC lift points in this SAR.

2.5.5 Structural Integrity of Damaged Fuel Containers (DFCs)

The Damaged Fuel Container (DFC) is used to store fuel that is physically impaired, fuel debris and non-fuel hardware (NFH). A typical DFC (see Drawings in Section 1.3), is equipped with a handle or several lift points connected to a square cellular box with a perforated baseplate structurally capable of supporting the weight of the internals (in case the DFC is lifted with the

internals) while permitting water (but not particulates) to pass through. The following acceptance criteria shall be satisfied.

- a. The interfacing lift points, used to handle DFC loaded with an entire spent fuel assembly, must satisfy NUREG-0612 stress limits [2.1.5].
- b. All other load bearing members of the DFC must be designed to satisfy Level A limits per ASME Code, Subsection NG [2.5.9] under normal conditions.
- c. For DFCs that are not designed to lift an entire spent fuel assembly, all load bearing members, including the interfacing lift points, must be designed to satisfy Level A limits per ASME Code, Subsection NG [2.5.9] under normal conditions.
- d. In the event of top-end and bottom-end drops, the containment of DFC internals must be maintained. A conservative approach is to design all load bearing members of the DFC to satisfy Level D limits per ASME Code, Appendix F [2.1.10] using the decelerations from top-end and bottom-end hypothetical accident drops in Table 2.7.2.

The structural load path in each of the analyzed DFC's ([2.5.7] and [2.5.8]) is evaluated using basic strength of materials formulations and/or finite element analyses. Depending on the particular DFC, the load path includes components such as the DFC tube, base plate, side pan plate, various weld configurations, closure components and lifting bolt. An inertial load amplification factor of 0.15 is used per [2.5.5] for lifting evaluations. The various structural components, including welds, are modeled as axial or bending members and their stresses are computed. Comparisons are then made with the appropriate allowable strengths at design temperature. Input data for all DFCs is obtained from the applicable drawings in Section 1.3. The design temperature for lifting evaluations is set at 200°F since the DFC is in the spent fuel pool although a conservatively higher temperature is used in one of the DFC structural evaluations [2.5.7]. The design temperature for accident conditions is set at 752°F.

The detailed structural analyses of both DFCs are documented in [2.5.7] and [2.5.8] and it is demonstrated that all safety factors are above 1.0 under normal and accident conditions.

Table 2.5.1: Key Safety Factors for HI-STAR 190 Trunnions

Item	Calculated Value	Minimum Safety Factor
Upper Solid Trunnion Bending Stress - ksi (MPa)	13.883 (95.72)	1.18 [†]
Upper Solid Trunnion Shear Stress - ksi (MPa)	6.942 (47.86)	1.36 [†]
Bearing Stress on Upper Hollow Trunnion - ksi (MPa)	24.784 (170.88)	1.31
Bearing Stress on Upper Solid Trunnion - ksi (MPa)	24.784 (170.88)	3.97
Lower Solid Trunnion Bending Stress - ksi (MPa)	8.59 (59.23)	1.91 [†]
Lower Solid Trunnion Shear Stress - ksi (MPa)	3.905 (26.92)	2.42 [†]
Bearing Stress on Lower Hollow Trunnion - ksi (MPa)	14.89 (102.67)	2.18
Bearing Stress on Lower Solid Trunnion - ksi (MPa)	14.89 (102.67)	6.6

[†] Represents the additional margin that is over and beyond the mandated safety factors per NUREG-0612 (i.e., a minimum safety factor of 10 on ultimate strength and 6 on yield strength)

Table 2.5.2: Key Safety Factor for HI-STAR 190 Closure Lid Lifting Holes

Item	Value, kg (lb.)	Capacity, kg (lb.)	Minimum Safety Factor
Closure Lid Direct Load	7,303 (16,100) †	15,170 (33,450)	2.08

† Includes 15% inertia load

Table 2.5.3: Top End Lift – Safety Factors

Item	Value- MPa (ksi) (From Figure 2.5.2b)	Allowable- MPa (ksi)	Safety Factor
Containment Shell, Primary Membrane Stress	< 22.68 (3.289)	143.8 (20.85)	> 6.3
Baseplate (Center), Membrane + Bending Stress	< 44.76 (6.492)	215.6 (31.275)	> 4.8
Baseplate (Joint with Shell), Membrane + Bending Stress Intensity	< 66.85 (9.696)	431.3 (62.55)	> 6.4
Notes: The loading case considers MNOP and temperature gradient on the applicable containment boundary in addition to the lifted load. Conservatively, bounding temperature is used to obtain the allowable stress limits.			

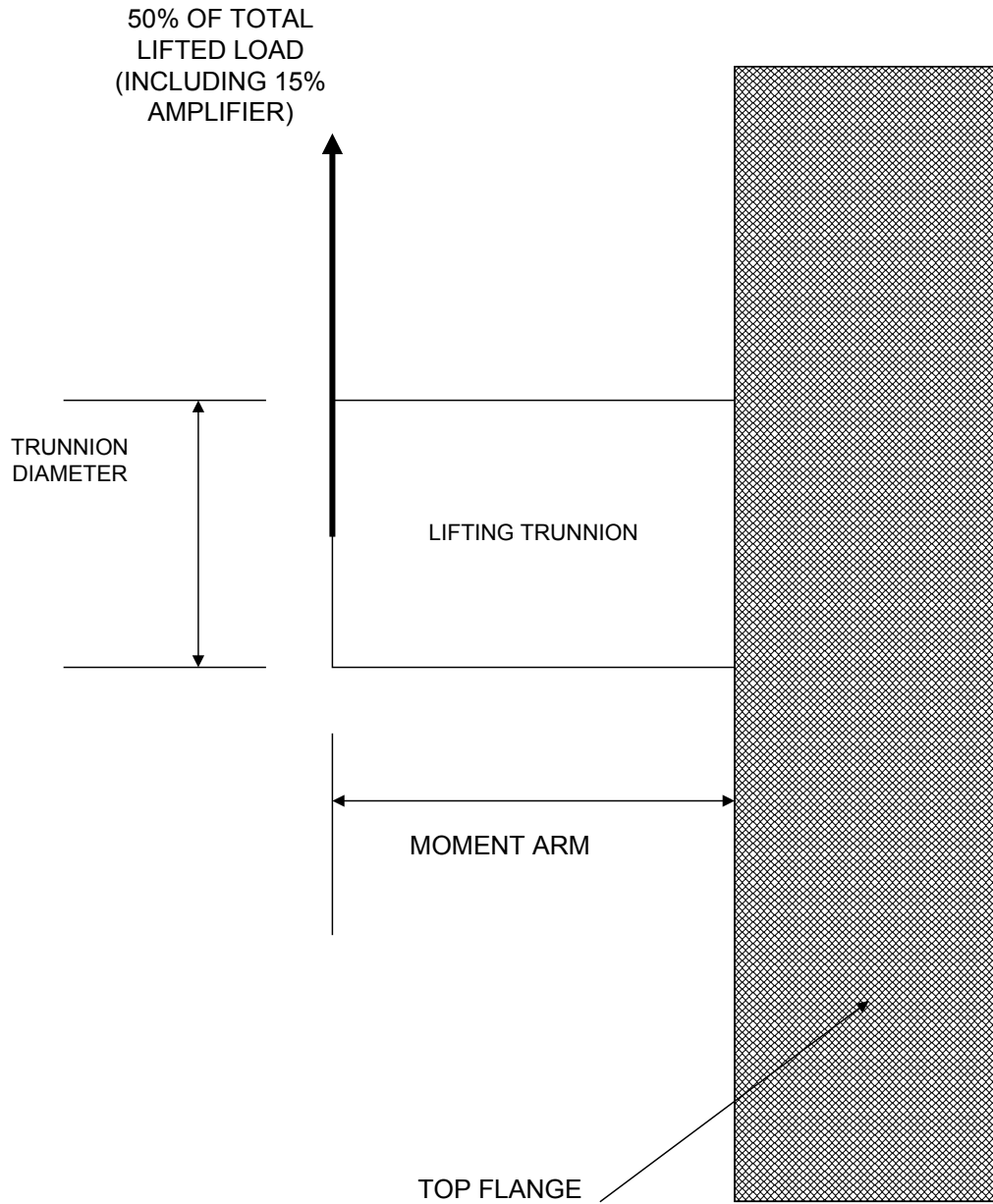

Figure 2.5.1: Top Lifting Trunnion with Applied Force

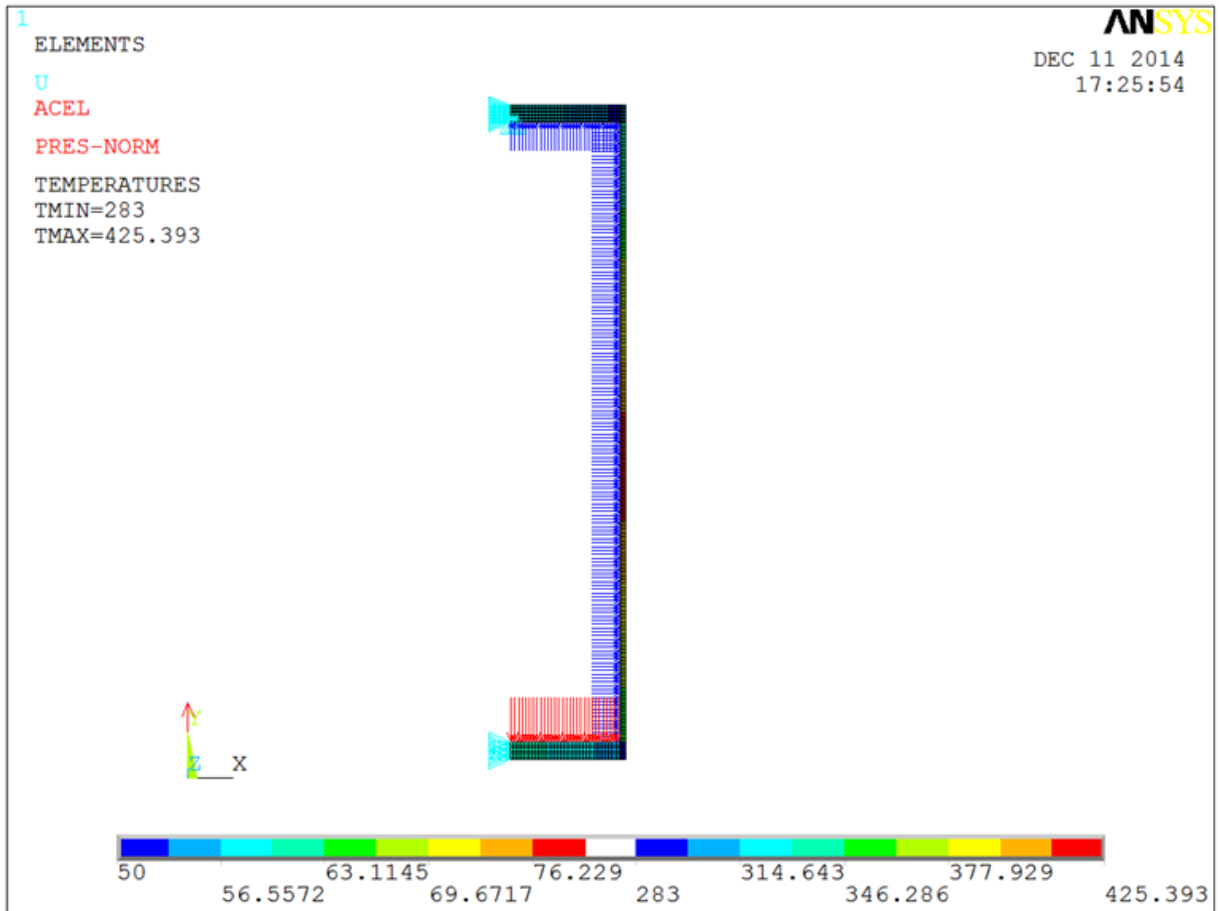

Figure 2.5.2a: Shell and Baseplate Finite Element Model for Lifting Load Case (Loaded MPC, MNOP and Self Weight)

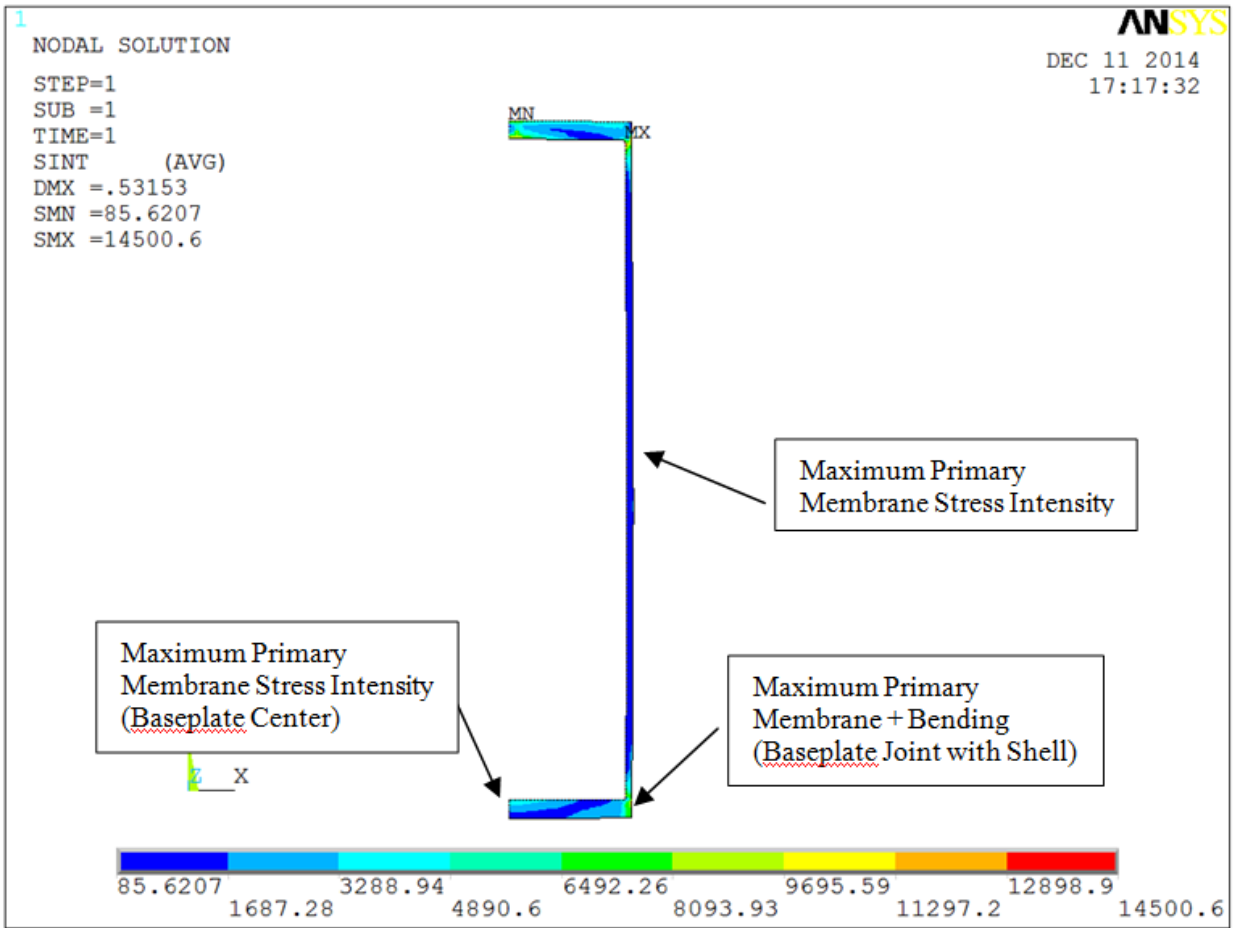

Figure 2.5.2b: Containment Boundary Under Normal Handling (with MNOP) - Stress Intensity Plot

2.6 NORMAL CONDITIONS OF TRANSPORT

All proposed fuel loading configurations (with and without DFC's), heat load patterns and cooling times in Chapter 7 are enveloped by the structural evaluations performed in this section as the calculations use:

- i) bounding fuel assembly weights (including DFC's, GTA's, ITTR's, fuel debris and non-fuel hardware) per Appendix 7.C;
- ii) bounding MPC and overpack loaded weights per Table 2.1.11;
- iii) bounding CG heights per Table 2.1.12;
- iv) bounding MPC and overpack internal pressures per Table 2.1.1;
- v) component temperatures bounding those in Tables 3.1.1 and 3.2.10, as applicable.

In this section, the HI-STAR 190 package consisting of the cask and the AL-STAR impact limiter, is shown to meet the design criteria in Section 2.1 (which are derived from the stipulations in 10CFR§71.43 and 10CFR§71.51) when subjected to the normal conditions of transport specified in 10CFR§71.71. The vehicle utilized for the stress/deformation analysis is a comprehensive 3-D finite element simulation of the package on Q.A.-validated codes (see Appendix 2.A). 3-D finite element models of the cask, the MPC, and the two impact limiters have been prepared and assembled into a complete system to evaluate all of the Normal and Accident Conditions of Transport that involve an impact event. The stress analysis of the cask containment boundary is carried out using a 3-D finite element model or a simplified plate-and-shell theory solution, as appropriate. The stress intensity limits applicable to the containment boundary, as summarized below, are the central focus of the required qualifications.

- i. The containment boundary must meet ASME Code Level A stress intensity limits under the design internal pressure and under operating internal pressure plus temperature appropriate to the normal condition of transport. For conservatism, only the containment boundary is considered, i.e., the strengthening effect of the Dose Blocker parts that girdle the containment shell is neglected.
- ii. The containment boundary must also meet the same Level A stress limits when subject to a 0.3-meter (1 ft) side drop with impact limiters in place. For this dynamic analysis, the entire package is modeled and a comprehensive 3-D finite element simulation of the package drop performed using a public domain, QA validated computer code (Appendix 2.A). For this purpose, 3-D finite element models of the cask, the MPC, and the two AL-STAR impact limiters have been prepared.

As discussed in Appendix 2.B of HI-STAR 180 SAR [1.0.4], the AL-STAR impact limiter was subjected to a series of "9-meter drop tests" on quarter-scale models during the licensing of HI-STAR 100 in the late 90's. The scale model was of the type A-4 in the parlance of Reference [2.7.11]. The quarter-scale drop test results were correlated with a classical contact mechanics-based simulation model to predict the HI-STAR 100 Package's response under *any* drop orientation [2.2.2, 2.7.9]. The test data and the analytical correlation model provided the basis of NRC's transport certification of the HI-STAR 100 package in the late 90s (Docket # 71-9261).

The scale model test data from the H-STAR 100 certification effort has been used to develop an LS-DYNA-based dynamic simulation model to prognosticate the response of the AL-STAR impact limiter. As discussed in Appendix 2.B of [1.0.4], the LS-DYNA model simulates the scale model crush tests with acceptable accuracy. Because of the benchmarked LS-DYNA model, it has been possible to simulate a far greater number of drop scenarios than could be done by physical testing. Equally important, the LS-DYNA solution provides insights into the crush phenomena, such as margin to failure, which was only crudely inferable from scale model physical tests.

[

PROPRIETARY INFORMATION WITHHELD PER 10CFR2.390

]

[

PROPRIETARY INFORMATION WITHHELD PER 10CFR2.390

]

2.6.1 Heat

This subsection, labeled “Heat”, in the format of Regulatory Guide 7.9, contains information on all structural (including thermoelastic) analyses performed on the cask to demonstrate positive safety margins under the normal condition of transport, except for lifting operations that are covered in Section 2.5. Accordingly, this subsection contains all necessary information on the applied loadings, differential thermal expansion considerations, stress analysis models, and results for all Normal Conditions of Transport. Assessment of compliance under “Cold” conditions is presented in Subsection 2.6.2.

The thermal evaluation of the HI-STAR 190 package is reported in Chapter 3, wherein the material temperatures that are needed for the structural evaluations are defined.

2.6.1.1 Summary of Pressures and Temperatures

Table 2.6.2 summarizes values for pressure and temperatures (based on the thermal analysis in Chapter 3) that are used as inputs, as necessary, for the analyses undertaken to structurally qualify the HI-STAR 190 under Normal (Hot) Conditions of Transport.

2.6.1.2 Differential Thermal Expansion

The effect of thermal expansion is closely related to the presence and consideration of gaps in the package, hence both thermal expansion and gaps are discussed together in this subsection.

The appropriate thermal solutions for the HI-STAR 190 system are discussed in Chapter 3, for the Normal Conditions of Transport under hot conditions. Conservative estimates of free thermal expansion of the components in the HI-STAR 190 package are obtained using the computed temperatures, together with conservatively chosen coefficients of thermal expansion, and the calculations and results are documented in the thermal calculation package referenced in Section 3.4. Table 3.4.2 documents the radial and axial expansions prior to and after heat-up.

[

PROPRIETARY INFORMATION WITHHELD PER 10CFR2.390

]

In summary, under Normal Hot Conditions of Transport, the HI-STAR 190 package internals are not subject to restraint of free thermal expansion. Therefore, subsequent buckling or significant MPC deformation due to differential thermal expansions is not credible for the HI-STAR 190 package.

2.6.1.3 Stress Calculations

In this subsection, the structural analysis of the package under the conditions of design pressure, normal operating pressure and temperature, together with the effects of bolt preload, is described. Also considered is the calculation of expenditure of fatigue life (usage factor) of the Containment Boundary parts under the above loads.

2.6.1.3.1 Structural Evaluation of the Package Subject to Pressure, Temperature, Bolt Preload – Normal Operating Condition and 1-foot Free Drop

The Package is analyzed for the Load Combinations N1 and N2 listed in Section 2.1 using the finite element codes ANSYS [2.5.2] and LS-DYNA [2.5.3], and the models described in Section 2.7 and in the Holtec Proprietary calculation packages [2.1.12] and [2.6.1]. For the simulation of the normal operating condition (Load Combination N1 consisting of design pressure and

temperature), the package orientation is not significant. For the 1-foot free drop condition (Load Combination N2), the package is oriented at a 0-degree angle with respect to the horizontal rigid target, and the package has an initial downward vertical velocity given by

$$V = \sqrt{2gH} \quad H = 12 \text{ inches (0.3 meters)}$$

so that $V = 96.3 \text{ inch/sec (244.6 cm/sec)}$

The drop of the package is simulated on LS-DYNA with full representation of elastic-plastic response as discussed in Subsection 2.7.1. The details of the material models and contact surface definitions are documented in the Holtec Proprietary calculation package for the finite element analyses [2.6.1]. This same finite element model is used for both the Normal Conditions of Transport (Load Combination N2) and the Hypothetical Accident Conditions of Transport (drop as well as puncture analyses reported in Section 2.7).

Results from the analysis of the 1-foot drop case (Load Combination N2) are documented in the Holtec Proprietary finite element analysis calculation package [2.6.1]. A discussion of the analysis of the 1 foot drop event and key safety factors are reported in Subsection 2.6.1.4 below.

2.6.1.3.2 Fatigue Considerations

Regulatory Guide 7.9 [2.6.3] suggests consideration of fatigue due to cyclic loading under Normal Conditions of Transport. Considerations of fatigue of individual components of the package, associated with long-term exposure to vibratory motion during normal conditions of transport, are presented below:

- Cask Fatigue Considerations

As shown in the following, the cask in the HI-STAR 190 Package does not require a detailed fatigue analysis because all applicable cyclic loadings are well within the range that permits exemption from fatigue analysis per the provisions of Section III of the ASME Code. Paragraph NB-3222.4 (d) of Section III of the ASME Code provides five criteria that are strictly material and design condition dependent to determine whether a component can be exempted from a detailed fatigue analysis. The sixth criterion pertains to bonded dissimilar materials subject to severe thermal ramps. Because of the large mass and thermal inertia of the cask and the relatively tepid rate of ambient temperature change associated with normal operations, fatigue effects are minimal in HI-STAR 190, as demonstrated by the simplified calculations below.

The Design Fatigue curves for the cask materials are given in Appendix I of Section III of the ASME Code. Each of the five ASME criteria is considered in the following:

i. Atmospheric to Service Pressure Cycle

The number of permissible cycles, n , is bounded by $f(3S_m)$, where $f(x)$ means the number of cycles from the appropriate fatigue curve at stress amplitude of “x” psi. In other words

$$n < f(3S_m)$$

From Tables 2.1.4 and 2.1.6 for normal conditions at a bounding temperature of 450°F, and from the fatigue curve in ASME Code Appendix I, the number of permissible cycles for the containment boundary is

$$n (\text{cask}) \leq 1,600 (3S_m = 62,500 \text{ psi}) \text{ (Figure I-9.1 of ASME Appendix I)}$$

Since 1,000 pressurizations in the 50-year life of the cask is an upper bound estimate, it is concluded that projected pressurizations of the HI-STAR 190 components do not warrant a usage factor evaluation.

ii. Normal Service Pressure Fluctuation

Fluctuations in the service pressure during normal operation of a component are considered if the total pressure excursion δ_p exceeds Δ_p .

where

$$\Delta_p = \text{Design pressure} * S / (3S_m)$$

$$S = \text{Value of } S_a \text{ for one million cycles.}$$

Using the above mentioned tables and appropriate fatigue curves,

$$(\Delta_p)_{\text{overpack}} = \frac{(100)(12,500)}{(3)(20,850)} = 19.98 \text{ psi (0.138 MPa)}$$

During normal operation the pressure field in the cask is steady state. Therefore, pressure fluctuations during normal operation are negligibly small and nowhere approach the limit computed. Therefore, normal service pressure oscillations do not warrant a fatigue usage factor evaluation.

iii. Temperature Difference - Startup and Shutdown

Fatigue analysis is not required if the temperature difference ΔT between any two adjacent points on the component during normal service does not exceed $S_a / 2E\alpha$, where S_a is the cyclic stress amplitude for the specified number of startup and shutdown cycles.

E and α are the Young's Modulus and instantaneous coefficients of thermal expansion (at the service temperature). Assuming 1,000 startup and shutdown cycles, Table 2.2.1 (conservatively assuming a service temperature of 450°F) and the appropriate ASME fatigue curve in Appendix I of Section III of the ASME Code give:

$$(\Delta T)_{\text{overpack}} = \frac{83,000}{(2)(25.95)(7.2)} = 222.1^{\circ}\text{F} \text{ (123.4}^{\circ}\text{C)}$$

There are no locations on the cask where ΔT between any two adjacent points approaches this value. Therefore, it is evident that this temperature criterion is satisfied for 1,000 startup and shutdown cycles.

iv. Temperature Difference - Normal Service

Significant temperature fluctuations that require consideration in this criterion are those in which the range of temperature difference between any two adjacent points under normal service conditions is larger than $S/2E\alpha$ where S corresponds to 10^6 cycles. Substituting gives:

$$(\Delta T)_{\text{overpack}} = \frac{12,500}{(2)(25.95)(7.2)} = 33.45^{\circ}\text{F} \text{ (18.6}^{\circ}\text{C)}$$

During normal operation, the temperature field in the cask is steady state. Therefore, normal temperature fluctuations are negligibly small. Therefore, normal temperature fluctuations do not warrant a fatigue usage factor evaluation.

v. Mechanical Loads

Mechanical loadings of appreciable cycling occur in the HI-STAR 190 Package only during transportation. The stress cycling under transportation conditions is considered significant if the stress intensity amplitude is greater than S_a corresponding to 10^6 cycles. It, therefore, follows that the stress intensity range that exempts the cask is 25,000 psi (172.4MPa).

Inertia loads typically associated with rail transport will produce stress intensity ranges in the cask that are a small fraction of the above limits. Therefore, the potential for large fatigue expenditure in the cask materials, under transportation conditions, is not credible.

In conclusion, the cask does not require fatigue evaluation under the exemption criteria of the ASME Code.

- Fatigue Analysis of Closure Bolts

The maximum tensile stress range, developed in the cask closure bolts during normal operating

conditions, occurs during the preload operation. The maximum bolt stress is permitted to have the value $2S_m$ (Table 2.1.3). For the closure lid bolt material (SA-564 630/705 (H1025)), the value of S_m at 350°F (177°C) is 47.65 ksi (328.5 MPa) per Table 2.1.8, and the Young's modulus is 26,950 ksi (185,800 MPa). Therefore, incorporating a fatigue strength reduction factor of 4, the effective stress intensity amplitude using Figure I-9.4 (ASME Code, Section III Appendices [2.1.10]) is (ratioing the modulus used in the figure to the modulus used here):

$$S_a = \frac{(47.65)(4)(30e+06)}{26.95e+06}$$

$$= 212.2 \text{ ksi} = 1463 \text{ MPa}$$

Using Figure I-9.4 of [2.1.10], the permissible number of cycles is 225; this sets a limit on the number of permitted loadings for a set of closure lid bolts.

A similar fatigue evaluation for an alternative closure lid bolting material SB-637 N07718 is performed and the corresponding permissible number of cycles is determined as follows:

$$S_a = \frac{(46.5)(4)(29.8e+06)}{27.7e+06}$$

$$= 200.1 \text{ ksi} = 1380 \text{ MPa}$$

Using Figure I-9.7 of [2.1.10], the permissible number of cycles is 256; this sets a limit on the number of permitted loadings if SB-637 N07718 material is used for the closure lid bolts.

- Fatigue Analysis of Closure Lid Port Cover Bolts

The maximum tensile stress range, developed in the cask closure lid port cover bolts during normal operating conditions, occurs during the preload operation. The maximum bolt stress is permitted to have the value $2S_m$ (Table 2.1.3). At a temperature of 350°F (177°C), Table 2.1.8 shows that the closure lid port cover lid bolt material (SA-193 B7) may be pre-stressed to a value not to exceed 61.9 ksi (426.8MPa). The alternating stress intensity in the bolt is equal to 1/2 of the maximum stress intensity, or 30.95 ksi (213.4MPa). Per Table 2.2.2, the Young's modulus is 28,250 ksi (194,800 MPa). Therefore, incorporating a fatigue strength reduction factor of 4, the effective stress intensity amplitude using Figure I-9.4 (ASME Code, Section III Appendices) is (ratioing the modulus used in the figure to the modulus used here):

$$S_a = \frac{(30.95)(4)(30e+06)}{28.25e+06}$$

$$= 131.5 \text{ ksi} = 906.7 \text{ MPa}$$

Using Figure I-9.4 of [2.1.10], the permissible number of cycles is 558; this sets a limit on the

number of permitted loadings for the closure lid port cover bolts.

- Fatigue Considerations for the Containment Closure Flange Internal Closure Bolt Threads

Fatigue of the threads in the containment closure flange is also evaluated. Based on the nominal diameter and the thread engagement length, the total shear area of the cask closure bolt threads can be computed. The maximum shear stress on the threaded area of the flange is calculated using 96.6 ksi (the maximum Level A allowable stress of the bolt per Table 2.6.3) as bolt stress. The resulting shear stress is less than:

$$\tau = 18 \text{ ksi (124.1 MPa)}$$

The primary membrane stress intensity in the closure flange threads is equal to twice the maximum shear stress, and the alternating stress intensity in the threads, S_a , is equal to 1/2 of the total stress. Conservatively, using the cask design temperature (450 °F per Table 3.2.10), the Young's Modulus (Table 2.2.1) is 25,950 ksi (178,900 MPa).

The effective stress amplitude accounting for the fatigue strength reduction and Young's Modulus effects is given by

$$S_a = \frac{(18)(4)(30)}{25.95} = 83.3 \text{ ksi (573.9 MPa)}$$

Using Figure I-9.1 of [2.1.10], the allowable number of cycles is approximately equal to 1000.

Therefore, the *maximum service life of the closure flange threads is 1000 cycles* of torque and un-torque of the cask closure system.

- Satisfaction of Regulatory Guide 7.6 Commitment (Condition 7 on Cyclic Stress Intensity Range)

The minimum alternating stress range, S_a , at 10 cycles from all appropriate fatigue curves is 580 ksi. Calculated stress intensities in the containment boundary under any of the analyses performed in this SAR under the required load combinations for Normal Conditions of Transport are less than the ultimate strength of the containment vessel material (70 ksi). Conservatively assuming a stress concentration of 4 regardless of specific location produces a stress intensity range below $4 \times (70 \text{ ksi}) = 280 \text{ ksi} (< 580 \text{ ksi})$. Therefore, satisfaction of the Regulatory Guide 7.6 commitment on alternating stress intensity range is assured.

2.6.1.3.3 Stability of the Metamic Fuel Basket Plates

Under certain conditions, the fuel basket plates may be under direct compressive load. Although the finite element simulations can predict the onset of an instability and post-instability behavior,

the computation in this subsection uses (the more conservative) classical instability formulations to demonstrate that an elastic instability of the basket plates is not credible.

[

PROPRIETARY INFORMATION WITHHELD PER 10CFR2.390

]

[

PROPRIETARY INFORMATION WITHHELD PER 10CFR2.390

]

2.6.1.3.4 Closure Lid Flanged Joint

The closure lid-to-flange joint in all HI-STAR family of casks is engineered to be a “controlled compression joint” (see Figure 2.6.1) widely used in the pressure vessel industry (see [2.7.7, Chapter 3, pp 144-51]).

[

PROPRIETARY INFORMATION WITHHELD PER 10CFR2.390

]

[

PROPRIETARY INFORMATION WITHHELD PER 10CFR2.390

[]

PROPRIETARY INFORMATION WITHHELD PER 10CFR2.390

[]

PROPRIETARY INFORMATION WITHHELD PER 10CFR2.390

[]

PROPRIETARY INFORMATION WITHHELD PER 10CFR2.390

]

[PROPRIETARY INFORMATION WITHHELD PER 10CFR2.390
]

2.6.1.3.5 Re-flood Event

[

PROPRIETARY INFORMATION WITHHELD PER 10CFR2.390

]

2.6.1.4 Comparison with Allowable Stresses

Following Regulatory Guide 7.9, calculated stress intensities in the containment component of the package from all analyses are compared with the allowable stress intensities defined in Section 2.1 (Tables 2.1.4 through 2.1.10) as applicable for conditions of normal transport. The results of these comparisons are presented in the form of factors of safety (SF) defined as:

$$SF = \frac{\text{Allowable Stress}}{\text{Calculated Stress}}$$

For convenience, those specific allowable strengths, loads, etc., that are used to develop the safety factors are summarized in Table 2.6.3. Data from Sections 2.1 and 2.2 are used to construct Table 2.6.3.

Safety factors associated with components identified as lifting and tie-down devices have been presented in Section 2.5 as set forth by Regulatory Guide 7.9.

2.6.1.4.1 Results for Pressure Boundary Stress Intensity

Results from the finite element analyses for Load Combinations N1 and N2 are tabulated for normal heat conditions of transport in Holtec Proprietary calculation packages [2.1.12] and [2.6.1], respectively. For Load Combination N1, a static axi-symmetric finite element model is constructed using ANSYS [2.5.2] using layered Plane42 elements to model the through-thickness behavior of the containment shell and the baseplate. The tabular results include contributions from mechanical and thermal loading and are needed to insure satisfaction of primary and primary plus secondary stress limits for normal conditions of transport. For the purpose of this calculation only, the closure lid-shell junction is modeled assuming a clamped connection in recognition that the large preload from the closure lid bolts, necessary to insure continued sealing during the drop events, will preclude relative rotations at the joint under the internal pressure. The analysis considers the combined effects of the design internal pressure in Table 2.1.1 and the operating temperature distribution (Table 2.6.2). Figure 2.6.3 shows the axi-symmetric finite element model, and Figure 2.6.4 shows the graphical results, both reproduced from [2.1.12].

For Load Combination N2, a dynamic finite element model implemented in LS-DYNA [2.5.3] is used to determine the peak deceleration of the cask and evaluate stresses in the cask components.

Results are evaluated against Level A stress intensity limits for locations in the containment shell, and in the baseplate, which together with the closure lid, make up the containment boundary. The bolted connection of the lid to the closure flange is not modeled for Load Combination N1, as this solution is not meant to evaluate the sealing performance of the gaskets.

The key results for Load Combinations N1 and N2 are summarized, in Tables 2.6.5 and 2.6.6, respectively, wherein the minimum safety factor for different components of the cask for each of the load combinations is presented. All safety factors are conservatively computed using allowable stresses based on the maximum normal operating temperatures (see Tables 2.1.1 and 2.6.2 for component temperatures, and Table 2.6.3 for allowable stress intensities).

2.6.1.4.2 Result Summary for Normal Heat Condition for Transport

- Maximum Cask Deceleration from Load Combination N2

Table 2.6.4 lists the maximum cask deceleration calculated for the 0.3-meter side drop using the LS-DYNA model.

- Stress Intensity Results from Overall Finite Element Analysis of the Cask

Table 2.6.5 is a summary table that includes primary and primary plus secondary stress intensity safety factors (per Table 2.1.2) for Load Combination N1 associated with the Normal (Heat) Conditions of Transport. Table 2.6.6 provides similar results for Load Combination N2. The tabular results demonstrate that all safety factors exceed 1.0 at the key locations for each component of the containment boundary.

- Status of Lid Bolts and Seals

[

PROPRIETARY INFORMATION WITHHELD PER 10CFR2.390

]

The closure lid port cover seals are analyzed using classical methods to demonstrate that the torque requirement for the closure lid port cover bolts (Tables 2.2.10 and 7.1.1) is sufficient to seat the gasket and maintain a positive contact load on the land under Normal Conditions of Transport.

Based on the results of the above analyses for Normal (heat) Conditions of Transport, the following conclusions are reached.

- i. No bolt overstress is indicated under any loading event associated with Normal Conditions of Transport. As expected, the tensile stress in the bolts remains essentially unchanged from its initial preload state for reasons discussed in Subsection 2.6.1.
- ii. The closure lid seals, including port cover seals, do not unload beyond the minimum force required to maintain the leak tightness under Load Combinations N1 and N2; therefore, the seals continue to perform their function under Normal Conditions of Transport.

- Performance of MPC Enclosure Vessel

The MPC enclosure vessel under Load Combination N1 has been structurally qualified in HI-STORM FW FSAR [2.1.13], where the MPC enclosure vessel was evaluated at bounding temperatures since the MPC is hotter when it's in HI-STORM FW. The LS-DYNA simulation results for Load Combination N2 demonstrate that all safety factors of the MPC enclosure vessel structural components are greater than 1.0, as shown in Table 2.6.6.

- ASME Pressure Test Condition

See Paragraph 8.1.3.2 for pressure test specifications.

- Performance of Non-Containment Components of Package

The Holtec Proprietary calculation package documenting all of the finite element solutions [2.6.1] contains graphical visualizations of the stress intensity and deformation for every component in the HI-STAR 190 package. Table 2.6.7 summarizes the acceptance criteria for performance of the non-containment components of the HI-STAR 190. From Table 2.6.7, it is established that the surveyed components meet the acceptance requirements stated for Load Combination N2.

- Summary of Results for Normal Heat Conditions of Transport

Tables 2.6.4 through 2.6.7 present a concise summary of safety factors and performance results for the HI-STAR 190 for the Normal Heat Condition of Transport.

Based on the results of all analyses, it is concluded that:

- i. All safety factors reported in the text and in the summary tables are greater than 1.0.
- ii. There is no buckling or plastic deformation distortion of the cask internals.
- iii. All performance requirements are met for the non-containment components.
- iv. The containment boundary seals, which includes the closure lid seals and the vent and drain port cover seals, do not unload beyond the useful springback required to maintain leak tightness (per Table 2.10).

Therefore, the HI-STAR 190 Package, under the Normal Heat Conditions of Transport, has adequate structural integrity to satisfy the subcriticality, containment, shielding, and temperature requirements of 10CFR71.

2.6.2 Cold

The Normal Cold Condition of Transport assumes an ambient environmental temperature of -20°F (-29°C) and maximum decay heat. A special condition of extreme cold is also defined in Regulatory Guide 7.8 where the package and environmental temperature is at -40°F (-40°C) and the package is exposed to increased external pressure with minimum internal pressure. A discussion of the resistance to failure due to brittle fracture is provided in Section 2.1.

The value of the ambient temperature has two principal effects on the HI-STAR 190 Package, namely:

- i. The steady-state temperature of all material points in the cask will go up or down by the amount of change in the ambient temperature.
- ii. As the ambient temperature drops, the absolute temperature of the contained helium will drop accordingly, producing a proportional reduction in the internal pressure in accordance with the Ideal Gas Law.

In other words, the temperature gradients in the cask components under steady-state conditions will remain the same regardless of the value of the ambient temperature. The internal pressure, on the other hand, will decline with the lowering of the ambient temperature. Since the stresses under normal transport condition arise principally from pressure and thermal gradients, it follows that the stress field in the cask under a bounding "cold" ambient would be smaller than the "heat" condition of normal transport, treated in the preceding subsection.

In addition, allowable stresses generally increase with decreasing temperatures. Safety factors, therefore, will be greater for an analysis at cold temperatures than at hot temperatures. Therefore, the safety factors reported for the hot conditions in Subsection 2.6.1 provide the limiting margins. However, since the bolt preloads may be altered by a change in the environmental temperature, the effect of bolt temperature changes on the level of preload, subsequent to the initial application of preload, must be considered and is evaluated in the Holtec Proprietary calculation package [2.1.12]. The methodology used is identical to that used for closure bolt analysis on the HI-STAR 180 Docket (71-9325). Based on the change in modulus and coefficients of thermal expansion, the relative growth (or shrinkage) of a preloaded bolt connecting the lid to the flange is established by classical strength of materials procedure. The results from that calculation are summarized below:

Evaluation of Environmental Temperature Changes on the Level of Preload	
Item	Value
Initial Bolt Prestress - Heat, ksi (MPa)	45 (310)
% Change from Heat to Cold	< 0.7

The computed change in stress due to the assumption of a severe local low temperature condition is insignificant compared to the initial bolt stress and to the change in the allowable bolt stress because of the lowered temperature. It is concluded that the small change in bolt preload stress will have an insignificant effect on structural calculations and therefore safety factors and sealing are essentially unaffected by the environmental change.

As no liquids are included in the HI-STAR 190 Package design, loads due to expansion of freezing liquids are not considered.

2.6.2.1 Differential Thermal Expansion

The methodology to determine differential thermal expansion in the Normal Heat Condition of Transport is presented in Chapter 3. The same methodology is applied for the Normal Cold Condition of Transport, and results are summarized in Chapter 3.

It can be verified by referring to the drawing packages in Section 1.3 that the clearances between the MPC and cask inside surface are sufficient to preclude temperature induced interference in the cold condition.

No further analysis is warranted for the cold condition since (a) the restraint of free thermal expansion is less under cold conditions and (b) material strength properties tend to be greater at lower temperatures, resulting in higher allowable stress limits.

It is concluded that the HI-STAR 190 package meets the requirement that there be no restraint of free thermal expansion, under Normal Cold Conditions of Transport, that would lead to primary stresses greater than the applicable ASME Level A limit.

2.6.3 Reduced External Pressure

The effects of a reduced external pressure equal to 25 kPa (3.5 psia) are bounded by results from the design internal pressure analysis for the cask (Load Combination N1). This case does not provide any bounding loads for other components of the cask containment boundary.

2.6.4 Increased External Pressure

The effect of an external pressure equal to 140 kPa (20 psia) on the package, which is stated in USNRC Regulatory Guide 7.8 [2.1.4], is bounded by the effect of the large value for the external pressure specified by 10CFR§71.61 (2 MPa (290 psia)). Instability of the containment boundary shell, under this external pressure is examined in Section 2.7. Therefore, no additional analyses are performed herein to demonstrate package performance.

2.6.5 Vibration

During transport, vibratory motions occur which could cause low-level stress cycles in the package due to beam-like deformations. If any of the package components have natural frequencies in the flexible range (i.e., below 33 Hz), or near the flexible range, then resonance may amplify the low level input into a significant stress response. Strength of materials calculations are performed to establish that vibrations are not an issue in transport of the HI-STAR 190.

The lowest frequency of vibration during normal transport conditions may occur due to vibrations of a fuel basket cell wall. An analysis to determine the lowest frequency of vibration of the component has been performed. For this computation, the fuel basket plate (cell wall) is assumed to vibrate like a simply supported beam. Based on the plate mass density and the plate dimensions, the lowest natural frequency is well in the rigid range (see the Holtec Proprietary calculation package [2.1.12]).

When in a horizontal position, the cask is supported over a considerable length of the dose blocker parts. Conservatively considering the HI-STAR as a supported beam at its two extremities and assuming the total mass of the fuel basket and its contents moves with the cask, a computation of the lowest natural frequency of the structure during transport provides a result in the rigid range. (see Holtec proprietary calculation package [2.1.12]).

Based on these frequency calculations, it is concluded that vibration effects are inconsequential to the structural integrity of the cask.

[

PROPRIETARY INFORMATION WITHHELD PER 10CFR2.390

[

]

PROPRIETARY INFORMATION WITHHELD PER 10CFR2.390

]

2.6.6 Water Spray

The condition is not applicable to the HI-STAR 190 Package per [2.1.4].

2.6.7 Free Drop

The structural analysis of a 0.3-meter (1-foot) free drop under the heat condition is documented in Subsection 2.6.1.4. As demonstrated in Subsection 2.6.1.4 safety factors are all over 1.0 (see Table 2.6.6 for Load Combination N2). The discussion in subsection 2.6.2 demonstrates why the cold condition is not a bounding condition for the 0.3-meter (1-foot) free drop.

2.6.8 Corner Drop

This condition is not applicable to the HI-STAR 190 Package per [2.1.3].

2.6.9 Compression

This condition is not applicable to the HI-STAR 190 Package per [2.1.3].

2.6.10 Penetration

This condition is not applicable to the HI-STAR 190 Package per [2.1.4].

Table 2.6.1: [PROPRIETARY INFORMATION WITHHELD PER 10CFR2.390]

HI-STAR 190 SAR
Report HI-2146214

2.6-23

Proposed Revision 2A

Table 2.6.2: Summary of Operating Pressure Difference and Bounding Average Metal Temperatures for Normal Condition of Transport (“Heat” Condition)

Location	Pressure kPa (psig)	Min. Component Temperature Used in the Safety Factor Evaluation °C (°F) ^{††}
Containment Shell	Refer to Table 2.1.1	177 (350)
Containment Baseplate		149 (300)
Containment Top Flange		107 (225)
Closure Lid		121 (250)
Closure Lid Seal and Bolt		98.9 (210)
Cylindrical Lead Layer		166 (330)
Intermediate Shell		163 (325)
Cylindrical Holtite B Layer		160 (320)
Outer Shell		135 (275)
Base Lead and Holtite		149 (300)
MPC Lid		177 (350)
MPC Shell		232 (450)
MPC Baseplate		177 (350)
Fuel Basket – Middle Periphery		325 (617)
Fuel Basket – Middle Center		350 (662)
Fuel Basket – Top and Base	300 (572)	

Notes:

^{††}Temperatures listed bound the calculated temperature results obtained from the thermal analysis discussed in Chapter 3. Added conservatism may be noted in some of the structural calculations where bounding temperatures are considered while evaluating the minimum safety margins.

**Table 2.6.3: Allowable Stresses for Level A and Level D Conditions
(Normal and Accident Conditions of Transport)**

ITEM	LEVEL A [†]	LEVEL D [†]	TEMPERATURE
Closure Lid – Primary Bending Stress Intensity – MPa (ksi)	233 (33.8)	506.8 (73.5)	121°C (250°F)
Containment Shell – Primary Membrane Stress Intensity – MPa (ksi)	150.0 (21.75)	337.8 (49.0)	177°C (350°F)
Containment Shell – Primary Membrane + Bending Stress Intensity – MPa (ksi)	225.0 (32.65)	506.8 (73.5)	177°C (350°F)
Containment Shell – Primary + Secondary Stress Intensity – MPa (ksi)	449.9 (65.25)	NA	177°C (350°F)
Baseplate – Primary Membrane + Bending Stress Intensity – MPa (ksi)	228.6 (33.2)	506.8 (73.5)	149°C (300°F)
Baseplate – Primary + Secondary Stress Intensity – MPa (ksi)	457.2 (66.3)	NA	149°C (300°F)
Lid Bolts (SA-564/750 630) – Average Service Stress – MPa (ksi)	666.0 (96.6)	920.5 (133.5)	98.9°C (210°F)
Lid Bolts (SA-564/750 630) – Maximum Service Stress at Extreme Fiber – MPa (ksi)	999.1 (144.9)	1068.7 (155)	98.9°C (210 °F)
Lid Bolts (SB-637 N07718) – Average Service Stress – MPa (ksi)	660.4 (95.78)	990.6 (143.67)	98.9°C (210°F)
Lid Bolts (SB-637 N07718) – Maximum Service Stress at Extreme Fiber – MPa (ksi)	990.6 (143.67)	1222 (177.19)	98.9°C (210 °F)
MPC Enclosure Vessel Primary Membrane Stress Intensity – MPa (ksi)	124.45 (18.05)	298.5 (43.3)	232°C (450 °F)
MPC Enclosure Vessel Primary Membrane and Bending Stress Intensity – MPa (ksi)	186.98 (27.12)	447.8 (64.95)	232°C (450 °F)
MPC Enclosure Vessel Primary + Secondary Stress Intensity – MPa (ksi)	399.2 (57.9)	NA	177°C (350 °F)
† Obtained from Section 2.1.			

Table 2.6.4: Maximum Deceleration under 1-Ft (0.3-M) Free Drop Condition (Side Drop)

Method	α_{\max} (g's)
Numerical (LS-DYNA) Solution	19.7
<p>Note: This simulation considers the limiting upper bound crush strength for the impact limiter material.</p>	

**Table 2.6.5: Key Containment Boundary Stress Intensities and Safety Factors
– Load Combination N1 (Static Analysis)**

Location and Stress Intensity Component [†]	Calculated Value*
Closure Lid – Primary Bending Stress Intensity – MPa (ksi)	33.2 (4.81) SF=6.50
Containment Shell – Primary Membrane Stress Intensity – MPa (ksi)	33.2 (4.81) SF=4.33
Containment Shell/Baseplate Joint – Primary + Secondary Stress Intensity – MPa (ksi)	87.3 (12.66) SF=4.94
Baseplate – Primary Membrane + Bending Stress Intensity at Center – MPa (ksi)	44.0 (6.38) SF=4.90

Note:

* “SF” means Safety Factor; safety factors are calculated conservatively based on allowable stresses at a bounding temperature of 450 °F, instead of the less conservative values listed in Table 2.6.3.

† Except for Load Combination N2, the MPC enclosure vessel is subjected to identical Level A pressure loadings under both normal storage (in HI-STORM FW) and transport (in HI-STAR 190) conditions. Moreover, the MPC enclosure vessel is hotter in HI-STORM FW. Therefore, the structural integrity of the MPC containment boundary has been qualified in the HI-STORM FW FSAR [2.1.13] for Level A pressure loading conditions (including Load Combination 1), except for Load Combination N2 which is reported in Table 2.6.6. Therefore, this table only reports the overpack containment boundary results for Load Combination N1.

Table 2.6.6: Key Containment Boundary Stress Intensities and Safety Factors – Load Combination N2 (1-Ft Drop, Dynamic Analysis)

Item	Allowable from Table 2.6.3	Calculated Value	Safety Factor
Primary Membrane Stress Intensity of the Containment Shell – MPa (ksi)	150.0 (21.75)	45.8 (6.64)	3.28
Primary + Secondary Stress Intensity of the Containment Shell – MPa (ksi)	449.9 (65.25)	95.6 (13.86)	4.71
Primary Membrane Stress Intensity of the MPC – MPa (ksi)	124.45 (18.05)	90.94 (13.19)	1.37
Primary + Secondary Stress Intensity of the MPC – MPa (ksi)	399.2 (57.9)	317.2 (46.0)	1.26

Notes:

* Safety factors are calculated based on the allowable stresses defined in Table 2.6.3.

† As an example, the stress distribution in the containment shell under 1-ft (0.3 m.) side drop is shown in Figure 2.6.5.

‡ The MPC enclosure vessel internal pressure and the cask cavity pressure are not considered in the MPC enclosure vessel model for conservatism, since the net positive MPC internal pressure works against the impact loading developed between the MPC and the cask cavity surfaces in the 1-ft side drop event.

Table 2.6.7: Key Performance Objectives for Non-Containment Components of the HI-STAR 190

Criterion	Load Combination N1	Load Combination N2
Stress Intensity in the steel dose blocker parts – Primary Stress Intensity Below Ultimate Strength	-	Yes
Fuel Basket Deformation – Maximum Deflection < 1 mm	Yes	Yes

Table 2.6.8: [PROPRIETARY INFORMATION WITHHELD PER 10CFR2.390]

Table 2.6.9: [PROPRIETARY INFORMATION WITHHELD PER 10CFR2.390]

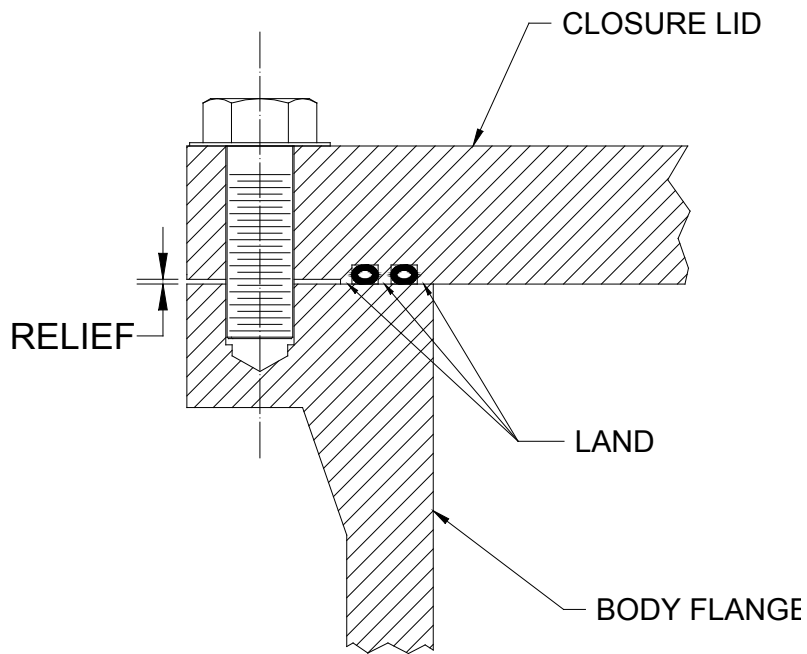

Note:
The sealing grooves may be
located in the flange or the cover.

Figure 2.6.1: Essential Elements of a Classical "Controlled Compression Joint"

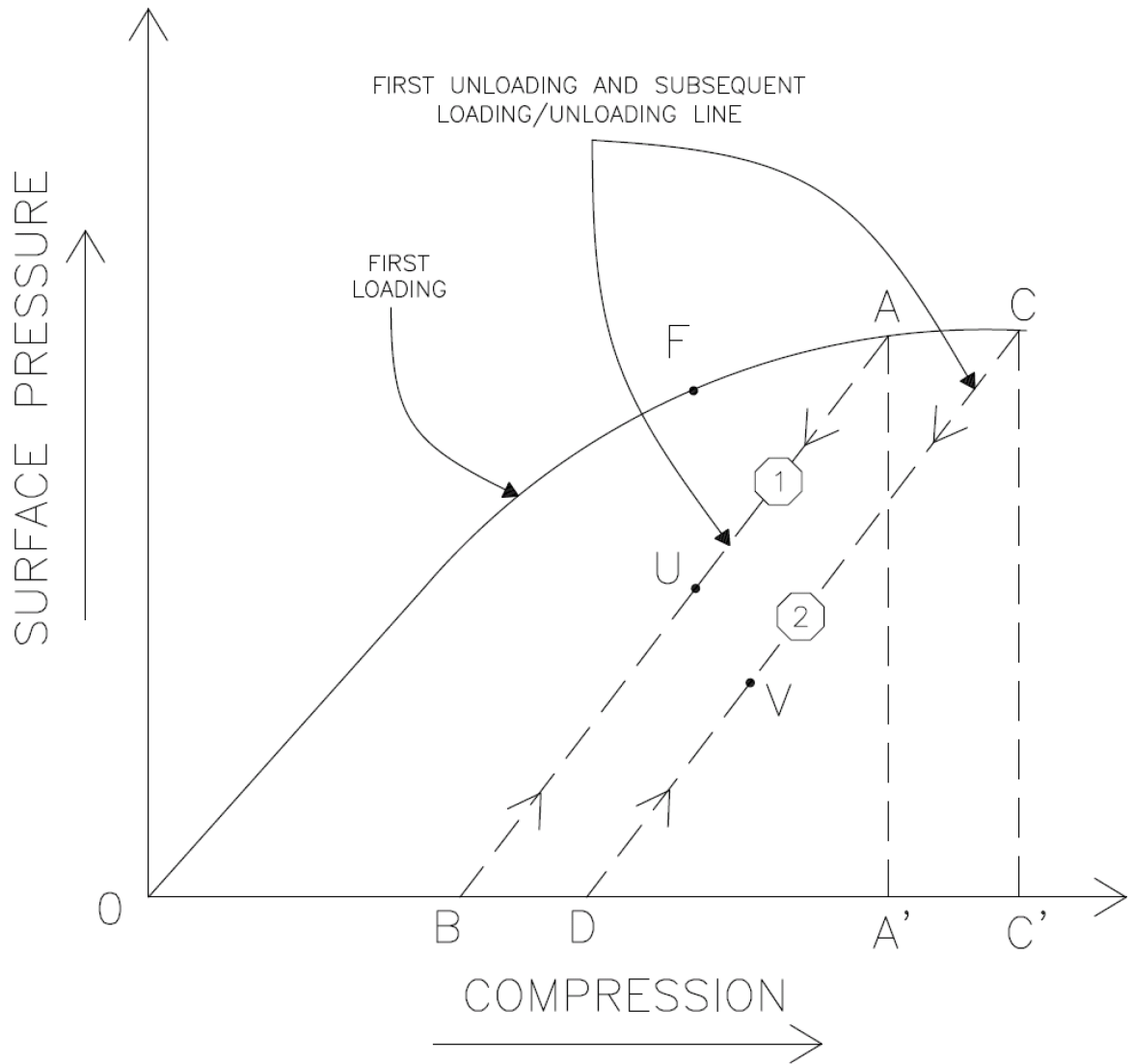

Figure 2.6.2: Loading and Unloading Curves for a Typical Gasket

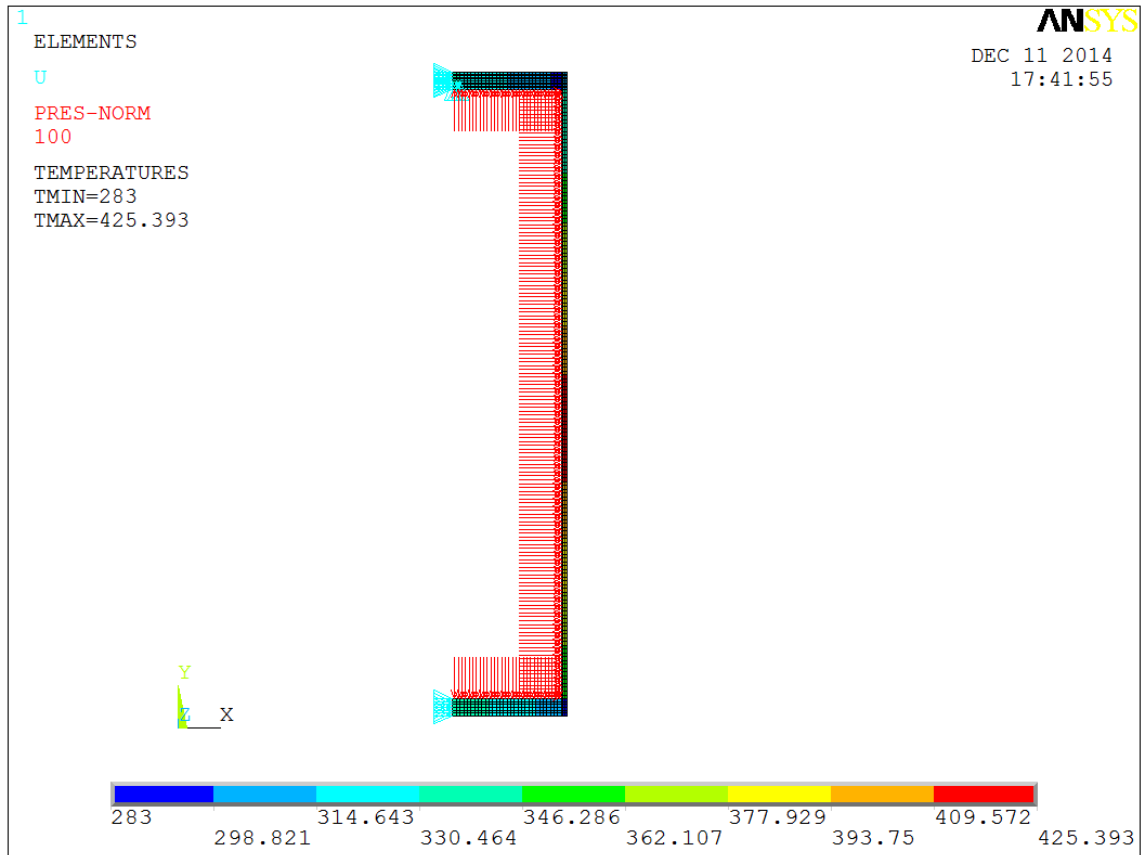

Figure 2.6.3: HI-STAR 190 Overpack Containment Boundary Finite Element Model for Load Combination N1

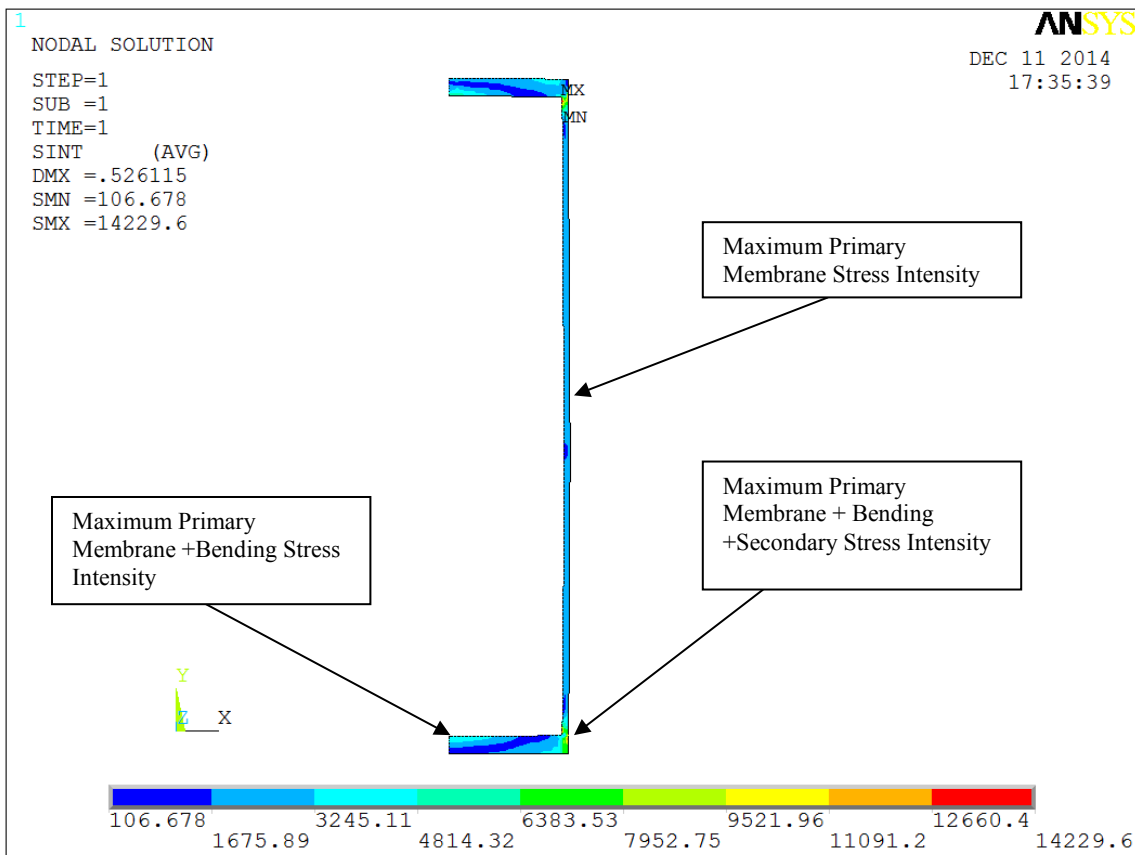

Figure 2.6.4: HI-STAR 190 Overpack Stress Intensity Results for Load Combination N1

HI-STAR 190 0.3M DROP - SIDE
Time = 0.0165
Contours of Tresca (max shear stress)
max IP. value
min=162.876, at elem# 417967
max=9182.75, at elem# 94717

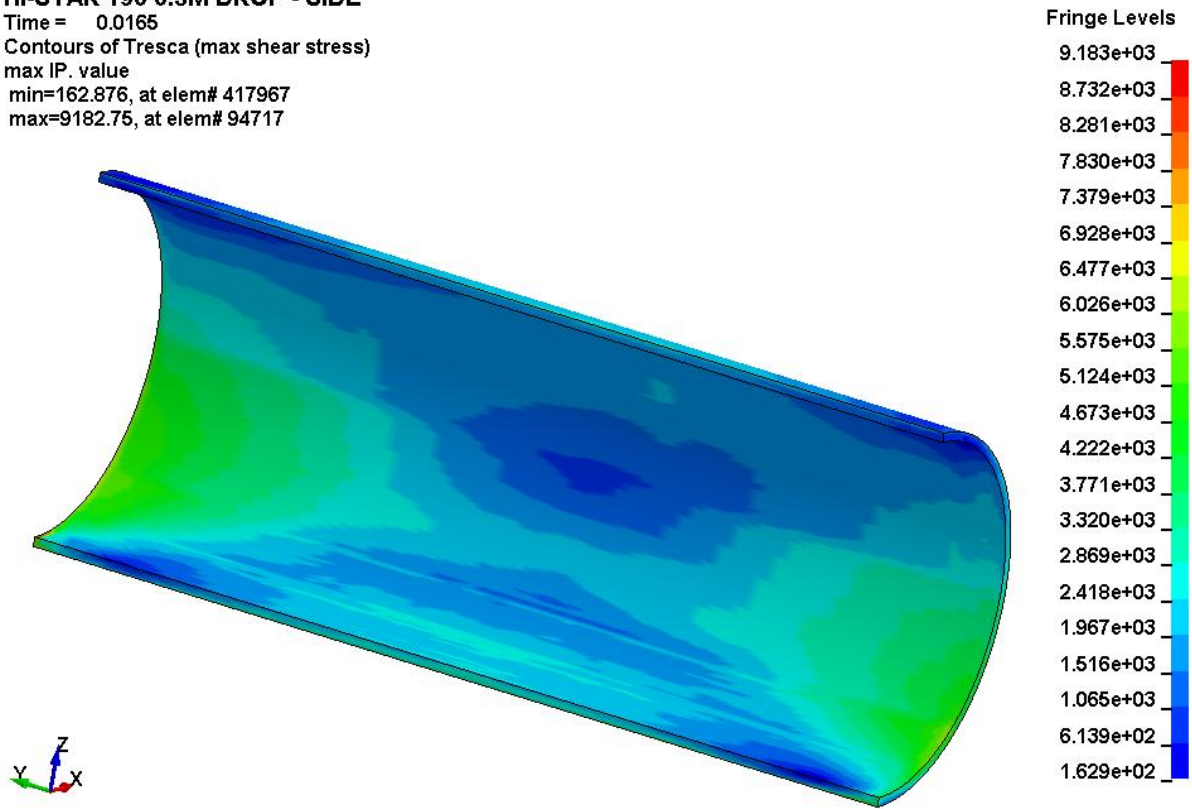

Figure 2.6.5: Maximum Shear (1/2 Times Stress Intensity) Distribution in Containment Shell for Load Combination N2 (1-Ft Side Drop)

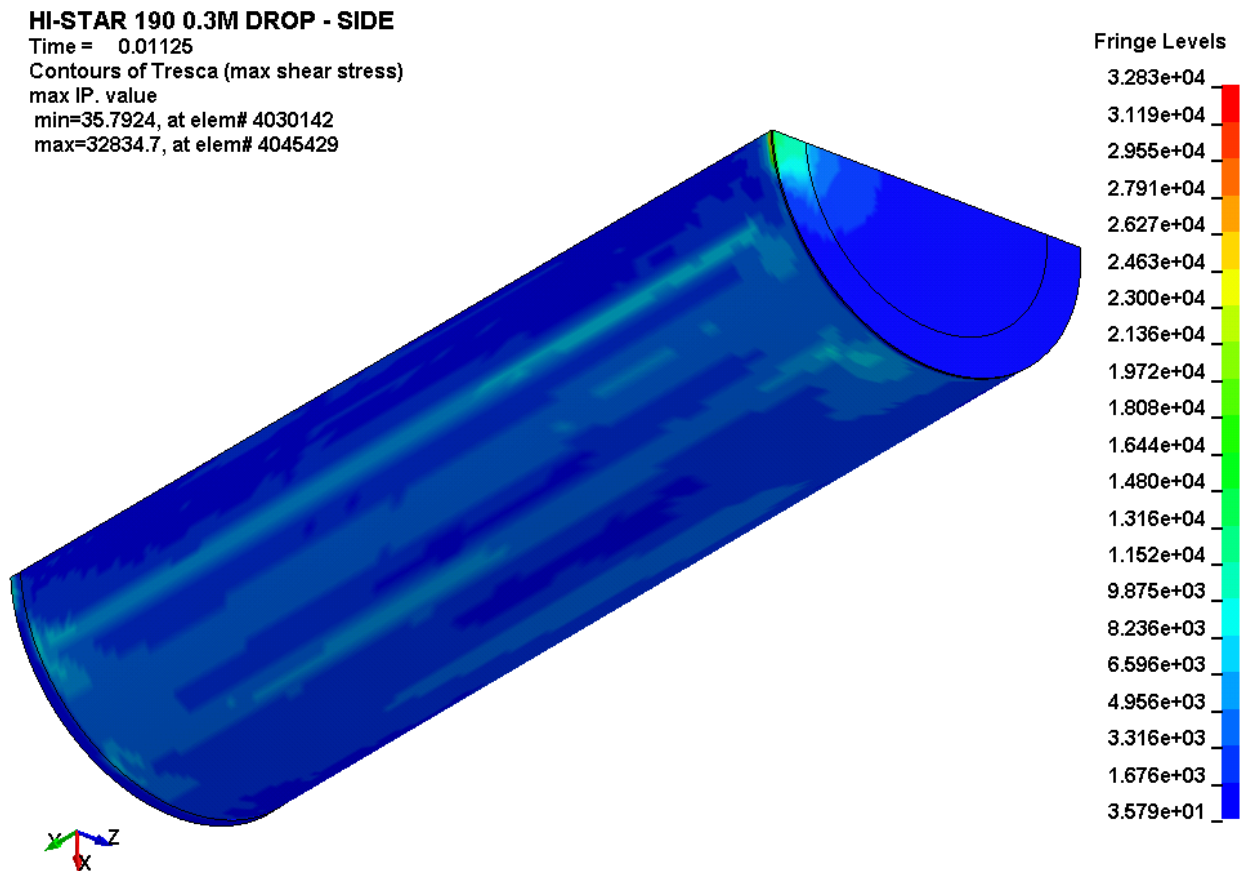

Figure 2.6.6: Maximum Shear (1/2 Times Stress Intensity) Distribution in MPC Enclosure Vessel for Load Combination N2 (1-Ft Side Drop)

2.7 HYPOTHETICAL ACCIDENT CONDITIONS

All proposed fuel loading configurations (with and without DFC's), heat load patterns and cooling times in Chapter 7 are enveloped by the structural evaluations performed in this section as the calculations use:

- i) bounding fuel assembly weights (including DFC's, GTA's, ITTR's, fuel debris and non-fuel hardware) per Appendix 7.C;
- ii) bounding MPC and overpack loaded weights per Table 2.1.11;
- iii) bounding CG heights per Table 2.1.12;
- iv) bounding MPC and overpack internal pressures per Table 2.1.1;
- v) component temperatures bounding those in Tables 3.1.1, 3.1.3, 3.1.4 and 3.2.10, as applicable.

It is shown in the following subsections that the HI-STAR 190 Package meets the safety criteria set forth in 10CFR71 when it is subjected to the hypothetical accident conditions specified in 10CFR§71.73. In particular, required technical data is presented herein to support the conclusion that HI-STAR 190 Package, when subjected to hypothetical accident conditions, will maintain its structural integrity to satisfy the subcriticality, containment, shielding, and temperature requirements of 10CFR71.

The hypothetical accident conditions, as defined in 10CFR§71.73 and explained in Regulatory Guide 7.9, are applied to the HI-STAR 190 Package as a sequence of loading events. The package is first subject to a 9-meter (30-foot) drop. As required by the regulations, the "free drop" should be assumed to occur in the orientation that will cause maximum damage. To identify the most vulnerable orientation the drop simulation is performed in four candidate orientations. From the post-impact package configuration determined to have the most damaging orientation, the package is then subject to a 1-meter (40-inch) drop onto a 15 cm (6.0 inch) diameter mild steel pin (of length sufficient to impart the impact energy to the cask structure through penetrant action). In the third step, the package is subject to a 800°C (1475°F) temperature fire environment for 30 minutes. Finally the package is subject to water immersion.

As a separate loading event, the cask containment boundary is also subjected to deep immersion in accordance with 10CFR§71.61.

[

PROPRIETARY INFORMATION WITHHELD PER 10CFR2.390

]

2.7.1 9-meter Free Drop

2.7.1.1 Problem Description and Dynamic Model

As specified in §71.73, the performance and structural integrity of the HI-STAR 190 Package must be evaluated for the most severe drop scenarios. The appurtenance that is critical to protecting the integrity of the containment boundary during a high momentum collision event is the AL-STAR impact limiter.

The central purpose of the impact limiter, defined as an essential package appurtenance in Section 1.2, is to limit the package maximum deceleration, α_{\max} . The HI-STAR package, consisting of the loaded cask and top and bottom impact limiters, is essentially a cylindrical body with a very rigid interior (namely, the cask) surrounded by a pair of relatively soft crushable structures. The crushable structure (impact limiter) should deform and absorb the kinetic energy of impact without detaching itself from the cask, disintegrating, or otherwise malfunctioning. A falling cylindrical body may theoretically impact the target surface in an infinite number of orientations; the impact limiter must limit decelerations to insure that stress intensity and performance limits, as described in Section 2.1, are satisfied, and to ensure that the impact limiter does not detach from the cask, regardless of the impact orientation. In general, a drop event orientation is defined by the angle of the HI-STAR 190 longitudinal axis, “ θ ”, with the impact surface. In this notation, $\theta = 0^\circ$ means a side drop and $\theta = 90^\circ$ implies a vertical or end drop scenario. In any orientation, the drop height is measured from the lowest point on the package.

An intermediate value of θ at which the point of impact is directly below the center of gravity (C.G.) of the HI-STAR package warrants special mention. This drop orientation is traditionally called the C.G.-over-corner (CGOC) configuration. The CGOC orientation, “ θ_c ”, is the demarcation line between single and dual impact events. At $90^\circ > \theta > \theta_c$ the leading end of the package (denoted as the “primary” impact limiter) is the sole participant in absorption of incident kinetic energy. At $\theta < \theta_c$ drop orientations, the initial impact and crush of the leading (primary) impact limiter is followed by the downward rotation of the package with the initial impact surface acting as the pivot, culminating in the impact of the opposite (secondary) impact limiter on the target surface. In the dual impact scenarios, the first and second impact limiter crush events are referred to as the “primary” and “secondary” impacts, respectively. It is reasonable to speculate that for certain values of θ , the secondary impact may be the more severe of the two. Figures 2.7.1 through 2.7.4 illustrate the orientation of a (generic) cask at the initiation of a drop event.

[

PROPRIETARY INFORMATION WITHHELD PER 10CFR2.390

]

Finally, the package design must satisfy all criteria in ambient temperature conditions (temperature and humidity) that may prevail during transport. Therefore, the impact limiter design must be functionally insensitive to the ambient temperature and humidity.

As the drawings in Chapter 1 indicate, in addition to the crushable material, the impact limiter contains a cylindrical shell that is stiffened with internal gussets. This buttressed steel shell is sized to be sufficiently robust to preclude gross plastic deformation or buckling during impact events and thus serve as the backbone of the impact limiter.

To summarize, the performance objectives of the impact limiter are set down as five discrete items, namely:

[

PROPRIETARY INFORMATION WITHHELD PER 10CFR2.390

]

The last two objectives are realized by utilizing crush material that is insensitive to the ambient psychrometric environment, and by using surface preservatives or corrosion resistant materials as indicated in the drawing package in Section 1.3. The stainless steel skin is procured to “bright annealed” finish to minimize absorption of solar thermal radiation.

[

PROPRIETARY INFORMATION WITHHELD PER 10CFR2.390

]

The remaining design objectives, namely, limiting of the maximum rigid body deceleration under the 9-meter drop event and preventing contact of the cask with the unyielding surface, is demonstrated by the LS-DYNA [2.5.3] finite element code, as discussed earlier. LS-DYNA has been benchmarked extensively by others [2.7.5, 2.7.6] and by Holtec using the test data from the static tests of the crush material and, more importantly, from the quarter-scale model 9-meter drop experiments carried out at the Oak Ridge National Laboratory in support of HI-STAR 100 Part 71 certification in the late 90s [2.7.4] (see Appendix 2.B of [1.0.4]). As discussed in Appendix 2.B of [1.0.4], the LS-DYNA simulation model for the family of AL-STAR impact limiters is a credible and reliable vehicle for determining the HI-STAR 190 Package's impact performance with respect to the extent of crush and the peak g-load. LS-DYNA has been used by Holtec International in a wide variety of impact scenarios in dry storage projects [2.7.10]. More recently Holtec performed additional LS-DYNA benchmark analyses against two well documented DOE drop tests conducted for a multi-canister overpack (without impact limiter). The LS-DYNA simulation results of the tests obtained by Holtec consistently match the test data (i.e., deformation measurements) and the simulation results predicted by another finite element code ABAQUS as demonstrated in Holtec report HI-2156765 [2.7.15]. This additional benchmark work, along with the previous result comparisons between ANSYS and LS-DYNA for the HI-STAR 180, HI-STAR 60, and HI-STAR 180D transport casks [1.04, 1.0.7, 1.0.9], provides the technical basis for using LS-DYNA in this application to predict not only the peak package deceleration, but also the structural response of the cask as part of one comprehensive analysis.

[

PROPRIETARY INFORMATION WITHHELD PER 10CFR2.390

[]

PROPRIETARY INFORMATION WITHHELD PER 10CFR2.390

[]

PROPRIETARY INFORMATION WITHHELD PER 10CFR2.390

[]

PROPRIETARY INFORMATION WITHHELD PER 10CFR2.390

]

The previously described key attributes implemented in the HI-STAR 190 LS-DYNA model take advantage of the state-of-art numerical analysis capability of the finite element code for simulating transient, nonlinear impact events. With good accuracy demonstrated in the benchmarking effort (Appendix 2.B of [1.0.4] and [2.7.15]) as well in the analysis independently performed by the NRC/PNNL investigators [2.7.5], the previously described HI-STAR 190 finite element model is deemed to be able to predict the structural response of the package under various accidental drop conditions with reliable accuracy.

[

PROPRIETARY INFORMATION WITHHELD PER 10CFR2.390

]

[

PROPRIETARY INFORMATION WITHHELD PER 10CFR2.390

]

2.7.1.2 Simulation of Drop Events

As discussed before, the free drop of the package from 9 meters onto an essentially unyielding surface is simulated for a number of orientations using LS-DYNA. The peak g-loads from each

drop simulation, α_{\max} , in both axial and lateral direction (to the cask's axis) are computed, as well as the stresses and strains in the HI-STAR 190 package.

The postulated free drop events belong to four broad categories, namely:

1. Vertical-end drop
2. Lateral (side drop)
3. C.G.-over-corner
4. Oblique (slap down)

Under certain categories of events, there may be more than one drop “orientation”. The orientation of drop, θ , is defined by the angle between the horizontal plane and the axis of the cask pointed from its base to its lid at the instant of impact. $\theta = 90^\circ$ is a vertical-end drop event with bottom-down configuration (see Figure 2.7.1). Similarly, $\theta = 0^\circ$ means side (lateral) drop (see Figure 2.7.3).

The various drop orientations analyzed using LS-DYNA to identify the most damaging scenario with reasonable assurance are summarized in Table 2.7.2. Of these, the slap-down event warrants special mention because it often produces the bounding decelerations in transport packages and has two candidate orientations in an axially nonsymmetrical package, namely:

- i. Wherein the top impact limiter strikes first, followed by the second impact at the bottom impact limiter.
- ii. The obverse of case (i) wherein the primary impact occurs at the bottom impact limiter followed by a second impact at the top impact limiter.

As can be seen from Table 2.7.2, upper as well as lower bound properties of the crush material are analyzed in LS-DYNA to ensure that the largest value of α_{\max} and maximum crush, d_{\max} , have been identified and evaluated.

The initial velocity of the package corresponding to a free fall from 9 meters at impact in all impact scenarios is 13.392 m/sec (43.9 ft/sec).

2.7.1.3 Summary of Results

Table 2.7.2 summarizes the maximum values of α_{\max} for the axial and lateral direction from all of the drop scenarios simulated on LS-DYNA.

Certain observations from the LS-DYNA numerical simulations provide valuable information with respect to the structural performance of the package.

- i. For the dual impact scenarios (i.e. slapdown drop accident), the secondary impact is always more severe than the primary impact. The maximum deceleration and impact limiter crush occur in the region of the secondary impact.

- ii. All body bolt stresses meet the acceptance criteria from Table 2.1.3 demonstrating that there is no risk of failure of any bolt fastened to the top forging.
- iii. The impact limiters remain connected to the cask subsequent to the drop accident.

The effect of lateral deceleration is to cause flexing of the fuel basket cell panels transverse to the direction of the load under the magnified inertia load of the fuel, and to load the panels oriented in the direction of the inertia load in direct compression.

For convenience, the allowable stress limits necessary for the safety evaluation of each part are compiled in Table 2.6.3. The corresponding results from the LS-DYNA runs are listed in Tables 2.7.3 and 2.7.5.

Based on the results presented in Tables 2.7.3 and 2.7.5, it is concluded that:

- The primary stress intensities for the containment components are below the ASME NB limits for all drop configurations.
- The closure lid bolts show no gross yielding and the gaskets remain under a compressed state at the conclusion of the event. Therefore, continued bolted joint effectiveness in the wake of the 9-meter free drop event is assured.
- The dose blocker parts surrounding the containment shell remain intact.
- The fuel basket does not undergo gross plastic deformation in the active fuel region, and the global average permanent deformation remains below the limit value established by the acceptance criteria in Section 2.1.
- The lead, used for shielding in the HI-STAR 190, is included in the LS-DYNA model. The lead is characterized by the properties given in Table 2.2.9. A review of all drop and puncture simulation results leads to the conclusion that the degree of lead slump is less than the limiting values assumed in the shielding evaluation (see Section 5.3.1).
- Since the ability to accurately predict and evaluate large displacements is included within the LS-DYNA algorithm, the effect of any instability is automatically accounted for. Based on the evaluated results, it is concluded that there is no buckling of the containment components during any of the postulated Hypothetical Accident events.

2.7.1.4 Fracture Analysis

[

PROPRIETARY INFORMATION WITHHELD PER 10CFR2.390

]

[

PROPRIETARY INFORMATION WITHHELD PER 10CFR2.390

]

2.7.2 Crush

An evaluation of package crush is not required for the HI-STAR 190.

2.7.3 Puncture

10CFR71 specifies that a puncture event be considered as a hypothetical accident condition subsequent to the hypothetical 9-meter drop event. For this event, it is postulated that the package falls freely through a distance of 1 meter (40 inch) and impacts a 15 cm (6 inch) diameter mild steel bar. The effects of the puncture drop will, quite ostensibly, be most severe when the steel bar is perpendicular to the impact surface. Therefore, all puncture analyses assume that the bar is perpendicular to the impact surface. Puncture is considered on the sidewall and on the top end (a puncture on the bottom end is not bounding since there is a full welded connection, rather than a bolted connection that needs to remain intact).

The LS-DYNA simulation method is used to examine the puncture accidents. The same model used for top-end drop is retained for the top end puncture analysis. A mild steel bar, having the appropriate dimensions, is added to the model, placed in the proper orientation, and fixed to the ground. The package is then assumed to have a known initial velocity at contact with the bar. The side puncture analysis is performed using a simplified package model with the puncture affected cask region modeled in detail. Further details of the simulation model and the results (all output figures) for the top end puncture and side puncture are provided in the Holtec Proprietary calculation packages [2.6.1]. The key results of the puncture analysis are also summarized in Table 2.7.3.

The results from the puncture analyses yield the following conclusions:

- i. The bolted joint maintains its integrity; the margin-against-leakage parameter, m , (defined in Table 2.6.1) remains at the maximum possible value of 10.
- ii. No complete penetration of the dose blocker parts that surround the containment shell is indicated. The total depth of local indentation does not yield unacceptable shielding consequences.
- iii. The primary stress levels in the closure lid, containment shell, and baseplate remain below their respective Level D condition limits.

The above results confirm the structural adequacy of the package under the “puncture” event of §71.73.

2.7.4 Thermal

In this subsection, the structural consequences of the 30-minute fire event, which occurs after hypothetical drop and puncture events, are evaluated using the metal temperature data from Chapter 3 where a detailed analysis of the fire and post-fire condition is presented. Specifically, the evaluations show that:

1. The metal temperature, averaged across any section of the containment boundary, remains below the maximum permissible temperature for the Level A condition in the ASME Code for NB components. Strictly speaking, the fire event is a Level D condition for which Subsection NB of the ASME Code, Section III does not prescribe a specific metal temperature limit. The Level A limit is imposed herein for convenience because it obviates the need for creep considerations to ascertain post-fire containment integrity.
2. The outer surface of the cask, directly exposed to the fire does not slump (i.e., suffer primary or secondary creep). This condition is readily ruled out for steel components since the metal temperature remains below 50% of the metal melting point (approximately 3000°F).
3. Internal interferences among the constituents of the HI-STAR 190 Package do not develop due to their differential thermal expansion during and after the fire event.
4. Cask closure lid bolts do not unload; therefore, there is no reduction of compression load on the gasket surfaces to a level that may precipitate leakage of gaseous contents from the containment boundary.

Table 2.7.4 provides a summary of the key results obtained from the continued sealing analysis under the fire accident; the details of the solution are documented in the Holtec Proprietary calculation package [2.1.12]. An analysis methodology previously used for the HI-STAR 180 licensing effort is used here, with the only loading being the temperature change of the bolted connection from the fire. Because of the differences in coefficient of thermal expansion between the lid and flange and the bolt, the bolt load increases from the starting value, but the increase is balanced by increased compression on the land. Therefore, the fire event, occurring after a 9-meter drop accident or a puncture, does not lead to loss of seal integrity in either lid. The package, therefore, meets all acceptance criteria set down in Section 2.1 for the postulated fire event.

2.7.4.1 Summary of Pressures and Temperatures

Section 3.4 contains a discussion of the peak temperatures occurring during and after the fire event. It is concluded in that section that:

1. The containment boundary, protected by the dose blocker parts, remains below 500 degrees F (SA-203 E material).
2. The containment boundary that is within the confines of the impact limiters remains below 700 degrees F (SA-350 LF3 material).
3. The portion of the containment boundary directly exposed to the fire may have local outer surface temperatures in excess of 700 degrees F, but the bulk metal temperature of the material volume remains under 700 degrees F. All metal temperatures remain well below the “threshold damage temperature”.
4. The Holtite-B neutron shield material experiences temperatures in excess of its design limit. The loss of the cask’s neutron shielding material due to the fire accident is considered in the shielding evaluation.
5. The maximum MPC internal pressure during the fire event exceeds the 200 psi pressure limit under accident conditions of storage specified in the HI-STORM FW SAR [2.1.13]. The MPC design internal pressure under accident conditions of transport is therefore conservatively increased to 220 psi in Table 2.1.1.

2.7.4.2 Differential Thermal Expansion

Differential thermal expansions under the limiting conditions of the fire event are evaluated in Subsection 3.4.4. The analyses show that, under the fire condition, there is no restraint of free thermal expansion of the fuel basket.

2.7.4.3 Stress Calculations

Strength of materials calculations are used to evaluate the performance of the bolted joint in the Containment Boundary. Analyses show that:

- i. The primary stress intensities in the Containment Boundary remain well below the Level D (Faulted Condition) limits.
- ii. The bolt stresses in the Containment Boundary joint, due to differential thermal expansion, rise but remain within Level D limits.

The MPC stress analysis documented in the HI-STORM FW structural calculation package [2.7.3] reported a minimum safety factor of 1.888 for the 200 psi internal pressure load case. Since the MPC stress analysis is a linear analysis, the minimum safety factor of the MPC under 220 psi internal pressure is calculated to be 1.716 (i.e., $1.888 \times 200 / 220$). Therefore, the MPC containment boundary can be maintained under the fire accident condition.

2.7.5 Immersion - Fissile Material

10CFR§71.73(c)(5) specifies that fissile material packages, in those cases where water leakage has not been assumed for criticality analysis, must be evaluated for immersion under a head of water of at least 0.9 m (3 ft) in the attitude for which maximum leakage is expected. Accordingly, the analysis is performed to demonstrate that there will be no water leakage in the

package subsequent to the fire.

A head of water at a depth of 0.9 m (3 ft) is equal to 1.3 psi. The head of water (1.3 psi) is bounded by the hypothetical accident condition external pressure for the cask (10CFR§71.61), which is considered later, and is also bounded by the accident external pressure of 55 psi for the MPC (see Table 2.1.1). Analyses summarized in this chapter demonstrate the containment components meet the applicable stress intensity allowables for Normal Conditions of Transport and for Hypothetical Accident Conditions (both conditions impose pressures larger than 1.3 psi on the components). Further, it is demonstrated that the sealing function is not impaired under these conditions. Therefore, there is no in-leakage of water into the cask under a head of water at a depth of 0.9 m (3 ft).

2.7.6 Immersion - All packages

This external pressure (i.e., a head of water at a depth of 15 m or 50 ft) mandated in 10CFR§71.73 is applicable to both overpack and MPC containment boundaries. This loading condition is bounded by the analysis in Subsection 2.7.7 for the overpack containment boundary. Moreover, this external pressure is bounded by the accident pressure of 55 psi for the MPC (see Table 2.1.1).

2.7.7 Deep Water Submergence

Pursuant to 10CFR§71.61, the loaded HI-STAR 190 is subject to an all-around external pressure of 2.0 MPa (290 psi). Note that HI-STAR 190 features two containment boundaries (the MPC and the overpack containment boundary) that must survive the hypothetical accidents described in 10CFR§71.73, but only the overpack containment boundary needs to be demonstrated that it can withstand the deep submergence pressure (DSP) without collapse, buckling, or inleakage of water.

Code Case N-284 is used to evaluate the propensity for containment shell instability assuming the outer dose blocker parts do not prevent the 290 psi pressure from acting directly on the outer surface of the containment shell. The Holtec Proprietary calculation package [2.1.12] contains the supporting details; it is demonstrated there that there is no yielding of the vessel and that there is no elastic or plastic instability of the containment shell. Since the external pressure acts in a direction to add additional pressure to the land of the lid, seal opening is not a concern for this accident. The primary stress intensity of the lid resulting from the 290 psi pressure loading meets the Level D ASME Code limit (this is easily demonstrated by examining the results for the N1 normal load condition summarized in Section 2.6). Inleakage of water through the containment system boundary seals is confirmed to be non-credible to satisfy the intent of ISG-19 [1.2.9]. Therefore, the package meets all acceptance criteria given in Section 2.1 under this immersion condition.

2.7.8 Summary of Damage

The results presented in Subsections 2.7.1 through 2.7.7 show that the HI-STAR 190 Package meets the requirements of 10CFR§71.61 and 10CFR§71.73. All (plausibly) vulnerable orientations of free drop have been analyzed. Two puncture events have also been considered and reported in the tables in Section 2.7. All safety factors are greater than 1.0 for the hypothetical accident conditions of transport, and the sealing function is maintained at the end of each event and at the end of the sequence. Therefore, the HI-STAR 190 package, under the Hypothetical Accident Conditions of Transport, has adequate structural integrity to satisfy the subcriticality, containment, shielding, and temperature requirements of 10CFR71.

Specifically, the analyses summarized in this section show that:

- i. The HI-STAR 190 containment space and the MPC will individually remain inaccessible to the moderator under the immersion event of §71.73, which follows free drop, puncture, and fire.
- ii. The overpack lid will continue to maintain a positive contact load at their interfaces with the flange subsequent to the hypothetical accident event, indicating that the seals will remain functional as effective leakage barriers to moderator intrusion into the containment cavity. The torque requirement for the closure lid port cover bolts (Table 7.1.1) is also determined to be adequate to maintain compression on the port cover seals under Hypothetical Accident Conditions.
- iii. Localized plastic deformation under the stabbing action of the mild steel bar is indicated. However, there is no through-wall puncture of either containment boundary.
- iv. The average basket panel deflection in the active fuel region is less than the limit (1 mm) specified in Table 2.6.7.

Table 2.7.1: [PROPRIETARY INFORMATION WITHHELD PER 10CRF2.390]

HI-STAR 190 SAR
Report HI-2146214

2.7-17

Proposed Revision 2A

Table 2.7.2: [PROPRIETARY INFORMATION WITHHELD PER 10CRF2.390]

Table 2.7.3: - Bounding Results from 9-M Drop and 1-M Drop Puncture Simulations

Item	Allowable Value[†]	Calculated Value	Safety Factor	Governing Accident
Closure Lid – Primary Bending Stress Intensity – MPa (ksi)	506.8 (73.5)	399.3 (57.92)	1.27	1-M Top End Drop Puncture
Containment Shell – Primary Membrane Stress Intensity – Mpa (ksi)	337.8 (49.0)	270.8 (39.28)	1.25	9-M Side Drop
Containment Shell – Primary Membrane + Bending Stress Intensity – Mpa (ksi)	506.8 (73.5)	372.7 (54.06)	1.36	1-M Side Drop Puncture
Cask Baseplate – Primary Bending Stress Intensity – Mpa (ksi)	506.8 (73.5)	270.4 (39.22)	1.87	9-M Bottom End Drop
MPC Enclosure Vessel – Primary Membrane + Bending Stress Intensity – Mpa (ksi)	447.8 (64.95)	323.2 (46.88)	1.39	9-M Slapdown Drop (Bottom End First)
Lid Bolts – Average Service Stress (Stress Intensity) – MPa (ksi) *	920.6 (133.5)	791.1 (114.74)	1.16	9-M Top End Drop
Lid Bolts – Maximum Service Stress at Extreme Fiber (Stress Intensity) – MPa (ksi) *	1068.7 (155)	922.5 (133.8)	1.16	9-M Top End Drop
Maximum Penetration into the Cask Body by the Puncture Bar (inches)	10.75	6.75	1.59	1-M Side Drop Puncture
Maximum Radial/Axial Lead Slumps (inches)	10*/2*	3.04/0.174	3.29	9-M Vertical/ 9-M Slapdown
Lid Seals Remain Sufficiently Compressed after the Drop Accident?	Yes			

Note: [†] Allowable stresses are obtained from Table 2.6.3; *Assumed lead slump values in Subsection 5.3.1 for the shielding evaluation.

Table 2.7.4: Bolted Joint Performance Under the Fire Event

ITEM	AT PEAK OF FIRE	BEFORE AND AFTER FIRE [†]
Closure Lid Bolt – Average Service Stress MPa (ksi)	417.8 (60.6)	310.3 (45)
[†] The tensile stress in each closure bolt under the preload condition is 45,000 psi.		

Table 2.7.5: Key Performance Objectives for Non-Containment Components of the HI-STAR 190

Criterion	Result
No Tearing of the Circumscribing Enclosures in the Dose Blocker Parts - Primary Effective Stress below Ultimate Strength	Yes
Fuel Basket Deformation – Maximum Deflection < 1 mm	Yes

**Figure 2.7.1: [PROPRIETARY INFORMATION WITHHELD PER
10CFR2.390]**

**Figure 2.7.2: [PROPRIETARY INFORMATION
WITHHELD PER 10CFR2.390]**

**Figure 2.7.3: [PROPRIETARY INFORMATION
WITHHELD PER 10CFR2.390]**

Figure 2.7.4: [PROPRIETARY INFORMATION WITHHELD PER 10CFR2.390]

Figure 2.7.5: [PROPRIETARY INFORMATION WITHHELD PER 10CFR2.390]

Figure 2.7.6: [PROPRIETARY INFORMATION WITHHELD PER 10CFR2.390]

Figure 2.7.7: [PROPRIETARY INFORMATION WITHHELD PER 10CFR2.390]

Figure 2.7.8: [PROPRIETARY INFORMATION WITHHELD PER 10CFR2.390]

Figure 2.7.9A: [PROPRIETARY INFORMATION WITHHELD PER 10CFR2.390]

Figure 2.7.9B: [PROPRIETARY INFORMATION WITHHELD PER 10CFR2.390]

Figure 2.7.9C: [PROPRIETARY INFORMATION WITHHELD PER 10CFR2.390]

Figure 2.7.10A: [PROPRIETARY INFORMATION WITHHELD PER 10CFR2.390]

Figure 2.7.10B: [PROPRIETARY INFORMATION WITHHELD PER 10CFR2.390]

Figure 2.7.11: [PROPRIETARY INFORMATION WITHHELD PER 10CFR2.390]

Figure 2.7.12: [PROPRIETARY INFORMATION WITHHELD PER 10CFR2.390]

Figure 2.7.13: [PROPRIETARY INFORMATION WITHHELD PER 10CFR2.390]

Figure 2.7.14: [PROPRIETARY INFORMATION WITHHELD PER 10CFR2.390]

Figure 2.7.15: [PROPRIETARY INFORMATION WITHHELD PER 10CFR2.390]

Figure 2.7.16: [PROPRIETARY INFORMATION WITHHELD PER 10CFR2.390]

Figure 2.7.17: [PROPRIETARY INFORMATION WITHHELD PER 10CFR2.390]

Figure 2.7.18: [PROPRIETARY INFORMATION WITHHELD PER 10CFR2.390]

2.8 ACCIDENT CONDITIONS FOR AIR TRANSPORT OF PLUTONIUM

This section is not applicable to the HI-STAR 190 Package. This application does not seek approval for air transport of plutonium and, therefore, does not address the accidents defined in 10CFR§71.74.

2.9 ACCIDENT CONDITIONS FOR FISSILE MATERIALS FOR AIR TRANSPORT

This section is not applicable to the HI-STAR 190 Package. This application does not seek approval for air transport of fissile materials and, therefore, does not address the accidents defined in 10CFR§71.55(f).

2.10 SPECIAL FORM

This section is not applicable to the HI-STAR 190 Package. This application does not seek approval for transport of special form radioactive material; therefore, the requirements of 10CFR§71.75 are not applied.

2.11 FUEL RODS

The cladding of the fuel rods is the first boundary for confining radiological matter in the HI-STAR 190 Transport Cask. Analyses have been performed in Chapter 3 to ensure that the maximum temperature of the fuel cladding is well below ISG-11, Rev. 3 regulatory limits [2.11.1].

The vertical drop of the package, leading to a rapid axial deceleration of the stored fuel and the consequent flexural strains, is recognized as the most vulnerable free drop configuration from the standpoint of potential damage to the fuel [2.11.2, 2.11.3]. Fortunately, the problem of large loading of fuel has been comprehensively studied in the published NUREG [2.11.5] and studies conducted by Pacific Northwest National Laboratory (PNNL) and USNRC [2.11.4], which obsolesces prior analyses and provides a robust and conservative basis for prognosticating fuel damage under vertical drop events.

[

PROPRIETARY INFORMATION WITHHELD PER 10CFR2.390

]

[

PROPRIERARY INFORMATION WITHHELD PER 10CFR2.390

]

[

PROPRIERARY INFORMATION WITHHELD PER 10CFR2.390

]

[

PROPRIERARY INFORMATION WITHHELD PER 10CFR2.390

]

[

PROPRIERARY INFORMATION WITHHELD PER 10CFR2.390

]

Table 2.11.1: [PROPRIETARY INFORMATION WITHHELD PER 10CFR2.390]

Table 2.11.2: [PROPRIETARY INFORMATION WITHHELD PER 10CFR2.390]

Table 2.11.3: [PROPRIETARY INFORMATION WITHHELD PER 10CFR2.390]

Figure 2.11.1: [PROPRIETARY INFORMATION WITHHELD PER 10CFR2.390]

Figure 2.11.2: [PROPRIETARY INFORMATION WITHHELD PER 10CFR2.390]

Figure 2.11.3: [PROPRIETARY INFORMATION WITHHELD PER 10CFR2.390]

Figure 2.11.4: [PROPRIETARY INFORMATION WITHHELD PER 10CFR2.390]

Figure 2.11.5a: [PROPRIETARY INFORMATION WITHHELD PER 10CFR2.390]

Figure 2.11.5b: [PROPRIETARY INFORMATION WITHHELD PER 10CFR2.390]

Figure 2.11.5c: [PROPRIETARY INFORMATION WITHHELD PER 10CFR2.390]

Figure 2.11.5d: [PROPRIETARY INFORMATION WITHHELD PER 10CFR2.390]

Figure 2.11.6a: [PROPRIETARY INFORMATION WITHHELD PER 10CFR2.390]

Figure 2.11.6b: [PROPRIETARY INFORMATION WITHHELD PER 10CFR2.390]

2.12 REFERENCES

The following generic industry and Holtec produced references may have been consulted in the preparation of this document. Where specifically cited, the identifier is listed in the SAR text or table. Active Holtec Calculation Packages, which are the repository of all relevant licensing and design basis calculations, are annotated as “latest revision”. Submittal of the latest revision of such Calculation Packages to the USNRC and other regulatory authorities during the course of regulatory reviews is managed under the company’s Configuration Control system.

- [2.1.1] ASME Boiler & Pressure Vessel Code, Section III, Subsection NB, American Society of Mechanical Engineers, 2007 Edition, 2008 Addenda.
- [2.1.2] Regulatory Guide 7.6, "Design Criteria for the Structural Analysis of Shipping Cask Containment Vessels", Revision 1, March, 1978, U.S. Nuclear Regulatory Commission.
- [2.1.3] 10CFR Part 71, "Packaging and Transportation of Radioactive Materials", Title 10 of the Code of Federal Regulations, Office of the Federal Register, Washington, D.C.
- [2.1.4] Regulatory Guide 7.8, "Load Combinations for the Structural Analysis of Shipping Casks for Radioactive Material", Revision 1, March, 1989, U.S. Nuclear Regulatory Commission.
- [2.1.5] NUREG-0612, "Control of Heavy Loads at Nuclear Power Plants," United States Nuclear Regulatory Commission, July, 1980.
- [2.1.6] ASME Boiler & Pressure Vessel Code, Section II, Parts A and D, American Society of Mechanical Engineers, 2007 Edition, 2008 Addenda.
- [2.1.7] Regulatory Guide 7.11, "Fracture Toughness Criteria of Base Material for Ferritic Steel Shipping Cask Containment Vessels with a Maximum Wall Thickness of 4 Inches", United States Nuclear Regulatory Commission, June, 1991.
- [2.1.8] Regulatory Guide 7.12, "Fracture Toughness Criteria of Base Material for Ferritic Steel Shipping Cask Containment Vessels with a Wall Thickness Greater Than 4 Inches But Not Exceeding 12 Inches", United States Regulatory Commission, June, 1991.
- [2.1.9] NUREG/CR-1815, "Recommendations for Protecting Against Failure by Brittle Fracture in Ferritic Steel Shipping Containers Up to Four Inches Thick."
- [2.1.10] ASME Boiler & Pressure Vessel Code, Section III, Appendices, American Society of Mechanical Engineers, 2007 Edition, 2008 Addenda.

- [2.1.11] NUREG-1617 Standard Review Plan for Transportation Packages for Spent Nuclear Fuel, USNRC, (2000).
- [2.1.12] Calculation Package for the HI-STAR 190 Transport Cask System, Holtec International Proprietary Report HI-2146413, Latest revision.*
- [2.1.13] “Final Safety Analysis Report on the HI-STORM FW Storage System”, Holtec Report HI-2114830, Revision 4, Docket No. 72-1032.
- [2.1.14] ASME Boiler & Pressure Vessel Code, Section III, Subsection NF, American Society of Mechanical Engineers, 2007 Edition, 2008 Addenda.
- [2.1.15] ASTM B221, Standard Specification for Aluminum and Aluminum-Alloy Extruded Bars, Rods, Wire, Profiles, and Tubes, 2008
- [2.1.16] Holtec Position Paper DS-331, “Structural Acceptance Criteria for the Metamic-HT Fuel Basket”, Rev. 1.*
- [2.1.17] NUREG/CR-3826, "Recommendations for Protecting Against Failure by Brittle Fracture in Ferritic Steel Shipping Containers Greater than Four Inches Thick."
- [2.1.18] “Metamic-HT Purchasing Specification”, Holtec Document ID PS-11, Latest Revision, (Holtec Proprietary).
- [2.1.19] “Development and Discussion of Design Code for Baskets Made of Aluminum Alloys and Borated Aluminum Alloys for Transport/Storage Packagings”, by M. Hirose, T. Saegusa, K. Miyata, T. Nakatani, H. Akamatsu, and T. Yamamoto, Proceedings of the 15th International Symposium on the Packaging and Transportation of Radioactive Materials, PATRAM 2007, Miami, Florida.
- [2.2.1] Hexweb Honeycomb Attributes and Properties, HEXCEL Corp, Pleasanton, CA., 2006. (web site is www.hexcel.com).
- [2.2.2] “Safety Analysis Report for the HI-STAR 100 Package”, Holtec Report HI-951251, latest revision, Docket No. 71-9261.
- [2.2.3] DOE-HDBK – 1017/2-93, DOE Fundamentals Handbook, Material Science, Vol. 2 of 2.
- [2.2.4] NRC Bulletin 96-04: Chemical, Galvanic or Other Reactions in Spent Fuel Storage and Transportation Casks, July 5, 1996.

* Supporting document submitted with the HI-STAR 190 License Application.

- [2.2.5] L.W. Ricketts, Fundamentals of Nuclear Hardening of Electronic Equipment, Robert E. Krieger Publishing Company, Malabar, FL, 1986.
- [2.2.6] Tietz, T.E., “Determination of the Mechanical Properties of High Purity Lead and a 0.05% Copper-Lead Alloy,” Stanford Research Institute, Mellon Park, CA, WADC Technical Report 57-695, ASITIA Document No. 151165.
- [2.2.7] Properties of Aluminum Alloys, Tensile, Creep, and Fatigue Data at High and Low Temperatures, ASM International, November 2006.
- [2.2.8] Letter (transmitted September 3rd, 2009) from Mark Armitage, Engineering Manager, American Seal and Engineering Inc. to John Griffiths, Design Manager, Holtec International (Including Proprietary American Seal Drawings - Internal and External Spring Energized C-Ring Drawing Numbers 050056 and 050057, respectively).
- [2.2.9] Gallagher, C., “NL Industrial Internal Test Report on Tensile Properties of Chemical Lead at Elevated Temperatures,” Central Research laboratory, March 1976.
- [2.2.10] NUREG/CR-0481, “An Assessment of Stress-Strain Data Suitable for Finite Element Elastic-Plastic Analysis of Shipping Containers,” H.J. Rack and G.A. Knorovsky, Sandia Laboratories, SAND77-1872, September 1978.
- [2.2.11] Baumeister, T. and L.S. marks, Standard Handbook for Mechanical Engineers, 7th Edition, New York, McGraw-Hill Book Co., 1966.
- [2.5.1] ANSI N14.6-1993, "American National Standard for Special Lifting Devices for Shipping Containers Weighing 10,000 Pounds (4,500 kg) or More for Nuclear Materials," American National Standards Institute, Inc.
- [2.5.2] ANSYS, Version 13.0, Ansys Inc., Copyright 2010 SAS IP, Inc.
- [2.5.3] LS-DYNA, Version 971, LSTC Software, 2006.
- [2.5.4] Field Manual of the A.A.R. Interchange Rules, Rule 88, American Association of Railroads, 1996.
- [2.5.5] Crane Manufacturer's Association of America (CMAA), Specification No. 70, 1988.
- [2.5.6] NUREG 1536, Standard Review Plan for Dry Cask Storage Systems, USNRC, Rev. 1.

- [2.5.7] Holtec Report HI-2177733, “Structural Evaluation of the Generic DFC for the MPC-37”, Revision 2.
- [2.5.8] Holtec Report HI-2156649, “Structural Analysis of Damaged Fuel Container at SONGS”, Revision 4.
- [2.5.9] ASME Boiler & Pressure Vessel Code, Section III, Subsection NG, American Society of Mechanical Engineers, 2007 Edition, 2008 Addenda.
- [2.6.1] Finite Element Analyses of the HI-STAR 190 Transport Package Drop Accident, Holtec Proprietary Report, HI-2146321, latest revision.*
- [2.6.2] Calculation Package of Humboldt Bay Impact Limiters, Holtec Proprietary Report HI-2063486, latest revision (Docket # 71-9261, TAC L24029).
- [2.6.3] Regulatory Guide 7.9, "Standard Format and Content of Part 71 Applications for Approval of Packaging for Radioactive Material", Rev. 2, USNRC, March 2005.
- [2.6.4] Buckling of Bars, Plates, and Shells, D.O. Brush and B.O. Almroth, McGraw-Hill, 1975, p.22.
- [2.6.5] Holtec Proprietary Report HI-2084137, “A Classical Dynamics Based and Experimentally Benchmarked Impact Response Computation Methodology for AL-STAR Equipped Casks”, Latest Revision.
- [2.6.6] NUREG/CR-1132, “A Survey of Potential Light Water Reactor Fuel Rod Failure Mechanisms and Damage Limits”, Courtright, E.L., July 1979.
- [2.6.7] Lanning, D. D. and Beyer, C. E., “Estimated Maximum Cladding Stresses for Bounding PWR Fuel Rods During Short Term Operations for Dry Cask Storage”, Pacific Northwest National Laboratory, January 2004.
- [2.6.8] BAW-10227-A, “Evaluation of Advanced Cladding and Structural Material (M5) in PWR Reactor Fuel,” Non-Proprietary Version, FCF, ML003686365, February 2000.
- [2.7.1] Holtec Proprietary Report HI-981891, “Impact Limiter Test Report - Second Series”, Rev 3, 1998.
- [2.7.2] Holtec Proprietary Report HI-2063591, “Benchmarking of LS-DYNA for Simulation of Hypothetical Drop Conditions of Transport”, Rev. 1, 2007.
- [2.7.3] Holtec Proprietary Report HI-2094418, “Structural Calculation Package for HI-STORM FW System”, Revision 11.

* Supporting document submitted with the HI-STAR 190 License Application.

- [2.7.4] Holtec Proprietary Report HI-2073743, “Benchmarking the LS-DYNA Impact Response Prediction Model for the HI-STAR Transport Package Using the AL-STAR Impact Limiter Test Data”, Rev. 1, 2008.
- [2.7.5] Shah, M.J., Klymyshyn N.A., and Kreppel B.J., “HI-STAR 100 Spent Fuel Transport Cask Analytic Evaluation for Drop Events”, Packaging, Transport, and Security of Radioactive Materials, Vol. 18, No. 1, W.S. Maney & Sons (2007).
- [2.7.6] Containment Performance of Transportable Storage Casks at 9-m Drop Test, Hitoshi Tobita and Kenji Araki, PATRAM 2004, Berlin, Germany, 9/2004.
- [2.7.7] "Mechanical Design of Heat Exchangers and Pressure Vessel Components", by K.P. Singh and A. I. Soler, Arcturus Publishers, Cherry Hill, New Jersey, 1100 pages, hardbound (1984).
- [2.7.8] Holtec Proprietary Report HI-2073715, Benchmarking of LS-DYNA For Use With Polyurethane Foam Filled Impact Limiter, 2007, Revision 0.
- [2.7.9] “Validation of an Impact Limiter Crush Prediction Model with Test Data: The Case of the HI-STAR 100 Package”, K.P. Singh, A.I. Soler, and C. Bullard, PATRAM 2004, Berlin, Germany, September 20-24, 2004.
- [2.7.10] USNRC ASLB, “Final Partial Initial Decision on F-16 Aircraft Accident Consequences”, Docket No. 72-22-ISFSI, ASLB# 97-732-02-ISFSI, dated 2/24/2005.
- [2.7.11] “Guidelines for Conducting Impact Tests on Shipping Packages for Radioactive Material”, Mok, Carlson, Lu, and Fischer, UCRL-ID-121673, Lawrence Livermore National Laboratory, September 1995.
- [2.7.12] QA Documentation Package for ANSYS (Versions 11.0 and Higher), HI-2012627, Rev. 9, 2012.
- [2.7.13] QA Documentation for LS-DYNA3D, HI-961519, Rev. 6, 2008.
- [2.7.14] “Acceptable Flaw Size for MPC Transportability Inspection,” Holtec Position Paper DS-438, Revision 1.
- [2.7.15] Holtec Proprietary Report HI-2156765, “Benchmark LS-DYNA for the Free Drops Involving Steel Casks Without Impact Limiters”, Revision 0, 2015.
- [2.11.1] SFPO-ISG-11, Revision 3, “Cladding Considerations for the Transportation and Storage of Spent Fuel”

- [2.11.2] “Threat of Hydride Re-orientation to Spent Fuel Integrity During Transportation Accidents: Myths or Reality?”, Proceedings of the 2007 International LWR Fuel Performance Meeting.
- [2.11.3] Spent Nuclear Fuel Structural Response When Subject to an End Impact Accident, D. Tang, J. Guttman, B. Koeppel, and H. Adkins, PATRAM 2004, Berlin, Germany, 9/2004.
- [2.11.4] PVP2004-2804, “Spent Nuclear Fuel Structural Response When Subject to an End Impact Accident”, PVP-Vol 483, Transportation, Storage and Disposal of Radioactive Materials-2004, Adkins, Koeppel, and Tang.
- [2.11.5] NUREG/CR-7189, “Mechanical Fatigue Testing of High-Burnup Fuel for Transportation Applications”, USNRC, Washington D.C., April 2015.
- [2.11.6] Hydride-Related Degradation of Spent-Fuel Cladding Under Repository Conditions, Energy Technology Division, Argonne National Laboratory, Argonne, IL.
- [2.11.7] NUREG/CR-1132 PNL-2787, “A Survey of Potential Light Water Reactor Fuel Rod Failure Mechanisms and Damage Limits”.
- [2.11.8] PNNL-17700, “PNNL Stress/Strain Correlation for Zircaloy”, July 2008.
- [2.11.9] Electric Power Research Institute-1015048, “Spent Fuel Transportation Applications - Assessment of Cladding Performance” A Synthesis Report.
- [2.11.10] 15th International Symposium on Zirconium in the Nuclear Industry, June 2007, “Evaluation of Hydride Reorientation Behavior and Mechanical Property for High Burnup Fuel Cladding Tube in Interim Dry Storage”.
- [2.11.11] “The Prometra Program: A Reliable Material Database for Highly Irradiated Zircaloy-4, Zirlo™ and M5™ Fuel Cladding,” B. Cazalis et. al, SMiRT18-C02-1, 18th International Conference on Structural Mechanics in Reactor Technology (SMiRT 18), Beijing, China, August 7-12, 2005.
- [2.11.12] “Quantification of the Margins Provided by M5 Cladding in Accidental Conditions,” Garat et. al, 2012 LWR Fuel Performance Meeting.

Appendix 2.A: Description of Computer Codes for Structural Evaluation*

Two commercial computer programs, both with a well established history of usage in the nuclear industry, have been utilized to perform structural and mechanical numerical analyses documented in this submittal. These codes are ANSYS Mechanical and LS-DYNA. A brief synopsis of the capabilities of each code is presented below:

ANSYS Mechanical

ANSYS is the original (and commonly used) name for ANSYS Mechanical general-purpose finite element analysis software. ANSYS Mechanical is the version of ANSYS commonly used for structural applications. It is a self contained analysis tool incorporating pre-processing (geometry creation, meshing), solver, and post processing modules in a unified graphical user interface. ANSYS Mechanical is a general purpose finite element modeling package for numerically solving a wide variety of mechanical problems. These problems include: static/dynamic structural analysis (both linear and non-linear), heat transfer and fluid problems, as well as acoustic and electro-magnetic problems.

ANSYS Mechanical has been independently QA validated by Holtec International and used for structural analysis of casks, fuel racks, pressure vessels, and a wide variety of SSCs, for over twenty years.

LS-DYNA

LS-DYNA is a general purpose finite element code for analyzing the large deformation static and dynamic response of structures including structures coupled to fluids. The main solution methodology is based on explicit time integration and is therefore well suited for the examination of the response to shock loading. A contact-impact algorithm allows difficult contact problems to be easily treated. Spatial discretization is achieved by the use of four node tetrahedron and eight node solid elements, two node beam elements, three and four node shell elements, eight node solid shell elements, truss elements, membrane elements, discrete elements, and rigid bodies. A variety of element formulations are available for each element type. Adaptive re-meshing is available for shell elements. LS-DYNA currently contains approximately one-hundred constitutive models and ten equations-of-state to cover a wide range of material behavior.

In this safety analysis report, LS-DYNA is used to analyze all loading conditions that involve short-time dynamic effects.

* This appendix contains generic information and is identical to the one submitted in the HI-STAR 60 SAR and HI-STAR 180 SAR. Under Holtec's configuration control, this appendix will be immediately revised in all submitted SARs if a USNRC request-for-additional-information (RAI) necessitates a change to its contents.

CHAPTER 3: THERMAL EVALUATION

3.0 INTRODUCTION

In this chapter, compliance of the HI-STAR 190 Package to 10CFR Part 71 [1.0.2] and ISG-11, Rev. 3 [1.2.6] thermal requirements is evaluated for normal transport and hypothetical accident conditions of transport. The analysis considers passive rejection of decay heat from the Spent Nuclear Fuel (SNF) to a 10CFR71- mandated environment for normal transport and hypothetical fire accident conditions.

The 10CFR Part 71 regulations define the thermal requirements of transport packages. The requirements are as follows:

1. A package must be designed, constructed, and prepared for shipment so that in still air at 38°C (100°F) and in the shade, no accessible surface of the package would have a temperature exceeding 85°C (185°F) in an exclusive use shipment [§71.43(g)].
2. With respect to the initial conditions for the events of normal conditions of transport and hypothetical accident conditions, the demonstration of compliance with the requirements of 10CFR71 must be based on the ambient temperature preceding and following the event remaining constant at that value between a bounding -40°C (-40°F) and 38°C (100°F) which is most unfavorable for the feature under consideration. The initial internal pressure within the containment must be considered to be the maximum normal operating pressure [§71.71(b) and §71.73(b)].
3. For normal conditions of transport, a heat event consisting of an ambient temperature of 38°C (100°F) in still air and prescribed insolation must be evaluated [§71.71(c)(1)].
4. For normal conditions of transport, a cold event consisting of an ambient temperature of -40°C (-40°F) in still air and shade must be evaluated [§71.71(c)(2)].
5. Evaluation for hypothetical accident conditions is to be based on sequential application of the specified events, in the prescribed order, to determine their cumulative effect on a package [§71.73(a)].
6. For hypothetical accident conditions, a thermal event consisting of a fully engulfing hydrocarbon fuel/air fire with an average emissivity coefficient of at least 0.9, with an average flame temperature of at least 802°C (1475°F) for a period of 30 minutes [§71.73(c)(4)].

Section 3.1 describes the thermal design features of the HI-STAR 190 Package. Section 3.2 lists the material properties data required to perform the thermal analyses and the applicable temperature limits criteria required to demonstrate the adequacy of the HI-STAR 190 Package design under normal and hypothetical accident conditions. Thermal analyses to evaluate the normal transport are described and evaluated in Section 3.3. Thermal analyses for hypothetical accident conditions are described and evaluated in Section 3.4.

To facilitate convenient access to the referenced material, Table 3.0.1 provides a listing of the material adopted in this chapter by reference to the HI-STORM FW FSAR [1.0.8].

Table 3.0.1: HI-STORM FW FSAR Material Germane to the Evaluations in this SAR

Location in HI-STAR 190 SAR	Reference Information	Location in HI-STORM FW FSAR [1.0.8]	Technical Justification of Applicability to HI-STAR 190
Paragraphs 3.3.1.1 and 3.3.1.4	Fuel region effective thermal conductivity	Paragraph 4.4.1.1	Same fuel types are to be certified in HI-STAR 190 and HI-STORM FW.
Sub-Section 3.3.3 and Paragraph 3.4.3.2	MPC free volume and pressure calculation method	Sub-Section 4.4.5	Same fuel types and MPCs are to be certified in HI-STAR 190 and HI-STORM FW.
Sub-Section 3.3.4	Loading operations	Sub-Section 4.5	Same fuel types and MPCs are to be certified in HI-STAR 190 and HI-STORM FW.

3.1 DESCRIPTION OF THERMAL DESIGN

3.1.1 Design Features

The principal design and performance objective for the HI-STAR 190 cask is transportation of MPCs initially loaded and stored under CoCs 72-1032 and 72-1040. In addition, it also allows for load-and-go transportation (as described in Chapter 1 of this SAR) of MPCs certified for loading and storage under CoCs 72-1032 and 72-1040. Design details of the HI-STAR 190 Package are presented in Chapter 1 and structural and mechanical features are described in Chapters 1 and 2. The HI-STAR 190 Package geometry is detailed in Holtec drawings included in Section 1.3. All materials of construction are itemized in the drawings. The assembled packaging with impact limiters installed is shown in Figure 1.2.4. As shown in this figure, the HI-STAR 190 Package is equipped with a personnel barrier to prevent access to hot cask surfaces. The package consists of a loaded MPC inside a thick steel cask with a bolted closure lid. HI-STAR 190 is available in two discrete lengths to accommodate all BWR and all PWR canisters. The two versions are identified as Version SL (standard length) and Version XL (extended length), respectively. In order to accommodate MPCs of various lengths (e.g. HI-STORM FW MPCs [1.0.8]), MPC spacers are used to restrict axial movement of the MPC and control the center of gravity of the package. Two MPC designs, the MPC-37 and MPC-89, which are certified for storage in the HI-STORM FW under CoC 72-1032 and HI-STORM UMAX under CoC 72-1040 are available for transporting up to 37 PWR and 89 BWR fuel assemblies in HI-STAR 190 cask. The height of MPC-37 is variable based on the SNF to be loaded similar to HI-STORM FW [1.0.8]. The fuel assemblies reside in a fuel basket within the MPC. The fuel basket is a honeycomb structure engineered with square-shaped compartments to store fuel assemblies. Prior to sealing the MPC lid, the MPC is backfilled with helium to levels specified in Tables 7.C.11 and 7.C.12. The helium backfilled MPC containing the SNF is placed within the HI-STAR 190 cask. Additionally prior to cask lid closure, the cavity space between the MPC and the cask overpack is also backfilled with helium to the levels specified in Table 7.1.2. This provides a stable and inert environment for the transport of the SNF. Heat is transferred from the cask to the environment by passive heat transport mechanisms only.

The HI-STAR 190 Package is designed to safely dissipate heat under passive conditions (no wind). During transport, the HI-STAR 190 Package is placed in a horizontal position with impact limiters installed at both ends of the cask. Under normal transport conditions, the cask contents (fuel, fuel basket, basket shims and MPC) rest on solid surfaces. Direct contact between the cask and its contents enhance heat dissipation. Prior to cask closure, the cavity space between the MPC and cask overpack is backfilled with helium. Presence of a substantially more conductive medium (helium) relative to air in the cavity spaces aids heat transfer by minimizing gap resistances and dissipating heat by natural convection in the cavity peripheral spaces.

The fuel baskets are a matrix of square-shaped fuel compartments sized to store PWR or BWR Spent Nuclear Fuel (SNF). The basket is formed by a honeycomb structure of thick Metamic-HT plates. The fuel basket is surrounded by an array of shaped aluminum spacers (basket shims) inserted in the MPC cavity peripheral spaces. Cross-sectional views of the two fuel basket designs within the MPC are provided in Chapter 1. Heat is dissipated in the fuel basket

principally by conduction of heat in the highly conductive Metamic-HT plates arrayed in two orthogonal directions. Heat dissipation in the fuel basket peripheral spaces is by a combination of contact heat transfer, helium conduction and radiation across narrow peripheral spacer gaps and by conduction through the basket shims. The fuel basket and the basket shims reside in a containment boundary formed by the MPC. The MPC itself resides in a cask containment boundary formed by the containment shell, baseplate and a closure lid. The cask overpack is a multi-shell cylindrical cask body that is made of three concentric shells joined to a solid annular top flange and a solid annular bottom flange. All three shells are fixed in place by longitudinal ribs which serve as radial connectors between the shells. These radial connectors provide a continuous path for radial heat transfer. The space between the innermost and middle shell is occupied by lead which provides the bulk of the cask's gamma radiation shielding capability. The space between the middle and outermost shell is occupied by neutron shield material (Holite-B) which provides the bulk of the cask's neutron radiation shielding capability.

The helium backfill gas is an integral part of the MPC and HI-STAR 190 overpack thermal design. The helium fills all the spaces between solid components and provides an improved conduction medium (compared to air) for dissipating decay heat in the MPC. Additionally, helium in the spaces between the fuel basket and the MPC shell is heated differentially and dissipates heat by the so-called "Rayleigh" convection. To ensure that the helium gas is retained and not diluted by lower conductivity air, the MPC helium retention boundary is designed to comply with the provisions of the ASME Code Section III. Similarly, the overpack containment boundary is designed as ASME Code Section III pressure vessel. It is equipped with high integrity double seals in the closure lid. The overpack containment boundary is leak-tight as described in Chapter 4 of this SAR which ensures the presence of helium during transport. The helium gas is therefore retained and undiluted during transport, and may be credited in the thermal analyses.

An important thermal design criterion imposed on the HI-STAR 190 Package is to ensure that the peak fuel cladding temperatures are below regulatory limits. An equally important design criterion is to minimize temperature gradients within the fuel basket to minimize thermal stresses. In order to meet these design objectives, the HI-STAR 190 fuel basket is designed to possess certain distinctive characteristics, which are summarized in the following.

The MPC design minimizes resistance to heat transfer within the basket and basket periphery regions. This is ensured by designing the fuel basket with highly conductive Metamic-HT plates. In the fuel basket peripheral spaces thick Aluminum basket extruded shims are inserted to facilitate basket-to-cask heat transfer. Thin solid shim plates may be inserted between the basket and extruded basket shims to ensure a good heat transfer path between the basket and extruded shims. The MPC design incorporates top and bottom plenums with interconnected downcomer paths to facilitate heat dissipation by internal helium circulation. This mode of heat transfer is active when the cask is tilted a few degrees from horizontal orientation. The top plenum is formed between the MPC lid and top of the fuel basket while the bottom plenum is formed by the lateral flow holes in the bottom section of each fuel cell wall. The MPC basket is designed to eliminate structural discontinuities (i.e., gaps) which introduce large thermal resistances to heat flow. Consequently, temperature gradients are minimized in this design, which results in lower

thermal stresses within the basket. Low thermal stresses are also ensured by an MPC design that permits unrestrained axial and radial growth of the basket to eliminate the possibility of thermally induced stresses due to restraint of free-end expansion. The fuel basket and the basket shims reside in a containment boundary formed by the MPC.

The HI-STAR 190 Package is designed to transport both PWR and BWR spent fuel assemblies. As explained next, thermal analysis of the HI-STAR 190 Package considers all three fundamental modes of heat transfer: conduction, natural convection and thermal radiation. On the outside surface of the package, heat is dissipated to the environment by buoyancy induced convective air-flow (natural convection) and thermal radiation. Within the cask body, heat dissipation is principally by heat conduction. Heat dissipation in the cavity space between the MPC and cask overpack is by both conduction and radiation. Inside the MPC cavity heat dissipation is conservatively limited to conduction and radiation. Between surfaces (e.g., between neighboring fuel rods) heat is transported by a combination of conduction through a gaseous medium (helium) and thermal radiation. Heat transfer between the fuel basket external surface and MPC shell inside wall is enhanced by the so-called “Rayleigh” effect in differentially heated cavities [3.1.1]. In the interest of conservatism convective heat transfer in the cavity spaces is neglected.

In Section 3.2 the thermal criteria for ensuring Spent Nuclear Fuel (SNF) integrity and cask effectiveness are provided. To ensure SNF integrity, the ISG-11 recommended cladding temperature limits [1.2.6] are adopted (Table 3.2.11). To ensure cask effectiveness the cask materials and components are required to be below the pressure and temperature limits for creep, yield, decomposition and melting (Tables 2.1.1, 3.2.10 and 3.2.12).

3.1.2 Contents Decay Heat

The HI-STAR 190 Package is designed to allow fuel loading under different loading patterns. The fuel loading is required to comply with the decay heat limits in Tables 7.C.7 and 7.C.9. These tables define the permissible heat load patterns for both MPC-37 and MPC-89. The heat generation in each fuel assembly is non-uniformly distributed over the active fuel to account for design basis fuel burnup distribution listed in Table 1.2.5. The complete HI-STAR 190 Package consisting of the overpack, impact limiters and MPC under transport conditions is analyzed for the imposed design heat loads.

3.1.3 Summary Table of Temperatures

The HI-STAR 190 Package temperatures are analyzed for normal transport condition for both MPC-37 and MPC-89 designs. All the permissible loading patterns for each MPC are evaluated and details on the bounding pattern are discussed in Section 3.3. The hypothetical fire accident event is evaluated for thermally bounding scenario i.e. MPC-37 canister under its limiting loading pattern. The modeling of the thermal problem is discussed in Sections 3.3 and 3.4. The analysis results are provided in Tables 3.1.1 and 3.1.3. Since the temperature of some cask components are higher for MPC-89 compared to MPC-37 under normal transport conditions (see Table 3.1.1), the temperature of such components are determined under fire conditions also. All

other component temperatures are bounded by the thermal evaluation of an MPC-37 under fire accident condition. The component temperatures of MPC-89 under fire accident conditions are tabulated in Table 3.1.4. The HI-STAR 190 normal transport and hypothetical accident temperatures comply with the normal and accident temperature limits specified in Tables 3.2.10, 3.2.11 and 3.2.12.

3.1.4 Summary Table of Maximum Pressures

The MPC cavity and HI-STAR 190 cavity pressures are computed for normal transport condition and hypothetical fire accident event. The numerical modeling is discussed in Sections 3.3 and 3.4. The analysis results are provided in Tables 3.1.2 and 3.1.5. The MPC cavity and HI-STAR 190 normal transport and hypothetical accident containment pressures comply with the pressure limits specified in Chapter 2, Table 2.1.1.

3.1.5 Cask Surface Temperature Evaluation

In accordance with the regulatory requirement specified in 10CFR71 (§71.43(g)), the cask surface temperature is computed in still air at 38°C (100°F) and in the shade. Under this scenario the maximum computed cask surface temperature for the limiting thermal scenario (see Section 3.3) reported in Table 3.1.6 is above the allowable surface temperature limit of 85°C (185°F). To meet the accessible surface temperature limit, a personnel barrier as defined in Chapter 1 will be required. The personnel barrier must be engineered to provide personnel protection without adversely impacting cask and fuel temperatures. In Section 3.3 a personnel barrier is conservatively defined and evaluated for the bounding scenario.

Table 3.1.1: HI-STAR 190 Normal Transport Maximum Temperatures

Material/Component	MPC-37 ^{Note 1} Temperature °C (°F)	MPC-89 ^{Note 1} Temperature °C (°F)
Fuel Cladding	365 (689)	352 (666)
Fuel Basket	332 (630)	335 (635)
Basket Shims	256 (493)	251 (484)
MPC Shell	210 (410)	210 (410)
MPC Base ^{Note 2}	153 (307)	170 (338)
MPC Lid ^{Note 2}	154 (309)	138 (280)
Containment Shell	164 (327)	159 (318)
Neutron Shield ^{Note 3}	159 (318)	154 (309)
Lead ^{Note 4}	162 (324)	157 (315)
Enclosure Shell	127 (261)	123 (253)
Containment Bottom Forging ^{Note 7}	111 (232)	108 (226)
Containment Top Forging ^{Note 7}	81 (178)	98 (208)
Closure Lid ^{Note 2}	82 (180)	102 (216)
Lid Spacer	88 (190)	114 (237)
Containment Seals ^{Note 5}		
Closure Lid Inner Seal	82 (180)	99 (210)
Port Cover Inner Seal	82 (180)	99 (210)
Impact Limiter Crush Material ^{Note 6}		
Bulk	81 (178)	79 (174)
Maximum	99 (210)	95 (203)
<p>Note 1: Temperatures for the most limiting loading scenario is reported (see Section 3.3). Note 2: In accordance with temperature limits Table 3.2.10 Note (a) the maximum section temperatures of structural members are reported. Note 3: The maximum temperature of the neutron shield component with the highest temperature is reported. Note 4: The maximum temperature of the gamma shield component with the highest temperature is reported. Note 5: The temperatures on lid seals relied upon for containment function are reported herein. The containment boundary seals are described in Chapter 4. Note 6: The temperature of the impact limiter crush material with the highest temperature is reported. Note 7: Bulk average temperature of component tabulated herein.</p>		

Table 3.1.2: HI-STAR 190 Maximum Operating Pressures¹

Condition	Gauge Pressure kPa (psig)	
	MPC-37	MPC-89
MPC Cavity MNOP ²		
Normal Condition	666.7 (96.7)	659.1 (95.6)
With 3% Rods Rupture ^(Note 1)	686.0 (99.5)	670.9 (97.3)
Cavity Space between MPC and HI-STAR 190 ³		
Normal Condition	166.2 (24.1)	187.5 (27.2)

Note 1: In accordance with NUREG-1617 [3.1.3], 3% of the rods are assumed to be breached releasing 100% fill gas and 30% fission gas to containment.

¹ Pressure analysis in accordance with heat condition specified in 10 CFR 71.71(c)(1) in the absence of venting, external ancillary cooling or operational controls.

² The MPC cavity MNOP is calculated based on an initial MPC cavity helium backfill pressure limits specified in Table 7.C.11. For a bounding evaluation the upperbound limit is used in the pressure calculations.

³ The HI-STAR 190 cavity helium backfill pressure limits are specified in Table 7.1.2.

Table 3.1.3: Hypothetical Fire Accident Maximum Temperatures for an MPC-37 in HI-STAR 190¹

Material/Component	During Fire °C (°F)	Post Fire Cooldown °C (°F)
Fuel Cladding	367 (693)	393 (739)
Fuel Basket	334 (633)	362 (684)
Basket Shims	258 (496)	287 (549)
MPC Shell	213 (415)	245 (473)
MPC Base ^{Note 1}	154 (309)	212 (414)
MPC Lid ^{Note 1}	155 (311)	189 (372)
Containment Shell	179 (354)	221 (430)
Containment Bottom Forging ^{Note 2}	148 (298)	191 (376)
Containment Top Forging ^{Note 2}	123 (253)	171 (340)
Closure Lid ^{Note 1}	86 (187)	160 (320)
Containment Seals ^{Note 3}		
Closure Lid Inner Seal	103 (217)	172 (342)
Port Cover Inner Seal	90 (194)	165 (329)
<p>Note 1: In accordance with temperature limits Table 3.2.10 Note (a) the maximum section temperatures of structural members are reported.</p> <p>Note 2: A bulk average temperature of the components is reported herein.</p> <p>Note 3: The temperatures on lid seals relied upon for containment function are reported herein. The containment boundary seals are described in Chapter 4.</p>		

¹ The initial condition for fire evaluation bounds that reported in Table 3.1.1.

Table 3.1.4: Hypothetical Fire Accident Maximum Temperatures for an MPC-89 in HI-STAR 190¹

Material/Component	Temperatures ^{Note 1} °C (°F)
Containment Top Forging ^{Note 2}	187 (369)
Closure Lid ^{Note 3}	179 (354)
Containment Seals ^{Note 4}	
Closure Lid Inner Seal	189 (372)
Port Cover Inner Seal	182 (360)
<p>Note 1: The temperatures of only those containment boundary components are reported herein for MPC-89 that are higher than those in an MPC-37 canister under normal conditions of transport (see Table 3.1.1).</p> <p>Note 2: A bulk average temperature of the components is reported herein.</p> <p>Note 3: In accordance with temperature limits Table 3.2.10 Note (a) the maximum section temperatures of structural members are reported.</p> <p>Note 4: The temperatures on lid seals relied upon for containment function are reported herein. The containment boundary seals are described in Chapter 4.</p>	

¹ The temperatures tabulated herein are computed by adding the temperature rise due to hypothetical fire accident computed for an MPC-37 canister in Table 3.1.3 to the component temperatures of MPC-89 under normal condition of transport as the initial condition shown in Table 3.1.1.

Table 3.1.5: Maximum HI-STAR 190 Hypothetical Fire Accident Pressures

Condition	Gauge Pressure kPa (psig)	
	MPC-37	MPC-89
MPC Cavity MNOP ^{Note 2}		
No Rods Rupture	712.2 (103.3)	Note 1
With assumed 100% Rods Rupture ^{Note 3}	1479.6 (214.6)	
Cavity Space between MPC and HI-STAR 190		
Cavity Pressure	189.6 (27.5)	211.0 (30.6)
<p>Note 1: The MPC-89 cavity temperature is bounded by the MPC-37 cavity temperature. Therefore, the MPC-37 cavity pressure is reported herein.</p> <p>Note 2: The cavity pressure for the most limiting combination of MPC free volume, contribution from BPRAs and cavity average temperature reported herein.</p> <p>Note 3: Pressure analysis is based on NUREG 1617 [3.1.3] requirements: Release of 100% of the rods fill gas and 30% of the significant radioactive gases from ruptured rods.</p>		

Table 3.1.6: HI-STAR 190 Normal Transport Surface Temperature in Shade

Material/Component	Temperature °C (°F)
Cask Surface Maximum	113 (235)

3.2 MATERIAL PROPERTIES AND COMPONENT SPECIFICATIONS

3.2.1 Material Properties

Materials present in the HI-STAR 190 Packaging include structural steels, stainless steel, aluminum, lead, neutron shielding material (Holtite-B), neutron absorber (Metamic-HT), impact limiter crush material and helium. In Table 3.2.1, a summary of references used to obtain cask material properties for performing all thermal analyses is presented.

Thermal conductivity data of cask structural steels, stainless steel, neutron shielding material, impact limiter, lead, and helium are provided in Table 3.2.2. Thermal conductivities of fuel, aluminum basket shims, solid shim plates and fuel basket (Metamic-HT) are provided in Tables 3.2.3, 3.2.4 and 3.2.5.

Surface emissivity data for key materials of construction are provided in Table 3.2.6. [PROPRIETARY INFORMATION WITHHELD IN ACCORDANCE WITH 10 CFR 2.390] A theoretical bounding solar absorbtivity coefficient of 1.0 is applied to all exposed cask surfaces.

In Table 3.2.7, the specific heat and density data of cask materials is presented. These properties are also used in performing transient (hypothetical fire accident condition) analyses. The viscosity of helium and air is presented in Table 3.2.8.

The HI-STAR 190 Package exposed surfaces heat transfer coefficient is calculated by accounting for both natural convection heat transfer and radiation. Natural convection from a heated horizontal cylinder depends upon the product of the Grashof (Gr) and Prandtl (Pr) numbers. Following the approach developed by Jakob and Hawkins [3.2.8], $GrPr$ is expressed as $L^3\Delta T Z$, where L is the diameter of the cask, ΔT is the cask surface-to-ambient temperature differential and Z is a parameter which is a function of air properties evaluated at the average film temperature. The temperature dependence of Z for air is provided in Table 3.2.9.

3.2.2 Component Specifications

The HI-STAR 190 Package materials and components which are required to be maintained below maximum pressure and temperature limits for safe operation, to ensure their intended functions, are summarized in Chapter 2 (Table 2.1.1) and Chapter 3 (Tables 3.2.10, 3.2.11 and 3.2.12). These materials and components do not degrade under exposure to extreme low temperatures. As defined by transport regulations, the HI-STAR 190 Package cold service temperature is conservatively limited to -40°C (-40°F).

Long-term stability of the neutron shield material (Holtite-B) under normal transport conditions is ensured when material exposure temperatures are maintained below the permissible limits. The cask closure lid seals ensure leak tightness of the closure plate if the manufacturer's recommended design temperature limits are not exceeded. Integrity of SNF during transport requires demonstration of HI-STAR 190 Package fuel cladding temperatures below regulatory limits for Moderate Burnup Fuel (MBF) and High Burnup Fuel (HBF). In the HI-STAR 190

thermal evaluation, the cladding temperature limits of ISG-11, Rev. 3 [1.2.6] are adopted (See Table 3.2.11). These limits are applicable to all fuel types, burnup levels and cladding materials approved for power generation. Neutron absorber material (Metamic-HT) used for criticality control is stable in excess of 538°C (1000°F). For conservatism temperature limits well below the threshold of material integrity[†] are adopted (See Tables 3.2.10, 3.2.11 and 3.2.12).

For evaluation of the HI-STAR Package's thermal performance under hypothetical accident conditions, lowerbound material temperature limits for short-duration events are defined in Tables 3.2.10, 3.2.11 and 3.2.12.

[†] Neutron absorber materials are manufactured using B₄C and aluminum. B₄C is a refractory material that is unaffected by high temperatures and aluminum is solid at temperatures in excess of 538°C (1000°F).

Table 3.2.1: Summary of HI-STAR Packaging Materials Thermal Property References

Material	Emissivity	Conductivity	Density	Heat Capacity
Helium	NA	Handbook [3.2.2]	Ideal Gas Law	Handbook [3.2.2]
Zircaloy Cladding (Note 2)	EPRI [3.2.3]	NUREG [3.2.6]	Rust [3.2.4]	Rust [3.2.4]
UO ₂	Not Used	NUREG [3.2.6]	Rust [3.2.4]	Rust [3.2.4]
Stainless Steel (machined forgings)	Kern [3.2.5]	ASME [3.2.7]	Marks' [3.2.1]	Marks' [3.2.1]
Stainless Steel Plates	ORNL [3.2.13], [3.2.9]	ASME [3.2.7]	Marks [3.2.1]	Marks [3.2.1]
Carbon Steel	Kern [3.2.5]	ASME [3.2.7]	Marks [3.2.1]	Marks [3.2.1]
Aluminum Extruded Basket Shims and Aluminum Solid Shim Plates/Sheets	Table 8.1.10B	ASM [3.2.12]	ASM [3.2.12]	ASM [3.2.12]
Holtite-B	Not Used	Handbook [1.2.10]		
Metamic-HT	Table 8.1.10A	Table 1.5.2	Table 1.5.2	Table 1.5.2
Impact Limiter Crush Material	NA	Note 1	Table 2.2.8	ASME [3.2.7]
Lead	NA	Handbook [3.2.2]	Handbook [3.2.2]	Handbook [3.2.2]
Air	NA	Handbook [3.2.2]	Ideal Gas Law	Handbook [3.2.2.]
Note 1: Nominal values of thermal conductivity are specified in Table 3.2.2. Note 2: The SAR permits Zircaloy 2, Zircaloy 4, ZIRLO and M5 claddings.				

Table 3.2.2: Thermal Conductivity of HI-STAR 190 Cask Materials

Material	At 100°F (Btu/ft-hr-°F)	At 200°F (Btu/ft-hr-°F)	At 450°F (Btu/ft-hr-°F)	At 700°F (Btu/ft-hr-°F)	At 1000°F (Btu/ft-hr-°F)	At 1500°F (Btu/ft-hr-°F)
Helium	0.0886	0.0976	0.1289	0.1575	0.1890	-
Air ^{Note 1}	-	0.0173	0.0225	0.0272	0.0336	-
Stainless Steel ^{Note 4}	8.3	8.8	10.0	11.2	12.5	-
SA 516 Gr 70 ^{Note 4}	34.7	33.7	30.1	26.6	22.4	15.5
SA 350 LF3	23.6	23.5	23	21.6	19.7	15.1
Lead	19.9	19.4	17.9	16.9	-	-
Holtite-B ^{Note 2}	0.25					
Impact Limiter Crush Material ^{Note 3}	Type 1 , High Density – 18.6 / Type 2 , Medium Density – 13.8 / Type 3, Low Density – 8.9					
<p>Note 1: At lower temperatures, air conductivity is between 0.0139 Btu/ft-hr-°F at 32°F and 0.0176 Btu/ft-hr-°F at 212°F.</p> <p>Note 2: [PROPRIETARY INFORMATION WITHELD IN ACCORDANCE WITH 10 CFR 2.390]</p> <p>Note 3: Since the impact limiters are located at cask ends and peak temperatures are seen at approximately fuel mid height, the thermal conductivity of impact limiter does not affect the cask peak temperatures significantly. For modeling completeness, conservatively lower values are used in thermal evaluations of normal conditions. However, no penalty in thermal conductivity is assumed during fire conditions (see Table 3.4.1).</p> <p>Note 4: Conservatively lower values are used in the thermal evaluations of normal conditions. Considering the thermal resistance of metal is much lower than other components, a small variation in metal thermal conductivity has a minor impact on the overall thermal performance of HI-STAR 190 system.</p>						

Table 3.2.3: Thermal Conductivity of Fuel Assembly Materials

Fuel Cladding (Note 1)		Fuel (UO ₂)	
Temperature (°F)	Conductivity (Btu/ft-hr-°F)	Temperature °C (°F)	Conductivity (Btu/ft-hr-°F)
392	8.28 (Note 2)	100	3.48
572	8.76	448	3.48
752	9.60	570	3.24
932	10.44	793	2.28 (Note 2)
Note 1: See Table 3.2.1, Note 3.			
Note 2: Lowest values of conductivity used in the thermal analyses for conservatism.			

Table 3.2.4: Thermal Conductivity of Extruded Basket Shims and Solid Shims Material

Material	Conductivity (Btu/ft-hr-°F)
[PROPRIETARY INFORMATION WITHELD IN ACCORDANCE WITH 10 CFR 2.390]	69.3
Solid Shim Plates	86.67

Table 3.2.5: Metamic-HT Thermal Conductivity Data

[PROPRIETARY INFORMATION WITHHELD IN ACCORDANCE WITH 10 CFR 2.390]

Table 3.2.6: Summary of Materials Surface Emissivity Data

[PROPRIETARY INFORMATION WITHHELD IN ACCORDANCE WITH 10 CFR 2.390]

Table 3.2.7: Materials Density and Specific Heat Properties Summary

[PROPRIETARY INFORMATION WITHHELD IN ACCORDANCE WITH 10 CFR 2.390]

Table 3.2.8: Helium and Air Viscosity Variation with Temperature¹

Temperature (°F)	Helium Viscosity (Micropoise)	Temperature (°F)	Air Viscosity (Micropoise)
167.4	220.5	32.0	172.0
200.3	228.2	70.5	182.4
297.4	250.6	260.3	229.4
346.9	261.8	338.4	246.3
463.0	288.7	567.1	293.0
537.8	299.8	701.6	316.7
737.6	338.8	1078.2	377.6

¹ Obtained from Rohsenow and Hartnett [3.2.2].

Table 3.2.9: Variation of Natural Convection Properties Parameter "Z" for Air with Temperature¹

Temperature (°F)	Z (ft ⁻³ °F ⁻¹)
40	2.1×10 ⁶
140	9.0×10 ⁵
240	4.6×10 ⁵
340	2.6×10 ⁵
440	1.5×10 ⁵

¹ Obtained from Jakob and Hawkins [3.2.8].

Table 3.2.10: HI-STAR 190 Materials Temperature Limits

Component	Material	Normal Condition Temperature Limits ^(a) °C (°F)	Accident Temperature Limits ^(a) °C (°F)
Fuel Basket	Metamic-HT	[PROPRIETARY INFORMATION WITHHELD IN ACCORDANCE WITH 10 CFR 2.390]	[PROPRIETARY INFORMATION WITHHELD IN ACCORDANCE WITH 10 CFR 2.390]
DFC	Stainless Steel	400 (752) ^(b)	570 (1058) ^(b)
Basket Shims and Solid Shim Plates	Aluminum Alloy	400 (752) ^(b)	500 (932) ^(b)
MPC Shell	Stainless Steel	316 (600) ^(b)	427 (800) ^(b)
MPC Lid	Stainless Steel	316 (600) ^(b)	427 (800) ^(b)
MPC Baseplate	Stainless Steel	204 (400) ^(b)	427 (800) ^(b)
Containment Shell	Cryogenic Steel	232 (450) ^(c)	371 (700) ^(d)
Containment Bottom and Top Forgings	Cryogenic Steel	232 (450) ^(c)	371 (700) (Structural Accidents) ^(d) 788 (1450) (Fire Accident) ^(e)
Closure Lid	Cryogenic Steel	232 (450) ^(c)	371 (700) (Structural Accidents) ^(d) 788 (1450) (Fire Accident) ^(e)
Remaining Cask Steel	Carbon Steel	232 (450) ^(c)	371 (700) (Structural accidents) ^(d) 788 (1450) (Fire Accident) ^(e)

Notes

(a) The ASME Code requires that the vessel design temperature be established with appropriate consideration of internal or external heat generation. In accordance with ASME Section III Code, Para. NCA-2142 the design temperature is set at or above the structural members' section temperature defined as the maximum through thickness mean metal temperature of the part under consideration. The section temperatures of the structural members shall not exceed the temperatures limits tabulated herein.

(b) The temperature limits of MPC, fuel basket and basket shims are the same as that in HI-STORM FW FSAR [1.0.8]. The temperature limit of DFCs is the same as that in the HI-STORM UMAX FSAR [3.3.3].

(c) The normal condition temperature limits conservatively bound the ASME Code temperature limits.

(d) The accident temperatures of structural members must not exceed the ASME code temperature limits.

(e) To preclude melting the short term and fire accident temperature limits are set well below the melting temperature of structural steel.

Table 3.2.11: Fuel Cladding Temperature Limits

Component	Material	Normal Condition Temperature Limits °C (°F)	Accident Temperature Limits °C (°F)
Fuel Cladding (Moderate or High Burnup Fuel)	See Note 1	400 (752)	570 (1058)
<p><u>Notes</u></p> <p>1. Fuel cladding temperature limits are applicable to all cladding materials approved for power generation [1.2.6].</p>			

Table 3.2.12: HI-STAR 190 Component Temperature Limits

Component	Material	Normal Condition Temperature Limits °C (°F)	Short Term Operations & Accident Temperature Limits °C (°F)
Lid Seal	Note 1	Table 2.2.11	Table 2.2.11
Neutron Shield	Holtite-B	Table 1.5.3	Note 2
Gamma Shield	Lead	316 (600)	316 (600) ^{Note4}
Impact Limiter Bulk	Aluminum Foam	Table 2.2.8	NA ^{Note 3}
<u>Notes</u> [PROPRIETARY INFORMATION WITHELD IN ACCORDANCE WITH 10 CFR 2.390]			

3.3 THERMAL EVALUATION UNDER NORMAL CONDITIONS OF TRANSPORT

3.3.1 Overview of the Thermal Model

The HI-STAR 190 Package is designed to safely dissipate heat under passive conditions (no wind). Under normal transport conditions, the cask contents (fuel, fuel basket, basket shims and MPC) rest on solid surfaces. Direct contact between the cask and its contents enhances heat dissipation. Nevertheless to engineer a robust measure of conservatism a hypothetical bounding configuration (levitating fuel basket and MPC) is assumed. Under this assumption, the fuel, fuel basket, basket shims, MPC and cask are in concentric alignment (i.e. they do not make physical contact).

The HI-STAR 190 cask is available in two discrete lengths to accommodate all BWR and all PWR canisters. The two versions are identified as Version SL (standard length) and Version XL (extended length), respectively. In order to accommodate MPCs of various lengths (see HI-STORM FW MPCs [1.0.8]), MPC spacers are used to restrict axial movement of the MPC and control the center of gravity of the package. Two distinct MPC designs, the MPC-37 and MPC-89, which are certified for storage in the HI-STORM FW under CoC 72-1032 and HI-STORM UMAX under CoC 72-1040 are available for transporting up to 37 PWR and 89 BWR fuel assemblies in HI-STAR 190 cask. The height of MPC-37 is variable based on the SNF to be loaded as described in HI-STORM FW FSAR [1.0.8]. The MPC-37 heights are catalogued into the categories discussed in Chapters 2 and 4 of HI-STORM FW FSAR [1.0.8] and are summarized below. PWR fuel assembly type 15x15I has a shorter fuel assembly height than the minimum fuel assembly height, therefore resulting in a shorter MPC height. A shorter MPC results in a smaller surface area for heat transfer and warrants thermal analysis. This type of fuel is referred to as 15x15I short fuel in this chapter.

Name	Fuel Assembly Nominal Length (in)
15x15I Short Fuel	149
Short Fuel (or Minimum)	157
Standard Fuel (or Reference)	167.2
Long Fuel (or Maximum)	199.2
BWR Fuel	176.2

To define the limiting MPC-37 fuel height, an array of calculations with different MPC-37 heights as stated above is analyzed using 3D thermal models, as discussed later in this section. The cask is rated for different heat loads for different MPC types, as discussed in Chapter 7. Apart from their storage capacity, the two MPC designs are similar with respect to the MPC material (stainless steel), basket material (Metamic-HT), basket construction (interlocking honeycomb panels), diameter of the MPCs and thicknesses of MPC shell, lid and baseplate. However, from a thermal-hydraulic standpoint all MPC types are evaluated. Both MPC-37 and MPC-89 placed within the HI-STAR 190 cask cavity are evaluated for compliance with transport regulations and design criteria.

The HI-STAR 190 Package thermal analysis is performed using the FLUENT CFD code [3.3.2]. FLUENT is a well-benchmarked CFD code validated by the code developer with an array of theoretical and experimental works from technical journals. Additionally, Holtec has Q.A. validated FLUENT within the company's quality assurance program and confirmed the code's capability to reliably predict temperature fields in dry storage [3.3.4] using independent full-scale test data from a loaded cask [3.2.3]. The code has a long history of usage for obtaining NRC approval of fuel storage in transport and storage casks. A list of dockets wherein USNRC relied on FLUENT thermal models for cask certification is given in Table 3.3.2.

The HI-STAR 190 cask is designed to allow fuel loading under different loading conditions. The maximum aggregate cask decay heat is limited to the values specified in Table 7.C.7 for MPC-37 and Table 7.C.9 for MPC-89. A sub-design heat load pattern is also defined to allow more flexibility in helium backfill pressure range (see Table 7.C.12). To define a limiting pattern, an array of bounding fuel loading configurations is analyzed using 3D thermal models of MPC-37 and MPC-89, as discussed later in this section. The results of pattern screening evaluation are presented in Table 3.3.4 and the heat load distribution with bounding results is highlighted in Table 3.3.4.

Fuel assemblies are allowed for various loading configurations and are summarized in Tables 7.C.5 and 7.C.6 for MPC-37 and MPC-89 respectively. Fuel loading in Damaged Fuel Container (DFC) is permitted in MPC-37 under following configurations:

- i) Placing all intact or undamaged 16x16A type PWR fuel assemblies in a thin square box referred to as damaged fuel container (DFC). The design details of DFCs are presented in the drawings provided in Section 1.3. Two DFC designs are defined: a baseline design (Dwg. 10234) and enhanced design (Dwg. 11107) with a slightly wider opening and top/bottom details to facilitate assembly placement. To facilitate thermal evaluation of fuel storage in DFCs the baseline design is adopted. These DFCs are in turn placed within a basket storage cell. A separate thermal evaluation to evaluate the presence of 16x16A intact fuel assemblies in DFCs is performed for the limiting heat load pattern in Sub-section 3.3.6.
- ii) Placing damaged fuel assemblies in DFCs articulated in Section 1.3 and locating them in basket cells as permitted by configuration Table 7.C.5. A thermal evaluation is performed for the limiting heat load pattern in Sub-section 3.3.6.

Modeling details of the principal thermal transport mechanisms are provided in the following.

3.3.1.1 Fuel Region Effective Planar Conductivity

In the HI-STAR 190 thermal modeling, the cross section bounded by the inside of a PWR storage cell and the channeled area of a BWR storage cell is replaced with an "equivalent" square section characterized by an effective thermal conductivity in the planar and axial directions. This methodology is exactly the same as that previously approved in HI-STORM FW

FSAR [1.0.8]. Figure 3.3.1 pictorially illustrates this concept. The two conductivities are unequal because while in the planar direction heat dissipation is interrupted by inter-rod gaps; in the axial direction heat is dissipated through a continuous medium (fuel cladding). The effective properties of the fuel region for various fuel categories and basket type used in the thermal analysis presented in this chapter are adopted from Chapter 4 of the HI-STORM FW FSAR [1.0.8].

Similarly, the fuel assembly within a DFC is replaced with an equivalent square section characterized by an effective thermal conductivity in the planar and axial directions. Helium in the annular space between the DFC and fuel basket is explicitly included in the 3D thermal model described in Sub-section 3.3.6. This methodology is exactly the same as that presented in HI-STORM UMAX FSAR [3.3.3].

3.3.1.2 Heat Rejection from Cask and Impact Limiter Surfaces

[PROPRIETARY INFORMATION WITHHELD IN ACCORDANCE WITH 10 CFR 2.390]

3.3.1.3 Determination of Solar Heat Input

The intensity of solar radiation incident on exposed surfaces depends on a number of time varying parameters. The solar heat flux strongly depends upon the time of the day as well as on latitude and day of the year. Also, the presence of clouds and other atmospheric conditions (dust, haze, etc.) can significantly attenuate solar intensity levels. In the interest of conservatism, the solar attenuation effects of dust, haze, angle of incidence and latitude are neglected.

The insolation energy absorbed by the HI-STAR 190 Package is the product of incident insolation and the package absorptivity. For conservatism theoretical bounding absorptivity equal to unity is assumed for the cask surfaces. For polished surfaces solar absorptivity obtained from robust sources is applied (See Table 3.2.6). The HI-STAR 190 Package thermal analysis is based on 12-hour daytime insolation specified in 10CFR71. During normal transport conditions, the HI-STAR Package is cyclically subjected to solar heating during the 12-hour daytime period followed by cooling during the 12-hour nighttime. However, due to the large mass of metal and the size of the Package, the dynamic time lag exceeds the 12-hour heating period. Accordingly, the HI-STAR Package model includes insolation at exposed surfaces averaged over a 24-hour time period. The 10CFR71 12-hour insolation is summarized in Table 3.3.1. This methodology is exactly the same as that approved in HI-STAR 180D SAR [1.0.9].

[PROPRIETARY INFORMATION WITHHELD IN ACCORDANCE WITH 10 CFR 2.390]

The HI-STAR 190 Package thermal analysis is based on a 3D thermal model of the HI-STAR 190 cask that properly accounts radiation, conduction and external natural convection modes of heat transfer. The model is constructed using an array of conservative assumptions to bias the results of the thermal analysis towards much reduced computed margins. [PROPRIETARY INFORMATION WITHHELD IN ACCORDANCE WITH 10 CFR 2.390]

Sectional and isometric views of the HI-STAR 190 thermal model are presented in Figures 3.3.2, 3.3.3 and 3.3.4 respectively.

3.3.1.5 Screening Calculations to Ascertain Limiting Scenario

To define the thermally most limiting MPC-37 fuel height in HI-STAR 190 overpack, the following cases are evaluated under the maximum decay heat load pattern defined in Table 7.C.7:

- (i) 15x15I short fuel in MPC-37 within HI-STAR 190 Version SL
- (ii) Short fuel (except 15x15I) in MPC-37 within HI-STAR 190 Version SL
- (iii) Standard fuel in MPC-37 within HI-STAR 190 Version SL
- (iv) Long fuel in MPC-37 within HI-STAR 190 Version XL

To evaluate the above scenarios, 3D FLUENT screening models of the HI-STAR 190 Package are constructed, Peak Cladding Temperatures (PCT) computed and tabulated in Table 3.3.3. The results of the calculations demonstrate that the 15x15I short fuel, which has the shortest fuel length, is the most limiting MPC-37 fuel height.

To define the thermally most limiting HI-STAR 190 transport scenario the following cases are evaluated:

- i) All loading patterns of MPC-37 defined in Table 7.C.7 for the limiting MPC-37 fuel height corresponding to 15x15I short fuel type within HI-STAR 190 Version SL
- ii) All loading patterns of MPC-89 defined in Table 7.C.9 within HI-STAR 190 Version SL

To evaluate the above scenarios, 3D FLUENT screening models of the HI-STAR 190 cask are constructed, PCT and MPC cavity pressure computed and tabulated in Table 3.3.4. The results of the calculations yield the following conclusion:

- (a) Fuel transport in MPC-37 produces a higher PCT and MPC cavity pressure than that in MPC-89
- (b) Although the PCT for heat load patterns 1 and 6 is essentially the same, pattern 1 is highlighted in Table 3.3.4 for MPC-37 as the limiting loading pattern since it results in a higher MPC cavity pressure.

To conservatively predict the HI-STAR 190 transport temperatures, the limiting scenario ascertained above i.e., MPC-37 with 15x15I fuel type under fuel loading pattern 1 is adopted for evaluation of all normal and accident conditions.

3.3.1.6 Grid Sensitivity Studies

To ensure mesh independent CFD results, a grid sensitivity study of the thermal model of the bounding MPC-37 in the HI-STAR 190 cask is performed with particular attention to mesh density in areas of high thermal resistance. The mesh density used for MPC-89 is similar to the licensing basis converged mesh described below and adopted for thermal evaluations of MPC-

37. The grid refinement is performed in the entire domain i.e. for both fluid and solid regions in both axial and radial directions.

A number of grids are generated to study the effect of mesh refinement on the fuel and component temperatures. All sensitivity analyses were carried out for the case of MPC-37 with 15x15I fuel type under thermally bounding loading pattern. Per ASME V&V [3.3.5], it is recommended that the mesh refinement in 3D be approximately 2.2 times the previous mesh. This recommended criterion is satisfied by the meshes specified in Table 3.3.5 that gives a brief summary of the different sets of grids evaluated and PCT results.

As can be seen from the above table, the PCT is essentially the same for all the three meshes. The small PCT difference between the meshes is negligible compared to the available PCT safety margin. Therefore, it can be concluded that the Mesh 3 is reasonably converged. To provide further assurance of convergence, the sensitivity results are evaluated in accordance with the ASME V&V 20-2009 [3.3.5]. Towards this end, the Grid Convergence Index (GCI) for is computed for these meshes and documented in Reference [3.3.1]. The discretization error is calculated as 3.3 K. Based on these results, Mesh 3 grid layout is adopted for the thermal analysis of the HI-STAR 190 Package.

To this model insolation heat (Table 3.3.1) is applied on all external surfaces of the HI-STAR 190 Package assuming 100% absorption for cask external surfaces. Natural convection and radiation from exposed surfaces is enabled to model heat dissipation to ambient air. Using this model, steady state HI-STAR 190 Package temperatures in still air for the limiting decay heat distribution defined in Section 3.3 are computed and evaluated in the next section.

3.3.2 Heat and Cold

3.3.2.1 Maximum Temperatures

As required by transport regulations the HI-STAR 190 Package is evaluated under hot ambient conditions defined in 10CFR71. These conditions are 38°C (100°F) ambient temperature, still air and insolation (Table 3.3.1). To ensure a bounding evaluation, design heat load and a limiting heat load distribution (See Paragraph 3.3.1.5) are assumed. Under this array of adverse conditions, the maximum steady state temperature of the package structural members and its contents (SNF) are computed. The temperatures are computed using the 3D thermal model described in Subsection 3.3.1 and results reported in Subsection 3.1.3. The following observations are derived by inspecting the temperature field obtained from the thermal analysis:

- The maximum fuel cladding temperature (Table 3.1.1) is well within the ISG-11, Rev. 3 temperature limit (Table 3.2.11).
- The maximum temperature of fuel basket (Table 3.1.1) is well within the design temperatures (Table 3.2.10).
- The maximum temperature of MPC components (Table 3.1.1) is well within the design

temperatures (Table 3.2.10).

- The maximum temperatures of the containment boundary and lid seals (Table 3.1.1) are well below the design temperatures (Tables 3.2.10 and 3.2.12, respectively).
- The maximum temperatures of the basket shims (Table 3.1.1) are well below the design temperature limits (Table 3.2.10).
- The neutron shielding material (Holtite-B) temperature (Table 3.1.1) is within its design limit (Table 3.2.12).

The above observations lead us to conclude that the temperature field in the HI-STAR 190 Package loaded with heat emitting SNF complies with all regulatory requirements for normal conditions of transport. In other words, the thermal environment in the HI-STAR 190 Package is conducive to safe transport of spent nuclear fuel.

3.3.2.2 Minimum Temperatures

As specified in 10CFR71, the HI-STAR 190 Package is evaluated for a cold environment at -40°C (-40°F). The HI-STAR Package design does not require minimum decay heat load restrictions for transport. Therefore zero decay heat load and no solar input are bounding conditions for cold evaluation. Under these conditions, the temperature distribution in the HI-STAR 190 Package uniformly approaches the cold ambient temperature. All HI-STAR 190 Package materials of construction satisfactorily perform their intended function in the transport mode at this minimum postulated temperature condition. Evaluations in Chapter 2 demonstrate the acceptable structural performance of the package materials at low temperature. The HI-STAR 190 shielding and criticality materials (Holtite-B, lead and Metamic-HT) are unaffected by exposure to cold temperatures.

3.3.2.3 Personnel Barrier Evaluation

As defined in Chapter 1, personnel barrier is an open lattice cage placed around the HI-STAR 190 cask to prevent access to the hot surfaces (See Figure 1.2.4). The open structure ensures that movement of ambient air is not unduly restricted and the cask temperatures are not impacted. To provide an additional layer of assurance a thermal calculation was performed assuming bounding personnel barrier characteristics defined in Table 3.3.6. The thermal calculation deployed the same 3D HI-STAR 190 thermal model articulated in Subsection 3.3.1.4 except for the following major differences:

[PROPRIETARY INFORMATION WITHHELD IN ACCORDANCE WITH 10 CFR 2.390]

The cask temperatures with the personnel barrier are tabulated in Table 3.3.7. The results show that the cask temperatures are essentially unchanged by the deployment of the personnel barrier.

3.3.3 Maximum Normal Operating Pressure (MNOP)

The MPC is initially filled with dry helium to specifications in HI-STORM FW CoC (Docket 72-1032) after fuel loading and prior to sealing the MPC lid port cover plates and closure ring. Additional heat load requirements and corresponding helium backfill specification are applicable for transportation in HI-STAR 190. The helium backfill requirements for transportation of MPCs in HI-STAR 190 are provided in Tables 7.C.11 and 7.C.12. Additionally, the cavity space between the MPC and HI-STAR 190 cavity is also backfilled with dry helium to the specification in Table 7.1.2 after MPC is placed within it. During normal transport conditions, the gas temperature within the MPC and cask cavity rises to its maximum operating temperature as determined by the thermal analysis methodology described earlier (see Subsection 3.3.1). The gas pressure inside the MPC and cask cavity will increase with rising temperature. The pressure rise is determined using the Ideal Gas Law which states that the absolute pressure of a fixed volume of entombed gas is proportional to its absolute temperature. The MPC MNOP evaluation considers the following source of gases:

Initial Backfill:

The MPC and cask cavity are assumed to be backfilled to the maximum permissible pressure (See Appendix 7.C).

Helium from radioactive decay:

The helium from radioactive decay is dwarfed by the generation of fission products during power generation. These products are assumed to be released into the MPC cavity under hypothetical rod ruptures. As radioactive decay is a small fraction of the fission gas releases it is neglected in the MNOP calculations.

Generation of flammable gases:

The HI-STAR 190 Package uses non-reactive materials of construction. Generation of flammable gases is not credible.

Fuel Rod Failures:

The MPC cavity pressure is also subject to substantial pressure rise under rupture of fuel rods and large gas inventory non-fuel hardware (PWR BPRAs). In accordance with NUREG 1617 [3.1.3], 3% of the fuel rods are assumed to be breached.

During normal transport conditions, the gas temperature within the cavity rises to its maximum operating temperature as determined by the thermal evaluation described earlier. The gas pressure inside the cavity increases monotonically with rising temperature. The pressure rise is determined using the Ideal Gas Law.

A summary of MPC free volumes are presented in Chapter 4 of HI-STORM FW FSAR. The MPC maximum gas pressure is computed for a postulated release of fission product gases from fuel rods into this free space. For these scenarios, the amounts of each of the release gas constituents in the MPC cavity are summed and the resulting total pressures determined from the ideal gas law. Based on fission gases release fractions (NUREG 1536 criteria [3.1.2]), rods' net

free volume and initial fill gas pressure, maximum gas pressures with 3% (normal) rod rupture is given in Table 3.1.2. The presence of non-fuel hardware like BPRA control elements and thimble plugs is also considered in computing the MPC cavity pressure. This is exactly the same as that previously approved by USNRC in HI-STORM FW FSAR.

The HI-STAR 190 Maximum Normal Operating Pressure (MNOP) is calculated for the §71.71(c)(1) heat condition (38°C (100°F) ambient, still air & insulation) and design maximum heat load. Based on a 30% release of the significant radioactive gases and 100% release of the rod fill gas from postulated cladding breaches (3%) the MPC cavity space MNOP is computed and reported in Subsection 3.1.4. The MPC cavity pressures presented in Table 3.1.2 show that the MNOP is well below the design pressure of the containment boundary (Table 2.1.1). Additionally, cask cavity pressure presented in Table 3.1.2 is also well below its design pressure (Table 2.1.1).

The evaluation of pressures and temperatures reached during transport provides reasonable assurance of safe transport of spent nuclear fuel packaged in a HI-STAR 190 Package. This conclusion is based on the technical data and analyses presented in this chapter in conjunction with provisions of 10 CFR Part 71, appropriate regulatory guides, applicable codes and standards, and accepted engineering practices.

3.3.4 Loading Operations

As stated in Chapter 1, this chapter does not cover loading and/or unloading of the MPCs that are assumed to have been loaded under the aegis of the HI-STORM FW FSAR (Docket # 72-1032) or the HI-STORM UMAX FSAR (Docket # 72-1040). All the loading operations are performed in HI-TRAC VW transfer cask that has been licensed and approved in the HI-STORM FW FSAR [1.0.8]. However, the loading/unloading operations of MPCs under the “load-and-go” scenario are discussed in the following.

3.3.4.1 Time-to-Boil Limits

In accordance with NUREG-1536 [3.1.2], water inside the MPC cavity is not permitted to boil during fuel loading operations. In this manner, the operational concerns due to vapor formation and two-phase conditions are avoided. To meet this requirement time limits are defined herein for completion of wet operations upon removal of a loaded HI-STAR 190 cask from the pool.

When the HI-STAR 190 cask is removed from the pool, the combined water, fuel and cask metal mass absorb the decay heat emitted by the fuel assemblies. This results in a slow temperature rise of the cask with time, starting from an initial temperature of the contents. The rate of temperature rise is limited by the thermal inertia of the HI-STAR 190. To obtain a bounding heat-up rate determination, the 3-D FLUENT methodology articulated in this section may be deployed or alternatively a conservative adiabatic heat up calculation defined below may be adopted. The adiabatic heat up calculation assumes the following:

- i. Obtain the heat input Q from the fuel assemblies loaded in the cask.

- ii. Heat dissipation to air by natural convection and radiation from the cask is neglected.
- iii. Water mass in the MPC cavity is understated by 50% for conservatism.

The rate of temperature rise of the cask under adiabatic heat up (assumption (ii) above) is computed as follows:

$$\frac{dT}{dt} = \frac{Q}{C_h}$$

where:

- Q = cask heat load, W (Btu/hr)
- C_h = thermal inertia of the loaded cask, J/°C (Btu/°F)
- T = cask temperature, °C (°F)
- t = time after inner closure lid is placed on the loaded cask while under water OR time after time to boil clock has been reset, s (hr)

Table 3.3.13 summarizes the weights and thermal inertias of a HI-STAR 190 cask and its components for 15x15I short fuel. The maximum permissible time duration, t_{max} for fuel to be submerged in water is computed as follows:

$$t_{\max} = \frac{T_{\text{boil}} - T_{\text{initial}}}{(dT/dt)}$$

where:

- T_{boil} = lowerbound boiling temperature of water (100°C (212°F) at the water surface)
- T_{initial} = initial cask temperature (pool temperature during in-pool fuel loading operations)

Example values of t_{max} for 15x15I short fuel under design maximum heat load are tabulated in Table 3.3.14 at several representative T_{initial} temperatures.

3.3.4.2 Drying Operation

The HI-STORM FW FSAR and HI-STORM UMAX FSAR specify the maximum allowable decay heat load when using Vacuum Drying System (VDS) to dry the MPC cavity. However, for MPCs that have not been previously stored in either HI-STORM FW or the HI-STORM UMAX system, the MPC cavity drying limits are presented in Table 3.3.10. To ensure compliance with ISG-11 Rev 3 temperature limits during vacuum drying condition, FLUENT 3-D thermal models for MPC-37 and MPC-89 canisters are constructed in the same manner as that described in Section 4.5 of HI-STORM FW FSAR [1.0.8]. The thermal model for MPC-37* i.e. short fuel under design basis heat load pattern 1 (Tables 3.3.3 and 3.3.4), is adopted for the thermal

* Only FHD is adopted as the drying method for MPCs containing one or more 15x15I fuel type. Therefore, the next most limiting thermal scenario is the short fuel under design-basis heat load pattern 1 (Tables 3.3.3 and 3.3.4).

analysis. Similarly, the most limiting design basis heat load (see Table 3.3.4) is adopted for MPC-89. Vacuum drying option is allowed for MPC-89 with moderate burnup fuel up to maximum design basis heat loads. However, for MPC-89s containing one or more high burnup fuel assemblies, vacuum drying is permitted only up to a threshold heat load as specified in Table 3.3.10. The bounding steady state temperature results for both MPC-37 and MPC-89 are tabulated in Tables 3.3.11 and 3.3.12, respectively. The results show that the cladding temperatures comply with the ISG-11 limits for all fuel burnups by robust margins.

In addition to MPC drying, loading/unloading operations also include but are not limited to wet transfer operations. Since this operation is performed in HI-TRAC VW transfer cask that has been licensed and approved in the HI-STORM FW FSAR [1.0.8], the methodology presented therein can be adopted for load-and-go canisters in this SAR.

3.3.5 Thermal Evaluation of Sub-design Basis Heat Load

A sub-design basis (SDB) heat load pattern is also defined for both MPC-37 and MPC-89 to allow more flexibility in helium backfill pressure range for less than design basis heat canisters. The SDB heat load patterns are defined as 80% of the design basis heat load patterns i.e. heat load in every storage location is at 80% of its design basis heat load. The helium backfill limits supporting this scenario are defined in Table 7.C.12.

A thermal evaluation is performed for the most limiting MPC i.e. MPC-37 under the most limiting SDB pattern. The predicted fuel and component temperatures for this scenario are bounded by the licensing basis thermal analysis articulated in Sub-section 3.3.1 since the licensing basis cask heat load is higher. However, since the initial helium backfill pressure range for SDB heat loads is different from the licensing basis analysis, the MPC cavity pressure is calculated for the most limiting SDB heat load scenario and tabulated in Table 3.3.8. The MPC cavity pressure is below the design pressure limit (Table 2.1.1). Therefore, the backfill limits provided in Table 7.C.12 may be additionally adopted by a cask user if the decay heats of the loaded fuel assemblies meet the SDB decay heat limits

3.3.6 Thermal Evaluation of an MPC-37 with Damaged Fuel Container (DFCs)

Intact PWR fuel assembly type 16x16A and damaged fuel types defined in Table 7.C.2 may be placed in a stainless steel square box referred to as DFC as articulated in drawing package (Section 1.3, Drawings 10234 & 11107). Damaged fuel storage in DFCs is limited to storage locations permitted by loading configurations Table 7.C.5. A quarter-symmetric model of the HI-STAR 190 cask with an MPC-37 containing DFCs is constructed in the same manner as was submitted to USNRC in HI-STORM UMAX [3.3.3]. A brief summary of the model attributes is provided below:

[PROPRIETARY INFORMATION WITHELD IN ACCORDANCE WITH 10 CFR 2.390]

The geometry and mesh of the HI-STAR 190 cask overpack except the MPC internals are exactly the same as that used in the licensing basis model described in Paragraph 3.3.1.4. All other modeling attributes are also exactly the same as that used in the licensing basis thermal model.

DFC configurations with intact fuel defined in Table 7.C.5 allow all storage locations in an MPC-37 fuel basket to contain intact 16x16A fuel assemblies with DFCs. Additionally, this configuration must comply with the heat load limit requirements presented in Table 7.C.7. DFC configurations for loading damaged fuel are permitted in limited number of locations as defined in Table 7.C.5 and required to comply with Table 7.C.7 limits. As damaged fuel in DFCs is restricted to limited number of cells the temperature effects is negligible¹. The case of all cells containing intact 16x16A fuel in DFCs is addressed next. Steady state thermal analysis is performed for a reasonably bounding configuration wherein all storage locations are loaded with DFCs containing intact 16x16A fuel under the limiting heat load pattern defined in Paragraph 3.3.1.5. Steady state analysis results are summarized in Table 3.3.9. The following conclusions can be drawn from the results:

- i. The maximum fuel cladding temperature is below the ISG-11, Rev. 3 temperature limit (Table 3.2.11) with robust margin.
- ii. The maximum temperatures of all MPC and cask components are below their respective limits set down in Section 3.2.
- iii. The maximum temperatures of the containment seals are well below the design temperatures (Table 3.2.12).
- iv. The MPC cavity pressure is well within the design pressure limit (Table 2.1.1).
- v. The PCT, component temperatures and MPC cavity pressure are all bounded by the limiting licensing basis thermal scenario for MPC-37 summarized in Table 3.1.1. Therefore, all the accident evaluations documented in this chapter remain bounding.

It is therefore concluded that the HI-STAR 190 cask provides a thermally acceptable transport environment for an MPC-37 loaded with intact or damaged fuel in DFCs under the permitted configurations defined in Table 7.C.5.

3.3.7 Fuel Reconfiguration under Normal Condition

Fuel assemblies are loaded in the fuel basket as intact and remain intact prior to and during normal conditions of transport. However, there is a potential (based on uncertainties) that the fuel may reconfigure during transportation. A vibration analysis and other structural evaluations according to the approach summarized in Section 2.11 show that there is no damage to the fuel assemblies during normal conditions of transport. However, as a defense-in-depth, a thermal analysis is performed assuming a hypothetical 3% fuel failure (see Chapter 1) to evaluate its impact on the containment boundary and its components. The details of the analysis are summarized below:

¹ Evaluation supported by thermal calculations [3.3.1].

- i. All heat producing fuel pellets from the ruptured rods (3% of total fuel rods) are uniformly deposited on the bottom surface of MPC lid.
- ii. The fuel region is modeled as the same as the intact fuel under normal condition with 97% of total heat load.
- iii. A steady state thermal analysis is performed for the bounding MPC-89 under heat load pattern 1.

The temperature results of such a steady state analysis for a defense-in-depth hypothetical scenario are reported in Table 3.3.15. The results show that all component temperatures are below their respective normal temperature limits. The cavity pressure also remains below the normal pressure limit.

Table 3.3.1: 10CFR71 Insolation Data

Surface Type	12-Hour Insolation	
	(g-cal/cm ²)	(W/m ²)
Horizontally Transported Flat Surfaces		
- Base	None	None
- Other Surfaces	800	774.0
Non-Horizontal Flat Surfaces	200	193.5
Curved Surfaces	400	387.0

Table 3.3.2: History of FLUENT for Securing Transport and Storage Cask Certifications

USNRC Docket Number	Project
72-1008	HI-STAR 100 Storage
71-9261	HI-STAR 100 Transport
72-1014	HI-STORM Storage
72-22	Private Fuel Storage Facility
72-27	Humboldt Bay ISFSI
72-26	Diablo Canyon ISFSI
72-17	Trojan ISFSI
71-9325	HI-STAR 180 Transport
71-9336	HI-STAR 60 Transport
71-9367	HI-STAR 180D Transport
72-1032	HI-STORM FW Storage
72-1040	HI-STORM UMAX Storage

Table 3.3.3: [PROPRIETARY INFORMATION WITHHELD IN ACCORDANCE WITH 10 CFR 2.390]

Table 3.3.4: [PROPRIETARY INFORMATION WITHHELD IN ACCORDANCE WITH 10 CFR 2.390]

Table 3.3.5: [PROPRIETARY INFORMATION WITHELD IN ACCORDANCE WITH 10 CFR 2.390]

Table 3.3.6: [PROPRIETARY INFORMATION WITHELD IN ACCORDANCE WITH 10
CFR 2.390]

Table 3.3.7: [PROPRIETARY INFORMATION WITHELD IN ACCORDANCE WITH 10
CFR 2.390]

Table 3.3.8: [PROPRIETARY INFORMATION WITHELD IN ACCORDANCE WITH 10 CFR 2.390]

Table 3.3.9: [PROPRIETARY INFORMATION WITHHELD IN ACCORDANCE WITH 10 CFR 2.390]

Table 3.3.10
MPC Cavity Drying Limits ^{Note 1}

MPC Type	Fuel Burnup	MPC Heat Load	Method of Moisture Removal
MPC-37	All Burnup	Up to Design Basis Heat Load (Table 7.C.7)	FHD only for 15x15I Fuel Type
			VDS or FHD for all other Fuel Types
MPC-89	Moderate Burnup Fuel Only	Up to Design Basis Heat Load (Table 7.C.9)	VDS or FHD
	One or more High Burnup Fuel	Up to 95% of Design Basis Heat Load ^{Note 2}	VDS or FHD
		Up to Design Basis Heat Load (Table 7.C.9)	FHD
<p>Note 1: The heat load limits for VDS presented in this table are applicable for MPCs that are directly loaded to HI-STAR 190, and will not be stored in HI-STORM FW (Docket # 72-1032) or HI-STORM UMAX (Docket # 72-1040). The MPC that will be stored in the HI-STORM FW or HI-STORM UMAX should meet the threshold heat load limits presented in either the FW or UMAX docket.</p> <p>Note 2: 95% of the allowable heat load in every storage location presented in Table 7.C.9.</p>			

Table 3.3.11

[PROPRIETARY INFORMATION WITHHELD IN ACCORDANCE WITH 10 CFR 2.390]

Table 3.3.12

[PROPRIETARY INFORMATION WITHHELD IN ACCORDANCE WITH 10 CFR 2.390]

Table 3.3.13
HI-STAR-190 Loaded with 15X15I Fuel Weights and Thermal Inertias

Component	Weight kg (lbs)	Heat Capacity J/kg-°C (Btu/lb-°F)	Thermal Inertia MJ/°C (Btu/°F)
HI-STAR 190			
Holtite-B	776 (1711)	1214 (0.29)	0.9x10 ⁶ (496)
Lead	5514 (12157)	130 (0.031)	0.7x10 ⁶ (376)
Carbon Steel	33765 (74437)	419 (0.1)	14.1x10 ⁶ (7443)
MPC-37			
Alloy-X	9467 (20871)	502 (0.12)	4.7x10 ⁶ (2504)
Aluminum	2260 (4983)	867 (0.207)	1.9x10 ⁶ (1031)
Metamic	3191 (7036)	823 (0.197)	2.6x10 ⁶ (1383)
Fuel	24335 (53650)	234 (0.056)	5.7x10 ⁶ (3004)
MPC Cavity Water	2777 (6123)	4183 (0.999)	11.6x10 ⁶ (6117)
		Total	42.2x10 ⁶ (22354)

Table 3.3.14
Maximum Permissible Time Duration for Flooded MPC-37 Loaded with 15X15I Short Fuel

Initial Temperature °C (°F)	Time Duration (hours)			
	@ 15 kW	@ 20 kW	@ 25 kW	@ 32.15 kW
37.8 (100)	48.6	36.5	29.2	22.7
43.3 (110)	44.3	33.2	26.6	20.7
48.9 (120)	39.9	30.0	24.0	18.6
54.4 (130)	35.6	26.7	21.4	16.6
60.0 (140)	31.3	23.4	18.8	14.6
65.6 (150)	26.9	20.2	16.2	12.6

Table 3.3.15
HI-STAR 190 Normal Transport Maximum Temperatures and Pressures
Due to Fuel Reconfiguration under Normal Conditions

Material/Components	MPC-89 ^{Note 1} Temperature °C (°F)
Fuel Cladding	347 (657)
Fuel Basket	330 (626)
Basket Shims	248 (478)
MPC Shell	208 (406)
MPC Base ^{Note 2}	167 (333)
MPC Lid ^{Note 2}	154 (309)
Containment Shell	158 (316)
Neutron Shield ^{Note 3}	153 (307)
Containment Seals ^{Note 4}	
Closure Lid Inner Seal	104 (219)
Port Cover Inner Seal	104 (219)
Pressure, kPa (psig)	
MPC Cavity with 3% Rod Rupture	668.1 (96.9)
Space between MPC and Cask Pressure	188.2 (27.3)
<p>Note 1: Temperatures for the most limiting loading scenario is reported (see Section 3.3).</p> <p>Note 2: In accordance with temperature limits Table 3.2.10 Note (a) the maximum section temperatures of structural members are reported.</p> <p>Note 3: The maximum temperature of the neutron shield component with the highest temperature is reported.</p> <p>Note 4: The temperatures of lid seals relied upon for containment function are reported herein. The containment boundary seals are described in Chapter 4.</p>	

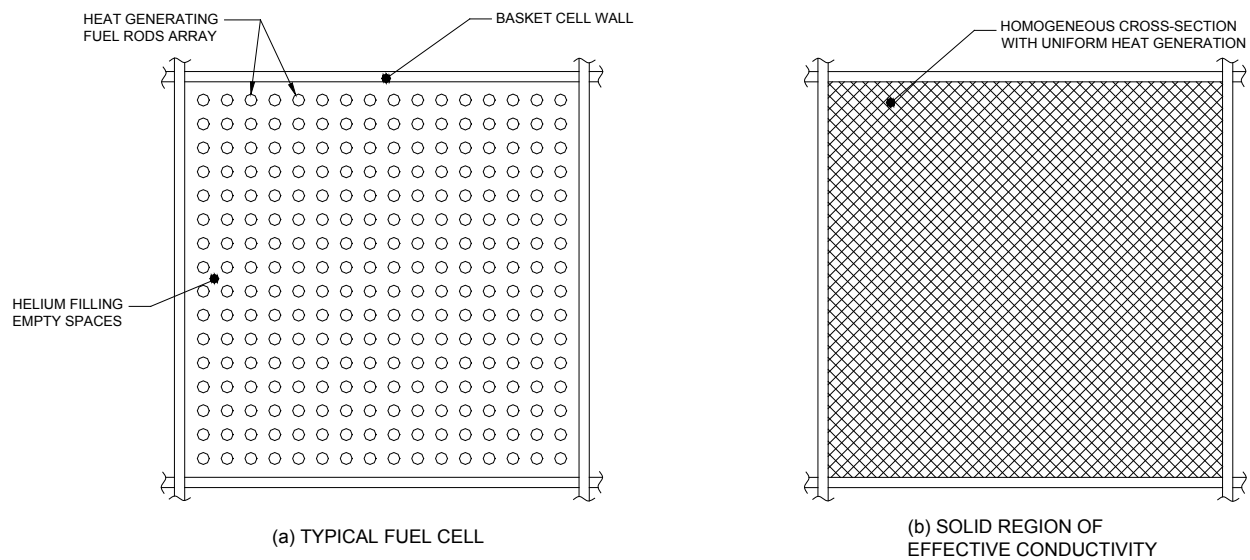

FIGURE 3.3.1: HOMOGENIZATION OF THE STORAGE CELL CROSS-SECTION

FIGURE 3.3.2: [PROPRIETARY INFORMATION WITHHELD IN ACCORDANCE WITH 10
CFR 2.390]

FIGURE 3.3.3: [PROPRIETARY INFORMATION WITHHELD IN ACCORDANCE WITH 10
CFR 2.390]

FIGURE 3.3.4: [PROPRIETARY INFORMATION WITHHELD IN ACCORDANCE WITH 10
CFR 2.390]

FIGURE 3.3.5: [PROPRIETARY INFORMATION WITHELD IN ACCORDANCE WITH 10
CFR 2.390]

3.4 THERMAL EVALUATION UNDER HYPOTHETICAL ACCIDENT

As mandated by 10 CFR Part 71 requirements, the HI-STAR 190 Package is subjected to a sequence of hypothetical accidents. The objective is to determine and assess the cumulative damage sustained by the package. The accident scenarios specified in order are: (1) a 9 m (30 foot) free drop onto an unyielding surface; (2) a 1 m (40-inch) drop onto a mild steel bar; (3) exposure to a 30-minute fire at 802°C (1475°F) and (4) immersion under a 0.9 m (3 ft) head of water. The initial conditions for the fire accident specify steady state at an ambient temperature between -40°C (-40°F) and 38°C (100°F). In the HI-STAR 190 Package hypothetical fire accident evaluation, insolation with a theoretical bounding absorbtivity equal to unity is applied. The effects of the accidents (1), (2) and (4) are evaluated in Chapter 2. In this section, the effects of accident (3) are evaluated for both MPC-37 and MPC-89 under their respective limiting loading scenario (see Section 3.3). The initial condition prior to fire accident is the hot ambient environment for normal transport. The fire accident evaluation is performed assuming an adverse combination of factors that overestimate heat input during fire followed by an underestimation of heat rejection to the environment after the fire.

During drop and puncture accidents some neutron shield pockets can rupture thereby reducing the ability of the package to reject heat after the fire. To conservatively evaluate this hypothetical accident condition, the neutron shield thermal conductivity is assumed during fire to maximize heat input and thermal conductivity of air is applied to the neutron shield pockets during post-fire cooldown to minimize post-fire cooling. During drop events, material in the impact limiter is locally crushed. However, the impact limiters survive the drop events without structural collapse and remain attached to the cask during and after the event. During a puncture event the cask's exterior shell may be locally pierced but with no gross damage to the cask or its internals. Because of these reasons the global thermal performance of the HI-STAR 190 cask is unaffected by the drop events.

During fire some portions of the neutron shield will be exposed to high temperatures. In computing the heat input to the package during fire the undegraded neutron shield thermal conductivity is assumed. During the post-fire cooldown phase, thermal conductivity of air is applied to the neutron shield pockets to minimize heat dissipation and thermal inertia properties of undegraded neutron shield material is assumed to maximize fire accumulated thermal energy. During fire a 10 CFR Part 71 mandated cask surface absorbtivity is assumed to maximize radiant heat input to the cask. During fire the resin bonding the impact limiter's corrugated aluminum honeycomb layers is destroyed thus severely degrading the normal-to-layers direction conductivity. In the interest of conservatism the undegraded honeycomb conductivity is assumed during fire to maximize heat input and an opposite assumption is used to minimize post-fire heat dissipation by applying air conductivity for the normal-to-layers direction (see Table 3.4.1).

The temperature history of the HI-STAR 190 Package is monitored during the 30-minute fire and during post-fire cooldown for a sufficient length of time for the cask and fuel to reach maximum temperatures. The impact of transient temperature excursions on HI-STAR 190 Package materials is evaluated.

3.4.1 Initial Conditions

In accordance with transport regulations the HI-STAR 190 Package fire accident is evaluated under hot ambient initial conditions (§10CFR71.71(c)(1) and §10CFR71.73(b)). These conditions are 38°C (100°F) ambient temperature, still air and insolation. The HI-STAR 190 bounding steady state temperature distribution under hot ambient conditions reported in Section 3.1.3 is adopted as the initial condition for fire accident evaluation.

3.4.2 Fire Conditions

As required by transport regulations the HI-STAR 190 Package is evaluated under an all-engulfing fire at 802°C (1475°F) lasting for 30 minutes (§10CFR71.73(c)(4)). The regulations specify a minimum fire emissivity (0.9) and lowerbound package absorbtivity (0.8) for hypothetical accident evaluation. In the HI-STAR 190 fire accident evaluation, the minimum specified emissivity and conservatively postulated absorbtivity are adopted.

Heat input to the HI-STAR 190 Package while engulfed in a fire is from a combination of radiation and forced convection heat transfer. This can be expressed by the following equation:

$$q_F = h_{fc} (T_F - T_s) + \sigma a \varepsilon [T_F^4 - T_s^4] \quad \text{Eq. (3.4-1)}$$

where:

- q_F = fire heat input, W/m² (Btu/ft²-hr)
- T_F = fire condition temperature 1075°K (1935°R)
- T_s = package surface temperature °K (°R)
- h_{fc} = forced convection heat transfer coefficient W/m²-°K [Btu/ft²-hr-°F] (See Table 3.4.3)
- ε = flame emissivity (0.9 (min.) in accordance with transport regulations)
- a = package absorbtivity (0.8 (min.) in accordance with transport regulations)
- σ = Stefan-Boltzmann Constant 5.67x10⁻⁸ W/m²-°K⁴ (0.1714x10⁻⁸ Btu/ft²-hr-°R⁴)

For conservatism, the reported Sandia large pool fires forced convection heat transfer coefficient (See Table 3.4.3) is adopted. In Table 3.4.1 the principal fire accident assumptions are summarized.

The HI-STAR 190 package fire accident analysis is based on a 3D thermal model that properly accounts for radiation, conduction and external natural convection modes of heat transfer. The thermal model incorporates several conservative assumptions listed below.

1. The undegraded neutron shield conductivity is assumed during fire to maximize heat input to the cask body.
2. To maximize initial temperatures, the limiting heat load pattern for the MPCs defined in Section 3.3 and bounding (steady state) temperatures are assumed.
3. To maximize the rate of heat input from the ends during fire the undegraded conductivity of impact limiter material is assumed (See Table 3.4.1).

4. To maximize fire heating of the cask, an all-engulfing fire, a high flame emissivity ($e = 0.9$) and a theoretically bounding package absorbtivity are assumed.
5. To minimize heat dissipation from the cask during post fire cooldown, the thermal conductivity of air is applied to the neutron shield pockets and complete destruction of the resin material bonding the corrugated Aluminum layers of the honeycomb impact limiters material is assumed. This methodology is exactly the same as that approved in the HI-STAR 180D SAR (Docket 71-9367).
6. The Sandia laboratories reported forced convection heat transfer during large pool fires (See Table 3.4.3) is adopted.
7. To maximize fire accumulated thermal energy, the thermal inertia properties of undegraded neutron shield and Aluminum honeycomb materials are assumed during post fire cooldown.

Using this model, the transient heat up of the cask and it's internals during the 30-minute fire is computed. At the end of the fire the hot ambient condition is restored and a post fire cooldown of the cask for a sufficiently long period of time is computed. As shown in Figures 3.4.1 and 3.4.2, this period is sufficient for the cask internals (principally the SNF) to reach their maximum temperatures and begin to recede. The results of the analysis are evaluated in the next section.

HI-STAR 190 loaded with MPC-37 results in bounding fuel cladding temperature and MPC cavity pressure as shown in Tables 3.1.1 and 3.1.2. Thermal analysis of the fire accident is therefore performed only for the thermally limiting scenario, i.e. MPC-37 loaded with 15x15I short fuel, determined in Section 3.3.1.5.

Although the PCT and MPC cavity pressure are bounding for MPC-37, the temperatures of some containment boundary components are higher for MPC-89 during normal conditions (see Table 3.1.1). Therefore, to demonstrate all the components of the cask including the containment boundary remains below the prescribed temperature limits during fire accident, an evaluation of these cask components is needed for MPC-89 under the fire accident. These cask component temperatures for MPC-89 are calculated by adding the component temperature differences between MPC-37 and MPC-89 under normal conditions to the predicted fire accident temperatures for MPC-37. It is reasonable to assume that the temperature increase of cask components due to fire is similar for both MPC-37 and MPC-85 because of the reasons outlined below:

- (1) Heat from fire is much higher than the decay heat stored inside MPC.
- (2) Fire temperature is much higher than the cask external surface temperature under normal condition. Therefore, similar heat from fire is absorbed by the cask with either MPCs, although the surface temperatures are slightly different for the two MPCs under normal condition.
- (3) MPC-37 and MPC-89 have the same HI-STAR 190 cask design.

3.4.3 Maximum Temperatures and Pressures

3.4.3.1 Maximum Temperatures

The HI-STAR 190 Package is evaluated under a hypothetical fire accident at 802°C (1475°F) lasting for 30 minutes. To ensure a bounding evaluation, MPC with bounding decay heat pattern (See Subsection 3.1.2) and hot initial conditions are assumed. Under this array of adverse conditions, the maximum temperatures reached in the cask structural members and its contents (SNF and MPC) are computed. The temperatures are computed using the 3D thermal model described in Section 3.3, applying the fire accident thermal loads and computing the time-dependent response of the package to the 30-minute fire followed by a post fire cooldown for a sufficient duration to allow the cask and its contents to reach their maximum temperatures. The results of the critical components (fuel cladding and containment seals) are graphed in Figures 3.4.1 and 3.4.2. The maximum temperatures reached during fire and post-fire cooldown are reported in Subsection 3.1.3. The following observations are derived by inspecting the temperature field obtained from the thermal analysis:

- The maximum fuel cladding temperature (Table 3.1.3) is well within the ISG-11, Rev. 3 accident temperature limit (Table 3.2.11).
- The maximum temperatures of fuel basket and MPC components (Table 3.1.3) are well within their accident design temperature (Table 3.2.10).
- The maximum temperatures of the cask containment boundary and seals (Tables 3.1.3 and 3.1.4) are well below their respective temperature limits (Tables 3.2.10 and 3.2.12, respectively).
- The maximum temperatures of the basket shims (Table 3.1.3) are well below the accident temperature limits (Table 3.2.10).

The HI-STAR 190 Package fire accident temperatures are reported in Section 3.1.3. The temperatures are below the regulatory temperature limits (Table 3.2.11), ASME Code temperature limits (Table 3.2.10) and components safe operating temperature limits (Table 3.2.12). The thermal evaluation provides reasonable assurance of safety in the event of a fire. This conclusion is based on the technical data and analyses presented in this chapter in conjunction with provisions of 10 CFR Part 71, appropriate regulatory guides, applicable codes and standards, and accepted engineering practices.

3.4.3.2 Maximum Pressures

The MPC cavity pressure is computed based on the maximum temperatures of the cask contents (fuel) reached during the fire accident. The calculations use an array of conservative assumptions listed below:

- i) Maximum initial fill pressure (See Table 7.C.11)
- ii) 100% rods rupture (includes contribution from non-fuel hardware)
- iii) 100% release of rods fills gas and 30% release of fission gases
- iv) Lowerbound cavity free volume (see Chapter 4 of HI-STORM FW FSAR [1.0.8])

- v) Upperbound MPC cavity average temperature from thermal analysis described in Paragraph 3.4.3.1.

Additionally, the HI-STAR 190 cavity pressure is also calculated during the fire accident. The maximum containment pressures are tabulated in Subsection 3.1.4. The results presented in Table 3.1.5 show that the pressures are well below the containment boundary design pressure (Table 2.1.1).

3.4.4 Maximum Thermal Stresses

The HI-STAR 190 Package is designed to ensure a low state of thermal stress in the structural members. This is ensured by using high conductivity materials (Metamic- HT and low alloy steels) to minimize temperature gradients and large fit-up gaps to allow unrestrained thermal expansion of the package internals (fuel basket) during normal transport. The differential thermal expansion of the fuel basket and MPC during normal transport is calculated and results provided in Table 3.4.2. The normal transport gaps are bounding during fire because of the expansion of the cask body under direct fire heating. As thermal interference is precluded during fire a low state of thermal stress prevails in the cask.

3.4.5 Fuel Reconfiguration under Accident Condition

Fuel assemblies are loaded in the fuel basket as intact and remain intact prior to and during normal conditions of transport. However, there is a potential (based on uncertainties) that the fuel may reconfigure during transportation. A vibration analysis and other structural evaluations, according to the approach summarized in Chapter 1, show that there is no damage to the fuel assemblies during hypothetical accident conditions of transport. [PROPRIETARY INFORMATION WITHHELD IN ACCORDANCE WITH 10 CFR 2.390]

Table 3.4.1: Hypothetical Fire Accident Assumptions

Description	Initial Condition	30-minute Fire	Post-Fire Equilibrium
Neutron shield conduction	Yes (Understated Conductivity)	Yes (Undegraded material Conductivity)	No (Air conductivity applied to the neutron shield pockets)
Insolation	Yes	Yes	Yes
Surface Convection	Natural	Forced	Natural
Impact Limiter Conduction ^{Note 1} Parallel to Aluminum Layers Normal to Aluminum Layers	Table 3.2.2 Table 3.2.2	Table 3.2.2 Table 3.2.2	Table 3.2.2 Air conductivity
Cask Surface Solar Absorbitivity	1.0	1.0	1.0
Emissivity - Cask surface - Polished Surfaces (impact limiter)	0.85 Table 3.2.6	0.9 (fire emissivity) 0.9 (fire emissivity)	0.66 Table 3.2.6
<p>Note 1: Parallel-to-layers direction honeycomb material conductivities are not affected by fire. However, normal-to-layers direction conductivity can be degraded because the resin bonding the corrugated Aluminum layers is destroyed. To maximize heat input during fire the normal-to-layers direction conductivity is assumed to be unaffected and during post-fire cooldown theoretical lowerbound conductivity of air assumed to minimize post-fire cooldown heat dissipation.</p>			

Table 3.4.2: [PROPRIETARY INFORMATION WITHELD IN ACCORDANCE WITH 10 CFR 2.390]

Table 3.4.3: Sandia Pool Fire Test Data¹

Test equipment	3 m (10 ft) OD propane railcar
Fuel	JP-4
Pool Size	9 m x 9 m (30 ft x 30 ft)
Fire Temperature	649°C to 1093°C (843°C avg.) 1200°F to 2000°F (1550°F avg.)
Convective Coefficient	25.5 W/m ² -°K (4.5 Btu/ft ² -hr-°F)

¹ From Sandia large pool fires report [3.4.1], Page 41.

Table 3.4.4: [PROPRIETARY INFORMATION WITHHELD IN ACCORDANCE WITH 10 CFR 2.390]

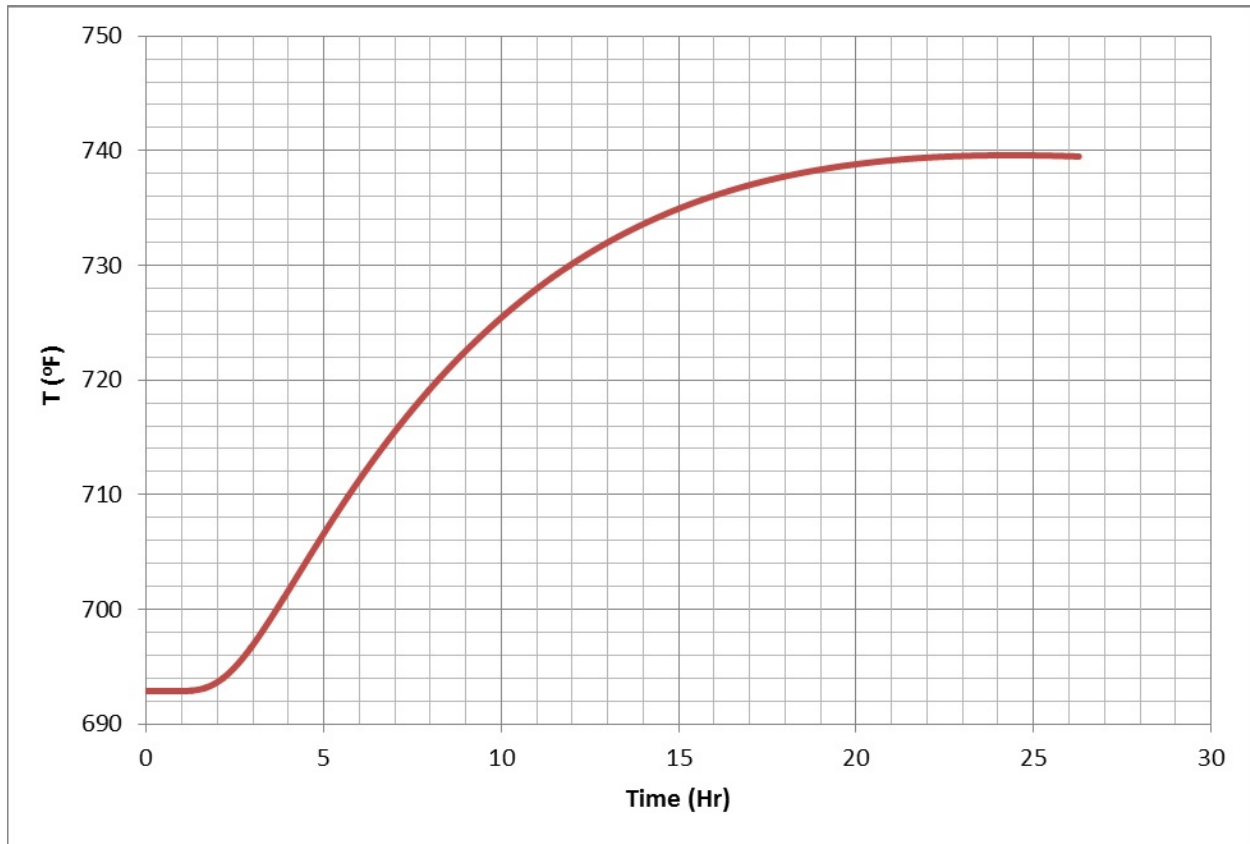

FIGURE 3.4.1: HI-STAR 190 FIRE AND POST FIRE COOLDOWN TEMPERATURE HISTORY OF FUEL CLADDING

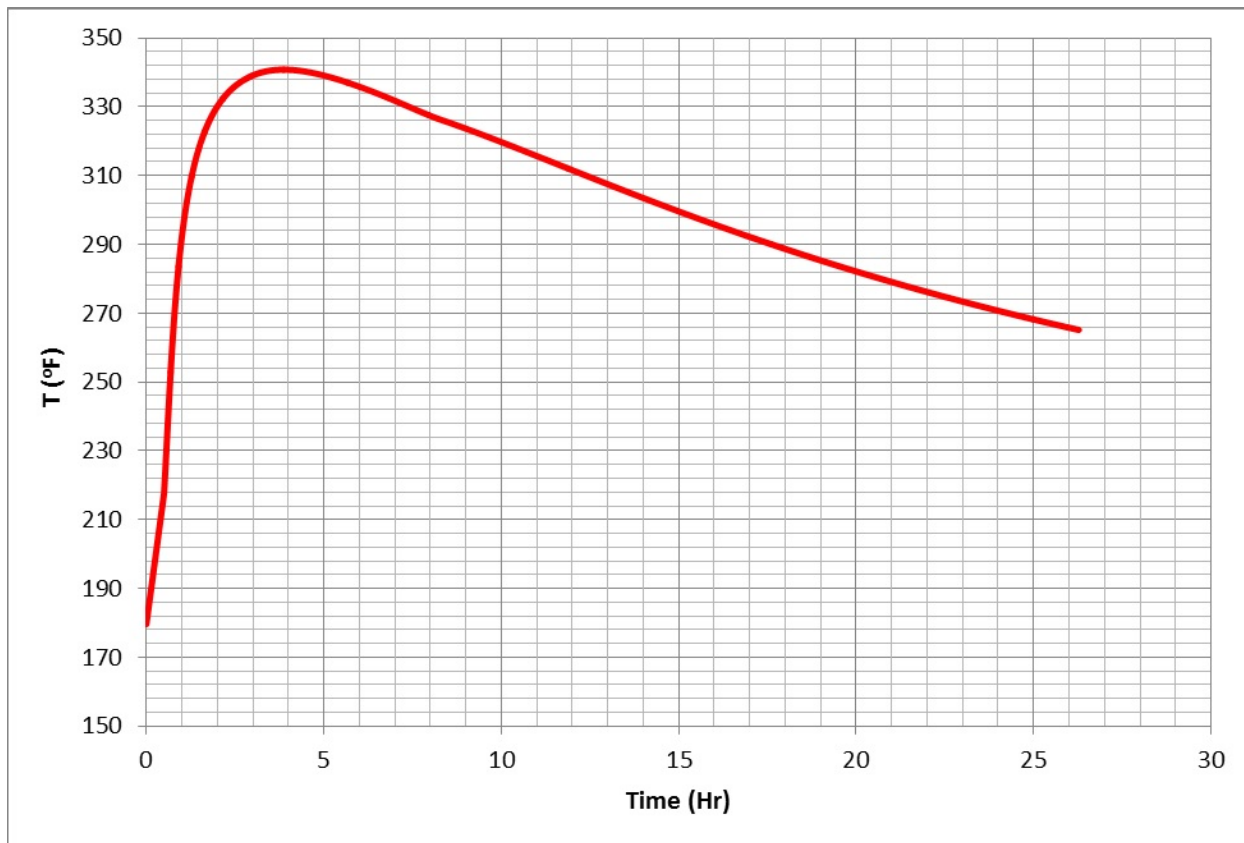

FIGURE 3.4.2: HI-STAR 190 FIRE AND POST FIRE COOLDOWN TEMPERATURE HISTORY OF CONTAINMENT SEALS

3.5 REFERENCES

The following generic industry and Holtec produced references may have been consulted in the preparation of this document. Where specifically cited, the identifier is listed in the SAR text or table. Active Holtec Calculation Packages which are the repository of all relevant licensing and design basis calculations are annotated as “latest revision”. Submittal of the latest revision of such Calculation Packages to the USNRC and other regulatory authorities during the course of regulatory reviews is managed under the company’s Configuration Control system.

- [3.1.1] Gebhart, B., Jaluria, Y., Mahajan, R.L. and Sammakia, B., “Buoyancy Induced Flows and Transport”, Hemisphere Publishing Corporation, NY, (1988).
- [3.1.2] NUREG-1536, “Standard Review Plan for Dry Cask Storage Systems,” USNRC, (January 1997).
- [3.1.3] NUREG-1617, "Standard Review Plan for Transportation Packages for Spent Nuclear Fuel", USNRC, March 2000.
- [3.2.1] Baumeister, T., Avallone, E.A. and Baumeister III, T., “Marks’ Standard Handbook for Mechanical Engineers”, 8th Edition, McGraw Hill Book Company, 1978.
- [3.2.2] Rohsenow, W.M. and Hartnett, J.P., “Handbook of Heat Transfer,” McGraw Hill Book Company, New York, 1973.
- [3.2.3] Greer et al., “The TN-24P Spent Fuel Storage Cask: Testing and Analyses,” EPRI NP-5128, PNL-6054, UC-85, (April 1987).
- [3.2.4] Rust, J.H., “Nuclear Power Plant Engineering,” Haralson Publishing Company, (1979).
- [3.2.5] Kern, D.Q., “Process Heat Transfer,” McGraw Hill Kogakusha, (1950).
- [3.2.6] "A Handbook of Materials Properties for Use in the Analysis of Light Water Reactor Fuel Rod Behavior", NUREG/CR-0497, (August 1981).
- [3.2.7] ASME Boiler and Pressure Vessel Code, Section II, Part D, 2007 Edition, 2008 Addenda.
- [3.2.8] Jakob, M. and Hawkins, G.A., “Elements of Heat Transfer,” John Wiley & Sons, New York, 1957.
- [3.2.9] “Scoping Design Analyses for Optimized Shipping Casks Containing 1-, 2-, 3-, 5-, 7-, or 10-Year-Old PWR Spent Fuel”, ORNL/CSD/TM-149 TTC-0316, (1983).

- [3.2.10] Kauder, L., “Spacecraft Thermal Control Coatings References,” NASA Technical Procedure, NASA/TP-2005-212792, NASA/Goddard Space Flight Center, Greenbelt, MD, July 2005.
- [3.2.11] “Fundamentals of Heat and Mass Transfer”, 4th Edition, F.P. Incropera and D.P. DeWitt, John Wiley & Sons, Inc., New York, 1996.
- [3.2.12] Aluminum Alloy 2219 Material Data Sheet, ASM Aerospace Specification Metals, Inc., Pompano Beach, FL.
- [3.2.13] “Nuclear Systems Materials Handbook, Vol. 1, Design Data”, ORNL TID 26666.
- [3.3.1] “Thermal Evaluations of HI-STAR 190 System”, Holtec Report HI-2146286, Latest Revision, (Holtec Proprietary).*
- [3.3.2] FLUENT Computational Fluid Dynamics Software (Fluent, Inc., Centerra Resource Park, 10 Cavendish Court, Lebanon, NH 03766).
- [3.3.3] “Holtec International HI-STORM UMAX Multipurpose Canister Storage System License Amendment Request 1040-2”, Holtec Letter 5021028, Dated March 31, 2015.
- [3.3.4] “Topical Report on the HI-STAR/HI-STORM Thermal Model and its Benchmarking with Full-Size Cask Test Data,” Holtec Report HI-992252, Rev. 1, Holtec International, Marlton, NJ, 08053. (Holtec Proprietary).
- [3.3.5] “Standard for Verification and Validation in Computational Fluid Dynamics and Heat Transfer”, ASME V&V 20-2009.
- [3.4.1] “Thermal Measurements in a Series of Large Pool Fires”, Sandia Report SAND85 – 0196 TTC – 0659 UC 71, (August 1971).

*Supporting document submitted with the HI-STAR 190 License Application.

CHAPTER 4: CONTAINMENT

4.0 INTRODUCTION

The compliance of the HI-STAR 190 cask containment system with the permitted activity release limits specified in 10CFR71 for both normal and hypothetical accident conditions of transport [4.0.1] is evaluated in this chapter. Satisfaction of the containment criteria, expressed as the leakage rate acceptance criterion, ensures that the loaded HI-STAR 190 cask will not exceed the allowable radionuclide release rates.

4.0.1 Double Containment credited for High Burnup Fuel (HBF)

The HI-STAR 190 packaging is designed to transport both moderate burn-up (MBF) and high burn-up fuel (HBF). In recognition of the uncertainty surrounding the cladding material properties of HBF, a multi-layered safety-focused strategy to transport HBF has been adopted for HI-STAR 190. The MPC's enclosure vessel serves as the inner Containment Boundary when loaded with HBF. MPC's loaded with HBF are tested for leak-tightness at the time of shipment to confirm the integrity of the MPC.

For MBF, the MPC, while present, just serves as unquantified additional barrier against water leakage and radiological release.

As stated in Chapter 1, HI-STAR 190 is restricted from transporting any un-canisterized fuel. All fuel to be transported in HI-STAR 190 must be packaged in a MPC that has been certified as a *leak tight* [8.1.6], [4.0.3] Confinement Boundary under the regulations of 10CFR72. In addition, the MPC must possess the features and undergo testing measures listed in Chapter 8 of this SAR that protect against migration of its contents to the environment. These features and measures listed in Chapter 8 provide reasonable assurance that the MPC can be relied upon to provide effective radiological confinement to the spent fuel during transport.

The HI-STAR 190 MPC is designated as the "welded" containment boundary, during the transport of high burnup fuel. In addition, HI-STAR 190 has a classical gasketed containment boundary that is integral to the body of the overpack, which is the only barrier credited during transport of moderately burned fuel. Thus, the HI-STAR 190 containment system consists of:

1. A welded containment defined by the Enclosure Vessel of the MPC, hereafter also referred to as the Inner Containment.
2. A gasketed containment made up of the overpack's Section III Subsection NB pressure retention boundary, hereafter also referred to as the "Outer Containment".

The outer containment system for the HI-STAR 190 cask consists of the components, seals, and welds identified in the drawing package in Section 1.3. The closure lid is a containment system component whose gasketed joint must also be tested prior to shipment.

Chapter 2 of this SAR shows that *both* containment systems continue to maintain leak-tightness

and seals in the outer containment boundary remain compressed after all normal and hypothetical accident conditions of transport defined in 10CFR71.71 and 10CFR71.73, respectively. Chapter 3 of this SAR shows that the peak containment system component temperatures and pressures are within the design basis limits for all normal and hypothetical accident conditions of transport as defined in 10CFR71.71 and 10CFR71.73.

Specifically, it is shown that under the most severe accident condition of transport:

1. The stresses in the welded (inner) containment remain within the ASME Section Subsection NB limits and that there is no risk of buckling instability in the Enclosure Vessel pressure boundary.
2. The seals in the outer containment boundary remain compressed before and after the accident event.
3. No failure of the body bolts in the outer containment is indicated.
4. No breach of the outer containment boundary under the postulated part 71 penetration event is indicated.

The HI-STAR 190 cask is subjected to a fabrication leakage rate test before the first loading. The fabrication leakage rate test is performed at the factory in accordance with the requirements of ANSI N14.5 [8.1.6] specified in Chapter 8 as part of the HI-STAR 190 cask acceptance testing. The HI-STAR 190 cask is also subjected to a pre-shipment leakage rate test after the cask is loaded for shipment. The pre-shipment leakage rate test is performed as described in Chapter 8. The elastomeric seals of the HI-STAR 190 cask are required to be retested for each cask loading and closure operation.

The above considerations form the logical basis for the safety conclusion that both containment systems in HI-STAR 190 are independently and autonomously capable of maintaining radiological isolation in the wake of all postulated transport accidents in part 71.

Sections 4.1-4.4 contain a detailed evaluation of the outer containment's integrity under all applicable transport loadings.

Sections 4.5-4.7 provide the corresponding evaluations for the inner containment (the MPC).

Section 4.8 provides a summation of the safety case for the leak tightness of both containments under all applicable part 71 loadings.

4.1 DESCRIPTION OF THE OUTER CONTAINMENT SYSTEM

The outer containment system for the HI-STAR 190 cask consists of the containment shell, the containment base plate, the containment closure flange, the closure lid, closure lid bolts, the closure lid port cover, closure lid port plug, and their respective elastomeric seals and welds as specified in the drawing package in Section 1.3. The outer Containment Boundary is delineated in the licensing drawing package in Section 1.3.

The containment system components for the HI-STAR 190 system are designed and fabricated in accordance with the requirements of ASME Code, Section III, Subsection NB [4.1.1], to the maximum extent practicable as clarified in Chapter 2 of this SAR. Chapter 1 specifies design criteria for the containment system. Section 2.1 provides the applicable code requirements. Exceptions to specific code requirements with complete justifications are presented in Table 8.1.8.

4.1.1 Containment Vessel

The cask containment vessel consists of components that form the containment space. The containment space houses the MPC that holds the spent nuclear fuel. The containment vessel is represented by the containment shell, containment base plate, containment closure flange, and the closure lid. These are the main containment system components that create an enclosed cylindrical cavity for the containment of the MPC, which holds the radiological contents. The materials of construction for the containment vessel are specified in the drawing package in Section 1.3. No valve or pressure relief device is specified on the HI-STAR 190 containment system.

4.1.2 Containment Penetrations

The outer containment system penetrations include the closure lid vent and drain ports. Each penetration has redundant elastomeric seals. The containment penetrations are designed and tested to ensure that the radionuclide release rate limits specified in 10CFR71.51 will not be exceeded.

4.1.3 Seals and Welds

The cask uses a combination of seals and welds designed and tested to provide containment during normal transport conditions, and during and after hypothetical accident conditions of transport.

The seals and welds provide for a containment system that is securely closed and cannot be opened unintentionally or by the internal pressure within the package as required in 10CFR71.43(c).

The containment system seals are designed and fabricated to meet the design requirements of the HI-STAR 190 cask specified in Section 2.2 and in accordance with the manufacturer's recommendations. Chapter 7 describes the operating procedures required for proper seal function. Seal and closure details are provided in the drawing package in Section 1.3 and Chapter 2.

The cask outer containment system welds consists of full penetration welds forming the containment shell, the full penetration weld connecting the containment shell to the containment closure flange, and the full penetration weld connecting the containment base plate to the containment shell. All containment system boundary welds are fabricated and inspected in accordance with ASME Code Section III, Subsection NB. The weld details and examinations are shown in the drawing package in Section 1.3.

4.1.4 Closure Lid

The cask closure lid uses two concentric elastomeric seals to form the closure with the containment closure flange surface. In the closure lid, the inner seal is the containment seal. To protect the sealing surfaces against corrosion, a stainless steel weld overlay is provided during manufacturing on both the inner closure lid and the mating containment closure flange. The inner closure lid inner seal is tested for leakage through an inter-seal test port. The inter-seal test port provides access to the volume between the two elastomeric lid seals. Following leakage rate testing of the closure lid inner seal, a threaded plug with a elastomeric seal is installed in the inter-seal test port hole to provide redundant containment.

The closure lid's containment sealing surfaces are not subject to corrosion due to the presence of redundant closure features that prevent exposure to the environment external to the cask. The seal materials of construction are highly corrosion resistant and the seal design is proven for the application.

The cask closure lid is secured using multiple closure bolts around the perimeter. Pre-tensioning of closure lid bolts compresses the concentric elastomeric seals between the closure lids and the containment closure flange forming the closure lid seal.

Closure of the closure lid vent and drain port cover plate is provided using multiple port cover plate closure bolts around the perimeter. Pre-tensioning of the port cover bolts compresses the port cover plate concentric elastomeric seals between the port cover plate and the inner closure lid to establish containment.

Bolt torquing patterns, lubrication requirements, and torque values are provided in Chapter 7. The torque values are established to maintain leak-tight containment during normal and accident conditions of transport. The bolt pre-tension values for the body bolts preclude separation of the closure lids from the containment closure flange as clarified in Chapter 2. The closure lid bolts cannot be opened unintentionally or by a pressure rise that may occur within the package during normal or accident conditions of transport.

4.2 OUTER CONTAINMENT INTEGRITY UNDER NORMAL CONDITIONS OF TRANSPORT

Section 2.6 of this SAR shows that all outer containment system components are maintained within their code-allowable stress limits and the elastomeric seals remain compressed during all normal conditions of transport as defined in 10CFR71.71 [4.0.1]. Section 3.1 of this SAR shows that all outer containment system components are maintained within their peak temperature and pressure limits for all normal conditions of transport as defined in 10CFR71.71. Since the outer containment system remains in full compliance with the applicable regulatory temperature and pressure limits, it is reasonable to conclude that the design basis leakage rate (see Table 8.1.1) will not be exceeded during normal conditions of transport.

4.2.1 Containment Criteria

The leak-tight criteria, as defined by ANSI N14.5 [8.1.6], are to be used for all outer containment system leakage tests. Compliance with the leak-tight criteria of ANSI N14.5 precludes any significant release of radioactive materials and ensures that the radionuclide release rates specified in 10CFR71.51(a)(1) will not be exceeded during normal conditions of transport. Therefore, no containment release analyses are performed for normal conditions of transport. Containment allowable leakage rate criteria and the type of tests specified are provided in Table 8.1.1 and Table 8.1.2.

The sensitivity for the leakage test instrument shall be as described in Table 8.1.1.

4.3 OUTER CONTAINMENT INTEGRITY UNDER HYPOTHETICAL ACCIDENT CONDITIONS OF TRANSPORT

Section 2.7 of this SAR shows that all outer containment system components are maintained within their code-allowable stress limits and the elastomeric seals remain compressed during the hypothetical accident conditions of transport as defined in 10CFR71.73 [4.0.1]. Section 3.1 of this SAR shows that all outer containment system components are maintained within their peak temperature and pressure limits for all hypothetical accident conditions of transport as defined in 10CFR71.73. Since the containment system remains intact without exceeding temperature and pressure limits, the design basis leakage rate (see Table 8.1.1) will not be exceeded during hypothetical accident conditions of transport.

4.3.1 Containment Criteria

The leak-tight criteria as defined by ANSI N14.5 [8.1.6] shall be used for all outer containment system leakage tests. Compliance with the leak-tight criteria of ANSI N14.5 precludes any significant release of radioactive materials and ensures that the radionuclide release rates specified in 10CFR71.51(a)(2) will not be exceeded during hypothetical accident conditions of transport. Therefore, no containment release rate analyses are performed for hypothetical accident conditions of transport. Containment allowable leakage rate criteria and the type of tests specified are provided in Table 8.1.1 and Table 8.1.2. The sensitivity for the leakage test instrument shall be as described in Table 8.1.1.

4.4 LEAKAGE INTEGRITY TESTS FOR THE HI-STAR 190 OVERPACK

A helium leak test is the principal means for ascertaining the integrity of the outer containment boundary in the HI-STAR 190 system. All leakage rate testing of the cask containment system shall be performed in accordance with the guidance in ANSI N14.5 [8.1.6]. Table 8.1.2 provides the containment system components to be tested and the type of leakage test to be performed for post-fabrication, pre-shipment, periodic, and maintenance qualification. The leak tests performed to ensure containment integrity at different stages in the cask's life cycle are summarized below.

4.4.1 Fabrication Leakage Rate Test

After fabrication of all overpack components, the closure lid is installed and the seals are tested to ensure that the fit-up of the lid with the containment flange will meet the leakage rate acceptance criteria after fuel loading.

4.4.2 Pre-Shipment Leakage Rate Test

The pre-shipment leakage rate test demonstrates that the containment system closure has been properly performed. The initial pre-shipment leakage rate test is performed by the user before shipment, after the contents are loaded and the containment system is assembled. The pre-shipment leakage rate test remains valid for 1 year.

4.4.3 Periodic Leakage Rate Test

The periodic leakage rate test demonstrates that the containment system closure capabilities have not deteriorated over time. A periodic leakage rate test is only required if the most current leakage rate test occurred more than twelve months prior to package transport. Periodic leakage rate testing is performed by the user before each shipment if the previous leakage rate test has expired. The periodic leakage rate test remains valid for 1 year.

4.4.4 Maintenance Leakage Rate Test

The maintenance leakage rate test demonstrates that the containment system provides the required level of containment after undergoing maintenance, repair, and or containment component replacement, and shall be performed prior to returning a package to service.

4.5 DESCRIPTION OF THE INNER CONTAINMENT SYSTEM

The MPC's Enclosure Vessel constitutes the inner containment system that is credited for HBF. The MPC enclosure vessel is a cylindrical weldment designed to provide a robust and impermeable barrier against release of radioactive matter from its cavity space. As shown in the drawings in Section 1, each MPC Enclosure Vessel consists of a thick baseplate, a cylindrical canister shell, a lid, and a closure ring.

The MPC enclosure vessel is a fully welded enclosure, which provides the confinement for the stored fuel and radioactive material. The MPC baseplate and shell are made of stainless steel (Alloy X, see Appendix 1.A [4.5.1]). The lid is a thick plate designed to provide confinement of radionuclides and pressure retention and handling operations. The confinement boundary in storage and the containment boundary in transport are both defined by the MPC baseplate, shell, lid, port covers, and closure ring.

The MPC incorporates a redundant closure system. The MPC lid is edge-welded (welds are depicted in the licensing drawing in Section 1.3) to the MPC outer shell. The lid is equipped with vent and drain ports that are utilized to remove moisture from the MPC and backfill the MPC with a specified amount of inert gas (helium). The vent and drain ports are closed tight and covered with a port cover (plate) that is seal welded before the closure ring is installed. The closure ring is a circular ring edge-welded to the MPC shell and lid; it covers the MPC lid-to-shell weld and the vent and drain port cover plates.

As explained in Appendix 1.A of [4.5.1], Alloy X may be one of the following materials.

- Type 316
- Type 316LN
- Type 304
- Type 304LN

Any stainless steel part in an MPC may be fabricated from any of the acceptable Alloy X materials listed above.

The Alloy X group approach is accomplished by qualifying the MPC for all mechanical, structural, radiological, and thermal conditions using material thermo-physical properties that are the least favorable for the entire group for the analysis in question. For example, when calculating the rate of heat rejection to the outside environment, the value of thermal conductivity used is the lowest for the candidate material group. Similarly, the stress analysis calculations use the lowest value of the ASME Code allowable stress intensity for the entire group. Stated differently, a material has been defined that is referred to as Alloy X, whose thermo-physical properties, from the MPC design perspective, are the least favorable of the above candidate materials.

The Alloy X approach is conservative because no matter which material is ultimately utilized in the MPC construction, it guarantees that the performance of the MPC will exceed safety analysis.

The following design features of the MPC Enclosure Vessel are relevant to its performance as a high integrity Containment Boundary:

1. All pressure boundary materials are 100% ultrasonically tested per ASME Section III, NB requirements to ensure absence of thru-thickness flaws.
2. All shop welds are radiographed to Section III NB acceptance criteria.
3. The field weld made to close the lid subsequent to fuel loading is a deep groove weld with a minimum of eight passes and whose depth exceeds the thickness of the shell being joined.
4. The vent and drain penetrations are confined to the lid and are also sealed by strength welding.
5. There is no reliance on seals or gaskets for radiological containment.
6. The vapor pressure in the MPC is reduced to less than 3 tors by a proven dehydration process to ensure that there will be negligible pressure rise during a thermal accident event such as fire.
7. The stresses in the Enclosure Vessel must remain below the applicable ASME code limit under all applicable storage and transport scenarios.
8. There will be no breach of the Enclosure Vessel pressure boundary under any of the postulated part 71 accident events.
9. Under the transport condition, the MPC lies in the cylindrical overpack cavity without any intervening protruding parts that may “stab” it under a transport accident event causing a potential breach in its pressure boundary.
10. The MPC is subject to a helium leak test upon completion of manufacturing. The fabrication leakage rate test demonstrates that the containment system, as fabricated, provides the required level of containment. The fabrication leakage test for the MPC for the HI-STAR 190 package is performed at the fabrication facility to ensure that the welded enclosure vessel (inner containment) will maintain its containment function.

References [4.5.2] and [4.5.3] from the published literature contain additional discussion of the structural capacity of the Holtec MPCs to withstand large mechanical loads encountered in transport conditions.

4.6 INNER CONTAINMENT SYSTEM UNDER NORMAL CONDITION OF TRANSPORT

4.6.1 Applicable Loadings and System Performance

Section 2.6 of this SAR shows that the inner containment system (credited for HBF) components are maintained within their code-allowable stress limits during all normal conditions of transport as defined in 10CFR71.71 [4.0.1]. Section 3.1 of this report shows that all containment system components are maintained within their peak temperature and pressure limits for all normal conditions of transport as defined in 10CFR71.71. Since the containment system remains in full compliance with the applicable regulatory temperature and pressure limits, it is reasonable to conclude that the design basis leakage rate (see Table 8.1.1) will not be exceeded during normal conditions of transport.

4.6.2 Containment Criteria

The leak-tight criterion, as defined by ANSI N14.5 [8.1.6], is applicable for all containment system leakage tests. Compliance with the leak-tight criteria of ANSI N14.5 precludes any significant release of radioactive materials and ensures that the radionuclide release rates specified in 10CFR71.51(a)(1) will not be exceeded during normal conditions of transport. Therefore, no containment release analyses are performed for normal conditions of transport. Containment allowable leakage rate criteria and the type of tests specified are provided in Table 8.1.1 and Table 8.1.2.

The sensitivity for the leakage test instrument shall be as described in Table 8.1.1.

4.7 INNER CONTAINMENT INTEGRITY UNDER HYPOTHETICAL ACCIDENT CONDITIONS OF TRANSPORT

4.7.1 Applicable Loadings and Package Performance

Section 2.7 of this SAR shows that all inner containment system components are maintained within their code-allowable stress limits during all hypothetical accident conditions of transport as defined in 10CFR71.73 [4.0.1]. Chapter 3 of this SAR shows that all containment system components are maintained within their peak temperature and pressure limits for all hypothetical accident conditions of transport as defined in 10CFR71.73. Since the inner containment system remains intact without exceeding temperature and pressure limits, the design basis leakage rate (see Table 8.1.1) will not be exceeded during hypothetical accident conditions of transport.

4.7.2 Containment Criteria

The leak-tight criterion, as defined by ANSI N14.5 [8.1.6], is applicable to inner containment system leakage tests. Compliance with the leak-tight criteria of ANSI N14.5 precludes any significant release of radioactive materials and ensures that the radionuclide release rates specified in 10CFR71.51(a)(2) will not be exceeded during hypothetical accident conditions of transport. Therefore, no containment release rate analyses are performed for hypothetical accident conditions of transport. Containment allowable leakage rate criteria and the type of tests specified are provided in Table 8.1.1 and Table 8.1.2. The sensitivity for the leakage test instrument shall be as described in Table 8.1.1.

4.8 SAFETY CASE FOR THE INTEGRITY OF INNER AND OUTER CONTAINMENTS

Table 4.8.1 provides a concise evaluation of the ability of the two containment boundaries in the HI-STAR 190 system to *individually* maintain leak-tightness under the various loading conditions germane to the HI-STAR 190 package's certification under 10CFR 71.

Table 4.8.1; Transport Condition Loads and Containment Integrity

Number	Condition of Service	Loading	Inner Containment	Outer Containment
1	Normal Transport	Does the analysis in Chapter 3 show that the pressure inside the Containment Boundary remains below the limit necessary to ensure leak tightness?	Yes	Yes
2.	Normal Transport	Does the analysis in Chapter 3 show that the temperature of the seals in the Containment boundary remains below their limits specified by the seal manufacturer for normal service?	Not applicable; there are no seals or gaskets in the inner containment	Yes
3	Normal Transport	Does the analysis in Section 2.6 show that the Containment Boundary will not leak under the 1-foot free drop event?	Yes	Yes
4	Normal Transport	Does the analysis in Section 2.6 show that the bolted joint in the Containment Boundary maintains its leak-tightness under reduced external pressure (3.5 psia) or increased external pressure (20 psia)?	Yes	Yes
5	Normal Transport	Will the containment Boundary remain leak tight if the environmental temperature dropped to the “cold” condition defined in Section 2.6?	Yes	Yes
6	Accident–Design Basis Fire	Do the Containment Boundary seals remain below their permissible temperature under the Design Basis Fire Event defined in Sub-section 2.7.4?	N/A; the Inner Containment Boundary has no seals or gaskets.	Yes
7	Accident-Free Drop from 9 meters	Does containment Boundary remain leak-tight after the Free drop from 9 meters described in sub-Section 2.7.1?	Yes	Yes
8	Accident–deep submergence	Does the Containment Boundary remain leak tight under 290 feet of submergence in water as defined in Sub-section 2.7.7?	Yes	Yes
8	Accident-impact with a penetrant (puncture)	Does the containment boundary maintain its integrity in the wake of a free drop of the package from 40 inches on to a 6 inch diameter mild steel bar oriented in the most adverse configuration as defined in subsection 2.7.3?	Yes; the indent caused by the bar does not reach the MPC surface.	Yes

4.9 REGULATORY COMPLIANCE

Chapter 4 of this SAR has been prepared to summarize the containment features and capabilities of the HI-STAR 190 packaging. The containment boundary of the HI-STAR 190 packaging are designed and tested to ensure that the radionuclide release rates specified in 10CFR71.51 [4.0.1] will not be exceeded.

The containment features and capabilities of the HI-STAR 190 packaging can be summarized in the following evaluation statements:

1. The HI-STAR 190 packaging, as presented in Chapter 4, complies with all applicable codes and standards for the containment system as identified in the chapter.
2. The containment boundary is securely closed by using multiple bolts and plugs. The closure of the containment boundary is sufficient to prevent unintentional opening or opening by pressure that may arise in the package as required by 10CFR71.43(c).
3. The materials of construction for the packaging containment are specified in the Bills-of-Material in Section 1.4. All materials and construction assure that there will be no significant chemical, galvanic, or other reaction as required by 10CFR71.43(d).
4. The overpack and MPC penetrations are designed to prevent leakage and protect against unauthorized operation by using cover plates to provide redundant closure as required by 10CFR71.43(e).
5. The inner containment system boundary for the HI-STAR 190 packaging consists of the MPC shell; MPC baseplate; MPC top lid; and welded joints, seams, and penetrations. Section 7.1 of Reference [4.5.2] provides further information on MPC welds.
6. The outer containment system boundary for the HI-STAR 190 packaging consists of the overpack inner shell, the bottom plate, the top flange, the top closure plate, closure bolts, the overpack vent and drain port plugs, and their respective seals.
7. The HI-STAR 190 packaging is design, constructed, and prepared for shipment so that under the tests specified in 10CFR71.71 (normal conditions of transport), the package satisfies the containment requirement of 10CFR71.43(f) with no dependence on filters or a mechanical cooling system as required by 10CFR71.51(c).
8. The HI-STAR 190 packaging satisfies the containment requirements of 10CFR71, and the packaging meets the leak tight containment criteria of ANSI N14.5.

4.10 REFERENCES

The following generic industry and Holtec produced references, directly or indirectly, undergird the safety evaluations reported in this chapter. Where explicitly cited, the reference number is identified (within square brackets) in the SAR text or table, as appropriate.

[4.0.1] 10CFR71. “Packaging and Transportation of Radioactive Materials,” Title 10 of the Code of Federal Regulations, Office of the Federal Register, Washington, D.C.

[4.0.2] Not Used.

[4.0.3] Holtec Proprietary Report HI-2022850, Revision 0, “Summary Report on MPC Leak Tightness Test”, April 2002.

[4.1.1] American Society of Mechanical Engineers (ASME), Boiler and Pressure Vessel Code, Section III, Division 1, Subsection NB, Class 1 Components, 2007 Edition, 2008 Addenda.

[4.5.1] USNRC Docket # 72-1032, HI-STORM FW FSAR, Holtec International Report number HI-2114830, USNRC, Washington D.C., 2011.

[4.5.2] “The Multi-Purpose Canister: A Bulwark of Safety in the Post-9/11 Age”, Krishna P. Singh and John Zhai, 2003 International High Level Radioactive Waste Management Conference, Las Vegas, NV, March 30-April 2, 2003.

[4.5.3] American Society of Mechanical Engineers, “Management of Spent Nuclear Fuel”, Tony Williams and K.P. Singh, Companion Guide to the ASME Boiler & Pressure Vessel Code, Third Edition, Volume 3, Chapter 56, Edited by Dr. K.R. Rao (2009).

CHAPTER 5 - SHIELDING EVALUATION

5.0 INTRODUCTION

The shielding analysis of the HI-STAR 190 Package to demonstrate compliance with 10CFR71.47 and 10CFR71.51 is presented in this chapter. HI-STAR 190 is designed to accommodate either MPC-37 or MPC-89, containing up to 37 PWR and 89 BWR fuel assemblies, respectively.

In order to offer the user flexibility in fuel loading, the HI-STAR 190 Package offers several different loading patterns, where different positions in the basket are qualified for different burnup/cooling time/enrichment combinations. The loading patterns used for shielding evaluations are described in Appendix 7.C. All loading patterns were analyzed and found to be acceptable compared to the regulatory limits.

In addition to storing intact PWR and BWR fuel assemblies, the HI-STAR 190 system is designed to transport BWR and PWR damaged fuel assemblies and fuel debris. Damaged fuel assemblies and fuel debris are defined in Glossary. Both damaged fuel assemblies and fuel debris are required to be loaded into Damaged Fuel Containers (DFCs).

The transport index in 10CFR71 is defined as the number determined by multiplying the radiation level in milliSievert per hour (mSv/h) at one meter from the external surface of the package by 100. Since HI-STAR 190 is designed to meet the dose rate limit of 10 mrem/hr (0.1 mSv/h) at 2 meters from the surface of the vehicle, the dose rate at 1 meter from the package could be greater than 10 mrem/hr (0.1 mSv/h) and the transport index could exceed 10. Therefore, HI-STAR 190 loaded with design basis fuel must be shipped by exclusive use shipment as discussed in Chapter 1.

The shielding analyses were performed with MCNP-5 Version 1.51 [5.0.1] developed by Los Alamos National Laboratory (LANL). The source terms for the design basis fuels were calculated with the TRITON and ORIGAMI/ORIGEN sequences from the SCALE 6.2.1 system [5.0.2]. This is the latest version on the SCALE code, providing substantial improvements over earlier versions such as SCALE 5.1 used in Holtec's approved Storage and Transportation FSARs and SAR under separate docket numbers [5.0.4], [5.0.5], [5.0.6]. Detailed descriptions of the MCNP models and the source term calculations are presented in Sections 5.3 and 5.2, respectively.

This chapter contains the following information:

- A description of the shielding features of HI-STAR 190.
- A description of the source terms.
- A general description of the shielding analysis methodology.
- A description of the analysis assumptions and results for HI-STAR 190.

- Analyses for the HI-STAR 190's content and results to show that the 10CFR71.47 dose rate limits are met during normal conditions of transport and that the 10CFR71.51 dose rate limit is not exceeded following hypothetical accident conditions.

To facilitate convenient access to the referenced material, Table 5.0.1 provides a listing of the material adopted in this chapter by reference to the applicable documents.

TABLE 5.0.1

APPLICABLE SECTIONS OF THE REFERENCED DOCUMENTS

Location in HI-STAR 190 SAR	Reference Information	Location in Reference Document	Technical Justification of Applicability to HI-STAR 190
Subsection 5.2.1	Cobalt impurity level in fuel hardware	Subsection 5.2.1 of [5.0.5]	The cobalt impurity level in fuel hardware is not a cask specific property.
Subsection 5.2.3 Subsection 5.4.8	CRAs and APSRs	Subsection 5.2.4 of [5.0.4]	The information about CRAs and APSRs source terms is not cask specific.
Subsection 5.2.4	NSAs	Subsection of 5.2.7 of [5.0.4]	The related information about NSAs source terms is not cask specific.
Subsection 5.3.1	Fuel homogenization	Subsection of 5.3.1 of [5.0.4]	The related information about fuel homogenization is not cask specific.
Subsection 5.4.1	Neutron source strength as a function of burnup	Section of 5.4 of [5.0.4]	The neutron source strength is not cask specific.
Subsection 5.4.5	Fuel reconfiguration	Subsection 5.4.5 of [5.2.1]	The related information about fuel reconfiguration is not cask specific.
Subsection 5.4.9	Damaged fuel assemblies	Subsection 5.4.2 of [5.0.4] Subsection 5.4.2 of [5.0.5]	The related information about damaged fuel assemblies does not change for similar cask designs.

5.1 DESCRIPTION OF SHIELDING DESIGN

5.1.1 Design Features

The principal design features of the HI-STAR 190 Package with respect to radiation shielding consist of the MPC, and the cask including the lid and the cask body.

The main shielding is provided by the cask body. The cask body steel, cask body lead, the lid and base plate provide the main gamma shielding, while the neutron shielding is provided by the Holtite neutron absorber. In the radial direction, the neutron absorber is located near the outer surface of the cask. An MPC spacer is utilized to limit the axial movement of the MPC if it is shorter than the cavity. The dimensions of the shielding components are shown in the drawing package in Section 1.3. The shielding material compositions and densities are listed in Table 5.3.2.

5.1.2 Summary of Maximum Radiation Levels

The Westinghouse 17x17 and GE 10x10 assemblies are selected as design basis assemblies since they are widely used throughout the industry. However, three other assembly types (alternative assemblies) are also evaluated, namely the B&W 15x15, the GE 7x7, and the CE 16x16 assembly. The B&W 15x15 and the GE 7x7 were evaluated since they contain a slightly larger fuel mass, which could lead to higher dose rates in some locations, and the CE 16x16 was selected to represent a group of assemblies with lower fuel mass that therefore are qualified for lower cooling times. The tables in this Section 5.1 present bounding dose rates over all those assembly types (including design basis and alternative assemblies). With this approach, the dose rates presented in this Section 5.1 bound all assemblies and burnup/enrichment/cooling time combinations listed in Appendix 7.C. For an indication of the differences between dose rates from the different assembly types see Subsection 5.4.7.

To cover a large population of fuel assemblies, including assemblies with unusual burnup and enrichment combinations, while keeping the fuel selection criteria simple, low minimum enrichment limits are specified in Appendix 7.C for the respective burnup levels. Typical fuel assemblies would have higher enrichments for the defined burnup levels, and hence show lower dose rates than those presented here.

The dose rates listed in the tables in this section represent maximum total values for each dose location, considering axial, radial and azimuthal variations as applicable. This is achieved by specifying a reasonably fine grid of dose locations around the cask, and searching for the highest total dose rate for each location. Details on dose locations are provided in Subsection 5.3.3.

Finally, all burnup, enrichment and cooling time combinations specified in Appendix 7.C were independently analyzed for each assembly, and for each dose location the combination resulting in the highest total dose rate was identified and used for the results in the tables in this subsection.

In summary, the reported dose rates in the tables in this subsection for each dose location present a full sweep determining the maximum total dose rate over all parameters, namely all assembly types; all burnup, enrichment and cooling time combinations; and all relevant axial, radial and azimuthal areas for the respective location. The reported individual dose components for each location represent the contribution to the maximum total value, but may or may not be a maximum in itself.

Additionally, the dose rates reported in this subsection include the effect of all applicable uncertainties and other considerations, namely

[

PROPRIETARY INFORMATION WITHHELD PER 10CFR2.390

]

5.1.3 Normal Conditions

As discussed in Chapter 1, HI-STAR 190 is transported by exclusive use shipment and complies with 10CFR71.47(b).

The removable HI-STAR transport impact limiters consist of aluminum honeycomb crush material arranged around a carbon steel structure and enclosed by a stainless steel shell, all of which would provide additional shielding. However, transport impact limiters' parts and materials are conservatively not credited in this analysis.

Dose rates were calculated on the cask surface, at locations shown in Figure 5.1.1. Results are presented in Tables 5.1.1 and 5.1.2 for MPC-37 and MPC-89, respectively. In these tables, the highest dose rates, either from the design basis or alternative assemblies are listed.

All values are below 200 mrem/hr, therefore showing that HI-STAR 190 complies with 10CFR71.47(b)(1). It should be noted that the additional conditions stated in 10CFR71.47(b)(1)(i) through (iii) (closed vehicle; fixed position; no loading/unloading) do not have to be met by HI-STAR 190, since the surface dose rates do not exceed 200 mrem/hr.

And since the calculated dose rates on the surface of the cask are below 200 mrem/hr, the dose rates at any point on the outer surface of the vehicle will also be below 200 mrem/hr. The HI-STAR 190 Package therefore complies with 10CFR71.47(b)(2).

The maximum dose rates for HI-STAR 190 at a distance of 2 m from the outer edges of the vehicle, for the locations shown in Figure 5.1.1, are presented in Tables 5.1.3 and 5.1.4 for MPC-37 and MPC-89, respectively. In these tables, the highest dose rates, either from the design basis or alternative assemblies are listed. The HI-STAR 190 Package therefore complies with 10CFR71.47(b)(3).

Dose rates were also calculated to determine the distance necessary to comply with the 2 mrem/hr requirement specified in 10CFR71.47(b)(4) for any normally occupied space. The results presented in Tables 5.1.5 and 5.1.6 for MPC-37 and MPC-89, respectively, identify the distances necessary from Dose Locations 4 and 5 (the top and bottom of HI-STAR 190, see Figure 5.1.1) which exposed personnel of private carriers must maintain in order meet the 2 mrem/hr requirement. If the normally occupied space of the vehicle is at a distance less than the values specified in Tables 5.1.5 and 5.1.6, radiation dosimetry is required for personnel to comply with 10CFR71.47(b)(4).

The analyses summarized in this section demonstrate HI-STAR 190's compliance with the 10CFR71.47(b) limits.

5.1.4 Hypothetical Accident Conditions

The hypothetical accident conditions of transport presented in Section 2.7 have three bounding consequences that affect the shielding materials. These are the damage to the neutron shield as a result of the design basis fire, damage to the impact limiters as a result of the 9-meter (30 foot) drop, and lead slump as a result of the 9-meter (30 foot) drop. The shielding analysis of the hypothetical accident condition assumes the neutron shield is completely lost and replaced by a void. Further, the impact limiters are also not credited for the hypothetical accident conditions. Overall these are conservative assumptions since some portion of the neutron shield would be expected to remain after the fire, and the impact limiters were shown through the calculations in Chapter 2 to remain attached following impact.

To model the lead slump of the lead in the base plate (Bottom Forging Gamma Shield) and the lead in the annular space around the Containment Shell (Gamma Shield), part of the lead is replaced with a void (see discussion in 5.3.1.1).

Chapter 2 shows that the HI-STAR 190 package remains essentially unaltered throughout the hypothetical accident conditions. Localized damage of the cask outer surface could be experienced during the pin puncture, and small localized deformations of the basket might be

possible during drop accidents. However, such localized deformations will have a negligible impact on the dose rate at 1 meter from the surface.

Figure 5.1.2 shows the dose locations at 1 meter from the surface for the conditions of the HI-STAR 190 Package after the postulated accident. Corresponding maximum dose rates are listed in Tables 5.1.7 and 5.1.8 for MPC-37 and MPC-89, respectively. In these tables, the highest dose rates, either from the design basis or alternative assemblies are listed. All values in these tables are below the regulatory limit of 1000 mrem/hr.

Analyses summarized in this section demonstrate the HI-STAR 190 Package's compliance with the 10CFR71.51 radiation dose limit.

TABLE 5.1.1

**MAXIMUM DESIGN BASIS DOSE RATES ON THE SURFACE OF THE HI-STAR 190 PACKAGE
WITH MPC-37 FOR NORMAL CONDITIONS**

Dose Point[†] Location	[PROPRIETARY INFORMATION WITHHELD PER 10CFR2.390]				Totals with Uncertainties (mrem/hr)	10 CFR 71.47 Limit (mrem/hr)
1					85.12	200
2					182.72	
3					9.25	
4					93.10	
5					90.10	

[†] Refer to Figure 5.1.1.

TABLE 5.1.2

MAXIMUM DESIGN BASIS DOSE RATES ON THE SURFACE OF THE HI-STAR 190 PACKAGE WITH MPC-89 FOR NORMAL CONDITIONS

Dose Point[†] Location	[PROPRIETARY INFORMATION WITHHELD PER 10CFR2.390]				Totals with Uncertainties (mrem/hr)	10 CFR 71.47 Limit (mrem/hr)
1					63.82	200
2					150.52	
3					11.70	
4					70.19	
5					60.59	

[†] Refer to Figure 5.1.1.

TABLE 5.1.3

**MAXIMUM DESIGN BASIS DOSE RATES AT 2 METERS FROM THE HI-STAR 190 PACKAGE
WITH MPC-37 FOR NORMAL CONDITIONS**

Dose Point[†] Location	[PROPRIETARY INFORMATION WITHHELD PER 10CFR2.390]				Totals with Uncertainties (mrem/hr)	10 CFR 71.47 Limit (mrem/hr)
2					8.85	10
4 ^{††††}				5.97		
5 ^{††††}				9.29		

[†] Refer to Figure 5.1.1.

^{††††} 1 m of the impact limiter height is credited.

TABLE 5.1.4

**MAXIMUM DESIGN BASIS DOSE RATES AT 2 METERS FROM THE HI-STAR 190 PACKAGE
WITH MPC-89 FOR NORMAL CONDITIONS**

Dose Point[†] Location	[PROPRIETARY INFORMATION WITHHELD PER 10CFR2.390]				Totals with Uncertainties (mrem/hr)	10 CFR 71.47 Limit (mrem/hr)
2					9.21	10
4					8.70	
5 ^{1††}					6.60	

[†] Refer to Figure 5.1.1.

^{1††} 1 m of the impact limiter height is credited.

TABLE 5.1.5

DISTANCES FOR THE 2 mrem/hr DOSE RATE REQUIREMENT FOR THE HI-STAR 190 PACKAGE WITH MPC-37 FOR NORMAL CONDITIONS

Dose Point[†] Location	Distance from Cask Surface (meters)	[PROPRIETARY INFORMATION WITHHELD PER 10CFR2.390]				Totals with Uncertainties (mrem/hr)	10 CFR 71.47 Limit (mrem/hr)
4	6					1.85	2
5	8					1.59	

[†] Refer to Figure 5.1.1.

TABLE 5.1.6

DISTANCES FOR THE 2 mrem/hr DOSE RATE REQUIREMENT FOR THE HI-STAR 190 PACKAGE WITH MPC-89 FOR NORMAL CONDITIONS

Dose Point[†] Location	Distance from Cask Surface (meters)	[PROPRIETARY INFORMATION WITHHELD PER 10CFR2.390]				Totals with Uncertainties (mrem/hr)	10 CFR 71.47 Limit (mrem/hr)
4	5					1.76	2
5	7					1.51	

[†] Refer to Figure 5.1.1.

TABLE 5.1.7

**MAXIMUM DESIGN BASIS DOSE RATES AT 1 METER FROM THE HI-STAR 190 PACKAGE
WITH MPC-37 FOR ACCIDENT CONDITIONS**

Dose Point[†] Location	[PROPRIETARY INFORMATION WITHHELD PER 10CFR2.390]				Totals with Uncertainties (mrem/hr)	10 CFR 71.51 Limit (mrem/hr)
2					632.48	1000
4				28.35		
5				605.86		

[†] Refer to Figure 5.1.2.

TABLE 5.1.8

MAXIMUM DESIGN BASIS DOSE RATES AT 1 METER FROM THE HI-STAR 190 PACKAGE WITH MPC-89 FOR ACCIDENT CONDITIONS

Dose Point[†] Location	[PROPRIETARY INFORMATION WITHHELD PER 10CFR2.390]				Totals with Uncertainties (mrem/hr)	10 CFR 71.51 Limit (mrem/hr)
2					792.55	1000
4					20.86	
5					479.16	

[†] Refer to Figure 5.1.2.

FIGURE 5.1.1: **[PROPRIETARY INFORMATION WITHHELD PER 10CFR2.390]**

FIGURE 5.1.2: **[PROPRIETARY INFORMATION WITHHELD PER 10CFR2.390]**

5.2 SOURCE SPECIFICATION

The principal sources of radiation in HI-STAR 190 are:

- Gamma radiation originating from the following sources (see Subsection 5.2.1)
 1. Decay of radioactive fission products
 2. Secondary photons from neutron capture in fissile and non-fissile nuclides
 3. Hardware activation products generated during core operations
- Neutron radiation originating from the following sources (see Subsection 5.2.2)
 1. Spontaneous fission
 2. α,n reactions in fuel materials
 3. Secondary neutrons produced by fission from subcritical multiplication
 4. γ,n reactions (this source is negligible)

The neutron and gamma source terms were calculated with the TRITON and ORIGAMI/ORIGEN modules of the SCALE 6.2.1 system [5.0.2] using the 252-group library.

The assemblies to be qualified for transportation in HI-STAR 190 contain UO₂ fuel. A description of the design basis fuel assemblies for the source term calculations is provided in Table 5.2.1 and Table 5.2.2. A description of the additional fuel assemblies analyzed is provided in Tables 5.2.14 and 5.2.15.

[PROPRIETARY INFORMATION WITHHELD PER 10CFR2.390]

Some of the fuel parameters listed in Table 5.2.1, Table 5.2.14 and Table 5.2.15 and **[PROPRIETARY INFORMATION WITHHELD PER 10CFR2.390]**

[PROPRIETARY INFORMATION WITHHELD PER 10CFR2.390]

Appendix 7.C specifies the burnup, cooling time and enrichment combinations for spent nuclear fuel that were analyzed for transport in HI-STAR 190. [

PROPRIETARY INFORMATION WITHHELD PER 10CFR2.390

|

The following Subsections 5.2.1 and 5.2.2 describe the calculation of the gamma and neutron source terms. Subsection 5.2.5 discusses the effect of uncertainties in the input parameters to the source term calculations.

5.2.1 Gamma Source

Table 5.2.3(a) and Table 5.2.3(b) provide the gamma source in MeV/s and photons/s as calculated with TRITON and ORIGAMI for selected burnup and cooling time combinations utilized in the shielding calculations of the assemblies in MPC-37 and MPC-89.

NUREG-1617 [5.2.2] states that "In general, only gammas from approximately 0.8 MeV-2.5 MeV will contribute significantly to the external radiation levels."

[PROPRIETARY INFORMATION WITHHELD PER 10CFR2.390]

[

PROPRIETARY INFORMATION WITHHELD PER 10CFR2.390

]

ORIGAMI was used to calculate a ^{60}Co activity level for the desired burnup and decay time. The methodology used to determine the activation level was developed from Reference [5.2.3] and is described here.

1. The activity of the ^{60}Co from ^{59}Co in steel and inconel was calculated using ORIGAMI. The flux used in the calculation was the in-core fuel region flux at full power.
2. The activity calculated in Step 1 for the region of interest was modified by the appropriate scaling factors listed in Table 5.2.4. These scaling factors were taken from Reference [5.2.3].

Table 5.2.5(a) and Table 5.2.5(b) provide the ^{60}Co activity utilized in the shielding calculations in the non-fuel regions of the assemblies in MPC-37 and MPC-89 for a selected burnup and cooling time combinations.

[PROPRIETARY INFORMATION WITHHELD PER 10CFR2.390]

5.2.2 Neutron Source

It is well known that the neutron source strength for a UO_2 assembly increases as enrichment decreases, for a constant burnup and decay time. This is due to the increase in Pu content in the fuel that increases the inventory of other transuranium nuclides such as Cm. The gamma source also varies with enrichment, although only slightly. [

PROPRIETARY INFORMATION WITHHELD PER 10CFR2.390

]

Table 5.2.6(a) and Table 5.2.6(b) provide the neutron source in neutrons/s as calculated with TRITON and ORIGAMI for selected burnup and cooling time combinations utilized in the shielding calculations of the assemblies in MPC-37 and MPC-89.

[

PROPRIETARY INFORMATION WITHHELD PER 10CFR2.390

]

5.2.3 Non-Fuel Hardware

The non-fuel hardware devices as integral but removable parts of a PWR fuel assembly are permitted for transport in HI-STAR 190, as discussed in Appendix 7.C. These devices include burnable poison rod assemblies (BPRAs), thimble plug devices (TPDs), control rod assemblies (CRAs), and axial power shaping rods (APSRs), and similar devices as noted. With some exceptions, BPRAs and TPDs may be placed in any fuel location while CRAs and APSRs are restricted as specified in Appendix 7.C. The exceptions are also specified in Appendix 7.C.

The dose rates for fuel assemblies with BPRAs, TPDs, CRAs, APSRs, and BPRAs+APSRs combination are analyzed. In that combination, BPRAs are placed in all Region 3 cells (to maximize side dose rates), and APSRs are placed at all Regions 1 and 2 cells (to maximize bottom dose rates).

5.2.3.1 BPRAs and TPDs

Burnable poison rod assembly (BPRAs) (including wet annular burnable absorbers) and thimble plug devices (TPD) (including orifice rod assemblies, guide tube plugs, and water displacement guide tube plugs) are an integral, yet removable, part of a large portion of PWR fuel. The TPDs are not used in all assemblies in a reactor core but are reused from cycle to cycle. Therefore, these devices can achieve very high burnups. In contrast, BPRAs are burned with a fuel assembly in core and are not reused. In fact, many BPRAs are removed after one or two cycles before the fuel assembly is discharged. Therefore, the achieved burnup for BPRAs is not significantly different from that of a fuel assembly. Vibration suppressor inserts are considered to be in the same category as BPRAs for the purposes of the analysis in this chapter since these devices have the same configuration (long non-absorbing thimbles which extend into the active fuel region) as a BPRAs without the burnable poison.

TPDs are made of stainless steel and contain a small amount of inconel. These devices extend down into the plenum region of the fuel assembly but typically do not extend into the active fuel region. Since these devices are made of stainless steel, there is a significant amount of cobalt-60 produced during irradiation. This is the only significant radiation source from the activation of steel and inconel.

BPRAs are made of stainless steel in the region above the active fuel zone and may contain a small amount of inconel in this region. Within the active fuel zone the BPRAs may contain 2-24 rodlets which are burnable absorbers clad in either zircaloy or stainless steel. The stainless steel clad BPRAs create a significant radiation source (Co-60) while the zircaloy clad BPRAs create a negligible radiation source. Therefore, the stainless steel clad BPRAs are bounding and are considered in the analyses.

Radiation source term calculations were performed for the TPDs and BPRAs by irradiating the appropriate mass of steel and inconel using the flux calculated for the design basis WE 17x17 fuel assembly. The masses considered are listed in Table 5.2.7, and the mass of material in the regions above the active fuel zone was scaled by the appropriate scaling factors listed in Table 5.2.4 in order to account for the reduced flux levels above the fuel assembly. These activation calculations were initially performed in [5.0.4] using an earlier version of the SCALE code system. A comparison of activation levels shows that for a given burnup and cooling time combination, and a given amount of steel, the version of SCALE utilized here results in slightly lower activity levels. Nevertheless, for added conservatism and consistency with previous evaluations, the earlier activation levels were used here as the basis for the consideration of BPRAs and TPDs. Corresponding BPRAs and TPDs sources are listed in Table 5.2.8 and Table 5.2.9 in curies for a selected burnup and cooling time combinations utilized in the shielding calculations of the assemblies in MPC-37.

To be qualified for loading, cooling times have to meet those in Table 7.C.13, or the minimum cooling time for the assembly that the insert is located in in the basket, whichever is larger. BPRAs and TPDs are permissible in every basket location, however, for 16x16 assemblies, different cooling times may apply for assemblies with and without TPDs, see Appendix 7.C.

Some TPD design variations also contain a limited number of absorbers rods, i.e. they present a hybrid between a TPD and BPRAs. Since both TPDs and BPRAs are evaluated and qualified, those design variations are also qualified, although the more limiting (longer) cooling time limit from TPDs and BPRAs would apply.

For examples the effect of the insertion of BPRAs or TPDs on dose rates please see Subsection 5.4.8.

5.2.3.2 CRAs and APSRs

Control rod assemblies (CRAs) (including control element assemblies and rod cluster control assemblies) and axial power shaping rod assemblies (APSRs) can also be an integral yet removable portion of a PWR fuel assembly. These devices are utilized for many years (upwards of 20 years) prior to discharge into the spent fuel pool. The manner in which the CRAs are utilized varies from plant to plant.

Some CRAs would be fully withdrawn during normal operation while others may operate partially inserted (approximately 10%) during normal operation. Even when fully withdrawn from the active fuel region, the ends of the CRAs are present in the upper portion of the fuel assembly since they are never fully removed from the fuel assembly during operation. The result of the different operating styles is a variation in the source term for the CRAs. In all cases, however, only the lower portion of the CRAs will be significantly activated. Therefore, when the CRAs are transported with the PWR fuel assembly, the activated portion of the CRAs will be in the lower portion of the cask. CRAs are fabricated of various materials. The cladding is typically stainless steel, although inconel has also been used. The absorber can be a single material or a combination of materials. AgInCd is possibly the most common absorber although B₄C in aluminum is used, and hafnium has also been used. AgInCd produces a noticeable source term in

the 0.3-1.0 MeV range due to the activation of Ag. The source term from the other absorbers is negligible, therefore the AgInCd CRAs are the bounding CRAs.

APSRs are used to flatten the power distribution during normal operation and as a result these devices achieve a considerably higher activation than CRAs. There are two types of B&W stainless steel clad APSRs: gray and black. According to Subsection 5.2.4 of reference [5.0.4], the black APSRs have 36 inches of AgInCd as the absorber while the gray ones use 63 inches of inconel as the absorber. Because of the cobalt-60 source from the activation of inconel, the gray APSRs produce a higher source term than the black APSRs and therefore are the bounding APSR.

5.2.3.2.1 Design Basis Source Terms for CRAs and APSRs

Configuration 1 with 10% insertion is described in Tables 5.2.10 for the CRAs and Table 5.2.12 for the APSR. As for the BPRAs and TPDs discussed in the previous subsection, activation levels were initially calculated in [5.0.4]. Those activation levels are still considered appropriate and are therefore used in the current analyses. Tables 5.2.11 and 5.2.13 present the source terms that were calculated in reference [5.0.4] for the CRAs and APSRs, respectively.

To limit the effect of the APSRs or CRAs on the dose rates around the cask, those devices are limited to certain locations in the basket, as specified in Chapter 7, Appendix 7.C. However, unlike for BPRAs and TPDs, cooling times for APSRs and CRAs are only based on the information in Table 7.C.13, without any further restriction based on the assembly cooling time.

For examples of the effect of the insertion of APSRs or CRAs on dose rates please see Subsection 5.4.8.

5.2.3.2.2 Source Terms for APSRs with Higher Activity Than Design Basis

It is permitted in Appendix 7.C for several loading patterns to be loaded with APSRs or CRAs with a higher activity than the design basis source terms for CRAs and APSRs. The loading requirements for these APSRs and CRAs are provided in Note 7 under Table 7.C.8(b). The higher-activity APSR source terms are shown in Table 5.2.13. It should be noted that since as discussed above APSRs bound CRAs, the calculations are only performed for the cask with APSRs.

The corresponding calculations are discussed in Subsection 5.4.15.

5.2.4 Fuel Assembly Neutron Sources

Neutron source assemblies (NSAs) are used in reactors for startup. There are different types of neutron sources (e.g. californium, americium-beryllium, plutonium-beryllium, polonium-beryllium, and antimony-beryllium). These neutron sources are typically inserted into the guide tubes of a fuel assembly and are usually removable. Some NSA types may also contain absorber rods and/or TPDs.

5.2.4.1 Design Basis NSA

During in-core operations, the stainless steel and inconel portions of the NSAs become activated, producing a significant amount of Co-60. A detailed discussion about NSAs is provided in Subsection 5.2.7 of reference [5.0.4]. The discussion concluded that activation from NSAs are bounded by activation from BPRAs, so no further evaluations are needed. Also the discussion concluded that loading of NSAs should be limited to one NSA per basket, placed in one of the inner regions. This is also applied here and included with the requirements in Appendix 7.C.

5.2.4.2 Source Terms for NSA with High Activity

It is permitted in Appendix 7.C for several loading patterns to be loaded with an NSA with a higher activity than the design basis NSA. The loading requirements for this case are provided in Notes 7 and 8 under Table 7.C.8(b). The total Co-60 activity is taken from the bounding burnup and 7 year cooling time ([5.2.5] Appendix I), and shown in Table 5.2.18.

The neutron source strength and average neutron energy are shown in Table 5.2.19, and obtained from References [5.2.5] Appendix I and [5.2.4].

The corresponding calculations are discussed in Subsection 5.4.15.

5.2.5 Source Term Input Uncertainties

[

PROPRIETARY INFORMATION WITHHELD PER 10CFR2.390]

[

[

PROPRIETARY INFORMATION WITHHELD PER 10CFR2.390

]

TABLE 5.2.1

[PROPRIETARY INFORMATION WITHHELD PER 10CFR2.390]

TABLE 5.2.2

[PROPRIETARY INFORMATION WITHHELD PER 10CFR2.390]

TABLE 5.2.3 (a)

**CALCULATED MPC-37 PWR FUEL GAMMA SOURCE PER ASSEMBLY
FOR SELECTED BURNUP AND COOLING TIMES (B&W 15x15)**

Lower Energy	Upper Energy	25,000 MWd/mtU 10 Year Cooling 2.1 wt% ²³⁵ U	60,000 MWd/mtU 10 Year Cooling 4.1 0 wt% ²³⁵ U
(MeV)	(MeV)	(Photons/s)	(Photons/s)
0.45	0.7	1.12E+15	2.71E+15
0.7	1.0	9.35E+13	3.11E+14
1.0	1.5	2.82E+13	8.45E+13
1.5	2.0	9.83E+11	2.71E+12
2.0	2.5	4.64E+10	6.97E+10
2.5	3.0	5.58E+09	9.50E+09
Total		1.24E+15	3.11E+15

TABLE 5.2.3 (b)

**CALCULATED MPC-89 BWR FUEL GAMMA SOURCE PER ASSEMBLY
FOR SELECTED BURNUP AND COOLING TIMES (GE 7x7)**

Lower Energy	Upper Energy	20,000 MWd/mtU 7 Year Cooling 1.6 wt% ²³⁵ U	60,000 MWd/mtU 6 Year Cooling 3.8 wt% ²³⁵ U
(MeV)	(MeV)	(Photons/s)	(Photons/s)
0.45	0.7	4.29E+14	1.49E+15
0.7	1.0	5.83E+13	3.54E+14
1.0	1.5	1.21E+13	5.46E+13
1.5	2.0	4.85E+11	1.76E+12
2.0	2.5	1.43E+11	4.27E+11
2.5	3.0	1.38E+10	4.61E+10
Total		5.00E+14	1.90E+15

TABLE 5.2.4

[PROPRIETARY INFORMATION WITHHELD PER 10CFR2.390]

TABLE 5.2.5 (a)**CALCULATED MPC-37 ⁶⁰Co SOURCE PER ASSEMBLY
FOR SELECTED BURNUP AND COOLING TIMES (B&W 15x15)**

Location	25,000 MWd/mtU 10 Year Cooling 2.1 wt% ²³⁵ U	60,000 MWd/mtU 10 Year Cooling 4.1 wt% ²³⁵ U
	(curies)	(curies)
Upper End Fitting	14.99	23.19
Gas Plenum Spacer	1.34	2.07
Gas Plenum Springs	2.33	3.61
Incore Grid Spacers	79.13	122.47
Lower End Fitting	30.55	47.29

TABLE 5.2.5 (b)

**CALCULATED MPC-89 ⁶⁰Co SOURCE PER ASSEMBLY
FOR SELECTED BURNUP AND COOLING TIMES (GE 7x7)**

Location	20,000 MWd/mtU 7 Year Cooling 1.6 wt% ²³⁵ U	60,000 MWd/mtU 6 Year Cooling 3.8 wt% ²³⁵ U
	(curies)	(curies)
Handle	0.98	1.93
Upper End Fitting	7.86	15.45
Expansion Springs	1.57	3.09
Gas Plenum Springs	8.65	17.00
Incore Grid Spacers	12.98	25.49
Lower End Fitting	28.31	55.62

TABLE 5.2.6 (a)

**CALCULATED MPC-37 NEUTRON SOURCE PER ASSEMBLY
FOR SELECTED BURNUPS AND COOLING TIMES (B&W 15x15)**

Lower Energy (MeV)	Upper Energy (MeV)	25,000 MWd/mtU 10 Year Cooling 2.1 wt% ²³⁵U	60,000 MWd/mtU 10 Year Cooling 4.1 wt% ²³⁵U
		(Neutrons/s)	(Neutrons/s)
1.0E-01	4.0E-01	5.85E+06	6.16E+07
4.0E-01	9.0E-01	1.28E+07	1.34E+08
9.0E-01	1.4	1.28E+07	1.34E+08
1.4	1.85	1.02E+07	1.07E+08
1.85	3.0	1.92E+07	1.99E+08
3.0	6.43	1.73E+07	1.82E+08
6.43	20.0	1.63E+06	1.74E+07
Totals		7.97E+07	8.36E+08

TABLE 5.2.6 (b)

**CALCULATED MPC-89 NEUTRON SOURCE PER ASSEMBLY
FOR SELECTED BURNUPS AND COOLING TIMES (GE 7x7)**

Lower Energy (MeV)	Upper Energy (MeV)	20,000 MWd/mtU 7 Year Cooling 1.6 wt% ²³⁵ U	60,000 MWd/mtU 6 Year Cooling 3.8 wt% ²³⁵ U
		(Neutrons/s)	(Neutrons/s)
1.0E-01	4.0E-01	1.46E+06	3.03E+07
4.0E-01	9.0E-01	3.18E+06	6.61E+07
9.0E-01	1.4	3.18E+06	6.60E+07
1.4	1.85	2.54E+06	5.26E+07
1.85	3.0	4.76E+06	9.75E+07
3.0	6.43	4.29E+06	8.92E+07
6.43	20.0	4.06E+05	8.62E+06
Totals		1.98E+07	4.10E+08

TABLE 5.2.7**DESCRIPTION OF DESIGN BASIS BURNABLE POISON ROD ASSEMBLY
AND THIMBLE PLUG DEVICE**

Region	BPRA	TPD
Upper End Fitting (kg of steel)	2.62	2.3
Upper End Fitting (kg of inconel)	0.42	0.42
Gas Plenum Spacer (kg of steel)	0.77488	1.71008
Gas Plenum Springs (kg of steel)	0.67512	1.48992
In-core (kg of steel)	13.2	N/A

TABLE 5.2.8

**CALCULATED BPRA SOURCE PER ASSEMBLY
FOR SELECTED BURNUP AND COOLING TIMES**

Location	25,000 MWd/mtU 10 Year Cooling 2.1 wt% ²³⁵ U	60,000 MWd/mtU 15 Year Cooling 4.1 wt% ²³⁵ U
	(curies)	(curies)
Upper End Fitting	16.94	8.78
Gas Plenum Spacer	2.59	1.34
Gas Plenum Springs	4.61	2.39
Incore	439.61	227.79

TABLE 5.2.9

**CALCULATED TPD SOURCE PER ASSEMBLY
FOR SELECTED BURNUP AND COOLING TIMES**

Location	25,000 MWd/mtU 10 Year Cooling 2.1 wt% ²³⁵ U	60,000 MWd/mtU 15 Year Cooling 4.1 wt% ²³⁵ U
	(curies)	(curies)
Upper End Fitting	36.84	19.09
Gas Plenum Spacer	13.21	6.84
Gas Plenum Springs	23.01	11.93

TABLE 5.2.10

DESCRIPTION OF DESIGN BASIS CONTROL ROD ASSEMBLIES

Axial Dimensions Relative to Bottom of Active Fuel			Flux Weighting Factor	Mass of Cladding (kg Inconel)	Mass of Absorber (kg AgInCd)
Start (in.)	Finish (in.)	Length (in.)			
Configuration 1 - 10% Inserted					
0.0	15.0	15.0	1.0	1.32	7.27
15.0	18.8125	3.8125	0.2	0.34	1.85
18.8125	28.25	9.4375	0.1	0.83	4.57

TABLE 5.2.11

DESIGN BASIS SOURCE TERMS FOR CONTROL ROD ASSEMBLIES

Axial Dimensions Relative to Bottom of Active Fuel			Photons/sec from AgInCd			Curies Co-60 from Inconel
Start (in.)	Finish (in.)	Length (in.)	0.3-0.45 MeV	0.45-0.7 MeV	0.7-1.0 MeV	
Configuration 1 - 10% Inserted						
0.0	15.0	15.0	1.91e+14	1.78e+14	1.42e+14	1111.38
15.0	18.8125	3.8125	9.71e+12	9.05e+12	7.20e+12	56.50
18.8125	28.25	9.4375	1.20e+13	1.12e+13	8.92e+12	69.92

TABLE 5.2.12

DESCRIPTION OF AXIAL POWER SHAPING ROD

Axial Dimensions Relative to Bottom of Active Fuel			Flux Weighting Factor	Mass of Cladding (kg Steel)	Mass of Absorber (kg Inconel)
Start (in.)	Finish (in.)	Length (in.)			
Configuration 1 - 10% Inserted					
0.0	15.0	15.0	1.0	1.26	5.93
15.0	18.8125	3.8125	0.2	0.32	1.51
18.8125	28.25	9.4375	0.1	0.79	3.73

TABLE 5.2.13

SOURCE TERMS FOR AXIAL POWER SHAPING ROD

Axial Dimensions Relative to Bottom of Active Fuel			Curies Co-60 (Design Basis)	Curies Co-60 (Higher Activity)
Start (in.)	Finish (in.)	Length (in.)		
Configuration 1 - 10% Inserted				
0.0	15.0	15.0	2682.57	3974.43
15.0	18.8125	3.8125	136.36	202.03
18.8125	28.25	9.4375	168.78	250.06

TABLE 5.2.14

[PROPRIETARY INFORMATION WITHHELD PER 10CFR2.390]

TABLE 5.2.15

[PROPRIETARY INFORMATION WITHHELD PER 10CFR2.390]

TABLE 5.2.16

[PROPRIETARY INFORMATION WITHHELD PER 10CFR2.390]

TABLE 5.2.17

[PROPRIETARY INFORMATION WITHHELD PER 10CFR2.390]

TABLE 5.2.18

[PROPRIETARY INFORMATION WITHHELD PER 10CFR2.390]

TABLE 5.2.19

[PROPRIETARY INFORMATION WITHHELD PER 10CFR2.390]

5.3 SHIELDING MODEL

The shielding analysis of HI-STAR 190 was performed with MCNP-5 Version 1.51 [5.0.1]. MCNP is a Monte Carlo transport code that offers a full three-dimensional combinatorial geometry modeling capability including such complex surfaces as cones and tori. This means that no gross approximations were required to represent HI-STAR 190 in the shielding analysis. MCNP is the same principal code that is used for the shielding calculations of Holtec's other approved dry storage and transportation systems under separate docket.

5.3.1 Configuration of Shielding and Source

5.3.1.1 Shielding Configuration

Section 1.3 provides the drawings that describe the HI-STAR 190 package. These drawings were used to create the MCNP models used in the radiation transport calculations. The drawing package also illustrates HI-STAR 190 on a typical transport vehicle with a personnel barrier installed, with the barrier aligned with the diameter of the impact limiters. The vehicle and barrier were not considered in the MCNP model, however the outer dimensions of the vehicle are assumed for the analyses to be identical to the outer envelope of the package with impact limiters. Figures 5.3.1 and 5.3.2 show the cross sectional views of the HI-STAR 190 cask loaded with MPC-37 and MPC-89 respectively, as they were modeled in MCNP. Figure 5.3.3 shows the MCNP model of a basket cell. Figure 5.3.4 shows a cross sectional view of HI-STAR 190. Figure 5.3.5 is an axial representation of the HI-STAR 190 cask. The figures were created with the MCNP plotter and are drawn to scale.

The conditions and tests specified in 10CFR 71.71 for normal conditions have no effect on the configuration of the cask, as concluded in Chapter 2. Therefore, no additional considerations are necessary for these conditions and tests.

The Drawings in Section 1.3 provide tolerances for selected dimensions. The dimensions where the effect of the tolerances are considered to have a significant effect of dose rates, with a special focus on those dose rates with smaller margins to the regulatory limits, are conservatively modeled as minimum values in the design basis calculations. For clarity, Table 5.3.6 lists all those dimensions together with their minimal values, and with the values used in the model.

Additionally, during the MCNP modeling process, a few modeling simplifications were made. The major simplifications resulting in a difference between model and drawings are listed and discussed here.

MPC-37 and MPC-89 Basket Modeling Simplifications

1. [

PROPRIETARY INFORMATION WITHHELD PER 10CFR2.390

]

2. The aluminum basket shims are modeled in MCNP for both MPC-37 and MPC-89 baskets. They are modeled with a thickness of 0.5 inches around the periphery of the basket and on the inside of the MPC shell. The modeled shims are conservative with respect to the actual shims in that the modeled shims contain less material.

HI-STAR Modeling Simplifications

1. [

PROPRIETARY INFORMATION WITHHELD PER 10CFR2.390

]

2. The impact limiters are not modeled. However, the tally locations 2 m from the package are taken from the outer dimensions of the impact limiters. In axial direction, the height (thickness) of the impact limiters are conservatively assumed to be 1 m, which is less than the actual dimension on the drawings.
3. The spacer ring (if present) is not modeled. This is conservative since it removes materials that may provide additional shielding.
4. The bolts utilized for closure lid are not modeled, but rather the bolt hole locations are modeled as a solid material. This is acceptable since the difference in the amount material is small, and not in an area where peak dose rates occur.
5. Penetrations in the lid are not modeled. This is acceptable since these penetrations are not aligned and are covered by the port covers, and additionally by the steel structure of the impact limiter. Any streaming through these penetrations would therefore have a negligible effect.
6. All empty spaces in and around the cask are represented by voids in the model. This is acceptable, since any absorption and scattering in air would have a very small effect in comparison to the dose rates at the close distances analyzed here.
7. In the MCNP model, the fuel is modeled as fresh UO_2 fuel with an enrichment of 3.0 wt% ^{235}U . The U-235 enrichment of 3.0 wt% in this assumption is used to calculate the material compositions (i.e., mass fractions) for ^{235}U and ^{238}U in the active fuel region for MCNP. This is a conservative assumption since the actual spent fuel has fewer amounts of fissile isotopes as compared to using a ^{235}U enrichment of 3.0 wt%. Also, fission products in the burned fuel, which decrease the neutron multiplication factor, are conservatively neglected.
8. To model the lead slump of the lead in the base plate (Bottom Forging Gamma Shield), it is conservatively assumed that 12.7 cm (5 inches) radially from the outer part of the lead are replaced with a void. To model the lead slump of the lead in the annular space around the Containment Shell (Gamma Shield), it is conservatively assumed that 5.08 cm (2 inches) of the lead in the top and bottom areas are replaced with void. The lead slump assumption is conservative since in reality no lead would be removed.

9. For MCNP model of 16x16 fuel, the HI-STAR 190 package was modeled shorter than actual. It is acceptable since the fuel spacers, which provide additional shielding, are neglected. Also, all top and bottom trunnions are conservatively axially modeled in front of the fuel assemblies, allowing more radiation streaming.

10. [PROPRIETARY INFORMATION WITHHELD PER 10CFR2.390]

The MCNP model of the HI-STAR 190 package for normal conditions has the neutron shield in place. The MCNP model for the hypothetical accident condition replaces the neutron shield with void, and also replaces part of the lead gamma shield with void as a result of the lead slump.

5.3.1.2 Fuel and Source Configuration

In the model homogenized regions represent the fuel. Calculations were performed for the HI-STORM 100 (Subsection 5.3.1 of reference [5.0.4]) to determine the acceptability of homogenizing the fuel assembly versus explicit modeling. Based on these calculations it is concluded that homogenization of the fuel assembly is acceptable without loss of accuracy. [

PROPRIETARY INFORMATION WITHHELD PER 10CFR2.390

|

5.3.1.3 Streaming Through Radial Steel Ribs

The HI-STAR 190 cask utilizes Holtite as a neutron absorber in radial and axial directions. [

PROPRIETARY INFORMATION WITHHELD PER 10CFR2.390

|

5.3.2 Material Properties

Composition and densities of the various materials used in the HI-STAR 190 shielding analyses are given in Tables 5.3.2 through 5.3.5. Further information on the Holtite and Metamic neutron absorbers is provided in Chapter 1. All of the materials and their actual geometries are represented in the MCNP model.

The Holtite-B density, hydrogen density and B₄C content used in shielding analysis are equal or less than those provided in Chapter 8.

Section 3.4 demonstrates that all materials used in HI-STAR 190 remain at or below their design temperatures during all normal conditions. Therefore, the shielding analysis does not address changes in the material density or composition as a result of temperature changes.

During normal operations, the depletion of B-10 in the Metamic and the Holtite neutron shield is negligible. Based on calculations prepared for a similar cask model, the fraction of B-10 atoms that are depleted in 50 years is less than 1E-6 in both the Metamic and Holtite. Therefore, the shielding analysis does not need to address any changes in the composition of the Metamic or Holtite as a result of neutron absorption.

5.3.3 Tally Specifications

The dose rate values listed in Tables 5.1.1 through 5.1.8, with corresponding dose point locations illustrated in Figures 5.1.1 and 5.1.2, are computed using MCNP volume and surface tallies. In radial direction, the dose locations are represented by cylindrical rings with a thickness of 1 cm or 2 cm each at the surface, at 1 m and at 2 m from the package, respectively. In axial direction there are circle surfaces at various distances from the cask. The fuel loading patterns and the placement of the neutron absorber in the cask wall potentially results in azimuthal variations in the dose rates. Additionally, the axial burnup profiles of the fuel assemblies result in axial dose rate variations. To ensure that the maximum dose rate is identified, a sufficiently fine grid of dose locations is used, and the highest combined dose rates was calculated for each pattern in the areas identified in Figures 5.1.1 and 5.1.2. Further details are discussed below.

Radial Tallies

- Dose Locations 1 and 3
These are the dose locations adjacent to the impact limiter skirt surrounding the upper and lower forgings of the cask. [

PROPRIETARY INFORMATION WITHHELD PER 10CFR2.390

]

- Dose Locations 2
This dose location captures the maximum dose rate around the radial shield cylinder, i.e. the axial section of the cask that contains the Holtite.

[

PROPRIETARY INFORMATION WITHHELD PER 10CFR2.390

]

Axial Tallies

The tally volumes located on the top and bottom surfaces, 1 meter and 2 meter positions of the cask are composed the following way:

- Dose Locations 4 and 5
In axial direction, the tally volumes are circular disks that are divided into radial sections, each about 20 cm wide.

TABLE 5.3.1

[PROPRIETARY INFORMATION WITHHELD PER 10CFR2.390]

TABLE 5.3.2

[PROPRIETARY INFORMATION WITHHELD PER 10CFR2.390]

TABLE 5.3.2 (CONTINUED)

[PROPRIETARY INFORMATION WITHHELD PER 10CFR2.390]

HI-STAR 190 SAR
Report HI-2146214

5.3-8

Revision 1

TABLE 5.3.2 (CONTINUED)

[PROPRIETARY INFORMATION WITHHELD PER 10CFR2.390]

HI-STAR 190 SAR
Report HI-2146214

5.3-9

Revision 1

TABLE 5.3.3

[PROPRIETARY INFORMATION WITHHELD PER 10CFR2.390]

TABLE 5.3.4

[PROPRIETARY INFORMATION WITHHELD PER 10CFR2.390]

TABLE 5.3.5

[PROPRIETARY INFORMATION WITHHELD PER 10CFR2.390]

TABLE 5.3.6

[PROPRIETARY INFORMATION WITHHELD PER 10CFR2.390]

FIGURE 5.3.1: **[PROPRIETARY INFORMATION WITHHELD PER 10CFR2.390]**

FIGURE 5.3.2: **[PROPRIETARY INFORMATION WITHHELD PER 10CFR2.390]**

FIGURE 5.3.3: **[PROPRIETARY INFORMATION WITHHELD PER 10CFR2.390]**

FIGURE 5.3.4: **[PROPRIETARY INFORMATION WITHHELD PER 10CFR2.390]**

HI-STAR 190 SAR
Report HI-2146214

5.3-17

Revision 1

FIGURE 5.3.5: **[PROPRIETARY INFORMATION WITHHELD PER 10CFR2.390]**

5.4 SHIELDING EVALUATION

5.4.1 Methods

The MCNP-5 code [5.0.1] was used for all of the shielding analyses. MCNP is a continuous energy, three-dimensional, coupled neutron-photon-electron Monte Carlo transport code. Continuous energy cross-section data is represented with sufficient energy points to permit linear-linear interpolation between these points. Cross section libraries are based on ENDF/B-V and ENDF/B-VI, except for Sn isotopes where the ENDL92 library is used, and uranium isotopes where LANL/T16 libraries are used. These are the default libraries for the MCNP code version used for the shielding analyses. The large user community has extensively benchmarked MCNP against experimental data. References [5.4.2], [5.4.3], and [5.4.4] are three examples of the benchmarking that was performed. MCNP-5 is essentially the same code that was used as the shielding code in all of Holtec's dry storage and transportation analyses. Also, the principal approach in the shielding analysis here is identical to the approach in licensing applications previously reviewed and approved by the USNRC.

[

PROPRIETARY INFORMATION WITHHELD PER 10CFR2.390

]

[

PROPRIETARY INFORMATION WITHHELD PER 10CFR2.390

]

[

PROPRIETARY INFORMATION WITHHELD PER 10CFR2.390

1

[PROPRIETARY INFORMATION WITHHELD PER 10CFR2.390]

5.4.2 Input and Output Data

[

PROPRIETARY INFORMATION WITHHELD PER 10CFR2.390

] The output of the post-processing are the dose rates listed in this chapter.

5.4.3 Flux-to-Dose-Rate Conversion

[

PROPRIETARY INFORMATION WITHHELD PER 10CFR2.390

]

5.4.4 External Radiation Levels

Tables 5.1.1 and 5.1.2 provide the maximum dose rates of all loading patterns on the surface of the cask during normal transport conditions for HI-STAR 190 with design basis fuel. Tables 5.1.3 and 5.1.4 list the maximum dose rate of all loading patterns at 2 m from the outer edge of the package during normal conditions.

Figure 5.1.1 shows the dose locations on the surface and the condition of the HI-STAR 190 package during normal transport. Each of these dose locations has a corresponding location at 2 m from the outer edge of cask. The azimuthal dose values are taken from the dose point locations that are shown in Figure 5.3.4. [PROPRIETARY INFORMATION WITHHELD PER 10CFR2.390].

Dose locations 1, 2 and 3 shown in Figure 5.1.1 and Figure 5.1.2 do not correspond to single dose locations. Rather the dose rates for multiple axial and azimuthal segments were calculated and the highest value was chosen for the corresponding dose location. Dose location 2 in on the outer edge of the cask and covers the whole side of the cask. The highest dose rate of the axial segments was chosen as the value for dose location 2. Dose location 1 corresponds to the surface

location directly below the neutron shield. Dose location 3 corresponds to the surface location directly above the neutron shield in the upper part of the cask. Dose location 4 corresponds to the surface location directly above the cover plate, and dose location 5 corresponds to the location directly below the bottom of the cask.

5.4.5 Fuel Reconfiguration

The licensing approach for HBF reconfiguration is discussed in Appendix 1.A. According to Section 1.2, the structural analyses demonstrate that fuel rod breakage under vibratory loads associated with the normal transport condition is not viable and therefore no noticeable impact on the dose rates is expected under normal condition. The structural analyses of fuel rods in Section 2.11 show that the fuel is expected to remain essentially undamaged during the hypothetical accident conditions. The principal calculational models for both design basis and hypothetical accident conditions therefore do not contain any reconfigured fuel.

Nevertheless, the current subsection presents additional calculations with some fuel reconfigurations under normal and accident conditions, and evaluates if any consideration of those need to be taken for the design basis calculations.

It should be noted that the analyses performed in this subsection are conservatively performed for all loading patterns, independent from their fuel burnup, except when stated otherwise in the following sections.

[

PROPRIETARY INFORMATION WITHHELD PER 10CFR2.390

]

[

PROPRIETARY INFORMATION WITHHELD PER 10CFR2.390

]

MPC-37 loaded with WE17x17 fuel assemblies and MPC-89 with GE10x10 fuel assemblies were analyzed for three scenarios. The results from the three scenarios described above along with a nominal reference case for accident conditions are shown in Table 5.4.2(a) and Table 5.4.2(b).

[

PROPRIETARY INFORMATION WITHHELD PER 10CFR2.390

]

Fuel Reconfiguration Under Normal Conditions

If there were some damage to the high burnup fuel (HBF) rods under normal conditions of transport, it would have been much less than the complete breakage of the fuel rods assumed for the accident conditions. Only local reconfiguration of fuel in the form of lattice deformation or rod/assembly sliding may be expected. Therefore the overall dose effect resulting from slight relocation of the radiation sources, if any at all, would be small.

Nevertheless, three reconfiguration scenarios are evaluated as follows:

1. A 10% axially fuel collapse scenario, with a corresponding increase in density, during normal conditions is analyzed. It is assumed that all fuel assemblies are collapsed, regardless of their burnup. Note that this is considered to be more conservative than the condition recommended in [5.4.6]. The MCNP model for this scenario is directly based on the MCNP model of the normal condition without any fuel collapse with the following modifications:
 - Fuel Geometry:
 - Active region: length reduced by 10% (by multiplying the active-region length by 0.9).
 - Upper and lower end fittings: unchanged, i.e. the support structure of the assembly is assumed to remain in place.
 - Material Densities:
 - Active region: Fuel density (density of material in the active region) increased by 10% (by dividing the active-region density by 0.9).
 - Upper and lower end fittings: unchanged.
 - Source Terms:
 - Active region: The source term per unit length is increased by 10%, so the total source term remains unchanged.
 - Upper and lower end fittings: unchanged.
 - Axial Profile: The principal profile remains unchanged, but is compressed by 10% to match the active region.
2. A 3% fuel rod collapse scenario (consistent with [5.4.6]). For this scenario, an additional set of calculations is performed for the 3% of the fuel rods that are considered collapsed, and the results from this additional set is added to the “standard” NCT case without any collapsed fuel. The additional set is only performed for neutrons and photons, and directly based on the “standard” NCT case, with the following modifications:
 - Fuel Geometry: The 3% of the collapsed fuel is assumed to be present in an axial area equivalent to 3% of the active fuel length, located directly at the bottom of the MPC cavity, which has less shielding in the axial direction than the top of the cask. This area is modeled with the same material composition and density as the active region of the fuel, but ignoring the non-fuel hardware that may still be present there.
 - Source Terms: 3% of the fuel neutron and photon source term corresponding to the assembly average burnup is allocated to the area where the collapsed rods are assumed.
 - Axial Profile: The source terms are allocated uniformly over the 3% area.

[

PROPRIETARY INFORMATION WITHHELD PER 10CFR2.390

]

3. This scenario is the same as Scenario 2, except the 3% fuel rod collapse is limited to Regions 1 and 2 fuel assemblies. For this scenario both HBF and Low Burnup Fuel (LBF) fuel are considered. This scenario is analyzed since usually the bounding loading pattern is when the fuel assemblies in Region 3 are LBF or MBF, and have relatively a low cooling time, thus maximizing the gamma dose rates. To find the maximum dose rates, the fuel-reconfiguration dose rates are added to dose rates of the design basis normal conditions with the same combination of burnup, cooling time and enrichment.

For all three scenarios, only the neutron, (n, γ) and gamma MCNP calculations are performed for simplification, since the dose rates from end fittings are not expected to be changed.

[

PROPRIETARY INFORMATION WITHHELD PER 10CFR2.390

]

5.4.6 Effect of Uncertainties and Sensitivity Studies

This subsection contains a brief summary description of the uncertainties considered, with a reference to the section in this SAR where the detailed evaluation or discussion is presented. As stated in Section 5.1, the uncertainties considered are

[

PROPRIETARY INFORMATION WITHHELD PER 10CFR2.390

]

[

PROPRIETARY INFORMATION WITHHELD PER 10CFR2.390

]

[

PROPRIETARY INFORMATION WITHHELD PER 10CFR2.390

]

5.4.7 Fuel Assembly Types

The Westinghouse 17x17 and GE 10x10 assemblies are selected as design basis assemblies since they are widely used throughout the industry.

Tables 5.4.4(a) and 5.4.5(a) present a dose rate comparison of Westinghouse 17x17, B&W 15x15 and CE 16x16, while Tables 5.4.4(b) and 5.4.5(b) present a dose rate comparison of GE 10x0 and GE 7x7. In the tables in Section 5.1, the highest dose rates, either from the design basis or alternative assemblies are listed.

5.4.8 Non-Fuel Hardware

As discussed in Subsection 5.2.3, non-fuel hardware in the form of BPRAs, TPDs, CRAs, and APSRs are permitted for transport, integral with a PWR fuel assembly, in the HI-STAR 190 cask. Since each device occupies the same location within an assembly, only one device will be present in a given assembly. ITTRs and GTAs, which are installed after core discharge and do not contain radioactive material, may also be placed in the assembly. BPRAs, TPDs, GTAs and ITTRs are authorized for unrestricted transport in MPC. The permissible locations of the CRAs and APSRs are provided in Appendix 7.C.

[

PROPRIETARY INFORMATION WITHHELD PER 10CFR2.390

]

Table 5.4.7 provides the dose rates at various locations on the surface and two meter from HI-STAR 190 due to the BPRAs, TPDs, CRAs, and APSRs for MPC-37 loaded with Westinghouse 17x17 assemblies. Table 5.4.8 provides the dose rates at various locations at a distance of one

meter from HI-STAR 190 due to the BPRAs, TPDs, CRAs and APSRs for MPC-37 loaded with Westinghouse 17x17 fuel assembly.

The results in Table 5.4.7 and Table 5.4.8 show that the maximum dose effect for BPRAs is at the side of the cask, the maximum dose effect for TPDs is at the top of the cask and the maximum dose effect for APSRs is at the bottom of the cask. All dose rates with NFH in this chapter are based on APSRs in Regions 1 and 2 and BPRAs in Region 3 fuel assemblies.

As discussed in Paragraph 5.2.3.2.2, Appendix 7.C allows the loading of APSRs and CRAs with higher activity than their design basis for several loading patterns. The shielding calculations for those cases are provided in Subsection 5.4.15.

5.4.9 Damaged Fuel Post-Accident Shielding Evaluation

The Holtec Generic PWR and BWR DFCs are designed to accommodate any PWR or BWR fuel assembly that can physically fit inside the DFC. Damaged fuel assemblies under normal conditions, for the most part, resemble intact fuel assemblies from a shielding perspective. Under accident conditions, it cannot be guaranteed that the damaged fuel assembly will remain intact. As a result, the damaged fuel assembly may begin to resemble fuel debris in its possible configuration after an accident.

Since damaged fuel is identical to intact fuel from a shielding perspective no specific analysis is required for damaged fuel under normal conditions. However, shielding evaluations were previously performed for the 100-ton HI-TRAC (as it is discussed in Subsection 5.4.2 of reference [5.0.4]) and HI-STAR 100 (as it is discussed in Subsection 5.4.2 of [5.0.5]) to demonstrate that fuel debris under normal or accident conditions, or damaged fuel in a post-accident configuration, will not result in a significant increase in the dose rates around the cask.

As a defense in depth, additional sensitivity analyses for fuel reconfiguration in normal and accident conditions are provided in Subsection 5.4.5, demonstrating that all analyzed regionalized loading patterns meet the dose rate regulatory requirements.

5.4.10 Axial Burnup Profile

The effect of the axial burnup profile on dose rates is discussed in Appendix 5.C.

5.4.11 Fuel Assemblies with Longer Active Fuel Length

As specified in Appendix 7.C, some PWR fuel assemblies have longer active fuel length than design basis fuel assembly (considering both evaluated Westinghouse 17x17 and B&W 15x15 fuel assemblies), thus those fuel assemblies may have more UO₂ mass than the design basis fuel

assembly, resulting in larger neutron and gamma source terms for a given burnup, enrichment and cooling time combination.

However, the required minimum cooling time specified in Appendix 7.C for fuel assemblies with longer active fuel length is more than that of design basis fuel assembly, calculated so that the neutron and gamma source terms (neutrons/s and photons/s) of the longer fuel assemblies are less than those of the design basis assembly. Since the minimum cooling times for these longer fuel assemblies are longer than those of design basis fuel assembly, the design basis fuel assembly will have a higher cobalt source term as well. Thus, it is concluded that the MPC/package configuration for the design basis fuel assembly results in maximum dose rates, considering fuel specifications provided in Appendix 7.C.

5.4.12 Sensitivity Study of the Accident Condition Model - Lead Slump Analysis

To show that the design basis model of hypothetical accident conditions is conservative, this subsection presents a sensitivity study for the lead slump with a different geometry. The sensitivity study evaluated lead slump geometry is based on the structure analysis.

[

PROPRIETARY INFORMATION WITHHELD PER 10CFR2.390

]

5.4.13 Acceptable Variations in Loading Patterns

As discussed in Subsection 5.4.1, several regionalized loading patterns are defined for each MPC in Appendix 7.C, namely in Tables 7.C.8(a) and (b), and 7.C.10. These loading patterns allow a large degree of flexibility in loading the cask, while at the same time ensuring that the regulatory dose limits are met. To determine the maximum dose rates, the dose rates at all dose locations for all loading patterns in Tables 7.C.8(a) and (b), and 7.C.10 are calculated.

For burnup values not listed in tables 7.C.8(a) and (b), and 7.C.10, corresponding minimum enrichment and minimum cooling time values can be determined by linear interpolation. This is acceptable since both enrichment and cooling time follow slightly concave functions between burnups, therefore a linear interpolation results in a slightly higher, i.e. conservative value. This is directly supported by the values in Tables 7.C.8(a) and (b), and 7.C.10. For example, for the burnups of 45, 50 and 55 GWd/mtU, the corresponding minimum enrichments listed in Table 7.C.8(a) are 3.0, 3.2 and 3.5 wt% respectively. If the enrichment for 50 GWd/mtU would be calculated by linear interpolation between the values for 45 and 55 GWd/mtU, it would be $(3.0+3.5)/2 = 3.25$ wt%. This is higher enrichment, i.e. more conservative than the value of 3.2 wt% actually listed for 50 GWd/mtU.

5.4.14 Fuel Assemblies with Stainless Steel Rods replacing Fuel Rods

[

PROPRIETARY INFORMATION WITHHELD PER 10CFR2.390

]

5.4.15 CE16x16 Assemblies with High Activity APSRs and/or NSA

[

PROPRIETARY INFORMATION WITHHELD PER 10CFR2.390

]

[

PROPRIETARY INFORMATION WITHHELD PER 10CFR2.390

]

TABLE 5.4.1
FLUX-TO-DOSE CONVERSION FACTORS
(FROM [5.4.1])

Gamma Energy (MeV)	(mrem/hr)/ (photon/cm²-s)
0.01	3.96E-06
0.03	5.82E-07
0.05	2.90E-07
0.07	2.58E-07
0.1	2.83E-07
0.15	3.79E-07
0.2	5.01E-07
0.25	6.31E-07
0.3	7.59E-07
0.35	8.78E-07
0.4	9.85E-07
0.45	1.08E-06
0.5	1.17E-06
0.55	1.27E-06
0.6	1.36E-06
0.65	1.44E-06
0.7	1.52E-06
0.8	1.68E-06
1.0	1.98E-06
1.4	2.51E-06
1.8	2.99E-06
2.2	3.42E-06

TABLE 5.4.1 (CONTINUED)
FLUX-TO-DOSE CONVERSION FACTORS
(FROM [5.4.1])

Gamma Energy (MeV)	(mrem/hr)/ (photon/cm²-s)
2.6	3.82E-06
2.8	4.01E-06
3.25	4.41E-06
3.75	4.83E-06
4.25	5.23E-06
4.75	5.60E-06
5.0	5.80E-06
5.25	6.01E-06
5.75	6.37E-06
6.25	6.74E-06
6.75	7.11E-06
7.5	7.66E-06
9.0	8.77E-06
11.0	1.03E-05
13.0	1.18E-05
15.0	1.33E-05

TABLE 5.4.1 (CONTINUED)
FLUX-TO-DOSE CONVERSION FACTORS
(FROM [5.4.1])

Neutron Energy (MeV)	Quality Factor	(mrem/hr)/(n/cm ² -s) †
2.5E-8	2.0	3.67E-06
1.0E-7	2.0	3.67E-06
1.0E-6	2.0	4.46E-06
1.0E-5	2.0	4.54E-06
1.0E-4	2.0	4.18E-06
1.0E-3	2.0	3.76E-06
1.0E-2	2.5	3.56E-06
0.1	7.5	2.17E-05
0.5	11.0	9.26E-05
1.0	11.0	1.32E-04
2.5	9.0	1.25E-04
5.0	8.0	1.56E-04
7.0	7.0	1.47E-04
10.0	6.5	1.47E-04
14.0	7.5	2.08E-04
20.0	8.0	2.27E-04

† Includes the Quality Factor

TABLE 5.4.2 (a)

[PROPRIETARY INFORMATION WITHHELD PER 10CFR2.390]

TABLE 5.4.2 (b)

[PROPRIETARY INFORMATION WITHHELD PER 10CFR2.390]

TABLE 5.4.3(a)

MAXIMUM DOSE RATES AT 2 METERS FROM THE HI-STAR 190 PACKAGE WITH MPC-37 LOADED WITH WE17x17 FUEL FOR FUEL COLLAPSE FOR NORMAL CONDITIONS

Dose Point [†] Location	Dose Rate ^{‡‡} (mrem/hr)				
	No Fuel Reconfigurations	Scenario 1: 10% Axially Fuel Collapse	Scenario 2: 3% Fuel Rod Collapse in All Cells, HBF	Scenario 3: 3% Fuel Rod Collapse in Regions 1 and 2 Cells	10 CFR 71.47 Limit
2 (Note 1)	7.71	7.68	7.78	7.91	10
4 ^{†††}	4.65	2.92	4.60	4.60	
5 ^{†††}	5.54	5.91	7.62	7.61	

Note 1: The maximum 2 m side dose rate for all scenarios is located about 30” above bottom trunnions.

[†] Refer to Figure 5.1.2.

^{‡‡} Non-fuel hardware devices (APSR in Regions 1 and 2 cells, BPRA in Region 3) are considered for all fuel reconfiguration scenarios, to maximize the dose rates at dose locations 2 and 5.

^{†††} 1 m of the impact limiter height is credited.

TABLE 5.4.3(b)

TOTAL DOSE RATES AT 2 METERS FROM THE HI-STAR 190 PACKAGE WITH MPC-89 LOADED WITH GE10x10 FUEL FOR FUEL COLLAPSE FOR NORMAL CONDITIONS

Dose Point [†] Location	Dose Rate (mrem/hr)				
	No Fuel Reconfigurations	Scenario 1: 10% Axially Fuel Collapse	Scenario 2: 3% Fuel Rod Collapse in All Cells, HBF	Scenario 3: 3% Fuel Rod Collapse in Regions 1 and 2 Cells	10 CFR 71.47 Limit
2 (Note 1)	7.65	7.63	7.99	7.82	10
4	7.68	4.95	7.68	7.68	
5	5.64	6.21	9.73	9.74	

Note 1: The maximum 2 m side dose rate for all scenarios is located at about 40” above bottom trunnions.

[†] Refer to Figure 5.1.1.

TABLE 5.4.4 (a)

MAXIMUM DOSE RATES ON THE SURFACE OF HI-STAR 190 WITH MPC-37 FOR NORMAL CONDITIONS (NO FUEL RECONFIGURATION)

Dose Point[†] Location	Total Dose Rate^{††} (mrem/hr)			
	WE17x17 Fuel	B&W15x15 Fuel	CE 16x16 Fuel	10 CFR 71.47 Limit
1	57.05	43.88	63.21	200
2	158.88	128.46	162.42	
3	6.19	7.82	8.87	
4	71.39	88.09	64.37	
5	48.10	35.52	60.04	

[†] Refer to Figure 5.1.1.

^{††} See Subsection 5.4.7 for description of calculations.

TABLE 5.4.4 (b)

MAXIMUM DOSE RATES ON THE SURFACE OF HI-STAR 190 PACKAGE WITH MPC-89 FOR NORMAL CONDITIONS (NO FUEL RECONFIGURATION)

Dose Point [†] Location	Total Dose Rate ^{††} (mrem/hr)		
	GE 10x10 Fuel	GE 7x7 Fuel	10 CFR 71.47 Limit
1	38.06	38.96	200
2	122.53	123.70	
3	9.69	10.09	
4	58.48	63.05	
5	27.40	27.78	

[†] Refer to Figure 5.1.1.

^{††} See Subsection 5.4.7 for description of calculations.

TABLE 5.4.5 (a)

MAXIMUM DOSE RATES AT 2 METERS FROM HI-STAR 190 PACKAGE WITH MPC-37 FOR NORMAL CONDITIONS (NO FUEL RECONFIGURATION)

Dose Point[†] Location	Total Dose Rate^{††} (mrem/hr)			
	17x17 Fuel	B&W15x15 Fuel	CE 16x16 Fuel	10 CFR 71.47 Limit
2	7.71	8.06	8.21	10
4 ^{†††}	4.65	5.72	4.13	
5 ^{†††}	5.54	4.24	6.61	

[†] Refer to Figure 5.1.1.

^{††} See Subsection 5.4.7 for description of calculations.

^{†††} 1 m of impact limiter height is credited.

TABLE 5.4.5 (b)

MAXIMUM DOSE RATES AT 2 METERS FROM HI-STAR 190 PACKAGE WITH MPC-89 FOR NORMAL CONDITIONS (NO FUEL RECONFIGURATION)

Dose Point [†] Location	Total Dose Rate ^{††} (mrem/hr)		
	GE 10x10 Fuel	GE 7x7 Fuel	10 CFR 71.47 Limit
2	7.65	8.04	10
4	7.68	7.45	
5	5.64	6.06	

† Refer to Figure 5.1.1.

†† See Subsection 5.4.7 for description of calculations.

TABLE 5.4.7

**MAXIMUM TOTAL DOSE RATES DUE TO NON-FUEL HARDWARE FROM HI-STAR 190 PACKAGE
WITH MPC-37 LOADED WITH WE17x17 FUEL
FOR NORMAL CONDITIONS (NO FUEL RECONFIGURATION)**

Dose Point[†] Location	Dose Rate Without NFH (mrem/hr)	Dose Rate with BPRAs (mrem/hr)	Dose Rate with TPDs (mrem/hr)	Dose Rate with CRAs (mrem/hr)	Dose Rate with BPRAs and APSRs^{†††} (mrem/hr)	10 CFR 71.47 Limit (mrem/hr)
ADJACENT to HI-STAR 190						
1	53.06	53.11	53.06	54.80	57.05	200
2	157.91	158.02	157.91	158.29	158.88	
3	5.21	5.58	6.19	5.21	5.42	
4	71.05	71.20	71.39	71.05	71.05	
5	30.15	30.16	30.15	36.71	48.10	
TWO METERS FROM HI-STAR 190						
2	7.02	7.65	7.05	7.06	7.71	10
4 ^{††††}	4.60	4.62	4.65	4.60	4.60	
5 ^{††††}	3.54	3.59	3.54	4.40	5.54	

[†] Refer to Figure 5.1.1.

^{†††} APSRs are placed in fuel storage Regions 1 and 2 while BPRAs in Regions 3.

^{††††} 1 m of impact limiter height is credited.

TABLE 5.4.8

**MAXIMUM TOTAL DOSE RATES DUE TO NON-FUEL
HARDWARE FROM HI-STAR 190 PACKAGE
WITH MPC-37 LOADED WITH WE17x17 FUEL
FOR ACCIDENT CONDITIONS (NO FUEL RECONFIGURATION)**

Dose Point[†] Location	Dose Rate Without NFH (mrem/hr)	Dose Rate with BPRAs (mrem/hr)	Dose Rate with TPDs (mrem/hr)	Dose Rate with CRAs (mrem/hr)	Dose Rate with BPRAs and APSRs^{†††} (mrem/hr)	10 CFR 71.51 Limit (mrem/hr)
ONE METER FROM HI-STAR 190						
2	541.63	541.73	541.63	541.84	542.15	1000
4	21.86	21.94	22.05	21.86	21.86	
5	170.22	170.30	170.22	175.70	183.00	

[†] Refer to Figure 5.1.2.

^{†††} APSRs are placed in fuel storage Regions 1 and 2 while BPRAs in Regions 3.

Tables 5.4.9 through 5.4.19 were deleted

TABLE 5.4.20

[PROPRIETARY INFORMATION WITHHELD PER 10CFR2.390]

TABLE 5.4.21

[PROPRIETARY INFORMATION WITHHELD PER 10CFR2.390]

TABLE 5.4.22

[PROPRIETARY INFORMATION WITHHELD PER 10CFR2.390]

TABLE 5.4.23

[PROPRIETARY INFORMATION WITHHELD PER 10CFR2.390]

TABLE 5.4.24

[PROPRIETARY INFORMATION WITHHELD PER 10CFR2.390]

5.5 REFERENCES

The following generic industry and Holtec produced references may have been consulted in the preparation of this document. Where specifically cited, the identifier is listed in the SAR text or table. Active Holtec Calculation Packages which are the repository of all relevant licensing and design basis calculations are annotated as “latest revision”. Submittal of the latest revision of such Calculation Packages to the USNRC and other regulatory authorities during the course of regulatory reviews is managed under the company’s Configuration Control system.

- [5.0.1] X-5 Monte Carlo Team, “MCNP – A General Monte Carlo N-Particle Transport Code, Version 5,” LA-UR-03-1987, Los Alamos National Laboratory (2003).
- [5.0.2] B. T. Rearden and M. A. Jessee, Eds., *SCALE Code System*, ORNL/TM-2005/39, Version 6.2.1, Oak Ridge National Laboratory, Oak Ridge, Tennessee (2016).
- [5.0.3] Not Used.
- [5.0.4] HI-STORM 100 FSAR, Revision 12 (Docket 72-1014).
- [5.0.5] HI-STAR 100 SAR, Revision 15 (Docket 71-9261).
- [5.0.6] HI-STORM FW FSAR, Revision 4 (Docket No. 72-1032).
- [5.0.7] Shielding Analysis for the HI-STAR 190 CASK, HI- 2146294, latest revision, Holtec International.
- [5.2.1] HI-STAR 180 SAR, latest revision, HI-2073681 (Docket No. 71-9325), Holtec International.
- [5.2.2] NUREG-1617, SRP for Transportation Packages for Spent Nuclear Fuel, USNRC, Washington, DC, March 2000.
- [5.2.3] A. Luksic, "Spent Fuel Assembly Hardware: Characterization and 10CFR 61 Classification for Waste Disposal," PNL-6906-vol. 1, Pacific Northwest Laboratory, June 1989.
- [5.2.4] Chilton, A. B., et. al., Principles of Radiation Shielding, Prentice-Hall, Inc., 1984.
- [5.2.5] HI-STAR 190 Source Terms and Loading Patterns Using SCALE 6.2.1, HI-2167524, latest revision, Holtec International.
- [5.4.1] "American National Standard Neutron and Gamma-Ray Flux-to-Dose Rate Factors", ANSI/ANS-6.1.1-1977.
- [5.4.2] D. J. Whalen, et al., “MCNP: Photon Benchmark Problems,” LA-12196, Los Alamos National Laboratory, September 1991.

- [5.4.3] D. J. Whalen, et al., “MCNP: Neutron Benchmark Problems,” LA-12212, Los Alamos National Laboratory, November 1991.
- [5.4.4] J. C. Wagner, et al., “MCNP: Criticality Safety Benchmark Problems,” LA-12415, Los Alamos National Laboratory, October 1992.
- [5.4.5] B.L. Broadhead, “Recommendations for Shielding Evaluations for Transport and Storage Packages,” NUREG/CR-6802 (ORNL/TM-2002/31), Oak Ridge National Laboratory, May 2003.
- [5.4.6] NRC Draft Regulatory Issue Summary 2015-XX Considerations in Licensing High Burnup Spent Fuel in Dry Storage and Transportation, ML14175A203.

Appendix 5.A

[PROPRIETARY APPENDIX WITHHELD PER 10CFR2.390]

Appendix 5.B

[PROPRIETARY APPENDIX WITHHELD PER 10CFR2.390]

APPENDIX 5.C

[PROPRIETARY APPENDIX WITHHELD PER 10CFR2.390]

CHAPTER 6 CRITICALITY EVALUATION

6.0 INTRODUCTION

This chapter documents the criticality evaluation of the HI-STAR 190 Cask for the transportation of the radioactive materials, such as high burnup (HBF) and moderate burnup (MBF) fuel, in accordance with 10CFR71. The results of this evaluation demonstrate that, for the designated fuel assembly classes and basket configurations, an infinite number of HI-STAR 190 Packages with variations in internal and external moderation remain subcritical with a subcriticality margin, respectively, of at least $0.02\Delta k$ for the misload conditions and greater than $0.05\Delta k$ under all the other conditions. This corresponds to a criticality safety index (CSI) of zero (0.0) and demonstrates compliance with criticality requirements in USNRC Interim Staff Guidance (ISG-8 Rev. 3), 10CFR71.55 and 10CFR71.59 for normal and hypothetical accident conditions of transport.

In addition to demonstrating that the criticality safety acceptance criteria are satisfied, this chapter describes the HI-STAR 190 design structures and components important to criticality safety and limiting fuel characteristics in sufficient detail to identify the package accurately and provides a sufficient basis for the criticality evaluation of the package.

Note that the analysis methodologies and modeling assumptions utilized in the safety evaluation documented in this chapter are based on those used in the licensing of HI-STAR 100 in Docket #71-9261 [6.0.1], HI-STAR 180 in Docket #71-9325 [6.0.2] and HI-STAR 180D in Docket #71-9367 [6.0.3], except the following:

- Actinide and fission product burnup credit, based on the latest NRC guidance, is used for the MPC-37 basket;
- A partial burnup credit is used for potentially reconfigured BWR HBF in the MPC-89 basket.

Finally, HI-STAR 190 is designed as the transportation cask for the MPCs certified for storage in HI-STORM FW in Docket #72-1032 [6.0.4] under 10CFR72. Thus, the fuel baskets characteristics and the permissible fuel loading content are identical to those utilized in the licensing of HI-STORM FW.

To facilitate convenient access to the referenced material, Table 6.0.1 provides a listing of the material adopted in this chapter by reference to the applicable documents.

TABLE 6.0.1

APPLICABLE SECTIONS OF THE REFERENCED DOCUMENTS

Location in HI-STAR 190 SAR	Reference Information	Location in Reference Document	Technical Justification of Applicability to HI-STAR 190
Subsection 6.2.2	Definition of assembly classes	Tables 2.1.2 and 2.1.3 of [6.0.4]	Subsection 6.2.2
Subsection 6.2.2	Analyses of the fuel dimensional variations	Section 6.2 of [6.0.1]	Subsection 6.2.2
Subsection 6.2.2	Additional fuel assembly characteristics	Subsection 6.2.1 of [6.0.4]	Subsection 6.2.2
Subsection 6.2.3	Annular pellets	Subsection 6.2.1 of [6.0.4]	Subsection 6.2.3
Subsection 6.2.3	15x15I with and without the guide rods	Subsection 6.2.1 of [6.0.4]	Subsection 6.2.3
Subsection 6.2.4	10x10G with the part-length rods	Subsection 6.2.1 of [6.0.4]	Subsection 6.2.4
Subsection 6.2.4	Uniform vs. distributed enrichment	Appendix 6.B of [6.0.1]	Subsection 6.2.4
Subsection 6.2.4	Uniform vs. distributed enrichment	Subsection 6.2.1 of [6.0.4]	Subsection 6.2.4
Subsection 6.2.4	8x8B and 8x8D with slight variation in the number of fuel and/or water rods	Subsection 6.2.1 of [6.0.4]	Subsection 6.2.4
Subsection 6.2.4	Two patterns of water rods for 9x9E/F	Subsection 6.2.1 of [6.0.4]	Subsection 6.2.4
Subsection 6.2.5	Damaged fuel assemblies	Paragraph 6.4.4.2 of [6.0.5]	Subsection 6.2.5
Subsection 6.2.6	Reconfiguration of PWR HBF	Subsection 6.3.5 of [6.0.2]	Subsection 6.2.6
Subsection 6.3.2	¹⁰ B depletion during the service life of Metamic-HT	Subsection 6.3.2 of [6.0.4]	Subsection 6.3.2
Paragraph 6.3.4.4	Preferential flooding	Paragraph 6.4.2.4 of [6.0.1]	Paragraph 6.3.4.4
Subsection 6.B.2.1	Core operation parameters	Appendix A of [6.B.4]	Subsection 6.B.2.1
Subsection 6.B.2.1	Soluble boron concentration	Section 6.E.3.3 of [6.0.1]	Subsection 6.B.2.1
Subsection 6.B.2.1	Ratio applied to the core operation parameters	Table 6.E.3 of [6.0.1]	Subsection 6.B.2.1
Subsection 6.B.2.1	Fuel temperature calculation	Paragraph 6.E.2.1.4 of [6.0.1]	Subsection 6.B.2.1
Subsection 6.B.2.2	Axial power shaping rods	Subsection 6.E.2.2 of [6.0.1]	Subsection 6.B.2.2
Paragraph 6.B.2.2.1	Fuel inserts and burnable poisons analysis	Paragraph 6.E.2.2.1 of [6.0.1]	Paragraph 6.B.2.2.1
Subsection 6.B.4.1	Bounding axial burnup profiles	Subsection 6.E.4.1 of [6.0.1]	Subsection 6.B.4.1
Subsection 6.B.4.1	Bounding axial burnup profiles	Appendix D of [6.B.4]	Subsection 6.B.4.1
Paragraph 6.B.4.3.1	Isotopic compositions interpolation step	Paragraph 6.E.4.3.1 of [6.0.1]	Paragraph 6.B.4.3.1
Paragraph 6.B.4.3.2	Assembly average vs. pin specific isotopic composition	Paragraph 6.E.4.3.2 of [6.0.1]	Paragraph 6.B.4.3.2

6.1 DESCRIPTION OF CRITICALITY DESIGN

In conformance with the principles established in 10CFR71 [6.1.1], NUREG-1617 [6.1.2], and NUREG-0800 Section 9.1.2 [6.1.3], the results in this chapter demonstrate that the effective multiplication factor (k_{eff}) of the HI-STAR 190 package, including all biases and uncertainties evaluated with a 95% probability at the 95% confidence level, does not exceed 0.95 under all credible normal and hypothetical accident conditions of transport. This criterion provides a large subcritical margin, sufficient to assure the criticality safety of the HI-STAR 190 package when fully loaded with fuel of the highest permissible reactivity.

6.1.1 Design Features

The HI-STAR 190 package consists of the HI-STAR 190 transport cask and Multi-Purpose-Canisters (MPCs) for PWR and BWR fuel (see Chapter 1). The HI-STAR 190 package is designed such that the fixed neutron absorber will remain effective for a period greater than 50 years, and there are no credible mechanisms that would cause its loss or a diminution of its effectiveness (see Chapter 2 and Paragraph 8.1.5.5 for further information on the qualification and testing of the neutron absorber material). Therefore, there is no need to provide a surveillance or monitoring program to verify the continued efficacy of the neutron absorber.

The containment system of HI-STAR 190 is a multi-purpose canister with a flat bottom and flat welded lids at the top (inner barrier) and the metal cask with its bolted lid (outer barrier). Thus, a double barrier approach is used to qualify HBF, while only the metal cask with its bolted lid is credited for the containment function for MBF (see Section 1.0). Inside the MPC, fuel assemblies are placed in a basket structure to maintain their location. During the normal and accident conditions of transport, the HI-STAR 190 package is dry (no moderator), and thus, the reactivity is very low ($k_{\text{eff}} < 0.50$). However, to demonstrate a compliance with 10CFR71 the HI-STAR 190 package is flooded, and thus, represents the limiting case in terms of reactivity. The calculational models for these conditions conservatively include: full flooding with ordinary water, corresponding to the highest reactivity, and the worst case (most conservative) combination of manufacturing and fabrication tolerances.

[

PROPRIETARY INFORMATION WITHHELD PER 10 CFR 2.390

]

[

PROPRIETARY INFORMATION WITHHELD PER 10 CFR 2.390

]

For general details of these baskets see the description and drawings in Section 1.3. Sketches showing the basket details that are important for criticality safety are shown in Subsection 6.3.1 of this chapter. The basket loading configurations, discussed above, are graphically shown in Appendix 6.D, Section D.6.

Criticality safety of HI-STAR 190 depends on the following principal design features:

- The inherent geometry of the fuel basket design within the MPC;
- The incorporation of permanent fixed neutron-absorbing material in the fuel basket structure. [PROPRIETARY INFORMATION WITHHELD PER 10 CFR 2.390]
- An administrative limit on the maximum average enrichment for PWR fuel and maximum planar-average enrichment for BWR fuel;
- An administrative limit on the minimum average assembly burnup for PWR fuel. The burnup credit methodology is described in detail in Appendix 6.B of this chapter, [PROPRIETARY INFORMATION WITHHELD PER 10 CFR 2.390] Also a partial burnup credit is used for potentially reconfigured BWR HBF (see Appendix 6.C); and
- The ability of the cask to prevent water inleakage under accident conditions. [PROPRIETARY INFORMATION WITHHELD PER 10 CFR 2.390]

Applicable codes, standards, and regulations, or pertinent sections thereof, include the following:

- U.S. Code of Federal Regulations, “Packaging and Transportation of Radioactive Materials,” Title 10, Part 71.
- NUREG-1617, “Standard Review Plan for Transportation Packages for Spent Nuclear Fuel” USNRC, Washington D.C., March 2000.
- U.S. Code of Federal Regulations, “Prevention of Criticality in Fuel Storage and Handling,” Title 10, Part 50, Appendix A, General Design Criterion 62.
- USNRC Standard Review Plan, NUREG-0800, Section 9.1.2, “New and Spent Fuel Storage”, Rev. 4, March 2007.
- USNRC Interim Staff Guidance 19 (ISG-19), Revision 0, “Moderator Exclusion under Hypothetical Accident Conditions and Demonstrating Subcriticality of Spent Fuel under the Requirements of 10 CFR 71.55(e)”.
- USNRC Interim Staff Guidance - 8 (ISG-8), Revision 3, “Burnup Credit in the Criticality Safety Analyses of PWR Spent Fuel in Transportation and Storage Casks”.

6.1.2 Summary Table of Criticality Evaluations

Confirmation of the criticality safety of the HI-STAR 190 package was accomplished with the three-dimensional Monte Carlo code MCNP5 [6.3.1]. K-factors for one-sided statistical tolerance limits with 95% probability at the 95% confidence level were obtained from the National Bureau of Standards (now NIST) Handbook 91 [6.4.1].

To assess the reactivity effects due to temperature and fuel density changes, CASMO5, a two-dimensional transport theory code [6.3.2 - 6.3.3] for fuel assemblies was used. CASMO5 was not used for quantitative information, but only to qualitatively indicate the direction and approximate magnitude of the reactivity effects. Additionally, CASMO5 was used to determine the isotopic composition of spent fuel for burnup credit in HI-STAR 190 (see Appendix 6.B).

Benchmark calculations were made to compare the primary code package (MCNP5) with experimental data, using critical experiments selected to encompass, insofar as practical, the design parameters of the HI-STAR 190 package. The most important parameters are (1) the enrichment, (2) cell spacing, and (3) the ^{10}B loading of the neutron absorber panels. The critical experiment benchmarking work is summarized in Appendix 6.A.

To assure that the true reactivity will always be less than the calculated reactivity, the following conservative assumptions were made:

[

PROPRIETARY INFORMATION WITHHELD PER 10 CFR 2.390

]

[PROPRIETARY INFORMATION WITHHELD PER 10 CFR 2.390

]

The principal calculational results address the following conditions both for MBF and HBF:

- A single package, under the conditions of 10 CFR 71.55(b), (d), and (e);
- An array of undamaged packages, under the conditions of 10 CFR 71.59(a)(1); and
- An array of damaged packages, under the conditions of 10 CFR 71.59(a)(2)

The results are summarized in Table 6.1.3 for all MPCs and for the most reactive configurations and fuel condition in each MPC. The results are conservatively evaluated for the worst combination of manufacturing tolerances (as identified in Section 6.3), and include the calculational bias, uncertainties, and calculational statistics. For package arrays, an infinite number of packages are analyzed. It is noted that the results for the internally flooded single package and package arrays are statistically equivalent for each basket. This shows that the physical separation between overpacks and the steel radiation shielding are each adequate to preclude any significant neutronic coupling between casks in an array configuration. In addition, the table shows the result for an unreflected, internally flooded cask for each MPC. This configuration is used in many calculations and studies throughout this chapter, and is shown to yield results that are statistically equivalent to the results for the corresponding reflected package. Further analyses for the various conditions of flooding that support the conclusion that the fully flooded condition corresponds to the highest reactivity, and thus is most limiting, are presented in Subsection 6.3.4. These analyses also include cases with various internal and external moderator densities and various cask-to-cask spacing's. The maximum k_{eff} value for all cases is below the limit of 0.95 recommended in NUREG-1617. The results therefore demonstrate that the HI-STAR 190 Package is in full compliance with 10CFR71 (71.55(b), (d), and (e) and 71.59(a)(1) and (a)(2)). The maximum k_{eff} value for misloading conditions is below the limit of 0.98 recommended in ISG-8 Rev. 3 (see Appendix 6.E).

Additional results of the design basis criticality safety calculations for single unreflected, internally flooded casks (limiting cases) are listed in Table 6.1.1 and Table 6.1.2, conservatively evaluated for the worst combination of manufacturing tolerances (as identified in Section 6.3), and including the calculational bias, uncertainties, and calculational statistics. For each of the MPC designs and fuel assembly classes[†], Tables 6.1.1 through 6.1.2 list the bounding maximum k_{eff} value, the associated maximum allowable enrichment, and the minimum required assembly average burnup (if applicable), as required by 10CFR71.33(b)(2). The maximum enrichment

[†] For each array size (e.g., 6x6, 7x7, 15x15, etc.), the fuel assemblies have been subdivided into a number of assembly classes, where an assembly class is defined in terms of the (1) number of fuel rods; (2) pitch; (3) number and location of guide tubes (PWR) or water rods (BWR); and (4) cladding material. The assembly classes for BWR and PWR fuel are defined in Section 6.2.

and minimum burnup acceptance criteria are defined in Chapter 1. Additional results for each of the candidate fuel assemblies, that are bounded by those listed in Tables 6.1.1 through 6.1.2, are given in Section 6.2.

6.1.3 Criticality Safety Index

The calculations for package arrays are performed for infinite arrays of HI-STAR 190 Packages under flooded conditions and results are below the NUREG-1617 limit of 0.95, i.e. N is infinite. Therefore, the criticality safety index (CSI) is zero (0.0).

TABLE 6.1.1
 BOUNDING MAXIMUM k_{eff} VALUES FOR MBF IN MPC-37

Cooling Time, Years	Maximum Allowable Enrichment (wt% ^{235}U)	Uniform Configuration ¹		Regionalized Configuration ²	
		Minimum Required Assembly Average Burnup ³ (GWd/mtU)	Maximum ⁴ k_{eff}	Minimum Required Assembly Average Burnup (GWd/mtU)	Maximum k_{eff} ⁵
15x15B, C, D, E, F, H, I and 17x17A, B, C, D, E					
3.0	2.0	0.00	0.9335	2.52	0.9447
	3.0	17.03	0.9454	21.02	0.9438
	4.0	31.16	0.9449	34.54	0.9454
	5.0	41.86	0.9458	45.29	0.9447
7.0	2.0	0.00	0.9352	2.77	0.9455
	3.0	16.37	0.9437	19.84	0.9444
	4.0	29.66	0.9438	32.60	0.9458
	5.0	39.90	0.9451	43.06	0.9457
16x16A, B, C					
3.0	2.25	0.00	0.9194	0.00	0.9477
	3.0	7.83	0.9463	10.26	0.9448
	4.0	20.02	0.9453	21.73	0.9440
	5.0	30.12	0.9440	32.98	0.9439
7.0	2.25	0.00	0.9194	0.00	0.9493
	3.0	7.85	0.9456	10.99	0.9454
	4.0	19.52	0.9444	23.06	0.9444
	5.0	28.99	0.9465	32.60	0.9451

¹ It represents Configuration 1 (see Section 6.B.5).

² It represents Configurations 2, 3 and 4 (see Section 6.B.5).

³ Other combinations of maximum enrichment and minimum burnup have been evaluated which result in the same maximum k_{eff} . See Appendix 6.B for a bounding polynomial function.

⁴ The term "maximum k_{eff} " as used here, and elsewhere in this document, means the highest possible k-effective, including bias, uncertainties, and calculational statistics, evaluated for the worst case combination of manufacturing tolerances.

⁵ The maximum k_{eff} value is the highest k_{eff} determined from the calculations of the Configurations 2, 3 and 4.

TABLE 6.1.2

BOUNDING MAXIMUM k_{eff} VALUES FOR MBF IN MPC-89

Fuel Assembly Class	Maximum Allowable Planar-Average Enrichment (wt% ^{235}U)	Maximum ¹ k_{eff}		
		Configuration 1	Configuration 3	Configuration 4
7x7B	4.8	0.9362	0.9378	0.9381
8x8B	4.8	0.9418	0.9434	0.9437
8x8C	4.8	0.9429	0.9435	0.9440
8x8D	4.8	0.9427	0.9446	0.9443
8x8E	4.8	0.9323	0.9341	0.9349
8x8F	4.5	0.9361	0.9374	0.9377
9x9A	4.8	0.9460	0.9478	0.9466
9x9B	4.8	0.9452	0.9470	0.9475
9x9C	4.8	0.9381	0.9401	0.9390
9x9D	4.8	0.9385	0.9410	0.9402
9x9E/F	4.5	0.9393	0.9406	0.9407
9x9G	4.8	0.9343	0.9363	0.9366
10x10A	4.8	0.9479	0.9483	0.9484
10x10B	4.8	0.9462	0.9473	0.9476
10x10C	4.8	0.9431	0.9439	0.9444
10x10F	4.7	0.9473	0.9487	0.9490
10x10G	4.6	0.9461	0.9477	0.9480

¹ The term "maximum k_{eff} " as used here, and elsewhere in this document, means the highest possible k-effective, including bias, uncertainties, and calculational statistics, evaluated for the worst case combination of manufacturing tolerances.

TABLE 6.1.3

SUMMARY OF THE CRITICALITY RESULTS
TO DEMONSTRATE COMPLIANCE WITH 10CFR71.55 AND 10CFR71.59

MPC-37, Assembly Class 15x15B						
Configuration	% Internal Moderation	% External Moderation	Applicable Requirement	Fuel Condition	Fuel Damage	Maximum k_{eff}
Single Package, unreflected	100%	0%	n/a	MBF	No	0.9454
				HBF	Minor	0.9465
				HBF in DFC	Minor	0.9488
Single Package, fully reflected	100%	100%	10CFR71.55 (b) and (d)	MBF	No	0.9447
				HBF	Minor	0.9473
				HBF in DFC	Minor	0.9496
Containment, fully reflected	100%	100%		MBF	No	0.9436
				HBF	Minor	0.9472
				HBF in DFC	Minor	0.9493
Single Package, Damaged	0%	100%	10CFR71.55 (e)	MBF	No	0.4805
				HBF	Major	0.4783
				HBF in DFC	Major	0.4772
Infinite Array of Undamaged Packages	0%	0%	10CFR71.59 (a)(1)	MBF	No	0.5096
				HBF	Minor	0.5096
				HBF in DFC	Minor	0.5068
Infinite Array of Damaged Packages	0%	100%	10CFR71.59 (a)(2)	MBF	No	0.4840
				HBF	Major	0.4821
				HBF in DFC	Major	0.4802

TABLE 6.1.3 (continued)

SUMMARY OF THE CRITICALITY RESULTS
TO DEMONSTRATE COMPLIANCE WITH 10CFR71.55 AND 10CFR71.59

MPC-89, Assembly Class 10x10A						
Configuration	% Internal Moderation	% External Moderation	Applicable Requirement	Fuel Condition	Fuel Damage	Maximum k_{eff}
Single Package, unreflected	100%	0%	n/a	MBF	No	0.9487
				HBF	Minor	0.9370
				HBF in DFC	Minor	0.9425
Single Package, fully reflected	100%	100%	10CFR71.55 (b) and (d)	MBF	No	0.9483
				HBF	Minor	0.9367
				HBF in DFC	Minor	0.9428
Containment, fully reflected	100%	100%		MBF	No	0.9488
				HBF	Minor	0.9353
				HBF in DFC	Minor	0.9420
Single Package, Damaged	0%	100%	10CFR71.55 (e)	MBF	No	0.4142
				HBF	Major	0.4226
				HBF in DFC	Major	0.4193
Infinite Array of Undamaged Packages	0%	0%	10CFR71.59 (a)(1)	MBF	No	0.4457
				HBF	Minor	0.4457
				HBF in DFC	Minor	0.4418
Infinite Array of Damaged Packages	0%	100%	10CFR71.59 (a)(2)	MBF	No	0.4178
				HBF	Major	0.4268
				HBF in DFC	Major	0.4235

6.2 FISSILE MATERIAL CONTENTS

6.2.1 General

Due to the large number of minor variations in fuel assembly dimensions, the use of explicit dimensions in defining the authorized contents could limit the applicability of the HI-STAR 190 package. To resolve this limitation, a number of fuel assembly classes for both fuel types (PWR and BWR) are defined based on bounding fuel dimensions. The results of parametric studies justify using those bounding fuel dimensions for defining the authorized contents.

6.2.2 Definition of Assembly Classes

For each array size (e.g., 7x7, 8x8, 15x15, etc.), the fuel assemblies have been subdivided into a number of classes, where a class is defined in terms of the (1) number of fuel rods; (2) pitch; and (3) number and locations of guide tubes (PWR) or water rods (BWR). The assembly classes for PWR and BWR fuel are defined in Chapter 7, Appendix 7.C. It should be noted that these assembly classes are consistent with the class designations in Tables 2.1.2 and 2.1.3 of the HI-STORM FW FSAR [6.0.4]. Specifically, assembly classes with the same identifier refer to the same set of limiting dimensions.

In Section 6.2 of HI-STAR 100 SAR [6.0.1], extensive analyses of fuel dimensional variations have been performed. These calculations demonstrate that the maximum reactivity corresponds to:

- maximum active fuel length,
- maximum fuel pellet diameter,
- maximum fuel rod pitch,
- minimum cladding outside diameter (OD),
- maximum cladding inside diameter (ID),
- minimum guide tube/water rod thickness, and
- maximum channel thickness (for BWR assemblies only).

The reason that those are bounding dimensions, i.e. that they result in maximum reactivity is directly based on, and can be directly derived from the three main characteristics affecting reactivity, namely 1) characteristics of the fission process; 2) the characteristics of the fuel assemblies and 3) the characteristics of the neutron absorber in the basket. These affect the reactivity as follows:

- The neutrons generated by fission are fast neutrons while the neutrons that initiate the fission need to be thermal neutrons. A moderator (water) is therefore necessary for the nuclear chain reaction to continue.

- Fuel assemblies are predominantly characterized by the amount of fuel and the fuel-to-water (moderator) ratio. Increasing the amount of fuel, or the enrichment of the fuel, will increase the amount of fissile material, and therefore increase reactivity. Regarding the fuel-to-water ratio, it is important to note that commercial PWR and BWR assemblies are undermoderated, i.e. they do not contain enough water for a maximum possible reactivity.
- The neutron poison in the basket walls uses ^{10}B , which is an absorber of thermal neutrons. This poison therefore also needs water (moderator) to be effective. This places a specific importance on the amount of water between the outer rows of the fuel assemblies and the basket cell walls. Note that this explains some of the differences in reactivity between the different assembly types in the same basket, even for the same enrichment, where assemblies with a smaller cross section, i.e. which have more water between the periphery of the assembly and the surrounding wall, generally have a lower reactivity.

Based on these characteristics, the following conclusions can be made:

[

PROPRIETARY INFORMATION WITHHELD PER 10 CFR 2.390

]

[PROPRIETARY INFORMATION WITHHELD PER 10 CFR 2.390

]

Since all assemblies have the same principal design, i.e. consist of bundles of clad fuel rods, most of them with embedded guide/instrument tubes or water rods or channels, the above conclusions apply to all of them, and the bounding dimensions are therefore also common to all fuel assemblies analyzed here. Nevertheless, to clearly demonstrate that the main assumption is true, i.e. that all assemblies are undermoderated, a study was performed for all assembly types where the pellet-to-clad gap is empty instead of being flooded (a conservative assumption for the design basis calculations, see Paragraph 6.4.2.3). The results are listed in Table 6.2.1, in comparison with the results of the cases with the flooded gap for those assembly types. In all cases, the reactivity is reduced compared to the reference case. This verifies that all assembly types considered here are in fact undermoderated, and therefore validates the main assumption stated above. All assembly types are therefore behaving in a similar fashion, and the bounding dimensions are therefore applicable to all assembly types. This discussion and the corresponding conclusions not only affect fuel behavior, but also other moderation effects, and is therefore further referenced in Subsections 6.3.1 and 6.3.4.

As a result, the authorized contents in Appendix 7.C are defined in terms of those bounding assembly parameters for each class.

Nevertheless, to further demonstrate that the aforementioned characteristics are in fact bounding for HI-STAR 190, parametric studies were performed on reference PWR and BWR assemblies, namely PWR assembly class 15x15B and BWR assembly class 10x10A. The results of these studies are shown in Table 6.2.2 and 6.2.3, and verify the bounding parameters listed above. Note that in the studies presented in Tables 6.2.2 and 6.2.3, the fuel pellet diameter and cladding inner diameter are changed together. This is to keep the cladding-to-pellet gap, which is conservatively flooded with pure water in all cases (see Paragraph 6.4.2.3), at a constant thickness, to ensure the studies evaluate the fuel parameters rather than the moderation conditions, as discussed above.

In addition to those dimensions, additional fuel assembly characteristics important to criticality control are the location of guide tubes, water rods, part length rods, and rods with differing dimensions (class 9x9E/F only). These are identified in the assembly cross sections provided in Appendix 6.D, Section D.5 and extensively analyzed in Subsection 6.2.1 of the HI-STORM FW FSAR [6.0.4]. Since the considered fuel assembly classes as well as the MPCs are identical to those analyzed in the HI-STORM FW FSAR, the calculations and conclusions are applicable to this analysis. They are discussed in the following subsections and the bounding fuel assembly characteristics are used in the HI-STAR 190 analysis.

6.2.3 PWR Fuel Assemblies

Typically, PWR fuel assemblies are designed with solid fuel pellets throughout the entire active fuel length. However, some PWR assemblies contain annular fuel pellets in the top and bottom 6

to 8 inches of the active fuel length. This changes the fuel to water ratio in these areas, which could have an effect on reactivity. However, the top and bottom of the active length are areas with high neutron leakage, and changes in these areas typically have no significant effect on reactivity. Studies with the annular pellets at the top and bottom of the active length were performed in Subsection 6.2.1 of the HI-STORM FW FSAR [6.0.4] and confirm this conclusion. Nevertheless, to further demonstrate that the above conclusion is applicable to HI-STAR 190, calculations with about 8 inches of annular pellets at the top and bottom were performed for the reference 15x15B assembly class with the applicable axial burnup distribution (see Subsection 6.B.4.1) and various pellet IDs. The results of these studies are shown in Table 6.2.4, and confirm no significant reactivity effects, even if the annular region of the pellet is flooded with pure water. All calculations for PWR fuel assemblies are therefore performed with solid fuel pellets along the entire length of the active fuel region, and the results are directly applicable to those PWR assemblies with annular fuel pellets.

For PWR assembly class 15x15I (see Section 6.D.5), calculations with and without the guide rods were performed in Subsection 6.2.1 of the HI-STORM FW FSAR [6.0.4]. Based on the results of these calculations, the case without the guide rods is used as the design basis case for this assembly type in the HI-STAR 190 analysis, therefore, no specific restriction on the location and number of the guide rods exists.

6.2.4 BWR Fuel Assemblies

Some BWR assembly classes contain partial length rods. There are differences in location of those partial length rods within the assembly that influence how those rods affect reactivity: assembly classes 9x9A, 10x10A, 10x10B and 10x10F have partial length rods that are completely surrounded by full length rods, whereas assembly class 10x10G has partial length rods on the periphery of the assembly or facing the water gap, where they directly only face two full length rods (see Appendix 6.D, Section D.5). To determine a bounding configuration for those assembly classes where partial length rods are completely surrounded by full length rods, calculations are listed in Table 6.2.3 for the actual (real) assembly configuration and for the axial segments (assumed to be full length) with and without the partial length rods. The results show that the configuration with only the full length rods present, i.e., where the partial length rods are assumed completely absent from the assembly, is bounding. This is an expected outcome, since LWR assemblies are typically undermoderated, therefore reducing the fuel-to-water-ratio within the rod array tends to increase reactivity. Consequently, all assembly classes that contain partial length rods surrounded by full-length rods are analyzed with the partial length rods absent. For assembly class 10x10G, calculations with different assumptions for the length of the part-length rods were performed in Subsection 6.2.1 of the HI-STORM FW FSAR [6.0.4]. The results show that reducing the length of the part length rods reduces reactivity. This means that the reduction in the fuel amount is more dominating than the change in moderation for this configuration. However, the typical active fuel length of the partial length rods is much less than 50% of the total active length. Therefore, for this class, all partial length rods are assumed half active fuel length. Note that neither of the bounding cases is the configuration with the actual part length

rods. The specification of the authorized contents has therefore no minimum requirement for the active fuel length of the partial length rods.

BWR assemblies are specified in Table 7.C.3 with a maximum planar-average enrichment. The analyses presented in this chapter use a uniform enrichment, equal to the maximum planar-average. Analyses presented in the HI-STAR 100 SAR ([6.0.1], Chapter 6, Appendix 6.B) show that this is a conservative approach, i.e. a uniform enrichment bounds the planar-average enrichment in terms of the maximum k_{eff} . To verify that this is applicable to MPC-89, those calculations were re-performed in Subsection 6.2.1 of the HI-STORM FW FSAR [6.0.4]. The results show that, as expected, the planar average enrichments bound or are statistically equivalent to the distributed enrichment in MPC-89 as they do in MPC-68 of HI-STAR 100. To confirm that this is also true for HI-STAR 190, additional calculations were performed and are presented in Table 6.2.3 in comparison with the results for the uniform enrichment. Since the maximum planar-average enrichment of 4.8 wt% ^{235}U is above the actual enrichments of those assemblies and actual (as-built) enrichment distributions are not available, several bounding cases are analyzed. Note that since the maximum planar-average enrichment of 4.8 wt% ^{235}U is close to the maximum rod enrichment of 5.0 wt% ^{235}U , the potential enrichment variations within the cross section are somewhat limited. To maximize the differences in enrichment under these conditions, the analyzed cases assume that about 50% of the rods in the cross section are at an enrichment of 5.0 wt% ^{235}U , while the rest of the rods are at an enrichment of about 4.6 wt%, resulting in an average of 4.8 wt%. Calculations are performed both for cross sections where all part-length rods are assumed to be full length and for cross sections where only full-length rods are present. For each case, two conditions are analyzed that places the different enrichment in areas with different local fuel-to-water ratios. Specifically, one condition places the higher enriched rods in locations where they are more surrounded by other rods, whereas the other condition places them in locations where they are more surrounded by water, such as near the water-rods or the periphery of the assembly. The results are also included in Table 6.2.3 and show that in all cases, the maximum k_{eff} calculated for the distributed enrichments are statistically equivalent to or below those for the uniform enrichments. Therefore, modeling BWR assemblies with distributed enrichments using a uniform enrichment equal to the planar-average value is acceptable and conservative. The assumed enrichment distributions analyzed are shown in Appendix 6.D, Section D.7.

In all cases, the gadolinia (Gd_2O_3) normally present in BWR fuel was conservatively neglected.

Note that for some BWR fuel assembly classes, the Zircaloy water rod tubes are artificially replaced by water in the bounding cases to remove the requirement for water rod thickness from the specification of the authorized contents. For these cases, the bounding water rod thickness is listed as zero.

Two BWR classes (8x8B and 8x8D) are specified with slight variation in the number of fuel and/or water rods (see Section 6.D.5). The calculations were performed in Subsection 6.2.1 of the HI-STORM FW FSAR [6.0.4], and the results show that the configurations with the minimum number of fuel rods, i.e. maximizing the water-to-fuel ratio, are in fact bounding.

Thus, the results listed in Section 6.1 also utilize the minimum number of fuel rods for 8x8B and 8x8D assembly classes.

For BWR assembly class 9x9E/F, two patterns of water rods (see Section 6.D.5) were analyzed in Subsection 6.2.1 of the HI-STORM FW FSAR [6.0.4]. The results show that the condition with the larger water rod spacing is bounding. This condition is also used in the HI-STAR 190 analysis.

6.2.5 Damaged Fuel Assemblies and Fuel Debris

6.2.5.1 General

All MPCs are designed to contain PWR or BWR damaged fuel and fuel debris, loaded into DFCs. The number and permissible location of DFCs are provided in Table 7.C.5, Table 7.C.6 and in the licensing drawing in Section 1.3. Because the entire height of the fuel basket contains the neutron absorber (Metamic-HT), the DFCs are covered by the neutron absorber even if they were to move axially (see additional discussion for BWR fuel in Subsection 6.3.12).

Damaged fuel assemblies, for the most part, are considered to be assemblies with known or suspected cladding defects greater than pinholes or hairline cracks, or with missing rods, but excluding fuel assemblies with gross defects (for the exact definition see the Glossary). To identify the configuration or configurations leading to the highest reactivity, a bounding approach is taken which is based on the analysis of the regular arrays of the fuel rods with cladding.

Fuel debris can include a large variety of configurations ranging from whole fuel assemblies with severe damage down to individual fuel pellets. To identify the configuration or configurations leading to the highest reactivity, a bounding approach is taken, which is based on the analysis of the regular arrays of bare fuel rods without cladding.

In modeling the damaged fuel and fuel debris in the DFCs, the following considerations are applied:

- Fuel in the DFCs is arranged in regular, rectangular arrays of fuel rods. All structural materials in the DFC, such as the instrument/guide tubes (PWR) and water rods (BWR), as well as the cladding in the fuel debris model, are replaced by water;
- To ensure the configuration with optimum moderation and highest reactivity is analyzed, the amount of fuel per unit length of the DFC is varied over a large range. This is achieved by changing the number of rods in the array and the rod pitch. The number of rods are varied between 16 (4x4) and 324 (18x18) for BWR fuel, and between 64 (8x8) and 576 (24x24) for PWR fuel;

- The active length of these rods is assumed to be the same as for the intact fuel rods in the basket, even for more densely packed fuel rod arrays where it results in a total amount of fuel in the DFC that exceeds that for the intact assembly;
- The fresh fuel composition with 5.0 wt% ^{235}U is assumed for the fuel debris both in MPC-37 and MPC-89 baskets;
- The spent fuel composition with the burnup, based on the lowest relative burnup in any axial node, along the entire assembly length and the fresh fuel composition are assumed for the damaged fuel assembly in MPC-37 and MPC-89 basket, respectively.

All calculations are performed for full cask models, containing the maximum permissible number of DFCs and with 10x10A, 15x15B or 16x16A undamaged assemblies. As an example of the damaged fuel model used in the analyses, Figure 6.2.1 shows the basket cell of MPC-37 with a DFC containing a 14x14 array of bare fuel rods.

The results are listed in Table 6.2.5 and Table 6.2.6 for MPC-37 and MPC-89, respectively. The bounding conditions are summarized in Table 6.2.7 and used in all subsequent calculations of the Configurations 3 and 4.

In Paragraph 6.4.4.2 of HI-STORM 100 [6.0.5], additional studies for damaged fuel assemblies were performed to further show that the above approach using arrays of fuel rods is bounding. The studies considered conditions including

- Fuel assemblies that are undamaged except for various numbers of missing rods
- Variations in the diameter of the bare fuel rods in the arrays
- Consolidated fuel assemblies with clad rods
- Enrichment variations in BWR assemblies

Results of those studies were shown in the HI-STORM 100 FSAR, Table 6.4.8 and 6.4.9 and Figure 6.4.13 and 6.4.14 (undamaged and consolidated assemblies); HI-STORM 100 FSAR Table 6.4.12 and 6.4.13 (bare fuel rod diameter); and HI-STORM 100 FSAR Subparagraph 6.4.4.2.3 and Table 6.4.8 (enrichment variations). In all cases the results of those evaluations are equivalent to, or bounded by those for the bare fuel rods arrays. Since the generic approach of modeling damaged fuel and fuel debris is similar to HI-STORM 100, these evaluations are still applicable for HI-STAR 190.

6.2.5.2 Light-Sized Fuel Debris for 16x16C Assembly Class

An alternative loading pattern for Configuration 3 with the 16x16C fuel assemblies is considered in this paragraph. Specifically, out of 12 specific basket cells, qualified for loading of DFCs with the damaged fuel assemblies, several cells may be alternatively loaded with light-sized fuel debris in DFC. This fuel debris consists, for the most part, from the individual fuel rods and fuel rod segments from the 16x16C fuel assembly, with a limited total amount of fuel rods, as

outlined in Table 6.2.8. Essentially, the fuel debris modeling approach discussed in Paragraph 6.2.5.1 is used for light-sized fuel debris. Specifically, an optimal rectangular 14x14 array of bare 16x16C fuel rods with fresh fuel composition (5.0 wt% ^{235}U) is used. However, the active length of these rods is reduced to maintain the cumulative amount of fuel equal to the upper bound limit presented in Table 6.2.8; the remainder of the DFC cavity is flooded with ordinary water. The top axial position of fuel debris in DFC is considered, since it is conservative and produces the maximum impact on reactivity in case of bounding condition of spent fuel assemblies with the axial burnup distribution. The criticality calculations to show compliance with the regulatory limit of 0.95 and justification for loading of DFCs with light-sized fuel debris into Configuration 3 with the 16x16C fuel assemblies are provided in Subsection 6.B.5.3.

6.2.6 High Burnup Fuel

MPCs are loaded into HI-STAR 190 for transport after a possible long period of storage. While cladding damage to HBF is not expected during the storage period, it is not feasible to physically examine the fuel at that time and verify the fuel condition. However, for compliance with 10 CFR 71.55(b) flooding of the containment needs to be assumed and moderator exclusion cannot be applied. Under this condition, the criticality evaluations for HI-STAR 190 are performed considering already a certain level of fuel reconfiguration (see Subsection 6.3.5). Expressed differently, the definition of undamaged HBF for HI-STAR 190 for the purpose of criticality evaluation already includes consideration of a certain level of fuel reconfiguration.

The criticality analyses performed in Subsection 6.3.5 of HI-STAR 180 [6.0.2] assuming reconfiguration of PWR HBF were still performed under the conservative assumption that the fuel is fresh or of low burnup, consistent with the MBF. This simplifies the analysis. However, it could lead to the false impression that reconfigured HBF has the same or even less criticality margin than MBF. To correct this, the criticality calculations for HI-STAR 190 apply additional burnup for the HBF, and hence show that the reactivity effect of potential fuel reconfiguration is more than compensated by the higher burnup. The minimum required burnup, specified in Table 6.1.1 (but not less than 45 GWd/mtU) is used for PWR HBF and a partial burnup credit of 15 GWd/mtU is used for BWR HBF. The detailed information about the partial burnup credit that is used for BWR HBF is provided in Appendix 6.C.

TABLE 6.2.1

PROPRIETARY INFORMATION WITHHELD PER 10 CFR 2.390

TABLE 6.2.1 (continued)

PROPRIETARY INFORMATION WITHHELD PER 10 CFR 2.390

TABLE 6.2.2

PROPRIETARY INFORMATION WITHHELD PER 10 CFR 2.390

TABLE 6.2.3

PROPRIETARY INFORMATION WITHHELD PER 10 CFR 2.390

TABLE 6.2.4

PROPRIETARY INFORMATION WITHHELD PER 10 CFR 2.390

TABLE 6.2.5

CALCULATED k_{eff} VALUES IN MPC-37 WITH UNDAMAGED AND DAMAGED FUEL¹

Rod Array inside the DFC	15x15B (5.0 wt% ²³⁵ U, 40 GWd/mtU, 3 years)		16x16A (5.0 wt% ²³⁵ U, 30 GWd/mtU, 3 years)	
	Configuration 3	Configuration 4	Configuration 3	Configuration 4
8x8	0.9238	0.9081	0.9157	0.9030
10x10	0.9304	0.9083	0.9201	0.9020
12x12	0.9376	0.9132	0.9254	0.9041
13x13	0.9396	0.9218	0.9286	0.9084
14x14	0.9372	0.9227	0.9299	0.9188
15x15	0.9346	0.9177	0.9292	0.9224
16x16	0.9324	0.9108	0.9278	0.9202
18x18	0.9280	0.9083	0.9239	0.9075
20x20	0.9267	0.9084	0.9204	0.9038
22x22	0.9262	0.9088	0.9197	0.9028
24x24	0.9257	0.9066	0.9181	0.9030

¹ The bounding case is bolded.

TABLE 6.2.6

CALCULATED k_{eff} VALUES IN MPC-89 WITH UNDAMAGED AND DAMAGED FUEL¹

Rod Array inside the DFC	10x10A,4.8 wt% ²³⁵ U	
	Configuration 3	Configuration 4
4x4	0.9365	0.9372
6x6	0.9382	0.9392
8x8	0.9411	0.9406
9x9	0.9405	0.9427
10x10	0.9421	0.9416
11x11	0.9415	0.9433
12x12	0.9404	0.9421
13x13	0.9403	0.9412
14x14	0.9397	0.9409
16x16	0.9388	0.9402
18x18	0.9392	0.9406

¹ The bounding case is bolded.

TABLE 6.2.7

DAMAGED FUEL AND FUEL DEBRIS ARRAY SIZE ASSUMPTIONS

Fuel Assembly	Damaged Fuel (Configuration 3)	Fuel Debris (Configuration 4)
15x15B	13x13	14x14
16x16A	14x14	15x15
10x10A	10x10	11x11

TABLE 6.2.8

LIGHT-SIZED FUEL DEBRIS MODEL ASSUMPTIONS IN CONFIGURATION 3

Fuel Assembly	Number of Fuel Rods per DFC	Number of DFCs¹	Array Size
16x16C	37	2	14x14
	57	1	
	11	12	

¹ A restriction on the number of DFCs with light-sized fuel debris is provided. The remaining specific basket cells are loaded with the damaged fuel assemblies, as appropriate.

FIGURE 6.2.1: PROPRIETARY INFORMATION WITHHELD PER 10 CFR 2.390

6.3 GENERAL CONSIDERATIONS

In compliance with the requirements of 10CFR71.31(a)(1), 10CFR71.33(a)(5), and 10CFR71.33(b), this section provides a description of the HI-STAR 190 package in sufficient detail to identify the package accurately and provides a sufficient basis for the evaluation of the package.

6.3.1 Description of Computational Model

Figures 6.3.1 through 6.3.4 show representative cross sections of the criticality models for the two baskets. Figures 6.3.1 and 6.3.2 show a single cell from each of the two baskets. Figures 6.3.3 and 6.3.4 show the entire MPC-37 and MPC-89 basket, respectively. Figure 6.3.5 shows a sketch of the calculational model in the axial direction.

[

PROPRIETARY INFORMATION WITHHELD PER 10 CFR 2.390

]

The discussion provided in Subsection 6.2.2 regarding the principal characteristics of neutron poison is also important for the various studies presented in this section, and supports the fact that those studies only need to be performed for a single BWR and PWR assembly type, and that the results of those studies are then generally applicable to all assembly types. The studies and the relationship to the discussion in Subsection 6.2.2 are discussed below. Note that this approach is consistent with that used for HI-STORM FW.

The basket geometry can vary due to manufacturing tolerances and due to potential deflections of basket walls as the result of accident conditions. The basket tolerances are defined on the drawings in Chapter 1. [

PROPRIETARY INFORMATION WITHHELD PER 10 CFR 2.390

]

[

PROPRIETARY INFORMATION WITHHELD PER 10 CFR 2.390

] Based on the calculations, the conservative dimensional assumptions listed in Table 6.3.2 were determined for the basket designs. Because the reactivity effect (positive or negative) of the manufacturing tolerances is not assembly dependent, these dimensional assumptions were employed for all criticality analyses.

[

PROPRIETARY INFORMATION WITHHELD PER 10 CFR 2.390

]

Variations of other parameters, namely fuel density and temperature in the cask, were analyzed using CASMO5. The results are presented in Table 6.3.4, and show that the maximum fuel density and the minimum water temperature (corresponding to a maximum water density) are bounding. These conditions are therefore used in all further calculations.

Calculations documented in Chapter 2 show that the baskets stay within the applicable structural limits during all normal and accident conditions. Furthermore, the neutron poison material is an integral and non-removable part of the basket material, and its presence is therefore not affected by the accident conditions. Except for the potential deflection of the basket walls that is already considered in the criticality models, damage to the cask under accident conditions is limited to damage to the neutron absorber on the outside of the cask. However, this external absorber is already neglected in the calculational models. Other parameters important to criticality safety are fuel type, fuel burnup and enrichment, which are not affected by the hypothetical accident conditions. The calculational models of the cask and basket for the accident conditions are therefore identical to the models for normal conditions, and no separate models need to be developed for accident conditions. There are, however, differences between the normal and accident models in terms of internal and external water density, external condition and level of potential fuel reconfiguration. The effect of these conditions is discussed in Subsections 6.3.4 and 6.3.5.

6.3.2 Material Properties

Composition of the various components of the principal designs of the HI-STAR 190 package is listed in Table 6.3.5. The nuclide identification number (ZAID), presented for each nuclide in Table 6.3.5, includes the atomic number, mass number and the cross-section evaluation identifier, which are consistent with the ZAIDs used in the benchmarking calculations documented in Appendix A. In this table only the composition of fresh fuel is listed. For a discussion of the composition of spent fuel for burnup credit see Appendices 6.B and 6.C.

HI-STAR 190 is designed such that the fixed neutron absorber will remain effective for a period greater than 50 years, and there are no credible means to lose it. A detailed physical description, historical applications, unique characteristics, service experience, and manufacturing quality assurance of the fixed neutron absorber are provided in Paragraph 1.2.1.6 and Chapter 2.

As specified in Table 8.1.4, the manufacturer's minimum B₄C content for the Metamic-HT fixed neutron absorber is 10 wt%. The continued efficacy of the fixed neutron absorber is assured by acceptance testing, documented in Paragraph 8.1.5.5, to validate the ¹⁰B (poison) concentration in the fixed neutron absorber. In addition, based on calculations performed in Subsection 6.3.2 of the HI-STORM FW FSAR [6.0.4], the fraction of ¹⁰B atoms destroyed during the service life in the fixed neutron absorber by neutron absorption is negligible (less than 10⁻⁷). Therefore, there is no need to provide a surveillance or monitoring program to verify the continued efficacy of the neutron absorber.

The only materials affected by the accident conditions are the Holtite neutron absorber on the outside of the cask, and the impact limiters. None of these materials are considered in the criticality model. Therefore, material properties of the materials used in the criticality analyses are not affected by the accidents.

6.3.3 Computer Codes and Cross Section Libraries

MCNP5-1.51 and CASMO5 Version 2.00.00 are used for the criticality analyses of the HI-STAR 190 package for the transportation of radioactive materials. Both codes were installed and validated on the Holtec International’s computer following the documentations provided by the code developers.

The principal code for the criticality analysis is the general three-dimensional continuous energy Monte Carlo N-Particle code MCNP5 [6.3.1] developed at the Los Alamos National Laboratory. MCNP5 was selected because it has been extensively used and verified and has all of the necessary features for this analysis. MCNP5 design basis calculations used continuous energy cross-section data, based on ENDF/B-VII, as distributed with the code.

[

PROPRIETARY INFORMATION WITHHELD PER 10 CFR 2.390

]

CASMO5 [6.3.2 – 6.3.3] was used for determining some incremental reactivity effects (see Subsection 6.3.1). [

PROPRIETARY INFORMATION WITHHELD PER 10 CFR 2.390

]

6.3.4 Demonstration of Maximum Reactivity

The basket designs are intended to safely accommodate fuel with enrichments and burnups (if applicable) indicated in Appendix 7.C. The calculations were based on the assumption that the HI-STAR 190 cask was fully flooded with water. The discussion provided in Subsection 6.2.2 regarding the principal characteristics of fuel assemblies and basket poison is also important for the various studies presented in this section, and supports the fact that those studies only need to be performed for a single BWR and PWR assembly types, and that the results of those studies are then generally applicable to all assembly types. The studies and the relationship to the discussion in Subsection 6.2.2 are presented below. Note that this approach is consistent with that used for HI-STAR 100.

6.3.4.1 Internal and External Moderation

The regulations in 10CFR71.55 include the requirement that the package remains subcritical when assuming moderation to the most reactive credible extent. The regulations in 10CFR71.59 require subcriticality for package arrays under different moderation conditions. Subparagraphs 6.3.4.1.1 through 6.3.4.4 present various studies to confirm or identify the most reactive configuration or moderation condition. Specifically, the following conditions are analyzed:

[

PROPRIETARY INFORMATION WITHHELD PER 10 CFR 2.390

]

The calculations that specifically demonstrate compliance with the individual requirements of 10CFR71.55 and 10CFR71.59 are presented in Sections 6.4 through 6.6.

Regarding the effect of low moderator density, it is noted that with a neutron absorber present (i.e., the neutron poison integral to the walls of the storage compartments), the phenomenon of a peak in reactivity at a hypothetical low moderator density (sometimes called "optimum" moderation) does not occur to any significant extent. In a definitive study, Cano, et al. [6.3.4] have demonstrated that the phenomenon of a peak in reactivity at low moderator densities does not occur when strong neutron absorbing material is present or in the absence of large water spaces between fuel assemblies. Nevertheless, calculations for a single reflected cask and for infinite arrays of casks were made to confirm that the phenomenon does not occur with low density water inside or outside HI-STAR 190.

6.3.4.1.1 Single Package Evaluation

The calculational model for a single package consists of the HI-STAR 190 cask surrounded by a hexagonal box filled with water. The neutron absorber on the outside of HI-STAR 190 is neglected, since it might be damaged under accident conditions, and since it is conservative to replace the neutron absorber (Holtite) with a neutron reflector (water). The minimum water thickness on each side of the cask is 30 cm, which effectively represents full water reflection. The outer surfaces of the surrounding box are conservatively set to be fully reflective, which effectively models a three dimensional infinite array of casks with a minimum surface to surface distance of 60 cm. The calculations with internal and external moderators of various densities are shown in Table 6.3.7. For comparison purposes, a calculation for a single, unreflected cask (Case 1) is also included in Table 6.3.7. At 100% external moderator density, Case 2 corresponds to a single, fully-flooded cask, fully reflected by water. Figure 6.3.6 plots calculated k_{eff} values as a function of internal moderator density for both MPC designs with 100% external moderator density (i.e., full water reflection).

Results listed in Table 6.3.7 and plotted in Figure 6.3.6 support the following conclusions:

- The calculated k_{eff} for a fully-flooded cask is independent of the external moderator (the small variations in the listed values are due to statistical uncertainties which are inherent to the Monte Carlo calculational method); and
- Reducing the internal moderation results in a monotonic reduction in reactivity, with no evidence of any optimum moderation. Thus, the fully flooded condition corresponds to the highest reactivity, and the phenomenon of optimum low-density moderation does not occur and is not applicable to the HI-STAR 190 package.

6.3.4.1.2 Evaluation of Package Arrays

In terms of reactivity, the normal conditions of transport (i.e., no internal or external moderation) are bounded by the hypothetical accident conditions of transport. Therefore, the calculations in this section evaluate arrays of HI-STAR 190 packages under hypothetical accident conditions (i.e., internal and external moderation by water to the most reactive credible extent and no neutron shield present).

In accordance with 10CFR71.59 requirements, calculations were performed to simulate an infinite three-dimensional square array of internally fully-flooded (highest reactivity) casks with varying cask spacing and external moderation density. The MPC-37 design was used for this analysis. The calculated k_{eff} results of these calculations are listed in Table 6.3.8 and confirm that the individual casks in a square-pitched array are independent of external moderation and cask spacing.

PROPRIETARY INFORMATION WITHHELD PER 10 CFR 2.390

]

[

PROPRIETARY INFORMATION WITHHELD PER 10 CFR 2.390

]

The calculations demonstrate that the thick wall of the overpack is more than sufficient to preclude neutron coupling between casks, consistent with the findings of Cano [6.3.4], et al. Neglecting the Holtite neutron shielding in the calculational model provides further assurance of conservatism in the calculations.

6.3.4.2 Partial Flooding

To demonstrate that HI-STAR 190 would remain subcritical if water were to leak into the containment system, as required by 10CFR71.55, calculations in this section address partial flooding in HI-STAR 190 and demonstrate that the fully flooded condition is the most reactive.

The reactivity changes during the flooding process were evaluated in both the vertical and horizontal positions for the MPC-37 and MPC-89 designs. For these calculations, the cask is partially filled (at various levels) with full density (1.0 g/cm^3) water and the remainder of the cask is filled with steam consisting of ordinary water at partial density (0.0002 g/cm^3). Results of these calculations are shown in Table 6.3.12(a). In general, the reactivity increases monotonically as the water level rises, confirming that the most reactive condition is fully flooded. The fully flooded case therefore represents the bounding condition for all MPC basket types.

6.3.4.3 Pellet-to-Clad Gap Flooding

The reactivity effect of flooding the fuel rod pellet-to-clad gap regions, in the fully flooded condition, has been investigated in Subsection 6.2.2. The results, presented in Table 6.2.1, confirm that it is conservative to assume that the pellet-to-clad gap regions are flooded. Thus, for all cases that involve flooding, the pellet-to-clad gap regions are assumed to be flooded.

6.3.4.4 Preferential Flooding

Two different potential conditions of preferential flooding are considered in Paragraph 6.4.2.4 of the HI-STAR 100 SAR [6.0.1]: preferential flooding of the MPC basket itself (i.e. different water levels in different basket cells), and preferential flooding involving DFCs. It was concluded that the MPC fuel baskets cannot be preferentially flooded, and that the potential preferential flooding conditions involving DFCs are bounded by the result for the fully flooded condition. Nevertheless, to further demonstrate that the above conclusions are applicable to HI-STAR 190, the additional calculations are performed and discussed below.

Preferential flooding of the MPC basket itself is not possible [

PROPRIETARY INFORMATION WITHHELD PER 10 CFR 2.390

6.3.4.5 Eccentric Positioning of Assemblies in Fuel Storage Cells

A fuel assembly located in the center of a basket cell is surrounded by equal amounts of water on all sides, and hence the thermalization of the neutrons that occur between the assembly and the poison in the cell wall, and also the effectiveness of the poison are equal on all sides. For an eccentric positioning, the effectiveness of the poison is now reduced on those sides where the assembly is located close to the cell walls, and increased on the opposite sides. This creates a compensatory situation for a single cell, where the net effect is not immediately clear. However,

for the entire basket, and for the condition where all assemblies are located closest to the center of the basket, the four assemblies at the center of the basket are now located close to each other, separated by poison plates with a reduced effectiveness since they are not surrounded by water on any side. This now becomes the dominating condition in terms of reactivity increase. This effect is applicable to all assembly types, since those assemblies are all located close to the center of the basket, i.e. the eccentric position with all assemblies moved towards the center will be bounding regardless of the assembly type.

Nevertheless, to conservatively account for eccentric fuel positioning in the fuel storage cells, four different configurations are analyzed for each basket configuration, and the results are compared to determine the bounding positioning of the assemblies:

- Cell Center Configuration: All assemblies are centered in their fuel storage cell;
- Basket Center Configuration: All assemblies in the basket are moved as closely to the center of the basket as permitted by the basket geometry;
- Basket Periphery Configuration: All assemblies in the basket are moved furthest away from the basket center, and as closely to the periphery of the basket as possible; and
- Displacement towards Specific Cells Configuration: All specific cells with DFCs (or fresh fuel) are moved as closely to the center of the basket as permitted by the basket geometry, while all other cells are moved furthest away from the basket center, and as closely to the periphery of the basket as possible.

It should be noted that the eccentric configurations are hypothetical, since there is no known physical phenomenon that could move all assemblies within a basket consistently to the center or periphery. However, since the configurations listed above bound all credible configurations, they are conservatively used in the analyses.

The results are presented in Table 6.3.13. The table shows the calculated k_{eff} values for centered and the three eccentric configurations for each condition, and the difference in k_{eff} between the centered and eccentric positioning. In most of the cases, moving the assemblies in the regular and specific cells (DFC or fresh fuel) to the periphery of the basket results in a reduction in reactivity, compared to the cell centered position, while moving the assemblies towards the center results in an increase in reactivity, compared to the cell centered position. All calculations are therefore performed with assemblies/DFCs moved towards the center of the basket.

6.3.5 Potential Fuel Reconfiguration

The cask is designed to remain internally dry under any normal or accident condition. Therefore, any fuel reconfiguration would be of no consequences. Additionally, the evaluation of the fuel performance under accident conditions presented in Chapter 2 indicate that no fuel damage, and hence no fuel reconfiguration is expected. However, the concerns about fuel damage are principally related to HBF, i.e. fuel with an assembly average burnup of about 45 GWd/mtU or more, which are discussed in the following subsections.

6.3.5.1 Potential Fuel Reconfiguration under Normal Conditions

[

PROPRIETARY INFORMATION WITHHELD PER 10 CFR 2.390

]

[

PROPRIETARY INFORMATION WITHHELD PER 10 CFR 2.390

]

These results show that even if there would be any damage and minor reconfiguration of the fuel assemblies, and even if the cask would be flooded during the accident, there would be no significant effect on the reactivity of the package. Nevertheless, the evaluations of the HBF fuel are performed in Section 6.4 through Section 6.6 to show compliance with the NUREG-1617 limit of 0.95.

6.3.5.2 Potential Fuel Reconfiguration under Accident Conditions

[

PROPRIETARY INFORMATION WITHHELD PER 10 CFR 2.390

]

[PROPRIETARY INFORMATION WITHHELD PER 10 CFR 2.390]

6.3.6 Partial Loading

Each basket cell is completely surrounded by the basket walls containing neutron absorber material (B_4C). Under a partial loading situation, i.e. where one or more basket locations are not occupied with fuel, the amount of fissile material is obviously reduced. Also, under the bounding condition of a fully flooded cask, the amount of water is increased. This will result in an increased moderation of neutrons in the empty cell locations. This increased moderation will increase the effectiveness of the surrounding thermal neutron absorber. Described differently, the now empty cell locations will act as additional flux traps. Therefore, due to the reduced amount of fissile material, and the increased neutron absorption, the reactivity of the package under partial loading conditions will be reduced, and will always be bound by the fully loaded conditions. No further evaluations of this condition are therefore necessary.

6.3.7 Fuel Assemblies with Missing Rods

For fuel assemblies that are qualified for damaged fuel storage, missing and/or damaged fuel rods are acceptable. However, for fuel assemblies to meet the limitations of undamaged fuel assembly storage, missing fuel rods must be replaced with dummy rods that displace a volume of water that is equal to, or larger than, that displaced by the original rods.

6.3.8 Sealed Rods Replacing BWR Water Rods

Some BWR fuel assemblies contain sealed rods filled with a non-fissile material instead of water rods. Compared to the configuration with water rods, the configuration with sealed rods has a reduced amount of moderator, while the amount of fissile material is maintained. Thus, the reactivity of the configuration with sealed rods will be lower compared to the configuration with water rods. Any configuration containing sealed rods instead of water rods is therefore bounded by the analysis for the configuration with water rods and no further analysis is required to demonstrate the acceptability. Therefore, for all BWR fuel assemblies analyzed, it is permissible that water rods are replaced by sealed rods filled with a non-fissile material.

6.3.9 Non-fuel Hardware in PWR Fuel Assemblies

Non-fuel hardware, as discussed in Subsection 5.2.3, is permitted for storage with all PWR fuel types. Non-fuel hardware is inserted in the guide tubes of the assemblies, except for ITTRs, which are placed into the instrument tube. Similar to discussion in Subsection 6.3.8, the presence of the non-fuel hardware reduces the amount of moderator, while the amount of fissile

material is maintained, and, therefore, the reactivity of the configuration with non-fuel hardware will be lower compared to the configuration with water in guide or instrument tubes. Therefore, non-fuel hardware inserted into PWR assemblies is acceptable for all allowable PWR types, and, depending on the assembly class, can increase the safety margin.

6.3.10 Neutron Sources in Fuel Assemblies

Fuel assemblies containing start-up neutron sources are permitted for transport in the HI-STAR 190 system. The reactivity of a fuel assembly is not affected by the presence of a neutron source (other than by the presence of the material of the source, which is discussed later). This is true because in a system with a k_{eff} less than 1.0, any given neutron population at any time, regardless of its origin or size, will decrease over time. Therefore, a neutron source of any strength will not increase reactivity, but only the neutron flux in a system, and no additional criticality analyses are required. Sources are inserted as rods into fuel assemblies, i.e., they replace either a fuel rod or water rod (moderator). Therefore, the insertion of the material of the source into a fuel assembly will not lead to an increase of reactivity either.

6.3.11 Low Enriched, Channeled BWR Fuel

The calculations in this subsection show that low enriched, channeled BWR fuel with indeterminable cladding condition is acceptable for loading in all storage locations of MPC-89 without placing those fuel assemblies into DFCs, hence classifying those assemblies as undamaged. The main characteristics that must be assured are:

- The channel is present and attached to the fuel assembly in the standard fashion;
- The channel is essentially undamaged; and
- The maximum planar average enrichment of the assembly is less than or equal to 3.3 wt% ^{235}U

This analysis covers older assemblies, where the cladding integrity is uncertain, and where a verification of the cladding condition is prohibitive. An example of this type of fuel is the so-called CILC fuel, which has potential corrosion-induced damaged to the cladding but does not have grossly breached spent fuel rods.

The presence of the essentially undamaged and attached channel confines the fuel rods to a limited volume and the low enrichment, required for all assemblies in the MPC, limits the reactivity of the fuel even under optimum moderation conditions. Due to the uncertain cladding condition, the analysis of this fuel follows essentially the same approach as that for the fuel debris (see Subsection 6.2.5), i.e. bare fuel rod arrays of varying sizes are analyzed within the confines of the channel. This is an extremely conservative modeling approach for this condition, since reconfiguration is not expected and cladding would still be present. The results of this conservative analysis are listed in Table 6.3.20 and show that CILC fuel without DFCs in all cells of MPC-89 is bounded by the reference undamaged 10x10A fuel assembly. These results

confirm that even with unknown cladding condition, any of the BWR candidate fuel assemblies may be loaded into the MPC-89 basket without DFC. Therefore, if the cladding is not grossly breached and the fuel assembly structurally sounds, it can be considered undamaged when loading in MPC-89.

6.3.12 BWR Fuel and MPC-89 Basket Misalignment

[

PROPRIETARY INFORMATION WITHHELD PER 10 CFR 2.390

] The additional discussion of BWR HBF with the major fuel reconfiguration is provided in Section 6.4 and Section 6.6, while the discussion of the BWR partial burnup credit is provided in Appendix 6.C.

TABLE 6.3.1

PROPRIETARY INFORMATION WITHHELD PER 10 CFR 2.390

TABLE 6.3.2

PROPRIETARY INFORMATION WITHHELD PER 10 CFR 2.390

TABLE 6.3.3

PROPRIETARY INFORMATION WITHHELD PER 10 CFR 2.390

TABLE 6.3.4

CASMO5 CALCULATIONS FOR EFFECT OF TOLERANCES AND TEMPERATURE

Changes in Parameters	Δk Maximum Tolerance		Action/Modeling Assumption
	MPC-37, 15x15B, 5.0 wt% ²³⁵ U, 40 GWd/mtU, 3 years	MPC-89, 10x10A, 4.8 wt% ²³⁵ U	
Maximum UO ₂ Density	Reference	Reference	Assume max UO ₂ density
Decrease in UO ₂ Density (10.52 g/cm ³)	-0.0017	-0.0019	
Increase in Temperature			Assume 20°C
20°C	Reference	Reference	
40°C	-0.0027	-0.0033	
70°C	-0.0079	-0.0097	
100°C	-0.0142	-0.0175	
10% Void in Moderator			Assume no void
20°C with no void	Reference	Reference	
20°C	-0.0214	-0.0255	
100°C	-0.0360	-0.0427	

TABLE 6.3.5

PROPRIETARY INFORMATION WITHHELD PER 10 CFR 2.390

TABLE 6.3.5 (continued)

PROPRIETARY INFORMATION WITHHELD PER 10 CFR 2.390

TABLE 6.3.6

PROPRIETARY INFORMATION WITHHELD PER 10 CFR 2.390

TABLE 6.3.7

MAXIMUM REACTIVITIES WITH REDUCED MODERATOR DENSITIES
FOR CASK ARRAYS¹

Case Number	Moderator Density		MPC-37, 15x15B, 5.0 wt% ²³⁵ U, 40 GWd/mtU, 3 years			MPC-89, 10x10A, 4.8 wt% ²³⁵ U		
	Internal	External	Calculated k _{eff}	1 σ	EALF (eV)	Calculated k _{eff}	1 σ	EALF (eV)
1	100%	single cask	0.9296	0.0004	0.4487	0.9405	0.0004	0.2859
2	100%	100%	0.9295	0.0004	0.4471	0.9413	0.0004	0.2860
3	100%	70%	0.9292	0.0004	0.4489	0.9399	0.0004	0.2876
4	100%	50%	0.9302	0.0004	0.4473	0.9403	0.0004	0.2864
5	100%	20%	0.9294	0.0004	0.4510	0.9403	0.0004	0.2869
6	100%	10%	0.9295	0.0004	0.4490	0.9403	0.0004	0.2869
7	100%	5%	0.9301	0.0004	0.4477	0.9405	0.0004	0.2869
8	100%	0%	0.9295	0.0003	0.4490	0.9412	0.0004	0.2860
9	70%	0%	0.8250	0.0004	1.0940	0.8428	0.0004	0.6236
10	50%	0%	0.7233	0.0003	3.2578	0.7400	0.0004	1.7048
11	20%	0%	0.5218	0.0003	122.57	0.5263	0.0003	73.507
12	10%	0%	0.4555	0.0002	1503.9	0.4684	0.0002	915.49
13	5%	0%	0.4318	0.0002	7529.0	0.4546	0.0002	4329.5
14	10%	100%	0.4504	0.0002	1649.2	0.4611	0.0002	1035.2

¹ This table is for an infinite hexagonal array of casks with 60 cm spacing between cask surfaces.

TABLE 6.3.8

PROPRIETARY INFORMATION WITHHELD PER 10 CFR 2.390

TABLE 6.3.9

PROPRIETARY INFORMATION WITHHELD PER 10 CFR 2.390

TABLE 6.3.10

PROPRIETARY INFORMATION WITHHELD PER 10 CFR 2.390

TABLE 6.3.11

PROPRIETARY INFORMATION WITHHELD PER 10 CFR 2.390

TABLE 6.3.12(a)

PROPRIETARY INFORMATION WITHHELD PER 10 CFR 2.390

TABLE 6.3.12(b)

PROPRIETARY INFORMATION WITHHELD PER 10 CFR 2.390

TABLE 6.3.13

PROPRIETARY INFORMATION WITHHELD PER 10 CFR 2.390

TABLE 6.3.14

PROPRIETARY INFORMATION WITHHELD PER 10 CFR 2.390

TABLE 6.3.15

PROPRIETARY INFORMATION WITHHELD PER 10 CFR 2.390

TABLE 6.3.16

PROPRIETARY INFORMATION WITHHELD PER 10 CFR 2.390

TABLE 6.3.17

PROPRIETARY INFORMATION WITHHELD PER 10 CFR 2.390

TABLE 6.3.18

PROPRIETARY INFORMATION WITHHELD PER 10 CFR 2.390

TABLE 6.3.19

PROPRIETARY INFORMATION WITHHELD PER 10 CFR 2.390

TABLE 6.3.20

PROPRIETARY INFORMATION WITHHELD PER 10 CFR 2.390

TABLE 6.3.21

PROPRIETARY INFORMATION WITHHELD PER 10 CFR 2.390

FIGURE 6.3.1: PROPRIETARY INFORMATION WITHHELD PER 10 CFR 2.390

FIGURE 6.3.2: PROPRIETARY INFORMATION WITHHELD PER 10 CFR 2.390

FIGURE 6.3.3: PROPRIETARY INFORMATION WITHHELD PER 10 CFR 2.390

FIGURE 6.3.4: PROPRIETARY INFORMATION WITHHELD PER 10 CFR 2.390

FIGURE 6.3.5: PROPRIETARY INFORMATION WITHHELD PER 10 CFR 2.390

FIGURE 6.3.6: PROPRIETARY INFORMATION WITHHELD PER 10 CFR 2.390

6.4 SINGLE PACKAGE EVALUATION

6.4.1 Configuration

The calculations in this section demonstrate that a single HI-STAR 190 Package remains subcritical for all credible conditions of moderation, and that the package fulfills all requirements of 10CFR71.55.

In modeling the single package, the following considerations are applied:

- The bounding geometric and temperature assumptions identified in Tables 6.3.2 and 6.3.4 are used;
- The assemblies are centered in the basket, which results in the highest k_{eff} as demonstrated in Paragraph 6.3.4.5;
- The pellet to clad gap is assumed to be flooded (see Paragraph 6.3.4.3);
- The baskets are assumed to be loaded with fuel of the maximum permissible reactivity, i.e.

[

PROPRIETARY INFORMATION WITHHELD PER 10 CFR 2.390

]

[
PROPRIETARY INFORMATION WITHHELD PER 10 CFR 2.390
]

Normal Conditions

The studies in Paragraphs 6.3.4.1 through 6.3.4.4 demonstrate that the moderation by water to the most reactive credible extent corresponds to the internally fully flooded condition of the basket, with the pellet-to-clad gap in the fuel rods also flooded with water. The external moderation has a statistically negligible effect.

Under normal condition, water is assumed to leak into the package, consistent with 10CFR71.55. Flooding with full density water is assumed, since this is the bounding condition as shown in Subsection 6.3.4.

To demonstrate compliance with 10CFR71.55 under normal conditions, the following calculations are performed for the HI-STAR 190 design:

[
PROPRIETARY INFORMATION WITHHELD PER 10 CFR 2.390
]

To satisfy the requirements of 10CFR71.55 (b)(1), the calculations are performed

[
PROPRIETARY INFORMATION WITHHELD PER 10 CFR 2.390
]

Additional calculations (CASMO5) at elevated temperatures confirm that the temperature coefficients of reactivity are negative as shown in Table 6.3.4. This confirms that the calculations are conservative.

Accident Conditions

The analyses presented in Chapter 2 and Chapter 3 demonstrate that the damage resulting from the hypothetical accident conditions of transport are limited to a loss of the neutron shield material as a result of the hypothetical fire accident. Because the criticality analyses do not take credit for the neutron shield material (Holtite), this condition has no effect on the criticality analyses.

HI-STAR 190 is designed for high burnup fuel (HBF), i.e. for fuel with burnups larger than 45 GWd/mtU. For fuel of this burnup, there are concerns that the fuel cladding could be damaged under accident conditions, with a potential effect on reactivity. Chapter 2 demonstrates that the cask remains leaktight under all credible accident conditions. Further, the cask lid provides additional assurance that water will not leak into the MPC as a result of an accident. The package therefore satisfies the intent of USNRC ISG-19, and flooding of the containment system under accident condition is not considered in the design basis analyses.

In summary, the impacts of the hypothetical transport accidents, which are important to criticality safety, are limited to potential major fuel reconfiguration and the effects on internal and external moderation evaluated in Paragraph 6.3.4.1.

To demonstrate compliance with 10CFR71.55 under accident conditions, the following calculations are performed for the HI-STAR 190 design:

- Single cask, internally dry, with full external water moderation. As for the single cask under normal conditions, the full external water moderation is modeled as water with a thickness of about 300 cm. The major fuel reconfiguration is applied to HBF instead of the minor fuel reconfiguration. All other fuel parameters are consistent with the single cask under normal conditions, except the conservative assumption of the fresh fuel assembly with 5.0 wt% ^{235}U for MBF and HBF in the MPC-37 basket and of the fresh fuel assembly with 4.8 wt% ^{235}U for HBF in MPC-89. The external neutron absorber is conservatively neglected in the model. This case addresses the requirement of 10CFR71.55 (e).

6.4.2 Results

[

PROPRIETARY INFORMATION WITHHELD PER 10 CFR 2.390

]

[
PROPRIETARY INFORMATION WITHHELD PER 10 CFR 2.390

]

Appendix 6.A presents the critical experiment benchmarking for fresh UO_2 and MOX fuel and the derivation of the corresponding bias and standard error of the bias (95% probability at the 95% confidence level). See Appendix 6.B, Section 6.B.3, for the benchmarking of spent fuel.

The maximum k_{eff} values, calculated with 95% probability at the 95% confidence level, are listed in Table 6.4.1 for the MPC-37 basket and in Table 6.4.2 for the MPC-89 basket. Overall, these results confirm that the effective multiplication factor (k_{eff}), including all biases and uncertainties at a 95-percent confidence level, does not exceed 0.95 under normal and accident conditions of transport.

Configurations 2 and 3 are selected for the MPC-37 and MPC-89 baskets, respectively, to show compliance with 10CFR71.55, and for the evaluations of package arrays to show compliance with 10CFR71.59 in the following Sections 6.5 and 6.6.

TABLE 6.4.1

HI-STAR 190 SINGLE PACKAGE WITH MPC-37 BASKET

Configuration	% Internal Moderation	% External Moderation	Fuel Condition	Fuel Damage	Max. k_{eff}	1 σ	EALF (eV)
Single Package, fully reflected	100%	100%	MBF	No	0.9447	0.0004	0.4263
			HBF	Minor	0.9473	0.0004	0.4215
			HBF in DFC	Minor	0.9496	0.0004	0.4227
Containment, fully reflected	100%	100%	MBF	No	0.9436	0.0004	0.4268
			HBF	Minor	0.9472	0.0004	0.4220
			HBF in DFC	Minor	0.9493	0.0004	0.4225
Single Package, Damaged ¹	0%	100%	MBF	No	0.4805	0.0001	132250
			HBF	Major	0.4783	0.0001	131590
			HBF in DFC	Major	0.4772	0.0001	127710

¹ The fresh fuel assembly with 5.0 wt% ²³⁵U is conservatively assumed for MBF and HBF.

TABLE 6.4.2

HI-STAR 190 SINGLE PACKAGE WITH MPC-89 BASKET

Configuration	% Internal Moderation	% External Moderation	Fuel Condition	Fuel Damage	Max. k_{eff}	1 σ	EALF (eV)
Single Package, fully reflected	100%	100%	MBF	No	0.9483	0.0004	0.2878
			HBF	Minor	0.9367	0.0004	0.3230
			HBF in DFC	Minor	0.9428	0.0004	0.3233
Containment, fully reflected	100%	100%	MBF	No	0.9488	0.0004	0.2876
			HBF	Minor	0.9353	0.0004	0.3233
			HBF in DFC	Minor	0.9420	0.0004	0.3240
Single Package, Damaged ¹	0%	100%	MBF	No	0.4142	0.0001	98549
			HBF	Major	0.4226	0.0001	108830
			HBF in DFC	Major	0.4193	0.0001	104150

¹ The fresh fuel assembly with 4.8 wt% ²³⁵U is conservatively assumed for HBF.

6.5 EVALUATION OF PACKAGE ARRAYS UNDER NORMAL CONDITIONS OF TRANSPORT

6.5.1 Configuration

The studies in Subsection 6.3.4 show that the spacing and external moderator densities have a negligible effect on the reactivity of the package. Therefore, any external condition can be used to represent the most reactive configuration. To represent package arrays under normal conditions, a hexagonal array of touching casks, infinite in planar and axial direction, internally and externally dry, is modeled. All other modeling assumptions are identical to the ones for the single package under normal conditions, except the conservative assumption of the fresh fuel assembly with 5.0 wt% ^{235}U for MBF and HBF in the MPC-37 basket, and of the fresh fuel assembly with 4.8 wt% ^{235}U for HBF in MPC-89. The analyses are performed for both baskets. This addresses the requirement of 10CFR71.59 (a) (1) and the determination of the criticality safety index according to 10CFR71.59 (b).

6.5.2 Results

The results presented in Table 6.5.1 show that the maximum k_{eff} is well below the NUREG-1617 limit of 0.95 for both baskets. Since an unlimited number of packages can be placed in an array, the value of N is infinite, and the CSI is therefore zero (0).

TABLE 6.5.1

HI-STAR 190 PACKAGE ARRAYS UNDER NORMAL CONDITIONS

Basket	% Internal Moderation	% External Moderation	Fuel Condition	Fuel Damage	Max. k_{eff}	1 σ	EALF (eV)
MPC-37 ¹	0%	0%	MBF	No	0.5096	0.0001	93341
			HBF	Minor	0.5096	0.0001	93025
			HBF in DFC	Minor	0.5068	0.0001	91200
MPC-89 ²	0%	0%	MBF	No	0.4457	0.0001	64697
			HBF	Minor	0.4457	0.0001	64655
			HBF in DFC	Minor	0.4418	0.0001	62214

¹ The fresh fuel assembly with 5.0 wt% ²³⁵U is conservatively assumed for MBF and HBF.

² The fresh fuel assembly with 4.8 wt% ²³⁵U is conservatively assumed for HBF.

6.6 PACKAGE ARRAYS UNDER HYPOTHETICAL ACCIDENT CONDITIONS

6.6.1 Configuration

The studies in Subsection 6.3.4 show that the spacing and external moderator density has a negligible effect on the reactivity of the package. Therefore, any external condition can be used to represent the most reactive configuration. To represent package arrays under accident conditions, a hexagonal array of touching casks, infinite in planar and axial direction, internally dry with full external water reflection, is modeled. This model is consistent with the model for the single cask under accident condition, and recognizes the fact that water intrusion under accident condition is not considered credible. This calculation addresses the requirement of 10CFR71.59 (a)(2).

6.6.2 Results

The results presented in Table 6.6.1 show that the maximum k_{eff} is well below the NUREG-1617 limit of 0.95 for both baskets. Since an unlimited number of packages can be placed in an array, the value of N is infinite, and the CSI is therefore zero (0).

As additional assurance that the package remains subcritical under hypothetical accident conditions, studies were performed for the major fuel reconfiguration under accident conditions with a fully flooded containment boundary. These studies, presented in Subsection 6.3.5, show a reactivity increase in comparison to the reference case. Therefore, additional evaluations are performed for the major fuel reconfiguration with the coinciding flooding of the cask. The results are presented in Table 6.6.2, and show that even under the assumption of fuel damage and flooding, the package remains subcritical, and the maximum k_{eff} value is still below the limit of 0.98, which is often used as a limit for the unlikely accident conditions.

TABLE 6.6.1

HI-STAR 190 PACKAGE ARRAYS UNDER ACCIDENT CONDITIONS

Basket	% Internal Moderation	% External Moderation	Fuel Condition	Fuel Damage	Max. k_{eff}	1 σ	EALF (eV)
MPC-37 ¹	0%	100%	MBF	No	0.4840	0.0001	125890
			HBF	Major	0.4821	0.0001	125640
			HBF in DFC	Major	0.4802	0.0001	122140
MPC-89 ²	0%	100%	MBF	No	0.4178	0.0001	93304
			HBF	Major	0.4268	0.0001	102920
			HBF in DFC	Major	0.4235	0.0001	98473

¹ The fresh fuel assembly with 5.0 wt% ²³⁵U is conservatively assumed for MBF and HBF.

² The fresh fuel assembly with 4.8 wt% ²³⁵U is conservatively assumed for HBF.

TABLE 6.6.2

HI-STAR 190 PACKAGE ARRAYS UNDER ACCIDENT CONDITIONS
(DEFENSE IN DEPTH)

Basket	% Internal Moderation	% External Moderation	Fuel Condition ¹	Fuel Burnup, GWd/mtU	Max. k_{eff}	1 σ	EALF (eV)
MPC-37	100%	100%	HBF	45.29	0.9764	0.0004	0.3636
			HBF in DFC		0.9703		
MPC-89	100%	100%	HBF	15.0	0.9549	0.0004	0.2440
			HBF in DFC		0.9600		
			HBF	45.0	0.9070	0.0004	0.2613
			HBF in DFC		0.9116		

¹ The major fuel reconfiguration is applied to HBF.

6.7 FISSILE MATERIAL PACKAGES FOR AIR TRANSPORT

Not Applicable. The HI-STAR 190 package will not be transported by air.

6.8 BENCHMARK EVALUATIONS

Benchmark calculations have been made on selected critical experiments, chosen insofar as possible, to bound the range of variables in the cask designs. The most important parameters are (1) the enrichment, (2) the cell spacing, and (3) the ^{10}B loading of the neutron absorber panels. Other parameters, within the normal range of cask and fuel designs, have a smaller effect, but are also included. Detailed benchmark calculations are presented in Appendix 6.A.

The benchmark calculations were performed with the same computer codes and cross-section data used to calculate the k_{eff} values for the cask as described in Section 6.3. Further, all calculations were performed on the same computer hardware, specifically, personal computers under Microsoft Windows.

Additional isotopic benchmark calculations performed for the burnup methodology for HI-STAR 190 are presented in Appendix 6.B.

6.9 CHAPTER 6 REFERENCES

The following generic industry and Holtec produced references may have been consulted in the preparation of this document. Where specifically cited, the identifier is listed in the SAR text or table. Active Holtec Calculation Packages which are the repository of all relevant licensing and design basis calculations are annotated as “latest revision”. Submittal of the latest revision of such Calculation Packages to the USNRC and other regulatory authorities during the course of regulatory reviews is managed under the company’s Configuration Control system.

- [6.0.1] Holtec International Report HI-951251, Safety Analysis Report HI-STAR 100 Cask System, USNRC Docket 71-9261, Revision 15.
- [6.0.2] Holtec International Report HI-2073681, Safety Analysis Report HI-STAR 180 Cask System, USNRC Docket 71-9325, Revision 6.
- [6.0.3] Holtec International Report HI-2125175, Safety Analysis Report HI-STAR 180D Cask System, USNRC Docket 71-9367, Revision 3.
- [6.0.4] Holtec International Report HI-2114830, Final Safety Analysis Report on the HI-STORM FW System, USNRC Docket 72-1032, Revision 4.
- [6.0.5] Holtec International Report HI-2002444, Final Safety Analysis Report for the HI-STORM 100 Cask System, USNRC Docket 72-1014, Revision 12.
- [6.1.1] U.S. Code of Federal Regulations, “Packaging and Transportation of Radioactive Materials,” Title 10, Part 71.
- [6.1.2] NUREG-1617, Standard Review Plan for Transportation Packages for Spent Nuclear Fuel, USNRC, Washington, D.C., March 2000.
- [6.1.3] USNRC Standard Review Plan, NUREG-0800, Section 9.1.2, Spent Fuel Storage, Rev. 2 - July 1981.
- [6.3.1] X-5 Monte Carlo Team, MCNP - A General Monte Carlo N-Particle Transport Code, Version 5, LA-UR-03-1987, Los Alamos National Laboratory, April 2003 (Revised 2/1/2008).
- [6.3.2] “CASMO5/CASMO5M A Fuel Assembly Burnup Program Methodology Manual”, SSP-08/405, Rev. 1, Studsvik Scandpower, Inc.
- [6.3.3] “CASMO5 A Fuel Assembly Burnup Program, User’s Manual,” SSP-07/431, Rev. 4, Studsvik Scandpower, Inc.

HI-STAR 190 SAR Report HI-2146214	6.9-1	Revision 1
--------------------------------------	-------	------------

- [6.3.4] J.M. Cano, R. Caro, and J.M Martinez-Val, “Supercriticality Through Optimum Moderation in Nuclear Fuel Storage,” *Nucl. Technol.*, 48, 251-260, (1980).
- [6.4.1] M.G. Natrella, “Experimental Statistics”, National Bureau of Standards, Handbook 91, August 1963.
- [6.4.2] Holtec International Report HI-2156424, “Criticality Evaluation of HI-STAR 190”, latest revision. (Holtec Proprietary)¹.

¹ Supporting document submitted with the HI-STAR 190 License application

Appendix 6.A

Proprietary Appendix Withheld per 10 CFR 2.390

Appendix 6.B

Proprietary Appendix Withheld per 10 CFR 2.390

Appendix 6.C

Proprietary Appendix Withheld per 10 CFR 2.390

Appendix 6.D

Proprietary Appendix Withheld per 10 CFR 2.390

Appendix 6.E

Proprietary Appendix Withheld per 10 CFR 2.390

CHAPTER 7: PACKAGE OPERATIONS

7.0 INTRODUCTION

This chapter provides a summary description of the essential elements and requirements to prepare the HI-STAR 190 package for shipment and to ensure that it operates in a safe and reliable manner under normal and accident conditions of transport pursuant to the provisions of 10CFR71. The information presented in this chapter, along with the technical basis of the package design described in Chapters 2 through 6 will be used by Holtec International's Site Services organization to develop more detailed generic procedures for users of the HI-STAR 190 Package. Equipment specific operating details, such as valve manipulation, onsite cask transporter handling methods, etc, will be provided to individual users of the HI-STAR 190 package based on the specific ancillary equipment selected by the user and the configuration of the site. It is the user's responsibility to utilize the information provided in this chapter, (treating it as an inviolable set of operation elements that must be included in the detailed operating procedures). In addition, the user must consult the conditions of the NRC issued Certificate of Compliance (CoC), equipment-specific operating instructions, and the plant's working procedures and apply them to develop the site-specific written loading, unloading, and handling procedures to ensure that the package is operated in accordance with the CoC and all applicable government regulatory requirements. The following generic criteria shall be used to qualify that the site specific operating procedures are acceptable for use:

- All heavy load handling instructions are in keeping with the guidance in industry standards, and Holtec's proprietary rigging manual.
- A careful technical evaluation of all potential modes of loss of load stability has been performed and accepted by Holtec International's site services organization.
- A technical evaluation is also performed for site specific conditions (such as thermal and shielding considerations) that may impact operational steps.
- Procedures are in conformance with the essential elements and conditions of this Chapter and the CoC.
- The operational steps are ALARA.
- Procedures contain provisions for documenting successful execution of all safety significant steps for archival reference.
- Holtec's lessons learned database has been consulted to incorporate all applicable lessons learned from prior cask handling and loading evolutions.
- Procedures contain provisions for classroom and hands-on training and for a Holtec approved personnel qualification process to insure that all operations personnel are adequately trained.
- The procedures are sufficiently detailed and articulated to enable craft labor to execute them in *literal compliance* with their content.

The operations described in this chapter assume that the MPC has been loaded with fuel in accordance with its governing CoC and FSAR in Docket #72-1032 [7.0.1] or Docket #72-1040 [7.0.2], and has met the requirements set forth in this SAR to merit designation as a competent containment barrier when containing any fuel assembly with an assembly-average larger than 45 GWd/mtU.

US Department of Transportation (USDOT) transportation regulations in 49CFR applicable to the transport of the HI-STAR 190 Package are only addressed in this chapter to the extent required to ensure compliance with 10CFR71 regulations and to provide a more complete package operation description. Applicable 49CFR regulations, including those explicitly called out in 10CFR 71.5, shall be complied with for package use in the US and/or for US package export and import. For transport outside US territory and under the approval or jurisdiction of one or more foreign competent authorities, other requirements such as the ADR, “European Agreement Concerning the International Carriage of Dangerous Goods by Road” and the RID, “European Agreement Concerning the International Carriage of Dangerous Goods by Rail” may be imposed in place of the 49CFR. It is the user’s responsibility to comply with the latest revision of these transportation regulations as required by the applicable competent authority.

Users shall develop or modify existing programs and procedures to account for the transport operation of the HI-STAR 190. Written procedures are required and will be developed or modified to account for such items as handling and storage of systems, structures and components identified as *important-to-safety*, heavy load handling, specialized instrument calibration, special nuclear material accountability, MPC handling procedures, training, equipment and process qualifications. Users shall implement controls to ensure that the lifted weights do not exceed the design limit of the lifting appurtenance. The cask user shall implement controls to ensure that the cask cannot be subjected to a fire event in excess of design limits during loading operations.

The procedures in this chapter contain generic ALARA notes and warnings to alert users to radiological issues. Actions identified with these notes and warnings are not mandatory and shall be implemented based on site specific conditions.

This SAR covers fuel loading of an MPC (in a transfer cask) and where the “load and go” scenario applies. Those MPCs already loaded into a storage overpack are assumed to have been loaded under the aegis of the HI-STORM FW FSAR (Docket # 72-1032) or the HI-STORM UMAX FSAR (Docket # 72-1040). Nevertheless, all MPCs must meet the content conditions set forth in Appendix 7.C, which are based on the loading requirements for the HI-STORM FW and HI-STORM UMAX with additional requirements for transportation in the HI-STAR 190. In either operational scenario, a transfer cask is used to transfer the MPC from the spent fuel pool or from the storage overpack into the HI-STAR 190. Thus the operations covered in this SAR address the following areas:

1. Transfer of the MPC from the HI-TRAC transfer cask to HI-STAR 190 and preparatory packaging for off-site transport
2. Unloading of the MPC at the shipping destination
3. Fuel loading of MPC for the “load and go” scenario
4. Fuel unloading of MPC in a spent fuel pool or appropriate facility

Appendix 7.A provides general operational weights and illustrations of typical operations for the HI-STAR 190 transport package.

Appendix 7.B contains the additional requirements for the transport of HBF including the qualification of the MPC as an inner containment boundary, the confirmation of the integrity of the HBF and the surface inspection of MPCs with HBF.

Appendix 7.C specifies the content conditions of the HI-STAR 190 Package.

Appendix 7.D provides burnup verification conditions of the HI-STAR 190 Package.

Control of the package operation shall be performed in accordance with the user’s Quality Assurance (QA) program to ensure critical steps are not overlooked and that the cask has been determined to meet all requirements of the CoC before being released for shipment.

7.1 PACKAGE LOADING

The HI-STAR 190 Package is dry loaded to transport an MPC meeting the requirements of Appendix 7.C. The essential elements required to prepare the HI-STAR 190 Package for MPC loading and to ready the cask for transport as a Transport Package are described below.

7.1.1 Preparation of the Overpack for Loading

1. If the HI-STAR 190 Packaging has previously been used to transport spent fuel, the HI-STAR 190 is received and the personnel barrier, if attached, is removed and security seals, if used, are inspected to verify there was no tampering and that they match the corresponding shipping documents.
2. The HI-STAR 190 Packaging is visually receipt inspected to verify that there are no outward visual indications of impaired physical conditions except for superficial marks and dents. Any issues are identified to site management. Any road dirt is washed off and any foreign material is removed.
3. Radiological surveys are performed in accordance with 49CFR173.443 [7.1.2] and 10CFR20.1906 [7.1.3]. If necessary, the HI-STAR 190 Packaging is decontaminated to meet survey requirements and/or notifications are made to affected parties.
4. The impact limiters, if attached, are removed and a second visual inspection to verify that there are no outward visual indications of impaired physical condition is performed.
5. The cask is upended and the neutron shield relief devices are inspected to confirm that they are installed, intact, and not covered by tape or any other covering.
6. The cask lid is removed and used seals are removed, and discarded if necessary. If equipped, the neutron shield pressure relief device(s) is inspected to confirm it is installed, intact, and not covered by tape or any other covering.
7. The containment closure flange sealing surfaces are inspected for damage that may compromise the performance of the seal. Any damage to the sealing surfaces is repaired by welding and/or polishing/machining damaged areas as necessary. If the cask sealing surface is weld repaired, the sealing surfaces shall be re-faced with a corrosion resistant veneer.
8. The closure lid bolts are inspected for distortion and damaged threads and any suspect bolts are replaced.
9. Any foreign material is removed from inside the cask.

7.1.2 Acceptance of the MPC with HBF

An MPC containing HBF must pass the acceptance criteria in Appendix 7.B to be deemed suitable as an inner containment boundary. Lastly, MPC's containing high burn-up fuel and stored under the provisions of 10CFR 72 shall undergo an MPC enclosure vessel shell surface defect inspection prior to shipment according to Appendix 7.B.

7.1.3 Transfer of MPC to the HI-STAR 190 overpack

Note:

HI-STAR 190 receipt inspection and preparation may be performed independent of procedural sequence, but prior to transfer of the loaded MPC.

1. Perform a HI-STAR receipt inspection and cleanliness inspection in accordance with a site-approved inspection site-approved inspection checklist, if required.

Note:

MPC transfer may be performed at any location deemed appropriate by the licensee. The following steps describe the general transfer operations. The HI-STAR 190 may be positioned on an air pad, roller skid or any other suitable equipment in the cask receiving area or at the ISFSI. The HI-STAR 190 or HI-TRAC VW may be handled using any equipment specifically designed for such a function. The licensee is responsible for assessing and controlling floor loading conditions during the MPC transfer operations. Installation of the lid and other components may vary according to the cask movement methods and location of MPC transfer. The operations for MPC fuel loading for the "load and go" scenario are provided in Subsection 7.1.6.

2. Position an empty HI-STAR 190 at the designated MPC transfer location.
3. Remove any road dirt with water. Remove any foreign objects from cavity locations.
4. Install the lower MPC Spacer in the HI-STAR 190, if required (top and/or bottom MPC spacers are required for MPCs that are short relative to the cask cavity).
5. Transfer the HI-TRAC VW to the MPC transfer location.
6. Install the mating device on top of the HI-STAR 190. If applicable per subsection 7.1.2 and Appendix 7.B, also install the Eddy Current Inspection Test Ring (See Figure 7.A.4 for illustration).
7. Position HI-TRAC VW above HI-STAR 190.
8. Align HI-TRAC VW over HI-STAR 190 and mate the components.
9. Attach the MPC to the lifting device in accordance with the site-approved rigging procedures.

10. Raise the MPC slightly to remove the weight of the MPC from the mating device.
11. Remove the HI-TRAC VW bottom lid using the mating device.

ALARA Warning:

Personnel should remain clear (to the maximum extent practicable) of the mating device open end during MPC lowering due to radiation streaming. The mating device may be used to supplement shielding during removal of the MPC lift rigging.

12. Lower the MPC into HI-STAR 190. If applicable per subsection 7.1.2 and Appendix 7.B, perform the Eddy Current Surface Inspection of the MPC with the Eddy Current Inspection Test Ring (See Figure 7.A.4 for illustration).
13. Disconnect the MPC lifting slings from the lifting device.
14. Remove HI-TRAC VW from on top of HI-STAR 190 with or without the HI-TRAC bottom lid.
15. Remove the MPC lift rigging and install plugs in the empty MPC bolt holes*.
16. Remove the mating device from on top of HI-STAR 190.
17. Install the upper MPC Spacer in the HI-STAR 190, if required (top and/or bottom MPC spacers are required for MPCs that are short relative to the cask cavity).

7.1.4 Cask Closure

1. The test port plugs on the inter-seal test ports of the closure lid and closure lid port covers are installed with new seals and torqued. The containment closure flange's sealing surface protective cover is removed. The sealing surfaces on the closure lid are inspected for signs of damage or particulate matter that might affect the seal performance. Any particulate matter or sealing surface damage that would prevent a seal is remedied. The closure lid is installed using either new or existing seals. The closure lid bolts are installed and torqued. Bolt torque requirements and recommended tightening procedure are provided in Table 7.1.1 and Figure 7.1.1, respectively. The user may attach security seals to the outer closure lid bolts at this time.
2. If the MPC contains HBF, then the cask cavity is leak tested to the required acceptance criteria in Chapter 8. Unacceptable leakage rates will require unloading of the MPC. Note – this leak test is for MPCs that contain HBF. The leak test of the overpack closure

* Upon installation, studs, nuts, and threaded plugs shall be cleaned and inspected for damage or excessive thread wear (replaced if necessary) and coated with a light layer of Loctite N-5000 High Purity Anti-Seize (or equivalent).

devices, which is performed regardless of MPC contents, is described below.

3. The cask cavity is dried, evacuated and backfilled to the requirements in Table 7.1.2.
4. The closure lid access port plug, fitted with a new seal, is closed.
5. The closure lid inner-seal and closure lid access port plug seal are leak tested to the required acceptance criteria in Chapter 8. Unacceptable leakage rates will require cleaning or repair of the sealing surfaces and replacement of the seals prior to retesting of the seals.

7.1.5 Preparation for Transport

1. A periodic leakage test of the overpack’s containment boundary shall be performed unless such test has been performed less than a year ago:
 - a. If installed, the closure lid inter-seal test port plug(s) and closure lid port cover inter-seal test port plug are removed. The closure lid inner seal and vent and drain port cover plate inner seals are leak tested to the required acceptance criteria set forth in Chapter 8. Unacceptable leakage rates will require cleaning or repair of the sealing surfaces and replacement of the seals prior to retesting of the seals.
 - b. If necessary, the closure lid inter-seal test port plug, closure lid port cover, cover plate inter-seal test port plug installed with new seals.
 - c. The closure lid bolts are installed and torqued. Bolt torque requirements and recommended tightening procedure are provided in Table 7.1.1 and Figure 7.1.1, respectively. The user may attach security seals are attached to the closure lid bolts at this time.
 - d. The overpack containment space is dried, evacuated and backfilled to the requirements in Table 7.1.2.

2. The cask neutron shield pressure relief devices are visually verified to be undamaged.

ALARA Warning:
Dose rates around the unshielded bottom end of the cask may be higher than other locations around the cask. After the cask is downended on the transport frame, the bottom impact limiter should be installed promptly. Personnel should remain clear and exercise other appropriate ALARA controls when working around the bottom end of the cask.

3. The cask is moved to the transport location, downended, and placed on the transport vehicle.

4. A visual inspection for signs of impaired condition is performed. Any non-satisfactory conditions are remedied.
5. Contamination surveys are performed per 49CFR173.443. If necessary, the cask is further decontaminated to meet the survey requirements.
6. If required, the cask lifting appurtenance is removed. The impact limiters are installed on the cask and the impact limiter bolts/nuts are torqued. Bolt/Nut torque requirements and recommended tightening procedure are provided in Table 7.1.1 and Figure 7.1.1, respectively.
7. The cask trunnions are made inaccessible by cap or cover or other appropriate ancillary device that renders the trunnions inoperable. The package tie-down and restraint system is installed, a cover is installed over at least one of the access tubes on the top impact limiter, and a security seal is installed on the top impact limiter. Security seal serial number(s) are recorded in the shipping documents.
8. Final radiation surveys of the package surfaces per 10CFR71.47 [7.1.4] and 49CFR173.443 [7.1.2] are performed and if necessary, the HI-STAR 190 Packaging is further decontaminated to meet the survey requirements. Survey results are recorded in the shipping documents. For packages containing HBF, the final radiation survey shall include the dose rate measurements required by the post-shipment fuel integrity acceptance test specified in Chapter 8, Paragraph 8.1.9.2 of this SAR. The final location of measurements and the measurements shall be recorded in the shipping documents.
9. The surface temperatures of the accessible areas of the package are measured if the personnel barrier will not be used.
10. For packages containing HBF, surface temperatures are measured as required by the post-shipment fuel integrity acceptance test specified in Chapter 8, Paragraph 8.1.9.2 of this SAR. The final location of measurements, ambient conditions (air temperature, date, time of day, and description of daylight (sunny, cloudy, overcast, in-shade or night time)) and the measurements shall be recorded in the shipping documents. Package surfaces shall be dry at the time of temperature measurements.
11. The personnel barrier is installed. The personnel barrier is optional if the package surface temperature and the dose rates without the personnel barrier are within 10CFR71.43 and 10CFR71.47 requirements, respectively; and no applicable 49CFR requirements are violated.
12. The assembled package is given a final inspection to verify that the following conditions for transport have been met (inspection steps may be performed in any order):
 - a. Verify that required radiation survey results are properly documented on the shipping documentation.
 - b. Perform a cask surface temperature check. The accessible surfaces of the Transport Package (impact limiters and personnel barrier) shall not exceed the exclusive use temperature limits of 49CFR173.442.

- c. Verify that all required leakage testing has been performed, the acceptance criteria have been met, and the results have been documented on the shipping documentation.
- d. Verify that the receiver has been notified of the impending shipment and that the receiver has the appropriate procedures and equipment available to safely receive and handle the Transport Package (10CFR20.1906(e)).
- e. Verify that the carrier has the written instructions and a list of appropriate contacts for notification of accidents or delays.
- f. Verify that the carrier has written instructions that the shipment is to be Exclusive Use in accordance with 49CFR173.441.
- g. Verify that route approvals and notification to appropriate agencies have been completed.
- h. Verify that the appropriate labels have been applied in accordance with 49CFR172.403 [7.1.1].
- i. Verify that the appropriate placards have been applied in accordance with 49CFR172.500.
- j. Verify that all required information is recorded on the shipping documentation.

Following the above checks, the Transport Package is released for transport.

7.1.6 Loading the MPC with Spent Fuel (“Load and go” Scenario)

Note, the HI-STAR 190 is dry loaded with an MPC using the HI-TRAC VW transfer cask. This section describes the operational steps for the “load and go,” scenario.

1. Visually inspect the MPC to ensure that it is clean and free of debris.
2. Place the MPC in the transfer cask.
3. Place the transfer cask containing the MPC into the spent fuel pool.
4. Prior to loading the fuel into the MPC, the user identifies the fuel to be loaded. A pre-loading verification is made to assure that damaged fuel and fuel debris will be placed in damaged fuel containers and that the DFCs will occupy authorized locations in the MPC. The fuel is independently verified to see that it meets the conditions of the CoC.
5. Install the drain line to the underside of the MPC lid, then install MPC lid and remove the transfer cask containing the loaded MPC from the spent fuel pool.

6. Lower the MPC internal water level in preparation for MPC lid-to-shell welding.
7. Perform combustible gas monitoring and purge the space under the MPC lid with an inert gas to ensure that there is no combustible mixture present in the welding area.
8. Weld the MPC lid, using the Automated Welding System (AWS), in accordance with the licensing drawings using approved procedures. Repair any weld defects in accordance with the applicable code and re-perform the NDE until the weld meets the required acceptance criteria.
9. Perform MPC lid-to-shell weld pressure testing in accordance with site-approved procedures.
10. Repeat liquid penetrant examination on the final pass of the MPC lid-to-shell weld, and repair any defects in accordance with the applicable code requirements and re-perform the NDE in accordance with approved procedures.
11. Drain the MPC.
12. Dry and backfill the MPC using either the Vacuum Drying System or Forced Helium Dehydration. Drying method restrictions are located in Table 7.C.14.
 - a. Vacuum Drying System (VDS) Method
 - i. Attach the VDS to the vent and drain port RVOAs. Other equipment configurations that achieve the same results may also be used.
 - ii. Start the VDS system and slowly reduce the MPC pressure to below 3 torr.
 - iii. When the MPC is dry in accordance with the acceptance criteria in Table 7.C.14, and backfill the MPC in accordance with Table 7.C.11 or 7.C.12 as applicable.
 - iv. Close the drain and vent port RVOAs.
 - b. Forced Helium Dehydration Method
 - i. Attach the moisture removal system to the vent and drain port RVOAs. Other equipment configurations that achieve the same results may also be used.
 - ii. Circulate the drying gas through the MPC while monitoring the circulating gas for moisture. Collect and remove the moisture from the system as necessary.
 - iii. Continue the monitoring and moisture removal until Table 7.C.14 requirements are met for MPC dryness.

- iv. Adjust the helium pressure in the MPC to provide a fill pressure as required by Table 7.C.11 or 7.C.12 as applicable.
13. Weld the vent and drain port cover plates and perform NDE in accordance with the applicable code and re-perform the NDE until the weld meets the required acceptance criteria.
14. Perform a leakage test of the MPC vent port cover plate and drain port cover plate in accordance with site-approved procedures.
15. Weld the MPC closure ring to the MPC shell and the MPC lid, and perform NDE in accordance with approved procedures. Repair any weld defects in accordance with the applicable code and re-perform the NDE until the weld meets the required acceptance criteria.
16. Decontaminate the external surface of the transfer cask to the limits established for the site, as required.
17. Proceed with the steps for MPC transport in HI-STAR 190 starting in Subsection 7.1.1.

Table 7.1.1

HI-STAR 190 Package Torque Requirements (Note 6)

Fastener (See Note 1)	Recommended Torque (N-m), τ (See Note 2)	Minimum Total Bolt Preload kN (See Note 7)	Comments
Closure Lid Bolts	1 st Pass: Wrench Tight Intermediate Pass: 30% to 45% of final torque value Final Pass: See Note 3	13,500	See Figure 7.1.1 and Notes 4 and 5. Intermediate pass is final pass for empty but previously used packages
Closure Lid Port Cover Bolts	See Note 3	68.2	None
Top Impact Limiter Attachment Bolts/Nuts	“Snug Tight”	N/A	None
Bottom Impact Limiter Attachment Bolts/Nuts	“Snug Tight”	N/A	None
Test Port Plugs	“Snug Tight”	N/A	None

Notes continued on next page:

Table 7.1.1

HI-STAR 190 Package Torque Requirements (continued)

Notes:

1. Fasteners shall be cleaned and inspected for damage or excessive wear (replaced if necessary) and coated with a light layer of lubricant, such as Fel-Pro Chemical Products, N-5000, Nuclear Grade Lubricant.
2. For conversion from Newton-meter (N-m) to foot pounds (ft-lb) divide by 1.356.
3. The nominal bolt torque, τ , is given by the semi-empirical formula,

$$\tau = (P_B)(K)(d)$$
 where, K = Torque coefficient
 The torque coefficient, K, varies from 0.12 (extremely effective lubricant such as Bowman Anti-Sieze) to 0.18 (commercial lubricant). The above formula is derived from Shigley, et. al.¹. The above torque values assume a high quality lubricant (K=0.12). A higher value may be used based on the lubricant supplier's recommendation.
 P_B = Minimum Bolt Preload.
 d = Nominal bolt diameter (soft conversion between metric and US units is permitted)
 Fastener sizes are provided in the drawing package referenced in the CoC.
4. Detorquing shall be performed by turning the bolts counter-clockwise in 1/3 turn +/- 30 degrees increments per pass for three passes. The bolts may then be removed.
5. Values listed are for the minimum number of passes permitted. Additional intermediate passes are permitted.
6. For empty packages, alternate torque requirements may be used with Holtec approval.
7. To determine individual bolt preload required, divide the total shown by the number of bolts for the lid/cover.

¹ Shigley J. D. and Mischke C. R., "Mechanical Engineering Design", 5th Edition, pp 346-347, Mc Graw Hill (1989).

Table 7.1.2**Cask Backfill Requirements**

Cask Space	Reference Pressure or Pressure Range
Cask Cavity Space (Notes 1 and 2)	41 kPa (6 psig) to 103 kPa (15 psig)
Closure Lid Port Space	atmospheric
Recommended Backfill Gas	
Type	Helium
Reference Purity	99.9 % Nom.

Notes:

1. The reference pressure is based on a reference cask space bulk temperature of $\geq 21.1^{\circ}\text{C}$ (70°F)
2. Following cask drying operations, the gas temperature inside the cask cavity will be higher than 21.1°C (70°F); therefore, direct measurement of the gas temperature is not required. Use of pressure gauges to confirm that the cask cavity pressure is within the pressure range is sufficient to establish the proper backfill conditions.

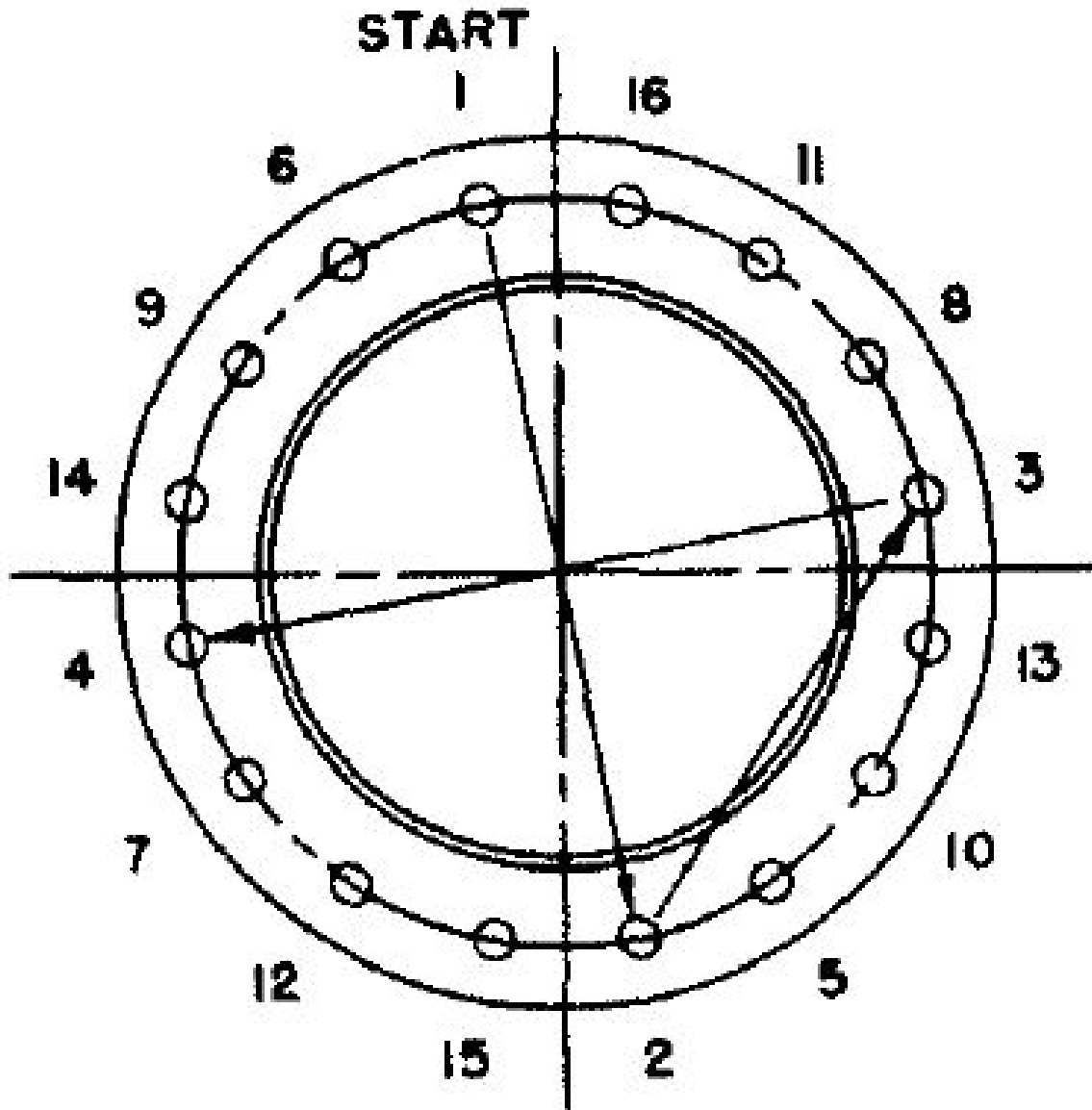

Note: It is important that all bolted joints be tightened uniformly and in a diametrically staggered pattern as illustrated above. Due to the large diameter of the closure lids and other factors, the standard star pattern with added flexibility is permitted with Holtec approval. Tools designed to torque more than one bolt at a time (e.g. bolts 1 and 2 simultaneously) may be implemented and are recommended as good ALARA practice. Alternate patterns shall be approved by the Certificate Holder.

FIGURE 7.1.1

SCHEMATIC DIAGRAM OF THE RECOMMENDED BOLT TIGHTENING PROCEDURE

7.2 PACKAGE UNLOADING

In the event that the HI-STAR 190 Package needs to be unloaded, the essential elements required to prepare the package for MPC unloading are described below.

7.2.1 Receipt of Package from Carrier

1. The HI-STAR 190 Package is received from the carrier and inspected to verify that there are no outward visual indications of impaired physical conditions except for superficial marks and dents. Any issues are identified to site management.
2. The personnel barrier, if used, is removed and the security seal installed on the top impact limiter is inspected to verify there was no tampering and that it matches the corresponding shipping documents.
3. Radiological surveys are performed in accordance with 49CFR173.443 [7.1.2] and 10CFR20.1906 [7.1.3]. If necessary, the HI-STAR 190 Packaging is decontaminated to meet survey requirements and/or notifications are made to affected parties. For packages containing HBF, the radiation survey shall include the dose rate measurements required by the post-shipment fuel integrity acceptance test specified in Chapter 8, Paragraph 8.1.9.2 of this SAR. The location of measurements shall correspond to the same locations recorded for Subsection 7.1.5. The measurements shall be recorded in the shipping documents.
4. For packages containing HBF, surface temperature measurements shall include the surface temperature measurements required by the post-shipment fuel integrity acceptance test specified in Chapter 8, Paragraph 8.1.9.2 of this SAR. The location of measurements shall correspond to the same locations recorded for Subsection 7.1.5. Ambient conditions (air temperature, date, time of day and description of daylight (sunny, cloudy, overcast, in-shade or night time)) and the measurements shall be recorded in the shipping documents. Package surfaces shall be dry at the time of temperature measurements.

ALARA Warning:
Dose rates around the bottom end of the HI-STAR 190 cask may be higher than other locations around the cask. After the impact limiter is removed, the cask should be opened promptly. Personnel should remain clear of the bottom of the unshielded cask and exercise other appropriate ALARA controls.

5. The impact limiters and tie-down system are removed.

6. The cask is visually inspected to verify there are no outward visual indications of impaired physical conditions and a radiation survey and a removable contamination survey are performed to establish appropriate radiological controls. Any issues are identified to site management.
7. The cask lifting appurtenance is installed. The cask is upended and returned to the fuel building or other unloading area.
8. The cask is placed in the designated preparation area.

7.2.2 Removal of MPC

1. The outer lid access port cover is removed and a gas sample is drawn from the cask cavity space to determine radiological conditions.
2. The cask cavity gas is handled in accordance with Radiation Protection directions and the closure lid is removed.
3. Position the HI-STAR 190 at the designated MPC transfer location.
4. Remove the upper MPC Spacer from the HI-STAR 190, if used.
5. Remove any road dirt with water. Remove any foreign objects from cavity locations.
6. Transfer the HI-TRAC VW to the MPC transfer location.
7. Install the mating device on top of the HI-STAR 190.
8. Position HI-TRAC VW above HI-STAR 190.
9. Remove any plugs from the MPC bolt holes.
10. Attach the MPC to the MPC lifting device in accordance with the site-approved rigging procedures.
11. Align HI-TRAC VW over HI-STAR 190 and mate the components.
12. Remove the HI-TRAC bottom lid using the mating device.

ALARA Warning:

<p>Personnel should remain clear (to the maximum extent practicable) of the mating device open end during MPC raising due to radiation streaming. The mating device may be used to supplement shielding during removal of the MPC lift rigging.</p>

13. Attach the MPC lifting device overhead lifting device and raise the MPC into HI-TRAC.
14. Install the HI-TRAC VW bottom lid using the mating device.
15. Lower the MPC onto the HI-TRAC bottom lid.
16. Disconnect the MPC lifting slings from the lifting device.
17. Remove HI-TRAC VW from on top of HI-STAR 190.
18. Remove the mating device from on top of HI-STAR 190.

19. Remove the lower MPC Spacer from the HI-STAR 190, if used.

7.2.3 Removal of Contents from MPC

1. The HI-TRAC VW annulus is filled with water. Water addition should be performed in a slow and controlled manner until water steam generation has ceased.
2. The MPC closure ring above the vent and drain ports and the vent and drain port cover plates are core-drilled and removed to access the vent and drain ports.
3. A temporary attachment is connected to the vent port to open the vent port and collect a gas sample from inside the MPC. A gas sample analysis is performed to assess the condition of the fuel assembly cladding.
4. The MPC is cooled as necessary to reduce the MPC internal temperature. This allows water flooding without thermally shocking the fuel assemblies or over-pressurizing the MPC from the formation of steam. The MPC is then filled with water.
5. Appropriate monitoring for combustible gas shall be performed prior to, and during MPC lid welding operations. The space below the MPC lid shall be vented/exhausted or purged with inert gas prior to, and during MPC lid cutting operations to provide additional assurance that flammable gas concentrations will not develop in this space. Purging is the recommended method to mitigate flammable gas accumulation.
6. The MPC lid to MPC shell weld is removed using an automated weld removal system or other suitable equipment. The weld removal equipment is removed with the MPC lid left in place.
7. The top surfaces of the MPC and HI-TRAC VW are cleared of metal shavings.
8. The inflatable annulus seal is installed.
9. The MPC lid slings are attached, and the lift yoke is engaged to the HI-TRAC VW lifting blocks.
10. The HI-TRAC VW is placed in the spent fuel pool or other appropriate unloading area and the MPC lid is removed.
11. The spent fuel assemblies are removed from the MPC using applicable site procedures.
12. The HI-TRAC VW and MPC are returned to the designated preparation area where any water in the MPC is pumped back into the spent fuel pool, liquid radwaste system, or other approved location as necessary.
13. The annulus water is drained and the MPC and overpack are decontaminated.

7.3 PREPARATION OF EMPTY PACKAGE FOR TRANSPORT

7.3.1 Overview of Empty Package Transport

The essential elements and minimum requirements for preparing an empty package (previously used) for transport are similar to those required for transporting the loaded package with some differences. A survey for removable contamination is performed to verify that the removable contamination on the internal and external surfaces of the cask is ALARA and that the limits of 49CFR173.428 [7.1.2] and 10CFR71.87(i) [7.1.4] are met. At the user's discretion, impact limiters and/or personnel barrier are installed. The procedures provided herein describe the installation of the impact limiters and personnel barrier. These steps may be omitted, as appropriate.

7.3.2 Preparation for Empty Package Shipment

1. The containment closure flange closure lid sealing surface protector is removed from the cask, if necessary.
2. The cask is surveyed for contamination and verified to be empty and contain less than 15 gram U-235 in accordance with 49 CFR 173.453(b)
3. The closure lid is installed and the bolts are torqued. See Table 7.1.1 for torque requirements.
4. The closure lid port covers are installed if necessary.
5. The cask is downended and positioned on the transport equipment.
6. A final inspection of the cask is performed and includes the following:
 - A final survey for removable contamination on the accessible external surfaces of the cask in accordance with 49CFR173.443(a). If necessary, the cask is decontaminated to meet the survey requirements.
 - A radiation survey of the cask to confirm that the radiation levels on any external surface of the cask do not exceed the levels required by 49CFR173.421(a)(2). Any issues are identified to site management and the cask is decontaminated as directed by site radiation protection.
 - A visual inspection of the cask to verify that there are no outward visual indications of impaired physical condition except for superficial marks and dents and that the empty package is securely closed in accordance with 49CFR173.428(b).

- Verification that the cask neutron shield pressure relief devices are installed, are intact and are not covered by tape or other covering.
7. Final radiation surveys of the empty package surfaces are performed per 10CFR71.47 and 49CFR173.428(a).
 8. If desired, the personnel barrier and personnel barrier locks are installed and the personnel barrier keys are transferred to the carrier.
 9. A final check to ensure that the empty package is ready for release is performed and includes the following checks:
 - Verification that the receiver has been notified of the impending shipment.
 - Verification that any labels previously applied in conformance with Subpart E of 49CFR172 [7.1.1] have been removed, obliterated, or covered and the "Empty" label prescribed in 49CFR172.450 [7.1.1] is affixed to the packaging in accordance with 49CFR173.428(e).
 - Verification that the empty package for shipment is prepared in accordance with 49CFR173.422.
 - Verification that all required information is recorded on the shipping documentation.
 10. The empty package is then released for transport.

7.4 OTHER OPERATIONS

There are no other operations for the HI-STAR 190 Package with regard to provisions for any special operational controls (e.g., route, weather, shipping time restrictions, etc.). Essential operations and conditions are detailed in this chapter.

7.5 REFERENCES

The following generic industry and Holtec produced references may have been consulted in the preparation of this document. Where specifically cited, the identifier is listed in the SAR text or table.

- [7.0.1] USNRC Docket #72-1032, HI-STORM FW FSAR and CoC
- [7.0.2] USNRC Docket #72-1040, HI-STORM UMAX FSAR and CoC
- [7.1.1] U.S. Code of Federal Regulations, Title 49 “Transportation”, Part 172 "Hazardous Materials Table, Special Provisions, Hazardous Materials Communications, Emergency Response Information, Training Requirements and Security Plans."
- [7.1.2] U.S. Code of Federal Regulations, Title 49 “Transportation”, Part 173, "Shippers – General Requirements for Shipments and Packagings,"
- [7.1.3] U.S. Code of Federal Regulations, Title 10, “Energy”, Part 20 "Standards for Protection against Radiation".
- [7.1.4] U.S. Code of Federal Regulations, Title 10, “Energy”, Part 71 "Packaging and Transportation of Radioactive Material".

APPENDIX 7.A

GENERAL WEIGHTS AND ILLUSTRATIONS OF TYPICAL LOADING OPERATIONS

Table 7.A.1: General Weights of HI-STAR 190

Item	Value, kg (lb)
Maximum Weight of Empty HI-STAR 190 Cask (no Personnel Barrier, no impact limiters, no MPC) – Note 1	124,100 (273,400)
Maximum Weight of HI-STAR 190 Cask with Loaded MPC (no impact limiter or personnel barrier) – Note 1	176,800 (389,800)
Maximum Gross Weight of HI-STAR 190 Package (no personnel barrier) – Note 2	197,700 (435,800)

Notes:

1. The weight shown is a conservative representation provided for information only. Weights include cask lids and bolting. Lifting, handling and tie down evaluations shall be performed using weights that match or bound as-built weights.
2. The maximum gross weight of the package is conservatively set and intended for package shipment purposes in compliance with the packaging marking requirement of 10CFR 71.85(c).

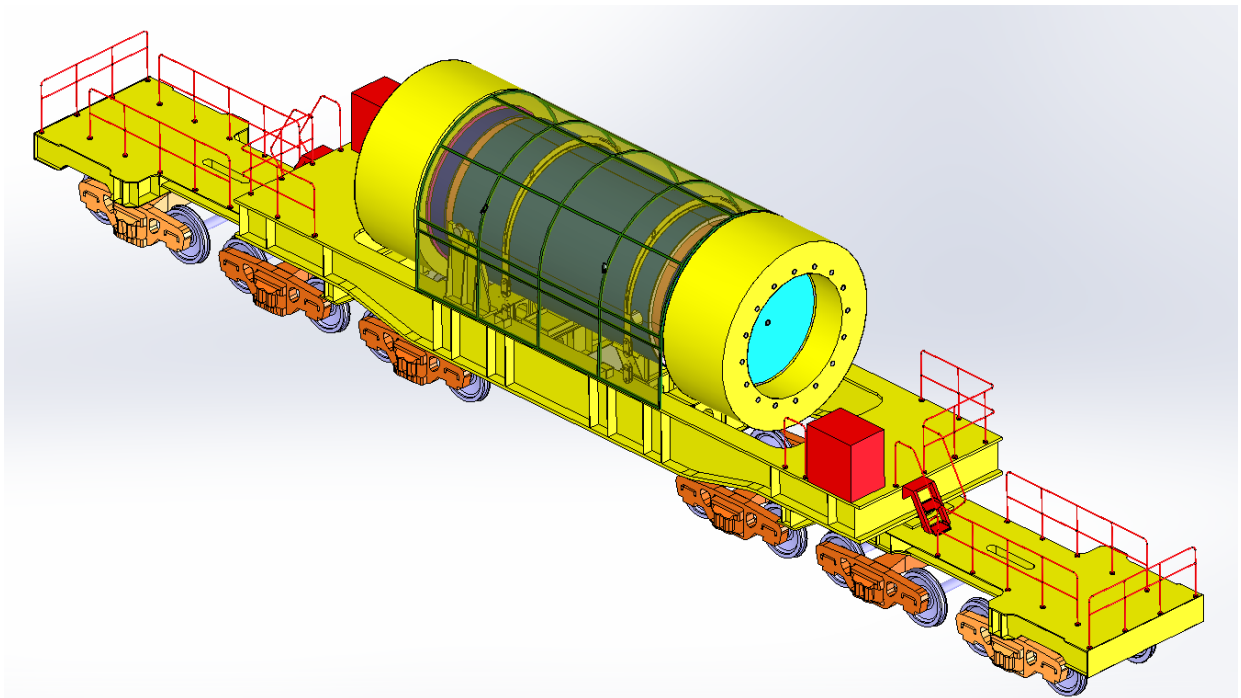

Note: Longitudinal Stops (axial restraints) not shown. The bottom trunnions are shown engaged by retractable downending device; however, all trunnions must be disengaged and rendered inoperable.

FIGURE 7.A.1: GENERAL ARRANGEMENT OF THE HI-STAR 190 ON A TRANSPORT VEHICLE WITH IMPACT LIMITER, AND TIE-DOWNS ATTACHED. PERSONNEL BARRIER INSTALLED (SHOWN FOR ILLUSTRATION ONLY)

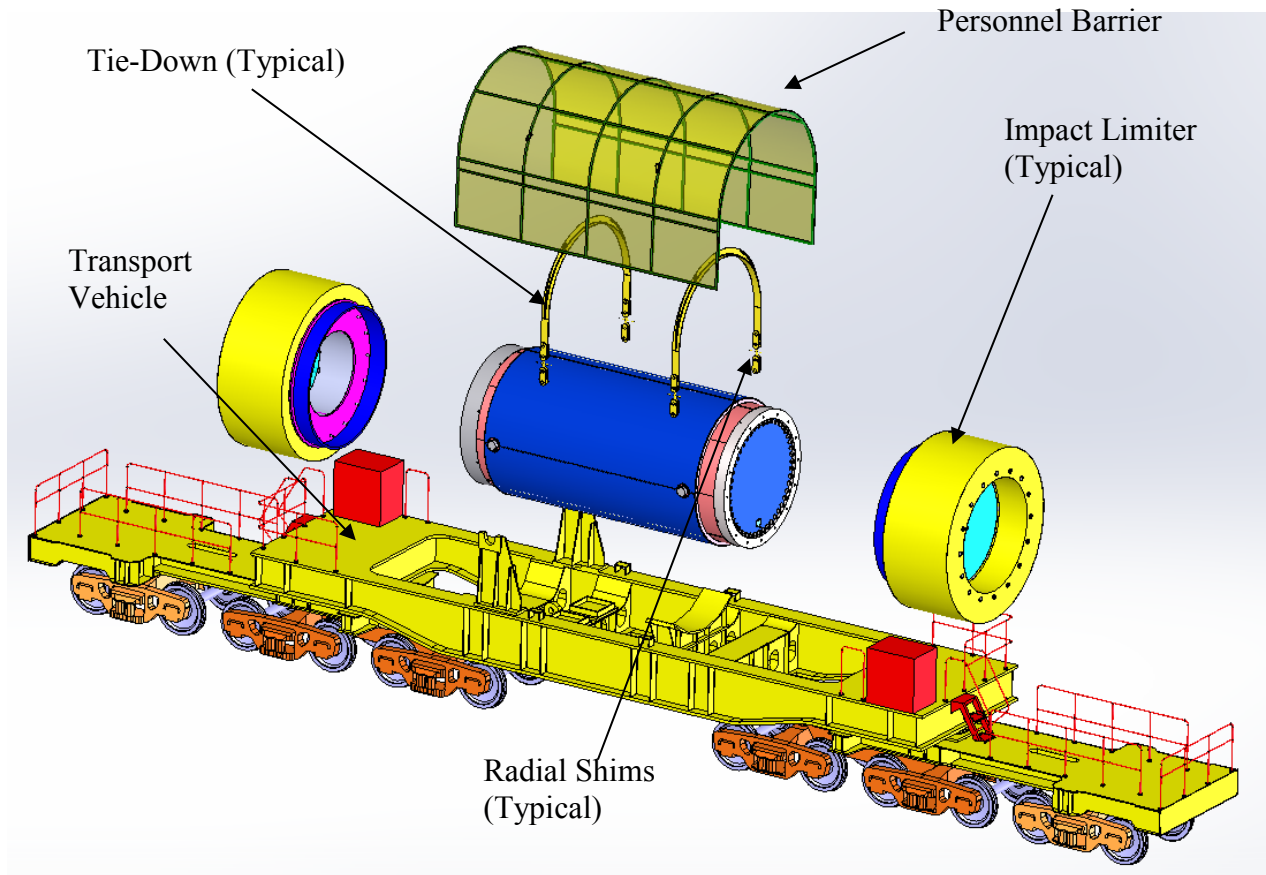

Note: Longitudinal Stops (axial restraints) not shown.

**FIGURE 7.A.2: HI-STAR 190 TRANSPORT ASSEMBLY ON RAIL CAR
(SHOWN FOR ILLUSTRATION ONLY)**

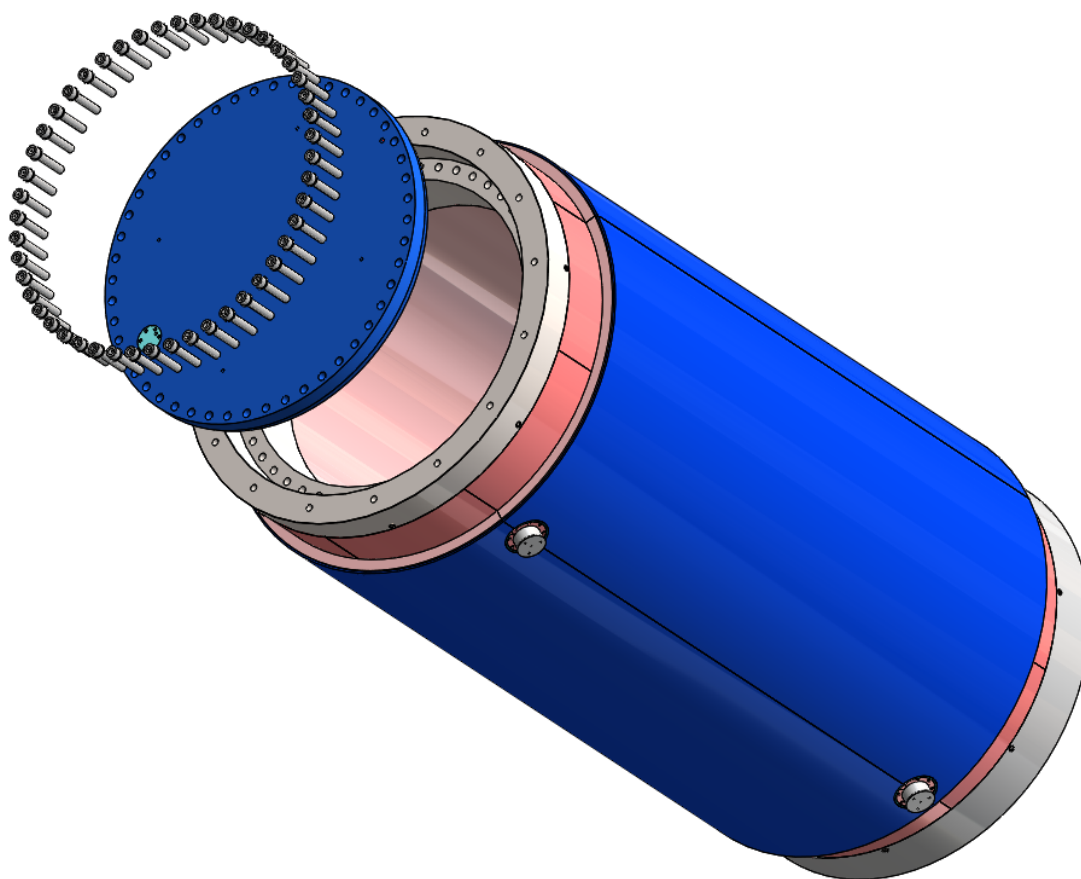
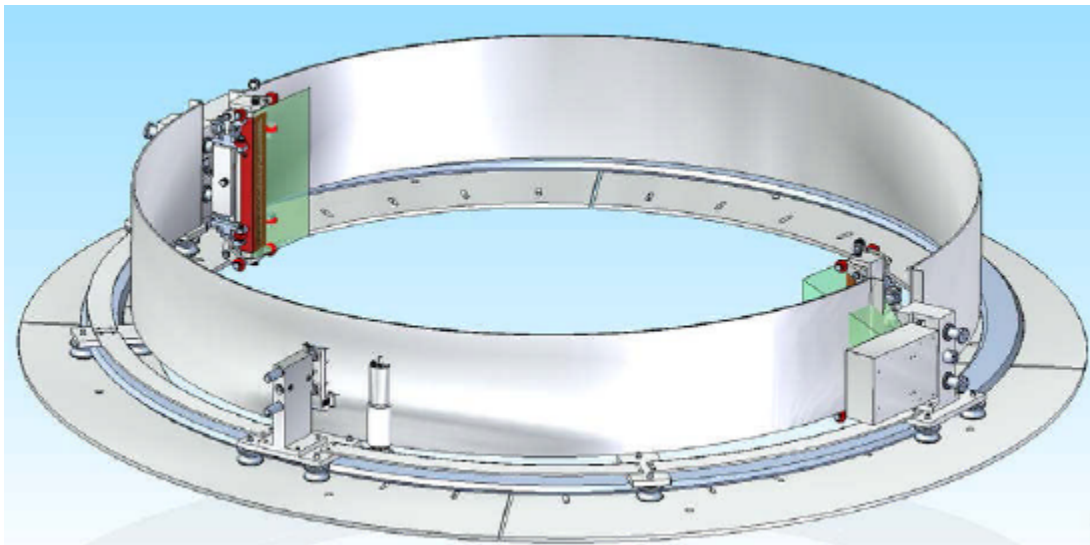

FIGURE 7.A.3: HI-STAR 190 CLOSURE LID, BOLTS



Note: The shielding ring surrounding the Eddy Current inspection ring is not shown for clarity. The Eddy Current inspection device consists of the Eddy Current inspection ring and the shielding ring. The Eddy Current inspection device is placed between the HI-STAR cask and the mating device for the transfer cask.

FIGURE 7.A.4: REPRESENTATIVE EDDY CURRENT INSPECTION RING

APPENDIX 7.B

Additional Requirements for the Transport of HBF

The MPC Enclosure Vessel is credited as an inner containment boundary for high burnup fuel (HBF). The acceptance criteria and supplemental requirements for crediting the MPC Enclosure Vessel are contained in Chapter 8 and Appendix 8.A. These requirements include the performance of the pre-shipment MPC leakage test included in Section 7.1.4.

The user of MPC's containing high burn-up fuel and stored beyond the duration of the initial 20 year license period under the provisions of 10CFR 72 shall confirm that the general licensee implementing the approved HBF Aging Management Program has not concluded that the analyzed configuration of the HBF has been compromised during the period of extended storage.

MPC's containing high burn-up fuel and stored under the provisions of 10CFR 72 shall undergo an MPC enclosure vessel shell surface defect inspection prior to shipment as specified in Subsection 8.1.8. A representative Eddy Current Test Ring is shown in Figure 7.A.4.

APPENDIX 7.C
PERMISSIBLE CONTENT CONDITIONS IN THE HI-STAR 190 PACKAGE

INDEX TO APPENDIX 7.C

Page:	Table/Figure:	Description:
7.C-3	Table 7.C.1	Fuel Assembly Limits
7.C-5	Table 7.C.2	PWR Fuel Assembly Characteristics
7.C-9	Table 7.C.3	BWR Fuel Assembly Characteristics
7.C-14	Table 7.C.4	Fuel Assembly Minimum Burnup and In-Core Operating Requirements for Transportation in MPC-37
7.C-16	Table 7.C.5	Loading Configurations for MPC-37
7.C-17	Table 7.C.6	Loading Configurations for MPC-89
7.C-18	Table 7.C.7	Loading Patterns for MPC-37
7.C-19	Table 7.C.8	Fuel Specification for MPC-37
7.C-24	Table 7.C.9	Loading Patterns for MPC-89
7.C-25	Table 7.C.10	Fuel Specification for MPC-89
7.C-26	Table 7.C.11 and Table 7.C.12	MPC Backfill Pressure Requirements
7.C-27	Table 7.C.13	Non-Fuel Hardware Burnup And Cooling Time Limits
7.C-28	Table 7.C.14	MPC Cavity Drying Limits
7.C-29	Table 7.C.15	Adjustments Of Burnup For Calculation Of Assembly Decay Heat
7.C-30	Figure 7.C.1	MPC-37 Region-Cell Identification
7.C-31	Figure 7.C.2	MPC-89 Region-Cell Identification

Table 7.C.1 (Page 1 of 2)
FUEL ASSEMBLY LIMITS

I. MPC MODEL: MPC-37

A. Allowable Contents

1. Uranium oxide, PWR undamaged fuel assemblies, damaged fuel assemblies, and/or fuel debris, meeting the criteria in Table 7.C.2, with or without non-fuel hardware and meeting the following specifications (Note 1):

a. Fuel Rod Cladding Material, Guide Tubes Material and Instrument Tubes Material:	ZR (Note 2)
b. Initial enrichment:	≤ 5 wt. % of U-235
c. Post-irradiation cooling time, average burnup per assembly:	≥ 3 years; ≤ 68.2 GWd/MTU and greater than minimum burnup requirement in Table 7.C.4 for applicable assemblies as specified in Table 7.C.5
d. Decay heat per assembly	See Table 7.C.7
e. Fuel assembly length:	≤ 199.2 inches (nominal design including non-fuel hardware and DFC)
f. Fuel assembly width:	≤ 8.54 inches (nominal design)
g. Fuel assembly weight:	≤ 2050 lbs (including NFH and DFC)
h. Initial Uranium Loading:	≤ 0.495 MTU

- B. Quantity per MPC: Up to 37 fuel assemblies can be stored in MPC-37 in one of the configuration listed in Table 7.C.5.
- C. One (1) Neutron Source Assembly (NSA) is authorized for loading in MPC-37
- D. Up to thirty (30) BPRAs are authorized for loading in MPC-37
- E. Minimum cooling time of NFH is equal to minimum cooling time required of the fuel assembly containing NFH per Table 7.C.7 and Table 7.C.8. In addition, NFH must satisfy specification provided in Table 7.C.13. An example is provided in notes to Table 7.C.8(a)
- F. Up to ten (10) irradiated steel rods per PWR assemblies are authorized for loading in Regions 1 and 2 of MPC-37.

Note 1: Fuel assemblies containing BPRAs, TPDs with or without absorber rodlets, WABAs, water displacement guide tube plugs, orifice rod assemblies, or vibration suppressor inserts, may be stored in any fuel storage location. Fuel assemblies with or without ITTRs or GTAs may also be stored in any fuel storage location. Fuel assemblies containing APSRs, RCCAs, CEAs, CRAs, NSAs may only be loaded in fuel storage Regions 1 and 2 (see Figure 7.C.1).

Note 2: Zircaloy 2, Zircaloy 4, ZIRLO and M5 material are permitted.

Table 7.C.1 (Page 2 of 2)
FUEL ASSEMBLY LIMITS

II. MPC MODEL: MPC-89

A. Allowable Contents

1. Uranium oxide, BWR undamaged fuel assemblies, damaged fuel assemblies, and/or fuel debris meeting the criteria in Table 7.C.3, with or without channels and meeting the following specifications (Note 1):

- | | |
|---|---|
| a. Fuel Rod Cladding Material, Water Rod Material and Channel Material: | ZR (Note 2) |
| b. Planar-average initial enrichment: | As specified in Table 7.C.3 for the applicable fuel assembly array/class. |
| c. Initial rod enrichment: | ≤ 5 wt. % of U-235 |
| d. Post-irradiation cooling time, average burnup,: | |
| i. Array/Class 8x8F: | Cooling time ≥ 10 years and an assembly average burnup ≤ 27.5 GWD/MTU |
| ii. All other Array Classes: | Cooling time ≥ 3 years and an assembly average burnup ≤ 65 GWD/MTU |
| e. Decay heat per assembly: | |
| i. Array/Class 8x8F: | ≤ 183.5 Watts |
| ii. All Other Array Classes: | See Table 7.C.9 |
| f. Fuel assembly length: | ≤ 176.5 inches (nominal design) |
| g. Fuel assembly width: | ≤ 5.95 inches (nominal design) |
| h. Fuel assembly weight: | ≤ 850 lbs, including a DFC as well as a channel |
| i. Initial Uranium Loading: | ≤ 0.198 MTU |

B. Quantity per MPC: Up to 89 fuel assemblies can be stored in MPC-89 in one of the configuration listed in Table 7.C.6.

C. Up to three (3) irradiated steel rods per BWR assemblies are authorized for loading in the Regions 1 and 2 of MPC-89.

Note 1: Deleted.

Note 2: Zircaloy 2, Zircaloy 4, ZIRLO and M5 material are permitted.

Table 7.C.2 (Page 1 of 4)

PWR FUEL ASSEMBLY CHARACTERISTICS (NOTE 1)

Fuel Assembly Array/Class	15x15B	15x15C
No. of Fuel Rod Locations	204	204
Fuel Clad O.D. (in.)	≥ 0.420	≥ 0.417
Fuel Clad I.D. (in.)	≤ 0.3736	≤ 0.3640
Fuel Pellet Dia. (in.) (Note 3)	≤ 0.3671	≤ 0.3570
Fuel Rod Pitch (in.)	≤ 0.563	≤ 0.563
Active Fuel Length (in.) (Note 5)	≤ 150	≤ 150
No. of Guide Tubes and/or Instrument Tubes	21	21
Guide/Instrument Tube Thickness (in.)	≥ 0.015	≥ 0.0165

Table 7.C.2 (Page 2 of 4)

PWR FUEL ASSEMBLY CHARACTERISTICS (NOTE 1)

Fuel Assembly Array/Class	15x15D	15x15E	15x15F	15x15H	15x15I
No. of Fuel Rod Locations	208	208	208	208	216
Fuel Clad O.D. (in.)	≥ 0.430	≥ 0.428	≥ 0.428	≥ 0.414	≥ 0.413
Fuel Clad I.D. (in.)	≤ 0.3800	≤ 0.3790	≤ 0.3820	≤ 0.3700	≤ 0.3670
Fuel Pellet Dia. (in.) (Note 3)	≤ 0.3735	≤ 0.3707	≤ 0.3742	≤ 0.3622	≤ 0.3600
Fuel Rod Pitch (in.)	≤ 0.568	≤ 0.568	≤ 0.568	≤ 0.568	≤ 0.550
Active Fuel Length (in.) (Note 5)	≤ 150	≤ 150	≤ 150	≤ 150	≤ 150
No. of Guide and/or Instrument Tubes	17	17	17	17	9 (Note 4)
Guide/Instrument Tube Thickness (in.)	≥ 0.0150	≥ 0.0140	≥ 0.0140	≥ 0.0140	≥ 0.0140

Table 7.C.2 (Page 3 of 4)

PWR FUEL ASSEMBLY CHARACTERISTICS (NOTE 1)

Fuel Assembly Array/ Class	16x16A	16x16B	16x16C
No. of Fuel Rod Locations	236	236	235
Fuel Clad O.D. (in.)	≥ 0.382	≥ 0.374	≥ 0.374
Fuel Clad I.D. (in.)	≤ 0.3350	≤ 0.3290	≤ 0.3290
Fuel Pellet Dia. (in.) (Note 3)	≤ 0.3255	≤ 0.3225	≤ 0.3225
Fuel Rod Pitch (in.)	≤ 0.506	≤ 0.506	≤ 0.485
Active Fuel Length (in.) (Note 5)	≤ 150	≤ 150	≤ 150
No. of Guide and/or Instrument Tubes	5 (Note 2)	5 (Note 2)	21
Guide/Instrument Tube Thickness (in.)	≥ 0.0350	≥ 0.0400	≥ 0.0157

Table 7.C.2 (Page 4 of 4)

PWR FUEL ASSEMBLY CHARACTERISTICS (NOTE 1)

Fuel Assembly Array/ Class	17x17A	17x17B	17x17C	17x17D	17x17E
No. of Fuel Rod Locations	264	264	264	264	265
Fuel Clad O.D. (in.)	≥ 0.360	≥ 0.372	≥ 0.377	≥ 0.372	≥ 0.372
Fuel Clad I.D. (in.)	≤ 0.3150	≤ 0.3310	≤ 0.3330	≤ 0.3310	≤ 0.3310
Fuel Pellet Dia. (in.) (Note 3)	≤ 0.3088	≤ 0.3232	≤ 0.3252	≤ 0.3232	≤ 0.3232
Fuel Rod Pitch (in.)	≤ 0.496	≤ 0.496	≤ 0.502	≤ 0.496	≤ 0.496
Active Fuel Length (in.) (Note 5)	≤ 150	≤ 150	≤ 150	≤ 170	≤ 170
No. of Guide and/or Instrument Tubes	25	25	25	25	24
Guide/Instrument Tube Thickness (in.)	≥ 0.0160	≥ 0.0140	≥ 0.0200	≥ 0.0140	≥ 0.0140

Notes:

1. All dimensions are design nominal values. Maximum and minimum dimensions are specified to bound variations in design nominal values among fuel assemblies within a given array/class.
2. Each guide tube replaces four fuel rods.
3. Annular fuel pellets are allowed in the top and bottom 8" of the active fuel length
4. One Instrument Tube and eight Guide Bars (Solid ZR)
5. Fuel assemblies with axial fuel blankets are allowed for loading.

Table 7.C.3 (Page 1 of 5)

BWR FUEL ASSEMBLY CHARACTERISTICS (NOTE 1)

Fuel Assembly Array/Class	7x7B	8x8B	8x8C	8x8D	8x8E
Maximum planar-average initial enrichment (wt.% ²³⁵ U) (Note 11)	≤ 4.8	≤ 4.8	≤ 4.8	≤ 4.8	≤ 4.8
No. of Fuel Rod Locations (Full Length or Total/Full Length)	49	63 or 64	62	60 or 61	59
Fuel Clad O.D. (in.)	≥ 0.5630	≥ 0.4840	≥ 0.4830	≥ 0.4830	≥ 0.4930
Fuel Clad I.D. (in.)	≤ 0.4990	≤ 0.4295	≤ 0.4250	≤ 0.4230	≤ 0.4250
Fuel Pellet Dia. (in.)	≤ 0.4910	≤ 0.4195	≤ 0.4160	≤ 0.4140	≤ 0.4160
Fuel Rod Pitch (in.)	≤ 0.738	≤ 0.642	≤ 0.641	≤ 0.640	≤ 0.640
Design Active Fuel Length (in.) (Note 12)	≤ 150	≤ 150	≤ 150	≤ 150	≤ 150
No. of Water Rods (Note 10)	0	1 or 0	2	1-4 (Note 6)	5
Water Rod Thickness (in.)	N/A	≥ 0.034	>0.00	> 0.00	≥ 0.034
Channel Thickness (in.)	≤ 0.120	≤ 0.120	≤ 0.120	≤ 0.120	≤ 0.100

Table 7.C.3 (Page 2 of 5)

BWR FUEL ASSEMBLY CHARACTERISTICS (NOTE 1)

Fuel Assembly Array/Class	8x8F	9x9A	9x9B	9x9C	9x9D
Maximum planar-average initial enrichment (wt.% ²³⁵ U) (Note 11)	≤ 4.5 (Note 11)	≤ 4.8	≤ 4.8	≤ 4.8	< 4.8
No. of Fuel Rod Locations	64	74/66 (Note 4)	72	80	79
Fuel Clad O.D. (in.)	≥ 0.4576	≥ 0.4400	≥ 0.4330	≥ 0.4230	≥ 0.4240
Fuel Clad I.D. (in.)	≤ 0.3996	≤ 0.3840	≤ 0.3810	≤ 0.3640	≤ 0.3640
Fuel Pellet Dia. (in.)	≤ 0.3913	≤ 0.3760	≤ 0.3740	≤ 0.3565	≤ 0.3565
Fuel Rod Pitch (in.)	≤ 0.609	≤ 0.566	≤ 0.572	≤ 0.572	≤ 0.572
Design Active Fuel Length (in.) (Note 12)	≤ 150	≤ 150	≤ 150	≤ 150	≤ 150
No. of Water Rods (Note 10)	N/A (Note 2)	2	1 (Note 5)	1	2
Water Rod Thickness (in.)	≥ 0.0315	> 0.00	> 0.00	≥ 0.020	≥ 0.030
Channel Thickness (in.)	≤ 0.055	≤ 0.120	≤ 0.120	≤ 0.100	≤ 0.100

Table 7.C.3 (Page 3 of 5)

BWR FUEL ASSEMBLY CHARACTERISTICS (NOTE 1)

Fuel Assembly Array/Class	9x9E (Note 2)	9x9F (Note 2)	9x9G	10x10A	10x10B
Maximum planar-average initial enrichment (wt.% ²³⁵ U) (Note 11)	≤ 4.5 (Note 11)	≤ 4.5 (Note 11)	≤ 4.8	≤ 4.8	≤ 4.8
No. of Fuel Rods	76	76	72	92/78 (Note 7)	91/83 (Note 8)
Fuel Clad O.D. (in.)	≥ 0.4170	≥ 0.4430	≥ 0.4240	≥ 0.4040	≥ 0.3957
Fuel Clad I.D. (in.)	≤ 0.3640	≤ 0.3860	≤ 0.3640	≤ 0.3520	≤ 0.3480
Fuel Pellet Dia. (in.)	≤ 0.3530	≤ 0.3745	≤ 0.3565	≤ 0.3455	≤ 0.3420
Fuel Rod Pitch (in.)	≤ 0.572	≤ 0.572	≤ 0.572	≤ 0.510	≤ 0.510
Design Active Fuel Length (in.) (Note 12)	≤ 150	≤ 150	≤ 150	≤ 150	≤ 150
No. of Water Rods (Note 10)	5	5	1 (Note 5)	2	1 (Note 5)
Water Rod Thickness (in.)	≥ 0.120	≥ 0.0120	≥ 0.0320	≥ 0.0300	> 0
Channel Thickness (in.)	≤ 0.120	≤ 0.120	≤ 0.120	≤ 0.120	≤ 0.120

Table 7.C.3 (Page 4 of 5)

BWR FUEL ASSEMBLY CHARACTERISTICS (NOTE 1)

Fuel Assembly Array/Class	10x10C	10x10F	10x10G
Maximum planar-average initial enrichment (wt.% ²³⁵ U) (Note 11)	≤ 4.8	≤ 4.7	≤ 4.6
No. of Fuel Rod Locations	96	92/78 (Note 7)	96/84
Fuel Clad O.D. (in.)	≥ 0.3780	≥ 0.4035	≥ 0.3870
Fuel Clad I.D. (in.)	≤ 0.3294	≤ 0.3570	≤ 0.3400
Fuel Pellet Dia. (in.)	≤ 0.3224	≤ 0.3500	≤ 0.3340
Fuel Rod Pitch (in.)	≤ 0.488	≤ 0.510	≤ 0.512
Design Active Fuel Length (in.) (Note 12)	≤ 150	≤ 150	≤ 150
No. of Water Rods (Note 10)	5 (Note 9)	2	5 (Note 9)
Water Rod Thickness (in.)	≥ 0.031	≥ 0.030	≥ 0.031
Channel Thickness (in.)	≤ 0.055	≤ 0.120	≤ 0.060

Table 7.C.3 (Page 5 of 5)

BWR FUEL ASSEMBLY CHARACTERISTICS (NOTE 1)

Notes:

1. All dimensions are design nominal values. Maximum and minimum dimensions are specified to bound variations in design nominal values among fuel assemblies within a given array/class.
2. This assembly is known as “QUAD+.” It has four rectangular water cross segments dividing the assembly into four quadrants.
3. For the SPC 9x9-5 fuel assembly, each fuel rod must meet either the 9x9E or the 9x9F set of limits or clad O.D, clad I.D., and pellet diameter.
4. This assembly class contains 74 total rods; 66 full length rods and 8 partial length rods.
5. Square, replacing nine fuel rods.
6. Variable
7. This assembly class contains 92 total fuel rods; 78 full length rods and 14 partial length rods.
8. This assembly class contains 91 total fuel rods, 83 full length rods and 8 partial length rods.
9. One diamond-shaped water rod replacing the four center fuel rods and four rectangular water rods dividing the assembly into four quadrants.
10. These rods may be sealed at both ends and contain Zr material in lieu of water.
11. In accordance with the definition of undamaged fuel, certain assemblies may be limited to 3.3 wt.% U-235. When loading these fuel assemblies, all assemblies in the MPC are limited to 3.3 wt.% U-235.
12. Fuel assemblies with axial fuel blankets are allowed for loading.

Table 7.C.4(a)

FUEL ASSEMBLY MINIMUM BURNUP REQUIREMENTS
FOR TRANSPORTATION IN MPC-37

Assembly Classes	Configuration (Note 2)	Minimum Cooling Time (years)	Minimum Burnup (B) (GWd/mtU) as a Function of the Initial Enrichment (E) (Note 1) (wt% ²³⁵ U)
15x15B, C, D, E, F, H, I and 17x17A, B, C, D, E	1	3.0	$B = (-0.079224)*E^3 - (0.76419)*E^2 + (22.411)*E - 41.183$
		7.0	$B = (0.013212)*E^3 - (1.685)*E^2 + (24.595)*E - 42.603$
	2, 3, 4	3.0	$B = (0.36976)*E^3 - (5.8233)*E^2 + (40.599)*E - 58.346$
		7.0	$B = (0.33423)*E^3 - (5.1647)*E^2 + (36.549)*E - 52.348$
16x16A, B, C (Note 4)	1	3.0	$B = (-1.0361)*E^3 + (11.386)*E^2 - (29.174)*E + 20.85$
		7.0	$B = (-0.96572)*E^3 + (10.484)*E^2 - (25.982)*E + 17.515$
	2, 3, 4	3.0 (Combined)	$B = (-0.49680)*E^3 + (4.9471)*E^2 - (4.2373)*E - 7.3936$

Notes:

1. E = Initial enrichment (e.g., for 4.05 wt.% , E = 4.05).
2. Configurations are given in Table 7.C.5.
3. Deleted
4. 0 GWD/MTU burnup required for enrichments 2.25% or less.

Table 7.C.4(b)

IN-CORE OPERATING REQUIREMENTS FOR FUEL ASSEMBLIES WITH MINIMUM BURNUP
REQUIREMENTS FOR TRANSPORTATION IN MPC-37

Assembly Type	Specific Power (MW/mtU)	Moderator Temperature (K)	Fuel Temperature (K)	Soluble Boron (ppm)
Bounding Values (for Design Basis Calculations)				
15x15D, E, F, H	47.36	604	1169	1000
15x15B, C, I 16x16C	52.33	620	1219	1000
16x16A, B	51.90	608	1113	1000
17x17A, B, C, D, E	61.61	620	1181	1000

Table 7.C.5
LOADING CONFIGURATIONS FOR MPC-37

CONF.	ASSEMBLY SPECIFICATIONS (Notes 1, 3)
1	<ul style="list-style-type: none"> • All fuel assemblies must be undamaged. • Minimum burnup requirement in Table 7.C.4(a) applies to all fuel assemblies in the MPC. • Note 2(a)
2	<ul style="list-style-type: none"> • All fuel assemblies must be undamaged. • The minimum burnup requirement in Table 7.C.4(a) applies to all fuel assemblies in the MPC except those in locations 3-4, 3-5, 3-12 and 3-13 which have no minimum burnup requirement. • Note 2
3	<ul style="list-style-type: none"> • All fuel assemblies must be undamaged except fuel assemblies in locations 3-1, 3-3, 3-4, 3-5, 3-6, 3-7, 3-10, 3-11, 3-12, 3-13, 3-14 and 3-16 which can be damaged. Damaged Fuel Assemblies need to be loaded in DFCs. • For fuel assembly class 16x16C while loading into the above DFC pattern, fuel debris can be stored according to one of the following options: <ul style="list-style-type: none"> • Two opposite cells (i.e. 3-1 and 3-16, or 3-3 and 3-14, or 3-4 and 3-13, or 3-5 and 3-12, or 3-6 and 3-11, or 3-7 and 3-10) can be loaded with fuel debris with a total amount equivalent to 37 fuel rods or less per DFC. • A single corner cell (i.e. one of the cells 3-1, 3-3, 3-4, 3-5, 3-6, 3-7, 3-10, 3-11, 3-12, 3-13, 3-14 or 3-16) can be loaded with fuel debris with a total amount equivalent to 57 fuel rods or less per DFC. • Twelve (12) corner cells (i.e. cells 3-1, 3-3, 3-4, 3-5, 3-6, 3-7, 3-10, 3-11, 3-12, 3-13, 3-14 and 3-16) can be loaded with fuel debris with a total amount equivalent to 11 fuel rods or less per DFC. • The minimum burnup requirement in Table 7.C.4(a) applies to all fuel assemblies. • Note 2
4	<ul style="list-style-type: none"> • All fuel assemblies must be undamaged except fuel assemblies in locations 3-1, 3-7, 3-10 and 3-16 which can be fuel debris or Damaged Fuel Assemblies. Fuel debris or Damaged Fuel Assemblies need to be in DFCs. Locations 2-1, 2-5, 2-8 and 2-12 must be empty. • The minimum burnup requirement in Table 7.C.4(a) applies to all undamaged fuel assemblies. There are no minimum burnup requirements for fuel debris or Damaged Fuel Assemblies. • Note 2

Notes:

1. For basket locations refer to Figure 7.C.1.
2. For undamaged fuel assemblies that need to meet the minimum burnup requirements specified in Table 7.C.4(a), verification is required that during full power operation:
 - a) All fuel classes: control rod bank insertion did not exceed 8 inches from the top of the active fuel. Number of these assemblies is limited by the full capacity of the MPC per configurations 1 through 4.
 - OR
 - b) 16x16A and 16x16B classes: part length control rod bank insertion did not exceed 41.7 inches from the top of the

active fuel. Number of these assemblies is limited by the full capacity of the MPC per configurations 2 through 4. Remaining fuel assemblies must meet Note 2(a).

OR

- c) 16x16A and 16x16B classes: full length control rod bank insertion did not exceed 33.3 inches from the top of the active fuel and/or part length control rod bank insertion did not exceed 41.7 inches from the top of the active fuel. Number of these assemblies is limited to 9 per MPC stored in the remaining cells that are not qualified for fresh fuel, damaged fuel assemblies or fuel debris. Remaining fuel assemblies must meet Note 2(a).
3. Undamaged fuel assemblies in class 16x16A can be stored in DFCs in any basket cell location. Number of these assemblies is limited by the full capacity of the MPC per configurations 1 through 4.

Table 7.C.6

LOADING CONFIGURATIONS FOR MPC-89

CONFIGURATION	ASSEMBLY SPECIFICATIONS (Note 1)
1	<ul style="list-style-type: none"> • All assemblies undamaged.
3	<ul style="list-style-type: none"> • All assemblies undamaged except assemblies in locations 3-1, 3-3, 3-4, 3-9, 3-10, 3-13, 3-16, 3-19, 3-22, 3-25, 3-28, 3-31, 3-32, 3-37, 3-38 and 3-40 which can be damaged. Damaged assemblies need to be in DFCs.
4	<ul style="list-style-type: none"> • All assemblies undamaged except assemblies in locations 3-1, 3-3, 3-16, 3-19, 3-22, 3-25, 3-38 and 3-40 which can be fuel debris. Fuel debris need to be in DFCs.

Notes:

- 1. For basket locations refer to Figure 7.C.2

Table 7.C.7

LOADING PATTERNS FOR MPC-37

Pattern	Region (Note 1)	Maximum Decay Heat Load per Assembly (kW) (Note 2)	Fuel Specification
1	1	0.38	Table 7.C.8 (a), (b)
	2	1.7	
	3	0.50	
2	1	0.42	
	2	1.54	
	3	0.61	
3	1	0.61	
	2	1.23	
	3	0.74	
4	1	0.74	
	2	1.05	
	3	0.8	
5	1	0.8	
	2	0.95	
	3	0.84	
6	1	0.95	
	2	0.84	
	3	0.8	
7 (Notes 4, 5)	1	0.775	
	2	0.875	
	3	0.7	
		1.1	

Notes:

1. For basket region numbering scheme refer to Figure 7.C.1
2. All MPC loading and drying operations (including for “load and go” canisters) are performed under the Part 72 docket of 72-1032 or 72-1040. Additional heat load restrictions from those certificates based on drying operations may apply.
3. The Maximum Decay Heat Load per Assembly is calculated considering fuel average burnup adjusted per Table 7.C.15.
4. Pattern 7 is applicable only to Table 7.C.8(b) Alternatives 3 and 4.
5. Pattern 7 Region 3: The lower heat load is for fuel assemblies in Cells 3-2, 3-6, 3-7, 3-8, 3-9, 3-10, 3-11, and 3-15.

Table 7.C.8(a)

GENERIC FUEL SPECIFICATION FOR MPC-37 (NOTES 1, 2, 3, 4, 5)

Maximum Burnup (MWd/mtU)	Minimum Enrichment (wt%)	Maximum Decay Heat Load per Assembly (kW)											
		1.7	1.54	1.23	1.05	0.95	0.84	0.8	0.74	0.61	0.50	0.42	0.38
		Minimum Cooling Time (years)											
5,000	0.7	3(3.5)	3(3.5)	3(3.5)	3(3.5)	3(3.5)	4(4.5)	4(4.5)	4(4.5)	4(4.5)	4(4.5)	3(3.5)	3(3.5)
10,000	1	3(4.5)	3(4.5)	3(4.5)	3(4.5)	3(4.5)	4(6)	4(6)	4(6)	4(6)	4(6)	4(6)	3.5(5)
15,000	1.5	3(4)	3(4)	3(4)	3(4)	3(4)	5(7)	5(7)	5(7)	5(7)	5(7)	5(7)	5(7)
20,000	1.8	3(4.5)	3(4.5)	3(4.5)	3(4.5)	3(4.5)	5(7)	5(7)	5(7)	5(7)	6(8)	6(8)	7(9)
25,000	2.1	3(4.5)	3(4.5)	3(4.5)	3.5(5)	3.5(5)	5(7)	5(7)	6(8)	6(8)	7(9)	10(12)	13(15)
30,000	2.4	3(5)	3(5)	3.5(6)	4(6)	4.5(7)	6(8)	6(8)	6(8)	8(10)	10(12)	18(20)	24(26)
35,000	2.7	3(5)	3(5)	4(6)	4.5(7)	5(7)	7(9)	8(10)	8(10)	10(12)	16(18)	28(30)	34(36)
40,000	3	3.5(6)	3.5(6)	4.5(7)	5(7)	6(8)	8(10)	9(11)	10(12)	16(18)	24(26)	37(40)	43(46)
45,000	3.2	3.5(6)	4(6)	5(7)	6(8)	7(9)	11(14)	11(14)	14(17)	23(26)	32(35)	45(48)	52(55)
50,000	3.5	4(7)	4.5(7)	6(9)	8(11)	10(13)	14(17)	16(19)	20(23)	30(33)	39(42)	53(56)	59(-)
55,000	3.8	4.5(7)	5(8)	7(10)	11(14)	14(17)	20(23)	22(25)	26(29)	36(39)	46(49)	59(-)	-(-)
60,000	4.1	5(8)	6(9)	10(13)	15(18)	19(22)	25(28)	27(30)	31(34)	42(45)	52(55)	-(-)	-(-)
65,000	4.4	6(9)	7(10)	15(18)	19(22)	23(26)	30(33)	32(35)	36(39)	47(50)	57(60)	-(-)	-(-)
68,200	4.7	7(10)	9(12)	20(23)	23(26)	28(31)	34(37)	37(40)	41(44)	52(55)	-(-)	-(-)	-(-)

Notes are provided after Table 7.C.8(b).

Table 7.C.8(b)

16x16 A/B/C FUEL SPECIFICATION FOR MPC-37 (NOTES 1, 2, 3, 4, 5, 6, 7)

Maximum Burnup (MWd/mtU)	Minimum Enrichment (wt%)	Maximum Decay Heat Load per Assembly (kW)											
		1.7	1.54	1.23	1.05	0.95	0.84	0.8	0.74	0.61	0.50	0.42	0.38
		Minimum Cooling Time (years)											
Alternative 1 Fuel Specification (Note 6)													
5,000	0.7	3	3	3	3	3	3	3	3	3	3	3	3
10,000	1	3	3	3	3	3	4	4	4	4	5	5	5
15,000	1.5	3	3	3	3	3	4	4	4	4	4.5	5	6
20,000	1.8	3	3	3	3	3	4	4	4.5	5	6	6	7
25,000	2.1	3	3	3	4	4.5	4.5	5	5	6	6	8	10
30,000	2.4	3	3	4	4.5	5	6	6	6	6	7	12	17
35,000	2.7	3	3	3.5	4	4.5	6	6	6	7	11	21	26
40,000	3	3	3	4	4.5	5	6	7	7	11	17	29	35
45,000	3.2	3	3.5	4.5	5	6	8	9	10	17	25	37	43
50,000	3.5	3	4	5	6	7	11	12	15	23	31	44	50
55,000	3.8	3.5	4.5	6	7	10	16	17	20	29	37	50	56
60,000	4.2	4.5	5	7	10	13	22	22	24	34	43	56	62
65,000	4.4	5	6	10	16	19	26	28	30	39	48	61	68
Alternative 2 Fuel Specification (Note 6)													
25,000	1.8	3	3	3	4	4.5	4.5	5	5	6	7	8	10
30,000	1.8	3	3	4	4.5	5	6	6	6	7	8	14	19
35,000	1.8	3	4	4.5	4	6	7	8	8	12	17	24	29
40,000	2.8	3	4	5	6	6	7	7	9	12	19	29	35
45,000	2.8	4.5	4.5	6	6	8	10	11	13	18	27	37	43
60,000	3.8	7	8	10	13	17	24	26	28	36	45	56	62

Table 7.C.8(b) (CONTINUE)
 16x16 A/B/C FUEL SPECIFICATION FOR MPC-37 (NOTES 1, 2, 3, 4, 5, 6, 8)

Maximum Burnup (MWd/mtU)	Minimum Enrichment (wt%)	Maximum Decay Heat Load per Assembly (kW)			
		1.1	0.875	0.775	0.7
		Minimum Cooling Time (years)			
Alternative 3 Fuel Specification (Note 6)					
20,000	1.8	-	32	32	-
25,000	1.8	8	-	-	8
30,000	2.3	8	-	-	12
40,000	4.0	12	-	-	8
60,000	4.4	8	-	-	8
Alternative 4 Fuel Specification (Note 6)					
50,000	2.3	-	-	17	-
55,000	3.9	-	-	17	-
45,000	2.8	9	-	-	9
50,000	3.9	9	-	-	9
55,000	3.8	-	13	-	-

Notes are provided on next page.

Notes for Table 7.C.8(a) and Table 7.C.8(b)

Note 1: Example: Qualifying a fuel assembly in class 17x17A with burnup of 44,000 MWD/MTU, enrichment 3.21 wt % and cooling time of 5 years and heat load of 1160 W and inserted NFH (BPRAs) with cooling time of 4 years and 20,000 MWD/MTU burnup and heat load of 17 W into Region 2 of Loading Pattern 1 in Table 7.C.7:

- a) **Allowable Heat Load:** In Table 7.C.7 find the maximum allowable decay heat load per basket cell for the loaded region and the loading pattern. In this example the maximum decay heat load per basket cell in region 2 of loading pattern 1 is 1.7 kW which is greater than the heat load of the fuel assembly 1160 W combined with 17 W heat load from inserts.
- b) **Burnup:** In Table 7.C.8(a) locate value of burnup that is equal or greater than 44,000 MWD/MTU. In this example the closest higher value is 45,000 MWD/MTU.
- c) **Enrichment:** In Table 7.C.8(a) confirm that the minimum enrichment next to selected maximum burnup is lower or equal to fuel assembly enrichment. In this example the minimum enrichment next to 45,000 MWD/MTU is 3.2 wt% which is lower than assembly enrichment of 3.21 wt%.
- d) **Cooling Time:**
 - i. Confirm that fuel assembly cooling time is equal or greater than value in Table 7.C.8(a). In this example, the minimum cooling time is found in the intersection of row for assembly with burnup of 45,000 MWD/MTU and enrichment of 3.21 wt% and column for minimum decay heat of 1.7 kW. The minimum cooling time is thus 3.5 years which is in this example lower than the actual assembly cooling of 5 years.
 - ii. **Interpolation:** A linear interpolation is allowed across burnups and enrichments to obtain the minimum required cooling time.
- e) **NFH:** Confirm that NFH cooling time is equal or greater than value in Table 7.C.8(a) and Table 7.C.13. In this example, the NFH is inserted in a fuel assembly for which the minimum required cooling time is 3.5 years. The minimum required cooling time for NFH with 20,000 MWD/MTU burnup in Table 7.C.1 is 3 years. See also Note 7.
- f) **Conclusion:** Assembly with burnup of 44,000 MWD/MTU, enrichment 3.21 wt % and cooling time of 5 years and inserted NFH burnup of 20,000 MWD/MTU and with cooling time of 4 years is acceptable for loading into Region 2 of Loading Pattern 1.

Note 2: Fuel specification in Table 7.C.8(a) is applicable to all fuel assembly classes in Table 7.C.2 with an active length less than or equal to 150 inches. Cooling times in the brackets are applicable to fuel types with an active length greater than 150 inches in Table 7.C.2. Alternatively, fuel specification in Table 7.C.8(b) is applicable to 16x16A/B/C fuel assembly classes listed in Table 7.C.2.

Note 3: Cooling times are limited to 60 years. Dash line (-) means that the fuel combination cannot be loaded in the corresponding region.

Note 4: The decay heat load limits must be satisfied independently of fuel burnup, enrichment and cooling times listed in this table. The listed burnup, enrichment and cooling times are not intended to show the compliance with decay heat limits.

Note 5: For fuel assemblies with natural Uranium or depleted axial blankets, the average burnup is calculated excluding axial blankets.

Note 6: For cask loaded under Table 7.C.8(b), a cask may be loaded using fuel specification alternative 1, 2, both 1 and 2, alternative 3 or alternative 4. Interpolation is not allowed between alternatives.

Note 7: For cask loaded under Table 7.C.8(b) Alternatives 1 or 2:

Option 1: TPDs, water displacement guide tube plugs, and orifice rod assemblies are not allowed. The minimum cooling time of BPRAs, WABAs, and vibration suppressor inserts is 25 years, independent of fuel cooling time. The requirements for other NFH devices are in Table

7.C.13.

Option 2: Except ITTRs and GTAs, NFH is not allowed in Region 1 and Region 3. The NFH devices allowed in Region 2 are APSRs, control components, ITTRs, GTAs and one NSA. The maximum burnup for the NFH devices of APSRs, control components and NSA is 630,000 MWD/MTU. Independent from burnup, the minimum cooling time for these devices is 7 years, except for ITTRs and GTAs with no required minimum cooling time. This option is only for loading patterns 4, 5 and 6, as specified in Table 7.C.7.

Option 3: Except ITTRs and GTAs, NFH is not allowed in Region 1 and Region 3. The NFH devices allowed in Region 2 are APSRs, and control components, GTAs and ITTRs. The maximum burnup for the NFH devices of APSRs and control components is 630,000 MWD/MTU. Independent from burnup, the minimum cooling time for these devices is 7 years, except for ITTRs and GTAs with no required minimum cooling time. The maximum fuel burnup for this option is limited to 60,000 MWD/MTU.

Note 8: For cask loaded under Table 7.C.8(b) Alternatives 3 or 4: Except ITTRs and GTAs, NFH is not allowed in Region 1 and Region 3. The NFH devices allowed in Region 2 are ITTRs, GTAs and one NSA. Independent from burnup, the minimum cooling time for NSA is 7 years. There is no required minimum cooling time for ITTRs and GTAs.

Table 7.C.9

LOADING PATTERNS FOR MPC-89 (BWR FUEL ASSEMBLY)

Pattern	Region (Note 1)	Maximum Decay Heat Load per Assembly (kW) (Note 2)	Fuel Specification
1	1	0.15	Table 7.C.10
	2	0.62	
	3	0.15	
2	1	0.18	
	2	0.58	
	3	0.18	
3	1	0.27	
	2	0.47	
	3	0.27	
4	1	0.32	
	2	0.41	
	3	0.32	
5	1	0.35	
	2	0.37	
	3	0.35	

Notes:

1. For basket region numbering scheme refer to Figure 7.C.2.
2. All MPC loading and drying operations (including for “load and go” canisters) are performed under the Part 72 docket of 72-1032 or 72-1040. Additional heat load restrictions from those certificates based on drying operations may apply.
3. The Maximum Decay Heat Load per Assembly is calculated considering fuel average burnup adjusted per Table 7.C.15.

Table 7.C.10

FUEL SPECIFICATION FOR MPC-89 (NOTES 1, 2, 3)

Maximum Burnup (MWd/mtU)	Minimum Enrichment (wt%)	Maximum Decay Heat Load per Assembly (kW)									
		0.62	0.58	0.47	0.41	0.37	0.35	0.32	0.27	0.18	0.15
		Minimum Cooling Time (years)									
5,000	0.7	3	3	3	3	3	3	3	3	4	4
10,000	0.7	3	3	3	3	3	4	4	4	5	5
15,000	1	3	3	3	3	3	5	5	5	6	7
20,000	1.6	3	3	3	3	3	5	5	5	7	8
25,000	2	3	3	3	3.5	3.5	6	6	6	10	13
30,000	2.3	3	3	3.5	4	4	6	6	7	16	22
35,000	2.6	3	3	4	4.5	5	6	7	9	26	32
40,000	2.8	3.5	3.5	4.5	5	6	9	10	15	34	40
45,000	3	4	4	5	6	7	13	15	22	43	50
50,000	3.2	4.5	4.5	6	8	10	20	22	28	51	58
55,000	3.4	5	5	8	11	14	25	28	34	56	-
60,000	3.8	5	6	10	14	18	29	31	38	60	-
65,000	4.2	6	7	12	18	22	32	35	45	-	-

Notes:

Note 1: Note 1 is provided under Table 7.C.8.

Note 2: Cooling times are limited to 60 years. Dash line (-) means that the fuel combination cannot be loaded in the corresponding region.

Note 3: The decay heat load limits must be satisfied independently of fuel burnup, enrichment and cooling times listed in this table. The listed burnup, enrichment and cooling times are not intended to show the compliance with decay heat limits.

Note 4: For fuel assemblies with natural Uranium or depleted axial blanket, the average burnup is calculated excluding the portion of axial blankets exceeding 6 inches in length on either side of the assembly.

Table 7.C.11

MPC BACKFILL PRESSURE REQUIREMENTS (NOTE 1)

MPC Type	Pressure Range (Note 2)
MPC-37	≥ 39.0 psig and ≤ 46.0 psig
MPC-89	≥ 39.0 psig and ≤ 47.5 psig
<p>Note 1: Canisters loaded under storage certificates 72-1032 and 72-1040 shall meet these requirements for transport in the HI-STAR 190.</p> <p>Note 2: Helium used for backfill of MPC shall have a purity of $\geq 99.995\%$. The pressure range is based on a reference temperature of 70°F.</p>	

Table 7.C.12

MPC BACKFILL PRESSURE REQUIREMENTS FOR SUB-DESIGN BASIS HEAT LOAD (NOTE 1)

MPC Type	Pressure Range (Note 2)
MPC-37	≥ 39.0 psig and ≤ 50.0 psig
MPC-89	≥ 39.0 psig and ≤ 50.0 psig
<p>Note 1: Sub-Design Basis Heat Load is defined as 80% of the design basis heat load in every storage location defined in Tables 7.C.7 and 7.C.9 for MPC-37 and MPC-89 respectively. Canisters loaded under storage certificates 72-1032 and 72-1040 shall meet these requirements for transport in the HI-STAR 190.</p> <p>Note 2: Helium used for backfill of MPC shall have a purity of $\geq 99.995\%$. The pressure range is based on a reference temperature of 70°F.</p>	

Table 7.C.13
NON-FUEL HARDWARE BURNUP AND COOLING TIME LIMITS (NOTES 1, 2, 8)

Post-irradiation Cooling Time (yrs)	Inserts (Note 4) Maximum Burnup (MWD/MTU)	NSA or Guide Tube Hardware (Note 5, 9) Maximum Burnup (MWD/MTU)	Control Component (Note 6) Maximum Burnup (MWD/MTU)	APSR Maximum Burnup (MWD/MTU)
≥ 3	≤ 24,635	N/A (Note 7)	N/A	N/A
≥ 4	≤ 30,000	≤ 20,000	N/A	N/A
≥ 5	≤ 36,748	≤ 25,000	≤ 630,000	≤ 45,000
≥ 6	≤ 44,102	≤ 30,000	-	≤ 54,500
≥ 7	≤ 52,900	≤ 40,000	-	≤ 68,000
≥ 8	≤ 60,000	≤ 45,000	-	≤ 83,000
≥ 9	-	≤ 50,000	-	≤ 111,000
≥ 10	-	≤ 60,000	-	≤ 180,000
≥ 11	-	≤ 75,000	-	≤ 630,000
≥ 12	-	≤ 90,000	-	-
≥ 13	-	≤ 180,000	-	-
≥ 14	-	≤ 630,000	-	-

NOTES:

1. Burnups for non-fuel hardware are to be determined based on the burnup and uranium mass of the fuel assemblies in which the component was inserted during reactor operation.
2. Linear interpolation between points is permitted, except that NSA or Guide Tube Hardware and APSR burnups > 180,000 MWD/MTU and ≤ 630,000 MWD/MTU must be cooled ≥ 14 years and ≥ 11 years, respectively.
3. Deleted
4. Includes Burnable Poison Rod Assemblies (BPRAs), Wet Annular Burnable Absorbers (WABAs), and vibration suppressor inserts. For TPDs with absorber rodlets refer to Note 9.
5. Includes Thimble Plug Devices (TPDs), water displacement guide tube plugs, and orifice rod assemblies.
6. Includes Control Rod Assemblies (CRAs), Control Element Assemblies (CEAs), and Rod Cluster Control Assemblies (RCCAs).
7. N/A means not authorized for loading at this cooling time.
8. Non-fuel hardware burnup and cooling time limits are not applicable to Instrument Tube Tie Rods (ITTRs) and Guide Tube Anchors (GTAs), since they are installed post-irradiation.
9. Maximum burnup for TPDs with absorber rodlets is limited to 60,000 MWD/MTU.

TABLE 7.C.14
MPC CAVITY DRYING LIMITS FOR “LOAD-AND-GO” MPCs (NOTE 1)

MPC Type	Fuel Burnup (MWD/MTU)	MPC Heat Load (kW)	Method of Moisture Removal (Notes 2 and 3)
MPC-37	All burnups up to maximum in Table 7.C.1	\leq Design Basis Heat Load (Table 7.C.7)	VDS or FHD
		\leq Design Basis Heat Load (Table 7.C.7) with one or more 15x15I Fuel Assemblies	FHD
MPC-89	All assemblies \leq 45,000	\leq Design Basis Heat Load (Table 7.C.9)	VDS or FHD
	One or more assemblies $>$ 45,000	\leq 95% of Design Basis Heat Load (Table 7.C.9) ^{Note 4}	VDS or FHD
		\leq Design Basis Heat Load (Table 7.C.9)	FHD

NOTES:

1. The limits presented in this table are applicable only for “load-and-go” MPCs where the contents are loaded and dried under this certificate. These requirements do not apply to MPCs that have been previously dried and stored under a 10 CFR Part 72 storage certificate.
2. VDS means a vacuum drying system. The acceptance criterion when using a VDS is the MPC cavity pressure shall be \leq 3 torr for \geq 30 minutes while the MPC is isolated from the vacuum pump. Vacuum drying of the MPC must be performed with the annular gap between the MPC and the TRANSFER CASK filled with water.
3. FHD means a forced helium dehydration system. The acceptance criterion when using an FHD system is the gas temperature exiting the demoisurizer shall be \leq 21°F for \geq 30 minutes or the gas dew point exiting the MPC shall be \leq 22.9°F for \geq 30 minutes.
3. 95% of the allowable heat load in every storage location presented in Table 7.C.9.

Table 7.C.15

ADJUSTMENTS OF BURNUP FOR CALCULATION OF ASSEMBLY DECAY HEAT

- PWR Assemblies
 - With blankets: No adjustment (see Note 5 in Table 7.C.8)
 - With exposure to APSRs
 - Up to 15 GWd/mtU: add 2 GWd/mtU
 - Up to 30 GWd/mtU: add 1 GWd/mtU
 - Above 30 GWd/mtU: no adjustment needed
 - All other
 - Up to 15 GWd/mtU: add 1 GWd/mtU
 - Up to 30 GWd/mtU: add 0.5 GWd/mtU
 - Above 30 GWd/mtU: no adjustment needed
- BWR Assemblies
 - Without part length rods
 - Up to 20 GWd/mtU: add 1 GWd/mtU
 - Up to 40 GWd/mtU: add 0.5 GWd/mtU
 - Above 40 GWd/mtU: no adjustment needed
 - With part length rods
 - Apply adjustment defined above for assemblies without part length rods
 - Then increase burnup by 8%

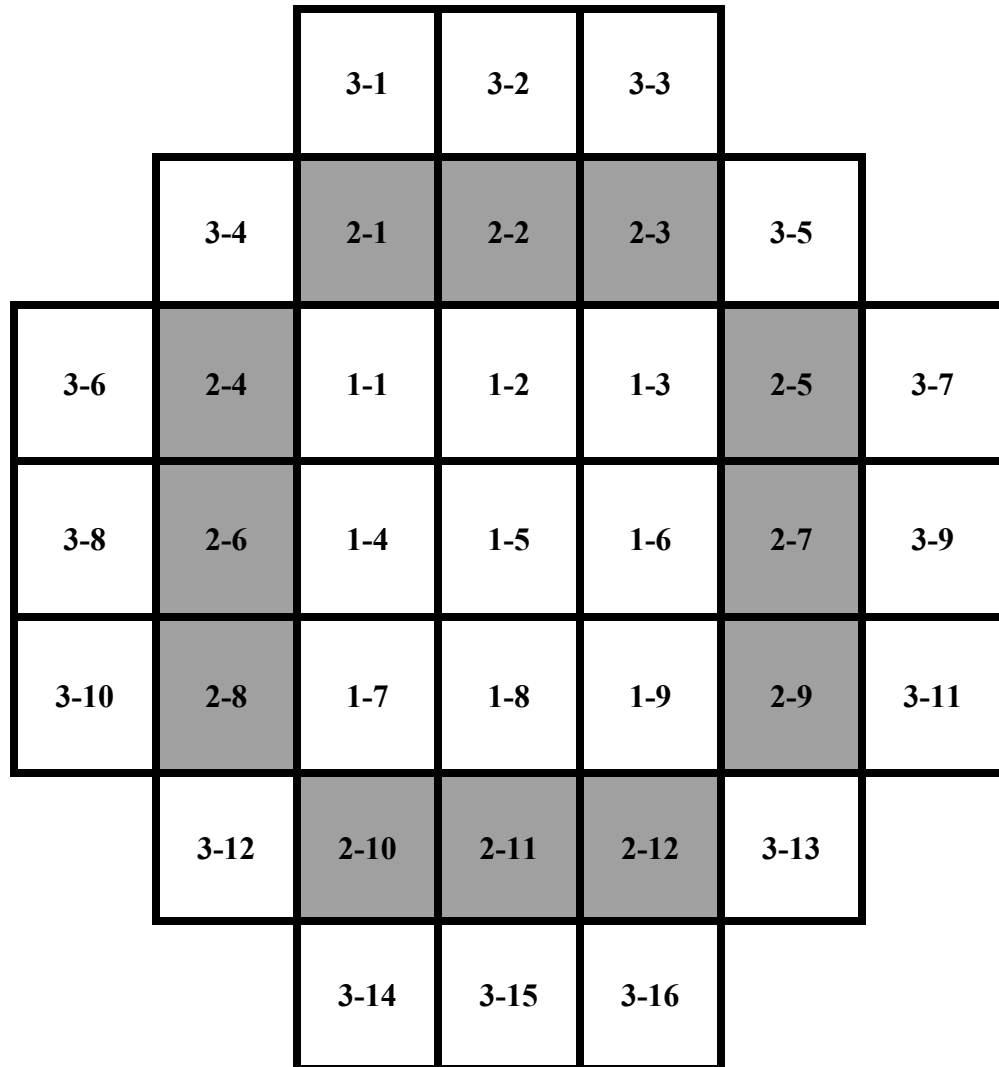

Legend

Region-Cell ID

Figure 7.C.1

MPC-37 REGION-CELL IDENTIFICATION

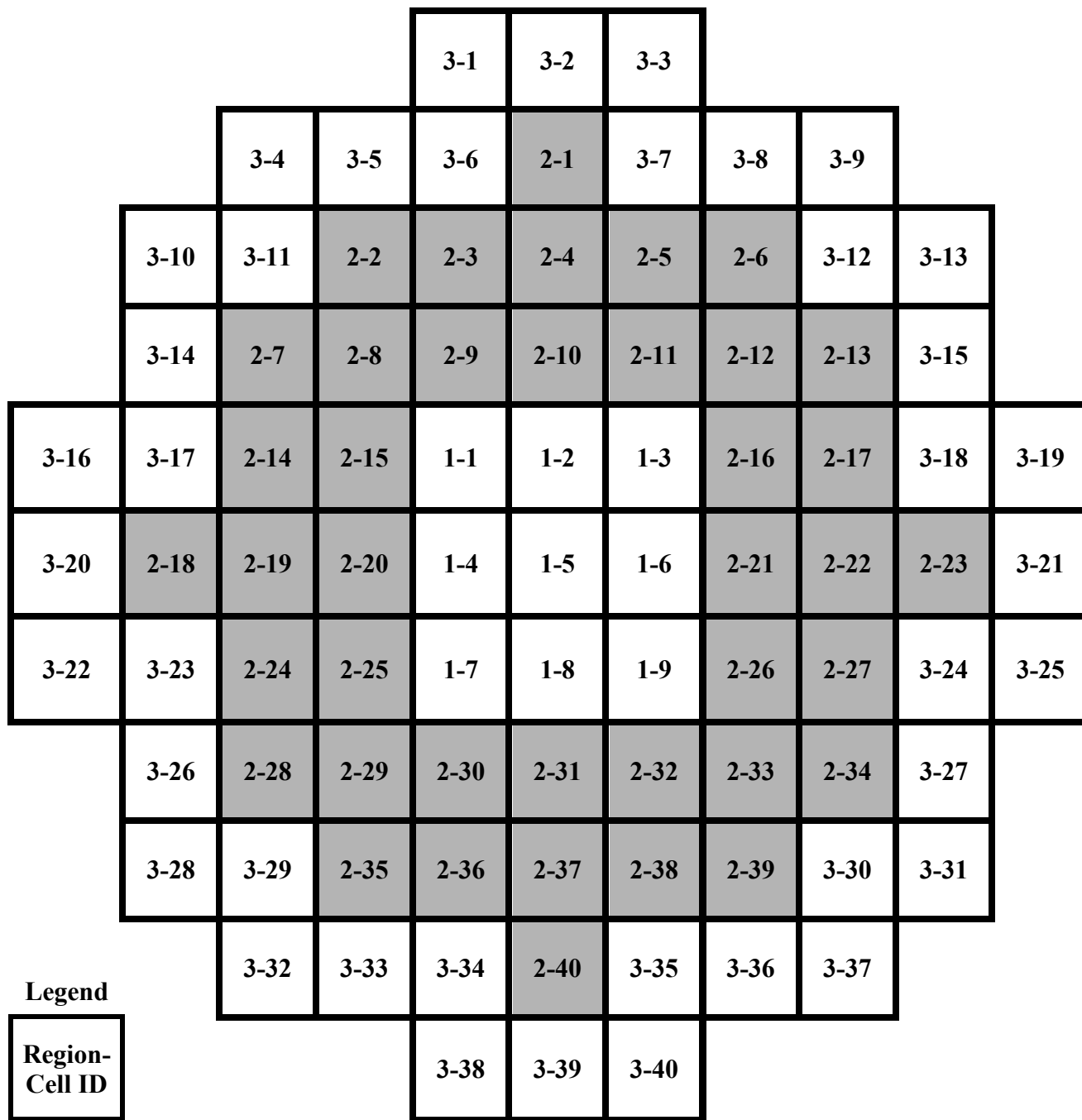

Figure 7.C.2

MPC-89 REGION-CELL IDENTIFICATION

APPENDIX 7.D

BURNUP VERIFICATION CONDITIONS OF THE HI-STAR 190 PACKAGE

For those spent fuel assemblies that need to meet the burnup requirements specified in Table 7.C.4(a), a burnup verification shall be performed in accordance with either Method A or Method B described below.

Method A: Burnup Verification Through Quantitative Burnup Measurement

For each assembly in the MPC-37 where burnup credit is required, the minimum burnup is determined from the burnup requirement applicable to the configuration chosen for the cask (see Table 7.C.4(a)). A measurement is then performed that confirms that the fuel assembly burnup exceeds this minimum burnup. The measurement technique may be calibrated to the reactor records for a representative set of assemblies. The assembly burnup value to be compared with the minimum required burnup should be the measured burnup value as adjusted by reducing the value by a combination of the uncertainties in the calibration method and the measurement itself.

Method B: Burnup Verification Through an Administrative Procedure and Qualitative Measurements

Depending on the location in the basket, assemblies loaded into a specific MPC-37 basket can either be fresh, or have to meet a single minimum burnup value. The assembly burnup value to be compared with the minimum required burnup should be the reactor record burnup value as adjusted by reducing the value by the uncertainties in the reactor record value. An administrative procedure shall be established that prescribes the following steps, which shall be performed for each cask loading:

- Based on a review of the reactor records, all assemblies in the spent fuel pool that have a burnup that is below the minimum required burnup of the loading curve for the cask to be loaded are identified.
- After the cask loading, but before the release for shipment of the cask, the presence and location of all those identified assemblies is verified, except for those assemblies that have been loaded as fresh assemblies into the cask.

Additionally, for all assemblies to be loaded that are required to meet a minimum burnup, a visual check or gross measurement shall be performed that verifies that the assembly is not a fresh assembly. This measurement is not applicable if reactor records show that at the time of fuel loading, no fresh fuel assemblies were present in the spent fuel pool.

CHAPTER 8: ACCEPTANCE TESTS AND MAINTENANCE PROGRAM

8.0 INTRODUCTION

This chapter identifies the acceptance tests and maintenance program to be conducted on the HI-STAR 190 Package to verify that the structures, systems and components (SSCs) classified as *important-to-safety* have been fabricated, assembled, inspected, tested, accepted, and maintained in accordance with the requirements set forth in this Safety Analysis Report (SAR), all applicable regulatory requirements, and the Certificate of Compliance (CoC). The acceptance criteria and maintenance program described in this chapter are in full compliance with the requirements of 10CFR Part 71 Subpart G [8.0.1].

An MPC acceptance test and maintenance program shall have been specified by and performed under the aegis of the HI-STORM FW FSAR (Docket # 72-1032) or the HI-STORM UMAX FSAR (Docket # 72-1040) whether or not the MPC is used in a “load and go” scenario as described in Chapter 7. Hence the Part 72 dockets essentially establish a minimum standard of pedigree for the MPCs. Nevertheless, this chapter independently specifies an MPC acceptance tests and maintenance program to set all the requirements necessary for the suitability of the MPC for use in HI-STAR 190 under Part 71 license. Finally, for MPCs deployed at an ISFSI, this chapter also identifies MPC supplemental requirements, some of which are reflected directly or indirectly in the safety analysis approach of the HI-STAR 190 Package documented in this SAR, to ensure total suitability of the MPC for use in HI-STAR 190. An MPC Transportability Checklist provided in Appendix 8.A of this chapter includes the MPC supplemental requirements that must be met prior to transportation of any MPC in HI-STAR 190.

8.1 ACCEPTANCE TESTS

In this section the inspections and acceptance tests to be performed on the HI-STAR 190 Package prior to its use are summarized. These inspections and tests provide assurance that the HI-STAR 190 Package has been fabricated, assembled and accepted for use and loading under the conditions specified in Chapter 7 of this SAR and the USNRC issued CoC in accordance with the requirements of 10CFR Part 71.

8.1.1 Visual Inspections and Measurements

The HI-STAR 190 Packaging (including the MPC) shall be assembled in accordance with the drawing package referenced in the CoC. Dimensional tolerances that define the limits on the dimensions critical to the licensing basis analysis are included in these drawings. Fabrication drawings provide additional dimensional tolerances necessary to ensure fit-up of parts as well as compliance with the design conditions. A fabrication sampling plan shall be made and controls shall be exercised to ensure that the packaging conforms to the dimensions and tolerances specified on the licensing and fabrication drawings. These dimensions are subject to independent confirmation and documentation in accordance with the Holtec QA program approved in NRC Docket No. 71-0784.

The following shall be verified as part of visual inspections and measurements:

- Visual inspections and measurements shall be made to ensure that the packaging effectiveness is not significantly reduced. Any *important-to-safety* component found to be under the minimum thickness requirement shall be repaired or replaced as required.
- Visual inspections shall be made to verify that neutron absorber panels and basket shims are present as required by the MPC basket design (solid shims may be required as specified in Table 8.1.10B).
- The packaging shall be visually inspected to ensure it is conspicuously and durably marked with the proper markings/labels in accordance with 10CFR71.85(c).
- The packaging shall be inspected for cleanliness and preparation for shipping in accordance with written and approved procedures.

The visual inspection and measurement results for the HI-STAR 190 Packaging shall become part of the final quality documentation package.

8.1.2 Weld Examination

The examination of HI-STAR 190 Packaging welds shall be performed in accordance with the drawing package referenced in the CoC and applicable codes and standards in Table 8.1.5, including alternatives as specified in Table 8.1.6. Weld examinations and repairs shall be performed as specified below. All code weld inspections shall be performed in accordance with written and approved procedures by personnel qualified in accordance with SNT-TC-1A

[8.1.2]. All required inspections, examinations, and tests shall become part of the final quality documentation package.

The following specific weld requirements shall be followed in order to verify fabrication in accordance with the drawings.

1. Cask containment boundary welds including any attachment welds (and temporary welds to the containment boundary) shall be examined in accordance with ASME Code Section V, with acceptance criteria per ASME Code Section III, Subsection NB, Article NB-5300. Examinations, Visual (VT), Radiographic (RT), and Liquid Penetrant (PT) or Magnetic Particle (MT), apply to these welds as defined by the code. These welds shall be repaired in accordance with the requirements of the ASME Code Section III, Article NB-4450 and examined after repair in the same manner as the original weld. Weld overlays for cask sealing surfaces shall be VT and PT examined to insure that a leakage path between the containment space and the outside environment that may violate the specified cask leak tightness criterion is detected and eliminated. Although ASME Code Section III, Subsection NB does not require visual examination of welds, the welds will be visually examined to ensure conformance with the fabrication drawings (e.g. proper geometry, workmanship etc.).
2. Code welds in the cask, impact limiter, and MPC spacer (excluding those listed above) shall be examined in accordance with ASME Code Section V, with acceptance criteria per ASME Code Section III, Subsection NF, Article NF-5300. These welds shall be repaired in accordance with ASME Code Section III, Article NF-4450 and examined after repair in the same manner as the original weld. These weld requirements are not applicable to NITS welds (e.g. seal welds) on the cask, impact limiters and MPC Spacer.
3. Code welds in the MPC shall be examined in accordance with ASME Code Section V, with acceptance criteria per ASME Code Section III, Subsection NB, NF, and NG (Articles NB-5300, NF-5300 and NG-5300) as applicable. Examinations, Visual (VT), Radiographic (RT), and Liquid Penetrant (PT) or Magnetic Particle (MT), apply to these welds as defined by the code. These welds shall be repaired in accordance with the requirements of the ASME Code Section III, Articles NB-4450, NF-4450, and NG-4450, as applicable, and examined after repair in the same manner as the original weld. Although ASME Code Section III, Subsection NB does not require visual examination of welds, the welds will be visually examined to ensure conformance with the fabrication drawings (e.g. proper geometry, workmanship etc.).
4. The MPC lid-to-shell weld shall be examined using a progressive multi-layer liquid penetrant (PT) examination during welding. The multi-layer PT must, at a minimum, include the root and final weld layers and one intermediate PT after each approximately 3/8 inch weld depth has been completed.

5. Basket welds shall be examined and repaired in accordance with NDE specified in the drawing package and with written and approved procedures developed specifically for welding Metamic-HT with acceptance criteria per ASME Section V, Article 1, Paragraph T-150 (2007 Edition). The basket welds, made by the Friction Stir Weld process, are classified as Category C per NG-3351.3 and belonging to Type III (by virtue of being corner joint with a thru-thickness “stir zone”) in Table NG-3352-1. These weld requirements are not applicable to welds identified as NITS on the drawing package.
6. Non-code welds shall be examined and repaired in accordance with written and approved procedures.

8.1.3 Structural and Pressure Tests

The cask containment boundary will be examined and tested by combination of methods (including helium leak test, pressure test, MT, and/or PT, as specified in the licensing drawing package and this chapter) to verify that it is free of cracks, pinholes, uncontrolled voids or other defects that could significantly reduce the effectiveness of the packaging. MPC containment boundary (or pressure boundary as applicable) will be examined and tested by a combination of methods (including helium leak test, pressure test, RT, UT, MT and/or PT, as applicable) to verify that it is free of cracks, pinholes, uncontrolled voids or other defects that could significantly reduce its confinement effectiveness..

8.1.3.1 Lifting Attachments

Two top trunnions are provided for vertical lifting and handling of the loaded or empty cask. The top trunnions are required to be designed, tested and inspected in accordance with ANSI N14.6 [8.1.3]. Two bottom trunnions are provided for rotation of the loaded or empty cask for downending/upending operations.

The top trunnions shall be tested in accordance with ANSI N14.6 at 300% of the maximum design service lifting load (the full weight of the loaded cask at a minimum). Load tests may be performed in excess of the test loads specified above provided an engineering evaluation is performed to ensure trunnions or other cask components will not be damaged by the load test. The test load shall be applied for a minimum of 10 minutes. The accessible parts of the top trunnions (the cantilevered portion outside the cask), and the local cask areas shall then be visually examined to verify no deformation, distortion, or cracking has occurred. Any evidence of deformation (other than minor localized surface deformation due to contact pressure between lifting device/load test device and top trunnion), distortion or cracking of the trunnion or adjacent cask areas shall require replacement of the trunnion and/or repair of the cask. Following any replacements and/or major repair, as defined in ANSI N14.6, the load testing shall be re-performed and the components re-examined in accordance with the original procedure and acceptance criteria. Testing shall be performed in accordance with written and approved procedures. Certified material test reports verifying trunnion material mechanical

properties meet ASME Code Section II requirements shall be provided. Test results shall be documented and shall become part of the final quality documentation package.

The requirements in the preceding paragraph do not apply to the bottom trunnions since the bottom trunnions are not used for cask lifting.

8.1.3.2 Pressure Testing

Pressure testing of the HI-STAR 190 cask containment boundary (cavity space) is required. The cask cavity shall be pressure tested in accordance with ASME Section III, Subsection NB, NB-6000 at a test pressure of not less than 150% of cask cavity maximum normal operating pressure per 10CFR71.85(b) or at a test pressure of 125% of the cask cavity design internal pressure; whichever is greater. Pressure testing may be performed using a single temporary test seal on the lid.

Pressure testing of the MPC containment boundary (or pressure boundary as applicable) is required to verify the lid-to-shell field weld in accordance with the requirements of the ASME Code Section III, Subsection NB, Article NB-6000 and applicable sub-articles, when field welding of the MPC lid-to-shell weld is completed. If hydrostatic testing is used, the MPC shall be pressure tested to 125% of design pressure. If pneumatic testing is used, the MPC shall be pressure tested to 120% of design pressure.

All pressure testing shall be performed in accordance with approved procedures written by qualified personnel in accordance with Holtec QA program. The written and approved test procedure shall clearly define the test equipment arrangement. For quality assurance, trained and qualified personnel shall perform the test and the leakage verification in accordance with written procedures and document the results. The leakage verification shall be performed in accordance with written quality assurance program.

Test results shall be documented and shall become part of the final quality documentation package.

8.1.4 Leakage Tests

Leakage rate tests on the HI-STAR 190 cask containment system and MPC containment boundary (See Appendix 8.A for applicability) shall be performed per written and approved procedures in accordance with the requirements of Chapter 7 and the requirements of ANSI N14.5 [8.1.6] specified in this Chapter. Tables 8.1.1 and 8.1.2 specify the allowable leakage rate and test sensitivity as well as components to be tested for fabrication, pre-shipment, periodic and maintenance leakage rate tests.

A pre-shipment leakage rate test of cask containment seals is performed following each loading of the sealed MPC into the HI-STAR 190 cask. This pre-shipment leakage rate test is valid for

1 year as long as the seals are not disturbed by removing closure fasteners or as justified by the requirements in SAR paragraph 8.2.3.6.

In case of an unsatisfactory leakage rate, weld repair, seal surface repair/polishing and/or seal change and retest shall be performed until the test acceptance criterion is satisfied.

Leakage rate testing procedures shall be approved by an ASNT Level III specialist. The written and approved test procedure shall clearly define the test equipment arrangement. Leakage rate testing shall be performed by personnel who are qualified and certified in accordance with the requirements of SNT-TC-1A [8.1.2]. Leakage rate testing shall be performed in accordance with a written quality assurance program.

The fabrication leakage rate test results shall become part of the final quality documentation package. The pre-shipment leakage rate test shall be documented in accordance with the user's quality assurance program.

8.1.5 Component and Material Tests

8.1.5.1 Seals

Cask closure seals are specified in the drawing package referenced in the CoC to provide a high degree of assurance of leak tightness under normal and accident conditions of transport. Seal tests under the most severe package service conditions including performance at pressure under high and low temperatures will not challenge the capabilities of these seals and thus are not required. Seal specifications are in accordance with the manufacturer recommendation.

8.1.5.2 Impact Testing

To provide protection against brittle fracture under cold conditions, fracture toughness test criteria of cask ferritic components, including containment boundary welds, are specified in Table 8.1.7 and Table 8.1.8. Code alternatives listed in Table 8.1.6 may apply.

Test results shall become part of the final quality documentation package.

8.1.5.3 Impact Limiter Crush Material Testing

Verification of the transport impact limiter crush material crush strength is accomplished by performance of a crush test of sample blocks. The verification tests may be performed by Holtec, the crush material supplier, or third party testing facility in accordance with approved procedures. Impact limiter material crush strength is specified in the drawing package referenced in the CoC.

The certified test results shall be retained by Holtec International as archive record for each batch of impact limiter crush material manufactured and used. Test results shall be documented and shall become part of the final quality documentation package.

8.1.5.4 Neutron Shielding Material

Manufacturing of Holtite neutron shielding material shall be conducted according to approved written procedures that shall ensure mix ratios and mixing methods are controlled in order to achieve proper material composition and distribution, and that emplacement is properly controlled. Each manufactured lot of Holtite neutron shield material shall be tested to verify that boron carbide content, hydrogen concentration (density) and bulk material density meet the requirements specified in Table 8.1.9. Boron carbide content shall be verified by spectrochemical and/or gravimetric analysis. A manufactured lot is defined as the total amount of material used to make any number of mixed batches comprised of constituent ingredients from the same lot/batch identification numbers supplied by the constituent manufacturer. Testing shall be performed in accordance with written and approved procedures.

Holtec International shall maintain samples of each manufactured lot of neutron shielding material. Test results for each manufactured lot of neutron shield material shall become part of the final quality documentation package.

8.1.5.5 Neutron Absorber Material

The manufacturing of Metamic-HT is governed by a set of quality validated standard procedures contained in the Metamic-HT Manufacturing Manual [8.1.8]. The material properties and characteristics have been tested and documented in Ref. [8.1.9]. The manufactured Metamic-HT is subject to all quality assurance requirements under Holtec International's NRC approved quality program. The minimum guaranteed values (MGVs) of the final manufactured panels are set forth in Table 8.1.3. Production testing requirements including acceptance criteria are provided in Table 8.1.4A.

The manufacturing processes for Metamic-HT are defined in the Metamic-HT Manufacturing Manual. Metamic-HT panels will be manufactured to Holtec's purchase specification [8.1.10] that incorporates all requirements set forth in Chapter 8 of this SAR, the drawing package referenced in the CoC and the fabrication drawings. The supplier of raw materials must be qualified under Holtec's quality program for important to safety materials and components or alternatively each lot of raw material shall be tested in accordance with Table 8.1.4A requirements. The manufacturing of Metamic-HT is subject to all quality assurance requirements under Holtec International's NRC approved quality program.

The tests conducted on Metamic-HT to establish the compliance of the manufactured panels with Holtec's Purchasing Specification are intended to ensure that critical characteristics of the final product will meet the minimum guaranteed values (MGVs) set forth in Table 8.1.3. The tests are performed at both the raw material and manufactured panels stages of production with

the former serving as the insurer of the properties in the final product and the latter serving the confirmatory function. The testing is conducted for each lot of raw material and finished panels as prescribed in Table 8.1.4A. A lot is defined as follows:

“Lot” means a population of an item that shares identical attributes that are central to defining a critical performance or operational characteristic required of it. Thus, a lot of boron carbide powder procured to a certified Purchasing Specification used in the manufacturing of Metamic-HT is the bulk quantity of the powder that has the same particle size distribution. A lot of finished panels drawn from a powder mix and manufactured in an extrusion run have identical aluminum and boron carbide characteristics and the same extrusion conditions.

The following tests are performed (see Table 8.1.4A):

(i) Testing and certification of powder material

- All lots of aluminum and boron carbide powder shall be certified to meet particle size distribution and chemistry requirements in the Metamic-HT Manufacturing Manual.
- All lots of B₄C will be certified as containing Boron with the minimum isotopic B-10 per the boron carbide purchase specifications incorporated in the Metamic-HT Manufacturing Manual.
- Homogenized mixtures of Al powder(s) and boron carbide powder(s) from traceable lots, prepared for sintering and billet forming operations, shall have the minimum boron carbide wt% verified by wet chemistry testing of one sample from each lot of blended powders. The mixing/blending of the batch shall be controlled via approved procedures.

(ii) Testing of finished panels

The number of panels subject to testing shall be governed by Table 8.1.4B. The panels that need to be tested per the statistical protocol of Table 8.1.4B, hereafter referred to as test panels, shall be subject to the following evaluations:

- The Metamic-HT panels shall be tested for all mechanical properties in Table 8.1.3 in accordance with Table 8.1.4B sampling plan.
- The thickness of each panel will be measured using the procedure set down in the Metamic-HT Manufacturing Manual. The average measured value must meet the minimum basket wall requirements specified in the Drawing Package referenced in the CoC.
- One coupon from a test panel drawn from cask manufactured lot shall be subject to neutron attenuation testing to quantify the boron carbide content for compliance with the minimum requirement in Table 8.1.4A using written procedures.

(iii) Testing of Basket

- Metamic-HT basket welds shall be tested/inspected as stated in Section 8.1.2 using written procedures.

FSW Procedure Qualification, Welder Operator Qualification and Welded Coupon Test:

A. Procedure qualification and welder operator qualification of the Friction Stir Welding (FSW) process shall meet the following requirements from ASME Section IX, 2013 Edition [8.1.1]:

- The Procedure Qualification Record (PQR) shall meet the essential variable requirements of QW-267.
- The Weld Procedure Specification (WPS) shall meet the essential variable requirements of QW-267, QW-361.1(e) and QW-361.2.
- Welder operator performance qualifications shall meet the essential variable requirements of QW-361.2.
- Welder operator may be qualified by volumetric NDE of a test coupon; or a coupon from their initial production welding within the limitations of QW-304 and QW-305; or by bend tests taken from a test coupon.

All welding by FSW process shall meet applicable requirements of ASME Section IX, 2013 Edition [8.1.1].

B. Procedure qualification of the Friction Stir Welding process may be accomplished by tensile testing the appropriate number of coupons per ASME Section IX (2007). Verification of weld soundness is performed by visual examination, radiography and bend testing per approved written procedures (bend testing emulates ASME Section IX). Bend test qualification of a representative weld sample emulating ASME Section IX paragraph QW 160 at a bend radius that produces at least 150% of the average tensile strain developed in the friction stir welded joint under the hypothetical free drop accident condition. The bend radius shall be recorded on the PQR. The bend test sample must meet the acceptance criteria of Section IX QW-163 and visual examination acceptance criteria of ASME Section III Subsection NG 5632 with any additional requirements per Holtec approved written procedure. In addition, at least one welded coupon from the population of Metamic-HT production panels used for manufacturing a fuel basket type must pass the criteria provided herein and shall be so documented in the Documentation Package of the manufactured fuel baskets.

Visual Inspection of Metamic-HT Panels:

Each plate of neutron absorber shall be visually inspected for damage such as scratches, cracks, burrs, foreign material embedded in the surfaces, voids, and delamination. Panels are also

visually inspected for contamination on the surface as specified in the Metamic-HT Manufacturing Manual. Panels not meeting the acceptance criteria will be reworked or rejected. Unless basket is fabricated at the same factory manufacturing Metamic-HT, all panels shall be inspected before being shipped to the cask manufacturing facility where they may be subject to receipt inspection prior to installation.

These test results shall be documented and shall become part of the final quality documentation package.

8.1.5.6 Conventional Surface Preservative Liner

The interior surfaces of the cask are protected with a surface preservative liner as specified in the drawing package in the CoC. Table 8.1.12 provides performance criteria guidance for alternate coatings.

8.1.5.7 Emissivity of Fuel Basket Shims

Surface emissivity requirements for extruded basket shims and solid shims are provided in Table 8.1.10B.

8.1.6 Shielding Tests

A shielding effectiveness test of each fabricated cask must be performed after loading with approved contents and prior to the first shipment as specified in the following paragraph.

A shielding effectiveness test shall be performed of the cask assembled as a package to verify the effectiveness of the shielding using written and approved procedures. Calibrated radiation detection equipment shall be used to take measurements at the surface of the HI-STAR package. Measurements shall be taken at three cross sectional planes through the radial shield and at four points along each plane's circumference. The average measurement results from each sectional plane shall be compared to calculated values to assess the continued effectiveness of the shielding. The calculated values shall be representative of the loaded contents (e.g. fuel type, enrichment, burnup, cooling time, etc.). Measurements shall be documented and become part of the final quality documentation package.

8.1.7 Thermal Tests

The first fabricated HI-STAR 190 cask shall be tested to confirm its heat dissipation capability.

A thermal test performed for a similar cask design may be used as proof of heat transfer capability in lieu of thermal testing of HI-STAR 190. In case of a proof with similar cask, an engineering evaluation between HI-STAR 190 and the previously-tested cask shall be documented and become part of the final quality documentation package.

The test shall be conducted after fabrication is complete. A test cover plate shall be used to seal the cask cavity. The cavity will be heated with steam.

Twelve (12) calibrated thermocouples shall be installed on the external walls of the cask using four thermocouples, equally spaced circumferentially, at three different elevations. Three calibrated thermocouples shall be installed on the internal walls of the cask in locations to be determined by procedure. Additional temperature sensors shall be used to monitor ambient temperature, steam supply temperature, and condensate drain temperature. The thermocouples shall be attached to strip chart recorders or other similar mechanism to allow for continuous monitoring and recording of temperatures during the test. Instrumentation shall be installed to monitor cask cavity internal pressure.

After the thermocouples have been installed, dry steam will be introduced through an opening in the test cover plate previously installed on the cask and the test initiated. Temperatures of the thermocouples, plus ambient, steam supply, and condensate drain temperature shall be recorded at hourly intervals until thermal equilibrium is reached. Appropriate criteria defining when thermal equilibrium is achieved shall be determined based on potential ambient test conditions and incorporated into the test procedure. In general, thermal equilibrium is expected approximately 12 hours after the start of steam heating. Air will be purged from the cask cavity via venting during the heat-up cycle. During the test, the steam condensate flowing out of the cask drain shall be collected and the mass of the condensate measured with a precision weighing instrument.

Once thermal equilibrium is established, the final ambient, steam supply, and condensate drain temperatures and temperatures at each of the thermocouples shall be recorded. The strip charts, hand-written logs, or other similar readout shall be marked to show the point when thermal equilibrium was established and final test measurements were recorded. The final test readings along with the hourly data inputs and strip charts (or other similar mechanism) shall become part of the quality records documentation package for the HI-STAR 190 Package.

The heat rejection capability of the cask at test conditions shall be computed using the following formula:

$$Q_{hm} = (h_1 - h_2) m_c$$

Where: Q_{hm} = Heat rejection rate of the cask (kW)

h_1 = Enthalpy of steam entering the cask cavity (KJ/kg)

h_2 = Enthalpy of condensate leaving the cask cavity (KJ/kg)

m_c = Average rate of condensate flow measured during thermal equilibrium conditions (kg/s)

Based on the HI-STAR 190 cask thermal model, a design basis minimum heat rejection capacity (Q_{hd}) shall be computed at the measured test conditions (i.e., steam temperature in the cask cavity and ambient air temperature). The thermal test shall be considered acceptable if the measured heat rejection capability is greater than the design basis minimum heat rejection capacity ($Q_{hm} > Q_{hd}$).

If the acceptance criteria above are not met, then the HI-STAR 190 cask shall not be accepted until the root cause is determined, appropriate corrective actions are completed, and the cask is re-tested with acceptable results.

- Testing shall be performed in accordance with written and approved procedures similar to the Holtec standard procedure used for the test performed on the HI-STAR 100 overpack and documented in Holtec Document DOC-5014-03 [8.1.7].

8.1.8 MPC Enclosure Vessel Shell Surface Defect Inspection

MPC's containing high burn-up fuel and stored for a duration greater than 5 years under the provisions of 10CFR 72 shall undergo an MPC enclosure vessel shell surface defect inspection prior to shipment according to Chapter 7 and as specified below to ensure that existing defects and flaws do not develop into cracks during hypothetical accident conditions of transport. This inspection serves as the MPC containment boundary integrity confirmation (which along with the required MPC pressure boundary structural integrity verification and MPC containment boundary leaktightness verification specified elsewhere in this chapter) conservatively confirms the moderator exclusion function of the MPC enclosure vessel under hypothetical accident conditions of transport.

The MPC shall be subject to an eddy current testing (ECT) regimen that is capable of identifying surface defect of depth specified in Table 8.1.13 anywhere on the external cylindrical surface of the enclosure vessel. Any flaw detected on the MPC's surface by ECT that meets the maximum allowable flaw depth specified in Table 8.1.13 shall be deemed to be acceptable. Any flaw that exceeds the maximum allowable flaw depth will disqualify the canister for transport until further investigation is performed and the NRC accepts, under the exemption process or other appropriate licensing action, the owner-provided evidence that the affected canister will survive a HAC. For additional information, if necessary, the entire surface of the MPC shell shall be subject to VT using a remotely actuated camera.

Not every MPC at a given ISFSI requires ECT. A user may either elect to conduct ECT of every MPC to be shipped or elect to conduct ECT on the population of MPCs at an ISFSI using a the lot-based statistical tier system for MPC selection specified in Table 8.1.11. The statistical approach for the selection of MPCs maximizes ALARA and minimizes lifting and handling of the loaded canisters. The statistical approach for the selection of MPCs to be ECT'd adopts the same tiering system used for selection of coupons for the production coupon testing program of

Metamic-HT neutron absorber for ensuring Minimum Guaranteed Values are met. This tiering system, which is based on Military Standard MIL-STD-105E [8.1.11], was initially developed and implemented by Holtec International in 2009 to ensure the nuclear pedigree of Metamic-HT material with respect to its critical characteristics. This tiering system continues to be implemented successfully with the large scale production of Metamic-HT. If the user elects the statistical approach, then the user shall also perform ECT of the ISFSI's lead canister(s) identified by the ISFSI's Part 72 aging management program. The lead canister(s) shall undergo ECT to inform the tiering system even if the lead canister(s) is not selected for shipment. At an ISFSI where an aging management program may not yet be established under the provisions of 10CFR72, the user shall identify the ISFSI lead canister(s) based on a written and approved lead canister selection procedure.

MPCs approved for transport (i.e. meeting the acceptance criteria in Table 8.1.13) must be shipped within 5 years of transport approval.

8.1.9 Miscellaneous Acceptance Tests

8.1.9.1 Post-Shipment HBF Integrity Acceptance Test

For packages containing HBF, cask surface temperatures and cask surface dose rates shall be measured in accordance with the procedures in Chapter 7 as a practical means of monitoring the condition of the fuel assemblies. Fuel reconfiguration and significant fuel cladding damage is not expected after the transportation period of each shipment.

A total of six measurements of both temperature and dose rate shall be recorded before and after each shipment with the loaded cask configured horizontally with impact limiters and no personnel barrier. Three measurements are taken from each side of the package below the cask axial centerline (below the top cask trunnion, at the middle of the cask (at or below the cask centerline) and below the bottom cask trunnion). The user may select measurement locations within the areas defined by the zones shown in Figure 8.1.1. The post-shipment measurement locations shall correspond to the pre-shipment measurement locations for proper comparison.

The post-shipment surface temperature measurements should not exceed the pre-shipment surface temperature measurements by more than 5 degrees C when adjusted under the same ambient conditions. The temperature criteria may be adjusted to account for the difference in ambient conditions such as solar insolation.

The post-shipment surface dose rate measurements should not exceed the pre-shipment surface dose rate measurements by more than 10%.

Failed tests shall be reported to USNRC within one month of the post-shipment measurement and shall include a description of the package contents, any available engineering justification for failed test(s), and if applicable any special precautions that will be implemented prior to

unloading the contents of the package. Package exhibiting tests results equal to or greater than twice the acceptance criteria shall not be unloaded without USNRC authorization.

8.1.9.2 10CFR72 AMP Based HBF Integrity Acceptance Test

For packages containing HBF, the integrity of the HBF shall be confirmed as specified in Appendix 7.B. Although fuel reconfiguration and significant fuel cladding damage is not expected to occur during extended storage periods, an Aging Management Program shall be in place to ensure HBF integrity prior to transport with reasonable assurance. The approved Aging Management Program shall have been specified and performed under the aegis of the HI-STORM FW FSAR (Docket # 72-1032) or the HI-STORM UMAX FSAR (Docket # 72-1040).

Table 8.1.1
Containment System Performance Specifications

Design Attribute	Design Rating
Reference Air Leakage Rate (L_R) Acceptance Criterion	1×10^{-7} ref-cm ³ /s air (Leaktight as defined by ANSI N14.5 [8.1.6])
Leakage Rate Test Sensitivity	5×10^{-8} ref-cm ³ /s air ($\frac{1}{2}$ of the leakage rate acceptance criterion per ANSI N14.5 [8.1.6])

Notes:

1. For helium as the tracer gas, the Leakage Rate Acceptance Criterion and Test Sensitivity are multiplied by a factor of 2.
2. Per ANSI N14.5 (para. 7.6.4), an alternative pre-shipment leakage rate acceptance criterion that may be used in lieu of the reference air leakage rate L_R , is “No Detected Leakage” when tested using a test method with a sensitivity of at least 1×10^{-3} ref-cm³/s. The following conditions apply to the testing of gasketed joints:
 - a. The joint gasket must be reusable (e.g. elastomeric seals).
 - b. The gasket was previously installed and the gasketed joint qualified to a leak rate not more than the reference air leakage rate L_R as specified in the table above. (i.e. the prequalified gasket was never replaced).

**Table 8.1.2 (Sheet 1 of 3)
Leakage Rate Tests For HI-STAR 190 and MPC Containment Systems**

Leakage Test	System Tested	Components Tested	Type of Leakage Rate Test (from ANSI N14.5 [8.1.6], App. A)	Allowable Leakage Rate
Fabrication Leakage Rate Test (Note 4)	HI-STAR 190 Cask	<ul style="list-style-type: none"> • Containment Shell • Containment Bottom Forging • Containment Top Forging • Closure Lid • Closure Lid Port Cover Plate • Containment Shell Welds • Containment Shell to Containment Bottom Forging Weld • Containment Shell to Containment Top Forging Weld 	A.5.3	Table 8.1.1
		<ul style="list-style-type: none"> • Closure Lid Inner Seal 	A.5.4	Table 8.1.1
		<ul style="list-style-type: none"> • Closure Lid Port Cover Inner Seal 	A.5.4	Table 8.1.1
Pre-shipment Leakage Rate Test (Note 4)	HI-STAR 190 Cask	<ul style="list-style-type: none"> • Closure Lid Inner Seal • Closure Lid Port Cover Inner Seal 	A.5.4 or Per Note 3	Table 8.1.1
	MPC (Note 4)	<ul style="list-style-type: none"> • Shell • Baseplate • Top closure assembly (consisting of lid, closure ring and vent and drain port cover plats) • Shell Welds • Shell to Baseplate Weld • Top closure assembly welds (consisting of Lid-to-shell weld, closure ring weld and vent and drain port cover plate welds) 	A.5.4	Table 8.1.1

**Table 8.1.2 (Sheet 2 of 3)
Leakage Rate Tests For HI-STAR 190 and MPC Containment Systems**

Leakage Test	System Tested	Components Tested	Type of Leakage Rate Test (from ANSI N14.5 [8.1.6], App. A)	Allowable Leakage Rate (Note 1)
Maintenance Leakage Rate Test (Note 2)	HI-STAR 190 Cask	<ul style="list-style-type: none"> • Containment Shell • Containment Bottom Forging • Containment Top Forging • Closure Lid • Closure Lid Port Cover Plate • Containment Shell Welds • Containment Shell to Containment Bottom Forging Weld • Containment Shell to Containment Top Forging Weld 	A.5.3	Table 8.1.1
		<ul style="list-style-type: none"> • Closure Lid Inner Seal 	A.5.4	Table 8.1.1
		<ul style="list-style-type: none"> • Closure Lid Port Cover Inner Seal 	A.5.4	Table 8.1.1
Periodic Leakage Rate Test (Note 2)	HI-STAR 190 Cask	<ul style="list-style-type: none"> • Closure Lid Inner Seal • Closure Lid Port Cover Inner Seal 	A.5.4	Table 8.1.1
	MPC (Note 4)	<ul style="list-style-type: none"> • Shell • Baseplate • Top closure assembly (consisting of lid, closure ring and vent and drain port cover plats) • Shell Welds • Shell to Baseplate Weld • Top closure assembly welds (consisting of Lid-to-shell weld, closure ring weld and vent and drain port cover plate welds) 	A.5.4	Table 8.1.1

Table 8.1.2 (Sheet 3 of 3)
Leakage Rate Tests For HI-STAR 190 and MPC Containment Systems

Notes:

1. 1. For a Leakage Rate Acceptance Criterion of “Leak-tight as defined by ANSI N14.5” [8.1.6], the summation of individual component leakage rates of the containment boundary of a package is not required.
2. Purpose of Leakage Rate Tests per ANSI N14.5:
 - a. Fabrication Leakage Rate Test: To demonstrate that the containment system, as fabricated, will provide the required level of containment.
 - b. Pre-shipment Leakage Rate Test: To confirm that the containment system is properly assembled for shipment.
 - c. Maintenance Leakage Rate Test: To confirm that any maintenance, repair, or replacement of components has not degraded the containment system.
 - d. Periodic Leakage Rate Test: To confirm that the containment capabilities of the packagings built to an approved design have not deteriorated during a period of use.
3. For a pre-shipment test implementing the alternative pre-shipment leakage rate acceptance criterion specified in Note 2 of Table 8.1.1, alternative types of leak rate tests may be used as supported by ANSI N14.5.
4. The leakage testing of an MPC is required if it contains HBF (See Appendix 8.A of this SAR). Leakage testing is performed according to the procedure(s) provided in Chapter 7 of this SAR.

Table 8.1.3: Minimum Guaranteed Values of Metamic-HT Properties

Property (Note 1)	Temperature, °C	Property Value (Note 2)
Yield strength, σ_y (ksi)	Ambient	19.5
	200/300/350/450	15.0/13.8/10.0/7.7
Tensile strength, σ_u (ksi)	Ambient	28.2
	200/300/350/450	18.8/15.6/11.9/8.1
Young's Modulus, E (Msi)	Ambient	11.8
	200/300/350/450	10.8/8.8/6.9/3.8
Area Reduction (%)	Ambient	20
	200/300/350/450	17.9/14.2/12.9/7.8

Note 1: All properties are critical characteristics.

Note 2: Properties can be interpolated, use 40°C for ambient when interpolating.

Table 8.1.4A (Sheet 1 of 2)
Metamic-HT Production Testing Requirements

	Item Tested	Property Tested For	Frequency of Test	Purpose of Test	Acceptance Criterion
i.	B ₄ C powder (raw material) (see note 1)	Particle size distribution	One sample per lot	To verify material supplier's data sheet	Per Holtec's Purchasing Specification [8.1.10]
		Purity	One sample per lot	To verify material supplier's data sheet	ASTM C-750
ii.	Al Powder (raw material)	Particle Size Distribution	One sample per lot	To verify material supplier's data sheet	Per Holtec's Purchasing Specification [8.1.10]
		Purity	One sample per lot	To verify material supplier's data sheet	Must be 99% (min.) pure aluminum
iii.	B ₄ C/Al Mix	B ₄ C Content (by the wet chemistry method)	One sample per mixed/blended powders lot	To ensure wt.% B ₄ C requirements compliance	The weight density of B ₄ C must lie in the range of 10 to 11% Nom.

Table 8.1.4A (Sheet 2 of 2)
Metamic-HT Production Testing Requirements

	Item Tested	Property Tested For	Frequency of Test	Purpose of Test	Acceptance Criterion
iv.	Finished Metamic-HT panel	Thickness and width, straightness, camber and bow	Holtec QA Program Sampling Plan	To ensure fabricability of the basket	Per Holtec's Purchasing Specification [8.1.10]
		Mechanical Properties in Table 8.1.3 (see Note 3)	Per Sampling Plan Table 8.1.4B (see note 2)	To ensure structural performance	MGV per Table 8.1.3
		B ₄ C content by areal density measurements (neutron attenuation method)	One coupon from a panel from each Metamic-HT manufactured lot	To ensure criticality safety	The B ₄ C content by weight shall be ≥ 10 wt. %

Notes:

1. The B₄C testing requirements apply if the raw material supplier is not in Holtec's Approved Vendor List.
2. Sampling Plan is included in the Metamic-HT Manufacturing Manual [8.1.8].
3. All properties shall be measured at room temperature on extruded coupons.

Table 8.1.4B: Tier System for Metamic-HT Production Coupon Testing

Tier No.	Number of Extrusions Tested as a Percent of Number of Extrusions in the Lot	Number of Continuous Lots that Must Pass to Drop Down to the Next Tier
1	20	5
2	12.5	5
3	5	10
4	1	N/A

Note 1: If a coupon fails with respect to any MGV property, then it may be replaced by two coupons from the extrusion that produced the failed coupon. If both of the replacement coupons pass the failed MGV property, then the lot can be accepted. If either of the replacement coupons is unsuccessful in meeting the failed MGV property, then the entire lot is rejected. As an alternative to rejecting the entire lot, testing of the failed MGV value on all extrusions within the lot is permitted to isolate acceptable panels.

Note 2: Testing shall be moved up to the next tier if any MGV property fails in two consecutive lots.

Note 3: Tiering defined on the basis of sample size. Higher tier testing requires greater percentage of sample testing (i.e. moving up the table).

Table 8.1.5 (Sheet 1 of 2): Applicability of ASME Code Boiler & Pressure Vessel Code and Other Standards

Component ID	Material Procurement	Component Design Acceptance Criteria	Stress and Deformation Analysis Methodology	Welding (Fabrication and Qualifications)	Inspection	Testing
Cask Containment System (pressure vessel except closure seals)	ASME Code Section III Subsection NB-2000	ASME Code Section III Subsection NB-3000	ASME Code Section III Subsection NB-3000	ASME Code Section III Subsection NB-4000 and Chapter 8 of this SAR	ASME Code Section III Subsection NB-5000 and Chapter 8 of this SAR	ASME Code Section III Subsection NB-6000 and Chapter 8 of this SAR
MPC Containment System/Pressure Boundary	ASME Code Section III Subsection NB-2000	ASME Code Section III Subsection NB-3000	ASME Code Section III Subsection NB-3000	ASME Code Section III Subsection NB-4000	ASME Code Section III Subsection NB-5000	ASME Code Section III Subsection NB-6000
Cask Top Lifting Trunnions	ASME Code Section II	ANSI N14.6	ANSI N14.6	Not Applicable	Chapter 8 of this SAR	Chapter 8 of this SAR
Cask Neutron Shielding Material	Holtec Manufacturing Manual	Holtec Qualification Sourcebook	Not Applicable	Not Applicable	Holtec Manufacturing Manual	Chapter 8 of this SAR
MPC Metamic-HT Fuel Basket	Chapter 8 of this SAR	Deflection limited to ensure subcriticality	Deflection Evaluation	Holtec Manufacturing Manual (Note 1)	Holtec Manufacturing Manual	Chapter 8 of this SAR
Cask Dose Blocker Steel Components	ASME Code Section II and/or ASTM	No gross failure leading to significant loss of shielding	ASME Code Subsection NF-3000 for Class 3 supports	ASME Code Section IX and Chapter 8 of this SAR	ASME Code Section V	Chapter 8 of this SAR
Impact Limiter Backbone Components	ASME Code Section II and/or ASTM	No gross yielding or buckling	ASME Code Section III Subsection NF-3000 for Class 3 supports	ASME Code Section IX and Chapter 8 of this SAR	ASME Code Section V and Chapter 8 of this SAR	Chapter 8 of this SAR

Table 8.1.5 (Sheet 2 of 2): Applicability of ASME Code Boiler & Pressure Vessel Code and Other Standards (continued)

Notes

1. The Holtec Manufacturing Manual contains detailed instructions for manufacturing of the subassemblies and the complete component in accordance with the applicable Codes and Standards. The Holtec Manufacturing Manual is a compilation of procedures, travelers, weld maps, specifications, standards, Metamic-HT Manufacturing Manual and other documents as applicable, to ensure the manufacturing of the components are in full accord with the design conditions of the CoC. The latest issues of the manufacturing manual(s) are maintained in the company's network under Holtec's configuration control system.

Table 8.1.6: ASME Code Requirements and Alternatives for the HI-STAR 190 Package
(Sheet 1 of 7)

Component	Code Section	Code Requirement	Alternative, Justification & Compensatory Measures
Cask Containment System	NB-1000	Statement of requirements for Code stamping of components.	Cask containment boundary is designed, and will be fabricated in accordance with ASME Code, Section III, Subsection NB to the maximum practical extent, but Code stamping is not required.
Cask Containment System	NB-2000	Requires materials to be supplied by ASME-approved material supplier.	Holtec approved suppliers will supply materials with CMTRs per NB-2000.
Cask Containment System	NB-7000	Vessels are required to have overpressure protection.	No overpressure protection is provided. Function of cask vessel is as a radionuclide containment boundary under normal and hypothetical accident conditions. Cask is designed to withstand maximum internal pressure and maximum accident temperatures.
Cask Containment System	NB-8000	States requirements for name, stamping and reports per NCA-8000.	HI-STAR 190 is to be marked and identified in accordance with 10CFR71. Code stamping is not required. QA data package prepared in accordance with Holtec's approved QA program.

**Table 8.1.6: ASME Code Requirements and Alternatives for the HI-STAR 190 Package
(Sheet 2 of 7)**

Component	Code Section	Code Requirement	Alternative, Justification & Compensatory Measures
Cask Containment System	NB-2330	Establish TNDT and test base metal, heat affected zone and weld metal at TNDT + 60°F	<p>Rather than testing to establish the RTNDT as defined in paragraph NB-2331, the guidance from Reg Guide 7.11 [8.1.4] is used for materials less than 4 inches thick and Reg Guide 7.12 & NUREG/CR 3826 are used for materials from greater than 4 up to 12 inches thick. Table 8.1.7 summarizes the specific impact testing requirements for the Containment Boundary components per Reg. Guides 7.11 endorsement of NUREG 1815, Reg. Guide 7.12 and NUREG/CR-3826 as applicable.</p> <p>All containment welds on the HI-STAR 190 will be involving the shell and have a nominal thickness of 50mm (2 inches). Therefore the TNDT for the containment welds will be the same as the TNDT for the containment shell as reflected in Table 8.1.7. Drop test to determine TNDT for containment weld is not required.</p>

**Table 8.1.6: ASME Code Requirements and Alternatives for the HI-STAR 190 Package
(Sheet 3 of 7)**

Component	Code Section	Code Requirement	Alternative, Justification & Compensatory Measures
Cask <ul style="list-style-type: none"> • Containment Shell • Containment Top Forging • Containment Bottom Forging • All non-pressure retaining components attached to containment boundary components by welding. 	NB-4622	All welds, including repair welds, shall be post-weld heat treated (PWHT).	All attachment welds less than 1/2 in. (13mm) joining non-pressure retaining material (non-containment boundary components) to pressure retaining material (containment boundary components) over 5/8 in. (16 mm) thick are exempt from PWHT per Table NB-4622.7(b)-1.
Cask Containment System	NB-5120	Perform radiographic examination after post-weld heat treatment (PWHT).	Radiography of the helium retention boundary welds after PWHT is not required. All welds (including repairs) will have passed radiographic examination prior to PWHT of the entire containment boundary. Confirmatory radiographic examination after PWHT is not necessary because PWHT is not known to introduce new weld defects in nickel steels.

**Table 8.1.6: ASME Code Requirements and Alternatives for the HI-STAR 190 Package
(Sheet 4 of 7)**

Component	Code Section	Code Requirement	Alternative, Justification & Compensatory Measures
MPC Enclosure Vessel	Subsection NCA	General Requirements. Requires preparation of a Design Specification, Design Report, Overpressure Protection Report, Certification of Construction Report, Data Report, and other administrative controls for an ASME Code stamped vessel.	<p>Because the MPC is not an ASME Code stamped vessel, none of the specifications, reports, certificates, or other general requirements specified by NCA are required. In lieu of a Design Specification and Design Report, the HI-STAR SAR includes the design criteria, service conditions, and load combinations for the design and operation of the MPCs as well as the results of the stress analyses to demonstrate that applicable Code stress limits are met. Additionally, the fabricator is not required to have an ASME-certified QA program. All important-to-safety activities are governed by the NRC-approved Holtec QA program.</p> <p>Because the cask components are not certified to the Code, the terms “Certificate Holder” and “Inspector” are not germane to the manufacturing of NRC-certified cask components. To eliminate ambiguity, the responsibilities assigned to the Certificate Holder in the Code, as applicable, shall be interpreted to apply to the NRC Certificate of Compliance (CoC) holder (and by extension, to the component fabricator) if the requirement must be fulfilled. The Code term “Inspector” means the QA/QC personnel of the CoC holder and its vendors assigned to oversee and inspect the manufacturing process.</p>
MPC Enclosure Vessel	NB-1100	Statement of requirements for Code stamping of components.	MPC Enclosure Vessel is designed and will be fabricated in accordance with ASME Code, Section III, Subsection NB to the maximum practical extent, but Code stamping is not required.
MPC Enclosure Vessel	NB-2000	Requires materials to be supplied by ASME-approved material supplier.	Materials will be supplied by Holtec approved suppliers with Certified Material Test Reports (CMTRs) in accordance with NB-2000 requirements.

**Table 8.1.6: ASME Code Requirements and Alternatives for the HI-STAR 190 Package
(Sheet 5 of 7)**

Component	Code Section	Code Requirement	Alternative, Justification & Compensatory Measures
MPC Enclosure Vessel	NB-3100 NF-3100	Provides requirements for determining design loading conditions, such as pressure, temperature, and mechanical loads.	These requirements are subsumed by the HI-STAR SAR, serving as the Design Specification, which establishes the service conditions and load combinations for the storage system.
MPC Enclosure Vessel	NB-4120	NB-4121.2 and NF-4121.2 provide requirements for repetition of tensile or impact tests for material subjected to heat treatment during fabrication or installation.	In-shop operations of short duration that apply heat to a component, such as plasma cutting of plate stock, welding, machining, and coating are not, unless explicitly stated by the Code, defined as heat treatment operations.
MPC Enclosure Vessel	NB-4220	Requires certain forming tolerances to be met for cylindrical, conical, or spherical shells of a vessel.	The cylindricity measurements on the rolled shells are not specifically recorded in the shop travelers, as would be the case for a Code-stamped pressure vessel. Rather, the requirements on inter-component clearances (such as the MPC-to-transfer cask) are guaranteed through fixture-controlled manufacturing. The fabrication specification and shop procedures ensure that all dimensional design objectives, including inter-component annular clearances are satisfied. The dimensions required to be met in fabrication are chosen to meet the functional requirements of the dry storage components. Thus, although the post-forming Code cylindricity requirements are not evaluated for compliance directly, they are indirectly satisfied (actually exceeded) in the final manufactured components.

**Table 8.1.6: ASME Code Requirements and Alternatives for the HI-STAR 190 Package
(Sheet 6 of 7)**

Component	Code Section	Code Requirement	Alternative, Justification & Compensatory Measures
MPC Enclosure Vessel	NB-4122	Implies that with the exception of studs, bolts, nuts and heat exchanger tubes, CMTRs must be traceable to a specific piece of material in a component.	MPCs are built in lots. Material traceability on raw materials to a heat number and corresponding CMTR is maintained by Holtec through markings on the raw material. Where material is cut or processed, markings are transferred accordingly to assure traceability. As materials are assembled into the lot of MPCs being manufactured, documentation is maintained to identify the heat numbers of materials being used for that item in the multiple MPCs being manufactured under that lot. A specific item within a specific MPC will have a number of heat numbers identified as possibly being used for the item in that particular MPC of which one or more of those heat numbers (and corresponding CMTRS) will have actually been used. All of the heat numbers identified will comply with the requirements for the particular item.
MPC Lid and Closure Ring Welds	NB-4243	Full penetration welds required for Category C Joints (flat head to main shell per NB-3352.3)	MPC lid and closure ring are not full penetration welds. They are welded independently to provide a redundant seal.
MPC Closure Ring, Vent and Drain Cover Plate Welds	NB-5230	Radiographic (RT) or ultrasonic (UT) examination required.	Root (if more than one weld pass is required) and final liquid penetrant examination to be performed in accordance with NB-5245. The closure ring provides independent redundant closure for vent and drain cover plates. Vent and drain port cover plate welds are helium leakage tested.
MPC Lid to Shell Weld	NB-5230	Radiographic (RT) or ultrasonic (UT) examination required.	Only progressive liquid penetrant (PT) examination is permitted. PT examination will include the root and final weld layers and each approx. 3/8" of weld depth.

**Table 8.1.6: ASME Code Requirements and Alternatives for the HI-STAR 190 Package
(Sheet 7 of 7)**

Component	Code Section	Code Requirement	Alternative, Justification & Compensatory Measures
MPC Enclosure Vessel and Lid	NB-6111	All completed pressure retaining systems shall be pressure tested.	<p>The MPC vessel is seal welded in the field following fuel assembly loading. The MPC vessel shall then be pressure tested as defined in Chapter 8. Accessibility for leakage inspections preclude a Code compliant pressure test. All MPC enclosure vessel welds (except closure ring and vent/drain cover plate) are inspected by volumetric examination. MPC shell and shell to baseplate welds are subject to a fabrication helium leak test prior to loading. The MPC lid-to-shell weld shall be verified by progressive PT examination. PT must include the root and final layers and each approximately 3/8 inch of weld depth.</p> <p>The inspection results, including relevant findings (indications) shall be made a permanent part of the user's records by video, photographic, or other means which provide an equivalent record of weld integrity. The video or photographic records should be taken during the final interpretation period described in ASME Section V, Article 6, T-676. The vent/drain cover plate and the closure ring welds are confirmed by liquid penetrant examination. The inspection of the weld must be performed by qualified personnel and shall meet the acceptance requirements of ASME Code Section III, NB-5350.</p>
MPC Enclosure Vessel	NB-7000	Vessels are required to have overpressure protection.	No overpressure protection is provided. Function of MPC enclosure vessel is to contain radioactive contents under normal, off-normal, and accident conditions of storage. MPC vessel is designed to withstand maximum internal pressure considering 100% fuel rod failure and maximum accident temperatures.
MPC Enclosure Vessel	NB-8000	States requirements for nameplates, stamping and reports per NCA-8000.	The HI-STAR 190 System is to be marked and identified in accordance with 10CFR71 and 10CFR72 requirements. Code stamping is not required. QA data package to be in accordance with Holtec approved QA program.

**Table 8.1.7: Fracture Toughness Test Criteria: HI-STAR 190 Cask Containment System
(Sheet 1 of 3)**

Item	Material	Thickness in. (mm)	Qualification to LST of -29°C (-20°F) (Note 3)		Qualification to LST of -40°C (-40°F) (Note 3)	
			Charpy V-Notch Temperature	Drop Test Temperature (Note 1)	Charpy V-Notch Temperature	Drop Test Temperature (Note 1)
Weld Metal for NB Welds	As required	NA	$T_{NDT} \leq -68^{\circ}\text{C}$ (-91°F) with testing and acceptance criteria per ASME Section III, Subsection NB, Article NB-2430 and Article NB-2330	$T_{NDT} \leq -68^{\circ}\text{C}$ (-91°F) based on containment shell thickness	$T_{NDT} \leq -79^{\circ}\text{C}$ (-111°F) with testing and acceptance criteria per ASME Section III, Subsection NB, Article NB-2430 and Article NB-2330	$T_{NDT} \leq -79^{\circ}\text{C}$ (-111°F) based on containment shell thickness
Containment Shell	SA-203 E/ SA-350 LF3	2 (50)	$T_{NDT} \leq -68^{\circ}\text{C}$ (-91°F) with testing and acceptance criteria per ASME Section III, Subsection NB, Article NB-2330	$T_{NDT} \leq -68^{\circ}\text{C}$ (-91°F) per R.G. 7.11	$T_{NDT} \leq -79^{\circ}\text{C}$ (-111°F) with testing and acceptance criteria per ASME Section III, Subsection NB, Article NB-2330	$T_{NDT} \leq -79^{\circ}\text{C}$ (-111°F) per R.G. 7.11
Containment Top Forging	SA-350 LF3	12.4 (315)	$T_{NDT} \leq -76.7^{\circ}\text{C}$ (- 106°F) with testing and acceptance criteria per ASME Section III, Subsection NB, Article NB-2330	$T_{NDT} \leq -76.7^{\circ}\text{C}$ (- 106°F) per fracture initiation criteria developed in the NUREG-CR-3826 (Notes 4 and 5)	$T_{NDT} \leq -87.8^{\circ}\text{C}$ (-126°F) with testing and acceptance criteria per ASME Section III, Subsection NB, Article NB-2330	$T_{NDT} \leq -87.8^{\circ}\text{C}$ (-126°F) per fracture initiation criteria developed in the NUREG-CR-3826 (Notes 4 and 5)
Containment Bottom Forging	SA-350 LF3	6 (151)	$T_{NDT} \leq -89.4^{\circ}\text{C}$ (-129°F) with testing and acceptance criteria per ASME Section III, Subsection NB, Article NB-2330	$T_{NDT} \leq -89.4^{\circ}\text{C}$ (-129°F) per R.G 7.12.	$T_{NDT} \leq -71.7^{\circ}\text{C}$ (-97°F) with testing and acceptance criteria per ASME Section III, Subsection NB, Article NB-2330	$T_{NDT} \leq -71.7^{\circ}\text{C}$ (-97°F) per fracture initiation criteria developed in the NUREG-CR-3826 (Notes 4 and 5)

**Table 8.1.7: Fracture Toughness Test Criteria: Containment System
(Sheet 2 of 3)**

Item	Material	Thickness in. (mm)	Qualification to LST of -29°C (-20°F) (Note 3)		Qualification to LST of -40°C (-40°F) (Note 3)	
			Charpy V-Notch Temperature	Drop Test Temperature (Note 1)	Charpy V-Notch Temperature	Drop Test Temperature (Note 1)
Closure Lid	SA-350 LF3	6.3 (160)	T _{NDT} ≤ -90°C (-130°F) with testing and acceptance criteria per ASME Section III, Subsection NB, Article NB-2330	T _{NDT} ≤ -90°C (-130°F) per R.G. 7.12	T _{NDT} ≤ -72.8°C (-99°F) with testing and acceptance criteria per ASME Section III, Subsection NB, Article NB-2330	T _{NDT} ≤ -72.8°C (-99°F) per fracture initiation criteria developed in the NUREG-CR-3826 (Notes 4 and 5)

**Table 8.1.7: Fracture Toughness Test Criteria: Containment System
(Sheet 3 of 3)**

Item	Material	Thickness in. (mm)	Qualification to LST of -29°C (-20°F) (Note 3)		Qualification to LST of -40°C (-40°F) (Note 3)	
			Charpy V-Notch Temperature	Drop Test Temperature (Note 1)	Charpy V-Notch Temperature	Drop Test Temperature (Note 1)
Closure Lid Bolt	SA-564 630 / SA- 705 630	1 1/2" (38)	Cv (lateral expansion): minimum 25 mils (per Table NB-2333-1) for each of three specimens. (Note 2) Min. test temperature = -29°C	No requirements (per Table NB-2333-1)	Cv (lateral expansion): minimum 25 mils (per Table NB-2333-1) for each of three specimens. (Note 2) Min. test temperature = -40°C	No requirements (per Table NB-2333-1)

Notes:

1. Materials to be tested in accordance with ASTM E208-87a.
2. An additional Charpy absorbed energy requirement of 5 ft-lb at -29°C (-20°F) or at -40°C (-40°F), depending on the desired cask LST qualification, is imposed on the closure lid bolts.
3. The cask may be qualified to either to an LST of either -29°C (-20°F) or -40°C (-40°F).
4. Component to undergo 100% volumetric examination to confirm absence of flaws which exceed the critical values as defined in NUREG/CR-3826 Table 3. 100% volumetric re-examination is required for cask components qualified per NUREG/CR-3826 following cask operations which result in impactive or impulsive loadings in excess of those defined in the normal conditions of transport.
5. In lieu of qualification per NUREG/CR-3826, qualification per Reg Guide 7.12 [8.1.5] may be applied.
6. Containment System components with exemption from brittle fracture testing in accordance with ASME Section III, Subsection NB-2300 may not be listed in this table.

Table 8.1.8: Fracture Toughness Test Criteria: HI-STAR 190 Cask Dose Blocker Steel Parts
 (Sheet 1 of 2)

Component	Material	Thickness in. (mm)	Charpy V-Notch Test Temperature	Acceptance Standards (Note 5)
Gamma Shield Rib (Note 1)	SA-516 Gr. 70	1 (50)	Test at -40°C (-40°F)	Charpy absorbed energy is 15 ft.-lb. (average of 3 specimens and minimum of 10 ft.-lb. for any single specimen) Charpy (lateral expansion) is 15 mils
Long Vertical Trunnion Rib (Note 1)	SA-516 Gr. 70	1 1/2 (38)	Test at -40°C (-40°F)	Charpy absorbed energy is 15 ft.-lb. (average of 3 specimens and minimum of 10 ft.-lb. for any single specimen) Charpy (lateral expansion) is 15 mils
Bottom Intermediate Shell (Note 1)	SA-516 Gr. 70	2 1/4 (57)	Test at -40°C (-40°F)	Charpy absorbed energy is 15 ft.-lb. (average of 3 specimens and minimum of 10 ft.-lb. for any single specimen) Charpy (lateral expansion) is 15 mils
Intermediate Shell (Note 1)	SA-516 Gr. 70	3 (76)	Test at -40°C (-40°F)	Charpy absorbed energy is 18 ft.-lb. (average of 3 specimens and minimum of 13 ft.-lb. for any single specimen) Charpy (lateral expansion) is 15 mils

Table 8.1.8: Fracture Toughness Test Criteria: HI-STAR 190 Cask Dose Blocker Steel Parts
(Sheet 2 of 2)

Misc. Dose Blocker Plates Plates (Enclosure Shell, , Bottom Outer Shell, Bottom Forging Cover Plate, and Top Forging Outer Shell) that encloses neutron shield material (Holtite) and lead shielding. (Note 1, 2, and 3)	SA-516 Gr. 70	Less than 1 (25)	Test at -40°C (-40°F)	Charpy absorbed energy is 15 ft.-lb. (average of 3 specimens and minimum of 10 ft.-lb. for any single specimen) (Note 4) Charpy (lateral expansion) is 15 mils
---	---------------	------------------	-----------------------	--

Notes:

1. SA-516 Gr. 70 plate may be normalized.
2. For miscellaneous dose blocker parts, impact testing only applies to dose blocker parts located at the exterior boundary of the cask.
3. For miscellaneous dose blocker parts, components may be exempt from impact testing as allowed by ASME Section III Subsection NF-2311 [8.1.1].
4. Charpy energy absorbed value maybe adjusted based on actual thickness and/or minimum specified yield strength per Fig. NF-2331(a)-2.
5. Components shall meet the acceptance standard applicable to either Charpy for Absorbed Energy or Charpy for Lateral Expansion.

Table 8.1.9: Critical Characteristics of Holtite-B for Shielding Function

Property (Note 1)	Property Value
Minimum Bulk Density, g/cm ³	1.13
Minimum Hydrogen Density, g/cm ³	0.1065
Minimum Boron Carbide Content, wt%	2

Note 1: All properties are critical characteristics.

Table 8.1.10A: Emissivity of Finished Metamic-HT Panels

	Subcomponent	Temperature, °C	Emissivity Value (dimensionless), e
1.	MPC-37 Metamic-HT Fuel Basket Panels	$150 \leq T \leq 500$	See Note 1
2.	MPC-89 Metamic-HT Fuel Basket Panels	$150 \leq T \leq 500$	See Note 1

Note 1: Emissivity Equation (Dark Grey Anodized Metamic-HT):

$$e = 0.2 + 0.6 \sin[\pi(T-100)/1304] \quad (100^\circ\text{F} \leq T \leq 752^\circ\text{F})$$

$$e = 0.8 \quad (T > 752^\circ\text{F})$$

Table 8.1.10B: Design Options for Extruded Basket Shims

Option	Emissivity Value of Extruded Basket Shims (dimensionless)	As-Built Average Cold Radial Gap (inch) (Note 2)	Solid Shims (Note 3)	Emissivity Value of Solid Shims (dimensionless)	Maximum Average Cold Radial Gap After Solid Shims are Placed (inch) (Note 4)
1	Note 1	≤ 0.281	NOT REQUIRED	Not Applicable	Not Applicable
2	Note 1	> 0.281	REQUIRED	Note 1	≤ 0.24

Notes:

1. Emissivity Equation (Dark Grey Anodized):

$$e = 0.2 + 0.6 \sin[\pi(T - 100)/1304] \quad (100^\circ\text{F} \leq T \leq 752^\circ\text{F})$$

$$e = 0.8 \quad (T > 752^\circ\text{F})$$
2. This is the average total combined radial cold air gap between the basket and extruded shims, and the extruded shim and the inner surface of the MPC shell before the placement of solid shims made of aluminum plates/sheets.
3. Extruded basket shims are shaped to conform to the geometry of its intended annular space and sized to provide a loose fit in the basket periphery. If the as-built average total combined radial cold gap between the basket and extruded shims and the extruded shim and the inner surface of the MPC enclosure shell exceeds the gap tabulated herein, solid shims, made of aluminum plates or sheet shall be inserted in the space between the basket external wall and extruded shims.
4. The average total combined radial cold air gap between the basket and extruded shims and the extruded shim and the inner surface of the MPC shell must be below the value tabulated herein if solid shim plates/sheets made of aluminum are placed between the basket wall and extruded shim.

Table 8.1.11: Tier System for MPC Selection for ECT

Tier No.	Number of MPCs Tested as a Percent of Number of MPCs in the Lot	Number of Continuous Lots that Must Pass to Drop Down to the Next Tier
1	20	5
2	12.5	5
3	5	10
4	1	N/A

Note 1: If an MPC (including a lead canister(s)) fails with respect to the ECT acceptance criterion, then every MPC to be shipped (within the Lot) must undergo ECT.

Note 2: Testing shall be moved up to the next tier for the next Lot to be qualified for transport if any MPC fails with respect to the ECT acceptance criterion.

Note 3: Tiering defined on the basis of sample size. Higher tier testing requires greater percentage of sample testing (i.e. moving up the table).

Note 4: A Lot is defined as a population of MPCs at an ISFSI identified by the user of the ISFSI. A Lot may comprise of one or more MPCs and may comprise of a subset of the ISFSI or the entire ISFSI. Only the MPCs within the Lot are eligible to be qualified for transport by the ECT statistical approach.

Note 5: The value for the calculated number of MPCs to be tested shall be rounded up to the nearest whole number. Example No. 1: The number of MPCs to be tested per Tier No. 2 for a Lot of 20 MPCs shall be 3 MPCs. Example No. 2: The number of MPCs to be tested per Tier No. 4 for a Lot of 2 MPCs shall be 1 MPC.

Note 6: See Subsection 8.1.8 of this SAR for additional information and lead canister requirements relevant to qualification of MPCs by ECT.

Table 8.1.12: Performance Criteria for Conventional Surface Preservative Liner

Rank	Criteria
1	Chemical Immersion Resistance (suitable for short-term immersion in borated water)
2	High Temperature Resistance (suitable for 220°C for the cask cavity surfaces and long-term dry helium environment)
3	High Radiation Resistance (suitable for 1×10^8 Rad)
4	Good Adhesion Characteristics (adhesion to steel or aluminum oxide as applicable)
5	Good Structural Performance (bendability/ductility/cracking resistance/abrasion resistance)
6	Emissivity 0.85 minimum
<p>Note 1: Performance criteria are specified conservatively for conventional surface preservatives in order of importance to guide the in the selection of equivalent surface preservatives.</p>	

Table 8.1.13: MPC Surface Inspection Criteria

Maximum Allowable Flaw Depth	2 mm
<p>Notes:</p> <ol style="list-style-type: none"> 1. The flaw criterion in this table is applicable to MPC's containing high burn-up fuel and stored under the provisions of 10CFR 72. See Subsection 8.1.8 for more details. 2. The ECT probe shall be capable of detecting a surface defect equal to or greater than 2 mm in depth. 	

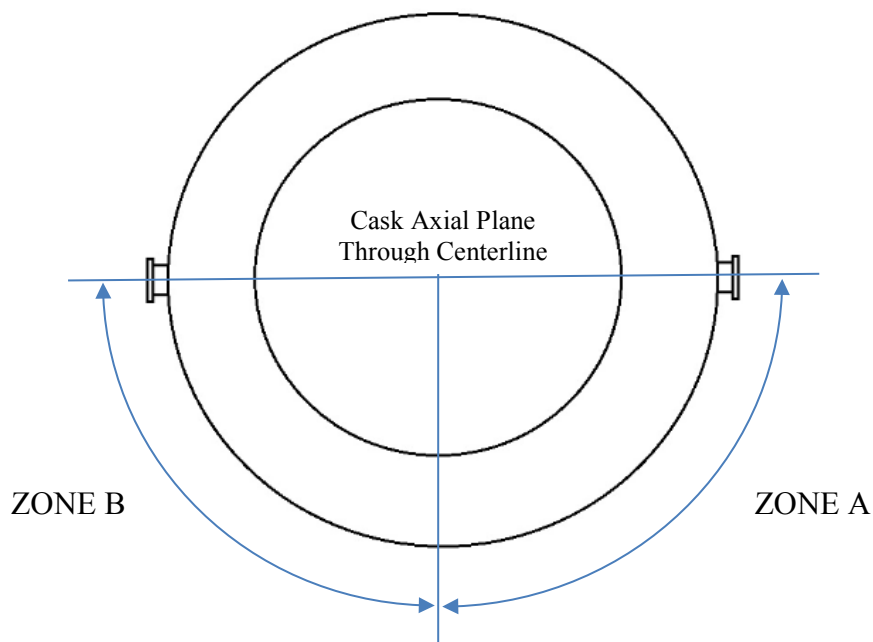

CASK BOTTOM END VIEW (SHOWN WITHOUT IMPACT LIMITERS)

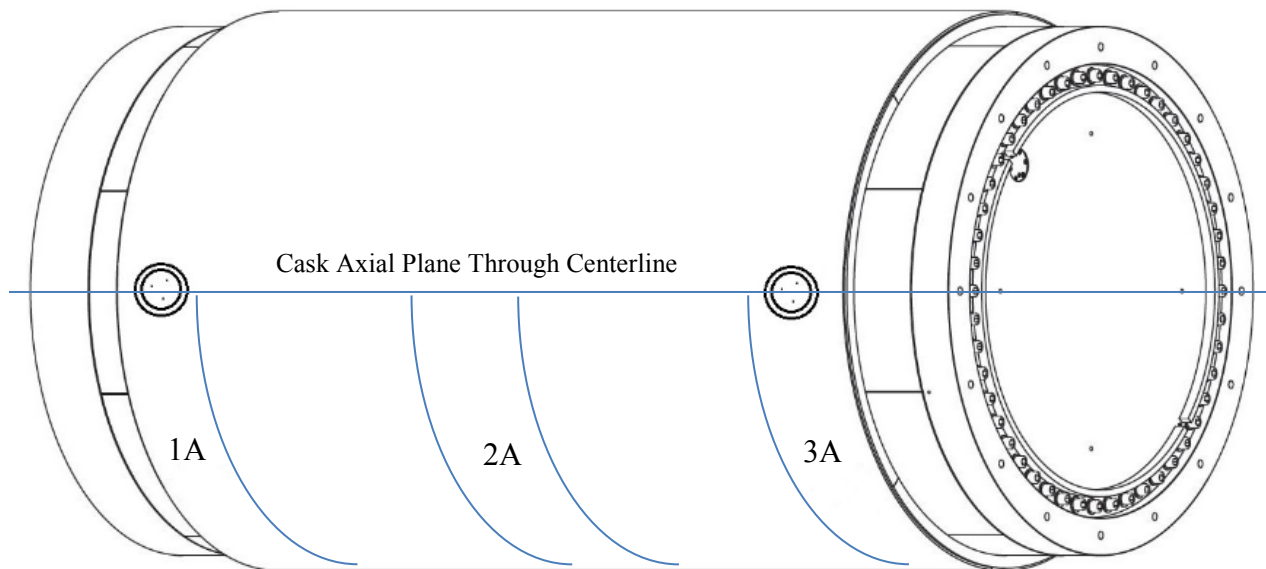

NOTE: THREE SUBZONES WITHIN "ZONE A" AS SHOWN. THREE SUBZONES WITHIN "ZONE B" ON THE OPPOSING SIDE OF THE CASK MIRRORING THE "ZONE A" SUBZONES. THE WIDTH OF THE SUBZONES IS 2 FEET NOMINAL.

HORIZONTAL CASK (SHOWN WITHOUT IMPACT LIMITERS)

Figure 8.1.1: Measurements Zones for the Post Shipment Fuel Integrity Acceptance Test

8.2 MAINTENANCE PROGRAM

An ongoing maintenance program for the HI-STAR 190 Cask, impact limiter and MPC will be prepared and issued prior to the delivery and first use of the HI-STAR 190 Package as a part of its O&M Manual. This document shall delineate the detailed inspections, testing, and parts replacement necessary to ensure continued radiological safety, proper handling, and containment performance of the HI-STAR 190 Package in accordance with 10CFR71, Ref [8.0.1], regulations, conditions in the Certificate of Compliance, and the design requirements and criteria contained in this Safety Analysis Report (SAR).

The HI-STAR 190 package is totally passive by design. There are no active components or systems required to assure the continued performance of its safety functions. As a result, only minimal maintenance will be required over its lifetime, and this maintenance would primarily result from weathering effects, and pre- and post-usage requirements for transportation. Typical of such maintenance would be the reapplication of corrosion inhibiting materials on accessible external surfaces, seal replacement, and leak testing following seal replacement. Such maintenance requires methods and procedures no more demanding than those currently in use at nuclear power plants.

A maintenance inspections and tests program schedule for the HI-STAR 190 Package is provided in Table 8.2.1.

8.2.1 Structural and Pressure Tests

No periodic structural or pressure tests on the packaging following the initial acceptance tests are required to verify continuing performance.

As defense-in-depth, the MPC maintenance program shall include an aging management program for any storage durations longer than the initial 20 year license period under the provisions of 10CFR 72 that verifies that the MPC pressure boundary is free of cracks, pinholes, uncontrolled voids or other defects that could significantly reduce the effectiveness of the packaging. Acceptance criteria established under the part 72 aging management program shall be considered acceptable. See Section 8.1.8, Appendix 8.A and Table 8.2.1.

8.2.2 Leakage Tests

Leakage rate tests on the HI-STAR 190 cask containment system and MPC containment boundary (See Appendix 8.A for applicability) shall be performed per written and approved procedures in accordance with the requirements of Chapter 7 and the requirements of ANSI N14.5 [8.1.6] specified in this Chapter. Tables 8.1.1 and 8.1.2 specify the allowable leakage rate and test sensitivity as well as components to be tested for fabrication, pre-shipment, periodic and maintenance leakage rate tests.

If the pre-shipment leakage rate test expires (Section 8.1.4), a periodic leakage rate test of the containment seals and MPC must be performed prior to transport. This periodic leakage rate test is valid for 1 year. Also see Table 8.2.1.

Maintenance leakage rate testing shall be performed prior to returning a cask to service following maintenance, repair (such as a weld repair), or replacement of containment system components (such closure lid or port cover plate). Only that portion of the containment system that is affected by the maintenance, repair or component replacement needs to be leak tested.

Leakage rate testing procedures shall be approved by an ASNT Level III specialist. The written and approved test procedure shall clearly define the test equipment arrangement. Leakage rate testing shall be performed by personnel who are qualified and certified in accordance with the requirements of SNT-TC-1A [8.1.2]. Leakage rate testing shall be performed in accordance with a written quality assurance program.

The periodic and maintenance leakage rate tests shall be documented in accordance with the user's quality assurance program.

8.2.3 Component and Material Tests

8.2.3.1 Relief Devices

The neutron shield relief devices on the cask shall be visually inspected for damage or indications of excessive corrosion prior to each transport of the HI-STAR 190 package. If the inspection determines an unacceptable condition, the neutron shield relief devices shall be replaced. The neutron shield relief devices shall be replaced periodically while the cask is in service if recommended by the manufacturer's O&M manual.

8.2.3.2 Periodic Neutron Shield Test

Periodic verification of the cask neutron shield integrity shall be performed within 5 years prior to shipment. The periodic verification shall be performed by radiation measurements with either loaded contents or a check source. Measurements shall be taken at three cross sectional planes through the radial shield and at four points along each plane's circumference. The average measurement results from each sectional plane shall be compared to calculated values to assess the continued effectiveness of the neutron shield. The calculated values shall be representative of the loaded contents (i.e., fuel type, enrichment, burn-up, cooling time, etc...) or the particular check source used for the measurements.

The test shall be documented and maintained in accordance with the user's quality assurance program.

8.2.3.3 Packaging Surfaces

Accessible external surfaces of the cask and impact limiters shall be visually inspected for damage prior to each fuel loading to ensure that the packaging effectiveness is not significantly reduced. Visual inspections of the cask and impact limiters shall be performed for external surface coating and component damage including surface denting, surface penetrations, weld cracking, chipped or missing coating. Where necessary, cask coatings shall be reapplied. Damage shall be evaluated for impact on packaging safety and shall be repaired or replaced accordingly. Wear and tear from normal use will not impact cask safety. Repairs or replacement in accordance with written and approved procedures, as set down in the O&M manual, shall be required if unacceptable conditions are identified.

Prior to installation or replacement of a closure seal, the cask sealing surface shall be cleaned and visually inspected for scratches, pitting or roughness, and affected surface areas shall be polished smooth or repaired as necessary in accordance with written and approved procedures.

8.2.3.4 Packaging Fasteners

Cask closure fasteners and impact limiter fasteners shall be visually inspected for damage such as excessive wear, galling, or indentations on the threaded surfaces prior to installation. Threaded fasteners shall be examined in accordance with paragraph NB-2582, ASME Section III, Subsection NB. Fasteners without sufficient usable thread length meeting the requirements of NB-2582 shall be replaced. Damaged internal threads may be repaired per standard industry practice (e.g. threaded inserts). Any repair shall be evaluated to ensure ASME Code stress limits applicable to bolted closure joints are met. Any required material or manufacturing process testing would also be performed in accordance with the original applicable code.

Bolting of the closure lid and port cover plate, shall be replaced as guided by fatigue analysis per the provisions of ASME Code Section III. The maintenance program in Table 8.2.1 provides a bolt change out schedule to insure that the cumulative damage factor accumulated by a bolt shall be less than 1.0 with sufficient margin. One bolting cycle is the complete sequence of torquing and removal of bolts.

Containment Top Flange internal threads for closure bolts have a maximum service life limit based on bolting cycles as determined by fatigue analysis per the provisions of Section III of the ASME Code. The bolting cycles specified in Table 8.2.1 shall not be exceeded. One bolting cycle is the complete sequence of torquing and removal of bolts.

8.2.3.5 Cask Trunnions

Cask trunnions shall be inspected prior to each fuel loading. The accessible parts of the trunnions (areas outside the cask), and the local cask areas shall be visually examined to verify no deformation, distortion, or cracking has occurred. Any evidence of deformation (other than minor localized surface deformation due to contact pressure between lifting device and trunnion), distortion or cracking of the trunnion or adjacent cask areas shall require repair or

replacement of the trunnion and/or repair of the cask. Following any replacements and/or repair, the load testing shall be re-performed and the components re-examined in accordance with the original procedure and acceptance criteria.

8.2.3.6 Closure Seals

The HI-STAR 190 Cask is equipped with elastomeric seals on the closure lid and port cover. The closure seals are shipped from the factory pre-inspected and carefully packaged. Once installed and compressed, the seals should not be disturbed by removal of closure fasteners. Removal of closure fasteners and closure lid or port cover plate may require the seals to be visually inspected to ensure it remains free of debris, it does not exhibit damage (i.e. no tears or gouges), and it does not exhibit excessive compression set (i.e. the seal projects past the plane of the top seating surface of the seal groove). If seals are deemed acceptable they may be re-used. Closure seals are specified for long-term use and do not require in-service maintenance if not disturbed. Reused elastomeric seals are subject to replacement based on seal design life as recommended by the seal manufacturer.

8.2.4 Periodic Thermal Tests

A periodic verification of adequate rate of heat dissipation from the cask to the environs shall be performed on each HI-STAR 190 cask upon first loading and subsequently within 5 years prior to shipment. Acceptable performance under test conditions ensures that design basis fuel cladding temperature limits to which the HI-STAR 190 Package is qualified under design basis heat loads will not be exceeded during transport.

Prior to performing the test, thermal equilibrium of the HI-STAR 190 Package shall be verified by measuring the HI-STAR 190 cask surface temperature using calibrated thermocouples or surface pyrometers at a suitably located plane of the cask as shown in Figure 8.2.1 and at periodic time intervals until a steady state condition is reached. The steady state condition for the purposes of this test, which must contend with varying ambient temperatures and state of quiescence during the test, shall be defined by measuring cask-to-ambient ΔT at one hour increments. A steady state condition is said to have been realized when two successive ΔT measurements vary by less than 5%. The average of two successive ΔT measurements shall be used to verify acceptability as defined next.

After thermal equilibrium is established, temperatures shall be measured and recorded using a calibrated thermocouple or surface pyrometer at the locations shown on Figure 8.2.1. The decay heat load and fuel cycle history of the fuel assemblies loaded in the HI-STAR 190 Package shall also be recorded. These records shall become part of the maintenance program quality records for the HI-STAR 190 cask. The HI-STAR 190 cask is considered acceptable if the average of two successive ΔT measurements comply with Table 8.2.2 limits.

8.2.5 Miscellaneous Tests

No additional tests are required for the HI-STAR 190 Packaging, packaging components, or packaging materials.

**Table 8.2.1 (Sheet 1 of 2)
Maintenance Inspections and Tests Program Schedule**

Task	Schedule
Cask and impact limiter surface visual inspection. (See Paragraph 8.2.3.3)	Prior to loading the loaded MPC into the cask
Cask closure fasteners/bolts visual inspection (See Paragraph 8.2.3.4)	Prior to installation and/or prior to transport
Cask trunnion visual inspection (See Paragraph 8.2.3.5)	Prior to loading the sealed MPC into the cask
Impact limiter and impact limiters fasteners visual inspection (See Paragraph 8.2.3.3 and 8.2.3.4)	Prior to installation and/or prior to transport
Neutron shield relief device visual inspection (See Paragraph 8.2.3.1)	Prior to package transport
Pre-shipment leakage rate test of cask containment system seals (See Subsection 8.1.4)	Prior to package transport following each MPC loading into the cask
Pre-shipment leakage rate test of MPC containment boundary for MPC's containing HBF (See Subsection 8.1.4 and Appendix 8.A)	Prior to package transport following each MPC loading into the cask
Periodic leakage rate test of cask containment system seals (See Subsection 8.2.2)	Prior to package transport if period from last test exceeds 1 year.
Periodic leakage rate test of MPC containment boundary for MPC's containing HBF (See Subsection 8.2.2 and Appendix 8.A)	Prior to package transport if period from last test exceeds 1 year.
Maintenance Leakage Rate Test of Cask containment boundary (See Subsection 8.2.2)	Following maintenance, repair or replacement of containment system components
Seal replacement for Closure Lid and/or Port Cover Plate (See Paragraph 8.2.3.6)	Following removal of closure bolting if the seal is not reusable or if the reusable seal is found to be damaged, is not free of debris, exhibits excessive compression set or does not meet the maintenance leakage rate test or pre-shipment test OR if required based on seal design life limitations

**Table 8.2.1 (Sheet 2 of 2)
Maintenance Inspections and Tests Program Schedule**

Task	Schedule
Bolt replacement (<i>Service Life</i>) for Closure Lid (See Paragraph 8.2.3.4)	Every 225 bolting cycles for SA-564/705 630 Every 256 bolting cycles for SB-637
Bolt replacement (<i>Service Life</i>) for port Cover Plate Bolts (See Paragraph 8.2.3.4)	558 bolting cycles for the bolt specified in drawing package referenced in the CoC.
Containment Top Forging closure bolt thread <i>Service Life</i> (See Paragraph 8.2.3.4)	1000 bolting cycles for the bolt specified in drawing package referenced in the CoC.
Neutron shield relief device replacement (See Paragraph 8.2.3.1)	As required by the manufacturer's O&M manual
Periodic Neutron Shield Test (See Paragraph 8.2.3.2)	Within 5 years prior to shipment
Periodic Thermal Test (See Subsection 8.2.4)	Within 5 years prior to shipment
MPC Enclosure Vessel pressure boundary structural integrity as confirmed by MPC aging management program for MPCs stored beyond the duration of the initial 20 year license period under the provisions of 10CFR 72 (See Subsection 8.2.1 and Appendix 8.A).	Prior to package transport following each MPC loading into the cask
MPC Enclosure Vessel Shell Surface Defect Inspection for MPCs containing HBF and stored beyond 5 years under the provisions of 10CFR 72. MPCs passing inspection (approved for transport) must be shipped within 5 years). (See Subsection 8.1.8 and Table 8.1.11 for details)	Prior to transport. This test may be conducted based on a statistical testing approach as indicated in Subsection 8.1.8 and Table 8.1.11. The statistical approach may result in inspection of every MPC or the user may elect not to follow the statistical approach and instead inspect every MPC.
Post-Shipment Fuel Integrity Acceptance Test. (See Paragraph 8.1.9.1)	Prior to package transport following each MPC loading into the cask (pre-shipment) and post-shipment, as applicable.
10CFR72 AMP Based HBF Integrity Acceptance Test. (See Paragraph 8.1.9.2)	Prior to package transport

**Table 8.2.2
HI-STAR 190 Periodic Thermal Test Criteria**

MPC Model:	MPC-37	MPC-89
ΔT (°F) Limit:	138	130
<p><u>Notes</u></p> <p>(1) The average of two successive ΔT measurements must comply with specified ΔT limit in order to qualify the cask for transport.</p> <p>(2) $\Delta T = T_c - T_a$ where T_c is the cask temperature defined as the average of the temperature measurements at the 8 circumferential locations shown in Figure 8.2.1 and T_a is the ambient temperature measured in the vicinity of the cask. To minimize cask effects, the user should avoid T_a measurements that are closer than 5 ft from the cask or directly above the cask.</p> <p>(3) The test criteria address a reference test configuration with test conducted outdoors under insolation with the package in the horizontal orientation with impact limiters installed and no personnel barrier.</p> <p>(4) When testing outdoors, suitable measures such as installation of wind breakers or sunshades may be implemented to minimize influence of environmental variations.</p> <p>(5) Test configuration may be modified to meet site needs such as an indoor located test with suitably adjusted criteria accounting differences in test configuration and environmental conditions.</p>		

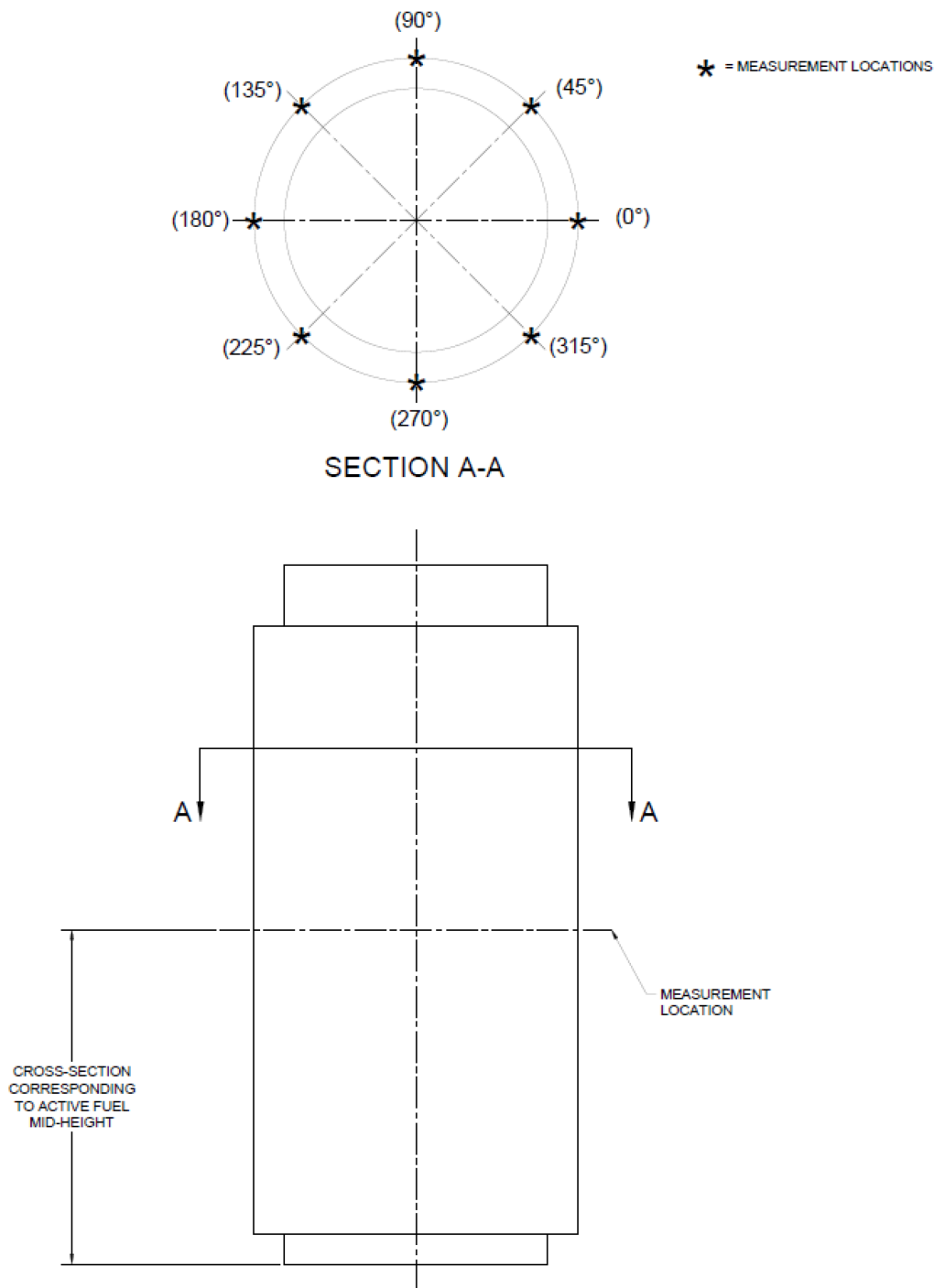

Note: For casks loaded with mixed fuel types, use an assembly count weighted active fuel mid-height for measurement location. A best estimate of this measurement location is also acceptable. The method of determination of the location of this measurement shall be documented.

Figure 8.2.1: Temperature Measurement Locations for the Periodic Thermal Test

8.3 REFERENCES

The following generic industry and Holtec produced references may have been consulted in the preparation of this document. Where specifically cited, the identifier is listed in the SAR text or table. Active Holtec Calculation Packages or Technical Reports, which are the repository of all relevant licensing and design basis calculations, are annotated as “latest revision”. Submittal of the latest revision of such Calculation Packages to the USNRC and other regulatory authorities during the course of regulatory reviews is managed under the company’s Configuration Control system.

- [8.0.1] U.S. Code of Federal Regulations, Title 10, "Energy", Part 71, "Packaging and Transportation of Radioactive Materials.”
- [8.1.1] American Society of Mechanical Engineers, "Boiler and Pressure Vessel Code," Sections II, III, V, IX, and XI, 2007 Edition, 2008 Addenda. (except 2007 Edition for MPCs and 2013 of Section IX for FSW)
- [8.1.2] American Society for Nondestructive Testing, "Personnel Qualification and Certification in Nondestructive Testing," Recommended Practice No. SNT-TC-1A, 2006.
- [8.1.3] American National Standards Institute, Institute for Nuclear Materials Management, "American National Standard for Radioactive Materials - Special Lifting Devices for Shipping Containers Weighing 10,000 Pounds (4500 kilograms) or More", ANSI N14.6, September 1993.
- [8.1.4] U.S. Nuclear Regulatory Commission, "Fracture Toughness Criteria of Base Material for Ferritic Steel Shipping Cask Containment Vessels with a Maximum Wall Thickness of 4 Inches (0.1m)," Regulatory Guide 7.11, June 1991.
- [8.1.5] U.S. Nuclear Regulatory Commission, "Fracture Toughness Criteria of Base Material for Ferritic Steel Shipping Cask Containment Vessels with a Wall Thickness Greater than 4 Inches (0.1m) But Not Exceeding 12 Inches (0.3m)," Regulatory Guide 7.12, June 1991.
- [8.1.6] American National Standards Institute, Institute for Nuclear Materials Management, "American National Standard for Radioactive Materials - Leakage Tests on Packages for Shipment", ANSI N14.5, 2014.
- [8.1.7] Holtec International Document DOC-5014-03, “Acceptance Testing of First HI-STAR Overpack (Thermal and He Leak Tests)”, September 2006
- [8.1.8] “Metamic-HT Manufacturing Manual”, Latest Revision, Holtec International (Proprietary)

- [8.1.9] “Metamic-HT Qualification Sourcebook”, HI-2084122, Latest Revision, Holtec International (Privileged Intellectual Property)
- [8.1.10] Metamic-HT Purchasing Specification”, Holtec Document ID PS-11, Latest Revision, Holtec International (Proprietary)
- [8.1.11] Military Standard MIL-STD-105E, “Sampling Procedures and Tables for Inspection by Attributes”, 1989

Appendix 8.A

MPC TRANSPORTABILITY CHECKLIST

Table 8.A.1 of this appendix provides a checklist of transportability requirements an MPC must meet prior to transport in HI-STAR 190. The requirements include MPC acceptance criteria, design features, design criteria, aging management program, and other requirements that, unless otherwise noted, provide defense-in-depth as well as consistency to the safety approach of HI-STAR 190. Table 8.A.1 features an applicability column to distinguish whether requirements are applicable to MPCs loaded with MBF (where only the MPC pressure boundary structural integrity is essential to the safety approach as defense-in-depth) or to MPCs loaded with HBF (where in addition to the MPC pressure boundary structural integrity, the MPC containment boundary leaktightness and containment boundary integrity under hypothetical accident conditions of transport are essential to the safety approach to ensure moderator exclusion under hypothetical accident conditions of transport).

Table 8.A.1 MPC Transportability Checklist (Sheet 1 of 2)		
Requirement	Applicability	
	MPC loaded with MBF	MPC loaded with HBF
MPC Acceptance Tests and Inspections (Primary Safety Case)		
Visual Inspection and Measurements (Subsection 8.1.1)	✓	✓
Weld Examination (Subsection 8.1.2)	✓	✓
Structural and Pressure Tests (Paragraph 8.1.3.2)	✓	✓
Containment Boundary Leakage Tests (Subsection 8.1.4)		✓
Metamic-HT Tests (Paragraph 8.1.5.5)	✓	✓
Containment Boundary Integrity Confirmation by Enclosure Vessel Shell Surface Defect Inspection (See Subsection 8.1.8, Table 8.1.11 and Table 8.2.1)		✓
MPC Structural Design Criteria (Primary Safety Case)		
The MPC's Enclosure Vessel must meet the stress intensity limits of ASME Section III Subsection NB under all applicable NCT and HAC of transport	✓	✓
The MPC is structurally qualified to remain “leaktight as defined by ANSI 14.5 [8.1.6]” under all normal and accident conditions of transport		✓
MPC Pressure Requirements		
The pressure inside the MPC remains < 100 psig (10CFR71.4) when prepared for transport in HI-STAR 190	✓	✓
MPC Design Features (Defense-in-Depth)		
The MPC must be all-welded, i.e., no reliance on mechanical seals or gaskets for radiological confinement	✓	✓
The MPC's Enclosure Vessel must be made of a corrosion resistant alloy	✓	✓
No pressure relief or pressure protection features or other form of breachable penetrations through the MPC pressure or containment boundary	✓	✓
Vent, drain or other penetrations must have a welded closure	✓	✓

Table 8.A.1 MPC Transportability Checklist (Sheet 2 of 2)		
Requirement	Applicability	
	MPC loaded with MBF	MPC loaded with HBF
MPC Inspections During Fabrication (Defense-in-Depth)		
All pressure boundary components in the MPC's Enclosure Vessel must be volumetrically tested	✓	✓
All butt welds in the MPC pressure boundary must be 100% radiographed.	✓	✓
The MPC top lid-to-shell weld joint must be progressively liquid penetrant (L.P.) tested	✓	✓
MPC Part 72 License of Origin (Primary Safety Case)		
Initially loaded and/or stored under CoC 72-1032 or CoC 72-1040	✓	✓
MPC Aging Management Program¹ (Defense-in-Depth)		
Enclosure vessel pressure boundary structural integrity confirmation (See Subsection 8.2.1 and Table 8.2.1)	✓	✓
MPC Maintenance Program (Primary Safety Case)		
The MPC has not suffered a handling accident that could significantly reduce the effectiveness of the packaging	✓	✓

¹ The Aging Management Program shall have been specified and performed under the aegis of the HI-STORM FW FSAR (Docket # 72-1032) or the HI-STORM UMAX FSAR (Docket # 72-1040) to ensure that aging effects that could compromise the MPC enclosure vessel integrity during dry storage are appropriately dispositioned under the Corrective Action Program of a Part 72 general licensee. The Aging Management Program is only applicable for storage durations longer than the initial 20 year license period under the provisions of 10CFR72.