

Non-Proprietary

Onsite AC Power System Analysis

Revision 4

Non-Proprietary

April 2018

Copyright © 2018

**Korea Electric Power Corporation &
Korea Hydro & Nuclear Power Co., Ltd
All Rights Reserved**

REVISION HISTORY

Revision	Date	Page(s)	Description
0	December 2014	All	First Issue
1	January 2016	10, 13~19, 21, 22, 24~36	Auxiliary loads are updated and acceptance criteria for bus voltage variation are revised.
2	March 2017	10, 13, 25, 27	Technical report supplement of response to RAI 413-8529, Question 08.03.01-22 is reflected.
		32	LC02N, 03N transformer taps are changed. (Regulatory Audit)
		15, 19~24	LC and MCC loadings are corrected as actual power consumption. (Regulatory Audit)
		27, 29, 30, 32, 34	The latest load information is considered. (Regulatory Audit)
		15, 16, 36	Bus transfer sequence and initiation scenarios are revised. (Regulatory Audit)
		25, 26, 29, 31, 33	Typographical errors are corrected. (Regulatory Audit)
		8, 9	The double incoming circuit breakers in response to RAI 16-7915, Question 08.01-1 are reflected.
		11~13	Figures are simplified for better understanding.
3	January 2018	8, 9	Several feeders from MCCs to regulating transformers (or battery charger) and a connection between LCs are corrected.
		15, 19~24, 27, 29, 30, 32~35	Loading values, analysis results, and etc. are updated according to the up-to-date loads information.
		31, 37	Description of analysis result is modified to meet the acceptance criteria for voltage limit of the equipment terminal.
		30, 32, 33	Motor starting cases are diversified for more conservative analysis result values.
		36	Bus transfer result (1-822-E-SW02M) is corrected.
4	April 2018	iv, 38	DCD revision is updated.
		8, 9	The term related to the 4.16 kV mobile generator is modified to allow COL applicant flexibility in selection of the generator type rated at 4.16 kV.
		25	Typographical error is corrected.

This document was prepared for the design certification application to the U.S. Nuclear Regulatory Commission and contains technological information that constitutes intellectual property of Korea Hydro & Nuclear Power Co., Ltd. Copying, using, or distributing the information in this document in whole or in part is permitted only to the U.S. Nuclear Regulatory Commission and its contractors for the purpose of reviewing design certification application materials. Other uses are strictly prohibited without the written permission of Korea Electric Power Corporation and Korea Hydro & Nuclear Power Co., Ltd.

ABSTRACT

This technical report addresses the adequacy of onsite ac power system in the Advanced Power Reactor 1400 (APR1400) by evaluating whether the electrical equipment operates properly in various plant operating modes and power source conditions. Steady-state load flow, short-circuit current, motor starting, harmonic, and bus transfer analysis are included in this report.

The plant power source conditions are categorized as main generator connected to normal preferred power supply system, unit auxiliary transformers connected to preferred power supply system through the main transformer when the generator circuit breaker is open, and standby auxiliary transformers connected to the alternate power supply system and alternate alternating current gas turbine generator. Operating modes are normal, startup, unit trip coincident with a loss-of-coolant accident, hot standby, and station blackout condition. In Section 5, assumptions and input data are provided for analyzing onsite ac power system and the acceptance criteria to verify that the electrical equipment operates as designed are described in Section 6. All of the results of the onsite ac power system analysis meet the acceptance criteria.

This document supports Chapter 8 of the APR1400 Design Control Document, Tier 2.¹⁾

1) APR1400-K-X-FS-14002, "APR1400 Design Control Document," Tier 2, Rev. 2, KEPCO and KHNP, [February 2018].

TABLE OF CONTENTS

TABLE OF CONTENTS.....	v
LIST OF TABLES	vii
LIST OF FIGURES	viii
ACRONYMS AND ABBREVIATIONS	ix
1 INTRODUCTION	1
2 SCOPE.....	2
3 APPLICABLE CODES, STANDARDS, AND REGULATORY GUIDES	3
3.1 U.S. Regulations.....	3
3.2 U.S. Nuclear Regulatory Commission Guidance	3
3.3 U.S. Industry Guidance	3
4 POWER SYSTEM DESCRIPTION.....	5
4.1 Offsite Power System	5
4.2 Onsite Power System.....	5
4.2.1 Non-Class 1E Onsite AC Power System.....	6
4.2.2 Class 1E Onsite AC Power System.....	7
4.3 Source Condition and Operating Mode	10
5 ASSUMPTIONS AND INPUT DATA	14
5.1 Assumptions	14
5.1.1 Switchyard System.....	14
5.1.2 Grid System Voltage Variation Range	14
5.1.3 Grid Short-Circuit Capability.....	14
5.1.4 Generator Characteristic Data.....	14
5.1.5 Power Transformer Data	15
5.1.6 Load Data	15
5.1.7 Harmonic Equipment Data	15
5.1.8 Bus Transfer Equipment Data	15
5.1.9 Cable Data.....	16
5.2 Input Data	16
5.2.1 Grid System Data	16
5.2.2 Generator	16
5.2.3 Ratings of Power Transformer.....	17
5.2.4 Ratings of Load Center Transformer	17
5.2.5 Switchgear Rating	17

5.2.6	Bus Ratings	18
5.2.7	Loads Connected to Bus	19
6	ANALYSIS.....	25
6.1	Steady-State Load Flow Analysis	25
6.1.1	Acceptance Criteria	25
6.1.2	Analysis Result	26
6.2	Short-Circuit Current Analysis	28
6.2.1	Acceptance Criteria	28
6.2.2	Analysis Result	29
6.3	Motor Starting Analysis	30
6.3.1	Acceptance Criteria	30
6.3.2	Analysis Result	31
6.4	Harmonic Analysis	33
6.4.1	Acceptance Criteria	33
6.4.2	Analysis Results	34
6.5	Bus Transfer Analysis	35
6.5.1	Acceptance Criteria	35
6.5.2	Analysis Results	35
7	CONCLUSIONS.....	37
8	REFERENCES	38

LIST OF TABLES

Table 5-1	Generator Characteristic Data.....	14
Table 5-2	Grid System Data	16
Table 5-3	Generator Input Data	16
Table 5-4	Ratings of Power Transformer.....	17
Table 5-5	Ratings of Load Center Transformer	17
Table 5-6	Bus Ratings	18
Table 5-7	13.8 kV Bus 1-821-E-SW01M Loads.....	19
Table 5-8	13.8 kV Bus 1-821-E-SW02M Loads.....	19
Table 5-9	4.16 kV PNS Bus 1-822-E-SW01M Loads	20
Table 5-10	4.16 kV Bus 1-822-E-SW02M Loads.....	20
Table 5-11	4.16 kV Bus 1-823-E-SW01A Loads	21
Table 5-12	4.16 kV Bus 1-823-E-SW01C Loads	21
Table 5-13	13.8 kV Bus 1-821-E-SW01N Loads	22
Table 5-14	13.8 kV Bus 1-821-E-SW02N Loads	22
Table 5-15	4.16 kV PNS Bus 1-822-E-SW01N Loads.....	23
Table 5-16	4.16 kV Bus 1-822-E-SW02N Loads	23
Table 5-17	4.16 kV AAC Bus 1-822-E-SW03N Loads.....	23
Table 5-18	4.16 kV Bus 1-823-E-SW01B Loads	24
Table 5-19	4.16 kV Bus 1-823-E-SW01D Loads	24
Table 6-1	Acceptance Criteria for Bus Voltage Variation at the Steady-state	25
Table 6-2	Minimum operating Voltage Summary of Non-Class 1E Buses (Unit: %).....	27
Table 6-3	Minimum operating Voltage Summary of Class 1E Buses (Unit: %).....	27
Table 6-4	Maximum operating Voltage Summary of Non-Class 1E Buses (Unit: %).....	28
Table 6-5	Maximum operating Voltage Summary of Class 1E Buses (Unit: %).....	28
Table 6-6	Acceptance Criteria for Bus Short-circuit Current	29
Table 6-7	Short-Circuit Current Summary of Non-Class 1E Buses at All Operating Conditions (Unit: kA).....	29
Table 6-8	Short-Circuit Current Summary of Class 1E Buses at All Operating Conditions (Unit: kA).....	30

Table 6-9	Acceptance Criteria for Bus Voltage Variation during the Starting of Large Motors	31
Table 6-10	Motor Starting Summary of Non-Class 1E Buses (Unit: %)	32
Table 6-11	Motor Starting Summary of Class 1E Buses (Unit: %)	32
Table 6-12	Acceptance Criteria for Harmonic Analysis	33
Table 6-13	Maximum Total Harmonic Distortion in Non-Class 1E Buses (Unit: %)	34
Table 6-14	Maximum Total Harmonic Distortion in Class 1E Buses (Unit: %)	34
Table 6-15	Transient Analysis Summary of Bus Transfer	36

LIST OF FIGURES

Figure 4-1	Onsite Power System	8
Figure 4-2	Source 1 - MG connected to 765 kV Offsite Power System	11
Figure 4-3	Source 2 - UATs connected to 765 kV Offsite Power System through the MT when the GCB opens (Back-feeding)	11
Figure 4-4	Source 3 - SATs connected to 154 kV Offsite Power System	12
Figure 4-5	Source 4 - AAC GTG	12
Figure 4-6	Source 5 - EDGs	13

ACRONYMS AND ABBREVIATIONS

AAC	alternate alternating current
ASME	American Society of Mechanical Engineers
bhp	brake horsepower
BTP	Branch Technical Position
CCW	component cooling water
CFR	Code of Federal Regulations
DCD	design control document
EDG	emergency diesel generator
ESF	engineered safety features
ETAP	electrical transient analyzer program
GCB	generator circuit breaker
GDC	general design criteria
GTG	gas turbine generator
IEEE	Institute of Electrical and Electronics Engineers
IPB	isolated phase bus
KEPCO	Korea Electric Power Corporation
KHNP	Korea Hydro & Nuclear Power Co., Ltd
LC	load center
LOCA	loss-of-coolant accident
LOOP	loss of offsite power
LV	low voltage
MCC	motor control center
MG	main generator
MT	main transformer
MV	medium voltage
NEMA	National Electrical Manufacturers Association
NFPA	National Fire Protection Association
NQA	Nuclear Quality Assurance
NSSS	nuclear steam supply system
PNS	permanent non-safety
PPS	preferred power supply
pu	per unit
RCP	reactor coolant pump
RG	Regulatory Guide

RPS	reactor protection system
SAT	standby auxiliary transformer
SBO	station blackout
SKN 3&4	Shin-Kori Nuclear Power Plant Units 3 and 4
TGB	turbine generator building
THD	total harmonic distortion
TS	trade secret
UAT	unit auxiliary transformer

1. INTRODUCTION

The purpose of this report is to provide the results of the analysis as referenced by the APR1400 Design Control Document (DCD) Tier 2, Subsection 8.3.1 (Reference 1), and to evaluate the design adequacy of the onsite ac power system in the APR1400. The analysis includes steady-state load flow, short-circuit current, motor starting, harmonics, and bus transfer. It is performed using the electrical transient analyzer program (ETAP), version 12.0.0N, which is qualified for nuclear power plants in conformance with 10 CFR 50, Appendix B (Reference 2), 10 CFR 50.21 (Reference 3), and American Society of Mechanical Engineers (ASME) NQA-1 (Reference 4).

2. SCOPE

This report includes the following electrical power system calculations and distribution system studies:

- Steady-state load flow analysis
- Short-circuit analysis
- Motor starting analysis
- Harmonic analysis
- Bus transfer analysis

3. APPLICABLE CODES, STANDARDS, AND REGULATORY GUIDES

The electric power system is designed to meet the following requirements of General Design Criteria (GDCs), Regulatory Guides (RGs), Branch Technical Positions (BTPs), and industry standards.

3.1. U.S. Regulations

- General Design Criterion 17, “Electric Power Systems,” 10 CFR 50, Appendix A.
- General Design Criterion 18, “Inspection and Testing of Electric Power Systems,” 10 CFR 50, Appendix A.
- 10 CFR 50, Appendix B, “Quality Assurance Criteria for Nuclear Power Plants and Fuel Reprocessing Plants.”
- 10 CFR 21, “Reporting of Defects and Noncompliance.”

3.2. U.S. Nuclear Regulatory Commission Guidance

- NRC RG 1.75, “Criteria for Independence of Electrical Safety Systems,” Rev. 3, U.S. Nuclear Regulatory Commission, February 2005.
- NRC RG 1.93, “Availability of Electric Power Sources,” Rev. 1, U.S. Nuclear Regulatory Commission, March 2012.
- NRC RG 1.155, “Station Blackout,” Rev. 0, U.S. Nuclear Regulatory Commission, August 1988.
- BTP 8-6, “Adequacy of Station Electric Distribution System Voltages,” Rev. 3, U.S. Nuclear Regulatory Commission, March 2007.

3.3. U.S. Industry Guidance

- IEEE Std 141-1993, “IEEE Recommended Practice for Electric Power Distribution for Industrial Plants,” Institute of Electrical and Electronics Engineers, 1993.
- IEEE Std 384-1992, “IEEE Standard Criteria for Independence of Class 1E Equipment and Circuits,” Institute of Electrical and Electronics Engineers, 1992.
- IEEE Std 387-1995, “IEEE Standard Criteria for Diesel-Generator Units Applied as Standby Power Supplies for Nuclear Power Generating Stations,” Institute of Electrical and Electronics Engineers, 1995.
- IEEE Std 399-1997, “IEEE Recommended Practice for Industrial and Commercial Power System Analysis,” Institute of Electrical and Electronics Engineers, 1997.
- IEEE Std 519-1992, “IEEE Recommended Practices and Requirements for Harmonic Control in Electrical Power Systems,” Institute of Electrical and Electronics Engineers, 1992.
- IEEE Std 765-2006, “IEEE Standard for Preferred Power Supply (PPS) for Nuclear Power Generating Stations (NPGS),” Institute of Electrical and Electronics Engineers, 2006.

- IEEE Std C37.010-1999, "IEEE Application Guide for AC High Voltage Circuit Breakers Rated on a Symmetrical Current Basis," Institute of Electrical and Electronics Engineers, 1999.
- NEMA MG-1, "Motors and Generators," National Electrical Manufacturers Association, 2009.
- ANSI C50.41, "American National Standard for Polyphase Induction Motors for Power Generating Stations," American National Standards Institute, 2000.
- NEMA WC 51, "Ampacities for Cables Installed in Cable Trays," National Electrical Manufacturers Association, 2009.
- NFPA 70, "National Electrical Code," National Fire Protection Association, 2008.
- ASME NQA-1, "Quality Assurance Requirements for Nuclear Facility Applications," The American Society of Mechanical Engineers, 2008.

4. POWER SYSTEM DESCRIPTION

4.1. Offsite Power System

The offsite power system is the preferred source of power for the reactor protection system (RPS) and engineered safety features (ESF) during normal, abnormal, and accident conditions. It includes two physically independent circuits from the transmission network. The switchyard is connected to the transmission lines to transmit the electricity produced by the APR1400 to the grid and to provide offsite power to auxiliary and service loads of the APR1400.

Electric power from the transmission network to the onsite electrical distribution system is supplied by two physically independent circuits.

The offsite power system encompasses the grid, overhead or underground transmission lines, transmission line towers, switchyard components and control systems, switchyard battery systems, the main generator (MG), generator circuit breaker (GCB), main transformer (MT), unit auxiliary transformers (UATs), standby auxiliary transformers (SATs), isolated phase buses (IPBs), and electrical components associated with them. The boundaries between the offsite power system and the onsite power system are the incoming circuit breakers of the switchgears and the circuit breakers, which are included in the onsite power system.

One separate circuit is connected to the switchyard via the MT. The MG is connected to the low-voltage (LV) winding of the MT and the high-voltage winding of the UATs through the GCB. The UATs are connected to the IPB between the GCB and the MT. Under normal operating conditions, the MG supplies power through the GCB to the MT and two UATs.

The other separate circuit is connected to the switchyard via two SATs, to provide an immediately available independent source of offsite power to the onsite power distribution system for safety and non-safety loads when power is not available through UATs.

The GCB is used as a means of providing immediate access of the onsite ac power systems to offsite circuits by isolating the MG from the MT and the UATs and allowing back-feeding of power through these circuits to the onsite ac power system. The GCB is capable of interrupting normal load current and maximum fault current during transient and various fault conditions.

Each preferred power circuit has capacity and capability to permit functioning of structures, systems, and components (SSCs) important to safety and all other auxiliary systems under normal, abnormal, and accident conditions.

4.2. Onsite Power System

The onsite power system for the APR1400, as shown in Figure 4-1, consists of the following systems and components:

- Non-Class 1E 13.8 kV system
- Non-Class 1E and Class 1E 4.16 kV systems
- Non-Class 1E and Class 1E 480V systems
- Emergency diesel generators (EDGs)
- An alternate alternating current (AAC) gas turbine generator (GTG)

The onsite power system is normally powered from the MG through the two UATs. In case power is unavailable from the UATs, the power source of UATs is automatically transferred to the SATs and all Class 1E and non-Class 1E MV switchgear buses are powered from the SATs.

During startup and shutdown, onsite ac power is supplied from the switchyard through the MT and UATs.

The Class 1E loads are divided into two redundant load groups, division I and division II, and each division has two independent subsystems. Each independent subsystem consists of trains A and C for division I and trains B and D for division II.

If both offsite power sources and the EDGs are unavailable, the Class 1E train A or train B is powered independently by the AAC GTG.

The onsite ac power system includes standby power sources, distribution systems, auxiliary supporting systems provided to supply power to safety-related equipment or equipment important to safety for all normal operating and accident conditions. The four EDGs and an AAC GTG are used as a standby power source for the onsite ac power system. The Class 1E EDGs provide backup power to the Class 1E 4.16 kV buses in the event of loss of offsite power (LOOP). The non-Class 1E AAC GTG provides backup power to the permanent non-safety (PNS) buses during a LOOP and to the dedicated Class 1E 4.16 kV bus during a station blackout (SBO).

4.2.1 Non-Class 1E Onsite AC Power System

There are one UAT and one SAT, which provide power to 13.8 kV and 4.16 kV switchgears in each division. During normal plant operation, two non-Class 1E 13.8 kV switchgears, one non-Class 1E 4.16 kV switchgear, one PNS 4.16 kV switchgear, and one non-Class 1E AAC 4.16 kV switchgear are powered from UAT.

The AAC GTG is automatically started by undervoltage relay and manually connected to two PNS buses (division I and division II) during a LOOP. The loads, which are not safety-related but required during a LOOP, are connected to PNS buses manually. The AAC GTG is adequately sized to meet the load requirements during LOOP or SBO conditions.

Load center (LC) transformers are connected to 13.8 kV or 4.16 kV switchgears, and provide power to its 480V LC buses. The non-Class 1E motor control center (MCC) buses are connected to the non-Class 1E LC buses.

4.2.1.1. 13.8 kV Onsite AC Power System

The 13.8 kV onsite ac power system consists of four non-Class 1E switchgears and supplies power to large motors such as the reactor coolant pump motors, condensate pump motors, feedwater booster pump motors, circulating water pump motors, startup feedwater pump motor, cooling tower fan, and associated 480V LCs.

4.2.1.2. 4.16 kV Onsite AC Power System

The 4.16 kV onsite ac power system consists of two non-Class 1E switchgears, two PNS switchgears, and a non-Class 1E switchgear with non-Class 1E AAC GTG. The two non-Class 1E switchgears supply power to the turbine generator building closed cooling water pump and 480V LCs. The PNS switchgear supplies power to the central chillers, central chilled water pump, and 480V LCs, which are required to operate in a LOOP condition.

4.2.1.3. 480V Onsite AC Power System

The 480V onsite ac power system is energized by the 13.8 kV and 4.16 kV switchgears through 13.8 kV / 480V and 4.16 kV / 480V transformers. The secondary of the transformer is connected to a 480V LC bus through a 480V LC incoming breaker. The 480V LCs are distributed throughout the plant area and located indoors. Motors, heaters, and 480V MCCs are assigned to the LCs. The non-Class 1E MCCs are located in the various indoor areas of the plant.

4.2.2 Class 1E Onsite AC Power System

The Class 1E onsite ac power system consists of two redundant load groups (division I and division II), which have four EDGs, 4.16 kV switchgears, 480V LCs, 480V MCCs, and miscellaneous low-voltage (LV) ac supplies.

The Class 1E 4.16 kV switchgears are connected to the offsite power sources through the UAT or the SAT in each division. Each Class 1E 4.16 kV switchgear is also powered by an EDG for a safe shutdown during a LOOP concurrent with loss-of-coolant accident (LOCA) conditions, and the Class 1E train A or train B switchgear has access to the non-Class 1E AAC GTG during an SBO condition. Each 4.16 kV bus supplies power to the motor loads and 4.16 kV / 480V LC transformers.

The Class 1E 4.16 kV switchgears are located in the auxiliary building. Each switchgear is arranged as an independent distribution system, located in a separate fire zone in a seismic Category I room.

LC transformers connected to the Class 1E 4.16 kV buses provide power to Class 1E 480V LC buses. The Class 1E 480V MCC buses are connected to the Class 1E LC buses.

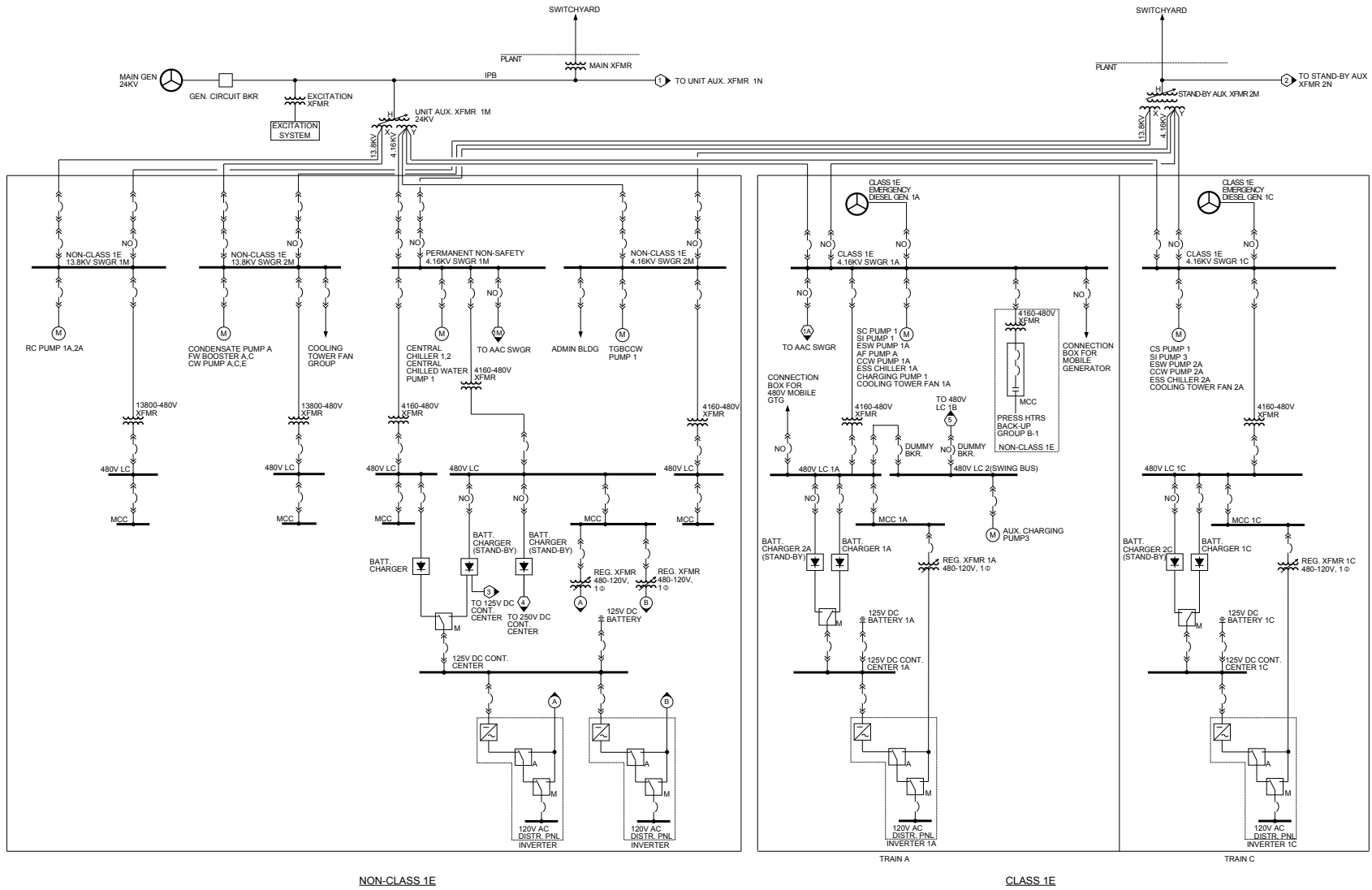

Figure 4-1. Onsite Power System (1 of 2)

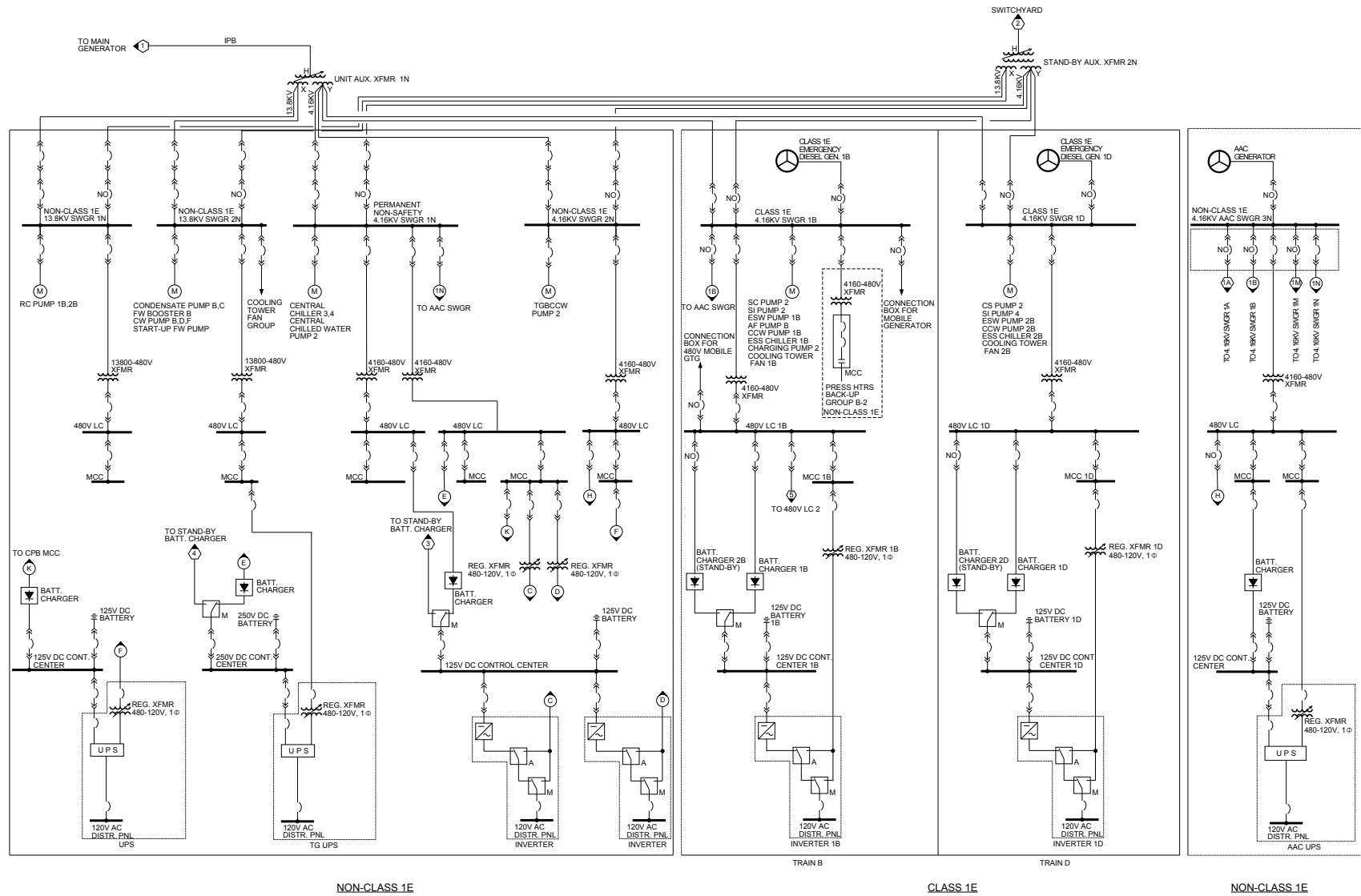

Figure 4-1. Onsite Power System (2 of 2)

4.3. Source Condition and Operating Mode

This section presents the source conditions based on operating modes of the APR1400 nuclear steam supply system (NSSS) response to postulated disturbances in process variables and to postulated malfunctions or failures of equipment. Such incidents (or events) are postulated and their consequences are analyzed despite the many precautions that are taken in the design, construction, quality assurance, and plant operation to prevent their occurrence. The effects of these incidents are examined to determine their consequences and to evaluate the capability built into the plant to control or accommodate such failures and situations.

To evaluate the adequacy of auxiliary power system design and load assignments, the various plant operating modes and the source conditions are considered. As part of the evaluation, the loading are categorized into the following eight levels according to plant conditions:

Loading Categories

- Category 1: Normal operation from UAT
- Category 2: Startup from UAT
- Category 3: Unit trip coincident with LOCA from UAT
- Category 4: Hot standby from UAT
- Category 5: Unit trip coincident with LOCA from SAT
- Category 6: Hot standby from SAT
- Category 7: SBO from AAC GTG
- Category 8: LOOP coincident with LOCA from EDG

The five sources of power feeding the auxiliary system loads are shown in Figures 4-2 through 4-6. These sources are as follows, and the valid load conditions for the respective sources are denoted in parentheses.

- Source 1: MG connected to 765 kV offsite power system. This source is valid for loading category 1 (Normal).
- Source 2: UATs connected to 765 kV offsite power system through the MT when the GCB opens (back-feeding). This source is valid for loading categories 2, 3, and 4 (startup, unit trip with LOCA, and hot standby).
- Source 3: SATs connected to 154 kV offsite power system. This source is valid for loading categories 5 and 6 (unit trip with LOCA, hot standby).
- Source 4: AAC GTG. This source is valid for loading category 7 (SBO).
- Source 5: EDGs. This source is valid for loading category 8 (LOOP with LOCA).

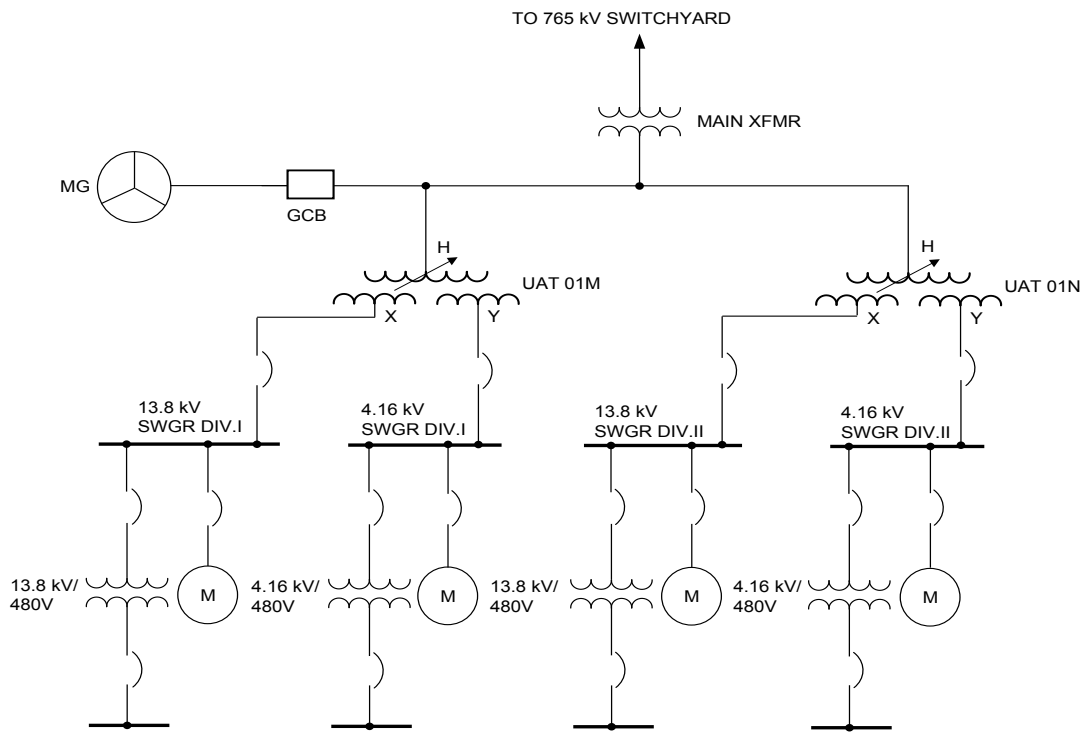

Figure 4-2. Source 1 - MG connected to 765 kV Offsite Power System

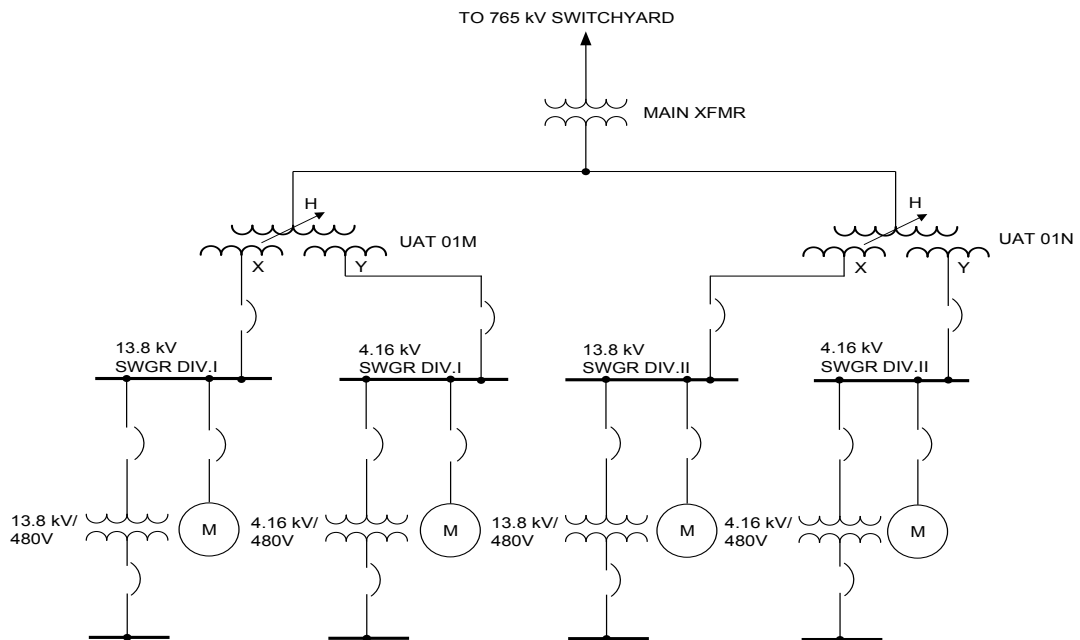

Figure 4-3. Source 2 - UATs connected to 765 kV Offsite Power System through the MT when the GCB opens (Back-feeding)

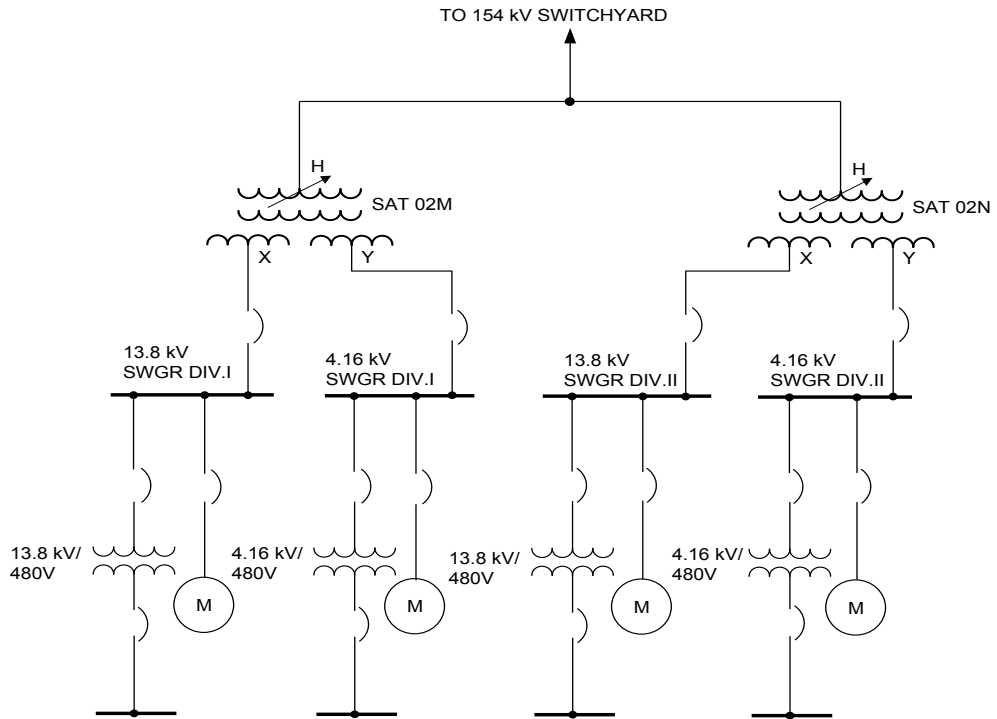

Figure 4-4. Source 3 - SATs connected to 154 kV Offsite Power System

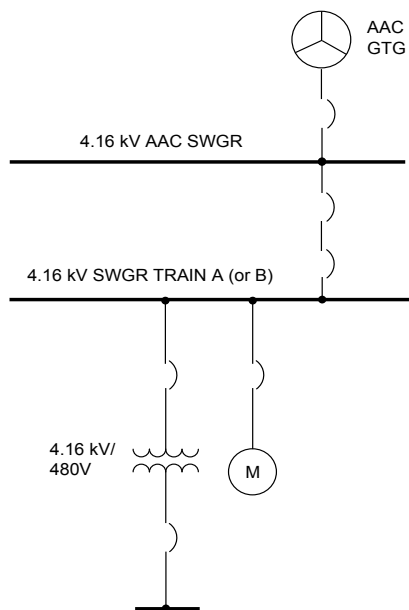

Figure 4-5. Source 4 - AAC GTG

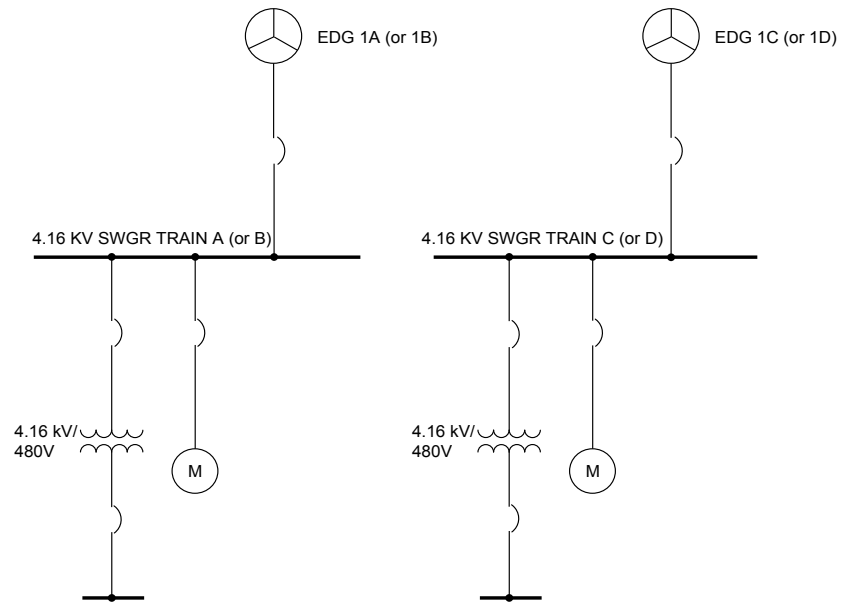

Figure 4-6. Source 5 - EDGs

5. ASSUMPTIONS AND INPUT DATA

5.1. Assumptions

The plant switchyard design is site-specific and some characteristic data of major equipment are obtained at the detailed design stage of the project. Therefore, the following data are assumed based on the reference plant, Shin-Kori Nuclear Power Plant Units 3 and 4 (SKN 3&4) to analyze the onsite ac power system.

5.1.1 Switchyard System

In the switchyard system, two switchyards that have different rated voltage level are assumed. One, the 765 kV switchyard, is connected to the MT and the other, the 154 kV switchyard, is connected to SATs.

5.1.2 Grid System Voltage Variation Range

The grid voltage variations between the maximum and the minimum are as follows:

- Maximum: 1.05 per unit (pu) of rated voltage
- Minimum: 0.95 pu of rated voltage

5.1.3 Grid Short-Circuit Capability

The maximum short-circuit capability and X/R ratio of the 765 kV grid and 154 kV grid are as follows:

- Maximum short-circuit capability: 63 kA, X/R: 40 (765 kV grid)
- Maximum short-circuit capability: 50 kA, X/R: 10 (154 kV grid)

5.1.4 Generator Characteristic Data

The following data are derived from the manufacturer's characteristic data for the reference plant of the APR1400.

Table 5-1. Generator Characteristic Data

Items	MG	EDG	AAC GTG
X _d "	0.245 pu	0.16 pu ¹⁾	0.16 pu ¹⁾
X/R ratio	120.7	50	50

Notes

- 1) These data are interpolated from the manufacturer's characteristics data from the reference plant of the APR1400.

5.1.5 Power Transformer Data

5.1.5.1 Main Transformer

- The MT consists of three single phase transformers.
- No load tap changer (NLTC) is applied at the primary winding of the main transformer.

5.1.5.2 Unit Auxiliary Transformers and Standby Auxiliary Transformers

- The UATs and SATs are designed as three phase transformer.
- On load tap changer (OLTC) is applied at the primary winding of UATs and SATs.
- The OLTC tap range and number of taps are determined based on the grid voltage variation, impedance and auxiliary loads of the onsite power system. The upper tap limit of the OLTC is plus 5 percent and the lower tap limit of the OLTC is minus 15 percent from the center tap for each UAT and SAT.
- The dead band (upper and lower band) of the OLTC is assumed to be plus/minus 2 percent of rated voltage of the regulated bus for reliable operation of the plant so that the regulated voltage of the switchgear is maintained between 98 and 102 percent of switchgear nominal voltage.

5.1.6 Load Data

Large loads for 13.8 kV switchgears, 4.16 kV switchgears, and 480V LCs are addressed in DCD Tier 2, Chapter 8, Tables 8.3.1-1 through 8.3.1-5, with consideration of the APR1400 site envelope design. Assumptions of the locked rotor currents (LRCs), X/R ratios, power factors, efficiencies, and subtransient reactances of medium voltage motors are derived from the experience data of the reference plant of the APR1400. The static and miscellaneous loads, and motor-operated valves (MOVs) fed from the 480V LCs and MCCs that are not within the scope of the APR1400 design certification are derived from the load list of the reference plant of the APR1400.

5.1.7 Harmonic Equipment Data

Harmonics are generated by nonlinear equipment such as battery chargers, inverters, and switch mode power supplies. Generated harmonics have an impact on the motors and generator, transformers, power cables, capacitors, electronic equipment, metering, and switching and relays. In this report, harmonic models for battery chargers are conservatively applied by selecting a six-pulse rectifier model.

5.1.8 Bus Transfer Equipment Data

The assumptions and load data in Sections 5.1 and 5.2 are used for bus transfer analysis.

The motor modeling, relay characteristic, and equipment operation data, which affect bus transfer analysis, are assumed based on the reference plant of the APR1400.

Major factors and assumptions for bus transfer analysis are as below;

- Voltage phase difference between two off-site sources : zero

- Bus transfer initiation scenarios
 - 3 phase fault at 13.8 kV winding of UAT (Div. I)
 - 3 phase fault at 4.16 kV winding of UAT (Div. I)
 - Line-to-ground fault at IPB
- Fault clearing time : 0.07 sec
- Bus dead time : 0.053 sec
- Dynamic modeling motor loads : All MV motor loads

5.1.9 Cable Data

Cable sizes and assumed lengths based on the reference plant of the APR1400, are used for feeders to MV switchgears and LV LCs. This is done to facilitate model updates when actual cable sizes and lengths become available.

5.2. Input Data

5.2.1 Grid System Data

Table 5-2. Grid System Data

Items	765 kV Switchyard	154 kV Switchyard
Circuit Breaker Rating	63 kA	50 kA
X/R ratio	40	10
Voltage Range	765 kV ± 5 %	154 kV ± 5 %

5.2.2 Generator

Table 5-3. Generator Input Data

Items	MG	EDG	AAC GTG
Capacity	1,690,000 kVA	9,100/7,500 kW (for trains A&B/C&D)	9,700 kW
Power Factor	90 %	80 %	80 %
Voltage	24 kV	4.16 kV	4.16 kV
X _d "	0.245 pu	0.16 pu	0.16 pu
Var Limit (MVAR)	Maximum	736.7	6.825
	Minimum	-527.6	-2.131
X/R Ratio	120.7	50	50

5.2.3 Ratings of Power Transformer

Table 5-4. Ratings of Power Transformer

Items	MT	UAT	SAT
Voltage	800-24 kV	24-14.49/4.37 kV	154-13.8/4.16 kV
MVA	1670 MVA	H = 71.0/94.7 MVA @ 55 °C X = 48.0/64.0 MVA @ 55 °C Y = 23.0/30.7 MVA @ 55 °C	H = 67.0/89.4 MVA @ 55 °C X = 44.0/58.7 MVA @ 55 °C Y = 23.0/30.7 MVA @ 55 °C
%Z	Z=19 % (Tolerance: ± 7.5 %)	ZHx = 10.5 % @ 71.0 MVA ZHy = 36.0 % @ 71.0 MVA Zxy = 46.5 % @ 71.0 MVA (Tolerance: ± 20 %)	ZHx = 11.1 % @ 67.0 MVA ZHy = 38.0 % @ 67.0 MVA Zxy = 49.1 % @ 67.0 MVA (Tolerance: ± 20 %)
X/R Ratio	79	25	25

5.2.4 Ratings of Load Center Transformer

Table 5-5. Ratings of Load Center Transformer

kVA (AA/FA)	350	500/667	750/1000	1000/1333	1500/2000
Voltage (kV)	4.16-0.48	13.8-0.48	4.16-0.48	4.16-0.48 13.8-0.48	4.16-0.48 13.8-0.48
%Z ¹⁾ (Tolerance) ²⁾	Z= 4 % (±7.5 %)	Z= 4 % (±7.5 %)	Z= 5.75 % (±7.5 %)	Z= 5.75 % (±7.5 %)	Z= 5.75 % (±7.5 %)
Cooling Class	AA ³⁾	AA/FA ⁴⁾	AA/FA	AA/FA	AA/FA

Notes

- 1) Percent impedance values are experience data from the reference plant of the APR1400.
- 2) Tolerances of percent impedances are applied in accordance with IEEE Std C57.12.01.
- 3) AA (ambient air; One of the transformer cooling class, which stands for ventilated self-cooled)
- 4) FA (forced air; One of the transformer cooling class, which stands for forced-air-cooled)

5.2.5 Switchgear Rating

5.2.5.1 13.8 kV Switchgear Breaker

- Rated short-circuit currents, rms: 50 kA
- Closing and latching capability, peak: 130 kA
- Rated voltage range factor: 1.0
- Rated maximum voltage: 15 kV
- Rated interrupting time: 5 cycles

5.2.5.2 4.16 kV Switchgear Breaker

- Rated short-circuit current, rms: 50 kA
- Closing and latching capability, peak: 130 kA
- Rated voltage range factor: 1.0
- Rated maximum voltage: 4.76 kV
- Rated interrupting time: 5 cycles

5.2.5.3 480V LC Breaker

- Rated short-circuit currents, rms: 30 kA or 50 kA
- Rated maximum voltage: 508V
- Rated interrupting time: within 3 cycles

5.2.5.4 480V MCC Breaker

- Rated short-circuit currents, rms: 30 kA or 50 kA¹⁾
- Rated maximum voltage: 508V
- Rated interrupting time: within 1 cycle

Notes

1) For the commercial availability and maintenance, the short-circuit rating of MCC breaker is selected as 50 kA.

5.2.6 Bus Ratings

Table 5-6. Bus Ratings

Items		Nominal Voltage (kV)	Continuous Current Rating (A)	Short-Time Current Rating (kA, rms)
Isolated Phase Bus (Main)		24.0	43,000	230
13.8 kV Switchgear Bus (Horizontal)		13.8	2,000	50
4.16 kV Switchgear Bus (Horizontal)		4.16	1,200	50
			2,000	50
			3,000	50
480V L/C Bus with Transformer (Horizontal)	350 kVA @ AA rating	0.48	1,600	30
	667 kVA @ FA rating		1,600	30
	1,000 kVA @ FA rating		1,600	30
	1,333 kVA @ FA rating		2,000	30

	2,000 kVA @ FA rating		3,000	50
480V MCC Bus (Horizontal)		0.48	600	30/42

5.2.7 Loads Connected to Bus

The load capacity in brake horsepower (bhp) is used under all operation modes.

5.2.7.1 13.8 kV Bus loads (Division I)

Table 5-7. 13.8 kV Bus 1-821-E-SW01M Loads

Load Name	Bus Voltage	Unit	Rated
Reactor Coolant Pump 1A	13.8 kV	hp	13,500
Reactor Coolant Pump 2A	13.8 kV	hp	13,500
LC 01M Loads	480V	kVA	-
LC 02M Loads	480V	kVA	-
LC 03M Loads	480V	kVA	-

TS

Table 5-8. 13.8 kV Bus 1-821-E-SW02M Loads

Load Name	Bus Voltage	Unit	Rated
Condensate Pump A	13.8 kV	hp	4,600
Feedwater Booster Pump A	13.8 kV	hp	5,000
Feedwater Booster Pump C	13.8 kV	hp	5,000
Circulating Water Pump A	13.8 kV	hp	4,357
Circulating Water Pump C	13.8 kV	hp	4,357
Circulating Water Pump E	13.8 kV	hp	4,357
LC 04M Loads	480V	kVA	-
LC 06M Loads	480V	kVA	-
LC 16M Loads	480V	kVA	-
Cooling Tower Fan Group Loads			
Load Group 1	480V	kVA	-
Load Group 2	480V	kVA	-
Load Group 3	480V	kVA	-
Load Group 4	480V	kVA	-
Fire Pump & Water/Wastewater Treatment Facility Area Loads (Future)			

TS

TS

Load Name	Bus Voltage	Unit	Rated
Load Group 1	480V	kVA	-
Load Group 2	480V	kVA	-

TS

5.2.7.2. 4.16 kV Bus Loads (Division I, Trains A and C)

Table 5-9. 4.16 kV PNS Bus 1-822-E-SW01M Loads

Load Name	Bus Voltage	Unit	Rated
Central Chiller 1	4.16 kV	hp	1,100
Central Chiller 2	4.16 kV	hp	1,100
Central Chilled Water Pump 1	4.16 kV	hp	500
LC 10M Loads	480V	kVA	-
LC 12M Loads	480V	kVA	-

TS

Table 5-10. 4.16 kV Bus 1-822-E-SW02M Loads

Load Name	Bus Voltage	Unit	Rated
TGB Closed Cooling Water Pump 1	4.16 kV	hp	672
LC 05M Loads	480V	kVA	-
LC 07M Loads	480V	kVA	-
LC 08M Loads	480V	kVA	-
LC 09M Loads	480V	kVA	-
LC 11M Loads	480V	kVA	-

TS

Table 5-11. 4.16 kV Bus 1-823-E-SW01A Loads

TS

Load Name	Bus Voltage	Unit	Rated
Shutdown Cooling Pump 1	4.16 kV	hp	1,000
Safety Injection Pump 1	4.16 kV	hp	1,000
Charging Pump 1	4.16 kV	hp	780
Component Cooling Water Pump 1A	4.16 kV	hp	2,355
Essential Service Water Pump 1A	4.16 kV	hp	1,248
Auxiliary Feedwater Pump A	4.16 kV	hp	1,260
Essential Chiller 01A	4.16 kV	hp	1,100
Cooling Tower Fan 1A	4.16 kV	hp	900
LC 01A Loads	480V	kVA	-
MCC 33M Loads	480V	kVA	-

Table 5-12. 4.16 kV Bus 1-823-E-SW01C Loads

TS

Load Name	Bus Voltage	Unit	Rated
Safety Injection Pump 3	4.16 kV	hp	1,000
Containment Spray Pump 1	4.16 kV	hp	1,000
Component Cooling Water Pump 2A	4.16 kV	hp	2,355
Essential Service Water Pump 2A	4.16 kV	hp	1,248
Essential Chiller 02A	4.16 kV	hp	1,100
Cooling Tower Fan 2A	4.16 kV	hp	900
LC 01C Loads	480V	kVA	-

5.2.7.3. 13.8 kV Bus Loads (Division II)

Table 5-13. 13.8 kV Bus 1-821-E-SW01N Loads

TS

Load Name	Bus Voltage	Unit	Rated
Reactor Coolant Pump 1B	13.8 kV	hp	13,500
Reactor Coolant Pump 2B	13.8 kV	hp	13,500
LC 01N Loads	480V	kVA	-
LC 02N Loads	480V	kVA	-
LC 03N Loads	480V	kVA	-

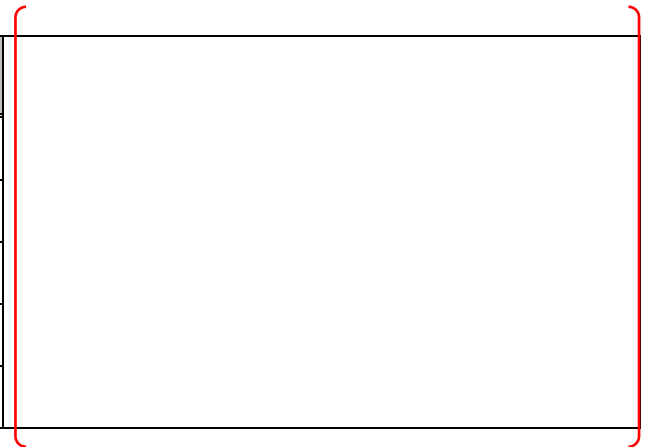
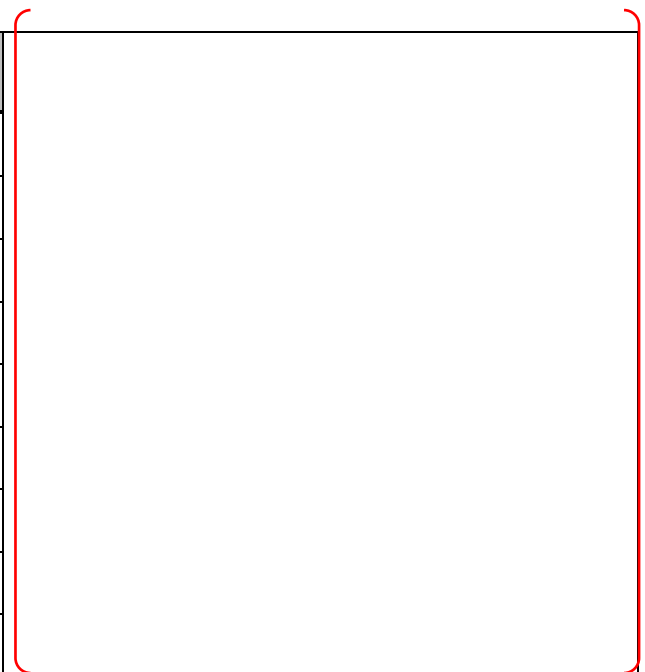

Table 5-14. 13.8 kV Bus 1-821-E-SW02N Loads

TS

Load Name	Bus Voltage	Unit	Rated
Condensate Pump B	13.8 kV	hp	4,600
Condensate Pump C	13.8 kV	hp	4,600
Feedwater Booster Pump B	13.8 kV	hp	5,000
Startup Feedwater Pump	13.8 kV	hp	2,681
Circulating Water Pump B	13.8 kV	hp	4,357
Circulating Water Pump D	13.8 kV	hp	4,357
Circulating Water Pump F	13.8 kV	hp	4,357
LC 04N Loads	480V	kVA	-
LC 06N Loads	480V	kVA	-



Cooling Tower Fan Group Loads			
Load Group 1	480V	kVA	-
Load Group 2	480V	kVA	-
Load Group 3	480V	kVA	-
Load Group 4	480V	kVA	-
Chlorination Loads (Future)			

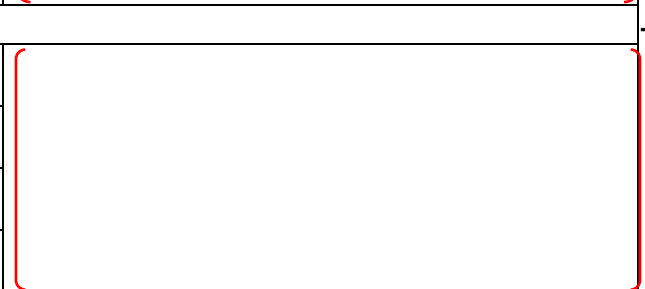

TS

Load Name	Bus Voltage	Unit	Rated	
Load Group 1	480V	kVA	-	

5.2.7.4. 4.16 kV Bus Loads (Division II, Trains B and D)

Table 5-15. 4.16 kV PNS Bus 1-822-E-SW01N Loads

Load Name	Bus Voltage	Unit	Rated	
Central Chiller 3	4.16 kV	hp	1,100	
Central Chiller 4	4.16 kV	hp	1,100	
Central Chilled Water Pump 2	4.16 kV	hp	500	
LC 10N Loads	480V	kVA	-	
LC 12N Loads	480V	kVA	-	

Table 5-16. 4.16 kV Bus 1-822-E-SW02N Loads

Load Name	Bus Voltage	Unit	Rated	
TGB Closed Cooling Water Pump 2	4.16 kV	hp	672	
LC 05N Loads	480V	kVA	-	
LC 07N Loads	480V	kVA	-	
LC 08N Loads	480V	kVA	-	
LC 09N Loads	480V	kVA	-	
LC 11N Loads	480V	kVA	-	
LC 15N Loads	480V	kVA	-	
LC 16N Loads	480V	kVA	-	
LC 17N Loads	480V	kVA	-	

Table 5-17. 4.16 kV AAC Bus 1-822-E-SW03N Loads

Load Name	Bus Voltage	Unit	Rated	
LC 19N Loads	480V	hp	-	

Table 5-18. 4.16 kV Bus 1-823-E-SW01B Loads

TS

Load Name	Bus Voltage	Unit	Rated
Shutdown Cooling Pump 2	4.16 kV	hp	1,000
Safety Injection Pump 2	4.16 kV	hp	1,000
Charging Pump 2	4.16 kV	hp	780
Component Cooling Water Pump 1B	4.16 kV	hp	2,355
Essential Service Water Pump 1B	4.16 kV	hp	1,248
Auxiliary Feedwater Pump B	4.16 kV	hp	1,260
Essential Chiller 01B	4.16 kV	hp	1,100
Cooling Tower Fan 1B	4.16 kV	hp	900
LC 01B Loads	480V	kVA	-
MCC 33N Loads	480V	kVA	-

Table 5-19. 4.16 kV Bus 1-823-E-SW01D Loads

TS

Load Name	Bus Voltage	Unit	Rated
Safety Injection Pump 4	4.16 kV	hp	1,000
Containment Spray Pump 2	4.16 kV	hp	1,000
Component Cooling Water Pump 2B	4.16 kV	hp	2,355
Essential Service Water Pump 2B	4.16 kV	hp	1,248
Essential Chiller 02B	4.16 kV	hp	1,100
Cooling Tower Fan 2B	4.16 kV	hp	900
LC 01D Loads	480V	kVA	-

6. ANALYSIS

6.1. Steady-State Load Flow Analysis

Steady-state load flow analysis determines the voltage, voltage angle, active power, and reactive power in the power plant.

The load flow analysis is to check the undervoltage and overvoltage of all buses during startup, normal operation, unit trip with LOCA, hot standby, SBO, LOOP with LOCA, and no load condition (as an extreme case of light load). The analysis also provides the necessary information to determine or verify the following:

- The operating voltage at the MV switchgears, LC buses, and MCC buses
- Setpoint of undervoltage relay of 13.8 kV and 4.16 kV switchgears
- Percent impedance (%Z) and tap rating of transformer
- Other data for power system analysis

6.1.1 Acceptance Criteria

The acceptance criteria for load voltage variation on continuous operation basis are +/-10 percent of the rated voltage at the equipment terminals.

Considering voltage drops across the cables between the buses and load terminals, different voltage ratings of motor loads, and transformer voltage restriction, the acceptance criteria for bus voltage variations are calculated as Table 6-1.

Table 6-1. Acceptance Criteria for Bus Voltage Variation at the Steady-state

Equipment	Nameplate Voltage (kV)	Acceptance Criteria ¹⁻²⁾	Remark
13.8 kV Switchgear	13.8		
4.16 kV Switchgear	4.16		
480V LC or MCC	0.48		

TS

TS

TS

6.1.2 Analysis Result

The results of load flow analysis show that the operating voltages at the MV switchgear, LC, and MCC buses are within the acceptable voltage limit at all loading conditions with maximum or minimum grid voltage. The operating voltages in heavy loading conditions with minimum grid voltage are summarized in Table 6-2 and 6-3. The operating voltages in no load condition (as an extreme case of light load) with maximum grid voltage are summarized in Tables 6-4 and 6-5.

Table 6-2. Minimum operating Voltage Summary of Non-Class 1E Buses (Unit: %)

Case	
Case 1: Normal operation from UAT	
Case 2: Startup from UAT	
Case 3: Unit trip coincident with LOCA from UAT	
Case 4: Hot stand-by from UAT	
Case 5: Unit trip coincident with LOCA from SAT	
Case 6: Hot stand-by from SAT	
Case 7: SBO from AAC GTG	
Case 8: LOOP coincident with LOCA	

Table 6-3. Minimum operating Voltage Summary of Class 1E Buses (Unit: %)

Case	
Case 1: Normal operation from UAT	
Case 2: Startup from UAT	
Case 3: Unit trip coincident with LOCA from UAT	
Case 4: Hot stand-by from UAT	
Case 5: Unit trip coincident with LOCA from SAT	
Case 6: Hot stand-by from SAT	
Case 7: SBO from AAC GTG	
Case 8: LOOP coincident with LOCA	

Table 6-4. Maximum operating Voltage Summary of Non-Class 1E Buses (Unit: %)

Case	
Case 1: No load operation from UAT	
Case 2: No load operation from SAT	

TS

TS

Table 6-5. Maximum operating Voltage Summary of Class 1E Buses (Unit: %)

Case	
Case 1: No load operation from UAT	
Case 2: No load operation from SAT	

TS

TS

6.2. Short-Circuit Current Analysis

The short-circuit current analysis verifies that bus withstand ratings and circuit breaker interrupting ratings for all equipment are adequate for the maximum fault current.

6.2.1 Acceptance Criteria

Circuit breakers for MV switchgears, 480V LCs, and 480V MCCs are selected to operate properly for continuous current and to withstand at the maximum short-circuit current.

The acceptance criteria for short-circuit current at the buses of different voltage levels are as follows:

Table 6-6. Acceptance Criteria for Bus Short-circuit Current

Circuit Breaker	Acceptance Criteria	
	Interrupting Rating (kA) (rms, sym)	Closing and Latching Amperes (kA) (peak)
13.8 kV	50	130
4.16 kV	50	130
480V LC	30/50 ¹⁾	-
480V MCC	30/42 ^{1),2)}	-

Notes

- 1) Interrupting rating value of the LC or MCC can be selected from the two values based on short-circuit current value.
- 2) Required interrupting rating of the MCC is 42 kA based on calculation, but 50 kA rating breaker is actually used for the commercial availability and maintenance as stated in Subsection 5.2.5.4.

6.2.2 Analysis Result

The results of the short-circuit calculations under all operating conditions are summarized in Tables 6-7 and 6-8.

The short-circuit calculation shows that the maximum short-circuit currents at the MV switchgears, 480V LCs, and 480V MCCs in all operating conditions are within the closing and latching and interrupting rating of circuit breaker.

Table 6-7. Short-Circuit Current Summary of Non-Class 1E Buses at All Operating Conditions (Unit: kA)

CASE	
Case 1 :Normal operation from UAT ¹⁾	TS
Case 2: Start-up from UAT	
Case 3: Unit trip coincident with LOCA from UAT	
Case 4: Hot stand-by from UAT	
Case 5: Unit trip coincident with LOCA from SAT	
Case 6: Hot stand-by from SAT	
Case 7: SBO from AAC GTG	

--	--	--	--	--	--	--	--

Notes

1) From conservative approach, parallel operation of an EDG with grid power is considered.

Table 6-8. Short-Circuit Current Summary of Class 1E Buses at All Operating Conditions (Unit: kA)

CASE	
Case 1 :Normal operation from UAT ¹⁾	
Case 2: Start-up from UAT	
Case 3: Unit trip coincident with LOCA from UAT	
Case 4: Hot stand-by from UAT	
Case 5: Unit trip coincident with LOCA from SAT	
Case 6: Hot stand-by from SAT	
Case 7: SBO from AAC GTG	

Notes

1) From conservative approach, parallel operation of an EDG with grid power is considered.

6.3. Motor Starting Analysis

The motor starting analysis provides reasonable assurance of the stable operation of the onsite power system by analyzing the voltage drop during starting of the large motors.

The motor starting study performs voltage drop analysis of the onsite ac power system during the starting of large motors and verifies whether the starting of large motors are successfully done and the terminal voltages are maintained within the allowable voltage limits during the starting conditions of the large motors.

6.3.1 Acceptance Criteria

The required motor minimum voltages during starting of the large motors are 80 percent of motor rated voltage for non-Class 1E motors and 75 percent for Class 1E motors at the equipment terminals. Considering voltage drops across the cables between the buses and load terminals, and different starting and running voltage requirements of motor loads, the acceptance criteria for bus voltage variations during the starting of large motors are calculated as Table 6-9.

Table 6-9. Acceptance Criteria for Bus Voltage Variation during the Starting of Large Motors

Equipment	Nameplate Voltage (kV)	Acceptance Criteria ^{1,2)}	Remark
13.8 kV non-Class 1E Switchgear	13.8	[] ^{TS}	[] ^{TS}
4.16 kV non-Class 1E Switchgear	4.16		
4.16 kV Class 1E Switchgear	4.16		
480V non-Class 1E LC or MCC	0.48		
480V Class 1E LC or MCC	0.48		

6.3.2 Analysis Result

The results of the motor starting analysis under all operating conditions are summarized in Tables 6-10 and 6-11.

The motors selected to evaluate allowable minimum bus voltages under starting conditions of the large motors are as follows:

- Reactor coolant pump (RCP) for 13.8 kV
- Component cooling water pump for 4.16 kV

As shown in Tables 6-10 and 6-11, the results of motor starting analysis demonstrate the selected large motors are successfully started and most of the bus voltages are maintained within the allowable minimum voltage limit during the large motor starting conditions under various plant operating modes.

In some cases (Cases 9, 10, 15, and 16), minimum required voltage at equipment terminal can be achieved by reducing feeder cable voltage drop from []^{TS} % to []^{TS} % (of bus nominal voltage).

Table 6-10. Motor Starting Summary of Non-Class 1E Buses (Unit: %)

TS

CASE
Case 1: Normal operation from UAT (CCW PP1A)
Case 2: Normal operation from UAT (CCW PP1B)
Case 3: Startup from UAT (RCP 1A)
Case 4: Startup from UAT (RCP 1B)
Case 5: Startup from UAT (CCW PP1A)
Case 6: Startup from UAT (CCW PP1B)
Case 7: Unit trip coincident with LOCA from UAT (CCW PP1A)
Case 8: Unit trip coincident with LOCA from UAT (CCW PP1B)
Case 9: Hot standby from UAT (RCP 1A)
Case 10: Hot standby from UAT (RCP 1B)
Case 11: Hot standby from UAT (CCW PP1A)
Case 12: Hot standby from UAT (CCW PP1B)
Case 13: Unit trip coincident with LOCA from SAT (CCW PP1A)
Case 14: Unit trip coincident with LOCA from SAT (CCW PP1B)
Case 15: Hot standby from SAT (RCP 1A)
Case 16: Hot standby from SAT (RCP 1B)
Case 17: Hot standby from SAT (CCW PP1A)
Case 18: Hot standby from SAT (CCW PP1B)

TS

Table 6-11. Motor Starting Summary of Class 1E Buses (Unit: %)

TS

CASE
Case 1: Normal operation from UAT (CCW PP1A)
Case 2: Normal operation from UAT (CCW PP1B)
Case 3: Startup from UAT (RCP 1A)
Case 4: Startup from UAT (RCP 1B)
Case 5: Startup from UAT (CCW PP1A)

Case 6: Startup from UAT (CCW PP1A)
Case 7: Unit trip coincident with LOCA from UAT (CCW PP1A)
Case 8: Unit trip coincident with LOCA from UAT (CCW PP1B)
Case 9: Hot standby from UAT (RCP 1A)
Case 10: Hot standby from UAT (RCP 1B)
Case 11: Hot standby from UAT (CCW PP1A)
Case 12: Hot standby from UAT (CCW PP1B)
Case 13: Unit trip coincident with LOCA from SAT (CCW PP1A)
Case 14: Unit trip coincident with LOCA from SAT (CCW PP1B)
Case 15: Hot standby from SAT (RCP 1A)
Case 16: Hot standby from SAT (RCP 1B)
Case 17: Hot standby from SAT (CCW PP1A)
Case 18: Hot standby from SAT (CCW PP1B)

TS

TS

6.4. Harmonic Analysis

Harmonics in the electrical system are an important indicator of poor power quality. They cause overheating in electrical components and can damage sensitive equipment. Harmonic analysis is typically conducted as part of a power quality study to identify the source of harmonics and develop a plan for corrective action.

The objective of harmonic analysis is to calculate individual and total harmonic distortion and to confirm that the result of harmonic analysis is within acceptable limits.

6.4.1 Acceptance Criteria

Simulations are performed to identify expected harmonic levels under various plant operating modes and source conditions. Variations in waveform (harmonic distortion) in the onsite power system and its components during any mode of plant operation are confirmed not to degrade the performance of any safety system load.

Acceptance criteria for harmonic analysis are as follows:

Table 6-12. Acceptance Criteria for Harmonic Analysis

Bus Voltage	Individual Voltage Distortion (%)	Total Voltage Distortion (%)
69 kV and below	3.0	5.0

6.4.2 Analysis Results

The harmonic analysis is summarized in Tables 6-13 and 6-14, and the total voltage harmonic distortion at the Class 1E buses meets the acceptance criteria of Subsection 6.4.1. It should be noted, however, that harmonic sources are conservatively assumed as six-pulse models because there are no harmonic data of suppliers. Therefore, the harmonic analysis should be performed and reviewed with actual data in the detailed design phase.

Table 6-13. Maximum Total Harmonic Distortion in Non-Class 1E Buses (Unit: %)

CASE	
Case 1: Normal operation from UAT	
Case 2: Startup from UAT	
Case 3: Unit trip coincident with LOCA from UAT	
Case 4: Hot standby from UAT	
Case 5: Unit trip coincident with LOCA from SAT	
Case 6: Hot stand-by from SAT	
Case 7-1: SBO from AAC GTG on Division I	
Case 7-2: SBO from AAC GTG on Division II	

Table 6-14. Maximum Total Harmonic Distortion in Class 1E Buses (Unit: %)

CASE	
Case 1: Normal operation from UAT	
Case 2: Startup from UAT	
Case 3: Unit trip coincident with LOCA from UAT	
Case 4: Hot standby from UAT	
Case 5: Unit trip coincident with LOCA from SAT	
Case 6: Hot stand-by from SAT	

CASE	
Case 7-1: SBO from AAC GTG on Division I	
Case 7-2: SBO from AAC GTG on Division II	

6.5. Bus Transfer Analysis

Bus transfer is a process of transferring bus loads from one power source to another. During bus transfer, resultant voltage and frequency decay may cause excessive transient torque so that mechanical damage occurs in the motor, the coupling to the load, or the load itself.

The purpose of bus transfer is to maintain process continuity and to supervise source transfer to avoid causing any damage to the motors, couplings, and connected loads. In this section, the bus transfer procedure and results are reviewed and evaluated to provide reasonable assurance that the results are within acceptable limits.

The loading and source condition, before and after a bus transfer, assumed in the bus transfer analysis is 'unit trip coincident with LOCA from UAT' and 'unit trip coincident with LOCA from SAT', respectively. Major factors and assumptions used for bus transfer analysis are provided in Subsection 5.1.8.

6.5.1 Acceptance Criteria

- The bus transfer occurs within a period of 10 cycles or less.
- The maximum phase angle between the motor residual V/Hz vector and the system equivalent V/Hz vector does not exceed 90 degrees.
- The resultant V/Hz between the motor residual V/Hz phasor and the incoming source V/Hz phasor at the instant of transfer or reclosing does not exceed 1.33 pu V/Hz on the motor rated voltage and frequency basis.

Notes: If the condition before a fast bus transfer does not satisfy above criteria, the bus transfer will be implemented by a residual voltage bus transfer.

6.5.2 Analysis Results

Results of the following three items are reviewed:

- Voltage profile of load bus during bus transfer
- Voltage phase angle between load bus and new source during bus transfer
- V/Hz between load bus and new source during bus transfer

The resultant V/Hz and phase angle values, calculated at the point of the new source breaker closure, are

monitored to confirm they are within the established maximum 1.33 pu V/Hz and 90 degrees.

As indicated in Table 6-15, the buses of which the analysis results are within the acceptance limits are expected to be transferred by fast bus transfer given the postulated loading condition, and the other buses are expected to be transferred by residual bus transfer.

It should be noted, however, that the major input data that affect the analysis results, such as characteristics of relay devices, motors, different voltage phase angles between two offsite sources, and accident scenarios, are assumed based on the reference plant data of the APR1400. Therefore, the bus transfer analysis should be performed and reviewed with refined data in the detailed design phase.

Table 6-15. Transient Analysis Summary of Bus Transfer

TS



7. CONCLUSIONS

The load flow analysis shows that the operating voltages at the MV switchgears, 480V LCs, and 480V MCCs for all loading conditions are maintained within the acceptable voltage limit (± 10 percent of rated voltage at the equipment terminals).

The short-circuit analysis shows that the maximum short-circuit currents at MV switchgears, 480V LCs, and 480V MCCs for all operating conditions are within the closing and latching, and interrupting ratings of the circuit breakers.

The motor starting analysis shows that the selected large motors are successfully started and most of the bus voltages are maintained within the allowable minimum voltage limit during the large motor starting conditions under various plant operating modes. In some cases (Cases 9, 10, 15, and 16), minimum required voltage at equipment terminal can be achieved by reducing feeder cable voltage drop.

The harmonic analysis shows that the individual and total voltage harmonic distortion at each Class 1E bus meets the respective acceptance criteria (3 percent individual voltage distortion, 5 percent total voltage distortion).

The bus transfer analysis shows that fast bus transfer is expected to be allowed for some buses under the postulated operating condition. For the other buses, for which fast bus transfer is blocked by the fast bus transfer relays (25F), residual voltage bus transfer will be performed instead of fast bus transfer. In detailed design phase, transfer strategies of buses, such as fast transfer and residual voltage transfer, will be reestablished and reassessed based on actual equipment data.

8. REFERENCES

1. APR1400-K-X-FS-14002, "APR1400 Design Control Document," Tier 2, Rev. 2, KEPCO and KHNP, [February 2018].
2. 10 CFR 50, Appendix B, "Quality Assurance Criteria for Nuclear Power Plants and Fuel Reprocessing Plants."
3. 10 CFR 21, "Reporting of Defects and Noncompliance."
4. ASME NQA-1, "Quality Assurance Requirements for Nuclear Facility Applications," American Society of Mechanical Engineers, 2008.