

**ATTACHMENT 4B**

**Emergency Plan Clean Copy Pages – Dresden Station**

Exelon Standardized Emergency Plan EP-AA-1000

and

Emergency Plan Annex EP-AA-1004

Affected Pages

**Exelon Standardized Emergency Plan EP-AA-1000**

**Affected Pages - Clean**

**EXELON NUCLEAR**

**STANDARDIZED  
RADIOLOGICAL EMERGENCY PLAN**

Shift Technical Advisor (STA): During normal plant operations, the Senior Reactor Operators report to the Shift Manager and directly supervise the licensed Reactor Operators and all activities in the Control Room. During an abnormal condition, the Shift Manager assumes direct supervision of personnel and all activities in the Control Room while a qualified individual steps back and assumes an overview role as an STA with the specific responsibility of monitoring the maintenance of core cooling and containment integrity. An individual assigned the duty as the STA shall be available to the Control Room at all times.

Radiation Protection: The Station Radiation Protection personnel are responsible for the handling and monitoring of radioactive materials. Included in this organization are Health Physicists, Radiation Protection Supervisors and Technicians.

Chemistry: The Station Chemistry personnel are responsible for sampling of system effluents, and the chemical and radio-analytical analysis of those samples. Included in this organization are Chemists, Chemistry Supervisors and Technicians.

Security: The Station Security personnel are responsible for the physical security of the site. Included in this organization are Security Supervisors and Security Guards.

## **2. Authority Over the Emergency Response Organization**

The Emergency Director in Command and Control is the designated Exelon Nuclear individual who has overall authority and responsibility, management ability, and technical knowledge for coordinating all emergency response activities at the nuclear power station.

- Control Room: Shift Emergency Director (Shift Manager)
- TSC: Station Emergency Director
- EOF: Corporate Emergency Director

## **3. Criteria for Assuming Command and Control (Succession)**

Emergency personnel assume responsibility for their positions upon receiving notification to activate. The responsibility for initial assessment of and response to an emergency rests with the Shift Manager. The Shift Manager is the Shift Emergency Director and has the Station and Corporate Emergency Director's responsibilities and authority until relieved. The Corporate Emergency Director, once having relieved the Shift Manager of the Emergency Director responsibilities, is responsible for continued assessment of the severity of the emergency and for the necessary functions as described in the E-Plan, the Station Annex, and the emergency implementing procedures.

The Shift Emergency Director is relieved of Command and Control as soon as possible after the declaration of an Alert (or higher classification if Alert not declared). Following the Command and Control turnover, the Corporate Emergency Director shall have overall Command and Control of the Emergency Response. Note that the Station Emergency Director takes responsibility for onsite Non-Delegable Responsibilities including Classification and Emergency Exposure Control. The Corporate Emergency Director takes responsibility for offsite Non-Delegable Responsibilities including Protective Action Recommendations and State/local Notifications. Command and Control does not transfer until the following criteria have been met:

- Adequate staff levels are present in support of the non-delegable responsibilities.
- The staff has been fully briefed as to the status of the event and the currently proposed plan of action.
- A turnover between the Emergency Director relinquishing Command and Control and the Emergency Director assuming Command and Control has been made.

Although Exelon Nuclear's ERO fulfills all regulatory requirements for emergency response, it may be altered by the Emergency Director. This type of alteration will be based upon identified needs within the ERO, event dependent criteria, and identified needs of the company as a whole.

#### **4. Non-Delegable Responsibilities**

Non-delegable responsibilities include the following functions:

- Event classification.
- Protective Action Recommendations (PARs) for the general public.
- Notification of offsite authorities (approval of state/local and NRC notifications).
- Authorization of emergency exposure controls in excess of 5 Rem TEDE and the issuance of potassium iodide (KI), for Exelon Nuclear emergency workers per EPA-400.

The Shift Manager is responsible for the initial classification of an event and assumes the position as Shift Emergency Director. In this capacity, the Shift Manager has responsibility for performing the non-delegable responsibilities until relieved.

The Shift Emergency Director is relieved of Command and Control as soon as possible after the declaration of an Alert (or higher classification if Alert not declared). Command and Control is transferred to the Station Emergency Director but may be transferred directly to the Corporate Emergency Director.

The Station Emergency Director assumes overall authority and responsibility for Classification and Emergency Exposure Control. The Corporate Emergency Director (EOF) will assume the non-delegable responsibilities for PAR determination and notifications to offsite authorities.

Transition of “Non-Delegable” Responsibilities

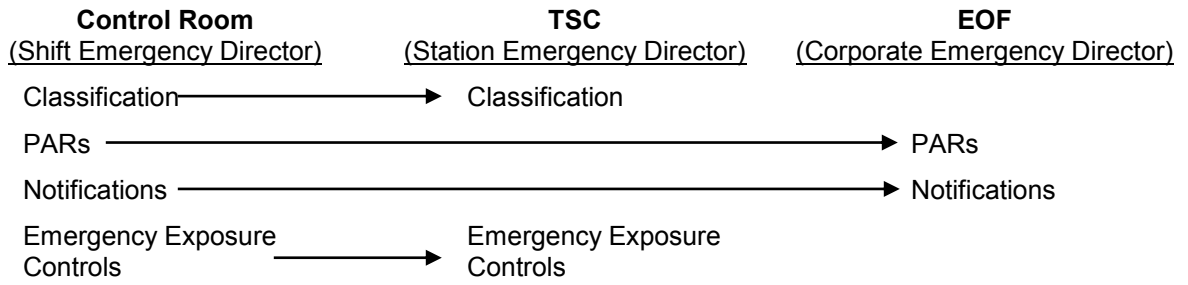

## 5. Emergency Response Organization Positional Responsibilities

The Emergency Plan designates two types of augmented ERO responders. Those designated as Minimum Staff are those key ERO needed to relieve the on-shift staff of key EP functions/tasks required in response to the Emergency and are those required to activate their respective Emergency Response Facility (ERF). Specifically, these are the ERO that are the absolute minimum needed to implement the emergency plan (i.e., if any position or function is not staffed then the emergency plan may not be effectively implemented). These positions in most cases are required to respond to their respective ERF within 60 minutes of the declaration of an Alert or higher. See Attachment 5, Table 5-1 for the list of On-shift and Minimum Staff positions.

The positions which are considered Full Augmented staff (i.e., non-min staff) are those positions which provide support for the minimum staff in their response to the Emergency. The Full Augmentation positions consist mostly of liaisons, coordinators and additional communicators which help facilitate communication and the emergency response effort over time, but are not directly needed to implement the functions/tasks identified in the Emergency Plan.

ERO staffing tables contained within this Emergency Plan, outlines ERO positions required to meet minimum staffing of the on-shift complement at an Alert or higher classification, and the major tasks assigned to each position. The full augmentation staffing levels are described in Emergency Preparedness Implementing Procedures (EPIPs). For extended events (one which lasts for more than 24 hours), actual staffing will be established by the Emergency Director based on the event and personnel availability. However, additional staffing or reduced staffing will only occur after discussion concerning the impact on plant operations and emergency response.

In addition to maintaining adequate documentation of the event, responsibilities for each position are as follows:

- a. Station Emergency Response Organization: The Station ERO is the onsite group that is activated during an emergency. It functions under the Station Emergency Director, who is responsible for organizing and coordinating the emergency efforts at and within the immediate vicinity of the station (including carrying out all onsite emergency efforts and the initial offsite environs monitoring efforts necessary to assess plant releases).

The Station ERO consists of station personnel who are involved with emergency response efforts necessary to control the plant during an incident. This organization operates out of the Control Room, the Technical Support Center (TSC) and the Operations Support Center (OSC). Collectively, members of the Station ERO provide for the following activities during an emergency:

- Plant systems operations
- Radiological survey and monitoring (including Environs Monitoring)
- Firefighting

- Rescue operations and First Aid
- Decontamination
- Security of plant and access control
- Repair and damage control
- Personnel protection including Assembly, Accountability and Evacuation
- Communications

When plant conditions warrant entry into the Severe Accident Management Guidelines (SAMGs), the Station Emergency Director or other qualified individual (e.g., Operations Manager) assumes the role of Decision-Maker. Other qualified individual(s) assumes the role of Evaluator (at least 2 are required), and the Control Room staff assumes the role of Implementers. Control Room personnel will perform mitigating actions for severe accidents per EOPs prior to TSC activation.

All Station ERO personnel shall have the authority to perform assigned duties in a manner consistent with the objectives of this plan.

1) Shift Manager (Shift Emergency Director) Control Room

A Shift Manager is on duty 24 hours a day and is the Shift Emergency Director in a declared emergency until relieved of this function. While serving in this capacity the Shift Manager is responsible for:

- Activating the ERO (as deemed appropriate or as procedurally required).
- Performing those duties outlined in Section B.5.a.2 for the Station Emergency Director. The responsibilities described for the Station Emergency Director applies to either the Shift Emergency Director or the Station Emergency Director depending on which individual is in Command and Control.

The on-duty Shift Manager directs the activities of the operating crew and is responsible for the safe operation of the plant in compliance with the station NRC operating license and the station operating procedures. The Shift Manager, after relinquishing Command and Control, functionally reports to the Operations Manager in the TSC.

The Shift Manager's responsibilities, when not in Command and Control, are described below:

- The authority and responsibility to shutdown the reactor when determined that the safety of the reactor is in jeopardy or when operating parameters exceed any of the reactor protection circuit set-points and automatic shutdown does not occur;



- To ensure a review has been completed to determine the circumstance, cause, and limits under which operations can safely proceed before the reactor is returned to power following a trip or an unscheduled or unexplained power reduction;
- The responsibility to be present at the plant and to provide direction for returning the reactor to power following a trip or an unscheduled or unexplained power reduction;
- The responsibility to adhere to the station Technical Specifications and to review routine operating data to assure safe operation;
- The responsibility to identify applicable EALs and emergency classifications; and
- The responsibility to adhere to plant operating procedures and the requirements for their use. During an emergency, operations personnel may depart from approved procedures where necessary to prevent injury to personnel, including the public, or damage to the facility consistent with the requirements of 10 CFR 50.54(x) and (y).
- Supervise the activities of the Control Room Crew.

## 2) Station Emergency Director TSC

The Station Emergency Director reports to the Corporate Emergency Director and supervises and directs the Station ERO. The Station Emergency Director's responsibilities include organizing and coordinating the onsite emergency efforts. Additionally, the Station Emergency Director has the requisite authority, plant operating experience and qualifications to implement in-plant recovery operations.

### a) Station Emergency Director Responsibilities

- Conduct personnel assembly/accountability and evacuation of non-essential personnel at Site Area Emergency, General Emergency or as conditions warrant.
- If the emergency involves a hazardous substance and/or oil discharges, ensure that appropriate notifications and responses have been made.
- Determine if the OSC is to remain activated at the Alert Classification.
- Event classification.
- Emergency exposure controls.
- Protective actions for all onsite personnel.

- Supervision of the Station ERO.
- Inform the Corporate Emergency Director and onsite NRC as to the status of the plant.
- Assist the Corporate Emergency Director in the acquisition of information for the state/local notifications, NRC notifications and offsite agency updates.
- Provide information and recommendations to the Corporate Emergency Director.
- Implement plans, procedures and schedules to meet emergency response objectives as directed by the Corporate Emergency Director.
- Request from the Corporate ERO any additional material, personnel resources or equipment needed to implement response plans and operations.
- Assume the duties and responsibilities of Decision-Maker when a transition to Severe Accident Management Guidelines (SAMGs) is initiated. This responsibility can be delegated to the Operations Manager if qualified.

### 3) ENS Communicators TSC

Responsibilities assigned to the ENS Communicators include:

- Establish communications with appropriate parties as directed.
- Transmit information that has been reviewed and/or approved by the responsible Manager or Coordinator.
- Document time, date and information being transmitted or received on appropriate forms.
- Record and relay inquiries and the responses to those inquiries.
- Assist appropriate Managers and Coordinators in maintaining proper records and logs of emergency related activities.
- Gather, record and post appropriate information.
- Notify the NRC of changes in event classification and assist in completing the NRC Event Notification Worksheet and responding to NRC inquiries.
- Provide real time updates of significant changes to plant and system status and responses to NRC inquiries.

- Maintain continuous communications with the NRC, if requested, via the NRC ENS phone or commercial telephone line.

#### 4) Operations Manager TSC

The Operations Manager reports to the Station Emergency Director. Major functions include determining the extent of station emergencies, initiating corrective actions, and implementing protective actions for onsite personnel. In the event that the Station Emergency Director becomes incapacitated and can no longer fulfill the designated responsibilities, the Operations Manager will normally assume the responsibilities until relieved by another qualified Station Emergency Director. Responsibilities include:

- Coordinate TSC efforts in determining the nature and extent of emergencies pertaining to equipment and plant facilities in support of Control Room actions.
- Initiate immediate corrective actions to limit or contain the emergency invoking the provisions of 10 CFR 50.54(x) if appropriate, and specifically when addressing Severe Accident Management Guidelines (SAMG).
- Recommend equipment operations checks and miscellaneous actions to the Control Room in support of restoration and accident mitigation.
- Approve emergency special procedures, and implement as required under the provisions of 10 CFR 50.54(x).
- Assist in determining the priority assigned to OSC activities.
- Organize and direct medical response efforts for injured personnel.
- Ensure adequate staffing of the Control Room and TSC subordinates.
- Ensure the Shift Manager is informed of OSC staffing utilization and activities.
- Identify steps or procedures that the Operations staff should be utilizing to properly respond to the emergency condition.
- Assist the Station Emergency Director in evaluating changes in event classification.
- Supervise the activities of the ENS Communicator in the TSC.
- Act as the TSC liaison with the appropriate NRC Site Team Representative.
- At the direction of the Station Emergency Director, assume the duties and responsibilities of the Evaluator, or Decision-Maker if qualified, when transition to Severe Accident Management Guidelines (SAMG) is initiated.

**5) Technical Support Staff TSC**

The TSC Technical Support Staff consists of the following minimum staff engineering positions:

- Electrical Engineer
- Mechanical Engineer
- Core/Thermal Hydraulic Engineer - serves as Core Damage Assessment Methodology (CDAM) Evaluator, as applicable.

In addition, station Engineering support will be augmented on an as needed basis to support accident assessment and mitigation activities.

**6) Radiation Protection Manager (RPM) TSC**

The Radiation Protection Manager reports to the Station Emergency Director. The TSC RPM directs a staff in determining the extent and nature of radiological or hazardous material problems onsite. Responsibilities include:

- Accumulate, tabulate and evaluate data on plant conditions such as meteorological and radiological monitoring readings, and other pertinent data.
- Act as the TSC liaison with the appropriate NRC Site Team representative.
- Ensure use of protective clothing, respiratory protection, and access control within the plant as deemed appropriate to control personnel exposures.
- Ensure that appropriate bioassay procedures have been implemented for onsite personnel when a radioactivity incident has occurred.
- Ensure that personnel are decontaminated, if necessary.
- Authorize personnel exposures below 5 Rem TEDE (EPA-400 lower limit).
- Assist the Station Emergency Director in determining if exposures in excess of the 5 Rem TEDE (EPA-400 lower limit) are necessary.
- Advise the Station Emergency Director of situations when the use of KI should be considered.
- Assist the Station Emergency Director in evaluating dose-based PARs (prior to Corporate Emergency Director accepting command and control) and changes in radiological event classification.
- Advise the Station Emergency Director and EOF Radiation Protection Manager of changes in radiological release status.

- Assist the Operations Manager in planning rescue operations and provide monitoring services as required, including the transfer of injured and/or contaminated personnel.
- Coordinate with the Security Coordinator to determine the routes to be used for evacuation of non-essential personnel.
- Assure additional radiation protection personnel and/or equipment is arranged for, as necessary.

7) Security Coordinator TSC

The Security Coordinator reports to the Station Emergency Director and maintains plant security and personnel accountability at the nuclear station. Responsibilities include:

- Maintain plant security and account for all personnel within the protected area.
- Assist the Station Emergency Director in evaluating changes in security related threats and event classifications.
- Identify any non-routine security procedures and/or contingencies that are in effect or that require a response.
- Expedite ingress and egress of emergency response personnel.
- Coordinate with the Radiation Protection Manager in controlling ingress and egress to and from the Protected Area if radiological concerns are present.
- Provide for access control to the Control Room, TSC and OSC, as appropriate.
- Expedite entry into the Protected Area, as necessary, for the NRC Site Team.
- Act as the TSC liaison with the appropriate NRC Site Team representative.
- Assist the Radiation Protection Manager in determining personnel evacuation routes as necessary.
- Coordinate the evacuation of station non-essential personnel with the appropriate Local Law Enforcement Agencies (LLEAs).

8) Operations Support Center Director OSC

The OSC Director reports to the Emergency Director and supervises the activities of OSC personnel. Responsibilities include:

- Assign tasks to designated Leads as available:
  - I&C Maintenance
  - Mechanical Maintenance
  - Electrical Maintenance
  - Radiation Protection
  
- Coordinate with the OSC Operations Lead in the dispatch of Operations personnel to support Control Room and OSC Team activities.
- Notify the Control Room and TSC prior to dispatch of any OSC teams into the plant.
- Maintain OSC resources including personnel, material, and equipment.
- Maintain accountability for all individuals dispatched from the OSC.
- Conduct periodic briefings on the overall plant status, emergency response activities, and station priorities.
- Assemble and dispatch the Field Monitoring Teams as required.

9) OSC Leads OSC

OSC Leads report to the OSC Director and are assigned from the following station departments:

- Mechanical Maintenance
- Electrical Maintenance
- Instrument and Control
- Radiation Protection

The OSC Lead assigned to an OSC team is responsible at all times for the safety of team personnel and to keep the OSC Director apprised of team status. Specifically, the OSC Leads are responsible for the managing and supervising OSC team personnel, including:

- Conduct of adequate pre-dispatch briefings.
- Ensuring adequate protective equipment and measures have been identified.

- Tracking of OSC team activities while dispatched.
- Debriefing of team personnel upon return to the OSC.

**b. Corporate Emergency Response Organization****1) Corporate Emergency Director EOF**

a) When the Station Emergency Director has Command and Control, the ongoing responsibilities include:

- Coordinate all Exelon Nuclear activities involved with the emergency response.
- Ensure off-site agency updates are periodically communicated as required/requested.
- Coordinate Exelon Nuclear press releases with the Nuclear Duty Officer and Exelon Communications and Public Affairs.
- Request assistance from non-Exelon Nuclear emergency response organizations, as necessary.

b) Following assumption of Command and Control, the additional responsibilities assigned to the Corporate Emergency Director include:

- Assumes overall Command and Control of emergency response activities and the non-delegable responsibilities for PAR determination and the notification of offsite authorities.
- Ensure that Federal, state and local authorities and industry support agencies remain cognizant of the status of the emergency situation. If requested, dispatch informed individuals to offsite governmental Emergency Operation Centers (EOCs).
- Approve the technical content of Exelon Nuclear press releases prior to their being released to the media.

**2) Radiation Protection Manager EOF**

The Radiation Protection Manager reports to the EOF Director and directs the activities of the EOF Radiation Protection staff. Specific responsibilities include:

- Recommend changes in event classification and PARs based upon effluent releases or dose projections.

- Assist the Emergency Director in the evaluation of the significance of an emergency with respect to the public.
- Notify the Emergency Director of meteorological changes that may impact identification of downwind areas.
- Advise the Corporate Emergency Director of protective actions taken by the station for plant personnel.
- Assist the TSC in the planning and coordination of activities associated with the evacuation of non-essential personnel.
- Advise the Corporate Emergency Director on the need for emergency exposures or for issuance of KI to the Field Monitoring Teams or Exelon personnel required to enter the plume.
- Determine the need for and contact Occupational Health/Industrial Safety Services personnel for assistance.
- Monitor plant radiological conditions and advise the TSC Radiation Protection Manager of any adverse trends or potential release pathways that may impact existing event classification.
- Assist in the completion and review of the state/local notification form.
- Maintain cognizance of environmental sampling activities.
- Ensure state authorities are provided information pertaining to Exelon Field Monitoring Team activities and sample results.
- Assist the affected station in the following areas:
  - Planning and coordination of activities associated with the evacuation of non-essential personnel.
  - Acquisition of additional instrumentation, dosimetry, protective equipment and radiological support personnel.
- Assist and interface with the EOF Technical Support Group and the station in the development of plans for plant surveys, sampling, shielding, and special tools in support of waste systems processing and design modification activities.
- Upon request, provide in-plant health physics data to Emergency Public Information personnel.
- Coordinate Field Monitoring Team activities.



- Determine needs of the Dose Assessment Coordinator and the ENS Communicator for updates on Field Monitoring Team data and ensure distribution of new data to them in accordance with those needs.
- Promptly report new environmental or Field Monitoring Team exposure data to the Dose Assessment Coordinator.

3) Dose Assessment Coordinator EOF

The Dose Assessment Coordinator reports to the EOF Radiation Protection Manager. Responsibilities include:

- Interpret radiological data and provide PARs based upon dose projections to the EOF Radiation Protection Manager.
- Advise the EOF Radiation Protection Manager of changes in event classification based on effluent releases or dose projections.
- Initiate evaluation of the need for administering KI to Exelon nuclear workers.
- Remain cognizant of forecast and meteorological data and ensure the status is updated periodically.
- Notify the EOF Radiation Protection Manager of meteorological changes that may impact identification of downwind areas.
- Upon request, provide release and dose assessment data to Emergency Public Information personnel.
- Perform dose projections using the Dose Assessment computer models as directed by the Dose Assessment Coordinator.
- Monitor meteorological and plant effluent conditions.
- Evaluate the need for administering KI to Exelon nuclear workers when requested by the Dose Assessment Coordinator.

4) Computer Specialist EOF

The Computer Specialist responsibilities include:

- Assist any personnel in logging in, initializing or using a desired computer program.
- Investigate and repair problems encountered with communications equipment and computer equipment/applications.

**5) State/Local Communicator EOF**

The State/Local Communicator reports to the Emergency Director. Responsibilities include:

- Communicate and receive information via the Nuclear Accident Reporting System (NARS) circuit or commercial telephone line with appropriate state and county agencies.
- Prepare state/local notification forms with the assistance of the Corporate Emergency Director.

**c. Public Information Emergency Response Organization****1) Corporate Spokesperson JIC**

The Corporate Spokesperson reports to the Corporate Emergency Director and is responsible for directing the Exelon Emergency Public Information Organization and providing news information to the media. Responsibilities include:

- Maintain command and control of the Joint Information Center.
- Coordinate with Federal, state and local agencies, as well as with other organizations involved in the emergency response, to maintain factual consistency of information to be conveyed to the news media/public.
- Conduct periodic briefings with the news media.
- Interface with the Public Information Director.
- Coordinate and direct responses to media inquiries.
- Ensure that the composition and timeliness of Exelon News Releases are adequate.
- Provide for timely exchange of information between other spokespersons.

**2) JIC Director JIC**

The JIC Director reports the Corporate Spokesperson to ensure the operability of and to supervise the activities in the JIC. Responsibilities include:

- Maintain cognizance of conditions of the plant and environment, and the actions of Exelon Nuclear and governmental support personnel.

- Coordinate with Federal, state and local agencies, as well as with other organizations involved in the emergency response, to maintain factual consistency of information to be conveyed to the news media/public.
- Participate, as needed, in rumor control activities.
- Ensure that adequate information flow between the EOF and the JIC is coordinated through the Public Information Director.
- Authorize admittance of non-Exelon Nuclear officials to the JIC.
- Until the JIC is fully staffed, work with Corporate Communications to compose draft news releases.
- Provide the drafted news releases to the Corporate Emergency Director for technical review prior to Public Information Director approval.
- Until the JIC is fully staffed, work with Corporate Communications to ensure that rumors are reviewed, documented and responded to by Exelon Nuclear personnel as deemed appropriate.
- Until the JIC is fully staffed, work with Corporate Communications to document and respond to rumors as quickly as possible, through the Exelon Communications and Public Affairs.
- Until the JIC is fully staffed, work with Corporate Communications to ensure that the media is being monitored and that Exelon Nuclear personnel review the information detailed or contained in media releases.

3) Public Information Director (PID) JIC

When the Emergency Public Information Organization is activated, the Public Information Director reports to the Corporate Spokesperson and is responsible for all emergency event related information intended to be conveyed from Exelon Nuclear to the news media/public. The Public Information Director may perform this function at remote locations. Responsibilities include:

- Provide the Corporate Emergency Director with an overview of the public and media impacts resulting from the Exelon Nuclear and governmental activities.
- Participate with the Corporate Emergency Director regarding information to be released to the public.
- Authorize the issuance of news releases.
- Interface with the Corporate Spokesperson at the JIC.

- Act as a liaison between the ERO and Exelon Nuclear's corporate executives.
- Maintain cognizance of conditions of the plant and environment, and the actions of Exelon Nuclear and governmental support personnel.
- Coordinate information flow between the EOF and the JIC.
- Review and access media coverage of the emergency event.

## 6. Exelon Emergency Response Organization Block Diagram

ERO staffing tables contained in Appendix 5, lists the key positions of the ERO. Figures B-1a through B-1d illustrates the overall emergency response organization. Section B.5 discusses specific responsibilities and the interrelationships for key positions.

## 7. Exelon Corporate Emergency Response Organization

The Corporate ERO consists of the EOF Organization and the Emergency Public Information Organization. Personnel staffing these corporate organizations are covered in detail in Section B.5 of this plan.

The Corporate Emergency Response Organization is staffed by Exelon personnel, and operates out of the Emergency Operations Facility (EOF) and the Joint Information Center (JIC). The Corporate ERO is supported by News Media Spokespersons, environmental assessment staff and monitoring teams that provide long-term support to the affected station. Additionally, the Corporate ERO has long term liaison responsibilities with federal, state, and local authorities. These positions are further described in the EPIPs.

The Emergency News Center (ENC) function is responsible for the collection and analysis of event information and status, and development of Company news statements. This information is then communicated to the JIC Corporate Spokesperson. The ENC function may be located at either the EOF or the JIC.

The EOF is activated at an Alert. The EOF Organization is responsible for evaluating, coordinating and directing the overall company activities involved in the emergency response. Within the EOF, the Corporate Emergency Director shall assume Command and Control from the Shift Emergency Director when classification escalates to an Alert or higher, unless the EOF capabilities are limited such that the overall control and responsibility for PARs and offsite notifications cannot be assumed. The JIC is activated within 90 minutes of an Alert. Some JIC functions may continue to be performed by the Exelon Communications organization until transferred to the JIC.

**Figure B-1a: Exelon Overall ERO Command Structure**

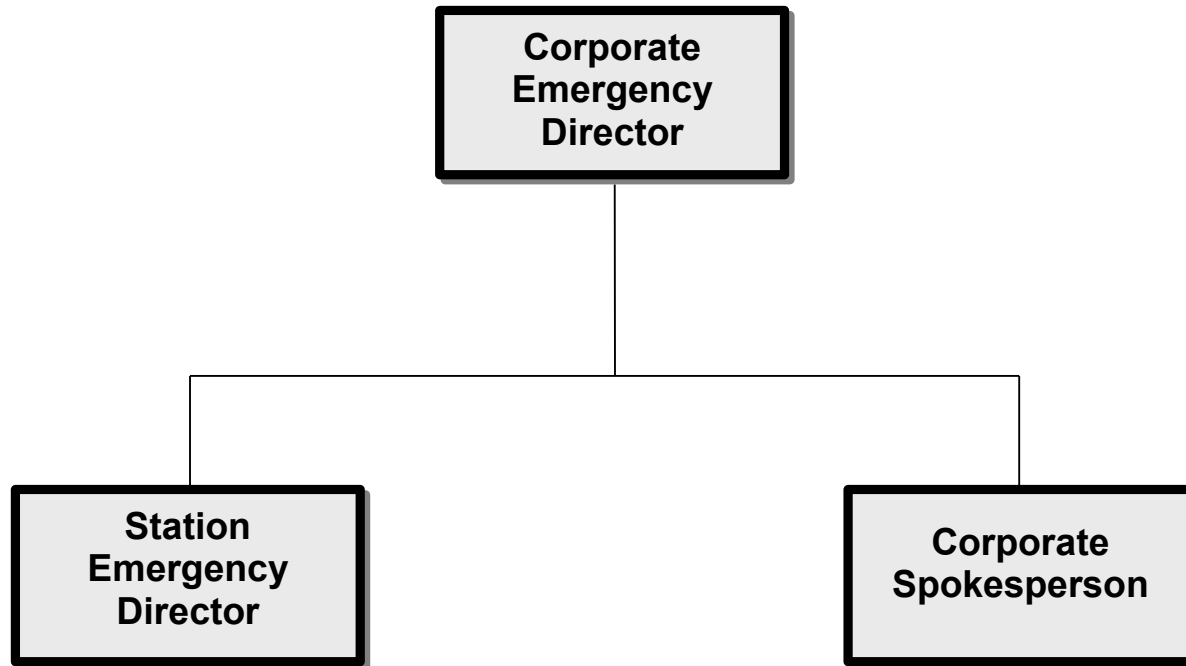

**Figure B-1b: Emergency Onsite Organization**

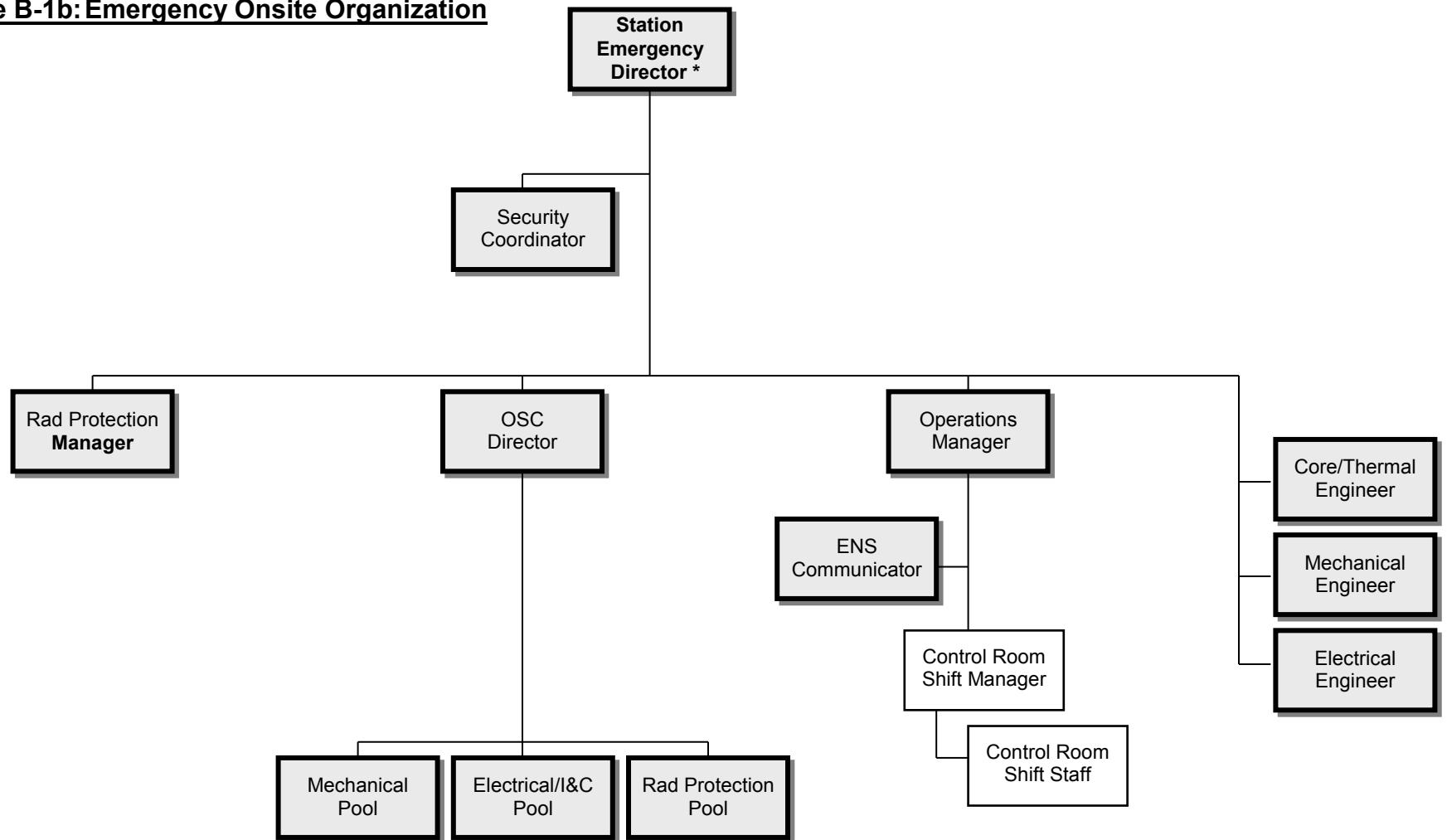

ERO response pool personnel do not include the on-shift complement.

SAMG functions requires 1 Decision-Maker and 2 Evaluators.

Figure B-1c: Emergency Offsite Organization

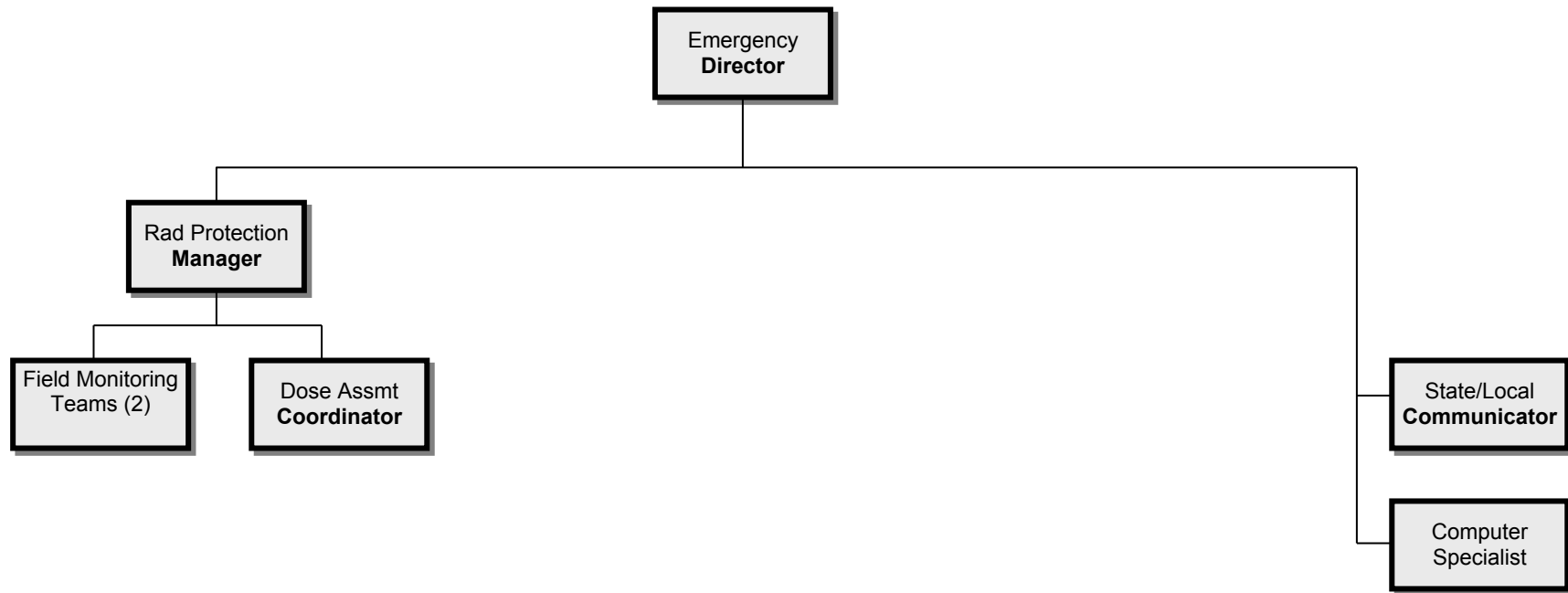

**Figure B-1d: Emergency Public Information Organization**

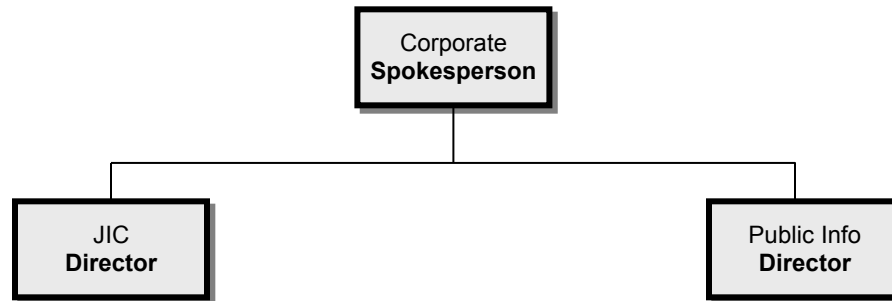



- 9) Field Monitoring Team (FMT) Communications: A separate communications system has been installed to allow coordinated environmental monitoring and assessment during an emergency. This system consists of the necessary hardware to allow communication between the Control Room, TSC, EOF, and mobile units in Exelon Nuclear vehicles. Though direct communications between the Control Room and the FMTs is not required per the prescribed methods of FMT coordination, the FMTs can be contacted from equipment in the Control Room if required. Commercial cell phones or other means are available as back up to the primary field team communications system.

In addition, station communication links exist to ensure appropriate information transfer capabilities during an emergency. The station may also utilize its Public Address System, station radios and notification devices to augment its emergency communications.

- e. ERO Notification System: Exelon Nuclear utilizes an automated ERO Notification System to rapidly notify members of the ERO. The system consists of a network of physical infrastructure capable of initiating and receiving contact via multiple notification devices. When activated, the system contacts the notification devices (e.g., through commercial and cellular phone, email, text message) belonging to members of the ERO. The System includes redundant activation methods via the internet, call-centers, or direct telephone activation, as well as redundant, geographically separated call centers and data centers, with redundant power sources. Implementing procedures specify the course of action to be taken if the primary ERO Notification System activation path fails to respond. The ERO Notification System provides primary and back-up notification functions. For the Exelon North East sites, the ERO notification system description is contained in the Station Annex and EP implementing procedures.

- f. NRC Communications (ENS)

Communications with the NRC Operations Center will be performed via the NRC ENS and HPN circuits or commercial telephone line. Information is normally communicated from an approved NRC Event Notification Worksheet prior to establishing an open ENS.

The actual configuration of these systems may vary from station to station. Installation and use of these NRC telephones is under the direction of the NRC (see Figure F-3).

Emergency Notification System (ENS): Dedicated telephone equipment is in place between each nuclear station's Control Room and the NRC, with an extension of that line in the TSC. A separate line is available in the EOF with the capability of being patched with the station through the NRC. This line is used for NRC event notifications and status updates.

**Figure F-3: NRC Communications for Nuclear Response**

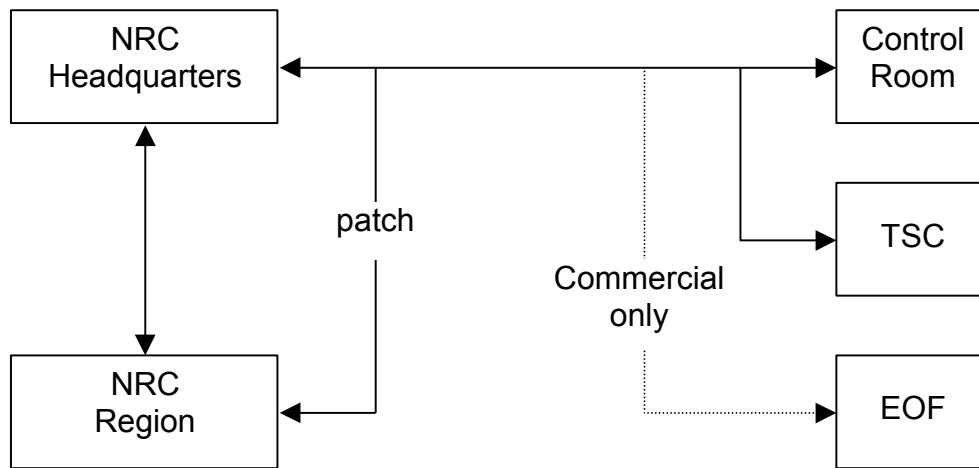

**NOTE:** ENS circuits may use the Federally maintained system, company tie lines or PBX as dedicated primary communications systems and have commercial backups.

The primary purpose of the Emergency Public Information Organization is to disseminate information from Exelon Nuclear's ERO about the emergency events to the public, via the news media. However, the authority for issuance of news releases for the classification of an Unusual Event or prior to ERO activation will always reside with the Exelon Communications and Public Affairs Department. Upon activation, the Emergency Public Information Organization has the responsibility and authority for issuance of news releases to the public.

The Emergency Public Information Organization is comprised of senior managers from Exelon Nuclear who will function as spokespersons, and other Exelon Nuclear individuals including personnel from the Governmental Affairs and Human Relations areas. Exelon Nuclear's spokespersons disseminate information to the news media/public concerning the emergency events out of a Joint Information Center (JIC).

- 2) The Joint Information Center (JIC): The JIC is the facility in which media personnel gather to receive information related to the emergency event. The JIC is the location where approved news releases will be provided to the media for dissemination to the public. News releases are coordinated between the EOF and JIC personnel and state and/or Federal representatives in the JIC. Exelon public information personnel operate from the EOF and the JIC, which is under the direction of the Corporate Spokesperson and functions as the single point contact to interface with Federal, state, and local authorities who are responsible for disseminating information to the public.

Each station has a designated JIC. Each JIC is equipped with appropriate seating, lighting and visual aids to allow for public announcements and briefings to be given to the news media. Additionally, JICs are equipped with commercial telephone lines for making outgoing calls. The Emergency Public Information Organization functions from the JIC and EOF in preparing and releasing utility information about the emergency event. The JIC is activated at the declaration of an Alert or higher classification. Some JIC personnel may perform functions remotely from alternate locations while remaining in contact with personnel in the JIC facility (e.g., media monitoring, rumor control, news writers, issuance of press releases). The JIC Director and Corporate Spokesperson will ensure communication and coordination of these functions with the EOF and JIC staff. Functions of the JIC include:

- Serving as the primary location for accumulating accurate and current information regarding the emergency conditions and writing news releases.
- Providing work space and phones for public information personnel from the state, counties, NRC, FEMA, and industry-related organizations.
- Providing telephones for use by the news media personnel.

- Providing responses to media inquiries through telephones that the media can call for information about an emergency.

b. The news media is not permitted into the EOF during an emergency.

#### **4. Coordination of Public Information**

- a. The JIC is staffed by Exelon and government public information representatives who will be the source of public information during an emergency at the station. The Corporate Spokesperson is the primary spokesperson for Exelon Nuclear. The Corporate Spokesperson has direct access to all necessary information (see Section B.5).
- b. The JIC is staffed by federal, state, county, and utility personnel to assure timely, periodic exchange and coordination of information. Representatives coordinate information prior to conducting news briefings.
- c. Rumors or misinformation are identified during an emergency by the JIC Staff. They respond to public and news media calls and monitor media reports.
- d. The common MW Region JIC is located west of Chicago, in Warrenville IL, in the Exelon Nuclear Cantera facility. This facility supports the Braidwood, Byron, Clinton, Dresden, LaSalle and Quad Cities stations.

The JIC for the MA Region Three Mile Island, Limerick and Peach Bottom Stations is co-located with the EOF at 175 North Caln Road, Coatesville, Pennsylvania.

The JIC for Calvert Cliffs Station is co-located with the EOF about twelve miles from the site, in Calvert Industrial Park, Skipjack Road at Hallowing Point Road.

The JIC for the Ginna Station is located at 1255 Research Forest, Macedon, NY.

The JIC for the Nine Mile Point Station is located near the Oswego County Airport, on County Route 176 in the Town of Volney, New York approximately 12 miles from the site.

#### **5. Media Orientation**

Emergency Preparedness, in conjunction with Exelon Communications and Public Affairs Department, offers training (at least annually) to acquaint news media with the E-Plan, information concerning radiation, and points of contact for release of public information in an emergency. Training is provided for those media agencies that accept the training offer.

Personnel in the TSC shall be protected from radiological hazards, including direct radiation and airborne contaminants under accident conditions with similar radiological habitability as Control Room personnel. To ensure adequate radiological protection, permanent radiation monitoring systems have been installed in the TSC and/or periodic radiation surveys are conducted. These systems indicate radiation dose rates and airborne radioactivity inside the TSC while in use. In addition, protective breathing apparatus (full-face air purifying respirators) and KI are available for use as required.

The TSC has access to a complete set of as-built drawings and other records, including general arrangement diagrams, P&IDs, and the electrical schematics. The TSC has the capability to record and display vital plant data, in real time, to be used by knowledgeable individuals responsible for engineering and management support of reactor operations, and for implementation of emergency procedures.

- c. Operations Support Center (OSC): Each nuclear generating station has established an OSC. The OSC is the onsite location to where station support personnel report during an emergency and from which they will be dispatched for assignments or duties in support of emergency operations. The OSC shall be activated whenever the TSC is activated, but need not remain activated at the Alert level if its use is judged unnecessary by the Station Emergency Director. At the Site Area and General Emergency levels, the OSC or an alternate OSC shall be activated at all times. The OSC is not activated for a HOSTILE ACTION when the Alternative Facility is implemented. Activation for other events is optional. Station disciplines reporting to the OSC include, but are not limited to:
- Operating personnel not assigned to the Control Room,
  - Radiation Protection Personnel,
  - Maintenance Personnel (mechanical, electrical and I&C).

Figure B-1b illustrates the staffing and organization for the OSC.

Each OSC is equipped with communication links to the Control Room, the TSC and the EOF (see Section F). A limited inventory of supplies will be kept for the OSC. This inventory will include respirators, protective clothing, flashlights and portable survey instruments.

## 2. Emergency Operations Facility (EOF)

The EOF is the location where the Corporate Emergency Director will direct a staff in evaluating and coordinating the overall company activities involved with an emergency. Activation of the EOF is mandatory upon declaration of an Alert or higher classification. The EOF provides for:

- Management of overall emergency response.
- Coordination of radiological and environmental assessments.

### 3. Emergency Operations Centers

EOCs operated by the state and local communities have been established to perform direction and control of emergency response functions.

The respective state EOCs are capable of continuous (24-hour) operations for a protracted period. These centers contain sufficient communications (radio, telephone and teletype) equipment, maps, emergency plans, and status boards to provide the necessary interfaces with other federal, state, county, and Exelon emergency facilities.

The county EOCs serve as Command and Control headquarters for local emergency response activities as well as a center for the coordination of communications to field units and to the state EOCs. These EOCs have the equipment necessary, (such as facsimile machines, telecommunications equipment, radio gear, photocopiers, wall maps, etc.) to carry out their emergency responsibilities.

### 4. Activation

**NOTE:** NUREG-0654 Criterion II.B.5 states that the “licensee must be able to augment on-shift capabilities within a short period after declaration of an emergency”. It further defines that short period as 30 and 60 minutes. The time frames for rapid augmentation of a nuclear power plant staff in the event of an emergency are not rigid inviolate requirements but rather goals. It is Exelon Nuclear’s intent to expend its best efforts to meet the augmentation criteria goals regarding staffing Emergency Response Facilities with sufficiently skilled individuals capable of handling an emergency. Both the NRC and Exelon Nuclear realize that due to diversity of normal residential patterns for the stations’ staff, possible adverse weather conditions, road congestion and site access restrictions, these time frames might be exceeded.

Exelon Nuclear has put into place plans and procedures to ensure timely activation of its emergency response facilities. The Shift Manager (as Shift Emergency Director) will initiate a call-out in accordance with the implementing procedures. The ERO augmentation process identifies individuals who are capable of fulfilling the specific response functions that are listed in ERO staffing tables contained within the station specific Annex. This table was developed based on the functions listed in NUREG-0654, Table B-1.

Although the response time will vary due to factors such as weather and traffic conditions, a goal of 60 minutes for minimum staffing, following the declaration of an Alert or higher emergency classification, has been established for the ERO personnel responding to the station emergency facilities and the EOF. Additionally, plans have been developed to ensure timely functional activation and staffing of the JIC within 90 minutes of when the classification of Alert is declared.

It is the goal of the organization to be capable of activating the applicable Emergency Response Facility upon achieving minimum staffing. The facility can be declared activated when the following conditions are met:

- a. Minimum staffing has been achieved.
- b. The facility is functional.

The Director in charge may elect to activate their facility without meeting minimum staffing; if it has been determined that sufficient personnel are available to fully respond to the specific event (this would not constitute a successful minimum staff response).

## 5. Monitoring Equipment Onsite

Each nuclear station is equipped with instrumentation for seismic monitoring, radiation monitoring, fire protection and meteorological monitoring. Instrumentation for the detection or analysis of emergency conditions is maintained in accordance with station Technical Specifications, if applicable, or commitments made to the NRC. The actual instrumentation varies somewhat from site to site and thus will not be described in detail in this plan. Descriptions of the equipment will appear in each Station Annex. This equipment includes but is not limited to the following:

### a. Geophysical Monitors

- 1) Meteorological Instrumentation: A permanent meteorological monitoring station is located near each station for display and recording of wind speed, wind direction, and ambient and differential temperature for use in making offsite dose projections. Meteorological information is presented in the CR, TSC, and EOF by means of the plant computer system. This information is remotely interrogated using a computer or other data access terminal.

With regard to Exelon Nuclear's meteorological monitoring program, there has been a quality assurance program adopted from 10 CFR 50, Appendix B. However, since the meteorological facilities are not composed of structures, systems, and components that prevent or mitigate the consequences of postulated accidents and are not "safety related," not all aspects of 10 CFR 50, Appendix B, apply. Those aspects of quality assurance germane to supplying good meteorological information for a nuclear power station were adopted into the meteorological quality assurance program. The meteorological program is also subject to the requirements of the QATR, Section 19, Augmented Quality.

The National Weather Service (NWS), or regional weather forecast providers, may be contacted during severe weather periods. These providers analyze national and local weather in order to provide localized weather forecasts for the system or for the station area as appropriate.

Appendix 5

Table 5-1: Emergency Response Organization (ERO) Staffing and Augmentation Plan

Emergency Preparedness (EP) Functions	On-Shift	TSC / OSC		EOF - Alert or Greater  Augment w/in 60 min.
		Alert or Greater  Augment w/in 60 min.	Alert or Greater  Augment w/in 90 min.	
<p><b>Command and Control</b></p> <ul style="list-style-type: none"> <li>• Provide overall ERO command and control, until relieved.</li> <li>• Approve emergency action level (EAL) and/ or protective action recommendation (PAR) classifications, until relieved.</li> <li>• Authorize personnel dose extensions, until relieved.</li> </ul>	(1) Shift Emergency Director	(1) Station Emergency Director	Not applicable	(1) Corporate Emergency Director
<p><b>Communications<sup>3</sup></b></p> <ul style="list-style-type: none"> <li>• Communicate EAL and PAR classifications to offsite response organizations (OROs), including the NRC, until relieved.</li> </ul>	Shift Communicator <sup>1</sup>	(1) ENS Communicator (TSC)	Not applicable	(1) State / Local Communicator
<p><b>Radiation Protection</b></p> <ul style="list-style-type: none"> <li>• Provide qualified radiation protection coverage for responders accessing potentially unknown radiological environments during emergency conditions.</li> <li>• Provide in-plant surveys.</li> <li>• Control dosimetry and radiologically controlled area access.</li> </ul>	(2) Radiation Protection Personnel	(3) Additional Radiation Protection Technicians [In addition to personnel on-shift] (OSC)	(3) Additional Radiation Protection Technicians [In addition to personnel on-shift and those responding within 60 min.] (OSC)	Not applicable



Emergency Preparedness (EP) Functions	On-Shift	TSC / OSC		EOF - Alert or Greater
		Alert or Greater Augment w/in 60 min.	Alert or Greater Augment w/in 90 min.	Augment w/in 60 min.
<p><b>Supervision of Radiation Protection Staff and Site Radiation Protection</b></p> <ul style="list-style-type: none"> <li>Evaluate and assess plant and offsite radiological data in the development of onsite protective actions and offsite PARs, until relieved.</li> <li>Recommend onsite protective actions and offsite PARs to the applicable decision- maker, until relieved.</li> <li>Direct all radiation protection activities, including field monitoring team (FMT) direction, until relieved.</li> <li>Provide relevant information to applicable communicators who are communicating offsite PARs to OROs, until relieved.</li> </ul>	(1) Shift Emergency Director	(1) TSC Radiation Protection Manager (RPM) (TSC)	Not applicable	(1) EOF Radiation Protection Manager (EOF)
<p><b>Dose Assessments/ Projections</b></p> <ul style="list-style-type: none"> <li>Perform dose assessments/projections and provide input to applicable PAR decision- maker, until relieved.</li> </ul>	(1) Shift Dose Assessor 1		Not applicable	(1) Dose Assessment Coordinator (EOF)

Emergency Preparedness (EP) Functions	On-Shift	TSC / OSC		EOF - Alert or Greater
		Alert or Greater Augment w/in 60 min.	Alert or Greater Augment w/in 90 min.	Augment w/in 60 min.
<b>Emergency Classifications</b> <ul style="list-style-type: none"> <li>Evaluate plant conditions and recommend emergency classifications, until relieved.</li> </ul>	Emergency Classification Advisor <sup>1</sup>	(1) Operations Manager (TSC)	Not applicable	Not applicable
<b>Engineering</b> <ul style="list-style-type: none"> <li>Provide engineering coverage related to the specific discipline of the assigned engineer, until relieved.</li> </ul>	(1) <b>Core/Thermal Hydraulics Engineer - STA<sup>1</sup></b> <ul style="list-style-type: none"> <li>Evaluate reactor conditions.</li> </ul>	<b>TSC Engineering Staff</b> <ul style="list-style-type: none"> <li>(1) Electrical/Instrumentation and Control (I&amp;C): Provide engineering coverage for the ERO related to electrical or I&amp;C equipment.</li> <li>(1) Mechanical: Provide engineering coverage for the ERO related to mechanical equipment.</li> <li>(1) Core/Thermal Hydraulics: Evaluate reactor conditions.</li> </ul>	As needed	Not applicable
<b>Security</b>	Security staffing per the site-specific security plan.	(1) <b>Security Coordinator (TSC)</b> <ul style="list-style-type: none"> <li>Coordinate security- related activities and information with the Emergency Coordinator.</li> </ul>	Not applicable	Not applicable

Emergency Preparedness (EP) Functions	On-Shift	TSC / OSC		EOF - Alert or Greater
		Alert or Greater Augment w/in 60 min.	Alert or Greater Augment w/in 90 min.	Augment w/in 60 min.
<b>Repair Team Activities</b>	<p><b>Operations Staff<sup>1,4</sup></b></p> <ul style="list-style-type: none"> <li>Limited maintenance capability needed on-shift. This is typically limited to minor electrical and/or mechanical work to restore power and/or emergency core cooling system (ECCS) flow.</li> </ul>	<p><b>Maintenance Personnel (OSC)</b></p> <ul style="list-style-type: none"> <li>(1) Electrical Maintenance Technician: Provide electrical support for ECCS equipment, event mitigation, and equipment repair.</li> <li>(1) Mechanical Maintenance Technician: Provide mechanical support for ECCS equipment, event mitigation, and equipment repair.</li> </ul>	<p><b>Maintenance Personnel (OSC)</b></p> <ul style="list-style-type: none"> <li>(1) I&amp;C Technician: Provide assistance with logic manipulation, support for event mitigation and equipment repair, and support of digital I&amp;C if applicable. Additional I&amp;C staff may be called out if needed.</li> <li>Electrical Maintenance Technicians – As needed.</li> <li>Mechanical Maintenance Technicians – As needed.</li> </ul>	Not applicable

Emergency Preparedness (EP) Functions	On-Shift	TSC / OSC		EOF - Alert or Greater
		Alert or Greater Augment w/in 60 min.	Alert or Greater Augment w/in 90 min.	Augment w/in 60 min.
<b>Supervision of Repair Team Activities</b>	(1) Repair Team Supervisor <sup>1</sup>	<p>(1) <b>OSC Director</b></p> <ul style="list-style-type: none"> <li>Supervise OSC activities as directed by Emergency Coordinator.</li> </ul>	<p><b>OSC Supervisors</b></p> <ul style="list-style-type: none"> <li>(1) Electrical Maintenance Supervisor /Lead: Supervise OSC activities related to electrical equipment.</li> <li>(1) Mechanical Maintenance Supervisor / Lead: Supervise OSC activities related to mechanical equipment.</li> <li>(1) I&amp;C Supervisor / Lead: Supervise OSC activities related to I&amp;C equipment. May be combined with Electrical Supervisor.</li> <li>(1) Radiation Protection Supervisor / Lead: Supervise OSC activities related to radiation protection.</li> </ul>	Not applicable

Emergency Preparedness (EP) Functions	On-Shift	TSC / OSC		EOF - Alert or Greater
		Alert or Greater Augment w/in 60 min.	Alert or Greater Augment w/in 90 min.	Augment w/in 60 min.
<b>Field Monitoring Teams (FMTs)</b>	Not applicable	<p><b>Onsite FM Individual</b></p> <ul style="list-style-type: none"> <li>• (1) Qualified individual to assess the protected area for radiation and contamination and provide input to the TSC RPM. Responsible for radiation protection coverage for the FMT as directed by TSC RPM or EOF RPM.</li> </ul> <p><b>Offsite FMT A</b></p> <ul style="list-style-type: none"> <li>• (1) Qualified individual to assess the area(s) outside the protected area for radiation and contamination, and for radioactive plume tracking, as directed by, and under the control of, the EOF DAC or RPM. Responsible for the radiation protection coverage of the FMT as directed by EOF RPM.</li> <li>• (1) Driver to provide transportation.</li> </ul>	<p><b>Offsite FMT B</b></p> <ul style="list-style-type: none"> <li>• (1) Qualified individual to assess the area(s) outside the protected area for radiation and contamination, and for radioactive plume tracking, as directed by, and under the control of, the EOF DAC or RPM. Responsible for the radiation protection coverage of the FMT as directed by EOF RPM.</li> <li>• (1) Driver to provide transportation.</li> </ul>	Not applicable

Emergency Preparedness (EP) Functions	On-Shift	TSC / OSC		JIC - Alert or Greater <sup>2</sup>
		Alert or Greater Augment w/in 60 min.	Alert or Greater Augment w/in 90 min.	Augment w/in 90 min.
<b>Media Information</b> <ul style="list-style-type: none"> <li>• Manage and coordinate media information related to the event.</li> </ul>	Not applicable	Not applicable	Not applicable	<ul style="list-style-type: none"> <li>• Corporate Spokesperson</li> <li>• Public Information Director</li> <li>• JIC Director</li> </ul>

Emergency Preparedness (EP) Functions	On-Shift	TSC / OSC		EOF/JIC - Alert or Greater <sup>2</sup>
		Alert or Greater Augment w/in 60 min.	Alert or Greater Augment w/in 90 min.	Augment w/in 90
JIC/EOF Information Technology (IT)	Not applicable	Not applicable	Not applicable	<ul style="list-style-type: none"> <li>(1) EOF/JIC Computer Specialist (@ 90 min from Alert or higher)</li> </ul>

1. Other personnel may be assigned this function if no collateral duties are assigned to an individual that are beyond the capability of that individual to perform at any given time.
2. Exelon’s Communication Department will perform necessary JIC functions at the Unusual Event declaration and initially upon a higher initial EAL declaration. The JIC facility will be activated within 90 minutes of an Alert declaration; however, some functions may continue to be performed by the Exelon Communications Department. Some JIC functions such as Public Information Director, New Writer, Media Monitor, Rumor Control may be performed remotely by Exelon’s Communication Department.
3. Additional Communications will be staffed at the EOF or TSC if needed.
4. At Clinton, one (1) Repair Team Activity position is filled by a station IMD person. The IMD person is annotated in this table to support performance of specific EOP activities such as lifting leads and installing jumpers. The IMD person is required on shift until such time that operators are trained and qualified to perform these tasks.

**Emergency Plan Annex EP-AA-1004**

**Affected Pages - Clean**



# **EXELON NUCLEAR**

## **RADIOLOGICAL EMERGENCY PLAN ANNEX FOR DRESDEN STATION**

## Table of Contents

<u>Section</u>	<u>Page</u>
Section 1: Introduction .....	DR 1-1
1.1 Facility Description .....	DR 1-1
1.2 Emergency Planning Zone .....	DR 1-2
Section 2: Organizational Control of Emergencies .....	DR 2-1
Section 3: Classification of Emergencies .....	DR 3-1
Section 4: Emergency Measures .....	DR 4-1
4.1 Notification of the Emergency Organization .....	DR 4-1
4.2 Assessment Actions .....	DR 4-1
4.3 Protective Actions for the Offsite Public .....	DR 4-1
4.4 Protective Actions for Onsite Personnel .....	DR 4-2
Section 5: Emergency Facilities and Equipment .....	DR 5-1
5.1 Emergency Response Facilities .....	DR 5-1
5.2 Assessment Resources .....	DR 5-2
5.3 Protective Facilities and Equipment .....	DR 5-6
5.4 First Aid and Medical Facilities .....	DR 5-6
5.5 Law Enforcement Agencies .....	DR 5-6
5.6 Fire Fighting Organizations .....	DR 5-7
5.7 EMS Support .....	DR 5-7

### **APPENDIXES**

Appendix 1: NUREG-0654 Cross-Reference

Appendix 2: Station Letters of Agreement

### **ADDENDUMS**

Addendum 1: On- Shift Staffing Technical Basis

Addendum 2: Evacuation Time Estimates for Dresden Generating Station Plume  
Exposure Pathway Emergency Planning Zone

Addendum 3: Emergency Action Levels for Dresden Station

**Section 2: Organizational Control of Emergencies**

Dresden's Emergency Response Organization (ERO) and its key positions are described in the Exelon Nuclear Standardized Radiological Emergency Plan (EP-AA-1000).

Exelon Nuclear has contractual agreements with several companies whose services would be available in the event of a radiological emergency. These agencies and their available services are listed in Appendix 3 of the Emergency Plan.

Site specific Agreements also exist on file at Dresden Station with several support agencies. These agencies and their support roles are listed in Appendix 2, Station Letters of Agreement.