



TENNESSEE VALLEY AUTHORITY  
Division of Nuclear Engineering



CIVIL ENGINEERING BRANCH INSTRUCTION

CEB-CI 21.100

TITLE: BFN CLASS I HVAC DUCT AND DUCT SUPPORT SEISMIC QUALIFICATION  
INTERIM OPERABILITY ACCEPTANCE CRITERIA

	REVISION NO	R1	R2	R3	R4	R5
ISSUE DATE	Feb. 25, 1988	3/31/88				
PREPARED	F. F. K. Lee	<i>[Signature]</i>				
REVIEWED	A. W. Chan	<i>[Signature]</i>				
APPROVED	D. R. Denton	<i>[Signature]</i>				

cc: RIMS, SL28 C-K

8805120068 880504  
PDR ADDCK 05000259  
P PDR

**TVA**

BFN CLASS I HVAC DUCT AND DUCT SUPPORT SEISMIC  
Title: QUALIFICATION OPERABILITY ACCEPTANCE CRITERIA

**REVISION LOG**

CEB-CI 21.100

Revision No.	DESCRIPTION OF REVISION	Date Approved
1	Revised allowable stress limits for bolting material to reflect US-NRC comments in a meeting on March 17, 1988 in Rockville, Maryland.	3/31/88

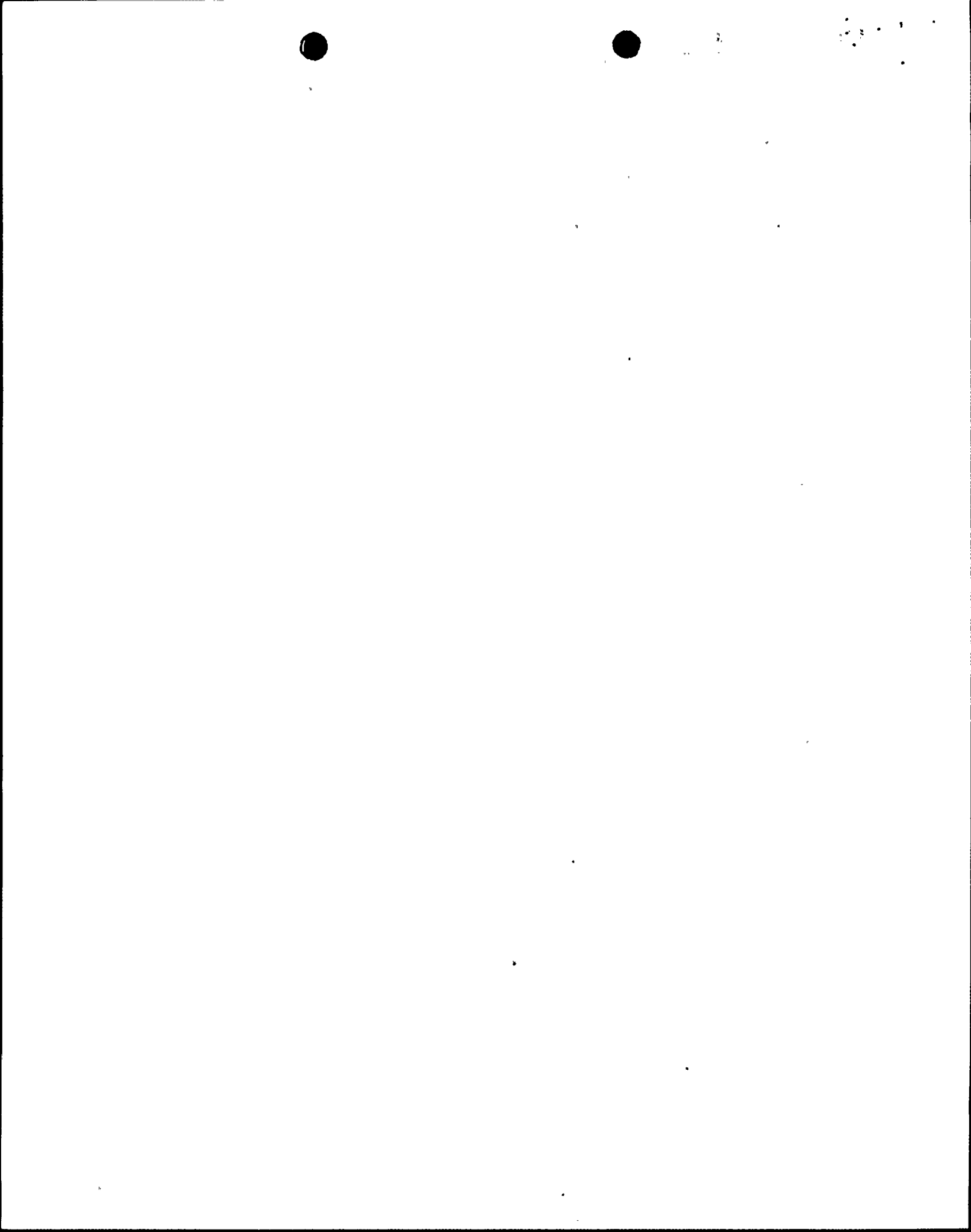

TABLE OF CONTENTS

	<u>Page</u>
1.0 PURPOSE.....	1
2.0 SCOPE.....	1
3.0 POLICY.....	1
4.0 INTERIM ACCEPTANCE CRITERIA.....	1
5.0 EXCEPTIONS.....	2
6.0 DOCUMENTATION.....	2
7.0 REFERENCES.....	2

## 1.0 PURPOSE

The purpose of this criteria is to provide a basis for interim acceptance of existing Class I HVAC ducts and duct supports which do not meet long-term design basis requirements. Ductwork and supports meeting requirements of this criteria shall be considered suitable for interim plant operation until physical modifications can be made.

## 2.0 SCOPE

This criteria applies to all existing BFN Class I HVAC ducts and duct supports which will require physical modification to meet the long-term design basis requirements given by Design Criteria BFN-50-C-7104, Attachment B.

## 3.0 POLICY

In general, Class I HVAC ductwork and duct supports shall be evaluated to requirements of Section 4.0 herein for interim acceptance. Specific exceptions may be approved on a case-by-case basis if thoroughly justified and documented by issued supporting calculations in accordance with NEP-3.1. Approved exceptions shall be recorded in Section 5.0 of this document. Each exception shall be assigned a subsection number (e.g., 5.1, 5.2, etc.) along with a brief descriptive title for the specific case to which it applies. Following this shall be a brief explanation of the rationale for allowing the exception, a statement of the specific requirements that vary from Section 4.0, and a reference to supporting calculations for the varied requirements. Issuance of exceptions shall be by revisions or CEB Interim Orders to this instruction in accordance with Civil Engineering Branch Instruction 21-CI 21.02.

Class I ductwork and duct supports which meet the interim acceptance criteria (including approved exceptions) shall be acceptable for interim plant operation; however, modifications to meet the long-term design basis requirements shall be scheduled and made as expeditiously as possible. Class I ductwork and duct supports failing to meet the interim acceptance requirements herein (including approved exceptions) shall not be allowed for plant operation until modifications are made to meet the long-term design basis requirements.

## 4.0 INTERIM ACCEPTANCE CRITERIA

Requirements of this section and/or Section 5.0 shall be met as the basis for interim acceptance of existing Class I HVAC ducts and duct supports. Figure 1 provides a logic diagram for applying this criteria.

### 4.1 DESIGN LOADS

Design loads shall be determined in accordance with requirements of Design Criteria BFN-50-C-7104, Attachment B; however, allowable stresses shall be as given below in subsection 4.2.

## 4.2 ALLOWABLE STRESSES

### 4.2.1 Ductwork

The maximum allowable stress in a duct section for load combinations involving the DBE seismic event shall be as follows (Reference 7.1):

- o Rectangular duct section stress  $\leq$  12,000 psi.
- o Circular duct section stress  $\leq$  15,000 psi

### 4.2.2 Support Members and Connections

The support member stresses shall not exceed the lesser of 1.2  $F_y$  or 0.7  $F_u$  for tensile and flexural stresses and 90 percent of the critical buckling stress as defined in AISC Specifications (Reference 7.2) for axial compression and compression in a flange due to bending. Shear stresses shall not exceed 60 percent of the allowable stresses for tension and flexure.

The allowable stress for bolting shall be the minimum specified yield stress of the bolt material. When the yield stress of the bolt material is not specified, the allowable stress shall be 70 percent of the minimum specified ultimate strength.

### 4.2.3 Concrete Expansion Anchors

Concrete expansion anchors shall be evaluated in accordance with section 10.2.1 of Civil Design Standard DS-C1.7.1 where the minimum factor of safety shall be 2.0.

## 5.0 EXCEPTIONS

No exceptions to the requirements of Section 4.0 have been taken as of the RO issue date.

## 6.0 DOCUMENTATION

Engineering evaluations performed to determine acceptability for interim operation shall be documented by calculations in accordance NEP-3.1. Modifications which may be postponed to after restart shall be tracked by marking "Post-Restart Modification Required" on the calculation cover sheet and on the calculation log.

## 7.0 REFERENCES

- 7.1 SWEC calculation No. CD-Q0000-871818, backup calculation for BFN-50-C-7104, RIMS No.
- 7.2 AISC, Manual of Steel construction, 8th Edition

LOGIC - HVAC PROGRAM

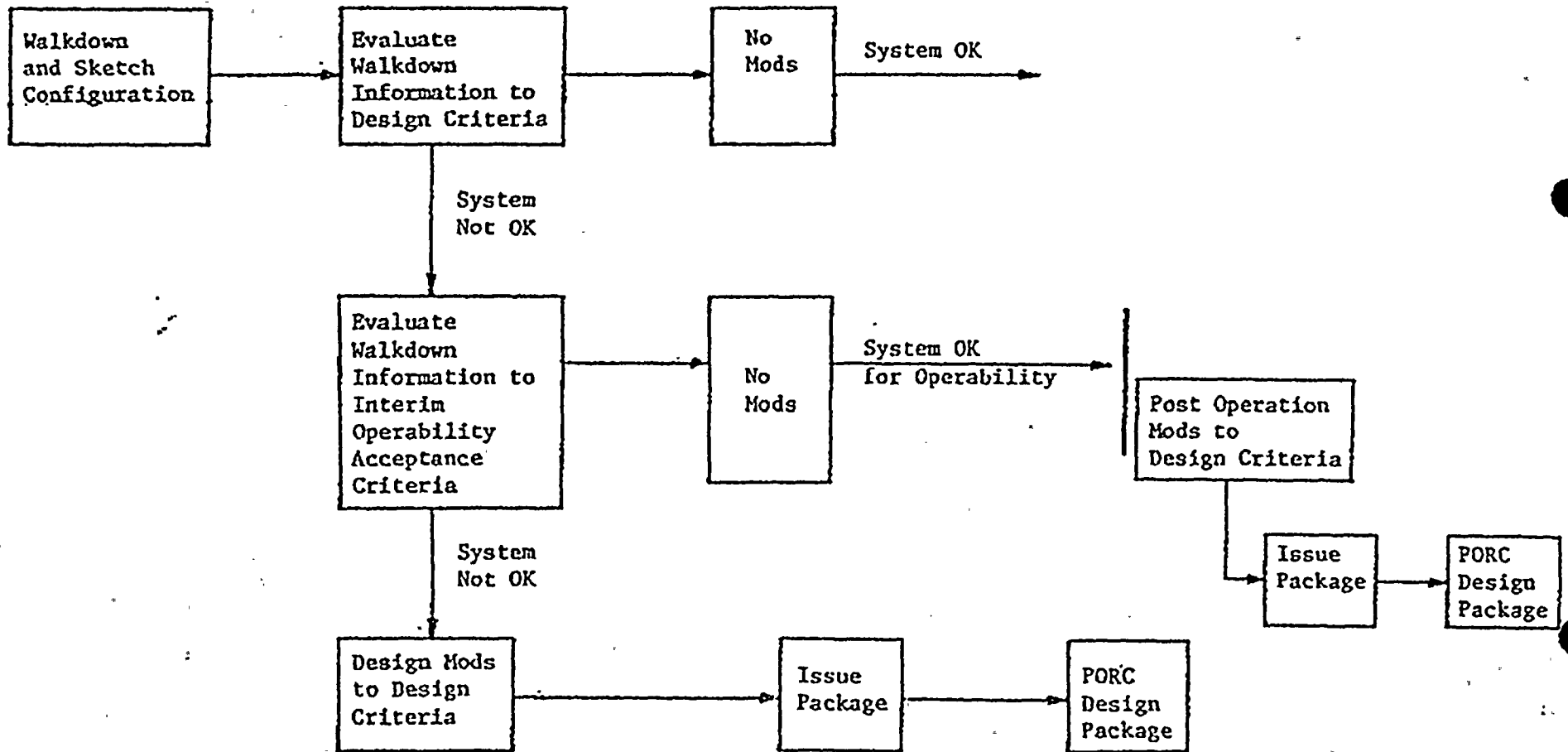

FIGURE 1



10

10

10

10