

REGULATORY INFORMATION DISTRIBUTION SYSTEM (RIDS)

ACCESSION NBR:7910170119 DOC.DATE: 79/10/12 NOTARIZED: NO DOCKET #  
 FACIL:50-387 Susquehanna Steam Electric Station, Unit 1, Pennsylva 05000387  
 50-388 Susquehanna Steam Electric Station, Unit 2, Pennsylva 05000388  
 AUTH.NAME: CURTIS, N.W. AUTHOR AFFILIATION: Pennsylvania Power & Light Co.  
 RECIP.NAME: SELLS, D.E. RECIPIENT AFFILIATION: Assistant Director for Environmental Projects

SUBJECT: Forwards addl info for environ review of Pond Hill low flow augmentation reservoir, in response to 790928 request. Eight oversized drawings encl. Also forwards "Monitoring Study of Community Impact" & update.

DISTRIBUTION CODE: C002B COPIES RECEIVED: LTR 1 ENCL 6 SIZE: 81+133  
 TITLE: Environ. Comments.

NOTES: SEND I & F 3 CYS FSAR x ALL AMDTs AICM EVERYTHING (ORNL) <sup>L.A.</sup>

ACTION:	RECIPIENT	COPIES		RECIPIENT	COPIES	
	ID CODE/NAME	LTR	ENCL		ID CODE/NAME	LTR
	05 PM P. LEECH	1	1	17 BC EPB #2	1	1
	18 LA EPB #2	1	1	AD MOORE	1	0
INTERNAL:	01 REG FILE	1	1	02 NRC PDR	1	1
	07 I&E	2	2	09 ENVN SPEC BR	1	1
	10 CST BNFT ANL	1	1	11 TA/EDO	1	1
	12 AD SITE TECH	2	2	14 ACIDENT ANALY	1	1
	15 EFLT TRT SYS	1	1	16 RAD ASMT BR	1	1
	19 DIR DSE	1	1	AD ENVIRON TECH	1	0
	AD SITE ANALY	1	0	OELD	1	0
EXTERNAL:	03 LPDR	1	1	04 NSIC	1	1
	20 NATL LAB ANL	5	5	ACRS	1	0

ENCL TO: FILES  
 NRC PDR  
 LPDR  
 TERA  
 ENV. P.M. (2)

LTR  
 LWR  
 LWR #3 BC  
 MINER  
 LWR #3 LA

ALL OTHERS RECEIVE LTR ONLY

OCT 17 1979

ENVIRD  
 1



TWO NORTH NINTH STREET, ALLENTOWN, PA. 18101 PHONE: (215) 821-5151

October 12, 1979

NORMAN W. CURTIS  
Vice President-Engineering & Construction  
821-5381

Donald E. Sells, Acting Branch Chief  
Environmental Projects Branch  
U.S. Nuclear Regulatory Commission  
Division of Site Safety & Environmental  
Washington, D.C. 20555

SUSQUEHANNA STEAM ELECTRIC STATION  
POND HILL RESERVOIR INFORMATION  
ER 100450 PLA-411 FILE 841-2, 991-2

DOCKET NOS. 50-387  
AND 50-388

Dear Mr. Sells:

The information requested in your letter of September 28, 1979, is contained on attachment 1. We hope these responses adequately address your concerns.

The Pond Hill Environmental Report is based on a "feasibility" design study. We are presently conducting detailed subsurface explorations and we are also beginning to do some preliminary detailed design engineering work. As a result of this work, some changes may be made in the "feasibility" design. If changes do occur which affect the environmental impact, we will promptly advise you.

We believe that your intention to conduct the Pond Hill review using the higher pool evaluation is appropriate. As you know, the size of the Pond Hill Reservoir depends on the outcome of Susquehanna River Basin Commission deliberations regarding financial support of the project. Reviewing the larger reservoir, however, should envelop the environmental impact of Pond Hill if SRBC ultimately approves the smaller size.

Other potential alternatives that have been considered or that may develop are described in the Pond Hill Environmental Report (Susquehanna SES Environmental Report, Appendix H).

If you have additional questions, please contact William Barberich (215-821-5833).

Very truly yours,

N. W. Curtis  
Project Director

/jm

cc-Mr. Robert J. Bielo  
Susquehanna River Basin Commission

Attach.

7910170119

*C002  
ES  
1/6  
EXC TO:  
FILES  
NRB POR  
LPOR  
TERA  
Ew. P.M. (2)  
ALL OTHERS  
RECEIVE  
ONLY*

**RETURN TO REACTOR DOCKET  
FILES**

SUSQUEHANNA STEAM ELECTRIC STATION  
COMMUNITY IMPACT MONITORING STUDY: AN UPDATE

Docket #	SD-387/388
Control #	791070119
Date	10/12/79 of Document
REGULATORY DOCKET FILE	

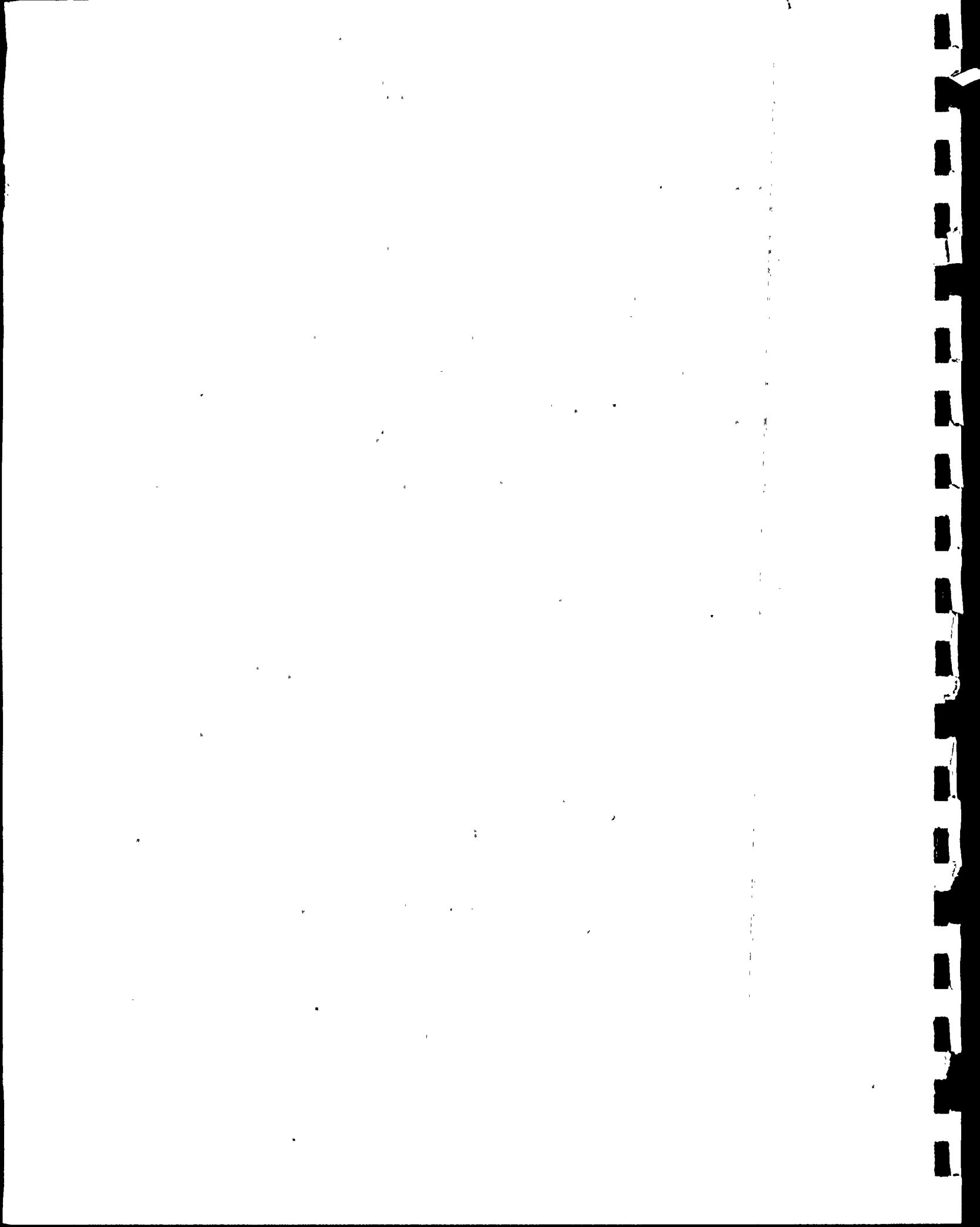
COMMUNITY SERVICES DEPARTMENT  
PENNSYLVANIA POWER & LIGHT COMPANY  
TWO NORTH NINTH STREET  
ALLENTOWN, PENNSYLVANIA 18101  
DECEMBER, 1978

TELEPHONE SERVICE OF THE  
FEDERAL BUREAU OF INVESTIGATION

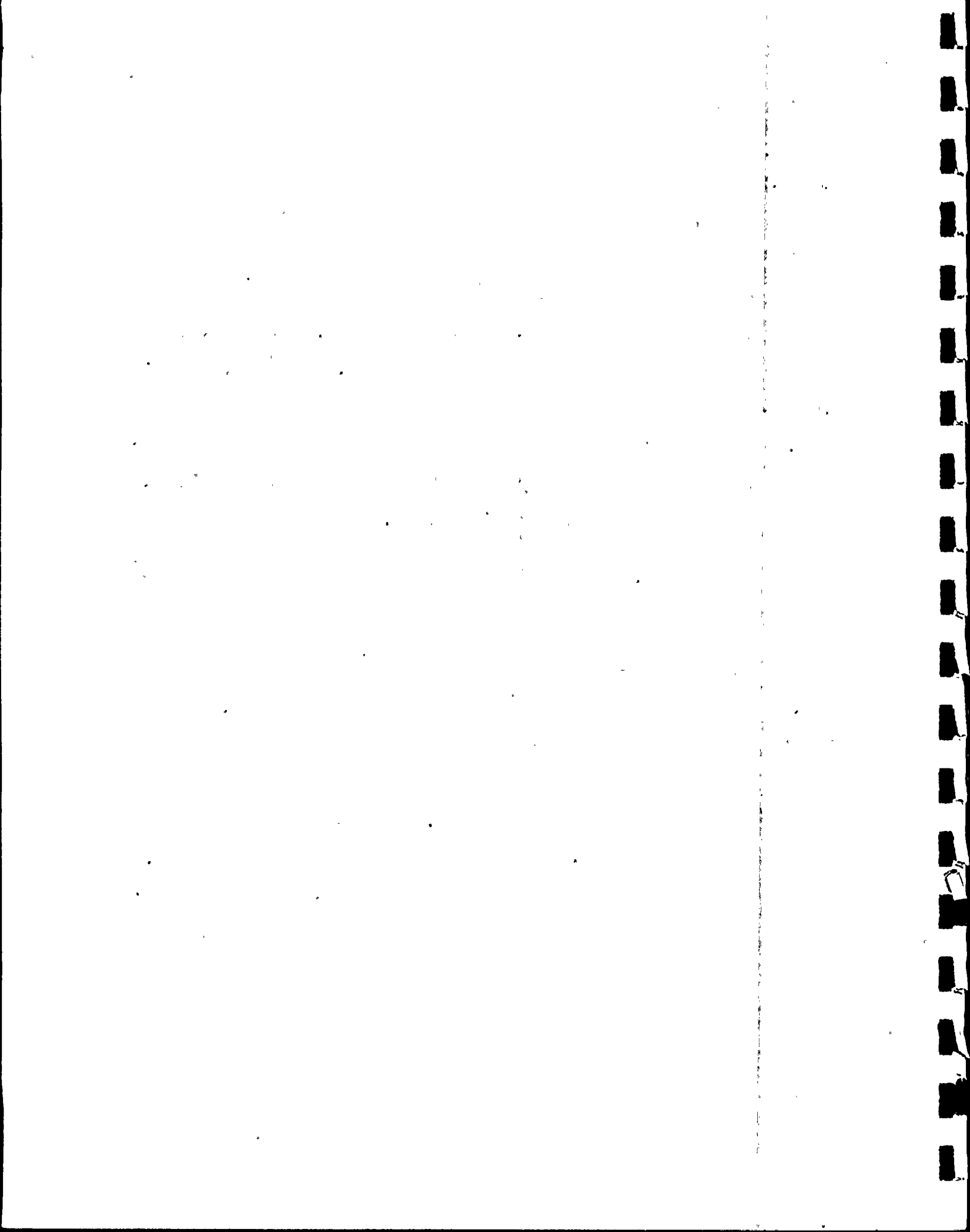


TABLE OF CONTENTS

	<u>Page</u>
CHAPTER I - SUMMARY AND CONCLUSIONS	1
A. Introduction . . . . .	1
B. Findings and Conclusions . . . . .	3
1. General . . . . .	3
2. Housing . . . . .	3
3. Employment . . . . .	3
4. Local Economy . . . . .	4
5. Community Infrastructure . . . . .	4
6. Inflationary Impact . . . . .	5
7. Public Attitudes . . . . .	5
C. Recommendations . . . . .	6
CHAPTER II - SURVEY OF NON-MANUAL EMPLOYEES	8
A. Summary of Survey Results . . . . .	8
B. Area of Residence . . . . .	10
C. Type and Tenure of Residence . . . . .	12
D. Family Size . . . . .	13
E. Age of Employees . . . . .	14
F. Number of Children by Grade Level and School District . . . . .	15
G. Shopping Patterns . . . . .	19
H. Recreational Activities . . . . .	19
I. Hospital Use and Purpose . . . . .	20
J. Attitude Towards Area of Residence . . . . .	21
K. PP&L Survey Responses . . . . .	23
CHAPTER III - BACKGROUND INFORMATION: POPULATION, EMPLOYMENT AND MANPOWER	26
A. Population . . . . .	26
B. Work Force Characteristics . . . . .	28
C. Manpower Needs at the Project Site . . . . .	30
1. Manual Work Force . . . . .	30
D. Non-Manual Employees . . . . .	31



	<u>Page</u>
E. PP&L Work Force . . . . .	36
<u>S O U R C E S</u> . . . . .	37
<b>CHAPTER IV - LOCAL VIEWS ON COMMUNITY IMPACTS</b>	
A. Housing . . . . .	38
B. Local Economy/Employment . . . . .	39
C. Educational Facilities . . . . .	41
D. General Community Impacts . . . . .	42
<u>S O U R C E S</u> . . . . .	44
<b>CHAPTER V - LOCAL ECONOMIC IMPACTS</b>	
A. Wage Distribution . . . . .	46
B. Purchase of Goods and Services . . . . .	47
C. Local Taxes . . . . .	48
1. Real Estate Tax Rates . . . . .	48
2. Tax Impacts: Salem Township . . . . .	48
D. Local Economic Impacts . . . . .	51
1. Housing Costs . . . . .	51
2. Food Costs . . . . .	53
<u>S O U R C E S</u> . . . . .	55
<b>CHAPTER VI - COMMUNITY FACILITIES</b>	
A. School Enrollment . . . . .	56
B. Hospital Facilities . . . . .	57
C. Water Supply (Make-up) . . . . .	59
D. Public Safety . . . . .	59
1. Police Force . . . . .	59
2. Emergency Services . . . . .	61
<u>S O U R C E S</u> . . . . .	62





## CHAPTER I

### SUMMARY AND CONCLUSIONS

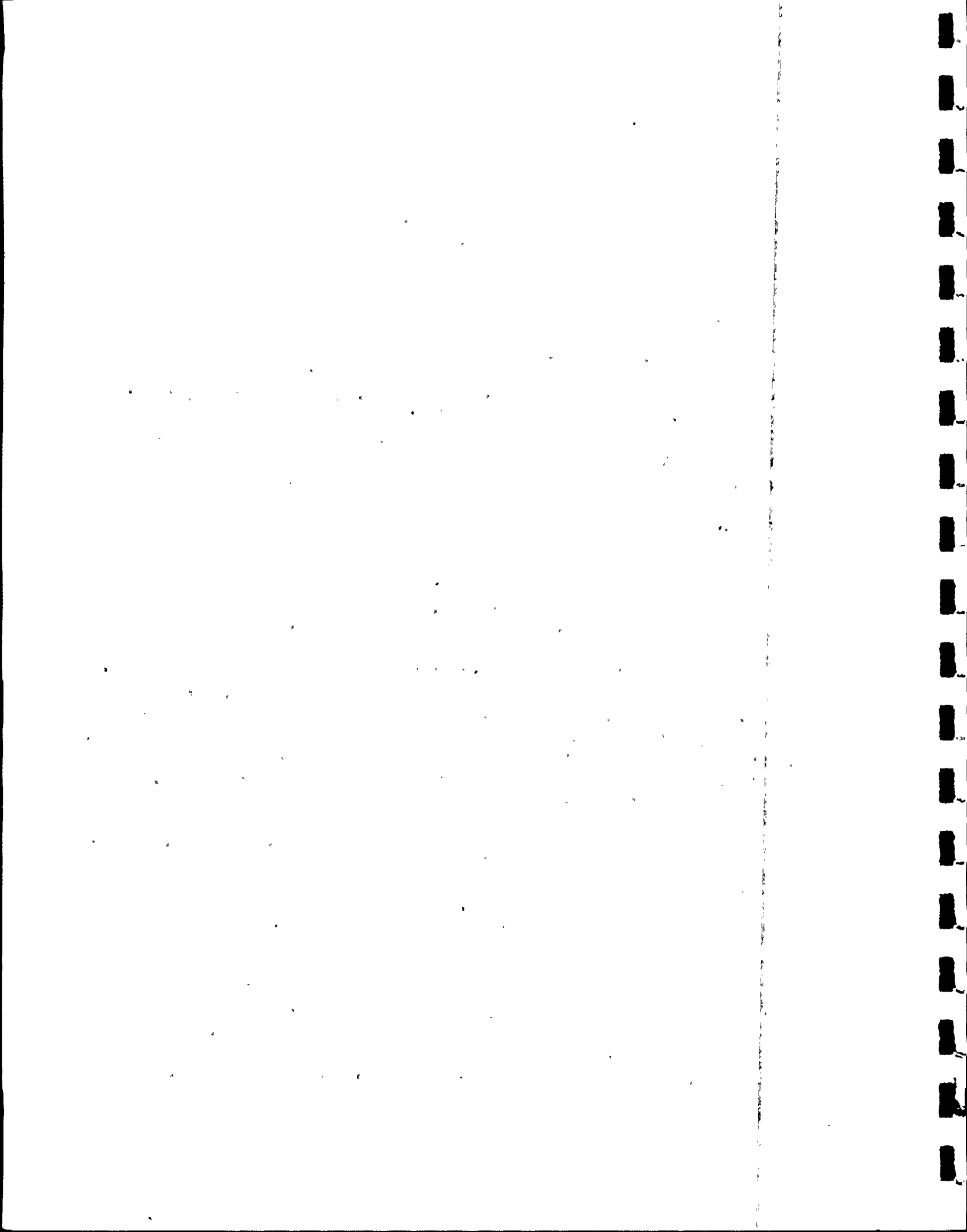
#### A. Introduction

In 1976, Pennsylvania Power & Light Company's (PP&L) Community Services Department published a report on a monitoring program of community impacts associated with the construction of PP&L's Susquehanna Steam Electric Station (SSES), a nuclear generating station under construction near Berwick, Pennsylvania (See Figure I-1). The purpose of the first study, conducted largely in 1975, was to establish a procedure to collect information during construction and operating phases of the SSES in order to assess short- and long-term social costs and benefits.

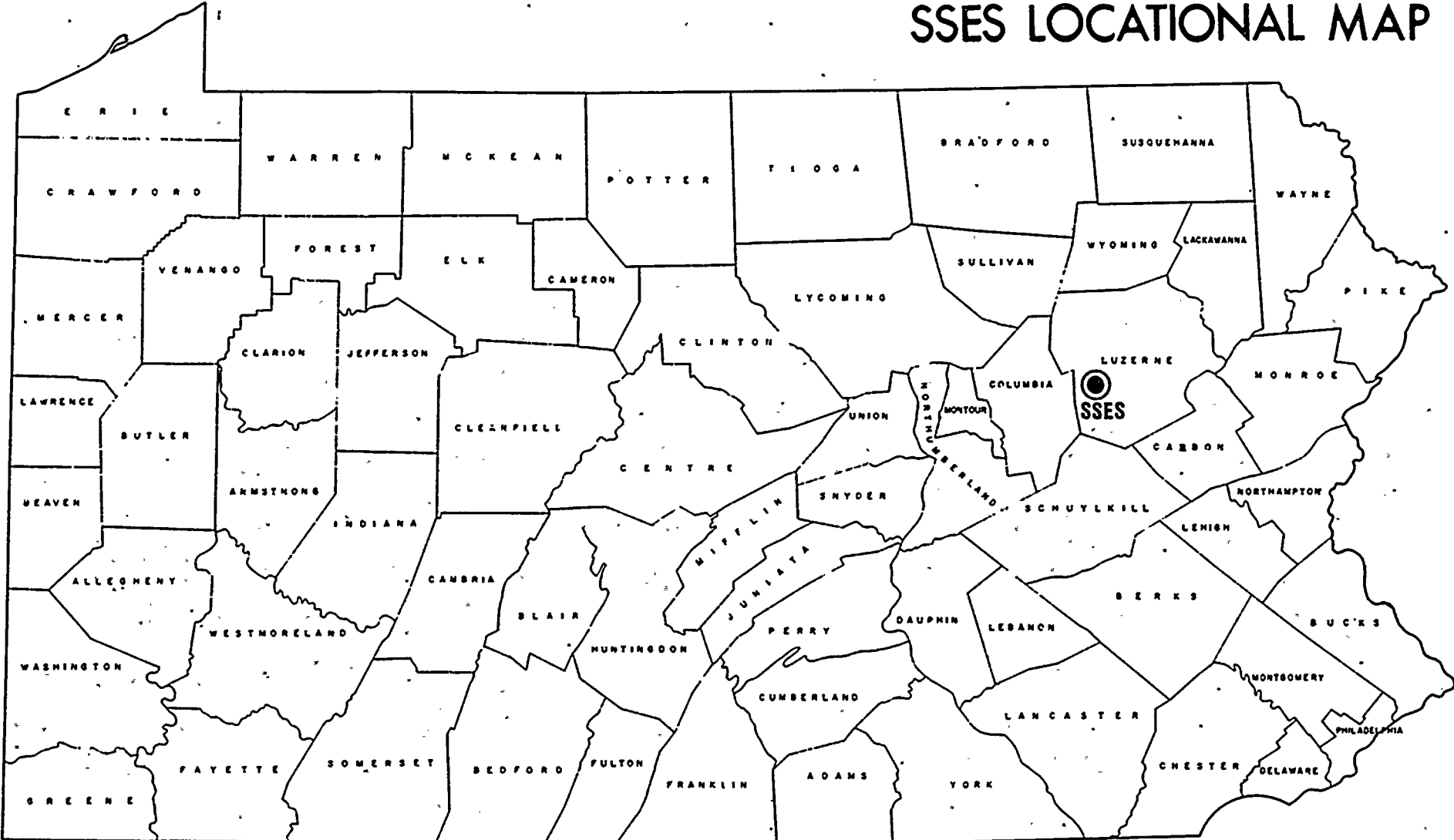
The major findings and conclusions of that study addressed several areas. Complaints from adjacent neighbors regarding construction nuisances and physical damage to structures resulting from construction blasting led to recommendations on improvements for site preparation and construction activities. Related to this concern was a recommendation to establish a project advisory committee on subsequent construction projects. Preconstruction inventories were recommended to establish information on housing stock and land costs. A stronger program for promoting employment opportunities for local residents was also recommended.

A commitment was also made in the 1976 study to continue monitoring efforts during SSES construction and operation phases. That commitment resulted in the publication of this document. Its purpose is to review construction impacts on local communities since the 1976 study as well as to examine the status of recommendations made in that first study.

The study techniques in this update were the same as those used for the 1976 study. The methods consisted primarily of a questionnaire survey of non-manual employees of Bechtel Power Corporation and PP&L and a series of interviews with local and regional officials, businessmen and community leaders. Because the SSES is five years into construction, the



# SSES LOCATIONAL MAP



DECEMBER 1978

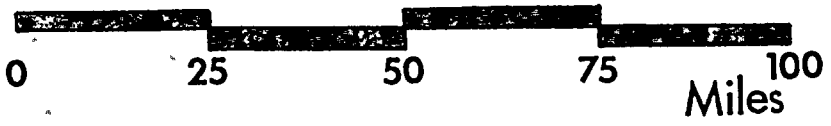
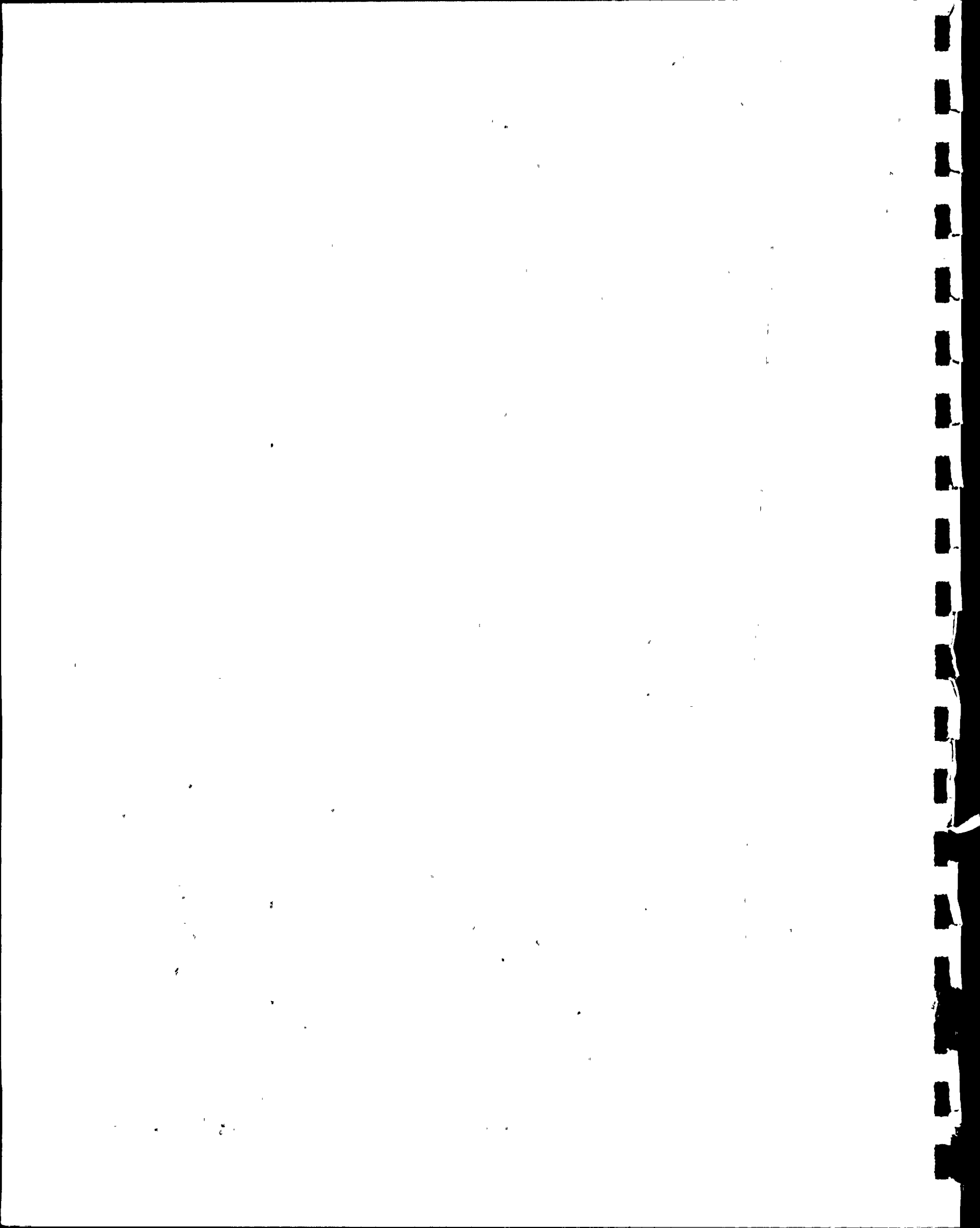


FIG. I-1



study's principal thrust is qualitative rather than quantitative. Most of the major socio-economic impacts related to construction have already occurred and there is little need to employ quantitative methods for predictive purposes. Consequently, the techniques employed herein are not necessarily intended to serve as models for all power facility projects.

## B. Findings and Conclusions

### 1. General

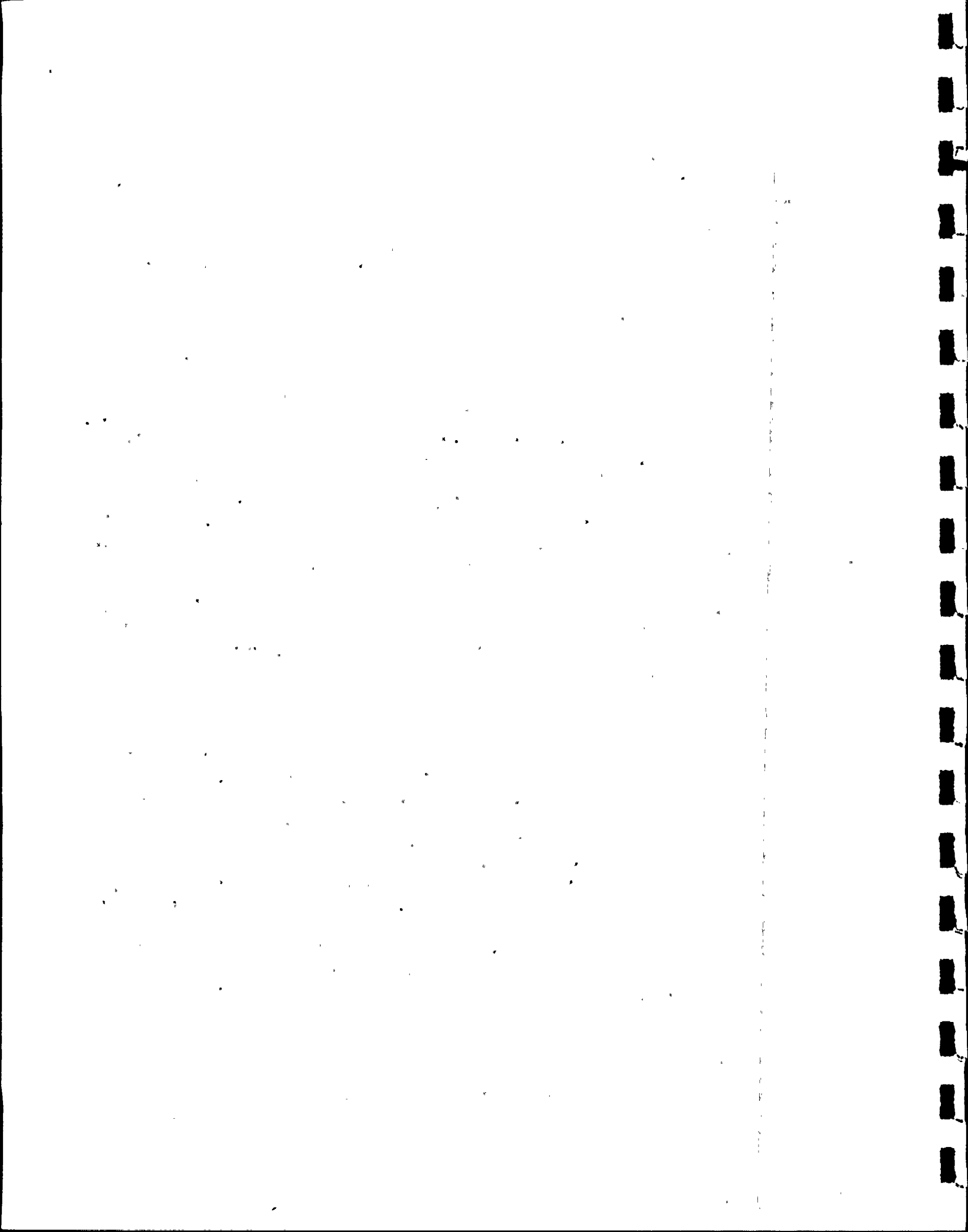
As indicated in the 1976 report, this update confirms that SSES construction avoided "boom town" syndromes experienced at other large construction projects in different parts of the country. No excessive or overwhelming demands were made on any community facilities or the community's capability to provide services, a conclusion shared by all local officials contacted in the course of the update. In large part the minimal impact on local communities was due to adequate supplies of workers from the regional labor market. Consequently, most workers commuted to the site daily. While those workers (primarily non-manual) who relocated to the project area initially created some pressure on the local housing market, early shortages have since been relieved through the local market.

### 2. Housing

As suggested above, housing availability or supply never materialized as a significant issue in the course of the update. Early in the construction period the local housing market was characterized by some scarcity. This was due largely as a result of the absence of a speculative market and the occurrence of a major natural disaster, Tropical Storm Agnes, which resulted in serious flooding in the Wilkes-Barre area, approximately twenty (20) miles northeast of the project site. Dislocated persons looking for housing subsequently spilled over into the Berwick-Bloomsburg area. Since that time the market has responded to this demand and housing is generally available, usually on a contract basis.

### 3. Employment

The availability of a large labor supply within commuting



distance proved to be both a boon and a loss with respect to local communities in Columbia County. On the one hand, communities such as Bloomsburg and Berwick were spared the burden of trying to provide additional community services facilities for new worker populations. On the other hand, hopes for significant local employment were disappointed when the majority of workers were hired from the larger labor market beyond the local communities. Although employment data indicates little local employment for manual workers, hiring from the local labor force for non-manual positions has increased since 1976.

Although local officials registered strong disappointment over the minimal amount of local hiring during early construction phases, recent contacts indicate a greater acceptance of the situation and an understanding that hiring practices were largely a reflection of union jurisdictions.

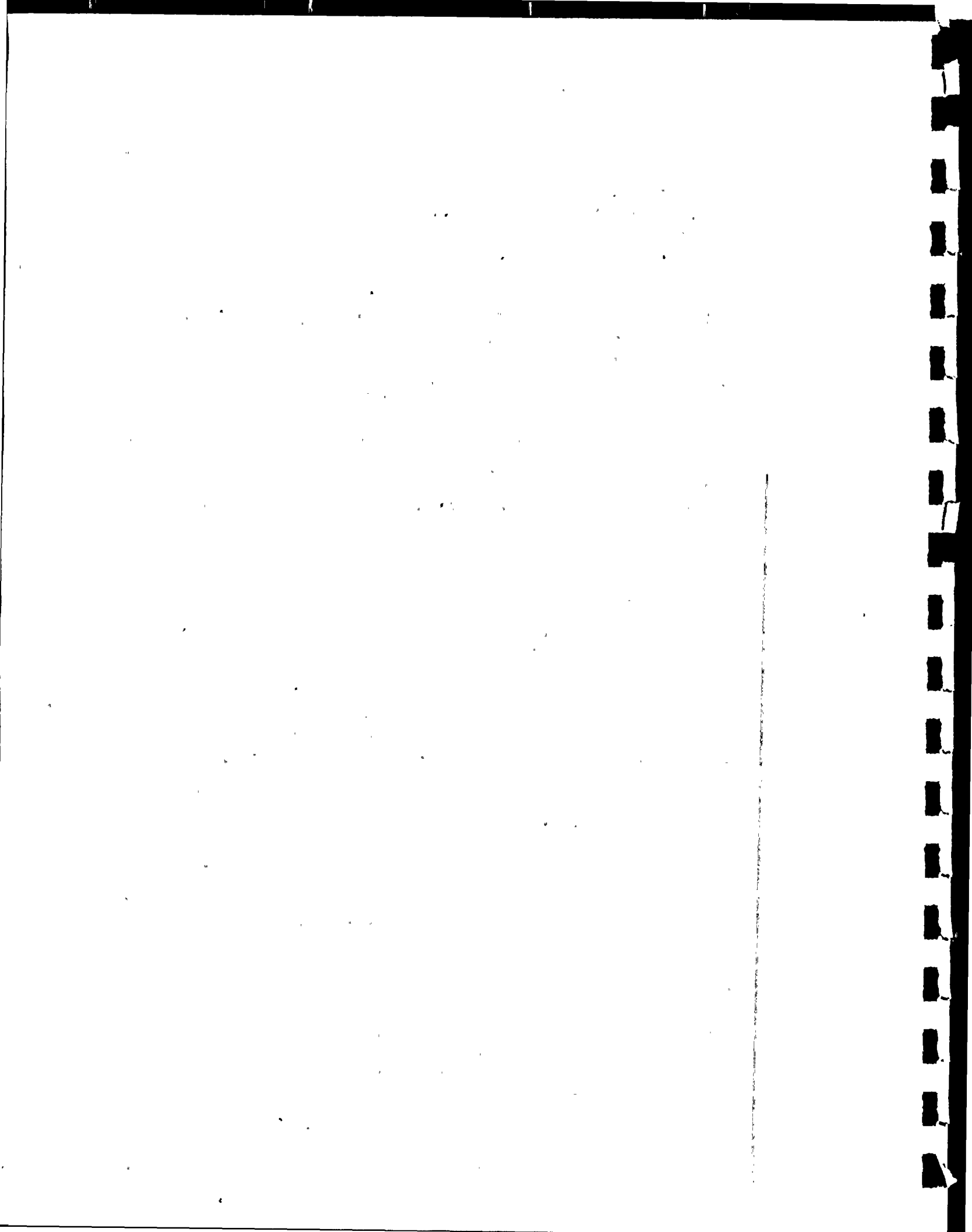
4. Local Economy

As with the employment picture, benefits to local economies are not in proportion to the size and cost of the SSES. A principal reason for minimal local economic benefits was the low levels of SSES employment in the immediate Bloomsburg-Berwick area. Additionally, contracts to vendors for specialized materials and/or services often went to non-local suppliers because such goods or services were not available at the local level.

Salem Township, the location of the plant site, will benefit from increases in local occupational and, to a lesser extent, local income tax revenues as a result of high numbers of construction personnel. Following plant construction, however, tax revenues associated with the plant are not likely to offset revenues forgone through the loss of tax rateables.

5. Community Infrastructure

With the exception of one instance where an additional policeman had to be provided for traffic control on a state highway, no unanticipated demands on schools, hospitals, emergency services or related community infrastructure systems have resulted from SSES construction. In several





cases additional or specialized facilities were required for emergency and health care services. In these cases, PP&L entered into agreements with a local hospital (Berwick) as well as local suppliers of ambulance and fire services to meet potential specialized demands caused by plant construction. PP&L also subsidized the cost of additional facilities and specialized training.

6. Inflationary Impact

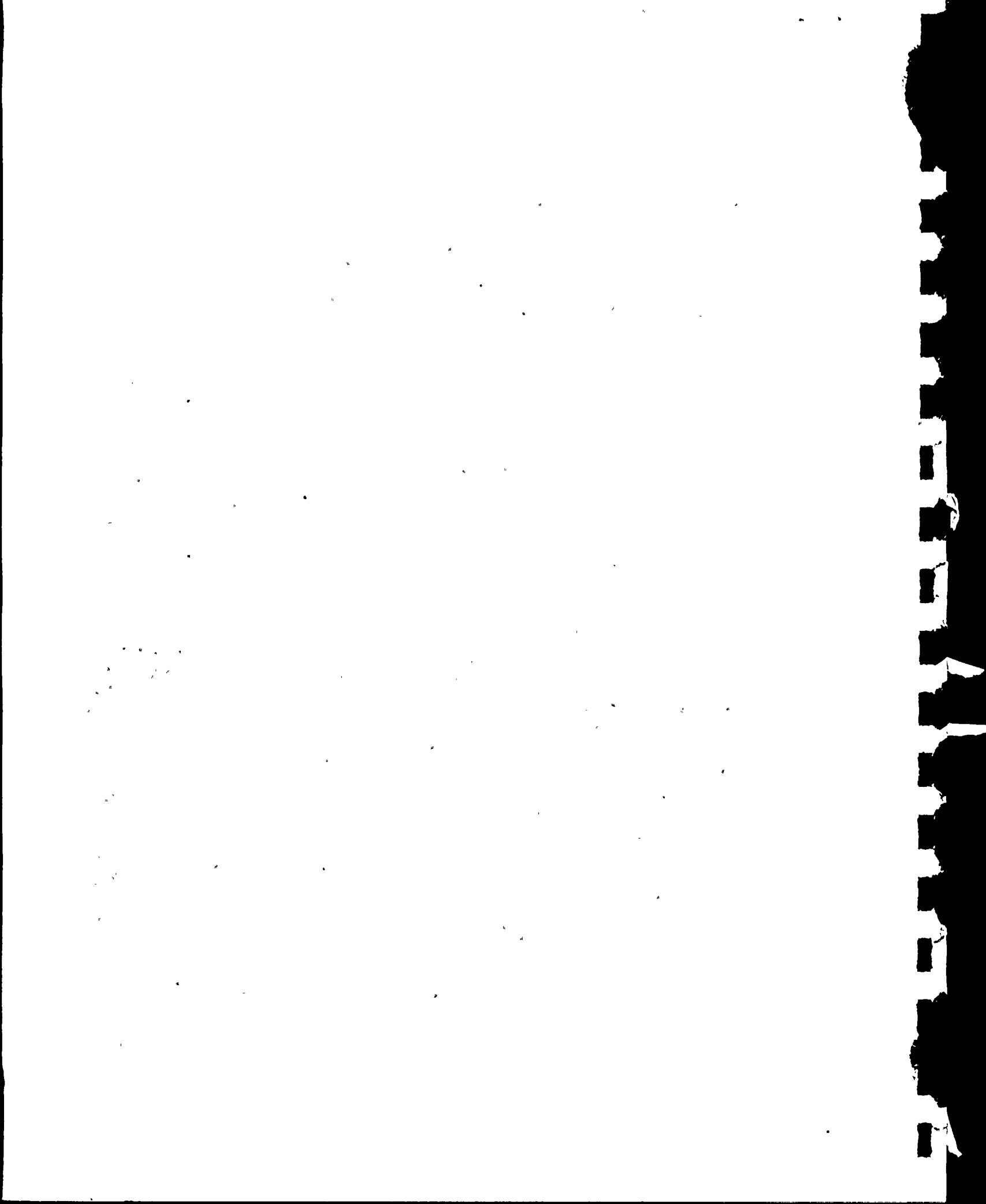
It is commonly held in the local communities near the plant site that construction activities have had substantial inflationary impacts on the local economy, particularly in the area of housing. Local businessmen and officials have been unable to provide specific instances or data to support this belief. Data assembled during the course of the update on housing and food costs suggest increases comparable to other areas of the state similar in the demographic and economic characteristics to the Bloomsburg-Berwick area.

7. Public Attitudes

Local officials are largely supportive of the construction phase of the plant as well as the subsequent operational phase. There also is agreement on the lack of impact which the plant has had on local communities. Such comments tend to be expressed in combined tones of disappointment and relief; relief that the construction phase has not placed severe demands on the community to provide support services and disappointment that the plant construction has not yielded greater economic benefits.

No community frictions have developed as a result of new people moving into the local community. While the number of new employees relocating to the local communities has been relatively small, there remained a potential for community friction arising from the newer or different values or attitudes brought into the community by new personnel. These problems never materialized to any significant extent.

A concern about recessionary impacts related to completion of SSES construction appears to be growing among certain



sectors of the business and labor communities in the region. A labor spokesman indicated that union enrollment is likely to shrink upon completion of the project. Furthermore, workers at the plant have become accustomed to long-term employment at higher wages which may not be available in the regional job market once the plant is completed.

Table I-1 summarizes by impact categories the types of mitigative measures proposed in the 1976 study and their current status.

C. Recommendations

Few new issues or problems requiring specific recommendations were raised as a result of this update of the 1976 Community Impact Monitoring Study. Consequently, the recommendations proposed in 1976 which dealt primarily with the physical impacts of construction on local communities remain critical to any future construction activities undertaken by PP&L.

Local concerns over possible "recessionary" impacts upon completion of construction activities should be addressed in a post-construction update examining housing surpluses, trends in construction employment and changes in local economic activities. Representatives of local labor unions should be advised of scheduling and extent of reductions in labor force.

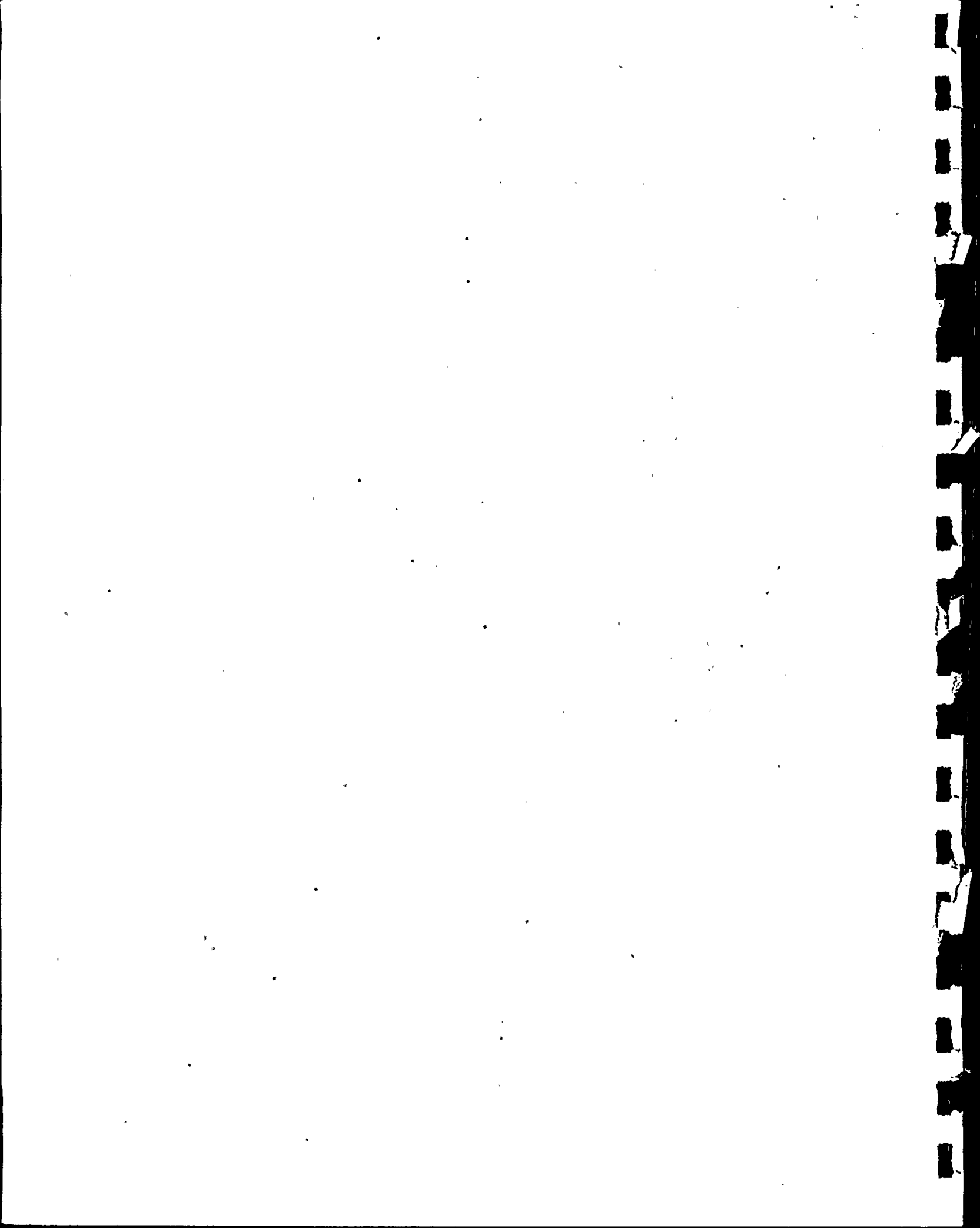
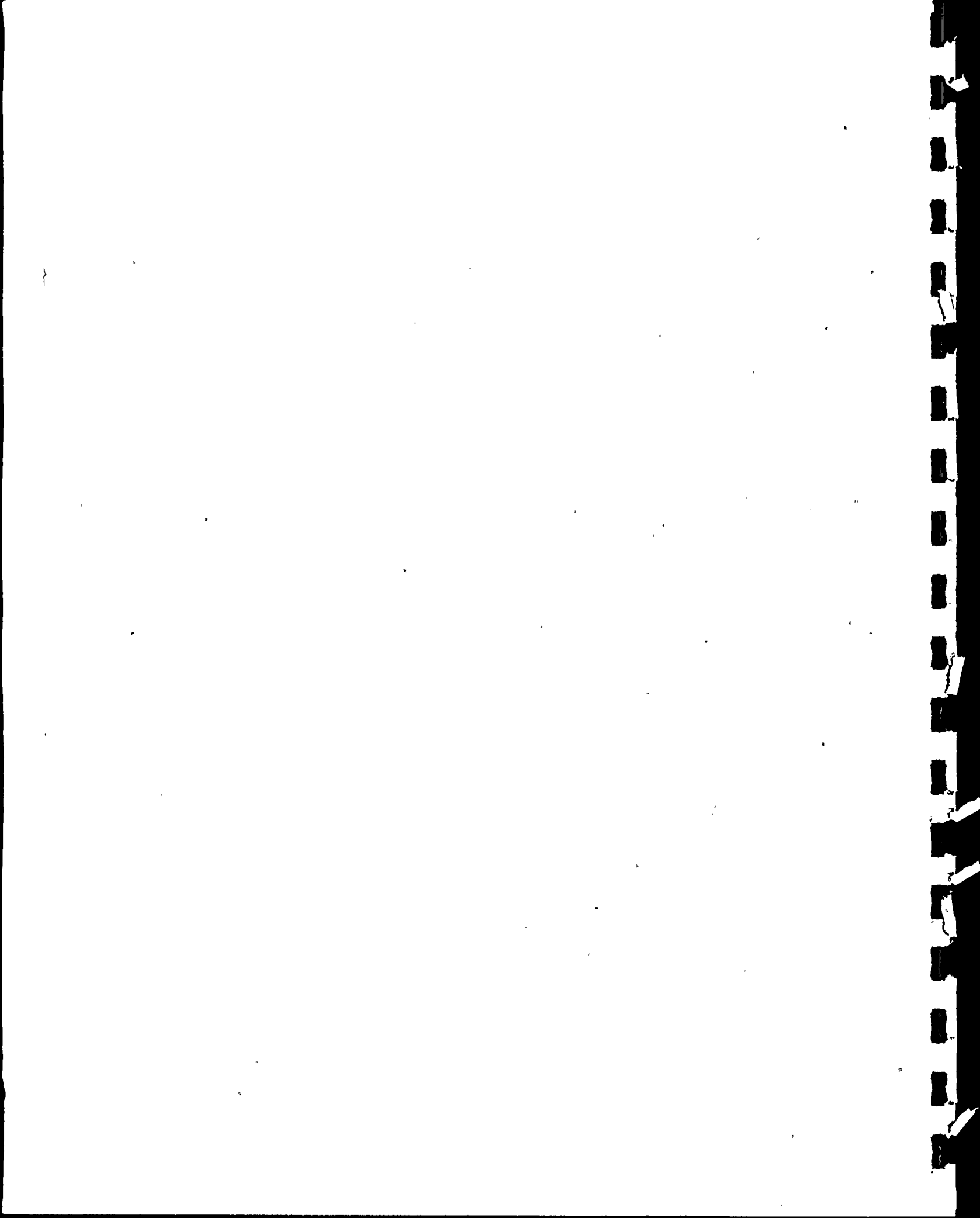


Table I-1

SUMMARY  
IMPACT CATEGORIES  
and  
STATUS OF MITIGATION STRATEGIES

<u>Impact Category</u>	<u>Proposal</u>	<u>Status</u>	<u>Comment</u>
1. Roads (traffic control)	Provide additional police personnel for local community (Shickshinny).	Adopted	Measure proposed by subcommittee of Project Advisory Committee; PP&L financial support provided.
2. Transportation	Form bus pools for commuting workers.	Adopted	Fourteen buses in operation as a result of "ad hoc" effort by manual work force.
3. Housing	Conduct housing inventory to assess needs of future plant sites.	No Action	Measure proposed in 1976 community impact report; would likely be adopted whenever future generating stations proposed.
4. Law Enforcement	-----	-----	None required, except as indicated in #1 above.
5. Health Care	Expand out-patient and emergency care facilities at local hospital.	Adopted	Both measures carried out; PP&L financial support provided.
	Provide facilities and staff training for treatment of radiation related injuries.	Adopted	
6. Make Up Water (low flow augmentation)	Construction of reservoir near plant site.	Adopted	Reservoir in planning and preliminary design stages
	Establish local mitigation/advisory committee.	Adopted	
7. Schools	-----	-----	None required; region experiencing declining enrollments
8. Employment	Develop stronger program for local hiring	No Action	Measure proposed in 1976 community impact report; likely to receive strong consideration if future generating stations proposed.
9. Construction Impacts	Establish project advisory committee.	Adopted	Ongoing effort.
	Implement policy to establish impact zones affected by construction activities (related to standing offer of purchase of homes within impact zone).	Under Evaluation	Proposed in 1976 study.
	Establish requirements for pre- and post-blasting inspections of structures in impact zone.	No Action	Proposed in 1976 study.
10. Emergency Services	Establish arrangements for local fire and ambulance companies to respond to emergencies during plant operation.	Adopted	Arrangements undertaken as part of overall Civil Defense planning effort. Staff training supported by PP&L.



CHAPTER II

SURVEY OF NON-MANUAL EMPLOYEES

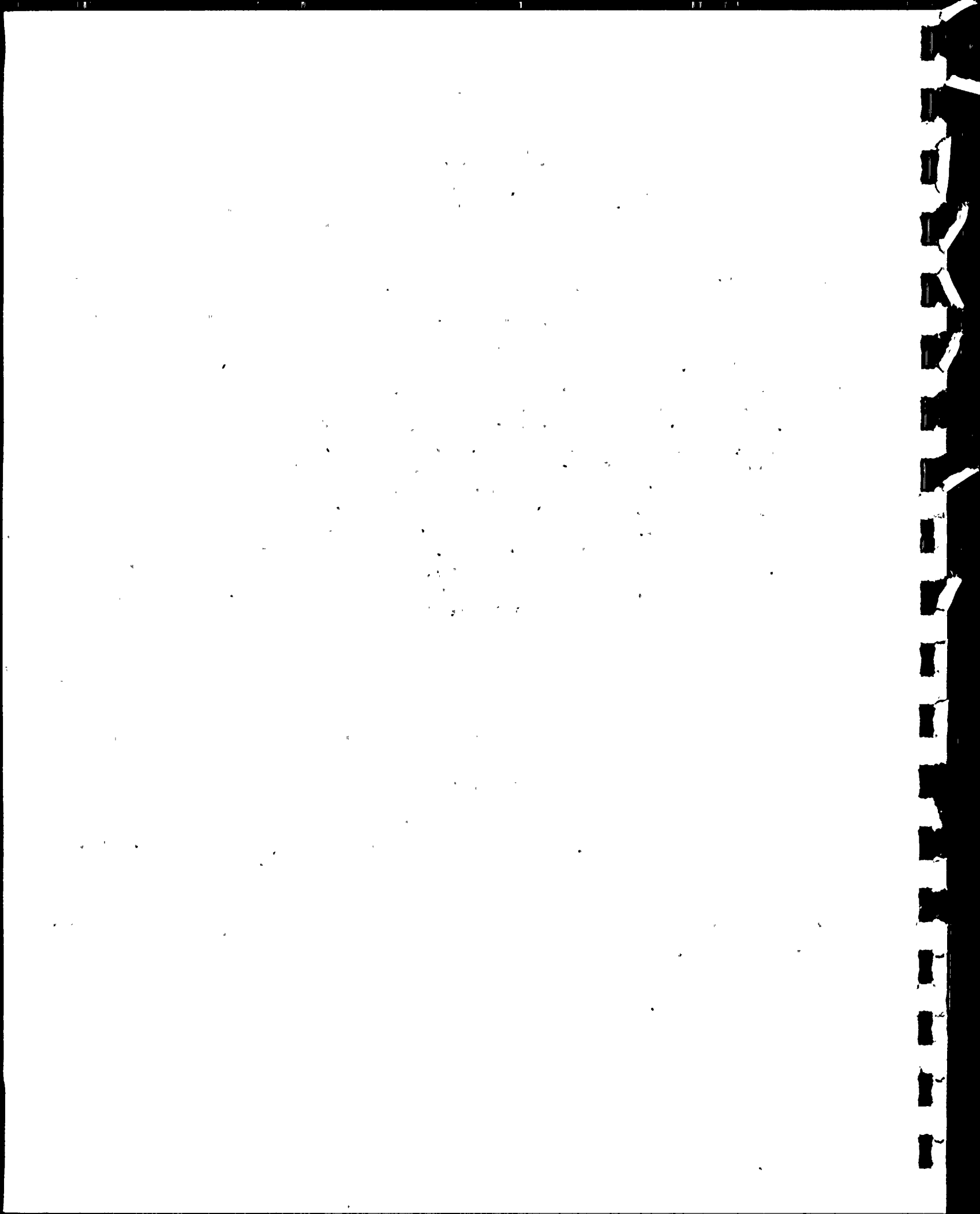
A. Summary of Survey Results

In June of 1978, a survey was distributed to Bechtel management employees at the SSES. The employment level among Bechtel non-manual employees at that time was approximately 591 (see Table II-1). A total of 469 completed surveys were returned, a response rate of over 79 percent. distinction was made between those Bechtel employees who are hired locally versus those respondents who were prior Bechtel employees transferred in from other job locations, i.e., non-local employees. The assumption is that non-local employees, as new residents to the area, constitute the major element of community change resulting in community impacts. Consequently, most of the data evaluated deals exclusively with non-local employees. Of the 469 completed surveys, 182 (39 percent) were classified as non-local employees. The remaining responses, 287 (61 percent) were considered local responses.

Table II-1

Bechtel Power Corporation Employees  
Susquehanna Steam Electric Station  
1975 and 1978

	<u>Total Bechtel</u>		<u>Permanent Employees</u>		<u>Local Hires</u>	
	<u>1975</u>	<u>1978</u>	<u>1975</u>	<u>1978</u>	<u>1975</u>	<u>1978</u>
Manager	62	83	62	80	0	3
Professional	204	306	156	146	48	160
Technical	58	102	10	2	48	100
Clerical	<u>78</u>	<u>100</u>	<u>23</u>	<u>3</u>	<u>55</u>	<u>97</u>
T O T A L	402	591	251	231	151	360





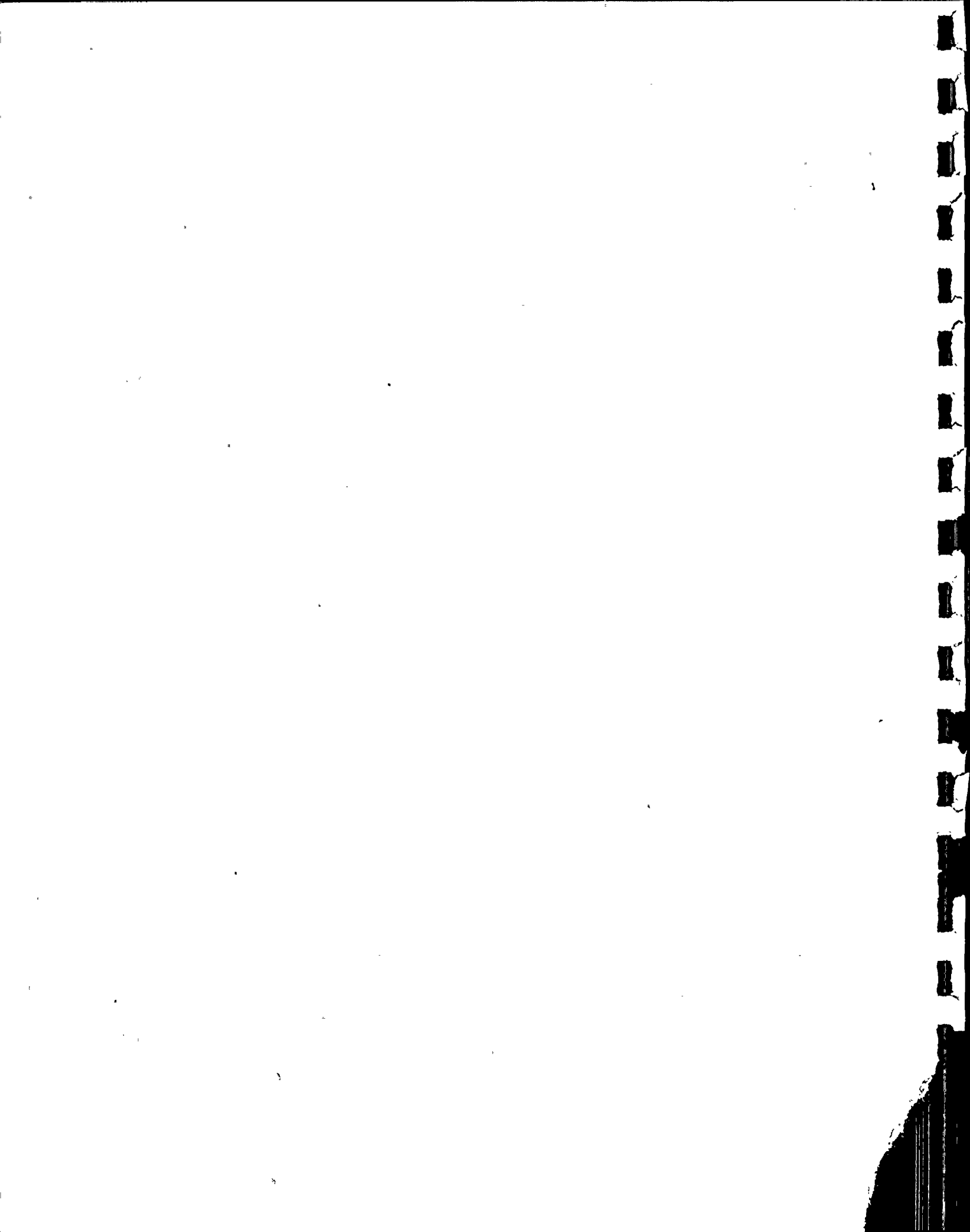
On a regional level, Berwick has declined in significance (in terms of residential location) relative to other locations in Columbia and Luzerne Counties. Most Bechtel employees, however, continue to live in the Berwick area, send their children to Berwick schools, and do most of their daily and major shopping in the Berwick area. In 1978, 40 percent (40%) of Bechtel employees lived in Berwick compared with 54 percent (54%) in 1975. Similarly, in 1978, 45 percent (45%) of the respondents resided in the Berwick Area School District, compared with 62 percent (62%) in 1975. In terms of shopping patterns, 39 percent (39%) of the respondents shop for their daily needs in Berwick compared with 54 percent (54%) in 1975. A similar drop was noted in the major needs category which indicated 28 percent (28%) of the respondents shopped in Berwick for major shopping needs compared with 35 percent (35%) in 1975.

Survey respondents continue to indicate a strong preference for single family detached homes over other types available in the study area. In 1978, 58 percent (58%) indicated a single family home as the type of residences they were currently living in compared with 50 percent (50%) in 1975. Although this trend of single family housing would suggest a high rate of ownership, the majority of respondents (53%) indicated that they rented.

Data on family size is largely inconclusive. Of 161 persons responding to a question on family size, only 14 percent (14%) indicated that there were five or more persons in their family (down from 20% in 1975), a reflection, perhaps, of the national trend towards smaller families.

Primary types of recreation engaged in included fishing, swimming, golf, tennis and hunting, all generally active types of recreation. Other popular activities included skiing, bowling, parks, camping, hiking and softball. Respondents seemed generally pleased with the availability of recreational resources within the study area.

When asked what aspects of the area were liked least and which were liked most, the best-liked aspects included the scenery, small town living, friendly people and availability of recreation. Least liked attributes included poor roads, poor traffic and parking conditions at the plant site, poor climate and high taxes.



B. Area of Residence

According to survey results, Berwick still ranks first concerning location preference for non-local employees. Table II-2 indicates 1978 distribution of residential choices compared with 1975.

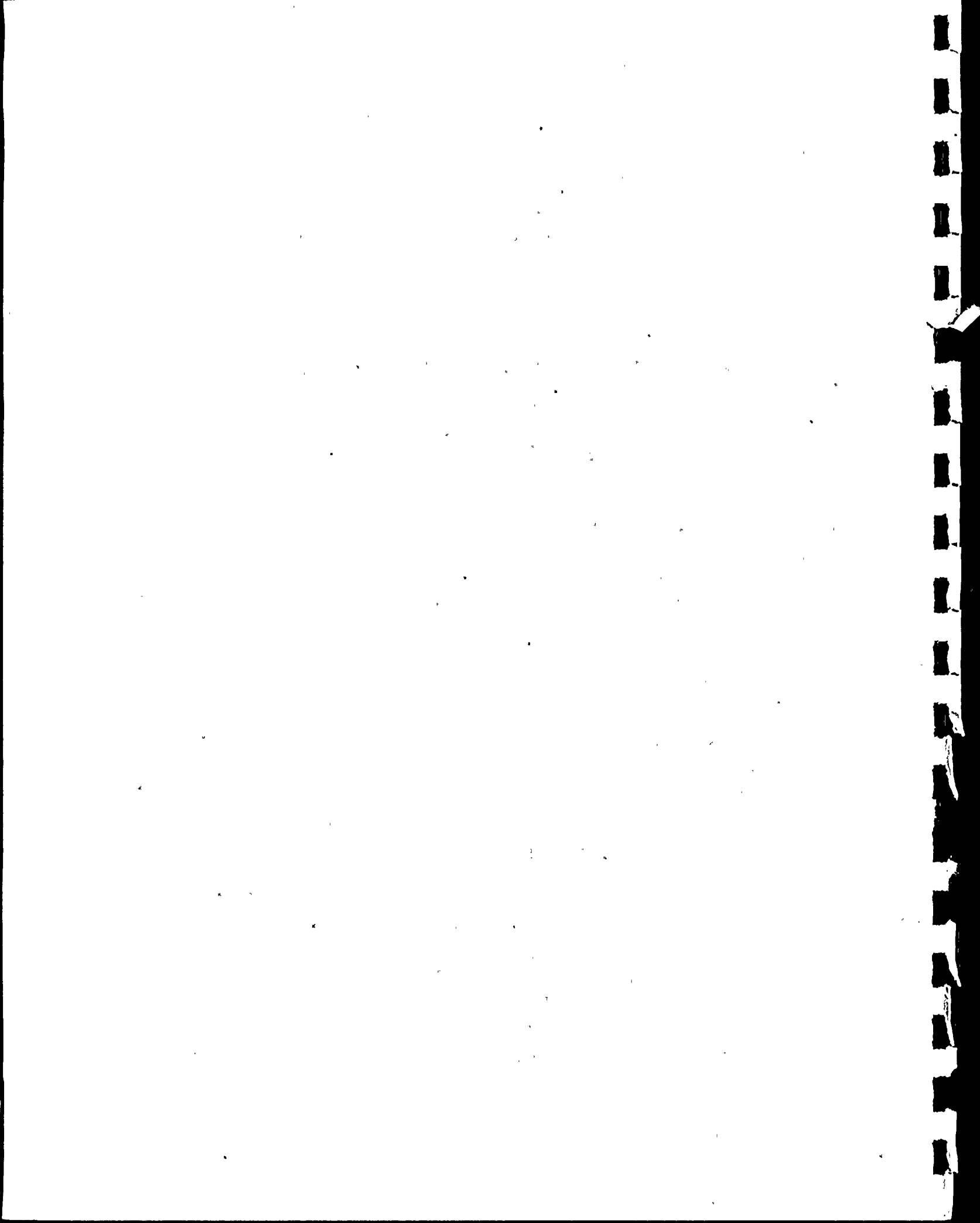
Table II-2

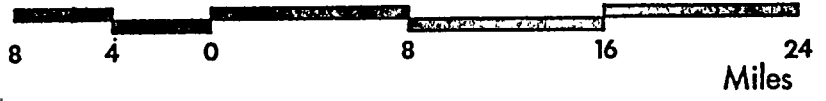
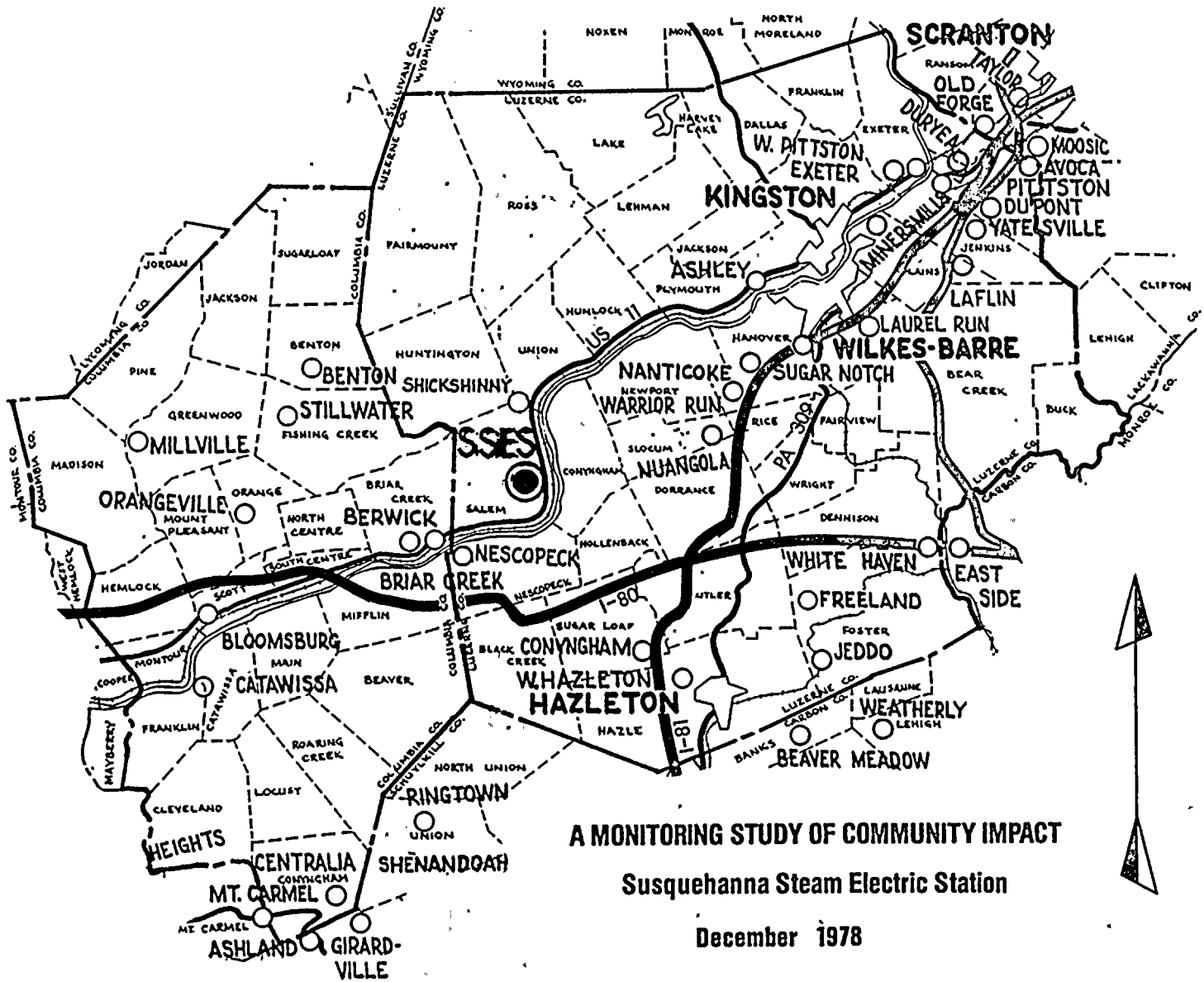
Bechtel Power Corporation Employees (Non-local): Area of Residence

	<u>No. of Families</u> <u>1975</u>		<u>No. of Families</u> <u>1978</u>	
	<u>No.</u>	<u>%</u>	<u>No.</u>	<u>%</u>
<u>Columbia County</u>				
Berwick Area	86	54	71	40
Bloomsburg Area	18	11	23	13
Other Columbia Co.	13	8	22	12
<u>Luzerne County</u>				
Wilkes-Barre Area	6	4	11	6
Other Luzerne Co.	29	19	30	17
<u>Other Counties</u>				
	<u>6</u>	<u>4</u>	<u>19</u>	<u>12</u>
	158	100	176	100

Summary by County

	<u>1975</u>		<u>1978</u>	
	<u>No.</u>	<u>%</u>	<u>No.</u>	<u>%</u>
Columbia	117	74	110	63
Luzerne	35	22	47	27
Other	<u>6</u>	<u>4</u>	<u>19</u>	<u>10</u>
TOTAL	158	100	176	100

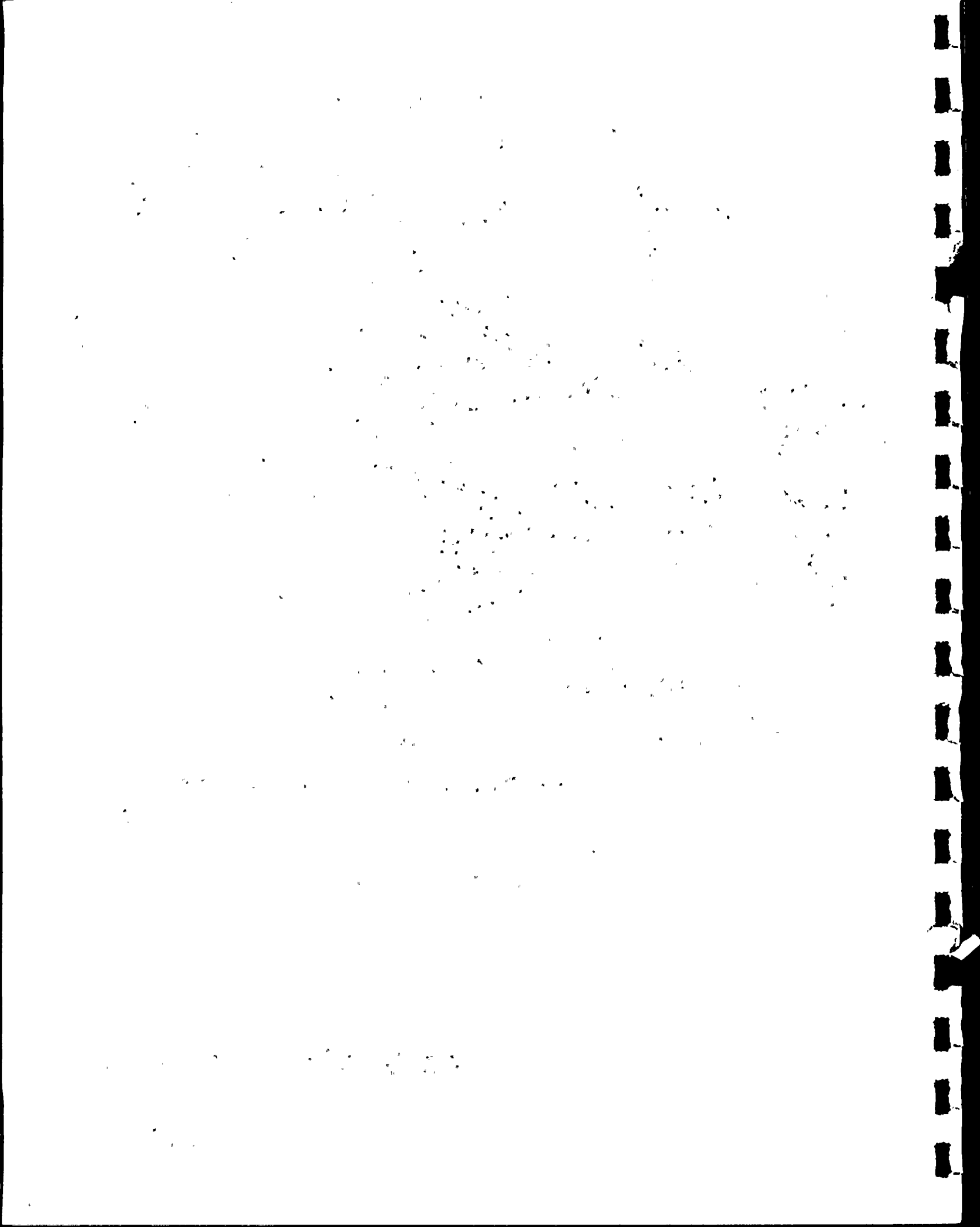




● PLANT LOCATION

# SSES REGIONAL MAP

FIG. II-1



The single discernible trend is the reduction in the number of families choosing to reside in the Berwick area. Seventy-one (71) families, or 40 percent (40%), live in the immediate site area which includes Salem Township (Luzerne County), Berwick Borough and Briar Creek Borough and Township (Columbia County), about 14 percent (14%) lower than the 1975 figures.

Luzerne County accounted for a greater share of Bechtel families in 1978 with most of the increases taking place in the Mountaintop area, a suburban residential community south of Wilkes-Barre. Other counties have also registered gains with most increases evenly distributed among Schuylkill, Northumberland, Lycoming and Montour Counties.

It is difficult to speculate on the reasons, or significances of changes in residential distributions. During the period in which the first community impact study was prepared (1975-1976), the Berwick Area School District was undergoing certain changes. Having a number of older schools, the district committed itself to a building program to create additional classroom space. Some local controversy arose around the issue and focused publicity on local schools in the district. Newspaper accounts suggested that the schools were responsible for a housing market lag at that time.<sup>1</sup> Conversations with local realtors suggest that the school system remains a significant locational factor concerning area of residence, despite the fact that the Berwick Area School District has recently completed a new middle school to replace space lost through the closing of the older buildings.

C. Type and Tenure of Residence

Fifty-eight percent (58%) of those respondents surveyed in 1978 owned or rented single family housing, compared to 50 percent (50%) in 1975. There were nine percent (9%) fewer respondents who lived in apartment-type housing in 1978. Mobile home housing increased slightly from eleven percent (11%) in 1975 to fifteen percent (15%) in 1978. Forty-seven percent (47%) of the respondents owned their housing in 1978, while only thirty-eight percent (38%) owned their homes in 1975. Table II-3 summarizes these data.

---

<sup>1</sup> Columbia County Enterprise, "Why Are Home Buyers Saying No to Berwick?", July 9, 1976.

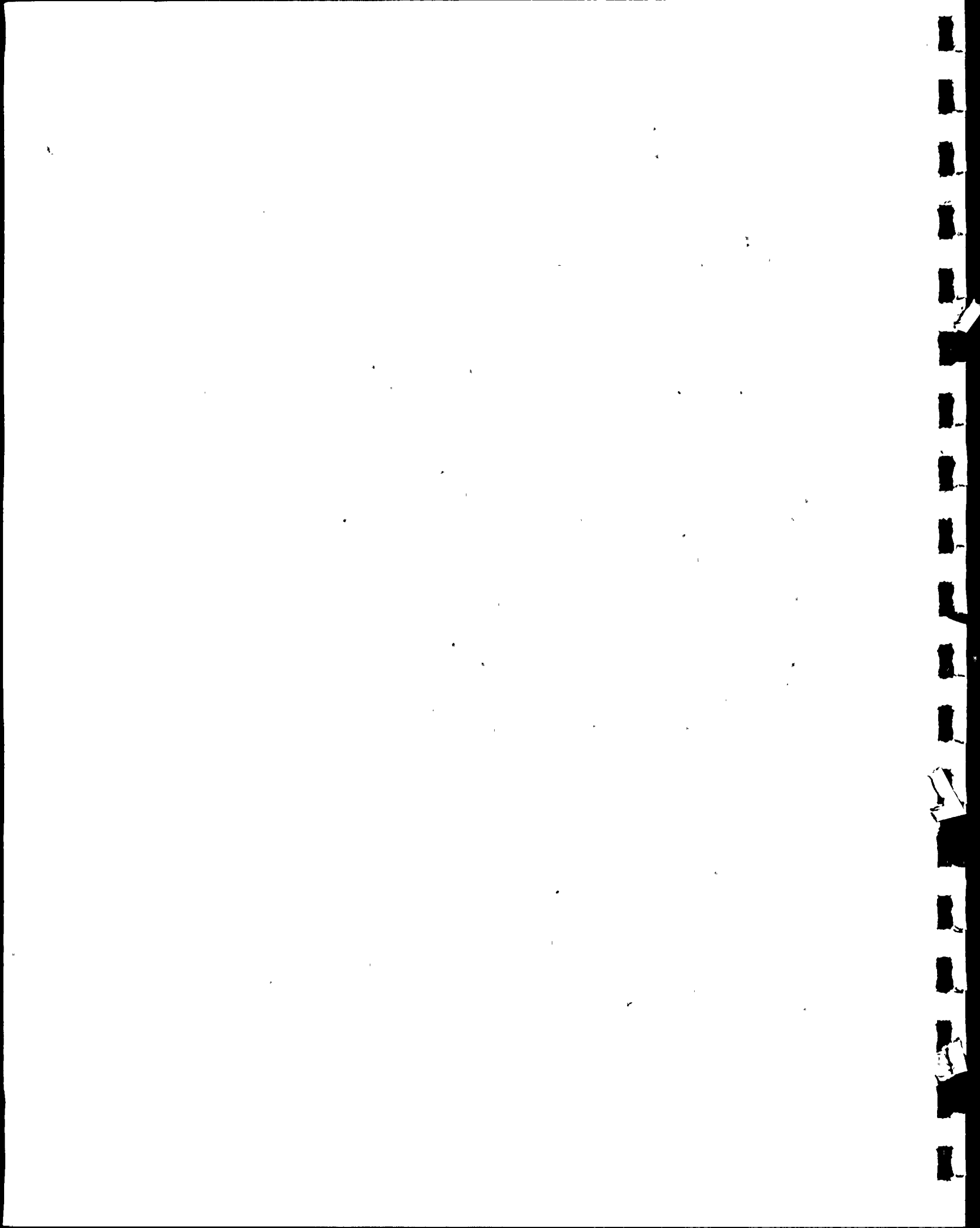




Table II-3

Housing Type and Tenure

A. Type of Residence

	1975		1978	
	<u>No.</u>	<u>%</u>	<u>No.</u>	<u>%</u>
1. Single Family	78	50	99	58
2. Apartment	46	30	36	21
3. Mobile Home	17	11	26	15
4. Motel/Rooming House	2	1	3	2
5. Duplex or Townhouse	<u>13</u>	<u>8</u>	<u>6</u>	<u>4</u>
T O T A L	156	100	170	100

B. Tenure

	1975		1978	
	<u>No.</u>	<u>%</u>	<u>No.</u>	<u>%</u>
1. Own	59	38	81	47
2. Rent	<u>96</u>	<u>62</u>	<u>90</u>	<u>53</u>
T O T A L	155	100	171	100

The above suggests little difference in trends between 1975 and 1978 survey results. A rise in ownership suggests greater availability of housing supply.

D. Family Size

Survey data indicates that one and two-person families transferred into the area remained virtually unchanged from 1975 to 1978. The most notable differences occurred in families with three or more persons.

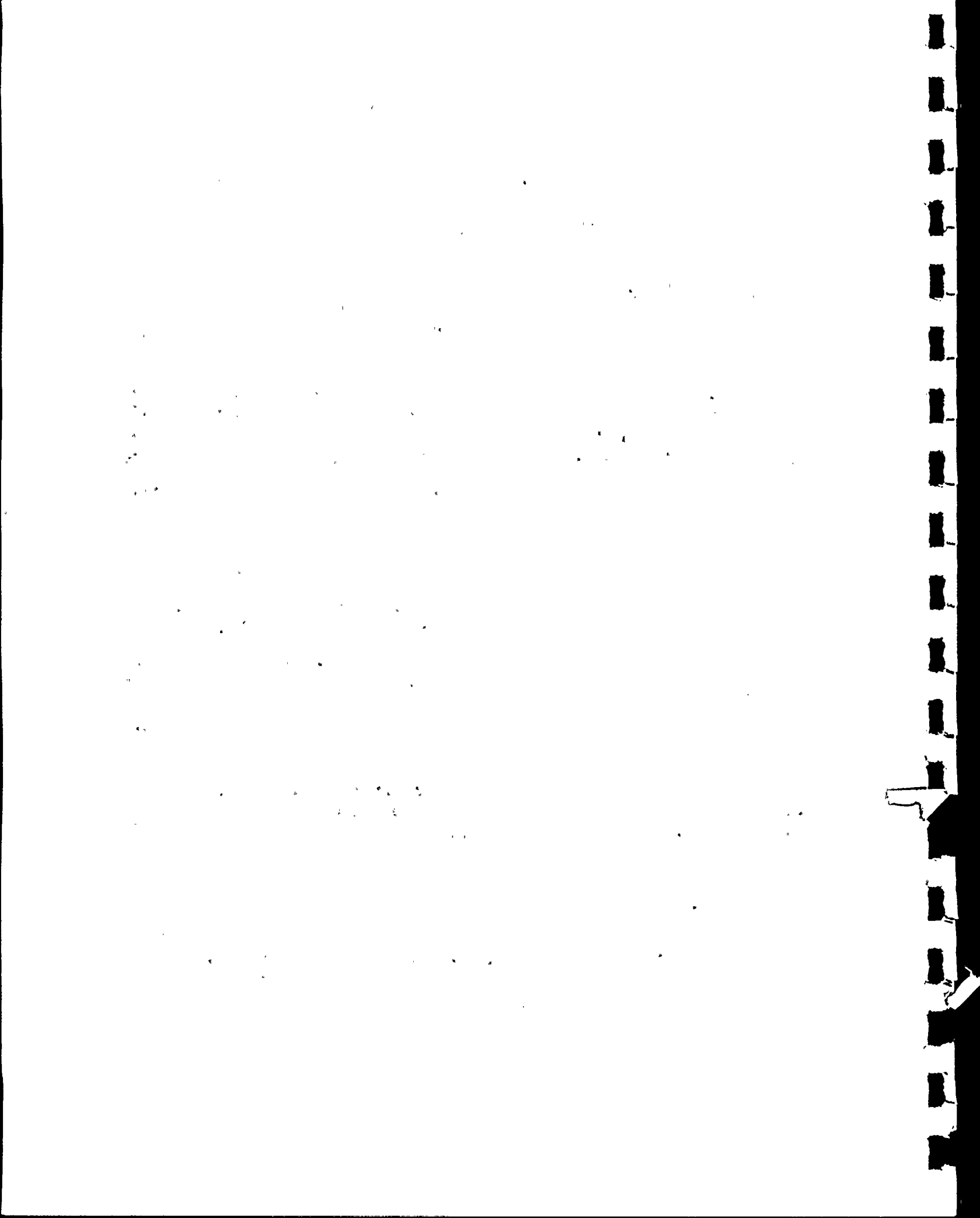


Table II-4

Family Size

	<u>1975</u>		<u>1978</u>	
	<u>No.</u>	<u>%</u>	<u>No.</u>	<u>%</u>
<u>Family Size</u>				
1. 1 person	22	15	22	14
2. 2 persons	46	32	52	32
3. 3 persons	20	14	28	17
4. 4 persons	28	19	37	23
5. 5 or more persons	<u>30</u>	<u>20</u>	<u>22</u>	<u>14</u>
T O T A L	146	100	161	100

The data suggest no particular significance except that the decrease in the number of larger families (5 or more persons) reflects a national trend towards smaller families.

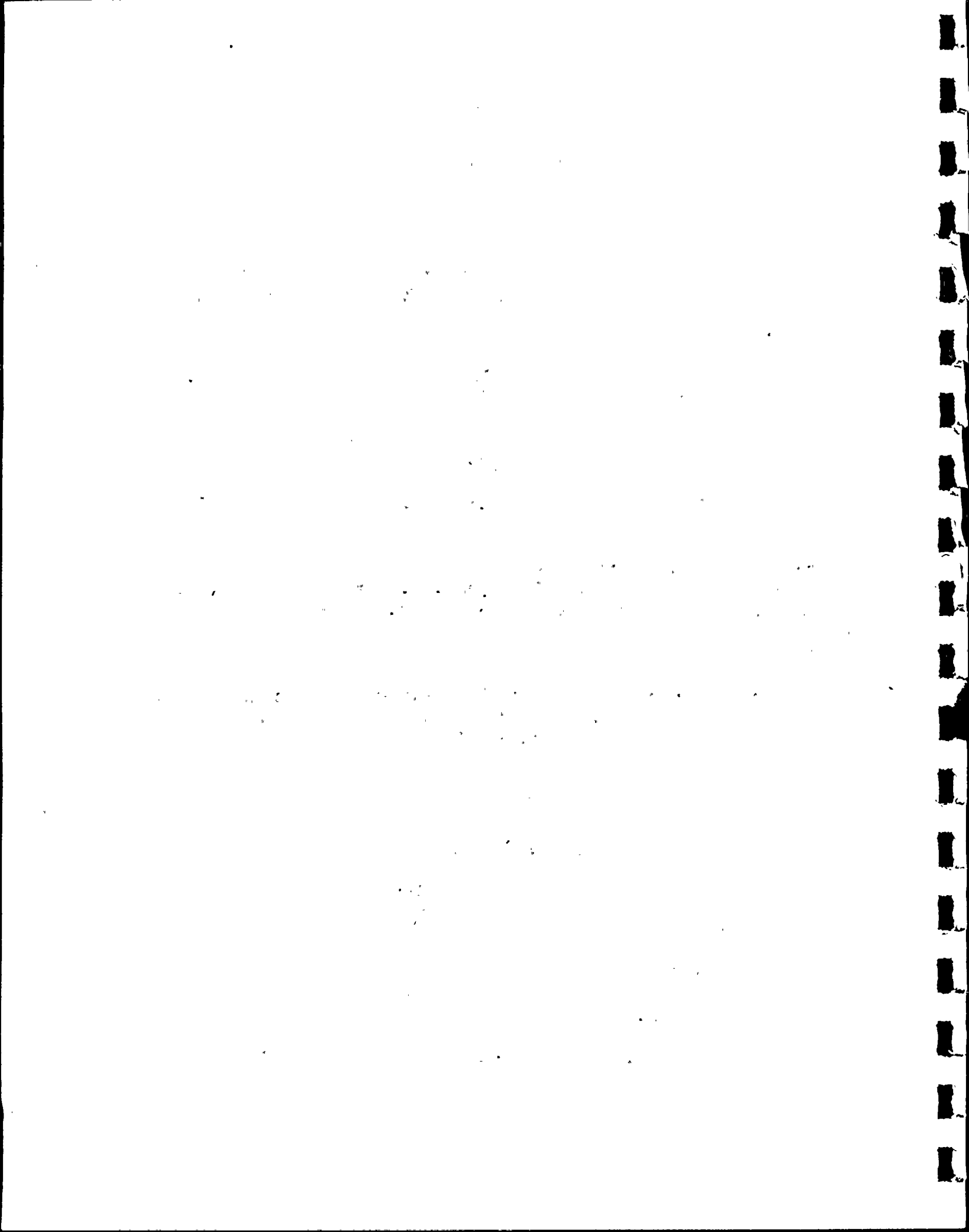
E. Age of Employees

The Bechtel employees surveyed constitute a relatively young work force with almost fifty percent (50%) of the employees under the age of thirty-five (35).

Table II-5

Age of Employees

<u>AGE</u>	<u>No.</u>	<u>%</u>
Under 25	11	6
25-35	73	41
36-45	33	18
46-60	51	29
60 or More	<u>11</u>	<u>6</u>
T O T A L	179	100



F. Number of Children by Grade Level & School District

Of those persons surveyed, about half indicated that they had children. Average family size remained unchanged since 1975, about 2.1 persons per family.

The percentage of pre-school children from 1975 to 1978 also remained unchanged. Decreases in the percentage of elementary and junior high school children occurred in 1978 when compared to the same grade levels in 1975. At the senior high school level, however, a seven percent (7%) increase was registered.

Table II-6

Number of Children by Grade Level

<u>Grade Level</u>	<u>1975</u>		<u>1978</u>	
	<u>No.</u>	<u>%</u>	<u>No.</u>	<u>%</u>
Pre-school	49	29	54	29
Elementary	67	39	68	37
Junior High School	32	19	27	14
Senior High School	<u>22</u>	<u>13</u>	<u>37</u>	<u>20</u>
T O T A L	170	100	186	100

Overall, there was an eleven percent (11%) increase in the number of children between 1978 and 1975.

In terms of enrollment trends, Table II-7 shows family residence by school district.

Table II-7

Family Residence by School District

<u>School District</u>	<u>1975</u>		<u>1978</u>	
	<u>No.</u>	<u>%</u>	<u>No.</u>	<u>%</u>
Berwick Area	48	62	40	45
Bloomsburg Area	5	6	7	8
Central Columbia	9	12	15	17
Luzerne County Districts	14	18	22	25
Other	<u>2</u>	<u>2</u>	<u>4</u>	<u>5</u>
T O T A L	78	100	88	100

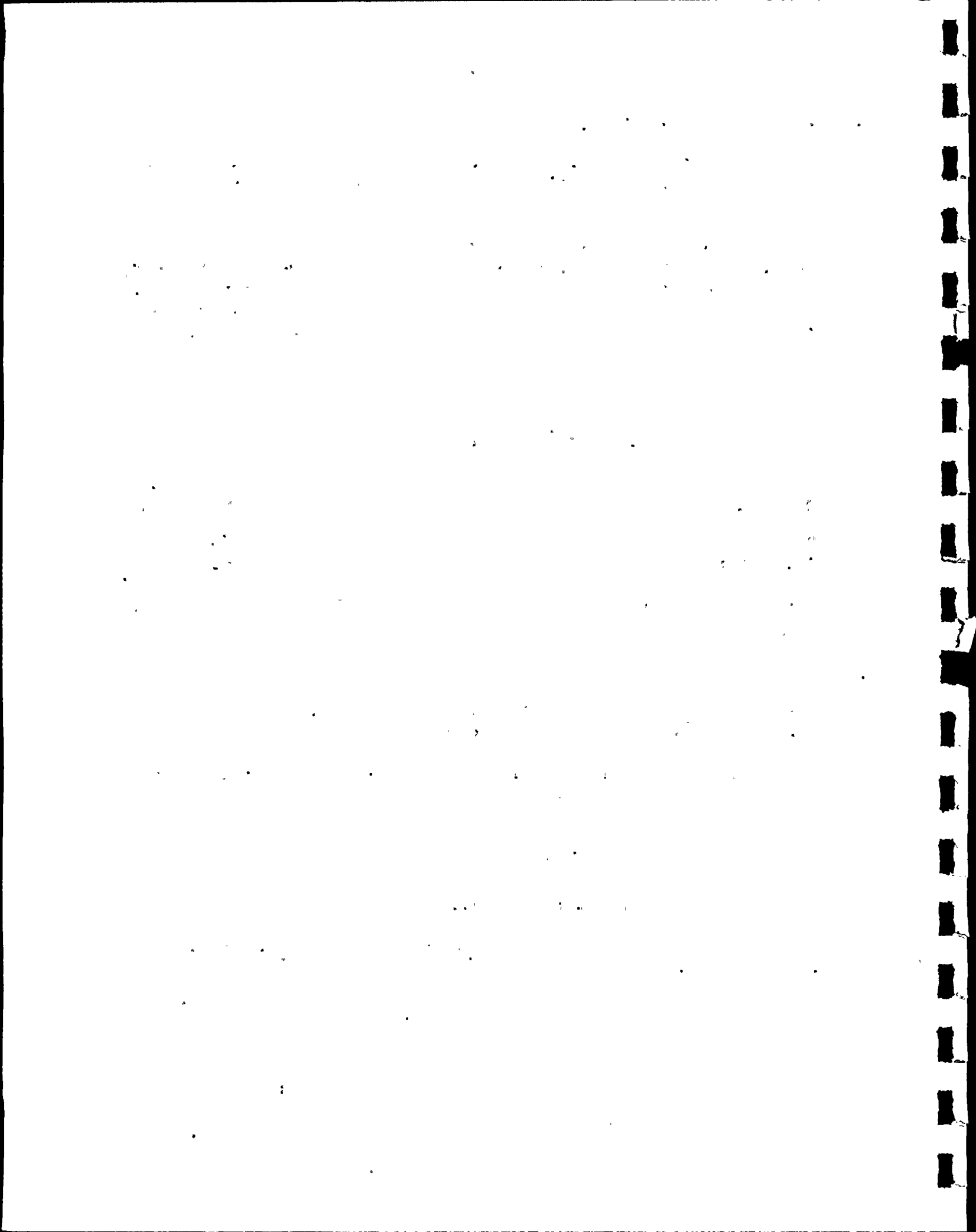


Table II-8 illustrates the distribution of children among school districts. Typically, the distribution among school districts reflects trends similar to residential location reported in Table II-2. Most children live within the Berwick School District, with a significant percentage living in the Central Columbia District. Luzerne County School Districts account for less than fifteen percent (15%) of children reported.

In 1975, the majority of families with children, sixty-two percent (62%), resided within the Berwick Area School District. Three years later, this figure dropped to forty-five percent (45%). The absolute numbers (48 families vs. 40 families) suggest a less dramatic effect on overall enrollment. Nevertheless, substantial gains were recorded in the Luzerne County and Central Columbia School Districts.

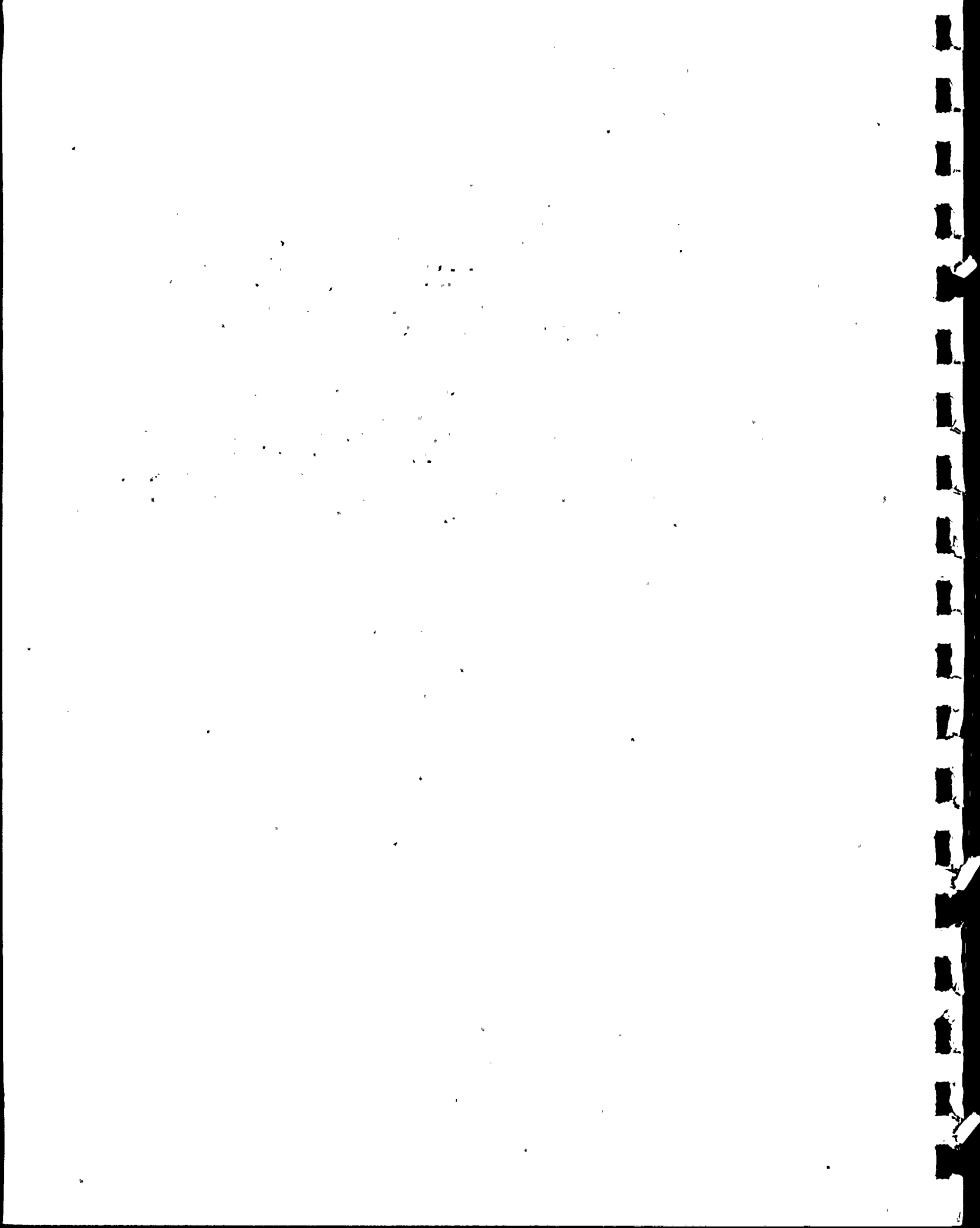
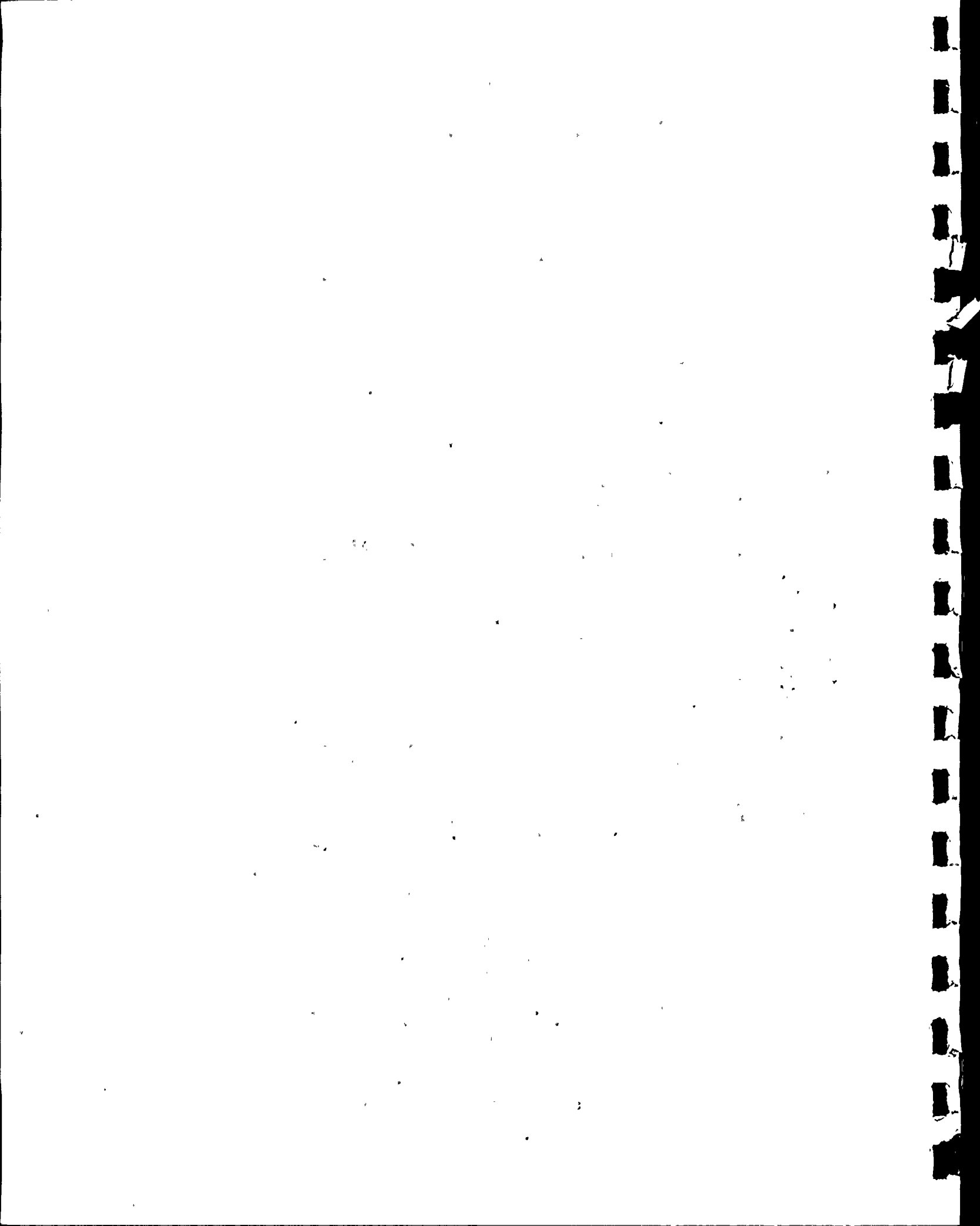


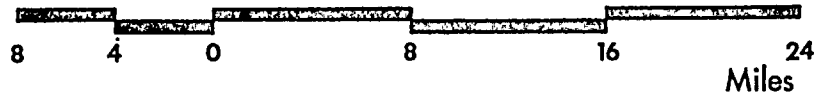
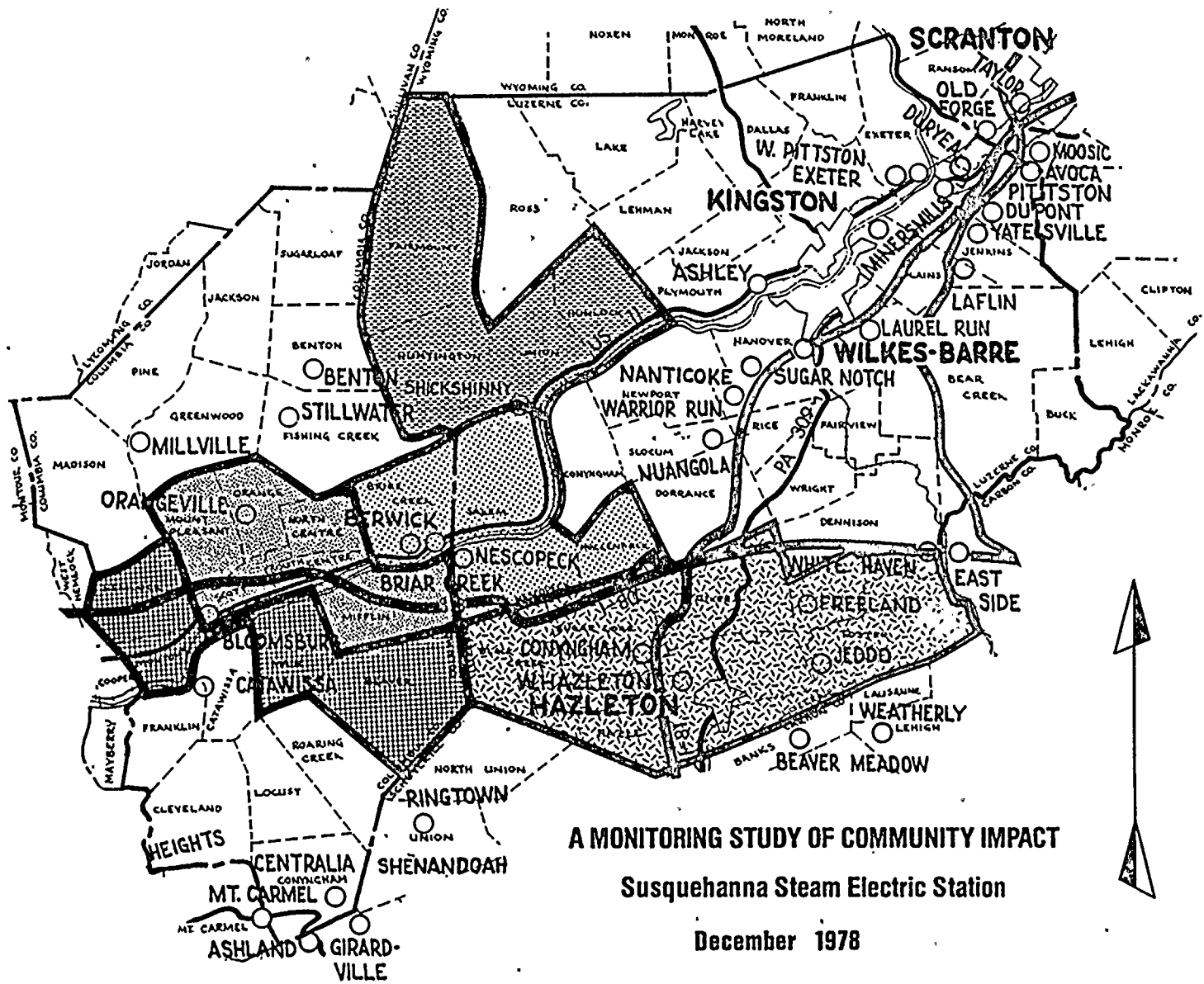







Table II-8

Number of Children  
by  
School District and Grade Level  
1978

<u>School Districts</u>	<u>Total</u>		<u>Pre-Schoolers</u>		<u>Elementary</u>		<u>Jr. High</u>		<u>Sr. High</u>	
	<u>No.</u>	<u>%</u>	<u>No.</u>	<u>%</u>	<u>No.</u>	<u>%</u>	<u>No.</u>	<u>%</u>	<u>No.</u>	<u>%</u>
1. Berwick	80	43	24	44	26	38	12	44	18	49
2. Central Columbia	42	23	10	19	19	28	7	26	11	30
3. Hazleton (Luzerne Co.)	21	11	7	13	8	12	3	11	--	--
4. Bloomsburg	17	9	5	9	3	4	2	8	--	--
5. Northwest (Luzerne Co.)	6	3	3	6	3	4	0	--	5	13
6. Other	<u>20</u>	<u>11</u>	<u>5</u>	<u>9</u>	<u>9</u>	<u>13</u>	<u>3</u>	<u>11</u>	<u>3</u>	<u>8</u>
T O T A L	186	100	54	100	68	100	27	100	37	100

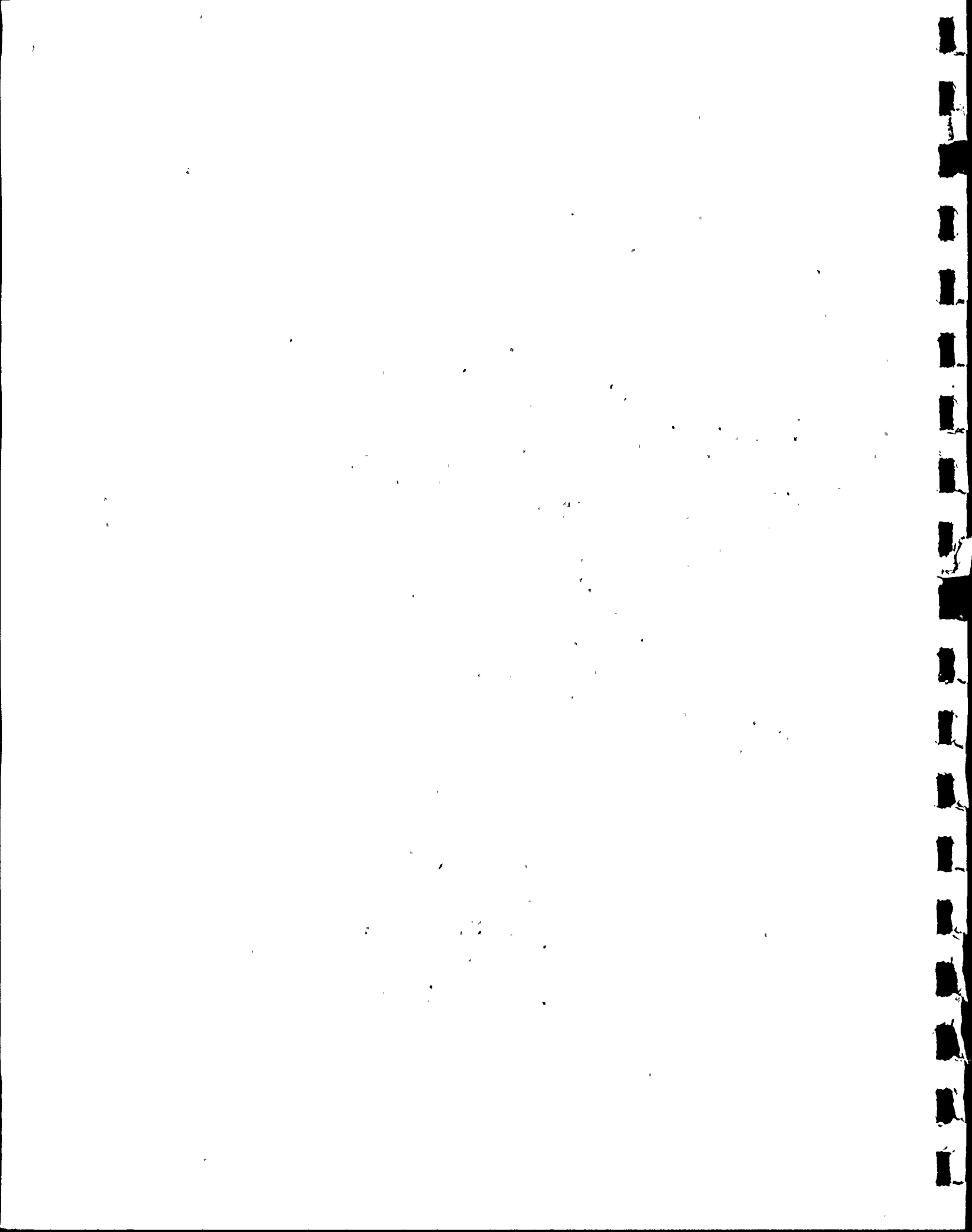




-  BERWICK AREA
-  CENTRAL COLUMBIA
-  BLOOMSBURG AREA
-  NORTHEAST AREA
-  HAZLETON AREA  
(LUZERNE COUNTY PORTION)

# SCHOOL DISTRICTS

FIG. II-2



G. Shopping Patterns

The 1978 survey, as did the 1975 effort, attempted to discern spending patterns of non-local Bechtel employees. The shopping patterns of new area residents were examined with respect to two types of purchases, daily shopping and shopping for major needs such as furniture, large appliances, etc. Table II-9 records those responses.

Table II-9

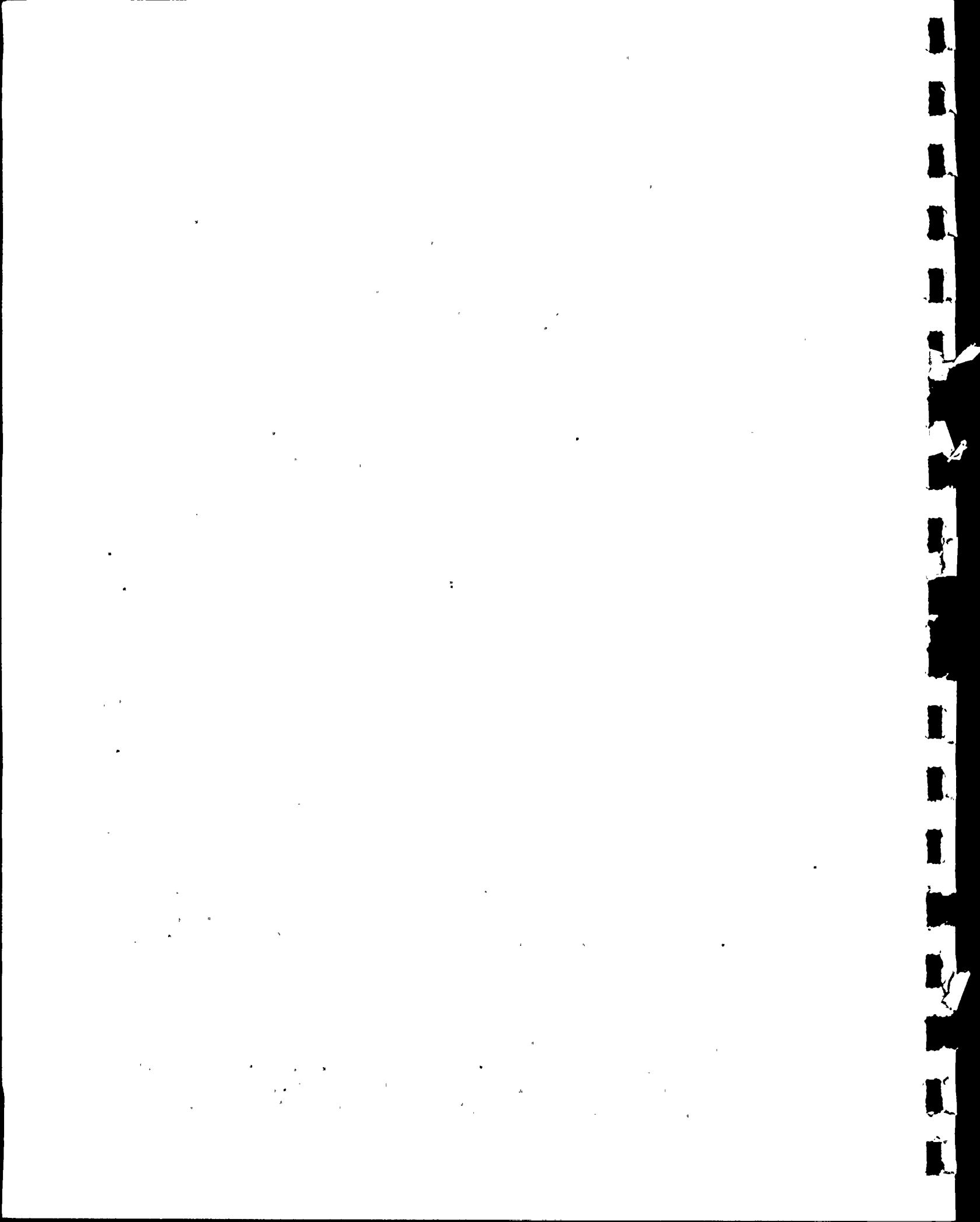
Shopping Patterns: Daily and Major Purchases  
(Respondents could answer more than once.)

	<u>Daily Needs</u>		<u>Major Needs</u>	
	<u>1975</u> <u>No.</u>	<u>1978</u> <u>%</u>	<u>1975</u> <u>No.</u>	<u>1978</u> <u>%</u>
Berwick	54	39	35	28
Bloomsburg	20	26	20	24
Wilkes-Barre	10	12	23	23
Hazleton	6	9	12	13
Other	<u>10</u>	<u>14</u>	<u>10</u>	<u>12</u>
T O T A L	100	100	100	100

Berwick's role as a local and regional shopping center, when compared to other areas, has declined. Meanwhile, the shopping activity in Bloomsburg, Wilkes-Barre and Hazleton increased.

H. Recreational Activities

The primary types of recreation used by families or respondents include fishing, swimming, golf, tennis and hunting. Skiing, bowling, parks, camping, hiking and softball were engaged in to a lesser extent. Data available from the 1975 survey was



not comparable; the information presented below is, therefore, for the 1978 survey only.

Table II-10  
Recreational Use

<u>Type</u>	<u>No.</u>	<u>%</u>	<u>Type</u>	<u>No.</u>	<u>%</u>
A. Fishing	47	14	H. Bowling	16	5
B. Swimming	43	12	I. Parks	12	3
C. Golf	39	11	J. Camping	11	3
D. Tennis	36	10	K. Hiking	8	2
E. Hunting	36	10	L. Softball	6	2
F. Skiing	25	7	M. YMCA	6	2
G. None	<u>25</u>	<u>7</u>	N. Other	<u>39</u>	<u>11</u>
			T O T A L	346	99

I. Hospital Use and Purpose

Of the 172 responses recorded, local hospitals have been used by sixty-three percent (63%) of the families, which was approximately the same as the 1975 rate. Two local hospitals are located in the vicinity of the plant site, in Berwick and Bloomsburg; a third facility, Geisinger Medical Center, is located twenty-five (25) miles to the southwest, in Danville.

The majority of respondents used local hospitals for emergency purposes, although the percentage of those visits from work-related causes is undetermined. Chapter VI, Section B, does report on the number of hospital referrals from work-related accidents.

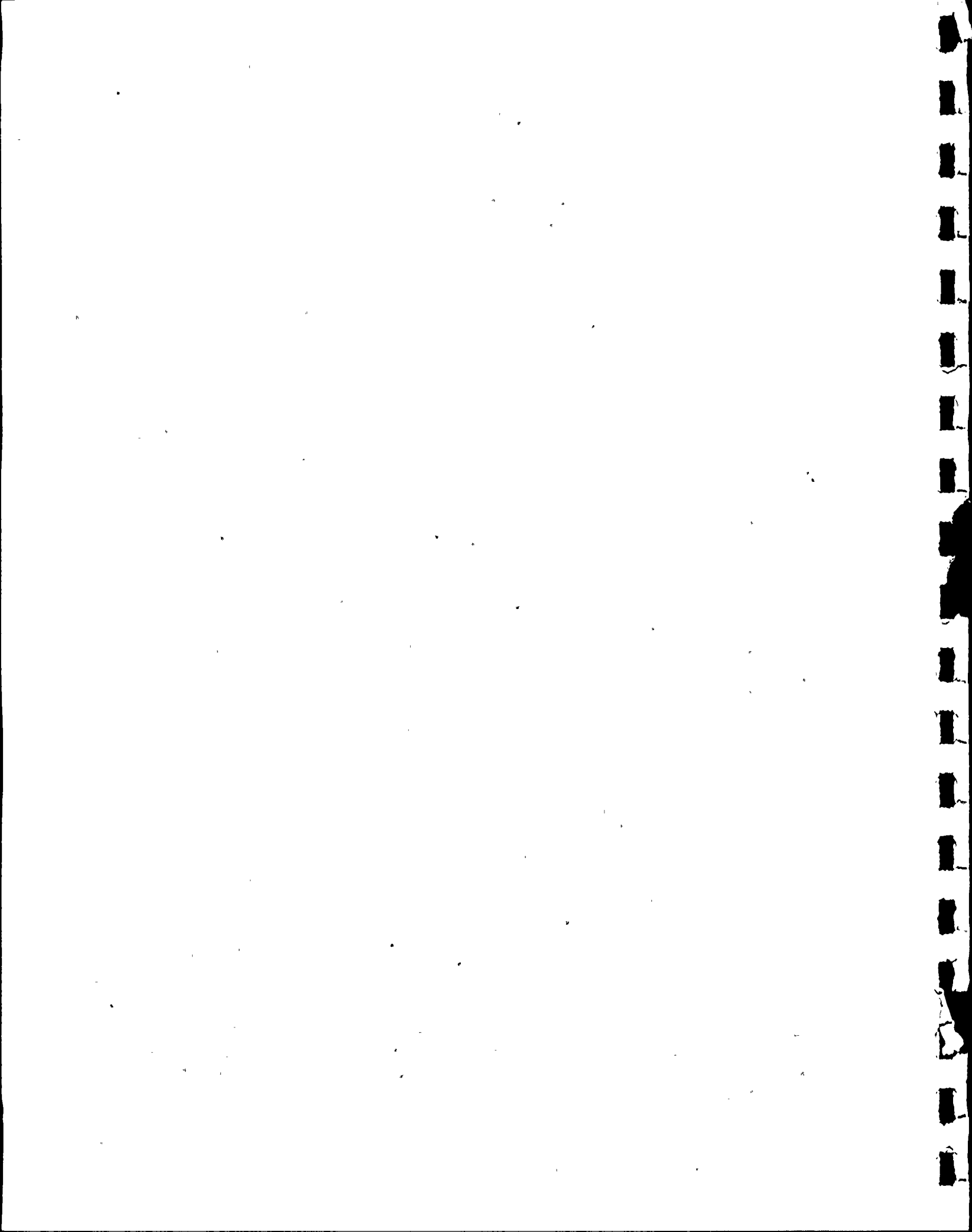




Table II-11

Hospital Use and Purpose

	<u>Hospital Use</u>		<u>Hospital Purpose</u>	
	<u>No.</u>	<u>%</u>	<u>No.</u>	<u>%</u>
A. Yes	109	63	A. Emergency	58 42
B. No	<u>63</u>	<u>37</u>	B. Surgery	38 27
T O T A L	172	100	C. Pregnancy	18 13
			D. Check-ups	12 9
			E. Tests	9 7
			F.. Other	<u>3</u> <u>2</u>
			T O T A L	138 100

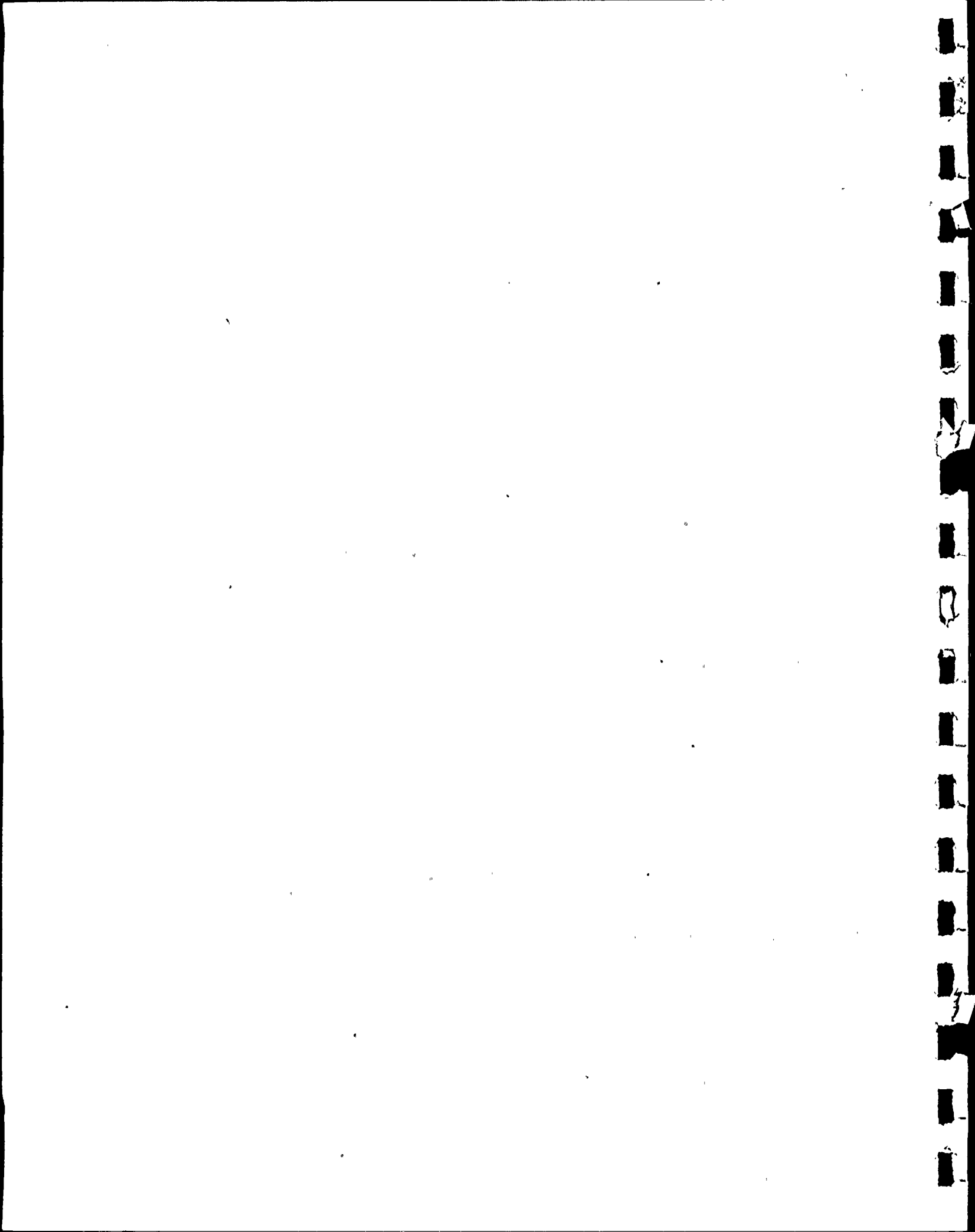
J. Attitude Towards Area of Residence

As with the 1975 survey, an attempt was made to gain insight into the attitudes of Bechtel employees concerning the aspects of the area liked most and least by asking open-ended questions. Response rates are reported below:

Table II-12

Attitude Towards Area of Residence  
(Respondents could choose more than one category.)

<u>Aspects Liked Best</u>	<u>1975</u>	<u>1978</u>
	<u>%</u>	<u>%</u>
1. Scenery	25	17
2. Small Town Life	23	17
3. Friendly People	18	21
4. Recreation	10	12
5. Near Metropolitan Areas	6	5
6. Good Schools	4	3
7. Shopping	2	4
8. Other	<u>12</u>	<u>21</u>
T O T A L	100	100



"Scenery" and "small town life" have yielded somewhat to "friendly people" and "recreation" as positive community features. Overall, however, the principal appeal of the Berwick-Bloomsburg area to those surveyed in 1978 is virtually unchanged from 1975, i.e., living in a small town in a rural setting.

The "other" category had a twenty-one percent (21%) response rate which included such responses as "good municipal service", "provided employment", and "low cost of living". Individually, responses in the other category were generally less than two percent (2%) of total responses.

In 1975, "poor shopping", "high cost of living", "high taxes" and "climate" topped the list of undesirable factors associated with local communities (see Table II-13). By 1978, the first two categories diminished in importance while climate and high taxes remained relatively stable. "Poor roads" emerged as a strong negative feature as did "poor traffic and parking conditions at plant site", a factor which was not even recorded in 1975.

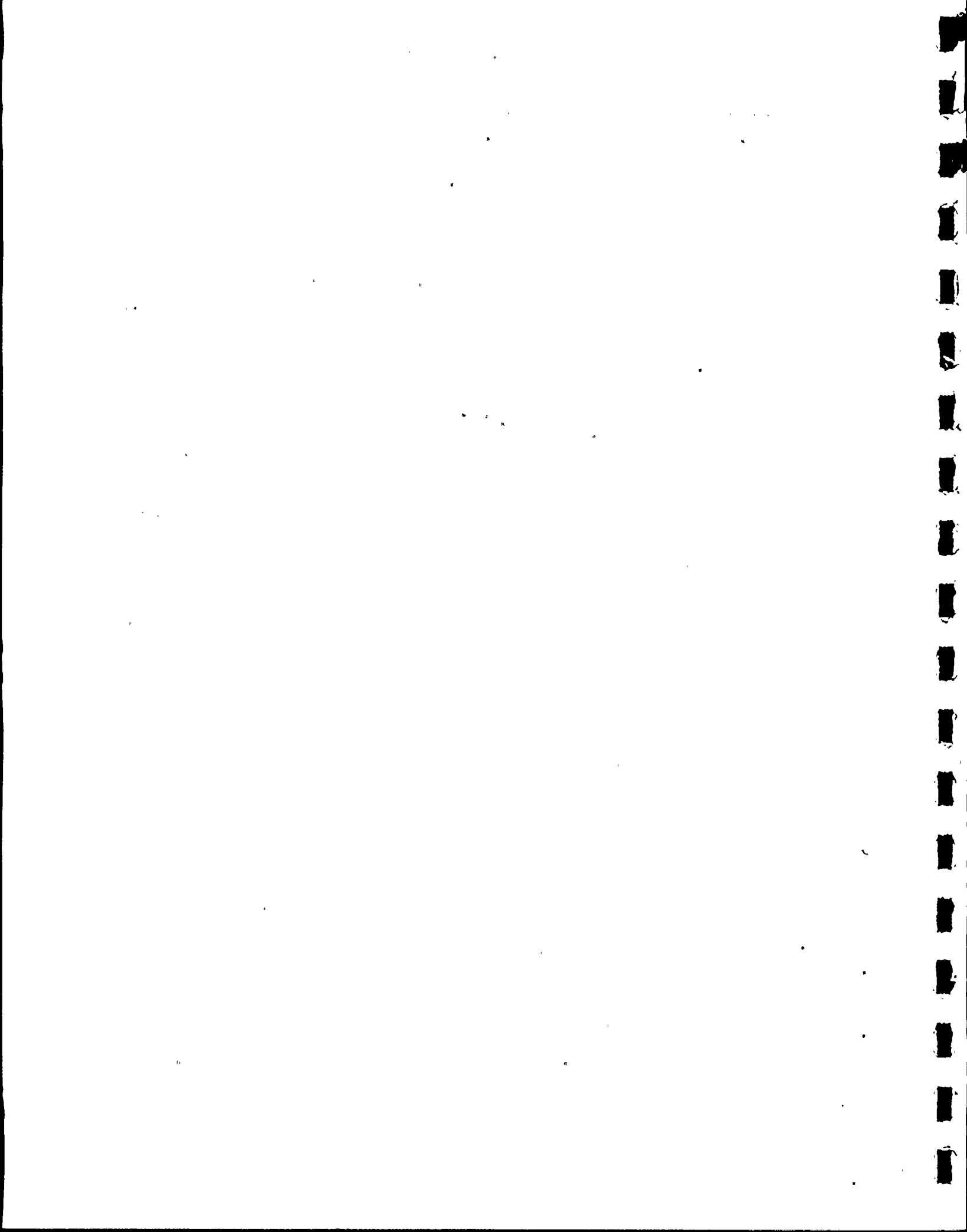
Similarly, three additional factors emerged since the 1975 survey which represents potential local issues. These new factors include "resentment to Bechtel", "poor government", and "high utility rates".

Table II-13

Aspects Liked Least

(Respondents could choose more than one category.)

	<u>1975</u>	<u>1978</u>
	<u>%</u>	<u>%</u>
1. Poor Shopping	17	8
2. High Cost of Living	12	3
3. Climate	12	14
4. High Taxes	11	13
5. Poor/Expensive Housing	9	2
6. Poor Roads	9	15
7. Unfriendly People	8	3
8. Lack of Culture Resources	6	4
9. Poor Schools	5	2
10. Traffic and Parking Conditions at the Plant Site	--	12
11. Resentment to Bechtel	--	4
12. Poor Government	--	3
13. High Utility Rates	--	3
14. Other	<u>11</u>	<u>14</u>
T O T A L	100	100



K. PP&L Survey Responses

As in 1975, all PP&L employees assigned to the SSES were surveyed in 1978. In 1975, the number of responses, thirty-one (31), was considered statistically insignificant. In three years, the size of the PP&L staff increased to ninety (90), eighty (80) of which responded to the survey. While the number of responses is statistically more significant in 1978, the absolute number of employees, in terms of local community impacts, is still low. Table II-14 summarizes 1978 responses. The terms "local" and "non-local" refer to those PP&L employees who did not have to move in to the plant site area as opposed to those employees hired, or transferred in, from other job locations.

Trends similar to those identified in the Bechtel survey are discernible in responses to the PP&L survey. Since 1975, the Bloomsburg-Berwick area, particularly Berwick, remains the principal area chosen by incoming PP&L personnel. Even those 1978 responses recorded as "Other Luzerne County" (Item No. 4) included many responses from the Nescopeck area which is located directly opposite Berwick across the Susquehanna River. Another determination of place of residence can be inferred from responses to Item No. 9, School District, which reflects a substantial response rate from the Berwick Area School District.

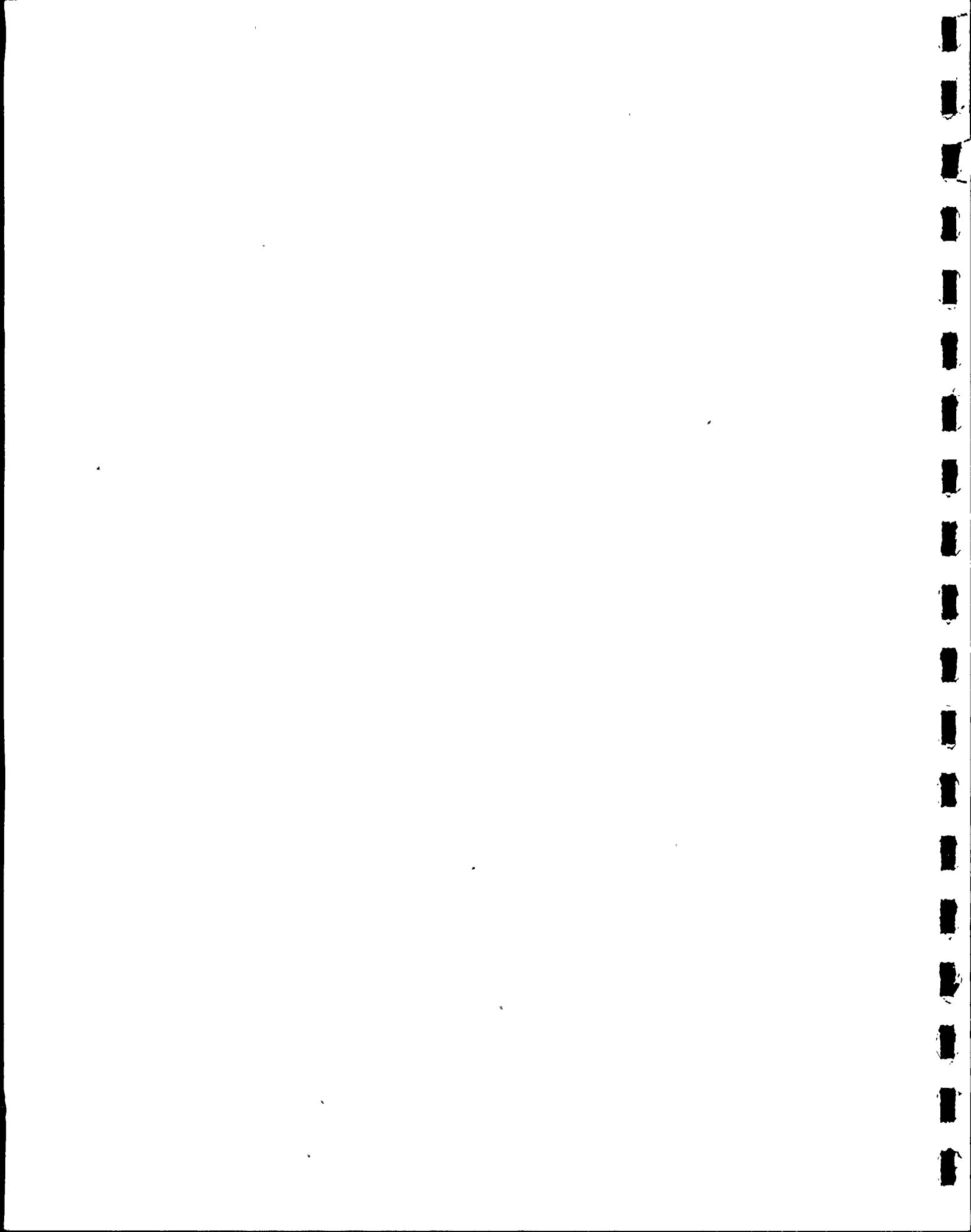


Table II-14  
PP&L Employee Profile

1. Total Responses

	<u>1975</u>	<u>1978</u>
Local	13	25
Nonlocal	18	55
Total	31	80

2. Age Distribution

<u>1975</u>		<u>1978</u>	
Age	#	Age	#
20-29	15	Under 25	5
30-39	8	25-35	58
40-49	3	36-45	13
50-59	4	46-60	4

3. Occupation

<u>1975</u>	<u>Local</u>	<u>Nonlocal</u>
Engineer	5	10
Accountant	2	-
Supervisor	2	4
Other Management	1	3
Clerk-Secretary	3	1

1978

	<u>Local</u>	<u>Nonlocal</u>
Manager	2	16
Professional	3	19
Technical	17	19
Clerical	3	1

4. Area of Residence

1975

	<u>Local</u>	<u>Nonlocal</u>
Berwick Area	1	5
Columbia Co.	2	6
Luzerne Co.	4	4
Other	6	3
Total	13	18

1978

	<u>Local</u>	<u>Nonlocal</u>
Berwick Area	1	17
Bloomsburg Area	1	13
Other Columbia Co.	5	6
Conyngham Boro (Luzerne Co.)	1	3
Wilkes-Barre	2	1
Other Luzerne Co.	5	14
Other	10	1
Total	25	55

5. Type of Residence - Nonlocal

	<u>1975</u>	<u>1978</u>
Single Family	12	45
Apartment	2	8
Mobile Home	1	1
Other	2	1
Total	17	55

6. Tenure

	<u>1975</u>	<u>1978</u>
Own	14	41
Rent	1	14
Total	15	55

7. Family Size

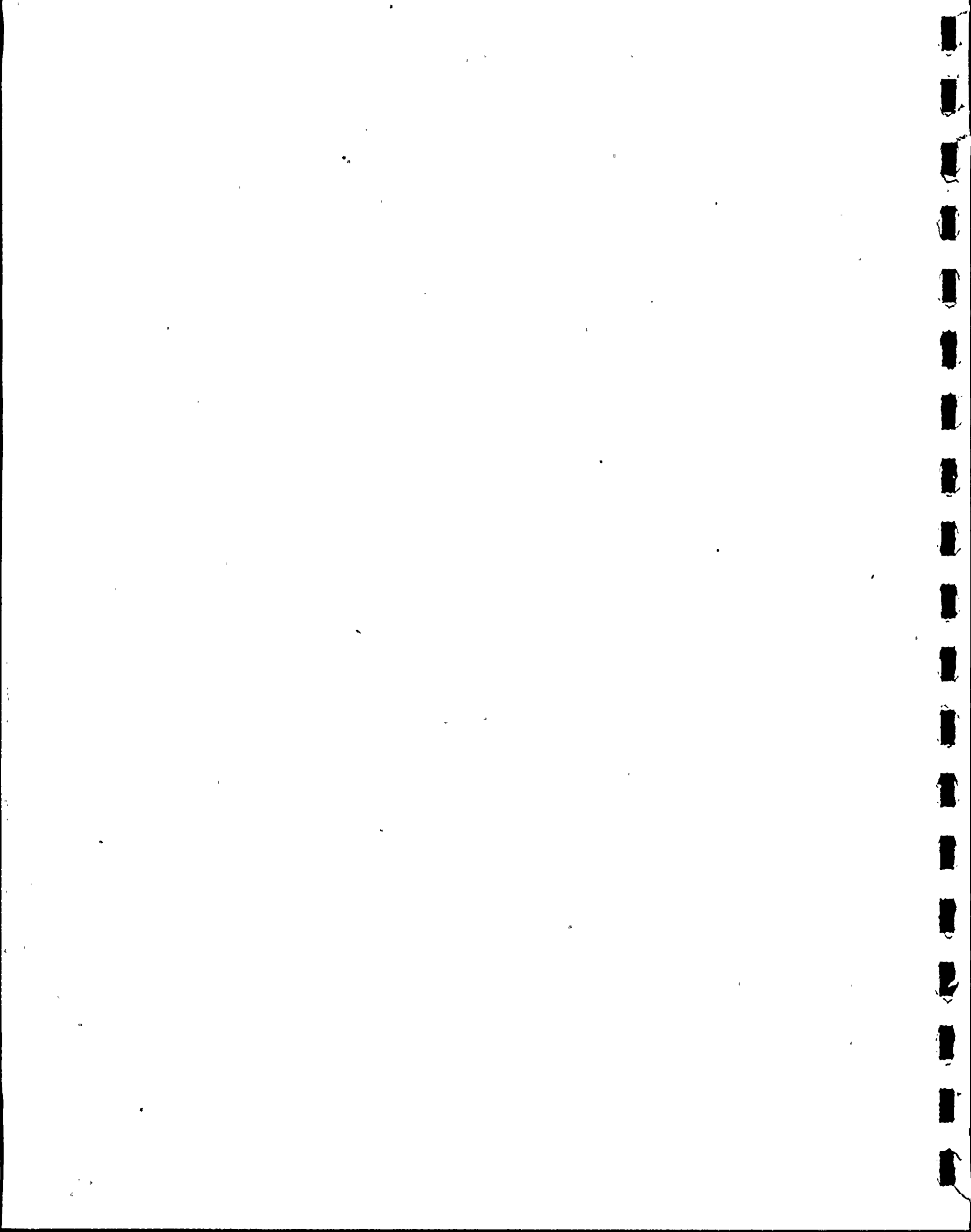
	<u>1975</u>	<u>1978</u>
1 Person	3	5
2 Persons	1	16
3 Persons	4	2
4 Persons	6	18
5+ Persons	2	8
Total	16	49

8. Number of Children

	<u>1975</u>	<u>1978</u>
Preschool	8	15
Elementary	6	20
Jr. High	4	6
Sr. High	-	3
Total	18	44

9. School District

	<u>1975</u>	<u>1978</u>
Berwick	4	23
Bloomsburg	-	2
Central Col.	2	11
Hazleton	-	7
Northwest	-	4
Benton	-	4
Luzerne Co.	-	3
Other	1	1
Total	7	55





10. Shopping Areas (Multiple Response)

	<u>1975</u>	<u>1978</u>
<u>Daily Purchases</u>		
Berwick	10	33
Bloomsburg	7	24
Wilkes-Barre	5	7
Hazleton	-	7
Other	2	15
Total	24	86
<u>Major Purchases</u>		
Berwick	6	16
Bloomsburg	8	21
Wilkes-Barre	6	20
Hazleton	-	13
Other	6	17
Total	26	87

Aspects Liked Least

	<u>1975</u>	<u>1978</u>
Poor Shopping Facilities	4	19
Poor Schools	3	5
Lack of Cultural Activities	-	8
Poor Roads	-	5
Poor/Expensive Housing	-	3
Unfriendly People	-	3
Other	5	10
Total	12	53

11. Recreational Activities (Multiple Response)

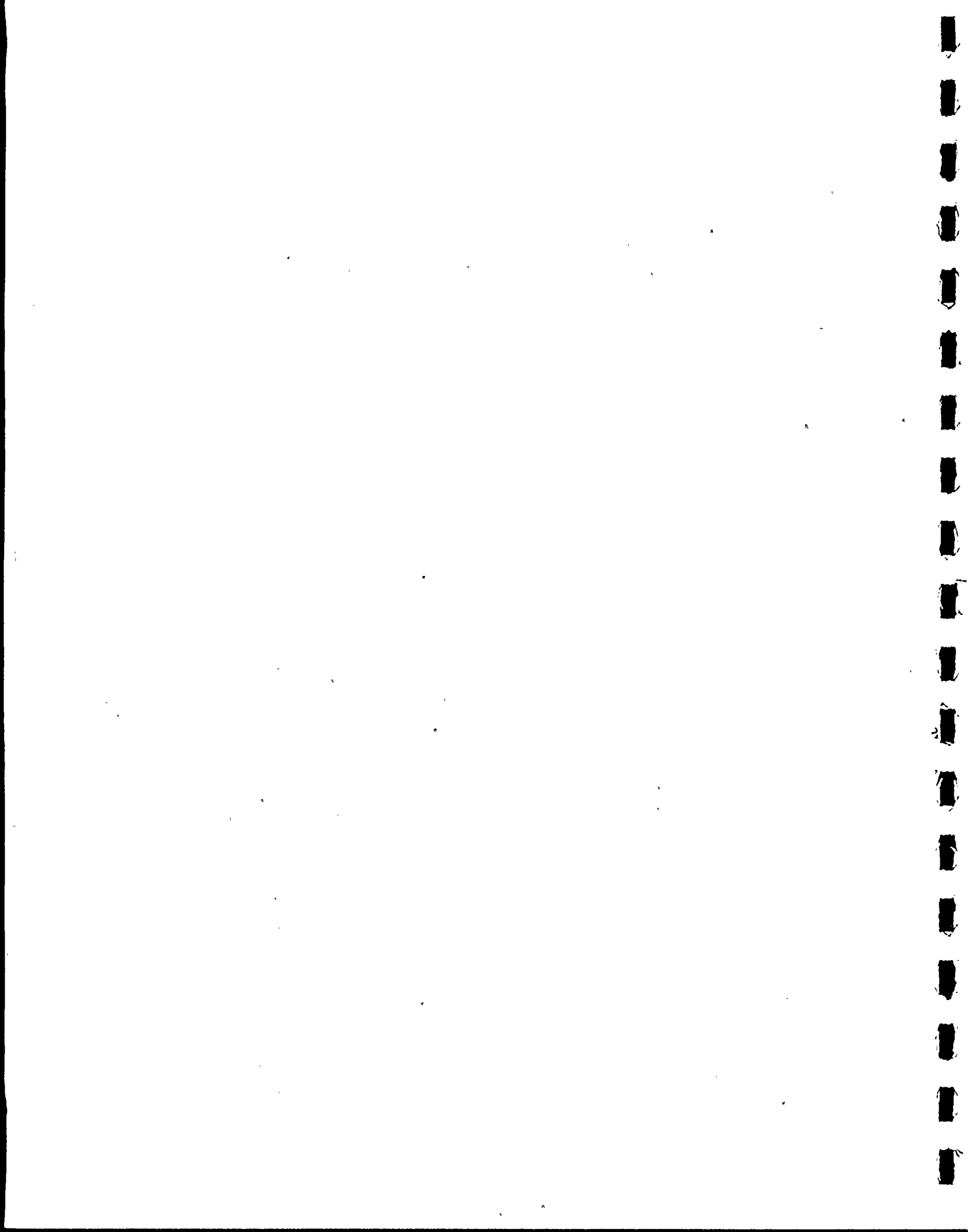
	<u>1975</u>	<u>1978</u>
Hunting & Fishing	8	43
Swimming	11	18
Tennis	8	17
Skiing (snow)	-	12
Camping	-	6
Golf	-	5
Parks	-	4
Other	10	19
None	-	10
Total	37	134

12. Hospital Use

	<u>1975</u>	<u>1978</u>
Yes	14	24
No	3	13
Total	17	27

13. Aspects Liked Best (Multiple Response)

	<u>1975</u>	<u>1978</u>
Rural Area/Small Town Life	11	29
Friendly People	3	8
Scenery	3	14
Available Recreation	-	6
Other	-	11
Total	17	68



CHAPTER III

BACKGROUND INFORMATION:  
POPULATION, EMPLOYMENT AND MANPOWER

A. Population

The project region reflects some of the demographic trends occurring in the Northeast U.S.A. as a whole, particularly in population losses. Table III-1 records population changes in the site region over a period of thirty-five years:

Table III-1

Population Changes of Counties  
Within 20 Miles of the Site<sup>1</sup>

<u>County</u>	<u>1940</u>	<u>1950</u>	<u>1960</u>	<u>1970</u>	<u>% Change 1940 to 1970</u>	<u>1975 Estimate</u>
Luzerne	441,518	392,241	346,972	342,301	-22.5	345,645
Columbia	51,413	53,460	53,489	55,114	7.2	59,288
Sullivan	7,504	6,745	6,751	5,961	-20.6	5,963
Schuylkill	228,331	200,577	173,089	160,089	-29.9	160,118
Carbon	61,735	57,558	52,889	50,573	-18.1	52,289

Columbia County is the only county to have recorded population increases over a 30-year period, a modest gain of 4,000 persons. Between 1940 and 1970, the remaining counties recorded significant population decreases. Recent Bureau of Census projections indicate a reversal of the long-term population decline in these counties. Table III-2 indicates population distribution by area of residence. It also reflects the urban-rural contrast between the two counties closest to the project site, Luzerne and Columbia:

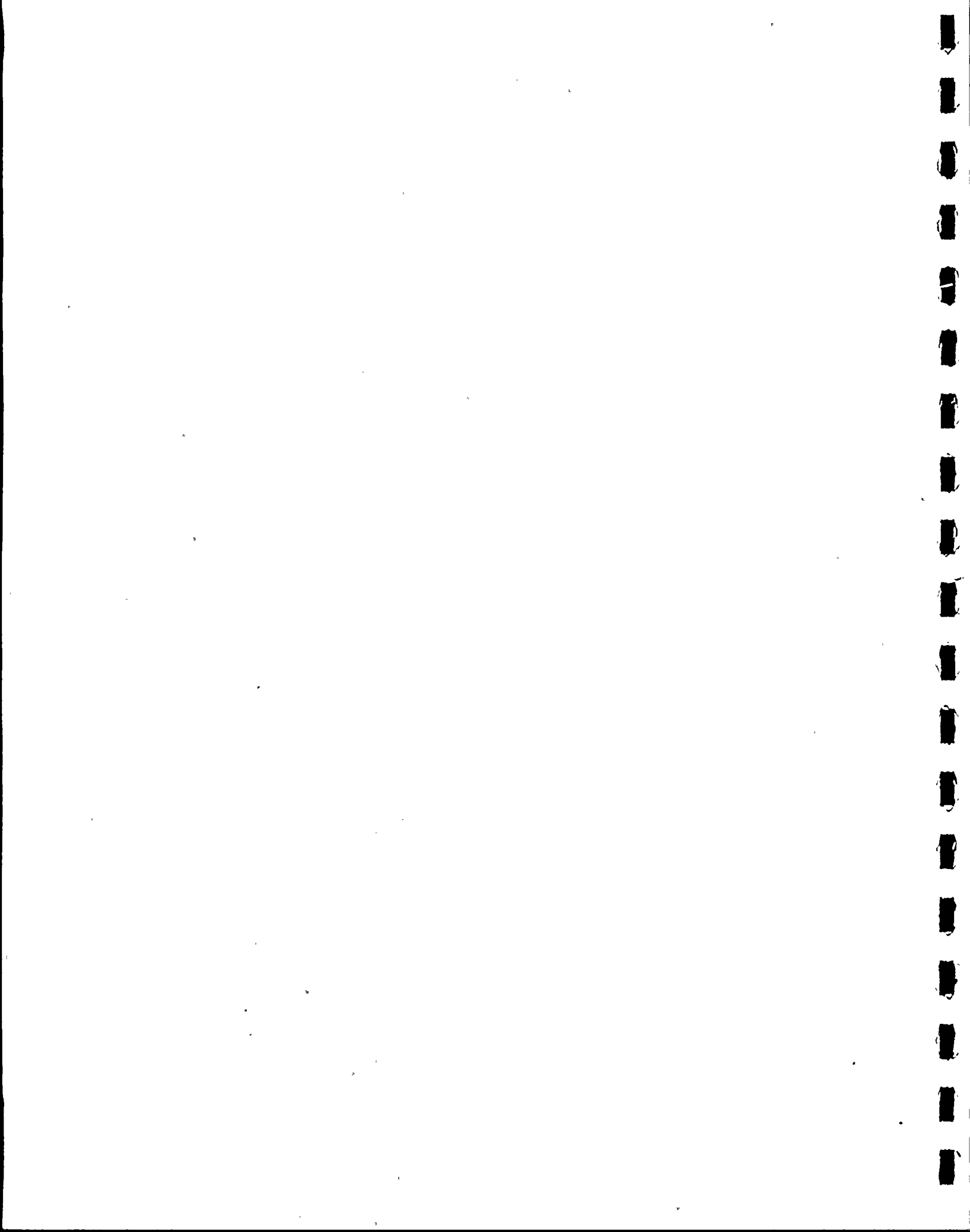


Table III-2

Population by Residence For  
Counties Within 20 Miles of the Site<sup>2</sup>

<u>County</u>	1 9 7 0		
	<u>Urban</u>	<u>Rural-Nonfarm</u>	<u>Rural-Farm</u>
Luzerne	267,510	66,461	2,699
Columbia	23,926	26,170	5,018
Sullivan	--	4,691	1,270
Schuylkill	83,133	73,251	3,705
Carbon	32,268	17,564	741

At the municipal level, the project area is characterized by small urban centers in a predominantly rural region.

Table III-3

Selected Local Municipal Populations<sup>3</sup>

	<u>1970</u>	<u>1975 Estimate</u>	<u>Distance From SSES (Miles)</u>
<u>Columbia County</u>			
Berwick	12,274	12,253	4.5
Bloomsburg	11,652	12,181	16
Scott Township	3,875	3,765	14
Briar Creek Township	2,150	2,804	9
<u>Luzerne County</u>			
Nescopeck	1,897	1,921	5
Shickshinny	1,685	1,590	4
Wilkes-Barre	58,856	57,040	20
Salem Township	3,890	4,397	-



Although the project site is in Salem Township, Luzerne County, Salem Township's orientation is to the communities of Columbia County, particularly Berwick, a well established retail center and the economic focus of the area. Bloomsburg, about sixteen (16) miles southwest of the plant site, approximates Berwick's size and is the county seat.

B. Work Force Characteristics

An assumption implicit in both the 1976 Community Impact Monitoring Study and this update is that most major community impacts associated with SSES construction are related, directly or indirectly, to the work force. Admittedly, the construction of a major facility like SSES can have significant community impacts when the acquisition of local homes results in the dislocation of families. Since land acquisition commenced on the SSES project, approximately thirty (30) homes have been acquired.<sup>4</sup> Long-term impacts, however, are more closely related to the interaction of the work force with local communities in such matters as traffic, housing, recreation, utilities (sewer and water), etc.

Before looking at work force characteristics at the project site, it would be helpful to examine the regional labor force characteristics. Table III-4 relates data on labor force size in Luzerne and Columbia Counties.

In the greater Wilkes-Barre/Hazleton area, the size of the civilian labor force had not changed appreciably in the reporting period. The number of persons unemployed increased significantly, however, and overall employment actually decreased. Contract construction, nevertheless, increased by fifty percent (50%). Much of that increase is a result of employment at the project site as well as the public and private rehabilitation carried out in the wake of Tropical Storm Agnes, which caused extensive damage in the Wilkes-Barre area in 1972.

Nor did the Bloomsburg-Berwick area demonstrate much improvement in the reporting period. Without a significant increase in the labor force size, the number of unemployed more than doubled. One of the few improvements was in contract construction, which registered a twenty-two percent (22%) gain.

At the project site, the labor force is at its peak with over 4,000 workers employed (July, 1978). As prime contractor for

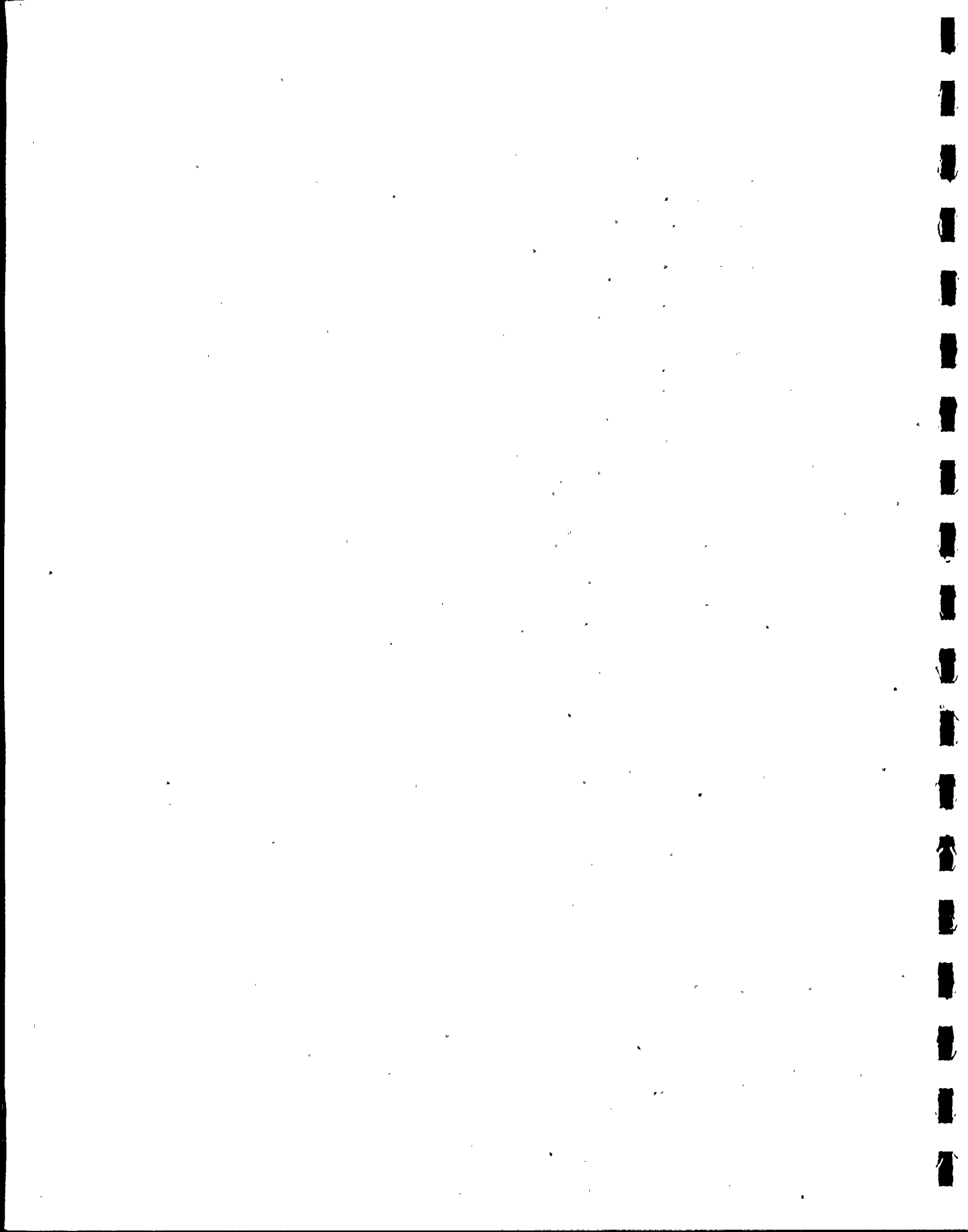




Table III-4

CIVILIAN LABOR FORCE, EMPLOYMENT AND UNEMPLOYMENT  
ANNUAL AVERAGE FOR SELECTED YEARS<sup>5</sup>  
(000's of Workers)

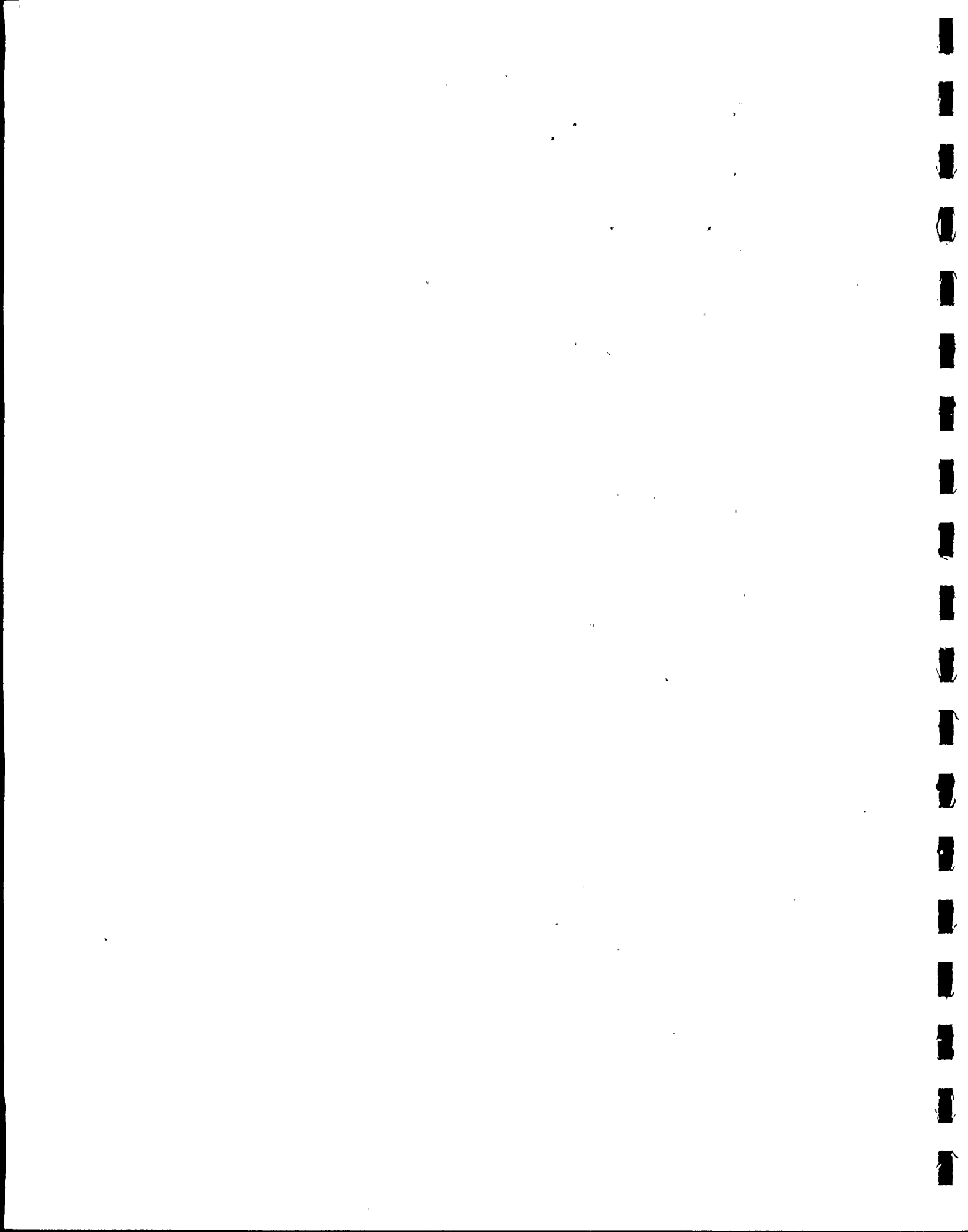
A. Wilkes-Barre - Hazleton

	<u>1970</u>	<u>1972</u>	<u>1974</u>	<u>1976</u>	<u>1977</u>	<u>% Change '70 - '77</u>
1. Civilian Labor Force	146.4	149.5	150.5	150.8	147.4	.1
2. Unemployment	7.9	12.7	9.5	14.5	14.7	86.0
% Labor Force	5.4	8.5	6.3	9.6	9.9	83.3
3. Employment*	138.5	136.8	141.0	136.3	132.7	-4.1
Non-Agriculture	NA	121.3	126.7	123.3	122.1	.6
(1) Manufacturing	52.1	47.9	46.4	40.6	39.3	-25.0
(2) Non-Manufacturing	70.6	73.2	79.9	82.1	82.7	17.1
Contract Construction	5.4	6.5	7.8	8.2	8.1	50.0

B. Berwick - Bloomsburg

1. Civilian Labor Force	24.7	25.6	26.6	26.5	26.0	5.3
2. Unemployment	1.4	1.5	2.1	3.2	2.9	107.1
% Labor Force	5.7	5.9	7.9	12.1	11.1	95.0
3. Employment	23.3	24.2	24.6	23.4	23.2	-
Non-Agriculture	20.1	21.4	21.7	20.6	20.9	4.0
(1) Manufacturing	11.2	11.6	10.5	9.1	8.8	-21.4
(2) Non-Manufacturing	8.9	9.7	11.0	11.4	12.1	36.0
Contract Construction	0.7	0.8	0.9	0.8	0.9	22.2

\* Data is an estimate of jobs by place of work and is not directly comparable to labor force data which estimates workers by place of residence.



the project, the Bechtel Power Corporation employs directly, or through its subcontractors, most of these workers. The labor force can be broken down into two broad categories, manual and non-manual personnel, for evaluation purposes. Manual workers consist primarily of skilled craftsmen such as carpenters, operating engineers, electricians, ironworkers, etc., but also includes laborers. Non-Manual workers generally fall into four categories, including managerial, professional, technical and clerical.

C. Manpower Needs at the Project Site

1. Manual Work Force

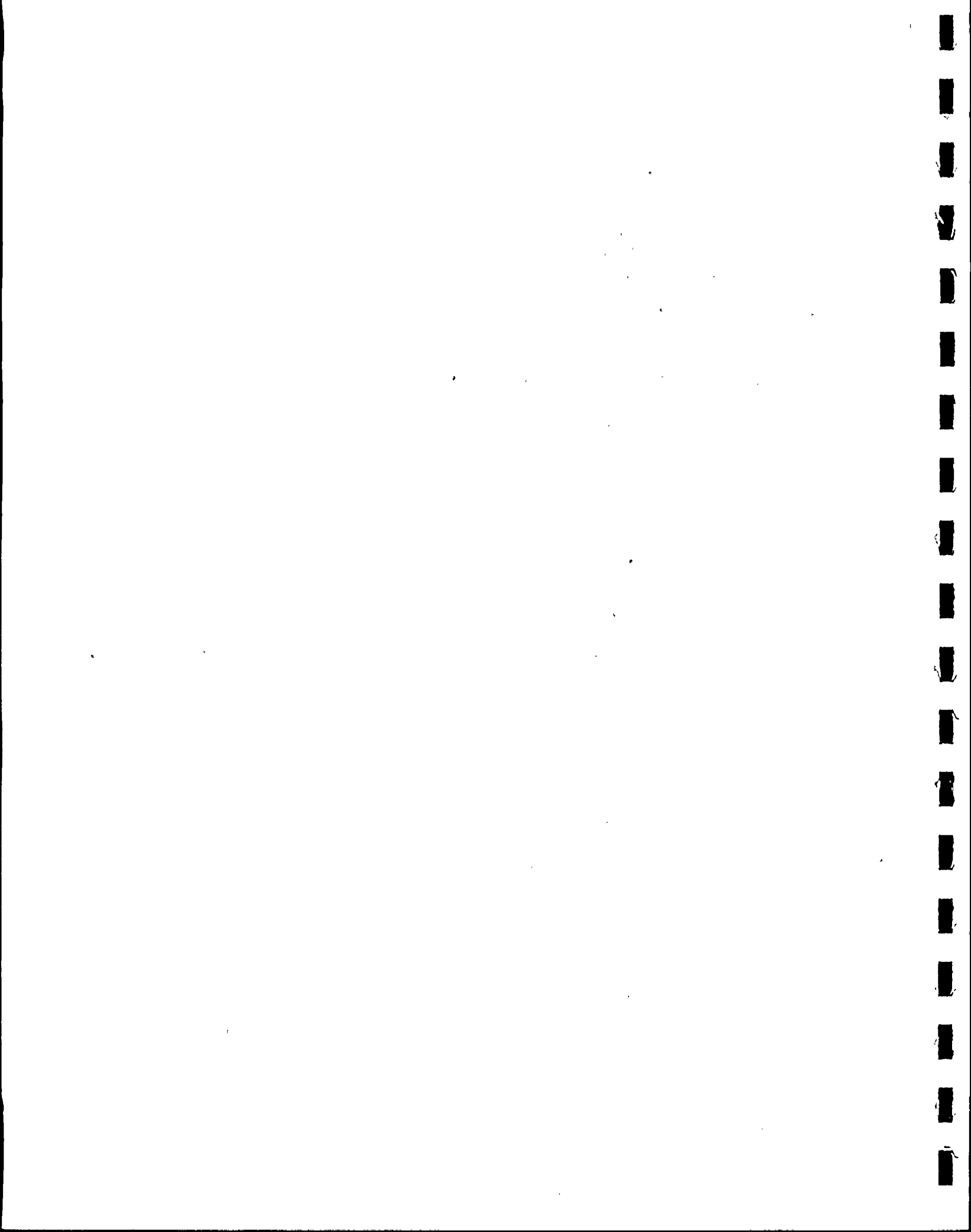
1973 was the initial year of significant construction activity at the project site. Under the present construction schedule, the first unit will be completed in 1981 and the second in 1982. Within that time frame it is possible to trace past and future manual work force needs at the project site. (See Figure III-1.)

Table III-5 indicates the average number of manual workers employed in August, 1978. The distribution of workers by occupational category would vary based on the construction phase.

Table III-5<sup>6</sup>

Distribution of Manual Employees  
by  
Labor Classification  
Susquehanna Steam Electric Station  
August, 1978

<u>CLASSIFICATION:</u> (1)	<u>WORKERS EMPLOYED</u> (2)		
	<u>PRIME</u> <u>CONTRACTOR</u>	<u>SUB</u> <u>CONTRACTORS</u>	<u>TOTAL</u>
Laborer	521	162	683
Carpenter	294	85	379
Operating Engineer	172	122	294
Electrician	640	34	674
Ironworker	209	58	267
Boilermaker	65	16	81



Pipefitter	885	75	960
Other <sup>(3)</sup>	<u>268</u>	<u>265</u>	<u>533</u>
T O T A L	3,054	817	3,871

Notes: (1) Include craft labor only, up through and including General Foreman

(2) Average number employed during month

(3) Includes all other craft labor

The 1976 monitoring study reported that over seventy percent (70%) of manual employees commuted from the Wilkes-Barre/Scranton area. Table III-6 reflects little change in those trends. Luzerne and Lackawanna Counties provide almost sixty percent (60%) of the manual work force. Figure III-2 indicates distance of Pennsylvania counties from the plant site.

#### D. Non-Manual Employees

This classification includes managerial, professional, technical and clerical workers. In 1978, the average number of non-manual personnel employed by Bechtel Power Corporation was expected to reach a peak of 658 employees. Actual and anticipated numbers of non-manual employees are listed in Table III-7.

Although significantly smaller in number than the manual work force, non-manual employees have a greater potential to affect some aspects of community infrastructure, such as schools, hospitals, emergency services, etc.

Initially, most of the non-manual personnel employed by Bechtel were transferred in from other Bechtel job locations. These "non-local" employees would, in most instances, relocate their families to the new job site area, placing additional demands on housing supply and area schools. More specific inquiries concerning community impacts associated with manual and non-manual personnel are addressed in Chapters V and VI of this report.

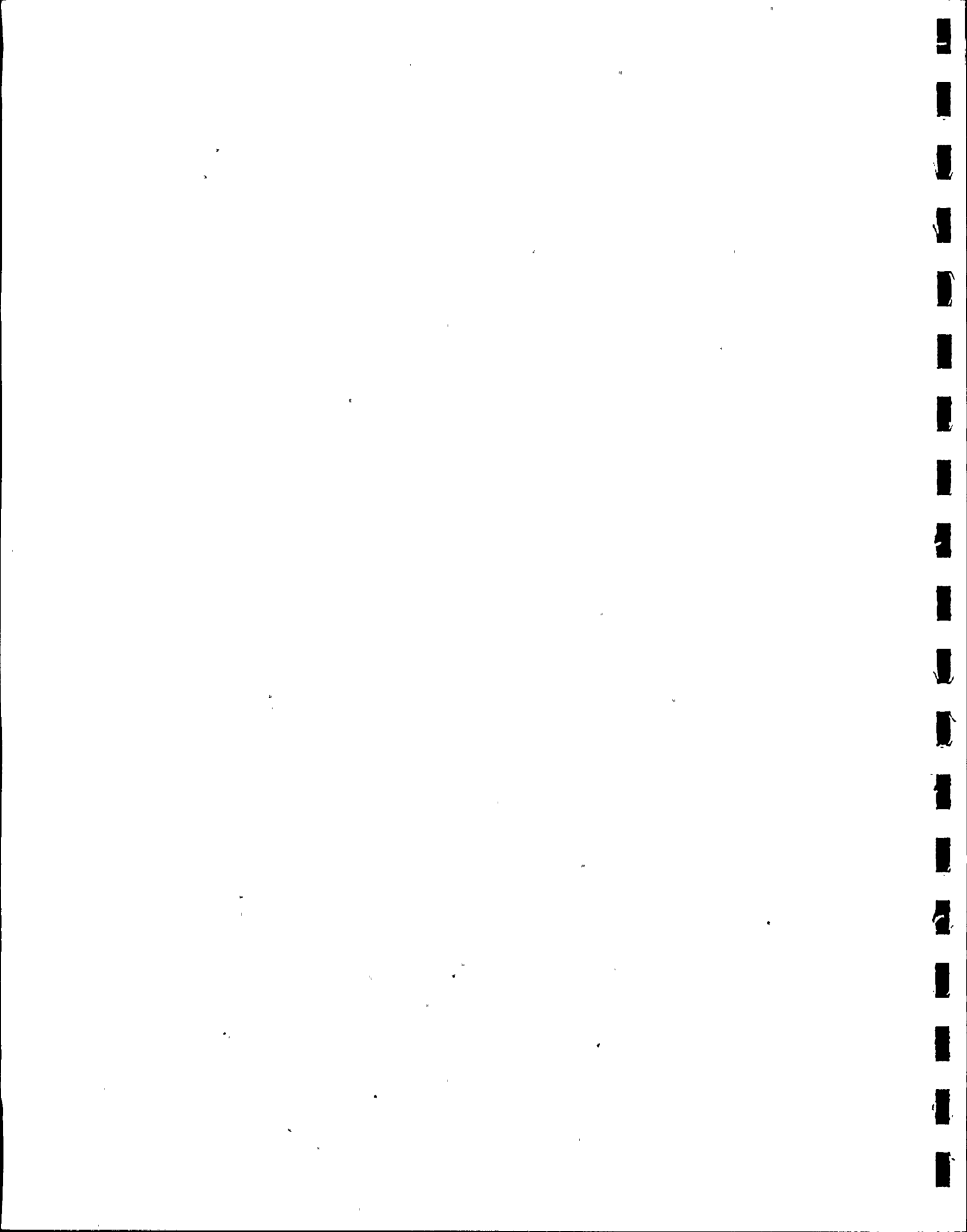
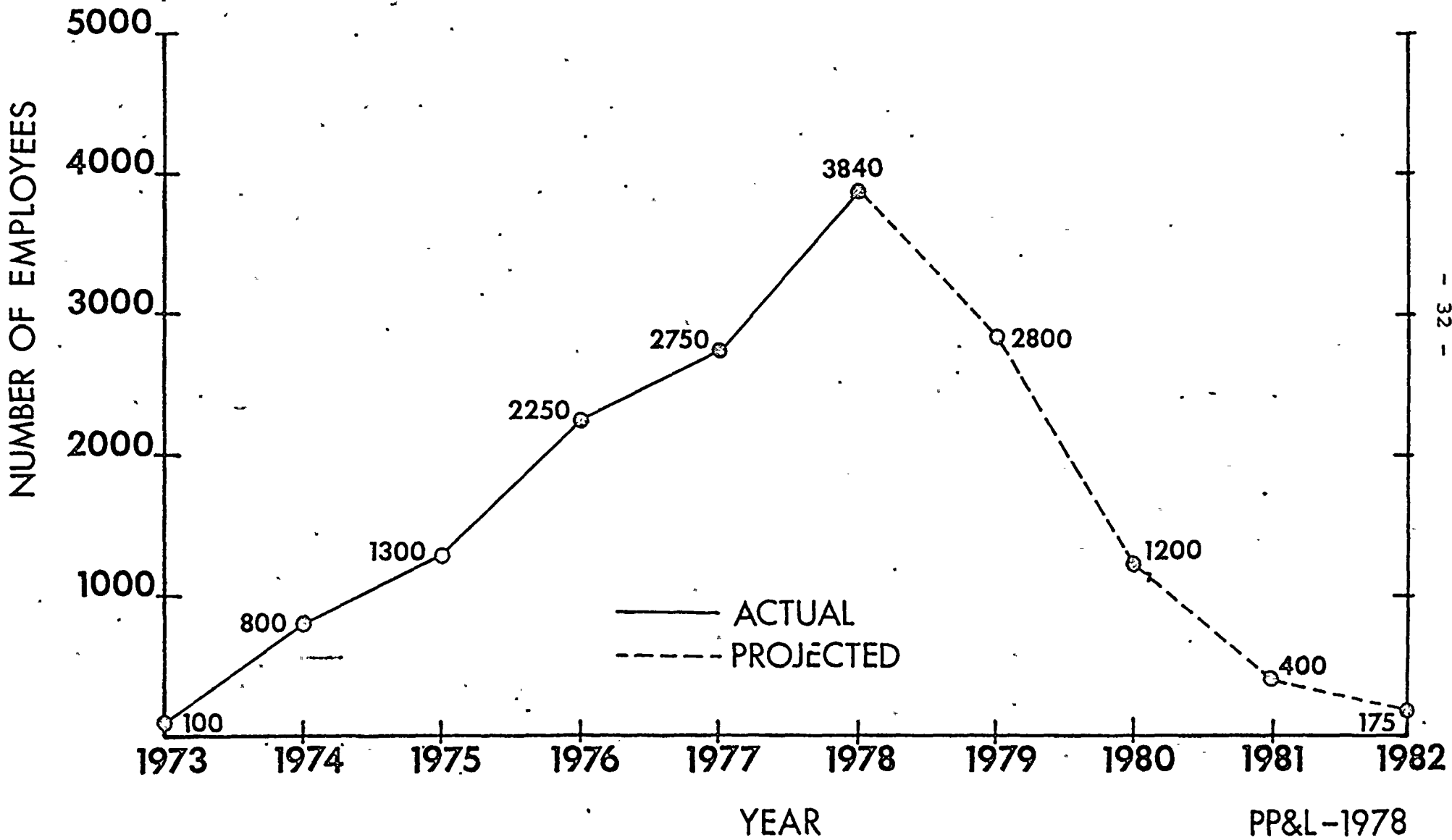


FIGURE III-1

# MANUAL EMPLOYEES ACTUAL AND PROJECTED SUSQUEHANNA STEAM ELECTRIC STATION



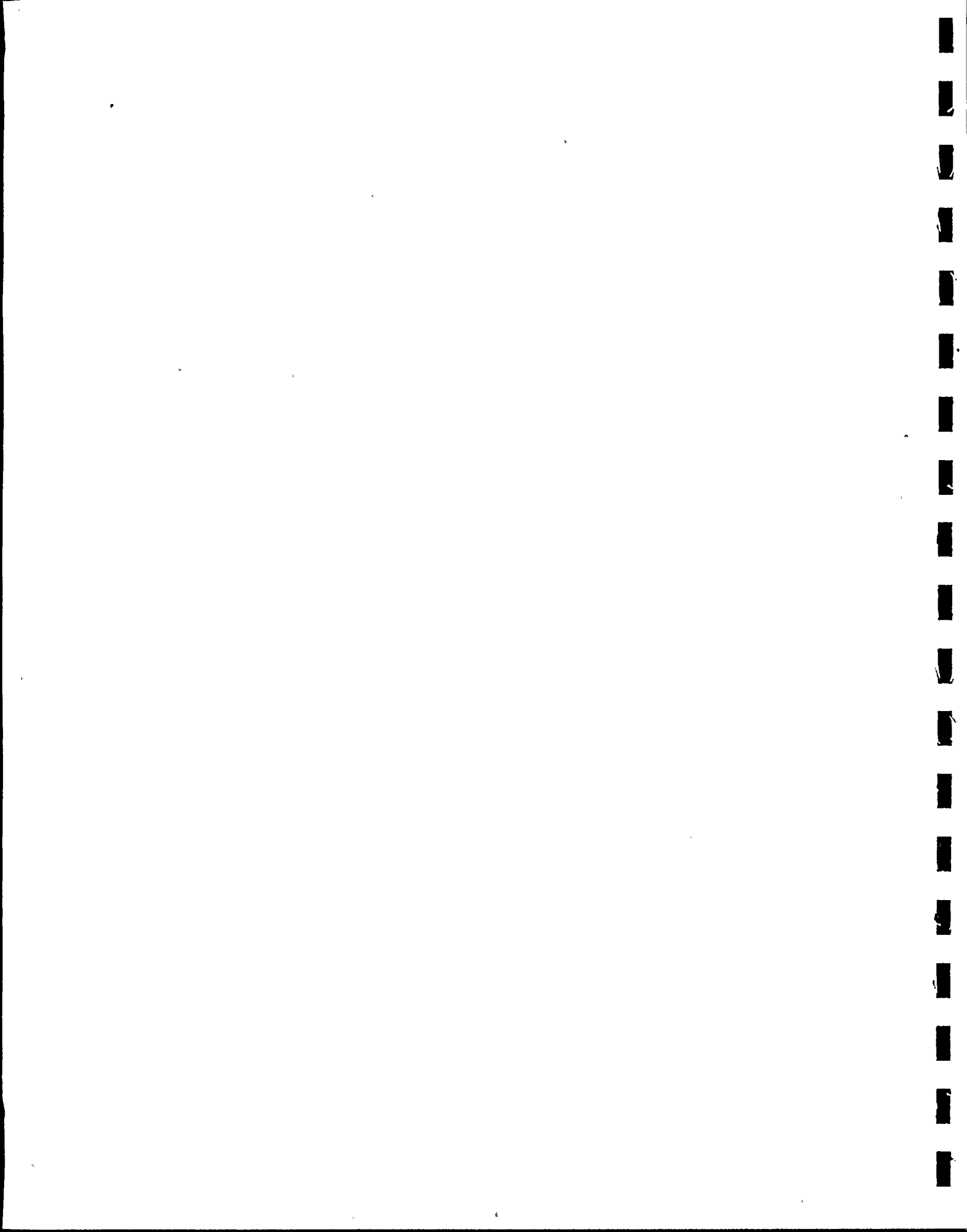




Table III-6<sup>7</sup>

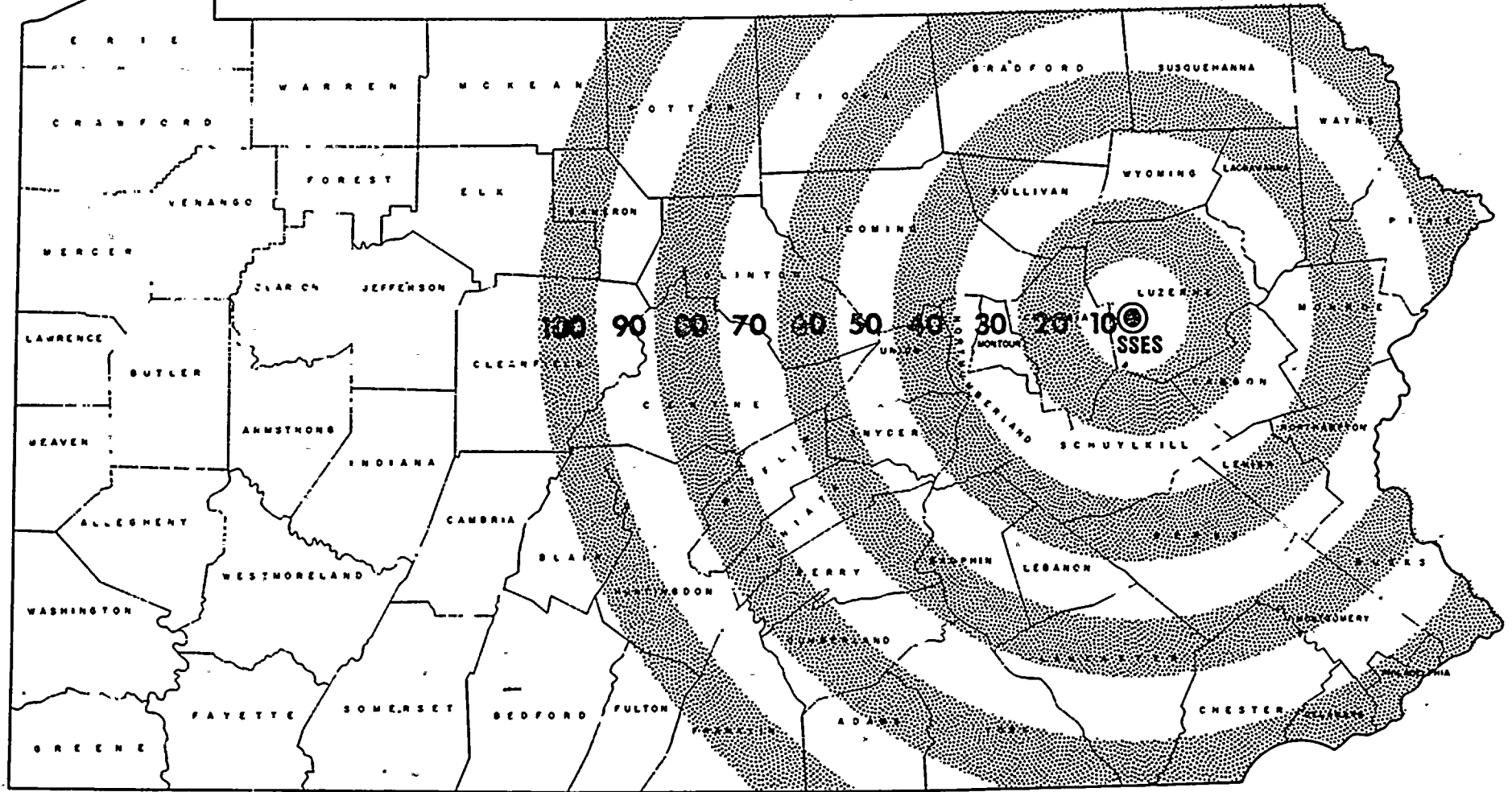
Residence of Manual Employees by County

1975 and 1978

<u>County</u>	<u>Number</u>		<u>Percent</u>	
	<u>1975</u>	<u>1978</u>	<u>1975</u>	<u>1978</u>
Luzerne	1122	1402	59	50
Lackawanna	239	243	13	8.6
Columbia	90	160	5	5.7
Schuylkill	77	252	4	9
Northumberland	64	142	3	5
Lycoming	35	110	2	3.9
Monroe	9	33	-	1.1
Dauphin	10	8	-	-
Lancaster	10	4	-	-
Wayne	12	0	-	-
Lebanon	11	1	-	-
Wyoming	38	0	2	-
Montour	3	0	-	-
Carbon	7	2	-	-
Cumberland	5	2	-	-
Juniata	3	1	-	-
Sullivan	5	0	-	-
Susquehanna	6	9	-	-
Perry	2	0	-	-
Pike	1	1	-	-
Tioga	1	1	-	-
Union	2	4	-	-
Bradford	2	0	-	-
Clinton	0	0	-	-
Snyder	2	5	-	-
Philadelphia	2	14	-	-
York	0	9	-	-
Adams	1	0	-	-
Bedford	0	0	-	-
Berks	4	20	-	-
Bucks	1	28	-	-
Crawford	0	0	-	-
Lehigh	3	61	-	2.2
Montgomery	1	5	-	-
Northampton	1	8	-	-
Wayne	0	31	-	-
Warren	0	0	-	-
Westmoreland	0	0	-	-
Centre	1	1	-	-
Delaware	1	1	-	-
Chester	0	1	-	-
Other States	118	236	6	8.3
Unknown	8	0	-	-
	1900	2795		



# DISTANCE FROM PLANT SITE (IN MILES)



DECEMBER 1978

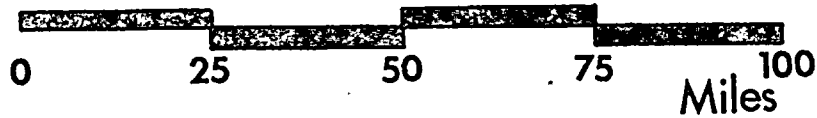


FIG. III-2

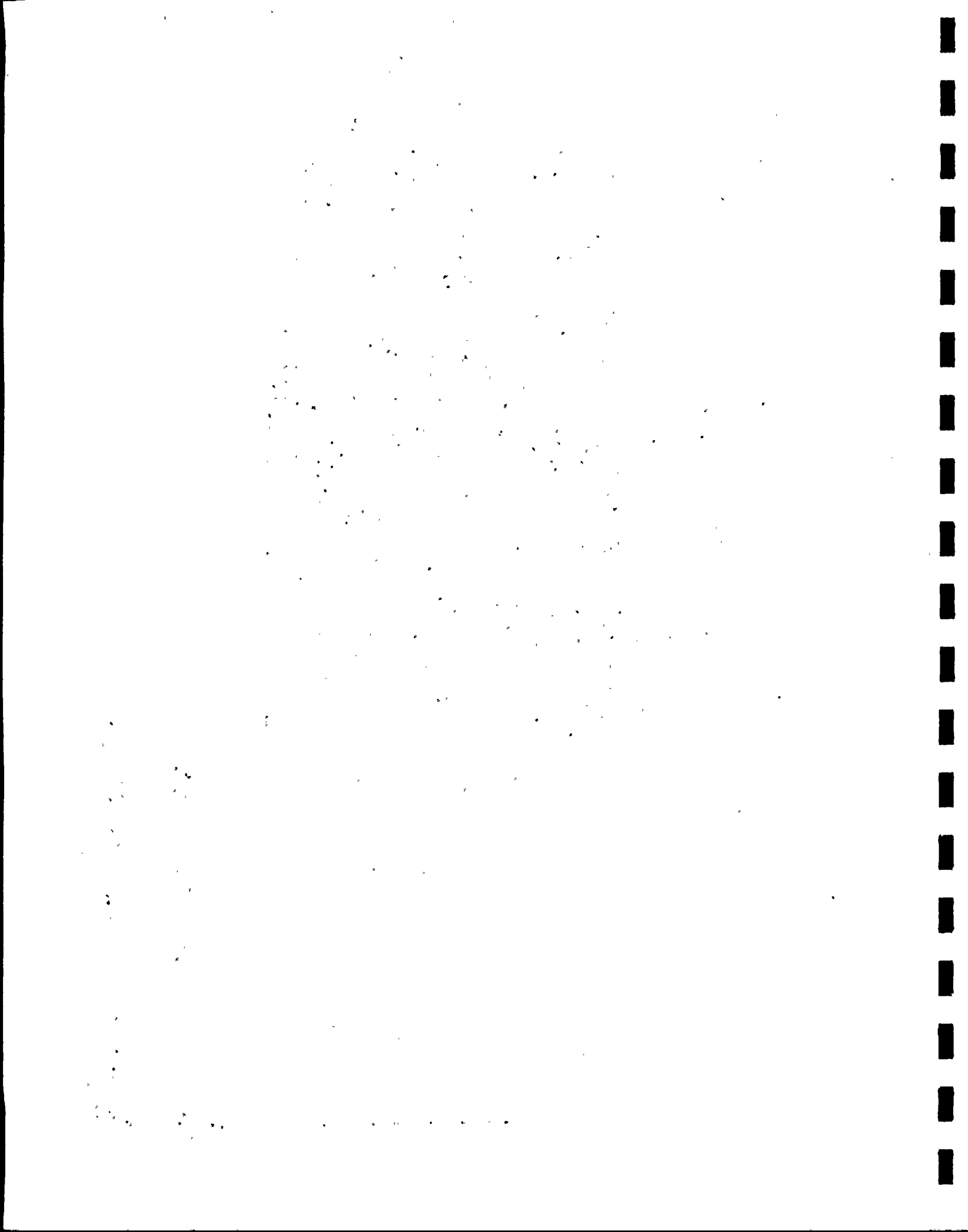


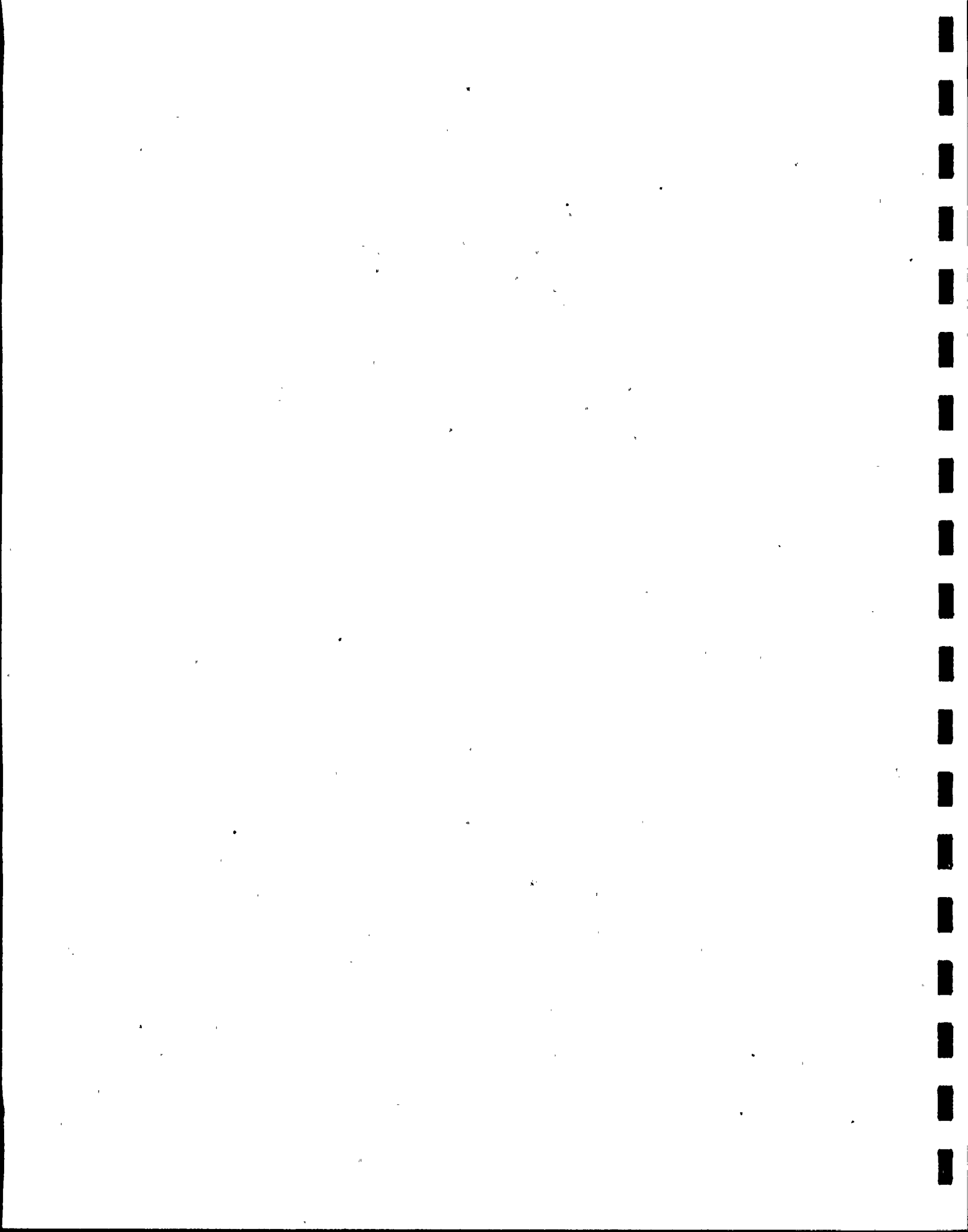
Table III-7<sup>8</sup>

Non-Manual Employees

Actual and Projected (Annual Average)

Susquehanna Steam Electric Station

<u>Year</u>	<u>Actual</u>	<u>Projected</u>
73	25	
74	175	
75	350	
76	465	
77	530	
78		658
79		628
80		472
81		256
82		90
83		0



E. PP&L Work Force

As construction on the SSES progresses, the size of the PP&L work force which operates the plant will gradually continue to expand beyond its present level of 168. These personnel are primarily involved in training and administrative operations in preparation of an anticipated start-up date in 1981. At that time, the entire work force required to operate and maintain the plant will consist of 356 persons, including security personnel.





Chapter III

S O U R C E S

- 1 . U.S. Census of Population, 1970 and "Current Population Reports: Population Estimates and Projections", Series P-25, No. 686, May 1977
- 2 U.S. Census of Population, 1970
- 3 "Current Population Reports: Population Estimates and Projections", Series P-25, No. 686, May 1977
- 4 PP&L Real Estate Department, September 1978
- 5 Bureau of Employment Security, Pennsylvania Department of Labor and Industry, unpublished data
- 6 Bechtel Power Corporation, SSES, March 1978
- 7 Bechtel Power Corporation, SSES Personnel Department, March 1978
- 8 Pennsylvania Power & Light Company, SSES Staff, May 1978



## CHAPTER IV

### LOCAL VIEWS ON COMMUNITY IMPACTS

The community impacts of plant construction as perceived by local residents are as important as information conveyed in quantitative evaluations of employee numbers or movements. In the initial 1976 community impact study, interviews were important in gauging community attitudes and documenting the most serious local impacts of early construction activities, i.e., noise, dust and alleged property damage.

The personal interview technique was also used for this update. A cross section of community officials, businessmen and educators was contacted in the summer and fall of 1978. The range and number of interviews were expanded over those conducted in 1975-76. Local viewpoints are categorized according to issues potentially affecting local communities in the plant site area.

#### A.. Housing

The 1976 community impact study suggested that plant construction could potentially affect housing costs and supply. The effects on housing were inconclusive, although local opinion indicated plant construction had a significant inflationary impact on local housing costs. On this point, local views seem to have remain unchanged. The director of the Columbia County Planning Commission felt that housing costs had been influenced by PP&L and Bechtel employees, largely because of the nature of the housing market in Columbia County.<sup>1</sup> Essentially a rural county with a history of slow economic growth, very little speculative building takes place. Houses are built on demand and are relatively modest three-bedroom homes. The planning director suggested that Bechtel and PP&L employees transferred into the region from other job locations were perhaps used to more "customized housing", offering greater diversity in architectural styles, amenities, size, etc. Generally higher incomes (than those paid in Columbia County) allowed project employees to build more expensive homes. He further suggested that the average cost of a new home was in the



"upper 30's" (exclusive of land costs) and that Bechtel personnel were building homes considerably in excess of that cost.\*

With the exception of the above effects on housing, the Columbia County Planning Commission staff saw little impact on planning concerns raised by SSES construction.

Local realtors provided additional views on the local housing market. A local Bloomsburg realtor suggested that housing costs in the Bloomsburg area have "doubled" since 1970, with a typical split level home costing \$60,000 (exclusive of land costs)<sup>2</sup>. While acknowledging rising housing costs, the realtor was uncertain how much of the increases were associated with plant construction. He did note, however, that certain portions of Columbia County began to develop a significant second home market in the early 1970's which was curtailed following the OPEC oil embargo and subsequent gasoline price rises.

The subsequent drop off in second home construction was more noticeable than inflationary impacts on the market associated with project construction. The realtor also confirmed that speculative housing is not strong in the Bloomsburg area which, he believed, was because of the absence of local bank support.

A local Berwick realtor stated that although housing demand had been dropping off in the Berwick area since 1972, SSES construction had resulted in increased inflationary impacts on the local market<sup>3</sup>. A major reason, he believed, for reduced housing activity was the proliferation of regulatory controls which discouraged local development.

#### B. Local Economy/Employment

The 1976 report indicated local concern over the relative absence of employment opportunities in Columbia County. And although the report indicates substantial boosts to the local economy, local opinion suggests that construction of the plant has done little to improve economic conditions. A Salem Township supervisor reflected that only two small restaurants had

---

\* Chapter V, Local Economic Impacts, examines rises in market value and assessed value for residential properties since 1973 in the project area.



opened along Route 11 in Salem Township.<sup>4</sup> Similarly, a vice president of a Berwick bank also observed that plant construction had not appreciably increased retail trade in Berwick<sup>5</sup>.

The reason for the absence of retail trade, according to the Columbia County Economic Development Coordinator<sup>6</sup>, is clearly associated with the movement of workers to and from the plant site. Economic benefits to local communities are commensurate to levels of local employment, which, in the case of Columbia County, are small. Local programs to improve the economy, such as those of the Bloomsburg Industrial Development Authority, had greater effect on the local economy than SSES construction.

This view was supported by the Mayor of Berwick who noted that a number of older established businesses had closed their doors since 1970, including the town's only hotel and a major furniture store. Some local fast food stores may be benefiting, he claimed, but there is no significant improvement in retail trade.

The project's lack of impact on local employment was also noted and apparently accepted by local persons. Berwick's Mayor acknowledged that, while the project offered opportunities for employment at higher wages than local markets, the number of tradespeople employed from the Berwick-Bloomsburg area seemed small. He recognized that the jurisdictions of local unions had an effect on local hiring practices.\*

---

\* As pointed out in the 1976 study, the SSES site is located within the jurisdictional boundaries of the Northeast Pennsylvania Building and Trades Council, which includes the major labor market areas in Luzerne and Lackawanna Counties. Consequently, most manual employees at the project site reside in the Wilkes-Barre/Scranton area. Only one craft union, Masons and Bricklayers, has jurisdiction within Columbia County. During the initial period of project construction in the early seventies, expectations were high that the plant would have a strong, positive effect on local employment. Strong disappointment was registered when these expectations were not met.

1  
2  
3  
4  
5  
6  
7  
8  
9  
10  
11  
12  
13  
14  
15  
16  
17  
18  
19  
20  
21  
22  
23  
24  
25  
26  
27  
28  
29  
30  
31  
32  
33  
34  
35  
36  
37  
38  
39  
40  
41  
42  
43  
44  
45  
46  
47  
48  
49  
50  
51  
52  
53  
54  
55  
56  
57  
58  
59  
60  
61  
62  
63  
64  
65  
66  
67  
68  
69  
70  
71  
72  
73  
74  
75  
76  
77  
78  
79  
80  
81  
82  
83  
84  
85  
86  
87  
88  
89  
90  
91  
92  
93  
94  
95  
96  
97  
98  
99  
100



C. Educational Facilities

Construction of the SSES has not required local school districts to expand their physical plants, largely as a result of two factors: (1) the proximity of a labor market sufficient to supply most manpower requirements, and (2) a history of declining school enrollments in Columbia County.

According to recent projections (see Chapter VI, Table VI-1), all school districts in Columbia County will face continuing enrollment declines, at least until 1983<sup>8</sup>. Among the affected school districts, Berwick faces a projected drop in enrollment of 528 students, over twelve percent (12%) of current enrollment. Although he believes the projections of the Pennsylvania Economy League to be high by over 100 students, the Berwick Area School District Superintendent nevertheless feels the location of the SSES in his district may exacerbate enrollment losses<sup>9</sup>. Berwick Area School District currently enrolls more children of Bechtel employees than any other school district in Columbia County. The district is likely to lose most of these students as Bechtel personnel move onto new job locations as the SSES project nears completion. Some of these losses might be replaced as PP&L operational staff move into the area, but the district suffers from an adverse image rising from a building program controversy. While the controversy seems to have resolved itself with the recent completion of a federally funded junior high school, a July 1976 news article commented on the effect of the school district's problems on the housing market:

Bob Ager, with Sweeney and Lukens Real Estate, also noted that people are steering clear of buying in the Berwick area. "Seven out of ten people want Central or Benton," he said. "People just don't realize the effect that the school system has. Even though the problems may not be as bad as some people think, new people coming into the area hear the reports about the schools and don't want to move to Berwick. The people who do move into Berwick are generally older couples who don't have children anyhow."<sup>10</sup>

The Berwick superintendent also expressed a concern that newcomers to Columbia would choose not to live in the Berwick area because of its proximity to a nuclear plant. He further



indicated that the land owned by PP&L for the project and related uses, over 1,000 acres in Salem Township, preempts future residential uses. The loss of this land for residential development could make it more difficult to stabilize declining enrollments.

D. General Community Impacts

With a few exceptions, SSES construction has avoided any of the "boom town" syndromes experienced with some large energy-related projects in other parts of the country. Local officials in Salem Township (location of the plant site) and the adjoining communities of Shickshinny and Berwick have stated that no physical facilities had to be expanded or rehabilitated as a result of SSES construction. The Borough of Shickshinny, a small community four miles northeast of the plant site, has recently undergone extensive surface and subsurface improvements to streets, water and sewer systems, sidewalks, curbs and related site improvements. All of these improvements, however, were conducted as part of a disaster renewal effort to repair the damages of Tropical Storm Agnes in 1972.<sup>11</sup>

Shickshinny found it necessary to supplement its one-man police force to control traffic flows at two intersections in the town's center. Traffic volumes at peak hour caused traffic control problems in the Borough as well as hampering egress across a bridge which served an adjoining small community across the Susquehanna River.

Although no mass transit systems serve the project site, an ad hoc system was developed among construction personnel, perhaps in response to some of the traffic conditions referred to above. By September of 1978, fourteen (14) buses were delivering workers to the plant site from seven (7) communities. These "bus pools" were arranged and coordinated by groups of individual workers.<sup>12</sup>

Despite the increase in traffic near the site and the concentrations of vehicles at the site, state police in the project area report no arrests have been made at the site. An increase in the total number of calls since 1972 within their service area has occurred, but no increases could be related to plant construction.<sup>13</sup>

Many of the local administrators and officials indicated that the absence of impacts on community infrastructure or facil-

1  
2  
3  
4  
5  
6  
7  
8  
9  
10  
11  
12  
13  
14  
15  
16  
17  
18  
19  
20  
21  
22  
23  
24  
25  
26  
27  
28  
29  
30  
31  
32  
33  
34  
35  
36  
37  
38  
39  
40  
41  
42  
43  
44  
45  
46  
47  
48  
49  
50  
51  
52  
53  
54  
55  
56  
57  
58  
59  
60  
61  
62  
63  
64  
65  
66  
67  
68  
69  
70  
71  
72  
73  
74  
75  
76  
77  
78  
79  
80  
81  
82  
83  
84  
85  
86  
87  
88  
89  
90  
91  
92  
93  
94  
95  
96  
97  
98  
99  
100

ities was because few people associated with the plant moved into the area. As a result, frictions and community tensions which often develop when "outsiders" move into a community, did not develop locally to any significant degree.

In April of 1978, a Bloomsburg paper printed a letter apparently written by wives of several Bechtel employees. The letter complained of price gouging, housing discrimination and other harassment. A Berwick newspaper subsequently editorialized on the complaint and expressed the hope that such incidents were isolated. In a later interview, the editor of the Berwick Enterprise indicated that incidents of the type described in the letter probably occurred but that hostility or discrimination against anyone associated with the SSES was not a widespread problem. The employees associated with the project have been accepted into the community in much the same way the community has accepted the physical presence of the plant.<sup>14</sup>

The editor of the Berwick Enterprise, as well as several local realtors and school officials, expressed concern over the possibility of certain recessionary impacts following completion of the SSES project. According to opinions expressed, high salaries paid to Bechtel employees afforded them opportunities to construct homes having a value greater than most houses offered by the local market. Once Bechtel employees move to new job locations, the local housing market will not provide sufficient buyers for what is considered to be more expensive housing. Similarly, the completion of project construction will significantly affect employment and earnings in the construction trades, according to a local labor union official.<sup>15</sup> Since 1972, the ranks of the local unions have grown in Luzerne and Lackawanna Counties. Much of that growth is attributed to the SSES construction. He expressed a belief that residential construction would be able to pick up some of the released labor force, assuming the "layoffs were orderly." Even with growth in residential construction, he expected decreases in union memberships following completion of SSES construction. He further indicated that one major effect would likely be a change in income once the plant had closed. Many of the workers at the plant from the Luzerne-Lackawanna Counties, he suggested, had become accustomed to high wages and long-term employment. He characterized employment in the Luzerne County area as "short-term residential construction" of a type which will materially reduce worker income.

1  
2  
3  
4  
5  
6  
7  
8  
9  
10  
11  
12  
13  
14  
15  
16  
17  
18  
19  
20  
21  
22  
23  
24  
25  
26  
27  
28  
29  
30  
31  
32  
33  
34  
35  
36  
37  
38  
39  
40  
41  
42  
43  
44  
45  
46  
47  
48  
49  
50  
51  
52  
53  
54  
55  
56  
57  
58  
59  
60  
61  
62  
63  
64  
65  
66  
67  
68  
69  
70  
71  
72  
73  
74  
75  
76  
77  
78  
79  
80  
81  
82  
83  
84  
85  
86  
87  
88  
89  
90  
91  
92  
93  
94  
95  
96  
97  
98  
99  
100

CHAPTER IV

S O U R C E S

- 1 Personal interview with Mr. Robert Beishline, Director, Columbia Cojnty Planning Commission and Staff Planner, Mr. Gary Hildebrandt, June 8, 1978.
- 2 Personal interview with Mr. John Robison, Robison Agency, Bloomsburg, Pennsylvania, June 16, 1978.
- 3 Personal interview with Mr. Ron Kile, J. D. Kile Realtors, Berwick, Pennsylvania, June 16, 1978.
- 4 Personal interview with Mr. Clyde Bowers, Salem Township, Supervisor, August 11, 1978.
- 5 Personal interview with Mr. Leroy Burdis, Vice President, First Eastern Bank, August 11, 1978.
- 6 Personal interview with Mr. Stephan Philips, Columbia County Economic Development Coordinator, September 28, 1978.
- 7 Personal interview with Mr. Louis Biacchi, Mayor, Berwick, Pennsylvania, August 11, 1978.
- 8 "Columbia County Public School Enrollment Trends and Projections", Pennsylvania Economy League, May 1978.
- 9 Personal interview with Mr. Lee Cook, Superintendent, Berwick Area School District, October 5, 1978.
- 10 Columbia County Sentinel, "Why Are Home Buyers Saying 'No' to Berwick", July 9, 1976.
- 11 Personal interview with Mr. Donald Hargraves, Mayor, Shickshinny, Pennsylvania, August 11, 1978.
- 12 Mr. Al Clarke, Bechtel Power Corporation Personnel Department, SSES site, September 1978.
- 13 Personal interview with Sargent Tony Matson, Pennsylvania State Police, Shickshinny Barracks, August 11, 1978.
- 14 Bloomsburg Morning Press, April 15, 1978; Berwick Enterprise, April 15, 1978; personal interview with Mr. J. W. Smith, Editor, Berwick Enterprise, October 5, 1978.

1  
2  
3  
4  
5  
6  
7  
8  
9  
10  
11  
12  
13  
14  
15  
16  
17  
18  
19  
20  
21  
22  
23  
24  
25  
26  
27  
28  
29  
30  
31  
32  
33  
34  
35  
36  
37  
38  
39  
40  
41  
42  
43  
44  
45  
46  
47  
48  
49  
50  
51  
52  
53  
54  
55  
56  
57  
58  
59  
60  
61  
62  
63  
64  
65  
66  
67  
68  
69  
70  
71  
72  
73  
74  
75  
76  
77  
78  
79  
80  
81  
82  
83  
84  
85  
86  
87  
88  
89  
90  
91  
92  
93  
94  
95  
96  
97  
98  
99  
100



- 15 Phone conversation with Mr. Charles DePolo, Secretary-Treasurer, Northeast Pennsylvania Building & Trades Council, Plains, Pennsylvania, September 13, 1978.

R  
E  
V  
I  
S  
I  
O  
N  
S  
O  
F  
T  
H  
E  
S  
E  
P  
A  
G  
E  
S  
A  
R  
E  
I  
N  
T  
E  
N  
D  
E  
D  
F  
O  
R  
C  
O  
R  
R  
E  
C  
T  
I  
O  
N  
S  
O  
N  
L  
Y  
I  
F  
T  
H  
E  
R  
E  
I  
S  
A  
N  
E  
R  
E  
C  
O  
R  
D  
S  
O  
F  
T  
H  
E  
S  
E  
P  
A  
G  
E  
S  
A  
R  
E  
I  
N  
T  
E  
N  
D  
E  
D  
F  
O  
R  
C  
O  
R  
R  
E  
C  
T  
I  
O  
N  
S  
O  
N  
L  
Y

CHAPTER V

LOCAL ECONOMIC IMPACTS

A. Wage Distribution

Direct economic impacts can be gauged by the amount of money entering communities in the form of wages and salaries. The 1976 report projected a distribution of total wages for the life of the construction period as follows:

Table V-1

Projected Distribution of Total Wages: 1973-82<sup>1</sup>

<u>County</u>	<u>Manual Employees</u>	<u>%</u>	<u>Non-Manual Employees</u>	<u>%</u>
Luzerne	\$168 Million	60	\$15 Million	23
Columbia	14 Million	5	44 Million	68
Lackawanna	36 Million	13	- - - -	--
Other	<u>62 Million</u>	<u>22</u>	<u>6 Million</u>	<u>9</u>
	\$280 Million	100	\$65 Million	100

Estimated distribution of first quarter wages (1978) and salaries are reported in Table V-2:

Table V-2

Distribution of Total Wages: 1st Quarter 1978<sup>2</sup>

<u>County</u>	<u>Manual Employees</u>	<u>%</u>	<u>Non-Manual Employees</u>	<u>%</u>
Luzerne	\$ 7.45 Million	50	\$ .75 Million	28
Columbia	.89 Million	16	1.68 Million	63
Lackawanna	1.34 Million	9	.05 Million	2
Other	<u>5.21 Million</u>	<u>35</u>	<u>.19 Million</u>	<u>7</u>
	\$14.89 Million	100	\$2.67 Million	100

1  
2  
3  
4  
5  
6  
7  
8  
9  
10  
11  
12  
13  
14  
15  
16  
17  
18  
19  
20  
21  
22  
23  
24  
25  
26  
27  
28  
29  
30  
31  
32  
33  
34  
35  
36  
37  
38  
39  
40  
41  
42  
43  
44  
45  
46  
47  
48  
49  
50  
51  
52  
53  
54  
55  
56  
57  
58  
59  
60  
61  
62  
63  
64  
65  
66  
67  
68  
69  
70  
71  
72  
73  
74  
75  
76  
77  
78  
79  
80  
81  
82  
83  
84  
85  
86  
87  
88  
89  
90  
91  
92  
93  
94  
95  
96  
97  
98  
99  
100

Actual distribution of wages closely approximated projected estimates except the "Other" categories, which are somewhat higher than originally projected. Most of the increase over projected wages resulted from higher manual employment from Schuylkill and Northumberland Counties.

Wages paid to plant personnel return to local communities and represent a direct economic benefit in the form of local purchases, particularly when evaluated in terms of a "multiplier effect" stimulated by wages spent by plant employees. The multiplier effect assumes that local merchants will, in turn, spend a portion of wages received for purchase of local goods and services and that the cycle will continue with decreasing impacts. The 1976 community impact report estimated an additional multiplier expenditure in Luzerne County of \$366 Million and \$87 Million in Columbia County through 1982.

B. Purchase of Goods and Services

The local economy has benefited from purchase of goods and services from local vendors, but not to the extent of other locations outside of the project region. Table V-3 indicates purchases for selected years by county:

Table V-3

Expenditures With Local Vendors (\$000)<sup>3</sup>

	<u>Luzerne</u>	<u>Columbia</u>	<u>Lackawanna</u>	<u>Other Pa.</u>
1974	\$ 2,269	\$ 555	\$ 643	\$ 4,269
1975	1,128	308	448	3,083
1976		(UNAVAILABLE)		
1977	137	592	126	5,992

As indicated in Table V-3, local counties have not compared favorably with the remainder of the state in terms of contract volume. Local contracts tended to be for conventional construction materials and erection of facilities for construction and administrative buildings. Larger volume contracts for specialized construction materials or engineering services were generally placed in the Pittsburgh or Philadelphia areas where they were more readily available.

1  
2  
3  
4  
5  
6  
7  
8  
9  
10  
11  
12  
13  
14  
15  
16  
17  
18  
19  
20  
21  
22  
23  
24  
25  
26  
27  
28  
29  
30  
31  
32  
33  
34  
35  
36  
37  
38  
39  
40  
41  
42  
43  
44  
45  
46  
47  
48  
49  
50  
51  
52  
53  
54  
55  
56  
57  
58  
59  
60  
61  
62  
63  
64  
65  
66  
67  
68  
69  
70  
71  
72  
73  
74  
75  
76  
77  
78  
79  
80  
81  
82  
83  
84  
85  
86  
87  
88  
89  
90  
91  
92  
93  
94  
95  
96  
97  
98  
99  
100

C. Local Taxes

1. Real Estate Tax Rates

Table V-4 indicates that combined real estate tax rates increased between 1975 and 1978 in all municipalities, except Scott Township in Columbia County, a trend reflected in both Columbia and Luzerne Counties. Rate changes ranged from a drop of 1.5 mills in the municipal rate of Scott Township to an increase of 22 mills in the Bloomsburg School District.

It is unlikely that construction of the SSES significantly influenced tax rate changes in the municipalities listed in Table V-4, owing primarily to the relatively small number of construction personnel taking up residence in the project area.

It is also interesting to note that although most rate increases were levied by school districts, school enrollments in both Luzerne and Columbia Counties have been declining since 1969-70 and are expected to continue to do so for at least the next five years.<sup>5</sup>

2. Tax Impacts: Salem Township

Because of existing local and state tax structures, Salem Township is likely to experience the greatest tax impact associated with SSES construction. In addition to the real estate tax rates reported in Table V-4, Salem Township levies the following nonproperty taxes:

Table V-5

Salem Township Nonproperty Taxes<sup>6</sup>

	<u>Municipal</u>	<u>School</u>
1. Per Capita	\$ 5.00	\$10.00
2. Earned Income	½%	½%
3. Occupational Privilege	\$ 5.00	\$ 5.00
4. Real Estate Transfer	½%	½%





Table V-4

Real Property Tax Rates, 1975 and 1978<sup>4</sup>

## Tax Rate - Millage

	1975		1978		Change	
	<u>Municipality</u>	<u>SD*</u>	<u>Municipality</u>	<u>SD</u>	<u>Municipality</u>	<u>SD</u>
Berwick	12.0	47.0	12.0	55.0	---	8.0
Briar Creek Borough	6.0	47.0	6.0	55.0	---	8.0
Briar Creek Township	5.0	47.0	5.0	55.0	---	8.0
Salem Township	1.5	47.0	1.5	52.3	---	5.3
Hollenback Township	5.0	47.0	5.0	52.3	---	5.3
North Centre Township	3.0	66.0	3.0	77.0	---	11.0
South Centre Township	2.0	66.0	3.0	77.0	1.0	11.0
Scott Township	6.5	66.0	5.0	77.0	(1.5)	11.0
Bloomsburg	15.0	52.0	15.0	77.0	---	22.0
Conyngham Township	2.0	51.0	2.0	71.0	---	20.0
Columbia County	12.5		15.0		2.5	
Luzerne County	16.2		18.0		1.8	

\* SD - School District

1  
2  
3  
4  
5  
6  
7  
8  
9  
10  
11  
12  
13  
14  
15  
16  
17  
18  
19  
20  
21  
22  
23  
24  
25  
26  
27  
28  
29  
30  
31  
32  
33  
34  
35  
36  
37  
38  
39  
40  
41  
42  
43  
44  
45  
46  
47  
48  
49  
50  
51  
52  
53  
54  
55  
56  
57  
58  
59  
60  
61  
62  
63  
64  
65  
66  
67  
68  
69  
70  
71  
72  
73  
74  
75  
76  
77  
78  
79  
80  
81  
82  
83  
84  
85  
86  
87  
88  
89  
90  
91  
92  
93  
94  
95  
96  
97  
98  
99  
100

It should also be noted that under the provisions of the Public Utility Realty Tax Act (PURTA), local taxing jurisdictions are preempted from directly collecting taxes on utility facilities. Instead, taxes are collected by the state and reapportioned to local governments based on a procedure established under the legislation. Presumably, the intent of the legislation is to prevent individual communities from reaping "excessive" tax revenues from large utility facilities.

Using available data, it is possible to examine Salem Township's tax revenue situation with and without the SSES from 1973 to 1978.

Of the taxes listed in Table V-5, the most significant revenue producer for Salem Township is likely to be the occupational privilege tax. This tax is levied at a flat rate upon persons employed in a taxing jurisdiction. The tax is limited to \$10.00 on individual taxpayers. When overlapping taxing jurisdictions levy rates which, in combination, exceed the \$10.00 statutory maximum, their combined rates are automatically reduced to \$10.00. To a lesser extent, Salem Township will benefit from its local income tax as well as from revenues received through PURTA. Based on five years of construction, estimated tax revenues to Salem Township associated with SSES construction are as follows:

Table V-6

Estimated Tax Revenues\* to  
Salem Township SSES Construction 1973-78

1. Occupational Privilege Tax (2,615 average annual work force x \$10.00 x 5 years)	\$130,750
2. Earned Income Tax (Estimate)	10,650
3. PURTA <sup>7</sup> Revenues	<u>7,282</u>
	\$148,682

---

\* Does not include transfer tax revenues to Salem Township resulting from sale of 10 percent (10%) interest in SSES to Allegheny Electric Cooperative, Inc.



The impact of these revenues is diminished, however, by the loss of rateable property (over 500 acres) pursuant to PURTA provisions. Based on current (1978) millage rates, annual property taxes (local and school district) would amount to approximately \$4,100 (or, \$20,500 over a five-year period) on that property no longer subject to local taxation.

Consequently, Salem Township has benefited during the construction period to date by over \$120,000 in tax revenues beyond that which would have been collected via local property taxes without plant construction. Similar benefits could be anticipated through 1982-83. Following plant construction, however, revenues from the occupational privilege tax and local income tax will be reduced significantly and will be offset only to the extent that plant operational staff move into Salem Township. Once the construction phase is completed, it is questionable whether revenues from the three sources in Table V-6 would replace foregone property tax revenues.

D. Local Economic Impacts

1. Housing Costs

Discussions with local realtors and area residents suggest a common belief that SSES construction has had a significant inflationary impact on housing costs on the plant site area. The 1976 report addressed this issue, but no conclusions were reached.

While some effort was made in 1978 to obtain past and present housing cost data from local realtors, more comprehensive data was obtained from the State Tax Equalization Board (STEB). This agency develops school subsidy formulae for apportioning state funds to school districts. STEB compiles annually the total market value, i.e., sales price, of all residential transactions in each county of the state based on deeds filed with the county assessor. A ratio of assessed value to market value for each municipality is used by STEB as part of their subsidy formula.

These ratios are useful for measuring changes in housing



costs in individual communities. In addition to being current and updated annually, the STEB methodology compensates for differences in assessment and millage rates so that individual communities can be compared. Table V-7 below illustrates changes in the assessment/market value ratios for selected communities in the plant site area during the period from 1973 to 1977. The table also lists information for several communities similar in demographic and economic conditions to the Bloomsburg-Berwick area yet sufficiently removed from the site to minimize the plant's influence on the local economy. These "test communities" are Milton, Sunbury and Selinsgrove and are located approximately forty-five (45) miles southwest of the plant site; they had 1970 populations of 7,225, 13,025 and 5,100 respectively.

Table V-7

Ratio of Assessed Value to Market Value

Residential Properties<sup>8</sup>

1973-1977

<u>Community</u>	<u>1973</u>	<u>1974</u>	<u>1975</u>	<u>1976</u>	<u>1977</u>	<u>% Change 1973-1977</u>
Bloomsburg	.171	.147	.141	.134	.117	32
Berwick	.169	.153	.135	.139	.128	24
South Centre Twp. (Columbia Co.)	.176	.153	.136	.140	.120	32
Milton	.186	.138	.148	.138	.125	33
Sunbury	.206	.176	.153	.145	.136	34
Selinsgrove	----	.189	.150	.152	.139	26

The ratio of assessed value to market value declined in all communities during the five-year period, indicating





greater increases in market value relative to assessed value. The percentage change in the last column indicates the overall rate at which market value increased relative to assessed value. For those communities within the plant site area, Berwick demonstrated the least appreciation in market value. This generally agrees with the local perception that property rose in value at a greater rate in outlying areas. It is notable, however, that appreciation in market value was slightly greater in communities removed from the project area. None of the "test communities" exhibited an economic growth nor major construction projects which would have influenced housing costs. Consequently, it would appear that the increased housing costs in the vicinity of the plant were not significantly different from similar communities in the region.

2. Food Costs

Food costs were examined both in project area communities and in communities outside of the project area. The results of a market basket comparison conducted during the summer of 1978 are presented in Table V-8.

1  
2  
3  
4  
5  
6  
7  
8  
9  
10  
11  
12  
13  
14  
15  
16  
17  
18  
19  
20  
21  
22  
23  
24  
25  
26  
27  
28  
29  
30  
31  
32  
33  
34  
35  
36  
37  
38  
39  
40  
41  
42  
43  
44  
45  
46  
47  
48  
49  
50  
51  
52  
53  
54  
55  
56  
57  
58  
59  
60  
61  
62  
63  
64  
65  
66  
67  
68  
69  
70  
71  
72  
73  
74  
75  
76  
77  
78  
79  
80  
81  
82  
83  
84  
85  
86  
87  
88  
89  
90  
91  
92  
93  
94  
95  
96  
97  
98  
99  
100

Table V-8  
 MARKET BASKET COMPARISON  
 FOR  
 SELECTED COMMUNITIES  
AUGUST, 1978

<u>Shopping List</u>	<u>Lewisburg</u>	<u>Milton</u>	<u>Berwick</u>	<u>Bloomsburg</u>
1. Cucumbers - each one	\$ .10	\$ .10	\$ .10	\$ .10
2. Potatoes - 10 lbs.	1.49	1.49	1.49	1.49
3. Sharp Cheese - 1 lb.	2.19	2.18	2.05	2.38
4. Corn - five (5) for:	.59	.59	.59	.59
5. Bananas - 1 lb.	.20	.33	.33	.33
6. Bread - 1 loaf	.39	.38	.39	.33
7. Haddock - 1 lb.	1.69	1.69	1.69	1.69
8. Eggs - 1 Medium Dozen	.77	.77	.77	.77
9. Chicken Breasts - 1 lb.	1.09	1.09	1.09	1.09
10. Detergent - 1 Giant Size Tide	1.63	1.63	1.63	1.39
11. T-Bone Steak - 1 lb.	2.89	2.89	2.89	2.89
12. Ground Beef - 1 lb.	1.25	1.29	1.25	1.49
13. Hot Dogs - 12 Pack	1.49	1.49	1.19	1.19
14. Bologna - 12 oz.	1.34	1.39	1.29	1.39
15. Tomatoes - 1 lb.	.79	.79	.79	.79
16. Lettuce - each head	.69	.69	.59	.69
17. Bacon - 1 lb.	1.49	1.59	1.59	1.49
18. Apples - 1 lb.	.89	.89	.89	.89
19. Oranges - five (5) for:	.99	.99	.75	.99
20. Soda - two (2) 28-oz. Bottles	<u>.69</u>	<u>.69</u>	<u>.69</u>	<u>.69</u>
	\$ 22.65	\$ 22.95	\$ 22.05	\$ 22.66

The total market basket price for all communities is comparable, with only \$ .90 separating the highest and lowest totals. The community closest to the plant site, Berwick, recorded the lowest market basket total. While the results of a single comparison are inconclusive relative to long-term trends, it is significant that food costs for the above items were not significantly different between communities.

1  
2  
3  
4  
5  
6  
7  
8  
9  
10  
11  
12  
13  
14  
15  
16  
17  
18  
19  
20  
21  
22  
23  
24  
25  
26  
27  
28  
29  
30  
31  
32  
33  
34  
35  
36  
37  
38  
39  
40  
41  
42  
43  
44  
45  
46  
47  
48  
49  
50  
51  
52  
53  
54  
55  
56  
57  
58  
59  
60  
61  
62  
63  
64  
65  
66  
67  
68  
69  
70  
71  
72  
73  
74  
75  
76  
77  
78  
79  
80  
81  
82  
83  
84  
85  
86  
87  
88  
89  
90  
91  
92  
93  
94  
95  
96  
97  
98  
99  
100

CHAPTER V

S O U R C E S

- 1 Pennsylvania Power & Light Company, "SSES: A Monitoring Study of Community Impact", 1976, Page 42.
- 2 Bechtel Power Corporation, SSES Personnel Department, May 1978.
- 3 Bechtel Power Corporation, SSES Personnel Department, May 1978.
- 4 Pennsylvania Economy League, Central Division, Wilkes-Barre, Pennsylvania, August 1978.
- 5 Pennsylvania Economy League, Central Division, "Tax Rates and Property Valuations - Part II", August 1978, Page 2.
- 6 Pennsylvania Economy League, Central Division, "Tax Rates and Property Valuations - Part II", August 1978, No Page.
- 7 Pennsylvania Department of Revenue, Bureau of Corporation Taxes, October 1978.
- 8 Personal Communications with Mr. Paul Weiss, Pennsylvania State Tax Equalization Board, October 2, 1978.



CHAPTER VI

COMMUNITY FACILITIES

A. School Enrollment

Surveys of non-manual personnel for both Bechtel and PP&L employees reveal that the majority live within school districts in Columbia County (See CHAPTER II). The number of children associated with the SSES work force enrolled in local school districts has not had the effect of burdening classroom space or crowding facilities. According to recent data prepared by the Pennsylvania Economy League, total enrollments in Columbia County have declined by 633 or 4.7 percent since 1969-1970. Three of the county's six districts, Berwick Area, Bloomsburg Area and Southern Columbia Area, had fewer students in 1976-1977 than in 1969-1970. The League's projections further reveal that enrollments will decline by 1,317 students, 10.2 percent, between school years 1976-1977 and 1982-1983 and that all districts will experience decreases.<sup>1</sup>

Table VI-1 indicates the enrollment trends as well as projections based on research of the Pennsylvania Economy League. Despite ongoing and projected decreases in school enrollments, total public school expenditures in the county increased by \$7.1 Million, or 70.4 percent, between 1969-1970 and 1975-1976 while the cost of educating each pupil increased by \$550 or 73.5 percent. All districts recorded increases.<sup>2</sup>

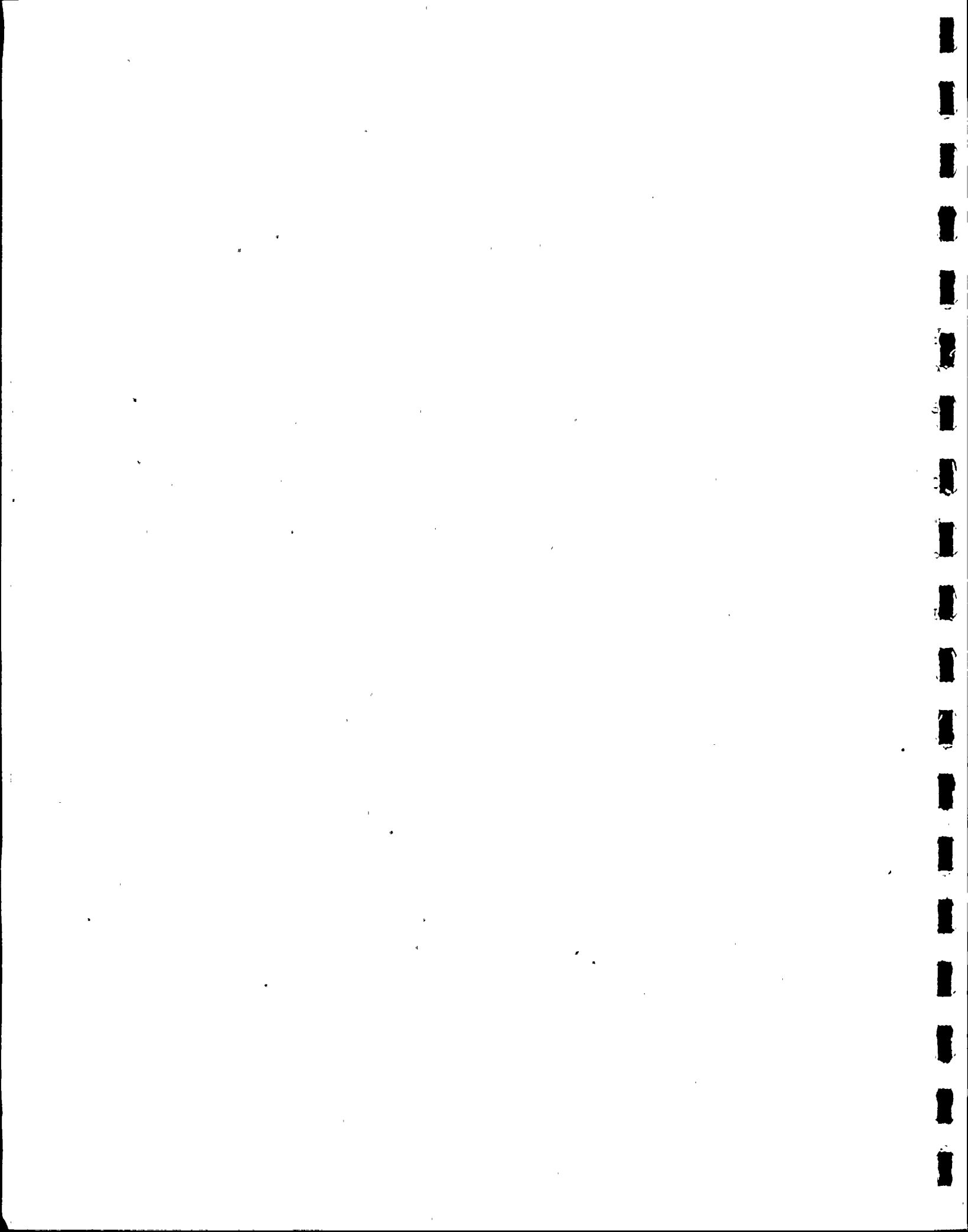




Table VI-1<sup>3</sup>

COLUMBIA COUNTY

Public School Enrollment

Trends and Projections

<u>School District</u>					<u>Projected</u>	<u>% Change 1977-83</u>
	<u>1969-70</u>	<u>1973-74</u>	<u>1976-77</u>	<u>% Change</u>	<u>1982-83</u>	
Benton Area	972	960	1,019	4.8	1,004	- 1
Berwick Area	4,682	4,567	4,293	- 8.3	3,765	-12.3
Bloomsburg Area	2,866	2,505	2,364	-17.5	1,805	-23.6
Central Columbia	2,363	2,506	2,530	7.1	2,458	- 2.8
Millville Area	1,028	1,144	1,145	11.4	1,098	- 4.1
Southern Columbia Area	<u>1,690</u>	<u>1,651</u>	<u>1,617</u>	<u>- 4.3</u>	<u>1,516</u>	<u>- 6.2</u>
<b>P O T A L</b>	13,601	13,333	12,968	- 4.7	11,651	-10.2

For the most part, increases appear to be a result of operational expenses rather than capital expenditures. Of the six school districts in Columbia County, Bloomsburg Area, Millville Area and Benton Area School Districts have had no new construction within the past ten (10) years. Berwick Area has recently completed a new junior high school which was principally funded by the U. S. Economic Development Administration. Central Columbia and Southern Area School Districts have recently completed new middle and elementary schools respectively. None of these expansions appear to have had any relationship to expanded requirements arising from SSES work force families.

B. Hospital Facilities

Primary health care for the construction workers is provided by a full-time staff of registered nurses at the SSES site. Emergency cases requiring further treatment are referred to local hospitals. Most cases are treated at the Berwick Hospital while those requiring specialized treatment are sent to Geisinger Medical Center located twenty (20) miles west in Danville. Table VI-2 indicates referrals of SSES accident cases to local hospitals:

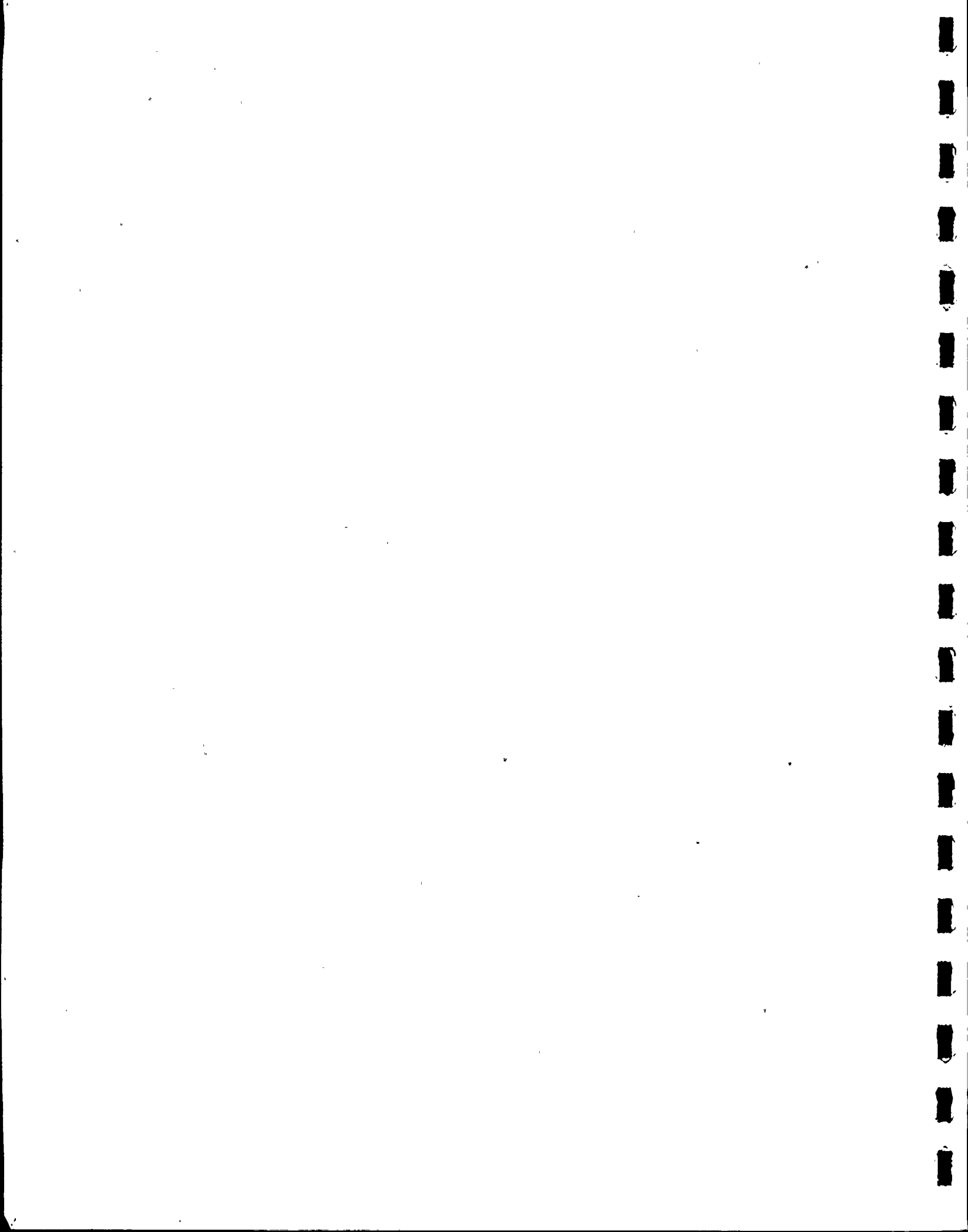


Table VI-2<sup>4</sup>

Hospital Referrals of SSES Accident Cases

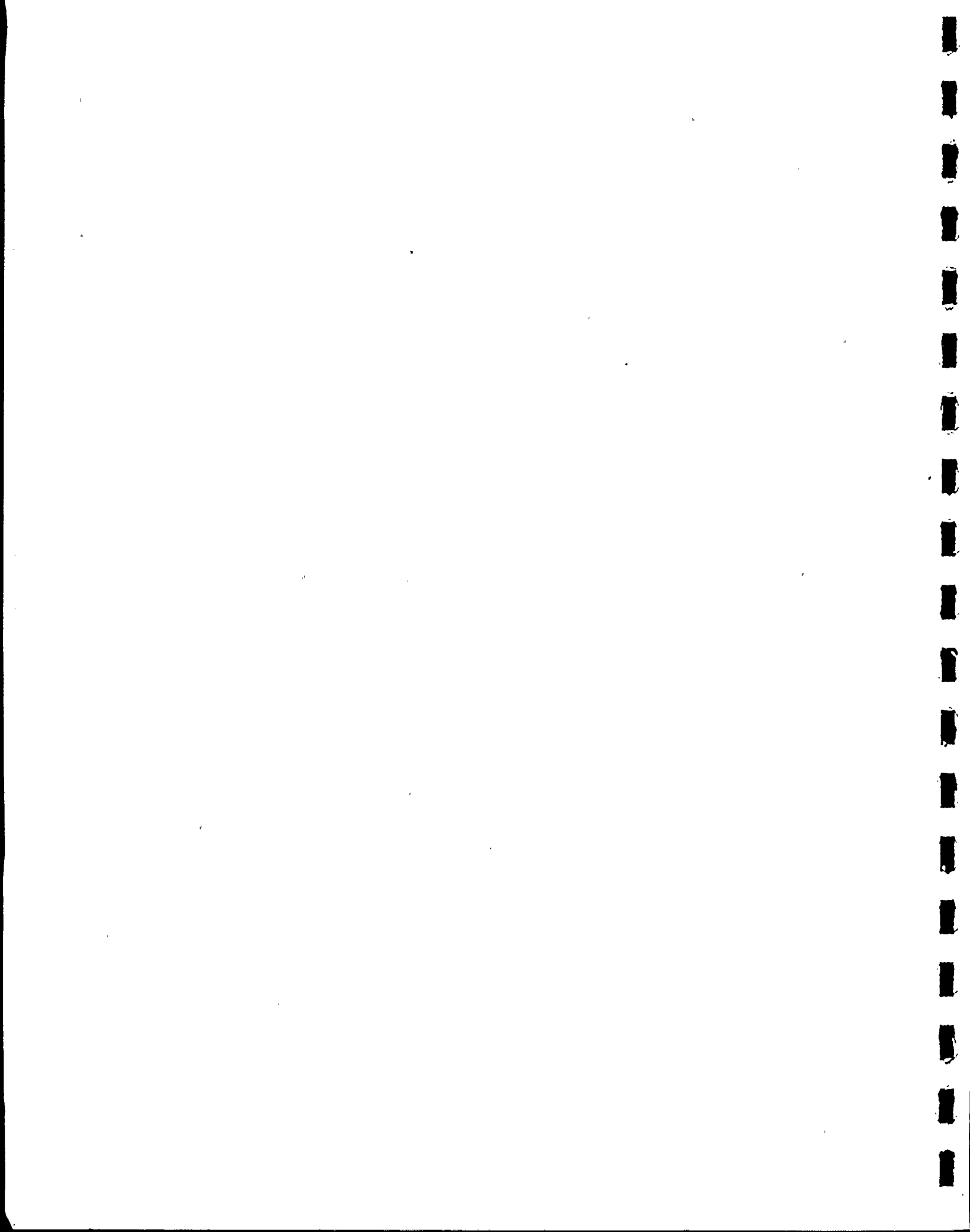
1974-1978

	<u>1974</u>	<u>1975</u>	<u>1976</u>	<u>1977</u>	<u>1978</u>
Number of Cases Referred:	197	199	305	270	203 (thru Sept.)

The increased out-patient load at the Berwick Hospital was also affected by PP&L job applicants (operational staff) who are referred to the Berwick Hospital for physical examinations upon placement.

According to administrative staff at the Berwick Hospital, the SSES referred accident cases and physical examination referrals have affected out-patient facilities and services at that institution. Since 1976, two additional staff nurses have been added for out-patient care; a cardiac treatment and test center has been established; and an audio-metric facility (hearing examinations) has been installed requiring the training of an additional staff person. Cardiac test facilities and audio testing facilities had been established, in part, as a response to the larger number of physical examinations required for plant employment. Hospital staff pointed out, however, that the increased demand for out-patient services resulting from SSES construction were anticipated and were incorporated into a hospital development program initiated in the early 1970's. The recently completed program, financially supported by PP&L, resulted in both an expansion of hospital facilities and services to the community.<sup>5</sup>

An additional new facility developed specifically for the SSES is a special emergency room for the treatment of radiation related injuries. The room, constructed to PP&L specifications, is completed although it has not been used for radiation related injuries since no nuclear fuels are presently at the SSES site. The construction of the room as well as the training of specialized staff was subsidized by PP&L.



C. Water Supply (Make-Up)

A source of river water supply will be required to replace water consumed by the operation of the Susquehanna SES during low-flow periods. The Susquehanna River Basin Commission (SRBC) regulates uses of the river as well as development affecting its tributaries. In September, 1976, the SRBC adopted a regulation requiring all new water users to provide enough standby water supply to replace river water consumed during periods of low flow.

PP&L has been identifying and assessing sources of potential water supply. Publically and privately owned existing reservoirs and reservoirs under construction have been considered as a potential source of water supply. Based on review of these possibilities the preferred approach to meeting the SRBC requirement is to purchase water from the Cowanesque Reservoir, a Corps of Engineers (COE) project under construction in Tioga Co., Pa. and scheduled for completion in 1980. PP&L has forwarded a formal request to the COE to purchase seasonal storage in the Cowanesque Reservoir. The SRBC has suggested that a study be made of all potential Cowanesque water supply uses, the effect of these uses on authorized project functions, and a determination of necessary re-authorizations. The COE estimates the study will take a minimum of 2 years to complete from the date of obtaining funds, which are not anticipated before early 1979.

In order to have an assured source of water, PP&L is preparing an application to construct its own water supply reservoir. The reservoir site, known as Pond Hill, was selected based on technical and environmental consideration from among several identified by PP&L and its consultant.

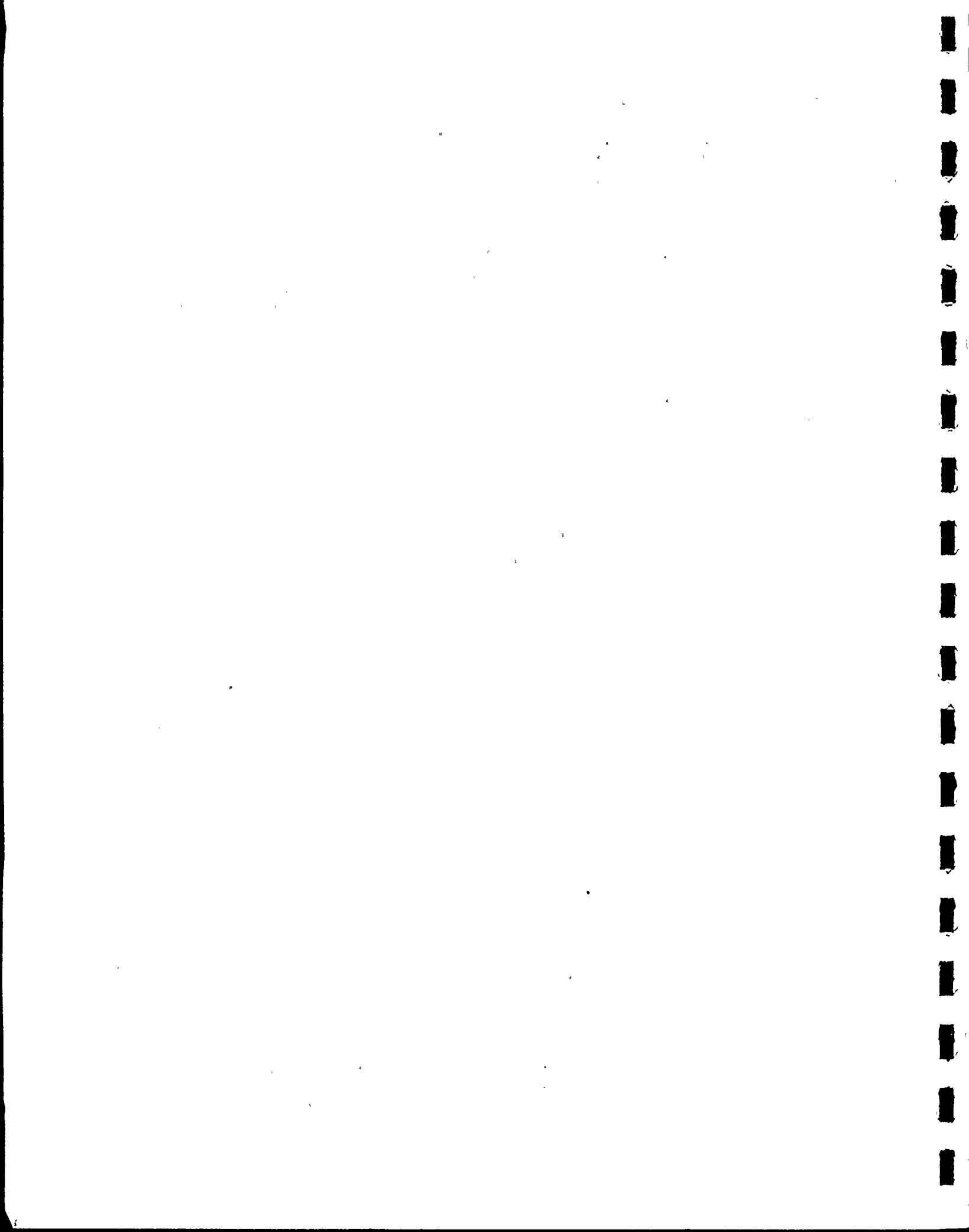
The proposed Pond Hill Reservoir site is a drainage basin of an unnamed tributary of the Susquehanna River near Pond Hill in Conyngham Township, Luzerne County. The site is located in an undeveloped wooded valley. All housing and ongoing agricultural activity occur above maximum water level. Land acquisition will involve approximately 1,200 acres although the surface area of the impounded water will be approximately 315 acres.

The impacts and design of the proposed reservoir are presently being studied. An environmental report and feasibility report are being prepared and are expected to be submitted to appropriate agencies in 1979. The planning effort has been aided by the establishment of public participation consisting of an advisory committee formed in the fall of 1977, the Pond Hill Reservoir Advisory Committee (PHRAC). The committee consists of 17 persons from eight communities in the area.

To date, this local committee has reviewed past studies, received presentations on technical and environmental aspects of construction and operation of the reservoir, and visited the Susquehanna SES station as well as the Pond Hill Reservoir site.

D. Public Safety

1. Police Force



Because of the small size of adjacent communities and the rural character of the project area, municipal police forces, where they exist, tend to be small - Berwick has a force of twelve (12) officers and Shickshinny has a force of one (1) police officer. Salem Township has no standing police force although a state police barracks, located on Route 11, has a staff of eighteen (18). (By contrast, the size of the security forces at the SSES is presently fifty-six (56). When the SSES becomes operational, a permanent on-site security force of seventy-seven (77) persons will be established.)

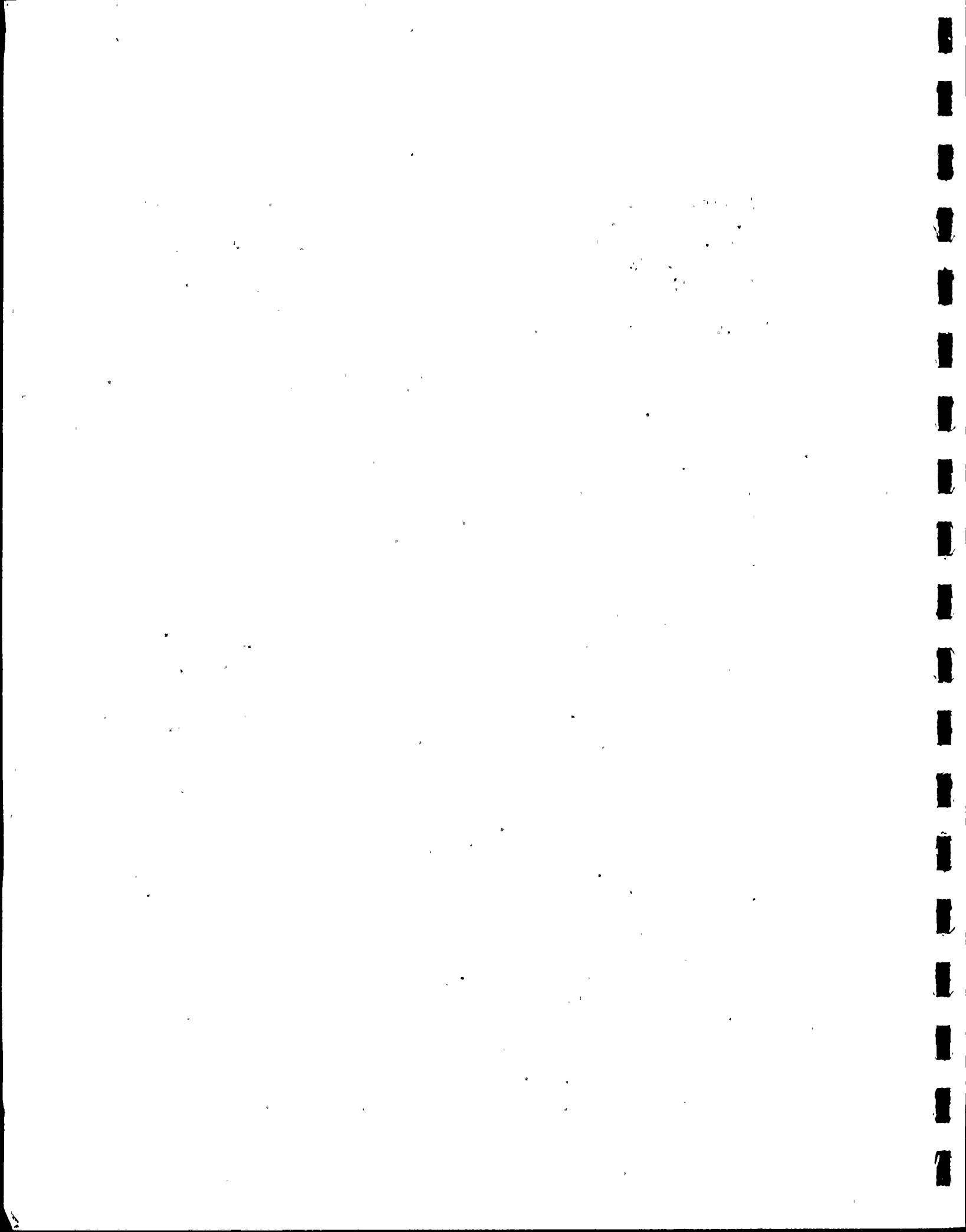
Only one instance has been identified where the plant construction has resulted in a need to increase personnel. As described in Chapter II, most of the work force originates from the Wilkes-Barre/Scranton area and commutes to the plant site on U. S. Route 11, resulting in substantial peak hour flows.

Route 11 changes from a three-lane highway to a two-lane local street in Shickshinny. At peak-hour traffic volumes, the effects in Shickshinny have resulted in considerable congestion. In some instances, traffic flows have ignored local traffic lights in an effort to proceed through town. Motorists crossing the Route 239 bridge from Mocanaqua (opposite Shickshinny) have reportedly been unable to egress onto Route 11 from the bridge during rush hours (See Figure II-1).

Community leaders solicited PP&L's help in resolving the problem. A part-time policeman was added to the force in the summer of 1978, the cost of which is underwritten by PP&L. While the additional patrolman has alleviated conditions somewhat, significant relief from traffic conditions will be experienced only with a reduction in work force as the SSES nears completion.

In other police matters, state police records indicate an increase in the number of arrests in the region since 1972 (See Table VI-4). The region includes eight (8) townships in Columbia and Luzerne Counties.

Local state police officials have indicated that the overall increase in the number of calls cannot be related to





SSES construction. The increase in the number of criminal arrests have occurred in residential areas and are following a national trend. State police have also reported no arrests on site during the construction period to date.

Table VI-4<sup>6</sup>

Total Annual Arrests

Pennsylvania State Police

Berwick Barracks

1972-1978

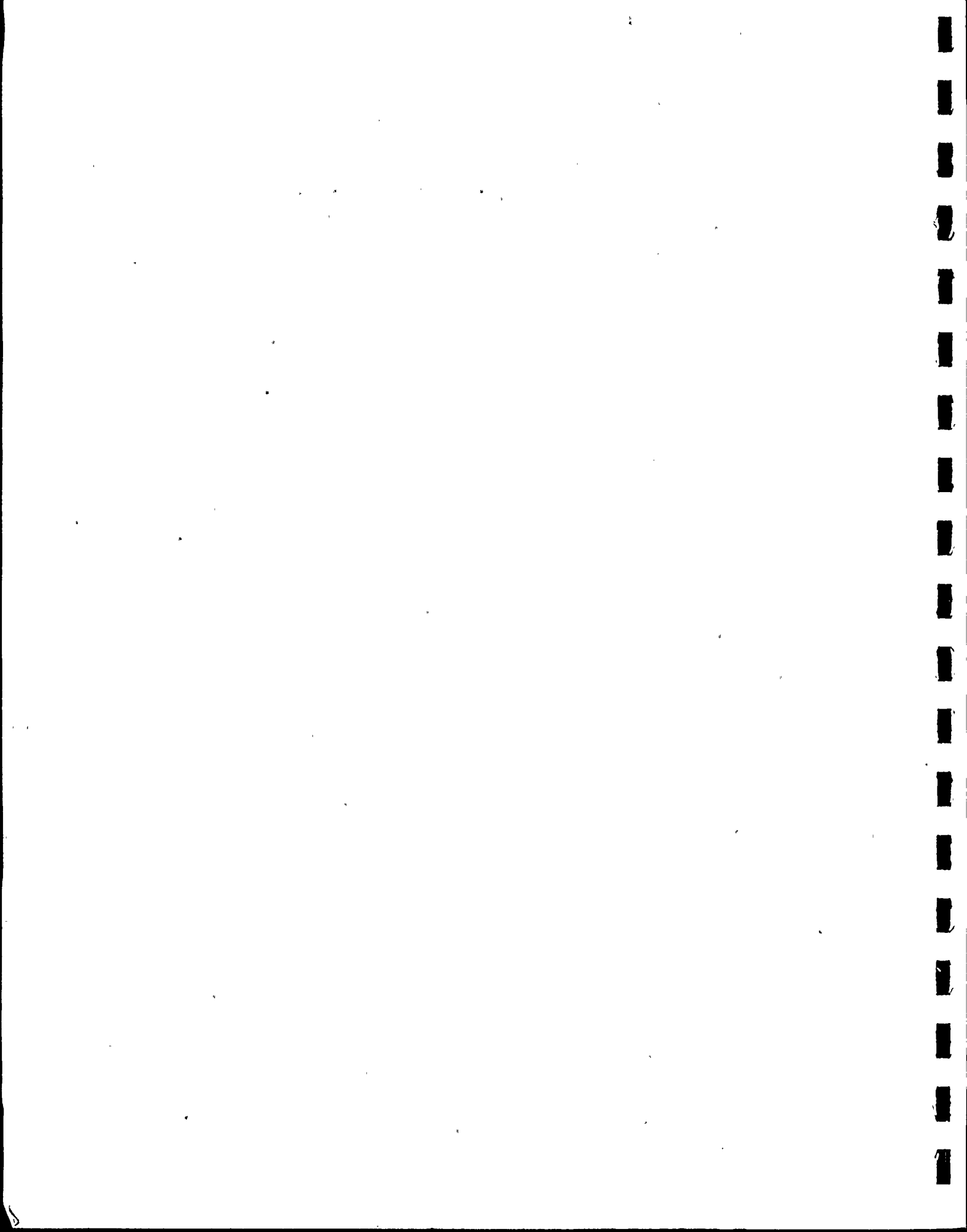
<u>Type of Arrest</u>	<u>1972</u>	<u>1973</u>	<u>1974</u>	<u>1975</u>	<u>1976</u>	<u>1977</u>	<u>(To June) 1978</u>
1. Criminal	69	131	164	180	202	162	56
2. Traffic	1,348	1,358	1,589	1,795	1,614	1,531	814

2. Emergency Services

Fire and emergency ambulance service in the plant area are provided through private, voluntary organizations, not as a service of local government. In the site vicinity, these organizations include --

- a. Shickshinny Area Volunteer Ambulance Association
- b. Pont Hill-Lily Lake Fire Company (Ambulance Service)
- c. Salem Township Fire Company, No. 1
- d. East Berwick Hose Company, No. 2

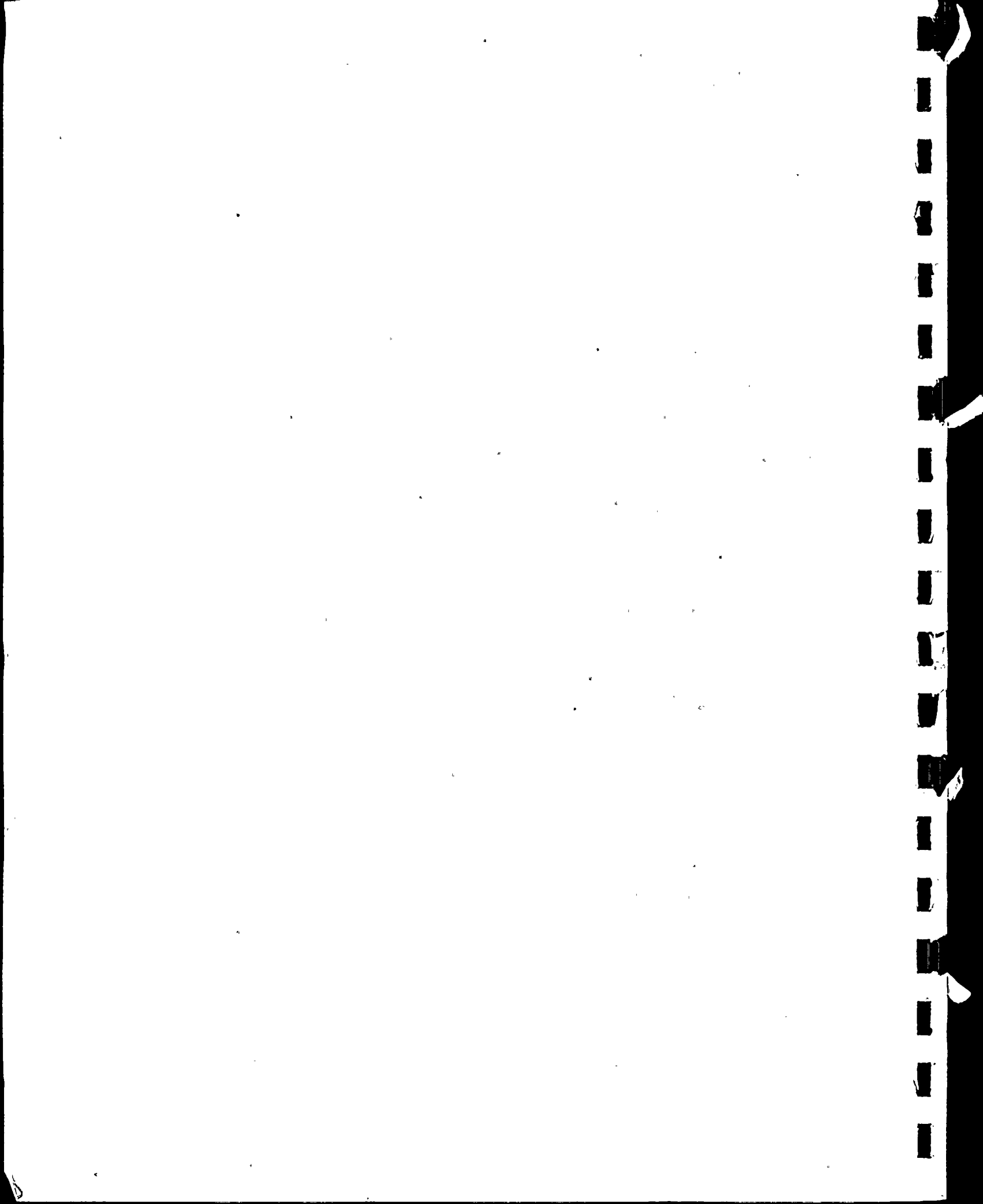
No special arrangements have been made with these organizations for their services during the construction phase of the project. During plant operation, the nature of an emergency could require responses from the above organizations to augment on-site response groups and facilities. Arrangements have been made with the above organizations to provide support upon notification by the SSES Emergency Director.<sup>7</sup>



CHAPTER VI

S O U R C E S

- 1 Pennsylvania Economy League, "Columbia County School Enrollment Trends and Projections", May 1978, Pages 2 to 4.
- 2 Pennsylvania Economy League, "Columbia County School Enrollment Trends and Projections", May 1978, Page 1.
- 3 Compiled from data of the Pennsylvania Economy League.
- 4 Bechtel Safety Enforcement Officer, SSES, October 1978.
- 5 Personal Conversation with Mr. Robert Robbins, Assistant Administrator, Berwick Hospital.
- 6 Sgt. Anthony Matson, Pennsylvania State Police, Shickshinny Barracks, August 1978.
- 7 Pennsylvania Power & Light Company, "Susquehanna Steam Electric Emergency Plan", Volume 1, Page 5-4.



**RETURN TO REACTOR DOCKET  
FILES**

SUSQUEHANNA STEAM ELECTRIC STATION  
COMMUNITY IMPACT MONITORING STUDY: AN UPDATE

Docket #	SD-387/388
Control #	791070119
Date	10/12/79 of Document
REGULATORY DOCKET FILE	

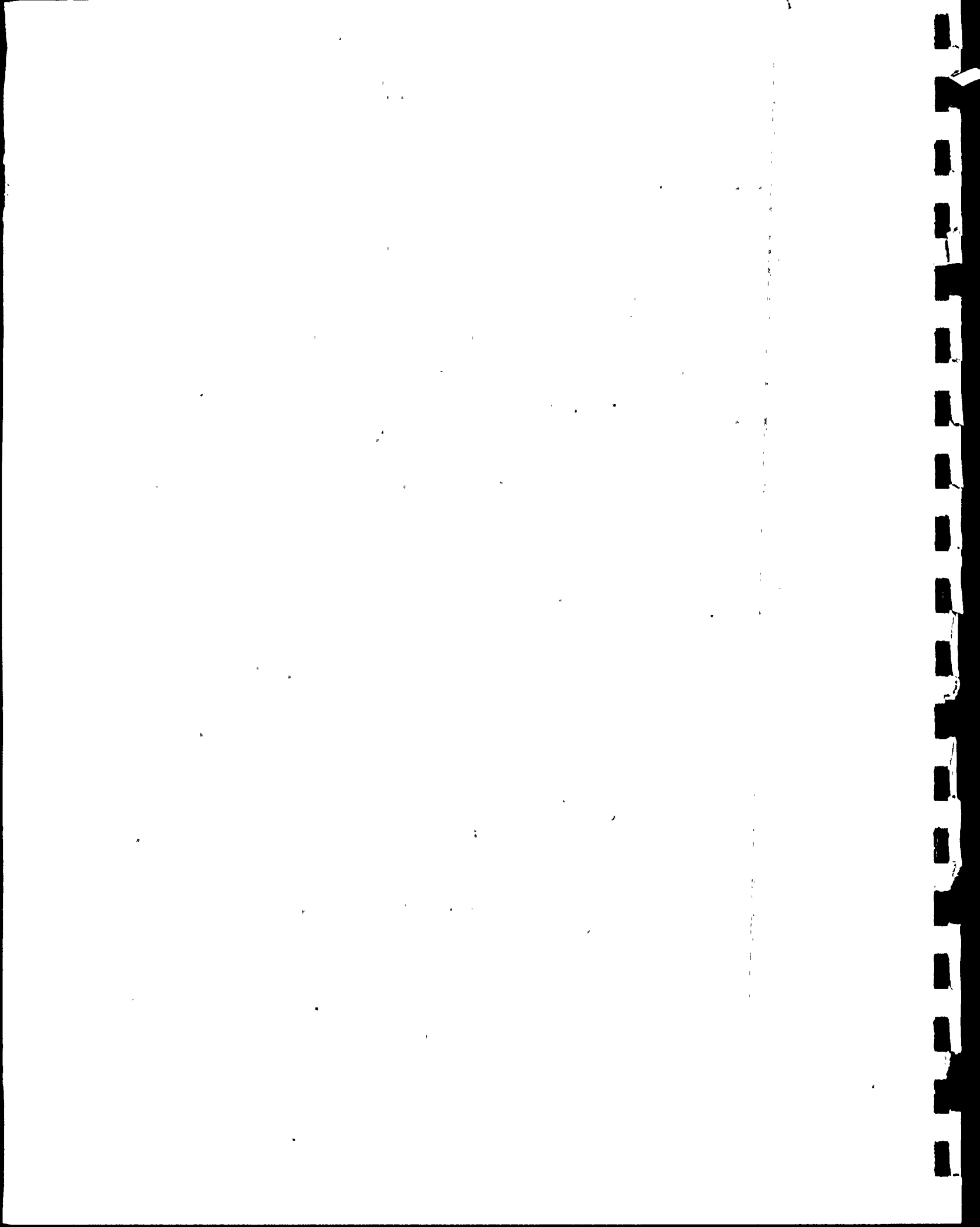
COMMUNITY SERVICES DEPARTMENT  
PENNSYLVANIA POWER & LIGHT COMPANY  
TWO NORTH NINTH STREET  
ALLENTOWN, PENNSYLVANIA 18101  
DECEMBER, 1978

TELEPHONE SERVICE OF THE  
FEDERAL BUREAU OF INVESTIGATION



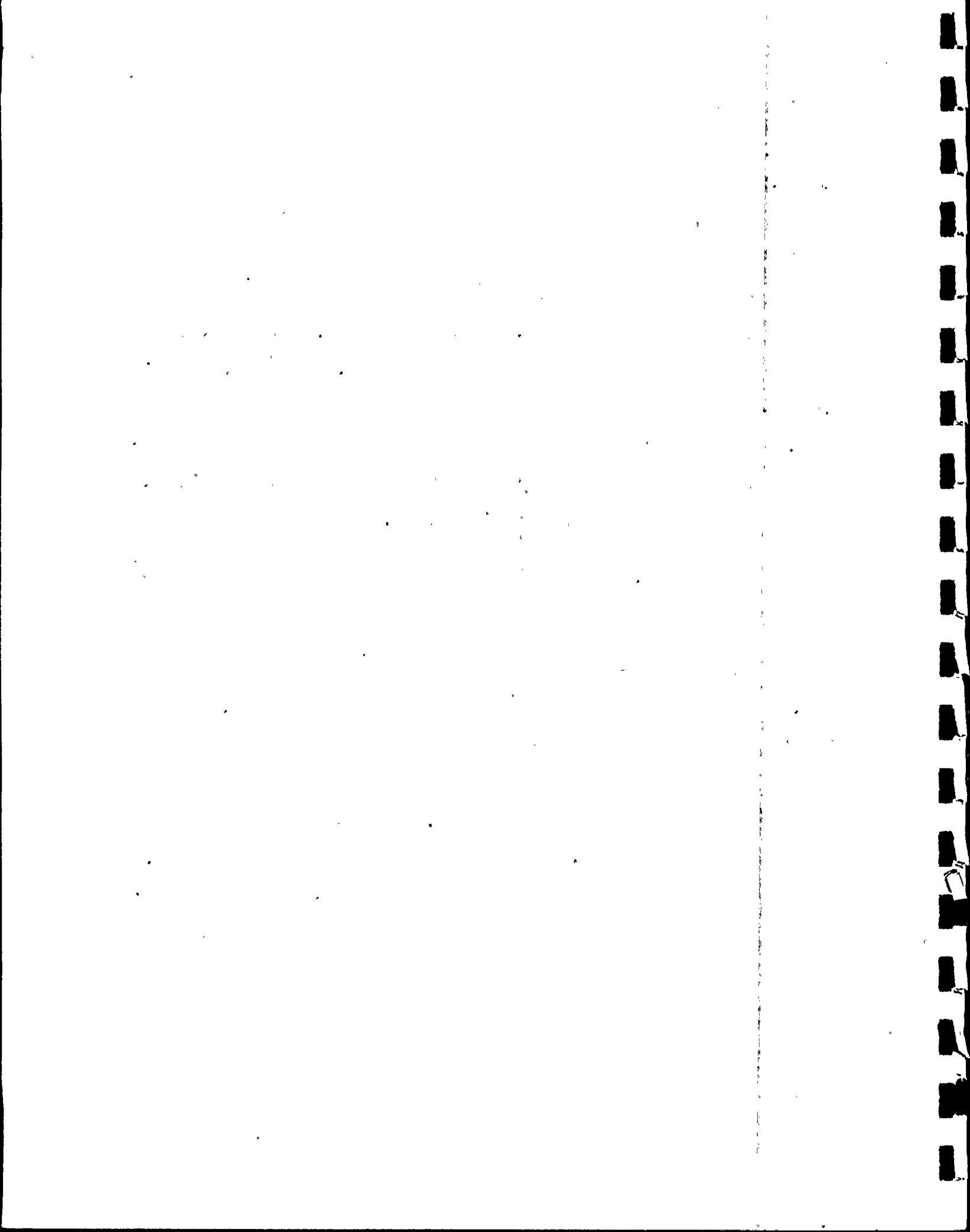
TABLE OF CONTENTS

	<u>Page</u>
CHAPTER I - SUMMARY AND CONCLUSIONS	1
A. Introduction . . . . .	1
B. Findings and Conclusions . . . . .	3
1. General . . . . .	3
2. Housing . . . . .	3
3. Employment . . . . .	3
4. Local Economy . . . . .	4
5. Community Infrastructure . . . . .	4
6. Inflationary Impact . . . . .	5
7. Public Attitudes . . . . .	5
C. Recommendations . . . . .	6
CHAPTER II - SURVEY OF NON-MANUAL EMPLOYEES	8
A. Summary of Survey Results . . . . .	8
B. Area of Residence . . . . .	10
C. Type and Tenure of Residence . . . . .	12
D. Family Size . . . . .	13
E. Age of Employees . . . . .	14
F. Number of Children by Grade Level and School District . . . . .	15
G. Shopping Patterns . . . . .	19
H. Recreational Activities . . . . .	19
I. Hospital Use and Purpose . . . . .	20
J. Attitude Towards Area of Residence . . . . .	21
K. PP&L Survey Responses . . . . .	23
CHAPTER III - BACKGROUND INFORMATION: POPULATION, EMPLOYMENT AND MANPOWER	26
A. Population . . . . .	26
B. Work Force Characteristics . . . . .	28
C. Manpower Needs at the Project Site . . . . .	30
1. Manual Work Force . . . . .	30
D. Non-Manual Employees . . . . .	31





	<u>Page</u>
E. PP&L Work Force . . . . .	36
<u>S O U R C E S</u> . . . . .	37
<b>CHAPTER IV - LOCAL VIEWS ON COMMUNITY IMPACTS</b>	
A. Housing . . . . .	38
B. Local Economy/Employment . . . . .	39
C. Educational Facilities . . . . .	41
D. General Community Impacts . . . . .	42
<u>S O U R C E S</u> . . . . .	44
<b>CHAPTER V - LOCAL ECONOMIC IMPACTS</b>	
A. Wage Distribution . . . . .	46
B. Purchase of Goods and Services . . . . .	47
C. Local Taxes . . . . .	48
1. Real Estate Tax Rates . . . . .	48
2. Tax Impacts: Salem Township . . . . .	48
D. Local Economic Impacts . . . . .	51
1. Housing Costs . . . . .	51
2. Food Costs . . . . .	53
<u>S O U R C E S</u> . . . . .	55
<b>CHAPTER VI - COMMUNITY FACILITIES</b>	
A. School Enrollment . . . . .	56
B. Hospital Facilities . . . . .	57
C. Water Supply (Make-up) . . . . .	59
D. Public Safety . . . . .	59
1. Police Force . . . . .	59
2. Emergency Services . . . . .	61
<u>S O U R C E S</u> . . . . .	62



## CHAPTER I

### SUMMARY AND CONCLUSIONS

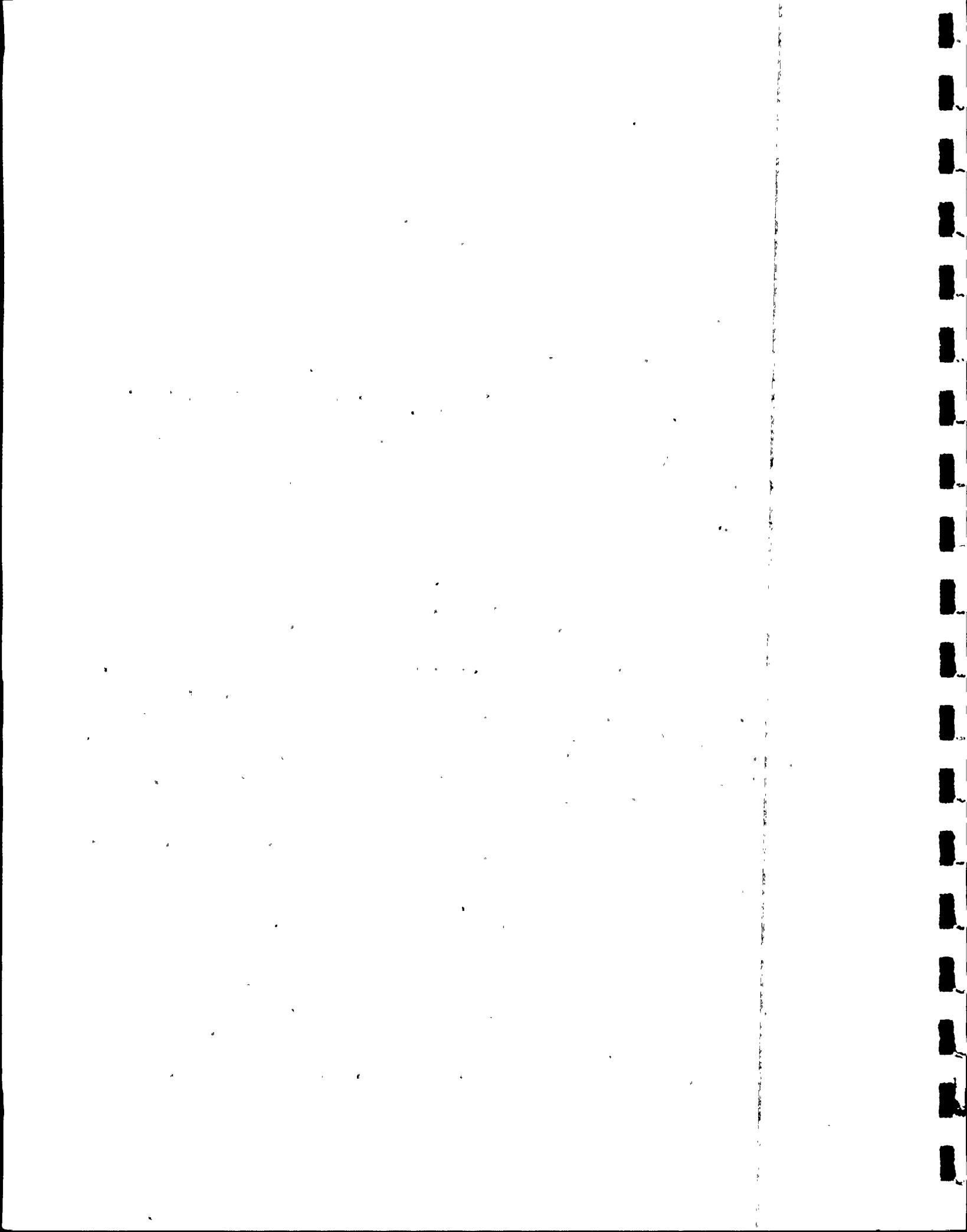
#### A. Introduction

In 1976, Pennsylvania Power & Light Company's (PP&L) Community Services Department published a report on a monitoring program of community impacts associated with the construction of PP&L's Susquehanna Steam Electric Station (SSES), a nuclear generating station under construction near Berwick, Pennsylvania (See Figure I-1). The purpose of the first study, conducted largely in 1975, was to establish a procedure to collect information during construction and operating phases of the SSES in order to assess short- and long-term social costs and benefits.

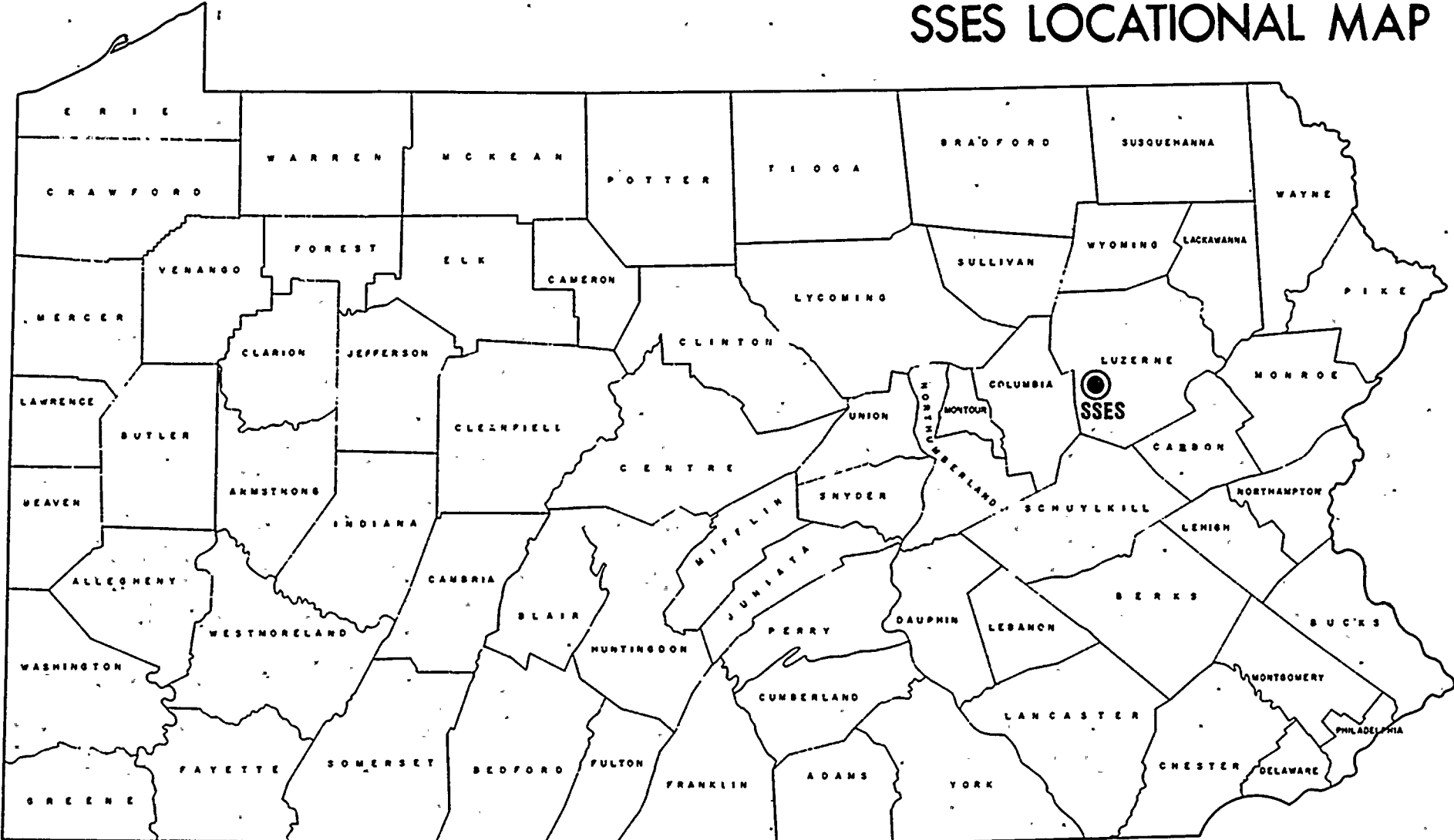
The major findings and conclusions of that study addressed several areas. Complaints from adjacent neighbors regarding construction nuisances and physical damage to structures resulting from construction blasting led to recommendations on improvements for site preparation and construction activities. Related to this concern was a recommendation to establish a project advisory committee on subsequent construction projects. Preconstruction inventories were recommended to establish information on housing stock and land costs. A stronger program for promoting employment opportunities for local residents was also recommended.

A commitment was also made in the 1976 study to continue monitoring efforts during SSES construction and operation phases. That commitment resulted in the publication of this document. Its purpose is to review construction impacts on local communities since the 1976 study as well as to examine the status of recommendations made in that first study.

The study techniques in this update were the same as those used for the 1976 study. The methods consisted primarily of a questionnaire survey of non-manual employees of Bechtel Power Corporation and PP&L and a series of interviews with local and regional officials, businessmen and community leaders. Because the SSES is five years into construction, the



# SSES LOCATIONAL MAP



DECEMBER 1978

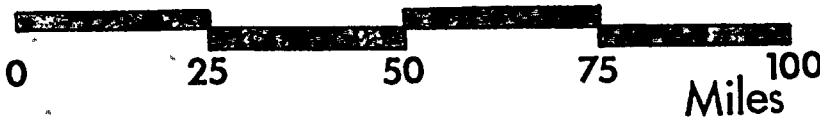
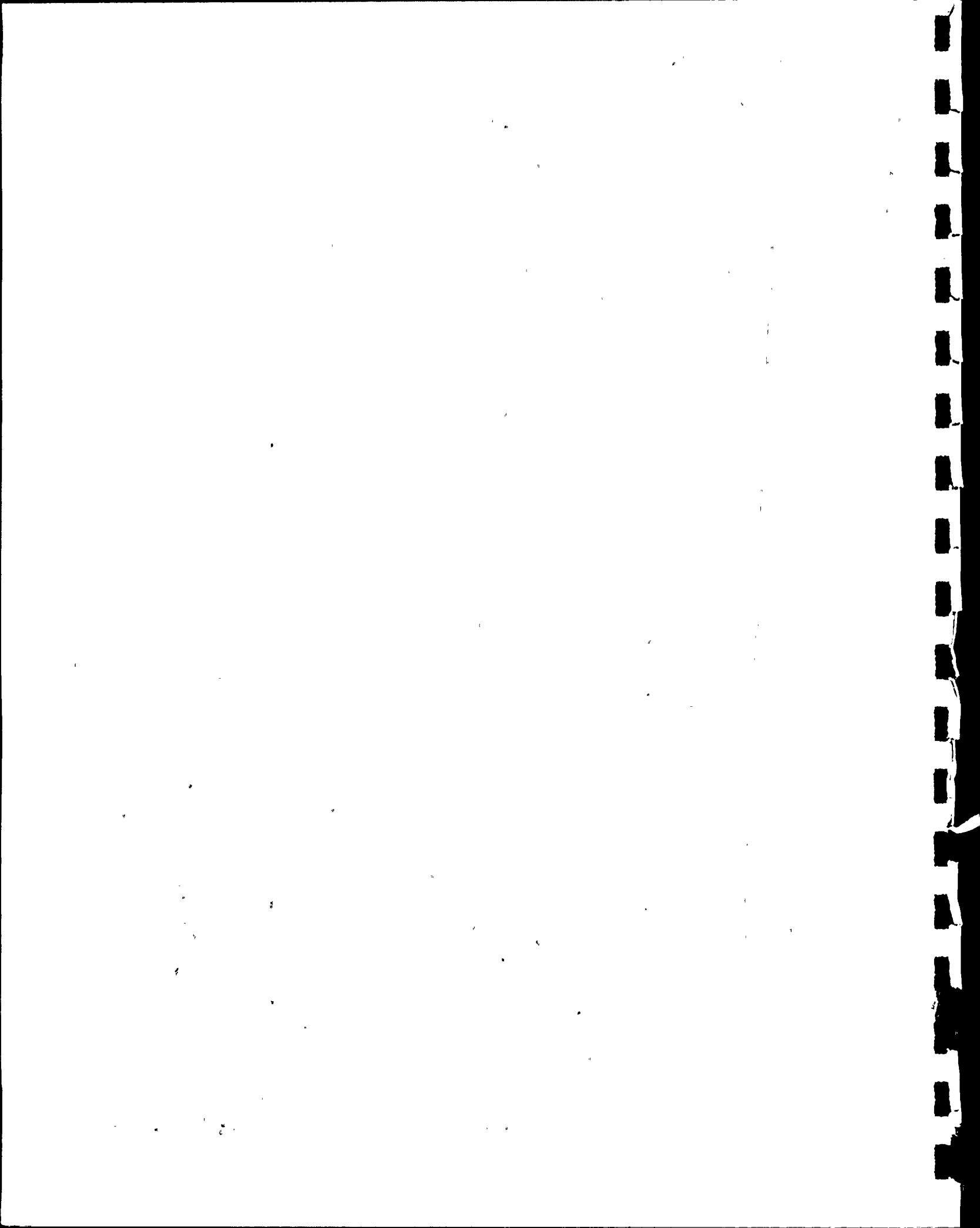


FIG. I-1



study's principal thrust is qualitative rather than quantitative. Most of the major socio-economic impacts related to construction have already occurred and there is little need to employ quantitative methods for predictive purposes. Consequently, the techniques employed herein are not necessarily intended to serve as models for all power facility projects.

## B. Findings and Conclusions

### 1. General

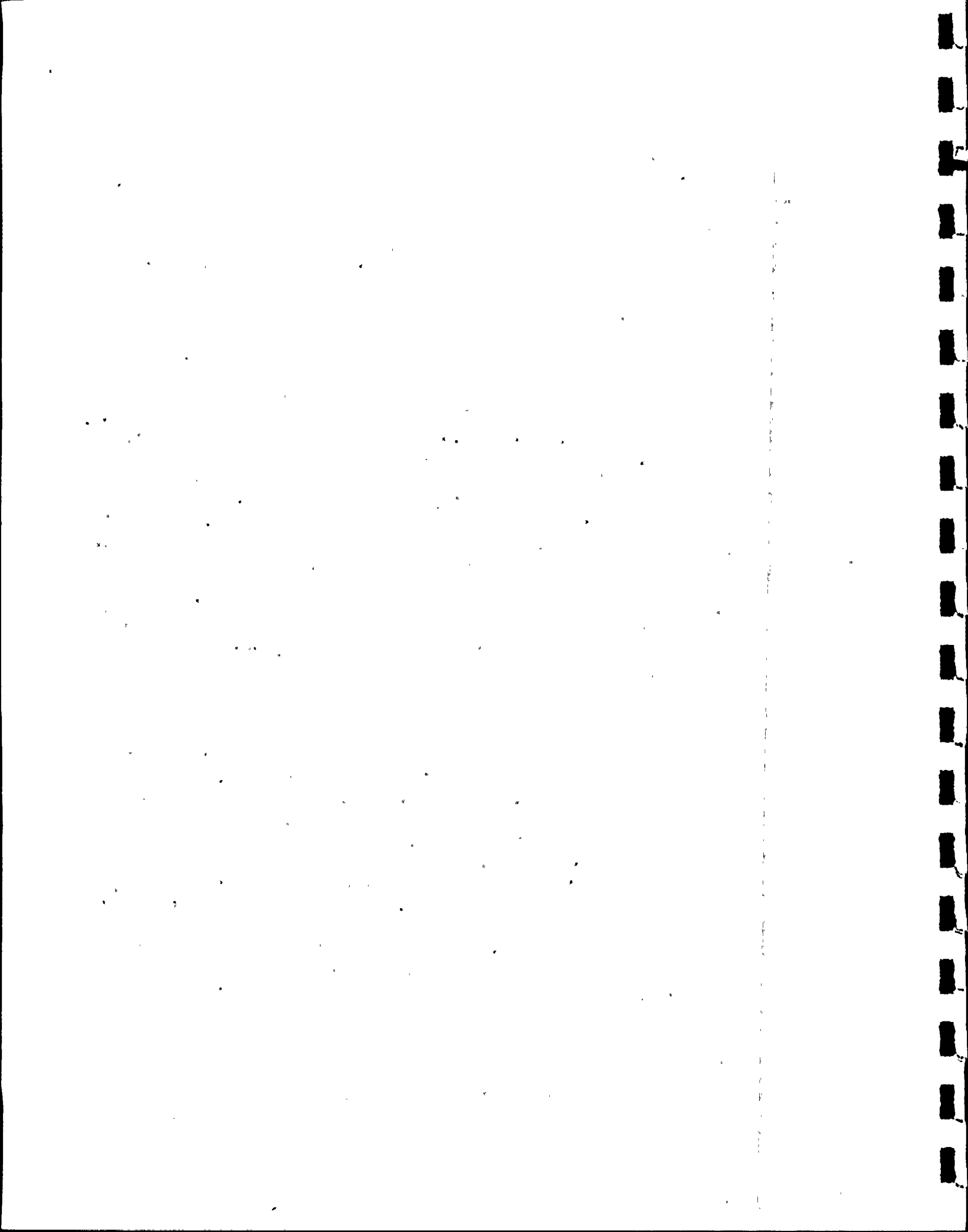
As indicated in the 1976 report, this update confirms that SSES construction avoided "boom town" syndromes experienced at other large construction projects in different parts of the country. No excessive or overwhelming demands were made on any community facilities or the community's capability to provide services, a conclusion shared by all local officials contacted in the course of the update. In large part the minimal impact on local communities was due to adequate supplies of workers from the regional labor market. Consequently, most workers commuted to the site daily. While those workers (primarily non-manual) who relocated to the project area initially created some pressure on the local housing market, early shortages have since been relieved through the local market.

### 2. Housing

As suggested above, housing availability or supply never materialized as a significant issue in the course of the update. Early in the construction period the local housing market was characterized by some scarcity. This was due largely as a result of the absence of a speculative market and the occurrence of a major natural disaster, Tropical Storm Agnes, which resulted in serious flooding in the Wilkes-Barre area, approximately twenty (20) miles northeast of the project site. Dislocated persons looking for housing subsequently spilled over into the Berwick-Bloomsburg area. Since that time the market has responded to this demand and housing is generally available, usually on a contract basis.

### 3. Employment

The availability of a large labor supply within commuting





distance proved to be both a boon and a loss with respect to local communities in Columbia County. On the one hand, communities such as Bloomsburg and Berwick were spared the burden of trying to provide additional community services facilities for new worker populations. On the other hand, hopes for significant local employment were disappointed when the majority of workers were hired from the larger labor market beyond the local communities. Although employment data indicates little local employment for manual workers, hiring from the local labor force for non-manual positions has increased since 1976.

Although local officials registered strong disappointment over the minimal amount of local hiring during early construction phases, recent contacts indicate a greater acceptance of the situation and an understanding that hiring practices were largely a reflection of union jurisdictions.

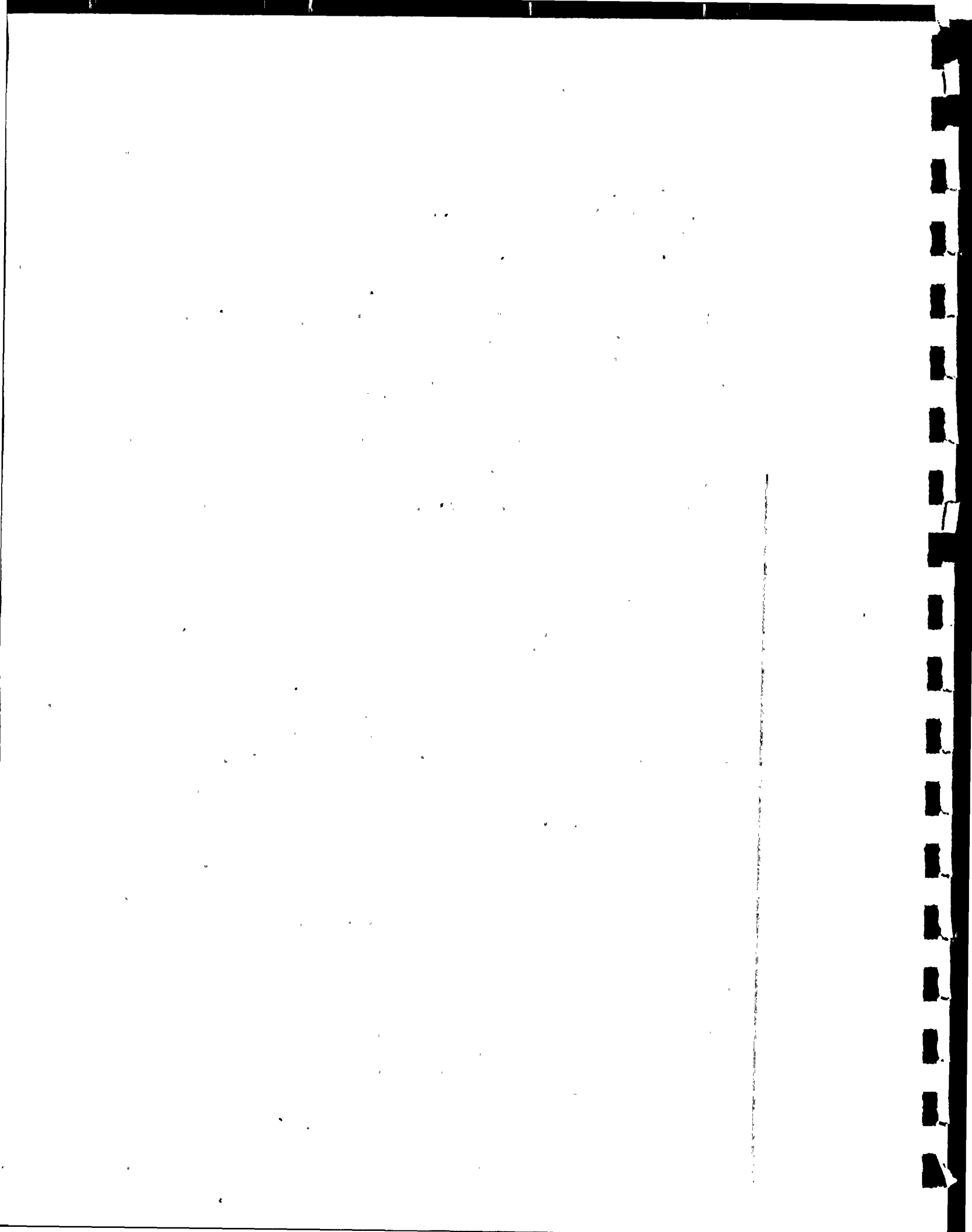
4. Local Economy

As with the employment picture, benefits to local economies are not in proportion to the size and cost of the SSES. A principal reason for minimal local economic benefits was the low levels of SSES employment in the immediate Bloomsburg-Berwick area. Additionally, contracts to vendors for specialized materials and/or services often went to non-local suppliers because such goods or services were not available at the local level.

Salem Township, the location of the plant site, will benefit from increases in local occupational and, to a lesser extent, local income tax revenues as a result of high numbers of construction personnel. Following plant construction, however, tax revenues associated with the plant are not likely to offset revenues forgone through the loss of tax rateables.

5. Community Infrastructure

With the exception of one instance where an additional policeman had to be provided for traffic control on a state highway, no unanticipated demands on schools, hospitals, emergency services or related community infrastructure systems have resulted from SSES construction. In several



cases additional or specialized facilities were required for emergency and health care services. In these cases, PP&L entered into agreements with a local hospital (Berwick) as well as local suppliers of ambulance and fire services to meet potential specialized demands caused by plant construction. PP&L also subsidized the cost of additional facilities and specialized training.

6. Inflationary Impact

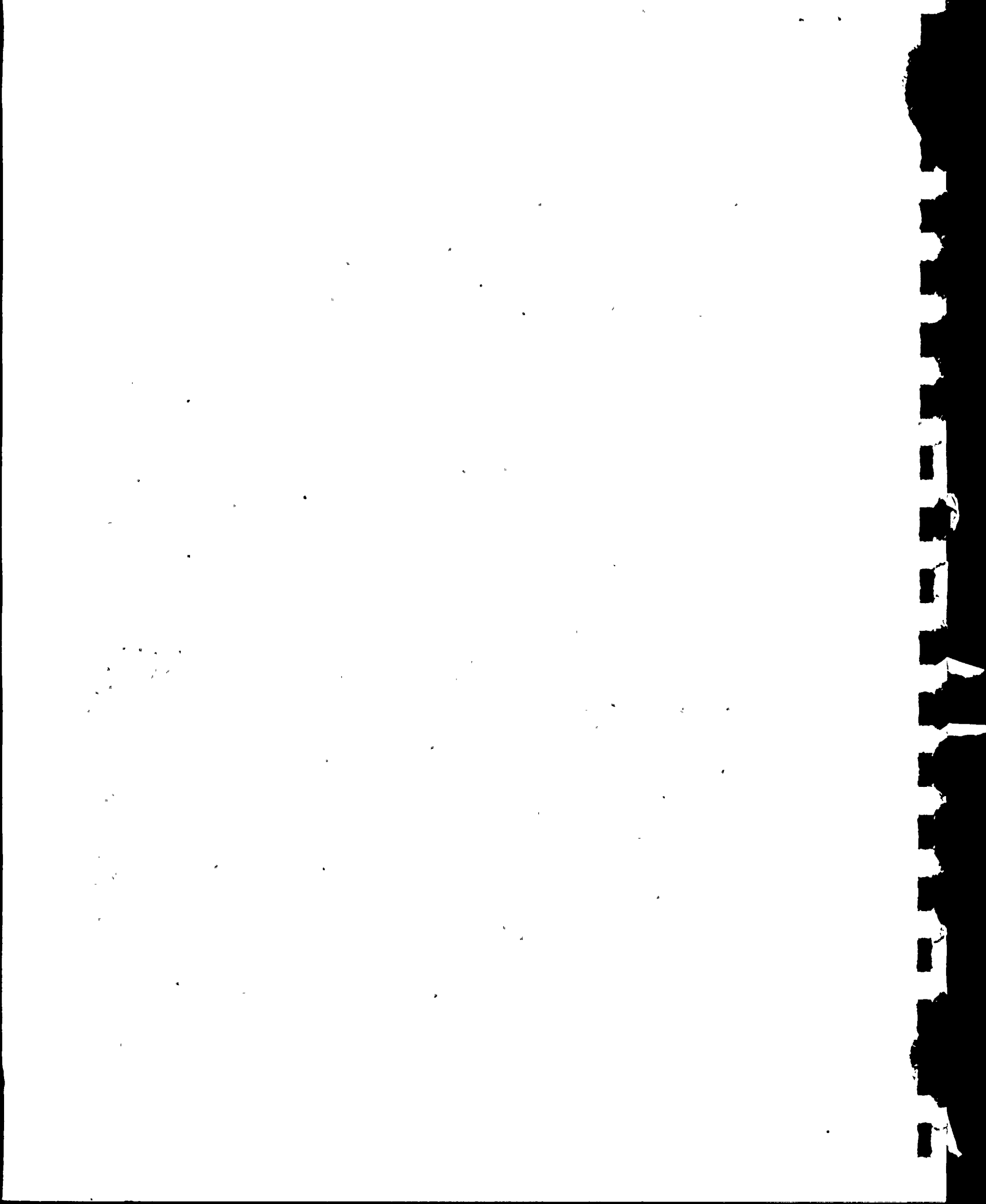
It is commonly held in the local communities near the plant site that construction activities have had substantial inflationary impacts on the local economy, particularly in the area of housing. Local businessmen and officials have been unable to provide specific instances or data to support this belief. Data assembled during the course of the update on housing and food costs suggest increases comparable to other areas of the state similar in the demographic and economic characteristics to the Bloomsburg-Berwick area.

7. Public Attitudes

Local officials are largely supportive of the construction phase of the plant as well as the subsequent operational phase. There also is agreement on the lack of impact which the plant has had on local communities. Such comments tend to be expressed in combined tones of disappointment and relief; relief that the construction phase has not placed severe demands on the community to provide support services and disappointment that the plant construction has not yielded greater economic benefits.

No community frictions have developed as a result of new people moving into the local community. While the number of new employees relocating to the local communities has been relatively small, there remained a potential for community friction arising from the newer or different values or attitudes brought into the community by new personnel. These problems never materialized to any significant extent.

A concern about recessionary impacts related to completion of SSES construction appears to be growing among certain



sectors of the business and labor communities in the region. A labor spokesman indicated that union enrollment is likely to shrink upon completion of the project. Furthermore, workers at the plant have become accustomed to long-term employment at higher wages which may not be available in the regional job market once the plant is completed.

Table I-1 summarizes by impact categories the types of mitigative measures proposed in the 1976 study and their current status.

C. Recommendations

Few new issues or problems requiring specific recommendations were raised as a result of this update of the 1976 Community Impact Monitoring Study. Consequently, the recommendations proposed in 1976 which dealt primarily with the physical impacts of construction on local communities remain critical to any future construction activities undertaken by PP&L.

Local concerns over possible "recessionary" impacts upon completion of construction activities should be addressed in a post-construction update examining housing surpluses, trends in construction employment and changes in local economic activities. Representatives of local labor unions should be advised of scheduling and extent of reductions in labor force.

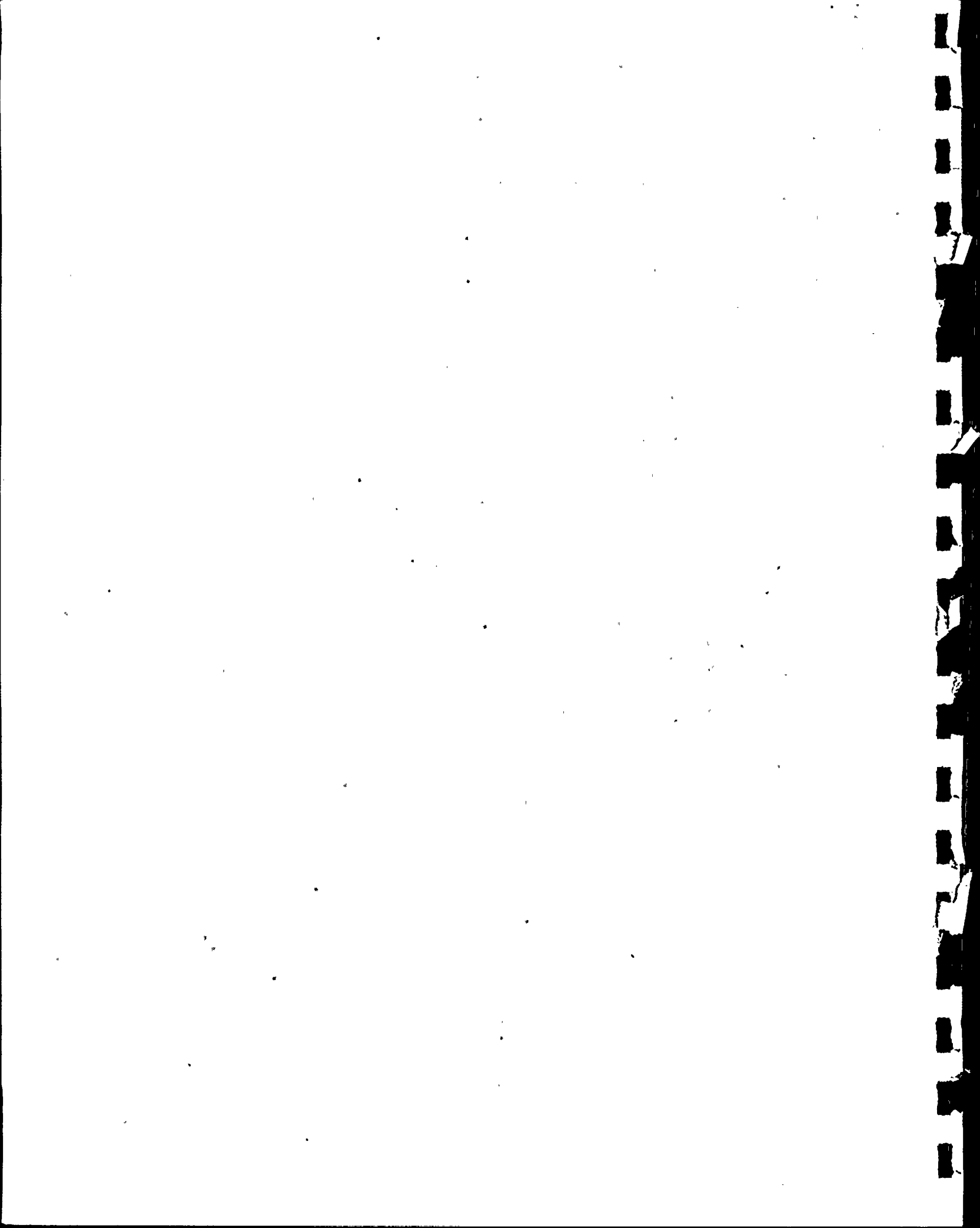
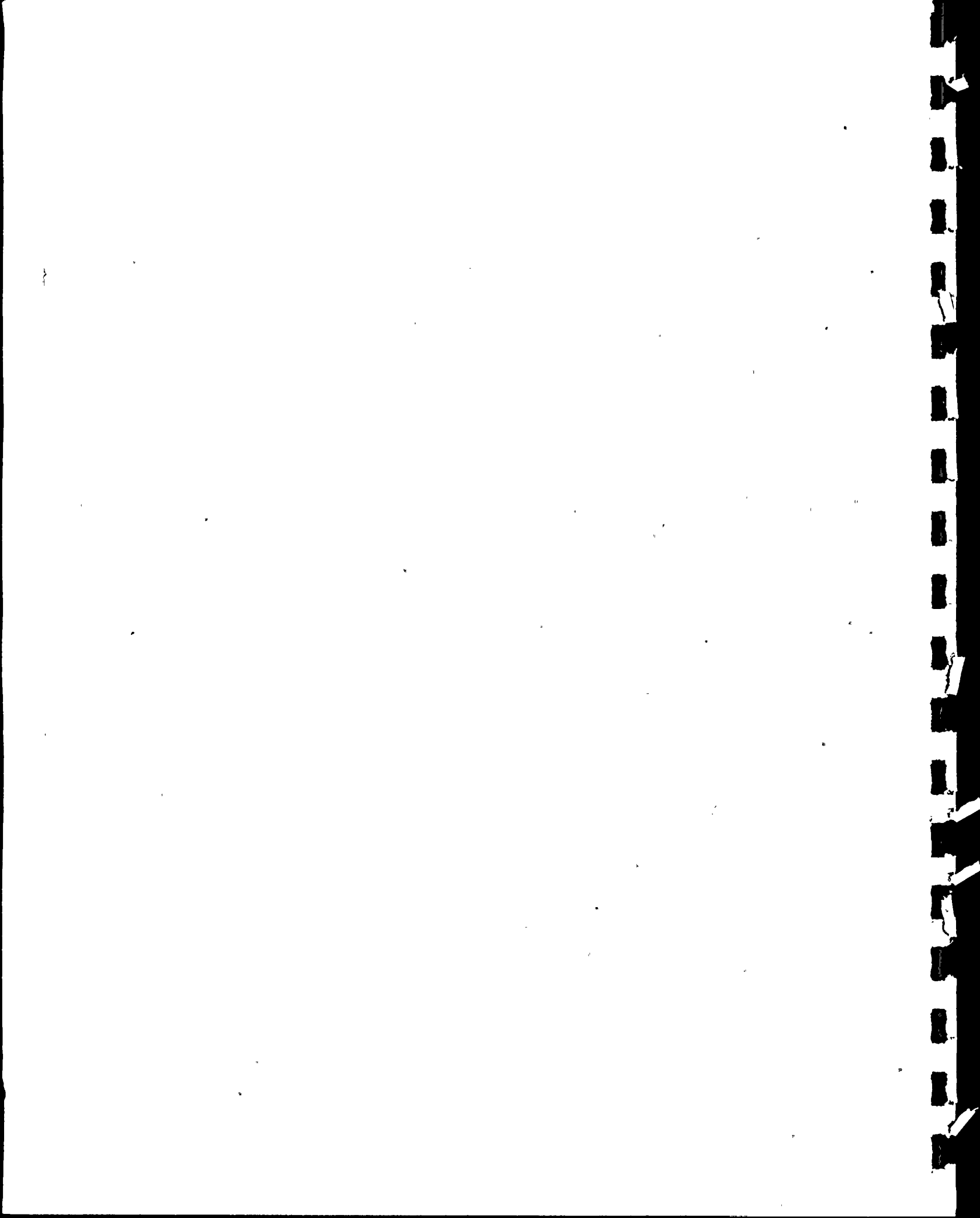


Table I-1

SUMMARY  
IMPACT CATEGORIES  
and  
STATUS OF MITIGATION STRATEGIES

<u>Impact Category</u>	<u>Proposal</u>	<u>Status</u>	<u>Comment</u>
1. Roads (traffic control)	Provide additional police personnel for local community (Shickshinny).	Adopted	Measure proposed by subcommittee of Project Advisory Committee; PP&L financial support provided.
2. Transportation	Form bus pools for commuting workers.	Adopted	Fourteen buses in operation as a result of "ad hoc" effort by manual work force.
3. Housing	Conduct housing inventory to assess needs of future plant sites.	No Action	Measure proposed in 1976 community impact report; would likely be adopted whenever future generating stations proposed.
4. Law Enforcement	-----	-----	None required, except as indicated in #1 above.
5. Health Care	Expand out-patient and emergency care facilities at local hospital.	Adopted	Both measures carried out; PP&L financial support provided.
	Provide facilities and staff training for treatment of radiation related injuries.	Adopted	
6. Make Up Water (low flow augmentation)	Construction of reservoir near plant site.	Adopted	Reservoir in planning and preliminary design stages
	Establish local mitigation/advisory committee.	Adopted	
7. Schools	-----	-----	None required; region experiencing declining enrollments
8. Employment	Develop stronger program for local hiring	No Action	Measure proposed in 1976 community impact report; likely to receive strong consideration if future generating stations proposed.
9. Construction Impacts	Establish project advisory committee.	Adopted	Ongoing effort.
	Implement policy to establish impact zones affected by construction activities (related to standing offer of purchase of homes within impact zone).	Under Evaluation	Proposed in 1976 study.
	Establish requirements for pre- and post-blasting inspections of structures in impact zone.	No Action	Proposed in 1976 study.
10. Emergency Services	Establish arrangements for local fire and ambulance companies to respond to emergencies during plant operation.	Adopted	Arrangements undertaken as part of overall Civil Defense planning effort. Staff training supported by PP&L.





CHAPTER II

SURVEY OF NON-MANUAL EMPLOYEES

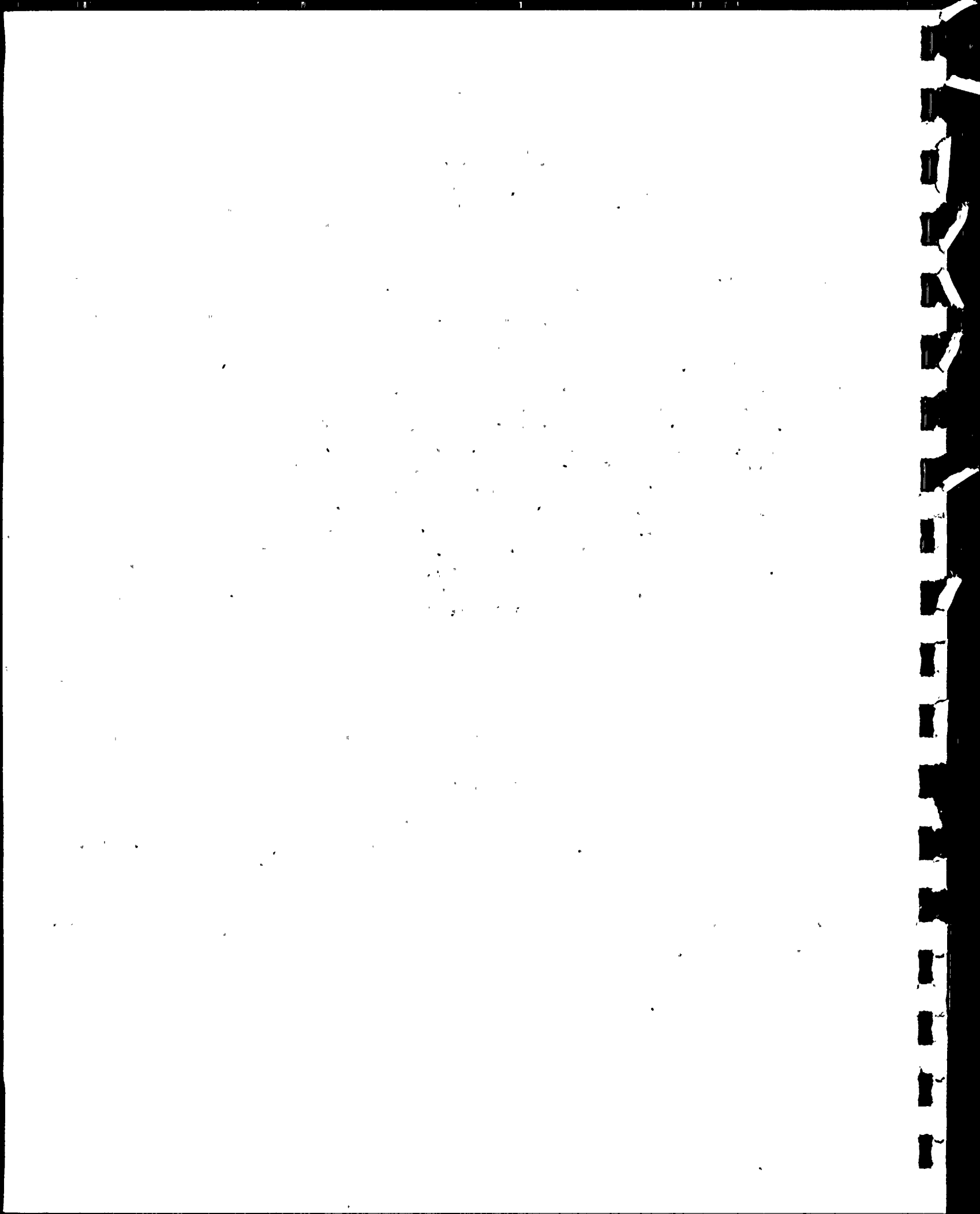
A. Summary of Survey Results

In June of 1978, a survey was distributed to Bechtel management employees at the SSES. The employment level among Bechtel non-manual employees at that time was approximately 591 (see Table II-1). A total of 469 completed surveys were returned, a response rate of over 79 percent. distinction was made between those Bechtel employees who are hired locally versus those respondents who were prior Bechtel employees transferred in from other job locations, i.e., non-local employees. The assumption is that non-local employees, as new residents to the area, constitute the major element of community change resulting in community impacts. Consequently, most of the data evaluated deals exclusively with non-local employees. Of the 469 completed surveys, 182 (39 percent) were classified as non-local employees. The remaining responses, 287 (61 percent) were considered local responses.

Table II-1

Bechtel Power Corporation Employees  
Susquehanna Steam Electric Station  
1975 and 1978

	<u>Total Bechtel</u>		<u>Permanent Employees</u>		<u>Local Hires</u>	
	<u>1975</u>	<u>1978</u>	<u>1975</u>	<u>1978</u>	<u>1975</u>	<u>1978</u>
Manager	62	83	62	80	0	3
Professional	204	306	156	146	48	160
Technical	58	102	10	2	48	100
Clerical	<u>78</u>	<u>100</u>	<u>23</u>	<u>3</u>	<u>55</u>	<u>97</u>
T O T A L	402	591	251	231	151	360



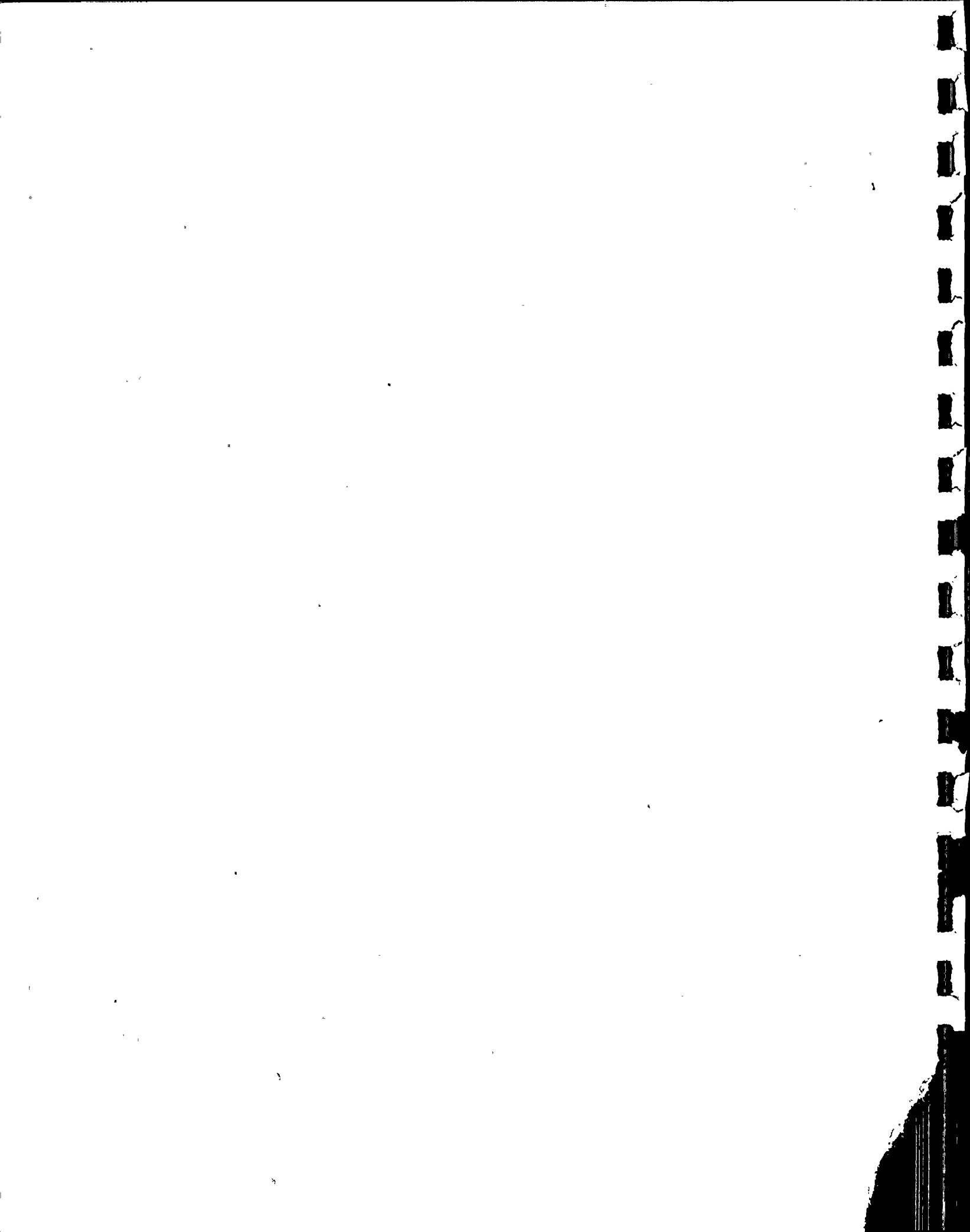
On a regional level, Berwick has declined in significance (in terms of residential location) relative to other locations in Columbia and Luzerne Counties. Most Bechtel employees, however, continue to live in the Berwick area, send their children to Berwick schools, and do most of their daily and major shopping in the Berwick area. In 1978, 40 percent (40%) of Bechtel employees lived in Berwick compared with 54 percent (54%) in 1975. Similarly, in 1978, 45 percent (45%) of the respondents resided in the Berwick Area School District, compared with 62 percent (62%) in 1975. In terms of shopping patterns, 39 percent (39%) of the respondents shop for their daily needs in Berwick compared with 54 percent (54%) in 1975. A similar drop was noted in the major needs category which indicated 28 percent (28%) of the respondents shopped in Berwick for major shopping needs compared with 35 percent (35%) in 1975.

Survey respondents continue to indicate a strong preference for single family detached homes over other types available in the study area. In 1978, 58 percent (58%) indicated a single family home as the type of residences they were currently living in compared with 50 percent (50%) in 1975. Although this trend of single family housing would suggest a high rate of ownership, the majority of respondents (53%) indicated that they rented.

Data on family size is largely inconclusive. Of 161 persons responding to a question on family size, only 14 percent (14%) indicated that there were five or more persons in their family (down from 20% in 1975), a reflection, perhaps, of the national trend towards smaller families.

Primary types of recreation engaged in included fishing, swimming, golf, tennis and hunting, all generally active types of recreation. Other popular activities included skiing, bowling, parks, camping, hiking and softball. Respondents seemed generally pleased with the availability of recreational resources within the study area.

When asked what aspects of the area were liked least and which were liked most, the best-liked aspects included the scenery, small town living, friendly people and availability of recreation. Least liked attributes included poor roads, poor traffic and parking conditions at the plant site, poor climate and high taxes.



B. Area of Residence

According to survey results, Berwick still ranks first concerning location preference for non-local employees. Table II-2 indicates 1978 distribution of residential choices compared with 1975.

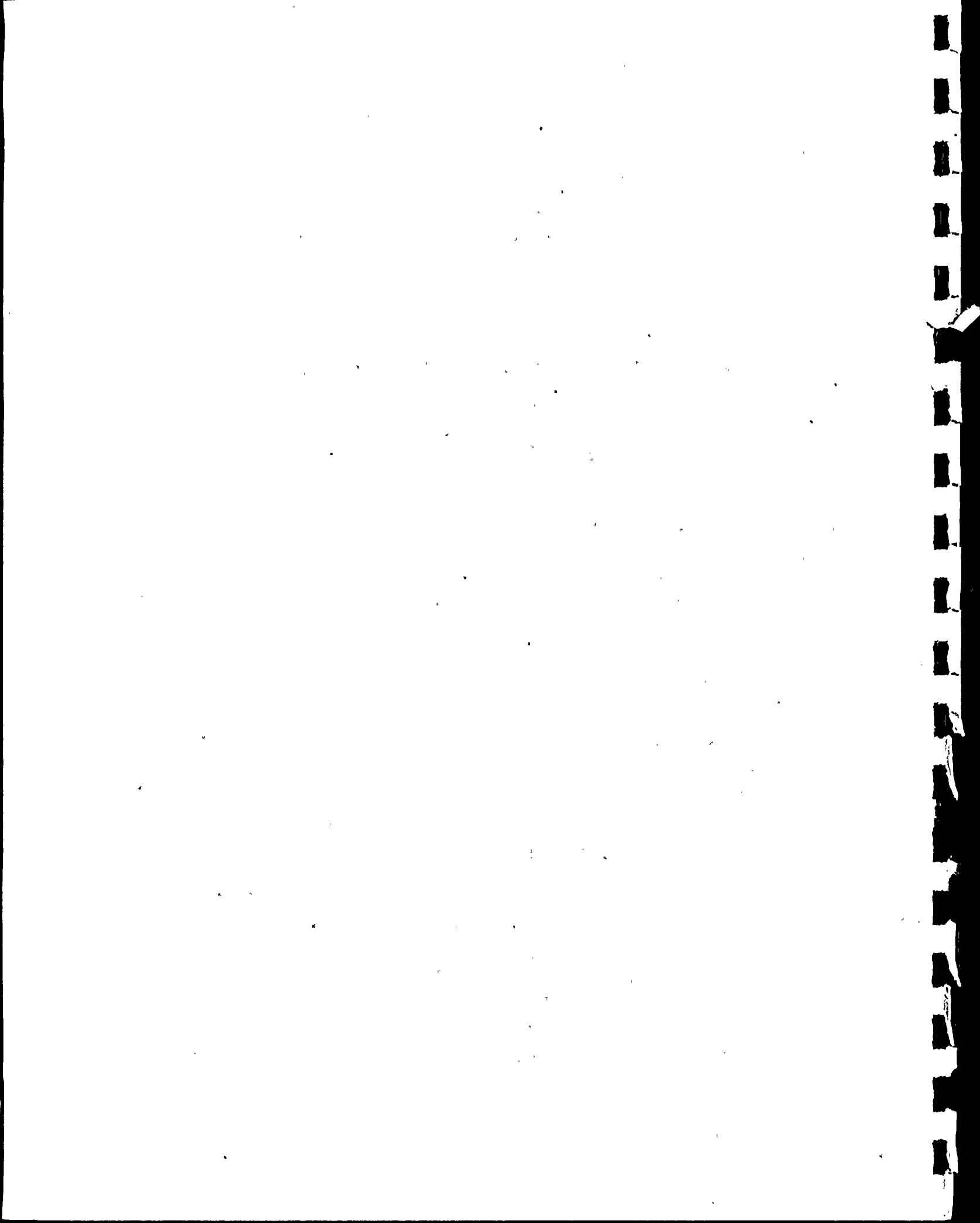
Table II-2

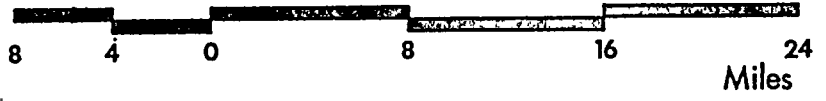
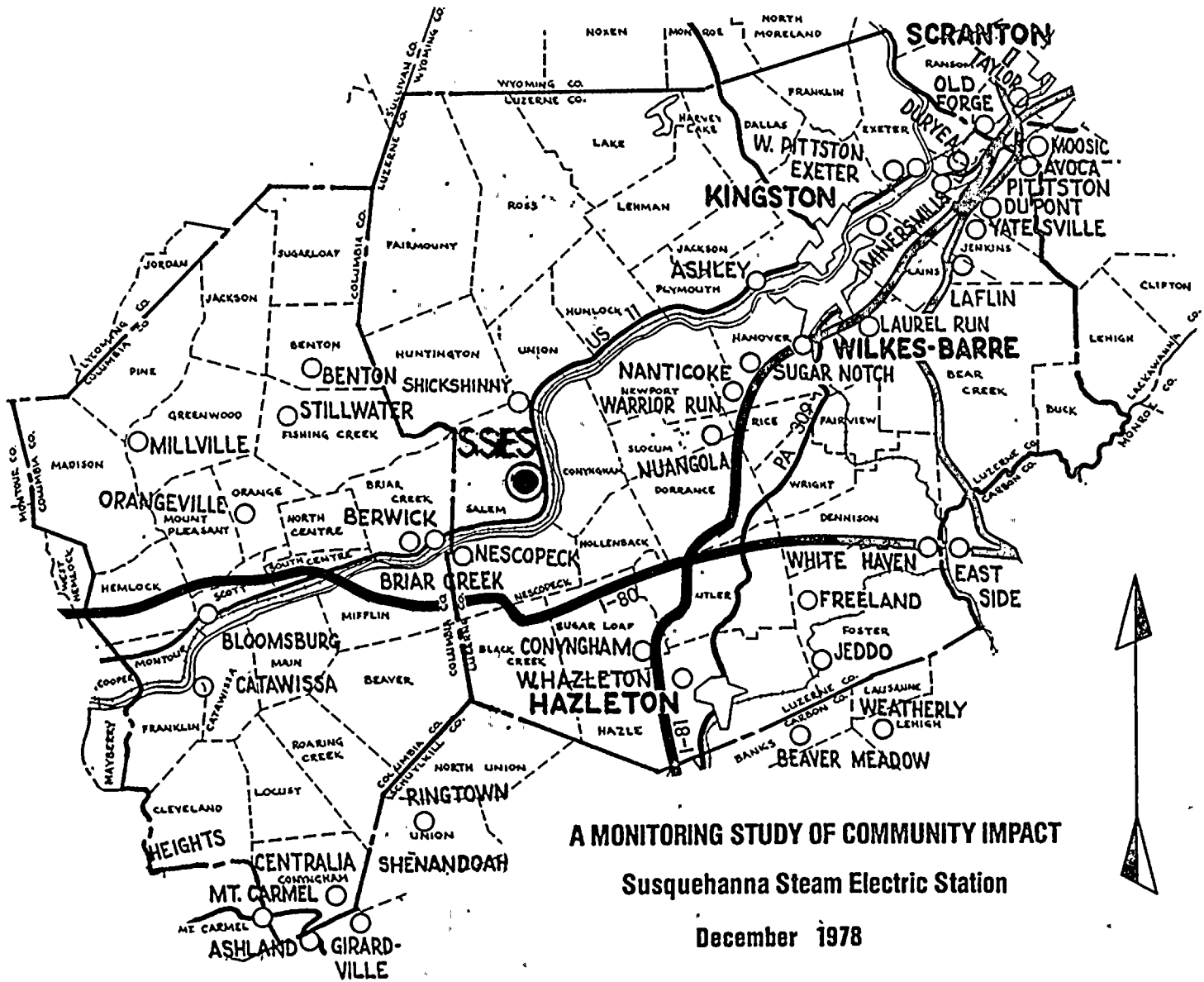
Bechtel Power Corporation Employees (Non-local): Area of Residence

	<u>No. of Families</u> <u>1975</u>		<u>No. of Families</u> <u>1978</u>	
	<u>No.</u>	<u>%</u>	<u>No.</u>	<u>%</u>
<u>Columbia County</u>				
Berwick Area	86	54	71	40
Bloomsburg Area	18	11	23	13
Other Columbia Co.	13	8	22	12
<u>Luzerne County</u>				
Wilkes-Barre Area	6	4	11	6
Other Luzerne Co.	29	19	30	17
<u>Other Counties</u>				
	<u>6</u>	<u>4</u>	<u>19</u>	<u>12</u>
	158	100	176	100

Summary by County

	<u>1975</u>		<u>1978</u>	
	<u>No.</u>	<u>%</u>	<u>No.</u>	<u>%</u>
Columbia	117	74	110	63
Luzerne	35	22	47	27
Other	<u>6</u>	<u>4</u>	<u>19</u>	<u>10</u>
TOTAL	158	100	176	100

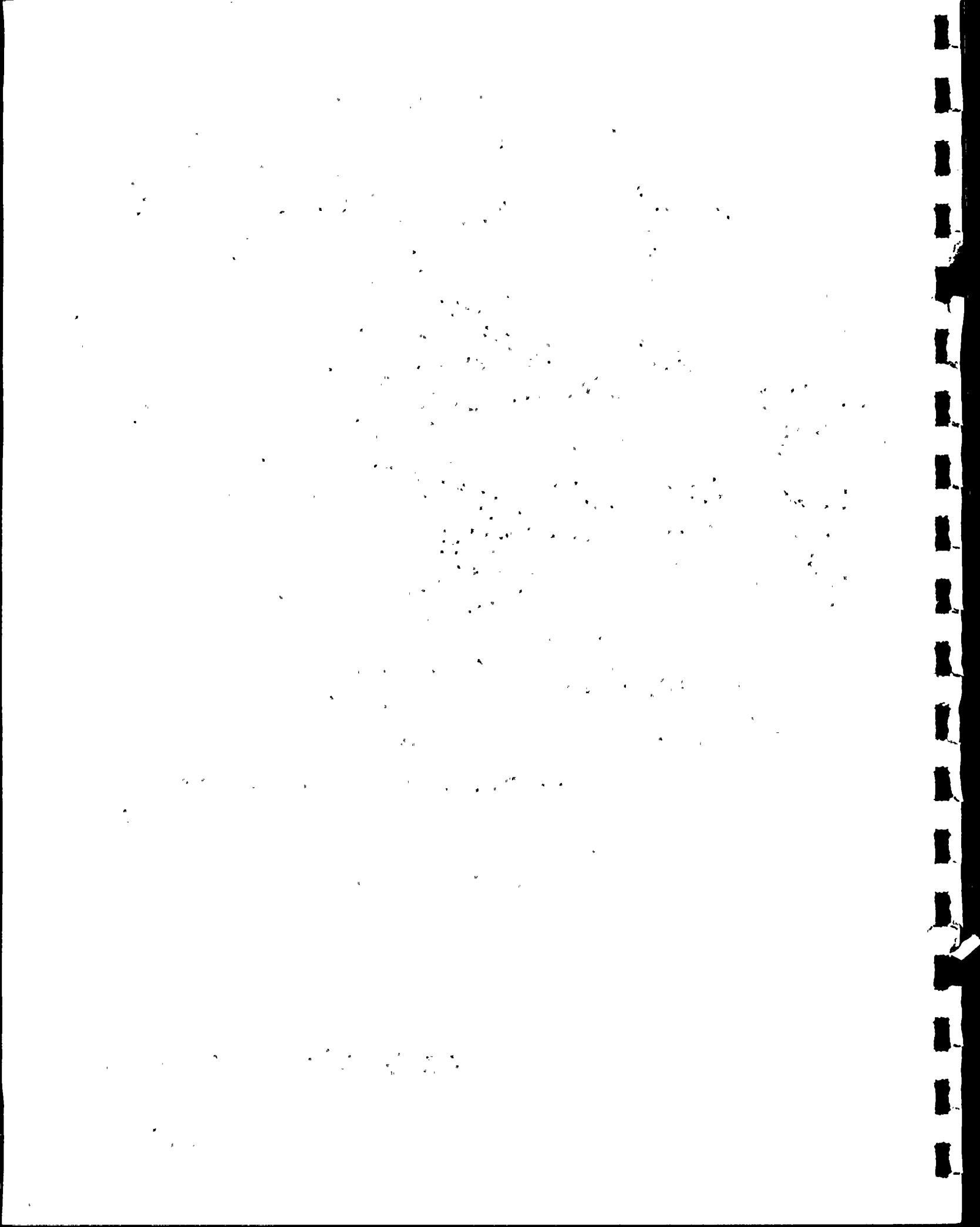




● PLANT LOCATION

# SSES REGIONAL MAP

FIG. II-1





The single discernible trend is the reduction in the number of families choosing to reside in the Berwick area. Seventy-one (71) families, or 40 percent (40%), live in the immediate site area which includes Salem Township (Luzerne County), Berwick Borough and Briar Creek Borough and Township (Columbia County), about 14 percent (14%) lower than the 1975 figures.

Luzerne County accounted for a greater share of Bechtel families in 1978 with most of the increases taking place in the Mountaintop area, a suburban residential community south of Wilkes-Barre. Other counties have also registered gains with most increases evenly distributed among Schuylkill, Northumberland, Lycoming and Montour Counties.

It is difficult to speculate on the reasons, or significances of changes in residential distributions. During the period in which the first community impact study was prepared (1975-1976), the Berwick Area School District was undergoing certain changes. Having a number of older schools, the district committed itself to a building program to create additional classroom space. Some local controversy arose around the issue and focused publicity on local schools in the district. Newspaper accounts suggested that the schools were responsible for a housing market lag at that time.<sup>1</sup> Conversations with local realtors suggest that the school system remains a significant locational factor concerning area of residence, despite the fact that the Berwick Area School District has recently completed a new middle school to replace space lost through the closing of the older buildings.

C. Type and Tenure of Residence

Fifty-eight percent (58%) of those respondents surveyed in 1978 owned or rented single family housing, compared to 50 percent (50%) in 1975. There were nine percent (9%) fewer respondents who lived in apartment-type housing in 1978. Mobile home housing increased slightly from eleven percent (11%) in 1975 to fifteen percent (15%) in 1978. Forty-seven percent (47%) of the respondents owned their housing in 1978, while only thirty-eight percent (38%) owned their homes in 1975. Table II-3 summarizes these data.

---

<sup>1</sup> Columbia County Enterprise, "Why Are Home Buyers Saying No to Berwick?", July 9, 1976.

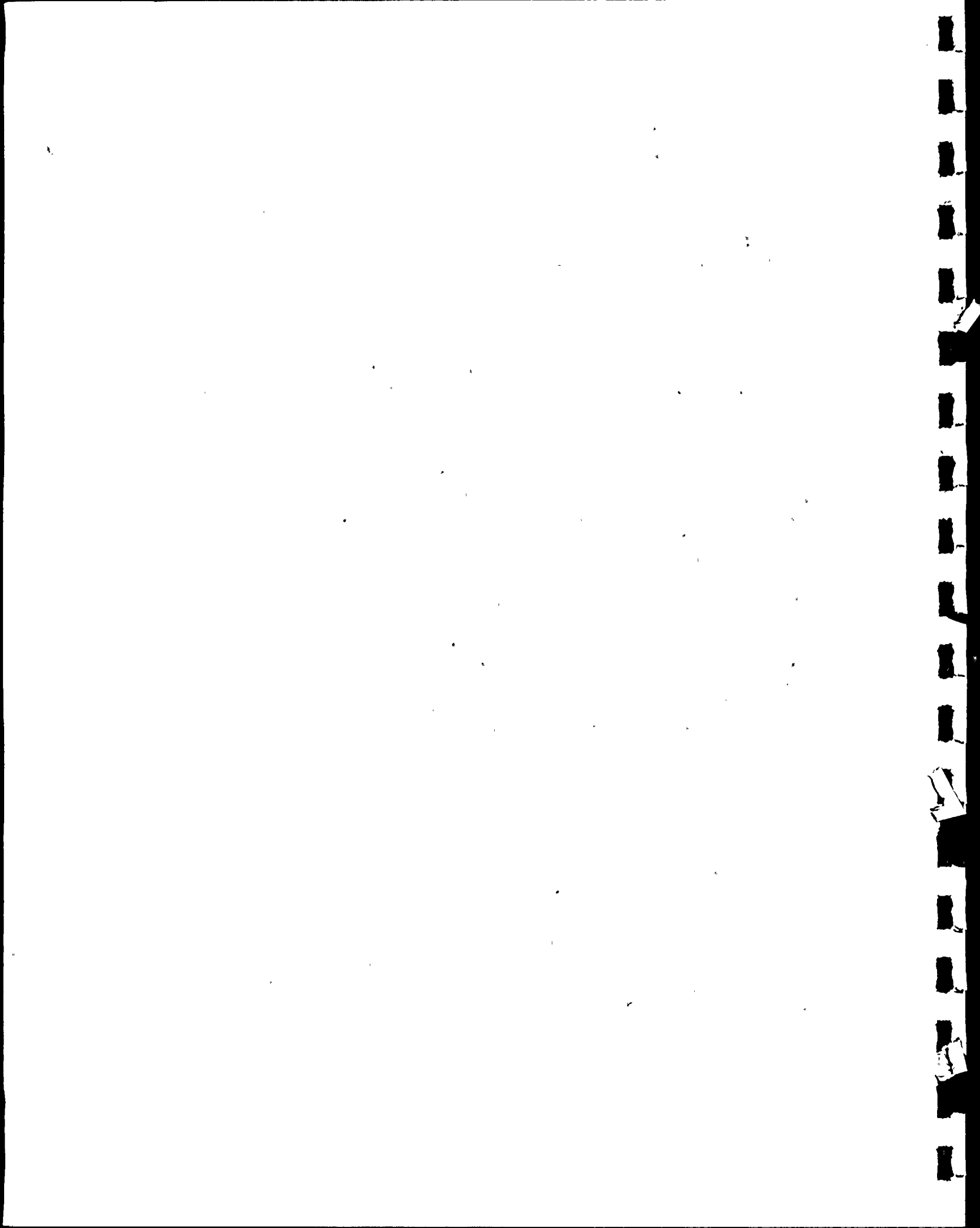


Table II-3

Housing Type and Tenure

A. Type of Residence

	1975		1978	
	<u>No.</u>	<u>%</u>	<u>No.</u>	<u>%</u>
1. Single Family	78	50	99	58
2. Apartment	46	30	36	21
3. Mobile Home	17	11	26	15
4. Motel/Rooming House	2	1	3	2
5. Duplex or Townhouse	<u>13</u>	<u>8</u>	<u>6</u>	<u>4</u>
T O T A L	156	100	170	100

B. Tenure

	1975		1978	
	<u>No.</u>	<u>%</u>	<u>No.</u>	<u>%</u>
1. Own	59	38	81	47
2. Rent	<u>96</u>	<u>62</u>	<u>90</u>	<u>53</u>
T O T A L	155	100	171	100

The above suggests little difference in trends between 1975 and 1978 survey results. A rise in ownership suggests greater availability of housing supply.

D. Family Size

Survey data indicates that one and two-person families transferred into the area remained virtually unchanged from 1975 to 1978. The most notable differences occurred in families with three or more persons.

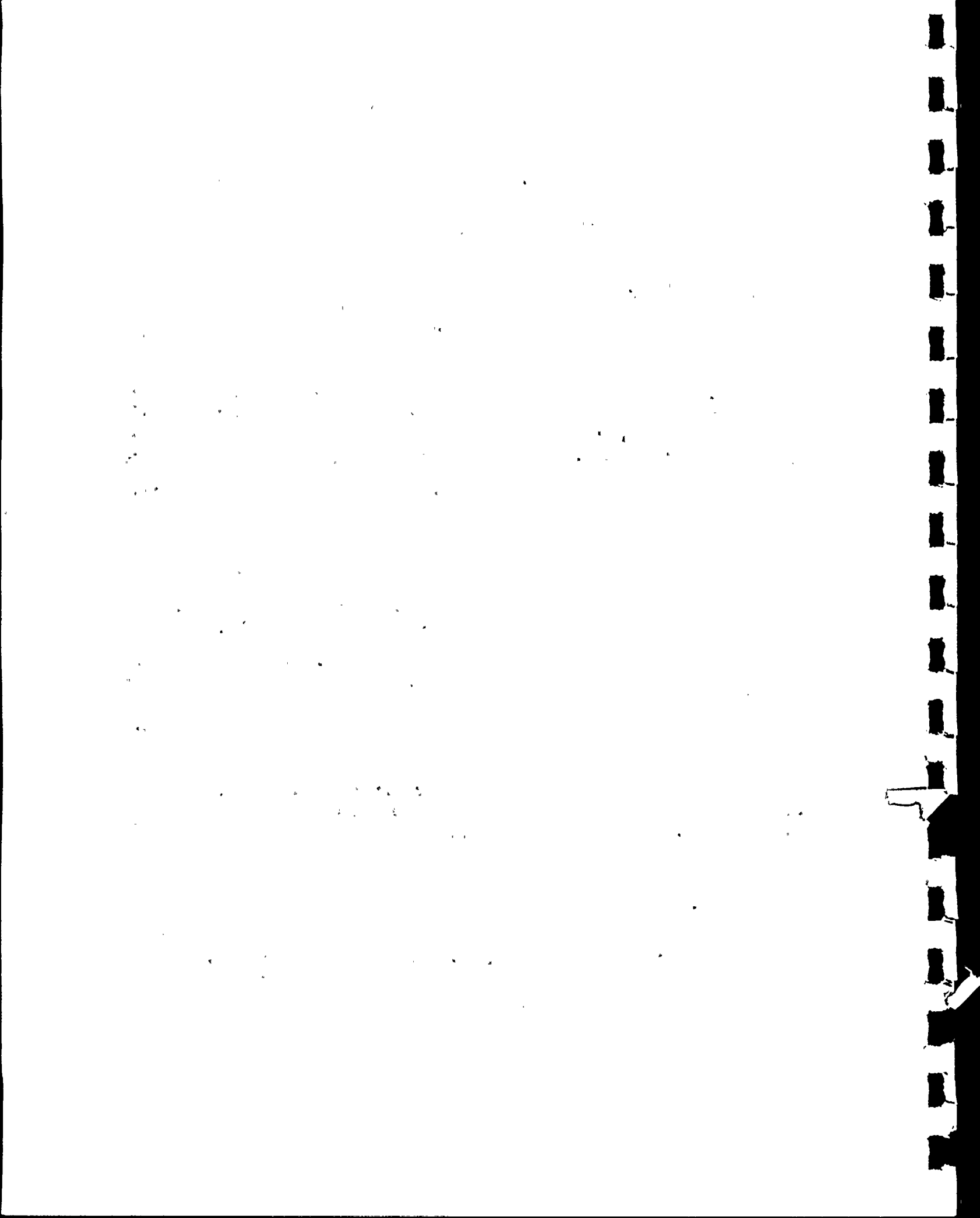


Table II-4

Family Size

	<u>1975</u>		<u>1978</u>	
	<u>No.</u>	<u>%</u>	<u>No.</u>	<u>%</u>
<u>Family Size</u>				
1. 1 person	22	15	22	14
2. 2 persons	46	32	52	32
3. 3 persons	20	14	28	17
4. 4 persons	28	19	37	23
5. 5 or more persons	<u>30</u>	<u>20</u>	<u>22</u>	<u>14</u>
T O T A L	146	100	161	100

The data suggest no particular significance except that the decrease in the number of larger families (5 or more persons) reflects a national trend towards smaller families.

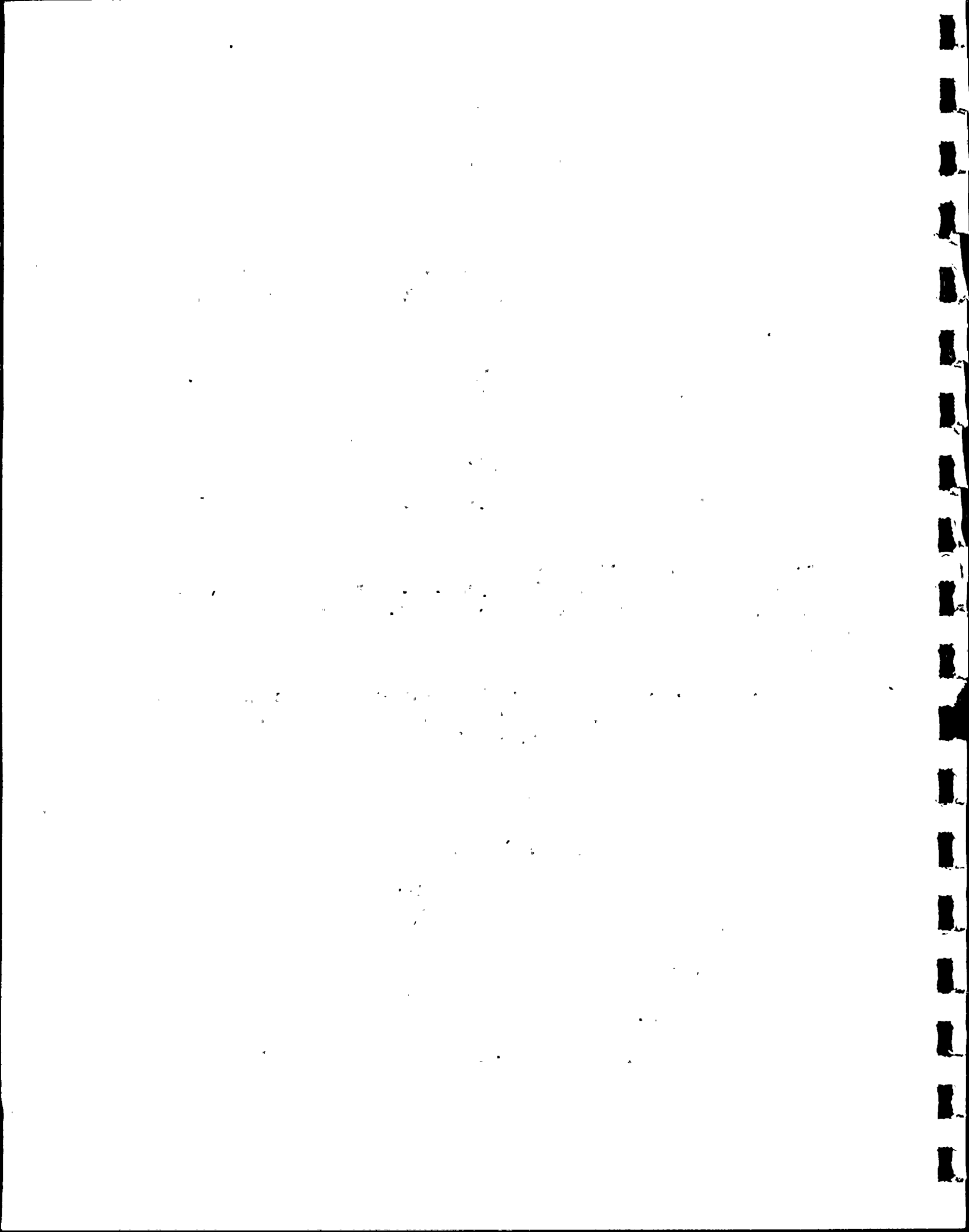
E. Age of Employees

The Bechtel employees surveyed constitute a relatively young work force with almost fifty percent (50%) of the employees under the age of thirty-five (35).

Table II-5

Age of Employees

<u>AGE</u>	<u>No.</u>	<u>%</u>
Under 25	11	6
25-35	73	41
36-45	33	18
46-60	51	29
60 or More	<u>11</u>	<u>6</u>
T O T A L	179	100



F. Number of Children by Grade Level & School District

Of those persons surveyed, about half indicated that they had children. Average family size remained unchanged since 1975, about 2.1 persons per family.

The percentage of pre-school children from 1975 to 1978 also remained unchanged. Decreases in the percentage of elementary and junior high school children occurred in 1978 when compared to the same grade levels in 1975. At the senior high school level, however, a seven percent (7%) increase was registered.

Table II-6

Number of Children by Grade Level

<u>Grade Level</u>	<u>1975</u>		<u>1978</u>	
	<u>No.</u>	<u>%</u>	<u>No.</u>	<u>%</u>
Pre-school	49	29	54	29
Elementary	67	39	68	37
Junior High School	32	19	27	14
Senior High School	<u>22</u>	<u>13</u>	<u>37</u>	<u>20</u>
T O T A L	170	100	186	100

Overall, there was an eleven percent (11%) increase in the number of children between 1978 and 1975.

In terms of enrollment trends, Table II-7 shows family residence by school district.

Table II-7

Family Residence by School District

<u>School District</u>	<u>1975</u>		<u>1978</u>	
	<u>No.</u>	<u>%</u>	<u>No.</u>	<u>%</u>
Berwick Area	48	62	40	45
Bloomsburg Area	5	6	7	8
Central Columbia	9	12	15	17
Luzerne County Districts	14	18	22	25
Other	<u>2</u>	<u>2</u>	<u>4</u>	<u>5</u>
T O T A L	78	100	88	100

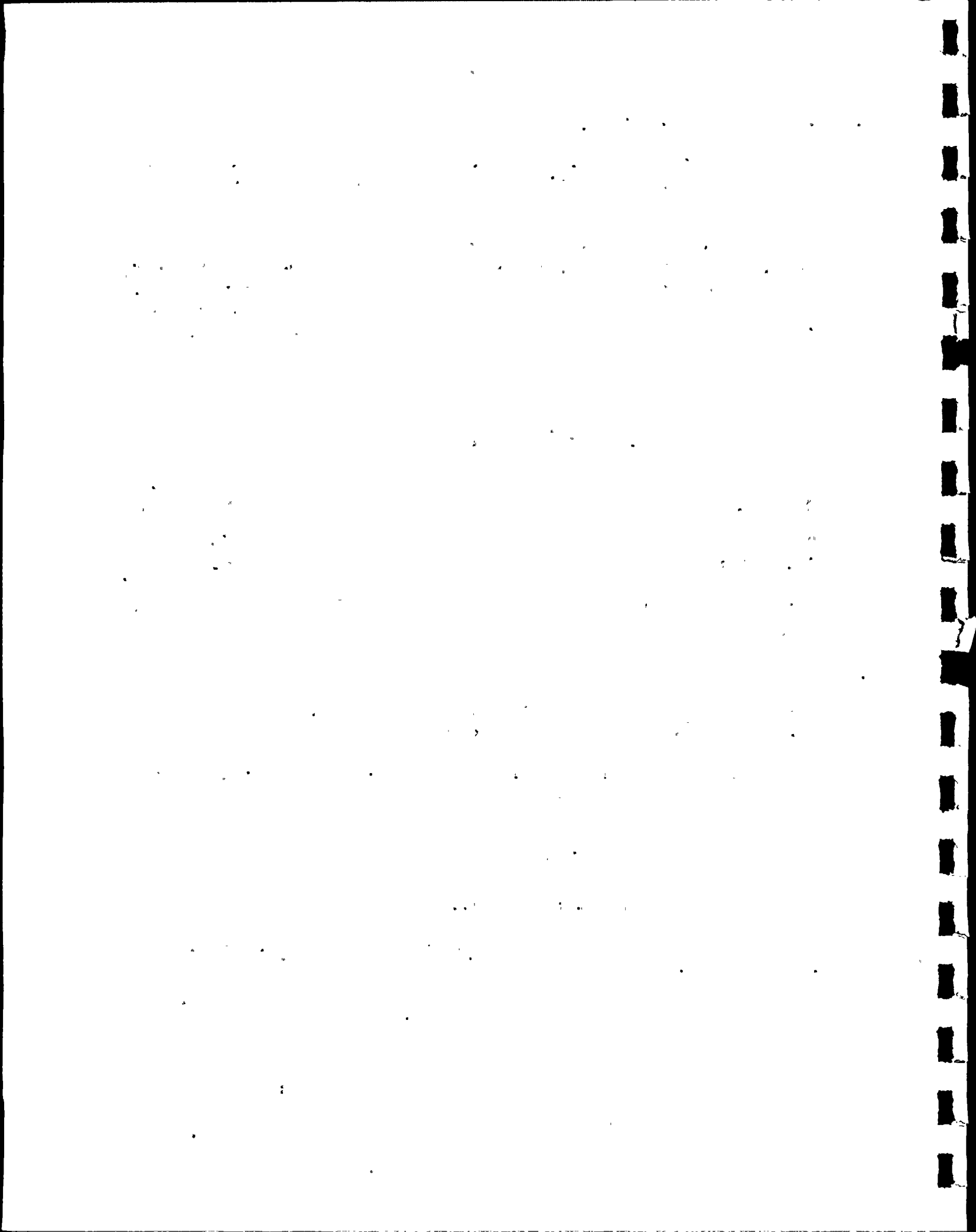




Table II-8 illustrates the distribution of children among school districts. Typically, the distribution among school districts reflects trends similar to residential location reported in Table II-2. Most children live within the Berwick School District, with a significant percentage living in the Central Columbia District. Luzerne County School Districts account for less than fifteen percent (15%) of children reported.

In 1975, the majority of families with children, sixty-two percent (62%), resided within the Berwick Area School District. Three years later, this figure dropped to forty-five percent (45%). The absolute numbers (48 families vs. 40 families) suggest a less dramatic effect on overall enrollment. Nevertheless, substantial gains were recorded in the Luzerne County and Central Columbia School Districts.

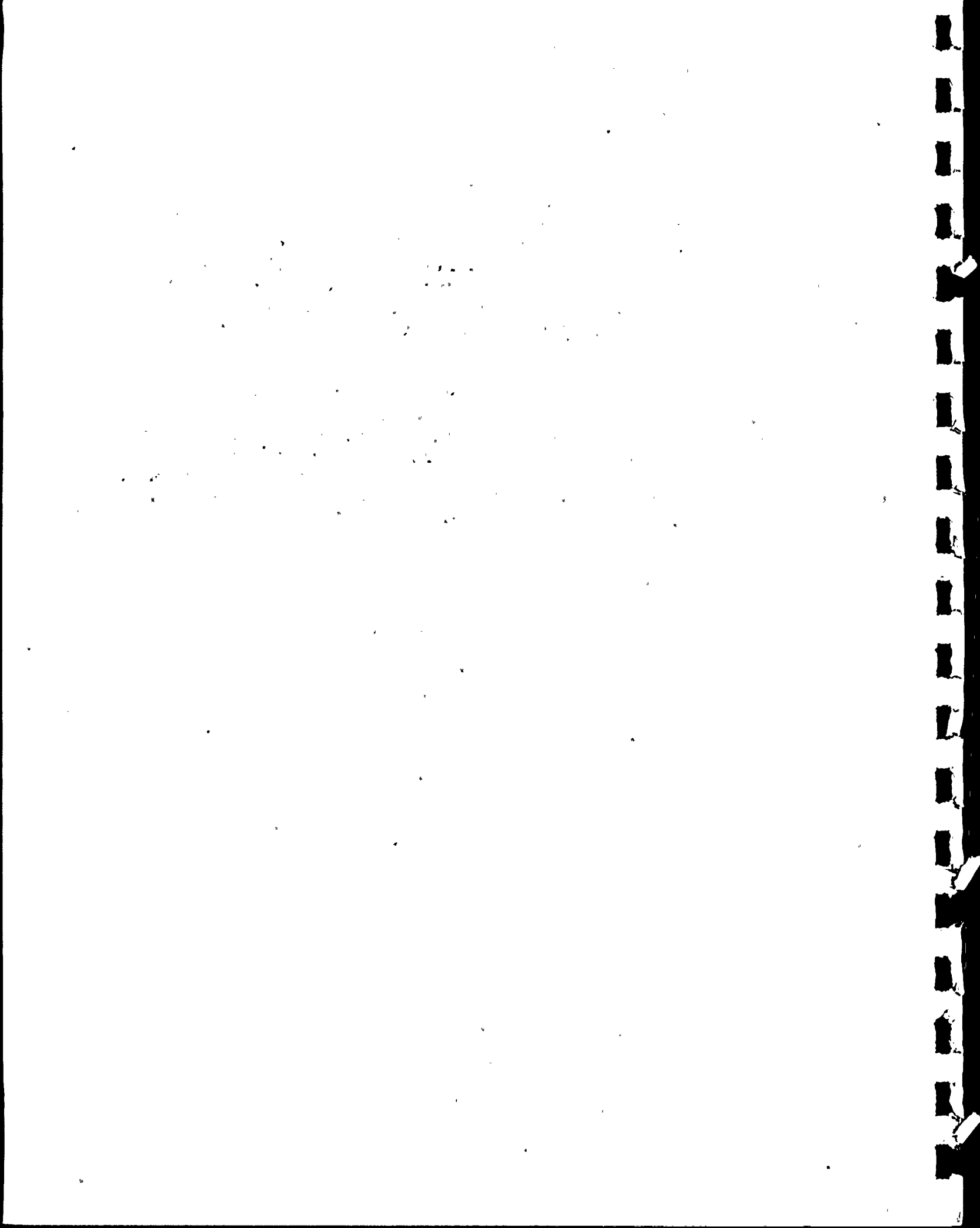
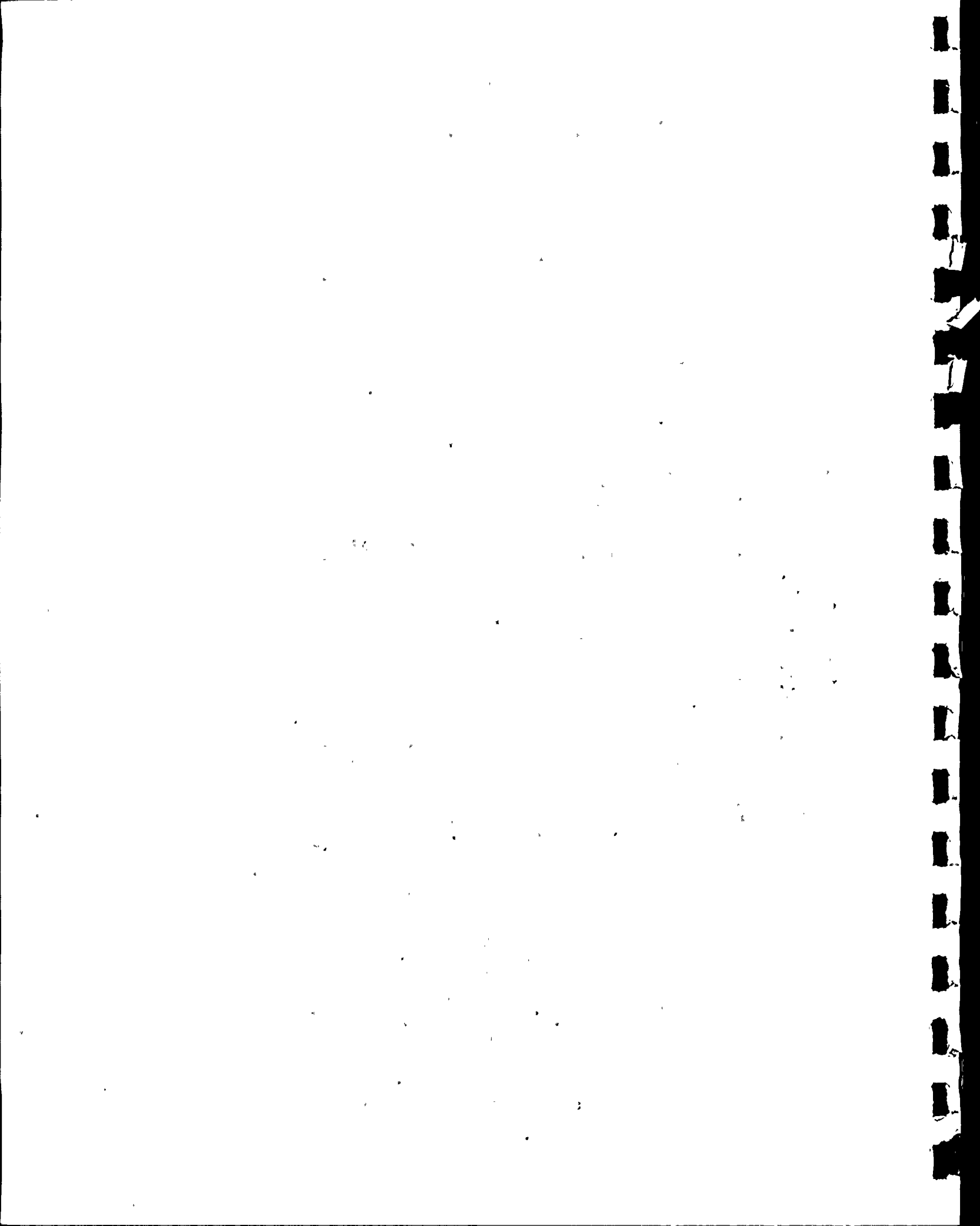
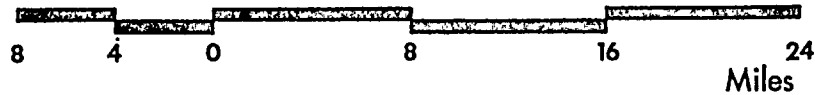
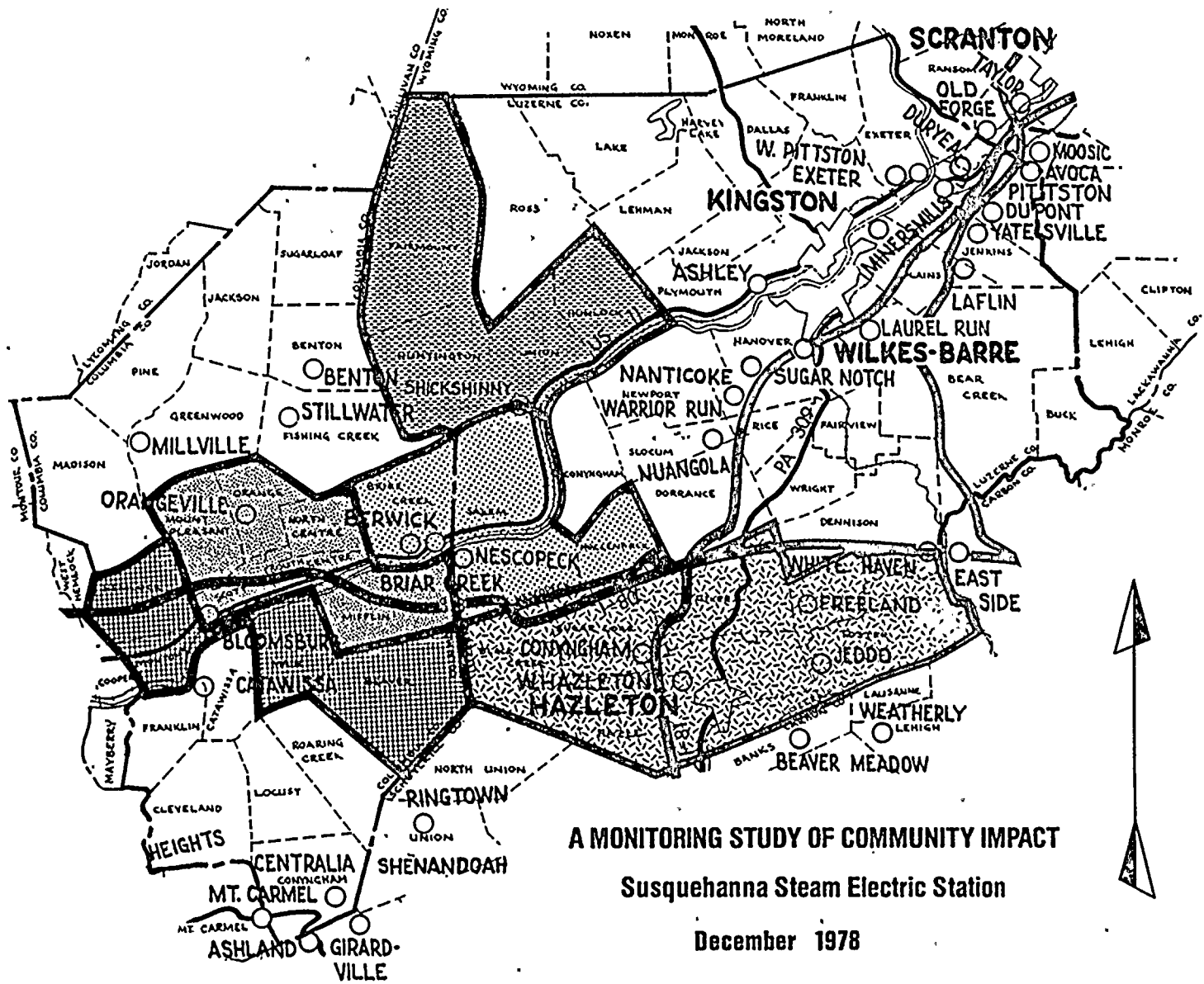







Table II-8

Number of Children  
by  
School District and Grade Level  
1978

<u>School Districts</u>	<u>Total</u>		<u>Pre-Schoolers</u>		<u>Elementary</u>		<u>Jr. High</u>		<u>Sr. High</u>	
	<u>No.</u>	<u>%</u>	<u>No.</u>	<u>%</u>	<u>No.</u>	<u>%</u>	<u>No.</u>	<u>%</u>	<u>No.</u>	<u>%</u>
1. Berwick	80	43	24	44	26	38	12	44	18	49
2. Central Columbia	42	23	10	19	19	28	7	26	11	30
3. Hazleton (Luzerne Co.)	21	11	7	13	8	12	3	11	--	--
4. Bloomsburg	17	9	5	9	3	4	2	8	--	--
5. Northwest (Luzerne Co.)	6	3	3	6	3	4	0	--	5	13
6. Other	<u>20</u>	<u>11</u>	<u>5</u>	<u>9</u>	<u>9</u>	<u>13</u>	<u>3</u>	<u>11</u>	<u>3</u>	<u>8</u>
T O T A L	186	100	54	100	68	100	27	100	37	100

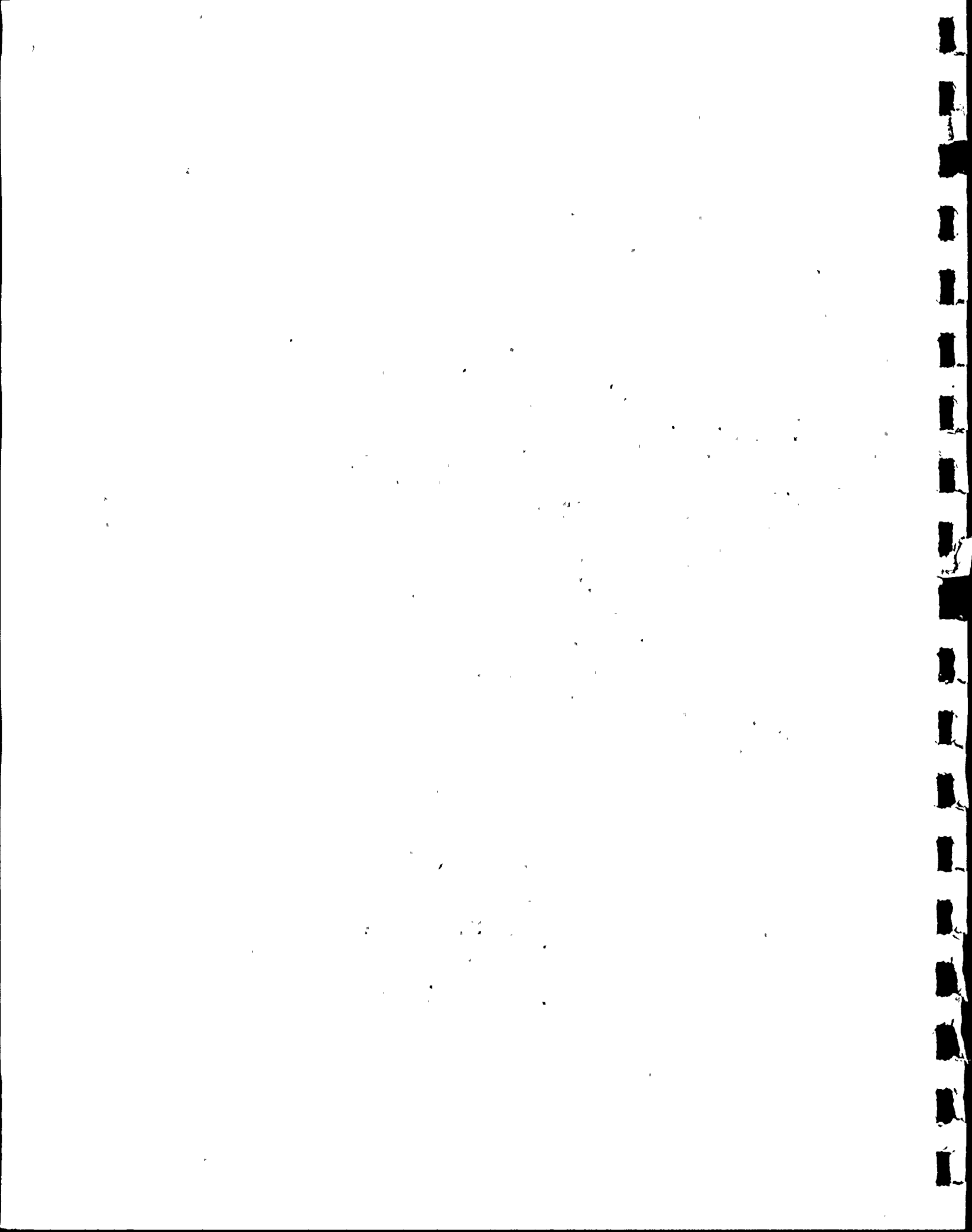




-  BERWICK AREA
-  CENTRAL COLUMBIA
-  BLOOMSBURG AREA
-  NORTHEAST AREA
-  HAZLETON AREA  
(LUZERNE COUNTY PORTION)

# SCHOOL DISTRICTS

FIG. II-2



G. Shopping Patterns

The 1978 survey, as did the 1975 effort, attempted to discern spending patterns of non-local Bechtel employees. The shopping patterns of new area residents were examined with respect to two types of purchases, daily shopping and shopping for major needs such as furniture, large appliances, etc. Table II-9 records those responses.

Table II-9

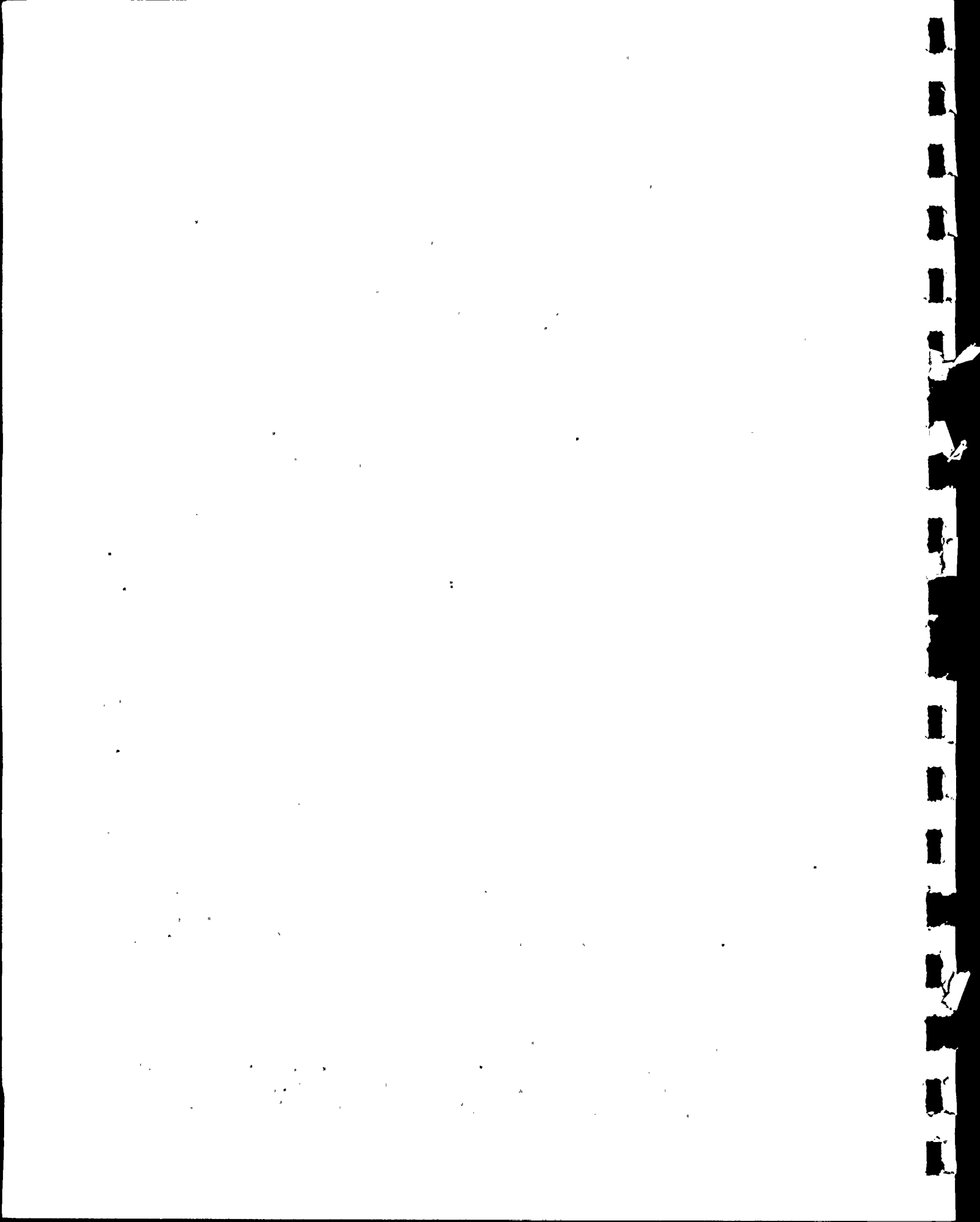
Shopping Patterns: Daily and Major Purchases  
(Respondents could answer more than once.)

	<u>Daily Needs</u>		<u>Major Needs</u>	
	<u>1975</u> <u>No.</u>	<u>1978</u> <u>%</u>	<u>1975</u> <u>No.</u>	<u>1978</u> <u>%</u>
Berwick	54	39	35	28
Bloomsburg	20	26	20	24
Wilkes-Barre	10	12	23	23
Hazleton	6	9	12	13
Other	<u>10</u>	<u>14</u>	<u>10</u>	<u>12</u>
T O T A L	100	100	100	100

Berwick's role as a local and regional shopping center, when compared to other areas, has declined. Meanwhile, the shopping activity in Bloomsburg, Wilkes-Barre and Hazleton increased.

H. Recreational Activities

The primary types of recreation used by families or respondents include fishing, swimming, golf, tennis and hunting. Skiing, bowling, parks, camping, hiking and softball were engaged in to a lesser extent. Data available from the 1975 survey was





not comparable; the information presented below is, therefore, for the 1978 survey only.

Table II-10  
Recreational Use

Type	No.	%	Type	No.	%
A. Fishing	47	14	H. Bowling	16	5
B. Swimming	43	12	I. Parks	12	3
C. Golf	39	11	J. Camping	11	3
D. Tennis	36	10	K. Hiking	8	2
E. Hunting	36	10	L. Softball	6	2
F. Skiing	25	7	M. YMCA	6	2
G. None	<u>25</u>	<u>7</u>	N. Other	<u>39</u>	<u>11</u>
			T O T A L	346	99

I. Hospital Use and Purpose

Of the 172 responses recorded, local hospitals have been used by sixty-three percent (63%) of the families, which was approximately the same as the 1975 rate. Two local hospitals are located in the vicinity of the plant site, in Berwick and Bloomsburg; a third facility, Geisinger Medical Center, is located twenty-five (25) miles to the southwest, in Danville.

The majority of respondents used local hospitals for emergency purposes, although the percentage of those visits from work-related causes is undetermined. Chapter VI, Section B, does report on the number of hospital referrals from work-related accidents.

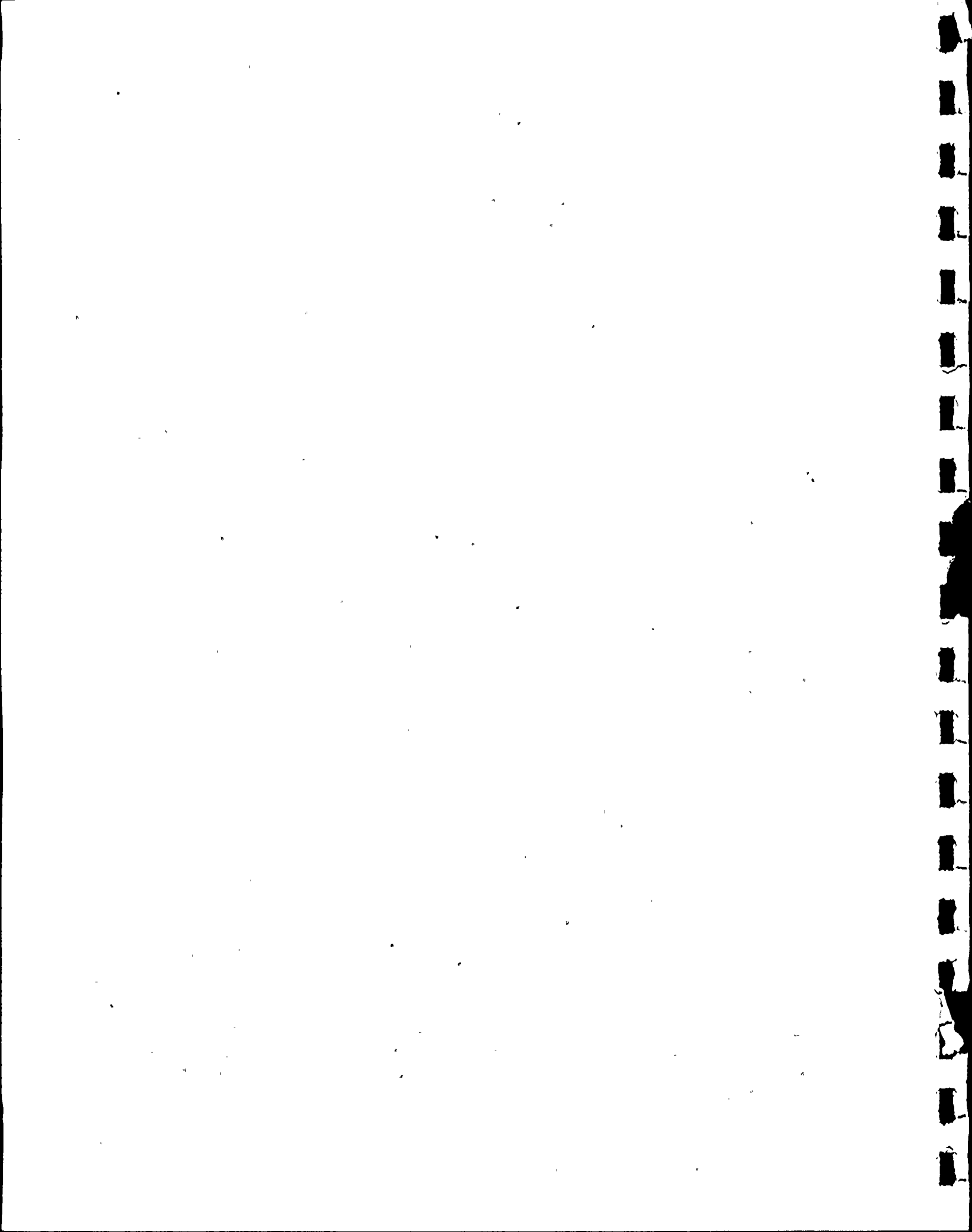


Table II-11

Hospital Use and Purpose

	<u>Hospital Use</u>		<u>Hospital Purpose</u>	
	<u>No.</u>	<u>%</u>	<u>No.</u>	<u>%</u>
A. Yes	109	63	A. Emergency	58 42
B. No	<u>63</u>	<u>37</u>	B. Surgery	38 27
T O T A L	172	100	C. Pregnancy	18 13
			D. Check-ups	12 9
			E. Tests	9 7
			F. Other	<u>3</u> <u>2</u>
			T O T A L	138 100

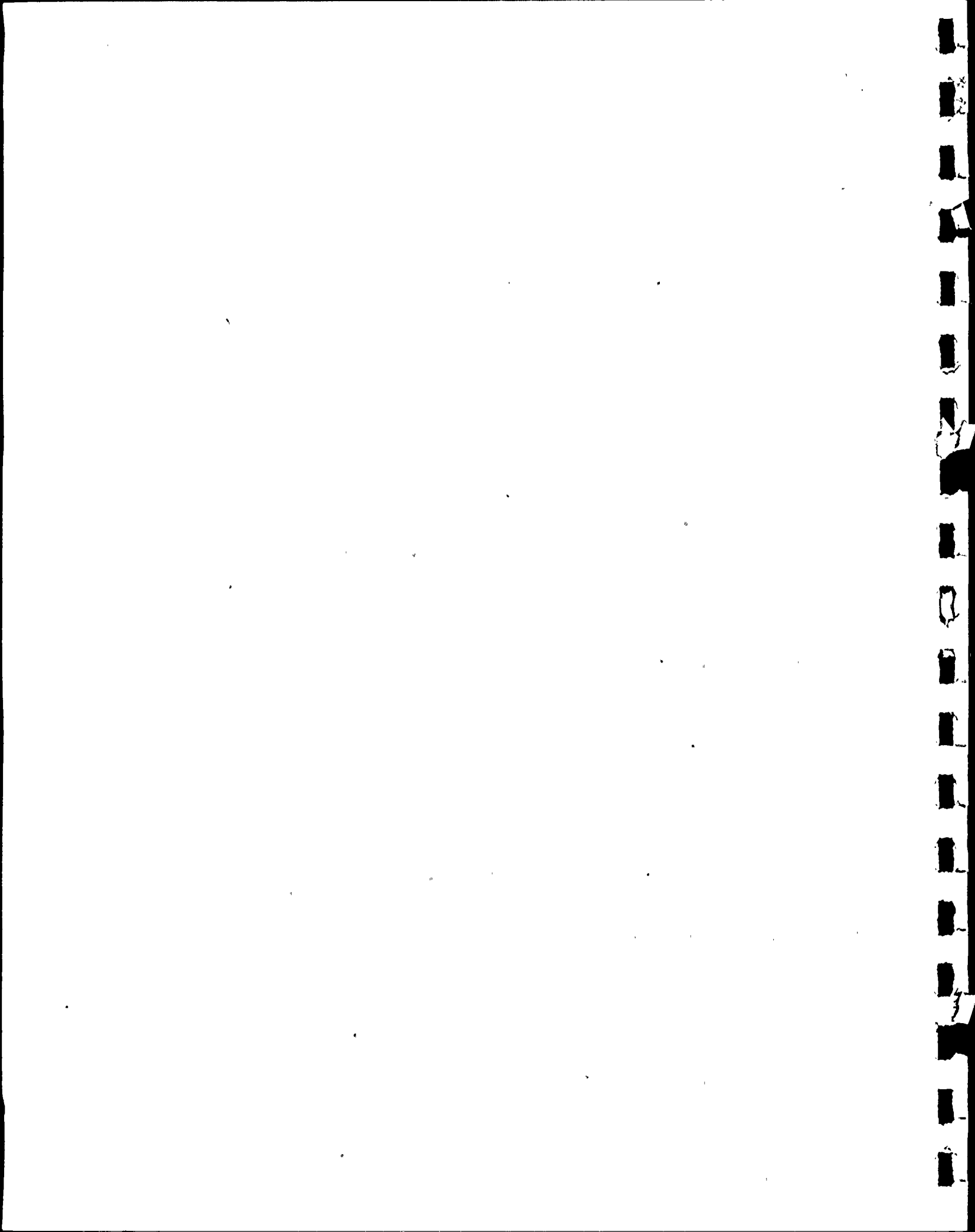
J. Attitude Towards Area of Residence

As with the 1975 survey, an attempt was made to gain insight into the attitudes of Bechtel employees concerning the aspects of the area liked most and least by asking open-ended questions. Response rates are reported below:

Table II-12

Attitude Towards Area of Residence  
(Respondents could choose more than one category.)

<u>Aspects Liked Best</u>	<u>1975</u>	<u>1978</u>
	<u>%</u>	<u>%</u>
1. Scenery	25	17
2. Small Town Life	23	17
3. Friendly People	18	21
4. Recreation	10	12
5. Near Metropolitan Areas	6	5
6. Good Schools	4	3
7. Shopping	2	4
8. Other	<u>12</u>	<u>21</u>
T O T A L	100	100



"Scenery" and "small town life" have yielded somewhat to "friendly people" and "recreation" as positive community features. Overall, however, the principal appeal of the Berwick-Bloomsburg area to those surveyed in 1978 is virtually unchanged from 1975, i.e., living in a small town in a rural setting.

The "other" category had a twenty-one percent (21%) response rate which included such responses as "good municipal service", "provided employment", and "low cost of living". Individually, responses in the other category were generally less than two percent (2%) of total responses.

In 1975, "poor shopping", "high cost of living", "high taxes" and "climate" topped the list of undesirable factors associated with local communities (see Table II-13). By 1978, the first two categories diminished in importance while climate and high taxes remained relatively stable. "Poor roads" emerged as a strong negative feature as did "poor traffic and parking conditions at plant site", a factor which was not even recorded in 1975.

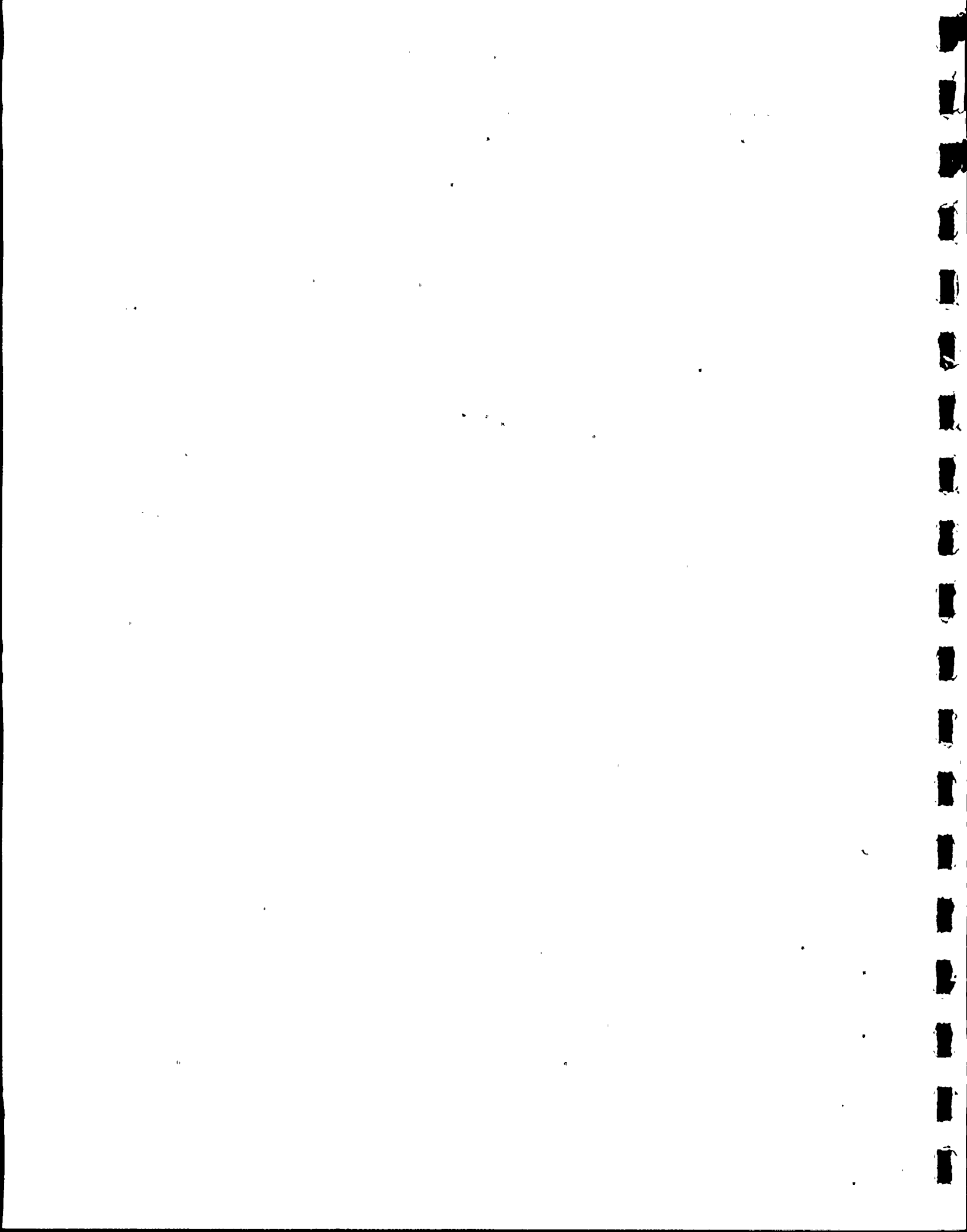
Similarly, three additional factors emerged since the 1975 survey which represents potential local issues. These new factors include "resentment to Bechtel", "poor government", and "high utility rates".

Table II-13

Aspects Liked Least

(Respondents could choose more than one category.)

	<u>1975</u>	<u>1978</u>
	<u>%</u>	<u>%</u>
1. Poor Shopping	17	8
2. High Cost of Living	12	3
3. Climate	12	14
4. High Taxes	11	13
5. Poor/Expensive Housing	9	2
6. Poor Roads	9	15
7. Unfriendly People	8	3
8. Lack of Culture Resources	6	4
9. Poor Schools	5	2
10. Traffic and Parking Conditions at the Plant Site	--	12
11. Resentment to Bechtel	--	4
12. Poor Government	--	3
13. High Utility Rates	--	3
14. Other	<u>11</u>	<u>14</u>
T O T A L	100	100



K. PP&L Survey Responses

As in 1975, all PP&L employees assigned to the SSES were surveyed in 1978. In 1975, the number of responses, thirty-one (31), was considered statistically insignificant. In three years, the size of the PP&L staff increased to ninety (90), eighty (80) of which responded to the survey. While the number of responses is statistically more significant in 1978, the absolute number of employees, in terms of local community impacts, is still low. Table II-14 summarizes 1978 responses. The terms "local" and "non-local" refer to those PP&L employees who did not have to move in to the plant site area as opposed to those employees hired, or transferred in, from other job locations.

Trends similar to those identified in the Bechtel survey are discernible in responses to the PP&L survey. Since 1975, the Bloomsburg-Berwick area, particularly Berwick, remains the principal area chosen by incoming PP&L personnel. Even those 1978 responses recorded as "Other Luzerne County" (Item No. 4) included many responses from the Nescopeck area which is located directly opposite Berwick across the Susquehanna River. Another determination of place of residence can be inferred from responses to Item No. 9, School District, which reflects a substantial response rate from the Berwick Area School District.

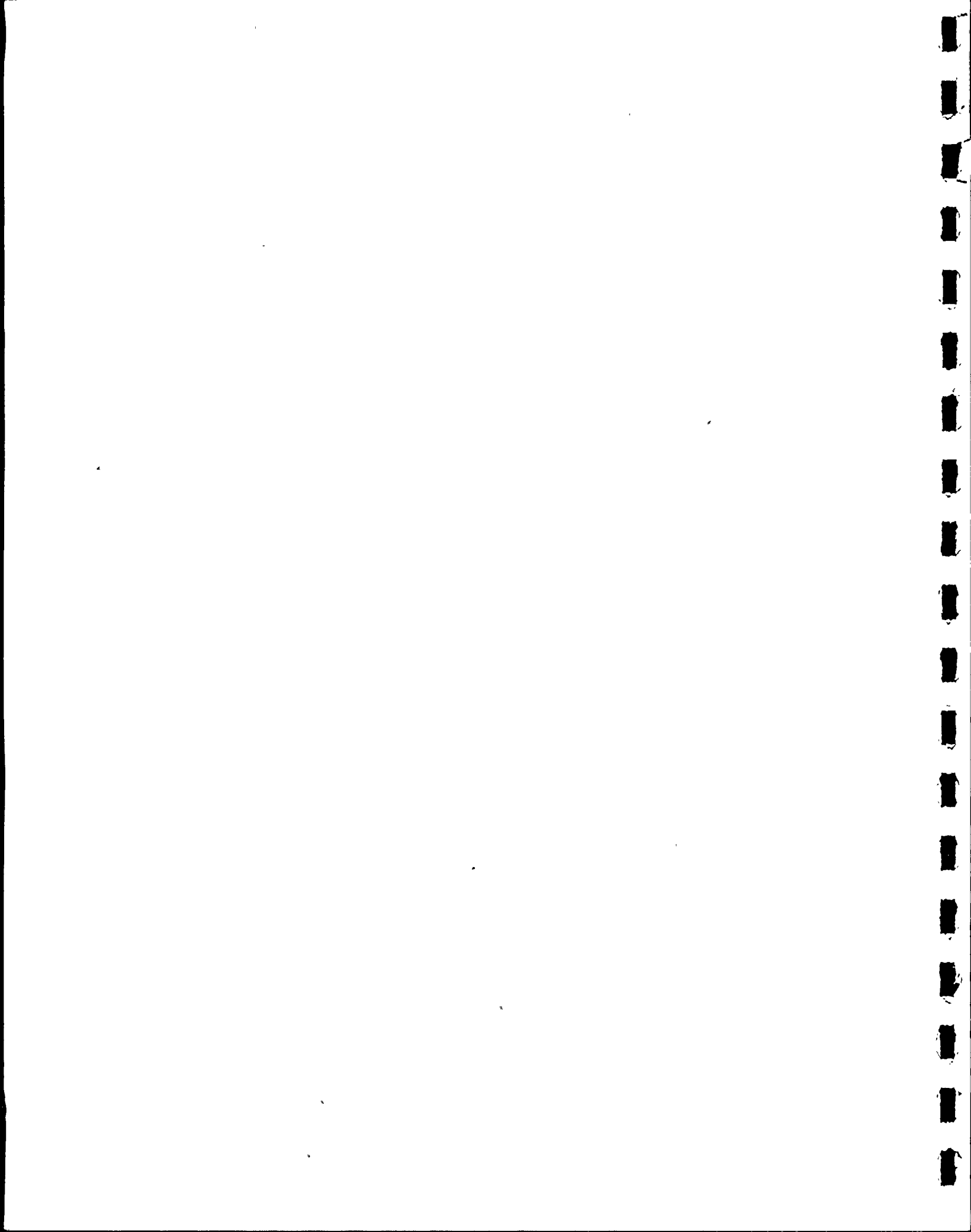




Table II-14  
PP&L Employee Profile

1. Total Responses

	<u>1975</u>	<u>1978</u>
Local	13	25
Nonlocal	18	55
Total	31	80

2. Age Distribution

<u>1975</u>		<u>1978</u>	
Age	#	Age	#
20-29	15	Under 25	5
30-39	8	25-35	58
40-49	3	36-45	13
50-59	4	46-60	4

3. Occupation

<u>1975</u>	<u>Local</u>	<u>Nonlocal</u>
Engineer	5	10
Accountant	2	-
Supervisor	2	4
Other Management	1	3
Clerk-Secretary	3	1

1978

	<u>Local</u>	<u>Nonlocal</u>
Manager	2	16
Professional	3	19
Technical	17	19
Clerical	3	1

4. Area of Residence

1975

	<u>Local</u>	<u>Nonlocal</u>
Berwick Area	1	5
Columbia Co.	2	6
Luzerne Co.	4	4
Other	6	3
Total	13	18

1978

	<u>Local</u>	<u>Nonlocal</u>
Berwick Area	1	17
Bloomsburg Area	1	13
Other Columbia Co.	5	6
Conyngham Boro (Luzerne Co.)	1	3
Wilkes-Barre	2	1
Other Luzerne Co.	5	14
Other	10	1
Total	25	55

5. Type of Residence - Nonlocal

	<u>1975</u>	<u>1978</u>
Single Family	12	45
Apartment	2	8
Mobile Home	1	1
Other	2	1
Total	17	55

6. Tenure

	<u>1975</u>	<u>1978</u>
Own	14	41
Rent	1	14
Total	15	55

7. Family Size

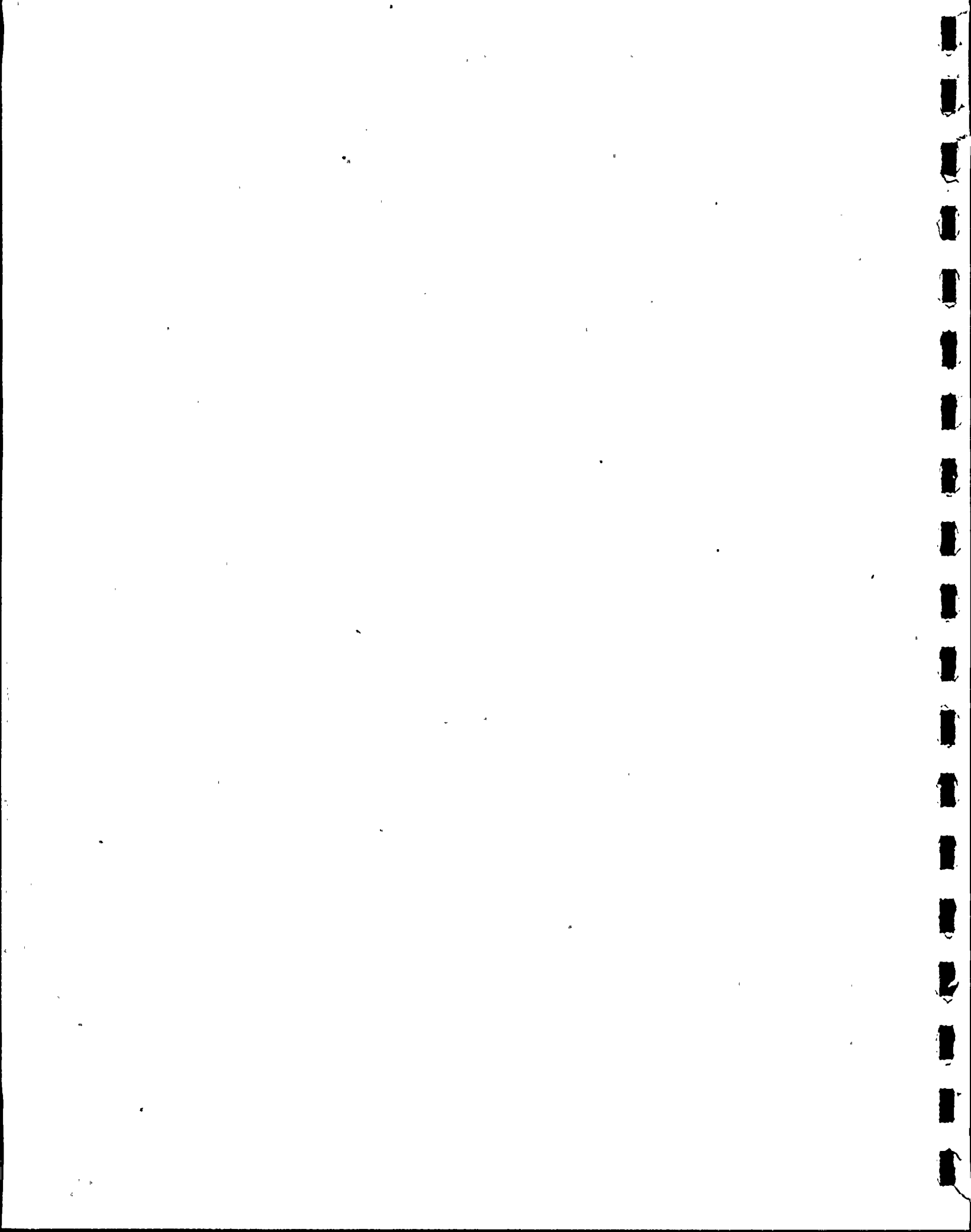
	<u>1975</u>	<u>1978</u>
1 Person	3	5
2 Persons	1	16
3 Persons	4	2
4 Persons	6	18
5+ Persons	2	8
Total	16	49

8. Number of Children

	<u>1975</u>	<u>1978</u>
Preschool	8	15
Elementary	6	20
Jr. High	4	6
Sr. High	-	3
Total	18	44

9. School District

	<u>1975</u>	<u>1978</u>
Berwick	4	23
Bloomsburg	-	2
Central Col.	2	11
Hazleton	-	7
Northwest	-	4
Benton	-	4
Luzerne Co.	-	3
Other	1	1
Total	7	55



10. Shopping Areas (Multiple Response)

	<u>1975</u>	<u>1978</u>
<u>Daily Purchases</u>		
Berwick	10	33
Bloomsburg	7	24
Wilkes-Barre	5	7
Hazleton	-	7
Other	2	15
Total	24	86
<u>Major Purchases</u>		
Berwick	6	16
Bloomsburg	8	21
Wilkes-Barre	6	20
Hazleton	-	13
Other	6	17
Total	26	87

Aspects Liked Least

	<u>1975</u>	<u>1978</u>
Poor Shopping Facilities	4	19
Poor Schools	3	5
Lack of Cultural Activities	-	8
Poor Roads	-	5
Poor/Expensive Housing	-	3
Unfriendly People	-	3
Other	5	10
Total	12	53

11. Recreational Activities (Multiple Response)

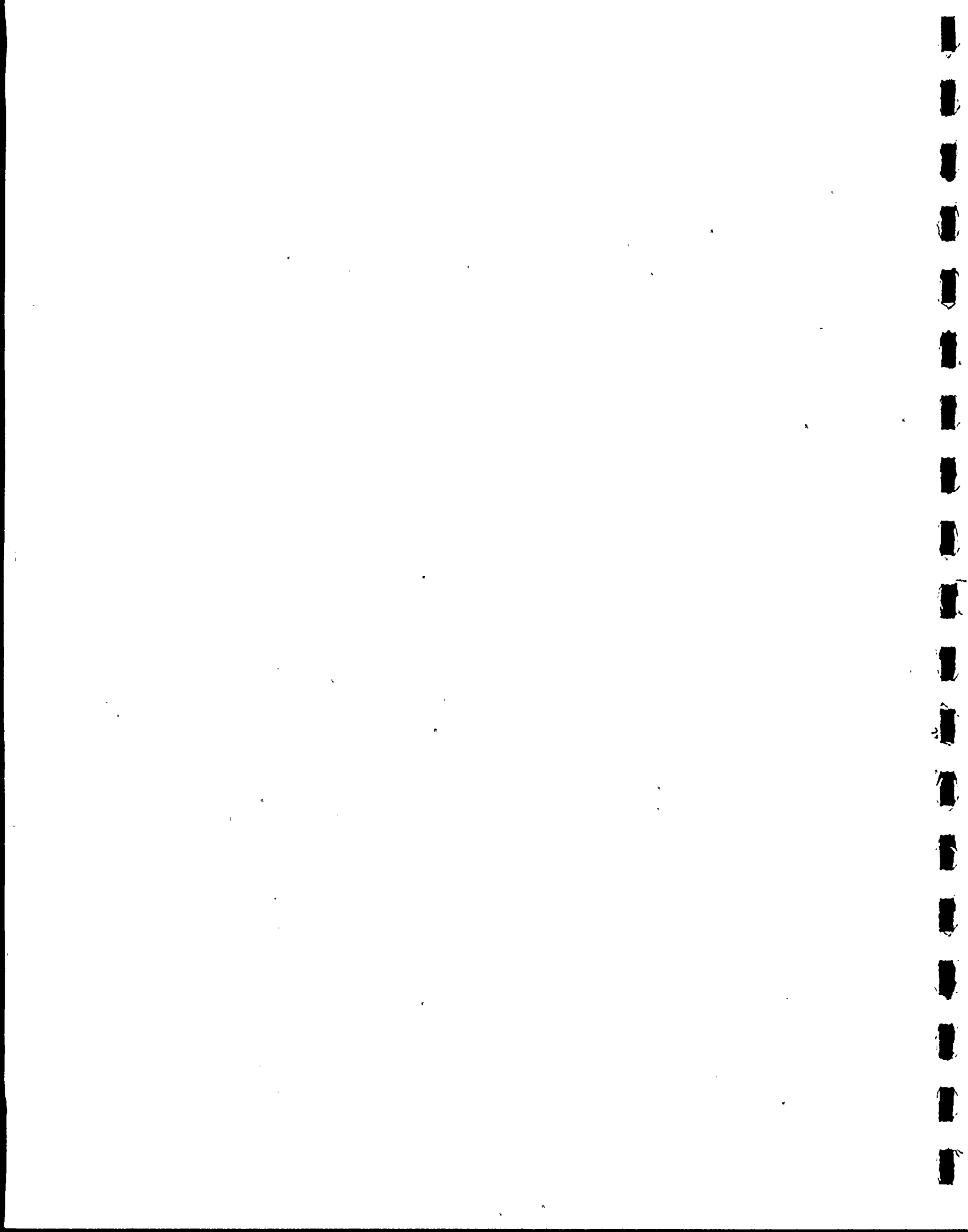
	<u>1975</u>	<u>1978</u>
Hunting & Fishing	8	43
Swimming	11	18
Tennis	8	17
Skiing (snow)	-	12
Camping	-	6
Golf	-	5
Parks	-	4
Other	10	19
None	-	10
Total	37	134

12. Hospital Use

	<u>1975</u>	<u>1978</u>
Yes	14	24
No	3	13
Total	17	27

13. Aspects Liked Best (Multiple Response)

	<u>1975</u>	<u>1978</u>
Rural Area/Small Town Life	11	29
Friendly People	3	8
Scenery	3	14
Available Recreation	-	6
Other	-	11
Total	17	68



CHAPTER III

BACKGROUND INFORMATION:  
POPULATION, EMPLOYMENT AND MANPOWER

A. Population

The project region reflects some of the demographic trends occurring in the Northeast U.S.A. as a whole, particularly in population losses. Table III-1 records population changes in the site region over a period of thirty-five years:

Table III-1

Population Changes of Counties  
Within 20 Miles of the Site<sup>1</sup>

<u>County</u>	<u>1940</u>	<u>1950</u>	<u>1960</u>	<u>1970</u>	<u>% Change 1940 to 1970</u>	<u>1975 Estimate</u>
Luzerne	441,518	392,241	346,972	342,301	-22.5	345,645
Columbia	51,413	53,460	53,489	55,114	7.2	59,288
Sullivan	7,504	6,745	6,751	5,961	-20.6	5,963
Schuylkill	228,331	200,577	173,089	160,089	-29.9	160,118
Carbon	61,735	57,558	52,889	50,573	-18.1	52,289

Columbia County is the only county to have recorded population increases over a 30-year period, a modest gain of 4,000 persons. Between 1940 and 1970, the remaining counties recorded significant population decreases. Recent Bureau of Census projections indicate a reversal of the long-term population decline in these counties. Table III-2 indicates population distribution by area of residence. It also reflects the urban-rural contrast between the two counties closest to the project site, Luzerne and Columbia:

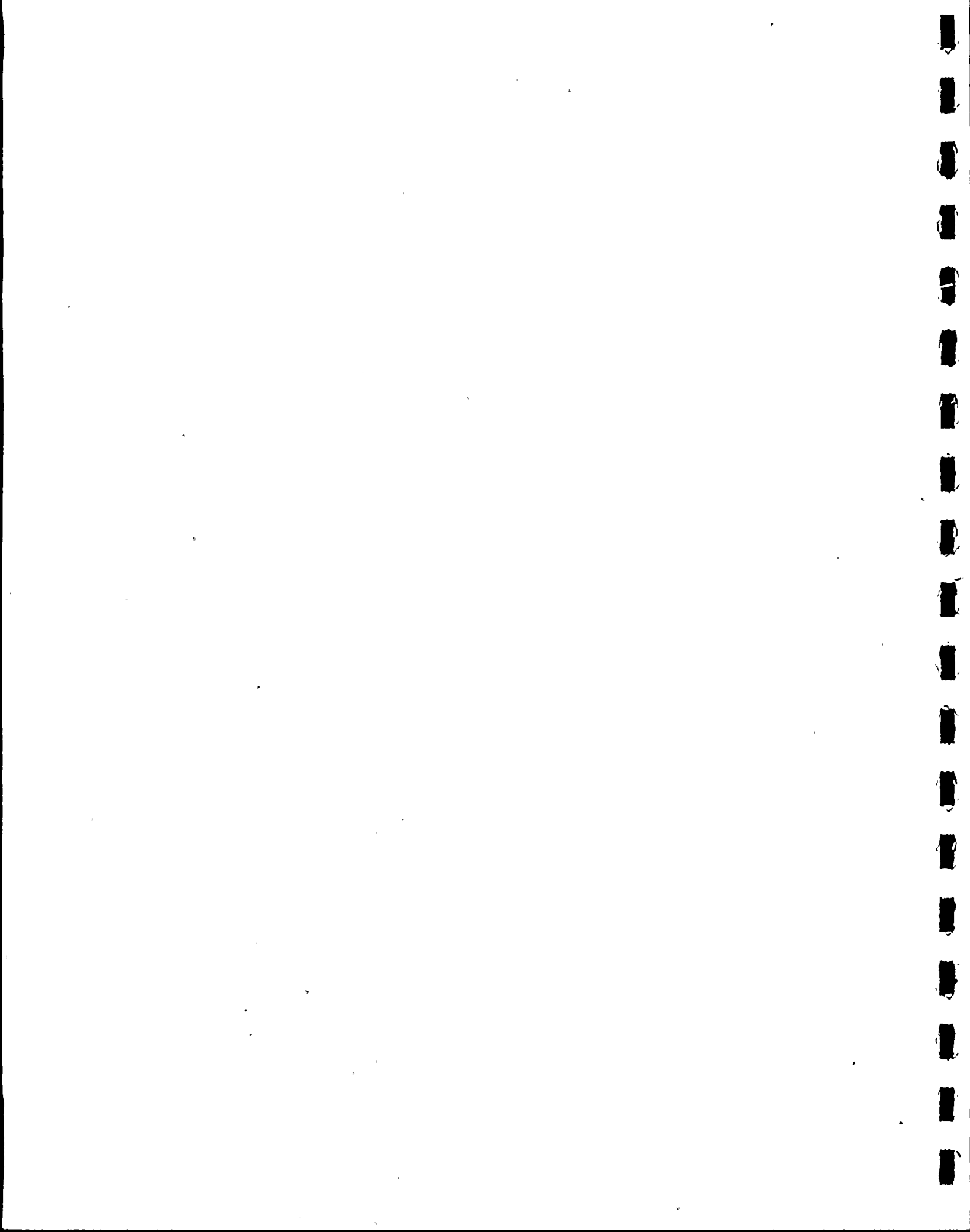


Table III-2

Population by Residence For  
Counties Within 20 Miles of the Site<sup>2</sup>

<u>County</u>	1 9 7 0		
	<u>Urban</u>	<u>Rural-Nonfarm</u>	<u>Rural-Farm</u>
Luzerne	267,510	66,461	2,699
Columbia	23,926	26,170	5,018
Sullivan	--	4,691	1,270
Schuylkill	83,133	73,251	3,705
Carbon	32,268	17,564	741

At the municipal level, the project area is characterized by small urban centers in a predominantly rural region.

Table III-3

Selected Local Municipal Populations<sup>3</sup>

	<u>1970</u>	<u>1975 Estimate</u>	<u>Distance From SSES (Miles)</u>
<u>Columbia County</u>			
Berwick	12,274	12,253	4.5
Bloomsburg	11,652	12,181	16
Scott Township	3,875	3,765	14
Briar Creek Township	2,150	2,804	9
<u>Luzerne County</u>			
Nescopeck	1,897	1,921	5
Shickshinny	1,685	1,590	4
Wilkes-Barre	58,856	57,040	20
Salem Township	3,890	4,397	-





Although the project site is in Salem Township, Luzerne County, Salem Township's orientation is to the communities of Columbia County, particularly Berwick, a well established retail center and the economic focus of the area. Bloomsburg, about sixteen (16) miles southwest of the plant site, approximates Berwick's size and is the county seat.

B. Work Force Characteristics

An assumption implicit in both the 1976 Community Impact Monitoring Study and this update is that most major community impacts associated with SSES construction are related, directly or indirectly, to the work force. Admittedly, the construction of a major facility like SSES can have significant community impacts when the acquisition of local homes results in the dislocation of families. Since land acquisition commenced on the SSES project, approximately thirty (30) homes have been acquired.<sup>4</sup> Long-term impacts, however, are more closely related to the interaction of the work force with local communities in such matters as traffic, housing, recreation, utilities (sewer and water), etc.

Before looking at work force characteristics at the project site, it would be helpful to examine the regional labor force characteristics. Table III-4 relates data on labor force size in Luzerne and Columbia Counties.

In the greater Wilkes-Barre/Hazleton area, the size of the civilian labor force had not changed appreciably in the reporting period. The number of persons unemployed increased significantly, however, and overall employment actually decreased. Contract construction, nevertheless, increased by fifty percent (50%). Much of that increase is a result of employment at the project site as well as the public and private rehabilitation carried out in the wake of Tropical Storm Agnes, which caused extensive damage in the Wilkes-Barre area in 1972.

Nor did the Bloomsburg-Berwick area demonstrate much improvement in the reporting period. Without a significant increase in the labor force size, the number of unemployed more than doubled. One of the few improvements was in contract construction, which registered a twenty-two percent (22%) gain.

At the project site, the labor force is at its peak with over 4,000 workers employed (July, 1978). As prime contractor for

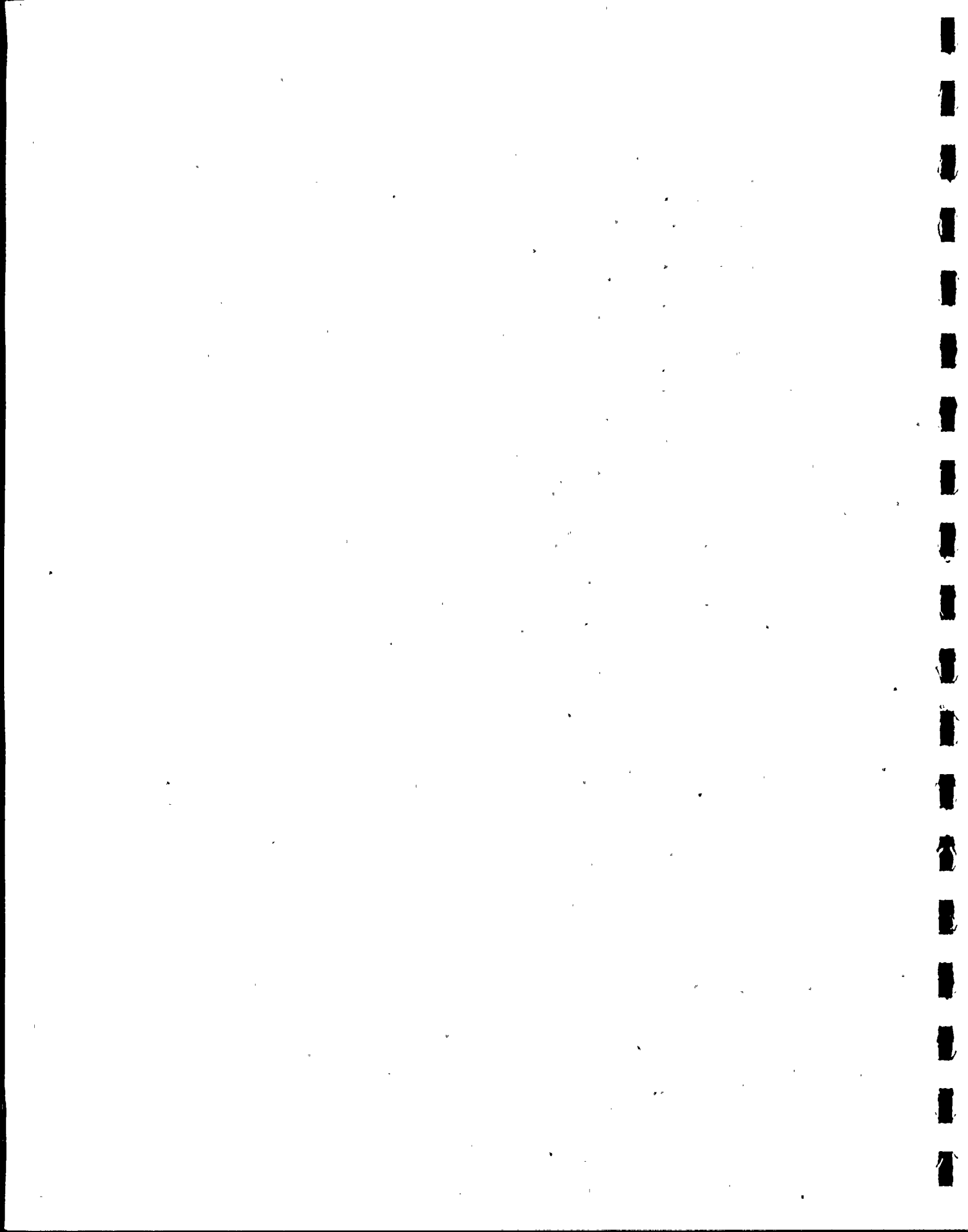


Table III-4

CIVILIAN LABOR FORCE, EMPLOYMENT AND UNEMPLOYMENT  
ANNUAL AVERAGE FOR SELECTED YEARS<sup>5</sup>  
(000's of Workers)

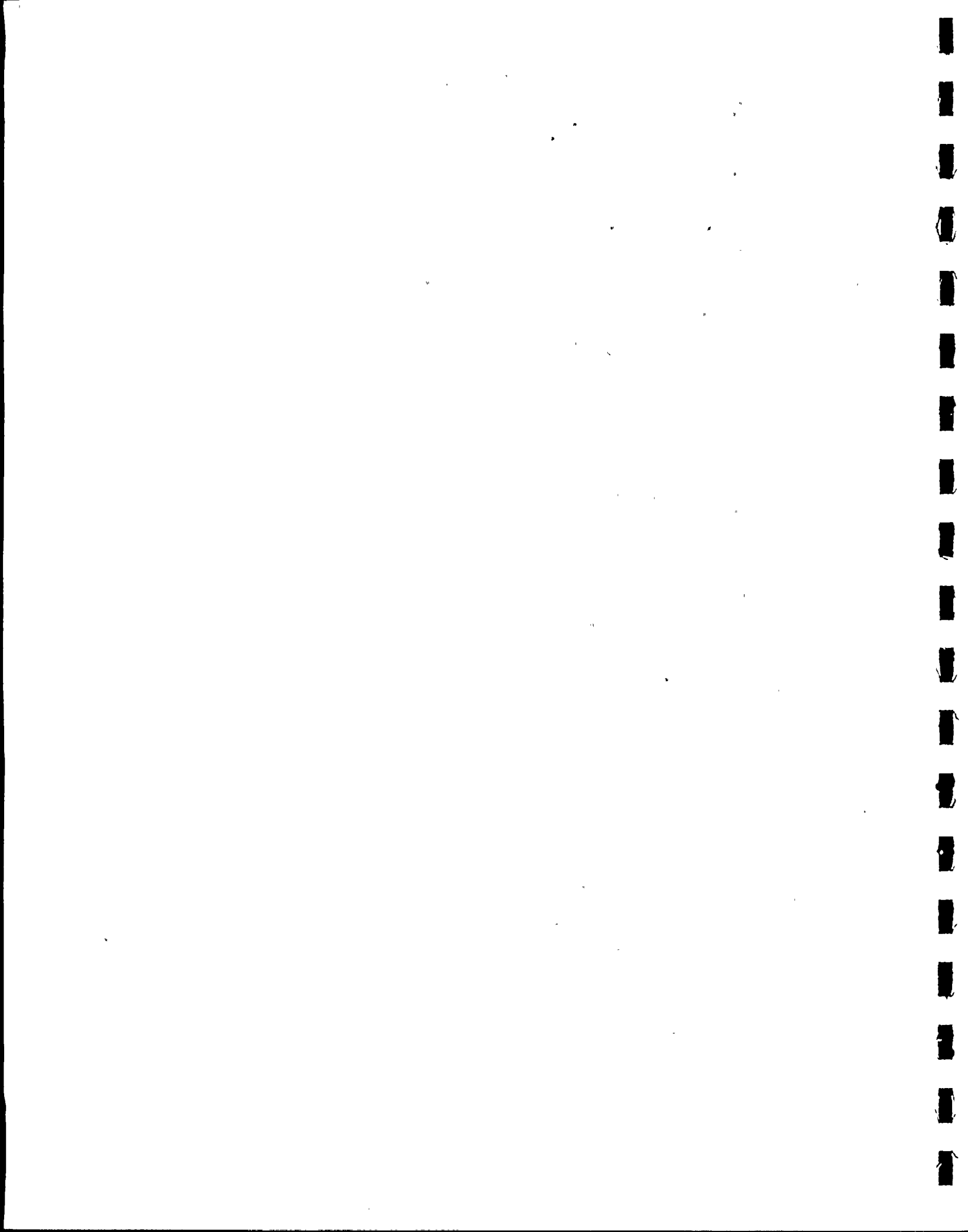
A. Wilkes-Barre - Hazleton

	<u>1970</u>	<u>1972</u>	<u>1974</u>	<u>1976</u>	<u>1977</u>	<u>% Change '70 - '77</u>
1. Civilian Labor Force	146.4	149.5	150.5	150.8	147.4	.1
2. Unemployment	7.9	12.7	9.5	14.5	14.7	86.0
% Labor Force	5.4	8.5	6.3	9.6	9.9	83.3
3. Employment*	138.5	136.8	141.0	136.3	132.7	-4.1
Non-Agriculture	NA	121.3	126.7	123.3	122.1	.6
(1) Manufacturing	52.1	47.9	46.4	40.6	39.3	-25.0
(2) Non-Manufacturing	70.6	73.2	79.9	82.1	82.7	17.1
Contract Construction	5.4	6.5	7.8	8.2	8.1	50.0

B. Berwick - Bloomsburg

1. Civilian Labor Force	24.7	25.6	26.6	26.5	26.0	5.3
2. Unemployment	1.4	1.5	2.1	3.2	2.9	107.1
% Labor Force	5.7	5.9	7.9	12.1	11.1	95.0
3. Employment	23.3	24.2	24.6	23.4	23.2	-
Non-Agriculture	20.1	21.4	21.7	20.6	20.9	4.0
(1) Manufacturing	11.2	11.6	10.5	9.1	8.8	-21.4
(2) Non-Manufacturing	8.9	9.7	11.0	11.4	12.1	36.0
Contract Construction	0.7	0.8	0.9	0.8	0.9	22.2

\* Data is an estimate of jobs by place of work and is not directly comparable to labor force data which estimates workers by place of residence.



the project, the Bechtel Power Corporation employs directly, or through its subcontractors, most of these workers. The labor force can be broken down into two broad categories, manual and non-manual personnel, for evaluation purposes. Manual workers consist primarily of skilled craftsmen such as carpenters, operating engineers, electricians, ironworkers, etc., but also includes laborers. Non-Manual workers generally fall into four categories, including managerial, professional, technical and clerical.

C. Manpower Needs at the Project Site

1. Manual Work Force

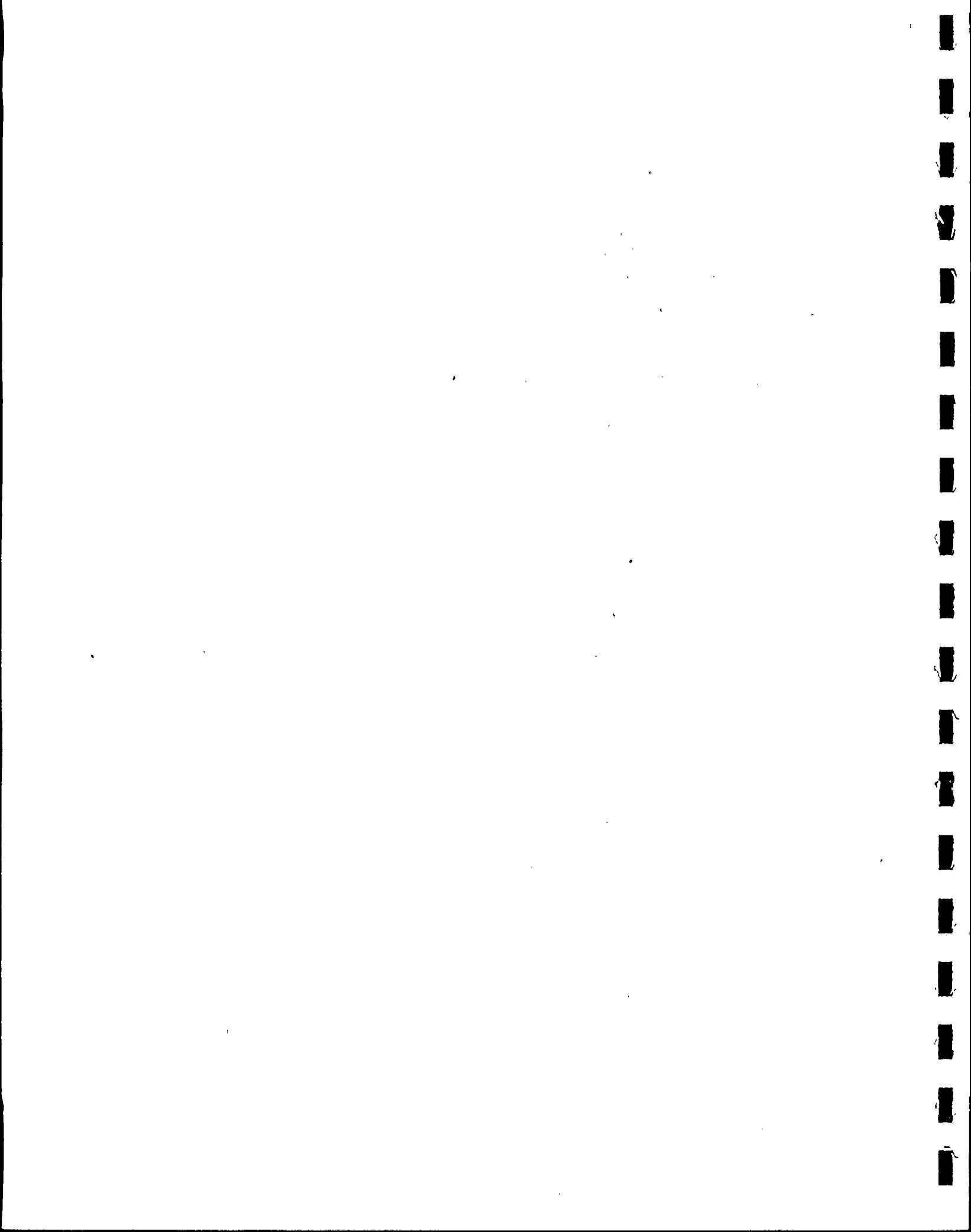
1973 was the initial year of significant construction activity at the project site. Under the present construction schedule, the first unit will be completed in 1981 and the second in 1982. Within that time frame it is possible to trace past and future manual work force needs at the project site. (See Figure III-1.)

Table III-5 indicates the average number of manual workers employed in August, 1978. The distribution of workers by occupational category would vary based on the construction phase.

Table III-5<sup>6</sup>

Distribution of Manual Employees  
by  
Labor Classification  
Susquehanna Steam Electric Station  
August, 1978

<u>CLASSIFICATION:</u> (1)	<u>WORKERS EMPLOYED</u> (2)		
	<u>PRIME</u> <u>CONTRACTOR</u>	<u>SUB</u> <u>CONTRACTORS</u>	<u>TOTAL</u>
Laborer	521	162	683
Carpenter	294	85	379
Operating Engineer	172	122	294
Electrician	640	34	674
Ironworker	209	58	267
Boilermaker	65	16	81



Pipefitter	885	75	960
Other <sup>(3)</sup>	<u>268</u>	<u>265</u>	<u>533</u>
T O T A L	3,054	817	3,871

- Notes: (1) Include craft labor only, up through and including General Foreman
- (2) Average number employed during month
- (3) Includes all other craft labor

The 1976 monitoring study reported that over seventy percent (70%) of manual employees commuted from the Wilkes-Barre/Scranton area. Table III-6 reflects little change in those trends. Luzerne and Lackawanna Counties provide almost sixty percent (60%) of the manual work force. Figure III-2 indicates distance of Pennsylvania counties from the plant site.

D. Non-Manual Employees

This classification includes managerial, professional, technical and clerical workers. In 1978, the average number of non-manual personnel employed by Bechtel Power Corporation was expected to reach a peak of 658 employees. Actual and anticipated numbers of non-manual employees are listed in Table III-7.

Although significantly smaller in number than the manual work force, non-manual employees have a greater potential to affect some aspects of community infrastructure, such as schools, hospitals, emergency services, etc.

Initially, most of the non-manual personnel employed by Bechtel were transferred in from other Bechtel job locations. These "non-local" employees would, in most instances, relocate their families to the new job site area, placing additional demands on housing supply and area schools. More specific inquiries concerning community impacts associated with manual and non-manual personnel are addressed in Chapters V and VI of this report.

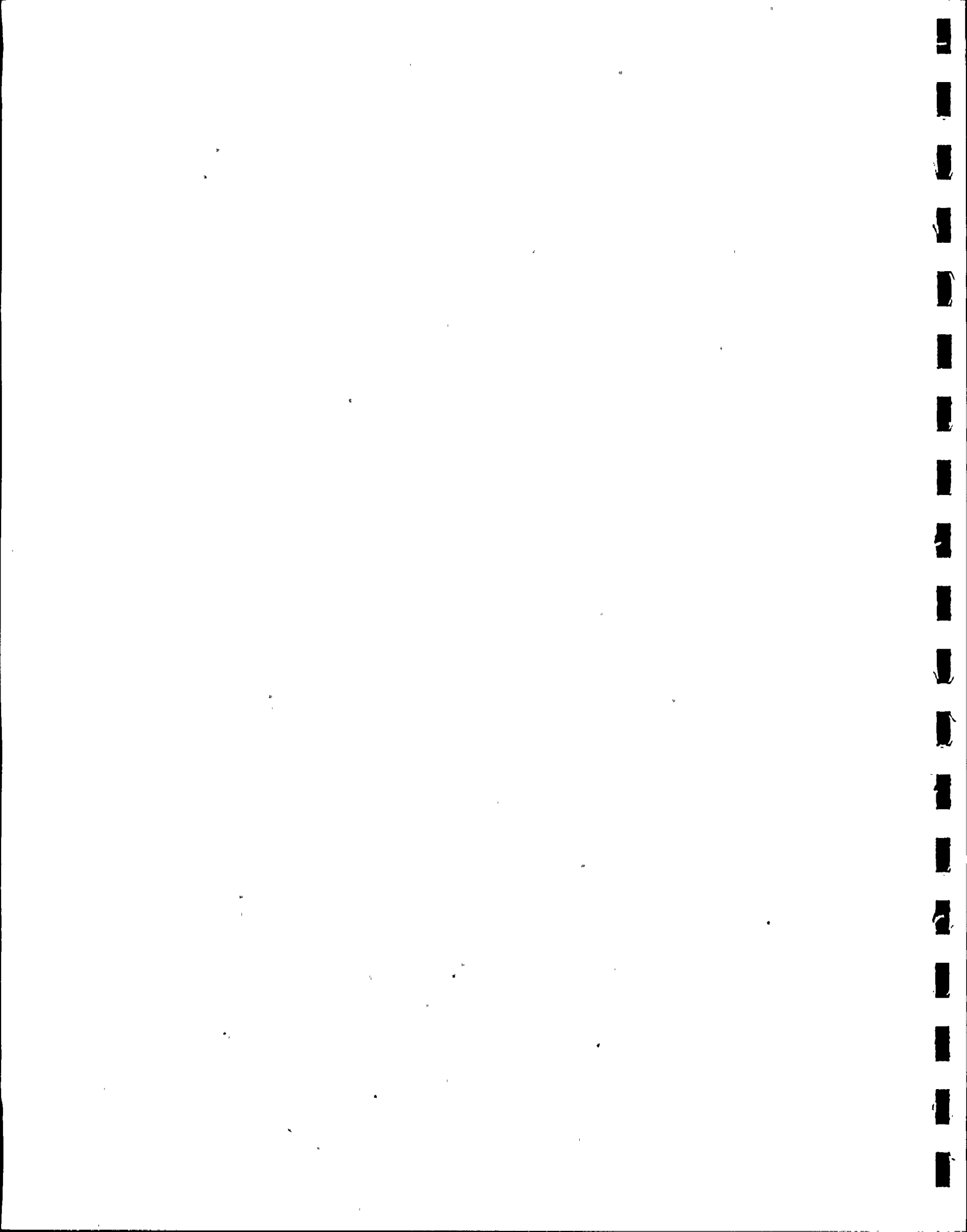
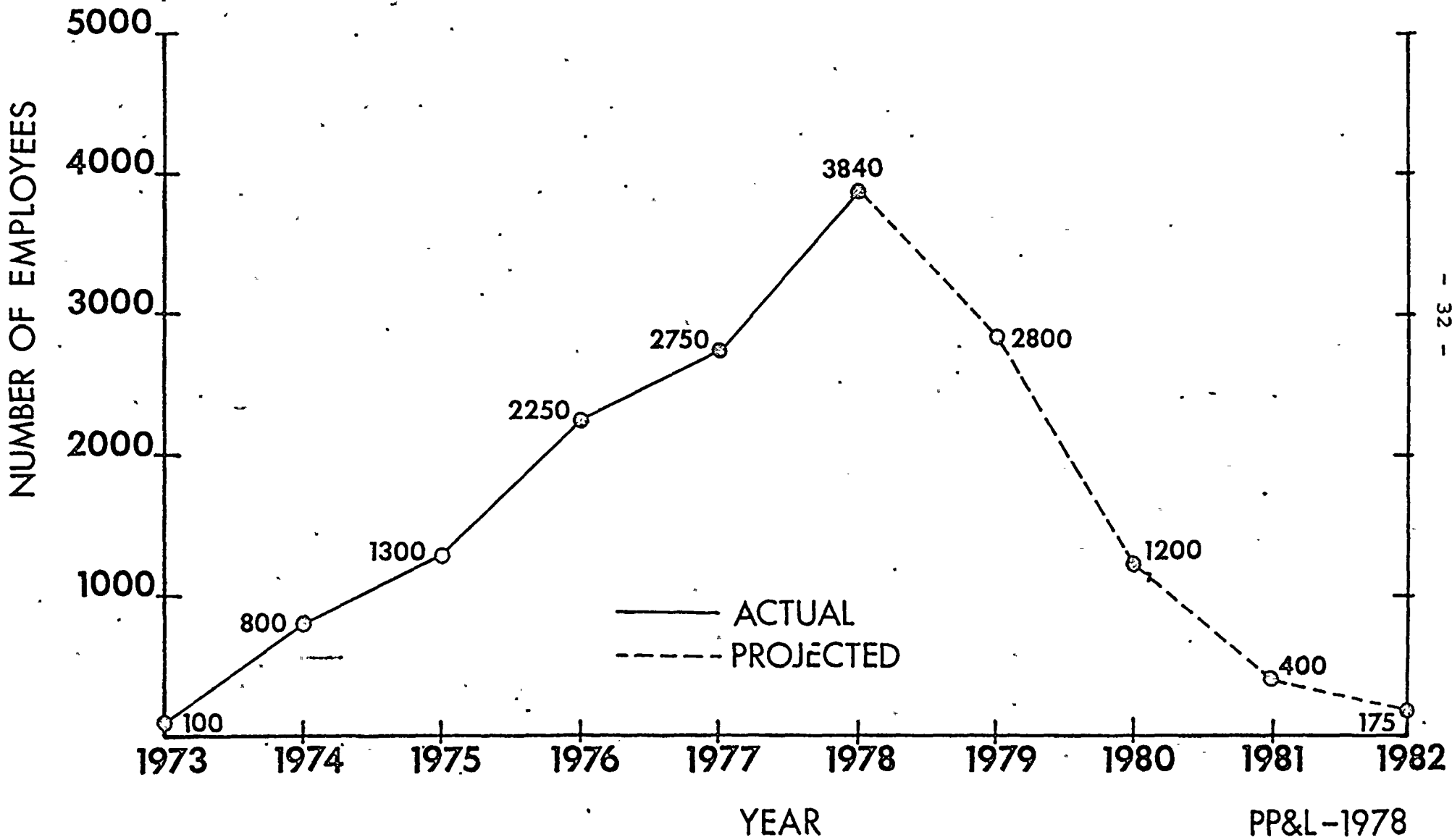




FIGURE III-1

# MANUAL EMPLOYEES ACTUAL AND PROJECTED SUSQUEHANNA STEAM ELECTRIC STATION



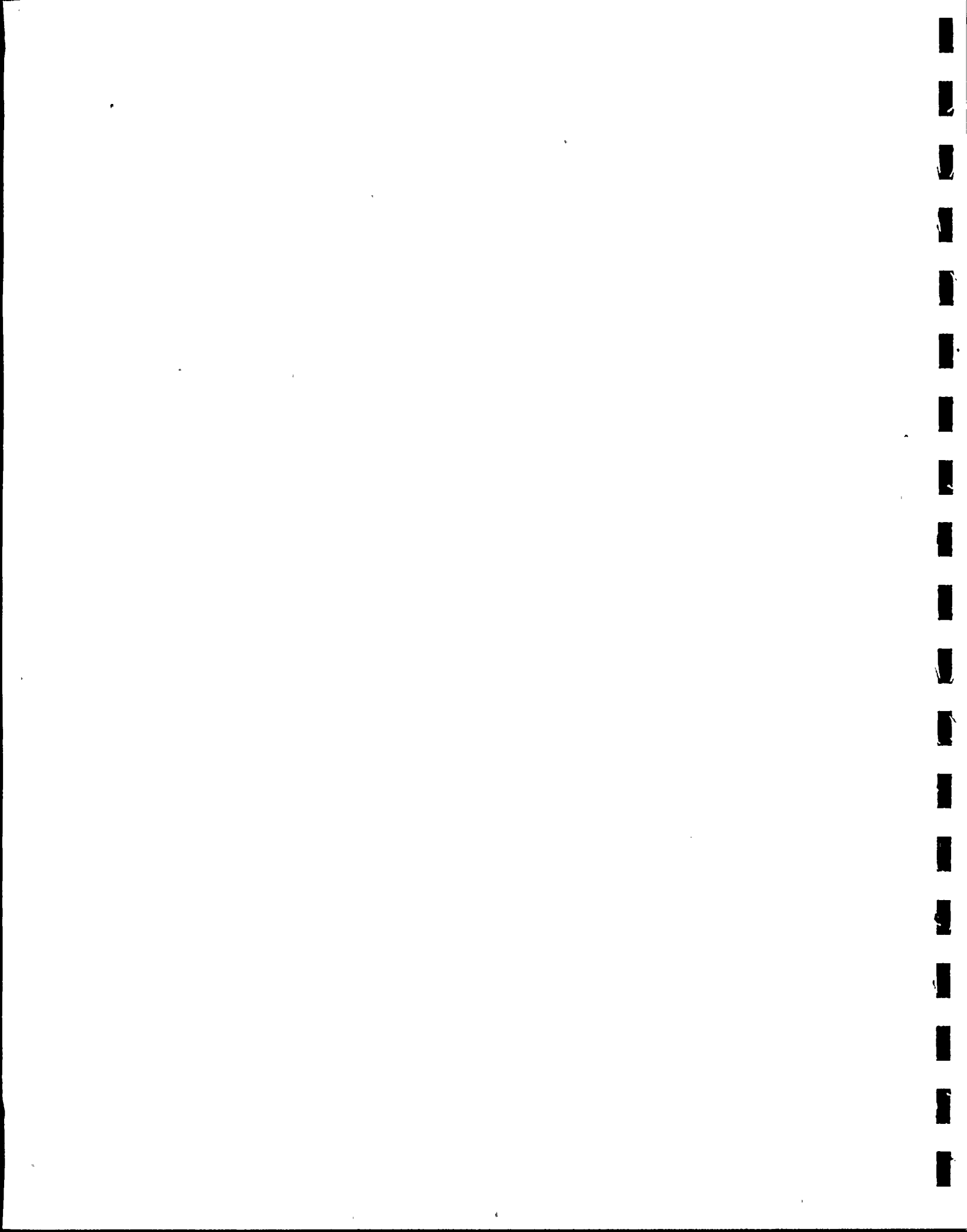


Table III-6<sup>7</sup>

Residence of Manual Employees by County

1975 and 1978

<u>County</u>	<u>Number</u>		<u>Percent</u>	
	<u>1975</u>	<u>1978</u>	<u>1975</u>	<u>1978</u>
Luzerne	1122	1402	59	50
Lackawanna	239	243	13	8.6
Columbia	90	160	5	5.7
Schuylkill	77	252	4	9
Northumberland	64	142	3	5
Lycoming	35	110	2	3.9
Monroe	9	33	-	1.1
Dauphin	10	8	-	-
Lancaster	10	4	-	-
Wayne	12	0	-	-
Lebanon	11	1	-	-
Wyoming	38	0	2	-
Montour	3	0	-	-
Carbon	7	2	-	-
Cumberland	5	2	-	-
Juniata	3	1	-	-
Sullivan	5	0	-	-
Susquehanna	6	9	-	-
Perry	2	0	-	-
Pike	1	1	-	-
Tioga	1	1	-	-
Union	2	4	-	-
Bradford	2	0	-	-
Clinton	0	0	-	-
Snyder	2	5	-	-
Philadelphia	2	14	-	-
York	0	9	-	-
Adams	1	0	-	-
Bedford	0	0	-	-
Berks	4	20	-	-
Bucks	1	28	-	-
Crawford	0	0	-	-
Lehigh	3	61	-	2.2
Montgomery	1	5	-	-
Northampton	1	8	-	-
Wayne	0	31	-	-
Warren	0	0	-	-
Westmoreland	0	0	-	-
Centre	1	1	-	-
Delaware	1	1	-	-
Chester	0	1	-	-
Other States	118	236	6	8.3
Unknown	8	0	-	-
	1900	2795		





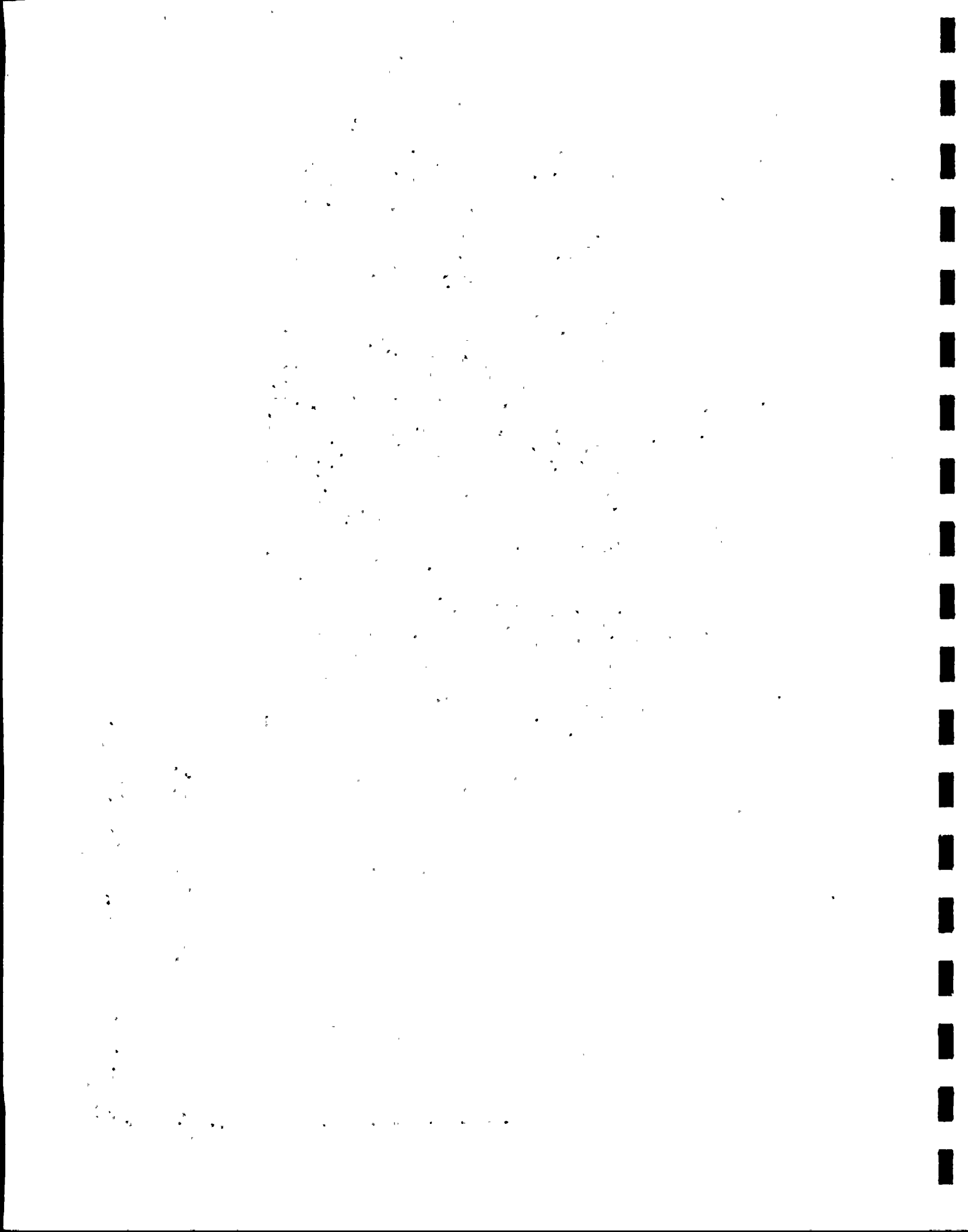


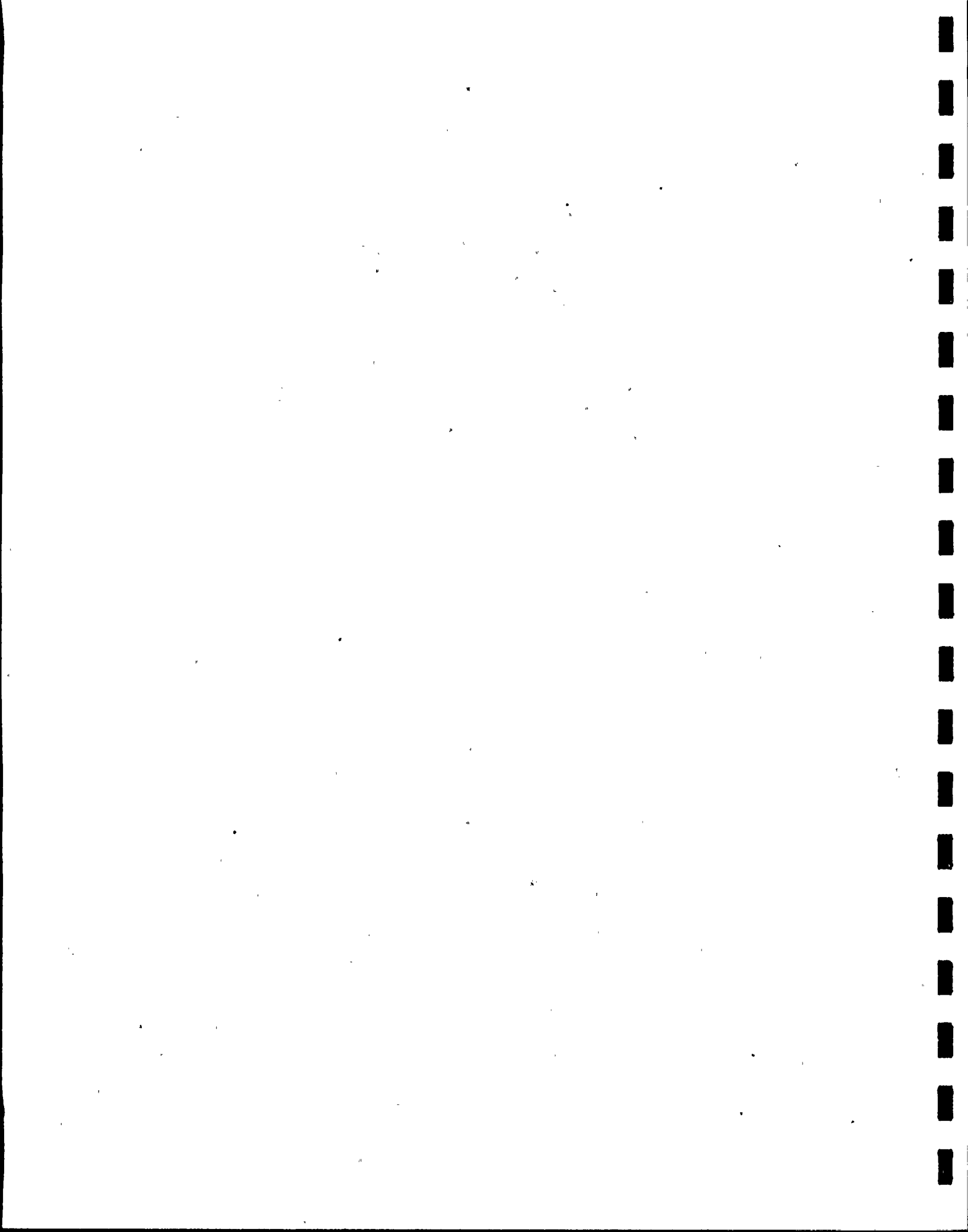
Table III-7<sup>8</sup>

Non-Manual Employees

Actual and Projected (Annual Average)

Susquehanna Steam Electric Station

<u>Year</u>	<u>Actual</u>	<u>Projected</u>
73	25	
74	175	
75	350	
76	465	
77	530	
78		658
79		628
80		472
81		256
82		90
83		0





E. PP&L Work Force

As construction on the SSES progresses, the size of the PP&L work force which operates the plant will gradually continue to expand beyond its present level of 168. These personnel are primarily involved in training and administrative operations in preparation of an anticipated start-up date in 1981. At that time, the entire work force required to operate and maintain the plant will consist of 356 persons, including security personnel.



Chapter III

S O U R C E S

- 1 . U.S. Census of Population, 1970 and "Current Population Reports: Population Estimates and Projections", Series P-25, No. 686, May 1977
- 2 U.S. Census of Population, 1970
- 3 "Current Population Reports: Population Estimates and Projections", Series P-25, No. 686, May 1977
- 4 PP&L Real Estate Department, September 1978
- 5 Bureau of Employment Security, Pennsylvania Department of Labor and Industry, unpublished data
- 6 Bechtel Power Corporation, SSES, March 1978
- 7 Bechtel Power Corporation, SSES Personnel Department, March 1978
- 8 Pennsylvania Power & Light Company, SSES Staff, May 1978



## CHAPTER IV

### LOCAL VIEWS ON COMMUNITY IMPACTS

The community impacts of plant construction as perceived by local residents are as important as information conveyed in quantitative evaluations of employee numbers or movements. In the initial 1976 community impact study, interviews were important in gauging community attitudes and documenting the most serious local impacts of early construction activities, i.e., noise, dust and alleged property damage.

The personal interview technique was also used for this update. A cross section of community officials, businessmen and educators was contacted in the summer and fall of 1978. The range and number of interviews were expanded over those conducted in 1975-76. Local viewpoints are categorized according to issues potentially affecting local communities in the plant site area.

#### A.. Housing

The 1976 community impact study suggested that plant construction could potentially affect housing costs and supply. The effects on housing were inconclusive, although local opinion indicated plant construction had a significant inflationary impact on local housing costs. On this point, local views seem to have remain unchanged. The director of the Columbia County Planning Commission felt that housing costs had been influenced by PP&L and Bechtel employees, largely because of the nature of the housing market in Columbia County.<sup>1</sup> Essentially a rural county with a history of slow economic growth, very little speculative building takes place. Houses are built on demand and are relatively modest three-bedroom homes. The planning director suggested that Bechtel and PP&L employees transferred into the region from other job locations were perhaps used to more "customized housing", offering greater diversity in architectural styles, amenities, size, etc. Generally higher incomes (than those paid in Columbia County) allowed project employees to build more expensive homes. He further suggested that the average cost of a new home was in the



"upper 30's" (exclusive of land costs) and that Bechtel personnel were building homes considerably in excess of that cost.\*

With the exception of the above effects on housing, the Columbia County Planning Commission staff saw little impact on planning concerns raised by SSES construction.

Local realtors provided additional views on the local housing market. A local Bloomsburg realtor suggested that housing costs in the Bloomsburg area have "doubled" since 1970, with a typical split level home costing \$60,000 (exclusive of land costs)<sup>2</sup>. While acknowledging rising housing costs, the realtor was uncertain how much of the increases were associated with plant construction. He did note, however, that certain portions of Columbia County began to develop a significant second home market in the early 1970's which was curtailed following the OPEC oil embargo and subsequent gasoline price rises.

The subsequent drop off in second home construction was more noticeable than inflationary impacts on the market associated with project construction. The realtor also confirmed that speculative housing is not strong in the Bloomsburg area which, he believed, was because of the absence of local bank support.

A local Berwick realtor stated that although housing demand had been dropping off in the Berwick area since 1972, SSES construction had resulted in increased inflationary impacts on the local market<sup>3</sup>. A major reason, he believed, for reduced housing activity was the proliferation of regulatory controls which discouraged local development.

#### B. Local Economy/Employment

The 1976 report indicated local concern over the relative absence of employment opportunities in Columbia County. And although the report indicates substantial boosts to the local economy, local opinion suggests that construction of the plant has done little to improve economic conditions. A Salem Township supervisor reflected that only two small restaurants had

---

\* Chapter V, Local Economic Impacts, examines rises in market value and assessed value for residential properties since 1973 in the project area.

1  
2  
3  
4  
5  
6  
7  
8  
9  
10  
11  
12  
13  
14  
15  
16  
17  
18  
19  
20  
21  
22  
23  
24  
25  
26  
27  
28  
29  
30  
31  
32  
33  
34  
35  
36  
37  
38  
39  
40  
41  
42  
43  
44  
45  
46  
47  
48  
49  
50  
51  
52  
53  
54  
55  
56  
57  
58  
59  
60  
61  
62  
63  
64  
65  
66  
67  
68  
69  
70  
71  
72  
73  
74  
75  
76  
77  
78  
79  
80  
81  
82  
83  
84  
85  
86  
87  
88  
89  
90  
91  
92  
93  
94  
95  
96  
97  
98  
99  
100



opened along Route 11 in Salem Township.<sup>4</sup> Similarly, a vice president of a Berwick bank also observed that plant construction had not appreciably increased retail trade in Berwick<sup>5</sup>.

The reason for the absence of retail trade, according to the Columbia County Economic Development Coordinator<sup>6</sup>, is clearly associated with the movement of workers to and from the plant site. Economic benefits to local communities are commensurate to levels of local employment, which, in the case of Columbia County, are small. Local programs to improve the economy, such as those of the Bloomsburg Industrial Development Authority, had greater effect on the local economy than SSES construction.

This view was supported by the Mayor of Berwick who noted that a number of older established businesses had closed their doors since 1970, including the town's only hotel and a major furniture store. Some local fast food stores may be benefiting, he claimed, but there is no significant improvement in retail trade.

The project's lack of impact on local employment was also noted and apparently accepted by local persons. Berwick's Mayor acknowledged that, while the project offered opportunities for employment at higher wages than local markets, the number of tradespeople employed from the Berwick-Bloomsburg area seemed small. He recognized that the jurisdictions of local unions had an effect on local hiring practices.\*

---

\* As pointed out in the 1976 study, the SSES site is located within the jurisdictional boundaries of the Northeast Pennsylvania Building and Trades Council, which includes the major labor market areas in Luzerne and Lackawanna Counties. Consequently, most manual employees at the project site reside in the Wilkes-Barre/Scranton area. Only one craft union, Masons and Bricklayers, has jurisdiction within Columbia County. During the initial period of project construction in the early seventies, expectations were high that the plant would have a strong, positive effect on local employment. Strong disappointment was registered when these expectations were not met.

1  
2  
3  
4  
5  
6  
7  
8  
9  
10  
11  
12  
13  
14  
15  
16  
17  
18  
19  
20  
21  
22  
23  
24  
25  
26  
27  
28  
29  
30  
31  
32  
33  
34  
35  
36  
37  
38  
39  
40  
41  
42  
43  
44  
45  
46  
47  
48  
49  
50  
51  
52  
53  
54  
55  
56  
57  
58  
59  
60  
61  
62  
63  
64  
65  
66  
67  
68  
69  
70  
71  
72  
73  
74  
75  
76  
77  
78  
79  
80  
81  
82  
83  
84  
85  
86  
87  
88  
89  
90  
91  
92  
93  
94  
95  
96  
97  
98  
99  
100

C. Educational Facilities

Construction of the SSES has not required local school districts to expand their physical plants, largely as a result of two factors: (1) the proximity of a labor market sufficient to supply most manpower requirements, and (2) a history of declining school enrollments in Columbia County.

According to recent projections (see Chapter VI, Table VI-1), all school districts in Columbia County will face continuing enrollment declines, at least until 1983<sup>8</sup>. Among the affected school districts, Berwick faces a projected drop in enrollment of 528 students, over twelve percent (12%) of current enrollment. Although he believes the projections of the Pennsylvania Economy League to be high by over 100 students, the Berwick Area School District Superintendent nevertheless feels the location of the SSES in his district may exacerbate enrollment losses<sup>9</sup>. Berwick Area School District currently enrolls more children of Bechtel employees than any other school district in Columbia County. The district is likely to lose most of these students as Bechtel personnel move onto new job locations as the SSES project nears completion. Some of these losses might be replaced as PP&L operational staff move into the area, but the district suffers from an adverse image rising from a building program controversy. While the controversy seems to have resolved itself with the recent completion of a federally funded junior high school, a July 1976 news article commented on the effect of the school district's problems on the housing market:

Bob Ager, with Sweeney and Lukens Real Estate, also noted that people are steering clear of buying in the Berwick area. "Seven out of ten people want Central or Benton," he said. "People just don't realize the effect that the school system has. Even though the problems may not be as bad as some people think, new people coming into the area hear the reports about the schools and don't want to move to Berwick. The people who do move into Berwick are generally older couples who don't have children anyhow."<sup>10</sup>

The Berwick superintendent also expressed a concern that newcomers to Columbia would choose not to live in the Berwick area because of its proximity to a nuclear plant. He further



indicated that the land owned by PP&L for the project and related uses, over 1,000 acres in Salem Township, preempts future residential uses. The loss of this land for residential development could make it more difficult to stabilize declining enrollments.

D. General Community Impacts

With a few exceptions, SSES construction has avoided any of the "boom town" syndromes experienced with some large energy-related projects in other parts of the country. Local officials in Salem Township (location of the plant site) and the adjoining communities of Shickshinny and Berwick have stated that no physical facilities had to be expanded or rehabilitated as a result of SSES construction. The Borough of Shickshinny, a small community four miles northeast of the plant site, has recently undergone extensive surface and subsurface improvements to streets, water and sewer systems, sidewalks, curbs and related site improvements. All of these improvements, however, were conducted as part of a disaster renewal effort to repair the damages of Tropical Storm Agnes in 1972.<sup>11</sup>

Shickshinny found it necessary to supplement its one-man police force to control traffic flows at two intersections in the town's center. Traffic volumes at peak hour caused traffic control problems in the Borough as well as hampering egress across a bridge which served an adjoining small community across the Susquehanna River.

Although no mass transit systems serve the project site, an ad hoc system was developed among construction personnel, perhaps in response to some of the traffic conditions referred to above. By September of 1978, fourteen (14) buses were delivering workers to the plant site from seven (7) communities. These "bus pools" were arranged and coordinated by groups of individual workers.<sup>12</sup>

Despite the increase in traffic near the site and the concentrations of vehicles at the site, state police in the project area report no arrests have been made at the site. An increase in the total number of calls since 1972 within their service area has occurred, but no increases could be related to plant construction.<sup>13</sup>

Many of the local administrators and officials indicated that the absence of impacts on community infrastructure or facil-

1  
2  
3  
4  
5  
6  
7  
8  
9  
10  
11  
12  
13  
14  
15  
16  
17  
18  
19  
20  
21  
22  
23  
24  
25

ities was because few people associated with the plant moved into the area. As a result, frictions and community tensions which often develop when "outsiders" move into a community, did not develop locally to any significant degree.

In April of 1978, a Bloomsburg paper printed a letter apparently written by wives of several Bechtel employees. The letter complained of price gouging, housing discrimination and other harassment. A Berwick newspaper subsequently editorialized on the complaint and expressed the hope that such incidents were isolated. In a later interview, the editor of the Berwick Enterprise indicated that incidents of the type described in the letter probably occurred but that hostility or discrimination against anyone associated with the SSES was not a widespread problem. The employees associated with the project have been accepted into the community in much the same way the community has accepted the physical presence of the plant.<sup>14</sup>

The editor of the Berwick Enterprise, as well as several local realtors and school officials, expressed concern over the possibility of certain recessionary impacts following completion of the SSES project. According to opinions expressed, high salaries paid to Bechtel employees afforded them opportunities to construct homes having a value greater than most houses offered by the local market. Once Bechtel employees move to new job locations, the local housing market will not provide sufficient buyers for what is considered to be more expensive housing. Similarly, the completion of project construction will significantly affect employment and earnings in the construction trades, according to a local labor union official.<sup>15</sup> Since 1972, the ranks of the local unions have grown in Luzerne and Lackawanna Counties. Much of that growth is attributed to the SSES construction. He expressed a belief that residential construction would be able to pick up some of the released labor force, assuming the "layoffs were orderly." Even with growth in residential construction, he expected decreases in union memberships following completion of SSES construction. He further indicated that one major effect would likely be a change in income once the plant had closed. Many of the workers at the plant from the Luzerne-Lackawanna Counties, he suggested, had become accustomed to high wages and long-term employment. He characterized employment in the Luzerne County area as "short-term residential construction" of a type which will materially reduce worker income.

1  
2  
3  
4  
5  
6  
7  
8  
9  
10  
11  
12  
13  
14  
15  
16  
17  
18  
19  
20  
21  
22  
23  
24  
25  
26  
27  
28  
29  
30  
31  
32  
33  
34  
35  
36  
37  
38  
39  
40  
41  
42  
43  
44  
45  
46  
47  
48  
49  
50  
51  
52  
53  
54  
55  
56  
57  
58  
59  
60  
61  
62  
63  
64  
65  
66  
67  
68  
69  
70  
71  
72  
73  
74  
75  
76  
77  
78  
79  
80  
81  
82  
83  
84  
85  
86  
87  
88  
89  
90  
91  
92  
93  
94  
95  
96  
97  
98  
99  
100



CHAPTER IV

S O U R C E S

- 1 Personal interview with Mr. Robert Beishline, Director, Columbia Cojnty Planning Commission and Staff Planner, Mr. Gary Hildebrandt, June 8, 1978.
- 2 Personal interview with Mr. John Robison, Robison Agency, Bloomsburg, Pennsylvania, June 16, 1978.
- 3 Personal interview with Mr. Ron Kile, J. D. Kile Realtors, Berwick, Pennsylvania, June 16, 1978.
- 4 Personal interview with Mr. Clyde Bowers, Salem Township, Supervisor, August 11, 1978.
- 5 Personal interview with Mr. Leroy Burdis, Vice President, First Eastern Bank, August 11, 1978.
- 6 Personal interview with Mr. Stephan Philips, Columbia County Economic Development Coordinator, September 28, 1978.
- 7 Personal interview with Mr. Louis Biacchi, Mayor, Berwick, Pennsylvania, August 11, 1978.
- 8 "Columbia County Public School Enrollment Trends and Projections", Pennsylvania Economy League, May 1978.
- 9 Personal interview with Mr. Lee Cook, Superintendent, Berwick Area School District, October 5, 1978.
- 10 Columbia County Sentinel, "Why Are Home Buyers Saying 'No' to Berwick", July 9, 1976.
- 11 Personal interview with Mr. Donald Hargraves, Mayor, Shickshinny, Pennsylvania, August 11, 1978.
- 12 Mr. Al Clarke, Bechtel Power Corporation Personnel Department, SSES site, September 1978.
- 13 Personal interview with Sargent Tony Matson, Pennsylvania State Police, Shickshinny Barracks, August 11, 1978.
- 14 Bloomsburg Morning Press, April 15, 1978; Berwick Enterprise, April 15, 1978; personal interview with Mr. J. W. Smith, Editor, Berwick Enterprise, October 5, 1978.

1  
2  
3  
4  
5  
6  
7  
8  
9  
10  
11  
12  
13  
14  
15  
16  
17  
18  
19  
20  
21  
22  
23  
24  
25

- 15 Phone conversation with Mr. Charles DePolo, Secretary-Treasurer, Northeast Pennsylvania Building & Trades Council, Plains, Pennsylvania, September 13, 1978.

R  
E  
V  
I  
S  
I  
O  
N  
S  
O  
F  
T  
H  
E  
S  
E  
P  
A  
G  
E  
S  
A  
R  
E  
I  
N  
T  
H  
E  
P  
R  
O  
O  
F  
O  
F  
T  
H  
E  
B  
O  
O  
K  
A  
N  
D  
S  
H  
O  
U  
L  
D  
N  
O  
T  
B  
E  
C  
O  
N  
S  
I  
D  
E  
R  
E  
D  
A  
S  
A  
C  
C  
U  
R  
A  
T  
E  
D  
C  
O  
P  
Y  
O  
F  
T  
H  
E  
F  
I  
N  
A  
L  
P  
R  
O  
O  
F  
O  
F  
T  
H  
E  
B  
O  
O  
K  
A  
N  
D  
S  
H  
O  
U  
L  
D  
N  
O  
T  
B  
E  
C  
O  
N  
S  
I  
D  
E  
R  
E  
D  
A  
S  
A  
C  
C  
U  
R  
A  
T  
E  
D  
C  
O  
P  
Y  
O  
F  
T  
H  
E  
F  
I  
N  
A  
L  
P  
R  
O  
O  
F  
O  
F  
T  
H  
E  
B  
O  
O  
K

CHAPTER V

LOCAL ECONOMIC IMPACTS

A. Wage Distribution

Direct economic impacts can be gauged by the amount of money entering communities in the form of wages and salaries. The 1976 report projected a distribution of total wages for the life of the construction period as follows:

Table V-1

Projected Distribution of Total Wages: 1973-82<sup>1</sup>

<u>County</u>	<u>Manual Employees</u>	<u>%</u>	<u>Non-Manual Employees</u>	<u>%</u>
Luzerne	\$168 Million	60	\$15 Million	23
Columbia	14 Million	5	44 Million	68
Lackawanna	36 Million	13	- - - -	--
Other	<u>62 Million</u>	<u>22</u>	<u>6 Million</u>	<u>9</u>
	\$280 Million	100	\$65 Million	100

Estimated distribution of first quarter wages (1978) and salaries are reported in Table V-2:

Table V-2

Distribution of Total Wages: 1st Quarter 1978<sup>2</sup>

<u>County</u>	<u>Manual Employees</u>	<u>%</u>	<u>Non-Manual Employees</u>	<u>%</u>
Luzerne	\$ 7.45 Million	50	\$ .75 Million	28
Columbia	.89 Million	16	1.68 Million	63
Lackawanna	1.34 Million	9	.05 Million	2
Other	<u>5.21 Million</u>	<u>35</u>	<u>.19 Million</u>	<u>7</u>
	\$14.89 Million	100	\$2.67 Million	100

1  
2  
3  
4  
5  
6  
7  
8  
9  
10  
11  
12  
13  
14  
15  
16  
17  
18  
19  
20  
21  
22  
23  
24  
25  
26  
27  
28  
29  
30  
31  
32  
33  
34  
35  
36  
37  
38  
39  
40  
41  
42  
43  
44  
45  
46  
47  
48  
49  
50  
51  
52  
53  
54  
55  
56  
57  
58  
59  
60  
61  
62  
63  
64  
65  
66  
67  
68  
69  
70  
71  
72  
73  
74  
75  
76  
77  
78  
79  
80  
81  
82  
83  
84  
85  
86  
87  
88  
89  
90  
91  
92  
93  
94  
95  
96  
97  
98  
99  
100

Actual distribution of wages closely approximated projected estimates except the "Other" categories, which are somewhat higher than originally projected. Most of the increase over projected wages resulted from higher manual employment from Schuylkill and Northumberland Counties.

Wages paid to plant personnel return to local communities and represent a direct economic benefit in the form of local purchases, particularly when evaluated in terms of a "multiplier effect" stimulated by wages spent by plant employees. The multiplier effect assumes that local merchants will, in turn, spend a portion of wages received for purchase of local goods and services and that the cycle will continue with decreasing impacts. The 1976 community impact report estimated an additional multiplier expenditure in Luzerne County of \$366 Million and \$87 Million in Columbia County through 1982.

B. Purchase of Goods and Services

The local economy has benefited from purchase of goods and services from local vendors, but not to the extent of other locations outside of the project region. Table V-3 indicates purchases for selected years by county:

Table V-3

Expenditures With Local Vendors (\$000)<sup>3</sup>

	<u>Luzerne</u>	<u>Columbia</u>	<u>Lackawanna</u>	<u>Other Pa.</u>
1974	\$ 2,269	\$ 555	\$ 643	\$ 4,269
1975	1,128	308	448	3,083
1976		(UNAVAILABLE)		
1977	137	592	126	5,992

As indicated in Table V-3, local counties have not compared favorably with the remainder of the state in terms of contract volume. Local contracts tended to be for conventional construction materials and erection of facilities for construction and administrative buildings. Larger volume contracts for specialized construction materials or engineering services were generally placed in the Pittsburgh or Philadelphia areas where they were more readily available.

1  
2  
3  
4  
5  
6  
7  
8  
9  
10  
11  
12  
13  
14  
15  
16  
17  
18  
19  
20  
21  
22  
23  
24  
25  
26  
27  
28  
29  
30  
31  
32  
33  
34  
35  
36  
37  
38  
39  
40  
41  
42  
43  
44  
45  
46  
47  
48  
49  
50  
51  
52  
53  
54  
55  
56  
57  
58  
59  
60  
61  
62  
63  
64  
65  
66  
67  
68  
69  
70  
71  
72  
73  
74  
75  
76  
77  
78  
79  
80  
81  
82  
83  
84  
85  
86  
87  
88  
89  
90  
91  
92  
93  
94  
95  
96  
97  
98  
99  
100



C. Local Taxes

1. Real Estate Tax Rates

Table V-4 indicates that combined real estate tax rates increased between 1975 and 1978 in all municipalities, except Scott Township in Columbia County, a trend reflected in both Columbia and Luzerne Counties. Rate changes ranged from a drop of 1.5 mills in the municipal rate of Scott Township to an increase of 22 mills in the Bloomsburg School District.

It is unlikely that construction of the SSES significantly influenced tax rate changes in the municipalities listed in Table V-4, owing primarily to the relatively small number of construction personnel taking up residence in the project area.

It is also interesting to note that although most rate increases were levied by school districts, school enrollments in both Luzerne and Columbia Counties have been declining since 1969-70 and are expected to continue to do so for at least the next five years.<sup>5</sup>

2. Tax Impacts: Salem Township

Because of existing local and state tax structures, Salem Township is likely to experience the greatest tax impact associated with SSES construction. In addition to the real estate tax rates reported in Table V-4, Salem Township levies the following nonproperty taxes:

Table V-5

Salem Township Nonproperty Taxes<sup>6</sup>

	<u>Municipal</u>	<u>School</u>
1. Per Capita	\$ 5.00	\$10.00
2. Earned Income	½%	½%
3. Occupational Privilege	\$ 5.00	\$ 5.00
4. Real Estate Transfer	½%	½%



Table V-4

Real Property Tax Rates, 1975 and 1978<sup>4</sup>

## Tax Rate - Millage

	1975		1978		Change	
	<u>Municipality</u>	<u>SD*</u>	<u>Municipality</u>	<u>SD</u>	<u>Municipality</u>	<u>SD</u>
Berwick	12.0	47.0	12.0	55.0	---	8.0
Briar Creek Borough	6.0	47.0	6.0	55.0	---	8.0
Briar Creek Township	5.0	47.0	5.0	55.0	---	8.0
Salem Township	1.5	47.0	1.5	52.3	---	5.3
Hollenback Township	5.0	47.0	5.0	52.3	---	5.3
North Centre Township	3.0	66.0	3.0	77.0	---	11.0
South Centre Township	2.0	66.0	3.0	77.0	1.0	11.0
Scott Township	6.5	66.0	5.0	77.0	(1.5)	11.0
Bloomsburg	15.0	52.0	15.0	77.0	---	22.0
Conyngham Township	2.0	51.0	2.0	71.0	---	20.0
Columbia County	12.5		15.0		2.5	
Luzerne County	16.2		18.0		1.8	

\* SD - School District

1  
2  
3  
4  
5  
6  
7  
8  
9  
10  
11  
12  
13  
14  
15  
16  
17  
18  
19  
20  
21  
22  
23  
24  
25  
26  
27  
28  
29  
30  
31  
32  
33  
34  
35  
36  
37  
38  
39  
40  
41  
42  
43  
44  
45  
46  
47  
48  
49  
50  
51  
52  
53  
54  
55  
56  
57  
58  
59  
60  
61  
62  
63  
64  
65  
66  
67  
68  
69  
70  
71  
72  
73  
74  
75  
76  
77  
78  
79  
80  
81  
82  
83  
84  
85  
86  
87  
88  
89  
90  
91  
92  
93  
94  
95  
96  
97  
98  
99  
100

It should also be noted that under the provisions of the Public Utility Realty Tax Act (PURTA), local taxing jurisdictions are preempted from directly collecting taxes on utility facilities. Instead, taxes are collected by the state and reapportioned to local governments based on a procedure established under the legislation. Presumably, the intent of the legislation is to prevent individual communities from reaping "excessive" tax revenues from large utility facilities.

Using available data, it is possible to examine Salem Township's tax revenue situation with and without the SSES from 1973 to 1978.

Of the taxes listed in Table V-5, the most significant revenue producer for Salem Township is likely to be the occupational privilege tax. This tax is levied at a flat rate upon persons employed in a taxing jurisdiction. The tax is limited to \$10.00 on individual taxpayers. When overlapping taxing jurisdictions levy rates which, in combination, exceed the \$10.00 statutory maximum, their combined rates are automatically reduced to \$10.00. To a lesser extent, Salem Township will benefit from its local income tax as well as from revenues received through PURTA. Based on five years of construction, estimated tax revenues to Salem Township associated with SSES construction are as follows:

Table V-6

Estimated Tax Revenues\* to  
Salem Township SSES Construction 1973-78

1. Occupational Privilege Tax (2,615 average annual work force x \$10.00 x 5 years)	\$130,750
2. Earned Income Tax (Estimate)	10,650
3. PURTA <sup>7</sup> Revenues	<u>7,282</u>
	\$148,682

---

\* Does not include transfer tax revenues to Salem Township resulting from sale of 10 percent (10%) interest in SSES to Allegheny Electric Cooperative, Inc.

1  
2  
3  
4  
5  
6  
7  
8  
9  
10  
11  
12  
13  
14  
15  
16  
17  
18  
19  
20  
21  
22  
23  
24  
25  
26  
27  
28  
29  
30  
31  
32  
33  
34  
35  
36  
37  
38  
39  
40  
41  
42  
43  
44  
45  
46  
47  
48  
49  
50  
51  
52  
53  
54  
55  
56  
57  
58  
59  
60  
61  
62  
63  
64  
65  
66  
67  
68  
69  
70  
71  
72  
73  
74  
75  
76  
77  
78  
79  
80  
81  
82  
83  
84  
85  
86  
87  
88  
89  
90  
91  
92  
93  
94  
95  
96  
97  
98  
99  
100

The impact of these revenues is diminished, however, by the loss of rateable property (over 500 acres) pursuant to PURTA provisions. Based on current (1978) millage rates, annual property taxes (local and school district) would amount to approximately \$4,100 (or, \$20,500 over a five-year period) on that property no longer subject to local taxation.

Consequently, Salem Township has benefited during the construction period to date by over \$120,000 in tax revenues beyond that which would have been collected via local property taxes without plant construction. Similar benefits could be anticipated through 1982-83. Following plant construction, however, revenues from the occupational privilege tax and local income tax will be reduced significantly and will be offset only to the extent that plant operational staff move into Salem Township. Once the construction phase is completed, it is questionable whether revenues from the three sources in Table V-6 would replace foregone property tax revenues.

D. Local Economic Impacts

1. Housing Costs

Discussions with local realtors and area residents suggest a common belief that SSES construction has had a significant inflationary impact on housing costs on the plant site area. The 1976 report addressed this issue, but no conclusions were reached.

While some effort was made in 1978 to obtain past and present housing cost data from local realtors, more comprehensive data was obtained from the State Tax Equalization Board (STEB). This agency develops school subsidy formulae for apportioning state funds to school districts. STEB compiles annually the total market value, i.e., sales price, of all residential transactions in each county of the state based on deeds filed with the county assessor. A ratio of assessed value to market value for each municipality is used by STEB as part of their subsidy formula.

These ratios are useful for measuring changes in housing





costs in individual communities. In addition to being current and updated annually, the STEB methodology compensates for differences in assessment and millage rates so that individual communities can be compared. Table V-7 below illustrates changes in the assessment/market value ratios for selected communities in the plant site area during the period from 1973 to 1977. The table also lists information for several communities similar in demographic and economic conditions to the Bloomsburg-Berwick area yet sufficiently removed from the site to minimize the plant's influence on the local economy. These "test communities" are Milton, Sunbury and Selinsgrove and are located approximately forty-five (45) miles southwest of the plant site; they had 1970 populations of 7,225, 13,025 and 5,100 respectively.

Table V-7

Ratio of Assessed Value to Market Value

Residential Properties<sup>8</sup>

1973-1977

<u>Community</u>	<u>1973</u>	<u>1974</u>	<u>1975</u>	<u>1976</u>	<u>1977</u>	<u>% Change 1973-1977</u>
Bloomsburg	.171	.147	.141	.134	.117	32
Berwick	.169	.153	.135	.139	.128	24
South Centre Twp. (Columbia Co.)	.176	.153	.136	.140	.120	32
Milton	.186	.138	.148	.138	.125	33
Sunbury	.206	.176	.153	.145	.136	34
Selinsgrove	----	.189	.150	.152	.139	26

The ratio of assessed value to market value declined in all communities during the five-year period, indicating



greater increases in market value relative to assessed value. The percentage change in the last column indicates the overall rate at which market value increased relative to assessed value. For those communities within the plant site area, Berwick demonstrated the least appreciation in market value. This generally agrees with the local perception that property rose in value at a greater rate in outlying areas. It is notable, however, that appreciation in market value was slightly greater in communities removed from the project area. None of the "test communities" exhibited an economic growth nor major construction projects which would have influenced housing costs. Consequently, it would appear that the increased housing costs in the vicinity of the plant were not significantly different from similar communities in the region.

2. Food Costs

Food costs were examined both in project area communities and in communities outside of the project area. The results of a market basket comparison conducted during the summer of 1978 are presented in Table V-8.

1  
2  
3  
4  
5  
6  
7  
8  
9  
10  
11  
12  
13  
14  
15  
16  
17  
18  
19  
20  
21  
22  
23  
24  
25  
26  
27  
28  
29  
30  
31  
32  
33  
34  
35  
36  
37  
38  
39  
40  
41  
42  
43  
44  
45  
46  
47  
48  
49  
50  
51  
52  
53  
54  
55  
56  
57  
58  
59  
60  
61  
62  
63  
64  
65  
66  
67  
68  
69  
70  
71  
72  
73  
74  
75  
76  
77  
78  
79  
80  
81  
82  
83  
84  
85  
86  
87  
88  
89  
90  
91  
92  
93  
94  
95  
96  
97  
98  
99  
100

Table V-8

MARKET BASKET COMPARISON  
FOR  
SELECTED COMMUNITIES  
AUGUST, 1978

<u>Shopping List</u>	<u>Lewisburg</u>	<u>Milton</u>	<u>Berwick</u>	<u>Bloomsburg</u>
1. Cucumbers - each one	\$ .10	\$ .10	\$ .10	\$ .10
2. Potatoes - 10 lbs.	1.49	1.49	1.49	1.49
3. Sharp Cheese - 1 lb.	2.19	2.18	2.05	2.38
4. Corn - five (5) for:	.59	.59	.59	.59
5. Bananas - 1 lb.	.20	.33	.33	.33
6. Bread - 1 loaf	.39	.38	.39	.33
7. Haddock - 1 lb.	1.69	1.69	1.69	1.69
8. Eggs - 1 Medium Dozen	.77	.77	.77	.77
9. Chicken Breasts - 1 lb.	1.09	1.09	1.09	1.09
10. Detergent - 1 Giant Size Tide	1.63	1.63	1.63	1.39
11. T-Bone Steak - 1 lb.	2.89	2.89	2.89	2.89
12. Ground Beef - 1 lb.	1.25	1.29	1.25	1.49
13. Hot Dogs - 12 Pack	1.49	1.49	1.19	1.19
14. Bologna - 12 oz.	1.34	1.39	1.29	1.39
15. Tomatoes - 1 lb.	.79	.79	.79	.79
16. Lettuce - each head	.69	.69	.59	.69
17. Bacon - 1 lb.	1.49	1.59	1.59	1.49
18. Apples - 1 lb.	.89	.89	.89	.89
19. Oranges - five (5) for:	.99	.99	.75	.99
20. Soda - two (2) 28-oz. Bottles	<u>.69</u>	<u>.69</u>	<u>.69</u>	<u>.69</u>
	\$ 22.65	\$ 22.95	\$ 22.05	\$ 22.66

The total market basket price for all communities is comparable, with only \$ .90 separating the highest and lowest totals. The community closest to the plant site, Berwick, recorded the lowest market basket total. While the results of a single comparison are inconclusive relative to long-term trends, it is significant that food costs for the above items were not significantly different between communities.

1  
2  
3  
4  
5  
6  
7  
8  
9  
10  
11  
12  
13  
14  
15  
16  
17  
18  
19  
20  
21  
22  
23  
24  
25  
26  
27  
28  
29  
30  
31  
32  
33  
34  
35  
36  
37  
38  
39  
40  
41  
42  
43  
44  
45  
46  
47  
48  
49  
50  
51  
52  
53  
54  
55  
56  
57  
58  
59  
60  
61  
62  
63  
64  
65  
66  
67  
68  
69  
70  
71  
72  
73  
74  
75  
76  
77  
78  
79  
80  
81  
82  
83  
84  
85  
86  
87  
88  
89  
90  
91  
92  
93  
94  
95  
96  
97  
98  
99  
100

CHAPTER V

S O U R C E S

- 1 Pennsylvania Power & Light Company, "SSES: A Monitoring Study of Community Impact", 1976, Page 42.
- 2 Bechtel Power Corporation, SSES Personnel Department, May 1978.
- 3 Bechtel Power Corporation, SSES Personnel Department, May 1978.
- 4 Pennsylvania Economy League, Central Division, Wilkes-Barre, Pennsylvania, August 1978.
- 5 Pennsylvania Economy League, Central Division, "Tax Rates and Property Valuations - Part II", August 1978, Page 2.
- 6 Pennsylvania Economy League, Central Division, "Tax Rates and Property Valuations - Part II", August 1978, No Page.
- 7 Pennsylvania Department of Revenue, Bureau of Corporation Taxes, October 1978.
- 8 Personal Communications with Mr. Paul Weiss, Pennsylvania State Tax Equalization Board, October 2, 1978.





CHAPTER VI

COMMUNITY FACILITIES

A. School Enrollment

Surveys of non-manual personnel for both Bechtel and PP&L employees reveal that the majority live within school districts in Columbia County (See CHAPTER II). The number of children associated with the SSES work force enrolled in local school districts has not had the effect of burdening classroom space or crowding facilities. According to recent data prepared by the Pennsylvania Economy League, total enrollments in Columbia County have declined by 633 or 4.7 percent since 1969-1970. Three of the county's six districts, Berwick Area, Bloomsburg Area and Southern Columbia Area, had fewer students in 1976-1977 than in 1969-1970. The League's projections further reveal that enrollments will decline by 1,317 students, 10.2 percent, between school years 1976-1977 and 1982-1983 and that all districts will experience decreases.<sup>1</sup>

Table VI-1 indicates the enrollment trends as well as projections based on research of the Pennsylvania Economy League. Despite ongoing and projected decreases in school enrollments, total public school expenditures in the county increased by \$7.1 Million, or 70.4 percent, between 1969-1970 and 1975-1976 while the cost of educating each pupil increased by \$550 or 73.5 percent. All districts recorded increases.<sup>2</sup>

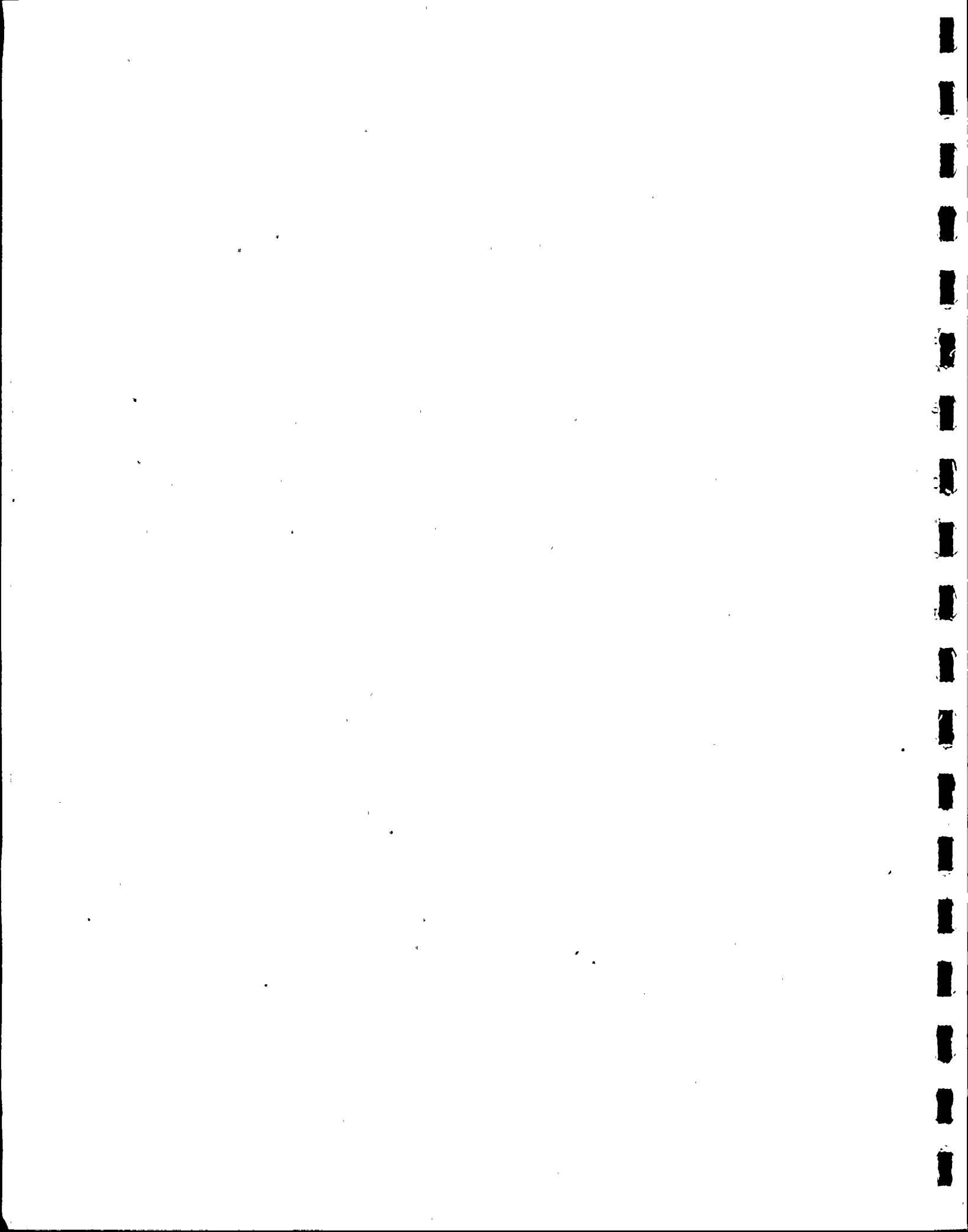


Table VI-1<sup>3</sup>

COLUMBIA COUNTY

Public School Enrollment

Trends and Projections

<u>School District</u>	<u>1969-70</u>	<u>1973-74</u>	<u>1976-77</u>	<u>% Change</u>	<u>Projected 1982-83</u>	<u>% Change 1977-83</u>
Benton Area	972	960	1,019	4.8	1,004	- 1
Berwick Area	4,682	4,567	4,293	- 8.3	3,765	-12.3
Bloomsburg Area	2,866	2,505	2,364	-17.5	1,805	-23.6
Central Columbia	2,363	2,506	2,530	7.1	2,458	- 2.8
Millville Area	1,028	1,144	1,145	11.4	1,098	- 4.1
Southern Columbia Area	<u>1,690</u>	<u>1,651</u>	<u>1,617</u>	<u>- 4.3</u>	<u>1,516</u>	<u>- 6.2</u>
<b>P O T A L</b>	13,601	13,333	12,968	- 4.7	11,651	-10.2

For the most part, increases appear to be a result of operational expenses rather than capital expenditures. Of the six school districts in Columbia County, Bloomsburg Area, Millville Area and Benton Area School Districts have had no new construction within the past ten (10) years. Berwick Area has recently completed a new junior high school which was principally funded by the U. S. Economic Development Administration. Central Columbia and Southern Area School Districts have recently completed new middle and elementary schools respectively. None of these expansions appear to have had any relationship to expanded requirements arising from SSES work force families.

B. Hospital Facilities

Primary health care for the construction workers is provided by a full-time staff of registered nurses at the SSES site. Emergency cases requiring further treatment are referred to local hospitals. Most cases are treated at the Berwick Hospital while those requiring specialized treatment are sent to Geisinger Medical Center located twenty (20) miles west in Danville. Table VI-2 indicates referrals of SSES accident cases to local hospitals:

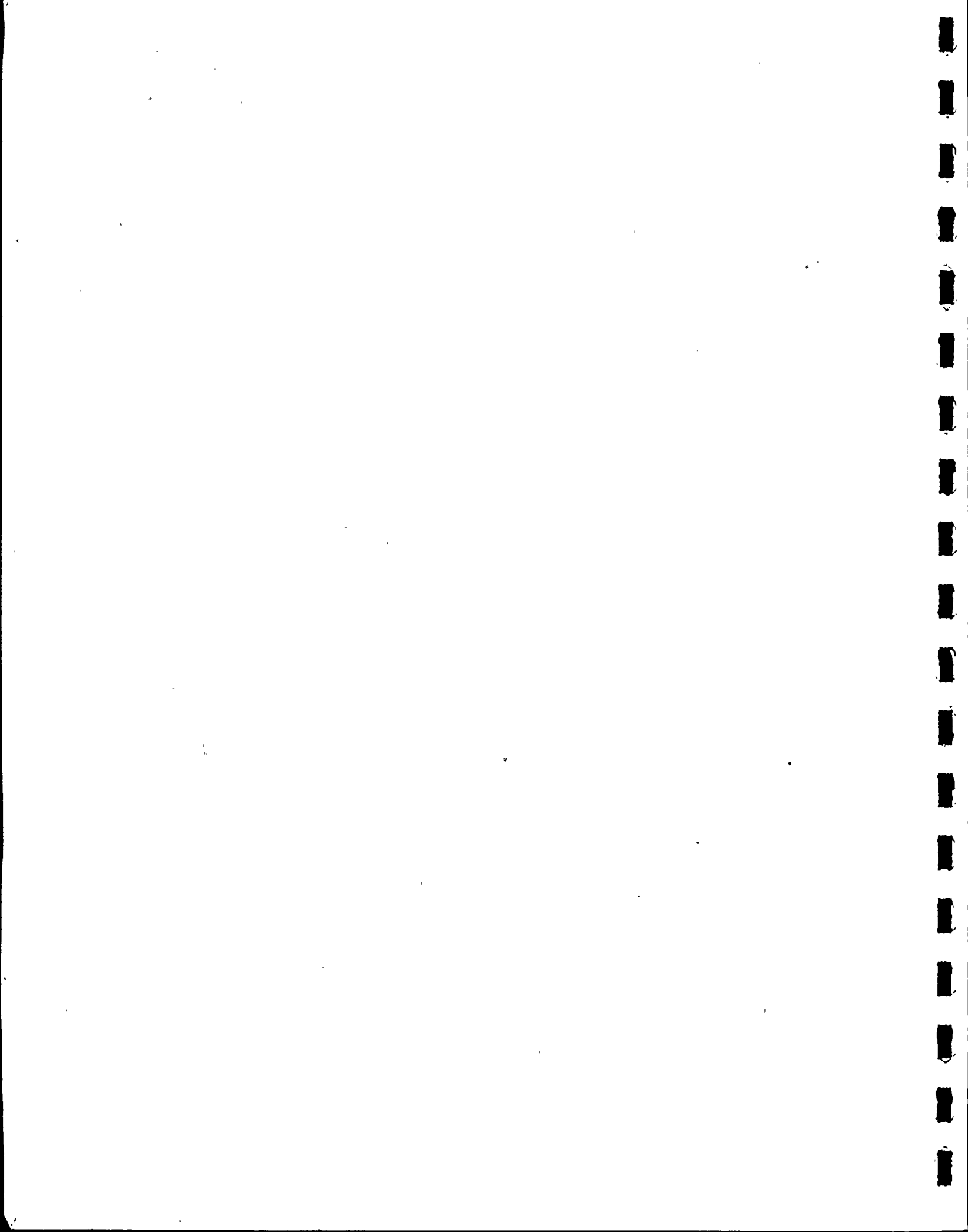


Table VI-2<sup>4</sup>

Hospital Referrals of SSES Accident Cases

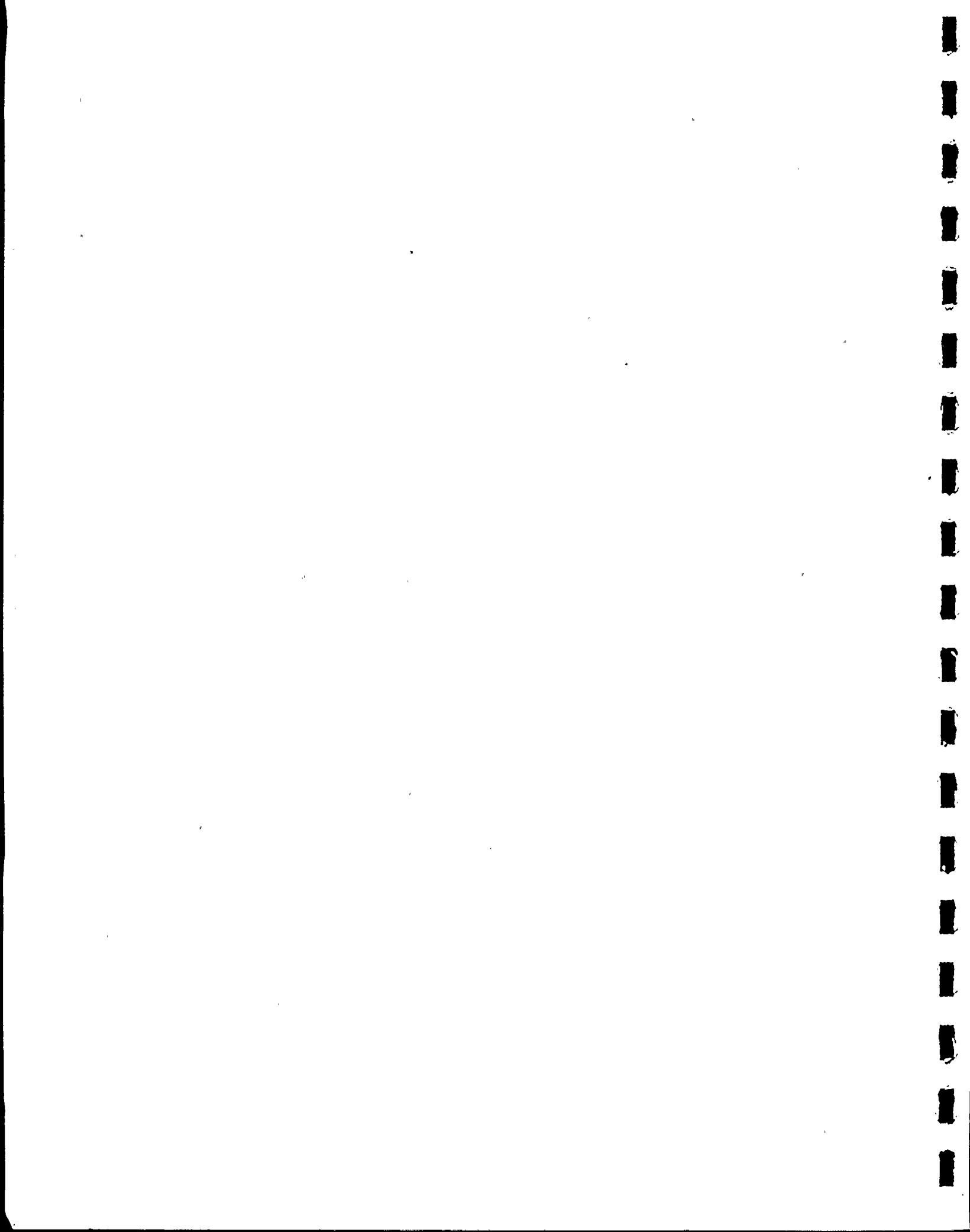
1974-1978

	<u>1974</u>	<u>1975</u>	<u>1976</u>	<u>1977</u>	<u>1978</u>
Number of Cases Referred:	197	199	305	270	203 (thru Sept.)

The increased out-patient load at the Berwick Hospital was also affected by PP&L job applicants (operational staff) who are referred to the Berwick Hospital for physical examinations upon placement.

According to administrative staff at the Berwick Hospital, the SSES referred accident cases and physical examination referrals have affected out-patient facilities and services at that institution. Since 1976, two additional staff nurses have been added for out-patient care; a cardiac treatment and test center has been established; and an audio-metric facility (hearing examinations) has been installed requiring the training of an additional staff person. Cardiac test facilities and audio testing facilities had been established, in part, as a response to the larger number of physical examinations required for plant employment. Hospital staff pointed out, however, that the increased demand for out-patient services resulting from SSES construction were anticipated and were incorporated into a hospital development program initiated in the early 1970's. The recently completed program, financially supported by PP&L, resulted in both an expansion of hospital facilities and services to the community.<sup>5</sup>

An additional new facility developed specifically for the SSES is a special emergency room for the treatment of radiation related injuries. The room, constructed to PP&L specifications, is completed although it has not been used for radiation related injuries since no nuclear fuels are presently at the SSES site. The construction of the room as well as the training of specialized staff was subsidized by PP&L.



C. Water Supply (Make-Up)

A source of river water supply will be required to replace water consumed by the operation of the Susquehanna SES during low-flow periods. The Susquehanna River Basin Commission (SRBC) regulates uses of the river as well as development affecting its tributaries. In September, 1976, the SRBC adopted a regulation requiring all new water users to provide enough standby water supply to replace river water consumed during periods of low flow.

PP&L has been identifying and assessing sources of potential water supply. Publically and privately owned existing reservoirs and reservoirs under construction have been considered as a potential source of water supply. Based on review of these possibilities the preferred approach to meeting the SRBC requirement is to purchase water from the Cowanesque Reservoir, a Corps of Engineers (COE) project under construction in Tioga Co., Pa. and scheduled for completion in 1980. PP&L has forwarded a formal request to the COE to purchase seasonal storage in the Cowanesque Reservoir. The SRBC has suggested that a study be made of all potential Cowanesque water supply uses, the effect of these uses on authorized project functions, and a determination of necessary re-authorizations. The COE estimates the study will take a minimum of 2 years to complete from the date of obtaining funds, which are not anticipated before early 1979.

In order to have an assured source of water, PP&L is preparing an application to construct its own water supply reservoir. The reservoir site, known as Pond Hill, was selected based on technical and environmental consideration from among several identified by PP&L and its consultant.

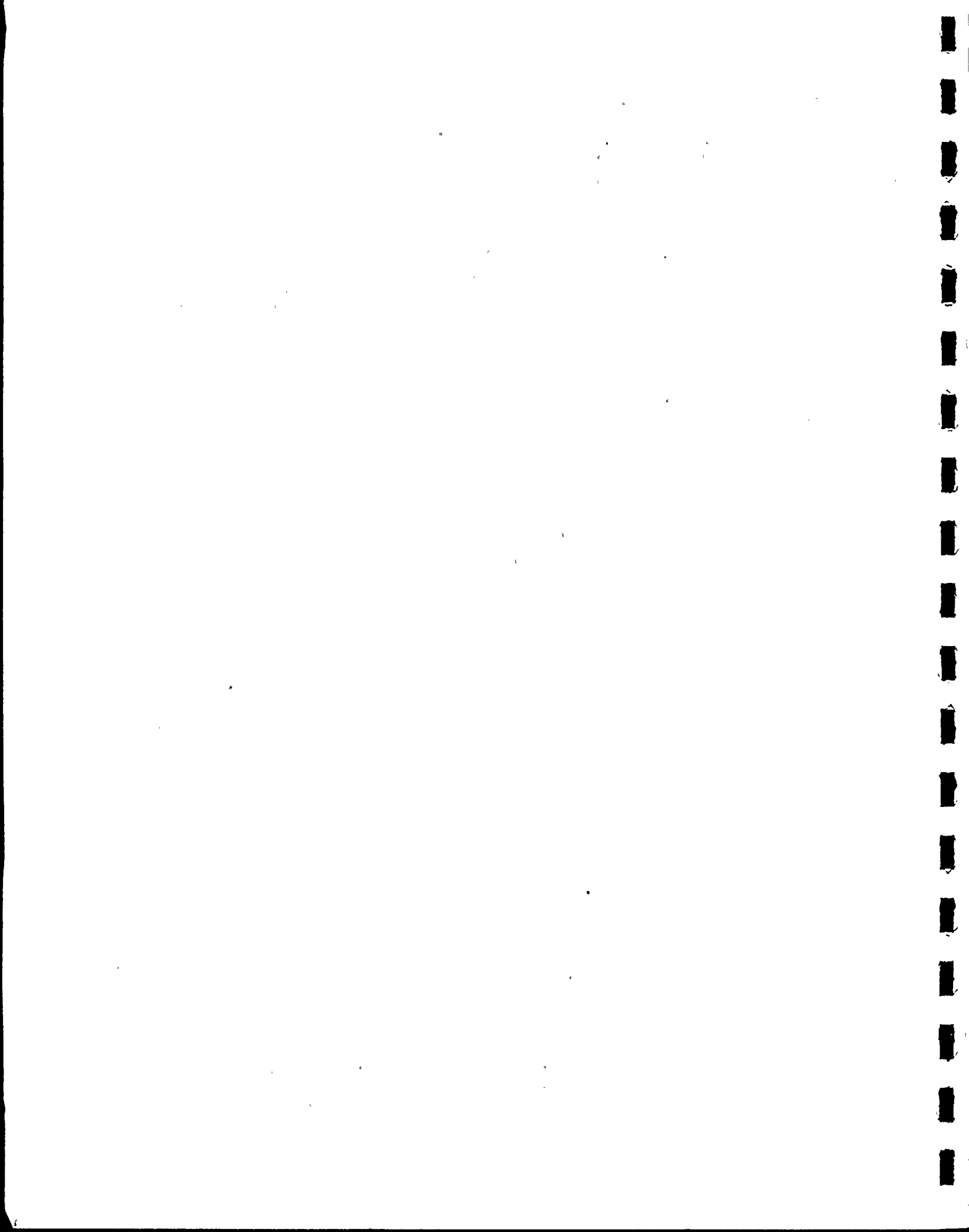
The proposed Pond Hill Reservoir site is a drainage basin of an unnamed tributary of the Susquehanna River near Pond Hill in Conyngham Township, Luzerne County. The site is located in an undeveloped wooded valley. All housing and ongoing agricultural activity occur above maximum water level. Land acquisition will involve approximately 1,200 acres although the surface area of the impounded water will be approximately 315 acres.

The impacts and design of the proposed reservoir are presently being studied. An environmental report and feasibility report are being prepared and are expected to be submitted to appropriate agencies in 1979. The planning effort has been aided by the establishment of public participation consisting of an advisory committee formed in the fall of 1977, the Pond Hill Reservoir Advisory Committee (PHRAC). The committee consists of 17 persons from eight communities in the area.

To date, this local committee has reviewed past studies, received presentations on technical and environmental aspects of construction and operation of the reservoir, and visited the Susquehanna SES station as well as the Pond Hill Reservoir site.

D. Public Safety

1. Police Force





Because of the small size of adjacent communities and the rural character of the project area, municipal police forces, where they exist, tend to be small - Berwick has a force of twelve (12) officers and Shickshinny has a force of one (1) police officer. Salem Township has no standing police force although a state police barracks, located on Route 11, has a staff of eighteen (18). (By contrast, the size of the security forces at the SSES is presently fifty-six (56). When the SSES becomes operational, a permanent on-site security force of seventy-seven (77) persons will be established.)

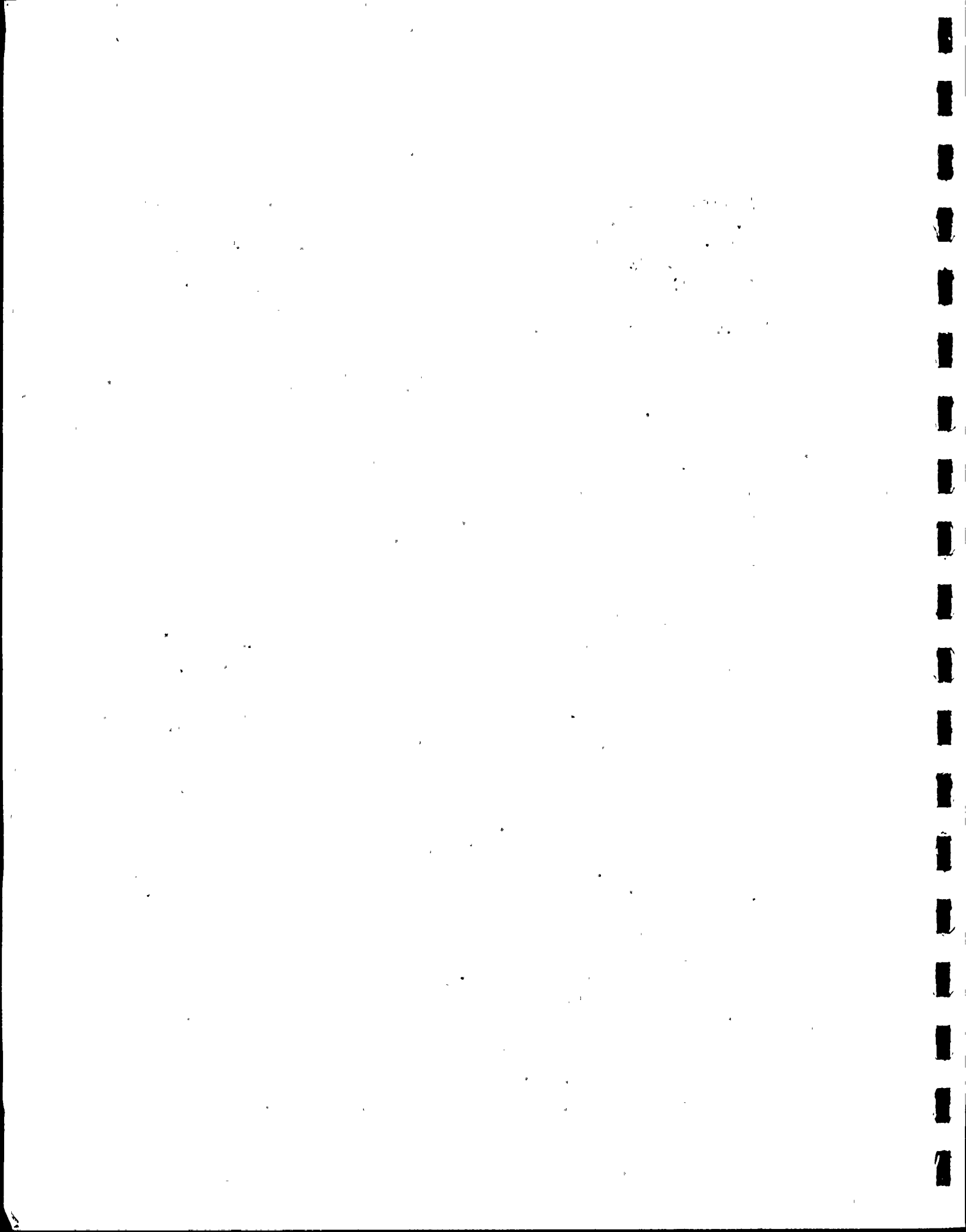
Only one instance has been identified where the plant construction has resulted in a need to increase personnel. As described in Chapter II, most of the work force originates from the Wilkes-Barre/Scranton area and commutes to the plant site on U. S. Route 11, resulting in substantial peak hour flows.

Route 11 changes from a three-lane highway to a two-lane local street in Shickshinny. At peak-hour traffic volumes, the effects in Shickshinny have resulted in considerable congestion. In some instances, traffic flows have ignored local traffic lights in an effort to proceed through town. Motorists crossing the Route 239 bridge from Mocanaqua (opposite Shickshinny) have reportedly been unable to egress onto Route 11 from the bridge during rush hours (See Figure II-1).

Community leaders solicited PP&L's help in resolving the problem. A part-time policeman was added to the force in the summer of 1978, the cost of which is underwritten by PP&L. While the additional patrolman has alleviated conditions somewhat, significant relief from traffic conditions will be experienced only with a reduction in work force as the SSES nears completion.

In other police matters, state police records indicate an increase in the number of arrests in the region since 1972 (See Table VI-4). The region includes eight (8) townships in Columbia and Luzerne Counties.

Local state police officials have indicated that the overall increase in the number of calls cannot be related to



SSES construction. The increase in the number of criminal arrests have occurred in residential areas and are following a national trend. State police have also reported no arrests on site during the construction period to date.

Table VI-4<sup>6</sup>

Total Annual Arrests

Pennsylvania State Police

Berwick Barracks

1972-1978

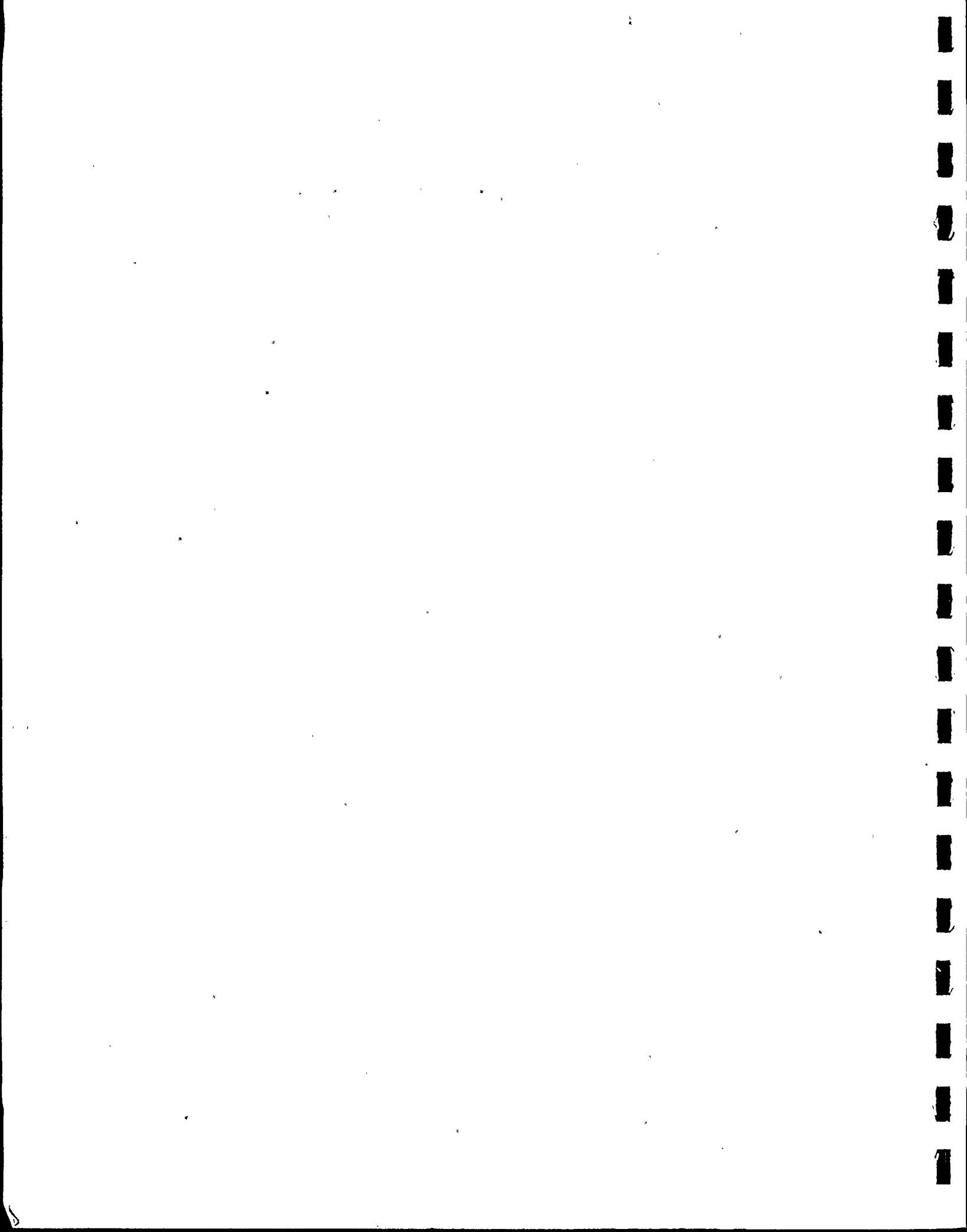
<u>Type of Arrest</u>	<u>1972</u>	<u>1973</u>	<u>1974</u>	<u>1975</u>	<u>1976</u>	<u>1977</u>	<u>(To June) 1978</u>
1. Criminal	69	131	164	180	202	162	56
2. Traffic	1,348	1,358	1,589	1,795	1,614	1,531	814

2. Emergency Services

Fire and emergency ambulance service in the plant area are provided through private, voluntary organizations, not as a service of local government. In the site vicinity, these organizations include --

- a. Shickshinny Area Volunteer Ambulance Association
- b. Pont Hill-Lily Lake Fire Company (Ambulance Service)
- c. Salem Township Fire Company, No. 1
- d. East Berwick Hose Company, No. 2

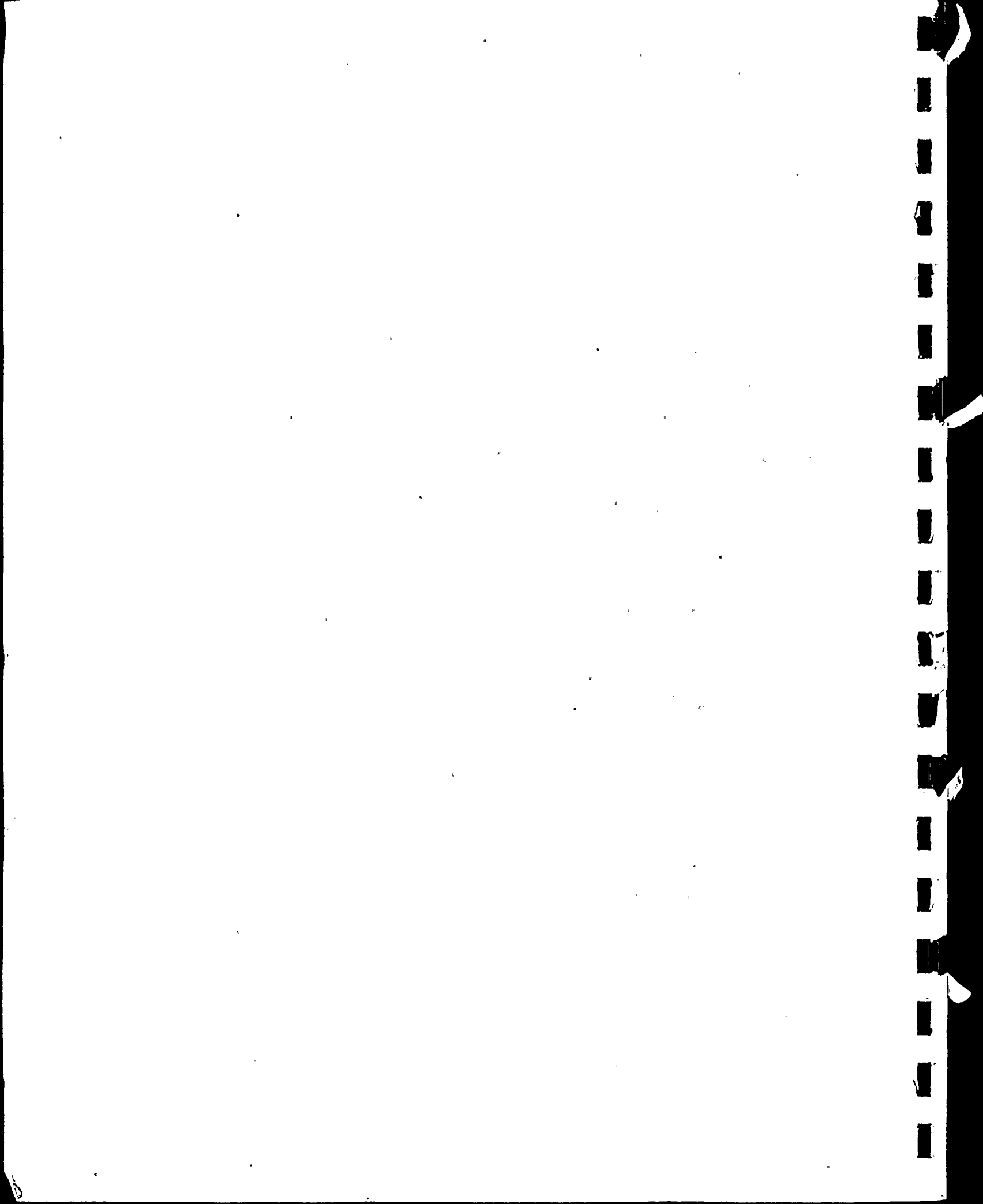
No special arrangements have been made with these organizations for their services during the construction phase of the project. During plant operation, the nature of an emergency could require responses from the above organizations to augment on-site response groups and facilities. Arrangements have been made with the above organizations to provide support upon notification by the SSES Emergency Director.<sup>7</sup>



CHAPTER VI

S O U R C E S

- 1 Pennsylvania Economy League, "Columbia County School Enrollment Trends and Projections", May 1978, Pages 2 to 4.
- 2 Pennsylvania Economy League, "Columbia County School Enrollment Trends and Projections", May 1978, Page 1.
- 3 Compiled from data of the Pennsylvania Economy League.
- 4 Bechtel Safety Enforcement Officer, SSES, October 1978.
- 5 Personal Conversation with Mr. Robert Robbins, Assistant Administrator, Berwick Hospital.
- 6 Sgt. Anthony Matson, Pennsylvania State Police, Shickshinny Barracks, August 1978.
- 7 Pennsylvania Power & Light Company, "Susquehanna Steam Electric Emergency Plan", Volume 1, Page 5-4.



Additional Information Requested for Environmental Review  
of the Low-Flow Augmentation Reservoir  
for Susquehanna Steam Electric Station  
Docket Nos. 50-387 and 50-388

---

General

1. Our understanding is that Susquehanna River Basin Commission (SRBC) policy is to require development of 85% or more of potential reservoir capacity. On the assumption that this requirement will result in changing the design maximum pool elevation of the proposed Pond Hill Reservoir from 940 ft. to 980 ft., provide the acreages for lands that will be inundated and the area required for the dam and spillway structures. Give the amounts and sources of additional fill materials required for construction and provide details concerning impacts associated with any borrow areas within the buffer zone. The contour map of the site (ER App. H., Fig. 1-3) indicates there may be a need for a dike at the 980-ft. level along portions of the south bank of the reservoir. Discuss the need for such a dike and provide design information if construction is necessary.

Response:

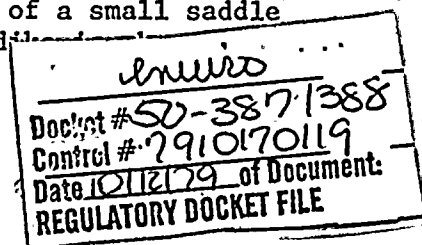
Based on the design as now envisioned with a reservoir with a normal pool elevation of 981, an area of approximately 315 acres would be inundated. Maximum pool under PMF with the recurrent flood two days later would inundate approximately 325 acres. The dam and dike shown in Plate 4 will have a base area of approximately 35 acres and the spillway and channel (shown in the attached Plate 5) will cover approximately 5 acres. Based on the dam cross section shown in the attached Plate 4 the total volume of the embankment will be approximately  $3.7 \times 10^6 \text{ yd.}^3$ . The proposed borrow areas, shown on Plate 19 are believed to have sufficient quantities of suitable embankment material. Based on our current knowledge of the soils in the area, much of this material will be acquired from within the area to be inundated. While additional areas may be disturbed for the larger reservoir, impacts will be similar to those described in section\* 4.2.5.6 for the small reservoir. Mitigative measures will be as described in\* section 4.3 and should minimize any additional impacts for the large reservoir.

Construction will be required in two saddle areas along the south rim of the reservoir immediately upstream from the embankment dam (Plate 3). The area closest to the embankment has a maximum elevation of approximately 986 feet and will require construction of a small saddle dike as shown on Plate 3. A typical section of the d

Plate 4.

---

\* Susquehanna SES ER-OL Appendix H.



The second area in the south rim of the reservoir, located approximately 1500 feet east of the first area, has a minimum elevation of 991 feet. Preliminary subsurface information indicates that an impervious cutoff may be required in this area. The approximate extent of the cutoff is shown on Plate 3 and a typical section is shown on Plate 4.



2. State the volume of water which would be stored behind the higher dam for the 980-ft. pool and the amount of water that would be released for river augmentation.

Response:

Based on a normal water surface elevation of 981, total water storage is estimated at approximately 24,100 acre feet. Of this approximately 22,000 acre feet would be available as active storage to compensate for consumptive uses with the remaining 2,100 acre feet being inactive storage. Preliminary design has assumed an average release rate of approximately 104 cfs for 106 days.

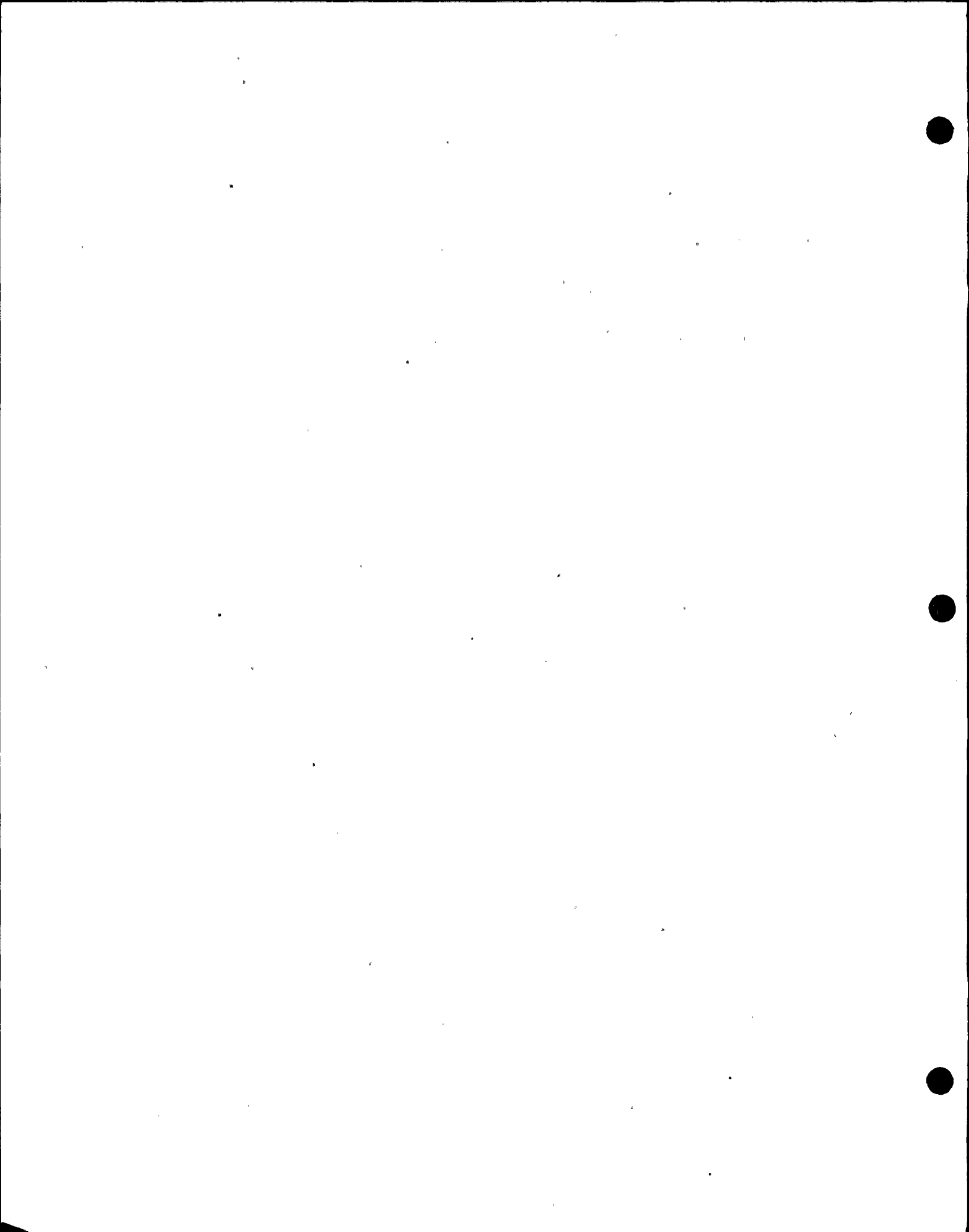
As the use of the additional storage has not been identified for feasibility design it was assumed that releases of this additional storage will be similar in time and duration to the releases required for SSES.. Refilling at a rate of 132 cfs was assumed to occur when river flows are greater than 3000 cfs. During a repeat of the drought of record refilling at this rate would guarantee a full reservoir prior to the next low flow season.

For the small reservoir report, published records (based on data thru 1972) for the source of Q7-10 was used. When SRBC reviewed our application using additional published and provisional data, they suggested a value for Q7-10 of 800 cfs be used. Based on a review of the entire period of record for the Wilkes Barre gage which is now available as either published or provisional data (April 1899 through April 1979), PP&L concurs that a value for Q7-10 of 800 cfs rather than the 770 cfs be used. Adding an average consumptive use of approximately 50 cfs gives a trigger point (for study purposes) for required releases of 850 cfs. The actual trigger point will be based on actual consumptive use. If flow at the Wilkes Barre gage were less than 850 cfs during a repeat of the drought of record, releases would be required on 106 days. An average release of approximately 104 cfs would empty the entire active storage volume in this period of time.

3. The SRBC indicates that the peak augmentation rate should be increased from 50 cfs to 64 cfs. Describe the design changes and cost required to satisfy this rate.

Response:

Average release rates of 50 cfs and peak release rates of 64 cfs are only applicable to the small size reservoir. For the large size reservoir, a release capability of approximately 104 cfs is currently planned. Each outlet port will be designed with this release capability under a 10 foot head. Since at design minimum reservoir level the lowest outlet port will be operating under approximately 18 feet of head, higher release rates will be possible without any design changes. Plates 6 and 7 (attached) show the proposed design of the inlet-outlet structure and pipeline. Project cost data is provided in the response to question 37.



4. The SRBC requires that releases during low river periods be equal to actual consumptive uses by the Susquehanna station. Describe how the actual consumptive use (withdrawal less blowdown) will be determined.

Response:

Plant intake is measured by a flow measuring device and monitored and recorded by the plant computer. This flow then divides into two components, cooling tower makeup, and deicing flows to the spray pond and intake structure. The cooling tower makeup portion is monitored by a flow measuring device which feeds its signal to the plant computer.

Plant blowdown is measured by devices on the three components of the discharge (unit 1 cooling tower blowdown, unit 2 cooling tower blowdown, and liquid radwaste discharge).

The spray pond, is connected to the plant blowdown line downstream of the flow monitors mentioned above. Since the spray pond is normally kept full, any inflow will be matched by outflow. The remaining discharge flow is the deicing flow which is the difference between the total intake flow and the cooling tower makeup flow.

The plant consumptive use is the difference between the quantity withdrawn from the river and the total blowdown to the river.

Withdrawal from river

Intake flow

Blowdown to river

Unit #1 cooling tower discharge  
Unit #2 cooling tower discharge  
Liquid radwaste discharge  
Deicing flow

5. Provide schematic diagrams of the proposed higher dam and of the site, with locations of parking lots, laydown areas, batch plant (if any), roads and other facilities required for the higher dam.

Response:

Plate 19 (attached) shows the preliminary location of the Contractor's staging area which will contain parking and laydown areas, batch plant, office trailers and other required facilities. The location of the staging area and facilities within the staging area will be dependent on the Contractor's work plan and requirements. As this area is adjacent to the existing Township road, no additional access roads may be required. The Contractor will be responsible for the location of any haul roads and/or additional access roads he may require.

The approximate areas of the various borrow areas and staging area are shown below

Borrow Area	1	45 Acres
	2	25 Acres
	3	55 Acres
	4	20 Acres
	5	40 Acres
Staging Area		35 Acres

## Terrestrial

6. Appendix H. Section 1.4.5.2, Page 1-11. Confirm whether or not a concrete batch plant will be erected onsite. If so, indicate the location of the plant and the acreage disturbed by construction and yarding requirements. Also discuss disposition of all waste effluents generated during plant operations, and indicate reclamation procedures if the plant is to be located within the buffer zone.

### Response:

At this point, it is assumed that a concrete batchplant will be needed and a location is indicated on Plate 19. The need for and location of a batch plant will be based on the construction Contractor's recommendations. The area which will be required by construction and yard requirements will depend on the contractors proposed plan of operation.

All effluents generated during the batch plant operation will be collected in a holding pond. After the solids have settled out it will either be reused or discharged via a pipeline to Pond Hill Creek. Waste effluent disposal will meet the requirements of the Pennsylvania Department of Environmental Resources for disposal of such waste. Reclamation procedures will be developed as part of the plan described in question 15.

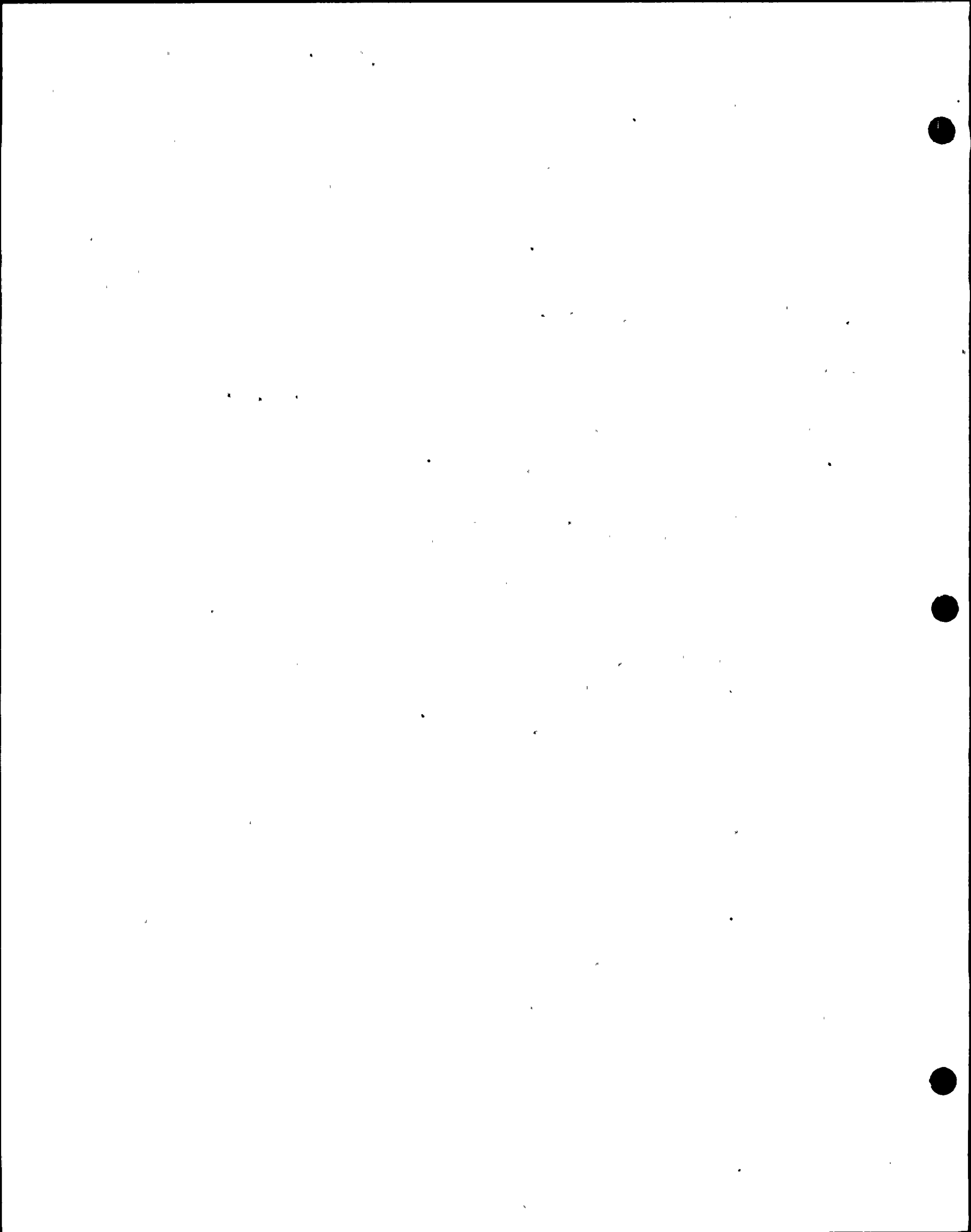
7. Appendix H, Section 2.3, Page 2-2. Provide specific information justifying the statement that expansion of "the most favorable existing, privately owned water supply reservoir was found less favorable" than other possibilities. Include details concerning reservoir location, needed reservoir expansion and discuss the basis for the "most favorable existing -- reservoir". Also indicate the economic environmental criteria used, and the results of comparing this alternative with the other potential sites considered in the TAMS (1977) report.

Response:

The most favorable existing privately owned water supply reservoir was the Pennsylvania Gas and Water Company's (PG&W) Nesbitt Reservoir located on Spring Brook in Lackawanna County adjacent to Pennsylvania Route 502. Expansion of the reservoir would require construction of a 210' high new dam about 7000 feet downstream of the existing Nesbitt Dam. Because the safe yield of Spring Brook could not supply the water needed by both PP&L and PG&W, a 5 mile long pipeline to the Lackawanna River would be required. Because of the poor quality of the Lackawanna River, it was believed that a 9 mile long pipeline from the Susquehanna River upstream of its confluence with the Lackawanna River would be necessary. Provision of water treatment facilities not presently required might have been required for municipal water supply because water pumped into the reservoir might be of poorer quality than that of Spring Brook. Expansion of the reservoir to provide approximately 27,000 ac. ft. of storage for PG&W and PP&L use was estimated in 1975 to cost \$55 million to \$65 million dependent on pumping source, exclusive of any water treatment facilities.

Approximately 290 acres would have been inundated and relocation of a short section of Route 502 would have been required. Except for the existing 120 acre reservoir and Route 502 the entire area is wooded. The most significant adverse impacts would have been related to the required pipeline and water quality. Any pipeline route could not have avoided developed areas. In addition to the impacts associated with pipeline construction in developed areas (traffic, noise, dust, etc.) real estate acquisition for a pipeline route potentially could have been difficult and time consuming.

Because of the relatively high cost, lack of significant environmental advantages and potential for delays, this site was eliminated from consideration. Other PG&W sites were previously judged less favorable and eliminated from further consideration based on topographic or hydrologic considerations or distance from a suitable pumping source.





8. Appendix H. Section 2.4.4, Page 2-8, indicates that terrestrial ecology studies at Graves Pond and the Little Meshoppen sites were conducted using methods described in Appendices A-1 and A-2. This appears in contradiction with a following statement that only reconnaissance studies were conducted at Graves Pond. Clarify and characterize the reconnaissance studies conducted at Graves Pond.

Response:

At the Graves Pond site, reconnaissances were conducted both along public roads within the site and on utility-owned (Pennsylvania Electric Company) land within 1 mile downstream of the site. These reconnaissances, for the purpose of generating species lists, were conducted in the same fashion as the reconnaissances at the Little Meshoppen and Pond Hill sites. The topics covered by these reconnaissances included vegetation (overstory, understory, and herb layer), birds, mammals, reptiles, and amphibians. Water chemistry samples were collected just below the proposed dam site before the stream passed under the road to the east of the embankment (\*see Fig. 2-3). Aquatic ecology samples were collected at the downstream (Penelec) property. Forest vegetation was not studied by quadrat analysis, nor were small mammals trapped, at the Graves Pond site.

---

\* Susquehanna SES ER-OL - Appendix H.

9. Appendix H. Section 3.2.2.2.1, Page 3-10. In view of PP&L's commitment to "conduct additional field studies to check for the presence of any rare or endangered plants," advise the scope, methodology and results of the additional studies that were undertaken.

Response:

Consultation with the Western Pennsylvania Conservancy, the Smithsonian Institute, and the United States Department of Interior indicated that two specimens of the grass Poa paludigena, listed as a proposed threatened plant species in 40 CFR 27872 (July 1, 1975) have been collected in Luzerne County and that suitable habitat may exist at Pond Hill. PP&L contracted Ichthyological Associates, who have a Terrestrial Ecologist on their staff, to conduct field studies. Results of these studies conducted during the species' flower and fruiting period (June-July 1979) showed no evidence of Poa paludigena. The results are attached.

# ICHTHYOLOGICAL ASSOCIATES, INC.

## SUSQUEHANNA RIVER ECOLOGICAL STUDY

EDWARD C. RANEY, Ph.D.  
President

301 Forest Drive  
Ithaca, N.Y. 14850  
(607) 257-7121

R.D. 1, BERWICK, PA. 18603  
(717) 542-2191

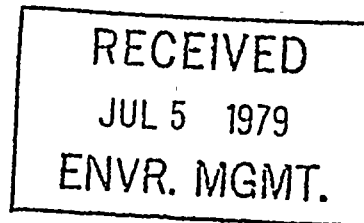
THEODORE V. JACOBSEN, M.S.  
Project Director

WILLIAM F. GALE, Ph.D.  
Aquatic Research Director

JAMES D. MONTGOMERY, Ph.D.  
Terrestrial Research Director

2 July 1979

Ms. Lynn Schroeder  
Pennsylvania Power and Light Company  
Two North Ninth Street  
Allentown, Penna. 18101



Dear Lynn:

I have had a chance to look over the material from Pond Hill today. We collected two species of *Poa*: *Poa pratensis*, the common Kentucky bluegrass, and *P. trivialis*, called rough bluegrass. The latter differs from *P. paludigena* in having the marginal nerves of the lemma (one of the bracts in the spikelet) smooth, rather than pubescent. This feature can be easily distinguished under a binocular microscope. Thus, we did not find any *Poa paludigena*.

Since our search was reasonably careful, and we collected samples of anything questionable, I feel that the *Poa paludigena* is probably not present; however, I will make another trip up to the area in the second week of July.

If you have any questions, please call.

Sincerely,

James D. Montgomery  
Terrestrial Research Director

# ICHTHYOLOGICAL ASSOCIATES, INC.

## SUSQUEHANNA RIVER ECOLOGICAL STUDY

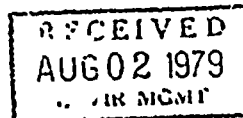
EDWARD C. RANEY, Ph.D.  
President  
301 Forest Drive  
Ithaca, N.Y. 14850  
(607) 257-7121

R.D. 1, BERWICK, PA. 18603  
(717) 542-2191

20 July 1979

THEODORE V. JACOBSEN, M.S.  
Project Director  
WILLIAM F. GALE, Ph.D.  
Aquatic Research Director  
JAMES D. MONTGOMERY, Ph.D.  
Terrestrial Research Director

Lynn Schroeder  
Pennsylvania Power & Light Company  
Two North Ninth Street  
Allentown, PA 18101

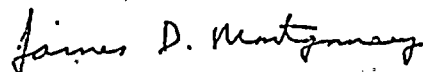


Dear Lynn:

I went up to the open wetlands on Pond Hill on Friday, 13 July. The marsh vegetation, especially *Scirpus*, *Solidago*, and *Spiraea*, has grown considerably, and grasses are much less evident than when we were there in mid-June. I found no *Poa* at all, except some old fruiting material of *Poa pratensis*. Apparently *Poa* flowers and fruits in June, as records indicate.

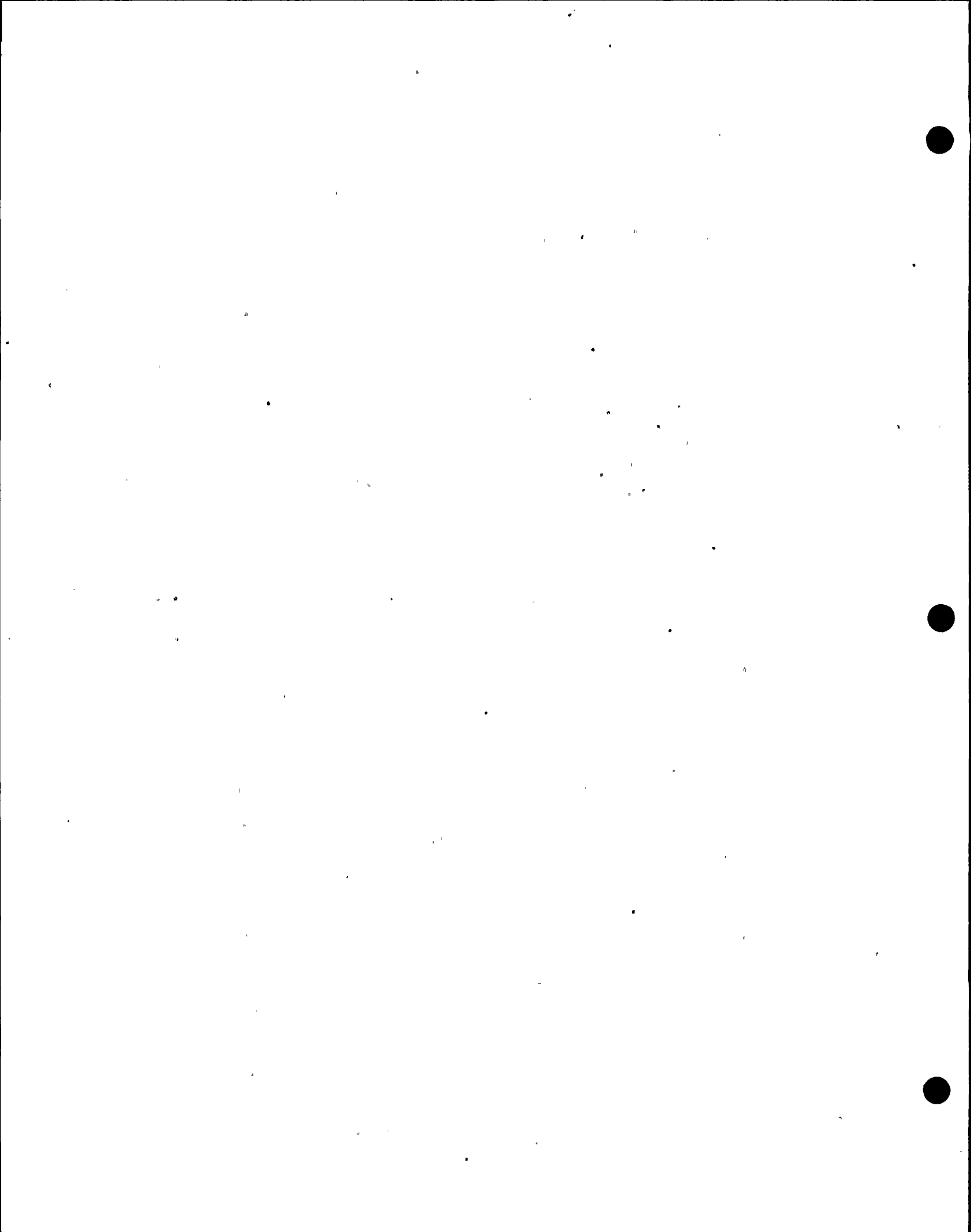
I compiled another species list to be added to the one from the June trip; if these would be useful to you, I'll put them together and send a copy along.

Sincerely,



James D. Montgomery, Ph.D.,  
Terrestrial Research Director

JDM/msh



# ICHTHYOLOGICAL ASSOCIATES, INC.

## SUSQUEHANNA RIVER ECOLOGICAL STUDY

EDWARD C. RANEY, Ph.D.  
President  
301 Forest Drive  
Ithaca, N.Y. 14850  
(607) 257-7121

R.D. 1, BERWICK, PA. 18603  
(717) 542-2191

THEODORE V. JACOBSEN, M.S.  
Project Director  
WILLIAM F. GALE, Ph.D.  
Aquatic Research Director  
JAMES D. MONTGOMERY, Ph.D.  
Terrestrial Research Director

20 August 1979

Lynn Schroeder  
Pennsylvania Power & Light Company  
Two North Ninth Street  
Allentown, PA 18101



Dear Lynn:

Enclosed is a list of the plants identified from the wet meadows of the Pond Hill site. I have divided the list into woody plants, grasses, sedges, ferns, and other herbaceous plants for convenience. Naturally, this is not a complete list of the flora, since our surveys were brief and covered only early summer. However, we should have covered those plants present at this season reasonably well, especially the grasses.

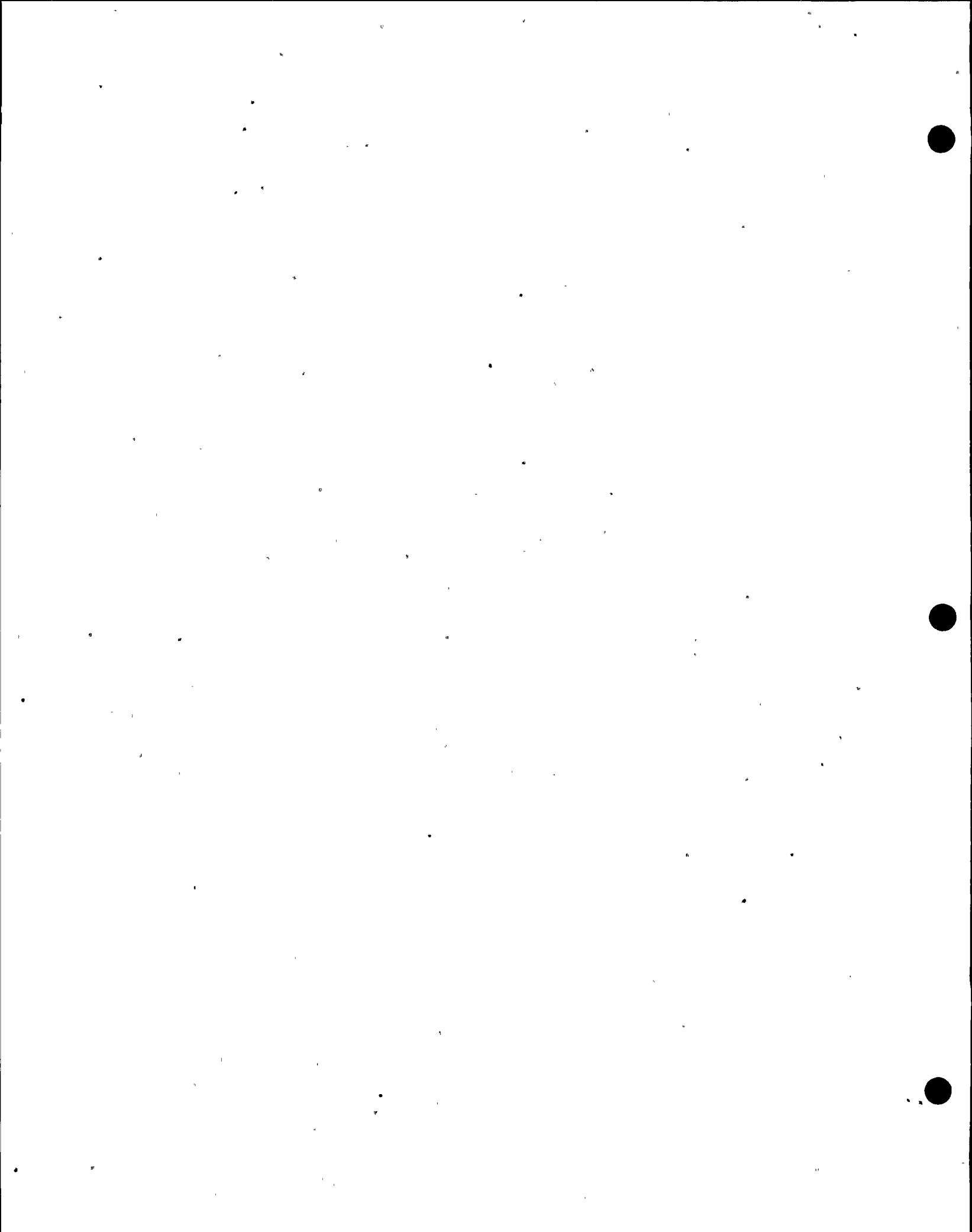
If you need additional information, please contact me.

Sincerely,

James D. Montgomery, Ph.D.,  
Terrestrial Research Director

JDM/msh

Enclosure



Plants observed in open wet meadows on Pond Hill site, June-July 1979

---

Woody Plants

<i>Acer rubrum</i>	Red Maple
<i>Rubus allegheniensis</i>	Blackberry
<i>Sambucus canadensis</i>	Common elderberry
<i>Spiraea latifolia</i>	Meadow-sweet
<i>S. tomentosa</i>	Steeplebush

Grasses

<i>Glyceria striata</i>	Fowl mannagrass
<i>Leersia oryzoides</i>	Rice cutgrass
<i>Poa pratensis</i>	Kentucky bluegrass
<i>P. trivialis</i>	Bluegrass
<i>Sphenopholis intermedia</i>	Wedgegrass
<i>Trisetum pensylvanicum</i>	Trisetum

Sedges

<i>Carex crinita</i>	Sedge
<i>C. intumescens</i>	Sedge
<i>C. lurida</i>	Sedge
<i>C. scoparia</i>	Sedge
<i>Carex</i> spp.	Sedge
<i>Eleocharis obtusa</i>	Spikerush
<i>Scirpus atrovirens</i>	Bulrush
<i>S. cyperinus</i>	Wool grass

Ferns

<i>Athyrium filix-femina</i>	Lady fern
<i>Dennstaedtia punctilobula</i>	Hay-scented fern
<i>Dryopteris cristata</i>	Crested wood fern
<i>D. spinulosa</i>	Spinulose wood fern
<i>Onoclea sensibilis</i>	Sensitive fern
<i>Osmunda cinnamomea</i>	Cinnamon fern
<i>Thelypteris palustris</i>	Marsh fern

Other Herbaceous Plants

<i>Aster puriceus</i>	Purple-stemmed aster
<i>Boehmeria cylindrica</i>	False nettle
<i>Campanula aparinoides</i>	Marsh bellflower
<i>Eupatorium maculatum</i>	Spotted Joe-Pye-weed
<i>E. perfoliatum</i>	Boneset
<i>Galium trifidum</i>	Bedstraw
<i>Hydrocotyle americanum</i>	Water-pennywort
<i>Hypericum mutilum</i>	St. John's wort
<i>Impatiens biflora</i>	Jewelweed
<i>Juncus effusus</i>	Rush
<i>J. tenuis</i>	Path rush



Other Herbaceous Plants (cont.)

*Myosotis scorpioides*

*Polygonum sagittatum*

*Solidago gigantea*

*S. graminifolia*

*S. rugosa*

*Stellaria longifolia*

*Symplocarpus foetidus*

*Verbena hastata*

*Veronica americana*

*V. officinalis*

*Viola* sp.

Forget-me-not

Arrow-leaved tearthumb

Late goldenrod

Flat-topped goldenrod

Rough goldenrod

Chickweed

Skunk cabbage

Blue vervain

American brooklime

Common speedwell

Violet

---

10. Appendix H. Section 3.2.2.3.1, Page 3-14. Discussions of local wildlife populations include references to a hunter survey conducted by Biometric Services Inc. and various estimates involving wildlife populations and/or habitat conditions by the "Pennsylvania Game Commission" (pages 3-14, 3-15, A-5). If this and similar site specific information is available in report form, please provide copies.

Response:

Seventy copies of a hunter survey were distributed in the Pond Hill area by handing them to hunters in the field, leaving them on car windshields around the site in hunting season, and leaving several copies for public availability at Larry Yokum's grocery store. Nine of these surveys were returned (12.9%). The following is a summary of the questions asked and the 9 responses.

1977 Hunter Survey

1. Did you take any deer from this specific area? NO-8, YES-1
- 2.A. Did you sight any deer in this area which were not taken? NO-2, YES-7.
- 2.B. If so, how many? The 7 responses were: "2"; "4"; "6"; "8"; "12"; "28"; and "about 30".
- 3.A. Did you take any other game animals from this area this year, including trapping? NO-7, YES-2
- 3.B. If so, what animals and how many? Response #1--18 muskrat and 3 raccoon. Response #2--1 rabbit, 6 squirrels, and 2 grouse.
4. Did you spot any non-game animals, including birds, in this area this year? If so, please identify them to the best of your ability. NO or no response-6, YES-3. Response #1--numerous songbirds, 1 broad-winged hawk, and 2 ruffed grouse. Response #2--grouse. Response #3--crows, hawks, woodpeckers and many other small birds.
5. Any comments you would like to make. No response-6. Response #1--How about asking the Game Commission to stock some turkeys here. Response #2--In July, 1976, I saw a hen turkey with about 12 young; 2 flocks of turkey in October; a black bear in deer season; and I shot a red fox here in 1975. Response #3--This valley has been rich with wildlife for all the years I can remember; and all efforts should be made to conserve them.

Following you will find an internal report summarizing the results of an interview with Pennsylvania Game Commission officials; and population harvest, and hunting data for various game species for some counties of Pennsylvania, courtesy of the Pennsylvania Game Commission. Pond Hill lies in Luzerne County. The draft statement from Mr. Palmer, noted on the internal report, was never received by BSI.

Summary of Pennsylvania Game Commission  
Comments Concerning  
The Proposed TAMS-PP&L-Susquehanna Reservoir Project

POND HILL SITE

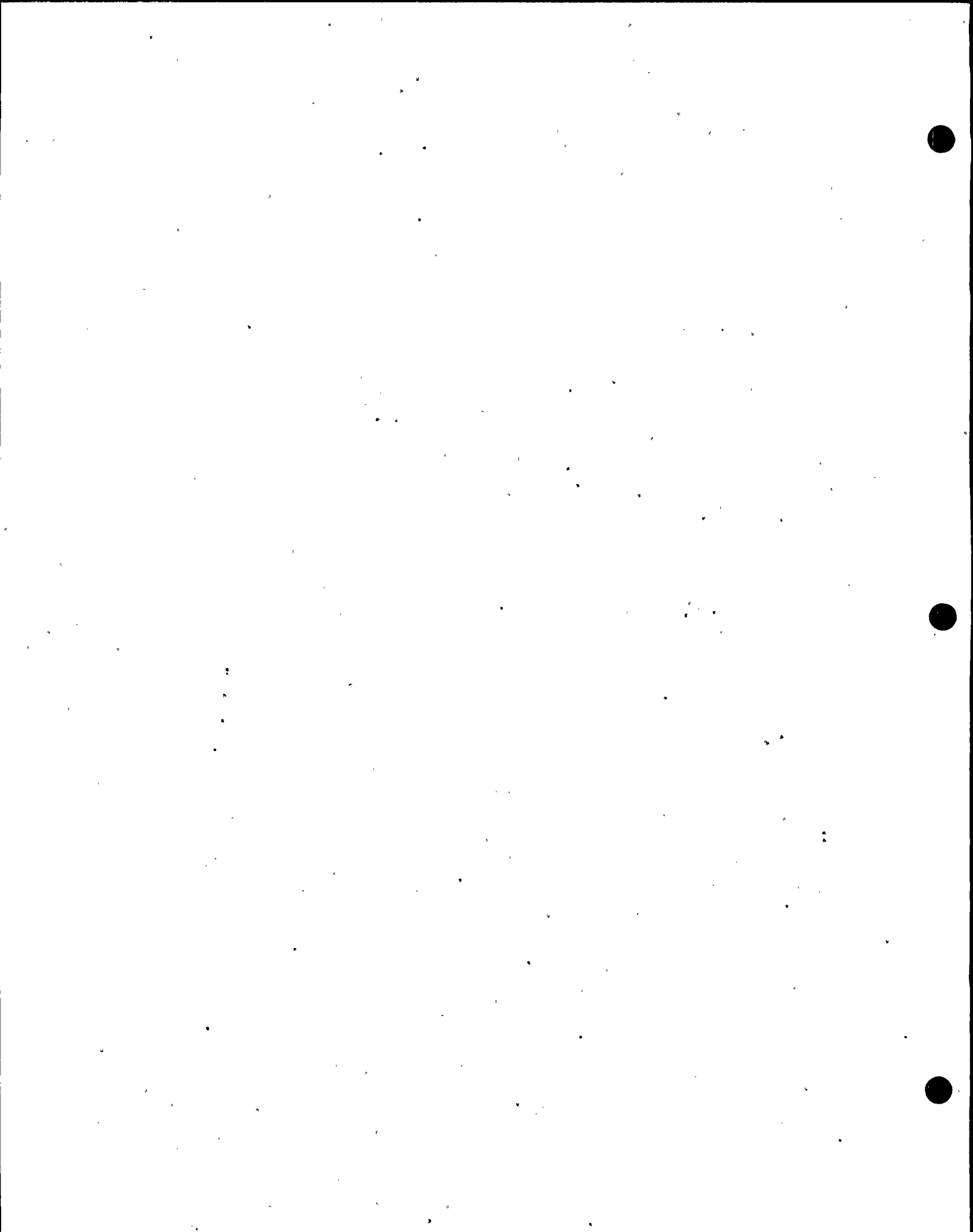
Meeting, 3/21/78

PA Game Commission personnel: J. Hugh Palmer, State Wildlife Biologist; R.W. Nolf, Luzerne County (South) Game Protector

Biometric Services personnel: Dr. Carl S. Oplinger, George E. Wieland III, Dennis A. Grube

[Biometric Services is awaiting a draft statement from Mr. Palmer, a copy of which will be received by T.A.M.S., concerning this meeting as well as one on 3/22/78 at the Graves Pond and Little Meshoppen sites. Bracketed [] phrases are Biometric additions and not necessarily the opinion of the Game Commission.]

- I. The land-- Creek bottom land is the best habitat for game, especially if it has clearings interspersed, such as the Pond Hill site's old beaver dam areas. Creek bottoms and clearings serve as a wildlife feeding, brooding, and seasonal or permanent residence site. Also, seep areas, or springs with little gradient and low discharge and of good water quality, serve as important winter food sources for game. [Many seeps are present in the Pond Hill creek bottom area.] Surrounding areas are of lower quality at the Pond Hill site because of: higher or steeper gradient; less moisture due to more wind exposure at the higher elevations and fewer seeps or springs; and the close proximity of man from the Pond Hill section of Conyngham Township, a community which is developing northward toward the valley. Moving species closer to man would increase the hunting pressure



on those species which could still find suitable habitat; or cause some species to attempt to relocate in other nearby habitats. The latter would have an effect similar to the loss of original habitat in the creek bottom in that if these surrounding areas are already at their carrying capacity, the introduction of more members of a given species would cause a critical loss of game until the surrounding areas again drop within their carrying capacity.

II. Existing wildlife--As far as is presently known, this site [nor the other two] contains no threatened or endangered species.

Beavers were in the area up to as recent as six years ago, but have since disappeared. They may have been trapped out of the area, had their dams damaged or destroyed by Hurricane Agnes in 1972 and emmigrated rather than rebuilding, or a combination of both. There are no signs of beaver activity in the site at present, although it has suitable habitat and a history of natural beaver repopulation.

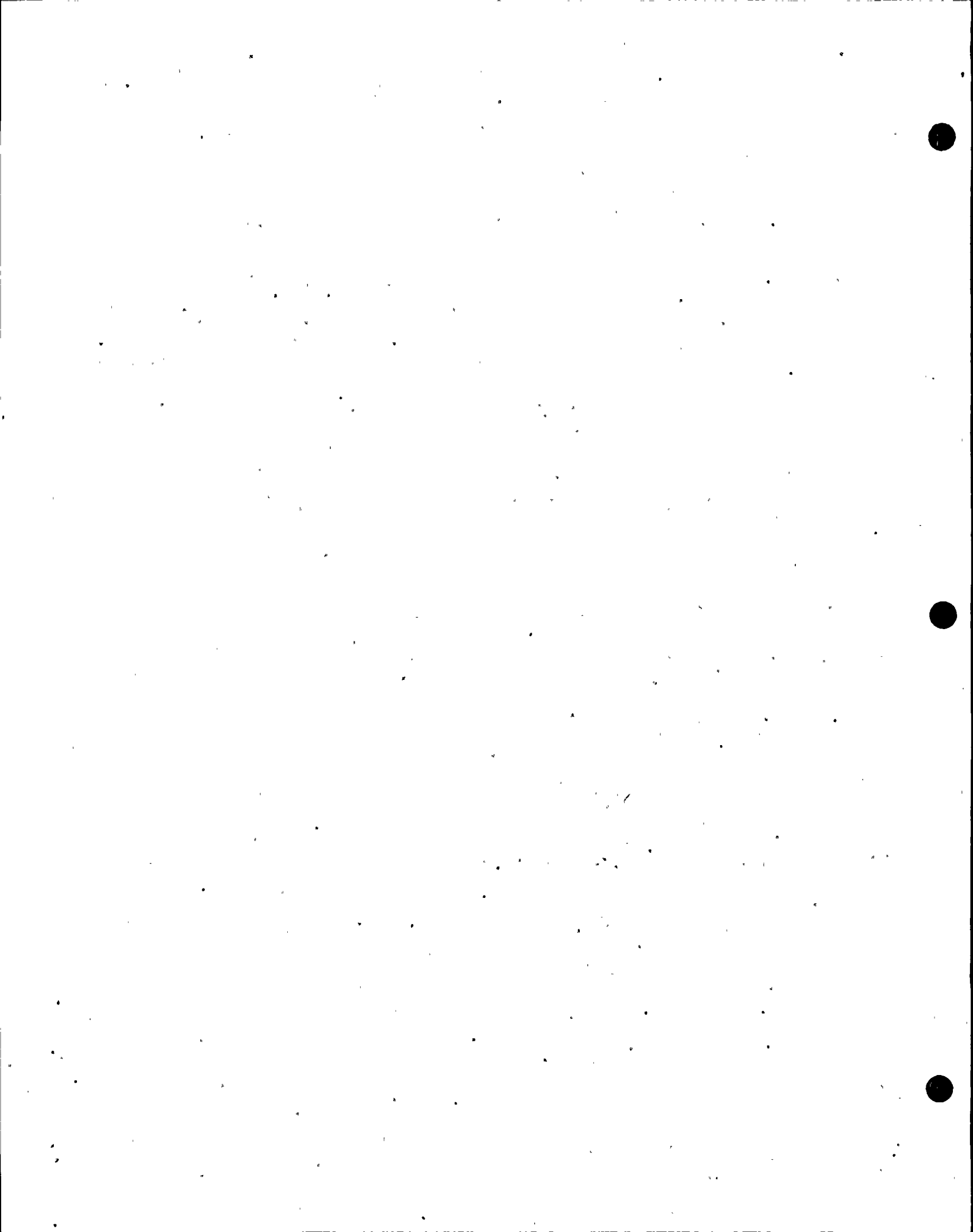
The site is characterized as class 3 for ring-necked pheasants on a scale of 1 to 3 with 1 as the highest. It is stocked with farm pheasants by the Game Commission between Lily Lake and a point east of the Hanover Rod and Gun Club-leased property. Pheasants here are in the put and take category, where few if any of these birds actually live and brood here, but rather are stocked and hunted out each season. Slocum Township, to the east of Conyngham Twsp., is heavily populated with pheasants.

The area is characterized as Class 2 (on a scale of 1 to 3)

turkey land, which means that there are some resident as well as stocked birds here, i.e. that some of the stocked turkeys are not taken by hunters the first year, survive the winter, and possibly breed. Stocked turkeys are released in the same areas as pheasants. Creek bottom land, especially the grassy areas of the old beaver dams, are good habitat for turkey brooding. The turkeys work, or feed, on Penobscot (Lee) Mountain. Being very sensitive to disturbances, the birds do not work the southern [Pond Hill] side of the valley as much due mostly to the activities of local farmers and other residents. The lack of roads through the stream valley enhances its value for turkey breeding. The seep areas in the creek bottom are important wintering areas for the turkeys; these seeps provide food both from aquatic vegetation and by supplying enough moisture for hemlocks and spruce, which are also eaten by wintering turkeys. In winters with prolonged continuous snow cover, such as the winter of 1977-78, seeps provide the only food source for these birds.

Black bears have been reported in and near the reservoir site. However, these sightings are very infrequent and it is believed that the bears are residents of Cranberry Swamp, which is to the east of Lily Lake. Swampy areas provide good cover for bears, and Cranberry is swampy year-round. The bears are probably looking for food when they are seen in this valley or near Pond Hill.

The inundation area is reported to be a good ruffed grouse





area. [Grouse have similar feeding requirements as turkey and pheasant.]

The site is a good American woodcock hunting area. It is reported to be typical woodcock habitat for the surrounding regions, which is enhanced by the presence of alders [hophornbeam and birch] in the site. The area has good migratory cover for woodcock.

Gray squirrels are numerous in the site. A variety of trees provides a good food source [e.g. oak, hawthorn, beech, hemlock, and white pine]. The (small) red squirrel population is low here due to predation and to red-gray interactions. No (large red) fox squirrels are known to inhabit the site or any surrounding area.

No snowshoe rabbits are known in the area. Snowshoes prefer swampy, cleared areas. Some cottontails are present. The cottontail population in the creek bottom hemlock areas is low because of high natural predation.

Beaver dams are good areas for waterfowl, especially in migrating season. Old beaver dams, as are found in the site, are potentially good habitat for wood duck residence.

The Pond Hill reservoir site is excellent for whitetail deer hunting. Hemlocks and spruces growing along creek bottom seep areas are an important winter food source for deer. The valley was labeled "...A-1 deer country and a good wintering area..." by Mr. Nolf.

The site is frequented by trappers who get muskrat, raccoon, mink, and some years beaver here. Comparable areas for these

furbearers are nearby in Luzerne County. Trappers in this region are often supplementing their income, not just seeking a recreational outlet; the value of pelts has been increasing over the past few years.

The major predators at this site are great horned owls and foxes. Wild dogs, which tend here to have shorter noses than domestic dogs, roam Penobscot Mountain. There have been reports of large cats in the area, but none of these have been confirmed. It is believed that these cats are not residents, but are merely moving through the area.

III. The impoundment: benefits, losses, possible mitigating factors--

As has been stated before, the creek bottom land, with its flowing water, grassy areas from old beaver dams, and seeps, is the best type of habitat for numerous wildlife species. An impoundment would destroy all of these areas via inundation, i.e. this habitat would be lost for the life of the reservoir.

Major mitigation of habitat loss could be undertaken at this site, as has been done by PP&L, in conjunction with the PA Game Commission, at the Montour Steam Generating Station.

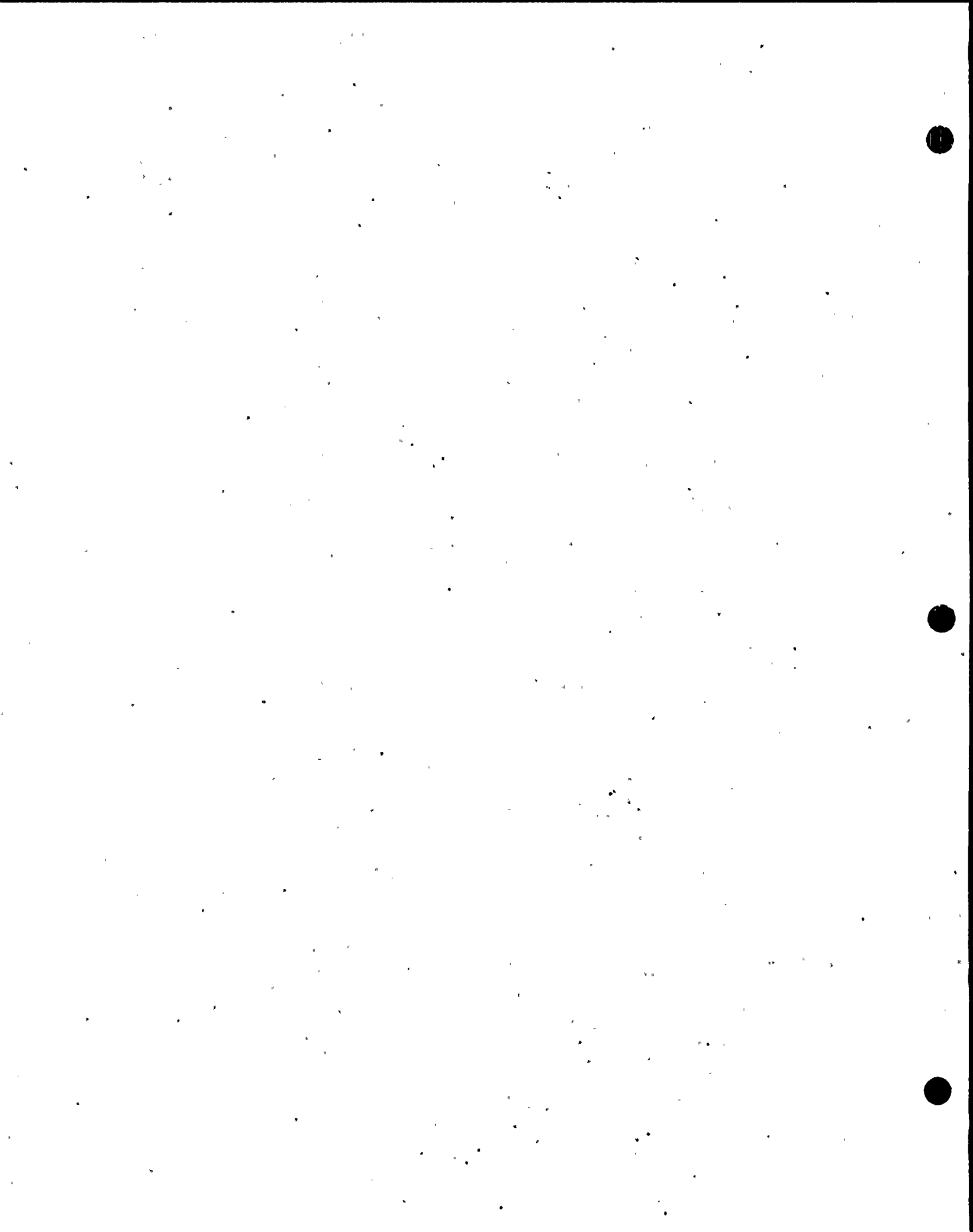
Clear cuts, i.e. permanent openings, could be maintained on the southern slope of Penobscot Mountain. These grassy areas would help offset the loss of the beaver dam creek bottom areas. Turkey brooding and deer residence would occur here. The same activity would provide substantially less benefit on the southern (Pond Hill) side of the reservoir due to distur-

bances from roads, residents, and farms.

Woodcock could find limited suitable habitat downstream from the dam if the gradient isn't too steep and if the amount of clearing is kept at an absolute minimum during construction and development. Seep areas higher up on Penobscot could be developed with coniferous plantings, helping to offset the loss of creek bottom seeps and to provide limited new winter habitat for turkey and deer.

The clear cuts could best be developed by rotating the land use. Clear 5 out of every 25 acres. Five years later, cut a new set of 5-acre sections. Cut the remaining fifths of the timber 5, 10, and fifteen years further on. As these latter cuttings are occurring, the originally cleared areas would be undergoing a succession back to a forest cover. The end result, once one 25-year cycle has been completed, would be to force various stages of plant growth, yielding grassland of 0-4 years of age, with 5-9, 10-14, 15-19, and 20-24-year old vegetation covers interspersed, providing numerous ecotones and a highly-varied habitat [grass---shrubs---pioneer trees---mixed mesophytic timber]. The tree clearcutting could be managed by PP&L or an outside wildlife consultant, and be performed either by commercial operators or by residents seeking firewood on a payment-for-wood basis.

Snowshoe rabbits prefer cleared swampy areas. Thus, if such a swampy area was present, snowshoe habitat could be created where none had previously existed, and a successful

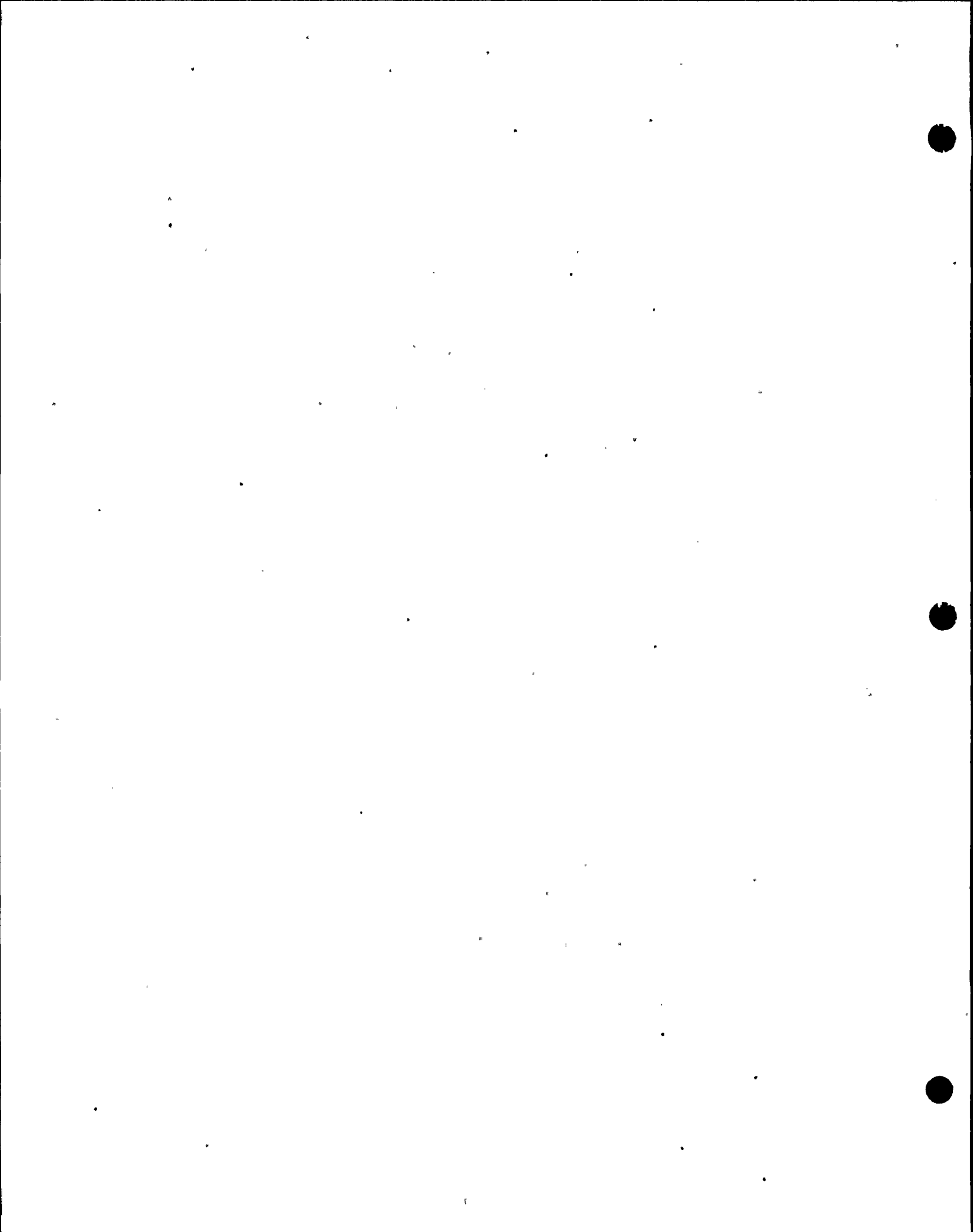


stocking of this species might be possible. [Swampy areas, are not known on the Penobscot side at present, reducing the chances of successful snowshoe introduction in drier cleared areas there.]

The grading of a few banks and the planting of hemlocks on the north side could replace some of the valuable deer habitat lost due to inundation. The deer presently in the valley would not migrate to the south due to the activities of man, and would be unlikely to migrate to the northern side of Penobscot Mountain due to its north-facing slope (colder in winter) and a major secondary road connecting Mocanaqua and Lee.

Should recreational development occur on the site, snowmobiles should be banned. Turkeys will not maintain residence here with snowmobile noise, and deer would be disrupted as well. Snowmobilers often purposely chase deer, which frequently results in either the deer collapsing from exhaustion or injuring itself attempting to escape. Even if the act is not purposeful, the deer often flee the noise with the same detrimental results.

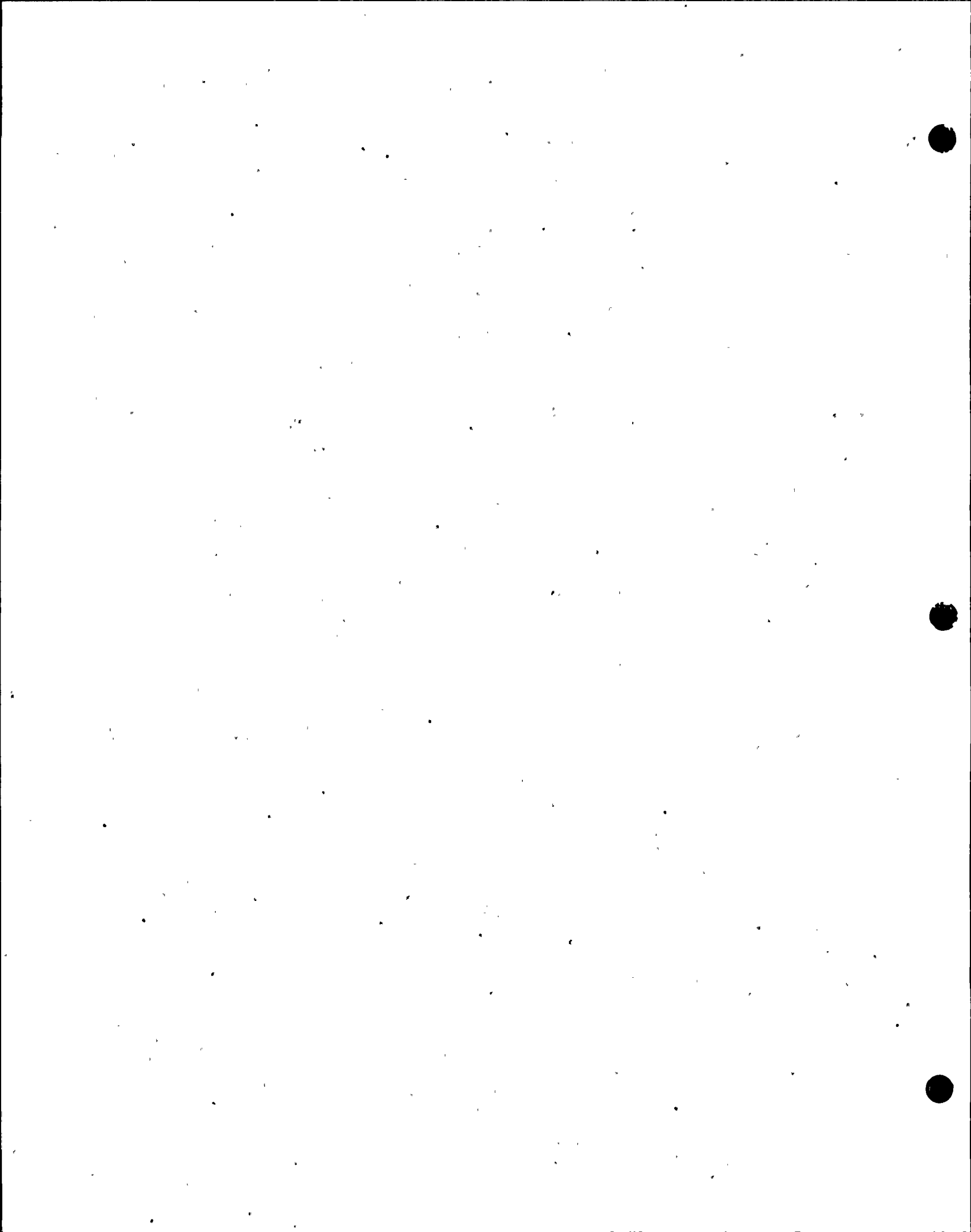
When clearing the valley's vegetation during reservoir construction, some careful planning can help mitigate habitat loss. The reservoir bottom (the deeply submerged inundation area) should be clear cut. However, the creation of a beach, or open band, between the trees left standing and the maximum water level elevation is not conducive to wildlife. Instead,



it is proposed that the trees should not be cleared some 0 to 15 or 30 feet below the maximum water level (or a 25-50 foot-wide band) except at the recreational access area, especially on the Penobscot side. This would leave various heights of tree tops emergent from the filled reservoir. Such a shoreline cover would maintain or possibly improve muskrat and raccoon habitat, although the reservoir in any form will no longer be suitable habitat for beaver and mink. The partially submerged trees (flooded timbers) would also provide excellent fish habitat.

The reservoir has the potential of providing new water fowl habitat. If the reservoir is built wide open (with a perimeter beach) mallards [and migrating geese] will be the only waterfowl to use the lake, except for an occasional wood duck or black duck which would stop only long enough during migration to recuperate. Wood ducks and black ducks like cover, so the proposed flooded timber areas would create new habitat for these species, some of which will nest on the site. Wood ducks may currently frequent the old beaver dams in the creek bottom, and the construction of an open reservoir would displace these birds. However, the ducks would not be driven completely out of the area because of the nearby refuge of the Susquehanna River.

Hunting pressure may keep waterfowl off the lake in the fall. Closing the lake to duck hunting would be ineffective





because: local hunters may retaliate against the project; enforcement of the "no hunting" area would be too expensive and difficult for the PGC personnel to effectively patrol; and the creation of a new waterfowl habitat with hunting permitted would help to take hunting pressure off the river and surrounding lakes and streams.

The Game Commission personnel were unsure of any possible effect the loss of the creek bottom habitat could have on the bear population of Cranberry Swamp.

It has been suggested that some small areas of the reservoir be graded to provide pool areas with flooded timbers during drawdowns. [This could be done at the eastern end of the valley, by creating small perimeter pools which could retain water from seeps or springs.]

- IV. Economics-- The Pennsylvania Game Commission is funded entirely by hunters' licenses and fees. Many local businesses sell hunting gear [including field clothing, footwear, arms, and ammunition]. A loss of wildlife here would cause an economic loss to the PGC (some licenses may not be renewed), local trappers (pelts), hunters (food and recreational value), and local businesses.
- V. Further contacts--1. PP&L's records for wildlife management around the Montour Steam Generating Station. 2. Local trappers: Bird [?], Yokum, Lapinsky, Ron Stevetsky. 3. Information: Charles Culp, US Fish & Wildlife Service, 112 W. Foster Ave., State College, PA (814) 234-4090, for recommendations concerning

waterfowl resting and nesting, and effects of reservoir drawdowns on waterfowl. Tom Wynrick [?] of the Dallas Timber Office. The Bureau of Forestry at Hazleton or Bloomsburg, the latter for Max Coy [?] on Old District Road.

VI. Hunter survey--The best days to survey deer hunters are opening day and the first Saturday of the season. These were among the days used by Biometric Services personnel. Biometric Services received a return of 9 out of about 70 surveys distributed to hunters' vehicles, to hunters in the field, and including about 25 copies left at Yokum's Grocery Store for public availability. Mr. Nolf stated that this percentage of returns was very good for the Luzerne County coal regions.

Average Annual Population, Harvest and Hunting Data for Cottontail Rabbits in Pennsylvania

Northeast Division

	Acres Habitat	Harvest '72-'73 Avg.	Harvest Rate	Harvest Per Acre	Value Har- vest Per Acre	Fall Pop- ulation Per Acre	Yearly Pop- ulation, Per Acre	Hunting Effort Man-Days/Acre
Bradford	541,020	31,588	10%	0.058	\$ 1.43	0.584	2,570	0.082
Carbon	89,736	22,023	20%	0.254	6.27	1.227	5,399	0.501
Columbia	208,662	35,130	15%	0.168	4.14	1.122	4,537	0.277
Lackawanna	138,752	32,815	20%	0.237	5.85	1.182	5,205	0.502
Luzerne	251,692	61,913	20%	0.246	6.07	1.230	5,412	0.506
Monroe	140,576	23,427	15%	0.167	4.12	1.111	4,888	0.222
Montour	66,842	8,632	15%	0.129	3.18	0.861	3,788	0.229
Northumberland	202,569	33,161	20%	0.164	4.05	0.819	3,604	0.338
Pike	43,030	4,708	10%	0.109	2.69	1.094	4,814	0.119
Sullivan	77,242	5,205	10%	0.067	1.65	0.674	2,956	0.133
Susquehanna	360,190	30,399	10%	0.084	2.07	0.844	3,714	0.130
Wayne	287,270	16,986	10%	0.059	1.46	0.591	2,600	0.123
Wyoming	155,851	21,531	15%	0.138	3.40	0.921	4,052	0.201
Div. Totals	2,203,242	327,518	-	0.149	\$ 3.68	-	-	-

Southeast Division

Berks	417,588	100,019	20%	0.240	\$ 5.92	1,198	5,271	0.426
Bucks	270,898	73,768	20%	0.272	6.71	1.362	5,993	0.426
Chester	404,856	40,033	15%	0.099	2.44	0.659	2,900	0.223
Dauphin	219,674	35,616	15%	0.162	4.00	1.081	4,756	0.257
Delaware	46,834	6,580	15%	0.140	3.45	0.937	4,123	0.180
Lancaster	479,004	112,617	20%	0.235	5.80	1.176	5,174	0.352
Lebanon	189,398	47,358	20%	0.250	6.17	1.250	5,500	0.384
Lehigh	163,955	39,654	20%	0.242	5.97	1.209	5,320	0.488
Montgomery	193,778	51,340	20%	0.265	6.54	1.325	5,830	0.470
Northampton	176,254	46,640	25%	0.265	6.54	1.059	4,660	0.578
Schuylkill	219,262	52,350	20%	0.239	5.90	1.194	5,254	0.471
York	490,186	70,354	20%	0.144	3.55	0.717	3,155	0.336
				0.206	\$ 5.08	-	-	-

Average Annual Population, Harvest and Hunting Data for Gray Squirrels in Pennsylvania

Northeast Division

	Acres Habitat	Harvest '72-'73 Avg.	Harvest Rate	Harvest Per Acre	Value Har- vest Per Acre	Fall Pop- ulation Per Acre	Yearly Pop- ulation Per Acre	Hunting Effort Man-Days/Acre
Bradford	344,000	43,524	10%	0.127	\$ 0.92	1.265	1.898	0.111
Carbon	196,400	10,896	10%	0.055	0.40	0.555	0.832	0.110
Columbia	158,800	32,732	10%	0.206	1.50	2.061	3.092	0.217
Lackawanna	174,700	15,355	10%	0.088	0.64	0.879	1.318	0.193
Luzerne	386,100	44,623	10%	0.116	0.84	1.156	1.734	0.151
Monroe	295,400	14,977	10%	0.051	0.37	0.507	0.761	0.056
Montour	30,300	9,554	10%	0.315	2.29	3.153	4.730	0.256
Northumberland	135,300	43,646	10%	0.323	2.34	3.226	4.839	0.281
Pike	318,000	11,204	10%	0.035	0.25	0.352	0.528	0.014
Sullivan	258,610	7,205	10%	0.028	0.20	0.279	0.418	0.030
Susquehanna	283,033	13,832	10%	0.049	0.36	0.489	0.733	0.092
Wayne	281,000	15,557	10%	0.055	0.40	0.554	0.830	0.010
Wyoming	147,464	20,287	10%	0.138	1.00	1.376	2.064	0.167
Div. Totals	3,009,107	283,592	10%	0.094	0.68	0.942	1.414	-

Southeast Division

Berks	178,100	56,735	10%	0.319	\$ 2.32	3.186	4.778	0.405
Bucks	100,700	55,756	10%	0.554	4.02	5.537	8.305	0.558
Chester	118,100	46,158	10%	0.391	2.84	3.908	5.863	0.453
Dauphin	161,200	47,132	10%	0.292	2.12	2.924	4.386	0.226
Delaware	17,555	9,391	10%	0.535	3.88	5.349	8.024	0.405
Lancaster	98,100	81,264	10%	0.828	6.01	8.284	12.426	0.697
Lebanon	69,939	26,146	10%	0.374	2.72	3.738	5.608	0.366
Lehigh	43,906	20,810	10%	0.474	3.44	4.740	7.110	0.748
Montgomery	50,700	38,072	10%	0.751	5.45	7.509	11.264	0.832
Northampton	58,523	28,698	10%	0.490	3.55	4.904	7.356	0.761
Schuylkill	345,200	37,529	10%	0.109	0.79	1.087	1.631	0.146
York	162,800	112,156	10%	0.689	5.00	6.889	10.334	0.645
Div. Totals	1,404,823	559,847	10%	0.399	2.90	3.985	5.978	-

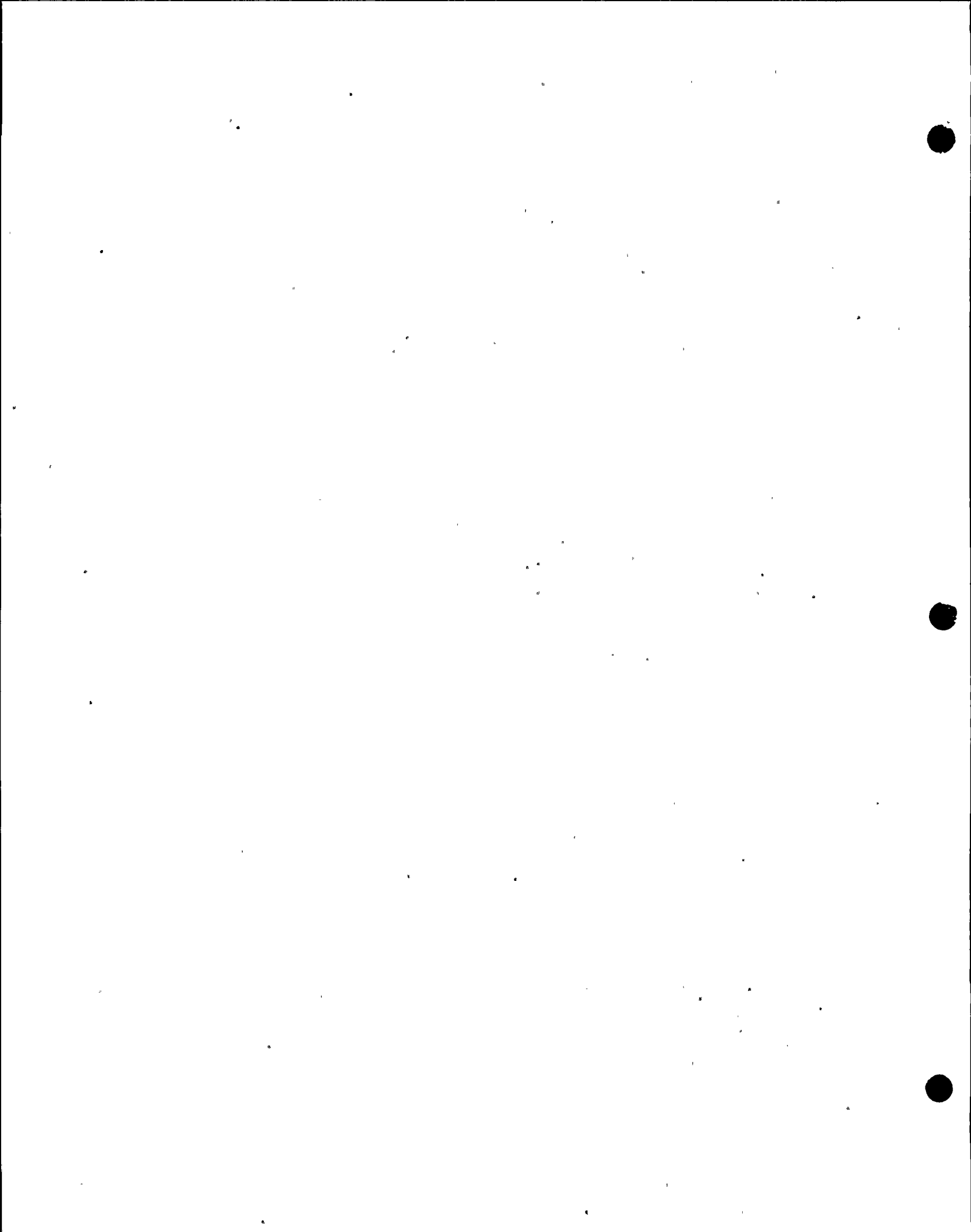
Average Annual Population, Harvest, and Hunting Data for White-Tailed Deer in Pennsylvania

Northeast Division

	Acres Habitat	Harvest '72-'75 Avg.	Harvest Rate	Harvest Per Acre	Value Har- vest Per Acre	Fall Pop- ulation Per Acre	Yearly Pop- ulation Per Acre	Hunting Effort Man-Days/Acr
Bradford	702,700	5,045	20%	0.0072	\$ 7.14	0.0359	0.0449	0.213
Carbon	239,000	1,456	30%	0.0061	6.06	0.0203	0.0254	0.181
Columbia	289,650	2,239	30%	0.0077	7.70	0.0257	0.0322	0.230
Lackawanna	243,572	931	20%	0.0038	3.80	0.0191	0.0239	0.113
Luzerne	514,240	2,797	25%	0.0054	5.41	0.0218	0.0272	0.161
Monroe	365,080	1,752	20%	0.0048	4.77	0.0240	0.0300	0.142
Montour	77,750	278	30%	0.0036	3.55	0.0119	0.0149	0.106
Northumberland	266,160	933	35%	0.0035	3.48	0.0100	0.0125	0.104
Pike	332,410	2,090	15%	0.0063	6.25	0.0419	0.0524	0.187
Sullivan	297,060	2,564	25%	0.0086	8.59	0.0345	0.0432	0.256
Susquehanna	510,170	2,101	20%	0.0041	4.09	0.0206	0.0257	0.122
Wayne	453,060	2,741	15%	0.0060	6.01	0.0404	0.0504	0.179
Wyoming	241,380	1,186	35%	0.0049	4.89	0.0140	0.0175	0.146
Div. Totals	4,532,232	26,113	-	0.0058	5.73	-	-	0.171

Southeast Division

Berks	474,580	1,331	30%	0.0028	2.79	0.0093	0.0117	0.083
Bucks	297,080	1,270	30%	0.0043	4.25	0.0142	0.0178	0.127
Chester	433,200	297	20%	0.0007	0.68	0.0034	0.0043	0.020
Dauphin	297,050	1,207	35%	0.0041	4.04	0.0115	0.0145	0.121
Delaware	46,960	35	15%	0.0007	0.74	0.0050	0.0062	0.022
Lancaster	494,700	514	35%	0.0010	1.03	0.0030	0.0037	0.031
Lebanon	210,380	651	25%	0.0031	3.08	0.0124	0.0155	0.092
Lehigh	172,736	340	30%	0.0020	1.95	0.0066	0.0082	0.058
Montgomery	201,890	158	35%	0.0008	0.78	0.0022	0.0028	0.023
Northampton	190,300	421	20%	0.0022	2.20	0.0111	0.0138	0.066
Schuylkill	457,450	2,615	35%	0.0057	5.68	0.0163	0.0204	0.170
York	535,772	900	20%	0.0017	1.66	0.0084	0.0105	0.050
Div. Totals	3,812,098	9,739	-	0.0026	2.54	-	-	0.076



Average Annual Population Harvest and Hunting Data for Ring-Necked Pheasants in Pennsylvania

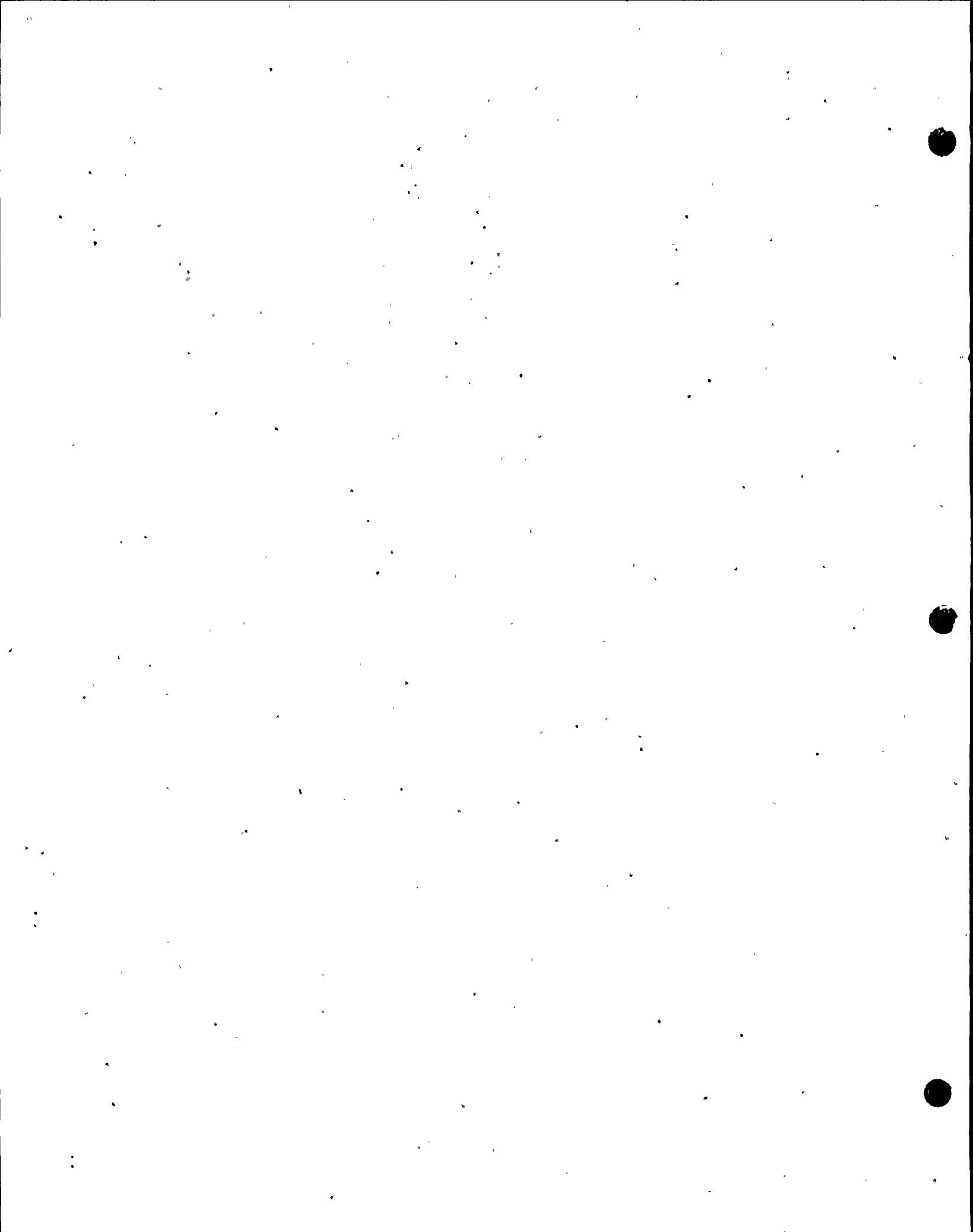
Northeast Division

	Range Type	Acres Habitat	Harvest '72-'73 Avg.	Harvest Rate	Harvest Per Acre	Value Harvest Per Acre	Fall Population Per Acre	Yearly Population Per Acre	Hunting Effo Man-Days/Acr	
Bradford	2nd Class	158,841	1,309	35% <sup>2</sup>	0.008	\$ 0.17	0.024	0.035	0.049 <sup>3</sup>	
	3rd Class	545,803	2,783	35% <sup>2</sup>	0.005	0.11	0.015	0.022		
Carbon	1st Class	30,546	3,357	80% <sup>1</sup>	0.110	2.34	0.275	0.412	0.328 <sup>3</sup>	
	2nd Class	21,660	910	60% <sup>1</sup>	0.042	0.82	0.140	0.210		
	3rd Class	54,428	1,423	50% <sup>1</sup>	0.026	0.55	0.105	0.157		
Columbia	1st Class	97,748	10,992	80% <sup>1</sup>	0.112	2.38	0.281	0.422	0.237 <sup>3</sup>	
	2nd Class	128,850	5,662	60% <sup>1</sup>	0.044	0.94	0.146	0.219		
Lackawanna	2nd Class	64,981	2,633	35% <sup>2</sup>	0.041	0.87	0.116	0.174	0.406 <sup>3</sup>	
	3rd Class	88,862	2,243	35% <sup>2</sup>	0.025	0.53	0.072	0.108		
Luzerne	1st Class	36,100	3,479	80% <sup>1</sup>	0.096	2.04	0.241	0.361	0.234 <sup>3</sup>	
	2nd Class	83,309	3,106	35% <sup>2</sup>	0.037	0.79	0.107	0.160		
	3rd Class	256,444	5,839	35% <sup>2</sup>	0.023	0.49	0.065	0.098		
Monroe	1st Class	31,651	2,272	80% <sup>1</sup>	0.072	1.53	0.179	0.269	0.187 <sup>3</sup>	
	2nd Class	39,433	1,100	60% <sup>1</sup>	0.028	0.60	0.093	0.139		
	3rd Class	11,103	178	35% <sup>2</sup>	0.016	0.34	0.046	0.069		
Montour	1st Class	77,647	6,275	80% <sup>1</sup>	0.081	1.72	0.202	0.303	0.202 <sup>3</sup>	
	2nd Class	3,000	63	60% <sup>1</sup>	0.021	0.45	0.699	0.105		
Northumberland	1st Class	153,934	15,853	80% <sup>1</sup>	0.103	2.19	0.257	0.386	0.238 <sup>3</sup>	
	2nd Class	91,639	3,612	60% <sup>1</sup>	0.039	0.83	0.131	0.197		
	3rd Class	24,993	602	50% <sup>1</sup>	0.024	0.51	0.096	0.146		
Pike	3rd Class	22,216	2,815	35% <sup>2</sup>	0.127	2.70	0.362	0.543	0.373	
Sullivan	3rd Class	86,085	Insufficient data for population calculations							
Susquehanna	2nd Class	4,443	88	35% <sup>2</sup>	0.020	0.43	0.057	0.085	0.199 <sup>3</sup>	
	3rd Class	167,172	2,110	35% <sup>2</sup>	0.013	0.28	0.036	0.054		
Wayne	2nd Class	17,772	Insufficient data for population calculations							
	3rd Class	91,639	Insufficient data for population calculations							
Wyoming	2nd Class	38,877	432	35% <sup>2</sup>	0.011	0.23	0.032	0.048	0.154 <sup>3</sup>	
	3rd Class	159,579	1,110	35% <sup>2</sup>	0.007	0.15	0.020	0.030		

Div. Totals - 2,538,760

NOTE: Kill of stocked birds not included in harvest figures. All data for wild populations only.

1. Cocks only
2. Cocks and hens
3. Use this value for all range classes in county





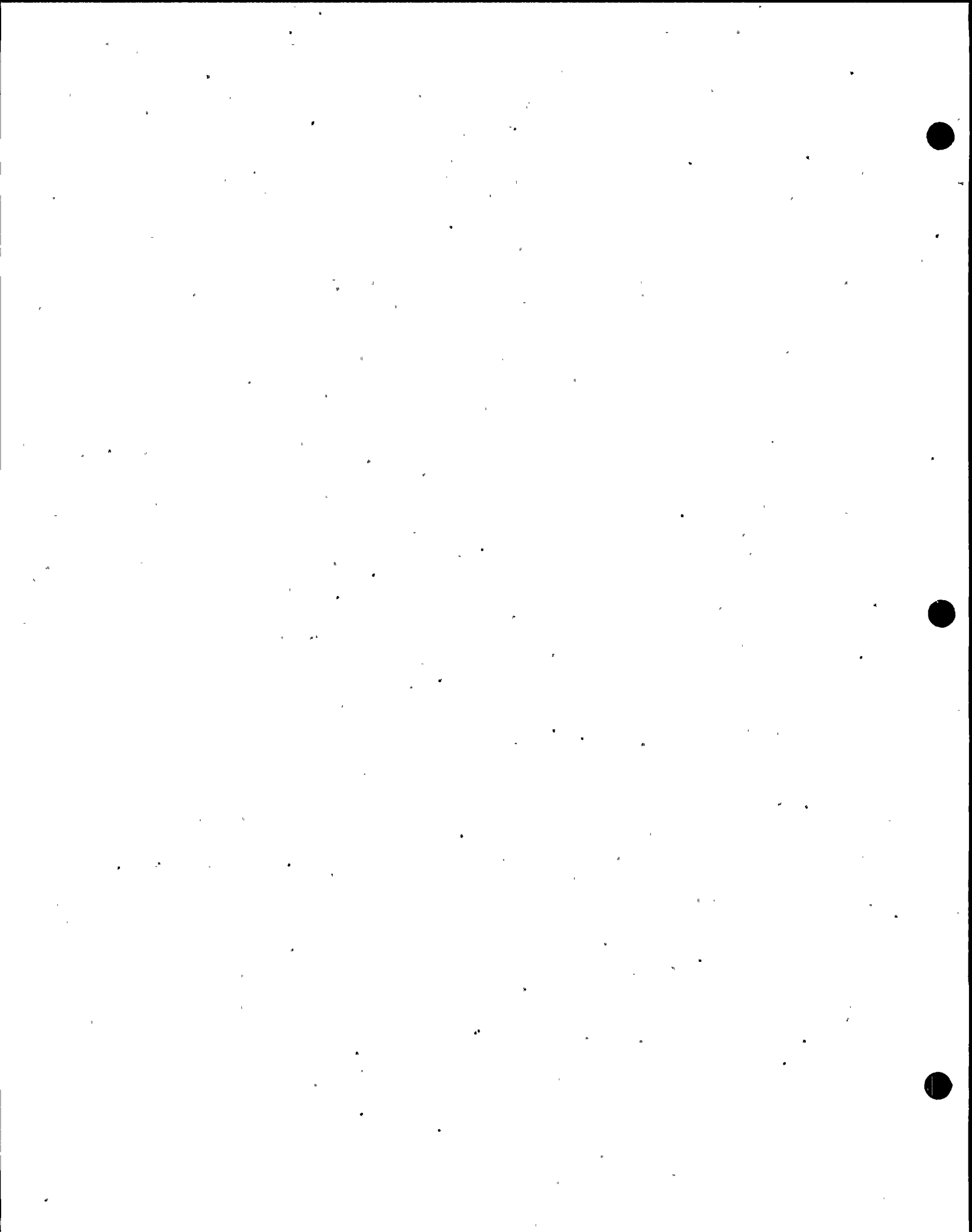
Average Annual Population, Harvest, and Hunting Data for Ruffed Grouse in Pennsylvania

Northeast Division

	Acres Habitat	Harvest '72-'73 Avg.	Harvest Rate	Harvest Per Acre	Value Har- vest Per Acre	Fall Pop- ulation Per Acre	Yearly Pop- ulation Per Acre	Hunting Effort Man-Days/Ac
Bradford	344,000	7,083	15%	0.021	\$ 0.19	0.137	0.206	0.099
Carbon	196,400	2,109	15%	0.011	0.10	0.072	0.107	0.124
Columbia	158,800	2,558	15%	0.016	0.15	0.107	0.161	0.120
Lackawanna	174,700	3,266	15%	0.019	0.17	0.125	0.187	0.262
Luzerne	386,100	7,033	15%	0.018	0.17	0.121	0.182	0.182
Monroe	295,400	2,530	15%	0.009	0.08	0.057	0.086	0.055
Montour	30,300	44	15%	0.001	0.01	0.010	0.015	-
Northumberland	135,300	2,511	15%	0.019	0.17	0.124	0.186	0.144
Pike	318,000	2,698	15%	0.008	0.08	0.057	0.085	0.024
Sullivan	258,610	1,454	15%	0.006	0.06	0.038	0.056	0.045
Susquehanna	283,033	4,301	15%	0.015	0.14	0.101	0.152	0.113
Wayne	281,000	2,517	15%	0.009	0.08	0.060	0.090	0.083
Wyoming	147,464	2,511	15%	0.017	0.16	0.114	0.170	0.145
Div. Totals	3,009,107	40,615	15%	0.013	0.12	0.090	0.135	-

Southeast Division

Berks	178,100	1,619	15%	0.009	0.08	0.061	0.091	0.102
Bucks	100,700	504	15%	0.005	0.05	0.033	0.050	0.097
Chester	118,100	808 <sup>1</sup>	15%	0.007	0.06	0.046	0.068	-
Dauphin	161,200	619	15%	0.004	0.04	0.026	0.038	0.078
Delaware	17,555	143 <sup>2</sup>	15%	0.008	0.07	0.054	0.081	0.037
Lancaster	98,100	297	15%	0.003	0.03	0.020	0.030	0.051
Lebanon	69,939	143 <sup>2</sup>	15%	0.002	0.02	0.014	0.020	0.057
Lehigh	43,906	430 <sup>2</sup>	15%	0.010	0.09	0.065	0.098	0.228
Montgomery	50,700	215 <sup>2</sup>	15%	0.004	0.04	0.028	0.042	0.075
Northampton	58,523	923	15%	0.016	0.15	0.105	0.158	0.218
Schuylkill	345,200	7,179	15%	0.021	0.19	0.139	0.208	0.183
York	162,800	217	15%	0.001	0.01	0.009	0.013	0.024
Div. Totals	1,404,823	13,097	15%	0.009	0.08	0.062	0.093	-



Average Annual Population, Harvest and Hunting Data for Wild Turkey in Pennsylvania

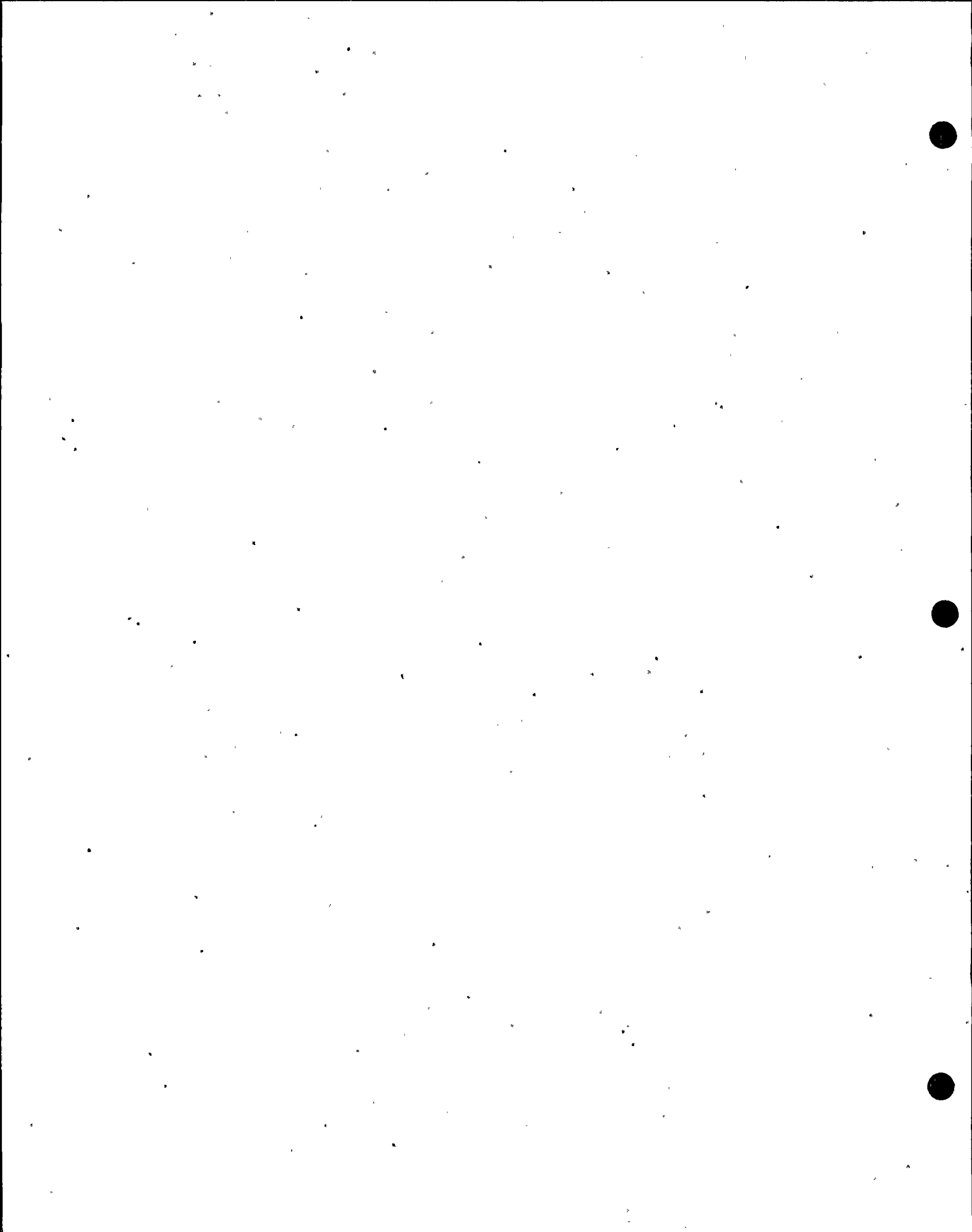
<u>Division</u>	<u>Acres</u> <u>Habitat</u>	<u>Harvest</u> <u>'72-'73 Avg.</u>	<u>Harvest</u> <u>Rate</u>	<u>Harvest</u> <u>Per</u> <u>Acre</u>	<u>Value Har-</u> <u>vest Per</u> <u>Acre</u>	<u>Fall Pop-</u> <u>ulation</u> <u>Per Acre</u>	<u>Yearly Pop-</u> <u>ulation</u> <u>Per Acre</u>	<u>Hunting Effort</u> <u>Man-Days/Acre</u>
Bradford	198,400	963	20%	0.0049	\$ 0.49	0.0243	0.0340	0.216
Carbon	Insufficient data for population calculations							
Columbia	Insufficient data for population calculations							
Lackawanna	Insufficient data for population calculations							
Luzerne	208,600	502	20%	0.0024	0.24	0.0121	0.0169	0.100
Monroe	140,800	401	20%	0.0028	0.28	0.0142	0.0199	0.058
Montour	Insufficient data for population calculations							
Northumberland	Insufficient data for population calculations							
Pike	206,080	502	20%	0.0024	0.24	0.0122	0.0170	0.041
Sullivan	288,000	719	20%	0.0025	0.25	0.0126	0.0177	0.124
Susquehanna	Insufficient data for population calculations							
Wayne	Insufficient data for population calculations							
Wyoming	Insufficient data for population calculations							

Div. Totals

Southeast  
Division

Berks	Insufficient data for population calculations							
Bucks	Insufficient data for population calculations							
Chester	Insufficient data for population calculations							
Dauphin	83,200	249	20%	0.0030	0.30	0.0150	0.0209	0.108
Delaware	Non-turkey range							
Lancaster	Insufficient data for population calculations							
Lebanon	44,300	202	20%	0.0045	0.45	0.0225	0.0316	0.140
Lehigh	Insufficient data for population calculations							
Montgomery	Insufficient data for population calculations							
Northampton	Insufficient data for population calculations							
Schuylkill	Insufficient data for population calculations							
York	Insufficient data for population calculations							

Div. Totals



11. Appendix H. Section 3.2.2.3.1, Page 3-16. Indicate the authority for stating the bird list for the region "totals" 135 species. Please explain in view of the markedly higher number of bird species identified during studies in the vicinity of the Susquehanna SES, about 2.3 miles down-river (see Susquehanna SES ER-OL).

Response:

The sentences on page 3-16 should read: "The list of birds for the region in which the inundated area is located totals 135 species, 75 of which have been verified by recent field work. The 60 species not field checked may also be using the area."

The New Jersey Audubon Society (NJAS) developed the ornithological portion of the Pond Hill Reservoir Environmental Report (PHRER). Their results were summarized and forwarded to Mr. Richard Heiderstadt (TAMS) under a cover letter from Richard Kane, of the NJAS Wildlife Research Unit, dated June 14, 1978. They determined that there were 132 species of birds which could inhabit the Pond Hill site based on range maps and the habitat types present in the Pond Hill site including the border. They field checked 59 of these species. Their sources for the range and habitat determinations were:

Pough, R.A., 1949. Audubon Land Bird Guide. Doubleday & Company  
Bull, J., 1964. Birds of the New York Area. Harper and Row.

Biometric Services, Inc. (BSI) asked certain field team members who were qualified in bird studies to prepare an independent checklist of bird species while they were in the study area for its own records. The BSI range and habitat source indicated that 61 bird species could be using the Pond Hill site. Of these 61, 51 were field checked. The source for the range and habitat information was:

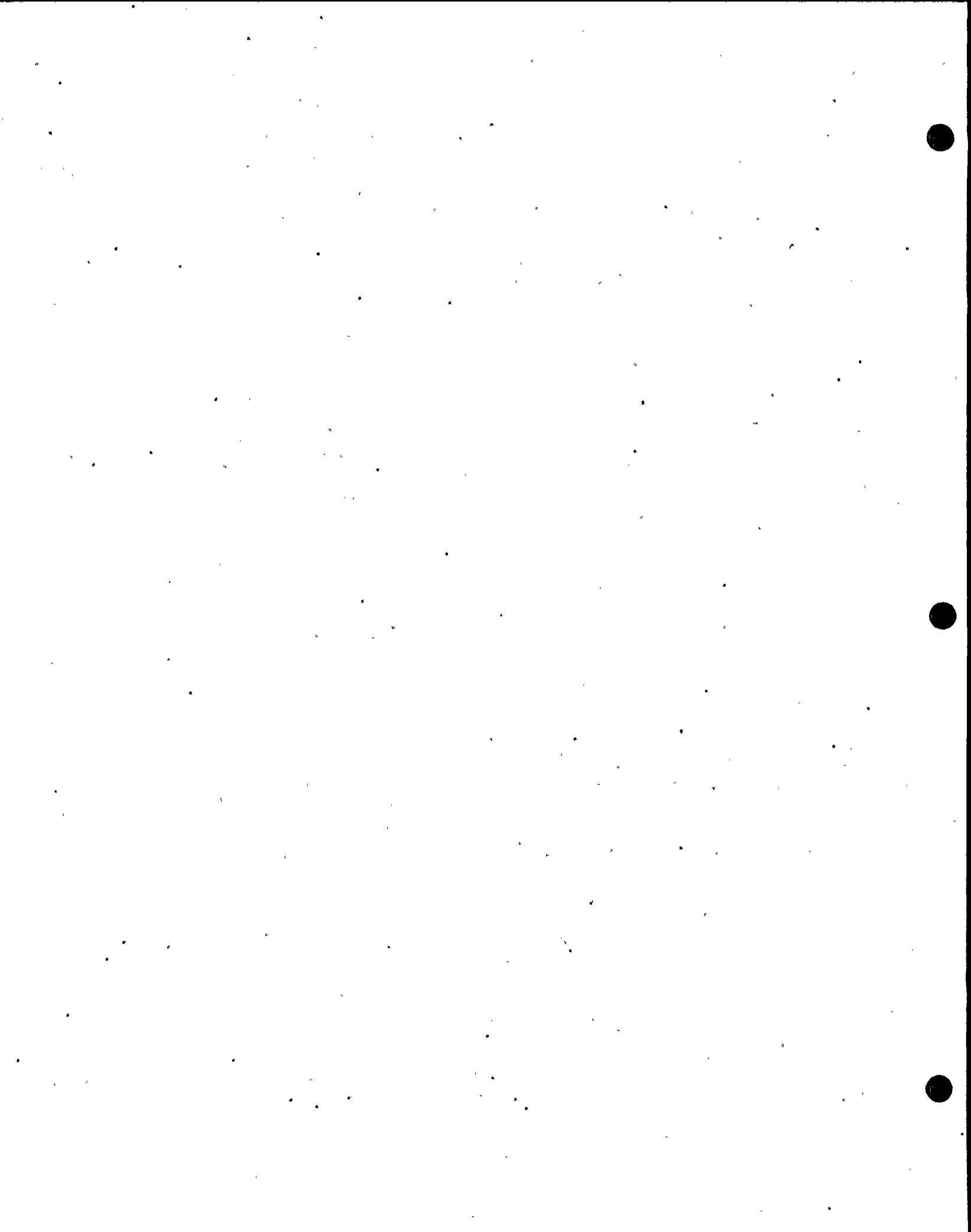
Robbins, C.S., B. Brunn, and H. S. Zim, 1966. A Guide to Field  
Identification of Birds of North America. The Golden Press, Inc.:  
New York, 340 pp.

Three of the species from BSI's range and habitat determinations were not among the NJAS list. These were the: Killdeer (Charadrius vociferous), Acadian flycatcher (Empidonax virescens), and mockingbird (Mimus polyglottos).

In reviewing the data in the PHRER for birds, and the NJAS and BSI bird data, it has been determined that 14 bird species field checked by the BSI team were not included in the PHRER. These species, all of

which should be added to the field check list of Table 3.2.2-6, part II. Birds, are:

<u>SPECIES</u>	<u>STATUS</u>	<u>HABITAT</u>
PASSERIFORMES		
Acadian Flycatcher ( <u>Empidonax virescens</u> )	M	forest
Black-throated Blue Warbler ( <u>Dendroica caerulescens</u> )	M, (SR?)	forest
Brown Thrasher ( <u>Toxostoma rufum</u> )	SR	edges
Cedar Waxwing ( <u>Bombycilla cedrorum</u> )	M, (SR?)	forest, edges
Chestnut-sided Warbler ( <u>Dendroica pensylvanica</u> )	M, (SR?)	forest, edges
Eastern Wood Pewee ( <u>Contopus virens</u> )	SR	forest
Evening Grosbeak ( <u>Hesperiphona vespertina</u> )	(PR?)	forest
Mockingbird ( <u>Mimus polyglottos</u> )	(PR?)	edges, meadows
Pine Warbler ( <u>Dendroica pinus</u> )	M	forest
Red-breasted Nuthatch ( <u>Sitta canadensis</u> )	(PR?)	forest
Starling ( <u>Sturnus vulgaris</u> )	PR	all terrestrial habitat
Swainson's Thrush ( <u>Hylocichla ustulata</u> )	M	forest
Tree Sparrow ( <u>Spizella arborea</u> )	M,W	forest edges



## STRIGIFORMES

### Screech Owl

(Otus asio)

PR

forest edges

In total, 35 bird species were common to the NJAS and BSI lists, 24 were unique to NJAS, and 16 were unique to BSI, for a total of 75 species field checked.

The NJAS study included 5 days of observation at the site by 2 NJAS wildlife biologists, who spent a small part of their time in the field looking for signs of other types of wildlife (amphibians, reptiles, mammals) and vegetation and habitat types. The BSI list was made by casual observation of bird species over a 9-month period (September, 1977, to May, 1978) while conducting other inventories.

The Susquehanna SES ER-OL, which identified 128 bird species in the field, was prepared by conducting 1 to 3 bird counts per month over a 2-year period. The SSES site is within the immediate Susquehanna River valley, and thus probably contains many migratory and waterfowl species not likely to be attracted to or found in the Pond Hill Creek valley, the latter of which is somewhat removed from and perpendicular to the river. The Pond Hill studies were limited to the inundation area and border. The SSES studies covered a potentially greater and more open coverage area at the plant site and along Penobscot Mountain. The 61 bird species field checked in the PHRER, plus the 14 species listed above, include all 75 species found in the Pond Hill Creek valley and border area during this study, by both NJAS and BSI.

Thus, the differences in numbers of species between the SSES ER-OL and the PHRER with the 14 additions, may be due to: 1) a much greater effort in terms of time spent in the field on the part of the SSES ER-OL ornithologist (4 seasons for 2 years as opposed to PHRER's 3 seasons for 9 months); 2) a larger site and/or study area at SSES; 3) a more suitable setting for observation at the SSES site than in the small, wooded valley containing Pond Hill Creek (better visibility on an open slope facing a river than in a small, wooded valley); and 4) better and more diverse types of bird habitat at the SSES study area than at the mostly-wooded Pond Hill site, the former thus attracting a greater variety of resident and migratory birds.



12. Appendix H, Table 3.2.2-3, Page 3-33. What is the basis for values listed under the column heading entitled "cover" (cumulative basal area)? Also, indicate the general location of sample plots (reservoir site, buffer zone, or both) and the type or types of sampled forest communities for which importance values of component species were calculated.

Response:

Cover, as defined in Appendix A, page A-2, is "the percent of unit area covered by a given species". The cover values given in Table 3.2.2-3 are the areas for any given species divided by the area of the 14 quadrats times 100. The area for any given species is the sum of the areas of the tree trunks at breast height from all 14 quadrats.

The vegetation cover map enclosed indicates the approximate location of the quadrats. Please note that the maximum water level line is the 940-foot line. The table below indicates the general location of the sample plots. The importance values were calculated for the combined results of the 14 overstory quadrats, which were located in forested areas of deciduous woodland and mixed coniferous/deciduous woodland.

<u>QUADRAT NO.</u>	<u>GENERAL LOCATION</u>
1	reservoir near high water level (980-foot)
2	reservoir near high water level (980-foot)
3	reservoir
4	border very near high water level
5	reservoir
6	reservoir
7	reservoir
8	reservoir
9	reservoir
10	reservoir
11	reservoir
12	reservoir
13	spillway
14	reservoir

13. Appendix H, Table 3.2.2-6 Page 3-39. Information presented in the Table is the basis for several uncertainties:

- Is the inventory applicable to the Pond Hill site or a local area including the site (see next item).
- Beaver is a listed species but "beaver left or were removed from the area sometime between 1969 and the present," (page 3-8) see also page 3-15.
- "Approximately 18 species of mammals -- are known (?) to inhabit area" (page 4-7) - 16 species listed in the inventory.
- "The site is frequented by trappers who get --- mink" (page 3-15) not listed.
- "The meadows --- provide habitat suitable for --- hairy-tailed and star-nosed moles --," (Page 3-13) - not listed.
- "The more mobile animals such as --- and foxes ---," (Page 3-7) not listed.
- "A representative for the Pennsylvania Game Commission -- provided population estimates for --- skunk and others" (Appendix A, page A-5) - not listed.

In view of the foregoing and other statements, provide clarification as to mammal species occurring in the vicinity of the proposed reservoir site.

Response:

- The inventory is applicable to the Pond Hill site, including the border, as shown in Figure 3-1.
- Beaver are not currently found in the site and should be removed from Table 3.2.2-6. Beaver found its way onto the list because abandoned beaver dams and meadows were found along Pond Hill Creek in the site; but no signs of their current presence (i.e., fresh cuttings, new dams, etc.) were found, so in keeping with the "present" nature of the other species on this list, beaver should be removed.
- The "18" was a numerical error in submission of the report. This paragraph should read as follows:

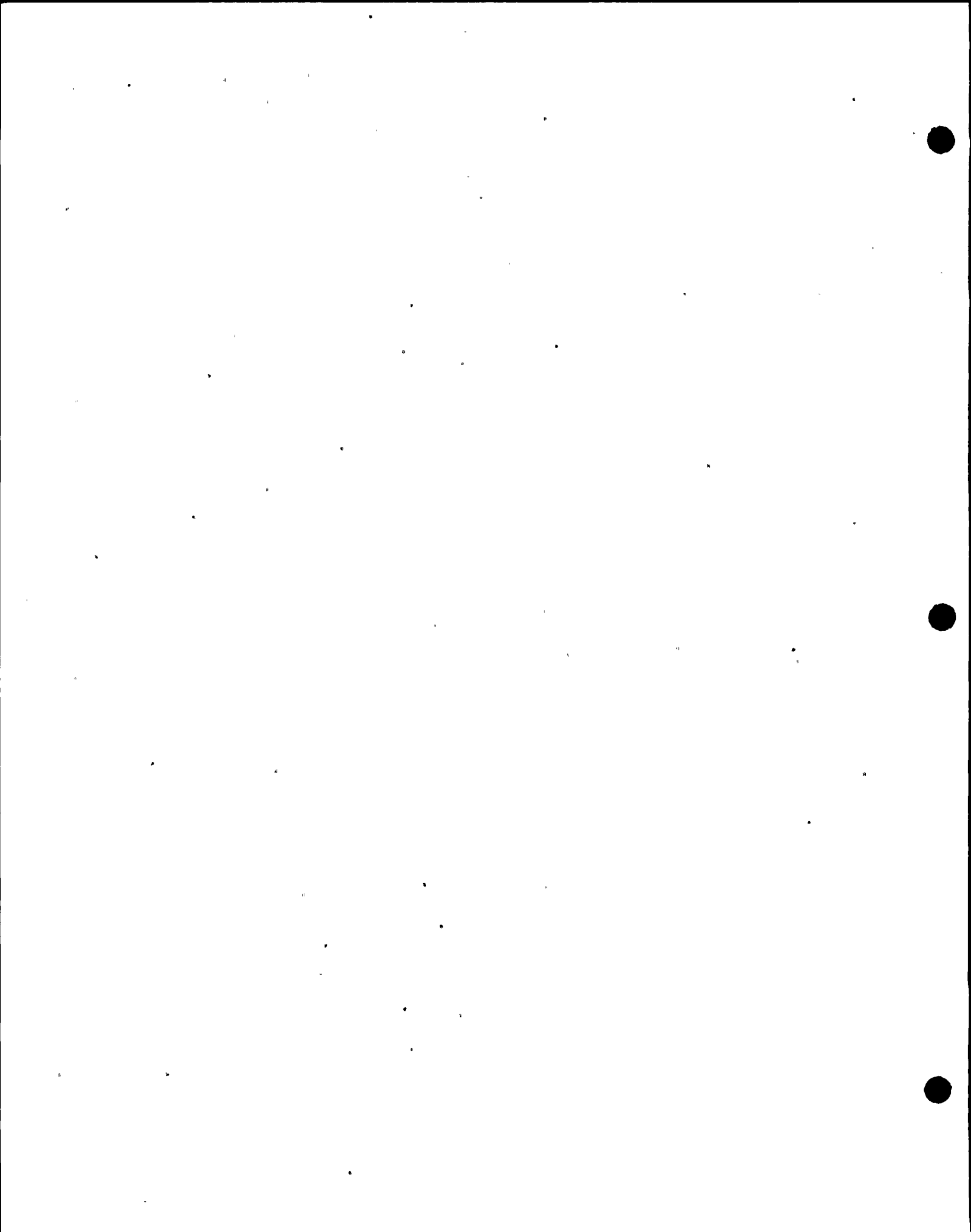
"Sixteen species of mammals, 5 species of reptiles, and 17 species of amphibians were observed in the area. Also, about 135 species of birds occur in the area, of which 75 species

were observed in the site (see Wildlife Species Inventory at the end of Section 3.2.2.2)."

The number "16" stands despite the removal of beaver from the species list (above) because a porcupine was seen by BSI personnel after the report was submitted. Porcupine should be added to the species list (Table 3.2.2-6, page 3-39) as follows:

<u>SPECIES</u>	<u>HABITAT</u>
RODENTIA	
Porcupine ( <u>Erethizon dorsatum</u> )	forests
- Mink were not observed in the field by BSI personnel, nor were there signs of their activities (see Appendix A, pages A-3 and A-5). However, PGC officials noted that mink have been taken from this valley in the past (see the report of that interview, Question 10).	
- These moles were not observed in the field, so are not included on the species list. The habitat present is suitable for their occurrence, but they were not observed by BSI.	
- Foxes were not seen by BSI personnel, so they are not included on the list of species field-checked. Their presence has been indicated by PGC officials and one respondent to the hunter survey, so foxes were included in the text, prefaced by "such as".	
- Skunks were not seen in the field by BSI personnel, so are not included in the list of species field-checked. Enclosed please find field kill records and population estimates of several game species of animals from Luzerne and several other eastern Pennsylvania counties. As this information was applicable to Luzerne County as a whole, and was not specific to the site, it was not included in the report. See question 10.	

In conclusion, the mammals of Table 3.2.2-6, excluding beaver but including porcupine, are those either actually seen by BSI personnel, or whose current presence was shown by some signs of their activity and observed by BSI personnel. The Table does not include any species likely to be there as a result of range or the presence of suitable habitat, nor does it include any species reported to be there by any source other than BSI's study, be it PGC data, hunter survey, or hearsay.

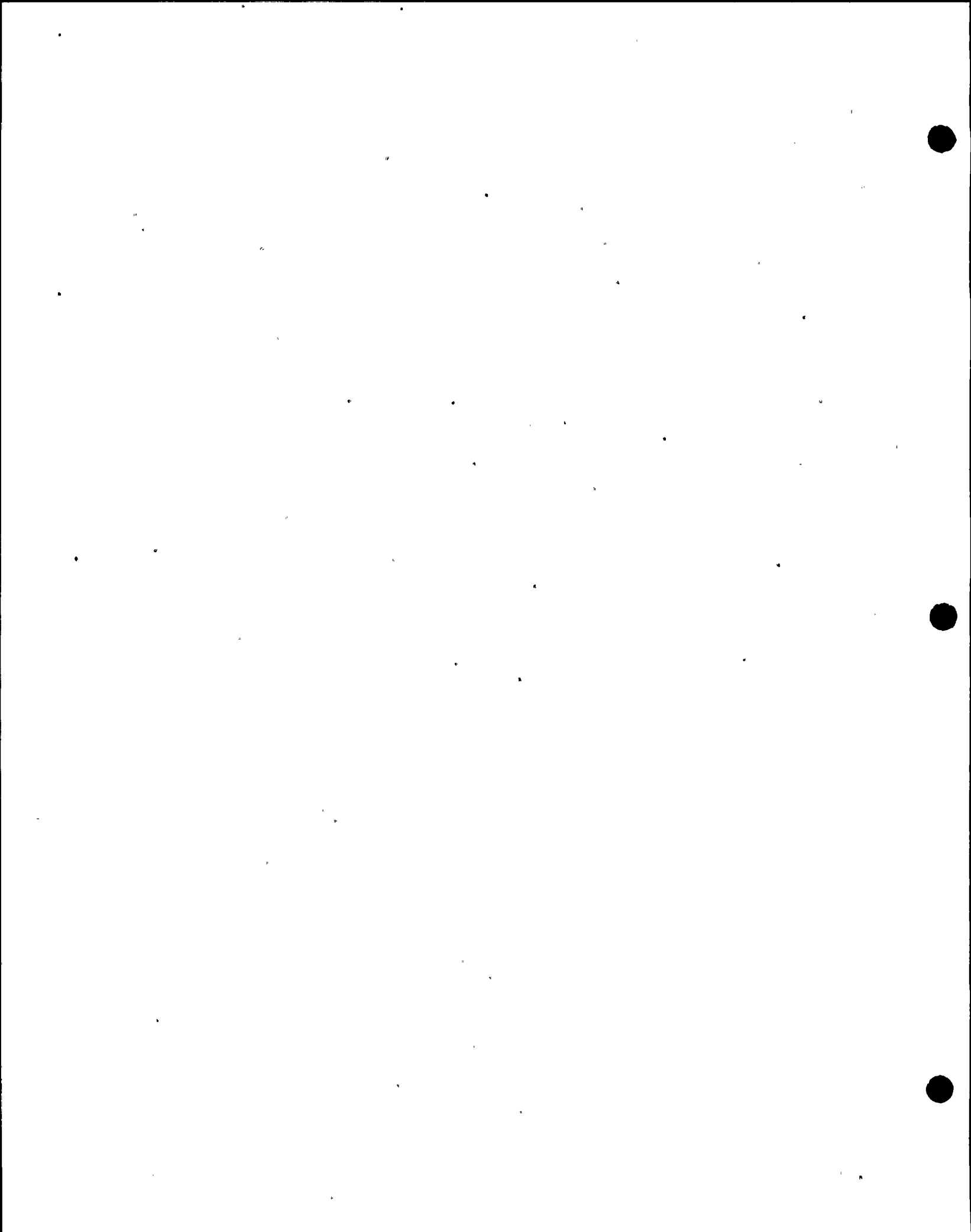


14. Appendix H, Section 4.2.2.2, Page 4-6. The principal impact area associated with reservoir construction is identified as involving 260 areas (or 315 acres for the higher pool). However, in view of the steep terrain, it is likely that sloughing at the edges of the reservoir will occur due to wave action. Discuss the potential of this impact in terms of additional area that may be disturbed and indicate proposed measures (if any) that will be used to control shoreline erosion. Also provide estimates of additional acreages of the buffer zone that will be disturbed for each of the following: "a staging area for construction, a parking lot for construction personnel," road construction (Page 4-55), and the utility right-of-way between the pumping station and the dam site (Page 8-3).

Response:

A geological reconnaissance of the reservoir did not reveal any areas where sloughing at the shore line will be a problem, mainly because the soil cover over the underlying rock is thin. However, a more detailed geological inspection will be made prior to construction and all areas where sloughing might be encountered, will be identified. Suitable ground cover of the slopes in the vicinity of the water line will be provided at all areas where sloughing may be a problem. If critical areas are found (i.e., where there is deep soil cover on a steep slope), riprap or other suitable methods may be used.

A summary of the area available for use during construction is discussed above in the response to question 5 and shown on Plate 19. A route for the utility right-of-way between the pump station and dam has not been determined.

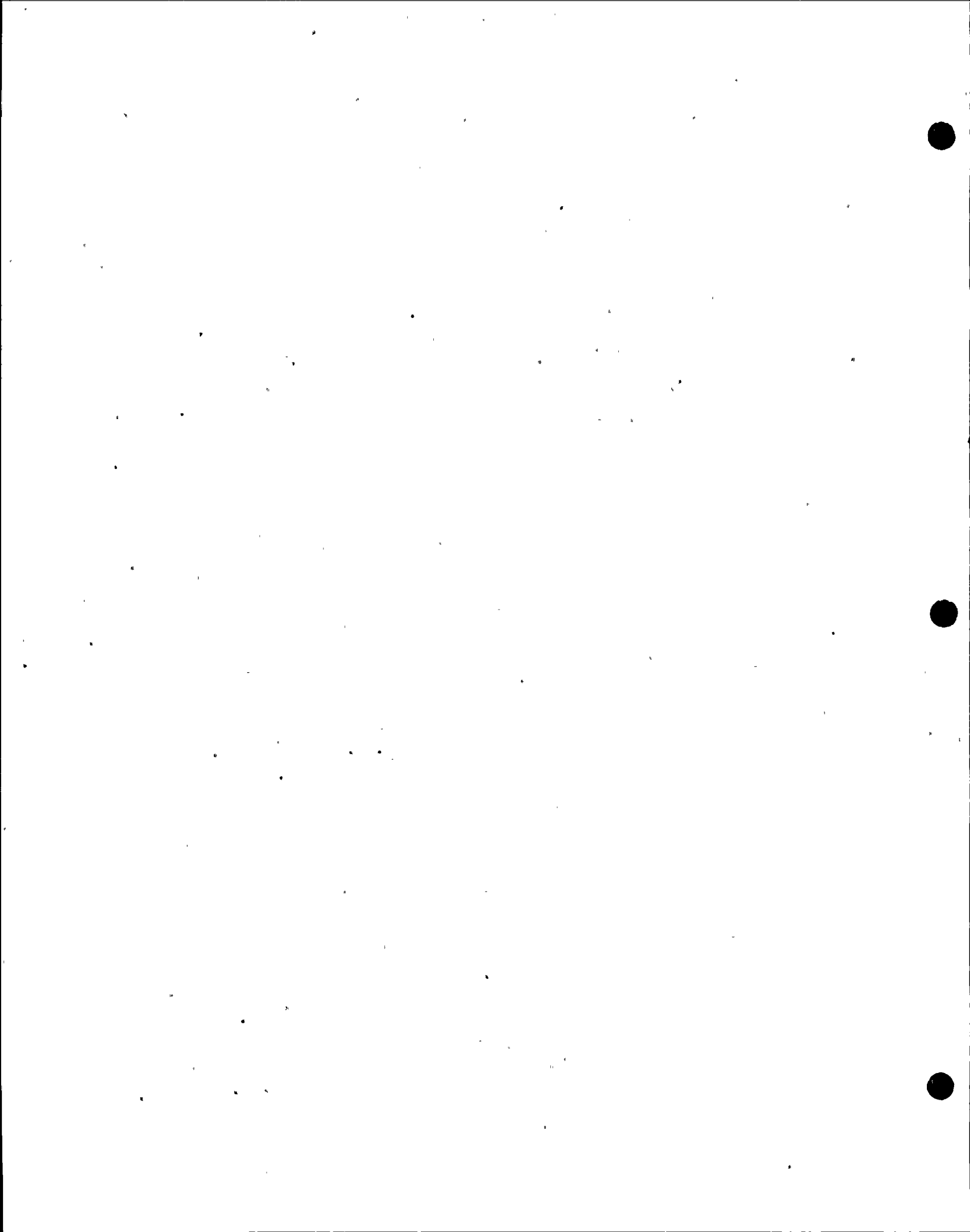


15. Appendix H. Section 4.2.2.2, Page 4-8. The text indicates that adverse impacts on terrestrial wildlife resulting from reservoir development will be "substantially offset" by management of the buffer zone to "improve the habitat --- as described in Section 4.3" (see also Page 7-2). However, this subject is not specifically addressed in Section 4.3. References to managing wildlife resources are limited to statements that plans "will be developed in cooperation with the Pennsylvania commission on fish and wildlife" and that diverse habitat will be maintained. Accordingly, please provide details of the jointly planned program for improving terrestrial wildlife habitat in the buffer zone; e.g., will selective timber harvesting be implemented to promote growth of browse and other important wildlife food plants? Also provide specific details of management practices or methods that will be used to maintain diverse habitat. In particular, indicate any instances, including utility right-of-way maintenance, whereby chemicals will be used to control vegetation.

Response:

Because negotiations with property owners are still underway, the exact boundaries of the buffer zone have not been established. After the size of the buffer zone is finalized, a detailed program will be prepared based on PP&L's experience with land management and the Pennsylvania Fish and Game Commissions' recommendations.

To the extent PP&L can influence utility right-of-way maintenance practices (since some of the utility services may be provided by another company), PP&L will follow accepted practices, including use of EPA approved chemicals to control vegetation.

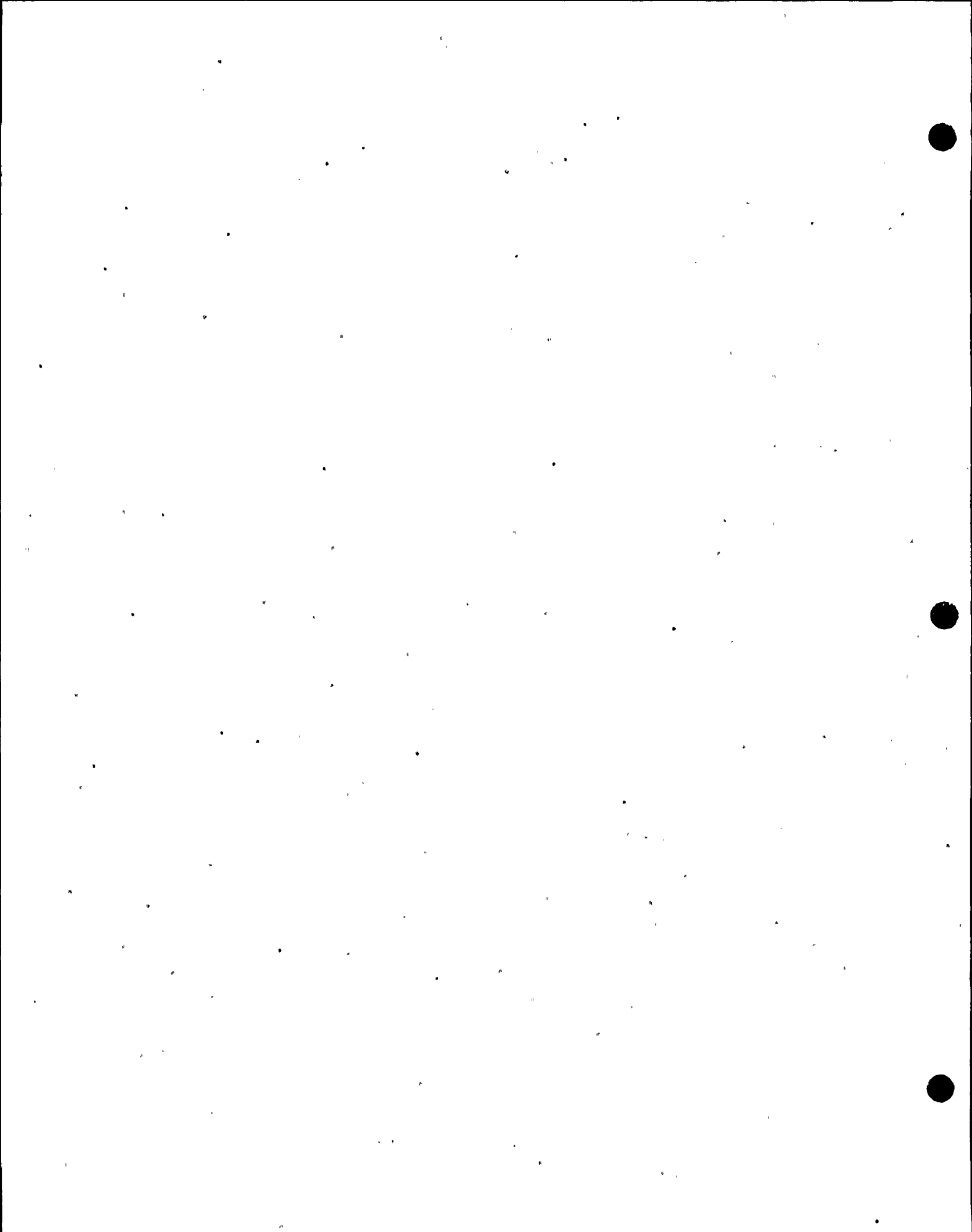




16. Appendix H, Section 4.2.7.4, Page 4-70. Provide acreages and general descriptions of existing plant communities that will be significantly altered as the result of construction and maintenance of the proposed 2.84 mile overhead distribution line for supplying energy to the pump station.

Response:

Since the distribution line to the pumping plant is not in PP&L's service territory, another electric utility may provide the service. Detailed plans for this have not been made. If the existing distribution line along Rt. 239 is used, the impact would be minimal.



17. Appendix H. Section 4.3.2.4, Page 4-87. Statements in the text indicate uncertainty as to the source area(s) of select borrow materials that will be used in dam construction (pages 1-11, 3-18, 4-88), and that "A more detailed search for" -- suitable materials -- "will be conducted" (Page 4-87). Accordingly, indicate if final plans entail borrowing materials from areas within the buffer zone. If so, provide details concerning locations, affected acreages and depths of excavation. In the event the area indicated in Figure 1-3 is the designated borrow site, provide justification for this selection (prime farmland) in view of land use policies established by the Pennsylvania Environmental Quality Board (Page 3-124) et. al.

Response:

Based on our current knowledge of the soils in the area, we anticipate that borrow for the dam will come from the areas shown in Plate 19. The approximate acreages for the various borrow areas are shown in the response to question 5. We expect that borrow depths will be between about 5 and 20 feet or more, depending on the depth of material present. Borrow area 4 is anticipated to be the source of rock materials. Borrow area 3 is anticipated to be the first source of core material with areas 1 and 2 secondary sources used only if needed. Area 5 has been identified as a possible source of suitable core material, but is not anticipated to be necessary. Filter material will either be purchased from local quarries (about 5 miles south of the site) or processed on the site.

While some of the proposed borrow areas are classified Class II farmland, none of these areas are currently being actively farmed except for hay production. As indicated in Sections 4.2.5.6 and 4.2.10.3.1, borrow areas will be regraded, topsoil replaced and the area revegetated which should minimize the effect of the borrow areas on this farmland. The selection of areas for borrow sites was based on the availability of suitable material for dam construction as there is a limited amount of suitable material available at the site, and such material, in general underlies Class II farmland, it will be necessary to utilize such farmland for borrow areas.

Aquatic

18. What time of year is construction scheduled for?

Response:

At the present time the preliminary construction schedule for the large reservoir is the same as shown in Figure 1-12 of the Susquehanna SES ER-OL - Appendix H.

19. What time of year will filling of the reservoir be initiated?

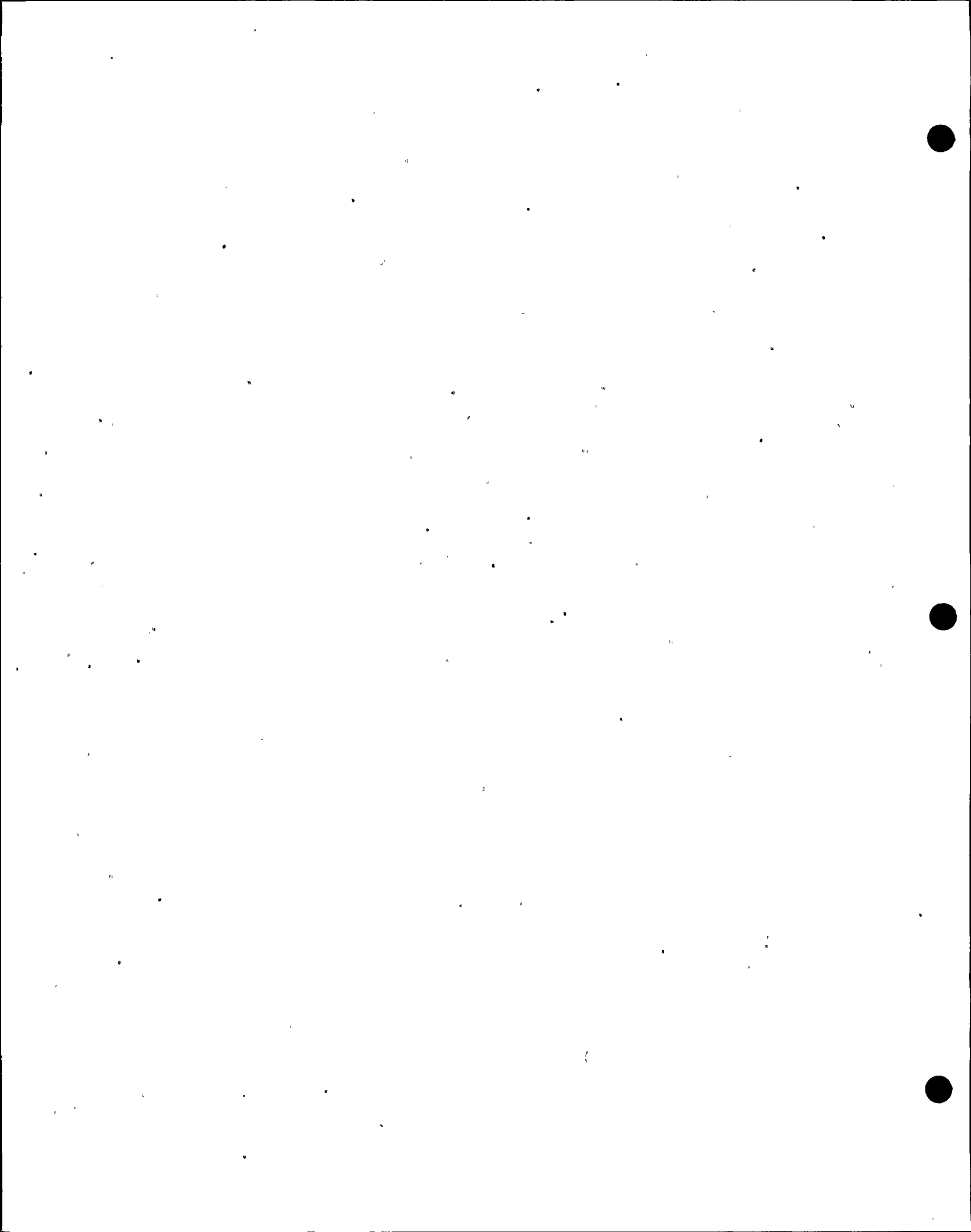
Response:

At the present time based on the preliminary schedule, initial reservoir filling for the large reservoir will be approximately the same as shown in Figure 1-12 of the Susquehanna SES ER-OL - Appendix H.

20. How often and by what means will the traveling screens be cleaned?

Response:

The design of the intake structure has not been finalized and other designs which might be more conducive to remote operation with no greater environmental impacts are being investigated. Based on the design shown, it is anticipated that the traveling screens will be a standard design unit utilizing screened water to wash the screens. Anticipated cleaning of the traveling screens will be automatic based on head loss across the screens when the pump station is operating. We also anticipate routine operation of the pumping system including traveling screens and their wash cycle to insure that it will perform satisfactorily when needed. The schedule for such operation will be determined during final design. Debris disposal will be as described in Section 1.4.2.5.



21. What mitigative measures will be used relative to scouring of the riverbed during times of discharge?

Response:

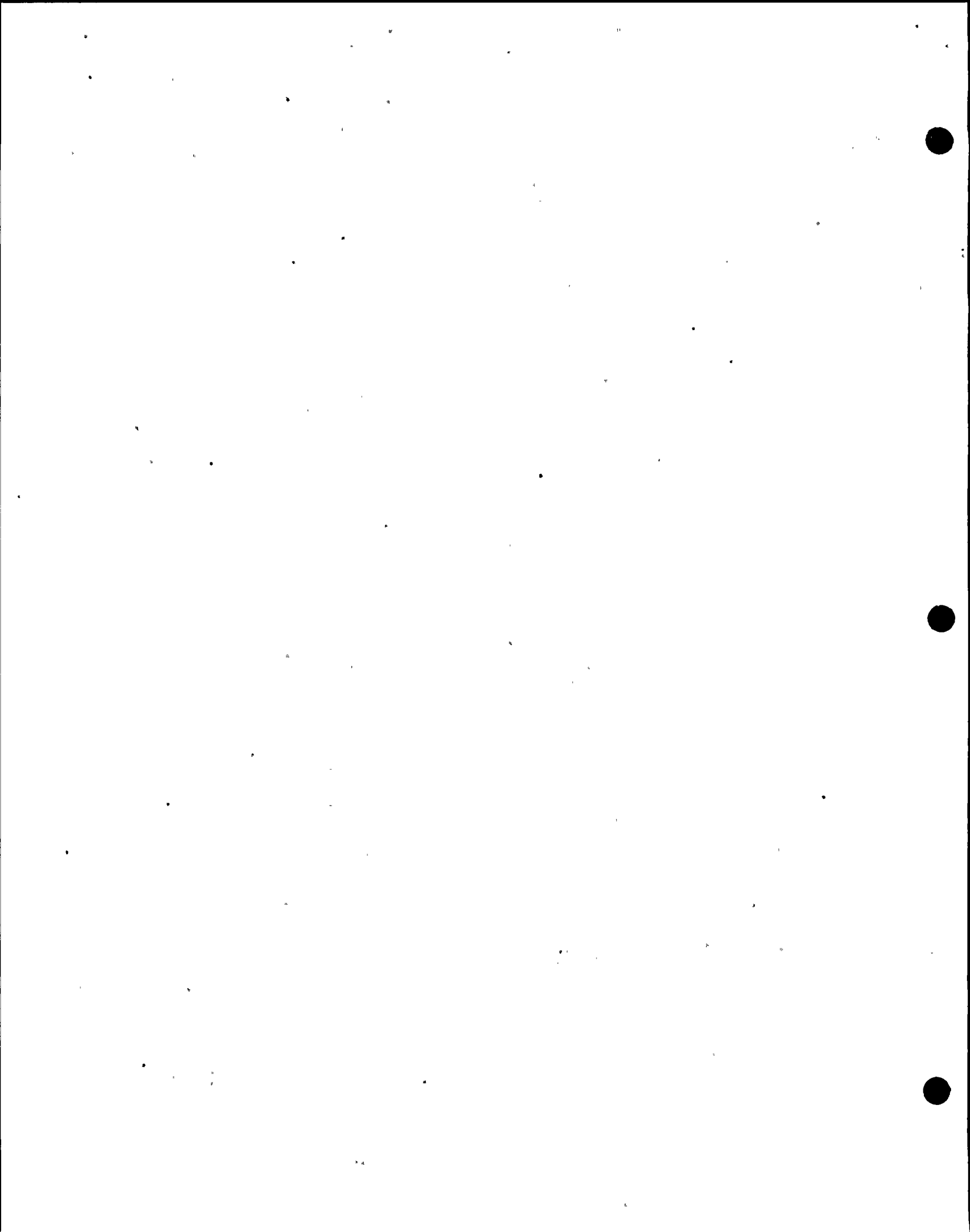
The pump station-outlet works shown on Plate 8 provides for energy dissipation in the sleeve valves. Water overflowing the weir will fall approximately 10 feet to a concrete apron (not shown) which, it is anticipated, will dissipate energy adequately to minimize scouring in the river.



22. How will the water returned to Pond Creek and the Susquehanna River be reoxygenated?

Response:

The project design provides a multiport inlet-outlet structure which will allow selection of the best quality water from the standpoint of temperature and dissolved oxygen for discharge to Pond Hill Creek and the Susquehanna River. In addition, the 10 foot free fall from the pump station-outlet works and impact on the concrete apron described in the response to question 21 will provide additional reoxygenation of the water discharged to the Susquehanna River.



23. What are the predicted evaporation rates from the reservoir?

Response:

Anticipated evaporation rates on a monthly basis are:

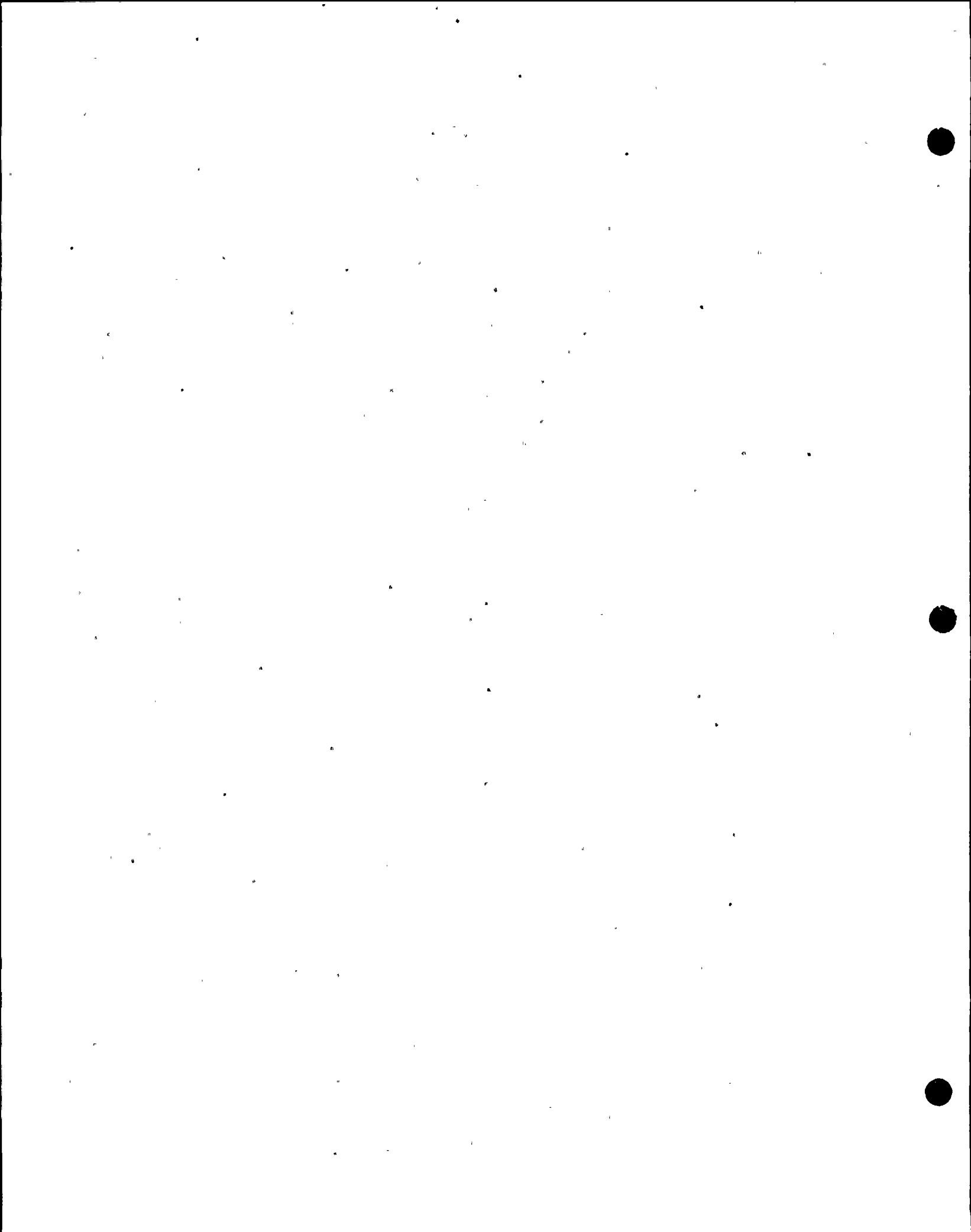
January	0.0 inches	July	4.9 inches
February	0.0 inches	August	4.3 inches
March	0.0 inches	September	3.1 inches
April	3.2 inches	October	2.0 inches
May	4.4 inches	November	1.5 inches
June	4.6 inches	December	0.0 inches

24. How often, and for what duration, will water be pumped from the river
- a. during initial filling of the reservoir and
  - b. for make-up purposes?

Response:

For the large reservoir it is expected the initial filling period of the reservoir will approximately be the same as the period shown in Appendix H, Fig. 1-12. To accomplish this, the pumping rate will be increased to approximately 132 cfs. This rate will be sufficient to fill the active storage volume in approximately 84 days. Pumping is anticipated to occur when river flows are greater than 3000 cfs.

Normally refilling will be from high spring flows when the best quality water will be available. Pumping will also be necessary on a routine basis to ensure equipment availability and to prevent the reservoir from becoming stagnant. Such a pumping schedule will be based on equipment manufacturers recommendations and actual reservoir operating experience.



Workforce Characteristics

25. Provide a profile of the workforce by time schedule including number, residence location, and estimated salary by category.

Response:

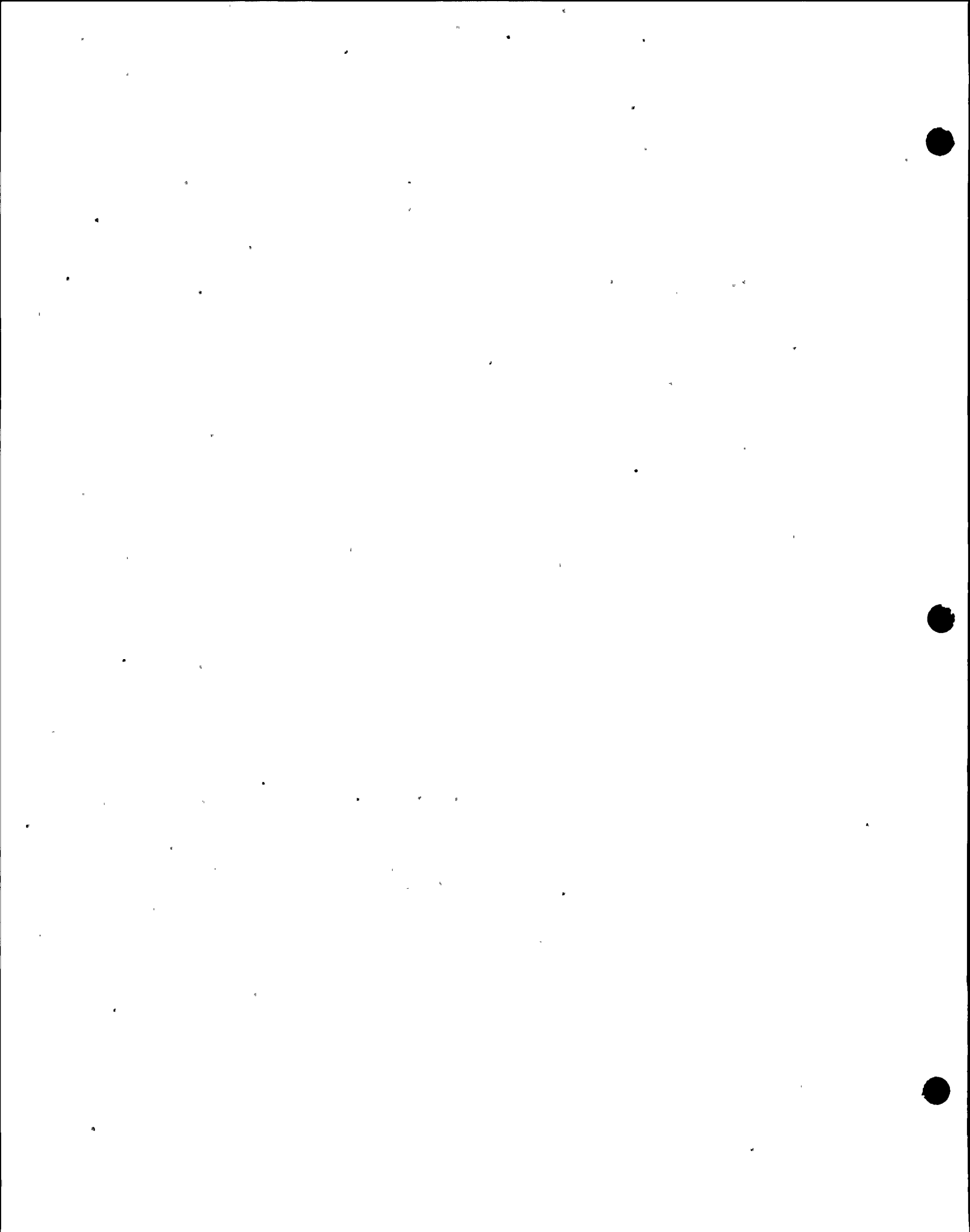
Please refer to Figure 1-12, "Construction Schedule - Pond Hill Reservoir", of Appendix H. Based on the current schedule Construction would commence in late-1980 and would reach a peak during the last quarter of 1981 when five of the six major construction activities would be underway simultaneously. At that time, the work force is expected to have approximately one hundred and twenty five (125) workers and reflect the following composition and salaries:

Pond Hill Reservoir Work Force Composition and Salary  
1980-81

<u>Manual Labor</u>	<u>Number of Workers</u>	<u>Hourly Rate</u>
Carpenters	15	\$13.85
Cement Masons	8	14.08
Electricians	7	17.05
Ironworkers	5	16.34
Laborers	15	12.38
Operating Engineers	15	17.25
Teamsters	10	12.54
Pipefitters/Plumbers	10	15.26
Other Craftlabor	<u>15</u>	12.39
Subtotal	100	
<u>Non-Manual</u>		
Supervision	15	\$11 - 15
Field Engineers	<u>10</u>	
Subtotal	25	

Salary information is based upon labor cost reports for the week ending 9/10/79 at the Susquehanna Steam Electric Station Project.

Concerning residence location, please refer to the response to question number 26.



26. How many workers will move into the area; where will they reside, how many people will they bring with them including the number of school age children, and what kind of housing will they prefer.

Response:

The Pond Hill Reservoir Project is located approximately five miles from the Susquehanna Steam Electric Station site. Consequently, the same labor force market providing workers for the nuclear station will also be a factor in providing workers for the Pond Hill Project. At the Susquehanna site, the work force, peaked in January/February, 1979 at 4620 manual and non-manual workers. In September, 1979, the work force stood at approximately 3450 manual workers and 845 non-manual workers, or a total of 4295 workers.

The effects of this work force on local socio-economic conditions has undergone considerable study by PP&L. In 1976, a community impact monitoring study was conducted and updated in 1978 (copies attached). One of the studies conclusions is that a "boom town syndrome" in the project area was avoided because over eighty percent (80%) of the manual work force lived within commuting distance (60 miles one way) of the plant site. Table III-6, Residence of Manual Employees by County, from the 1978 update is attached as is Figure III-2 from the same report.

By way of contrast, the Pond Hill Reservoir Project will employ a peak work force of approximately 125 as shown in Figure 1-7 of the Environmental Report. An alternative project design utilizing a higher dam elevation, i.e., the "full development alternative", is not expected to add substantially to the size of the work force (larger equipment and longer peak).

Using the data from Table III-6 above, it is assumed that for a work force of 125, 85 percent (106 workers) will be daily commuters to the project site. The remaining workers would be considered transient. Experience at the Susquehanna site has shown that the majority of the transient workers choose temporary housing quarters, i.e., motels, boarding house, etc. and return home on weekends. It is expected that the transient workers at the Pond Hill site will make similar arrangements.

Transient housing is virtually non-existent in the smaller communities surrounding the immediate project area, i.e., Pond Hill, Mocanaqua, Shickshinny, etc. Transient housing would be available in Wilkes-Barre or Nanticoke, approximately 15 and 5 miles, respectively, northeast of the project site. As the size of the work force at Susquehanna site is reduced, additional transient housing will become available in the Berwick-Bloomsburg area.



Consequently, it is anticipated that fewer than 5 workers will move into the project area on a permanent basis. Assuming 2 school age children per worker, ten children would be added to local school enrollments, probably in the Berwick or Bloomsburg (Columbia County) school districts. It is not expected that enrollments of this size will create significant demands for additional classrooms, staff, etc. Both the Bloomsburg Area School Districts and the Berwick Area School Districts have experienced declining enrollments in the 1969-79 decade, despite the location of a significant work force at the Susquehanna site.

Table III-6

Residence of Manual Employees by County1975 and 1978

<u>County</u>	<u>Number</u>		<u>Percent</u>	
	<u>1975</u>	<u>1978</u>	<u>1975</u>	<u>1978</u>
Luzerne	1122	1402	59	50
Lackawanna	239	243	13	8.6
Columbia	90	160	5	5.7
Schuylkill	77	252	4	9
Northumberland	64	142	3	5
Lycoming	35	110	2	3.9
Monroe	9	33	-	1.1
Dauphin	10	8	-	-
Lancaster	10	4	-	-
Wayne	12	0	-	-
Lebanon	11	1	-	-
Wyoming	38	0	2	-
Montour	3	0	-	-
Carbon	7	2	-	-
Cumberland	5	2	-	-
Juniata	3	1	-	-
Sullivan	5	0	-	-
Susquehanna	6	9	-	-
Perry	2	0	-	-
Pike	1	1	-	-
Tioga	1	1	-	-
Union	2	4	-	-
Bradford	2	0	-	-
Clinton	0	0	-	-
Snyder	2	5	-	-
Philadelphia	2	14	-	-
York	0	9	-	-
Adams	1	0	-	-
Bedford	0	0	-	-
Berks	4	20	-	-
Bucks	1	28	-	-
Crawford	0	0	-	-
Lehigh	3	61	-	2.2
Montgomery	1	5	-	-
Northampton	1	8	-	-
Wayne	0	31	-	-
Warren	0	0	-	-
Westmoreland	0	0	-	-
Centre	1	1	-	-
Delaware	1	1	-	-
Chester	0	1	-	-
Other States	118	236	6	8.3
Unknown	8	0	-	-
	1900	2795		



27. What effect will commuters and construction related traffic have on local roads? Include data on traffic increases, peak traffic loads, road damage and mitigation programs.

Response:

The effect of commuters and construction related traffic is discussed in Section 4.2.7.1, B-2 and Appendix B-3 of Appendix H, and is not expected to change for the "Full Size" Reservoir.

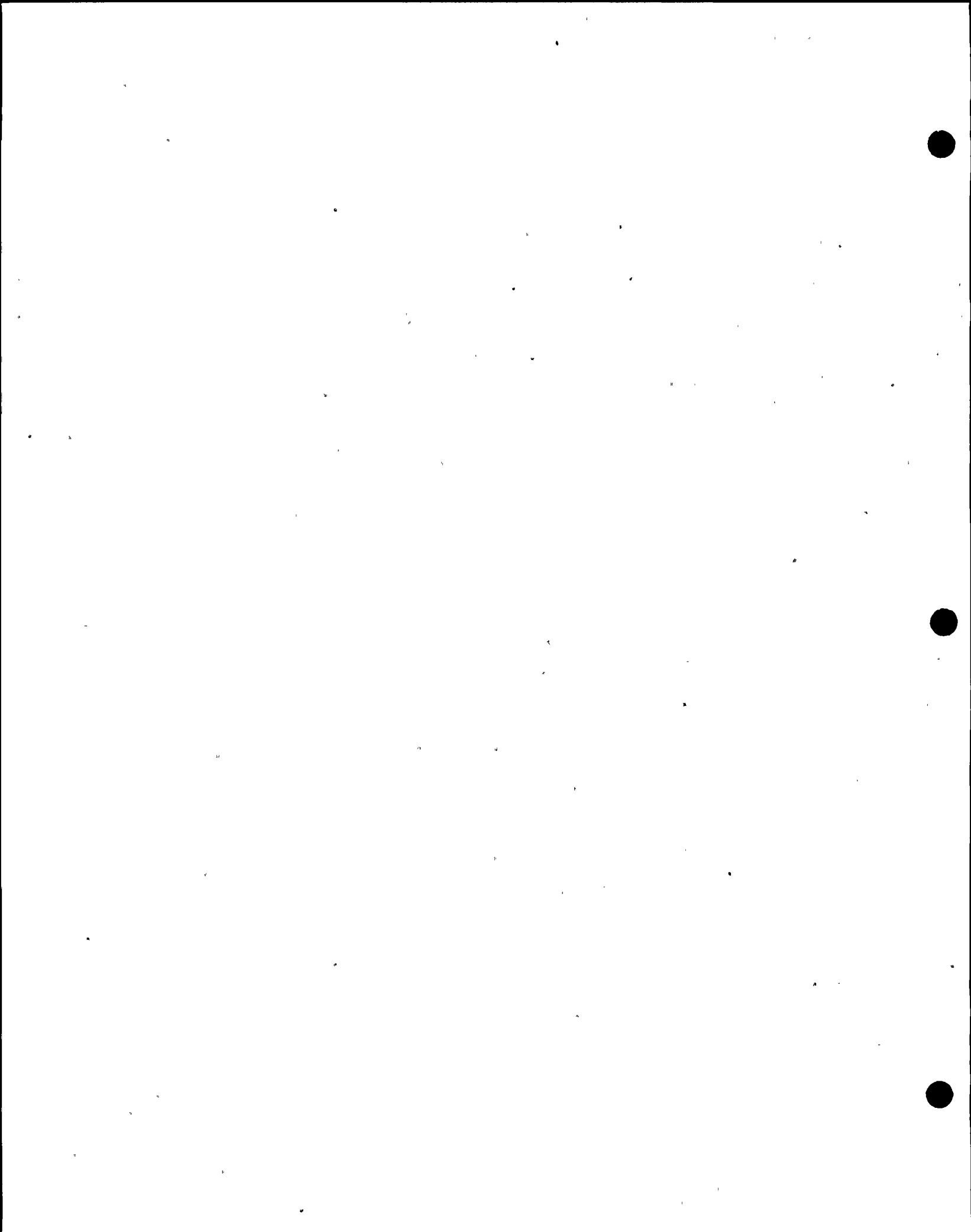
28. Provide details on the recreational facilities and uses planned for the Pond Hill Lake.

Response:

Recreational facilities for Pond Hill Lake are discussed in \*Section 4.2.8 and Appendix B-4. PP&L is consulting with the Pond Hill Reservoir Advisory Committee to determine which type of facilities would be most appropriate before formulating detailed plans.

---

\* Susquehanna SES ER-OL - Appendix H.



29. How will the Pond Hill Lake affect land use, recreational development and real estate prices in the nearby area? Are these changes compatible with long and short term local and county plans? Provide documentation.

Response:

Land use, recreational development and real estate prices in the nearby area are discussed in \*Sections 4.2.5.7, Impact of Land Use Changes on the Site Vicinity, \*4.2.8, Recreation, and \*4.2.5.7.1, Direct Impact on Township. This should not change significantly for the "Full Size" Reservoir. \*Section 4.2.5.7.1 indicates that the township has no comprehensive land use plan, but township officials "indicated that use of the land for the reservoir would be viewed positively."

---

\* Susquehanna SES ER-OL - Appendix H.

30. Provide a profile of all communities within 5 miles of the site. Include a brief description of the demography, settlement pattern, social organization, political organization and economic organization.

Response:

Communities in the reservoir site vicinity are discussed in Appendix H, Section 3.2.5.2 and 3.2.5.3. The Susquehanna SES Environmental Report, Tables 2.1-3, 2.1-4 and 2.1-5 contain population data for the surrounding area.



31. Provide a research design for location and evaluation of culture resources that may be within the site boundaries.

Response:

PP&L is presently developing a comprehensive plan for locating and evaluating cultural resources within the Pond Hill site boundaries. It is expected that the plan will be available by mid-November 1979. Because of weather restriction it is not anticipated that work will begin before the Spring of 1980.

32. Provide a cultural-historical profile of the local prehistory and history.

Response:

The local history of the area is discussed in Appendix H, Section 3.2.4.2, Social and Economic Characteristics of the Region and Site Vicinity. Prehistory is discussed in Section 3.2.9 Archaeological and Historic Sites.

### Alternatives and Cost-Benefit

33. Provide details of the estimated \$27 million present worth of outage cost. Include description of the methodology, the average amount and the price of electricity, and the discount rate used to arrive at the estimated present worth of outage cost.

#### Response:

Details of the estimated \$27 million outage cost are included in response 34. The response to this request will be made in terms of current estimates for replacement energy, which are based on present and projected fuel prices. The increased costs are primarily due to higher projected fuel prices.

Analysis of historical river flow data by TAMS for the period of record (1900-1978 inclusive) shows that the river will be below the allowable minimum an average of about four (4) days per year. During the periods of low flow, if no flow augmentation is available, Susquehanna will, in all probability, have to curtail operation, *i.e.*, shut down until the river flow is again greater than the minimum allowable. The relatively low cost energy provided by Susquehanna will have to be replaced by higher cost coal and/or oil energy. The average annual energy requirement including that for start-up time is estimated to be between 160,000 MWH and 170,000 MWH. This energy range is due to the difference in length of start up time associated with a cold or hot shutdown condition of the reactor at the time the plant is scheduled to return to service. It is uncertain at this time in which condition the reactor would be held (cold or hot) if plant operation were curtailed (shutdown) for several days due to low river flow. Average replacement energy costs in 1983 are estimated to be about \$35/MWH. The total 1983 present worth of the average annual replacement energy costs over a plant life of approximately 30 years is estimated at about \$100 million. Costs are referenced to 1983 because it represents the earliest expected in-service date for the Pond Hill Reservoir.

The above outage costs were computed using replacement energy cost estimates which recognize PP&L's involvement in PJM. Representative values for 1983, 1985, 1990 and 1995 are shown below. Beyond 1995 replacement rates were assumed to escalate at a conservative 5%/year rate. The present worth value of the replacement energy was computed using eleven percent (11%) as the discount rate.

Projected Replacement Energy Rates  
(mills/kWh)

	<u>On-Peak</u>	<u>Off-Peak</u>	<u>Weighted Average</u>
1983	45	25	35
1985	55	30	40
1990	95	40	65
1995	150	60	100

34. A. Provide on-peak and off-peak replacement energy costs.
- B. Explain the assumptions and the methodology used to estimate the present worth of replacement energy cost of between \$3 million and \$58 million for the best and worst case.
- C. How was the estimate made of \$48.7 million cost for 3 years, 30 days (per year) outage?

Response:

- A. On-peak and off-peak replacement energy costs for 1979 through 2000 are shown in the following table. These replacement energy costs were the current PP&L estimates for planning studies at the time the Pond Hill environmental report was prepared. These data have been revised and the revised figures are discussed in response 33.

<u>YEAR</u>	<u>MILLS/WKH</u>	
	<u>ON PEAK</u>	<u>OFF PEAK</u>
1979	24.9	14.8
1980	28.0	15.8
1981	27.4	16.1
1982	27.7	16.6
1983	31.6	18.4
1984	32.9	19.3
1985	34.8	19.7
1986	37.8	20.6
1987	41.7	22.1
1988	44.9	23.0
1989	48.9	24.3
1990	53.9	25.7
1991	59.4	28.5
-----		
1992	63.6	30.2
1993	68.0	32.0
1994	72.8	33.9
1995	77.9	36.0
1996	83.3	38.1
1997	89.1	40.4
1998	95.4	42.9
1999	102.1	45.4
2000	109.2	48.2

These replacement energy costs through 1991 were estimated based on PP&L and PJM interconnection production costing studies. The values after 1991 were estimated using escalation of 7% for on-peak costs and 6% for off peak costs.

B. The method used for estimating the range and average present worth of replacement energy costs is based on the following assumptions.

Cost of money	- 11.15%
Weekday on peak hours	- 15
Weekday off peak hours	- 9
Weekend day off peak hours	- 24
Normal forced outage rate, where applicable	- 21%
Overall outage rate, where applicable	- 30%
Plant output per day, full load	- 50,400,000 KWH
Plant output per day, allowing for forced outages	- 40,000,000 KWH
Plant outage per day, allowing for all outages	- 35,300,000 KWH
Timing of plant outages through life of plant	- random years

Calculation of cost of outages for week days, weekend days in each year through the life of the plant were made. An example of the results of this calculation and a brief description of the method follows.

The total cost of a one day outage is equal to the value of the energy that would have been generated on peak and off peak minus the value of the fuel saved as a result of the outage plus any operating capacity charges lost or incurred because of the loss of operational capacity on the system. This can be written as follows:

$$\begin{aligned} \text{Cost of an Outage} &= (\text{MWH on Peak})(\text{On Peak Rate}-\text{Fuel Cost}) \\ &+ (\text{MWH Off Peak})(\text{Off Peak Rate}-\text{Fuel Cost}) \\ &+ (\text{Unit Rating})(\text{Operating Capacity Rate}) \end{aligned}$$

EXAMPLE:

The cost of one weekday outage of Susquehanna 1 (assuming 100% load).

On Peak Rate	= \$27.4/MWH
Off Peak Rate	= \$16.1/MWH
Fuel Cost	= \$ 6.2/MWH
Operating Capacity Rate	= \$56.4/MW-Day

is equal to

$$\begin{aligned} & (1050\text{MW} \times 15 \text{ hrs})(\$27.4/\text{MWH}-\$6.2/\text{MWH}) + (1050\text{MW} \times 9 \text{ hrs})(\$16.1/\text{MWH}-\$6.2/\text{MWH}) \\ & + (\$56.4/\text{MW-Day})(1050\text{MW}) = \$487,000 \end{aligned}$$

The following partial table of such results is included for illustration and for reference later.

COST PER DAY  
OF OUTAGE  
OTHERWISE AT FULL LOAD

Year	<u>Weekday - 24 Hours</u>			<u>Weekend - 24 Hours</u>		
	<u>Unit 1</u>	<u>Unit 2</u>	<u>Total</u>	<u>Unit 1</u>	<u>Unit 2</u>	<u>Total</u>
1981	487,000	--	487,000	250,000	--	250,000
1982	502,000	485,000	987,000	262,000	247,000	509,000
1983	582,000	570,000	1,152,000	306,000	292,000	598,000
1984	596,000	583,000	1,179,000	311,000	299,000	610,000
1985	617,000	606,000	1,223,000	314,000	293,000	607,000
2008	3,150,000	3,145,000	4,275,000	1,130,000	1,120,000	2,250,000

The next step was to determine the present worth of a random one day outage occurring any time through the life of the plant. Because outages for other reasons could also occur at any time, the outages could be concurrent and therefore a 70% capacity factor was assumed to evaluate outage energy lost. The present worth of a random-one-day outage is the present worth of a full day of outage spread equally over the study life of the plant, and is equal to:

$$\sum_{n=x}^z \frac{(\text{Full Year Outage Cost})n}{(365)(z - x)(1.1115)^{n-x}}$$

where: z = last year of study, x = first year of study

$$\begin{aligned} &(\text{Full Year Outage Cost})n = \\ &(\text{Annual MWH On Peak})(\text{On Peak Rate-Fuel Cost}) + (\text{Annual MWH Off Peak})(\text{Off Peak Rate-Fuel Cost}) \\ &+ (\text{Unit Rating})(\text{Weekdays Normally Operational})(\text{Operating Capacity Rate}) \end{aligned}$$

PRESENT WORTH OF A RANDOM  
ONE DAY OUTAGE OTHERWISE AT  
70% CAPACITY FACTOR

Present Worth 1981	For Unit 1	\$187,264 Per Day
Present Worth 1982	For Unit 2	201,713 Per Day

Reference is made to Table 1.3.2-1 page 1-4 in the environmental report, the summary of reservoir operation if based on historical flow records. During the 30 year period from 1909 to 1938 inclusive, the Pond Hill reservoir drawdown would have been necessary for SSES operation only 7 days. However, during the period 1939 to 1968 inclusive, it would have been needed a total of 217 days. These records were taken as the minimum and maximum exposure to random outages through a 30 year life of SSES. The same chart indicates a

total of 236 days of reservoir hypothetical need in the historical 71 years of record or an average of 100 days per 30 year life. The 1) minimum, 2) maximum, and 3) average needs were evaluated as follows:

	<u>Unit 1</u>	<u>Unit 2</u>
From previous tabulation - present worth of one day outage	\$187,264 (1981)	\$201,713 (1982)
1) Minimum Number of Days	7	7
Present worth minimum days	\$1,310,848 (1981)	\$1,411,911 (1982)
Present worth factor to 1978	.728235	.655182
Present worth 1978 minimum days	\$954,605	\$925,111
Sum of units 1 & 2	\$1,879,716	
2) Maximum Number of Days	217	217
Present Worth	\$40,636,288 (1981)	\$43,771,721 (1982)
Present worth factor to 1978	.728235	.655182
Present worth 1978 maximum days	\$29,592,767	\$28,678,444
Sum of Units 1 & 2	\$58,271,211	
3) Average number days	100	100
Present worth average days	\$18,726,400 (1981)	\$20,171,300 (1982)
Present worth factor to 1978	.728235	.655182
Present worth 1978 average days	\$13,637,720	\$13,215,873
Sum of Units 1 & 2	\$26,853,093	

The immediately preceding value of about \$27,000,000 for present worth (1978) of average historical replacement energy is that referred to in response 33. The present worth (1978) of replacement energy cost was thusly estimated to be between \$2 million and \$58 million. (The \$3 million minimum in the environmental report is apparently in error.)

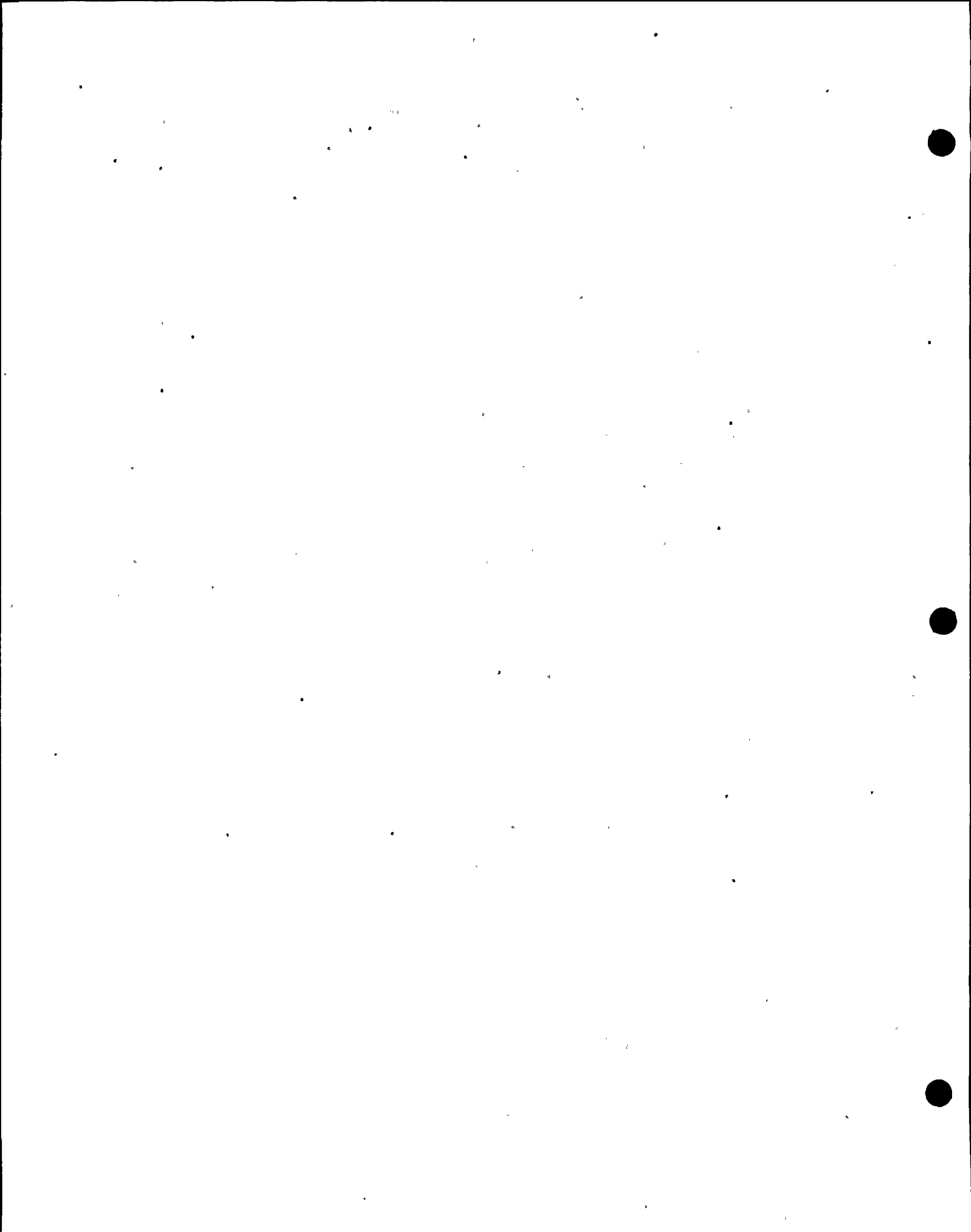
C. The financial exposure to a lengthy drought in the early years of operation was quantified by assuming 30 day outages in each of the years 1983, 1984, and 1985. It was arbitrarily assumed that plant load would otherwise be at full output to maximize this exposure. From the table titled "Cost per Day of Outage" in part B of this response the following calculation of replacement costs was made:



	Cost per Day of Outage		Cost per Week of Outage		Total	Weighted Average Cost Per Day of Outage
	Weekdays 24 hours	Weekends 24 Hours	Weekdays	Weekends		
1983	\$1,152,000	\$598,000	\$5,760,000	\$1,196,000	\$6,956,000	\$ 994,000
1984	1,179,000	610,000	5,895,000	1,220,000	7,115,000	1,016,000
1985	1,223,000	607,000	6,115,000	1,214,000	7,329,000	1,047,000

	Weighted Average Cost Per Day of Outage	30 Day Outages	Present Worth Factor to 1978	Present Worth in 1978
1983	\$ 994,000	\$29,820,000	.589	\$17,600,000
1984	1,016,000	30,480,000	.530	16,200,000
1985	1,047,000	31,410,000	.477	<u>14,950,000</u>
				\$48,750,000

The estimate of present worth (1978) is \$48.7 million for three years, 30 days (per year) outage.



35. The ER indicates that the detrimental effects of plant shutdown on (1) fuel cycle economics and (2) system reliability have been taken into consideration. Provide an estimates of such costs and the effect on the reserve margin. How would it differ from the historical margin? A tabular representation of the last ten years historical reserve margin and the next ten years margin(considering the latest forecast) under the shutdown condition for the applicants and PJM is necessary.

Response:

In Section 2.2 No Action Alternative - "River Following" on pg. 2.1 of the ER the Applicant states:

"However, the cost of Susquehanna SES outages only includes the cost of replacement energy and does not consider possible detrimental effects of plant shutdown on fuel cycle efficiency or on plant and system reliability. These effects would tend to increase the cost of the average outages."

The Applicant feels that these costs are not quantifiable at this time.

System reliability.

Good engineering and operating practice requires that cycling of mechanical and electrical equipment should be minimized. Most components including packing, seals, bearings, welds and motors are subject to increased failure when subjected to other than steady-state conditions. It is anticipated that the Susquehanna units will be operated at full power most of the time, shutting down periodically for refueling. Any reduction from full power or unit shutdown caused by low flow conditions will result in off normal equipment operation (e.g. varying loads or varying temperatures). As stated above, the end result of such fluctuations from steady-state operation would be decreased equipment reliability (i.e., increased equipment failure rates). Because of the built in redundancy in many Susquehanna systems, the inherent safety of the plant would not be degraded nor would plant availability be greatly reduced by this decreased reliability. However, maintenance effort and costs would increase and, since repairs often occur in radiation fields, the total manrem exposure would increase. These increased maintenance costs (manhours, material and manrem) should be added to the lost generation costs when computing the impact of low flow induced power reductions. Unfortunately there is not a sufficient data base on specific equipment failure rates in order to accurately quantify the costs involved.

The effect of the outages on the reserve margin is shown on the following table. Historical reserve margins since 1970 are shown for comparison.

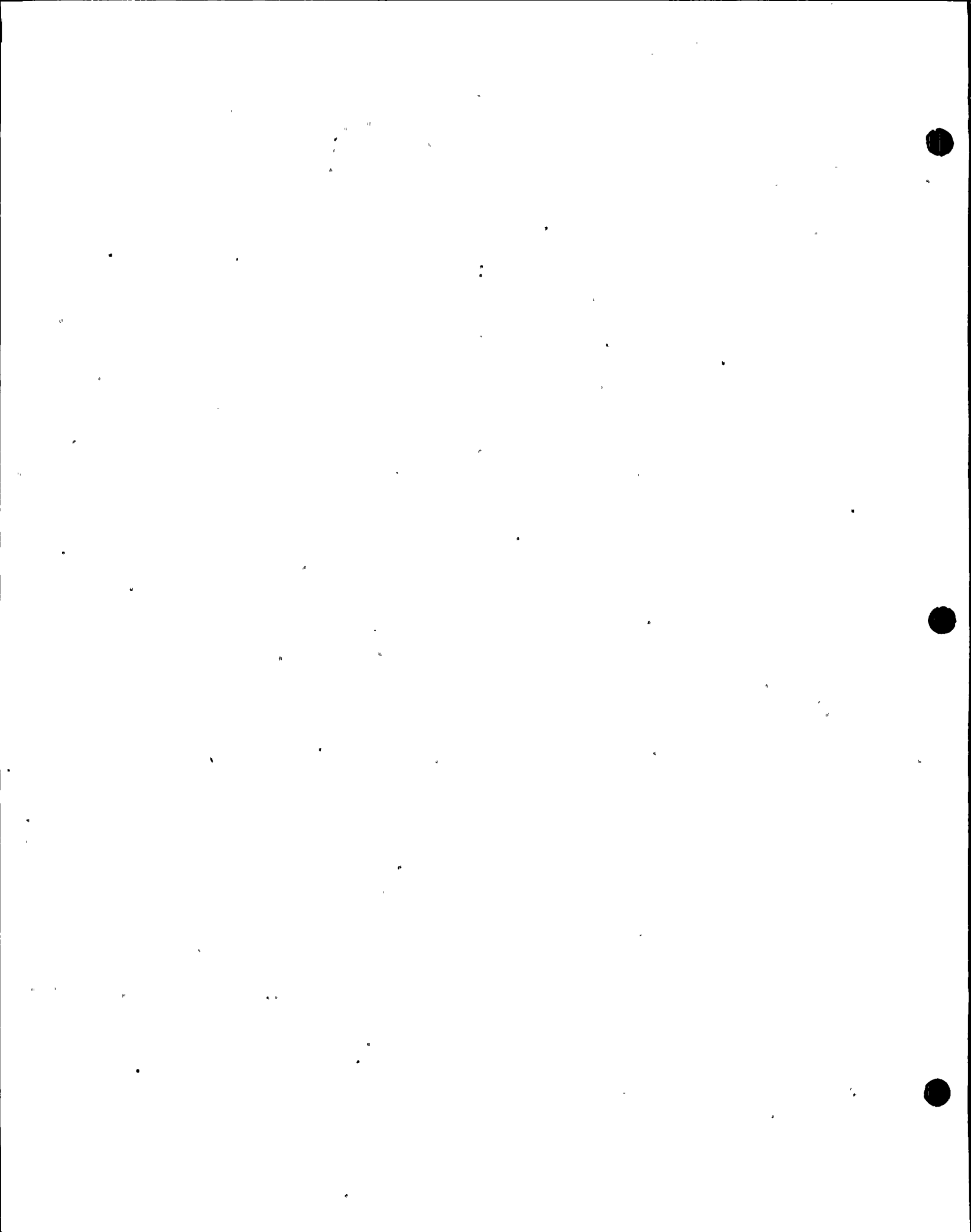
PJM/PP&L RESERVE MARGIN

<u>Projected</u>	<u>1980</u>	<u>1981</u>	<u>1982</u>	<u>1983</u>	<u>1984</u>	<u>1985</u>	<u>1986</u>	<u>1987</u>	<u>1988</u>	<u>1989</u>
<u>With Susquehanna</u>										
PJM	34	33	34	30	30	31	30	31	29	27
PP&L	29	44	58	53	48	46	42	35	33	30
<u>Without Susquehanna</u>										
PJM	37	30	29	25	25	27	26	27	25	23
PP&L	29	26	23	18	15	13	10	4	2	1
<u>Historical</u>	<u>1970</u>	<u>1971</u>	<u>1972</u>	<u>1973</u>	<u>1974</u>	<u>1975</u>	<u>1976</u>	<u>1977</u>	<u>1978</u>	<u>1979</u>
PJM	13	21	22	16	28	39	42	38	40	35
PP&L	1	6	14	34	30	39	27	48	39	35

36. Please quantify, if possible, the statement in the ER that "The exposure to higher shutdown costs due to early draught is considerable."

Response:

The drought referred to in the above statement is the drought of record which was 106 days. Should this drought occur, the energy loss @ 70% capacity factor would be about 3,366,000 MWH. The value of this energy in 1985 is estimated to be about \$130 million. The present worth value in 1983 of the energy is about \$110 million.



37. Provide a summary breaddown of the project cost components by year for the storage size required by PP&L and separately for larger project which may be agreed upon with SRBC.

Response:

Since engineering specifications and design have not been finalized, the following annual cash flows for both reservoir sizes are preliminary estimates only.

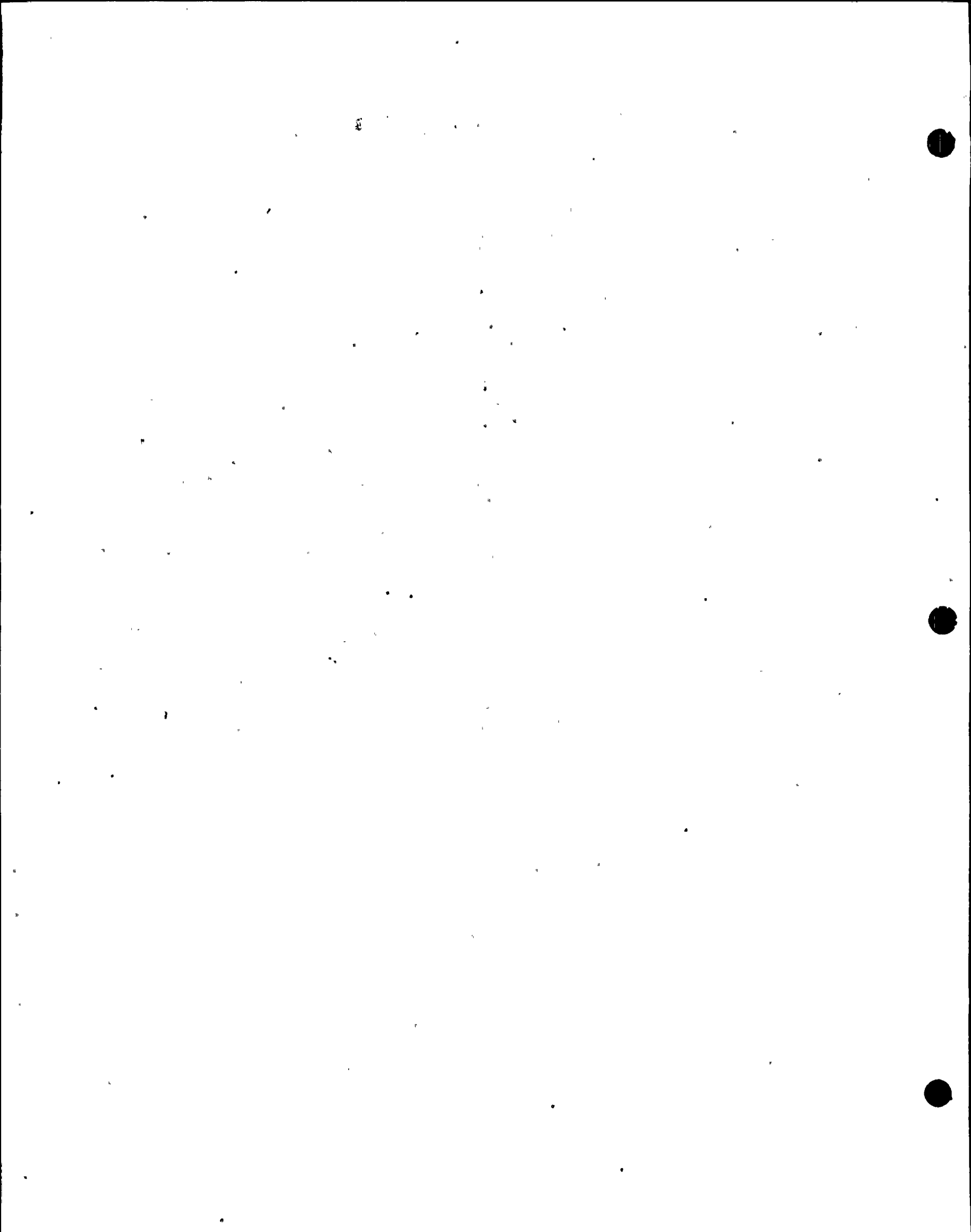
	Prior to <u>1980</u>	<u>Cash Flows (Million \$)</u>					<u>Total</u>
		<u>1980</u>	<u>1981</u>	<u>1982</u>	<u>1983</u>		
Susquehanna Needs Only	2.1	3.2	17.0	19.3	5.6	47.2	
Full Size Reservoir	2.1	4.5	24.1	26.6	7.7	65	

38. For the "river follower" alternative, indicate the alternative supply sources of electricity (e.g., PJM, own peaking units, etc.) to meet demand during Susquehanna SES shutdown period. Please provide the detail back up of the cost associated with each alternative.

Response:

The Applicant is a member of the Pennsylvania-New Jersey-Maryland Interconnection (PJM) and shares in the reliability and economic benefits which are provided by the coordinated operation of the power pool. The pool functions under a one system concept and at any instant, the total load requirement of the Interconnection is supplied by the lowest cost generation available (within reliability and transmission constraints) in the pool. If Susquehanna were unavailable, the lost energy would be supplied from the lowest cost equipment whether the Applicant's or that of another utility on the interconnection. The replacement energy costs currently estimated are identified in the response to questions 33. These costs are somewhat less than estimated operating costs for the alternative of using combustion turbines. Operating costs for new combustion turbines in the early 1980's are expected to be about 80 mills/kWh. These costs are exclusive of capital costs which are estimated to be about \$175-\$200/kW in this time frame.





39. For Cowanesque Reservoir as a water supply storage for flow augmentation, provide the associated cost (fixed and/or yearly) of this alternative.

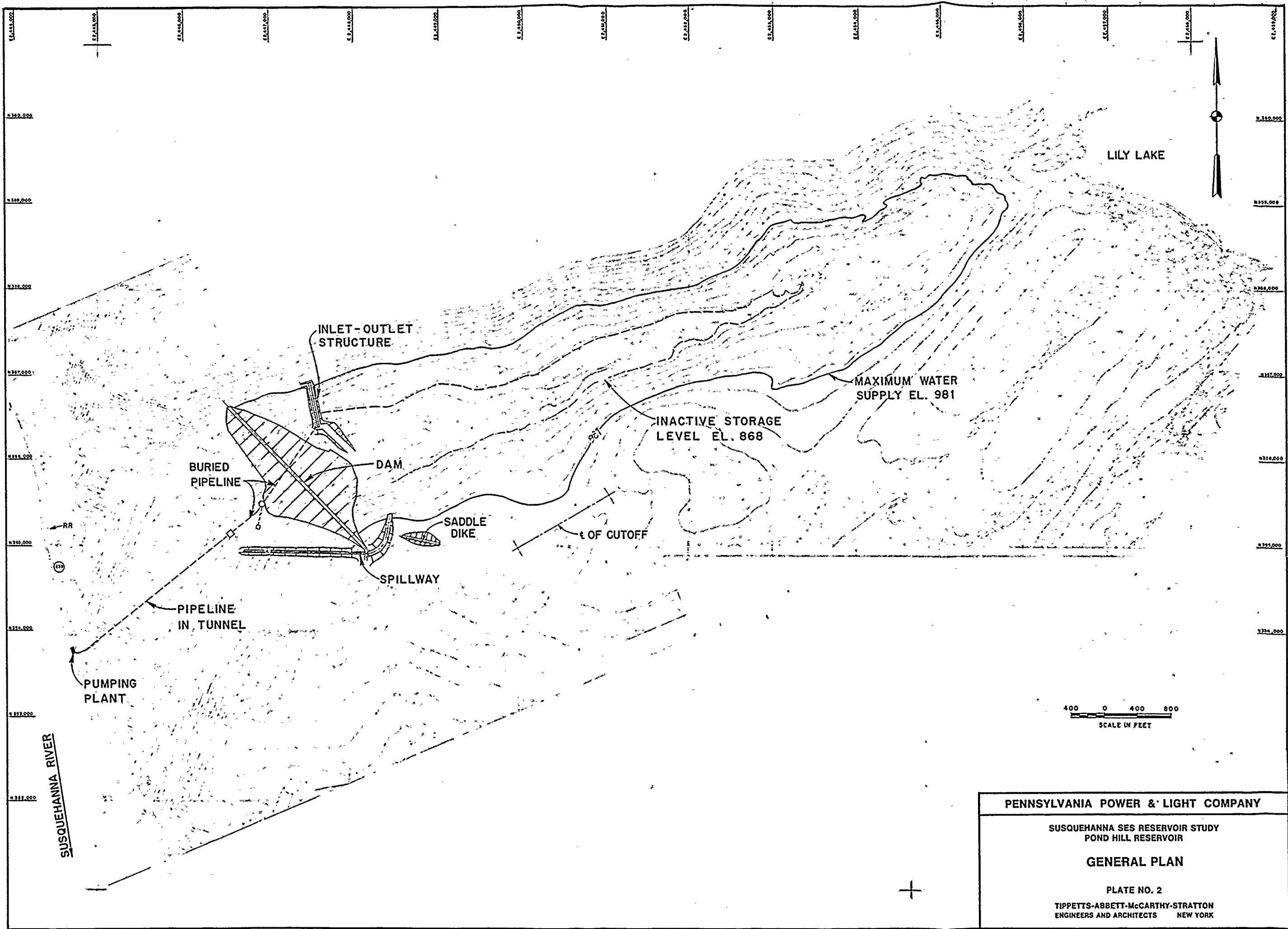
Response:

There is no practical way to anticipate the entire range of factors which will affect the costs of pursuing Cowanesque Lake as a source of makeup water for the Susquehanna Steam Electric Station. We have attempted to estimate the actual water costs of this option. The U.S. Army Corps of Engineers has yet to supply definitive pricing data for its dam project, which is still under construction. Assuming costing similar to that for Corps projects in the Delaware River Basin, we have for planning purposes estimated a life of the plant cost of approximately twelve million dollars.

However, at this time we cannot predict whether such costs will be the most significant factor affecting the desirability of this option. The Corps is presently conducting a study into the availability of water at Cowanesque Lake for storage and the existence of users for that water. The Susquehanna River Basin Commission has stated that the availability of water storage generally at the Lake and its use specifically for the Susquehanna Steam Electric Station are subject to substantial, unresolved questions.

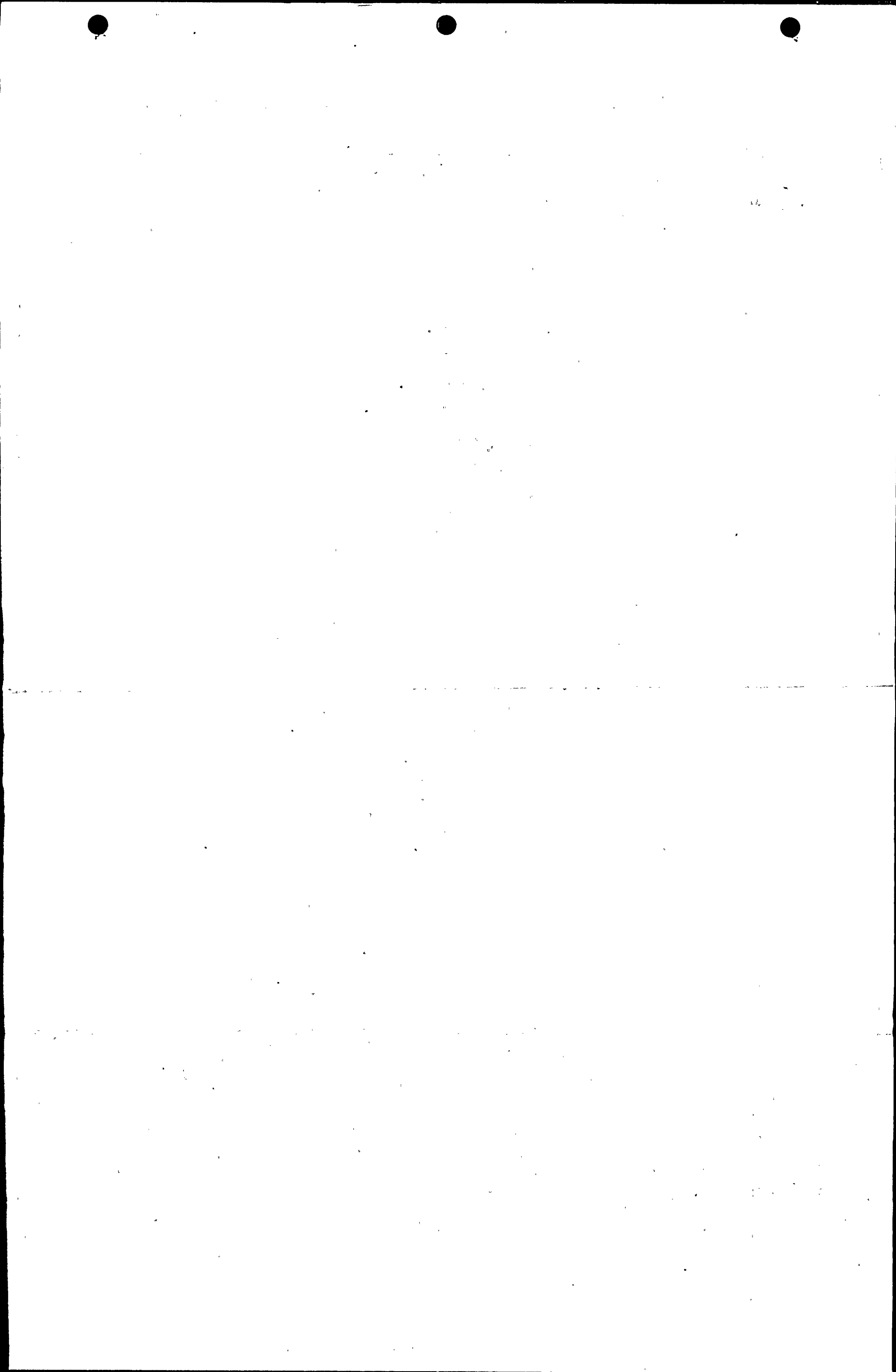
The present schedule for the Corps study sets a completion date in 1982. In addition, present indications from the Corps are that Congressional action, after that time, will be necessary to add water storage as an authorized use at Cowanesque Lake.

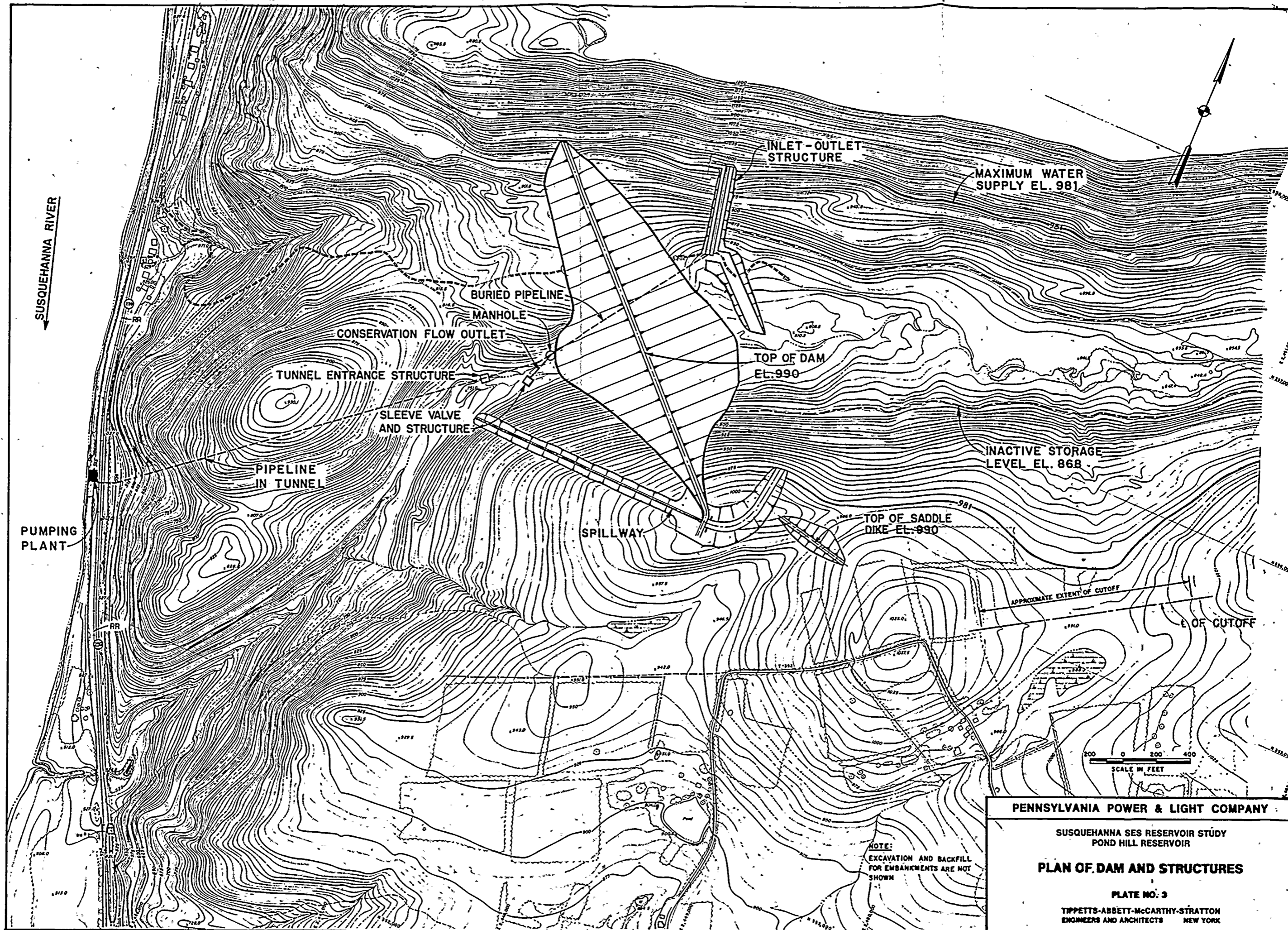
The risks of; a) lengthy extension in the Corps schedule, and b) delay in Congressional action increase our exposure to shutdown during low flow periods. The indefinite length of that exposure and its attendant costs (see answer to question 38), make projections of the costs of the Cowanesque Lake option speculative. Moreover, should the Corps study produce negative results or should necessary Congressional action not occur, the cost of pursuing the Cowanesque option exclusively, would be equivalent to the "river following" option. These uncertainties have, in fact, led the Susquehanna River Basin Commission to state publicly that Cowanesque Lake cannot be presently considered as a timely alternative for supplying makeup water for Susquehanna Steam Electric Station.



**PENNSYLVANIA POWER & LIGHT COMPANY**  
 SUSQUEHANNA SES RESERVOIR STUDY  
 POND HILL RESERVOIR  
**GENERAL PLAN**  
 PLATE NO. 2  
 TIPPETTS-ABBETT-McCARTHY-STRATTON  
 ENGINEERS AND ARCHITECTS NEW YORK

Copyright 1964 by P. P. & L. Co., Inc.





SUSQUEHANNA RIVER

PUMPING PLANT

INLET-OUTLET STRUCTURE

MAXIMUM WATER SUPPLY EL. 981

BURIED PIPELINE  
MANHOLE

CONSERVATION FLOW OUTLET

TUNNEL ENTRANCE STRUCTURE

SLEEVE VALVE AND STRUCTURE

PIPELINE IN TUNNEL

TOP OF DAM EL. 990

SPILLWAY

TOP OF SADDLE DIKE EL. 990

INACTIVE STORAGE LEVEL EL. 868

APPROXIMATE EXTENT OF CUTOFF

E. OF CUTOFF

SCALE IN FEET  
0 200 400

NOTE:  
EXCAVATION AND BACKFILL FOR EMBANKMENTS ARE NOT SHOWN

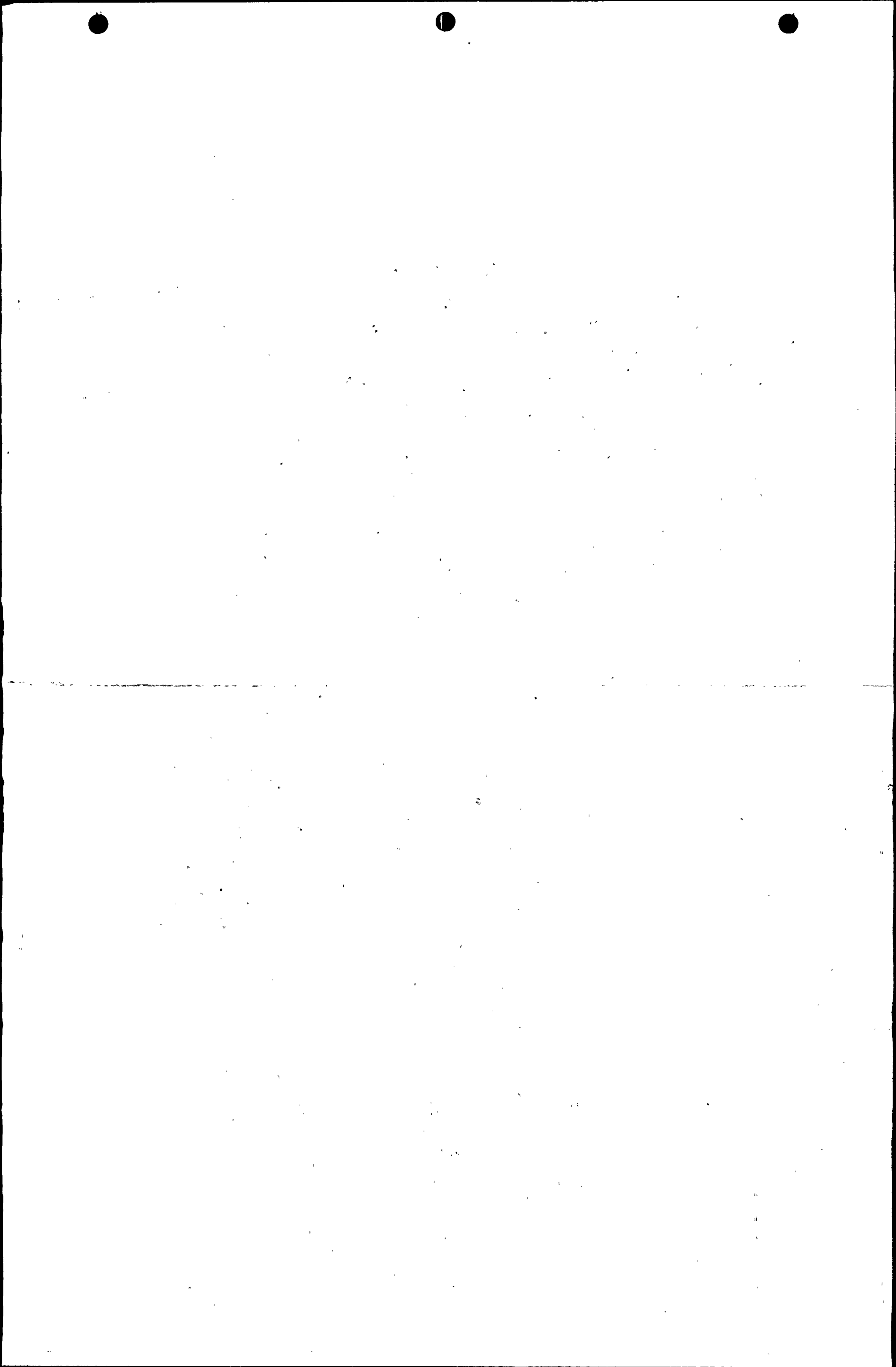
PENNSYLVANIA POWER & LIGHT COMPANY

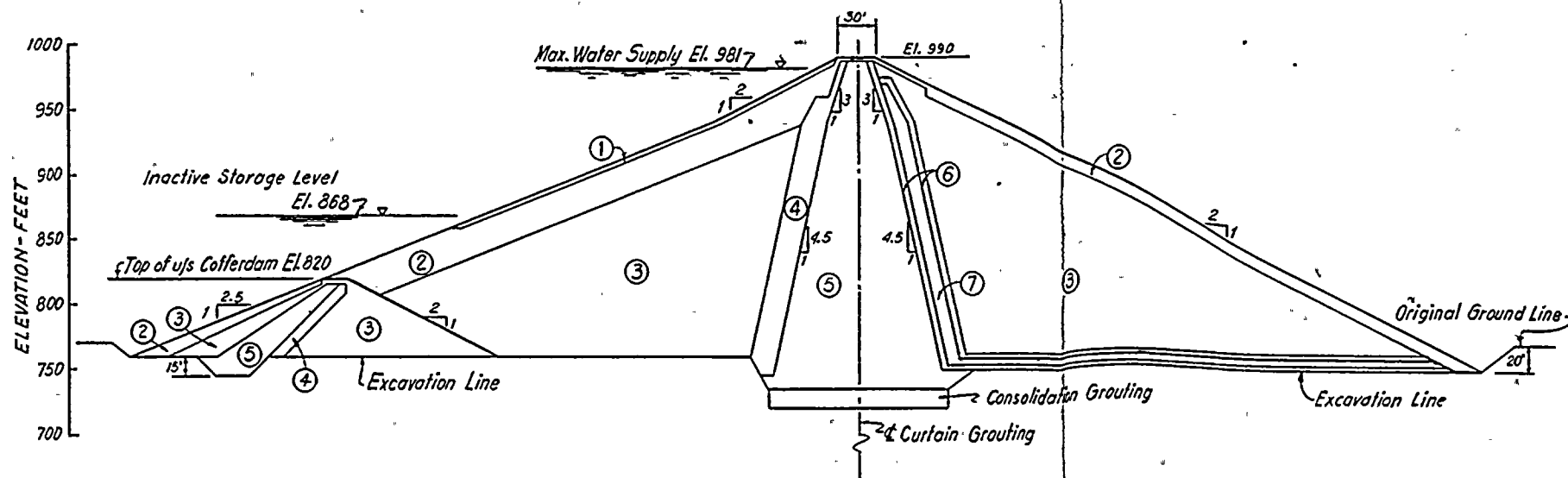
SUSQUEHANNA SES RESERVOIR STUDY  
POND HILL RESERVOIR

PLAN OF DAM AND STRUCTURES

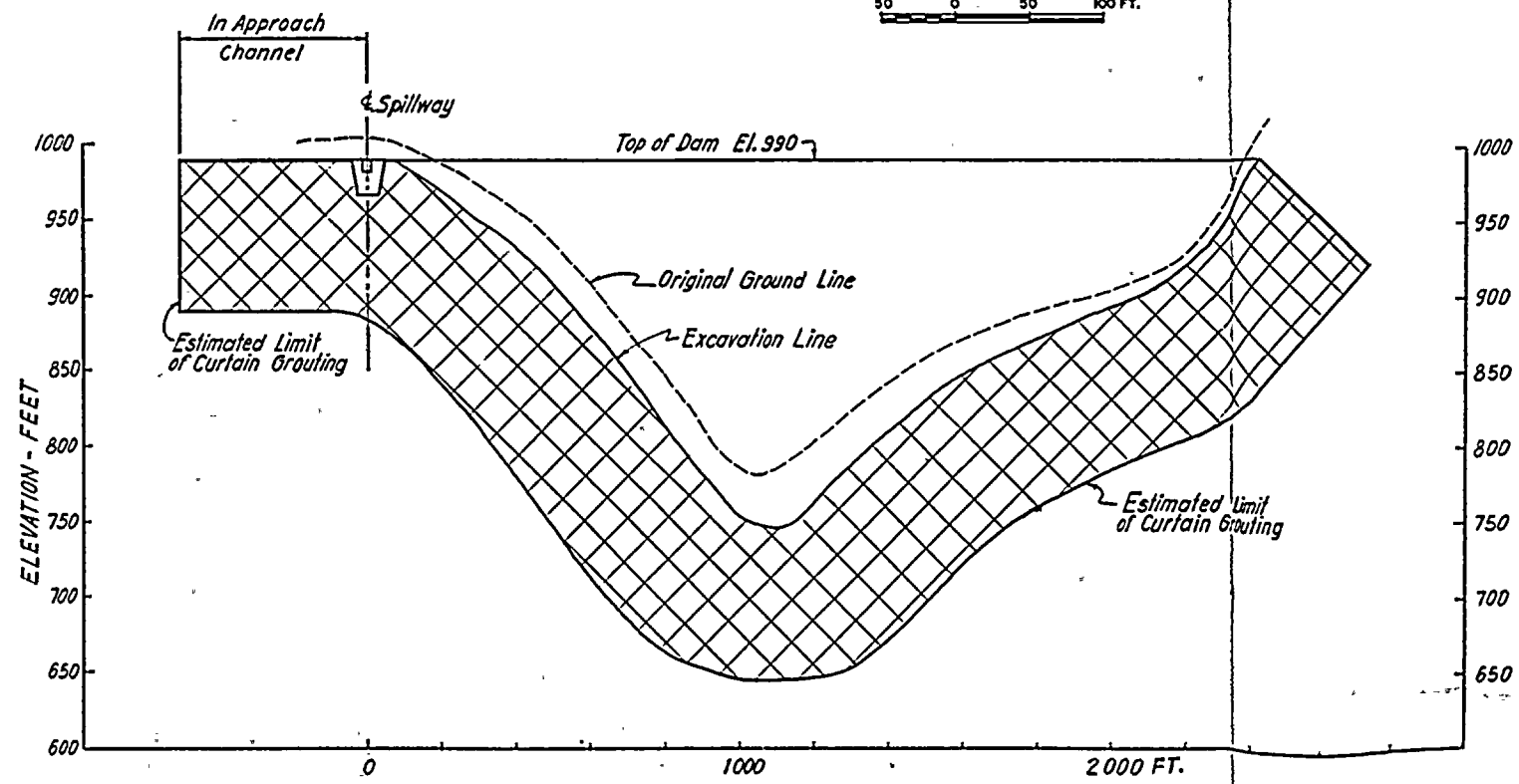
PLATE NO. 3

TIPPETTS-ABBETT-McCARTHY-STRATTON  
ENGINEERS AND ARCHITECTS NEW YORK

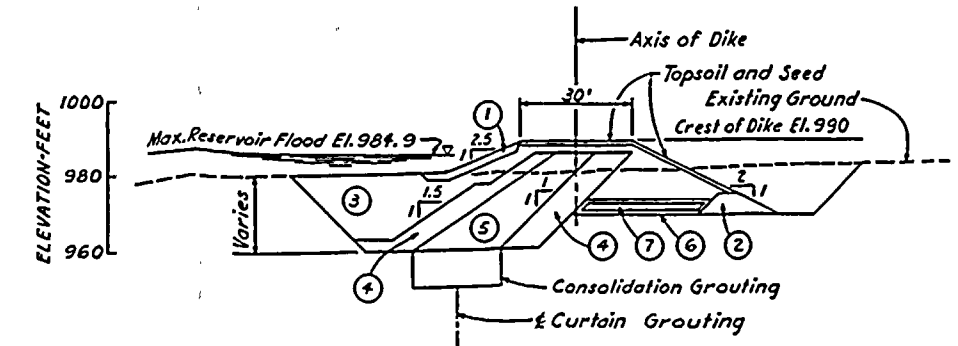




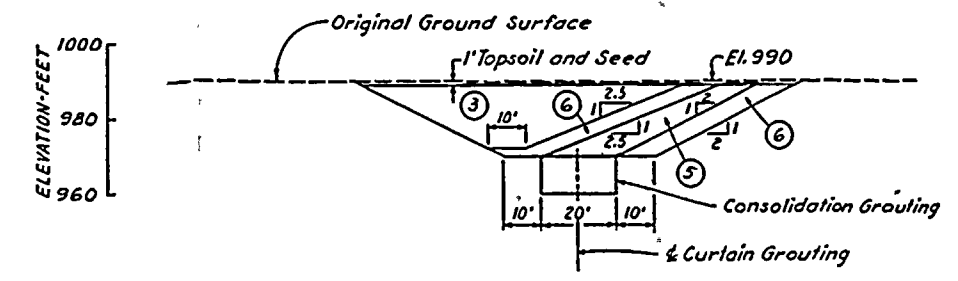
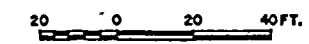
TYPICAL DAM SECTION



PROFILE ALONG DAM SHOWING CURTAIN GROUTING  
( LOOKING DOWNSTREAM )



TYPICAL DIKE SECTION



TYPICAL CUTOFF SECTION



LEGEND

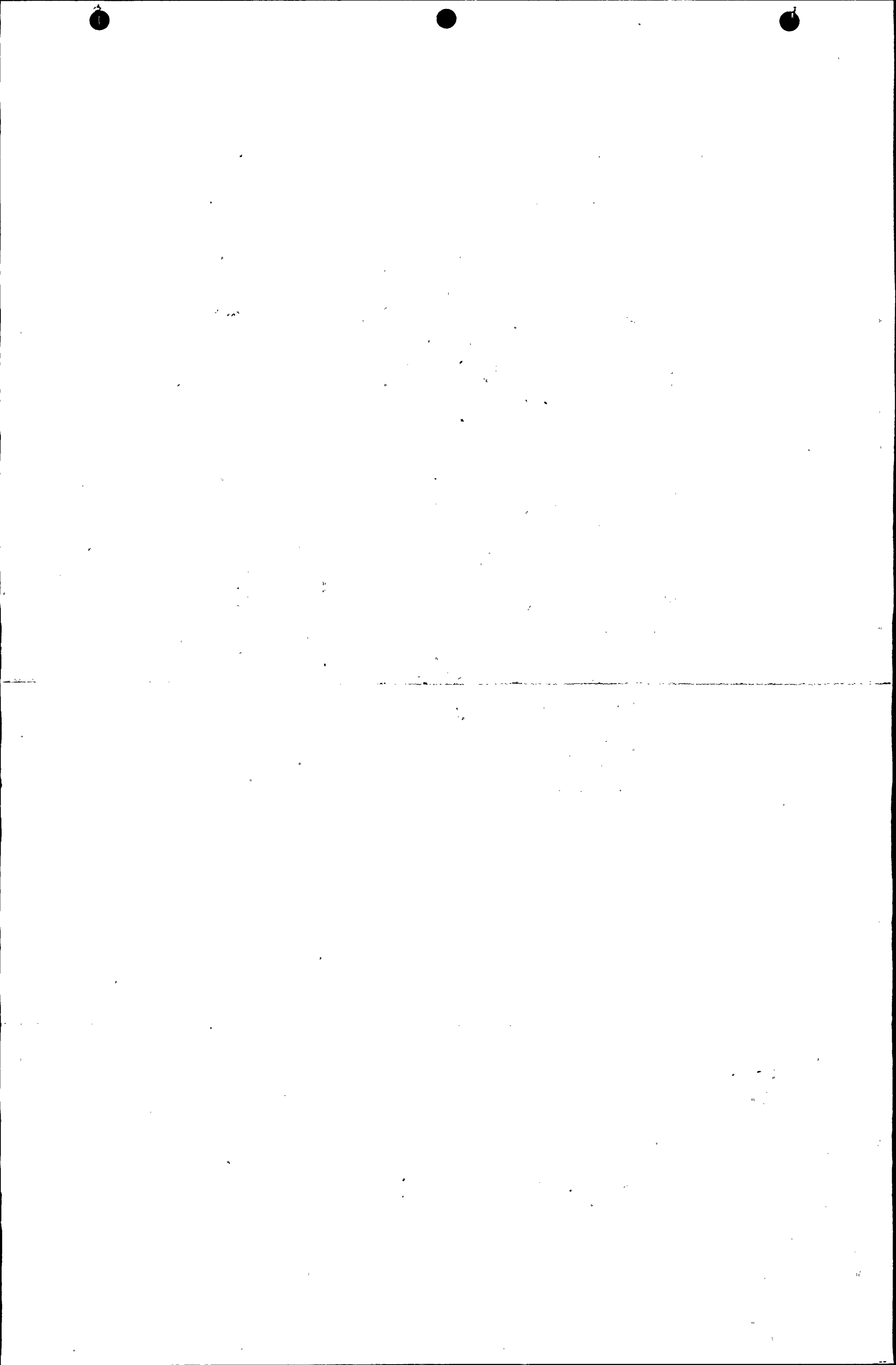
- Zone ① Riprap
- ② Pervious Rockfill
- ③ Random Fill
- ④ Transition
- ⑤ Impervious Core
- ⑥ Filler
- ⑦ Drainage

**PENNSYLVANIA POWER & LIGHT COMPANY**

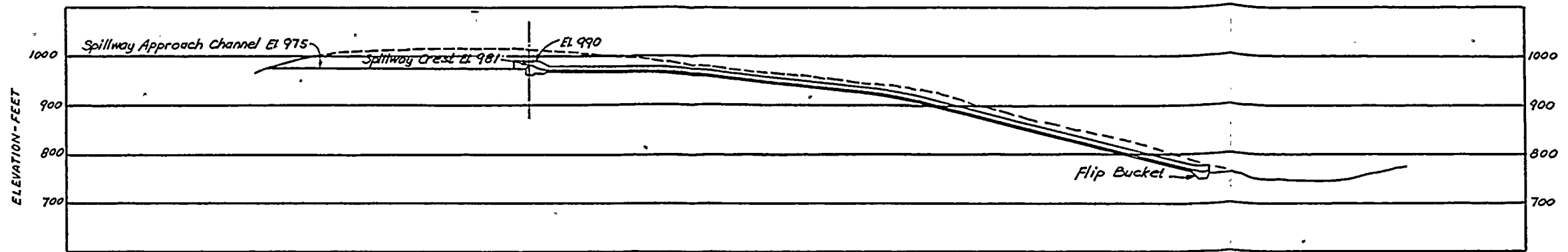
SUSQUEHANNA SES RESERVOIR STUDY  
POND HILL RESERVOIR,  
**TYPICAL EMBANKMENT SECTION  
AND GROUT CURTAIN PROFILE**

PLATE NO. 4

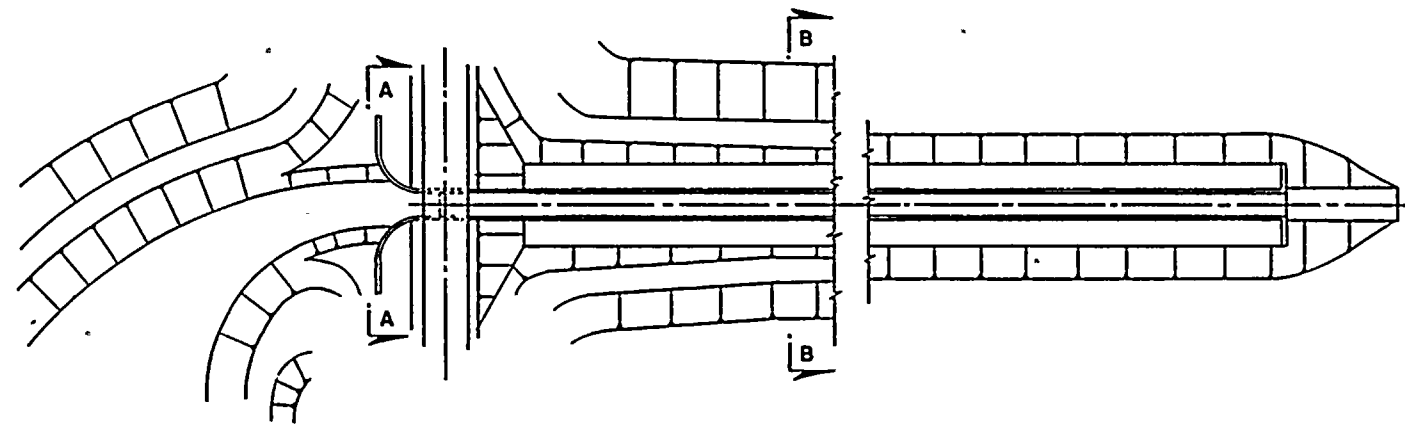
TIPPETTS-ABBETT-McCARTHY-STRATTON  
ENGINEERS AND ARCHITECTS NEW YORK



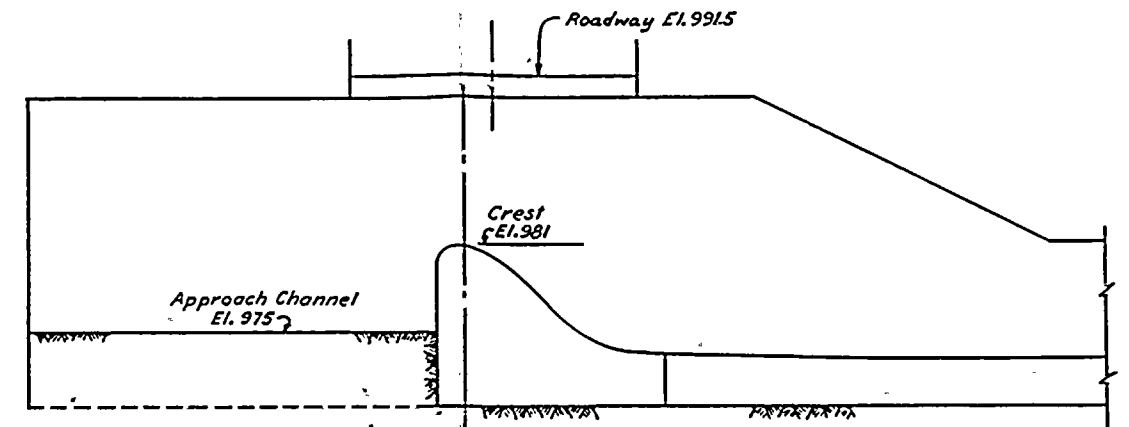
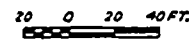




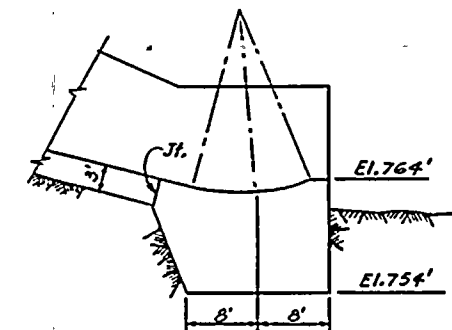
PROFILE



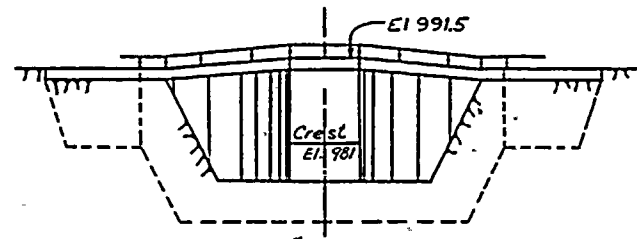
PLAN



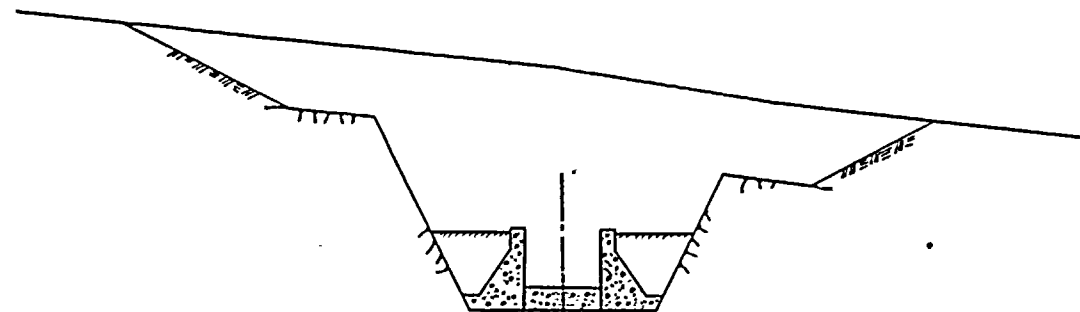
CREST DETAIL



FLIP BUCKET  
DETAIL



SECTION A-A



SECTION B-B



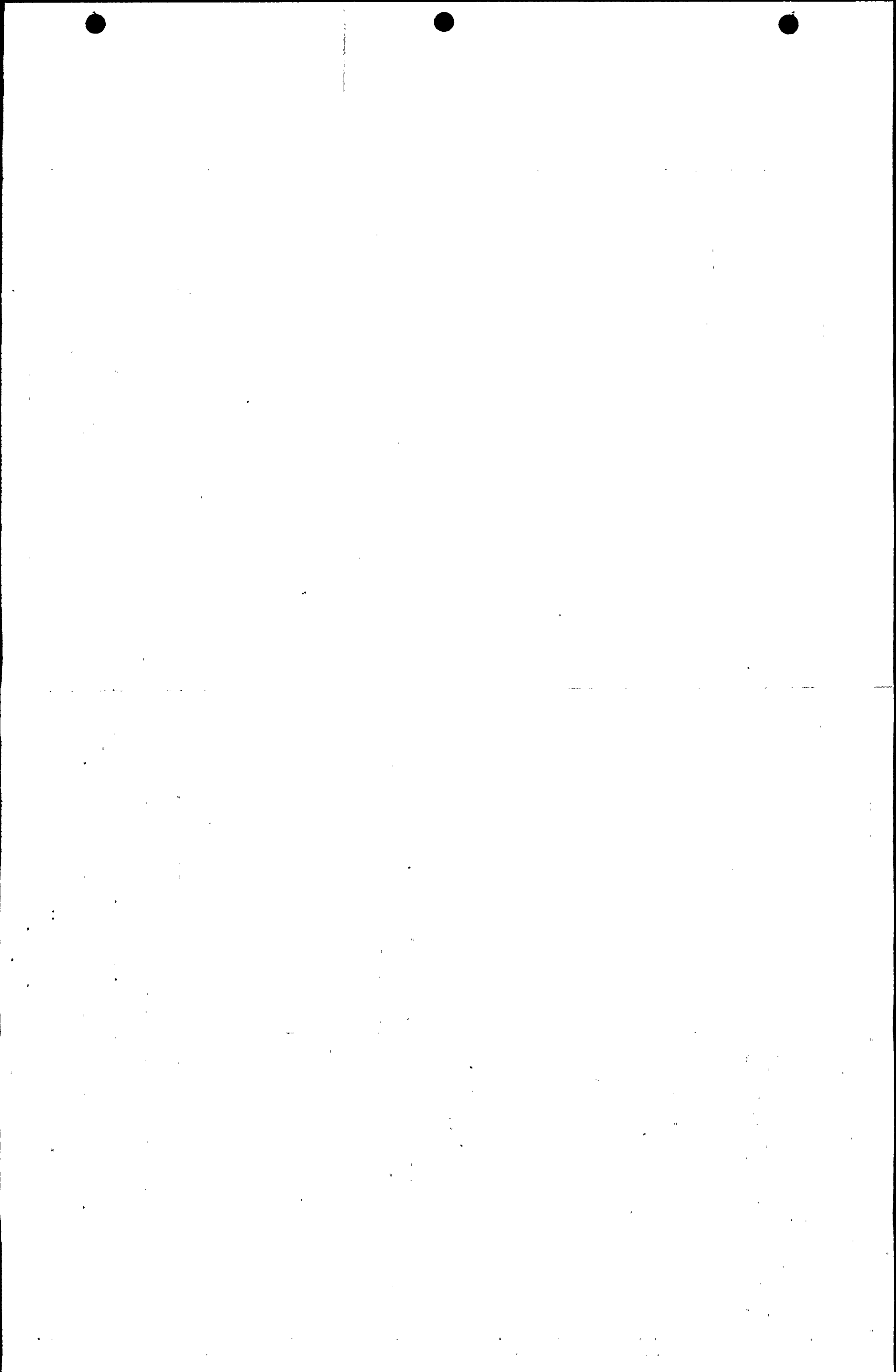
PENNSYLVANIA POWER & LIGHT COMPANY

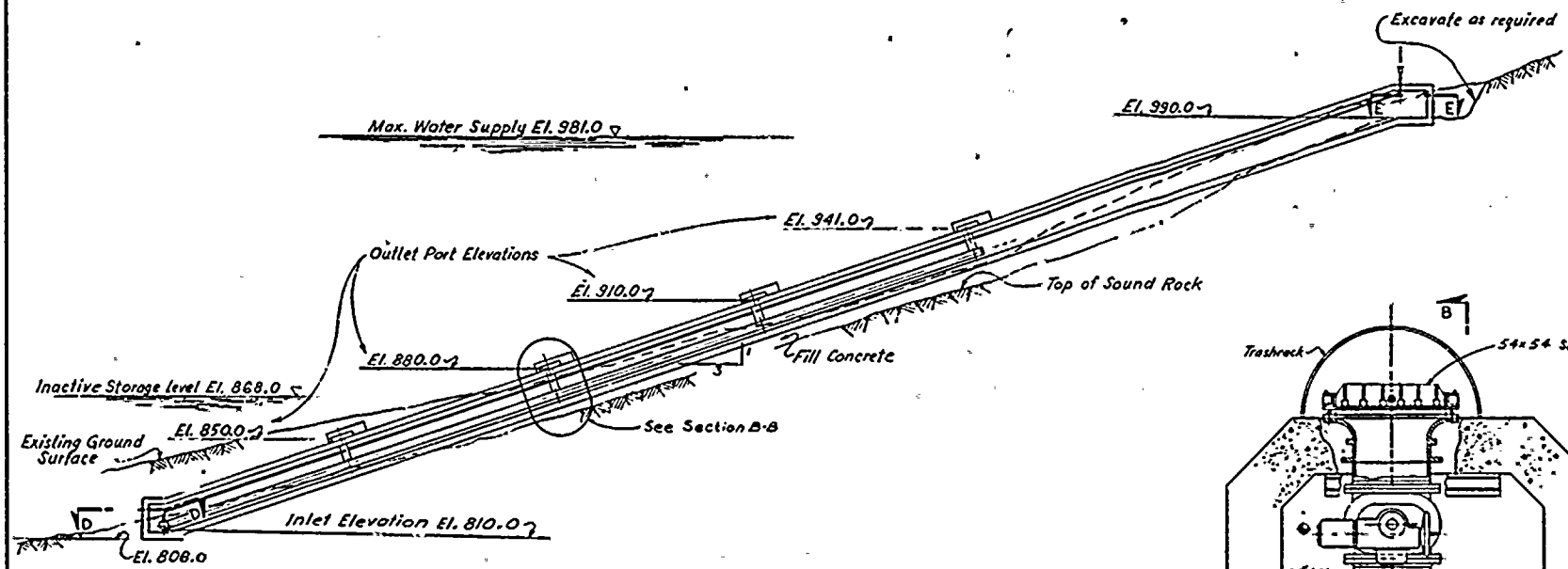
SUSQUEHANNA SES RESERVOIR STUDY  
POND HILL RESERVOIR

SPILLWAY

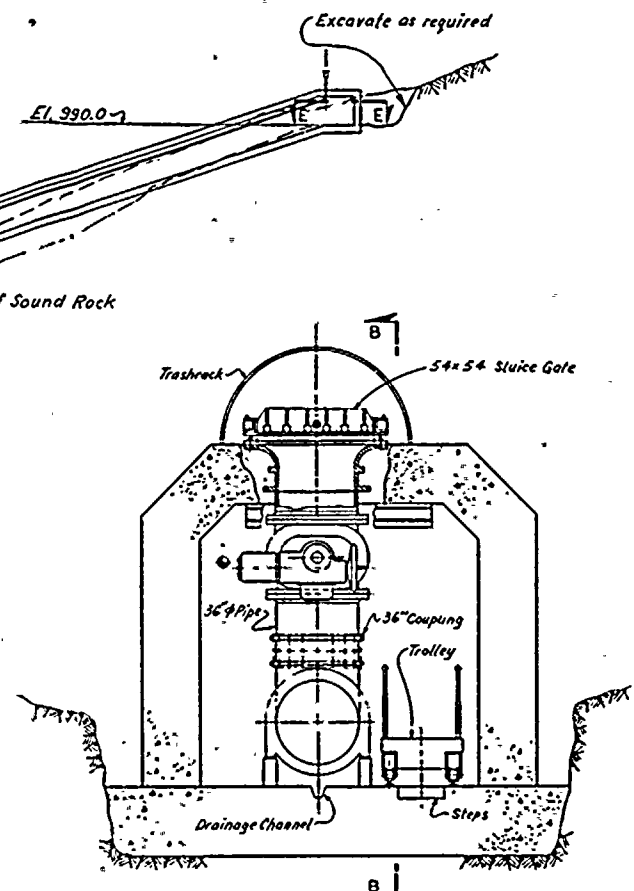
PLATE NO. 5

TIPPETTS-ABBETT-McCARTHY-STRATTON  
ENGINEERS AND ARCHITECTS NEW YORK

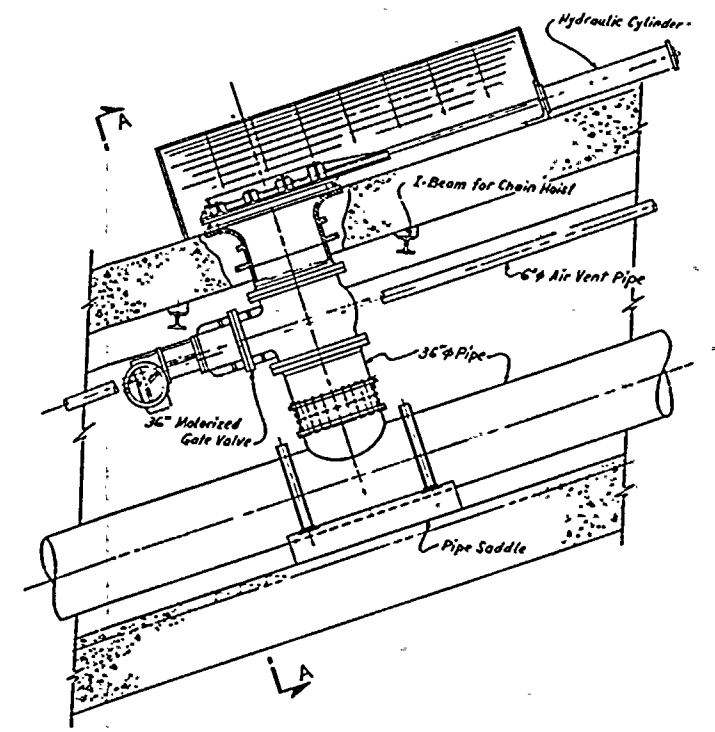




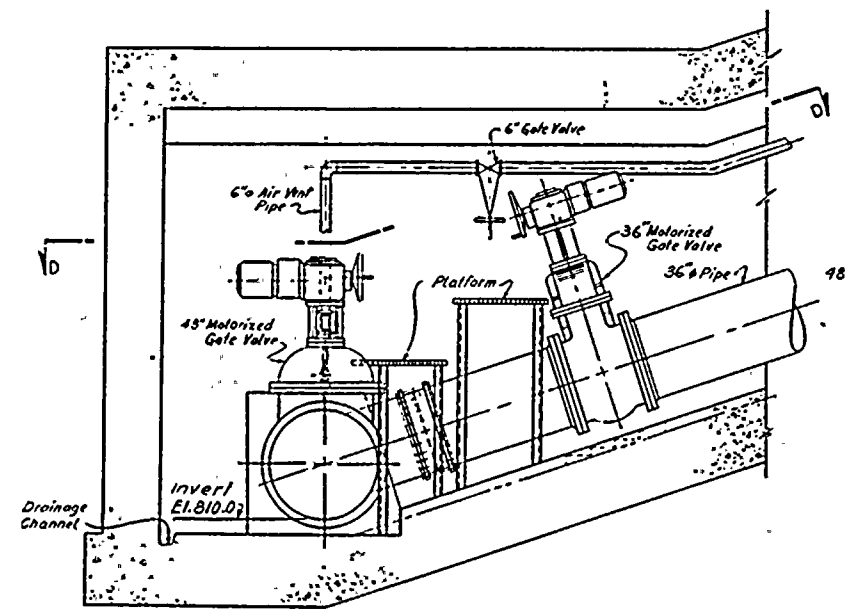
SECTION THROUGH RIGHT ABUTMENT  
LOOKING DOWNSTREAM



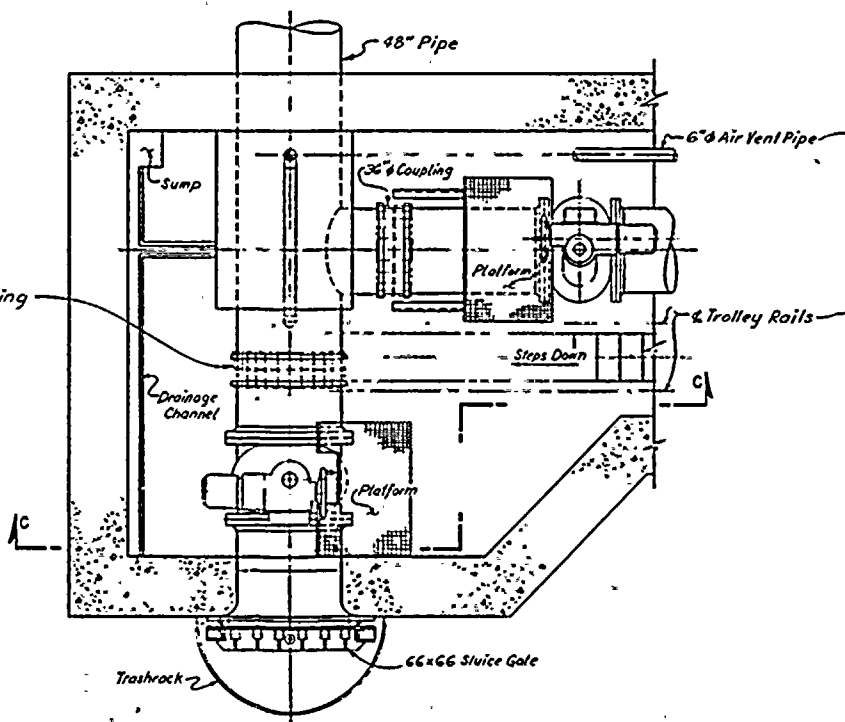
SECTION A-A



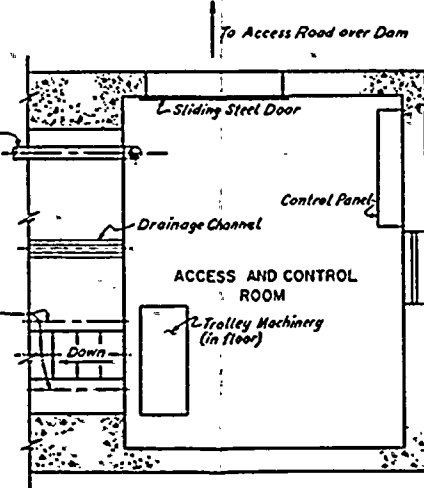
SECTION B-B



SECTION C-C



SECTION D-D



SECTION E-E

NOTE:  
Pumped Inflow 132 cfs  
Rated Release 110 cfs



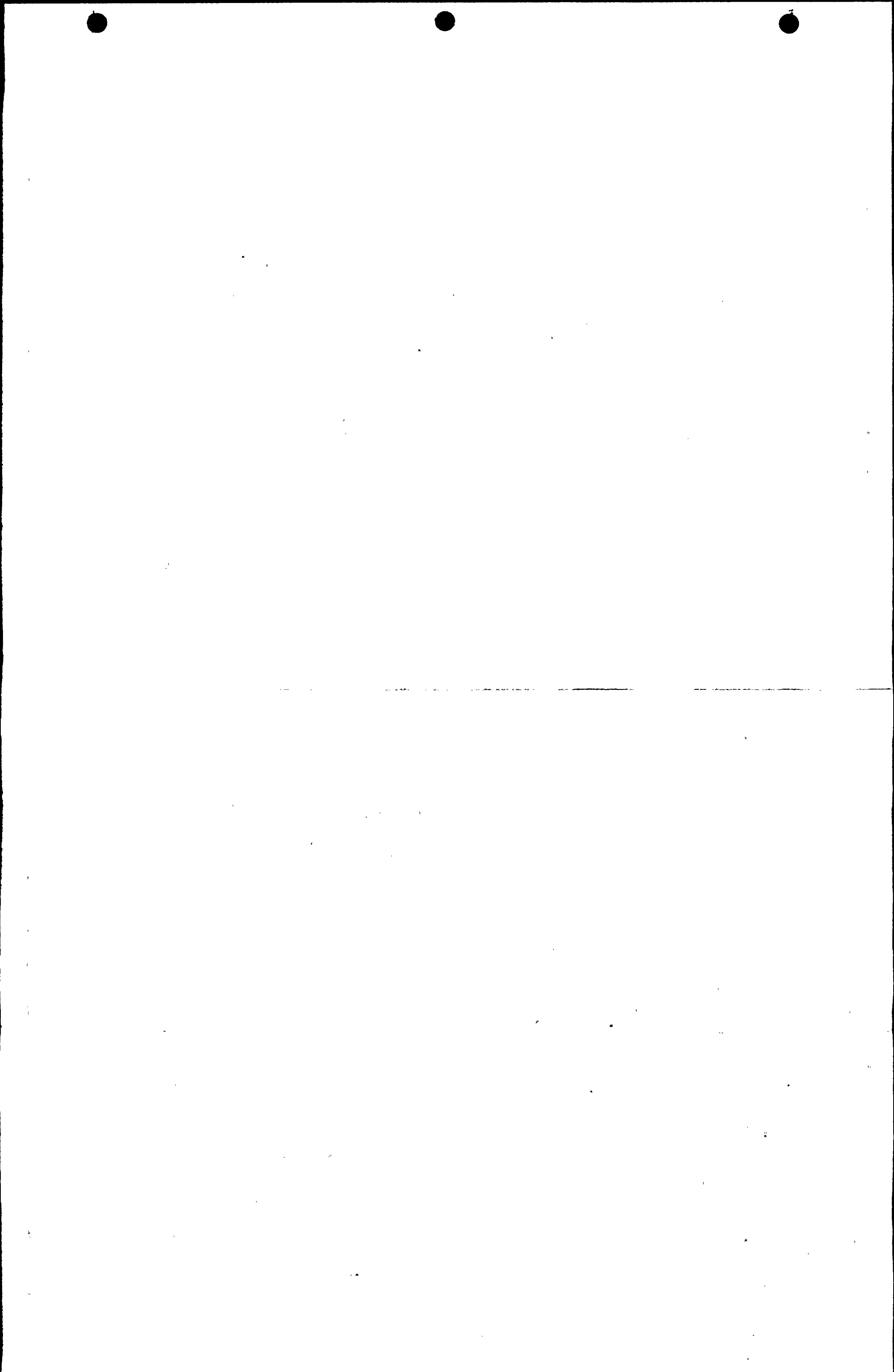
**PENNSYLVANIA POWER & LIGHT COMPANY**

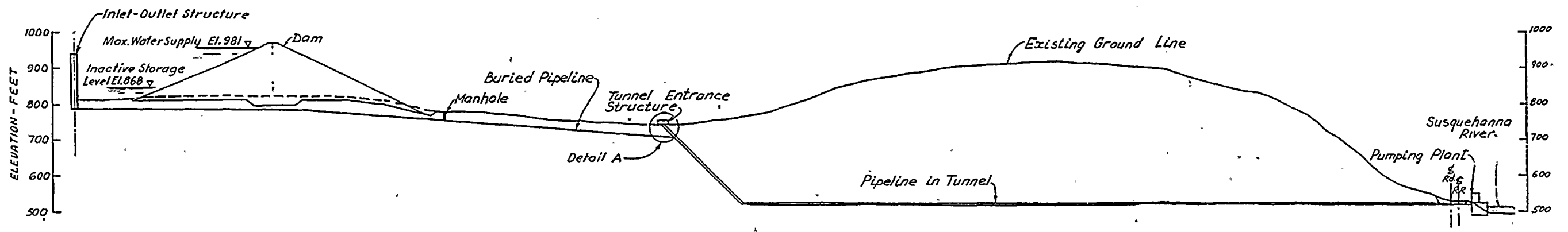
SUSQUEHANNA SES RESERVOIR STUDY  
POND HILL RESERVOIR

**INLET-OUTLET STRUCTURE**

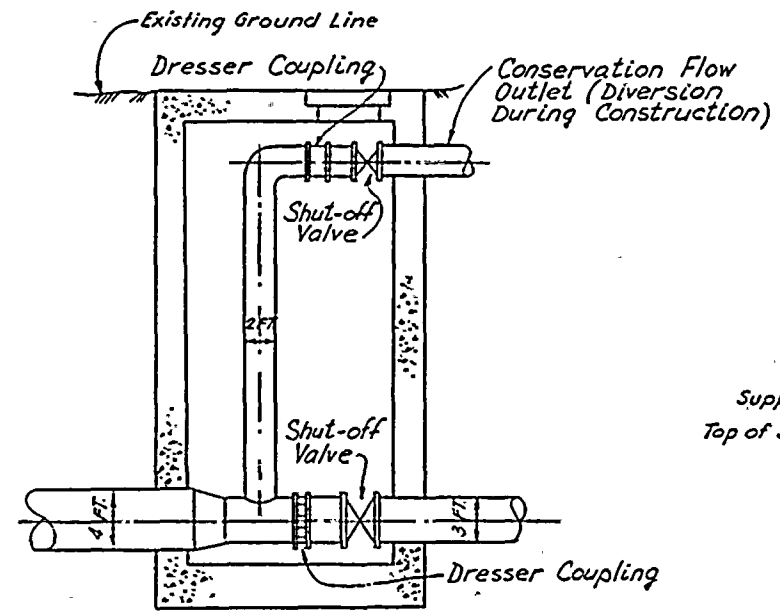
PLATE NO. 6

TIPPETTS-ABBETT-McCARTHY-STRATTON  
ENGINEERS AND ARCHITECTS NEW YORK

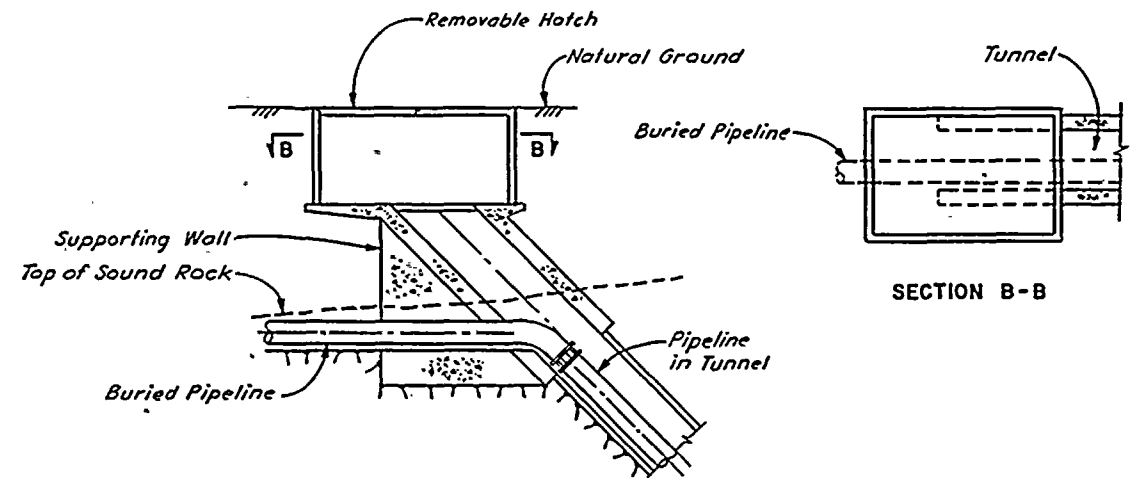




**WATER CONDUIT PROFILE**

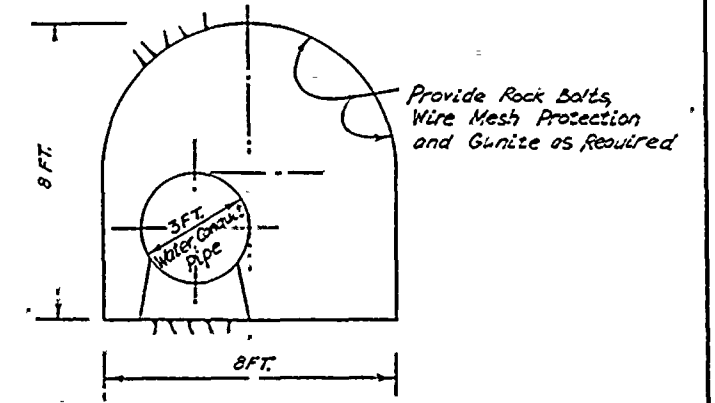


**MANHOLE**  
2 0 2 4 6 8 FT.

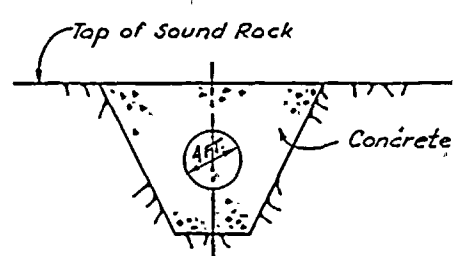


**DETAIL A**  
0 10 20 FT.

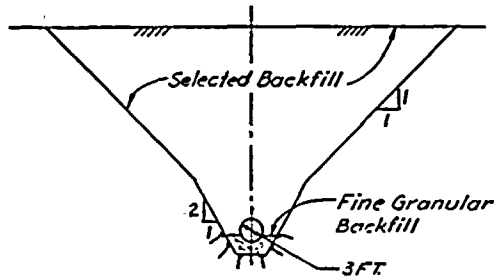
**SECTION B-B**



**TYPICAL TUNNEL SECTION**  
1 FT. 0 5 FT.



**TYPICAL PIPELINE SECTION UNDER DAM**  
2 0 2 4 6 8 FT.



**TYPICAL BURIED PIPELINE SECTION**  
8 4 0 8 K.F.T.

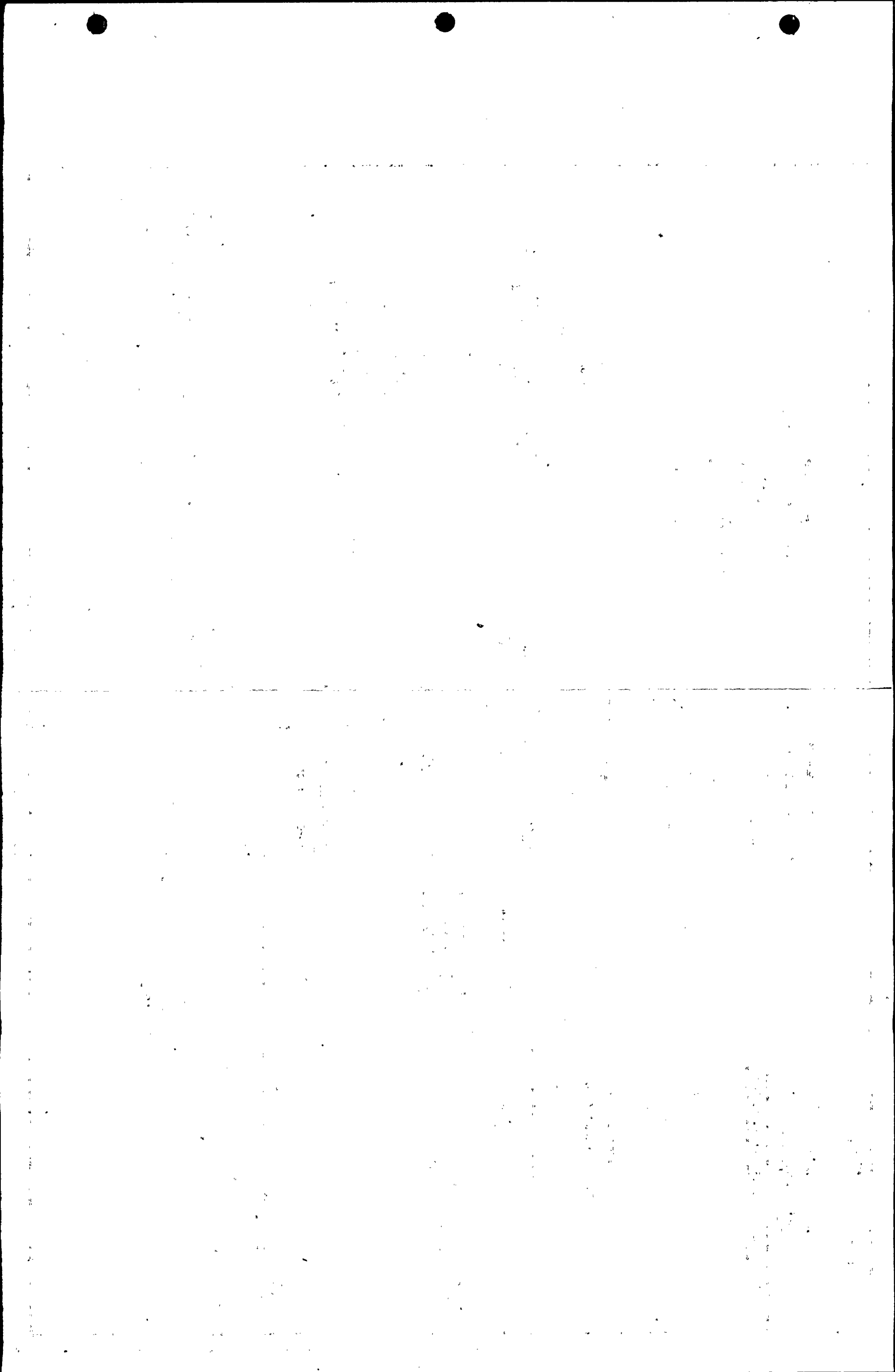
**PENNSYLVANIA POWER & LIGHT COMPANY**

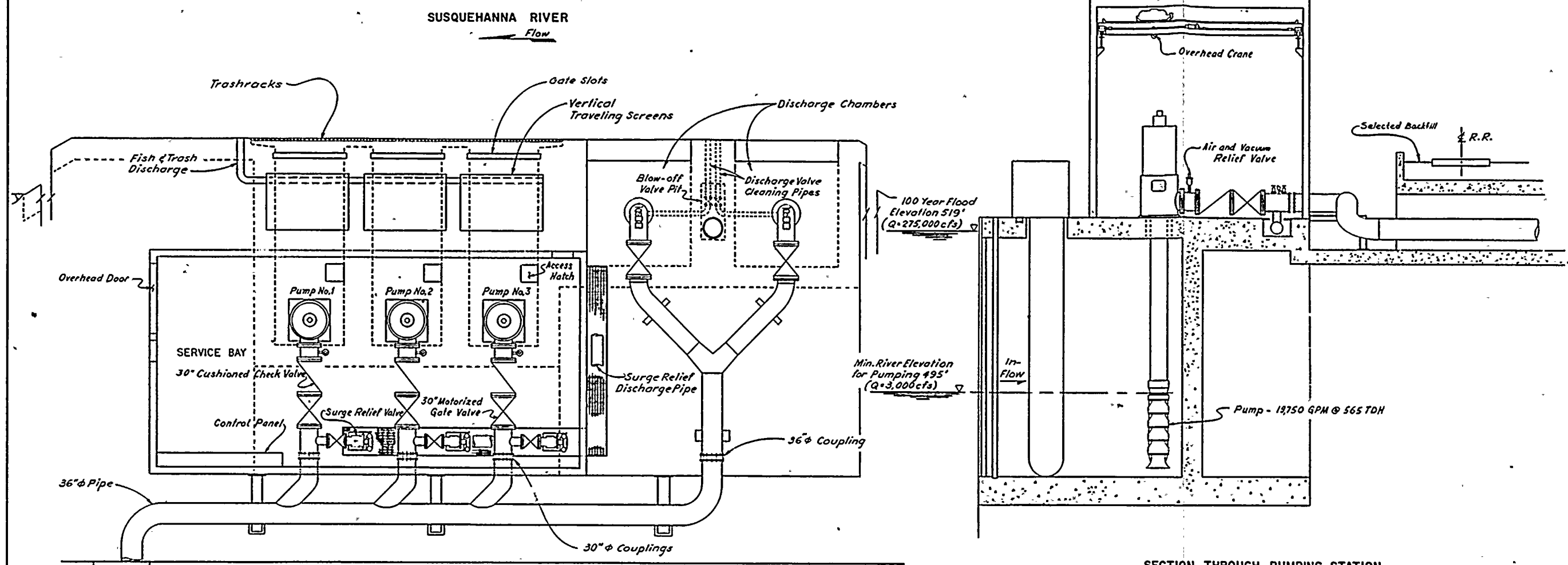
SUSQUEHANNA SES RESERVOIR STUDY  
POND HILL RESERVOIR

**WATER CONDUIT**

PLATE NO. 7

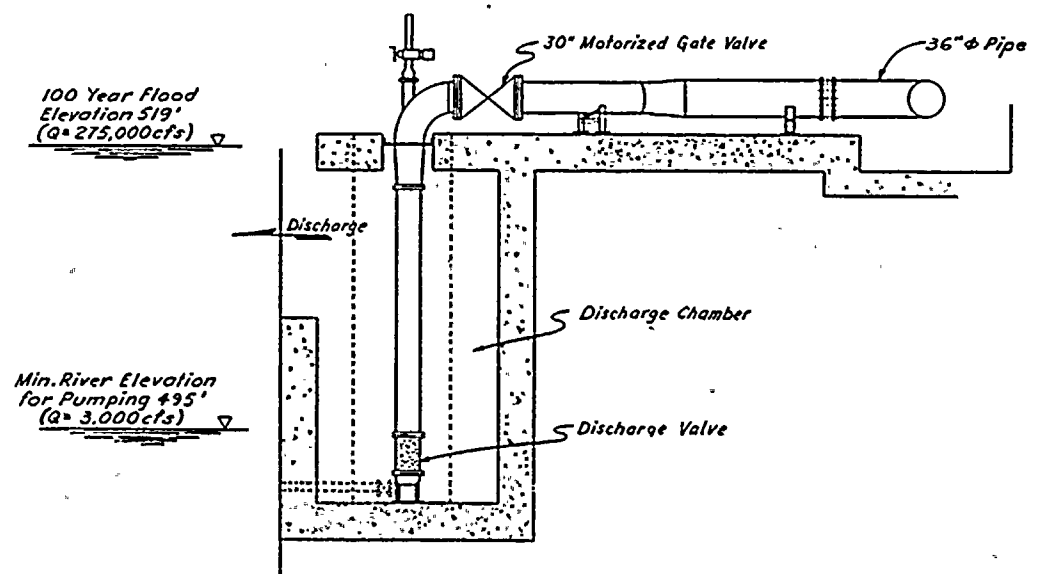
TIPPETTS-ABBETT-McCARTHY-STRATTON  
ENGINEERS AND ARCHITECTS NEW YORK





PLAN OF PUMPING STATION

SECTION THROUGH PUMPING STATION



SECTION THROUGH DISCHARGE CHAMBER



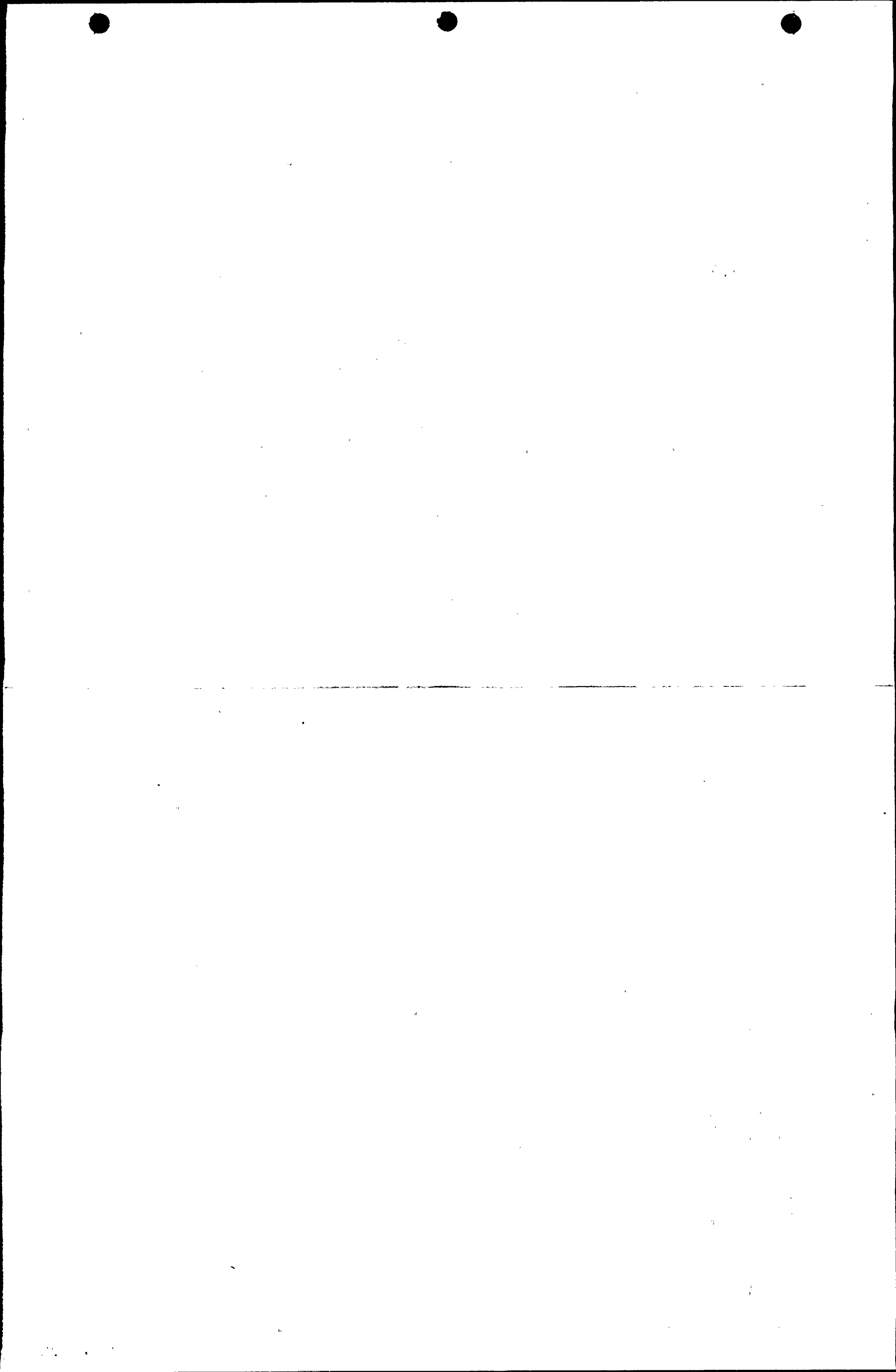
**PENNSYLVANIA POWER & LIGHT COMPANY**

SUSQUEHANNA SES RESERVOIR STUDY  
POND HILL RESERVOIR

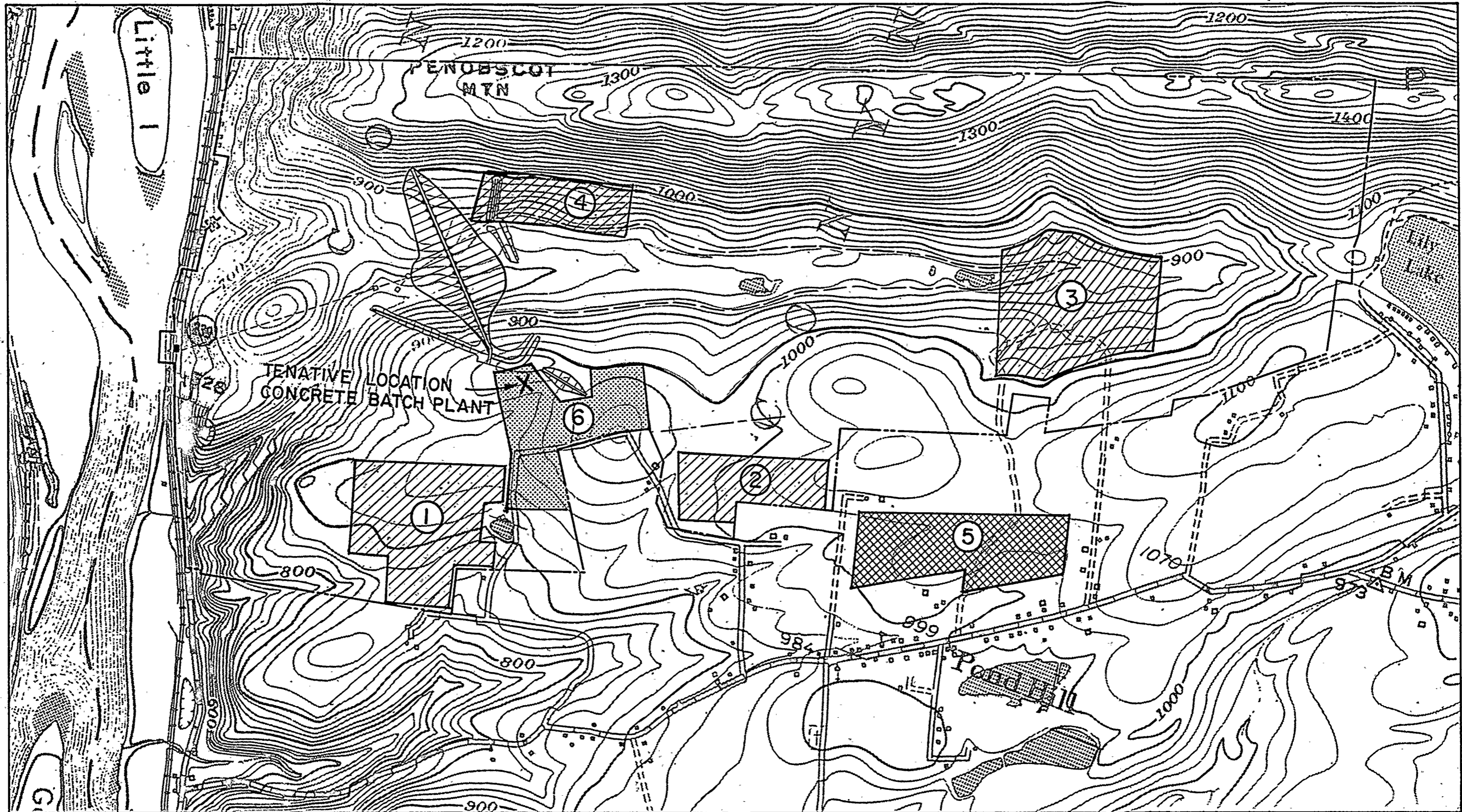
**PUMPING PLANT**

PLATE NO. 8

TIPPETTS-ABBETT-McCARTHY-STRATTON  
ENGINEERS AND ARCHITECTS NEW YORK

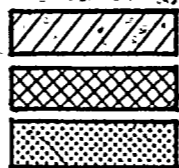




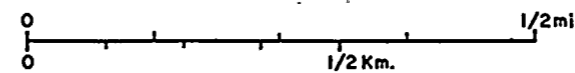


KEY

- MINIMUM POOL ELEVATION
- RESERVOIR MAXIMUM WATER SUPPLY ELEVATION
- ..... SITE PERIMETER



- PRIMARY BORROW AREAS
- ADDITIONAL BORROW AREA IF REQUIRED
- CONSTRUCTION STAGING AREA



PENNSYLVANIA POWER & LIGHT COMPANY

SUSQUEHANNA SES RESERVOIR STUDY  
POND HILL RESERVOIR

CONSTRUCTION AREAS

PLATE NO. 19

TIPPETTS-ABBETT-McCARTHY-STRATTON  
ENGINEERS AND ARCHITECTS NEW YORK

