

REGULATORY INFORMATION DISTRIBUTION SYSTEM (RIDS)

ACCESSION NBR: 8706100221 . DOC. DATE: 87/06/02 NOTARIZED: NO DOCKET #  
 FACIL: 50-250 Turkey Point Plant, Unit 3, Florida Power and Light C 05000250  
 AUTH. NAME AUTHOR AFFILIATION  
 WOODY, C. O. Florida Power & Light Co.  
 RECIP. NAME RECIPIENT AFFILIATION  
 Document Control Branch (Document Control Desk)

SUBJECT: Requests relief from visual (VT-2) exam required by  
 IWA-5246, "Repaired or Replaced Components & Alteration of  
 Sys." required by ASME Boiler & Pressure Vessel Code Section  
 XI. Basis for request encl. Fee paid.

DISTRIBUTION CODE: A001D COPIES RECEIVED: LTR 1 ENCL 1 SIZE: 124  
 TITLE: OR Submittal: General Distribution

NOTES:

	RECIPIENT ID CODE/NAME	COPIES LTTR ENCL	RECIPIENT ID CODE/NAME	COPIES LTTR ENCL
	PD2-2 LA. McDONALD, D	1 0 1 1	PD2-2 PD	5 5
INTERNAL:	ARM/DAF/LFMB	1 0	NRR/DEST/ADE	1 1
	NRR/DEST/ADS	1 1	NRR/DOEA/TSB	1 1
	NRR/PMAS/ILRB	1 1	OGC/HDS2	1 0
	<u>REG FILE</u> 01	1 1		
EXTERNAL:	EG&G BRUSKE, S	1 1	LPDR	1 1
	NRC PDR	1 1	NSIC	1 1

*Rec'd w/ check \$150.00*

PH  
of  
3

STREETS

STREETS

STREETS

STREETS

STREETS

STREETS

STREETS

STREETS

STREETS

STREETS

STREETS

STREETS

STREETS

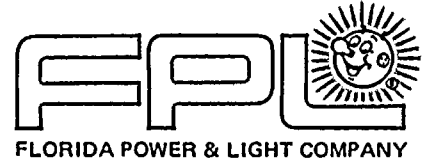

JUNE 02 1987  
L-87-230

U. S. Nuclear Regulatory Commission  
Attn: Document Control Desk  
Washington, D. C. 20555

Gentlemen:

Re: Turkey Point Unit 3  
Docket No. 50-250  
Request for Relief for the  
Second Inservice Inspection Interval

Pursuant to 10 CFR 50.55a(g)(5)(iii), Florida Power & Light Company (FPL) has determined that conformance with certain code requirements is impractical following repairs to Turkey Point Unit 3 control rod drive housings G7 and G9.

Accordingly, FPL requests relief from the visual (VT-2) examination required by IWA-5246, "Repaired or Replaced Components and Alteration of a System", of Section XI of the ASME Boiler and Pressure Vessel Code - Rules for Inservice Inspection of Nuclear Power Plant Components. The basis for relief is provided in the attached Relief Request No. 15.

In accordance with 10 CFR 170.12(c), an application fee (FPL Check No. 4795) for \$150.00 is attached.

If there are any questions, please call us.

Very truly yours,

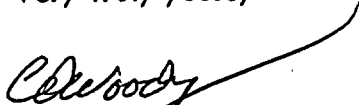
  
C. O. Woody  
Group Vice President  
Nuclear Energy

COW/TCG/gp

Attachment

cc: Dr. J. Nelson Grace, Regional Administrator, Region II, USNRC  
Mr. D. R. Brewer, USNRC Senior Resident Inspector, Turkey Point Plant

*Acc'd  
1/1*

8706100221 870602  
PDR ADDCK 05000250  
Q PDR

*Rec'd w/ check \$150.00*



[The text in this section is extremely faint and illegible due to the quality of the scan. It appears to be several paragraphs of a document.]

TURKEY POINT PLANT UNIT NO. 3  
SECOND INSPECTION INTERVAL  
INSERVICE INSPECTION

RELIEF REQUEST NO. 15

A. COMPONENT IDENTIFICATION

- CLASS 1
- REACTOR PRESSURE VESSEL
- CONTROL ROD DRIVE DUMMIES G7 AND G9
- EXAMINATION CATEGORY: B-O AND B-P
- EXAMINATION ITEM NUMBER: B14.10 AND B15.11
- EXAMINATION DESCRIPTION: PRESSURE RETAINING WELDS IN CONTROL ROD DRIVE HOUSINGS

B. EXAMINATION REQUIREMENTS

- IWB-2500-1, PERFORM VOLUMETRIC OR SURFACE EXAMINATIONS OF 10% OF THE PERIPHERAL CONTROL ROD DRIVE HOUSINGS DURING THE INSPECTION INTERVAL. DRAWING NO. CIS-V-02B PROVIDES THE EXAMINATION REQUIREMENTS FOR A TYPICAL CRDM HOUSING WELD.
- IWA-7530 AND IWA-4500, PRIOR TO RETURN OF THE PLANT TO SERVICE, AND FOLLOWING A REPAIR OR REPLACEMENT, A PRESERVICE INSPECTION SHALL BE PERFORMED.
- IWA-5000, AFTER REPAIRS BY WELDING ON THE PRESSURE RETAINING BOUNDARY, A SYSTEM HYDROSTATIC TEST SHALL BE PERFORMED.
- IWA-5246, THE VISUAL (VT-2) EXAMINATION FOLLOWING A REPAIR OR REPLACEMENT OF A COMPONENT; MAY BE LIMITED TO THE REPAIRED OR REPLACED COMPONENT, BUT SHALL INCLUDE ANY CONNECTION MADE TO THE EXISTING SYSTEM.

C. RELIEF REQUESTED

- FPL REQUESTS RELIEF FROM THE VISUAL (VT-2) EXAMINATION REQUIREMENTS OF THE REPAIRED CONTROL ROD DRIVE HOUSING NUMBER G7 AND G9.

D. BASIS FOR RELIEF

1. LOCATION

THE (2) TWO REPAIRED CONTROL ROD DRIVE HOUSINGS (BOTH DUMMIES) ARE LOCATED IN THE CENTER OF THE REACTOR PRESSURE VESSEL HEAD. DRAWING NUMBER CIS-V-02A, COLOR CODED IN RED, PROVIDES THE LOCATION OF THE (2) TWO REPAIRED HOUSINGS WELDS NUMBERS G7 AND G9.

TURKEY POINT PLANT UNIT NO. 3  
SECOND INSPECTION INTERVAL  
INSERVICE INSPECTION

RELIEF REQUEST NO. 15

2. INITIAL PREPARATION FOR EXAMINATIONS

IN ORDER TO PERFORM THE INITIAL VISUAL AND LIQUID PENETRANT EXAMINATIONS THE FOLLOWING PREPARATIONS HAD TO BE PERFORMED.

- a. THE RPI CABLES HAD TO BE REMOVED FROM THE SURROUNDING CRD HOUSINGS.
- b. THE SURROUNDING CRDM COIL STACKS HAD TO BE REMOVED.
- c. RADIATION SURVEYS WERE TAKEN ON THE HEAD. THE OUTSIDE DIAMETER OF THE CLOSURE HEAD AREA RANGED FROM 2 TO 3 R DEPENDING ON WHERE YOU WERE LOCATED.
- d. ACCESS REQUIREMENTS WERE LOOKED AT. THE CLEARANCE BETWEEN THE CRDM HOUSINGS WERE RECORDED AS 8.1/2" BETWEEN EACH HOUSING.

3. INITIAL EXAMINATIONS

- a. VISUAL EXAMINATION WAS PERFORMED IN ORDER TO IDENTIFY AND LOCATE THE LEAKING CRDMS.
- b. THE LIQUID PENETRANT EXAMINATION METHOD WAS USED TO CONFIRM THE SUSPECT AREAS. IN ORDER TO PERFORM THE LIQUID PENETRANT EXAMINATION, A EXAMINER HAD TO BE LOWERED DOWN ON TO THE HEAD FROM ABOVE.
- c. FOLLOWING THE ABOVE EXAMINATIONS, A REMOTE VISUAL EXAMINATION WAS CONDUCTED AND RECORDED ON VIDEO TAPE. THE CRDM HOUSINGS EXAMINED ARE IDENTIFIED ON DRAWING NO. CIS-V-02A. THESE EXAMINATIONS INCLUDED THE TWO LEAKING DUMMIES (RED), THE FOUR ADJACENT CRDM WHICH HAD EVIDENCE OF RECEIVING THE MOST SPRAY (BLUE), THE SURROUNDING CRDMS IN WHICH TO BOUND IN THE LEAKERS (GREEN), THE ADDITIONAL THREE DUMMIES (TURQUOISE), AND THE TWO ADDITIONAL CRDMS CODED IN (PURPLE) RECEIVED A VISUAL AND LIQUID PENETRANT EXAMINATION IN ORDER TO SATISFY THE TEN-YEAR INSPECTION REQUIREMENTS.
- d. THE TOTAL RADIATION EXPOSURE FOR CONDUCT OF THESE EXAMINATIONS WERE IN EXCESS OF 5.5 REM.

TURKEY POINT PLANT UNIT NO. 3  
SECOND INSPECTION INTERVAL  
INSERVICE INSPECTION

RELIEF REQUEST NO. 15

4. REPAIR

THE REPAIR OF THE LEAKING CRDM DUMMIES CONSISTED OF REMOVING THE EXISTING WELD AND REPLACING IT WITH A STAINLESS STEEL CAP WELDED BY A FULL PENETRATION BUTT WELD. DRAWING NUMBER CIS-V-02C PROVIDES A DETAIL OF THE REPAIR WELD AND CAP CONFIGURATION.

EXAMINATIONS PERFORMED DURING THE REPAIR ACTIVITY CONSISTED OF THE VISUAL, LIQUID PENETRANT AND RADIOGRAPHIC EXAMINATION METHODS. FOLLOWING THE REPAIR A FINAL VISUAL, LIQUID PENETRANT AND RADIOGRAPHIC EXAMINATION WAS PERFORMED THAT INCLUDED BOTH THE CONSTRUCTION AND SECTION XI EXAMINATION REQUIREMENTS.

5. DESIGN AND CONFIGURATION RESTRICTIONS

THE CURRENT DESIGN CONFIGURATION OF THE REPAIR DUMMIES REQUIRE THE CRDM TO BE INSULATED WITH A SOCK. THE INSULATION SOCK AS IDENTIFIED IN ATTACHED DRAWING NO. CIS-V-02D RESTRICTS BOTH THE DIRECT OR REMOTE VISUAL EXAMINATION BY COMPLETELY COVERING THE ENTIRE CRDM HOUSING, THEREFORE OBSTRUCTING THE DIRECT OR REMOTE VISUAL EXAMINATION OF THE NEW WELD.

6. ACCESSIBILITY DURING SYSTEM PRESSURE TESTS

FOLLOWING THE REPAIR AND AFTER THE CLOSURE HEAD IS BACK ON THE VESSEL, THE FOLLOWING RESTRICTIONS PROHIBIT THE VT-2 EXAMINATION DURING THE RCS OVER PRESSURE TEST: SEE DRAWING NO. CIS-V-02F FOR GENERAL ARRANGEMENT DETAIL.

- a. THE RPV HEAD SHROUD OBSTRUCTS THE ENTIRE LENGTH OF THE CRDM HOUSINGS. SEE DRAWING NO. CIS-V-02B FOR AREA OF OBSTRUCTION.
- b. THE CRDM COIL STACKS AND RFI CABLES ARE INSTALLED ON THE INSTRUMENT PORTS.
- c. THE INSULATION SOCK IS INSTALLED ON THE REPAIRED DUMMIES. SEE DRAWING NO. CIS-V-02D FOR DETAILS.
- d. A BLANK COIL STACK IS INSTALLED OVER THE INSULATED SOCK, AND IS ATTACHED BY A CLAMP TO THE ADJACENT CRDM HOUSING. SEE DRAWING NO. CIS-V-02G FOR DETAILS.

TURKEY POINT PLANT UNIT NO. 3  
SECOND INSPECTION INTERVAL  
INSERVICE INSPECTION

RELIEF REQUEST NO. 15

- e. THE TEST TEMPERATURE AND PRESSURE 2350 PSI AND 547 DEGREES F, PROHIBIT ACCESS TO THE EXAMINATION AREAS.
- f. THE INSTALLATION OF THE MISSILE SHIELDS.

7. IN ADDITION TO THE ABOVE OBSTRUCTIONS THE AMOUNT OF ASSOCIATED EFFORT AND SUPPORTING WORK TO COMPLY WITH THE CODE REQUIREMENTS IS NOT JUSTIFIED FOR THE FOLLOWING REASONS:

- a. FPL FEELS THAT BECAUSE OF THE DESIGN CHANGE FROM A FULL PENETRATION SEAL WELD TO A FULL PENETRATION BUTT WELD AND COUPLED WITH THE VISUAL, LIQUID PENETRANT AND RADIOGRAPHIC EXAMINATIONS PERFORMED ON THE REPAIR WELD, WILL PROVIDE AN ASSURANCE OF AN ACCEPTABLE LEVEL OF QUALITY AND SAFETY.
- b. FPL FEELS THAT WITH THE ADDITION OF THE THREE INSPECTION PORTS THAT EARLY IDENTIFICATION OF LEAKS FROM THE CRDM PORTS WILL ASSURE A CONTINUED ACCEPTABLE LEVEL OF QUALITY AND REDUCE THE RADIATION EXPOSURE TO THE EXAMINERS.
- c. FPL FEELS THAT THE REMOVAL OF THE ABOVE IDENTIFIED OBSTRUCTIONS SOLELY FOR THE PURPOSE OF VIEWING THE REPLACEMENT WELDS BY THE VISUAL EXAMINATION METHOD COUPLED WITH THE LARGE EXPENDITURES OF MANHOURS AND MAN-REM THAT WILL BE REQUIRED WITH ESSENTIALLY NO COMPENSATING INCREASE IN PLANT SAFETY.

E. ALTERNATIVE EXAMINATIONS

1. PERFORM THE VISUAL (VT-2) EXAMINATION DURING THE REACTOR COOLANT SYSTEM OVERPRESSURE TEST TO THE EXTENT PRACTICAL WITHOUT THE REMOVAL OF THE INSULATION BY EXAMINING THE ACCESSIBLE PORTIONS AND EXPOSED SURFACES AND THE SURROUNDING AREAS LOCATED AROUND THE CLOSURE HEAD FLANGE SURFACE FOR EVIDENCE OF LEAKAGE.
2. FPL HAS INSTALLED WITHIN THE SHROUD, THREE (3) REMOVABLE INSPECTION/EXAMINATION PORTS AND WITH THE POSITION OF THE PORTS AND THE USE OF A HIGH INTENSITY LIGHT THESE VIEWING PORTS WILL PROVIDE THE EXAMINER WITH A MEANS OF LOCATING AND IDENTIFYING LEAKS THAT MAY BE PRESENT DURING THE OVERPRESSURE TEST.



TURKEY POINT PLANT UNIT NO. 3  
SECOND INSPECTION INTERVAL  
INSERVICE INSPECTION

RELIEF REQUEST NO. 15

F. IMPLEMENTATION SCHEDULE

- THE SECOND REFUELING OUTAGE OF THE SECOND TEN-YEAR  
INSERVICE INSPECTION INTERVAL

G. ATTACHMENTS

DRAWING NUMBER	DESCRIPTION
CIS-V-02A	RPV CLOSURE HEAD LOCATION AND EXAMINATION DETAIL
CIS-V-02B	CLOSURE HEAD HOUSING DETAIL
CIS-V-02C	CLOSURE HEAD DUMMY MODIFICATION
CIS-V-02D	INSULATION SOCK DETAIL FOR REPAIRED CRDMS
CIS-V-02E	VISUAL EXAMINATION PORTS
CIS-V-02F	GENERAL ARRANGEMENT DRAWING
CIS-V-02G	DUMMY COIL STACK ARRANGEMENT



RELIEF REQUEST NO. 15

**NOTE:**

- 1) ASME B&PV CODE SECTION III, 1985 EDITION  
CODE CASE - 1935  
CODE CASE - 1332-2
- 2) CODE CATEGORY: B-0
- 3) CODE ITEM NUMBER: B14.10
- 4) EXAM REQUIREMENTS: IWB-2598-18

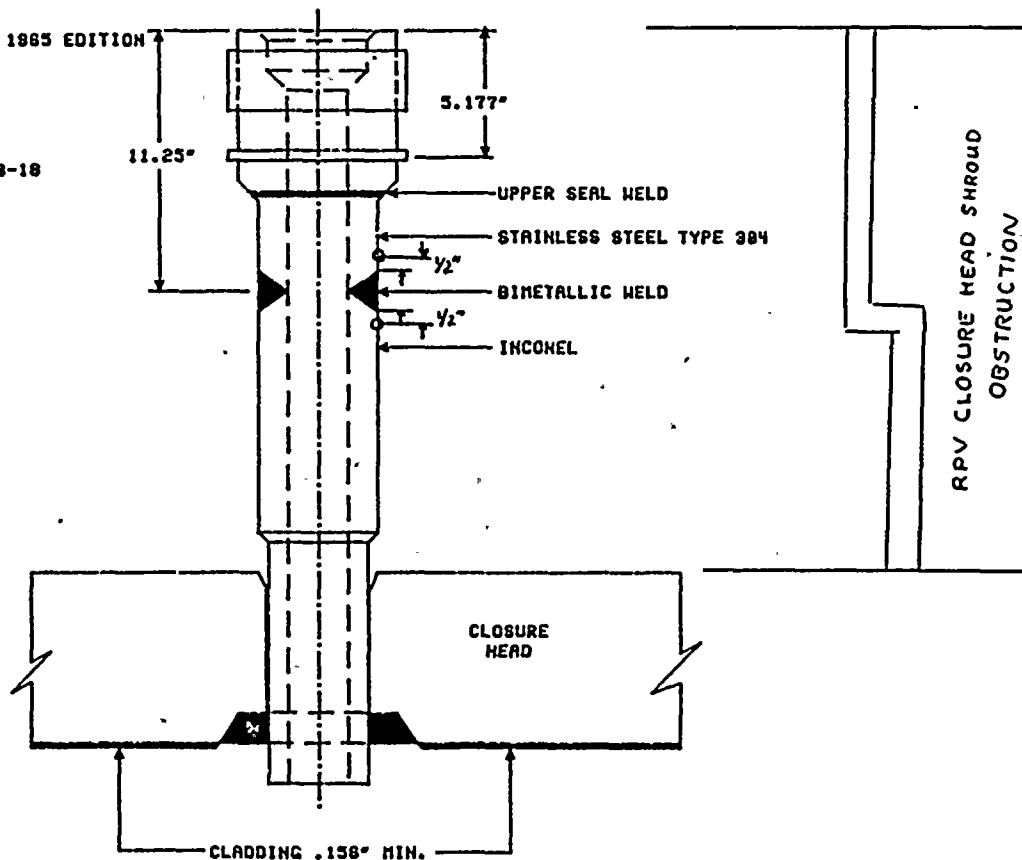

REFERENCE DRAWINGS: REV:	PRESSURE & TEMPERATURE STATS	SIZE	MATERIAL SPECS	CODES & PROGRAMS GROUP
153811E R O WESTINGHOUSE				TURKEY POINT UNIT 3
	DESIGN PSIG: 2485      TEMP(F): 680	4.25" .075" T	S8 187 INCONEL ALLOY 688	TITLE: CLOSURE HEAD HOUSING DETAIL
	OPERATING PSIG: 2295      TEMP(F): 547	4.25" .075" T	SA 182 TYPE 304 STAINLESS STEEL	DATE: 5-14-87      ZONE: 2
	HYDROSTATIC PSIG: 3107      TEMP(F): 547			REV. 1      APPROVED BY: <i>J. E. Anderson</i> DRAWING NUMBER: C18-V-02B



1  
2  
3  
4  
5  
6  
7  
8  
9  
10  
11  
12  
13  
14  
15  
16  
17  
18  
19  
20  
21  
22  
23  
24  
25  
26  
27  
28  
29  
30  
31  
32  
33  
34  
35  
36  
37  
38  
39  
40  
41  
42  
43  
44  
45  
46  
47  
48  
49  
50  
51  
52  
53  
54  
55  
56  
57  
58  
59  
60  
61  
62  
63  
64  
65  
66  
67  
68  
69  
70  
71  
72  
73  
74  
75  
76  
77  
78  
79  
80  
81  
82  
83  
84  
85  
86  
87  
88  
89  
90  
91  
92  
93  
94  
95  
96  
97  
98  
99  
100

[Faint, illegible text or markings covering the majority of the page]

RELIEF REQUEST NO. 15

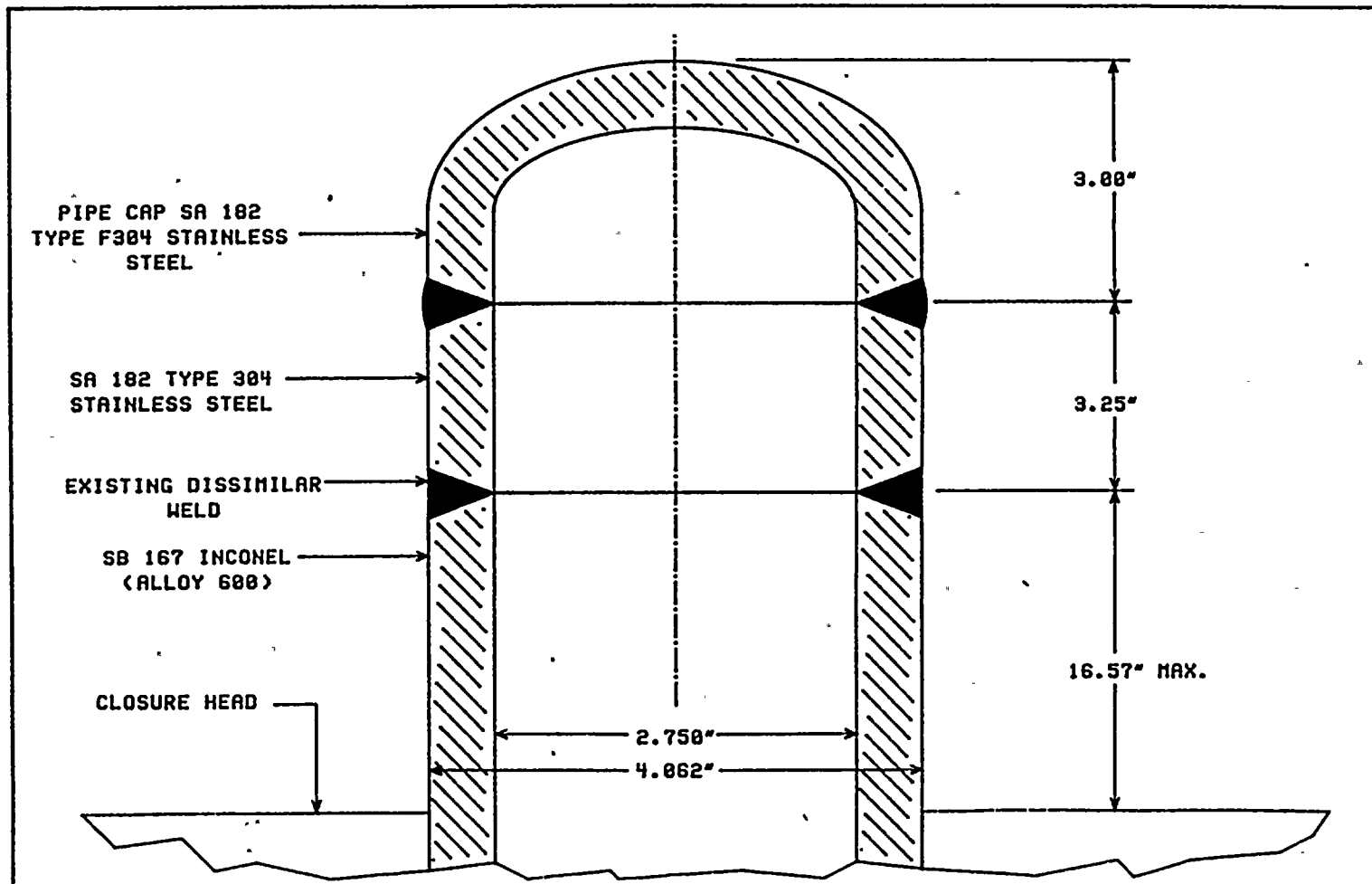

REFERENCE DRAWINGS: REV:	PRESSURE & TEMPERATURE STATS	SIZE	MATERIAL SPECS	CODES & PROGRAMS GROUP
		SCH	TYPE	TURKEY POINT UNIT 3
	DESIGN PSIG:            TEMP(F):	PIPE CAP	SA 182 TP304 SS	TITLE: CLOSURE HEAD DUMMY PENETRATION
	OPERATING PSIG:        TEMP(F):	STUB	SA 182 TP304 SS	MODIFICATION (HEAD ADAPTER CAP)
	HYDROSTATIC PSIG:    TEMP(F):	DUMMY	SB 167 INCONEL	DATE: 5-14-87            ZONE: 2
			ALLOY 600	REV.    APPROVED BY:    DRAWING
				1 <i>[Signature]</i> NUMBER: C18-V-82C

CRDM  
INSULATION  
SOCK

INSULATION  
CLOSURE  
HEAD

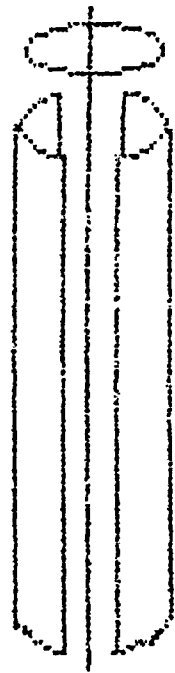
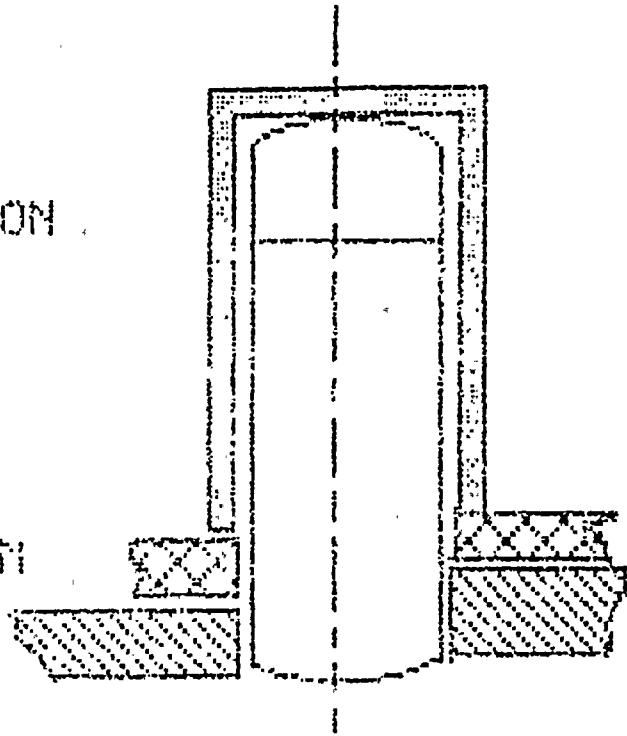

TOP  
SIDE  
(2)

SECURED BY  
VELCRO STRIPS

TURKEY POINT UNIT NO. 3  
RELIEF REQUEST NO. 15  
CIS-U-020  
CRDM INSULATION SOCK



VISUAL EXAMINATION PORTS IN RPV SHROUD

NOTE:

- 1. (3) SEPERATE PORTS SHALL BE INSTALLED

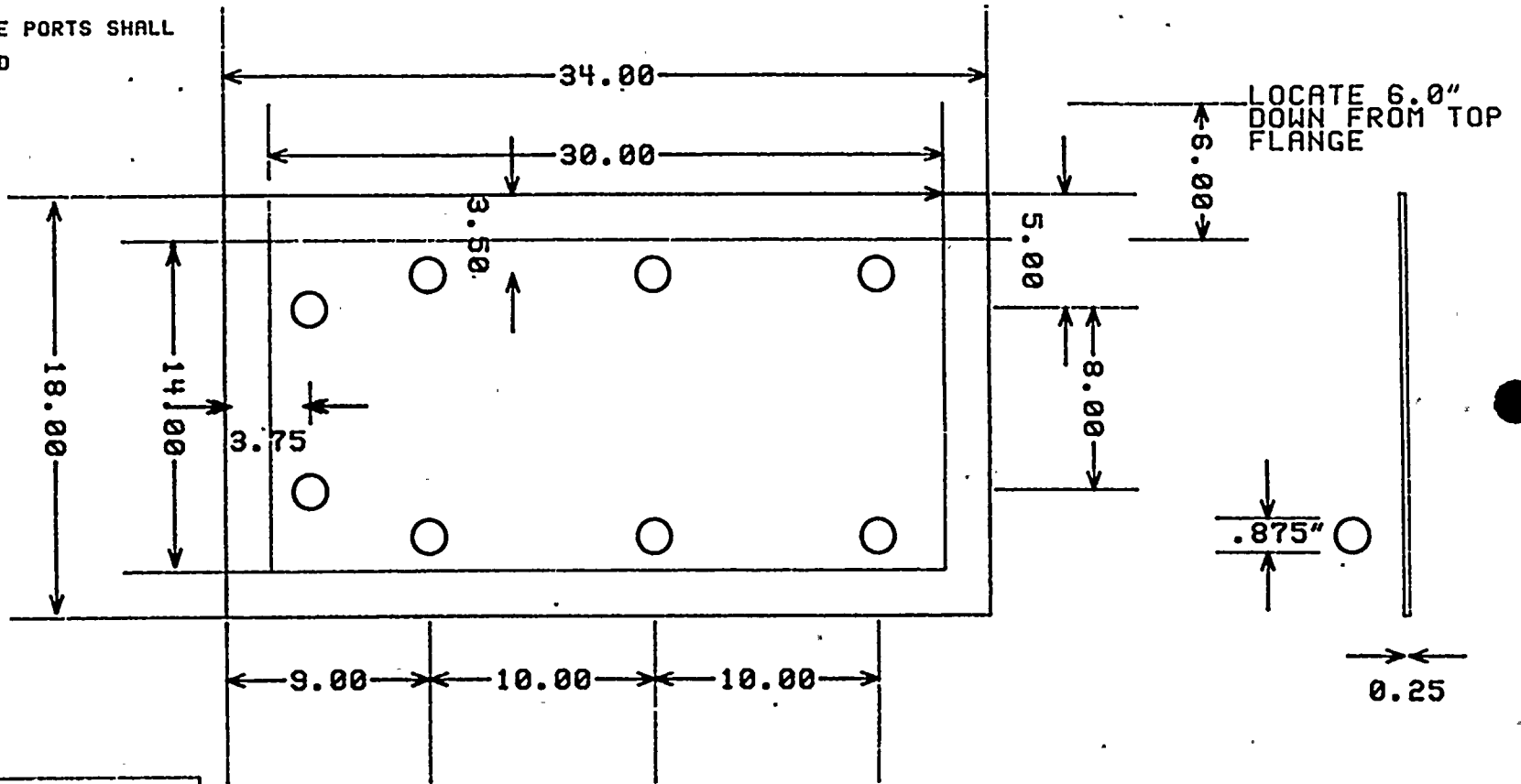

RELIEF REQUEST NO. 15  
 TURKEY POINT PLANT  
 UNIT 3 & 4  
 21 MAY 1987  
 CIS-V-02E

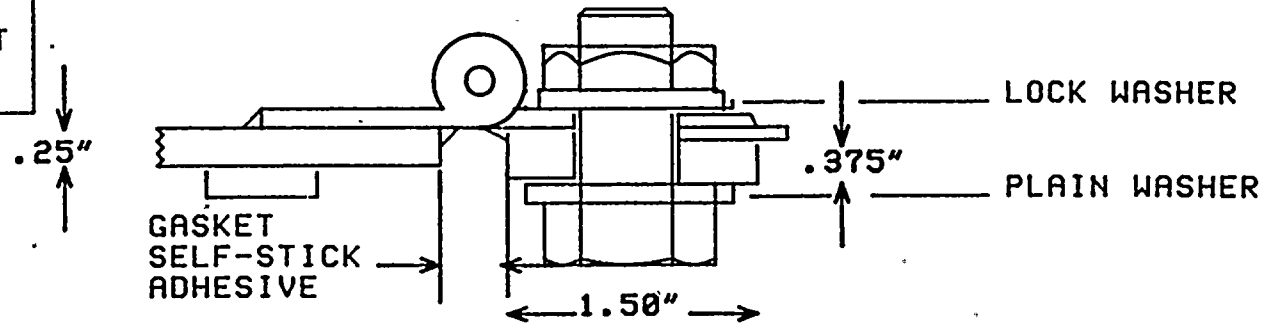



# GENERAL ARRANGEMENT DRAWING

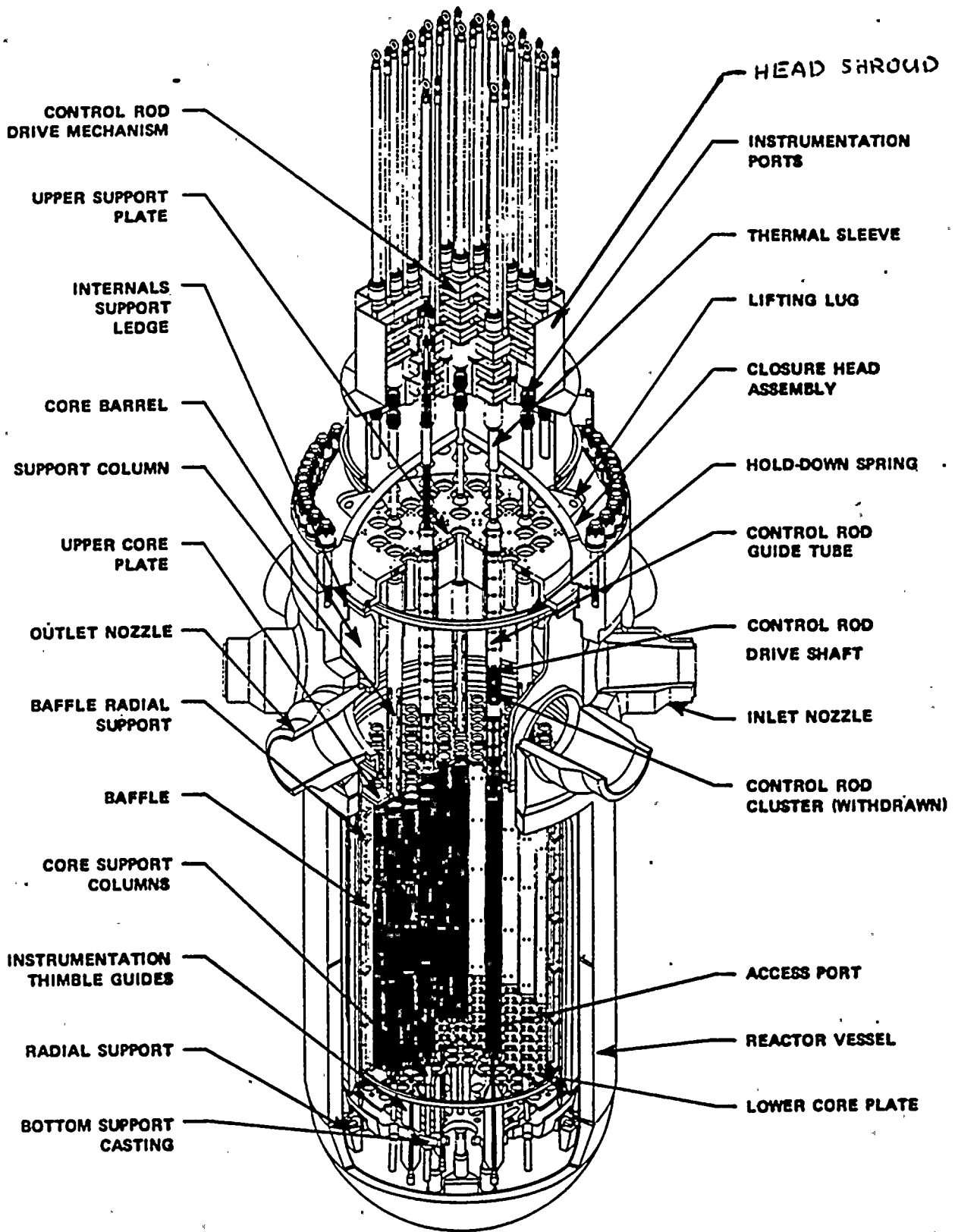

RELIEF REQUEST NO. 15  
CIS-V-02F



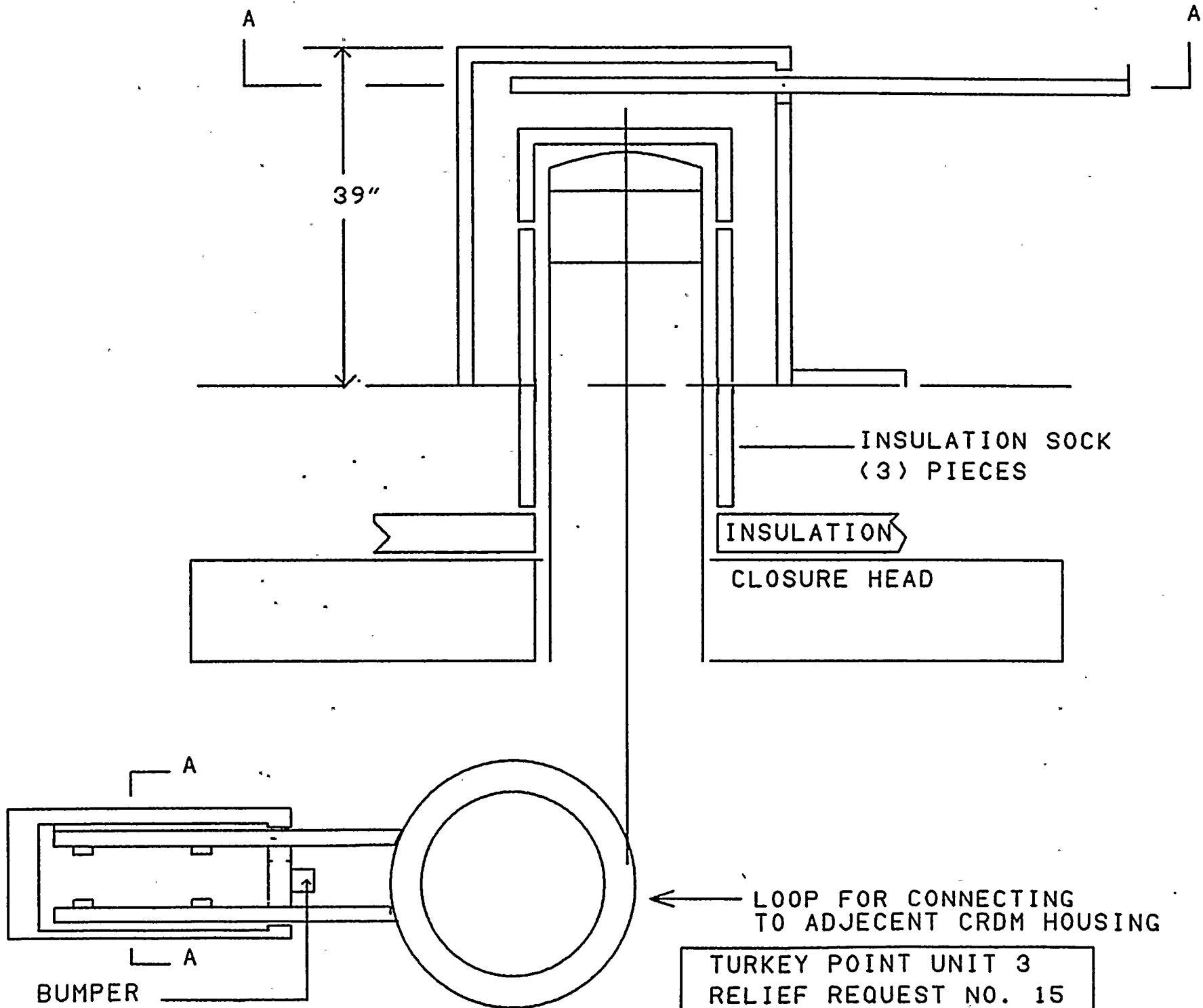

39"

INSULATION SOCK  
(3) PIECES

INSULATION

CLOSURE HEAD

LOOP FOR CONNECTING  
TO ADJECENT CRDM HOUSING

TURKEY POINT UNIT 3  
RELIEF REQUEST NO. 15  
CIS-V-02G

BUMPER



NOTE: LIGHT BORIC ACID RESIDUE WAS NOTED ON ALL BUT THE FOLLOWING PENETRATIONS:  
K-2, L-3, M-4 AND P-6.

TURKEY POINT UNIT 3  
RPV CLOSURE HEAD LEAK DETAIL  
CIS-V-02A

MAY 13, 1987

RED = LEAKERS G-7 INITIAL LEAKER CONFIRMED PT.  
G-9 SUSPECT LEAKER CONFIRMED PT.  
H-8 SUSPECT PT NRI. PLANT QC, VT-2 & PT.

BLUE = BORIC ACID ACCUMULATION  
GREEN = ISI VT-1 BOUNDARY TO INCLUDE CRDM AND BASEMETAL FOR EVIDENCE OF WASTAGE.  
PURPLE = 10 YEAR ISI, PT OF THE DISSIMILAR METAL WELD.  
TURQUOISE = ADDITIONAL SAMPLE TO INCLUDE ALL DUMMY PENETRATIONS.

CONOSEALS (4)

CRDM PARTIAL LENGTH (8)

OPERATING CRDM CONTROL RODS (29)

OPERATING CRDM SHUTDOWN RODS (16)

DUMMY CRDM (8)

TI APERTURE CARD

Also Available On Aperture Card

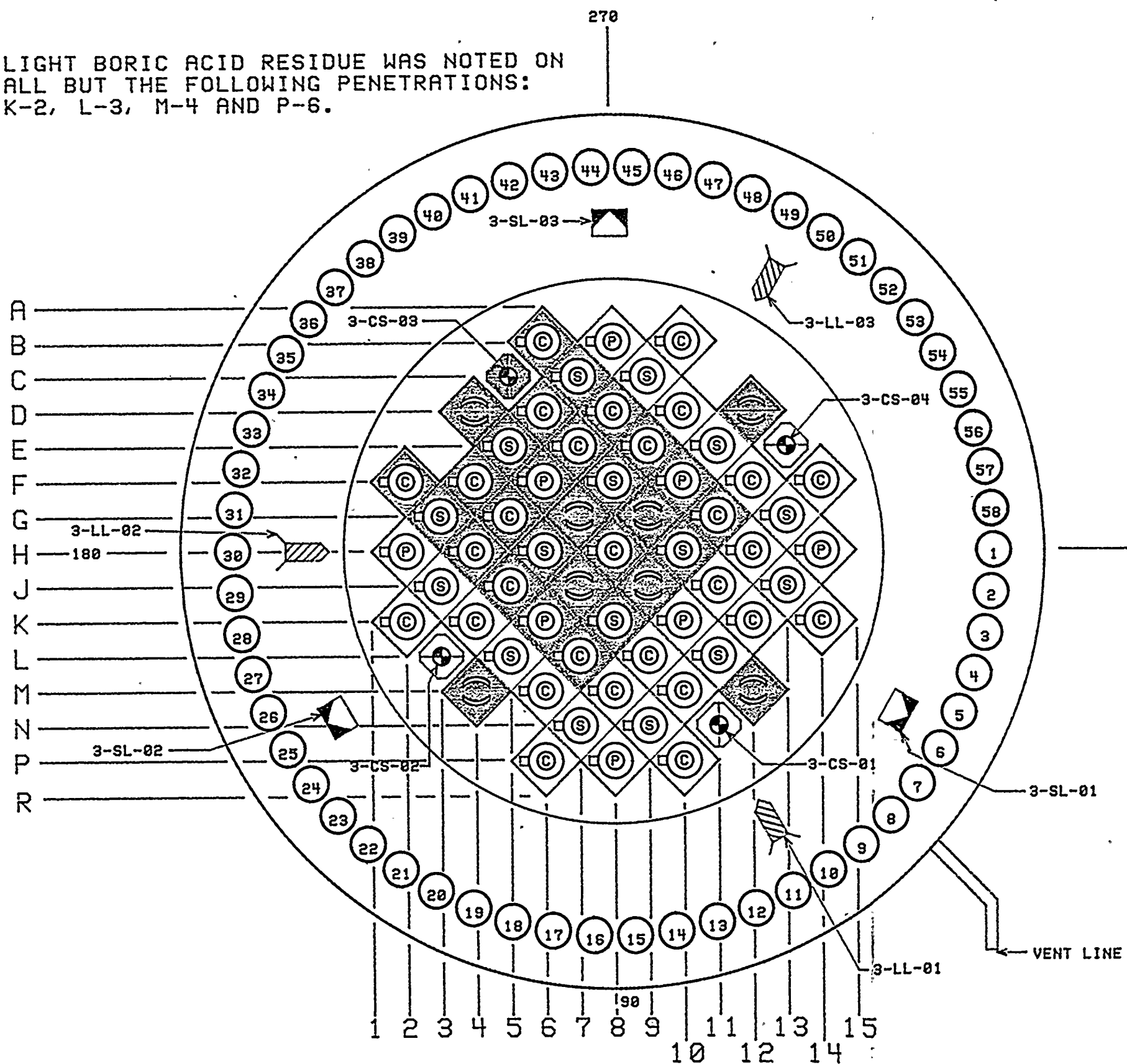

8706100221-01